

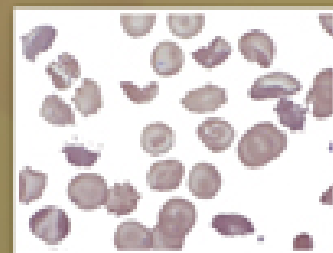

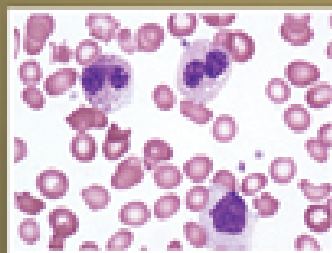
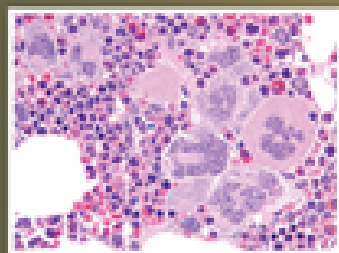
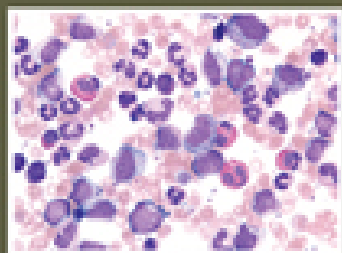

Wintrobe's Clinical Hematology

Thirteenth Edition

INCLUDES
fulltext online
with regular
content updates



John P. Greer
Daniel A. Arber
Bertil Glader
Alan F. List
Robert T. Means, Jr.
Frixos Paraskevas
George M. Rodgers

 Wolters Kluwer | Lippincott
Health Williams & Wilkins

inking

Editors

Editors

John P. Greer MD

Professor

Departments of Medicine and Pediatrics

Divisions of Hematology/Oncology

Vanderbilt University Medical Center

Nashville, Tennessee

Daniel A. Arber MD

Professor and Vice Chair

Department of Pathology

Stanford University

Director of Anatomic and Clinical Pathology Services

Stanford University Medical Center

Stanford, California

Bertil Glader MD, PhD

Professor

Departments of Pediatrics and Pathology

Stanford University Medical Center

Stanford, California

Lucile Packard Children's Hospital

Palo Alto, California

Alan F. List MD

Senior Member

Department of Malignant Hematology

President and CEO

Moffitt Cancer Center

Tampa, Florida

Robert T. Means, Jr., MD

Professor of Internal Medicine

Executive Dean

University of Kentucky College of Medicine

Lexington, Kentucky

Frixos Paraskevas MD

Professor of Internal Medicine and Immunology
(Retired)

University of Manitoba Medical School

Associate Member

Institute of Cell Biology—Cancer Care Manitoba

Winnipeg, Manitoba, Canada

George M. Rodgers MD, PhD

Professor of Medicine and Pathology

University of Utah School of Medicine

Health Sciences Center

Medical Director, Coagulation Laboratory

ARUP Laboratories

Salt Lake City, Utah

John Foerster MD, FRCPC

Professor and Physician Emeritus

Winnipeg, Manitoba, Canada

Contributors

Darryl J. Adamko, MD, FRCPC

Associate Professor

Department of Pediatrics

University of Saskatchewan

Saskatoon, Saskatchewan

Canada

Archana M. Agarwal, MD

Assistant Professor

Department of Pathology

University of Utah

Medical Director

Special Genetics

ARUP Laboratories

Salt Lake City, Utah

Blanche P. Alter, MD, MPH

Senior Clinician

Clinical Genetics Branch

Division of Cancer Epidemiology and Genetics

National Cancer Institute

Rockville, Maryland

Claudio Anasetti, MD

Professor

Oncologic Sciences

University of South Florida

Senior Member

Department Chair

Department of Blood and Marrow Transplantation

H. Lee Moffitt Cancer Center

Tampa, Florida

Stephen M. Ansell, MD, PhD

Professor of Medicine

Mayo Clinic College of Medicine

Consultant

Division of Hematology

Department of Internal Medicine

Mayo Clinic

Rochester, Minnesota

Daniel A. Arber, MD

Professor and Vice Chair

Department of Pathology

Stanford University

Director of Anatomic and Clinical Pathology Services

Stanford University Medical Center
Stanford, California

Robert J. Arceci, MD, PhD

Professor
Department of Pediatric Oncology
Johns Hopkins University
Baltimore, Maryland

Donald M. Arnold, MD, MSc

Associate Professor
Department of Medicine
McMaster University
Associate Medical Director
Medical Affairs
Canadian Blood Services
Hamilton, Ontario
Canada

Maria R. Baer, MD

Professor
Department of Medicine
University of Maryland School of Medicine
Director
Hematologic Malignancies
University of Maryland Marlene and Stewart
Greenebaum Cancer Center
Baltimore, Maryland

Charles D. Bangs, BS

Cytogenetics Laboratory Supervisor
Clinical Laboratories
Stanford Hospital and Clinics
Palo Alto, California

Kirstin F. Barnhart, DVM, PhD, DACVP

Principal Pathologist
AbbVie, Inc.
Preclinical Safety
North Chicago, Illinois

James C. Barton, MD

Clinical Professor of Medicine
Department of Medicine
University of Alabama at Birmingham
Medical Director
Southern Iron Disorders Center
Brookwood Medical Center
Birmingham, Alabama

Minoo Battiwalla, MD, MS

Staff Clinician, Hematology Branch
National Heart, Lung and Blood Institute
National Institutes of Health
Bethesda, Maryland

A. Dean Befus, PhD

Professor
Department of Medicine
University of Alberta
Edmonton, Alberta
Canada

P. Leif Bergsagel, MD

Professor
College of Medicine
Mayo Clinic Medical School
Rochester, Minnesota
Department of Hematology/Oncology
Mayo Clinic
Phoenix, Arizona

Nancy Berliner, MD

Professor
Department of Medicine
Harvard Medical School
Chief
Division of Hematology
Department of Medicine
Brigham and Women's Hospital
Boston, Massachusetts

Kristie A. Blum, MD

Associate Professor
Division of Hematology, Internal Medicine
The Ohio State University
The Ohio State University Wexner Medical Center
Columbus, Ohio

Caterina Borgna-Pignatti, MD

Full Professor of Pediatrics
Clinical and Experimental Medicine
University of Ferrara
Chief
Department of Pediatrics
Arcispedale Sant'Anna
Ferrara, Italy

Linette Bosques, MPhil

PhD Candidate
Departments of Cell Biology and Pathology
Yale School of Medicine
New Haven, Connecticut

Sylvia S. Bottomley, MD

Professor Emeritus of Medicine
Department of Medicine
University of Oklahoma College of Medicine
Staff Physician
Medical Service
VA Medical Center
Oklahoma City, Oklahoma

Robert A. Brodsky, MD

Professor of Medicine and Oncology
 Division of Hematology
 Department of Medicine
 Director
 Division of Hematology
 Johns Hopkins University
 Baltimore, Maryland

Kathleen E. Brummel-Ziedins, PhD

Associate Professor
 Department of Biochemistry
 University of Vermont
 Burlington, Vermont

Francis K. Buadi, MD, ChB

Assistant Professor
 Consultant Hematologist
 Department of Internal Medicine
 Mayo Clinic
 Rochester, Minnesota

David C. Calverley, MD

Associate Professor of Medicine
 Division of Hematology/Medical Oncology
 Oregon Health and Science University
 Portland, Oregon

Ralph Carmel, MD

Professor of Medicine
 Department of Medicine
 Weill Cornell Medical College
 New York, New York
 Director of Research
 Department of Medicine
 New York Methodist Hospital
 Brooklyn, New York

Howard H. W. Chan, MBChB, FRCP(C), MSC

Assistant Professor
 Department of Medicine
 McMaster University
 Hamilton, Ontario
 Canada

Karen L. Chang, MD

Physician-in-Charge
 Histology/Immunohistochemistry
 Kaiser Permanente Southern California Regional
 Laboratory
 North Hollywood, California

William C. Chapman, MD

Professor of Surgery
 Department of Surgery
 Washington University—St. Louis
 Attending/Chief of Surgery
 Department of Surgery

Barnes Jewish Hospital
 St. Louis, Missouri

Athena M. Cherry, PhD

Professor
 Department of Pathology
 Stanford University School of Medicine
 Cytogenetics Laboratory Director
 Clinical Laboratories
 Stanford Hospital and Clinics
 Stanford, California

Andrew Chow, BA

MD-PhD Candidate
 Stem Cell Institute
 Albert Einstein College of Medicine
 New York, New York

Robert D. Christensen, MD

Director of Neonatology Research
 Women and Newborn Services
 Intermountain Healthcare
 Salt Lake City, Utah

Matthew Collin, BM, BCh, DPhil, FRCPath

Professor of Hematology
 Institute of Cellular Medicine
 Newcastle University
 Consultant Hematologist
 Northern Centre for Cancer Care
 Newcastle upon Tyne Hospitals
 Newcastle upon Tyne, United Kingdom

Steven E. Coutre, MD

Professor of Medicine (Hematology)
 Department of Medicine
 Stanford University School of Medicine
 Stanford Cancer Center
 Stanford, California

Utpal P. Davé, MD

Assistant Professor
 Department of Medicine
 Division of Hematology/Oncology
 Vanderbilt University School of Medicine
 Attending Physician
 Department of Medicine/Division of
 Hematology/Oncology
 Tennessee Valley Health Systems VA
 Nashville, Tennessee

Michael W. N. Deininger, MD, PhD

M.M. Wintrobe Professor of Medicine
 Chief, Division of Hematology and Hematologic
 Malignancies
 Department of Internal Medicine

University of Utah/Huntsman Cancer Institute
Salt Lake City, Utah

Judah A. Denburg, MD, FRCPC

William J. Walsh Professor of Medicine
Department of Medicine
McMaster University
Hamilton, Ontario
Canada

Robert J. Desnick, PhD, MD

Dean for Genetic and Genomic Medicine
Professor and Chairman Emeritus Genetic and Genomic
Sciences
Mount Sinai School Medicine
Physician-in-Chief
Genetics and Genomic Medicine
Mount Sinai Hospital
New York, New York

David Dingli, MD, PhD

Professor of Medicine
Hematology and Internal Medicine
Mayo Clinic
College of Medicine
Consultant, Hematology
Mayo Clinic
Rochester, Minnesota

Angela Dispenzieri, MD

Professor of Medicine and Laboratory Medicine
Department of Medicine
Mayo College of Medicine
Mayo Clinic
Rochester, Minnesota

Ahmet Dogan, MD, PhD

Professor of Pathology
Department of Laboratory Medicine and Pathology
Mayo Medical School
Consultant
Department of Laboratory Medicine and Pathology
Mayo Clinic
Rochester, Minnesota

M.B. Majella Doyle, MD

Assistant Professor of Surgery
Department of Surgery
Washington University—St. Louis
Attending, Department of Surgery
Barnes Jewish Hospital
St. Louis, Missouri

P.ix

Cynthia E. Dunbar, MD

Senior Investigator and Section Head
Hematology Branch
The National Heart, Lung and Blood Institute
National Institutes of Health
Bethesda, Maryland

Anne F. Eder, MD, PhD

Executive Medical Officer
National Headquarters, Biomedical Services
American Red Cross
Rockville, Maryland
Adjunct Assistant Professor
Department of Pathology and Laboratory Medicine
Georgetown University School of Medicine
Washington, D.C.

Corwin Q. Edwards, MD

Professor of Medicine
Department of Medicine
University of Utah School of Medicine
Director of Graduate Medical Education
Intermountain Medical Center and LDS Hospital
Salt Lake City, Utah

Ashkan Emadi, MD, PhD

Associate Professor
Department of Medicine
Division of Hematology/Oncology
Leukemia and Hematologic Malignancies
University of Maryland School of Medicine
Marlene and Stewart Greenebaum Cancer Center
Baltimore, Maryland

Stephen J. Everse, PhD

Associate Professor
Department of Biochemistry
University of Vermont
Burlington, Vermont

Rafael Fonseca, MD

Professor of Medicine
Hematology/Oncology
Mayo Clinic
Scottsdale, Arizona

Magali J. Fontaine, MD, PhD

Assistant Professor
Department of Pathology
Stanford University
Associate Medical Director
Department of Pathology, Transfusion Service
Stanford, California

Haydar Frangoul, MD

Professor
 Director
 Pediatric Blood and Marrow Transplant Program
 Division of Pediatric Hematology/Oncology
 Vanderbilt University School of Medicine
 Monroe Carell Jr. Children's Hospital at Vanderbilt
 Nashville, Tennessee

Paul S. Frenette, MD

Chair and Director
 Ruth L. and David S. Gottesman Institute for Stem Cell
 and Regenerative Medicine
 Albert Einstein College of Medicine
 New York, New York

Richard C. Friedberg, MD, PhD

Professor and Deputy Chairman
 Department of Pathology
 Tufts University School of Medicine Western Campus
 Chair
 Department of Pathology
 Baystate Medical Center
 Springfield, Massachusetts

Debra L. Friedman, MD, MS

Associate Professor
 Department of Pediatrics
 Vanderbilt University School of Medicine
 Director, Division of Pediatric Hematology/Oncology
 Monroe Carell Jr. Children's Hospital at Vanderbilt
 Nashville, Tennessee

Michael M. Fry, DVM, MS, DACVP

Associate Professor
 Department of Biomedical and Diagnostic Sciences
 College of Veterinary Medicine, University of Tennessee
 Knoxville, Tennessee

Vijayakrishna K. Gadi, MD, PhD

Assistant Member
 Clinical Research Division
 Fred Hutchinson Cancer Research Center
 Assistant Professor
 Medical Oncology
 University of Washington
 Seattle, Washington

Renzo Galanello, MD

Professor of Pediatrics
 Department of Biomedical Sciences and Biotechnologies
 University of Cagliari
 Head, 2nd Pediatric Clinic
 Thalassemia Unit
 Cagliari, Italy

Susan A. Galel, MD

Associate Professor
 Department of Pathology
 Stanford University
 Stanford, California
 Director of Clinical Operations
 Stanford Blood Center
 Palo Alto, California

Patrick G. Gallagher, MD

Professor
 Department of Pediatrics and Genetics
 Yale University School of Medicine
 Attending Physician
 Yale—New Haven Hospital
 New Haven, Connecticut

Jacob R. Garcia, MD

Associate Hematologist/Oncologist Pediatric
 Hematology/Oncology
 Children's Hospital and Research Center Oakland
 Oakland, California

Guillermo Garcia-Manero, MD

Professor
 Department of Leukemia
 University of Texas MD Anderson Cancer Center
 Houston, Texas

Amy E. Geddis, MD, PhD

Associate Professor
 Pediatric Hematology/Oncology
 University of Southern California, San Diego
 Rady Children's Hospital San Diego
 San Diego, California

Tracy I. George, MD

Associate Professor of Pathology
 Chief, Hematopathology Division
 Director, Hematopathology Fellowship
 University of New Mexico Health Sciences Center
 Albuquerque, New Mexico

Morie A. Gertz, MD, MACP

Professor and Chair
 Department of Medicine
 Mayo Clinic
 Rochester, Minnesota

P.x

Spencer B. Gibson, PhD

Professor
 Biochemistry and Medical Genetics
 Manitoba Institute of Cell Biology
 University of Manitoba

Provincial Director of Research
Manitoba Institute of Cell Biology
CancerCare Manitoba
Winnipeg, Manitoba
Canada

Bertil Glader, MD, PhD

Professor
Departments of Pediatrics and Pathology
Stanford University Medical Center
Stanford, California
Lucile Packard Children's Hospital
Palo Alto, California

Christopher L. Gonzalez, MD

Assistant Clinical Professor
Department of Pathology
Assistant Medical Director
Stanford Blood Center
Stanford University
Palo Alto, California

Lawrence T. Goodnough, MD

Professor
Department of Pathology and Medicine Division of
Hematology
Stanford University
Director
Transfusion Service
Stanford University Medical Center
Stanford, California

Siamon Gordon, MB, ChB, PhD, FRS

Glaxo Professor of Cellular Pathology
Emeritus
Sir William Dunn School of Pathology
University of Oxford
Oxford, United Kingdom

Jason Gotlib, MD, MS

Associate Professor of Medicine (Hematology)
Department of Medicine/Division of Hematology
Stanford University School of Medicine
Stanford, California

John P. Greer, MD

Professor
Departments of Medicine and Pediatrics
Divisions of Hematology/Oncology
Vanderbilt University Medical Center
Nashville, Tennessee

Michael R. Grever, MD

Professor
Department of Internal Medicine
The Ohio State University
Chairman

Department of Internal Medicine
Arthur G. James Cancer Hospital and Richard J. Solove
Research Institute
Columbus, Ohio

Thomas G. Gross, MD, PhD

Professor
Department of Pediatrics
The Ohio State University Medical Center
Gordon Teter Chair for Pediatric Cancer
Hematology/Oncology/BMT
Nationwide Children's Hospital
Columbus, Ohio

Roy M. Gulick, MD

Professor
Department of Medicine
Chief, Division of Infectious Disease
Weill Cornell Medical College
New York, New York

Kenneth R. Hande, MD

Professor
Departments of Medicine and Pharmacy
Division of Hematology/Oncology
Vanderbilt University Medical Center
Nashville, Tennessee

Jane S. Hankins, MD, MS

Associate Member
Hematology
St. Jude Children's Research Hospital
Memphis, Tennessee

Suzanne R. Hayman, MD

Assistant Professor of Medicine
Department of Internal Medicine/Hematology
Mayo Clinic College of Medicine
Consultant

Department of Internal Medicine/Hematology
Mayo Clinic
Rochester, Minnesota

Nancy M. Heddle, MSc

Professor
Department of Medicine
McMaster University
Hamilton, Ontario
Canada

Derralynn A. Hughes, MA, DPhil, FRCP, FRCPath

Senior Lecturer
Department of Haematology
University College London
London, United Kingdom

Caron A. Jacobson, MD

Instructor	McMaster University
Department of Medicine	Hamilton, Ontario
Harvard Medical School	Canada
Clinical Instructor	P.xi
Medical Oncology	
Division of Hematologic Malignancies	
Dana-Farber Cancer Institute	
Boston, Massachusetts	Annette S. Kim, MD, PhD
Madan Jagasia, MBBS, MS	Assistant Professor
Associate Professor	Department of Pathology, Microbiology, and
Department of Medicine	Immunology
Division of Hematology/Oncology	Vanderbilt University Medical Center
Section Chief, Hematology and Stem Cell Transplant	Nashville, Tennessee
Vanderbilt University Medical Center	Rami Komrokji, MD
Nashville, Tennessee	Clinical Director
Vandita P. Johari, MD	Associate Member
Assistant Professor	Department of Malignant Hematology
Department of Pathology	H. Lee Moffitt Cancer Center & Research Institute
Tufts University School of Medicine	Tampa, Florida
Western Campus	Ashish Kumar, MD, PhD
Chief, Clinical Pathology	Assistant Professor of Pediatrics
Department of Pathology	Division of Bone Marrow Transplantation and Immune
Baystate Health	Deficiency
Springfield, Massachusetts	University of Cincinnati College of Medicine
James B. Johnston, MD	Staff Physician
Professor	Division of Bone Marrow Transplantation and Immune
Department of Internal Medicine	Deficiency
University of Manitoba	Cancer and Blood Diseases Institute
Hematologist/Oncologist	Cincinnati Children's Hospital Medical Center
Department of Medical Oncology and Hematology	Cincinnati, Ohio
CancerCare Manitoba	Shaji Kumar, MD
Winnipeg, Manitoba	Professor of Medicine
Canada	Division of Hematology
Dan Jones, PhD	Mayo Clinic
Medical Director	Rochester, Minnesota
Cancer Diagnostics	Thomas J. Kunicki, PhD
Quest Diagnostics Nichols Institute	Senior Scientist II
Chantilly, Virginia	Department of Hematology Research
Adetola A. Kassim, MD	CHOC Children's Hospital
Associate Professor	University of California—Irvine
Department of Medicine	Orange, California
Division of Hematology/Oncology	Gary M. Kupfer, MD
Vanderbilt University Medical Center	Professor
Nashville, Tennessee	Department of Pediatrics
John G. Kelton, MD	Yale School of Medicine
Dean and Vice President	Chief, Pediatric Hematology/Oncology
Faculty of Health Sciences	Department of Pediatrics
Professor	Yale New Haven Children's Hospital
Department of Pathology and Molecular	New Haven Connecticut
Medicine and Department of Medicine	Paul J. Kurtin, MD

Professor of Pathology
 Mayo Medical School
 Department of Laboratory Medicine and Pathology
 Mayo Clinic
 Rochester, Minnesota

Larry W. Kwak, MD, PhD
 Professor and Chairman
 Department of Lymphoma/Myeloma
 The University of Texas MD Anderson Cancer Center
 Houston, Texas

Robert A. Kyle, MD
 Professor of Medicine
 Laboratory Medicine and Pathology
 Department of Internal Medicine
 Division of Hematology
 College of Medicine
 Mayo Clinic
 Rochester, Minnesota

Paige Lacy, PhD
 Associate Professor
 Department of Medicine
 University of Alberta
 Edmonton, Alberta
 Canada

Martha Q. Lacy, MD
 Department of Hematology
 Mayo Clinic
 Rochester, Minnesota

Jeffrey E. Lancet, MD
 Associate Professor
 University of South Florida
 Section Chief—Leukemia
 Associate Member of Malignant Hematology/Oncology
 H. Lee Moffitt Cancer Center & Research Institute
 Tampa, Florida

Andre Larochelle, MD, PhD
 Principal Investigator, Hematology Branch
 The National Heart, Lung and Blood Institute
 National Institutes of Health
 Bethesda, Maryland

Christopher M. Lehman, MD
 Professor (Clinical) Pathology Department
 University of Utah
 Medical Director of Hospital Laboratories
 Pathology Department
 University of Utah Health Care
 Salt Lake City, Utah

Meghan S. Liel, MD

Fellow
 Department of Hematology and Medical Oncology
 Oregon Health and Science University
 Portland, Oregon

Jeffrey M. Lipton, MD, PhD
 Professor
 Pediatrics and Molecular Medicine
 Hofstra North Shore—LIJ School of Medicine
 Hempstead, New York
 Chief
 Hematology/Oncology and Stem Cell Transplantation
 Steven and Alexandra Cohen Children's Medical Center
 of New York
 New Hyde Park, New York

Frederick L. Locke, MD
 Assistant Professor
 Oncologic Sciences
 University of South Florida
 Assistant Member
 Blood and Marrow Transplantation
 H. Lee Moffitt Cancer Center
 Tampa, Florida

Mignon Lee-Chuen Loh, MD
 Professor of Clinical Pediatrics
 Department of Pediatrics
 University of California
 San Francisco Benioff Children's Hospital
 San Francisco, California

John A. Lust, MD, PhD
 Associate Professor of Medicine
 Mayo Clinic College of Medicine
 Consultant
 Division of Hematology
 Department of Internal Medicine
 Mayo Clinic
 Rochester, Minnesota

William R. Macon, MD
 Professor of Pathology
 Mayo Medical School
 Consultant
 Department of Laboratory Medicine and Pathology
 Mayo Clinic
 Rochester, Minnesota

Suman Malempati, MD
 Assistant Professor
 Department of Pediatrics
 Oregon Health and Science University
 Doernbecher Children's Hospital
 Portland, Oregon

Kenneth G. Mann, PhD

Professor Emeritus, Biochemistry
 University of Vermont
 Burlington, Vermont
 P.xii

Catherine A. Manno, MD
 Chair
 Department of Pediatrics
 Pat and John Rosenwald Professor of Pediatrics
 New York University Langone Medical Center
 New York, New York

Peter Maslak, MD
 Professor of Clinical Medicine
 Department of Internal Medicine
 Weill Cornell Medical College
 Chief
 Hematology Laboratory Service
 Laboratory Medicine
 Memorial Sloan-Kettering Cancer Center
 New York, New York

Thomas L. McCurley, MD
 Associate Clinical Professor
 Department of Pathology
 Vanderbilt University Medical Center
 Nashville, Tennessee

Laura Y. McGirt, MD
 Assistant Professor of Medicine/Dermatology
 Division of Dermatology
 Department of Medicine
 Vanderbilt University School of Medicine
 Nashville, Tennessee

Margaret M. McGovern, MD, PhD
 Professor and Chair
 Department of Pediatrics
 Stony Brook University School of Medicine
 Physician in Chief
 Stony Brook Long Island Children's Hospital
 Stony Brook, New York

Kelly M. McNagny
 Professor
 Medical Genetics
 The Biomedical Research Centre
 University of British Columbia
 Vancouver, British Columbia
 Canada

Robert T. Means, Jr., MD
 Professor of Internal Medicine
 Executive Dean

University of Kentucky College of Medicine
 Lexington, Kentucky
 Dean D. Metcalfe, MD
 Chief
 Laboratory of Allergic Diseases
 Division of Intramural Research
 National Institute of Allergy and Infectious Diseases
 National Institutes of Health
 Bethesda, Maryland

Joseph R. Mikhael, MD
 Associate Professor
 Department of Medicine
 Mayo Clinic
 Scottsdale, Arizona

Andrew J. Moore, MD
 Clinical Fellow
 Department of Medicine
 Division of Hematology/Oncology
 Vanderbilt University Medical Center
 Nashville, Tennessee

Redwan Moqbel, PhD, FRCPath
 Professor and Head
 Department of Immunology
 Faculty of Medicine
 University of Manitoba
 Winnipeg, Manitoba, Canada

David S. Morgan, MD
 Associate Professor
 Department of Medicine
 Division of Hematology/Oncology
 Vanderbilt University Medical Center
 Nashville, Tennessee

William G. Morice, II MD, PhD
 Associate Professor
 Laboratory Medicine and Pathology
 Mayo School of Graduate Medical Education
 Consultant
 Division of Hematopathology
 Department of Laboratory Medicine and Pathology
 Mayo Clinic
 Rochester, Minnesota

Claudio A. Mosse, MD, PhD
 Assistant Professor of Pathology
 Department of Pathology
 Vanderbilt University School of Medicine
 Chief of Pathology and Laboratory Medicine
 Department of Pathology and Laboratory Medicine
 Tennessee Valley Health Systems VA
 Nashville, Tennessee

Richard A. Nash, MD

Affiliate Member
 Affiliate Professor
 Clinical Division/Medical Oncology
 Fred Hutchinson Cancer Research Center
 University of Washington
 Seattle, Washington
 Transplant Physician
 Colorado Blood Cancer Institute Presbyterian/St. Luke's
 Denver, Colorado

Sattva S. Neelapu, MD

Associate Professor
 Department of Lymphoma and Myeloma
 The University of Texas MD Anderson Cancer Center
 Houston, Texas

Elizabeta Nemeth, PhD

Associate Professor
 Department of Medicine
 David Geffen School of Medicine
 University of California, Los Angeles
 Los Angeles, California

Huong (Marie) Nguyen, MD

Hematology/Oncology Fellow
 Department of Medicine
 Stanford School of Medicine
 Stanford Hospital and Clinics Cancer Institute
 Stanford, California

H. Stacy Nicholson, MD, MPH

Professor and Chair
 Department of Pediatrics
 Oregon Health and Science University
 Physician-in-Chief
 Doernbecher Children's Hospital
 Portland, Oregon

Ariela Noy, MD

Associate Member, Associate Attending
 Department of Medicine
 Memorial Sloan-Kettering Cancer Center and Cornell
 Weill Medical College
 New York, New York

Diane J. Nugent, MD

Pediatric Hematology
 Chief of Hematology
 Department of Hematology
 CHOC Children's Hospital
 University of California—Irvine
 Orange, California

P.xiii

Maureen M. O'Brien, MD

Assistant Professor
 Department of Pediatrics
 University of Cincinnati
 Associate Director
 Leukemia/Lymphoma Program
 Department of Oncology
 Cincinnati Children's Hospital Medical Center
 Cincinnati, Ohio

Robin K. Ohls, MD

Professor
 Department of Pediatrics
 University of New Mexico
 Director of Pediatric Integration
 Clinical Translational Science Center
 University of New Mexico Health Sciences Center
 Albuquerque, New Mexico

Mihaela Onciu, MD

Hematopathologist
 OncoMetrix
 Memphis, Tennessee

Attilio Orazi, MD, FRCPath (Engl.)

Professor of Pathology and Laboratory Medicine
 Vice Chair for Hematopathology
 Department of Pathology and Laboratory Medicine
 Weill Cornell Medical College
 Director
 Division of Hematopathology
 Department of Pathology and Laboratory Medicine
 New York, New York

Thomas Orfeo, PhD

Research Associate
 Department of Biochemistry
 University of Vermont
 Colchester, Vermont

Eric Padron, MD

Assistant Member
 Department of Malignant Hematology
 H. Lee Moffitt Cancer Center & Research Institute
 Tampa, Florida

Frixos Paraskevas, MD

Professor of Internal Medicine and Immunology
 (Retired) University of Manitoba Medical School
 Associate Member
 Institute of Cell Biology—Cancer Care
 Manitoba
 Winnipeg, Manitoba
 Canada

Charles J. Parker, MD
 Professor
 Department of Medicine
 University of Utah School of Medicine
 Salt Lake City, Utah

Robert C. Pendleton, MD, FACP

Associate Professor
 Department of Medicine
 University of Utah
 Director
 Hospitalist Program
 Medical Director
 Thrombosis Service
 Department of Medicine
 University of Utah Healthcare
 Salt Lake City, Utah

Sherrie L. Perkins, MD, PhD

Professor of Hematology
 Department of Pathology
 University of Utah
 Salt Lake City, Utah

Joseph Pidala, MD, MS

Assistant Professor
 Oncologic Sciences
 College of Medicine—University of South Florida
 Assistant Member
 Blood and Marrow Transplantation
 H. Lee Moffitt Cancer Center
 Tampa, Florida

Annette Plüddemann, PhD

Senior Researcher
 Department of Primary Care Health Sciences
 University of Oxford
 Oxford, United Kingdom

Michael R. Porembka, MD

Department of Surgery
 Washington University School of Medicine
 St. Louis, Missouri

Anna Porwit, MD, PhD

Professor
 Department of Laboratory Medicine and Pathobiology
 University of Toronto
 Hematopathologist
 Department of Laboratory Hematology
 University Health Network
 Toronto General Hospital
 Toronto, Ontario
 Canada

Jerry S. Powell, MD

Professor of Medicine
 Division of Hematology/Oncology
 University of California
 University of California Davis Medical Center, Davis
 Sacramento, California

John G. Quigley, MB, FRCPC

Associate Professor
 Department of Medicine
 University of Illinois at Chicago
 Attending Physician
 Division of Hematology/Oncology
 Department of Medicine
 University of Illinois Hospital and Health Sciences System
 Chicago, Illinois

Charles T. Quinn, MD, MS

Associate Professor
 Department of Pediatrics
 University of Cincinnati College of Medicine
 Director of Hematology
 Clinical and Translational Research
 Department of Hematology
 Cincinnati Children's Hospital Medical Center
 Cincinnati, Ohio

Elizabeth A. Raetz, MD

Associate Professor
 Department of Pediatrics
 Division of Hematology/Oncology
 New York University
 New York, New York

S. Vincent Rajkumar, MD

Professor of Medicine
 Division of Hematology
 Mayo Clinic
 Rochester, Minnesota

Michael Recht, MD, PhD

Associate Professor of Pediatrics and Medicine
 Pediatric Hematology-Oncology
 Oregon Health & Science University
 Portland, Oregon

Nishitha M. Reddy, MD

Assistant Professor
 Department of Medicine
 Division of Hematology/Oncology
 Vanderbilt University Medical Center
 Nashville, Tennessee

Matthew M. Rees, MD

Rutherford Hospital
 Rutherford, North Carolina

P.xiv

George M. Rodgers, MD, PhD
Professor of Medicine and Pathology
University of Utah School of Medicine
Health Sciences Center
Medical Director
Coagulation Laboratory
ARUP Laboratories
Salt Lake City, Utah

Stephen J. Russell, MD, PhD
Dean for Discovery and Experimental Research
Department of Molecular Medicine
Richard O. Jacobson Professor of Molecular Medicine
Mayo Clinic
Rochester, Minnesota

John T. Sandlund, Jr., MD
Member
Department of Oncology
St. Jude Children's Research Hospital
Professor
Department of Pediatrics
University of Tennessee College of Medicine
Memphis, Tennessee

Bipin N. Savani, MBBS
Associate Professor of Medicine
Director
Long Term Transplant Clinic, Hematology and Stem Cell
Transplant
Vanderbilt University Medical Center
Nashville, Tennessee

Matthew Seftel, MD
Assistant Professor
Department of Internal Medicine
University of Manitoba
Hematologist
Department of Medical Oncology and Hematology
CancerCare Manitoba
Winnipeg, Manitoba
Canada

Paul J. Shami, MD
Professor of Medicine
Division of Hematology and Hematologic Malignancies
Adjunct Professor
Department of Pharmaceutics and Pharmaceutical
Chemistry
University of Utah
Salt Lake City, Utah

Luke R. Shier, MD

Assistant Professor
Department of Pathology
University of Ottawa
Hematopathologist
Pathology and Laboratory Medicine
The Ottawa Hospital
Ottawa, Ontario
Canada

Akiko Shimamura, MD, PhD
Associate Member
Clinical Research Division
Fred Hutchinson Cancer Research Center
Associate Professor of Pediatrics
Pediatric Hematology/Oncology
Seattle Children's Hospital
Seattle, Washington

Keith M. Skubitz, MD
Professor
Division of Hematology, Oncology and Transplantation
Department of Medicine
Musculoskeletal Tumor Program, Masonic Cancer
Center
University of Minnesota
Attending Physician
University of Minnesota Medical Center
Minneapolis, Minnesota

James W. Smith, MT, BSc
Assistant Professor
Department of Medicine
McMaster University
Coordinator/Technical Director
Platelet Immunology Laboratory
Hamilton Health Sciences
Hamilton, Ontario
Canada

Kristi J. Smock, MD
Assistant Professor
Department of Pathology
University of Utah Health Sciences Center
Medical Director
Hemostasis/Thrombosis Laboratory
ARUP Laboratories
Salt Lake City, Utah

Susan S. Smyth, MD, PhD
Professor and Chief
Division of Cardiovascular Medicine
University of Kentucky
Attending Physician
Medical Services
Lexington VA Medical Center
Lexington, Kentucky

Steven L. Soignet, MD	P.xv
Arcus Advisory New York, New York	
Nicole I. Stacy, DVM, DrMedVet	Han-Mou Tsai, MD
Adjunct Clinical Assistant Professor Department of Large Animal Clinical Sciences University of Florida College of Veterinary Medicine Gainesville, Florida	Professor Department of Medicine Pennsylvania State University College of Medicine Chief Section of Hemostasis and Thrombosis Milton S. Hershey Medical Center Hershey, Pennsylvania
Martin H. Steinberg, MD	Luc Van Kaer, MD
Professor of Medicine Department of Pediatrics, Pathology and Laboratory Medicine Boston University School of Medicine Director Center of Excellence in Sickle Cell Disease Boston Medical Center Boston, Massachusetts	Professor Department of Pathology, Microbiology and Immunology Vanderbilt University School of Medicine Nashville, Tennessee
A. Keith Stewart, MBChB	Srdan Verstovsek, MD, PhD
Dean for Research Division of Hematology/Oncology Mayo Clinic Scottsdale, Arizona	Professor of Medicine Chief Section for Myeloproliferative Neoplasms (MPNs) Department of Leukemia Director Clinical Research Center for MPNs University of Texas MD Anderson Cancer Center Houston, Texas
Stephen A. Strickland, MD, MSCI	Maurene K. Viele, MD
Assistant Professor Department of Medicine Division of Hematology/Oncology Vanderbilt University Medical Center Nashville, Tennessee	Clinical Associate Professor Department of Pathology Stanford University Associate Medical Director Transfusion Service Stanford University Medical Center Stanford, California
Mary Ann Thompson, MD, PhD	Mary A. Vu, MD
Associate Professor Department of Pathology Vanderbilt University Medical Center Nashville, Tennessee	Clinical Fellow Department of Medicine Division of Hematology/Oncology Vanderbilt University Medical Center Nashville, Tennessee
John Tisdale, MD	Mark C. Walters, MD
Senior Investigator and Section Head Hematology Branch The National Heart, Lung and Blood Institute National Institutes of Health Bethesda, Maryland	Associate Adjunct Professor Department of Pediatrics University of California—San Francisco, San Francisco Director Blood Marrow Transplant Program Department of Hematology/Oncology Children's Hospital and Research Center Oakland, California
Troy R. Torgerson, MD, PhD	Winfred C. Wang, MD
Assistant Professor Department of Pediatrics University of Washington School of Medicine Attending Physician Department of Immunology Seattle Children's Hospital Seattle, Washington	

Member
Department of Hematology
St. Jude Children's Research Hospital
Memphis, Tennessee

Russell E. Ware, MD, PhD

Professor and Vice-Chair for Global Health
Department of Pediatrics
Baylor College of Medicine
Director
Texas Children's Hematology Center
Director
Texas Children's Center for Global Health
Texas Children's Hospital
Houston, Texas

Kathryn E. Webert, MD, MSc, FRCPC

Associate Professor
Department of Medicine and Department of Molecular
Medicine and Pathology
McMaster University
Director of Operations, Transfusion Medicine
Hamilton Regional Laboratory Medicine Program
Hamilton Health Sciences
Hamilton, Ontario
Canada

Lawrence M. Weiss, MD

Senior Consulting Pathologist
Clariant Pathology Services, Inc. Aliso Viejo, California

James A. Whitlock, MD

Professor
Department of Pediatrics

University of Toronto
Division Head
Division of Hematology/Oncology
The Hospital for Sick Children
Toronto, Ontario
Canada

Michael E. Williams, MD

Byrd S. Leavell Professor of Medicine
Hematology/Oncology Division
University of Virginia School of Medicine
Department of Medicine
University of Virginia Health System
Charlottesville, Virginia

Steven R. Zeldenrust, MD, PhD

Assistant Professor
Hematology
Mayo Clinic
Rochester, Minnesota

John A. Zic, MD

Associate Professor of Medicine/Dermatology
Division of Dermatology
Department of Medicine
Vanderbilt University School of Medicine
Nashville, Tennessee

Jeff P. Zwerner, MD, PhD

Assistant Professor of Medicine/Dermatology
Division of Dermatology
Department of Medicine
Vanderbilt University School of Medicine
Nashville, Tennessee

Dedication

TO DR. MAXWELL M. WINTROBE



Preface

Preface

Welcome to the thirteenth edition of Wintrobe's Clinical Hematology. This textbook strives to continue the Wintrobe tradition of being comprehensive yet accessible to all who seek to understand the history, science, and clinical practice of hematology. We have brought together clinicians and scientists who have given their time and expertise to produce a state-of-the-art resource which includes an online presence with expanded bibliographies, appendices, and updates.

THE WINTROBE LEGACY

Few have appreciated the wealth of information to be gained by the study of blood more than Maxwell Myer Wintrobe (1906 to 1986). He cited poets, including John Donne's "pure and eloquent blood" and Goethe's "Blood is a juice of a very special kind"; but he added that "It is for the scientist that the blood has been especially eloquent."¹ It has been over 70 years since Wintrobe wrote the first edition of Clinical Hematology (1942); and at the time, he was uncertain if it would have much readership owing to the priorities of World War II. His objective was "to bring together the accumulated information in the field of hematology in a systematic and orderly form." He felt the book should be "comprehensive, complete, and authoritative." He emphasized the importance of "an accurate diagnosis as a prerequisite to efficacious treatment." His goals were to link science to the clinical practice of hematology and to provide the best therapy possible for an individual patient. We have recruited an outstanding group of scientists and clinicians who have given their expertise and time to accomplish similar goals for the thirteenth edition of Wintrobe's Clinical Hematology.

Wintrobe's career included medical school at the University of Manitoba (1921 to 1925) and academic appointments at Tulane University (1927 to 1930), The Johns Hopkins University (1930 to 1943), and the University of Utah (1943 to 1986). His interests were broad and his contributions to medicine and hematology were many.² He had access to an abundance of clinical material at Charity Hospital (New Orleans, LA), where he invented the hematocrit glass tube, which came to bear his name and allowed him to collect information about the blood (Figure 1). The Wintrobe hematocrit tube not only allowed determination of the volume of packed red blood cells after centrifugation but also allowed measurement of the erythrocyte sedimentation rate, determination of the volume of packed white cells and platelets, and detection of changes in the appearance of the plasma.

At Johns Hopkins University, Wintrobe made peripheral smears available to the clinic, reorganized the teaching of the third-year student laboratory course, and established himself as an investigator and leader in hematology.³ He and his colleagues showed that hypochromic anemia responded to iron,⁴ gave the first account of cryoglobulin in the blood,⁵ and provided the first evidence that thalassemias were inherited.⁶ He became chief of the Clinic for Nutritional, Gastrointestinal, and Hematologic Disorders in 1933 and was promoted to the position of Associate in Medicine in 1935. During World War II, he was assigned to study chemical warfare agents and his efforts led to a landmark paper with Louis Goodman et al. on the efficacy of nitrogen mustard as a chemotherapeutic agent.⁷

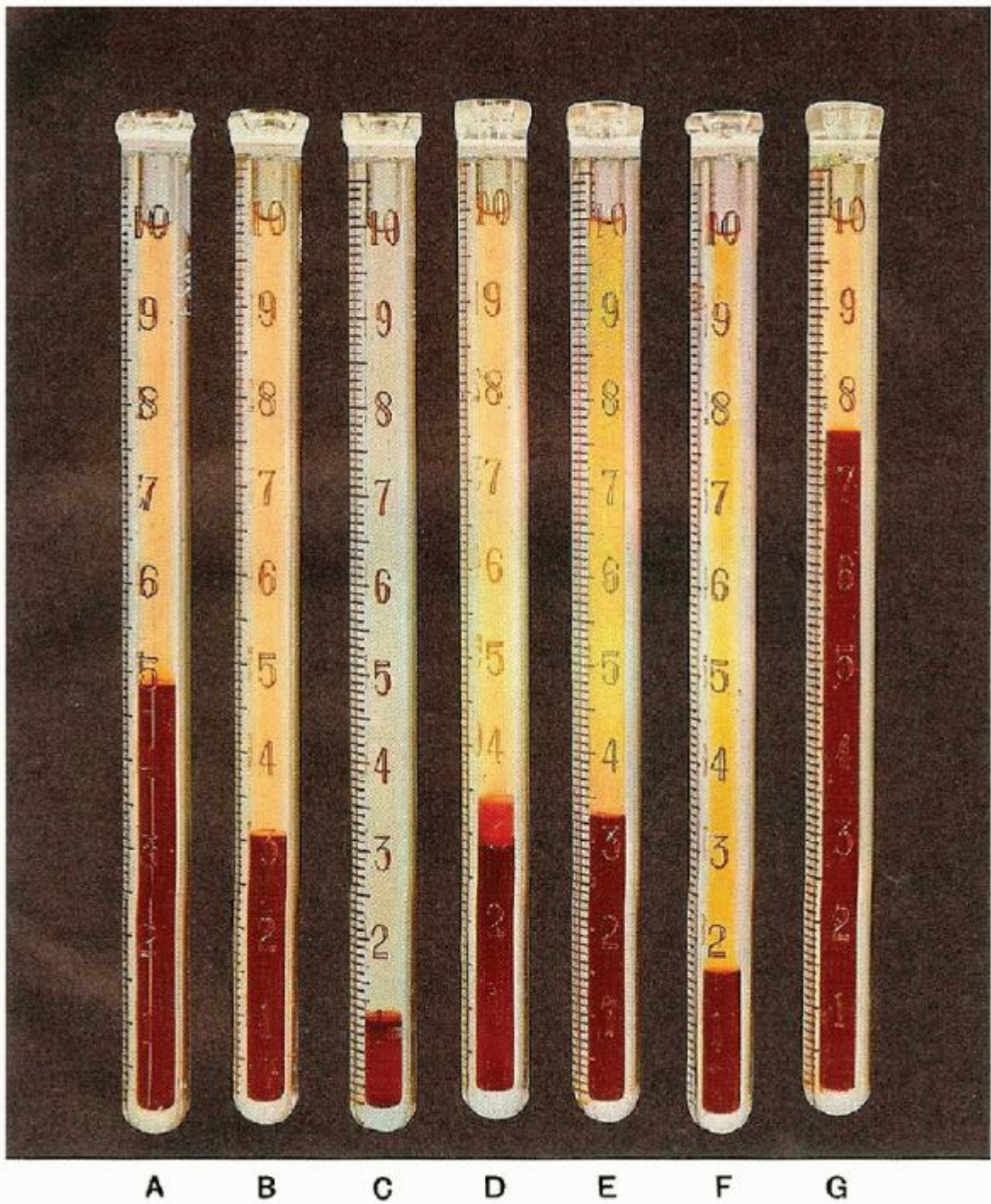

FIGURE 1. Original illustration of Wintrobe tubes depicting the appearance of centrifugal blood in various conditions, as published in the seventh edition.

In 1943, Wintrobe was offered the first Chair of Medicine at the University of Utah. He served as Chair for 24 years and in 1970 was named Distinguished Professor of Internal Medicine. He studied the role of nutritional factors, particularly the B vitamins, in hematopoiesis, and attempted to develop an animal model for pernicious anemia.^{3, 8} His work with pig's nutritional requirements resulted in discovering the effects of pyridoxine deficiency and the role of copper in iron metabolism.³ He studied the effects of the newly discovered adrenocorticosteroids on hematopoiesis,⁹ described the association of chloramphenicol with aplastic anemia,¹⁰ and became an advocate for reporting the adverse reactions to drugs.¹¹

Wintrobe's clinical interests extended beyond hematology, and he received the first research grant ever awarded by the National Institutes of Health. The grant was to study hereditary muscular dystrophy (a disorder that affected a number of Utah families) and was renewed annually for 23 years.^{2, 3} He directed the Laboratory for the Study of Hereditary and Metabolic Disorder and Training Institute (1969 to 1973). Together with George Cartwright, he established a premier hematology training program at Utah. They trained 110 fellows, 85% of whom became associated with medical schools or research institutes.¹²

Wintrobe was the sole author of the first six editions, and he recruited former fellows to assist him on the seventh and eighth editions: Jack Athens, Tom Bithell, Dane Boggs, John Foerster, and Richard Lee with John Lukens joining them on the eighth edition (1981), the last one to involve Wintrobe. Lee, Bithell, Foerster, Athens, and Lukens were the editors for the ninth edition (1993). John Greer, Frixos Paraskevas, and George Rodgers joined Lee, Foerster, and Lukens for the tenth edition (1999) and Bert Glader was added for the eleventh edition (2004). Robert Means, Jr., and Daniel Arber joined Foerster, Glader, Greer, Paraskevas, and Rodgers for the twelfth edition (2009). We welcome Alan List as a new editor for this edition and honor John Foerster as the editor emeritus.

IN MEMORY OF JOHN N. LUKENS

We remember our friend, John Nevius Lukens, Jr. (1932 to 2010), who was dedicated to the Wintrobe legacy and committed to the education of the next generation of health care providers. He was a graduate of Princeton University (1954) and Harvard Medical School (1958). After an internship in Medicine and Pediatrics at the University of North Carolina, he completed his residency at The Children's Hospital in Cincinnati (1959 to 1961). He served 2 years in the U.S. Army Medical Corps at the Letterman General Hospital in San Francisco and became a research fellow at the University of Utah School of Medicine with Eugene Lahey and Wintrobe (1964 to 1967). His research contributed to the understanding of the anemia of chronic disease and iron deficiency. John was a founding member of the Children's Cancer Group and was among the pioneers of pediatric hematology who contributed to a steady and marked increase in the curability of childhood acute lymphoblastic leukemia and other cancers. He held faculty appointments at the University of Missouri School of Medicine (1967 to 1971), Tufts Medical School (1971 to 1973), and the Charles R. Drew Postgraduate Medical School (1973 to 1975) before becoming Director of Pediatric Hematology/Oncology (1975 to 1997) at Vanderbilt University's Children's Hospital. He became an Emeritus in 2001 until his death in 2010. John is remembered as a role model as a physician, a loving husband to his wife Cauley of 51 years, a father devoted to their daughters, Ann, Rachel, and Betsy, and a grandfather to five.

THIRTEENTH EDITION

Our goal in the thirteenth edition is to continue Wintrobe's commitment to link the past accomplishments in hematology to the present state of the art and to future developments. We are honored to have some of the best hematologists in the world contribute to this edition. They have continued the Wintrobe tradition of providing historical perspective and combining basic science with clinical practice. There are 74 new authors, and all of the chapters are new or have been completely revised. All of the authors are worth singling out, but space limits our ability to thank them individually. One of the new contributors is Michael Deininger, who is the Maxwell M. Wintrobe Professor of Medicine at the University of Utah Huntsman Cancer Institute.

The audience for the book encompasses the entire spectrum of health care providers, including medical students, nurses, residents, clinicians, and scientists, who seek answers about hematology. The textbook reviews the science, the methods of diagnosis, and the evidence for the basis of therapeutic decisions. The artwork has been extensively redrawn for color and consistency and there are numerous photomicrographs, which illustrate the role of hematopathology in diagnosis.

The book is divided into eight parts: Laboratory Hematology; The Normal Hematologic System; Transfusion Medicine; Disorders of Red Cells, Hemostasis, and Coagulation; Benign Disorders of Leukocytes; The Spleen and/or Immunoglobulins; Hematologic Malignancies; and Transplantation. Throughout the chapters, there is an emphasis on the four components in hematology that contribute to diagnosis: the morphological exam of the peripheral blood smear, bone marrow, lymph nodes, and other tissues; flow cytometry, cytogenetics, and molecular markers.

The expanding role of molecular genetics and flow cytometry is not only improving diagnosis but also providing targets for novel therapies. The role of tyrosine kinase inhibitors in chronic myeloid leukemia serves as a model for molecularly targeted therapy. The detection of minimal residual disease by either flow cytometry or polymerase chain reaction techniques is impacting therapeutic decisions. Chapters on gene therapy and immunotherapy are up-to-date reviews on these unique therapies for a variety of hematologic disorders. The role of stem cell transplantation is addressed in chapters on specific diseases and in an entirely new part, which reviews its application for both benign and malignant disorders, graft-versus-host disease, and the importance of long-term follow-up of transplantation survivors.

For a textbook to meet its audience needs in the 21st century, there must be an online presence and a way to interact with and update its readers. The online text has a complete reference list for each chapter and two appendices, one reviewing the clusters of differentiation molecules by Dan Arber and Frixos Paraskevas and another by veterinarians Nicole Stacy, Kirstin Barnhart, and Michael Fry, who review lab values and photomicrographs of the blood of animals. We plan to issue updates online when there is either unique or sufficient information that influences the practice of hematology.

We are indebted to the efforts of Jonathan Pine, who has kindly supported us as Senior Executive Editor at Lippincott Williams & Wilkins since the 10th edition; Emilie Moyer, Senior Product Manager; and Frannie Murphy, Development Editor.

REFERENCES

1. Wintrobe MM. Blood, pure and eloquent: a story of discovery, of people, and of ideas. New York: McGraw-Hill Book Company, 1980.
2. Herbert LF. Maxwell Myer Wintrobe: new history and a new appreciation. *Tex Heart Inst J* 2007;34:328-335.
3. Spivak JL. Maxwell Wintrobe, in his own words. *Br J Haematol* 2003;121:224-232.
4. Wintrobe MM, Beebe RT. Idiopathic hypochromic anemia. *Medicine* 1933;12:187-243.
5. Wintrobe MM, Buell MV. Hyperproteinemia associated with multiple myeloma. *Bull Johns Hopkins Hosp* 1933;52:156-165.
6. Wintrobe MM, Matthews E, Pollack R, et al. A familial hemopoietic disorder in Italian adolescents and adults; resembling Mediterranean disease (thalassemia). *J Am Med Assoc* 1940;114:1530-1538.
7. Goodman LS, Wintrobe MM, Dameshek W, et al. Nitrogen mustard therapy; use of methyl-bis (beta-chloroethyl) amine hydrochloride and tris (betachloroethyl) amine hydrochloride for Hodgkin's disease, lymphosarcoma, leukemia and certain allied and miscellaneous disorders. *J Am Med Assoc* 1946;132:126-132.
8. Wintrobe MM. The search for an experimental counterpart of pernicious anemia. *AMA Arch Intern Med* 1957;100:862-869.
9. Wintrobe MM, Cartwright GE, Palmer JG, et al. Effect of corticotrophin and cortisone on the blood in various disorders in man. *AMA Arch Intern Med* 1951;88:310-336.
10. Smiley RK, Cartwright GE, Wintrobe MM. Fatal aplastic anemia following chloramphenicol (chloromycetin) administration. *J Am Med Assoc* 1952;149:914-918.
11. Wintrobe MM. The problems of drug toxicity in man—a view from the hematopoietic system. *Ann N Y Acad Sci* 1965;123:316-325.
12. Boggs DR. Maxwell M. Wintrobe. *Blood* 1973;41:1-5.

Acknowledgments

Thanks to my wife, Gay, for her support and our grown children, Lesley, Adam, and Scott; Pamela Johnson, who diligently and kindly prepared manuscripts; Billi Bean, who worked on editions 9 through 12 and handed the reins to Pamela; Meera Kumar, P.A., the nurse practitioners and nurses who provide extraordinary care to the patients at Vanderbilt University Medical Center; and mentors and colleagues: Robert Collins, John Flexner, Stanley Graber, Marsha Kinney, Mark Koury, Sanford Krantz, Friedrich Schuening, Richard Stein, and Steven Wolff; and a special thanks to John Lukens, who brought me into the world of Maxwell M. Wintrobe, and my lifelong friend, Thomas McCurley.

John P. Greer, MD

I wish to thank my wife, Carol Park, for her constant support. I also thank my current and past trainees, colleagues, and mentors, all of whom are continuous sources of knowledge.

Daniel A. Arber, MD

I wish to acknowledge the many outstanding colleagues, both chapter authors and fellow editors, whom I have had the privilege to work with in the development of this new edition. I also want to acknowledge my students, residents, and fellows who continue to make the teaching of clinical hematology so meaningful. Lastly, but most of all, I want to recognize the understanding and support of my wonderful wife Lou Ann, my children, and their families.

Bertil Glader, MD, PhD

As I am sure our readers understand, creating a state-of-the-art reference text is by no means a simple task. It begins with the authors who graciously give their time, often juggling deadlines with immediate demands from their own research, clinical duties, etc. I thank them for their diligence and perseverance to create an outstanding reference. Individuals at Lippincott Williams & Wilkins such as Emilie Moyer, Franny Murphy, and Jonathan Pine worked ever so patiently in providing the guidance and focus necessary to see this to completion. Finally, my sincere thanks to our senior editor and master medical coordinator of Wintrobe, Dr. John Greer, for his faith in the process, admirable leadership, and sensitivity to the mission.

Alan F. List, MD

I wish to thank my wife Stacey and our children, Casey, Robert, and Patrick, for their support and tolerance during the preparation of this book; the many teachers and colleagues who have guided me as mentors and examples in science and medicine, particularly Shu-Yung Chen, Joachim Pfitzner, James B. Walker, Robert D. Collins, Roger M. DesPrez, Richard Borreson, Richard Vilter, Herbert Flessa, John Flexner, and Sanford B. Krantz; and above all my late parents, Ann and Bob Means, who were my first and best teachers.

Robert T. Means, Jr. MD

I am deeply indebted to my pathologist wife, Dr. Maria Paraskevas, for her unwavering support, encouragement, and advice throughout the writing of my chapters.

Frixos Paraskevas, MD

I acknowledge Stephen Kling for expert word processing and my numerous contributors for their outstanding chapters. This is the fourth edition of this textbook I have been involved with; it has been a pleasure working with my coeditors and publishing colleagues on this edition.

George Rodgers, MD, PhD

I wish to thank my wife Gisela, who bore my commitments to this tome for seven editions with encouragement, patience, and grace. Deeply felt gratitude is extended to my mentors, Dr. L. G. Israels and Dr. M. M. Wintrobe, both now regrettably deceased, and Dr. B. Benacerraf, who nurtured my interests in Immunology. Dr. Israel's enthusiasm for Hematology and his ability to combine effectively clinical excellence, teaching, and research drew me to this specialty as a medical student. Dr. Wintrobe taught me in his own unique way and gave me the opportunity to contribute as author and associate editor to this great textbook. Special thanks to my colleagues who have contributed valuable chapters to this text.

John Foerster, MD

Introduction

The study of the blood has a long history. Humankind probably always has been interested in the blood because it is likely that even primitive peoples realized that loss of blood, if sufficiently great, was associated with death. In biblical references, to shed blood meant to kill.¹

THE FOUNDATIONS OF DIAGNOSIS

When and in what manner blood was first examined is unknown, but before the days of microscopy only the gross appearance of the blood could be studied. Blood allowed to clot in a glass vessel can be seen to form several distinct layers: at the bottom a dark red, almost black, jellylike material is seen; above this is a red layer; and still nearer the top of the clot is a pale green or whitish layer. Above these is the transparent, yellow serum. It has been suggested that perception of these layers in the blood after its removal from the body may have given rise to the doctrine of the four humors (black bile, sanguis, phlegm, and yellow bile), which were believed to constitute the substance of the human body. Health and disease were thought to be the result of the proper mixture or imbalance, respectively, of these four humors. This doctrine corresponding to the pervading concept of matter founded on the interrelationship of the four elements—earth, water, air, and fire—was set out clearly in the Hippocratic writings and was systematized into a complex metaphysical pattern by Galen in the 2nd century ad. It dominated medical thinking even into the 17th century.

Microscopic examination of the blood by Leeuwenhoek and others in the 17th century, and subsequent improvements in their rudimentary equipment, provided the means whereby theory and dogma would gradually be replaced by scientific understanding. The advance of knowledge was slow; however; those who were willing to observe and to seek greater understanding were few compared with the multitudes who repeated the age-old formulations. In the 18th century,

William Hewson (1739 to 1774) made many important observations, and over the next 150 years or more, others gradually left their mark, including Gabriel Andral (1797 to 1876), Alexander Donné (1801 to 1878), Georges Hayem (1841 to 1933), and Paul Ehrlich (1854 to 1915), as well as Virchow, Aschoff, Maximow, Pappenheim, and still others in more recent times.²

However, it was not until the 1920s, beginning with the investigations of Whipple, Minot, and Castle, that the modern era of hematology started. From that time on, the field of hematology has flourished, and knowledge and understanding have grown at an ever-accelerating pace. The story has been told elsewhere.² The reader will find revealing the comparison of the first edition of this textbook published in 1942, with subsequent editions.

At one time, hematology was a purely laboratory endeavor concerned with quantitation of the formed elements of the blood and the study of their morphology and that of the bone marrow, spleen, and lymphoid tissues. In the past 70 years, however, hematology has become a broad-based science that, in seeking to understand the normal and pathologic physiology of the hematopoietic system, uses all the methods of diverse scientific disciplines such as biochemistry, cell biology, immunology, physical chemistry, molecular biology, genetics, and nuclear medicine. As a consequence, the study of a hematologic problem can involve the use of procedures of great complexity.

Nevertheless, in the majority of patients whose illness may be regarded as being directly or indirectly related to the blood or blood-forming organs, examination requires only simple procedures. These begin with the steps fundamental and essential in the study of any clinical problem: a carefully taken history and a meticulous, discerning physical examination. It should be emphasized that the hematologist must be conversant with illness on a broad scale because, although certain diseases affect primarily the blood and blood-forming tissues, more often, disorders of other organ systems result in alterations in the hematopoietic system. A sound and thorough background is essential for the hematologist because modern oncologic therapy affects tissues other than those of the hematopoietic system and can be associated with diverse complications.

The symptoms of hematologic disorders are so varied and nonspecific that in themselves they may not suggest a hematologic problem. Thus, unexplained fever, extreme fatigability, or recurrent infections may or may not be caused by a hematologic condition. Likewise, physical examination may or may not direct attention to the hematopoietic system. The physical signs may be mainly those of congestive heart failure when the primary condition is pernicious anemia in relapse, adenopathy and splenomegaly when the underlying condition is a self-limited childhood infection, or nothing other than pallor when leukemia or aplastic anemia is the underlying disorder. In other instances, sternal tenderness, or bone tenderness elsewhere, hemorrhages, or spoon nails may direct attention to the hematopoietic system.

Certain details of history must receive special inquiry. These include exposure to physical or chemical agents, which may have caused injury, and to drugs, prescribed or self-medicated. Often overlooked are substances used at work and in the home, such as pesticides and solvents. Especially misleading is the fact that only the exceptional individual is harmed by most of these agents, thereby giving the patient and the physician a false sense of security. For example, in patients given chloramphenicol, only rarely did aplastic anemia develop. Also deserving special inquiry is the diet, the degree and frequency of menstrual blood loss, evidence of intestinal blood loss, and the presence or the absence of fever.

In addition, family history is important in the differential diagnosis of hematologic disorders. Knowledge of ethnic origin or a history of jaundice, anemia, cholelithiasis, splenectomy, or bleeding in male rather than in female members of the family, for example, may offer useful clues. Furthermore, history alone may be insufficient. Although symptoms may be denied, a palpable

P.xxvi

spleen on physical examination or morphologic changes seen in the blood smear, such as target cells and basophilic stippling, may direct attention to the hitherto unsuspected hereditary disorder. A family history is only as good as the thoroughness of the inquiry.

In the physical examination, careful attention should be given to the color of the skin, the sclerae and the nails, the presence of lymphadenopathy, sternal or other bone tenderness, splenomegaly, and petechiae in the mouth, ocular fundi, or skin. Unless the patient has been examined while lying on his or her right side, with the abdomen relaxed, as well as in the usual manner in the supine position, a search for an enlarged spleen cannot be considered complete. One also should be careful not to miss a renal tumor or mistake it for an enlarged spleen.

In addition to the history and physical examination, it is necessary to determine whether anemia is present, to calculate the red cell indices, and to measure the concentrations of the leukocytes and platelets. The erythrocyte sedimentation

rate may be included as a useful, nonspecific indicator of acute or chronic conditions. Blood chemical examinations, especially those for blood urea nitrogen, creatinine, and uric acid, are also essential. Usually, in an automated laboratory, it is faster, equally accurate, and less costly in time and money to obtain a battery of such data as part of the initial evaluation.

The stained blood smear must be examined not only to determine the differential leukocyte count but also to search for other signs of abnormality. The latter, at least, should be done by the hematologist. Even if one could count on perfect laboratory examinations and reports (which one cannot, even with the best laboratories), nothing can replace the careful scrutiny of the blood smear by a physician who knows the patient's complaints and physical findings. Subtle abnormalities in red cell morphology may have been overlooked or a rare nucleated red cell or an immature or abnormal leukocyte may have been missed; a platelet count may have been reported as being low, but the blood smear may show otherwise.

The indiscriminate selection of a battery of hematologically oriented tests, such as obtaining a Coombs test and levels of serum iron, B₁₂, and folic acid, in every anemic patient is wasteful, unwise, and unnecessary. In particular, bone marrow examination, which too often is done almost automatically in conditions suspected to be hematopoietic, is unjustified as a routine part of the hematologic examination. Bone marrow examination is useful in certain situations but cannot be expected to be helpful in others.

Again, the tendency to order procedures such as red cell survival studies, liver and spleen scans, or other costly or time-consuming examinations when the same information can be obtained or inferred by simpler means only taxes the financial resources of the patient and the health care system.

Results of the initial investigation often direct further study in one of three or four areas, the approaches to which are described in later chapters. Thus, if anemia appears to be the outstanding feature, refer Chapter 22 for steps to follow in investigating its nature and cause. The investigation of patients with bleeding disorders is outlined in Chapter 45. Abnormalities in the numbers or morphologic characteristics of leukocytes, splenomegaly, lymphadenopathy, recurrent infection, or other signs of abnormal immunologic or phagocytic function are explored in Chapter 56. If all of the formed blood elements are deficient (pancytopenia), consult Chapters 37 and 38. The steps outlined in these chapters, along with the guidance of a provisional diagnosis on the basis of evidence disclosed to that point, make the diagnostic process a logical and orderly procedure. In such a stepwise fashion, an accurate diagnosis can be reached with a minimum of trouble to the patient and at minimal cost. Only in the most complex cases is an exhaustive investigation justified.

PRINCIPLES OF MANAGEMENT

The successful and intelligent management of disease depends on three elements: accuracy of diagnosis, understanding of the nature of the abnormalities discovered and their ultimate prognosis if unchecked, and appreciation of the character of the patient and his or her reaction to the illness. Other important factors that must be considered in this connection are the patient's age, responsibilities, concerns, and fears.

Accuracy of diagnosis obviously is fundamental and influences the treatment of the patient. If the diagnosis is uncertain, one must consider what additional steps must be undertaken in seeking the diagnosis; whether the suspected possibilities justify those steps; whether consultation might be helpful; whether one is justified in waiting to allow the disease process to progress without interference, thereby permitting it to declare itself more clearly; and whether a therapeutic trial based on the most likely diagnosis is justified. One must avoid diffuse testing and data gathering, which may be expensive and of limited value.

Physicians should regard the discovery of anemia in a patient as a challenge. Anemia is a manifestation of disease, not a disease in itself. The anemia may be a subtle sign of chronic renal insufficiency, of malignancy, or of chronic infection that has not otherwise declared itself. In such cases, management depends on the nature of the underlying cause. If the anemia is of the iron-deficient type, it is a signal to search for its cause and eliminate it if possible; moreover, the anemia can usually be relieved by appropriate iron therapy.

In addition, it is essential that the physician understand the nature of the abnormality or the disease that has been discovered. It is as wrong to alarm the patient when this is not justified as it is to fail to discover some disorder that should have been recognized and treated. It is especially important to be cautious in the way one uses terms such as leukemia that have life-threatening implications. Some forms of chronic lymphocytic leukemia, for example, are so slow in their progress (even requiring no treatment for many years) that this term is misleading. Likewise, other terms that have serious implications and yet refer to diseases with wide ranges of prognostic implication must be used most cautiously.

Accurate diagnosis and knowledge of the prognosis, both with and without various modes of therapy, should guide the physician in answering the three major questions of therapy:

WHETHER to treat

WHEN to treat

with WHICH modality

The therapeutic measures, particularly the chemotherapeutic agents available to hematologists, carry a substantial potential for harm. Potential gain must be weighed against potential risks. This is especially true when therapeutic expectation is palliation rather than cure of the disease.

Although it is self-evident that the physician must be mindful of the patient's fears and hopes and those of his or her family, it is too easy to overlook this need. The physician must take the time to give the patient and his or her family some understanding of the illness (if there is one) with sensitivity and sympathy. The physician must choose carefully each word he or she uses and consider how comments may be interpreted or misinterpreted. The nature and course of certain hematologic disorders are such that in some patients reassurance may be far more helpful than any other measure the physician can offer. Consultation with another physician, preferably an expert, may be of value to the emotional well-being of certain patients, even when the physician is certain of the diagnosis and the appropriate treatment.

Undertaking meaningless therapy, treating only because of the magnitude of the white blood cell count, for example, without considering the psychological effects of such attention to what may be a minor manifestation of the disease, and risking the possibility

P.xxvii

of injury by the therapeutic agents used without considering the normal course of the disease are common errors in judgment.

Dealing with the terminally ill patient and his or her family requires compassion, wisdom, and tact. One must be truthful and also understanding; what is especially important is how the truth is told. Furthermore, it is rare that a patient wants to know the whole truth. It is wise to give the patient and his or her family an opportunity to ask questions. In that way, the facts come out more gradually, and a blunt announcement of the likely outcome is avoided.

Patients and their families often ask how long the patient will live. No physician is able to predict this with any accuracy. On the one hand, the stamina of patients and their will to live vary greatly; on the other, it is difficult to guess what unexpected events may occur that will bring closer, or postpone, the ultimate end.

REFERENCES

1. Wintrobe MM. Blood, pure and eloquent: a story of discovery, of people and of ideas. New York, NY: McGraw-Hill, 1980.
2. Wintrobe MM. The blossoming of a science, a story of inspiration and effort. Philadelphia, PA: Lea & Febiger, 1985.

Part I - Laboratory Hematology

Chapter 1 Examination of the Blood and Bone

Marrow

Careful assessment of the blood is often the first step in assessment of hematologic function and diagnosis of related diseases, and many hematologic disorders are defined by specific blood tests. Examination of blood smears and hematologic parameters yields important diagnostic information about cellular morphology, quantification of the blood cellular components, and evaluation of cellular size and shape that allows formation of broad differential diagnostic impressions, directing additional testing. This chapter introduces the fundamental concepts and limitations that underlie laboratory evaluation of the blood and outlines additional testing that may aid in evaluating a hematologic disorder, including special stains and bone marrow examination.

Blood elements include erythrocytes or red cells, leukocytes or white cells, and platelets. Red blood cells (RBCs) are the most numerous blood cells in the blood and are required for tissue respiration. RBCs lack nuclei and contain hemoglobin, an iron-containing protein that acts in the transport of oxygen and carbon dioxide. White blood cells (WBCs) serve an immune function and include a variety of cell types that have specific functions and characteristic morphologic

appearances. In contrast to mature red cells, WBCs are nucleated and include neutrophils, lymphocytes, monocytes, eosinophils, and basophils. Platelets are cytoplasmic fragments derived from marrow megakaryocytes that function in coagulation and hemostasis.

Blood evaluation requires quantification of each of the cellular elements by either manual or automated methods. Automated methods, using properly calibrated equipment,^{1,2} are more precise than manual procedures. In addition, automated methods may provide additional data describing cellular characteristics such as cell volume. However, the automated measurements describe average cellular characteristics but do not adequately describe the scatter of individual values around the average. Hence, a bimodal population of small (microcytic) and large (macrocytic) RBCs might be reported as normal cell size. Therefore, a thorough blood examination also requires microscopic evaluation of a stained blood film to complement hematology analyzer data, especially when new findings are identified.^{3,4} and ⁵

SPECIMEN COLLECTION

Proper specimen collection is required for acquisition of reliable and accurate laboratory data for any hematologic specimen. Before a specimen is obtained, careful thought as to what studies are needed will aid in optimal collection of samples. Communication with laboratory personnel analyzing the specimen is often helpful in ensuring proper handling and test performance.

A number of factors may affect hematologic measurements, and specimens should be collected in a standardized manner to reduce data variability. Factor example, patient activity, level of hydration, medications, sex, age, race, smoking, and anxiety may significantly affect hematologic parameters.^{6,7,8} Similarly, the age of the specimen may affect the quality of the data collected.^{9,10} Thus, data such as patient age, sex, and time of specimen collection should be noted, as well as pertinent correlative clinical information.

Most often, blood is collected by venipuncture into collection tubes containing anticoagulant.¹¹ The three most commonly used anticoagulants are tripotassium or trisodium salts of ethylenediaminetetraacetic acid (EDTA), trisodium citrate, and heparin. EDTA and disodium citrate act to remove calcium, which is essential for the initiation of coagulation, from the blood.¹¹ Heparin acts by forming a complex with antithrombin in the plasma to prevent thrombin formation. EDTA is the preferred anticoagulant for blood counts because it produces complete anticoagulation with minimal morphologic and physical effects on cells. Heparin causes a bluish coloration of the background when a blood smear is stained with Wright-Giemsa stains, but does not affect cell size or shape. Heparin is often used for red cell testing, osmotic fragility testing, and functional or immunologic analysis of leukocytes. Heparin does not completely inhibit white blood cell or platelet clumping. Trisodium citrate is the preferred anticoagulant for platelet and coagulation studies.

The concentration of the anticoagulant used may affect cell concentration measures if it is inappropriate for the volume of blood collected and may also distort cellular morphology. Most often, blood is collected directly into commercially prepared negative-pressure vacuum tubes (Vacutainer tubes; Becton Dickinson, Franklin Lakes, NJ), which contain the correct concentration of anticoagulant when filled appropriately, thereby minimizing error.¹¹ Anticoagulated blood may be stored at 4°C for a 24-hour period without significantly altering cell counts or cellular morphology.⁹ However, it is preferable to perform hematologic analysis as soon as possible after the blood is obtained.

RELIABILITY OF TESTS

In addition to proper acquisition of specimens, data reliability requires precise and reproducible testing methods. Both manual and automated testing of hematologic specimens must be interpreted in light of expected test precision, particularly when evaluating the significance of small changes. All laboratory tests

P.2

are evaluated with respect to both accuracy and reproducibility. Accuracy is the difference between the measured value and the true value, which implies that a true value is known. Clearly, this may present difficulties when dealing with biologic specimens. The National Committee for Clinical Laboratory Standards (NCCLS) and the Clinical and Laboratory Standards Institute (CLSI) have attempted to develop standards to assess the accuracy of blood smear examination¹¹ and automated blood cell analyzers.² Automated instrumentation requires regular quality assurance evaluations and careful calibration to reach expected performance goals and the ability to collect accurate and reproducible data.^{2,12,13} In addition, the International Consensus Group for Hematology Review has suggested criteria that should lead to manual review of a specimen after automated analysis and differential counting.³

CELL COUNTS

Cell counts are important parameters in evaluating the blood. Cell counts may be determined either manually or by automated hematology analyzers. Whether performed by manual or automated methodologies, the accuracy and precision of the counts depend on proper dilution of the blood sample, even distribution of cells, and precise sample measurement. As blood contains large numbers of cells, sample dilution is usually required for accurate analysis. The type of diluent is dependent on the cell type to be enumerated. Thus, red cell counts require dilution with an isotonic medium, whereas in white cell or platelet counts, a diluent that lyses the more numerous red cells is often used to simplify counting. The extent of dilution also depends on the cell type. In general, red cell counts need more dilution than is required for the less abundant WBCs. Errors in cell counts are caused primarily by errors in sample measurement, dilution, or enumeration of cells. The highest degree of precision occurs when a large number of cells can be evaluated. Clearly, automated methods are superior to manual methods for counting large numbers of cells and minimizing statistical error. Table 1.1 lists the comparable values of reproducibility for automated and manual (hemocytometer) counting methods.

Manual counts are done using a microscope after appropriate dilution of the sample in a hemocytometer, a specially constructed counting chamber that contains a specific volume. Red cells, leukocytes, and platelets may be counted. Due to the inherent imprecision of manual counting and the amount of technical time required, most cell counting is now performed by automated instruments that increase the accuracy and speed of analysis by the clinical laboratory, thereby minimizing levels of human manipulation for test entry, sampling, sample dilution, and analysis.¹⁶ With increasing automation, some hematology analyzers can be coupled with instruments performing other laboratory tests using the same tube of blood.¹⁷ There is a variety of different automated hematology analyzers available, dependent on the volume of samples to be tested and the specific needs of the physician ordering testing. The analyzers range in price and workload capacity from those that would be appropriate for an individual physician's office or point-of-care facility to those needed in a busy reference laboratory with capacity for over 100 samples to be analyzed per hour.¹⁶

TABLE 1.1 REPRODUCIBILITY OF BLOOD COUNTING PROCEDURES

Two Coefficients of Variation

Cell Type Counted	Hemocytometer^a (%)	Automated Hematology Analyzer (%)
Red cells	±11.0	±1.0
White cells	±16.0	±1.5
Platelets ^b	±22.0	±2.0
Reticulocytes	±33.9	±5.0

^a Minimum error. Usual error.

^b Error may be greater with low (<35 × 10⁹/L) or very high (>450 × 10⁹/L) platelet counts. Data derived from Bentley S, Johnson A, Bishop C. A parallel evaluation of four automated hematology analyzers. *Am J Clin Pathol* 1993;100:626-632¹⁴ and Wintrobe M. A simple and accurate hematocrit. *J Lab Clin Med* 1929;15:287-289¹⁵.

Most automated hematology analyzers perform a variety of hematologic measurements, in addition to cell counting, such as hemoglobin concentration (Hb), red cell size, and leukocyte differentials. Many instruments also perform more specialized testing, such as reticulocyte counts.¹⁸ The ability of analyzers to perform accurate WBC differential counts, particularly those that can perform a five-part differential (enumerating neutrophils, lymphocytes, monocytes, eosinophils, and basophils), has been a significant technologic advance over the past 15 years. Automated methods for white cell counts and differentials use several distinct technical approaches, including measurement of electrical impedance, differential light scatter, optical properties, or surface antigen/cytochemical staining either alone or in combination.^{19,20}

Most of the newer-generation hematology analyzers utilize optical flow cytometric technologies with or without additional cytochemical staining to detect specific cell types such as red cells, white cells, and platelets (Fig. 1.1).^{19,21,22} The newer analyzers have the additional ability to detect reticulocytes as part of the normal complete blood count (CBC) differential using a fluorescent RNA dye and many will also enumerate nucleated red blood cell numbers based on their optical properties.²³ In addition, many of the current analyzers do auto sampling directly from tubes

and use a very small sample ranging from 35 to 150 μl for a full CBC analysis. Using flow cytometric technologies, some analyzers also have the ability to detect specific blood cell populations by specific antigen expression, such as detection of CD34 peripheral blood stem cells or leukemic blasts.^{24,25} and ²⁶ Integration of data from cytochemical or antigenic staining and light scatter properties has improved the accuracy of the five-part differential and decreased the numbers of unidentifiable cells requiring technician review for identification.

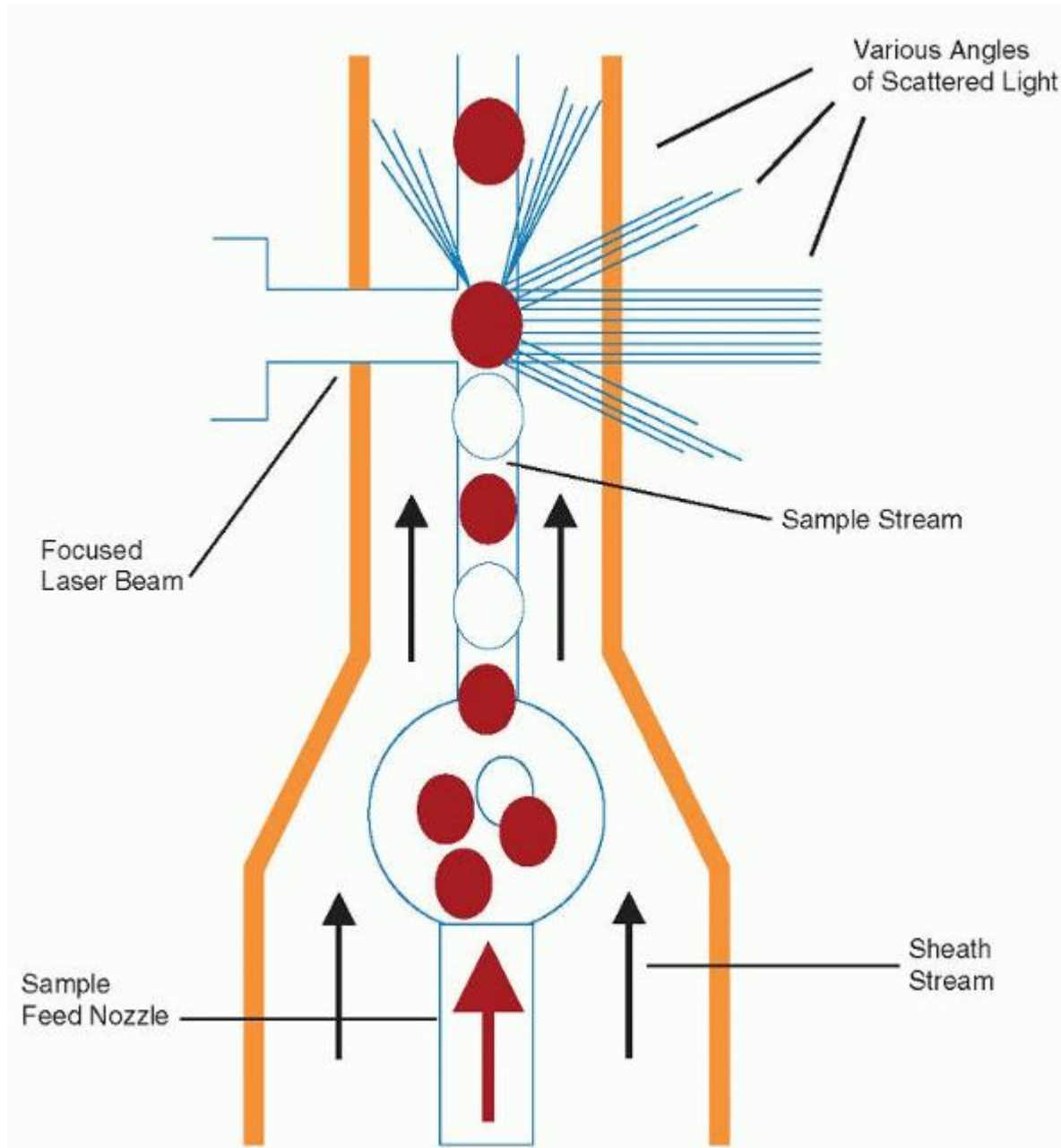
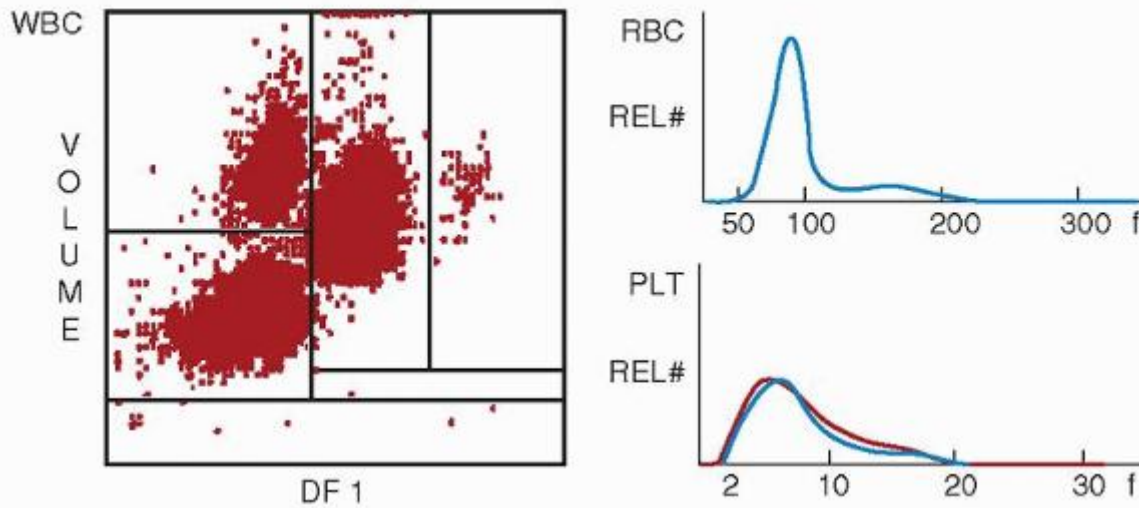

FIGURE 1.1. Optical flow cytometric type of automated hematology analyzer. A suspension of cells is passed through a flow chamber and focused into a single cell sample stream. The cells pass through a chamber and interact with a laser light beam. The scatter of the laser light beam at different angles is recorded, generating signals that are converted to electronic signals giving information about cell size, structure, internal structure, and granularity. (Adapted and redrawn from Cell-Dyn 3500 Operator's Manual. Santa Clara, CA: Abbott Diagnostics, 1993.)

Instruments from Abbott Laboratories (CELL-DYN),^{16,27} Horiba Medical (ABX Pentra series), and Sysmex (XE series, XT series, and XS series)^{16,28,29} primarily utilize fluorescent-based flow cytometry as the modality for analysis. Each system has slightly different fluorochrome staining combinations that aid in the identification of white cells, red cells, and platelets in

combination with light scatter characteristics. All provide integrated reticulocyte counts and five-part differentials. Workload capacities range from 70 to 106 samples analyzed per hour. When reticulocytes are ordered as a part of the differential, the capacity falls to between 40 and 60 samples per hour (allowing for the staining and detection of the RNA dye fluorescence). Instruments by Siemens (Advia 120 and 2120 series) use a combination of flow cytometric techniques and a cytochemical peroxidase stain for the five-part differential. This instrument integrates electrical impedance data, flow cytometric light scatter, characteristic fluorescent staining, and cytochemical staining to generate an accurate white blood cell differential. Siemens technology also calculates hemoglobin levels, claiming that this causes less interference by high white blood cell counts or lipemia in the specimen.^{16,30,31} Instruments from Beckman/Coulter (Coulter DxH series, LH 500 series, LH 750 series, LH 780 series) also utilize electrical impedance or conductivity in combination with light scatter approaches, integrating these technologies to provide full analysis and five-part differentials (Fig. 1.2). The Beckman/Coulter series includes nucleated RBCs and reticulocyte counts in every differential. Its capacity is 45 samples per hour when reticulocytes are included and 100 samples per hour for a CBC without reticulocyte counts.¹⁶



ID# 1	WBC	6.7		RBC	4.56
ID# 2	%		#	HGB	13.5
Sequence #	NE	59.4	4.1	HCT	40.3
	LY	31.6	2.1	MCV	88.3
DATE: 06/21/96	MO	7.7	0.5	MCH	29.5
TIME: 08:55:45	EO	0.7	0.0	MCHC	33.5
Cass/Pos S	BA	0.6	0.0	RDW	13.4
Normal WBC Pop				PLT	202
Normal RBC Pop				MPV	8.2
Normal PLT Pop					

FIGURE 1.2. Histograms and printout generated by the Coulter automated hematology analyzer utilizing light scatter and electrical impedance. BA, basophil; EO, eosinophil; HCT, hematocrit; HGB, hemoglobin; LY, lymphocyte; MCH, mean corpuscular hemoglobin; MCHC, mean corpuscular hemoglobin concentration; MCV, mean corpuscular volume; MO, monocyte; MPV, mean platelet volume; NE, neutrophil; PLT, platelet; RBC, red blood cell; RDW, red cell distribution width; WBC, white blood cell.

RED BLOOD CELL ANALYTIC PARAMETERS

RBCs are defined by three quantitative values: the volume of packed red cells or hematocrit (Hct), the amount of hemoglobin (Hb), and the red cell concentration per unit volume. Three additional indices describing average qualitative characteristics of the red cell population are also collected. These are mean corpuscular volume (MCV), mean corpuscular

hemoglobin (MCH), and mean corpuscular hemoglobin concentration (MCHC). All of these values are routinely collected and calculated by automated hematology analyzers, largely replacing many of the previously used manual or semi-automated methods of RBC characterization, with certain exceptions as noted below. The use of hematology analyzers imparts a high degree of precision compared to manual measurements and calculations (Tables 1.1 and 1.2).

Volume of Packed Red Cells (Hematocrit)

The hematocrit is the proportion of the volume of a blood sample that is occupied by red cells. Hct may be determined manually by centrifugation of blood at a given speed and time in a standardized glass tube with a uniform bore, as was originally described by Wintrobe.¹⁵ The height of the column of red cells after centrifugation compared with total blood sample volume yields the Hct. Macromethods (using 3-mm test tubes) with low-speed centrifugation or micromethods using capillary tubes and high-speed centrifugation may also be used.

Manual methods of measuring Hct are simple and accurate means of assessing red cell status. They are easily performed with little specialized equipment, allowing adaptation for situations in which automated cell analysis is not readily available or for office use. However, several sources of error are inherent in the technique. The spun Hct measures the red cell concentration, not red cell mass. Therefore, patients in shock or with volume depletion may have normal or high Hct measurements due to hemoconcentration despite a decreased red cell mass. Technical sources of error in manual Hct determinations usually arise from inappropriate concentrations of anticoagulants,³² poor mixing of samples, or insufficient centrifugation.¹⁵ Another inherent error

P.4

in manual Hct determinations arises from trapping of plasma in the red cell column. This may account for 1% to 3% of the volume in microcapillary tube methods, with macrotube methods trapping relatively more plasma.^{33,34} It should be noted that abnormal red cells (e.g., sickle cells, microcytic cells, macrocytic cells, or spherocytes) often trap higher volumes of plasma due to increased cellular rigidity, possibly accounting for up to 6% of the red cell volume.³⁴ Very high Hcts, as in polycythemia, may also have excess plasma trapping. Manual Hct methods typically have a precision coefficient of variation (CV) of approximately 2%.³³

TABLE 1.2 REPRODUCIBILITY OF RED CELL INDICES

Index	Method Used	% Error (±2 Coefficients of Variation)
Hemoglobin concentration	Spectrophotometric Automated	1.0-2.0 <1.0
Mean corpuscular volume	Hemocytometer Automated	9.5 <1.0
Mean corpuscular hemoglobin	Hemocytometer Automated	10.0 0.6-1.2
Mean corpuscular hemoglobin concentration	Automated	1.0-1.5

Data derived from Bentley S, Johnson A, Bishop C. A parallel evaluation of four automated hematology analyzers. *Am J Clin Pathol* 1993;100:626-632; NCCLS. Reference and standard procedure for quantitative determination of haemoglobin in blood, 2nd ed. Document H15-A2. Villanova, PA: NCCLS, 1994 and International Committee for Standardization in Haematology. Recommendations for reference method for haemoglobinometry in human blood (ICSH Standard 1986) and specifications for international haemoglobincyanide reference preparation, 3rd ed. *Clin Lab Haematol* 1987;9:73-79.

Automated analyzers do not depend on centrifugation techniques to determine Hct, but instead calculate Hct by direct measurements of red cell number and red cell volume (Hct = red cell number × mean red cell volume). Automated Hct values closely parallel manually obtained measurements, and the manual Hct is used as the reference method for hematology analyzers (with correction for the error induced by plasma trapping). Errors of automated Hct calculation are more common in patients with polycythemia³⁵ or abnormal plasma osmotic pressures.³⁶ Manual methods of Hct determination may be preferable in these cases. The precision of most automated Hcts is <1% (CV).¹⁶

Hemoglobin Concentration

Hemoglobin (Hb) is an intensely colored protein, allowing its measurement by spectrophotometric techniques. Hemoglobin is found in the blood in a variety of forms, including oxyhemoglobin, carboxyhemoglobin, methemoglobin, and other minor components. These may be converted to a single stable compound, cyanmethemoglobin, by mixing blood with Drabkin solution (containing potassium ferricyanide and potassium cyanide).^{37,38} Sulfhemoglobin is not converted but is rarely present in significant amounts. The absorbance of the cyanhemoglobin is measured in a spectrophotometer at 540 nm to determine Hb. This technique is used both in manual determinations and automated hematology analyzers. Hb is expressed in grams per deciliter (g/dl) of whole blood. The main errors in measurement arise from dilution errors or increased sample turbidity due to improperly lysed red cells, leukocytosis, or increased levels of lipid or protein in the plasma.^{39,40} and ⁴¹ With automated methods the precision for hemoglobin determinations is <1% (CV).¹⁶

Red Cell Count

Manual methods for counting red cells have proven to be very inaccurate, and automated counters provide a much more accurate reflection of red cell numbers.⁴² Both erythrocytes and leukocytes are counted after whole blood dilution in an isotonic solution. As the number of red cells greatly exceeds the number of white cells (by a factor of 500 or more), the error introduced by counting both cell types is negligible. However, when marked leukocytosis is present, red cell counts and volume determinations may be erroneous unless corrected for white cells. The observed precision for RBC counts using automated hematology analyzers is <1% (CV)¹⁶ compared with a minimum estimated value of 11% with manual methods.⁴²

Mean Corpuscular Volume

The average volume of the red blood cell is a useful parameter that is used in classification of anemias and may provide insights into pathophysiology of red cell disorders.^{43,44} and ⁴⁵ The MCV is usually measured directly with automated instruments but may also be calculated from the erythrocyte count and the Hct by means of the following formula¹⁵:

$$\text{MCV} = \text{Hct (L/L)} \times 1,000 / \text{red cell count (} 10^{12}/\text{L)}$$

The MCV is measured in femtoliters (fl, or 10^{-15} L). Using automated methods, this value is derived by dividing the summation of the red cell volumes by the erythrocyte count. The CV in most automated systems is approximately 1%,¹⁶ compared to ~10% for manual methods.³³

Agglutination of cells, as in cold agglutinin disease or paraproteinemia, may result in a falsely elevated MCV.⁴⁶ Most automated analyzers gate out MCV values above 360 fl, thereby excluding most red cell clumps, although this may falsely lower Hct determinations. In addition, severe hyperglycemia (glucose >600 mg/dl) may cause osmotic swelling of the red cells, leading to a falsely elevated MCV.^{36,47}

Mean Corpuscular Hemoglobin

MCH is a measure of the average hemoglobin content per red cell. It may be calculated manually or by automated methods using the following formula¹⁵:

$$\text{MCH} = \text{hemoglobin (g/L)} / \text{red cell count (} 10^{12}/\text{L)}$$

MCH is expressed in picograms (pg, or 10^{-12} g). Thus, the MCH is a reflection of hemoglobin mass. In anemias secondary to impaired hemoglobin synthesis, such as iron deficiency anemia, hemoglobin mass per red cell decreases, resulting in a lower MCH value. MCH measurements may be falsely elevated by hyperlipidemia,⁴¹ as increased plasma turbidity will erroneously elevate hemoglobin measurement. Centrifugation of the blood sample to eliminate the turbidity followed by manual hemoglobin determination allows correction of the MCH value. Leukocytosis may also spuriously elevate MCV values.³⁹ The CV for automated analysis of MCH is <1% in most modern analyzers, compared with approximately 10% for manual methods.³³

Mean Corpuscular Hemoglobin Concentration

The average concentration of hemoglobin in a given red cell volume or MCHC may be calculated by the following formula¹⁵:

$$\text{MCHC} = \text{hemoglobin (g/dl)} / \text{Hct (L/L)}$$

The MCHC is expressed in grams of hemoglobin per deciliter of packed RBCs, representing the ratio of hemoglobin mass to the volume of red cells. With the exception of hereditary spherocytosis and some cases of homozygous sickle cell or hemoglobin C disease, MCHC values will not exceed 37 g/dl. This level is close to the solubility value for hemoglobin, and further increases in Hb may lead to crystallization. The accuracy of the MCHC determination is affected by factors that

have an impact on measurement of either Hct (plasma trapping or presence of abnormal red cells) or hemoglobin (hyperlipidemia, leukocytosis).³⁹ The CV for MCHC for automated methods ranges between 1.0% and 1.5%.¹⁶

As noted above, the MCV, MCH, and MCHC reflect average values and may not adequately describe blood samples when mixed populations of red cells are present. For example, in sideroblastic anemias, a dimorphic red cell population of both hypochromic and normochromic cells may be present, yet the indices may be normochromic and normocytic. It is important to examine the blood smear as well as red cell histograms to detect such dimorphic populations.³ The MCV is an extremely useful value in classification of anemias,^{16,45,48} but the MCH and MCHC often do not add significant, clinically relevant information. However, the MCH and MCHC play an important role in laboratory quality control because these values will remain stable for a given specimen over time.⁴⁹

Red Cell Distribution Width

The red cell distribution width (RDW) is a red cell measurement that quantitates cellular volume heterogeneity reflecting the range of red cell sizes within a sample.^{43,50,51,52} RDW has been proposed to be useful in early classification of anemia as it becomes

P.5

abnormal earlier in nutritional deficiency anemias than other red cell parameters, especially in cases of iron deficiency anemia.^{43,53} RDW is particularly useful in characterizing microcytic anemia, allowing discrimination between uncomplicated iron deficiency anemia (high RDW, normal to low MCV) and uncomplicated heterozygous thalassemia (normal RDW, low MCV),^{43,53,54} and⁵⁵ although other tests are usually required to confirm the diagnosis.⁵⁶ RDW is also useful in identifying red cell fragmentation, agglutination, or dimorphic cell populations (including patients who have had transfusions, have sideroblastic anemias, or have been recently treated for a nutritional deficiency).^{53,57}

Reticulocyte Counts

Determination of the numbers of reticulocytes or immature, nonnucleated RBCs that still retain RNA provides useful information about the bone marrow's capacity to synthesize and release red cells in response to a physiologic challenge, such as anemia. In the past, reticulocyte counts were performed manually using supravital staining with methylene blue that will stain precipitated RNA as a dark blue meshwork or granules (at least two per cell), allowing reticulocytes to be identified and enumerated manually.⁵⁸ Normal values for reticulocytes in adults are 0.5% to 1.5%, although they may be 2.5% to 6.5% in newborns (falling to adult levels by the second week of life). Because there are relatively low numbers of reticulocytes, the CV for reticulocyte counting is relatively large (10% to 20%).⁵⁹

To increase accuracy of reticulocyte counting, automated detection methods to detect staining allow for many more cells to be analyzed, thereby increasing accuracy and precision of counts.^{18,60,61} Most of the newest automated hematology analyzers have automated reticulocyte counting as part of the testing capabilities and allow reticulocyte counts to be included with routine complete blood count parameters. Reticulocytes are detected by a fluorescent dye that binds to RNA. Comparisons of stand-alone instruments and integrated hematology analyzers demonstrate superior accuracy when compared to manual counting methods, with CVs of 5% to 8%.^{16,62}

LEUKOCYTE ANALYSIS

White Blood Cell Counts

Leukocytes may be enumerated by either manual methods or automated hematology analyzers. Leukocytes are counted after dilution of blood in a diluent that lyses the RBCs (usually acid or detergent). The much lower numbers of leukocytes present require less dilution of the blood than is needed for red blood cell counts (usually a 1:20 dilution, although it may be less in cases of leukocytopenia or more with leukocytosis). Manual counts are done using a hemocytometer or counting chamber. As with red cell counts, manual leukocyte counts have more inherent error, with CVs ranging from 6.5% in cases with normal or increased white cell counts to 15% in cases with decreased white cell counts. Automated methods characteristically yield CVs in the 1% to 3% range.¹⁶ Automated leukocyte counts may be falsely elevated in the presence of cryoglobulins or cryofibrinogen,⁶³ aggregated platelets,⁶⁴ and nucleated RBCs, or when there is incomplete lysis of red cells, requiring manual counting. Falsely low neutrophil counts have also been reported due to granulocyte agglutination secondary to surface immunoglobulin interactions.^{65,66}

Leukocyte Differentials

White cells are analyzed to find the relative percentage of each cell type by a differential leukocyte count. Uniform standards for performing manual differential leukocyte counts on blood smears have been proposed by the CLSI⁶⁷ to

ensure reproducibility of results between laboratories. It is important to scan the entire blood smear at low power to ensure that all atypical cells and cellular distribution patterns are recognized. In wedge-pushed smears, leukocytes tend to aggregate in the feathered edge and side of the blood smear rather than in the center of the slide. Larger cells (blasts, monocytes) also tend to aggregate at the edges of the blood smear.⁶⁸ Use of coverslip preparations and spinner systems tends to minimize this artifact of cell distribution. For wedge-pushed smears, it is recommended that a battlement pattern of smear scanning be used in which one counts fields in one direction, then changes direction and counts an equal number of fields before changing direction again to minimize distributional errors.⁶⁷

In manual leukocyte counts, three main sources of error are found: distribution of cells on the slide, cell recognition errors, and statistical sampling errors. Poor blood smear preparation and staining are major contributors to cell recognition and cell distribution errors.⁶⁹ Statistical errors are the main source of error inherent in manual counts, due to the small sample size in counts of 100 or 200 cells. The CV in manual counts is between 5% and 10% and is also highly dependent on the skill of the technician performing the differential. Accuracy may be improved by increasing the numbers of cells counted, but for practical purposes, most laboratories will do a differential on 100 white cells.^{70,71}

Automated leukocyte differentials markedly decrease the time and cost of performing routine examinations as well as increasing accuracy to a CV of 3% to 5%.^{70,71,72} However, automated analysis is incapable of accurately identifying and classifying all types of cells and is particularly insensitive to abnormal or immature cells. Therefore, most analyzers will flag possible abnormal white cell populations, indicating the need for examination by a skilled morphologist for identification.⁷² The capacity for performing automated leukocyte differentials is incorporated into hematology analyzers, which identify cells on the basis of cellular size, cell complexity, or staining characteristics as part of the complete blood count, allowing for generation of a five-part differential count that enumerates neutrophils, monocytes, lymphocytes, eosinophils, and basophils.¹⁶

Most systems perform cell counts on specimens via continuous-flow cytometric analysis of blood samples in which the red cells have been lysed and white cells fixed. The cells are suspended in diluent and passed through an optical flow cell in a continuous stream so that single cells are analyzed for cell size (forward scatter) and complexity (dark-field light scatter) (Fig. 1.1) or cytochemical characteristics of myeloperoxidase staining (bright-field detector). The data are plotted as a scattergram (Fig. 1.2), which allows white cells to be divided into a five-part differential (neutrophils, lymphocytes, monocytes, eosinophils, and basophils) and also indicates large unstained or unclassified cells. Lymphocytes are characterized as small (low-scatter) unstained cells. Larger atypical lymphocytes, blasts, or circulating plasma cells fall into the larger cell with a low-complexity channel. Neutrophils have higher complexity and appear as larger cells. Eosinophils appear smaller than neutrophils because they tend to absorb some of their own light scatter. Monocytes have lower levels of complexity and are usually found between neutrophils and lymphocytes. To enumerate basophils, which lack specific staining characteristics and are difficult to enumerate with automated flow-through techniques, a basophil-nuclear lobularity channel may be utilized. For this determination, RBCs and WBCs are differentially lysed, leaving bare leukocyte nuclei, with the exception of basophils, which are resistant to lysis and can then be counted based on relatively large cell size due to the retained cytoplasm. Light scatter data obtained from the leukocyte nuclei may also help identify blasts, which have a lower light scatter than do mature

P.6

lymphocyte nuclei. Abnormal cell populations will generate a flag, indicating a need for morphologic review of the peripheral smear.³ Analysis using this technique examines thousands of cells per sample, increasing statistical accuracy.¹⁶

Most of the current hematology analyzers have settings that will allow for evaluation of very hypocellular specimens, such as body fluids. They may be used for analysis of these fluids for enumeration of red cells and white cells, as well as providing a five-part differential count of the white cells. Because of the sampling of higher numbers of cells in these relatively hypocellular specimens, accuracy of cell counts and differential counting is improved.^{30,31,73,74} and ⁷⁵

A few instruments, such as the Advia 2120 and the Coulter LH755, also have integrated automated blood smear preparation technology allowing smear preparation directly from the tube upon which the CBC analysis is performed. Thus, the tube is loaded once into a single machine to allow for CBC analysis as well as peripheral blood smear preparation.¹⁶ Many manufacturers also have automated slide makers and stainers, which provide wedge smears from up to 80 slides per hour directly from CBC tubes; however, these are generally free-standing instruments separated from the hematology analyzer. The automated push smear technology helps to provide technical uniformity in blood smear preparation as well as staining. However, there is less flexibility in adjusting stain characteristics. These instruments sample directly from the tube, also minimizing handling of samples by technical staff.

In addition to technology that has the ability to make and stain slides, some automated differential technology via imaging is now available. For instance, Sysmex (CellaVision) has an automated image analyzer that by pattern recognition will capture digital images of 100 to 500 cells in a smear and classify them into morphologic categories to provide a five-part differential. Depending on the model utilized, these technologies have the abilities to perform between 20 and 60 automated digital differentials per hour. The systems have the capacity to store images and are useful in training technologists in the recognition of the specific cell types as well as providing an easily accessible means whereby smears obtained at different times from a single patient may be compared morphologically.⁷⁶ These systems have limitations in ability to identify morphologically abnormal cells, so specimens with dysplastic changes, unusual morphologic variants, or significant artifacts may not be evaluable or may provide false data.^{77,78,79} Often these systems will place a certain percentage of cells in an unclassifiable area, requiring review by a technologist for definitive identification of the cell type and completion of the differential. As microscopy is automated, there is a uniform scanning of each slide and images are presented on a computer screen, decreasing technician microscope time and scanning pattern variability, and also allowing for the ability to greatly enlarge digitally captured images.^{78,80}

PLATELET ANALYSIS

Platelets are anucleate cytoplasmic fragments that are 2 to 4 μm in diameter. As with the other blood components, they may be counted by either manual or automated methods. Manual methods involve dilution of blood samples and enumeration in a counting chamber or hemocytometer using phase contrast microscopy. Sources of error are similar to other manual counting techniques and include dilution errors and low numbers of events counted. The CV, especially in patients with thrombocytopenia, may be >15%.^{81,82} Platelets are counted in automated hematology analyzers after removal of red cells by sedimentation or centrifugation, or using whole blood. Platelets are identified by light scatter, impedance characteristics, or platelet antigen staining.^{16,83} These give highly reliable platelet counts with a CV of <2%. Falsely low platelet counts may be caused by the presence of platelet clumps or platelet agglutinins⁶⁴ or adsorption of platelets to leukocytes.^{84,85} Fragments of red or WBCs may falsely elevate the automated platelet count, but this usually gives rise to an abnormal histogram that identifies the spurious result.^{86,87}

Automated hematology analyzers also determine mean platelet volume (MPV), which has been correlated with several disease states.^{88,89,90} In general, MPV has an inverse relationship with platelet number, with larger platelet volumes (secondary to new platelet production) seen in thrombocytopenic patients in whom platelets are decreased due to peripheral destruction (as in idiopathic thrombocytopenic purpura).^{90,91,92} MPV is also increased in myeloproliferative disorders.⁹³ However, it should be noted that platelets tend to swell during the first 2 hours in EDTA anticoagulant, shrinking again with longer storage.^{94,95} Decreased MPV has been associated with megakaryocytic hypoplasia and cytotoxic drug therapy.⁹⁶

Reticulated platelets are newly released platelets that retain residual RNA, analogous to red cell reticulocytes. Reticulated platelet counts give an estimate of thrombopoiesis and may be useful in distinguishing platelet destruction syndromes from hypoplastic platelet production.^{97,98} Reticulated platelets can be detected by flow cytometric methods using thiazole orange dyes that bind to RNA⁹⁹ or by automated hematology analyzers,^{100,101} although they are not routinely measured. Normal values vary between 3% and 20%, and 2.5- to 4.5-fold increases in reticulated platelet counts are seen in the clinical setting of idiopathic thrombocytopenic purpura.¹⁰² Increased reticulated platelets may herald the return of platelet production after chemotherapy.¹⁰³

ADVANTAGES AND SOURCES OF ERROR WITH AUTOMATED HEMATOLOGY

Clearly, the use of automated hematology analyzers has reduced laboratory costs and turnaround time coincident with improving the accuracy and reproducibility of blood counts. The CV for most of the parameters measured is in the range of 1% to 2%. This level of reproducibility is not achievable with the use of most manual techniques (Tables 1.1 and 1.2).

Despite this high degree of accuracy, several potential errors may invalidate automated collection of data. Proper calibration of instrumentation is essential for collection of accurate data. Faulty current settings, which determine threshold counting values as well as variation in either the counting volumes or flow characteristics of a sample, negatively affect data accuracy. Electrical or mechanical failures as well as minor voltage fluctuations may induce marked errors in data collection. Careful calibration of the instrumentation initially, followed by frequent evaluation of reproducibility by analysis of samples with known cell concentrations, is an essential quality control measure.¹⁰⁴ Reference methods for instrument calibration have been developed by both the NCCLS and the ICSH and are widely used by hospital and clinical laboratories to ensure regulatory compliance.^{49,67,105}

Certain disease states are also associated with spuriously high or low results, although some of these are specific to a particular type of instrumentation (summarized in Table 1.3). Therefore, the individual values obtained from the

automated hematology analyzer must be interpreted in context with the clinical findings. In addition, careful examination of the stained blood film often imparts additional information that may not be reflected in the average values that constitute the automated data. For example, decreased red blood cell counts, macrocytosis, and extremely high MCHC have been observed in patients with cold agglutinin disease with a higher thermal amplitude and in some patients with elevated serum viscosity.⁶³ High levels of paraprotein may lead to falsely elevated hemoglobin levels, therefore affecting MCH and

P.7

MCHC calculations.⁴⁰ Older analyzers reported spurious increases in hemoglobin levels when white cell counts exceeded $30 \times 10^9/L$ due to increased turbidity, but this is decreased with newer flow systems so that hemoglobin levels remain extremely accurate in the face of white blood cell counts as high as $100 \times 10^9/L$.¹⁶ Extremely high white cell counts may also falsely raise the red cell count and Hct as the white cell count is incorporated into the red cell count. High glucose levels (>400 to 600 mg/dl) and the associated hyperosmolarity cause red cell swelling and generate a high MCV and Hct with a falsely low MCHC.^{36,106} Increased turbidity associated with hyperlipidemia may also cause falsely elevated hemoglobin determinations, MCH, and MCHC.⁴¹

TABLE 1.3 DISORDERS AND CONDITIONS THAT MAY REDUCE THE ACCURACY OF BLOOD CELL COUNTING^a

Component	Disorder/Condition	Effect on Cell Count	Rationale
Red cells	Microcytosis or schistocytes	May underestimate RBC	Lower threshold of RBC counting window is greater than microcyte size
	Howell-Jolly bodies	May spuriously elevate platelet count (in whole blood platelet counters only)	Howell-Jolly bodies are similar in size to platelets
	Polycythemia	May underestimate RBC	Increased coincidence counting
White cells	Leukocytosis	Overestimate RBC	Increased coincidence counting
	Acute leukemia and chronic lymphocytic leukemia, viral infections	May spuriously lower WBC	Increased fragility of leukocytes, including immature forms
	Chemotherapy of acute leukemia	May artifactually increase platelet count	Leukemic cell nuclear or cytoplasmic fragments identified as platelets
Platelets	Platelet agglutinins	May underestimate platelet count, sometimes with spurious increase in WBC	Platelet clumping Aggregates may be identified as leukocytes
Plasma	Cold agglutinins	May underestimate RBC with spurious macrocytosis	Red cell doublets, triplets, and so forth have increased volume
	Cryoglobulins, cryofibrinogens	Variation in platelet count	Protein precipitates may be identified as platelets

RBC, red blood cell count; WBC, white blood cell count.

^aSome of these examples affect counts only when certain instruments are used. The effects depend on dilution, solutions used, and specimen temperatures.

Adapted from Koepke JA. Laboratory hematology. New York, NY: Churchill Livingstone, 1984.

Despite the high level of accuracy and precision, the automated hematology analyzers usually have data that create a warning flag in 10% to 25% of samples, requiring manual examination of the blood smear.^{3,4,16,107} Blood smear examination still plays an important role in characterizing these samples or showing findings outside the preset parameters for the laboratory. In addition, some cells require morphologic examination to identify, such as Sézary cells,¹⁰⁸ and red cell morphology is best analyzed by direct smear examination.^{45,48}

MORPHOLOGIC ANALYSIS OF BLOOD CELLS

Careful evaluation of a well-prepared blood smear is an important part of the evaluation of hematologic disease. Although a specific diagnosis may be suggested by the data obtained from an automated hematology analyzer, many diseases may have normal blood counts but abnormal cellular morphology. Examples of abnormal red cells that may be seen in the peripheral blood smear examination and which are associated with specific disease states are found in Table 1.4. However, morphologic analysis may be greatly hampered by poorly prepared or stained blood smears. Preparation of satisfactory blood smears requires careful attention to preparation of the blood smear and staining techniques and familiarity with the morphologic appearances of normal and pathologic cells.

Preparation of Blood Smears

Blood films may be prepared on either glass slides or coverslips. Each method has specific advantages and disadvantages.^{2,109,110,111} Blood smears are often prepared from samples of anticoagulated blood remaining after automated hematologic analysis or prepared at the time of analysis. However, artifacts in cell appearance and staining may be induced by anticoagulant.¹¹ Optimal morphology and staining are obtained from nonanticoagulated blood, most often from a fingerstick procedure. Mechanical dragging of the cells across the glass of the slide or coverslip and uneven distribution of blood may also distort the cells; however, these artifacts may be minimized with proper technique.²

Coverslip smears (Fig. 1.3A) are prepared using a good grade of flat, no. 1, 0.5-inch square (or 22 × 22 mm) coverslips that are free of lint, dust, and grease. Such coverslips allow optimal spreading of the blood over the surface and minimal artifact. Usually, high-quality coverslips do not require additional cleaning, although there may be some deterioration with age. Plastic “nonwettable” coverslips are not satisfactory for these preparations. The smear is prepared by holding the coverslip by two adjacent corners between the thumb and index finger. A small drop of either fresh or anticoagulated blood is placed in the center of the coverslip. The size of the drop of blood is critical. If the drop is too large, a thick smear results. If the drop of blood is too small, a very thin smear is obtained. A second coverslip is then grasped in a similar fashion with the other hand, placed across the first coverslip, and rotated 45° with a steady, rapid, and gentle motion. The two coverslips are then immediately pulled apart and allowed to air dry. If done properly, this procedure produces two coverslips with even dispersion of blood without holes or excessively thick areas.^{112,113}

Blood smears may also be prepared on clean glass slides by the wedge method (Fig. 1.3B). This often leads to irregular distribution of cells on the slide, a distinct disadvantage over the coverslip procedure. However, glass slides are less fragile, are easier to handle, and may be labeled more easily than coverslips. To prepare a slide blood smear, a drop of blood is placed in the middle of the slide approximately 1 to 2 cm from one end. A second spreader slide is placed at a 30° to 45° angle and moved

P.8

backward to make contact with the blood drop. The blood drop will spread along the slide edge, and then the spreader slide is moved rapidly forward. This technique creates a film of blood that is 3 to 4 cm long. Artifact may be introduced by irregular edges in the spreader and by the speed at which the spreader is moved. Glass slide preparations have increased incidence of accumulation of the larger white cells at the edges of the film, introducing cellular distribution errors. Fast movement of the spreader results in a more uniformly distributed population of cells.^{112,113,114}

TABLE 1.4 PATHOLOGIC RED CELLS IN BLOOD SMEARS

Red Cell Type	Description	Underlying Change	Disease State Associations
Acanthocyte (spur cell)	Irregularly spiculated red cells with projections of varying length and dense center	Altered cell membrane lipids	Abetalipoproteinemia, parenchymal liver disease, postsplenectomy

Basophilic stippling	Punctuate basophilic inclusions	Precipitated ribosomes (RNA)	Coarse stippling: Lead intoxication, thalassemia Fine stippling: A variety of anemias
Bite cell (degmacyte)	Smooth semicircle taken from one edge	Heinz body pitting by spleen	Glucose-6-phosphate dehydrogenase deficiency, drug-induced oxidant hemolysis
Burr cell (echinocyte) or crenated red cell	Red cells with short, evenly spaced spicules and preserved central pallor	May be associated with altered membrane lipids	Usually artifactual; seen in uremia, bleeding ulcers, gastric carcinoma
Cabot rings	Circular, blue, threadlike inclusion with dots	Nuclear remnant	Postsplenectomy, hemolytic anemia, megaloblastic anemia
Ovalocyte (elliptocyte)	Elliptically shaped cell	Abnormal cytoskeletal proteins	Hereditary elliptocytosis
Howell-Jolly bodies	Small, discrete, basophilic, dense inclusions; usually single	Nuclear remnant (DNA)	Postsplenectomy, hemolytic anemia, megaloblastic anemia
Hypochromic red cell	Prominent central pallor	Diminished hemoglobin synthesis	Iron deficiency anemia, thalassemia, sideroblastic anemia
Leptocyte	Flat, waferlike, thin, hypochromic cell	—	Obstructive liver disease, thalassemia
Macrocyte	Red cells larger than normal ($>8.5 \mu\text{m}$), well filled with hemoglobin	Young red cells, abnormal red cell maturation	Increased erythropoiesis; oval macrocytes in megaloblastic anemia; round macrocytes in liver disease
Microcyte	Red cells smaller than normal ($<7.0 \mu\text{m}$)	—	Hypochromic red cell (see Chapter 27)
Pappenheimer bodies	Small, dense, basophilic granules	Iron-containing siderosome or mitochondrial remnant	Sideroblastic anemia, postsplenectomy
Polychromatophilia	Grayish or blue hue often seen in macrocytes	Ribosomal material	Reticulocytosis, premature marrow release of red cells
Rouleaux	Red cell aggregates resembling stack of coins	Red cell clumping by circulating paraprotein	Paraproteinemia
Schistocyte (helmet cell)	Distorted, fragmented cell; two or three pointed	Mechanical distortion in microvasculature by fibrin strands, disruption	Microangiopathic hemolytic anemia (disseminated intravascular coagulation, thrombotic)

	ends	by prosthetic heart valve	thrombocytopenic purpura, prosthetic heart valves, severe burns)
Sickle cell (drepanocyte)	Bipolar, spiculated forms, sickle shaped, pointed at both ends	Molecular aggregation of HbS	Sickle cell disorders, not including S trait
Spherocyte	Spherical cell with dense appearance and absent central pallor, usually decreased diameter	Decreased membrane surface area	Hereditary spherocytosis, immunohemolytic anemia
Stomatocyte	Mouth or cuplike deformity	Membrane defect with abnormal cation permeability	Hereditary stomatocytosis, immunohemolytic anemia
Target cell (codocyte)	Targetlike appearance, often hypochromic	Increased redundancy of cell membrane	Liver disease, postsplenectomy, thalassemia, hemoglobin C disease
Teardrop cell (dacryocyte)	Distorted, drop-shaped cell	—	Myelofibrosis, myelophthisic anemia

Adapted from Kjeldsberg C, Perkins SL, ed. Practical diagnosis of hematologic disorders, 5th ed. Chicago: ASCP Press, 2010.

Automated techniques for blood smear preparation have also been developed. Two major types of approaches are used: centrifugation and mechanical spreaders. Centrifugation techniques are often most useful when a small number of cells must be concentrated in a small area, as in preparing smears of cells in fluids such as cerebrospinal fluid.^{112,115} Mechanical spreaders mimic the manual technique and are useful when large numbers of blood smears are prepared.¹¹⁶ In general, smears made by automated techniques are often inferior to those made by an experienced technician.

Routine Staining of Blood Smears

Blood smears are usually stained with either Wright or May-Grünwald-Giemsa stains. Both stains are modifications of the Romanowsky procedure.^{113,114} The stain may be purchased commercially or may be made in the laboratory. The basic stain is formulated from methylene blue and eosin. Giemsa stains use known quantities of acid bichromate to form the converted azure compounds. The Wright stain formulation uses sodium bicarbonate to convert methylene blue to methylene azure, which stains

P.9

the cell. All types of Romanowsky stains are water insoluble but can be dissolved in methyl alcohol. The stain must be free of water, which induces red blood cell artifacts. Water artifacts may be avoided by fixation of slides or coverslips in anhydrous methanol before staining.¹¹³

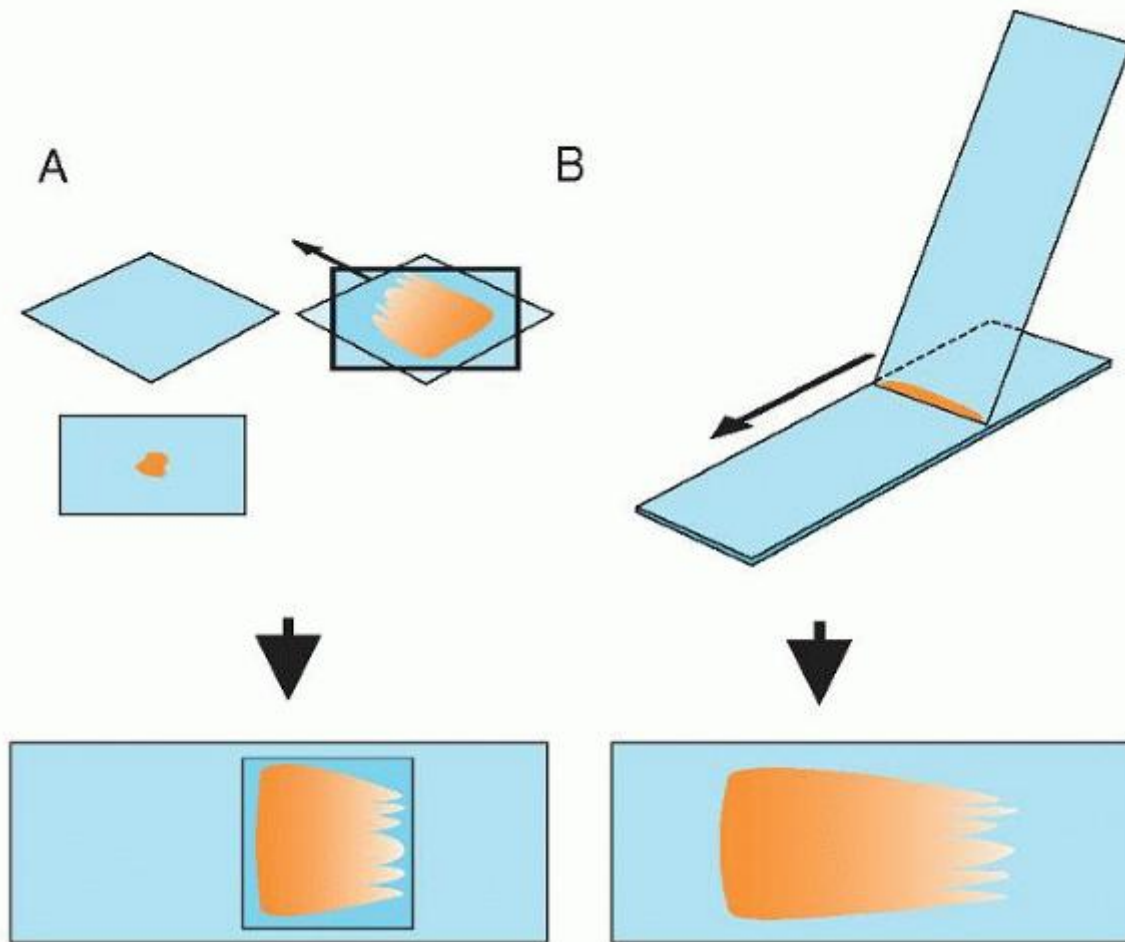

FIGURE 1.3. Preparation of blood smears. Blood smears may be prepared by the coverslip (A) or slide wedge method (B). Coverslip smears are prepared by placing a drop of blood in the center of a coverslip and spreading the blood by rotating a second coverslip over it. Wedge smears are prepared by placing a drop of blood on a slide and using a second slide to push the blood out along the length of the slide. (Adapted and redrawn from Bauer J. *Clinical laboratory methods*, 9th ed. St. Louis: C.V. Mosby, 1982.)

Optimal staining conditions must be established for each new batch of stain. The methylene blue conversion to azure compounds continues to occur while the stain is in the bottle, so staining conditions may change over time. Methyl azures are basic dyes that impart a violet-blue coloration when binding to the acidic components of the cell, such as nucleic acids and proteins. The eosin reacts with the basic cellular elements, imparting a reddish hue to cytoplasmic components and hemoglobin. A properly stained slide has a pink tint. The red cells will have an orange to pink coloration, and leukocytes have purplish-blue nuclei. The Romanowsky stains differentially stain leukocyte granules, which aids in morphologic analysis of the cells. Thus, neutrophil granules are slightly basic and stain weakly with the azurophilic component. The eosinophils contain a strongly basic spermine derivative and stain strongly with eosin. In contrast, basophil granules contain predominately acidic proteins and stain a deep blue-violet. No precipitate should overlie the cells because this indicates use of slides or coverslips that were not cleaned properly. Dust on slides may also induce artifacts. Staining solutions should be filtered or replaced weekly if used heavily to avoid precipitation.^{113,114}

Occasionally, an excessive blue coloration of the cells is seen. This may be caused by excessive staining times, improperly prepared or aged buffer that is too alkaline, old blood smears, or blood smears that are too thick. The quality of the staining may be improved by quick and vigorous rinsing with distilled water. If the areas of the slide between cells are staining, it usually indicates inadequate washing of the slide, heparin anticoagulation, or possible paraproteinemia. When the staining appears too pink or red, the usual problem is buffer that is too acidic. This results in pale-stained leukocyte nuclei, excessively orange-RBCs, and bright red eosinophil granules. Other causes of excessive red or pink coloration include inadequate staining times or excessive washing of the slide. Most often, problems with staining are caused by problems with the pH of the solutions, and use of new buffer solutions often corrects the problem.¹¹³

Examination of the Blood Smear

The blood smear should be initially examined under an intermediate power (10 to 20× objective) to assess the adequacy of cellular distribution and staining. An estimate of the white blood cell count may also be made at this power, and scanning for abnormal cellular elements, such as blasts or nucleated RBCs, can be performed. It is important to scan over the entire blood smear to ensure that abnormal populations, which may be concentrated at the edges of the smear, are not missed. Use of an oil immersion lens (50 or 100×) or high-power dry lens (40×) is usually sufficient for performing leukocyte differential counts, although a 100× oil lens may be necessary for identification of cellular inclusions or abnormal cytoplasmic granules. Systematic evaluation of the blood smear is essential so that all cell types are examined and characterized. Each cell type should be evaluated for both quantitative and qualitative abnormalities.^{117,118}

It is difficult to evaluate quantitative abnormalities of red cells on a blood smear; however, the RBCs should be evaluated for variations in size, shape, hemoglobin distribution, and the presence of cellular inclusions. The red cells are usually unevenly distributed throughout the blood film. Optimal red cell morphology is seen in an area of the smear where the red cells are close together but do not overlap. Areas where the red cells are spread too thinly or thickly have increased artifacts. In some blood smears, the red cells appear to stick together, forming what appear to be stacks of RBCs, termed rouleaux. This finding may be mimicked in normal patients in areas of the smear where the red cells are too closely packed. However, if rouleaux are seen even in thinner areas of the blood film, it suggests the presence of a paraprotein coating the red cells and causing agglutination due to loss of normal electrostatic repulsion between red cells. Areas of the blood smear that are too thin will have loss of red cell central pallor, mimicking spherocytes.¹¹⁷

Red cells should be uniform in size and shape with an average diameter of 7.2 to 7.9 μm . This may be evaluated by use of a micrometer or by comparison with the diameter of a small lymphocyte nucleus, which is approximately the same size or slightly smaller. Variations in red cell size is called anisocytosis. Cells that are larger than 9 μm and well hemoglobinated are considered macrocytes. Less mature erythrocytes are macrocytic and have a bluish tint to the hemoglobin (polychromatophilia) or have fine basophilic stippling of the cell due to remnant RNA and ribosomes. Microcytes are cells with a diameter of <6 μm .^{117,118}

Normal erythroid cells are round. Variations in red cell shape are called poikilocytosis. The red cell should have a pale central area (central pallor) with a rim of red to orange hemoglobin. Hypochromia reflects poor hemoglobinization and results in a very thin rim of hemoglobin or an increased area of central pallor. Abnormal distribution of hemoglobin may result in formation of a cell with a central spot of hemoglobin surrounded by an area of pallor, called a target cell. Abnormal hemoglobins may also form crystals. Spherocytes and macrocytes lack an area of central pallor because of increased thickness of the cell. Red cells may also contain inclusions, such as remnants of nuclear material (Howell-Jolly bodies), remnants of mitochondria or siderosomes (Pappenheimer bodies),¹¹⁸ or infectious agents (malarial parasites, babesiosis).^{119,120} In addition, red cell fragments or schistocytes suggestive of red cell mechanical destruction are more easily detected by blood smear examination.¹²¹

Platelet numbers and morphology are then evaluated. Platelets appear as small blue cytoplasmic fragments with red to purple granules. Platelets are usually 1 to 2 μm in diameter with wide variation in shape. Platelet numbers may be estimated from the blood film. Normal platelet counts should have several (5 to 15) platelets per oil immersion field or approximately 1 platelet for 10 to 20 RBCs.¹²² It should be noted that platelets may aggregate if blood is not anticoagulated, properly, or a fingerstick preparation

P.10

is used, and this may cause the spurious impression of a low platelet count.^{122,123}

Leukocyte morphology and distribution are analyzed last. The number of leukocytes may be estimated by scanning the blood film at an intermediate power. Mechanical effects leading to abnormal distribution of larger cells should be excluded by examination of the edges of the blood film in particular.^{2,117} White cells at the edges of the blood smear may appear artifactually smaller (because of cellular shrinkage and poor spreading of the cell) or larger (because of cell disruption and excessive spreading). Care must be taken when making the smear because cells, particularly neoplastic cells, may be more easily disrupted by excessive mechanical pressure than normal leukocytes. Optimal morphology of the leukocytes requires that blood smears be made promptly. Significant artifacts begin to be observed in blood that has been held for several hours and include cytoplasmic vacuolation, nuclear karyorrhexis, and cytoplasmic disruption.¹¹

The WBCs normally seen in the blood smear include neutrophils, eosinophils, basophils, lymphocytes, and monocytes. The presence of immature myeloid cells (myelocytes, metamyelocytes, promyelocytes, and blasts) is distinctly abnormal.^{118,124,125} At least 100 cells should be identified and counted to yield a manual white blood cell differential.^{117,118}

In addition to identifying relative populations of white cells by performing a differential count, the cells should be closely examined for morphologic abnormalities of the cytoplasm and nucleus. For example, infection or growth factor therapy often leads to increased prominence of the primary (azurophilic) granules in neutrophils, termed toxic granulation.^{126,127} In contrast, many myelodysplastic disorders are characterized by hypogranularity of neutrophils in addition to abnormal nuclear segmentation.¹²⁸ Cytoplasmic inclusions may be seen in some storage disorders, lysosomal disorders, or infections.^{118,120,129}

Other Means of Examining Blood

Occasionally, it is necessary to examine fresh blood as a wet mount. Wet preparations are made by placing a drop of blood on a slide, covering the drop with a coverslip, and surrounding the coverslip with petroleum jelly or paraffin wax to seal the edges. If needed, the blood may be diluted with isotonic saline, or in some cases, it may be fixed with buffered glutaraldehyde for later examination. The blood may then be viewed with light or phase contrast microscopy. Some organisms, such as spirochetes and trypanosomes, may be detected by movement in wet mount preparations although more definitive testing, such as serology or molecular organism detection is more frequently used.¹³⁰

Supravital staining is performed on living motile cells and helps avoid artifacts induced by smear preparation, fixation, and staining.¹³¹ However, such preparations are not permanent, a distinct disadvantage. Supravital stains are often used to detect red cell inclusions. These include crystal violet staining that detects Heinz bodies or denatured hemoglobin inclusions that appear as irregularly shaped purple bodies within the red cell. Brilliant cresyl blue may be used to precipitate and stain unstable hemoglobins, such as hemoglobin Zurich and hemoglobin H.¹³² The most commonly used supravital stain is new methylene blue or brilliant cresyl blue, used for manual reticulocyte determinations,^{60,133} although the use of automated methods of reticulocyte determination by CBC analyzers has largely replaced manual methods.⁶¹ Reticulocytes are not identified positively on Wrightstained blood smears, although their presence is suggested by polychromatophilia of RBCs. Automated reticulocyte counts may have increased errors in the presence of Heinz bodies¹³⁴ or Howell-Jolly bodies¹³⁵ in the red cells. Normal reference values for reticulocytes are influenced by patient age, sex, and physical activity level.¹³⁶

BONE MARROW EXAMINATION

Diagnosis and management of many hematologic diseases depend on bone marrow evaluation. Bone marrow examination usually involves two separate, but interrelated, specimens. The first is a cytologic preparation of bone marrow cells obtained by aspiration of the marrow and a smear of the cells, allowing excellent visualization of cell morphology and enumeration of the marrow cellular elements.¹³⁷ The second specimen is a needle biopsy of the bone and associated marrow, which allows optimal evaluation of bone marrow cellularity, fibrosis, infections, or infiltrative diseases.¹¹¹

Indications for bone marrow examination include further work-up of hematologic abnormalities observed in the peripheral blood smear; evaluation of primary bone marrow tumors; staging for bone marrow involvement by metastatic tumors; assessment of infectious disease processes, including fever of unknown origin; and evaluation of metabolic storage diseases. Before a bone marrow examination is performed, clear diagnostic goals about the information to be obtained from the procedure should be defined and decisions made about whether any special studies are needed, to ensure that all necessary specimens may be collected and handled correctly.¹¹¹

Several sites may be used for bone marrow aspiration and biopsy.^{138,139} In part, the site chosen reflects the normal distribution of bone marrow with the age of the patient. At birth, hematopoietic marrow is found in all of the bones of the body. However, by early childhood, fat cells begin to replace the bone marrow hematopoietic cells in the extremities so that adults have hematopoiesis limited to the axial skeleton and proximal portions of the extremities.¹³⁸ Thus, younger children may have marrow examinations from the anterior medial tibial area, whereas adult marrow is best sampled from the sternum at the second intercostal space or from either the anterior or posterior iliac crest areas. Sternal marrows do not allow a biopsy to be performed, and several possible complications, including hemorrhage and pericardial tamponade, may occur if the inner table of the sternum is penetrated by the needle at areas other than the second intercostal space. The sternal marrow space in an adult is only approximately 1 cm thick at the second intercostal space, so care must be taken to avoid penetrating the chest cavity, although sternal bone marrow needles have guards to prevent penetration of the needle beyond the sternal plate. In contrast, little morbidity is associated with iliac crest aspiration and biopsy, and the posterior iliac crest is the most common site for bone marrow sampling.¹⁴⁰ The anterior iliac crest may be used if previous radiation, surgery, or discomfort does not allow a posterior approach.¹³⁹

Bone Marrow Aspiration and Biopsy

Bone marrow is semifluid and easily aspirated through a needle. Many types of needles have been used for performing marrow aspiration. Most are 14 to 18 gauge, and many have a removable obturator, which prevents plugging of the needle before aspiration, and a stylet that may be used to express the bone marrow biopsy sample (Fig. 1.4). Some models, primarily used for sternal bone marrow aspiration procedures, have adjustable guards that limit the extent of needle penetration and reduce morbidity.¹⁴⁰ Most bone marrow needles are disposed of after one use, and specific longer needles that may be used for obese patients and mechanical drills to aid in bone penetration are available commercially.

In most cases, marrow aspiration and biopsy may be carried out with little risk of patient discomfort, provided adequate local anesthesia is used. Apprehensive patients may be sedated before the procedure.^{139,141} The procedure is performed under sterile conditions. The skin at the site of the biopsy is shaved,

P.11

if necessary, and cleaned with a disinfectant solution. The skin, subcutaneous tissue, and periosteum in the area of the biopsy are anesthetized with a local anesthetic, such as 1% lidocaine, using a 25-gauge needle. Care must be taken to fully anesthetize the periosteum, where most of the bone pain fibers are located. After the anesthetic has taken effect, a small cut is made in the skin overlying the biopsy site, and the marrow aspiration needle is inserted through the skin, subcutaneous tissues, and bone cortex with a slight rotating motion. Entrance of the needle into the bone marrow cavity should be sensed as a slight give or increase in the speed of needle advancement. The needle obturator is removed, and the needle is attached to a 10- or 20-ml syringe. Aspiration of the marrow is achieved by rapid suctioning with the syringe so that 0.2 to 2.0 ml of bloody fluid is obtained. Aspiration may cause a very brief, sharp pain. If no pain is noted and no marrow is obtained, the needle may be rotated and suction applied again. If no marrow is obtained, relocation to another sampling site may be required.^{137,139}

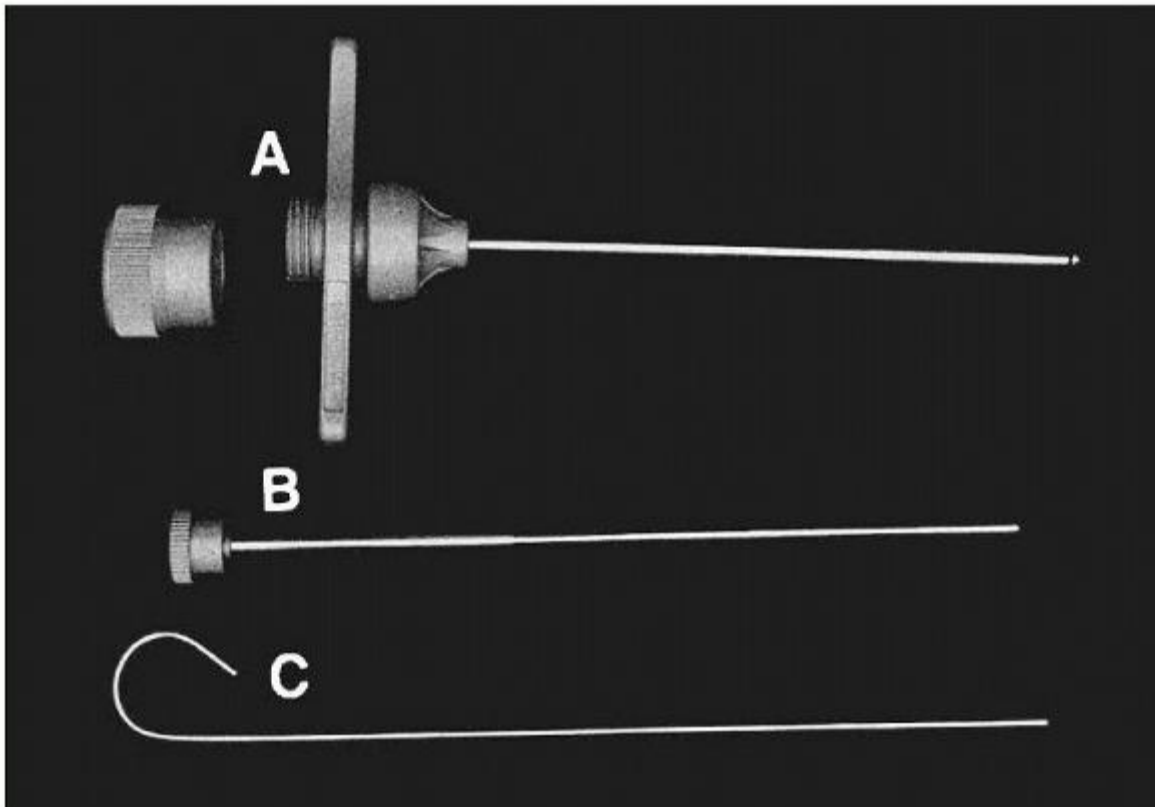

FIGURE 1.4. Jamshidi bone marrow aspiration and biopsy needle. This type of hollow needle with a beveled tip (A) is satisfactory for percutaneous biopsy of the bone marrow. The needle is inserted with the obturator (B) in place. The biopsy is expressed from the needle using the stylet (C).

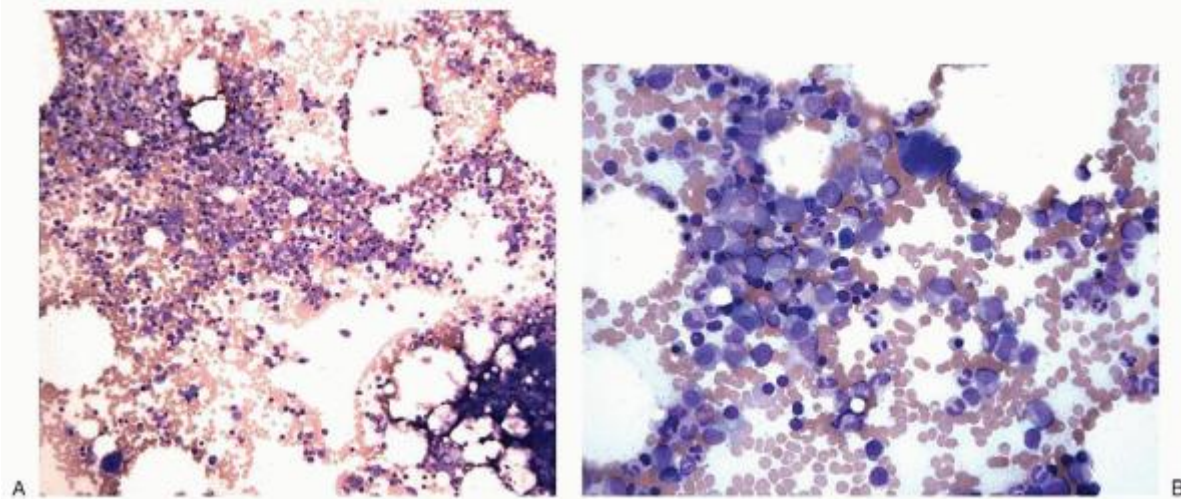

FIGURE 1.5. Bone marrow aspirate smear stained with Wright-Giemsa stain. The bone marrow aspirate shows a central spicule with dispersion of hematopoietic precursor cells around the spicule. The preparation allows for optimal evaluation of cytologic features of the bone marrow precursor cells. Panel A (low power) demonstrating distribution of hematopoietic cells near the darkly staining bone marrow spicule in a bone marrow aspirate. Panel B (high power) demonstrating cytologic features of bone marrow aspirate hematopoietic cells.

The aspirated material is usually given to a technical assistant, who makes smears of the material (Fig. 1.5) and assesses the quality of the material by noting the presence of marrow spicules. The smears must be made quickly to avoid clotting in a manner similar to that described for blood smears using either coverslips or slides to spread the marrow (Fig. 1.3). After smears are made, the aspirate may be allowed to clot to form a histologic clot section for processing. In some cases, where immediate slide preparation is not available, the bone marrow may be aspirated into a tube containing a small amount of anticoagulant to impede clotting. The aspirate may later be filtered and submitted for histologic processing into a particle clot section. EDTA is the best anticoagulant to use because it introduces the least amount of morphologic artifact to the specimen.¹³⁷ If additional material is needed for flow cytometry, cytogenetics, culture, or other special studies, additional aspirations may be performed by withdrawing the needle and repositioning it in a new site and drawing marrow into tubes containing anticoagulant. Morphologic examination requires the best sample and the aspirations for ancillary studies should be made subsequent to the initial aspiration for such an examination. Occasionally, a portion of an anticoagulated marrow aspirate is spun down to obtain a buffy coat, thereby concentrating the cellular elements. In some instances, no marrow can be aspirated (dry tap). In these cases, it is essential to make smears from material at the tip of the needle and also to make touch preparations from the biopsy, as outlined below, to allow cytologic examination of the bone marrow elements.^{137,139}

The bone marrow biopsy (Fig. 1.6) may be performed using the same skin incision if the aspirate has been performed in the iliac crest area. A separate biopsy needle that is slightly larger than the needle used for aspiration may be used, or the same needle that was used for the bone marrow aspiration may be reused. Care must be taken to reposition the needle biopsy site away from the area where the aspiration was performed to avoid collection of a specimen with extensive artifact induced by the aspiration procedure.^{139,142} Use of a biopsy needle may require more pressure to enter the bone because of the larger bore size. Once the needle is in place in the bone, the stylet may be inserted to give an approximation of the size of the bone core within the needle. The biopsy needle is rotated and gently

P.12

rocked to free the biopsy from the surrounding bone and then advanced slightly farther. The biopsy is then removed from the bone by withdrawing the needle, and slight positive pressure may be applied using a syringe. The biopsy is expressed from the needle by the stylet. Touch preparations of the bone biopsy should be made, particularly if no aspirate was obtained, to allow cytologic examination of the bone marrow elements. The bony core is then fixed, decalcified, and processed for histologic examination.^{138,143} Ancillary testing can often be performed on additional bone marrow cores when no material can be aspirated, so collection of more than one core biopsy may be necessary.

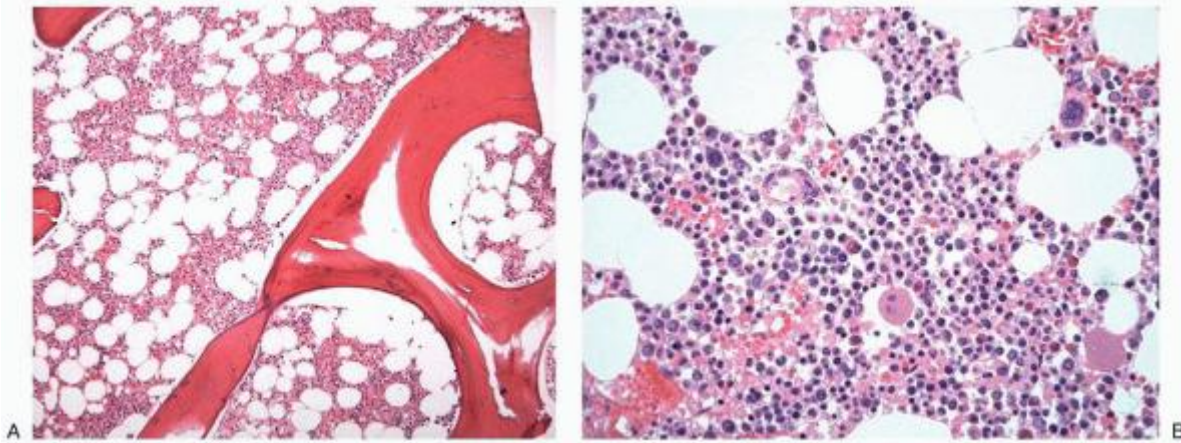

FIGURE 1.6. Bone marrow core biopsy. Histologic preparation of the bone marrow core biopsy following fixation and decalcification. The biopsy is stained with hematoxylin and eosin. This preparation allows for optimal evaluation of bone marrow cellularity and interaction of bone marrow cells with bony trabeculae and is helpful in evaluating extrinsic features such as metastatic tumor or fibrosis in the marrow. Panel A (low power) shows bony spicules and marrow in section of bone marrow core biopsy. Panel B (high power) shows morphologic detail of hematopoietic tissue within the section.

Once the biopsy is completed, manual pressure is applied to the site for several minutes to achieve hemostasis. The site is then bandaged and the patient instructed to remain recumbent so as to apply further pressure for approximately 30 to 60 minutes. If a patient is thrombocytopenic, pressure bandages should be applied and the site checked frequently for prolonged bleeding.

Staining and Evaluation of Bone Marrow Aspirates and Touch Preparations

The bone marrow aspirate or touch preparation slides are stained with either Wright or May-Grünwald-Giemsa stains, similar to blood smears. These stains allow excellent morphologic detail and allow differential counts to be performed. Unstained smears should be retained for possible special stains if indicated.^{137,139}

Evaluation of bone marrow aspirates gives little information about the total cellularity of the bone marrow because of fluctuations in cell counts induced by peripheral blood contamination of the bone marrow specimen and preparation artifacts. An overall impression of the cellularity may be given (i.e., cellular or paucicellular). More accurate evaluation of bone marrow cellularity requires examination of the bone marrow biopsy or particle clot section, although the biopsy represents a tiny fraction of the total marrow and may also be subject to sampling error.^{111,139,144} The stained aspirate smear will have a central zone of dark marrow particles and stroma surrounded by a thinner area of dispersed bone marrow cells and red cells (Fig. 1.5). Low-power examination allows evaluation of the adequacy of cellularity and of the presence of megakaryocytes. Tumor cells or granulomas may also be seen by scanning the aspirate smear at low power.¹³⁷

The aspirate smear allows cytologic examination of the bone marrow cells. A minimum of 500 nucleated cells should be evaluated under oil immersion magnification in most marrows. Only intact cells are evaluated; all bare nuclei are excluded. Counting is performed in an area where few bare nuclei are present and the cells are not overlapping, found in clusters, or artifactually distorted due to spreading artifact. This is usually in the dispersed cell zone adjacent to the spicule. It should be noted that spicules may be absent in pediatric marrows where marrow cells will be uniformly dispersed. Reference ranges for the percentage of bone marrow cell types vary widely between laboratories and are used only as guides for what is to be expected in normal bone marrow samples¹³⁷ (see Table 1.5 for example reference ranges). The proportions of each cell type and progression of the maturational sequence for myeloid and erythroid elements are determined from the differential counts. In addition, the myeloid-to-erythroid ratio may be calculated.

Differences in cell differential results among infants, children, and adults exist (Table 1.6).^{137,139,144,145} In general, lymphocytes are more commonly seen in the marrow of children, especially those younger than 4 years of age, where they may compose up to 40% of the marrow cellularity.¹⁴⁶ Plasma cells are rare in the marrow of infants and children. Lymphocytes are much less numerous in adult bone marrows, usually making up <20% of adult marrow cellularity. Lymphocyte and plasma cell counts in adults tend to be quite variable, perhaps reflecting the tendency of these cells to be unevenly distributed in the bone marrow of adults. Often, lymphoid cells are found in nodular aggregates in older adults, and plasma cells tend to be associated with blood vessels.¹¹¹

During the first month of life, bone marrow erythroid cells are prominent because of high levels of erythropoietin¹⁴⁷; thereafter, the erythroid cells make up 10% to 40% of the marrow cells. Relatively few early erythroid precursors (normoblasts) are usually seen, and more mature forms predominate. Erythroid cells should be examined for abnormalities in morphology as well as iron content as these features are often deranged in pathologic states. Myeloid cells are usually the predominant bone marrow element, and more mature cells predominate over myeloblasts. Children tend to have higher

P.13

numbers of eosinophils and eosinophilic precursor cells than do adults, although many medications or allergies may increase the bone marrow eosinophil count. Megakaryocytes constitute the least abundant cell type seen in the bone marrow, usually making up <1% of the cells.^{137,139}

TABLE 1.5 DIFFERENTIAL COUNTS OF BONE MARROW ASPIRATES FROM 12 HEALTHY MEN

	Mean (%)	Observed Range (%)	95% Confidence (%)
Neutrophilic series (total)	53.6	49.2-65.0	33.6-73.6
Myeloblast	0.9	0.2-1.5	0.1-1.7
Promyelocyte	3.3	2.1-4.1	1.9-4.7
Myelocyte	12.7	8.2-15.7	8.5-16.9
Metamyelocyte	15.9	9.6-24.6	7.1-24.7
Band	12.4	9.5-15.3	9.4-15.4
Segmented	7.4	6.0-12.0	3.8-11.0
Eosinophilic series (total)	3.1	1.2-5.3	1.1-5.2
Myelocyte	0.8	0.2-1.3	0.2-1.4
Metamyelocyte	1.2	0.4-2.2	0.2-2.2
Band	0.9	0.2-2.4	0-2.7
Segmented	0.5	0-1.3	0-1.1
Basophilic and mast cells	<0.1	0-0.2	—
Erythrocytic series (total)	25.6	18.4-33.8	15.0-36.2
Pronormoblasts	0.6	0.2-1.3	0.1-1.1
Basophilic	1.4	0.5-2.4	0.4-2.4
Polychromatophilic	21.6	17.9-29.2	13.1-30.1
Orthochromatic	2.0	0.4-4.6	0.3-3.7
Lymphocytes	16.2	11.1-23.2	8.6-23.8
Plasma cells	1.3	0.4-3.9	0-3.5
Monocytes	0.3	0-0.8	0-0.6
Megakaryocytes	<0.1	0-0.4	—
Reticulum cells	0.3	0-0.9	0-0.8
Myeloid-to-erythroid ratio	2.3	1.5-3.3	1.1-3.5

In addition to the hematopoietic cells mentioned above, a variety of other cells may be seen in bone marrow aspirates in varying proportions. These include macrophages, mast cells, stromal cells, and fat cells. In children, osteoblasts and osteoclasts may be seen, although these cells are rare in adults and their presence may indicate metabolic bone

disease.^{137,139,144} Normally, these other cells make up <1% of the total marrow cellularity; however, they may be increased in a variety of reactive and pathologic processes. Aspirate smears are excellent for evaluation of macrophage hemophagocytosis¹⁴⁸ or storage disorders.¹³⁷

Examination of Bone Marrow Histologic Sections

Bone marrow core biopsies and the clot obtained from the aspiration procedure are usually fixed in formalin or in a coagulative fixative, such as B5 or zinc formalin. The bony core will require decalcification before histologic processing. The fixed materials are processed and embedded in paraffin or plastic, and sections are made for examination. The bone marrow biopsy and clot sections are stained with either hematoxylin and eosin or Giemsa stains for morphologic examination^{139,144} (Fig. 1.6).

Bone marrow biopsies are useful in evaluation of the cellularity of the bone marrow sampled. Several caveats must be kept in mind when assessing cellularity. Studies show variations in cellularity even within the same biopsy site¹⁴⁵ as well as between different anatomic sites. However, comparisons of the relative proportions of myeloid, erythroid, and megakaryocytic cells appear to be constant even in widely separated biopsy sites.^{139,145} In older patients, the subcortical area is often hypocellular, and care must be taken to obtain a large enough biopsy to allow adequate evaluation of the marrow away from this area.¹⁴⁵ The bone marrow biopsy section provides the best representation of the bone marrow and its anatomic relationships, such as normal localization of immature myeloid cells adjacent to bony trabeculae. Evaluation of nonhematopoietic elements, such as bony trabeculae, blood vessels, and stroma, requires a biopsy specimen.

The clot section, which is prepared from the bone marrow aspirate material, has a degree of inherent artifact because the bone marrow is removed from its normal relationships with bone, blood vessels, and other stromal elements. In particular, cellularity estimations may be falsely elevated secondary to collapse of the normal stromal network in a clot section.¹³⁹

In addition to providing information about the anatomic distribution and relationships of hematopoietic cells, the bone marrow biopsy is useful for evaluation of infiltrative processes such as carcinoma, lymphoma, other tumors, granulomatous inflammation, and fibrosis.^{111,139} Occasionally, the marrow is so involved with an infiltrative process that no aspiration can be obtained (dry tap), and the biopsy provides the only diagnostic material.^{149,150}

SPECIAL STAINS

Several special stains may be performed on peripheral blood smears, bone marrow aspirate smears, bone marrow touch preparations, and bone marrow biopsy materials and will provide additional information about the cell lineage beyond what is obtained by standard staining with Giemsa or hematoxylin

P.14

and eosin stains. Special stains generally fall into two categories: cytochemical stains that use cellular enzymatic reactions to impart staining and immunocytochemical stains that identify cell-specific antigen epitopes. These stains are particularly useful in characterization of primary hematologic or metastatic malignancies.

TABLE 1.6 CHANGES IN DIFFERENTIAL COUNTS OF BONE MARROW WITH AGE

		Birth	1 Mo-1 Y	1-4 Y	4-12 Y	Adult
Neutrophilic series	Mean (%)	60	33	50	52	57
	95% limits	42-78	17-47	32-68	35-69	39-79
Eosinophilic series	Mean (%)	3	3	6	3	3
	95% limits	1-5	1-5	2-10	1-5	1-5
Lymphocytes	Mean (%)	14	47	22	18	17
	95% limits	3-25	34-63	8-36	12-28	10-24
Erythrocytic	Mean (%)	14	8	19	21	0
	95% limits	2-28	2-16	11-27	11-31	10-30

Myeloid-to-erythroid	Mean ratio	4.3	4.0	2.6	2.5	2.6
----------------------	------------	-----	-----	-----	-----	-----

The means and 95% confidence limits in this table were calculated by combining data published in Osgood EE, Seaman AJ. The cellular composition of bone marrow as obtained by sternal puncture. *Physiol Rev* 1939;24:105-114, with the data in Table 1.5.

Cytochemical Stains

Cytochemical stains are extremely useful in the diagnosis and classification of acute leukemias, although this utility has been lessened by identification of lineage-specific markers by flow cytometry. They allow identification of myeloid and lymphoid acute leukemias, as well as providing one basis for subclassification of the acute myeloid leukemias. These stains were widely used in morphologic subclassifications, such as the French-American-British (FAB)¹⁵¹ but with wide usage of flow cytometric and other ancillary tests are not as widely used for classification purposes in the current era of the World Health Organization (WHO) classification.¹⁵² Cytochemical stains are usually performed on peripheral blood films, bone marrow aspirates, or touch preparations made from bone marrow biopsies. Best results are obtained by using freshly obtained materials; however, some reactions may be carried out on materials that are several years old.¹⁵³

Myeloperoxidase

Primary granules of neutrophils and secondary granules of eosinophils contain myeloperoxidase. Monocytic lysosomal granules are faintly positive. Lymphocytes and nucleated RBCs lack the enzyme.¹⁵⁴ Staining is due to oxidation of 3-amino-9-ethylcarbazole or 4-chloro-1-naphthol¹⁵⁵ substrates by myeloperoxidase in the cell to form a brown-colored precipitate.

The myeloperoxidase enzyme is sensitive to light, and smears should be stained immediately or sheltered from light. Enzymatic activity in cells may diminish over time, so the stain should not be performed in blood or marrow aspirate smears older than 3 weeks. Permount coverslip mounting medium (Fisher Scientific, Pittsburgh, PA) may cause fading of the stain. Myeloperoxidase is also sensitive to heat and methanol treatment. Erythroid cells may stain for peroxidase after methanol treatment due to a nonenzymatic interaction between the staining reagents and hemoglobin (pseudoperoxidase or Lepehne reaction). Antibodies to myeloperoxidase are available for both flow cytometric analysis and immunohistochemical staining in fixed tissue sections.¹⁵⁶

Sudan Black B

Sudan black B stains intracellular lipid and phospholipids. The pattern of staining closely parallels the myeloperoxidase reaction, with positive staining of granulocytic cells and eosinophils, weak monocytic staining, and no staining of lymphocytes, although some positivity may be seen in azurophilic granules of lymphoblasts. Sudan black B has an advantage over myeloperoxidase in that it may be used to stain older blood or bone marrow smears, and there is little fading of the stain over time.¹⁵⁴

Specific (Naphthol AS-D Chloroacetate) Esterase

The specific (naphthol AS-D chloroacetate) esterase stain, also called the Leder stain, is used to identify cells of the granulocytic series.¹⁵⁴ It does not stain lymphocytes and monocytes. Because of enzymatic stability in formalin-fixed, paraffin-embedded tissues, this stain is extremely useful for identifying granulocytes and mast cells in tissue sections and is particularly helpful in diagnosis of extramedullary myeloid tumors (granulocytic sarcoma, chloroma) of blasts found in tissues.¹⁵³ The cellular esterase enzyme hydrolyzes the naphthol AS-D chloroacetate substrate.¹⁵⁴ This reaction product is then coupled to a diazo salt to form a bright red-pink reaction product at the site of enzymatic activity. The enzyme activity is inhibited by the presence of mercury, acid solutions, heat, and iodine that may give rise to false-negative staining results.

Nonspecific (α -Naphthyl Butyrate or α -Naphthyl Acetate) Esterases

Nonspecific (α -naphthyl butyrate or α -naphthyl acetate) esterase stains are used to identify monocytic cells but do not stain granulocytes or eosinophils.^{154,157} Mature T-lymphocytes stain with a characteristic focal, dotlike pattern. The stain also reacts with macrophages, histiocytes, megakaryocytes, and some carcinomas. The α -naphthyl butyrate stain is considered to be more specific, although slightly less sensitive, than the α -naphthyl acetate stain.¹⁵⁴ Differential staining with the different esterases is seen in megakaryoblasts, which do not stain with the α -naphthyl butyrate, but stain with the α -naphthyl acetate substrate.¹⁵³

Terminal Deoxynucleotidyl Transferase

Terminal deoxynucleotidyl transferase (TdT) is an intranuclear enzyme that catalyzes the addition of deoxynucleotide triphosphates to the 3'-hydroxyl ends of oligonucleotides or

polydeoxynucleotides without need for a template strand.¹⁵⁸ TdT is found normally in the nucleus of thymocytes and immature lymphoid cells within the bone marrow, but is not found in mature lymphocytes, and it is a useful marker in identifying acute lymphoblastic leukemias and lymphomas.¹⁵² TdT activity is found in approximately 90% of acute lymphoblastic leukemias as well as in a small subset of acute myelogenous leukemias.^{159,160} TdT levels may be measured biochemically, by cytochemical staining with an immunofluorescent detection technique, by flow cytometry after permeabilization of freshly collected cells, or by immunohistochemical methods.^{161,162} and ¹⁶³ Indirect immunofluorescent staining is very sensitive and may be applied to air-dried samples several weeks after collection, although it is no longer used as often with the widespread use of flow cytometry.¹⁶² Immunohistochemical methods of TdT detection are useful in paraffin-embedded tissue sections and can be used on touch preps.¹⁶¹

Leukocyte Alkaline Phosphatase

Alkaline phosphatase activity is found in the cytoplasm of neutrophils, osteoblasts, vascular endothelial cells, and some lymphocytes. The alkaline phosphatase level of peripheral blood neutrophils is quantitated by the leukocyte alkaline phosphatase (LAP) score and is useful as a screening test to differentiate chronic myelogenous leukemia from leukemoid reactions and other myeloproliferative disorders.¹⁶⁴ The LAP score is usually performed using the Kaplow procedure.¹⁶⁵ This method uses a naphthol AS-BI phosphate as the substrate, which is coupled to fast violet B salt by the enzyme to produce a bright red reaction product that is visualized over neutrophils. The LAP score is determined by evaluation of the staining intensity (ranging from 0 to 4+) of 100 counted neutrophils or bands. Normal LAP scores range from 15 to 130, but there may be variation in these ranges between laboratories. Many different disease states may cause elevation or depression of the LAP score (Table 1.7). Patients with chronic myelogenous leukemia have low LAP scores (usually between 0 and 13). Paroxysmal nocturnal hemoglobinuria and some myelodysplastic syndromes may also be characterized by low LAP scores. Leukemoid reactions in response to infection and other myeloproliferative disorders (myelofibrosis with myeloid metaplasia and polycythemia vera) often have an elevated LAP score.^{93,164} There is rapid loss of alkaline phosphatase activity in samples drawn in EDTA anticoagulant.¹⁶⁵ The test is optimally performed on fresh capillary blood fingerstick smears or on blood anticoagulated with heparin and should be performed within 48 hours after collection of the sample. The blood smears may be held in the freezer for 2 to 3 weeks with little loss of activity.

TABLE 1.7 CONDITIONS ASSOCIATED WITH ABNORMAL LEUKOCYTE ALKALINE PHOSPHATASE (LAP) SCORES

Low LAP Score (<15)

CML

Paroxysmal nocturnal hemoglobinuria

Hematologic neoplasms (rare)

Myelodysplastic neoplasms

Rare infections or toxic exposures

High LAP Score (>130)

Infections

Growth factor therapy

Myeloproliferative neoplasms other than CML

Inflammatory disorders

Pregnancy, oral contraceptives

Stress

Drugs (lithium, corticosteroids, estrogen)

CML, chronic myelogenous leukemia.

Acid Phosphatase

Acid phosphatase is found in all hematopoietic cells, but the highest levels are found in macrophages and osteoclasts. A localized dotlike pattern is seen in many T-lymphoblasts, but this staining pattern is not reliable. The tartrate-resistant acid phosphatase (TRAP) is an isoenzyme of acid phosphatase that is found in high levels in the cells of hairy cell leukemia¹⁶⁶ and osteoclasts. Several methods of measuring TRAP activity have been described, but one using naphthol AS-BI phosphoric acid coupled to fast garnet GBC is reliable and reproducible.¹⁶⁷ Not all cases of hairy cell leukemia stain for TRAP, and staining intensity may be variable. Positive TRAP staining may also be seen in some activated T-lymphocytes, macrophages, some histiocytes (such as Gaucher cells), mast cells, and some marginal zone lymphomas.¹⁶⁸ TRAP staining may also be detected by immunohistochemical methods in fixed tissue sections.¹⁶⁹

Periodic Acid-Schiff

The periodic acid-Schiff (PAS) stain detects intracellular glycogen and neutral mucopolysaccharides, which are found in variable quantities in most hematopoietic cells.^{154,170} PAS staining is seen in blasts of both acute lymphoblastic and acute myelogenous leukemias, although there is great variability between cases.¹⁷⁰ Erythroleukemias demonstrate an intense diffuse cytoplasmic positivity with PAS, which may be helpful in diagnosis.¹⁵² In addition, PAS staining is very useful in demonstrating the abnormal glucocerebrosidase accumulation in Gaucher disease.¹⁷¹

Iron

Cellular iron is found as either ferritin or hemosiderin. It is identified in cells by the Perls or Prussian blue reaction, in which ionic iron reacts with acid ferrocyanide to impart a blue color.^{154,170,172} The stain is used to identify iron in nucleated RBCs (sideroblastic iron) and histiocytes (reticuloendothelial iron) or to identify Pappenheimer bodies in erythrocytes. Normally, red cell precursors contain one or more small (<1 μm in diameter) blue granules in 20% to 50% of the cells. When increased numbers of these granules surround at least two thirds of the nucleus of the red cell precursor, the cell is called a ringed sideroblast.¹⁷³ The stain is best used on bone marrow aspirate smears but can also be used on blood films and aspirate clot tissue sections. Decalcification of the bone marrow core biopsy may lead to loss of iron from the cells, leading to a false impression of low iron.

Toluidine Blue

Toluidine blue specifically marks basophils and mast cells by reacting with the acid mucopolysaccharides in the cell granules to form metachromatic complexes. Malignant mast cells or basophils may have low levels of acid mucopolysaccharides and may not react with this stain.¹⁷⁴ Specific immunohistochemical markers, such as staining for mast cell tryptase may be more specific in identification of mast cells than toluidine blue staining.¹⁷⁵

Immunocytochemical Stains

Immunocytochemical staining is based on the use of an antibody that recognizes a specific antigenic epitope on a cell. There is a high level of specificity. In general, these stains may be applied to

P.16

blood smears, bone marrow aspirates, cellular suspensions, or tissue sections. Not all antibody preparations are equally effective on all types of specimens, and staining procedures may vary depending on the specimen type. A wide variety of antibodies specific to hematopoietic cellular antigens is available commercially. Some of the newer antibodies have replaced classical cytochemical stains and may be useful on older or fixed specimens.

Immunocytochemical staining of fresh blood or bone marrow cell suspensions or cell suspensions from tissues and analysis by flow cytometry is a common ancillary testing modality that is employed when a hematologic malignancy is suspected.^{176,177} The flow cytometer detects both light scatter data and the presence of specific fluorochrome-labeled antibodies that have bound to the cell surface. Use of different fluorochromes can allow more than one antibody to be studied simultaneously on the same cell by means of different excitation wavelengths. The study of these cell surface markers allows rapid and accurate analysis of lymphomas and leukemias, enumeration of T-cell subsets, and identification of tumor cells. In addition, recent advances have allowed detection of intracytoplasmic or nuclear antigens, such as myeloperoxidase and TdT, by flow cytometric analysis.¹⁷⁶ In many cases, particularly in the acute leukemias, the flow cytometric analysis of an acute leukemia provides important prognostic information that is not available through cytochemical staining and is useful in detection of minimal residual disease.^{159,178} Clinical and technical aspects of flow cytometric analysis of hematologic tumors are covered in detail in Chapter 2.

Immunohistochemical staining is the use of specific antibody probes on tissue sections or smears of blood and bone marrow. This allows the localization of a specific antigenic epitope to the cell surface, cytoplasm, or nucleus. The antigen

binding may then be detected by immunofluorescence, which requires a special fluorescence microscope, or by enzymatic formation of a colored reaction product linked to the antigen-antibody complex. Immunoenzymatic staining techniques include immunoperoxidase, immunoalkaline phosphatase, and avidin-biotin techniques.^{179,180} These procedures allow study of the specimen with standard light microscopy and provide a permanent record of staining that may be re-examined. In the past, the repertoire of antibodies available for use on paraffin-embedded tissues was limited, and many antibodies required frozen sections of fresh tissues to be used. Over time, however, there has been a large increase in the number of antibodies that can be used on fixed and processed tissues.^{181,182} Automated immunostaining instruments have become available that allow highly reproducible results and require less technician time and expertise for highly reproducible staining.^{179,183}

OTHER LABORATORY STUDIES

Cytogenetic Analysis

Many hematologic malignancies and premalignant conditions are associated with specific cytogenetic changes.^{152,184,185,186,187} These include distinctive changes in chromosome number, translocations, and inversions of genetic material. These chromosomal changes are often associated with activation or increased transcription of oncogenes and may contribute to acquisition of a malignant phenotype.¹⁸⁸ Cytogenetic analysis is an important element in the diagnosis of hematologic disorders, identifying specific prognostic subgroups, and monitoring for progression of disease or residual disease after therapy, and is integral to the most current classification of hematologic malignancies, such as the WHO classification.^{152,159,189,190,191} Both standard chromosomal preparations and fluorescent-labeled in situ hybridization techniques may be used for cytogenetic analysis of chromosomal changes.^{192,193} Further details about cytogenetic techniques and analysis are provided in Chapter 3.

Molecular Genetics

In addition to standard morphologic analysis and cytogenetics, technology has been developed that allows analysis of molecular changes in hematologic malignancies.^{189,190,194,195} By use of Southern blot and polymerase chain reaction (PCR) techniques, hematopoietic proliferations may be studied for genetic alterations associated with the development of malignancy.¹⁹⁶ Molecular genetic analysis was initially used to identify monoclonality in lymphoid neoplasms by identifying either immunoglobulin (B-cell) or T-cell-receptor gene rearrangements.^{197,198} This finding is extremely useful in classification of lymphoproliferative disorders that may be difficult to diagnose on morphologic grounds alone or that lack specific phenotypic markers.¹⁹⁷ In the past few years, there has been an explosion in the use of molecular techniques to detect translocations that previously had been detected only by conventional cytogenetics. Common tests include the BCR-ABL1 translocations seen in chronic myelogenous leukemia and acute leukemia and used to monitor efficacy of treatment,^{189,199} BCL2 translocations characteristic of follicular lymphomas,²⁰⁰ the t(15;17) translocation associated with acute promyelocytic leukemia,^{201,202} JAK2 translocations associated with myeloproliferative disorders,^{203,204} and NPM1 and FLT3 mutations, which are prognostic factors in acute myeloid leukemia.^{205,206} and ²⁰⁷ In chronic myelogenous leukemia, BCR-ABL1 kinase domain mutation analysis can be performed to detect mutations that lead to imatinib resistance^{208,209}. As molecular characterization and genetic profiling of specific hematologic disorders expand, such as through microarray analysis,^{210,211} and ²¹² it may be anticipated that more PCR and molecular tests will be developed. Molecular studies have an advantage over conventional morphologic and cytogenetic analyses in that they may detect very small populations of malignant cells (as few as 1% to 5% of the cells in a sample), may allow for quantification of low levels of transcripts to allow monitoring of disease status, and can lead to more rapid test completion (especially with PCR-based testing).^{199,201} Molecular tests are most useful when a known specific entity is being tested for or in monitoring residual disease as they do not provide effective screening capability for additional genetic alterations that may affect prognosis, as does conventional cytogenetic analysis.^{184,192,213}

The high degree of sensitivity makes molecular testing, particularly by PCR or in situ hybridization, very attractive for the purpose of monitoring for tumor persistence or recurrence after therapy. Previously, molecular genetic studies required collection of fresh or frozen diagnostic material; however, many of the newer assays can make use of formalin-fixed materials with sensitivity similar to that of fresh or frozen materials.^{214,215} This allows analysis to be performed on a wider range of cases, including archival materials. The topic of molecular genetics is covered in further detail in Chapter 4.

Electron Microscopy

The electron microscope allows examination of ultrastructural details of a cell. In the past, electron microscopy was used as a research tool and, occasionally, as a diagnostic tool for difficult hematologic diagnoses. However, with the advent of increasing numbers of specific immunocytochemical stains, the use of the electron microscope as a diagnostic tool for hematopathologic processes has been largely discontinued.

Erythrocyte Sedimentation Rate

The erythrocyte sedimentation rate (ESR) is a common but nonspecific test that is often used as an indicator of active disease. It reflects the tendency of RBCs to settle more rapidly in the face of some disease states, usually because of increases in plasma fibrinogen, immunoglobulins, and other acute-phase-reaction proteins. In addition, changes in red cell shape or

P.17

numbers may affect the ESR. Sickle cells and polycythemic disorders tend to decrease the ESR, whereas anemia may increase it. ESR also increases with age in otherwise healthy people (although it tends to fall in adults older than age 75)²¹⁶ and tends to be higher in women. People with liver disease, carcinomas, or other serious diseases may have a normal to low ESR because of an inability to produce the acute-phase proteins.²¹⁷

A common cause of ESR elevation is infection, but monoclonal gammopathy must be ruled out in patients who have a persistent unexplained elevation in ESR. Elevated ESRs are also seen with pregnancy, malignancies, collagen vascular diseases, rheumatic heart disease, and other chronic disease states, including human immunodeficiency virus infection.^{218,219} and ²²⁰ The ESR is a poor screening test in asymptomatic individuals, detecting elevations in 4% to 8% of normal adults and, hence, should not be used to screen asymptomatic people for disease.²²⁰ The test is probably best used in the clinical scenario of a patient with vague complaints to aid in the clinical decision to undergo further testing or as a tool to follow the clinical disease course in temporal arteritis, rheumatoid arthritis, polymyalgia rheumatica, or lymphomas.²²⁰

The ESR is measured by the Westergren or Wintrobe method or by a modification of these tests.²²¹ Both are measured in millimeters per hour, but the normal values for each method vary because of differences in tube length and shape. Both methods require correction for patient anemia. Several technical variations to the method of ESR determination have been introduced, including micromethods, sedimentation at a 45° angle, and the zeta sedimentation rate. The zeta sedimentation rate measures erythrocyte packing in four 45-second cycles of dispersion and compaction in capillary tubes. This requires a special instrument, the Zetafuge (Coulter Electronics, Hialeah, FL), but gives reproducible results on very small amounts of blood and is not affected by patient anemia.²²²

Plasma and Blood Viscosity

Plasma viscosity measurements are advocated by some authors as being superior to ESR measurements for monitoring disease states, particularly in autoimmune diseases and diseases characterized by the secretion of large amounts of immunoglobulin into the plasma (such as plasma cell dyscrasias).²²³ Plasma viscosity measurements have the advantage of no red cell influences on the value obtained and yield a narrower reference range of normal values than observed with ESR.²²⁴ However, plasma viscosity is used more rarely than ESR, probably reflecting clinical familiarity with the latter test. As with ESR, plasma viscosity may increase with age.²²³ Direct measurement of acute-phase proteins, such as C-reactive protein, may also be used to monitor the course of inflammatory diseases and cardiac risk.^{225,226} However, these tests are usually more expensive than ESR determinations and may not provide sufficient additional clinical information to justify the added expense.²²⁷ Whole blood viscosity measurements are of limited clinical use because the measured blood viscosity may have little bearing on the viscosity of the blood in the circulation. Increased blood viscosity may contribute to the morbidity and mortality of patients with sickle cell disease, polycythemia, and ischemic vascular disease.

Blood Volume Measurement

In most cases, the total number of erythrocytes is closely related to the red cell concentration of the blood or Hct. However, blood volume may not always reflect erythrocyte concentration, including immediately after severe hemorrhage, severe dehydration, or overhydration. To accurately assess the blood volume in these patients, plasma volume or red cell mass or volume must be determined,^{44,228} although these tests are rarely performed. The plasma volume is measured by dilution methods using a substance that is confined to the intravascular plasma compartment, such as Evans blue dye,²²⁹ ¹³¹I-labeled albumin, or radioactive indium-labeled transferrin, is injected and the volume of distribution calculated from the degree of dilution of the injected substance over 15 to 30 minutes. Radiolabeled albumin is the most commonly used, but corrections must be made because the label is gradually removed from the circulation into the extravascular space, leading to errors of 10% or more in plasma volume determinations.²³⁰ Plasma volume may also be estimated from red cell volume.²³¹

Total red cell volume is calculated by the Ashby technique, which uses radiolabeled RBCs. A number of radioisotopes may be used, but ⁵¹Cr and ^{99m}Tc are the most common. Biotinylated cells may also be used.²³² The red cell volume is then calculated by the dilution of the labeled cells over time using the following formula:

Red cell volume = cpm of isotope injected/cpm/ml red cell concentration per unit volume in sample

Usually, the measurements are made after a 15-minute interval, although longer periods may be needed with high blood viscosity due to high Hcts to ensure complete labeled cell mixing. Total red cell volume measurements must be corrected with splenic enlargement secondary to sequestration of the labeled cells within this organ. Red cell volume may also be calculated from the total plasma volume and measured Hct by means of the following equation:

Red cell volume = Hct × plasma volume/100 - Hct

Total plasma volume may be useful in monitoring fluid and blood replacement. Red cell volume measurements are used to document true polycythemia, although some authors advocate the use of erythropoietin levels and red cell colony growth as less invasive surrogate tests for red cell volume or red cell mass measurements.⁴⁴ Total blood volume may be calculated from the sum of total red cell volume and plasma volume measurements.

REFERENCES

1. van Assendelft OW. Calibration, control of hematology analyzers. *Adv Administrators Lab* 2002;22:43-47.
2. CLSI. Performance goals for the internal quality control of multichannel hematology analyzers; Approved Standard. CLSI document H26-A. Clinical and Laboratory Standards Institute, 1996.
3. Barnes PW, McFadden SL, Machin SJ, et al. The international consensus group for hematology review: suggested criteria for action following automated CBC and WBC differential analysis. *Lab Hematol* 2005;11(2):83-90.
4. Novis DA, Walsh M, Wilkinson D, et al. Laboratory productivity and the rate of manual peripheral blood smear review: a College of American Pathologists Q-Probes study of 95,141 complete blood count determinations performed in 263 institutions. *Arch Pathol Lab Med* 2006;130(5):596-601.
5. Fromm P, Havis R, Barak M. The rate of manual peripheral blood smear reviews in outpatients. *Clin Chem Lab Med: CCLM/FESCC* 2009;47(11): 1401-1405.
6. Cheng CK, Chan J, Cembrowski GS, et al. Complete blood count reference interval diagrams derived from NHANES III: stratification by age, sex, and race. *Lab Hematol* 2004;10(1):42-53.
7. Schwartz J, Weiss ST. Cigarette smoking and peripheral blood leukocyte differentials. *Ann Epidemiol* 1994;4(3):236-242.
8. Lim EM, Cembrowski G, Cembrowski M, et al. Race-specific WBC and neutrophil count reference intervals. *Int J Lab Hematol* 2010;32(6 Pt 2):590-597.
9. Wood BL, Andrews J, Miller S, et al. Refrigerated storage improves the stability of the complete blood cell count and automated differential. *Am J Clin Pathol* 1999;112(5):687-695.
10. Song KS, Song JW. Changes of platelet parameters determined by the Bayer ADVIA 120 with EDTA sample age. *Platelets* 2005;16(3-4):223-224.
11. CLSI. Tubes and additives for venous blood specimen collection, 5th ed. Approved Standard, 2003.
12. CLSI. Evaluation of precision performance of quantitative measurement methods, 2nd ed. Approved Guideline, 2004.
13. CLSI. Preliminary evaluation of quantitative clinical laboratory measurement procedures, 3rd ed. Approved Guideline, 2006.
14. Bentley SA, Johnson A, Bishop CA. A parallel evaluation of four automated hematology analyzers. *Am J Clin Pathol* 1993;100(6):626-632.
15. Wintrobe M. A simple and accurate hematocrit. *J Lab Clin Med* 1929;15: 287-289.
16. Bournier G, Dhaliwal J, Sumner J. Performance evaluation of the latest fully automated hematology analyzers in a large, commercial laboratory setting: a 4-way, side-by-side study. *Lab Hematol* 2005;11(4):285-297.
17. Chapman M. Hematology analyzers offer new technology and user-friendliness. *Lab Med* 2000;31:146-150.
18. Davis BH, Bigelow NC. Automated reticulocyte analysis. Clinical practice and associated new parameters. *Hematol Oncol Clin North Am* 1994;8(4):617-630.

19. Kang SH, Kim HK, Ham CK, et al. Comparison of four hematology analyzers, CELL-DYN Sapphire, ADVIA 120, Coulter LH 750, and Sysmex XE-2100, in terms of clinical usefulness. *Int J Lab Hematol* 2008;30(6):480-486.
 20. DeNicola DB. Advances in hematology analyzers. *Top Companion Anim Med* 2011;26(2):52-61.
 21. Tan BT, Nava AJ, George TI. Evaluation of the Beckman Coulter UniCel DxH 800 and Abbott Diagnostics Cell-Dyn Sapphire hematology analyzers on pediatric and neonatal specimens in a tertiary care hospital. *Am J Clin Pathol* 2011;135(6):929-938.
 22. Tan BT, Nava AJ, George TI. Evaluation of the Beckman Coulter UniCel DxH 800, Beckman Coulter LH 780, and Abbott Diagnostics Cell-Dyn Sapphire hematology analyzers on adult specimens in a tertiary care hospital. *Am J Clin Pathol* 2011;135(6):939-951.
 23. Kratz A, Maloum K, O'Malley C, et al. Enumeration of nucleated red blood cells with the ADVIA 2120 Hematology System: an International Multicenter Clinical Trial. *Lab Hematol* 2006;12(2):63-70.
 24. Wang FS, Rowan RM, Creer M, et al. Detecting human CD34+ and CD34- hematopoietic stem and progenitor cells using a Sysmex automated hematology analyzer. *Lab Hematol* 2004;10(4):200-205.
 25. Shelat SG, Canfield W, Shibutani S. Differences in detecting blasts between ADVIA 2120 and Beckman-Coulter LH750 hematology analyzers. *Int J Lab Hematol* 2010;32(1 Pt 2):113-116.
 26. Barnes PW, Eby CS, Shimer G. Blast flagging with the UniCel DxH 800 Coulter Cellular Analysis System. *Lab Hematol* 2010;16(2):23-25.
 27. Muller R, Mellors I, Johannessen B, et al. European multi-center evaluation of the Abbott Cell-Dyn sapphire hematology analyzer. *Lab Hematol* 2006;12(1):15-31.
 28. Langford K, Luchtman-Jones L, Miller R, et al. Performance evaluation of the Sysmex XT-2000i automated hematology analyzer. *Lab Hematol* 2003;9(1):29-37.
 29. Fernandes B, Hamaguchi Y. Performance characteristics of the Sysmex XT-2000i hematology analyzer. *Lab Hematol* 2003;9(4):189-197.
 30. Harris N, Jou JM, Devoto G, et al. Performance evaluation of the ADVIA 2120 hematology analyzer: an international multicenter clinical trial. *Lab Hematol* 2005;11(1):62-70.
 31. Harris N, Kunicka J, Kratz A. The ADVIA 2120 hematology system: flow cytometry-based analysis of blood and body fluids in the routine hematology laboratory. *Lab Hematol* 2005;11(1):47-61.
 32. Lampasso JA. Error in hematocrit value produced by excessive ethylenediaminetetraacetate. *Am J Clin Pathol* 1965;44:109-110.
- P.18
33. Fairbanks VF. Nonequivalence of automated and manual hematocrit and erythrocytic indices. *Am J Clin Pathol* 1980;73(1):55-62.
 34. Pearson TC, Guthrie DL. Trapped plasma in the microhematocrit. *Am J Clin Pathol* 1982;78(5):770-772.
 35. Guthrie DL, Pearson TC. PCV measurement in the management of polycythaemic patients. *Clin Lab Hematol* 1982;4(3):257-265.
 36. Beautyman W, Bills T. Letter: osmotic error in measurements of red-cell volume. *Lancet* 1974;2(7885):905-906.
 37. Zwart A, van Assendelft OW, Bull BS, et al. Recommendations for reference method for haemoglobinometry in human blood (ICSH standard 1995) and specifications for international haemoglobinocyanide standard (4th edition). *J Clin Pathol* 1996;49(4):271-274.
 38. NCCLS. Reference and selected procedures for the quantitative determination of hemoglobin in blood, 3rd ed. Approved Standard. NCCLS document H15-A3. Wayne, PA, 2000.
 39. Cornbleet J. Spurious results from automated hematology cell analyzers. *Lab Med* 1983;14:509-514.
 40. Linz LJ. Elevation of hemoglobin, MCH, and MCHC by paraprotein: how to recognize and correct the interference. *Clin Lab Sci* 1994;7(4):211-212.

41. Campbell NR, Edwards AL, Brant R, et al. Effect on lipid, complete blood count and blood proteins of a standardized preparation for drawing blood: a randomized controlled trial. *Clin Invest Med* 2000;23(6):350-354.
42. Reference method for the enumeration of erythrocytes and leucocytes. International Council for Standardization in Haematology; prepared by the Expert Panel on Cytometry. *Clin Lab Hematol* 1994;16(2):131-138.
43. Bessman JD, Gilmer PR Jr, Gardner FH. Improved classification of anemias by MCV and RDW. *Am J Clin Pathol* 1983;80(3):322-326.
44. Tefferi A. The diagnosis of polycythemia vera: new tests and old dictums. *Best Pract Res Clin Haematol* 2006;19(3):455-469.
45. Hermiston ML, Mentzer WC. A practical approach to the evaluation of the anemic child. *Pediatr Clin North Am* 2002;49(5):877-891.
46. Bessman JD, Banks D. Spurious macrocytosis, a common clue to erythrocyte cold agglutinins. *Am J Clin Pathol* 1980;74(6):797-800.
47. Holt JT, DeWandler MJ, Arvan DA. Spurious elevation of the electronically determined mean corpuscular volume and hematocrit caused by hyperglycemia. *Am J Clin Pathol* 1982;77(5):561-567.
48. Tefferi A, Hanson CA, Inwards DJ. How to interpret and pursue an abnormal complete blood cell count in adults. *Mayo Clin Proc* 2005;80(7):923-936.
49. CLSI. Validation, verification, and quality assurance of automated hematology analyzers, 2nd ed. Approved Standard. CLSI document H26-A2. Wayne, PA: Clinical and Laboratory Standards Institute, 2010.
50. ICSH recommendations for the analysis of red cell, white cell and platelet size distribution curves: I general principles. *J Clin Pathol* 1982;35(12):1320-1322.
51. ICSH recommendations for the analysis of red cell, white cell and platelet size distribution curves. Methods for fitting a single reference distribution and assessing its goodness of fit. International Committee for Standardization in Haematology. ICSH Expert Panel on Cytometry. *Clin Lab Hematol* 1990;12(4):417-431.
52. Evans TC, Jehle D. The red blood cell distribution width. *J Emerg Med* 1991;9(Suppl 1):71-74.
53. Roberts GT, El Badawi SB. Red blood cell distribution width index in some hematologic diseases. *Am J Clin Pathol* 1985;83(2):222-226.
54. Aslan D, Gumruk F, Gurgey A, et al. Importance of RDW value in differential diagnosis of hypochromic anemias. *Am J Hematol* 2002;69(1):31-33.
55. Liu TC, Seong PS, Lin TK. The erythrocyte cell hemoglobin distribution width segregates thalassemia traits from other nonthalassemic conditions with microcytosis. *Am J Clin Pathol* 1997;107(5):601-607.
56. Brittenham GM, Koepke JA. Red blood cell volume distributions and the diagnosis of anemia. Help or hindrance? *Arch Pathol Lab Med* 1987;111(12):1146-1148.
57. Fossat C, David M, Harle JR, et al. New parameters in erythrocyte counting. Value of histograms. *Arch Pathol Lab Med* 1987;111(12):1150-1154.
58. Proposed reference method for reticulocyte counting based on the determination of the reticulocyte to red cell ratio. The Expert Panel on Cytometry of the International Council for Standardization in Haematology. *Clin Lab Hematol* 1998;20(2):77-79.
59. Davis BH, Bigelow NC, Koepke JA, et al. Flow cytometric reticulocyte analysis. Multiinstitutional interlaboratory correlation study. *Am J Clin Pathol* 1994;102(4):468-477.
60. Riley RS, Ben-Ezra JM, Tidwell A, et al. Reticulocyte analysis by flow cytometry and other techniques. *Hematol Oncol Clin North Am* 2002;16(2): 373-420.
61. Piva E, Brugnara C, Chiandetti L, et al. Automated reticulocyte counting: state of the art and clinical applications in the evaluation of erythropoiesis. *Clin Chem Lab Med: CCLM/FESCC* 2010;48(10):1369-1380.
62. Siekmeier R, Bierlich A, Jaross W. Determination of reticulocytes: three methods compared. *Clin Chem Lab Med: CCLM/FESCC* 2000;38(3):245-249.

63. Fohlen-Walter A, Jacob C, Lecompte T, et al. Laboratory identification of cryoglobulinemia from automated blood cell counts, fresh blood samples, and blood films. *Am J Clin Pathol* 2002;117(4):606-614.
64. Lombarts AJ, de Kieviet W. Recognition and prevention of pseudothrombocytopenia and concomitant pseudoleukocytosis. *Am J Clin Pathol* 1988;89(5):634-639.
65. Berliner S, Fusman R, Rotstein R, et al. Electronic counter-related pseudoleukopenia: more than a rare occurrence. *Haematologica* 2001;86(2):210-211.
66. Zelster D, Fusman R, Chapman J, et al. Increased leukocyte aggregation induced by gamma-globulin: a clue to the presence of pseudoleukopenia. *Am J Med Sci* 2000;320(3):177-182.
67. CLSI. Reference leukocyte (WBC) differential count (proportional) and evaluation of instrumental methods, 2nd ed. Approved Standard. CLSI document H20-A2. Wayne, PA, 2007.
68. Benattar L, Flandrin G. Comparison of the classical manual pushed wedge films, with an improved automated method for making blood smears. *Hematol Cell Ther* 1999;41(5):211-215.
69. Hecker F. Practical microscopic hematology, 4th ed. Philadelphia, PA: Lea and Febinger, 1994.
70. Koepke JA, Dotson MA, Shifman MA. A critical evaluation of the manual/visual differential leukocyte counting method. *Blood Cells* 1985;11(2):173-186.
71. Rumke C. The statistically expected variability in differential counting. Skokie, IL: College of American Pathologists, 1978.
72. Hyun BH, Gulati GL, Ashton JK. Differential leukocyte count: manual or automated, what should it be? *Yonsei Med J* 1991;32(4):283-291.
73. Aulesa C, Mainar I, Prieto M, et al. Use of the Advia 120 hematology analyzer in the differential cytologic analysis of biological fluids (cerebrospinal, peritoneal, pleural, pericardial, synovial, and others). *Lab Hematol* 2003;9(4):214-224.
74. Paris A, Nhan T, Cornet E, et al. Performance evaluation of the body fluid mode on the platform Sysmex XE-5000 series automated hematology analyzer. *Int J Lab Hematol* 2010;32(5):539-547.
75. de Jonge R, Brouwer R, van Rijn M, et al. Automated analysis of pleural fluid total and differential leukocyte counts with the Sysmex XE-2100. *Clin Chem Lab Med: CCLM/FESCC* 2006;44(11):1367-1371.
76. Horiuchi Y, Tabe Y, Idei M, et al. The use of CellaVision competency software for external quality assessment and continuing professional development. *J Clin Pathol* 2011;64(7):610-617.
77. Cornet E, Perol JP, Troussard X. Performance evaluation and relevance of the CellaVision DM96 system in routine analysis and in patients with malignant hematological diseases. *Int J Lab Hematol* 2008;30(6):536-542.
78. Briggs C, Longair I, Slavik M, et al. Can automated blood film analysis replace the manual differential? An evaluation of the CellaVision DM96 automated image analysis system. *Int J Lab Hematol* 2009;31(1):48-60.
79. Ceelie H, Dinkelaar RB, van Gelder W. Examination of peripheral blood films using automated microscopy; evaluation of Diffmaster Octavia and Cellavision DM96. *J Clin Pathol* 2007;60(1):72-79.
80. Kratz A, Bengtsson HI, Casey JE, et al. Performance evaluation of the CellaVision DM96 system: WBC differentials by automated digital image analysis supported by an artificial neural network. *Am J Clin Pathol* 2005;124(5):770-781.
81. Yacko M, Swedlund J, Weil SC. Multiple methods for platelet enumeration. Observation of a newly introduced bias. *Am J Clin Pathol* 1987;87(1): 109-112.
82. Lawrence JB, Yomtovian RA, Dillman C, et al. Reliability of automated platelet counts: comparison with manual method and utility for prediction of clinical bleeding. *Am J Hematol* 1995;48(4):244-250.
83. Segal HC, Harrison P. Methods for counting platelets in severe thrombocytopenia. *Curr Hematol Rep* 2006;5(1):70-75.
84. Dale N, Shumacher H. Platelet satellitism-new results with automated instruments. *Lab Med* 1982;13:300-304.
85. Criswell KA, Breider MA, Bleavins MR. EDTA-dependent platelet phagocytosis. A cytochemical, ultrastructural, and functional characterization. *Am J Clin Pathol* 2001;115(3):376-384.
86. Akwari AM, Ross DW, Stass SA. Spuriously elevated platelet counts due to microspherocytosis. *Am J Clin Pathol* 1982;77(2):220-221.

87. Hammerstrom J. Spurious platelet counts in acute leukaemia with DIC due to cell fragmentation. *Clin Lab Hematol* 1992;14(3):239-243.
88. Jackson SR, Carter JM. Platelet volume: laboratory measurement and clinical application. *Blood Rev* 1993;7(2):104-113.
89. Threatte GA. Usefulness of the mean platelet volume. *Clin Lab Med* 1993;13(4):937-950.
90. Noris P, Klersy C, Zecca M, et al. Platelet size distinguishes between inherited macrothrombocytopenias and immune thrombocytopenia. *J Thromb Haemost* 2009;7(12):2131-2136.
91. Niethammer AG, Forman EN. Use of the platelet histogram maximum in evaluating thrombocytopenia. *Am J Hematol* 1999;60(1):19-23.
92. Diquattro M, Gagliano F, Calabro GM, et al. Relationships between platelet counts, platelet volumes and reticulated platelets in patients with ITP: evidence for significant platelet count inaccuracies with conventional instrument methods. *Int J Lab Hematol* 2009;31(2):199-206.
93. Michiels JJ, De Raeve H, Berneman Z, et al. The 2001 World Health Organization and updated European clinical and pathological criteria for the diagnosis, classification, and staging of the Philadelphia chromosome-negative chronic myeloproliferative disorders. *Semin Thromb Hemost* 2006; 32(4 Pt 2):307-340.
94. Gulati GL, Ashton JK, Hyun BH. Structure and function of the bone marrow and hematopoiesis. *Hematol Oncol Clin North Am* 1988;2(4):495-511.
95. McShine RL, Sibinga S, Brozovic B. Differences between the effects of EDTA and citrate anticoagulants on platelet count and mean platelet volume. *Clin Lab Hematol* 1990;12(3):277-285.
96. Bessman JD, Gilmer PR, Gardner FH. Use of mean platelet volume improves detection of platelet disorders. *Blood Cells* 1985;11(1):127-135.
97. Kurata Y, Hayashi S, Kiyoi T, et al. Diagnostic value of tests for reticulated platelets, plasma glycofibrinogen, and thrombopoietin levels for discriminating between hyperdestructive and hypoplastic thrombocytopenia. *Am J Clin Pathol* 2001;115(5):656-664.
98. Pons I, Monteagudo M, Lucchetti G, et al. Correlation between immature platelet fraction and reticulated platelets. Usefulness in the etiology diagnosis of thrombocytopenia. *Eur J Haematol* 2010;85(2):158-163.
99. Joutsu-Korhonen L, Sainio S, Riikonen S, et al. Detection of reticulated platelets: estimating the degree of fluorescence of platelets stained with thiazole orange. *Eur J Haematol* 2000;65(1):66-71.
100. Koike Y, Miyazaki K, Higashihara M, et al. Clinical significance of detection of immature platelets: comparison between percentage of reticulated platelets as detected by flow cytometry and immature platelet fraction as detected by automated measurement. *Eur J Haematol* 2010;84(2):183-184.
101. Pankraz A, Bauer N, Moritz A. Comparison of flow cytometry with the Sysmex XT2000iV automated analyzer for the detection of reticulated platelets in dogs. *Vet Clin Pathol* 2009;38(1):30-38.
102. Saxon BR, Blanchette VS, Butchart S, et al. Reticulated platelet counts in the diagnosis of acute immune thrombocytopenic purpura. *J Pediatr Hematol Oncol* 1998;20(1):44-48.
103. Rynningen A, Apelseth T, Hausken T, et al. Reticulated platelets are increased in chronic myeloproliferative disorders, pure erythrocytosis, reactive thrombocytosis and prior to hematopoietic reconstitution after intensive chemotherapy. *Platelets* 2006;17(5):296-302.
104. Bentley SA. Quality control and the differential leukocyte count. *Clin Lab Hematol* 1990;12(Suppl 1):101-109.
105. Recommendations of the International Council for Standardization in Haematology for Ethylenediaminetetraacetic Acid Anticoagulation of Blood for Blood Cell Counting and Sizing. International Council for Standardization in Haematology: Expert Panel on Cytometry. *Am J Clin Pathol* 1993;100(4): 371-372.
106. Savage RA, Hoffman GC. Clinical significance of osmotic matrix errors in automated hematology: the frequency of hyperglycemic osmotic matrix errors producing spurious macrocytosis. *Am J Clin Pathol* 1983;80(6): 861-865.
107. Sireci A, Schlaberg R, Kratz A. A method for optimizing and validating institution-specific flagging criteria for automated cell counters. *Arch Pathol Lab Med* 2010;134(10):1528-1533.
108. Hoyer JD. Leukocyte differential. *Mayo Clinic Proc* 1993;68(10):1027-1028.

109. Vives Corróns JL, Van Blerk M, Albareda S, et al. Guidelines for setting up an external quality assessment scheme for blood smear interpretation. Part II: survey preparation, statistical evaluation and reporting. *Clin Chem Lab Med*: CCLM/FESCC 2006;44(8):1039-1043.
110. Vives Corróns JL, Albareda S, Flandrin G, et al. Guidelines for blood smear preparation and staining procedure for setting up an external quality assessment scheme for blood smear interpretation. Part I: control material. *Clin Chem Lab Med*: CCLM/FESCC 2004;42(8):922-926.
111. Hassserjian RP. Reactive versus neoplastic bone marrow: problems and pitfalls. *Arch Pathol Lab Med* 2008;132(4):587-594.
112. Wenk RE. Comparison of five methods for preparing blood smears. *Am J Med Technol* 1976;42(3):71-78.
113. Dunning K, Safo AO. The ultimate Wright-Giemsa stain: 60 years in the making. *Biotech Histochem* 2011;86(2):69-75.
114. Houwen B. Blood film preparation and staining procedures. *Clin Lab Med* 2002;22(1):1-14.
115. McGoogan E, Colgan TJ, Ramzy I, et al. Cell preparation methods and criteria for sample adequacy. International Academy of Cytology Task Force summary. *Diagnostic Cytology Towards the 21st Century: an International Expert Conference and Tutorial*. *Acta Cytol* 1998;42(1):25-32.
116. Adler SL, Groner W, Ornstein L. Fully automated preparation of high-quality stained blood films. *Anal Quant Cytol* 1981;3(3):216-224.
117. Barth D. Approach to peripheral blood film assessment for pathologists. *Semin Diagn Pathol* 2012;29(1):31-48.
118. Jenkins C, Hewamana S. The blood film as a diagnostic tool. *Br J Hosp Med* 2008;69(9):M144-147.
119. Prokocimer M, Potasman I. The added value of peripheral blood cell morphology in the diagnosis and management of infectious diseases—part 1: basic concepts. *Postgrad Med J* 2008;84(997):579-585.
120. Blevins SM, Greenfield RA, Bronze MS. Blood smear analysis in babesiosis, ehrlichiosis, relapsing fever, malaria, and Chagas disease. *Cleve Clin J Med* 2008;75(7):521-530.
121. Tefferi A, Elliott MA. Schistocytes on the peripheral blood smear. *Mayo Clin Proc* 2004;79(6):809.
122. Moreno A, Menke D. Assessment of platelet numbers and morphology in the peripheral blood smear. *Clin Lab Med* 2002;22(1):193-213.
123. Zhou X, Wu X, Deng W, et al. Amikacin can be added to blood to reduce the fall in platelet count. *Am J Clin Pathol* 2011;136(4):646-652.
124. Garcia-Manero G. Myelodysplastic syndromes: 2011 update on diagnosis, risk-stratification, and management. *Am J Hematol* 2011;86(6):490-498.
125. Yin CC, Medeiros LJ, Bueso-Ramos CE. Recent advances in the diagnosis and classification of myeloid neoplasms—comments on the 2008 WHO classification. *Int J Lab Hematol* 2010;32(5):461-476.
126. Al-Gwaiz LA, Babay HH. The diagnostic value of absolute neutrophil count, band count and morphologic changes of neutrophils in predicting bacterial infections. *Med Princ Pract* 2007;16(5):344-347.
127. Kabutomori O, Kanakura Y, Watani YI. Induction of toxic granulation in neutrophils by granulocyte colony-stimulating factor. *Eur J Haematol* 2002;69(3):187-188.
128. Widell S, Hellstrom-Lindberg E, Kock Y, et al. Peripheral blood neutrophil morphology reflects bone marrow dysplasia in myelodysplastic syndromes. *Am J Hematol* 1995;49(2):115-120.
129. Kaplan J, De Domenico I, Ward DM. Chediak-Higashi syndrome. *Curr Opin Hematol* 2008;15(1):22-29.
130. Aguero-Rosenfeld ME. Lyme disease: laboratory issues. *Infect Dis Clin North Am* 2008;22(2):301-313.
131. Schwind JL. The supravital method in the study of the cytology of blood and marrow cells. *Blood* 1950;5(7):597-622.
132. Williamson D. The unstable haemoglobins. *Blood Rev* 1993;7(3):146-163.
133. Pierre RV. Reticulocytes. Their usefulness and measurement in peripheral blood. *Clin Lab Med* 2002;22(1):63-79.
134. Espanol I, Pedro C, Remacha AF. Heinz bodies interfere with automated reticulocyte counts. *Haematologica* 1999;84(4):373-374.

135. Lofsness KG, Kohnke ML, Geier NA. Evaluation of automated reticulocyte counts and their reliability in the presence of Howell-Jolly bodies. *Am J Clin Pathol* 1994;101(1):85-90.
136. Banfi G, Mauri C, Morelli B, et al. Reticulocyte count, mean reticulocyte volume, immature reticulocyte fraction, and mean spheroid cell volume in elite athletes: reference values and comparison with the general population. *Clin Chem Lab Med: CCLM/FESCC* 2006;44(5):616-622.
137. Bain BJ, Bailey K. Pitfalls in obtaining and interpreting bone marrow aspirates: to err is human. *J Clin Pathol* 2011;64(5):373-379.
138. Hyun BH, Stevenson AJ, Hanau CA. Fundamentals of bone marrow examination. *Hematol Oncol Clin North Am* 1994;8(4):651-663.
139. Riley RS, Hogan TF, Pavot DR, et al. A pathologist's perspective on bone marrow aspiration and biopsy: I. Performing a bone marrow examination. *J Clin Lab Anal* 2004;18(2):70-90.
140. Bain BJ. Bone marrow biopsy morbidity and mortality. *Br J Haematol* 2003;121(6):949-951.
141. Iannalfi A, Bernini G, Caprilli S, et al. Painful procedures in children with cancer: comparison of moderate sedation and general anesthesia for lumbar puncture and bone marrow aspiration. *Pediatr Blood Cancer* 2005;45(7):933-938.
142. Islam A. Bone marrow aspiration before bone marrow core biopsy using the same bone marrow biopsy needle: a good or bad practice? *J Clin Pathol* 2007;60(2):212-215.
143. Wilkins BS, Clark DM. Making the most of bone marrow trephine biopsy. *Histopathology* 2009;55(6):631-640.
144. Hyun BH, Gulati GL, Ashton JK. Bone marrow examination: techniques and interpretation. *Hematol Oncol Clin North Am* 1988;2(4):513-523.
145. Hartsock RJ, Smith EB, Petty CS. Normal variations with aging of the amount of hematopoietic tissue in bone marrow from the anterior iliac crest. A study made from 177 cases of sudden death examined by necropsy. *Am J Clin Pathol* 1965;43:326-331.
146. Rosse C, Kraemer MJ, Dillon TL, et al. Bone marrow cell populations of normal infants; The predominance of lymphocytes. *J Lab Clin Med* 1977;89(6):1225-1240.
147. Kling PJ, Schmidt RL, Roberts RA, et al. Serum erythropoietin levels during infancy: associations with erythropoiesis. *J Pediatr* 1996;128(6): 791-796.
148. Gupta A, Tyrrell P, Valani R, et al. The role of the initial bone marrow aspirate in the diagnosis of hemophagocytic lymphohistiocytosis. *Pediatr Blood Cancer* 2008;51(3):402-404.
149. Humphries JE. Dry tap bone marrow aspiration: clinical significance. *Am J Hematol* 1990;35(4):247-250.
150. Novotny JR, Schmucker U, Staats B, et al. Failed or inadequate bone marrow aspiration: a fast, simple and cost-effective method to produce a cell suspension from a core biopsy specimen. *Clin Lab Hematol* 2005;27(1): 33-40.
151. Bennett JM, Catovsky D, Daniel MT, et al. Proposals for the classification of the acute leukaemias. French-American-British (FAB) co-operative group. *Br J Haematol* 1976;33(4):451-458.
152. WHO. World Health Organization classification of tumours of haematopoietic and lymphoid tissues, 4th ed. Lyon, France: IARC Press, 2008.
153. Klobusicka M. Reliability and limitations of cytochemistry in diagnosis of acute myeloid leukemia. Minireview. *Neoplasma* 2000;47(6):329-334.
154. Hayhoe FG. Cytochemistry of the acute leukaemias. *Histochem J* 1984;16(10):1051-1059.
155. Laboratory Haematology. In: Chanarin I, ed. *Laboratory haematology: an account of laboratory techniques*. London: Church Livingstone, 1989:170-172.
156. Saravanan L, Juneja S. Immunohistochemistry is a more sensitive marker for the detection of myeloperoxidase in acute myeloid leukemia compared with flow cytometry and cytochemistry. *Int J Lab Hematol* 2010;32 (1 Pt 1):e132-136.
157. Strober W. Wright-Giemsa and nonspecific esterase staining of cells. *Current protocols in cytometry/editorial board*, J Paul Robinson, managing editor [et al]. 2001; Appendix 3: Appendix 3D.
158. Thai TH, Kearney JF. Isoforms of terminal deoxynucleotidyltransferase: developmental aspects and function. *Adv Immunol* 2005;86:113-136.

159. McGregor S, McNeer J, Gurbuxani S. Beyond the 2008 World Health Organization classification: the role of the hematopathology laboratory in the diagnosis and management of acute lymphoblastic leukemia. *Semin Diagn Pathol* 2012;29(1):2-11.
160. Drexler HG, Sperling C, Ludwig WD. Terminal deoxynucleotidyl transferase (TdT) expression in acute myeloid leukemia. *Leukemia* 1993;7(8):1142-1150.
161. Al Gwaiz LA, Bassioni W. Immunophenotyping of acute lymphoblastic leukemia using immunohistochemistry in bone marrow biopsy specimens. *Histol Histopathol* 2008;23(10):1223-1228.
162. Bettelheim P, Paietta E, Majdic O, et al. Expression of a myeloid marker on TdT-positive acute lymphocytic leukemic cells: evidence by double-fluorescence staining. *Blood* 1982;60(6):1392-1396.
163. Roma AO, Kutok JL, Shaheen G, et al. A novel, rapid, multiparametric approach for flow cytometric analysis of intranuclear terminal deoxynucleotidyl transferase. *Am J Clin Pathol* 1999;112(3):343-348.
164. Li CY. The role of morphology, cytochemistry and immunohistochemistry in the diagnosis of chronic myeloproliferative diseases. *Int J Hematol* 2002;76(Suppl 2):6-8.
165. Kaplow LS. Leukocyte alkaline phosphatase in disease. *CRC Crit Rev Clin Lab Sci* 1971;2(2):243-278.
166. Moss DW, Raymond FD, Wile DB. Clinical and biological aspects of acid phosphatase. *CRC Crit Rev Clin Lab Sci* 1995;32(4):431-467.
167. Lamp EC, Drexler HG. Biology of tartrate-resistant acid phosphatase. *Leuk Lymphoma* 2000;39(5-6):477-484.
168. Dunphy CH. Reaction patterns of TRAP and DBA.44 in hairy cell leukemia, hairy cell variant, and nodal and extranodal marginal zone B-cell lymphomas. *Appl Immunohistochem Mol Morphol* 2008;16(2):135-139.
169. Sherman MJ, Hanson CA, Hoyer JD. An assessment of the usefulness of immunohistochemical stains in the diagnosis of hairy cell leukemia. *Am J Clin Pathol* 2011;136(3):390-399.
170. Crook L, Liu PI, Cannon A, et al. Histochemistry of bone marrow aspirations. *Ann Clin Lab Sci* 1980;10(4):290-304.
171. Chen M, Wang J. Gaucher disease: review of the literature. *Arch Pathol Lab Med* 2008;132(5):851-853.
172. Gomori G. Microtechnical demonstration of iron: a criticism of its methods. *Am J Pathol* 1936;12(5):655-664.
173. Tham KT, Cousar JB. Combined silver Perls's stain for differential staining of ringed sideroblasts and marrow iron. *J Clin Pathol* 1993;46(8):766-768.
174. Klatt EC, Lukes RJ, Meyer PR. Benign and malignant mast cell proliferations. Diagnosis and separation using a pH-dependent toluidine blue stain in tissue section. *Cancer* 1983;51(6):1119-1124.
175. Johnson MR, Verstovsek S, Jorgensen JL, et al. Utility of the World Health Organization classification criteria for the diagnosis of systemic mastocytosis in bone marrow. *Mod Pathol* 2009;22(1):50-57.
176. Davis BH, Holden JT, Bene MC, et al. 2006 Bethesda International Consensus recommendations on the flow cytometric immunophenotypic analysis of hematolymphoid neoplasia: medical indications. *Cytometry B Clin Cytom* 2007;72(Suppl 1):S5-13.
177. Weir EG, Borowitz MJ. Flow cytometry in the diagnosis of acute leukemia. *Semin Hematol* 2001;38(2):124-138.
178. Peters JM, Ansari MQ. Multiparameter flow cytometry in the diagnosis and management of acute leukemia. *Arch Pathol Lab Med* 2011;135(1):44-54.
179. Leong TY, Cooper K, Leong AS. Immunohistology—past, present, and future. *Adv Anat Pathol* 2010;17(6):404-418.
180. Scanziani E. Immunohistochemical staining of fixed tissues. *Methods Mol Biol* 1998;104:133-140.
181. Lu J, Chang KL. Practical immunohistochemistry in hematopathology: a review of useful antibodies for diagnosis. *Adv Anat Pathol* 2011;18(2):133-151.
182. Garcia CF, Swerdlow SH. Best practices in contemporary diagnostic immunohistochemistry: panel approach to hematolymphoid proliferations. *Arch Pathol Lab Med* 2009;133(5):756-765.
183. O'Leary TJ. Standardization in immunohistochemistry. *Appl Immunohistochem Mol Morphol* 2001;9(1):3-8.
184. Swansbury J. Cytogenetic studies in hematologic malignancies: an overview. *Methods Mol Biol* 2003;220:9-22.

185. Kwon WK, Lee JY, Mun YC, et al. Clinical utility of FISH analysis in addition to G-banded karyotype in hematologic malignancies and proposal of a practical approach. *Korean J Hematol* 2010;45(3):171-176.
186. Morrissette JJ, Bagg A. Acute myeloid leukemia: conventional cytogenetics, FISH, and molecuocentric methodologies. *Clin Lab Med* 2011;31(4): 659-686.
187. Tiu RV, Visconte V, Traina F, et al. Updates in cytogenetics and molecular markers in MDS. *Curr Hematol Malig Rep* 2011;6(2):126-135.
188. Rowley JD. The critical role of chromosome translocations in human leukemias. *Annu Rev Genet* 1998;32:495-519.
189. Misra RR, Pinsky PF, Srivastava S. Prognostic factors for hematologic cancers. *Hematol Oncol Clin North Am* 2000;14(4):907-924.
190. Kolialexi A, Tsangaris GT, Kitsiou S, et al. Impact of cytogenetic and molecular cytogenetic studies on hematologic malignancies. *Anticancer Res* 2005;25(4):2979-2983.
191. Arber DA, Stein AS, Carter NH, et al. Prognostic impact of acute myeloid leukemia classification. Importance of detection of recurring cytogenetic abnormalities and multilineage dysplasia on survival. *Am J Clin Pathol* 2003;119(5):672-680.
192. Bain BJ. Overview. Cytogenetic analysis in haematology. *Best Pract Res Clin Haematol* 2001;14(3):463-477.
193. Dewald GW, Brockman SR, Paternoster SF. Molecular cytogenetic studies for hematological malignancies. *Cancer Treat Res* 2004;121:69-112.
194. Frohling S, Scholl C, Gilliland DG, et al. Genetics of myeloid malignancies: pathogenetic and clinical implications. *J Clin Oncol* 2005;23(26):6285-6295.
195. Yeung DT, Parker WT, Branford S. Molecular methods in diagnosis and monitoring of haematological malignancies. *Pathology* 2011;43(6):566-579.
196. Morgan GJ, Pratt G. Modern molecular diagnostics and the management of haematological malignancies. *Clin Lab Hematol* 1998;20(3):135-141.
197. Sen F, Vega F, Medeiros LJ. Molecular genetic methods in the diagnosis of hematologic neoplasms. *Semin Diagn Pathol* 2002;19(2):72-93.
198. Gleissner B, Thiel E. Detection of immunoglobulin heavy chain gene rearrangements in hematologic malignancies. *Expert Rev Mol Diagn* 2001;1(2):191-200.
199. Hughes T, Branford S. Molecular monitoring of BCR-ABL as a guide to clinical management in chronic myeloid leukaemia. *Blood Rev* 2006;20(1):29-41.
200. Wrench D, Montoto S, Fitzgibbon J. Molecular signatures in the diagnosis and management of follicular lymphoma. *Curr Opin Hematol* 2010;17(4): 333-340.
201. Randolph TR. Acute promyelocytic leukemia (AML-M3)—part 2: molecular defect, DNA diagnosis, and proposed models of leukemogenesis and differentiation therapy. *Clin Lab Sci* 2000;13(2):106-116.
202. Hasan SK, Lo-Coco F. Utilization of molecular phenotypes to detect relapse and optimize the management of acute promyelocytic leukemia. *Clin Lymphoma Myeloma Leuk* 2010;10(Suppl 3):S139-143.
203. Anastasi J. The myeloproliferative neoplasms including the eosinophiliarelated myeloproliferations associated with tyrosine kinase mutations: changes and issues in classification and diagnosis criteria. *Semin Diagn Pathol* 2011;28(4):304-313.
204. Smith CA, Fan G. The saga of JAK2 mutations and translocations in hematologic disorders: pathogenesis, diagnostic and therapeutic prospects, and revised World Health Organization diagnostic criteria for myeloproliferative neoplasms. *Hum Pathol* 2008;39(6):795-810.
205. Gale RE, Green C, Allen C, et al. The impact of FLT3 internal tandem duplication mutant level, number, size, and interaction with NPM1 mutations in a large cohort of young adult patients with acute myeloid leukemia. *Blood* 2008;111(5):2776-2784.
206. Schlenk RF, Dohner K, Krauter J, et al. Mutations and treatment outcome in cytogenetically normal acute myeloid leukemia. *N Engl J Med* 2008;358(18):1909-1918.

207. Schnittger S, Schoch C, Kern W, et al. Nucleophosmin gene mutations are predictors of favorable prognosis in acute myelogenous leukemia with a normal karyotype. *Blood* 2005;106(12):3733-3739.
208. La Rosee P, Hochhaus A. Molecular pathogenesis of tyrosine kinase resistance in chronic myeloid leukemia. *Curr Opin Hematol* 2010;17(2):91-96.
209. Weisberg E, Manley PW, Cowan-Jacob SW, et al. Second generation inhibitors of BCR-ABL for the treatment of imatinib-resistant chronic myeloid leukaemia. *Nat Rev Cancer* 2007;7(5):345-356.
210. Dunphy CH. Gene expression profiling data in lymphoma and leukemia: review of the literature and extrapolation of pertinent clinical applications. *Arch Pathol Lab Med* 2006;130(4):483-520.
211. Dawson AJ, Yanofsky R, Vallente R, et al. Array comparative genomic hybridization and cytogenetic analysis in pediatric acute leukemias. *Curr Oncol* 2011;18(5):e210-217.
212. Kolquist KA, Schultz RA, Furrow A, et al. Microarray-based comparative genomic hybridization of cancer targets reveals novel, recurrent genetic aberrations in the myelodysplastic syndromes. *Cancer Genet* 2011;204(11):603-628.
213. Brazier RM, Shipp MA, Feldman AL, et al. Molecular diagnostics. *Hematol Am Soc Hematol Educ Program* 2003;1:279-293.
214. Scarpa A, Achille A. Molecular techniques in hematopathology. *Leuk Lymphoma* 1997;26(Suppl 1):77-82.
215. Lehmann U, Kreipe H. Real-time PCR analysis of DNA and RNA extracted from formalin-fixed and paraffin-embedded biopsies. *Methods* 2001;25(4):409-418.
216. Caswell M, Pike LA, Bull BS, et al. Effect of patient age on tests of the acute-phase response. *Arch Pathol Lab Med* 1993;117(9):906-910.
217. Solter PF. Clinical pathology approaches to hepatic injury. *Toxicol Pathol* 2005;33(1):9-16.
218. Schwartlander B, Bek B, Skarabis H, et al. Improvement of the predictive value of CD4+ lymphocyte count by beta 2-microglobulin, immunoglobulin A and erythrocyte sedimentation rate. The Multicentre Cohort Study Group. *AIDS* 1993;7(6):813-821.
219. Zlonis M. The mystique of the erythrocyte sedimentation rate. A reappraisal of one of the oldest laboratory tests still in use. *Clin Lab Med* 1993;13(4): 787-800.
220. Brigden M. The erythrocyte sedimentation rate. Still a helpful test when used judiciously. *Postgrad Med* 1998;103(5):257-262, 72-74.
221. ICSH recommendations for measurement of erythrocyte sedimentation rate. International Council for Standardization in Haematology (Expert Panel on Blood Rheology). *J Clin Pathol* 1993;46(3):198-203.
222. Bull BS, Brailsford JD. The zeta sedimentation ratio. *Blood* 1972;40(4):550-559.
223. Rosencranz R, Bogen SA. Clinical laboratory measurement of serum, plasma, and blood viscosity. *Am J Clin Pathol* 2006;125(Suppl):S78-86.
224. Lowe GD. Should plasma viscosity replace the ESR? *Br J Haematol* 1994;86(1):6-11.
225. Martin CM, Almond J. New frontiers for cardiac risk assessment: C-reactive protein. *Consult Pharm* 2006;21(3):188-191, 95-96, 205-206.
226. van Leeuwen MA, van Rijswijk MH. Acute phase proteins in the monitoring of inflammatory disorders. *Baillieres Clin Rheumatol* 1994;8(3):531-552.
227. Dinant GJ, de Kock CA, van Wersch JW. Diagnostic value of C-reactive protein measurement does not justify replacement of the erythrocyte sedimentation rate in daily general practice. *Eur J Clin Invest* 1995;25(5):353-359.
228. Jones JG, Wardrop CA. Measurement of blood volume in surgical and intensive care practice. *Br J Anaesth* 2000;84(2):226-235.
229. el-Sayed H, Goodall SR, Hainsworth R. Re-evaluation of Evans blue dye dilution method of plasma volume measurement. *Clin Lab Hematol* 1995;17(2):189-194.
230. Pearson TC, Guthrie DL, Simpson J, et al. Interpretation of measured red cell mass and plasma volume in adults: expert Panel on Radionuclides of the International Council for Standardization in Haematology. *Br J Haematol* 1995;89(4):748-756.

231. Cosgriff PS, Blunkett M, Morrish O. Estimating plasma volume from red cell volume. *Nucl Med Commun* 1999;20(12):1165-1167.

232. Mock DM, Lankford GL, Widness JA, et al. Measurement of circulating red cell volume using biotin-labeled red cells: validation against ⁵¹Cr-labeled red cells. *Transfusion* 1999;39(2):149-155.

Chapter 2 Clinical Flow Cytometry

DEFINITION

One of the meanings of the word flow is “to move with a continual shifting of the component particles.” The term cytometry refers to counting (metry) cells (cyto). Thus, flow cytometry (FCM) is a method that employs a fluid stream to carry cells through a counter. FCM evaluates multiple parameters of individual cells (or other particles) by measuring the characteristics of light they scatter or the photons they emit as they stream through a light source. The strength of this technology lies in its high throughput (measurement of high numbers of cells in short time) and in its ability to capture many parameters per cell, assessing them individually. Currently, the principal applications of FCM in the clinical practice are routine cell counters and immunophenotyping. This chapter focuses on clinical application of FCM in hematology, mainly in diagnosis of hematologic malignancies. However, some functional assays (e.g., phosphorylation, cytokine secretion, apoptotic) that are being introduced into clinical practice are also briefly discussed.

HISTORICAL BACKGROUND

FCM dates back to the work done in Stockholm by T. Caspersson and coworkers, who in the 1930s demonstrated that DNA content, measured by ultraviolet and visible light absorption in unstained cells, doubled during the cell cycle.^{1,2} In 1950, Coons and Kaplan reported on the detection of antigens in tissues using fluorescein conjugated antibody methods, which prompted wide use of fluorescence microscopes.³ In 1953, W. H. Coulter patented the so-called Coulter principle and built the first FCM machine, in which blood cells in saline suspensions passed one by one through a small orifice and were detected by changes of electrical impedance at the orifice.⁴ After the first paper in *Science* by M. Fulwyler,⁵ the era of standard use of FCM for cell sorting started, beginning with publications from the L.A. Herzenberg Laboratory at Stanford University, CA, USA in the early 1970s.⁶ Soon after, the first flow cytometers became commercially available from Becton Dickinson (now BD Biosciences), followed by other companies. FCM came into clinical use in the late 1980s, at first only in specialized laboratories. In the 1990s and early 2000s, three and four-color analysis became a standard diagnostic method for immunophenotyping of hematologic samples. Many clinical solutions and standardization efforts were initialized by A. Orfao and coworkers, from the University of Salamanca, Spain.^{7,8} In 2010, eight- and ten-color FCM became a standard clinical method.^{9,10} In research settings, applications using 19-parameter FCM combining 17 fluorescence channels with forward scatter (FS) and side scatter (SS) have been reported.¹¹

PRINCIPLES OF FLOW CYTOMETRY

For reliable analysis, the specimen must be in a monodisperse suspension. In a flow cytometer, isotonic fluid is forced under pressure into a tube that delivers it to the flow cell, where a fluid column with laminar flow and a high flow rate is generated (so-called sheath fluid). The sample is introduced into the flow cell by a computer-driven syringe in the center of the sheath fluid, creating a coaxial stream within a stream (the so-called sample core stream). The pressure of the sheath stream hydrodynamically aligns the cells or particles so that they are presented to the light beam one at a time. Flow cytometers measure the amount of light emitted by fluorochromes associated with individual cells or particles (Fig. 2.1). New flow cytometers have three to four lasers.¹² For application in FCM, antibodies are conjugated with fluorochromes, dyes that absorb the light from the laser and emit light at longer wavelengths. The list of fluorochromes commonly used in clinical FCM is given in Table 2.1.¹³ The emitted light is focused by a lens onto fiberoptic cables and transmitted to octagonal detectors (Fig. 2.1). Filters in front of each of a series of detectors restrict the light that reaches the detector to only a small particular range of wavelengths (referred to as channels). The sensors convert the photons to electrical impulses that are proportional to the number of photons received and to the number of fluorochrome molecules bound to the cell. The fluorescent emissions are of low intensity and have to be amplified by photomultiplier tubes (PMT). PMTs count the specific photons and the remaining light is reflected to the next filter, where the process is repeated. Thus, most of the cell-associated fluorescence detected in a given channel is emitted by fluorochrome-coupled antibodies or other fluorescent reagents of interest. Electrical impulses from photoelectrons collected by PMTs are converted to digital signals. Acquired FCM data are electronically stored in so-called list-mode files that are a part of the medical record of the patient.¹⁴

A pair of light scatter channels provides an approximate measure of cell size (FS) and granularity (SS). FS and SS are used to set the threshold for separating debris, erythrocytes, and platelets from viable nucleated cells. Live cells scatter more light than dead and apoptotic cells and therefore have higher FS. SS is collected together with fluorescent light at right angles to the beam and is due to light reflected from internal structures of the cell. Cells with high granularity or vacuoles such as granulocytes or monocytes will have higher SS than ones with no granules such as lymphocytes or blast cells.

Most cells have low numbers of native fluorescent molecules that define their background fluorescence. Some of the light may come from spillover fluorescence emitted by a reagent measured

P.20

in a different channel. The interference is corrected by applying fluorescence compensation based on data from single-stained samples. This is usually done using cells or beads before or during the data acquisition phase. However, modern FCM data analysis software also allows collection of uncompensated data and applying compensation during analysis. Before data acquisition, standard reference particles (fluorescent microspheres) should be used to adjust the PMT voltage settings so that the beads fall in approximately the same location or the same "target channels," predetermined for each fluorochrome.

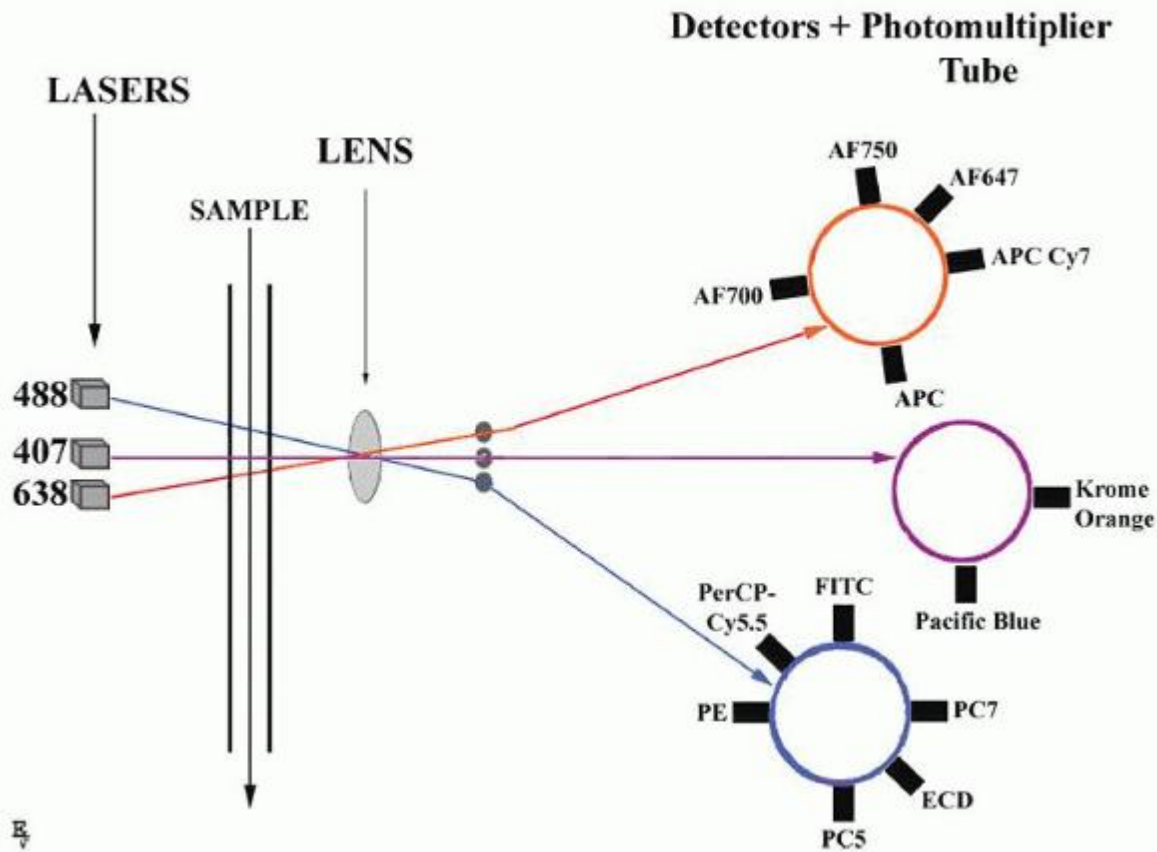

FIGURE 2.1. Principles of multicolor flow cytometry. A single cell suspension is hydrodynamically focused with sheath fluid to intersect lasers (three-laser system is shown). Fluorescence signals are collected by multiple fluorescence emission detectors, separate for every laser. Examples of fluorochromes detected by different lasers are given according to Table 2.1. Detected signals are amplified by photomultiplier tubes and converted to digital form for analysis.

TABLE 2.1 TABLE OF FLUOROCHROMES COMMONLY USED IN CLINICAL FLOW CYTOMETRY

Probe	Ex (nm)	Em (nm)	MW	Acronym/Comments
Reactive and Conjugated Probes				
R-Phycoerythrin	480;565	578	240 k	PE

Red 613	480;565	613		PE-Texas Red
Fluorescein isothiocyanate	495	519	389	FITC
Rhodamine isothiocyanate	547	572	444	TRITC
X-Rhodamine	570	576	548	XRITC
Peridinin chlorophyll protein	490	675		PerCP
Texas Red	589	615	625	TR
Allophycocyanin	650	660	104	kAPC
TruRed	490,675	695		PerCP-Cy5.5
Alexa Fluor 647	650	668	1250	
Alexa Fluor 700	696	719		
Alexa Fluor 750	752	779		
Cyanine 5	(625);650	670	792	Cy5
Cyanine 5.5	675	694	1128	Cy5.5
Cyanine 7	743	767	818	Cy7
PE-TR-X	595	620	625	ECD
PE-Cy5 conjugates	480;565;650	670		Cychrome, Tri-Color, Quantum Red
PE-Cy7 conjugates	480;565;743	767		PE-Cy7
APC-Cy7 conjugates	650;755	767		APC-CY7

Nucleic Acid Probes

4',6-Diamidino-2-phenylindole	345	455		DAPI ,AT-selective
SYTOX Blue	431 480	~400		DNA
SYTOX Green	504	523	~600	DNA
Ethidium bromide	493	620	394	
7-Aminoactinomycin D	546	647		7-AAD, CG-selective
Acridine Orange	503	530/640		DNA/RNA
Thiazole Orange	510	530		TO (RNA)
Propidium iodide	536	617	668.4	PI

Em, peak emission wavelength (nm); Ex, peak excitation wavelength (nm); MW, molecular weight.

Cell Sorting

Some flow cytometers are capable of physically separating the cells (fluorescence activated cell sorter, FACS) based on differences in any measurable parameters. Sorting is achieved by droplet formation. The basic components of any sorter are:

- A droplet generator
- A droplet charging and deflecting system
- A collection component
- The electronic circuitry for coordinating the timing and generation of droplet-charging pulses

The flow chamber is attached to a piezoelectric crystal, which vibrates at a certain frequency so that when the fluid carrying the cells passes through the nozzle, forming a jet in air with a velocity of 15 m/s, the vibration causes the jet to

break up in precisely uniform droplets, approximately 30,000 to 40,000/s. Each droplet, when separated from the jet, can be charged and deflected by a steady electric field and is collected in a receptacle. Almost every cell is isolated in a separate droplet. When the cell is analyzed a sorting decision is made, and until the proper electrical charge pulse is applied to the droplet containing the cell, there is a transit time determined by several factors, such as flow velocity, droplet separation, and the cell preparation. If two cells cannot be separated the sorting is aborted.

Monoclonal Antibodies

Advances of FCM would not be possible without development of monoclonal antibodies (MAbs). By the Nobel Prize winning hybridoma technology developed in 1975 by Köhler and Milstein,¹⁵ lymphocytes from the spleen of an immunized mouse can be immortalized by fusion to myeloma cells that have lost the ability to make their own immunoglobulins (Igs) but are capable of unlimited mitotic divisions. Through limited dilutions, individual

P.21

cell lines (hybridomas) that produce an antibody of unique specificity, avidity, and isotype can be established. In the early days of the application of MAbs to immunology, many laboratories were immunizing mice with leukocytes. The obtained hybridomas produced many antibodies that reacted with leukocytes, but the identities of the molecular targets were not known. The reactivity spectrum of the antibody could be described by staining multiple different cell types, and in most cases the target antigen could be isolated by immunoprecipitation or Western blotting and its molecular weight and other structural characteristics determined.

The first round of multilaboratory, blind, comparative analyses of antibodies was performed during the first Human Leukocyte Differentiation Antigen (HLDA) Workshop 1982 in Paris, France.¹⁶ Statistical analysis of data from several laboratories revealed "clusters of differentiation," named for the statistical procedure of cluster analysis and for the focus on leukocyte differentiation. Antibodies thought to be detecting the same molecule, and the molecule itself, were given a "CD" designation.¹⁷ An organization called the Human Leukocyte Differentiation Antigen Council has been established and nine subsequent HLDA workshops have characterized 350 CD antigens. The HLDA council reviewed and modified the objectives of HLDA in 2004, and changed the name of the organization to Human Cell Differentiation Molecules (HCDM). The reasoning behind the name change to HCDM was to break with tradition while retaining the letters "CD," to maintain emphasis on molecules of human origin, to extend focus from leukocytes to other cell types interacting with leukocytes such as endothelial cell or stromal cell molecules, and to broaden the scope from cell-surface molecules to any molecule whose expression reflects differentiation, recognizing the growing values of intracellular molecules. The HCDM council keeps a comprehensive database of CD molecules (www.hcdm.org). CD antigens, which are most often applied in hematologic immunophenotyping are listed in Table 2.2 and are described in Appendix A.

Sample Preparation

Appropriate samples for clinical FCM include peripheral blood (PB), bone marrow (BM) aspirate, disaggregated tissue including lymph node (LN) and other soft tissue biopsies as well as fine needle aspirations (FNA) and BM core biopsies, cerebrospinal fluid (CSF), other body fluids including effusions and lavage fluids, and nuclei from paraffin-embedded tissue for DNA ploidy assays. With the exception of the latter, all other clinical FCM specimens should be considered biohazardous and labeled as such in accordance with national or regional safety standards. A test requisition form, whether printed or electronic, should accompany all specimens. This form should include unique patient identifiers, age, sex, diagnosis (if previously established) or suspect condition under consideration, name of the physician submitting the specimen, pertinent medication or recent treatment (including dates of chemotherapy or radiation), date and time of specimen collection, and source of the specimen (e.g., bone marrow aspirate, CSF, etc.). The requested test should appear on the specimen label or on the requisition accompanying the specimen. Complete blood count (CBC) should be provided for PB and BM samples. For PB, ethylene-diaminetetraacetic acid (EDTA), sodium heparin, or acid citrate dextrose (ACD) may be used. For BM aspirates, sodium heparin is the preferred anticoagulant, and is required if cytogenetic testing is to be performed on the same specimen. All tissue biopsies intended for FCM evaluation, including LN or other tissue biopsies should be transported in an adequate volume of an appropriate transport medium in a sterile container to optimize cell viability. CSF samples should be stabilized or analyzed immediately due to potential toxic effect on cell viability.¹⁸

All clinical samples should be analyzed as soon as possible. As a general rule, 24 hours is preferred but 48 hours is considered the longest acceptable time frame for analysis. If transport time is longer, a viability report is mandatory and the results should be interpreted cautiously. Room temperature (18°C to 25°C) is recommended for storage and transport. For specimens that are not highly degenerated, nonviable cells can be excluded from the analysis by meticulous FS versus SS gating. Dead cells trap fluorochrome-conjugated antibodies and increase background fluorescence. Fluorescent, DNA-

binding dyes (Table 2.1) that are excluded from viable cells with intact plasma membranes and thus positive in nonviable cells, can also be applied.

Whole PB/BM analysis with erythrocyte lysis is recommended for clinical immunophenotyping. Immunophenotyping of density gradient (Ficoll) separated mononuclear cells should not be used due to selective cell loss. For surface(s) staining, the so-called “stain-lyse-wash” method gives the best signal discrimination. Cells are first incubated with appropriate amounts of titrated MAb, then erythrocytes are lysed and cells finally are washed before acquisition. Several commercial lysis reagents, most of which also contain a fixative, are available. Samples to be stained for sIg should be thoroughly washed before incubation with MAb, in order to avoid false negative results due to the presence of serum Igs.

Evaluation of intracellular epitopes, including proteins, epigenetic protein modifications (e.g., protein phosphorylation, methylation, etc.), DNA, or RNA generally require that the target cell population be fixed and permeabilized in order to allow antibodies or target-binding dyes to cross the cytoplasmic and nuclear membranes. Commercial fixation and permeabilization kits, with recommended protocols, are available from several manufacturers.^{19,20} For newly developed tests, it is useful to check whether the obtained intracellular staining is associated with an expected localization, using fluorescence microscopy. The specificity of the applied antibody should also be ensured. For cytoplasmic (cyt.) or nuclear (n) staining, it is important to use antibody conjugates that are free of unconjugated fluorochrome molecules that can stick to intracellular proteins nonspecifically. When simultaneous detection of surface and intracellular epitopes is necessary, the surface staining is performed first, then cells are fixed and permeabilized, and finally intracellular epitopes are stained.

Fluorochromes and Panels

Panel selection should be based on specimen type with consideration of information provided by clinical history, medical indication, and morphology.²¹ Several guidelines and consensus papers giving lists of antigens proposed for diagnosis of hematologic malignancies have been published.^{21,22} Selecting which antibody combinations best delineate, distinguish, and measure key differences within the target populations of interest and the number of simultaneously measured antibodies is a critical step for FCM assays. Serial dilution antibody titrations against both positive and negative cellular targets are necessary for antibody optimization. Choice of fluorochrome conjugate can affect background, specificity, and dynamic range of measurement. Typically, one would choose a fluorochrome with the best quantum efficiency/yield as the antibody conjugate to identify the lowest antigen density so as to obtain the best possible signal-to-noise ratio possible. It is of high importance to reliably distinguish between antigen-positive and antigen-negative cell populations in order to accurately measure the population of positive cells. This can be a challenge in populations of cells weakly expressing antigens. Fluorescence-minus-one (FMO) controls give the maximum fluorescence expected for a given population in a given channel when the reagent used in that channel is omitted.²³ These controls include both autofluorescence of the cells and the spillover that may be present even after compensation corrections and therefore such controls are best suited to determine boundaries between positive and negative cells for each subset.

P.22

TABLE 2.2 LIST OF CD ANTIGENS MOST COMMONLY USED IN FLOW CYTOMETRY IMMUNOPHENOTYPING OF HEMATOLOGIC SAMPLES

CD	Expression in Normal Hematopoietic Cell Types	MW (kD)	Function
CD1a	Cortical thymocytes, Langerhans cells, dendritic cells	49	Antigen presentation, w/ β 2m
CD2	Thymocytes, T-cells, NK cells	50	CD58 ligand, adhesion, T-cell activation
CD3	T-cells, thymocyte subset		w/TCR, TCR surface expression/signal transduction
CD4	Thymocyte subset, T-cell subset, monocytes, macrophages	55	MHC class II coreceptor, HIV receptor, T-cell differentiation/activation
CD5	Thymocytes, T-cells, B-cell subset	67	CD72 receptor, TCR or BCR signaling, T-B

			interaction
CD7	Thymocytes, T-cells, NK cells, small subset of hematopoietic progenitors	40	T costimulation
CD8	Thymocyte subset, T-cell subset, NK subset	32-34	MHC class I coreceptor, receptor for some mutated HIV-1, T-cell differentiation/activation
CD9	Eosinophils, basophils, platelets, activated T-cells	22-27	Cellular adhesion and migration
CD10	B-precursors, germinal center B-cells, thymocyte subset, neutrophils	100	Zinc-binding metalloproteinase, B-cell development
CD11a	Lymphocyte subsets, granulocytes, monocytes, macrophages	180	CD11a/CD18 receptor for ICAM-1, -2,-3, intercellular adhesion, T costimulation
CD11b	Granulopoietic cells, NK cells	170	Binds CD54, ECM, and iC3b
CD11c	Dendritic cells, granulopoietic cells, NK cells, and B-cell and T-cell subsets	150	Binds CD54, fibrinogen, and iC3b
CD13	Granulopoietic cells, monocytes	150-170	Zinc-binding metalloproteinase, antigen processing, receptor for corona virus strains
CD14	Monocytes, macrophages, Langerhans cells	53-55	Receptor for LPS/LBP, LPS recognition
CD15	Neutrophils, eosinophils, monocytes		Adhesion
CD16	Neutrophils, macrophages, NK cells	50-65	Component of low-affinity Fc receptor, phagocytosis, and ADCC
CD19	B-cells, plasma cells	95	Complex w/CD21and CD81, BCR coreceptor, B-cell activation/differentiation
CD20	B-cells	33-37	B-cell activation
CD21	B-cells and T-cells subsets	145, 110	Complement C3d and EBV receptor, complex w/CD19 and CD81, BCR coreceptor
CD22	B-cells	150	Adhesion, B-mono, B-T interactions
CD23	B-cells, eosinophils, platelets	45	CD19-CD21-CD81 receptor, IgE low-affinity receptor, signal transduction
CD24	Thymocytes, erythrocytes, lymphocytes, myeloid cells	35-45	Binds P-selectin
CD25	Activated B-cells and T-cells	55	IL-2R α , w/IL-2R β , and γ to form high affinity complex
CD33	Granulopoietic cells, monocytes, dendritic cells	67	Adhesion
CD34	Hematopoietic precursors	105-120	Stem cell marker, adhesion, CD62L receptor
CD36	Platelets, monocytes, erythropoietic precursors	88	ECM receptor, adhesion, phagocytosis
CD38	High expression on B-cell precursors, plasma cells and	45	Ecto-ADP-ribosyl cyclase, cell activation

	activated T-cells, low on granulopoietic cells		
CD41	Platelets, megakaryocytes	125/22	w/CD61 forms GPIIb, binds fibrinogen, fibronectin, vWF, thrombospondin, platelet activation and aggregation
CD42a	Platelets, megakaryocytes	22	Complex w/CD42b, c and d, receptor for vWF and thrombin, platelet adhesion to subendothelial matrices
CD45	Hematopoietic cells, multiple isoforms from alternative splicing	180-240	Tyrosine phosphatase, enhanced TCR and BCR signals
CD56	NK subset, T-cell subset	CD175-185	Neural cell adhesion molecule
CD57	NK subset, T-cell subset	110	HNK-1
CD59	Ubiquitous	18-20	Complement regulatory protein
CD61	Platelets, megakaryocytes	105	Integrin $\beta 3$, adhesion, CD41/CD61 or CD51/CD61 mediate adhesion to ECM
CD62L	B-cells, T-cells subsets, monocytes, granulocytes, NK-cells, thymocytes	74, 95	CD34, GlyCAM, and MAdCAM-1 receptor, leukocyte homing, tethering, rolling
CD64	Monocytes, neutrophils	72	FC γ RI, increases on neutrophils in sepsis
CD65	Granulopoietic cells		Phagocytosis
CD66	Neutrophils	90	Cell adhesion
CD68	Monocytes, neutrophils, basophils, mast cells,	110	Macrosialin
CD71	Proliferating cells, erythroid precursors, reticulocytes	95	Transferrin receptor, iron uptake
CD79	B-cells, plasma cells	33-37	Component of BCR, BCR surface expression and signal transduction
CD103	B- and T-cell subsets	150, 25	w/integrin $\beta 7$, binds E-cadherin, lymph homing/retention
CD117	Hematopoietic progenitors, mast cells	145	Stem cell factor receptor, hematopoietic progenitor development/differentiation
CD123	Basophils, dendritic cell subset, hematopoietic progenitors	70	IL-3R α , w/CDw131
CD133	Hematopoietic stem cells subset	120	
CD159cNK		40	w/MHC class I HLA-E molecules, forms heterodimer with CD94
CD235a	Erythropoietic precursors	36	Glycophorin A

For a comprehensive list and characteristics please see www.hcdm.org.

Often the same anchor gating antibodies are used in every tube thereby allowing consistent population gating strategies across all tubes of a panel. In immunophenotyping of lymphocyte subsets and in the diagnosis of leukemia/lymphoma, CD45 anchor gating has been shown to provide differential population identification correlated to morphologic microscopic differentials (Fig. 2.2)^{24,25}:

- Mature lymphocytes are characterized by low side scatter and strong CD45 expression (lymph region, Fig. 2.2 plot B).
- Monocytes have higher SS and strong CD45 expression (monocyte region, Fig. 2.2 plot B).
- Erythropoietic precursors are CD45 negative and have low SS (CD45- ery region, Fig. 2.2 plot B).
- Granulopoietic precursors and granulocytes are weakly CD45 positive and have high SS (CD45 dim, gran region, Fig. 2.2 plot B).
- Early hematopoietic precursors of various lineages, including CD34+ stem cells, are characterized by low CD45 expression and low SS (blast region, Fig. 2.2, plot B).

The localization of these subpopulations on the CD45/SS plot can be confirmed by multicolor staining of various lineage-associated antigens together with CD45 (Fig. 2.2, plots C-K) and visualization of cell clusters positive for given antigen combinations on the CD45/SS plot (Fig. 2.2, plot B) by so-called back-gating using color-coding.²⁵

In multicolor FCM, lineage-associated antigens that are broadly expressed through maturation of investigated cell lineage can be used for gating in conjunction with SS and CD45 (e.g., CD19 for B-cells, CD3 for T-cells Figs. 2.2 and 2.3). Examples of 10-color panels for leukemia and lymphoma, currently used at the Flow Cytometry Laboratory at the Department of Laboratory Medicine, University Health Network, Toronto General Hospital, Toronto, Ontario, Canada are given in Table 2.3.

Data Analysis and Reporting

Fluorescence data may be presented using either linear or logarithmic amplification. In linear amplification, fluorescence differences are directly proportional to differences of fluorochrome concentration between cells. Logarithmic amplification compresses a wide input range, which may cause difficulties in resolving populations with similar fluorescence intensities. "Logicle" (or "bixponential") displays have recently been designed for the display of FCM data so that they incorporate the useful features of logarithmic displays but also provide accurate visualization of populations with low or background fluorescence.¹² During analysis, data is presented in form of:

- Histograms (for one parameter), where relative fluorescence or scatter is on the x-axis and the number of events with given characteristics on the y-axis
- Two-parameter dot plots, where each signal is visualized by one dot and given a parameter on the x- and y-axes; various cell populations can be then "painted" with different colors
- Density plots, where hotspots indicate large numbers of events resulting from discrete population of cells and colors can give the graph a three-dimensional feel
- Contour diagrams, where joined lines represent similar numbers of cells

New software where multiparameter data can be analyzed using principal component analysis is also available.^{9,26}

Analysis is usually focused on identifying and quantifying subsets of cells. Successful analysis will depend on correct marker selection and panel design. Cell counts and percentages are typically reported. The choice of gating strategy depends on the panel used and specific populations of interest. In immunophenotyping of PB and BM, the analysis can be focused on lymphocytes (CD45 bright gate, Fig. 2.4), B-lymphocytes (Fig. 2.3), blasts (CD45 dim gate, Figs. 2.2 and 2.5), T-lymphocytes and natural killer (NK) cells, on monocytes, or include all living cells in the sample (debris excluded). In tissue samples (lymph nodes, FNA, body fluids) a broad lymphocyte gate is usually applied. The parent population should be clearly identified when percentages are reported: a fraction may represent a percentage of all living cells in the sample (debris excluded), a percentage of lymphocytes, a percentage of B-cells, a percentage of T-cells, or a percentage of blasts.

In hematology, assays are usually designed to characterize abnormal cell populations or stages of cell development. In these tests, marker intensities are used to identify the immunophenotype of the cells at various stages of differentiation. Therefore, markers with good dynamic range and proper spillover compensation are critical. Intensity results are typically reported as medians or geometric means. A comparison to control populations either external such as beads or internal such as normal mature cells is often used. If fluorescence intensity is comparable to normal mature cells, it is reported as

“normal”: positive if it corresponds to normal cells, “dim” if it is weaker than in normal cell population, or “bright” if it is stronger than in normal cells.

Most currently used analysis software allows cross-platform application for analysis and makes it possible to create analysis templates that are a useful tool for assuring that the analysis is always performed in the same way.^{9,26} Templates help to include all critical elements, and they can serve as an example of how the analysis should be performed. Due to the highly complex nature of multiparameter analysis, it is recommended that experienced interpreters with knowledge of instrumentation, software, and data analysis produce the templates and supervise the reporting. The final report should contain:

- Demographic identification of patient
- Identification of the hospital or division sending the sample

P.24

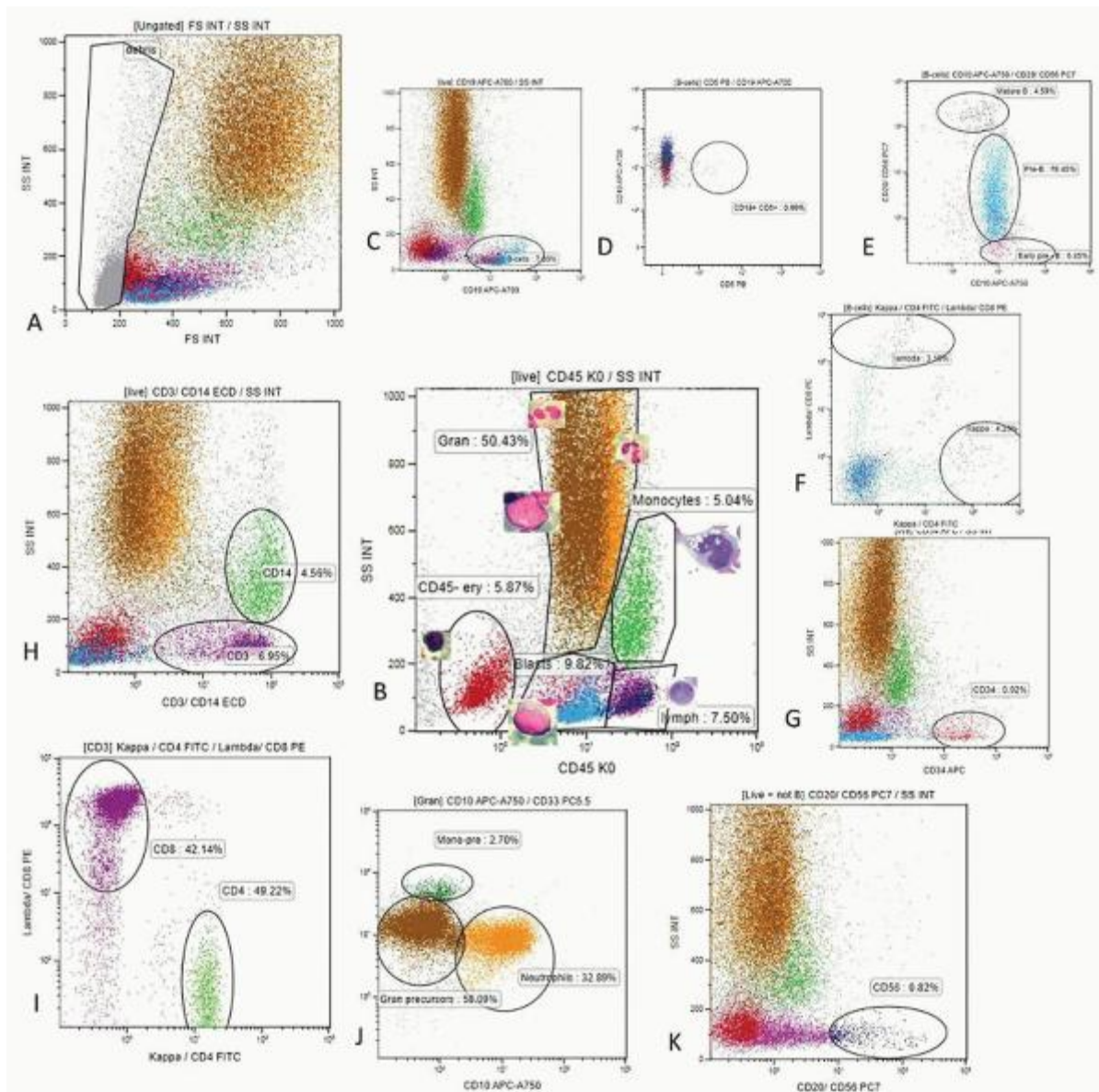

FIGURE 2.2. Bone marrow mapping with polychromatic flow cytometry. Reactive bone marrow sample from a young patient was analyzed with a screening ten-color 14 MAb panel on a Navios flow cytometer and Kaluza software (Beckman Coulter). The MAb panel consisted of kappa+CD4 FITC/Lambda+CD8-PE/CD3 + CD14

ECD/CD34 APC/CD20+CD56-PC7/CD10-APC-A750/CD19-APC-A700/CD33 PC5.5/CD5-Pac Blue/CD45 Krom Orange. Analysis starts with the creating of the "live cells" gate by removal of dead cells, erythrocyte, and platelet aggregates on FS/SS plot (A). A CD45/SS plot is created within the live cell gate (B). Regions for lymphocytes (CD45bright/low SS), monocytes (CD45 bright/high SS), granulopoietic cells (CD45 dim/high SS), CD45dim/low SS blasts, and CD45-low SS erythropoietic cells are determined. The B-cell gate is created from the live cell gate on the CD19/SC plot (C). Presence of CD5 positive B-cells is investigated using a CD5/CD19 plot (D). The presence of CD10+ B-cells is looked for by analysis of CD20 and CD10 expression within the B-cell gate (E). In this patient, no CD5+ B-cells were detected but a significant fraction of B-cells showed B-precursor immunophenotype with normal maturation pattern (E). If a CD5+ or CD10+ B-cell population is present, a new gate can be created within plot D or E. B-cell clonality is analyzed within the B-cell gate (F). In this patient most B-cells are negative for light chain expression, consistent with B-cell precursors. Note that most of CD10+/CD20 dim B-cell precursors (cyan dots) fall into the blast gate in the CD45/SS plot (B). Kappa and lambda positive B-cells have normal kappa to lambda ratio. If CD5 and/or aberrant CD10+ B-cells were present, clonality of B-cells would be analyzed within the specific CD5+/CD19+ or CD10+/CD19+ gate. The fraction of CD34+ cells (red dots) is estimated within the live cell gate on the CD34/SS plot (G). If increased numbers of CD34+ cells are found, they are further analyzed for CD33, CD19, and CD10 expression. CD3+ T-cell and CD14+ monocyte gates are created on the CD45/CD3+CD14 plot within the live cell gate (H). Fractions of CD4+ (violet dots) and CD8+ T-cells (light green dots) are estimated within the CD3+ gate (I). CD4/CD8 ration was normal (1.16). Granulopoietic cells are analyzed on CD33/CD10 plot within the "Gran" gate and fractions of mature neutrophils (CD33+CD10, orange dots) and granulopoietic precursors (CD33+ CD10, brown dots) are estimated (J). CD14-CD33bright monocytic precursors can also be enumerated (green dots). Finally the fraction of CD56+ NK cells (dark blue dots) can be evaluated on a CD20+56/SS plot using the Boolean gate of live cells + non-B-cells to exclude CD20+ B-cell from analysis (K). Various cell populations are back-gated and visualized on both FS/SS and CD45/SS plots (A and B).

P.25

- Type of specimen (bone marrow aspirate, peripheral blood, other biologic fluids)
- Timing of observation (first diagnosis or follow-up)
- Diagnostic hypothesis made by the sender
- List of antigens and type of immunofluorescence analysis carried out
- Absolute number of cells in the sample
- Quality of the sample, in terms of viability
- General description of the gating procedure
- Immunophenotype of abnormal cells present in the sample
- Description of other (normal) cells

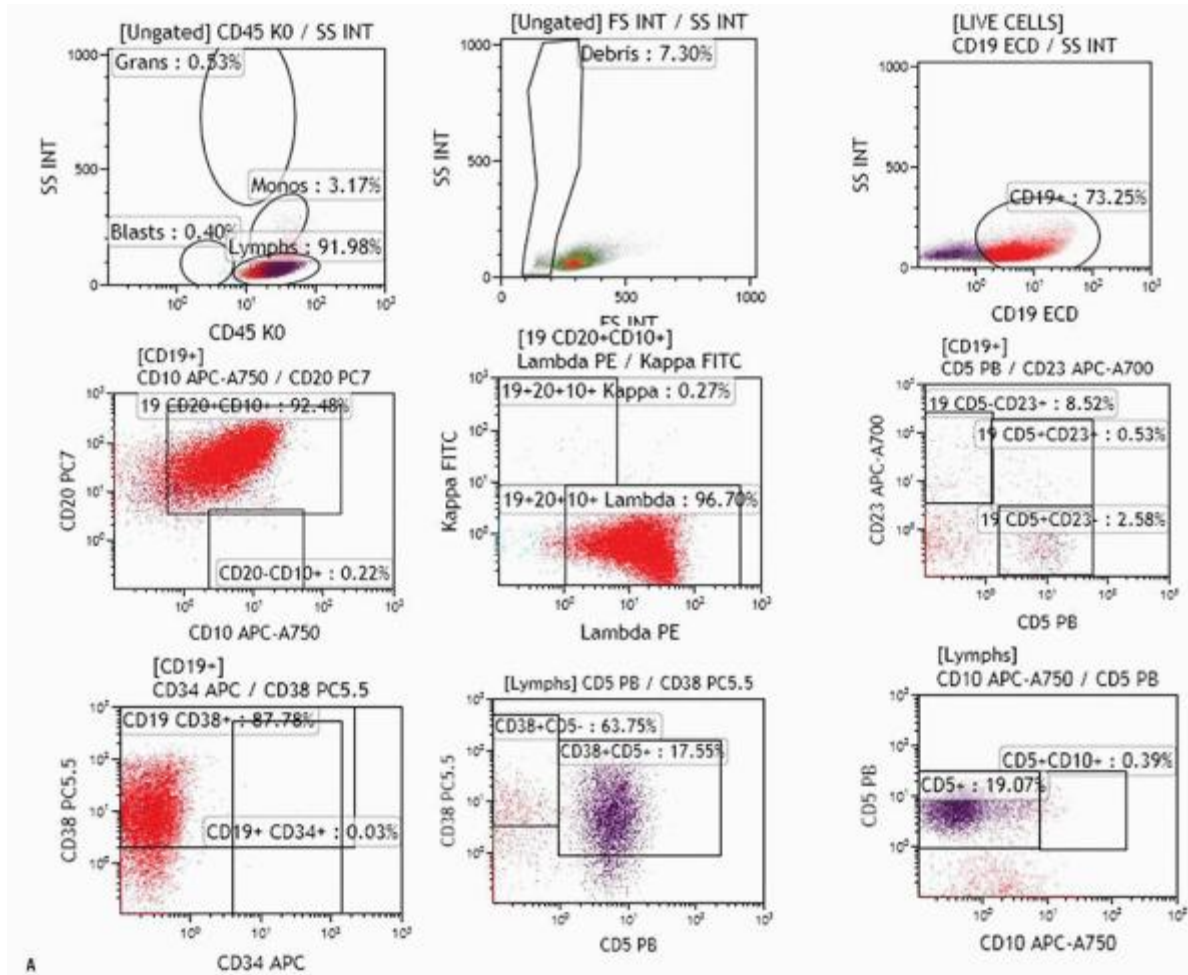

FIGURE 2.3. A. Examples of analysis of B-cell compartment in bone marrow samples. Ten-color MAb panel, Navios flow cytometer, and Kaluza software (Beckman Coulter) were applied. Panel consists of Kappa-FITC/Lambda-PE/CD19 ECD/CD34-APC/CD10-APC-A750/CD23-APC-A700/CD20-PC7/CD38-PC5.5/CD5 Pc Blue/CD45-Krom Orange. The live cell gate is created and fractions of lymphocytes, granulocytes, monocytes, and the like are evaluated as shown in Figure 2.2. The B-cell gate is created on a CD19/SS plot and expression of CD5, CD23, and CD10 is analyzed within the B-cell population. Kappa and lambda light chain expression is analyzed within total B-cell, CD5+ B-cell, or CD10+ B-cells as appropriate. Expression of CD34 and CD38 within the CD19+ B-cell population can also be analyzed (see Fig. 2.3B). The fraction of plasma cells can be estimated using CD38 bright expression and high SS on the CD38/SS plot (not shown). Upper row: population of B-cells with B-CLL/small lymphocytic lymphoma-related phenotype (CD19+, CD5+, CD23+, CD20 dim, kappa dim, CD10-) consistent with bone marrow involvement in a patient who was diagnosed with small lymphocytic lymphoma in a lymph node biopsy and had no peripheral lymphocytosis. Bone marrow biopsy showed rare nodular lymphoid infiltrates. Middle row: CD5-CD10-CD23- lambda+ B-cell population in a patient with Waldenström macroglobulinemia. Lower row: population of CD19+ CD10+ B-cells strongly expressing CD20 and kappa in a patient with bone marrow involvement by a follicular lymphoma. B. Examples of analysis of B-cell compartment in a lymph node cell suspension. Ten-color MAb panel, Navios flow cytometer, and Kaluza software (Beckman Coulter) were applied. Panel consists of Kappa-FITC/Lambda-PE/CD19 ECD/CD34-APC/CD10-APC-A750/CD23-APC-A700/CD20-PC7/CD38-PC5.5/CD5 Pc Blue/CD45-Krom Orange. The live cell gate is created and fractions of lymphocytes, granulocytes, monocytes, and the like are evaluated as shown in Figure 2.2. The B-cell gate is created on the CD19/SS plot and expression of CD5, CD23, and CD10 is analyzed within the B-cell population. Most B-cells were positive for CD20, CD38, and CD10, and showed monotypic lambda expression.

- Diagnostic conclusions
- Comments and/or recommendations for further testing.^{21,27}

Validation of Assays and Quality Assurance

In clinical settings, the results obtained in FCM must be interpreted in relation to clinical information and to the results of other techniques (morphology, cytogenetics, molecular genetics, fluorescence in situ hybridization [FISH]), which are used as a validation of the information provided by FCM.²¹ Newly established panels have to be validated by comparison to reference

P.26

methodology, interlaboratory comparison, or verification with specimens obtained from patients with a confirmed diagnosis. A minimum of 10 to 20 samples (10 normal, 10 abnormal) is recommended for accuracy assessment. The acceptance criteria will also be variable depending on the required degree of accuracy for the intended use, nevertheless should be clearly defined for each assay. Ninety percent, or greater, agreement between methods is generally required for accuracy.

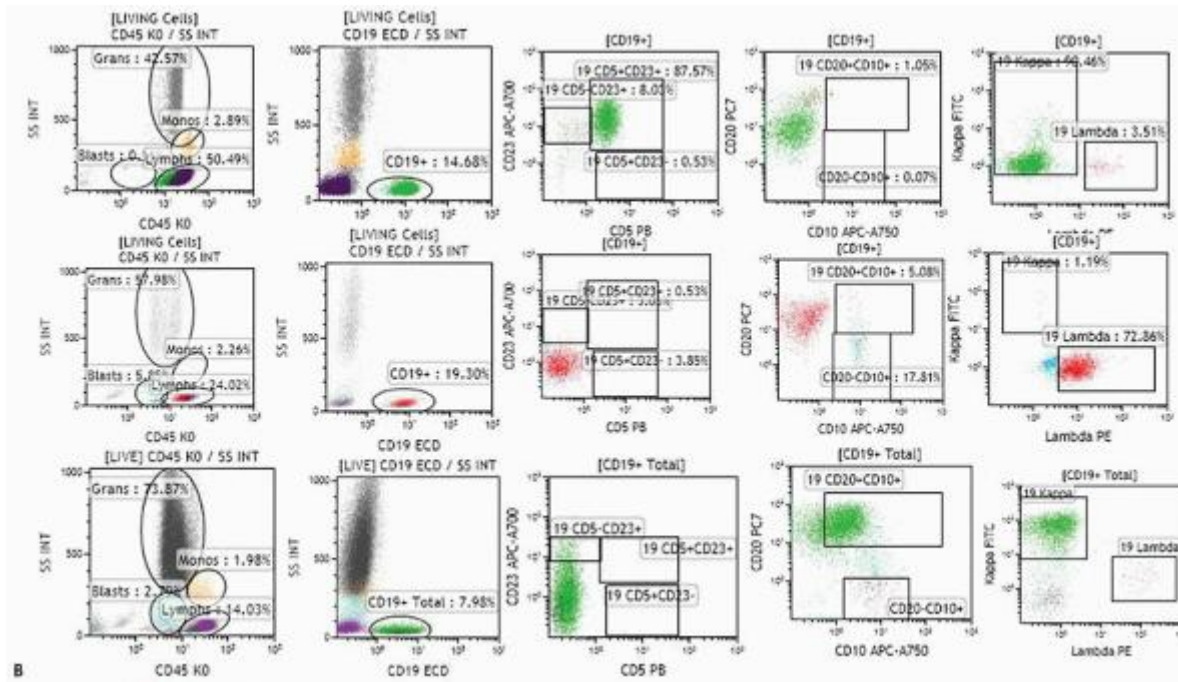

FIGURE 2.3. (Continued)

All instruments have to follow daily quality checks according to manufacturers' recommendations. Participation in a suitable external quality assurance (EQA) program should be undertaken. Many proficiency testing programs are in existence operating at local, national, or international levels. The more common uses of FCM should be subjected to EQA and many of the larger international programs such as those operated by UK NEQAS for Leukocyte Immunophenotyping²⁸ and the College of American Pathologists offer FCM EQA programs for leukemia and lymphoma diagnosis, lymphocyte subset monitoring, paroxysmal nocturnal hemoglobinuria (PNH), and CD34+ stem cell enumeration. Many of these programs use stabilized material enabling samples to be transported long distances such that data from large international cohorts can be examined to search for any instrument or reagent bias. The frequency of the samples issued by such programs is recommended to be at least four times per year to ensure continued performance monitoring.

TABLE 2.3 EXAMPLES OF 10-COLOR FLOW CYTOMETRY PANELS^a IN IMMUNOPHENOTYPING OF LEUKEMIA AND LYMPHOMA

Panel	FITC ^b	PE	ECD	PC5.5	PC7	APC	APC-AF700	APC-AF750	PB	KO
B-cell	kappa	lambda	CD19	CD38	CD20	CD34	CD23	CD10	CD5	CD45
T-cell	CD57	CD11c	CD8	CD3	CD2	CD56	CD7	CD4	CD5	CD45
AML-granulo	CD65	CD13	CD14	CD33	CD34	CD117	CD7	CD11b	CD16	CD45

AML-mono	CD36	CD64	CD56	CD33	CD34	CD123	CD19	CD38	HLA-DR	CD45
AML-ery-ly	CD71	CD11c	CD4	CD33	CD34	CD2	CD10	CD235a	CD15	CD45
ALL-B	CD58	CD22	CD38	CD33	CD34	CD123	CD10	CD19	CD20	CD45
ALL-T	CD7	CD1a	CD8	CD33	CD34	CD2	CD10	CD4	CD5	CD45
AL-cytoplasmic	TdT	MPO	CD14	CD33	CD34	cytCD79	cytCD22	CD19	cytCD3	CD45

^aThese panels are in current clinical use at the Flow Cytometry Lab., Department of Laboratory Medicine, University Health Network, Toronto General Hospital, Toronto, Ontario, Canada.

^bCharacteristics of fluorochromes are given in Table 2.1.

NORMAL HEMATOPOIESIS

Knowledge of levels and expression patterns of various antigens in normal hematopoietic cells at different stages of development provides a frame of reference for recognition of abnormal differentiation

P.27

patterns. Following reports by Terstappen et al.,^{29,30} and³¹ several groups provided descriptions of clearly delineated differentiation stages of various hematopoietic cell lineages.^{32,33,34,35} and^{36,37,38} A detailed review of all available data is beyond the scope of this chapter; a summary of the most important and well-established issues is provided below.

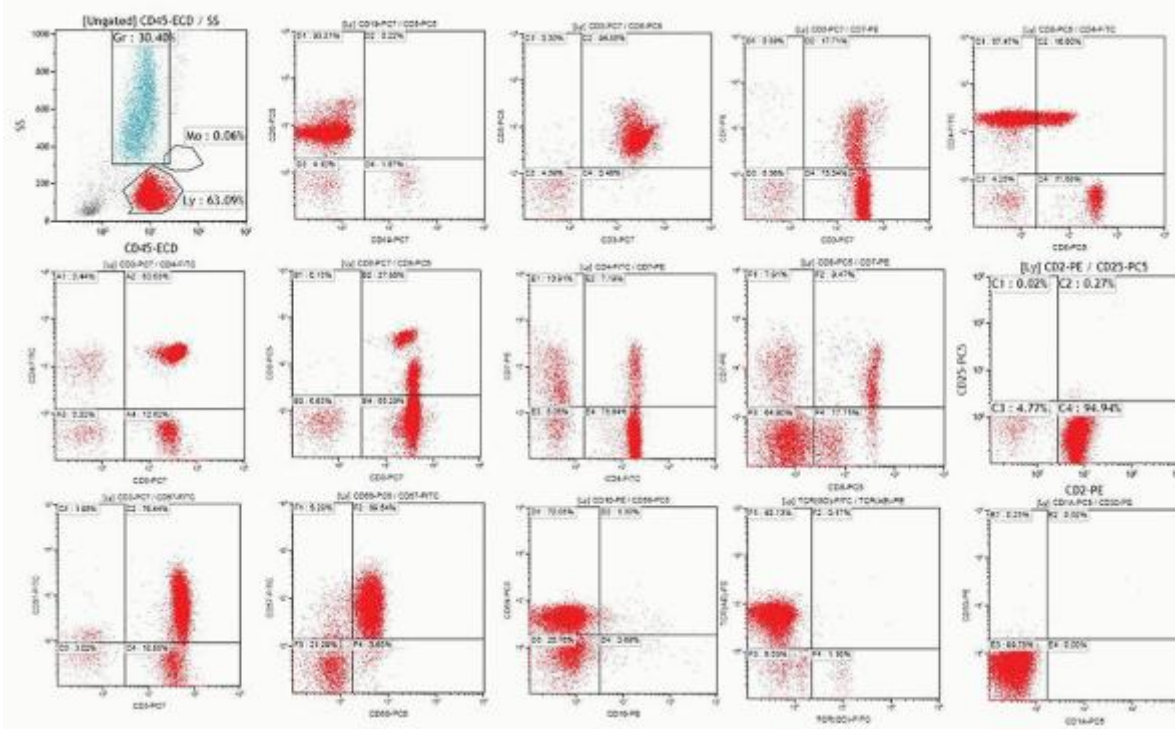

FIGURE 2.4. Example of aberrant T-cell population detected in peripheral blood of a patient with lymphocytosis. Five-color MAb panel and FC500 flow cytometer (Beckman Coulter) were used. Analysis shows that 63% of blood cells were lymphocytes (Ly, red dots on upper left plot). Analysis was performed within lymphocyte gate. Analysis revealed an aberrant population of CD3+ T-cells (75% of lymphocytes) that lack CD7 are positive for CD5 and CD4 with partial co-expression of CD8 (upper row). Small populations of normal CD4+CD7+ and CD8+CD7+ T-cells are also noted (7% and 9% of lymphocytes, respectively, middle row). All T-cells were positive for CD2 and negative for CD25 (left middle row). Further analysis that showed that the aberrant T-cell population was positive for NK-cell-associated antigens CD56 and CD57 (lower row) and had large granular lymphocyte morphology (not shown). MAb to TCR alpha/beta was positive and

TCR gamma/delta negative. No expression of CD30 or CD1a was noted (left lower plot).

Immature Cells of Normal Bone Marrow

CD34+ hematopoietic progenitor and precursor cells (HPC) that constitute most cells of the CD45/dim (blast) region are a heterogeneous cell population. A small fraction of pluripotent stem cells with long-term repopulating cell activity have been associated with the CD34/CD38- phenotype.^{39,40} These cells are very rare in normal BM (usually <0.1%)⁴¹, but may increase in regenerating BM and in myelodysplastic syndromes (MDS).^{42,43} CD34/CD45dim cells also include a major fraction of HPC already committed to different hematopoietic lineages (erythroid, neutrophil, monocytic, dendritic cell (DC), basophil, mast cell (MC), eosinophil, and megakaryocytic) and variable numbers of CD34+ B-cell precursors (BCP).³⁵ Human stem cells are defined by expression of CD90 and CD49f and are CD45RA negative. Early myeloid progenitors were isolated based on the expression of IL-3 receptor, a chain (CD123) or FLT3 (CD135), and CD45RA. Myeloid, but not erythroid, progenitors express CD123 and CD135, and the transition from common myeloid to granulocyte-macrophage progenitor is marked by acquisition of CD45RA [reviewed in Ref. 44].

Granulocytic Differentiation

Several antigens change their expression intensity during maturation of granulopoiesis. Characteristic normal patterns for various antigen combinations have been identified using multicolor analysis.^{25,36,37,45} Continuous variation in the expression of CD13, CD11b, and CD16 that occurs as the blasts/promyelocytes mature to neutrophils makes the combinations of these antigens very useful in delineating granulocyte maturation (Fig. 2.6). CD13 is expressed at high levels on CD34+ HPCs and CD117+ precursors (promyelocytes). CD13 is then down-regulated and dimly expressed on intermediate precursors (myelocytes) and it is gradually up-regulated again as the granulocytic cells develop into segmented neutrophils. CD11b and CD16 are initially expressed at low levels, but their expression increases during maturation (Fig. 2.6).

Expression of CD33 is particularly useful if followed together with expression of HLA-DR. CD34+ cells are HLA-DR positive and become weakly positive for CD33. With maturation, CD34 disappears and CD33 expression is up-regulated, followed by down-regulation of HLA-DR and slight down-regulation of CD33 in most mature forms.³⁷ CD15 and CD65 appear when cells are restricted to neutrophil differentiation. CD66, CD16, and CD10 are the markers of mature, band, and segmented neutrophil granulocytes and can be applied to evaluate blood contamination of aspirate.^{46,47} and ⁴⁸ The sequence of marker expression during neutrophil differentiation is summarized in Table 2.4. It has been confirmed by cell culture studies and sorting experiments.^{36,49,50}

P.28

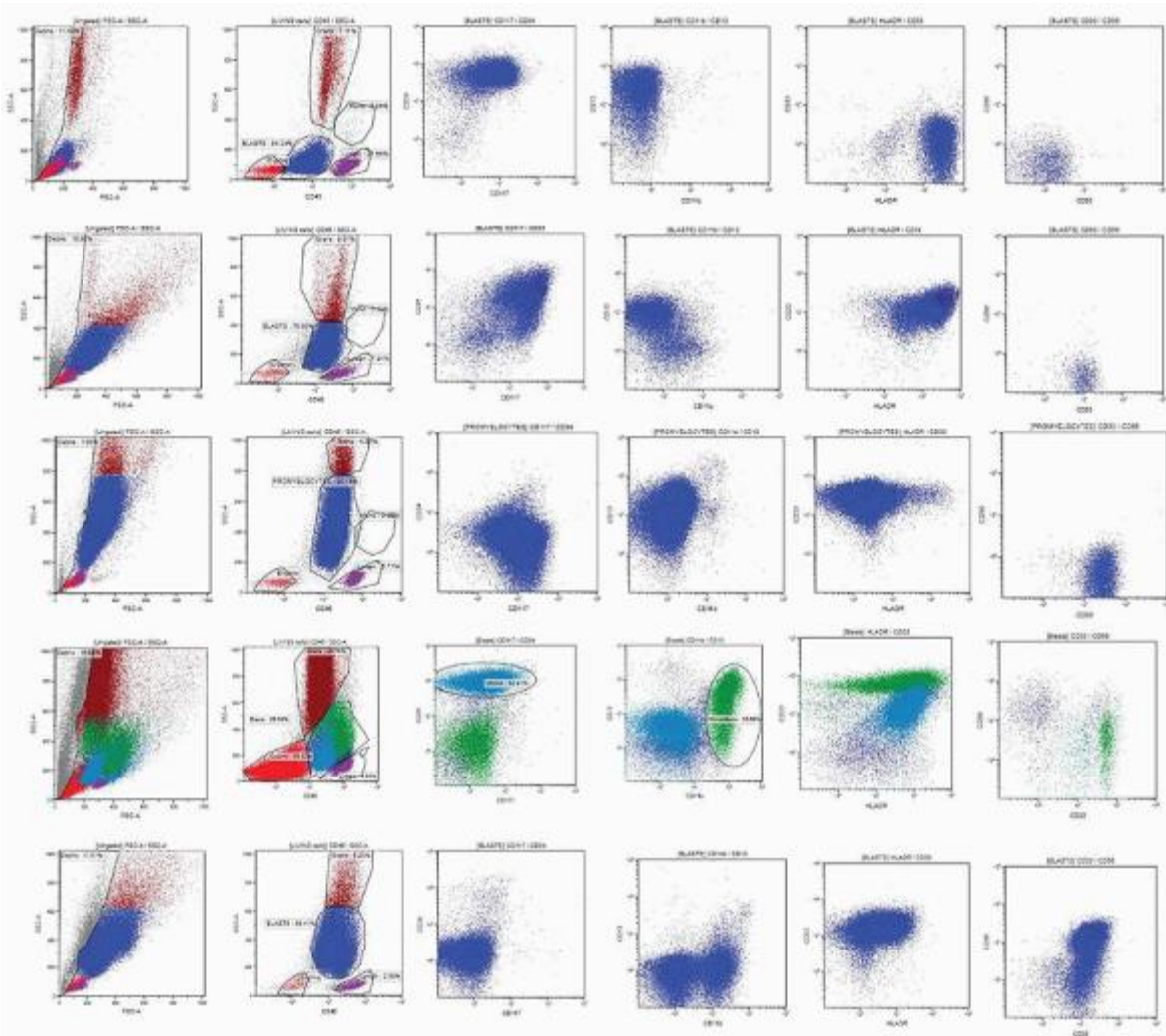

FIGURE 2.5. Examples of various scatter characteristics of CD45 dim blast population and patterns of antigen expression in acute myeloid leukemia. Bone marrow samples were stained with an eight-color MAb panel and acquired on a FACS-CANTOII flow cytometer (BD Bioscience). Panel consisted of CD56-FITC/CD13-PE/CD34 PerCP-Cy5.5/CD117-PE-Cy7/CD33-APC/CD11b APC-Cy7/HLA-DR Pac Blue/CD45 AmCyan. Analysis was performed using Kaluza software (Beckman Coulter). After removal of dead cells and debris, blasts, lymphocytes, monocytes, and granulopoietic precursors/granulocytes were gated on the CD45/SS plot. Further analysis of antigen expression was performed within the blast population (dark blue dots) except for myelomonocytic leukemia (fourth row) where the monocyte gate was added (green dots). The upper row of plots shows an example of AML without differentiation showing agranular blasts, positive for CD34, CD117, CD13, and HLA-DR, but negative for CD33 and CD56. The second row shows an example of AML with granulocytic differentiation as demonstrated by partial expression of CD11b and SS characteristics. Blasts are strongly positive for CD34, CD117, CD13, CD33, and HLA-DR but negative for CD56. The third row shows an example of APL with characteristic high SS and negative CD34, HLA-DR, CD11b, heterogeneous CD13, strong CD33, and no expression of CD56. The fourth row shows an example of myelomonocytic AML where a population of blasts (dark blue) and a population of aberrant monocytes were detected. Blasts were positive for CD34, CD33, CD11b, and HLA-DR but negative for CD117 and CD13. Both blasts and monocytes showed aberrant expression of CD56. The lower row shows an example of monoblastic leukemia, which was negative for CD34, CD117, and CD13 but showed strong expression of CD33 and CD56, dim HLA-DR, and partial expression of CD11b.

Monocytic Differentiation

CD14, CD36, and CD64 are considered as monocyte-associated markers, CD14 being the most specific. During maturation toward promonocytes, progenitors down-regulate CD34 and CD117 and gain the expression of CD64, CD33, HLA-DR, CD36, and CD15, with an initial mild decrease in CD13 and an increase in CD45. Maturation toward mature monocytes leads to a progressive increase in CD14, CD11b, CD13, CD36, and CD45, with a mild decrease in HLA-DR and CD15. Mature monocytes show expression of bright CD14, bright CD33, variably bright CD13, bright CD36 and CD64, and low CD15.^{36,51}

Erythropoietic Differentiation

Early erythropoietic precursors are found in the blast area and can be identified by very bright CD44, bright CD71, intermediate CD36, positivity for HLA-DR, and expression of CD117 with “dim” CD45. Glycophorin A (CD235a) is expressed at a low level at this stage. Maturation to the basophilic erythroblast is accompanied

P.29

by a decrease in CD44, disappearance of CD45 and acquisition of bright CD235a expression. At transition to the polychromatophilic/orthochromatophilic stage, erythroblasts show loss of HLA-DR, further decrease in CD44, and a mild decrease in CD36.^{51,52}

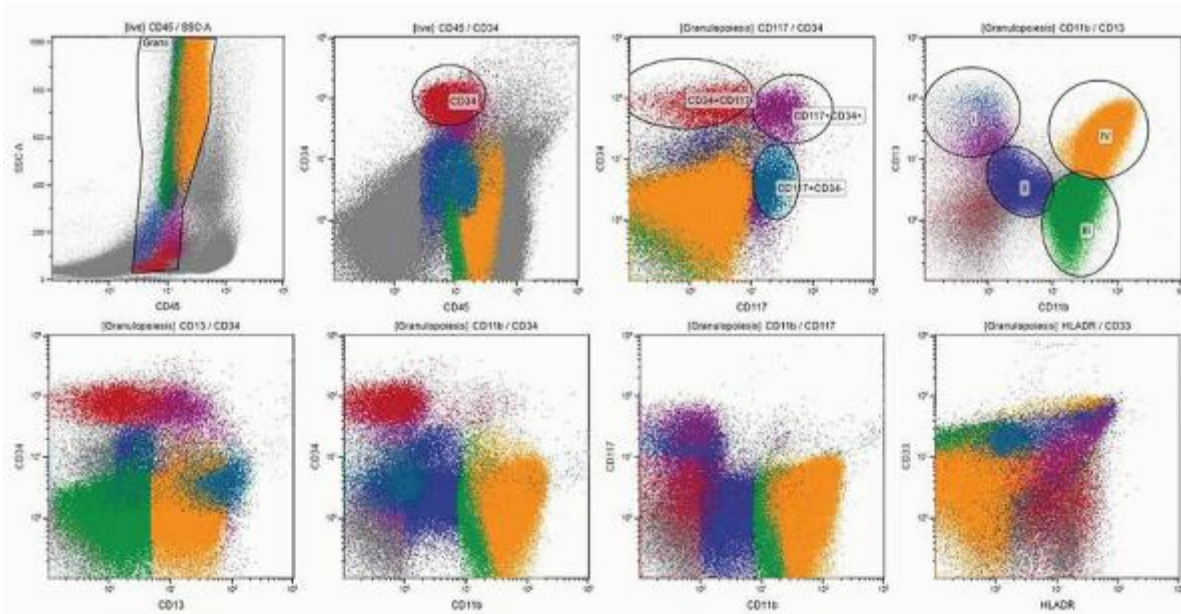

FIGURE 2.6. Flow cytometry analysis of maturation in granulopoiesis. Reactive bone marrow samples were stained with an eight-color MAb panel and acquired on a FACS-CANTOII flow cytometer (BD Bioscience). Panel consisted of CD56-FITC/CD13-PE/CD34 PerCP-Cy5.5/CD117-PE-Cy7/CD33-APC/CD11b APC-Cy7/HLA-DR Pac Blue/CD45 AmCyan. Analysis was performed using Kaluza software (Beckman Coulter). Granulopoietic cells and blasts were gated on CD45/SSC plot within a live cell gate (upper left). CD34+ cells were gated in a live cell gate and a Boolean gate was created by adding both gates (called granulopoiesis). Expression of CD34 and CD117 showed three populations: CD34+/CD117-CD34+/CD117+ and CD117+/CD34-. The right upper plot shows maturation in granulopoiesis corresponding to promyelocytes (I: CD13+ CD11b-), myelocytes (II: CD13+/dim, CD11b dim), metamyelocytes/bands (III: CD13 dim, CD11bright), and mature neutrophils (IV: CD13bright, CD11b bright). The lower row of plots illustrates the position of these various subsets in other antigen expression plots. All granulopoietic cells were negative for CD56 (not shown).

Lymphocyte Differentiation

The average reported relative frequencies of major lymphoid subsets in various types of tissues are given in Table 2.5. Each laboratory should establish its own ranges.

B-cells

B-cell differentiation in the normal human bone marrow has been extensively studied by several groups that described characteristic patterns of antigen expression on consecutive stages of B-cell precursors (Table 2.6, Fig. 2.7).^{33,36,53,54,55} and ⁵⁶ The changes in antigen expression in B-lineage committed cells can be summarized as follows⁵⁷:

- CD34+CD10+ Terminal deoxynucleotidyl transferase (TdT)+CD79a+CD19neg common lymphoid progenitor (CLP): early B (E-B) stage.
- CD34+CD19+CD10+TdT+CD20-cytIgM- pro-B-cell stage.
- After down-regulation of CD34 and TdT they become CD34-CD19+ CD10+ CD20 heterogenous pre-B that can be further subdivided in I and II subsets.

- CD34-CD19+CD20+CD10dim/- IgM+ immature (IM)-B-cells.
- After expression of light chains, cells become CD10-CD19+ CD20+ IgM+ IgD+ mature B-cells.

Pre-B and IM B-cells constitute the majority of B-cells in BM of children, whereas mature B-cells are most frequent in adult BM.^{33,36}

In children with BM regeneration after infection or chemotherapy and in transient hyperplasia of B-cell progenitors, subpopulations of IM and mature B-cells co-expressing CD5 have been identified.⁵⁸ CD5+ B-cells are the major population of B-cells in fetal life, and their percentage decreases with age.⁵³ Knowledge of antigen expression patterns of B-cell subsets in normal BM is essential for follow-up studies of minimal residual disease (MRD) in patients treated for B-precursor acute lymphoblastic leukemia (ALL).^{33,59,60}

T-cells

T-cell production is maintained throughout life by thymic seeding of BM-derived progenitors. Rare (<0.1%) T-cell-restricted precursors, which express pre-T α protein on the cell surface and are CD34+CD7+CD45RA+, were identified in human BM.^{57,61} Recently, it has been suggested that CD34+ CD10+ CD24- progenitors present in both BM and thymus constitute a thymus-seeding population and may replace CD34+ CD7+ CD45RA+ cells in the post-natal period.⁶² However, frequency of these cells in normal BM is lower than 1/10-4.³⁴ No TdT-positive T-cells expressing cytoplasmic CD3 are found in normal BM.³⁴ Most mature T-cells in the BM co-express CD7, CD5, CD2, and membrane CD3 and are either CD4 or CD8 positive. However, minor subsets of CD7+ cells lacking other “pan-T” antigens, small subsets with co-expression of CD4 and CD8, and a subset lacking CD4 and CD8 have been identified.³⁴ A small population of CD7- T-cells (<10% of T-cells) can also be seen in normal and reactive conditions.⁶³

Minor Bone Marrow Cell Subsets

In healthy donors, eosinophils represent 2% to 3% of blood leukocytes. Numbers of eosinophilic precursors may vary considerably

P.30

in reactive BM. Eosinophilic myelocytes can be identified by high side scatter, intermediate CD45 (at a level slightly higher than neutrophilic myelocytes), low to intermediate CD11b, intermediate CD13, and low CD33 with bright CD66b and no CD16 expression. Mature eosinophils show increased levels of CD45 and CD11b with a decrease in CD33 and are negative for CD16.^{51,64}

TABLE 2.4 SURFACE MARKER EXPRESSION DURING MATURATION OF GRANULOPOIETIC PRECURSORS IN THE BONE MARROW

Antigen	Blasts	Promyelocytes	Myelocytes	Metamyelocytes	Bands	Segmented Neutrophils
CD10	-	-	-	-	-	+
CD11a	d	d	d	+	+	+
CD11b	-	-	d	+	+	b
CD11c	-	-	d	d	d	d
CD13	d	+	+	d	d/+	b
CD15	-/+	d/+	+	+	+	+
CD16	-	-	-	d	+	b
CD18	+	+	b	+	+	+
CD24	-	-	+	+	+	+
CD33	-/d/+	b	+	d	d	d
CD34	d/+	-	-	-	-	-
CD35	-	-	-	-	d	d

CD44	b	+	d	d	+	b
CD45RA	d	d	-	-	-	-
CD45RO	-	-	-	d	+	b
CD54	+	+	-/d	-/d	-/d	-/d
CD55	b	+	+	b	b	b
CD59	b	b	b	b	b	b
CD62L	+	+	+	+	+	+
CD64	d	d	+	+	-	-
CD65	-/+	d	+	+	b	b
CD66a	-	-	+	+	+	+
CD66b	-	b	b	+	+	+
CD66c	-	b	b	+	+	+
CD117	d	+	-	-	-	-
CD133	d	-	-	-	-	-

-, Negative; -/+ or (d), partially positive (or dim); d, dim, weakly positive; +, positive; b, bright, strongly positive.

TABLE 2.5 AVERAGE RELATIVE FREQUENCY OF MAJOR LYMPHOID CELL SUBSETS IN NORMAL TISSUES

Subset	Peripheral Blood ^a	Peripheral Blood ^a	Bone marrow ^b	Lymph Nodes ^a	Tonsils ^a	Spleen ^a		
	(%)	(%)	(%)	(%)	(%)	(%)	(%)	(%)
	2-5 Years	5-15 Years	Children	Adults				
CD19+ B-cells	24	17	12	10	3	41	51	55
CD3+ T-cells	64	68	72	6	12	56	49	31
CD4+ CD3+ T-helper	37	38	44	3.2	6.5	48	42	17
CD4+CD8+ T-cytotoxic	24	26	24	2.6	4.2	10	6	14
Natural killer (all NK subsets)	10	13	13	2	4	1	<11	5

^a Percentage of cells in the lymphocyte region (CD45 bright).

^b Percentage of total bone marrow cells.

Basophils are the least common granulocyte subset (0.5% of total blood leukocytes and about 0.3% of nucleated BM cells in

P.31

healthy individuals). Basophils are positive for CD9, CD13, CD22 (dimmer than mature B-lymphocytes), CD25 (dim), CD33, CD38 (bright), CD45 (dimmer than lymphocytes and brighter than myeloblasts), and CD123 (bright), and are negative for CD3, CD4, CD19, CD34, CD15, CD64, CD117, and HLA-DR. In some individuals, basophils are positive for CD11b.⁶⁵

TABLE 2.6 IMMUNOPHENOTYPIC CHANGES DETECTED BY FLOW CYTOMETRY DURING B-CELL DEVELOPMENT IN

	NORMAL BONE MARROW							
	Early CLPB	Pro-B	Pre-BI	Large Pre-BII	Small Pre-BII	Immature-BB	Mature	Plasma cells
CD34	+	+	+	-	-	-	-	-
CD10	+	+	+	+	+	+	+/ <i>dim</i>	-
CD19	-	-	+	+	+	+	+	+
Cyt.CD79a	-	+	+	+	+	+	+	+
Cyt.CD22	-	+	+	+	+	+	+	+
TdT	-	-	+	-	-	-	-	-
mCD22	-	<i>dim</i>	<i>dim</i>	+	+	+	+	-
CD20	-	-	-	+	+	+	+	-
sIgM	-	-	-	-	-	-	+	-
sIgD	-	-	-	-	-	-	-	+
sIg κ or λ	-	-	-	-	-	-	-	+
cyt.Ig κ or λ	-	-	-	-	-	-	-	+

CLP, common lymphatic precursor; cyt., cytoplasmic; s, surface; TdT, terminal deoxynucleotidyl transferase.

Bone marrow mast cells (BMMCs) are present in normal BM at a very low frequency 0.021% +/- 0.0025% of the nucleated cells.⁶⁶ BMMCs are clearly identifiable on the basis of their light scatter properties and strong CD117 expression. Normal BMMCs are virtually always positive for the CD9, CD11c, CD29, CD33, CD43, CD44, CD45, CD49d, CD49e, CD51, CD54, CD71, and FcεRI antigens. Other markers such as CD11b, CD13, CD18, CD22, CD35, CD40, and CD61 display a variable expression in normal individuals. BMMC are negative for the CD34, CD38, and CD138 antigens.^{67,68}

Dendritic cells (DCs) comprise two main subpopulations: conventional DCs (cDCs) and interferon-producing plasmacytoid (p) DCs. Human cDCs are Lineage (Lin) negative HLA-DR+ cells that express high levels of CD11c and consist of a major blood dendritic cell antigen (BDCA)3- and a minor BDCA3+ population. Human Lin-HLA-DR+ pDCs are defined by absence of CD11c expression and by high levels of CD123 (the IL-3Rα chain) and BDCA2.⁶⁹ The CD11c+HLA-DR+BDCA3- population can be further subdivided into CD16+ and CD16- populations. Recent studies indicate that cDCs in lymphoid tissues arise from a distinct population of committed cDC precursors (pre-cDCs) that originate in bone marrow and migrate via blood. Spleen cDCs arise from a distinct population of Lin neg CD11c+ major histocompatibility complex (MHC) class II neg immediate cDC precursors (pre-cDCs). Pre-cDCs originate from bone marrow Lin neg CD117int FLT3+ CD115+ common DC progenitors.⁷⁰ The direct progenitor of pDCs is contained within the CD34 low compartment of cord blood, fetal liver, and bone marrow. These progenitors (pro-pDCs) co-express CD45RA, CD4, and high levels of CD123.⁵⁷

NK cells are positive for CD2 and CD7 but negative for CD3 and CD5. In humans, there are two major subsets of NK cells: one expressing high levels of CD56 and low or no CD16 (CD56hiCD16+/-), and the second that is CD56+CD16hi⁷¹ CD56hiCD16+/- cells display relatively lower cytolytic activity and produce more cytokines than the CD56+CD16hi cells. A putative committed NK precursor has been found within CD34lo CD45RA+ α4β7hiCD7+/-CD10- BM population and gives rise to CD56hi CD16- NK cells in vitro. The immature NK cells developing from committed NK-cell precursors are defined by expression of CD161 (NKR-P1).⁷² These cells do not express CD56 or CD16. Immature NK cells can be induced to express these markers as well as the activating and inhibitory receptors, CD94 (NKG2A) and killer inhibitory receptors (KIR), upon culture with stromal cells and cytokines such as IL-15 or Flt3-L.⁵⁷ A total of 30% to 60% of CD56dim CD16bright NK cells in healthy adults express CD57, which is not expressed on immature CD56bright NK cells. CD57+ NK cells express a repertoire of NK-cell receptors, suggestive of a more mature phenotype, and proliferate less when stimulated with target cells and/or cytokines.⁷³

MULTICOLOR ANALYSIS OF HEMATOLOGIC MALIGNANCIES

Detailed immunophenotypic information necessary for diagnosis and prognosis of various hematologic diseases, based on both FCM and immunohistochemistry, are provided in their respective chapters. The FCM findings important for diagnosis of most common entities are summarized below.

Immunophenotyping of B-Cell Lymphoproliferative Disorders

Normal/reactive B-cell populations in blood, bone marrow, and lymphatic tissue are polyclonal with an average Igκ/Igλ ratio of 1.5 (range 0.9-3) (Fig. 2.2).⁷⁴ An increase of polyclonal B-cells in blood, called the persistent polyclonal B-cell lymphocytosis (PPBL) is characterized by a chronic, stable, persistent, and polyclonal increase of B-cells (median $5 \times 10^9/L$), the presence of binucleated lymphocytes in the PB, and a polyclonal increase in serum immunoglobulin-M (IgM). Most patients are asymptomatic but isochromosome 3q and development of malignant lymphoma has been described in some cases.⁷⁵

B-cell malignancies are clonal expansions of B-cells that express only one type of Ig light chain (κ or λ). Analysis of light chain expression in total B-cell population and in CD5/CD19 or CD10/CD19 positive cells forms the basis for B-cell lymphoma diagnosis (Fig. 2.3). Typical immunophenotypes found in various

P.32

mature B-cell lymphoma subtypes are summarized in Table 2.6. An issue that may cause diagnostic problems is the demonstration of small monoclonal B-cell populations in the BM samples taken during investigations for staging of lymphoma. As FCM sensitivity increases, it becomes more likely that small abnormal populations are detected; how these relate to the neoplastic cells found in other organs is not clear. In some cases a clonal relationship to the diagnostic lymphoma sample has been demonstrated.⁷⁶ However, if the histopathologic signs of lymphoma involvement are missing, these cells may represent sc. monoclonal B-cell lymphocytosis (MBL, see below). Therefore, interpretation of FCM results in BM samples should be always integrated with clinical findings and BM biopsy analysis.

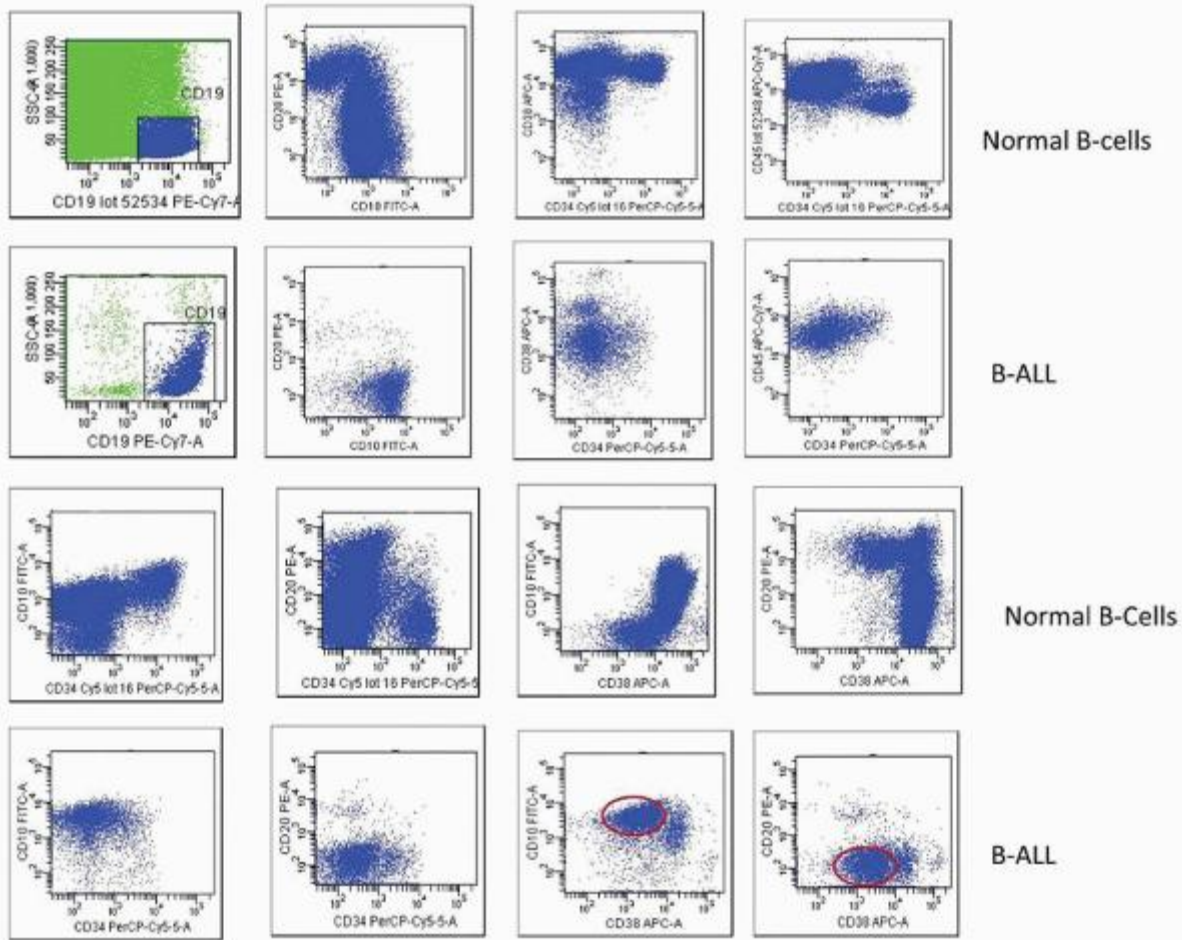

FIGURE 2.7. Example of antigen expression in a case of B-precursor lymphoblastic leukemia/lymphoma in comparison to

normal bone marrow B-cells in a child. Bone marrow samples were analyzed with a six-color MAb panel, FACS-CANTOII flow cytometer, and Diva software (BD Bioscience). The panel consisted of CD10 FITC/CD20-PE/CD34 PerCp-Cy5.5/CD38-APC/CD19-PE-CY7/CD45 AmCyan (not shown). To acquire a sufficient number of B-cells, 500,000 events were analyzed on a normal bone marrow sample and 30,000 cells were acquired on the B-ALL sample. CD19+ B-cells were gated on the CD19/SS plot. Normal antigen expression patterns are shown in the upper and third row and corresponding plots for the B-ALL case are shown below (in the second and lower rows). In two lower right plots leukemic cells are found in “empty spaces,” areas where normal cells are not found (red circles).

B-cell Chronic Lymphatic Leukemia

The characteristic immunophenotype of chronic lymphatic leukemia (CLL) includes positivity for CD19, CD5, CD23, and CD200, weak expression of CD20 and Ig light chains, and often expression of IgM with or without IgD. FMC7 (antibody recognizing one of CD20 epitopes⁷⁷) is negative or only partially expressed in most cases; CD79b and CD22 are absent or weakly expressed in the cell membrane (reviewed in Ref. 78). CD11c, CD25, and other markers that recognize adhesion molecules are variably positive in CLL. CD52 is often included in the panel of markers in CLL diagnosis inasmuch as Alemtuzumab (anti-CD52) is increasingly used in therapy.⁷⁹

Monoclonal B-cell Lymphocytosis

Monoclonal B-cell lymphocytosis (MBL) is an asymptomatic hematologic condition defined by the presence of monoclonal B-lymphocytes detected in PB of persons who do not have CLL, other B-lymphoproliferative disorders, or underlying conditions such as infectious and autoimmune diseases.⁸⁰ Initial criteria have been based on detection of a monoclonal B-cell population in the PB with an overall κ:λ ratio >3:1 or 0.3:1, or >25% of B-cells lacking or expressing low-level surface Ig in conjunction

P.33

with a specific phenotype.⁸⁰ Three different types of MBL have been described, defined on the basis of CD19 positivity, CD5 presence or absence, and CD20 intensity. The most common MBL type is the CLL-like MBL that co-express CD19 and CD5, and CD23 with dim expression of CD20. The second type is similar to CLL but shows bright CD20 expression. B-cells in the third type of MBL do not express CD5; these are classified as CD5-MBL or non-CLL-like MBL.⁸¹ The reported prevalence depends on the sensitivity of applied FCM methodology. Studies performed using four-color FCM with a sensitivity of detection commonly used for detection of MRD in patients with CLL (1 clonal cell per 1×10^5 events) showed a 5% prevalence of CLL-like MBL in adults aged over 60.^{82,83} A more recent study, using a much higher sensitivity of FCM, analyzed 5×10^6 PB cells per individual and identified CLL-like MBL in 12% of all tested subjects and in 20% of adults over 60 years old.⁸⁴ Finding of peripheral MBL should always be correlated with clinical data and interpreted in the absence of peripheral lymphadenopathy, splenomegaly, and extensive lymphatic bone marrow infiltrates.

Mantle Cell Lymphoma

Mantle cell lymphoma (MCL) cells typically express bright CD20, CD5, FMC7, and bright to moderate sIg but lack CD23 and CD200 (Table 2.7).^{85,86} However, MCL cases positive for CD23 and negative for FMC7 as well as rare CD5 negative cases have been found.^{87,88} Therefore, confirmation of MCL diagnosis by FISH for t(11,14) is recommended. Cyclin D1 expression can also be detected by FCM⁸⁹ but this method is not routinely applied in most diagnostic laboratories.

Lymphoplasmacytic Lymphoma and Marginal Zone Lymphoma

These two entities are difficult to differentiate by FCM. The typical immunophenotype findings include the strong expression of sIg and cyt. Ig (IgM in Waldenströms macroglobulinemia [WM], IgG, or IgA in lymphoplasmacytic lymphoma [LPL]). The characteristic antigen expression pattern includes: sIgD+/- CD19+ CD20+ CD22+ CD79a+ FMC7+CD38+ CD103- CD5- CD10- CD23-CD25-CD11c+/- CD43+/- CD27+/-.⁹⁰ A minority of splenic marginal zone lymphoma (SMZL) cases express CD5, which often correlates with higher WBC.⁹¹ However, leukemic presentation of MCL should be excluded. Some cases are CD23 positive. In LPL, a monotypic plasma cell population that is strongly CD38/CD138 positive and also positive for CD19 and CD45 can be found.⁹² Splenic diffuse red pulp small B-cell lymphoma cells in blood and BM are characterized by similar phenotype as given above but are usually CD11c positive.⁹³

TABLE 2.7 FLOW CYTOMETRY IMMUNOPHENOTYPIC FEATURES OF MAJOR B-LINEAGE LYMPHOPROLIFERATIVE DISORDERS

WHO 2008

Category ^a	CD19	CD20	CD22	CD23	CD10	CD5	CD11c	CD103	CD25	CD123	sIg
-----------------------	------	------	------	------	------	-----	-------	-------	------	-------	-----

CLL	+#	+d/-	d/-	+	-	+	±	-	±	-	d
HCL	+	+b	+	-	-/(+)	-	+	+	+	+	b
HCLv	+	+	+	-	-/(+)	-	±	+/(-)	-	-(+)	b
SMZL	+	+	+	-	-	-	+	-/(+)	±	-	+
MCL	+	+b	+	-/(+d)	-	+	-	-	-	-	b
FL	+	+	+	±	+	-	-	-	-	-	+
DLBCL	+	+/(-)	+	±	±	±	±	-/(+)	±	-	±
BL	+	+	+	-	+	-	-	-	-	-	+/(-)

^a BL, Burkitt lymphoma; CLL, chronic lymphocytic leukemia; DLBCL, diffuse large cell B-lymphoma; FL, follicular lymphoma; HCL; HCLv, hairy cell leukemia (v) variant; MCL, mantle cell lymphoma; SMZL/SLVL, splenic marginal zone lymphoma, splenic lymphoma with villous lymphocytes. # + = most cases positive, - = most cases negative, ± = can be positive or negative, +/(-) = usually positive, rarely negative, -/(+) = usually negative, rarely positive, d, “dim”, b, “bright.”

Hairy Cell Leukemia and Hairy Cell Leukemia Variant

Both hairy cell leukemia (HCL) and HCLv strongly express CD103, CD11c, CD20, CD22, CD19, and are negative for CD5, CD23, and in most cases negative for CD38.⁹⁴ HCL cells are often large (can be found in the monocyte region) and are positive for CD25 and CD123 in contrast to HCLv cells that are smaller and CD25 negative.^{94,95}

Follicular Lymphoma

The follicular lymphoma (FL) cells usually express slg, more frequently IgM +/-IgD than IgG or rarely IgA, together with B-cell-associated antigens (CD19, CD20, CD22, CD79a, and CD79b), and in most cases CD10. Expression of CD19 and CD22 is often weaker than in normal B-cells.^{96,97} FL cells are usually CD5-, CD43-, and CD23-/+ , CD11c-/+ . The weaker expression of CD38 helps to differentiate FL cells from CD10 positive B-cell precursors.

Burkitt Lymphoma

Burkitt lymphoma (BL) cells display often similar phenotype to FL cells (CD19+, CD20+, CD10+), but have bright CD38 expression. The CD23-/FMC7+ immunophenotype have recently been reported as significantly associated with MYC rearrangement.⁹⁸ BL cells usually lack CD44 and CD54 expression, which are often expressed in CD10 positive diffuse large B-cell lymphomas (DLCLB).^{99,100} So-called double-hit lymphomas with two translocations including MYC [e.g., t(8;14)] and BCL2 [t(14;18)] or BCL6 (involving chromosome 3q27), which can present in the leukemic phase, have recently been shown to display a common phenotype including a marked decrease in expression of CD20 ranging from dim to absent as compared to normal follicle center B-cells. Other common features of this immunophenotype include positivity for CD10, variably decreased expression of CD45; and variably increased expression of CD38. In addition, Ig light chain restriction with decreased intensity or complete absence of light chain expression was noted in these cases.¹⁰¹ The latter cases have to be tested for nuclear TdT expression and differential diagnosis of B-precursor lymphoblastic leukemia/lymphoma should be considered.

P.34

Diffuse Large B-cell Lymphoma

Two major subgroups of diffuse large B-cell lymphoma (DLBCL) (germinal center type, usually CD10+, and activated B-cell type, usually CD10-) have been described. Rare CD5 positive cases have been reported.¹⁰² Pathologic findings may include highscatter, low/negative expression of slg, CD20, and CD45 (Fig. 2.7). Recent studies suggested that FCM may improve prognostic value of BM staging procedures.^{103,104} However, small populations of pathologic large cells that are easily seen in BM biopsies may in some cases be difficult to delineate by FCM against a background of reactive BM cells. In staging of DLCLB it is important to analyze high numbers of BM cells to be able to evaluate B-cell light chain slg expression even in cases where B-cells represent only a minor portion of the BM cell population.

Immunophenotyping of T-Cell Lymphoproliferative Disorders

FCM detection of aberrant T-cell populations requires good understanding of T-cell biology and knowledge of normal T-cell subsets (Fig. 2.5). Reactive conditions may cause predominance of some T-cell subpopulation, which can be interpreted as immunophenotypic “aberrancy.” Also, reactive T-cell populations, particularly in the setting of chronic stimulation, may comprise a limited number of clonotypes (i.e., are oligoclonal) and therefore are prone to producing clonal TCR rearrangement results. A characteristic dynamic of CD8+ immune response including CD8+ lymphocytosis with increase of CD38 and HLA-DR expression in acute phase and expansion of CD57+CD8+ subset in chronic phase was described in viral infections such as Epstein-Barr virus (EBV) and human immunodeficiency virus (HIV).^{105,106} Chronic activation of the immune system may lead to an increase of CD8+ cells with NK-markers.¹⁰⁷

An integrated approach combining morphology, immunophenotyping, and molecular analysis is necessary to differentiate between reactive and malignant T-cell lymphoproliferations. Immunophenotypic findings in the most common T-cell lymphoproliferative disorders are summarized in Table 2.8.

T-cell Prolymphocytic Leukemia

Leukemic cells are usually positive for CD7, CD2, CD5, and CD3 although about 20% express cytoplasmic (cyt.CD3) but not membrane CD3 (mCD3). CD7 negative cases have been reported. T-cell prolymphocytic leukemia (T-PLL) cells are usually CD4 positive and CD8 negative (60%) but in a fraction of cases T-PLL cells may express both CD4 and CD8, are CD4 negative, and CD8 positive or negative for both CD4 and CD8.¹⁰⁸ CD25 and NK-cell markers (CD56, CD57, CD16) as well as T-precursor-related markers CD1a and TdT are negative.

TABLE 2.8 FLOW CYTOMETRY IMMUNOPHENOTYPIC FINDINGS IN MAJOR CATEGORIES OF MATURE T/NK-CELL NON-HODGKIN LEUKEMIA/LYMPHOMA

WHO Category ^a	Cyt			HLA-										
	mCD3	CD3	CD4	CD8	CD2	CD5	CD7	CD10	DR	CD25	CD56	CD57	CD16	
T-PLL	+/-	+	+/-	-	(+)	+	+	+	(-)	-	-	(+)	-	--
ATLL	+	+	+	-	+	+	-/d	-	+	+	-	-	-	-
SS	+/d	+	+	-	+	(-)	+	-	(+)	-	+/-	-	(+)	--
AILT	+/-	+	+	-	+/d	+/d	+/d	+	+/-	-	-	-	-	-
ALC	+/-	+/-	+/-	-	(+)	+/-	-	-	-	+/-	-	+	+	-
LGL	+	+	(-)	-	+	+	-/+	-/+	-	+	-	-	(+)	++/-
ANKL	-	-	-	-/+	+	-	-	-	-/+	-	+b	-/-	+	-
HSTCL	+/-	+	-	-/d/++	-	(+)	+	(-)	-	+	-	-/+	- (+)-	/+
PTCL	+/-	-	+/-	+/-	+	-/+	+/-	-	+/-	-	(+)	-	(+)	--

^a Diagnostic categories of WHO 2008 classification. AILT, angioimmunoblastic T-cell lymphoma; ALC, anaplastic large cell lymphoma; ANKL, aggressive NK-cell leukemia; ATLL, adult T-cell leukemia/lymphoma; HSTCL, hepatosplenic T-cell lymphoma; LGL; T-cell large granular lymphocyte leukemia; PTCL, peripheral T-cell lymphoma; SS, Sézary syndrome; T-PLL, T-cell prolymphocytic leukemia.

d (dim), weak positive staining; b (bright) strong positive staining; (+) or (-) some cases positive or negative.

Adult T-cell Leukemia/Lymphoma

In most patients, adult T-cell leukemia/lymphoma (ATLL) cells express CD2, CD5, CD25, CD45RO, CD29, T-cell receptor αβ, and HLA-DR (the phenotype of activated CD4+ memory T-cells). ATLL cells usually lack CD7 and CD26 and exhibit lower CD3 expression than normal T-cells.¹⁰⁹

Sézary Syndrome

The typical immunophenotype of Sézary Syndrome (SS) cells in blood includes positivity for CD2, CD3, CD4, and CD5. CD7 is expressed in only 50% of patients. Loss of CD3, CD2 and unusually bright CD5 expression has been reported.¹¹⁰ CD8 and

CD25 are usually negative. Recent studies have shown that Sézary cells have an immunophenotype characteristic for T-central memory cells (CD4+CD27+ CD26-CD45RA-). By comparison, CD4+ cells in patients with inflammatory erythroderma are CD27 negative.¹¹¹

Angioimmunoblastic T-cell Lymphoma

A predominant T-cell population is usually positive for CD2, CD4, CD5, CD7, and CD45 but negative for CD8, CD19, CD20, CD30, CD38, and CD56. Lack of one or more of the “pan-T” cell markers in a subset of T-cells may be found. Aberrant expression of CD10 in at least a fraction of CD4+ T-cell population is a characteristic feature.^{110,112}

T-cell Large Granular Lymphocyte Leukemia

Most cases of T-cell large granular lymphocyte (T-LGL) leukemia are characterized by an expansion of CD3+ CD8+ TCRαβ T-cells. Rarely CD3+CD4+ CD8+ TCRαβ or CD4- CD8-TCRγδ T-cells may be found. It has recently been shown that leukemic T-LGLs have CD3+CD8+CD45RA+ CD62L- phenotype consistent with

P.35

effector/memory RA T-cells (TEMRA). Leukemic T-LGLs often express CD57.¹¹³ Loss of CD5 and/or CD7 may occur.¹¹⁰ Correlation of the flow cytometric and molecular genetic results with the other clinical and laboratory findings is critical before the final diagnosis of T-LGL leukemia is established.¹¹⁴ The level of aberrant T-cell population $\geq 2 \times 10^9/L$ is the suggested level for diagnosis of T-LGL leukemia. However, in appropriate clinical settings lower counts ($>0.4 \times 10^9/L$) may be compatible with diagnosis.¹¹³

Chronic NK-cell proliferations are characterized by CD3-CD56+ and/or CD16+ cells¹¹³ (Fig. 2.5). Further information can be obtained by investigation of expression pattern of killer cell Ig-like receptors (KIRa, CD158) on these cells. These receptors are encoded by at least two distinct families of genes and gene products, which are members of the Ig gene superfamily.¹¹⁵ In NK-LGL, approximately one third of cases exhibit restricted expression of a single (or multiple) KIR isoform. The remaining NK-LGL cases lack detectable expression of the three ubiquitously expressed KIRs, CD158a, CD158b, and CD158e. The uniform absence of these KIRs on NK cells is aberrant because in normal NK-cell populations, there are subsets positive for each.¹¹⁶ In contrast to normal NK cells that show variable staining intensity, NK lymphoproliferations also often show uniform bright expression of CD94 exclusively paired with NKG2A to form an inhibitory receptor complex. Abnormal loss of CD161 expression is also frequent in NK-LGL.¹¹⁶

Aggressive NK-cell Leukemia

The typical immunophenotype in aggressive NK-cell leukemia is: CD2+, CD16+, and CD56+, with loss of CD7 and variable expression of CD8 and CD57, but blasts are negative for myeloid markers and CD123.^{117,118}

Hepatosplenic T-cell Lymphoma

The most common immunophenotype is CD2+, CD3+, CD4-, CD5-, CD7+, CD8-, γδ TCR+, but CD8+ positive cases do occur. Decreased expression of CD3 and/or CD7 has also been reported. Usually some NK-cell markers (CD56 and/or CD16) are present. The normal T-cell counterpart for hepatosplenic T-cell lymphoma (HSTCL) is thought to be a functionally immature cytotoxic γδ T-cell of the splenic pool with Vδ1 gene usage. A “variant form” showing αβ TCR+ and similar clinical features has been described.¹¹⁹

Immunophenotyping of Plasma Cell Myeloma

Recently, the European Myeloma Network has reported consensus recommendations about the clinical utility of FCM in multiple myeloma (MM) and other clonal plasma cell (PC)-related disorders and instructions how to apply FCM in a routine diagnostic laboratory.¹²⁰ Simultaneous assessment of the expression of CD38 and CD138 is recommended as the best combination of markers for the specific identification of BM PC, due to the bright CD38 and CD138 expression.¹²¹ It is recommended to acquire at least 100,000 “events” to ensure that at least 3,000 “events” with broad gated CD38bright/CD138+ characteristics and at least 100 PC are analyzed. At least four-color analysis panels are recommended.¹²¹ Clonality of PC should be evaluated by analysis of cytoplasmic Ig expression.¹²²

The most common aberrant features of PC in myeloma in comparison to normal PC are:

- Decreased or absent expression of CD19, CD27, CD38, and CD45
- Overexpression of CD28, CD33, and CD56
- Asynchronous expression of CD20, CD117, and sIg¹²¹

It is important to enumerate the fraction of aberrant PC within the total BM PC population because it has been shown that in most (>80%) patients with monoclonal gammopathy of unknown significance (MGUS) at least 5% of PC are normal, whereas in patients with symptomatic myeloma most PC are aberrant.¹²³ The presence of >5% normal PC in patients with symptomatic MM is of good prognostic significance and patients with MGUS or smoldering myeloma who have <5% normal PC usually rapidly progress.¹²³

Immunophenotyping of Acute Leukemia

The use of CD45/SS gating is widely used for the identification of pathologic cells in acute leukemia because blasts usually appear in a position where only few cells are located in the SS/CD45 dot plots of normal BM (Figs. 2.2 and 2.4). In rare cases CD45 is not suitable for gating purposes because of the marked heterogeneity of the leukemic population or the limited number of blasts present in the hemodiluted sample. In such cases other markers such as CD34, CD117, CD13, or CD33 may be of help. A good correlation between frequencies of blasts determined by FCM and by morphology has been reported.¹²⁴ Lower blast counts by FCM in comparison to percentages of cells with blast morphology in BM smears may be due to enrichment of blasts in BM fragments (spicules). A possible bias can also be introduced by hematopathologists who choose "representative" areas of the smear for blast counting or by a relative hemodilution of samples submitted for FCM analysis.^{46,125} In patients with $\geq 20\%$ of blasts in smears required for acute leukemia diagnosis, immunophenotyping gives information needed for lineage assignment, analysis of the degree of heterogeneity of the abnormal cell population due to either the existence of different pathologic clones or the presence of cells in different stages of maturation, and further characterization of aberrant phenotypes for MRD follow-up.

Lineage Assignment and Mixed-Phenotype Acute Leukemias

One of the major changes in the 2008 revision of the WHO classification was to simplify the definition of biphenotypic acute leukemia (BAL).¹²⁶ The new entity of mixed phenotype acute leukemias (MPAL) among leukemias of ambiguous lineage have been defined.¹²⁶ The FCM patterns observed in most cases are characterized by co-expression of the markers on the same cells. In cases of biclonal/bilineal proliferations, two different blast populations can be detected. In other cases, transitional patterns with only part of the blast population being biphenotypic can be seen.¹²⁷ For the myeloid lineage, cytoplasmic myeloperoxidase (MPO) detected by cytochemistry, or immunohistochemistry, or by FCM with an anti-MPO antibody is considered as the most significant marker. FCM allows for the detection of MPO even in some cases of minimally differentiated acute myeloid leukemia (AML) that are negative by cytochemistry.¹²⁸ It has to be pointed out that MPO positivity is not required for myeloid lineage assignment in leukemias that are not MPAL, i.e., that lack B- and T-lineage-associated markers. To establish differentiation toward monocytic lineage, which may lack MPO, the presence of nonspecific esterase by cytochemistry, or the detection of surface CD14, CD11c, CD36, CD64 or intracytoplasmic lysozyme can be used.¹²⁹ B-lineage assignment is based on CD19 expression. If the CD19 labeling is bright, the presence of another B-lymphocyte marker is considered enough to establish B-lineage. If CD19 expression is of low intensity, the presence of two other B-lineage-associated markers will be necessary. Cytoplasmic CD79a, CD22, CD24, CD10, intracytoplasmic μ chains, or (less frequently expressed in MPAL) CD20 or CD21 can be applied. The strongest marker indicating T-lineage is the

P.36

strong cytoplasmic expression of CD3. The presence of other T-cell-associated markers such as CD2, CD5 or CD7 can add to the diagnosis of MPAL, although some of these markers can be seen on myeloid cells in AML and MDS.

Acute Myeloid Leukemia

The utility of individual myeloid-associated markers (Table 2.4) for AML diagnosis is limited due to aberrant expression of these markers in many cases of ALL. Immunologic diagnosis of AML is established by expression of at least two myeloid-associated markers in the absence of criteria for diagnosis of B-ALL, T-ALL, and MPAL.¹³⁰ Immunophenotyping by FCM is especially useful in differential diagnosis between ALL and minimally differentiated AML¹³¹ and in diagnosis of plasmacytoid dendritic cell neoplasms that are characterized by coexpression of bright CD123, bright HLA-DR, CD4, CD56, and the absence of other lineage-associated markers (MPO-, cyt. CD3-, CD19-).¹³²

Characteristic antigen expression patterns have been associated with AML with recurrent chromosomal abnormalities (Table 2.9).¹³³ These patterns may help in planning directed FISH or PCR studies in cases with limited material.

TABLE 2.9 IMMUNOPHENOTYPIC PATTERNS ASSOCIATED WITH RECURRENT SPECIFIC CYTOGENETIC ABNORMALITIES IN LEUKEMIA

	Cytogenetic Abnormality	Characteristic Flow Cytometry Findings
AML	t(8;21)(q22;q22), <i>RUNX1-RUNX1T1</i>	At least a fraction of blasts with CD34 ^{bright} , often co-expressing CD19 and TdT but not CD10 Granulocytic differentiation (CD13, CD33, MPO and CD15), aberrant expression of CD56 common No monocytic differentiation
AML	Inv.(16)(p13.1q22) or t(16;16)(p13.1(q22) <i>CBF-MYH11</i>	Distinct populations of blasts, granulocytic and monocytic (CD14, CD4, CD64) precursors Co-expression of CD34 and CD64 common Eosinophils can be delineated by high SS and low FS than neutrophils and CD16 neg Often CD2 on blasts and precursors
AML	t(9;11)(p22;q23) <i>MLLT3-MLL</i>	MAb 7.1 positivity Monocytic differentiation (HLA-DR, CD4dim, CD11b, CD13, CD15, CD36, CD33, and CD64)
AML	<i>NPM1</i> mutated	Most often blasts CD34-, often HLA-DR-, CD117+, CD123+, CD33 ^{bright} , CD110+ Show granulocytic differentiation (CD15+) Monocytic differentiation in 30% of cases Some cases only CD33 ^{bright} and MPO ^{bright} with no differentiation
AML	Inv.(3)(q21;q26.2) or t(3;3)(g21;q26.2) <i>RPN1-EVII</i>	Positive for CD34, CD117, CD13, CD33, HLA-DR, and MPO
AML	t(6,9)(p23;q34) <i>DEK-NUP214</i>	CD9+, CD13+, CD33+, CD117+, and HLA-DR+, May be CD34- at presentation but CD34+ at relapse Basophils are often increased (CD123++, HLA-DR-)
AMkL	t(1;22)(p13;q13) <i>RBM15-MKLI</i>	Megakaryocytic differentiation CD41+, CD61+ often together with CD34, HLA-DR
APL	t(15;17)(q22;q12) <i>PML-RARα</i>	Hypergranular: most cases CD34-, HLA-DR-, CD11b-, CD11c-, CD117+, MPO+, CD33 ^{bright} , CD13 heterogenous, CD15- ^{dim} , Hypogranular: often CD2+, subsets positive for CD34 and/or HLA-DR present
ALL (B)	t(4;11)(q21;q23) <i>AF4-MLL</i>	CD34+, CD19+, CD10-, CD20-, CD13 and/or CD33 may be positive, often CD15 and/or CD65+, 7.1+, cyt.IgM-
ALL (B)	t(9;22)(q34;q11.2) <i>BCR-ABL1</i>	CD34++, CD19+, CD10+, CD20-/+ , CD13, CD33, CD66c often positive, CD15-, CD65-, 7.1-, cyt.IgM-
ALL (B)	t(12;21)(p12;q22) <i>TEL-AML1</i>	CD34+ or -, CD19+, CD10+, CD20-/+ , CD13, and/or CD33 often positive, CD66c-, CD15-, CD65-, 7.1-, cyt.IgM-
ALL (B)	hyperdiploid	CD34+ or subset, CD19+, CD10+++ , CD123++, CD20-/+ , CD13-, CD33-, CD66c-/+ , CD15-, CD65-, 7.1-, cyt.IgM-
ALL	t(1;19)(q23;p13.3) <i>TCF3-</i>	CD34- or subset, CD19+, CD10- or subset, CD20+, CD13-, CD33-

(B) *PBX1* CD66c-/+, CD15-, CD65-, 7.1-, cyt.IgM+
 ALL *FLT3* activating mutation Expression of CD117
 (T)

Several attempts at immunologic classification of AML have been published, however showing limited clinical utility.^{134,135} and¹³⁶ Most prognostic implications are most probably due to immunophenotypes reflecting underlying genetic aberrancies. However, due to the genetic complexity of AML clear-cut correlations are difficult to establish. Even in homogeneous and genetically not complex groups of AML categories such as AML with normal karyotype, NPM1 mutation, and lack of *FLT3* mutation, immunophenotypic heterogeneity for some markers such as CD56 expression was demonstrated.¹³⁷

In general, immunophenotypic patterns of AML (Fig. 2.4) can be described as less differentiated (blastic) or as showing signs of maturation toward one or several lineages. Consequently AML can show one single or two or more populations of malignant cells. AML showing maturation toward granulocytic lineage usually displays (at least on a fraction of cells) markers associated with myeloid immaturity (CD34 and CD117) combined with variable expression of other myeloid lineage (CD13 and/or CD33) and positivity for markers associated with granulocytic maturation such as CD15 and/or CD65 (again, at least on a fraction of cells). AMLs with myelomonocytic differentiation also display a population of cells demonstrating expression of CD14, co-expression of CD36 and CD64, or bright expression of CD33, CD4, CD11b,

P.37

and/or CD11c. By contrast, acute monoblastic and monocytic leukemias usually show a single population of aberrant cells with evidence of monocytic differentiation (bright CD36, CD64, CD14, and/or CD4), which are usually CD34 and/or CD117 positive. Positivity for megakaryocytic [CD41a, CD42b, and CD61] or erythroid lineage involvement [glycophorin A, CD36, CD71++] must be interpreted cautiously inasmuch as the possible adherence of platelets or red cell membrane fragments to the blast cells may lead to unspecific positivity and misclassification. Correlation with morphologic and immunohistochemical findings is necessary. The rare cases of acute basophilic leukemia reported have shown expression of common myeloid antigens such as CD13 and CD33, as well as CD9, CD11b, CD22, and CD123.^{138,139}

Using modern FCM, aberrant phenotypes (also called leukemia-associated immunophenotypes, LAIP) can be detected in >90% of patients with AML.^{140,141} For correct interpretation of follow-up samples and detection of MRD, the immunophenotypic pattern of diagnostic sample and thorough knowledge of immunophenotype of various cell populations in normal and regenerating BM is necessary.²⁵ Most approaches used in reported studies included construction of patient-specific panels dependent on immunophenotype at diagnosis.^{142,143,144} New 8-10 color approaches rely on common comprehensive panels applied at both diagnosis and follow-up, allowing detection of aberrant cells in most patients using sequential gating strategy.^{145,146}

Acute Lymphoblastic Leukemia

Leukemic cells in ALL clearly disclose their belonging to a B- or T-cell lineage. As in AML, specific immunophenotypes in ALL have been associated with major groups of chromosomal aberrations (Table 2.9).

B-lymphoblastic leukemia/lymphoma (or B-ALL) is characterized by expression of CD19, HLA-DR, and TdT together with several B-cell markers such as membrane and/or cytoplasmic CD22 and cyt. CD79a. In many cases, CD45 is negative. Five immunologic subtypes, roughly corresponding to sequential stages of B-cell differentiation have been recognized. However, the existence of CD10 negative normal early B-cell progenitors is controversial. B-ALL can be immunologically classified into^{130,138}:

- B I/Pro-B/Early B: CD10- CD20-, cytIgM-, sIg-
- B II/common/Early B: CD10+, CD20+/-, cyt. IgM-, sIg-
- B III/Pre-B: CD10+, CD20+/-, cyt IgM+, sIg-
- B III/Pre-B/B (very rare): CD10+, CD20+/-, cyt. IgM+, sIg+ (κ or λ-)
- B IV/B-mature: Tdt+/-, CD10+/-, CD20+, cyt. IgM-, sIg+ (κ or λ-).

T-cell lineage in T-lymphoblastic leukemia/lymphoma (or T-ALL) is established by expression of cyt. CD3, TdT,¹⁴⁷ and CD7, which is found in most cases.³⁴ Other T-cell-associated markers are variably expressed. In some cases, weak expression of cyt CD79b has been reported.¹⁴⁸ There is no clear consensus concerning immunologic classification of T-ALL. The European Group for the Immunologic Classification of Leukemia (EGIL) classification included:

- pro-T (or T-I) positive for only CD7
- Pre-T (or T-II) positive for CD2 and/or CD5 and/or CD8
- Cortical T (or T-III) positive for CD1a (irrespective of other markers)
- Mature T (T-IV) positive for surface CD3 and negative for CD1a (irrespective of other markers)¹³⁰

An early T-precursor subtype, characterized by an aggressive clinical course and carrying immunophenotype associated with early T-cell precursors (ETPs) has recently been identified.¹⁴⁹ ETPs are a subset of thymocytes that recently migrated from the BM to the thymus; they retain multilineage differentiation potential, suggesting their direct derivation from hematopoietic stem cells. The immunophenotype of ETP subtype of T-ALL includes a lack of CD1a and CD8, very weak or negative CD5, and expression of one or more early precursor or myeloid-associated markers: CD117, CD34, HLA-DR, CD13, CD33, CD11b, and/or CD65.¹⁴⁹

In >95% of both B- and T-ALL cases, leukemic blasts display aberrant immunophenotypes that allow us to distinguish them from normal B-cell precursors (Fig. 2.7) and normal bone marrow T-cells.^{34,150} MRD detection by FCM is well established and already included in some clinical trials.¹⁵¹ Characteristic immunophenotypes must be identified at diagnosis for each patient by comparing the cell marker profile of leukemic blasts to that of normal and regenerating bone marrow samples. Transient changes in immunophenotypes of residual leukemic cells have been reported, but some aberrant features are usually retained.¹⁵² Sensitivity of MRD detection at 0.01% can be achieved, provided that sufficient numbers of cells are analyzed (5 to 10×10^5) in each antibody combination.

Myelodysplastic Syndromes and Chronic Myelomonocytic Leukemia

Although several authors described various aberrant immunophenotypic features in the bone marrow of patients with MDS, the WHO 2008 classification recommended that, only if three or more phenotypic abnormalities are found involving one or more of the myeloid lineages, the aberrant FCM findings can be considered as suggestive of MDS.¹⁵³

Standardization efforts concerning FCM diagnostics in MDS were started under the auspices of the European Leukemia Network's Work Packages 8 (MDS) and 10 (Diagnostics) (www.leukemia-net.org). The report resulting from the first International Workshop on Standardization of FCM in MDS reached consensus concerning standard methods for cell sampling, handling, and processing.¹²⁵ As well, it was recommended that standards be set that would define a minimum panel of antibody combinations, which could provide effective characterization of aberrant immunophenotypes.¹²⁵ These minimal criteria have been further refined as a result of the second and third workshops.¹⁵⁴ During all three workshops it was stressed that FCM results should not be reported alone but rather as a part of an integrated MDS diagnostic approach.

A detailed knowledge of normal immunophenotypes of BM cells is necessary for evaluation of aberrant features suggestive of MDS. Findings in CMML are similar to those described in MDS, the high numbers of monocytes and monocytic precursors being the main difference. Some of most important immunophenotypic characteristics of dysplasia are summarized below.

Progenitor cells: Both lymphoid and myeloid progenitor cells are found in the CD45dim/SS low region (Fig. 2.2). A large study by Kern et al. found a very good correlation between numbers of blasts counted by morphology and FCM in MDS patients.¹⁵⁵ Several authors consider 3% of blasts as a significant limit for increased blast number in the bone marrow.¹⁵³ Regardless of the numbers, aberrant phenotypes of blasts give very important diagnostic information.¹⁵⁶ Of note, the CD34+CD38- cell population, which is responsible for the long-term repopulating activity in human stem cells⁴⁰ is often increased in MDS patients.^{43,157} This cell population has also been recognized as the leukemic stem cell compartment in acute myeloid leukemia (AML) and displays aberrant phenotypes in MDS.^{42,158}

Maturing myeloid compartment: The most consistently reported aberration of the maturing myeloid cell compartment is the lower SS that is due to lower than normal granularity seen also by morphology in BM smears. The aberrant maturation patterns detected using CD13 and CD16 and/or CD13 and CD11b MAb combinations, altered expression of CD45, CD33, asynchronous expression of CD34, expression of lineage infidelity markers such as CD2, CD7, and CD56 are the frequently reported

P.38

changes.¹⁵³ However, it has to be pointed out that various aberrant features observed in MDS patients can occasionally be found in patients with nonclonal cytopenias and some authors suggest that aberrant FCM findings in the immature precursor population are more specific for MDS than those in maturing granulopoietic cells.¹⁵⁹

Monocytes: The numbers of monocytes in BM and PB of MDS patients are usually not increased, but this population may show aberrant features in approximately 25% of patients.^{155,160} The finding of two or more aberrant features is very rare in reactive monocytes.¹⁶¹ Aberrant features described in MDS are similar to those found in CMML.¹⁶¹ Increased expression of CD56 is most frequently reported. However, this feature is not specific for MDS and could be found in 9% of patients with nonclonal cytopenia and after growth-factor treatment.^{155,161} Findings that were only rarely found in monocytes from patients with reactive monocytosis are: decreased expression of CD13, CD11b, CD43, and/or HLA-DR, and aberrant expression of CD2.^{155,162}

Erythropoietic cells: The erythropoietic fraction is often increased in MDS patients.¹⁶³ Asynchronous aberrant expression of the three markers CD71 (transferrin receptor), CD45, and CD235a (glycophorin A) was detected in 20% to 77% of MDS patients in various studies.^{38,45,155,163} The most often observed feature is a decreased CD71 expression in CD235a positive erythropoietic precursors. However, FCM signs of erythropoietic dysplasia have also been found in single patients with hemolytic anemia and aplastic anemia (AA).^{38,45}

Lymphoid Cells

B-cell lymphoid progenitors (CD19+/CD10+/CD34±) are usually markedly diminished or absent in MDS bone marrows.^{35,164,165,166,167,168} and ¹⁶⁹ This has recently been confirmed by multicenter studies, in which FCM files have been obtained using different flow cytometers and antibody combinations. Files have been analyzed in a standardized way to validate a simple model to distinguish International Prognostic Scoring System (IPSS) low-risk MDS from nonclonal cytopenias.^{168,170} Analysis of the mature B-cell compartment should be carried out to exclude underlying B-cell lymphoma.^{125,22}

Myeloproliferative Neoplasms

In chronic myelogenous leukemia (CML) reported abnormalities include aberrant expression of CD56 on blasts and myeloid cells,¹⁷¹ decreased CD16 on granulocytes,¹⁷² decreased L-(CD62L) and P-selectin (CD62P) expression on CD34+ cells,^{173,174} and aberrant expression of lymphoid antigens such as CD2, CD5, and CD7 on the blasts in CML blast crisis.¹⁷⁵ In non-CML MPN, the most common changes were aberrant expression of CD13, CD33, HLA-DR, and/or CD16 on maturing granulopoietic precursors. BM eosinophils, identified by expression of relatively bright CD11b, CD13, CD15, and CD45, without CD16, are expanded markedly in the patients with putative chronic eosinophilic leukemia. A higher rate of basophils with abnormal immunophenotype was also detected in different MPNs.¹⁷⁶

Increased CD56 expression and small size of granulocytes as measured by FS were described in primary myelofibrosis.¹⁷⁷ Increase of cells in the blast gate and emerging aberrant phenotypes in the blast population herald transformation to AML.

OTHER APPLICATIONS OF FLOW CYTOMETRY IN HEMATOLOGY

Paroxysmal Nocturnal Hemoglobinuria

FCM is a standard method for diagnosis of paroxysmal nocturnal hemoglobinuria (PNH). In PNH, the somatic mutation of the X-linked phosphatidylinositol glycan complementation Class A (PIGA) gene causes a partial or absolute inability to make GPI-anchored proteins. Antigens such as CD55, CD58, CD59, CD14, CD16, and CD24 are affected. The channel-forming toxin aerolysin and its preform pro-aerolysin bind selectively and with high affinity to GPI anchor. An inactive aerolysin variant conjugated with Alexa Fluor 488 (FLAER-A) is now widely used to detect GPI-anchor-deficient cell populations.^{178,179} Current guidelines include a combination of CD235a-FITC and CD59-PE for detection of GPI-deficient RBC, FLAER-A/CD24-PE/CD15-PECy5/CD45-PECy7 for detection of GPI-deficient granulocytes, and FLAER-A/CD14-PE/CD64-PECy5/CD45-PECy7 for GPI-deficient monocytes¹⁸⁰ (Fig. 2.8). High-resolution assays allow detection of GPI-deficient RBC at sensitivity level 10^{-5} and GPI-deficient WBC at 10^{-4} ,¹⁸⁰ which has been noted in patients with aplastic anemia and MDS.

Red Blood Cell Analysis

Clinical application of FCM to study erythropoiesis and nonclonal RBC disorders has been reviewed by Chesney et al.¹⁸¹ Enumeration of reticulocytes and detection of hemoglobin F (HbF) positive erythrocytes are briefly summarized below.

Reticulocyte Enumeration

Several RNA dyes may be applied in hematology analyzers and flow cytometers to enumerate reticulocytes (e.g., Oxazine 750, CD4K 530, New Methylene Blue, Auramine O, and Thiazole Orange [TO]). Dyes show differing sensitivities to stain the RNA of reticulocytes. Various analyzers use different technologies to identify positive cells (fluorescence, light scattering, absorbance), and the software that is more or less capable of separating reticulocytes from erythrocytes (because there is

a physiologic continuum between these populations) and from other cells, such as platelets or nucleated RBCs.¹⁸² Fluorescence intensity will depend on the RNA content and is correlated to reticulocyte maturity. The immature reticulocyte fraction (the sum of reticulocyte fractions with medium and high fluorescence) gives information on activity of erythropoiesis.¹⁸³ TO can also be applied together with CD59-PE for detection of GPI-deficient reticulocytes, which may be of advantage in transfused PNH patients.¹⁸⁴

Hemoglobin F (Fetal-Maternal Hemorrhage and Sickle Cell Anemia)

Fetal-maternal hemorrhage from a rhesus factor positive (Rh+) fetus to an Rh-mother may lead to immunization of the mother against fetal alloantigens. Therefore, standard clinical practice is to administer Rh immune globulin to all Rh-women at 28 weeks of gestation and within 72 h of delivery of an Rh+ infant. Measurement of the amount of HbF in the maternal circulation helps to determine the amount of Rh immune globulin to administer. FCM method for fetal-maternal hemorrhage detection uses a fluorochrome conjugated anti-HbF MAb to detect HbF inside permeabilized RBCs.¹⁸⁵ Weakly positive red cells (termed F cells) may be found in genetic disorders such as hereditary persistence of fetal hemoglobin (HPFH), sickle cell anemia, and thalassemia major. In patients with sickle cell anemia treated with hydroxyurea, monitoring the percentages of F cells can be applied to determine treatment efficacy.¹⁸⁶

Fetal cells can be distinguished from F cells by much higher fluorescence intensity. Adequate gating is necessary to determine the percentage of fetal cells in the mother's RBCs, where only the "bright" cluster is considered as fetal cells. In order to determine the quantity of fetal hemorrhage (in ml of fetal blood) the percentage of fetal RBC is multiplied by a factor of 50 (assuming that maternal blood volume is 5.0 L).¹⁸¹

P.39

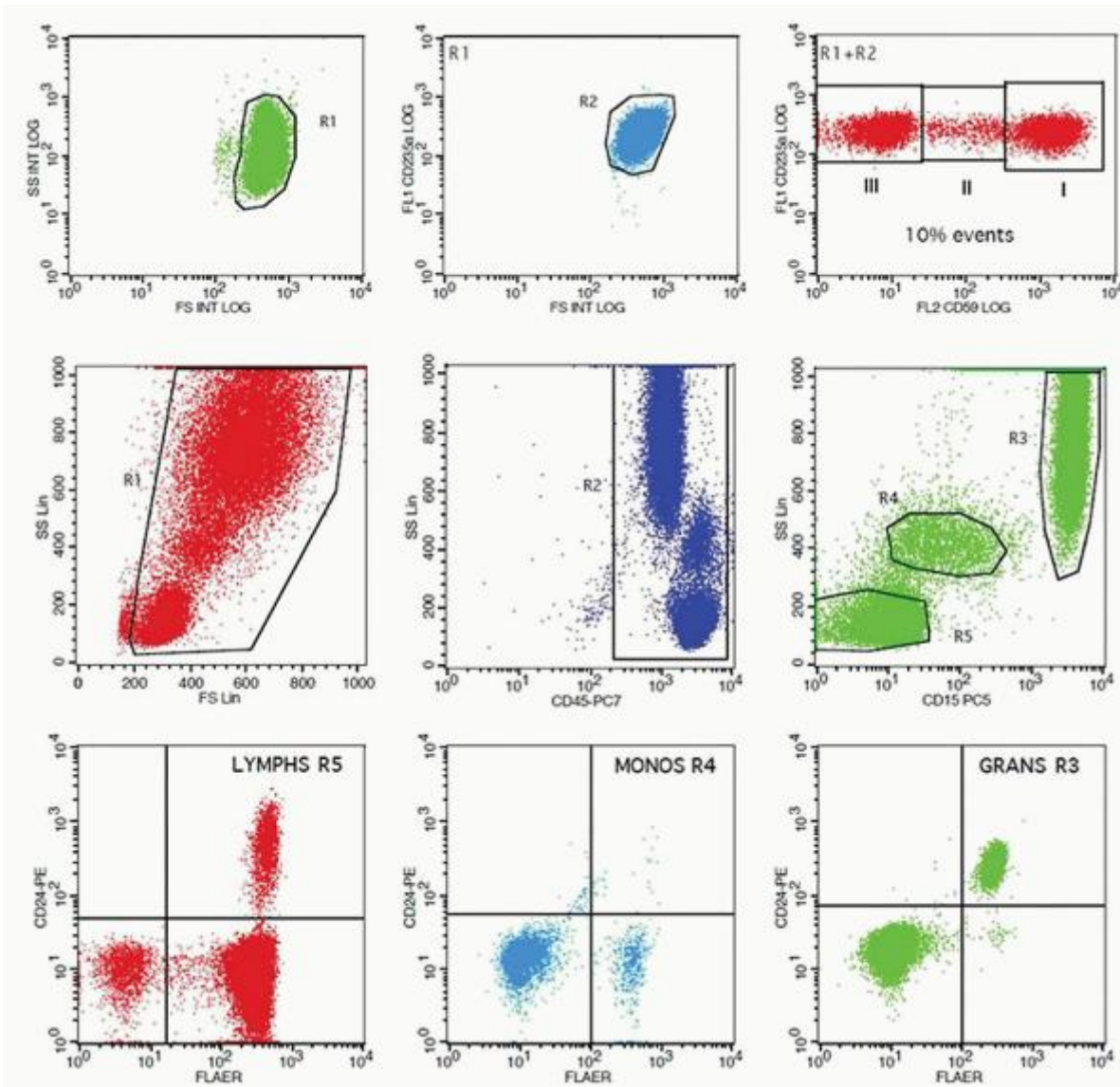

FIGURE 2.8. Enumeration of blood for markers associated with paroxysmal nocturnal hemoglobinuria (PNH). Upper row: the red blood cell (RBC) assay using CD23a-FITC/CD59-PE staining. RBCs are gated on FS and SS (R1, Upper left plot) and displayed on FCS versus CD235a-FITC plot (upper middle). CD235a positive RBCs are gated (R2). RBCs from region R1 + R2 are analyzed for CD59 expression (right upper plot). Normal RBCs (CD59 bright) are in region I. RBCs with PNH-related phenotypes (i.e., with CD59dim expression or CD59 negative) are in regions II and III, respectively. Middle and lower row: white blood cell (WBC assay) using staining with FLAER, CD24PE, CD15PECy5, and CD45PECy7. Light scatter voltages were established so that all nucleated cells were visible above the forward scatter threshold (middle left) and debris was excluded with a combination of light scatter and CD45 gating (middle plot). CD45+ events were displayed on CD15 versus SS plot (middle right plot) and granulocytes (bright CD15, high SS), monocytes (dim CD15 and intermediate SS) and lymphocytes (CD15-negative, low SS) were gated. Each of these populations was displayed on a FLAER versus CD24 plot (bottom row). PNH granulocytes (FLAER-negative, CD24-negative) were enumerated in the bottom right plot (lower left quadrant). Normal granulocytes were enumerated in the upper right quadrant. Gated monocytes were similarly displayed (bottom row middle) and the PNH monocytes (FLAER-negative, CD24-negative) were enumerated in the lower left quadrant. Gated lymphocytes (bottom row left) were assessed for PNH phenotypes in the lower left quadrant. Normal T-lymphocytes (FLAER+, CD24-negative) are visible in the lower right quadrant and normal B-lymphocytes (FLAER+, CD24+) are visible in the upper right quadrant. (Courtesy of Dr. D. Robert Sutherland, Laboratory Medicine Program, University Health Network, Toronto General Hospital, Toronto, Ontario, Canada.)

Analysis of Platelets

FCM analysis of platelets is usually performed on whole blood drawn into 3.2% to 3.8% citrate anticoagulant. Other anticoagulants can also be applied for platelet enumeration but EDTA and heparin are not recommended for analysis of platelet activation or activity due to interference with glycoprotein (GP) IIb-IIIa complex. Blood samples should not be subjected to cold and should be processed within 15 min of drawing. Platelets can be

P.40

differentiated from other blood cells by their FS and SS properties and/or expression of platelet-specific antigens (e.g., CD41, CD42, or CD61). FCM analysis of platelets can help to establish a diagnosis of specific platelet disorders (reviewed in Ref. 187) such as:

- Bernard-Soulier syndrome, inherited deficiency of the GPIb-IX-V complex, where decreased expression of GPIb (CD42b), GPIX (CD42a), and GPV (CD42d) is noted
- Glanzmann thrombasthenia, inherited deficiency of integrin $\alpha\text{IIb}\beta_3$, where aberrant expression of CD41 (GPIIb) and CD61 (GPIIIa) is found
- Dense granule storage pool deficiency can be detected by studying uptake and release of mepacrine as fluorescent marker¹⁸⁸
- von Willebrand disease where the FCM method is used for the determination of the von Willebrand factor (VWF) activity, utilizing formalin-fixed platelets, FITC-conjugated chicken anti-VWF antibodies (Fab-fragments), and PE-conjugated anti-GPIIb/IIIa antibodies.¹⁸⁹

Immature platelets (also called reticulated platelets) may be identified using TO dye. This method can be applied to differentiate regenerative versus nonregenerative thrombocytopenia and assess regeneration after BM transplant.¹⁹⁰

Several antibodies bind to activated but not to resting platelets (activation-dependent antibodies). Markers of platelet activation include PAC1 (detecting conformational changes in integrin $\alpha\text{IIb}\beta_3$), CD62P (P-selectin), and formation of platelet-derived microparticles (PMPs). Measurements of platelet activation by FCM may assist in diagnosis and treatment of acute coronary syndromes, acute cerebrovascular ischemia, and several other conditions. Studies of platelet activation have also been widely employed in monitoring of specific anti-platelet therapies (reviewed in Ref. 187).

Heparin-induced Thrombocytopenia

Heparin-induced thrombocytopenia (HIT) is a rare but potentially serious complication of heparin use. Prompt diagnosis is crucial and requires the integration of clinical assessment and laboratory testing. FCM detection of leukocyte-platelet aggregates (defined as events positive for both the presence of CD45 and platelet glycoprotein IIb) as a marker of platelet activation with different heparin concentrations, using plasma from HIT-positive patients detected leukocyte-platelet aggregates in 75% of HIT-positive patients, and correlated with levels of anti-H-PF4 antibodies. An FCM-based platelet microparticle generation assay as a marker of platelet activation in HIT has also been described. Platelet microparticles ranged in size from 0.5 to 1.0 μm , and were also defined by the expression of platelet glycoprotein Ib, CD41, and annexin V. However, another FCM-based functional assay measuring CD62 has been reported as a more reliable marker of platelet activation as a result of the presence of pathogenic H-PF4 antibodies than the procoagulant phospholipid annexin V (reviewed in Ref. 191).

STEM CELL TRANSPLANTATION

CD34+ Cell Enumeration

Enumeration of CD34+ cells is an essential tool for peripheral blood stem cell (PBSC) harvest, providing a rapid assessment of graft adequacy.¹⁹² Most transplant centers determine graft adequacy based on the number of CD34+ cells/Kg of patient body weight. Mobilization of PBSC is typically done using granulocyte colony stimulating factor (G-CSF) alone or in combination with chemotherapy. Peripheral blood (PB)-CD34+ counts have been shown to correlate with PB-CD34 apheresis collections and have been utilized to decide when apheresis should start. Mobilization success is influenced by several factors such as prior therapy, mobilization strategy, and underlying disease. Clinical guidelines for CD34+ cell quantitation in peripheral blood and PBSC for the International Society for Hematotherapy and Graft Engineering (ISHAGE) based CD34+ cell enumeration on four parameters: FS, SS, CD45, and CD34 staining intensity.¹⁹³ A viability dye 7-amino actinomycin D (7-AAD) and fluorescent counting beads were subsequently added to create a single platform assay (Fig. 2.9) and to avoid potential calculation errors from using FCM and hematology analyzer.¹⁹⁴ UK-NEQUAS surveys showed that methodology is still in need of standardization and that several laboratories did not perform the gating correctly.¹⁹⁵

New flow cytometers allowing direct volumetric cell analyses (CD34+ cells/ μ L) and quantitation without the need of the beads has recently been introduced and shown to give comparable results as the standard single platform protocol.¹⁹⁶

Human Leukocyte Antigen Antibody Detection

The primary goal of human leukocyte antigen (HLA) antibody testing for transplant patients is to assess potential risk for graft rejection. The selection of a matched donor and appropriate post-transplant treatment is determined by patient HLA antibody status. Post-transplant formation of antibodies against HLA Class I and II antigens heralds graft rejection. FCM cross-match (FCXM), introduced in the 1980s, involves incubation of purified donor mononuclear cells with the patient's serum and subsequent detection of cell-bound antibodies by fluorochrome-conjugated antihuman Ig serum (reviewed in Ref. 197). By varying the type of secondary antibody, the isotype of antibody (IgG, IgM, or IgA) can be determined, and by adding MAbs to B- and T-associated markers, reactivity in B- and T-lymphocytes can be evaluated separately.

Solid-phase immunobinding assays utilized purified HLA proteins as targets. Beads that can be identified by a unique level of fluorescence are coated with HLA class I or II proteins to create a screening pool of HLA antigens. By using multiple different phenotypes distributed over several arrays, patient-specific HLA specificities can be determined (reviewed in Ref. 197). However, these assays are every cumbersome and require up to 15 tubes per patient. Recently, a new type of FCM platform (Luminex Corp, Austin, TX, USA) has been developed that allows up to 100 individual beads to be evaluated in a single multiplexed assay. Each bead has a unique fluorescent signature and is coated by a different antigen. A PE-conjugated antihuman IgG is used to detect the binding of patient serum to the beads. However, a fraction of patients display very broadly reactive HLA antibodies making all beads positive. Introduction of recombinant technology and coating the beads with single HLA antigens make it possible to clearly delineate the antibody reactivity of each patient (reviewed in Ref. 197). Combination of the highly sensitive antibody assessment with FCXM contributes to better selection of donor/recipient pairs and better transplant outcomes.

SOME APPLICATIONS OF FLOW CYTOMETRY IN IMMUNODEFICIENCY, AUTOIMMUNE, AND INFECTIOUS DISEASES

Primary Immunodeficiency Diseases

Over 200 primary immunodeficiency diseases (PIDs) have been clinically identified.¹⁹⁸ The majority of PIDs have an abnormality that could be detected by FCM assay, such as:

- Mutations in genes that affect the relative representation of a specific cell subset

P.41

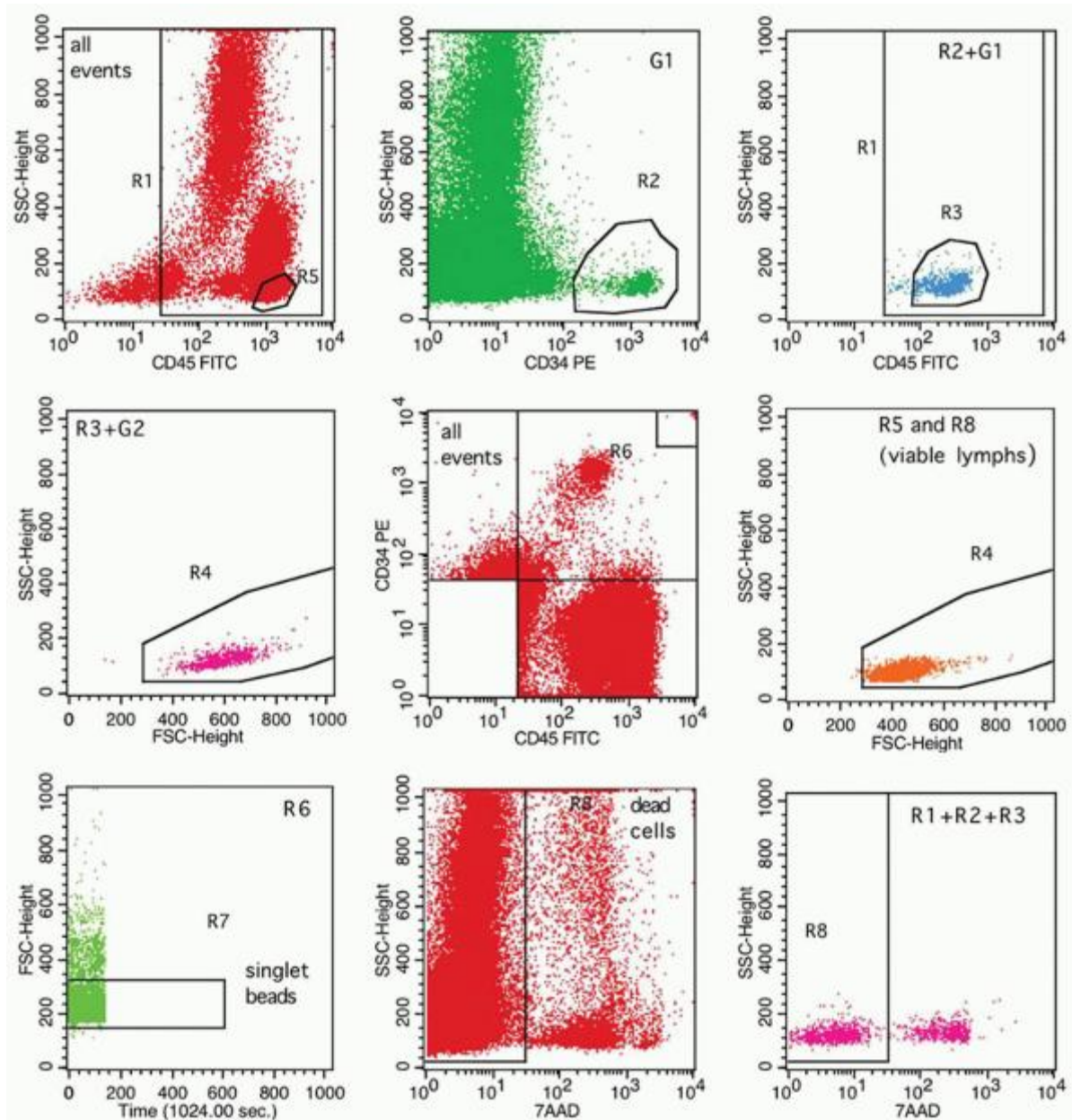

FIGURE 2.9. Enumeration of viable CD34+ cells according to ISHAGE protocol. An apheresis sample that had been stored overnight at room temperature was stained with the Stem-Kit reagent set and analyzed on a BD Biosciences FACSCalibur cytometer equipped with CellQuest™. Viable CD34+ cells were identified using Boolean gating and regions R1 through R4 (all upper plots and left middle row plots), including only viable (7-AAD-) cells from region R8 (right lower row plot). Viable lymphocytes from region R5 (left upper plot) and R8 are displayed on left middle plot and the duplicate blast-lymphocyte region R4 adjusted to include the smallest viable lymphocytes. Duplicate gating region R4 on plot 4 self-adjusts accordingly. Middle plot shows the position of a “live” gate in the bottom left corner, which excludes debris resulting from lyse-no-wash sample processing of PB, CB, and BM sample types. The number of CD34+ cells in region R4 is compared with the total number of singlet beads counted during the same acquisition and present in the same listmode file. In the example shown, total beads are gated in region R6 in the middle plot and displayed in the left lower plot (time versus forward scatter). Singlet beads are then delineated and enumerated in gating region R7. Sample analysis was performed using Cellquest Pro™ software using semi-automated Expression Editors. For earlier versions of Cellquest, the absolute number of viable CD34+ cells/ μl is calculated as follows:

$$\frac{\#CD34 + \text{ cells} \times \text{ bead concentration} \times \text{ DF}}{\# \text{ singlet beads}}$$

where #CD34+ cells are determined from logical gate G4 (vCD34 in gate stats = R1+R2+R3+R4+R8), the bead concentration is specified by the manufacturer, DF is the sample dilution factor, and the singlet bead count is determined from plot 7 (singlet beads in gate stats = R6 + R7). The right lower plot shows the total CD34+ cells (viable and nonviable) from gating regions R1 + R2 + R3 only and shows viable cells onscale in about the first decade of fluorescence. This plot is useful when samples with poor viability are to be analyzed as it is easier to set region R8 in this plot versus the middle lower plot. Additionally, it shows that the fluorescence compensation between PMT 2 (CD34PE) and PMT 3 (7-AAD) is optimally set. (Courtesy of Dr. D. Robert Sutherland, Laboratory Medicine Program, University Health Network, Toronto General Hospital, Toronto, Ontario, Canada.)

P.42

- Mutations in genes that affect the expression of a specific antigen
- Mutations in genes that affect a particular cell function

Routine immunophenotyping of blood lymphocyte subsets, detection of CD154 up-regulation, and oxidative burst assay for the screening diagnosis of granulomatous diseases are most commonly employed FCM assays in PID diagnosis (reviewed in Ref. 199). FCM findings in the most common PID categories are summarized in Table 2.10 (reviewed in Ref. 200).

Flow Cytometry Detection of HLA-B27

HLA-B27, an MHC class I molecule is related to a major risk factor for a group of diseases now called spondyloarthritis that consists of psoriatic arthritis, reactive arthritis, arthritis related to inflammatory bowel disease, a subgroup of juvenile idiopathic arthritis, and ankylosing spondylitis [the prototype of spondyloarthritis²⁰¹]. This association is present in many genetically diverse populations and across all major HLA-B27 subtypes.

The presence of HLA-B27 in 80% to 90% of patients with ankylosing spondylitis and the spontaneous spondyloarthritis-like disease in HLA-B27 transgenic rats suggests a direct and dominant effect of the gene encoding this molecule. However, only a small proportion of people in the general population who harbor HLA-B27 (5% to 6% in Caucasians) develop ankylosing spondylitis, and HLA-B27 explains only 20% to 40% of the genetic susceptibility to ankylosing spondylitis, suggesting the contribution of additional genes. Genomewide association studies (GWASs) have allowed the identification of several of these additional genes. HLA-B27 typing using MAbs and FCM analysis of their reactivity in a gated T-cell population is used extensively. However, the cross-reactivity of anti-“B27” murine MAbs, particularly with the common HLA-B7 antigen has been a problem. Recently a one-tube test, employing two “B27” MAb reagents, has been developed.²⁰² This test securely detects the HLA-B*27 allele product B*2705, B*2702, and B*2708 and reacts with many of the other rare B*27 allele products tested. In addition, other HLAB antigens, notably HLAB7, do not interfere with accurate HLA-B27 assignment. However, even when using the recommended dual anti-B27 typing reagents, patients reacting with one antibody only should be retested using a DNA-based technique.

TABLE 2.10 FLOW CYTOMETRY (FCM) IN THE DIAGNOSIS OF MAJOR PRIMARY IMMUNE DEFICIENCY

Primary Immune Deficiency Type	FCM Findings
Congenital agammaglobulinemia X-linked (XLA)	Absence (or very low numbers) of CD20+ and/or CD19+ B-lymphocytes Absence of intracellular Bruton tyrosine kinase (BTK) in monocytes and platelets
Common variable immunodeficiency (CVID)	Expansion of CD21 ^{low} B-cells Absence of memory switched B-cells

	Lack of inducible costimulator (ICOS) up-regulation on T-cells following activation
	CD19 deficiency (in presence of CD20)
	B-cell activating factor-receptor (BAFF-R) deficiency
Severe combined immune deficiency (SCID)	Wide range of defects: Adenosine deaminase deficiency: lack of T-, B-, NK-cells Janus kinase 3 deficiency: lack of T- and NK-cells RAG1/2 deficiency: lack of T- and B-cells CD3 δ , ϵ or ζ deficiency: lack of T-cells
Hyper IgM syndromes	Decrease of CD40 and/or CD40 ligand (CD154) expression on activated CD4+ cells
Wiscott Aldrich syndrome (WAS)	Decrease of CD8+ cells and increase of NK-cells Decreased expression of WAS protein
Defects in the interleukin-12/23-Interferon γ circuit	Aberrant expression of IL-12 receptor β 1 and interferon (IFN)- γ receptor 1
Toll-like receptor pathway defects	Absence of shedding of CD62L from the surface of granulocytes
Chronic granulomatous disease	Low results of nicotinamide adenine dinucleotide phosphate (NADPH) oxidase activity assay following granulocyte activation
Leukocyte adhesion deficiency type 1 (LAD1)	Decreased or absent CD11a, CD11b, CD11c, and CD18 on granulocytes
Immune dysregulation, polyendocrinopathy, enteropathy, X-linked inheritance syndrome	Decreased/absent factor forkhead box protein 3 (FOXP3) expression in T-cells
Autoimmune lymphoproliferative syndrome	
Elevated levels of CD4-CD8- (double negative) T-cell receptor α/β positive T-cells	
Low memory B-cells (CD20+CD27+)	
Increased CD8+CD57+ T-cells	
X-linked lymphoproliferative syndrome	Very low numbers of NK T-cells CD3+CD16+CD56+V α 24+V β 11+ Decreased/absent signaling lymphocyte activation molecule (SLAM)-associated protein (SAP) or X-linked inhibitor of apoptosis (XIAP) protein
Familial hemophagocytic lymphohistiocytosis	Defects in expression of perforin, syntaxin-11 Diminished expression of CD107 on NK-cells
Human Immunodeficiency Virus Infection	

FCM studies provide important clinical information that helps predict disease outcome and guide treatment decisions in HIV+ patients. CD4+ T-cell counts are, together with viral load, the strongest predictors of disease progression. Single platform technology (SPT) is designed to enable determinations of both absolute and percentage lymphocyte subset values using a single tube. Previously, most absolute T-cell numbers were derived from three measurements determined with two different instruments, a hematology analyzer and a flow cytometer (dual-platform technology [DPT]). A gating strategy for identifying lymphocytes using CD45 fluorescence and side-scattering characteristics is now the preferred method for identifying lymphocytes. The preferred

P.43

four-color panel includes CD45, CD3, CD4, and CD8. Commercial bead-counting reagents for SPT have resulted in decreased interlaboratory variability. A single tube model can easily be employed even in countries with limited resources.²⁰⁰

However, CD4+ T-cell counts do not fully capture an individual's risk for disease progression. A substantial proportion of patients with more than 350 CD4+ T-cells/ μL in blood (the current threshold for treatment initiation) will progress to AIDS within only 3 years. Only a few markers that could identify, early in disease, more HIV+ individuals at risk for rapid disease progression have been reported. For example, in the setting of early HIV disease, the ability of Ki-67 to predict disease progression independently of CD4+ T-cell count or viral load was recently recognized. Similarly, in the setting of chronic infection, CD38 expression is a CD4 count- and viral load-independent predictor of disease outcome (reviewed in Ref. 203). FCM studies have greatly contributed to the understanding of HIV pathogenesis. Coreceptors for the virus have been identified: CCR5 in memory T-cells and CXCR4 in CD4+ T-cells. Loss of CD4+ cells is accompanied by T-cell activation (shown by expression of CD38, HLA-DR, and CD69) and by an increase of senescent CD8+ cells (CD28-) with high cytolytic activity (CD57+, perforin+). Naive and central memory T-cells are progressively depleted (reviewed in Ref. 203).

Analysis of Antigen-Specific T-cells

FCM detection of antigen-specific T-cells became possible by the development of fluorochrome-labeled MHC-peptide complex (so-called tetramers) technology. MHC class I tetramers usually consist of four MHC class I glycoproteins loaded with peptide and labeled with streptavidin bound to a fluorochrome (reviewed in Ref. 204). During incubation with the lymphocytes, the tetramer will bind to CD8+ T-cells that express a T-cell receptor capable of recognizing the specific peptide. MHC class II tetramers are more difficult to produce but have also been developed and applied to study CD4+ cell responses (reviewed in Ref. 205).

At present, standardized FCM methodology has a detection limit of 0.02% specific CD8+ cells in blood, mostly used in vaccine studies. Magnetic bead enrichment using beads coated with antibodies to fluorochrome (mostly PE) has been employed to reach higher sensitivity.

Tetramer technology is also used in functional assays to study proliferation of epitope-specific T-cells or for analysis of T-cells responding to viruses or vaccines. Tetramer-positive T-cell subset analysis is used to determine the quality of the T-cell response and to sort antigen-specific T-cells (reviewed in Ref. 204).

CELLULAR DNA CONTENT AND CELL CYCLE ANALYSIS

FCM methods for measuring DNA content rely on cells being labeled with a fluorochrome that is expected to stain DNA stoichiometrically and the intensity DNA associated fluorescence is obtained. Staining of live cells (so-called supravital staining) is used mainly for cell sorting based on their DNA content. A variety of methods for FCM DNA analysis of fixed cells has been reported, differing in cell permeabilization, choice of fluorochrome, and applicability to different cell populations.²⁰⁶ In general, precipitating fixatives (alcohols, acetone) are preferred over cross-linking reagents (formaldehyde, glutaraldehyde). The most commonly used fluorochromes are DAPI, PI, and 7-AAD (Table 2.1). Staining with PI required pre-incubation with RNA-se to digest RNA; RNA-se should be free of DNA-se activity. The method of isolating nuclei from paraffin-embedded tissue can be applied to determine DNA ploidy and cell phase in archival material.²⁰⁷ The results of cellular DNA content are presented in the form of frequency histograms (Fig. 2.10). The DNA analysis software allows estimation of the percentage of cells in the G1, S, and G2/M phase of the cell cycle as well as the frequency of apoptotic cells with fractional (sub-G1) DNA content (reviewed in Ref. 208). Before DNA content is analyzed, cell aggregates have to be removed from the analysis window by gating single cells on FL-width versus FL-area plots (Fig. 2.10).

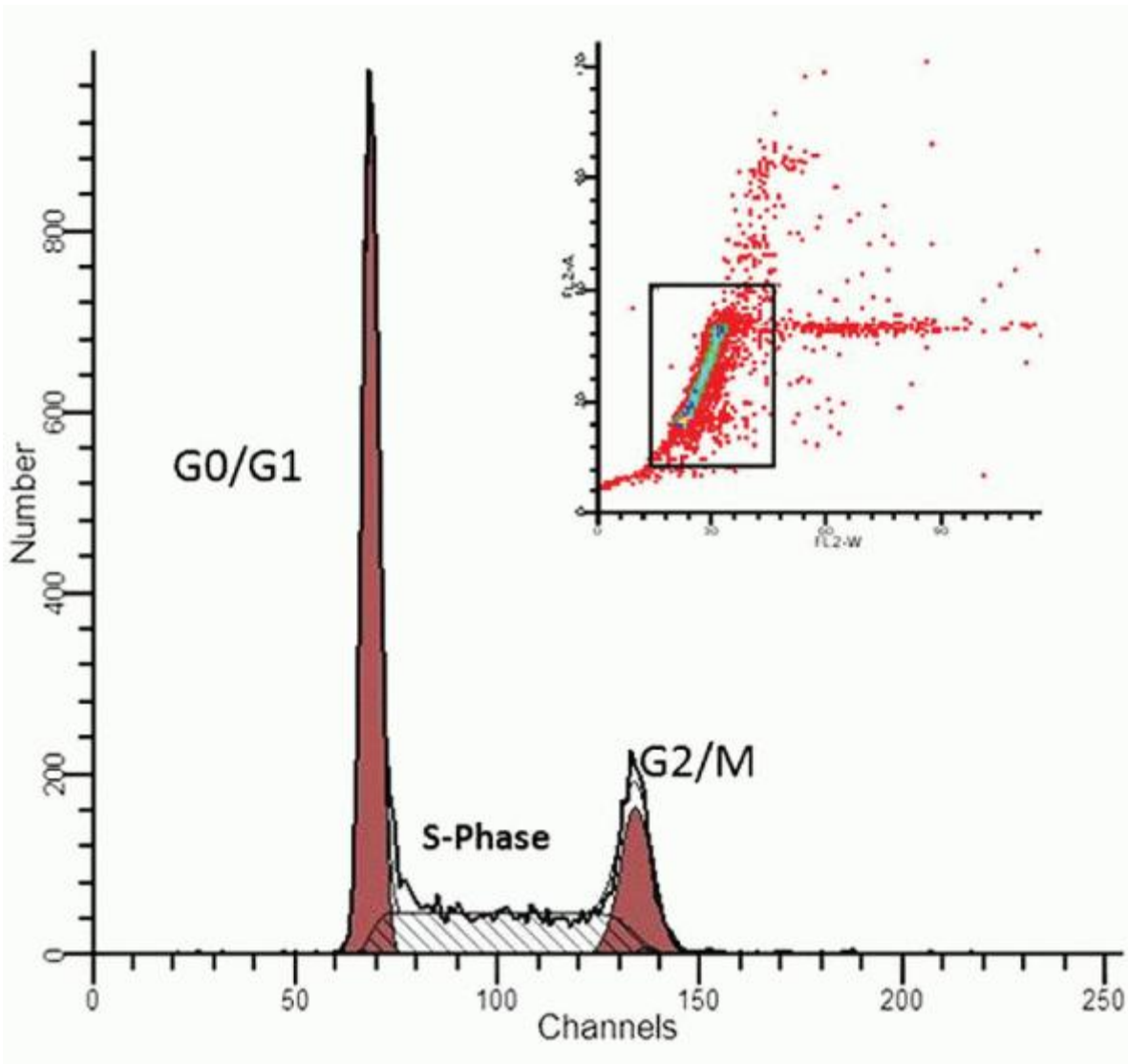

FIGURE 2.10. Schematic presentation of DNA analysis using DNA fluorochrome. Frequency of cells in G0/1, S, and G2/M phases can be determined. Insert shows gating of single cells using FL-W versus FL-A plot.

DNA staining can be combined with immunophenotyping by labeling of live cells with a fluorochrome-conjugated MAb and supravital DNA staining or subsequent short fixation in 0.5% to 1% paraformaldehyde in PBS before DNA fluorochrome is applied. During analysis, cell populations of interest can be evaluated separately for DNA content after appropriate gating procedures.²⁰⁸

In hematology and oncology, estimation of cell fractions in the proliferation phase and DNA ploidy are frequently assessed. For ploidy assessment, the ratio of peak channel of DNA fluorescence of G0/1 population of the tumor and that of normal cells is established (sc. DNA index, DI). Normal lymphocytes from the same patient are often used as the standard of DI = 1.0.

In hematology, DNA ploidy studies by FCM have determined prognosis in B-ALL and plasma cell myeloma. In ALL, DI \geq 1.16, so-called hyperdiploidy, is of favorable significance, whereas hypodiploidy (DI > 0.9) is related to a worse response to treatment.²⁰⁹ In myeloma, hyperdiploidy is related to a better response to bortezomib treatment.²¹⁰

Analysis of DNA replication was at first performed using direct incorporation of ^3H - or ^{14}C -labeled thymidine, and ^3H -uridine incorporation was used for RNA content. Incorporation of 5-bromo-2-deoxyuridine (BrdU) was subsequently applied, based on quenching of Hoechst 33358 fluorescence by BrdU. Distribution of BrdU containing cells through the cell cycle was studied by combining Hoechst 33358 with BrdU-resistant dye such as ethidium bromide or with mithramycin. Recently introduced, the so-called "click chemistry" approach allows measuring DNA synthesis and RNA replication simultaneously, by applying 5-ethyl-2'-deoxyuridine as a DNA precursor and 5-ethyluridine as an RNA precursor. These

precursors can be detected with fluorochrome-tagged azides by means of a copper(I) catalyzed [3 + 2] cycloaddition reaction (reviewed in Ref. 206).

P.44

FUNCTIONAL ASSAYS

Monitoring of Cytokine Profiles

Current FCM technologies allow the simultaneous quantification of multiple cytokines with characterization of cytokine-producing cell subsets. Antibodies to studied cytokines can be combined with lineage markers such as CD4, CD8, CD3, and/or memory/effector phenotype markers such as CCR7, CD57, CD27, or CD45RO.

Intracellular cytokine assays are usually performed after short-term stimulation required for induction of cellular activation and cytokine production. Cytokines can be detected after secretion inhibitors such as monensin or brefeldin are applied, and proteins are retained intracellularly. Intracellular staining is performed after fixation and permeabilization (reviewed in Ref. 211). One of the clinical applications includes monitoring of IFN- γ and tumor necrosis factor (TNF)- α producing CD3+ T-cells in aplastic anemia patients under immunosuppressive therapy.²¹²

Multiplex cytokine bead arrays are used to quantify soluble plasma cytokines (e.g., Luminex technology). Distinct cytokine profiles were detected allowing differentiation between patients with aplastic anemia and hypoplastic MDS.²¹³ Very high levels of several cytokines were detected with Luminex methodology in children with anaplastic large cell lymphoma by comparison to other non-Hodgkin lymphoma subtypes.²¹⁴

Protein Phosphorylation

The use of phospho-specific antibodies allows detection of the transient alterations induced by kinases and phosphatases involved in cell signaling. Phosphorylation refers to the addition of a phosphate to one of the amino acid side chains of a protein. Many of the proteins that are phosphorylated upon reception of a signal are protein kinases as well. This organization of kinases produces a phosphorylation cascade, in which one protein kinase is activated by phosphorylation upon reception of a signal; this kinase then phosphorylates the next kinase in the cascade. However, FCM methodology to detect phosphorylation is considered challenging and has not been, as yet, widely introduced for clinical use (reviewed in Ref. 215). Signaling responses have to be determined by comparing the basal level to the activated state of the enzyme. Often, multiple growth factors have to be applied for studies of activation (e.g., SCF and FLT3 for the extracellular signal-regulated kinase [ERK] pathway) and inhibitors are used for appropriate controls (e.g., MEK inhibitor U0126 for the ERK pathway). An appropriate fixation and permeabilization protocol has to be applied, depending on the studied protein. Responses are usually transient and the time-point of measurement is crucial. A high level of consistency in experimental procedures is needed (reviewed in Ref. 215). An example of clinical use is measuring of levels of the phosphorylated signal transducer and activator of transcription (STAT) 5 (P-STAT5) in CML patients. P-STAT5 levels are increased in most untreated CML patients but decrease upon BCR/ABL1 kinase inhibitor treatment.²¹⁶

Apoptosis

Apoptosis (or programmed cell death) plays an essential role in the survival of the organism and is considered to be an imperative component of various processes including normal cell turnover, proper development and functioning of the immune system, multiplication of mutated chromosomes, hormone-dependent atrophy, normal embryonic development, elimination of indisposed cells, and maintenance of cell homeostasis. The importance of apoptosis has prompted development of FCM assays capable of measuring this process. FCM methods employed in apoptosis research include (reviewed in²¹⁷:

- Detection of scatter changes corresponding to cell shrinkage (lower FS and unchanged or increased SC in early phase, and low FS and SC in late phase)
- FCM detection of mitochondrial inner transmembrane potential ($\Delta\pi_m$) loss using lipophilic cationic probes [e.g., Rh123 or DiOC₆(3)] that are readily taken up by live cells and accumulate in mitochondria
- FCM detection of caspase activation using fluorochrome-labeled inhibitors of caspases (FLICA) or detection of cleavage of poly ADP ribose polymerase (PARP) using an antibody that recognized 89-kD product of cleavage
- FCM detection of changes in the plasma membrane during apoptosis using fluorochrome-labeled Annexin V that binds to exposed phosphatidylserine on the cell surface

- FCM detection of changes in plasma membrane permeability
- FCM detection of nuclear fragmentation using sub-G0 fraction in DNA analysis or assessment of DNA strand breaks by TdT-mediated dUTP-biotin nick-end labeling (TUNEL)
- Gradual decrease of cyanine SYTO staining in apoptotic cells

Since Apoptosis is a rapid process, knowledge of the timewindow when specific markers can be detected is crucial. Moreover, antigen loss often occurs at early stages of apoptosis, causing problems in immunophenotyping apoptotic cells.

REFERENCES

1. Caspersson TO. History of the development of cytophotometry from 1935 to the present. *Anal Quant Cytol Histol* 1987;9(1):2-6.
2. Shapiro HM. The evolution of cytometers. *Cytometry A* 2004;58(1):13-20.
3. COONS AH. The beginnings of immunofluorescence. *J Immunol* 1961;87: 499-503.
4. Graham MD. The Coulter Principle: foundation of an industry. *J Lab Autom* 2012;8:72-81.
5. Fulwyler MJ. Electronic separation of biological cells by volume. *Science* 1965;150(3698):910-911.
6. Hulett HR, Bonner WA, Barrett J, Herzenberg LA. Cell sorting: automated separation of mammalian cells as a function of intracellular fluorescence. *Science* 1969;166(3906):747-749.
7. Orfao A, Ruiz-Arguelles A, Lacombe F, Ault K, Basso G, Danova M. Flow cytometry: its applications in hematology. *Haematologica* 1995;80(1):69-81.
8. Orfao A, Ortuno F, De SM, Lopez A, San MJ. Immunophenotyping of acute leukemias and myelodysplastic syndromes. *Cytometry A* 2004;58(1):62-71.
9. Pedreira CE, Costa ES, Almeida J, et al. A probabilistic approach for the evaluation of minimal residual disease by multiparameter flow cytometry in leukemic B-cell chronic lymphoproliferative disorders. *Cytometry A* 2008;73A(12):1141-1150.
10. Cherian S, Levin G, Lo WY, et al. Evaluation of an 8-color flow cytometric reference method for white blood cell differential enumeration. *Cytometry B Clin Cytom* 2010;78(5):319-328.
11. Chattopadhyay PK, Perfetto SP, Roederer M. The colorful future of cell analysis by flow cytometry. *Discov Med* 2004;4(23):255-262.
12. Tung JW, Heydari K, Tirouvanziam R, et al. Modern flow cytometry: a practical approach. *Clin Lab Med* 2007;27(3):453-468, v.
13. Cunningham RE. Overview of flow cytometry and fluorescent probes for cytometry. *Methods Mol Biol* 1994;34:219-224.
14. Davis BH, Holden JT, Bene MC, et al. 2006 Bethesda International Consensus recommendations on the flow cytometric immunophenotypic analysis of hematolymphoid neoplasia: medical indications. *Cytometry B Clin Cytom* 2007;72(Suppl 1):S5-S13.
15. Kohler G, Milstein C. Continuous cultures of fused cells secreting antibody of predefined specificity. *Nature* 1975;256(5517):495-497.
16. Bernard A, Boumsell L. The clusters of differentiation (CD) defined by the First International Workshop on Human Leucocyte Differentiation Antigens. *Hum Immunol* 1984;11(1):1-10.
17. Zola H, Swart B. The human leucocyte differentiation antigens (HLDA) workshops: the evolving role of antibodies in research, diagnosis and therapy. *Cell Res* 2005;15(9):691-694.
18. Kraan J, Gratama JW, Haioun C, et al. Flow cytometric immunophenotyping of cerebrospinal fluid. *Curr Protoc Cytom* 2008;Chapter 6:Unit.
19. Kappelmayer J, Gratama JW, Karaszi E, et al. Flow cytometric detection of intracellular myeloperoxidase, CD3 and CD79a. Interaction between monoclonal antibody clones, fluorochromes and sample preparation protocols. *J Immunol Methods* 2000;242(1-2):53-65.
20. Koester SK, Bolton WE. Intracellular markers. *J Immunol Methods* 2000;243(1-2):99-106.

21. Wood BL, Arroz M, Barnett D, et al. 2006 Bethesda International Consensus recommendations on the immunophenotypic analysis of hematolymphoid neoplasia by flow cytometry: optimal reagents and reporting for the flow cytometric diagnosis of hematopoietic neoplasia. *Cytometry B Clin Cytom* 2007;72(Suppl 1):S14-S22.
22. Bene MC, Nebe T, Bettelheim P, et al. Immunophenotyping of acute leukemia and lymphoproliferative disorders: a consensus proposal of the European LeukemiaNet Work Package 10. *Leukemia* 2011;25(4):567-574.
23. Roederer M. Spectral compensation for flow cytometry: visualization artifacts, limitations, and caveats. *Cytometry* 2001;45(3):194-205.
24. Stelzer GT, Shults KE, Loken MR. CD45 gating for routine flow cytometric analysis of human bone marrow specimens. *Ann N Y Acad Sci* 1993;677:265-280.
25. Arnoulet C, Bene MC, Durrieu F, et al. Four- and five-color flow cytometry analysis of leukocyte differentiation pathways in normal bone marrow: a reference document based on a systematic approach by the GTLLF and GEIL. *Cytometry B Clin Cytom* 2010;78(1):4-10.
26. Costa ES, Pedreira CE, Barrena S, et al. Automated pattern-guided principal component analysis vs expert-based immunophenotypic classification of B-cell chronic lymphoproliferative disorders: a step forward in the standardization of clinical immunophenotyping. *Leukemia* 2010;24(11):1927-1933.
27. Del VL, Brando B, Lanza F, et al. Recommended reporting format for flow cytometry diagnosis of acute leukemia. *Haematologica* 2004;89(5):594-598.
28. Reilly JT, Barnett D. UK NEQAS for leucocyte immunophenotyping: the first 10 years. *J Clin Pathol* 2001;54(7):508-511.
29. Terstappen LW, Safford M, Loken MR. Flow cytometric analysis of human bone marrow. III. Neutrophil maturation. *Leukemia* 1990;4(9):657-663.
30. Terstappen LW, Levin J. Bone marrow cell differential counts obtained by multidimensional flow cytometry. *Blood Cells* 1992;18(2):311-330.
31. Terstappen LW, Huang S, Picker LJ. Flow cytometric assessment of human T-cell differentiation in thymus and bone marrow. *Blood* 1992;79(3):666-677.
32. Macedo A, Orfao A, Ciudad J, et al. Phenotypic analysis of CD34 subpopulations in normal human bone marrow and its application for the detection of minimal residual disease. *Leukemia* 1995;9(11):1896-1901.
33. Lucio P, Parreira A, van den Beemd MW, et al. Flow cytometric analysis of normal B cell differentiation: a frame of reference for the detection of minimal residual disease in precursor-B-ALL. *Leukemia* 1999;13(3):419-427.
34. Porwit-MacDonald A, Bjorklund E, Lucio P, et al. BIOMED-1 concerted action report: flow cytometric characterization of CD7+ cell subsets in normal bone marrow as a basis for the diagnosis and follow-up of T-cell acute lymphoblastic leukemia (T-ALL). *Leukemia* 2000;14(5):816-825.
35. Matarraz S, Lopez A, Barrena S, et al. The immunophenotype of different immature, myeloid and B-cell lineage-committed CD34+ hematopoietic cells allows discrimination between normal/reactive and myelodysplastic syndrome precursors. *Leukemia* 2008;22(6):1175-1183.
36. van Lochem EG, van der Velden VH, Wind HK, Te Marvelde JG, Westerdaal NA, van Dongen JJ. Immunophenotypic differentiation patterns of normal hematopoiesis in human bone marrow: reference patterns for age-related changes and disease-induced shifts. *Cytometry B Clin Cytom* 2004; 60(1):1-13.
37. Kussick SJ, Wood BL. Using 4-color flow cytometry to identify abnormal myeloid populations. *Arch Pathol Lab Med* 2003;127(9):1140-1147.
38. Della Porta MG, Malcovati L, Invernizzi R, et al. Flow cytometry evaluation of erythroid dysplasia in patients with myelodysplastic syndrome. *Leukemia* 2006;20(4):549-555.
39. Huang S, Terstappen LW. Lymphoid and myeloid differentiation of single human CD34+, HLA-DR+, CD38- hematopoietic stem cells. *Blood* 1994;83(6):1515-1526.
40. Yahata T, Mugeruma Y, Yumino S, et al. Quiescent human hematopoietic stem cells in the bone marrow niches organize the hierarchical structure of hematopoiesis. *Stem Cells* 2008;26(12):3228-3236.

41. Bjorklund E, Gruber A, Mazur J, Martensson A, Hansson M, Porwit A. CD34+ cell subpopulations detected by 8-color flow cytometry in bone marrow and in peripheral blood stem cell collections: application for MRD detection in leukemia patients. *Int J Hematol* 2009;90(3):292-302.
42. van RA, Feller N, Kelder A, et al. High stem cell frequency in acute myeloid leukemia at diagnosis predicts high minimal residual disease and poor survival. *Clin Cancer Res* 2005;11(18):6520-6527.
43. Goardon N, Nikolousis E, Sternberg A, et al. Reduced CD38 expression on CD34+ cells as a diagnostic test in myelodysplastic syndromes. *Haematologica* 2009;94(8):1160-1163.
44. Doulatov S, Notta F, Laurenti E, Dick JE. Hematopoiesis: a human perspective. *Cell Stem Cell* 2012;10(2):120-136.
45. Stetler-Stevenson M, Arthur DC, Jabbour N, et al. Diagnostic utility of flow cytometric immunophenotyping in myelodysplastic syndrome. *Blood* 2001;98(4):979-987.
46. Loken MR, Chu SC, Fritschle W, Kalnoski M, Wells DA. Normalization of bone marrow aspirates for hemodilution in flow cytometric analyses. *Cytometry B Clin Cytom* 2008;76B(1):27-36.
47. Brooimans RA, Kraan J, van PW, Cornelissen JJ, Lowenberg B, Gratama JW. Flow cytometric differential of leukocyte populations in normal bone marrow: influence of peripheral blood contamination. *Cytometry B Clin Cytom* 2008;76B(1):18-26.
48. Elghetany MT, Ge Y, Patel J, Martinez J, Uhrova H. Flow cytometric study of neutrophilic granulopoiesis in normal bone marrow using an expanded panel of antibodies: correlation with morphologic assessments. *J Clin Lab Anal* 2004;18(1):36-41.
49. Edvardsson L, Dykes J, Olsson ML, Olofsson T. Clonogenicity, gene expression and phenotype during neutrophil versus erythroid differentiation of cytokine-stimulated CD34+ human marrow cells in vitro. *Br J Haematol* 2004;127(4):451-463.
50. Elghetany MT. Surface antigen changes during normal neutrophilic development: a critical review. *Blood Cells Mol Dis* 2002 ;28(2):260-274.
51. Wood B. Multicolor immunophenotyping: human immune system hematopoiesis. *Methods Cell Biol* 2004;75:559-576.
52. Chen K, Liu J, Heck S, Chasis JA, An X, Mohandas N. Resolving the distinct stages in erythroid differentiation based on dynamic changes in membrane protein expression during erythropoiesis. *Proc Natl Acad Sci U S A* 2009;106(41):17413-17418.
53. Loken MR, Shah VO, Dattilio KL, Civin CI. Flow cytometric analysis of human bone marrow. II. Normal B lymphocyte development. *Blood* 1987;70(5):1316-1324.
54. McKenna RW, Washington LT, Aquino DB, Picker LJ, Kroft SH. Immunophenotypic analysis of hematogones (B-lymphocyte precursors) in 662 consecutive bone marrow specimens by 4-color flow cytometry. *Blood* 2001;98(8):2498-2507.
55. Campana D, Janossy G, Bofill M, et al. Human B cell development. I. Phenotypic differences of B lymphocytes in the bone marrow and peripheral lymphoid tissue. *J Immunol* 1985;134(3):1524-1530.
56. Janossy G, Bofill M, Schuurman HJ. Human B-lymphoid differentiation: normal versus malignant. *Neth J Med* 1991;39(3-4):232-243.
57. Blom B, Spits H. Development of human lymphoid cells. *Annu Rev Immunol* 2006;24:287-320.
58. Fuda FS, Karandikar NJ, Chen W. Significant CD5 expression on normal stage 3 hematogones and mature B Lymphocytes in bone marrow. *Am J Clin Pathol* 2009;132(5):733-737.
59. Campana D, Coustan-Smith E. Minimal residual disease studies by flow cytometry in acute leukemia. *Acta Haematol* 2004;112(1-2):8-15.
60. Seegmiller AC, Kroft SH, Karandikar NJ, McKenna RW. Characterization of immunophenotypic aberrancies in 200 cases of B acute lymphoblastic leukemia. *Am J Clin Pathol* 2009;132(6):940-949.
61. Klein F, Feldhahn N, Lee S, et al. T lymphoid differentiation in human bone marrow. *Proc Natl Acad Sci U S A* 2003;100(11):6747-6752.
62. Six EM, Bonhomme D, Monteiro M, et al. A human postnatal lymphoid progenitor capable of circulating and seeding the thymus. *J Exp Med* 2007;204(13):3085-3093.

63. Reinhold U, Abken H, Kukul S, et al. CD7- T-cells represent a subset of normal human blood lymphocytes. *J Immunol* 1993;150(5):2081-2089.

P.45

64. Bjornsson S, Wahlstrom S, Norstrom E, et al. Total nucleated cell differential for blood and bone marrow using a single tube in a five-color flow cytometer. *Cytometry B Clin Cytom* 2008;74(2):91-103.

65. Han X, Jorgensen JL, Brahmandam A, et al. Immunophenotypic study of basophils by multiparameter flow cytometry. *Arch Pathol Lab Med* 2008;132(5):813-819.

66. Escribano L, Orfao A, Diaz-Agustin B, et al. Indolent systemic mast cell disease in adults: immunophenotypic characterization of bone marrow mast cells and its diagnostic implications. *Blood* 1998;91(8):2731-2736.

67. Orfao A, Escribano L, Villarrubia J, et al. Flow cytometric analysis of mast cells from normal and pathological human bone marrow samples: identification and enumeration. *Am J Pathol* 1996;149(5):1493-1499.

68. Escribano L, Navalon R, Nunez R, Diaz AB, Bravo P. Immunophenotypic analysis of human mast cells by flow cytometry. *Curr Protoc Cytom* 2001;Chapter 6:Unit.

69. Dzionek A, Fuchs A, Schmidt P, et al. BDCA-2, BDCA-3, and BDCA-4: three markers for distinct subsets of dendritic cells in human peripheral blood. *J Immunol* 2000;165(11):6037-6046.

70. Diao J, Zhao J, Winter E, Cattral MS. Recruitment and Differentiation of Conventional Dendritic Cell Precursors in Tumors. *J Immunol* 2009;184(3):1261-7.

71. Cooper MA, Fehniger TA, Caligiuri MA. The biology of human natural killer-cell subsets. *Trends Immunol* 2001;22(11):633-640.

72. Bennett IM, Zatsepina O, Zamai L, Azzoni L, Mikheeva T, Perussia B. Definition of a natural killer NKR-P1A+/CD56-/. *J Exp Med* 1996;184(5):1845-1856.

73. Lopez-Verges S, Milush JM, Pandey S, et al. CD57 defines a functionally distinct population of mature NK cells in the human CD56dimCD16+ NK-cell subset. *Blood* 2010;116(19):3865-3874.

74. Deneys V, Mazzon AM, Marques JL, Benoit H, De BM. Reference values for peripheral blood B-lymphocyte subpopulations: a basis for multiparametric immunophenotyping of abnormal lymphocytes. *J Immunol Methods* 2001;253(1-2):23-36.

75. Cornet E, Lesesve JF, Mossafa H, et al. Long-term follow-up of 111 patients with persistent polyclonal B-cell lymphocytosis with binucleated lymphocytes. *Leukemia* 2009;23(2):419-422.

76. Tierens AM, Holte H, Warsame A, et al. Low levels of monoclonal small B cells in the bone marrow of patients with diffuse large B-cell lymphoma of activated B-cell type but not of germinal center B-cell type. *Haematologica* 2010;95(8):1334-1341.

77. Deans JP, Polyak MJ. FMC7 is an epitope of CD20. *Blood* 2008;111(4): 2492-2494.

78. Matutes E, Attygalle A, Wotherspoon A, Catovsky D. Diagnostic issues in chronic lymphocytic leukaemia (CLL). *Best Pract Res Clin Haematol* 2010;23(1):3-20.

79. Ginaldi L, De MM, Matutes E, et al. Levels of expression of CD52 in normal and leukemic B and T cells: correlation with in vivo therapeutic responses to Campath-1H. *Leuk Res* 1998;22(2):185-191.

80. Marti GE, Rawstron AC, Ghia P, et al. Diagnostic criteria for monoclonal B-cell lymphocytosis. *Br J Haematol* 2005;130(3):325-332.

81. Shim YK, Middleton DC, Caporaso NE, et al. Prevalence of monoclonal B-cell lymphocytosis: a systematic review. *Cytometry B Clin Cytom* 2010;78 (Suppl 1):S10-S18.

82. Rawstron AC, Green MJ, Kuzmicki A, et al. Monoclonal B lymphocytes with the characteristics of "indolent" chronic lymphocytic leukemia are present in 3.5% of adults with normal blood counts. *Blood* 2002;100(2):635-639.

83. Ghia P, Prato G, Scielzo C, et al. Monoclonal CD5+ and CD5- B-lymphocyte expansions are frequent in the peripheral blood of the elderly. *Blood* 2004;103(6):2337-2342.

84. Nieto WG, Almeida J, Romero A, et al. Increased frequency (12%) of circulating chronic lymphocytic leukemia-like B-cell clones in healthy subjects using a highly sensitive multicolor flow cytometry approach. *Blood* 2009;114(1): 33-37.
85. Palumbo GA, Parrinello N, Fargione G, et al. CD200 expression may help in differential diagnosis between mantle cell lymphoma and B-cell chronic lymphocytic leukemia. *Leuk Res* 2009;33(9):1212-1216.
86. Kraus TS, Sillings CN, Saxe DF, Li S, Jaye DL. The role of CD11c expression in the diagnosis of mantle cell lymphoma. *Am J Clin Pathol* 2010;134(2): 271-277.
87. Gao J, Peterson L, Nelson B, Goolsby C, Chen YH. Immunophenotypic variations in mantle cell lymphoma. *Am J Clin Pathol* 2009;132(5):699-706.
88. Golardi N, Velasco MR, Elghetany MT. Marginal zone variant of mantle cell lymphoma: CD5-negative cyclin D1-positive variant posing a diagnostic dilemma. *Pathol Int* 2009;59(5):317-321.
89. Jain P, Giustolisi GM, Atkinson S, et al. Detection of cyclin D1 in B cell lymphoproliferative disorders by flow cytometry. *J Clin Pathol* 2002;55(12):940-945.
90. Berger F, Traverse-Glehen A, Felman P, et al. Clinicopathologic features of Waldenstrom's macroglobulinemia and marginal zone lymphoma: are they distinct or the same entity? *Clin Lymphoma* 2005;5(4):220-224.
91. Baseggio L, Traverse-Glehen A, Petinataud F, et al. CD5 expression identifies a subset of splenic marginal zone lymphomas with higher lymphocytosis: a clinico-pathological, cytogenetic and molecular study of 24 cases. *Haematologica* 2010;95(4):604-612.
92. Morice WG, Chen D, Kurtin PJ, Hanson CA, McPhail ED. Novel immunophenotypic features of marrow lymphoplasmacytic lymphoma and correlation with Waldenstrom's macroglobulinemia. *Mod Pathol* 2009;22(6):807-816.
93. Kanellis G, Mollejo M, Montes-Moreno S, et al. Splenic diffuse red pulp small B-cell lymphoma: revision of a series of cases reveals characteristic clinicopathological features. *Haematologica* 2010;95(7):1122-1129.
94. Dong HY, Weisberger J, Liu Z, Tugulea S. Immunophenotypic analysis of CD103+ B-lymphoproliferative disorders: hairy cell leukemia and its mimics. *Am J Clin Pathol* 2009;131(4):586-595.
95. Del G, I, Matutes E, Morilla R, et al. The diagnostic value of CD123 in B-cell disorders with hairy or villous lymphocytes. *Haematologica* 2004;89(3):303-308.
96. Yang W, Agrawal N, Patel J, et al. Diminished expression of CD19 in B-cell lymphomas. *Cytometry B Clin Cytom* 2005;63(1):28-35.
97. Sanchez ML, Almeida J, Vidriales B, et al. Incidence of phenotypic aberrations in a series of 467 patients with B chronic lymphoproliferative disorders: basis for the design of specific four-color stainings to be used for minimal residual disease investigation. *Leukemia* 2002;16(8):1460-1469.
98. Maleki A, Seegmiller AC, Uddin N, Karandikar NJ, Chen W. Bright CD38 expression is an indicator of MYC rearrangement. *Leuk Lymphoma* 2009;50(6):1054-1057.
99. Attarbaschi A, Mann G, Schumich A, et al. CD44 deficiency is a consistent finding in childhood Burkitt's lymphoma and leukemia. *Leukemia* 2007;21(5):1110-1113.
100. Schniederjan SD, Li S, Saxe DF, et al. A novel flow cytometric antibody panel for distinguishing Burkitt lymphoma from CD10+ diffuse large B-cell lymphoma. *Am J Clin Pathol* 2010;133(5):718-726.
101. Wu D, Wood BL, Dorer R, Fromm JR. "Double-Hit" mature B-cell lymphomas show a common immunophenotype by flow cytometry that includes decreased CD20 expression. *Am J Clin Pathol* 2010;134(2):258-265.
102. Harada S, Suzuki R, Uehira K, et al. Molecular and immunological dissection of diffuse large B cell lymphoma: CD5+, and CD5- with CD10+ groups may constitute clinically relevant subtypes. *Leukemia* 1999;13(9):1441-1447.
103. Palacio C, Acebedo G, Navarrete M, et al. Flow cytometry in the bone marrow evaluation of follicular and diffuse large B-cell lymphomas. *Haematologica* 2001;86(9):934-940.
104. Talaulikar D, Shadbolt B, Bell J, et al. Clinical role of flow cytometry in redefining bone marrow involvement in diffuse large B-cell lymphoma (DLBCL)—a new perspective. *Histopathology* 2008;52(3):340-347.
105. Giorgi JV. Characterization of T lymphocyte subset alterations by flow cytometry in HIV disease. *Ann N Y Acad Sci* 1993;677:126-137.

106. Lynne JE, Schmid I, Matud JL, et al. Major expansions of select CD8+ subsets in acute Epstein-Barr virus infection: comparison with chronic human immunodeficiency virus disease. *J Infect Dis* 1998;177(4):1083-1087.
107. Tarazona R, DelaRosa O, Alonso C, et al. Increased expression of NK-cell markers on T lymphocytes in aging and chronic activation of the immune system reflects the accumulation of effector/senescent T cells. *Mech Ageing Dev* 2000;121(1-3):77-88.
108. Herling M, Khoury JD, Washington LT, Duvic M, Keating MJ, Jones D. A systematic approach to diagnosis of mature T-cell leukemias reveals heterogeneity among WHO categories. *Blood* 2004;104(2):328-335.
109. Tsukasaki K, Hermine O, Bazarbachi A, et al. Definition, prognostic factors, treatment, and response criteria of adult T-cell leukemia-lymphoma: a proposal from an international consensus meeting. *J Clin Oncol* 2009;27(3):453-459.
110. Cady FM, Morice WG. Flow cytometric assessment of T-cell chronic lymphoproliferative disorders. *Clin Lab Med* 2007;27(3):513-532, vi.
111. Fierro MT, Novelli M, Quaglino P, et al. Heterogeneity of circulating CD4+ memory T-cell subsets in erythrodermic patients: CD27 analysis can help to distinguish cutaneous T-cell lymphomas from inflammatory erythroderma. *Dermatology* 2008;216(3):213-221.
112. Khokhar FA, Payne WD, Talwalkar SS, et al. Angioimmunoblastic T-cell lymphoma in bone marrow: a morphologic and immunophenotypic study. *Hum Pathol* 2010;41(1):79-87.
113. Shah MV, Zhang R, Loughran TP, Jr. Never say die: survival signaling in large granular lymphocyte leukemia. *Clin Lymphoma Myeloma* 2009;9(Suppl 3):S244-S253.
114. Lamy T, Loughran TP, Jr. How I treat LGL leukemia. *Blood* 2011;117(10): 2764-2774.
115. Purdy AK, Campbell KS. Natural killer cells and cancer: regulation by the killer cell Ig-like receptors (KIR). *Cancer Biol Ther* 2009;8(23):2211-2220.
116. Morice WG. The immunophenotypic attributes of NK cells and NK-cell lineage lymphoproliferative disorders. *Am J Clin Pathol* 2007;127(6):881-886.
117. Liang X, Graham DK. Natural killer cell neoplasms. *Cancer* 2008;112(7): 1425-1436.
118. Yoo EH, Kim HJ, Lee ST, Kim WS, Kim SH. Frequent CD7 antigen loss in aggressive natural killer-cell leukemia: a useful diagnostic marker. *Korean J Lab Med* 2009;29(6):491-496.
119. Tripodo C, Iannitto E, Florena AM, et al. Gamma-delta T-cell lymphomas. *Nat Rev Clin Oncol* 2009;6(12):707-717.
120. Rawstron AC, Orfao A, Beksac M, et al. Report of the European Myeloma Network on multiparametric flow cytometry in multiple myeloma and related disorders. *Haematologica* 2008;93(3):431-438.
121. Paiva B, Almeida J, Perez-Andres M, et al. Utility of flow cytometry immunophenotyping in multiple myeloma and other clonal plasma cell-related disorders. *Cytometry B Clin Cytom* 2010;78(4):239-252.
122. Ocqueteau M, San Miguel JF, Gonzalez M, Almeida J, Orfao A. Do myelomatous plasma cells really express surface immunoglobulins? *Haematologica* 1996;81(5):460-463.
123. Paiva B, Vidriales MB, Mateo G, et al. The persistence of immunophenotypically normal residual bone marrow plasma cells at diagnosis identifies a good prognostic subgroup of symptomatic multiple myeloma patients. *Blood* 2009;114(20):4369-4372.
124. Lacombe F, Durrieu F, Briais A, et al. Flow cytometry CD45 gating for immunophenotyping of acute myeloid leukemia. *Leukemia* 1997;11(11):1878-1886.
125. van de Loosdrecht AA, Alhan C, Bene MC, et al. Standardization of flow cytometry in myelodysplastic syndromes: report from the first European LeukemiaNet working conference on flow cytometry in myelodysplastic syndromes. *Haematologica* 2009;94(8):1124-1134.
126. Borowitz M., Bene MC, Harris NC, Porwit A, Matutes E. Acute leukemia of ambiguous origin. In: Swerdlow S, Campo E, Harris N, et al., eds. *World Health Organization classification of tumours. Pathology and genetics of tumours of haematopoietic and lymphoid tissues.* Lyon: IARC Press, 2008:150-155.
127. Matutes E, Pickl WF, Van't Veer M, et al. Mixed-phenotype acute leukemia: clinical and laboratory features and outcome in 100 patients defined according to the WHO 2008 classification. *Blood* 2011;117(11):3163-3171.

128. Knapp W, Strobl H, Majdic O. Flow cytometric analysis of cell-surface and intracellular antigens in leukemia diagnosis. *Cytometry* 1994;18(4):187-198.
129. Strobl H, Knapp W. Myeloid cell-associated lysosomal proteins as flow cytometry markers for leukocyte lineage classification. *J Biol Regul Homeost Agents* 2004;18(3-4):335-339.
130. Bene MC, Castoldi G, Knapp W, et al. Proposals for the immunological classification of acute leukemias. European Group for the Immunological Characterization of Leukemias (EGIL). *Leukemia* 1995;9(10):1783-1786.
131. Bene MC, Bernier M, Casasnovas RO, et al. Acute myeloid leukaemia M0: haematological, immunophenotypic and cytogenetic characteristics and their prognostic significance: an analysis in 241 patients. *Br J Haematol* 2001;113(3):737-745.
132. Garnache-Ottou F, Feuillard J, Ferrand C, et al. Extended diagnostic criteria for plasmacytoid dendritic cell leukaemia. *Br J Haematol* 2009;145(5):624-636.
133. Hrusak O, Porwit-Macdonald A. Antigen expression patterns reflecting genotype of acute leukemias. *Leukemia* 2002;16(7):1233-1258.
134. Casasnovas RO, Slimane FK, Garand R, et al. Immunological classification of acute myeloblastic leukemias: relevance to patient outcome. *Leukemia* 2003;17(3):515-527.
135. Del PG, Stasi R, Venditti A, et al. Prognostic value of cell marker analysis in de novo acute myeloid leukemia. *Leukemia* 1994;8(3):388-394.
136. Derolf AR, Bjorklund E, Mazur J, Bjorkholm M, Porwit A. Expression patterns of CD33 and CD15 predict outcome in patients with acute myeloid leukemia. *Leuk Lymphoma* 2008;49(7):1279-1291.
137. Nomdedeu J, Bussaglia E, Villamor N, et al. Immunophenotype of acute myeloid leukemia with NPM mutations: prognostic impact of the leukemic compartment size. *Leuk Res* 2011;35(2):163-168.
138. Basso G, Buldini B, De ZL, Orfao A. New methodologic approaches for immunophenotyping acute leukemias. *Haematologica* 2001;86(7):675-692.
139. Peters JM, Ansari MQ. Multiparameter flow cytometry in the diagnosis and management of acute leukemia. *Arch Pathol Lab Med* 2011;135(1):44-54.
140. Rubnitz JE, Inaba H, Dahl G, et al. Minimal residual disease-directed therapy for childhood acute myeloid leukaemia: results of the AML02 multicentre trial. *Lancet Oncol* 2010;11(6):543-552.
141. Al-Mawali A, Gillis D, Hissaria P, Lewis I. Incidence, sensitivity, and specificity of leukemia-associated phenotypes in acute myeloid leukemia using specific five-color multiparameter flow cytometry. *Am J Clin Pathol* 2008;129(6):934-945.
142. San-Miguel JF, Vidrales MB, Orfao A. Immunological evaluation of minimal residual disease (MRD) in acute myeloid leukaemia (AML). *Best Pract Res Clin Haematol* 2002;15(1):105-118.
143. Shook D, Coustan-Smith E, Ribeiro RC, Rubnitz JE, Campana D. Minimal residual disease quantitation in acute myeloid leukemia. *Clin Lymphoma Myeloma* 2009;9(Suppl 3):S281-S285.
144. Kern W, Danhauser-Riedl S, Ratei R, et al. Detection of minimal residual disease in unselected patients with acute myeloid leukemia using multiparameter flow cytometry for definition of leukemia-associated immunophenotypes and determination of their frequencies in normal bone marrow. *Haematologica* 2003;88(6):646-653.
145. Wood B. 9-color and 10-color flow cytometry in the clinical laboratory. *Arch Pathol Lab Med* 2006;130(5):680-690.
146. Walter RB, Gooley TA, Wood BL, et al. Impact of pretransplantation minimal residual disease, as detected by multiparametric flow cytometry, on outcome of myeloablative hematopoietic cell transplantation for acute myeloid leukemia. *J Clin Oncol* 2011;29(9):1190-1197.
147. Campana D, Thompson JS, Amlot P, Brown S, Janossy G. The cytoplasmic expression of CD3 antigens in normal and malignant cells of the T lymphoid lineage. *J Immunol* 1987;138(2):648-655.
148. Pillozzi E, Pulford K, Jones M, et al. Co-expression of CD79a (JCB117) and CD3 by lymphoblastic lymphoma. *J Pathol* 1998;186(2):140-143.
149. Coustan-Smith E, Mullighan CG, Onciu M, et al. Early T-cell precursor leukaemia: a subtype of very high-risk acute lymphoblastic leukaemia. *Lancet Oncol* 2009;10(2):147-156.

150. Lucio P, Gaipa G, van Lochem EG, et al. BIOMED-I concerted action report: flow cytometric immunophenotyping of precursor B-ALL with standardized triple-stainings. BIOMED-1 concerted action investigation of minimal residual disease in acute Leukemia: international standardization and clinical evaluation. *Leukemia* 2001;15(8):1185-1192.
151. Campana D. Should Minimal Residual Disease Monitoring in Acute Lymphoblastic Leukemia be Standard of Care? *Curr Hematol Malig Rep* 2012;7(2):170-7.
152. Gaipa G, Basso G, Maglia O, et al. Drug-induced immunophenotypic modulation in childhood ALL: implications for minimal residual disease detection. *Leukemia* 2005;19(1):49-56.
153. Porwit A. Role of flow cytometry in diagnostics of myelodysplastic syndromes—beyond the WHO 2008 classification. *Semin Diagn Pathol* 2011;28(4):273-282.
154. Westers TM, Ireland R, Kern W, et al. Standardization of flow cytometry in myelodysplastic syndromes: a report from an international consortium and the European LeukemiaNet Working Group. *Leukemia* 2012;26(7):1730-41.
155. Kern W, Haferlach C, Schnittger S, Haferlach T. Clinical utility of multiparameter flow cytometry in the diagnosis of 1013 patients with suspected myelodysplastic syndrome: correlation to cytomorphology, cytogenetics, and clinical data. *Cancer* 2010;116(19):4549-4563.
156. Ogata K, Yoshida Y. Clinical implications of blast immunophenotypes in myelodysplastic syndromes. *Leuk Lymphoma* 2005;46(9):1269-1274.
167. Monreal MB, Pardo ML, Pavlovsky MA, et al. Increased immature hematopoietic progenitor cells CD34+/CD38dim in myelodysplasia. *Cytometry B Clin Cytom* 2006;70(2):63-70.
158. Xie W, Wang X, Du W, Liu W, Qin X, Huang S. Detection of molecular targets on the surface of CD34+. *Cytometry A* 2010;77(9):840-848.
159. Truong F, Smith BR, Stachurski D, et al. The utility of flow cytometric immunophenotyping in cytopenic patients with a non-diagnostic bone marrow: a prospective study. *Leuk Res* 2009;33(8):1039-1046.
160. Kussick SJ, Fromm JR, Rossini A, et al. Four-color flow cytometry shows strong concordance with bone marrow morphology and cytogenetics in the evaluation for myelodysplasia. *Am J Clin Pathol* 2005;124(2):170-181.
161. Xu Y, McKenna RW, Karandikar NJ, Pildain AJ, Kroft SH. Flow cytometric analysis of monocytes as a tool for distinguishing chronic myelomonocytic leukemia from reactive monocytosis. *Am J Clin Pathol* 2005;124(5):799-806.
162. Kyriakou D, Liapi D, Kyriakou E, et al. Aberrant expression of the major sialoglycoprotein (CD43) on the monocytes of patients with myelodysplastic syndromes. *Ann Hematol* 2000;79(4):198-205.
163. Malcovati L, Della Porta MG, Lunghi M, et al. Flow cytometry evaluation of erythroid and myeloid dysplasia in patients with myelodysplastic syndrome. *Leukemia* 2005;19(5):776-783.
164. Ogata K, Kishikawa Y, Satoh C, Tamura H, Dan K, Hayashi A. Diagnostic application of flow cytometric characteristics of CD34+ cells in low-grade myelodysplastic syndromes. *Blood* 2006;108(3):1037-1044.
165. Veltroni M, Sainati L, Zecca M, et al. Advanced pediatric myelodysplastic syndromes: can immunophenotypic characterization of blast cells be a diagnostic and prognostic tool? *Pediatr Blood Cancer* 2009;52(3):357-33.
166. Ribeiro E, Matarraz SS, de SM, et al. Maturation-associated immunophenotypic abnormalities in bone marrow B-lymphocytes in myelodysplastic syndromes. *Leuk Res* 2006;30(1):9-16.
167. Reis SC, Traina F, Metzke K, Saad ST, Lorand-Metze I. Variation of bone marrow CD34+ cell subsets in myelodysplastic syndromes according to who types. *Neoplasma* 2009;56(5):435-440.
168. Ogata K, Della Porta MG, et al. Diagnostic utility of flow cytometry in low-grade myelodysplastic syndromes: a prospective validation study. *Haematologica* 2009;94(8):1066-1074.
169. Sternberg A, Killick S, Littlewood T, et al. Evidence for reduced B-cell progenitors in early (low-risk) myelodysplastic syndrome. *Blood* 2005;106(9):2982-2991.
170. Della Porta MG, Picone C, Pascutto C, et al. Multicentre validation of a reproducible flow cytometric score for the diagnosis of low-risk myelodysplastic syndromes: results of a European LeukemiaNET study. *Haematologica* 2012;97(8):1209-17.
171. Lanza F, Bi S, Castoldi G, Goldman JM. Abnormal expression of N-CAM (CD56) adhesion molecule on myeloid and progenitor cells from chronic myeloid leukemia. *Leukemia* 1993;7(10):1570-1575.

172. Carulli G, Gianfaldoni ML, Azzara A, et al. FcRIII (CD16) expression on neutrophils from chronic myeloid leukemia. A flow cytometric study. *Leuk Res* 1992;16(12):1203-1209.
173. Martin-Henao GA, Quiroga R, Sureda A, Gonzalez JR, Moreno V, Garcia J. L-selectin expression is low on CD34+ cells from patients with chronic myeloid leukemia and interferon- α up-regulates this expression. *Haematologica* 2000;85(2):139-146.
174. Sullivan C, Chen Y, Shan Y, et al. Functional ramifications for the loss of P-selectin expression on hematopoietic and leukemic stem cells. *PLoS One* 2011;6(10):e26246.
175. Khalidi HS, Brynes RK, Medeiros LJ, et al. The immunophenotype of blast transformation of chronic myelogenous leukemia: a high frequency of mixed lineage phenotype in "lymphoid" blasts and A comparison of morphologic, immunophenotypic, and molecular findings. *Mod Pathol* 1998;11(12):1211-1221.
176. Kussick SJ, Wood BL. Four-color flow cytometry identifies virtually all cytogenetically abnormal bone marrow samples in the workup of non-CML myeloproliferative disorders. *Am J Clin Pathol* 2003;120(6):854-865.
177. Feng B, Verstovsek S, Jorgensen JL, Lin P. Aberrant myeloid maturation identified by flow cytometry in primary myelofibrosis. *Am J Clin Pathol* 2010;133(2):314-320.
178. Brodsky RA, Mukhina GL, Li S, et al. Improved detection and characterization of paroxysmal nocturnal hemoglobinuria using fluorescent aerolysin. *Am J Clin Pathol* 2000;114(3):459-466.
179. Sutherland DR, Kuek N, Azcona-Olivera J, et al. Use of a FLAER-based WBC assay in the primary screening of PNH clones. *Am J Clin Pathol* 2009;132(4):564-572.
180. Sutherland DR, Keeney M, Illingworth A. Practical guidelines for the high-sensitivity detection and monitoring of paroxysmal nocturnal hemoglobinuria clones by flow cytometry. *Cytometry B Clin Cytom* 2012;82(4):195-208.
181. Chesney A, Good D, Reis M. Clinical utility of flow cytometry in the study of erythropoiesis and nonclonal red cell disorders. *Methods Cell Biol* 2011;103:311-332.
182. Buttarello M, Bulian P, Farina G, et al. Flow cytometric reticulocyte counting. Parallel evaluation of five fully automated analyzers: an NCCLS-ICSH approach. *Am J Clin Pathol* 2001;115(1):100-111.
183. Buttarello M, Plebani M. Automated blood cell counts: state of the art. *Am J Clin Pathol* 2008;130(1):104-116.
184. Hochsmann B, Rojewski M, Schrezenmeier H. Paroxysmal nocturnal hemoglobinuria (PNH): higher sensitivity and validity in diagnosis and serial monitoring by flow cytometric analysis of reticulocytes. *Ann Hematol* 2011;90(8):887-899.
185. Davis BH, Olsen S, Bigelow NC, Chen JC. Detection of fetal red cells in fetomaternal hemorrhage using a fetal hemoglobin monoclonal antibody by flow cytometry. *Transfusion* 1998;38(8):749-756.
186. Italia KY, Colah R, Mohanty D. Evaluation of F cells in sickle cell disorders by flow cytometry—comparison with the Kleihauer-Betke's slide method. *Int J Lab Hematol* 2007;29(6):409-414.
187. Linden MD, Frelinger AL, III, Barnard MR, Przyklenk K, Furman MI, Michelson AD. Application of flow cytometry to platelet disorders. *Semin Thromb Hemost* 2004;30(5):501-511.
188. Wall JE, Buijs-Wilts M, Arnold JT, et al. A flow cytometric assay using mepacrine for study of uptake and release of platelet dense granule contents. *Br J Haematol* 1995;89(2):380-385.
189. Lindahl TL, Fagerberg IH, Larsson A. A new flow cytometric method for measurement of von Willebrand factor activity. *Scand J Clin Lab Invest* 2003;63(3):217-223.
190. Kienast J, Schmitz G. Flow cytometric analysis of thiazole orange uptake by platelets: a diagnostic aid in the evaluation of thrombocytopenic disorders. *Blood* 1990;75(1):116-121.
191. Tan CW, Ward CM, Morel-Kopp MC. Evaluating heparin-induced thrombocytopenia: the old and the new. *Semin Thromb Hemost* 2012;38(2):135-143.
192. Chapple P, Prince HM, Quinn M, et al. Peripheral blood CD34+ cell count reliably predicts autograft yield. *Bone Marrow Transplant* 1998;22(2):125-130.
193. Sutherland DR, Anderson L, Keeney M, Nayar R, Chin-Yee I. The ISHAGE guidelines for CD34+ cell determination by flow cytometry. *International Society of Hematotherapy and Graft Engineering. J Hematother* 1996;5(3):213-226.

194. Keeney M, Chin-Yee I, Weir K, Popma J, Nayar R, Sutherland DR. Single platform flow cytometric absolute CD34+ cell counts based on the ISHAGE guidelines. *International Society of Hematotherapy and Graft Engineering. Cytometry* 1998;34(2):61-70.
195. Whitby A, Whitby L, Fletcher M, et al. ISHAGE protocol: are we doing it correctly? *Cytometry B Clin Cytom* 2012;82(1):9-17.
196. Gutensohn K, Nikolitsis A, Gramatzki M, Spitzer D, Buwitt-Beckmann U, Humpe A. Direct volumetric flow cytometric quantitation of CD34+ stem and progenitor cells. *Transfus Med* 2012;22(3):205-10.
197. Bray RA, Tarsitani C, Gebel HM, Lee JH. Clinical cytometry and progress in HLA antibody detection. *Methods Cell Biol* 2011;103:285-310.
198. Samarghitean C, Ortutay C, Vihinen M. Systematic classification of primary immunodeficiencies based on clinical, pathological, and laboratory parameters. *J Immunol* 2009;183(11):7569-7575.
199. O'Gorman MR, Zollett J, Bensen N. Flow cytometry assays in primary immunodeficiency diseases. *Methods Mol Biol* 2011;699:317-335.
200. Oliveira JB, Notarangelo LD, Fleisher TA. Applications of flow cytometry for the study of primary immune deficiencies. *Curr Opin Allergy Clin Immunol* 2008;8(6):499-509.
201. Dougados M, Baeten D. Spondyloarthritis. *Lancet* 2011;377(9783):2127-2137.
202. Darke C, Coates E. One-tube HLA-B27/B2708 typing by flow cytometry using two "Anti-HLA-B27" monoclonal antibody reagents. *Cytometry B Clin Cytom* 2010;78(1):21-30.
203. Chattopadhyay PK, Roederer M. Good cell, bad cell: flow cytometry reveals T-cell subsets important in HIV disease. *Cytometry A* 2010;77(7):614-622.
204. Sims S, Willberg C, Klenerman P. MHC-peptide tetramers for the analysis of antigen-specific T cells. *Expert Rev Vaccines* 2010;9(7):765-774.
205. Nepom GT. MHC class II tetramers. *J Immunol* 2012;188(6):2477-2482.
206. Darzynkiewicz Z, Traganos F, Zhao H, Halicka HD, Li J. Cytometry of DNA replication and RNA synthesis: historical perspective and recent advances based on "click chemistry". *Cytometry A* 2011;79(5):328-337.
207. Hedley DW, Friedlander ML, Taylor IW, Rugg CA, Musgrove EA. Method for analysis of cellular DNA content of paraffin-embedded pathological material using flow cytometry. *J Histochem Cytochem* 1983;31(11):1333-1335.
208. Darzynkiewicz Z, Halicka HD, Zhao H. Analysis of cellular DNA content by flow and laser scanning cytometry. *Adv Exp Med Biol* 2010;676:137-147.
209. Paulsson K, Johansson B. High hyperdiploid childhood acute lymphoblastic leukemia. *Genes Chromosomes Cancer* 2009;48(8):637-660.
210. Mateos MV, Gutierrez NC, Martin-Ramos ML, et al. Outcome according to cytogenetic abnormalities and DNA ploidy in myeloma patients receiving short induction with weekly bortezomib followed by maintenance. *Blood* 2011;118(17):4547-4553.
211. Lovelace P, Maecker HT. Multiparameter intracellular cytokine staining. *Methods Mol Biol* 2011;699:165-178.
212. Dufour C, Ferretti E, Bagnasco F, et al. Changes in cytokine profile pre- and post-immunosuppression in acquired aplastic anemia. *Haematologica* 2009;94(12):1743-1747.
213. Feng X, Scheinberg P, Wu CO, et al. Cytokine signature profiles in acquired aplastic anemia and myelodysplastic syndromes. *Haematologica* 2011;96(4):602-606.
214. Mellgren K, Hedegaard CJ, Schmiegelow K, Muller K. Plasma cytokine profiles at diagnosis in pediatric patients with non-hodgkin lymphoma. *J Pediatr Hematol Oncol* 2012;34(4):271-275.
215. Hedley DW, Chow S, Shankey TV. Cytometry of intracellular signaling: from laboratory bench to clinical application. *Methods Cell Biol* 2011;103:203-220.
216. Jacobberger JW, Sramkoski RM, Frisa PS, et al. Immunoreactivity of Stat5 phosphorylated on tyrosine as a cell-based measure of Bcr/Abl kinase activity. *Cytometry A* 2003;54(2):75-88.

217. Wlodkowic D, Telford W, Skommer J, Darzynkiewicz Z. Apoptosis and beyond: cytometry in studies of programmed cell death. *Methods Cell Biol* 2011;103:55-98.

Chapter 3 Cytogenetics

INTRODUCTION

Cytogenetics is the study of chromosome structure and function. Chromosome analysis is an integral part of diagnosing hematologic malignancies and is important for determining prognosis (or risk category) and/or treatment. According to the WHO classification of leukemias and lymphomas from 2008,¹ there are several categories of leukemias and lymphomas that are defined by their specific clonal chromosome abnormalities. Chromosome and/or fluorescence in situ hybridization (FISH) analyses are considered “standard of care” for diagnosing and following patients with most hematologic malignancies. Array analyses of these same malignancies, using either array comparative genomic hybridization (CGH) or single nucleotide polymorphism (SNP) array analysis, have been used for identification of smaller, more subtle or complex anomalies not appreciated by chromosome analysis and/or FISH; however, the diagnostic and prognostic value of this technology is just beginning to emerge.

HISTORY

As early as 1890, von Hanseemann² recognized that mitotic irregularities were associated with the malignant process. He suggested that such nuclear abnormalities could be used as a criterion for diagnosing the malignant state. In 1914, Boveri³ published his chromosome (or mutation) theory of cancer in his monograph “The Origin of Malignant Tumors.” This theory proposed that chromosome aberrations were the cause of the change from normal to malignant growth. He saw cancer as a cellular problem which originated from a single cell with an abnormal chromosome constitution. This single abnormal cell was the founder of a population of cells with the same abnormality (and therefore, clonal, by current definition). Therefore, chromosome abnormalities were seen as the cause of the rapid cellular proliferation observed in malignancies.

By the 1920s, it was widely accepted that the units of heredity in living organisms were chromosomes. In 1923, studying paraffin-embedded preparations of testicular tissue, Painter⁴ reported that there were 46 or 48 human chromosomes in the normal karyotype; however, it was popularly believed that there were 48 human chromosomes. With technical advances involving the use of hypotonic solution and mitotic arrest, in 1956 Tjio and Levan⁵ determined that the normal diploid number of human chromosomes was actually 46. In 1966, Levan⁶ and van Steenis⁷ studied published reports of human tumor karyotypes. They found nonrandom karyotypic changes in human tumors. These 40 published cases, which consisted primarily of ascitic forms of gastric, mammary, uterine, and ovarian carcinomas, showed certain chromosomes tended to be increased in number, while others tended to be decreased, in what appeared to be a nonrandom fashion. Nonrandom chromosomal changes are either primary or secondary. Nonrandom primary changes are generally thought to be the cytogenetic changes that are consistently found in a cell population and are believed to be specific for a particular type or subtype of malignancy. Specific nonrandom secondary changes are believed to be related to the progression or the evolution of the tumor.

This is not to say that chromosome alterations are or are not the first step in carcinogenesis. Whether one considers Sandberg's chromosome theory of cancer, in which the key event in oncogenesis involves chromosomal rearrangement,⁸ or Knudson's two-hit hypothesis, in which there are at least two mutational events that lead to the malignant state,⁹ carcinogenesis is generally thought to be a multistage process, where a number of different barriers must be breached for a malignancy to occur.¹⁰

Shortly after Tjio and Levan determined the normal diploid number of human chromosomes, a number of constitutional (or germ line) chromosome abnormalities and syndromes were described, beginning with the association of trisomy 21 and Down syndrome by Lejeune in 1959.¹¹ It should be noted that chromosome abnormalities can be thought of as consisting of two types—constitutional (germ line) or acquired (somatic). Constitutional anomalies typically affect every cell in the body and are congenital, while acquired anomalies affect only the tumor cell population (somatic mutations).

At first, chromosomes were identified only by their size and the placement of their centromere or primary constriction, as they were solid stained. It was not until the advent of chromosome banding in the 1970s that chromosomes could be recognized and identified individually by their banding patterns.

In 1960, Nowell and Hungerford¹² recognized the first chromosome abnormality known to be specific to a particular type of cancer. This was the “Philadelphia” chromosome (or Ph) associated with chronic myelogenous leukemia (CML), so named because of its discovery in that city. The chromosome origin and nature of this minute chromosome was uncertain

at the time, as chromosomes were only non-banded and could not be specifically identified (Fig. 3.1). In 1973, after the advent of banding, Rowley¹³ and colleagues at the University of Chicago discovered that the Philadelphia chromosome was actually a balanced translocation involving the long arms of chromosomes #9 and #22

P.47

[t(9;22)] (Fig. 3.2). The Philadelphia chromosome or a variant rearrangement is seen in nearly all patients with CML. In later studies, it was shown that the translocation involved breakpoints in two genes, BCR on chromosome #22 at band 22q11.2 and ABL1 on chromosome #9 at band 9q34 (Fig. 3.3). These breakpoints were in very specific regions of both genes and the translocated segment of ABL1 juxtaposed to BCR created a functional chimeric fusion protein with increased tyrosine kinase activity. This BCR/ABL1 fusion protein upregulates the growth of these cells and causes them to have a proliferative advantage over the normal cells.¹⁴ Today, inhibitors of tyrosine kinase activity (most notably Gleevec or imatinib) have been used to treat patients with CML and acute lymphoblastic leukemia who have the Ph chromosome. This type of treatment has been very successful in treating these patients.¹⁵ Since then, numerous other chromosome abnormalities have shown associations with specific hematologic disease entities (Table 3.1), some of which have targeted or specific therapy directed toward their fusion protein.

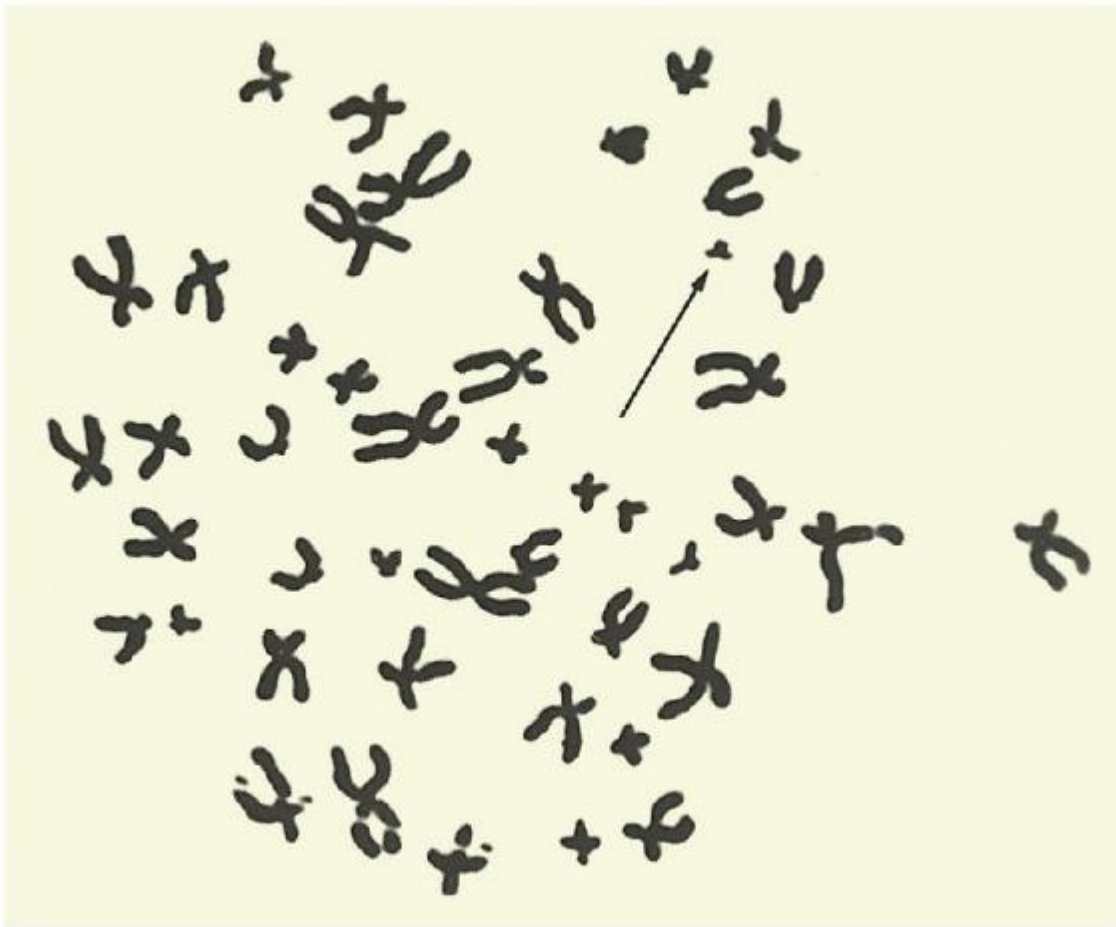

FIGURE 3.1. An unbanded metaphase spread from bone marrow cells of a patient with chronic myelogenous leukemia showing the Ph chromosome.

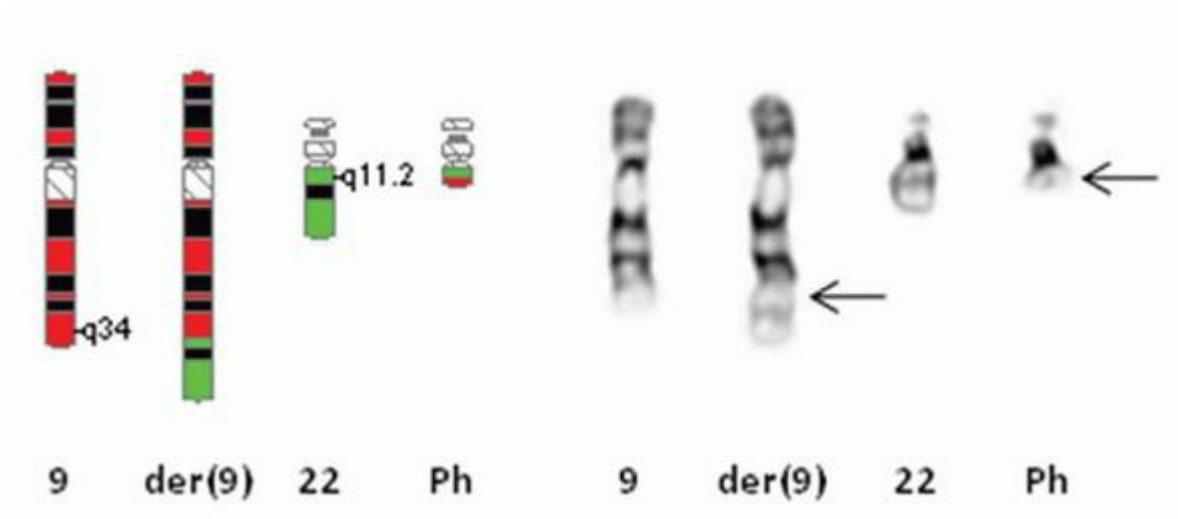

FIGURE 3.2. Illustration of t(9;22) observed in chronic myelogenous leukemia and acute lymphoblastic leukemia. Ideogram of chromosomes #9 and #22 on left with partial karyotype on right. Arrows indicate breakpoints.

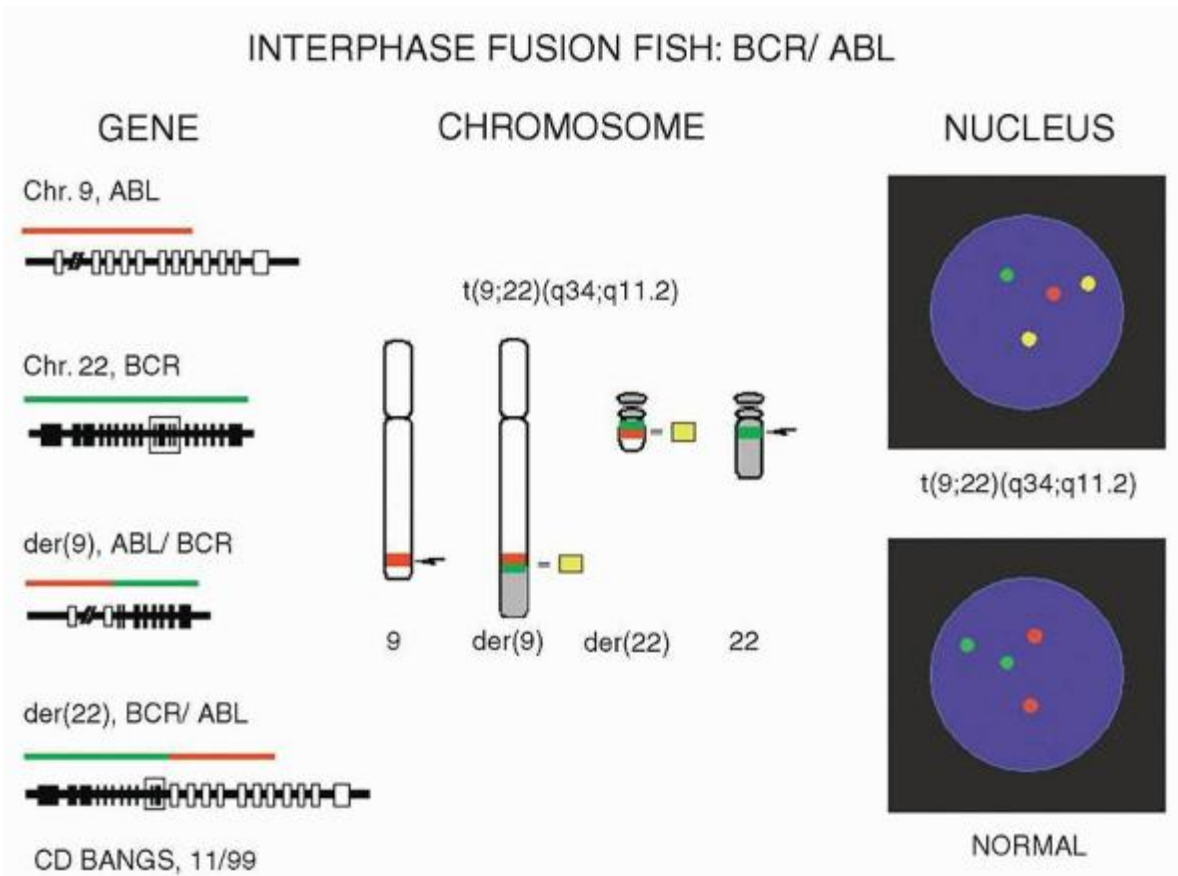

FIGURE 3.3. Fluorescence in situ hybridization illustration of t(9;22) with red-labeled ABL1 probe spanning the breakpoint at 9q34 and green-labeled BCR probe spanning the breakpoint at 22q11.2. At right, nuclei showing abnormal and normal signal pattern with yellow fusions.

CYTOGENETIC ANALYSIS OF HEMATOLOGIC MALIGNANCIES

Cytogenetic analysis of hematologic malignancies involves at least two, if not three, different approaches. The first is “classic chromosome analysis” (CCA). The second is FISH using DNA probes labeled with fluorochrome(s). Whether FISH is performed on metaphase cells (metaphase chromosomes) or interphase cells (resting, non-dividing nuclei), this technique can be used to ask very specific questions. However, to determine the correct interrogating probe, one must know the

question to be answered. The advantage of using interphase FISH is that mitotic cells are not necessary for analysis, as they are for CCA and metaphase FISH. In addition, even formalin-fixed paraffin-embedded tissue can be studied in this fashion. The third approach involves arrays, either CGH arrays, utilizing primarily oligonucleotides spaced throughout the genome, or SNP arrays, with heterozygous SNPs positioned throughout the genome. Both of these array types can be used to determine DNA copy number (one vs. two vs. three); however, loss of heterozygosity (LOH) can only be detected if one uses SNP arrays. In addition, balanced rearrangements (copy neutral), i.e., translocations, inversions, etc., cannot be appreciated by either array method. Malignancies are often made up of both normal and abnormal cells, as well as varying percentages of abnormal clones. This heterogeneity, which can be seen as low levels of mosaicism, typically below 15% to 20%, cannot be detected by array analysis.

CHROMOSOME ANALYSIS

Chromosome analysis can be performed on numerous types of dividing tissue and can help to render diagnoses for constitutional (germ line) chromosome conditions (i.e., trisomy 21), as

P.48

well as acquired (somatic) chromosome abnormalities associated with different types of cancer. Chromosome analysis requires living, dividing cells which are arrested in metaphase by using a substance that inhibits spindle fiber formation during mitosis (e.g., Colcemid, Velban). Typically, leukemias and lymphomas are studied by preparing short-term cultures (direct, 24-, 48-, or 72-hour) grown in suspension. The cells are then “harvested” using a hypotonic solution (sodium chloride or sodium citrate) and fixed using a mixture of methanol and acetic acid. Slides are made by dropping the cell suspension on the slides and drying them. The slides are aged and then banded using trypsin (or pepsin) and Giemsa (or Wright's or Leischman's) stain. This produces the G-banding pattern widely used to recognize and identify chromosomes and their abnormalities (Fig. 3.4). Chromosome analysis is performed by individuals who have been trained to recognize the banding patterns of each individual chromosome pair, chromosomes #1 through #22 and the X and Y sex chromosomes. Banded metaphases are identified and analyzed using a light microscope equipped with high resolution objectives (typically 10× oculars, with 63× or 100× objectives—enlarged up to 1000× their normal size). Images are then acquired using a CCD (charged coupled device) camera, and proprietary software is used to create the karyotype. A karyotype is the chromosomal makeup of a particular cell or individual. The software enables a technologist to create the digital karyotype, but the software/computer cannot completely recognize nor interpret the karyotype; this must be done interactively by the trained technologist. Chromosome analysis of leukemias and lymphomas requires complete analysis of a minimum 20 metaphase cells if possible.¹⁶ This is not a random process. Technologists (or automated imaging systems) scan the slides looking for abnormal metaphases. Often, there are normal metaphases that are part of the milieu. These are typically avoided, if there are abnormal metaphases present. All cells are completely analyzed—matched band-by-band, chromosome-by-chromosome pair, looking for any inconsistencies or abnormalities, be they structural or numerical. Clonal abnormalities are described and documented. Clonal anomalies are defined as two or more cells with the same structural abnormality or same extra chromosome, while loss of a chromosome must be observed in three or more cells in order to be considered clonal.¹⁷ Karyotypes are then created as both an analytical and a documentary tool and the chromosome diagnosis rendered.

TABLE 3.1 CHROMOSOME ABNORMALITIES AND ASSOCIATED DISEASES

Chromosome Abnormality	Genes (HUGO)	Disease
t(9;22)(q34;q11.2)	<i>ABL1, BCR</i>	CML, ALL
del(6)(q23)	<i>MYB</i>	CLL
del(11)(q22)	<i>ATM</i>	CLL
+12		CLL
del(13)(q14)		CLL, MDS, AML
del(17)(p13)	<i>TP53</i>	CLL
t(1;19)(q23;p13.3)	<i>PBX1, TCF3</i>	ALL
t(4;11)(q21;q23)	<i>AFF1, MLL</i>	ALL

t(variant;11)(variant;q23)	<i>MLL</i>	ALL, AML
t(12;21)(p13;q22)	<i>ETV6, RUNX1</i>	ALL
t(1;22)(p13;q13)	<i>RBM15, MKL1</i>	AML (M7)
inv(3)(q21q26.2)/t(3;3)(q21;q26.2)	<i>RPN1, MECOM</i>	AML
t(6;9)(p23;q34)	<i>DEK, NUP214</i>	AML
t(8;21)(q22;q22)	<i>RUNX1T1, RUNX1</i>	AML (M2)
t(9;11)(p22;q23)	<i>MLLT3, MLL</i>	AML
t(15;17)(q24;q21)	<i>PML, RARA</i>	APL (M3)
inv(16)(p13.1q22)/t(16;16)(p13.1;q22)	<i>MYH11, CBFβ</i>	AML (M4)
-5/del(5q)		MDS, AML
-7/del(7q)		MDS, AML
+8		MDS, AML
del(20q)		MDS, AML
t(8;14)(q24;q32)	<i>MYC, IGH@</i>	BL
t(2;8)(p12;q24)	<i>IGK@, MYC</i>	BL
t(8;22)(q24;q11.2)	<i>MYC, IGL@</i>	BL
t(2;5)(p23;q35)	<i>ALK, NPM1</i>	ALCL
t(2;variant)(p23;variant)	<i>ALK</i>	ALCL
t(18;variant)(q21;variant)	<i>BCL2</i>	DLBCL
t(3;variant)(q27;variant)	<i>BCL6</i>	DLBCL
t(8;variant)(q24;variant)	<i>MYC</i>	DLBCL
t(14;18)(q32;q21)	<i>IGH@, BCL2</i>	FL
t(2;18)(p12;q21)	<i>IGK@, BCL2</i>	FL
t(18;22)(q21;q11.2)	<i>BCL2, IGL@</i>	FL
t(11;14)(q13;q32)	<i>CCND1, IGH@</i>	MCL
del(13)(q14)		PCM
del(17)(p13)	<i>TP53</i>	PCM
t(4;14)(p16.3;q32)	<i>FGFR3, IGH@</i>	PCM
t(14;16)(q32;q23)	<i>IGH@, MAF</i>	PCM
t(14;20)(q32;q12)	<i>IGH@, MAFB</i>	PCM

ALCL, anaplastic large cell lymphoma; ALL, acute lymphoblastic leukemia; AML, acute myeloid leukemia; APL, acute promyelocytic leukemia; BL, Burkitt lymphoma/B-cell lymphoma; CLL, chronic lymphocytic leukemia; CML, chronic myelogenous leukemia; DLBCL, diffuse large B-cell lymphoma; FL, follicular lymphoma; MCL, mantle cell lymphoma; MDS, myelodysplastic syndrome; PCM, plasma cell myeloma.

Samples for chromosome analysis—fresh bone marrow, bone core biopsy, or peripheral blood—are transported at room temperature in either a sodium heparinized green-topped tube or in transport media with sodium heparin added to prevent clotting. These samples should be received within 24 hours of collection, if possible. Some bone marrow samples

are particularly finicky and the abnormal clonal cells are fragile (e.g., acute lymphocytic leukemia). Lymphomas are minced and placed into short-term suspension culture.

CYTOGENETIC NOMENCLATURE

It is important for the hematopathologist to have a basic understanding of cytogenetic nomenclature, as he/she is often asked to incorporate this data into an integrated or comprehensive report including all clinical laboratory analytic data on individuals with hematologic malignancies (i.e., flow cytometry, molecular and cytogenetic analytic data). The International System of Cytogenetic Nomenclature (ISCN)¹⁸ is the accepted method of describing the karyotype of an individual or tumor. There are very specific rules for how this information is presented. This is the internationally accepted cytogenetic language that, using alpha/numeric/symbolic string text allows one laboratory to describe what was observed in the karyotype and another laboratory to understand what that means. Every few years this system of nomenclature is updated. The most recent update was in 2009. ISCN first came into existence in 1978; however, there were several conferences held from 1960 until then to codify the human karyotype, with banded ideograms first introduced in 1971. An ideogram is a scientific representation of the light and dark bands, sub-bands

P.49

and sub-sub-bands observed by metaphase chromosome analysis. Each chromosome has its own particular set of recognized bands, which allows it to be identified as such (Fig. 3.5). For instance, all human chromosome #1's look very similar to one another, having the same pattern of light and dark bands, with the exception of a known variant region near the centromere. Chromosomes are divided into short arm and long arm by the centromere or primary constriction, which mediates attachment to the spindle fiber apparatus in mitosis. Bands in the short arm are labeled "p," while bands in the long arm are labeled "q." Each chromosome arm has landmark bands which demarcate the regions of the chromosome arm (this is the first number indicated after the p or q designation). These regions are then divided into bands, and possibly sub-bands or sub-sub-bands. Bands are numbered in increasing order starting at the centromere and proceeding toward the end of the chromosome arm (or telomere). The total number of chromosomes observed is stated first, with the sex chromosome designation given following a comma. There are normally no spaces between the numbers, letters, and punctuations that make up the karyotype designation. As an example, a female patient with the Philadelphia chromosome would have a karyotype written as "46,XX,t(9;22)(q34;q11.2)[18]/46,XX[2]," meaning that she has the Ph or t(9;22) in 18 of her metaphases (18 in []), a slash designating a second normal cell line with 46,XX (or normal chromosomes) in two metaphases (2 in []). The breakpoint in chromosome #9 is at band 9q34 (long arm or q arm, region 3, band 4 or band three four, not thirty-four) and the breakpoint in chromosome #22 is at sub-band 22q11.2 (long arm or q arm, region 1, band 1, sub-band .2 or band one one point two, not eleven point two). There are rules as well for describing both interphase and metaphase FISH (Table 3.2).

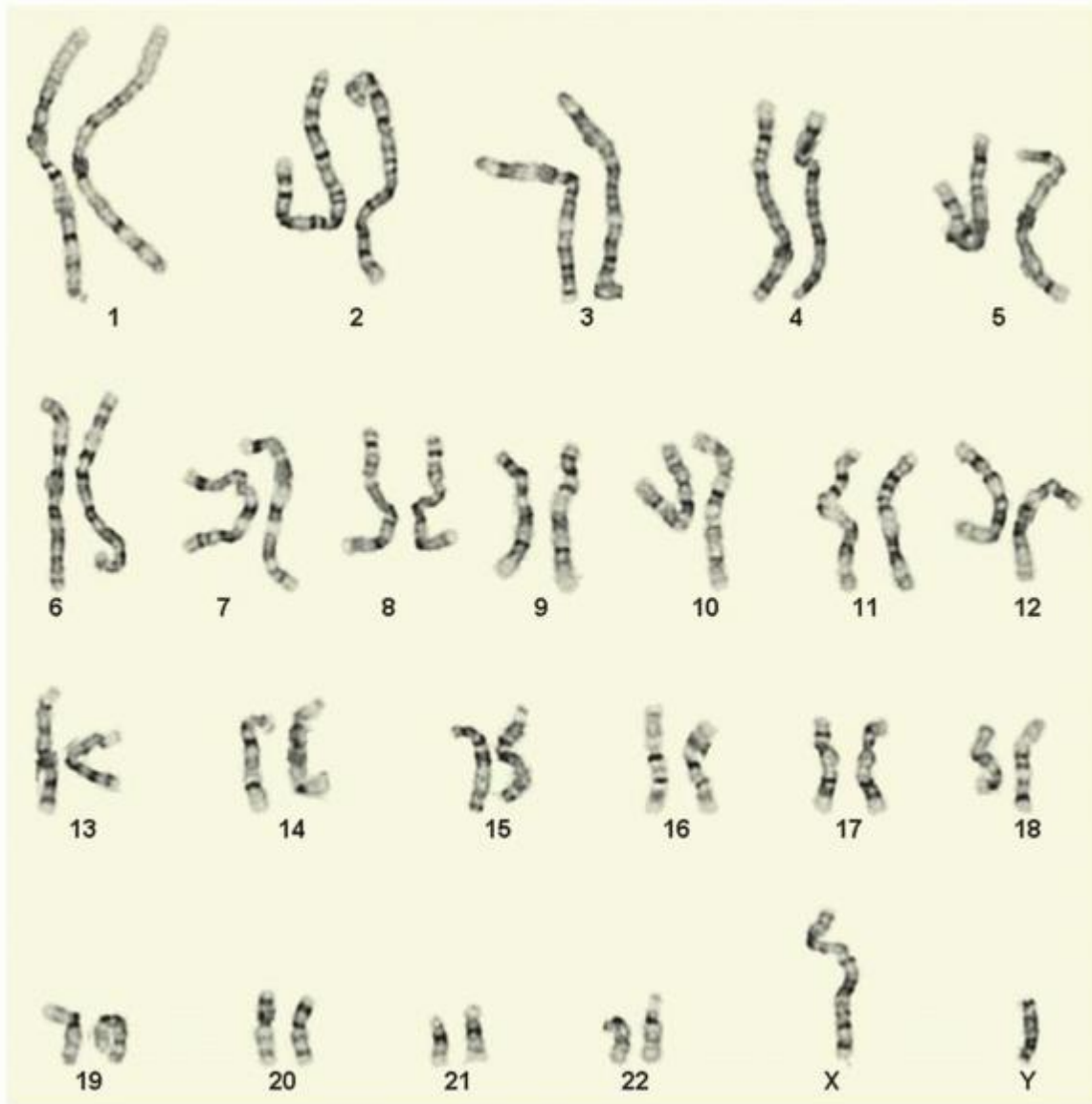

FIGURE 3.4. Normal male G-banded karyotype.

FLUORESCENCE IN SITU HYBRIDIZATION ANALYSIS

In situ hybridization was first described by Gall and Pardue in 1969,¹⁹ when they hybridized radioactively labeled probes to highly repetitive sequences in mouse and *Drosophila*. In 1981 Harper and Saunders²⁰ used a similar technique using tritiated (³H) nucleotides to label probes and autoradiographic methods to map human genes. Also in 1981, Langer et al.²¹ introduced biotinlabeled probes for gene mapping purposes, which then could be detected with streptavidin conjugated antibodies which had been fluorescently tagged. In 1988, Pinkel et al.²² described chromosome painting probes, while Kallioniemi et al. in 1992²³ introduced CGH using metaphase chromosomes as the interrogator.

P.50

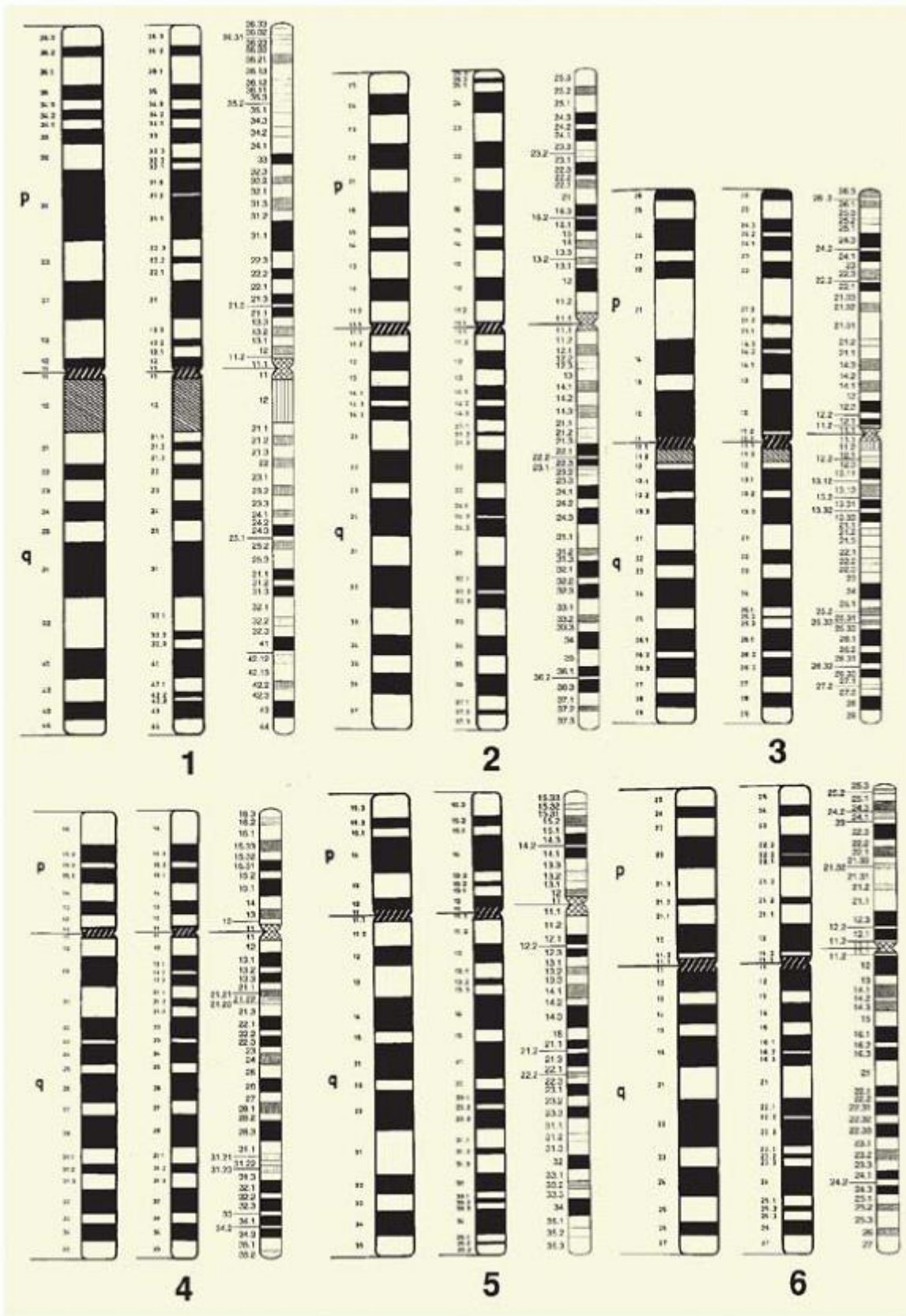

FIGURE 3.5. Ideogram of normal G-banded chromosomes showing banding at 400, 550, and 850 band level of resolution.

TABLE 3.2 FREQUENTLY USED ISCN SYMBOLS AND ABBREVIATED TERMS

Symbol or Term	Interpretation
Add	Additional material of unknown origin
approximate sign (~)	Denotes intervals and boundaries of a chromosome segment or number of chromosomes, fragments, or markers; also used to denote a range of number of copies of a chromosome region
arr	Microarray, array
brackets, angle (<>)	Surround the ploidy level
brackets, square (□)	Surround the number of cells
c	Constitutional anomaly
chr	Chromosome
comma (,)	Separates chromosome number, sex chromosomes, and chromosome abnormalities
con	Connected signals in interphase FISH
cp	Composite karyotype (when karyotype is very heterogeneous)
decimal point (.)	Denotes sub-bands
del	Deletion
der	Derivative chromosome (from a translocation or other rearrangement)
dic	Dicentric chromosome (two centromeres)
dmin	Double minute (amplified material, acentric fragments)
dup	Duplication
hsr	Homogeneously staining region (amplified material within a chromosome)
i	Isochromosome (2 long arms or 2 short arms without the other)
idem	Denotes the stemline karyotype in a subclone
inc	Incomplete karyotype (partially analyzable)
ins	Insertion
inv	Inversion
ish	In situ hybridization
mar	Marker chromosome (unidentified origin)
minus sign (-)	Loss
multiplication sign (×)	Multiple copies
nuc	Nuclear
p	Short arm of a chromosome

parentheses ()	Surround structurally altered chromosomes and breakpoints
period (.)	Separates various techniques
plus sign (+)	Gain
q	Long arm of a chromosome
question mark (?)	Questionable identification of a chromosome, chromosome structure, or breakpoint
r	Ring chromosome
sep	Separated signals (in FISH)
slant line, single (/)	Separates clones
slant line, double (//)	Separates chimeric clones (cross-sex transplant; host//donor)
t	Translocation

In situ hybridization takes advantage of the genetic code, the complementary strands of DNA and their unique, as well as repetitive, sequences. Probes are designed with a particular DNA sequence in mind. These probes are labeled so that they can be detectable, once they have hybridized to the DNA. Target DNA, whether it is in the form of metaphase chromosomes or interphase nuclei, is denatured, as is the DNA probe, using formamide, heat, and salt. The slide/DNA is then re-annealed, so that the DNA probe can hybridize to its complementary target DNA sequence. After hybridization is complete (from a few hours to overnight), the slides are washed and counterstained and the hybridization is visualized. In this manner, questions of loss, gain, or juxtapositioning of target sequences can be answered.

Most DNA probes used for in situ hybridization are directly labeled with fluorochromes and visualized using a fluorescent microscope and the proper filter sets, once the hybridization has taken place. FISH probes can be single copy, unique sequence probes, repetitive probes, or whole chromosome painting probes. Single copy probes can be used to determine copy number (gain or loss) of a single locus or specific chromosome, or can be designed in combination to detect gene rearrangements (either by dual color, dual fusion, or break apart probes, spanning the known breakpoints of critical rearrangements). Single copy probes can also be used to detect amplification of a locus, as in HER2 (ERBB2) amplification in invasive breast carcinoma. Repetitive probes can also be used primarily for chromosome enumeration. These are typically chromosome specific alpha satellite repeats (e.g., DXZ1 and DYZ3 located at the centromeres of the X and Y chromosomes, respectively). There are also chromosome arm specific subtelomeric repeat sequences that are generally within 300 kb of the ends of the chromosomes.

FLUORESCENCE IN SITU HYBRIDIZATION NOMENCLATURE

FISH nomenclature has also been established by the ISCN.¹⁸ FISH can be of either metaphase chromosomes or interphase nuclei. Both have different nomenclature rules. Metaphase FISH is always prefaced by the term “ish,” followed by the locus of the DNA probe used or the abnormality observed. The presence, absence, or appearance of the FISH probes is then described. As an example, an individual who has CML and is Ph chromosome positive might have metaphase FISH (using a dual fusion FISH strategy) which would be written:

46,XX,t(9;22)(q34;q11.2).ish t(9;22)(ABL1+,BCR+;BCR+,ABL1+)[20]

The semicolon separates one chromosome from the other descriptively and shows that while some of ABL1 has remained at 9q34, some is now translocated to 22q11.2, next to BCR, and vice versa. Interphase FISH of this same individual would typically involve scoring 200 interphase nuclei for their signal patterns. This would be described by using the term “nuc ish” followed by the pattern that was observed. This can best be expressed as:

nuc ish(ABL1,BCR)×3(ABL1 con BCR×2)[200]

The above scenario shows that there are three ABL1 signals and three BCR signals; however, two each of these signals are connected (“con”) or fused, representing both the BCR/ABL1 and the ABL1/BCR sequence fusions.

Alternatively, if the patient has a normal karyotype and no evidence of the BCR/ABL1 translocation:

“nuc ish(ABL1,BCR)×2[200]” or “nuc ish(ABL1×2,BCR×2)[200]”

In other words, there are two distinct ABL1 signals and two distinct BCR signals, with no fusion of the two.

It is important to note that while many of the FISH probes used for leukemias, lymphomas, and other solid tumors are FDA approved, all must be validated in the laboratory. Such validation must determine the analytic sensitivity and specificity of each

P.52

probe, and establish normal cutoff values or thresholds for determining whether or not a FISH assay is positive or negative for the aberrant signal pattern.

DIAGNOSTIC AND PROGNOSTIC IMPACT OF CHROMOSOME ABNORMALITIES

As stated earlier, the WHO system¹ has classified many leukemias and lymphomas according to their cytogenetic and/or molecular abnormalities. Many of these have not only diagnostic significance, but prognostic significance as well. While this list is by no means exhaustive, it does inform the reader as to the significance of a number of anomalies (Table 3.3). Please refer to online resources The Atlas of Genetics and Cytogenetics in Oncology and Haematology (<http://atlasgeneticsoncology.org>) and the Mitelman Database of Chromosome Aberrations in Cancer (<http://cgap.nih.gov/Chromosomes/Mitelman>).

Acute Myeloid Leukemia

According to the WHO 2008,¹ there are certain entities of acute myeloid leukemia (AML) defined by their cytogenetic or molecular abnormalities (recurrent genetic abnormalities). The t(8;21) and the inv(16) and its variants, both core binding factor (CBF) abnormalities, as well as the t(15;17) when observed by either CCA, FISH, or PCR, are considered distinct forms of AML, even if the percent blasts is below 20%. All of these have been associated with a good or favorable risk. The t(9;11)(p22;q23) is an entity with an intermediate risk. While the t(6;9)(p23;q34), inv(3)(q21q26) and its variants, as well as the t(1;22)(p13;q13) are distinct AML entities, all with an associated poor risk, it is unclear if cases with blasts below 20% are actually considered AML, or technically should be classified as myelodysplastic syndrome (or MDS).

Acute Myeloid Leukemia Risk Categories

Slovak et al.,²⁹ stratified patients with AML into four risk categories. Those in the favorable group had inv(16), t(15;17) or t(8;21), while those in the unfavorable group had monosomy 5/5q deletion, monosomy 7/7q deletion, inv(3), 11q23 (or MLL) rearrangements, abnormalities of 17p, 20q or 21q, t(6;9), or complex karyotypes (with 3 or more abnormalities). Those in the intermediate group had a normal karyotype, trisomy 8, trisomy 6, deletion of the 12p, or loss of the Y chromosome. There was also an indeterminant group that contained all other chromosome anomalies. Grimwade et al.³⁰ proposed a slightly different prognostic classification scheme. Individuals with inv(16), t(15;17) or t(8;21) were in the favorable group, while those in the adverse group included abnormalities of 3q [excluding t(3;5)(q21~25;q31~35)], inv(3), monosomy 5/5q deletion, monosomy 7/7q deletion, t(6;11), t(10;11), 11q23 (or MLL) rearrangements [excluding t(9;11) and t(11;19)], t(9;22), monosomy 17/abnormalities of 17p, and complex karyotypes (with 4 or more abnormalities). All others fell into the intermediate group.

More recently, several groups have described the “monosomal karyotype” (or MK) which is believed to have a worse prognosis even when compared to those patients with complex karyotypes (with 3 or more abnormalities).^{31,36,37} The concept of a “monosomal karyotype” defined by Breems et al.³¹ was defined as a karyotype with loss of at least one chromosome and at least one structural chromosome abnormality or loss of at least two chromosomes. This concept is rather problematic in that most of the MK+ patients also have complex karyotypes, and so are included in the poor prognostic group despite their MK status. Secondly, MK is often a misnomer because many of the karyotypes are not truly monosomic (missing an entire chromosome), as there are often multiple rearrangements and/or marker chromosomes present (a “marker” is a chromosome whose chromosomal origin is unknown or unidentified). Often cytogeneticists designate an abnormality as a marker, even if it is possible to at least partially identify its origin. These markers may contain obvious or cryptic segments of the monosomic chromosome. As CCA is often subjective, two cytogeneticists might describe the same karyotype in different ways. This makes classification of a karyotype as MK problematic. While there might indeed be a difference in outcome for patients with AML that have complex karyotypes (CK) versus those with monosomal karyotypes (MK) per the Breems et al. definition, separating these two entities is not at all straightforward.

TABLE 3.3 PROGNOSTIC RISKS ASSOCIATED WITH CHROMOSOME ABNORMALITIES

Disease	Risk Categories
---------	-----------------

CML	Poor: additional abnormalities (extra Ph, +8, i(17q), etc.)
CLL	Good: 13q-, normal, +12 Intermediate: 11q- (<i>ATM</i> deletion) Poor: 17p- (<i>TP53</i> deletion) Dohner et al. ²⁴
Adult ALL	Favorable: hyperdiploidy with +4 and +10, 9p- Unfavorable: t(9;22), t(4;11), t(8;14), low hypodiploidy/near triploidy, complex (5 or more abnormalities) Moorman et al. ²⁵
Childhood ALL	Favorable: hyperdiploidy (>50 and <60) with +4, +10 (+17?), t(12;21) Unfavorable: t(9;22), t(v;11q23), 9p-, hypodiploid (<44), t(1;19) Pui et al. ²⁶ ; Heerema et al. ²⁷ ; Raimondi et al. ²⁸
AML	Favorable: inv(16), t(8;21), t(15;17) Intermediate: normal, +8, +6, -Y, 12p- Unfavorable: -5/5q-, -7/7q-, inv(3), 11q23 abnormality, abnormal 17p, 20q or 21q, t(6;9), t(9;22), complex (3 or more abnormalities Very poor: monosomal karyotype (MK) * Slovak et al. ²⁹ ; Grimwade et al. ³⁰ ; Breems et al. ³¹
MDS	High: -7/7q-, complex (3 or more)[en]Intermediate: +8, other anomalies Low: normal, -Y, 5q-, 20q- Greenberg et al. ³²
PCM	Standard: hyperdiploidy (without <i>TP53</i> deletion), t(11;14), t(6;14) Intermediate: t(4;14), 13q- or hypodiploidy by chromosome analysis Poor: 17p-, t(14;16), t(14;20), *1q+/1p- Rajkumar ³³ ; Klein et al. ³⁴ ; Wu et al. ⁵⁵

ALL, acute lymphoblastic leukemia; AML, acute myeloid leukemia; CLL, chronic lymphocytic leukemia; CML, chronic myelogenous leukemia; MDS, myelodysplastic syndrome; PCM, plasma cell myeloma.

ARRAY ANALYSIS

Comprehensive analysis of the cancer genome has become a standard research approach to identify new disease loci that may ultimately lead to new therapeutic strategies. One way of studying

P.53

the genomes of malignancies is to use array analysis (either array CGH or SNP array, or a combination) to discern copy number changes and/or LOH.

While CCA relies upon metaphase chromosome analysis and the ability to recognize differences in banding patterns visible on metaphase chromosomes by light microscopy, array analysis uses any number of known DNA sequences (SNPs, exons, introns, etc.) and determines their copy number. CCA has a resolution of approximately 5 to 10 Mb (megabase pairs or million base pairs of DNA) even at its highest resolution, while array analysis can detect much smaller anomalies on the order of a 50 to 100 kilobase (kb) pairs (a 1,000 times higher resolution). CCA can detect structural rearrangements, whether balanced (two copies of every gene or DNA sequence, just not in the correct order) or unbalanced (one or three copies versus the normal two); however, array analysis cannot detect balanced rearrangements (i.e., balanced translocations or inversions). Array CGH analysis can detect only copy number changes, often referred to as copy number variants (CNVs). CNVs can be benign, disease-associated or of unknown significance.

There are at least two different types of arrays—CGH arrays, which can be made up of probes that are either BACs (bacterial artificial chromosomes) or oligonucleotides (typically 60 base pairs in length that are synthesized and are specific, unique DNA sequences), or SNP arrays. BAC CGH arrays were the first arrays used clinically for the detection of copy number changes.^{38,39} and ⁴⁰ This was seen as a way to do multiple FISH tests simultaneously. These arrays were initially “targeted” arrays which had about 800 probes specific for numerous microdeletion/microduplication syndromes, as well as other Mendelian disorders with associated disease loci. Over the years, because of their reliability and reproducibility, these have been replaced by the more robust oligonucleotide arrays. Oligo arrays typically have anywhere from 44,000 unique sequence probes to over a million. Most clinical laboratories that employ oligo arrays use ones that have between 60,000 and 180,000 probes to detect copy number changes (or CNVs). This detection is performed by labeling patient or tumor DNA and control DNA with different fluorochromes (typically Cy3 and Cy5), denaturing the array DNA as well as the target and control DNAs and hybridizing them together, along with Cot-1 DNA to reduce binding to repetitive sequences. The DNAs will find and hybridize to complementary array probe sequences. After washing, the array is read by a laser which determines the color and intensity of each spot on the array. Using proprietary software, correcting for dye bias and other artifacts, copy number calls are made according to established parameters, typically the \log_2 ratios of the intensities of the different fluorochromes. In most cases the imbalanced regions can be detected by as few as three to five consecutive oligonucleotide probes (Fig. 3.6).

SNP arrays were initially used for genome-wide association studies (GWAS) to find associations of particular SNPs with disease; however, it was discovered that they could also be used to determine copy number.^{41,42} SNP array analysis is slightly different, in that it utilizes SNPs to determine copy number changes with comparison to expected SNP frequencies, as control DNA is not used. SNPs vary from individual to individual. Individuals have different SNPs, one that is arbitrarily called the “A allele” and the other one the “B allele.” It is expected that everyone has two different SNP alleles at various loci (they are AA, AB, or BB). The copy number analysis of SNP array data generally uses two parameters, comparing observed test sample values to expected reference values, the \log_2 R intensity ratio and the allelic intensity ratio or “B allele frequency.” The latter is used to determine stretches of homozygosity (copy neutral changes where only one SNP allele is detected, presumably from either loss of heterozygosity or identity by descent/relatedness/consanguinity). Most SNP arrays now also include unique sequences, other than the SNPs, as they enhance the ability of the SNP array to detect copy number changes. Most SNP arrays contain about 1 million SNPs and another 1 million unique features. More recently, a few companies have created CGH arrays that include SNPs as well as single copy loci. These are called “oligo + SNP” arrays. While the number of SNPs used is much reduced when compared to SNP arrays, they are sufficient to detect clinically significant LOH, particularly in cancer analysis (Fig. 3.7). Many laboratories have adopted either oligonucleotide arrays or these new oligo + SNP arrays due to their robustness and ease of use, particularly when compared to SNP arrays. While it would seem that the more probes the better, the resolution of both CGH and SNP arrays are very similar.

Array analysis has now become “standard of care” and is considered a first line clinical test in individuals with intellectual disability (ID) and congenital anomalies.⁴³ While CCA can detect abnormalities in around 5% of individuals with ID and congenital anomalies, array analysis can detect abnormalities in around 15% to 20% of such individuals.

Although many researchers have used array analysis in hematologic malignancies and other tumors, this type of analysis has yet to become “standard of care.”

Array analysis can detect smaller, cryptic anomalies, and help to further characterize the karyotype of a tumor better than CCA or FISH; however, there are some problems. Malignancies can often be heterogeneous with multiple clones present in only a few cells. These underrepresented clones may well be missed, if they are in less than 15% of the cells. Arrays cannot detect balanced rearrangements, which are commonly observed in hematologic malignancies. Yet another issue is determining whether CNVs or regions of LOH observed in a tumor are constitutional (and not disease related) or acquired, as often normal control DNA from the patient is unavailable.

Chronic Lymphocytic Leukemia and Array Analysis

In chronic lymphocytic leukemia (CLL), CCA of blood or bone marrow has not been very successful, in part due to the lack of neoplastic B-cells that are actively dividing. Investigators have shown that approximately 80% of patients with B-CLL have clonal chromosome abnormalities that can be detected in non-dividing cells of the blood using interphase FISH employing a number of DNA probes specific for the chromosome abnormalities known to be associated with B-CLL. This group of probes is called a “FISH Panel.” Not only are these clonal chromosome abnormalities detectable, they are also of prognostic value. In a study reported by Dohner et al.,²⁴ it was shown that patients could be placed into different risk categories by their FISH abnormalities alone. They found that those patients with a FISH result that was normal, trisomy 12 or 13q deletion (13q-), had a good prognosis, while those with an ATM deletion (11q deletion) were in the intermediate group, and those with a TP53 deletion (17p deletion) were in the poor prognostic group. Currently, FISH

helps to stratify CLL patients. More recently,^{44,45} in vitro stimulation with CpG oligonucleotide DSP30 with mitogens has been shown to improve the proliferation of CLL cells and yield metaphases with abnormal karyotypes. These abnormalities are not detected by the standard FISH panel, and when complex, have been shown to impart a worse prognosis.

More recently, array analysis has been performed on CLL patients. Many authors have shown a high concordance with FISH analysis.^{46,47,48} and ⁴⁹ Array analysis has detected several recurrent chromosome abnormalities that are not part of the standard FISH panel for CLL, including 14q32 abnormalities^{46,48,50,51} and gains of 2p.^{46,50} The clinical significance of these anomalies is unknown. Array analysis has also shown that 13q deletions vary

P.54

P.55

P.56

greatly in size, with some being homozygous deletions and others heterozygous deletions of different sizes.^{46,47} There is some evidence that the larger 13q deletions (>1.25 Mb) have a worse prognosis than those with the smaller deletions (<1.25 Mb).⁵⁰ Overall, array analysis has shown that individuals with a more complex karyotype, either because of overall genomic complexity or clonal diversity, typically have a poorer outcome than those with a simpler karyotype.^{49,51,52} and ⁵³

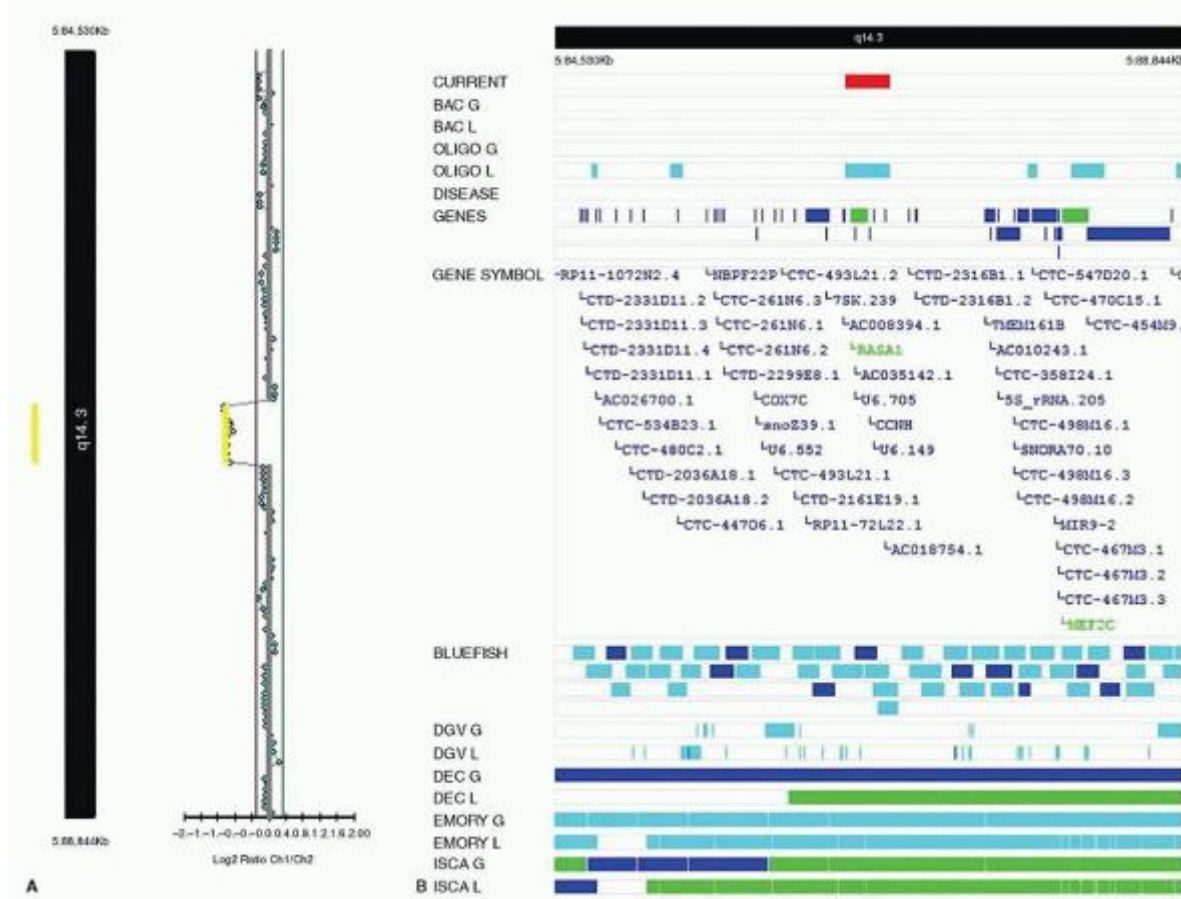

FIGURE 3.6. Oligonucleotide array showing 313 kb loss of 5q14.3. A. log₂ ratio showing loss of approximately 20 oligonucleotide probes. B. 5q14.3 abnormality with loss of RASA1 and CCNH gene loci.

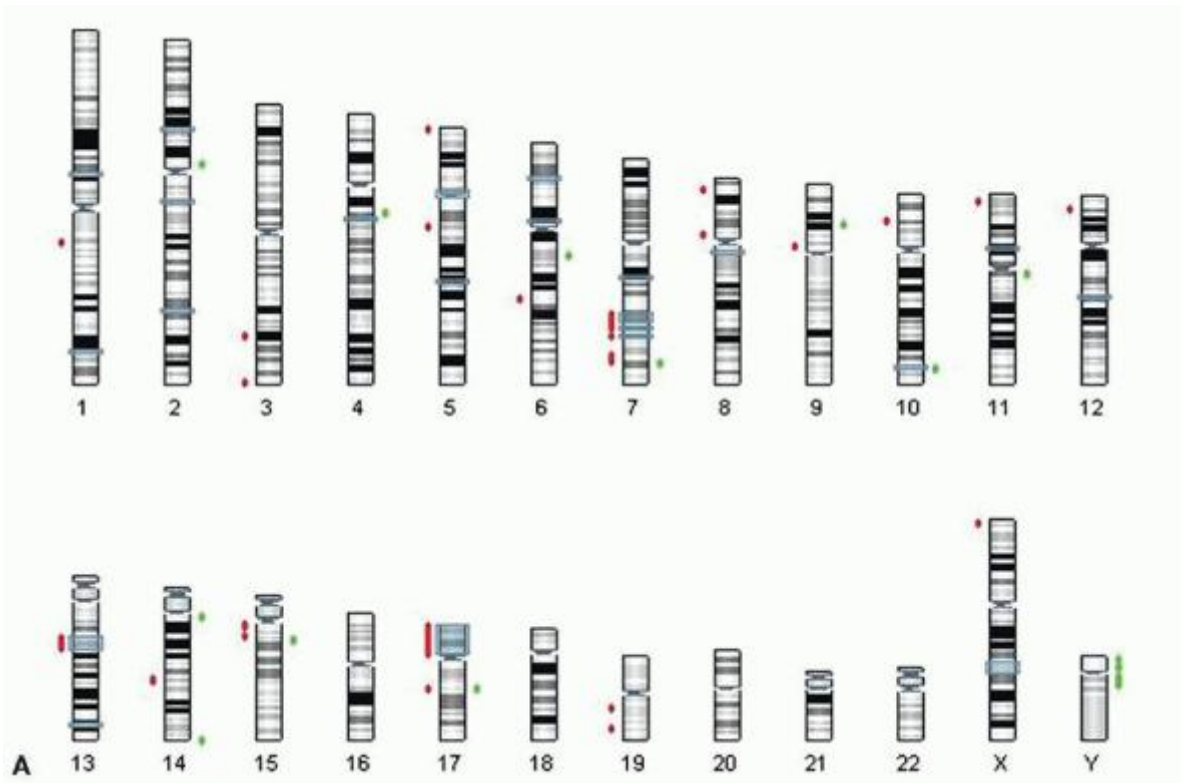

FIGURE 3.7. Oligo + SNP array results for chronic lymphocytic leukemia patient. A. Array karyotype with red blocks indicating areas of loss, green blocks indicating areas of gain and gray blocks denoting LOH. B. \log_2 ratio of X chromosome showing no copy number change. C. Single nucleotide polymorphism array showing only one allele present consistent with loss of heterozygosity (LOH) on the X chromosome. D. Software call of LOH with copy neutral change on the X chromosome including bands Xq22.1 to Xq22.3.

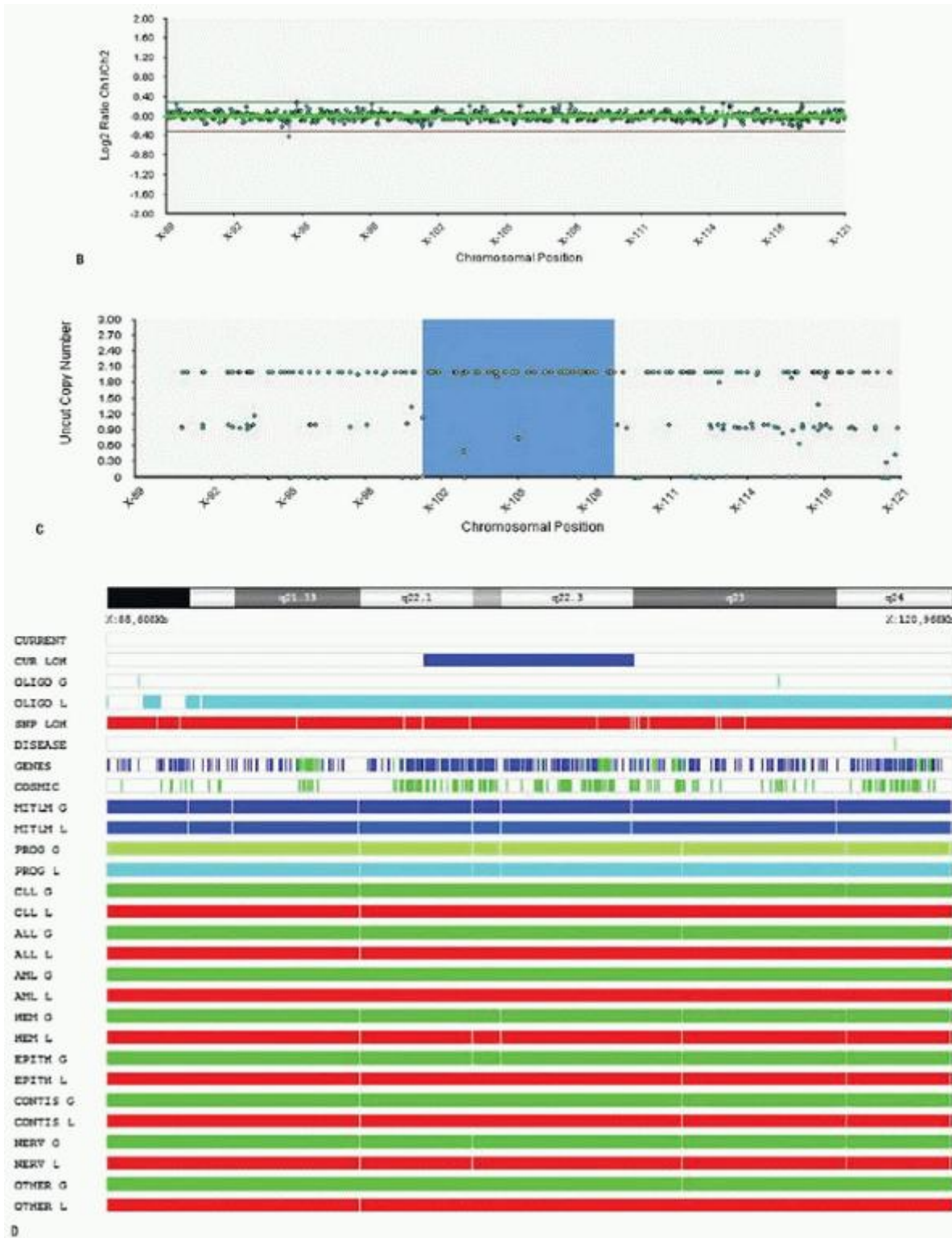

FIGURE 3.7. (Continued)

TABLE 3.4 ABNORMALITIES DETECTED BY ARRAY ANALYSIS IN ACUTE LYMPHOBLASTIC LEUKEMIA

Chromosome Location	Gene (HUGO)	Prognostic Significance
5q34	<i>EBF1</i>	
6q21	<i>FYN</i>	

7p12.2	<i>IKZF1</i>	Poor prognosis (>50% of Ph+ patients) ^{56,57}
7q22.2	<i>NAMPT</i>	
8q21.13	<i>PAG1</i>	
9p21.3	<i>CDKN2A</i>	?poor prognosis
9p13.2	<i>PAX5</i>	?poor prognosis
11p13	<i>RAG1, RAG2</i>	
11q23	<i>MLL</i>	
12p13.2	<i>ETV6</i>	
12p13.1	<i>CDKN1B</i>	
13q14.2	<i>RBI</i>	
18q21	<i>TCF4</i>	
21q22	<i>RUNX1</i>	

Data from Dougherty MJ, Wilmoth DM, Tooke LS, et al. Implementation of high resolution single nucleotide polymorphism array analysis as a clinical test for patients with hematologic malignancies. *Cancer Genet* 2011;204:26-38; Martinelli G, Iacobucci I, Storlazzi CT, et al. *IKZF1* (Ikaros) deletions in BCR-ABL1-positive acute lymphoblastic leukemia are associated with short disease-free survival and high rate of cumulative incidence of relapse. A GIMEMA AL WP report. *J Clin Oncol* 2009;27:5202-5207; Mullighan CG, Su X, Zhang J, et al. Deletion of *IKZF1* and prognosis in acute lymphoblastic leukemia. *N Engl J Med* 2006;360:470-480.

For a good review of abnormalities detected by array analysis of hematologic malignancies, see van der Veken and Buijs⁵⁴ (Table 3.4).

REFERENCES

1. Swerdlow SH, Campo E, Harris NL, et al., eds. WHO classification of tumours of haematopoietic and lymphoid tissues. Lyon, France: WHO Press, 2008.
2. von Hansemann D. Ueber asymmetrische Zelltheilung in Epithelkrebsen und deren biologische Bedeutung. *Virchow's Arch Path Anat* 1890;119:299.
3. Boveri T. Zur Frage der Entstehung maligner Tumoren (The origin of malignant tumors). Gustav Fischer, Jena, Germany, 1914.
4. Painter TS. Studies in mammalian spermatogenesis. II. The spermatogenesis of man. *J Exp Zool* 1923;37:291-321.
5. Tjio HJ, Levan A. The chromosome numbers of man. *Hereditas* 1956;42:1-6.
6. Levan A. Non-random representation of chromosome types in human tumor stemlines. *Hereditas* 1966;55:28-38.
7. van Steenis H. Chromosomes and cancer. *Nature* 1966;209:819-821.
8. Sandberg AA. A chromosomal hypothesis of oncogenesis. *Cancer Genet Cytogenet* 1983;78:277-285.
9. Knudson AG. Mutation and cancer. Statistical study of retinoblastoma. *Proc Natl Acad Sci USA* 1971;68:820-823.
10. Weinberg RA. Oncogenes, antioncogenes, and the molecular basis of multistep carcinogenesis. *Cancer Res* 1989;49:3713-3721.
11. Lejeune J, Gautier M, Turpin MR. Etude des chromosomes somatiques de neuf enfants mongoliens. *CR Acad Sci (Paris)* 1959;248:1721-1722.
12. Nowell PC, Hungerford DA. A minute chromosome in human chronic granulocytic leukemia. *Science* 1960;132:1497-1501.
13. Rowley JD. A new consistent chromosomal abnormality in chronic myelogenous leukaemia identified by quinacrine fluorescence and Giemsa staining. *Nature* 1973;243:290-293.

14. Chissoe SL, Bodenteich A, Wang YF, et al. Sequence and analysis of the human ABL gene, the BCR gene, and regions involved in the Philadelphia chromosomal translocation. *Genomics* 1995;27:67-82.
15. Deininger MW, Druker BJ. Specific targeted therapy of chronic myelogenous leukemia with imatinib. *Pharmacol Rev* 2003;55:401-423.
16. American College of Medical Genetics and Genomics, Standards and Guidelines for Clinical Genetics Laboratories, 2009 edition, Section E: Clinical Cytogenetics E6.2.2.1.
17. Second International Workshop on Chromosomes in Leukemia. General Report. *Cancer Genet Cytogenet* 1980;2:93-96.
18. Shaffer LG, Slovak ML, Campbell LJ, eds. An international system for human cytogenetic nomenclature. Basel, Switzerland: S. Karger, 2009.
19. Gall JG, Pardue ML. Formation and detection of RNA-DNA hybrid molecules in cytological preparations. *Proc Natl Acad Sci USA* 1969;63:378-383.
20. Harper ME, Saunders GF. Localization of single copy DNA sequences on G-banded human chromosomes by in situ hybridization. *Chromosoma* 1981;83:431-439.
21. Langer PR, Waldrop AA, Ward DC. Enzymatic synthesis of biotin-labeled polynucleotides. Novel nucleic acid affinity probes. *Proc Natl Acad Sci USA* 1981;78:6633-6637.
22. Pinkel D, Landergent J, Collins C, et al. Fluorescence in situ hybridization with human chromosome specific libraries. Detection of trisomy 21 and translocations of chromosome 4. *Proc Natl Acad Sci USA* 1988;85:9138-9142.
23. Kallioniemi A, Kallioniemi OP, Sudar D, et al. Comparative genomic hybridization for molecular cytogenetic analysis of solid tumors. *Science* 1992;258:818-821.
24. Dohner H, Stilgenbauer S, Benner A, et al. Genomic aberrations and survival in chronic lymphocytic leukemia. *N Engl J Med* 2000;343:1910-1916.
25. Moorman AV, Harrison CJ, Buck GAN, et al. Karyotype is an independent prognostic factor in adult acute lymphoblastic leukemia (ALL). Analysis of cytogenetic data from patients treated on the Medical Research Council (MRC) UKALLXII/Eastern Cooperative Oncology Group (ECOG) 2993 trial. *Blood* 2007;109:3189-3197.
26. Pui CH, Raimondi SC, Dodge RK, et al. Prognostic importance of structural chromosomal abnormalities in children with hyperdiploid (greater than 50 chromosomes) acute lymphoblastic leukemia. *Blood* 1989;73:1963-1967.
27. Heerema NA, Arthur DC, Sather H, et al. Cytogenetic features of infants less than 12 months of age at diagnosis of acute lymphoblastic leukemia. Impact of the 11q23 breakpoint on outcome. A report of the Children's Cancer Group. *Blood* 1994;83:2274-2284.
28. Raimondi SC, Zhou Y, Mathew S, et al. Reassessment of the prognostic significance of hypodiploidy in pediatric patients with acute lymphoblastic leukemia. *Cancer* 2003;98:2715-2722.
29. Slovak ML, Kopecky KJ, Cassileth PA, et al. Karyotypic analysis predicts outcome preremission and postremission therapy in adult acute myeloid leukemia. A Southwest Oncology Group/Eastern Cooperative Oncology Group study. *Blood* 2000;96:4075-4083.
30. Grimwade D, Hills RK, Moorman AV, et al. Refinement of cytogenetic classification in acute myeloid leukemia. Determination of prognostic significance of rare recurring chromosomal abnormalities among 5876 younger adult patients treated in the United Kingdom Medical Research Council trials. *Blood* 2010;116:354-365.
31. Breems DA, Van Putten WL, De Greef GE, et al. Monosomal karyotype in acute myeloid leukemia. A better indicator of poor prognosis than a complex karyotype. *J Clin Oncol* 2008;26:4791-4797.
32. Greenberg P, Cox C, LeBeau MM, et al. International scoring system for evaluating prognosis in myelodysplastic syndromes. *Blood* 1997;89:2079-2088.
33. Rajkumar SV. Multiple myeloma. 2012 update on diagnosis, risk-stratification and management. *Am J Hematol* 2012;87:79-88.
34. Klein U, Jauch A, Hielscher T, et al. Chromosomal aberrations +1q21 and del(17p13) predict survival in patients with recurrent multiple myeloma treated with lenalidomide and dexamethasone. *Cancer* 2011;117:2136-2144.

35. Dougherty MJ, Wilmoth DM, Tooke LS, et al. Implementation of high resolution single nucleotide polymorphism array analysis as a clinical test for patients with hematologic malignancies. *Cancer Genet* 2011;204:26-38.
36. Medeiros BC, Orthus M, Fang M, Roulston D, Appelbaum FR. Prognostic impact of monosomal karyotype in young adult and elderly acute myeloid leukemia. The Southwest Oncology Group (SWOG) experience. *Blood* 2010;116:2224-2228.
37. Fang M, Storer B, Estey E, et al. Outcome of patients with acute myeloid leukemia with monosomal karyotype who undergo hematopoietic cell transplantation. *Blood* 2011;118:1490-1494.
38. Shaw-Smith C, Redon R, Rickman L, et al. Microarray based comparative genomic hybridisation (array-CGH) detects submicroscopic chromosomal deletions and duplications in patients with learning disability/mental retardation and dysmorphic features. *J Med Genet* 2004;41:241-248.
39. Cheung SW, Shaw CA, Yu W, et al. Development and validation of a CGH microarray for clinical cytogenetic diagnosis. *Genet Med* 2005;7:422-432.
40. Shaffer LG, Kashork CD, Saleki R, et al. Targeted genomic microarray analysis for identification of chromosome abnormalities in 1500 consecutive clinical cases. *J Pediatr* 2006;149:98-102.
41. Gunderson KL, Steemers FJ, Lee G, Mendoza LG, Chee MS. A genome-wide scalable SNP genotyping assay using microarray technology. *Nat Genet* 2005;37:549-554.
42. Syvanen AC. Toward genome-wide SNP genotyping. *Nat Genet* 2005;37:S5-S10.

P.57

43. Miller DT, Adam MP, Aradhya S, et al. Consensus statement. Chromosomal microarray is a first-tier clinical diagnostic test for individuals with developmental disabilities or congenital anomalies. *Am J Hum Genet* 2006;86:749-764.
44. Muthusamy N, Breidenbach H, Andritsos L, et al. Enhanced detection of chromosomal abnormalities in chronic lymphocytic leukemia by conventional cytogenetics using CpG oligonucleotide in combination with pokeweed mitogen and phorbol myristate acetate. *Cancer Genet* 2011;204:77-83.
45. Rigolin GM, Cibien F, Martinelli S, et al. Chromosome aberrations detected by conventional karyotyping using novel mitogens in chronic lymphocytic leukemia with "normal" FISH. Correlations with clinicobiologic parameters. *Blood* 2012;119:2310-2313.
46. Gunn SR, Mohammed MS, Gorre ME, et al. Whole-genome scanning by array comparative genomic hybridization as a clinical tool for risk assessment in chronic lymphocytic leukemia. *J Mol Diagn* 2008;10:441-451.
47. Hagenkord JM, Monzon FA, Kash SF, Lilleberg S, Xie Q, Kant, JA. Array-based karyotyping for prognostic assessment in chronic lymphocytic leukemia. Performance comparison of affymetrix 10K2.0, 250K Nsp and SNP6.0 arrays. *J Mol Diagn* 2010;12:184-196.
48. O'Malley DP, Giudice C, Chang AS, et al. Comparison of array comparative genomic hybridization (aCGH) to FISH and cytogenetics in prognostic evaluation of chronic lymphocytic leukemia. *Intl J Lab Hematol* 2011;33:238-244.
49. Zhang L, Znoyko I, Costa LJ, et al. Clonal diversity analysis using SNP micro-array. A new prognostic tool for chronic lymphocytic leukemia. *Cancer Genet* 2011;204:654-665.
50. Gunnarsson R, Mansouri L, Isaksson A, et al. Array-based genomic screening at diagnosis and during follow-up in chronic lymphocytic leukemia. *Haematologica* 2011;96:1161-1169.
51. Kay NE, Eckel-Passow JE, Braggio E, et al. Progressive but previously untreated CLL patients with greater array CGH complexity exhibit a less durable response to chemoimmunotherapy. *Cancer Genet Cytogenet* 2010;203:161-168.
52. Kujawski L, Ouillette P, Erba H, et al. Genomic complexity identifies patients with aggressive chronic lymphocytic leukemia. *Blood* 2008;112:1993-2003.
53. Zenz T, Mertens D, Dohner H, Stilgenbauer S. Molecular diagnostics in chronic lymphocytic leukemia. Pathogenetic and clinical implications. *Leuk Lymphoma* 2008;49:864-873.
54. van der Veken LT, Buijs A. Array CGH in human leukemia. From somatics to genetics. *Cytogenet Genome Res* 2011;135:260-270.

55. Wu KL, Beverloo B, Lokhorst HM, et al. Abnormalities of chromosome 1p/1q are highly associated with chromosome 13/13q deletions and are an adverse prognostic factor for the outcome of high-dose chemotherapy in patients with multiple myeloma.
56. Martinelli G, Iacobucci I, Storlazzi CT, et al. IKZF1 (Ikaros) deletions in BCR-ABL1-positive acute lymphoblastic leukemia are associated with short disease-free survival and high rate of cumulative incidence of relapse. A GIMEMA AL WP report. *J Clin Oncol* 2009;27:5202-5207.
57. Mullighan CG, Su X, Zhang J, et al. Deletion of IKZF1 and prognosis in acute lymphoblastic leukemia. *N Engl J Med* 2006;360:470-480.

Chapter 4 Molecular Diagnosis in Hematology

INTRODUCTION

Molecular diagnostics, including DNA- and RNA-based testing and genomics, play an increasingly important role in diagnosis and monitoring of patients. The tremendous explosion of knowledge about the molecular pathogenesis of both benign and neoplastic hematologic conditions over the last 20 years has now been translated into routine laboratory assays of high complexity. Such clinical molecular diagnostic assays, including advanced DNA sequencing, microarrays, and highly sensitive polymerase chain reaction (PCR) tests, now impact diagnosis, subclassification, minimal residual disease (MRD) monitoring, outcome prediction, and therapy selection. In this chapter, we review the basis of these molecular techniques and discuss their uses in hematology currently and in the future.

AN OVERVIEW OF MOLECULAR BIOLOGY

DNA, the chromosomal material in the cell nucleus, is transcribed by polymerases to form RNA species with different functions. These include messenger RNA (mRNA) produced from each of the ~20,000 protein coding genes, microRNAs (miRNAs) transcribed from the ~500 regulatory miR genes, and ribosomal and transfer RNAs that are components of the ribosome and the protein biosynthesis machinery. mRNAs are then translated into proteins by the ribosome and then typically degraded quickly because of the actions of miRNAs and cellular nucleases. The set of mRNAs and miR genes that get transcribed in any particular cell is regulated by growth factor-responsive transcription factors, cell type-specific enhancer complexes, and the epigenetic state of the DNA surrounding genes as well as their scaffold histone proteins. Epigenetic modulation of DNA and histones occurs commonly through methylation and acetylation and is dynamically regulated during hematopoietic cell development and during the development of leukemias and lymphomas.^{1,2}

Acquired (somatic) defects in one or more of these processes underlie the development of hematologic conditions (Table 4.1). In addition, inherited gene defects or normal population variations in these cellular functions lead to predisposition to subsequent development of hematologic conditions.^{11,12} With improved understanding of the basic mechanisms underlying disease, therapies which target the type of molecular aberrations in hematologic conditions have increasingly been developed (Table 4.2).

Extraction of Nucleic Acids: The Starting Point for Molecular Assays

Because mutations and alterations in the DNA of disease-causing genes usually lead to detectable aberrations in RNA and protein levels, a variety of analytes are available to diagnose most conditions. DNA is the most stable analyte and can be easily extracted from fresh cells, frozen cells, and formalin-fixed paraffin-embedded (FFPE) tissues. Therefore, DNA is the preferred starting material for most PCR assays and is used for DNA sequencing, for mutation detection by PCR, and for genomic microarrays. DNA is stable at room temperatures for several days, for months to years when refrigerated, and essentially indefinitely when frozen. One exception to the stable preservation of DNA is in decalcified bone marrow trephines where the acid treatment usually fragments the DNA, often making it unsuitable for PCR and microarrays.

DNA can be extracted from cells by a variety of methods, with the first step usually being disruption of the cells using a powerful protease, such as proteinase K, along with a detergent to help solubilize the cell membranes. An RNase enzyme can also be used during this step to degrade the interfering mRNA present. DNA can then be selectively isolated from this mixture using column chromatography, organic extraction of proteins followed by alcohol precipitation, or by the binding of DNA to solid substrates such as glass beads.

RNA is much more labile than DNA and can be quickly degraded in unprocessed blood and bone marrow samples and in FFPE tissues. However, RNA is still the preferred substrate to detect fusion transcripts that occur in hematologic neoplasms (e.g., BCR-ABL1) and when mRNA or miR expression analysis is needed. Most RNAs begin to degrade within

two to three days of blood or bone marrow collection even if the unprocessed sample is refrigerated; RNA must be stored frozen once extracted from cells.

RNA can be isolated from cells using methods similar to those described for DNA extraction above. Care must be taken during extraction to neutralize the RNA-degrading enzymes present in the environment and within the cells themselves. For most molecular assays, RNA is next converted into complementary DNA (cDNA) using reverse transcriptase as the first step in the protocol.

P.59

Isolation of miRs often requires modified extraction methods, but they can also be quantified using reverse transcriptase (RT)-PCR and may be more stable than mRNAs.

TABLE 4.1 DEFECTS IN THE CELLULAR MOLECULAR MACHINERY UNDERLYING HEMATOLOGIC DISORDERS

Alteration Type	Hematologic Condition(s)	Methods to Detect	References
Large DNA deletions	Thalassemias	Southern blot, genomic assays	3
DNA repeats/insertions	Inherited cytopenias, drug response in leukemia	Southern blot, genomic arrays, PCR	4,5
DNA point mutations	Acute and chronic leukemias, lymphomas	AS-PCR, DNA sequencing, arrays	6,7
Epigenetic regulation	Bone marrow failure, myelodysplasia	Methylation sequencing, methylationsensitive PCR, pyrosequencing	8
Ribosomal biogenesis	Diamond Blackfan anemia	Transcript profiling, protein expression	9
Alternate mRNA species	Coagulopathy	Transcript profiling, protein expression	10

AS-PCR, allele-specific PCR; mRNA, messenger RNA; PCR, polymerase chain reaction.

TABLE 4.2 TARGETABLE PATHWAYS ACTIVATED IN HEMATOLYMPHOID TUMORS

Tumor type	Genetic alteration/mutation	Tumor type(s)	Effect(s)
Myeloid neoplasms (all)	<i>TET2</i> , <i>IDH1/2</i> , DNMT3A gene mutations	MPNs, MDS, AML, CMML	Epigenetic regulation of transcription ¹³
Myeloproliferative neoplasms	<i>BCR-ABL1</i> fusion PM <i>MPL</i> receptor kinase fusion <i>KIT</i> receptor PM <i>PDGFR</i> kinase PM	CML MPNs MPNs HES/MCD MCD	Activation of kinase or ligand-independent signaling or hypersensitivity to lower levels of growth factor ¹⁴
Acute myeloid leukemia	<i>KIT</i> receptor PM <i>FLT3</i> receptor PM, ITD	CBF-AML AML	Ligand-independent signaling ¹⁵
Lymphoma	<i>AKT1</i> & <i>TCL1</i> activation kinase activation <i>LCK</i> fusion/mutation	B-NHL PTCL ALL-T	Hypersensitivity to BCR, TCR, and growth factor signaling ^{16,17 and 18}

MPN, myeloproliferative neoplasm; MDS, myelodysplastic syndrome; AML, acute myeloid leukemia; CMML, chronic myelomonocytic leukemia; CML, chronic myelogenous leukemia; PM, point mutation; ITD, internal tandem duplication; HES, hypereosinophilic syndrome; MCD, mast cell

disease; CBF, core binding factor leukemia; B-NHL, B-cell non-Hodgkin's lymphoma; BCR, B-cell receptor; TCR, T-cell receptor; PTCL, peripheral T-cell lymphoma; ALL-T, T-cell acute lymphoblastic leukemia/lymphoma.

More recently, clinical assays have begun to assess the cellular epigenetic state through the detection of methylated DNA, which is typically analyzed after the methylated cytosines have been converted following deamination by bisulfite treatment. Abnormalities in protein expression are commonly assessed using immunohistochemistry on fixed tissues, or blotting or immunoassays on fresh samples. A more complete view of the genome can be obtained using conventional karyotyping of chromosomes in fresh samples, or by fluorescence in situ hybridization (FISH) and genomic DNA microarrays on fresh and fixed materials. These techniques are described in more detail in Chapter 3.

Polymerase Chain Reaction: The Indispensable Molecular Technique

From its first application to bacterial genetics in the early 1980s, PCR has been the central technique for amplifying genes so they can be sized to look for pathogenic insertions or deletions; sequenced to look for base pair mutations; and labeled with radioactivity, fluorochromes, or chromogenic moieties to use as probes in blots and reverse microarrays. The PCR technique involves the sequential amplification by repeated cycles of DNA denaturation, reannealing, and polymerase extension of DNA targets using flanking oligonucleotides (Fig. 4.1A). In the initial cycles of the PCR, the target is exponentially amplified before gradually plateauing when the large amount of product present tends to favor reannealing of double-stranded templates rather than primer binding/extension.

To detect the products that have been amplified by PCR, the reaction is typically run out on a solid agarose or polyacrylamide substrate or gel. These PCR amplicons can be detected by a laser using capillary electrophoresis if one of the primers has been labeled with a fluorochrome (Fig. 4.1B), or by slab gel electrophoresis followed by post-staining with a DNA-binding dye (e.g., ethidium bromide) that can be visualized with ultraviolet light (see Fig. 4.2, Step 1). As described above, if RNA is to be analyzed by PCR, it is first converted into cDNA in a technique known as RT-PCR.

If fluorescent probes are added into the reaction, real-time or quantitative PCR (qPCR) can be performed to calculate the amount of an RNA or DNA target present in the initial sample. A common qPCR design is the TaqMan short, gene-specific probe that has a reporter fluorophore at its 5' end and a quencher molecule at the 3' end. The probe hybridizes to its target amplicon during the annealing step of each PCR cycle and is then hydrolyzed by the 5' exonuclease activity of Taq polymerase during DNA extension. When the TaqMan probe is hydrolyzed, the reporter fluorophore is detached from the adjacent quencher molecule and fluoresces in an amount proportional to the degree of PCR product amplification. Thus, as probe is bound to template and its reporter released by the polymerase extension, the detected fluorescence rises exponentially.

In qPCR, the amount of initial target present in a PCR is backcalculated by observing the PCR cycle in which the fluorescence signal first becomes detectable. This threshold cycle (Ct) can then be used for absolute or relative quantitation. For absolute quantitation, the observed Ct is converted to a target copy number by plotting it on a standard curve (log Ct vs. starting copy number) constructed from samples with a known target copy number (Fig. 4.1C). For relative quantitation, target quantities are expressed relative to a co-amplified normalizer control (e.g., a highly expressed housekeeping gene such as ACTB [β -ACTIN] or ABL1). The quantity is then represented as a relative ratio most commonly the delta-Ct calculation: [relative quantity] = $2^{-(Ct \text{ of gene target} - Ct \text{ of reference gene})}$.

A specialized form of qPCR used to detect single base pair changes in DNA is allele-specific (AS)-PCR. This method compares the amplification levels of a PCR probe or primer that recognizes one allele versus the signal from a probe that recognizes only the other allele. This same protocol can also be used to sensitively detect the level of mutated sequences in neoplasms.¹⁹ This method can routinely detect the presence of a mutation down to 0.1% of the template in the sample (Fig. 4.1D).

DNA Sequencing: The Technique Driving the Genomic Revolution

The DNA sequence of genes is built up from combinations of four nucleotides, adenine (A), cytosine (C), guanine (G), and thymine (T), and their epigenetically modified variants, particularly 5-methylcytosine. DNA sequencing to determine the base composition of the genome was first routinely applied in the late 1970s but has remained a difficult and expensive technique until the last several years.

The accurate but costly gold-standard technique for determining DNA base composition, developed by Frederic Sanger, is called the dideoxy chain termination method.²⁰ After an initial PCR step to amplify the gene of interest, this method relies on a second asymmetric PCR step in which stops in the PCR extension are randomly introduced at each position in the product by adding fluorescently labeled chain terminating variants of the A, C, G, and T nucleotides, each terminating

nucleotide being labeled with a different color (green, blue, black, and red). This range of DNA molecules each terminated at a different position are then separated by size using electrophoresis and the sequence read by laser detection of the terminally labeled nucleotide (Fig. 4.2).

P.60

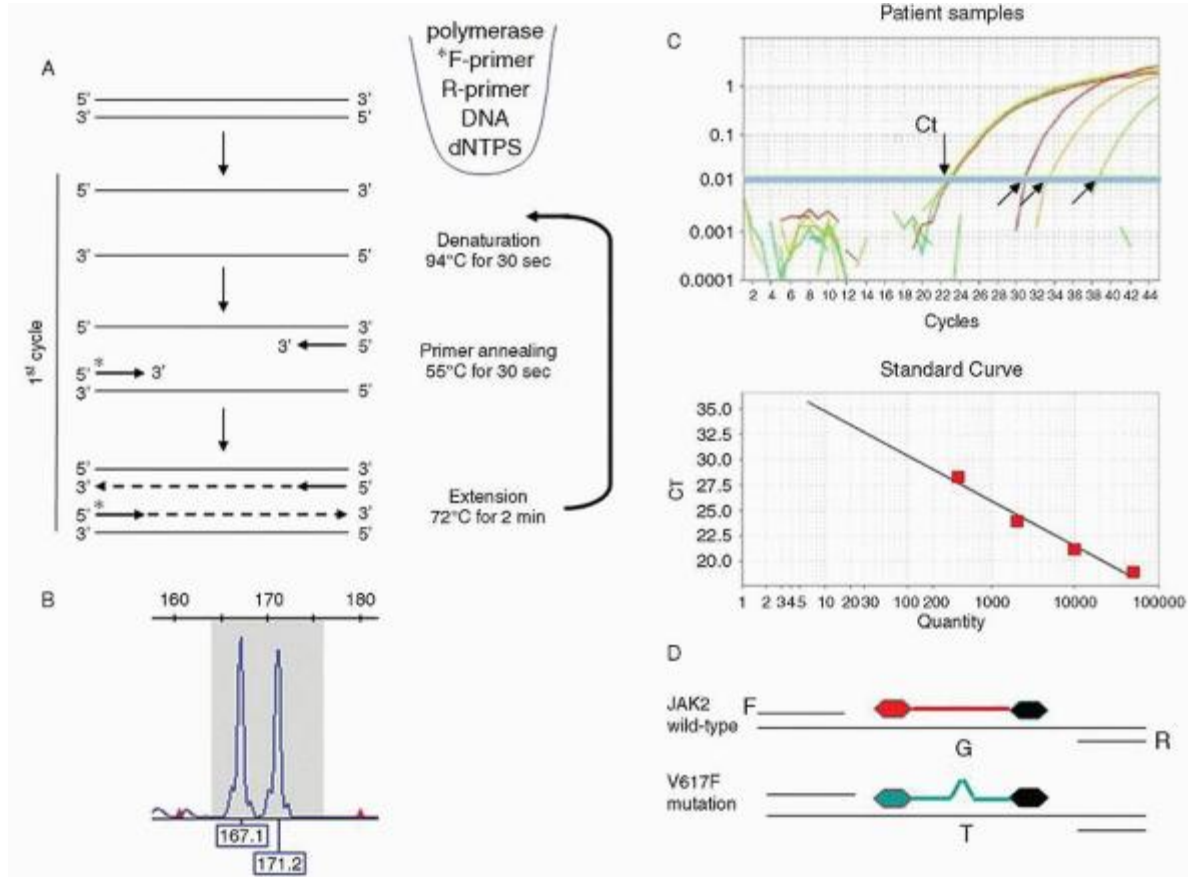

FIGURE 4.1. Polymerase chain reaction (PCR). A. A three-stage conventional PCR, with denaturation, annealing, and extension steps. Components of the typical PCR are illustrated including a DNA template (e.g., target gene), unlabeled nucleotides (dNTPs), a DNA polymerase to copy the templates and forward (F) and reverse (R) DNA primers, one of which is fluorescently labeled (*). B. Fluorescent products from the above PCR are then detected by capillary electrophoresis. Shown is a trace with a normally sized 167 base pair NPM1 gene product and an abnormal copy with a 4 base pair insertion (171b) characteristic of acute myeloid leukemia. C. Quantitative PCR using the TaqMan method with four samples showing differing amounts of the target gene as indicated by Cts ranging from 23 to 39 cycles (arrows). A graph showing 10-fold dilutions of a reference sample is plotted below, which are used to convert Ct in patient sample into copy number. D. Design of a TaqMan qPCR assay for detection of the JAK2 V617F mutation, with identical F and R primers but two different fluorescent probes; the red one detecting the normal JAK2 sequence (“G” at that position), and a green probe recognizing the mutated “T” sequence. The black 3’ moiety on the probes represents the quencher dye.

Newer generations of sequencing technologies that are much faster and cheaper to perform are currently replacing the Sanger method and typically use a sequencing-by-synthesis approach. As each nucleotide is added to a growing chain of DNA by the polymerase, its incorporation is detected by release of product or by its chemical or electrochemical properties.^{21,22}

Blotting and Array Methods

An alternate method for investigating DNA sequences is solid phase hybridization, in which enzymatically-digested total genomic DNA or RNA from a cell (or specific PCR products) are size-separated using slab gel electrophoresis and then the products are transferred in place from the gel to a nylon or nitrocellulose membrane. This membrane is hybridized with a

labeled DNA probe that detects the gene target. The binding of that probe is then visualized using autoradiography or colorimetric detection. In the Southern blot application, prior to electrophoresis genomic DNA is digested with one or more restriction endonucleases that cut(s) within the gene(s) of interest, so that any disruption of the gene (by insertion, deletion, or recombination) is detected by an alternately-sized banding pattern following electrophoresis and probing (Fig. 4.3).

Southern blot is a labor-intensive technique which typically requires several days. For this reason, currently the principal uses of Southern blot in hematology are detecting deletions or amplifications in large genes and their enhancer control regions, such as the globin genes in thalassemia. In these applications, the size of the chromosomal area to be investigated and thus the number of DNA nucleotides to be analyzed are usually too large to be conveniently spanned by PCR and PCR-based DNA sequencing.

A related blotting application is reverse hybridization, in which DNA sequences from a tumor or patient's normal DNA are PCR amplified and then labeled and hybridized against an array of probes that have been spotted on a membrane or other matrix. These applications are widely used to detect the specific strain of a particular virus present in a sample but in hematology are mostly used for large scale cytogenetic microarray applications that are covered elsewhere in Chapter 3.

P.61

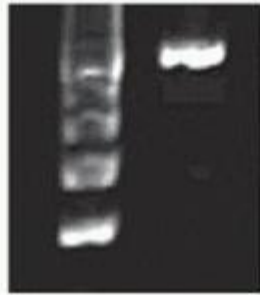

Step 2: Cycle-sequence by PCR with chain terminator fluorescent dNTPs

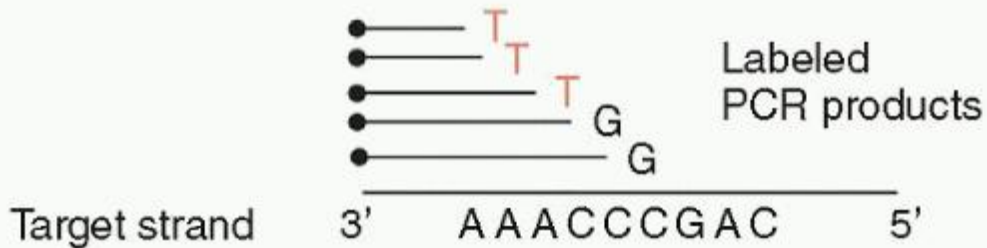

Step 3: Detect products with capillary electrophoresis

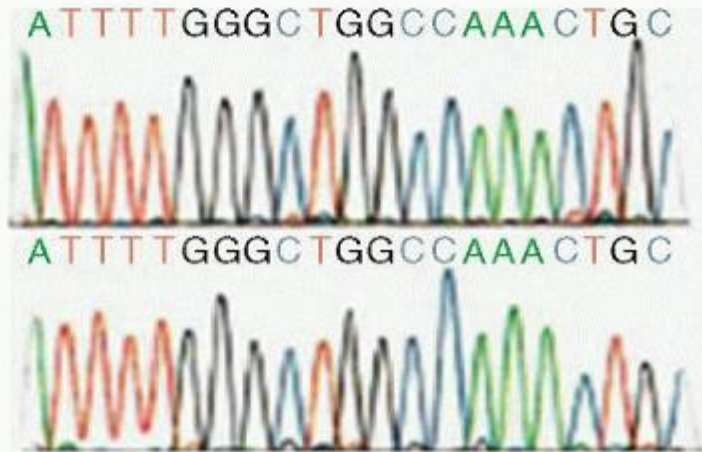

FIGURE 4.2. DNA Sequencing. Steps in the dideoxy chain termination (Sanger) method include: Step 1: Standard polymerase chain reaction (PCR) to produce large amounts of a genespecific template, detected by slab electrophoresis followed by ethidium bromide staining of the gel. Step 2: Unidirectional (or asymmetric) PCR using the template from the first PCR along with either a forward or reverse primer in a reaction containing normal nucleotides mixed with chain terminating A, C, G, and T bases. Step 3: The range of products from the asymmetric PCR which are terminated at every possible base in the PCR amplicon are then separated by capillary electrophoresis and detected by a laser recognizing the fluorochrome/nucleotide present at the end of products. Base-calling is performed using software which normalizes the peak heights to produce the depicted electropherogram.

MOLECULAR DIAGNOSTIC APPLICATIONS IN HEMATOLOGY

The diagnosis of specific types of lymphoid and myeloid malignancies is discussed elsewhere in this volume, but here we summarize generally how molecular techniques are used to assist in their diagnosis. The current schema for diagnosis of hematologic neoplasms is the World Health Organization (WHO) Classification of Hematologic and Lymphoid Neoplasms.²³

This classification incorporates morphology and immunophenotypic features but also increasingly relies on molecular and cytogenetic testing for definitive diagnosis.

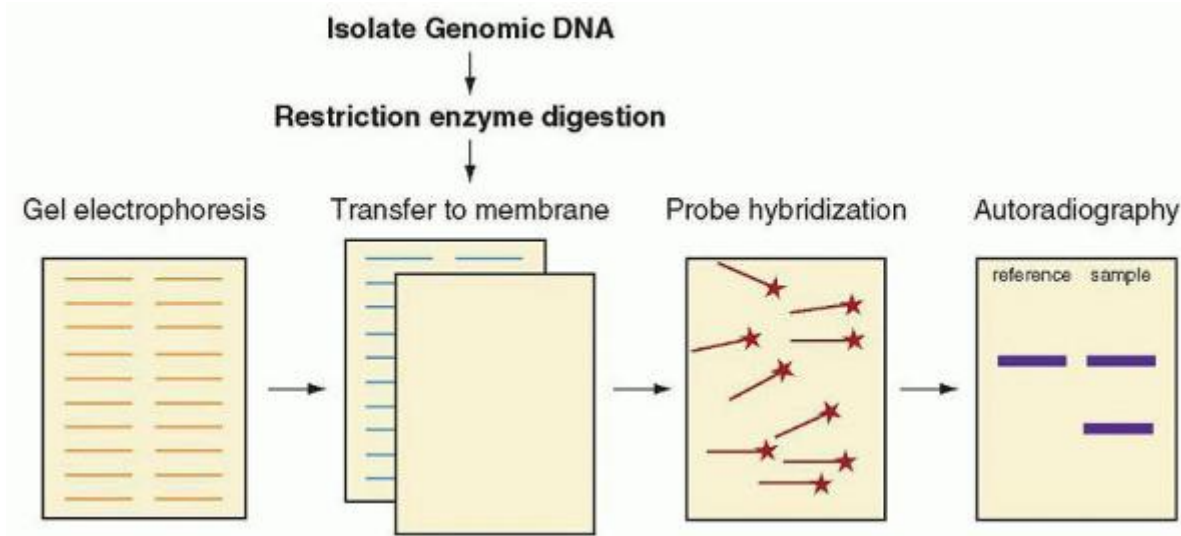

FIGURE 4.3. Blot hybridization. Steps in the Southern blot are illustrated for a reference and patient sample. See text for additional explanation.

Molecular Diagnostics of Myeloid Neoplasms

Myeloid malignancies can be divided into myeloproliferative neoplasms (MPNs), in which the pathogenetic mutations do not significantly impair cell maturation but instead drive growth, and acute myeloid leukemia (AML) and myelodysplastic syndrome (MDS), in which maturation is impaired (see also Chapter 72).

MPNs show a range of recurrent chromosomal translocations, such as the BCR-ABL1 fusion in chronic myelogenous leukemia (CML) that can be detected by RT-PCR as well as by FISH.²⁴ In CML, levels of the BCR-ABL1 fusion transcript detected by a realtime RT-PCR method are now used to monitor the course of CML therapy with imatinib and other drugs, and to trigger a change in treatment in drug-resistant cases.²⁵ Given the importance of this test for clinical management, significant progress has been made in standardizing both the PCR protocol^{26,27} and the reference materials used to calibrate the BCR-ABL1 PCR assay.²⁸ Mutations in the tyrosine kinase JAK2 are the most commonly detected pathogenetic marker for a group of MPNs that include polycythemia vera, essential thrombocythemia, and primary myelofibrosis.²⁹ Detection of the most common JAK2 mutation (V617F) can be done by AS-PCR, providing a highly sensitive method of monitoring disease course in JAK2-mutated MPNs (Fig. 4.1D).

In AML and MDS, karyotypic findings along with hematologic parameters remain the principle determinants of diagnostic classification and outcome prediction, as codified in WHO classification and the International Prognostic Scoring System (IPSS) for MDS.^{23,30,31,32} Some of the chromosomal translocations that occur in AML, such as the inv(16)/t(16;16) in acute myelomonocytic leukemia and the t(15;17) in acute promyelocytic leukemias, are best monitored by RT-PCR.^{33,34}

However, characteristic mutations, such as NPM1 duplications seen in a subset of normal diploid karyotype AML, can be detected by PCR sizing assays (Fig. 4.1B).³⁵ Other mutations provide important prognostic information in AML, including activating insertions/duplications in the FLT3 receptor tyrosine kinase (RTK), which can be detected by PCR sizing assays; and mutations in the KIT RTK, which can be detected by DNA sequencing (Fig. 4.4A,B). Another set of genes, including TET2, IDH1, IDH2, KRAS, NRAS, EZH2, and ASXL1, are mutated in MPNs as well as AML and MDS, making a common molecular panel useful for diagnosis and risk stratification in all myeloid neoplasms.^{36,37}

Molecular Diagnostics in Lymphomas and Benign Lymphoid Expansions

The lymphoid neoplasms were the first tumor types to have a standardized diagnostic schema based on lymphocyte maturation stage, beginning in the 1960s. The current standard for diagnosis

P.62

in hematopathology, the WHO Classification of Hematologic and Lymphoid Neoplasms,²³ represents an evolution and integration of the previous largely separate efforts in morphology and molecular genetics.

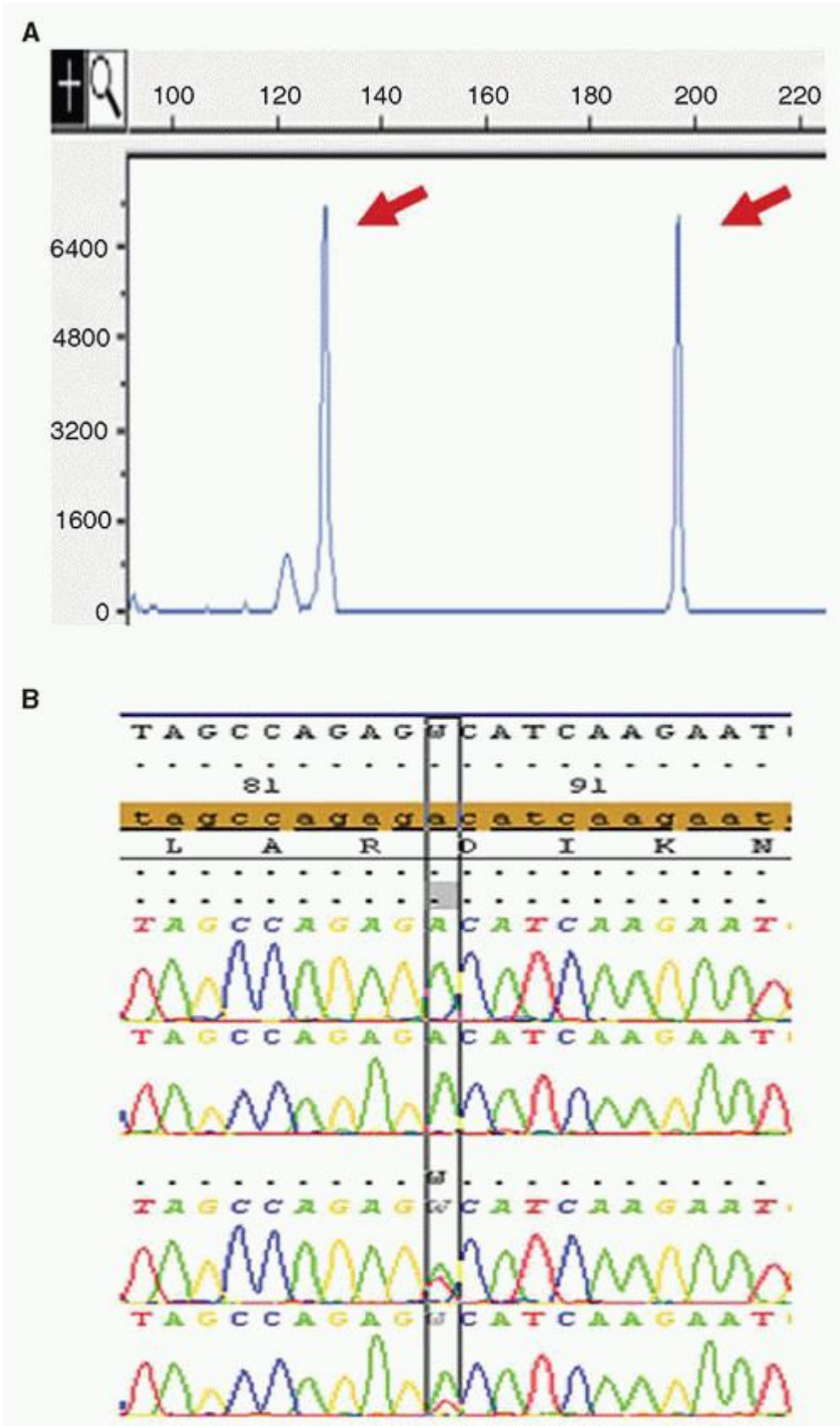

FIGURE 4.4. Detection of mutations in acute myeloid leukemia (AML). A. FLT3 duplication detected by PCR followed by capillary electrophoretic fragment analysis. B. KIT mutation (D816V) in AML is illustrated by a double peak (boxed) in the

lower electropherogram present in both forward and reverse sequences, as opposed to the single wild-type peak noted in the reference unmutated sequence above. The method is dideoxy chain termination DNA sequencing, as in Figure 4.3. Images courtesy of Dr. Zhong Zhang.

The general principle of classification in the WHO schema and its predecessors is to map neoplasms to the maturation stage of the normal counterpart which they most resemble.³⁸ Although this simplistic model does not account for all the observed heterogeneity in lymphomas, it has been incredibly successful in placing tumor entities in a comprehensible and easy to remember framework for diagnosis. Therefore, we summarize below how the genetic changes detected by molecular diagnostics correlate with the morphologic groups of both mature and immature B-cell and T-cell neoplasms,³⁹ with a more detailed review provided in Chapter 87.

Defining Molecular Events in Lymphoid Neoplasms

In acute lymphoid leukemia/lymphoblast lymphoma of B-cell lineage (ALL/LBL), these diagnostic changes include chromosomal fusions that can be detected by RT-PCR, FISH, or by expression microarray.⁴⁰ In T-cell lineage ALL/LBL, diagnostic molecular events include mutations in the NOTCH1 gene⁴¹ and gene activation of HOX regulatory genes through the chromosomal rearrangements that juxtapose the target oncogene next to the T-cell receptor (TCR) enhancer, which selectively drives aberrant expression in the T-cell clone. The gene expression changes induced by oncogene activation can also be detected with RNA expression microarrays.⁴²

In mature B-cell lymphomas, chromosomal translocations that juxtapose a variety of different oncogenes next to an immunoglobulin gene (Ig) enhancer (usually) are important initiating events and can be detected by PCR or FISH.⁴³ In follicular lymphoma, Burkitt lymphoma, marginal zone lymphoma, and mantle cell lymphoma, these Ig-enhancer-driven oncogenes typically include BCL2, MYC, MALT1, and Cyclin D1/CCND1, respectively (Table 4.3). Molecular variants of these lymphomas that lack these classical translocations often activate homologous genes, e.g., the activation of Cyclin D3/CCND3 in variants of mantle cell lymphoma.⁴⁴

In mature T-cell lymphomas, reciprocal chromosomal translocations are much less common, occurring generally only in classical anaplastic large cell lymphoma and T-cell prolymphocytic leukemia. In these two neoplasms, PCR, FISH, or immunohistochemistry to detect the abnormally expressed protein (ALK and TCL1, respectively) are diagnostic modalities.⁴⁵ Recently, other translocations which affect signaling pathways have been identified.⁴⁶ However, in other T-cell neoplasms, gene instability resulting in multiple chromosomal alteration and gene mutations, similar to that seen in poor-risk AML, is commonly seen. This finding suggests that genomic arrays may be useful diagnostic tests for these uncommon tumors.^{47,48}

Using Polymerase Chain Reaction to Detect B-cell and T-cell Clonality

One of the other key diagnostic issues in hematology is distinguishing benign lymphoid expansions, as seen in autoimmune diseases and

P.63

infections, from clonal proliferations associated with lymphoid leukemias and lymphomas. The core methodology in making this distinction is multiparameter flow cytometry, which can determine even subtle emerging clonal expansions. However, PCR analysis of the B-cell receptor (BCR) and TCR has an important ancillary role, especially when fixed tissue specimens, which cannot be used for flow cytometry, are the only available samples.

TABLE 4.3 DIAGNOSTIC TESTS USED FOR THE WORKUP OF LYMPHOMA

	Test type
All cases	<ul style="list-style-type: none"> • Morphologic examination • IHC or flow cytometry panel
Subtyping by FISH, PCR, or IHC CLL/SLL	FISH for D13/del13q, del17p13/ <i>TP53</i> , del11q/ <i>ATM</i> , <i>CEP12</i>
Mantle cell lymphoma	Cyclin D1 IHC or t(11;14)/ <i>CCND1-IGH</i> @ FISH
Follicular lymphoma	<i>BCL2/BCL6</i> IHC or t(14;18)/ <i>IGH-BCL2</i> FISH
Marginal zone lymphoma	t(18q21;var)/ <i>MALT1</i> FISH del7q FISH for splenic variants

High-grade B-cell/Burkitt
ALCL

MYC; IGH@ BCL2; BCL6 FISH
ALK IHC or t(2;5)/*ALK-NPM1*

IHC, immunohistochemistry; FISH, fluorescence in situ hybridization; PCR, polymerase chain reaction; CLL/SLL, chronic lymphocytic leukemia/small lymphocytic lymphoma; ALCL, anaplastic large cell lymphoma; ALK, anaplastic lymphoma kinase.

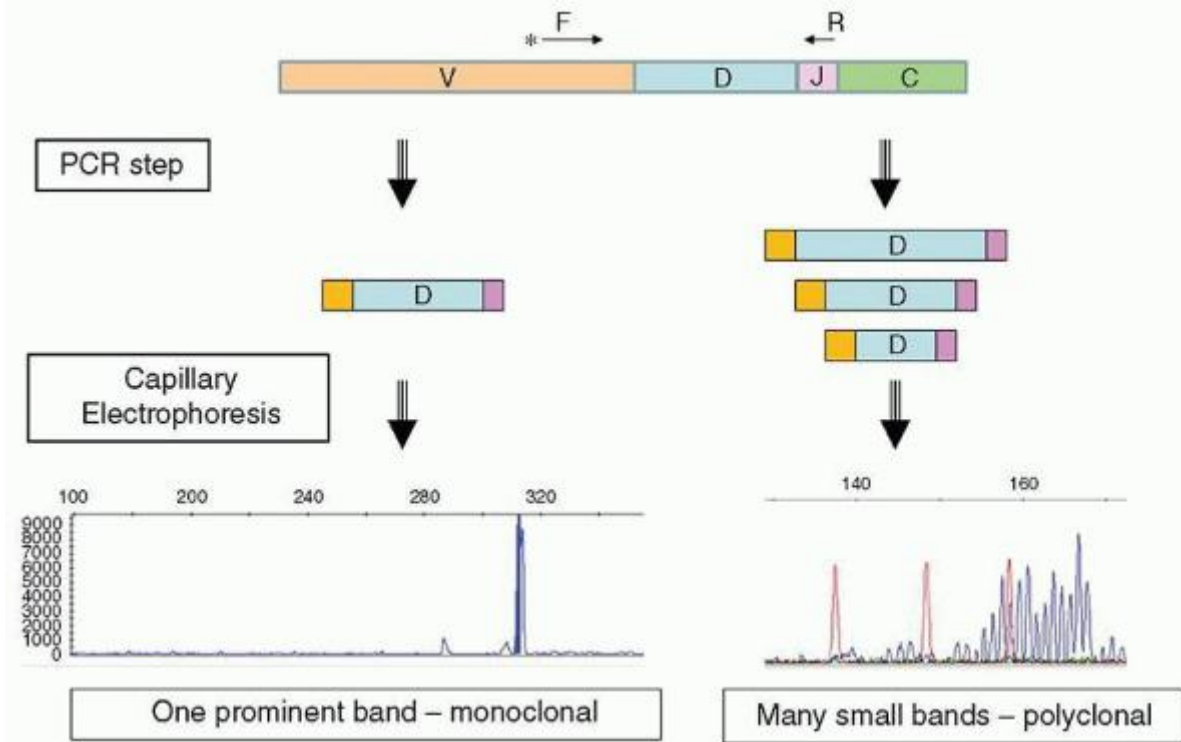

FIGURE 4.5. Principle of B-cell and T-cell clonality assessment by polymerase chain reaction (PCR). (Top) Schematic representation of the immunoglobulin heavy chain (IGH@) gene locus following rearrangement in a B cell; the locations of primers used in IGH@ PCR are indicated by the forward (F) and reverse (R) arrows with one labeled with a fluorochrome (*). The variable region (V) segments are represented in orange, the diversity region (D) segments are represented in blue, and the joining (J) region segments are shown in pink. A unique template-independent sequence is added to the VD and DJ junctions in each individual precursor B cell during IGH@ rearrangement in the bone marrow. A similar process involving the T-cell receptor happens in a precursor T cell in the thymus. (Middle) After PCR, a monoclonal B-cell population characteristic of B-cell lymphoma shows a single predominant “clonal” VDJ amplicon of a particular size due to all the B cells being derived from a common precursor cell. Polyclonal/reactive B-cell expansions show VDJ amplicons of varying sizes derived from the range of different B cells in the population. (Bottom) The range of VDJ amplicons is visualized by running the IGH@ PCR on capillary electrophoresis. The peaks are detected using the fluorochrome-labeled PCR products run on capillary electrophoresis with the peak height proportional to the amount of PCR products of any particular size. Red peaks represent internal size standards; blue peaks are from the IGH@ PCR.

B cells arise as precursors in the bone marrow called lymphoblasts or hematogones and then migrate into the peripheral blood as long-lived naive forms, a process that is largely completed in childhood. Further maturation of B cells is dependent on recognition of an appropriate antigen that binds to a specific antibody molecule, also known as the BCR, comprised of immunoglobulin heavy chain (IGH@) and one of two types of immunoglobulin light chain (IGK@ or IGL@). Similarly, precursor T cells arise in the bone marrow and migrate to the thymus early in development, where they rearrange their TCR to produce a unique clonotypic TCR in each precursor T cell and all of its progeny.

The basis of B-cell and T-cell clonality determination by PCR is that since clonal lymphoid expansions arise from a single founder cell, all cells in that expansion will share the same BCR or TCR, which has a particular size following PCR. The structure of the TCR or BCR in a precursor lymphocyte is determined by the process of VDJ recombination that occurs in the DNA during lymphocyte maturation. Due to variation in the size of the diversity (D) region between the variable (V) and joining (J) segments, all cells within a clonal B-cell proliferation will have an identically sized IGH@ gene

rearrangement that can be detected by PCR (Fig. 4.5). In contrast, mixed/polyclonal non-neoplastic B-cell expansion will have IGH@ PCR products of varying sizes, giving a normal distribution of PCR products. A similar process occurs in T cells, with PCR for either the TCR-gamma or TCR-beta gene used to determine the presence of a clonal, oligoclonal, or polyclonal T-cell expansion.⁴⁹

Standardized protocols for IGH@, IGK@, TCRG@, TCRB@ PCR have been developed,^{50,51} and these can be performed on fresh cells isolated from blood or bone marrow aspirate or from fixed tissue sections. Also, given the exquisite sensitivity of PCR, very small samples (such as minute amounts of cerebrospinal fluid) can be used to detect clonality in limited samples.

Minimal Residual Disease Testing for Leukemias and Lymphomas

One of the principal benefits of real-time PCR is that it is both a highly sensitive and quantitative technique to track residual disease.^{27,52,53} If a PCR assay can be designed to selectively amplify an initiating molecular aberration in a leukemia or lymphoma, then a highly sensitive and specific PCR assay can be designed to track disease levels over the treatment course and to monitor for relapse (Table 4.4). The mostly widely used group of these PCR assays are those to detect fusion transcripts in leukemias, including BCR-ABL1 in CML, PML-RARA in acute promyelocytic leukemia, and MLL and ETV6-RUNX1 fusions in lymphoblastic leukemia.^{27,54}

Similarly, mutation-specific PCRs that detect only the mutant but not the wild-type base pair changes can be used when specific point mutations characterize the molecular pathogenesis of a tumor, such as JAK2 mutations in MPNs⁵⁵ and FLT3 and NPM1 mutations in a subset of AML.^{56,57} This PCR MRD approach is limited to those mutations that occur early in the disease course, since mutations occurring later may be present only in subclones that disappear or evolve under treatment. Deep sequencing using

P.64

next-generation platforms shows promise for a more comprehensive approach to the use of mutations for MRD analysis.⁵⁸

TABLE 4.4 TYPES OF MOLECULAR MONITORING ASSAYS FOR LEUKEMIAS AND LYMPHOMAS

Methodology	Examples	Disease Types (References)
Fusion transcript RT-PCR (RNA)	<i>BCR-ABL1, PML-RARA, CFBF-MYH11 RUNX1-RUNX1T1 NPM1-ALK, BIRC3-MALT1</i>	CML, AML ALL/LBL Lymphoma
Translocation detection by PCR of DNA	<i>IGH@-BCL2</i>	Follicular lymphoma ⁵²
Leukemia-associated quantitative mutation detection	<i>NPM1, FLT3</i>	AML ^{56,57}
Leukemia-associated elevated gene expression	<i>BAALC, WT1</i>	AML ⁵⁶
Clone-specific IGH PCR	IGH@ VDJ/FR3 custom-designed primers	Lymphoblastic leukemia ⁵⁹
Surrogate markers	EBV and HHV8 viral load	Virus-associated lymphomas

RT-PCR, reverse transcriptase polymerase chain reaction; CML, chronic myelogenous leukemia; AML, acute myeloid leukemia; ALL/LBL, acute lymphoid leukemia/lymphoblastic lymphoma of B-cell lineage; IGH, immunoglobulin heavy chain; EBV, Epstein-Barr virus; HHV, human herpesvirus.

Finally, highly complex, leukemia-specific MRD qPCR assays can be designed for B-cell and T-cell neoplasms which rely on designed primers based on the specific TCR or BCR expressed by a patient's tumor.⁵⁹ These types of assays, if well-designed, provide the most sensitive methods available for tracking low-levels of residual ALL/LBL, but given their expense have not been widely implemented.

MOLECULAR DIAGNOSIS IN THE NEXT 5 YEARS: THE COMING ASSAYS AND METHODOLOGIES

The above methodologies have evolved relatively slowly, giving practicing hematologists time to integrate these methods into the routine workups. However, the large number of new high-throughput testing methodologies that are likely to be implemented in the next few years, particularly single nucleotide polymorphism arrays and genomic sequencing identifying both germline and somatic mutations, may be more difficult to integrate into routine clinical practice. These methodologies will require integrating complex datasets to derive a treatment plan including:

- interpreting how advanced sequencing panels will be used to relate diagnosis to treatment selection and a molecular monitoring strategy⁶⁰;
- integration of acquired and germline polymorphisms into further understanding of bone marrow failure⁶¹;
- combining single cell analysis using flow cytometry with molecular profiles to characterize normal and abnormal stem cells.⁶²

REFERENCES

1. Alemdehy MF, Erkeland SJ. Stop the dicing in hematopoiesis: what have we learned? *Cell Cycle* 2012;11.
2. Joshi D, Gosh K, Vundinti BR. MicroRNAs in hematological malignancies: a novel approach to targeted therapy. *Hematology* 2012;17:170-175.
3. Cao A, Murru S. Molecular pathology and detection of beta-thalasseмии. *Prog Clin Biol Res* 1989;309:3-11.
4. Breunis WB, van Mirre E, Bruin M, et al. Copy number variation of the activating FCGR2C gene predisposes to idiopathic thrombocytopenic purpura. *Blood* 2008;111:1029-1038.
5. Huang RS, Chen P, Wisel S, et al. Population-specific GSTM1 copy number variation. *Hum Mol Genet* 2009;18:366-372.
6. Auerbach AD. Fanconi anemia. *Dermatol Clin* 1995;13:41-49.
7. Tefferi A. Novel mutations and their functional and clinical relevance in myeloproliferative neoplasms: JAK2, MPL, TET2, ASXL1, CBL, IDH and IKZF1. *Leukemia* 2010;24:1128-1138.
8. Plass C, Oakes C, Blum W, Marcucci G. Epigenetics in acute myeloid leukemia. *Semin Oncol* 2008;35:378-387.
9. Lipton JM, Ellis SR. Diamond Blackfan anemia 2008-2009: broadening the scope of ribosome biogenesis disorders. *Curr Opin Pediatr* 2010;22:12-19.
10. Bogdanov VY. Blood coagulation and alternative pre-mRNA splicing: an overview. *Curr Mol Med* 2006;6:859-869.
11. Fertrin KY, Costa FF. Genomic polymorphisms in sickle cell disease: implications for clinical diversity and treatment. *Expert Rev Hematol* 2010;3:443-458.
12. Oldenburg J, Schwaab R. Molecular biology of blood coagulation. *Semin Thromb Hemost* 2001;27:313-324.
13. Cimmino L, Abdel-Wahab O, Levine RL, Aifantis I. TET family proteins and their role in stem cell differentiation and transformation. *Cell Stem Cell* 2011;9:193-204.
14. Tefferi A, Skoda R, Vardiman JW. Myeloproliferative neoplasms: contemporary diagnosis using histology and genetics. *Nat Rev Clin Oncol* 2009;6:627-637.
15. Al-Kali A, Cortes J, Faderl S, et al. Patterns of molecular response to and relapse after combination of sorafenib, idarubicin, and cytarabine in patients with FLT3 mutant acute myeloid leukemia. *Clin Lymphoma Myeloma Leuk* 2011;11:361-366.
16. Herling M, Patel KA, Weit N, et al. High TCL1 levels are a marker of B-cell receptor pathway responsiveness and adverse outcome in chronic lymphocytic leukemia. *Blood* 2009;114:4675-4686.
17. Herling M, Patel KA, Teitell MA, et al. High TCL1 expression and intact T-cell receptor signaling define a hyperproliferative subset of T-cell prolymphocytic leukemia. *Blood* 2008;111:328-337.
18. Feldman AL, Sun DX, Law ME, et al. Overexpression of Syk tyrosine kinase in peripheral T-cell lymphomas. *Leukemia* 2008;22:1139-1143.
19. Gibson NJ. The use of real-time PCR methods in DNA sequence variation analysis. *Clin Chim Acta* 2006;363:32-47.
20. Sanger F, Nicklen S, Coulson AR. DNA sequencing with chain-terminating inhibitors. *Proc Natl Acad Sci U S A* 1977;74:5463-5467.

21. Mardis ER. Genome sequencing and cancer. *Curr Opin Genet Dev* 2012;22:245-250.
22. Thompson JF, Milos PM. The properties and applications of single-molecule DNA sequencing. *Genome Biol* 2011;12:217.
23. Swerdlow SH, Campo E, Harris NL, et al. WHO Classification of Tumors of Haematopoietic and Lymphoid Tissues. Lyon: IARC Press; 2008.
24. Vardiman JW, Thiele J, Arber DA, et al. The 2008 revision of the World Health Organization (WHO) classification of myeloid neoplasms and acute leukemia: rationale and important changes. *Blood* 2009;114:937-951.
25. Baccarani M, Castagnetti F, Gugliotta G, Palandri F, Soverini S. Response definitions and European Leukemianet Management recommendations. *Best Pract Res Clin Haematol* 2009;22:331-341.
26. Branford S, Fletcher L, Cross NC, et al. Desirable performance characteristics for BCR-ABL measurement on an international reporting scale to allow consistent interpretation of individual patient response and comparison of response rates between clinical trials. *Blood* 2008;112:3330-3338.
27. van Dongen JJ, Macintyre EA, Gabert JA, et al. Standardized RT-PCR analysis of fusion gene transcripts from chromosome aberrations in acute leukemia for detection of minimal residual disease. Report of the BIOMED-1 Concerted Action: investigation of minimal residual disease in acute leukemia. *Leukemia* 1999;13:1901-1928.
28. White HE, Matejtschuk P, Rigsby P, et al. Establishment of the first World Health Organization International Genetic Reference Panel for quantitation of BCR-ABL mRNA. *Blood* 2010;116:e111-e117.
29. Goldin LR, Bjorkholm M, Kristinsson SY, Samuelsson J, Landgren O. Germline and somatic JAK2 mutations and susceptibility to chronic myeloproliferative neoplasms. *Genome Med* 2009;1:55.
30. Arber DA, Stein AS, Carter NH, Ikle D, Forman SJ, Slovak ML. Prognostic impact of acute myeloid leukemia classification. Importance of detection of recurring cytogenetic abnormalities and multilineage dysplasia on survival. *Am J Clin Pathol* 2003;119:672-680.
31. Greenberg PL, Tuechler H, Schanz J, et al. Revised International Prognostic Scoring System (IPSS-R) for myelodysplastic syndromes. *Blood* 2012;120:2454-2465.
32. Schanz J, Tuchler H, Sole F, et al. New comprehensive cytogenetic scoring system for primary myelodysplastic syndromes (MDS) and oligoblastic acute myeloid leukemia after MDS derived from an international database merge. *J Clin Oncol* 2012;30:820-829.
33. Sun X, Zhang W, Ramdas L, et al. Comparative analysis of genes regulated in acute myelomonocytic leukemia with and without inv(16)(p13q22) using microarray techniques, real-time PCR, immunohistochemistry, and flow cytometry immunophenotyping. *Mod Pathol* 2007;20:811-820.
34. Gallagher RE, Yeap BY, Bi W, et al. Quantitative real-time RT-PCR analysis of PML-RAR alpha mRNA in acute promyelocytic leukemia: assessment of prognostic significance in adult patients from intergroup protocol 0129. *Blood* 2003;101:2521-2528.
35. Foran JM. New prognostic markers in acute myeloid leukemia: perspective from the clinic. *Hematology (Am Soc Hematol Educ Program)* 2010;2010:47-55.
36. Nagoshi H, Horiike S, Kuroda J, Taniwaki M. Cytogenetic and molecular abnormalities in myelodysplastic syndrome. *Curr Mol Med* 2011;11:678-685.
37. Schlegelberger B, Gohring G, Thol F, Heuser M. Update on cytogenetic and molecular changes in myelodysplastic syndromes. *Leuk Lymphoma* 2012;53:525-536.
38. Campo E, Swerdlow SH, Harris NL, Pileri S, Stein H, Jaffe ES. The 2008 WHO classification of lymphoid neoplasms and beyond: evolving concepts and practical applications. *Blood* 2011;117:5019-5032.
39. Nogai H, Dorken B, Lenz G. Pathogenesis of non-Hodgkin's lymphoma. *J Clin Oncol* 2011;29:1803-1811.
40. Ferrando AA, Look AT. DNA microarrays in the diagnosis and management of acute lymphoblastic leukemia. *Int J Hematol* 2004;80:395-400.
41. Weng AP, Ferrando AA, Lee W, et al. Activating mutations of NOTCH1 in human T cell acute lymphoblastic leukemia. *Science* 2004;306:269-271.

42. Ferrando AA, Neuberg DS, Staunton J, et al. Gene expression signatures define novel oncogenic pathways in T cell acute lymphoblastic leukemia. *Cancer Cell* 2002;1:75-87.
43. Willis TG, Dyer MJ. The role of immunoglobulin translocations in the pathogenesis of B-cell malignancies. *Blood* 2000;96:808-822.
44. Wlodarska I, Dierickx D, Vanhentenrijk V, et al. Translocations targeting CCND2, CCND3, and MYCN do occur in t(11;14)-negative mantle cell lymphomas. *Blood* 2008;111:5683-5690.
45. Herling M, Khoury JD, Washington LT, Duvic M, Keating MJ, Jones D. A systematic approach to diagnosis of mature T-cell leukemias reveals heterogeneity among WHO categories. *Blood* 2004;104:328-335.
46. de Leval L, Gaulard P. Tricky and terrible T-cell tumors: these are thrilling times for testing: molecular pathology of peripheral T-cell lymphomas. *Hematology Am Soc Hematol Educ Program* 2011;2011:336-343.
47. Caprini E, Cristofolletti C, Arcelli D, et al. Identification of key regions and genes important in the pathogenesis of Sézary syndrome by combining genomic and expression microarrays. *Cancer Res* 2009;69:8438-8446.
48. Hartmann S, Gesk S, Scholtysik R, et al. High resolution SNP array genomic profiling of peripheral T cell lymphomas, not otherwise specified, identifies a subgroup with chromosomal aberrations affecting the REL locus. *Br J Haematol* 2010;148:402-412.
49. Vega F, Luthra R, Medeiros LJ, et al. Clonal heterogeneity in mycosis fungoides and its relationship to clinical course. *Blood* 2002;100:3369-3373.
50. Droese J, Langerak AW, Groenen PJ, et al. Validation of BIOMED-2 multiplex PCR tubes for detection of TCRB gene rearrangements in T-cell malignancies. *Leukemia* 2004;18:1531-1538.
51. van Dongen JJ, Langerak AW, Bruggemann M, et al. Design and standardization of PCR primers and protocols for detection of clonal immunoglobulin and T-cell receptor gene recombinations in suspect lymphoproliferations: report of the BIOMED-2 Concerted Action BMH4-CT98-3936. *Leukemia* 2003;17:2257-2317.
52. Bowman A, Jones D, Medeiros LJ, Luthra R. Quantitative PCR detection of t(14;18) bcl-2/JH fusion sequences in follicular lymphoma patients: comparison of peripheral blood and bone marrow aspirate samples. *J Mol Diagn* 2004;6:396-400.
53. Damm-Welk C, Busch K, Burkhardt B, et al. Prognostic significance of circulating tumor cells in bone marrow or peripheral blood as detected by qualitative and quantitative PCR in pediatric NPM-ALK-positive anaplastic large-cell lymphoma. *Blood* 2007;110:670-677.
54. Elia L, Grammatico S, Paoloni F, et al. Clinical outcome and monitoring of minimal residual disease in patients with acute lymphoblastic leukemia expressing the MLL/ENL fusion gene. *Am J Hematol* 2011;86:993-997.
55. Millecker L, Lennon PA, Verstovsek S, et al. Distinct patterns of cytogenetic and clinical progression in chronic myeloproliferative neoplasms with or without JAK2 or MPL mutations. *Cancer Genet Cytogenet* 2010;197:1-7.
56. Kristensen T, Moller MB, Friis L, Bergmann OJ, Preiss B. NPM1 mutation is a stable marker for minimal residual disease monitoring in acute myeloid leukaemia patients with increased sensitivity compared to WT1 expression. *Eur J Haematol* 2011;87:400-408.
57. Schiller J, Praulich I, Krings RC, Kreuzer KA. Patient-specific analysis of FLT3 internal tandem duplications for the prognostication and monitoring of acute myeloid leukemia. *Eur J Haematol* 2012;89:53-62.
58. Thol F, Kolking B, Damm F, et al. Next-generation sequencing for minimal residual disease monitoring in acute myeloid leukemia patients with FLT3-ITD or NPM1 mutations. *Genes Chromosomes Cancer* 2012;51:689-695.
59. Cazzaniga G, Biondi A. Molecular monitoring of childhood acute lymphoblastic leukemia using antigen receptor gene rearrangements and quantitative polymerase chain reaction technology. *Haematologica* 2005;90:382-390.
60. Harris TJ, McCormick F. The molecular pathology of cancer. *Nat Rev Clin Oncol* 2010;7:251-265.
61. Lieberman L, Dror Y. Advances in understanding the genetic basis for bone-marrow failure. *Curr Opin Pediatr* 2006;18:15-21.
62. Becker MW, Jordan CT. Leukemia stemness signatures step toward the clinic. *Cell Stem Cell* 2011;9:185-186.

Part II - The Normal Hematologic System

Section 1 - Hematopoiesis

Chapter 5 Origin and Development of Blood Cells

> Table of Contents > Part II - The Normal Hematologic System > Section 1 - Hematopoiesis > Chapter 5 - Origin and Development of Blood Cells

Chapter 5

Origin and Development of Blood Cells

Andrew Chow

Paul S. Frenette

BLOOD CELLS

The blood contains several different types of cells. Each of these cell types is quite distinct in appearance, and each has a specific biologic function. Erythrocytes are anucleate, biconcave discoid cells filled with hemoglobin, the major protein that binds oxygen. Erythrocytes transport the respiratory gases oxygen and carbon dioxide. Granulocytes and monocytes are cells that can exit from blood vessels and migrate into many tissues. These two cell types play key roles in inflammation and phagocytosis. Platelets are very small, anucleate cells that contain molecules required for hemostasis. In addition, platelets provide hemostasis through their abilities to adhere, aggregate, and provide a surface for coagulation reactions. Lymphocytes mediate highly specific immunity against microorganisms and other sources of foreign macromolecules. B-lymphocytes confer immunity through the production of specific, soluble antibodies, whereas T lymphocytes direct a large variety of immune functions, including killing cells that bear foreign molecules on their surface membranes. Despite these extreme structural and functional differences among the cells of the blood, strong evidence exists that the vast majority of blood cells are the progeny of a single type of cell: the hematopoietic stem cell (HSC). The processes involved in the production of all of the various cells of the blood from the HSCs are collectively called hematopoiesis. Hematopoiesis includes HSC self-renewal, HSC commitment to specific lineages, and maturation of lineage-committed progenitors into functional blood cells. Self-renewal may occur by symmetric HSC division, such as expansion of the HSC pool during fetal life or post-HSC transplantation. Other possible fates of HSC divisions include apoptosis or mobilization to the peripheral circulation following stress such as growth factor stimulation or depletion of marrow cells by irradiation or chemotherapy. During normal steady-state conditions, HSCs reside mainly in the marrow cavity, but under certain stress conditions, HSCs can migrate and colonize other organs such as the liver and spleen in a process termed extramedullary hematopoiesis.

Hematopoiesis begins early during embryogenesis and undergoes many changes during fetal and neonatal development. Unlike some organ systems that form in early life and are not continually replaced, turnover and replenishment of the hematopoietic system continue throughout life. Cells of the blood have finite life spans, which vary depending on the cell type. In humans, granulocytes and platelets have life spans of only a few days, whereas some lymphocytes can exist for many months. Cells are replaced as the older cells are removed and the newly formed, mature cells are added. The numbers of the various cell types in the blood are normally kept in relatively constant ranges. In particular, variations in the erythrocyte number are normally minimal, and values 30% above or below the norm for the population have significant health effects. Although the numbers of other blood cell types are not as constant as the number of erythrocytes, the production of other blood cells is also highly regulated. The regulation of hematopoiesis is complex. Some regulatory factors influence overall hematopoiesis by affecting very early progenitor cells: the HSCs and/or their progeny that have not undergone commitment to a single cell lineage. Also, specific regulatory growth factors play key roles in fostering the production of cells of each lineage. Lineage-specific regulation is necessary because of the widely varying life spans and functions of the different mature blood cell types.

This chapter presents an overview of hematopoiesis. Many conclusions presented here are based on experiments carried out in murine systems. All cell lineages that compose blood will be discussed. Some cell types such as dendritic cells and mast cells are derived from the HSCs but are found mostly in tissues rather than blood, where the final steps of differentiation occur. Figure 5.1 is an illustration of the cell types that constitute the hematopoietic spectrum.

ORIGIN OF HEMATOPOIESIS

Sites of Hematopoiesis

During prenatal development, the sites of hematopoiesis change several times in the mouse^{1,2} and³ and human^{3,4} (Fig. 5.2). Since better characterized in mice (Fig. 5.2A) than humans (Fig. 5.2B), the discussion below will focus on murine developmental hematopoiesis. In humans and other vertebrates, the first hematopoietic cells arise during late gastrulation in the extraembryonic yolk sac (YS) in structures known as blood islands. This initial hematopoiesis is termed primitive hematopoiesis and serves a supportive role to rapidly produce erythroid cells, platelets, and macrophages prior to the formation of the circulatory system. Primitive hematopoiesis is transient, occurring on embryonic

P.66

days 7.25 (E7.25) through 13 (E13) in mice and day 19 through week 8 in humans. Primitive erythrocytes, which are the first embryonic hematopoietic cells, are large nucleated cells morphologically resembling erythrocytes of phylogenetically lower primitive vertebrate groups, such as birds, amphibians, and fish. These primitive erythrocytes have reduced erythropoietin (EPO) requirements during their development compared to definitive erythroid cells⁵ that develop later. Also unlike their definitive counterparts, primitive erythrocytes typically circulate as nucleated cells before enucleating, and additionally express ζ , β H1, and $\epsilon\gamma$ globin genes.^{6,7} These cells and primitive platelets⁸ derive from a primitive bipotent megakaryocyte erythroid progenitor found in the yolk sac in mice (E7.25) and humans.^{9,10} Along with maternally derived macrophages (M Φ) that exist, but are declining in numbers, in the yolk sac at E8, two other M Φ progenitors exist in the yolk sac: one with strictly M Φ potential

P.67

and one with bipotential for M Φ and erythrocytes.¹¹ Importantly, since circulation does not commence until E8.25, this indicates in situ M Φ development in the yolk sac. Thus, primitive hematopoiesis in the yolk sac provides the developing embryo with three crucial hematopoietic cell types prior to contribution from multipotent stem cells deriving from definitive hematopoiesis (see below).

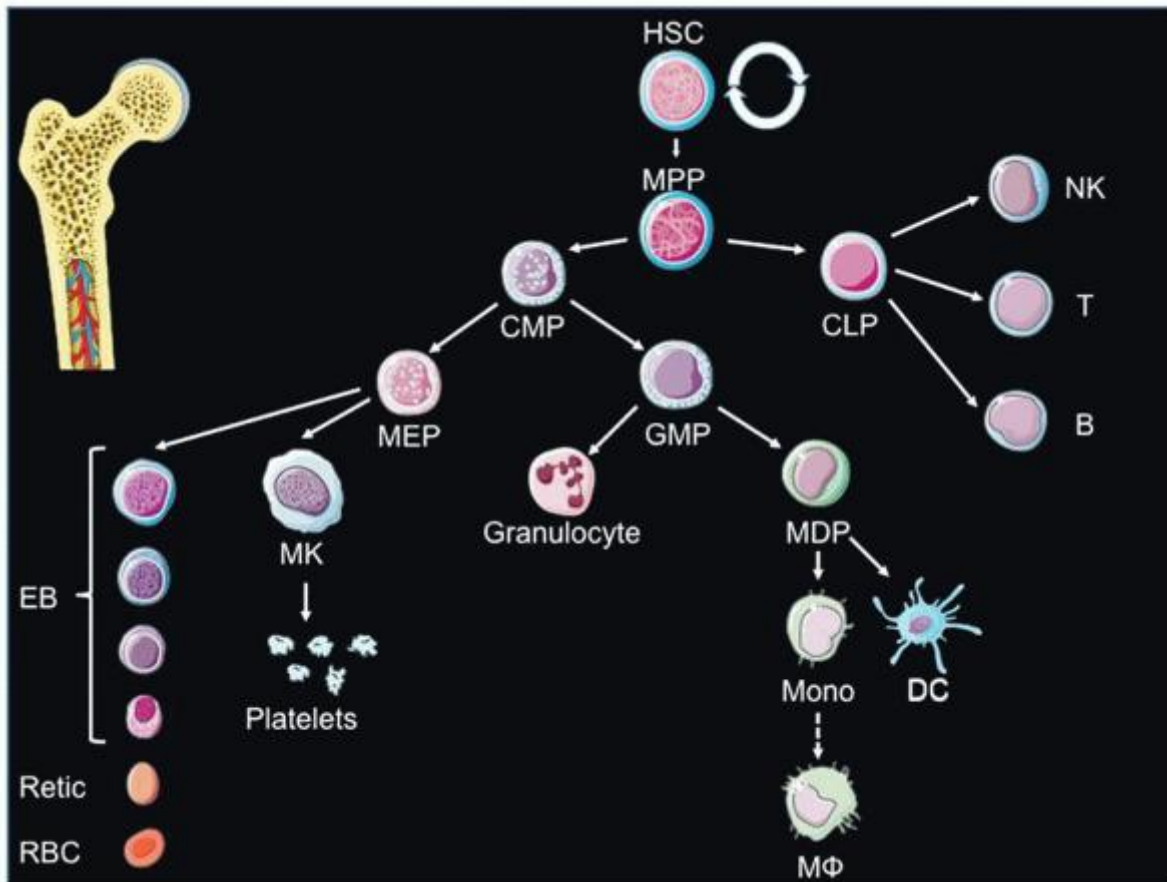

FIGURE 5.1. Cells of the blood and lymphoid organs and their precursors in the bone marrow. CMP, common myeloid progenitors; DC, dendritic cells; EB, erythroblast; GMP, granulocyte macrophage progenitor; HSC, hematopoietic stem cell; MDP, macrophage dendritic cell progenitor; MEP, megakaryocyte erythrocyte progenitor; MK, megakaryocyte; M ϕ , macrophage; mono, monocyte; MPP, multipotent progenitors; RBC, red blood cell; Retic, reticulocyte.

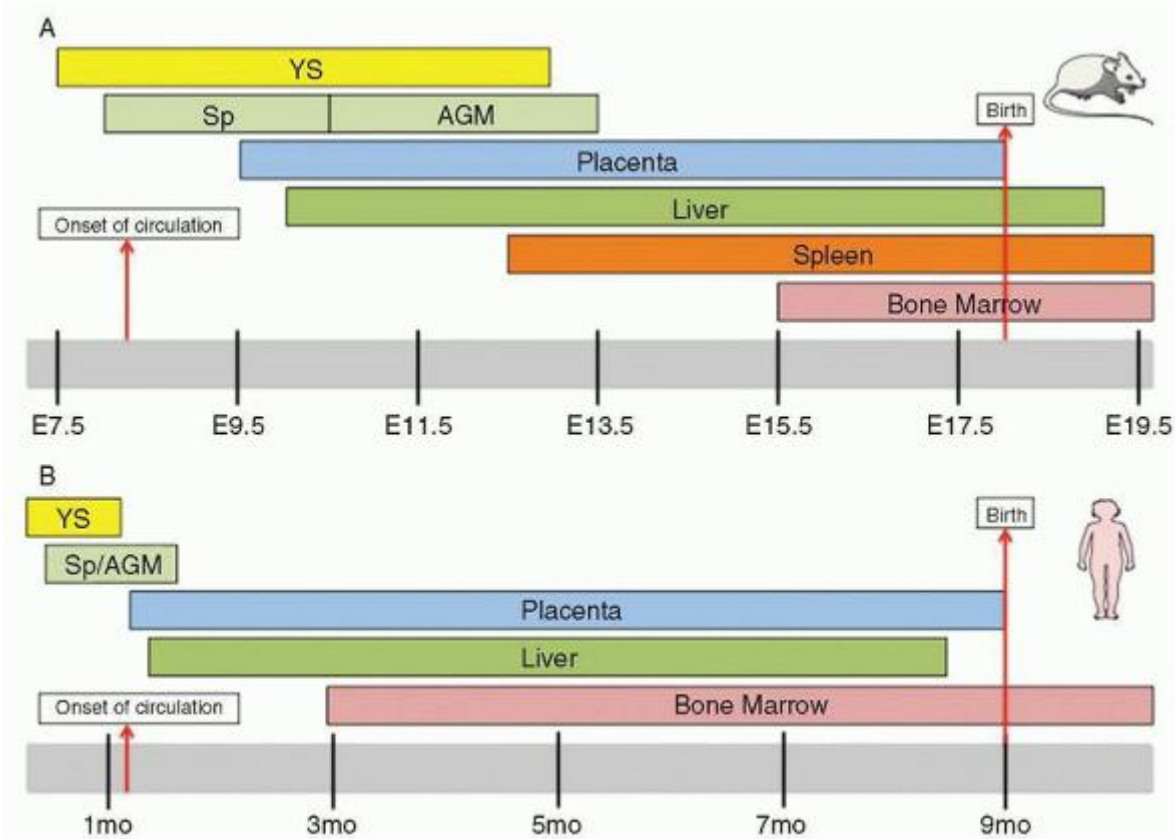

FIGURE 5.2. Sites of hematopoiesis. A: Sites of mouse hematopoietic development. AGM, aorta-gonad-mesonephros; Sp, splanchnopleura; YS, yolk sac. B: Sites of human hematopoietic development.

Since the first hematopoietic cells arise in the extraembryonic yolk sac, it was widely believed in the 1970s that the first HSCs developed in the yolk sac. However, experiments in avian chimeras demonstrated for the first time that although the YS had early contribution, the hematopoietic cells present in the stages closer to birth were exclusively derived from the intraembryonic compartment.¹² Similar avian chimeric experiments subsequently demonstrated that the intraembryonic compartment, rather than the YS, was the exclusive source of B and T cells in the adults.¹³ Godin and colleagues subsequently demonstrated in mice that the aortic region of E9 embryos, but not YS precursors, were capable of contributing to B cells in irradiated adult recipients.¹⁴ In the same journal issue, Medvinsky, Dzierzak, and colleagues demonstrated that the E10.5 AGM (aorta-gonad-mesonephros) region had substantially higher and earlier onset of CFU-S activity, an early coarse assay for multipotency, compared to YS cells.¹⁵ Soon afterward, Dzierzak's group demonstrated the ability of E10.5 AGM precursors to provide long-term multilineage reconstitution activity (LTR) in lethally irradiated adult mice.¹⁶ Together, these seminal publications affirmed the intraembryonic contribution to adult mammalian hematopoiesis.

Since the AGM region above was harvested after the establishment of circulation (E8.25), migration of HSCs from a separate undescribed site of origin could not be excluded. To investigate whether HSC development occurred *de novo* in the AGM, the E8 splanchnopleura (Sp, the future site of the AGM) and the concomitant yolk sac, neither of which have LTR activity, were cultured. While the cultured Sp and YS both produced hematopoietic cells, confirming two independent waves of hematopoietic generation, the YS progenitors were unable to produce lymphoid progeny or have LTR activity.^{17,18} Further dissection of the AGM determined that most of the HSC activity is found in hematopoietic intra-aortic clusters found on the ventral wall of the dorsal aorta.² HSC activity is also found in the proximal vitelline and umbilical arteries, although these sites have been less characterized. Two reports from the Dzierzak and Mikkola groups established that the placenta represents a previously overlooked major site of hematopoiesis in which HSC emergence parallels that of HSC appearance at E10.5 in the AGM.^{19,20} In fact, when LTR HSCs are enumerated, there are 25-fold more LTR HSCs in the placenta than in the AGM.¹⁹ Since the placenta is directly upstream of the fetal liver circulation and since the dramatic expansion of HSC in the FL mirrors that of the placenta, it has been proposed that the placenta is at least a major contributor of LTR HSCs. It has also been proposed that the placenta is a site of *de novo* HSC emergence independent from the AGM. Indeed, explant and stromal co-culture experiments of mesodermal tissue of the placenta prior to the

establishment of circulation demonstrated erythroid and myeloid potential.^{21,22} The concept of a de novo generated HSC was bolstered by in vitro culture of E8-9 placenta from *Ncx1*^{-/-} animals, which lack a heartbeat and die by E10.5. Without circulatory contribution, the midgestation site had definitive hematopoietic cells with myelo-erythroid and lymphoid potential.²³ Although LTR HSC cannot be isolated from the placenta of *Ncx1*^{-/-} animals because of developmental retardation and death by E10.5, these experiments show that definitive hematopoiesis emerges in this organ de novo. Whether the AGM, uterine and vitelline arteries, placenta, or a combination of the above are the genuine origin of HSCs, this LTR activity around E10.5 represents the start of definitive hematopoiesis.

Once definitive hematopoiesis begins, lymphocytes, monocytes, granulocytes, and platelets are formed as well as definitive erythrocytes. At E10, hematopoietic cells (both primitive and definitive) colonize the fetal liver (FL). Dramatic expansion of HSCs occurs at this site (daily doubling in absolute numbers of HSC from E12.5 to E14.5).²⁴ Eventually, LTR HSCs migrate from the fetal liver to the bone marrow via the circulation, and the bone marrow becomes the primary site of hematopoiesis, with a very small reserve of stem cells remaining in the liver. In the late stages of mammalian fetal development, the bone marrow becomes the main site of hematopoiesis. In humans, the bone marrow is the exclusive site of postnatal hematopoiesis under normal circumstances, whereas in the mouse, the spleen is also a hematopoietic organ throughout life.

Cellular Origin of Hematopoiesis

The cellular intermediates through which mesodermal tissue gives rise to hematopoietic tissue in embryonic development is an area of intense investigation. One candidate cellular ancestor is either (a) a mesoderm-derived bipotent hemangioblast capable of giving rise to either vessels and blood cells or (b) a specialized vascular cell type, called hemogenic endothelium, that serves as a precursor for blood cells. A non-mutually exclusive origin points to HSC derivation from mesenchymal tissue below the endothelial layer. Cytologic analyses of the AGM provide evidence for both endothelial-derived and sub-endothelial-derived HSCs through identification of HIACs and subaortic patches (SAPs), respectively.² The strict temporal overlap in the appearance at E10.5 and disappearance at E12.5 of HIACs and SAPs suggests that HSCs derived in SAPs can potentially transendothelially migrate to form HIACs prior to release into the bloodstream.² Keller and colleagues definitively showed that a bipotential hemangioblast could be found in the posterior region of the primitive streak in vivo.²⁵ However, until recently, the existence of a bona fide endothelial intermediate had been under debate. Supportive of an endothelial origin of HSCs is the presence of numerous vessel markers on AGM HSCs, including CD31, VE-Cadherin, and Tie-2.² Furthermore, AGM HSCs and endothelial cells in the ventral wall of the E10-E11 dorsal aorta both express Ly6A (Sca-1), c-Kit, CD34, Runx1, SCL, and GATA-2.¹ Fate mapping studies elegantly showed that VE-cadherin expressing endothelium contributes to AGM and adult HSCs, while lineage tracing of subendothelial mesenchyme with Myocardin-Cre animals did not result in labeling of HSCs.²⁶ Subsequently, novel imaging studies of embryonic stem cell-derived mesodermal cells demonstrated a hemogenic endothelial intermediate in the formation of blood cells.^{27,28} Moreover, when Runx1, an essential gene in definitive hematopoiesis, was specifically deleted in VE-cadherin-expressing cells (endothelial and hematopoietic cells), but not Vav1-expressing cells (only hematopoietic cells), there was a severe disruption in hematopoietic development that was associated with 65% fetal lethality.²⁹ Finally, Nancy Speck's group recently showed that expression of core binding factor beta (CBF β) in Ly6a-expressing hemogenic endothelium was sufficient for HSC formation.³⁰ Together, these observations have supported the concept of blood cell development commencing with mesodermal cells that pass through hemangioblastic and hemogenic endothelial intermediates.

Common Critical Genes in Independent Origins of Hematopoiesis

Gene knockout experiments have provided significant insight into the critical regulators of embryonic hematopoiesis. In both primitive and definitive hematopoiesis, *Bmp4*, *Flk1*, *Tal1/Scf*, *Lmo2*, *Gata2*, and *Runx1* are all critical for HSC generation.² *Bmp4* (bone morphogenetic protein 4) is a critical signaling molecule

P.68

to specify the dorsal-ventral axis in development. Although the posterior portion of the epiblast in development is fated to give rise to hematopoietic activity, the neurally fated anterior fragment can retain the ability to produce hematopoietic cells by addition of *Bmp4*.³¹ *Bmp4* is crucial for hematopoietic development as *Bmp4*-deficient embryos mostly die around the gastrulation stage, and those that do survive have less yolk sac mesoderm and less lateral plate mesoderm (from which the AGM will develop).^{32,33} In definitive hematopoiesis, *Bmp-4* is expressed by endothelial cells in the ventral portion of the developing dorsal aorta and the subjacent mesoderm.² Using murine ES cells, it was recently shown that

Bmp4 is necessary for mesodermal precursor expression of the receptor tyrosine kinase Flk-1 and the bHLH transcription factor Tal-1/SCL.³⁴

The initiation of yolk sac hematopoiesis is dependent on the mesoderm and endoderm layers acting in concert, as soluble factors from endoderm substantially bolster the production of endothelial and hematopoietic cells by murine YS mesoderm explants.³⁵ One of the candidate soluble factor interactions is VEGF derived from endoderm and its receptor Flk1 on the mesoderm.^{36,37} Indeed, Flk-1-deficient embryos do not develop vessels or YS blood islands and die in utero between E8.5 and E9.5.³⁸ To overcome this early developmental mortality, Shalaby and colleagues performed complementation studies with chimeras of Flk-1^{+/-} and Flk1^{-/-} ES cells and demonstrated convincingly that Flk-1 is also required for the generation of definitive endothelial and hematopoietic cells.³⁹ It was later shown that Flk-1 signaling appears to not be required intrinsically for endothelial and hematopoietic formation, as Flk1^{-/-} ES cells are able to give rise to endothelial and hematopoietic lineages in vitro^{40,41}; instead, Flk-1 is likely required for the migration of mesoderm cells from the posterior primitive streak to the yolk sac.³⁹ In concordance with the importance of the VEGF-Flk-1 signaling axis, VEGF derived from the visceral endoderm (but interestingly, not mesoderm) is sufficient for endothelial and hematopoietic differentiation.⁴²

The transcription factor Tal-1/Scl^{43,44} and ⁴⁵ and the transcriptional regulator Lmo2⁴⁶ are both expressed in the yolk sac mesoderm prior to the onset of primitive hematopoiesis and then subsequently expressed in both endothelial and hematopoietic cells. Gene knockout of both Tal-1/Scl^{47,48} and Lmo2⁴⁹ results in decreased endothelial cells and abrogates YS blood cell production. These genes are also critical for definitive hematopoiesis, as demonstrated by complementation studies with ES cells chimeras.^{50,51} and ⁵² Gata-2-deficient animals have severely impaired primitive hematopoiesis and die at E10.5.⁵³ Gata2 haploinsufficient embryos have normal yolk sac hematopoiesis,⁵⁴ but have a reduction in AGM HSCs, which is consistent with its expression on aortic endothelium⁵⁵ and its proposed role in the expansion of hemogenic endothelial progenitors.⁵⁵ Runx1 has also been demonstrated to be crucial in definitive hematopoiesis, as Runx1 invalidation abrogates definitive myeloid, lymphoid, and HSC accumulation in the YS, AGM, and fetal liver.^{56,57} and ⁵⁸ Runx1 is thought to be crucial cell autonomously, as complementation studies fail to demonstrate hematopoietic contribution by Runx1-null ES cells.⁵⁷ While Runx1 was initially thought to be dispensable in murine primitive erythropoiesis, recent studies have recently shown that the morphology and gene expression of erythrocytes are aberrant in Runx1-deficient animals.⁵⁹

HEMATOPOIETIC STEM CELLS

Age of Morphologists

Fascinating accounts of the history of experimental efforts in hematopoiesis are presented in Wintrobe's Blood, Pure and Eloquent.^{60,61} One milestone in understanding the origins and development of blood cells was the recognition by Neumann and Bizzozero in the mid-nineteenth century that the bone marrow is a site of red blood cell production throughout postnatal life. Another major advance made in the late nineteenth century by Paul Ehrlich, Artur Pappenheim, and others was the application of synthetic dyes and various staining/fixing techniques that led to precise morphologic characterization and classification of blood and marrow cells. A third milestone was the development of the idea of a multipotent stem (ancestral) cell that gives rise to all of the mature blood cell types through extensive proliferation and differentiation. By the use of refined staining methods, Pappenheim observed various transitional cells and organized them into a relational scheme—a tree whose various branches when traced backward converged to a mononuclear cell that had none of the distinct features of the end-stage blood cells or the transitional stages. He proposed the notion that this cell was so morphologically primitive that it could be the common ancestor of all blood cells. Although most morphologists between 1900 and 1940 accepted the idea of ancestral cells in a hematopoietic series leading to progressively more mature types, there was much debate about how many ancestral cell types existed. Many workers believed that lymphocytes had a separate origin from myeloblasts and thus that there were dual or perhaps plural ancestral cells. Reviews of the conflicting concepts of the origin of hematopoietic cells as of the late 1930s are presented in detail in Handbook of Hematology.⁶²

Advent of Hematopoietic Progenitor Transplantation

In the late 1940s and the 1950s, several new approaches were developed to study hematopoiesis. Among them were radiation exposure followed by grafting of hematopoietic tissue, development of chromosome cytogenetics, and use of radioactive materials. Lorenz et al.⁶³ showed that mice and guinea pigs can be protected against otherwise lethal whole-body irradiation by injections of bone marrow from other animals of their respective species. Ford et al.⁶⁴ used bone marrow from donor mice that had a morphologically identifiable chromosomal marker to show that hematopoiesis in the irradiated recipient mice was reconstituted by cells from the donor marrow—that is, the protected animals were chimeras

with respect to their hematopoietic tissues. These experiments did not settle the question about how many types of ancestral cells there were, but experiments generating radiation chimeras have since been used with great power to study the nature of stem cells and their progeny.

Till and McCulloch⁶⁵ used radiation/grafting experiments to prove directly the existence of an ancestral cell with multilineage potential. In spleens of mice at 1 week after transplantation, they found growth of macroscopic colonies containing cells of multiple hematopoietic lineages. These colonies were the progeny of individual transplanted cells that were called colony-forming units spleen (CFU-S). Because the cells in these spleen colonies could, in turn, be injected into secondary, irradiated mice and give rise to spleen colonies, the CFU-S apparently replicated themselves within the colonies. When the observation time for CFU-S assays was extended from 1 to 2 weeks after transplantation, a series of evanescent colonies was found, and those appearing on later days had greater self-replication and multilineage differentiation capacities.^{66,67} Early studies could not demonstrate lymphoid cells in spleen colonies,^{68,69} but more recent studies indicate that CFU-S colonies contain lymphoid progenitors as well as myeloid progenitors.⁷⁰ Several studies showed that cells with the capacity for long-term hematopoietic reconstitution of irradiated mice can be separated from most CFU-S by size and density.⁷¹ Thus, many CFU-S, although multipotent, do not have long-term repopulating capacity.

P.69

Definitive Evidence for a Multipotent Stem Cell

Animal reconstitution experiments with hematopoietic cells that were individually genetically marked have verified the existence of HSCs and demonstrated their capacity for extensive self-renewal.^{72,73} In these marking experiments, hematopoietic cells were infected *in vitro* with a recombinant retrovirus that was able to integrate its DNA (provirus) into a cell but could not replicate and spread to other cells. The one-time, random integration of the provirus into the DNA of an individual cell provides a specific marker for the progeny of that cell that develop in an animal after transplantation. Random integration assures that each provirus has unique flanking sequences of DNA and thus has a high probability of yielding a DNA fragment of a distinguishable size after cutting with a restriction enzyme that does not cut the provirus. Several months after transplantation of the genetically marked cells and establishment of hematopoiesis, it is typically observed that all types of cells in the blood and lymphoid organs contain progeny of an individually marked cell, proving that it was multipotent. Often, these clones of marked cells continue to contribute to all of the hematopoietic lineages in the animal for an extended period. Also, when these primary recipient animals are subsequently used as donors for secondary recipient animals, frequently the same clones of HSCs are apparent in these secondary recipients. This persistence can even be demonstrated in tertiary recipients.^{74,75} Thus, clearly many HSCs reproduce themselves (self-renew) over a long period. Long-term reconstitution of the myeloid and lymphoid compartments can be achieved by transplantation of a single murine HSC,^{76,77,78} indicating that a single HSC is the smallest repopulating unit. Dick and colleagues recently demonstrated that a single cell transplant of human CD34⁺ CD38⁻ CD45RA⁻ Thy1⁺ Rho^{lo} CD49f⁺ cells into immunocompromised mice was able to provide multilineage reconstitution,⁷⁹ indicating that the HSC is also the smallest repopulating unit in humans.

It has been noted that not all HSC clones are long lived; some produce progeny for varying periods and then apparently become extinct. Finally, marked clones have been observed to begin contributing to hematopoiesis after some period of post-transplantation latency, indicating that dormancy is possible. Thus, these studies have demonstrated that, after transplantation, some HSCs contribute continuously to hematopoiesis for a long time—in mice, apparently for the whole lifetime of the animal. Other HSCs contribute and then become extinct, and finally, some may remain dormant for some period and then contribute. Additional transplantation studies of marked HSCs in mice⁸⁰ have suggested that polyclonal hematopoiesis is more common and that long-term contribution by individual stem cells is more rare than the earlier studies indicated.^{74,75} Recent novel technologies combining viral barcoding and high throughput sequencing of HSC confirmed this polyclonal contribution of HSCs.⁸¹ Studies using retroviral insertion site analyses for larger animals, particularly non-human primates, have provided some evidence of polyclonal hematopoiesis.^{82,83,84} To what extent these possible behaviors are manifest in normal, nontransplanted mice or larger animals is not clear.

Enrichment of Hematopoietic Stem Cells

The identification of relatively immature HSCs from more committed progenitor cells on the basis of various physical properties, immunophenotypic markers, and functional attributes has greatly advanced the field of hematopoiesis.⁸⁵ HSC markers that are expressed from fetal stages through adult life include CD34, CD31 (PECAM1), and Kit, but these markers can also be identified in endothelial cells.⁸⁶ In humans, CD34⁺, CD38⁻, CD90 (Thy-1)⁺, CD45RA⁻ cells that are negative for

lineage markers (CD2, CD3, CD4, CD7, CD8, CD10, CD11b, CD14, CD19, CD20, CD56, CD235a) are considered highly enriched for in vivo repopulating HSCs.^{87,88} In mice, there is no single consensus panel of HSC markers to identify, enumerate, and sort HSCs. Many markers derive from work by Weissman's lab, which proposes the combination of Sca-1 (Ly-6A/E)⁺, Kit⁺, Flk2⁻, CD90 (Thy-1)⁺ and negative for lineage markers (CD3, B220, Mac-1, Gr-1 and Ter119) as a highly purified population enriched for in vivo repopulating HSCs^{89,90,91,92} (Table 5.1). Nakauchi's group subsequently showed the enrichment of long-term repopulating activity in the CD34^{lo} fraction.⁷⁶ In 2005, Morrison's group developed a novel marker set to identify highly enriched HSCs. They demonstrated that signaling lymphocyte and activation molecule (SLAM) markers were found to be differentially expressed on BM Lineage⁻ Sca-1⁺ c-kit⁺ populations such that CD150⁺ CD244⁻ CD48⁻ CD41⁻ was the population enriched for murine HSC in vivo repopulation capacity.⁹³ Since the aforementioned phenotypic descriptions involve the use of multiple markers, which are moreover not exclusively expressed on HSC, Mulligan's group proposed the use of endothelial protein C receptor (EPCR, CD201) as a novel "explicit" marker of HSC, since HSCs express high levels of EPCR, while downstream progenitors express only intermediate levels.⁹⁴ Importantly, prospective isolation with only EPCR enriched for hematopoietic reconstitution activity. The most immature HSCs with in vivo hematopoietic repopulation potential are detectable within the CD150⁺CD244⁻CD48⁻ population. Other studies have pointed to CD105 (endoglin) as an enriching marker for HSCs.^{95,96} In addition to immunostaining, HSCs can also be identified by the ability of HSCs to efficiently efflux dyes. The most common methods utilize the dye Hoechst 33342, which when excited at two wavelengths yields a characteristic "side population" on flow cytometry⁹⁷ due to dye efflux.

TABLE 5.1 FLOW CYTOMETRIC DEFINITIONS OF HSCs, MPPs, AND SINGLE LINEAGE PROGENITORS

Population	Phenotype	Reference
Hematopoietic stem Cell (HSC)	Lin ⁻ Sca-1 ⁺ Kit ⁺ Flk2 ⁻ CD34 ⁻	76, 89
	CD90 (Thy-1) ⁺	91, 92
	CD150 ⁺ CD244 ⁻ CD48 ⁻	93
	EPCR ⁺	94
	Hoescht 33342 Side Population ⁺	97
Hoescht 33342 Side Population ⁺ CD105 ⁺	95	
	Lin ⁻ Sca-1 ⁺ , Kit ⁺ CD105 ⁺ CD150 ⁺	96
Multipotent progenitors (MPP)	Lin ⁻ Sca-1 ⁺ kit ⁺ Thy1 ⁻ Flk2 ⁺	90
	Lin ⁻ Sca-1 ⁺ kit ⁺ CD150 ⁻ CD105 ⁻	96
Common lymphoid progenitor (CLP)	Lin ⁻ Sca-1 ^{lo} Kit ^{lo} Thy1 ^{lo} IL-7R ⁺	183
Common myeloid progenitor (CMP)	Lin ⁻ Sca-1 ⁻ Kit ⁺ FcYR ^{int} CD34 ⁺	184
Granulocyte macrophage progenitor (GMP)	Lin ⁻ Sca-1 ⁻ Kit ⁺ FcYR ^{hi} CD34 ⁺	184
Megakaryocyte erythrocyte progenitor (MEP)	Lin ⁻ Sca-1 ⁻ Kit ⁺ FcYR ⁻ CD34 ⁻	184
Macrophage dendritic cell progenitor (MDP)	Lin ⁻ Sca-1 ⁻ Kit ^{hi} Flk2 ⁺ CX ₃ CR1 ⁺ CD115 ⁺	185

Lin⁻, Lineage negative (Gr1⁻ CD11b⁻ CD3⁻ B220⁻ Ter119⁻); Sca-1, stem cell antigen 1; Flk2, fms-like kinase 2; CD, cluster of designation.

P.70

With the advances in technology, procedures have been developed to enrich greatly the proportion of HSCs in isolated cell populations from mouse, human, and other sources. In mice, with immunophenotyping alone, 50% to 96% of prospectively isolated HSCs have long-term repopulating activity.⁹⁸ Isolation of candidate HSCs based on phenotypic markers expressed on the cell surface was first tested in congenic mouse transplantation models and subsequently purified human HSCs were successfully transplanted in a xenogeneic immunodeficient mouse model.⁸⁵ The successes in

mouse models have led to three human phase I clinical trials that successfully demonstrated sustained hematopoiesis when HSCs purified by immunophenotyping were transplanted into irradiated patients.^{99,100} and ¹⁰¹

Hematopoietic Stem Cell Assays

While immunophenotyping is the only feasible option for human HSC therapeutics because of a narrow window for successful transplantation, reliance on surface markers has the major limitation that different clinical scenarios may modulate the expression of utilized markers. For example, the content of long-term repopulating HSCs within the same immunophenotyped Lineage⁻ Sca-1⁺ c-kit⁺ (LSK) Thy1^{lo} fraction can change in aged mice, previously transplanted mice, and mobilized mice.¹⁰² Reliability of CD34 in mice of various age has also been questioned.¹⁰³ Use of the CD150⁺ CD48⁻ gating scheme, rather than Thy1, with LSK gating retains the fidelity in frequency of long-term repopulating HSCs in aged, transplanted, and mobilized mice.¹⁰² Nonetheless, it still is unknown if the SLAM markers retain fidelity in mutant mice. Moreover, other surface markers can also be modulated by environmental cues. This is illustrated by the Sca-1 upregulation that occurs in inflammatory settings likely secondary to type I interferon exposure,^{104,105} which can erroneously lead to conclusions about HSCs based on a population of committed progenitors that artifactually acquired the Sca-1 antigen. Furthermore, not all mouse strains express the prospective HSC antigens, such as Thy1.1 or Sca-1.^{106,107} Thus, conclusions drawn about HSCs in mouse or man need to be verified by functional assays in order to demonstrate (a) multipotency and (b) long-term repopulation. There are numerous assays with differing levels of stringency, limitations, and appropriateness to the question being addressed, as recently reviewed.⁹⁸

Long-term In Vitro Assays

In humans and mice, two types of progenitor cells called long-term culture initiating cells (LTC-ICs) and cobblestone area-forming cells (CAFC) can be detected using long-term cell culture assays. Since most committed progenitors have differentiated by 3 weeks in culture, they can be quantified by counting colonies at this time. The various progenitors quantified by in vitro assays are shown in Table 5.2. By 5 weeks or more of long-term culture, more immature progenitors that are dormant during the initial weeks but which possess extensive proliferating capacity continue to proliferate. Counting colonies at these later time points allows quantification of the number of more immature progenitors at the time of culture initiation. One type of long-term culture assay detects early-stage hematopoietic progenitors that are capable of initiating long-term hematopoiesis in culture after seeding them onto irradiated stromal cell monolayers (human^{108,109}; mouse^{110,111}). These LTC-ICs¹⁰⁸ sustain production of multilineage progenitors for 4 to 6 weeks. In some instances, these cultures have been extended for more than 10 to 12 weeks.^{112,113} This continued production of hematopoietic progenitors of multiple lineages in individual cultures is measured after several weeks by harvesting the cultured cells and doing secondary assays for various types of lineage-committed progenitors. Long-term cultures require a supporting stromal monolayer that is commonly generated from bone marrow-derived mesenchymal or fibroblast cells. The stromal layer supports the proliferation and differentiation of seeded hematopoietic progenitor cells, but at later times, it sloughs from the culture dish and fails to sustain continuation of the culture. In CAFC assays, islands or colonies of hematopoietic cells can be recognized morphologically in situ.¹¹⁰ These cobblestone colonies integrate within the supporting stromal layer, forming clusters of flattened, optically dense, morphologically homogenous-appearing cells tightly adherent with the stromal layer.^{114,115} CAFC assays are one-step cultures in contrast to LTC-IC assays, which require plating of fresh hematopoietic cells on established stromal layers. Using limiting dilution and Poisson statistics, the frequency of CAFC or LTC-IC in a test population or following culture can be determined.^{109,110} and ^{111,113,116}

TABLE 5.2 COLONY-FORMING CAPACITY OF HEMATOPOIETIC PROGENITORS ASSAYED IN VITRO

In Vitro Progenitor Name	Progenitor Stage/Potential	Factors
CAFC (#)—“cobblestone area-forming cell”	Mouse CAFC (28-40), possible stem cells Mouse CAFC (<28), multilineage	Irradiated BM stromal layer with horse serum and hydrocortisone
LTC-IC—“long-term culture-initiating cell”	Multilineage, possibly stem cells	Irradiated BM stromal layer with horse serum and hydrocortisone
CFU-GEMM—“CFU-granulocyte, erythrocyte, macrophage,	Multi-lineage	Kit ligand, IL-11, GM-CSF,

megakaryocyte”		EPO
CFU-GM—“CFU-granulocyte macrophage”	Granulocytes and macrophages	Kit ligand, GM-CSF
CFU-E—“CFU-erythrocyte”	Late stage erythrocyte progenitor	EPO and IGF-1
BFU-E—“burst forming unit-erythrocyte”	Early stage erythrocyte progenitor	EPO, Kit ligand, IGF-1
CFU-G—“CFU-granulocyte”	Granulocytes	G-CSF
CFU-M—“CFU-macrophage”	Macrophages	CSF-1
CFU-Mk—“CFU-megakaryocyte”	Megakaryocytes	TPO, IL-3, Kit ligand
CFU-preB—“CFU-pre-B lymphocytes”	B cells	Kit ligand, IL-7
CFU-DL—“CFU dendritic/Langerhans cells”	Dendritic cells/Langerhans cells	GM-CSF, TNF- α

CFU, colony-forming unit; EPO, erythropoietin; G-CSF, granulocyte colony-stimulating factor; GM-CSF, granulocyte-macrophage colony-stimulating factor; IGF-1, insulin-like growth factor-1; IL, interleukin; #, number of days of culture.

Assays of murine bone marrow cells for LTC-ICs and for day 28 CAFCs yield estimates of 1 to 4 LTC-ICs or CAFCs per 10^5 marrow mononuclear cells—a value comparable to that obtained for HSCs in repopulation assays.^{117,118} A modification of the mouse LTC-IC assay^{119,120} has led to a demonstration that some LTC-ICs form lymphoid as well as myeloid progenitors in vitro. However, LTCICs do not necessarily correspond in a 1:1 ratio to hematopoietic repopulating units. For example, several studies have shown that

P.71

ex vivo expansion of hematopoietic cell populations with growth factors in culture leads to a loss of in vivo repopulating cells,^{121,122} although measured LTC-ICs do not decrease in parallel. For these shortcomings, the LTC-IC assays is advantageous when an estimate of HSC frequency is required in scenarios in which the test population of HSCs have a defect in homing or engraftment capability, which would result in underestimation of the reduction in HSC activity when used in transplant assays (see below).

In Vivo Hematopoietic Assays

In vivo assays can measure various features of HSCs including homing, survival, proliferation, and differentiation into hematopoietic lineages. Homing and subsequent development of donor-derived blood cells is termed hematopoietic engraftment. To sustain life-long hematopoiesis in the host, transplanted HSCs must self-renew and re-establish an HSC pool. Because in vivo assays can be monitored for a prolonged period for survival, proliferation, and differentiation of transplanted HSCs and, ultimately, the establishment of donor-derived hematopoiesis, they remain the gold standard for measuring the true functional potential of HSC grafts. It is worth noting here again that these assays confirm HSC activity and these methods cannot prospectively isolate HSCs. There are broadly three ways to assess long-term repopulating HSC activity in vivo: competitive repopulation assay,¹²³ limiting dilution assay,¹¹⁷ and serial transplantation.¹²⁴ The nomenclature of these assays is unfortunate since the former two are both actually competitive repopulation assays. Further confusing the matter, limiting dilution assays are frequently called competitive repopulating unit (CRU) assays, while competitive repopulation assays use the unit RU. All three assays rely on availability of a method to discriminate between the test and standard cells (see below). Whereas previous studies utilized retroviral marks to label and track cell lineages, the availability of congenic mice has made the process more convenient. Congenic mice are two strains of mice that are genetically identical with the exception of one gene, which allows discrimination between the two populations. The most commonly utilized congenic mice are CD45.1 and CD45.2 mice, which are both on a C57BL/6 background, and antibodies that specifically recognize the two CD45 markers are widely available.

In the competitive repopulation assay and limiting dilution assay, lethally irradiated animals are typically supplied with a standard, quantified competitor cell population to provide short-term hematopoietic reconstitution. These competitor

“support” marrow cells eliminate the chance of potential replicative stress on the small number of HSCs in the test sample following transplantation.¹¹⁸ Competitive repopulation assays involve transplanting a test population with unknown HSC content (i.e., total BM or a population of cells sorted based on immunophenotypic markers) along with a population of standard, although not definitively known, HSC content (typically $1-2 \times 10^5$ total BM cells). The clonal contribution of HSCs is not a linear process and can display stochastic fluctuations in the short term after transplantation. Jordan and colleagues determined that individual oncoretroviral-marked HSCs gave stable contribution to hematopoiesis starting at 6 months post-transplant.⁷⁴ The laboratory of Eaves et al. has demonstrated in a congenic system that this stability arises 16 weeks after transplantation, while more committed stem cells gradually lose reconstituting capacity by 16 weeks post-transplant.¹²⁵ Thus, Purton and Scadden have suggested 16 weeks and an optimal time-frame of 6 months after transplant to assess donor contribution in transplantation-based HSC assays.⁹⁸ The major drawback of the competitive repopulation assay is that it makes a statement regarding the relative number of HSCs, precluding a definitive statement on the actual HSC content of a test sample.

In order to enumerate the actual number of HSCs in a test population, limiting dilution analyses with Poisson statistics is used instead.¹¹⁷ In this assay, serial dilutions of a test cell population are transplanted into a group of animals. From the known dilutions of test cells given in the transplants and the percentage of mice without donor chimerism (defined as <0.1% or <1%, see below) yielded by each test cell dose, one can calculate the number of HSCs in a test sample by using limiting dilution analysis and Poisson statistics.^{80,117} A variation of this assay uses limiting dilutions of genotypically distinct donor cells to transplant into stem cell-deficient W/W^v mice that can be used as hosts rather than lethally irradiated mice.¹²⁶ A second variation uses, as hosts, mice that have been transplanted previously and thus have a reduced or weakened endogenous stem cell competition capacity. While the limiting dilution assay is the gold standard to enumerate HSCs, it is resource-intensive. In addition to being time- and resource-intensive, other vagaries and considerations must be undertaken when designing limiting dilution experiments. When chimerism studies relied on southern blot detection, a threshold of <5% test-derived cells was considered as a mouse negative for engraftment. However, as flow cytometry and congenic markers have allowed for much enhanced sensitivity in detecting fine changes in engraftment, most studies utilize <1% as the threshold. While some investigators propose a <0.1% threshold, it is controversial whether detecting such low levels of chimerism is accurate.⁹⁸ Caution should also be taken when enumerating HSC numbers in animals with mutations that affect the proliferation kinetics of progenitors. If progenitors specifically have increased proliferative capacity, they may erroneously indicate enhanced HSC repopulating capacity; and likewise decreased proliferative potential of progenitors might artifactually suggest reduced HSC repopulating activity.

The most stringent functional test (although not necessarily as sensitive or quantitative) is the serial transplantation assay, which involves successive rounds of transplantation, a 16-week engraftment period, and re-transplantation of recipient BM into new recipients. This is the preferred method to demonstrate changes in HSC numbers when there is a perturbation in homing, engraftment, differentiation, or altered progenitor proliferative capacity.⁹⁸ Using serially diluted amounts of BM in the primary transplant, the serial transplantation assay can be combined with the limiting dilution assay to add further stringency to this assay. However, this is rarely done because of the enormous resource requirements.

Hematopoietic Stem Cell Studies in Xenograft Models

Humans vary from mice in many aspects, including their body size, life span, and daily demand for hematopoietic cell production.^{84,121,127} These differences result in species-specific selective pressures regarding genotoxic stress, tumorigenesis, telomerase activity, and genetic fidelity during proliferation. For example, because of larger body size, proliferative demand on human HSCs is greater than that for mice. The substantially greater life span also places unique selective pressure on human HSCs to not develop deleterious oncogenic mutations.¹²⁸ With this said, there are numerous evolutionarily conserved facets of hematopoiesis, and both mouse and human studies are essential and complementary. The need to study human hematopoiesis generated a demand to create xenogenic transplant models into mice. The first humanized mouse models were developed in 1988, as recently reviewed.¹²⁸ Murine models that are commonly used are derivatives of the NOD/SCID strain,^{129,130} strains deficient in the RAG1 or RAG2 genes necessary for T- and B-cell receptor rearrangements,^{131,132} and a fetal ovine system.^{133,134} NOD/SCID/ β_2 -microglobulin^{null} mice support proliferation and differentiation of immature human hematopoietic progenitors.^{129,135,136,137} Residual NK cell activity of NOD/SCID mice has been inhibited by administration of monoclonal antibodies against IL-2R β ¹³⁸ or by genetic manipulation to create γc null strains (NSG mice)¹³⁹.

P.72

NSG mice have 50-fold higher CD34⁺ cell engraftment compared to NOD/SCID mice. The hematopoietic repopulation ability of transplanted human cells in a sublethally irradiated mouse is quantified as SCID mouse repopulating cells (SRC),

the frequency of which can also be determined by limiting dilution analyses.¹⁴⁰ A technical advance in the study of human hematopoiesis in these xenogenic models was the injection of human cells directly into the femurs of NSG mice, leading to more rapid early engraftment of CD34⁺ cells.¹⁴¹ Another recent technical advance was the observation that female NSG mice have as much as 11-fold higher chimerism compared to male syngenic NSG mice.¹⁴² One of the most significant recent reports has been the identification of Thy1⁺ Rho^{lo} CD49f⁺ as being a marker set to purify human HSCs such that 14% to 28% of single Thy1⁺ Rho^{lo} CD49f⁺ cells could give rise to multilineage reconstitution in NSG mice.⁷⁹ With the ability to assess the long-term repopulating contribution of single human HSCs for over 8 months and with subsequent serial transplantation studies, the field is moving toward the capability to stringently test human HSC activity.

Hematopoietic Stem Cell Studies in Large Animal Models

Abkowitz et al. have identified important differences between the kinetics and behavior of HSCs in large animals and rodents.¹⁴³ The production of blood cells for the whole life span of a mouse is equivalent to the blood cell production of a human in a single day. This limited replication demand due to the relatively short murine life span poses a significant challenge to determine the long-term repopulation activity of human hematopoietic cell populations transplanted into immunodeficient mice. Human cells have been found to persist for several years after transplantation in a pre-immune in utero fetal sheep model.¹⁴⁴ Several large animal models are available for HSC studies, including feline, canine, ovine, and non-human primates,¹⁴⁵ but the genetic and biologic similarities between humans and non-human primates suggest that the non-human primate model is probably the best available model with which to study human hematopoiesis.^{84,127} Another advantage of using non-human primates is that their relatively long life span (up to 30 years) compared to rodents (up to 3 years) allows long-term monitoring after transplantation, irradiation, cytokine therapy, chemotherapy, etc. Simultaneous transplantation of genetically marked autologous cells in lethally irradiated non-human primates and immune-deficient mice demonstrated that the reconstituting cells in primates and in mice are distinct, suggesting a lack of overlap between these two cell populations.¹⁴⁶

Hematopoietic Stem Cells in Culture

Repopulation studies in irradiated mice, as well as experience with bone marrow transplantation in humans, provide strong evidence that HSCs can replicate and expand extensively in vivo (self-renewal). A very significant advance for clinical medicine would be the in vitro expansion of transplantable HSCs. However, mouse HSCs generally decline substantially relative to input numbers over a period of 1 to 4 weeks in culture,^{147,148} and ¹⁴⁹ even though clonal analysis indicates that some HSC clones proliferate.¹⁴⁸ Also, for unknown reasons, repopulating activity is lost with the entrance of cultured HSCs into the active cell cycle.¹⁵⁰ Similarly, homing of actively cycling HSCs is reduced by decreased expression of several molecules on the cell surface.^{122,151} Despite this inability to expand transplantable HSCs in vitro, more mature types of progenitors, including those with multilineage or single lineage potential, can be greatly expanded in vitro. Thus, cell expansion technology may be useful to obtain high numbers of hematopoietic progenitor cells that may support patients in the short term after high-dose chemotherapy or marrow transplantation.

In principle, a successful ex vivo expansion strategy must preserve HSC function and permit HSCs to self-renew in order to maintain or expand the number of transplantable HSCs during the culture. Human umbilical cord blood (CB) has been established as an important alternative source of transplantable HSCs instead of bone marrow or peripheral blood stem cells (PBSC) in children especially, because of its decreased GVHD probability.¹⁵² However, the limited number of HSCs present in a single unit of CB poses a significant risk for its use in adult patients, who require greater numbers of input HSCs. Although double cord blood transplants have improved the rate of sustained engraftment, it is still associated with delayed engraftment and elevated engraftment failure when compared to BM or PBSC transplants, indicating the need for more optimal CB expansion protocols.¹⁵²

Early ex vivo culture of human CD34⁺ CB cells with cytokines for 10 to 14 days demonstrated moderate increases in progenitor cell numbers and safety in patients, but had only modest effects on clinically relevant outcomes, such as time to neutrophil recovery.¹⁵³ The ideal culture conditions suitable for such abundant HSC expansion has remained elusive; however, over the last decade, substantial progress has been made to increase the number of phenotypic hematopoietic stem and progenitor cells and more importantly, the number of SCID repopulating units through ex vivo culture. Clinical trials typically involves ex vivo culturing (“manipulating”) one cord blood unit and co-infusing with a nonmanipulated cord blood unit. Patients co-infused with these mixed units are compared to patients receiving a conventional double cord blood transplant. A few of these modalities currently being tested in clinical trials include Notch ligands, stromal cell-based culture, copper chelators, and prostaglandin E2.¹⁵³

Bernstein's group showed that culture of CD34⁺ CB cells with immobilized Notch ligand Delta1 combined with fibronectin fragments and the cytokines stem cell factor (SCF), thrombopoietin (TPO), Flt3 ligand (Flt3l), IL-3, and IL-6 resulted in a

222-fold expansion after 17 days of culture and a 16-fold increase in NOD/SCID repopulating units.¹⁵⁴ Importantly, in phase I clinical trials, patients that received a mixed infusion of one conventional CB unit and one ex vivo cultured CB unit demonstrated a pronounced reduction in median time to neutrophil recovery compared to patients receiving the conventional dCBT.¹⁵⁴ In addition, 2 out of 10 patients had persistence of the expanded graft 180 days after transplantation, suggesting the preservation of at least short-term self-renewing cells during ex vivo culture in spite of co-infusion with a non-manipulated unit containing T cells capable of rejecting the expanded unit.¹⁵³

As HSCs develop in vivo in a microenvironment with stromal interactions, Elizabeth J. Shpall and colleagues have pursued HSC expansion by co-culture with mesenchymal stem cells (MSCs) and SCF, TPO, Flt3l, and G-CSF. These culture conditions yield an 8- to 12-fold expansion of CD34⁺ cells and importantly, resulted in a reduction of median neutrophil recovery to 14 days, compared to 23 for patients receiving conventional DCBT.¹⁵² In spite of these remarkable clinical advances, still, to date, there is no evidence that ex vivo expanded CB cells can contribute to long-term hematopoiesis in human trials.¹⁵⁵

Use of the copper chelator tetraethylenepentamine (TEPA) with SCF, TPO, Flt3l, and IL-6 resulted in a 159-fold increase in CD34⁺ cells after 7 weeks of culture and showed improved engraftment in NOD-SCID mice.^{156,157} However, early clinical trials reported by Shpall and colleagues have failed to show an improvement in neutrophil recovery,¹⁵⁸ but clinical trials are ongoing.¹⁵³ Preclinical data showed that the brief pre-incubation of HSCs¹⁵⁹ with prostaglandin E2 enhances their homing, survival, and proliferation in mice,¹⁶⁰ and clinical trials are ongoing to assess this target in humans.¹⁵³ Other promising candidates¹⁵³ to enhance the self-renewal of ex vivo cultured HSCs that have yet to reach clinical trials include the aryl hydrocarbon receptor antagonist

P.73

SR1 (StemRegenin 1),¹⁶¹ the endothelial-derived soluble factors Angiopoietin-like 5 (Angptl5), IGFBP2,¹⁶² and pleiotrophin,¹⁶³ and the homeobox gene Hoxb4.¹⁶⁴

Quiescence of Hematopoietic Stem Cells

Compared to downstream CD34⁺ LSK multipotent progenitors (Fig. 5.2), 90% of which are in cell cycle, <10% of CD34⁻ CD48⁻ CD150^{hi} LSK HSCs are cycling.¹⁶⁵ Even within this phenotypically identified HSC pool, the laboratories of Trumpp and Hock have used label-retaining tracking approaches to functionally distinguish the existence of two types of murine HSC: homeostatic (or hematopoietic stress-activated) and dormant HSCs, which represent ~70% and ~30% of the HSC pool, respectively.^{105,165} Whereas homeostatic HSCs divide every 28 to 36 days, dormant HSCs divide only every 145 to 193 days, or about 5 times per lifetime.^{165,166} This differential cycling has functional consequences for transplantation, as although both homeostatic and dormant HSCs provide long-term repopulation in lethally irradiated recipients, only dormant HSCs provide complete long-term repopulation in secondary transplants.^{159,165} Notably, activated HSCs can return to the dormant state.

HEMATOPOIETIC PROGENITOR CELLS

Committed Hematopoietic Progenitor Cells

Committed hematopoietic progenitor cells are progeny of HSCs that have begun to differentiate and can no longer convey long-term reconstitution of all hematopoietic lineages in ablated animals. Figure 5.1 depicts the HSCs and downstream committed progenitors, and notably, only HSCs have the capacity to self-renew, as indicated by the reflexive arrows. This schematic is a working model that is constantly under revision, with numerous nuances that preclude neat boundaries in differentiation potentials of progenitor cells.^{167,168} Nonetheless, whichever branching scheme is utilized, each successive stage has a more restricted differentiation potential, and there is a succession of commitment steps. Just as molecular processes determining self-renewal versus commitment decisions for stem cells are not completely understood, neither are the molecular events that lead to subsequent commitment steps. Although phenotypic markers can largely, although not definitively, differentiate cells with stem cell, as opposed to just progenitor cell, potential, the unique contribution of progenitor cells, as opposed to progenitor cells that derive from transferred HSCs, is not well understood. It is known that although a single HSC can yield long-term, multilineage donor contribution, supporting total BM or progenitor cells must be coinfused to allow short-term hematopoiesis; otherwise, survival is not possible. This demonstrates that in clinical transplantation or hematopoietic recovery from myeloablative regimens, progenitor cells are just as critical, if not more critical, than HSCs in the short-term after conditioning.

Multilineage Progenitors

The first committed progenitor without capacity to self-renew is the multipotent progenitor (MPP). Although initially regarded as an HSC assay, the majority of CFU-S colonies cannot provide long-term reconstitution of ablated animals, and

what are being quantified are mostly MPPs. Under culture conditions in semisolid medium with adequate supportive growth factors, these progenitor cells can form colonies of multiple cell lineages *in vitro*.^{169,170} Similar multilineage colonies can also be demonstrated *in vitro* in human hematopoietic cell populations.¹⁷¹ When the hematopoietic cells reach maturity, the lineage composition of the colonies can be determined by picking out the colonies and spreading the cells on microscope slides, followed by conventional staining or by immunostaining using lineage marker antibodies. Not all multilineage colonies that appear in *in vitro* or *in vivo* assays contain all cell lineages. For example, some colonies contain granulocytes, erythrocytes, macrophages, and megakaryocytes (mixed colonies); other colonies contain granulocytes and macrophage (GM colonies); and so forth. Table 5.2 describes a variety of hematopoietic progenitor stages that are defined by *in vitro* assays.

The observation that colonies with various combinations of lineages occur has been interpreted in several ways (models) to explain how cells are committed to become a particular type of blood cell.¹⁷² The data favor the idea that there are multiple commitment steps and that these steps lead to loss of specific lineage potential in a definite order. The first lineage commitment step separates lymphoid from myeloid potential, then granulocyte/macrophage potential is separated from erythroid/megakaryocyte potential, and so on, until finally, a descendant cell has only one lineage capability. This idea of successive commitment steps is embodied in Figure 5.1. Although this idea is probably generally correct, there are variant models that differ somewhat in their interpretation.¹⁶⁸ Also, it must be remembered that *in vitro* growth conditions may not be permissive for all possible lineages to appear in a colony. Thus, caution must be exercised in interpreting the exact lineage commitment pathways. For example, multilineage progenitors, CFU-S and *in vitro*-derived multilineage colonies, had been thought to be incapable of generating lymphoid cells. However, several studies have shown that lymphoid cells are produced by several such progenitors, but that they were not observed previously because growth factor support for colony development was not permissive for descendant lymphoid cells.^{70,119,173}

These multipotent progenitors, first described by Morrison and Weissman,^{89,174} have been characterized by flow cytometry as Lin⁻ Sca-1⁺ c-kit⁺ Thy1.1⁻ Flk2⁺ (Table 5.1). Even within this Flk2⁺ MPP population, there is heterogeneity in multipotency, which can be subdivided based on VCAM1 expression.¹⁷⁵ Recent studies point to improved resolution with the marker set Lin⁻ Sca-1⁺ c-kit⁺ CD150⁻ CD105⁻.⁹⁶ Recently, in an elegant mouse model utilizing Flk2-Cre animals, fate mapping revealed that all hematopoietic cells in the blood, BM, and spleen arise from a Flk2-expressing cell in the steady state and hematopoietic stress, confirming the hub role of multipotent progenitors.¹⁷⁶

Single Lineage Progenitors

The descendants of the multilineage colony-forming cells are ultimately restricted to a single lineage potential. The more mature, single lineage-committed progenitor cells are assayed *in vitro* by their ability to form colonies. These progenitor cells include CFUG, CFU-M, CFU-E, CFU-MK,^{177,178} and¹⁷⁹ CFU-preB,^{119,180} and CFU-DL^{181,182} for colony-forming units granulocyte, macrophage, erythrocyte, megakaryocyte, B-lymphocyte, and dendritic/Langerhans cells, respectively (Table 5.2). In some lineages, it is possible to observe stages of maturity within the lineage-committed progenitors. For example, the single lineage producing burst-forming unit erythroid (BFU-E) is a more immature erythroid progenitor than the CFU-E, forming colonies of many more mature erythroid cells after a longer period of time than the CFU-E.

With the advent of flow cytometry, many of these populations now have phenotypic counterparts (Table 5.1). In fact, flow cytometry allows for a more precise separation of populations and assessment of the progenitor activity, even to the single cell level. The MPP is thought to give rise to the common lymphoid progenitor (CLP)¹⁸³ and common myeloid progenitor (CMP),¹⁸⁴ with the former giving rise to B cells, T cells, and NK cells, while the latter spawns the erythroid, megakaryocyte, and myeloid lineages. The CMP subsequently branches off to the megakaryocyte erythroid progenitor (MEP) and granulocyte macrophage progenitor (GMP).

P.74

The GMP subdivides into granulocytes and macrophage dendritic cell progenitors (MDP),¹⁸⁵ which produce the respective eponymous lineages. A review of the surface markers for these populations can be found in Table 5.1.

Terminal Phases of Differentiation

Cells in the final stages of hematopoiesis are sufficiently differentiated that they can be identified by morphology using light microscopy with preparations of hematopoietic tissue. These cells are erythroblasts, myelocytes, monocytes, and megakaryocytes, and, because of the vastly amplifying cell divisions that occur by the time the final stages are reached, these cells are by far the most prevalent cells seen in hematopoietic tissues. They are capable of only a few cell divisions, on the order of one to four, yet they are undergoing dramatic specialized changes associated with terminal phases of differentiation/maturation. The erythroblasts rapidly accumulate hemoglobin and begin to assemble a unique membrane

skeleton that later maintains the shape and deformation properties of the mature erythrocytes. The nucleus of the erythroblast becomes condensed and is extruded from the cell, leaving an irregular, organelle-containing reticulocyte. Subsequently, over the course of a few days, extensive remodeling occurs within the reticulocyte that eliminates the internal organelles and changes the membrane so that the biconcave erythrocyte is formed. This remodeling process involves extensive, selective proteolysis. In granulocyte progenitors, granules that contain specific proteolytic enzymes are formed in the cytoplasm. The nuclei undergo a condensation process that ultimately results in a multilobular nucleus that is retained in the mature cell. Maturing monocyte precursors undergo similar changes. The terminal-stage megakaryocytes replicate their DNA and undergo several nuclear divisions without cytokinesis; thus, they become polyploid. Dense granules and α -granules form in the cytoplasm, and the cytoplasm becomes highly compartmentalized by demarcation membranes. Platelets form as small portions of the demarcated megakaryocyte cytoplasm separate from the whole cell.

TRAFFICKING OF HEMATOPOIETIC STEM AND PROGENITOR CELLS

Adhesion Molecule Interactions of Hematopoietic Stem Cells and Stroma

Direct molecular interactions between the hematopoietic cells and stromal cells involve ligand-receptor relationships between adhesion molecules on the surfaces of the hematopoietic and stromal cells. There are many cytoadhesion molecules known, and they generally can be classified into several families: sialomucins, selectins, integrins, and members of the immunoglobulin super-family.¹⁸⁶ Numerous interactions are possible, and there appears in some cases to be redundancy in the systems involved in trafficking within the hematopoietic microenvironment.

Retention and Homing of Hematopoietic Stem Cells

Besides providing a source of growth factors for hematopoietic cells, the stroma of hematopoietic organs directs the trafficking of these cells. This trafficking occurs during embryonic development as the primary organs of hematopoiesis change from the AGM to the fetal liver to the spleen and bone marrow. Also, some HSC/progenitors migrate continuously between bone marrow and blood in normal adult animals.¹⁸⁷ Although not discussed further here, such trafficking to particular tissues is also critical for mature cells, such as monocytes and T lymphocytes, to perform their effector functions with spatial efficiency in order to maximize target tissue effector function (i.e., combating pathogens) while limiting tissue toxicity. Migration is composed of two parts: (1) egress from the source tissue (typically the BM), termed "mobilization," and (2) directed movement towards the target tissue, termed "homing."

With respect to the BM, homing is the process by which circulating HSC/progenitors migrate into the extravascular space within the bone marrow stroma where they selectively interact with specific stromal cells and matrix proteins to initiate and sustain long-term hematopoiesis.¹⁸⁸ Homing occurs not only for HSC/progenitors that are circulating normally, but is also essential for the success of clinical stem cell transplantation. Similar to the receptor-counterreceptor interactions that govern the inflammatory recruitment of mature leukocytes (reviewed in^{189,190}), the endothelial progenitor cell interaction for homing is dependent on selectins, integrins, and chemokines.

The selectin family of cytoadhesion molecules are designated E, P, and L. HSC/progenitors have receptors for the selectins, and they can exhibit the rolling phenomenon similar to that of mature leukocytes.^{191,192} The initial tethering/rolling of HSC/progenitors is dependent on endothelial P- and E-selectin binding to fucosylated PSGL-1 on HSC/progenitors.^{193,194,195} and¹⁹⁶

Integrins are heterodimeric, transmembrane proteins in which the α and β subunits are joined noncovalently. Both subunits have extracellular and intracellular domains. Eighteen types of α subunits and eight types of β subunits are known, although only a few of the possible heterodimer combinations have been found on hematopoietic or stromal cells and implicated in hematopoiesis. The definitive homing and subsequent retention of HSC/progenitors into the extravascular space is dependent on integrins $\alpha_4\beta_1$,^{193,195,197,198,199,200,201} and²⁰² $\alpha_4\beta_7$,²⁰³ $\alpha_5\beta_1$,^{200,204,205} and β_6 ,²⁰⁶ CD44,^{207,208} and²⁰⁹ and also VCAM-1 presumably from the endothelia.^{193,195,197,210}

The most critical chemokine receptor in HSC/progenitor homing is CXCR4 binding to CXCL12.^{211,212} CXCL12, secreted by bone marrow stroma, is the only known chemokine that elicits directed chemotactic response in HSCs via interactions with CXCR4 on their cell surface.^{213,214} Mice lacking SDF-1 or CXCR4 have defective hematopoiesis in fetal bone marrow, due to a decreased ability of HSCs to home from the fetal liver to the marrow cavity.^{215,216} Antibodies against CXCR4 block engraftment of severe combined immunodeficiency (SCID) mouse bone marrow by transplanted CD34-enriched HSCs and hematopoietic progenitor cells.^{212,217} Once HSC/progenitors are arrested on the endothelia due to selectin/adhesion molecule interactions, stromal-derived CXCL12 can guide HSC/progenitor migration into the BM parenchyma in cooperation with $\alpha_4\beta_1$ -, LFA-, CD44-, and Flt3-dependent interactions.^{204,207,218}

The adhesion molecules of all families are transmembrane proteins, and many can act as receptors that activate specific intracellular signaling pathways. These adhesion molecules/receptors, in turn, may be regulated by other intracellular signaling pathways.^{219,220} and ²²¹ Thus, the interactions of hematopoietic cells with stromal cells and matrix can be highly modulated by the adhesion receptors, both in transmitting signals from the microenvironment into the cell and in translating the state of intracellular signaling pathways into changes in the number and affinities of adhesion molecules. Activation of Kit by its ligand (KL) modulates adhesion functions that are mediated by integrins $\alpha_4\beta_1$ (VLA-4) and $\alpha_5\beta_1$ (VLA-5).^{202,222,223} Another example is CXCL12 inducing binding of circulating progenitors to the vascular endothelium by activating the integrins VLA-4, VLA-5, and lymphocyte function-associated antigen,^{204,224,225} as well as CD44 and hyaluronic acid.²⁰⁷

Several of the adhesion molecules on hematopoietic cells specifically bind to sites on particular matrix macromolecules. For example, HSC/progenitors bind to fibronectin, primarily through

P.75

interaction with the integrin receptors $\alpha_4\beta_1$ and $\alpha_5\beta_1$.^{220,226,227,228} and ²²⁹ Another cytoadhesion molecule that interacts with several matrix macromolecules is CD44, which binds with glycosaminoglycans (hyaluronic acid being the major CD44 ligand).²³⁰ The proteoglycans, proteins with extensive sulfation such as heparan sulfate and chondroitin sulfate, are extracellular matrix proteins that may contribute to adhesion between the stroma and the hematopoietic progenitor cells.^{231,232,233,234} and ²³⁵ The proteoglycans can also concentrate soluble growth factors. For example, granulocytemacrophage colony-stimulating factor (GM-CSF) binds to heparan sulfate in the marrow matrix.^{236,237}

Mobilization of Hematopoietic Stem Cells

Recruitment of circulating HSC/progenitors has been implicated in toll-like receptor-induced myeloid differentiation in tissues²³⁸ and the development of repair-phenotype macrophages after liver injury,²³⁹ but their in vivo steady-state relevance is still unclear. Despite this, their enforced egress to the circulation with pharmacologic agents, such as chemotherapy or hematopoietic growth factor administration, has been utilized in clinical medicine to less invasively procure HSC/progenitors for transplantation, a process termed stem cell mobilization. Mobilized peripheral blood now represents the majority of donor sources for HSC/progenitor transplantations.²⁴⁰ These mobilized grafts have several advantages over traditional bone marrow grafts for transplantation, including ease of harvesting, higher HSC yields, and faster hematopoietic engraftment following transplantation. Granulocyte colony-stimulating factor (G-CSF) is the most commonly utilized mobilizing agent. Although early observations suggested that the mechanism of G-CSF mobilization depended on the enhanced levels of proteolytic enzymes in the marrow cavity to cleave adhesion factors tethering HSC/progenitors in the BM, unperturbed levels of mobilization in animals deficient of virtually all serine protease activity has cast doubt on this as the primary mechanism.²⁴¹ More recent data indicate that reduced production of stem cell retention factors, such as CXCL12, angiopoietin-1, kit ligand, and VCAM-1 in the stroma, rather than increased degradation, mediates mobilization.²⁴² β -adrenergic signals from sympathetic nerve terminals in the BM are critical for this abrogated stromal production of retention factors.^{242,243} Furthermore, there is a circadian time-dependent oscillation in HSC/progenitor trafficking,²⁴⁴ which indicate optimal times to harvest peripheral blood HSC/progenitors in mobilized mice and humans.²⁴⁵ Recent data indicate that abrogation of BM macrophage-derived retention signals is another mechanism of G-CSF-induced mobilization.^{246,247} and ²⁴⁸ The other widely utilized agent for clinical HSC/progenitor mobilization is the CXCR4 antagonist AMD3100. AMD3100 is capable of mobilizing HSCs within hours and synergizes with the mobilizing effects of G-CSF.²⁴⁹ Since up to 30% of patients are "poor mobilizers" and thus do not mobilize a sufficiently high yield of HSC/progenitors with standard clinical protocols, novel strategies to enhance mobilization efficiency are under active investigation.²⁵⁰ Among the agents being investigated as adjuncts to G-CSF are GM-CSF, stem cell factor, thrombopoietin, human growth hormone, IL-8 analog, antibodies to VLA-4, retinoic acid receptor- α agonists, and thrombopoietin receptor agonists.²⁵¹ Recent preclinical data indicate that abrogation of BM macrophages²⁴⁶ or antagonism of the epithelial growth factor receptor²⁵² may be promising strategies to synergize with G-CSF.

LINEAGE COMMITMENT

Branch Points of Hematopoiesis

Multiple lineage relationship models of hematopoiesis have been proposed over the years (reviewed in¹⁶⁸). Discrepancies among multiple models can be partially explained by the differential predication of the models on differentiation potential versus physiologic production. Whereas certain progenitors may have particular differentiation potentials when cultured in vitro with the appropriate cytokines or in vivo in emergency scenarios, these potentials may not be evident under

steady-state physiology. Where possible, assessment of lineage commitment by genetic lineage tracing is the best physiologic method to assess physiologic progenitor-progeny relationships *in vivo*.

Role of Particular Transcription Factors

Some specific transcription factors exhibit hematopoietic lineage-restricted expression, and some are known to be essential for the complete differentiation of individual lineages. Two examples of transcription factors whose lineage associations are more fully understood are GATA-1, which is essential for terminal erythrocyte and megakaryocyte differentiation, and PU.1, which is essential for B-lymphocyte as well as macrophage development.^{253,254} Specific factors not only play a direct role in the expression of lineage-specific genes but, in some cases, appear to antagonize transcription factors important for other lineages; thus, they can repress the expression of genes characteristic of other lineages. For example, GATA-1 can suppress PU.1 activity, and PU.1 can suppress GATA-1 activity by direct protein interactions that block the function of each other.²⁵⁴ PU.1 and GATA-1 play positive roles in the transcription of their own genes (autoregulatory loops).^{255,256} Thus, hypothetically, an excess of GATA-1 over PU.1 could downregulate PU.1 expression at the level of transcription, and excess PU.1 could likewise downregulate GATA-1. In multipotent cells, it is known that there is expression at low levels of sets of genes characteristic of multiple hematopoietic lineages.²⁵⁷ Thus, commitment appears to occur not only by upregulation of a single lineage program of gene expression but also by the irreversible suppression of competing differentiation programs. Because of observations such as those described above for GATA-1 and PU.1, and because the forced overexpression of particular transcription factors can cause lineage switches in certain *in vitro* cell systems, some investigators have proposed that the transcription factor profile (stoichiometry relationships) of multipotent cells directs their lineage commitment decisions through cross-antagonism mechanisms.^{254,258} How variations in transcription factor stoichiometry occur could be either by extrinsic signals or by stochastic mechanisms. A transcription factor network has been proposed in which combinations of specific lineage-instructive transcription factors at various stages of hematopoietic differentiation from HSCs through the lineage-specific progenitor cells play roles in cell fate decisions.²⁵⁹

Role of MicroRNAs

MicroRNAs are 18 to 24 nucleotide noncoding RNAs that bind the 3' untranslated region of target mRNA, resulting in mRNA degradation or impaired translation efficiency.²⁶⁰ MicroRNAs rise and fall as cells differentiate along the hematopoietic spectrum, as these microRNAs fine-tune the response to cytokines and transcription factors that are required for lineage commitment and differentiation. Since Chen and colleagues first demonstrated the role of miR-181 in B-lymphoid differentiation in 2004,²⁶¹ there has been an explosion of investigations into the role of miRNAs in hematopoiesis, as previously reviewed.²⁶² Loss of function of all miRNAs can be studied broadly using gene-knockdown models of Dicer, an RNase that is critical for miRNA biosynthesis. For example, conditional knockout of Dicer in the B²⁶³ and T²⁶⁴ cell compartments impairs development of mature B and T lymphocytes, respectively, indicating a role for miRNAs in lymphocyte differentiation. More precisely, particular hematopoietic populations can be assessed for miRNAs that are expressed and these candidate

P.76

miRNAs can be specifically knocked down. This has been used to show that miR-155 inhibits erythropoiesis and megakaryopoiesis^{265,266}, but is critical in T and B cell function.^{267,268,269,270} and²⁷¹ Our knowledge in this area is rapidly evolving. It is already clear, however, that the influence of microRNAs is broad-based, as they play essential roles in the regulation of erythropoiesis,²⁷² megakaryopoiesis,²⁷³ myelopoiesis,²⁷⁴ and lymphopoiesis.²⁷⁵

Hematopoietic Cytokines

The purification of erythropoietin from the urine of anemic patients in 1977 initiated extensive investigations to find other comparable growth factors for other hematopoietic lineages.²⁷⁶ Although taken for granted now because most of the discovered hematopoietic cytokines are readily available in recombinant protein form and validated by genetic mouse models, there was substantial controversy in the hematopoietic growth factor field in the 1970s through the 1990s. Most of the early work on these glycoprotein growth factors derived from studies of "conditioned media," which were necessary and greatly stimulatory for hematopoietic cell colony growth. What partially confounded researchers about the discovered colony-stimulating factors (CSFs) was their polyfunctionality.²⁷⁶ For example, until specialized utilization of different cytoplasmic domains downstream of the same receptor was described, it was unclear how G-CSF could promote the battery of cellular responses for survival, proliferation, differentiation commitment, maturation induction, and functional stimulation.^{276,277} Another puzzling aspect of hematopoietic growth factors was the ability of one cytokine to act on many cell types and the ability of multiple cytokines to exert influence on a single cell type. Exemplifying the latter,

G-CSF, GM-CSF, IL-3, CSF-1, SCF, and IL-6 all expand granulocytic colonies.²⁷⁶ This does not necessarily just reflect redundancy, as there is synergistic activity among IL3, G-CSF, GM-CSF, and CSF-1 in myeloid colony formation.²⁷⁸ Based on certain structural and functional features of the receptors for hematopoietic growth factors, two families of ligands/receptors have been recognized: the cytokine receptor family and the tyrosine kinase receptor family (Table 5.3). Notably, synergy is most prominent when utilizing combinations of cytokines using both sets of receptors. Table 5.3 shows a list of cytokines, their receptors, and expression patterns.

Factors That Act on Multilineage Progenitors

In vitro cultures of hematopoietic colony-forming cells have continued to be very useful in defining growth factor effects on various lineages of cells.^{279,280,281,282,283} and ²⁸⁴ Many of the hematopoietic growth factors exhibit positive growth effects on HSCs or progenitors with multilineage potential, or both. These include KL, GM-CSF, G-CSF, CSF-1, IL-3, IL-4, IL-6, IL-11, IL-12, FL, leukemia inhibitory factor, oncostatin M, and TPO.^{285,286,287} and ²⁸⁸ In addition, some members of this same group can support differentiation of certain cell types to late stages or even to full maturity. For example, G-CSF, GM-CSF, CSF-1, IL-3, KL, and IL-6 can all support formation of small neutrophilic granulocytic colonies, and CSF-1 and GM-CSF can also support macrophage colonies and mixed granulocyte/macrophage colonies.²⁸⁵

Potential of hematopoietic cell production in in vitro assays by combinations of growth factors can occur in two basic ways. A combination of growth factors may allow proliferation and differentiation of individual cells that would otherwise die or remain dormant in the presence of a single factor. Second, potentiation can occur by enhanced proliferation in the presence of the combined factors. The latter effect appears to apply to the examples of the combined effect of KL with G-CSF, GM-CSF, IL-3, IL-6, or EPO on expansion of populations of progenitors.^{289,290} and ²⁹¹ The numbers of colonies formed in the presence of the combinations are not increased greatly, but there is a large increase in the size of the colonies. The proliferation of HSCs, however, appears to be an example of a requirement of a combination of factors for recruitment of dormant cells into proliferation and differentiation.^{172,285,292,293} and ²⁹⁴

TABLE 5.3 CLASSIFICATION OF HEMATOPOIETIC FACTORS BASED ON THEIR RECEPTOR TYPES

	Receptors consisting of:	Examples
Cytokine type receptors	A single unique peptide chain	EPO, TPO, G-CSF
	Complexes containing gp130*	IL-6, IL-11, IL-12, LIF, OSM
	A ligand-specific common α subunit and/or common gp140 β_c subunits	IL-3, , IL-5, GM-CSF
	A common γ_c subunit and ligand-specific α and/or β subunits	IL-2, IL-4, IL-7, IL-9, IL-15
	Two or more unique subunits	IFN- α , IFN- β , IFN- γ
RTK type receptors	EGF family receptors (type I)	TGF- α
	Insulin family receptors (type II)	IGF-1
	PDGF subfamily with 5 Ig-like domains (type III)	Kit ligand, CSF-1, Flk-2 ligand
	PDGF subfamily with 7 Ig-like domains (type V)	Flk-1 ligand

* gp130 serves as the signal transducer, plus an additional ligand binding unit. gp, glycoprotein; EPO, erythropoietin; TPO, thrombopoietin; G-CSF, granulocyte colonystimulating factor; IL, interleukin; LIF, leukemia inhibitory factor; OSM, oncostatin M; GM-CSF, granulocyte-macrophage colony-stimulating factor; IFN, interferon; EGF, epidermal growth factor; TGF, transforming growth factor; IGF, insulin growth factor; PDGF, plateletderived growth factor; CSF-1, colony-stimulating factor 1 (also known as macrophage colony-stimulating factor, or M-CSF); Flk-2 ligand, fms-like kinase 2 (also known as fms-like tyrosine kinase 3 ligand, or Flt3l).

When growth factors with effects on multilineage progenitors act alone or in combination, the result of early rounds of proliferation and differentiation is the generation of progeny that become committed individually to form different

lineages of mature cells. For some lineages, the resultant single lineage progenitors cannot complete differentiation and maturation without lineage-specific factors; thus, caution must be taken in interpreting negative results. For example, late committed erythroid progenitors (CFU-E) require EPO, or they die. Likewise, appearance of lymphoid cells requires IL-7, and maturation of megakaryocytes and formation of platelets is greatly enhanced by TPO. Thus, the full development of hematopoietic cells from stem cells or early-stage progenitors requires the action of growth factors (alone or in combination) that support the multilineage progenitors and, in addition, growth factors that support terminal differentiation of committed single lineage progenitors.

Granulocyte Growth Factors

Granulocytes are composed of neutrophils, eosinophils, and basophils. Neutrophils are best known for their ability to rapidly arrive and exert effector responses at sites of tissue injury, while basophils and eosinophils are critical in responding to parasitic infections and also promoting allergic reactions. In vitro colonyforming assays have indicated the importance of G-CSF and IL-5 in the support of differentiation of neutrophils^{169,269} and eosinophils,^{295,296} respectively. This is substantiated by the neutropenia and increased bacterial susceptibility observed in mice deficient in G-CSFR²⁹⁷ and impaired parasite-induced eosinophilia observed

P.77

in IL-5-deficient animals²⁹⁸ (Table 5.4). Nonetheless, the existence of neutrophils and eosinophils in these animals in the steady state indicates redundancy with other cytokines. GM-CSF has also been implicated in in vitro granulocyte colony formation^{177,299}; however, no neutropenia is observed in GM-CSF-deficient animals.³⁰⁰ Interestingly, mice deficient in G-CSF, GM-CSF, and CSF-1 still have neutrophils, suggesting extensive redundancy/collaboration among the hematopoietic cytokines.³⁰¹ G-CSF and GM-CSF not only support differentiation of late-stage progenitors, but also can activate the resulting mature blood cells, stimulating functions such as phagocytosis.^{302,303} and ³⁰⁴ Importantly, G-CSF (filgrastim) is used clinically to treat patients with neutropenia.

Mast Cell Growth Factors

Mast cell differentiation in vitro is supported by the Kit receptor.^{295,305,306,307} and ³⁰⁸ The importance of Kit ligand (also called stem cell factor or SCF)-Kit receptor signaling in mast cell differentiation is validated in vivo by the absence of mast cells in animals deficient in KL (Sl/Sl^d mice) or Kit (W/W^v)³⁰⁹ (Table 5.4). KL also activates mature mast cells, causing them to release histamine.³⁰⁸

Monocyte/Macrophage Growth Factors

In mice, monocytes in circulation and tissues consist of at least two subtypes: (1) the classical Gr1^{hi} subset (CD14⁺CD16⁻ in humans, also known as “inflammatory monocytes”) and (2) the nonclassical Gr1^{lo} subset (CD14^{-/lo}CD16⁺ in humans, also known as “resident monocytes”).³¹⁰ Monocytes are critical mediators of inflammation, whether beneficially in combating pathogens or detrimentally in contributing to atherosclerotic plaques and mediating inflammatory disorders. Although monocytes express high levels of the CSF-1R, they are still present in normal numbers in animals with defects in CSF-1 (Csf1^{op/op}) or deficiency in CSF-1R (Csf1r^{-/-})³¹¹ (Table 5.4), indicating that other cytokines contribute or at least can compensate for defective CSF-1R signaling. Monocytes are also present at normal levels in GM-CSF-deficient animals.³⁰⁰ Mice deficient in G-CSF, GM-CSF, and CSF-1 still have monocytes present, albeit at reduced numbers, again suggesting redundancy among cytokines for differentiation and maintenance of monocytes.³⁰¹

TABLE 5.4 PHENOTYPES CAUSED BY NONFUNCTIONAL MUTATIONS IN GENES FOR HEMATOPOIETIC GROWTH FACTORS OR THEIR RECEPTORS

Factor Observed Effects

Kit ligand	No functional alleles: Embryonic death associated with no production of fetal hematopoietic cells and other developmental failures. Partially functional allele: Deficiency of hematopoiesis, mast cell deficiency, anemia, and also other defects in pigmentation and in gametogenesis
IL-3	Lack of function does not appear to affect hematopoiesis
GM-CSF	Alveolar proteinosis
CSF-1	Osteopetrosis, alveolar proteinosis, reduced macrophages, normal monocytes

- G-CSF Neutrophil deficiency; approximately 20% of normal numbers; impaired mobilization of neutrophils; demonstrated to be susceptible to some infections
- IL-5 Eosinophil deficiency
- TPO Platelet deficiency, approximately 10% of normal numbers
- EPO Embryonic death; failure to produce fetal erythrocytes due to apoptosis of the late progenitors in the fetal liver; production of some embryonic blood cells
- Flt3 Deficiencies in immune system and in myeloid progenitors and CLP; more severe defects in ligand the case of knockout of the ligand than knockout of the receptor (FLT3)
- IL-7 Reduced thymic and peripheral lymphoid cellularity, including B- and T-cell development
- IL, interleukin; CLP, common lymphoid progenitor; CSF-1, colony-stimulating factor 1; GM-CSF, granulocyte-macrophage colony-stimulating factor; G-CSF, granulocyte colony-stimulating factor; TPO, thrombopoietin; EPO, erythropoietin; Flt3 ligand, fms-like tyrosine kinase 3 (also known as fms-like kinase 2 ligand, or Flk2 ligand).

Macrophage differentiation and survival in vitro can be supported by the CSF-1 cytokine.³¹² Tissue resident macrophages are severely reduced in $Csf1^{op/op}$ or deficiency in $Csf1r^{-/-}$ ³¹¹ (Table 5.4). Both of these deficient strains develop osteopetrosis because of failure to develop osteoclasts. Although other macrophage populations are normal, lung macrophages are severely reduced in numbers in GM-CSF-deficient animals and develop a characteristic alveolar proteinosis.³⁰⁰ Importantly, CSF-1 treatment in patients has demonstrated an improved survival benefit in patients with invasive fungal infection in the post-myeloablative setting.³¹³

Megakaryocyte Growth Factors

In vitro colony assays have been developed for quantifying megakaryocyte progenitor cells, termed colony-forming units megakaryocyte (CFU-MK). As in the case of other early committed progenitors, the growth of such colonies is augmented by several of the CSFs with multilineage activity, such as IL-3, IL-6, GM-CSF, KL, and IL-11.^{179,314,315} Unlike granulocytes and monocytes, bone marrow production of platelets is regulated by the number of platelets in the blood. Reduction of platelet numbers in rodents by antiplatelet antibodies or by exchange transfusion of platelet-poor blood causes an increase in the number of megakaryocytes in the hematopoietic tissues as well as an increase in their size and ploidy; conversely, platelet transfusion decreases these parameters.¹⁷⁹ However, such manipulations did not affect CFU-MK numbers in the hematopoietic tissues,³¹⁶ leading to the speculation that megakaryocyte differentiation and platelet production are controlled by a thrombopoietic factor that is induced by thrombocytopenia.^{179,317}

A growth factor has been identified that has some properties of a physiologic regulator of platelet production. This factor, thrombopoietin (TPO), exerts its effect through the activation of a cytokine receptor termed Mpl.^{318,319} and ³²⁰ Mpl was identified earlier as the viral oncogene product of the mouse retrovirus, myeloproliferative leukemia virus.³²¹ Recombinant TPO increases megakaryocyte and platelet numbers in vivo and stimulates CFU-MK growth in vitro.^{322,323} Mice bearing homozygous, nonfunctional alleles of *c-mpl* are viable with greatly diminished platelet numbers,²⁸⁶ indicating that although TPO is not essential for platelet production, it is a strong in vivo regulator of the process. TPO production has been shown to be regulated by blood platelet numbers,³²³ and platelet numbers regulate the mRNA for TPO in the marrow and spleen but not in the liver and kidney.³²⁴ It is not yet clear that the modulation of TPO mRNA in these organs is responsible for the regulation of overall TPO protein levels. Several studies indicate that TPO is constitutively synthesized in the liver and that its level in blood is determined by its removal from circulation by binding to c-Mpl receptors on platelets and bone marrow megakaryocytes.³¹⁸ Mice lacking TPO have only approximately 10% of the normal number of platelets²⁸⁶ (Table 5.4). Although early efforts to treat thrombocytopenia with recombinant TPO was complicated by the development of antibodies to endogenous TPO, causing thrombocytopenia, two newly FDA-approved drugs, including a TPO mimetic and TPO-R agonists, offer new hope for treating clinical thrombocytopenia.³²⁵

P.78

Growth Factors for Erythroid Cells

The physiologic regulator of erythrocyte production is erythropoietin (EPO), and this regulation is very precise, keeping the red blood cell mass within very narrow limits.³²⁶ EPO acts on committed erythroid progenitors to support the later phases of erythroid differentiation.³²⁶ The regulation is achieved by EPO's action to modulate apoptosis of these progenitors. The production of EPO is regulated by the O₂ activity in the vicinity of specialized EPO-producing cells in the kidney. These cells are peritubular cells, located in the renal cortex.^{327,328} and ³²⁹ By sensing O₂ activity, they essentially measure the oxygen delivery capacity of the blood, and they adjust EPO production to achieve the number of erythrocytes needed for normal tissue O₂ tension. The liver also contains specialized cells that can produce EPO in an oxygen-dependent manner, although in adult animals, the contribution of the liver to total EPO production is much less than that of the kidney. In specialized kidney and liver cells, the transcription of the EPO gene is controlled by an oxygen-dependent transcription factor, hypoxia-inducible factor (HIF), that interacts with DNA sequences corresponding to the 3' untranslated sequence of the mRNA and also with sequences in the EPO promoter region.³³⁰ HIF ubiquitination and subsequent proteasomal degradation are dependent upon the hydroxylation of two specific prolines^{331,332} and ³³³ and an asparagine of HIF^{334,335} by non-heme, iron-containing hydroxylases that use molecular oxygen as a substrate for the reactions. With normoxia, HIF is rapidly hydroxylated and degraded. With hypoxia, HIF is not hydroxylated and degraded, but it does form part of a transcription complex that binds the 3' enhancer sequence and induces EPO gene transcription. In addition, tissue specificity of expression in the kidney requires specific, cis-acting DNA sequences far upstream (between 6 kilobase pairs and 14 kilobase pairs) of the coding sequence.^{336,337} EPO is secreted rapidly into the circulation, and it binds in the bone marrow to EPO-receptors on erythroid progenitor cells in the CFU-E through early erythroblast stages. The EPO-EPO-receptor interaction not only triggers signal transduction but leads to endocytosis and degradation of both the EPO and EPO-R.³³⁸ This erythroid progenitor-mediated consumption of EPO appears to be a major determinant of the metabolic fate of EPO both in vitro³³⁹ and in vivo.³⁴⁰ Loss of function of EPO or the EPO receptor in knockout mice leads to embryonic death at approximately day 13 of gestation due to failure of production of definitive erythrocytes^{341,342} (Table 5.4). Also, importantly, recombinant EPO has been used clinically to treat patients with anemia.

KL is also required for erythroid cell development as shown by its requirement for growth of human BFU-E in vitro under serumfree conditions.³⁴³ The Kit receptor is present on multilineage progenitors and on the BFU-E, and it persists on erythroid progenitors up to the proerythroblast stage. KL thus has a stimulatory effect on erythroid progenitors throughout most early stages, including those of the CFU-E and proerythroblast, when EPO stimulation becomes essential for further development. In addition, IGF-1 appears to have a specific role in erythroid development, as it appears necessary for proper erythroid differentiation in serum-free cultures.^{344,345} Other multilineage growth factors, such as IL-3 and GM-CSF, have a stimulatory effect on BFU-E growth in vitro, although there does not appear to be a specific requirement for these factors.

Growth Factors for Lymphocytes

Methods for culture of B-lymphocytes and their progenitor cells were originally described by Whitlock and Witte.³⁴⁶ Subsequently, a colony assay for B-cell progenitors, CFU-preB, was described, in which it was found that IL-7 is a very potent growth stimulatory factor for such progenitors.¹⁸⁰ The role of IL-7 in lymphoid cell development in vivo was demonstrated by generating mice in which the gene for the IL-7 receptor is nonfunctional. Such mice have a profound reduction in thymic and peripheral lymphoid cellularity with defects in B- and T-cell development³⁴⁷ (Table 5.4). Because of its importance in B-cell growth in vitro, IL-7 has been incorporated into culture media when examining the lineage potential of early multilineage progenitors.^{119,120,173} Flt3 ligand and SCF are crucial in lymphoid commitment, as CLPs are severely reduced in deficient animals.³⁴⁸

Supportive versus Instructive Signals

There remains controversy over whether cytokines play a stochastic (supportive) or deterministic (instructive) role in determining cell fate, as there are clear examples that accommodate both models. The idea that lineage differentiation is random, and thus that cytokines merely play a role in proliferation or survival of the progeny after a differentiation decision has been made, is supported by the persistence of myeloid cells in animals deficient in G-CSF, GM-CSF, and CSF-1.³⁰¹ Along the same lines, overexpression of anti-apoptotic proteins can make up for erythroid and T lymphocyte deficiencies caused by the absence of EPO³⁴⁹ and IL-7R,^{350,351} respectively, indicating that these cytokines are not critical for differentiation.

Still, even in the example of anti-apoptotic rescue of IL-7R deficient mice, B cell development is not rescued.³⁵⁰ In fact, IL-7 receptor signaling upregulates expression of the B cell-specific transcription factor EBF and its target genes; otherwise, B cells become arrested at the pre-proB cell stage, indicating that IL-7 instructs B cell differentiation.³⁵² Other examples of an instructive role of cytokines on committed progenitors include the demonstration that enforced GM-CSF signaling can redirect lymphoid progenitors to a myeloid fate³⁵³; that G-CSF upregulates expression of C/EBP α , a critical transcription

factor in neutrophil production, in bipotent granulocyte macrophage progenitors³⁵⁴; and that G-CSF and CSF-1 differentially instruct common myeloid progenitors to adopt a granulocyte or macrophage fate, respectively.³⁵⁵ Interestingly, Sieweke and colleagues showed recently that when HSCs deficient in the transcription factor MafB were treated with CSF-1, the myeloid master regulator PU.1 was upregulated, promoting myelomonocytic commitment³⁵⁶; thus, CSF-1 could have an instructive role even on HSCs.

HEMATOPOIETIC MICROENVIRONMENTS

Stroma of Hematopoietic Organs

The stroma is composed of non-hematopoietic cells that provide structure and regulate hematopoietic cells in lymphoid tissues. These cells include nerves, endothelial cells, bone, adipocytes, and mesenchymal stem and progenitor cells. The bone marrow houses two major stem cell types: HSCs and non-hematopoietic stem cells that form bone structures.^{357,358} These non-hematopoietic stem cells can give rise to mesodermal-derived cells,³⁵⁹ endothelial cells,³⁶⁰ or even diverse cell types associated with multiple embryonic germ layers.²⁸⁴ Among non-hematopoietic stem cells in the bone marrow, mesenchymal stem cells (MSCs) were originally described as undifferentiated cells capable of differentiating in vitro into multiple mesenchymal lineages including bone and cartilage.³⁵⁷ MSCs are plastic-adherent, fibroblast-like multipotent cells that do not express hematopoietic markers (CD45, CD34, CD14, CD11b, CD79a or CD19, and HLA-DR) but do express other specific surface antigens (CD105, CD73, CD90).^{361,362} A relative lack of immunogenicity of MSCs has bolstered its therapeutic use in repair or regeneration of damaged or mutated bone, cartilage, and cardiac tissues.³⁶² The transplantability of MSC remains

P.79

controversial since numerous studies have indicated that following allogeneic, unfractionated whole bone marrow cell transplantation, the bone marrow stroma remains entirely of host origin, while the hematopoietic cells are completely of donor origin.³⁶³ Injured tissue or a constitutive defect in a tissue may provide additional signals for the induction of differentiation of the MSCs present in infused bone marrow cells.^{364,365} Horwitz et al.³⁶⁶ have reported that allogeneic whole bone marrow grafts contain sufficient osteoblast progenitor cells to alter the clinical course of children with osteogenesis imperfecta, a disease caused by mutation of a gene encoding type 1 collagen, the major structural protein of bone. MSCs and HSCs are believed to be derived from two distinct stem cells in the bone marrow; but transplantation of HSCs encoding green fluorescent protein (GFP) have indicated that fibroblasts and myofibroblasts in other organs (lungs, intestine, liver, skin, etc.) may be derived from HSCs.³⁶⁷ Although these results supporting a common origin of hematopoietic and stromal cells were suggested earlier by other investigators,^{368,369} they remain controversial.

The stroma also contains an extracellular matrix that provides a structural network to which hematopoietic progenitors and stromal cells are anchored. This matrix is composed of various fibrous proteins, glycoproteins, and proteoglycans that are produced by the stromal cells.²²⁷ These include collagens (types I, III, IV, V, and VI),^{370,371} fibronectin,³⁷² and ^{373,374,375} and ³⁷⁶ laminin,³⁷⁷ hemonectin,^{234,378,379} tenascin,³⁸⁰ thrombospondin,^{381,382,383,384} and ³⁸⁵ and proteoglycans.^{231,232,233,234} and ²³⁵

The stroma is functionally important in hematopoiesis through its regulation of hematopoietic progenitor cell proliferation and differentiation, HSC renewal, homing of HSCs to the hematopoietic organs, and egress of mature hematopoietic cells from the bone marrow into the blood. The stroma aids in these functions through the synthesis and secretion of growth factors, direct cell-cell interactions between stromal and hematopoietic cells, and molecular interactions between hematopoietic cells and the extracellular matrix of the hematopoietic organs. One example that illustrates the multiple functions and mechanisms of stromal hematopoietic interactions was discovered in studies of mice that have mutations in either of two particular genes³⁸⁶: the white spotting locus (nonfunctional allele W) and the steel locus (nonfunctional allele Sl). Each of these genes is essential for hematopoiesis. Mouse embryos that are homozygous for null alleles of either of these genes die at an early stage of embryogenesis without forming any blood cells. However, mice have been found and bred that bear mutant alleles of each of the two genes that retain partial function (W^v and Sl^d alleles). Heterozygous mice of the Sl/Sl^d or the W/W^v genotypes are phenotypically similar to one another, with a lack of cutaneous pigment, sterility, and congenital anemia.³⁸⁶ Reciprocal bone marrow transplantation studies between normal, wild-type mice and heterozygous mice, Sl/Sl^d and W/W^v, revealed that W/W^v mice have defective HSCs but a functional microenvironment that can support transplants of normal HSCs. Conversely, the Sl/Sl^d mice have functional HSCs and can thus serve as donors for marrow transplants, but these mice have a defective microenvironment (stroma) for hematopoiesis; thus, their defect cannot be corrected by the receipt of HSCs from normal donor mice. The mechanism of impaired hematopoiesis caused by mutations in these two genes was understood after the cloning of the genes at the W and Sl loci. The W gene

encodes the cell-surface receptor protein Kit (gene designated c-kit),^{387,388} and the Sl gene encodes the ligand for that receptor, which was discussed in the above section and variably called steel factor, kit ligand, or stem cell factor.^{389,390} and³⁹¹ The Kit protein is a cell-surface receptor on HSCs and hematopoietic progenitor cells, and KL is expressed by stromal cells. KL is produced in two forms because of alternative splicing of the mRNA: a soluble form and an integral membrane form.^{392,393} Both the soluble form and the stromal cell membrane-bound form of KL can stimulate HSCs, the former by free ligand-receptor binding and the latter by cell-cell contact. Activation of Kit is essential for the survival and development of immature hematopoietic progenitors. Kit and KL are not only important in hematopoiesis but are also produced in certain other developing tissues, where they have roles in pigmentation and gonadal function. KL is just one of a large number of hematopoietic growth factors produced by stromal cells, some of which also exist in both soluble and membrane-bound forms, including Flt-3 ligand (FL)^{284,394,395} and macrophage colony-stimulating factor (colony-stimulating factor-1 [CSF-1]).^{396,397} and³⁹⁸

Hematopoietic Stem Cell Niches in Bone Marrow

The concept of the HSC niche as a microenvironment promoting the maintenance of HSCs was proposed by Schofield in 1978, but the bone marrow niche's role in supporting HSC activity has only recently been identified in experimental animal models.³⁹⁹ There has been rapid progress in what we have learned about HSC niches. The putative cellular components of the niche to date include endothelial cells, osteoblasts, mesenchymal lineage cells, and very recently, nonmyelinating Schwann cells. A comparison of these candidate cell types can be found in Table 5.5. Whereas osteoblasts were widely implicated as a critical component of the HSC niche,^{400,401} and⁴⁰² a number of observations have called into question the niche activity of osteoblasts: (1) organs with extramedullary hematopoiesis, such as the spleen and liver, do not have osteoblasts; (2) reductions in osteoblasts are not necessarily associated with reductions in HSC^{403,404,405}; (3) compared to nestin⁺ mesenchymal stem cells, sorted osteoblasts from bone have low expression of Cxcl12, Angpt1, Kitl, and Vcam1, four microenvironmental factors implicated in the maintenance and retention of HSC²⁴⁶; (4) DT injection in CXCL12-DTR-GFP mice did not reduce osteoblast numbers, suggesting that osteoblasts do not express high levels of Cxcl12⁴⁰⁶; and (5) although homotypic interactions between N-cadherin on osteoblasts and HSCs have been implicated as a critical niche interaction,⁴⁰² there have been conflicting data on the effect of N-cadherin loss of function on HSCs.^{405,407,408} and⁴⁰⁹

The so-called “vascular zone” at the center of the marrow cavity consisting of a thin meshwork of fenestrated sinusoidal vessels has been suggested as the site of a possible vascular niche.⁴¹⁰ The vascular niche was also an early cellular candidate of the HSC niche based on the proximity of CD150⁺ HSC to sinusoidal endothelial cells in the BM.⁹³ Although abrogation of VEGFR2 signaling can reduce sinusoidal endothelial cells and impair HSC/progenitor recovery after sublethal irradiation,^{411,412} compared to nestin⁺ MSCs, endothelial cells produce only low levels of niche factors, such as Cxc12, Angpt1, Kitl, and Vcam1.²⁴⁶ However, Morrison and colleagues recently demonstrated that knockdown of stem cell factor (SCF, kit ligand) on Tie2⁺ cells reduced HSC content in the BM by 5.2 fold.⁴¹³ Endothelial cells were implicated as the Tie2-expressing population, but SCF expression on other Tie2⁺ stromal populations, including mesenchymal lineage cells, has not been ruled out.

The strongest candidate for the HSC niche cell is a mesenchymal lineage cell type. Three independent groups have described steady-state HSC niche candidate populations with evidence of mesenchymal stem/progenitor cell activity, namely, CXCL12-abundant reticular (CAR) cells,⁴⁰⁶ nestin⁺ cells,²⁴² and leptin receptor (LepR⁺) perivascular cells.⁴¹³ These cells express high levels of Cxcl12 and other molecules implicated in HSC maintenance (Kitl, Angpt1, and Vcam1), and loss of function studies with these cell types demonstrate reductions in HSCs (Table 5.5).^{242,406,413} Furthermore, human CD146⁺ mesenchymal stromal cells/adventitial reticular cells (ARCs) express angiopoietin and are able to self-renew and form hematopoietic

P.80

microenvironments in immunocompromised mice.⁴¹⁴ Since all these mesenchymal stromal populations have been anatomically and/or functionally associated with pericytes/mural cells, these cells, which are found in both the endosteum and bone marrow proper, can potentially reconcile the previous findings supporting both an osteoblastic and vascular HSC niche.⁴¹⁵

TABLE 5.5 CANDIDATES FOR CELLULAR IDENTITY OF THE HEMATOPOIETIC STEM AND PROGENITOR CELL NICHE

Cell Type	Phenotype	Produce Frequency in BM	Niche Factors?	Evidence of Functional Niche Activity
-----------	-----------	-------------------------	----------------	---------------------------------------

Osteoblasts	N-cadherin ⁺ CD45 ⁻⁴⁰²	NQ	N-cadherin ⁴⁰²	Increase in LSK and LTC-ICs in Col1-caPRR and PTH-treated mice. ⁴⁰⁰ Increase in osteoblasts and LSK and CRU in Bmpr1 mutants. ⁴⁰² Reduction in LSK cells in GCV-treated Col2.3tk mice. ⁴⁰¹
Endothelial cells (“Vascular niche”)	VE-Cadherin ⁺ VEGFR2 ⁺ VEGFR3 ^{+411,412}	NQ	Jagged1, Jagged2 ⁴¹²	Reduced LSK and CRU in sublethally irradiated mice treated with anti-VECadherin and anti-VEGFR2. ⁴¹²
	Tie2 ⁺⁴¹³	NQ	Kitl ⁴¹³	5.2-fold reduction in LSKCD150 ⁺ CD48 ⁻ CD41 ⁻ HSC in Tie2-cre;Scf ^{f1/-} mice. ⁴¹³
Mesenchymal lineage cells	CD45 ⁻ Ter119-CXCL12 ⁺ Vcam1 ⁺ CD44 ⁺ CD51 ⁺ PDGFR α ⁺ PDGFR β ⁺⁴⁰⁶	0.27% ⁴⁰⁶	Cxcl12, Kitl, Vcam1 ⁴⁰⁶	Reduction in LSKCD34 ⁻ CD150 ⁺ CD48 ⁻ and competitive repopulation units in DT-treated Cxcl12-DTR-GFP mice. ⁴⁰⁶
	CD45 ⁻ CD31 ⁻ Nestin ⁺²⁴²	0.08% ²⁴²	Cxcl12, Angpt1, Kitl, Vcam1, Il7 ²⁴²	Reduction in LSKCD150 ⁺ CD48 ⁻ CD41 ⁻ cells and LTC-IC after depletion of Nestin ⁺ cells in TAM and DT-treated Nestin-Cre ^{ERT2} ; iDTR mice. ²⁴²
	LeptinR ⁺⁴¹³	NQ	Cxcl12, Kitl ⁴¹³	>5-fold reduction in LSKCD150 ⁺ CD48 ⁻ CD41 ⁻ HSC in Lepr-cre;Scf ^{f1/-} mice. ⁴¹³
Nonmyelinating Schwann cells	GFAP ⁺⁴¹⁶	0.004% ⁴¹⁶	Cxcl12, Angpt1, Kitl, Tpo ⁴¹⁶	Reduction in LSKCD34 ⁻ and competitive repopulation units after surgical lumbar sympathectomy. ⁴¹⁶

NQ, not quantified; Kitl, Kit ligand; Vcam1, vascular cell adhesion molecule 1, Il, Interleukin, TPO, thrombopoietin.

Recently, Nakauchi and colleagues have asserted that latent TGF β -expressing, GFAP⁺ populations of nonmyelinating Schwann cells are critical for HSC maintenance, as celiac ganglionectomy rapidly led to the degeneration and loss of nonmyelin Schwann cells and reduced HSC content in the BM.⁴¹⁶ Whether this population of cells expresses the appropriate HSC maintenance factors and whether more specific depletion of this population results in the same reduction in HSC content will further elucidate the relative contribution of this niche to HSC maintenance.

Multiple stromal cell populations contribute to HSC maintenance, and future work will further dissect whether there are subsets of niches that are more suitable for HSCs versus hematopoietic progenitors, or among progenitors.

Erythroid Niches in Bone Marrow

Before stromal niches for HSCs were proposed by Schofield in 1978, the first nurse cell in the hematopoietic system was proposed by Bessis in 1958 to be a macrophage promoting red blood cell development in erythroblastic islands.^{417,418} Although not yet formally proven to have a role in erythropoiesis in vivo, these macrophage-erythroblast interactions

have been shown in vitro to support the proliferation and viability of developing red cells. It is unknown how macrophages maintain erythroblasts, but VCAM-1-VLA-4, CD51-ICAM4, and homotypic interactions between erythrocyte membrane protein (EMP) have been shown to be critical for adhesive interactions in vitro.⁴¹⁸ Future work should elucidate the contribution of these erythroblast island niches in vivo.

B Cell Niches in Bone Marrow

The CXCR4-CXCL12 axis has been implicated in B cell development because chimeric mice reconstituted with CXCR4-deficient fetal liver cells have reduced B cell precursors.⁴¹⁹ As Nagasawa and colleagues pursued CXCL12-expressing niches for B cells in the bone marrow, they discovered that the earliest committed B cell precursors, the pre-proB cells, localized around CAR cells, which did not express IL-7.⁴²⁰ As they mature to proB cells, they migrate away from CAR cells to IL-7-expressing stromal cells. Then, after peripheral maturation, plasma cells home back to the BM to reside near CAR cells. It is unclear how CAR cells that do not express IL-7 promote B cell development. It is possible that CAR cells retain pre-proB cells and plasma cells so that a third cell type can exert regulation. Indeed, there is evidence that macrophage inhibitory factor (MIF) derived from BM resident dendritic cells is able to promote survival B cells⁴²¹ in the bone marrow. Future work will uncover the mesenchymal and hematopoietic contributions to the B cell niche in the bone marrow.

PERSPECTIVES

The hematologic system is a tightly regulated organ system in which a host of different cell types with varied developmental potential and effector capacity work in concert to ensure efficient

P.81

oxygen delivery, hemostasis, and immunosurveillance. They are regulated by each other and also by the non-hematopoietic stroma. In spite of all this complexity, most hematopoietic cells originate from HSCs in the bone marrow. This is critical in the context of bone marrow transplantation and other clinical scenarios in which a rebooted hematopoietic system is desired. The following chapters will discuss lineage-specific examples when the hematopoietic system becomes dysregulated.

ACKNOWLEDGMENTS

We would like to acknowledge the contribution of Mark Koury, who wrote a previous version of this chapter, as some parts of this previous version remain in the current version. We are also grateful for his critical reading and helpful suggestions for this updated version. Figures were produced using Servier Medical Art (<http://www.servier.com>).

REFERENCES

1. Dzierzak E, Speck NA. Of lineage and legacy: the development of mammalian hematopoietic stem cells. *Nat Immunol* 2008;9(2):129-136.
2. Cumano A, Godin I. Ontogeny of the hematopoietic system. *Annu Rev Immunol* 2007;25:745-785.
3. Mikkola HK, Orkin SH. The journey of developing hematopoietic stem cells. *Development* 2006;133(19):3733-3744.
4. Muench MO, Barcena A. Stem cell transplantation in the fetus. *Cancer Control* 2004;11(2):105-118.
5. Palis J, Yoder MC. Yolk-sac hematopoiesis: the first blood cells of mouse and man. *Exp Hematol* 2001;29(8):927-936.
6. Palis J. Ontogeny of erythropoiesis. *Curr Opin Hematol* 2008;15(3):155-161.
7. Trimborn T, Gribnau J, Grosveld F, Fraser P. Mechanisms of developmental control of transcription in the murine alpha- and beta-globin loci. *Genes Dev.* 1999;13(1):112-124.
8. Xu MJ, Matsuoka S, Yang FC, et al. Evidence for the presence of murine primitive megakaryocytopoiesis in the early yolk sac. *Blood* 2001;97(7):2016-2022.
9. Tober J, Koniski A, McGrath KE, et al. The megakaryocyte lineage originates from hemangioblast precursors and is an integral component both of primitive and of definitive hematopoiesis. *Blood* 2007;109(4):1433-1441.
10. Klimchenko O, Mori M, Distefano A, et al. A common bipotent progenitor generates the erythroid and megakaryocyte lineages in embryonic stem cell-derived primitive hematopoiesis. *Blood* 2009;114(8):1506-1517.
11. Bertrand JY, Jalil A, Klaine M, Jung S, Cumano A, Godin I. Three pathways to mature macrophages in the early mouse yolk sac. *Blood* 2005;106(9): 3004-3011.

12. Dieterlen-Lievre F. On the origin of haemopoietic stem cells in the avian embryo: an experimental approach. *J Embryol Exp Morphol* 1975;33(3): 607-619.
13. Lassila O, Eskola J, Toivanen P, Martin C, Dieterlen-Lievre F. The origin of lymphoid stem cells studied in chick yolk sac-embryo chimaeras. *Nature* 1978;272(5651):353-354.
14. Godin IE, Garcia-Porrero JA, Coutinho A, Dieterlen-Lievre F, Marcos MA. Para-aortic splanchnopleura from early mouse embryos contains B1a cell progenitors. *Nature* 1993;364(6432):67-70.
15. Medvinsky AL, Samoylina NL, Muller AM, Dzierzak EA. An early pre-liver intraembryonic source of CFU-S in the developing mouse. *Nature* 1993;364(6432):64-67.
16. Muller AM, Medvinsky A, Strouboulis J, Grosveld F, Dzierzak E. Development of hematopoietic stem cell activity in the mouse embryo. *Immunity* 1994;1(4):291-301.
17. Cumano A, Dieterlen-Lievre F, Godin I. Lymphoid potential, probed before circulation in mouse, is restricted to caudal intraembryonic splanchnopleura. *Cell* 1996;86(6):907-916.
18. Cumano A, Ferraz JC, Klaine M, Di Santo JP, Godin I. Intraembryonic, but not yolk sac hematopoietic precursors, isolated before circulation, provide long-term multilineage reconstitution. *Immunity* 2001;15(3):477-485.
19. Gekas C, Dieterlen-Lievre F, Orkin SH, Mikkola HK. The placenta is a niche for hematopoietic stem cells. *Dev Cell* 2005;8(3):365-375.
20. Ottersbach K, Dzierzak E. The murine placenta contains hematopoietic stem cells within the vascular labyrinth region. *Dev Cell* 2005;8(3):377-387.
21. Corbel C, Salaun J, Belo-Diabangouaya P, Dieterlen-Lievre F. Hematopoietic potential of the pre-fusion allantois. *Dev Biol* 2007;301(2):478-488.
22. Zeigler BM, Sugiyama D, Chen M, Guo Y, Downs KM, Speck NA. The allantois and chorion, when isolated before circulation or chorio-allantoic fusion, have hematopoietic potential. *Development* 2006;133(21):4183-4192.
23. Rhodes KE, Gekas C, Wang Y, et al. The emergence of hematopoietic stem cells is initiated in the placental vasculature in the absence of circulation. *Cell Stem Cell* 2008;2(3):252-263.
24. Morrison SJ, Hemmati HD, Wandycz AM, Weissman IL. The purification and characterization of fetal liver hematopoietic stem cells. *Proc Natl Acad Sci USA* 1995;92(22):10302-10306.
25. Huber TL, Kouskoff V, Fehling HJ, Palis J, Keller G. Haemangioblast commitment is initiated in the primitive streak of the mouse embryo. *Nature* 2004;432(7017):625-630.
26. Zovein AC, Hofmann JJ, Lynch M, et al. Fate tracing reveals the endothelial origin of hematopoietic stem cells. *Cell Stem Cell* 2008;3(6):625-636.
27. Eilken HM, Nishikawa S, Schroeder T. Continuous single-cell imaging of blood generation from haemogenic endothelium. *Nature* 2009;457(7231):896-900.
28. Lancrin C, Sroczyńska P, Stephenson C, Allen T, Kouskoff V, Lacaud G. The haemangioblast generates haematopoietic cells through a haemogenic endothelium stage. *Nature* 2009;457(7231):892-895.
29. Chen MJ, Yokomizo T, Zeigler BM, Dzierzak E, Speck NA. Runx1 is required for the endothelial to haematopoietic cell transition but not thereafter. *Nature* 2009;457(7231):887-891.
30. Chen MJ, Li Y, De Obaldia ME, et al. Erythroid/myeloid progenitors and hematopoietic stem cells originate from distinct populations of endothelial cells. *Cell Stem Cell* 2011;9(6):541-552.
31. Kanatsu M, Nishikawa SI. In vitro analysis of epiblast tissue potency for hematopoietic cell differentiation. *Development* 1996;122(3):823-830.
32. Johansson BM, Wiles MV. Evidence for involvement of activin A and bone morphogenetic protein 4 in mammalian mesoderm and hematopoietic development. *Mol Cell Biol* 1995;15(1):141-151.
33. Winnier G, Blessing M, Labosky PA, Hogan BL. Bone morphogenetic protein-4 is required for mesoderm formation and patterning in the mouse. *Genes Dev* 1995;9(17):2105-2116.
34. Park C, Afrikanova I, Chung YS, et al. A hierarchical order of factors in the generation of FLK1- and SCL-expressing hematopoietic and endothelial progenitors from embryonic stem cells. *Development* 2004;131(11): 2749-2762.

35. Belaoussoff M, Farrington SM, Baron MH. Hematopoietic induction and respecification of A-P identity by visceral endoderm signaling in the mouse embryo. *Development* 1998;125(24):5009-5018.
36. Breier G, Clauss M, Risau W. Coordinate expression of vascular endothelial growth factor receptor-1 (flt-1) and its ligand suggests a paracrine regulation of murine vascular development. *Dev Dyn* 1995;204(3):228-239.
37. Dumont DJ, Fong GH, Puri MC, Gradwohl G, Alitalo K, Breitman ML. Vascularization of the mouse embryo: a study of flk-1, tek, tie, and vascular endothelial growth factor expression during development. *Dev Dyn* 1995;203(1):80-92.
38. Shalaby F, Rossant J, Yamaguchi TP, et al. Failure of blood-island formation and vasculogenesis in Flk-1-deficient mice. *Nature* 1995;376(6535):62-66.
39. Shalaby F, Ho J, Stanford WL, et al. A requirement for Flk1 in primitive and definitive hematopoiesis and vasculogenesis. *Cell* 1997;89(6):981-990.
40. Hidaka M, Stanford WL, Bernstein A. Conditional requirement for the Flk-1 receptor in the in vitro generation of early hematopoietic cells. *Proc Natl Acad Sci USA* 1999;96(13):7370-7375.
41. Schuh AC, Faloon P, Hu QL, Bhimani M, Choi K. In vitro hematopoietic and endothelial potential of flk-1(-/-) embryonic stem cells and embryos. *Proc Natl Acad Sci USA* 1999;96(5):2159-2164.
42. Damert A, Miquerol L, Gertsenstein M, Risau W, Nagy A. Insufficient VEGFA activity in yolk sac endoderm compromises haematopoietic and endothelial differentiation. *Development* 2002;129(8):1881-1892.
43. Drake CJ, Brandt SJ, Trusk TC, Little CD. TAL1/SCL is expressed in endothelial progenitor cells/angioblasts and defines a dorsal-to-ventral gradient of vasculogenesis. *Dev Biol* 1997;192(1):17-30.
44. Elefanty AG, Begley CG, Hartley L, Papaevangelou B, Robb L. SCL expression in the mouse embryo detected with a targeted lacZ reporter gene demonstrates its localization to hematopoietic, vascular, and neural tissues. *Blood* 1999;94(11):3754-3763.
45. Kallianpur AR, Jordan JE, Brandt SJ. The SCL/TAL-1 gene is expressed in progenitors of both the hematopoietic and vascular systems during embryogenesis. *Blood* 1994;83(5):1200-1208.
46. Manaia A, Lemarchandel V, Klaine M, et al. Lmo2 and GATA-3 associated expression in intraembryonic hemogenic sites. *Development* 2000;127(3):643-653.
47. Robb L, Lyons I, Li R, et al. Absence of yolk sac hematopoiesis from mice with a targeted disruption of the scl gene. *Proc Natl Acad Sci USA* 1995;92(15):7075-7079.
48. Shivdasani RA, Mayer EL, Orkin SH. Absence of blood formation in mice lacking the T-cell leukaemia oncoprotein tal-1/SCL. *Nature* 1995;373(6513): 432-434.
49. Warren AJ, Colledge WH, Carlton MB, Evans MJ, Smith AJ, Rabbitts TH. The oncogenic cysteine-rich LIM domain protein rbtn2 is essential for erythroid development. *Cell* 1994;78(1):45-57.
50. Porcher C, Swat W, Rockwell K, Fujiwara Y, Alt FW, Orkin SH. The T cell leukemia oncoprotein SCL/tal-1 is essential for development of all hematopoietic lineages. *Cell* 1996;86(1):47-57.
51. Robb L, Elwood NJ, Elefanty AG, et al. The scl gene product is required for the generation of all hematopoietic lineages in the adult mouse. *Embo J* 1996;15(16):4123-4129.
52. Yamada Y, Warren AJ, Dobson C, Forster A, Pannell R, Rabbitts TH. The T cell leukemia LIM protein Lmo2 is necessary for adult mouse hematopoiesis. *Proc Natl Acad Sci USA* 1998;95(7):3890-3895.
53. Tsai FY, Keller G, Kuo FC, et al. An early haematopoietic defect in mice lacking the transcription factor GATA-2. *Nature* 1994;371(6494):221-226.
54. Ling KW, Ottersbach K, van Hamburg JP, et al. GATA-2 plays two functionally distinct roles during the ontogeny of hematopoietic stem cells. *J Exp Med* 2004;200(7):871-882.
55. Minegishi N, Ohta J, Yamagiwa H, et al. The mouse GATA-2 gene is expressed in the para-aortic splanchnopleura and aorta-gonads and mesonephros region. *Blood* 1999;93(12):4196-4207.
56. Cai Z, de Bruijn M, Ma X, et al. Haploinsufficiency of AML1 affects the temporal and spatial generation of hematopoietic stem cells in the mouse embryo. *Immunity* 2000;13(4):423-431.

57. Okuda T, van Deursen J, Hiebert SW, Grosveld G, Downing JR. AML1, the target of multiple chromosomal translocations in human leukemia, is essential for normal fetal liver hematopoiesis. *Cell* 1996;84(2):321-330.
58. Wang Q, Stacy T, Binder M, Marin-Padilla M, Sharpe AH, Speck NA. Disruption of the Cbfa2 gene causes necrosis and hemorrhaging in the central nervous system and blocks definitive hematopoiesis. *Proc Natl Acad Sci USA* 1996;93(8):3444-3449.
59. Yokomizo T, Hasegawa K, Ishitobi H, et al. Runx1 is involved in primitive erythropoiesis in the mouse. *Blood* 2008;111(8):4075-4080.
60. Lajitha LG. The common ancestral cell In: Wintrobe MM, ed. *Blood, pure and eloquent: a story of discovery, of people, and of ideas*. New York, NY: McGraw-Hill, 1980:80-95.
61. Tavassoli MV. Bone marrow: the seedbed of blood. In: Wintrobe MM, ed. *Blood, pure and eloquent: a story of discovery, of people, and of ideas*. New York, NY: McGraw-Hill, 1980:57-79.
62. Downey H. *Handbook of hematology*. New York, NY: Hoeber, 1938.
63. Lorenz E, Uphoff D, Reid TR, Shelton E. Modification of irradiation injury in mice and guinea pigs by bone marrow injections. *J Natl Cancer Inst* 1951;12(1):197-201.
64. Ford CE, Hamerton JL, Barnes DW, Loutit JF. Cytological identification of radiation-chimaeras. *Nature* 1956;177(4506):452-454.
65. Till JE, Mc CE. A direct measurement of the radiation sensitivity of normal mouse bone marrow cells. *Radiat Res* 1961;14:213-222.
66. Curry JL, Trentin JJ. Hemopoietic spleen colony studies. I. Growth and differentiation. *Dev Biol* 1967;15(5):395-413.
67. Magli MC, Iscove NN, Odartchenko N. Transient nature of early haematopoietic spleen colonies. *Nature* 1982;295(5849):527-529.
68. Siminovitch L, McCulloch EA, Till JE. The distribution of colony-forming cells among spleen colonies. *J Cell Physiol* 1963;62:327-336.
69. Wu AM, Till JE, Siminovitch L, McCulloch EA. A cytological study of the capacity for differentiation of normal hemopoietic colony-forming cells. *J Cell Physiol* 1967;69(2):177-184.
70. Lepault F, Ezine S, Gagnerault MC. T- and B-lymphocyte differentiation potentials of spleen colony-forming cells. *Blood* 1993;81(4):950-955.
71. Jones RJ, Wagner JE, Celano P, Zicha MS, Sharkis SJ. Separation of pluripotent haematopoietic stem cells from spleen colony-forming cells. *Nature* 1990;347(6289):188-189.
72. Keller G, Paige C, Gilboa E, Wagner EF. Expression of a foreign gene in myeloid and lymphoid cells derived from multipotent haematopoietic precursors. *Nature* 1985;318(6042):149-154.
73. Lemischka IR, Rautel DH, Mulligan RC. Developmental potential and dynamic behavior of hematopoietic stem cells. *Cell* 1986;45(6):917-927.
74. Jordan CT, Lemischka IR. Clonal and systemic analysis of long-term hematopoiesis in the mouse. *Genes Dev* 1990;4(2):220-232.
75. Capel B, Hawley RG, Mintz B. Long- and short-lived murine hematopoietic stem cell clones individually identified with retroviral integration markers. *Blood* 1990;75(12):2267-2270.
76. Osawa M, Hanada K, Hamada H, Nakauchi H. Long-term lymphohematopoietic reconstitution by a single CD34-low/negative hematopoietic stem cell. *Science* 1996;273(5272):242-245.
77. Smith LG, Weissman IL, Heimfeld S. Clonal analysis of hematopoietic stem-cell differentiation in vivo. *Proc Natl Acad Sci USA* 1991;88(7):2788-2792.
78. Matsuzaki Y, Kinjo K, Mulligan RC, Okano H. Unexpectedly efficient homing capacity of purified murine hematopoietic stem cells. *Immunity* 2004;20(1):87-93.
79. Notta F, Doulatov S, Laurenti E, Poepl A, Jurisica I, Dick JE. Isolation of single human hematopoietic stem cells capable of long-term multilineage engraftment. *Science* 2011;333(6039):218-221.

80. Zhong RK, Astle CM, Harrison DE. Distinct developmental patterns of short-term and long-term functioning lymphoid and myeloid precursors defined by competitive limiting dilution analysis in vivo. *J Immunol* 1996;157(1):138-145.
81. Lu R, Neff NF, Quake SR, Weissman IL. Tracking single hematopoietic stem cells in vivo using high-throughput sequencing in conjunction with viral genetic barcoding. *Nat Biotechnol* 2011;29(10):928-933.
82. Kim HJ, Tisdale JF, Wu T, et al. Many multipotential gene-marked progenitor or stem cell clones contribute to hematopoiesis in nonhuman primates. *Blood* 2000;96(1):1-8.
83. Shi PA, Hematti P, von Kalle C, Dunbar CE. Genetic marking as an approach to studying in vivo hematopoiesis: progress in the non-human primate model. *Oncogene*. 2002;21(21):3274-3283.
84. Schmidt M, Zickler P, Hoffmann G, et al. Polyclonal long-term repopulating stem cell clones in a primate model. *Blood* 2002;100(8):2737-2743.
85. Shizuru JA, Negrin RS, Weissman IL. Hematopoietic stem and progenitor cells: clinical and preclinical regeneration of the hemato-lymphoid system. *Annu Rev Med* 2005;56:509-538.
86. Baumann CI, Bailey AS, Li W, Ferkowicz MJ, Yoder MC, Fleming WH. PECAM-1 is expressed on hematopoietic stem cells throughout ontogeny and identifies a population of erythroid progenitors. *Blood* 2004;104(4): 1010-1016.
87. Pang WW, Price EA, Sahoo D, et al. Human bone marrow hematopoietic stem cells are increased in frequency and myeloid-biased with age. *Proc Natl Acad Sci USA* 2011;108(50):20012-20017.
88. Czechowicz A, Weissman IL. Purified hematopoietic stem cell transplantation: the next generation of blood and immune replacement. *Hematol Oncol Clin North Am* 2011;25(1):75-87.
89. Morrison SJ, Weissman IL. The long-term repopulating subset of hematopoietic stem cells is deterministic and isolatable by phenotype. *Immunity* 1994;1(8):661-673.
90. Christensen JL, Weissman IL. Flk-2 is a marker in hematopoietic stem cell differentiation: a simple method to isolate long-term stem cells. *Proc Natl Acad Sci USA* 2001;98(25):14541-14546.
91. Spangrude GJ, Heimfeld S, Weissman IL. Purification and characterization of mouse hematopoietic stem cells. *Science* 1988;241(4861):58-62.
92. Ikuta K, Weissman IL. Evidence that hematopoietic stem cells express mouse c-kit but do not depend on steel factor for their generation. *Proc Natl Acad Sci USA* 1992;89(4):1502-1506.
93. Kiel MJ, Yilmaz OH, Iwashita T, Terhorst C, Morrison SJ. SLAM family receptors distinguish hematopoietic stem and progenitor cells and reveal endothelial niches for stem cells. *Cell* 2005;121(7):1109-1121.
94. Balazs AB, Fabian AJ, Esmon CT, Mulligan RC. Endothelial protein C receptor (CD201) explicitly identifies hematopoietic stem cells in murine bone marrow. *Blood* 2006;107(6):2317-2321.
95. Chen CZ, Li M, de Graaf D, et al. Identification of endoglin as a functional marker that defines long-term repopulating hematopoietic stem cells. *Proc Natl Acad Sci USA* 2002;99(24):15468-15473.
96. Pronk CJ, Rossi DJ, Mansson R, et al. Elucidation of the phenotypic, functional, and molecular topography of a myeloerythroid progenitor cell hierarchy. *Cell Stem Cell* 2007;1(4):428-442.
97. Goodell MA, Brose K, Paradis G, Conner AS, Mulligan RC. Isolation and functional properties of murine hematopoietic stem cells that are replicating in vivo. *J Exp Med* 1996;183(4):1797-1806.
98. Purton LE, Scadden DT. Limiting factors in murine hematopoietic stem cell assays. *Cell Stem Cell* 2007;1(3):263-270.
99. Michallet M, Philip T, Philip I, et al. Transplantation with selected autologous peripheral blood CD34+Thy1+ hematopoietic stem cells (HSCs) in multiple myeloma: impact of HSC dose on engraftment, safety, and immune reconstitution. *Exp Hematol* 2000;28(7):858-870.
100. Negrin RS, Atkinson K, Leemhuis T, et al. Transplantation of highly purified CD34+Thy-1+ hematopoietic stem cells in patients with metastatic breast cancer. *Biol Blood Marrow Transplant* 2000;6(3):262-271.
101. Vose JM, Bierman PJ, Lynch JC, et al. Transplantation of highly purified CD34+Thy-1+ hematopoietic stem cells in patients with recurrent indolent non-Hodgkin's lymphoma. *Biol Blood Marrow Transplant* 2001;7(12):680-687.
102. Yilmaz OH, Kiel MJ, Morrison SJ. SLAM family markers are conserved among hematopoietic stem cells from old and reconstituted mice and markedly increase their purity. *Blood* 2006;107(3):924-930.

103. Matsuoka S, Ebihara Y, Xu M, et al. CD34 expression on long-term repopulating hematopoietic stem cells changes during developmental stages. *Blood* 2001;97(2):419-425.
104. Essers MA, Offner S, Blanco-Bose WE, et al. IFN α activates dormant haematopoietic stem cells in vivo. *Nature* 2009;458(7240):904-908.
105. Trumpp A, Essers M, Wilson A. Awakening dormant haematopoietic stem cells. *Nat Rev Immunol.* 2010;10(3):201-209.
106. Spangrude GJ, Brooks DM. Mouse strain variability in the expression of the hematopoietic stem cell antigen Ly-6A/E by bone marrow cells. *Blood* 1993;82(11):3327-3332.
107. Spangrude GJ, Brooks DM. Phenotypic analysis of mouse hematopoietic stem cells shows a Thy-1-negative subset. *Blood* 1992;80(8):1957-1964.
108. Sutherland HJ, Lansdorp PM, Henkelman DH, Eaves AC, Eaves CJ. Functional characterization of individual human hematopoietic stem cells cultured at limiting dilution on supportive marrow stromal layers. *Proc Natl Acad Sci USA* 1990;87(9):3584-3588.
109. Murray L, Chen B, Galy A, et al. Enrichment of human hematopoietic stem cell activity in the CD34+Thy-1+Lin-subpopulation from mobilized peripheral blood. *Blood* 1995;85(2):368-378.
110. Ploemacher RE, van der Sluijs JP, van Beurden CA, Baert MR, Chan PL. Use of limiting-dilution type long-term marrow cultures in frequency analysis of marrow-repopulating and spleen colony-forming hematopoietic stem cells in the mouse. *Blood* 1991;78(10):2527-2533.
111. Neben S, Anklesaria P, Greenberger J, Mauch P. Quantitation of murine hematopoietic stem cells in vitro by limiting dilution analysis of cobblestone area formation on a clonal stromal cell line. *Exp Hematol* 1993;21(3):438-443.
112. Hao QL, Thiemann FT, Petersen D, Smogorzewska EM, Crooks GM. Extended long-term culture reveals a highly quiescent and primitive human hematopoietic progenitor population. *Blood* 1996;88(9):3306-3313.
113. Kusadasi N, Oostendorp RA, Koevoet WJ, Dzierzak EA, Ploemacher RE. Stromal cells from murine embryonic aorta-gonad-mesonephros region, liver and gut mesentery expand human umbilical cord blood-derived CAFC(week 6) in extended long-term cultures. *Leukemia* 2002;16(9):1782-1790.
114. Ploemacher RE, van der Sluijs JP, Voerman JS, Brons NH. An in vitro limiting-dilution assay of long-term repopulating hematopoietic stem cells in the mouse. *Blood* 1989;74(8):2755-2763.
115. Breems DA, Blokland EA, Neben S, Ploemacher RE. Frequency analysis of human primitive haematopoietic stem cell subsets using a cobblestone area forming cell assay. *Leukemia* 1994;8(7):1095-1104.
116. Mahmud N, Patel H, Hoffman R. Growth factors mobilize CXCR4 low/negative primitive hematopoietic stem/progenitor cells from the bone marrow of nonhuman primates. *Biol Blood Marrow Transplant* 2004;10(10):681-690.
117. Szilvassy SJ, Humphries RK, Lansdorp PM, Eaves AC, Eaves CJ. Quantitative assay for totipotent reconstituting hematopoietic stem cells by a competitive repopulation strategy. *Proc Natl Acad Sci USA* 1990;87(22):8736-8740.
118. Harrison DE, Jordan CT, Zhong RK, Astle CM. Primitive hemopoietic stem cells: direct assay of most productive populations by competitive repopulation with simple binomial, correlation and covariance calculations. *Exp Hematol* 1993;21(2):206-219.
119. Lemieux ME, Rebel VI, Lansdorp PM, Eaves CJ. Characterization and purification of a primitive hematopoietic cell type in adult mouse marrow capable of lymphomyeloid differentiation in long-term marrow "switch" cultures. *Blood* 1995;86(4):1339-1347.
120. Lemieux ME, Eaves CJ. Identification of properties that can distinguish primitive populations of stromal-cell-responsive lympho-myeloid cells from cells that are stromal-cell-responsive but lymphoid-restricted and cells that have lympho-myeloid potential but are also capable of competitively repopulating myeloablated recipients. *Blood* 1996;88(5):1639-1648.
121. Brandt JE, Bartholomew AM, Fortman JD, et al. Ex vivo expansion of autologous bone marrow CD34(+) cells with porcine microvascular endothelial cells results in a graft capable of rescuing lethally irradiated baboons. *Blood* 1999;94(1):106-113.
122. Szilvassy SJ, Meyerrose TE, Ragland PL, Grimes B. Homing and engraftment defects in ex vivo expanded murine hematopoietic cells are associated with downregulation of beta1 integrin. *Exp Hematol* 2001;29(12):1494-1502.

123. Harrison DE. Competitive repopulation: a new assay for long-term stem cell functional capacity. *Blood* 1980;55(1):77-81.
124. Rosendaal M, Hodgson GS, Bradley TR. Organization of haemopoietic stem cells: the generation-age hypothesis. *Cell Tissue Kinet* 1979;12(1):17-29.
125. Dykstra B, Kent D, Bowie M, et al. Long-term propagation of distinct hematopoietic differentiation programs in vivo. *Cell Stem Cell* 2007;1(2):218-229.
126. Orlic D, Fischer R, Nishikawa S, Nienhuis AW, Bodine DM. Purification and characterization of heterogeneous pluripotent hematopoietic stem cell populations expressing high levels of c-kit receptor. *Blood* 1993;82(3):762-770.
127. Mahmud N, Devine SM, Weller KP, et al. The relative quiescence of hematopoietic stem cells in nonhuman primates. *Blood* 2001;97(10):3061-3068.
128. Doulatov S, Notta F, Laurenti E, Dick JE. Hematopoiesis: a human perspective. *Cell Stem Cell* 2012;10(2):120-136.
129. Christianson SW, Greiner DL, Hesselton RA, et al. Enhanced human CD4+ T cell engraftment in beta2-microglobulin-deficient NOD-scid mice. *J Immunol* 1997;158(8):3578-3586.
130. Lapidot T, Fajerman Y, Kollet O. Immune-deficient SCID and NOD/SCID mice models as functional assays for studying normal and malignant human hematopoiesis. *J Mol Med* 1997;75(9):664-673.
131. Mazurier F, Fontanellas A, Salesse S, et al. A novel immunodeficient mouse model—RAG2 x common cytokine receptor gamma chain double mutants—requiring exogenous cytokine administration for human hematopoietic stem cell engraftment. *J Interferon Cytokine Res* 1999;19(5):533-541.
132. Shultz LD, Lang PA, Christianson SW, et al. NOD/LtSz-Rag1null mice: an immunodeficient and radioresistant model for engraftment of human hematolymphoid cells, HIV infection, and adoptive transfer of NOD mouse diabetogenic T cells. *J Immunol* 2000;164(5):2496-2507.
133. Zanjani ED, Pallavicini MG, Ascensao JL, et al. Engraftment and long-term expression of human fetal hemopoietic stem cells in sheep following transplantation in utero. *J Clin Invest* 1992;89(4):1178-1188.
134. Srour EF, Zanjani ED, Cornetta K, et al. Persistence of human multilineage, self-renewing lymphohematopoietic stem cells in chimeric sheep. *Blood* 1993;82(11):3333-3342.
135. Kollet O, Peled A, Byk T, et al. beta2 microglobulin-deficient (B2m(null)) NOD/SCID mice are excellent recipients for studying human stem cell function. *Blood* 2000;95(10):3102-3105.
136. Glimm H, Eisterer W, Lee K, et al. Previously undetected human hematopoietic cell populations with short-term repopulating activity selectively engraft NOD/SCID-beta2 microglobulin-null mice. *J Clin Invest*. 2001;107(2): 199-206.
137. Ishikawa F, Livingston AG, Wingard JR, Nishikawa S, Ogawa M. An assay for long-term engrafting human hematopoietic cells based on newborn NOD/SCID/beta2-microglobulin(null) mice. *Exp Hematol* 2002;30(5): 488-494.
138. Kerre TC, De Smet G, De Smedt M, et al. Adapted NOD/SCID model supports development of phenotypically and functionally mature T cells from human umbilical cord blood CD34(+) cells. *Blood* 2002;99(5):1620-1626.
139. Hiramatsu H, Nishikomori R, Heike T, et al. Complete reconstitution of human lymphocytes from cord blood CD34+ cells using the NOD/SCID/gammacnull mice model. *Blood* 2003;102(3):873-880.
140. Araki H, Mahmud N, Milhem M, et al. Expansion of human umbilical cord blood SCID-repopulating cells using chromatin-modifying agents. *Exp Hematol* 2006;34(2):140-149.
141. Mazurier F, Doedens M, Gan OI, Dick JE. Rapid myeloerythroid repopulation after intrafemoral transplantation of NOD-SCID mice reveals a new class of human stem cells. *Nat Med* 2003;9(7):959-963.
142. Notta F, Doulatov S, Dick JE. Engraftment of human hematopoietic stem cells is more efficient in female NOD/SCID/IL-2Rgc-null recipients. *Blood* 2010;115(18):3704-3707.
143. Abkowitz JL, Catlin SN, McCallie MT, Guttorp P. Evidence that the number of hematopoietic stem cells per animal is conserved in mammals. *Blood* 2002;100(7):2665-2667.
144. Srour EF, Zanjani ED, Brandt JE, et al. Sustained human hematopoiesis in sheep transplanted in utero during early gestation with fractionated adult human bone marrow cells. *Blood* 1992;79(6):1404-1412.

145. Wagner JL, Storb R. Preclinical large animal models for hematopoietic stem cell transplantation. *Curr Opin Hematol* 1996;3(6):410-415.
146. Horn PA, Thomasson BM, Wood BL, Andrews RG, Morris JC, Kiem HP. Distinct hematopoietic stem/progenitor cell populations are responsible for repopulating NOD/SCID mice compared with nonhuman primates. *Blood* 2003;102(13):4329-4335.
147. Rebel VI, Dragowska W, Eaves CJ, Humphries RK, Lansdorp PM. Amplification of Sca-1+ Lin⁻ WGA⁺ cells in serum-free cultures containing steel factor, interleukin-6, and erythropoietin with maintenance of cells with long-term in vivo reconstituting potential. *Blood* 1994;83(1):128-136.
148. Fraser CC, Szilvassy SJ, Eaves CJ, Humphries RK. Proliferation of totipotent hematopoietic stem cells in vitro with retention of long-term competitive in vivo reconstituting ability. *Proc Natl Acad Sci USA* 1992;89(5):1968-1972.
149. van der Sluijs JP, van den Bos C, Baert MR, van Beurden CA, Ploemacher RE. Loss of long-term repopulating ability in long-term bone marrow culture. *Leukemia* 1993;7(5):725-732.
150. Glimm H, Oh IH, Eaves CJ. Human hematopoietic stem cells stimulated to proliferate in vitro lose engraftment potential during their S/G(2)/M transit and do not reenter G(0). *Blood* 2000;96(13):4185-4193.
151. Berrios VM, Dooner GJ, Nowakowski G, et al. The molecular basis for the cytokine-induced defect in homing and engraftment of hematopoietic stem cells. *Exp Hematol* 2001;29(11):1326-1335.
152. Robinson SN, Simmons PJ, Yang H, Alousi AM, Marcos de Lima J, Shpall EJ. Mesenchymal stem cells in ex vivo cord blood expansion. *Best Pract Res Clin Haematol* 2011;24(1):83-92.
153. Dahlberg A, Delaney C, Bernstein ID. Ex vivo expansion of human hematopoietic stem and progenitor cells. *Blood* 2011;117(23):6083-6090.
154. Delaney C, Heimfeld S, Brashem-Stein C, Voorhies H, Manger RL, Bernstein ID. Notch-mediated expansion of human cord blood progenitor cells capable of rapid myeloid reconstitution. *Nat Med* 2010;16(2):232-236.
155. Bernstein ID, Delaney C. Engineering stem cell expansion. *Cell Stem Cell*. 2012;10(2):113-114.
156. Peled T, Mandel J, Goudsmid RN, et al. Pre-clinical development of cord blood-derived progenitor cell graft expanded ex vivo with cytokines and the polyamine copper chelator tetraethylenepentamine. *Cytotherapy* 2004;6(4):344-355.
157. Peled T, Landau E, Mandel J, et al. Linear polyamine copper chelator tetraethylenepentamine augments long-term ex vivo expansion of cord blood-derived CD34⁺ cells and increases their engraftment potential in NOD/SCID mice. *Exp Hematol* 2004;32(6):547-555.
158. de Lima M, McMannis J, Gee A, et al. Transplantation of ex vivo expanded cord blood cells using the copper chelator tetraethylenepentamine: a phase I/II clinical trial. *Bone Marrow Transplant* 2008;41(9):771-778.
159. Foudi A, Hochedlinger K, Van Buren D, et al. Analysis of histone 2B-GFP retention reveals slowly cycling hematopoietic stem cells. *Nat Biotechnol* 2009;27(1):84-90.
160. Hoggatt J, Singh P, Sampath J, Pelus LM. Prostaglandin E2 enhances hematopoietic stem cell homing, survival, and proliferation. *Blood* 2009;113(22):5444-5455.
161. Boitano AE, Wang J, Romeo R, et al. Aryl hydrocarbon receptor antagonists promote the expansion of human hematopoietic stem cells. *Science* 2010;329(5997):1345-1348.
162. Zhang CC, Kaba M, Iizuka S, Huynh H, Lodish HF. Angiopoietin-like 5 and IGFBP2 stimulate ex vivo expansion of human cord blood hematopoietic stem cells as assayed by NOD/SCID transplantation. *Blood* 2008;111(7):3415-3423.
163. Himburg HA, Muramoto GG, Daher P, et al. Pleiotrophin regulates the expansion and regeneration of hematopoietic stem cells. *Nat Med* 2010;16(4):475-482.
164. Antonchuk J, Sauvageau G, Humphries RK. HOXB4-induced expansion of adult hematopoietic stem cells ex vivo. *Cell* 2002;109(1):39-45.
165. Wilson A, Laurenti E, Oser G, et al. Hematopoietic stem cells reversibly switch from dormancy to self-renewal during homeostasis and repair. *Cell* 2008;135(6):1118-1129.
166. van der Wath RC, Wilson A, Laurenti E, Trumpp A, Lio P. Estimating dormant and active hematopoietic stem cell kinetics through extensive modeling of bromodeoxyuridine label-retaining cell dynamics. *PLoS One* 2009;4(9):e6972.

167. Ceredig R, Rolink AG, Brown G. Models of haematopoiesis: seeing the wood for the trees. *Nat Rev Immunol* 2009;9(4):293-300.
168. Kawamoto H, Ikawa T, Masuda K, Wada H, Katsura Y. A map for lineage restriction of progenitors during hematopoiesis: the essence of the myeloid-based model. *Immunol Rev* 2010;238(1):23-36.
169. Johnson GR, Metcalf D. Pure and mixed erythroid colony formation in vitro stimulated by spleen conditioned medium with no detectable erythropoietin. *Proc Natl Acad Sci USA* 1977;74(9):3879-3882.
170. Nakahata T, Ogawa M. Identification in culture of a class of hemopoietic colony-forming units with extensive capability to self-renew and generate multipotential hemopoietic colonies. *Proc Natl Acad Sci USA* 1982;79(12):3843-3847.
171. Fauser AA, Messner HA. Proliferative state of human pluripotent hemopoietic progenitors (CFU-GEMM) in normal individuals and under regenerative conditions after bone marrow transplantation. *Blood* 1979;54(5):1197-1200.
172. Ogawa M. Differentiation and proliferation of hematopoietic stem cells. *Blood* 1993;81(11):2844-2853.
173. Ball TC, Hirayama F, Ogawa M. Lymphohematopoietic progenitors of normal mice. *Blood* 1995;85(11):3086-3092.
174. Morrison SJ, Wandycz AM, Hemmati HD, Wright DE, Weissman IL. Identification of a lineage of multipotent hematopoietic progenitors. *Development* 1997;124(10):1929-1939.
175. Lai AY, Lin SM, Kondo M. Heterogeneity of Flt3-expressing multipotent progenitors in mouse bone marrow. *J Immunol* 2005;175(8):5016-5023.
176. Boyer SW, Schroeder AV, Smith-Berdan S, Forsberg EC. All hematopoietic cells develop from hematopoietic stem cells through Flk2/Flt3-positive progenitor cells. *Cell Stem Cell* 2011;9(1):64-73.
177. Metcalf D. Control of granulocytes and macrophages: molecular, cellular, and clinical aspects. *Science* 1991;254(5031):529-533.
178. Eaves AC, Eaves CJ. Erythropoiesis in culture. *Clin Haematol* 1984;13(2): 371-391.
179. Hoffman R. Regulation of megakaryocytopoiesis. *Blood* 1989;74(4):1196-1212.
180. Suda T, Okada S, Suda J, et al. A stimulatory effect of recombinant murine interleukin-7 (IL-7) on B-cell colony formation and an inhibitory effect of IL-1 alpha. *Blood* 1989;74(6):1936-1941.
181. Reid CD, Stackpoole A, Meager A, Tikerpae J. Interactions of tumor necrosis factor with granulocyte-macrophage colony-stimulating factor and other cytokines in the regulation of dendritic cell growth in vitro from early bipotent CD34+ progenitors in human bone marrow. *J Immunol* 1992;149(8):2681-2688.
182. Szabolcs P, Avigan D, Gezelter S, et al. Dendritic cells and macrophages can mature independently from a human bone marrow-derived, post-colonyforming unit intermediate. *Blood* 1996;87(11):4520-4530.
183. Kondo M, Weissman IL, Akashi K. Identification of clonogenic common lymphoid progenitors in mouse bone marrow. *Cell* 1997;91(5):661-672.
184. Akashi K, Traver D, Miyamoto T, Weissman IL. A clonogenic common myeloid progenitor that gives rise to all myeloid lineages. *Nature* 2000;404(6774):193-197.
185. Fogg DK, Sibon C, Miled C, et al. A clonogenic bone marrow progenitor specific for macrophages and dendritic cells. *Science* 2006;311(5757):83-87.
186. Bouvard D, Brakebusch C, Gustafsson E, et al. Functional consequences of integrin gene mutations in mice. *Circ Res* 2001;89(3):211-223.
187. Wright DE, Wagers AJ, Gulati AP, Johnson FL, Weissman IL. Physiological migration of hematopoietic stem and progenitor cells. *Science* 2001;294(5548):1933-1936.
188. Tavassoli M, Hardy CL. Molecular basis of homing of intravenously transplanted stem cells to the marrow. *Blood* 1990;76(6):1059-1070.
189. Frenette PS, Wagner DD. Adhesion molecules—part II: blood vessels and blood cells. *N Engl J Med* 1996;335(1):43-45.
190. Frenette PS, Wagner DD. Adhesion molecules—part 1. *N Engl J Med* 1996;334(23):1526-1529.
191. Etzioni A, Doerschuk CM, Harlan JM. Of man and mouse: leukocyte and endothelial adhesion molecule deficiencies. *Blood* 1999;94(10):3281-3288.

192. Greenberg AW, Kerr WG, Hammer DA. Relationship between selectin-mediated rolling of hematopoietic stem and progenitor cells and progression in hematopoietic development. *Blood* 2000;95(2):478-486.
193. Frenette PS, Subbarao S, Mazo IB, von Andrian UH, Wagner DD. Endothelial selectins and vascular cell adhesion molecule-1 promote hematopoietic progenitor homing to bone marrow. *Proc Natl Acad Sci USA* 1998;95(24): 14423-14428.
194. Hidalgo A, Frenette PS. Enforced fucosylation of neonatal CD34+ cells generates selectin ligands that enhance the initial interactions with microvessels but not homing to bone marrow. *Blood* 2005;105(2):567-575.
195. Mazo IB, Gutierrez-Ramos JC, Frenette PS, Hynes RO, Wagner DD, von Andrian UH. Hematopoietic progenitor cell rolling in bone marrow microvessels: parallel contributions by endothelial selectins and vascular cell adhesion molecule 1. *J Exp Med* 1998;188(3):465-474.
196. Xia L, McDaniel JM, Yago T, Doeden A, McEver RP. Surface fucosylation of human cord blood cells augments binding to P-selectin and E-selectin and enhances engraftment in bone marrow. *Blood* 2004;104(10):3091-3096.
197. Papayannopoulou T, Craddock C, Nakamoto B, Priestley GV, Wolf NS. The VLA4/VCAM-1 adhesion pathway defines contrasting mechanisms of lodgement of transplanted murine hemopoietic progenitors between bone marrow and spleen. *Proc Natl Acad Sci USA* 1995;92(21):9647-9651.
198. Zanjani ED, Flake AW, Almeida-Porada G, Tran N, Papayannopoulou T. Homing of human cells in the fetal sheep model: modulation by antibodies activating or inhibiting very late activation antigen-4-dependent function. *Blood* 1999;94(7):2515-2522.
199. Scott LM, Priestley GV, Papayannopoulou T. Deletion of alpha4 integrins from adult hematopoietic cells reveals roles in homeostasis, regeneration, and homing. *Mol Cell Biol* 2003;23(24):9349-9360.
200. Potocnik AJ, Brakebusch C, Fassler R. Fetal and adult hematopoietic stem cells require beta1 integrin function for colonizing fetal liver, spleen, and bone marrow. *Immunity* 2000;12(6):653-663.
201. Papayannopoulou T, Nakamoto B. Peripheralization of hemopoietic progenitors in primates treated with anti-VLA4 integrin. *Proc Natl Acad Sci USA* 1993;90(20):9374-9378.
202. Papayannopoulou T, Priestley GV, Nakamoto B. Anti-VLA4/VCAM-1-induced mobilization requires cooperative signaling through the kit/mkit ligand pathway. *Blood* 1998;91(7):2231-2239.
203. Katayama Y, Hidalgo A, Peired A, Frenette PS. Integrin alpha4beta7 and its counterreceptor MAdCAM-1 contribute to hematopoietic progenitor recruitment into bone marrow following transplantation. *Blood* 2004;104(7): 2020-2026.
204. Peled A, Kollet O, Ponomaryov T, et al. The chemokine SDF-1 activates the integrins LFA-1, VLA-4, and VLA-5 on immature human CD34(+) cells: role in transendothelial/stromal migration and engraftment of NOD/SCID mice. *Blood* 2000;95(11):3289-3296.
205. van der Loo JC, Xiao X, McMillin D, Hashino K, Kato I, Williams DA. VLA-5 is expressed by mouse and human long-term repopulating hematopoietic cells and mediates adhesion to extracellular matrix protein fibronectin. *J Clin Invest* 1998;102(5):1051-1061.
206. Qian H, Tryggvason K, Jacobsen SE, Ekblom M. Contribution of alpha6 integrins to hematopoietic stem and progenitor cell homing to bone marrow and collaboration with alpha4 integrins. *Blood* 2006;107(9):3503-3510.
207. Avigdor A, Goichberg P, Shvitiel S, et al. CD44 and hyaluronic acid cooperate with SDF-1 in the trafficking of human CD34+ stem/progenitor cells to bone marrow. *Blood* 2004;103(8):2981-2989.
208. Christ O, Kronenwett R, Haas R, Zoller M. Combining G-CSF with a blockade of adhesion strongly improves the reconstitutive capacity of mobilized hematopoietic progenitor cells. *Exp Hematol* 2001;29(3):380-390.
209. Vermeulen M, Le Pesteur F, Gagnerault MC, Mary JY, Sainteny F, Lepault F. Role of adhesion molecules in the homing and mobilization of murine hematopoietic stem and progenitor cells. *Blood* 1998;92(3):894-900.
210. Ulyanova T, Scott LM, Priestley GV, et al. VCAM-1 expression in adult hematopoietic and nonhematopoietic cells is controlled by tissue-inductive signals and reflects their developmental origin. *Blood* 2005;106(1):86-94.
211. Kim CH, Broxmeyer HE. In vitro behavior of hematopoietic progenitor cells under the influence of chemoattractants: stromal cell-derived factor-1, steel factor, and the bone marrow environment. *Blood* 1998;91(1):100-110.

212. Peled A, Petit I, Kollet O, et al. Dependence of human stem cell engraftment and repopulation of NOD/SCID mice on CXCR4. *Science* 1999;283(5403):845-848.
213. Aiuti A, Webb IJ, Bleul C, Springer T, Gutierrez-Ramos JC. The chemokine SDF-1 is a chemoattractant for human CD34+ hematopoietic progenitor cells and provides a new mechanism to explain the mobilization of CD34+ progenitors to peripheral blood. *J Exp Med* 1997;185(1):111-120.
214. Wright DE, Bowman EP, Wagers AJ, Butcher EC, Weissman IL. Hematopoietic stem cells are uniquely selective in their migratory response to chemokines. *J Exp Med* 2002;195(9):1145-1154.
215. Nagasawa T, Hirota S, Tachibana K, et al. Defects of B-cell lymphopoiesis and bone-marrow myelopoiesis in mice lacking the CXC chemokine PBSF/SDF-1. *Nature* 1996;382(6592):635-638.
216. Zou YR, Kottmann AH, Kuroda M, Taniuchi I, Littman DR. Function of the chemokine receptor CXCR4 in haematopoiesis and in cerebellar development. *Nature* 1998;393(6685):595-599.
217. Kollet O, Spiegel A, Peled A, et al. Rapid and efficient homing of human CD34(+)CD38(-/low)CXCR4(+) stem and progenitor cells to the bone marrow and spleen of NOD/SCID and NOD/SCID/B2m(null) mice. *Blood* 2001;97(10):3283-3291.
218. Fukuda S, Broxmeyer HE, Pelus LM. Flt3 ligand and the Flt3 receptor regulate hematopoietic cell migration by modulating the SDF-1alpha(CXCL12)/CXCR4 axis. *Blood* 2005;105(8):3117-3126.
219. Giancotti FG, Ruoslahti E. Integrin signaling. *Science* 1999;285(5430): 1028-1032.
220. Levesque JP, Simmons PJ. Cytoskeleton and integrin-mediated adhesion signaling in human CD34+ hemopoietic progenitor cells. *Exp Hematol* 1999;27(4):579-586.
221. Liu S, Kiosses WB, Rose DM, et al. A fragment of paxillin binds the alpha 4 integrin cytoplasmic domain (tail) and selectively inhibits alpha 4-mediated cell migration. *J Biol Chem* 2002;277(23):20887-20894.
222. Takahira H, Gotoh A, Ritchie A, Broxmeyer HE. Steel factor enhances integrin-mediated tyrosine phosphorylation of focal adhesion kinase (pp125FAK) and paxillin. *Blood* 1997;89(5):1574-1584.
223. Kapur R, Cooper R, Zhang L, Williams DA. Cross-talk between alpha(4) beta(1)/alpha(5)beta(1) and c-Kit results in opposing effect on growth and survival of hematopoietic cells via the activation of focal adhesion kinase, mitogen-activated protein kinase, and Akt signaling pathways. *Blood* 2001;97(7):1975-1981.
224. Imai K, Kobayashi M, Wang J, et al. Selective secretion of chemoattractants for haemopoietic progenitor cells by bone marrow endothelial cells: a possible role in homing of haemopoietic progenitor cells to bone marrow. *Br J Haematol* 1999;106(4):905-911.
225. Peled A, Grabovsky V, Habler L, et al. The chemokine SDF-1 stimulates integrin-mediated arrest of CD34(+) cells on vascular endothelium under shear flow. *J Clin Invest* 1999;104(9):1199-1211.
226. Verfaillie CM, Benis A, Iida J, McGlave PB, McCarthy JB. Adhesion of committed human hematopoietic progenitors to synthetic peptides from the C-terminal heparin-binding domain of fibronectin: cooperation between the integrin alpha 4 beta 1 and the CD44 adhesion receptor. *Blood* 1994;84(6):1802-1811.
227. Yoder MC, Williams DA. Matrix molecule interactions with hematopoietic stem cells. *Exp Hematol* 1995;23(9):961-967.
228. Yin Z, Giacomello E, Gabriele E, et al. Cooperative activity of alpha4beta1 and alpha4beta7 integrins in mediating human B-cell lymphoma adhesion and chemotaxis on fibronectin through recognition of multiple synergizing binding sites within the central cell-binding domain. *Blood* 1999;93(4): 1221-1230.
229. Chan JY, Watt SM. Adhesion receptors on haematopoietic progenitor cells. *Br J Haematol* 2001;112(3):541-557.
230. Ghaffari S, Smadja-Joffe F, Oostendorp R, et al. CD44 isoforms in normal and leukemic hematopoiesis. *Exp Hematol* 1999;27(6):978-993.
231. Wight TN, Kinsella MG, Keating A, Singer JW. Proteoglycans in human longterm bone marrow cultures: biochemical and ultrastructural analyses. *Blood* 1986;67(5):1333-1343.
232. Siczkowski M, Clarke D, Gordon MY. Binding of primitive hematopoietic progenitor cells to marrow stromal cells involves heparan sulfate. *Blood* 1992;80(4):912-919.

233. Minguell JJ, Hardy C, Tavassoli M. Membrane-associated chondroitin sulfate proteoglycan and fibronectin mediate the binding of hemopoietic progenitor cells to stromal cells. *Exp Cell Res* 1992;201(1):200-207.
234. Uhlman DL, Luikhart SD. The role of proteoglycans in the adhesion and differentiation of hematopoietic cells. In: Long MW, Wicha MS, eds. *The hematopoietic microenvironment*. Baltimore, MD: The Johns Hopkins University Press, 1993:232-245.
235. Bruno E, Luikart SD, Long MW, Hoffman R. Marrow-derived heparan sulfate proteoglycan mediates the adhesion of hematopoietic progenitor cells to cytokines. *Exp Hematol*. 1995;23(11):1212-1217.
236. Gordon MY, Riley GP, Watt SM, Greaves MF. Compartmentalization of a haematopoietic growth factor (GM-CSF) by glycosaminoglycans in the bone marrow microenvironment. *Nature* 1987;326(6111):403-405.
237. Roberts R, Gallagher J, Spooncer E, Allen TD, Bloomfield F, Dexter TM. Heparan sulphate bound growth factors: a mechanism for stromal cell mediated haemopoiesis. *Nature* 1988;332(6162):376-378.
238. Massberg S, Schaerli P, Knezevic-Maramica I, et al. Immunosurveillance by hematopoietic progenitor cells trafficking through blood, lymph, and peripheral tissues. *Cell* 2007;131(5):994-1008.
239. Si Y, Tsou CL, Croft K, Charo IF. CCR2 mediates hematopoietic stem and progenitor cell trafficking to sites of inflammation in mice. *J Clin Invest*. 2010;120(4):1192-1203.
240. van Rood JJ, Oudshoorn M. Eleven million donors in Bone Marrow Donors Worldwide! Time for reassessment? *Bone Marrow Transplant* 2008; 41(1):1-9.
241. Levesque JP, Liu F, Simmons PJ, et al. Characterization of hematopoietic progenitor mobilization in protease-deficient mice. *Blood* 2004;104(1):65-72.
242. Mendez-Ferrer S, Michurina TV, Ferraro F, et al. Mesenchymal and haematopoietic stem cells form a unique bone marrow niche. *Nature* 2010;466(7308):829-834.
243. Katayama Y, Battista M, Kao WM, et al. Signals from the sympathetic nervous system regulate hematopoietic stem cell egress from bone marrow. *Cell* 2006;124(2):407-421.
244. Mendez-Ferrer S, Lucas D, Battista M, Frenette PS. Haematopoietic stem cell release is regulated by circadian oscillations. *Nature* 2008;452(7186):442-447.
245. Lucas D, Battista M, Shi PA, Isola L, Frenette PS. Mobilized hematopoietic stem cell yield depends on species-specific circadian timing. *Cell Stem Cell* 2008;3(4):364-366.
246. Chow A, Lucas D, Hidalgo A, et al. Bone marrow CD169+ macrophages promote the retention of hematopoietic stem and progenitor cells in the mesenchymal stem cell niche. *J Exp Med* 2011;208(2):261-271.
247. Christopher MJ, Rao M, Liu F, Woloszynek JR, Link DC. Expression of the G-CSF receptor in monocytic cells is sufficient to mediate hematopoietic progenitor mobilization by G-CSF in mice. *J Exp Med* 2011;208(2):251-260.
248. Winkler IG, Sims NA, Pettit AR, et al. Bone marrow macrophages maintain hematopoietic stem cell (HSC) niches and their depletion mobilizes HSCs. *Blood* 2010;116(23):4815-4828.
249. Broxmeyer HE, Orschell CM, Clapp DW, et al. Rapid mobilization of murine and human hematopoietic stem and progenitor cells with AMD3100, a CXCR4 antagonist. *J Exp Med* 2005;201(8):1307-1318.
250. Bensinger W, DiPersio JF, McCarty JM. Improving stem cell mobilization strategies: future directions. *Bone Marrow Transplant* 2009;43(3):181-195.
251. Bakanay SM, Demirer T. Novel agents and approaches for stem cell mobilization in normal donors and patients. *Bone Marrow Transplant* 2011.
252. Ryan MA, Nattamai KJ, Xing E, et al. Pharmacological inhibition of EGFR signaling enhances G-CSF-induced hematopoietic stem cell mobilization. *Nat Med*. 2010;16(10):1141-1146.
253. Shivdasani RA, Orkin SH. The transcriptional control of hematopoiesis. *Blood* 1996;87(10):4025-4039.
254. Graf T. Differentiation plasticity of hematopoietic cells. *Blood* 2002;99(9): 3089-3101.
255. Chen H, Ray-Gallet D, Zhang P, et al. PU.1 (Spi-1) autoregulates its expression in myeloid cells. *Oncogene* 1995;11(8):1549-1560.

256. Tsai SF, Strauss E, Orkin SH. Functional analysis and in vivo footprinting implicate the erythroid transcription factor GATA-1 as a positive regulator of its own promoter. *Genes Dev* 1991;5(6):919-931.
257. Hu M, Krause D, Greaves M, et al. Multilineage gene expression precedes commitment in the hemopoietic system. *Genes Dev* 1997;11(6):774-785.
258. Nerlov C, Tenen DG, Graf T. Regulatory interactions between transcription factors and their role in hematopoietic lineage determination. In: Zon LI, ed. *Hematopoiesis: a developmental approach*. Oxford: Oxford University Press, 2001:363-367.
259. Laiosa CV, Stadtfeld M, Graf T. Determinants of lymphoid-myeloid lineage diversification. *Annu Rev Immunol* 2006;24:705-738.
260. Ambros V. The functions of animal microRNAs. *Nature* 2004;431(7006): 350-355.
261. Chen CZ, Li L, Lodish HF, Bartel DP. MicroRNAs modulate hematopoietic lineage differentiation. *Science* 2004;303(5654):83-86.
262. Havelange V, Garzon R. MicroRNAs: emerging key regulators of hematopoiesis. *Am J Hematol* 2010;85(12):935-942.
263. Koralov SB, Muljo SA, Galler GR, et al. Dicer ablation affects antibody diversity and cell survival in the B lymphocyte lineage. *Cell* 2008;132(5):860-874.
264. Muljo SA, Ansel KM, Kanellopoulou C, Livingston DM, Rao A, Rajewsky K. Aberrant T cell differentiation in the absence of Dicer. *J Exp Med* 2005;202(2):261-269.
265. Georgantas RW, 3rd, Hildreth R, Morisot S, et al. CD34+ hematopoietic stem-progenitor cell microRNA expression and function: a circuit diagram of differentiation control. *Proc Natl Acad Sci USA* 2007;104(8):2750-2755.
266. Romania P, Lulli V, Pelosi E, Biffoni M, Peschle C, Marzali G. MicroRNA 155 modulates megakaryopoiesis at progenitor and precursor level by targeting Ets-1 and Meis1 transcription factors. *Br J Haematol* 2008;143(4):570-580.
267. Rodriguez A, Vigorito E, Clare S, et al. Requirement of bic/microRNA-155 for normal immune function. *Science* 2007;316(5824):608-611.
268. Thai TH, Calado DP, Casola S, et al. Regulation of the germinal center response by microRNA-155. *Science* 2007;316(5824):604-608.
269. Vigorito E, Perks KL, Abreu-Goodger C, et al. microRNA-155 regulates the generation of immunoglobulin class-switched plasma cells. *Immunity* 2007;27(6):847-859.
270. Teng G, Hakimpour P, Landgraf P, et al. MicroRNA-155 is a negative regulator of activation-induced cytidine deaminase. *Immunity* 2008;28(5):621-629.
271. Dorsett Y, McBride KM, Jankovic M, et al. MicroRNA-155 suppresses activation-induced cytidine deaminase-mediated Myc-Igh translocation. *Immunity* 2008;28(5):630-638.
272. Zhao G, Yu D, Weiss MJ. MicroRNAs in erythropoiesis. *Curr Opin Hematol* 2010;17(3):155-162.
273. Li H, Zhao H, Wang D, Yang R. microRNA regulation in megakaryocytopoiesis. *Br J Haematol* 2011;155(3):298-307.
274. O'Connell RM, Zhao JL, Rao DS. MicroRNA function in myeloid biology. *Blood* 2011;118(11):2960-2969.
275. Belver L, Papavasiliou FN, Ramiro AR. MicroRNA control of lymphocyte differentiation and function. *Curr Opin Immunol* 2011;23(3):368-373.
276. Metcalf D. Hematopoietic cytokines. *Blood* 2008;111(2):485-491.
277. Santini V, Scappini B, Indik ZK, Gozzini A, Ferrini PR, Schreiber AD. The carboxy-terminal region of the granulocyte colony-stimulating factor receptor transduces a phagocytic signal. *Blood* 2003;101(11):4615-4622.
278. Metcalf D, Nicola NA. The clonal proliferation of normal mouse hematopoietic cells: enhancement and suppression by colony-stimulating factor combinations. *Blood* 1992;79(11):2861-2866.
279. Matsunaga T, Kato T, Miyazaki H, Ogawa M. Thrombopoietin promotes the survival of murine hematopoietic long-term reconstituting cells: comparison with the effects of FLT3/FLK-2 ligand and interleukin-6. *Blood* 1998;92(2):452-461.
280. Matsunaga T, Hirayama F, Yonemura Y, Murray R, Ogawa M. Negative regulation by interleukin-3 (IL-3) of mouse early B-cell progenitors and stem cells in culture: transduction of the negative signals by beta2c and beta2L-3 proteins of IL-

- 3 receptor and absence of negative regulation by granulocyte-macrophage colony-stimulating factor. *Blood* 1998;92(3):901-907.
281. Metcalf D. Lineage commitment in the progeny of murine hematopoietic preprogenitor cells: influence of thrombopoietin and interleukin 5. *Proc Natl Acad Sci USA* 1998;95(11):6408-6412.
282. Yagi M, Ritchie KA, Sitnicka E, Storey C, Roth GJ, Bartelmez S. Sustained ex vivo expansion of hematopoietic stem cells mediated by thrombopoietin. *Proc Natl Acad Sci USA* 1999;96(14):8126-8131.
283. Zandstra PW, Lauffenburger DA, Eaves CJ. A ligand-receptor signaling threshold model of stem cell differentiation control: a biologically conserved mechanism applicable to hematopoiesis. *Blood* 2000;96(4):1215-1222.
284. Gilliland DG, Griffin JD. The roles of FLT3 in hematopoiesis and leukemia. *Blood* 2002;100(5):1532-1542.
285. Metcalf D. Hematopoietic regulators: redundancy or subtlety? *Blood* 1993;82(12):3515-3523.
286. Alexander WS, Roberts AW, Nicola NA, Li R, Metcalf D. Deficiencies in progenitor cells of multiple hematopoietic lineages and defective megakaryocytopoiesis in mice lacking the thrombopoietic receptor c-Mpl. *Blood* 1996;87(6):2162-2170.
287. Ku H, Yonemura Y, Kaushansky K, Ogawa M. Thrombopoietin, the ligand for the Mpl receptor, synergizes with steel factor and other early acting cytokines in supporting proliferation of primitive hematopoietic progenitors of mice. *Blood* 1996;87(11):4544-4551.
288. Young JC, Bruno E, Luens KM, Wu S, Backer M, Murray LJ. Thrombopoietin stimulates megakaryocytopoiesis, myelopoiesis, and expansion of CD34+ progenitor cells from single CD34+Thy-1+Lin- primitive progenitor cells. *Blood* 1996;88(5):1619-1631.
289. McNiece IK, Langley KE, Zsebo KM. Recombinant human stem cell factor synergizes with GM-CSF, G-CSF, IL-3 and epo to stimulate human progenitor cells of the myeloid and erythroid lineages. *Exp Hematol* 1991;19(3): 226-231.
290. Metcalf D, Nicola NA. Direct proliferative actions of stem cell factor on murine bone marrow cells in vitro: effects of combination with colony-stimulating factors. *Proc Natl Acad Sci USA* 1991;88(14):6239-6243.
291. Muta K, Krantz SB, Bondurant MC, Dai CH. Stem cell factor retards differentiation of normal human erythroid progenitor cells while stimulating proliferation. *Blood* 1995;86(2):572-580.
292. Migliaccio G, Migliaccio AR, Valinsky J, et al. Stem cell factor induces proliferation and differentiation of highly enriched murine hematopoietic cells. *Proc Natl Acad Sci USA* 1991;88(16):7420-7424.
293. Leary AG, Zeng HQ, Clark SC, Ogawa M. Growth factor requirements for survival in G0 and entry into the cell cycle of primitive human hemopoietic progenitors. *Proc Natl Acad Sci USA* 1992;89(9):4013-4017.
294. Miura N, Okada S, Zsebo KM, Miura Y, Suda T. Rat stem cell factor and IL-6 preferentially support the proliferation of c-kit-positive murine hemopoietic cells rather than their differentiation. *Exp Hematol* 1993;21(1):143-149.
295. Yamaguchi Y, Suda T, Suda J, et al. Purified interleukin 5 supports the terminal differentiation and proliferation of murine eosinophilic precursors. *J Exp Med* 1988;167(1):43-56.
296. Dickason RR, Huston DP. Creation of a biologically active interleukin-5 monomer. *Nature* 1996;379(6566):652-655.
297. Lieschke GJ, Grail D, Hodgson G, et al. Mice lacking granulocyte colony-stimulating factor have chronic neutropenia, granulocyte and macrophage progenitor cell deficiency, and impaired neutrophil mobilization. *Blood* 1994;84(6):1737-1746.
298. Herbert DR, Lee JJ, Lee NA, Nolan TJ, Schad GA, Abraham D. Role of IL-5 in innate and adaptive immunity to larval *Strongyloides stercoralis* in mice. *J Immunol* 2000;165(8):4544-4551.
299. Metcalf D, Nicola NA. The hemopoietic colony stimulating factors: from biology to clinical applications. Cambridge: Cambridge University Press, 1995.
300. Stanley E, Lieschke GJ, Grail D, et al. Granulocyte/macrophage colony-stimulating factor-deficient mice show no major perturbation of hematopoiesis but develop a characteristic pulmonary pathology. *Proc Natl Acad Sci USA* 1994;91(12):5592-5596.
301. Hibbs ML, Quilici C, Kountouri N, et al. Mice lacking three myeloid colony-stimulating factors (G-CSF, GM-CSF, and M-CSF) still produce macrophages and granulocytes and mount an inflammatory response in a sterile model of peritonitis. *J Immunol* 2007;178(10):6435-6443.

302. Fleischmann J, Golde DW, Weisbart RH, Gasson JC. Granulocyte-macrophage colony-stimulating factor enhances phagocytosis of bacteria by human neutrophils. *Blood* 1986;68(3):708-711.
303. Vadas MA, Nicola NA, Metcalf D. Activation of antibody-dependent cell-mediated cytotoxicity of human neutrophils and eosinophils by separate colony-stimulating factors. *J Immunol* 1983;130(2):795-799.
304. Handman E, Burgess AW. Stimulation by granulocyte-macrophage colony-stimulating factor of *Leishmania tropica* killing by macrophages. *J Immunol* 1979;122(3):1134-1137.
305. Wershil BK, Tsai M, Geissler EN, Zsebo KM, Galli SJ. The rat c-kit ligand, stem cell factor, induces c-kit receptor-dependent mouse mast cell activation in vivo. Evidence that signaling through the c-kit receptor can induce expression of cellular function. *J Exp Med.* 1992;175(1):245-255.
306. Valent P, Spanblochl E, Sperr WR, et al. Induction of differentiation of human mast cells from bone marrow and peripheral blood mononuclear cells by recombinant human stem cell factor/kit-ligand in long-term culture. *Blood* 1992;80(9):2237-2245.
307. Irani AM, Nilsson G, Miettinen U, et al. Recombinant human stem cell factor stimulates differentiation of mast cells from dispersed human fetal liver cells. *Blood* 1992;80(12):3009-3021.
308. Lukacs NW, Kunkel SL, Strieter RM, et al. The role of stem cell factor (c-kit ligand) and inflammatory cytokines in pulmonary mast cell activation. *Blood* 1996;87(6):2262-2268.
309. Galli SJ, Kitamura Y. Genetically mast-cell-deficient W/W^v and Sl/Sl^d mice. Their value for the analysis of the roles of mast cells in biologic responses in vivo. *Am J Pathol* 1987;127(1):191-198.
310. Auffray C, Sieweke MH, Geissmann F. Blood monocytes: development, heterogeneity, and relationship with dendritic cells. *Annu Rev Immunol* 2009;27:669-692.
311. Chitu V, Stanley ER. Colony-stimulating factor-1 in immunity and inflammation. *Curr Opin Immunol* 2006;18(1):39-48.
312. Davies JQ, Gordon S. Isolation and culture of murine macrophages. *Methods Mol Biol* 2005;290:91-103.
313. Nemunaitis J, Shannon-Dorcy K, Appelbaum FR, et al. Long-term follow-up of patients with invasive fungal disease who received adjunctive therapy with recombinant human macrophage colony-stimulating factor. *Blood* 1993;82(5):1422-1427.
314. Broudy VC, Lin NL, Kaushansky K. Thrombopoietin (c-mpl ligand) acts synergistically with erythropoietin, stem cell factor, and interleukin-11 to enhance murine megakaryocyte colony growth and increases megakaryocyte ploidy in vitro. *Blood* 1995;85(7):1719-1726.
315. Banu N, Wang JF, Deng B, Groopman JE, Avraham H. Modulation of megakaryocytopoiesis by thrombopoietin: the c-Mpl ligand. *Blood* 1995;86(4):1331-1338.
316. Burstein SA, Adamson JW, Erb SK, Harker LA. Megakaryocytopoiesis in the mouse: response to varying platelet demand. *J Cell Physiol* 1981; 109(2):333-341.
317. Williams N, Eger RR, Jackson HM, Nelson DJ. Two-factor requirement for murine megakaryocyte colony formation. *J Cell Physiol* 1982;110(1): 101-104.
318. Kuter DJ, Begley CG. Recombinant human thrombopoietin: basic biology and evaluation of clinical studies. *Blood* 2002;100(10):3457-3469.
319. Kaushansky K. Thrombopoietin: the primary regulator of platelet production. *Blood* 1995;86(2):419-431.
320. Debili N, Wendling F, Cosman D, et al. The Mpl receptor is expressed in the megakaryocytic lineage from late progenitors to platelets. *Blood* 1995;85(2):391-401.
321. Souyri M, Vigon I, Penciolelli JF, Heard JM, Tambourin P, Wendling F. A putative truncated cytokine receptor gene transduced by the myeloproliferative leukemia virus immortalizes hematopoietic progenitors. *Cell* 1990;63(6):1137-1147.
322. Farese AM, Hunt P, Boone T, MacVittie TJ. Recombinant human megakaryocyte growth and development factor stimulates thrombocytopoiesis in normal nonhuman primates. *Blood* 1995;86(1):54-59.
323. Wendling F, Maraskovsky E, Debili N, et al. cMpl ligand is a humoral regulator of megakaryocytopoiesis. *Nature* 1994;369(6481):571-574.

324. McCarty JM, Sprugel KH, Fox NE, Sabath DE, Kaushansky K. Murine thrombopoietin mRNA levels are modulated by platelet count. *Blood* 1995;86(10):3668-3675.
325. Kuter DJ. Biology and chemistry of thrombopoietic agents. *Semin Hematol* 2010;47(3):243-248.
326. Koury MJ, Bondurant MC. The molecular mechanism of erythropoietin action. *Eur J Biochem* 1992;210(3):649-663.
327. Koury ST, Bondurant MC, Koury MJ. Localization of erythropoietin synthesizing cells in murine kidneys by in situ hybridization. *Blood* 1988;71(2): 524-527.
328. Lacombe C, Da Silva JL, Bruneval P, et al. Peritubular cells are the site of erythropoietin synthesis in the murine hypoxic kidney. *J Clin Invest* 1988;81(2):620-623.
329. Koury ST, Koury MJ, Bondurant MC, Caro J, Graber SE. Quantitation of erythropoietin-producing cells in kidneys of mice by in situ hybridization: correlation with hematocrit, renal erythropoietin mRNA, and serum erythropoietin concentration. *Blood* 1989;74(2):645-651.
330. Wang GL, Jiang BH, Rue EA, Semenza GL. Hypoxia-inducible factor 1 is a basic-helix-loop-helix-PAS heterodimer regulated by cellular O₂ tension. *Proc Natl Acad Sci USA* 1995;92(12):5510-5514.
331. Jaakkola P, Mole DR, Tian YM, et al. Targeting of HIF- α to the von Hippel-Lindau ubiquitylation complex by O₂-regulated prolyl hydroxylation. *Science* 2001;292(5516):468-472.
332. Ivan M, Kondo K, Yang H, et al. HIF α targeted for VHL-mediated destruction by proline hydroxylation: implications for O₂ sensing. *Science* 2001;292(5516):464-468.
333. Yu F, White SB, Zhao Q, Lee FS. HIF-1 α binding to VHL is regulated by stimulus-sensitive proline hydroxylation. *Proc Natl Acad Sci USA* 2001;98(17):9630-9635.
334. Lando D, Peet DJ, Whelan DA, Gorman JJ, Whitelaw ML. Asparagine hydroxylation of the HIF transactivation domain a hypoxic switch. *Science* 2002;295(5556):858-861.
335. Sang N, Fang J, Srinivas V, Leshchinsky I, Caro J. Carboxyl-terminal trans-activation activity of hypoxia-inducible factor 1 α is governed by a von Hippel-Lindau protein-independent, hydroxylation-regulated association with p300/CBP. *Mol Cell Biol*. 2002;22(9):2984-2992.
336. Semenza GL, Koury ST, Nejfelt MK, Gearhart JD, Antonarakis SE. Cell-typespecific and hypoxia-inducible expression of the human erythropoietin gene in transgenic mice. *Proc Natl Acad Sci USA* 1991;88(19):8725-8729.
337. Koury ST, Bondurant MC, Semenza GL, Koury MJ. The use of in situ hybridization to study erythropoietin gene expression in murine kidney and liver. *Microsc Res Tech* 1993;25(1):29-39.
338. Sawyer ST, Krantz SB, Goldwasser E. Binding and receptor-mediated endocytosis of erythropoietin in Friend virus-infected erythroid cells. *J Biol Chem* 1987;262(12):5554-5562.
339. Gross AW, Lodish HF. Cellular trafficking and degradation of erythropoietin and novel erythropoiesis stimulating protein (NESP). *J Biol Chem* 2006;281(4):2024-2032.
340. Chapel S, Veng-Pedersen P, Hohl RJ, Schmidt RL, McGuire EM, Widness JA. Changes in erythropoietin pharmacokinetics following busulfan-induced bone marrow ablation in sheep: evidence for bone marrow as a major erythropoietin elimination pathway. *J Pharmacol Exp Ther* 2001; 298(2):820-824.
341. Wu H, Liu X, Jaenisch R, Lodish HF. Generation of committed erythroid BFU-E and CFU-E progenitors does not require erythropoietin or the erythropoietin receptor. *Cell* 1995;83(1):59-67.
342. Lin CS, Lim SK, D'Agati V, Costantini F. Differential effects of an erythropoietin receptor gene disruption on primitive and definitive erythropoiesis. *Genes Dev* 1996;10(2):154-164.
343. Dai CH, Krantz SB, Zsebo KM. Human burst-forming units-erythroid need direct interaction with stem cell factor for further development. *Blood* 1991;78(10):2493-2497.
344. Sawada K, Krantz SB, Dessypris EN, Koury ST, Sawyer ST. Human colony-forming units-erythroid do not require accessory cells, but do require direct interaction with insulin-like growth factor I and/or insulin for erythroid development. *J Clin Invest* 1989;83(5):1701-1709.
345. Muta K, Krantz SB, Bondurant MC, Wickrema A. Distinct roles of erythropoietin, insulin-like growth factor I, and stem cell factor in the development of erythroid progenitor cells. *J Clin Invest* 1994;94(1):34-43.

346. Whitlock CA, Witte ON. Long-term culture of B lymphocytes and their precursors from murine bone marrow. *Proc Natl Acad Sci USA* 1982;79(11): 3608-3612.
347. Peschon JJ, Morrissey PJ, Grabstein KH, et al. Early lymphocyte expansion is severely impaired in interleukin 7 receptor-deficient mice. *J Exp Med* 1994;180(5):1955-1960.
- P.82
348. Nagasawa T. Microenvironmental niches in the bone marrow required for B-cell development. *Nat Rev Immunol* 2006;6(2):107-116.
349. Dolznig H, Habermann B, Stangl K, et al. Apoptosis protection by the Epo target Bcl-X(L) allows factor-independent differentiation of primary erythroblasts. *Curr Biol* 2002;12(13):1076-1085.
350. Kondo M, Akashi K, Domen J, Sugamura K, Weissman IL. Bcl-2 rescues T lymphopoiesis, but not B or NK cell development, in common gamma chain-deficient mice. *Immunity* 1997;7(1):155-162.
351. Akashi K, Kondo M, von Freeden-Jeffry U, Murray R, Weissman IL. Bcl-2 rescues T lymphopoiesis in interleukin-7 receptor-deficient mice. *Cell* 1997;89(7):1033-1041.
352. Kikuchi K, Lai AY, Hsu CL, Kondo M. IL-7 receptor signaling is necessary for stage transition in adult B cell development through up-regulation of EBF. *J Exp Med* 2005;201(8):1197-1203.
353. Iwasaki-Arai J, Iwasaki H, Miyamoto T, Watanabe S, Akashi K. Enforced granulocyte/macrophage colony-stimulating factor signals do not support lymphopoiesis, but instruct lymphoid to myelomonocytic lineage conversion. *J Exp Med* 2003;197(10):1311-1322.
354. Dahl R, Walsh JC, Lancki D, et al. Regulation of macrophage and neutrophil cell fates by the PU.1:C/EBPalpha ratio and granulocyte colony-stimulating factor. *Nat Immunol* 2003;4(10):1029-1036.
355. Rieger MA, Hoppe PS, Smejkal BM, Eitelhuber AC, Schroeder T. Hematopoietic cytokines can instruct lineage choice. *Science* 2009;325(5937):217-218.
356. Sarrazin S, Mossadegh-Keller N, Fukao T, et al. MafB restricts M-CSF-dependent myeloid commitment divisions of hematopoietic stem cells. *Cell* 2009;138(2):300-313.
357. Friedenstein AJ, Deriglasova UF, Kulagina NN, et al. Precursors for fibroblasts in different populations of hematopoietic cells as detected by the in vitro colony assay method. *Exp Hematol* 1974;2(2):83-92.
358. Ratajczak MZ, Kucia M, Reza R, Majka M, Janowska-Wieczorek A, Ratajczak J. Stem cell plasticity revisited: CXCR4-positive cells expressing mRNA for early muscle, liver and neural cells 'hide out' in the bone marrow. *Leukemia* 2004;18(1):29-40.
359. Pittenger MF, Mackay AM, Beck SC, et al. Multilineage potential of adult human mesenchymal stem cells. *Science* 1999;284(5411):143-147.
360. Reyes M, Dudek A, Jahagirdar B, Koodie L, Marker PH, Verfaillie CM. Origin of endothelial progenitors in human postnatal bone marrow. *J Clin Invest* 2002;109(3):337-346.
361. Dominici M, Le Blanc K, Mueller I, et al. Minimal criteria for defining multipotent mesenchymal stromal cells. The International Society for Cellular Therapy position statement. *Cytotherapy* 2006;8(4):315-317.
362. Keating A. Mesenchymal stromal cells. *Curr Opin Hematol* 2006;13(6): 419-425.
363. Keating A, Singer JW, Killen PD, et al. Donor origin of the in vitro haematopoietic microenvironment after marrow transplantation in man. *Nature* 1982;298(5871):280-283.
364. Devine SM, Cobbs C, Jennings M, Bartholomew A, Hoffman R. Mesenchymal stem cells distribute to a wide range of tissues following systemic infusion into nonhuman primates. *Blood* 2003;101(8):2999-3001.
365. Mahmud N, Pang W, Cobbs C, et al. Studies of the route of administration and role of conditioning with radiation on unrelated allogeneic mismatched mesenchymal stem cell engraftment in a nonhuman primate model. *Exp Hematol* 2004;32(5):494-501.

366. Horwitz EM, Prockop DJ, Fitzpatrick LA, et al. Transplantability and therapeutic effects of bone marrow-derived mesenchymal cells in children with osteogenesis imperfecta. *Nat Med* 1999;5(3):309-313.
367. Ogawa M, LaRue AC, Drake CJ. Hematopoietic origin of fibroblasts/myofibroblasts: its pathophysiologic implications. *Blood* 2006;108(9):2893-2896.
368. Olmsted-Davis EA, Gugala Z, Camargo F, et al. Primitive adult hematopoietic stem cells can function as osteoblast precursors. *Proc Natl Acad Sci USA* 2003;100(26):15877-15882.
369. Dominici M, Pritchard C, Garlits JE, Hofmann TJ, Persons DA, Horwitz EM. Hematopoietic cells and osteoblasts are derived from a common marrow progenitor after bone marrow transplantation. *Proc Natl Acad Sci USA* 2004;101(32):11761-11766.
370. Bentley SA. Collagen synthesis by bone marrow stromal cells: a quantitative study. *Br J Haematol* 1982;50(3):491-497.
371. Gay RE, Prince CW, Zuckerman KS, Gay S. The collagenous hemopoietic microenvironment In: Tavassoli M, ed. *Handbook of the hemopoietic micro-environment*. Clifton, NJ: Humana Press, 1989:369-398.
372. Williams DA, Rios M, Stephens C, Patel VP. Fibronectin and VLA-4 in haematopoietic stem cell-microenvironment interactions. *Nature* 1991;352(6334):438-441.
373. Teixido J, Hemler ME, Greenberger JS, Anklesaria P. Role of beta 1 and beta 2 integrins in the adhesion of human CD34hi stem cells to bone marrow stroma. *J Clin Invest* 1992;90(2):358-367.
374. Hynes RO. Integrins: versatility, modulation, and signaling in cell adhesion. *Cell* 1992;69(1):11-25.
375. Lerat H, Lissitzky JC, Singer JW, Keating A, Herve P, Charbord P. Role of stromal cells and macrophages in fibronectin biosynthesis and matrix assembly in human long-term marrow cultures. *Blood* 1993;82(5):1480-1492.
376. Kerst JM, Sanders JB, Slaper-Cortenbach IC, et al. Alpha 4 beta 1 and alpha 5 beta 1 are differentially expressed during myelopoiesis and mediate the adherence of human CD34+ cells to fibronectin in an activation-dependent way. *Blood* 1993;81(2):344-351.
377. Zuckerman KS, Prince CW, Gay S. The hematopoietic extracellular matrix. In: Tavassoli M, ed. *Handbook of the hemopoietic microenvironment*. Clifton, NJ: Humana Press, 1989:399-432.
378. Campbell AD, Long MW, Wicha MS. Haemonectin, a bone marrow adhesion protein specific for cells of granulocyte lineage. *Nature* 1987;329(6141):744-746.
379. White H, Totty N, Panayotou G. Haemonectin, a granulocytic-cell-binding protein, is related to the plasma glycoprotein fetuin. *Eur J Biochem* 1993;213(1):523-528.
380. Klein G, Beck S, Muller CA. Tenascin is a cytoadhesive extracellular matrix component of the human hematopoietic microenvironment. *J Cell Biol* 1993;123(4):1027-1035.
381. Long MW, Dixit VM. Thrombospondin functions as a cytoadhesion molecule for human hematopoietic progenitor cells. *Blood* 1990;75(12):2311-2318.
382. Suchard SJ, Burton MJ, Dixit VM, Boxer LA. Human neutrophil adherence to thrombospondin occurs through a CD11/CD18-independent mechanism. *J Immunol* 1991;146(11):3945-3952.
383. Stomski FC, Gani JS, Bates RC, Burns GF. Adhesion to thrombospondin by human embryonic fibroblasts is mediated by multiple receptors and includes a role for glycoprotein 88 (CD36). *Exp Cell Res* 1992;198(1):85-92.
384. Dixit VM LM. The role of thrombospondin in human hematopoietic progenitor cell cytoadhesion. In: Long MW, Wicha MS, eds. *The hematopoietic microenvironment*. Baltimore, MD: The Johns Hopkins University Press, 1993:206-216.
385. Li WX, Howard RJ, Leung LL. Identification of SVTCG in thrombospondin as the conformation-dependent, high affinity binding site for its receptor, CD36. *J Biol Chem* 1993;268(22):16179-16184.
386. Russell ES. Hereditary anemias of the mouse: a review for geneticists. *Adv Genet* 1979;20:357-459.
387. Chabot B, Stephenson DA, Chapman VM, Besmer P, Bernstein A. The protooncogene c-kit encoding a transmembrane tyrosine kinase receptor maps to the mouse W locus. *Nature* 1988;335(6185):88-89.
388. Geissler EN, Ryan MA, Housman DE. The dominant-white spotting (W) locus of the mouse encodes the c-kit proto-oncogene. *Cell* 1988;55(1):185-192.

389. Copeland NG, Gilbert DJ, Cho BC, et al. Mast cell growth factor maps near the steel locus on mouse chromosome 10 and is deleted in a number of steel alleles. *Cell* 1990;63(1):175-183.
390. Huang E, Nocka K, Beier DR, et al. The hematopoietic growth factor KL is encoded by the Sl locus and is the ligand of the c-kit receptor, the gene product of the W locus. *Cell* 1990;63(1):225-233.
391. Zsebo KM, Williams DA, Geissler EN, et al. Stem cell factor is encoded at the Sl locus of the mouse and is the ligand for the c-kit tyrosine kinase receptor. *Cell* 1990;63(1):213-224.
392. Anderson DM, Lyman SD, Baird A, et al. Molecular cloning of mast cell growth factor, a hematopoietin that is active in both membrane bound and soluble forms. *Cell* 1990;63(1):235-243.
393. Flanagan JG, Chan DC, Leder P. Transmembrane form of the kit ligand growth factor is determined by alternative splicing and is missing in the Sld mutant. *Cell* 1991;64(5):1025-1035.
394. Hannum C, Culpepper J, Campbell D, et al. Ligand for FLT3/FLK2 receptor tyrosine kinase regulates growth of haematopoietic stem cells and is encoded by variant RNAs. *Nature* 1994;368(6472):643-648.
395. McClanahan T, Culpepper J, Campbell D, et al. Biochemical and genetic characterization of multiple splice variants of the Flt3 ligand. *Blood* 1996;88(9):3371-3382.
396. Ladner MB, Martin GA, Noble JA, et al. Human CSF-1: gene structure and alternative splicing of mRNA precursors. *Embo J* 1987;6(9):2693-2698.
397. Uemura N, Ozawa K, Takahashi K, et al. Binding of membrane-anchored macrophage colony-stimulating factor (M-CSF) to its receptor mediates specific adhesion between stromal cells and M-CSF receptor-bearing hematopoietic cells. *Blood* 1993;82(9):2634-2640.
398. Tsuboi I, Revol V, Blanchet JP, Mouchiroud G. Role of the membrane form of human colony-stimulating factor-1 (CSF-1) in proliferation of multipotent hematopoietic FDCP-mix cells expressing human CSF-1 receptor. *Leukemia* 2000;14(8):1460-1466.
399. Yin T, Li L. The stem cell niches in bone. *J Clin Invest* 2006;116(5): 1195-1201.
400. Calvi LM, Adams GB, Weibrecht KW, et al. Osteoblastic cells regulate the haematopoietic stem cell niche. *Nature* 2003;425(6960):841-846.
401. Visnjic D, Kalajzic Z, Rowe DW, Katavic V, Lorenzo J, Aguila HL. Hematopoiesis is severely altered in mice with an induced osteoblast deficiency. *Blood* 2004;103(9):3258-3264.
402. Zhang J, Niu C, Ye L, et al. Identification of the haematopoietic stem cell niche and control of the niche size. *Nature* 2003;425(6960):836-841.
403. Wilson A, Trumpp A. Bone-marrow haematopoietic-stem-cell niches. *Nat Rev Immunol* 2006;6(2):93-106.
404. Zhu J, Garrett R, Jung Y, et al. Osteoblasts support B-lymphocyte commitment and differentiation from hematopoietic stem cells. *Blood* 2007;109(9): 3706-3712.
405. Kiel MJ, Radice GL, Morrison SJ. Lack of evidence that hematopoietic stem cells depend on N-cadherin-mediated adhesion to osteoblasts for their maintenance. *Cell Stem Cell* 2007;1(2):204-217.
406. Omatsu Y, Sugiyama T, Kohara H, et al. The essential functions of adipoosteogenic progenitors as the hematopoietic stem and progenitor cell niche. *Immunity* 2010;33(3):387-399.
407. Hosokawa K, Arai F, Yoshihara H, et al. Cadherin-based adhesion is a potential target for niche manipulation to protect hematopoietic stem cells in adult bone marrow. *Cell Stem Cell* 2010;6(3):194-198.
408. Hosokawa K, Arai F, Yoshihara H, et al. Knockdown of N-cadherin suppresses the long-term engraftment of hematopoietic stem cells. *Blood* 2010;116(4):554-563.
409. Kiel MJ, Acar M, Radice GL, Morrison SJ. Hematopoietic stem cells do not depend on N-cadherin to regulate their maintenance. *Cell Stem Cell* 2009;4(2):170-179.
410. Kopp HG, Avecilla ST, Hooper AT, Rafii S. The bone marrow vascular niche: home of HSC differentiation and mobilization. *Physiology (Bethesda)* 2005;20:349-356.
411. Hooper AT, Butler JM, Nolan DJ, et al. Engraftment and reconstitution of hematopoiesis is dependent on VEGFR2-mediated regeneration of sinusoidal endothelial cells. *Cell Stem Cell* 2009;4(3):263-274.

412. Butler JM, Nolan DJ, Vertes EL, et al. Endothelial cells are essential for the self-renewal and repopulation of Notch-dependent hematopoietic stem cells. *Cell Stem Cell* 2010;6(3):251-264.
413. Ding L, Saunders TL, Enikolopov G, Morrison SJ. Endothelial and perivascular cells maintain haematopoietic stem cells. *Nature* 2012;481(7382): 457-462.
414. Sacchetti B, Funari A, Michienzi S, et al. Self-renewing osteoprogenitors in bone marrow sinusoids can organize a hematopoietic microenvironment. *Cell* 2007;131(2):324-336.
415. Bianco P. Bone and the hematopoietic niche: a tale of two stem cells. *Blood* 2011;117(20):5281-5288.
416. Yamazaki S, Ema H, Karlsson G, et al. Nonmyelinating Schwann cells maintain hematopoietic stem cell hibernation in the bone marrow niche. *Cell* 2011;147(5):1146-1158.
417. Bessis M. Erythroblastic island, functional unity of bone marrow. *Rev Hematol.* 1958;13(1):8-11.
418. Chasis JA, Mohandas N. Erythroblastic islands: niches for erythropoiesis. *Blood* 2008;112(3):470-478.
419. Egawa T, Kawabata K, Kawamoto H, et al. The earliest stages of B cell development require a chemokine stromal cell-derived factor/pre-B cell growth-stimulating factor. *Immunity* 2001;15(2):323-334.
420. Tokoyoda K, Egawa T, Sugiyama T, Choi BI, Nagasawa T. Cellular niches controlling B lymphocyte behavior within bone marrow during development. *Immunity* 2004;20(6):707-718.
421. Sapozhnikov A, Pewzner-Jung Y, Kalchenko V, Krauthgamer R, Shachar I, Jung S. Perivascular clusters of dendritic cells provide critical survival signals to B cells in bone marrow niches. *Nat Immunol* 2008;9(4):388-395.

Section 2 - The Erythrocyte

Chapter 6 The Birth, Life, and Death of Red Blood Cells: Erythropoiesis, The Mature Red Blood Cell, and Cell Destruction

> Table of Contents > Part II - The Normal Hematologic System > Section 2 - The Erythrocyte > Chapter 6 - The Birth, Life, and Death of Red Blood Cells: Erythropoiesis, The Mature Red Blood Cell, and Cell Destruction

Chapter 6

The Birth, Life, and Death of Red Blood Cells: Erythropoiesis, The Mature Red Blood Cell, and Cell Destruction

John G. Quigley

Robert T. Means, Jr.

Bertil Glader

ERYTHROPOIESIS

Concept of the Erythron

“There is, unfortunately, no name for this tissue (or organ), and it will save a good deal of paraphrasing and probably some confusion if we make one and call it erythron.”¹

The entire process by which red cells are produced in the bone marrow is termed erythropoiesis. For descriptive purposes, the process can be divided into various stages, including the commitment of pluripotent stem cell progeny to erythroid differentiation, the erythropoietin (Epo)-independent or early phase of erythropoiesis, and the Epo-dependent or late phase of erythropoiesis. Under normal conditions, erythropoiesis results in a red cell production rate such that the red cell mass in the body remains constant, indicating the presence of regulatory control mechanisms. The control mechanisms regulating the later phases of erythropoiesis are better understood than those regulating the early phases. The hormone Epo is established as the major factor governing red cell production.^{2,3} and ⁴ Erythropoiesis involves a great variety and number of cells at different stages of maturation, from stem cell progeny committed to erythroid differentiation to the mature circulating red cell (Fig. 6.1). The whole mass of these erythroid cells has been termed the erythron,¹ a concept that emphasizes the functional unity of the red cells, their morphologically recognizable marrow precursors, and the

functionally defined progenitors of these precursors. The concept of erythron as a tissue has thus far contributed significantly to the understanding of the physiology and pathology of erythropoiesis.

ERYTHROID CELLS

Committed Erythroid Progenitors

The processes leading from the undifferentiated hematopoietic stem cell to erythroid commitment are discussed in Chapter 5. Erythroblasts in the bone marrow are generated from proliferating and differentiating earlier, more immature erythroid cells termed erythroid progenitors. These progenitor cells are detectable functionally by their ability to form in vitro erythroid colonies.⁵ The development of tissue culture techniques for cloning hematopoietic progenitor cells in semisolid culture media in vitro has led to the recognition and assay in the human and murine bone marrow of at least two erythroid progenitors, the colony-forming unit-erythroid (CFU-E) and the burst-forming unit-erythroid (BFU-E). Under the influence of Epo, these progenitors can grow in semisolid culture media and give rise to colonies of well-hemoglobinized erythroblasts. A two-phase liquid culture system that models human erythroid development has also been described.⁶

Colony-forming Unit-Erythroid

The CFU-E is an erythroid cell closely related to the proerythroblast.⁷ Under the influence of low concentrations of Epo, it gives rise (in 2 to 3 days in murine and in 5 to 8 days in human marrow) to colonies of 8 to 32 well-hemoglobinized cells^{7,8,9} and¹⁰ (Fig. 6.2). The clonal origin of these colonies has been demonstrated by glucose-6-phosphate dehydrogenase-isoenzyme analysis.¹¹ Morphologically, CFU-E purified from progenitor cell cultures appear as immature cells with fine nuclear chromatin; a well-defined, large nucleolus; a high nuclear-cytoplasmic ratio; a perinuclear clear zone; and basophilic cytoplasm with pseudopods.^{12,13} On electron microscopy, this cell appears as a primitive blast with dispersed nuclear chromatin, a prominent nucleolus, and an agranular cytoplasm containing clumps of mitochondria and frequent pinocytotic vesicles.¹² The number of CFU-E in the human marrow ranges from 50 to 400/10⁵ light-density, nonadherent, nucleated cells and varies significantly with the methods used for cell separation and the culture conditions. The majority of CFU-E are in a phase of active DNA synthesis (S phase) as demonstrated by a 70% to 90% killing of cells after short exposure to ³H-thymidine in vitro (³H-thymidine suicide) or after administration of cycle-specific chemotherapeutic agents in vivo.^{14,15} and¹⁶ The size of the CFU-E compartment in intact animals depends on the levels of circulating Epo. Anemia associated with high Epo levels or the administration of Epo leads to expansion of the CFU-E compartment, whereas transfusion-induced polycythemia leads to low Epo levels and a significant reduction of the CFU-E compartment.¹⁶ From a number of in vitro studies, it has been established that the CFU-E is the most Epo-sensitive cell, carrying the highest density of Epo receptors (EpoR) on its surface, and it is also absolutely dependent on Epo for its survival. In the absence of Epo, CFU-E rapidly undergoes programmed cell death (apoptosis)^{12,17,18,19,20} Although the first phase of CFU-E differentiation is Epo-dependent, the later stages are not.²¹

Highly purified CFU-E has been isolated from murine fetal liver cells; this is defined in flow cytometry studies as expressing c-kit, the receptor for the cytokine stem cell factor (SCF), negative for a number of lineage markers (Ter119, B220, Mac-1, CD3, Gr-1, CD32/16, Sca-1, and CD41), and having high cell surface expression of the transferrin receptor (TfR) (CD71) and the heat stable antigen, CD24.¹³

Burst-forming Unit-Erythroid

The BFU-E is an erythroid progenitor that is much more immature than the CFU-E, and more closely related to the multipotent hematopoietic stem cell, as indicated by its cell size, buoyant density, and the relatively low percentage of these cells in active DNA synthesis (0% to 25%).^{15,16,22,23} In contrast to CFU-E, BFU-E also has a (limited) capacity for self-renewal and is detectable in

P.84

the peripheral blood at a concentration of 0.02% to 0.05% of light-density mononuclear blood cells.^{24,25} BFU-E can be separated from CFU-E by its slower velocity sedimentation at unit gravity.²⁶ Morphologically, the BFU-E appears as a very immature blast cell with slightly oval, moderately basophilic cytoplasm with occasional pseudopods, very fine nuclear chromatin, and large nucleoli.^{13,19} On electron microscopy, the cytoplasm contains polyribosomes and is less abundant than in CFU-E, whereas the nucleus contains small amounts of clumped heterochromatin and prominent nucleoli.¹⁹

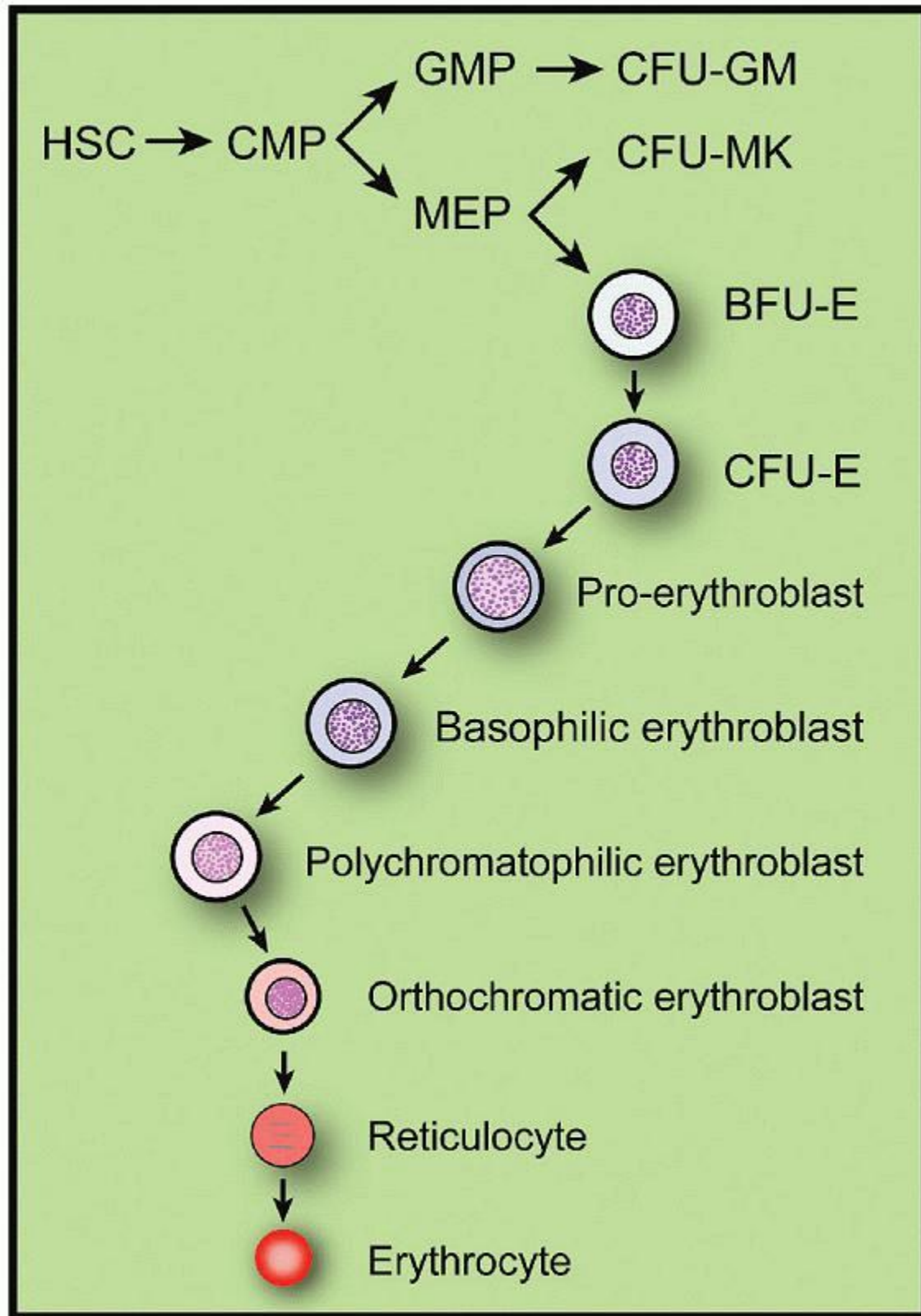

FIGURE 6.1. Schematic representation of the differentiation of erythroid cells from multipotent hematopoietic stem cells. BFU-E, burst-forming unit-erythroid; CFU-E, colony-forming unit-erythroid; CFU-GM, colony-forming unit-granulocyte-monocyte; CFU-MK, colony-forming unit-megakaryocyte; CMP, common myeloid progenitor; GMP, granulocyte-monocyte progenitor; MEP, megakaryocyte/erythroid progenitor.

In the presence of Epo and under the influence of other cytokines that act on early hematopoietic cells, such as interleukin-3 (IL-3), IL-6, granulocyte-macrophage colony-stimulating factor (GM-CSF), thrombopoietin (Tpo), and SCF, the BFU-E progenitor gives rise in 5 to 7 days in mice and in 14 to 16 days in humans to clusters of many erythroid colonies (a large “burst”) containing a total of 500 to more than 30,000 to 40,000 well-hemoglobinized erythroblasts (Fig. 6.3). Cytokines such as transforming growth factor (TGF) β , tumor necrosis factor (TNF) α , and interferon (IFN) γ , on the other hand, suppress progenitor proliferation. The clonal origin of BFU-E-derived erythroblasts has been demonstrated by characterization of the type of hemoglobin produced by cells in single colonies in co-culture experiments of bone marrow cells from a patient with homozygous hemoglobin C and marrow cells from another patient with homozygous hemoglobin S disease.²⁷ The BFU-E can be considered as a progenitor of the CFU-E. Indeed, after 6 to 8 days in culture, cells generated from human BFU-E have all the functional characteristics of CFU-E.¹² The concentration of BFU-E in human bone marrow varies from 10 to 50/10⁵ nucleated cells; however, this number fluctuates widely depending on the cell separation methods and culture conditions. From both in vitro and in vivo experiments, it has been established that the early stages of BFU-E proliferation and differentiation are Epo independent.^{16,19,23} BFU-E can survive in vitro for 48 to 72 hours in the absence of Epo, but it is absolutely dependent on IL-3 for survival.¹⁹ Only 20% of blood BFU-E expresses a very low density of EpoR detectable by autoradiography.¹⁹ The size of the BFU-E compartment in the marrow of animals remains unaffected by the acute changes in the levels of circulating Epo induced by anemia or transfusional polycythemia.¹⁶ Anemia can induce an increase in the cycling of BFU-E without affecting their numbers,²⁸ and in vitro Epo can induce BFU-E into DNA synthesis.²⁹ In humans, chronic administration of Epo is associated with an increase in the concentration and cycling status of marrow BFU-E; however, these changes are also seen in granulocytic-monocytic and megakaryocytic CFUs (CFU-GM, CFU-MK), and multilineage progenitors such as CFU-GEMM, indicating that, at the early progenitor cell level, the marrow responds to Epo as an organ in a non-lineage-specific manner.³⁰ All these evidences indicate that the early stages of erythropoiesis at the BFU-E level are Epo independent, and Epo dependence develops at a stage between BFU-E and CFU-E.¹⁹ The distinction between early (BFU-E) and late (CFU-E) erythroid progenitors, although valid, is by itself artificial. There is a variety of cells

P.85

between BFU-E and CFU-E that form a continuum of erythroid progenitors at different stages of differentiation with properties between those of BFU-E and CFU-E. As an example, a subclass of erythroid progenitors termed mature BFU-E has been described in human and murine marrow.^{14,15} These cells share properties of both CFU-E and BFU-E. They have a proliferative potential lower than BFU-E but higher than CFU-E, their cycling status is also intermediate between CFU-E and BFU-E, and they do not exhibit IL-3 dependence, but show relative Epo dependence.^{14,15,18} Thus, the evidence suggests that during erythroid development, early progenitors of high proliferative potential in a relatively low cycling status with absolute dependence on IL-3 and responsiveness to, but not dependence on, Epo differentiate progressively through various stages into later progenitors of low proliferative potential with a high cycling status that are IL-3 independent and totally Epo dependent.

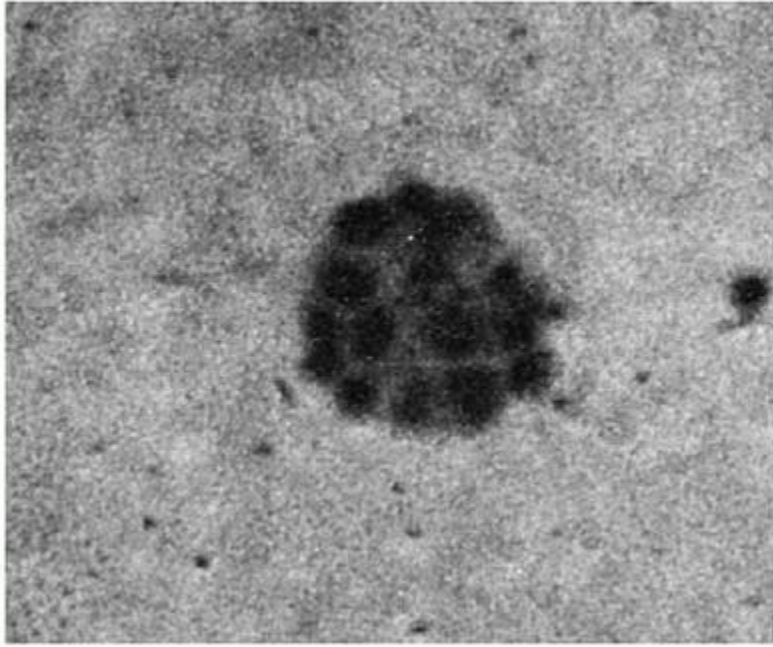

FIGURE 6.2. A day 7 colony-forming unit-erythroid-derived colony of erythroblasts containing 16 cells.



FIGURE 6.3. A day 15 human bone marrow burst-forming unit-erythroid-derived burst (group of colonies) of erythroblasts containing over 1,000 cells.

Increasingly, in place of functional definition of erythroid progenitors, studies, especially in mice but also in humans, allow for prospective identification of progenitors using cell surface markers.^{31,32} As noted above, recent work, for example, using murine fetal liver cells as a source of hematopoietic—at the fetal liver stage predominantly erythroid—cells allows isolation of BFU-E and CFU-E progenitors with 94% and 95% purity, respectively: although both these erythroid progenitors express c-kit, BFU-E is distinguished from CFU-E as it has much lower cell surface expression of CD24 and CD71.¹³

Erythroid Precursors

The least mature recognizable erythrocyte precursor cell is known as the proerythroblast (or pronormoblast). The various stages of maturation, in order of increasing maturity, are proerythroblasts, basophilic erythroblasts, polychromatophilic erythroblasts, and orthochromatic erythroblasts. The morphologic characteristics of each stage, as seen with light microscopy after staining with Romanowsky dyes, are widely agreed upon. Cytoplasmic maturation is assessed by the change in staining characteristics, as the deep blue color derived from the high RNA content of immature cells gives way to the red color characteristic of hemoglobin. Nuclear maturation is evaluated by the disappearance of nucleoli and the condensation of chromatin as nuclear activity decreases. In addition, there is a gradual decrease in cell size and EpoR expression and terminally exit from the cell cycle.

Stages of Erythroblastic Differentiation

The proerythroblast is a round or oval cell of moderate to large size (14 to 19 μm diameter; Figs. 6.4A and 6.5A). It possesses a relatively large nucleus, occupying perhaps 80% of the cell, and a rim of basophilic cytoplasm. The nucleus of the youngest cells in this group differs little from that of the myeloblast. Nucleoli are seen and may be prominent. Only small amounts of hemoglobin are present that cannot be detected by Giemsa stain. As compared with that of myeloblasts and lymphoblasts, the cytoplasm is more homogeneous and condensed and may appear granular. A small pale area may be found in the cytoplasm, probably corresponding to the Golgi apparatus.³³ The nuclear chromatin is somewhat coarser than that in myeloblasts or lymphoblasts.

The basophilic erythroblast is similar to the proerythroblast except that nucleoli are no longer visible and the cell is smaller (12 to 17 μm in diameter; Figs. 6.4B and 6.5B). Condensation of chromatin (formation of heterochromatin) begins and, on light microscopy, the chromatin may appear coarse and granular; thus, there is little resemblance to the myeloblast. The nuclear structure may assume a wheel-spoke arrangement. Ribosomes reach their maximum number during this stage, and thus the cytoplasm is deeply basophilic. Cytoplasmic color changes during subsequent stages reflect the increase in acidophilic hemoglobin and the decreasing amount of ribosomal RNA.

The first faint blush of hemoglobin, as indicated by one or more pink areas near the nucleus in dry fixed preparations, introduces the next stage, the polychromatophilic erythroblast (Figs. 6.4C and 6.5C,D). Increasing chromatin condensation is seen and irregular masses of chromatin are formed. Nucleoli are not visible. The nucleus is smaller (7 to 9 μm) as is the cell as a whole (12 to 15 μm).

When the cytoplasm possesses almost its full complement of hemoglobin, the cell is termed an orthochromatic erythroblast (Figs. 6.4D and 6.5E). It is the smallest of the nucleated erythrocyte precursors (8 to 12 μm in diameter). At this stage, the nucleus undergoes pyknotic degeneration, the chromatin becomes greatly condensed, and the nucleus shrinks. It may assume various bizarre forms such as buds, rosettes, and clover leaves prior to extrusion (Fig. 6.6).

After the nucleus is extruded, the cell is known as a reticulocyte. These cells are larger than mature erythrocytes, perhaps 20% greater in volume.³⁴ They retain certain cytoplasmic organelles, such as ribosomes, mitochondria, and the Golgi complex (Fig. 6.6C,D), and have special staining characteristics. Methyl alcohol or similar fixative agents used in staining cause precipitation of the ribosomal RNA. Such cells may thus appear uniformly blue or gray (diffuse basophilia), or basophilic shades may be intermingled with pink-staining areas (polychromatophilia or polychromasia). Certain supravital staining techniques (see Chapter 1) cause the ribosomal RNA to precipitate or aggregate into a network of strands or clumps termed reticulum; for example, cresyl blue agglutinates the ribosomes. As the reticulocyte matures, the various organelles decrease in number. Usually the mitochondria disappear first and the ribosomes last. "Autophagic vacuoles" (secondary lysosomes) containing degenerated organelles may be seen. The shape of the reticulocyte, as revealed by the scanning electron microscope, differs from that of the mature erythrocyte. Only in the late stages of maturation does the bilaterally indented disc shape of the mature red cell appear.

Flow Cytometric Analysis of Erythroid Precursors

It is now possible to broadly distinguish populations of murine or human erythroid precursors by analyzing patterns of antibodies binding to cell surface antigens. Analyses of murine hematopoietic tissues (bone marrow, spleen,³¹ or fetal

liver³⁵) demonstrate that the TfR (CD71) is expressed at very high levels by the early erythroid precursors, proerythroblasts, and early basophilic erythroblasts (for iron uptake for high-level heme synthesis) and that CD71 expression then decreases with erythroid maturation (and decreasing heme synthesis). On the other hand, Ter-119 (an antibody that recognizes an antigen associated with the predominant mature red cell membrane glycoprotein, glycophorin A) is expressed at intermediate levels in proerythroblasts and subsequently at high levels in more differentiated precursors.³¹ Thus, double immunostaining for these antigens (while excluding anucleate red cells) results in four cell populations, CD71^{high}Ter119^{med}, CD71^{high}Ter119^{high}, CD71^{med}Ter119^{high}, and CD71^{low}Ter119^{high} corresponding broadly to proerythroblasts, basophilic, polychromatophilic, and orthochromatic erythroblasts, respectively. Similar immunostaining has also been examined during differentiation of human erythroid precursors; however, TfR expression appears to be more variable. Recent studies of human proerythroblast maturation indicate that the combination of CD36 (a high-affinity scavenger receptor³⁶) and CD71 expression can be reliably used to discern basophilic, polychromatophilic, and orthochromatic erythroblasts by flow cytometry.³⁷

P.86

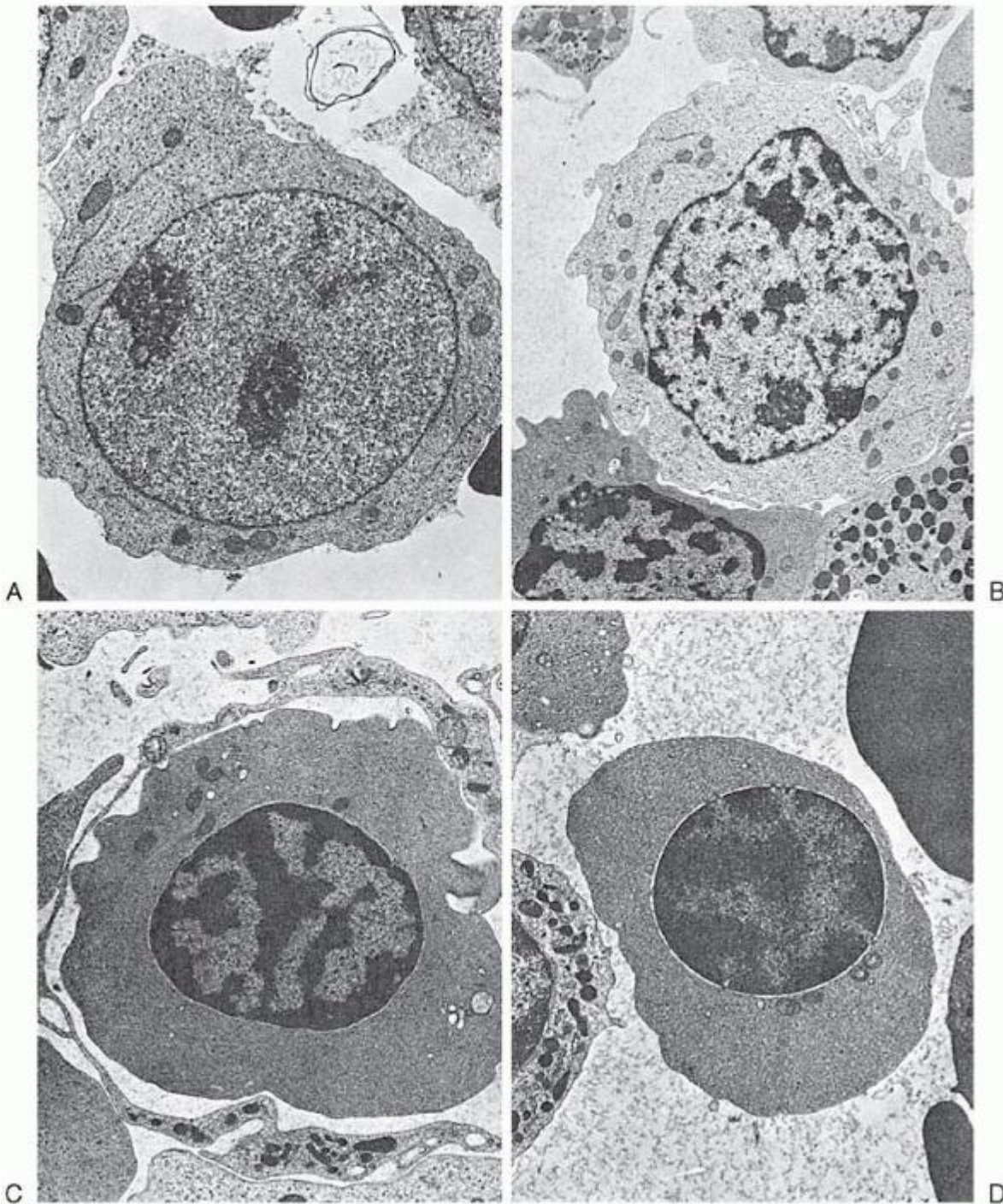

FIGURE 6.4. Maturation of erythroblasts as seen with transmission electron microscopy. Proerythroblast (A), basophilic erythroblast (B), polychromatophilic erythroblast (C), and orthochromatic erythroblast (D). (Courtesy of Dr. Carl Kjeldsberg.)

Proliferation and Maturation of the Erythron

Within the erythron, cellular maturation and proliferation proceed simultaneously. Although BFU-E progenitors have limited self-renewal capacity, CFU-E and the erythrocyte precursors are functionally destined to mature; thus, they are incapable of self-maintenance. In response to acute demands, such as hemorrhage and hemolysis, maintenance of the erythron occurs primarily through the action of Epo promoting both progenitor proliferation (in part through increasing the CFU-E pool by reducing apoptosis¹⁹) and accelerating terminal maturation. As discussed, a majority of CFU-E progenitors, however, are already in cycle and can undergo at most three to five divisions with maximal Epo stimulation,

thus limiting the erythron response. With greater or more chronic demands there appears to be an increase in BFU-E self-renewal divisions to further increase the size of the CFU-E pool.³⁸ Obviously even greater requirements, for example, during recovery from bone marrow irradiation, necessitate input from the stem cell compartment (see Chapter 5). When severe anemia is present from birth, for example, in patients with thalassemia major, a congenital hemolytic anemia (Chapter 38), there is, in addition to maximal expansion of the various erythroid progenitor and precursor compartments, expansion of the sites of erythropoiesis from the axial bones (vertebra, pelvis, clavicles, ribs, and sternum) to other sites, potentially including the femurs, humeri, skull, spleen, liver, and even thymus.

A scheme of the proliferation of the erythron and its various stages of development is presented in Figure 6.1. It takes approximately 12 to 15 days for a cell at the BFU-E stage to mature into erythroblasts. Within 6 to 8 days, a BFU-E proliferates and differentiates into a CFU-E, which needs another 5 to 7 days to proliferate and develop into basophilic erythroblasts: a period during which the CFU-E undergoes three to five successive divisions. Probably, three to five cell divisions also occur during the maturation of erythroid precursors.³⁹ Thus, 8 to 32 mature red cells are derived from each proerythroblast. Cell division ceases at the stage of polychromatophilic erythroblasts. Orthochromatic erythroblasts cannot synthesize DNA and, therefore, cannot divide. Two events may decrease the theoretic yield of cells. One of these is the death of erythrocytes before or shortly after release from the marrow (ineffective erythropoiesis) (Chapter 22). The second is a skipped cell division, a phenomenon that may occur with increased Epo stimulation and that results in a large hemoglobin-poor cell (Chapter 22). These events occur only to a limited extent in normal subjects but occur much more frequently under pathologic circumstances.

P.87

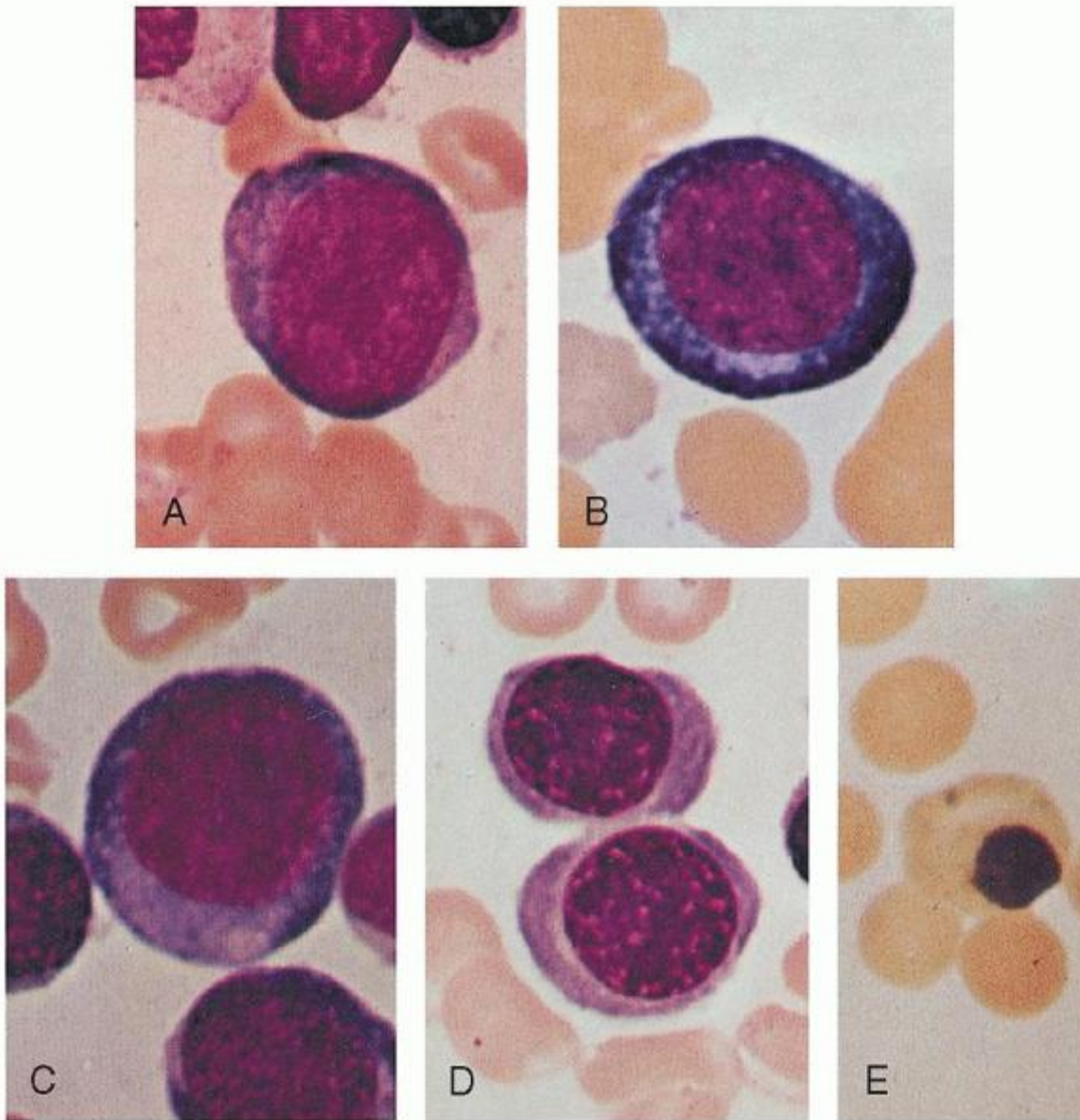

FIGURE 6.5. Erythroblasts. Proerythroblast (A); basophilic erythroblast (B); early (C) and late (D) polychromatophilic erythroblasts; orthochromatophilic erythroblast with stippling (E). Magnification $\times 1,000$; Wright stain.

The biochemical events that occur in stem cell progeny during commitment to erythroid differentiation are incompletely understood. The same holds true for the committed early erythroid progenitor BFU-E. This cell is IL-3 dependent and expresses only small numbers of EpoR.¹⁹ Within 72 hours in culture, these cells become fully dependent on Epo ("mature" BFU-E) and, in its presence, proliferate and differentiate into CFU-E progenitors.^{12,19} With Epo stimulation there is selective up-regulation of transcription factors, including GATA1,⁴⁰ KLF1 (previously called EKLF⁴¹), and NFE2.⁴² GATA1 interacts with SCL/Tal1 (with LMO2, LDB1, and E2A), or with KLF1 and others in multiprotein complexes that associate with and activate (or, for example, with FOG1 and Gfi-1b and repress) erythroid genes.^{38,43,44,45}

At this (CFU-E) stage, a number of differentiation events can be detected. From studies in murine erythroid cells, it has been established that Epo induces an increase in mRNA synthesis and that this is closely followed by the induction of murine globin gene transcription.⁴⁶ Other biochemical events associated with terminal erythroid differentiation include increased uptake of calcium and glucose, synthesis of TfRs, increased iron uptake, hemoglobin synthesis, and the appearance of erythrocyte membrane proteins (e.g., bands 3 and 4.1).^{47,48,49} and ⁵⁰ It appears that there is a GATA1-dependent phase of differentiation, controlling EpoR, antiapoptotic genes, and alpha (α -) globin gene expression that is succeeded by a KLF1-dependent phase.^{44,51} KLF1 appears to regulate the expression of genes essential for many key

aspects of terminal erythroid differentiation including those encoding for major cytoskeletal and cell membrane proteins (ankyrin, band 3, band 4.1, dematin, and glycophorins A and C), iron transport proteins (TfR at the cell membrane and mitoferrin-1 [Mfrn1] in mitochondria⁵²), heme synthesis enzymes, α - and beta (β)-globin chains, and α -hemoglobin stabilizing protein (AHSP, which stabilizes α -globin chains and increases their affinity for β -globin chains^{41,51,53}). Hemoglobin synthesis continues as the cell matures into a basophilic erythroblast, and, at the polychromatophilic erythroblast stage, enough hemoglobin has accumulated in the cytoplasm to give the cell the mild acidophilic reaction that is detected by Romanowsky stains. Hemoglobin synthesis continues through the orthochromatic stage and persists at a very low rate in the reticulocyte after enucleation. Mature red cells, being devoid of ribosomes, are unable to synthesize hemoglobin.

As previously noted, morphologic evidence of decreasing erythroid precursor nuclear activity (heterochromatin formation) can be seen as early as the basophilic erythroblast stage. By the orthochromatic stage, the nucleus is completely inactive, unable to synthesize either DNA or RNA. The factors leading to cessation of nuclear activity are not fully understood, but it has been suggested that it is related to the intracellular hemoglobin concentration.⁵⁴ Hemoglobin is found within the nucleus, possibly gaining entrance through pores in the nuclear membrane.^{54,55} and ⁵⁶ After reaching a critical concentration,⁵⁴ nuclear hemoglobin may react with nucleohistones, thereby bringing about chromosomal inactivation and nuclear condensation. According to this hypothesis, the number of cell divisions and the ultimate erythrocyte size are related to the rate of hemoglobin synthesis. For example, microcytic cells are produced in iron deficiency because it takes longer to reach the critical hemoglobin concentration and the generation time is unaffected; hence, more cell divisions occur before nuclear inactivation, and the resulting cell is small. In contrast, the macrocytes observed when erythropoiesis is stimulated may be the end results of an Epo-induced acceleration of hemoglobin synthesis, which in turn leads to an earlier onset of nuclear degeneration and a reduced number of cell divisions. Consistent with this hypothesis is the observation that the mean corpuscular hemoglobin concentration is relatively constant in a variety of mammalian species, even though erythrocyte size varies greatly.⁵⁷ Recent studies indicate that deacetylation of nucleohistones is critical for formation of heterochromatin and nuclear condensation, and inhibition of deacetylation (by, e.g., HDAC inhibition or ectopic expression of the histone acetyl transferase Gcn5) impedes chromatin condensation and enucleation during terminal erythroid differentiation.⁵⁸

After the nucleus degenerates, it is extruded from the cell.⁵⁹ This process, as observed in living erythroblasts by phase contrast microscopy,⁶⁰ is completed in 5 to 60 minutes. During the extrusion process, mitochondria and cytoplasmic vesicles accumulate near the nuclear border.^{33,61} The role of these structures in nuclear extrusion is not entirely clear, but supravital staining with Janus green B, a mitochondrial toxin, inhibits enucleation.⁵⁹ The extruded nucleus carries with it a rim of cytoplasm, including ribosomes, hemoglobin, and occasional mitochondria.

Enucleation is a process similar to cytokinesis during asymmetric cell division and does not seem to depend on either the presence of extracellular matrix proteins or accessory cells.⁶² However, the rate of enucleation of murine erythroleukemia (MEL) cells is increased when cultured in fibronectin-coated tissue culture dishes.⁶³ Among the various cytoskeletal proteins, filamentous actin plays an important role in the process of enucleation, accumulating between the extruding nucleus and the incipient reticulocyte ("cortical actin ring"). Supporting the major role of filamentous actin in the process of enucleation is the fact that low concentrations of cytochalasin D cause complete inhibition of enucleation.⁶² A Rac GTPase that activates mDia2, a formin involved in nucleation of actin filaments, is absolutely required for formation of the actin ring and enucleation.⁶⁴ Colchicine, which disrupts microtubule formation also impairs enucleation.⁶⁵ Interestingly, none of the major erythroid cytoskeletal proteins are found in the region of the plasma membrane that surrounds the extruded nucleus, suggesting degradation at the site of extrusion. Nurse cells are macrophages at the center of an island of erythroblasts that appear to regulate terminal erythropoiesis, supplying developmental signals and iron (and perhaps heme⁶⁶) to adjacent erythroid cells.⁶⁷ Erythroblast macrophage protein, expressed on erythroblasts and macrophages, appears to be important for the formation of erythroblast islands and erythroblast enucleation.⁶⁸

P.88

However, as with Rac GTPase-deficient cells, EMP-deficient erythroid cells have impaired differentiation which may decrease nuclear condensation and enucleation rates.⁶⁸ The importance of microRNAs (miRNA)—small nonprotein-coding RNAs that each down-regulate multiple genes posttranscriptionally—in erythropoiesis is being increasingly recognized.⁶⁹ Recent studies suggest a role for miR-191 in erythroid enucleation. miR-191 is normally down-regulated with erythroid differentiation; overexpression, however, represses Mxi1 and Rlok3, preventing the physiologic down-regulation of Gcn5 expression, chromatin condensation, and enucleation.³⁸

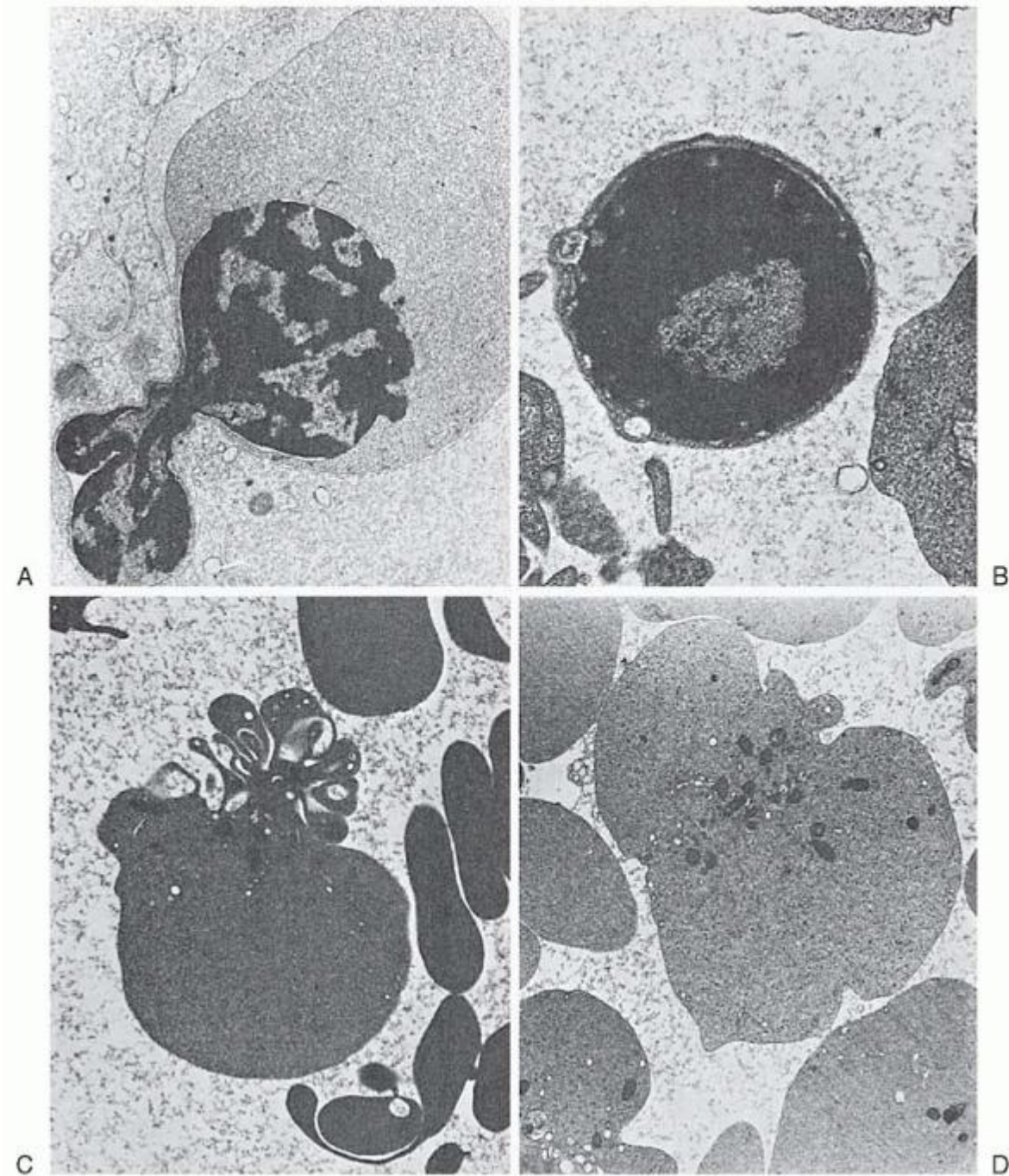

FIGURE 6.6. Formation of reticulocytes. (A) Erythroblast expelling nucleus. (B) Erythroblast nucleus after expulsion, with rim of cytoplasm. (C) Reticulocyte immediately after expulsion of nucleus. (D) Reticulocyte. (Courtesy of Dr. Carl Kjeldsberg.)

Within the marrow, enucleation may sometimes occur as the erythroblast traverses the endothelial cell that forms the sinus wall.⁷⁰ The erythroblast cytoplasm and small organelles (ribosomes and mitochondria) squeeze through endothelial cell cytoplasmic pores 1 to 4 μm in diameter, but the more rigid nucleus cannot conform to this pore size. The nucleus thus becomes caught and “pitted” from the cell. Passage through the endothelial pores is not essential to enucleation, however, because the whole process can be observed *in vitro*.^{60,62} Soon after enucleation, the nucleus is engulfed by an adjacent macrophage. The cell may remain within the marrow as a reticulocyte for several days. After release, the reticulocyte may be sequestered for 1 to 2 days in the spleen.⁷¹ Here, additional maturation may occur, and the composition of the membrane lipids may be altered. As the reticulocyte matures to an adult erythrocyte, it loses its ability to synthesize hemoglobin.⁷² RNA appears to be catabolized by a ribonuclease. The resulting oligonucleotides are probably

further degraded by phosphodiesterases and phosphatases to pyrimidine nucleotides. A specific pyrimidine 5'-nucleotidase found in reticulocytes dephosphorylates these nucleotides, and the free pyrimidine bases can then leak out of the cell.⁷³ If the pyrimidine 5'-nucleotidase is lacking because of hereditary deficiency⁷³ or lead poisoning,⁷⁴ RNA degradation is greatly retarded, and basophilic stippling due to retained RNA aggregates becomes prominent.

BIOSYNTHESIS OF HEMOGLOBIN

As hemoglobin accounts for approximately 90% of the dry weight of the mature red cell, the biosynthesis of hemoglobin is intimately related to erythropoiesis. As detailed in the previous section, many of the morphologic criteria used in staging the maturation of erythrocyte precursors are related to hemoglobin production and content. Furthermore, the initial events associated with the differentiation of CFU-E into erythrocyte precursors include the activation of genes relating to hemoglobin synthesis.⁴⁶

P.89

Three complex metabolic pathways are required for hemoglobin synthesis, corresponding to the three structural components of hemoglobin: protein (globin), protoporphyrin, and iron. The first two of these are discussed in the pages to follow. Iron metabolism is described in Chapter 23.

Globin Synthesis

Globin Genes and the Structure of Chromatin

Distinct structural genetic loci exist for each of the polypeptide chains in hemoglobin (see also Chapter 34). Thus, there are α , β , γ , δ , and ϵ genes. In most human populations, the α genetic locus is duplicated, and there are four (two pairs of) identical α genes in normal subjects.^{75,76} There are also at least two different pairs of γ genes, one ($G\gamma$) coding for a γ -chain with glycine at position 136 and another ($A\gamma$) coding for a γ -chain with alanine at the same position.⁷⁷ In contrast, only single (pairs of) genes code for the β - and δ -chains, respectively.

The α -gene cluster (approximately 30 kb) is located on the short arm of chromosome 16 and also contains the locus encoding for the ζ -chain,⁷⁸ while the β -gene cluster (approximately 50 kb) is located on chromosome 11 and includes the genes for the $G\gamma$ -, $A\gamma$ -, δ -, and ϵ -globins.^{78,79} A schematic representation is shown in Figure 6.7.

The differentiation of erythroid progenitors to erythroblasts is accompanied by the activation of the genes involved in erythroid differentiation, including the globin genes.^{46,80} The active genetic regions of DNA (5% to 10% of the genetic material in erythroblasts⁷⁸) make up the open portion, or euchromatin, of nuclear material, whereas unexpressed genes (the majority of genes in the nucleus) are included in the condensed, or heterochromatin, fraction. Chromatin is described as a nucleoprotein that contains, packages, and provides an instructive scaffold for nuclear DNA.⁸¹ Thus modulation of the expression of genes, including the globin genes may be imposed by the chromatin structure, which includes not only strands of DNA, but also histone and nonhistone proteins.

Transcription, Messenger RNA Processing, and Translation

Globin mRNA, like most eukaryotic mRNAs, is synthesized in a precursor form that is two to three times as long as the molecule that ultimately serves as the template for protein synthesis.^{75,78,80} These precursor molecules, heterogeneous nuclear RNA, undergo "processing" to be converted into the final mRNA.⁸² Posttranscriptional processing includes "capping" at the 5' end of the molecule, polyadenylation at the 3' end, and "splicing," which results in removal of so-called intervening sequences or introns. Abnormal splicing of, for example, β -globin mRNA transcripts is a common cause of thalassemia.

The primary structure of mRNA can be divided into four regions: the 5' untranslated region (which includes the cap), the translated or coding region, the 3' untranslated region, and the polyadenosine region. The "cap" is characterized by an atypical 5'-triphosphate-5' linkage with guanosine-5'-triphosphate (GTP) and methylation of adjacent nucleotides. This structure appears to be essential for maximal translational activity and enhances mRNA stability. The cap is followed by an untranslated region ("5-UTR") of 36 nucleotide bases in α -globin mRNA and 53 bases in β -globin mRNA. The difference may explain the observation that β -mRNA is translated more efficiently than α -mRNA.^{78,80} Normally, this relatively inefficient translation of the α -chain is compensated for by an increased amount of α -mRNA. The translated sequence begins with an initiator sequence of three bases (AUG) followed by a sequence of triplet codons, each of which corresponds to an amino acid in globin, according to the genetic code. The translated sequence ends with a terminator codon (UAA), which is followed by a noncoding area and a terminal polyadenosine region, of variable length, that affects the stability or half-life of the molecule. The number of adenosine residues appears to decrease as mRNA ages⁸³; in older

reticulocytes, mRNA may contain little or no polyadenosine. Globin mRNA is quite stable, with a half-life of up to 48 hours, allowing reticulocytes to continue to produce hemoglobin after enucleation.

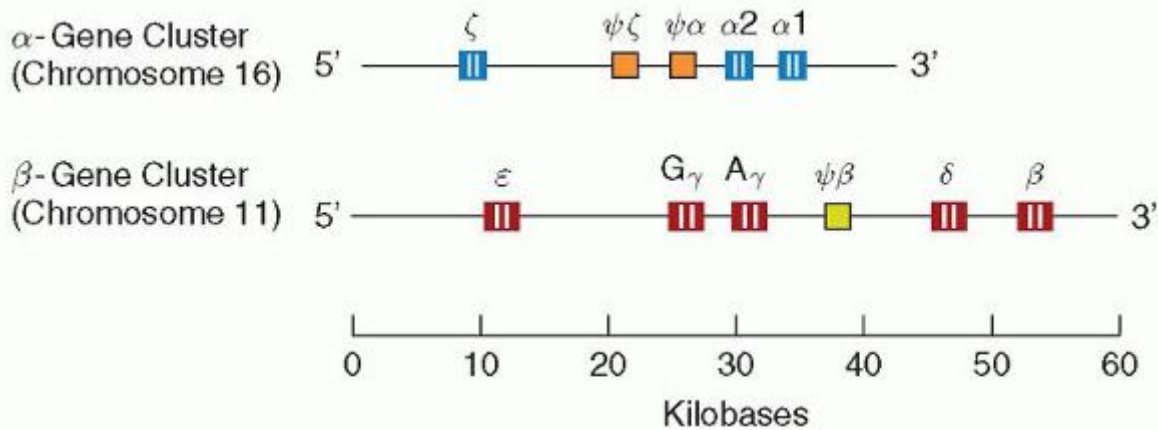

FIGURE 6.7. Organization of the human globin gene clusters on chromosomes 16 and 11. Solid areas within genes represent coding sequences; open areas represent intervening sequences. Each cluster includes pseudogenes ($\Psi\zeta$, $\Psi\alpha$, $\Psi\beta$), which have sequence homology to functional genes but include mutations that prevent their expression.

Regulation of Globin Synthesis

Heme is of particular importance in controlling the rate of globin synthesis.^{84,85} It stimulates globin synthesis in intact reticulocytes and cell-free systems, and, in its absence, polyribosomes disaggregate.^{86,87} and ⁸⁸ The major effect of heme is exerted on the chain-initiation step in translation. In the absence of heme, an inhibitor of globin synthesis accumulates.^{89,90} This inhibitor, heme-regulated eIF2 α kinase (HRI), acts by phosphorylating the α -subunit of an initiation factor, eIF-2 that promotes binding of tRNA^{met} to ribosomes, to shut down protein synthesis.^{91,92} HRI, which has two heme binding sites thus serves as a sensitive intracellular heme “sensor” that closely coordinates heme availability with globin chain production to prevent the accumulation of excessive unfolded globin proteins.⁹³ Studies of the hri knockout mouse verify the importance of this protective mechanism during high-level hemoglobin synthesis. HRI function is especially important in iron (resulting in heme) deficiency: In these circumstances, the continued globin production in hri^{-/-} mice results in cytotoxic globin protein precipitates, causing oxidative stress, and apoptosis of late erythroid precursors.⁹⁴ Interestingly, the red cells of iron deficient hri^{-/-} mice are normocytic/hyperchromic rather than microcytic/hypochromic and have globin chain inclusions. HRI also serves to ameliorate the phenotype of β -thalassemia in mice models, minimizing the production and accumulation of α -globin aggregates, erythroid precursor apoptosis, and ineffective erythropoiesis. Recent work indicates that HRI is activated by oxidative stress (e.g., during erythropoiesis in β -thalassemia).⁹⁵

In addition to its effects on globin translation, heme also exerts positive effects on globin transcription, through nuclear binding to the globin transcriptional repressor Bach1 during erythroid differentiation.⁹⁶

Heme Biosynthetic Pathway

Porphyrins are heterocyclic organic rings composed of four pyrrole subunits that are usually linked by methine bridges; their conjugation to diverse divalent metal ions such as Mg²⁺, Co⁺, and Fe²⁺ gives rise to the “pigments of life,” i.e., chlorophyll, vitamin B12, and heme, respectively. Heme, which is a complex of ferrous iron with the tetrapyrrole protoporphyrin IX, is ubiquitous in aerobic cells and essential for cellular oxidation-reduction reactions. It serves as a critical component of hemoproteins, including cytochromes (for mitochondrial respiratory chain electron transfer and drug metabolism), oxidases (e.g., NADPH oxidase) and peroxidases, and catalases and synthases (e.g., nitric oxide synthase,

P.90

NOS), in addition to the oxygen storage and transport molecules, myoglobin and hemoglobin.^{97,98,99,100,101} and ^{102,103,104,105} and ¹⁰⁶ The four pyrrole rings of protoporphyrin IX are designated A, B, C, and D. At the periphery of the tetrapyrrole are eight sites where side chains are located. In heme, the iron atom is inserted “like a gem”¹⁰⁵ into the center of the tetrapyrrole. Note that heme is the ferrous iron complex of protoporphyrin IX; however, the term heme is also used in the

generic sense in the literature to indicate iron protoporphyrin IX without regard to the oxidation state (valence) of the iron.

Porphyryns, by definition, are cyclicly conjugated tetrapyrroles. As such, they have a number of common properties. They are very stable, essentially flat molecules and the macrocyclic ring itself has little or no affinity for water. All porphyryns are intensely colored and they have an extremely intense absorption band at approximately 400 nm, the so-called Soret band. All porphyryns fluoresce, but fluorescence is characteristically lost when metals are bound to form metalloporphyryns. Exceptions include Mg-porphyryns and Zn-porphyryns, which fluoresce despite their metal content (Chapter 26). Of the known porphyryns, five are of importance in humans: uroporphyrin (two isomers), coproporphyrin (two isomers), and protoporphyrin (one isomer). When porphyryns are fully reduced they are called porphyrynogens. These latter compounds are colorless, do not fluoresce, cannot bind metal ions, and are extremely unstable with regard to oxidation. If uroporphyrinogen or coproporphyrinogen (intermediates in heme biosynthesis) are oxidized to their corresponding porphyryns, they can no longer function as substrates for the heme biosynthetic enzymes and must eventually be excreted in the urine and stool. Uroporphyrinogen and coproporphyrinogen can occur in four isomeric forms. Of these, only two are known to occur naturally in mammalian tissues, namely, the I and III isomer forms. Without exception, all biologically functional tetrapyrroles are derived from uroporphyrinogen III. Uroporphyrinogen I and coproporphyrinogen I are useless by-products of heme synthesis (see Chapter 26). Once formed, most uroporphyrinogen I is enzymatically decarboxylated to coproporphyrinogen I and excreted as the oxidized compound, coproporphyrin I. The difference between the type I and type III isomers is apparent on examination of the D ring. In the type I isomer, the 7 and 8 positions are occupied by acetate and propionate, respectively. In the type III isomer, the order in the D ring is reversed, and propionate and acetate are at positions 7 and 8, respectively. Note that in the case of protoporphyrin IX, the acetate at position 8 has been decarboxylated to form a methyl group (Fig. 6.8).

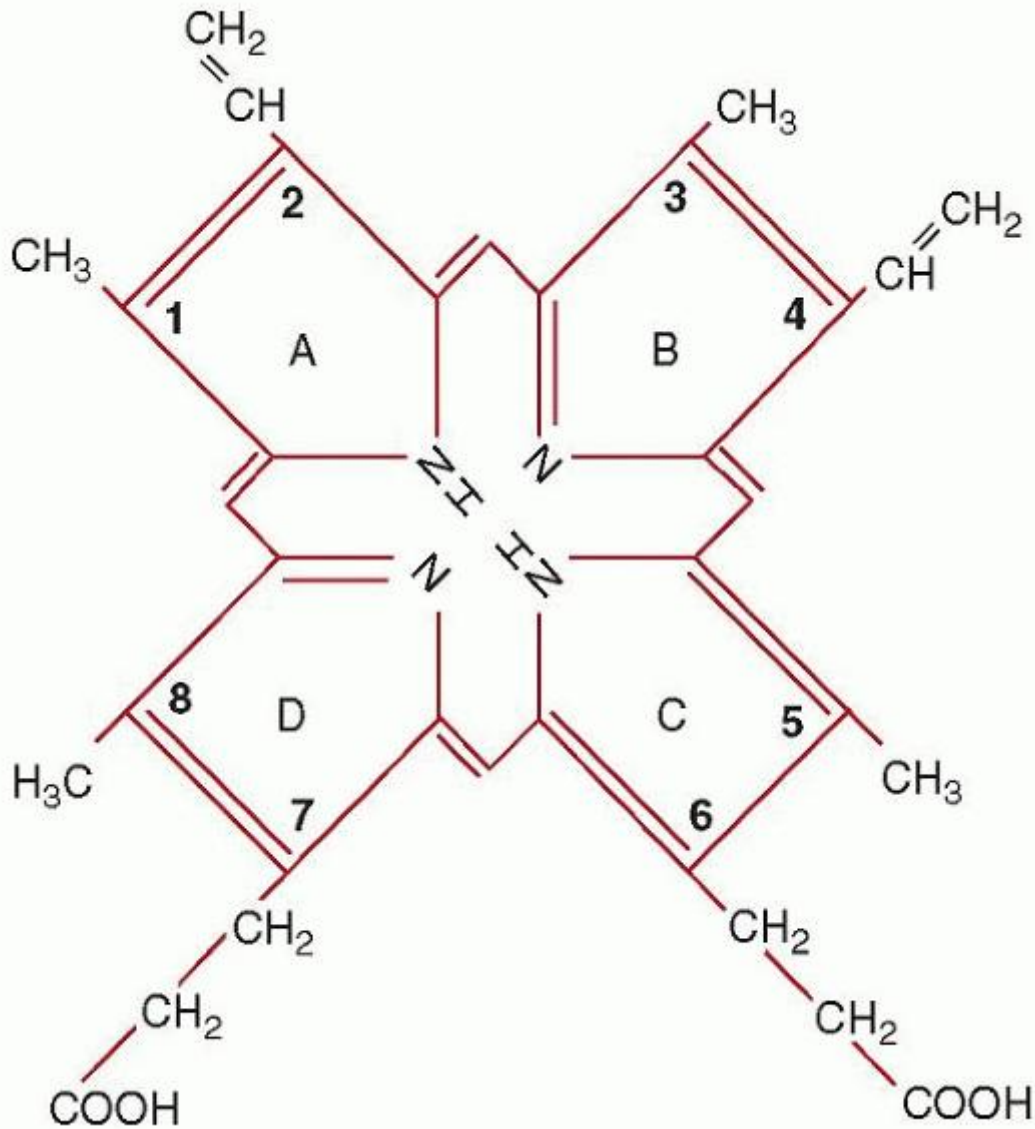

FIGURE 6.8. The chemical structure of protoporphyrin IX.

The first of eight steps in the biosynthesis of heme (Fig. 6.9) is the condensation of glycine and succinyl coenzyme A (CoA) to yield δ -aminolevulinic acid (ALA).^{107,108,109} This reaction occurs in the mitochondrial matrix and is highly exergonic and essentially irreversible. The enzyme catalyzing this reaction (ALA synthase) plays a key regulatory role in the biosynthesis of heme. In the cytosol the reduced cyclic tetrapyrrole coproporphyrinogen III is formed from ALA in a series of four enzymatic reactions. Note that the product of step 2 is the monopyrrole porphobilinogen, the primary building block for all natural tetrapyrroles, including hemes, chlorophylls, and the vitamin B₁₂ derivatives (cobalamins). How the heme synthesis intermediates are transferred from one cytosolic enzyme to the next in the pathway is at present unknown, but a macrocomplex comprising all four cytosolic enzymes, as has also been proposed for the terminal pathway enzymes, may occur.

Coproporphyrinogen III is then transported back by an unknown mechanism across the outer mitochondrial membrane into the mitochondrial intermembranous space for the three subsequent reactions required to form heme. First, propionic acid side chains at positions 2 and 4 are oxidatively decarboxylated by the enzyme coproporphyrinogen oxidase, forming protoporphyrinogen IX which is then oxidized by protoporphyrinogen IX oxidase to protoporphyrin IX. The enzymes protoporphyrin IX oxidase and ferrochelatase (Fech), catalyzing the penultimate and final steps of heme synthesis, are both localized at the mitochondrial inner membrane (protoporphyrinogen IX oxidase is an intermembrane space-facing protein whereas Fech is exposed to the matrix); thus, a channeling of protoporphyrinogen IX and protoporphyrin IX through a enzyme complex formed by protoporphyrinogen IX oxidase and Fech within the inner membrane has been

proposed, based on biochemical studies and the crystal structure of the two enzymes.^{110,111} The final step, the addition of one atom of Fe^{2+} to protoporphyrin IX by Fech, which results in the formation of protoheme or heme b, occurs on the matrix side of the inner membrane, necessitating heme transfer, by as yet unidentified transporters, across both the inner and outer membranes again in order to reach the cytosol.

Biosynthesis of δ -Aminolevulinic Acid

The enzyme responsible for catalyzing the condensation of succinyl CoA and glycine is ALA synthase (ALAS; EC 2.3.1.37). The products of the condensation reaction are ALA, CO_2 , and free CoA. ALAS requires pyridoxal 5'-phosphate as a cofactor in the reaction as first suggested by nutritional studies in pigs.¹¹² There are two forms of the enzyme, one specific for erythroid cells (ALAS2) and the other (ALAS1) present in all other tissues, especially liver. ALAS2 uniquely appears to associate with succinyl CoA synthetase in the mitochondria to promote heme synthesis.¹¹³ The genes encoding for human ALAS have been identified and cloned.¹¹⁴ The erythroid-specific gene is present on chromosome Xp11, whereas ALAS1 is encoded by a gene on chromosome 3p21.^{115,116}

ALAS1 and ALAS2 differ predominantly at their amino terminal ends. The ALAS2 gene has 11 exons and extends over 22 kb. Notably, the mRNA contains a 5' iron-response element (IRE) in exon 1. IRE are short hairpin structures that allow binding by the iron regulatory proteins 1 and 2 (IRP1 and IRP2) according to the cellular iron status, regulating the expression or stability of mRNAs encoding proteins involved in iron uptake, storage, utilization, or export^{117,118} (see Chapter 23). ALAS2 translation begins in exon 2, which encodes the mitochondrial targeting sequence for this nuclear-encoded gene. As also seen with ALAS1 the catalytic domain is encoded by exons 5 to 11. Mutations of ALAS2, especially of exons 5 and 9, are the most common cause of sideroblastic anemias (see Chapter 24). The promoter contains binding sites for GATA1, KLF1, and NF-E2 (although assays suggest the latter may not be functional¹¹⁹). However, regions further P.91

upstream may also be important for erythroid-specific ALAS2 induction.¹²⁰ In addition, analysis of intron 8 indicated the presence of DNase I hypersensitive sites; the intron appears to contain functional binding sites for GATA1 and Sp1.¹²¹ Of relevance, recent studies identifying SLC25A38 as another frequent genetic cause of congenital sideroblastic anemias indicate it also affects either ALA synthesis or transport. Studies of yeast deficient in the yeast ortholog suggest the gene encodes a mitochondrial transporter mediating either ALA export into the cytosol or glycine import into the mitochondrial matrix, as ALA levels were low and the heme synthesis impairment was rescued by glycine or ALA supplementation.¹²²

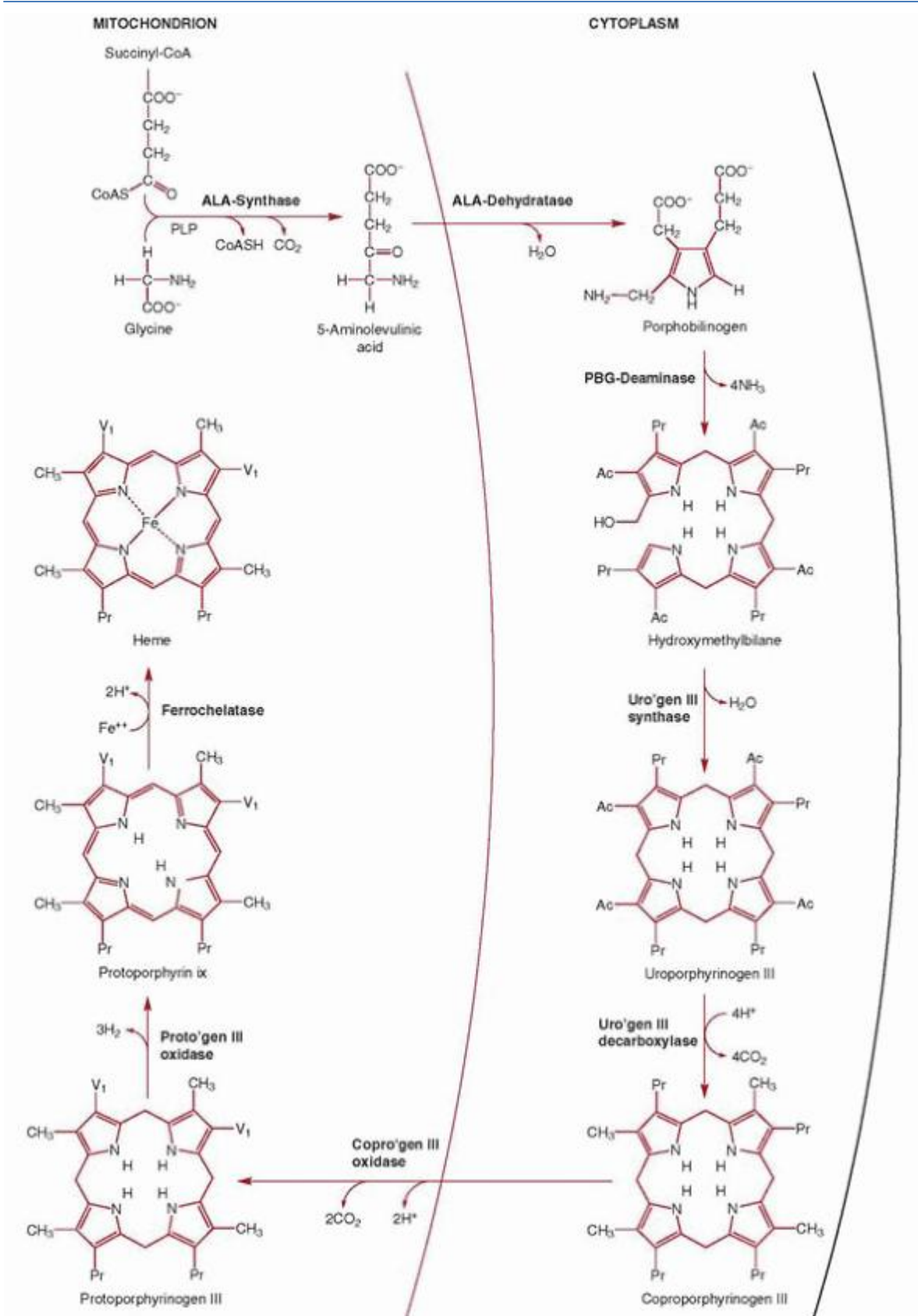

FIGURE 6.9. Heme biosynthetic pathway. Ac, acetate; ALA, δ -aminolevulinic acid; CoA, coenzyme A; CoAS, succinyl-CoA; CoASH, uncombined coenzyme A; COPRO'GEN, coproporphyrinogen; PBG, porphobilinogen; PLP, pyridoxal 5'-phosphate; Pr, propionate; PROTO'GEN, protoporphyrinogen IX (not III); URO'GEN, uroporphyrinogen; Vi, vinyl. (Modified from

Bottomley SS, Eberhard Muller U. Pathophysiology of heme synthesis. *Semin Hematol* 1988;25:282.)

Biosynthesis of Porphobilinogen

The monopyrrole porphobilinogen functions as a precursor of the hemes, chlorophylls, and the cobalamins.¹²³ Because virtually all known forms of life require at least one of these classes

P.92

of tetrapyrroles, it follows that porphobilinogen is biologically ubiquitous. Porphobilinogen is formed by the condensation of two molecules of ALA and the loss of two water molecules. The enzyme that catalyzes this reaction is porphobilinogen synthase or ALA dehydratase (EC 4.2.1.24). ALA dehydratase is a soluble enzyme found in the cytosol⁹⁸ and abundant in tissues such as bone marrow and liver where heme biosynthesis is active. It is also active in mature circulating erythrocytes, even though these cells are not actively synthesizing heme. Its persistence results from the enzyme's inherent stability.

The mammalian enzyme is an octamer of 31 kDa subunits containing zinc atoms required for stability and activity.¹²⁴ The enzyme is inhibited by heavy metals, particularly lead, which displaces the catalytically active zinc ions and thus enzyme activity can serve as an index of environmental pollution by lead.^{125,126} Free sulfhydryl groups (-SH) are also essential for activity,^{127,128} and these -SH groups seem to be protected by the zinc. Three isoforms of ALA dehydratase have been reported and the gene identified (on chromosome 9q34) and cloned.^{129,130} The gene consists of 12 exons, with two promoters generating different transcripts (but encoding the same protein) in erythroid and nonerythroid tissues. The erythroid promoter contains GATA1-binding and CACCC sites.

Biosynthesis of Uroporphyrinogens I and III

Porphobilinogen is a rather unstable, chemically reactive molecule. Within a few hours, a solution of porphobilinogen exposed to air and light develops a deep orange-red color. The color results from the formation of porphobilin, a poorly defined mixture of mono-, di-, and tripyrrolic oxidation products.⁹⁸ This phenomenon can be observed in the urine of patients with acute intermittent porphyria, who excrete large quantities of porphobilinogen (see Chapter 30).

If instead porphobilinogen is incubated in solution at an acid pH then nonenzymic condensation or cyclization occurs, forming the tetrapyrrole macrocycle uroporphyrinogen.⁹⁸ All four possible isomers of uroporphyrinogen are formed under these conditions. The reaction is often referred to as a "head-to-tail" condensation because of the apparent orientation of the precursor molecules. The penultimate reaction product apparently is an open-chain (linear) tetrapyrrole called hydroxymethylbilane (HMB). On loss of the amino group attached to ring A, the $-CH_2^+$ can attack the free α -position on the D-ring pyrrole, thus forming the macrocycle.¹²⁴

In vivo at neutral pH, these reactions are catalyzed by the cytosolic enzyme HMB synthase, formerly known as uroporphyrinogen I synthase or porphobilinogen deaminase (EC 2.5.1.61). In the cytosol HMB synthase works in concert with a second enzyme, uroporphyrinogen III synthase¹³¹ (EC 4.2.1.75), to form uroporphyrinogen III, an asymmetric cyclic tetrapyrrole that serves as the common precursor of all known functional tetrapyrroles. Uroporphyrinogen III synthase is a very fast enzyme, outcompeting the uncatalyzed reaction of HMB that results in uroporphyrinogen I (above). HMB synthase is present in humans in two tissue-specific isoenzymes, an erythroid tissue-specific and a shorter nonerythroid form, both of which are products of a single gene located on chromosome 11q23.^{98,124,132,133} and ¹³⁴

The molecular mechanism by which uroporphyrinogen III synthase effects the "turning around" of the D ring has been studied intensively.^{98,135,136} The molecular mechanism involved in this reaction has been clarified by nuclear magnetic resonance spectroscopy.^{123,135,136} and ¹³⁷ HMB synthase first catalyzes the head-to-tail condensation of four porphobilinogen molecules, yielding the aminomethyl tetrapyrrole. The tetrapyrrole is then deaminated, yielding a macrocycle that has been termed preuroporphyrinogen,¹³⁷ which is released from the surface of HMB synthase and serves as the substrate for uroporphyrinogen III synthase.¹³⁷ This enzyme opens the bond linking the methylene bridge carbon to the D ring, allowing the D ring to rotate 180° about the carbon-nitrogen bond linking rings A and D. A new carbon-carbon bond is formed linking rings C and D (1,3-sigmatropic shift). The carbon-nitrogen bond then opens, and a new carbon-carbon bond is formed linking rings A and D (1,5-sigmatropic shift) and yielding uroporphyrinogen III.¹³⁷

The gene for uroporphyrinogen III synthase, located on 10q25.3, has alternative promoters in nonerythroid tissues (with transcripts starting in exon 1) and erythroid tissues (transcripts begin in exon 2). As there is no translation initiation site in exon 1, however, identical transcripts are generated. The intron between exons 1 and 2 contains multiple putative GATA1 binding sites. Mutations of the uroporphyrinogen III synthase gene are associated with congenital erythropoietic porphyria (Chapter 26).

Biosynthesis of Coproporphyrinogen III

The formation of coproporphyrinogen III is accomplished by the enzymic decarboxylation of the four acetic acid side chains of uroporphyrinogen III,⁹⁹ a reaction catalyzed by the cytosolic enzyme, uroporphyrinogen decarboxylase (EC 4.1.1.37). The decarboxylation proceeds in a clockwise fashion, starting with the acetic acid on the D ring of uroporphyrinogen III and continuing with the successive decarboxylations of the acetic acid residues on rings A, B, and C.¹³⁸ The enzyme exists as a dimer and it was proposed that the two catalytic centers interact functionally, perhaps shuttling reaction intermediates between subunits.¹³⁹ Recent mutational studies, however, indicate that shuttling is unlikely: Dimerization mediates a more active enzyme than the monomer but without any change in the reaction products.¹⁴⁰

The gene, located on chromosome 1p34, consists of 10 exons spread over 3 kb. Mutations of the gene encoding uroporphyrinogen decarboxylase are associated with porphyria cutanea tarda (PCT), the most common human porphyria. The structural consequences of some of these mutations have been described.¹⁴¹ The genetics of the disease are complex, however, with some variants without evidence of gene mutations (sporadic PCT type I; see Chapter 30 for details). A cytosolic competitive inhibitor of the enzyme, porphomethene, has been described in a murine model of PCT as a potential explanation for PCT patients with normal levels of the protein but reduced hepatic enzyme activity.¹⁴²

Biosynthesis of Protoporphyrinogen IX

The formation of protoporphyrinogen IX from coproporphyrinogen III is catalyzed by the enzyme coproporphyrinogen oxidase (EC 1.3.3.3). The exact location of coproporphyrinogen oxidase in the mitochondria is unknown, with studies suggesting it is present in the intermembranous space and/or loosely associated with the inner surface of the outer membrane.^{143,144} It may instead form a macrocomplex with protoporphyrinogen IX oxidase and FeCh to allow funneling of the substrates from the cytosol into the matrix¹¹¹ (reaction products after uroporphyrinogen III being poorly soluble in aqueous solutions). The enzyme, which has a long mitochondrial targeting sequence, functions as a dimer and has an absolute requirement for molecular oxygen.^{143,145,146} and ¹⁴⁷ It sequentially and oxidatively decarboxylates the propionic acid side chains in rings A and B (but not C or D) of coproporphyrinogen III to form vinyl groups.¹⁴⁸ The transporter mediating influx of cytosolic coproporphyrinogen III into the intermembranous space is unknown.

The gene encoding coproporphyrinogen oxidase is located at 3q12, contains seven exons and spans 14 kb. Studies of the murine promoter indicate that SP1, GATA1 binding sites, and a novel transcription factor-binding sequence termed CPRE are important for induction of the enzyme during erythroid

P.93

differentiation of MEL cells.¹⁴⁹ Mutations of the gene are associated with hereditary coproporphyria and, more rarely, with erythropoietic harderoporphyria (see Chapter 30).

Biosynthesis of Protoporphyrin IX

The product of the coproporphyrinogen III oxidase reaction is protoporphyrinogen IX. To serve as a substrate for the final enzyme in the pathway (ferrochelatase), protoporphyrinogen IX must first be oxidized to protoporphyrin IX. Although protoporphyrinogen IX is easily oxidized nonenzymatically to protoporphyrin in vitro (or in the cytosol), an enzyme is required to catalyze this reaction in vivo. A membrane-associated, mitochondrial, oxidizing dimeric enzyme—protoporphyrinogen IX oxidase (EC 1.3.3.4)—has been demonstrated in mammalian cells, including rat liver, human fibroblasts, reticulocytes, and leukocytes.¹⁵⁰ The crystal structure of the tobacco plant mitochondrial enzyme has been described.¹¹¹ The protein lacks a typical mitochondrial targeting leader sequence and is targeted by just 17 residues in the amino terminus.¹⁴⁵ Flavin adenine dinucleotide (FAD) serves as an essential cofactor and molecular oxygen is utilized to terminally accept the electrons.¹⁴⁴

The gene is present on chromosome 1q23.3 and consists of 13 exons extending over 4.2 kb. The promoters of the murine and human genes have been characterized^{151,152}; both contain SP1 and GATA1 binding sites that may be of importance during erythroid differentiation. Mutations of the gene are associated with variegate porphyria (see Chapter 30).

Biosynthesis of Heme

The insertion of ferrous iron into protoporphyrin IX to form heme is catalyzed by the enzyme ferrochelatase within the mitochondrial matrix. Ferrochelatase (EC 4.99.1.1) is the best characterized of the heme biosynthesis enzymes.¹⁵³ The enzyme, which functions as a dimer appears to be tightly bound to or is an integral part of the inner mitochondrial membrane,¹⁵⁴ likely complexed with protoporphyrinogen IX oxidase dimers on the opposite side of the membrane.¹⁴⁴

Insertion of the iron appears to involve distortion of the planar porphyrin by ferrochelatase.¹⁵³ No cofactors are required for activity. Although the *in vivo* substrates are ferrous iron and protoporphyrin, *in vitro*, the enzyme can also catalyze incorporation of several metals (iron, cobalt, and zinc) into several dicarboxylic porphyrins (protoporphyrin, mesoporphyrin, and deuteroporphyrin).⁹⁸

Studies in cell lines demonstrate that ferrochelatase interacts with Mfrn1, a mitochondrial inner membrane importer of iron up-regulated during erythroid differentiation.¹⁵⁵ In elegant studies it has been shown that Mfrn1 is stabilized by an inner membrane ATP-binding cassette (ABC) transporter known as ABC-me or ABCB10,¹⁵⁶ allowing high-efficiency iron uptake into mitochondria for optimal heme synthesis.¹⁵⁷ Further studies show that ferrochelatase, Mfrn1, and ABCB10 are co-induced during MEL cell erythroid differentiation and that Mfrn1 and ABCB10 interact with ferrochelatase.¹⁵⁵ The gene encoding ABCB10 was originally identified in a screen of mouse genes up-regulated by GATA1 and expression is regulated by heme.¹⁵⁶ The potential substrate of the ABCB10 transporter has not been identified, but heme, which needs to be transferred from the matrix across two mitochondrial membranes into the cytosol, is a candidate.

Apart from its use for heme synthesis, mitochondrial iron is also required for mitochondrial Fe-S cluster biogenesis. Fe-S clusters are modular protein co-factors consisting of iron and sulfur, usually linked by bonds joining the cysteine sulfur atoms of a polypeptide (“scaffold”) protein to iron atoms of the cluster. They function, for example, as part of enzyme catalytic centers (e.g., aconitase, succinate dehydrogenase).¹⁵⁸ Ferrochelatase contains a NO-sensitive Fe-S cluster that is attached at the C-terminus.¹⁵³ Although the cluster is not required for catalytic function or as a supply of ferrous iron, the enzyme is sensitive to the availability of Fe-S clusters. For example, when Fe-S cluster synthesis is impaired in MEL cells, due to deficiency of the scaffold proteins or iron required for Fe-S cluster biosynthesis, then apo-Fech is rapidly degraded in mitochondria, indicating a direct link between biosynthesis of Fe-S clusters and heme.¹⁵⁹

The gene encoding ferrochelatase is comprised of 11 exons spread out across 45 kb on chromosome 18q21.3.¹⁶⁰ The promoter region has been examined in detail using *in vitro* and *in vivo* studies.^{161,162} and ¹⁶³ Sp1, NF-E2, and GATA1 elements have been identified in the promoter region and a fragment of the promoter containing these binding sites allows expression in hematopoietic cells derived from transgenic embryonic mouse cells where a single copy of the reporter construct was inserted. *In vivo* erythroid specificity is mediated by NF-E2 elements ~300 bp upstream of the transcriptional start site (-275 bp) along with additional erythroid-specific elements that lie between -375 bp and -1,100 bp upstream from the start site.¹⁶¹ *In vitro* assays in K562 cells, the Kruppel-like transcription factor KLF-13 activates the promoters for porphobilinogen deaminase, δ -aminolevulinic synthase, and ferrochelatase genes.¹⁶⁴ Mutations of the ferrochelatase gene are associated with erythropoietic porphyria (see Chapter 26).

Regulation of the Heme Biosynthetic Pathway

δ -Aminolevulinic Acid Synthase

The regulation of a biosynthetic pathway is generally effected at the first enzymatic reaction synthesizing a precursor compound committed to ultimate incorporation into the final product.¹⁶⁵ Frequently, such reactions are strongly exergonic and essentially irreversible. These generalizations hold true for the heme biosynthetic pathway. Control of the pathway is exerted primarily through the enzyme catalyzing the first committed and rate-limiting step, ALA synthase. However, what is also apparent is that the regulation of the ubiquitous enzyme ALAS1 differs markedly from that of the erythroid-specific enzyme ALAS2.^{105,107}

Nonerythroid ALAS1 Regulation

About 15% of the daily production of heme is generated in the liver by ALAS1 for cytochromes and enzymes. The amount of ALAS1 is regulated by induction and repression of enzyme synthesis¹²⁷ and may increase by a factor as great as 300-fold.¹⁶⁶ The enzyme has a short half-life, allowing a rapid response to changes in the demand for heme and, thus, ALA.¹⁶⁷ The enzyme may be induced by a number of chemicals, drugs, and nonglucocorticoid steroids.¹²⁷ Heme plays a critical central role in ALAS1 regulation, repressing transcription,¹⁶⁸ decreasing the half-life of the mRNA, and, through binding to heme regulatory motifs (HRMs) in the 5' end of the protein, translocation of the enzyme into the mitochondrial matrix.¹⁶⁹ When the amount of intracellular heme is high, ALAS1 synthesis is repressed; when the amount of heme is low, synthesis is induced. Thus, agents that interfere with heme synthesis can induce ALAS1, and agents that induce the synthesis of hemoproteins (e.g., induction of cytochrome p450 enzymes by barbiturates), potentially depleting a putative pool of “free” or “uncommitted” heme, can produce a similar effect.^{170,171} Agents that exert these effects on ALAS1 synthesis induction are clinically important, as they may precipitate acute attacks in patients with acute intermittent porphyria and related disorders of porphyrin metabolism (Chapter 26).

Early studies indicated that ALAS1 synthesis is induced during fasting, which can precipitate porphyria attacks, and that nutritional supplements (e.g., glucose loading) may ameliorate

these acute episodes. Handschin et al. recently demonstrated that this occurs because ALAS1 is induced by the concerted actions of peroxisome proliferator-activated receptor γ coactivator 1 α (PGC-1 α) and the transcription factors FOXO1 and nuclear respiratory factor-1 (NRF-1) on the ALAS1 promoter.¹⁷² PGC-1 α , which co-activates nuclear receptors or transcription factors to regulate mitochondrial biogenesis and oxidative phosphorylation, is induced by low glucose levels or glucagon and repressed by high glucose or insulin.¹⁷³ Presumably ALAS1-mediated heme synthesis is required for de novo respiratory cytochrome synthesis with mitochondrial biogenesis as a response to decreased cellular ATP levels. In contrast, regulation of ALAS2 in erythroid cells is coordinated with heme synthesis, iron assimilation, and globin synthesis.

Erythroid ALAS2 Regulation

With erythroid differentiation there is coordination of cellular iron assimilation, heme, and globin synthesis to safely allow maximal hemoglobin synthesis within a short timespan without the buildup of individual, potentially cytotoxic components (see below). Regulation of erythroid heme involves the induction of the enzymes of the heme biosynthetic pathway and their regulation once induced,^{105,107} regulation of iron uptake and its delivery to ferrochelatase in the mitochondria, and the regulated export of the newly formed heme from the mitochondria to the cytosol to bind to globin chains.

Initial studies suggested that the heme biosynthesis pathway enzymes were sequentially induced with erythroid differentiation (from ALAS2 to ferrochelatase¹⁷⁴); however, subsequent studies in MEL cells¹⁵² and maturing populations of human erythroblasts¹⁷⁵ indicate early up-regulation of ferrochelatase with ALAS2, with synthesis of mRNAs for the terminal three pathway enzymes up-regulated within 12 hours of erythroid induction of MEL cells with dimethylsulfoxide (DMSO). In contrast to the repressive effects of heme on ALAS1 in hepatocytes, in erythroid cells intracellular heme appears to be necessary for induction of the biosynthetic pathway enzymes, perhaps through up-regulation of the erythroid transcription factor NF-E2,¹⁷⁶ and/or inhibition of the transcriptional repressor Bach1.⁹⁶ For example, studies of ALAS2-deficient MEL cells following their “erythroid” induction with DMSO demonstrate a lack of erythroid differentiation (as assessed by a lack of up-regulation of mRNAs for ALA dehydratase, porphobilinogen deaminase, ferrochelatase, and β -globin) that is at least partially reversed by addition of heme to DMSO, in keeping with studies by others of ALAS2-deficient cell lines.¹⁷⁷

As discussed above, unlike ALAS1, there is an IRE in the 5'-UTR of the ALAS2 gene. Therefore depletion of cytosolic iron (believed to exist in a putative labile iron pool) in erythroid precursors should result in binding by IRP1 and IRP2 to the IRE of ALAS2 transcripts, preventing translation. Thus, it is the supply of iron to the erythroid precursor that ultimately controls heme synthesis. To allow maximal heme synthesis—which requires ~20 mg of iron for the 20 g of erythrocytes generated in adult humans every day—iron is delivered to the bone marrow in the form of ferric-transferrin (Fe-Tf) that is rapidly bound by Tfr1 present in large numbers on the cell surface of erythroid precursors (up to 10⁶ receptors per cell¹⁷⁸). In addition, as noted above, the mitochondrial iron importer MFN1 becomes stabilized in a macrocomplex with ferrochelatase and ABCB10 following up-regulation of ABCB10 with erythroid differentiation, thus facilitating the transfer of iron across the mitochondrial inner membrane to ferrochelatase. By necessity, there must also be up-regulation of an unidentified heme transporter to export heme from the mitochondria into the cytosol. As a feedback mechanism “uncommitted” or “free” heme appears to inhibit either Fe-Tf-Tfr endocytosis or iron release from Tf to prevent unnecessary iron uptake.^{105,179} Like ALAS1, ALAS2 also has HRMs located in the 5' end of the preALAS2 protein and, in vitro, micromolar quantities of heme inhibit translocation of ALAS2 into isolated mitochondria; however, whether excess uncommitted heme also impedes ALAS2 translocation in erythroid precursors is unknown.¹⁶⁹

ALAS2 and ferritin transcripts both contain an IRE in their 5'-UTR and their translation is thus susceptible to low cytosolic iron levels; on the other hand, Tfr1 contains five IRE modules in its long 3'-UTR and the mRNA should be stabilized (predominantly by IRP2¹⁸⁰) under the same conditions. However, the standard posttranscriptional regulatory model involving cytosolic iron levels controlling iron transport, utilization, and storage via the IRE/IRP system (see Chapter 23) appears to become uncoupled in differentiating erythroid cells: Here ALAS2 is translated yet ferritin translation blocked, whereas high expression of Tfr1 persists despite high Fe-Tf delivery. Recent analyses of mass cultures of erythroid progenitors indicate that, with differentiation, these cells behave as if a “low cytosolic iron level” condition exists.¹⁸¹ This is in keeping with the “kiss and run” hypothesis of iron delivery proposed by Ponka and co-workers,¹⁸² whereby iron released from Fe-Tf-Tfr complexes in the endosome bypasses the cytosol to be delivered to the mitochondria by direct contact between these two organelles. An alternative theory is that MFN1 functions as a highly efficient mitochondrial iron importer driving cytosolic iron transfer across inner mitochondrial membranes for heme or Fe/S synthesis. In addition, it is suggested that the presence of large numbers of ALAS2 transcripts may overwhelm the IRE/IRP system.¹⁸¹

Critical Balance between Iron Assimilation, Heme, and Globin Synthesis

In closing this section, note should be made of a number of recently described mechanisms to protect erythroid precursors from the results of any imbalance among iron assimilation, heme, and globin synthesis. Although each component is essential for hemoglobin synthesis, individually they are all potentially cytotoxic and it is therefore crucial that the α - and β -globin chains and heme are produced in the 2:2:4 ratio necessary to form the stable complex of $\alpha_2\beta_2$ and 4 heme molecules that comprise hemoglobin A. The toxicity of free iron is well known, related to its intrinsic ability to generate highly reactive hydroxyl radicals from hydrogen peroxide in the Fenton reaction, whereas “free” or uncommitted heme is lipophilic and toxic to cells, promoting lipid peroxidation and ROS production, resulting in membrane injury and ultimately cell apoptosis.^{106,183,184} The cytotoxicity derived from an imbalance in the production of α -globin and β -globin chains is best illustrated by the pathophysiology of β -thalassemia (Chapter 34), where the relative excess in α -globin production and the resultant precipitation of these globin chains triggers oxidative stress and cytotoxicity (first described in the 1960s^{185,186}).

These protective systems include the following.

(i) The heme-regulated inhibitor of translation, HRI

As mentioned, HRI, a heme-regulated protein kinase that phosphorylates and inhibits eIF2 α and thus general protein translation, serves as a sensor of intracellular heme and is important for coordinating heme and globin production. Studies of the hri knockout mouse verify the importance of this protective mechanism during high-level hemoglobin synthesis. HRI function appears to be especially important in iron (resulting in heme) deficiency: In these circumstances, the cessation of globin production seen in control mice presumably does not occur in hri^{-/-} mice, resulting in the observed cytotoxic globin protein precipitates, ROS production and oxidative stress, and apoptosis of late erythroid precursors.⁹⁴ Interestingly, the red cells of iron-deficient hri^{-/-} mice are normocytic/hyperchromic (rather than

P.95

microcytic/hypochromic, as observed in the iron-deficient control mice), have globin chain inclusions, and a more severe anemia. Similarly, mice with combined HRI and severe ferrochelatase deficiency (Fech^{m1Pas/m1Pas} mice, another model of heme deficiency) have more severe anemia and globin chain inclusions than control Fech^{m1Pas/m1Pas} mice. Notably, these mice have a 30-fold increase in red cell protoporphyrin IX compared with Fe^{chm1Pas/m1Pas} mice, emphasizing that HRI-mediated regulation of erythroid precursor protein synthesis also affects heme enzyme biosynthesis and the severity of the porphyria.¹⁷²

HRI also ameliorates the phenotype of β -thalassemia in mice models, minimizing the imbalance in production between α - and β -globins, the accumulation of α -globin aggregates, apoptosis of erythroid precursors, and the resultant ineffective erythropoiesis. Recent work indicates that HRI is also activated by oxidative stress (e.g., during stress erythropoiesis or erythropoiesis in β -thalassemia).⁹⁵ HRI, by activating the transcription factor ATF4, induces an antioxidant stress response that seems to be important for erythroid differentiation.

(ii) The feline leukemia virus subgroup C receptor, FLVCR

FLVCR1 is the human ortholog of the feline cell surface receptor for feline leukemia virus subgroup C (FeLV-C). The virus infects all feline hematopoietic cells, impairing feline FLVCR1 function due to binding of the receptor by viral envelope that is continuously synthesized within infected cells. Cats infected with FeLV-C develop a red cell aplasia characterized by a block in erythroid differentiation at the CFU-E/proerythroblast stage. The impairment in differentiation is also observed upon conditional deletion of flvcr1 in neonatal mice,¹⁸⁷ who develop a severe anemia within 5 weeks of deletion¹⁸⁷ that may be due to erythroid cell apoptosis.¹⁸⁸ FLVCR1 functions as a mammalian cell-surface heme exporter that thus appears to protect differentiating erythroid progenitors from potential heme excesses and subsequent cytotoxicity resulting from any imbalances between heme and globin synthesis.^{104,188} As noted, heme synthesis by erythroid ALAS2 is not subject to transcriptional repression by heme and catabolism by heme oxygenases does not normally occur during differentiation of human erythroid progenitors¹⁸⁹ or murine erythroid cell lines.¹⁹⁰ It is hypothesized that heme oxygenase is not induced in order to prevent futile cycles of simultaneous erythroid heme synthesis and catabolism.^{188,189} The severity of the anemia in feline and murine models of FLVCR knockdown suggests that excess heme synthesis occurs frequently at the CFU-E/proerythroblast stage (likely prior to initiation of high-level globin synthesis) or that FLVCR has yet another cell function. A recent study suggests another FLVCR isoform functions to export heme from its site of synthesis in the mitochondria into the cytosol.^{190a} Of interest, knockdown of murine flvcr1 is embryonic lethal with the embryos displaying a phenotype similar to that of patients with Diamond-Blackfan anemia (DBA), a congenital red cell aplasia.¹⁹¹ The most common genetic

cause of DBA is haplo-insufficiency of large or small ribosomal protein subunits, impairing erythroid protein (i.e., predominantly globin) synthesis, suggesting DBA is caused by an imbalance of heme and globin synthesis.¹⁹²

(iii) The α -hemoglobin stabilizing protein, AHSP

The gene encoding this small protein (102 aa) is strongly induced by GATA-1 during erythroid differentiation. AHSP primarily binds α Hb (i.e., the holoprotein, α -globin-heme), stabilizing it and inhibiting its pro-oxidant properties.⁵³ It functions as a chaperone, helping newly synthesized apo α -globin chains to fold and promoting the refolding of denatured chains, which may be particularly important in heme deficiency.¹⁹³ Studies have shown that AHSP forms a heterodimer with α Hb and when β Hb is added to these complexes, the AHSP is displaced and tetrameric HbA ($\alpha_2\beta_2$) forms, suggesting that AHSP stabilizes α Hb and then passes it to β Hb to help form HbA in vivo. Deletion of the gene in mice¹⁹⁴ results in a mild hemolytic anemia with the red cells containing Heinz bodies (eosinophilic inclusions derived from denatured hemoglobin), indicating perhaps that AHSP function is critical only when there is a large imbalance in synthesis between α Hb and β Hb, such as occurs in β -thalassemia. In subsequent studies, interbreeding of AHSP^{-/-} mice with β -thalassemic mice (like the Hri knockout above) was indeed shown to worsen the β -thalassemic phenotype.¹⁹⁵

Lastly, “protein quality control mechanisms” has been proposed as a name for a number of cellular posttranslational mechanisms that serve to stabilize and aid folding of newly forming proteins (e.g., chaperones such as AHSP), or recognize misfolded proteins or protein aggregates and target them for degradation by the ubiquitin proteasome system or autophagy.¹⁹⁶ These protein quality control mechanisms appear to be particularly important in erythroid precursors during high-level hemoglobin synthesis, and when these systems are overwhelmed—for example, in severe thalassemias—accumulation of unstable insoluble proteins and cytotoxicity occurs.¹⁹⁷

CONTROL OF ERYTHROPOIESIS

It is evident that a well-balanced mechanism exists that maintains the erythron within “normal” limits and mediates the response to a variety of normal and abnormal situations. In broad outlines, this control system operates in the following manner. Alterations in the concentration of hemoglobin in the blood lead to changes in tissue oxygen tension within the kidney. In response to hypoxia, the kidney secretes a hormone called Epo. This hormone induces differentiation of erythroid progenitor cells, expansion of the erythroid marrow, and increased red cell production. This, in turn, leads to an increase in the size of the erythron and an increase in tissue oxygen levels. The major steps in this process are discussed in greater detail in the sections that follow.

Tissue Oxygen

Tissue oxygen tension depends on the relative rates of oxygen supply and demand. Oxygen supply is a complex function of interacting but semi-independent variables, including (a) blood flow, (b) blood hemoglobin concentration, (c) hemoglobin oxygen saturation, and (d) hemoglobin oxygen affinity. Each of these functions may be altered to compensate for a deficiency in one of the others. For example, in severe anemia, cardiac output and respiratory rate may increase, and hemoglobin oxygen affinity may be reduced through the 2,3-biphosphoglycerate effect. Conversely, in respiratory insufficiency, secondary polycythemia occurs.

Despite cardiovascular and respiratory adjustments, tissue oxygen tension decreases roughly in proportion to the degree of anemia. Conversely, induced polycythemia of moderate degree leads to normal or increased tissue oxygen tension and an increased tolerance to hypoxia. These changes occur despite the increase in blood viscosity that accompanies polycythemia, suggesting that peripheral vascular resistance decreases to compensate for increased viscosity. However, with advanced degrees of polycythemia, the increase in viscosity may be great enough to negate the advantages of increased oxygen-carrying capacity.

Tissue hypoxia is the fundamental stimulus to erythropoiesis, as first suggested by Miescher in 1893. This concept has been amply confirmed.² However, hypoxia does not exert its effects by a direct action on the marrow, as Miescher believed, but instead induces a hormone, Epo. The nature of the tissue oxygen receptors (or oxygen sensor) has only recently been understood. These sensors are located within the kidney and Epo production can be induced by renal artery constriction or by hypoxic perfusion of the isolated kidney.

P.96

Erythropoietin

Structure of Erythropoietin

Epo is a glycoprotein hormone produced by the kidney, which functions as the major humoral regulator of red cell production. The hormone was originally purified from the urine of patients with aplastic anemia.¹⁹⁸ It has an MW of 34 kDa as determined electrophoretically and contains 30% carbohydrate (11% sialic acid, 11% total hexose, and 8% N-acetylglucosamine).¹⁹⁹ The potency of Epo is expressed in units, with one unit defined as the amount of Epo present in one tenth of the International Reference Preparation.²⁰⁰ This unit was originally defined in starved rats as the amount of Epo that produced the same erythropoietic response (increase in serum Epo level) as treatment with 5 μmol of cobalt.² The potency of purified human urinary Epo has been determined to be 70,400 U/mg of protein.¹⁹⁸

The Epo gene has been isolated and cloned²⁰¹; the genomic locus extends over 5.4 kb on chromosome 7q22²⁰² and contains four introns and five exons, encoding a 193-amino acid polypeptide. The protein includes a 27-amino acid signal peptide, which is cleared during Epo secretion, and a 166-amino acid peptide with an MW of 18.4 kDa.⁴⁶ The C-terminal arginine is absent from the recombinant and native proteins, presumably because of posttranslational modification by a carboxypeptidase.²⁰³ Human Epo contains four cysteine residues linked by disulfide bonds, which, when reduced or alkylated, lead to significant loss of activity.^{199,204}

Recombinant Epo (rEpo), as synthesized by mammalian cells such as a Chinese hamster ovary cell line, is highly glycosylated, and the carbohydrate structure of the recombinant hormone is similar to but distinct from the glycosylation pattern of native Epo in kidney cells.²⁰³ Glycosylation is absolutely necessary for *in vivo* activity of Epo, with the bulk of glycosylation occurring at a single site of N-linked carbohydrate. Asialated Epo and nonglycosylated rEpo produced in bacteria have no activity *in vivo*, which is at least partially attributed to rapid clearance of the hormone by the liver via hepatocyte galactose receptors.^{205,206}

Recognition of the importance of glycosylation of Epo to its *in vivo* activity and half-life led to modifications of the Epo gene/protein to make a more effective pharmaceutical. For example, the gene has been modified by adding a second site of N-linked glycosylation, such that when the gene is expressed in Chinese hamster ovary cells, the amount of carbohydrate attached to the modified protein is almost doubled. This new product, called darbepoetin, has a longer *in vivo* half-life than rEpo, thus fewer injections per week are required for therapeutic efficacy.²⁰⁷

Studies on the amino acid sequences of human and murine Epo have shown a very high degree of conservation of the molecule structure in these two species.^{208,209} Analyses of the NMR structure of Epo and the crystal structure of Epo complexed to the extracellular component of the EpoR have been performed.²¹⁰ Similar to the structure of hGH and GCSF (Chapter 5), Epo consists topologically of a bundle of α -helices (four in Epo²¹⁰). Two Epo-EpoR binding sites on Epo have been identified, a high-affinity site 1 ($K_d \sim 1 \text{ nM}$) and low-affinity site 2 ($K_d \sim 1 \mu\text{M}$).²¹¹ The studies are in keeping with the interaction of a single molecule of Epo with EpoR dimers.

Site and Regulation of Erythropoietin Production

More than 50 years ago Jacobson et al. established that the kidney is the major site of Epo production in adult rats.²¹² Humans with end-stage renal failure were also found to have low serum Epo concentrations, which were restored to normal following renal transplantation.²¹³ The cloning of the murine Epo gene has allowed studies on the production of Epo-specific mRNA in anemic mice. Induction of anemia leads, within an hour, to the appearance of Epo-encoding mRNA in the kidney and liver of anemic mice and rats.^{213,214} After bleeding, the Epo mRNA in the kidney increases 500 to 1,000 times when compared with Epo mRNA levels in normal kidney, whereas the liver produces only 7% of the total Epo mRNA.²¹⁵ These changes in Epo mRNA synthesis are followed by parallel changes in serum Epo concentration, as determined by radioimmunoassay, indicating that Epo production in response to anemia represents *de novo* synthesis rather than the release of preformed hormone.²¹⁴ Murine Epo mRNA is detectable by ribonuclease protection assay at 14 days of gestation in the fetal liver and a week later in the kidneys, which assume a major role in Epo production after birth.²¹⁶ In cases of paraneoplastic erythrocytosis, Epo mRNA is detected in the neoplastic cells.^{217,218}

Specialized cells producing Epo have been identified in renal and hepatic parenchyma by *in situ* hybridization techniques, using radioactive probes specific for Epo mRNA.^{216,219,220} These rare Epo-producing cells are found in the renal parenchymal interstitium (outside the tubular basement membrane), predominantly in the inner cortex and outer medulla. The bulk of experimental evidence indicates that these are fibroblast-like type I interstitial cells.^{221,222} In the liver, Epo mRNA is detected in hepatocytes. The number of interstitial renal Epo-producing cells increases (approximately exponentially) in response to anemia, indicating that increased Epo production is met by an increase in the number of Epo-producing cells; presumably with worsening anemia, increased numbers of these cells become sufficiently hypoxic to trigger Epo synthesis.⁶² Notably, there is no detectable storage of the hormone, and increased levels of circulating Epo do not repress further Epo production. Epo and EpoR are also expressed at low levels in other tissues including the spleen, bone marrow, lung, testis, eye, and brain.²²³ A possible paracrine function, potentially supporting low-level erythropoiesis,

has been ascribed to Epo production within bone marrow hematopoietic progenitors,^{224,225} and production of Epo within the CNS appears to protect EpoR-bearing neurons from ischemic damage and apoptosis.^{226,227}

The mechanism by which hypoxia leads to Epo synthesis has been determined. A sequence located in a region flanking the 3' end of the Epo gene is oxygen-sensitive and involved in regulation of expression.²²⁷ It has been shown, for example, that this oxygen-sensitive enhancer sequence when fused to a plasmid construct comprising the Epo promoter and a reporter gene confers to transfected cells the ability to respond to hypoxia as detected by an increase of the protein encoded by the reporter gene and studies of transgenic mice expressing defined 5' or 3' sequences of the human Epo gene support these findings.²²⁸ The ligand for this oxygen-sensitive enhancer was identified as a 120 kDa protein termed hypoxia-inducible factor 1 (HIF-1).^{228,229} This DNA-binding protein is tightly regulated by intracellular oxygen tension and serves as the physiologic regulator of Epo transcription.²³⁰

HIFs are heterodimeric helix-loop-helix transcription factors consisting of two subunits, an oxygen-labile protein, HIF- α , and a constitutively expressed β subunit, HIF- β .²³¹ Note that three genes, HIF1A, HIF2A or EPAS1, and HIF3A, encoding different isoforms of HIF- α are present in the human genome; here HIF- α refers to HIF-1 α or HIF-2 α . The concentration and transcriptional activity of HIF- α increase in a geometric fashion upon exposure to hypoxia. HIF- α mRNA is constitutively expressed under normoxic conditions, but the protein is rapidly degraded via the ubiquitin proteasome complex following binding by von Hippel-Lindau protein (pVHL). The recognition of HIF- α by pVHL requires prior hydroxylation of specific HIF- α proline residues by prolyl-hydroxylase domain (PHD)-containing proteins.^{232,233,234} and²³⁵ These PHDs are oxygen- and iron-dependent enzymes. Under hypoxic conditions, little or no proline hydroxylation takes place; thus, pVHL does not bind to HIF- α , which accumulates in the nucleus, heterodimerizes with HIF- β , and recruits the transcriptional coactivators p300/CREB-binding

P.97

protein, with the whole complex then binding to the Epo enhancer to positively influence Epo promoter activity and gene transcription. The recruitment of p300 to the complex can itself be inhibited by hydroxylation of asparagine-803 in HIF- α , which is catalyzed by asparaginyl-hydroxylase, another oxygen-sensitive enzyme.²³⁶ It seems that these two amino acid hydroxylases, by their dependence on normal intracellular oxygen for their function, act as the oxygen sensor in the Epo-producing interstitial cells in the kidney, and, by regulating the function of HIF- α at two distinct points,²³⁵ ultimately control Epo synthesis and production. Not surprisingly, mutations of this pathway may be associated with an increased red cell mass: Chuvash polycythemia is due to a homozygous mutation of Vhl that impairs HIF-1 α degradation, resulting in a mild increase in Epo levels²³⁷ whereas mutations of the genes encoding HIF-2 α or PHD2 are rarer causes of familial erythrocytosis.²³⁸

In addition to Epo, a large number of other HIF target genes (e.g., glucose transporters, glycolytic enzymes, and vascular endothelial growth factors) are up-regulated during hypoxia to aid cells adapt to hypoxic conditions.²³⁹ Apart from the indirect effects of hypoxia on erythropoiesis through HIF-mediated renal Epo production, erythroid progenitor cells are also subject to direct cellular effects of hypoxia and HIF production. A recent analysis of early erythroid progenitor genes up-regulated by glucocorticoids (such as cortisol, which is released from the adrenal glands during acute anemic or hypoxic "stress erythropoiesis"^{38,240}) found that the promoter regions of many of these erythroid cell genes also contain HIF binding sites. Furthermore, in *in vitro* studies, HIF synergizes with glucocorticoids to expand erythroid progenitors dramatically, perhaps by increasing BFU-E progenitor self-renewal,³⁸ a HIF effect previously observed by others during stress erythropoiesis.²⁴¹

Action of Erythropoietin

Erythropoietin Receptors

Epo binds to specific molecules on the cell surface, the EpoR. The expression of both Epo and EpoR is necessary for adult life. Deletion of either of the genes encoding for Epo or EpoR in mice results in the identical phenotype of fetal death at embryonic days E11.5 to E13.5 because of a lack of definitive erythropoiesis in the fetal liver and severe anemia.²⁴² Arguably, the most important control point of erythropoiesis is the interaction of Epo with the receptor for Epo.^{38,243,244} and²⁴⁵ The activation of EpoR generates an intracellular signal in immature erythroid cells that promotes survival of cells that would otherwise undergo apoptosis. Epo also appears to promote erythroblast proliferation and differentiation.

EpoR is expressed on hematopoietic cells that respond to Epo and has been identified on human¹² and murine erythroid cells,²¹⁶ on erythroleukemia cell lines,²¹⁶ in murine fetal liver tissue rich in erythroid elements, in mouse and rat placenta,^{217,246} and on megakaryocytes.^{246,247} EpoR expression on erythroid cells is relatively low (approximately 1,000 molecules per cell) and correlates with the cell's responsiveness to and dependence on Epo.²⁴⁷ EpoR is detectable by

autoradiography on human BFU-E; its density increases as BFU-E matures to CFU-E.¹⁹ Erythroid cells at a stage between CFU-E and proerythroblast seem to have the highest density of EpoR, which decreases as the proerythroblast matures and eventually disappears at the stage of orthochromatic erythroblast.^{19,246} The receptor is not expressed on reticulocytes or red cells. The presence of EpoR on megakaryocytes^{246,247} and ²⁴⁸ explains why Epo at physiologic concentrations promotes megakaryocyte differentiation and can thus affect platelet levels. Receptors for Epo are also observed on nonhematopoietic tissues including neurons and cardiac myocytes, endothelial cells, the kidneys, and embryonic muscle. The expression of EpoR in nonerythroid tissues was not believed to be required for normal embryonic development as erythroid tissue-specific EpoR expression (under control of the GATA-1 promoter) in EpoR^{-/-} embryonic stem cells gives rise to apparently normal mice.²⁴⁹ However, recent studies indicate that EpoR^{-/-} murine embryos develop neural defects,²⁵⁰ defects in angiogenesis,²⁵¹ and cardiac ventricular hypoplasia, which is not a result of generalized hypoxia.²⁵² In addition, some of the adverse effects observed in patients with certain solid tumors receiving Epo have been ascribed to activation of EpoR expressed on tumor cells.²⁵³

The MEL EpoR gene encodes a 507-amino acid peptide of 62 kDa with extracellular, single-membrane-spanning and intracellular domains.²⁵⁴ The EpoR undergoes glycosylation and phosphorylation before being incorporated into the cell membrane as a 70 to 78 kDa protein.²⁵⁴ Cells transfected with this gene express both high- and low-affinity EpoR.²⁵⁴ The human gene is located on chromosome 19p13.2, encodes a protein of 508 aa, and is 68 to 72 kDa depending on the degree of glycosylation.²⁵⁵

It is now recognized that structurally EpoR is part of a large family of type I cytokine receptors, which includes receptors for IL-2 to IL-7, GM-CSF, and Tpo. Type I cytokine receptors share basic structural features and are characterized by four conserved cysteine residues and a tryptophan-serine-x-serine-tryptophan (WSXSW) motif in the extracellular domain and by conserved box1/box2 regions in the intracytoplasmic domain adjacent to the membrane. Some of these type I cytokine receptors share common subunits and thus are heterodimeric; however, the receptors for Epo, Tpo, and G-CSF consist of homodimers.^{256,257} Crystallographic studies confirm that, as is seen with other cytokine receptors, one molecule of Epo simultaneously binds to two EpoR.²⁵⁸ After binding, both Epo and EpoR are rapidly endocytosed and degraded.^{12,216,247,255} Although it is clear that EpoR activation by Epo can lead to formation of EpoR homodimers,²⁵⁹ evidence also indicates these dimers exist prior to Epo binding, and that binding shifts and stabilizes an active receptor conformation bringing the two EpoR into closer contact.^{260,261}

EpoR signaling pathways are outlined in Figure 6.10. Tyrosine phosphorylation of the EpoR²⁶² is the first observable event after Epo binding. Because EpoR lacks a kinase domain, a tyrosine protein kinase must therefore associate with the receptor. JAK2, a member of the Janus family of cytoplasmic tyrosine kinases, is the primary EpoR-associated kinase and binds to a conserved sequence of amino acids found in cytoplasmic domains of the EpoR^{263,264} (and other receptors related in sequence to EpoR). Interestingly, recent studies indicate that the activation of EpoR through binding of Epo initiates a scissorlike rotation of the EpoR dimers, separating the intracellular domains of the two receptor molecules to allow room for the associated Jak2 molecules; in addition there appears to be a self-rotation of each monomer to allow them to orient properly for transphosphorylation of Jak2.²⁶⁵ Deletion of the JAK2 gene in mice results in fetal death on days 12 to 13 that is associated with a severe anemia mirroring the phenotype after deletion of Epo or EpoR,²⁶⁶ indicating the importance of Jak2 for Epo signaling.

To summarize current research,^{38,243,244} and ²⁴⁵ one Epo molecule binds two EpoR molecules, activating JAK2 kinases associated with the juxtamembrane regions (box 1/box 2) of each receptor by physically bringing the inactive (or low-activity) kinases into close proximity during the induced rotational shift in EpoR conformation,²⁶⁷ such that these kinases cross-phosphorylate each other, gaining full activity. The activated kinases phosphorylate all eight conserved tyrosine residues of the EpoR cytoplasmic tail. The phosphorylated tyrosine (PY) residues then serve as docking sites for up to 20 different signaling molecules or adaptor proteins that may be phosphorylated by JAK2 to become active, and leading to various mitogenic, differentiative, and antiapoptotic responses. The signaling molecules and adaptor proteins contain either Src homology 2 (SH2) or other phosphotyrosine binding domains that mediate recognition of a PY residue in the context of specific

P.98

adjacent (EpoR) amino acids. The major pathways activated by Epo binding to EpoR include the signal transduction activator of transcription 5 (STAT5) pathway, and the phosphatidylinositol-3-kinase (PI3-kinase)/Akt and ras/raf/MAPK (mitogen-activated protein kinase) signaling cascades (Fig. 6.10).

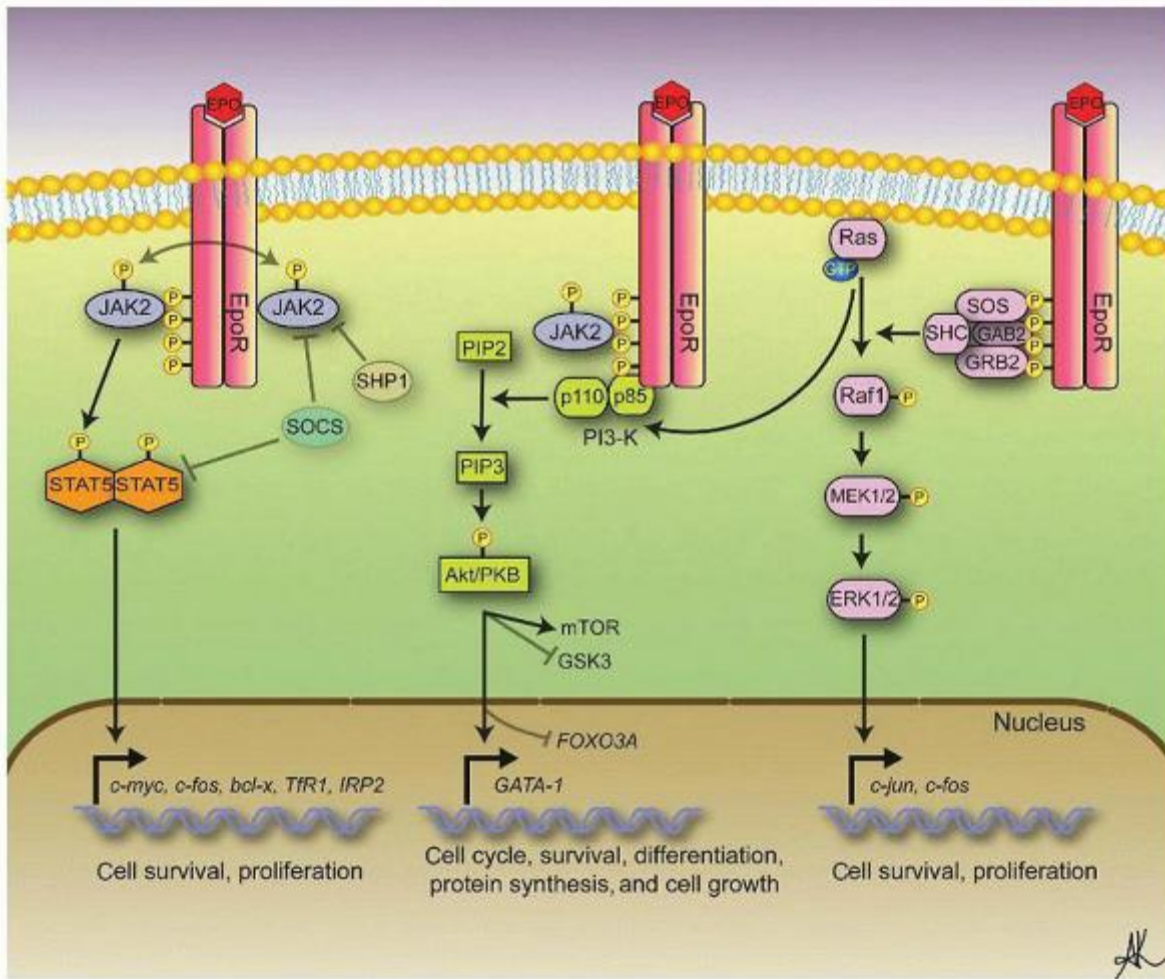

FIGURE 6.10. Overview of the erythropoietin receptor signaling pathways. Conformational changes in EpoR dimers induced by Epo binding facilitate the activation of EpoR-associated Jak2 kinases. Jak2 kinase activation results in phosphorylation of several tyrosines in the EpoR cytoplasmic tail that then serve as docking sites for signaling or adaptor proteins containing phosphotyrosine-binding domains. The signaling proteins become phosphorylated and function in numerous downstream signaling cascades. (1) A major target of Jak2 is Stat5, which is phosphorylated, dimerizes, and travels to the nucleus where it activates genes important for cell survival and proliferation. (2) Binding of the regulatory subunit of PI3-kinase, p85, to EpoR phosphotyrosines results in phosphorylation of membrane lipids and the downstream activation of Akt. This kinase regulates cell-cycle, cell differentiation, and pro-survival pathways and modulates metabolism and protein translation. (3) The ras/raf/MEK/ERK pathway is activated with binding of the SHC/GRB2/SOS complex to EpoR phosphotyrosines. Activation of the downstream kinase ERK1/2 results in phosphorylation of ELK1, a transcription factor important for cell survival and proliferation (via *c-jun* and *c-fos* expression). Negative regulatory proteins are necessary to dampen EpoR signaling. SOCS proteins inhibit Jak2 and Stat5 activation whereas phosphatases such as SHP1 and SHIP inhibit other phosphorylation-dependent pathways. Note that other EpoR pathways, such as activation of calcium-dependent isoforms of the PKC family of serine/threonine kinases, are not shown. See text for details.

Upon binding to EpoR at PY343 (EpoR numbering here refers to the murine protein), STAT5 is phosphorylated by Jak2,²⁶⁸ dimerizes, and translocates to the nucleus to mediate gene transcription (e.g., of the mitogenic transcription factor *c-myc*, *Id1*,¹⁰ *Tfr1*, and *IRP-2*²⁶⁹). Targeted deletions of the eight potential PY residues in EpoR, to dissect the Epo/EpoR/Jak2 signaling axis, have also revealed the importance of pathways downstream of Jak2.²⁷⁰ Although deletion of all eight residues results (surprisingly) in only mild anemia (the hematocrit in adult mice is reduced by 25% to ~0.37),²⁷¹ restoration solely of Epo/EpoR/Jak2/STAT5 signaling (i.e., by deletion of all tyrosines except the Y343 residue) results in near-wild-type EpoR activities,²⁷² and in particular, STAT5 signaling restores the erythron capacity for proliferative, stress erythropoiesis responses. The precise role of STAT5 in EpoR signaling in steady-state erythropoiesis, however, is still unclear. STAT5 is expressed from two very similar genes, STAT5a and STAT5b. In animal studies in which both genes were

deleted or “knocked out” (STAT5a/b^{-/-} mice), a marked fetal anemia was reported with lesser but significant anemia in newborn and adult animals.²⁷³ More recent studies indicate these knockout STAT5a/b^{-/-} animals contain hypomorphic rather than null STAT5a/b^{-/-} alleles, expressing an N-terminally truncated phosphorylated Stat5 in erythroblasts that appears to retain some biologic STAT5 functions.²⁷⁴ In addition, Epo weakly activates other STATs in primary erythroid cells, such that STAT3²⁶⁹ and/or STAT1 activation²⁷⁴ may also partially compensate for STAT5, resulting in a relatively mild inhibition of murine erythropoiesis.²⁷⁵

A potential target of STAT5 is the Bcl-x gene, which encodes an antiapoptotic protein, Bcl-x_L, believed to be essential for Epo-dependent survival. Two recent studies of Bcl-x_L-deficient animals confirmed Bcl-x_L expression is required for normal erythropoiesis, but also demonstrate that it promotes the survival of mature erythroid cells that no longer depend on Epo for survival.^{276,277} Thus, Bcl-x_L must also be regulated by factors other than Epo-activated STAT5,²⁷⁴ likely the interplay of GATA-1 and Gf-1B at the Bcl-x promoter.²⁷⁸ Epo/EpoR signaling may promote survival earlier, at the proerythroblast stage, through up-regulation of a

P.99

number of other antiapoptotic genes including Pim1, Pim3, Trib3, and Serpina 3g.²⁵⁵

The distal end of the EpoR cytoplasmic domain and phosphorylation of Y479 are required for activation of the PI3-kinase/Akt and MAP kinase signaling cascades (Fig. 6.10). Binding of the p85 regulatory subunit of PI3-kinase to EpoR mediates translocation of the kinase from the cytoplasm to phosphorylate lipids at the cell membrane,²⁷⁹ resulting in modulation of survival, metabolism, and translation through the subsequent effects of Akt (a kinase directly downstream of PI3-kinase) on mTOR, GSK3, FOXO, and GATA-1 transcription factors.^{280,281} The central role of PI3 kinase in signaling downstream of the receptor for Epo is suggested by the ability of a constitutively active Akt partially to rescue erythroid development when expressed in JAK2^{-/-} fetal liver cells.²⁸⁰ With regard to the ras/raf/MAPK cascade, Jak2-initiated phosphorylation of tyrosines at the distal end of EpoR allows a Shc adaptor protein to associate with the receptor, which then recruits GRB2 and SOS, resulting in activation of cell membrane-bound Ras and then Raf activation. This signaling cascade gives rise (via MEK) to phosphorylation of ERK1/2 which subsequently phosphorylates up to 60 substrates, promoting erythroid cell-cycle progression and proliferation.²⁸² In contrast to the two pathways described above, however, knockdown of Ras in erythroid cells has only subtle effects on terminal erythropoiesis.²⁸³ Although Epo may act on progenitor cells to promote survival, drive proliferation, and direct erythroid maturation, it is not clear if some intracellular signaling pathways can distinctly activate only one of these events. Epo-dependent activation of the PI3-kinase pathway appears important for both cell survival and proliferation whereas the MAP kinase pathway appears more important in directing proliferation.²⁷⁹

Apart from these three major pathways there are a number of other well-described mediators of responses downstream of Epo/EpoR that likely affect erythropoiesis. These include the inositide-specific phospholipases C (e.g., knockdown of the PLC-γ isoform impedes erythroid development²⁸⁴) and the protein kinase C pathways (e.g., inhibition of the PKCα isoform impairs Epo-induced differentiation, whereas PKCε up-regulation protects erythroid cells from TRAIL-induced apoptosis^{285,286}). In addition, knockdown of the Src family tyrosine kinase Lyn results in attenuated EpoR signaling and decreased erythroid precursor survival.^{270,287,288} The adaptor SH2-containing proteins CrkL (which is phosphorylated by Lyn and indirectly activates Erk1/2²⁸⁹), Lnk (which attenuates JAK2 signaling²⁹⁰), and Spry1, which appears to down-regulate Erk1/2 and Jak2 activation²⁹¹ also appear to be important regulators of EpoR signals. Of interest, recent studies indicate that polymeric IgA (pIgA1-oligomers of IgA joined by their J-chains), produced in small amounts by plasma cells, binds to TfR1 present on the erythroblast cell surface. Binding of pIgA1 or Fe-Tf to TfR1 appears to transmit an intracellular signal that results in activation of erythroblast Akt and ERK1/2, stimulating erythroblast proliferation and differentiation.²⁹² This pathway may be important to boost erythroid output during stress erythropoiesis as hypoxia increases pIgA1 levels, or during iron deficiency when Fe-Tf levels are low. Recent studies identify over 160 genes that are significantly affected by Epo/EpoR signaling in murine primary bone marrow derived CFU-E-like progenitors,²⁵⁵ suggesting much remains to be learned.

As is found with other cell signaling cascades there is a need for checks and balances in the form of inhibitory or regulatory factors, to prevent overstimulation of erythroid cells by Epo/EpoR-mediated growth and survival signals. The distal end of EpoR, for example, acts as a negative regulatory domain to which SH2-containing tyrosine protein phosphatases dock (to PY401, 429, 431) to dephosphorylate substrates such as Jak2 and STAT5 and attenuate Epo signaling. For example, a transgenic animal expressing a truncated human receptor Epo developed severe erythrocytosis, mimicking primary familial and congenital polycythemia (PFCP, see Chapter 44) where patients have elevated red cell mass due to mutations in the EpoR gene.²⁹³ A number of kindreds with PFCP due to mutations in this distal regulatory

region of EpoR have since been reported.²⁹⁴ Identified regulatory phosphatases²⁹⁵ include the SH2-containing tyrosine phosphatases SHP1, SHP2 (PTPN11³²), and PTP-1B. Other regulatory factors include the control of EpoR trafficking from the ER by Jak2,²⁹⁶ EpoR internalization upon interaction with Epo,²⁹⁷ proteasomal degradation of EpoR²⁹⁸ and signaling adaptor molecules, and the inducible expression of specific inhibitors such as the suppressor of cytokine signaling protein family members SOCS-1, SOCS-3, and CIS-1 (cytokine inducible SH2-containing protein) by STATs. The SOCS family of proteins down-regulates receptor signaling in a negative feedback manner by (a) competing with STAT5 for binding to EpoR phosphotyrosines and (b) binding and inhibiting the Jak2 kinase activation loop, or (c) ubiquitination and proteasomal targeting of Jak2.²⁹⁹

The Epo gene has been incompletely deleted in 8-week-old mice using a conditional knockout strategy,³⁰⁰ reducing renal Epo gene expression by 95% compared with controls.³⁰¹ This animal serves as a model of the Epo/EpoR interactions that likely occur in patients with renal failure, with decreased steady-state erythropoiesis, and a chronic normocytic, normochromic anemia that is moderate (Hct ~75% of control), related to residual Epo production. Remarkably, despite the severe knockdown in Epo expression the animals appear to have normal stress erythropoiesis responses, as they recover normally from acute hypoxic stress (induced by phenylhydrazine-induced hemolysis), indicating the importance of other mechanisms such as glucocorticoids, hypoxia, BMP4, and SCF in supporting murine stress erythropoiesis.^{38,240}

Abnormal Epo/EpoR Signaling

In addition to human erythrocytosis related to excessive stimulation of Epo production by HIF or pVHL mutations (see above), a point mutation of the extracytosolic domain of murine EpoR (R129C, a substitution of cysteine for arginine at position 129) that results in constitutive activation of EpoR by homodimerization in the absence of Epo, and erythrocytosis, has been described.^{302,303} Murine EpoR may also be activated by interaction with the Friend spleen focus-forming virus (SFFV) envelope glycoprotein, gp55, promoting EpoR dimerization and polycythemia.²⁷⁶ Deletions of negative regulatory EpoR domains in humans and mouse models, as noted, also increase EpoR signaling and result in erythrocytosis whereas overexpression of a constitutively active mutant of STAT5A, STAT5A1*6, in human cord blood CD34+ cells favors erythroid over myeloid differentiation *in vitro*.³⁰⁴

Building on previous studies,^{305,306} constitutive activation of EpoR in patients with the myeloproliferative disease polycythemia vera (PV) was discovered to be due to an activating mutation of Jak2 that encodes a substitution of valine for phenylalanine at position 617 in the protein (^{V617F}Jak2 mutation).³⁰⁷ The role of JAK2 in PV is discussed in Chapter 82.

Mechanism of Action

Epo is a hormone that promotes erythroid differentiation.² The role of Epo during the very early stages of erythropoiesis is still undefined. Cell lines with features of multipotent hematopoietic progenitor cells^{308,309} and purified human blood BFU-E¹⁹ express a small number of EpoR, suggesting a possible role for Epo in mediating their survival and differentiation. Although, *in vivo*, the BFU-E pool is unaffected by acute changes in serum Epo levels, they can respond to the hormone by increasing their cycling, part of the process of erythroid differentiation.²⁹ Chronic administration of rEpo to humans with end-stage renal disease results in global stimulation of the bone marrow with an increase in the

P.100

concentration and cycling of all types of hematopoietic progenitors, but this effect is most likely indirect.³⁰

The erythroid cell that is the most sensitive to Epo is a cell between the CFU-E and the proerythroblast,^{19,246} and this erythroid cell is considered the primary target of Epo action. These cells express the highest density of EpoR on their cell surface and are absolutely dependent on Epo for survival.^{19,47,216} Studies on murine splenic erythroid cells infected with the anemia strain of Friend virus³¹⁰ have shown that Epo binding is followed by a series of biochemical events, including increased Ca²⁺ uptake,⁴⁹ internalization of Epo,¹² an increase in RNA synthesis,³¹¹ glucose and iron uptake,²⁴⁷ transcription of the α - and β -globin genes,^{46,215} expression of TfR,⁴⁸ and eventually increase of hemoglobin synthesis as well as synthesis of membrane bands 3 and 4.1.^{47,215} All of these changes result in an increased rate of erythroid differentiation, ending with an increase in the reticulocyte production and an eventual increase in the erythron.

One of the most impressive effects of Epo is the ability of the hormone to maintain the viability of erythroid cells irrespective of any effect on cycling and differentiation.^{47,216} It has been shown that Epo retards the cleavage of DNA that occurs normally in CFU-E.¹⁹ In the absence of Epo, DNA cleavage is rapid and proceeds to cell death. The pattern of rapid DNA cleavage is characteristic of cells undergoing caspase-mediated apoptosis.¹⁹ In the presence of Epo, cell death is avoided and the erythroid cells differentiate and form mature red cells. These findings suggest that the hormone promotes erythroid differentiation simply by allowing cell survival. This model also suggests that, under normal conditions

—due to their variable sensitivities to Epo—large numbers of generated CFU-E undergo apoptosis, and that high Epo levels cause expansion of the erythroid marrow simply through allowing survival of more CFU-E, resulting in increased red cell production. Similarly, once the red cell mass is restored to normal, the ensuing decrease of Epo levels leads to a rapid turn-off of erythropoiesis by allowing programmed cell death to occur.¹⁹

The observation that relatively immature erythroid progenitor cells continue to develop in fetal mice in which either the gene encoding for Epo or EpoR is deleted²⁴² supports the model that Epo acts primarily by promoting survival of more mature erythroid cells and that Epo has no, or a less significant, role in proliferation of erythroid precursors or in directing the erythroid differentiation of immature hematopoietic cells. The abundant erythroid cells (proerythroblasts near the CFU-E stage of erythroid development) from the spleens of either Epo^{-/-} or EpoR^{-/-} mice undergo apoptosis unless they are either cultured in vitro in Epo (Epo^{-/-} mice) or forced (by transfection with EpoR cDNA) to express EpoR (EpoR^{-/-} mice) and then cultured in the presence of Epo. Thus, neither Epo nor receptors for Epo are necessary for the proliferation and differentiation of stem cells and early progenitor cells into relatively mature erythroid cells. Both Epo and the receptors for Epo, however, are absolutely required for erythroid cells to survive the transition from CFU-E/proerythroblasts to mature erythroblasts, suggesting a clear role for Epo in directing the survival of these cells.

Studies of normal murine fetal liver-derived erythroblasts that are transduced with (and thus overexpress) antiapoptotic proteins such as BCL-X_L and Bcl-2 have emphasized the importance of survival factors at this defined stage of erythropoiesis.³¹² These erythroblasts require Epo, SCF, and dexamethasone to allow sustained proliferation; however, with removal of these factors (including Epo) there is initiation of what appears to be normal erythroid differentiation with induction of the erythroid transcription factors (GATA1, KLF1, and NFE2), differentiation divisions, size reduction, hemoglobinization, nuclear condensation, and enucleation. These studies would suggest that Epo-induced survival allows cell-autonomous terminal erythroid differentiation. Interestingly, studies also demonstrate that controlled caspase activation is actually necessary for erythroblast maturation.³¹³ It is hypothesized that caspase-mediated cleavage of proteins such as Lamin B, PARP-1, and Acinus is required for terminal maturation, perhaps for initiation of enucleation.³¹⁴ In the absence of Epo there is excessive activation of caspases, resulting in cleavage of GATA1 and maturation arrest or apoptosis. However, Epo induces nuclear migration of a molecular chaperone, the heat shock protein Hsp70, to protect GATA1 from cleavage during caspase activation.³¹⁵ Notably, recent studies³¹⁶ indicate that abrogation of this protective mechanism may underlie the ineffective erythropoiesis seen in patients with early myelodysplastic syndrome (see Chapter 73).

In addition to erythroid cells, Epo has also been shown to affect megakaryocytes and their progenitors CFU-MK. Epo acts as a colony-stimulating factor for murine CFU-MK,³¹⁷ whereas in humans, it potentiates the effect of megakaryocyte colony-stimulating factors present in lymphocyte-conditioned media.¹² It also promotes differentiation of murine megakaryocytes,³¹⁸ which express EpoR,³¹⁹ and, when injected at high doses into mice, increases platelet production.³²⁰ In patients with renal failure treated with Epo, a minor increase in the platelet count, averaging approximately 30,000/ μ l, has been noted.³²¹

ASSAYS FOR ERYTHROPOIETIN AND LEVELS IN HEALTH AND DISEASE

The presence of Epo in serum, urine, or other body fluids can be detected by bioassays or immunoassays. Historically, Epo was detected by the polycythemic mouse assay in which the serum sample was injected with ⁵⁹Fe into polycythemic mice and the amount of ⁵⁹Fe incorporated into newly released red cells was measured.^{2,322,323}

Radioimmunoassays for Epo were developed initially by using purified human urinary Epo as antigen and standard^{324,325,326,327} and ³²⁸; these have been replaced by purified human rEpo.^{326,327} Using the same principles of immunologic detection of the protein, an enzyme-linked immunosorbent assay was developed, which is commercially available and currently used as the method for determining serum Epo concentrations. The immunoassays have the advantages of being quick, accurate, relatively inexpensive, and capable of quantifying very low Epo levels ordinarily not detectable by bioassays. Normal serum Epo levels, although variable with the type of assay, usually range between 5 and 30 mU/ml. An inverse correlation has been established between the logarithm of serum Epo concentration and the concentration of hemoglobin in the blood^{324,327}; however, the magnitude of the increase in the serum Epo concentration in response to anemia is variable among individuals. A disadvantage of the immunoassays is that they detect immunoreactive but not necessarily bioactive hormone. Thus, in renal failure, when serum Epo levels are low or undetectable by bioassays, the immunoassays detect higher levels.^{326,327} and ³²⁸ The utility of Epo assays in clinical practice is discussed in later chapters in relation to specific clinical disorders.

THE MATURE RED BLOOD CELL

Erythrocytes were first described in the 17th century. The Dutch microscopist, Leeuwenhoek, took note of them, as did Malpighi, who mistook them for fat globules "looking like a rosary of red coral." For many years, erythrocytes were not thought to be of any importance. The presence of iron in blood was demonstrated by Lemery in the 17th century, but not until 1851 did Funke isolate hemoglobin in crystalline form. The functional significance of red corpuscles was only appreciated, however, when Hoppe-Seyler demonstrated that hemoglobin has the property of readily taking up and discharging oxygen. This, then, was considered the primary

P.101

or even sole function of the red cell (along with CO₂ exchange) until the late 20th century. This section provides a description of RBC membrane structure and function, red cell metabolism, and hemoglobin function. More detailed historic discussion of these erythrocyte features is found in Maxwell Wintrobe's history of hematologic science, *Blood, Pure and Eloquent*.³²⁹

STRUCTURAL FEATURES OF ERYTHROCYTES

Lacking a nucleus, mitochondria, or ribosomes, the red cell is unable to synthesize new protein, carry out the oxidative reactions associated with mitochondria, or undergo mitosis. More than 95% of the cytoplasmic protein is hemoglobin. The remainder includes those enzymes required for energy production and for the maintenance of hemoglobin in a functional reduced state.

Shape and Dimensions

At rest, the normal human erythrocyte is shaped like a flattened, bilaterally indented sphere, a shape often referred to as a biconcave disc (Fig. 6.11). In fixed, stained blood smears, only the flattened surfaces are observed; hence, on fixed blood films the erythrocyte appears circular, with a diameter of about 7 to 8 μm and an area of central pallor.

Average values for the mean cellular volume in normal subjects range from 80 to 100 fl, depending on the combination of methods used. The variation in cell size can be documented by means of a frequency distribution curve of red cell volumes generated from the output of an electronic cell counter (Fig. 6.12).³³⁰

Total hemoglobin content and red cell volume vary considerably more than does hemoglobin concentration.^{330,331} and^{332,333} It has been proposed that mature red cell size and hemoglobin content are primarily dependent on erythroid precursor cell size at the last cell division during erythropoiesis.³³⁰ Reticulocytes are 24% to 35% larger than mature red cells, although they have similar total hemoglobin content (and thus a lower hemoglobin concentration).³³⁴

The disc shape is well suited to erythrocyte function. The ratio of surface to volume approaches the maximum possible value in such a shape,³³⁵ thereby facilitating both gas transfer and deformability as the red cell traverses the microcirculation. When red cell movements within small blood vessels are observed by cinemamicrography,³³⁶ the plane of the biconcave disk is oriented in the direction of flow with the leading edge pointed and the following edge blunted. When deformed in this way, the erythrocyte can pass through a vessel of about 4 μm in maximum diameter. Erythrocyte shape may also vary between large and small vessels and under conditions of high or low shear stress.

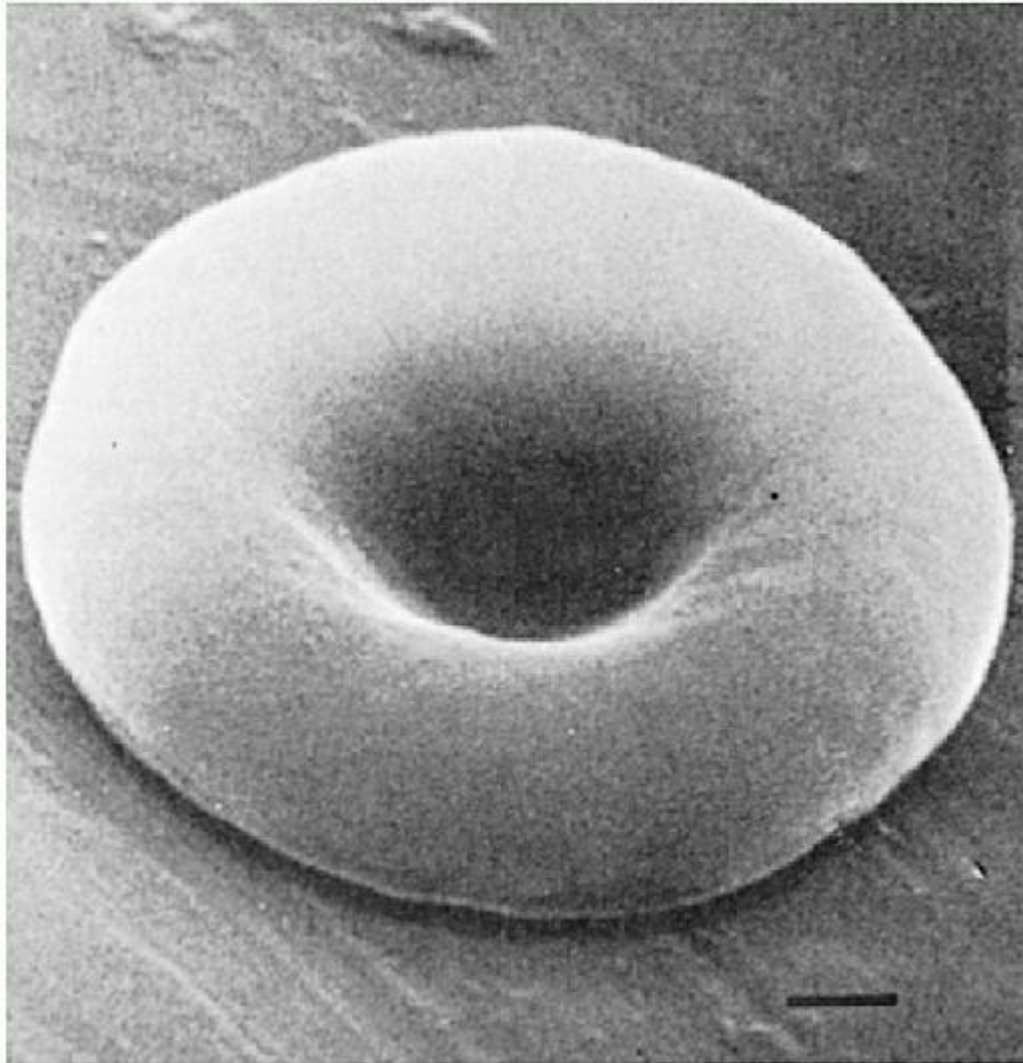

FIGURE 6.12. Frequency distribution curve of erythrocyte volume. The cells are normally distributed about a mean volume of 90 fl. (Modified with permission from Bessman JD, Johnson RK. Erythrocyte volume distribution in normal and abnormal subjects. *Blood* 1975;46:369.)

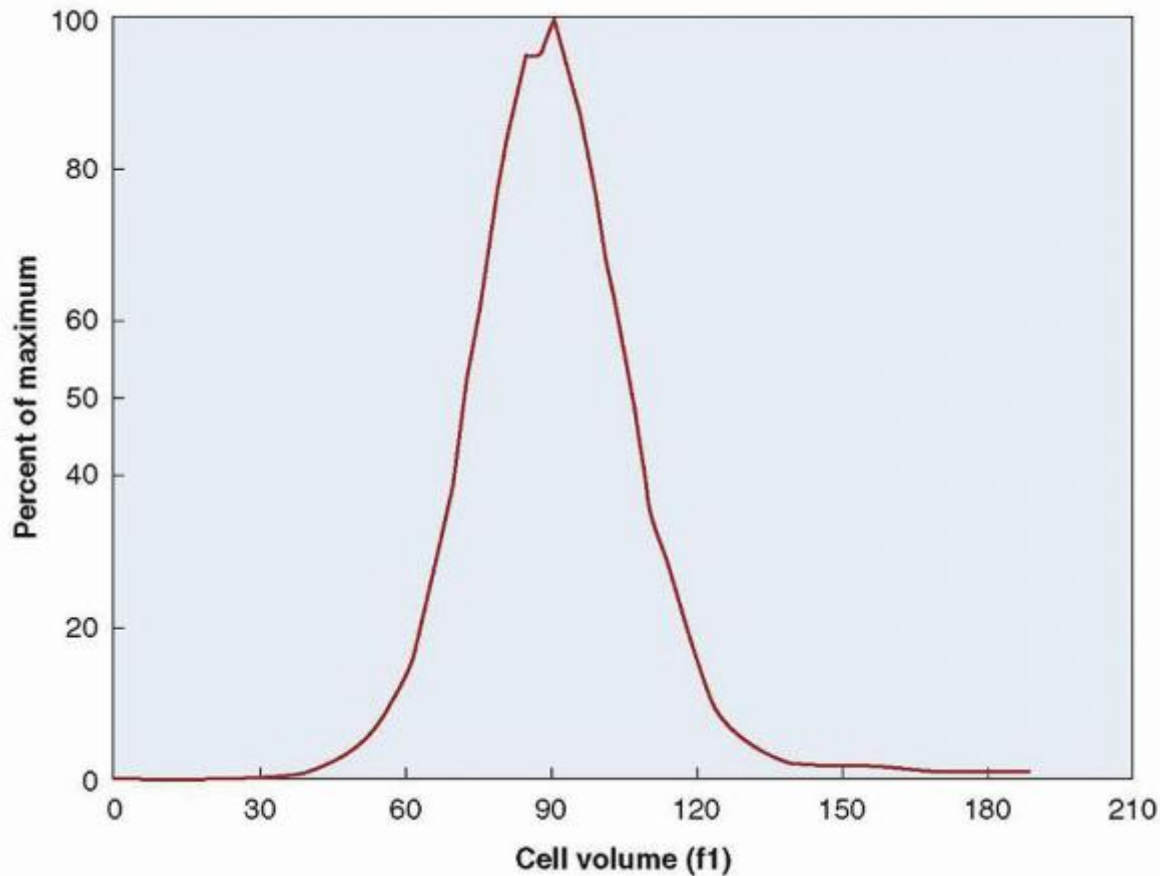

FIGURE 6.11. The normal mature erythrocyte as visualized by the scanning electron microscope ($\times 9,800$). (Courtesy of Dr. Wallace N. Jensen.)

Deformability

The erythrocyte is remarkable for its ability to maintain membrane integrity while exhibiting extreme deformability under normal physiologic circumstances.³³⁷ Without undergoing extensive remodeling, the erythrocyte membrane withstands high shear stresses, rapid elongation and folding in the microcirculation, and deformation as the erythrocyte passes through the small fenestrations of the spleen. Cell deformability depends on both the membrane and the cytoplasm; however, the cytoplasm of normal

P.102

erythrocytes at physiologic concentration has very low viscosity.³³⁷ Thus, it is the elasticity and viscosity of the membrane that are most crucial for deformability.

Among the factors that affect membrane deformability and stability are membrane lipid content, lipid distribution, cytoskeletal proteins, and transmembrane proteins.³³⁸ The cytoskeleton, formed by a latticelike network of proteins, undoubtedly contributes to the bending energy necessary for assumption of the biconcave shape, as well as to membrane stability.³³⁹ Abnormalities in cytoskeletal proteins cause a variety of pathologically shaped red cells, including spherocytes and elliptocytes (Chapter 27). In addition, proteins adsorbed to the outer surface of the red cell, especially albumin, may also play a role in both maintaining normal cell shape and effecting changes in that shape under some conditions. Red cells suspended in an isotonic medium tend toward an echinocytic shape until albumin is added, and increasing amounts of albumin move cells toward the discoid shape.³⁴⁰

THE ERYTHROCYTE MEMBRANE AND CYTOSKELETON

The central feature of membrane structure is a matrix formed by a double layer of phospholipids. The lipid bilayer hypothesis was first proposed in 1925³⁴¹ and refined by Danielli and Davson a decade later.^{342,343} and³⁴⁴ Lipid molecules in the bilayer are oriented with the nonpolar groups directed toward one another, forming hydrophobic interactions. The

hydrophilic polar head groups are directed outward, where they interact with the aqueous environment on both the cytoplasmic and plasma surfaces.

The best accepted concept of how proteins fit into the lipid membrane structure is the so-called fluid mosaic model.^{345,346} Within this “sea of lipids” float globular proteins, some that penetrate the membrane completely and others that penetrate the membrane only partially and may be exposed at only one surface. Some proteins appear to have considerable lateral mobility, but in the red cell, many proteins interact with other membrane components, giving them a degree of immobility. Some proteins traverse the lipid bilayer once, whereas others have multiple membrane-spanning domains. On the cytoplasmic side of the membrane lies a network of structural proteins that form a cytoskeleton. Certain membrane-spanning proteins appear to interact with various cytoskeletal proteins.³⁴⁷ Some transmembrane proteins also appear to become covalently linked to lipid,³⁴⁸ whereas the glycosylphosphatidylinositol-anchored class of proteins has no membrane-spanning domain but instead has phospholipid “tails” by which they are attached to the membrane.³⁴⁹

TABLE 6.1 LIPIDS OF THE NORMAL HUMAN ERYTHROCYTE MEMBRANE

Lipid	Molar Concentration ³⁵¹		Weight Concentration ³⁵⁰	
	$\mu\text{mol}/10^{10}$ Cells	% of Total	$\text{mg}/10^{10}$ Cells	% of Total
Phospholipids				
Phosphatidylcholine (lecithin)	1.3		1.0	
Phosphatidylethanolamine (cephalin)	1.2		0.9	
Sphingomyelin	1.0		0.8	
Phosphatidylserine	0.6		0.4	
Lysolecithin	0.04			
Others	0.07			
Total phospholipids	4.2		49.53.1 (1.7-3.2) ^a	69
Cholesterol	4.0		47.11.3 (1.1-1.4) ^a	29
Glycolipids (globoside)	0.21		3.40.1	2
Total lipids	8.41	100	4.5 (3.9-5.2) ^a	100

^a Range in parentheses.

Much that is known about red cell membranes is derived from studies of the insoluble portion of the cell remaining after hemolysis induced by osmotic rupture. This material has been called stroma and, if the membrane remains intact after hemolysis, red cell “ghosts.” It consists largely of components of the membrane, including the cytoskeleton. Such preparations contain about 52% protein, 40% lipid, and 8% carbohydrate by weight.³⁵⁰ Most of the carbohydrate is accounted for by the oligosaccharide portion of glycoproteins, but a small fraction (about 7%) is carried by glycolipids.^{350,351}

Lipid Composition

Virtually all of the lipids in the mature erythrocyte are found in the membrane^{351,352,353,354} and³⁵⁵ (Table 6.1). The majority of erythrocyte membrane lipids are phospholipids or unesterified cholesterol, which are present in approximately equimolar quantities. Four classes of compounds account for most of the phospholipid: phosphatidylcholine (lecithin), phosphatidylethanolamine, sphingomyelin, and phosphatidylserine (Table 6.1). Two fatty acid side chains are attached to all of these lipids except sphingomyelin, which has only one. In addition, trace amounts are found of other phospholipids containing only one fatty acid (“lysophospholipids,” e.g., lysolecithin). Fatty acids in the membrane are almost evenly divided between saturated and unsaturated fatty acids.³⁵⁴

Phospholipids are distributed asymmetrically between the two lipid layers of the membrane.^{356,357} Eighty percent or more of the aminophosphatides (phosphatidylethanolamine and phosphatidylserine) lie within the inner (cytoplasmic) monolayer, whereas the choline-containing lipids (phosphatidylcholine and sphingomyelin) are the major components of the outer monolayer (Fig. 6.13). Little or no phosphatidylserine is detectable in the outer lipid layer of normal, nonsenescent red cells. Maintenance of normal asymmetry results in improved mechanical membrane stability under

applied shear stress and further appears to supply additional means for cytoskeleton attachment to the lipid bilayer through spectrin-phosphatidylserine interaction.³⁵⁸

P.103

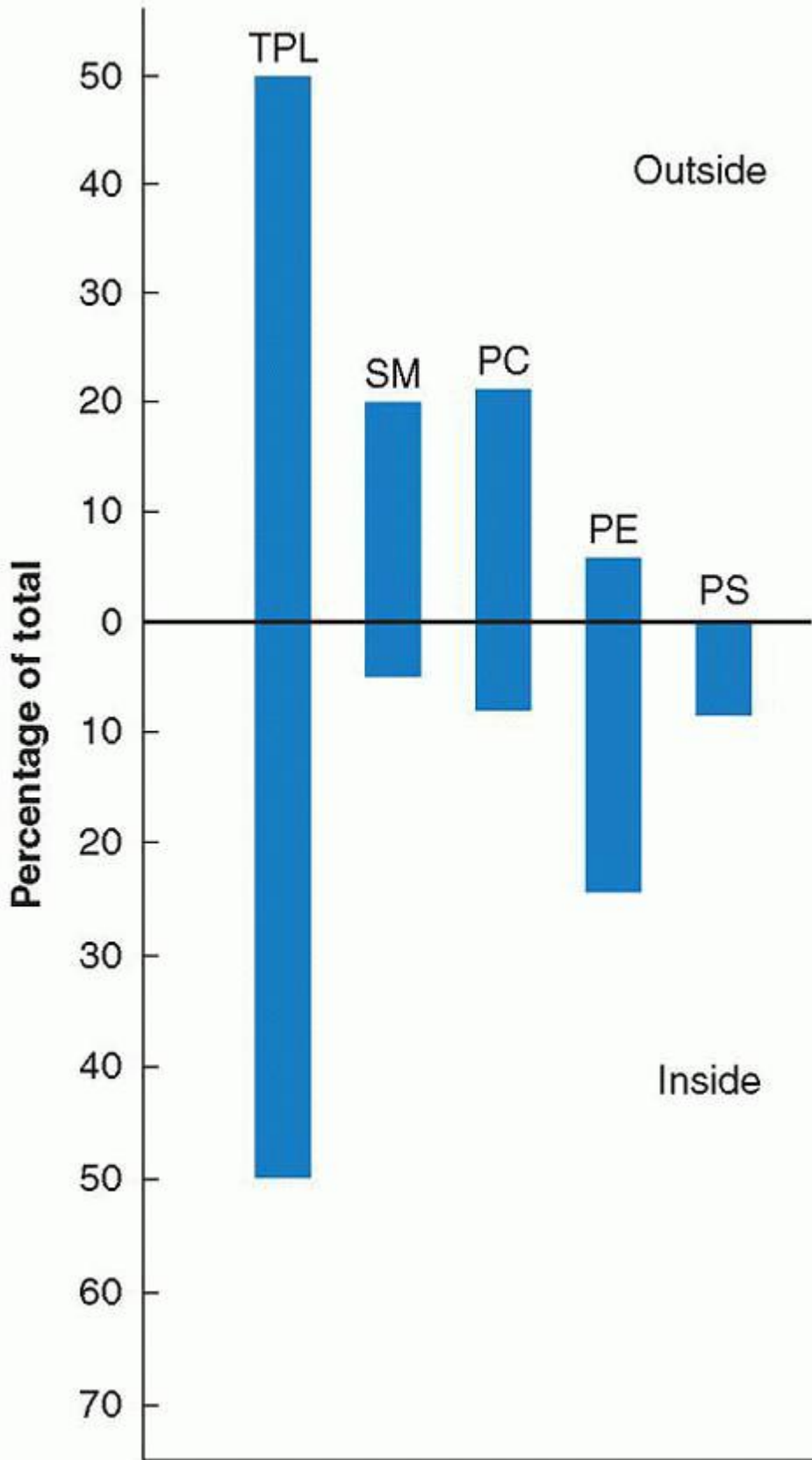

FIGURE 6.13. Distribution of erythrocyte phospholipids between the inner and outer layers of the membrane. PC, phosphatidylcholine; PE, phosphatidylethanolamine; PS, phosphatidylserine; SM, sphingomyelin; TPL, total phospholipids.

(From Rothman JE, Lenard J. Membrane asymmetry. *Science* 1977;195:743, with permission. Copyright 1977 by the American Association for the Advancement of Science.)

The lateral mobility of lipids in the outer membrane layer exceeds that of lipids in the inner layer. Although cholesterol is known to restrict lipid lateral mobility,³⁵⁹ the outer lipid layer likely is relatively enriched in cholesterol.³⁶⁰ Lipids in the inner layer may be restricted in their mobility because of interactions of phospholipids with cytoskeletal proteins.^{358,361,362}

An additional effect on lipid mobility and membrane deformability may come from the fact that the fatty acids found in erythrocyte phospholipids are also not distributed evenly between the two bilayers.^{353,357,363,364} Overall, about one half of the fatty acids in the membrane are unsaturated. Unsaturated fatty acids, however, and particularly the polyunsaturated acyl chains with four or more double bonds, are a disproportionately large part of the inner leaflet phospholipids, phosphatidylethanolamine and phosphatidylserine. In contrast, phosphatidylcholine, which is predominantly in the outer lipid layer, contains most of the shorter-chain saturated fatty acids. Sphingomyelin is especially enriched in fatty acids, with a chain length longer than 20. Membranes rich in sphingomyelin are less “fluid” than those with relatively larger amounts of lecithin.³⁶⁵ An increased ratio of sphingomyelin to lecithin is found in abetalipoproteinemia and probably accounts for the erythrocyte abnormalities associated with that disorder³⁶³ (see Chapter 27).

The neutral lipid of the erythrocyte consists almost entirely of free nonesterified cholesterol.³⁶⁵ The distribution of cholesterol in the two membrane layers has been difficult to study, at least in part because the translocation rate of cholesterol between the two layers is extremely rapid. Cholesterol has a pronounced effect on membrane fluidity.^{366,367} It interacts with phospholipids to form what has been called an “intermediate gel state.” Thus, compared with pure phospholipid membranes, membranes containing cholesterol are less fluid, that is, more viscous. Relatively modest increases in membrane cholesterol content decrease membrane deformability.³⁶⁸ Abnormally high levels of cholesterol lead to distortions in red cell shape; bizarre spicules form (“spur cells”), deformability of the cells is reduced, and they are destroyed in the spleen (Chapter 27).

Lipid Turnover and Acquisition

The mature erythrocyte is unable to synthesize lipids *de novo*; therefore, any lipid loss must be compensated for by renewal from pathways of interchange with the plasma³⁶⁴ (Fig. 6.14). Quantitatively, the most important of these pathways is the transfer of cholesterol and phosphatidylcholine (lecithin) from plasma lipoproteins to red cells (pathways 1 and 3). The rates of transfer are functions of the relative plasma and red cell levels of these lipids and are indirectly affected by the activity of the cholesterol-esterifying enzyme in plasma, lecithin-cholesterol acyltransferase (LCAT).³⁶⁹ This enzyme catalyzes the reaction in which a fatty acid in the 2 position of lecithin is transferred to free cholesterol, forming cholesterol ester and lysolecithin (Fig. 6.14, reaction 1A). Neither of the LCAT reaction products can enter the membrane. In patients with congenital LCAT deficiency, membrane cholesterol and lecithin are increased and the red cells are target-shaped.³⁷⁰

The exchange of cholesterol and lecithin between red cells and plasma is also affected by the plasma bile salt concentration.³⁷¹ If erythrocytes are incubated in normal plasma to which bile salts have been added, the cells acquire cholesterol, and this change is accompanied by an increase in surface area and the formation of target cells. Although the mechanism of bile salt action is not fully understood, at least two properties appear to be important: Bile salts inhibit the LCAT reaction and, in addition, they bring about a shift in the distribution of free cholesterol between plasma and cell. Phospholipids also may be added to the membrane. One example of this is that albumin-bound lysophospholipid may be transferred to the membrane (Fig. 6.14, pathway 4) and acylated (reactions 5a and 6a) to form a complete phospholipid.³⁶⁴

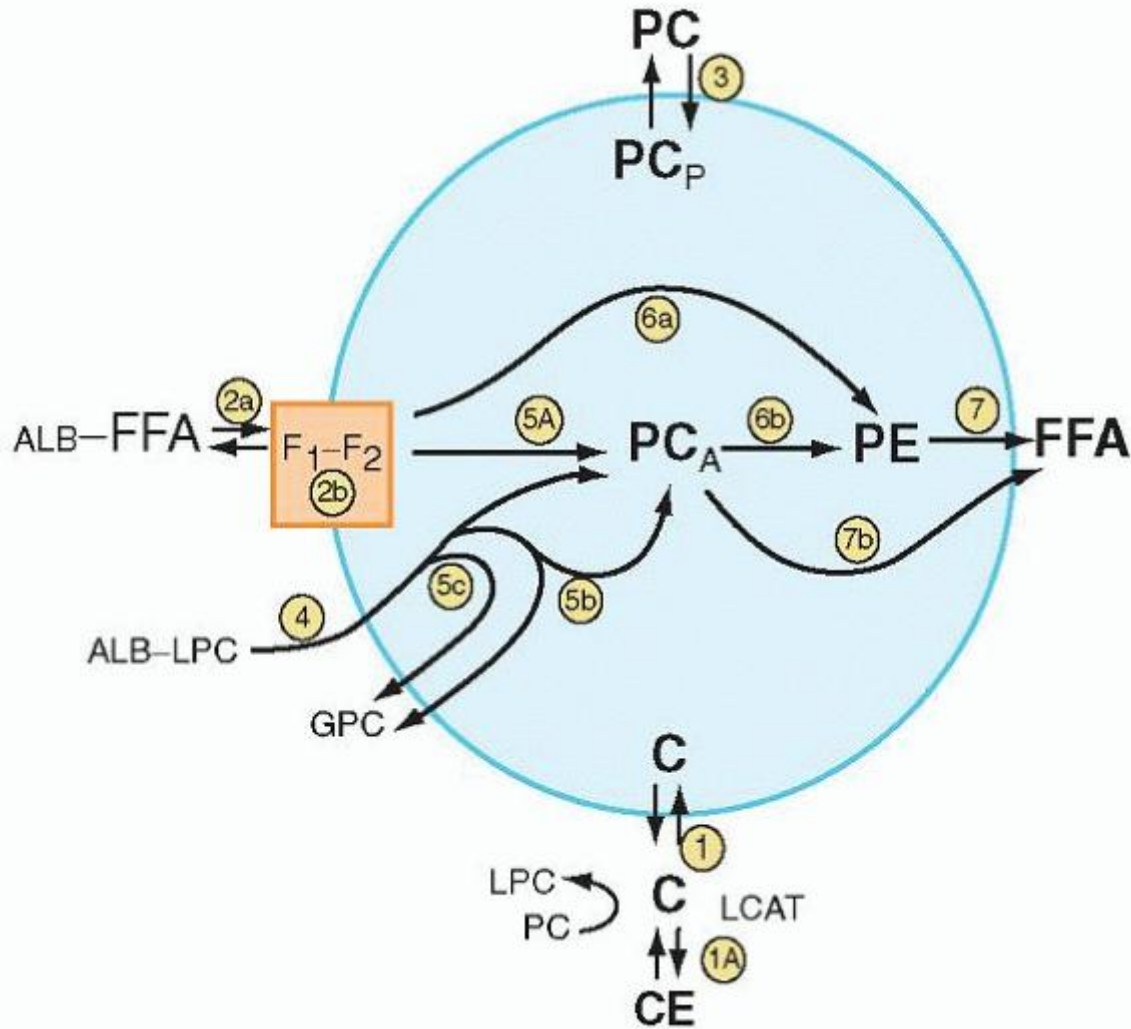

FIGURE 6.14. Pathways of lipid acquisition and turnover in the mature red cell membrane. Reactions and pathways: (1) exchange of cholesterol with plasma lipoprotein; (1A) the LCAT reaction; (2a) transfer of FFA from albumin to membrane; (2b) penetration of FFA to a metabolically active site; (3) exchange of PC with plasma lipoprotein; (4) transfer of LPC from albumin to membrane; (5A) $\text{LPC} + \text{FFA} \rightarrow \text{PC}$; (5b) $2\text{LPC} \rightarrow \text{FFA} + \text{GPC}$; (5c) $\text{LPC} \rightarrow \text{FFA} + \text{GPC}$; (6a) $\text{LPE} + \text{FFA} \rightarrow \text{PE}$; (6b) $\text{PC} + \text{LPE} \rightarrow \text{LPC} + \text{PE}$; (7) $\text{PE} \rightarrow \text{LPE} + \text{FFA}$; (7b) $\text{PC} \rightarrow \text{LPC} + \text{FFA}$. Alb, albumin; C, cholesterol; CE, cholesterol ester; FFA, free fatty acid; GPC, glycerylphosphoryl choline; LCAT, lecithin-cholesterol acyltransferase; LPC, lysophosphatidyl choline; LPE, lysophosphatidyl ethanolamine; PC, phosphatidyl choline (lecithin); PE, phosphatidyl ethanolamine. (From Shoheit SB. Hemolysis and changes in erythrocyte membrane lipids. *N Engl J Med* 1972;286:577, with permission.)

P.104

Membrane Proteins

Early in the history of membrane biochemistry, erythrocytes were used as a model system for the study of plasma membranes because they lacked organelle and nuclear membranes, making the membranes easy to isolate. Solubilization of membrane proteins can be accomplished by the addition of detergent. Detergent usually is added to red cell ghosts, made relatively hemoglobinfree after hypotonic lysis of red cells.³⁵² Use of an ionic detergent, most commonly sodium dodecyl sulfate (SDS), accomplishes solubilization of essentially all membrane proteins. Proteins extracted from membranes by detergent solubilization can be separated and analyzed with relatively high resolution by means of

electrophoresis in polyacrylamide gels.^{372,373} Such gels are stained by protein stains, usually Coomassie Brilliant Blue or by reagents that react with carbohydrate, such as periodic acid-Schiff (PAS).

On Coomassie-stained gels, seven major bands are usually identified, whereas PAS stains four major bands and several minor ones (Fig. 6.15). Originally, the seven major protein bands were referred to by number. As further refinements in SDS-PAGE have produced greater resolution, other bands have been given decimal or alphanumeric designations, such as bands 2.1 and 4.2, sometimes with even further divisions such as in 4.1a and 4.1b. Most of these proteins are no longer identified by this numeric nomenclature because they have been given specific names as their chemical structures and membrane function have been defined. The major PAS-stained bands contain three proteins, two of which form both hetero- and homomultimers. These three proteins have been termed glycoporphins, or sialoglycoproteins, with letter designations that vary according to the investigator.^{373,374,375} and ³⁷⁶ Glycophorins A and B are proteins that are derived from highly homologous genes and form both homo- and heterodimers. Glycophorins C and D are two proteins produced by a single gene and are structurally unrelated to glycophorins A and B.

With recent advancements in mass spectrometry and the availability of protein databases, the field of proteomics has evolved. The proteome is the entire complement of proteins in a tissue, including all the particular modifications made to a given protein (phosphorylation, glycosylation, acetylation, ubiquitination, etc.). The RBC proteome contains hundreds of membrane and soluble proteins. The significance of erythrocyte protein patterns in normal, aging, and RBC disorders is currently an active area of investigation and should provide important information in the future.³⁷⁷ and ^{378,379}

Historically, as noted above, membrane proteins were first characterized by whether they were stainable by protein-binding or carbohydrate-specific dyes. Now, however, they are classified on the basis of their relationship to the membrane or their functions. One common classification of membrane proteins comprises the categories of integral membrane proteins and peripheral membrane proteins.³⁴⁵ Integral membrane proteins are most often globular and amphipathic; in their folded, three-dimensional form, they have distinct hydrophobic and hydrophilic domains. Of the major Coomassie-stainable proteins, bands 3, 4.5, and 7 are integral membrane proteins. These proteins have one or more membrane-spanning domains. Band 3 has several extracellular domains, of which some are highly glycosylated. Band 4.5 is the glucose transporter. All other Coomassie-stained bands are situated within the cell, either as part of the cytoskeleton or bound in a more or less loose fashion to the inner leaflet of the membrane. All the PAS-stainable proteins are integral membrane proteins. Integral membrane proteins require detergent for removal from the membrane, whereas peripheral membrane proteins can often be extracted from "ghosts" by manipulation of the pH and ion content of buffers and tend to be soluble in neutral aqueous buffers. Proteins attached by phosphatidylinositol anchors to the outer membrane layer also require detergents or other reagents capable of disrupting the lipid bilayer for solubilization.³⁴⁹

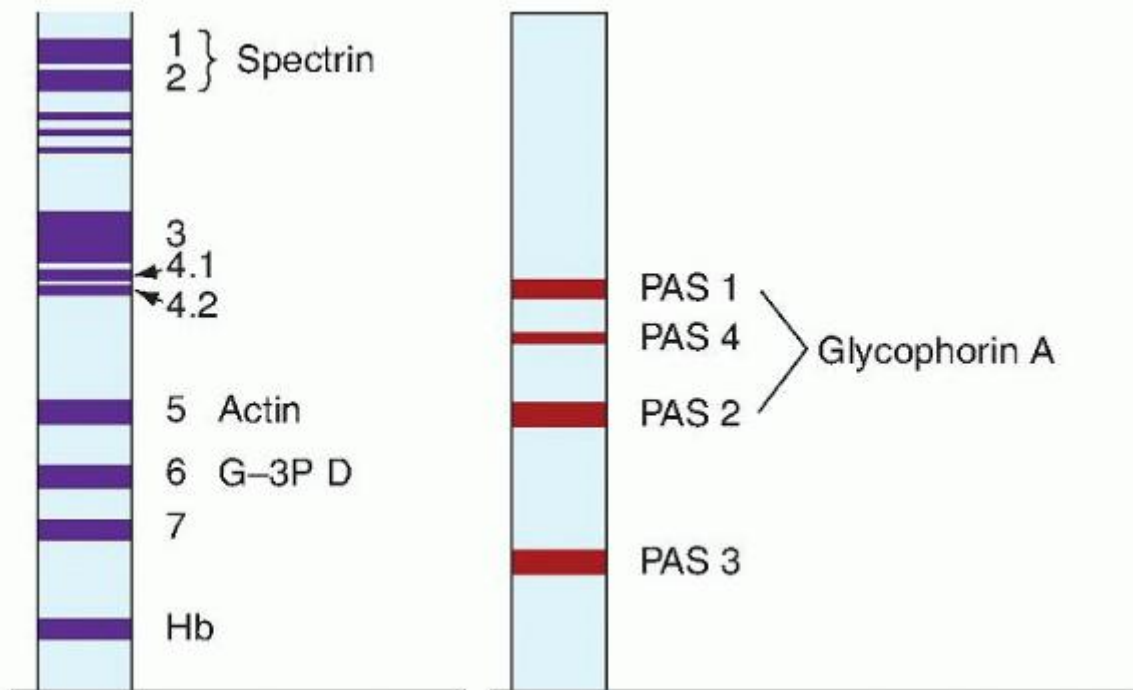

FIGURE 6.15. Polyacrylamide gel electrophoresis of erythrocyte membrane proteins. In this system, polypeptides migrate

according to molecular size, with the smaller molecules moving the farthest. Gels were stained with Coomassie Brilliant Blue (left) and periodic acid-Schiff (PAS) reaction (right). (From Steck TL. The organization of proteins in the human red blood cell membrane. *J Cell Biol* 1974;62:1, with permission.)

Transmembrane Proteins

The two predominant erythrocyte transmembrane proteins are glycophorin A (GPA) and the anion channel (AE1, formerly known as band 3). AE1 has a number of crucial roles in red cell biology, whereas the importance of GPA is less clear.

Glycophorin A is the principal PAS-stainable glycoprotein of erythrocyte membranes, accounting for approximately 85% of PAS-positive membrane protein. The N terminus of GPA bears the M or N antigen. GPA has also been found to be a binding site for several pathogens, including *Plasmodium falciparum*.³⁸⁰ Numerous variants of GPA have been described and may cause production of alloantibodies after transfusion. Rarely, some persons lack this protein totally. Although absence of GPA causes no clinically significant hematologic problems, persons with this deficiency may make antibodies that render blood transfusion difficult, given the general unavailability of blood from other GPA-deficient donors.

Glycophorin B, the second most abundant PAS-staining protein, is present on the erythrocyte in one tenth to one third the copy number of GPA.³⁸¹ Glycophorin B is highly homologous to GPA and the N terminus of glycophorin B carries the "N" amino acid sequence of GPA and always expresses the N antigen. At amino acid 29, within a region of glycophorin B that is less homologous to GPA, expression of methionine or threonine accounts for the S and s blood group antigens, respectively.

AE1, the erythrocyte anion-channel or anion-exchange protein, is expressed on erythrocytes in about the same copy number as GPA. Human erythroid AE1 cDNA has been cloned.^{382,383} The deduced cDNA sequence, as well as confirmatory biochemical analyses, has demonstrated that AE1 most likely traverses the membrane 12 times. It has several extracellular domains, but the fourth is the major bearer of carbohydrate. This domain is heavily glycosylated and bears carbohydrate blood group antigens, including I and i and the antigens of the ABO major blood group system. The function of AE1 relates to Cl-HCO₃ exchange and it also interacts with the erythroid cytoskeleton by binding ankyrin. Complete absence of erythroid AE1 is rare in humans and has been associated with severe hemolytic anemia and renal tubular acidosis. However, many different mutations of AE1 have been described in association with hereditary spherocytosis and other RBC membrane disorders associated with hemolysis (Chapter 27).

The Rh proteins are also important integral membrane proteins. Although they are present in only 100,000 copies per cell,³⁸¹ these proteins are clearly important both to erythrocyte biology as well as to transfusion medicine. The RhD protein is

P.105

the most immunodominant determinant of red cells outside the ABO antigens and is thus the only non-ABO determinant routinely taken into account when blood is selected for nonalloimmunized recipients. Absence of all Rh proteins, as in the Rh_{null} syndrome, is associated with multiple erythrocyte defects and mild hemolytic anemia.³⁸⁴ The proteins that carry the D, C (or c), and E (or e) Rh antigens are highly homologous to one another and traverse the membrane multiple times.³⁸⁵ Two Rh genes situated very near each other on chromosome 1 encode the proteins that bear Rh antigens; in a normal situation, one gene encodes the D antigen and the other encodes a protein that bears both the E/e and C/c antigens.³⁸⁶

Cytoskeletal Proteins

The most abundant of the peripheral proteins are those that make up the so-called spectrin-actin cytoskeletal complex, accounting for about 35% of the membrane protein. The complex includes large α and β spectrin polypeptide chains (bands 1 and 2 on gel electrophoresis, molecular weight about 240 and 225 kDa, respectively) and the smaller actin chain corresponding to band 5. The relationship between the integral and peripheral proteins of the membrane is illustrated in Figure 6.16.

Spectrin proteins are long, rod-shaped molecules that self-associate into a two-dimensional network with the help of other cytoskeletal proteins.³⁴⁷ The two forms of spectrin are homologous to each other; however, they are encoded by genes on two different chromosomes, chromosome 1 (α spectrin) and chromosome 14 (β spectrin).^{387,388} and ³⁸⁹ The α and β spectrin molecules form heterodimers by aligning in antiparallel pairs. These heterodimers then form tetramers by head-to-head association.³⁴⁷ Incorporation of these tetramers into the latticework of the cytoskeleton occurs with the interaction of other peripheral membrane proteins (Fig. 6.16).³⁴⁷

Erythrocyte actin, or band 5 as identified in Coomassie-stained gels of erythrocyte membrane proteins (Fig. 6.15), is an abundant erythrocyte protein of about 45 kDa. Like actin in skeletal muscle cells, erythrocyte actin can polymerize into filaments and can activate myosin ATPase activity. Actin filaments associate with spectrin tetramers at the ends containing the carboxy terminus of the α chain and the amino terminus of the β chain. This association, however, is a low-affinity interaction in the absence of other accessory proteins.

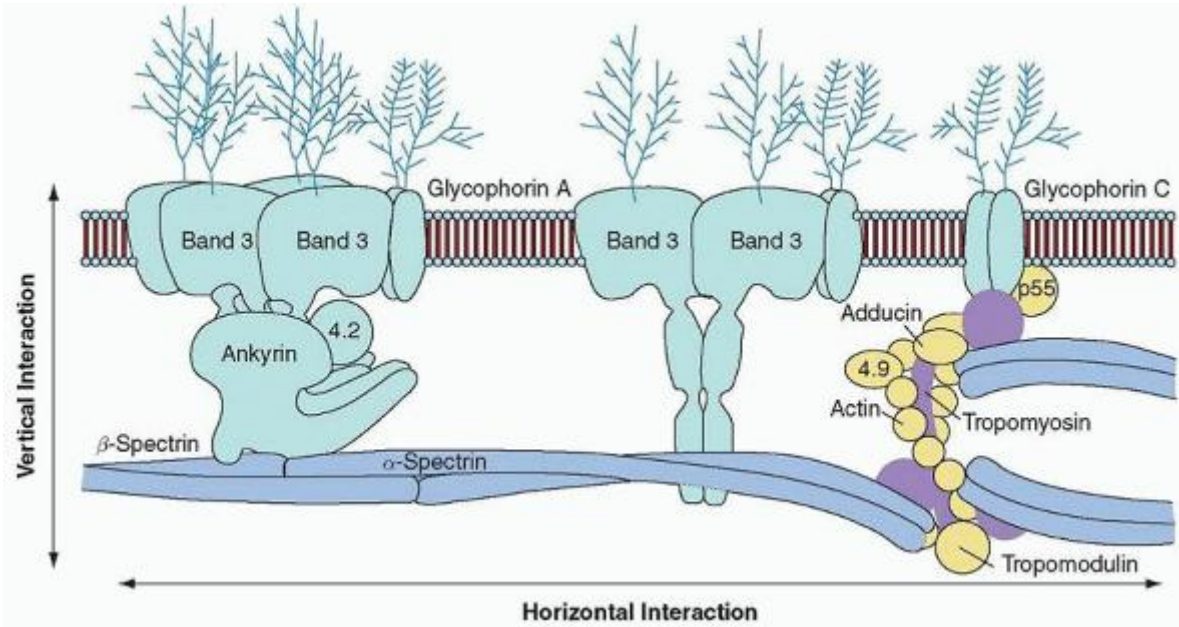

FIGURE 6.16. The erythrocyte membrane. A schematic model of the major proteins of the erythrocyte membrane is shown: α - and β -spectrin, ankyrin, band 3 (the anion exchanger), 4.1 (protein 4.1) and 4.2 (protein 4.2), actin, and glycophorin. Membrane protein-protein and protein-lipid interactions are often divided into two categories: (1) vertical interactions, which are perpendicular to the plane of the membrane and involve spectrin-ankyrin-band 3-protein 4.2 interactions and weak interactions between spectrin and the negatively charged lipids of the inner half of the membrane lipid bilayer; and (2) horizontal interactions, which are parallel to the plane of the membrane and include interactions between junctional complex proteins and spectrin or other membrane proteins. (Reprinted with permission from Tse WT, Lux SE. Red blood cell membrane disorders. *Br J Haematol* 1999;104:2.)

In addition to spectrin and actin, other cytoskeletal proteins are important for membrane stability and maintenance of cell shape. Protein 4.1 contains a spectrin-binding domain and is known to promote spectrin-actin interaction. Ankyrin (Protein 2.1) also serves as a mode of attachment of the cytoskeleton to the membrane.³⁹⁰ Ankyrin binds to both the anion exchanger band 3 and spectrin. As discussed in Chapter 27, deficiencies or abnormalities in these cytoskeletal proteins are associated with abnormal erythrocyte shapes, abnormal membrane stability, and hereditary hemolytic anemias.³⁹¹

Membrane Transport Proteins and Membrane Permeability

In general, the membrane acts as a partial barrier to penetration of all solutes. Nonpolar substances diffuse through the membrane at a rate proportional to their solubility in organic solvents. Polar solutes cross the membrane at specialized sites. The erythrocyte membrane has a number of specialized transport proteins, including the anion transporter (AE1, band 3), several cation transporters, a glucose transporter, and a water channel.

The red blood cell behaves as an osmometer; RBC water always is in osmotic equilibrium. In large part this occurs because erythrocytes have an abundant and highly active water channel protein, aquaporin-1, which contributes as much as 85% of the osmotic water permeability pathway.³⁹² Aquaporin-1, originally described as CHIP-28 (channel-forming integral protein-28 kDa), occurs as a homotetrameric protein that expresses on its extracellular domain both ABH and Colton blood group antigens and can be inhibited by a variety of mercurial compounds.³⁹³ Red cells that lack aquaporin-1 have only slightly reduced lifespan *in vivo*.³⁹²

There are several pathways that regulate water and solute homeostasis, the major determinant being the monovalent cation content. The erythrocyte membrane is only slightly permeable to the major monovalent cations (Na^+ and K^+) whereas it is much more permeable to monovalent anions (Cl^- and HCO_3^-). Cation

concentrations within the erythrocyte are approximately 130 mM K^+ and 8 mM Na^+ , whereas the plasma contains approximately 140 mM Na^+ and 4 mM K^+ . The steady-state cation concentrations within the erythrocyte are the result of an equilibrium between passive diffusion ("leak") and active transport ("pump"). With respect to sodium, the direction of leak is inward and the direction of pump is outward; in contrast, potassium leaks out and is pumped in. The major cation pump represents a process in which sodium inside the cell is exchanged for potassium on the outside and energy is supplied by ATP. For each molecule of ATP converted to ADP, three sodium ions are pumped out and two potassium ions enter.³⁹⁴ Active Na^+ and K^+ transport depends on the activity of the membrane protein Na-K ATPase. Anions cross the membrane by one of two pathways. The first represents an exchange reaction in which an internal anion is exchanged for an external anion. This rapid exchange is mediated by the band 3 anion-exchange protein and plays an important role in the chloride-bicarbonate exchanges that occur as the red cell moves between the lungs and tissues (Fig. 6.17).³⁹⁵ The second anion pathway represents considerably slower ionic diffusion, accounting for net loss or gain of anions in response to excess K^+ loss or Na^+ entry into the cell, respectively. It should be noted that anions are distributed passively across the cell membrane with steady-state concentrations determined by the Donnan equilibrium. Because the total cation content must equal the total anion charge, the presence of negatively charged impermeant intracellular anions (hemoglobin, 2,3-BPG, adenine nucleotides) influences the RBC monovalent anion content, and thereby explains why concentration of intracellular Cl^- and HCO_3^- is less than the intracellular monovalent cation content. Red cells have two additional monovalent transport processes that specifically result in KCl and water loss with a reduction in cell volume. KCl co-transport is stimulated by RBC swelling, leading to K^+ and Cl^- exit from the cell, with an obligatory water loss to maintain isotonicity.³⁹⁶ Of interest, KCl co-transport also is activated by urea.³⁹⁷ This pathway utilizes KCl co-transporters whose activity is determined by the protein phosphorylation/dephosphorylation state. This KCl transport pathway is particularly important in regulating cell volume, and is most active in reticulocytes. By decreasing the cell volume of reticulocytes the hemoglobin concentration is thereby increased to the levels seen in mature red cells. KCl transport is active in sickle and hemoglobin C disorders, and may account for some of the hydration abnormalities seen in these conditions. The calcium-activated K^+ channel was first described many years ago by Gardos.³⁹⁸ Under conditions where Ca^{+2} accumulates in red cells, there is a rapid loss of K^+ (and Cl^-) also causing cellular dehydration. This Gardos effect can be demonstrated in RBC of all ages. The physiologic function of the calcium-activated K^+ channel is not known. It too may be related to some of the RBC hydration changes that are seen in sickle cell anemia.³⁹⁹

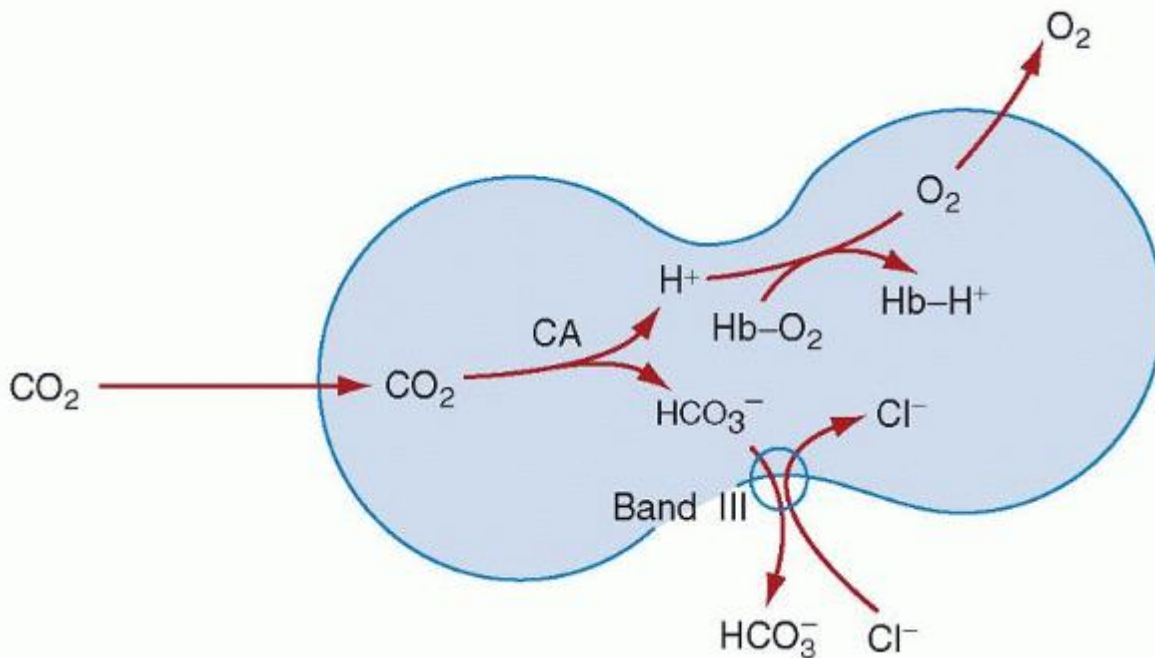

FIGURE 6.17. Role of band 3 in anion and CO₂ transport. The ability of band 3 to accelerate anion transport across the membrane allows rapid equilibration of bicarbonate with the extracellular plasma and concomitant influx of chloride ion. CA, carbonic anhydrase; Hb, hemoglobin. (From Kopito RR, Lodish HF. Structure of the murine anion exchange protein. J

Cell Biochem 1985;29:1, with permission.)

Glucose and other monosaccharides constitute an important exception to the generalization regarding nonpolar solutes in that the monosaccharides easily cross the membrane barrier, whereas the more lipid-soluble disaccharides do not. The speed of the process depends on molecular structure. Fructose is not transported under physiologic conditions ($K_m > 200$ mM). Glucose enters the erythrocyte by facilitated diffusion, mediated by a transmembrane protein designated the glucose transporter, encoded by the gene GLUT1.⁴⁰⁰ The glucose transporter has an asymmetric effect on glucose transit across the membrane: Glucose influx exhibits a higher V_{max} and a lower K_m than does glucose efflux. The transport of glucose into the erythrocyte provides the energy substrate for anaerobic glycolysis; however, the energy requirement of the erythrocyte appears to be relatively low, and the efficiency of glucose transport is relatively high. Therefore, glucose transport is not rate-limiting for glycolysis.^{401,402}

Membrane and Membrane-associated Enzymes

At least 50 enzymes are either membrane proteins or are bound to the erythrocyte membrane in some fashion; certain enzymes are both free in the cytoplasm as well as associated with the membrane. Their functions range from facilitating transport of a variety of molecules necessary to the erythrocyte to playing important roles in producing and using energy from glucose metabolism.

Some erythrocyte enzymes are externally oriented and can therefore react with substrates in the red cell environment. A classic example of an externally oriented enzyme is acetylcholinesterase, first of several membrane proteins discovered to be missing from the affected erythrocytes of patients with paroxysmal nocturnal hemoglobinuria (see Chapter 31).^{403,404} It belongs to a class of proteins that are attached to the membrane by a phosphatidylinositol-glycan anchor, so that the entire polypeptide portion of the molecule is extracellular.³⁴⁹ The role of acetylcholinesterase on the red cell remains obscure⁴⁰⁵; however, some other proteins in this class are complement regulatory proteins. It is the absence of these proteins that causes the characteristic hemolysis of paroxysmal nocturnal hemoglobinuria.⁴⁰⁴

Among the enzymes required for the production and use of ATP there are three that form a membrane-bound enzyme complex: Aldolase, glyceraldehyde 3-phosphate dehydrogenase (G3PD), and phosphoglycerate kinase. Together, these three enzymes convert fructose diphosphate to 3-phosphoglycerate with the production of ATP. G3PD is the enzyme present in greatest amount in membrane preparations and is seen as band 6 in polyacrylamide gels. G3PD is also found in the erythrocyte cytoplasm and can be demonstrated to bind to a cytoplasmic segment of band 3.

Enzymes that use and degrade ATP are also found in the membrane, although they are not present in large enough quantities to account for bands seen in Coomassie-stained polyacrylamide gels of membrane proteins. Like protein kinases, ATPases phosphorylate membrane proteins, but instead of forming phosphoserine or phosphothreonine bonds, they form acyl bonds as transient intermediates in the catalytic cycle. Important and well-studied ATPases of the erythrocyte membrane include $\text{Na}^+ - \text{K}^+$ ATPase, $\text{Ca}^{2+} - \text{Mg}^{2+}$ ATPase, and Mg^{2+} ATPase. The $\text{Na}^+ - \text{K}^+$ ATPase is also known as the sodium pump, or sodium-potassium pump.

Protein kinases are enzymes that phosphorylate other proteins in the presence of ATP by forming phosphoserine, or phosphothreonine bonds. Phosphorylation is a major step in the regulation of a variety of target molecules, including structural proteins and enzymes. Both red cell membrane-bound and cytosolic kinases may phosphorylate membrane proteins.⁴⁰⁶ In general, phosphorylated structural proteins demonstrate lower-affinity binding

P.107

to their target proteins than do unphosphorylated proteins. For example, phosphorylation of protein 4.1 leads to a decreased affinity for spectrin and a decreased ability of 4.1 to promote spectrin-actin association.³⁴⁷

HEMOGLOBIN AND ERYTHROCYTE FUNCTION

Hemoglobins are one of the most widespread and specialized hemoproteins existing in nature and have been found in prokaryotes, fungi, plants, and animals. These proteins permit the reversible binding of O_2 to heme while keeping the iron in the 2+ state. They also facilitate the exchange of carbon dioxide between the lungs and the tissues. Studies have also demonstrated the importance of hemoglobin in control of vascular tone mediated by NO. In vertebrates, hemoglobin is the major constituent of the red cell cytoplasm, accounting for about 90% of the dry weight of the mature cell.

In most invertebrates, oxygen-carrying pigment is transported freely in the plasma rather than within cells. This is an inefficient delivery system. Hemoglobin, as a protein free in the plasma, would exert an osmotic pressure about five times greater than that produced by the plasma proteins. By the inclusion of this pigment in corpuscles, the viscosity of the

blood can be maintained at a low level, water is not drawn from the tissues by it, and the flow of blood containing such a large amount of protein is made possible. Furthermore, free hemoglobin is not maintained in the circulation and is subject to oxidative denaturation. Attempts to make hemoglobin substitutes have revealed that infusion of free hemoglobin or derivatives causes a significant increase in blood pressure, as a result of the scavenging of NO produced by vascular endothelium.^{407,408}

In humans at rest, about 250 ml of oxygen are consumed and 200 ml of carbon dioxide are produced per minute. During exercise, these quantities increase tenfold. If the respiratory gases were carried in physical solution in the plasma, human activity would be restricted to only one fiftieth of that possible in the presence of hemoglobin-containing red cells. Red cell hemoglobin permits the transportation of 100 times more oxygen than could be carried by the plasma alone.

Evolution and Structure of Hemoglobin

Vertebrate hemoglobin is a conjugated protein with a molecular weight near 64.5 kDa. It is a tetramer, consisting of two pairs of similar polypeptide chains called globins, that exhibits a dyad axis of symmetry. Each of the four chains is covalently attached to a heme complex, ferroprotoporphyrin IX, which is a complex of iron and protoporphyrin⁴⁰⁹ (Fig. 6.18).

Human hemoglobins share a common ancestry with a simpler, single chain molecule that was similar to myoglobin. The divergence of the invertebrate and vertebrate globin genes occurred >670 million years ago, and the divergence of the α and non- α -globin genes probably descended from a common gene >450 million years ago.⁴¹⁰ Such an evolution would explain the high degree of homology between the α and non- α (ϵ , γ , β , and δ) chains, as well as the extraordinary similarities among the non- α globins. The non- α -globin gene family is sometimes designated the β -globin gene family. The α and non- α peptide chains most likely arose because of gene duplication, after which time the genes for these individual proteins evolved independently.^{411,412} The occurrence of subunit cooperativity (discussed below) brought with it the advantage of increased physiologic effectiveness of the hemoglobin molecule and added a new pressure on further evolution of the hemoglobin chains.⁴¹³

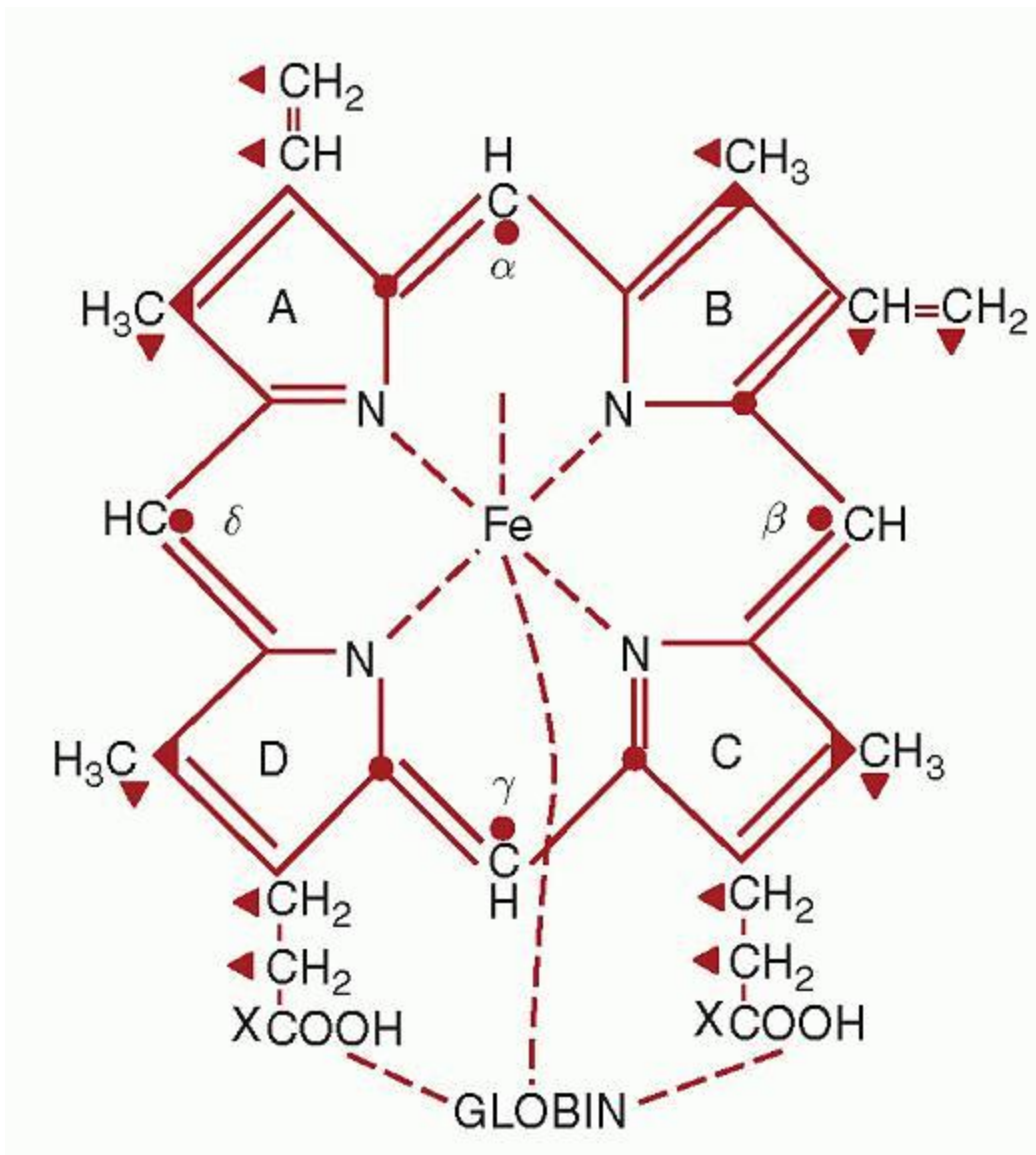

FIGURE 6.18. Chemical structure of heme and its manner of union with globin to form hemoglobin. The carbon atoms derived from the α carbon of glycine are represented by \bullet , those supplied from the methyl carbon of acetate by \blacktriangle and those derived from the carboxyl group of acetate by \times . The unmarked carbons are those derived from either the methyl carbon atom of acetate or from the carboxyl atom. (Prepared by Dr. G. E. Cartwright.)

Ontogeny of Hemoglobins

Erythroid development is divided into three developmental periods: embryonic, fetal, and adult. In each developmental period, the oxygen delivery requirements are different, and erythroid development has evolved to meet these needs. The genes that encode the α -globin gene family are on chromosome 16, whereas the genes that encode the members of the non- α -globin gene family are on chromosome 11.^{78,414} These genes are developmentally and coordinately regulated, and through the production of different pairs of globins, different hemoglobins are produced to permit their appropriate expression during different developmental periods. The α -globin gene cluster is capable of producing two types of globins, zeta (ζ) and α . The ζ is an embryonic globin chain produced during the first 8 weeks of fetal development, whereas α is produced during the remainder of the fetal and adult developmental periods.⁴¹⁵ The β -globin gene family members include the embryonic globin ϵ , the fetal globin γ , and two globins expressed primarily during the adult period, δ and β .

During early embryonic development, the expression of ζ - and ϵ -globin genes leads to the production and assembly of these globins into the embryonic hemoglobin Gower-1 ($\zeta_2\epsilon_2$).⁴¹⁶ α and γ globins are also produced at low levels during this period, and this permits the production of two other embryonic hemoglobins, designated Gower-2 ($\alpha_2\epsilon_2$) and Portland ($\zeta_2\gamma_2$).⁴¹⁷ These embryonic hemoglobins display subunit cooperativity and serve as physiologic oxygen carriers in erythroid

cells that were derived from yolk-sac hematopoietic progenitors.⁴¹⁸ Embryonic erythrocytes carrying these hemoglobins have an affinity for oxygen that is similar to fetal blood.

After the 8th week of development, erythropoiesis shifts from the yolk sac to the fetal liver, and the embryonic hemoglobins normally are not detectable in fetal blood.⁴¹⁹ Embryonic hemoglobins are replaced with hemoglobin F ($\alpha_2\gamma_2$), which remains as the predominant hemoglobin until after birth. The γ chains are encoded by pairs of genes located near the normal β -globin gene on chromosome 11. The two γ genes encode nearly identical proteins: G γ has a glycine at position 136, whereas A γ has an alanine.^{77,420} In addition, many A γ genes also encode a threonine-for-isoleucine substitution at position 75 of the protein.^{421,422} During fetal life, G γ constitutes about 75% of γ chains, whereas hemoglobin F in adults contains about 60% A γ chains.^{237,423} This has no known physiologic significance.

P.108

Red cells containing hemoglobin F have higher oxygen affinity than adult red cells. This permits the fetus to compete effectively for oxygen in the maternal blood. However, hemoglobin lysates from adult and fetal cells have nearly identical oxygen affinity when they are dialyzed against saline or a neutral buffer.⁴²⁴ This property of fetal hemoglobin is due to amino acid differences in the amino terminus of the γ chains that impair binding of 2,3-diphosphoglycerate (2,3-DPG, also known as 2,3-bisphosphoglycerate, 2,3-DPG), an allosteric modifier of oxygen binding.⁴²⁵ Hemoglobin F also has an enhanced alkaline Bohr effect,⁴²⁶ whereby oxygen affinity is increased as hemoglobin passes through the pulmonary vasculature.

At about 20 weeks of fetal development, the site of erythropoiesis begins to switch from the liver and spleen to the bone marrow, where progenitors show increased expression of adult globins, α and β . Hemoglobin A may constitute 5% of β -family globin expression during this time. Beginning at the 30th week and proceeding to the time of birth, a significant switch from fetal to adult erythropoiesis takes place, such that at the time of birth, fetal hemoglobin constitutes approximately 80% of the total hemoglobin. Over the next 25 to 30 weeks following birth, fetal hemoglobin concentration decreases by approximately 10% every 2 weeks until it reaches its normal adult level of <2% by 30 weeks of age.⁴²⁷ Neonates with hemoglobinopathies or erythropoietic stress can have a greatly prolonged production of hemoglobin F, sometimes extending into adulthood.⁴²⁸

Hemoglobin A, $\alpha_2\beta_2$, is the predominant adult hemoglobin and normally constitutes approximately 96% of the total adult hemoglobin. Hemoglobin A₂ is a minor hemoglobin produced beginning at 35 weeks of gestation but has little physiologic relevance. Hemoglobin A₂ is composed of α globins and the minor adult globin δ . It normally constitutes <3.5% of total adult hemoglobin; however, it is typically increased in β -thalassemias. Clinically, its major importance is its value in diagnosing β -thalassemias.⁴²⁹

Modifications of Normal Hemoglobin

Analysis of human red cell hemolysates by cation-exchange chromatography reveals several negatively charged minor hemoglobins that are designated A_{1a}, A_{1b}, and A_{1c}, corresponding to their order of elution. These hemoglobins are formed by the nonenzymic interaction of glucose with the α -amino groups of valine residues at the N terminus of the β chains of hemoglobin (Fig. 6.19).⁴³⁰

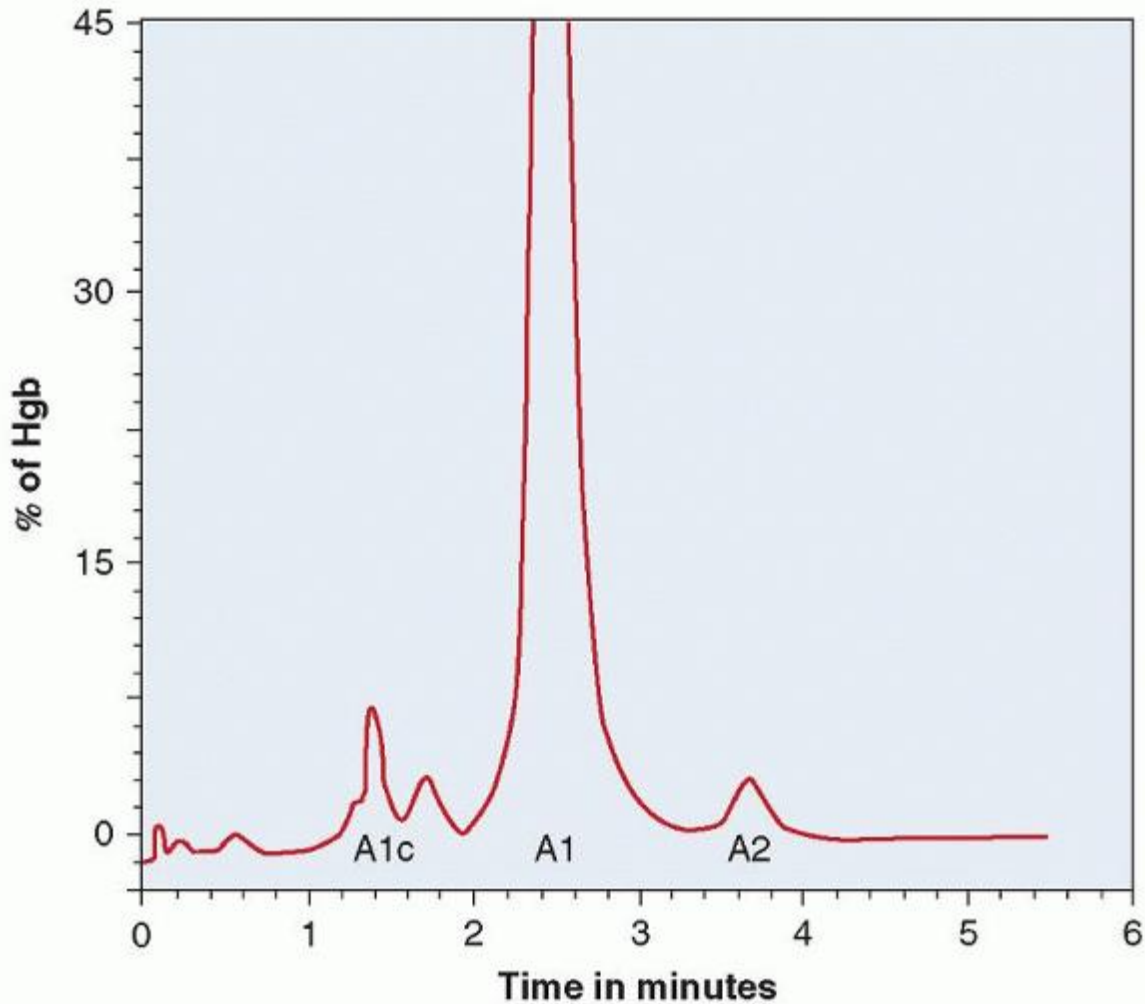

FIGURE 6.19. High-performance liquid chromatography showing modified Hb A variants. (Image provided through the courtesy of the copyright holder, Dr. Edward C. Klatt.)

The best characterized of the acquired variants is hemoglobin A_{1c}, which constitutes about 3.5% of the hemoglobin in normal subjects and may be increased two- to threefold in individuals with diabetes mellitus. Its level is directly proportional to the time-integrated mean blood glucose concentration over the life of the red cell, typically the preceding 2 to 3 months.⁴³¹ In the nonenzymic glycation of hemoglobin A, a molecule of glucose forms a Schiff base with the N terminal of the β chain, then undergoes an Amadori rearrangement to a stable ketamine, 1-amino,1-deoxy fructose.^{432,433} Because the glycated (or, as often called, glycosylated) hemoglobins are synthesized throughout the lifespan of the red cell, older cells contain a higher proportion of these modified hemoglobins than younger ones.⁴³⁴ Preferential destruction of older cells explains the observation that the proportion of hemoglobin A_{1c} is reduced in hemolytic anemia.⁴³⁵ Because the rate of synthesis of hemoglobin A_{1c} depends on the blood glucose level, the concentration of hemoglobin A_{1c} at any one time is proportional to the average blood sugar over the previous 2 to 3 months.⁴³⁶ For this reason, the level of hemoglobin A_{1c} is used widely as a measure of glucose control in diabetic patients, as well as a tool for diagnosis of diabetic states⁴³⁷). Clinical laboratories currently use a variety of assays to detect and quantify glycated hemoglobins, most commonly, high-pressure liquid chromatography.⁴³⁸ Commonly encountered hemoglobin variants, such as Hb S, Hb C, Hb E, and Hb F, can interfere with these assays, and may help explain discordant assay results.

Laboratory Analysis of Hemoglobins

Normal and variant hemoglobins can be detected and quantified by standard clinical laboratory techniques. Standard cellulose acetate electrophoresis performed at alkaline pH or isoelectric focusing (IEF) can detect most of the common variants.⁴³⁹ Usually, confirmation can be achieved by citrate agar electrophoresis, IEF, or high-performance liquid chromatography (HPLC). The analysis of hemoglobin A₂ and fetal hemoglobin levels deserves special attention because the levels of these components are indicative of common conditions affecting hemoglobin synthesis.

Hemoglobin A₂ normally constitutes <3.5% of the total hemoglobin in adults. In cases of β -thalassemia trait hemoglobin A₂ levels are increased, ranging from 3.6% to 8.0%.^{440,441} These subtle increases in hemoglobin A₂ that are characteristic of β -thalassemia trait cannot be quantified accurately by electrophoretic methods. Instead, most laboratories utilize HPLC or ion-exchange-resin microchromatography.⁴⁴² It is an error to use hemoglobin electrophoresis as the sole method to rule out β -thalassemia, and most large laboratories add the chromatographic quantification of hemoglobin A₂ as part of their routine hemoglobin analysis. HPLC provides a clear separation of hemoglobins A, F, and A₂ and this technology is commonly used in clinical laboratories.

Hereditary persistence of fetal hemoglobin (HPFH) and δ - β -thalassemia are types of β -thalassemia caused by deletion of δ - and β -globin genes, but distinguished from typical β -thalassemia by more balanced α - and non- α -globin chain synthesis resulting from an increase in γ -globin production. In both of these thalassemias, Hb A₂ levels are reduced as a result of deletion of δ -globin genes.

Elevated levels of hemoglobin F can be caused by thalassemias, disorders of hematopoiesis, or hereditary disorders of globin synthesis such as HPFH and δ - β -thalassemia.⁴⁴³ Diagnosis requires the precise measurement of hemoglobin F levels, which can be achieved in clinical laboratories by taking advantage of the resistance of hemoglobin F to alkali denaturation.⁴⁴⁴ This resistance to alkali denaturation of fetal hemoglobin is due to the greater stability under these conditions of α - γ -globin dimers compared to α - β -globin dimers.⁴⁴⁵ In lysates exposed to alkali under controlled conditions, only fetal hemoglobin remains undenatured, and its concentration can be quantified after the other denatured hemoglobins are removed from solution.⁴⁴⁶ Routine electrophoretic

P.109

procedures do not completely separate hemoglobin F from A, but a more adequate separation can be accomplished at pH 6.0 in agar gel, or more commonly by HPLC at present.^{447,448}

In adults, fetal hemoglobin is unevenly distributed in erythrocytes, being restricted to between 0.1% and 7% of total cells.⁴⁴⁵ Cells containing fetal hemoglobin are designated F or A/F cells, wherein the hemoglobin F concentration is normally between 14% and 25% of the total hemoglobin.⁴⁴⁹ In certain thalassemias and HPFH, the number of F cells is increased. This can be detected by acid treatment of erythrocytes on a glass slide followed by elution of the acid-sensitive hemoglobins (Kleihauer-Betke technique). Counterstaining can identify hemoglobin F-containing cells among a sea of ghosts.⁴⁵⁰

Examination of normal blood by the Kleihauer-Betke method demonstrates both colorless cells and fetal hemoglobin containing (light pink) cells that vary in intensity. By comparison, analysis of cord blood mixed with adult blood demonstrates that true fetal cells in cord blood stain intensely, reflecting the high level of fetal hemoglobin in fetal cells. This assay can be performed on maternal blood to detect fetomaternal hemorrhage or other contamination of the maternal circulation with fetal blood. This can also be tested using flow cytometry with a phycoerythrinconjugated antiglycophorin antibody to detect fetomaternal hemorrhage.⁴⁵¹

Structure of Globin

Proteins have at least four levels of structural organization: (a) primary structure, or the linear sequence of amino acids; (b) secondary structure, which describes how the amino acids within segments of the protein are spatially organized (e.g., by folding into an α helix or β -pleated sheet); (c) tertiary structure, which refers to the steric relationships of sequence domains separate from each other when analyzed as part of the linear sequence of the protein; and (d) quaternary structure, or the way in which several polypeptide chains join to form a single molecule.

The exact primary structure of all normal globin chains has been determined based on the DNA sequence of the individual globin genes,⁴⁵² and the polypeptide chains in hemoglobin differ from one another in amino acid sequence. The α chain contains 141 amino acids and the non- α chains, 146. The members of the non- α -chain family are more similar than any member of the non- α chain and any member of the α -chain family. The δ chain differs from the β chain in only 10 of the 146 amino acid residues, whereas the γ and β chains differ by 39 amino acids.

In spite of the differences in the primary structure of α and non- α -globin chains, their secondary structures are remarkably similar. Each has eight helical segments designated by the letters A through H.⁴⁵³ The helices of all the non- α -chain members are of identical length; however, a significant difference exists between the α - and non- α -globin chains in the region of the D helix, which contains seven amino acids in the ϵ , γ , δ , and β chains, but only two amino acids in the α chain. Because of the size of the D helix in the α -globin chains, many do not assign it a helix designation. The helices make up about 75% of the molecule. Interspersed between them are seven nonhelical segments: NA, AB, CD, EF, FG, GH, and

HC. This arrangement is important structurally, because the helices are relatively rigid and linear, whereas the nonhelical segments allow bending.

A given amino acid in a polypeptide chain may be denoted either by its sequential number or by a helical number. In the sequential system, amino acids are numbered from 1 at the N terminus to 141 at the C terminus in the α chain and from 1 to 146 in the β , γ , and δ chains. In the helical system, each amino acid is designated by a letter and a number that indicate the helix and the position in the helix, respectively. The helical system is gradually gaining favor, because it illustrates the homology between chains and has more structural significance. For example, the histidine to which heme attaches is amino acid #87 in the α chain and #92 in the β , γ , and δ chains; the helical designation for this histidine is the same in all the normal chains, F8.

The tertiary and quaternary structures of hemoglobin have been studied by x-ray diffraction techniques, especially by Perutz and co-workers.^{453,454} In aqueous solutions and in crystals, the polypeptide chains assume a structure in which the polar amino acids face the molecular surface, where they interact with water, rendering the molecule soluble. The groups directed toward the inner core of the molecule are all nonpolar, and the hydrophobic (van der Waals) bonding that occurs between them makes the structure stable. The resulting, roughly spherical, tertiary structure is similar for all the normal hemoglobin polypeptides (Fig. 6.20) as well as for certain other heme proteins, such as myoglobin.

The heme pocket is the site of many dynamic interactions involving oxygen binding to hemoglobin. Heme is suspended in a nonpolar crevice between the E and F helices (Fig. 6.20), and helices B, G, and H constitute the floor of the pocket. Heme iron forms a covalent bond with the imidazole nitrogen of the "proximal" histidine at F8. In addition, heme forms van der Waals bonds with many other parts of the molecule and in this way makes an important contribution to tertiary structure. If heme is extracted, the central helical regions, C, D, E, and F, unfold with a consequent decrease in solubility.⁴⁵⁵ Not surprisingly, some unstable hemoglobins (see Chapter 35) result from amino acid substitutions in the residues that line the heme pocket.⁴⁵⁶

The binding of oxygen to the iron molecule causes the hemoglobin molecule to undergo conformational changes that affect the binding of oxygen to other heme sites.⁴⁵⁷ In deoxyhemoglobin, the bond between the imidazole nitrogen of the proximal histidine and iron undergoes considerable strain, displacing iron from the plane of the ring. This strain is conveyed to other parts of the molecule and is in part responsible for the T or tense state of deoxyhemoglobin.^{458,459} The addition of two molecules of oxygen, which is bound to the iron atom in the heme ring by end-on geometry, results in the formation of a hydrogen bond between the oxygen atom that is not bound directly to the iron and the imidazole nitrogen of the histidine at E7 (the "distal" histidine).⁴⁵⁹ The binding of oxygen to iron changes the electron spin state of iron and relaxes the covalent bond with the proximal histidine, permitting the iron to move into the plane of the ring and relaxing the molecule, contributing to the R or relaxed state.⁴⁶⁰ The overall conformational changes to hemoglobin appear to be the greatest after three molecules of O₂ have been added. In general, proteins that undergo an allosteric change from the tense (T) to a relaxed (R) state are better able to interact with substrate in the relaxed state. As a result,

P.110

there are two quaternary structures for hemoglobin: one for the oxygenated form and one for the deoxygenated form.

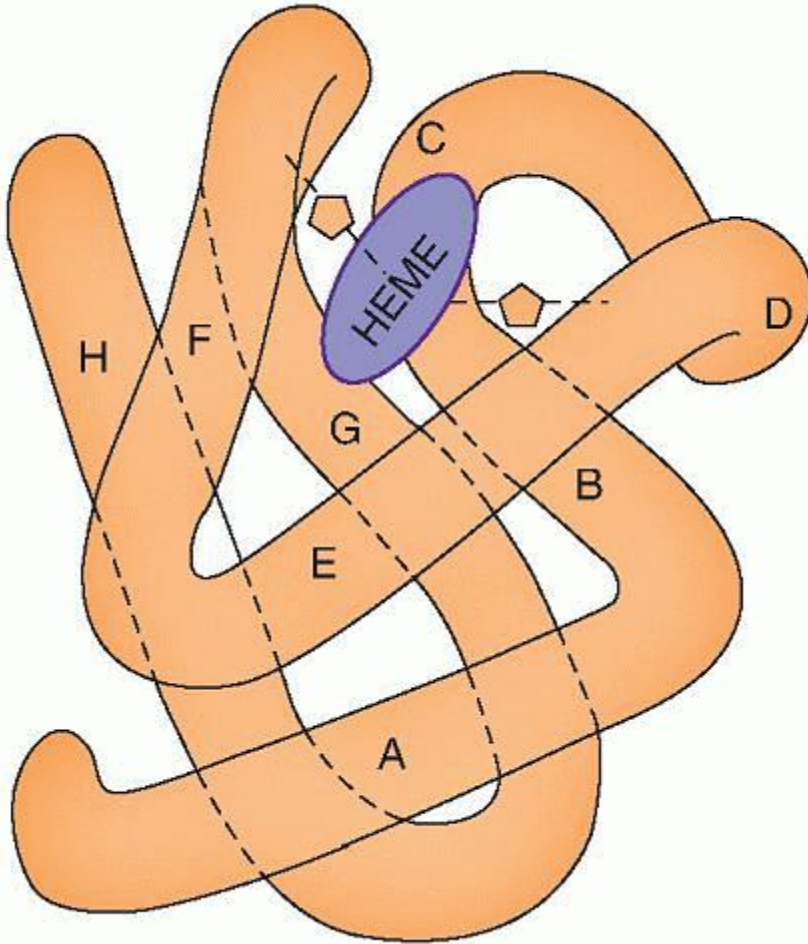

FIGURE 6.20. The tertiary structure of a single globin polypeptide chain. The helical segments, labeled A through H, are relatively linear; bending of the chains occurs between helices. Heme is suspended in a crevice between the E and F helices. (Courtesy of C.A. Finch.)

Assembly of Hemoglobin

In general, there is little posttranscriptional regulation of the synthesis of globins, although factors such as the availability of heme can affect translation of globin mRNA.⁴⁶¹ Aside from several variants, such as hemoglobin Lepore, which are synthesized at a slower rate, the synthesis rate of most normal or mutant globins is the same.⁴⁶² Nevertheless, individuals with β -chain variants often express less of the variant hemoglobin than hemoglobin A. This observation has been attributed to an increased rate of catabolism of newly synthesized globin chains resulting from decreased solubility, defective heme binding, or abnormal subunit assembly. The best data indicate that the variations seen in most stable hemoglobin variants result from differences in subunit assembly.^{463,464}

Following translation of globin mRNA and globin-chain synthesis, heme associates with globins and α -globin chains pair with members of the β -globin family. In large part this binding is a consequence of the different charges on α globins, which are positively charged ($pI = 8.1$), and β globins, which are negatively charged ($pI = 6.6$).⁴⁶⁵ The greater the charge difference, the greater is the electrostatic attraction. Positively charged variants, such as β_c and the uncharged β_s , bind to α globin and assemble into α - β dimers at approximately half the rate of β_A during in vitro mixing experiments.⁴⁶⁴ Conversely, more negatively charged variants such as $\beta_{N-Baltimore}$ bind with a greater association rate. This phenomenon has been suggested as an explanation for the ratio of 60:40 seen for hemoglobin A and hemoglobin S in heterozygotes for β_s .

In conditions of α -globin deficiency, this competition is more pronounced and the percentage of the more positively charged variant is further reduced. Patients who are heterozygous for β_s and α -thalassemia carry percentages of hemoglobin S of approximately 35%, 30%, and 25%, corresponding to one-, two-, or threegene α -thalassemia.⁴⁶⁶

Hemoglobin A₂ is decreased in certain α -thalassemias and sometimes in iron deficiency, which causes an acquired reduction in α -globin synthesis as a result of decreased heme synthesis. Under these conditions, the more positively charged δ globin would be expected to compete less well with the normal β globin. On the contrary, during β -globin deficiency associated with β -thalassemia, δ globin would be expected to compete more effectively for α -globin chains, and the predicted increase in hemoglobin A₂ is observed.⁴⁶⁷

Oxygen Transport

In order to function as the primary medium of exchange of oxygen and carbon dioxide, hemoglobin must fulfill the four requirements first delineated by Barcroft in the 1920s⁴⁶⁸: it must be capable of transporting a large quantity of oxygen, it must be highly soluble, it must take up and release oxygen at "appropriate pressures," and it must also be a good buffer. Normal hemoglobin fulfills these requirements well, although many abnormal variants fail to meet one or more of these conditions.

Each gram of hemoglobin, when fully saturated, binds 1.34 ml of oxygen. The degree of saturation is related to the oxygen tension (pO_2), which normally ranges from 100 mm Hg in arterial blood to about 35 mm Hg in veins. The relation between oxygen tension and hemoglobin oxygen saturation is described by the oxygen dissociation curve of hemoglobin (Fig. 6.21). The characteristics of this curve are related in part to properties of hemoglobin itself and in part to the environment within the erythrocyte, with pH, temperature, and concentration of 2,3-DPG being the most important factors affecting oxygen affinity.

Oxygen affinity of a particular hemoglobin is generally expressed in terms of the oxygen tension at which 50% saturation occurs, the so-called P_{50} . When measured in whole erythrocytes, this value averages about 26 mm Hg in normal nonsmoking males.⁴⁶⁹ When oxygen affinity increases, the dissociation curve shifts leftward, and the value for P_{50} is reduced. Conversely, with decreased oxygen affinity, the curve shifts to the right and P_{50} is increased.

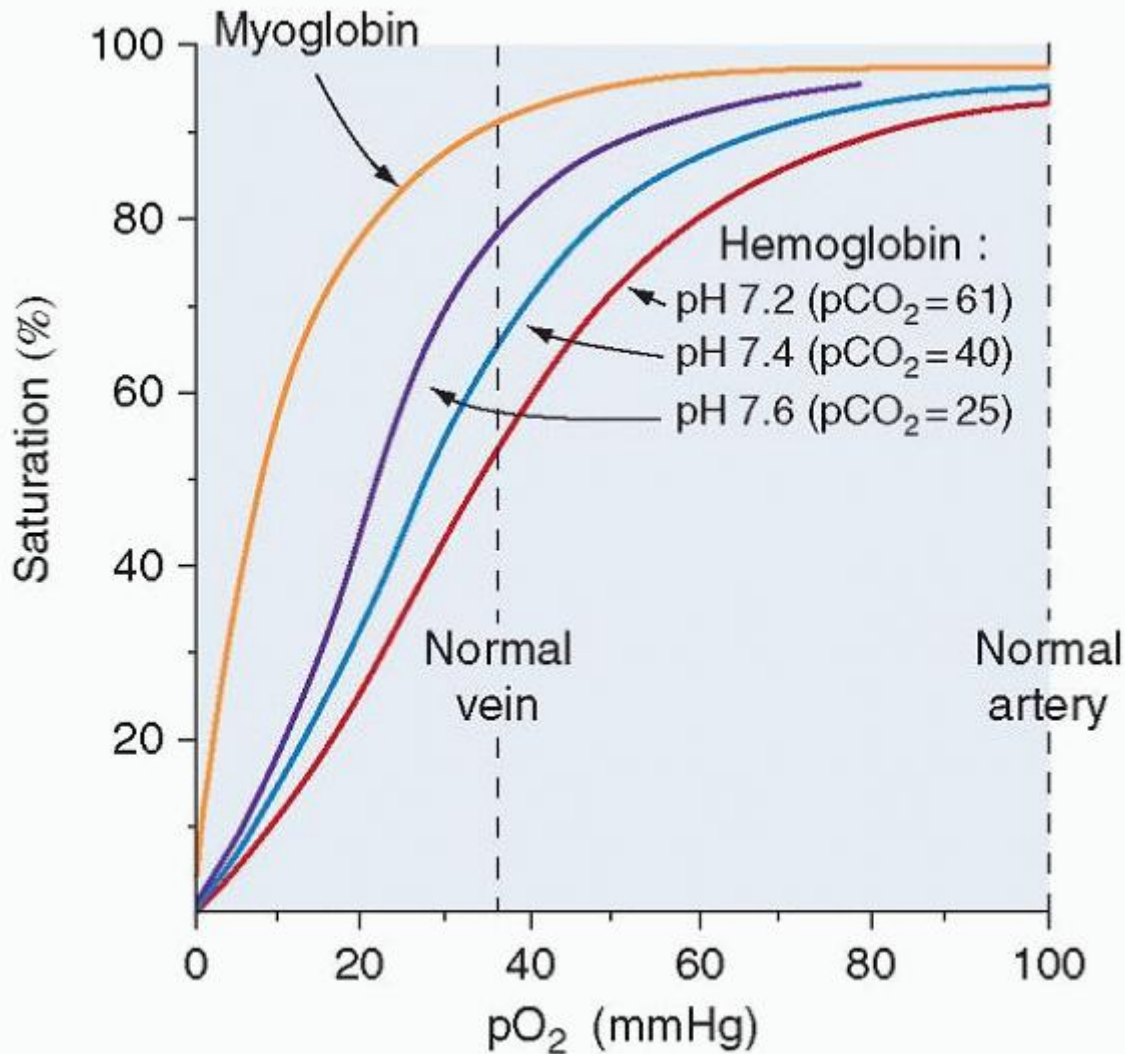

FIGURE 6.21. Oxygen dissociation curve of hemoglobin, at three values for pH, compared with that of myoglobin. $p\text{CO}_2$, partial pressure of carbon dioxide; $p\text{O}_2$, partial pressure of oxygen.

Regulation of Oxygen Affinity

The oxygen dissociation curve of single-subunit heme polypeptides (e.g., myoglobin) is hyperbolic, and oxygen affinity is considerably greater than that of hemoglobin (Fig. 6.21). In contrast, the oxygen curve of hemoglobin is distinctly sigmoidal; the steepest part of its slope occurs at levels of oxygen tension corresponding to those found in tissues. This difference between the hemoglobin and myoglobin curves is the result of interaction between the four heme-polypeptide units of hemoglobin. Although it was called heme-heme interaction in the past, subunit cooperativity better describes the process whereby the binding of oxygen by one subunit increases the oxygen affinity of other subunits; no direct interaction among heme moieties is involved. This allosteric property of hemoglobin permits rapid changes in oxygen affinity during the time the red blood cell passes through the capillary bed.

The change in oxygen affinity with pH is known as the Bohr effect.⁴⁷⁰ and ^{471,472} Hemoglobin oxygen affinity is reduced as the acidity increases (Fig. 6.21). Because the tissues are relatively rich in carbon dioxide, and because red cell carbonic anhydrase readily converts carbon dioxide to carbonic acid, the pH is lower there than in arterial blood; therefore, the Bohr effect facilitates transfer of oxygen to tissues. In the lungs, as oxygen is taken up and carbon dioxide is released, the pH rises and the oxygen-affinity curve shifts to the left. This event, termed the alkaline Bohr effect, increases the oxygen affinity of hemoglobin, helping to maximize oxygen uptake. Thus, the Bohr effect links and enhances the transport of both oxygen and carbon dioxide.

Another important factor affecting the oxygen affinity of hemoglobin is the concentration of 2,3-DPG.^{473,474,475} and ⁴⁷⁶ The molecule can insert into the pocket between β -globin subunits in tetrameric hemoglobin and reduces oxygen affinity. 2,3-DPG is synthesized from glycolytic intermediates by means of a pathway known as the Rapoport-Luebering shunt (Fig. 6.22). In the erythrocyte, 2,3-DPG is the predominant phosphorylated compound, accounting for about two thirds of the red cell phosphorus; in contrast, it is present in only trace amounts in other tissues.

The production of 2,3-DPG depends on the rate of formation of its precursor, 1,3-DPG, and the relative amounts of 1,3-DPG going

P.111

into the Rapoport-Luebering shunt and into the ATP-forming glycolytic pathway. Actual 2,3-DPG concentration also depends on the rate of hydrolysis of 2,3-DPG. It is the relative concentrations of ATP and ADP that are most directly linked to the rate of 2,3-DPG production. A relative increase in the amount of ADP is associated with an increase in the production of 3-phosphoglycerate and a decrease in 2,3-DPG. Two multifunctional enzymes (BPG mutase and BPG phosphatase/synthase) are important to the synthesis and degradation of 2,3-DPG. Both enzymes are capable of promoting three reactions: the synthesis of 2,3-DPG from 1,3-DPG; the breakdown of 2,3-DPG into 3-PG, water, and phosphorus; and the conversion of 3-PG to 2-PG.^{477,478} and ^{479,480}

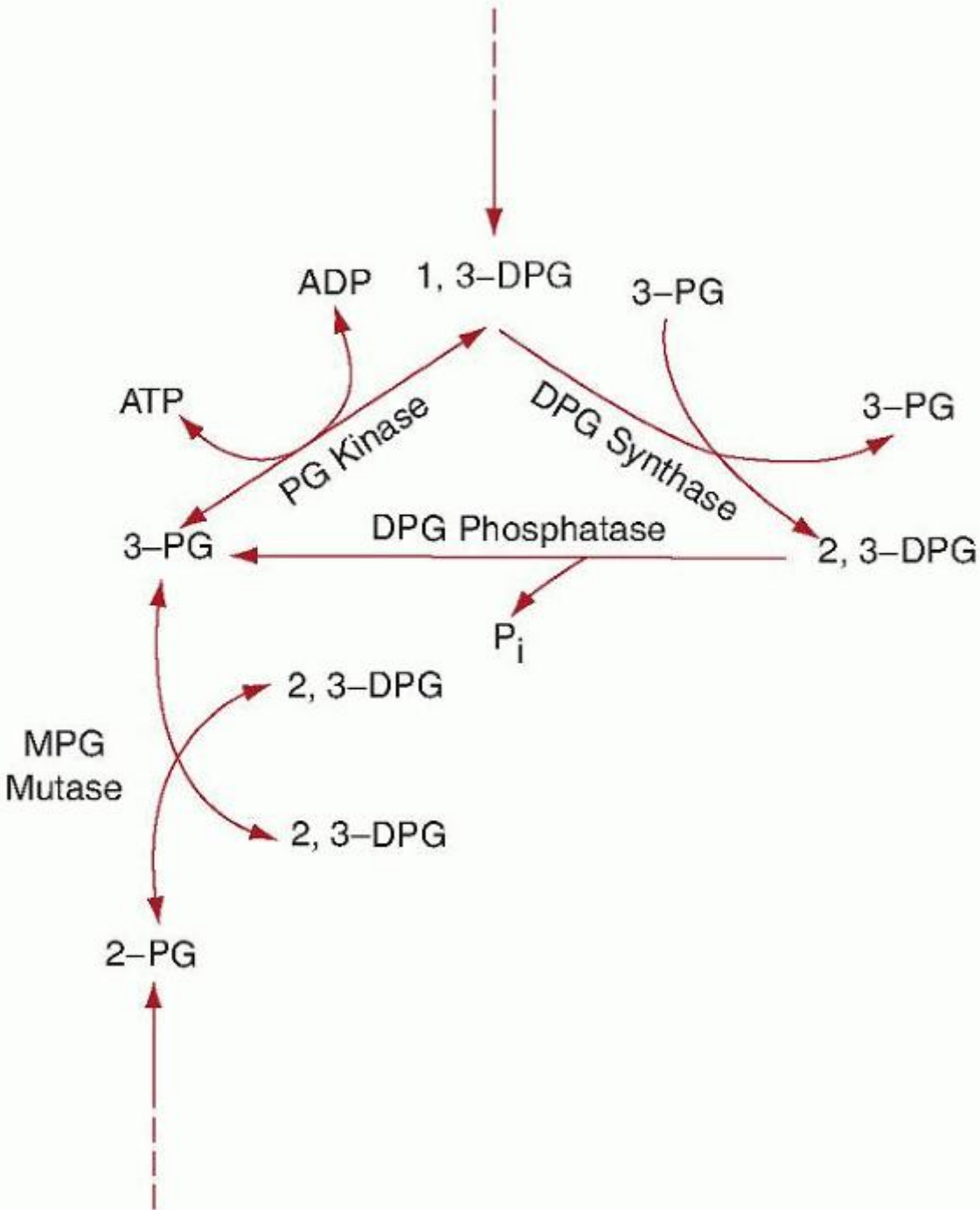

FIGURE 6.22. The synthesis of 2,3-diphosphoglycerate (2,3-DPG) or 3-phosphoglycerate (3-PG) and ATP from 1,3-diphosphoglycerate (1,3-DPG) by the Rapoport-Luebering cycle. (Modified from Keitt AS. Pyruvate kinase deficiency and related disorders of red cell glycolysis. *Am J Med* 1966;41:762-85 and from Bunn HF, Forget BG. Hemoglobin: molecular, genetic and clinical aspects. Philadelphia, WB Saunders, 1986.)

The most important function of 2,3-DPG is its effect on the oxygen affinity of hemoglobin. In the deoxygenated state, hemoglobin A can bind 2,3-DPG in a molar ratio of 1:1, a reaction that leads to reduced oxygen affinity and improved oxygen delivery to tissues. The increased oxygen affinity of fetal hemoglobin appears to be related to its diminished ability to bind 2,3-DPG.⁴⁸¹ The increased oxygen affinity of stored blood is accounted for by reduced levels of 2,3-DPG. Transfusion of such blood results in an *in vivo* increase in oxygen affinity that returns toward normal in 7 to 12 hours as the function of the glycolytic pathway is restored. The reduction in 2,3-DPG levels in stored blood can be mitigated by

adding inosine or phosphate to the storage solutions.⁴⁸² The actual clinical impairment in oxygen delivery resulting from low 2,3-DPG levels remains to be determined.

Changes in 2,3-DPG levels play a significant role in adaptation to hypoxia. In some situations associated with hypoxemia, 2,3-DPG levels in red cells increase, oxygen affinity is reduced, and delivery of oxygen to tissues is facilitated. Such situations include abrupt exposure to high altitude, anoxia resulting from pulmonary or cardiac disease, blood loss, and anemia.^{483,484} and ⁴⁸⁵ Increased 2,3-DPG levels also play a role in adaptation to exercise.⁴⁸² The compound is not essential to life, however; an individual who lacked the enzymes necessary for 2,3-DPG synthesis was perfectly well except for mild polycythemia (due to increased oxygen affinity). Heme-heme interaction, the Bohr effect, and the effect of 2,3-DPG have been explained on a molecular basis in a model proposed by Perutz.⁴⁵³ In the completely deoxygenated state, hemoglobin assumes a quaternary structure termed T ("taut" or "tense"). This structure is stabilized by salt bridges involving the carboxy terminals of the peptide chains. The deoxy form is also stabilized by the presence of 2,3-DPG, which joins the β chains.

The tertiary structure of deoxygenated subunits also differs from that of the oxygenated form. In the deoxy form, heme iron is in a high-spin state and, in this form, is displaced slightly from the plane of the porphyrin ring. The penultimate tyrosine is wedged firmly between the F and H helices. When oxygen is added, iron changes to a low-spin state and moves to a position in the plane with the porphyrin ring, a distance of about 0.2 nm, and pulls the attached F helix with it. This movement narrows the space between the F and H helices, expelling the penultimate tyrosine from its pocket. The C-terminal amino acid moves with the tyrosine, thereby breaking the salt bridges with adjacent chains.

Fully oxygenated hemoglobin assumes the R or "relaxed" structure (Fig. 6.23). The exact series of events that bring about this change, along with the change in oxygen affinity that accompanies it, has been difficult to ascertain, in part because of the large number of variables that need to be controlled (e.g., temperature, pH, 2,3-DPG concentration, and hemoglobin concentration) and the extraordinarily large number of thermodynamic measurements that need to be made.

Nevertheless, at least some of the molecular events that contribute to this shift in quaternary structure and oxygen affinity have been delineated.^{486,487} Hemoglobin appears to exist in a third molecular form, intermediate between the T and R conformations. Achievement of the R conformation occurs when at least one oxygen molecule is bound on each side of the $\alpha_1\beta_2$ interaction; however, significant subunit cooperativity also exists within each $\alpha_1\beta_1$ dimer of the T-state tetramer. Conversion to the R form is also accompanied by expulsion of the 2,3-DPG and disruption of the salt bridges and hydrophobic interactions at the $\alpha_1\beta_2$ contact point (Fig. 6.23). Oxygen affinity then becomes much increased, and oxygen is added to the remaining β chain or chains. Because hemoglobin A has four subunits, it might be expected that the switch from the T state to the R state would occur in four distinct steps. Experimentally, it appears to switch abruptly. This is best explained by the relationship of the four subunits. The α and β chains in the dimers have many more

P.112

contacts than the two dimers with each other, and the dimers can move onto each other. As oxygen is either loaded or unloaded onto the hemoglobin tetramer, tension is created, and the point where the two dimer subunits slide onto each other is determined by the concentration of the allosteric mediators in the cell, including pH, Cl^- concentration, and 2,3-DPG levels.

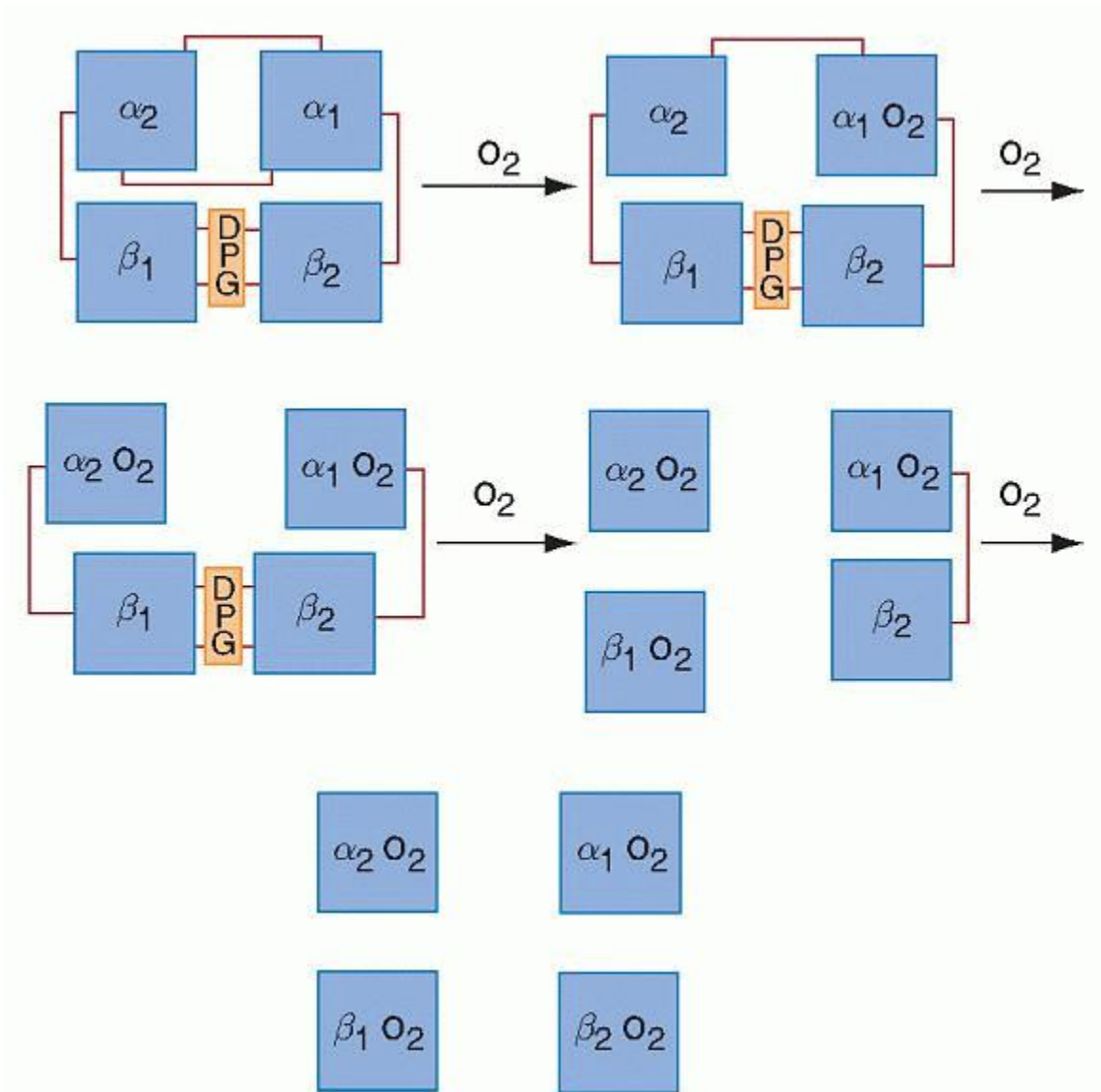

FIGURE 6.23. Diagrammatic representation of the subunit interaction in hemoglobin as oxygen is added. Deoxyhemoglobin (upper left), with low oxygen affinity, is in the T (taut) conformation, constrained by salt bridges (interconnecting lines) and the 2,3-DPG molecule. As O_2 is added, salt bridges are broken, and eventually the BPG molecule is expelled, resulting in the R (relaxed) configuration with higher oxygen affinity.

The alkaline Bohr effect is explained by rupture of the salt bridges involving the β -chain C-terminal histidine and the α N-terminal valine. When these bridges are broken, the pK of the dissociation of hydrogen ion is reduced. It has also been suggested that about 25% of the alkaline Bohr effect may be accounted for by histidine at $\alpha 122$.⁴⁸⁸

Carbon Dioxide Transport

Transport of carbon dioxide by red cells, unlike that of oxygen, does not occur by direct binding to heme.^{489,490,491} In aqueous solutions, carbon dioxide undergoes a pair of reactions:

1. $CO_2 + H_2O \rightarrow H_2CO_3$
2. $H_2CO_3 \rightarrow H^+ + HCO_3^-$

Carbon dioxide diffuses freely and rapidly into the red cell, where the presence of the enzyme carbonic anhydrase facilitates reaction 1. The H^+ liberated in reaction 2 is accepted by deoxygenated hemoglobin, a process facilitated by the Bohr effect. The bicarbonate formed in this sequence of reactions diffuses freely across the red cell membrane and a portion is exchanged with plasma Cl^- , a phenomenon called the chloride shift. The bicarbonate is carried in plasma to the

lungs, where ventilation keeps the $p\text{CO}_2$ low, resulting in reversal of these reactions and excretion of CO_2 in the expired air. About 85% of tissue carbon dioxide is processed in this way, and 5% is carried in simple solution.

The remainder of the CO_2 is bound to the N-terminal amino group of each polypeptide chain by a carbamino complex, the result of an attack by the electron-poor carbon atom of CO_2 on the electron-rich terminal amino acids. This nonenzymic process varies directly with pH. Approximately 10% of CO_2 is bound to deoxygenated hemoglobin, forming carbaminohemoglobin (Hb-NH-COO^-).

Earlier, the effect of CO_2 on oxygen affinity was noted and attributed to the Bohr effect. An additional, more direct, effect results from CO_2 binding to hemoglobin. At a given pH, carbaminohemoglobin has a lower affinity for oxygen than has hemoglobin in the absence of CO_2 . This is felt to be a result of the stabilization of the T state through additional bonds, especially involving arginine 141.⁴⁹²

The carbon dioxide dissociation curve is analogous to the oxygen dissociation curve, in that it depicts the relationship between CO_2 tension ($p\text{CO}_2$) and CO_2 content. It is somewhat more nearly linear than the oxygen curve, especially in the physiologic range ($p\text{CO}_2$ of 40 to 60 mm Hg). Because of the Bohr effect, blood containing deoxyhemoglobin has greater affinity for CO_2 than does oxygenated blood. The shift in the CO_2 dissociation curve related to this phenomenon, known as the Haldane effect, facilitates CO_2 binding in the tissues and release in the lungs (Fig. 6.24).

Carbonic anhydrase (CA) is the second most abundant cytoplasmic protein of the erythrocyte. It is a zinc-containing enzyme for which three separately encoded isoenzymes, CAI, CAII, and CAIII, are recognized. The predominant form in the human erythrocyte is CAI, although CAII is also found. Largely absent from fetal erythrocytes, erythrocyte CAI expression reaches adult levels during the first year of life, in a manner analogous to the expression of adult hemoglobin (hemoglobin A).^{493,494} Although carbonic anhydrase clearly facilitates carbon dioxide metabolism, its presence in erythrocytes does not appear to be essential. Carbonic anhydrase expression appears to be under endocrinologic regulation.⁴⁹⁵ Hereditary absence of CAI has been reported to occur without hematologic sequelae, and acquired deficiency is often seen with hyperthyroidism.^{496,497}

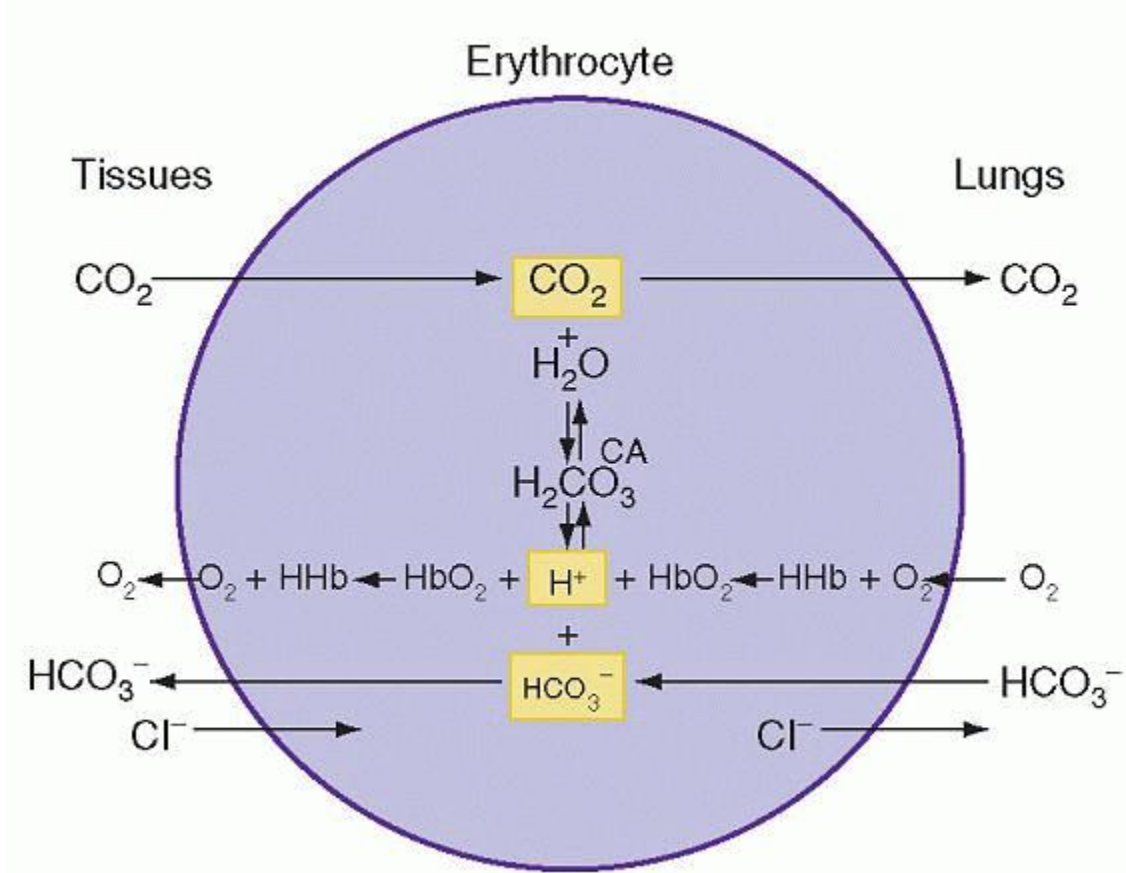

FIGURE 6.24. Interrelations of oxygen and carbon dioxide transport in the erythrocyte. Arrows to the left indicate direction of reactions taking place in the tissues; and those to the right, in the lungs. In the tissue, CO_2 diffuses into the red cell, and

its hydration is catalyzed by carbonic anhydrase (CA). Dissociation of the resulting carbonic acid produces bicarbonate and a proton (H^+). The bicarbonate is exchanged for chloride in the plasma. The proton is accepted by oxyhemoglobin (HbO_2), a reaction that, by means of the Bohr effect, facilitates the dissociation of oxygen. These reactions are reversed in the lungs because of the low pCO_2 and high pO_2 .

Nitric Oxide: Another Allosteric Effector of Hemoglobin

The discovery of nitric oxide as an important regulator of vascular and smooth muscle tone has provided many insights into our understanding of vascular physiology. Nitric oxide is produced by the vascular endothelium and relaxes muscles surrounding vessels, thereby controlling blood pressure. Subsequently, it was determined that free hemoglobin could act as a scavenger of nitric oxide and inactivate it, explaining the observation that the infusion of free hemoglobin results in significant elevations of blood pressure.⁴⁹⁸ This reaction occurs because oxygenated heme iron scavenges nitric oxide in a reaction that yields methemoglobin.

Early studies of the interaction of hemoglobin with NO predicted that a function of hemoglobin was to eliminate or limit the biologic activity of NO and did not predict any functional effect on hemoglobin other than the oxidation of heme iron. This model did not explain how NO could be maintained at observed levels based on its known low levels of production. This was clarified with the discovery of S-nitrosohemoglobin (SNO-Hb).⁴⁹⁹ When free hemoglobin is incubated with NO or S-nitrosothiols, S-nitrosothiols (SNOs) rapidly form on the two 93 β cysteines of hemoglobin rather than reacting with the oxygenated heme groups as might be expected. The infusion of the SNO-hemoglobin results in no increase in blood pressure.⁵⁰⁰

In the pulmonary circulation, coincident with oxygenation of hemoglobin, nitric oxide is added to hemoglobin, and rather than oxidizing the heme iron, it binds to the iron or forms SNO-Hb through the reactive sulfhydryl groups of cysteine 93 β of hemoglobin.^{501,502} This function for cysteine 93 β may explain why this amino acid is invariant in mammals and birds. Reactivity of nitric oxide with the SH groups of cysteine 93 β is controlled by the allosteric transition of hemoglobin and the spin state of heme iron. Thus, oxygen binding and conversion to the R state increase reactivity.⁴⁹⁹

Likewise, loss of oxygen in the peripheral tissues results in transition of hemoglobin to the T state and release of NO. NO is bound to either small thiols or the anion exchanger AE1. The latter is facilitated because hemoglobin can bind to the RBC membrane through specific, high-affinity binding to the amino-terminal cytoplasmic domain of the chloride/bicarbonate anion-exchange protein AE1 (band-3 protein).⁵⁰³ The amino terminus of AE1 inserts into the cleft usually occupied by 2,3-DPG.⁵⁰³ NO-mediated vasodilatory activity is released from AE1 by deoxygenation and NO then binds to receptors on the vascular endothelium to induce vasodilation. SNO-Hb is therefore detected

P.113

in arterial but not in venous blood. Several reviews have been published on the relationship of nitric oxide and SNO-Hb and the regulation of blood flow.^{504,505} and ⁵⁰⁶

Oxidative Denaturation of Hemoglobin: Its Reversibility and Prevention

Oxyhemoglobin in solution gradually undergoes auto-oxidation, becoming methemoglobin ($HbFe^{3+}$). To bind oxygen reversibly, however, the iron in the heme moiety must be maintained in the reduced (ferrous, Fe^{2+}) state, despite exposure to a variety of endogenous and exogenous oxidizing agents. The red cell maintains several metabolic pathways to prevent the action of these oxidizing agents and to reduce hemoglobin iron if it becomes oxidized. Under certain circumstances, these mechanisms fail and hemoglobin becomes nonfunctional. At times, hemolytic anemia supervenes as well. These abnormalities are particularly likely to occur (a) if the red cell is exposed to certain oxidant drugs or toxins, (b) if the intrinsic protective mechanisms of the cell are defective, or (c) if genetic abnormalities of the hemoglobin molecule affect globin stability or the heme crevice (see Chapter 35).

The oxidation of hemoglobin occurs in a stepwise fashion from fully reduced hemoglobin to fully oxidized hemoglobin. Intermediate forms are called valence hybrids. In deoxyhemoglobin, the heme iron is in the "high-spin" ferrous state, in which six electrons are in the outer shell, four of which are unpaired. When oxygen is added, one of these electrons is partially transferred to the bound oxygen. Usually, when oxygen is given up, oxyhemoglobin dissociates into partially deoxygenated hemoglobin and molecular oxygen:



A superoxide anion rather than molecular oxygen may dissociate, however, thus oxidizing the Fe to the ferric state, producing methemoglobin:

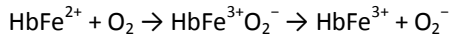

This type of dissociation is particularly likely if water gains access to the heme crevice. Methemoglobin formation may also occur in vivo as the result of exposure to superoxide anions:

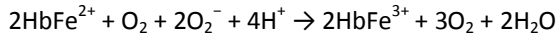

The formation of methemoglobin may also result from a direct reaction of reduced hemoglobin with the reduction product of the superoxide ion, peroxide:

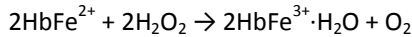

As a result of these processes, methemoglobin is formed in normal cells at the rate of about 0.5% to 3% per day.^{507,508}

Methemoglobin is unable to bind oxygen. It has a distinctive, pH-dependent spectrum (Fig. 6.25), and, in concentrations >10% of the total hemoglobin, imparts to blood a distinctive brownish hue that does not disappear on vigorous shaking in air.⁵⁰⁹ When methemoglobin is present in vivo in concentrations >1.5 to 2.0 g/dl, patients appear visibly cyanotic.

Methemoglobin combines readily with cyanide to form cyanomethemoglobin, a pigment so stable that it is used in laboratory procedures for quantifying hemoglobin.

As oxidative denaturation continues, methemoglobin is converted to derivatives known as hemichromes.^{508,510}

Hemichromes also may form directly from hemoglobin without methemoglobin as an intermediate. The hemichromes are low-spin, ferric compounds with a greenish hue and a characteristic spectrum (Fig. 6.25). They are formed when the sixth coordination position of iron becomes covalently attached to a ligand within the globin molecule, a change that requires alteration of tertiary protein structure. Probably the most common internal ligand is the "distal" histidine at E7. The compound so formed has been called a "reversible" hemichrome, because relatively mild treatment with reducing agents and dialysis under anaerobic conditions converts it to deoxyhemoglobin. It may not be reversible in vivo, however, because it cannot be reduced by methemoglobin reductase.

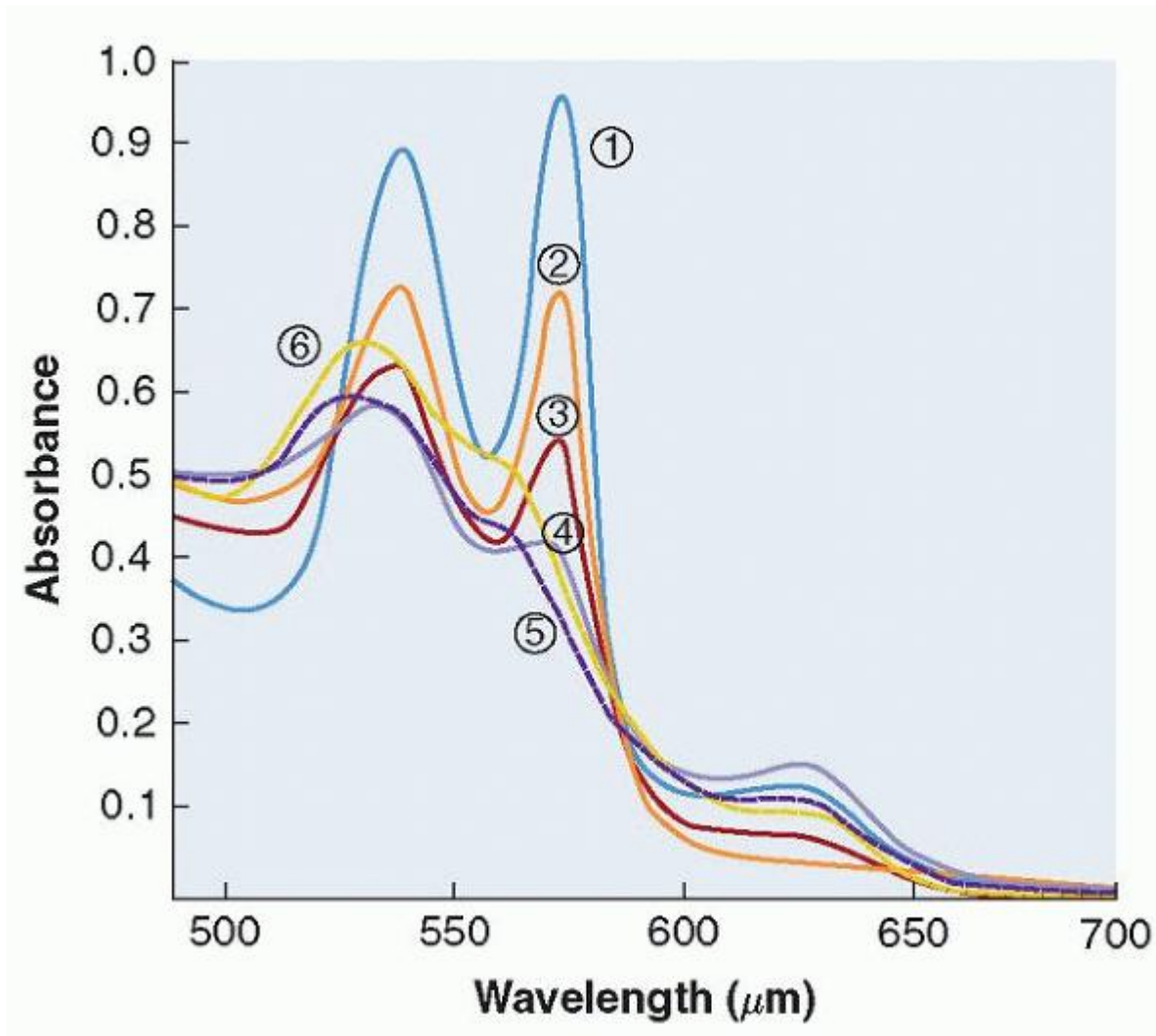

FIGURE 6.25. Change in hemoglobin spectrum as oxyhemoglobin changes to methemoglobin. The numbers 1 through 6 represent curves taken in sequence as oxidation proceeds. Note in particular the disappearance of the band at 575 μm and the appearance of the band at 631 μm .

In contrast, the “irreversible” hemichromes cannot be converted back to normal hemoglobin again *in vivo* or *in vitro*, implying that more severe distortions of tertiary protein structure have occurred. In one of the irreversible hemichromes, the histidine imidazole groups are protonated; that is, they participate in hydrogen bonding. The other irreversible hemichrome is characterized by a mercaptide and nitrogenous linkage at the fifth and sixth positions. Presumably, the mercaptide link is provided by a cysteine residue in the globin chain, perhaps at $\beta 93$.

As these changes occur in the vicinity of the heme group, oxidative changes also occur in other parts of the hemoglobin molecule. Once the cell's supply of glutathione (GSH) is exhausted, the titratable sulfhydryl groups at $\beta 93(\text{F9})\text{Cys}$ are oxidized, often forming a mixed disulfide with glutathione.⁵¹¹ This change is reversible; however, as further alterations in globin conformation occur, normally protected or “buried” sulfhydryl groups at $\beta 112(\text{G14})\text{Cys}$ and $\alpha 104(\text{G11})\text{Cys}$ become exposed and are oxidized, changes that disrupt the $\alpha_1\beta_2$ contacts. These changes facilitate dissociation of polypeptide chains, first into $\alpha\beta$ dimers and finally into monomers.⁵¹² In some instances, heme may dissociate from globin, particularly in the case of certain unstable hemoglobins.

The end products of these changes are precipitated hemichromes and precipitated heme-free globin. In intact erythrocytes, these precipitates take the form of globular inclusions known as Heinz bodies, which are not visible with ordinary Wright stain but can be seen easily after supravital staining with crystal violet or brilliant cresyl blue. Heinz bodies may become attached to the cell membrane and shorten red cell survival.

Another nonfunctional hemoglobin derivative that is occasionally formed during the oxidative denaturation of hemoglobin is sulfhemoglobin. This is a relatively stable pigment and, once formed, cannot be reconverted to hemoglobin *in vivo*.

Instead, it tends to remain within the cell throughout the cell's life. Sulfhemoglobin is bright green and has a distinctive spectrum characterized by an absorption band at about 618 nm. It is a ferrous compound with one sulfur atom attached to each heme group. The sulfur is probably attached to a β carbon in the porphyrin ring, forming a thiochlorin.^{511,513}

P.114

Although the exact mode of synthesis of sulfhemoglobin remains to be established, proposed models suggest that methemoglobin is first converted to ferrylhemoglobin in the presence of hydrogen peroxide.^{513,514}

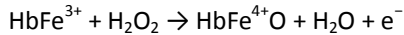

With the addition of a sulfur-containing compound, such as hydrogen sulfide, the iron in ferrylhemoglobin is reduced and sulfur is incorporated into the porphyrin ring:

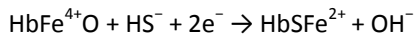

Although the iron in sulfhemoglobin is reduced, it binds oxygen with an affinity one hundredth that of unmodified hemoglobin.

Known mechanisms for preventing or reversing oxidative denaturation of hemoglobin in the erythrocyte include (a) the methemoglobin reductases, (b) superoxide dismutase, (c) glutathione peroxidase, and (d) catalase.

Methemoglobin Reduction

Most methemoglobin in erythrocytes is reduced through the action of an enzyme, cytochrome b_5 methemoglobin reductase, which acts in the presence of two electron carriers, cytochrome b_5 and NADH. Only a small amount of methemoglobin is reduced by all other pathways of methemoglobin reduction together. These other pathways involve two compounds that cause the nonenzymic reduction of methemoglobin, ascorbic acid and glutathione, as well as a second enzyme, NADPH-flavin reductase. Deficiency of cytochrome b_5 reductase, but not of NADPH-flavin reductase, is associated with methemoglobinemia, confirming that cytochrome b_5 reductase is the most important physiologic means of reducing methemoglobin.⁵¹⁵

Cytochrome b_5 reductase has been referred to by several other names, including diaphorase I, DPNH dehydrogenase I, NADH dehydrogenase, NADH methemoglobin reductase, and NADH methemoglobin-ferrocyanide reductase. Work in the 1940s established a relationship between the reduction of methemoglobin and the metabolism of lactate to pyruvate, thus implying an important role for NADH.⁵¹⁶ Eventually, two methemoglobin-reducing enzymes were isolated. The NADH-dependent enzyme, which was absent from several patients with methemoglobinemia, has been shown to be a flavoprotein, with one mole of FAD per mole of apo-enzyme. Its molecular weight is approximately 34 kDa. The reduction of methemoglobin by highly purified cytochrome b_5 reductase in the presence of NADH is extremely slow, implying that another factor is most likely required as an electron carrier. In vitro, this role can be filled by dyes or by ferrocyanide. In vivo, cytochrome b_5 acts as the intermediate electron carrier.⁵¹⁷ Erythrocyte cytochrome b_5 greatly accelerates reduction of methemoglobin by cytochrome b_5 reductase and can also serve as a substrate for hepatic microsomal cytochrome b_5 reductase. Congenital methemoglobinemia resulting from a deficiency in cytochrome b_5 has been described (Chapter 35).^{518,519} The process by which cytochrome b_5 reductase and cytochrome b_5 reduce methemoglobin in the presence of NADH probably involves three steps. In the first, NADH binds to the FAD-reductase complex and, in the presence of hydrogen ion, the NAD is converted to NAD^+ , and the FAD becomes FADH_2 . In the second step, cytochrome b_5 - Fe^{3+} is reduced to cytochrome b_5 - Fe^{2+} , and the FADH_2 reverts to FAD. Finally, methemoglobin forms a bimolecular complex with reduced cytochrome b_5 through electrostatic interactions between negatively charged groups around the cytochrome heme and positively charged groups around the heme moieties of methemoglobin. The reduction of methemoglobin then takes place as follows:

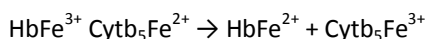

Of lesser physiologic importance is the enzyme system that depends on NADPH for its activity. It probably accounts for only about 5% of the methemoglobin-reducing activity of normal red cells, and its hereditary deficiency does not lead to methemoglobinemia.⁵¹⁸ The lack of physiologic activity may result from the absence of an intermediate electron carrier analogous to cytochrome b_5 . If methylene blue is supplied as the carrier, however, the NADPH-dependent enzyme becomes highly effective in methemoglobin reduction. This property is used in the therapy of methemoglobinemia from various causes.

Enzymes That React with Products of Oxygen Reduction

As molecular oxygen undergoes successive univalent reductions, a variety of reactive species is generated. These species constitute the oxidizing agents most likely to be responsible for the oxidative denaturation of hemoglobin, and they may damage other cellular components as well, especially lipid-containing elements such as the cell membrane.^{520,521} A variety of mechanisms has evolved in respiring organisms to deal with these potential toxins, and some are found within the erythrocyte.

Superoxide anions are produced in biologic tissues from several sources, including oxyhemoglobin itself, as well as oxidative reactions catalyzed by flavin enzymes, such as xanthine oxidase.⁵²¹ In addition, many drugs and toxins have oxidant activity and appear to generate superoxide.⁵²² Once superoxide has been generated in aqueous solution, additional toxic products of oxygen may form spontaneously (Fig. 6.26). Thus, superoxide can undergo spontaneous dismutation, yielding peroxide and oxygen:

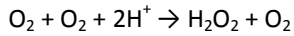

In addition, in the presence of catalytic quantities of transition metals, superoxide and peroxide may react to form the highly reactive hydroxyl radical (OH·):

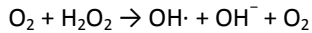

Any of these oxygen derivatives may exert toxic effects on cellular components. As previously noted, superoxide induces P.115

methemoglobin formation.^{523,524} Hydrogen peroxide is the most stable intermediate in the reduction of oxygen. Although hydrogen peroxide has often been shown to induce the oxidative denaturation of hemoglobin in vitro, whether it does so directly or by giving rise to other products, such as the hydroxyl radical, is not clear.

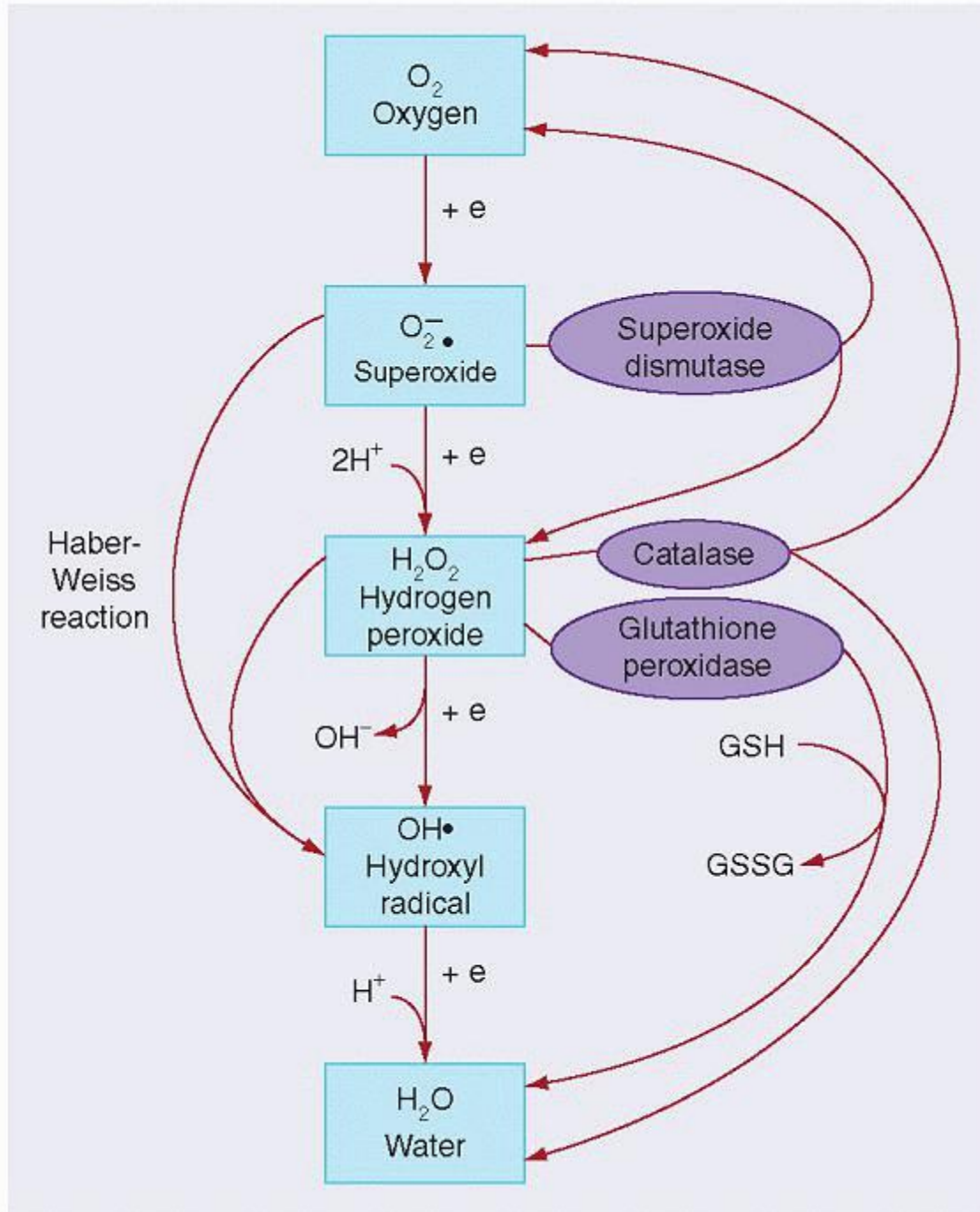

FIGURE 6.26. Steps in the univalent reduction of oxygen and enzymatic pathways affecting the intermediates. The enzymatic pathways, shown on the right, provide the means for processing these intermediates without formation of the highly reactive hydroxyl radical. This potent oxidant can be formed by the reaction shown on the left if superoxide and peroxide concentrations are sufficient and if catalytic quantities of transition metals are present.

The hydroxyl radical, one of the most potent redox agents known, may be generated from superoxide and peroxide, as described previously, and from peroxide in the presence of certain metals:



Thus, enzymes that scavenge superoxide and peroxide may be viewed as mechanisms for preventing the accumulation of these intermediates in sufficient quantities to allow the hydroxyl radical to form.^{525,526}

The superoxide dismutases are enzymes that catalyze the dismutation of superoxide to oxygen and peroxide. Although this reaction occurs spontaneously, the presence of the enzyme speeds the reaction to a rate as much as 109 times faster than the spontaneous rate.⁵²¹ In the erythrocyte, superoxide dismutase is a soluble, copper/zinc enzyme with a molecular weight of about 32 kDa. This enzyme, formerly known as erythrocuprein or hemocuprein, accounts for most of the copper content of the red cell. Once hydrogen peroxide is formed, two enzymes catalyze the decomposition of hydrogen peroxide in erythrocytes. These are glutathione peroxidase and catalase. Glutathione (GSH) peroxidase is a component of the following reaction^{413,527}:

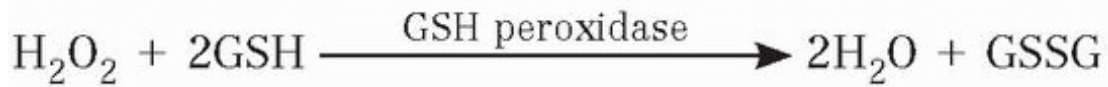

The enzyme is effective at very low concentrations of peroxide ($K_m = 1 \times 10^{-6}$ M).⁵²⁷

Glutathione peroxidase is the major human selenoprotein, which may account for the antioxidant properties of selenium as a micronutrient.^{528,529} Human cells grown in the absence of selenium express significantly reduced glutathione peroxidase activity, despite normal glutathione peroxidase mRNA and transcription levels. It had been proposed that a genetic defect in glutathione peroxidase may lead to a drug-sensitive hemolytic anemia.⁵³⁰ However, it is unlikely that acquired or genetic defects in this enzyme are associated with hemolysis (see Chapter 28).

Catalase, a heme enzyme, decomposes hydrogen peroxide to water and molecular oxygen.⁵³¹ It appears to be less important to the red cell than peroxidase, presumably because it is effective only when the peroxide concentration is relatively high.⁵³² Individuals with hereditary acatalasemia do not develop methemoglobinemia or hemolytic disease.^{533,534} Some evidence suggests, however, that erythrocyte catalase may be important in preventing oxidant damage to somatic tissues.⁵³⁵

Glutathione Metabolism

Reduced glutathione (GSH) is a tripeptide (γ -glutamyl-cysteinyl-glycine). Two ATP-dependent enzymatic reactions are required for the de novo synthesis of glutathione:

1. Glutamic acid + cysteine \rightarrow γ -glutamyl-cysteine
2. γ -Glutamyl-cysteine + glycine \rightarrow GSH

Reaction 1 is catalyzed by glutamyl-cysteine synthetase, reaction 2 by glutathione synthetase. Both reactions can take place in normal erythrocytes.⁵³⁶ The capacity of normal red cells to synthesize glutathione exceeds the rate of turnover by 150-fold. Deficiencies of both of these glutathione synthetic enzymes have been associated with hemolytic anemia (see Chapter 28).

In the course of reactions that protect hemoglobin from oxidation, GSH is oxidized, forming oxidized glutathione (GSSG), which consists of two GSH molecules joined by a disulfide linkage, and mixed disulfides with hemoglobin. GSSG rapidly leaves the erythrocyte.⁵³⁷ Thus, maintaining a continuous supply of GSH requires a system to reduce the oxidized forms of glutathione. Such a system is provided by glutathione reductase, which catalyzes the reduction of GSSG by NADPH, a product of the pentose phosphate pathway (Fig. 6.27). Glutathione reductase also catalyzes the reduction of hemoglobin-glutathione disulfides, yielding GSH and hemoglobin.⁵³⁸

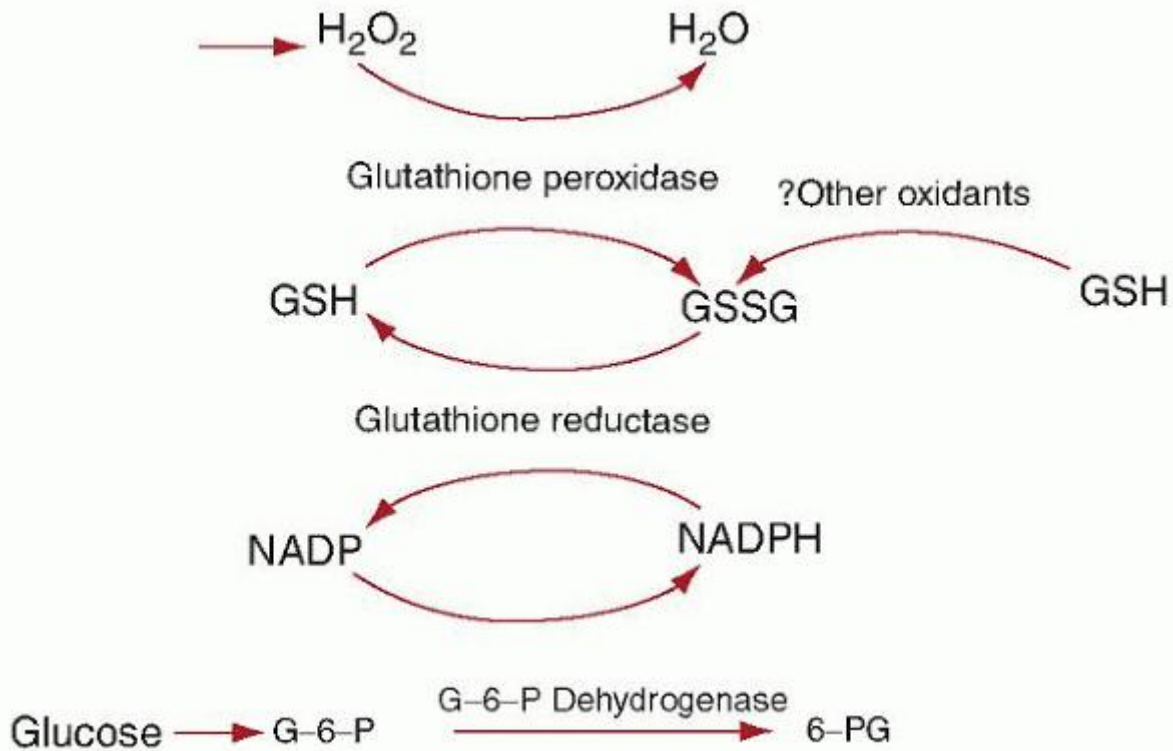

FIGURE 6.27. Glutathione metabolism in the erythrocyte.

The gene for glutathione reductase maps to chromosome 8. This enzyme is a flavoprotein consisting of two identical peptide chains of 478 amino acids. Because of its flavin component, the activity of glutathione reductase depends on the dietary intake of riboflavin. Erythrocyte glutathione reductase activity may be increased by administration of riboflavin, even in apparently normal subjects.⁵³⁷

Energy Metabolism

Lacking a storage compound, the normal erythrocyte must have constant access to glucose if its energy metabolism is to be sustained. As previously discussed, glucose enters the cell by means of a facilitated, carrier-mediated transport mechanism. Insulin or other hormones are not required, and transport is not ordinarily the rate-limiting factor in glucose utilization. Without mitochondria, erythrocytes must depend on two less efficient pathways for production of high-energy compounds, the anaerobic glycolytic (Embden-Meyerhof) pathway and the aerobic pentose phosphate pathway, also known as the hexose monophosphate shunt (Fig. 6.28). Under normal circumstances, about 90% of glucose entering the red cell is metabolized by the anaerobic pathway and 10% by the aerobic pathway.⁵³⁹ Under conditions of oxidative stress, however, the oxidative pentose pathway may account for up to 90% of glucose consumption.⁵⁴⁰

Three important products are formed by the anaerobic glycolytic pathway: NADH, a co-factor in the methemoglobin reductase reaction; ATP, the major high-energy phosphate nucleotide that powers the cation pump; and 2,3-DPG, a regulator of hemoglobin function (Fig. 6.28). For each molecule of glucose that enters the pathway, two molecules of NADH are generated (Fig. 6.29, reaction 6). The yields of ATP and 2,3-DPG vary depending on the activity of the Rapoport-Luebering shunt (Fig. 6.29, reactions 7b and 7c), a side pathway unique to the red cell. Two molecules of ATP are used in the early steps of glycolysis (Fig. 6.29, reactions 1 and 3), and a maximum of four molecules is produced late in the pathway (two in reaction 7a and two in reaction 10). Thus, at maximum efficiency, a net yield of two molecules of ATP may be expected for each molecule of glucose catabolized. This net yield may be decreased, however, to the extent that 2,3-DPG is formed (Fig. 6.29, reactions 7b and 7c). For this reason, the BPG-forming step is sometimes referred to as an energy clutch.

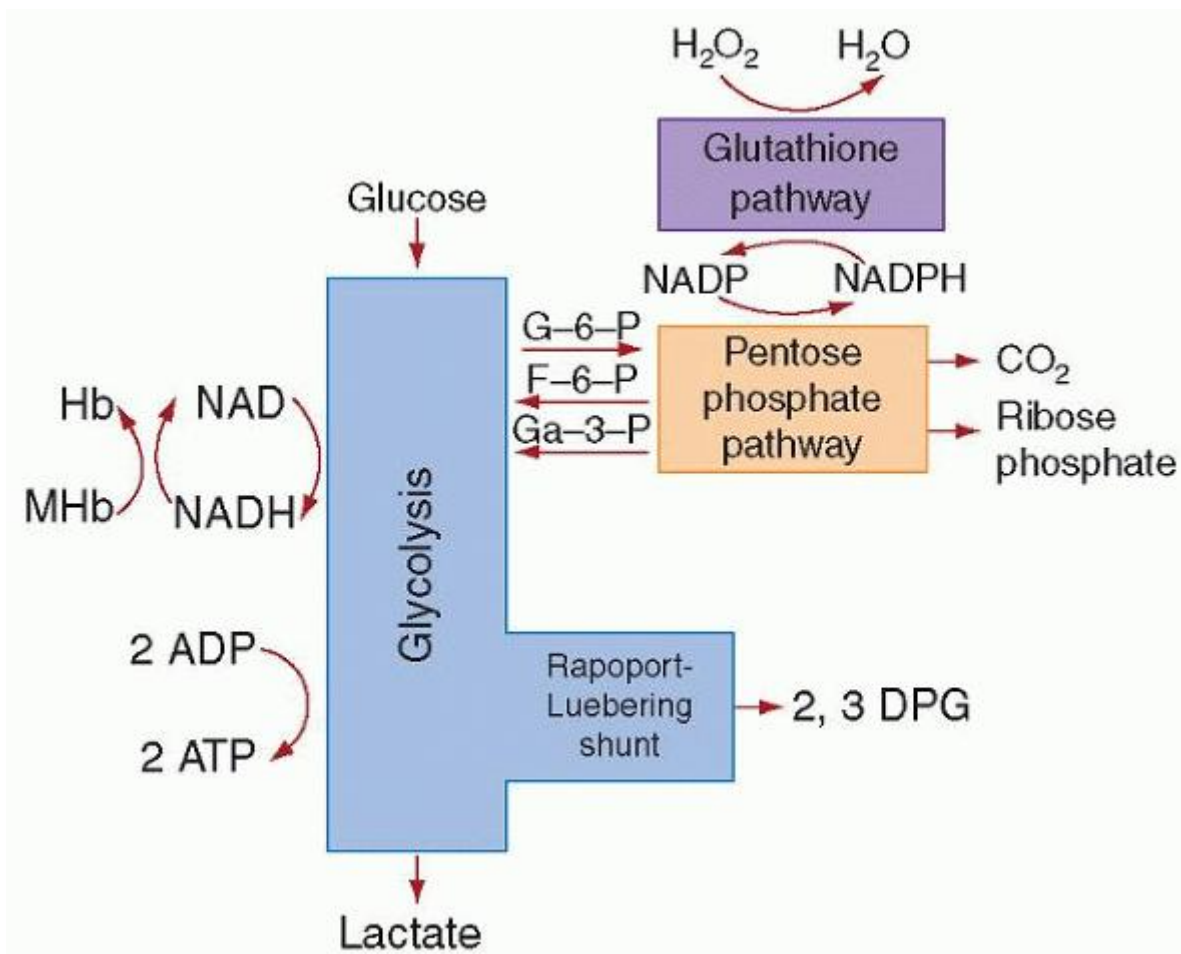

FIGURE 6.28. Energy metabolism in the erythrocyte. Main pathways are shown as boxes; major substrates and products of each are shown outside the boxes. More details of the pathways are given in Figures 6.27 and 6.29. ADP, adenosine diphosphate; ATP, adenosine triphosphate; 2,3-DPG, 2,3-diphosphoglycerate; F-6-P, fructose 6-phosphate; G-6-P, glucose 6-phosphate; Ga-3-P, glyceraldehydes 3-phosphate; Hb, hemoglobin; MHb, methemoglobin; NAD, NADH, nicotinamide adenine dinucleotide; NADP, NADPH, nicotinamide adenine dinucleotide phosphate.

Of the 11 enzymes in the glycolytic pathway, 3 appear to be particularly important in regulation of glycolytic rate. These are hexokinase, phosphofruktokinase, and pyruvate kinase (Fig. 6.29). Hexokinase is the least active enzyme in the series and is therefore often rate-limiting. It is inhibited by its product, glucose 6-phosphate, and is stimulated by one of its substrates, Mg-ATP. The activity of phosphofruktokinase is greatly affected by intracellular pH. Because the pH optimum of this enzyme is 8.0, the activity of the enzyme and the overall rate of glycolysis tend to increase with increased pH (alkalosis) and decrease with decreased pH (acidosis). Phosphofruktokinase may also be activated by the product of the further phosphorylation of fructose 6-phosphate.⁵⁴¹ Pyruvate kinase is strongly inhibited by its product, ATP, and pyruvate kinase activity may therefore be related to the rate at which ATP is used in the cell's metabolic processes.

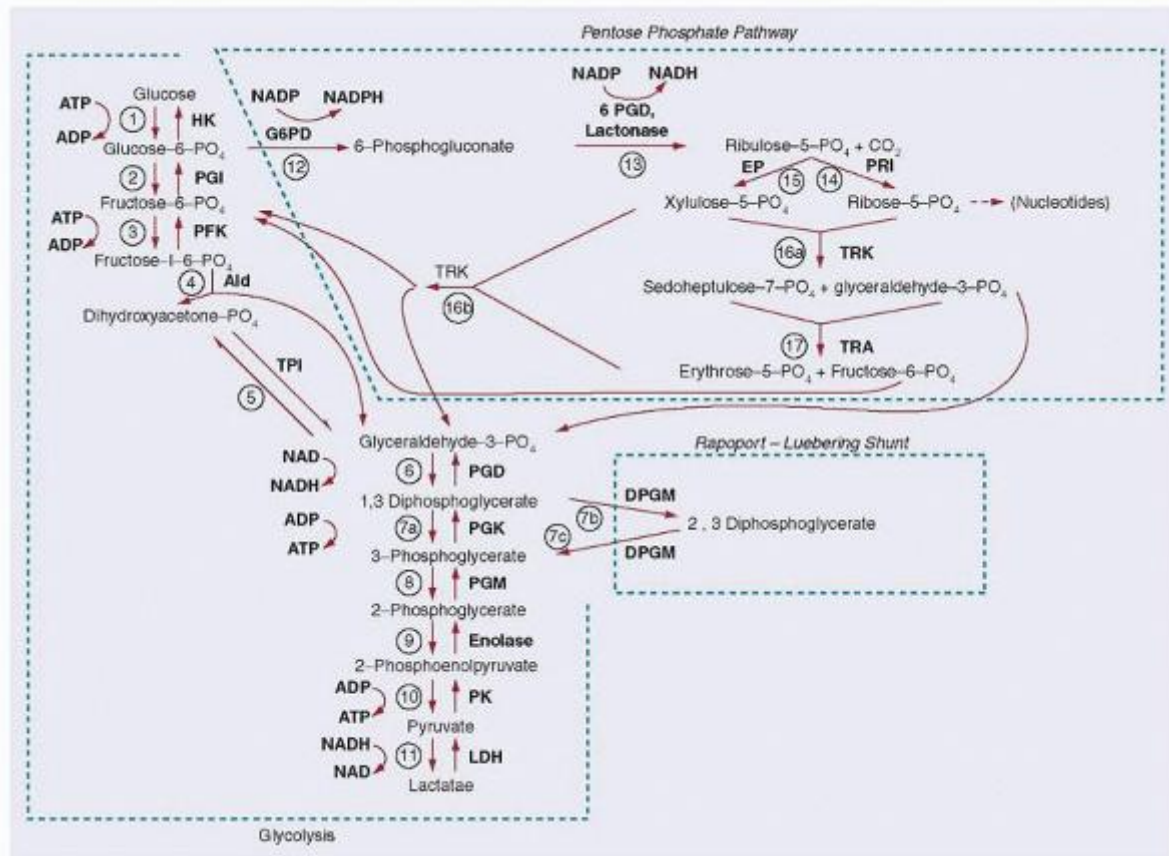

FIGURE 6.29. Energy metabolism in the erythrocyte. Circled numbers represent reactions referred to in the text. Enzymes are designated by abbreviations and are shown in bold to the right or above arrows representing reactions. Cofactors are shown in bold to the left of the arrows or above the enzymes. ADP, adenosine diphosphate; Ald, aldolase; ATP, adenosine triphosphate; DPGM, diphosphoglyceratemutase; Ep, epimerase; G6PD, glucose 6-phosphate dehydrogenase; HK, hexokinase; LDH, lactate dehydrogenase; NAD-NADH, nicotinamide adenine dinucleotide; NADP-NADPH, nicotinamide adenine dinucleotide phosphate; PFK, phosphofructokinase; PGD, phosphoglyceraldehyde dehydrogenase; 6PGD, 6-phosphogluconate dehydrogenase; PGI, phosphoglucose isomerase; PGK, phosphoglycerate kinase; PGM, phosphoglyceromutasetransaldolase; TRK, transketolase.

The importance of glycolysis to the red cell confirmed by the clinical phenotype of the hereditary deficiencies of any of the glycolytic enzymes, which is characterized by decreased red cell survival and consequent hemolytic anemia (Chapter 28).

The most important product of the pentose phosphate pathway in erythrocytes is reduced NADPH. In the red cell, NADPH, serves as a co-factor in the reduction of oxidized glutathione (GSSG), the major reducing agent in the cell and the ultimate source of protection against oxidative attack. The utilization of NADPH is the main stimulus to the utilization of glucose 6-phosphate by the pathway. Redox agents such as methylene blue, cysteine, ascorbate, and others induce up to a 20-fold increase in pentose metabolism, presumably by bringing about oxidation of glutathione.^{542,543} This metabolic flexibility allows the red cell to respond to unexpected oxidant challenge. The initial reaction of the pentose phosphate pathway is catalyzed by the enzyme glucose 6-phosphate dehydrogenase (G6PD). Hereditary deficiency of red cell G6PD is one of the most common genetic abnormalities in the world associated with hemolysis (Chapter 28).

P.117

A second function of the pentose pathway is the conversion of hexoses to pentoses. For the most part, the latter are recycled into the glycolytic pathway; however, D-ribose 5-phosphate may be used for nucleotide synthesis.

CELL DESTRUCTION

Mechanisms and Site of Red Cell Destruction

Each day approximately 1% of the body's red cells (3×10^9 cells/kg) die and are replaced by reticulocytes. Why red blood cells die after 100 to 120 days is not known. Through the years various hypotheses have been proposed to explain normal red cell death. The explanations have included changes in red cell enzymes and energy depletion with age; alterations in calcium balance; changes in membrane surface charge; oxidative injury; development of autologous antibodies to membrane antigens; and changes in membrane phospholipid asymmetry (see Wintrobe 12th edition for discussion of these hypotheses). No one of these changes explains RBC senescence and the mechanism of red cell senescence remains elusive. It may be that human erythrocyte aging and destruction results from a combination of the abnormalities noted above or from some as yet unrecognized phenomenon. Most certainly, emerging studies of RBC proteomics should help clarify the process of red cell death.

Under normal conditions, 80% to 90% of this normal erythrocyte destruction occurs without release of hemoglobin into plasma.^{544,545} Thus, most of the destructive process is considered to be extravascular, within macrophages of the spleen and, to a lesser extent, the liver and bone marrow. Approximately 10% to 20% of normal destruction is estimated to occur intravascularly.

Extravascular Hemolysis

Erythrophagocytosis appears to be the primary mode of extravascular destruction of senescent red cells.^{546,547} This is supported by two observations. Heme oxygenases responsible for heme degradation (primarily the inducible enzyme, HO-1) are located in the phagocytic cells of the spleen, liver, and bone marrow (and also in hepatocytes). Second, iron derived from heme degradation is largely stored within the macrophage. Thus, it seems that the processes of red cell destruction and hemoglobin degradation normally occur within these phagocytes. This is also true when red cell destruction is increased in the hemolytic anemias. Likewise, when red cells are damaged *in vitro* and then reinfused, they are mostly removed from the circulation by macrophages of the spleen and liver.⁵⁴⁸

The relative importance of the spleen and liver in erythrocyte destruction is influenced by the degree of cell damage.⁵⁴⁸ Severe red cell damage leads to their destruction in all macrophage-containing organs, but especially in the liver because of its greater blood flow. The spleen, in contrast, preferentially removes minimally damaged erythrocytes.⁵⁴⁹ Most senescent red cells are therefore likely destroyed in the spleen; however, after splenectomy, macrophages found in other organs, especially the liver, assume this function, and there is no increase in survival of normal red cells.⁵⁵⁰ Recent studies have cleverly attempted to assess splenic sensing and sequestration of spherocytic red cells, as occurs in a number of hemolytic anemias, such as hereditary spherocytosis (Chapter 27). Red cells were first treated with a phospholipid, lysophosphatidylcholine, which causes a dose-dependent decrease in the red cell surface area-to-volume (S/V) ratio through cell membrane loss. A decrease in the S/V ratio of more than 27% (resulting from a decrease in surface area of more than 18%) leads to rapid and complete sequestration of red cells during passage through freshly isolated human spleens.⁵⁵¹ Notably, the integrity of splenic parenchymal structure, blood flow, and metabolic activity is preserved during the *ex vivo* perfusion of these intact spleens for up to 6 hours, potentially allowing analysis of human red cell entrapment during physiologic or pathologic conditions.⁵⁵²

Intravascular Hemolysis

Analysis of haptoglobin kinetics in humans suggests 10% to 20% of erythrocyte destruction occurs intravascularly.^{544,545} Although both osmotic lysis and red cell fragmentation can cause intravascular destruction, it is unlikely that osmotic lysis plays a role in normal red cell destruction. Fragmentation is the loss of part of the cell membrane, usually accompanied by a loss of cellular contents, including hemoglobin. This is the characteristic mode of destruction in the "microangiopathic" hemolytic anemias (Chapters 32 and 48). The blood smear reveals small, misshapen, often triangular- or helmet-shaped cells (schistocytes or schizocytes). Fragmentation of red cells is usually due to interactions with injured endothelium, or results from fibrin deposition or increased shear stresses. In response, the cell membrane is capable of limited self-repair. Fragmentation also occurs when reticulocytes are pitted with inclusions, such as residual organelles and hemosiderin granules during passage through the spleen. The enucleation of erythroblasts that normally occurs in the bone marrow may also contribute to hemoglobin release into the circulation, a process that may be increased with ineffective erythropoiesis.

FATE OF INTRAVASCULAR HEMOGLOBIN

Intravascular hemolysis is increased significantly in certain hemolytic anemias (e.g., sickle cell disease, thalassemias, paroxysmal nocturnal hemoglobinuria [Chapters 31 and 34], during infections (e.g., malaria or sepsis due to *Clostridium perfringens*), or trauma. The hemoglobin released into the plasma is pro-oxidant and thus potentially toxic, promoting, for example, the formation of hydroxyl radicals via the Fenton reaction ($\text{H}_2\text{O}_2 + \text{Fe}^{2+} \rightarrow \text{Fe}^{3+} + \text{OH}\cdot + \text{OH}^-$), and oxidative tissue damage.⁵⁵³ In addition, plasma hemoglobin is a potent scavenger of nitric oxide (NO), mediating its nitrosylation to

produce methemoglobin and nitrate. NO serves as an important regulator of smooth muscle tone (of special relevance in small blood vessels), platelet activation and aggregation, and endothelial integrin expression. Intravascular hemolysis may therefore result in smooth muscle dystonias, endothelial dysfunction, and thromboses, problems commonly encountered in sickle cell disease^{554,555} and paroxysmal nocturnal hemoglobinuria.⁵⁵⁶ Fortunately, there are several physiologic mechanisms to remove free hemoglobin from the circulation (Fig. 6.30).

Haptoglobin

At low rates of release of hemoglobin into the circulation, it is completely bound by haptoglobin (Hp), and, once irreversibly bound to haptoglobin, loses its oxidizing ability.^{553,557} Once released from red cells into the plasma, tetrameric hemoglobin rapidly dissociates into $\alpha\beta$ dimers that bind haptoglobin tightly in a noncovalent manner ($K_d \sim 1$ pM).⁵⁵⁸ Heme-free globin (but not heme) can also be bound by haptoglobin.⁵⁵⁹ Binding of hemoglobin by haptoglobin prevents H_2O_2 -mediated peroxidative modifications to the hemoglobin molecule,⁵⁶⁰ allowing productive interactions of the Hp-Hb complex with the receptor, CD163 (see below). The role of haptoglobin as a hemoglobin-binding protein and as the principal factor affecting the apparent "renal threshold" for hemoglobin was originally described by Laurell and Nyman.⁵⁶¹

Haptoglobins are a family of α_2 -glycoproteins that bind hemoglobin.⁵⁶² The tetrameric molecule is comprised of two dimers of an α chain (containing a complement control protein or sushi

P.118

domain) and β chain (with a serine protease domain) linked in humans by disulfide bonds to form $(\alpha\beta)_2$.^{563,564} The gene, located on chromosome 16q22,^{565,566} and⁵⁶⁷ encodes a single polypeptide chain that is cleaved posttranslationally to generate the α and β subunits.^{568,569} Transcriptional activity is promoted by IL-1, IL-6, and glucocorticoids as a part of the acute-phase response to systemic inflammation,^{570,571,572} and⁵⁷³ explaining why haptoglobin levels are increased with inflammation.

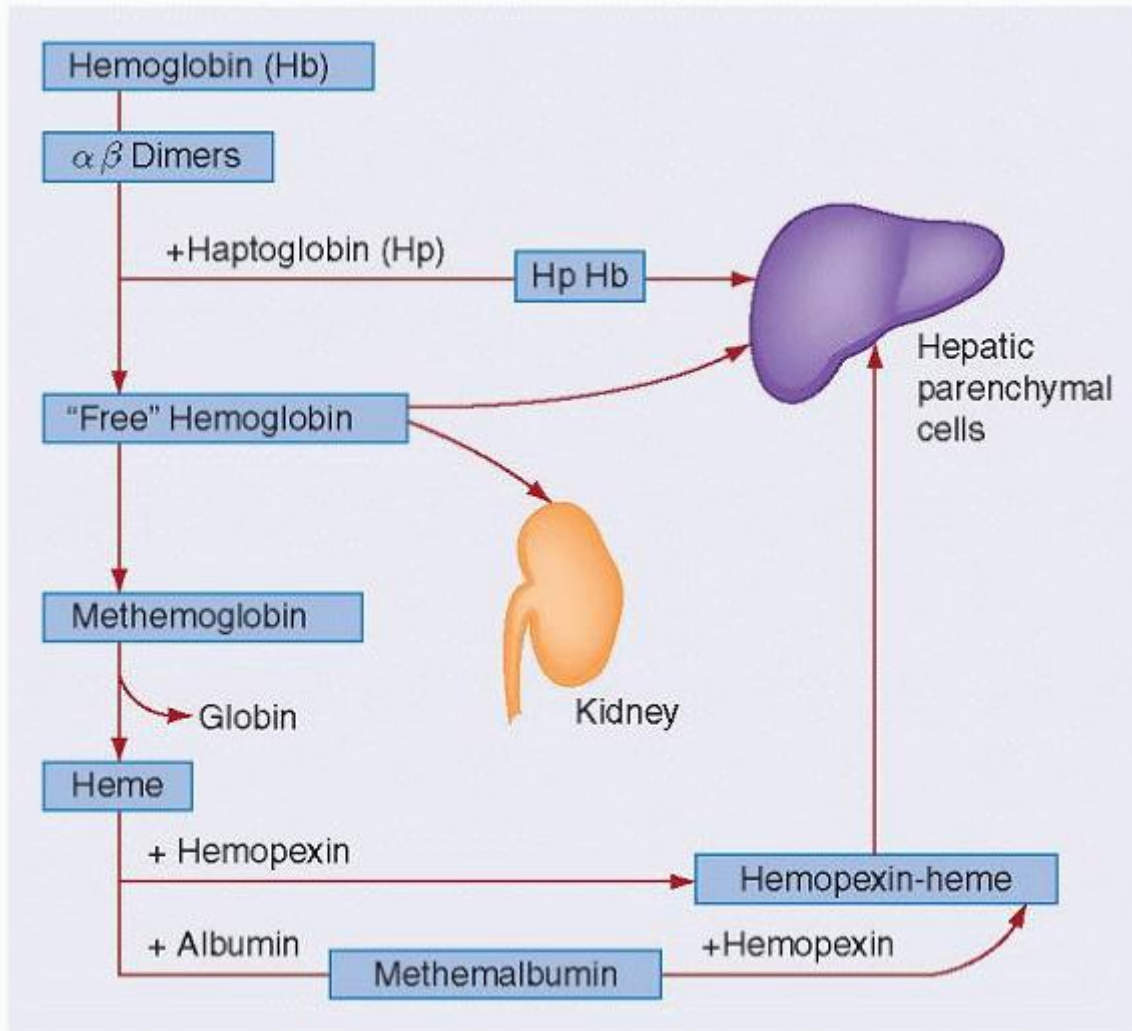

FIGURE 6.30. Pathways for the disposal of hemoglobin in plasma. Hemoglobin freely dissociates into $\alpha\beta$ dimers. These are bound by haptoglobin with subsequent removal of the hemoglobin-haptoglobin complex by hepatic parenchymal cells. Hemoglobin in excess of the haptoglobin-binding capacity circulates as the unbound (free) protein. In this form it is partially removed by hepatic cells, but it may also follow two other pathways; it may be excreted by the kidney or oxidized to methemoglobin, from which heme is easily dissociated. Heme is initially bound to hemopexin, which transports it to the hepatic parenchymal cell. Heme may also be bound nonspecifically by albumin, forming methemalbumin. This complex probably transfers its heme to hemopexin as the latter becomes available.

Human haptoglobin was first described as polymorphic by Smithies et al., who used starch gel electrophoresis to separate the various types. There are two major allelic forms of the hp gene (hp1, hp2) that can therefore give rise to three major phenotypes referred to as Hp1-1, Hp2-1, and Hp2-2. These were distinguished using starch gel or polyacrylamide gel electrophoresis according to their different sizes and band patterns (Hp1-1 = 100 kDa; Hp2-1 = 120 to 220 kDa; Hp2-2 = 160 to 500 kDa).⁵⁷⁴ The β chain of Hp contains the binding domain for the $\alpha\beta$ hemoglobin dimer, thus dimeric Hp1-1 binds 2 hemoglobin dimers whereas Hp2-1 and Hp2-2, which are multimeric, may bind several.⁵⁷⁵ Differences in the haptoglobin phenotypes observed in different ethnic groups or in association with various diseases (hemochromatosis, diabetes, malaria) have been investigated extensively.⁵⁶² For example, in the recent past haptoglobin phenotype analysis was used to study the origin of different populations, and in forensic science; however, these uses have been eclipsed by the development of DNA-sequence-based technologies. Uniquely among mammals is the presence in primates, including humans of an hpr gene located 2.2 kb downstream of hp on 16q22, and encoding haptoglobin-related protein. Hpr is poorly expressed compared with Hp, with approximately tenfold lower levels in the serum. Hpr, however, does bind hemoglobin and functions in our innate defenses against certain trypanosomal parasites in the bloodstream, forming part of a decoy toxin-containing complex that is taken up by the parasite receptor for haptoglobin-hemoglobin.⁵⁷⁶

Clinical laboratories now measure haptoglobin directly by radial immunodiffusion or immunonephelometric methods, and phenotyping, if performed, employs monoclonal antibodies and immunoblotting.^{577,578} Normal haptoglobin concentrations differ substantially with technique; ranges such as 0.5 to 1.6 g/L⁵⁷⁹ are representative, but each clinical laboratory normally establishes its own reference values. The concentration is also influenced by age. Haptoglobin levels are very low in newborns, but are measurable by 3 months of age, and increase gradually throughout childhood.⁵⁸⁰ Decreased haptoglobin concentrations may be observed with hemolytic anemias, ineffective erythropoiesis, liver disease, and pregnancy or estrogen therapy. Increased concentrations are also seen in diseases where acute-phase proteins are increased, such as infections and malignancies.

Haptoglobin is synthesized in hepatocytes.^{581,582} When not bound to hemoglobin, it leaves the plasma with a half-disappearance time of 3.5 to 5 days.^{545,583,584} The haptoglobin-hemoglobin (Hp-Hb) complex leaves much more rapidly, with a half-disappearance time of 9 to 30 minutes. In hemolytic anemias characterized by intravascular hemolysis, catabolism of Hp may be so rapid that it essentially disappears from the plasma, a change that is not accompanied by a compensatory increase in haptoglobin synthesis such that it may take 5 to 7 days for serum haptoglobin levels to recover. Hypohaptoglobinemia also occurs in hemolytic states associated with predominantly extravascular hemolysis,^{585,586} suggesting some hemoglobin may be regurgitated from macrophages when the rate of phagocytosis of erythrocytes or erythrocyte fragments reaches a maximum.⁵⁴⁴

The Hp-Hb complex is removed from the circulation after high-affinity binding to a receptor (CD163) that is found solely on the cell surface of peripheral blood monocytes (to allow immediate uptake⁵⁸⁷) and tissue macrophages.^{588,589} Hp-Hb complexes may also be taken up by hepatocytes by an unidentified mechanism.^{584,590} CD163 is a 130 kDa type I transmembrane protein and a member of the scavenger receptor superfamily, which function in binding polyanionic structures such as modified lipoproteins or (bacterial) lipopolysaccharides.⁵⁹¹ In addition to high-affinity binding of Hp-Hb, CD163 is one of five known macrophage cell surface proteins that bind erythroblasts in erythroblastic islands ("nurse cells"^{67,592}). After binding to the receptor the Hb-Hp complex is endocytosed into the macrophage. CD163 recycles to the cell membrane whereas the globin moieties of Hp and Hb are degraded within the lysosome, and the heme released into the cytoplasm to be catabolized by HO-1. Subsequently, the iron is transported back to the bone marrow via transferrin, for synthesis of new hemoglobin.

CD163 expression may be stimulated by the effects of glucocorticoids, IL6, and IL10 on a distinct "anti-inflammatory" macrophage population termed "alternatively activated" (or M2-polarized) macrophages⁵⁹³ that, for example, are important for wound-healing and chronic inflammation (see Chapter 10). Notably, recent studies of chronic leg venous ulcers demonstrate that engulfment of extravasated red blood cells by tissue macrophages and the release of hemoglobin iron activates a "proinflammatory" M1 macrophage population that has anomalous high expression of CD163. These M1 macrophages demonstrate enhanced ROS production and TNF- α release, which perpetuates pro-inflammatory M1 activation and impairs wound healing.⁵⁹⁴ A soluble form of CD163, sCD163, has also been described. It is present in relatively high concentrations in the plasma (0.7 to 3.9 mg/L) and is derived from ectodomain shedding in response to LPS-mediated activation of Toll-like receptor (TLR) 4, as well as by ligands activating TLR2 and TLR5.⁵⁹⁵ Although the function of sCD163 is unclear, levels are markedly elevated when macrophages accumulate, such as in the lysosomal storage disorder, Gauchers disease, or are activated, for example, in the acquired hemophagocytic syndrome⁵⁹⁶ (Chapter 61).

CD163 has been recently knocked out in mice to examine the effects on hemoglobin clearance. In control animals hemoglobin was in fact cleared from the circulation faster than the Hb-Hp complex, whereas deletion of CD163 had little or no effect on hepatic Hb-Hp complex uptake, suggesting the presence of another uptake system for Hb-Hp and/or Hb.⁵⁹⁷ In contrast,

P.119

two acute myeloid leukemia patients treated with gemtuzumab ozogamicin, an immunotoxin to CD33, who later experienced intravascular hemolysis (due to infection) were noted to have high serum free hemoglobin and haptoglobin levels without an increase in bilirubin. Subsequent studies showing that significant numbers of CD163-expressing macrophages (which also express the myeloid marker CD33) were eradicated by gemtuzumab treatment and that sCD163 levels were similarly decreased,⁵⁹⁸ lend support for an important role for CD163 in clearance of plasma hemoglobin in humans. These somewhat conflicting results illustrate the significant differences in the haptoglobin genes, haptoglobin expression regulation and haptoglobin and hemoglobin clearance that exist between rodents and humans, differences believed to be due to the evolutionary pressure on primates from prevalent hemolytic diseases such as malaria and trypanosomiasis.

Hemoglobin and the Kidney

The hemoglobin-haptoglobin complex is too large (approximately 150 kDa) to pass into the glomerular filtrate. Thus, the level of circulating haptoglobin is the most important determinant of the apparent renal threshold.⁵⁶¹ When haptoglobin is saturated, free (unbound) hemoglobin circulates briefly in plasma. As discussed, hepatic parenchymal cells are responsible for removal of some of the free hemoglobin from plasma.^{584,590} The dissociation of free hemoglobin into $\alpha\beta$ dimers results in a molecular weight of about 32 kDa, which readily passes through the glomerulus.⁴⁸¹ There is a low (<0.6 g/L) renal threshold for free hemoglobin present after haptoglobin saturation related to renal tubular reabsorption through the endocytic receptors megalin and cubilin.^{599,600} Once this reabsorption capacity is exceeded, hemoglobin appears in the urine.

Hemoglobinuria, when it is of considerable magnitude, may cause precipitation of heme pigment as casts in the distal tubules, proximal tubule cell necrosis, and acute renal failure. The mechanism is disputed, but several theories have been proposed: (a) hemoglobin or hemoglobin products are directly toxic to proximal tubule cells, (b) precipitation of hemoglobin results in tubular obstruction and renal failure, or (c) direct renal injury by hemoglobin does not occur but instead products of intravascular hemolysis result in systemic or local hypotension (e.g., by scavenging of NO), and these lead to renal failure.^{601,602,603} and ⁶⁰⁴

Within the tubular epithelial cell, hemoglobin iron is rapidly extracted by heme-induced HO-1, and stored in the cell as ferritin and hemosiderin.⁴⁸¹ Some tubular epithelial iron may be reused for hemoglobin synthesis, but its mobilization for this purpose occurs at a very slow rate. When iron-laden tubular cells are sloughed into the urine, the urine iron concentration increases and both ferritin and hemosiderin may be detected.⁶⁰⁴ Clinically, hemosiderinuria is usually detected by Prussian blue staining of the urinary sediment.⁶⁰⁵ Detectable hemosiderin usually does not appear in the urine for 48 hours after a specific episode of hemoglobinuria⁶⁰⁵ and may persist for more than a week.⁶⁰¹ In chronic intravascular hemolysis, such as occurs in red cell fragmentation associated with abnormal prosthetic heart valves, hemosiderinuria is continuous⁶⁰⁶ and can result in iron deficiency.

Animal studies of deletion of Hp (or the Hb-Hp receptor, CD163⁵⁹⁷) confirm that the primary function of Hp is not plasma clearance of hemoglobin (which is equivalent in control animals) but rather the diversion of hemoglobin to hepatic and splenic macrophages and the prevention of renal losses of hemoglobin (and thus iron). With time, Hp-deleted animals accumulate hemoglobin-derived iron in the proximal tubular cells of the kidneys. Notably, the redistribution of iron from the liver to the kidney with deletion of Hp ameliorates the hepatic iron loading observed in a mouse model of hereditary hemochromatosis.^{607,608}

Plasma Heme, Hemopexin, and Methemalbumin

Heme

When the buffering capacity of haptoglobin is exceeded, any free hemoglobin present in plasma is readily oxidized to methemoglobin, which then dissociates nonenzymatically into ferriheme (Fe^{3+}) (also known as hemin) and globin.⁶⁰⁹ Apart from intravascular hemolysis, plasma heme may also originate from hemoglobin released during normal erythroblast enucleation or derive from the breakdown of hemoproteins such as myoglobin, catalases, cytochromes, and neutrophil myeloperoxidase during tissue damage (e.g., rhabdomyolysis). Heme must be chaperoned within the circulation (and likely within cells⁶¹⁰) as free heme is lipophilic and toxic to cells, promoting lipid peroxidation and ROS production—the heme-iron is redox-active readily donating or accepting electrons—that can lead to cell membrane injury and apoptosis.¹⁰⁶ In addition, the removal from the circulation and recycling of heme iron prevents iron loss and, importantly, removes a source of readily available iron for invading microorganisms. The heme is immediately taken up by the low-density and high-density lipoproteins, LDL and HDL,⁶⁰⁷ and then rapidly transferred to albumin or the heme-binding glycoprotein, hemopexin, ameliorating the strong oxidative and pro-inflammatory effects of free heme. Heme is removed from these proteins primarily by hepatocytes.

Hemopexin

Hemopexin, after haptoglobin, forms the second line of defense against hemoglobin-mediated oxidative damage during intravascular hemolysis or internal hemorrhage.⁶¹¹ Hemopexin is a 439-amino acid β_1 -glycoprotein, consisting of a single polypeptide chain with a molecular weight of about 70 kDa. It binds heme with the highest known affinity of any heme-binding protein ($K_d < 1$ pM) and plays an important role in receptor-mediated hepatocyte heme uptake. Hemopexin is mainly synthesized in the liver,⁶¹² but is also expressed in the kidney, eye, and CNS.¹⁰³ The human gene encoding hemopexin is located at 11p15.4-p15.5, close to the β -globin gene cluster.^{613,614} and ⁶¹⁵ The crystal structure of the rabbit hemopexin-heme complex has been described.⁶¹⁶ Hemopexin consists of two homologous N- and C-terminal domains (fourbladed β -propeller folding motifs) that resemble two thick discs that abut each other at a 90° angle and are joined by

a short linker domain. Heme sits in a pocket formed between the two domains and the linker protein with the heme iron coordinated to a histidine residue in the linker region and another in the C-terminal domain. In addition to heme, hemopexin can also bind other porphyrins and bilirubin, but with less avidity.^{617,618}

The half-life of hemopexin in normal subjects is about 7 days,⁶¹⁹ whereas the heme-hemopexin complex is removed from the circulation with a half-disappearance time of 7 to 8 hours.⁶⁰⁶ Hemopexin, like haptoglobin, is an acute-phase reactant and plasma levels rise with an inflammatory stimulus.⁶²⁰ Hemopexin is also an abundant plasma protein in humans, with levels (0.5 to 1.5 mg/ml) similar to that of transferrin (2.0 to 3.6 mg/ml).

Hepatocyte uptake of this complex is by receptor-mediated endocytosis.^{621,622} The receptor, LRP/CD91,⁶²³ is a member of the LDL receptor-related protein (LRP) superfamily, also known as CD91. LRP/CD91 is a large protein, 600 kDa, with multiple extracellular domains and binds more than 40 different ligands.²⁴¹ This receptor is expressed by a variety of cells and heme-hemopexin complexes are taken up by hepatocytes, macrophages, neurons, fibroblasts, and syncytiotrophoblasts. After endocytosis, the receptor recycles to the cell surface and the heme-hemopexin complex dissociates within the endosome, facilitated by the decrease in pH (and potentially the reduction of ferriheme to ferrous heme), with hemopexin returning to the plasma as an intact

P.120

protein.^{621,624,625} and ⁶²⁶ The heme is discharged into the cytoplasm to undergo catabolism by HO-1. LRP/CD91 is expressed highly by M2-polarized “anti-inflammatory” macrophages that also express CD163 and both receptors are up-regulated by glucocorticoids.⁶²⁷ Similarities between the heme-hemopexin-LRP/CD91 and the Fe-Tf-TfR endocytic transport systems have also been described.⁶²¹ Some studies⁶²³ suggest that when large amounts of heme are released into the circulation, recycling of hemopexin becomes saturated and significant amounts are then degraded in the lysosome. Thus, plasma hemopexin levels may decrease following intravascular hemolysis.⁶¹⁹ The depletion is less pronounced than that of haptoglobin, and low values imply a relatively severe degree of hemolysis.

Like Hp, hemopexin has been deleted in mice. Interestingly, in animals with deletion of Hp or hemopexin the expression of the other protein is up-regulated as a compensatory mechanism,⁶²⁸ perhaps by heme. Animals with deletion of both genes show no obvious alterations in heme catabolism unless they are subject to acute hemolytic stress when they develop liver inflammation and fibrosis and splenomegaly. Analysis suggests that with acute hemolysis large amounts of hemoglobin and/or heme are deposited in the liver and the splenomegaly appears to be related to red cell congestion.⁶²⁸ Of note, recent in vitro studies indicate a role for hemopexin in the coordinated extracellular uptake of heme exported by the cell surface transporter FLVCR—in the absence of hemopexin there is a marked decrease of FLVCR-mediated export of cytosolic heme.⁶²⁹ In addition to the importance of FLVCR for proerythroblast survival^{187,188} (see above), in vitro studies of FLVCR-deleted bone marrow-derived macrophages suggest FLVCR may also facilitate some recycling of heme from erythrophagocytic macrophages.^{104,187}

Methemalbumin

Each mole of human albumin can bind several moles of heme ($K_d \sim 10^{-6}$) to form methemalbumin.⁶³⁰ The disappearance of methemalbumin from the circulation is kinetically complex.⁶³¹ Heme added to human serum associates primarily with albumin (K_d 5 nM, concentration 35 to 55 mg/ml) before being transferred to hemopexin ($K_d < 1$ pM, concentration 0.5 to 1.5 mg/ml), presumably because the molar concentration of albumin is much greater than that of hemopexin.^{617,632} The heme binding site on albumin can be inhibited in an allosteric or competitive fashion by fatty acids whereas increased heme binding to albumin (e.g., during an acute hemolytic episode) can decrease the protein binding of medications such as warfarin.⁶⁰⁷

EXTRAVASCULAR HEMOGLOBIN DEGRADATION

The Heme Oxygenase System and the Formation of Bilirubin

The heme oxygenases (HO) comprise the major physiologically relevant mechanism of heme catabolism.⁶³³ HO is present in humans in two active isoforms, HO-1 and HO-2, encoded by different genes. HO is a mixed function oxidase [i.e., it utilizes molecular oxygen, generating oxidized products and H₂O (Fig. 6.31)]. The oxidase catalyzes cleavage of the α -methine bridge of heme—producing iron, CO, and biliverdin IX α —and is the rate-limiting step in the degradation sequence. The concerted activity of NADPH-cytochrome P450 reductase is necessary to supply electrons and activate oxygen. Biliverdin IX α , a physiologic inhibitor of HO function, is rapidly converted to bilirubin IX α by the enzyme biliverdin reductase. HO and NADPH-cytochrome P450 reductase are present in the endoplasmic reticulum, forming a complex with each other and, at least in vitro, with cytosolic biliverdin reductase.⁶³⁴ Bilirubin IX α is in turn conjugated, once it reaches

the liver, by UDP-glucuronyl transferase and eventually excreted into the bile. The daily production of bilirubin in humans is approximately 400 mg, of which approximately 300 mg is derived from the breakdown of hemoglobin,⁶³⁵ with the remainder derived from catabolism of other hemoproteins, such as cytochromes, catalase, and myoglobin.

Studies in mammals initially focused mostly on the role of HO in heme catabolism during breakdown of hemoglobin. However, it has become widely recognized that HO-mediated degradation of heme has various roles in mammals, including antioxidative and iron reutilization functions.¹⁰⁴

Antioxidative Function of the Heme Oxygenases

Apart from up-regulation by heme, the inducible heme oxygenase isoform, HO-1, is activated by more stimuli than perhaps any other gene.⁶³³ Expression is induced by various metals (including sodium arsenite, cobalt, and selenium); hypoxia or hyperoxia; environmental chemicals and UV light; hydrogen peroxide and nitric oxide; depletion of intracellular glutathione; and heat shock (another name for HO-1 is HSP32). The enzyme is also induced by hormones, various drugs, fever, starvation, and stress.⁶³⁶ and ^{637,638,639,640} and ⁶⁴¹ Basic leucine zipper "stress-responsive" transcription factors, including members of the ATF family, c-Fos, c-Jun, and Nrf2, maf family members and Bach-1, all regulate HO-1 expression.^{96,642} Biliverdin reductase also regulates HO-1. In addition to catalyzing the reduction of biliverdin to bilirubin, biliverdin reductase has kinase, transcription factor, and intracellular heme transport activities. The transport of heme into the nucleus may increase HO-1 levels as it enables derepression of Bach-1-mediated repression of HO-1 transcription.^{96,642,643}

In general, HO-1 expression appears to be rapidly induced in response to an increase in cellular oxidative stress and subsequently repressed again to low levels once the stimulus is removed. In contrast, HO-2, the predominant HO protein expressed in the brain and testis, is constitutively expressed in all cells, with the promoter responding solely to glucocorticoids.⁶³³ Notably, the N-terminus of HO-2 protein contains HRMs,⁶⁴⁴ an ancient motif found in proteins in bacteria, yeast, and mammals that binds heme and serves a regulatory function (e.g., in ALAS-2, Bach-1, and HRI; see above and Refs. 169,645,646). In addition, HRM allow protein regulation by the heme-binding gases. For example, HO-2 binds the vasodilator NO with high affinity¹⁶³ and, with less affinity, the potential vasodilator (and neurotransmitter) CO, or O₂. In addition, HO-2 interacts with and, through production of CO, stimulates the calcium-sensitive potassium (BK) channels that mediate excitatory responses of the carotid body to hypoxia.⁶⁴⁷

The reason for the reduction of biliverdin IX α to bilirubin has been questioned, as the former is water soluble and thus easily excreted, whereas bilirubin is lipid soluble, toxic to the developing brain and requires conjugation to allow efficient excretion in bile.⁶⁴⁸ However, being lipophilic, bilirubin also crosses the placenta from fetus to mother and thus the fetus can utilize the mother's excretory mechanisms. Studies^{649,650,651} and ⁶⁵² indicate that bilirubin at intracellular nanomolar (i.e., physiologic) concentrations is a potent antioxidant that protects cells from up to a 10,000-fold excess of H₂O₂; in so doing, it is itself oxidized to biliverdin IX α , which is then recycled back to form bilirubin.⁶⁵¹ However, some studies suggest it is less important than, for example, other major intracellular antioxidants such as the glutathione system.⁶⁵³

Iron Reutilization Function of Heme Oxygenases

Under normal physiologic conditions, approximately 25 mg of iron is consumed daily by erythroblasts for heme biosynthesis. With a daily dietary iron intake of only 1 to 2 mg, the recycling

P.121

of heme-iron from senescent erythrocytes constitutes the main source of iron for erythropoiesis. As mentioned, heme degradation by HO-1 occurs within erythrophagocytic macrophages in the liver, spleen, and bone marrow, releasing iron, which is subsequently exported into the circulation by the sole cell iron exporter ferroportin.^{117,654}

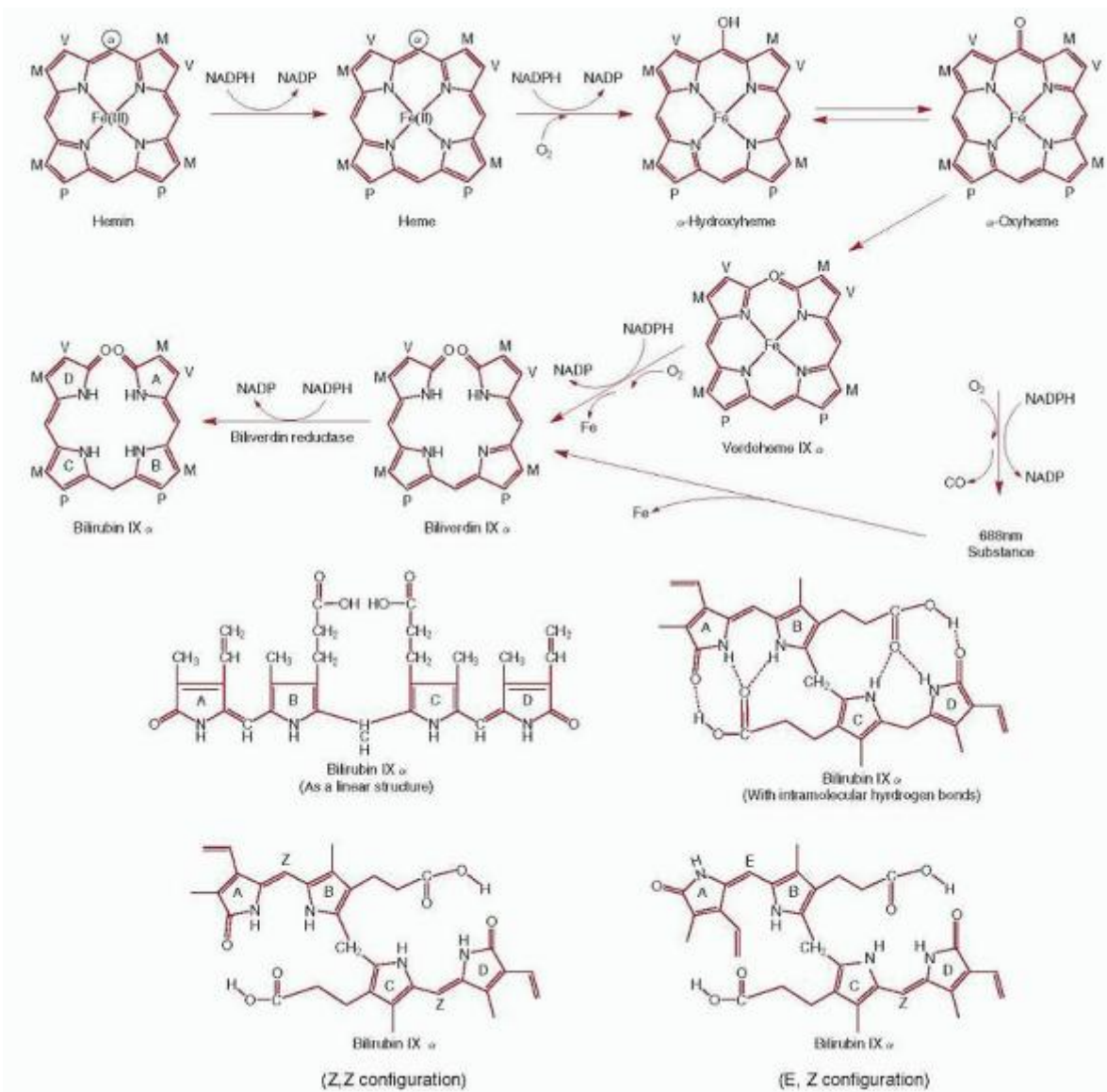

FIGURE 6.31. Formation of bilirubin IX α from heme. The initial reactions are catalyzed by microsomal heme oxygenase and require nicotin-amide adenine dinucleotide phosphate (NADPH) as a co-factor. The reaction has a high specificity for the α -methene bridge, and α -oxyheme is a probable intermediate that is oxidized by molecular oxygen to biliverdin. In mammals, biliverdin is converted to bilirubin by biliverdin reductase. Bottom: alternative methods of representing the structure of bilirubin. The intramolecular hydrogen bonding that occurs with the Z,Z configuration is less extensive in the geometric isomers designated E,Z, and E,E (not shown); hence, the latter are more soluble in water.

A patient with homozygous HO-1 deficiency has been described in detail.⁶⁵⁵ The child, who died at age 6 years, had evidence of severe hemolytic anemia with high serum heme levels, low serum bilirubin, absent Hpx but increased haptoglobin, and hypoferrremia. Very high von Willebrand factor and thrombomodulin levels with evidence of disseminated intravascular coagulation were observed, suggesting widespread endothelial injury. There was iron overload of the liver (involving both Kupffer cells and parenchymal cells) and kidney (proximal tubule cells). Asplenia was noted. The child also had hyperlipidemia, and, at autopsy, aortic atheroma were noted. These findings indicate an important role for HO-1-mediated heme breakdown for heme iron reutilization and protection of the vascular endothelium from heme exposure.

Animals with deletion of HO-1 develop hypoferrremia, microcytic anemia (hematocrit approximately 0.30), and a similar tissue iron overload phenotype.^{652,656} More recently, the murine model of HO-1 deficiency has been re-examined from 6 weeks out to 22 months.⁶⁵⁷ The animals develop asplenia over time, due to splenic fibrosis and loss of the red pulp. Notably, there is a marked loss of the (LRP/CD91- and CD163-expressing) erythrophagocytes in the liver, spleen, and bone

marrow, due to the toxicity of heme released within macrophages during ingestion of senescent erythrocytes. Thus the high haptoglobin levels observed in the human subject with HO-1 deficiency are explained by the specific loss of erythrophagocytic macrophages expressing the haptoglobin receptor (whereas hemopexin is low as it is also taken up by hepatocytes). Hepatic parenchymal and the proximal renal tubular epithelial cells are the cells regulating iron reutilization from erythrocytes in these mice, likely relying on HO-2 function.⁶⁵⁷ In sum, these studies in mice and humans demonstrate the importance of erythrophagocytic macrophage and endothelial cell HO-1 function in ameliorating heme toxicity and the need for the heme oxygenase system for heme iron recycling.

Bilirubin Transport

After release from sites of heme catabolism, bilirubin appears in the plasma. The normal concentration of plasma bilirubin is <1.0 mg/dl. At equilibrium, the concentration is directly related to bilirubin production (mostly from erythropoiesis and red cell destruction) and inversely related to hepatic clearance.^{658,659}

The structure of the bilirubin IX α molecule is asymmetric and several isomeric forms exist (Fig. 6.31).⁶⁶⁰ In the naturally occurring configuration, all pyrrole rings are similarly rotated, representing the Z,Z or trans configuration. If either outer ring is rotated, then the E,Z or Z,E geometric isomers are formed. Photoisomerization of the Z,Z configuration of bilirubin results in formation of these more soluble photoisomers, which can be excreted without conjugation.^{660,661} and ⁶⁶² This is the basis for using phototherapy to prevent neurotoxicity in newborns with hyperbilirubinemia.^{660,661,663}

Bilirubin is normally present in plasma in several forms.^{664,665} Although unconjugated bilirubin is essentially insoluble in water, it combines reversibly with albumin in neutral or alkaline solution. At normal plasma albumin concentrations, the theoretical bilirubin-binding capacity is approximately 70 mg/dl, of which half is tightly bound. These values are reduced by a decrease in plasma albumin concentration or by the presence of organic anionic substances that compete for albumin-binding sites, such as heme, fatty acids, sulfonamides, and salicylates.⁶⁶⁶ When the binding capacity is exceeded, bilirubin readily crosses membranes (e.g., the blood-brain barrier, placental and vascular endothelial or hepatocyte membranes) to diffuse into the tissues, and in jaundiced infants the amount of bilirubin outside the vascular circulation exceeds that within it.⁶⁶³ The tendency of bilirubin to bind to tissues, such as brain, may be due to complex formation with cell membrane polar groups, such as phosphatidylcholine.⁶⁶²

In normal adults, <5% of measurable bilirubin is of the conjugated form,^{667,668} but under certain pathologic circumstances, the proportion of conjugated bilirubin is greater. This relatively soluble bilirubin derivative may also bind albumin. Most is less tightly bound than the unconjugated form, but a portion is covalently and irreversibly bound.⁶⁶⁹ That portion of esterified bilirubin that is reversibly bound to albumin is ultrafilterable. In contrast to the other forms of bilirubin, this complex enters the glomerular filtrate, is not reabsorbed in the tubules, and is excreted in the urine.

In normal adults, <5% of measurable bilirubin is of the conjugated form,^{667,668} but under certain pathologic circumstances, the proportion of conjugated bilirubin is greater. This relatively soluble bilirubin derivative may also bind albumin. Most is less tightly bound than the unconjugated form, but a portion is covalently and irreversibly bound.⁶⁶⁹ That portion of esterified bilirubin that is reversibly bound to albumin is ultrafilterable. In contrast to the other forms of bilirubin, this complex enters the glomerular filtrate, is not reabsorbed in the tubules, and is excreted in the urine.

Hepatic Bilirubin Metabolism

Processing of bilirubin by the liver is part of a general mechanism whereby plasma protein-bound, organic anions are metabolized and excreted. Hepatic bilirubin metabolism is divided into three distinct phases: uptake, conjugation, and excretion⁶³⁵ (Fig. 6.32). All three phases are necessary for bilirubin to be excreted at a normal rate; however, the excretion step is normally the slowest, and therefore the rate-limiting, step.

Within the hepatic sinusoids, the albumin-bilirubin complex dissociates, and bilirubin passes into the hepatocyte where it binds ligandin and is transferred to the ER. How transport into the hepatocyte occurs remains unclear.⁶⁶³ It may be a dissociation-limited carrier-independent (diffusion) process,⁶⁷⁰ or a bidirectional energy-dependent process.^{671,672} and ⁶⁷³ Bidirectional movement of bilirubin appears to be extensive.⁶⁷⁴ In addition, small amounts formed within the hepatocyte from degradation of hepatic hemoproteins reflux into the plasma in the unconjugated form.⁶⁷⁵

Within the hepatocyte, bilirubin is conjugated with glucuronic acid to form bilirubin diglucuronide, which comprises 80% of the bilirubin present in normal bile; the two monoglucuronide isomers make up most of the remainder.⁶⁷⁶ Conjugated bilirubins are more water soluble than unconjugated bilirubin, allowing biliary excretion. Little or no unconjugated bilirubin is found in bile, and if conjugation is impaired, bilirubin content is low. The conjugation reaction is catalyzed by uridine diphosphate-glucuronyl transferase (UGT). Hepatocyte UGT exists in several isoforms, catalyzing glucuronidation of various substrates, such as steroid hormones and medications. Bilirubin serves as the substrate for two isoforms (B-UGT 1 and B-UGT 2),⁶⁷⁷ but only B-UGT 1 is quantitatively significant in humans.⁶⁷⁸ B-UGT activity is also modulated by medications such as phenobarbital, and hormones, such as cortisol and thyroxine.⁶⁷⁹

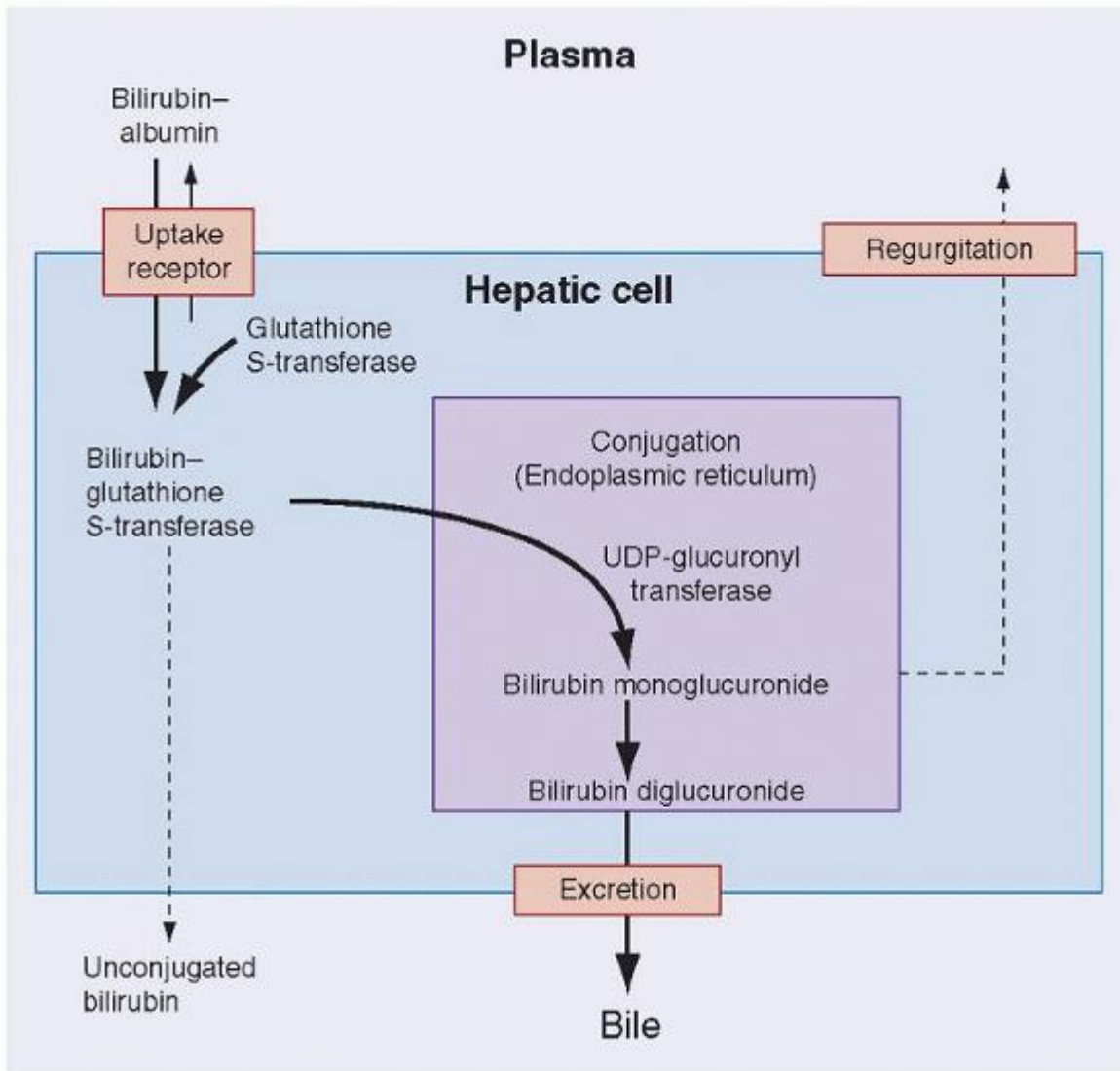

FIGURE 6.32. Normal and abnormal pathways of bilirubin excretion by the hepatic cell. The normal pathways (solid arrows) include uptake and conjugation of bilirubin and excretion of the conjugated derivative. Abnormal pathways (dashed arrows) include regurgitation of bilirubin glucuronide into plasma and excretion of unconjugated bilirubin into bile.

In hepatocellular disease or biliary obstruction, some conjugated bilirubin may be “regurgitated” into the plasma. In addition, a small portion of conjugated bilirubin within the hepatocyte is deconjugated and may reflux into the plasma.⁶⁷⁵ These pathways explain the increase of both bilirubin fractions in cholestatic liver disease. In other clinical situations, hyperbilirubinemia is mainly due to an increase in unconjugated bilirubin. The most common of these is hemolytic disease, where hemoglobin catabolism and thus bilirubin production are increased. However, inherited disorders may also cause unconjugated hyperbilirubinemia because of an impaired capacity for bilirubin conjugation.

The decreased ability to conjugate bilirubin is the common feature of three inherited disorders: in Crigler-Najjar syndrome type I, severe unconjugated hyperbilirubinemia is present from birth and kernicterus is common; in Crigler-Najjar syndrome type II, less severe jaundice occurs; and in Gilbert syndrome, the jaundice is quite mild and often not obvious clinically.^{677,680} These disorders are recessively transmitted, and most patients are therefore homozygous for the mutant gene, B-UGT 1, although occasionally heterozygotes have minimal jaundice. In the two Crigler-Najjar syndromes, the mutation frequently involves exon 1, which confers substrate specificity to the enzyme, resulting in a structurally abnormal protein. In Crigler-Najjar syndrome type I, and in the Gunn rat, an animal model of this disease, the enzyme is nonfunctional, whereas in type II, enzyme activity is variably reduced.^{678,681,682,683} and ⁶⁸⁴ In Gilbert syndrome, the mutation in some patients affects the promoter sequence of exon 1.^{683,685} Gilbert syndrome is very common, occurring in up to 10% of the population, but the Crigler-Najjar syndromes are rare. In Crigler-Najjar type I, the heme oxygenase inhibitor Sn-

protoporphyrin may be effective in reducing bilirubin levels. Early orthotopic liver transplantation is curative.⁶⁸⁶ No treatment is usually necessary for the other two disorders.

The degree of hyperbilirubinemia seen in children with chronic hemolytic states is influenced by simultaneous inheritance of the gene for Gilbert disease.^{687,688} Infants with hereditary spherocytosis who also have Gilbert syndrome usually require phototherapy for hyperbilirubinemia.⁶⁸⁸ The variable hyperbilirubinemia seen in G6PD-deficient neonates may also reflect the presence or absence of the variant form of uridine-diphosphoglucoronylsyl-transferase responsible for Gilbert

P.123

syndrome.⁶⁸⁷ In infants known to be G6PD deficient, prevention of severe hyperbilirubinemia by administration of a single intramuscular dose of Sn-mesoporphyrin, another inhibitor of heme oxygenase, is highly effective and safe.^{173,689}

Excretion of conjugated bilirubin from the hepatic cell into the bile canaliculus proceeds against a 40:1 gradient, when concentration in the bile is compared with that in plasma.⁶⁹⁰ Animal studies indicated that bilirubin excretion, normally the rate-limiting step in overall hepatic bilirubin transport, is mediated by an ATP-dependent transport system shared by a variety of organic anions.⁶⁸⁴ The Dubin-Johnson syndrome^{691,692} is an autosomal recessive disorder characterized by mild conjugated hyperbilirubinemia, and by impaired biliary secretion of non-bile-acid organic anions. Bilirubin uptake and conjugation are normal. The syndrome is due to mutations in the ATP-dependent transporter ABCC2/MRP2, a member of the multidrug resistance protein subfamily that is localized exclusively to the apical membranes of polarized cells including hepatocytes, renal proximal tubules, and intestinal epithelium.^{693,694}

Intestinal Bile Pigment Metabolism

Bilirubin diglucuronide is excreted in bile into the duodenum.⁶⁹⁵ There is little intestinal absorption of the conjugated form, although unconjugated bilirubin is readily absorbed. Bilirubin diglucuronide probably remains conjugated during its transit through the small intestine. However, with intestinal stasis, and in newborns, increased deconjugation occurs and intestinal absorption occurs. This enterohepatic circulation of bilirubin may contribute to the severity of jaundice associated with the physiologic hyperbilirubinemia of the newborn.⁶⁹⁶ When bilirubin diglucuronide reaches the terminal ileum and colon, it is hydrolyzed by bacterial β -glucuronidases. The methine bridges and usually the vinyl groups are then reduced by bacterial flora forming colorless tetrapyrroles called urobilinogens.⁶⁹⁶ Because urobilinogen formation is accomplished by bacteria, it does not occur in newborns, and may be affected by administration of antibiotics. The urobilinogens are easily dehydrogenated to form the orange-yellow pigments, urobilins, which contribute to the color of feces. Up to 20% of the urobilinogen formed in the gut is reabsorbed. The reabsorbed fraction is efficiently excreted by the normal liver without being conjugated.⁶⁹⁵ A portion of the reabsorbed pigment may be excreted into the urine. Urobilinogen is filtered by the glomerulus, secreted by the renal tubule, and reabsorbed. If the liver's capacity to excrete urobilinogen is impaired, a disproportionate amount appears in the urine.

Alternate Pathways of Heme and Bilirubin Catabolism

Evidence suggests that some heme may be degraded by pathways other than catabolism by the heme oxygenases. On a stoichiometric basis, 35 mg of bilirubin should result from degradation of 1 g of hemoglobin. However, the recovery of fecal urobilinogen is less than expected, suggesting that up to 40% of heme may be degraded by some other pathway.⁶⁹⁷ Only minimal amounts of unconjugated bilirubin are excreted in the urine. Excretion of conjugated bilirubin is substantial despite complete biliary obstruction. In rats with biliary fistulas, only 60% to 80% of administered radioactive hemoglobin or heme is recovered as bilirubin; a portion of the remainder is found in nonbilirubin fractions of bile.^{698,699} Radioactive bilirubin in patients with prolonged complete biliary obstruction gradually disappears via an unidentified route.⁶⁹⁹ Furthermore, in severe inherited defects of bilirubin conjugation, such as those found in infants with the Crigler-Najjar syndrome and the Gunn rat, the alternate pathways appear to be increased.⁷⁰⁰ One explanation for these observations is that bilirubin is converted by a series of light-stimulated reactions to a variety of water-soluble derivatives, including hydroxyrubins, bilichrysin, and a dipyrrole.⁶⁹⁷ A microsomal P450-dependent mono-oxygenase may contribute to these alternate pathways; in addition, a mitochondrial bilirubin oxygenase has been identified that, in vitro, degrades bilirubin to a variety of products.^{701,702}

Laboratory Evaluation of Hemoglobin Catabolism and Bile Pigments

The serum bilirubin concentration is an important marker of the rate of bilirubin production and of hepatobiliary function. Traditionally, it has been measured by the van den Bergh test in which a mixture of sulfanilic acid, hydrochloric acid, and sodium nitrite (dialo reagent) yields a reddish-violet color with a maximum absorption at 450 nm when added to plasma or other solutions containing bilirubin.⁷⁰³ A direct reaction, in which the color reaches its maximum intensity at once

indicates conjugated bilirubin, as is seen in plasma or urine from patients with obstructive jaundice. Detection of the unconjugated bilirubin found in plasma of patients with hemolytic disease requires addition of an accelerator, such as alcohol (indirect reaction).

In situations where bilirubin production may be increased and the bilirubin load is likely high, precise measurements of heme catabolism can be determined by measuring endogenous bilirubin production or generation of carbon monoxide (produced in equimolar amounts during heme breakdown). CO production is estimated by measuring blood carboxyhemoglobin levels; endtidal CO concentration corrected for ambient CO and pulmonary excretion rates of CO are also measured.⁷⁰⁴

Acknowledgments

The authors gratefully acknowledge the contributions of Drs. Emmanuel Dessypris, Stephen Sawyer, and Marilyn Telen to the chapters covering this content in the previous edition of this textbook. These chapters provided the basis for the current revision.

REFERENCES

1. Boycott AE. President's address: the blood as a tissue: hypertrophy and atrophy of the red corpuscles. *Proc R Soc Med* 1929;23(1):15-25.
2. Krantz SB, Jacobson LO. Erythropoietin and the regulation of Erythropoiesis. Chicago: University of Chicago Press; 1970.
3. Erslev AJ, Adamson JW, Eschbach JW, Winearls CG. Erythropoietin: molecular, cellular, and clinical biology. Baltimore, MD: Johns Hopkins University Press, 1991.
4. Elliott S, Foote MA, Molineux G. Erythropoietins and erythropoiesis. New York, NY: Birkhuser-Verlag, 2006.
5. Eaves JC, Eaves AC. Erythropoiesis. In: Golde DW, Takaku F, eds. Hematopoietic stem cells. New York, NY: Marcel Dekker Inc, 1985.
6. Fibach E, Rachmilewitz EA. The two-step liquid culture: a novel procedure for studying maturation of human normal and pathological erythroid precursors. *Stem Cells* 1993;11(Suppl 1):36-41.
7. Gregory CJ, Tepperman AD, McCulloch EA, Till JE. Erythropoietic progenitors capable of colony formation in culture: response of normal and genetically anemic W-W-V mice to manipulations of the erythron. *J Cell Physiol* 1974;84(1):1-12.
8. Ogawa M, Parmley RT, Bank HL, Spicer SS. Human marrow erythropoiesis in culture. I. Characterization of methylcellulose colony assay. *Blood* 1976;48(3):407-417.
9. Stephenson JR, Axelrad AA, McLeod DL, Shreeve MM. Induction of colonies of hemoglobin-synthesizing cells by erythropoietin in vitro. *Proc Natl Acad Sci U S A* 1971;68(7):1542-1546.
10. Wood AD, Chen E, Donaldson IJ, et al. ID1 promotes expansion and survival of primary erythroid cells and is a target of JAK2V617F-STAT5 signaling. *Blood* 2009;114(9):1820-1830.
11. Prchal JF, Adamson JW, Steinmann L, Fialkow PJ. Human erythroid colony formation in vitro: evidence for clonal origin. *J Cell Physiol* 1976;89(3):489-492.
12. Sawada K, Krantz SB, Kans JS, et al. Purification of human erythroid colony-forming units and demonstration of specific binding of erythropoietin. *J Clin Invest* 1987;80(2):357-366.
13. Flygare J, Rayon Estrada V, Shin C, Gupta S, Lodish HF. HIF1alpha synergizes with glucocorticoids to promote BFU-E progenitor self-renewal. *Blood* 24;117(12):3435-3444.
14. Gregory CJ, Eaves AC. Human marrow cells capable of erythropoietic differentiation in vitro: definition of three erythroid colony responses. *Blood* 1977;49(6):855-864.
15. Gregory CJ, Eaves AC. Three stages of erythropoietic progenitor cell differentiation distinguished by a number of physical and biologic properties. *Blood* 1978;51(3):527-537.
16. Iscove NN. The role of erythropoietin in regulation of population size and cell cycling of early and late erythroid precursors in mouse bone marrow. *Cell Tissue Kinet* 1977;10(4):323-334.
17. Krantz SB. Erythropoietin. *Blood* 1991;77(3):419-434.
18. Braun JL, Greenberg HM, Robinson SH. Hemopoietic progenitor cells in short-term culture: effects of erythropoietin and endotoxin contamination of erythropoietin preparations. *Exp Hematol* 1979;7(4):189-196.

19. Sawada K, Krantz SB, Dai CH, et al. Purification of human blood burst-forming units-erythroid and demonstration of the evolution of erythropoietin receptors. *J Cell Physiol* 1990;142(2):219-230.
20. Sawada K, Krantz SB, Dessypris EN, Koury ST, Sawyer ST. Human colony-forming units-erythroid do not require accessory cells, but do require direct interaction with insulin-like growth factor I and/or insulin for erythroid development. *J Clin Invest* 1989;83(5):1701-1709.
21. Kieran MW, Perkins AC, Orkin SH, Zon LI. Thrombopoietin rescues in vitro erythroid colony formation from mouse embryos lacking the erythropoietin receptor. *Proc Natl Acad Sci U S A* 1996;93(17):9126-9131.
22. Humphries RK, Eaves AC, Eaves CJ. Characterization of a primitive erythropoietic progenitor found in mouse marrow before and after several weeks in culture. *Blood* 1979;53(4):746-763.
23. Wagemaker G. Induction of erythropoietin responsiveness in vitro. In: Golde DW, Cline MJ, Metcalf D, Fox CT, eds. Hemopoietic cell differentiation. New York, NY: Academic Press, 1978:109-118.
24. Clarke BJ, Housman D. Characterization of an erythroid precursor cell of high proliferative capacity in normal human peripheral blood. *Proc Natl Acad Sci U S A* 1977;74(3):1105-1109.
25. Nathan DG, Chess L, Hillman DG, et al. Human erythroid burst-forming unit: T-cell requirement for proliferation in vitro. *J Exp Med* 1978;147(2):324-339.
26. Hara H, Ogawa M. Erythropoietic precursors in murine blood. *Exp Hematol* 1977;5(3):161-165.
27. Papayannopoulou T, Brice M, Stamatoyannopoulos G. Hemoglobin F synthesis in vitro: evidence for control at the level of primitive erythroid stem cells. *Proc Natl Acad Sci U S A* 1977;74(7):2923-2927.
28. Peschle C. Erythropoiesis. *Annu Rev Med* 1980;31:303-314.
29. Dessypris EN, Krantz SB. Effect of pure erythropoietin on DNA-synthesis by human marrow day 15 erythroid burst forming units in short-term liquid culture. *Br J Haematol* 1984;56(2):295-306.
30. Dessypris E, Graber SE, Krantz SB, Stone WJ. Effects of recombinant erythropoietin on the concentration and cycling status of human marrow hematopoietic progenitor cells in vivo. *Blood* 1988;72(6):2060-2062.
31. Socolovsky M, Nam H, Fleming MD, Haase VH, Brugnara C, Lodish HF. Ineffective erythropoiesis in Stat5a(−/−)5b(−/−) mice due to decreased survival of early erythroblasts. *Blood* 2001;98(12):3261-3273.
32. Tirelli V, Ghinassi B, Migliaccio AR, et al. Phenotypic definition of the progenitor cells with erythroid differentiation potential present in human adult blood. *Stem Cells Int* 2011:602483.
33. Tanaka Y, Goodman JR. Electron microscopy of human blood cells. New York, NY: Harper & Row, 1972.
34. Killmann SA. On the Size of Normal Human Reticulocytes. *Acta Med Scand* 1964;176:529-533.
35. Zhang J, Socolovsky M, Gross AW, Lodish HF. Role of Ras signaling in erythroid differentiation of mouse fetal liver cells: functional analysis by a flow cytometry-based novel culture system. *Blood* 2003;102(12):3938-3946.
36. Calvo D, Gomez-Coronado D, Suarez Y, Lasuncion MA, Vega MA. Human CD36 is a high affinity receptor for the native lipoproteins HDL, LDL, and VLDL. *J Lipid Res* 1998;39(4):777-788.
37. di Giacomo V, Matteucci A, Stellacci E, et al. Expression of signal transduction proteins during the differentiation of primary human erythroblasts. *J Cell Physiol* 2005;202(3):831-838.
38. Hattangadi SM, Wong P, Zhang L, Flygare J, Lodish HF. From stem cell to red cell: regulation of erythropoiesis at multiple levels by multiple proteins, RNAs, and chromatin modifications. *Blood* 2011;118(24):6258-6268.
- 39 Schumacher HR, Erslev AJ. Bone marrow kinetics. In: Szirmai E, ed. Nuclear hematology, vol. 89. New York, NY: Academic Press, 1956:89.
40. Simon MC, Pevny L, Wiles MV, Keller G, Costantini F, Orkin SH. Rescue of erythroid development in gene targeted GATA-1- mouse embryonic stem cells. *Nat Genet* 1992;1(2):92-98.
41. Hodge D, Coghill E, Keys J, et al. A global role for EKLF in definitive and primitive erythropoiesis. *Blood* 2006;107(8):3359-3370.
42. Sawado T, Igarashi K, Groudine M. Activation of beta-major globin gene transcription is associated with recruitment of NF-E2 to the beta-globin LCR and gene promoter. *Proc Natl Acad Sci U S A* 2001;98(18):10226-10231.

43. Kim SI, Bresnick EH. Transcriptional control of erythropoiesis: emerging mechanisms and principles. *Oncogene* 2007;26(47):6777-6794.
44. Kerenyi MA, Orkin SH. Networking erythropoiesis. *J Exp Med* 2010;207(12):2537-2541.
45. Anantharaman A, Lin IJ, Barrow J, et al. Role of helix-loop-helix proteins during differentiation of erythroid cells. *Mol Cell Biol* 2011;31(7):1332-1343.
46. Bondurant MC, Lind RN, Koury MJ, Ferguson ME. Control of globin gene transcription by erythropoietin in erythroblasts from friend virus-infected mice. *Mol Cell Biol* 1985;5(4):675-683.
47. Koury MJ, Bondurant MC, Atkinson JB. Erythropoietin control of terminal erythroid differentiation: maintenance of cell viability, production of hemoglobin, and development of the erythrocyte membrane. *Blood Cells* 1987;13(1-2):217-226.
48. Miller BA, Scaduto RC Jr, Tillotson DL, Botti JJ, Cheung JY. Erythropoietin stimulates a rise in intracellular free calcium concentration in single early human erythroid precursors. *J Clin Invest* 1988;82(1):309-315.
49. Sawyer ST, Krantz SB. Erythropoietin stimulates 45Ca^{2+} uptake in friend virus-infected erythroid cells. *J Biol Chem* 1984;259(5):2769-2774.
50. Sawyer ST, Krantz SB. Transferrin receptor number, synthesis, and endocytosis during erythropoietin-induced maturation of friend virus-infected erythroid cells. *J Biol Chem* 1986;261(20):9187-9195.
51. Tallack MR, Perkins AC. KLF1 directly coordinates almost all aspects of terminal erythroid differentiation. *IUBMB Life* 2010;62(12):886-890.
52. Troadec MB, Warner D, Wallace J, et al. Targeted deletion of the mouse *Mitoferrin1* gene: from anemia to protoporphyria. *Blood* 2011;117(20): 5494-5502.
53. Weiss MJ, Zhou S, Feng L, et al. Role of alpha-hemoglobin-stabilizing protein in normal erythropoiesis and beta-thalassemia. *Ann NY Acad Sci* 2005; 1054:103-117.
54. Stohlman F. Kinetics of erythropoiesis. In: Gordon AS, ed. *Regulation of hematopoiesis*, vol. 1. New York, NY: Appleton-Century-Crofts, 1970:317.
55. Orlic D. Ultrastructural analysis of erythropoiesis. In: Gordon AS, ed. *Regulation of hematopoiesis*, vol. 1. New York, NY: Appleton-Century-Crofts, 1970:271.
56. Tooze J, Davies HG. The occurrence and possible significance of haemoglobin in the chromosomal regions of mature erythrocyte nuclei of the newt *Triturus cristatus cristatus*. *J Cell Biol* 1963;16:501-511.
57. Wintrobe MM. Variations in the size and hemoglobin content of erythrocytes in the blood of various vertebrates. *Folia Haematol* 1933;51:32-36.
58. Ji P, Murata-Hori M, Lodish HF. Formation of mammalian erythrocytes: chromatin condensation and enucleation. *Trends Cell Biol* 2011;21(7): 409-415.
59. Awai M, Okada S, Takebayashi J, Kubo T, Inoue M, Seno S. Studies on the mechanism of denucleation of the erythroblast. *Acta Haematol* 1968;39(4):193-202.
60. Rind H. Kinetik der erythroblastenentkernung. *Folia Haematol* 1956;74: 262-266.
61. Skutelsky E, Danon D. An electron microscopic study of nuclear elimination from the late erythroblast. *J Cell Biol* 1967;33(3):625-635.
62. Koury ST, Koury MJ, Bondurant MC. Cytoskeletal distribution and function during the maturation and enucleation of mammalian erythroblasts. *J Cell Biol* 1989;109(6 Pt 1):3005-3013.
63. Patel VP, Lodish HF. A fibronectin matrix is required for differentiation of murine erythroleukemia cells into reticulocytes. *J Cell Biol* 1987;105 (6 Pt 2):3105-3118.
64. Ji P, Jayapal SR, Lodish HF. Enucleation of cultured mouse fetal erythroblasts requires Rac GTPases and mDia2. *Nat Cell Biol* 2008;10(3):314-321.
65. Chasis JA, Prenant M, Leung A, Mohandas N. Membrane assembly and remodeling during reticulocyte maturation. *Blood* 1989;74(3):1112-1120.

66. Knutson MD, Oukka M, Koss LM, Aydemir F, Wessling-Resnick M. Iron release from macrophages after erythrophagocytosis is up-regulated by ferroportin 1 overexpression and down-regulated by hepcidin. *Proc Natl Acad Sci U S A* 2005;102(5):1324-1328.
67. Chasis JA, Mohandas N. Erythroblastic islands: niches for erythropoiesis. *Blood* 2008;112(3):470-478.
68. Soni S, Bala S, Hanspal M. Requirement for erythroblast-macrophage protein (Emp) in definitive erythropoiesis. *Blood Cells Mol Dis* 2008;41(2):141-147.
69. Zhao G, Yu D, Weiss MJ. MicroRNAs in erythropoiesis. *Curr Opin Hematol* 2010;17(3):155-162.
70. Tavassoli M, Crosby WH. Fate of the nucleus of the marrow erythroblast. *Science* 1973;179(4076):912-913.
71. Song SH, Groom AC. Sequestration and possible maturation of reticulocytes in the normal spleen. *Can J Physiol Pharmacol* 1972;50(5):400-406.
72. Izak G, Karsai A, Eylon L, Hershko C. Ribonucleic acid production and breakdown in synchronized erythroid cohorts from actinomycin-treated animals. *J Lab Clin Med* 1971;77(6):923-930.
73. Valentine WN, Fink K, Paglia DE, Harris SR, Adams WS. Hereditary hemolytic anemia with human erythrocyte pyrimidine 5'-nucleotidase deficiency. *J Clin Invest* 1974;54(4):866-879.
74. Paglia DE, Valentine WN, Dahlgren JG. Effects of low-level lead exposure on pyrimidine 5'-nucleotidase and other erythrocyte enzymes. Possible role of pyrimidine 5'-nucleotidase in the pathogenesis of lead-induced anemia. *J Clin Invest* 1975;56(5):1164-1169.
75. Collins FS, Weissman SM. The molecular genetics of human hemoglobin. *Prog Nucleic Acid Res Mol Biol* 1984;31:315-462.
76. Lehmann H, Carrell RW. Differences between alpha- and beta-chain mutants of human haemoglobin and between alpha- and beta-thalassaemia. Possible duplication of the alpha-chain gene. *Br Med J* 1968;4(5633):748-750.
77. Schroeder WA, Huisman TH, Shelton JR, et al. Evidence for multiple structural genes for the gamma chain of human fetal hemoglobin. *Proc Natl Acad Sci U S A* 1968;60(2):537-544.
78. Deisseroth A, Nienhuis A, Turner P, et al. Localization of the human alpha-globin structural gene to chromosome 16 in somatic cell hybrids by molecular hybridization assay. *Cell* 1977;12(1):205-218.
79. Fritsch EF, Lawn RM, Maniatis T. Molecular cloning and characterization of the human beta-like globin gene cluster. *Cell* 1980;19(4):959-972.
80. Nienhuis AW, Marriettis T. Structure and expression of globin genes in erythroid cells. In: Stamatoyannopoulos G, Nienhuis AW, Leder P, Majerus PW, eds. *The molecular basis of blood diseases*. Philadelphia: WB Saunders, 1987:28.
81. Kouzarides T. Chromatin modifications and their function. *Cell* 2007;128(4):693-705.
82. Perry RP. Processing of RNA. *Annu Rev Biochem* 1976;45:605-629.
83. Merkel CG, Wood TG, Lingrel JB. Shortening of the poly(A) region of mouse globin messenger RNA. *J Biol Chem* 1976;251(18):5512-5515.
84. Adamson SD, Herbert E, Godchaux W. Factors affecting the rate of protein synthesis in lysate systems from reticulocytes. *Arch Biochem Biophys* 1968;125(2):671-683.
85. Bruns GP, London IM. The Effect of Hemin on the Synthesis of Globin. *Biochem Biophys Res Commun* 1965;18:236-242.
86. Lodish HF. Translational control of protein synthesis. *Annu Rev Biochem* 1976;45:39-72.
87. Waxman HS, Freedman ML, Rabinovitz M. Studies with ⁵⁹Fe-labeled hemin on the control of polyribosome formation in rabbit reticulocytes. *Biochim Biophys Acta* 1967;145(2):353-360.
88. Waxman HS, Rabinovitz M. Control of reticulocyte polyribosome content and hemoglobin synthesis by heme. *Biochimica et Biophysica Acta (BBA)—Nucleic Acids and Protein Synth* 1966;129(2):369-379.
89. Balkow K, Mizuno S, Fisher JM, Rabinovitz M. Hemin control of globin synthesis: effect of a translational repressor on Met-tRNA^f binding to the small ribosomal subunit and its relation to the activity and availability of an initiation factor. *Biochim Biophys Acta* 1973;324(3):397-409.

90. Howard GA, Adamson SD, Herbert E. Studies on cessation of protein synthesis in a reticulocyte lysate cell-free system. *Biochim Biophys Acta* 1970;213(1):237-240.
91. Kramer G, Cimadevilla JM, Hardesty B. Specificity of the protein kinase activity associated with the hemin-controlled repressor of rabbit reticulocyte. *Proc Natl Acad Sci U S A* 1976;73(9):3078-3082.
92. Ranu RS, Levin DH, Delaunay J, Ernst V, London IM. Regulation of protein synthesis in rabbit reticulocyte lysates: characteristics of inhibition of protein synthesis by a translational inhibitor from heme-deficient lysates and its relationship to the initiation factor which binds Met-tRNA^f. *Proc Natl Acad Sci U S A* 1976;73(8):2720-2724.
93. Chen JJ. Regulation of protein synthesis by the heme-regulated eIF2alpha kinase: relevance to anemias. *Blood* 2007;109(7):2693-2699.
94. Han AP, Yu C, Lu L, et al. Heme-regulated eIF2alpha kinase (HRI) is required for translational regulation and survival of erythroid precursors in iron deficiency. *EMBO J* 2001;20(23):6909-6918.
95. Suragani RN, Zachariah RS, Velazquez JG, et al. Heme-regulated eIF2alpha kinase activated Atf4 signaling pathway in oxidative stress and erythropoiesis. *Blood* 2012;119(22):5276-5284.
96. Igarashi K, Sun J. The heme-Bach1 pathway in the regulation of oxidative stress response and erythroid differentiation. *Antioxid Redox Signal* 2006;8(1-2):107-118.
97. Bottomley SS, Eberhard Muller U. Pathophysiology of heme synthesis. *Semin Hematol* 1988;25:282-302.
98. Burnham BF. The chemistry of the porphyrins. *Semin Hematol* 1968;5(4):296-322.
99. Burnham BF, Lascelles J. Control of porphyrin biosynthesis through a negative-feedback mechanism. *Biochem J* 1963;87:462-472.
100. Dolphin D. The porphyrins, vol. 1-7. New York, NY: Academic Press, 1978, 1979.
101. Lascelles J. Tetrapyrrole biosynthesis and its regulation. New York, NY: WA Benjamin Inc., 1964.
102. Smith KM. Porphyrins and metalloporphyrins. Amsterdam: Elsevier Science, 1975.
103. Warren MJ, Smith AG. Tetrapyrroles: birth, life, and death. Austin, TX, New York, NY: Landes Bioscience, Springer Science & Business Media, 2009.
104. Khan AA, Quigley JG. Control of intracellular heme levels: heme transporters and heme oxygenases. *Biochim Biophys Acta* 2011;1813(5):668-682.
105. Ponka P. Tissue-specific regulation of iron metabolism and heme synthesis: distinct control mechanisms in erythroid cells. *Blood* 1997;89(1):1-25.
106. Ryter SW, Tyrrell RM. The heme synthesis and degradation pathways: role in oxidant sensitivity. Heme oxygenase has both pro- and antioxidant properties. *Free Radic Biol Med* 2000;28(2):289-309.
107. Medlock AE, Dailey HA. Regulation of mammalian heme biosynthesis. In: Warren MJ, Smith AG, eds. Tetrapyrroles: birth, life and death. Austin, TX: Landes Bioscience, 2009:116-127.
108. Heinemann IU, Jahn M, Jahn D. The biochemistry of heme biosynthesis. *Arch Biochem Biophys* 2008;474(2):238-251.
109. Ajioka RS, Phillips JD, Kushner JP. Biosynthesis of heme in mammals. *Biochim Biophys Acta* 2006;1763(7):723-736.
110. Ferreira GC, Dailey HA. Reconstitution of the two terminal enzymes of the heme biosynthetic pathway into phospholipid vesicles. *J Biol Chem* 1987;262(9):4407-4412.
111. Koch M, Breithaupt C, Kiefersauer R, Freigang J, Huber R, Messerschmidt A. Crystal structure of protoporphyrinogen IX oxidase: a key enzyme in haem and chlorophyll biosynthesis. *EMBO J* 2004;23(8):1720-1728.
112. Cartwright GE, Wintrobe MM. Studies on free erythrocyte protoporphyrin, plasma copper, and plasma iron in normal and in pyridoxine-deficient swine. *J Biol Chem* 1948;172(2):557-565.
113. Furuyama K, Sassa S. Interaction between succinyl CoA synthetase and the heme-biosynthetic enzyme ALAS-E is disrupted in sideroblastic anemia. *J Clin Invest* 2000;105(6):757-764.
114. Bawden MJ, Borthwick IA, Healy HM, Morris CP, May BK, Elliott WH. Sequence of human 5-aminolevulinic acid synthase cDNA. *Nucleic Acids Res* 1987;15(20):8563.

115. Astrin KH, Bishop DF. Assignment of human erythroid δ -aminolevulinic synthase to X-chromosome. *Cytogenet Cell Genet* 1989;51:953-954.
116. Astrin KH, Desnick RJ, Bishop DF. Assignment of human δ -aminolevulinic synthase to chromosome 3. *Cytogenet Cell Genet* 1988;46:573.
117. Hentze MW, Muckenthaler MU, Andrews NC. Balancing acts: molecular control of mammalian iron metabolism. *Cell* 2004;117(3):285-297.
118. Anderson CP, Shen M, Eisenstein RS, Leibold EA. Mammalian iron metabolism and its control by iron regulatory proteins. *Biochim Biophys Acta* 2012. doi: <http://dx.doi.org.easysaccess1.lib.cuhk.edu.hk/10.1016/j.bbamcr.2012.05.010>.
119. Surinya KH, Cox TC, May BK. Transcriptional regulation of the human erythroid 5-aminolevulinic synthase gene. Identification of promoter elements and role of regulatory proteins. *J Biol Chem* 1997;272(42):26585-26594.
120. Kramer MF, Gunaratne P, Ferreira GC. Transcriptional regulation of the murine erythroid-specific 5-aminolevulinic synthase gene. *Gene* 2000;247(1-2):153-166.
121. Surinya KH, Cox TC, May BK. Identification and characterization of a conserved erythroid-specific enhancer located in intron 8 of the human 5-aminolevulinic synthase 2 gene. *J Biol Chem* 1998;273(27):16798-16809.
122. Guernsey DL, Jiang H, Campagna DR, et al. Mutations in mitochondrial carrier family gene SLC25A38 cause nonsyndromic autosomal recessive congenital sideroblastic anemia. *Nat Genet* 2009;41(6):651-653.
123. Battersby AR. The discovery of nature's biosynthetic pathways. *Experientia* 1978;34(1):1-13.
124. Schubert HL, Erskine PT, Cooper JB. 5-Aminolaevulinic acid dehydratase, porphobilinogen deaminase and uroporphyrinogen III synthase. In: Warren MJ, Smith AG, eds. *Tetrapyrroles: birth, life and death*. Austin, TX: Landes Bioscience, 2009:43-73.
125. Cheh A, Nielsens JB. The δ aminolevulinic dehydratases: molecular and environmental properties. *Struct Bond* 1976;29:123-170.
126. Hammond PB. The relationship between inhibition of delta-aminolevulinic acid dehydratase by lead and lead mobilization by ethylenediamine tetraacetate (EDTA). *Toxicol Appl Pharmacol* 1973;26(3):466-475.
127. Gidari AS, Levere RD. Enzymatic formation and cellular regulation of heme synthesis. *Semin Hematol* 1977;14(2):145-168.
128. Shemin D. δ -Aminolevulinic dehydratase. In: Boyer PD, ed. *The enzymes*, 3 ed. New York, NY: Academic Press, 1972:323.
129. Wetmur JG, Bishop DF, Cantelmo C, Desnick RJ. Human delta-aminolevulinic dehydratase: nucleotide sequence of a full-length cDNA clone. *Proc Natl Acad Sci U S A* 1986;83(20):7703-7707.
130. Potluri VR, Astrin KH, Wetmur JG, Bishop DF, Desnick RJ. Human δ -aminolevulinic dehydratase: chromosomal localization to 9q34 by in situ hybridization. *Hum Genet* 1987;76(3):236-239.
131. Levin EY. Uroporphyrinogen 3 cosynthetase from mouse spleen. *Biochemistry* 1968;7(11):3781-3788.
132. Bogorad L. The enzymatic synthesis of porphyrins from porphobilinogen. I. Uroporphyrin I. *J Biol Chem* 1958;233(2):501-509.
133. Grandchamp B, De Verneuil H, Beaumont C, Chretien S, Walter O, Nordmann Y. Tissue-specific expression of porphobilinogen deaminase. Two isoenzymes from a single gene. *Eur J Biochem* 1987;162(1):105-110.
134. Wang AL, Arredondo-Vega FX, Giampietro PF, Smith M, Anderson WF, Desnick RJ. Regional gene assignment of human porphobilinogen deaminase and esterase A4 to chromosome 11q23 leads to 11qter. *Proc Natl Acad Sci U S A* 1981;78(9):5734-5738.
135. Frydman RB, Feinstein G. Studies on porphobilinogen deaminase and uroporphyrinogen 3 cosynthase from human erythrocytes. *Biochim Biophys Acta* 1974;350(2):358-373.
136. Battersby AR, McDonald E, Williams DC, Wurziger HKW. Biosynthesis of the natural (type-III) porphyrins: proof that rearrangement occurs after head-tail bilane formation. *J Chem Society, Chem Commun* 1977(4):113-115.
137. Burton G, Nordlov H, Hosozawa S, et al. Structure of preuroporphyrinogen. Exploration of an enzyme mechanism by carbon-13 and nitrogen-15 NMR spectroscopy. *J Am Chem Society* 1979;101(11):3114-3116.

138. Jackson AH, Sancovich HA, Ferramola AM, et al. Macrocyclic intermediates in the biosynthesis of porphyrins. *Philos Trans R Soc Lond B Biol Sci* 1976;273(924):191-206.
139. Martins BM, Grimm B, Mock HP, Huber R, Messerschmidt A. Crystal structure and substrate binding modeling of the uroporphyrinogen-III decarboxylase from *Nicotiana tabacum*. Implications for the catalytic mechanism. *J Biol Chem* 2001;276(47):44108-44116.
140. Phillips JD, Warby CA, Whitby FG, Kushner JP, Hill CP. Substrate shuttling between active sites of uroporphyrinogen decarboxylase is not required to generate coproporphyrinogen. *J Mol Biol* 2009;389(2):306-314.
141. Phillips JD, Parker TL, Schubert HL, Whitby FG, Hill CP, Kushner JP. Functional consequences of naturally occurring mutations in human uroporphyrinogen decarboxylase. *Blood* 2001;98(12):3179-3185.
142. Phillips JD, Bergonia HA, Reilly CA, Franklin MR, Kushner JP. A porphomethene inhibitor of uroporphyrinogen decarboxylase causes porphyria cutanea tarda. *Proc Natl Acad Sci U S A* 2007;104(12):5079-5084.
143. Lee DS, Flachsova E, Bodnarova M, Demeler B, Martasek P, Raman CS. Structural basis of hereditary coproporphyria. *Proc Natl Acad Sci U S A* 2005;102(40):14232-14237.
144. Cornah JE, Smith AG. Transformation of uroporphyrinogen III into protohaem. In: Warren MJ, Smith AG, eds. *Tetrapyrroles: birth, life and death*. Austin, TX: Landes Bioscience, 2009:74-88.
145. Dailey TA, Woodruff JH, Dailey HA. Examination of mitochondrial protein targeting of haem synthetic enzymes: in vivo identification of three functional haem-responsive motifs in 5-aminolaevulinic synthase. *Biochem J* 2005;386(Pt 2):381-386.
146. del Batlle AM, Benson A, Rimington C. Purification and properties of coproporphyrinogenase. *Biochem J* 1965;97(3):731-740.
147. Sano S, Granick S. Mitochondrial coproporphyrinogen oxidase and protoporphyrin formation. *J Biol Chem* 1961;236:1173-1180.
148. Jackson AH, Games DE. The later stages of porphyrin biosynthesis. *Ann NY Acad Sci* 1975;244:591-602.
149. Takahashi S, Taketani S, Akasaka JE, et al. Differential regulation of coproporphyrinogen oxidase gene between erythroid and nonerythroid cells. *Blood* 1998;92(9):3436-3444.
150. Poulson R. The enzymic conversion of protoporphyrinogen IX to protoporphyrin IX in mammalian mitochondria. *J Biol Chem* 1976;251(12):3730-3733.
151. Dailey TA, McManus JF, Dailey HA. Characterization of the mouse protoporphyrinogen oxidase gene. *Cell Mol Biol (Noisy-le-grand)* 2002;48(1):61-69.
- P.124
152. Taketani S, Inazawa J, Abe T, et al. The human protoporphyrinogen oxidase gene (PPOX): organization and location to chromosome 1. *Genomics* 1995;29(3):698-703.
153. Dailey HA, Dailey TA, Wu CK, et al. Ferrochelatase at the millennium: structures, mechanisms and [2Fe-2S] clusters. *Cell Mol Life Sci* 2000;57(13-14):1909-1926.
154. Jones MS, Jones OT. The structural organization of haem synthesis in rat liver mitochondria. *Biochem J* 1969;113(3):507-514.
155. Chen W, Dailey HA, Paw BH. Ferrochelatase forms an oligomeric complex with mitoferrin-1 and Abcb10 for erythroid heme biosynthesis. *Blood* 2010;116(4):628-630.
156. Shirihai OS, Gregory T, Yu C, Orkin SH, Weiss MJ. ABC-me: a novel mitochondrial transporter induced by GATA-1 during erythroid differentiation. *EMBO J* 2000;19(11):2492-2502.
157. Chen W, Paradkar PN, Li L, et al. Abcb10 physically interacts with mitoferrin-1 (Slc25a37) to enhance its stability and function in the erythroid mitochondria. *Proc Natl Acad Sci U S A* 2009;106(38):16263-16268.
158. Ye H, Rouault TA. Human iron-sulfur cluster assembly, cellular iron homeostasis, and disease. *Biochemistry* 2010;49(24):4945-4956.

159. Crooks DR, Ghosh MC, Haller RG, Tong WH, Rouault TA. Posttranslational stability of the heme biosynthetic enzyme ferrochelatase is dependent on iron availability and intact iron-sulfur cluster assembly machinery. *Blood* 2010;115(4):860-869.
160. Whitcombe DM, Carter NP, Albertson DG, Smith SJ, Rhodes DA, Cox TM. Assignment of the human ferrochelatase gene (FECH) and a locus for protoporphyria to chromosome 18q22. *Genomics* 1991;11(4):1152-1154.
161. Magness ST, Tugores A, Brenner DA. Analysis of ferrochelatase expression during hematopoietic development of embryonic stem cells. *Blood* 2000;95(11):3568-3577.
162. Magness ST, Tugores A, Diala ES, Brenner DA. Analysis of the human ferrochelatase promoter in transgenic mice. *Blood* 1998;92(1):320-328.
163. Taketani S, Mohri T, Hioki K, Tokunaga R, Kohno H. Structure and transcriptional regulation of the mouse ferrochelatase gene. *Gene* 1999;227(2): 117-124.
164. Asano H, Li XS, Stamatoyannopoulos G. FKLf-2: a novel Kruppel-like transcriptional factor that activates globin and other erythroid lineage genes. *Blood* 2000;95(11):3578-3584.
165. Stadtman ER. Allosteric regulation of enzyme activity. *Adv Enzymol Relat Areas Mol Biol* 1966;28:41-154.
166. Granick S, Urata G. Increase in activity of alpha-aminolevulinic acid synthetase in liver mitochondria induced by feeding of 3,5-dicarbethoxy-1,4-dihydrocollidine. *J Biol Chem* 1963;238:821-827.
167. Marver HS, Collins A, Tschudy DP, Rechcigl M Jr. Delta-aminolevulinic acid synthetase. II. Induction in rat liver. *J Biol Chem* 1966;241(19):4323-4329.
168. Sassa S, Granick S. δ -Aminolevulinic acid synthetase and the control of heme and chlorophyll synthesis. In: Vogel JH, ed. *Metabolic pathways, vol. V, Metabolic regulation*. New York, NY: Academic Press, 1971.
169. Lathrop JT, Timko MP. Regulation by heme of mitochondrial protein transport through a conserved amino acid motif. *Science* 1993;259(5094):522-525.
170. De Matteis F. Drug interactions in experimental hepatic porphyria. A model for the exacerbation by drugs of human variegate porphyria. *Enzyme* 1973;16(1):266-275.
171. De Matteis F, Gibbs AH. Stimulation of the pathway of porphyrin synthesis in the liver of rats and mice by griseofulvin, 3,5-Diethoxycarbonyl-1,4-dihydrocollidine and related drugs: evidence for two basically different mechanisms. *Biochem J* 1975;146(1):285-287.
172. Handschin C, Lin J, Rhee J, et al. Nutritional regulation of hepatic heme biosynthesis and porphyria through PGC-1alpha. *Cell* 2005;122(4):505-515.
173. Drummond GS, Kappas A. Chemoprevention of severe neonatal hyperbilirubinemia. *Semin Perinatol* 2004;28(5):365-368.
174. Fujita H, Yamamoto M, Yamagami T, et al. Sequential activation of genes for heme pathway enzymes during erythroid differentiation of mouse Friend virus-transformed erythroleukemia cells. *Biochim Biophys Acta* 1991;1090(3):311-316.
175. Houston T, Moore MR, McColl KE, Fitzsimons EJ. Regulation of haem biosynthesis in normoblastic erythropoiesis: role of 5-aminolaevulinic acid synthase and ferrochelatase. *Biochim Biophys Acta* 1994;1201(1):85-93.
176. Sassa S, Nagai T. The role of heme in gene expression. *Int J Hematol* 1996;63(3):167-178.
177. Lake-Bullock H, Dailey HA. Biphasic ordered induction of heme synthesis in differentiating murine erythroleukemia cells: role of erythroid 5-aminolevulinic acid synthase. *Mol Cell Biol* 1993;13(11):7122-7132.
178. Iacopetta BJ, Morgan EH, Yeoh GC. Transferrin receptors and iron uptake during erythroid cell development. *Biochim Biophys Acta* 1982;687(2): 204-210.
179. Sheftel AD, Richardson DR, Prchal J, Ponka P. Mitochondrial iron metabolism and sideroblastic anemia. *Acta Haematol* 2009;122(2-3):120-133.
180. Kerenyi MA, Grebien F, Gehart H, et al. Stat5 regulates cellular iron uptake of erythroid cells via IRP-2 and TfR-1. *Blood* 2008;112(9):3878-3888.
181. Schranzhofer M, Schifrer M, Cabrera JA, et al. Remodeling the regulation of iron metabolism during erythroid differentiation to ensure efficient heme biosynthesis. *Blood* 2006;107(10):4159-4167.

182. Sheftel AD, Zhang AS, Brown C, Shirihai OS, Ponka P. Direct interorganellar transfer of iron from endosome to mitochondrion. *Blood* 2007;110(1):125-132.
183. Balla J, Vercellotti GM, Nath K, et al. Haem, haem oxygenase and ferritin in vascular endothelial cell injury. *Nephrol Dial Transplant* 2003;18(Suppl 5:v):8-12.
184. Halliwell B, Gutteridge JM. Role of free radicals and catalytic metal ions in human disease: an overview. *Methods Enzymol* 1990;186:1-85.
185. Nathan DG, Gunn RB. Thalassemia: the consequences of unbalanced hemoglobin synthesis. *Am J Med* 1966;41(5):815-830.
186. Rund D, Rachmilewitz E. Pathophysiology of alpha- and beta-thalassemia: therapeutic implications. *Semin Hematol* 2001;38(4):343-349.
187. Keel SB, Doty RT, Yang Z, et al. A heme export protein is required for red blood cell differentiation and iron homeostasis. *Science* 2008;319(5864):825-828.
188. Quigley JG, Yang Z, Worthington MT, et al. Identification of a human heme exporter that is essential for erythropoiesis. *Cell* 2004;118(6):757-766.
189. Alves LR, Costa ES, Sorgine MH, et al. Heme-oxygenases during erythropoiesis in K562 and human bone marrow cells. *PLoS One* 2011;6(7):e21358.
190. Fujita H, Sassa S. The rapid and decremental change in haem oxygenase mRNA during erythroid differentiation of murine erythroleukaemia cells. *Br J Haematol* 1989;73(4):557-560.
- 190a. Chiabrando D, Marro S, Mercurio S, Giorgi C, Petrillo S, Vinchi F, Fiorito V, Fagoonee S, Camporeale A, Turco E, Merlo GR, Silengo L, Altruda F, Pinton P, Tolosano E. The mitochondrial heme exporter FLVCR1b mediates erythroid differentiation. *J Clin Invest*. 2012 Dec 3;122(12):4569-79.
191. Lipton JM, Ellis SR. Diamond-Blackfan anemia: diagnosis, treatment, and molecular pathogenesis. *Hematol Oncol Clin North Am* 2009;23(2): 261-282.
192. Chiabrando D, Tolosano E. Diamond blackfan anemia at the crossroad between ribosome biogenesis and heme metabolism. *Adv Hematol* 2010;2010:790632.
193. Weiss MJ, dos Santos CO. Chaperoning erythropoiesis. *Blood* 2009; 113(10):2136-2144.
194. Kihm AJ, Kong Y, Hong W, et al. An abundant erythroid protein that stabilizes free alpha-haemoglobin. *Nature* 2002;417(6890):758-763.
195. Kong Y, Zhou S, Kihm AJ, et al. Loss of alpha-hemoglobin-stabilizing protein impairs erythropoiesis and exacerbates beta-thalassemia. *J Clin Invest* 2004;114(10):1457-1466.
196. Khandros E, Weiss MJ. Protein quality control during erythropoiesis and hemoglobin synthesis. *Hematol Oncol Clin North Am* 2010;24(6):1071-1088.
197. Khandros E, Thom CS, D'Souza J, Weiss MJ. Integrated protein quality-control pathways regulate free alpha-globin in murine beta-thalassemia. *Blood* 2012;119(22):5265-5275.
198. Miyake T, Kung CK, Goldwasser E. Purification of human erythropoietin. *J Biol Chem* 1977;252(15):5558-5564.
199. Dordal MS, Wang FF, Goldwasser E. The role of carbohydrate in erythropoietin action. *Endocrinology* 1985;116(6):2293-2299.
200. Cotes PM, Bangham DR. The international reference preparation of erythropoietin. *Bull WHO* 1966;35(5):751-760.
201. Lin FK, Suggs S, Lin CH, et al. Cloning and expression of the human erythropoietin gene. *Proc Natl Acad Sci U S A* 1985;82(22):7580-7584.
202. Watkins PC, Eddy R, Hoffman N, et al. Regional assignment of the erythropoietin gene to human chromosome region 7pter—q22. *Cytogenet Cell Genet* 1986;42(4):214-218.
203. Recny MA, Scoble HA, Kim Y. Structural characterization of natural human urinary and recombinant DNA-derived erythropoietin. Identification of desarginine 166 erythropoietin. *J Biol Chem* 1987;262(35):17156-17163.
204. Davis JM, Arakawa T, Strickland TW, Yphantis DA. Characterization of recombinant human erythropoietin produced in Chinese hamster ovary cells. *Biochemistry* 1987;26(9):2633-2638.

205. Sytkowski AJ. Denaturation and renaturation of human erythropoietin. *Biochem Biophys Res Commun* 1980;96(1):143-149.
206. Goldwasser E, Kung CK, Eliason J. On the mechanism of erythropoietin-induced differentiation. 13. The role of sialic acid in erythropoietin action. *J Biol Chem* 1974;249(13):4202-4206.
207. Egrie JC, Browne JK. Development and characterization of novel erythropoiesis stimulating protein (NESP). *Nephrol Dial Transplant* 2001;16(Suppl 3):3-13.
208. McDonald JD, Lin FK, Goldwasser E. Cloning, sequencing, and evolutionary analysis of the mouse erythropoietin gene. *Mol Cell Biol* 1986;6(3):842-848.
209. Shoemaker CB, Mitscock LD. Murine erythropoietin gene: cloning, expression, and human gene homology. *Mol Cell Biol* 1986;6(3):849-858.
210. Cheetham JC, Smith DM, Aoki KH, et al. NMR structure of human erythropoietin and a comparison with its receptor bound conformation. *Nat Struct Biol* 1998;5(10):861-866.
211. Philo JS, Aoki KH, Arakawa T, Narhi LO, Wen J. Dimerization of the extracellular domain of the erythropoietin (EPO) receptor by EPO: one high-affinity and one low-affinity interaction. *Biochemistry* 1996;35(5):1681-1691.
212. Jacobson LO, Goldwasser E, Fried W, Plzak L. Role of the kidney in erythropoiesis. *Nature* 1957;179(4560):633-634.
213. Beru N, McDonald J, Lacombe C, Goldwasser E. Expression of the erythropoietin gene. *Mol Cell Biol* 1986;6(7):2571-2575.
214. Koury ST, Koury MJ, Bondurant MC, Caro J, Graber SE. Quantitation of erythropoietin-producing cells in kidneys of mice by in situ hybridization: correlation with hematocrit, renal erythropoietin mRNA, and serum erythropoietin concentration. *Blood* 1989;74(2):645-651.
215. Bondurant MC, Koury MJ. Anemia induces accumulation of erythropoietin mRNA in the kidney and liver. *Mol Cell Biol* 1986;6(7):2731-2733.
216. Koury MJ, Bondurant MC, Graber SE, Sawyer ST. Erythropoietin messenger RNA levels in developing mice and transfer of 125I-erythropoietin by the placenta. *J Clin Invest* 1988;82(1):154-159.
217. Trimble M, Caro J, Talalla A, Brain M. Secondary erythrocytosis due to a cerebellar hemangioblastoma: demonstration of erythropoietin mRNA in the tumor. *Blood* 1991;78(3):599-601.
218. Ascensao JL, Gaylis F, Bronson D, Fraley EE, Zanjani ED. Erythropoietin production by a human testicular germ cell line. *Blood* 1983;62(5):1132-1134.
219. Koury ST, Bondurant MC, Koury MJ, Semenza GL. Localization of cells producing erythropoietin in murine liver by in situ hybridization. *Blood* 1991;77(11):2497-2503.
220. Lacombe C, Da Silva JL, Bruneval P, et al. Peritubular cells are the site of erythropoietin synthesis in the murine hypoxic kidney. *J Clin Invest* 1988;81(2):620-623.
221. Bachmann S, Le Hir M, Eckardt KU. Co-localization of erythropoietin mRNA and ecto-5'-nucleotidase immunoreactivity in peritubular cells of rat renal cortex indicates that fibroblasts produce erythropoietin. *J Histochem Cytochem* 1993;41(3):335-341.
222. Maxwell PH, Osmond MK, Pugh CW, et al. Identification of the renal erythropoietin-producing cells using transgenic mice. *Kidney Int* 1993;44(5):1149-1162.
223. Ebert BL, Bunn HF. Regulation of the erythropoietin gene. *Blood* 1999;94(6):1864-1877.
224. Hermine O, Beru N, Pech N, Goldwasser E. An autocrine role for erythropoietin in mouse hematopoietic cell differentiation. *Blood* 1991;78(9):2253-2260.
225. Stopka T, Zivny JH, Stopkova P, Prchal JF, Prchal JT. Human hematopoietic progenitors express erythropoietin. *Blood* 1998;91(10):3766-3772.
226. Marti HH. Erythropoietin and the hypoxic brain. *J Exp Biol* 2004;207(Pt 18):3233-3242.
227. Goldberg MA, Dunning SP, Bunn HF. Regulation of the erythropoietin gene: evidence that the oxygen sensor is a heme protein. *Science* 1988;242(4884):1412-1415.

228. Beck I, Ramirez S, Weinmann R, Caro J. Enhancer element at the 3'-flanking region controls transcriptional response to hypoxia in the human erythropoietin gene. *J Biol Chem* 1991;266(24):15563-15566.
229. Wang GL, Semenza GL. Characterization of hypoxia-inducible factor 1 and regulation of DNA binding activity by hypoxia. *J Biol Chem* 1993;268(29):21513-21518.
230. Semenza GL. Regulation of erythropoietin production. New insights into molecular mechanisms of oxygen homeostasis. *Hematol Oncol Clin North Am* 1994;8(5):863-884.
231. Greer SN, Metcalf JL, Wang Y, Ohh M. The updated biology of hypoxia-inducible factor. *EMBO J* 2012;31(11):2448-2460.
232. Ivan M, Kondo K, Yang H, et al. HIF α targeted for VHL-mediated destruction by proline hydroxylation: implications for O₂ sensing. *Science* 2001;292(5516):464-468.
233. Jaakkola P, Mole DR, Tian YM, et al. Targeting of HIF- α to the von Hippel-Lindau ubiquitylation complex by O₂-regulated prolyl hydroxylation. *Science* 2001;292(5516):468-472.
234. Bruick RK, McKnight SL. A conserved family of prolyl-4-hydroxylases that modify HIF. *Science* 2001;294(5545):1337-1340.
235. Bruick RK, McKnight SL. Transcription. Oxygen sensing gets a second wind. *Science* 2002;295(5556):807-808.
236. Lando D, Peet DJ, Gorman JJ, Whelan DA, Whitelaw ML, Bruick RK. FIH-1 is an asparaginyl hydroxylase enzyme that regulates the transcriptional activity of hypoxia-inducible factor. *Genes Dev* 2002;16(12):1466-1471.
237. Jensen M, Attenberger H, Schneider C, Walther JU. The developmental change in the G gamma and A gamma globin. Proportions in hemoglobin F. *Eur J Pediatr* 1982;138(4):311-314.
238. Lee FS, Percy MJ. The HIF pathway and erythrocytosis. *Annu Rev Pathol* 2011;6:165-192.
239. Semenza GL. Regulation of mammalian O₂ homeostasis by hypoxia-inducible factor 1. *Annu Rev Cell Dev Biol* 1999;15:551-578.
240. Paulson RF, Shi L, Wu DC. Stress erythropoiesis: new signals and new stress progenitor cells. *Curr Opin Hematol* 2011;18(3):139-145.
241. Perry JM, Harandi OF, Paulson RF. BMP4, SCF, and hypoxia cooperatively regulate the expansion of murine stress erythroid progenitors. *Blood* 2007;109(10): 4494-4502.
242. Wu H, Liu X, Jaenisch R, Lodish HF. Generation of committed erythroid BFU-E and CFU-E progenitors does not require erythropoietin or the erythropoietin receptor. *Cell* 1995;83(1):59-67.
243. Tsiftoglou AS, Vizirianakis IS, Strouboulis J. Erythropoiesis: model systems, molecular regulators, and developmental programs. *IUBMB Life* 2009;61(8):800-830.
244. Watowich SS. The erythropoietin receptor: molecular structure and hematopoietic signaling pathways. *J Investig Med* 2011;59(7):1067-1072.
245. Ingley E. Integrating novel signaling pathways involved in erythropoiesis. *IUBMB Life* 2012;64(5):402-410.
246. Berridge MV, Fraser JK, Carter JM, Lin FK. Effects of recombinant human erythropoietin on megakaryocytes and on platelet production in the rat. *Blood* 1988;72(3):970-977.
247. Sawyer ST. Receptors for erythropoietin. Distribution, structure, and role in receptor-mediated endocytosis in erythroid cells. In: Harris JR, ed. *Blood cell biochemistry*, vol. I. New York, NY: Plenum Publishing, 1990:365.
248. Papayannopoulou T, Brice M, Farrer D, Kaushansky K. Insights into the cellular mechanisms of erythropoietin-thrombopoietin synergy. *Exp Hematol* 1996;24(5):660-669.
249. Suzuki N, Ohneda O, Takahashi S, et al. Erythroid-specific expression of the erythropoietin receptor rescued its null mutant mice from lethality. *Blood* 2002;100(7):2279-2288.
250. Chen ZY, Asavaritikrai P, Prchal JT, Noguchi CT. Endogenous erythropoietin signaling is required for normal neural progenitor cell proliferation. *J Biol Chem* 2007;282(35):25875-25883.
251. Kertesz N, Wu J, Chen TH, Sucov HM, Wu H. The role of erythropoietin in regulating angiogenesis. *Dev Biol* 2004;276(1):101-110.

252. Wu H, Lee SH, Gao J, Liu X, Iruela-Arispe ML. Inactivation of erythropoietin leads to defects in cardiac morphogenesis. *Development* 1999;126(16):3597-3605.
253. Oster HS, Neumann D, Hoffman M, Mittelman M. Erythropoietin: the swinging pendulum. *Leuk Res* 2012;36(8):939-944.
254. D'Andrea AD, Lodish HF, Wong GG. Expression cloning of the murine erythropoietin receptor. *Cell* 1989;57(2):277-285.
255. Singh S, Verma R, Pradeep A, et al. Dynamic ligand modulation of EPO receptor pools, and dysregulation by polycythemia-associated EPOR alleles. *PLoS One* 2012;7(1):e29064.
256. Bazan JF. A novel family of growth factor receptors: a common binding domain in the growth hormone, prolactin, erythropoietin and IL-6 receptors, and the p75 IL-2 receptor beta-chain. *Biochem Biophys Res Commun* 1989;164(2):788-795.
257. D'Andrea AD, Fasman GD, Lodish HF. A new hematopoietic growth factor receptor superfamily: structural features and implications for signal transduction. *Curr Opin Cell Biol* 1990;2(4):648-651.
258. Livnah O, Stura EA, Johnson DL, et al. Functional mimicry of a protein hormone by a peptide agonist: the EPO receptor complex at 2.8 Å. *Science* 1996;273(5274):464-471.
259. Youssoufian H, Longmore G, Neumann D, Yoshimura A, Lodish HF. Structure, function, and activation of the erythropoietin receptor. *Blood* 1993;81(9):2223-2236.
260. Livnah O, Stura EA, Middleton SA, Johnson DL, Jolliffe LK, Wilson IA. Crystallographic evidence for preformed dimers of erythropoietin receptor before ligand activation. *Science* 1999;283(5404):987-990.
261. Kubatzky KF, Ruan W, Gurezka R, et al. Self assembly of the transmembrane domain promotes signal transduction through the erythropoietin receptor. *Curr Biol* 2001;11(2):110-115.
262. Dusanter-Fourt I, Casadevall N, Lacombe C, et al. Erythropoietin induces the tyrosine phosphorylation of its own receptor in human erythropoietin-responsive cells. *J Biol Chem* 1992;267(15):10670-10675.
263. Witthuhn BA, Quelle FW, Silvennoinen O, et al. JAK2 associates with the erythropoietin receptor and is tyrosine phosphorylated and activated following stimulation with erythropoietin. *Cell* 1993;74(2):227-236.
264. Parganas E, Wang D, Stravopodis D, et al. Jak2 is essential for signaling through a variety of cytokine receptors. *Cell* 1998;93(3):385-395.
265. Pang X, Zhou HX. A common model for cytokine receptor activation: combined scissor-like rotation and self-rotation of receptor dimer induced by class I cytokine. *PLoS Comput Biol* 2012;8(3):e1002427.
266. Neubauer H, Cumano A, Muller M, Wu H, Huffstadt U, Pfeffer K. Jak2 deficiency defines an essential developmental checkpoint in definitive hematopoiesis. *Cell* 1998;93(3):397-409.
267. Remy I, Wilson IA, Michnick SW. Erythropoietin receptor activation by a ligand-induced conformation change. *Science* 1999;283(5404):990-993.
268. Damen JE, Wakao H, Miyajima A, et al. Tyrosine 343 in the erythropoietin receptor positively regulates erythropoietin-induced cell proliferation and Stat5 activation. *EMBO J* 1995;14(22):5557-5568.
269. Zhu BM, McLaughlin SK, Na R, et al. Hematopoietic-specific Stat5-null mice display microcytic hypochromic anemia associated with reduced transferrin receptor gene expression. *Blood* 2008;112(5):2071-2080.
270. Menon MP, Karur V, Bogacheva O, Bogachev O, Cuetara B, Wojchowski DM. Signals for stress erythropoiesis are integrated via an erythropoietin receptor-phosphotyrosine-343-Stat5 axis. *J Clin Invest* 2006;116(3): 683-694.
271. Zang H, Sato K, Nakajima H, McKay C, Ney PA, Ihle JN. The distal region and receptor tyrosines of the Epo receptor are non-essential for in vivo erythropoiesis. *EMBO J* 2001;20(12):3156-3166.
272. Sathyanarayana P, Dev A, Fang J, et al. EPO receptor circuits for primary erythroblast survival. *Blood* 2008;111(11):5390-5399.
273. Socolovsky M, Fallon AE, Wang S, Brugnara C, Lodish HF. Fetal anemia and apoptosis of red cell progenitors in Stat5a-/-5b-/- mice: a direct role for Stat5 in Bcl-X(L) induction. *Cell* 1999;98(2):181-191.

274. Dolznig H, Grebien F, Deiner EM, et al. Erythroid progenitor renewal versus differentiation: genetic evidence for cell autonomous, essential functions of EpoR, Stat5 and the GR. *Oncogene* 2006;25(20):2890-2900.
275. Penta K, Sawyer ST. Erythropoietin induces the tyrosine phosphorylation, nuclear translocation, and DNA binding of STAT1 and STAT5 in erythroid cells. *J Biol Chem* 1995;270(52):31282-31287.
276. Wagner KU, Claudio E, Rucker EB 3rd, et al. Conditional deletion of the Bcl-x gene from erythroid cells results in hemolytic anemia and profound splenomegaly. *Development* 2000;127(22):4949-4958.
277. Rhodes MM, Kopsombut P, Bondurant MC, Price JO, Koury MJ. Bcl-x(L) prevents apoptosis of late-stage erythroblasts but does not mediate the antiapoptotic effect of erythropoietin. *Blood* 2005;106(5):1857-1863.
278. Kuo YY, Chang ZF. GATA-1 and Gfi-1B interplay to regulate Bcl-xL transcription. *Mol Cell Biol* 2007;27(12):4261-4272.
279. Sawyer ST, Jacobs-Helber SM. Unraveling distinct intracellular signals that promote survival and proliferation: study of erythropoietin, stem cell factor, and constitutive signaling in leukemic cells. *J Hematother Stem Cell Res* 2000;9(1):21-29.
280. Zhao W, Kitidis C, Fleming MD, Lodish HF, Ghaffari S. Erythropoietin stimulates phosphorylation and activation of GATA-1 via the PI3-kinase/AKT signaling pathway. *Blood* 2006;107(3):907-915.
281. Polak R, Buitenhuis M. The PI3K/PKB signaling module as key regulator of hematopoiesis: implications for therapeutic strategies in leukemia. *Blood* 2012;119(4):911-923.
282. Steelman LS, Franklin RA, Abrams SL, et al. Roles of the Ras/Raf/MEK/ERK pathway in leukemia therapy. *Leukemia* 2011;25(7):1080-1094.
283. Zhang J, Lodish HF. Identification of K-ras as the major regulator for cytokine-dependent Akt activation in erythroid progenitors in vivo. *Proc Natl Acad Sci U S A* 2005;102(41):14605-14610.
284. Liao HJ, Kume T, McKay C, Xu MJ, Ihle JN, Carpenter G. Absence of erythropoiesis and vasculogenesis in Plcg1-deficient mice. *J Biol Chem* 2002;277(11):9335-9341.
285. von Lindern M, Parren-van Amelsvoort M, van Dijk T, et al. Protein kinase C alpha controls erythropoietin receptor signaling. *J Biol Chem* 2000;275(44):34719-34727.
286. Mirandola P, Gobbi G, Ponti C, Sponzilli I, Cocco L, Vitale M. PKCepsilon controls protection against TRAIL in erythroid progenitors. *Blood* 2006;107(2):508-513.
287. Ingley E, McCarthy DJ, Pore JR, et al. Lyn deficiency reduces GATA-1, EKLF and STAT5, and induces extramedullary stress erythropoiesis. *Oncogene* 2005;24(3):336-343.
288. Ingley E. Src family kinases: regulation of their activities, levels and identification of new pathways. *Biochim Biophys Acta* 2008;1784(1):56-65.
289. Arai A, Kanda E, Nosaka Y, Miyasaka N, Miura O. CrkL is recruited through its SH2 domain to the erythropoietin receptor and plays a role in Lyn-mediated receptor signaling. *J Biol Chem* 2001;276(35):33282-33290.
290. Tong W, Zhang J, Lodish HF. Lnk inhibits erythropoiesis and EPO-dependent JAK2 activation and downstream signaling pathways. *Blood* 2005;105(12):4604-4612.
291. Singh S, Dev A, Verma R, et al. Defining an EPOR- Regulated Transcriptome for Primary Progenitors, including Tnfrsf13c as a Novel Mediator of EPO-Dependent Erythroblast Formation. *PLoS One* 2012;7(7):e38530.
292. Coulon S, Dussiot M, Grapton D, et al. Polymeric IgA1 controls erythroblast proliferation and accelerates erythropoiesis recovery in anemia. *Nat Med* 2011;17(11):1456-1465.
293. Divoky V, Liu Z, Ryan TM, Prchal JF, Townes TM, Prchal JT. Mouse model of congenital polycythemia: homologous replacement of murine gene by mutant human erythropoietin receptor gene. *Proc Natl Acad Sci U S A* 2001;98(3):986-991.
294. Huang LJ, Shen YM, Bulut GB. Advances in understanding the pathogenesis of primary familial and congenital polycythaemia. *Br J Haematol* 2010;148(6):844-852.
295. Fibach E. Involvement of phosphatases in proliferation, maturation, and hemoglobinization of developing erythroid cells. *J Signal Transduct* 2011;2011:860985.

296. Huang LJ, Constantinescu SN, Lodish HF. The N-terminal domain of Janus kinase 2 is required for Golgi processing and cell surface expression of erythropoietin receptor. *Mol Cell* 2001;8(6):1327-1338.
297. Sulahian R, Cleaver O, Huang LJ. Ligand-induced EpoR internalization is mediated by JAK2 and p85 and is impaired by mutations responsible for primary familial and congenital polycythemia. *Blood* 2009;113(21): 5287-5297.
298. Meyer L, Deau B, Forejtnikova H, et al. beta-Trcp mediates ubiquitination and degradation of the erythropoietin receptor and controls cell proliferation. *Blood* 2007;109(12):5215-5222.
299. Croker BA, Kiu H, Nicholson SE. SOCS regulation of the JAK/STAT signalling pathway. *Semin Cell Dev Biol* 2008;19(4):414-422.
300. Seibler J, Zevnik B, Kuter-Luks B, et al. Rapid generation of inducible mouse mutants. *Nucleic Acids Res* 2003;31(4):e12.
301. Zeigler BM, Vajdos J, Qin W, Loverro L, Niss K. A mouse model for an erythropoietin-deficiency anemia. *Dis Model Mech* 2010;3(11-12):763-772.
302. Longmore GD, Pharr P, Lodish HF. Mutation in murine erythropoietin receptor induces erythropoietin-independent erythroid proliferation in vitro, polycythemia in vivo. *Leukemia* 1992;6(Suppl 3):130S-134S.
303. Yoshimura A, Longmore G, Lodish HF. Point mutation in the exoplasmic domain of the erythropoietin receptor resulting in hormone-independent activation and tumorigenicity. *Nature* 1990;348(6302):647-649.
304. Schuringa JJ, Chung KY, Morrone G, Moore MA. Constitutive activation of STAT5A promotes human hematopoietic stem cell self-renewal and erythroid differentiation. *J Exp Med* 2004;200(5):623-635.
305. Levine RL, Gilliland DG. Myeloproliferative disorders. *Blood* 2008;112(6): 2190-2198.
306. Kleppe M, Levine RL. New pieces of a puzzle: the current biological picture of MPN. *Biochimica et Biophysica Acta (BBA)—Rev Cancer* 2012;1826: 415-422.
307. James C, Ugo V, Le Couedic JP, et al. A unique clonal JAK2 mutation leading to constitutive signalling causes polycythaemia vera. *Nature* 2005; 434(7037):1144-1148.
308. Sakaguchi M, Koishihara Y, Tsuda H, et al. The expression of functional erythropoietin receptors on an interleukin-3 dependent cell line. *Biochem Biophys Res Commun* 1987;146(1):7-12.
309. Tsao CJ, Tojo A, Fukamachi H, et al. Expression of the functional erythropoietin receptors on interleukin 3-dependent murine cell lines. *J Immunol* 1988;140(1):89-93.
310. Koury MJ, Sawyer ST, Bondurant MC. Splenic erythroblasts in anemia-inducing Friend disease: a source of cells for studies of erythropoietin-mediated differentiation. *J Cell Physiol* 1984;121(3):526-532.
311. Koury MJ, Bondurant MC, Duncan DT, Krantz SB, Hankins WD. Specific differentiation events induced by erythropoietin in cells infected in vitro with the anemia strain of Friend virus. *Proc Natl Acad Sci U S A* 1982;79(2): 635-639.
312. Dolznig H, Habermann B, Stangl K, et al. Apoptosis protection by the Epo target Bcl-X(L) allows factor-independent differentiation of primary erythroblasts. *Curr Biol* 2002;12(13):1076-1085.
313. Carlile GW, Smith DH, Wiedmann M. Caspase-3 has a nonapoptotic function in erythroid maturation. *Blood* 2004;103(11):4310-4316.
314. Droin N, Cathelin S, Jacquelin A, et al. A role for caspases in the differentiation of erythroid cells and macrophages. *Biochimie* 2008;90(2):416-422.
315. Ribeil JA, Zermati Y, Vandekerckhove J, et al. Hsp70 regulates erythropoiesis by preventing caspase-3-mediated cleavage of GATA-1. *Nature* 2007;445(7123):102-105.
316. Frisan E, Vandekerckhove J, de Thonel A, et al. Defective nuclear localization of Hsp70 is associated with dyserythropoiesis and GATA-1 cleavage in myelodysplastic syndromes. *Blood* 2012;119(6):1532-1542.
317. Clark DA, Dessypris EN. Effects of recombinant erythropoietin on murine megakaryocytic colony formation in vitro. *J Lab Clin Med* 1986;108(5): 423-429.
318. Ishibashi T, Koziol JA, Burstein SA. Human recombinant erythropoietin promotes differentiation of murine megakaryocytes in vitro. *J Clin Invest* 1987;79(1):286-289.

319. Fraser JK, Tan AS, Lin FK, Berridge MV. Expression of specific high-affinity binding sites for erythropoietin on rat and mouse megakaryocytes. *Exp Hematol* 1989;17(1):10-16.
320. McDonald TP, Cottrell MB, Clift RE, Cullen WC, Lin FK. High doses of recombinant erythropoietin stimulate platelet production in mice. *Exp Hematol* 1987;15(6):719-721.
321. Eschbach JW, Abdulhadi MH, Browne JK, et al. Recombinant human erythropoietin in anemic patients with end-stage renal disease. Results of a phase III multicenter clinical trial. *Ann Intern Med* 1989;111(12):992-1000.
322. Caro J, Erslev AJ. Erythropoietin assays and their use in the study of anemias. *Contrib Nephrol* 1988;66:54-62.
323. Kazal LA, Erslev AJ. The measurement of erythropoietin. *Ann Clin Lab Sci* 1975;5(2):91-97.
324. Cotes PM. Immunoreactive erythropoietin in serum. I. Evidence for the validity of the assay method and the physiological relevance of estimates. *Br J Haematol* 1982;50(3):427-438.
325. Garcia JF. The radioimmunoassay of human plasma erythropoietin. In: Gordon AS, Condorelli M, Peschle C, eds. *Regulation of erythropoiesis*. Milan: Il Ponte, 1972:132.
326. Sherwood JB, Goldwasser E. A radioimmunoassay for erythropoietin. *Blood* 1979;54(4):885-893.
327. Egrie JC, Cotes PM, Lane J, Gaines Das RE, Tam RC. Development of radioimmunoassays for human erythropoietin using recombinant erythropoietin as tracer and immunogen. *J Immunol Methods* 1987;99(2):235-241.
328. Sherwood JB, Carmichael LD, Goldwasser E. The heterogeneity of circulating human serum erythropoietin. *Endocrinology* 1988;122(4):1472-1477.
329. Wintrobe MM, ed. *Blood, pure and eloquent*. New York, NY: McGraw Hill, 1980.
330. Lew VL, Raftos JE, Sorette M, Bookchin RM, Mohandas N. Generation of normal human red cell volume, hemoglobin content, and membrane area distributions by "birth" or regulation? *Blood* 1995;86(1):334-341.
331. Allen FH Jr, Beiser SM, Boyd WC, et al. Blood-group nomenclature. *Science* 1958;127(3308):1255.
332. Wintrobe MM. The volume and hemoglobin content of the red blood corpuscle. *Am J Med Sci* 1929;177:513-523.
333. Wintrobe MM. The erythrocyte in man. *Medicine* 1930;9(2):195.
334. D'Onofrio G, Chirillo R, Zini G, Caenaro G, Tommasi M, Micciulli G. Simultaneous measurement of reticulocyte and red blood cell indices in healthy subjects and patients with microcytic and macrocytic anemia. *Blood* 1995;85(3):818-823.
335. Lenard JG. A note on the shape of the erythrocyte. *Bull Math Biol* 1974;36(1):55-58.
336. Skalak R, Branemark PI. Deformation of red blood cells in capillaries. *Science* 1969;164(3880):717-719.
337. Evans EA. Structure and deformation properties of red blood cells: concepts and quantitative methods. *Methods Enzymol* 1989;173:3-35.
338. Manno S, Takakuwa Y, Mohandas N. Identification of a functional role for lipid asymmetry in biological membranes: phosphatidylserine-skeletal protein interactions modulate membrane stability. *Proc Natl Acad Sci U S A* 2002;99(4):1943-1948.
339. Chasis JA, Shohet SB. Red cell biochemical anatomy and membrane properties. *Annu Rev Physiol* 1987;49:237-248.
340. Jay AW. Geometry of the human erythrocyte. I. Effect of albumin on cell geometry. *Biophys J* 1975;15(3):205-222.
341. Gorter E, Grendel F. On bimolecular layers of lipoids on the chromocytes of the blood. *J Exp Med* 1925;41(4):439-443.
342. Danielli JF. The Thickness of the Wall of the Red Blood Corpuscle. *J Gen Phys* 1935;19(1):19-22.
343. Adam NK, Askew FA, Danielli JF. Further experiments on surface films of sterols and their derivatives. *Biochem J* 1935;29(7):1786-1801.
344. Davson H, Danielli JF. Studies on the permeability of erythrocytes: factors in cation permeability. *Biochem J* 1938;32(6):991-1001.
345. Singer SJ. A fluid lipid-globular protein mosaic model of membrane structure. *Ann NY Acad Sci* 1972;195:16-23.
346. Schiffmann Y. The "fluid mosaic model" and the "lattice model" as two non-equilibrium states of the same membrane and the significance for biochemical control. *Mol Cell Biochem* 1982;42(2):117-124.

347. Bennett V. Spectrin: a structural mediator between diverse plasma membrane proteins and the cytoplasm. *Curr Opin Cell Biol* 1990;2(1):51-56.
348. de Vetten MP, Agre P. The Rh polypeptide is a major fatty acid-acylated erythrocyte membrane protein. *J Biol Chem* 1988;263(34):18193-18196.
349. Telen MJ. Phosphatidylinositol-linked red blood cell membrane proteins and blood group antigens. *Immunohematol/Am Red Cross* 1991;7(3):65-72.
350. Cooper RA. Lipids of human red cell membrane: normal composition and variability in disease. *Semin Hematol* 1970;7(3):296-322.
351. Schwartz RS, Chiu DT, Lubin B. Plasma membrane phospholipid organization in human erythrocytes. *Curr Top Hematol* 1985;5:63-112.
352. Dodge JT, Mitchell C, Hanahan DJ. The preparation and chemical characteristics of hemoglobin-free ghosts of human erythrocytes. *Arch Biochem Biophys* 1963;100:119-130.
353. Dodge JT, Phillips GB. Composition of phospholipids and of phospholipid fatty acids and aldehydes in human red cells. *J Lipid Res* 1967;8(6):667-675.
354. Ways P, Hanahan DJ. Characterization and quantification of red cell lipids in normal man. *J Lipid Res* 1964;5(3):318-328.
355. Lubin BH, Kuypers FA, Chiu DTY, Shohet SB. Analysis of red cell membrane lipids. In: Shohet SB, ed. *Red cell membranes*, vol. 19. New York, NY: Churchill Livingstone, 1988:171-202.
356. Rothman JE, Lenard J. Membrane asymmetry. *Science* 1977; 195(4280): 743-753.
357. Bretscher MS. Membrane structure: some general principles. *Science* 1973;181(4100):622-629.
358. Van Dort HM, Knowles DW, Chasis JA, Lee G, Mohandas N, Low PS. Analysis of integral membrane protein contributions to the deformability and stability of the human erythrocyte membrane. *J Biol Chem* 2001;276(50):46968-46974.
359. Cogan U, Schachter D. Asymmetry of lipid dynamics in human erythrocyte membranes studied with impermeant fluorophores. *Biochemistry* 1981;20(22):6396-6403.
360. Fisher KA. Analysis of membrane halves: cholesterol. *Proc Natl Acad Sci U S A* 1976;73(1):173-177.
361. Haest CW, Deuticke B. Possible relationship between membrane proteins and phospholipid asymmetry in the human erythrocyte membrane. *Biochim Biophys Acta* 1976;436(2):353-365.
362. Haest CW, Plasa G, Kamp D, Deuticke B. Spectrin as a stabilizer of the phospholipid asymmetry in the human erythrocyte membrane. *Biochim Biophys Acta* 1978;509(1):21-32.
363. Cooper RA. Abnormalities of cell-membrane fluidity in the pathogenesis of disease. *N Engl J Med* 1977;297(7):371-377.
364. Shohet SB. Hemolysis and changes in erythrocyte membrane lipids. I. *N Engl J Med* 1972;286(11):577-583.
365. Nelson GJ. Composition of neutral lipids from erythrocytes of common mammals. *J Lipid Res* 1967;8(4):374-379.
366. Bull BS, Brailsford JD. The biconcavity of the red cell: an analysis of several hypotheses. *Blood* 1973;41(6):833-844.
367. Cooper RA. Influence of increased membrane cholesterol on membrane fluidity and cell function in human red blood cells. *J Supramolecular Struct* 1978;8(4):413-430.
368. Tishler RB, Carlson FD. A study of the dynamic properties of the human red blood cell membrane using quasi-elastic light-scattering spectroscopy. *Biophys J* 1993;65(6):2586-2600.
369. Glomset JA. The plasma lecithins: cholesterol acyltransferase reaction. *J Lipid Res* 1968;9(2):155-167.
370. Norum KR, Gjone E. Familial serum-cholesterol esterification failure. A new inborn error of metabolism. *Biochim Biophys Acta* 1967;144(3):698-700.
371. Cooper RA, Jandl JH. Bile salts and cholesterol in the pathogenesis of target cells in obstructive jaundice. *J Clin Invest* 1968;47(4):809-822.
372. Steck TL. The organization of proteins in the human red blood cell membrane. A review. *J Cell Biol* 1974;62(1):1-19.

373. Fairbanks G, Steck TL, Wallach DFH. Electrophoretic analysis of the major polypeptides of the human erythrocyte membrane. *Biochemistry* 1971;10:2606-2617.
374. Anstee DJ, Mawby WJ, Tanner MJ. Abnormal blood-group-Ss-active sialoglycoproteins in the membrane of Miltenberger class III, IV and V human erythrocytes. *Biochem J* 1979;183(2):193-203.
375. Dahr W, Uhlenbruck G, Gunson HH, van der Hart M. Studies on glycoproteins and glycopeptides from Tn-polyagglutinable erythrocytes. *Vox Sang* 1975;28(3):249-252.
376. Furthmayr H. Glycophorins A, B, and C: a family of sialoglycoproteins. Isolation and preliminary characterization of trypsin derived peptides. *J Supramolecular Struct* 1978;9(1):79-95.
377. Goodman SR, Kurdia A, Ammann L, Kakhniashvili D, Daescu O. The human red blood cell proteome and interactome. *Exp Biol Med (Maywood)* 2007;232(11):1391-1408.
378. Pasini EM, Kirkegaard M, Mortensen P, Lutz HU, Thomas AW, Mann M. In-depth analysis of the membrane and cytosolic proteome of red blood cells. *Blood* 2006;108(3):791-801.
379. D'Alessandro A, Righetti PG, Zolla L. The red blood cell proteome and interactome: an update. *J Proteome Res* 2010;9(1):144-163.
380. Pasvol G, Wainscoat JS, Weatherall DJ. Erythrocytes deficiency in glycophorin resist invasion by the malarial parasite *Plasmodium falciparum*. *Nature* 1982;297(5861):64-66.
381. Anstee DJ. The nature and abundance of human red cell surface glycoproteins. *J Immunogenet* 1990;17(4-5):219-225.
382. Lux SE, John KM, Kopito RR, Lodish HF. Cloning and characterization of band 3, the human erythrocyte anion-exchange protein (AE1). *Proc Natl Acad Sci U S A* 1989;86(23):9089-9093.
383. Tanner MJ, Martin PG, High S. The complete amino acid sequence of the human erythrocyte membrane anion-transport protein deduced from the cDNA sequence. *Biochem J* 1988;256(3):703-712.
384. Issitt PD. Null red blood cell phenotypes: associated biological changes. *Transfus Med Rev* 1993;7(3):139-155.
385. Cherif-Zahar B, Bloy C, Le Van Kim C, et al. Molecular cloning and protein structure of a human blood group Rh polypeptide. *Proc Natl Acad Sci U S A* 1990;87(16):6243-6247.
386. Smythe JS, Avent ND, Judson PA, Parsons SF, Martin PG, Anstee DJ. Expression of RHD and RHCE gene products using retroviral transduction of K562 cells establishes the molecular basis of Rh blood group antigens. *Blood* 1996;87(7):2968-2973.
387. Huebner K, Palumbo AP, Isobe M, et al. The alpha-spectrin gene is on chromosome 1 in mouse and man. *Proc Natl Acad Sci U S A* 1985;82(11): 3790-3793.
388. Prchal JT, Morley BJ, Yoon SH, et al. Isolation and characterization of cDNA clones for human erythrocyte beta-spectrin. *Proc Natl Acad Sci U S A* 1987;84(21):7468-7472.
389. Winkelmann JC, Leto TL, Watkins PC, et al. Molecular cloning of the cDNA for human erythrocyte beta-spectrin. *Blood* 1988;72(1):328-334.
390. Lambert S, Bennett V. From anemia to cerebellar dysfunction. A review of the ankyrin gene family. *Eur J Biochem* 1993;211(1-2):1-6.
391. Delaunay J. The molecular basis of hereditary red cell membrane disorders. *Blood Rev* 2007;21(1):1-20.
392. Mathai JC, Mori S, Smith BL, et al. Functional analysis of aquaporin-1 deficient red cells. The Colton-null phenotype. *J Biol Chem* 1996;271(3):1309-1313.
393. Agre P, Preston GM, Smith BL, et al. Aquaporin CHIP: the archetypal molecular water channel. *Am J Physiol* 1993;265(4 Pt 2):F463-F476.
394. Orringer EP, Parker JC. Ion and water movements in red blood cells. *Prog Hematol* 1973;8:1-23.
395. Tanner MJ. Molecular and cellular biology of the erythrocyte anion exchanger (AE1). *Semin Hematol* 1993;30(1):34-57.
396. Adragna NC, Di Fulvio M, Lauf PK. Regulation of K-Cl cotransport: from function to genes. *J Membr Biol* 2004;201(3):109-137.

397. Joiner CH, Rettig RK, Jiang M, Risinger M, Franco RS. Urea stimulation of KCl cotransport induces abnormal volume reduction in sickle reticulocytes. *Blood* 2007;109(4):1728-1735.
398. Gardos G. The function of calcium in the potassium permeability of human erythrocytes. *Biochimica et Biophysica Acta* 1958;30(3):653-654.
399. Lew VL, Etzion Z, Bookchin RM. Dehydration response of sickle cells to sickling-induced Ca(++) permeabilization. *Blood* 2002;99(7):2578-2585.
400. Mueckler M, Caruso C, Baldwin SA, et al. Sequence and structure of a human glucose transporter. *Science* 1985;229(4717):941-945.
401. Baly DL, Horuk R. The biology and biochemistry of the glucose transporter. *Biochim Biophys Acta* 1988;947(3):571-590.
402. Elbrink J, Bihler I. Membrane transport: its relation to cellular metabolic rates. *Science* 1975;188(4194):1177-1184.
403. Chow FL, Telen MJ, Rosse WF. The acetylcholinesterase defect in paroxysmal nocturnal hemoglobinuria: evidence that the enzyme is absent from the cell membrane. *Blood* 1985;66(4):940-945.
404. Rosse WF. Phosphatidylinositol-linked proteins and paroxysmal nocturnal hemoglobinuria. *Blood* 1990;75(8):1595-1601.
405. Telen MJ. Erythrocyte blood group antigens: polymorphisms of functionally important molecules. *Semin Hematol* 1996;33(4):302-314.
406. Plut DA, Hosey MM, Tao M. Evidence for the participation of cytosolic protein kinases in membrane phosphorylation in intact erythrocytes. *Eur J Biochem* 1978;82(2):333-337.
407. Arnaud F, Scultetus AH, Haque A, et al. Sodium nitroprusside ameliorates systemic but not pulmonary HBOC-201-induced vasoconstriction: an exploratory study in a swine controlled haemorrhage model. *Resuscitation* 2012;83(8):1038-45.
408. de Figueiredo LF. Vasoactive properties of synthetic blood substitutes. *Medicina* 1998;58(4):403-410.
409. Hsia CC. Respiratory function of hemoglobin. *N Engl J Med* 1998;338(4): 239-247.
410. Hardison RC. A brief history of hemoglobins: plant, animal, protist, and bacteria. *Proc Natl Acad Sci U S A* 1996;93(12):5675-5679.
411. Braunitzer G, Hilschmann N, Mueller R. [On the site of specific exchange of amino acids in the beta-chain of pathological human hemoglobins]. *Hoppe-Seyler's Zeitschrift fur physiologische Chemie* 1960;318:284-287.
412. Goodman M. Decoding the pattern of protein evolution. *Prog Biophys Mol Biol* 1981;38(2):105-164.
413. Hill RL, Buettner-Janusch J. Evolution of hemoglobin. *Federation Proc* 1964;23:1236-1242.
414. Deisseroth A, Nienhuis A, Lawrence J, Giles R, Turner P, Ruddle FH. Chromosomal localization of human beta globin gene on human chromosome 11 in somatic cell hybrids. *Proc Natl Acad Sci U S A* 1978;75(3):1456-1460.
415. Peschle C, Mavilio F, Migliaccio G, et al. Erythropoietic development and hemoglobin switching in human embryos: cellular and molecular aspects. *Prog Clin Biol Res* 1985;191:383-396.
416. Huehns ER, Dance N, Beaven GH, Hecht F, Motulsky AG. Human embryonic hemoglobins. *Cold Spring Harb Symp Quant Biol* 1964;29:327-331.
417. Kamuzora H, Lehmann H. Human embryonic haemoglobins including a comparison by homology of the human beta and alpha chains. *Nature* 1975;256(5517):511-513.
418. Huehns ER, Farouqi AM. Oxygen dissociation properties of human embryonic red cells. *Nature* 1975;254(5498):335-337.
419. Cooper HA, Hoagland HC. Fetal hemoglobin. *Mayo Clinic proceedings*. *Mayo Clin* 1972;47(6):402-414.
420. Bunn HF, Jandl JH. Control of hemoglobin function within the red cell. *N Engl J Med* 1970;282(25):1414-1421.
421. Ricco G, Mazza U, Turi RM, et al. Significance of a new type of human fetal hemoglobin carrying a replacement isoleucine replaced by threonine at position 75 (E 19) of the gamma chain. *Hum Genet* 1976;32(3):305-313.

422. Schroeder WA, Huisman TH, Efremov GD, et al. Further studies of the frequency and significance of the Tgamma-chain of human fetal hemoglobin. *J Clin Invest* 1979;63(2):268-275.
423. Alter BP. The G gamma: a gamma composition of fetal hemoglobin in fetuses and newborns. *Blood* 1979;54(5):1158-1163.
424. Allen DW, Wyman J Jr, Smith CA. The oxygen equilibrium of fetal and adult human hemoglobin. *J Biol Chem* 1953;203(1):81-87.
425. Tyuma I, Shimizu K. Different response to organic phosphates of human fetal and adult hemoglobins. *Arch Biochem Biophys* 1969;129(1):404-405.
426. Poyart C, Bursaux E, Guesnon P, Teisseire B. Chloride binding and the Bohr effect of human fetal erythrocytes and HbFII solutions. *Pflugers Archiv : Eur J Physiol* 1978;376(2):169-175.
427. Bard H. The postnatal decline of hemoglobin F synthesis in normal full-term infants. *J Clin Invest* 1975;55(2):395-398.
428. Dover GJ, Boyer SH, Charache S, Heintzelman K. Individual variation in the production and survival of F cells in sickle-cell disease. *N Engl J Med* 1978;299(26):1428-1435.
429. Ley TJ, Nienhuis AW. Induction of hemoglobin F synthesis in patients with beta thalassemia. *Annu Rev Med* 1985;36:485-498.
430. De Rosa MC, Sanna MT, Messana I, et al. Glycated human hemoglobin (HbA1c): functional characteristics and molecular modeling studies. *Biophys Chem* 1998;72(3):323-335.
431. McDonald MJ, Shapiro R, Bleichman M, Solway J, Bunn HF. Glycosylated minor components of human adult hemoglobin. Purification, identification, and partial structural analysis. *J Biol Chem* 1978;253(7):2327-2332.
432. Spicer KM, Allen RC, Hallett D, Buse MG. Synthesis of hemoglobin A_{1c} and related minor hemoglobin by erythrocytes. In vitro study of regulation. *J Clin Invest* 1979;64(1):40-48.
433. Bunn HF, Haney DN, Gabbay KH, Gallop PM. Further identification of the nature and linkage of the carbohydrate in hemoglobin A_{1c}. *Biochem Biophys Res Commun* 1975;67(1):103-109.
434. Fitzgibbons JF, Koler RD, Jones RT. Red cell age-related changes of hemoglobins A_{1a}+b and A_{1c} in normal and diabetic subjects. *J Clin Invest* 1976;58(4):820-824;525(2):195-200
435. Abraham EC, Cameron BF, Abraham A, Stallings M. Glycosylated hemoglobins in heterozygotes and homozygotes for hemoglobin C with or without diabetes. *J Lab Clin Med* 1984;104(4):602-609.
436. Bernstein RE. Nonenzymatically glycosylated proteins. *Adv Clin Chem* 1987;26:1-78.
437. Katsiki N, Papanas N, Mikhailidis DP, Fonseca VA. Glycated hemoglobin A(1)c (HbA(1)c) and diabetes: a new era? *Curr Med Res Opin* 2011;27 (Suppl 3):7-11.
438. Bry L, Chen PC, Sacks DB. Effects of hemoglobin variants and chemically modified derivatives on assays for glycohemoglobin. *Clin Chem* 2001;47(2):153-163.
439. IHIC variants list. International hemoglobin information center. *Hemoglobin* 1989;13(3):223-297.
440. Schmidt RM, Rucknagel DL, Necheles TF. Comparison of methodologies for thalassemia screening by Hb A₂ quantitation. *J Lab Clin Med* 1975;86(5):873-882.
441. Steinberg MH, Adams JG 3rd. Hemoglobin A₂: origin, evolution, and aftermath. *Blood* 1991;78(9):2165-2177.
442. Huisman TH, Schroeder WA, Brodie AN, Mayson SM, Jakway J. Microchromatography of hemoglobins. II. A simplified procedure for the determination of hemoglobin A₂. *J Lab Clin Med* 1975;86(4):700-702.
443. Bollekens JA, Forget BG. Delta beta thalassemia and hereditary persistence of fetal hemoglobin. *Hematol Oncol Clin North Am* 1991;5(3):399-422.
444. Pembrey ME, McWade P, Weatherall DJ. Reliable routine estimation of small amounts of foetal haemoglobin by alkali denaturation. *J Clin Pathol* 1972;25(8):738-740.
445. Boyer SH, Belding TK, Margolet L, Noyes AN. Fetal hemoglobin restriction to a few erythrocytes (F cells) in normal human adults. *Science* 1975;188(4186):361-363.
446. Chernoff AI. A method for the quantitative determination of Hgb A₂. *Ann NY Acad Sci* 1964;119:557-560.

447. Lafferty J, Ali MA, Carstairs K, Crawford L. Proficiency testing of hemoglobinopathy techniques in Ontario laboratories. *Am J Clin Pathol* 1997;107(5):567-575.
448. Robinson AR, Robson M, Harrison AP, Zuelzer WW. A new technique for differentiation of hemoglobin. *J Lab Clin Med* 1957;50(5):745-752.
449. Zago MA, Wood WG, Clegg JB, Weatherall DJ, O'Sullivan M, Gunson H. Genetic control of F cells in human adults. *Blood* 1979;53(5):977-986.
450. Kleihauer E, Braun H, Betke K. [Demonstration of fetal hemoglobin in erythrocytes of a blood smear]. *Klinische Wochenschr* 1957;35(12):637-638.
451. Lloyd-Evans P, Guest AR, Austin EB, Scott ML. Use of a phycoerythrin-conjugated anti-glycophorin. A monoclonal antibody as a double label to improve the accuracy of FMH quantification by flow cytometry. *Transfus Med* 1999;9(2):155-160.
452. Lehmann H, Carrell RW. Variations in the structure of human haemoglobin. With particular reference to the unstable haemoglobins. *Br Med Bull* 1969;25(1):14-23.
453. Bolton W, Perutz MF. Three dimensional fourier synthesis of horse deoxyhaemoglobin at 2.8 Angstrom units resolution. *Nature* 1970;228(5271): 551-552.
454. Shaanan B. Structure of human oxyhaemoglobin at 2.1 Å resolution. *J Mol Biol* 1983;171(1):31-59.
455. Hrkal Z, Vodrazka Z. A study of the conformation of human globin in solution by optical methods. *Biochim Biophys Acta* 1967;133(3):527-534.
456. de Castro CM, Devlin B, Fleenor DE, Lee ME, Kaufman RE. A novel beta-globin mutation, beta Durham-NC [beta 114 Leu→Pro], produces a dominant thalassemia-like phenotype. *Blood* 1994;83(4):1109-1116.
457. Henry ER, Bettati S, Hofrichter J, Eaton WA. A tertiary two-state allosteric model for hemoglobin. *Biophys.Chem* 2002;98(1-2):149-164.
458. Perutz MF, Kilmartin JV, Nagai K, Szabo A, Simon SR. Influence of globin structures on the state of the heme. Ferrous low spin derivatives. *Biochemistry* 1976;15(2):378-387.
459. Baldwin J, Chothia C. Haemoglobin: the structural changes related to ligand binding and its allosteric mechanism. *J Mol Biol* 1979;129(2):175-220.
460. Chance MR, Parkhurst LJ, Powers LS, Chance B. Movement of Fe with respect to the heme plane in the R-T transition of carp hemoglobin. An extended x-ray absorption fine structure study. *J Biol Chem* 1986;261(13):5689-5692.
461. Kurlekar N, Mehta BC. Haemoglobin A2 levels in iron deficiency anaemia. *Indian J Med Res* 1981;73:77-81.
462. Forget BG, Cavallero C, Benz EJ Jr, et al. Studies of globin chain synthesis and globin mRNA content in a patient homozygous for hemoglobin Lepore. *Hemoglobin* 1978;2(2):117-128.
463. Bunn HF. Subunit assembly of hemoglobin: an important determinant of hematologic phenotype. *Blood* 1987;69(1):1-6.
464. Shaeffer JR, McDonald MJ, Bunn HF. Assembly of normal and abnormal human hemoglobins. *Trends Biochem Sci* 1981;6(0):158-161.
465. Bunn HF, McDonald MJ. Electrostatic interactions in the assembly of haemoglobin. *Nature* 1983;306(5942):498-500.
466. Embury SH, Dozy AM, Miller J, et al. Concurrent sickle-cell anemia and alpha-thalassemia: effect on severity of anemia. *N Engl J Med* 1982;306(5):270-274.
467. Steinberg MH. Case report: effects of iron deficiency and the -88 C→T mutation on HbA2 levels in beta-thalassemia. *Am J Med Sci* 1993;305(5):312-313.
468. Barcroft J. The respiratory function of the blood; the transition from placental to pulmonary respiration. *J R Instit Pub Health Hyg* 1946;9:86-95.
469. Humpeler E, Amor H. Sex differences in the oxygen affinity of hemoglobin. *Pflugers Archiv : Eur J Physiol* 1973;343(2):151-156.
470. Astrup P. Red-cell pH and oxygen affinity of hemoglobin. *N Engl J Med* 1970;283(4):202-204.
471. Riggs A. Functional properties of hemoglobins. *Physiol Rev* 1965;45(4):619-673.

472. Yonetani T, Park SI, Tsuneshige A, Imai K, Kanaori K. Global allosteric model of hemoglobin. Modulation of O₂ affinity, cooperativity, and Bohr effect by heterotropic allosteric effectors. *J Biol Chem* 2002;277(37):34508-34520.
473. Benesch R, Benesch RE. The effect of organic phosphates from the human erythrocyte on the allosteric properties of hemoglobin. *Biochem Biophys Res Commun* 1967;26(2):162-167.
474. Brewer GJ, Eaton JW. Erythrocyte metabolism: interaction with oxygen transport. *Science* 1971;171(3977):1205-1211.
475. Marschner JP, Seidlitz T, Rietbrock N. Effect of 2,3-diphosphoglycerate on O₂-dissociation kinetics of hemoglobin and glycosylated hemoglobin using the stopped flow technique and an improved in vitro method for hemoglobin glycosylation. *Int J Clin Pharmacol Ther* 1994;32(3):116-121.
476. Chanutin A, Curnish RR. Effect of organic and inorganic phosphates on the oxygen equilibrium of human erythrocytes. *Arch Biochem Biophys* 1967;121(1):96-102.
477. Haggarty NW, Dunbar B, Fothergill LA. The complete amino acid sequence of human erythrocyte diphosphoglycerate mutase. *EMBO J* 1983;2(7): 1213-1220.
478. Rosa R, Calvin MC. Comparative effects of two sulfhydryl reagents on the activities of a multifunctional red cell enzyme: bisphosphoglycerate mutase. *Biochem Biophys Res Commun* 1988;153(3):945-951.
479. Rose ZB. The enzymology of 2,3-bisphosphoglycerate. *Adv Enzymol Relat Areas Mol Biol* 1980;51:211-253.
480. Yu KT, Pendley C, 2nd, Herczeg T, Pendleton RG. 2,3-Diphosphoglycerate phosphatase/synthase: a potential target for elevating the diphosphoglycerate level in human red blood cells. *J Pharmacol Exp Ther* 1990;252(1):192-200.
481. Bunn HF, May MH, Kocholaty WF, Shields CE. Hemoglobin function in stored blood. *J Clin Invest* 1969;48(2):311-321.
482. Oski FA, Travis SF, Miller LD, Delivoria-Papadopoulos M, Cannon E. The in vitro restoration of red cell 2,3-diphosphoglycerate levels in banked blood. *Blood* 1971;37(1):52-58.
483. Lenfant C, Torrance J, English E, et al. Effect of altitude on oxygen binding by hemoglobin and on organic phosphate levels. *J Clin Invest* 1968;47(12): 2652-2656.
484. Edwards MJ, Canon B. Oxygen transport during erythropoietic response to moderate blood loss. *N Engl J Med* 1972;287(3):115-119.
485. Torrance J, Jacobs P, Restrepo A, Eschbach J, Lenfant C, Finch CA. Intraerythrocytic adaptation to anemia. *N Engl J Med* 1970;283(4): 165-169.
486. Ackers GK. The energetics of ligand-linked subunit assembly in hemoglobin require a third allosteric structure. *Biophys Chem* 1990;37(1-3):371-382.
487. Daugherty MA, Shea MA, Johnson JA, LiCata VJ, Turner GJ, Ackers GK. Identification of the intermediate allosteric species in human hemoglobin reveals a molecular code for cooperative switching. *Proc Natl Acad Sci U S A* 1991;88(4):1110-1114.
488. Rorth M. Hemoglobin interactions and red cell metabolism. *Series haematol* 1972;5(1):1-104.
489. Kuhn HJ, Marti E. The active transport of oxygen and carbon dioxide into the swim-bladder of fish. *J Gen Physiol* 1966;49(6):1209-1220.
490. Rees SE, Andreassen S. Mathematical models of oxygen and carbon dioxide storage and transport: the acid-base chemistry of blood. *Crit Rev Biomed Eng* 2005;33(3):209-264.
491. De Rosa MC, Carelli Alinovi C, Galtieri A, Scatena R, Giardina B. The plasma membrane of erythrocytes plays a fundamental role in the transport of oxygen, carbon dioxide and nitric oxide and in the maintenance of the reduced state of the heme iron. *Gene* 2007;398(1-2):162-171.
492. Arnone A. X-ray studies of the interaction of CO₂ with human deoxyhaemoglobin. *Nature* 1974;247(437):143-145.
493. Boyer SH, Siegel S, Noyes AN. Developmental changes in human erythrocyte carbonic anhydrase levels: coordinate expression with adult hemoglobin. *Dev Biol* 1983;97(1):250-253.
494. Brady HJ, Edwards M, Linch DC, Knott L, Barlow JH, Butterworth PH. Expression of the human carbonic anhydrase I gene is activated late in fetal erythroid development and regulated by stage-specific trans-acting factors. *Br J Haematol* 1990;76(1):135-142.

495. Jeffery S, Carter ND, Wilson C. Carbonic anhydrase II isoenzyme in rat liver is under hormonal control. *Biochem J* 1984;221(3):927-929.
496. Tashian RE, Kendall AG, Carter ND. Inherited variants of human red cell carbonic anhydrases. *Hemoglobin* 1980;4(5-6):635-651.
497. Yoshida K, Kiso Y, Kurihara H, et al. Erythrocyte carbonic anhydrase I concentration in patients receiving thyroxine. *Endocrinol Jpn* 1991;38(4): 363-367.
498. Cabrales P, Han G, Nacharaju P, Friedman AJ, Friedman JM. Reversal of hemoglobin-induced vasoconstriction with sustained release of nitric oxide. *Am J Physiol. Heart Circ Physiol* 2011;300(1):H49-H56.
499. Lancaster JR Jr. Simulation of the diffusion and reaction of endogenously produced nitric oxide. *Proc Natl Acad Sci U S A* 1994;91(17):8137-8141.
500. Jia L, Bonaventura C, Bonaventura J, Stamler JS. S-nitrosohaemoglobin: a dynamic activity of blood involved in vascular control. *Nature* 1996; 380(6571):221-226.
501. Gow AJ, Stamler JS. Reactions between nitric oxide and haemoglobin under physiological conditions. *Nature* 1998;391(6663):169-173.
502. Gow AJ, Luchsinger BP, Pawloski JR, Singel DJ, Stamler JS. The oxyhemoglobin reaction of nitric oxide. *Proc Natl Acad Sci U S A* 1999;96(16): 9027-9032.
503. Pawloski JR, Hess DT, Stamler JS. Export by red blood cells of nitric oxide bioactivity. *Nature* 2001;409(6820):622-626.
504. Gladwin MT. Role of the red blood cell in nitric oxide homeostasis and hypoxic vasodilation. *Adv Exp Med Biol* 2006;588:189-205.
505. Sonveaux P, Lobysheva, II, Feron O, McMahon TJ. Transport and peripheral bioactivities of nitrogen oxides carried by red blood cell hemoglobin: role in oxygen delivery. *Physiology* 2007;22:97-112.
506. Singel DJ, Stamler JS. Chemical physiology of blood flow regulation by red blood cells: the role of nitric oxide and S-nitrosohemoglobin. *Annu Rev Physiol* 2005;67:99-145.
507. Jaffe ER, Hsieh HS. DPNH-methemoglobin reductase deficiency and hereditary methemoglobinemia. *Semin Hematol* 1971;8(4):417-437.
508. Mansouri A. Methemoglobin reduction under near physiological conditions. *Biochem Med Metabol Biol* 1989;42(1):43-51.
509. Feiner JR, Bickler PE. Improved accuracy of methemoglobin detection by pulse CO-oximetry during hypoxia. *Anesth Analg* 2010;111(5):1160-1167.
510. Jarolim P, Lahav M, Liu SC, Palek J. Effect of hemoglobin oxidation products on the stability of red cell membrane skeletons and the associations of skeletal proteins: correlation with a release of hemin. *Blood* 1990;76(10): 2125-2131.
511. Berzofsky JA, Peisach J, Blumberg WE. Sulfheme proteins. I. Optical and magnetic properties of sulfmyoglobin and its derivatives. *J Biol Chem* 1971;246(10):3367-3377.
512. Rachmilewitz EA. Denaturation of the normal and abnormal hemoglobin molecule. *Semin Hematol* 1974;11(4):441-462.
513. Morell DB, Chang Y. The structure of the chromophore of sulphmyoglobin. *Biochim Biophys Acta* 1967;136(1):121-130.
514. Berzofsky JA, Peisach J, Horecker BL. Sulfheme proteins. IV. The stoichiometry of sulfur incorporation and the isolation of sulfhemin, the prosthetic group of sulfmyoglobin. *J Biol Chem* 1972;247(12):3783-3791.
515. Sass MD, Caruso CJ, Farhangi M. TPNH-methemoglobin reductase deficiency: a new red-cell enzyme defect. *J Lab Clin Med* 1967;70(5):760-767.
516. Gibson QH. The reduction of methaemoglobin in red blood cells and studies on the cause of idiopathic methaemoglobinaemia. *Biochem J* 1948;42(1):13- 23.
517. Hultquist DE, Passon PG. Catalysis of methaemoglobin reduction by erythrocyte cytochrome B5 and cytochrome B5 reductase. *Nature: New Biol* 1971;229(8):252-254.

518. Bloom GE, Zarkowsky HS. Heterogeneity of the enzymatic defect in congenital methemoglobinemia. *N Engl J Med* 1969;281(17):919-922.
519. Hegesh E, Hegesh J, Kaftory A. Congenital methemoglobinemia with a deficiency of cytochrome b5. *N Engl J Med* 1986;314(12):757-761.
520. Carrell RW, Winterbourn CC, Rachmilewitz EA. Activated oxygen and haemolysis. *Br J Haematol* 1975;30(3):259-264.
521. Fridovich I. Oxygen: boon and bane. *Am Sci* 1975;63(1):54-59.
522. Misra HP, Fridovich I. The oxidation of phenylhydrazine: superoxide and mechanism. *Biochemistry* 1976;15(3):681-687.
523. Lynch RE, Lee R, Cartwright GE. Inhibition by superoxide dismutase of methemoglobin formation from oxyhemoglobin. *J Biol Chem* 1976;251(4): 1015-1019.
524. Sutton HC, Roberts PB, Winterbourn CC. The rate of reaction of superoxide radical ion with oxyhaemoglobin and methaemoglobin. *Biochem J* 1976;155(3):503-510.
525. Fridovich I. Oxygen: aspects of its toxicity and elements of defense. *Curr Eye Res* 1984;3(1):1-2.
526. Fridovich I. Oxygen toxicity: a radical explanation. *J Exp Biol* 1998;201(Pt 8):1203-1209.
527. Cohen G, Hochstein P. Glutathione peroxidase: the primary agent for the elimination of hydrogen peroxide in erythrocytes. *Biochemistry* 1963;2: 1420-1428.
528. Prohaska JR, Ganther HE. Selenium and glutathione peroxidase in developing rat brain. *J Neurochem* 1976;27(6):1379-1387.
529. Prohaska JR, Oh SH, Hoekstra WG, Ganther HE. Glutathione peroxidase: inhibition by cyanide and release of selenium. *Biochem Biophys Res Commun* 1977;74(1):64-71.
530. Necheles TF, Steinberg MH, Cameron D. Erythrocyte glutathione-peroxidase deficiency. *Br J Haematol* 1970;19(5):605-612.
531. Tudhope GR. Red cell catalase in health and in disease, with reference to the enzyme activity in anaemia. *Clin Sci* 1967;33(1):165-182.
532. Jacob HS, Ingbar SH, Jandl JH. Oxidative hemolysis and erythrocyte metabolism in hereditary acatalasia. *J Clin Invest* 1965;44:1187-1199.
533. Ogata M. Acatalasemia. *Hum Genet* 1991;86(4):331-340.
534. Goth L, Nagy T. Acatalasemia and diabetes mellitus. *Arch Biochem Biophys* 2012;525(2):195-200.
535. Agar NS, Sadrzadeh SM, Hallaway PE, Eaton JW. Erythrocyte catalase. A somatic oxidant defense? *J Clin Invest* 1986;77(1):319-321.
536. Minnich V, Smith MB, Brauner MJ, Majerus PW. Glutathione biosynthesis in human erythrocytes. I. Identification of the enzymes of glutathione synthesis in hemolysates. *J Clin Invest* 1971;50(3):507-513.
537. Srivastava SK, Beutler E. The transport of oxidized glutathione from human erythrocytes. *J Biol Chem* 1969;244(1):9-16.
538. Srivastava SK, Beutler E. Glutathione metabolism of the erythrocyte. The enzymic cleavage of glutathione-haemoglobin preparations by glutathione reductase. *Biochem J* 1970;119(3):353-357.
539. Murphy JR. Erythrocyte metabolism. I. The equilibration of glucose-C14 between serum and erythrocytes. *J Lab Clin Med* 1960;55:281-285.
540. Schuster R, Holzhutter HG, Jacobasch G. Interrelations between glycolysis and the hexose monophosphate shunt in erythrocytes as studied on the basis of a mathematical model. *Bio Systems* 1988;22(1):19-36.
541. Tanaka KR, Zerez CR. Red cell enzymopathies of the glycolytic pathway. *Semin Hematol* 1990;27(2):165-185.
542. Davidson WD, Tanaka KR. Factors affecting pentose phosphate pathway activity in human red cells. *Br J Haematol* 1972;23(3):371-385.
543. Szeinberg A, Marks PA. Substances stimulating glucose catabolism by the oxidative reactions of the pentose phosphate pathway in human erythrocytes. *J Clin Invest* 1961;40:914-924.

544. Giblett ER. Recent advances in heptoglobin and transferrin genetics. *Bibl Haematol* 1968;29:10-20.
545. Noyes WD, Garby L. Rate of haptoglobin in synthesis in normal man. Determinations by the return to normal levels following hemoglobin infusion. *Scand J Clin Lab Invest* 1967;20(1):33-38.
546. Rifkind RA. Destruction of injured red cells in vivo. *Am J Med* 1966;41(5): 711-723.
547. Bratosin D, Mazurier J, Tissier JP, et al. Cellular and molecular mechanisms of senescent erythrocyte phagocytosis by macrophages. A review. *Biochimie* 1998;80(2):173-195.
548. Rosse WF, Dourmashkin R, Humphrey JH. Immune lysis of normal human and paroxysmal nocturnal hemoglobinuria (PNH) red blood cells. 3. The membrane defects caused by complement lysis. *J Exp Med* 1966;123(6): 969-984.
549. Cooper RA, Shattil SJ. Mechanisms of hemolysis—the minimal red-cell defect. *N Engl J Med* 1971;285(27):1514-1520.
550. Singer K, Weisz L. The life cycle of the erythrocyte after splenectomy and the problems of splenic hemolysis and target cell formation. *Am J Med Sci* 1945;210:301-323.
551. Safeukui I, Buffet PA, Deplaine G, et al. Quantitative assessment of sensing and sequestration of spherocytic erythrocytes by the human spleen. *Blood* 2012;120(2):424-430.
552. Buffet PA, Milon G, Brousse V, et al. Ex vivo perfusion of human spleens maintains clearing and processing functions. *Blood* 2006;107(9): 3745-3752.
553. Sadrzadeh SM, Graf E, Panter SS, Hallaway PE, Eaton JW. Hemoglobin. A biologic fenton reagent. *J Biol Chem* 1984;259(23):14354-14356.
554. Wood KC, Hsu LL, Gladwin MT. Sickle cell disease vasculopathy: a state of nitric oxide resistance. *Free Radic Biol Med* 2008;44(8):1506-1528.
555. Bunn HF, Nathan DG, Dover GJ, et al. Pulmonary hypertension and nitric oxide depletion in sickle cell disease. *Blood* 2010;116(5):687-692.
556. Pu JJ, Brodsky RA. Paroxysmal nocturnal hemoglobinuria from bench to bedside. *Clin Transl Sci* 2011;4(3):219-224.
557. Gutteridge JM, Smith A. Antioxidant protection by haemopexin of haemstimulated lipid peroxidation. *Biochem J* 1988;256(3):861-865.
558. Okazaki T, Yanagisawa Y, Nagai T. Analysis of the affinity of each haptoglobin polymer for hemoglobin by two-dimensional affinity electrophoresis. *Clin Chim Acta* 1997;258(2):137-144.
559. McCormick DJ, Atassi MZ. Hemoglobin binding with haptoglobin: delineation of the haptoglobin binding site on the alpha-chain of human hemoglobin. *J Protein Chem* 1990;9(6):735-742.
560. Buehler PW, Abraham B, Vallelian F, et al. Haptoglobin preserves the CD163 hemoglobin scavenger pathway by shielding hemoglobin from peroxidative modification. *Blood* 2009;113(11):2578-2586.
561. Laurell CB, Nyman M. Studies on the serum haptoglobin level in hemoglobinemia and its influence on renal excretion of hemoglobin. *Blood* 1957;12(6):493-506.
562. Carter K, Worwood M. Haptoglobin: a review of the major allele frequencies worldwide and their association with diseases. *Int J Lab Hematol* 2007;29(2):92-110.
563. Mominoki K, Nakagawa-Tosa N, Morimatsu M, Syuto B, Saito M. Haptoglobin in Carnivora: a unique molecular structure in bear, cat and dog haptoglobins. *Comp Biochem Physiol B Biochem Mol Biol* 1995;110(4):785-789.
564. Wejman JC, Hovsepian D, Wall JS, Hainfeld JF, Greer J. Structure and assembly of haptoglobin polymers by electron microscopy. *J Mol Biol* 1984;174(2):343-368.
565. Povey S, Jeremiah SJ, Barker RF, et al. Assignment of the human locus determining phosphoglycolate phosphatase (PGP) to chromosome 16. *Ann Hum Genet* 1980;43(3):241-248.
566. Robson EB, Polani PE, Dart SJ, Jacobs PA, Renwick JH. Probable assignment of the alpha locus of haptoglobin to chromosome 16 in man. *Nature* 1969;223(5211):1163-1165.
567. Simmers RN, Stupans I, Sutherland GR. Localization of the human haptoglobin genes distal to the fragile site at 16q22 using in situ hybridization. *Cytogenet Cell Genet* 1986;41(1):38-41.
568. Raugei G, Bensi G, Colantuoni V, et al. Sequence of human haptoglobin cDNA: evidence that the alpha and beta subunits are coded by the same mRNA. *Nucleic Acids Res* 1983;11(17):5811-5819.

569. Wassler M, Fries E. Proteolytic cleavage of haptoglobin occurs in a subcompartment of the endoplasmic reticulum: evidence from membrane fusion in vitro. *J Cell Biol* 1993;123(2):285-291.
570. Sevaljevic LJ, Marinkovic-Pajovic S, Grigorov I, Bogojevic D, Ivanovic-Matic S, Petrovic M. Acute phase-dependent changes in the binding of rat liver nucleoproteins to the cytokine response element of the rat haptoglobin gene. *Int J Biochem Cell Biol* 1995;27(2):185-194.
571. Baumann H, Morella KK, Jahreis GP, Marinkovic S. Distinct regulation of the interleukin-1 and interleukin-6 response elements of the rat haptoglobin gene in rat and human hepatoma cells. *Mol Cell Biol* 1990;10(11):5967-5976.
572. Hanasaki K, Powell LD, Varki A. Binding of human plasma sialoglycoproteins by the B cell-specific lectin CD22. Selective recognition of immunoglobulin M and haptoglobin. *J Biol Chem* 1995;270(13):7543-7550.
573. Pajovic S, Jones VE, Prowse KR, Berger FG, Baumann H. Species-specific changes in regulatory elements of mouse haptoglobin genes. *J Biol Chem* 1994;269(3):2215-2224.
574. Smithies O, Connell GE, Dixon GH. Inheritance of haptoglobin subtypes. *Am J Hum Genet* 1962;14:14-21.
575. Melamed-Frank M, Lache O, Enav BI, et al. Structure-function analysis of the antioxidant properties of haptoglobin. *Blood* 2001;98(13):3693-3698.
576. Vanhollebeke B, De Muylder G, Nielsen MJ, et al. A haptoglobin-hemoglobin receptor conveys innate immunity to *Trypanosoma brucei* in humans. *Science* 2008;320(5876):677-681.
577. Cox KJ, Thomas AS. The application of immunoblotting to the phenotyping of haptoglobin. *J Forensic Sci* 1992;37(6):1652-1655.
578. Viedma JA, de la Iglesia A, Navarro A. Immunoturbidimetry of haptoglobin and transferrin in the EPOS 5060 analyzer. *Clin Chem* 1987;33(7):1257.
579. van Rijn HJ, van der Wilt W, Stroes JW, Schrijver J. Is the turbidimetric immunoassay of haptoglobin phenotype-dependent? *Clin Biochem* 1987;20(4):245-248.
580. Salmi TT. Haptoglobin levels in the plasma of newborn infants with special reference to infections. *Acta Paediatr Scand Suppl* 1973;241:1-55.
581. Alper CA, Peters JH, Birtch AG, Gardner FH. Haptoglobin Synthesis. I. In vivo studies of the production of haptoglobin, fibrinogen, and gamma-globulin by the Canine liver. *J Clin Invest* 1965;44:574-581.
582. Wada T, Oara H, Watanabe K, Kinoshita H, Nishio H. Studies on haptoglobin synthesis in reticuloendothelial tissues. *J Reticuloendothel Soc* 1970;8(3):195-207.
583. Javid J. Human haptoglobins. *Curr Top Hematol* 1978;1:151-192.
584. Bissell DM, Hammaker L, Schmid R. Hemoglobin and erythrocyte catabolism in rat liver: the separate roles of parenchymal and sinusoidal cells. *Blood* 1972;40(6):812-822.
585. Brus I, Lewis SM. The haptoglobin content of serum in haemolytic anaemia. *Br J Haematol* 1959;5:348-355.
586. Hershko C, Cook JD, Finch CA. Storage iron kinetics. II. The uptake of hemoglobin iron by hepatic parenchymal cells. *J Lab Clin Med* 1972;80(5): 624-634.
587. Schaer CA, Vallelan F, Imhof A, Schoedon G, Schaer DJ. CD163-expressing monocytes constitute an endotoxin-sensitive Hb clearance compartment within the vascular system. *J Leukoc Biol* 2007;82(1):106-110.
588. Higa Y, Oshiro S, Kino K, Tsunoo H, Nakajima H. Catabolism of globin-haptoglobin in liver cells after intravenous administration of hemoglobin-haptoglobin to rats. *J Biol Chem* 1981;256(23):12322-12328.
589. Kristiansen M, Graversen JH, Jacobsen C, et al. Identification of the haemoglobin scavenger receptor. *Nature* 2001;409(6817):198-201.
590. Weinstein MB, Segal HL. Uptake of free hemoglobin by rat liver parenchymal cells. *Biochem Biophys Res Commun* 1984;123(2):489-496.
591. Van Gorp H, Delputte PL, Nauwynck HJ. Scavenger receptor CD163, a Jack-of-all-trades and potential target for cell-directed therapy. *Mol Immunol* 2010;47(7-8):1650-1660.

592. Rhodes MM, Kopsombut P, Bondurant MC, Price JO, Koury MJ. Adherence to macrophages in erythroblastic islands enhances erythroblast proliferation and increases erythrocyte production by a different mechanism than erythropoietin. *Blood* 2008;111(3):1700-1708.
593. Biswas SK, Mantovani A. Macrophage plasticity and interaction with lymphocyte subsets: cancer as a paradigm. *Nat Immunol* 2010;11(10):889-896.
594. Sindrilaru A, Peters T, Wieschalka S, et al. An unrestrained proinflammatory M1 macrophage population induced by iron impairs wound healing in humans and mice. *J Clin Invest* 2011;121(3):985-997.
595. Nielsen MJ, Moller HJ, Moestrup SK. Hemoglobin and heme scavenger receptors. *Antioxid Redox Signal* 2009;12(2):261-273.
596. Moller HJ. Soluble CD163. *Scand J Clin Lab Invest* 2012;72(1):1-13.
597. Etzerodt A, Kjolby M, Nielsen MJ, Maniecki MB, Svendsen P, Moestrup SK. Plasma clearance of hemoglobin and haptoglobin in mice and effect of CD163 gene targeting disruption. *Antioxid Redox Signal* 2012. [Epub ahead of print]
598. Maniecki MB, Hasle H, Friis-Hansen L, et al. Impaired CD163-mediated hemoglobin-scavenging and severe toxic symptoms in patients treated with gemtuzumab ozogamicin. *Blood* 2008;112(4):1510-1514.
599. Lathem W. The renal excretion of hemoglobin: regulatory mechanisms and the differential excretion of free and protein-bound hemoglobin. *J Clin Invest* 1959;38(4):652-658.
600. Gburek J, Verroust PJ, Willnow TE, et al. Megalin and cubilin are endocytic receptors involved in renal clearance of hemoglobin. *J Am Soc Nephrol* 2002;13(2):423-430.
601. Zager RA, Gamelin LM. Pathogenetic mechanisms in experimental hemoglobinuric acute renal failure. *Am J Physiol* 1989;256(3 Pt 2):F446-F455.
602. Feola M, Simoni J, Tran R, Canizaro PC. Nephrotoxicity of hemoglobin solutions. *Biomater Artif Cells Artif Organs* 1990;18(2):233-249.
603. Cheng TS, Ko WH, Swaminathan R, Tam SC. Effect of lysine on hemolysis-induced kidney damage. *J Lab Clin Med* 1992;119(5):496-502.
604. Sears DA, Anderson PR, Foy AL, Williams HL, Crosby WH. Urinary iron excretion and renal metabolism of hemoglobin in hemolytic diseases. *Blood* 1966;28(5):708-725.
605. Marsh GW, Lewis SM. Cardiac haemolytic anaemia. *Semin Hematol* 1969;6(2):133-149.
606. Muller-Eberhard U. Hemopexin. *N Engl J Med* 1970;283(20):1090-1094.
607. Ascenzi P, Bocedi A, Visca P, et al. Hemoglobin and heme scavenging. *IUBMB Life* 2005;57(11):749-759.
608. Fagoonee S, Gburek J, Hirsch E, et al. Plasma protein haptoglobin modulates renal iron loading. *Am J Pathol* 2005;166(4):973-983.
609. Altruda F, Poli V, Restagno G, Argos P, Cortese R, Silengo L. The primary structure of human hemopexin deduced from cDNA sequence: evidence for internal, repeating homology. *Nucleic Acids Res* 1985;13(11):3841-3859.
610. Severance S, Hamza I. Trafficking of heme and porphyrins in metazoa. *Chem Rev* 2009;109(10):4596-4616.
611. Delanghe JR, Langlois MR. Hemopexin: a review of biological aspects and the role in laboratory medicine. *Clin Chim Acta* 2001;312(1-2):13-23.
612. Morgan WT, Liem HH, Sutor RP, Muller-Eberhard U. Transfer of heme from heme-albumin to hemopexin. *Biochim Biophys Acta* 1976;444(2):435-445.
613. Law ML, Cai GY, Hartz JA, Jones C, Kao FT. The hemopexin gene maps to the same location as the beta-globin gene cluster on human chromosome 11. *Genomics* 1988;3(1):48-52.
614. Naylor SL, Altruda F, Marshall A, Silengo L, Bowman BH. Hemopexin is localized to human chromosome 11. *Somat Cell Mol Genet* 1987;13(4): 355-358.
615. Thorbecke GJ, Liem HH, Knight S, Cox K, Muller-Eberhard U. Sites of formation of the serum proteins transferrin and hemopexin. *J Clin Invest* 1973;52(3):725-731.
616. Paoli M, Anderson BF, Baker HM, Morgan WT, Smith A, Baker EN. Crystal structure of hemopexin reveals a novel high-affinity heme site formed between two beta-propeller domains. *Nat Struct Biol* 1999;6(10):926-931.

617. Seery VL, Muller-Eberhard U. Binding of porphyrins to rabbit hemopexin and albumin. *J Biol Chem* 1973;248(11):3796-3800.
618. Cox MC, Le Brun N, Thomson AJ, Smith A, Morgan WT, Moore GR. MCD, EPR and NMR spectroscopic studies of rabbit hemopexin and its heme binding domain. *Biochim Biophys Acta* 1995;1253(2):215-223.
619. Smith A, Morgan WT. Haem transport to the liver by haemopexin. Receptor-mediated uptake with recycling of the protein. *Biochem J* 1979;182(1):47-54.
620. Carmel N, Gross J. Hemopexin metabolism in mice with transplantable tumors. *Isr J Med Sci* 1977;13(12):1182-1190.
621. Smith A, Hunt RC. Hemopexin joins transferrin as representative members of a distinct class of receptor-mediated endocytic transport systems. *Eur J Cell Biol* 1990;53(2):234-245.
622. Wu ML, Morgan WT. Conformational analysis of hemopexin by Fourier-transform infrared and circular dichroism spectroscopy. *Proteins* 1994;20(2):185-190.
623. Hvidberg V, Maniecki MB, Jacobsen C, Hojrup P, Moller HJ, Moestrup SK. Identification of the receptor scavenging hemopexin-heme complexes. *Blood* 2005;106(7):2572-2579.
624. Wu ML, Morgan WT. Characterization of hemopexin and its interaction with heme by differential scanning calorimetry and circular dichroism. *Biochemistry* 1993;32(28):7216-7222.
625. Potter D, Chronos ZC, Baynes JW, et al. In vivo fate of hemopexin and heme-hemopexin complexes in the rat. *Arch Biochem Biophys* 1993;300(1): 98-104.
626. Sinclair PR, Bement WJ, Gorman N, Liem HH, Wolkoff AW, Muller-Eberhard U. Effect of serum proteins on haem uptake and metabolism in primary cultures of liver cells. *Biochem J* 1988;256(1):159-165.
627. Maniecki MB, Moller HJ, Moestrup SK, Moller BK. CD163 positive subsets of blood dendritic cells: the scavenging macrophage receptors CD163 and CD91 are coexpressed on human dendritic cells and monocytes. *Immunobiology* 2006;211(6-8):407-417.
628. Tolosano E, Fagoonee S, Hirsch E, et al. Enhanced splenomegaly and severe liver inflammation in haptoglobin/hemopexin double-null mice after acute hemolysis. *Blood* 2002;100(12):4201-4208.
629. Yang Z, Philips JD, Doty RT, et al. Kinetics and specificity of feline leukemia virus subgroup C receptor (FLVCR) export function and its dependence on hemopexin. *J Biol Chem* 2010;285(37):28874-28882.
630. Sears DA. Disposal of plasma heme in normal man and patients with intravascular hemolysis. *J Clin Invest* 1970;49(1):5-14.
631. Liem HH, Muller-Eberhard U. Do heme and bilirubin have identical binding sites on the albumin molecule? *Biochem Biophys Res Commun* 1971;42(4):634-639.
632. Coburn RF, Williams WJ, Kahn SB. Endogenous carbon monoxide production in patients with hemolytic anemia. *J Clin Invest* 1966;45(4):460-468.
633. Maines MD, Gibbs PE. 30 some years of heme oxygenase: from a "molecular wrecking ball" to a "mesmerizing" trigger of cellular events. *Biochem Biophys Res Commun* 2005;338(1):568-577.
634. Yoshinaga T, Sassa S, Kappas A. The occurrence of molecular interactions among NADPH-cytochrome c reductase, heme oxygenase, and biliverdin reductase in heme degradation. *J Biol Chem* 1982;257(13):7786-7793.
635. Berk PD, Howe RB, Bloomer JR, Berlin NI. Studies of bilirubin kinetics in normal adults. *J Clin Invest* 1969;48(11):2176-2190.
636. Maines MD, Ibrahim NG, Kappas A. Solubilization and partial purification of heme oxygenase from rat liver. *J Biol Chem* 1977;252(16):5900-5903.
637. Mitani K, Fujita H, Fukuda Y, Kappas A, Sassa S. The role of inorganic metals and metalloporphyrins in the induction of haem oxygenase and heat-shock protein 70 in human hepatoma cells. *Biochem J* 1993;290(Pt 3):819-825.
638. Kappas A, Drummond GS, Henschke C, Valaes T. Direct comparison of Sn-mesoporphyrin, an inhibitor of bilirubin production, and phototherapy in controlling hyperbilirubinemia in term and near-term newborns. *Pediatrics* 1995;95(4):468-474.

639. Rizzardini M, Carelli M, Cabello Porras MR, Cantoni L. Mechanisms of endotoxin-induced haem oxygenase mRNA accumulation in mouse liver: synergism by glutathione depletion and protection by N-acetylcysteine. *Biochem J* 1994;304(Pt 2):477-483.
640. Rizzardini M, Terao M, Falciani F, Cantoni L. Cytokine induction of haem oxygenase mRNA in mouse liver. Interleukin 1 transcriptionally activates the haem oxygenase gene. *Biochem J* 1993;290(Pt 2):343-347.
641. Mitani K, Fujita H, Sassa S, Kappas A. Heat shock induction of heme oxygenase mRNA in human Hep 3B hepatoma cells. *Biochem Biophys Res Commun* 1989;165(1):437-441.
642. Kapitulnik J, Maines MD. Pleiotropic functions of biliverdin reductase: cellular signaling and generation of cytoprotective and cytotoxic bilirubin. *Trends Pharmacol Sci* 2009;30(3):129-137.
643. Zenke-Kawasaki Y, Dohi Y, Katoh Y, et al. Heme induces ubiquitination and degradation of the transcription factor Bach1. *Mol Cell Biol* 2007;27(19):6962-6971.
644. Zhang L, Guarente L. Heme binds to a short sequence that serves a regulatory function in diverse proteins. *EMBO J* 1995;14(2):313-320.
645. Ogawa K, Sun J, Taketani S, et al. Heme mediates derepression of Maf recognition element through direct binding to transcription repressor Bach1. *EMBO J* 2001;20(11):2835-2843.
646. de Haro C, Mendez R, Santoyo J. The eIF-2 α kinases and the control of protein synthesis. *FASEB J* 1996;10(12):1378-1387.
647. Williams SE, Wootton P, Mason HS, et al. Hemoxygenase-2 is an oxygen sensor for a calcium-sensitive potassium channel. *Science* 2004;306(5704): 2093-2097.
648. Brown SB, King RF. The mechanism of haem catabolism. Bilirubin formation in living rats by [¹⁸O]oxygen labelling. *Biochem J* 1978;170(2):297-311.
649. Stocker R, Yamamoto Y, McDonagh AF, Glazer AN, Ames BN. Bilirubin is an antioxidant of possible physiological importance. *Science* 1987;235(4792): 1043-1046.
650. Sedlak TW, Saleh M, Higginson DS, Paul BD, Juluri KR, Snyder SH. Bilirubin and glutathione have complementary antioxidant and cytoprotective roles. *Proc Natl Acad Sci U S A* 2009;106(13):5171-5176.
651. Baranano DE, Rao M, Ferris CD, Snyder SH. Biliverdin reductase: a major physiologic cytoprotectant. *Proc Natl Acad Sci U S A* 2002;99(25):16093-16098.
652. Dore S, Takahashi M, Ferris CD, et al. Bilirubin, formed by activation of heme oxygenase-2, protects neurons against oxidative stress injury. *Proc Natl Acad Sci U S A* 1999;96(5):2445-2450.
653. Maghzal GJ, Leck MC, Collinson E, Li C, Stocker R. Limited role for the bilirubin-biliverdin redox amplification cycle in the cellular antioxidant protection by biliverdin reductase. *J Biol Chem* 2009;284(43):29251-29259.
654. Zhang AS, Enns CA. Molecular mechanisms of normal iron homeostasis. *Hematol Am Soc Hematol Educ Program* 2009:207-214.
655. Yachie A, Niida Y, Wada T, et al. Oxidative stress causes enhanced endothelial cell injury in human heme oxygenase-1 deficiency. *J Clin Invest* 1999;103(1):129-135.
656. Poss KD, Tonegawa S. Heme oxygenase 1 is required for mammalian iron reutilization. *Proc Natl Acad Sci U S A* 1997;94(20):10919-10924.
657. Kovtunovych G, Eckhaus MA, Ghosh MC, Ollivierre-Wilson H, Rouault TA. Dysfunction of the heme recycling system in heme oxygenase 1 deficient mice: effects on macrophage viability and tissue iron distribution. *Blood* 2010;116:6054-62.
658. Bloomer JR, Berk PD, Howe RB, Berlin NI. Interpretation of plasma bilirubin levels based on studies with radioactive bilirubin. *JAMA* 1971;218(2): 216-220.
659. McDonagh AF, Lightner DA. Phototherapy and the photobiology of bilirubin. *Semin Liver Dis* 1988;8(3):272-283.
660. Itoh S, Onishi S. Kinetic study of the photochemical changes of (ZZ)-bilirubin IX alpha bound to human serum albumin. Demonstration of (EZ)-bilirubin IX alpha as an intermediate in photochemical changes from (ZZ)-bilirubin IX alpha to (EZ)-cyclobilirubin IX alpha. *Biochem J* 1985;226(1):251-258.
661. Bonnett R, Ioannou S. Phototherapy and the chemistry of bilirubin. *Mol Aspects Med* 1987;9(5):457-471.

662. Gordon ER, Seligson D, Flye MW. Serum bilirubin pigments covalently linked to albumin. *Arch Pathol Lab Med* 1996;120(7):648-653.
663. McDonagh AF. Controversies in bilirubin biochemistry and their clinical relevance. *Semin Fetal Neonatal Med* 2010;15(3):141-147.
664. Doumas BT, Wu TW. The measurement of bilirubin fractions in serum. *Crit Rev Clin Lab Sci* 1991;28(5-6):415-445.
665. Jacobsen J. Binding of bilirubin to human serum albumin—determination of the dissociation constants. *FEBS Lett* 1969;5(2):112-114.
666. Mustafa MG, King TE. Binding of bilirubin with lipid. A possible mechanism of its toxic reactions in mitochondria. *J Biol Chem* 1970;245(5):1084-1089.
667. Rosenthal P, Pincus M, Fink D. Sex- and age-related differences in bilirubin concentrations in serum. *Clin Chem* 1984;30(8):1380-1382.
668. Muraca M, Fevery J, Blanckaert N. Analytic aspects and clinical interpretation of serum bilirubins. *Semin Liver Dis* 1988;8(2):137-147.
669. Reed RG, Davidson LK, Burrington CM, Peters T, Jr. Non-resolving jaundice: bilirubin covalently attached to serum albumin circulates with the same metabolic half-life as albumin. *Clin Chem* 1988;34(10):1992-1994.
670. Zucker SD, Goessling W. Mechanism of hepatocellular uptake of albumin-bound bilirubin. *Biochim Biophys Acta* 2000;1463(2):197-208.
671. Berk PD, Stremmel W. Hepatocellular uptake of organic anions. *Prog Liver Dis* 1986;8:125-144.
672. Sorrentino D, Berk PD. Mechanistic aspects of hepatic bilirubin uptake. *Semin Liver Dis* 1988;8(2):119-136.
673. Gollan JL, Schmid R. Bilirubin update: formation, transport, and metabolism. *Prog Liver Dis* 1982;7:261-283.
674. Zucker SD, Goessling W, Gollan JL. Kinetics of bilirubin transfer between serum albumin and membrane vesicles. Insight into the mechanism of organic anion delivery to the hepatocyte plasma membrane. *J Biol Chem* 1995;270(3):1074-1081.
675. Zucker SD, Goessling W, Zeidel ML, Gollan JL. Membrane lipid composition and vesicle size modulate bilirubin intermembrane transfer. Evidence for membrane-directed trafficking of bilirubin in the hepatocyte. *J Biol Chem* 1994;269(30):19262-19270.
676. Frydman RB, Tomaro ML, Awruch J, Frydman B. Interconversion of the molecular forms of biliverdin reductase from rat liver. *Biochim Biophys Acta* 1983;759(3):257-263.
677. Bosma PJ, Seppen J, Goldhoorn B, et al. Bilirubin UDP-glucuronosyltransferase 1 is the only relevant bilirubin glucuronidating isoform in man. *J Biol Chem* 1994;269(27):17960-17964.
678. Crawford JM, Ransil BJ, Narciso JP, Gollan JL. Hepatic microsomal bilirubin UDP-glucuronosyltransferase. The kinetics of bilirubin mono- and diglucuronide synthesis. *J Biol Chem* 1992;267(24):16943-16950.
679. Jansen PL, Oude Elferink RP. Hereditary hyperbilirubinemias: a molecular and mechanistic approach. *Semin Liver Dis* 1988;8(2):168-178.
680. Labrune P, Myara A, Hadchouel M, et al. Genetic heterogeneity of Crigler-Najjar syndrome type I: a study of 14 cases. *Hum Genet* 1994;94(6):693-697.
681. Aono S, Yamada Y, Keino H, et al. Identification of defect in the genes for bilirubin UDP-glucuronosyl-transferase in a patient with Crigler-Najjar syndrome type II. *Biochem Biophys Res Commun* 1993;197(3):1239-1244.
682. Bosma PJ, Goldhoorn B, Oude Elferink RP, Sinaasappel M, Oostra BA, Jansen PL. A mutation in bilirubin uridine 5'-diphosphate-glucuronosyltransferase isoform 1 causing Crigler-Najjar syndrome type II. *Gastroenterology* 1993;105(1):216-220.
683. Ritter JK, Yeatman MT, Kaiser C, Gridelli B, Owens IS. A phenylalanine codon deletion at the UGT1 gene complex locus of a Crigler-Najjar type I patient generates a pH-sensitive bilirubin UDP-glucuronosyltransferase. *J Biol Chem* 1993;268(31):23573-23579.
684. Bosma PJ, Chowdhury JR, Bakker C, et al. The genetic basis of the reduced expression of bilirubin UDP-glucuronosyltransferase 1 in Gilbert's syndrome. *N Engl J Med* 1995;333(18):1171-1175.

685. Sampietro M, Iolascon A. Molecular pathology of Crigler-Najjar type I and II and Gilbert's syndromes. *Haematologica* 1999;84(2):150-157.
686. Jansen PL. Diagnosis and management of Crigler-Najjar syndrome. *Eur J Pediatr* 1999;158(Suppl 2):S89-S94.
687. Kaplan M, Algur N, Hammerman C. Onset of jaundice in glucose-6-phosphate dehydrogenase-deficient neonates. *Pediatrics* 2001;108(4):956-959.
688. Iolascon A, Faienza MF, Moretti A, Perrotta S, Miraglia del Giudice E. UGT1 promoter polymorphism accounts for increased neonatal appearance of hereditary spherocytosis. *Blood* 1998;91(3):1093.
689. Kappas A, Drummond GS, Munson DP, Marshall JR. Sn-Mesoporphyrin interdiction of severe hyperbilirubinemia in Jehovah's Witness newborns as an alternative to exchange transfusion. *Pediatrics* 2001;108(6):1374-1377.
690. Nishida T, Gatmaitan Z, Roy-Chowdhry J, Arias IM. Two distinct mechanisms for bilirubin glucuronide transport by rat bile canalicular membrane vesicles. Demonstration of defective ATP-dependent transport in rats (TR-) with inherited conjugated hyperbilirubinemia. *J Clin Invest* 1992;90(5): 2130-2135.
691. Wolkoff AW, Cohen LE, Arias IM. Inheritance of the Dubin-Johnson syndrome. *N Engl J Med* 1973;288(3):113-117.
692. Dubin IN, Johnson FB. Chronic idiopathic jaundice with unidentified pigment in liver cells; a new clinicopathologic entity with a report of 12 cases. *Medicine (Baltimore)* 1954;33(3):155-197.
693. Toh S, Wada M, Uchiumi T, et al. Genomic structure of the canalicular multi-specific organic anion-transporter gene (MRP2/cMOAT) and mutations in the ATP-binding-cassette region in Dubin-Johnson syndrome. *Am J Hum Genet* 1999;64(3):739-746.
694. Nies AT, Keppler D. The apical conjugate efflux pump ABCC2 (MRP2). *Pflugers Archiv : Eur J Physiol* 2007;453(5):643-659.
695. Elder G, Gray CH, Nicholson DC. Bile pigment fate in gastrointestinal tract. *Semin Hematol* 1972;9(1):71-89.
696. Gustafsson BE, Lanke LS. Bilirubin and urobilins in germfree, ex-germfree, and conventional rats. *J Exp Med* 1960;112:975-981.
697. Watson CJ. The continuing challenge of hemoglobin and bile pigment metabolism. *Ann Intern Med* 1965;63(6):931-944.
698. Landaw SA, Callahan EW Jr, Schmid R. Catabolism of heme in vivo: comparison of the simultaneous production of bilirubin and carbon monoxide. *J Clin Invest* 1970;49(5):914-925.
699. Cameron JL, Pulaski EJ, Abei T, Iber FL. Metabolism and excretion of bilirubin-C14 in experimental obstructive jaundice. *Ann Surg* 1966;163(3): 330-338.
700. Kotal P, Fevery J. Urobilinogen-i is a major derivative of bilirubin in bile of homozygous Gunn rats. *Biochem J* 1990;268(1):181-185.
701. Cardenas-Vazquez R, Yokosuka O, Billing BH. Enzymic oxidation of unconjugated bilirubin by rat liver. *Biochem J* 1986;236(3):625-633.
702. Maines MD. The heme oxygenase system: a regulator of second messenger gases. *Annu Rev Pharmacol Toxicol* 1997;37:517-554.
703. Fevery J, Muraca M, Mesa V, Van Steenberghe W, Blanckaert N. Plasma bilirubin pigments in health and disease. *Mol Aspects Med* 1987;9(5): 391-404.
704. Stevenson DK, Vreman HJ. Carbon monoxide and bilirubin production in neonates. *Pediatrics* 1997;100(2 Pt 1):252-254.

Section 3 - Granulocytes and Monocytes

Chapter 7 Neutrophilic Leukocytes

> Table of Contents > Part II - The Normal Hematologic System > Section 3 - Granulocytes and Monocytes > Chapter 7 - Neutrophilic Leukocytes

Chapter 7

Neutrophilic Leukocytes

Keith M. Skubitz

Three types of granulocytes are readily identified in peripheral blood smears. Neutrophils are so named because of their neutral staining with Wright stain, whereas eosinophils avidly stain with the dye eosin, and basophils have readily identified large darkstaining granules with Wright stain. Neutrophils play a critical role in host defense by phagocytizing and digesting microorganisms, and inappropriate activation of neutrophils may result in damage to normal host tissues. In the resting uninfected host, the production and elimination of neutrophils are balanced, resulting in a fairly constant concentration of neutrophils in peripheral blood. When an infection occurs, chemotactic agents are generated that result in migration of neutrophils to the site of the infection and activation of neutrophil defensive functions. This effect is often associated with an increased production and release of neutrophils from the bone marrow. This chapter reviews the structure, morphology, production, distribution and kinetics, and functions of neutrophils.

SUBCELLULAR STRUCTURE OF NEUTROPHILS

Mature neutrophils contain several types of granules and other subcellular organelles. Many studies have been performed to identify and characterize the molecular composition of the various subcellular compartments of neutrophils. Two techniques are commonly used for this purpose: immunoelectron microscopy and subcellular fractionation. Most recent subcellular fractionation studies used the technique of nitrogen cavitation to disrupt the neutrophils. In this technique, cells are equilibrated with nitrogen at high pressure and then released into a pressure of 1 atm. The rapid decrease in extracellular pressure results in disruption of the cells by the formation of nitrogen gas within the cell. The disrupted cells are then fractionated by density-gradient centrifugation.^{1,2} Many types of subcellular organelles and structures are present in neutrophils, as seen by electron microscopy (EM). Although the granules of neutrophils may be best viewed as a continuous spectrum of granules, possibly resulting from differential production of different granule contents during neutrophil development, studies of neutrophils have operationally defined several types of granules. Four well-defined types of granules in neutrophils are primary granules, secondary granules, tertiary granules, and secretory vesicles, although additional heterogeneity of these fractions may exist. Some of the known constituents of these granules are indicated in Table 7.1.

Azurophilic (Primary) Granules

The azurophilic, or primary, granules are formed during the promyelocytic stage and in general contain many antimicrobial compounds. These granules fuse with phagocytic vesicles, resulting in the delivery of their contents to the ingested organism. Among the azurophilic granule contents is myeloperoxidase (MPO), a protein that catalyzes the production of hypochlorite (OCl⁻) from chloride and hydrogen peroxide produced by the oxidative burst. MPO constitutes approximately 5% of the dry weight of the neutrophil¹⁸ and imparts the greenish coloration to pus. The human neutrophil defensins (HNP-1 to -3), a group of cationic proteins that kill a variety of bacteria, fungi, and viruses,^{19,20,21} also constitute approximately 5% of total neutrophil protein.²² Other components of azurophilic granules include lysozyme, which degrades bacterial peptidoglycans,²³ bactericidal permeability-increasing protein, which has antibacterial activity against certain gram-negative bacteria,^{24,25,26,27} and ²⁸ azurocidin, which has antibacterial as well as antifungal activity against *Candida albicans*,^{29,30} and the serine proteinases elastase, cathepsin G, proteinase 3, esterase N, and others.^{31,32,33} and ³⁴ The granule membrane itself contains a large amount of CD66c^{35,36} and CD63 antigens.³⁷ Heterogeneity among azurophilic granules is likely.³

Specific (Secondary) Granules

Although some specific (also called secondary) granules, like azurophilic granules, fuse with phagocytic vesicles, it is believed that these granules are largely for release into the extracellular space. Some of the known contents of these granules are also indicated in Table 7.1 and include apolactoferrin, the major specific granule protein, vitamin B₁₂-binding protein, plasminogen activator, and collagenase. Lysozyme and some gelatinase are also present in specific granules. Release of specific granule contents may modify the inflammatory process. For example, collagenase may degrade collagen, thus augmenting movement through collagen and participating in tissue remodeling. Apolactoferrin, by binding iron, may have an antibacterial effect by preventing bacteria from obtaining necessary iron for growth.³⁸ Iron binding by apolactoferrin may also modify hydroxyl radical formation and cell adhesion.^{39,40,41} and ⁴² Although the antimicrobial and proinflammatory defensins are stored in azurophilic granules, proHNPs produced at more mature stages of differentiation are not cleaved to the antimicrobial form and are stored in specific granules. ProHNPs are constitutively exocytosed, though their function is unclear.¹⁵ Haptoglobin released from specific granules could also inhibit bacterial growth and inflammation.¹⁶ Specific granules also contain a number of membrane-bound molecules that are also expressed on the cell surface. This includes CD11, CD18, CD66a, CD66b, NB-1 (CD177), f-met-leu-phe (FMLP) receptors, C5a receptors, and

cytochrome b₅₅₈. When cells are stimulated, the surface expression of many of these membrane proteins is increased, and some of the upregulated molecules may be derived from specific granules. The importance of the specific granules in neutrophil function is shown in patients who lack specific granules; these patients are susceptible to repeated skin and respiratory infections and have defective neutrophil chemotaxis and adhesion.

Gelatinase (Tertiary) Granules

Gelatinase, or tertiary, granules, which cosediment with specific granules in some subcellular fractionation techniques, were initially identified as gelatinase-containing granules.⁴³ Like specific granules, tertiary granules also contain many membrane proteins

P.126

that are upregulated to the cell surface with stimulation.² The relative contribution of tertiary granules and specific granules to upregulation of membrane proteins is not clear.

TABLE 7.1 CONTENTS OF HUMAN NEUTROPHIL GRANULES

Azurophil (Primary) Granules	Specific (Secondary) Granules	Gelatinase (Tertiary) Granules ^a	Secretory Vesicles
Membrane	Membrane	Membrane	Membrane
CD63	CD15 antigens	CD11b	Alkaline phosphatase
CD66c	CD66a	FMLP receptor	Cytochrome b ₅₅₈ ^b
CD68	CD66b	Diacylglycerol deacylating enzyme	CD11b
Matrix	Cytochrome b ₅₅₈ ^b	Cytochrome b ₅₅₈ ^b	u-PA receptor
Lysozyme	FMLP receptor	Laminin receptor	FMLP receptor
Defensins	Fibronectin receptor	Matrix	CD10, CD13, CD45
Elastase	G-protein α -subunit	Gelatinase ^a	CD16
Cathepsin G	Laminin receptor	Acetyltransferase	DAF
Proteinase 3	CD11b	Lysozyme	CR1 (CD35)
Esterase N	NB 1 antigen	NRAMP1	Matrix
α_1 -Antitrypsin	Rap 1, Rap 2	Ficolin-1	Plasma proteins (including tetranectin and albumin) pro-u-PA/u-PA
α -Mannosidase	Thrombospondin receptor		
Azurocidin	Tumor necrosis factor receptor		
Bactericidal permeability-increasing protein	Vitronectin receptor		
	u-PA receptor		
β -Glycerophosphatase	Matrix		
β -Glucuronidase	Apolactoferrin		
β -Galactosidase	Lysozyme		
β -Glucosaminidase β_2 -Microglobulin			
α -Fucosidase	Collagenase		

Cathepsin B	Gelatinase ^a
Cathepsin D	Histaminase
Acid mucopolysaccharide	Heparinase
Heparin binding protein	pro-u-PA
<i>N</i> -Acetyl- β -glucosaminidase	Vitamin B ₁₂ -binding protein
Sialidase	Sialidase
Ubiquitin protein	Protein kinase C inhibitor
	hCAP-18
	SGP28
	PTX3
	Haptoglobin
	Prodefensins (proHNPs)

DAF, decay accelerating factor; FMLP, f-met-leu-phe; u-PA, urokinase-type plasminogen activator.

^a Gelatinase is present in only a subset of specific granules; most is present in gelatinase granules.

^b Cytochrome b₅₅₈ is also called b₂₄₅.

Adapted from references (2) through (17).

Secretory Vesicles

Secretory vesicles, which largely distribute in the plasma membrane fraction using subcellular fractionation techniques, have also been described. Complement receptor (CR)1, recognized by CD35 monoclonal antibodies, has been found exclusively in the light membrane fractions containing secretory vesicles and plasma membranes using subcellular fractionation techniques.¹¹ The observation that CR1 can be readily upregulated to the neutrophil surface with weak stimulation demonstrates that secretory vesicles provide an intracellular reservoir from which membrane proteins can be recruited to the cell surface. CR3 (HMac-1), recognized by CD11b antibodies and present in both secretory vesicles and specific granules, is also upregulated to the cell surface with weak stimulation. In contrast to CR1, a more marked upregulation of CR3 is observed with more potent stimulation, demonstrating that specific granules can also serve as an intracellular reservoir from which membrane proteins can be upregulated to the cell surface.¹¹ By EM, the secretory vesicles appear as smooth-surfaced vesicles. A defining feature of secretory vesicles is their rapid and complete translocation to the surface membrane with weak stimulation.¹¹ These secretory vesicles also contain alkaline phosphatase, cytochrome b₅₅₈, and FMLP receptors. Secretory vesicles can be upregulated to the cell surface in the absence of extracellular calcium, in contrast to specific and gelatinase granules, which require extracellular calcium for release.¹¹ The secretory vesicles appear to be formed by a process of endocytosis and contain albumin.

P.127

Plasma Membrane

Many constituents of the neutrophil plasma membrane have been defined. These include membrane channels, adhesive proteins, receptors for various ligands, ion pumps, and ectoenzymes. For example, CD11/CD18 and CD62L (L-selectin) are involved in neutrophil adhesion. The FMLP- and C5a-receptors sense stimuli and activate neutrophils, while aminopeptidase N (CD13) can inactivate interleukin (IL)-8, eliminating its chemotactic activity,⁴⁴ and neutrophil endopeptidase (CD10) can inactivate the chemotactic peptide FMLP.⁴⁵ CD66a, b, c, can activate neutrophils,⁴⁶ and some CD45 antibodies, which recognize a transmembrane protein with tyrosine phosphatase activity in its cytoplasmic domain,

inhibit neutrophil chemotaxis.⁴⁷ Some of the various clusters of differentiation (CD) expressed on neutrophils are shown in Table 7.2. The components of the membrane are not uniformly distributed. Studies have indicated the presence of differentiated domains in the membrane called rafts, which are described in the section "Lipid Rafts."

TABLE 7.2 SOME CD ANTIGENS EXPRESSED ON NEUTROPHILS

CD	CD Antigen
CD10	Common acute lymphoid leukemia antigen, neutral endopeptidase
CD11a	Leukocyte factor antigen-1, $\alpha_L\beta_2$
CD11b	Mac-1, $\alpha_M\beta_2$
CD11c	p150, 95, $\alpha_X\beta_2$
CD13	Aminopeptidase N
CD15	Le ^x (Ga1 β 1 \rightarrow 4G1cNAc(Fuca1 \rightarrow 3) β 1 \rightarrow 3Ga1 β 1 \rightarrow 4G1cNAc \rightarrow R)
CD15s	sLe ^x
CD16	FcRIII
CDw17	LacCer
CD18	β_2 -Integrin
CD24	Glycosyl phosphatidylinositol-linked protein
CD31	Platelet endothelial cell adhesion molecule-1
CD32	FcRII
CD43	Leukosialin, sialophorin
CD44	Pgp-1
CD45	Leukocyte common antigen (a protein tyrosine phosphatase)
CD50	Intercellular adhesion molecule-3
CD53	Tetraspan molecule
CD55	Decay accelerating factor
CD62L	L-Selectin
CD63	Tetraspan family member
CD64	FcRI
CD65	Ga1 β 1 \rightarrow 4G1cNAc β 1 \rightarrow 3Ga1 β 1 \rightarrow G1cNAc(Fuca1 \rightarrow 3) \rightarrow R
CD65s	Sialylated CD65
CD66a	CEACAM1 (Biliary glycoprotein)
CD66b	CEACAM8 (CGM6)
CD66c	CEACAM6 (NCA)
CD66d	CEACAM3 (CGM1)
CD82	Tetraspan family member
CD88	C5a receptor
CD95	Fas, APO-1
CD114	Granulocyte colony-stimulating factor receptor

CD156 ADAM-8 (a disintegrin and metalloprotease domain)

CD157 Bifunctional ectoenzyme (adenosine diphosphate ribosylase)

CD177 NB1, HNA-2a

NOTE: When used to describe the antigen, the term *CD* antigen should be used.

Cytoskeletal Matrix

Like many other cells, neutrophils contain a complex cytoskeleton. Alterations in the distribution of cytoskeletal elements may be important in chemotaxis, phagocytosis, and exocytosis. Many protein components of this cytoskeleton have been identified, including actin, actin-binding protein, α -actinin, gelsolin, profilin, myosin, tubulin, and tropomyosin. Actin accounts for approximately 10% of neutrophil protein.⁴⁸ The role of the cytoskeleton in neutrophil function is reviewed in detail elsewhere.⁴⁹

Neutrophil Lipids

Although most studies of neutrophil structure have concentrated on proteins, lipids and carbohydrates also serve important functions. Lipids account for approximately 5% of neutrophils by weight,^{50,51} of which approximately 35% is phospholipid.⁵² Phosphatidylcholine and phosphatidylethanolamine account for approximately 75% of the phospholipid in intact neutrophils.⁵² Subcellular distribution studies reveal that plasma membranes and secretory vesicles contain approximately half the cellular phospholipid. Most of the phosphatidylinositol and phosphatidylcholine are present in plasma membrane and secretory granules, whereas a large part of the phosphatidylethanolamine is found in the specific granules.⁵² Among the phospholipids, the phosphoinositides are important as sources of inositol 1,4,5-triphosphate (IP₃) (a signal-transduction molecule that results in calcium release) and diacylglycerol (which activates protein kinase C [PKC]). The occurrence of arachidonic acid in phospholipids, especially phosphatidylcholine, is important as a precursor for the production of leukotrienes, prostaglandins, thromboxanes, and lipoxins.^{53,54} Cholesterol and triglycerides constitute most of the nonphospholipid neutrophil lipid. Glycolipids, which include both neutral glycosphingolipids and gangliosides, constitute the remaining neutrophil lipids. The study of glycolipids is complex, and the glycolipid composition of neutrophils is not well understood. Glycolipids are important because their carbohydrate components contain many neutrophil differentiation antigens with a multitude of potential functions. The major neutrophil glycolipid is lactosylceramide (LacCer: Gal β 1 \rightarrow 4Glc β 1 \rightarrow 1Cer)^{55,56,57} and is recognized by CDw17 monoclonal antibodies. Interestingly, the surface expression of LacCer decreases after neutrophil stimulation. More than 75% of neutrophil LacCer is found in intracellular granules.^{56,58} It has been hypothesized that most LacCer in the granule membranes is found in the outer leaflet and may contribute to the ability of these membranes to form the highly convex surfaces necessary to form these submicrometer particles.⁵⁴ Approximately 75% of the five major glycosphingolipids are located intracellularly.⁵⁸ Studies of the subcellular distribution of glycosphingolipids in neutrophils have found no differences among the plasma membrane, primary granules, or secondary granules in the relative amounts of these five glycosphingolipids.⁵⁸

Lipid Rafts

Studies have demonstrated the existence of large noncovalent detergent-resistant complexes in cell extracts that contain important signaling molecules, including protein kinases and many glycosyl phosphatidylinositol-linked membrane proteins capable of transmitting signals.^{59,60} and ^{61,62} These complexes have been termed lipid rafts or large detergent-resistant complexes. It is postulated that these complexes or rafts reflect the existence of specific membrane microdomains that have a particular lipid composition, and that these clusters of molecules may be important in transmembrane signaling by proteins in the complex. There is

P.128

evidence that in neutrophils, proteins may enter these rafts when they are translocated to the cell surface. For example, it appears that CD63 and CD11b/CD18 are not present in detergent-resistant complexes when they are intracellular, but they enter such complexes after translocation to the cell surface.⁶³

Cytoplasmic Lipid Bodies

Cytoplasmic lipid bodies, non-membrane-bound cytoplasmic inclusions, have been described in neutrophils.⁶⁴ In inflammation, the number of cytoplasmic lipid bodies in neutrophils increases.⁶⁵ These lipid bodies may provide nonmembrane stores of esterified arachidonate. In addition, some signaling proteins, including phosphatidylinositol-3-kinase, are localized to these lipid bodies,⁶⁶ although the exact role of these lipid bodies in cell function is unclear.^{66,67}

Cytosol

Although neutrophil cytoplasm contains many components common to all cells, approximately 45% of neutrophil cytosolic protein appears to be attributable to migration inhibitory factor-related proteins (MRPs), MRP-8, and MRP-14.⁶⁸ MRP-8 and MRP-14 are members of the S100 family of calcium-binding proteins and form homo- and heterodimers. MRP-14 has been variously called p14, L1 heavy chain, and calgranulin b, and MRP-8 is also known as p8, L1 light chain, calgranulin a, and cystic fibrosis antigen.^{69,70,71,72} and ⁷³ Although the role of these proteins in neutrophil function is unclear, the quantity of MRP-8 and MRP-14 associated with neutrophil plasma membranes has been reported to increase after stimulation.⁶⁸ MRP-8/MRP-14 are also present in secondary and/or tertiary granules and are released when neutrophils are stimulated.⁷³ MRP-14 can inhibit macrophage activation.⁷⁴ Annexin I or lipocortin I comprises approximately 3% of cytosolic protein.⁷⁵ Annexin I is partially regulated by glucocorticoids and appears to be a mediator of the anti-inflammatory effects of glucocorticoids.⁷⁵

One other notable cytoplasmic constituent is glycogen. Because neutrophils are sometimes required to function in hypoxic conditions, as in an abscess, they are very capable of obtaining energy by glycolysis. The presence of large intracellular glycogen stores gives them the additional ability to function in areas of low extracellular glucose.

Nucleus

In the past, it has been felt that neutrophils, as end-stage cells, undergo little RNA or protein synthesis. Subsequently, it was shown that mature neutrophils can synthesize both RNA and protein. This is likely particularly important when neutrophils migrate into sites of inflammation and begin to synthesize proteins and chemokines that may regulate activation and resolution of the innate immune response.^{76,77,78,79,80} and ^{81,82}

MORPHOLOGY OF NEUTROPHILS AND PRECURSORS

The replenishment of marrow and blood cells from a stem cell compartment is described in Chapter 5. Neither multipotent hematopoietic stem cells nor more committed progenitors are readily identified morphologically by traditional methods.^{83,84,85,86} and ⁸⁷ Only the more mature forms of each hematopoietic cell series can be reliably distinguished from one another. In the following pages, the cells identifiable as neutrophils and their precursors are described.

Neutrophils follow a pattern of proliferation, differentiation, maturation, and storage in the bone marrow and delivery to the blood. In the first three morphologic stages, the myeloblast, promyelocyte, and myelocyte cells are capable of replication, as shown by their uptake of tritiated thymidine (³H-TdR) and the presence of mitoses; in later stages, cells cannot divide but continue to differentiate. The morphologic boundaries of each cell compartment were defined many years ago and were based on criteria such as cell size, ratio of size of nucleus to cytoplasm, fineness of nuclear chromatin, nuclear shape, the presence or absence of nucleoli, the presence and type of cytoplasmic granules, and the cytoplasmic color of stained cells (Table 7.3).

Because changes in nuclear chromatin and cell size occur during each cell replication cycle, and the formation of granules and other cytoplasmic changes occur gradually during the stages of cell development, morphologic definitions are necessarily arbitrary and do not always conform to significant biochemical or physiologic changes. Classifying a cell in one category or another often is difficult because it is actually in transition between the two. Nevertheless, it is useful to separate the cell lines into morphologic compartments and to define normal limits of cell distribution therein, because gross changes from these patterns indicate disease.

DEVELOPMENT OF NEUTROPHILS AND THEIR PRECURSORS

Neutrophil development is summarized in Figure 7.1.

Cell division is limited to myeloblasts, promyelocytes, and myelocytes, with later developmental stages undergoing differentiation but no further cell division. The myeloblast contains few granules and is derived from more primitive cells as described in Chapter 5. As the cell differentiates to the promyelocyte stage, development of primary or azurophil granule formation becomes evident. This granule contains MPO, an enzyme whose activity is a classic marker of myeloid differentiation. Azurophil granule production ceases at the end of the promyelocyte stage, coincident with the loss of peroxidase activity from the rough endoplasmic reticulum. Secondary granule, or specific granule, formation begins as the neutrophil enters the myelocyte stage. The peroxidase-negative specific granules are smaller (approximately 200-nm diameter) than the azurophil granules (approximately 500-nm diameter) and are near the limit of resolution by light microscopy. The specific granules impart a pinkish ground-glass background color to neutrophils in Wright-stained smears. Because azurophil granule formation ceases in the promyelocyte stage and the subsequent myelocyte form is still capable of cell division, the density of azurophil granules is lower in differentiation stages past the promyelocyte. The result is that

mature neutrophils contain approximately two specific granules for every azurophil granule. With maturation, the azurophil granules, which generate reddish-purple staining in the promyelocytes, lose this metachromasia as they leave the myelocyte stage. This alteration in staining properties is thought to be caused by an increase in acid mucosubstances, which complex with basic proteins already present in the azurophil granules.⁸⁸ Thus, in the mature neutrophil, the azurophil granules appear as light blue-violet granules on Wright-stained smears. The azurophil granules are readily demonstrated by peroxidase staining with light microscopy.

Data concerning antigenic differences between granulocytes and monocytes and their stages of maturation have largely been developed using monoclonal antibodies. Such monoclonal antibodies have been analyzed in a series of international workshops in which antibodies are grouped into CD. Some of the CD antigens expressed on neutrophils are shown in Table 7.2. Immunogold and enzyme-linked immunologic methods⁸⁹ permit simultaneous morphologic and immunologic examination of individual cells.

P.129

TABLE 7.3 MORPHOLOGIC CHARACTERISTICS OF LEUKOCYTES (WRIGHT STAIN)

Type of Cell	Nucleus				Cytoplasm						
	Size (μm)	Position	Shape	Color	Chromatin	Nuclear Membrane	Nucleoli	Relative Amount	Color	Perinuclear Clear Zone	Granules
Granulocytes											
Myeloblast	10-18	Eccentric or central	Round or oval	Light reddish purple	Very fine meshwork	Very fine	2-5	Scanty	Blue	None	None
Promyelocyte	12-20	Eccentric or central	Round or oval	Light reddish purple	Very fine meshwork	Fine	2-5	Moderate	Blue	None	Primary (azurophilic, eosinophilic, or basophilic)
Myelocyte	12-18	Eccentric	Oval or slightly indented	Reddish purple	Fine but becomes coarser	Indistinct	Rare	Moderate	Bluish pink	None	Primary plus, in neutrophils, secondary or sp
Metamyelocyte	10-18	Central or eccentric	Thick horseshoe or indented	Light purplish blue	Basophilic and clearly distinguished	Present	None	Plentiful	Pink	None	Neutrophilic, eosinophilic, or basophilic
Juvenile or band form	10-16	Central or	Band shape	Light purplish	Basophilic and	Present	None	Plentiful	Pink	None	Neutrophilic,

	eccentric	of uniform thickness	shaded blue	thin clearly distinguished					eosinophilic, or basophilic		
Polymorphonuclear neutrophil	10-15	Central or eccentric	2-5 or more distinct lobes	Deep purplish blue	Rather coarse	Present	None	Plentiful	Faint pink	None	Fine, pink, or violet pink

Myeloblast

The word myeloblast describes an immature cell, typically found in the bone marrow and not in the blood. This cell can divide and give rise to promyelocytes, which in turn give rise to myelocytes. The neutrophil and macrophage lines share a common stem cell, colony-forming unit granulocyte-monocyte (CFU-GM).^{90,91,92} and ⁹³

The myeloblast (Fig. 7.2) has a large nucleus, is round or slightly oval, and has a small amount of cytoplasm. In preparations treated with Wright stain (Table 7.3), the nuclear membrane is smooth and even in outline and is exceedingly thin, with no condensation of chromatin near its inner surface, as noted in lymphoblasts. The chromatin shows an even, diffuse distribution with no aggregation into larger masses, although some condensation may be noted about the nucleoli. The chromatin may appear in the form of fine strands, thus giving the nucleus a sieve-like appearance; alternatively, it may have the form of fine dust-like granules, producing a uniform stippled effect. Generally, the myeloblast contains two to five pale, sky-blue nucleoli. The cytoplasm is basophilic (blue), and usually, although not invariably, no clear zone is evident about the nucleus. Sometimes, the cytoplasm is reticular, spongy, or foamy. By definition, no granules are present in the cytoplasm. Leukemic myeloblasts that contain no perceptible granules often are identified by special stains that demonstrate the presence of MPO or esterase, thus providing early evidence of differentiation.⁹⁴

EM reveals similar findings.^{95,96} The nuclear membrane is thin and indistinct, with minimal or no chromatin condensation. The numerous particles of ribonucleoprotein in the cytoplasm produce deep blue basophilia in stained preparations. Mitochondria are abundant but small, and the endoplasmic reticulum is flat and appears infrequently. The Golgi apparatus is indistinct, and no cytoplasmic granules are present. EM studies of myeloblasts show peroxidase activity in the rough endoplasmic reticulum and Golgi.

Some authors classify what may be slightly more mature cells with several rather large, angular, irregular, and dark-staining azurophilic cytoplasmic granules as myeloblasts. A simpler approach is to include such forms in the promyelocyte stage, thus making the separation between the two cell types clear-cut. The EM classification of myeloid cells, primarily on stages of granule formation, also places cells with beginning granule formation in the promyelocyte category.^{87,97}

In wet films, myeloblasts appear immobile, with thin, tenacious borders. In video studies of hanging-drop preparations, myeloblasts manifest a characteristic snail-like movement.^{98,99}

Because they are in the process of growth and division, myeloblasts vary in diameter from 10 to 20 µm. In patients with acute leukemia, there may be asynchronous development of the nucleus and cytoplasm; such myeloblasts (sometimes called Rieder cells^{100,101}) suggest more rapid maturation on the part of the nucleus than of the cytoplasm (asynchronism of Di Guglielmo). Auer bodies, a marker for acute leukemia, are evident in the cytoplasm of cells that otherwise look like myeloblasts (Fig. 7.3).

Neutrophil Promyelocytes and Myelocytes

The developmental stages in the granulocyte series and some of their morphologic variations are shown in Figure 7.1. In the past, the several stages beyond the myeloblast were differentiated primarily on the basis of the number and type of granules. EM histochemical and biochemical findings demonstrated that the azurophilic or primary granules first appear at the promyelocyte stage and can be identified on fine structural study as characteristic of the neutrophil, eosinophil, or basophil series.^{87,95,97,102,103} They do not transform into specific granules but persist throughout the remainder of the maturation sequence and are seen in

P.130

all subsequent stages, including the polymorphonuclear forms (Fig. 7.1).^{97,103,104}

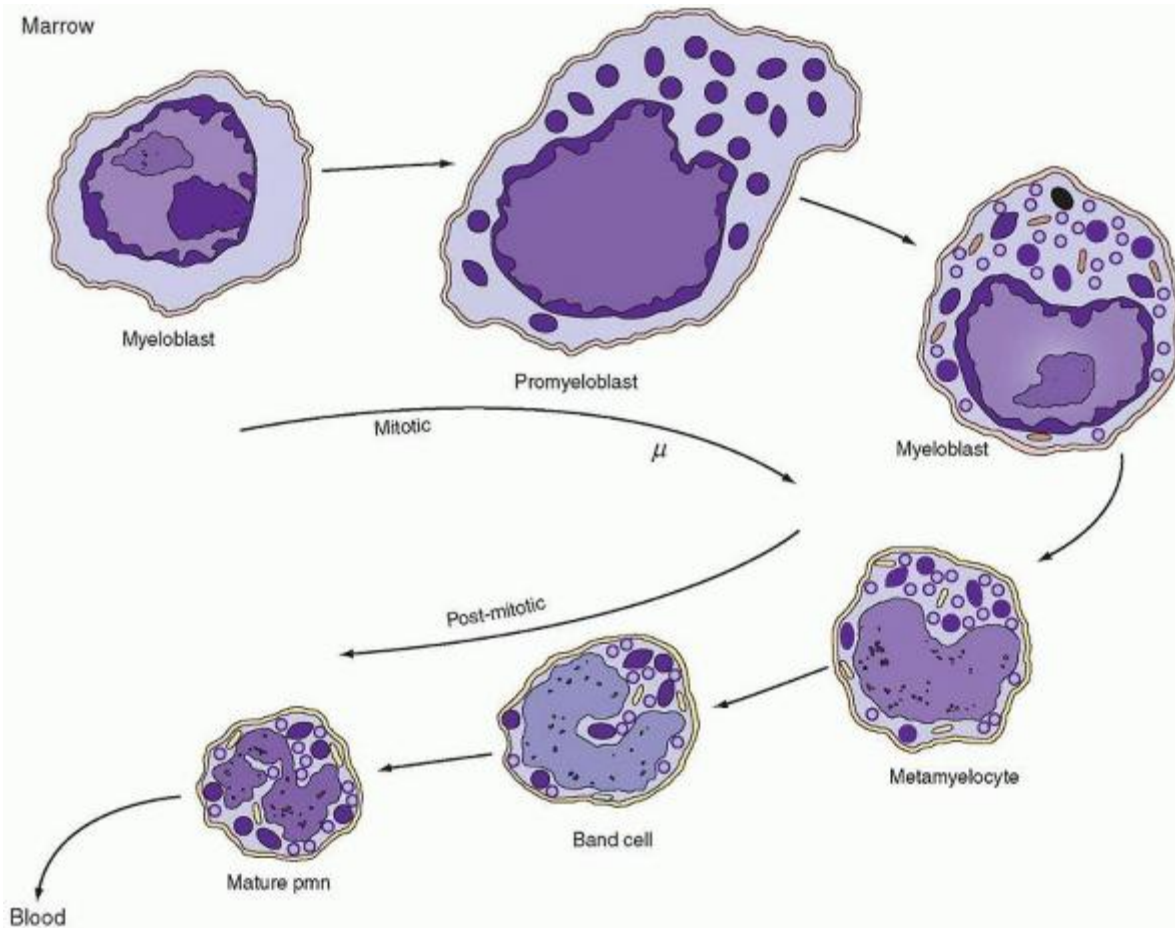

FIGURE 7.1. Appearance of granules during neutrophil maturation. Myeloblasts are undifferentiated cells with a large oval nucleus, large nucleoli, and cytoplasm lacking granules. They originate from a precursor pool of stem cells. Subsequently, there are two stages—the promyelocyte and the myelocyte—each of which produces a distinct type of secretory granule: azurophilic (dark granules) are produced only during the promyelocyte stage; specific granules (light granules) are produced during the myelocyte stage. The metamyelocyte and band forms are nonproliferating stages that develop into the mature polymorphonuclear neutrophil characterized by a multilobulated nucleus and cytoplasm containing primarily glycogen and granules. Both nonspecific azurophilic granules and specific granules persist throughout these later stages. PMN, polymorphonuclear leukocyte. (Modified from Bainton DF, Ulliyot JL, Farquhar MG. The development of neutrophilic PMN leukocytes in human bone marrow: origin and content of azurophil and specific granules. *J Exp Med* 1971;134:907.)

The neutrophil promyelocyte is somewhat larger on average than the myeloblast. In both light and EM preparations, it has a round or oval nucleus in which the nuclear chromatin is diffusely distributed, as in the myeloblast; in later stages, slight chromatin condensation is discerned around the nuclear membrane. Nucleoli are present, but as the cell develops, they become less prominent. Compared with the myeloblast, the endoplasmic reticulum in EM preparations is more prominent and takes on a dilated, vesicular appearance. The azurophilic, primary granules appear and accumulate in increasing numbers during this stage, but the specific or secondary granules are not yet present (Fig. 7.4).^{87,96,97,102,104} In early promyelocytes, the few granules present may be difficult to see by using light microscopy; they often lie over the nucleus and are evident only on examination at several focal planes.

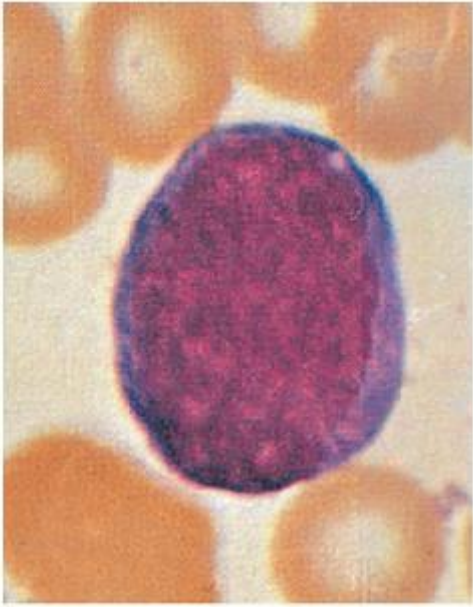

FIGURE 7.2. Myeloblast ($\times 1,000$, Wright stain).

Like the myeloblast, the promyelocyte is immobile in flat slide and cover glass preparations; only in the last stage is slight locomotion evident. Even then, the streaming of granules so characteristic of mature granulocytes is lacking.¹⁰⁵ In hanging-drop preparations, however, promyelocytes are actively mobile.

The neutrophilic myelocyte may be defined as the stage in which specific (secondary) granules appear in the cytoplasm and the cell consequently can be identified as belonging to the neutrophilic series when stained and observed to have a pinkish ground-glass background color with the light microscope. As mentioned previously, earlier identification of a cell that will become neutrophilic can be made by EM examination of the azurophilic, or primary, granules.⁹⁵ The nucleus of the neutrophilic myelocyte usually is eccentric and round or oval; one side may appear flattened. The nuclear chromatin is somewhat coarse, and nucleoli are small and often not visible, although they are seen clearly with the electron microscope.¹⁰² Primary granules

P.131

persist in myelocytes, but formation of new primary granules is limited to the promyelocyte, and each succeeding cell division leads to a decrease in their number in the daughter population (Fig. 7.1).^{97,104,105} The secondary granules of the neutrophil series are smaller than the primary granules; in the rabbit, cat, and human, they are formed in increasing numbers on the convex surface and lateral borders of the somewhat less prominent Golgi apparatus.^{97,102,104} The amount of granular endoplasmic reticulum is lower in the myelocyte than in earlier forms, so the cytoplasmic basophilia decreases and disappears. The mitochondria remain small and are few.

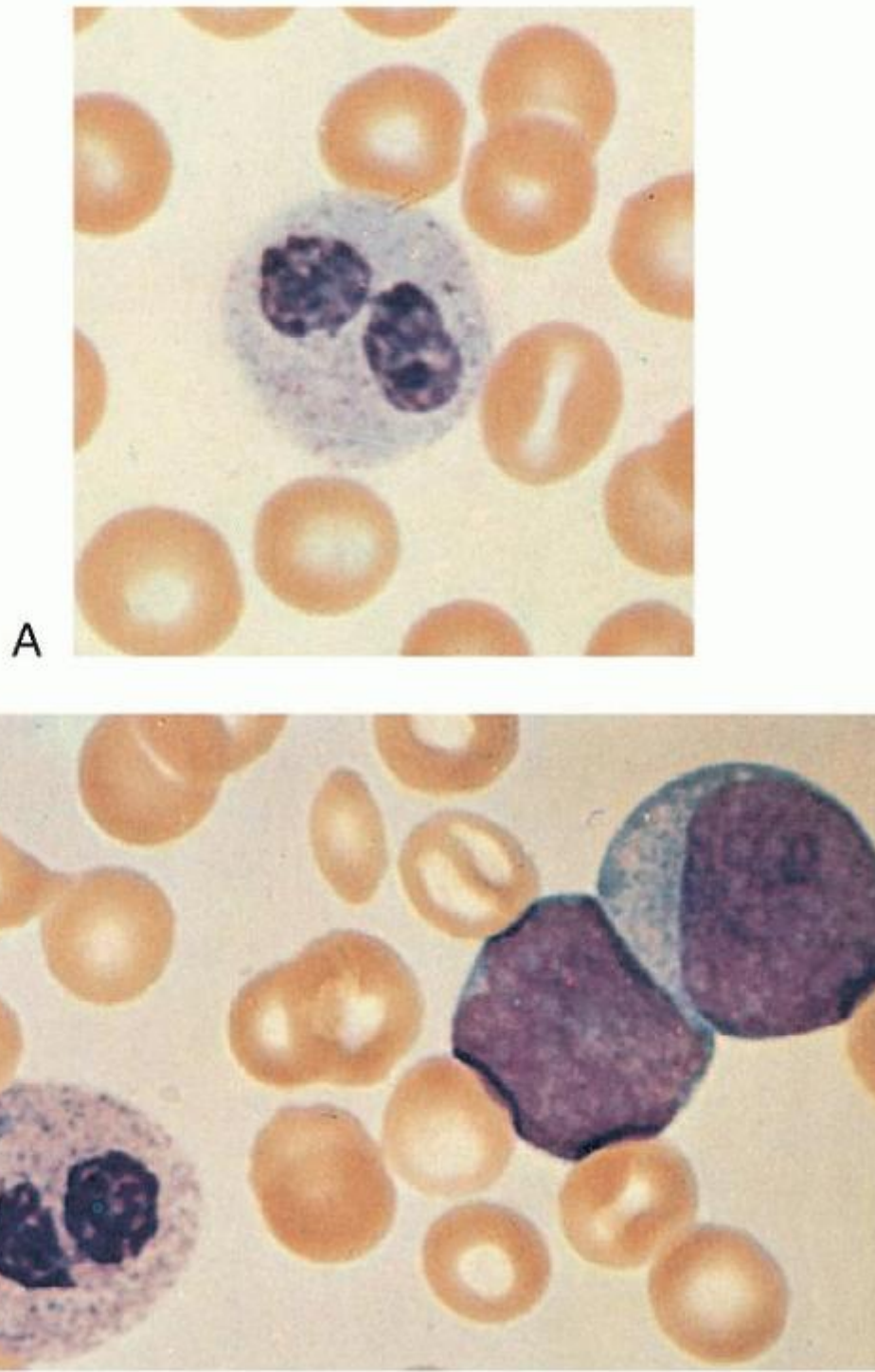

FIGURE 7.3. A, B: Pseudo-Pelger-Huët cells, the latter from the blood of a patient with acute myeloblastic leukemia ($\times 1,000$, Wright stain).

Neutrophil Granule Development

It has been suggested that the different neutrophil granules are formed because of temporal differences in gene expression of the granule contents^{82,106} and this model fits well with the data. Studies in rabbits, cats, and humans suggest that the primary granules are packaged and released from the inner, concave surface of the Golgi apparatus (Fig. 7.5A)—in contrast to the specific or secondary granules of the myelocyte and later granulocyte stages that appear to be formed and released from the outer, convex surface.^{97,102,103,104} Studies of membranes from rabbit azurophil and specific granules, although demonstrating similar ultrastructure, have shown them to be distinct and different in cholesterol-phospholipid

ratios and protein components.¹⁰⁷ In the mature neutrophil, a ratio of secondary to primary granules of approximately 9:1 is seen in the rabbit¹⁰⁸ and 2 or 3:1 in humans.^{97,109}

The mature primary granules of human neutrophils usually contain central crystalloids when lightly stained.¹⁰³ They apparently bind neutral red dye and thus are seen easily as neutral red bodies in supravital preparations.¹¹⁰ These membrane-bound lysosomes contain enzymes and other substances (Table 7.1).^{87,97,111,112} Acid phosphatase activity varies considerably, as reported in different studies and in different species.^{102,103,113,114} This may be because of variation in the histochemical assays or to species variations.⁸⁷ Peroxidase has been associated with primary granules by histochemical, cytochemical, and biochemical methods and is considered a marker enzyme for primary granules in mammals.^{87,115} Sulfated mucosubstance presumably accounts for the azurophilic staining of the primary granules; the uptake of radi sulfate by early-stage neutrophils may be the result of incorporation into this substance.^{116,117}

The secondary granules of the neutrophil were once thought to be characterized by their content of alkaline phosphatase and lack of acid phosphatase.^{87,97,118} However, subsequent studies demonstrated that alkaline phosphatase is localized in a previously unrecognized organelle, the secretory vesicle (Table 7.1).¹¹⁹ Lysozyme is present in human neutrophil secondary granules,¹²⁰ as well as in primary granules; approximately two thirds of this antibacterial basic protein is in the secondary granule. The standard marker enzymes for specific granules are lactoferrin¹¹⁵ and B₁₂-binding protein.¹²¹

A third type of granule, the tertiary granule, also known as the gelatinase granule (Table 7.1),^{103,122} is synthesized mainly during the band and segmented neutrophil stages.^{103,123,124}

Neutrophil Metamyelocytes

The metamyelocyte is characterized by a clearly indented or horseshoe-shaped nucleus without nucleoli, and the nuclear chromatin is moderately dense, with considerable clumping evident along the nuclear membrane. The cytoplasm is filled with primary, secondary, and tertiary^{93,116} granules, but the secondary granules predominate. The endoplasmic reticulum is sparse, as are polysomes, thus signifying the virtual completion of protein synthesis.

The boundary between the myelocyte and metamyelocyte compartments is best defined physiologically by the fact that myelocytes synthesize DNA, take up ³H-TdR into their nuclear chromatin, divide, and are actively involved in protein synthesis, as evidenced by the presence of nucleoli, abundant endoplasmic reticulum, and polysomes. Before such techniques became available, differentiation between myelocytes and metamyelocytes was defined mainly in terms of nuclear shape. This characteristic now is recognized as a poor criterion because it has been shown in time-lapse microcinematographic studies of human neutrophils that myelocyte nuclei may assume a markedly indented shape and may subsequently revert to an oval configuration and enter mitosis.⁹⁵ Consequently, in classifying cells at this stage, the observer should pay particular attention to evidence in the nucleus and cytoplasm that protein synthesis has decreased or stopped. This determination is made on the basis of the fact that the nuclear chromatin is coarse and clumped and that the cytoplasm is faint pink and is essentially the color of the mature cell in stained preparations. These features are also helpful in differentiating metamyelocytes (Fig. 7.6A,B) from monocytes (Fig. 7.6C) because in monocytes, nuclear chromatin remains fine, and evidence of protein synthesis persists. Amoeboid movement is apparent in metamyelocytes, even in cover glass slide preparations, and it is at this stage that directional migration can regularly be demonstrated.¹²⁵

Band Neutrophils

The band stage is characterized by further condensation of nuclear chromatin and transformation of nuclear shapes into sausage or band configurations that have approximately uniform diameters throughout their length (Fig. 7.1). Subsequently, one or more constrictions begin to develop and progress until the nucleus is divided into two or more lobes connected by filamentous strands of heterochromatin, the polymorphonuclear stage. Some workers require a clearly visible filamentous strand between lobes (Fig. 7.7A,B) before classifying a cell as a polymorphonuclear form; anything less clearcut, whether because of overlapping of nuclear lobes or incomplete constriction, is classified as a band form.^{126,127}

Other investigators

P.132

P.133

P.134

have regarded a constriction greater than one half or two thirds of the nuclear breadth as adequate evidence of lobulation and classify such cells as polymorphonuclear^{128,129} or use slightly different criteria.¹³⁰ Still others avoid the issue entirely. Because no clear difference has been shown between band and segmented stages other than nuclear shape and a slightly earlier appearance of ³H-TdR in the band forms, the distinction becomes arbitrary. However, a clear and easily recognizable separation is needed if one wishes to count nuclear lobes for diagnostic purposes, as in the early detection of folic acid deficiency¹³¹ or in assessing marrow release of young forms into the blood.¹³² For such purposes, we have chosen the clear separation of nuclear lobes as the criterion for inclusion in the polymorphonuclear category.¹²⁷ Cells without this complete formation of distinct lobes (usually connected by a filamentous strand) are classified as band forms.

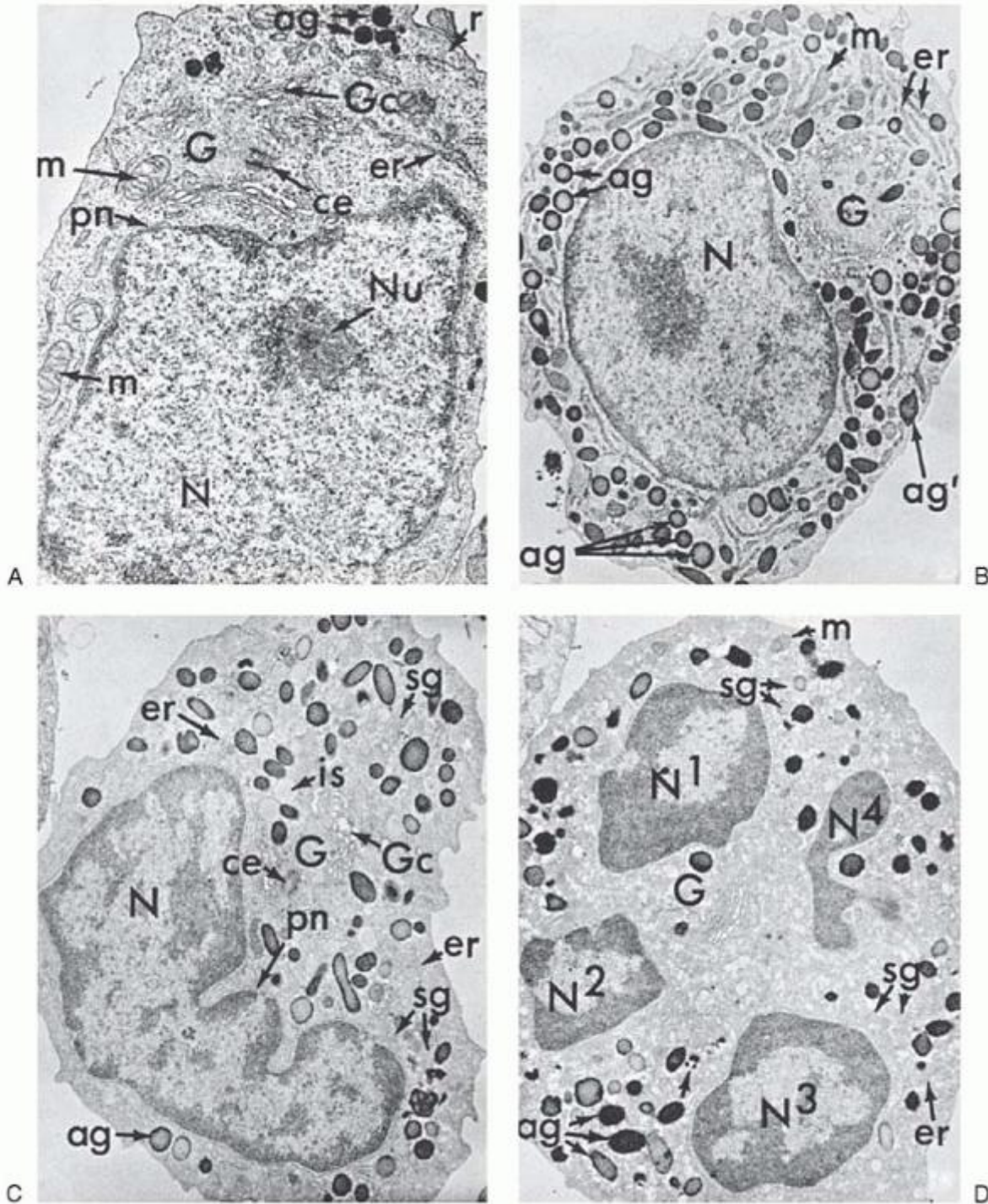

FIGURE 7.4. Early and late promyelocytes, a myelocyte, and a polymorphonuclear neutrophil (PMN) viewed by electron

microscopy. (Courtesy of Bainton D, University of California, San Francisco.) A: Early neutrophilic promyelocyte (reacted for peroxidase, 10,500). The nucleus (N) with its prominent nucleolus (Nu) occupies the bulk of this immature cell. The surrounding cytoplasm contains a few azurophil granules (ag), a large Golgi complex (G), Golgi cisternae (Gc), several mitochondria (μ), scanty rough endoplasmic reticulum (er), and many free polysomes (r). A centriole (ce) is present in the Golgi region. All of the azurophil granules (ag) appear dense because they are strongly reactive for peroxidase. The secretory apparatus, i.e., the perinuclear cisterna (pn), rough endoplasmic reticulum (er), and Golgi cisternae (Gc), are also reactive, although less so than the granules. Specimen was fixed in glutaraldehyde for 16 hours at 4°C, incubated in the peroxidase medium of Graham and Karnovsky for 1 hour at 22°C, postfixed in osmium tetroxide, treated in block with uranyl acetate, dehydrated in ethanol, infiltrated with propylene oxide, and embedded in Araldite. Section stained for 1 minute with lead citrate. B: Late neutrophilic promyelocyte (reacted for peroxidase, 7,000). This cell is the largest (15 μ m) of the neutrophilic series. It has a sizable, slightly indented nucleus (N), a prominent Golgi region (G), and cytoplasm packed with peroxidase-positive azurophil granules (ag). Note the two general shapes of the azurophil granules: spherical (ag) and ellipsoid (ag'). Most are spherical, with a homogeneous matrix, but a few ellipsoid forms containing crystalloids also are present. Many of the spherical forms (ag) have a dense periphery and a lighter core, presumably because of incomplete penetration of substrate into the compact centers of mature granules. Peroxidase reaction product is visible (under higher magnification) in less concentrated form within all compartments of the secretory apparatus (endoplasmic reticulum, perinuclear cisterna, and Golgi cisternae). No reaction product is seen in the cytoplasmic matrix, mitochondria, or nucleus. Specimen was fixed in glutaraldehyde for 10 minutes at 4°C and subsequently processed exactly as was the specimen in A. C: Neutrophilic myelocyte (reacted for peroxidase, 9,000). At this stage, the cell is smaller (10 μ m) than the promyelocyte, the nucleus is more indented, and the cytoplasm contains two different types of granules: large, peroxidase-positive azurophils (ag) and the generally smaller specific granules (sg), which do not stain for peroxidase. A number of immature specific granules (is), which are larger, less compact, and more irregular in contour than mature granules, are seen in the Golgi region (G). Note that peroxidase reaction product is present only in azurophil granules and is not seen in the rough endoplasmic reticulum (er), perinuclear cisterna (pn), and Golgi cisternae (Gc), in keeping with the fact that azurophil production has ceased, and only peroxidase-negative specific granules are produced during the myelocyte stage. D: Mature PMN (reacted for peroxidase, 10,500). The cytoplasm is filled with granules; the smaller peroxidase-negative specific granules (sg) are more numerous, the azurophils (ag) having been reduced in number by cell divisions after the promyelocyte stage. Some small, irregularly shaped azurophil granule variants are also present (unlabeled arrow). The nucleus is condensed and lobulated (N1-N4), the Golgi region (G) is small and lacks forming granules, the endoplasmic reticulum (er) is scanty, and mitochondria (μ) are few. Note that the cytoplasm of this cell has a rather ragged, moth-eaten appearance because the glycogen, which is normally present, has been extracted in this preparation by staining in block with uranyl acetate.

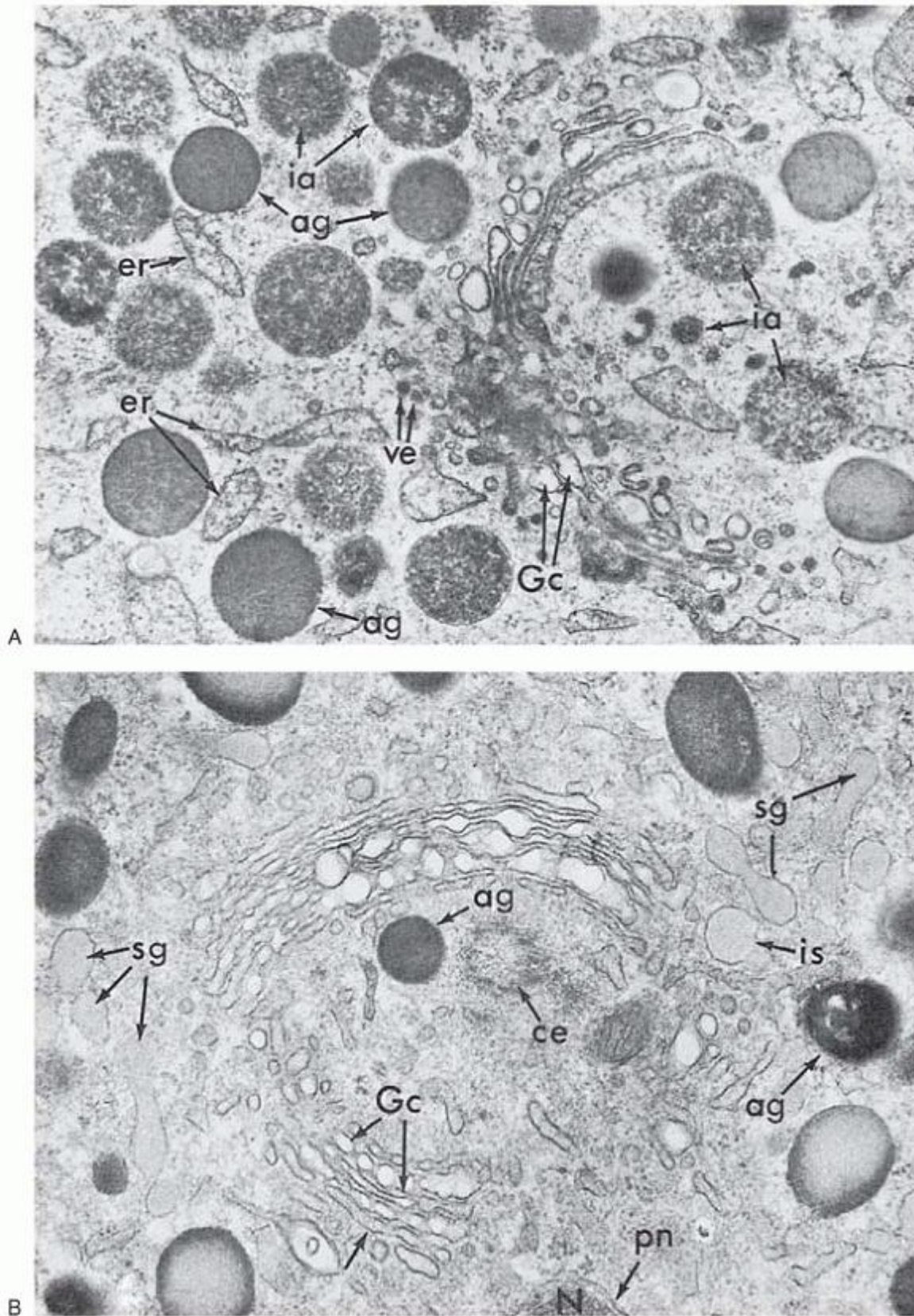

FIGURE 7.5. Granule formation in neutrophil precursors viewed by electron microscopy. (Courtesy of Bainton D, University of California, San Francisco.) A: Golgi region of a neutrophilic promyelocyte reacted for peroxidase ($\times 40,000$). At this stage, the peroxidase reaction product is present within the rough endoplasmic reticulum (er), the clusters of smooth vesicles

(ve) at the periphery of the Golgi cisternae (Gc), in the Golgi cisternae, and in the immature (ia) and mature (ag) azurophilic granules. The immature granules are larger and less compact than the uniformly dense mature granules. B: Golgi region of a neutrophilic myelocyte reacted for peroxidase ($\times 40,000$). Peroxidase-reactive material is seen in the primary or azurophilic granules (ag) but not in the specific (secondary) granules (sg). At this stage (myelocyte), no peroxidase reaction product is seen in the endoplasmic reticulum, Golgi cisternae (Gc), or newly formed, immature specific granules (is). The stacked Golgi cisternae are oriented around the centriole (ce), and the outer cisternae (unlabeled arrow) contain material of intermediate density that is similar to the content of the specific granules, suggesting that the specific granules arise from the convex face of the Golgi complex as in the rabbit. pn, perinuclear cisternae.

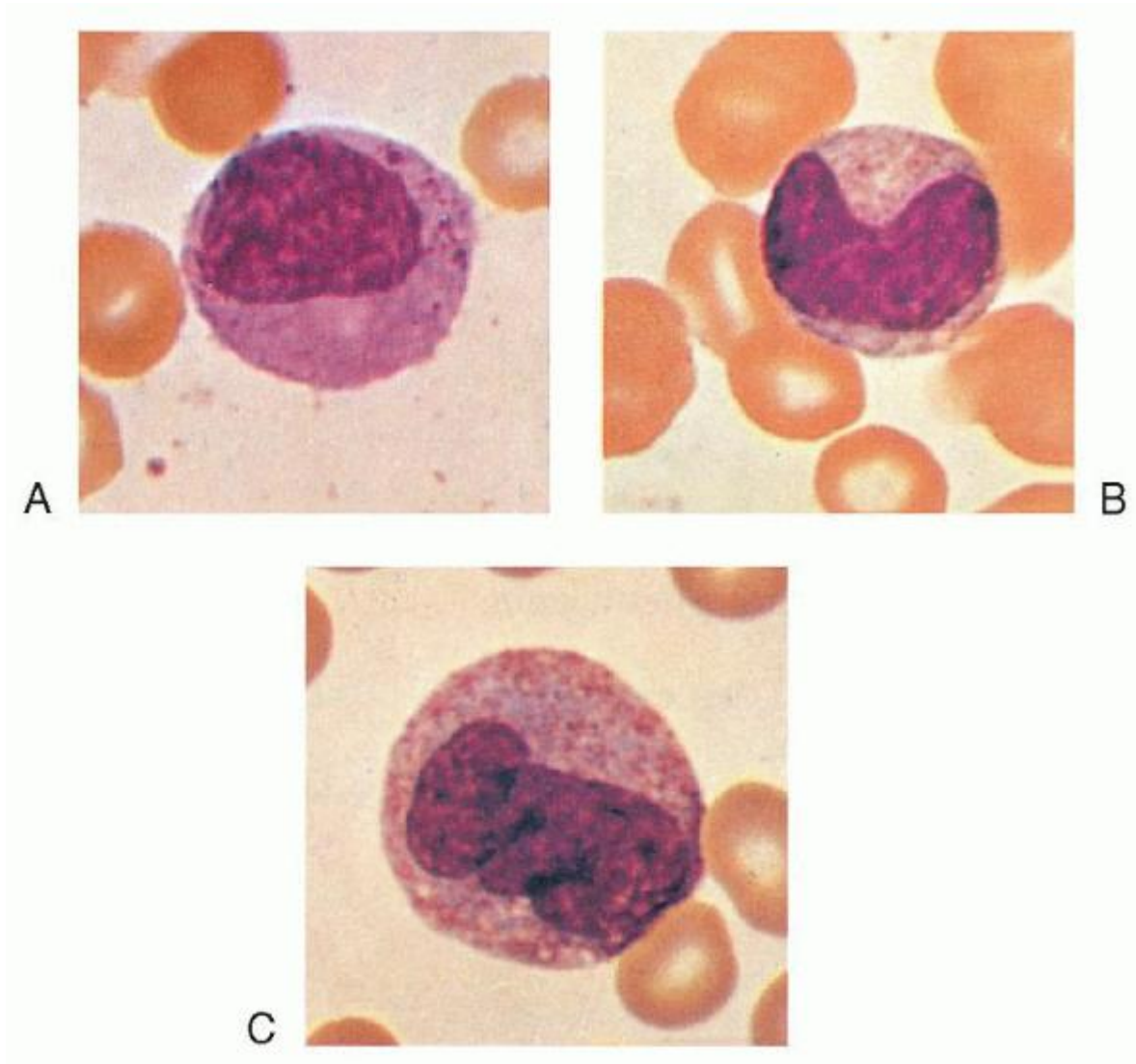

FIGURE 7.6. A: Late myelocyte or early metamyelocyte. B: Metamyelocyte. C: Monocyte ($\times 1,000$, Wright stain).

Polymorphonuclear Neutrophils

In the polymorphonuclear stage, the nucleus in Wright-stained preparations is a deep purplish color and contains coarse, condensed chromatin. The lobes are joined by thin filaments of chromatin, although the filaments may not be easily visible if the lobes are partially superimposed. The cytoplasm is faint pink and contains fine, specific granules that sometimes give only a ground-glass appearance. The azurophilic or primary granules have usually lost their dark-staining characteristics by this stage but can be seen with EM. With this technique, the granules exhibit considerable variation in density, presumably a reflection of variation in enzyme content, and they maintain a minimum distance of 100 nm from the cell membrane.¹³³ Large masses of glycogen become evident for the first time in mature neutrophils; this finding may contribute to their capacity for anaerobic metabolism.

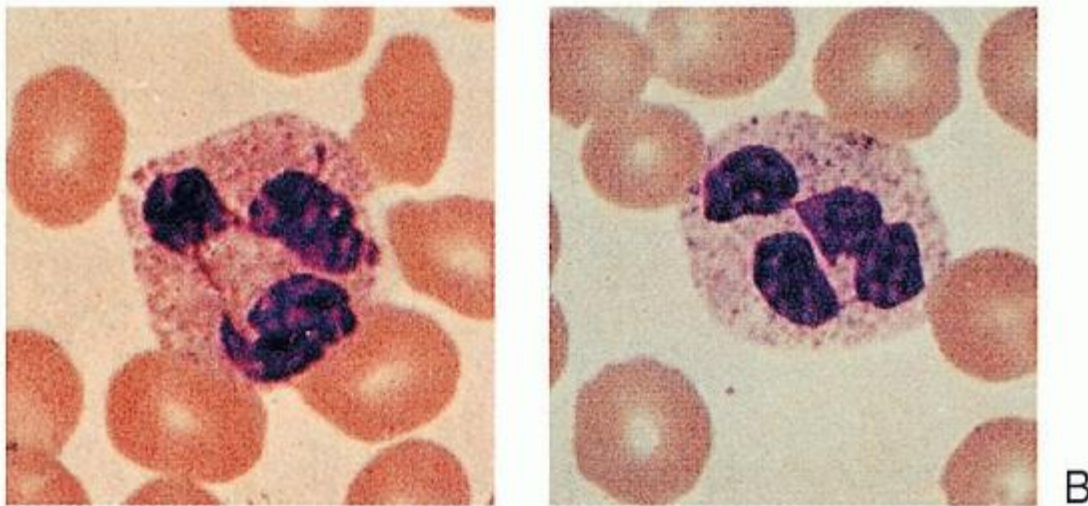

FIGURE 7.7. A, B: Polymorphonuclear neutrophils.

The mechanism and purpose of nuclear lobulation are the subject of speculation. Perhaps it enhances cell deformability and movement through vessel walls and into sites of inflammation, or perhaps nuclear segmentation results from nucleolar emptying and has no function.¹³⁴ Thus, the mechanism and purpose of nuclear segmentation remain unclear.

It was suggested that granulocytes with three or four lobes are more mature than those with only two.¹³⁵ However, the number of lobes a neutrophil develops appears to be determined in the band stage (or earlier), and the time of appearance of neutrophils in the blood after pulse labeling with ³H-TdR is unrelated to the number of nuclear lobes.¹³⁶

In wet films, marked amoeboid activity of polymorphonuclear neutrophils at physiologic temperatures is characteristic.¹³⁷ "Senile" polymorphonuclear leukocytes that are no longer motile and fail to take up neutral red stain have been identified in *in vitro* preparations.¹³⁸ They are seen in small numbers in the blood, where their survival time is short.¹³⁹

Pelger-Huët Anomaly

Pelger-Huët anomaly is a benign anomaly of leukocytes and is inherited as a non-sex-linked, dominant trait. It is characterized by distinctive shapes of the nuclei of leukocytes, a reduced number of nuclear segments (best seen in the neutrophils), and coarseness of the chromatin of the nuclei of neutrophils, lymphocytes, and monocytes. The nuclei appear rod-like, dumbbell-shaped, peanut-shaped, and spectacle-like ("pince-nez") with smooth, round, or oval individual lobes (Fig. 7.3), contrasted with the irregular lobes seen in normal neutrophils. Pelger-Huët cells appear to be normal functionally. Pseudo- or acquired Pelger-Huët anomaly may also be seen, in which cells with morphologic changes, such as described above, have been observed occasionally in association with myxedema, acute enteritis, agranulocytosis, multiple myeloma, malaria, leukemoid reactions secondary to metastases to the bone marrow, drug sensitivity, or chronic lymphocytic leukemia. More commonly, pseudo-Pelger-Huët cells are seen in patients with myeloid leukemia or myeloid metaplasia. Pelger-Huët anomaly is discussed further in Chapter 58.

Neutrophil Heterogeneity

Polymorphonuclear neutrophils were first thought to be a homogeneous population of end-stage cells incapable of protein synthesis and of essentially uniform size, granule content, and functional capability. Sabin first suggested potential heterogeneity among neutrophils when she reported that myelocytes were less motile than more mature neutrophils.¹³⁸

A range of rates of motility among neutrophils from a single individual has been observed,^{140,141} and Harvath and Leonard suggested the existence of two neutrophil populations based on chemotaxis.¹⁴² Subsequently, several monoclonal antibodies were described that recognize subpopulations of neutrophils, including one that appears to recognize the classic NB1 (HNA-2a) neutrophil antigen, and one that recognizes an activation epitope on CD11/CD18.^{143,144} and ¹⁴⁵ Another antibody, 31D8, appears to recognize a neutrophil subset that is more responsive to FMLP as determined by chemotaxis and respiratory burst activity.¹⁴³ Neonates have a larger percentage of neutrophils that express low levels of 31D8 antigen.¹⁴⁶ It has been reported that CR2 (CD21), the receptor for C3d, is present on immature neutrophils but not mature blood neutrophils.^{147,148} One report found that neutrophils from patients with localized juvenile periodontitis express CD21 (CR2) on their surface, whereas normal neutrophils do not.¹⁴⁹

Neutrophil heterogeneity has also been demonstrated in the case of olfactomedin 4 expression. Olfactomedin 4 is highly induced in myeloid progenitors by G-CSF. Although olfactomedin 4 mRNA is expressed in all myelocytes and metamyelocytes, only ~25% of neutrophils in peripheral blood contain olfactomedin 4, which is localized to the specific granules.¹⁵⁰

Some studies of these different populations of polymorphonuclear neutrophils have been interpreted as reflecting maturation or environmental influences,¹⁵¹ in some cases possibly reflecting intravascular exposure to stimuli.^{152,153} The clinical significance of neutrophil subpopulations is unclear.

MACROPOLYCYTES

Macropolycyte is the name applied to giant polymorphonuclear neutrophils with a diameter greater than 16 μm and with 6 to 14 nuclear lobes.¹⁵⁴ Such cells are seen only occasionally in healthy subjects (1.3%), but they are found in approximately 5% of people with infections of various types or with intoxications, usually in association with a neutrophilic leukocytosis and myelocytes in the blood.¹⁵⁴ Macropolycytes are commonly seen in association with folic acid or vitamin B₁₂ deficiency, as well as in patients recovering from the pancytopenia that attends treatment with cytotoxic agents, especially hydroxyurea.

Some authors describe cells with hypersegmented nuclei but of a normal size and call them polycytes¹²⁶ or polylobocytes¹²⁹; similar cells with complex nuclei but without hypersegmentation are called propolycytes.¹²⁶ The latter forms are seen in approximately 10% of patients recovering from leukocytosis with a marked shift to the left and appear in increasing numbers when anticoagulated blood is allowed to stand in vitro.^{126,155}

The mechanism of macropolycyte formation is unknown, but one suggestion is that the skipping of one of the usual cell divisions that occurs during maturation results in a hypersegmented cell.¹⁵⁶

GENETIC SEX AS INDICATED BY LEUKOCYTES

Only one X chromosome is essential to the normal activity of a cell; the other in the normal XX female remains unextended and thus is visible as a chromatin body. Sex chromatin (Barr) bodies are present in 80% to 90% of the somatic cells of the normal female subject. The sex chromatin body of the neutrophil of females is a small mass, usually adjacent to the nuclear membrane, that stains deeply with hematoxylin and is approximately 0.7 to 1.2 μm in diameter. It takes the form of a drumstick projecting from one of the nuclear lobes of approximately 2% to 3% (extreme range, 1% to 17%) of the segmented neutrophils in the blood.¹⁵⁷ They are well-defined, solid, round projections of chromatin connected to a lobe by a single, fine chromatin strand (Fig. 7.8). They must be distinguished from small clubbed or racket-structured, nonspecific nodules that may be smaller or larger as well as irregular in shape or lacking in chromatin, as well as from small (minor) lobes attached to the rest of the nucleus by two strands. Confirmation of the X chromosome in the drumstick has been provided by in situ hybridization.¹⁵⁸ Sessile nodules are equally gender-specific but are more difficult to recognize. Drumsticks are not found in normal male subjects.¹⁵⁹

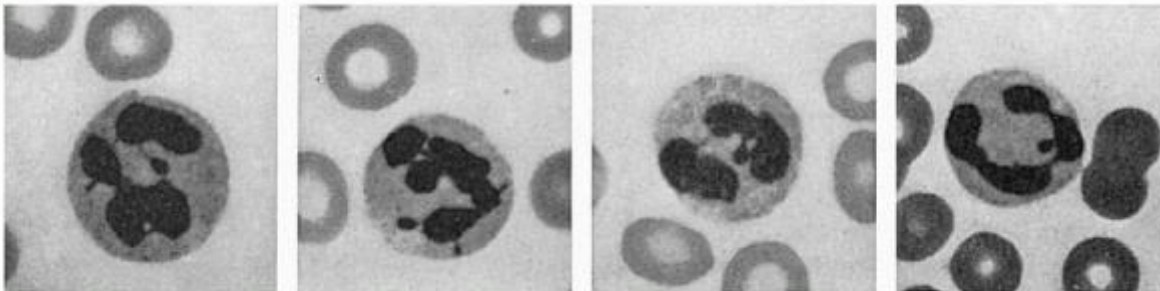

FIGURE 7.8. Granulocytes and sex chromatin patterns. Two cells on the left show the characteristic drumsticks found in the female subjects. The thin strand of chromatin joining the head to a nuclear lobe can be seen clearly. In the two cells on the right, small clubs, such as may be seen in male subjects, should not be confused with drumsticks (Wright stain, $\times 1,300$).

The number of chromatin bodies seen in a cell is one less than the number of X chromosomes present. With the increased numbers of X chromosomes found in certain disorders of human development, the number of Barr bodies and drumsticks increases, and isochromosomes formed by duplication of the long arms of the X chromosome give rise to larger drumsticks than are found in the normal female subject.¹⁶⁰ Drumsticks or sessile nodules are seen in chromatin-positive

male patients with Klinefelter syndrome and are absent in chromatin-negative female patients with Turner syndrome. Eosinophils and probably basophils also have drumsticks. Drumsticks may be difficult to find in the presence of a marked shift to the left. Double drumsticks¹⁵⁹ or a sessile nodule plus a drumstick in the same neutrophil are rare.¹⁶¹

DIFFERENTIAL CELL COUNTING AND NORMAL VALUES FOR LEUKOCYTES

Differential cell counting is the enumeration and classification of the leukocytes seen on the blood smear. The usual procedure is to count at least 100 consecutive leukocytes in an area of good cell distribution. A uniformly thin smear of blood on a cover glass is the best preparation for such examination. Differential cell counting in general is discussed in Chapter 1.

Distributional errors are reduced as more cells are counted. Confidence tables or curves can be used to estimate the probable error of a differential count when various numbers of cells are counted. Clearly, as more cells of a given type are counted and as the total number of cells enumerated increases, the accuracy of the differential count is greater. From the total leukocyte count and the differential count, the absolute concentration of each leukocyte type can be calculated. The accuracy of the result depends on the validity of the total leukocyte count and the differential count. With automatic cell counters, the major component of error now lies in the differential count.

The absolute leukocyte concentration provides a more accurate picture than the differential count because each leukocyte type is a separate cell system with its own functions, control mechanisms, and responses to disease processes; for example, a patient with chronic lymphocytic leukemia whose total leukocyte count is 100×10^9 cells/L, 7% of which are neutrophils and 93% are lymphocytes, does not have granulocytopenia. With a blood neutrophil concentration of 7.0×10^9 cells/L, the problem is lymphocytosis.

Normal values for absolute leukocyte concentrations obtained by using a Coulter counter and differential counts are shown in Table 7.4. Similar values have been reported with the use of other methods.¹⁶² Some variation is evident in values obtained in different population groups and appears to depend on age, sex, pregnancy, time of day, activity level, and other factors.¹⁶³ Racial variation has been reported, especially in Ethiopian Jews¹⁶⁴

P.136

and black Africans, who have significantly lower neutrophil and monocyte counts.¹⁶⁵ Lower counts are less evident in black Americans¹²⁷ and in Africans eating a Western diet.¹⁶³

TABLE 7.4 NORMAL BLOOD LEUKOCYTE CONCENTRATIONS (95% CONFIDENCE LIMITS)

Subject Sex (Age)	No.	Time of Day (hours)	WB C	Neutrophils	Lymphocytes	Monocytes	Eosinophils	Basophils	WBC Count (per	Differential (No. Cells)	Reference
Neonates (day 4)	53	Variabile, 96 h of life	1,981-7,553	2,200-7,100	421-2,022	200-1,900			Coulter 200 ? model	109	
Infants (9-12 mo)									Model S		105
White	50		5,400-24,200	1,062-10,890	2,178-11,718						
Black	50		4,100-14,300	121-6,732	900-11,400						

Europe M an adults	72	0930-1130	3,487-5,641	1,539-5,641							
(media n age, 25 y)	26	1430-1630	3,722-9,828	1,775-6,508							
	F	70	0930-1130	3,839-6,821	1,861-6,821	1,158-3,460	221-843	25-590	0-140	Model 1500 S	97
		29	1430-1630	4,450-7,836	2,137-7,836						
Europe M an adults	85	0900-1530	3,956-9,592	2,075-6,557	962-3,784	59-658				200	99
(age, 54-65 y)	F	76	0900-1530	3,428-5,476	1,833-5,476	776-3,455	59-732			Model B	
Pregna nt Europe ans (third trimeste r)	F	50	0930-1630	5,913-10,769	3,656-10,769	1,023-3,128	349-1,140	22-330	0-90	Model 1500 S	97
Americ an white adults (age, 16-44 y)		226	a.m. or early p.m.	4,550-10,100	2,050-6,800	1,500-4,000	220-950	30-860	0-160	Model 1200 s A and F	102
Black Americ an adults (age, 16-49 y)	M	65	a.m. or early p.m.	3,600-10,200	1,300-7,400	1,450-3,750	210-1,050	30-720	0-100	Model 1200 s A and F	102

Black African adults	M	250	0900-2,587	775-4,131	1,012-3,876	62-688	47-3,371	Counting chamber	200	106
(age, 20-45 y)	Mostly M	109	3,363	-	8,977		Model S		108	

WBC, white blood cell.

NOTE: Values obtained by using a Coulter counter and differential counts of at least 200 cells (except in one African study). Values are expressed in cells $10^9/L$.

Various systems for differential counting have been used.¹⁶⁶ Arneth, for example, painstakingly recorded and tabulated from left to right the number of neutrophilic leukocytes with 1, 2, 3, etc., lobes and made other subdivisions.¹³⁵ The term shift to the left is derived from this practice and indicates an increase in the proportion of cells with only one or few lobes, whereas shift to the right represents an increase in the proportion of multisegmented forms.

From a clinical viewpoint, it is useful to determine whether young forms of neutrophils (band forms and younger) are increased and whether the proportion of multinucleated forms is increased. An increase of younger forms (band cells, metamyelocytes, and myelocytes) (shift to the left) suggests increased release of young neutrophils from the bone marrow, which is seen in association with acute infections¹³² and inflammation. If a shift to the right is suspected, a neutrophil lobe count may be useful. This process involves counting the total number of nuclear lobes in 100 or 200 neutrophils, calculating the average lobe number/neutrophil, and comparing the results with normal values. The chief difficulty associated with this count is clear definition of what constitutes a separate lobe (see "Band Neutrophils" earlier in this chapter). If complete separation of nuclear lobes with or without a connecting filament is the definition used, the normal mean neutrophil lobe count is 2.04, with 95% of normal values falling between 1.66 and 2.42. An increase in mean neutrophil lobe count suggests vitamin B₁₂ or folic acid deficiency, congenital hypersegmentation of neutrophils, or renal disease.¹³¹ A ratio of five-lobed to four-lobed polymorphonuclear cells that is greater than 0.17 is said to be associated more regularly with B₁₂ deficiency than is an increase in mean nuclear lobe count.¹²⁹

P.137

Alterations in the total number of leukocytes and in their relative proportions are significant as measures of the reactions of the body to noxious agents. The reactions of leukocytes in association with certain diseases are discussed later in this book, as is the presence of abnormal inclusions, such as toxic granulation, Döhle bodies, and various inherited abnormalities in leukocyte morphology.

NEUTROPHIL KINETICS

The importance of leukocytes in the defense of the organism is well known. Basic to their roles are cell multiplication, maturation, storage, and delivery to the tissues and sites of infection or cell damage. These processes are called leukocyte kinetics and are different for each leukocyte type. To simplify the discussion, each type of leukocyte is considered as a separate system, but these systems constantly interact and complement one another in the defense of the body.

Neutrophil Kinetics in the Adult

In Chapter 5, the process of mitotic cell division, the cell generation cycle, and the origin of neutrophils and other cell types from a multipotent hematopoietic stem cell were discussed. The production, kinetics, and lifespan of the neutrophil have been the subject of a number of reviews.^{167,168,169,170,171,172,173,174,175,176,177,178,179,180} and¹⁸¹ A model of these processes in adult humans is shown in Figure 7.9. The neutrophil system appears to be incompletely developed in premature babies and in early neonatal life; this topic is discussed in the section "Neutrophil Kinetics in the Fetus and Newborn" later in the chapter.

Mitotic and Maturation Compartments

Neutrophil production in normal adult humans appears to take place only in the bone marrow. The life cycle of the neutrophil can be divided conveniently into bone marrow, blood, and tissue phases. The assumption is that cells move

through the system in an orderly manner as if in a pipeline; this view is supported by the progressive movement of isotopic tracers^{117,178,182,183} and azurophilic granules^{87,97,104} through the system.

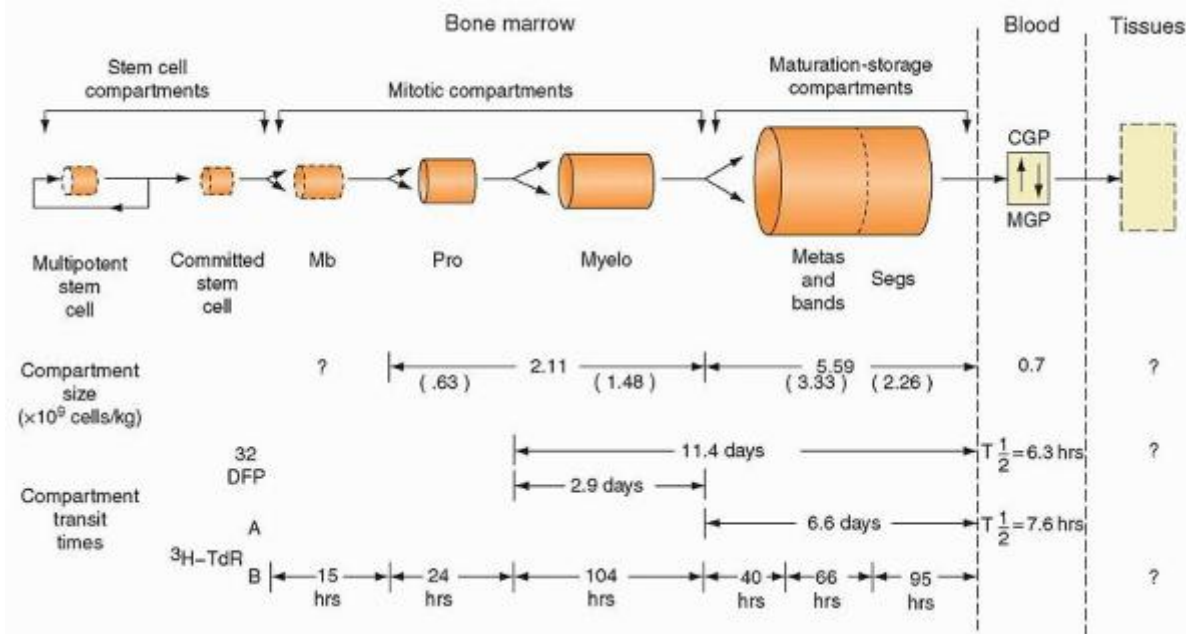

FIGURE 7.9. Model of the production and kinetics of neutrophils in humans. The marrow (555) and blood compartments (147) are drawn to show their relative sizes. In the lower one third of the figure, the compartment transit times as derived from di-isopropylfluorophosphate ($DF^{32}P$) studies (138,147) and from tritiated thymidine (3H -TdR) studies (151,555) are compared. CGP, circulating granulocyte pool; MB, myeloblast; MGP, marginal granulocyte pool; myelo, myelocyte; pro, promyelocyte.

The myeloblast, promyelocyte, and myelocyte are capable of cell division, as judged by direct observation in cultures⁹⁵ and by their ability to incorporate 3H -TdR into their nuclear DNA.¹⁸³ These forms, therefore, constitute the mitotic compartment (Fig. 7.9). Simultaneously, they undergo differentiation, as evidenced by the appearance of azurophilic and specific granules in their cytoplasm. The more mature forms of the neutrophil series (metamyelocyte, band, and polymorphonuclear neutrophil) are usually considered incapable of cell division (except perhaps in unusual circumstances)¹⁸⁴ and do not incorporate 3H -TdR into their nuclei, but they do exhibit continuing maturational changes and thus constitute the maturation compartment. From the maturation compartment, cells flow into the blood and are distributed in two sites: the circulating blood granulocyte pool (CGP) and the marginal granulocyte pool (MGP). Cells in these two pools are in constant equilibrium. Eventually, the cells move through vessel walls to enter the tissues. The exact nature of the MGP is not clear. In the past, it was felt to represent transient adhesion to, and rolling along the surface of, endothelial cells, primarily in postcapillary venules. However, subsequent studies of a patient with leukocyte adhesion deficiency-2 (LAD-2) demonstrated the presence of a marginating pool,¹⁸⁵ although the MGP in this patient with LAD-2 was reduced. Patients with LAD-2 lack the ligands for the selectins CD62P and CD62E and have a marked decrease in neutrophil rolling in postcapillary venules. Normally, the MGP is approximately equal in size to the CGP. Studies of this patient suggested that approximately 20% of neutrophils are in a selectin-independent MGP and approximately 30% are in a selectin-dependent MGP.¹⁸⁵ Surprisingly, this patient's neutrophils had a shorter than normal half-life in the circulation with an increased turnover rate. The inability of CD18 or CD62L antibodies to shift neutrophils from the MGP to the CGP also suggests that the transient adhesion to endothelial cells manifest as rolling does not account for the MGP.^{186,187}

P.138

In this model, cell production can be estimated either by assessing the production rate in the mitotic compartment or by measuring cell flow through subsequent stages, such as the blood. Accuracy of these measurements is facilitated if the system is studied in the steady state when compartment sizes are constant and cell flow reflects net production and destruction.¹⁷⁴

If one assumes a steady state in a scheme such as that shown in Figure 7.5, the flow of cells out of any pool (K_{out}) is equal to the flow of cells into that pool (K_{in}) plus any cells produced in the pool (K_b); thus,

$$K_{out} = K_{in} + K_b$$

Clearly, in pools other than those in the mitotic compartment, K_b is 0, and measurements of cell flow (K_{in} or K_{out}) equal effective cell production, provided no cell death occurs within the pool.

Production in the Mitotic Compartment

Because myeloblasts, promyelocytes, and myelocytes constitute approximately 0.9%, 3.3%, and 12.7% of the marrow cells, respectively, it has been assumed that the system has four or five divisions.¹⁸⁰ From a review of blood neutrophil radioactivity curves obtained after di-isopropylfluorophosphate ($DF^{32}P$) injection into humans, investigators raised the possibility of at least three divisions at the myelocyte stage.¹⁸⁰ Another suggestion generated from marrow differential counts was that only four or five divisions occur in the entire neutrophil proliferation scheme.¹⁸⁰ This supposition agreed with results from experiments in dogs¹⁸⁸ and with data from model studies.¹⁸⁹ In contrast, studies of myeloid islands in the rat thymus provided evidence for seven divisions during granulocytopoiesis: one in the myeloblast stage, two in the promyelocyte stage, three in the myelocyte stage, and a final one in the metamyelocyte stage.^{134,190}

Calculations made from mitotic index (MI) data^{172,191,192} and¹⁹³ provide estimates of cell generation time (t_g) and pool turnover time. MI^{191,192,194} is defined as

$$MI = N_m/N$$

in which MI is the mitotic index for any morphologic cell pool, N_m is the number of mitoses in that pool, and N is the total number of cells in the pool. MI can also be expressed as the ratio of the time spent in mitosis (t_m) to the cell generation time (t_g): $MI = t_m/t_g$

By combining both definitions,

$$MI = N_m/N = t_m/t_g$$

By providing determined values for MI and mitotic time (t_m) in the last equation, the generation time (t_g) for a particular cell pool can be approximated. From t_g and the pool size (N), the birth rate, K_b , can be obtained if all cells in the pool are in cycle, because each mitosis gives rise to one new cell:

$$K_b = N/t_g$$

In effect, the cell birth rate is equal to the number of mitoses occurring per unit time (t), or

$$K_b = N_m/t$$

Although the concept is simple, several problems arise.^{193,195} A major problem is that the morphologic boundaries of most cell pools are not clearly delineated in terms of the cell cycle.¹⁹⁵ For example, to calculate cell production in the myelocyte pool, it must be assumed that all myelocytes are destined to divide; that is, no cells are recognized as myelocytes that are not going to divide again. Because the daughter cells of the last myelocyte mitosis almost certainly do not suddenly become metamyelocytes on completion of division, N in the preceding equation will be erroneously large, and thus estimates of t_g will be erroneously long. If the fraction of nonmitotic cells in the myelocyte population

were known, the calculations could be corrected for this error, as has been attempted.¹⁷⁰ A second major problem is the fact that values for the MI have varied considerably.^{191,193,196,197,198,199} and²⁰⁰ In addition, a considerable diurnal variation exists in the MI in humans, as well as in animals.^{193,199,200,201} and²⁰²

Finally, to calculate the absolute neutrophil production rate (in cells per unit of time), the size of the marrow mitotic compartment must be known. Methods for measuring the sizes of marrow myeloid pools have been developed^{203,204,205} and²⁰⁶ (see "Size of Marrow Compartments and Their Morphologic Subdivisions," later in the chapter), but to date no one has measured these sizes and MI in the same animal at the same time and then calculated neutrophil production rate. Nevertheless, values for the MI for each of the neutrophil precursors capable of mitosis have been determined,^{193,200} and within the assumptions inherent in such calculations,¹⁹⁵ neutrophil production has been estimated.^{176,192}

Similar calculations of neutrophil production can be made from 3H -TdR-labeling index data. After flash labeling with 3H -TdR, autoradiographs of the bone marrow are obtained, and the proportion of nucleated cells that have incorporated the label into their nuclei is determined.^{171,177} This labeling index (LI) represents the ratio of labeled cells, $*N$, or cells in DNA synthesis (N_s) to total cells (N) of a defined morphologic type:

$$LI = *N/N = N_s/N$$

The LI can also be defined in terms of DNA synthesis time (t_s) and the cell generation time (t_g), because $^3\text{H-TdR}$ is taken into the cell only during the period of DNA synthesis; thus,

$$\text{LI} = t_s/t_g$$

By combining both definitions,

$$\text{LI} = N_s/N = t_s/t_g$$

and from determined values for LI and t_g , the generation time and turnover of a given cell population can be estimated. As with MI data, birth rate is a function of the population turnover time, which can be approximated from the generation time or time spent in various phases of the cell cycle:

$$K_b = N/t_g = N_s/t_s$$

Some of the same problems arise with the $^3\text{H-TdR}$ LI that are encountered in the use of the MI.^{195,207} In addition, the use of labeled compounds raises questions of label reuse^{208,209} or elution²⁰⁷ and perturbation of the cell population by the compound^{168,188,210,211} and²¹² or by its radioactivity.^{207,213,214}

The LI reported for humans is myeloblast, 0.85; promyelocyte, 0.65; and myelocyte, 0.33.¹⁷¹ Somewhat different values have been reported in dogs¹⁷⁷ and rats.²⁰⁰ By using the LI for humans and a value for t_s of 5 hours (based on studies in dogs) and by determining relative compartment sizes for each cell type from the bone marrow differential count, the relative birth rates (K_b) of cells have been calculated.^{170,200}

Some authors have found good agreement between neutrophil production as calculated from the MI and the LI,²⁰⁰ but considerable discrepancy has been reported by other authors.¹⁷⁰ This difference may result from the fact that the MI values obtained were low, the studies were done in different subjects at different times, and too small a value for t_s was used in the calculations.

The turnover time of a labeled compartment and neutrophil production rate also may be estimated by measuring the grain count halving time. The generation time is derived only if each cell in a given class divides and if no label feeds into the compartment from a labeled precursor class or as a result of label reuse.²¹⁵ If any of these criteria are not met, the half-time for grain count decrease is longer than the true value, and the estimate of generation time is only a maximal value. Additional disadvantages of this method are that at least several bone marrow samples distributed

P.139

throughout several half-times are needed, and that grain counting is extraordinarily tedious and subject to considerable error. Nevertheless, estimates of compartment turnover time have been made with this method by using $^3\text{H-TdR}$ and radiosulfate.¹²²

After flash labeling with $^3\text{H-TdR}$, the cohort of cells labeled during DNA synthesis may be followed as it subsequently enters mitosis, and the time course of labeled mitoses can be recorded.^{215,216} Theoretically, such curves should permit measurement of the post-DNA synthesis gap (G2), mitotic time (t_m), DNA synthesis time (t_s), cell generation time (t_g), and pre-DNA synthesis gap (G1) (see Chapter 5 and Fig. 7.10). In actual practice, biologic variation rounds off the percentage of labeled mitosis curves, and rapid damping of the waves of cells passing through mitosis (Fig. 7.10) renders such measurements less precise than ideal. However, estimates of myeloid DNA synthesis time obtained with this method are approximately 11 to 13 hours in humans^{215,216} and are in good agreement with estimates made in gastrointestinal mucosal cells. From the level of the damped plateau reached after a few hours, the ratio of t_s to t_g can be obtained (Fig. 7.10), and the generation time can then be calculated. If the generation time and compartment transit time are presumed to be the same or if the proportion of cells in a compartment that is actively proliferating is known, the neutrophil production rate can be calculated.

Neutrophil Production as Measured by Cell Flow in Other Compartments

Another method for approximating neutrophil production involves following the appearance of $^3\text{H-TdR}$ -labeled cells in the metamyelocyte compartment. Because metamyelocytes do not divide or take up $^3\text{H-TdR}$, the appearance of labeled cells in this compartment should reflect the flow of cells into it from the myelocyte compartment; in the steady state, this influx of cells should also reflect the turnover of the metamyelocyte compartment and thus cell production.

Approximately 3 hours pass after the injection of $^3\text{H-TdR}$ before the label appears in metamyelocytes both in dogs¹⁷⁷ and in humans²¹⁵; this time interval is the minimum time for myelocytes taking up the label to pass through G2 and mitosis and become metamyelocytes. After this lag, the rate of labeled cell inflow into the metamyelocyte compartment is approximately 3% to 5%/hour in both species. In the dog, cell inflow into the metamyelocyte compartment measured in

this fashion is less than 50% of that calculated from LI data,¹⁷⁷ suggesting the existence of a major component of ineffective granulocytopoiesis, a myelocyte sink, in the normal animal. However, similar calculations in humans do not confirm the findings of such studies.¹⁷⁰ The resolution of this enigma requires the simultaneous measurement of cell production by using several methods in the same animal at the same time.

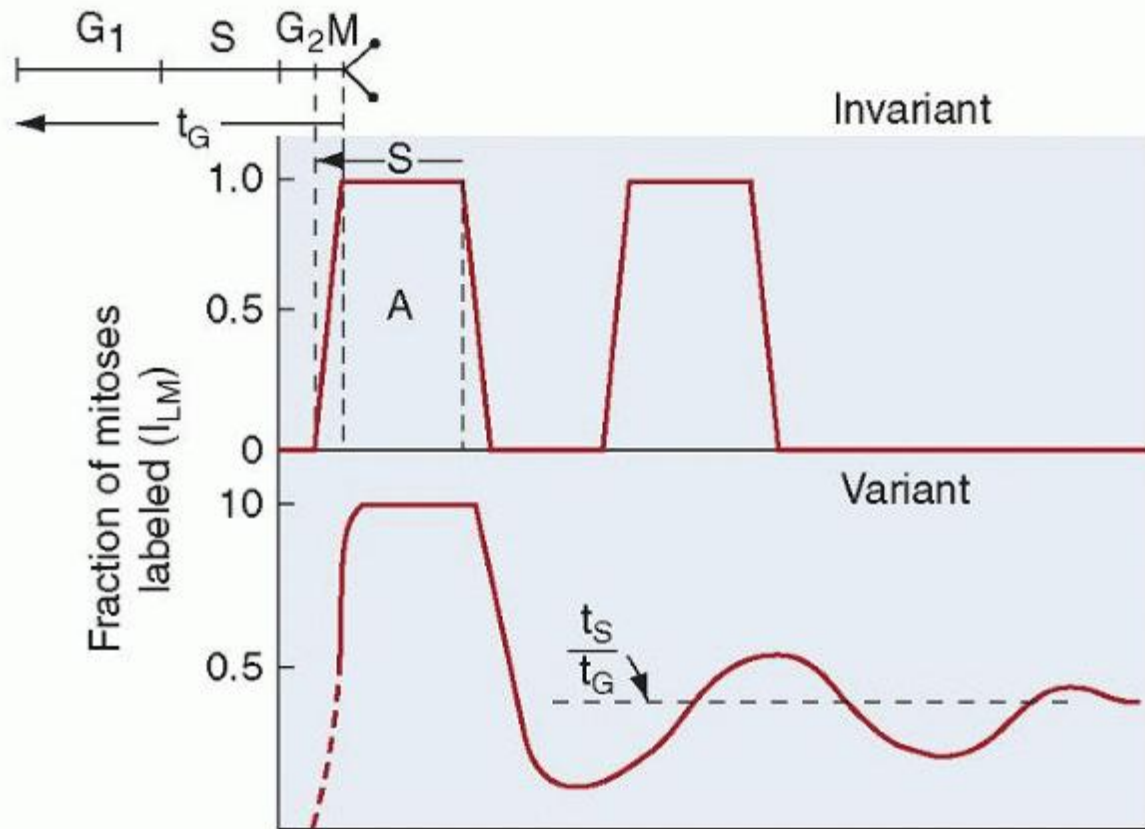

FIGURE 7.10. The percentage of labeled mitoses in the course of cell generation. At the top of the diagram is the theoretical configuration that would be seen if cells flowed through the proliferation cycle with no variation. The effects of moderate variation in time spent in the several cycle phases on the percent labeled mitosis curve are shown at the bottom. G_1 is the pre-DNA synthesis resting phase (gap), S is the DNA synthetic period, G_2 is the post-DNA synthesis gap, and M is mitosis. t_s is the time spent in S , and t_g is the duration of the entire generative cycle. (From Cronkite EP, the Brookhaven National Laboratory, and the National Cancer Institute. Kinetics of granulocytopoiesis. Natl Cancer Inst Monogr 30, Human Tumor Cell Kinetics 1969;51.)

Similarly, the marrow production of neutrophils has been estimated from the size of the postmitotic maturation storage compartment and the compartment turnover time.^{200,204,217} The compartment size is calculated from the marrow neutrophil-to-erythroid (NE) ratio (determined in marrow sections) and the mean normal marrow normoblast pool size (calculated by multiplying the ratio of subjects' erythroid iron turnover value over the mean normal value for this determination by the mean normal erythroblast population).²⁰⁴ The compartment transit time is estimated by injecting ^3H -TdR and noting the time required for labeled neutrophils to appear in the blood. By this method, marrow neutrophil production in humans has been calculated to be 0.85×10^9 cells/kg/day in the normal steady state.

Neutrophil production also can be approximated by measuring the flow of cells through the blood, the blood granulocyte turnover rate (GTR). DF^{32}P binds irreversibly with a number of esterase enzymes and has been shown to label neutrophils primarily.^{218,219} By means of this agent, a subject's own cells can be labeled, and the total blood granulocyte pool (TBGP) and the rate of disappearance of labeled neutrophils from the blood can be determined.¹⁷⁵ Similar measurements can be made by transfusing ^3H -TdR-labeled cells from a suitable donor.²⁰⁴ Because neutrophils leave the blood in a random manner (exponential disappearance curve), the GTR is calculated as follows from the TBGP and the $t_{1/2}$:

$$\text{GTR} = 0.693/t_{1/2} \text{ TBGP}$$

in which 0.693 is the natural logarithm of 2 and $t_{1/2}$ is the blood neutrophil half-disappearance time.

All of these methods assume that the system is in a steady state during the entire course of the measurements. If neutrophil death in the marrow is not significant, the blood GTR equals total neutrophil production. If neutrophil death in the bone marrow is significant, the blood GTR measures effective neutrophil production, and the difference between this determination and total neutrophil production is ineffective granulocytopoiesis. Measurements of neutrophil production by compartment turnover methods have given values ranging from 62 to 400 × 10⁷ neutrophils/kg/day in humans (Table 7.5)^{204,220} and 150 to 560 × 10⁷ neutrophils/kg/day in dogs.^{204,217,221}

Of the methods for assessing neutrophil production just described, only the measurement of blood neutrophil turnover rate with DF³²P or ³H-TdR can be performed easily enough to be of use in studying groups of patients in a clinical setting, and even this is possible in only a few research centers.

Size of Marrow Compartments and Their Morphologic Subdivisions

In all of the procedures described, with the exception of DF³²P and ³H-TdR blood kinetic measurements, the number of marrow myeloid cells under study must be known in order to calculate neutrophil production. In the absence of such data, only calculations of relative cell production are possible.¹⁷⁰ Direct measurements of the volume and cellularity of the marrow (isolation of skeleton and cell counting or bone biopsy and radioactivity measurement) have been made in dogs,²⁰⁴ rats,²²² mice,²²³ and guinea pigs.^{224,225}

Several methods for estimating marrow myeloid mass have been devised, but probably the best data are those derived by P.140

using marrow NE ratios and measurement of marrow erythroblast mass by the iron dilution technique as originally suggested by Suit.²²⁶ In early studies,^{23,206} marrow erythroblast radioactivity and NE ratios were counted in marrow suspension smears. Corrections were made for incomplete iron localization in the erythron and for an estimated 30% cell destruction that occurred in preparing the marrow suspensions. In later studies,²²⁷ the NE ratios and radioactivity measurements were made on marrow sections in the hope of avoiding the problem of possible cell destruction. Values for marrow erythroid mass were somewhat lower than those reported by Donohue et al.,^{205,206} but they agreed with results obtained when no correction for cell destruction was made. By using marrow sections and the ⁵⁹Fe isotope dilution technique, investigators directly determined the marrow myeloid mass in the dog.²⁰⁴ In humans, however, direct measurement of the marrow normoblast mass has not been feasible in normal subjects, so marrow normoblast mass was estimated from erythron iron turnover values.^{204,228} The mean values obtained in 13 normal subjects are presented in Figure 7.9.

TABLE 7.5 BLOOD NEUTROPHIL KINETIC PARAMETERS IN NORMAL HUMANS

Parameter ^a	Diisopropylfluorophosphate (Autologous) ^a		Tritiated Thymidine (Isologous) ^b	
	Mean	95% Limits	Mean	Range
Total blood granulocyte pool (cells × 10 ⁷ /kg)	61	27-128	40	30-48
Circulating blood granulocyte pool (cells × 10 ⁷ /kg)	31	13-49	22	15-29
Marginated granulocyte pool (cells × 10 ⁷ /kg)	29	8-115	17	12-26
Half-life (h)	6.3	4-10	7.6	5.4-9.6
Granulocyte turnover rate (cells × 10 ⁷ /kg/d)	160	62-400	87	69-100

^a Based on data from 71 normal subjects whose own blood was labeled in vitro and reinfused; see reference 240.

^b Based on five subjects transfused with cells labeled in compatible donors; see Dancey JT,

Deubelbeiss KA, Harker LA, Finch CA. Neutrophil kinetics in man. *J Clin Invest* 1976;58:705.

Transit Time Through the Nondividing Maturation Pool

After injection of a pulse label of $^3\text{H-TdR}$ or radiophosphate, a delay of several days occurs before labeled segmented neutrophils appear in the blood. This interval represents the minimum time from DNA synthesis in the last myelocyte generative cycle until the cell has matured into a segmented neutrophil (or band form) and is released into the blood. In patients in a normal steady state, this minimum transit time or emergence time was between 96 and 144 hours^{229,230}; in patients with infection, it was as short as 48 hours. Emergence time in dogs is 2 to 3 days²³¹; in the rat, it is 36 to 42 hours.¹³⁶

The mean value for myelocyte-to-blood transit time after DNA labeling (defined as the time from $^3\text{H-TdR}$ or radiophosphate injection to the peak of the blood granulocyte radioactivity curve) was 6 to 9 days in hematologically normal convalescent patients and 7.2 days in eight normal subjects.²⁰³ In contrast, studies in which DF^{32}P was injected intravenously into normal volunteers led to the conclusion that the mean promyelocyte-to-blood transit time was 11.4 days, with a myelocyte compartment transit time of 2.9 days^{169,180}—in other words, an 8.5-day myelocyte-to-blood transit time. Results of studies involving the simultaneous use of $^3\text{H-TdR}$ and DF^{32}P in the same subjects suggest that the discrepancies reflect differences between normal ambulatory subjects and hematologically normal convalescent patients.²³² In dogs, the average myelocyte-to-blood transit time was 5 days, as measured with both $^3\text{H-TdR}$ and DF^{32}P .²³²

Neutrophil Release from Marrow into Blood

After $^3\text{H-TdR}$ injection and at the time of first seeing label in band and segmented neutrophils in the bone marrow, some labeled cells are also seen in the blood.¹⁷⁰ Authors have suggested that the release of band or segmented neutrophils from the marrow does not follow a strict pipeline or first-in, first-out sequence.^{170,229} However, it is not clear whether these observations reflected variance around a mean transit time^{180,231,233} or random release of mature neutrophils from the marrow.²²⁹ Findings in dogs strongly favor the mean transit time concept rather than random release.²³¹ In fact, because the ratio of band to segmented cells is much higher in marrow than in blood, selective release of segmented cells must occur.

The mechanisms controlling the release of marrow cells into the blood are only partially understood. Endotoxin disturbs the relationship between marrow sinus endothelial cells and the adventitial (reticular) cells.^{234,235} and ²³⁶ Findings of in vitro studies of factors influencing marrow granulocyte migration through membranes demonstrate that pore diameter, morphologic age of cells, and the presence of a chemical attractant may be important in marrow cell release.²³⁷ Thus, immature granulocytes (myeloblasts and promyelocytes) could not penetrate membranes with pores smaller than 8 μm and were not responsive to chemoattractants. Mature granulocytes (band and segmented) could penetrate membranes with pores as small as 1 μm , and egress was accelerated by increasing pore size and by use of a chemoattractant. Myelocytes and metamyelocytes exhibited intermediate activity. Integrins and immunoglobulin (Ig) superfamily members appear to play an important role in the organization of the bone marrow microenvironment, and stem cell factor alters the avidity of $\alpha_4\beta_1$ and $\alpha_5\beta_1$ integrins on hematopoietic cell lines for their ligands.²³⁸ A number of mediators of neutrophil release from the bone marrow have been identified, including tumor necrosis factor (TNF)- α , TNF- β , granulocyte colony-stimulating factor (G-CSF), granulocyte-macrophage colony-stimulating factor (GM-CSF), IL-8, and C5a.^{185,239,240}

P.141

Kinetics in the Blood

Di-isopropylfluorophosphate Studies

With the development of the DF^{32}P labeling technique, in which neutrophils are labeled in vitro with DF^{32}P and returned to the donor, two pools of neutrophils in the blood have been demonstrated: a CGP and an MGP.^{175,241,242} In normal humans, neutrophils in these two pools are in constant equilibrium, and the pools are of approximately equal size (Table 7.5). The CGP is calculated from the blood leukocyte count and the blood volume. The TBGP is measured by the dilution of DF^{32}P -labeled neutrophils after their reinjection.²⁴¹ MGP is the difference between the TBGP and the CGP.

Brief exercise or epinephrine injection increases the size of the CGP by approximately 50%, but the TBGP is unchanged; the neutrophilia produced reflects a demargination of cells that lasts only a few minutes.²⁴¹ The location of at least some of the marginated cells is thought to be along the walls of small blood vessels, primarily postcapillary venules, in many body tissues, where neutrophils roll along the vessel wall in loose contact with the endothelial cell surface.²⁴³ The

distribution of cells in the CGP and MGP can be altered by other means. For example, transient neutropenia was noted 90 minutes after endotoxin injection, but the TBGP was not significantly increased; thus, essentially a shift from CGP to MGP occurred. At the end of 5 hours, the TBGP increased significantly as a result of an outpouring of cells from the bone marrow, and the CGP and MGP were of approximately equal size.²⁴² The administration of steroids also produced an increase in the size of the TBGP, in part for the same reason but also because of decreased outflow into the tissues.²⁴⁴ A rapid transient increase in the marginating pool was observed during hemodialysis when cuprophane membranes were used.^{245,246} Activation of the complement system by contact with the dialyzer membrane was found to produce inflammatory mediators (C5a being a major contributor) that stimulated an increase in neutrophil margination manifest both by an increase in rolling along small vessel endothelium and by the formation of homotypic aggregates of neutrophils with sludging in small vessels.^{247,248,249,250,251} This neutrophil margination was transient, being maximal by approximately 15 minutes and resolving by 1 hour of dialysis.

After the return of DF³²P-labeled neutrophils to their donor, the disappearance of labeled cells from the blood follows a single exponential curve with a half-disappearance time (t₂) of approximately 7 hours in most normal subjects.^{169,175,203,252,253,254} and ²⁵⁵ This finding implies that neutrophils are destroyed or leave the blood randomly rather than according to their age (senescence), as is the case for erythrocytes and platelets.¹⁷⁵ Support for this theory is found in the fact that ³H-TdR-labeled neutrophils appear in the blood and in saliva almost simultaneously.¹³⁹

Studies involving leukapheresis²⁵⁶ and other experiments²⁵⁷ reveal that neutrophils that have crossed the endothelial barrier between blood and tissues probably do not re-enter the circulation, at least not in significant numbers. The number of neutrophils that pass through the blood each day has been estimated at 62 to 400 × 10⁷ cells/kg/day (Table 7.5)—that is, the GTR. In 1964, it was proposed that neutrophils became senescent and developed pyknotic nuclear lobes over time, this process truncating the exponential curve of disappearance of DF³²P-labeled neutrophils.¹³⁹ Although this concept seemed plausible, no truncation of DF³²P curves has been noted. Similar blood kinetic results have been obtained with the use of ³H-TdR and autoradiographic techniques.²⁵⁸ More recent studies describe the occurrence of apoptosis in neutrophils, and this may be an important mechanism of senescence in some circumstances.

⁵¹Cr Studies

Leukocytes can also be labeled in vitro with radiochromate (⁵¹CrO₄) and then returned to the body.^{259,260} and ²⁶¹ Unlike DF³²P, which labels primarily granulocytes,^{217,219,258} leukocyte types other than neutrophils are heavily labeled by the ⁵¹Cr technique.^{230,259,261,262,263} and ²⁶⁴ Under some circumstances (such as chronic lymphocytic leukemia), this capacity is advantageous because the distribution and turnover of leukocytes other than neutrophils can be followed.^{259,262,264,265} In addition, ⁵¹Cr is a γ-emitting isotope, so external counting techniques may detect sites of sequestration or destruction.

Results of studies of the infusion of autologous, radiochromatelabeled leukocytes into hematologically normal subjects are more variable than those using the DF³²P method. The proportion of cells recovered in the blood is sometimes less than that associated with DF³²P-labeled neutrophils,²⁶¹ and complex curves are often noted.²⁶⁵ Furthermore, there is no general agreement on t_{1/2} values; most investigators report values similar to those obtained with DF³²P,^{230,259,261,262,266} but values two to three times longer have been described.^{267,268} Several factors may explain these differences, but a major one is probably ⁵¹Cr labels of multiple cell populations. No significant organ sequestration of labeled leukocytes has been detected in normal subjects.²⁶¹

¹¹¹In Studies

After the evaluation of a variety of other radioactive agents for labeling leukocytes in vitro,²⁶⁹ ¹¹¹In chelated with 8-hydroxyquinoline (oxine) was thought to be promising for evaluating the in vivo localization of abscesses. The ¹¹¹In-oxine complex labels blood cells effectively (95% uptake in 15 minutes) and exhibits minimal elution (<1% released in 2 hours).²⁷⁰ This label is nonspecific, however, in that it binds to all cell types; thus, cell separation and purification are necessary before labeling occurs.²⁷¹ Nevertheless, the labeling of autologous neutrophils (or leukocyte suspensions containing mostly neutrophils) and their reinjection was sometimes useful in localizing abscesses in humans, although much of the radioactivity initially localizes in the lungs and subsequently appears in the spleen and liver.²⁷⁰

Apoptosis

Neutrophils undergo apoptosis in tissue culture (approximately 50% of cells in 24 hours); this process is accompanied by a fall in intracellular pH.^{272,273} and ²⁷⁴ Apoptosis is manifest by characteristic morphologic changes with nuclear condensation and the formation of pyknotic nuclei. Importantly, the cell remains intact and does not release its potentially toxic contents before it is phagocytosed by macrophages and removed. The addition of G-CSF, GM-CSF, or IL-1 delays but does not prevent this process.^{272,275} Macrophages phagocytose senescent (apoptotic) neutrophils (as observed more than a century ago), and this is probably one fate of the short-lived blood neutrophil.^{273,274,276,277} and ^{278,279} Interestingly,

glucocorticoids inhibit neutrophil apoptosis,²⁸⁰ but they induce it in susceptible lymphocytes. Fas (CD95) is expressed on neutrophils and is capable of inducing apoptosis as it does in other susceptible cells.^{280,281} Neutrophil apoptosis is reversibly inhibited by hypoxia, possibly playing a role in neutrophil survival at sites of inflammation.²⁸² Neutrophil apoptosis is also delayed in pregnancy, and both estradiol and progesterone can delay neutrophil apoptosis in men and women.^{283,284} Neutrophils may also undergo cell death by another mechanism that is caspase-independent, is not associated with DNA laddering, and appears to depend on mitochondria-derived reactive oxygen metabolites.²⁸⁵ As discussed later, in general diapedesis seems to induce an antiapoptotic state, while phagocytosis seems to promote apoptosis, at least partly by upregulating death receptors, thus providing the conditions for resolution of inflammation and avoidance of tissue damage.¹⁵⁰

Migration into Tissues and Sites of Destruction

At a local site of tissue damage or infection, adherence of neutrophils to the endothelial cells of the vessel wall and their
P.142

subsequent migration into the tissues can be seen within minutes. After initial adherence, neutrophils project microscopically visible pseudopods between or through the endothelial cells and force a passage across the endothelial layer.^{286,287} This directed movement, chemotaxis, is induced by the binding of a variety of chemoattractant molecules, such as n-formyl peptides (e.g., FMLP), a cleavage product of the fifth component of complement (C5a), leukotriene B₄, and platelet-activating factor, to specific membrane receptors. Further migration is then delayed by the basement membrane and periendothelial cells, and the neutrophils may move parallel to, but beneath, the endothelium until a passage into the surrounding connective tissue is found. Once neutrophils leave the blood, they do not return in significant numbers.^{257,288}

The sites into which neutrophils normally disappear are poorly understood. Labeled blood neutrophils are found in saliva,¹³⁶ but loss into saliva may reflect subclinical infections, because few if any cells are found in the salivary ducts²⁸⁹; the rate at which granulocytes enter the oral cavity has been correlated with the degree of gingivitis.²⁹⁰ Some cells do penetrate the oral mucosa in healthy subjects, presumably as a result of diapedesis.²⁸⁹ Loss of leukocytes in the urine also has been demonstrated in normal subjects.²⁹¹ Leukocyte loss increases significantly in association with pyelonephritis.²⁹² In addition, arteriovenous catheterization studies in dogs²⁹³ and in humans²⁹⁴ provide evidence that suggests leukocytes also are removed in the lungs, liver, and spleen. Significant numbers may be lost into the gastrointestinal tract. No quantitative data concerning the rate of loss through these various organs are available. Interestingly, bone marrow and blood leukocyte counts were essentially the same in germ-free and normal mice, suggesting that loss via subclinical infections at the various body surfaces is not a major factor in neutrophil turnover.^{295,296}

Neutrophil Kinetics in the Fetus and Newborn

The fetus exists in a sterile environment and, unlike the adult, does not require antibacterial defenses. However, if the systems ensuring adequate neutrophil production, storage, delivery to tissues, phagocytosis, and bacterial killing are not intact at birth, extrauterine existence is seriously compromised. Maturation of the neutrophil system is not complete in the midgestation fetus, and even the neonate delivered at term has a neutrophil system that in several respects is quantitatively and qualitatively immature. Therefore, one might anticipate that newborns, particularly those delivered prematurely, would be at significant risk for serious bacterial infection, and many studies reveal a strong correlation between prematurity and serious bacterial infection.^{297,298,299,300} and ³⁰¹ Of all the risk factors for bacterial infection analyzed by the national collaborative study on neonatal infection, premature birth showed the strongest correlation.³⁰² In addition, babies delivered at term experience a higher incidence of bacterial infection than do older children or adults^{303,304} and, when infected, often display poor resolution of infection despite antibiotic therapy.

Newborn infants, particularly if premature, display many other deficiencies in antibacterial defense, such as low levels of IgG antibody, complement components, fibronectin, and lymphokine production,³⁰⁵ but only maturational differences in neutrophil kinetics are discussed here. Realizing that the neutrophil system of a fetus is underdeveloped and in a state of maturation, a difference in neutrophil pool sizes and kinetics in this group from those in adults can be expected. In addition, rapid somatic growth in the fetus and newborn places added demands, unique to the neonate, on neutrophil production³⁰⁶; cells are needed not only for ongoing antibacterial defense, but also for a rapidly increasing body mass.

The investigation of neutrophil kinetics during fetal and neonatal life in humans has been hampered by lack of applicability of the techniques used for such studies in adults. For instance, DF³²P and ³H-TdR blood kinetic measurements have not been used in babies because of the radiation exposure and the large volumes of blood required. Nevertheless, the results

of clinical studies, coupled with extensive investigation in developing animals, illustrate several developmental differences.

Granulocyte-Macrophage Progenitor Cells

CFU-GM have been isolated from the livers of aborted 5- to 6-week human fetuses.³⁰⁷ Although early fetal CFU-GM produced colonies of mature neutrophils in vitro, no mature neutrophils could be located in the liver, marrow, or blood of the 5- to 6-week fetuses from which this CFU-GM was obtained.³⁰⁷ In separate studies, mature neutrophils were not detected in the human fetus until approximately 15 to 16 weeks' gestation,^{308,309,310} and³¹¹ at least 10 weeks after the first appearance of CFU-GM.

The concentration of CFU-GM in blood is higher in the fetus and newborn than in adults: 20 to 300 CFU-GM/ml of venous blood in adults and approximately 2,000 CFU-GM/ml in term neonates.^{312,313,314,315,316,317,318} and³¹⁹ Even higher venous blood concentrations are found in prematurely delivered infants,^{313,318} with the highest values noted in the most premature subjects.³¹³ The total body pool of CFU-GM has not been measured in human neonates; in rats, the number of CFU-GM/g body weight is small in the fetus ($0.5 \pm 0.1 \times 10^3$ CFU-GM/g) and increases to adult levels ($10.5 \pm 0.2 \times 10^3$ /g) at 4 weeks of age.³²⁰

The proliferative rate of CFU-GM during human gestation, assessed by thymidine suicide, is rapid in the second trimester.³¹³ Whereas CFU-GM in venous blood of adults displays a thymidine suicide rate ranging from 0 to 7%,^{313,321,322} and³²³ rates of 45% have been observed in term neonates, and rates of 75% were noted in prematurely born neonates.³¹³ Similarly, in fetal and neonatal rats²²⁵ and mice,³²² the CFU-GM proliferative rate is high and appears to be near maximal at birth, even in the noninfected state.^{324,325} Unlike in adult animals, no further increase in CFU-GM number³²⁶ or CFU-GM proliferative rate³²⁴ has been detected during either sublethal or lethal bacterial infection, suggesting that the system operates at capacity. It has been suggested that the inability to accelerate neutrophil production above baseline might handicap neonates by limiting their neutrophil supply during a bacterial infection.

Neutrophil Storage Pool

In the fetus, as in the adult, mature neutrophils are stored within the skeletal marrow but also are found in the liver and spleen.³²⁶ Techniques that measure the size of the neutrophil storage pool, such as radioisotopic iron labeling, with subsequent liver, spleen, and bone marrow biopsy, have not been applied to normal human neonates. In fetal and neonatal animals, however, the liver and spleen, as well as the long bones, can be removed, and the neutrophils within them can be quantified. Such studies in rats show that the neutrophil storage pool is considerably smaller in prematurely delivered animals (1.0 to 1.3×10^6 cells/g body weight) than in term (1.3 to 2.5×10^6 cells/g) and adult animals (4.5 to 7.5×10^6 /g).³²⁷

During experimental bacterial sepsis in neonatal dogs and rats, the size of the neutrophil storage pool has been serially quantified. Experiments performed with a variety of organisms^{326,328,329,330,331,332,333} and³³⁴ demonstrate depletion of the storage pool and neutropenia before death. Similarly, in human neonates with lethal bacterial sepsis, neutropenia and depletion of the neutrophil storage pool, as assessed by bone marrow aspiration, are nearly universal findings.^{310,332,335,336}

Release from Storage Pool into Blood

Within 1 hour of inoculating adult animals with as few as 10^4 type III group B streptococci/g body weight, an accelerated rate of egress of neutrophils from the storage pool into the blood can

P.143

be detected.³³⁵ In contrast, when newborn animals were given the same or a larger inoculum of 10^6 organisms/g, a 4-hour delay occurred before this acceleration in neutrophil storage pool release was observed.³³⁵ This delay between bacterial inoculation and accelerated release of marrow neutrophils may be a significant physiologic disadvantage, which permits prolific initial bacterial multiplication. In other studies, this delay in release of marrow neutrophils was completely corrected by prior administration of type-specific antibody directed toward the organism with which the animal was inoculated.^{329,335}

Alterations in Migration into Tissues and Sites of Destruction in Neonates

In many studies, investigators have demonstrated defective neutrophil chemotaxis in neonates. In early investigations, Eitzman and Smith, using the Rebeck skin window technique, demonstrated that a preponderance of eosinophils, not neutrophils, was attracted to the abraded dermis of neonates.³³⁷ Using the same technique, Bullock et al. demonstrated that neutrophils in neonates remained at the site of abrasion longer than they did in adults.³³⁸

Using the Boyden chamber method, neutrophils from newborns were found to be less responsive than adult neutrophils in chemotaxis.³³⁹ In addition, factors generated from neonatal serum attracted neutrophils less well than did factors from adult serum. Diminished chemotaxis of cord blood neutrophils was also demonstrated, with reduction to approximately 80% of levels observed with adult neutrophils.^{340,341} and ³⁴² Using a different in vitro technique for quantification of neutrophil movement (agarose gel), newborn neutrophil chemotaxis was found to be reduced to approximately 20% to 27% of that seen with adult neutrophils.³⁴³ In prematurely delivered neonates, neutrophil chemotaxis was even more defective,³⁴⁴ and the defect persists for a considerable time after birth.

A further reduction in chemotaxis of neutrophils from ill neonates compared to healthy neonates³⁴⁵ and decreased chemotaxis in preterm neonates with bacterial sepsis followed by a return to normal neonatal values (approx. 20% of adult values) with resolution of the infection³⁴⁶ have been reported.

Neutrophil migration has also been investigated in vivo in neonatal and adult animals. One technique involved surgical implantation of a sterile polyvinyl sponge disc, standardized for body weight, into rats. At various intervals, the sponges were removed, and neutrophils that had migrated into them were chemically quantified. Concurrent with sponge removal, the long bones (and the liver and spleen in neonates) were also removed, and the size of the total body neutrophil storage pool was determined.³³¹ By comparison with control animals, only approximately 9% of the neutrophils released from the storage pool in neonates could be accounted for in the sponge. In contrast, approximately 60% of the neutrophils released from the marrow in adults migrated to the sponge, indicating more efficient neutrophil migration in the adult. Another study found that the accumulation of neutrophils in the peritoneal cavity of rats after intraperitoneal inoculation with various chemical attractants was impaired in neonates.³⁴⁷

The mechanism responsible for deficient neutrophil chemotaxis in neonates is only partly known. By measuring the pressure needed to aspirate neutrophils into a glass pipet, Miller determined that the neonatal neutrophil was more rigid and less deformable than the adult neutrophil, a characteristic that may be detrimental to movement of neutrophils through tissues.³⁴⁸ In addition, neutrophils from human neonates irreversibly aggregated after activation by C5a, whereas after exposure to the same stimulus, adult neutrophils aggregated and then deaggregated.^{247,248,249,250,351} Irreversible aggregation of neonatal neutrophils has also been seen in response to activation by FMLP.³⁵⁰ If irreversible neutrophil aggregation occurs in vivo in neonates, then independent neutrophil mobility would probably be impaired. A deficiency in the redistribution of cell-surface adhesion sites, factors related to impaired migration, and impairment of neutrophil adhesiveness has also been reported^{351,352} and would impair neutrophil function in vivo. Response to complement-derived peptides was also impaired, as shown in the response of cord blood neutrophils to endotoxin-activated serum.³⁵³ Concanavalin A capping,³⁵⁴ phytohemagglutinin-induced aggregation,³⁵⁵ and C5a-induced chemotaxis,³³⁰ as well as FMLP-induced membrane potential change,³⁵⁶ are reduced in the neonatal neutrophil. No difference in calcium uptake in FMLP-stimulated neutrophils was noted between human neonates and adults, but reduction in calcium uptake by resting neonatal neutrophils was significant.³⁵⁷ Diminished orientation of neonatal neutrophils after exposure to a chemotactic gradient was noted, and a significant decrease both in the number of microtubules/cell and in the assembly of microtubules was observed.³⁵⁸

PHYSIOLOGIC VARIATION IN LEUKOCYTES

By the age of 4 to 8 years, the blood differential cell count approaches that seen in the adult. Normal values are presented in Table 7.4. Metamyelocytes or myelocytes are not often seen on routine examination of the blood smear, but a few such cells can be found in normal blood after a careful search or, more readily, by examination of buffy coat smears (3.6/3,000 granulocytes)³⁵⁹; atypical mononuclear forms and megakaryocyte fragments containing nuclei are also seen in such smears. Whether a significant difference exists in leukocyte concentration between the sexes or with advancing years has been debated.^{360,361,362} and ³⁶³ Racial variations were reported in black Africans, with lower neutrophil and monocyte counts and higher eosinophil counts; however, these differences were less evident in Africans eating a Western diet³⁶⁴ or in black Americans.^{127,163}

Although leukocyte concentration is maintained within definite limits in normal humans, fluctuations occur during a single day and from day to day. The suggestion that a characteristic hourly rhythm occurs has not been confirmed,^{365,366} nor has the occurrence of a digestive leukocytosis been established.³⁶⁷ Light influences the diurnal variation of neutrophils.^{202,368} Under conditions of complete physical and mental relaxation, a basal level of 5.0 to 7.0×10^9 cells/L is usual.³⁶⁹ Ordinary activity may be associated with a moderate increase, and a somewhat higher level is common in the afternoon. Under all these conditions, however, the leukocyte count tends to remain within the normal range (Table 7.4).

Conclusive demonstration of the effects of climate or season on the leukocyte count is lacking. Some authors claim that meteorologically conditioned fluctuations occur.³⁷⁰ Heat and intense solar radiation are said to cause leukocytosis.³⁷¹

Prolonged residence in Antarctica has been reported to cause leukopenia.³⁷² Artificially induced heat, sunlight, and ultraviolet light have been reported to cause lymphocytosis.³⁷³ Acute anoxia, both anoxic and anemic, causes neutrophilic leukocytosis³⁷⁴ that does not develop in adrenodemedullated rats. In the first few days after a subject has arrived at a high altitude, some leukocytosis, accompanied by lymphopenia and eosinopenia, has been observed, followed quickly by slight lymphocytosis and eosinophilia.³⁷⁵

Marked leukocytosis occurs regularly with strenuous exercise. Counts as high as $22.0 \times 10^9/L$ have been recorded for a runner after an 11-second 100-yard dash, and $35.0 \times 10^9/L$ has been recorded after completing a quarter-mile run in less than 1 minute.³⁶⁹ The increment of cells usually consists of segmented neutrophils, but lymphocytosis may be prominent as well. Such leukocytosis recedes to normal in less than 1 hour and, in the neutrophil series, is related to a shift of cells from marginal sites

P.144

(MGP) to the circulation (CGP) (shift leukocytosis).^{240,241} This leukocytosis occurs in the absence of the spleen, suggesting that the spleen is not a major site of cell margination. Leukocyte counts $>20.0 \times 10^9/L$, mainly neutrophils, are regularly recorded for runners who complete a 26-mile marathon in 2.5 to 3.0 hours; whether a shift to the left, suggesting mobilization of marrow neutrophils, occurs in this circumstance is debatable.³⁶⁹ Postmarathon leukocytosis subsides slowly over a number of hours and probably reflects a redistribution of granulocytes in the blood, combined with mobilization of cells from the marrow with an increase in TBGP size. The magnitude of the leukocytosis associated with exercise appears to depend primarily on the intensity of the activity rather than on its duration.³⁷⁶

Convulsive seizures, from whatever cause, are associated with an increase in leukocyte count similar to that noted after violent exercise. Electrically induced convulsions are followed by a reduction in eosinophil and lymphocyte number and an increase in neutrophil number, findings consistent with the effects of adrenal hormone secretion.³⁷⁷ Epinephrine injection produces leukocytosis, the nature and duration of which appear to vary with the mode of administration. Intramuscular injection causes leukocytosis in two phases.^{378,379} In the first phase, maximal at 17 minutes, the number of neutrophils, lymphocytes, and eosinophils increases and then returns toward normal over several hours. This pattern almost certainly represents a shift leukocytosis. In the second phase, the number of neutrophils rises again at approximately 4 hours, although the number of lymphocytes and eosinophils remains at or below preinjection levels³⁷⁹; this phase may reflect an adrenal steroid effect and consists of an absolute neutrophilia. After intravenous injection, leukocytosis peaking at 5 to 10 minutes and of total duration of less than 20 minutes occurs and has been shown to be purely shift neutrophilia.^{241,242} The leukocytosis that follows subcutaneous injection is more variable.

During attacks of paroxysmal tachycardia, leukocytosis with cell counts of 13.0 to 22.0×10^9 cells/L has been reported.³⁸⁰ Pain, nausea and vomiting, and anxiety may cause leukocytosis in the absence of infection.³⁸¹ The paucity of band forms and metamyelocytes indicates that the neutrophilia results from the redistribution of the cells between the marginal and circulating pools.

Ether anesthesia produces leukocytosis, probably because of emotional and reflex reactions, as well as struggling during the stage of excitement. Narcosis with barbital compounds usually reduces the leukocyte count.

During the ovulatory period, eosinopenia and a slight rise in the number of leukocytes, as well as increased 17-hydroxycorticosteroid levels, have been reported.^{382,383} Slight leukocytosis occurs during pregnancy, and neutrophilia increases as term approaches.^{161,382} The onset of labor is accompanied by neutrophilic leukocytosis, which sometimes is pronounced ($34.0 \times 10^9/L$). This state continues for 1 day after delivery, receding to normal only after 4 or 5 days. These changes are accompanied by a reduction in the number of circulating eosinophils.³⁸²

Many of the physiologic variations in leukocytes that have been described can be explained as manifestations of stimulation of the adrenal cortex. The administration of cortisone or hydrocortisone results in increased blood levels of 17-hydroxycorticosteroids that peak at 1 hour³⁸⁴ and are associated with neutrophilia.³⁸⁵ Eosinopenia and lymphopenia follow, become maximal at 4 to 8 hours, and are proportional to the quantity of hormone administered. Neutrophilia was less constant than the depression in eosinophil and lymphocyte numbers but is probably caused by a steroid hormone-mediated decreased efflux of neutrophils from the blood and increased cell release from the bone marrow.^{242,244} Just as exercise can raise the circulating neutrophil count, intense exercise has also been reported to induce neutrophil activation as determined by studies of cell-surface antigen expression.³⁸⁶ In contrast, ultraviolet B radiation, at doses similar to those naturally received, inhibits neutrophil phagocytosis and adhesion, although the practical significance of these observations is unknown.³⁸⁷

CONTROL MECHANISMS REGULATING NEUTROPHIL PRODUCTION

It is evident that a true steady state of neutrophil kinetics exists only for brief periods. Shifts of cells between marginal and circulating sites may occur without changes in blood neutrophil turnover,²⁴² but any change in TBGP size must result from changes in cell inflow or egress. Studies involving leukapheresis have shown that a normal animal replenishes a depleted TBGP by mobilizing cells from the marrow granulocyte reserves.²⁴ This increase in neutrophil concentration and TBGP size, like that seen with most bacterial infections or after endotoxin or steroid administration, must be triggered by some signal, and some means of stimulating cell production must be available to replenish depleted marrow reserves, whatever the etiology.

The nature of these control mechanisms is complex, but several control points exist: recruitment of pluripotent stem cells and their induction into committed stem cells, stimulation (and perhaps inhibition) of stem cell and myeloid proliferative cell growth, and selective release of cells from the marrow.

Blood cell development is discussed in Chapter 5 and is only briefly discussed here. Pluripotent stem cells are mostly in the G₀ state and must be induced into actively proliferating committed stem cells. Hematopoietic cell growth and development are usually restricted to certain tissues (e.g., bone marrow in adult humans and bone marrow and spleen in mice). Because cell differentiation is influenced by organ microenvironment (e.g., erythropoiesis is favored in mouse spleen, but granulocytopoiesis is favored in the bone marrow), the concept of local control of pluripotent stem cell induction was developed (the hematopoietic microenvironment).³⁸⁸ The importance of the hematopoietic microenvironment is exemplified by the anemia of Steel mice, which results from a defective hematopoietic microenvironment.³⁸⁸ The defect in Steel mice involves the granulocyte system as well as erythropoiesis³⁸⁹ and results from a diminished ability of organ stroma in the bone marrow and spleen to induce committed stem cells from pluripotent stem cells.³⁹⁰ The demonstration that the Steel (Sl) gene product, deficient in Steel mice, is a growth factor (stem cell factor or stem cell colony-stimulating factor) that binds to a receptor coded by the c-kit proto-oncogene (or white-spotting locus, W) has provided a molecular basis for understanding the hematopoietic abnormalities in mice with genetic defects in the Steel or W genes.^{238,391}

As judged from suspension cultures, at least three cell types (giant fat cells, epithelial cells, and phagocytic mononuclear cells) provide the microenvironment needed for multipotent stem cell proliferation.³⁹² Presumably, these stromal cells produce sufficient concentrations of hematopoietic cell growth factors locally to promote multipotent stem cell proliferation and renewal when required.³⁹³

Growth Factors

A large number of growth factors or colony-stimulating factors have been identified that regulate neutrophil production in the bone marrow, as described in Chapter 5. Two of these, G-CSF and GM-CSF, are in clinical use. Exogenous administration of G-CSF expands the granulocyte mitotic pool and also decreases the bone marrow transit time of the postmitotic cells without changing the blood neutrophil half-life.³⁹⁴ These factors not only speed the recovery of neutrophil counts after chemotherapy and may decrease associated infectious complications,^{395,396,397,398} and³⁹⁹ but also have effects on mature neutrophils. For example, G-CSF transiently increases CD11b expression^{396,400,401} and the affinity of CD62L (L-selectin) for its ligand and then causes CD62L surface expression to decrease.⁴⁰² G-CSF also primes neutrophils for subsequent superoxide production in response to FMLP.^{403,404,405} and⁴⁰⁶ Intravenous administration of G-CSF can result in an immediate transient neutropenia^{407,408} similar to the transient increase in the MGP

P.145

seen with hemodialysis. Evidence of neutrophil degranulation in vivo after administration of G-CSF has also been observed.⁴⁰⁹ A number of other cytokines among this class can also activate or prime neutrophils, including TNF- α , IL-6, IL-1, and IL-8.^{410,411,412} and⁴¹³

In addition to locally produced stimulators of colony-forming unit stem cell proliferation,⁴¹⁴ inhibitors of proliferation have also been described.^{415,416} Lactoferrin (present in the secondary or specific neutrophil granule) binds to specific receptors on some monocytemacrophages and suppresses release of GM-CSF (and other cytokines), thus inhibiting colony formation. Transferrin also exhibits colony-suppression activity, possibly through inhibition of GM-CSF production by T lymphocytes.⁴¹⁷ Soluble forms of receptors for cytokines may also regulate the response of bone marrow progenitors to growth factors.⁴¹⁸ Neural mechanisms controlling hematopoietic cell proliferation and release have also been suggested.⁴¹⁹

Another control point in the system is the selective release of granulocytes from the marrow. In studies of perfused rat hind limbs, the release of neutrophils from the marrow into the blood⁴²⁰ increased with an increase in perfusion flow rate or with a low leukocyte content of the perfusate.⁴²¹ Serum or plasma from animals or humans made neutropenic by

endotoxin, vinblastine, or nitrogen mustard also induced neutrophilia.^{422,423,424} and ⁴²⁵ The activity was present during the period of neutropenia and rising neutrophil concentration—but not before or after this period. This neutrophilia-inducing activity was qualitatively dissimilar from that noted after endotoxin, epinephrine, or cortisone administration and acted by causing release of marrow cells. The results of these studies suggest that an endogenously produced humoral factor causes neutrophil release from the marrow.⁴²² Several factors that stimulate neutrophil release from the bone marrow have been identified, including G-CSF, GM-CSF, C5a, TNF- α , TNF- β , IL-8, and, possibly, a cleavage product of the third component of complement.^{185,239,240} Studies in rabbits have found that IL-8 induces neutrophil release from the bone marrow without altering the transit time through the mitotic and postmitotic marrow pools.²⁴⁰

Thus, evidence exists that several factors, including cell nuclear and cytoplasmic deformability, cell motility, affinity of cell adhesion molecules for ligands, blood flow, and others are important in the control of marrow cell release.^{238,426,427} and ⁴²⁸

NEUTROPHIL FUNCTION

The major role of neutrophils is to protect the host against infectious agents. To accomplish this task, the neutrophil must first sense infection, migrate to the site of the infecting organism, and then destroy the infectious agents. Although neutrophils can sense a stimulus in suspension, they can migrate only when in contact with a surface. Thus, although in some cases neutrophils in blood may respond to a stimulus by adhering to other blood cells or foreign bodies, such as bacteria or biomaterials, the usual first step of the neutrophil after sensing an inflammatory stimulus is to adhere more strongly to the blood vessel wall. Usually, this occurs in a postcapillary venule. After adhesion to the endothelial surface, the neutrophil follows a gradient of chemotactic factors to the site of infection and interacts with the organisms. Finally, when the neutrophil reaches the infecting organism, it must destroy it. This destruction is generally accomplished by phagocytosis of the agent followed by release of granules into the phagocytic vesicle, followed by killing of the organism. The mechanisms by which these phenomena occur are very complex and not completely understood.

History

An important role of pus in infections has been long recognized. White, creamy pus, due to the presence of many neutrophils, suggested a better outcome than thin watery pus, and was known as “good and laudible pus” (pus bonum et laudabile).^{429,430} Antibacterial properties of blood were described by the British surgeon John Hunter in ~1761 during the Seven Years' War. He observed that the cellular (buffy coat) component of blood could retard the “spoilage” of blood⁴³¹; we now would recognize these effects as reflecting the antibacterial properties of leukocytes. In these classic studies, Hunter observed that when blood was allowed to stand, a “buff colored” layer was visible on top of the red cells. He noted that blood from patients with infected wounds had a thicker “buff colored inflammatory crust” than observed in blood from healthy subjects, which we now understand reflects the neutrophilia associated with infection. With time, he noted that blood would “spoil,” as determined by the development of an odor typical of spoiled food. Hunter found that the addition of the “buff colored inflammatory crust” to a blood sample would delay the time to “spoilage,” now understood to reflect the antibacterial abilities of neutrophils.

The response to infection by neutrophils in the microvasculature was elegantly described in *An American Text-Book of Surgery* in 1892.²⁷⁹ This description remains instructive and is summarized here. At one time, the inflammatory cells at sites of infection were thought to be caused by proliferation of connective tissue cells. After the observations of von Recklinghausen that many of these cells were capable of locomotion (and called “amoeboid cells from their resemblance to the amoeba”), and the work of Addison, who suggested that leukocytes in blood could extravasate to tissues,^{429,432} Cohnheim identified the cells in the inflamed tissue as leukocytes.²⁷⁹ Microscopic examination of a frog's mesentery or tongue reveals “an arteriole with its rapid pulsating current of blood, and nearby a small vein in which the blood flows with a more steady movement. The red blood corpuscles occupy the axis of the blood vessel, and the few white corpuscles which are seen float in the more sluggish stream of plasma which occupies the borders of the lumen and appears as a transparent layer” (Fig. 7.11). Induction of inflammation by the application of a caustic agent leads to hyperemia. “The rapidity of the flow of blood is greatly increased and a greater amount of blood is observed in the part. The lumen of the artery is greater

P.146

than before, and the column of red corpuscles is much broader, and fills a comparatively greater portion of the lumen of the vessel. The capillaries are now quite distinctly seen, and are crowded with blood corpuscles” (Fig. 7.12). This is followed by

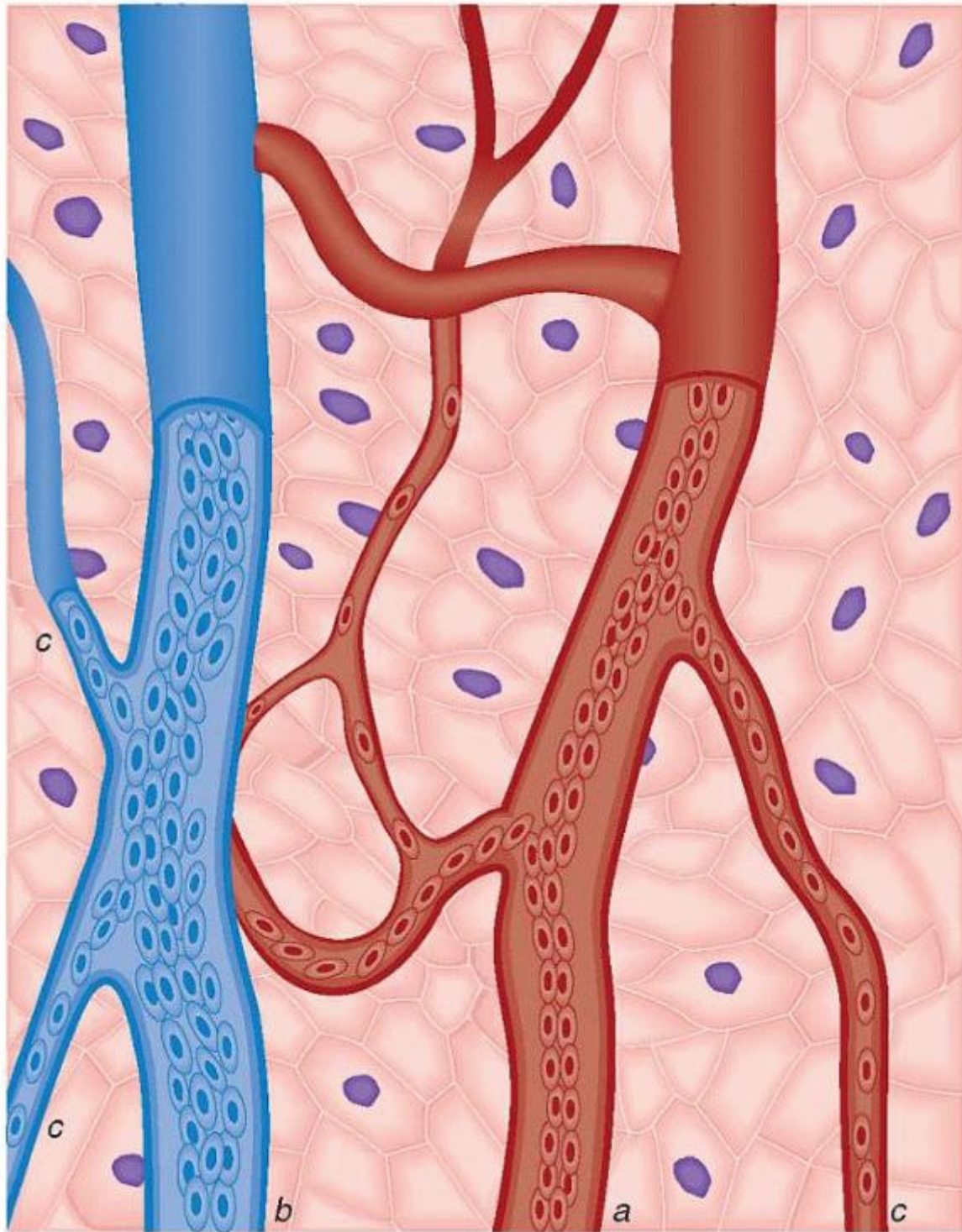

FIGURE 7.11. Diagram of normal vessels and bloodstream: α , artery; β , vein; c, capillary. (Adapted from Keen WW, White JW, eds. An American textbook of surgery. Philadelphia, PA: WB Saunders, 1892:14.)

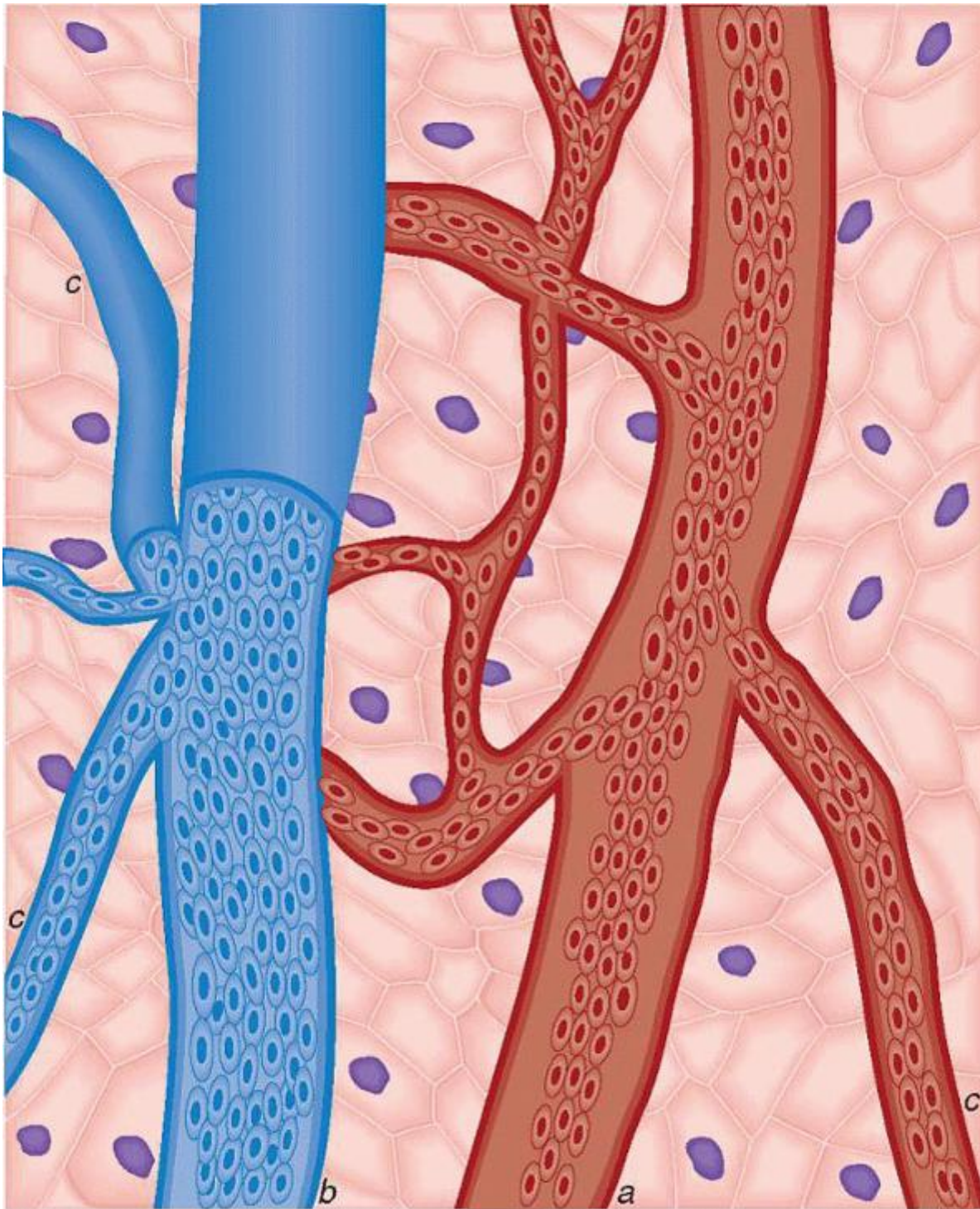

FIGURE 7.12. Diagram of dilation of the vessels in inflammation: α , artery; b, vein; c, capillary. (Adapted from Keen WW, White JW, eds. An American textbook of surgery. Philadelphia, PA: WB Saunders, 1892:14.)

a slowing of the current, which soon becomes much more sluggish than in the normal state. This is first noticed in the capillaries, and soon after in the veins. The pulsation, however, continues in the arteries. As a result of this diminution of speed the column of blood corpuscles becomes broader and almost completely fills the interior of the vessels. In the veins a great accumulation of white corpuscles takes place on the interior of the walls.... Finally, they are so greatly increased in numbers that the entire wall of the vessel appears to be lined with leukocytes. The white corpuscles also accumulate in the capillaries, but not to the same extent (Fig. 7.13).

The margination of the neutrophils is shown schematically in Figure 7.14 (platelets or “blood plaques” are also shown).

Beginning concurrently with the slowing of the blood stream, is the emigration of the leukocytes from the interior of the veins. Many leukocytes, by a change of shape, send out little prolongations of protoplasm into the substance of the wall, and slight protuberances are soon seen projecting from its outer surface. These enlarge, and we now see the corpuscles presenting an hour-glass appearance. The portions within the vessel soon follow those without, and the leukocytes escape from all contact with the vessel. Many corpuscles appear to follow one another through the same point in the wall (Fig. 7.15).

Migration takes place to a limited extent also from the capillary vessels, but no such process is observed in the walls of the arteries. These same actions of neutrophils, as well as the formation of neutrophil-neutrophil aggregates with infections in rabbit ear veins, were videotaped by W.B. Wood in the 1960s. Using fluorescein-labeled neutrophils, Hammerschmidt et al. later demonstrated that injection of C5a reproduced the increase in neutrophil margination and aggregation in rat mesentery.⁴³³

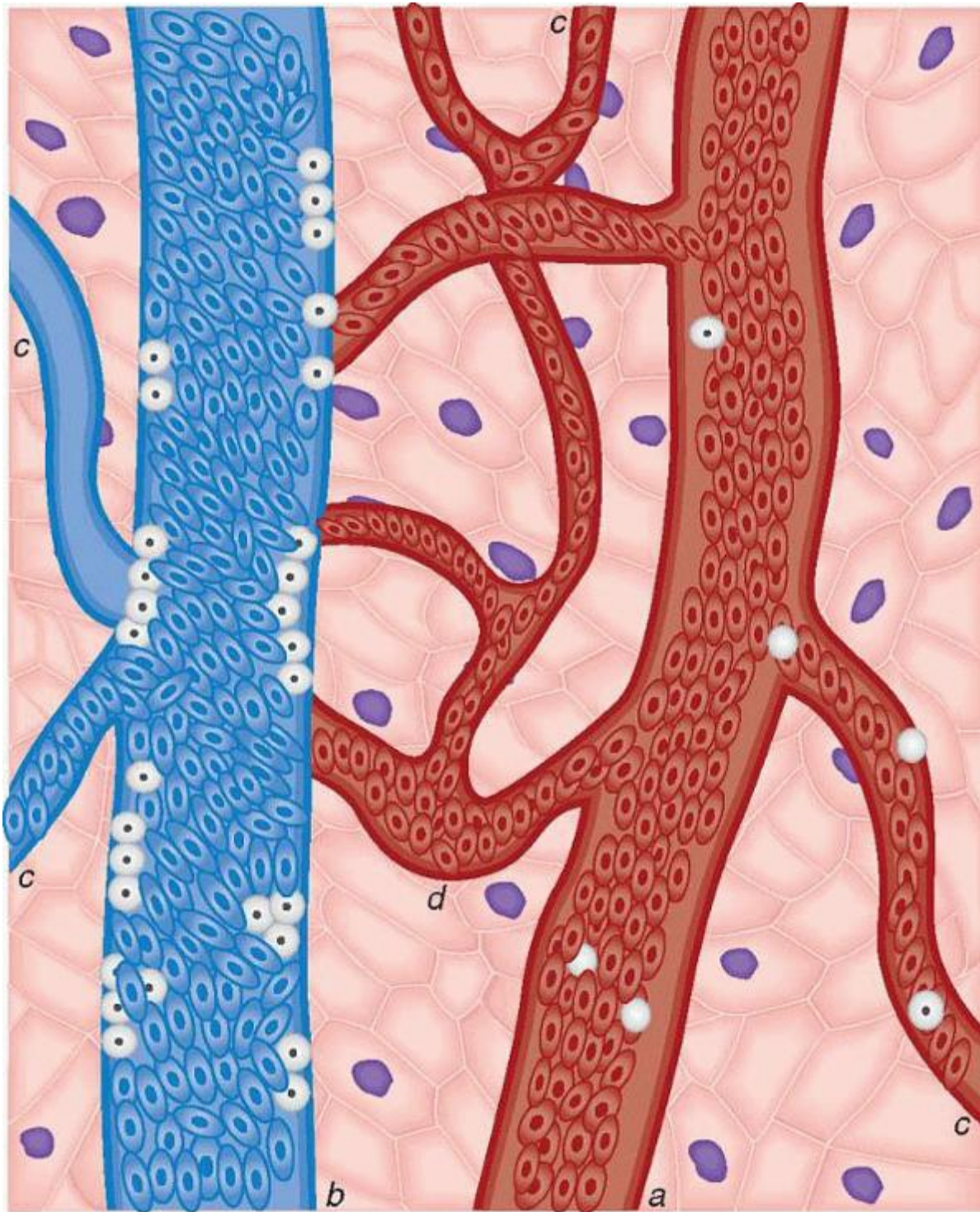

FIGURE 7.13. Diagram of stasis of blood and diapedesis of white corpuscles in inflammation: α , artery; β , vein; c , capillary. (Adapted from Keen WW, White JW, eds. An American textbook of surgery. Philadelphia, PA: WB Saunders, 1892:14.)

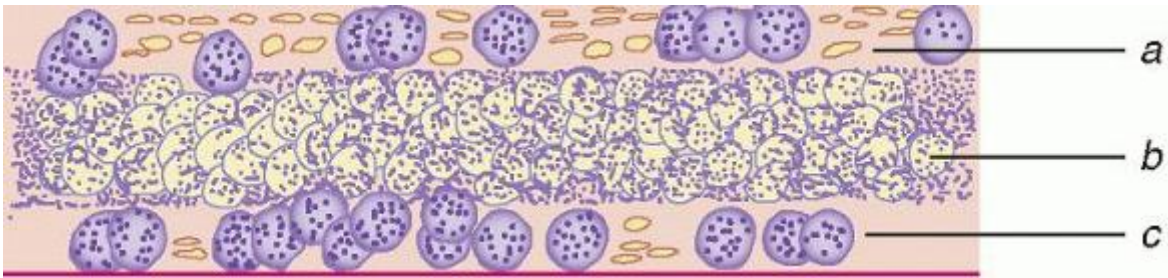

FIGURE 7.14. Blood plaques or third corpuscles (a). Red corpuscles (b). White corpuscles (c). (Adapted from Keen WW, White JW, eds. An American textbook of surgery. Philadelphia, PA: WB Saunders, 1892:14.)

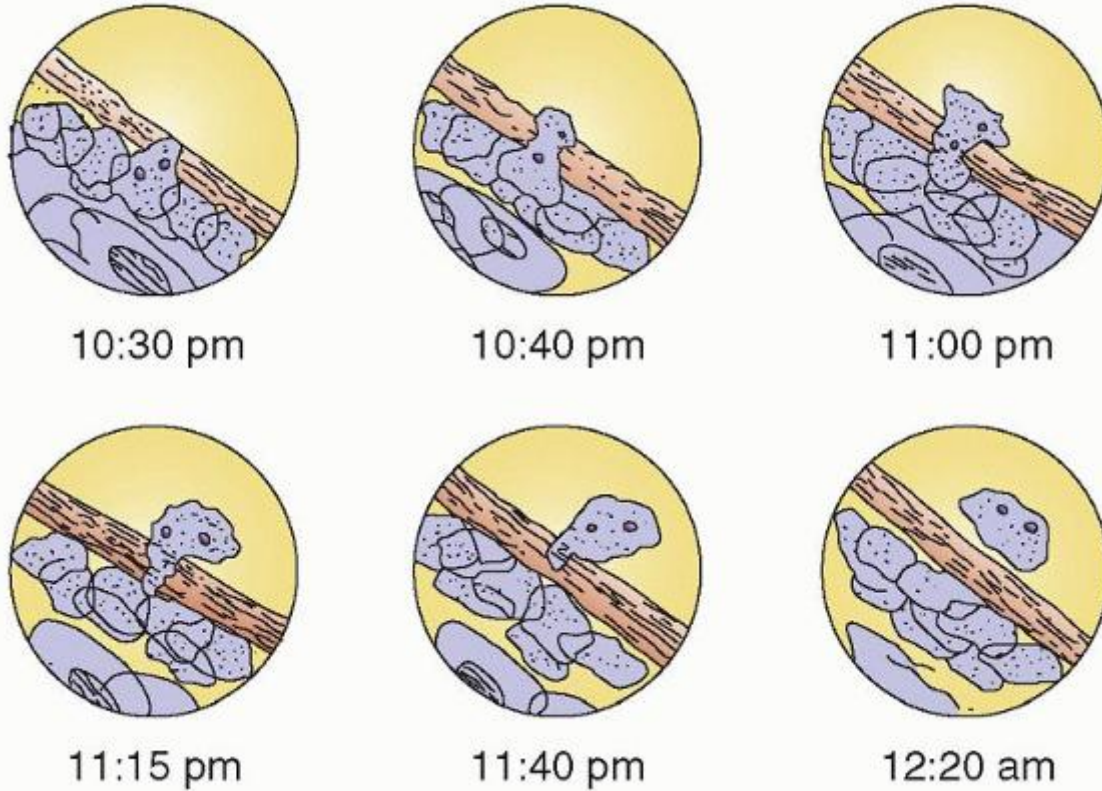

FIGURE 7.15. Diagram of stages of the migration of a single white blood corpuscle through the wall of a vein in 1 hour and 50 minutes (mesentery of the frog). (From Keen WW, White JW, eds. An American textbook of surgery. Philadelphia, PA: WB Saunders, 1892:13, with permission.)

P.147

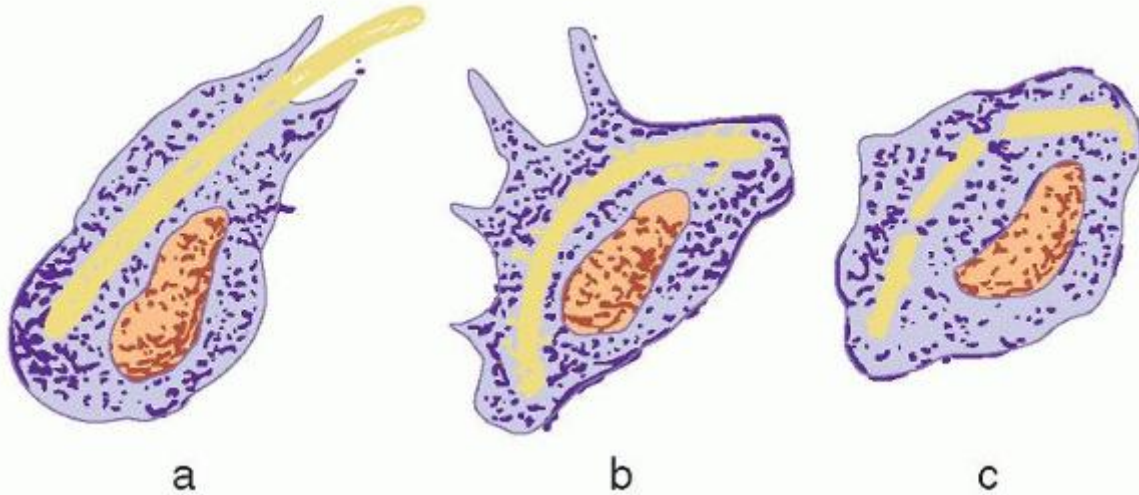

FIGURE 7.16. Diagram of a phagocyte destroying a bacillus. The cell is shown at three different times (a, b, and c). (From Keen WW, White JW, eds. *An American textbook of surgery*. Philadelphia, PA: WB Saunders, 1892:16, with permission.)

Early views of neutrophil function at the site of inflammation included a role in the repair process. Later, their ability to phagocytose was recognized. Metchnikoff advanced the theory known as phagocytosis,

Here according to this theory, the cells of the inflamed part, by virtue of their ability to consume foreign substances, attack and destroy the invading bacteria (Fig. 7.16). These cells are called phagocytes (from the Greek “to eat” and “cell”). If they are able to destroy the bacteria, the system is protected from the invading organisms. The leukocytes are called micro-phagocytes (or microphages), and the larger cells developed from the fixed connective tissue cells are called the macro-phagocytes (or macrophages).²⁷⁹

Chemotactic Factor Receptors

The initial step of the neutrophil response to infection is the detection of an appropriate signal. The interaction of bacteria with blood components, especially antibodies and the complement system, results in the formation of various chemotactic factors. In some instances, the bacteria directly release factors that are chemotactic for neutrophils. The interaction of bacteria or their products with other host cells may also result in the formation of chemotactic factors. Neutrophils express specific receptors on their cell surface for a variety of chemotactic factors. These receptors include those for n-formylated peptides such as n-formylmet-leu-phe (FMLP), C5a, leukotriene B₄, and platelet-activating factor. The initial activation of the neutrophil occurs when soluble chemotactic factors bind their receptors on the neutrophil surface. As with the interaction of antibodies and haptens, the association kinetics for these receptor-ligand interactions are very rapid. Typically, sufficient receptor-ligand interaction to initiate neutrophil activation occurs within seconds.

Signaling

Many chemotactic factor receptors appear to be coupled to guanine nucleotide-binding proteins (G proteins).⁴³⁴ The role of G proteins in neutrophil signal transduction is supported by a variety of studies, including classic studies using pertussis toxin. Pertussis toxin adenosine diphosphate ribosylates certain G proteins and inhibits neutrophil responses to a number of stimuli, including FMLP. In contrast, some neutrophil responses, such as phorbol ester-induced secretion, are not inhibited by pertussis toxin. Although the details of signal transduction in neutrophils are not fully elucidated, it appears that the G proteins associated with chemotactic factor receptors are important in receptor activation of phospholipase C, which then hydrolyzes phosphatidylinositol bisphosphate (PIP₂), resulting in the generation of two second messengers, IP₃ and 1,2-diacylglycerol (DAG). Experiments suggest that IP₃ binds to specific receptors on intracellular membranes, resulting in the release of calcium from intracellular stores, which is rapidly augmented by an influx of extracellular calcium. Thus, shortly after receptor-ligand binding, the intracellular calcium rapidly rises from a resting level of approximately 0.1 mmol/L to approximately 1 mmol/L.^{435,436} and ⁴³⁷ This rise in free intracellular calcium is transient and returns to baseline in approximately 1 to 3 minutes.

It appears that the initial rise in intracellular calcium caused by the release of intracellular calcium stores plays a critical part in the alteration of membrane permeability to allow the influx of extracellular calcium. To some extent, variations in

intracellular calcium transients may direct specific cellular functions, in that specific granule release occurs at very low (submicromolar) free calcium concentrations, whereas in studies using permeabilized cells, higher (micromolar) levels of free calcium result in release of both specific and azurophil granules.^{438,439} and ⁴⁴⁰ Although the extracellular calcium influx is critical for many neutrophil responses, it is not critical for all, as degranulation is not blocked by ethyleneglycol-bis(2-aminoethyl) tetra-acetic acid.⁴⁴¹ Similarly, phagocytosis of particles opsonized with C3bi can occur without apparent intracellular calcium transients.⁴⁴²

Protein phosphorylation is an important mechanism of the regulation of protein function, and a number of studies suggest its role in neutrophil activation. Phorbol myristate acetate, which activates a number of neutrophil functions, binds to PKC and results in its activation. Although phorbol myristate acetate is not present in neutrophils, DAG, released when phospholipase C hydrolyses PIP₂, also binds and activates PKC. Because calcium is also important in PKC activation and IP₃ increases intracellular calcium, the hydrolysis of PIP₂ to IP₃ and DAG may contribute to PKC activation via both DAG and IP₃. Interestingly, the specific granules have been reported to contain a PKC inhibitor, thus providing a possible mechanism to downregulate PKC-mediated responses.⁴⁴³

Although this model explains many observations, it has become clear that signal transduction in neutrophils is far more complex, with both Ca²⁺ and PKC-independent pathways. Tyrosine phosphorylation has been found to play a critical role in signal transduction from various chemotactic factor receptors. Multiple neutrophil proteins are rapidly phosphorylated after activation, including Src family kinases; the Lyn kinase is activated by chemotaxins, increasing its ability to phosphorylate substrates. Serine and threonine kinases also appear to be involved in signaling, and some are activated by FMLP. In addition, phosphatidylinositol 3-kinase is also activated by chemotaxins. Phosphatidylinositol 3-kinase catalyzes the phosphorylation of PIP₂ to PIP₃. Phosphatidylinositol 3-kinase binds some phosphotyrosine residues via the SH2 domain on one of its subunits. Protein tyrosine phosphatases probably also play a role, as the transmembrane protein phosphatase CD45 has been implicated as a regulator of neutrophil function.^{47,444} Chemotactic factors have also been found to activate phospholipase A₂ and phospholipase D. Finally, the importance of low-molecular-weight guanosine triphosphatases (LMWG) is also being recognized. Knowledge of signal transduction is rapidly advancing, and the reader is referred to the current literature.

Physiologic soluble inhibitors of neutrophil function have also been identified. For example, adenosine inhibits neutrophil aggregation, adhesion, chemotaxis, and superoxide production.^{445,446,447} and ⁴⁴⁸ These inhibitory effects appear to act via A₂ receptors without preventing the transient rise in intracellular Ca²⁺.^{445,446} and ⁴⁴⁷

Neutrophil Priming

“Priming” is an important concept in neutrophil signaling. Signaling in neutrophils is complex and can be initiated by many different stimuli that may share downstream signaling pathways. When neutrophils are exposed to an appropriate low level of a stimulus, they can be primed to a condition such that they display a much more prominent response to a second stimulus than they would if they had not been primed.^{448,449,450} and ^{451,452} Neutrophils can

P.148

be primed by one stimulus for a response to a different agonist. Priming occurs at doses that do not result in a rise in cytoplasmic free calcium, but still cause protein tyrosine phosphorylation of signaling molecules. After priming, neutrophils exhibit a more prominent respiratory burst or secretory response to a given stimulus than would occur if priming had not occurred. This phenomenon may be involved in many physiologic neutrophil responses in vivo. Neutrophil priming can be reversible, with the cells still capable of being reprimed.⁴⁵³

The mechanism of priming is gradually becoming better understood. In resting neutrophils, the various components of the nicotinamide adenine dinucleotide phosphate (NADPH) oxidase are sequestered within the cell. Following neutrophil stimulation, cytoplasmic components of the NADPH oxidase translocate to the phagosome membrane and assemble to form the active oxidase. This activation process is not “all-or-none.” Some stimuli can prime neutrophils, resulting in a state in which agents that normally do not activate neutrophils can stimulate oxidase activity, and in which the oxidase response to suboptimal concentrations of agents that do stimulate the oxidase results in a greater than expected oxidase response. For example, TNF-α does not stimulate neutrophil NADPH oxidase activity, while FMLP does. However, when neutrophils are pretreated with TNF-α, these primed neutrophils respond to suboptimal concentrations of FMLP with increased oxidase activity. The mechanism of neutrophil priming appears to be the result of a conformational change in p47phox.^{454,455} TNF-α priming results in phosphorylation of ser354 in p47phox, which then binds the peptidyl prolyl cis-trans isomerase Pin1, resulting in conformational changes in p47phox that result in phosphorylation of other serine

residues. This leads to other conformational changes exposing cryptic SH3 sites that can then bind p22phox, resulting in oxidase assembly, making the oxidase more responsive to stimuli.^{454,455}

Desensitization

After previous exposure to a stimulus, neutrophils react less to subsequent stimulation by the same stimulus.^{456,457} and⁴⁵⁸ This phenomenon has been termed desensitization. In some cases, the desensitization appears to be specific to the original stimulus, but in other cases desensitization to different stimuli is also observed (cross-desensitization).^{456,457,458} and⁴⁵⁹

Such desensitization has been observed in patients undergoing hemodialysis, in which exposure of blood to a cuprophane dialyzer membrane results in the generation of C5a and possibly other factors, which causes a transient neutropenia due to pulmonary leukostasis, as described in Chapter 58.^{247,248} Although C5a generation persists throughout dialysis, the neutropenia is transient.²⁴⁹ In contrast to neutrophils obtained at the start of dialysis, neutrophils obtained after 2 hours of dialysis (after the leukostasis has resolved) do not aggregate in response to plasma leaving the dialyzer membrane, demonstrating desensitization *in vivo*.²⁴⁹ A patient with cytomegalovirus infection, whose serum induced granulocyte aggregation (presumably due to C5a), did not experience neutropenia during dialysis, and his neutrophils did not aggregate in response to serum leaving the dialyzer, in contrast to control cells, also demonstrating *in vivo* desensitization.²⁴⁹ Similar desensitization was demonstrated in rabbits using the chemotactic peptide FMLP, wherein continuous intravenous infusion of FMLP reproduced a transient neutropenia due to pulmonary sequestration.⁴⁶⁰ It is likely that neutrophil desensitization may also occur in other pathologic states, including infection, trauma, and multiorgan failure syndrome, and may contribute to neutrophil dysfunction, although the clinical significance of this phenomenon is unclear.

Neutrophil function can also be regulated by the neuroendocrine axis. For example, glucocorticoids can regulate neutrophil function, at least partly through annexin I or lipocortin I.⁷⁵ The phenomenon of desensitization has also been implicated as the mechanism by which glucocorticoids inhibit neutrophil function. It appears that the glucocorticoid-regulated protein annexin 1 (lipocortin 1) can bind a formyl-peptide receptor, induce calcium transients, and desensitize neutrophils to subsequent stimulation by other agents.^{461,462} Two formyl-peptide receptors are expressed in neutrophils, the classical FPR and the related receptor FPRL-1/AXL. Annexin 1 appears to bind to FRPL-1/AXL, whereas some peptides derived from annexin 1 may bind both receptors.^{461,462} Opiates have been reported to alter many immune functions, including neutrophil functions such as the respiratory burst, in many species.⁴⁶³ MRP-14, a prominent component of neutrophils, can inhibit the function of activated macrophages and, possibly by this mechanism, can decrease inflammatory pain.⁷⁴

Neutrophil-Endothelial Adhesion

Both neutrophils and endothelial cells express a variety of adhesive molecules on their cell surface, and the expression and activity of these molecules in many cases can be regulated by stimuli. Some of the known adhesion molecules of neutrophils and endothelial cells are indicated in Table 7.6. Approximately one half of the circulating neutrophils exist in the so-called marginating pool, some of which can be seen microscopically to be rolling along the endothelial surface, maintaining a loose intermittent contact with endothelial cells. The importance of hemodynamic forces, especially of red cells, in directing leukocytes outward from the flowing blood toward the endothelium was described many years ago and subsequently confirmed.^{279,464,465} and⁴⁶⁶ An attractive model of neutrophil-endothelial cell adhesion has been proposed by Springer, which accounts well for the known data.^{106,467} In this model, selectin molecules on the cell surface are responsible for neutrophil rolling along the vessel wall. This loose adhesion brings the neutrophil in close proximity to the endothelial cell, where chemoattractants can be released or displayed on the cell surface. The interaction of these chemoattractants with neutrophil receptors results in signal transmission and the activation of integrin molecules. These integrins can then bind their ligands on the endothelial cell surface, resulting in a marked increase in adhesion to the endothelial cell and cessation of rolling. After this, the cells sense further chemoattractant gradients and migrate into the tissue where the neutrophils produce compounds that attract other inflammatory cells such as monocytes, lymphocytes, and other neutrophils, as well as promote wound healing. Subsequently they undergo changes promoting apoptosis and resolution of inflammation.¹⁰⁶

Selectins

Three selectins have been identified that each have an N-terminal domain that is homologous to Ca²⁺-dependent lectins (Fig. 7.17). L-selectin (CD62L) is expressed on the neutrophil surface. The main ligand for L-selectin is the glycoprotein known as Gly-CAM-1 (glycosylation-dependent cell adhesion molecule-1). Endothelial cells express both E-selectin (CD62E, endothelial-leukocyte adhesion molecule-1) and P-selectin (CD62P, granule membrane protein-140). E-selectin and P-

selectin both recognize Lewis^x-related sialylated carbohydrates, mostly on PSGL-1 (P-selectin ligand 1), and also L-selectin. Both PSGL-1 and L-selectin are localized on the tips of neutrophil microvilli, organized by the ERM proteins ezrin, radixin, and moesin that connect to the actin cytoskeleton.¹⁰⁶ Expression of E-selectin on the endothelial cell surface can be induced with stimuli such as IL-1 and TNF but requires protein synthesis. In contrast, P-selectin (CD62P) is found in both the Weibel-Palade granules of endothelial cells and the platelet α -granule. Thus, stimulation of endothelial cells with the appropriate stimulus, such as thrombin or histamine, can result in a rapid mobilization of CD62P (P-selectin) to the endothelial cell surface.

P.149

TABLE 7.6 NEUTROPHIL-ENDOTHELIAL CELL ADHESION PROTEINS

Neutrophil Integrin		Ligand
$\alpha_L\beta_2$	Leukocyte function antigen-1, CD11a/CD18	ICAM-1 (CD54), CAM-2 (CD102) ICAM-3 (CD50)
$\alpha_M\beta_2$	HMac-1, CD11b/CD18	ICAM-1, iC3b, fibrinogen, factor X
$\alpha_X\beta_2$	p150,95,CD11c/CD18	? iC3b, fibrinogen
Neutrophil Selectins		Ligand
L-selectin	CD62L, leukocyte adhesion molecule-1, Mel-14	Sialylated carbohydrates related to sLe ^x (CD15s) and sLe ^a on Gly-CAM-1
Endothelial Selectins		Ligand
E-selectin	CD62E, ELAM-1	Sialylated carbohydrates
P-selectin	CD62P, granule membrane protein-140, platelet activation-dependent granule-external membrane protein	Sialylated carbohydrates including PSGL-1 on neutrophils
Endothelial Ig Family		Ligand
CD54	ICAM-1	CD11a/CD18, CD11b/CD18
CD102	ICAM-2	CD11a/CD18
CD31	PECAM-1	NB1/CD177, CD31
Neutrophil Ig Family		Ligand
CD31	PECAM-1	CD31
CD50	ICAM-3	CD11a/CD18
CD66a	CEACAM1 (Biliary glycoprotein)	CD66a, CD66c, CD66e
CD66b	CEACAM8 (CGM6)	CD66c
CD66c	CEACAM6 (NCA 50/90)	CD66a, CD66b, CD66c, CD66e
Neutrophil		Ligand

LeukocyteAntigen-6
superfamily

CD177

NB1

CD31 (PECAM-1)

ELAM, endothelial-leukocyte adhesion molecule; ICAM, intercellular adhesion molecule; Ig, immunoglobulin; PECAM, platelet-endothelial cell adhesion molecule; PSGL, P-selectin glycoprotein ligand.

Integrins

Integrins are noncovalently associated heterodimers of α and β subunits, each of which has characteristic structural motifs (Figs. 7.18 and 7.19). The major integrins of neutrophils are the β_2 integrins made up of $\alpha_L\beta_2$ (leukocyte function antigen-1, CD11a/CD18), $\alpha_M\beta_2$ (HMac-1, CD11b/CD18), and $\alpha_X\beta_2$ (p150,95, CD11c/CD18). Intercellular adhesion molecule (ICAM)-1 (CD54) expressed on the endothelial cell surface is a ligand for both CD11a/CD18 and CD11b/CD18. Other Ig superfamily members are probably also involved in neutrophil-endothelial cell adhesion, including platelet endothelial cell adhesion molecule-1 (CD31), ICAM-3 (CD50) (expressed on the neutrophil but not the endothelial cell), and the CD66 family of neutrophil-activation antigens.

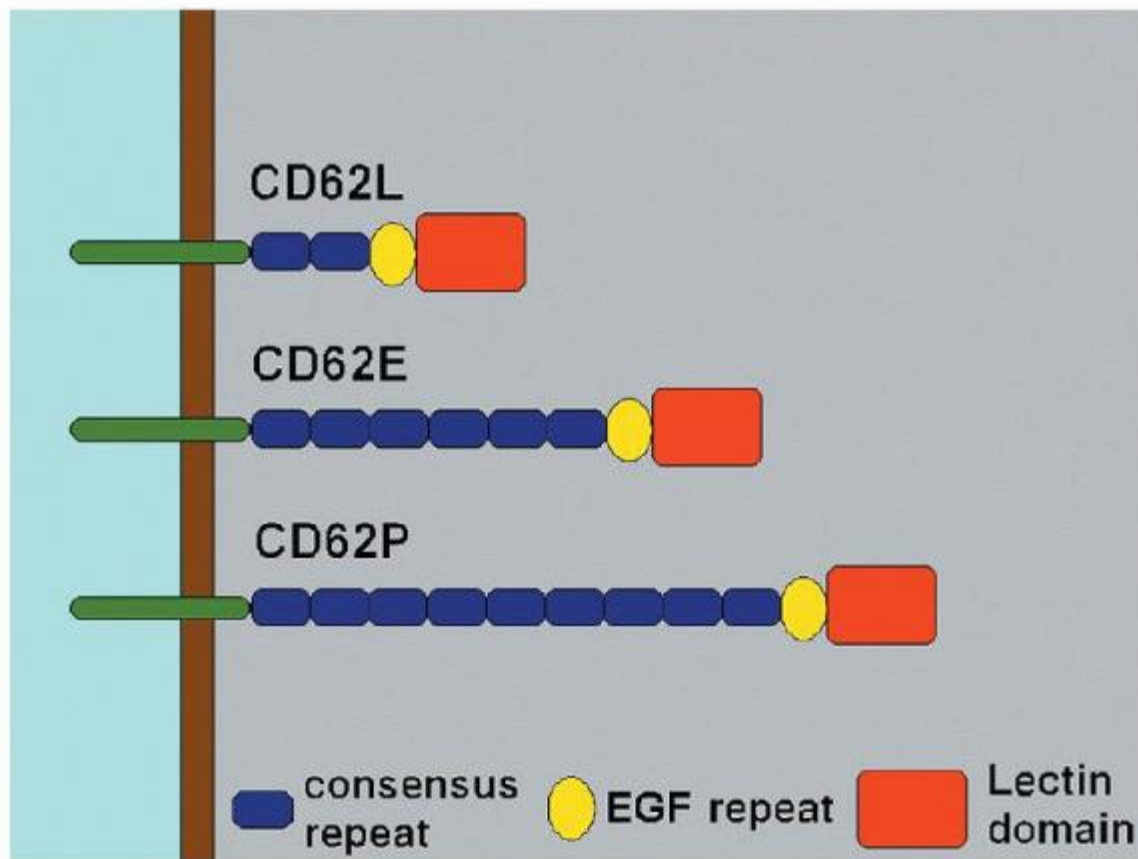

FIGURE 7.17. Schematic of selectin structure. The selectins are attached to the cell via a transmembrane domain with an extracellular domain consisting of a series of short consensus repeats (blue) that form a stalk-like structure linked by an epidermal growth factor-like domain (yellow) to a carbohydrate-binding C-type lectin domain (red). CD62L contains a membraneproximal site that is cleaved by a protease after neutrophil activation, resulting in shedding of the extracellular domain. EGF, epidermal growth factor. (From Skubitz A, with permission.)

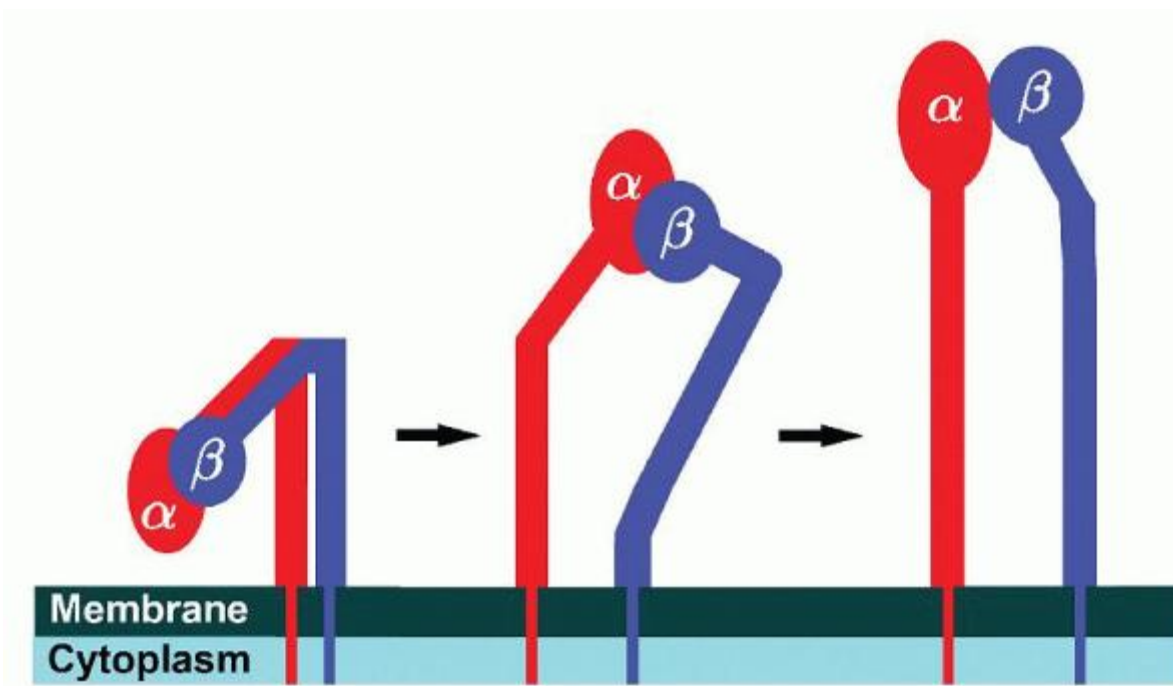

FIGURE 7.18. Schematic of an α, β_2 integrin dimer, showing the inactive, low-affinity state (left) and the active, high-affinity state (right). Integrins are heterodimers of α and β subunits with a globular “head” region and two “legs.” The head of the α subunit contains EF hand repeats that are divalent metal-binding sites, and a “ β propeller” domain with an I domain that contains a binding site for Mg^{2+} and Mn^{2+} . The β subunit contains an I-like domain. In the low-affinity, inactive state with no ligand bound, the integrin is either bent toward the membrane with a closed headpiece facing toward the membrane, or extended with a closed headpiece. With activation, the integrin straightens and rotates the head region outward and the headpiece opens, with an associated change to higher ligand affinity. This change in structure is associated with a separation of the α and β subunits. (From Skubitz A, with permission.)

P.150

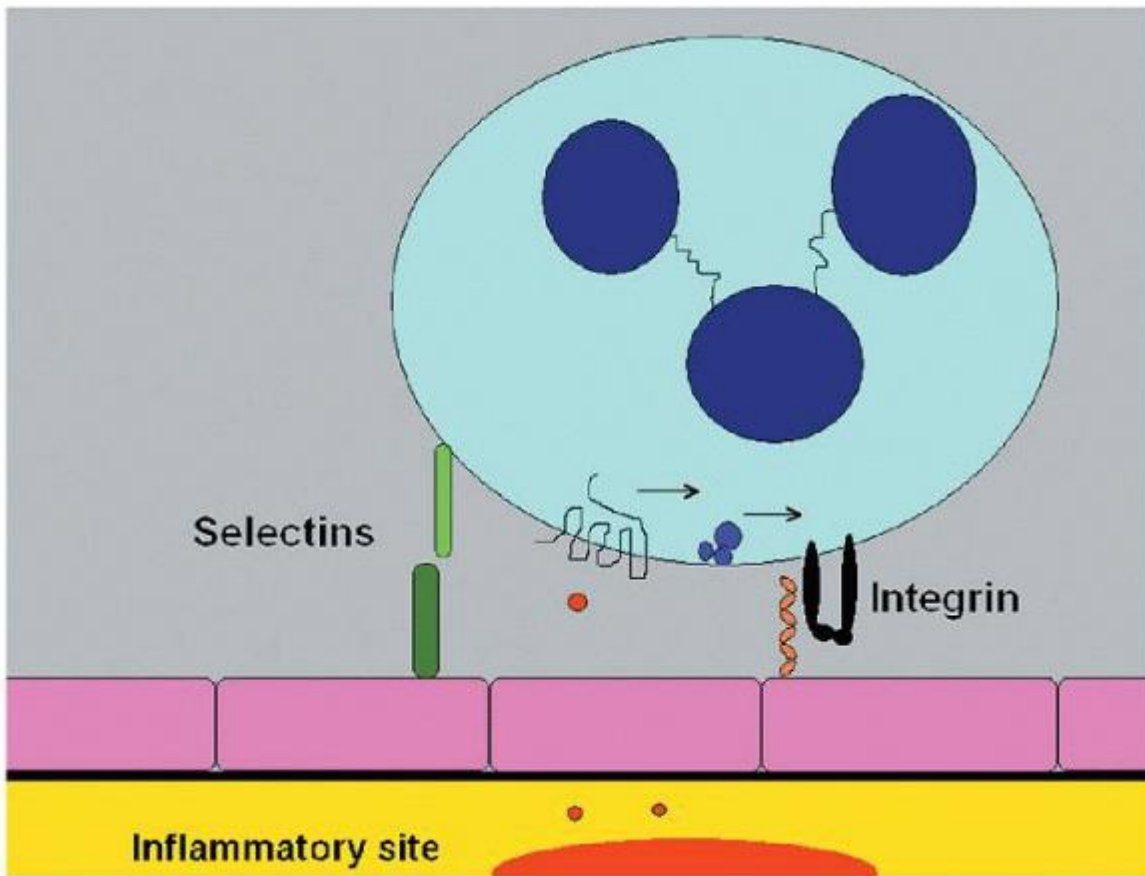

FIGURE 7.19. Neutrophil adhesion to inflamed endothelium follows three sequential steps. First, selectin molecules (green) that recognize carbohydrate ligands bind their ligand and result in tethering and rolling along the vascular wall, bringing the neutrophil in close proximity to the endothelial cell surface. Chemotactic agents (red balls) released from the site of inflammation (red) and bound to or released from the endothelial cell surface interact with specific receptors that span the neutrophil membrane seven times and transduce activation signals via G proteins (purple) that activate integrins (black). These integrins then bind their ligands (immunoglobulin superfamily members, orange) on the endothelial cell surface, resulting in arrest of the neutrophil and subsequent transmigration across the endothelial surface and subsequent chemotaxis to the site of chemoattractant production. (From Skubitz L, with permission.)

Sequence of Neutrophil-Endothelial Cell Adhesion

In the Springer model, selectins are responsible for the initial rolling of the neutrophil along the endothelial cell. The association and disassociation constants of selectins for their ligands are very high, and stimulation of neutrophils can result in a rapid increase in L-selectin affinity for its ligand, resulting in tethering of a flowing cell and rolling within a millisecond.^{467,468} This increase in affinity is transient, and, in fact, by 5 minutes after stimulation, much of the CD62L is shed from the neutrophil surface. The close interaction of the neutrophil with the endothelial cell surface, mediated by the selectins, allows the neutrophils to sense chemoattractants released from or displayed on the endothelial surface. These chemoattractants bind to specific receptors on the neutrophil surface, many of which span the membrane seven times, are coupled with G proteins, and result in transduction of signals that activate integrin-adhesive activity (Fig. 7.19). Some of the known chemoattractants for neutrophils are listed in Table 7.7. Many tissue-derived chemotactic factors form a protein family termed chemokines. These proteins have four conserved cysteines that form two disulfide bonds. The chemokine family is composed of CXC and CC chemokines. The CXC chemokines have their first two cysteines separated by a single amino acid and stimulate neutrophils, whereas the CC chemokines do not. Among the classically described chemoattractants are the n-formyl peptides. These chemoattractants were initially identified by studies of the observation that supernatants of bacterial cultures were chemotactic for neutrophils. Subsequent studies identified a number of n-formyl peptides with chemotactic activity, and it was hypothesized that the presence of such a receptor would provide a preimmune receptor for the neutrophil to sense bacterial infections, because bacterial protein synthesis begins with n-formyl methionine, whereas mammalian protein synthesis does not. Interestingly, mammalian mitochondria do

synthesize n-formyl methionyl peptides, and these may in some cases also result in neutrophil activation. Another classic chemoattractant is C5a, a cleavage fragment of the fifth component of complement.

TABLE 7.7 NEUTROPHIL CHEMOATTRACTANTS

Chemoattractant

C5a

N-Formyl peptides

Platelet-activating factor (PAF)

Neutrophil-activating peptide (NAP)-2

IL-8 (NAP-1)

Leukotriene B₄ (LTB₄)

Epithelial cell-derived neutrophil attractant (ENA)-78

Growth-related oncogene (GRO)- α , GRO- β , GRO- γ

Macrophage inflammatory protein (MIP)-1, MIP-2

Platelet factor (PF)-4

Integrins form a family of adhesive molecules whose affinity for ligand can be rapidly regulated. Stimulation of neutrophils with n-formyl peptides or C5a results in rapid upregulation of CD11b/CD18 expression on the neutrophil surface. This increase in expression is caused by fusion of secretory vesicles with the cell membrane. With strong stimulation, it is possible that secondary/tertiary granule fusion contributes as well. However, mere translocation to the cell surface with an increase in cell-surface expression of CD11/CD18 is not sufficient for an increase in adhesiveness. Similarly, studies of cytoplasts have demonstrated that alterations in β_2 integrin-mediated cell adhesion can be manifest without a change in surface expression of CD11b/CD18. Data suggest that alterations in CD11b/CD18-mediated cell adhesiveness are the result of a conformational change of the integrin, causing an alteration in ligand binding.^{145,469} Studies have shown that, after activation of neutrophils by chemoattractants, approximately 10% of the surface CD11b/CD18 molecules express an activation epitope recognized by a monoclonal antibody.¹⁴⁵ Cell surface integrins are in equilibrium between three conformational states. The bent conformation has a closed headpiece, while two extended conformations have either a closed or open headpiece. The extended open conformation has a much higher affinity for ligand and mediates integrin adhesion.^{470,471}

As shown in Table 7.7, several Ig superfamily members are expressed on endothelial cells and are ligands for leukocyte integrins. Mac-1 (CD11b/CD18) binds to a specific site in the third Ig domain of ICAM-1. Leukocyte function antigen-1 (CD11a/CD18) binds to the N-terminal domains of both ICAM-1 and ICAM-2. Thus, the model for neutrophil adhesion and transmigration through vessel walls can be depicted as in Figures 7.19 and 7.20. The initial rolling of neutrophils along the vessel wall is mediated by selectins (L-selectin, E-selectin, and P-selectin), and their expression and affinity for ligand can be regulated by inflammatory stimuli. At sites of inflammation, leukocyte rolling along the vessel wall is increased, and cells may become more closely apposed to the vessel wall, allowing better interaction with chemoattractants released from or presented on the surface of the endothelial cells. Interactions of these chemoattractants with the neutrophil then result in activation of integrin affinity for its ligand, with a resultant firm adhesion of the neutrophil to the endothelial cell surface. Subsequent migration of the neutrophil through the endothelial cell proceeds along the gradient of the chemotactic agent. Extravasation via transcellular (through the endothelial cells) has been demonstrated, and the endothelial cell may play a role in this process.⁴⁷² The relative contribution of transcellular and intercellular extravasation is unclear, and may depend on the particular tissue and stimuli involved. The presence of multiple adhesion molecules and ligands on both the neutrophil and the endothelial cell, which may vary among endothelial cells in different environments, coupled with the array of chemoattractant agents that may be released locally, provides potentially high

P.151

specificity for localizing the interaction of a particular type of cell within a particular endothelial environment, based on the large number of combinatorial adhesive molecule-ligand pair combinations available.⁴⁶⁷

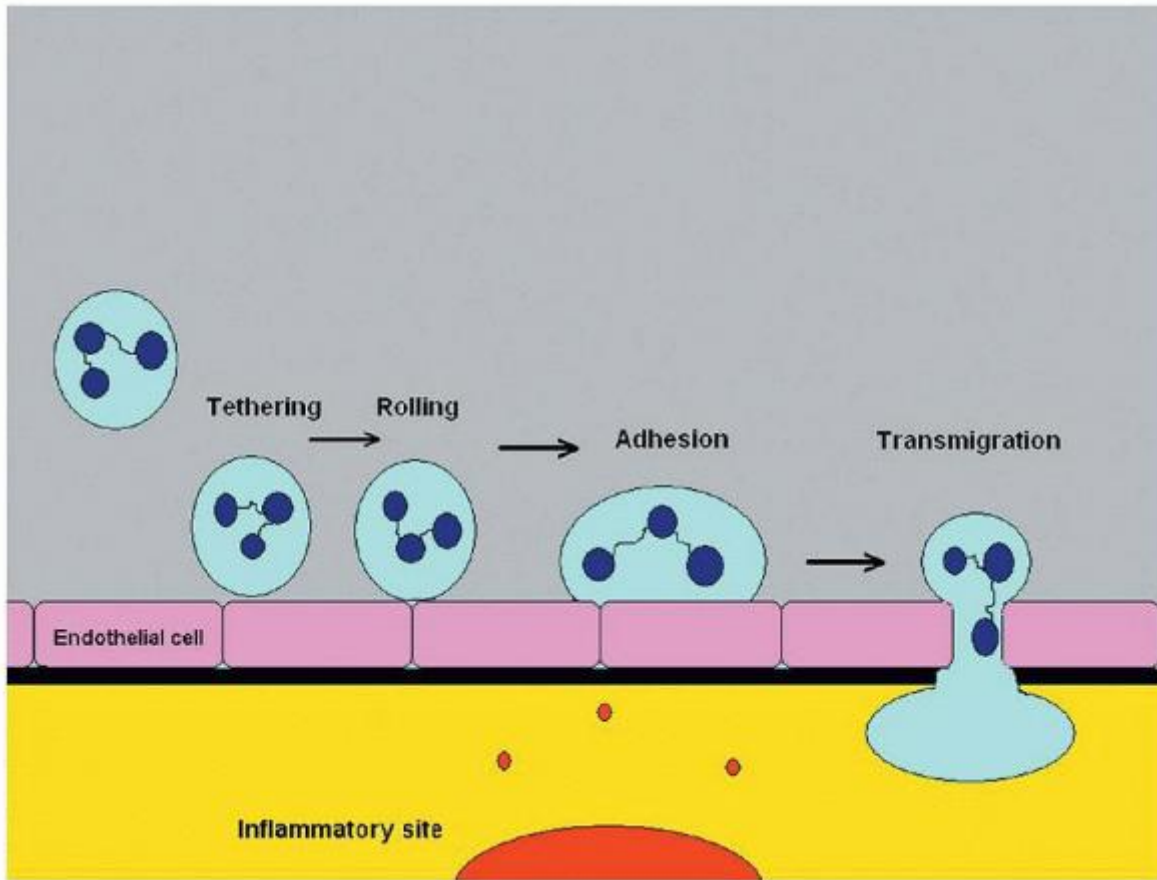

FIGURE 7.20. Neutrophil adhesion to the vascular wall at a site of inflammation. Sequential interactions of neutrophils with selectins result in rolling along the vascular wall, followed by sensing chemoattractants (red balls), which activate integrins to cause increased adhesion to the endothelial cells, followed by transmigration through the endothelial cells and basement membrane, followed by chemotaxis to the site of inflammation. (From Skubitz L, with permission.)

This model is supported by elegant studies demonstrating that at physiologic shear stress, neutrophils form rolling adhesions on phospholipid bilayers containing P-selectin but not on those containing ICAM-1. Chemoattractants result in integrin-mediated adhesion to bilayers containing ICAM-1 under static conditions but not under shear conditions. In contrast, neutrophils rolling on bilayers containing both P-selectin and ICAM-1 respond to chemoattractants by spreading and becoming firmly adherent via an integrin-ICAM-1 interaction. Chemoattractants do not increase adhesion or rolling on bilayers containing P-selectin alone.⁴⁶⁷

Feedback systems also exist that can inhibit neutrophil rolling and adhesion to endothelial cells (Fig. 7.21). The pentraxin PTX3 is stored in specific granules. While PTX3 can bind pathogens and activate complement, it can also inhibit neutrophil recruitment to inflammatory sites. It appears that neutrophils can release PTX3 from specific granules, and that the PTX3 can then bind P-selectin (CD62P) on endothelial cells. The binding of PTX3 to CD62P inhibits CD62P binding to PSGL-1 on neutrophils, thus inhibiting rolling.⁴⁷³ Endothelial cells can release the glycoprotein Del-1, which can bind CD11a/CD18 on neutrophils. Del-1 binding to CD11a/CD18 inhibits CD11a/CD18 binding to ICAM-1, inhibiting neutrophil adhesion.^{474,475} CD11/CD18 complexes can also be shed by neutrophils, and may further regulate neutrophil function in inflammation.^{476,477}

Neutrophil Aggregation

The increase in polymorphonuclear neutrophil adhesion after stimulation is manifest not only by increased adhesion to endothelial cells, but also by neutrophil-neutrophil and neutrophil-platelet adhesion. Although the *in vivo* formation of neutrophil aggregates was clearly visualized by W.B. Wood in a rabbit ear model of inflammation in the 1960s, the possibility of neutrophil homotypic aggregation was considered novel when it was formally demonstrated by Craddock et al.^{247,248} Craddock's observations stemmed from earlier descriptions of the phenomenon of hemodialysis neutropenia.^{245,246} The initiation of hemodialysis, using cuprophane membranes, is followed by a rapid fall in the

circulating neutrophil count caused by a transient sequestration of neutrophils in the lung, with a return to the circulation by 1 hour.^{245,246} Craddock demonstrated that neutrophils undergo homotypic aggregation in response to plasma that had been

P.152

exposed to cuprophane, largely because of generation of C5a by complement activation.^{247,248,250,251} Aggregation was also induced by other neutrophil stimuli. Further studies demonstrated that the transient nature of hemodialysis neutropenia was caused by desensitization of neutrophils to the continued infusion of stimulus from the hemodialysis machine, thus demonstrating *in vivo* the phenomenon of desensitization.²⁴⁹ This phenomenon, in some clinical situations (e.g., viral infections), may result in neutrophil dysfunction as described later in this book. Subsequent studies have suggested that neutrophil aggregation and sludging, with resultant organ damage or dysfunction, may play a role in a variety of pathologic processes, including adult respiratory distress syndrome and reperfusion injury.

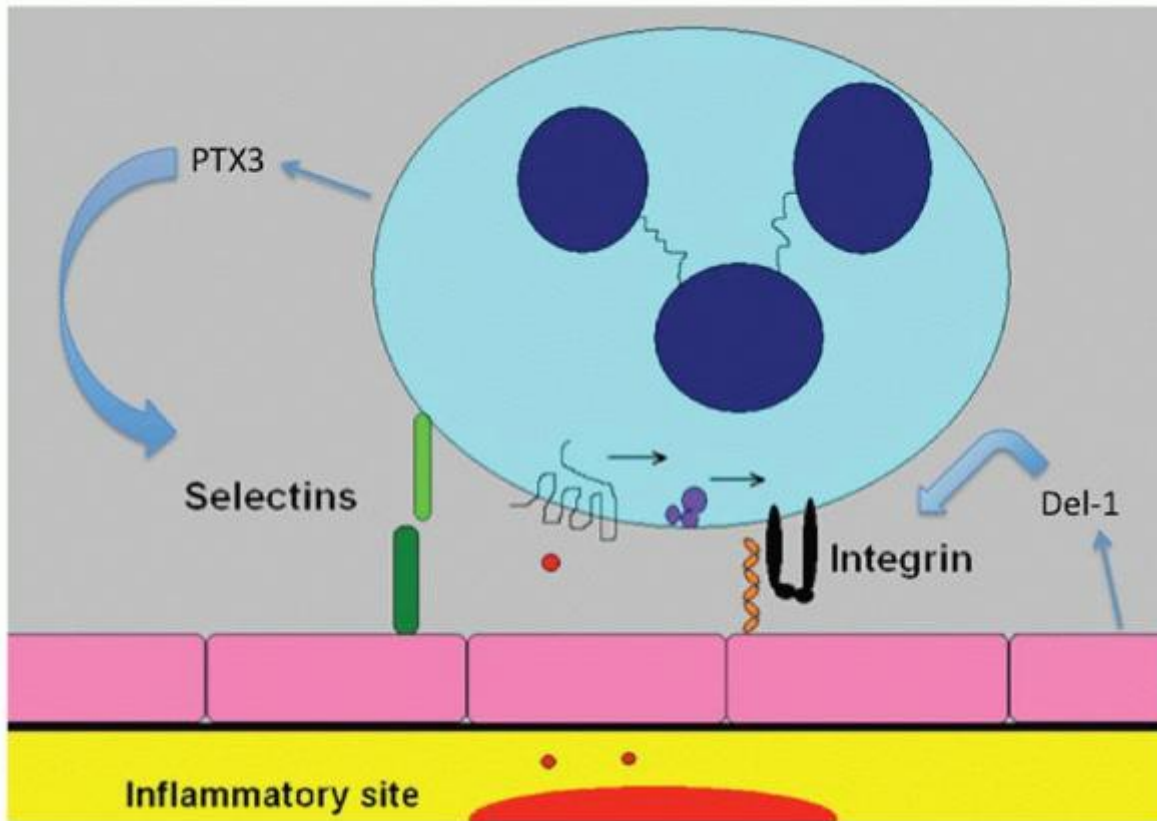

FIGURE 7.21. Feedback mechanisms inhibit neutrophil recruitment to inflammatory sites. Neutrophils can release PTX3 from specific granules, and the PTX3 can then bind P-selectin (CD62P) on endothelial cells. The binding of PTX3 to CD62P inhibits CD62P binding to PSGL-1 on neutrophils, thus inhibiting rolling. Endothelial cells can release the glycoprotein Del-1, which can bind CD11a/CD18 on neutrophils. Del-1 binding to CD11a/CD18 inhibits CD11a/CD18 binding to ICAM-1, inhibiting neutrophil adhesion. (From Skubitz L, with permission.)

Chemotaxis

The work of von Recklinghausen and Conheim described amoebalike movement of leukocytes more than a century ago.²⁷⁹ The neutrophil moves on a surface through a gradient of chemotactic agent by advancing a projection called a lamellipodium or pseudopodium. Chemotaxis begins with the protrusion of a pseudopodium or lamellipodium at the front of the cell. This occurs where the submembranous actin filament network (the cortex) becomes less filamentous. As the cell moves, the pseudopodium ruffles rapidly. Part of the pseudopodium adheres to the underlying surface, and the contents of the cell move forward into the pseudopodium, making the pseudopodium less prominent. This cycle is then repeated with the protrusion of another pseudopodium. Chemotaxis occurs by repetitions of this process, although often the process is so well coordinated as to appear as a continuous gliding motion. The mechanism of these cell movements

appears to involve alterations in the polymerization state of actin, regulated by several proteins, including actin-binding protein, gelsolin, and others, as well as adenosine triphosphate-dependent contraction of the actin network mediated by myosin.^{49,478} Local contraction of the cytoskeleton could move intracellular components forward into an area where the cortical gel has weakened because of shortening of actin filaments beneath the surface of the advancing pseudopodium. Characteristic contraction waves have been observed in human leukocytes and likened to those seen in amoebae and earthworms (Fig. 7.22).⁴⁷⁹ In leukocytes, the contraction wave appears to originate in the superficial layer of the submembranous organelle-excluding region called the cortex, producing a concave area, and the anterior part of the cell stretches or is propelled forward as a pseudopodium.⁴⁷⁹ How localized changes in the state of actin assembly are established and maintained at a single site in neutrophils during chemotaxis is unclear. Data suggest that a change in plasma membrane tension is the main factor limiting the spread of the leading front and suppressing the development of secondary fronts.⁴⁸⁰ While integrin-mediated adhesion plays an important role in migration on a two-dimensional surface, and in crossing tissue barriers such as the endothelium, integrins do not appear important in interstitial migration. In studies of migration in three-dimensional environments, elimination of all integrin heterodimers in mouse leukocytes did not affect migration. Thus, the migration in this system was shown to be due solely to the force of changes in the actin network.⁴⁷⁸

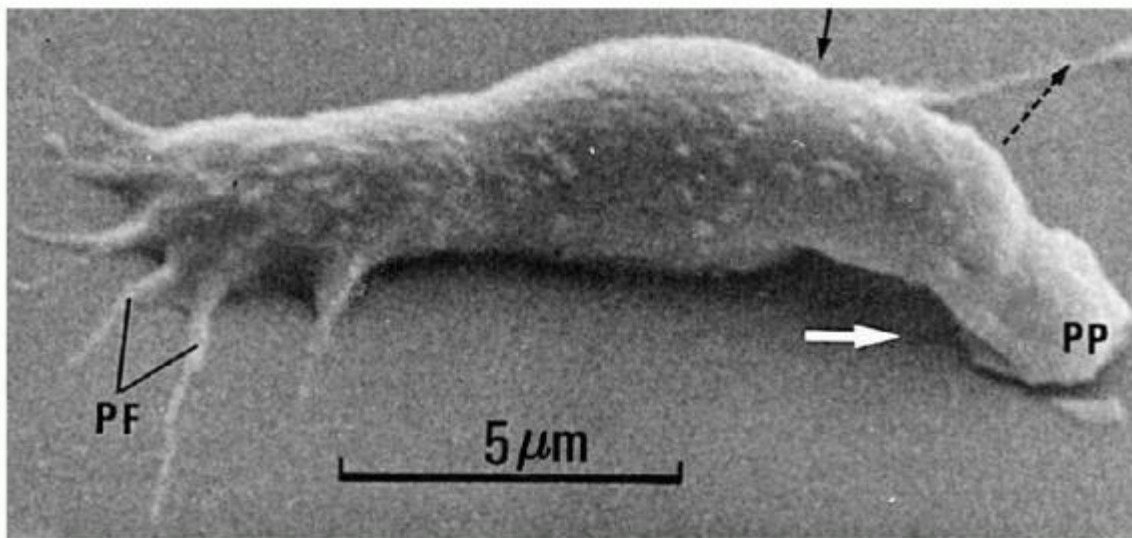

FIGURE 7.22. Scanning electron micrograph of a moving neutrophil. The contraction wave is observed as a concave (black solid arrow) and a convex (black dashed arrow) area. The advancing pseudopodium (PP) is seen being pushed out in the direction of movement (white arrow). Pseudoflagellae (PF) are seen in the rear of the cell. (From Senda N, Tamura H, Shibata N, Yoshitake J, Konko K, Tanaka K. The mechanism of the movement of leucocytes. *Exp Cell Res* 1975;91:393, with permission.)

Interestingly, mice that express no gelsolin can breed in captivity and have a prolonged bleeding time and abnormal neutrophil chemotaxis.⁴⁹ Thus, gelsolin is important in neutrophil chemotaxis, but other proteins can compensate to some extent in its absence. The increase in free calcium that alters the cytoskeleton by activating gelsolin, and thereby decreasing filamentous actin with a resultant decrease in viscosity, may play a role in locomotion; in addition, the transient dissolution of the submembranous cytoskeletal network may allow closer contact of intracellular granules with the plasma membrane, facilitating granule fusion and release. Some granule release occurs with chemotaxis.

Although the mobility of neutrophils and their concentration in inflammatory lesions were appreciated in early experiments, the development of a two-compartment chamber separated by a leukocyte-permeable membrane has permitted quantitation of chemotaxis *in vitro* and facilitated the investigation of chemotactic factors.^{481,482} Such studies revealed that neutrophils show directional migration under the influence of chemotactic agents, but a concentration gradient is needed for migration to occur. Even in the absence of a gradient, however, in the presence of a chemotactic factor, random migration is enhanced, and localization, or trapping, of the phagocytes occurs.

Phagocytosis

Metchnikoff played an important role in describing the phenomenon of phagocytosis (Figs. 7.16 and 7.23). When a neutrophil meets a particle, it envelops it with pseudopodia, which fuse around it, forming a phagosome that rapidly fuses

with azurophilic and specific granules. Endocytosis is the process by which material is taken into a cell enclosed within pieces of plasma membrane and, therefore, never occurs free within the cytoplasm of the cell.⁴⁸³ Endocytosis is further divided into pinocytosis (drinking by cells) and phagocytosis (eating by cells). Phagocytosis is usually visible by light microscopy, whereas pinocytosis is not, involving ingestion of small particles, such as macromolecules. Both processes proceed through invagination

P.153

of the cell membrane and the formation of vesicles or vacuoles (phagosomes).

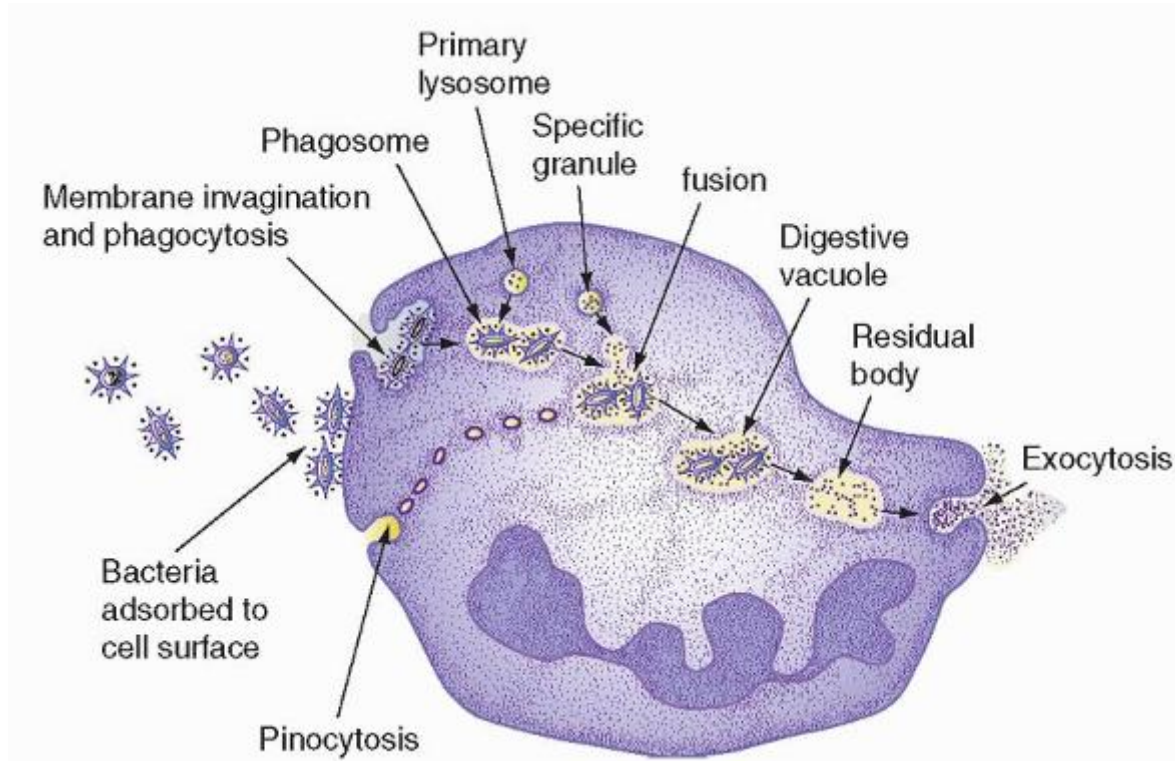

FIGURE 7.23. Diagram of endocytosis; both phagocytosis of immunoglobulin-coated bacteria and pinocytosis are shown. The fusion of a primary lysosome and a specific granule with the phagosome to form the digestive vacuole, the subsequent degradation of the bacteria leading to the formation of a residual body, and the expulsion of indigestible components are also depicted.

Neutrophils and macrophages are motile and thus are free to migrate into sites of inflammation. Once they are in the area of inflammation, they come in contact with the foreign material, engulf it, and subject it to the microbicidal and digestive enzymes they contain. This sequence was appreciated by Metchnikoff in the 1880s,⁴⁸⁴ when he observed the migration of phagocytes into areas of tissue damage in sponges and lower animals. How phagocytes distinguish foreign particles and damaged autologous cells from normal self-components is complex, but this capacity is critical to effective phagocytic function.

Granule Release

Neutrophils contain four well-defined types of intracellular granules: azurophilic, specific, and gelatinase granules; and secretory vesicles. The azurophilic granules contain many antibacterial compounds, and it appears that the fusion of these granules with phagocytic vesicles is important in bacterial killing. Azurophilic granules also contain compounds, such as elastase, that may alter locomotion by hydrolyzing certain extracellular matrix components. The specific granules are more readily released from the cell, suggesting an important function in the extracellular milieu. For example, specific granules contain products that activate the complement cascade.⁴⁸⁵ Collagenase may be important in hydrolyzing extracellular matrix proteins and facilitating locomotion. Apolactoferrin, which binds iron, may exert an antibacterial effect by depriving bacteria of iron, altering hydroxyl radical formation, and altering cell adhesion.^{39,40} The tertiary granules contain gelatinase in addition to other components, and, like collagenase, this enzyme may play a role in extracellular matrix remodeling during locomotion. Finally, both tertiary granules and the secretory vesicles contain

membrane proteins that can be rapidly upregulated to the cell surface and may play a role in alterations of the functional use of these surface proteins after stimulation. Membrane components of secondary granules are also upregulated during granule release and may play a role in regulating the expression of these membrane proteins on the cell surface. The specific granules are more readily released than the azurophilic granules, and their secretion, therefore, must be regulated somewhat differently.

Bacterial Killing and Digestion

Bacterial killing by neutrophils can be ascribed to two general and often synergistic mechanisms: oxidative and nonoxidative. Bacterial killing in the phagosome is augmented by the generation of superoxide. Activated neutrophils produce superoxide via a multicomponent NADPH-dependent oxidase that is activated by neutrophil stimulation. In resting cells, the oxidase components are found in both the plasma membrane and intracellular stores. After stimulation, intracellular components are translocated to the plasma membrane and activated, producing superoxide. Subsequent reactions result in the formation of H_2O_2 and hypochlorous acid (HOCl), which increase bacterial killing. Small amounts of other species (such as singlet oxygen and hydroxyl radical) may also form but are probably of little import in bacterial killing.

Bacterial killing decreases under anaerobic conditions, whereas phagocytosis does not, so the respiratory burst is important to bactericidal activity. Furthermore, because chronic granulomatous disease is one of the most severe clinical disorders characterized by a defect in bacterial killing, and the defect in this disorder is an inability to develop all of the reactions associated with the respiratory burst, the oxygen-dependent mechanisms appear to be of major importance in bacterial killing.^{486,487} However, other bactericidal mechanisms that do not require oxygen also operate within phagocytes (Table 7.7).

Oxygen-dependent Antimicrobial Systems

Neutrophil activation is accompanied by a prominent increase in O_2 use called the oxidative burst or respiratory burst, described by Baldrige and Gerard in 1933.⁴⁸⁸ In 1964, Rossi and Zatti suggested that the respiratory burst is due to an NADPH oxidase⁴⁸⁹; and in 1973, Babior et al. reported the production of superoxide by the NADPH oxidase.⁴⁹⁰ The respiratory burst or oxidative burst is a series of metabolic events that takes place when phagocytes are appropriately stimulated, resulting in an increase in oxygen consumption, the production of superoxide (O_2^-), the production of H_2O_2 , and an increase in glucose oxidation via the hexose monophosphate shunt.^{486,491,492} Most of the oxidative burst is caused by activation of an NADPH oxidase that catalyzes the oneelectron reduction of oxygen to superoxide, using the electron donor NADPH^{486,493}:

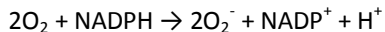

Activation of the hexose monophosphate shunt occurs because of the increased NADP^+ produced.

The NADPH oxidase exists in a latent state consisting of both membrane and cytosolic components in distinct subcellular compartments. Activation involves multiple steps, including assembly at the membrane of two membrane-bound components ($\text{gp91}^{\text{phox}}$ and p22^{phox}), three cytosolic components (p40^{phox} , p47^{phox} , and p67^{phox}) (the term phox indicates that the protein is a component of the phagocyte oxidase), and a low-molecular-weight G protein (rac1 or rac2) to form the membrane-bound oxidase complex^{492,494,495} (Figs. 7.24 and 7.25). The activated oxidase is readily detected by nitroblue tetrazolium or cytochrome reduction or the production of chemiluminescence; several mechanisms by which this series of oxygen-dependent reactions may kill bacteria have been postulated (Table 7.8). When stimulated by phagocytosis, reactive oxygen metabolites are found localized at the phagosome, and not on parts of the plasma membrane that are not involved in phagocytosis.⁴⁹⁵ Although O_2^- has some antibacterial activity, most O_2^- is rapidly converted to H_2O_2 by dismutation, either spontaneously or catalytically by superoxide dismutase:

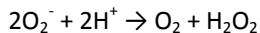

Of the microbicidal oxidants generated by the respiratory burst, O_2^- and H_2O_2 are not potent microbicides; rather, they function as starting materials to generate more potent oxidizing radicals, such as oxidized halogens and oxidizing radicals.⁴⁹⁵

Myeloperoxidase-mediated Oxygen-dependent Bacterial Killing with Oxidized Halogens

The antibacterial effect of OCl^- was demonstrated by Koch in 1881, and chlorine-based disinfectants have been widely used since, though their use was suggested even earlier in the 19th century by both Alcock and Semmelweis.⁴⁹⁶ MPO is present in high concentration in the azurophilic or primary granules of neutrophils and is released into the phagosome during granulephagosome fusion. MPO, together with H_2O_2 generated during phagocytosis^{497,498} and an oxidizable

cofactor such as halide (e.g., Cl^- or Br^-), forms oxidized halogens that are potent antimicrobials effective against bacteria, fungi, viruses, mycoplasma, and tumor cells⁴⁸⁷:

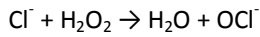

The combination of MPO, halide, and H_2O_2 is efficient in killing bacteria at H_2O_2 concentrations as low as $10 \mu\text{M}$, whereas H_2O_2 in the absence of MPO requires 0.5 mmol/L or greater levels to produce similar killing.⁴⁸⁶ Thus, H_2O_2 alone is a weak antimicrobial. Several mechanisms that have been proposed to explain bacterial killing by this system include halogenation of the bacterial cell

P.154

wall, oxidation of various bacterial components, the decarboxylation of bacterial wall amino acids,^{486,487} and the generation of long-lived chloramines that have antimicrobial activity^{486,499}:

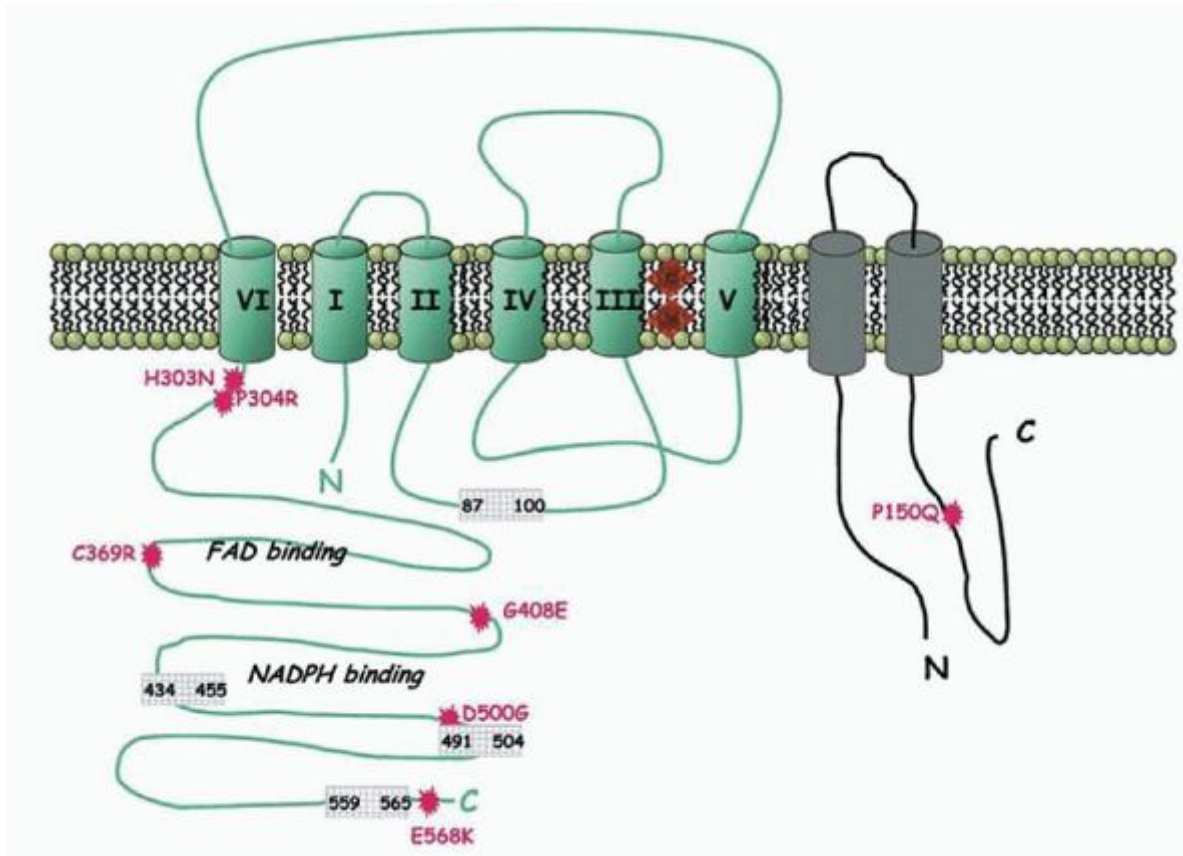
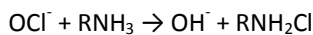

FIGURE 7.24. Model of flavocytochrome b558. Both $\text{gp91}^{\text{phox}}$ and p22^{phox} are shown, with the aligned bis-hemes and the sites for FAD and NADPH binding on $\text{gp91}^{\text{phox}}$ indicated. The seven specific mutations identified in patients with chronic granulomatous disease and associated with defective oxidase assembly are indicated in red bursts. Regions in the cytoplasmic loops of $\text{gp91}^{\text{phox}}$ that have been implicated in mediating oxidase assembly by studies using synthetic peptides or specific monoclonal antibodies are indicated in partially filled rectangles. FAD, flavin adenine dinucleotide; NADPH, nicotinamide adenine dinucleotide phosphate. (Nauseef WM. From *Histochem Cell Biol* 2004;122:277-291, with permission.)



There is some evidence that reactive nitrogen intermediates may also be produced.^{500,501}

Regardless of the mechanisms of killing, the fact that azide inhibition of MPO greatly decreases the microbicidal activity of normal leukocytes provides strong evidence for the importance of this system.⁴⁹⁷ In patients with MPO deficiency (which is often quantitative rather than qualitative), the activity of other antimicrobial systems is increased, thus partially compensating for the MPO deficiency.⁴⁹⁷ This finding may explain the increased susceptibility to infection in only approximately 20% of MPO-deficient patients.⁵⁰²

TABLE 7.8 ANTIMICROBIAL SYSTEMS OF THE NEUTROPHIL**Oxygen-dependent**

Myeloperoxidase-mediated

Myeloperoxidase-independent

H₂O₂

Superoxide

Oxygen-independent

Acid

Lysozyme

Lactoferrin

Defensins

Bactericidal permeability-increasing protein

Cationic granule proteins

Myeloperoxidase-independent (but Oxygen Radical-dependent) Bacterial Killing

This antimicrobial system is important because cells with no detectable MPO activity retain antibacterial actions that require oxygen; in fact, bacterial killing in MPO-deficient cells is associated with greater oxygen consumption than in normal cells.⁴⁸⁷

Hydrogen Peroxide

As mentioned, H₂O₂ at high concentrations (>0.5 mmol/L) has antimicrobial activity in the absence of MPO.⁵⁰³ Some organisms are more sensitive than others to H₂O₂, and this sensitivity may depend in part on their ability to degrade it (i.e., catalase or peroxidase content). Certain substances such as iodide or ascorbic acid may enhance the bactericidal action of H₂O₂ or render organisms more sensitive to still other killing mechanisms, such as lysozyme.⁴⁸⁷

Superoxide Anion

After the discovery that O₂⁻ was generated in phagocytes, some authors postulated that O₂⁻ itself might be microbicidal. The microbicidal activity of O₂⁻ appears to be weak, however, when compared to that of the H₂O₂ formed from it, especially if MPO is present. Superoxide by itself has minimal bactericidal activity.^{486,487}

Hydroxyl Radicals

Human neutrophils and monocytes generate OH· radicals, which have a very short half-life in vivo (~10⁻⁹ seconds), but the role of this highly reactive compound in microbial killing is unclear.^{486,487}

P.155

P.156

OH· production from H₂O₂ and superoxide is catalyzed by iron in the Haber-Weiss reaction:

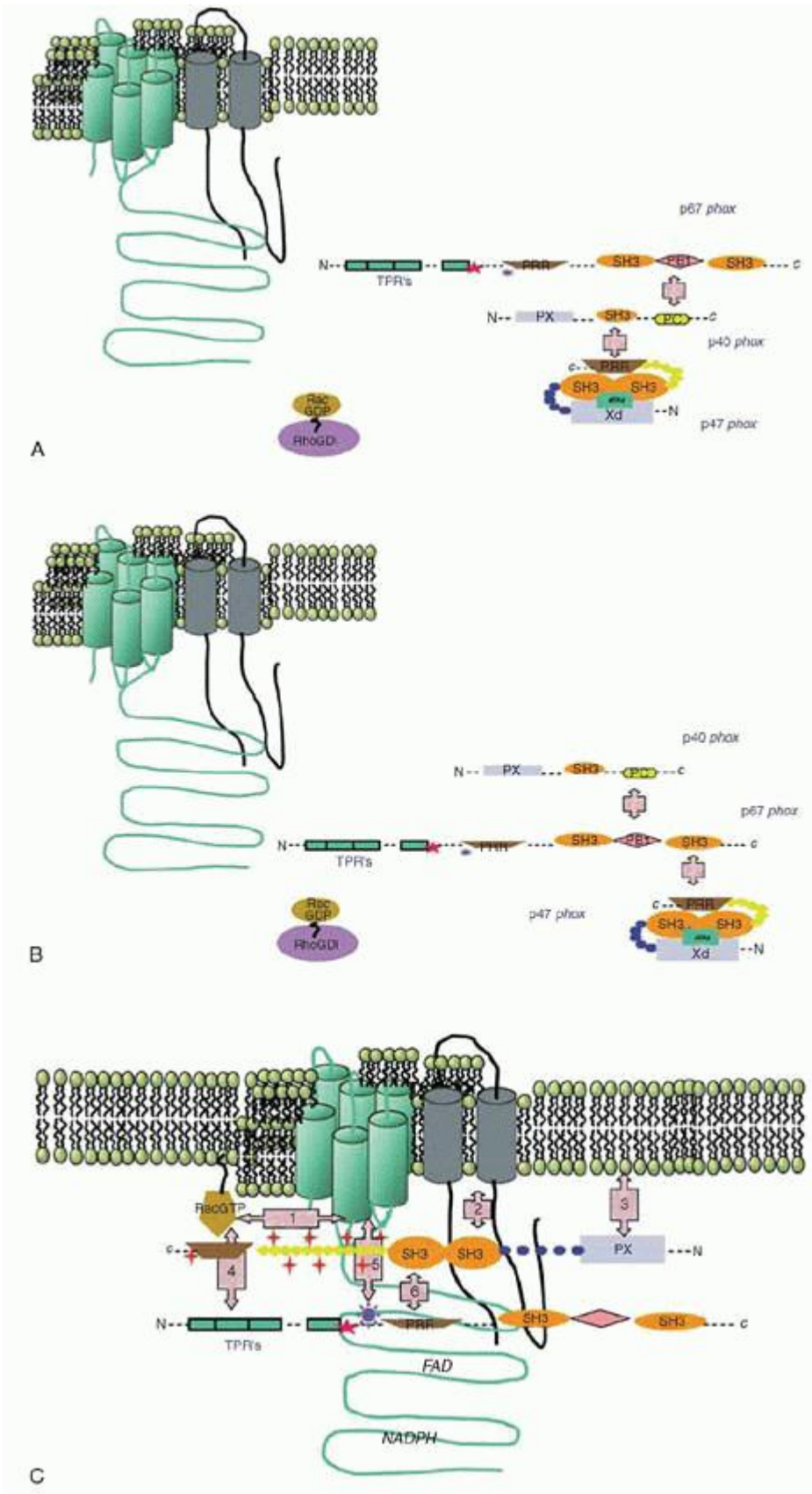
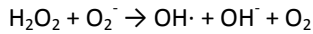

FIGURE 7.25. Oxidase assembly. Two models for the organization of the cytosolic oxidase complex in resting phagocytes are shown. A: In the first model, p40^{phox} provides the organizing central structure, interacting via its PC motif with the PB1

region of p67^{phox}, and via its SH3 domain with the PRR of p47^{phox}. B: In the second model, p67^{phox} is at the center of the complex, bound to p40^{phox} in the same fashion as in A but associated via its C-terminal SH3 domain with the PRR of p47^{phox}. C: In the activated phagocyte, the cytosolic components associate at the phagosomal or plasma membrane via several contact points (bidirectional arrows). With stimulation of the cell, RacGDP dissociates from RhoGDI, undergoes guanine nucleotide exchange, and the RacGTP associates with the membrane via its C-terminal prenyl group and associates directly with gp91^{phox} (1). p47^{phox}, released from its autoinhibited conformation by multiple phosphorylations in the polybasic region, associates via its N-terminal SH3 domain with the PRR of p22^{phox} (2) and via its PX domain with the phosphoinositides in the target membrane (3). The TPRs of p67^{phox} associate with RacGTP (4), while its activation domain binds directly to gp91^{phox} (5) and its PRR associates with the C-terminal SH3 domain of p47^{phox} (6). FAD, flavin adenine dinucleotide; NADPH, nicotinamide adenine dinucleotide phosphate. (Nauseef WM. From *Histochem Cell Biol* 2004;122:277-291, with permission.)



OH· could also be produced from a reaction between ozone and H₂O₂.⁴⁹⁴

Singlet Oxygen

Singlet oxygen (¹O₂) is a highly reactive form of oxygen that is capable of attacking compounds containing double bonds. However, significant amounts of singlet oxygen are unlikely to form, so its role in bacterial killing is probably not significant.⁵⁰²

Nitric Oxide

Nitric oxide may interact with neutrophil-derived oxidants to yield other relevant oxidant species, though its role in neutrophil function is unclear.⁴⁹⁶ Nitric oxide can react with superoxide to produce reactive nitrogen intermediates that can react with a variety of biologic targets. Though the clinical significance of neutrophil-derived reactive nitrogen intermediates is unclear, MPO potentiates NO-mediated nitrosation.⁵⁰⁴ Nitric oxide reacts with superoxide to form the potent oxidant peroxynitrate (ONOO⁻). Nitrite (NO₂⁻), a major end product of nitric oxide metabolism, has been found to interact with HOCl or MPO, or both, to form nitrylchloride (NO₂Cl) and thus promotes tyrosine nitration.^{505,506} Activated neutrophils can convert NO₂⁻ to NO₂Cl and NO₂⁻ through an MPO-dependent pathway and inactivate endothelial angiotensin-converting enzyme.⁵⁰⁵ Thus, neutrophil conversion of NO₂⁻ to nitrating and chlorinating species may play important physiologic roles. Nitric oxide synthase has been found in primary granules of resting neutrophils,⁵⁰⁷ and nitric oxide production by neutrophils has been observed.⁵⁰⁶ The expression of the NOS2 isoform can be induced in neutrophils by endotoxin, whereas NOS1 is present in the resting state.^{508,509}

Oxygen-independent Antimicrobial Systems

Because an anaerobic environment does not abolish antimicrobial activity, other mechanisms must be operative, and several have been identified, including the effects of acid, lysozyme, lactoferrin, defensins, cationic proteins, and neutral proteases. The delivery of the wide array of antibacterial compounds to the phagosome by fusion with azurophilic and specific granules generally results in bacterial killing caused by the direct actions of the granule contents. In addition, these effects are potentiated by the acidification of the phagosome, caused partly by the granule contents themselves, as well as by active translocation of H⁺ ions into the phagosome by ion pumps. The effectiveness of these mechanisms in the absence of superoxide production is demonstrated by both bacterial killing in anaerobic environments and killing by cells from patients with chronic granulomatous disease, in which catalase-positive organisms have an advantage over catalase-negative species. Nonoxidative killing is of obvious importance in hypoxic environments such as an abscess.

Acid

After particle ingestion, the intraphagosomal pH has been reported to decrease to between 3.0 and 6.5.^{510,511} and ⁵¹² Some organisms, such as pneumococci, are sensitive to an acid pH, whereas others tolerate acid environments without damage. In addition, the acid environment may enhance the effect of lysosomal hydrolytic enzymes, most of which have optimal activity at acid pH.

Lysozyme

Lysozyme, a low-molecular-weight (14,500-dalton) basic protein, is present in both primary and secondary neutrophil granules and is capable of hydrolyzing the cell wall of certain bacteria. Most organisms are resistant to the direct action of lysozyme,⁴⁸⁷ although they may become sensitive to its action after exposure to antibody and complement or to H₂O₂ and ascorbic acid.⁴⁸⁷ Usually, bacterial death appears to precede the action of lysozyme, so its action may be mostly digestive. The leukocytes of Guernsey and Hereford cattle contain no lysozyme but kill organisms normally.⁵¹³

Lactoferrin

Lactoferrin is a microbistatic protein (molecular weight 77,000 daltons) that is found in the specific granules of rabbit heterophils⁵¹⁴ and in human neutrophils⁵¹⁵ as well as in many secretions (e.g., milk and mucus) and exudates.⁵¹⁶ It inhibits bacterial growth by binding the essential nutrient iron (two atoms per molecule); and, in contrast to transferrin, this property is maintained at the low pH values encountered in exudates. A synergistic relationship between lactoferrin and other antimicrobial systems may exist, and lactoferrin may be bactericidal for some organisms.⁵¹⁷

Defensins

Prominent among the cationic neutrophil granule proteins are the defensins. These small microbicidal peptides kill a variety of bacteria, fungi, and viruses.^{19,20} and ²¹ Defensins appear to exert their effects by forming voltage-dependent ion channels. They are present in very high concentration compared to other stored antibacterial peptides (about. 5% of total neutrophil weight).

Bactericidal Permeability-increasing Protein

Bactericidal permeability-increasing protein has antibacterial activity against certain gram-negative bacteria.^{24,25,26,27} and ²⁸ It also has the property of neutralizing the toxic effects of endotoxin.

Ficolin-1

Ficolins are soluble molecules that form part of the innate immune system. They can act as pattern recognition molecules, and recognize carbohydrates on microorganisms and damaged cells. As part of the innate immune system, ficolins can bind a serine protease and activate the complement system via the lectin pathway. Ficolin-1 has been shown to be present in both gelatinase granules, and also a readily exocytosable gelatinase-poor granule.¹⁷ Ficolin-1 becomes associated with the surface membrane following stimulated release.

Other Granule Proteins

Leukocyte granules from humans, rabbits, guinea pigs, and chickens contain several other basic proteins that migrate toward the cathode on electrophoresis in agarose and exhibit antimicrobial activity.^{24,515} These proteins differ from species to species,^{24,515} and their relative importance as antimicrobial agents probably also varies. For example, because chicken leukocytes lack MPO, the cationic proteins presumably are of greatest importance in that species. In rabbit heterophils⁵¹⁸ and in chicken⁵¹⁹ and human^{19,20} and ²¹ polymorphs, the cationic proteins are located in the primary granules and are delivered into the phagosome, where they coat the bacteria and are presumed to kill them.^{23,515} Other antibacterial granule components include azurocidin^{29,30} and the serine proteinases elastase, cathepsin G, and proteinase 3.^{31,32,33} and ^{34,520}

Digestion

Digestion of bacteria is demonstrated both by changes in the morphologic appearance of organisms after phagocytosis and by the release of labeled fragments of bacteria into the surrounding

P.157

medium.^{520,521} Digestion is thought to result from the action of the acid hydrolytic enzymes released into the phagosome from the primary lysosome. Metabolic blocking agents, such as iodoacetate, cyanide, and arsenite, which inhibit glycolysis and respiration, have no effect on digestion once the bacteria are within the cell.⁵²² Some bacteria ingested by neutrophils (e.g., certain pneumococci) may be killed and digested slowly, the undigested material remaining as myelin or residual bodies.

Unsuccessful Ingestion, Killing, or Digestion

Phagocytosis and bacterial killing are not always completed successfully. Some organisms (e.g., certain virulent staphylococci) may survive and multiply within neutrophils and appear to kill them, thus overcoming the defense mechanism.⁵²³ Still other materials ingested by neutrophils, such as the uric acid crystals of gout or the hydroxyapatite crystals of pseudogout, may cause a breakdown of the phagosome wall and release the hydrolytic enzymes into the cell sap.⁵²⁴ This action may be fatal to the cell, which then lyses and releases its enzymes into the surrounding tissues, where they cause tissue damage and secondary inflammation. In certain streptococcal and other infections, bacterial exotoxins (e.g., streptolysin) are released and damage the phagosomal membrane, thus killing the cell in a similar manner⁵²⁵; the infecting organism is freed in the process. Also, certain vitamins (vitamin A) and drugs, when incorporated into

phagosomal membranes, render the membranes fragile and readily susceptible to rupture, thereby leading to inflammation.⁵²⁵

Secretory Functions of the Neutrophil

While the contents of the neutrophil can be released passively as a result of cell lysis, a variety of substances probably are actively secreted by leukocytes *in vitro*. Most of these substances have been shown to originate from the granule (including secretory vesicle) fraction. Specific granule contents (lactoferrin, B₁₂-binding protein, or both) are released before primary granule contents, and tertiary granules and secretory vesicles are secreted even more rapidly and completely, providing evidence for a differential secretion of granule contents.⁵²⁶ Because some of these substances are present in plasma normally and the concentration increases in patients with diseases involving the neutrophil system,^{527,528} and⁵²⁹ some authors suggest that neutrophils may serve a secretory function as well as a phagocytic role *in vivo*.^{530,531}

Two modes of enzyme release or exocytosis are (a) release into phagocytic vacuoles (including release outside the cell during phagocytosis but before the phagosome is sealed off from the exterior of the cell, or release during attempted phagocytosis that cannot be completed because of particle size)⁵³¹; and (b) granule content release that is not associated with phagocytosis—that is, true secretion.⁵²⁶

Among the well-studied released granule proteins are the B₁₂-binding proteins or transcobalamins. Granulocytes contain and actively release B₁₂-binding protein.^{530,532} It appears that transcobalamin III is derived from granulocytes; it is unsaturated with B₁₂.⁵³³ Markedly elevated transcobalamin I levels are seen in cases of chronic myelocytic leukemia and myeloid metaplasia; low values occur in patients with chronic leukopenia and aplastic anemia,⁵³⁴ and good correlation with blood granulocyte pool size has been reported.⁵²⁷

Lysozyme is present in primary, secondary, and tertiary granules and is also present in monocytes, serum, and tears and other secretions.^{529,536} Increased concentrations in serum and urine are found in association with monocytic and myeloblastic leukemias.^{528,535} Although it was proposed that serum lysozyme may provide a measure of GTR,⁵³⁶ lysozyme is present in several cell types, and the GTR does not correlate with serum lysozyme levels in neutropenic patients. In addition, the plasma kinetics of lysozyme do not mirror the kinetics of other neutrophil granule proteins or short-term alterations in the number of circulating neutrophils (in contrast to the kinetics of lactoferrin and gelatinase).⁵²⁹

Stimulated neutrophils also synthesize and release a variety of cytokines that may regulate the inflammatory response. For example, neutrophils stimulated with lipopolysaccharides synthesize IL-1, TNF- α , and IL-1 receptor antagonist,⁷⁹ whereas GM-CSF induces synthesis of TNF- α and IL-6.^{80,81} Neutrophil gene expression has two major peaks, one during marrow development when much of the granule content is synthesized, and one when the neutrophil leaves the circulation and enters tissues. On entering the tissue, neutrophils begin to synthesize proteins and cytokines, including ones that might attract monocytes, lymphocytes, and other neutrophils, and assist wound healing.⁸² In general, diapedesis seems to induce an antiapoptotic state, while phagocytosis seems to promote apoptosis, at least partly by upregulating death receptors, thus providing the conditions for resolution of inflammation and avoidance of tissue damage.⁸²

Some granule proteins originally viewed as primarily antimicrobial agents may have other effects as well. For example, neutrophil serine proteases also appear to play a regulatory role in granulopoiesis by antagonizing growth factor effects.^{537,538} and⁵³⁹ Mutations in neutrophil elastase result in many cases of cyclic and severe congenital neutropenia.⁵³⁹ The defensins (HNP-1 to -3) also can regulate lipoprotein metabolism by stimulating the binding of lipoprotein(a) and low-density lipoprotein to vascular cells, and can regulate smooth muscle cell contraction.⁵⁴⁰

Inflammasomes

IL-1 β , a member of the IL-1 β family of cytokines, is involved in many inflammatory responses. Toll-like (TLR) binding to pathogen-associated molecular patterns (PAMPs) results in transcription of the IL-1 β precursor pro-IL-1 β . Pro-IL-1 β is processed by a multi-molecular complex termed the inflammasome, which converts pro-caspase-1 to its active form, which then cleaves pro-IL-1 β to IL-1 β . Inflammasomes are present in both neutrophils and macrophages. In neutrophils, LPS activates the caspase-1 inflammasome, resulting in IL-1 β production.⁵⁴¹ Studies also suggest that other neutrophil proteases, including elastase, proteinase 3, and cathepsin G, can also process pro-IL-1 β to its active form.⁵⁴² The inflammasome may be an important component of the regulation of gene expression in neutrophils when they extravasate into the tissue at sites of inflammation.

Neutrophil Extracellular Traps (NETs)

Studies have observed that under some conditions neutrophils can extrude DNA, histones, and granule contents to form structures termed NETs.⁵⁴³ Although studies have also reported that microbes can be trapped in these NETs and killed, at present there is some controversy as to their physiologic role.⁵⁴⁴

Other Effects of Oxygen Metabolites

Reactive oxygen metabolites may also contribute to the physiologic effects of activated neutrophils by activating latent enzyme activities of granule proteases such as collagenase.⁵⁴⁵ The significance of this process for bacterial killing is unclear but is relevant to other pathophysiologic processes.

Superoxide produced by neutrophils may also stimulate fibroblast proliferation and wound healing, as well as lymphocyte proliferation^{546,547}; and also may regulate gene expression and the function of some enzymes, including protein kinases.⁵⁴⁸

Neutrophil Antigens

Neutrophil antigens have been identified by the use of both monoclonal antibodies and patient sera using classic blood-banking

P.158

techniques. Some neutrophil antigens defined by monoclonal antibodies are shown in Table 7.2. Neutrophil antigens relevant to blood banking and immune neutropenia are discussed more fully in Chapters 21 and 22. The first clinically relevant neutrophil antigens were described by Lalezari et al. and termed NA1 and its allele NA2, and a second antigen termed NB1. The NA1 and NA2 alleles were found to be present on the glycosyl phosphatidylinositol-linked receptor FcγRIIIB.^{549,550} The NB1 antigen (HNA-2a)⁵⁵¹ is present on an N-glycosylated, glycosyl phosphatidylinositol-linked 58- to 64-kDa protein that is present in secondary granules as well as the cell surface.^{552,553} and ⁵⁵⁴ The NB1 antigen is also known as CD177, and is upregulated on the cell surface with stimulation. NB1/CD177 also functions as a binding partner for PECAM-1 (CD31) on endothelial cells. Interestingly, the ability of CD177-positive neutrophils to migrate through endothelial cell monolayers correlates with a specific endothelial cell PECAM-1 polymorphism in a region that is the putative binding site of CD177.⁵⁵⁵ Thus, CD177/PECAM-1 binding appears to affect neutrophil transmigration across the endothelial lining.

Subsequently, a new nomenclature was established.^{556,557} In this system the antigens are termed HNA, for human neutrophil antigen, with the protein/antigen denoted by an integer, and the epitope by a letter. In this system NA1 became HNA-1a, NA2 became HNA-1b, and NB1 became HNA-2a (Table 7.9). Most clinically relevant allo- and autoantibodies appear to react with the HNA-1 and HNA-2 systems. Transfusion-related acute lung injury (TRALI) is a major cause of transfusion-related mortality, and is often due to antibodies against HNA-3a. The HNA-3a antigen results from a nucleotide polymorphism in the choline transporter-like protein-2 gene (SLC44A2).^{558,559} Some differences in neutrophil function have been reported based on HNA phenotype. For example, neutrophils that are homozygous for HNA-1b have a lower affinity for IgG3, and phagocytose targets opsonized with IgG1 and IgG3 at a lower rate than neutrophils homozygous for HNA-1a.^{560,561} and ⁵⁶² HNA-1a is typically expressed on about 45% to 65% of circulatory neutrophils,^{556,563} but on about 90% of circulating neutrophils in healthy people receiving G-CSF for several days.⁵⁶⁴

Infections That Exhibit Tropism for Neutrophils

Human granulocytic anaplasmosis (previously known as human granulocytic ehrlichiosis) is a tick-borne zoonosis caused by *Anaplasma phagocytophilum*.^{565,566,567,568} and ⁵⁶⁹ *Anaplasma phagocytophilum* is an obligate gram-negative intracellular bacterium that targets and replicates in neutrophils and their progenitors, and is related to rickettsia. *Anaplasma phagocytophilum* may target neutrophils via α-(1,3) fucosylated PSGL-1, although it may also use other targets, and replicates in vacuoles that do not fuse with lysosomes, forming microcolonies that appear as morulae.⁵⁶⁹ Human granulocytic anaplasmosis is an acute febrile illness accompanied by severe myalgias and headaches, usually occurring within 2 weeks of contact with ixodid ticks. Common laboratory findings include leukopenia, thrombocytopenia, and increased transaminases. Although most patients respond promptly to doxycycline, death has been reported to occur in approximately 5% of reported cases, and complications such as pneumonia, renal failure, and central nervous system damage have been reported. Characteristic intracytoplasmic inclusions in neutrophils (morulae) are not always seen or recognized. Human granulocytic anaplasmosis is closely related to the veterinary pathogen *Anaplasma phagocytophilum* that infect granulocytes in cattle.

TABLE 7.9 NEUTROPHIL ANTIGENS

Antigen System Antigen Name Old Name Molecule

HNA-1	HNA-1a	NA1	FCRgammaIIIb
	HNA-1b	NA2	FCRgammaIIIb
	HNA-1c	SH	FCRgammaIIIb
HNA-2	HNA-2a	NB1	CD117
HNA-3	HNA-3a	5b	SLC44A2
HNA-4	HNA-4a	Mart	CD11b
HNA-5	HNA-5a	Ond	CD11a

Francisella tularensis, a gram-negative bacterium that causes tularemia, can evade intracellular killing when ingested by neutrophils, in part by disrupting the respiratory burst.⁵⁷⁰ In neutrophils infected with live *F. tularensis*, the NADPH oxidase assembly was disrupted and the cells did not generate reactive oxygen species. At the same time, *F. tularensis* also impaired neutrophil activation by heterologous stimuli. Later in infection, the bacteria can escape the phagosome, and persist in the neutrophil cytosol for at least 12 hours.⁵⁷⁰

REFERENCES

1. Borregaard N, Heiple JM, Simons ER, Clark RA. Subcellular localization of the b-cytochrome component of the human neutrophil microbicidal oxidase: translocation during activation. *J Cell Biol* 1983;97:52-61.
2. Kjeldsen L, Sengelov H, Lollike K, et al. Isolation and characterization of gelatinase granules from human neutrophils. *Blood* 1994;83:1640-1649.
3. Oren A, Taylor JMG. The subcellular localization of defensins and myeloperoxidase in human neutrophils: immunocytochemical evidence of azurophil granule heterogeneity. *J Lab Clin Med* 1995;125:340-347.
4. Borregaard N, Lollike K, Kjeldsen L, et al. Human neutrophil granules and secretory vesicles. *Eur J Haematol* 1993;51:187-198.
5. Ducker TP, Skubitz KM. Subcellular localization of CD66, CD67, and NCA in human neutrophils. *J Leukoc Biol* 1992;52:11-16.
6. Kjeldsen L, Bainton DF, Sengelov H, Borregaard N. Identification of neutrophil gelatinase-associated lipocalin as a novel matrix protein of specific granules in human neutrophils. *Blood* 1994;83:799-807.
7. Plesner T, Ploug M, Ellis V, et al. The receptor for urokinase-type plasminogen activator and urokinase is translocated from two distinct intracellular compartments to the plasma membrane on stimulation of human neutrophils. *Blood* 1994;83:808-815.
8. de Haas M, Vosseveld PJM, von dem Borne AEGK, Roos D. Fcγ receptors of phagocytes. *J Lab Clin Med* 1995;126:330-341.
9. Borregaard N, Christensen L, Bjerrum OW, et al. Identification of a highly mobilizable subset of human neutrophil intracellular vesicles that contains tetranectin and latent alkaline phosphatase. *J Clin Invest* 1990;85:408-416.
10. Kuroki M, Matsuo Y, Kinugasa T, Matsuoka Y. Three different NCA species, CGM6/CD67, NCA-95, and NCA-90, are comprised in the major 90 to 100-kDa band of granulocyte NCA detectable upon SDS-polyacrylamide gel electrophoresis. *Biochem Biophys Res Commun* 1992;182:501-506.
11. Sengelov H, Kjeldsen L, Kroeze W, et al. Secretory vesicles are the intracellular reservoir of complement receptor 1 in human neutrophils. *J Immunol* 1994;153:804-810.
12. Lecal P, Pulido R, Sanchez-Madrid F, Mollinedo F. Intracellular location of T200 and Mo1 glycoproteins in human neutrophils. *J Biol Chem* 1988;263:9946-9951.
13. Borregaard N, Cowland JB. Granules of the human neutrophilic polymorphonuclear leukocyte. *Blood* 1997;89:3503-3521.
14. Canonne-Hergaux F, Calafat J, Richer E, et al. Expression and subcellular localization of NRAMP1 in human neutrophil granules. *Blood* 2002;100(1):268-275.
15. Faurschou M, Kamp S, Cowland JB, et al. Prodefensins are matrix proteins of specific granules in human neutrophils. *J Leukoc Biol* 2005;78(3):785-793.

16. Theilgaard-Monch K, Jacobsen LC, Neilsen MJ, et al. Haptoglobin is synthesized during granulocyte differentiation, stored in specific granules, and released by neutrophils in response to activation. *Blood* 2006;108(1):353-361.
17. Rorvig S, Honore C, Larsson LI, et al. Ficolin-1 is present in a highly mobilizable subset of human neutrophil granules and associates with the cell surface after stimulation with fMLP. *J Leukoc Biol* 2009;86:1439.
18. Schultz J, Kaminker K. Myeloperoxidase of the leukocyte of normal human blood. I. Content and localization. *Arch Biochem* 1962;96:465-467.
19. Ganz T, Lehrer RI. Defensins. *Pharmacol Ther* 1995;66:191-205.
20. Martin E, Ganz T, Lehrer RI. Defensins and other endogenous peptide antibiotics of vertebrates. *J Leukoc Biol* 1995;58(2):128-136.
21. Levy O, Ooi CE, Elsbach P, et al. Antibacterial proteins of granulocytes differ in interaction with endotoxin. Comparison of bactericidal/permeability-increasing protein, p15s, and defensins. *J Immunol* 1995;154:5403-5410.
22. Lehrer RI, Ganz T, Selsted ME. Phagocytic defects. I. Abnormalities outside of the respiratory burst. Oxygen-independent bactericidal systems. Mechanisms and disorders. *Hematol Oncol Clin North Am* 1988;2:159-169.
23. Arnheim N, Inouye M, Law L, Laudin A. Chemical studies on the enzymatic specificity of goose egg white lysozyme. *J Biol Chem* 1973;248:233-236.
24. Spitznagel JK. Antibiotic proteins of human neutrophils. *J Clin Invest* 1990;86:1381-1386.
25. Elsbach P, Weiss J. Prospects for use of recombinant BPI in the treatment of gram-negative bacterial infections. *Infect Agents Dis* 1995;4:102-109.
26. Elsbach P, Weiss J, Doerfler M. The bactericidal/permeability increasing protein of neutrophils is a potent antibacterial and anti-endotoxin agent in vitro and in vivo. *Prog Clin Biol Res* 1994;388:41-51.
27. Shafer WM, Martin LE, Spitznagel JK. Cationic antimicrobial proteins isolated from human neutrophil granulocytes in the presence of diisopropyl flu-orphosphate. *Infect Immun* 1984;45:29-35.
28. Wasiluk KR, Skubitz KM, Gray BH. Comparison of granule proteins for human polymorphonuclear leukocytes which are bactericidal toward *Pseudomonas aeruginosa*. *Infect Immun* 1991;59:4193-4200.
29. Campanelli D, Detmers PA, Nathan CF, Gabay JE. Azurocidin and a homologous serine protease from neutrophils. Differential antimicrobial and proteolytic properties. *J Clin Invest* 1990;85:904-915.
30. Gabay JE, Scott RW, Campanelli D, et al. Antibiotic proteins of human polymorphonuclear leukocytes. *Proc Natl Acad Sci U S A* 1989;86:5610-5614.
31. Baggolini M, Dewald B. The neutrophil. *Int Arch Allergy Appl Immunol* 1985;76:13-20.
32. Henson PM, Johnson RM Jr. Tissue injury in inflammation. *J Clin Invest* 1987;79:669-674.
33. Kao RC, Wehner NG, Skubitz KM, et al. Proteinase 3: a distinct polymorphonuclear leukocyte protease which produced emphysema. *J Clin Invest* 1988;82:1963-1973.
34. Tanaka T, Minematsu Y, Reilly CF, et al. Human leukocyte cathepsin G. Subsite mapping with 4-nitroanilides, chemical modification, and effect of possible cofactors. *Biochemistry* 1985;24:2040-2047.
35. Kuroki M, Yamanaka T, Matsuo Y, et al. Immunochemical analysis of carcinoembryonic antigen (CEA)-related antigens differentially localized in intracellular granule of human neutrophils. *Immun Invest* 1995;24:829-843.
36. Skubitz KM, Campbell KD, Iida J, Skubitz APN. CD63 associates with tyrosine kinase activity and CD11/CD18, and transmits an activation signal in neutrophils. *J Immunol* 1996;157:3617-3626.
37. Kuijpers TW, Tool ATJ, van der Schoot EC, et al. Membrane surface antigen expression on neutrophils: a reappraisal of the use of surface markers for neutrophils activation. *Blood* 1991;78:1105-1111.
38. Oram JD, Reiter B. Inhibition of bacteria by lactoferrin and other iron-chelating agents. *Biochim Biophys Acta* 1968;170:351-365.
39. Oseas R, Yang HH, Baehner RL, Boxer LA. Lactoferrin: a promoter of polymorphonuclear leukocyte adhesiveness. *Blood* 1981;57:939-945.
40. Boxer LA, Haak RA, Yang HH, et al. Membrane-bound lactoferrin alters the surface properties of polymorphonuclear leukocytes. *J Clin Invest* 1982;70:1049-1057.

41. Halliwell B, Gutteridge JMC. Oxygen free radicals and iron in relation to biology and medicine: some problems and concepts. *Arch Biochem Biophys* 1986;246:501-514.
42. Aruoma OI, Halliwell B. Superoxide-dependent and ascorbate-dependent formation of hydroxyl radicals from hydrogen peroxide in the presence of iron: are lactoferrin and transferrin promoters of hydroxyl-radical generation? *Biochem J* 1987;241:273-278.
43. Dewald B, Bretz U, Baggiolini M. Release of gelatinase from a novel secretory compartment of human neutrophils. *J Clin Invest* 1982;70:518-525.
44. Kanayama N, Kajiwara Y, Goto J, et al. Inactivation of interleukin-8 by aminopeptidase N (CD13). *Blood* 1995;57:129-134.
45. Painter RG, Dukes R, Sullivan J, et al. Function of neutral endopeptidase on the cell membrane of human neutrophils. *J Biol Chem* 1988;263:9456-9461.
46. Skubitz KM, Campbell KD, Skubitz APN. CD66a, CD66b, CD66c, and CD66d each independently stimulate neutrophils. *J Leukoc Biol* 1996;60:106-117.
47. Harvath L, Balke JA, Christiansen NP, et al. Selected antibodies to leucocyte common antigen (CD45) inhibit human neutrophil chemotaxis. *J Immunol* 1991;146:949-957.
48. Southwick FS, Stossel TP. Contractile proteins in leukocyte function. *Semin Hematol* 1983;20:305-321.
49. Stossel TP. The machinery of blood cell movements. *Blood* 1994;367-379.
50. Gottfried EL. Lipids of human leukocytes: relation to cell type. *J Lipid Res* 1967;8:321-327.
51. Gottfried EL. Lipid patterns of leukocytes in health and disease. *Semin Hematol* 1972;9:241-250.
52. Bjerrum OW, Nielsen H, Borregaard N. Quantitative analysis of phospholipids and demonstration of plasmalogen in human neutrophil subcellular fractions by high-performance liquid chromatography. *Scand J Clin Lab Invest* 1989;49:613-622.
53. Samuelsson B, Dahlen SE, Lindgren JA, et al. Leukotrienes and lipoxins: structures, biosynthesis and biological effects. *Science* 1987;237:1171-1176.
54. Samuelsson B, Goldyne M, Granstrom E, et al. Prostaglandins and thromboxanes. *Annu Rev Biochem* 1978;47:997-1029.
55. Symington FW. CDw17: a neutrophil glycolipid antigen regulated by activation. *J Immunol* 1989;8:2784-2790.
56. Symington FW, Murray WA, Bearman SI, Hakomori SI. Intracellular localization of lactosylceramide, the major human neutrophil glycosphingolipid. *J Biol Chem* 1987;262:11356-11363.
57. Kiguchi K, Henning-Chubb CB, Huberman E. Glycosphingolipid patterns of peripheral blood lymphocytes, monocytes, and granulocytes are cell specific. *J Biochem* 1990;107:8-14.
58. Kniep B, Skubitz KM. Subcellular localization of glycosphingolipids in human neutrophils. *J Leukoc Biol* 1998;63(1):83-88.
59. Cinek T, Horejsi V. The nature of large noncovalent complexes containing glycosyl-phosphatidylinositol-anchored membrane glycoproteins and protein tyrosine kinases. *J Immunol* 1992;149(7):2262-2270.
60. Surviladze Z, Draberova L, Kubinova L, Draber P. Functional heterogeneity of Thy-1 membrane microdomains in rat basophilic leukemia cells. *Eur J Immunol* 1998;28(6):1847-1858.
61. Brown DA, Rose JK. Sorting of GPI-anchored proteins to glycolipid-enriched membrane subdomains during transport to the apical cell surface. *Cell* 1992;68(3):533-544.
62. Stefanova I, Horejsi V, Ansoategui IJ, Knapp W, Stockinger H. GPI-anchored cell-surface molecules complexed to protein tyrosine kinases. *Science* 1991;254(5034):1016-1019.
63. Skubitz KM, Campbell KD, Skubitz A. CD63 associates with CD11/CD18 in large detergent-resistant complexes after translocation to the cell surface in human neutrophils. *FEBS Lett* 2000;469(1):52-56.
64. Bozza PT, Payne JL, Goulet JL, Weller PF. Mechanisms of platelet-activating factor-induced lipid body formation: requisite roles for 5-lipoxygenase and de novo protein synthesis in the compartmentalization of neutrophil lipids. *J Exp Med* 1996;183(4):1515-1525.

65. Yu W, Cassara J, Weller PF. Phosphatidylinositide 3-kinase localizes to cytoplasmic lipid bodies in human polymorphonuclear leukocytes and other myeloid-derived cells. *Blood* 2000;95(3):1078-1085.
66. Weller PF, Ryeom SW, Picard ST, et al. Cytoplasmic lipid bodies of neutrophils: formation induced by cis-unsaturated fatty acids and mediated by protein kinase C. *J Cell Biol* 1991;113:137-146.
67. Lemarchand P, Vaglio M, Mauel J, Markert M. Translocation of a small cytosolic calcium-binding protein (MRP-8) to plasma membrane correlates with human neutrophil activation. *J Biol Chem* 1992;267:19379-19382.
68. Odink K, Cerletti N, Bruggen J, et al. Two calcium-binding proteins in infiltrate macrophages of rheumatoid arthritis. *Nature* 1987;330:80-82.
69. Hogg N, Allen C, Edgeworth J. Monoclonal antibody 5.5 reacts with p8, 14, a myeloid molecule associated with some vascular endothelium. *Eur J Immunol* 1989;19:1053-1061.
70. Dale I, Fagerhol MK, Naesgaard I. Purification and partial characterization of a highly immunogenic human leukocyte protein, the L1 antigen. *Eur J Biochem* 1983;134:1-6.
71. Wilkinson MM, Busuttill A, Hayward C, et al. Expression pattern of two related cystic fibrosis-associated calcium-binding proteins in normal and abnormal tissues. *J Cell Sci* 1988;91:221-230.
72. Dorin JR, Novak M, Hill RE, et al. A clue to the basic defect in cystic fibrosis from cloning the CF antigen gene. *Nature* 1987;326:614-617.
73. Stroncek DF, Shankar RA, Skubitz KM. The subcellular distribution of myeloid-related protein 8 (MRP8) and MRP14 in human neutrophils. *J Transl Med* 2005;3:36.
74. Giorgi R, Pagano RL, Dias MA, Aguiar-Passeti T, Sorg C, Mariano M. Antinociceptive effect of the calcium-binding protein MRP-14 and the role played by neutrophils on the control of inflammatory pain. *J Leukoc Biol* 1998;64(2):214-220.
75. Perretti M, Wheller SK, Flower J, Wahid S, Pitzalis C. Modulation of cellular annexin I in human leukocytes infiltrating DTH skin reactions. *J Leukoc Biol* 1999;65(5):583-589.
76. Ezekowitz RAB, Orkin SH, Newburger PE. Recombinant interferon gamma augments phagocyte superoxide production and X-chronic granulomatous disease gene expression in X-linked variant chronic granulomatous disease. *J Clin Invest* 1987;80:1009-1016.
77. LaFleur M, Beaulieu AD, Kreis C, Poubelle P. Fibronectin gene expression in polymorphonuclear leukocytes. Accumulation of mRNA in inflammatory cells. *J Biol Chem* 1987;262:2111-2115.
78. Woodman RC, Curnutte JT, Babior BM. Evidence that de novo protein synthesis participates in a time-dependent augmentation of the chemotactic peptide-induced respiratory burst in neutrophils. Effects of recombinant human colony stimulating factors and dihydrocytochalasin B. *J Free Radicals Biol Med* 1988;5:355-361.
79. Lord PC, Wilmoth LM, Mizel SB, McCall CE. Expression on interleukin 1 alpha and beta genes by human blood polymorphonuclear leukocytes. *J Clin Invest* 1991;87:1312-1321.
80. Lindemann A, Riedel D, Oster W, et al. Granulocyte-macrophage colony stimulating factor induces cytokine secretion by human polymorphonuclear leukocytes. *J Clin Invest* 1989;83:1308-1312.
81. Melani C, Mattia GF, Silvani A, et al. Interleukin-6 expression in human neutrophil and eosinophil peripheral blood granulocytes. *Blood* 1993;81:2744-2749.
82. Borregaard N, Sorensen OE, Theilgaard-Monch K. Neutrophil granules: a library of innate immunity proteins. *Trends in Immunol* 2007;28:340.
83. Breton-Gorius J, Reyes F. Ultrastructure of human bone marrow cell maturation. *Int Rev Cytol* 1976;46:251.
84. Orlic D, Gordon AS, Rhodin JA. An ultrastructural study of erythropoietin-induced red cell formation in mouse spleen. *J Ultrastruct Res* 1965;13:516.
85. Rifkind RA, Chul D, Epler H. An ultrastructural study of early morphogenetic events during the establishment of fetal hepatic erythropoiesis. *J Cell Biol* 1969;40:343.
86. Tooze J, Davies HG. Light- and electron-microscope studies on the spleen of the newt *Triturus cristatus*: the fine structure of erythropoietic cells. *J Cell Sci* 1967;2:617.

87. Wetzel BK. The fine structure and cytochemistry of developing granulocytes, with special reference to the rabbit. In: Gordon AS, ed. Regulation of hematopoiesis, vol. II. White cell and platelet production. New York, NY: Appleton-Century-Crofts, 1970:769-817.
88. Hardin JH, Spicer SS. Ultrastructural localization of dialyzed iron-reactive mucosubstance in rabbit heterophils, basophils, and eosinophils. *J Cell Biol* 1971;48:368-386.
89. Erber WN, Ghosh AK, Mason DY. Immunocytochemical labeling of haematological samples using monoclonal antibodies. *Hamatol Bluttransfus* 1985;29:180.
90. Dao C, Metcalf D, Bilski-Pasquier G. Eosinophil and neutrophil colony-forming cells in culture. *Blood* 1977;50:833.
91. Denburg JA, Telizyn S, Messner H, et al. Heterogeneity of human peripheral blood eosinophil-type colonies: evidence for a common basophil-eosinophil progenitor. *Blood* 1985;66:312.
92. Ogawa M, Porter PN, Nakahata T. Renewal and commitment to differentiation of hemopoietic stem cells (an interpretive review). *Blood* 1983;61:823.
93. Quesenberry P, Levitt L. Hematopoietic stem cells. *N Engl J Med* 1979;301:755, 819, 868.
94. Hayhoe FGJ, Quaglino D. Haematological cytochemistry. Edinburgh: Churchill Livingstone, 1980.
95. Boll I, Kuhn A. Granulocytopoiesis in human bone marrow cultures studied by means of cinematography. *Blood* 1965;26:449.
96. Capone RJ, Weinreb L, Chapman GB. Electron microscope studies on normal human myeloid elements. *Blood* 1964;23:300.
97. Bainton DF, Ulliyot JL, Farquhar MG. The development of neutrophilic PMN leukocytes in human bone marrow: origin and content of azurophil and specific granules. *J Exp Med* 1971;134:907.
98. Rich AR, Wintrobe MM, Lewis MR. The differentiation of myeloblasts from lymphoblasts by their manner of locomotion. *Bull Johns Hopkins Hosp* 1939;65:291.
99. Senda N. The movement of leucocytes. *J Clin Electron Microsc* 1974;7:3.
100. Downey . The myeloblast. In: Cowdry EV, ed. Special cytology, 2nd ed. New York , NY: Paul B Hoeber, 1932.
101. Jordan HE. Comparative hematology. In: Downey H, ed. Handbook of hematology II. New York , NY: Paul B Hoeber, 1938.
102. Ackerman GA. Ultrastructure and cytochemistry of the developing neutrophil. *Lab Invest* 1968;19:290.
103. Scott RE, Horn RG. Ultrastructural aspects of neutrophil granulocyte development in humans. *Lab Invest* 1970;23:202.
104. Bainton DF, Farquhar MG. Origin of granules in polymorphonuclear leukocytes: two types derived from opposite faces of the Golgi complex. *J Cell Biol* 1966;28:277.
105. Ackerman GA, Bellios NC. A study of the morphology of the living cells of blood and bone marrow in vital films with the phase contrast microscope. I. Normal blood and bone marrow. *Blood* 1955;10:3.
106. Borregaard N. Neutrophils, from marrow to microbes. *Immunity* 2010;33:657.
107. Nachman R, Hirsch JG, Baggiolini M. Studies on isolated membranes of azurophil and specific granules from rabbit polymorphonuclear leukocytes. *J Cell Biol* 1972;54:133.
108. West BC, Gelb NA, Rosenthal AS. Isolation and partial characterization of human eosinophil granules. *Am J Pathol* 1975;81:575.
109. Bainton DF, Nichols BA, Farquhar MG. Primary lysosomes of blood leukocytes. In: Dingle JT, Dean RT, eds. Lysosomes in biology and pathology, vol. 5. New York, NY: Elsevier, 1976:3-32. (Frontiers of Biology series, vol. 45).
110. Ackerman GA. Histochemical differentiation during neutrophil development and maturation. *Ann N Y Acad Sci* 1964;113:537.
111. Baggiolini M. The neutrophil. In: Weissmann G, ed. The cell biology of inflammation. New York , NY: Elsevier, 1980.
112. Dewald B, Rindler-Ludwig R, Bretz U, Baggiolini M. Subcellular localization and heterogeneity of neutral proteases in neutrophilic polymorphonuclear leukocytes. *J Exp Med* 1975;141:709.

113. Bainton DF, Farquhar MG. Difference in enzyme content of azurophil and specific granules of polymorphonuclear leukocytes. *J Cell Biol* 1968;39:299.
114. Farquhar MG, Bainton DF, Baggolini M, De Duve C. Cytochemical localization of acid phosphatase activity in granule fractions from rabbit polymorphonuclear leukocytes. *J Cell Biol* 1972;54:141.
115. Cramer E, Pryzwansky KB, Villeval JL, Testa U, Breton-Gorius J. Ultrastructural localization of lactoferrin and myeloperoxidase in human neutrophils by immunogold. *Blood* 1985;65:423.
116. Lajtha LG, Ellis F, Oliver R. Uptake of S35 sulphate by human bone marrow cells in vitro. *Br J Cancer* 1953;7:401.
117. Vodopick HA, Athens JW, Warner HF, Boggs DR, Cartwright GE, Wintrobe MM. An evaluation of radiosulfate as a granulocyte label in the dog. *J Lab Clin Med* 1966;68:47.
118. Zeya HI, Spitznagel JK. Cationic protein-bearing granules of polymorphonuclear leukocytes: separation from enzyme-rich granules. *Science* 1969;163:1069.
119. Rustin GJ, Wilson PD, Petrs TJ. Studies on the subcellular localization of human neutrophil alkaline phosphatase. *J Cell Sci* 1979;36:401.
120. Hirschhorn R, Weissmann G. Isolation and properties of human leukocyte lysosomes in vitro. *Proc Soc Exp Biol Med* 1965;119:36.
121. Dewald B, Bretz U, Baggolini M. Release of gelatinase from a novel secretory compartment of human neutrophils. *J Clin Invest* 1982;70:518.
122. Watanabe I, Donahue S, Hoggatt N. Method for electron microscopic studies of circulating human leukocytes and observations on their fine structure. *J Ultrastruct Res* 1967;20:366.
123. Payne DN, Ackerman GA. Ultrastructural autoradiographic study of the uptake and intracellular localization of 35S-sulfate by developing human neutrophils. *Blood* 1977;50:841.
124. Borregaard N, Sehested M, Nielsen BS, et al. Biosynthesis of granule proteins in normal human bone marrow cells. Gelatinase is a marker of terminal neutrophil differentiation. *Blood* 1995;85:812-817.
125. Wilkinson PC. The locomotion of leucocytes: definitions and descriptions. In: *Chemotaxis and inflammation*, 2nd ed. New York, NY: Churchill Livingstone, 1982.
126. Ponder E, Mineola LI. The polycyte. *J Lab Clin Med* 1942;27:866.
127. Orfanakis NG, Ostlund RE, Bishop CR, Athens JW. Normal blood leukocyte concentration values. *Am J Clin Pathol* 1970;54:647.
128. Cartwright GE. *Diagnostic laboratory hematology*. New York, NY: Grune & Stratton, 1968.
129. Edwin E. The segmentation of polymorphonuclear neutrophils. *Acta Med Scand* 1967;182:401.
130. Osgood EE, Ashworth CM. *An atlas of hematology*. San Francisco, CA: JW Stacey, 1937.
131. Herbert V. *Megaloblastic anemias: mechanisms and management*. Chicago, IL: Year Book, 1965.
132. Marsh JC, Boggs DR, Cartwright GE, Wintrobe MM. Neutrophil kinetics in acute infection. *J Clin Invest* 1967;46:1943.
133. Zucker-Franklin D. Electron microscopic studies of human granulocytes: structural variations related to function. *Semin Hematol* 1968;5:109.
134. Sin YM, Sainte-Marie G. Granulocytopoiesis in the rat thymus. I. Description of the cells of the neutrophilic and eosinophilic series. *Br J Haematol* 1965;11:613.
- P.159
135. Arneth J. *Die Neutrophilen wiessen Blutkörperchen bei Infections-Krankheiten*. Jena, Germany: Fischer, 1904.
136. Fliedner TM, et al. Das Studium der Proliferationsdynamik der Myelopoese unter Verwendung der Einzellautoradiographie. *Folia Haematol (Leipz)* 1961;6:210.
137. Lewis WH. On the locomotion of the polymorphonuclear neutrophils of the rat in autoplasm cultures. *Bull Johns Hopkins Hosp* 1934;55:273.

138. Sabin FR. Studies of living human blood cells. *Bull Johns Hopkins Hosp* 1923;34:277-288.
139. Fliedner TM, Cronkite EP, Robertson JS. Granulocytopoiesis. I. Senescence and random loss of neutrophilic granulocytes in human beings. *Blood* 1964;24:402.
140. McCutcheon M. Studies on the locomotion of leukocytes I. The normal rate of locomotion of human neutrophilic leukocytes in vitro. *Am J Physiol* 1923;66:180-195.
141. Howard TH. Quantitation of the locomotive behavior of polymorphonuclear leukocytes in clot preparation. *Blood* 1982;59:946-951.
142. Harvath L, Leonard EJ. Two neutrophil populations in human blood with different chemotactic activities: separation and chemoattractant binding. *Infect Immun* 1982;36:443-551.
143. Seligman B, Malech HL, Melnich DA, Gallin JI. An antibody binding to human neutrophils demonstrates antigenic heterogeneity detected early in myeloid maturation which correlates with functional heterogeneity of mature neutrophils. *J Immunol* 1985;135:2647-2653.
144. Clement LT, Lehmyer JE, Garland GL. Identification of neutrophil subpopulations with monoclonal antibodies. *Blood* 1983;61:326-332.
145. Diamond MS, Springer TA. A subpopulation of Mac-1 (CD11b/CD18) molecules mediates neutrophil adhesion to ICAM-1 and fibrinogen. *J Cell Biol* 1993;120:545-556.
146. Krause PJ, Malech HL, Kristie J, et al. Polymorphonuclear leukocyte heterogeneity in neonates and adults. *Blood* 1986;68:200-204.
147. Ross GD. Structure and function of membrane complement receptors. *Fed Proc* 1982;41:3089-3093.
148. Ross GD, Jarowsky CI, Rabellino EM, Winchester RJ. The sequential appearance of Ia-like antigens and two different complement receptors during the maturation of human neutrophils. *J Exp Med* 1978;147:730-744.
149. Genco RJ, van Dyke TE, Levine MJ, et al. Molecular factors influencing neutrophil defects in periodontal disease J. *Dent Res* 1986;64:1377-1391.
150. Clemmensen SN, Bohr CT, Rorvig S, et al. Olfactomedin 4 defines a subset of human neutrophils. *J Leuk Biol* 2012;91:495.
151. Berkow RL, Baehner RL. Volume-dependent human blood polymorphonuclear leukocyte heterogeneity demonstrated with counterflow centrifugal elutriation. *Blood* 1985;65:71.
152. Gallin JI. Human neutrophil heterogeneity exists, but is it meaningful? *Blood* 1984;63:977.
153. Scott CS, Bynoe AG, Hough D, Roberts BE. C3b receptor-negative peripheral blood neutrophils. *Scand J Haematol* 1984;32:183.
154. Kennedy WP, MacKay I. The macropolycyte in health and disease in Iraq. *J Pathol* 1937;44:701.
155. Oria J, Yoneda S. Variation of the form and structure of the nucleus in the various types of plurisegmented neutrophils. In: Dameshek W, Taylor FHL, eds. *George R Minot symposium of hematology*. New York, NY: Grune & Stratton, 1949.
156. Weicker H. A quantitative model of granulopoiesis. *Schweiz Med Wochenschr* 1956;86:1459.
157. Davidson WM, Smith DR. A morphological sex difference in the polymorphonuclear neutrophil leucocytes. *Br Med J* 1954;2:6.
158. Hochstenbach PF, Scheres JM, Hustinx TW, Wieringa B. Demonstration of X chromatin in drumstick-like nuclear appendages of leukocytes by in situ hybridization on blood smears. *Histochemistry* 1986;84:383-386.
159. Maclean N, Edin MB. The drumsticks of polymorphonuclear leucocytes in sex-chromosome abnormalities. *Lancet* 1962;1:1154.
160. Davidson WM. Sexing the blood leucocytes in abnormalities of the sex chromosomes. *Minerva Pediatr* 1965;17:585.
161. Davidson WM, Winn S. The relationship between the sex nodule and the sex chromosomes. In: Davidson WM, Smith DR, eds. *Human chromosomal abnormalities*. London: Staples Press, 1961.
162. Simmons A, Leaverton P, Elbert G. Normal laboratory values for differential white cell counts established by normal and automated cytochemical methods (Hemalog D-TM). *J Clin Pathol* 1974;27:55-58.

163. Bain BJ, England JM. Normal haematological values: sex difference in neutrophil count. *Br Med J* 1975;1:306.
164. Berrebi A, Melamed Y, Van Dam U. Leukopenia in Ethiopian Jews. *N Engl J Med* 1987;316:549.
165. Shaper AG, Lewis P. Genetic neutropenia in people of African origin. *Lancet* 1971;2:1021.
166. Haden RL. Qualitative changes in neutrophilic leukocytes. *Am J Clin Pathol* 1935;5:354; also in *Principles of hematology*. Philadelphia, PA: Lea & Febiger, 1939.
167. Athens JW. Neutrophilic granulocyte kinetics and granulocytopoiesis. In: Gordon AS, ed. *Regulation of hematopoiesis*. New York, NY: Appleton-Century-Crofts, 1970.
168. Boggs DR. The kinetics of neutrophilic leukocytes in health and in disease. *Semin Hematol* 1967;4:359.
169. Cartwright GE, Athens JW, Wintrobe MM. The kinetics of granulopoiesis in normal man. *Blood* 1964;24:780.
170. Cronkite EP. Enigmas underlying the study of hemopoietic cell proliferation. *Fed Proc* 1964;23:649.
171. Cronkite EP, Fliedner TM. Granulocytopoiesis. *N Engl J Med* 1964;270: 1347-1403.
172. Cronkite EP, Vincent PC. Granulocytopoiesis. In: Stohlman F Jr, ed. *Hemopoietic cellular proliferation*. New York, NY: Grune & Stratton, 1970.
173. Cronkite EP, Vincent PC. Granulocytopoiesis. *Ser Haematol* 1969;2:3.
174. LoBue J. Analysis of normal granulocyte production and release. In: Gordon AS, ed. *Regulation of hematopoiesis*, vol. II. New York, NY: Appleton-Century-Crofts, 1970.
175. Mauer AM, Athens JW, Ashenbrucker H, Cartwright GE, Wintrobe MM. Leukokinetic studies. II. A method for labeling granulocytes in vitro with radioactive diisopropylfluorophosphate (DFP32). *J Clin Invest* 1960;39:1481.
176. Patt HM. A consideration of myeloid-erythroid balance in man. *Blood* 1957;12:777.
177. Patt HM, Maloney MA. An evaluation of granulocytopoiesis. In: Lamerton LF, Fry RJM, eds. *Cell proliferation*. Philadelphia, PA: FA Davis, 1963.
178. Patt HM, Maloney MA. Kinetics of neutrophil balance. In: Stohlman F Jr, ed. *The kinetics of cellular proliferation*. New York, NY: Grune & Stratton, 1959.
179. Perry S, Godwin HA, Zimmerman TS. Physiology of the granulocyte. *JAMA* 1968;203:937.
180. Warner HR, Athens JW. An analysis of granulocyte kinetics in blood and bone marrow. *Ann N Y Acad Sci* 1964;113:523.
181. Wilbur DW. The neutrophil system. Lawrence Radiation Laboratory Report. Springfield, VA: National Bureau of Standards, US Department of Commerce, 1966.
182. Maloney MA, Patt HM. Neutrophil life cycle with tritiated thymidine. *Proc Soc Exp Biol Med* 1958;98:801.
183. Bond VP, Fliedner TM, Cronkite EP, Rubini JR, Brecher G, Schork PK. Proliferative potentials of bone marrow and blood cells studied by in vitro uptake of ³H-thymidine. *Acta Haematol (Basel)* 1959;21:1.
184. Lord BI. Cellular proliferation in normal and continuously irradiated rat bone marrow studied by repeated labeling with tritiated thymidine. *Br J Haematol* 1965;11:130.
185. Price TH, Ochs HD, Gershoni-Baruch R, et al. In vivo neutrophil and lymphocyte function studies in a patient with leukocyte adhesion deficiency type II. *Blood* 1994;84:1635-1639.
186. Jagels MA, Chambers JD, Arfors KE, Hugli TE. C5a- and tumor necrosis factor- α -induced leukocytosis occurs independently of β_2 integrins and L-selectin: differential effects on neutrophil adhesion molecule expression in vivo. *Blood* 1995;85:2900-2909.
187. Jagels MA, Hugli TE. Neutrophil chemotactic factors promote leukocytosis, a common mechanism for cellular recruitment from bone marrow. *J Immunol* 1992;148:1119-1128.
188. Patt HM, Maloney MA. A model of granulocyte kinetics. *Ann N Y Acad Sci* 1964;113:515.
189. Lajtha LG, Gilbet CW, Porteous DD, Alexanian R. Kinetics of a bone-marrow stem-cell population. *Ann N Y Acad Sci* 1964;113:742.

190. Sin YM, Sainte-Marie G. Granulocytopoiesis in the rat thymus. II. Pattern for granulocyte formation based on cell counts in granulocytopoietic islands. *Br J Haematol* 1965;2:624.
191. Fliedner TM, Cronkite EP, Bond VP, Rubini JR, Andrews G. The mitotic index of human bone marrow in healthy individuals and irradiated human beings. *Acta Haematol (Basel)* 1959;22:65.
192. Killmann S, Cronkite EP, Fliedner TM, Bond VP. Mitotic indices of human bone marrow cells. III. Duration of some phases of erythrocytic and granulocytic proliferation computed from mitotic indices. *Blood* 1964;24:267.
193. Killmann S, Cronkite EP, Fliedner TM, Bond VP. Mitotic indices of human bone marrow cells. I. Number and cytologic distribution of mitoses. *Blood* 1962;19:743.
194. Leblond CP, Walker BF. Renewal of cell populations. *Physiol Rev* 1956;36:255.
195. Killmann S, Cronkite EP, Fliedner TM, Bond VP, Brecher G. Mitotic indices of human bone marrow cells. II. The use of mitotic indices for estimation of time parameters of proliferation in serially connected multiplicative cellular compartments. *Blood* 1963;21:141.
196. Cronkite EP, Fliedner TM, Bond VP, Robertson JS. Anatomic and physiologic facts and hypotheses about hemopoietic proliferating systems. In: Stohlman F Jr, ed. *The kinetics of cellular proliferation*. New York, NY: Grune & Stratton, 1959:1-18.
197. Dacie JV, White JC. Erythropoiesis with particular reference to its study by biopsy of human bone marrow: a review. *J Clin Pathol* 1949;2:1.
198. Japa J. A study of the mitotic activity of normal human bone marrow. *Br J Exp Pathol* 1942;23:272.
199. Mauer AM. Diurnal variation of proliferative activity in the human bone marrow. *Blood* 1965;26:1.
200. Lala PK, Maloney MA, Patt HM. A comparison of two markers of cell proliferation in bone marrow. *Acta Haematol (Basel)* 1964;31:1.
201. Golobova MT. Changes in mitotic activity in rats in relation to the time of day and night. *Bull Exp Biol Med Trans* 1958;46:1143.
202. Haus E, Nicolau GY, Lakatua D, Sackett-Lundeen L. Reference values for chronopharmacology. *Ann Rev Chronopharmacol* 1988;4:333-351.
203. Dancey JT, Deubelbeiss KA, Harker LA, Finch CA. Neutrophil kinetics in man. *J Clin Invest* 1976;58:705.
204. Deubelbeiss KA, Dancey JT, Harker LA, Cheney B, Finch CA. Marrow erythroid and neutrophil cellularity in the dog. *J Clin Invest* 1975;55:825.
205. Donohue DM, Gabrio BW, Finch CA. Quantitative measurement of hematopoietic cells of the marrow. *J Clin Invest* 1958;37:1564.
206. Donohue DM, Reiff RH, Hanson ML, Betson Y, Finch CA. Quantitative measurement of the erythrocytic and granulocytic cells of the marrow and blood. *J Clin Invest* 1958;37:1571.
207. Cronkite EP, Bond VP, Fliedner TM, Rubini JR. The use of tritiated thymidine in the study of DNA synthesis and cell turnover in hemopoietic tissues. *Lab Invest* 1959;3:263.
208. Feinendegen LE, Bond VP, Hughes WL. Physiological thymidine reutilization in rat bone marrow. *Proc Soc Exp Biol Med* 1966;122:448.
209. Feinendegen LE, Bond VP, Cronkite EP, Hughes WL. RNA turnover in normal rat bone marrow. *Ann N Y Acad Sci* 1964;113:727.
210. Friedkin M. Speculations on the significance of thymidylic acid synthesis in the regulation of cellular proliferation. In: Stohlman F Jr, ed. *The kinetics of cellular proliferation*. New York, NY: Grune & Stratton, 1959.
211. Greulich RC, Cameron IL, Thrasher JD. Stimulation of mitosis in adult mice by administration of thymidine. *Proc Natl Acad Sci U S A* 1961;47:743.
212. Hiatt HH, Bojarski TB. Stimulation of thymidylate kinase activity in rat tissues by thymidine administration. *Biochem Biophys Res Commun* 1960;2:35.
213. Hughes WL, Robertson JS, Hamilton LD, et al. Discussion of radiation effects of cellular labels. In: Stohlman F Jr, ed. *The kinetics of cellular proliferation*. New York, NY: Grune & Stratton, 1959:135-141.

214. Samuels LD, et al. Tritiated thymidine toxicity in mammalian systems. *Atompraxis* 1964;18:144.
215. Cronkite EP. Kinetics of granulocytopoiesis. *Natl Cancer Inst Monogr* 30, Human Tumor Cell Kinetics, 1969.
216. Stryckmans P, Cronkite EP, Fliedner TM. DNA synthesis time of erythropoietic and granulopoietic cells in human beings. *Nature* 1966;211:717.
217. Deubelbeiss KA, Dancey JT, Harker LA, Finch CA. Neutrophil kinetics in the dog. *J Clin Invest* 1975;55:833.
218. Brubaker LH, Evans WH. Separation of granulocytes, monocytes, lymphocytes, erythrocytes, and platelets from human blood and relative tagging with diisopropylfluorophosphate (DFP). *J Lab Clin Med* 1969;73:1036.
219. Kurth D, Athens JW, Cronkite EP, Cartwright GE, Wintrobe MM. Leukokinetic studies. V. Uptake of tritiated diisopropylfluorophosphate by leukocytes. *Proc Soc Exp Biol Med* 1964;140:422.
220. Bishop CR, Rothstein G, Ashenbrucker HE, Athens JW. Leukokinetic studies. XIV. Blood neutrophil kinetics in chronic, steady-state neutropenia. *J Clin Invest* 1971;50:1678.
221. Raab SO, Athens JW, Haab OP, et al. Granulokinetics in normal dogs. *Am J Physiol* 1964;206:83.
222. Kindred JE. A quantitative study of the hemopoietic organs of young adult albino rats. *Am J Anat* 1942;71:297.
223. Papayannopoulou T, Finch CA. On the in vivo action of erythropoietin: a quantitative analysis. *J Clin Invest* 1972;51:1179.
224. Hudson G. Bone marrow volume in guinea-pigs. *J Anat* 1958;92:150.
225. Hudson G, Osmond DG, Roylance PJ. Cell-populations in the bone marrow of the normal guinea pig. *Acta Anat (Basel)* 1963;52:234.
226. Suit HD. A technique for estimating bone marrow cellularity in vivo using ⁵⁹Fe. *J Clin Pathol* 1957;10:267.
227. Harker LA. Megakaryocyte quantitation. *J Clin Invest* 1968;47:452.
228. Finch CA, Harker LA, Cook JD. Kinetics of the formed elements of human blood. *Blood* 1977;50:699.
229. Fliedner TM, Cronkite EP, Killmann SA, Bond VP. Granulocytopoiesis. II. Emergence and pattern of labeling of neutrophilic granulocytes in humans. *Blood* 1964;24:683.
230. Perry S, Craddock CG Jr, Lawrence JS. Rates of appearance and disappearance of white blood cells in normal and in various disease states. *J Lab Clin Med* 1958;51:501.
231. Maloney MA, Patt HM. Granulocyte transit from bone marrow to blood. *Blood* 1968;31:195.
232. Bishop CR, Athens JW. Studies of granulocytopoiesis in abnormal conditions. In: Stohlman F Jr, ed. Hemopoietic cellular proliferation. New York, NY: Grune & Stratton, 1970.
233. Boggs DR, Athens JW, Cartwright GE, Wintrobe MM. Leukokinetic studies. IX. Experimental evaluation of a model of granulopoiesis. *J Clin Invest* 1965;44:642.
234. Weiss L. The hematopoietic microenvironment of the bone marrow: an ultrastructural study of the stroma in normal and eosinophilic rats. *Anat Rec* 1976;186:161.
235. Weiss L. Transmural cellular passage in vascular sinuses of rat bone marrow. *Blood* 1970;36:189.
236. Leblond PF, Chamberlain JK, Weed RI. Scanning electron microscopy of erythropoietin-stimulated bone marrow. *Blood Cells* 1975;1:639.
237. Giordano GF, Lichtman MA. Marrow cell egress. The central interaction of barrier pore size and cell maturation. *J Clin Invest* 1973;52:1154.
238. Kovich NL, Lin N, Yednock T, et al. Stem cell factor modulates avidity of $\alpha_4\beta_1$ and $\alpha_5\beta_1$ integrins expressed on hematopoietic cell lines. *Blood* 1995;85:159-167.
239. Rother K. Leucocyte mobilizing factor: a new biological activity derived from the third component of complement. *Eur J Immunol* 1972;2:550.
240. Terashima T, English D, Hogg JC, van Eeden SF. "Release of polymorphonuclear leukocytes from the bone marrow by interleukin-8." *Blood* 1998;92(3):1062-1069.

241. Athens JW, Raab SO, Haab OP. Leukokinetic studies. III. The distribution of granulocytes in the blood of normal subjects. *J Clin Invest* 1961;40:159.
242. Athens JW, Haab OP, Raab SO. Leukokinetic studies. IV. The total blood, circulating and marginal granulocyte pools and the granulocyte turnover rate in normal subjects. *J Clin Invest* 1961;40:989.
243. Vejls G. The distribution of leucocytes in the vascular system. *Acta Pathol Microbiol Immunol Scand [Suppl]* 1938;33:1.
244. Bishop CR, Athens JW, Boggs DR, Warner HR, Cartwright GE, Wintrobe MM. Leukokinetic studies. XIII. A non-steady state kinetic evaluation of the mechanism of cortisol-induced granulocytosis. *J Clin Invest* 1968;47:249.
245. Toren M, Goffinet JA, Kaplow LS. Pulmonary bed sequestration of neutrophils during hemodialysis. *Blood* 1970;36:337-340.
246. Brubaker LH, Nolph KD. Mechanisms of recovery from neutropenia induced by hemodialysis. *Blood* 1971;38:623-631.
247. Craddock PR, Fehr J, Dalmasso AP, et al. Hemodialysis leukopenia: pulmonary vascular leukostasis resulting from complement activation by dialyzer cellophane membranes. *J Clin Invest* 1977;59:879-888.
248. Craddock PR, Hammerschmidt DE, White JG, et al. Complement (C5a)-induced granulocyte aggregation in vitro. A possible mechanism of complement-mediated leukostasis and leukopenia. *J Clin Invest* 1977;60:260-264.
249. Skubitz KM, Craddock PR. Reversal of hemodialysis granulocytopenia and pulmonary leukostasis. *J Clin Invest* 1981;67:1383-1391.
250. Craddock PR, Fehr J, Brigham KL, et al. Complement and leukocyte-mediated pulmonary dysfunction in hemodialysis. *N Engl J Med* 1977;769-774.
251. Hammerschmidt DE, Weaver LJ, Hudson LD, et al. Association of complement activation and elevated plasma-C5a with adult respiratory distress syndrome. Pathophysiological relevance and possible prognostic value. *Lancet* 1980;1:947-949.
252. Alexanian R, Donohue DM. Neutrophilic granulocyte kinetics in normal man. *J Appl Psychol* 1965;20:803.
253. Athens JW, Raab SO, Haab OP, et al. Leukokinetic studies. X. Blood granulocyte kinetics in chronic myelocytic leukemia. *J Clin Invest* 1965;44:765.
254. Athens JW, Haab OP, Raab SO, et al. Leukokinetic studies. XI. Blood granulocyte kinetics in polycythemia vera, infection, and myelofibrosis. *J Clin Invest* 1965;44:778.
255. Galbraith PR, Valberg LS, Brown M. Patterns of granulocyte kinetics in health, infection and in carcinoma. *Blood* 1965;25:683.
256. Craddock CG, Perry S, Ventzke LE, Lawrence JS. Evaluation of marrow granulocytic reserves in normal and disease states. *Blood* 1960;15:849; *Am J Med* 1960;28:711; In: Stohlman F Jr, ed. *The kinetics of cellular proliferation*. New York, NY: Grune & Stratton, 1959; *Blood* 1959;14:50; *Ser Haematol* 1965;1:13.
257. Mauer AM, Athens JW, Warner HR, et al. An analysis of leukocyte radioactivity curves obtained with radioactive diisopropylfluorophosphate (DFP32). In: Stohlman F Jr, ed. *The kinetics of cellular proliferation*. New York, NY: Grune & Stratton, 1959:231-239.
258. Meuret G, Hoffmann G, Flidner TM, et al. Neutrophil kinetics in man. Studies using autotransfusion of 3H-DFP labeled blood cells and autoradiography. *Blut* 1972;26:97.
259. Duvall CP, Perry S. The use of 51-chromium in the study of leukocyte kinetics in chronic myelocytic leukemia. *J Lab Clin Med* 1968;71:614.
260. McCall MS, Sutherland DA, Eisentraut AM, Lanz H. The tagging of leukemic leukocytes with radioactive chromium and measurement of the in vivo cell survival. *J Lab Clin Med* 1955;45:717.
261. McMillan R, Scott JL. Leukocyte labeling with ⁵¹chromium. I. Technic and results in normal subjects. *Blood* 1968;32:738.
262. Davidson JG, McMillan R, Marino JV, Scott JL. The kinetics of radiochromatelabeled normal and leukemic lymphocytes. *Clin Res* 1969;17:150.

263. Eyre HJ, Rosen PJ, Perry S. Relative labeling of leukocytes, erythrocytes and platelets in human blood by ⁵¹chromium. *Blood* 1970;36:250.
264. McMillan R, et al. Radiochromate leukokinetics in chronic myelocytic leukemia (CML). *Abstr XII Cong Intl Soc Hematol*, 1968.
265. Scott JL, McMillan R, Marino JV, Davidson JG. Leukocyte labeling with ⁵¹chromium. IV. The kinetics of chronic lymphocytic leukemic lymphocytes. *Blood* 1973;41:155.
266. Spivak JL, Perry S. Evaluation of 51Cr as a leucocyte label. *Br J Haematol* 1973;25:321.
267. Vincent PC. The measurement of granulocyte kinetics. *Br J Haematol* 1977;36:1.
268. Dresch C, Najean Y, Bauchet J. Kinetic studies of 51Cr and DF32P-labelled granulocytes. *Br J Haematol* 1975;29:67.
269. McAfee JG, Thaker ML. Survey of radioactive agents for in vitro labeling of phagocytic leukocytes. I & II. *J Nucl Med* 1976;17:480-488.
270. Thakur ML, Lavender JP, Arnot RN,, Silvester DJ, Segal AW. Indium-111-labeled autologous leukocytes in man. *J Nucl Med* 1977;18:1014-1021.
271. Goodwin DA. Cell labeling with oxine chelates of radioactive metal ions. *J Nucl Med* 1978;19:557.
272. Gottlieb RA, Giesing HA, Zhu JY, et al. Cell acidification in apoptosis. G-CSF delays programmed cell death in neutrophils by upregulating the vacuolar H⁺-ATPase. *Proc Natl Acad Sci U S A* 1995;92:5965-5968.
273. Squier MK, Sehnert AJ, et al. Apoptosis in leukocytes. *J Leukoc Biol* 1995;57(1):2-10.
274. Moulding DA, Quayle JA, Hart CA, Edwards SW. Mcl-1 expression in human neutrophils: regulation by cytokines and correlation with cell survival. *Blood* 1998;92(7): 2495-2502.
275. Gottlieb RA, Giesing HA, Engler RL, Babior BM. The acid deoxyribonuclease of neutrophils: a possible participant in apoptosis-associated genome destruction. *Blood* 1995;86:2414-2418.
276. Savill JS, Wyllie AH, Henson JE, et al. Macrophage; phagocytosis of aging neutrophils in inflammation. *J Clin Invest* 1989;83:865-875.
277. Savill JS, Henson PM, Haslett C. Phagocytosis of aged human neutrophils by macrophages is mediated by a novel "charge-sensitive" recognition mechanism. *J Clin Invest* 1989;84:1518-1527.
278. Savill J, Dransfield I, Hogg N, Haslett C. Vitronectin receptor-mediated phagocytosis of cells undergoing apoptosis. *Nature* 1990;343:170-173.
279. Burnett CH, Conner PS, Dennis F, et al. Inflammation. In: Keen WW, White JW, eds. *An American text-book of surgery*. Philadelphia, PA: WB Saunders, 1892:10-25.
280. Liles WC, Dale DC, Klebanoff SJ. Glucocorticoids inhibit apoptosis of human neutrophils. *Blood* 1995;86:3181-3188.
281. Iwai K, Miyawaki T, Takizawa T, et al. Differential expression of bcl-2 and susceptibility to anti-fas-mediated cell death in peripheral blood lymphocytes, monocytes, and neutrophils. *Blood* 1994;84:1201-1208.
282. Mecklenburgh KI., Walmsley SR, Cowburn AS, et al. Involvement of a ferroprotein sensor in hypoxia-mediated inhibition of neutrophil apoptosis. *Blood* 2002;100(8):3008-3016.
283. Molloy EJ, O'Neill AJ, Grantham JJ, et al. Sex-specific alterations in neutrophil apoptosis: the role of estradiol and progesterone. *Blood* 2003;102(7):2653-2659.
284. Tulchinsky D, Hobel CJ. Plasma human chorionic gonadotropin, estrone, estradiol, estriol, progesterone, and 17 alpha-hydroxyprogesterone in human pregnancy. 3. Early normal pregnancy. *Am J Obstet Gynecol* 1973;117(7):884-893.
285. Maianski NA., Roos D, Kuijpers TW. Tumor necrosis factor alpha induces a caspase-independent death pathway in human neutrophils. *Blood* 2003;101(5):1987-1995.
286. Florey HW, Grant LH. Leucocyte migration from small blood vessels stimulated with ultraviolet light: an electron-microscope study. *J Pathol* 1961;82:13.
287. Marchesi VT, Florey HW. Electron micrographic observations on the emigration of leukocytes. *Q J Exp Physiol* 1960;458:343.

288. Boggs DR, Athens JW, Haab OP, Raab SO, Cartwright GE, Wintrobe MM. Leukokinetic studies. VIII. A search for an extramedullary tissue pool of neutrophilic granulocytes. *Proc Soc Exp Biol Med* 1964;115:792.
289. Isaacs R, Danielian AC. A study of the white blood corpuscles appearing in the saliva and their relation to those in the blood. *Am J Med Sci* 1927;174:70.
290. Klinkhamer JM. Quantitative evaluation of gingivitis and periodontal disease. I. The progranulocytic migratory rate. *Periodontics* 1968;6:297.
291. Addis T. The number of formed elements in the urinary sediment of normal individuals. *J Clin Invest* 1926;2:409.
292. Garnett ES. Observation on the kinetics of urinary granulocytic excretion. *Clin Sci* 1965;28:157.
293. Ambrus CM, Ambrus JL. Regulation of the leukocyte level. *Ann N Y Acad Sci* 1959;77:445.
294. Bierman HR, Kelly KH, King FW, Petrakis NL. The pulmonary circulation as a source of leukocytes and platelets in man. *Science* 1951;114:276.
295. Boggs DR, Chervenick PA, Marsh JC, Pilgrim HI, Cartwright GE, Wintrobe MM. Granulocytopoiesis in germfree mice. *Proc Soc Exp Biol Med* 1967;125:325.
296. Fliedner TM, et al. Über die Umsatzkinetik der Leukocyten bei keimfreien Mäusen. *Schweiz Med Wochenschr* 1966;96:1236.
297. Crosson FJ, Feder HM Jr, Bocchini JA Jr, Hackell JM, Hackell JG. Neonatal sepsis at the Johns Hopkins Hospital, 1969-1975: bacterial isolates and clinical correlates. *Johns Hopkins Med J* 1977;140:37.
298. Eickhoff TC, Klein JO, Daly AK, Ingall D, Finland M. Neonatal sepsis and other infections due to group B streptococci. *N Engl J Med* 1964;271:1221.
299. Freedman RM, Ingram DL, Gross I, Ehrenkranz RA, Warshaw JB, Baltimore RS. A half century of neonatal sepsis at Yale: 1928-1978. *Am J Dis Child* 1981;135:140.
300. McCracken GH Jr, Shinefield HR. Changes in the pattern of neonatal septicemia and meningitis. *Am J Dis Child* 1966;112:33.
301. Overall JC Jr. Neonatal bacterial meningitis. *J Pediatr* 1970;76:499.
302. Ziai M, Haggerty RJ. Neonatal meningitis. *N Engl J Med* 1958;259:314.
303. Niswander KR, Gordon M. The women and their pregnancies. The collaborative perinatal study of the National Institute of Neurological Diseases and Stroke. Department of Health, Education and Welfare Publication No. (NIH) 73-379. Washington, DC: US Government Printing Office, 1972.
304. Klein JO, March SM. Bacterial sepsis and meningitis. In: Remington JS, Klein JO, eds. *Infectious diseases of the fetus and newborn infant*. Philadelphia, PA: WB Saunders, 1983.
305. Cates KL, Rowe JC, Ballow M. The premature infant as a compromised host. *Curr Probl Pediatr* 1983;13:1.
306. Lubchenco LO, Hansman C, Dressler M, Boyd E. Intrauterine growth as estimated from liveborn birthweight data at 24 to 42 weeks of gestation. *Pediatrics* 1963;32:793.
307. Barak Y, Karov Y, Levin S, et al. Granulocyte-macrophage colonies in culture of human fetal liver cells: morphologic and ultrastructural analysis of proliferation and differentiation. *Exp Hematol* 1980;8:837.
308. Kelemen E, Calvo W, Fliedner TM. Intravascular hemopoietic cells. In: *Atlas of human hematopoietic development*. Berlin: Springer-Verlag, 1979.
309. Thomas UB, Yoffey JM. Human fetal haematopoiesis. I. The cellular composition of foetal blood. *Br J Haematol* 1962;8:290.
310. Wheeler JG, Chauvenet AR, Johnson CA, et al. Neutrophil storage pool depletion in septic, neutropenic neonates. *Pediatr Infect Dis* 1984;3:407.
311. Ijima H, Suda T, Miura Y. Predominance of macrophage-colony formation in human cord blood. *Exp Hematol* 1982;10:324.
312. Chervenick PA, Boggs DR. In vitro growth of granulocytic and mononuclear cell colonies from blood of normal individuals. *Blood* 1971;37:131.

313. Christensen RD, Harper TE, Rothstein G. Granulocyte-macrophage progenitor cells in term and preterm neonates. *J Pediatr* 1986;109:1047.
314. Issaragrisil S. Correlation between hematopoietic progenitors and erythroblasts in cord blood. *Am J Clin Pathol* 1983;80:865.
315. Knudtzon S. In vitro growth of granulocytic colonies from circulating cells in human cord blood. *Blood* 1974;43:375.
316. Kurnick JE, Robinson WA. Colony growth of human peripheral white blood cells in vitro. *Blood* 1971;37:136.
317. McCredie KB, Hersh EM, Freireich EJ. Cells capable of colony formation in the peripheral blood of man. *Science* 1971;171:293.
318. Prindull G, Gabriel M, Prindull B. Circulating myelopoietic stem cells (CFUc). *Blut* 1981;43:109.
319. Prindull G, Prindull B, Meulen N. Haematopoietic stem cells (CFUc) in human cord blood. *Acta Paediatr Scand* 1978;129:413.
320. Christensen RD, Rothstein G. Pre- and postnatal development of granulocytic stem cells in the rat. *Pediatr Res* 1984;18:599.
321. Greenberg PF, Schrier SL. Granulopoiesis in neutropenic disorders. *Blood* 1973;41:753.
322. Richard KA, Brown RD, Kronenberg H. Studies on the proliferative capacity of the in vitro colony-forming cell in human bone marrow. *Aust N Z J Med* 1973;3:361.
323. Tebbi K, Rubin S, Cowan DH, McCulloch FA. A comparison of granulopoiesis in culture from blood and marrow cells of nonleukemic individuals and patients with acute leukemia. *Blood* 1976;48:235.
324. Christensen RD, Hills HR, Rothstein G. Granulocytic stem cell (CFUc) proliferation in experimental group B streptococcal sepsis. *Pediatr Res* 1983;17:278.
325. Metcalf D. Hemopoietic colonies, recent results. In: *Cancer research*. New York, NY: Springer-Verlag, 1977.
326. Christensen RD, MacFarlane JL, Taylor NL, Hill HR, Rothstein G. Blood and marrow neutrophils during experimental group B streptococcal infection: quantification of the stem cell, proliferative, storage and circulating pools. *Pediatr Res* 1982;16:549.
327. Erdman SH, Christensen RD, Bradley PP, Rothstein G. The supply and release of storage neutrophils; a development study. *Biol Neonate* 1982;41:132.
328. Christensen RD, Shigeoka AO, Hill HR, Rothstein G. Circulating and storage neutrophil changes in experimental type II group B streptococcal sepsis. *Pediatr Res* 1980;14:806.
329. Christiansen RD. Treatment of experimental group B streptococcal infection with hybridoma antibody. *Pediatr Res* 1984;18:1093.
330. Christensen RD. The effect of hybridoma antibody administration upon neutrophil kinetics during experimental type III streptococcal sepsis. *Pediatr Res* 1983;17:795.
331. Christensen RD, Rothstein G. Efficiency of neutrophil migration in the neonate. *Pediatr Res* 1980;14:1147.
332. Christensen RD, Bradley PP, Priebat DA, Anstall H, Rothstein G. Granulocyte transfusion in septic canine neonates. *Pediatr Res* 1982;16:57.
333. Christensen RD, Bradley PP, Rothstein G. The leukocyte left shift in clinical and experimental neonatal sepsis. *J Pediatr* 1981;98:101.
334. Harper TE, et al. Neonatal meningitis: measurement of neutrophil kinetics and evaluation of experimental treatments. *Pediatr Res* 1986;20:397.
335. Christensen RD, Rothstein G, Hill HR, Hall RT. Fatal early onset group B streptococcal sepsis with normal leukocyte counts. *Pediatr Infect Dis* 1985;4:242.
336. Zeligs BJ, Armstrong CD, Walser JB, Bellanti JA. Age-dependent susceptibility of neonatal rats to group B streptococcal type III infection: correlation of severity of infection and response of myeloid pools. *Infect Immun* 1982;37:255.
337. Eitzman DV, Smith RT. The nonspecific inflammatory cycle in the neonatal infant. *Am J Dis Child* 1959;97:326.

338. Bullock JD, Robertson AF, Bodenbender JG, Kontras SB, Miller CE. Inflammatory response in the neonate re-examined. *Pediatrics* 1969;44:58.
339. Miller ME. Chemotactic function in the human neonate: humoral and cellular aspects. *Pediatr Res* 1971;5:487.
340. Boher A, Zeligs BJ, Bellanti JA. Chemotactic responses of various differentional stages of neutrophils from human cord and adult blood. *Infect Immun* 1982;35:922.
341. Pahwa SG, Pahwa R, Grimes E, Smithwick E. Cellular and humoral components of monocyte and neutrophil chemotaxis in cord blood. *Pediatr Res* 1977;11:677.
342. Tono-Oka T, Nakayama M, Uehara H, Matsumoto S. Characteristics of impaired chemotactic function in cord blood leukocytes. *Pediatr Res* 1979;13:148.
343. Klein RB, Fischer TJ, Gard SE, Biberstein M, Rich KC, Stiehm ER. Decreased mononuclear and polymorphonuclear chemotaxis in human newborns, infants, and young children. *Pediatrics* 1977;60:467.
344. Sacchi F, Rondini G, Mingrat G, et al. Different maturation of neutrophil chemotaxis in term and preterm newborn infants. *J Pediatr* 1982;101:272.
345. Krause PJ, Hreson VC, Boutin-Lebowitz J, et al. Polymorphonuclear leukocyte adherence and chemotaxis in stressed and healthy neonates. *Pediatr Res* 1986;20:296.
346. Laurenti F, Ferro R, Marzetti G, Rossini M, Bucci G. Neutrophil chemotaxis in preterm infants with infections. *J Pediatr* 1980;96:468.
347. Schuit KE, Homisch L. Inefficient in vivo neutrophil migration in neonatal rats. *J Leukoc Biol* 1984;35:583.
348. Miller ME. Pathology of chemotaxis and random mobility. *Semin Hematol* 1975;12:59.
349. Mease AD, Burgess DP, Thomas FJ. Irreversible neutrophil aggregation: a mechanism of decreased newborn neutrophil chemotactic response. *Am J Pathol* 1981;104:98.
350. Olson TA, Ruymann FB, Cook BA, Burgess DP, Henson SA, Thomas PJ. Newborn polymorphonuclear leukocyte aggregation: a study of physical properties and ultrastructure using chemotactic peptides. *Pediatr Res* 1983;17:993.
351. Strauss RG, Snyder EL. Chemotactic peptide binding by intact neutrophils from human neonates. *Pediatr Res* 1984;18:63.
352. Anderson DC, Hughes BJ, Smith CW. Abnormal mobility of neonatal polymorphonuclear leukocytes: relation to impaired redistribution of surface adhesion sites by chemotactic factor or colchicine. *J Clin Invest* 1981;68:863.
353. Stark B, Kahane I. Cord blood polymorphonuclear leukocyte chemotaxis: differential response to formyl peptide and endotoxin-activated serum. *Isr J Med Sci* 1983;19:34.
354. Kimura GM, Miller ME, Leake RD, Raghunathan R, Cheung AT. Reduced concanavalin A capping of neonatal polymorphonuclear leukocytes (PMNs). *Pediatr Res* 1981;15:1271.
355. Mease AD, Fischer GW, Hunter KW, Ruymann FB. Decreased phytohemagglutinin-induced aggregation and C5a-induced chemotaxis of human newborn neutrophils. *Pediatr Res* 1980;14:142.
356. Sacchi F, Hill HR. Defective membrane potential changes in neutrophils from human neonates. *J Exp Med* 1984;160:1247.
357. Strauss RG, Snyder EL. Uptake of extracellular calcium by neonatal neutrophils. *J Leukoc Biol* 1985;37:423.
358. Anderson DC, Hughes BJ, Wible LJ, Perry GJ, Smith CW, Brinkley BR. Impaired motility of neonatal PMN leukocytes: relationship to abnormalities of cell orientation and assembly of microtubules in chemotactic gradients. *J Leukoc Biol* 1984;36:1.
359. Efrati P, Rozenszajn L. The morphology of buffy coat in normal human adults. *Blood* 1960;16:1012.
360. Allan RN, Alexander MK. A sex difference in the leucocyte count. *J Clin Pathol* 1968;21:691.
361. Gabbert WR, Hutaff LW, Harrell GT. The effect of age on the leukocyte count. *Geriatrics* 1947;2:96.
362. Olbrich O. Blood changes in the aged. *Edinburgh Med J* 1947;54:306.
363. Sturgis CC, Bethell FH. Quantitative and qualitative variations in normal leukocytes. *Physiol Rev* 1943;23:279; *Med Scand* 1958;160:99.

364. Ezeilo G. Non-genetic neutropenia in Africans. *Lancet* 1972;2:1003.
365. Casey AE. The diurnal levels of blood leukocytes in the normal rabbit. *Proc Soc Exp Biol Med* 1940;45:863.
366. Kennon BR, et al. A study of the white blood cell picture in six young men. *Am J Physiol* 1937;118:690.
367. Wachholder K, et al. Änderungen des weissen Blutbildes nach Nahrungsaufnahme. Alimentäre Leukopenie und alimentäre Leukocytose. *Pflugers Arch* 1949;251:459.
368. Sharp GWG. The effect of light on diurnal leucocyte variation. *J Endocrinol* 1960;21:213.
369. Garrey WE, Bryan WR. Variations in white blood cell counts. *Physiol Rev* 1935;15:597.
370. Petersen WF, Berg M. Meteorological influences on leukocytic partition. *Proc Soc Exp Biol Med* 1933;30:832.
371. Kennedy WP, MacKay L. The normal leucocyte picture in a hot climate. *J Physiol* 1936;87:336.
372. Muchmore HG, Blackburn AB, Shurley JT, Pierce CM, McKown BA. Neutropenia in healthy men at the south polar plateau. *Arch Intern Med* 1970;125:646.
373. Forwell GD. The response of the leukocyte count in man to environmental heat and to exercise. *J Physiol* 1954;124:66.
374. Cress CH, et al. The effect of anoxic and anemic anoxia on the leukocyte count. *Am J Physiol* 1943;140:299.
375. Verzar F. Die Zahl der Lymphocyten und eosinophilen Leukocyten in 1800 und 3450 m Höhe. *Schweiz Med Wochenschr* 1952;82:324.
376. Farris EJ. The blood picture of athletes as affected by intercollegiate sports. *Am J Anat* 1943;72:223.
377. Altschule MD, Altschule LH, Tillotson KJ. Changes in leukocytes of the blood in man after electrically induced convulsions. *Arch Neurol* 1949;62:624.
378. Gabrilove JL, Volterra M, Jacobs MD, Soffer LW. The effect of the parenteral injection of epinephrine on leukocyte counts in normal subjects and in patients with Addison's disease. *Blood* 1949;4:646.
379. Samuels AJ. Primary and secondary leucocyte changes following the intramuscular injection of epinephrine hydrochloride. *J Clin Invest* 1951;30:941.
380. Levine SA, Golden R. Some observations on paroxysmal rapid heart action with special reference to roentgen-ray measurements of the heart in and out of attacks. *Arch Intern Med* 1922;29:836.
381. Milhorat AT, et al. Leukocytosis during various emotional states. *Arch Neurol Psych* 1942;47:779.
382. Davis ME, Hult BE. Changes in circulating eosinophils in women during the menstrual cycle and reproduction. *J Clin Endocrinol* 1949;9:714.
383. Pepper H, Lindsay S. Levels of eosinophils, platelets, leukocytes and 17-hydroxycorticosteroids during normal menstrual cycle. *Proc Soc Exp Biol Med* 1960;104:145.
384. Nelson DH, Sandberg AA, Palmer JG, Tyler FH. Blood levels of 17-hydroxycorticosteroids following the administration of adrenal steroids and their relation to levels of circulating leukocytes. *J Clin Invest* 1952;31:843.
385. John TJ. Leukocytosis during steroid therapy. *Am J Dis Child* 1966;111:68.
386. Gray AB, Telford RD, Collins M, Baker MS, Weidemann MJ. Granulocyte activation induced by intense interval running. *J Leukoc Biol* 1993;53(5):591-597.
387. Leino L, Saarinen K, Kivisto K, Koulu L, Jansen CT, Punnonen K. Systemic suppression of human peripheral blood phagocytic leukocytes after whole-body UVB irradiation. *J Leukoc Biol* 1999;65(5):573-582.
388. Trentin JJ. Determination of bone marrow stem cell differentiation by stromal hemopoietic inductive microenvironments (HIM). *Am J Pathol* 1971;65:621.
389. Cline MJ, LeFevre C, Golde DW. Organ interactions in the regulation of hematopoiesis: in vitro interactions of bone, thymus, and spleen with bone marrow stem cells in normal, S1/S1d and W/Wv mice. *J Cell Physiol* 1977;90:105.
390. Wolf NS. Dissecting the hematopoietic microenvironment. Stem cell lodgment and commitment, and the proliferation and differentiation of erythropoietic descendants in the S1/S1d mouse. *Cell Tissue Kinet* 1974;7:89; Reversibility of hematopoietic stem cell direction (not "commitment") as influenced by the microenvironment. *Blood Cells* 1978;4:37.

391. Witte ON. Steel locus defines new multipotent growth factor. *Cell* 1990;63:5.
392. Dexter TM, Allen TD, Lajtha LD. Conditions controlling the proliferation of haemopoietic stem cells in vitro. *J Cell Physiol* 1977;91:335.
393. Dexter TM, Boettiger D, Spooncer E. Self-renewal of haemopoietic stem cells: the roles of the environment, of growth factors and of the src oncogene. *Haematol Blood Transfus* 1985;29:363.
394. Price TH, Chatta GS, Dale DC. Effect of recombinant granulocyte colony-stimulating factor on neutrophil kinetics in normal young and elderly humans. *Blood* 1996;88(1):335-340.
395. Demetri GD, Griffin JD. Granulocyte colony-stimulating factor and its receptor. *Blood* 1991;78:2791-2808.
396. Gabrilove J. The development of granulocyte colony-stimulating factor in its various clinical applications. *Blood* 1992;80:1382-1385.
397. Metcalf D. The molecular biology and functions of the granulocyte-macrophage colony-stimulating factors. *Blood* 1986;67:257-267.
398. Rowe JM, Andersen JW, Mazza JJ, et al. A randomized placebo-controlled phase III study of granulocyte-macrophage colony-stimulating factor in adult patients (55 to 70 years of age) with acute myelogenous leukemia: a study of the Eastern Cooperative Oncology Group (E1490). *Blood* 1995;86:457-462.
399. Bunn P, Crowley J, Kelly K, et al. Chemoradiotherapy with or without granulocyte-macrophage colony-stimulating factor in the treatment of limited-stage small-cell lung cancer: a prospective phase III randomized study of the southwest oncology group. *J Clin Oncol* 1995;13:1632-1641.
400. Yuo A, Kitagawa S, Osaka A. Recombinant human granulocyte colony-stimulating factor as an activator of human granulocytes: potentiation of responses triggered by receptor mediate agonists and stimulation of C3bi receptor expression and adherence. *Blood* 1990;74:2114-2149.
401. Yong KL, Linch DC. Differential effects of granulocyte- and granulocyte-macrophage colony-stimulating factors (G- and GM-CSF) on neutrophil adhesion in vitro and in vivo. *Eur J Haematol* 1992;49:251-259.
402. Spertini O, Kansas GS, Munro JM, et al. Regulation of leukocyte migration by activation of the leukocyte adhesion molecule-1 (LAM-1) selectin. *Nature* 1991;349:691-694.
403. Ohsaka A, Kitagawa S, Sakamoto S, et al. In vivo activation of human neutrophil functions by administration of recombinant human granulocyte colony stimulating factor in patients with malignant lymphoma. *Blood* 1989;74:2743-2748.
404. Avalos B, Gassos JC, Hedvat C, et al. Human granulocyte colony-stimulating factor: biologic activities and receptor characterization on hematopoietic cells and small cell lung cancer cell lines. *Blood* 1990;75:851-857.
405. Balazovich KJ, Almeida HI, Boxer LA. Recombinant human G-CSF and GM-CSF prime human neutrophils for superoxide production through different signal transduction mechanisms. *J Lab Clin Med* 1991;118:576-584.
406. Khwaja A, Carver JE, Linch DC. Interactions of granulocyte-macrophage colony-stimulating factor (CSF), granulocyte CSF, and tumor necrosis factor α in the priming of the neutrophil respiratory burst. *Blood* 1992;79:745-753.
407. Morstyn G, Souza LM, Keech J, et al. Effect of granulocyte colony-stimulating factor on neutropenia induced by cytotoxic chemotherapy. *Lancet* 1988;1:667-672.
408. Lindemann A, Herrmann F, Oster F, et al. Hematologic effects of recombinant granulocyte colony-stimulating factor in patients with malignancy. *Blood* 1989;74:2644-2651.
409. de Haas M, Kerst JM, van der Schoot CE, et al. Granulocyte colony-stimulating factor administration to healthy volunteers: analysis of the immediate activating effects on circulating neutrophils. *Blood* 1994;84:3885-3894.
410. Berkow RL, Wang D, Larrick JW, et al. Enhancement of neutrophil superoxide production by preincubation with recombinant human tumor necrosis factor. *J Immunol* 1987;139:3783-3791.
411. Borish L, Rosenbaum R, Albury L, Clark S. Activation of neutrophils by recombinant IL-6. *Cell Immunol* 1989;121:280-289.
412. Sullivan GW, Carper HT, Sullivan JA, et al. Both recombinant interleukin-1 (beta) and purified human monocyte interleukin-1 prime human neutrophils for increased oxidative activity and promote neutrophils spreading. *J Leukoc Biol* 1989;45:389-395.

413. Yuo A, Kitagawa S, Kasahara T, et al. Stimulation and priming of human neutrophils by interleukin-8: cooperation with tumor necrosis factor and colony-stimulating factors. *Blood* 1991;78:2708-2714.
414. Lord BI, Mori KJ, Wright EG. A stimulator of stem cell proliferation in regenerating bone marrow. *Biomedicine* 1977;27:223.
415. Broxmeyer HE, Moore MA, Ralph P. Cell-free granulocyte colony inhibiting activity derived from human polymorphonuclear neutrophils. *Exp Hematol* 1977;5:87; *Science* 1978;199:552.
416. Oshita AK, Rothstein G, Lonngi G. cGMP stimulation of stem cell proliferation. *Blood* 1977;49:585.
417. Broxmeyer HE, Lu L. Control of myelopoietic growth factor production. *Progr Clin Biol Res* 1985;184:145-155.
418. Heaney ML, Golde DW. Soluble cytokine receptors. *Blood* 1996;87:847-857.
419. Fliedner TM, Calvo W, Haas R, Forteza J, Bohne F. Morphologic and cytokinetic aspects of bone marrow stroma. In: Stohman F Jr, ed. Hemopoietic cellular proliferation. New York, NY: Grune & Stratton, 1970:67-86.
420. Katz R, Gordon AS, Lapin DM. Studies of the purification of the leukocytosis-inducing factor (LIF). *J Reticuloendothel Soc* 1966;3:103.
421. Dornfest BS, LoBue J, Handler ES, Gordon AS, Questler H. Mechanisms of leukocyte production and release. II. Factors influencing release from isolated perfused rat legs. *J Lab Clin Med* 1962;60:777.
422. Boggs DR, Marsh JC, Cartwright GE. Mechanisms controlling homeostasis of neutrophilic leukocytes. *Haematol Lat* 1967;10:43.
423. Boggs DR, Cartwright BE, Wintrobe MM. Neutrophilia-induced activity in plasma of dogs recovering from drug-induced myelotoxicity. *Am J Physiol* 1966;211:51.
424. Handler ES, Varsa EE, Gordon AS. Mechanisms of leukocyte production and release. V. Studies on the leukocytosis-inducing factor in the plasma of rats treated with typhoid-paratyphoid vaccine. *J Lab Clin Med* 1966;67:398.
425. Boggs DR, Marsh JC, Chervenick PA, Cartwright GE, Wintrobe MM. Neutrophil releasing activity in plasma of normal human subjects injected with endotoxin. *Proc Soc Exp Biol Med* 1968;127:689.
426. Lichtman MA, Chamberlain JK, Weed RI, Pincus A, Santillo PA. The regulation of the release of granulocytes from normal marrow. In: Greenwelt TJ, Jamieson GA, eds. The granulocyte: function and clinical utilization. New York, NY: Alan R. Liss, 1977:53-75.
427. Lichtman MA. Cellular deformability during maturation of the myeloblast: possible role in marrow egress. *N Engl J Med* 1970;283:943.
428. Lichtman MA, Weed RI. Alteration of the cell periphery during granulocyte maturation: relationship to cell function. *Blood* 1972;39:301.
429. Dale DC, Boxer L, Liles WC. The phagocytes: neutrophils and monocytes. *Blood* 2008;112:935.
430. Majno G. The healing hand: man and wound in the ancient world. Cambridge, MA: Harvard University Press; 1975:4.
431. Hunter J. A treatise on the blood, inflammation and gun-shot wounds. London: Nicol, 1774.
432. Craddock CG. Defenses of the body; the initiators of defense; the ready reserves and the scavengers. In: Wintrobe MM, ed. *Blood, Pure and Eloquent*, New York, NY; McGraw-Hill 1980:417-454.
433. Hammerschmidt DE, Harris PD, Wayland H, et al. Complement-induced granulocyte aggregation in vivo. *Am J Pathol* 1981;102:146-150.
434. Gerard NP, Gerard C. The chemotactic receptor for human C5a anaphylatoxin. *Nature* 1991;349:614-617.
435. von Tschanner V, Deranleau DA, Baggiolini M. Calcium fluxes and calcium buffering in human neutrophils. *J Biol Chem* 1986;261:10163-10168.
436. Krause KH, Lew PD. Subcellular distribution of Ca²⁺ pumping sites in human neutrophils. *J Clin Invest* 1987;80:107-116.
437. Theler JM, Lew DP, Jaconi ME, et al. Intracellular pattern of cytosolic Ca²⁺ changes during adhesion and multiple phagocytosis in human neutrophils. Dynamics of intracellular Ca²⁺ stores. *Blood* 1995;85:2194-2201.

438. Barrowman MM, Cockcroft S, Gomperts BD. Differential control of azurophilic and specific granule exocytosis in Sendai-virus-permeabilized rabbit neutrophils. *J Physiol* 1987;383:115.
439. Lew PD, Monod A, Waldvogel FA, et al. Quantitative analysis of the cytosolic free calcium deficiency of exocytosis from three subcellular compartments in intact human neutrophils. *J Cell Biol* 1986;102:2197.
440. Smolen JE, Stoehr SJ, Boxer LA. Human neutrophils permeabilized with digitonin respond with lysosomal enzyme release when exposed to micromolar levels of free calcium. *Biochem Biophys Acta* 1986;886:1-17.
441. Smolen JE, Korchak HM, Weissmann G. The roles of extracellular and intracellular calcium in lysosomal enzyme release and superoxidized anion generation by human polymorphonuclear leukocytes. *Biochim Biophys Acta* 1981;677:512.
442. Lew PD, Andersson T, Hed J, et al. Ca^{2+} -dependent and Ca^{2+} -independent phagocytosis in human neutrophils. *Nature* 1985;315:509.
443. Balazovich KJ, Smolen JE, Boxer LA. Endogenous inhibitor of protein kinase C: association with human peripheral blood neutrophils but not with specific granule-deficient neutrophils or cytoplasts. *J Immunol* 1986;137:1665.
444. Cui Y, Harvey K, Akard L, et al. Regulation of neutrophil responses by phosphotyrosine phosphatase. *J Immunol* 1994;152:5420-5428.
445. Cronstein BN, Levin RI, Belanoff J, et al. Adenosine: an endogenous inhibitor of neutrophil-mediated injury to endothelial cells. *J Clin Invest* 1986;78:760-770.
446. Cronstein BN, Levin RI, Philips M, et al. Neutrophil adherence to endothelium is enhanced via adenosine A1-receptors and inhibited by adenosine A2-receptors. *J Immunol* 1992;148:2201-2206.
447. Skubitz KM, Wickham NW, Hammerschmidt DE. Endogenous and exogenous adenosine inhibit granulocyte aggregation without altering the associated rise in intracellular calcium concentration. *Blood* 1988;72:29-33.
448. Condliffe AM, Chilvers ER, Haslett C, Dransfield I. Priming differentially regulates neutrophil adhesion molecule expression/function. *Immunology* 1996;89(1):105-111.
449. Brandolini L, Bertini R, Bizzarri C, et al. IL-1 beta primes IL-8-activated human neutrophils for elastase release, phospholipase D activity, and calcium flux. *J Leukoc Biol* 1996;59(3):427-434.
450. Roberts PJ, Williams SL, Linch DC. The regulation of neutrophil phospholipase A2 by granulocyte-macrophage colony-stimulating factor and its role in priming superoxide production. *Br J Haematol* 1996;92(4):804-814.
451. Mansfield PJ, Hinkovska-Galcheva V, Shayman JA, Boxer LA. Granulocyte colony-stimulating factor primes NADPH oxidase in neutrophils through translocation of cytochrome b(558) by gelatinase-granule release. *J Lab Clin Med* 2002;140(1):9-16.
452. El-Benna J, Dang PM-C, Gourgout-Pocidallo M-A. Priming of the neutrophil NADPH oxidase activation: role of p47phox phosphorylation and NOX2 mobilization to the plasma membrane. *Semin Immunopathol* 2008;30:279.
453. Brown GE, Reiff J, Allen RC, Silver GM, Fink MP. Maintenance and down-regulation of primed neutrophil chemiluminescence activity in human whole blood. *J Leukoc Biol* 1997;62(6):837-844.
454. Nauseef WM. Pin-ning down PMN priming. *Blood* 2010;116:5788.
455. Boussetta T, Gougert-Pocidallo M-A, Hayem G, et al. The prolyl isomerase Pin1 acts as a novel molecular switch for TNF- α -induced priming of the NADPH oxidase in human neutrophils. *Blood* 2010;116:5795.
456. Ward PA, Becker EL. The deactivation of rabbit neutrophils by chemotactic factor and the nature of the activatable esterase. *J Exp Med* 1968;127(4): 693-709.
457. O'Flaherty JT, Kreutzer DL, Showell HJ, Vitkauskas G, Becker EL, Ward PA. Selective neutrophil desensitization to chemotactic factors. *J Cell Biol* 1979;80(3):564-572.
458. Webster RO, Hong SR, Johnston RB Jr., Henson PM. Biological effects of the human complement fragments C5a and C5ades Arg on neutrophil function. *Immunopharmacology* 1980;2(3):201-219.
459. Genco RJ, Van Dyke TE, Levine MJ, Nelson RD, Wilson ME. 1985 Kreshover lecture. Molecular factors influencing neutrophil defects in periodontal disease. *J Dent Res* 1986;65(12):1379-1391.
460. Skubitz KM, Craddock PR, Hammerschmidt DE, August JT. Corticosteroids block binding of chemotactic peptide to its receptor on granulocytes and cause disaggregation of granulocyte aggregates in vitro. *J Clin Invest* 1981;68(1):13-20.

461. Walther A, Riehemann K, Gerke V. A novel ligand of the formyl peptide receptor: annexin I regulates neutrophil extravasation by interacting with the FPR. *Mol Cell* 2000;5(5):831-840.
462. Hayhoe RP, Kamal AM, Solito E, Flower RJ, Cooper D, Perretti M. Annexin 1 and its bioactive peptide inhibit neutrophil-endothelium interactions under flow: indication of distinct receptor involvement. *Blood* 2006;107(5):2123-2130.
463. Chadzinska M, Kolaczowska E, Seljelid R, Plytycz B. Morphine modulation of peritoneal inflammation in Atlantic salmon and CB6 mice. *J Leukoc Biol* 1999;65(5):590-596.
464. Blixt A, Johnson P, Braide M, Bagge U. Microscopic studies on the influence of erythrocyte concentration on the post-junctional radial distribution of leukocytes at small venular bifurcations. *Int J Microcirc Clin Exp* 1985;4:141-156.
465. Schmid-Schonbein GW, Usami S, Skalak R, Chien S. The interaction of leukocytes and erythrocytes in capillary and postcapillary vessels. *Microvasc Res* 1980;19:45-70.
466. Metchnikoff E. In: *Lectures on the comparative pathology of inflammation*. New York, NY: Dover, 1968:135-137.
467. Springer TA. Traffic signals for lymphocyte recirculation and leukocyte emigration: the multistep paradigm. *Cell* 1994;76:301-314.
468. Alon R, Hammer DA, Springer TA. Lifetime of the P-selectin-carbohydrate bond and its response to tensile force in hydrodynamic flow. *Nature* 1995;374:539-542.
469. Carman CV, Springer TA. A transmigratory cup in leukocyte diapedesis both through individual vascular endothelial cells and between them. *J Cell Biol* 2004;167(2):377-388.
470. Springer TA, Dustin ML. Integrin inside-out signaling and the immunological synapse. *Curr Opin Cell Biol* 2012;107.
471. Chen X, Xie C, Nishada N, et al. Requirement of open headpiece conformation for activation of leukocyte integrin $\alpha\zeta\beta_2$. *PNAS* 2010;107:14727.
472. Kim M, Carman CV, Yang W, et al. The primacy of affinity over clustering in regulation of adhesiveness of the integrin $\alpha_4\beta_2$. *J Cell Biol* 2004;167(6): 1241-1253.
473. Deban L, Russo RC, Sironi M, et al. Regulation of leukocyte recruitment by the long pentraxin PTX3. *Nat Immunol* 2010;11:328.
474. Choi EY, Chavakis E, Czabanka MA, et al. Del-1, an endogenous leukocyte-endothelial adhesion inhibitor, limits inflammatory cell recruitment. *Science* 2008;322:1101.
475. Eskin MA, Jotwani R, Abe T, et al. The leukocyte integrin antagonist Del-1 inhibits IL-17-mediated inflammatory bone loss. *Nature Immunol* 2012;13:465.
476. Gjelstrup LC, Boesen T, Kragstrup TW, et al. Shedding of large functionally active CD11/CD18 integrin complexes from leukocyte membranes during synovial inflammation distinguishes three types of arthritis through differential epitope exposure. *J Immunol* 2010;185:4154.
477. Evans BJ, McDowall A, Taylor PC, et al. Shedding of lymphocyte function-associated antigen-1 (LFA-1) in a human inflammatory response. *Blood* 2006;107:3593.
478. Lammermann T, Bader BL, Monkeley SJ, et al. Rapid leukocyte migration by integrin-independent flowing and squeezing. *Nature* 2008;453:51.
479. Senda N, Tamura H, Shibata N, Yoshitake J, Konko K, Tanaka K. The mechanism of the movement of leucocytes. *Exp Cell Res* 1975;91:393.
480. Houk AR, Jilkine A, Mejean CO, et al. Membrane tension maintains cell polarity by confining signals to the leading edge during neutrophil migration. *Cell* 2012;148:175.
481. Boyden SV. The chemotactic effect of mixtures of antibody and antigen on polymorphonuclear leucocytes. *J Exp Med* 1962;115:453.
482. Baum J, Mowat AG, Kirk JA. A simplified method for the measurement of chemotaxis of polymorphonuclear leukocytes from human blood. *J Lab Clin Med* 1971;77:501.
483. de Duve C, Wattiaux R. Functions of lysosomes. *Annu Rev Physiol* 1966;28:435.

484. Metchnikoff E. Sur la lutte des cellules de l'organisme contre l'invasion des microbes. *Ann Inst Pasteur Microbiol* 1887;1:321.
485. Wright DG, Gallin JI. A functional differentiation of human neutrophil granules: generation of C5a by a specific (secondary) granule product and inactivation of C5a by azurophil (primary) granule products. *J Immunol* 1977;119:1068-1076.
486. Babior BM. The respiratory burst of phagocytes. *J Clin Invest* 1984;73:599.
487. Klebanoff SJ. Antimicrobial mechanisms in neutrophilic polymorphonuclear leukocytes. *Semin Hematol* 1975;12:117; In: Bellanti JA, Dayton DH, eds. *The phagocytic cell in host resistance*. New York, NY: Raven Press, 1975.
488. Baldrige CW, Gerard RW. The extra respiration of phagocytosis. *Am J Physiol* 1933;103:235-236.
489. Rossi F, Zatti M. Biochemical aspects of phagocytosis in polymorphonuclear leucocytes. NADH and NADPH oxidation by the granules of resting and phagocytizing cells. *Experientia* 1964;20(1):21-23.
490. Babior BM, Kipnes RS, Curnutte JT. Biological defense mechanisms. The production by leukocytes of superoxide, a potential bactericidal agent. *J Clin Invest* 1973;52(3):741-744.
491. Hampton MB, Kettle AJ, Winterbourn CC. Inside the neutrophil phagosome: oxidants, myeloperoxidase, and bacterial killing. *Blood* 1998;92(9):3007-3017.
492. DeLeo FR, Quinn MT. Assembly of the phagocyte NADPH oxidase: molecular interaction of oxidase proteins. *J Leukoc Biol* 1996;60(6):677-691.
493. Curnutte JT. Chronic granulomatous disease: the solving of a clinic riddle at the molecular level. *Clin Immunol Immunopathol* 1993;67:S2-S15.
494. Babior BM. NADPH oxidase. *Curr Opin Immunol* 2004;16(1):42-47.
495. Nauseef WM. Assembly of the phagocyte NADPH oxidase. *Histochem Cell Biol* 2004;122(4):277-291.
496. Klebanoff SJ. Myeloperoxidase: friend and foe. *J Leukoc Biol* 2005;77(5): 598-625.
497. Klebanoff SJ. Myeloperoxidase: contribution to the microbicidal activity of intact leukocytes. *Science* 1970;169:1095.
498. Klebanoff SJ, White LR. Iodination defect in the leukocytes of a patient with chronic granulomatous disease of childhood. *N Engl J Med* 1969;280:460.
499. Test ST, Lampert MB, Ossanna PJ, et al. Generation of nitrogen-chlorine oxidants by human phagocytes. *J Clin Invest* 1984;74:1341-1349.
500. Malawista SE, Montgomery RR, Van Blaricom G. Evidence for reactive nitrogen intermediates in killing of staphylococci by human neutrophil cytoplasts. A new microbicidal pathway for polymorphonuclear leukocytes. *J Clin Invest* 1992;90:631-636.
501. Maly FE, Schurer-Maly CC. How and why cells make superoxide: the "phagocytic" NADPH oxidase. *NIPS* 1995;10:233-238.
502. Lehrer RI, Cline MJ. Leukocyte myeloperoxidase deficiency and disseminated candidiasis. *J Clin Invest* 1969;48:1478.
503. Babior BM. Oxidants from phagocytes: agents of defense and destruction. *Blood* 1984;64:959.
504. Lakshmi VM, Nauseef WM, Zenser TV. Myeloperoxidase potentiates nitric oxide-mediated nitrosation. *J Biol Chem* 2005;280(3):1746-1753.
505. Eiserich JP, Hristova M, Cross CE, et al. Formation of nitric oxide-derived inflammatory oxidants by myeloperoxidase in neutrophils. *Nature* 1998;391(6665):393-397.
506. Nath J, Powledge A. Modulation of human neutrophil inflammatory responses by nitric oxide: studies in unprimed and LPS-primed cells. *J Leukoc Biol* 1997;62(6):805-816.
507. Evans TJ, BATTERY LD, Carpenter A, Springall DR, Polak JM, Cohen J. Cytokine-treated human neutrophils contain inducible nitric oxide synthase that produces nitration of ingested bacteria. *Proc Natl Acad Sci U S A* 1996;93(18):9553-9558.
508. Weinberg JB. Nitric oxide production and nitric oxide synthase type 2 expression by human mononuclear phagocytes: a review. *Mol Med* 1998;4(9): 557-591.

509. Wheeler MA, Smith SD, Garcia-Cardena G, Nathan CG, Weiss RM, Sessa WC. Bacterial infection induces nitric oxide synthase in human neutrophils. *J Clin Invest* 1997;99(1):110-116.
510. Jensen MS, Bainton DF. Temporal changes in pH within the phagocytic vacuole of the polymorphonuclear neutrophilic leukocyte. *J Cell Biol* 1973;56:379.
511. Mandell GL. Intraphagosomal pH of human polymorphonuclear neutrophils. *Proc Soc Exp Biol Med* 1970;134:447.
512. Rous PJ. On the mobilization of acid material within cells. *J Exp Med* 1925;41:399.
513. Padgett GA, Hirsch JG. Lysozyme: its absence in tears and leukocytes of cattle. *Aust J Exp Biol Med Sci* 1967;45:569.
514. Baggilioni M, De Duve C, Masson PL, Heremans JF. Association of lactoferrin with specific granules in rabbit heterophil leukocytes. *J Exp Med* 1970;131:559.
515. Spitznagel JK. Nonoxidative antimicrobial reactions of leukocytes. In: Snyderman R, ed. *Contemporary topics in immunobiology*, vol. 14. New York, NY: Plenum, 1984.
516. Masson PL, Heremans JF, Schonke E. Lactoferrin, an iron-binding protein in neutrophilic leukocytes. *J Exp Med* 1969;130:643.
517. Arnold RR, Cole MF, McGhee JR. A bactericidal effect for human lactoferrin. *Science* 1977;197:263.
518. Baggilioni M, Hirsch JG, De Duve C. Further biochemical and morphological studies of granule fractions from rabbit heterophil leukocytes. *J Cell Biol* 1970;45:586.
519. Brewer DB. Electron microscopy of phagocytosis of staphylococci. *J Pathol* 1963;86:299.
520. Owen CA, Campbell EJ. The cell biology of leukocyte-mediated proteolysis. *J Leukoc Biol* 1999;65(2):137-150.
521. Ayoub EM, Wannamaker LW. The fate of group A streptococci following phagocytosis. *J Immunol* 1967;99:1099.
522. Cohn ZA. The fate of bacteria within phagocytic cells. I. *J Exp Med* 1963;117:27.
523. Rogers DE, Tompsett R. The survival of staphylococci within human leukocytes. *J Exp Med* 1952;95:209.
524. Weissman G. Effect on lysosomes of drugs useful in connective tissue disease. In: Campbell PN, ed. *Interaction of drugs and subcellular components in animal cells*. London: J & A Churchill, 1968.
525. Zucker-Franklin D. Electron microscope study of the degranulation of polymorphonuclear leukocytes following treatment with streptolysin. *Am J Pathol* 1965;47:419.
526. Baggilioni M, Dewald B. Exocytosis by neutrophils. In: Snyderman R, ed. *Contemporary topics in immunobiology*, vol. 14. New York, NY: Plenum, 1984.
527. Chikkappa G, Corcino J, Greener ML, Herert V. Correlation between various blood white cell pools and the serum B₁₂-binding capacities. *Blood* 1971;37:142.
528. Wiernik P, Sepick AA. Clinical significance of serum and urinary muramidase activity in leukemia and other hematologic malignancies. *Am J Med* 1969;46:330.
529. Lollike K, Kjeldsen L, Sengelov H, Borregaard N. Lysozyme in human neutrophils and plasma. A parameter of myelopoietic activity. *Leukemia* 1995;9:159-164.
530. Corcino J, Krauss S, Waxman S, Herbert V. Release of vitamin B₁₂-binding proteins by human leukocytes in vitro. *J Clin Invest* 1970;49:2250.
531. Stormorhen H. The release reaction of secretion. *Scand J Haematol [Suppl]* 1969;9:1.
532. Simons K, Weber T. The vitamin B₁₂-binding protein in human leukocytes. *Biochim Biophys Acta* 1966;117:201.
533. Allen RH. Human vitamin B₁₂ transport proteins. *Prog Hematol* 1975;9:57.
534. Herbert V. Diagnostic and prognostic values of measurement of serum vitamin B₁₂-binding proteins. *Blood* 1968;32:305.
535. Osserman EF, Lawlor DF. Serum and urinary lysozyme in monocytic and monomyelocytic leukemia. *J Exp Med* 1966;124:921.
536. Fink ME, Finch SC. Serum neuramidase and granulocyte turnover. *Proc Soc Exp Biol Med* 1968;127:365.

537. El Ouriaghli F, Fujiwara H, Melenhorst JJ, Sconocchia , Hensel N, Barrett AJ. Neutrophil elastase enzymatically antagonizes the in vitro action of G-CSF: implications for the regulation of granulopoiesis. *Blood* 2003;101(5):1752-1758.
538. Horwitz M, Benson KF, Person RE, Aprikyan AG, Dale DC. Mutations in ELA2, encoding neutrophil elastase, define a 21-day biological clock in cyclic haematopoiesis. *Nat Genet* 1999;23(4):433-436.
539. Dale DC, Person RE, Bolyard AA, et al. Mutations in the gene encoding neutrophil elastase in congenital and cyclic neutropenia. *Blood* 2000;96(7): 2317-2322.
540. Nassar T, Akkawi S, Bar-Shavit R, et al. Human alpha-defensin regulates smooth muscle cell contraction: a role for low-density lipoprotein receptor-related protein/alpha 2-macroglobulin receptor. *Blood* 2002;100(12):4026-4032.
541. Lu R, Pan H, Shively JE. CEACAM1 negatively regulates IL-1 β production in LPS activated neutrophils by recruiting SHP-1 to SYK-TLR4-CEACAM1 complex. *PLoS Pathogens* 2012;8:e1002597.
542. Netea MG, Simon A, van de Veerdonk F, et al. IL-1 β processing in host defense: beyond the inflammasomes. *PLoS Pathogens* 2010;6:e100661.
543. Brinkmann V, Reichard U, Goosmann C, et al. Neutrophil extracellular traps kill bacteria. *Science* 2004;303:1532.
544. Nauseef WM. Nyet to NETs? A pause for healthy skepticism. *J Leuk Biol* 2012;91:353.
545. Weiss SJ. Tissue destruction by neutrophils. *N Engl J Med* 1989;320:365-376.
546. Murrell GA, Francis MJ, Bromley L Modulation of fibroblast proliferation by oxygen free radicals. *Biochem J* 1990;265(3):659-665.
547. Stirpe F, Higgins T, Tazzari PL, Rozengurt E. Stimulation by xanthine oxidase of 3T3 Swiss fibroblasts and human lymphocytes. *Exp Cell Res* 1991;192(2):635-638.
548. McCord JM. The evolution of free radicals and oxidative stress. *Am J Med* 2000;108(8):652-659.
549. Lalezari P, Nussbaum M, Gelman S, Spaet TH. Neonatal neutropenia due to maternal isoimmunization. *Blood* 1960;15:236-243.
550. Huizinga TWJ, Kleijer M, Tetteroo PAT, et al. Biallelic neutrophil NA-antigen system is associated with a polymorphism on the phospho-inositol-linked Fc γ -receptor III (CD16). *Blood* 1990;75:213-217.
551. Lalezari P, Murphy GB, Allen FH. NB1, a new neutrophil antigen involved in the pathogenesis of neonatal neutropenia. *J Clin Invest* 1971;50:1108-1115.
552. Stroncek DF, Skubitz KM, McCullough JJ. Biochemical characterization of the neutrophil-specific antigen NB1. *Blood* 1990;75:744-755.
553. Skubitz KM, Stroncek DF, Sun B. The neutrophil-specific antigen NB1 is anchored via a glycosyl-phosphatidylinositol linkage. *J Leukoc Biol* 1991;49:163-171.
554. Goldschmeding R, van Dalen CM, Faber N, et al. Further characterization of the NB1 antigen as a variably expressed 56-62 kD GPI-linked glycoprotein of plasma membranes and specific granules of neutrophils. *Br J Haematol* 1992;81:336-345.
555. Bayat B, Werth S, Sachs UJH, et al. Neutrophil transmigration mediated by the neutrophil-specific antigen CD177 is influenced by the endothelial S₅₃₆N dimorphism of platelet endothelial cell adhesion molecule-1. *J Immunol* 2010;184:3889.
556. Bux J. Molecular nature of granulocyte antigens. *Transfus Clin Biol* 2001;8(3):242-247.
557. Bux J. Nomenclature of granulocyte alloantigens. ISBT Working Party on Platelet and Granulocyte Serology, Granulocyte Antigen Working Party, International Society of Blood Transfusion. *Transfusion* 1999;39(6):662-663.
558. Greinacher A, Wesche J, Hammer E, et al. Characterization of the human neutrophil alloantigen-3a. *Nature Medicine* 2010;16:45.
559. Curtis BR, Cox NJ, Sullivan MJ, et al. The neutrophil alloantigen HNA-3a (5b) is located on choline transporter-like protein 2 and appears to be encoded by an R>Q154 amino acid substitution. *Blood* 2010;115:2073.
560. Salmon JE, Edberg JC, Kimberly RP. Fc gamma receptor III on human neutrophils. Allelic variants have functionally distinct capacities. *J Clin Invest* 1990;85(4):1287-1295.

561. Bredius RG, Fijen CA, De Haas M, et al. Role of neutrophil Fc gamma RIIa (CD32) and Fc gamma RIIIb (CD16) polymorphic forms in phagocytosis of human IgG1- and IgG3-opsonized bacteria and erythrocytes. *Immunology* 1994;83(4):624-630.
562. Nagarajan S, Chesla S, Cobern L, Anderson P, Zhu C, Selvaraj P. Ligand binding and phagocytosis by CD16 (Fc gamma receptor III) isoforms. Phagocytic signaling by associated zeta and gamma subunits in Chinese hamster ovary cells. *J Biol Chem* 1995;270(43):25762-25770.
563. Matsuo K, Lin A, Procter JL, Clement L, Stroncek D. Variations in the expression of granulocyte antigen NB1. *Transfusion* 2000;40(6):654-662.
564. Stroncek DF, Jaszcz W, Herr GP, Clay ME, McCullough J. Expression of neutrophil antigens after 10 days of granulocyte-colony-stimulating factor. *Transfusion* 1998;38(7):663-668.
565. Chen SM, Dummler JS, Bakken JS, et al. Identification of a granulocytotropic Ehrlichia species as the etiologic agent of human disease. *J Clin Microbiol* 1994;32:589-595.
566. Bakken JS, Dummler JS, Chen SM, et al. Human granulocytic ehrlichiosis in the upper Midwest United States: a new species emerging? *JAMA* 1994;272:212-218.
567. Bakken JS, Kreuth J, Wilson-Nordskog C, et al. Clinical and laboratory characteristics of human granulocytic ehrlichiosis. *JAMA* 1996;275:199-205.
568. Goodman JL, Nelson C, Vitale B, et al. Direct cultivation of the causative agent of human granulocytic ehrlichiosis. *N Engl J Med* 1996;334:209-215.
569. Lee HC, Kioi M, Han J, et al. Anaplasma phagocytophilum-induced gene expression in both human neutrophils and HL-60 cells. *Genomics* 2008;92:144.
570. McCaffrey RL, Allen LA. Pivotal Advance: Francisella tularensis LVS evades killing by human neutrophils via inhibition of the respiratory burst and phagosome escape. *J Leuk Biol* 2006;80:1224-1230.

Chapter 8 The Human Eosinophil

> Table of Contents > Part II - The Normal Hematologic System > Section 3 - Granulocytes and Monocytes > Chapter 8 - The Human Eosinophil

Chapter 8

The Human Eosinophil

Paige Lacy

Darryl J. Adamko

Redwan Moqbel

INTRODUCTION

The eosinophil was first described for its characteristic intracytoplasmic granules exhibiting a high affinity for the negatively charged dye, eosin. Although rare in healthy individuals, the eosinophil is prominent in peripheral blood and tissue in association with various disease conditions including allergy,^{1,2,3} inflammatory responses against metazoan helminthic parasites,^{4,5} and certain skin and malignant conditions. The eosinophil has received special attention for its potential pathophysiologic role in the manifestation of allergic diseases such as asthma, rhinitis, eczema, eosinophilic esophagitis, and Crohn's disease. Disorders of the respiratory tract, particularly allergic asthma and rhinitis, exhibit a strong correlation with the number as well as activation status of infiltrating tissue eosinophils. Similarly, many disorders of the gastrointestinal system exhibit prominent eosinophilic inflammation in the mucosa. The presence of eosinophils in the airway and gut mucosa has been associated with both allergic (IgE-dependent) and nonallergic (IgE-independent) manifestations of disease. Although clinically these conditions have been characterized as either allergic or nonallergic, it appears that the mechanisms underlying recruitment and activation of eosinophils in both types of disease are similar. Despite some difficulties in defining the exact immunologic role of the eosinophil in disease, there is evidence that the eosinophil remains a major effector cell in many types of allergic and nonallergic inflammation.

Eosinophils are mobile, terminally differentiated granulocytes that arise principally from the bone marrow.⁶ They are approximately 8 μm in diameter and their nuclei are usually bilobed, although three or more lobes are also often

observed. The eosinophil is characterized by large crystalloid granules, also known as secondary or specific granules, as shown in light microscopy by their bright red staining properties with acidic dyes such as eosin (Fig. 8.1). As apparent in electron micrographs, the crystalloid granules contain electron-dense crystalline cores surrounded by an electron-lucent granule matrix (Fig. 8.2). Eosinophils contain up to four other “granule” types: primary granules, small granules, lipid bodies, and small secretory vesicles. Crystalloid granules are membrane-bound and contain a number of highly cationic basic proteins. The latter have been implicated in the tissue damage observed in asthma and other similar allergic conditions. Allergen and parasite-induced eosinophilia have been shown to be T-cell-dependent and are mediated by soluble factors (cytokines) released from sensitized lymphocytes.⁷ Recent advances in human eosinophil research have also indicated that eosinophil infiltration into the tissue in allergic-type responses and asthma is regulated by a series of biologic events which includes a complex interplay between immunologic and inflammatory mechanisms including cytokines and chemokines.^{1,3}

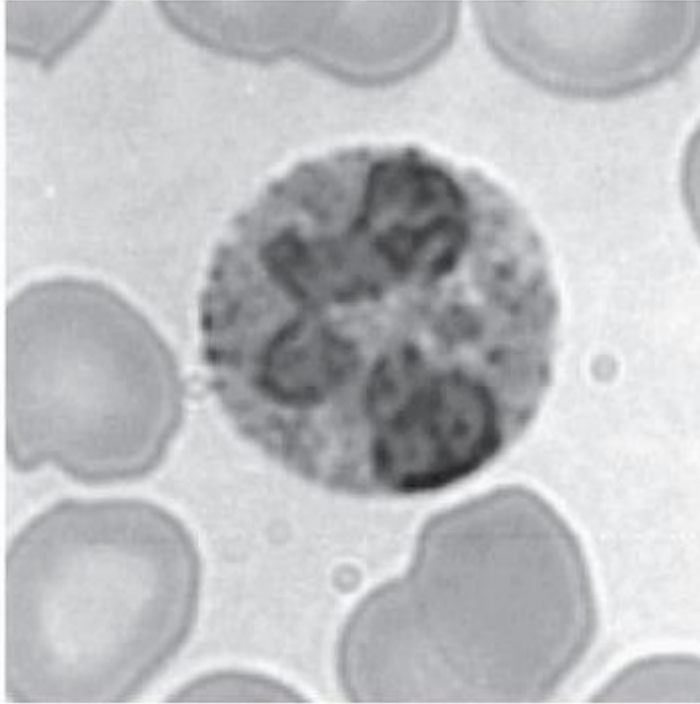

FIGURE 8.1. Photomicrograph of a peripheral blood eosinophil stained with May-Grünwald-Giemsa.

EOSINOPHIL MEDIATORS

The eosinophil is considered to be both a factory and a store for a large array of mediators that are released upon activation and are thought to be important in various inflammatory reactions associated with this cell (Fig. 8.3).

Eosinophil Granule Proteins

Eosinophils contain at least five different populations of phospholipid bilayer membrane-bound granules.

- **Crystalloid granules:** these specialized and unique granules measure between 0.5 and 0.8 μm in diameter, contain crystalline electron-dense cores (internum) surrounded by an electron-lucent matrix, and can take up acidic dyes avidly due to their cationic nature.^{8, 9} They are mainly present in mature eosinophils, although coreless granules have been observed in immature eosinophils. These granules contain the bulk of highly charged cationic proteins present in eosinophils, including major basic protein (MBP), eosinophil peroxidase (EPO), eosinophil cationic protein (ECP), and eosinophil-derived neurotoxin (EDN). There are approximately 200 crystalloid granules in each cell. The core is predominantly comprised of crystallized MBP (Fig. 8.4).
- **Primary granules:** these coreless granules are enriched with Charcot-Leyden crystal protein (CLC) and are present mainly in immature eosinophils, although mature eosinophils have been found to contain primary granules as well. Some authors refer to immature crystalloid granules as primary granules in eosinophil promyelocytes. These measure between 0.1 and 0.5 μm in diameter and are less abundant than crystalloid granules.

- Small granules: these granules are free of cores, are less than 0.1 μm in diameter, and contain acid phosphatase, arylsulfatase B, catalase, and cytochrome β_{558} .
- Lipid bodies: there are around five lipid bodies per mature eosinophil, the number of which increase in certain eosinophilic disorders, especially in idiopathic hypereosinophilia. Lipid bodies are enriched in arachidonic acid esterified into glycerophospholipids.
- Secretory vesicles: eosinophils are densely packed with small secretory vesicles in their cytoplasm. These vesicles appear as dumbbell-shaped structures in cross-sections, and contain albumin, suggesting an endocytotic origin. These structures are also known as microgranules or tubulovesicular structures.

Eosinophil MBP (13.8 kDa) is an arginine-rich 117 amino acid protein that constitutes a significant proportion of total cell protein in human eosinophils (5 to 10 pg/cell). MBP was originally named for its abundance in guinea pig eosinophils, which contain as many as 250 pg/cell, making up 50% of the total cellular protein.¹⁰ The high calculated pI point of MBP (11.4) cannot be measured accurately due to the extremely basic nature of the protein.¹¹ MBP is initially translated as pro-MBP (23 to 25 kDa)

P.161

with a calculated pI of 6 to 6.2 in maturing eosinophils.^{12,13} The synthesis of MBP is initiated during the promyelocytic stage of eosinophil development, characterized by the presence of message encoding this protein, in a neutral prepro-form which is later processed to form pro-MBP that is subsequently transported to the immature crystalloid granule and cleaved to form MBP.^{12,13} The pro-segment of pro-MBP is postulated to protect the cell from cytotoxic effects of MBP during trafficking of pro-MBP from the Golgi apparatus to the crystalloid granule. Mature MBP undergoes condensation from the periphery of immature crystalloid granules to the internum, where it develops a crystalline core as its concentration is increased.^{13,14} Once eosinophils have reached full maturity, MBP is no longer synthesized and messenger RNA encoding MBP disappears from the cell.^{13,15}

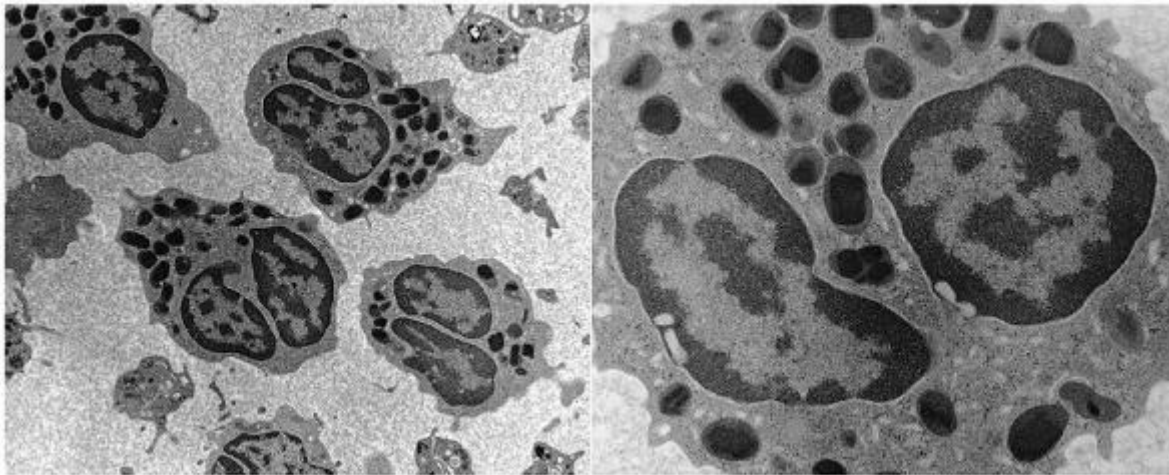

FIGURE 8.2. Electron photomicrographs of peripheral blood eosinophils from buffy-coat. Original magnification 7,655 \times and 22,000 \times . Courtesy of Dr. G.E. Quinonez, Department of Pathology, University of Manitoba.

MBP has been shown to exert cytotoxic effects on helminthic parasites and certain bacteria.⁸ It is also cytotoxic to human cells and especially airway tissues, including bronchial epithelial cells and pneumocytes, by disruption of cell membrane lipid bilayers.¹⁶ Such disruption leads to cell permeabilization and lysis, and leakage of cell contents to the extracellular milieu. Thus, MBP may be at least partly responsible for tissue damage and neural dysfunction associated with eosinophil infiltration into the bronchial mucosa in asthma.^{9,17,18} Indeed, airway sections from patients with status asthmaticus exhibit intense MBP-specific immunofluorescence, suggesting that infiltrated eosinophils were fully activated, undergoing extracellular secretion of their contents of MBP.¹⁹ MBP acts on other inflammatory cells, including neutrophils and eosinophils, to induce degranulation and lipid mediator release.^{20,21} Parasympathetic ganglia in the airways of patients dying of asthma exhibit eosinophil infiltration, and MBP is an allosteric antagonist for the M2 muscarinic receptor. Loss of M2 receptor function results in airway hyperreactivity.¹⁸ A homolog of MBP has been recently discovered, MBP2, with a calculated pI of 8.7, that possesses similar activities to MBP in cell killing as well as neutrophil and basophil stimulation, but with reduced potency.²²

De novo-synthesized lipid mediatorsLTC₄, PGE₁, PGE₂, TXB₂, 15-HETE, PAF**Oxidative metabolites**

Reactive oxygen species

Preformed granule-derived cationic proteins

Major basic protein (MBP)
Eosinophil peroxidase (EPO)
Eosinophil cationic protein (ECP)
Eosinophil-derived neurotoxin (EDN)
Charcot-Leyden crystal protein (CLC)

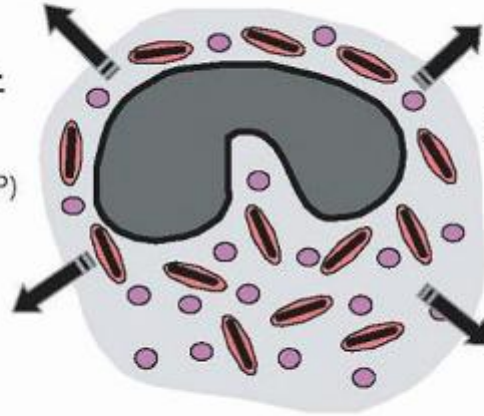
**Cytokines, chemokines, and growth factors**

IL-1 α , IL-2, IL-3, IL-4,
IL-5, IL-6, IL-8, IL-9,
IL-10, IL-12, IL-16,
TGF- α , TGF- β , SCF,
PDGF-B, NGF,
IFN- γ , TNF, GM-CSF,
RANTES, eotaxin,
MIP-1 α

FIGURE 8.3. Mediators released by activated eosinophils. De novo-synthesized lipid mediators and oxidative metabolites are elaborated directly from the cell membrane or lipid bodies following enzyme activation, while granule-derived cationic proteins and cytokines, chemokines, and growth factors are released following granule-plasma membrane fusion during degranulation. GM-CSF, granulocytemacrophage colony-stimulating factor; IFN, interferon; IL, interleukin; MIP, macrophage inhibitory protein; NGF, nerve growth factor; PAF, platelet-activating factor; PDGF, platelet-derived growth factor; PGE₂, prostaglandin E₂; SCF, stem cell factor; TGF, transforming growth factor; TNF, tumor necrosis factor; TXB₂, thromboxane B₂.

Other eosinophil basic proteins, including EPO, ECP, and EDN, reside in the matrix compartment of the crystalloid granule. EPO is a highly basic (pI of 10.9) heme-containing protein composed of two subunits, a heavy chain of 50 to 57 kDa and a light chain of 11 to 15 kDa. EPO is a haloperoxidase with 68% sequence identity to neutrophil and monocyte-expressed myeloperoxidase, suggesting that a peroxidase multigene family may have developed through gene duplication.^{11,23} Eosinophils store approximately 15 pg/cell of EPO, which is important in catalyzing the peroxidative oxidation of halides and pseudohalides, leading to the formation of bactericidal hypohalous acids in reaction with hydrogen peroxide generated during respiratory burst.^{24,25,26}

P.162

Unlike myeloperoxidase, EPO preferentially uses bromide over chloride in its enzyme activity, generating hypobromous acid.²⁷ EPO in the presence of H₂O₂ and halide (usually bromide) kills a variety of microorganisms, but also inflicts collateral damage on host tissue such as mast cells, and possesses antitumor activity. Binding of EPO to bacterial and parasitic pathogens also enhances their killing by phagocytic cells.

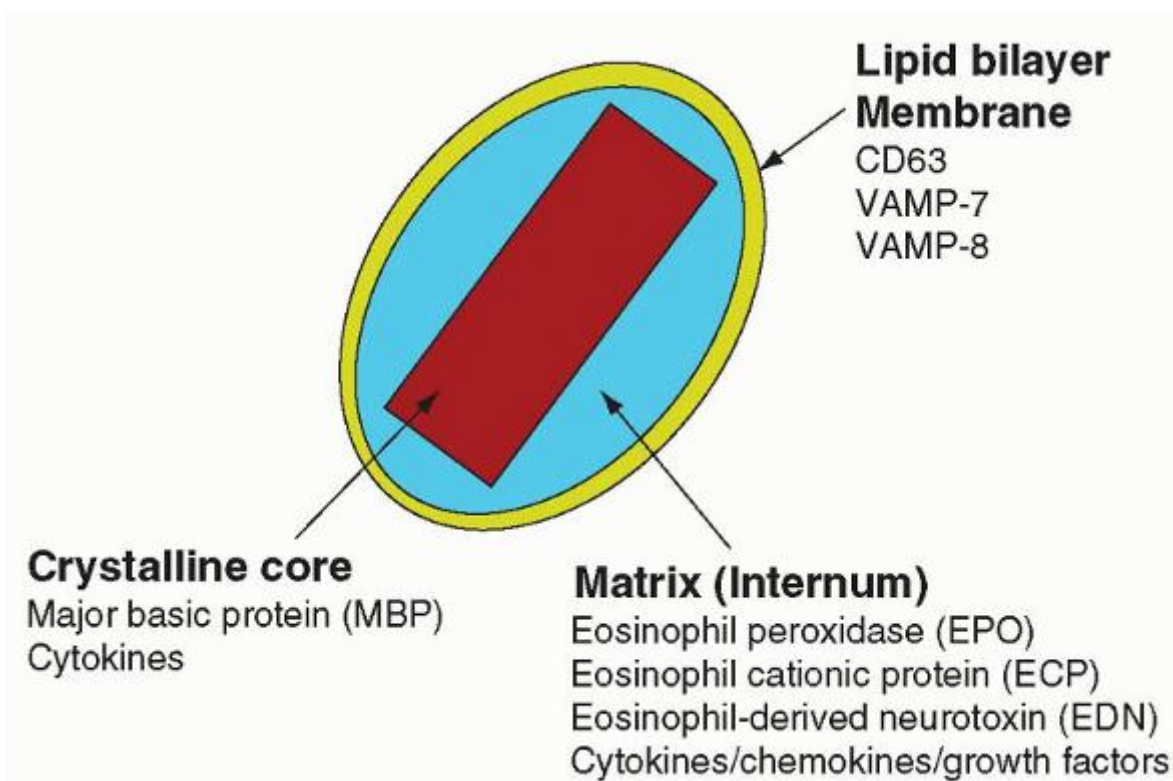

FIGURE 8.4. Structure of the eosinophil crystalloid granule. This membrane-bound organelle is a major site of storage of eosinophil cationic granule proteins as well as a number of cytokines, chemokines, and growth factors.

The molecular mass of ECP is 15 kDa, with around 15 pg/cell expressed in human eosinophils. The pI of ECP (10.8) is similar to that of MBP due to a similar arginine-rich sequence. ECP, also known as RNase-3, possesses intrinsic ribonuclease (RNase) activity and is a member of a subfamily of RNase A multigenes, with homology to pancreatic RNase. It is also antiviral, bactericidal, promotes degranulation of mast cells, and is toxic to helminthic parasites.^{28,29,30} and³¹ The mechanism of action of ECP is thought to involve the formation of pores or channels in the target membrane, which is apparently not dependent on its reversible RNase activity.³² ECP is also neurotoxic as derived from its ability to elicit the Gordon phenomenon, involving the destruction of nerve cells.^{33,34}

EDN, another member of the RNase A multigene family of 18.5 kDa with approximately a hundredfold higher RNase activity than ECP, is less basic than MBP or ECP with a pI of 8.9 due to a relatively smaller number of arginine residues in its sequence. ECP and EDN share a remarkable sequence homology of 67% at the amino acid level for the pre-form of both proteins, suggesting that evolutionarily, these proteins are derived from the same gene.^{35,36} Eosinophils express approximately 10 pg/cell of EDN, but there is marked variation between individuals. EDN also induces the Gordon phenomenon.^{33,34} Similar to ECP, EDN also has significant toxicity against viruses, bacteria, and helminths.^{31,37} Messenger RNA encoding EPO, ECP, and EDN has been detected in mature eosinophils, suggesting that eosinophils have the capacity to continue to synthesize these proteins.¹⁵

The gene family expressing ECP and EDN has among the highest rates of mutation in the primate genome, ranking with those of immunoglobulins, T-cell receptors, and major histocompatibility complex (MHC) classes.³⁶ These genes effectively comprise a superfamily of RNases expressed in the mammalian genome. Such an extreme rate of mutation suggests that the evolutionary constraints acting on the ECP/EDN superfamily have promoted the acquisition of a specialized antiviral activity. This may be inferred from the high mutation rates of other genes commonly associated with host protection against viral infection. Whether ECP or EDN possess any antiviral activity has yet to be demonstrated, although some studies have indicated that EDN may be a potent antiviral factor in respiratory infections.³¹

The CLC protein (17.4 kDa) is produced in eosinophils at very high levels (accounting for 10% of the total cellular protein) although its functional role is still obscure. CLC is a hydrophobic protein with lysophospholipase activity and bears a strong sequence homology to the carbohydrate-binding galectin family of proteins. For this reason, CLC protein has been designated galectin-10.³⁸ CLC is released in large quantities in the tissues in eosinophilic disorders, resulting in the formation of distinct, needle-shaped structures which are colorless and measure 20 to 40 μm in length and 2 to 4 μm

across. CLC crystals are abundant in the sputum and feces of patients with severe respiratory and gastrointestinal eosinophilia, which were first observed by Charcot and Robin in 1853.

A list of these and other granule proteins synthesized and stored in eosinophils is presented in Table 8.1 and published elsewhere.^{1,2,39,40} and ⁴¹

Eosinophil-derived Cytokines, Chemokines, and Growth Factors

Human eosinophils have been shown to produce at least 30 different cytokines, chemokines, and growth factors (Table 8.2) with the potential to regulate various immune responses. These cytokines have been identified in eosinophils by detecting mRNA and/or protein using RT-PCR, in situ hybridization, and immunocytochemical staining.^{42,43,44,45} In addition, picogram amounts of cytokines, chemokines, and growth factors were measured in supernatants of stimulated eosinophils.^{43,46} These cytokines are likely to act in an autocrine, paracrine, or juxtacrine manner, thereby regulating local inflammatory events. Studies have demonstrated that the production of eosinophil-activating cytokines (e.g., IL-3 and GM-CSF) by eosinophils may be important in prolonging the survival of these cells by a putative autocrine loop.^{43,47} For instance, adherence of highly purified eosinophils to the extracellular matrix protein, fibronectin, resulted in prolongation of survival of these cells in the absence of exogenous cytokines.⁴⁷ Fibronectin-induced eosinophil survival was inhibitable by antibodies against fibronectin and VLA-4 and up-regulated by picogram amounts of IL-3 and GM-CSF derived from eosinophils.⁴⁷ Observations on eosinophil cytokine release have been mainly studied in vitro, but a few have been confirmed in vivo.^{48,49,50} and ⁵¹ A recent study demonstrated that eosinophils elaborate APRIL (a proliferation-inducing ligand) and IL-6 which were essential for maintaining plasma cells in the bone marrow.⁵²

A major distinction in cytokine production between eosinophils and T-cells is that the former store their cytokines intracellularly as pre-formed mediators, and the latter produce and release cytokines only following activation. Although many eosinophil-derived cytokines are elaborated at lower concentrations than other leukocytes, eosinophils possess the ability to release these cytokines immediately (within minutes) following stimulation. Stored cytokines include IL-2, IL-4, IL-5, IL-6, IL-10, IL-13, IL-16, GM-CSF, TNF α , CC chemokine ligand 11 (CCL11)/eotaxin, IL-8, CCL5/RANTES, NGF, and TGF α .⁴⁵ Studies using immunogold electron microscopic analysis or confocal laser scanning microscopy coupled with double immunofluorescence labeling have indicated that several of these cytokines are found in close association with either the crystalline core or matrix of the crystalloid-specific granules of the cell (Table 8.2).^{44,53,54,55} and ^{56,57,58} For example, CCL5/RANTES was found to be associated predominantly with the matrix compartment of the crystalloid granule in eosinophils (Fig. 8.5).

P.163

TABLE 8.1 CONTENT OF HUMAN EOSINOPHIL GRANULES AND SECRETORY VESICLES

Crystalloid Granules	Primary Granules	Small Granules	Lipid Bodies	Secretory Vesicles
Core				
Catalase				
Cathepsin D				
Enoyl-CoA-hydrolase				
β -Glucuronidase				
Major basic protein				
Matrix				
Acid phosphatase	Charcot-Leyden crystal protein (galectin-10)	Acid phosphatase	Arachidonic acid	Plasma proteins [Albumin]
Acyl-CoA oxidase		Arylsulfatase B (active)	Cyclooxygenase	

Arylsulfatase B (inactive)	Catalase	Eosinophil peroxidase
Acid β -glycerophosphatase	Elastase	Esterase
Bactericidal/permeability-increasing protein	Eosinophil cationic protein	5-Lipoxygenase
Catalase		15-Lipoxygenase
Cathepsin D		LTC ₄ synthase
Collagenase		
Elastase		
Enoyl-CoA-hydrolase (also in core)		
Eosinophil cationic protein		
Eosinophil-derived neurotoxin		
Eosinophil peroxidase		
Flavin adenine dinucleotide (FAD)		
β -Glucuronidase		
β -Hexosaminidase		
3-Ketoacyl-CoA thiolase		
Lysozyme		
Major basic protein		
Phospholipase A ₂ (Type II)		
Nonspecific esterases		
Membrane		
CD63	VAMP-7	Cytochrome b ₅₅₈ [p22 $phox$]
V-type H ⁺ -ATPase	VAMP-8	VAMP-2
VAMP-7		VAMP-7
VAMP-8		VAMP-8

Developing eosinophils possess the ability to express cytokine message and protein at early stages of maturation. Eosinophils generated from semi-solid culture of cord blood-derived CD34⁺ cells in the presence of IL-3 and IL-5 were shown to express IL-5 and GM-CSF mRNA after 10 days of culture.⁵⁹ Freshly purified CD34⁺ cells expressed IL-4 and CCL5/RANTES mRNA, but not IL-4 and CCL5/RANTES protein. On day 23 of culture, IL-4 and CCL5/RANTES localized to the matrix of MBP⁺ crystalloid granules as determined by immunofluorescence.⁶⁰ In addition, IL-6 protein expression was found in cells after day 16 of culture.¹⁴

Another site of storage of cytokines and chemokines is within the small secretory vesicle. At least two such proteins were shown to be associated with these vesicles, namely CCL5/RANTES and TGF α immunolabeling.^{44,61} These organelles belong to the same group of secretory vesicles identified by electron microscopy analysis as tubulovesicular structures. CCL5/RANTES-positive vesicles are highly sensitive to stimulation by IFN γ and are rapidly mobilized (within 10 minutes of stimulation) to secrete CCL5/RANTES extracellularly.^{44,62} Crystalloid granules, which also contain CCL5/RANTES within their matrix compartment, were found to release this chemokine more slowly in response to IFN γ (1 hour), whereas the

majority of MBP remained associated with the core of these granules. These observations suggest that eosinophils have the ability to “shuttle” CCL5/RANTES from the crystalloid granules to the cell exterior, and may provide an important in vitro model for eosinophil piecemeal degranulation.

Eosinophil Degranulation

Degranulation is defined as the exocytotic fusion of granules with the plasma membrane during receptor-mediated secretion. During exocytosis, the outer leaflet of the lipid bilayer membrane surrounding the granule encounters the inner leaflet of the plasma membrane,

P.164

a process known as “docking.” The docking step is hypothesized to be regulated by intracellular membrane-associated proteins that act as receptors directing the specificity of granule targeting. After docking, the granule and plasma membrane fuse together and form a reversible structure called the fusion pore, which is also thought to be regulated by similar, or the same, membrane-associated proteins regulating granule docking. Depending on the intensity of the stimulus, the fusion pore may either retreat, leading to re-separation of the granule from the plasma membrane, or it may expand and allow complete integration of the granule membrane into the plasma membrane as a continuous sheet. The inner leaflet of the granule membrane becomes outwardly exposed, and the granule contents are subsequently expelled to the exterior of the cell.⁶³

TABLE 8.2 CYTOKINES, CHEMOKINES, AND GROWTH FACTORS PRODUCED BY HUMAN EOSINOPHILS

Cytokine	Products	Stored Protein in Resting Cells (per 10⁶ cells)	Intracellular Site of Storage
Interleukins			
Interleukin-1 α	mRNA, protein	-	-
Interleukin-2	mRNA, protein	6 \pm 2 pg	Crystalloid granules (core)
Interleukin-3	mRNA, protein	-	-
Interleukin-4	mRNA, protein	~75 \pm 20 pg	Crystalloid granules (core)
Interleukin-5	mRNA, protein	-	Crystalloid granules (core/matrix?)
Interleukin-6	mRNA, protein	25 \pm 6 pg	Crystalloid granules (matrix)
Interleukin-9	mRNA, protein	-	-
Interleukin-10	mRNA, protein	~25 pg	-
Interleukin-11	mRNA	-	-
Interleukin-12	mRNA, protein	-	-
Interleukin-13	mRNA, protein	-	-
Interleukin-16	mRNA,	1.6 \pm 0.8 ng	-

	protein		
Leukemia inhibitory factor (LIF)	mRNA, protein	-	-
Interferons and Others			
Interferon- γ (IFN γ)	mRNA, protein	-	-
APRIL (a proliferation-inducing ligand)	Protein	-	-
Granulocyte/macrophage colony-stimulating factor (GM-CSF)	mRNA, protein	15.1 \pm 0.3 pg	Crystalloid granules (core)
Tumor necrosis factor (TNF)	mRNA, protein	-	Crystalloid granules (matrix)
Chemokines			
Eotaxin	mRNA, protein	19 \pm 4 pg	Crystalloid granules
Interleukin-8	mRNA, protein	140 pg	Cytoplasmic
Macrophage inflammatory protein-1 α (MIP-1 α)	mRNA, protein	-	-
Monocyte chemoattractant protein-1 (MCP-1)	Protein	-	-
MCP-3	mRNA	-	-
MCP-4	mRNA	-	-
RANTES	mRNA, protein	72 \pm 15 pg	Crystalloid granules (matrix) and small secretory vesicles
Growth Factors			
Heparin-binding epidermal growth factor-like binding protein (HB-EGF-LBP)	mRNA, protein	-	-
Nerve growth factor (NGF)	mRNA, protein	4 \pm 2 pg	-
Platelet-derived growth factor, B chain (PDGF-B)	mRNA	-	-
Stem cell factor (SCF)	mRNA, protein	-	Membrane, cytoplasm
Transforming growth factor- α (TGF α)	mRNA, protein	22 \pm 6 pg	Crystalloid granules (matrix) and small secretory vesicles
Transforming growth factor- β 1 (TGF- β 1)	mRNA, protein	-	-

There are four main forms of eosinophil granule release, which have been observed in vitro and in vivo (Fig. 8.6). The first is the classical sequential release of single crystalloid granules, which was the original hypothesis suggested for a predominant route of degranulation in eosinophils. This type of release is typically seen in vitro and can be elegantly

demonstrated electrophysiologically using patch-clamp procedures that measure changes in membrane capacitance, which are directly proportional to increases in the surface area of the cell membrane. During the

P.165

sequential release of individual crystalloid granules, a stepwise increment in capacitance may be observed as their membranes fuse with that of the cell membrane.^{64,65,66} The second mode of granule release is compound exocytosis, also demonstrated by patch-clamp analysis in which sudden, very large increments in whole-cell capacitance occur resulting from individual granules fusing with the cell membrane.⁶⁷ Ultrastructural studies of guinea pig eosinophils have also demonstrated evidence for compound exocytosis⁶⁸ similar to that observed in rat eosinophils adhering to the outer surface of opsonized parasitic larvae.^{67,69} Additional evidence for compound exocytosis was suggested in eosinophils stimulated with a cocktail of IL-3, IL-5, and GM-CSF, which were observed to fuse their granules following activation as determined by immunofluorescence for CD63, a marker for crystalloid granules.⁷⁰

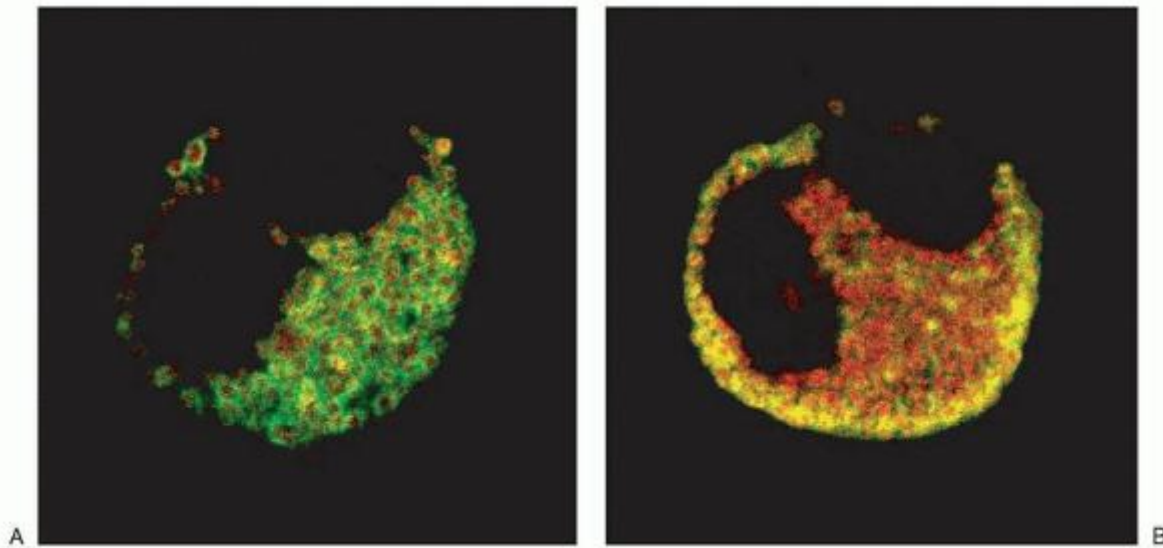

FIGURE 8.5. Translocation of the chemokine CCL5/RANTES in human eosinophils activated by interferon- γ in vitro. Immunoreactivities for CCL5/RANTES (green fluorescence) and eosinophil major basic protein (red fluorescence) are shown in control (A) and IFN- γ -stimulated (10 min, 500 U/ml) (B) cells. The yellow color in (B) resulted from co-localization of green and red immunofluorescence stains. Note that immunoreactivity for MBP remained associated with the cores of the crystalloid granules in both cells, whereas the green label for CCL5/RANTES translocated toward the cell membrane. CCL5/RANTES was proposed to be released from eosinophils by piecemeal degranulation. Experimental conditions described in Lacy et al. (1999) *Blood* 94:23-32.

The third manner in which eosinophils degranulate is by piecemeal degranulation (PMD). PMD was first characterized by Dvorak and colleagues for the appearance of numerous small vesicles in the cytoplasm coupled with the apparent loss of crystalloid granule core and matrix components, creating a “mottled” appearance in the crystalloid granules by electron microscopy analysis.⁷¹ This was thought to be due to small vesicles budding off from the larger secondary granules and moving to the plasma membrane for fusion, thereby causing gradual emptying of the crystalloid granules to the outside of the cell. PMD was the most commonly observed pattern of degranulation seen in situ in biopsy samples from the upper airways of allergic individuals,⁷² and is likely to be physiologically the most important mechanism for eosinophil mediator release in allergic disease. An in vitro model for PMD has been established using IFN γ -stimulated eosinophils, in which a piecemeal manner of CCL5/RANTES release was observed.^{44,62} More recent studies have demonstrated that PMD occurs through the formation of tubular structures budding off from crystalloid granules.^{73,74} Vesicles associated with PMD are also necessary for the transportation of MBP⁷⁵ and eosinophil-derived IL-4.^{73,76}

Airway tissue eosinophils in allergic subjects also appear necrotic, which is a fourth pattern of granule release, also termed “cytolysis”.⁷⁷ This type of release has been previously observed to occur following in vitro stimulation of human eosinophils with the calcium ionophore A23187,⁷⁸ and appears to be a physiologically relevant event in granule release.

Eosinophil degranulation may be induced by immobilized or soluble stimuli. Degranulation responses to immobilized stimuli have been extensively characterized in eosinophils in view of their role in helminth infections. When incubated

with opsonized helminths, eosinophils degranulate onto the surface of the parasite.^{69,79} A similar phenomenon occurs when eosinophils are incubated with Sepharose beads coated with antibodies, specifically IgG, IgA, and secretory IgA (sIgA), with sIgA being the most potent inducer of degranulation.⁸⁰ Cross-linking of immunoglobulin receptors on eosinophils has been shown to be highly effective at inducing respiratory burst and EDN degranulation in eosinophils, with a hierarchy of effectiveness in degranulation demonstrated to be on the order of secretory IgA (sIgA) = IgA > IgG >> IgE.⁸⁰ Eosinophil cytokines such as IL-3, IL-5, and GM-CSF were demonstrated to enhance this process.⁸¹

Eosinophils express a range of receptors for immunoglobulins that may contribute to chemotactic and activation responses in

P.166

tissues. These include receptors for IgA, IgD, IgE, IgG, and IgM, which may possess up to three chains (α , β , and γ). Human eosinophils express Fc α R, which is enhanced in allergic individuals,⁸² as well as Fc γ RII (CD32), but not Fc γ R I (CD64) or Fc γ R III (CD16). Mucosal tissues are enriched in sIgA, potentially as a mechanism against invasive pathogens. IgA, particularly the secretory isoform, is an important mucosal antibody involved in supporting the body's first line of defense. Thus, the sensitivity of the eosinophil to IgA is in agreement with its proposed role in protection against invasive organisms in mucosal tissues. Taken together, these findings along with eosinophil localization in mucosal tissues suggest an important role for sIgA and IgG in mediating the effector functions of eosinophils in vivo.

Modes of degranulation in eosinophils

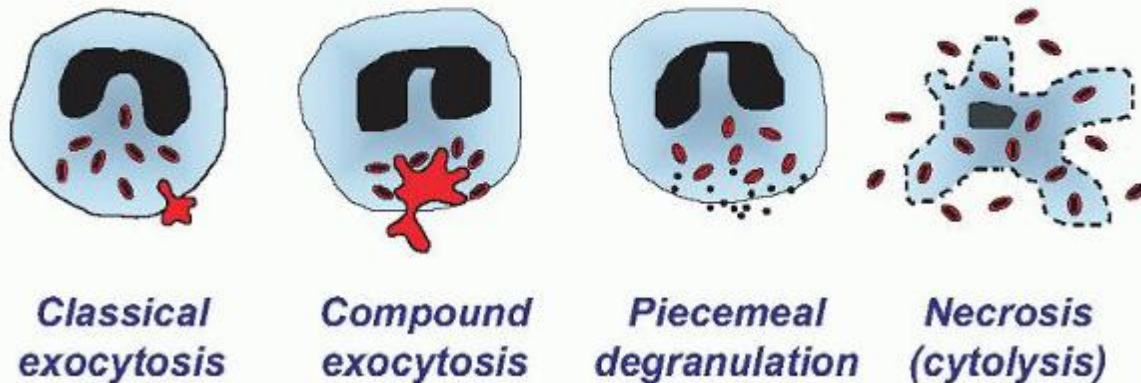

FIGURE 8.6. Four putative physiologic modes of eosinophil degranulation. The most commonly observed forms of degranulation in allergic disease are piecemeal degranulation and necrosis (cytolysis). Parasitic and fungal diseases typically exhibit eosinophils undergoing compound exocytosis.

Some controversy has surrounded the existence of the high-affinity receptor for IgE (Fc ϵ R I) on eosinophils. Studies have shown that the α subunit of Fc ϵ R I in eosinophils is expressed intracellularly rather than on the cell surface in resting cells, which may be mobilized to the surface and released during activation.^{83,84} Interestingly, although mouse Fc ϵ R I contains α , β , and γ subunits, the human homologue lacks the β subunit, suggesting that this subunit is redundant in signaling in cells expressing Fc ϵ R I. Eosinophils express an IgE-binding protein, galectin-3 (Mac-2/ ϵ binding protein), as well as the low-affinity Fc ϵ R II (CD23), which may have contributed to apparent high-affinity binding for IgE in earlier studies.

Degranulation from eosinophils may also be induced by a range of soluble stimuli. Cytokines and chemokines induce eosinophil degranulation, with IL-5 and GM-CSF having a more potent effect than CCL3/MIP-1 α or CCL5/RANTES.^{85,86,87} Eosinophil granule proteins (MBP and EPO) themselves can cause degranulation, suggesting that eosinophil granule proteins may promote degranulation in an autocrine manner.²¹ Many other soluble stimuli can also induce degranulation, including complement fragments C3a and C5a, f-Met-Leu-Phe, PAF, and naturally occurring peptides such as substance P and melittin.^{88,89} In addition, artificial stimuli potently evoke degranulation such as calcium ionophore (A23187) and phorbol myristate acetate (PMA).^{78,90} In particular, PAF is a potent secretagogue for eosinophils, inducing the release of granule proteins, reactive oxygen species, and lipid mediators.^{89,91,92} Furthermore, PAF activates at least two distinct effector pathways in eosinophils, one of which is independent of known PAF receptors.^{91,93} Eosinophils also respond by

degranulation to endogenous molecules released by stressed or damaged tissues. These include uric acid, ATP, high mobility group box (HMGB)-1 protein, and the S100 family of calcium-binding proteins.^{94,95} and ⁹⁶ Recently, eosinophils have been shown to express a newly discovered seven-transmembrane receptor, the chemoattractant receptor-homologous molecule expressed on Th2 cells (CRTh2),⁹⁷ which responds to prostaglandin D₂, a major prostanoid released by mast cells. PGD₂ induces morphologic changes, chemokinesis, and degranulation in eosinophils through CRTh2.

A role for eosinophils and their degranulation in the maintenance of innate immunity has been shown by their expression of Toll-like receptors (TLRs), which serve a role in recognition of conserved motifs in pathogens.⁹⁸ Eosinophils express the lipopolysaccharide (LPS)-binding receptor, TLR4, together with CD14,^{99,100} and respond to LPS stimulation. Furthermore, eosinophils constitutively express TLR1, TLR7, TLR9, and TLR10 mRNAs, and are activated by the TLR7 ligand.¹⁰¹ This may represent an important mechanism for eosinophil-mediated host defense against viral and bacterial infections.

Proteolytic enzymes also have the capacity to induce eosinophil degranulation. These are produced by microbes and are also present in various allergens, including house dust mites, fungi, and cockroaches. These enzymes interact with a family of G protein-coupled protease-activated receptors (PARs), and eosinophils constitutively transcribe mRNA for PAR2 and PAR3, but not PAR1 or PAR4.¹⁰² Exposure of eosinophils to trypsin, a potent serine protease that serves as an agonist for PAR2, induces respiratory burst and degranulation in eosinophils. Eosinophils also degranulate in response to cysteine proteases such as those from cockroaches and Der f 1 from mite allergens.^{103,104} Finally, eosinophils can degranulate in response to aspartate proteases produced by the fungus *Alternaria alternata*.¹⁰⁵ These findings suggest that eosinophils are able to recognize and respond to proteases in the environment, and that this results in the release of proinflammatory mediators.

Eosinophils also undergo degranulation upon stimulation of a β 2 integrin, Mac-1 (CD11b/CD18, α M β 2). This molecule has multiple roles in eosinophils; it is not only important in eosinophil adhesion and recruitment but also for activation of eosinophil effector functions. Integrins and especially Mac-1, play a crucial role in eosinophil activation by immobilized stimuli such as IgG.¹⁰⁶ Degranulation responses induced by soluble stimuli are potently enhanced by adhesion of eosinophils through integrins. Moreover, Mac-1 can directly recognize fungal molecules such as β -glucan, and eosinophils react by degranulation to fungi through this mechanism.¹⁰⁷ Thus, integrins play a major role in recognition of external pathogens and in eosinophil effector functions.

The mechanisms associated with classical exocytosis, compound exocytosis, and PMD, but not cytolysis, are thought to require specific intracellular membrane-associated proteins acting as receptors for granule docking and fusion. These proteins include a family of molecules known as SNAREs (an acronym for SNAP receptors). The paradigm associated with the SNARE molecule function predicts that these proteins are essential for exocytosis. SNAREs were originally described in neuronal tissues and were found to group themselves into two distinct locations, the granule-associated SNAREs (the so-called vesicular SNAREs or v-SNAREs) and the plasma membrane-associated SNAREs (target SNAREs or t-SNAREs).¹⁰⁸ In order for a functional SNARE complex to form, allowing the granule to dock with the plasma membrane, one v-SNARE binds to two t-SNARE molecules. In neuronal cells, a commonly observed v-SNARE is vesicle-associated membrane protein (VAMP)-1 or its isoform VAMP-2. In these cells, the t-SNAREs associating with VAMP-2 that were originally described were the synaptosome-associated protein of 25 kDa (SNAP-25) and syntaxin-1A. These three molecules form a stable detergent-resistant four-helix coiled-coil bundle, which may be regulated by protein phosphorylation.

Nonneuronal cells also express SNAREs, although some isoforms have been identified with high sequence homology to the neuronal SNAREs. At least three SNAP-25 and 16 syntaxin isoforms have been characterized based on detection of homologous SNARE motif messenger RNA sequences. Interestingly, most nonneuronal secretory cells appear to require SNAP-23 and syntaxin-3, syntaxin-4, or syntaxin-6^{109,110} and ¹¹¹ for control of exocytosis. Eosinophils have been shown to express the v-SNARE, VAMP-2, in their small secretory vesicles containing CCL5/RANTES, but not their crystalloid granules.¹¹² Crystalloid granules express mainly VAMP-7 and VAMP-8, the former being important in regulation of crystalloid granule secretion during degranulation responses from permeabilized eosinophils.¹¹³ The t-SNARE isoforms syntaxin-4 and SNAP-23 are expressed in the cell membrane of eosinophils, and these have the potential to act as cognate membrane binding partners for VAMP-2 and VAMP-7 degranulation.¹¹⁴ The SNARE molecules VAMP-2, SNAP-23, and syntaxin-4 identified in eosinophils are proposed to regulate docking and fusion of CCL5/RANTES-containing small secretory vesicles during piecemeal degranulation (Fig. 8.7).

A fascinating study has identified a hitherto unrecognized functional capacity for eosinophil granules that have been cytolitically released extracellularly (cell-free), a phenomenon known to occur *in vivo*.¹¹⁵ Isolated eosinophil granules were shown to respond to specific cytokine and chemokine stimuli via cognate receptors expressed on granule membranes, *in vitro*.¹¹⁶

These cytokine and chemokine receptors were found expressed on the granule membrane, in the same orientation as those on plasma membranes. Stimulating cell-free granule receptors resulted in activation of intragranular signaling pathways, which in turn, elicited secretion of cytokines and cationic proteins from within granules.¹¹⁶ This study has identified a novel postcytolytic capacity of intracellular organelles to function autonomously outside the eosinophil as ligand-responsive secretion competent structures for regulated secretion of eosinophil granule proteins. Such observations have implications for the notion that tissue-discharged, intact eosinophil granules may continue to contribute to eosinophil-mediated inflammation and immunomodulation.

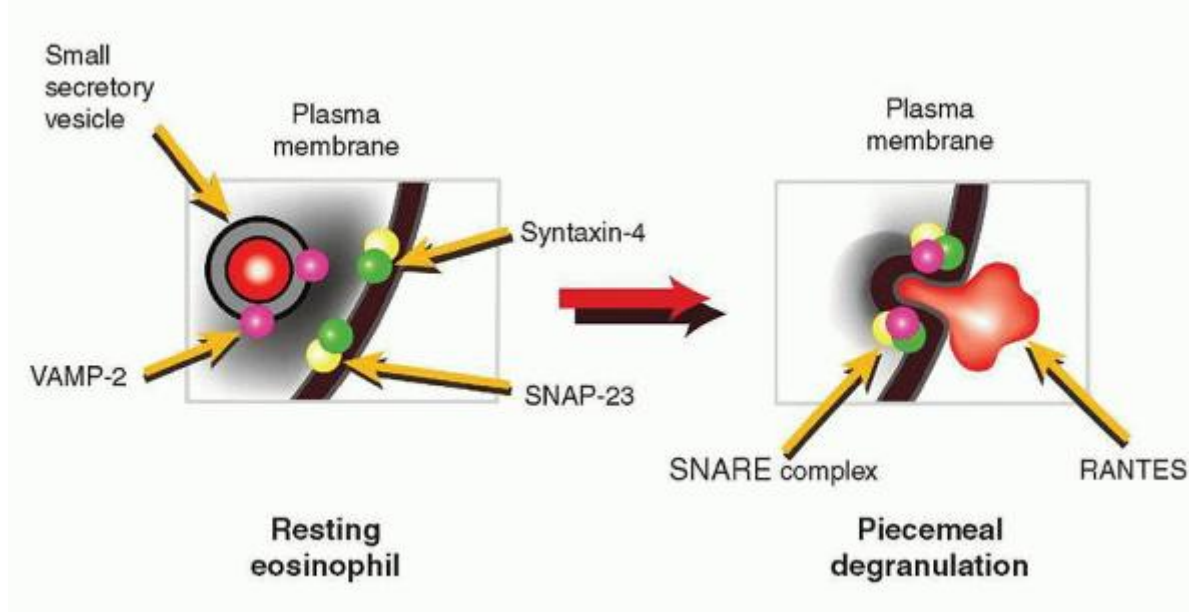

FIGURE 8.7. Schematic model for molecular regulation of granule-plasma membrane fusion proposed to occur in piecemeal degranulation in eosinophils. In this model, the v-SNARE VAMP-2 is expressed on small secretory vesicles that store CCL5/RANTES as a preformed mediator, and t-SNAREs, SNAP-23, and syntaxin-4 reside on the inside of the plasma membrane. Following cell activation, v- and t-SNAREs bind together to form a SNARE complex, resulting in fusion and release of vesicular contents including CCL5/RANTES. (See Lacy P, Logan MR, Bablitz B, Moqbel R. Fusion protein vesicle-associated membrane protein 2 is implicated in IFN- γ -induced piecemeal degranulation in human eosinophils from atopic individuals. *J Allergy Clin Immunol* 2001;107:671-678 and Logan MR, Lacy P, Bablitz B, Moqbel R. Expression of eosinophil target SNAREs as potential cognate receptors for vesicle-associated membrane protein-2 in exocytosis. *J Allergy Clin Immunol* 2002;109:299-306.

Mechanisms associated with granule release in eosinophils are critical for effector function of eosinophils. In the absence of degranulation and mediator secretion, the eosinophil is a relatively inert cell, and does not affect surrounding tissues, as seen in cases of idiopathic pulmonary eosinophilia and eosinophilic pneumonia. In these conditions, eosinophil numbers are increased in the capillaries and tissues of the lung, but no cellular or structural damage is evident, likely because of the lack of eosinophil degranulation. In contrast, asthmatic patients show profound eosinophil activation in the airways combined with significant tissue destruction, suggesting that, in addition to eosinophilic infiltration, their undergoing degranulation may contribute to mucosal damage in the airways and related symptoms of asthma. Thus, degranulation is a key event in eosinophil-mediated tissue damage.

Membrane-derived Mediators

Eosinophils produce a wide variety of lipid-derived mediators, which have profound biologic activity. The more important products are eicosanoids, which include leukotrienes (especially LTC₄), prostaglandins (particularly PGE₂), thromboxane, and lipoxins (especially LXA₄) as well as PAF. The main substrate for these mediators is arachidonic acid (AA), which is specifically liberated from membrane phospholipids possessing this fatty acid at the sn-2 position by phospholipase A₂ (PLA₂) during receptor stimulation. Of the nine known families of PLA₂, two families are expressed in eosinophils, the type IIA and type IV enzymes, which are commonly known as secretory and cytosolic PLA₂, respectively.^{117,118} These enzymes are distinguished by their distribution, size, and sensitivity to Ca²⁺, where granule-stored sPLA₂ (13 to 15 kDa) requires

millimolar amounts of Ca^{2+} for activity and cytosolically localized cPLA₂ (85 kDa) is catalytically active in the presence of micromolar amounts of Ca^{2+} . Interestingly, eosinophils express twenty- to a hundredfold higher levels of secretory PLA₂ in their granules than other circulating leukocytes, suggesting a functional role in inflammatory processes involving eosinophil degranulation.

Eosinophils are a rich source of LTC₄ (5S-hydroxy-6R, S-glutathionyl-7,9,-trans-11,14-cis-eicosatetraenoic acid).^{119,120} Stimulation with the calcium ionophore A23187 generates up to 40 ng/10⁶ cells of LTC₄ from normal density eosinophils, whereas light density eosinophils elaborate 70 ng/10⁶ cells. Eosinophils produce negligible amounts (6 ng/10⁶ cells) of LTB₄ (5S-12R-dihydroxy-6,14-cis-8,10-trans-eicosatetraenoic acid) compared with up to 200 ng/10⁶ cells from neutrophils. LTC₄ generation by human eosinophils was also observed after stimulation with both opsonized zymosan and via an FcγRII-dependent mechanism using Sepharose beads coated with IgG.¹²¹ Release was maximal at 45 minutes, greater in hypodense eosinophils than normal density eosinophils and was enhanced by fMLF (see Eosinophil Heterogeneity below for a description of hypodense eosinophils). The production of LTC₄ is critically dependent upon the activation of 5-lipoxygenase, an enzyme that resides in the euchromatin region of the nucleus which translocates to the nuclear membrane upon cell activation, where it activates an 18 kDa protein called FLAP.¹²² The substrate for 5-lipoxygenase is AA, which may be released from membrane phospholipids by PLA₂. The first product of this enzyme is an intermediary compound, 5-HPETE, which is transformed into the unstable epoxide LTA₄. At this point, human eosinophils predominantly generate LTC₄ through the action of LTC₄ synthetase.^{119,120} Eosinophils are particularly rich in LTC₄ synthetase, and account for 70% of all LTC₄ synthetase-positive cells in the airway mucosa of normal and asthmatic individuals.¹²³ LTC₄ is generated intracellularly in human eosinophils stimulated with the calcium ionophore A23187. LTC₄ is later exported from the cell in a regulated manner.¹²⁴

The production of 15-HETE, a lipid mediator generated via the 15-lipoxygenase pathway, occurs in activated eosinophils. The product 15-HETE has proinflammatory actions and can modulate the chemotactic effects of LTB₄ on neutrophils.¹²⁵ The enzyme 15-lipoxygenase may be distinguished from 5-lipoxygenase in that it can modify a larger pool of fatty acid substrates than the latter enzyme, and will oxygenate fatty acids that are esterified in phospholipids. Substrates include arachidonic acid, linoleic acid, polyenoic acids, and more complex lipids, such as lipoproteins. Eosinophils are the major cellular source of elevated 15-HETE in asthmatic airways, and are capable of generating 100 to 300 times more 15-HETE than neutrophils, endothelial cells, and fibroblasts.¹²⁶ Eosinophils also account for 85% of cells positive for 15-lipoxygenase in the airway submucosa of normal and asthmatic subjects.^{127,128}

P.168

Eosinophils generate large amounts of PAF after stimulation with either calcium ionophore, opsonized zymosan, or IgG-coated Sepharose beads.^{129,130,131} and ¹³² PAF (1-O-alkyl-2-acetyl-snglycerol-3-phosphocholine) is a potent phospholipid mediator, which causes leukocyte activation. For instance, eosinophils elaborated 25 ng/10⁶ cells of PAF after stimulation with calcium ionophore and up to 2 ng/10⁶ cells after IgG stimulation. Much of the PAF remained cell-associated, possibly acting as an intracellular messenger, or alternatively binding to PAF receptors on eosinophils thus acting as an autocrine agent. Interestingly, stimulation of eosinophils with fMLF did not augment PAF release and hypodense eosinophils from patients with a marked eosinophilia released less PAF than normal eosinophils. [³H]PAF added to hypodense eosinophils was more rapidly incorporated into the phospholipid pool than [³H]PAF with normal density cells.¹³¹ This suggested that hypodense eosinophils were metabolizing the exogenous PAF at a greater rate than normodense cells and may explain why stimulation with fMLF did not result in an increased amount of PAF generation. As with leukotriene synthesis, eosinophil-derived release of PAF was maximal at 45 minutes. Regulated PAF production is controlled by the release of biologically inactive lyso-PAF from membrane phospholipids by PLA₂, which is later acetylated to form PAF by an acetyltransferase.¹³⁰

The cyclooxygenase pathway is prominent in eosinophils as well, and eosinophils are capable of producing PGE₁ and PGE₂, and thromboxane B₂ from cyclooxygenase acting on free AA. In studies with guinea pig eosinophils, thromboxane B₂ and PGE₂ were shown to be generated following PAF or A23187 stimulation.^{133,134}

Many of the enzymes associated with membrane-derived mediator release from eosinophils, including cyclooxygenase and 5-lipoxygenase, are found stored in association with lipid bodies (see Table 8.1).^{135,136,137}

Respiratory Burst

Eosinophils undergo respiratory burst concurrently with the release of other mediators during cell activation. The immune function of respiratory burst is to mediate killing of invasive pathogenic microorganisms; it also has the undesired effect of

collateral tissue damage when dysregulated. Respiratory burst is defined as the increase in cell metabolism (measured by the elevated activity of the hexose monophosphate shunt) and oxygen consumption, coupled with the inducible release of reactive oxygen species (ROS) in response to specific stimuli. Many stimuli are capable of inducing respiratory burst in eosinophils, including LTB₄, PAF, fMLF, C5a, opsonized particles, and CCL5/RANTES.³⁹ The principal product of respiratory burst is superoxide (O₂^{-•}), a potent oxidant with a highly reactive electron in its outer valence, possessing relatively weak intrinsic microbicidal activity and a very brief half-life. The function of O₂^{-•} is thought to reside in its ability to dismutate rapidly into more reactive ROS, including hydrogen peroxide (H₂O₂), the hydroxyl radical (OH^{-•}), and formation of hypohalous acids (HOBr) upon reaction with EPO produced following eosinophil degranulation. The formation of ROS subsequent to O₂^{-•} generation is dependent upon the presence of a number of catalysts, such as superoxide dismutase (SOD), which accelerates the formation of H₂O₂, and the ferrous ion, which induces OH^{-•} production from H₂O₂. O₂^{-•} is also able to react with nitric oxide (NO) produced from nitric oxide synthase enzymes (e.g., iNOS, eNOS) to form the highly reactive peroxynitrite (ONOO⁻), which alters cell functions and is cytotoxic.

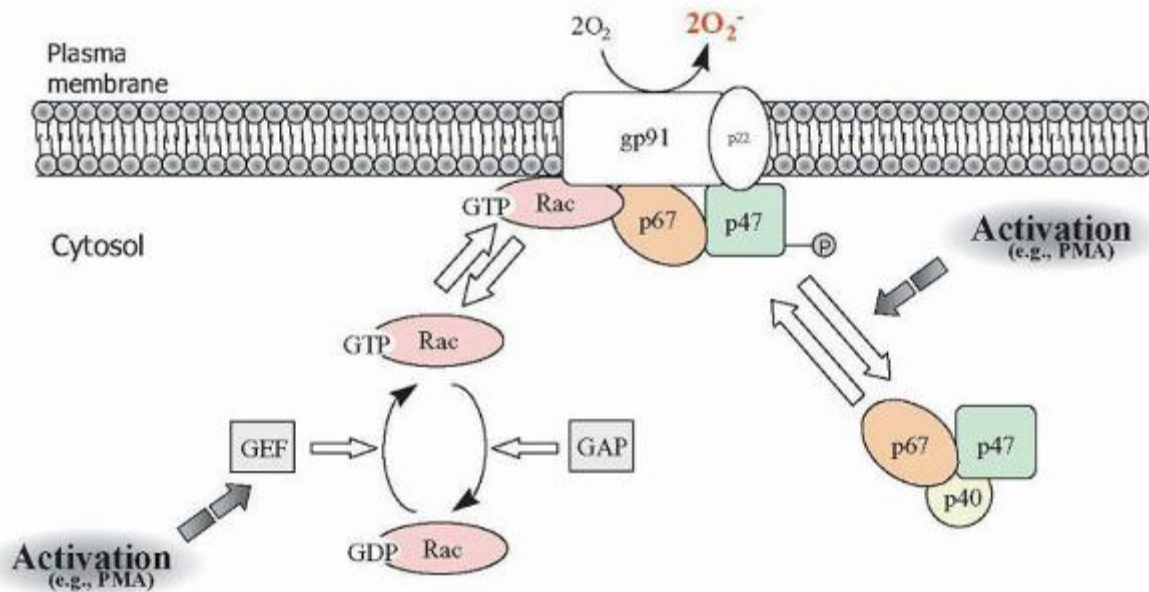

FIGURE 8.8. Assembly and activation of the NADPH oxidase complex during respiratory burst. This complex is essential for the inducible release of superoxide for microbicidal reactions and is also present in neutrophils. During cell activation, the GTPase Rac, normally bound to GDP in the resting cell, is activated by a guanine exchange factor (GEF) to bind to GTP. This results in translocation of Rac-GTP to the cell membrane, where other cytosolic proteins p67phox and p47phox have also translocated, to bind to the two subunits of cytochrome b₅₅₈ (gp91phox and p22phox). Following the assembly of the oxidase, electrons are transferred from NADPH in the cytosol via flavin adenine dinucleotide (a co-factor) to oxygen molecules to form the highly reactive oxygen intermediate, superoxide. Assembly of this complex is reversed by GTPase-activating protein (GAP), which hydrolyzes GTP on Rac to GDP, and by the dissociation of the phox subunits.

The regulated burst of O₂^{-•} production is mediated through the activation of a membrane-associated enzyme complex, the NADPH oxidase. This enzyme complex is crucial for maintenance of host defense as it is a key mechanism in the destruction of ROS-sensitive organisms. In addition, overactivation of the NADPH oxidase is likely to be cytotoxic to tissues, and has been implicated in the pathogenesis of many eosinophil-related disorders including allergic asthma.¹³⁸

Interestingly, eosinophils possess the ability to generate up to tenfold more superoxide than other phagocytes, including neutrophils, in which the mechanisms associated with NADPH oxidase activation have been studied in greater detail.¹³⁹ The ability of eosinophils to release more O₂^{-•} is thought to be the result of higher levels of expression of the protein components that make up the NADPH oxidase complex.^{140,141} and ^{142,143,144} In addition, preferential assembly of NADPH oxidase occurs at the cell membrane in eosinophils, eliciting a predominantly extracellular form of O₂^{-•} release.¹⁴⁵ This is in contrast to neutrophils, which show predominantly intracellular NADPH oxidase assembly during respiratory burst stimulation and bacterial infection.^{145,146}

NADPH oxidase is a complex of at least 6 proteins consisting of phagocytic oxidase (phox) subunits, of which two (p22phox and gp91phox) reside in the membrane as part of the cytochrome b₅₅₈ protein, and the remaining proteins (p40phox,

p47phox, p67phox, and Rac1 or Rac2) are cytosolic in resting cells.¹³⁹ The minimal components of the NADPH oxidase complex were determined using cell-free assays,¹⁴⁷ although several other proteins, such as p40phox and Rap1a, also translocate to the membrane-associated oxidase complex during activation, and may be involved in “finetuning” the activity of the oxidase.¹⁴⁸ Under normal nonstimulated conditions, the phagocytic oxidases p40phox, p47phox, and p67phox are complexed in the cytosol, whereas Rac1 or Rac2 are bound to the cytosolic guanine dissociation inhibitor RhoGDI (Fig. 8.8). Binding between p47phox and p67phox occurs through the C-terminal SH3 domain of p67phox and a proline-rich region (PRR) in p47phox. The p67phox protein also contains a C-terminal Bem1p (PB1) motif that allows a high-affinity interaction with a C-terminal phox and Cdc motif in p40phox.^{149,150} An SH3 domain also exists in p40phox that is capable of interacting with the PRR domain in p47phox,

P.169

although *in vitro* binding studies indicate that the affinity of this interaction is lower than that of p40phox for p67phox.^{151,152}

During activation by cell surface receptors engaged by opsonized microbes or inflammatory mediators, p47phox is phosphorylated by cellular kinases on multiple serine residues, unmasking tandem SH3 domains to allow binding to p22phox in the membrane. Concurrently, p67phox and p40phox, which are still complexed to p47phox, translocate to the cell membrane, and the “activation domain” in p67phox promotes electron transfer between NADPH and flavin adenine dinucleotide.¹⁵³ Superoxide generation from NADPH oxidase also requires concurrent activation and membrane translocation of Rac1 or Rac2, which binds to tetratricopeptide repeat motifs in the N-terminus of p67phox and cytochrome b_{558} to induce additional conformational changes necessary for efficient electron transport to O_2 .¹⁵⁴ The function of p40phox is still uncertain, although a recent study suggests that it may have a role in activating superoxide production during IgG-mediated phagocytosis.¹⁵⁰

Rac1 and Rac2 are monomeric guanine triphosphatases (GTPases), which exhibit 92% homology in their amino acid sequence, and are functionally interchangeable in their ability to activate NADPH oxidase, although they differ in their tissue distribution. Another potential modulator of the oxidase is the monomeric GTPase Rap1a, although its precise role is unknown. Rac1 is ubiquitously expressed throughout the body, whereas neutrophils, eosinophils, and other blood cells predominantly express Rac2, which is mainly expressed in hemopoietic tissues.^{145,155,156} and ¹⁵⁷ Activation of the respiratory burst in eosinophils leads to translocation of Rac to NADPH complexes predominantly at the cell membrane, in contrast to neutrophils which form NADPH complexes mainly at intracellular sites.¹⁴⁵ These patterns of NADPH oxidase complex formation align with the concept that eosinophils undergo “frustrated phagocytosis” upon encountering large extracellular organisms such as helminthic parasites, whereas neutrophils preferentially phagocytose smaller microbes for intracellular killing. Eosinophils are partially dependent on Rac2 for the activation of respiratory burst responses, based on findings with Rac2^{-/-} mouse eosinophils, inferring that Rac1 may also be required for NADPH oxidase activation in these cells.¹⁵⁸

The pathway leading from receptor stimulation to activation of the oxidase is still poorly understood. Many studies on NADPH oxidase activation use phorbol esters, such as phorbol myristate acetate (PMA), as highly potent artificial stimuli to activate respiratory burst in eosinophils. Phorbol esters are classically known for their ability to activate protein kinase C (PKC) directly.^{159,160} and ¹⁶¹ The use of pharmacologic inhibitors of PKC in respiratory burst has generated paradoxical results, in that PKC inhibitors only partially inhibit agonist-induced H_2O_2 release in guinea pig eosinophils.^{160,162} However, there is a species difference in sensitivity to PMA, as in human eosinophils, where PKC inhibitors actually augment the rate of oxygen consumption in response to opsonized particles.¹⁶³ These findings suggest that PKC is not critical for agonist-induced respiratory burst in eosinophils, although stimulation of PKC appears to be able to induce superoxide release on its own.

Taken together, eosinophils generate substantial amounts of $O_2^{\cdot-}$ as part of their role in host defense, and the mechanisms associated with the release of this toxic mediator are under investigation. The release of $O_2^{\cdot-}$ from eosinophils is likely to be a crucial component of the pathophysiologic processes underlying eosinophilic inflammation in mucosal tissues.

Eosinophils as Immunoregulatory Cells

The consistent association of eosinophils with a specific pattern of immune response common to helminth infection and atopy suggests that eosinophils may be either a bystander cell or an active component of a complex immune disease. To determine the involvement of eosinophil-derived factors in modulating the immune response, the expression and bioactivity of cytokines released from eosinophils have been explored for their potential physiologic effects in immune

regulation. Studies have shown that a striking diversity of cytokines and chemokines, including IL-2, IL-4, IL-12, IL-16, GM-CSF, CCL5/RANTES, and TGF β , are derived from eosinophils and are capable of exerting bioactive effects.^{41,45} For example, IL-2 and IFN γ from CD28-stimulated eosinophils were shown to stimulate proliferation in an IL-2-dependent cell line and MHC Class II expression on Colo 205 cells, respectively.¹⁶⁴ The release of IL-4 from eosinophils is important in driving the initiation of a Th2-type response in *Schistosoma mansoni* infection in mice.¹⁶⁵ Eosinophil-derived IL-4 also plays an immunoregulatory role in pulmonary cryptococcosis, as determined in 4get mice (IL-4-IRES-eGFP mice, with eGFP+ IL-4 expressing cells) treated with *Cryptococcus neoformans*, contributing to a susceptibility to Th2-dependent allergic responses during bronchopulmonary mycosis.¹⁶⁶ Secretion of the cytokines APRIL and IL-6 from eosinophils has been shown to be critical for the maintenance of plasma cells in the bone marrow.⁵² These studies have demonstrated that eosinophil-derived cytokines and chemokines have the ability to regulate a range of immune and inflammatory responses.

Generally speaking, eosinophils produce significantly smaller amounts of cytokines than T-cells, B-cells, and other cells. However, in eosinophilic inflammation, eosinophils outnumber T-cells in the tissues by as much as a hundredfold. As such, the magnitude of the presence of eosinophils may be a determining factor in regulating immune responses at a local level. The release of eosinophil cytokines often takes place within a much shorter period than cytokines released by T-cells (which may be several hours), as eosinophil-derived cytokines are stored as pre-formed mediators in crystalloid granules and may be secreted in response to stimuli in a matter of minutes. The production of cytokines by eosinophils is postulated to contribute to an immunoregulatory role by these cells, and may promote an allergic phenotype by influencing the production of Th2 cytokines by T-cells.

Allergy is often characterized by a significant polarization of the immune response toward enhanced production of Th2 cytokines and a dramatic increase in allergen-specific and total immunoglobulin E (IgE) levels. Allergic disease is initiated by the generation of allergen-specific CD4⁺ cells that produce the Th2 cytokines IL-4, IL-5, IL-9, and IL-13. These cytokines are crucial for the maturation, proliferation, survival, and activation of mast cells, basophils, and eosinophils, important effector cells. Th2 cytokines also regulate IgE synthesis by B-cells and mucus production by epithelial cells. In contrast, Th1 cells are characterized by the production of the Th1 cytokines IL-2 and IFN- γ . The immunologic responses of eosinophils are dependent on an array of cytokines and chemokines that may traditionally be associated with Th1 or Th2 responses. Eosinophils synthesize many of these cytokines and chemokines to which they can also respond. Based on their ability to synthesize, store, and release both Th1 and Th2 cytokines and chemokines, and significant evidence indicating the bioactivity of their released cytokines, eosinophils have been implicated as active components of allergic disease, rather than as bystander cells.

Classically, the Th1 response has been modeled as an immune response that exerts inhibitory effects on Th2 responses. It is therefore paradoxical that eosinophils, as a cell type marking Th2-type responses to allergic diseases or helminthic infections, synthesize and store both Th1 and Th2 cytokines (see Table 8.2). For example, binding of CD28 on human eosinophils induced the release of bioactive IL-2 and IFN- γ ,¹⁶⁴ both of which are Th1 cytokines, and IL-13, a Th2 cytokine.¹⁶⁷ Because Th1 and Th2 responses are mutually inhibitory, it has been very difficult to dissect the specific roles of eosinophil-derived cytokines in the

P.170

initiation and effector phases of the allergic immune response. The role of eosinophil-derived Th1 or Th2 cytokines may therefore depend on the timing of eosinophil infiltration into sites of allergic inflammation. Indeed, recent studies using a mouse model of *Nippostrongylus brasiliensis* infection have shown that although eosinophils may be crucial for secondary Th2 polarized immune response against this parasite, the primary response does not require eosinophil-derived IL-4 or IL-13.¹⁶⁸ However, in the context of viral infections, IFN γ -mediated stimulation of eosinophils leads to the production of CCL5/RANTES that may serve to recruit further immune cells and limit the spread of viruses.¹⁶⁹

Experimental models that induced eosinophilia in the absence of tissue infiltration of eosinophils have exquisitely demonstrated the importance of the timing and location of chemokine release in recruitment of eosinophils. For example, CCL11/eotaxin gene knockout (*Eo*^{-/-}) mice showed decreased tissue eosinophils during the early (but not late) phase of allergic inflammation.¹⁷⁰ Moreover, *Eo*^{-/-} mice also showed a significant defect in clearing the larvae of *Trichinella spiralis* from skeletal muscles compared to wild-type animals in spite of similar levels of blood eosinophilia.¹⁷¹ Thus, the presence of eosinophils in allergic disease results from a carefully orchestrated process that involves cytokines and chemokines controlling the maturation and recruitment of eosinophils to the site of allergen exposure.

The implications of eosinophil cytokine production are extensive, such as in the case of IL-4, where this cytokine may be released from eosinophils to direct Th2 cell differentiation in local lymph nodes. In support of this possibility, eosinophils

have been shown to traffic to paratracheal draining lymph nodes (in a mouse model of asthma), where they were demonstrated to function as anti-gen-presenting cells expressing MHC Class II and co-stimulatory CD80 and CD86 to stimulate CD4⁺ T cells.^{172,173} In humans, eosinophils can be induced to express MHC class II and co-stimulatory molecules following cytokine stimulation and transmigration through endothelial monolayers.^{174,175,176} and ¹⁷⁷ Moreover, human eosinophils constitutively express a Notch ligand, Jagged1, suggesting that they have the capacity to polarize naïve CD4⁺ T cells.¹⁷⁸

During intimate cell-cell contact, the production of IL-4 and IL-13 is not required in abundance to effect important immunoregulatory events, such as enhanced switching of T-cells to Th2 phenotype and increased IgE synthesis, both of which are hallmarks of allergic disorders.^{179,180} Mouse eosinophils can process and present antigens to T-cells.^{181,182} Under such conditions, antigen-loaded eosinophils, acting as antigen-presenting cells, were found to preferentially initiate the generation of a Th2 response to ovalbumin in an experimental mouse model.^{183,184} Furthermore, antigen-pulsed eosinophils were sufficient for expansion of Th2 cells in draining lymph nodes.¹⁸⁴

Earlier studies suggested that eosinophil recruitment into sites of inflammation was the result of IL-5 and CCL11/eotaxin generation from the adaptive immune response.¹ However, numerous studies in mouse models have shown that the influx of eosinophils into sites of inflammation precedes that of lymphocytes, and that it can occur in mice with a deficient adaptive immune system.^{165,168,185,186} and ¹⁸⁷ These studies suggest that eosinophils may regulate the adaptive Th2 immune response in allergic inflammation. A major role for eosinophils in the localized recruitment of effector T-cells into the lungs of allergen-sensitized and -challenged mice has been demonstrated, whereby lung eosinophils elicit the expression of CCL17/thymus- and activation-regulated chemokine (TARC) and CCL22/ macrophage-derived chemokine (MDC).¹⁸⁸ These studies have supported the notion that eosinophils can participate in the generation of allergic immune response through the secretion of a wide diversity of immunomodulatory cytokines, either directly or indirectly through other tissues.

Eosinophils also engage in the maintenance of immune homeostasis by being involved in major histocompatibility complex (MHC) class I-restricted thymocyte deletion in the thymus.¹⁸⁹ In the thymus, eosinophils express MHC class I and co-stimulatory molecules CD86 and CD30L, and are also positive for CD11b/CD11c, CD25, and CD69, with decreased expression of CD62L, suggestive of an activated phenotype. These eosinophils are anatomically localized within specific compartments of the thymus coinciding with negative selection of double-positive thymocytes. Thus, eosinophils may be associated with MHC class I-restricted thymocyte deletion as part of the maintenance of immune function in early life.

Indeed, abundant numbers of eosinophils were detected in human thymus tissue in infants ranging between the ages of 2 weeks to 12 years undergoing open-heart surgery for congenital cardiac disease. Eosinophils constituted 2% of total thymic cell count post-natally; the counts were shown to be highest during the early stages of life and declined with age.¹⁹⁰ Confirming what was shown previously for peripheral blood eosinophils,¹⁹¹ thymic eosinophils were shown to express constitutively biologically active IDO as suggested by the detection of copious kynurenine catabolites deriving from tryptophan breakdown in eosinophil/IDO-rich thymic tissue.¹⁹⁰ The study also showed that thymic eosinophil numbers, IDO expression, and tryptophan catabolites correlated with mRNA expression for Th2, but not Th1 markers. A fascinating observation was the detection of numerous eosinophils within unique thymic Hassall's corpuscles. The latter were suggested to play a major role in regulatory T-cell (Treg) differentiation via the epithelial lining of these corpuscles.^{190,192} The lining of Hassall's corpuscles synthesizes and releases thymic stromal lymphopoietin (TSLP) that instructs resident thymic dendritic cells to effect the conversion of self-reactive T-cells into CD4⁺CD25⁺Foxp3⁺ cells.¹⁹³ Indeed, in the mouse, inflammatory Th2-type responses to TSLP were shown to be eosinophil-dependent.¹⁹⁴ Together, these observations imply an immune regulating and/or modulating role for eosinophils in the thymus. This has potential relevance for the development of early-in-life immune response patterns especially in regard to polarization of the immature immune system. These observations may have significant relevance for the role of the eosinophil in health and disease.

Eosinophils are also likely to play a role in long-term maintenance of bone marrow plasma cells, inasmuch as plasma cell numbers were decreased in the bone marrow of eosinophil-deficient mice; a defect that was reversed by eosinophil reconstitution.⁵² Eosinophils supported the survival of plasma cells by secretion of APRIL and IL-6.

Apart from these, other eosinophil-derived immunoregulatory factors have been recently recognized. Based on initial data showing that its inhibition resulted in an immune-mediated abortion in mice,¹⁹⁵ studies in the last 5 years have shown that indoleamine 2,3 dioxygenase (IDO), the rate-limiting enzyme in the oxidative catabolism of tryptophan, may play a central role in immune regulation.¹⁹⁶ Subsequent studies have associated tryptophan catabolism with mechanisms of tumor escape from T-cells,¹⁹⁷ dysfunctional tolerance in autoimmune diabetes mellitus in NOD mice,¹⁹⁸ and protective negative regulation of trinitrobenzene-induced (Th1) model of colitis in the mouse.¹⁹⁹ According to this mechanism, a discrete

population of dendritic cells (DCs) that express functional IDO in lymphoid tissues is able to inhibit T-cell proliferation and induce T-cell apoptosis.²⁰⁰ The presence of this minority population of inhibitory DCs in lymphoid tissue can override the activating properties of other DCs and, therefore, act as a strong negative feedback mechanism on immune activation.²⁰¹ Further studies have shown that regulatory T-cells (Tregs) that constitutively express cytotoxic T-lymphocyte antigen-4 (CTLA-4), the so-called central Tregs, down-regulate the immune response using this mechanism.^{202,203}

Human eosinophils constitutively express the enzyme IDO,¹⁹¹ in contrast to DCs where IDO is inducible. Furthermore, coculture of IDO-expressing eosinophils with T-lymphocytes

P.171

selectively inhibited the proliferation of Th1 cells while having no effect on Th2 cells. Immunostaining of histologic sections of human lymphoid tissues and those from ovalbumin-sensitized and -challenged mice also showed the presence of IDO-expressing eosinophils. Similarly, a study investigating the expression of IDO in tumor biopsies from 25 cases of non-small-cell lung cancer showed that eosinophils were the only IDO-expressing cells in these tissues, and concluded that eosinophil-derived IDO may play a significant role in the escape of non-small-cell lung cancer from immune surveillance.²⁰⁴ In this study, the presence of IDO-expressing tumor-infiltrating eosinophils was strongly correlated with poor survival. When these findings are juxtaposed with previous studies investigating the prognostic value of tumor-associated tissue eosinophilia, it becomes apparent that eosinophil-derived IDO may be a major immunoregulatory mechanism in several eosinophil-associated conditions^{205,206} (Fig. 8.9).

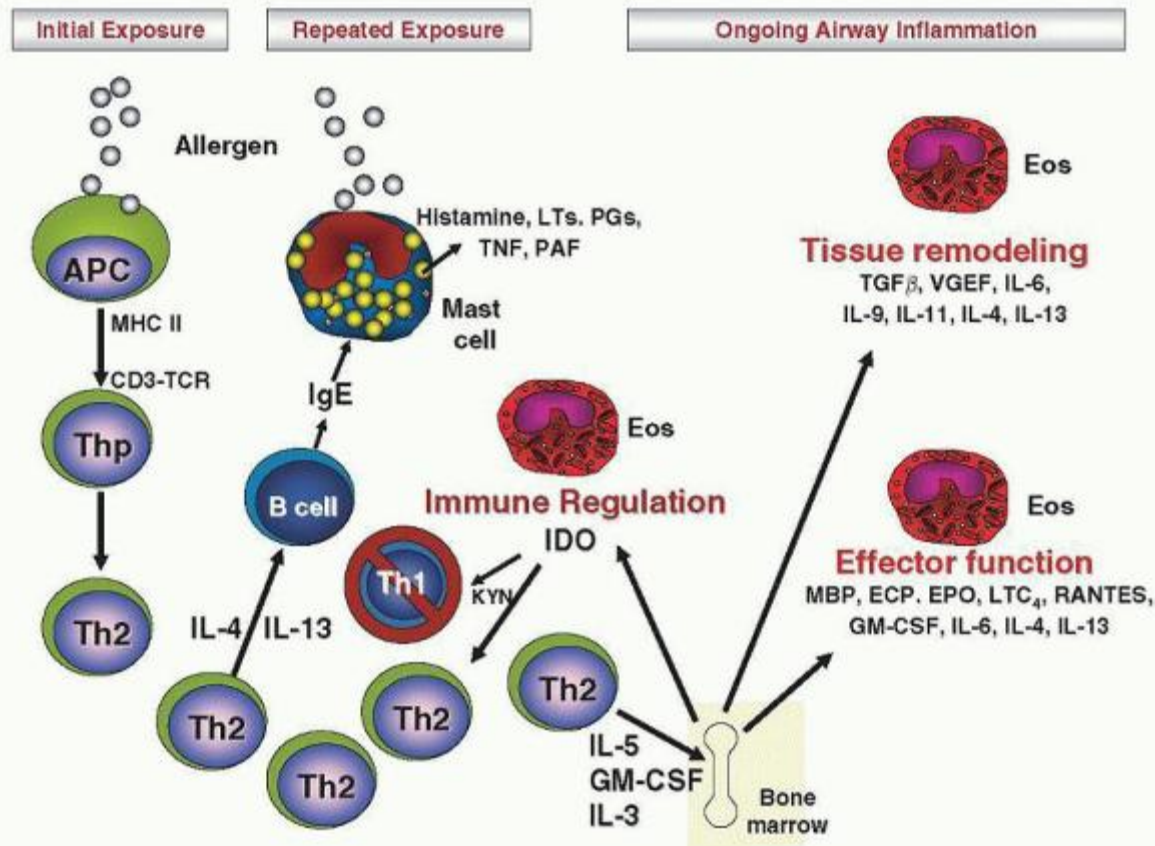

FIGURE 8.9. A proposed scheme addressing an immunoregulatory role that the eosinophil may play in asthma and allergy. Eosinophils have the capacity to exert powerful effector functions against mucosal tissues that may contribute to airway hyperresponsiveness. One way that eosinophils may regulate immune cells is through indoleamine 2,3 dioxxygenase (IDO), a rate-limiting enzyme in the metabolism of the amino acid tryptophan. Eosinophils constitutively express IDO, and when stimulated by $\text{IFN}\gamma$, eosinophils lower the level of extracellular tryptophan and catalyze the production of kynurenines (KYN). KYN have been shown to target Th1 cells to reduce their proliferation by apoptosis, and in this manner allow the proliferation of Th2 cells. APC, antigen-presenting cell; ECP, eosinophil cationic protein; EPO, eosinophil peroxidase; GM-

CSF, granulocyte-macrophage colony-stimulating factor; IL, interleukin; LT, leukotriene; MBP, major basic protein; MHC, major histocompatibility complex; PAF, platelet-activating factor; PG, prostaglandin; TCR, T-cell receptor; TGF, transforming growth factor; TNF, tumor necrosis factor; VEGF, vascular endothelial growth factor.

Another immunomodulatory molecule generated by the eosinophil is one of its granule proteins, EDN. In addition to its RNase activity and antiviral properties, EDN is a chemoattractant for dendritic cells,²⁰⁷ and can induce maturation and activation of dendritic cells.²⁰⁸ In addition, EDN has the capacity to act as an alarmin by enhancing Th2 responses through a Toll-like receptor 2 (TLR2)-dependent mechanism.²⁰⁹

The recognition of the capacity of the eosinophil to synthesize and release cytokines, and produce other immunomodulatory molecules, introduced a paradigm shift in understanding the potential of the eosinophil as an effector cell in allergic inflammation and other eosinophil-associated conditions. However, the full capacity of the eosinophil to elaborate cytokines, the precise microenvironment requirements for such synthesis, the intracellular pattern of production and storage, including the timing of its immunomodulatory function during immune responses, remain the subject of intensive investigation.

EOSINOPHIL DIFFERENTIATION

Peripheral blood and tissue eosinophils are derived by hemopoiesis from CD34⁺ myelocytic progenitors found in the bone marrow and in inflamed tissues. Eosinophils make up approximately 3% of the bone marrow from healthy individuals, of which 37% is fully differentiated, and the remainder is promyelocytes/myelocytes and metamyelocytes.^{6,210} The appearance of newly matured cells in the blood occurs approximately 2.5 days from the time of the last mitotic division.⁶ The turnover of eosinophils is approximately 2.2×10^8 cells/kg/day, and the bone marrow possesses the largest end-differentiated eosinophil reservoir in the healthy body (9 to 14×10^8 cells/kg).²¹¹ Progenitors differentiate upon exposure to a network of cytokines and chemokines to become committed to the eosinophil/basophil (Eo/B) lineage.²¹² Transcription factors regulate the production of eosinophils in the bone marrow, involving at least three classes: GATA-1 (a zinc finger family member), PU.1, and C/EBP members (CCAAT/enhancer-binding protein family).²¹³ The fate of distinct lineages is regulated by PU.1, in which low levels induce lymphocytic cells and high levels promote myeloid differentiation.²¹⁴ Eosinophil lineage differentiation is synergistically induced by GATA-1 and PU.1.²¹⁵ However, GATA-1 is likely the most important transcription factor for eosinophil differentiation, as mice lacking GATA-1 have a specific deficiency in eosinophils.²¹⁶

Eosinophils are more closely related to basophils than neutrophils and monocytes due to lineage differentiation at this stage.²¹⁷ In addition, eosinophils retain elements of expression of basophil/mast cell-specific high-affinity Fcε receptor (α subunit),²¹⁸ whereas basophils continue expression of low concentrations of eosinophil major basic protein (MBP).²¹⁹ Cytokines and chemokines are generated under appropriate stimulation from T-cells in the bone marrow. The three key cytokines that are critical for stimulation of bone marrow production of eosinophils are interleukin-3 (IL-3), IL-5, and granulocyte/macrophage colony-stimulating factor (GM-CSF).^{220,221} These three cytokines are also produced by CD4⁺ and CD8⁺ T-lymphocytes from peripheral blood as well as inflamed tissues.²²² In bone marrow samples, committed eosinophil precursors can be recognized by their expression of the IL-5 receptor (IL-5R) and the C-C chemokine receptor, CCR3, in addition to CD34.²²³ It is now well recognized that IL-5 is a key cytokine in terminal differentiation of eosinophils,²²⁴ and expression of the IL-5R on the progenitor cell is one of the first signs of commitment to the eosinophil lineage. The expression of IL-5R is almost exclusively limited to eosinophil progenitors and mature peripheral blood eosinophils, with some expression on basophils but not neutrophils or monocytes. This selectivity in receptor distribution indicates that IL-5 acts primarily as an eosinophilopoietic cytokine. This has resulted in several groups proposing that inhibition of IL-5 with anti-IL-5 antibody therapy will result in the complete loss of eosinophils from the body, thus preventing the manifestation of allergic symptoms. The obligatory role of IL-5 in the differentiation of the eosinophil has

P.172

been confirmed by numerous studies on transgenic mice in which overexpression of the gene for IL-5 caused marked eosinophilia and increased numbers of eosinophil precursors in their bone marrow.^{225,226} Interestingly, eosinophil differentiation in this transgenic model appeared to be completely independent of IL-3 and GM-CSF, suggesting that IL-5 alone may be sufficient to generate an eosinophilia from stem cell precursors. Gene deletion of IL-5 results in depletion of eosinophils from the circulation, as IL-5 gene-deficient mice exhibit a complete ablation of peripheral blood eosinophils.^{227,228} However, although IL-5 gene-deficient mice exhibit almost no eosinophils in their blood, a small pool of apparently IL-5-independent eosinophils persist in the mucosal tissues of these animals.²²⁹

Additional eosinophilopoietic factors may assist in inducing the differentiation of Eo/B progenitors in the bone marrow, including IL-4, IL-6, IL-11, IL-12, SCF, and others.³⁹ C-C chemokines, named for their adjacent cysteine residues in the C-terminus amino acid sequence as distinct from the CXC chemokines, include CCL11/eotaxin and CCL5/RANTES, which have also been shown to be important in the development of eosinophils.²³⁰ CCL11/eotaxin facilitates the efflux of fully mature eosinophils into the peripheral circulation and promotes the recruitment of eosinophils to target tissues. Overall, at the level of the bone marrow, the early development of Eo/B progenitors is driven by IL-3 and GM-CSF, among other factors, whereas at later stages, IL-5 regulates the terminal differentiation of eosinophils.

The half-life of eosinophils in the circulation is approximately 18 hours with a mean blood transit time of 26 hours,²³¹ although this is extended in eosinophilic conditions, possibly due to the elevation of systemic eosinophil-activating cytokines that promote eosinophil survival. Based on a study of 740 medical students, the normal range of blood eosinophils was shown to be between 0 and $0.5 \times 10^9/L$, with counts ranging from 0.015 to $0.65 \times 10^9/L$.²³² Circulating eosinophil counts exhibit diurnal variation in humans, in which the lowest and highest levels are seen in the morning and evening, respectively, often exhibiting more than 40% variation within a day.^{233,234} Mild eosinophilia is generally considered to be 0.5 to $1.5 \times 10^9/L$, moderate eosinophilia as 1.5 to $5.0 \times 10^9/L$, and marked eosinophilia greater than $5.0 \times 10^9/L$. Allergy is commonly associated with eosinophilia in the mild range, whereas parasitic infestation is often characterized by a marked eosinophilia.

Eosinophils are predominantly tissue cells, and their major target organs for homing in the healthy individual is the gastrointestinal tract (outside of the esophagus), mammary gland, uterus, thymus, and bone marrow. The gastrointestinal tract is the predominant site of homing for tissue eosinophils in healthy humans.²³⁵ In states of disease, eosinophils appear in the lungs, esophagus, skin, and brain (e.g., during strokes). Once they enter target tissues, eosinophils do not return to the blood circulation. Eosinophil numbers can remain high in tissues even when peripheral numbers are low, suggesting that their survival is enhanced upon extravasation. Curiously, pathogen-free laboratory animals have no eosinophils in their blood, and tissue eosinophils are scarce, suggesting that the appearance of eosinophils may be environment- or disease-related.²¹⁰

Eosinophil Production and Survival in Peripheral Tissue

Eosinophil development and maturation may also occur in situ in peripheral (extramedullary) sites outside of the bone marrow. In this case, Eo/B precursors are released into the bloodstream directly from the bone marrow to circulate to sites where they specifically transmigrate in response to locally produced cytokines and chemokines. This may provide an alternative mechanism for the persistence or accumulation of tissue eosinophils. Like neutrophils, eosinophils are end-stage cells, which, in culture, rapidly undergo cell death by either apoptosis or necrosis. However, eosinophil-active cytokines, such as IL-3, IL-5, and GM-CSF, as well as interferon- γ (IFN γ), prolong eosinophil survival in culture for up to 2 weeks.^{236,237,238} They also enhance receptor expression and cell function, including cytotoxicity against metazoan targets, and mediator release. Cytokines derived from eosinophils may lead to autocrine prolongation of eosinophil maturation and survival in tissues.⁴⁵ Local tissue types such as endothelial cells, fibroblasts, and epithelial cells may also contribute to the production of IL-5 and GM-CSF for in situ eosinophil maturation and differentiation in airway or gut mucosa.

Extracellular matrix proteins have been shown to modulate eosinophil responses to soluble physiologic stimuli.²³⁹ Eosinophils were shown to adhere specifically to fibronectin⁴⁷ an abundant extracellular matrix protein. Moreover, VLA-4, a known receptor for fibronectin,²⁴⁰ is involved in mediating eosinophil/fibronectin interactions.⁴⁷ Similarly, VLA-6 expressed on eosinophils interacts with the connective tissue protein laminin. These receptors function to enhance eosinophil responses and are likely to promote the activation of tissue eosinophils by cytokines and other signaling molecules.

The eosinophil-specific cytokine, IL-5, delays eosinophil apoptosis and promotes eosinophil priming and activation.²⁴¹ IL-5 production by airway CD4⁺ T-cells may be directly stimulated by eosinophils in a paracrine manner to enhance survival of tissue eosinophils.²⁴² Eosinophil progenitors in nasal explants from atopic patients have been shown to survive and develop into fully mature eosinophils ex vivo using similar mechanisms.²⁴³ Allergen challenge of these explants, as well as lung explants of brown Norway rats, was shown to evoke a rapid (6 hours) accumulation of MBP-positive cells after allergen challenge.²⁴⁴ This was shown to be dependent on IL-5 production within the explant, a key cytokine in eosinophil survival.

The IL-5R consists of two subunits, an α subunit of 60 to 80 kDa, and a common β_c subunit of between 120 and 140 kDa, which is shared with IL-3R and GM-CSFR. IL-5 interacts with its α subunit specifically but at a lower affinity than the β_c subunit.²⁴⁵ IL-5 stimulation through the β_c subunit leads to phosphorylation of the tyrosine kinases, Jak2, Lyn, and Syk. Jak2 signals through the nuclear translocation factor STAT1, but Lyn and Syk signal through the mitogenic Ras-Raf1-MEK-

ERK pathway (Fig. 8.10). Tyrosine phosphorylation enhances the expression of the antiapoptotic protein Bcl-x_L in eosinophils, and decreases translocation of the proapoptotic signaling molecule Bax, resulting in decreased activation of apoptotic signaling through the caspase family.^{246,247} GM-CSF prolongs the survival of eosinophils bound to tissue sites via α4 integrin for up to 2 weeks,⁴⁷ and has also been shown to inhibit eosinophil apoptosis similarly to IL-5. Thus, the growth, maturation, and prolongation of survival of eosinophils in extramedullary tissues may occur in sites other than the bone marrow.

EOSINOPHIL HETEROGENEITY

Human peripheral blood eosinophils exhibit marked heterogeneity based on their physical, morphologic, and functional properties. There are three different populations of eosinophils that can be characterized based on their intrinsic buoyant density and responsiveness to stimuli. These are the normodense, hypodense, and primed eosinophils, which can be described in both normal and eosinophilic subjects. Each of these populations responds differently to stimuli, which may be related to their stage of maturation. In addition, they may derive from distinct pools of eosinophils that are genetically regulated. The majority of blood eosinophils (>90%) from normal individuals are normodense, which separate out from other leukocytes in the lower interfaces of Percoll or metrizamide discontinuous density gradients. Hypodense eosinophils can be seen in a proportion of

P.173

eosinophils from individuals with a raised eosinophil count that exhibit lower density (<1.085 g/ml) than eosinophils from normal subjects, resulting in a spread of eosinophil populations in the gradient, with contaminating mononuclear cell bands.^{237,248} Morphologically, hypodense eosinophils appear vacuolated, contain more lipid bodies, express less MBP, and possess smaller size crystalloid granules that appear to be slightly more lucent and take up less cell volume, although these are of equal numbers to normodense eosinophils.²⁴⁹ They also exhibit a greater cell volume than normodense eosinophils.²⁵⁰ The mechanism for this heterogeneity is not clear. The presence of low density (or hypodense) eosinophils appears to be a nonspecific phenomenon that occurs in any eosinophilic condition including parasitosis, asthma, allergic rhinitis, idiopathic hypereosinophilic syndrome, and certain malignancies. It was originally thought that the numbers of hypodense cells correlated with the degree of eosinophilia, although this has not been consistently observed.^{248,251,252,253} and²⁵⁴ Thus, the mechanisms governing the production of hypodense eosinophils are likely to be distinct from those that control eosinopoiesis.

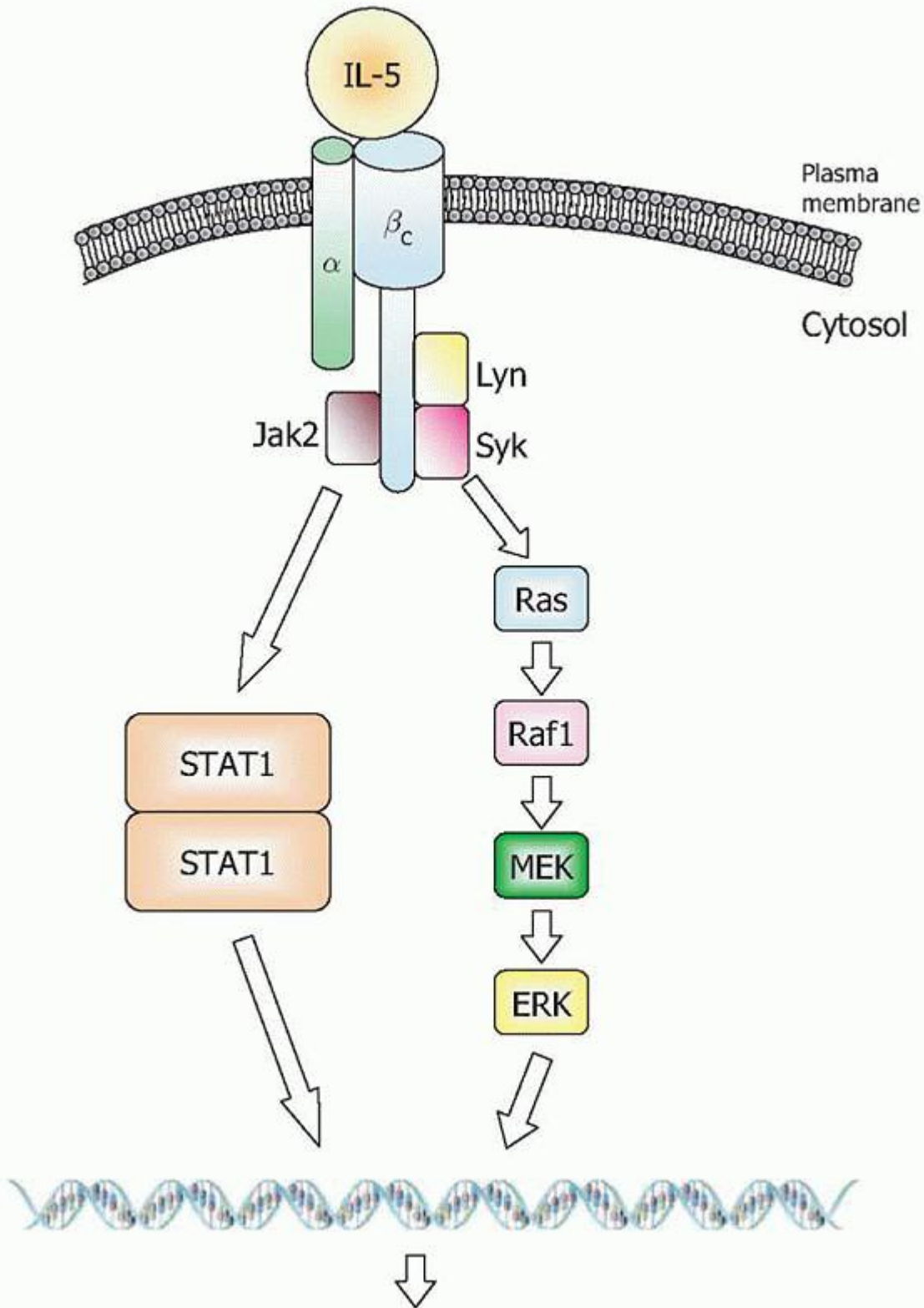

Transcriptional activation leading to antiapoptotic effects

FIGURE 8.10. Signaling pathway leading from binding of IL-5 to its receptor in the membrane to transcriptional activation in the cell nucleus via the Ras-Raf1-MEK-ERK pathway. The β subunit of the receptor is also able to activate the Jak2-STAT1

pathway. Transcriptional activation is proposed to generate antiapoptotic effects in eosinophils.

Functionally, hypodense eosinophils appear to be more activated, because they exhibit elevated oxygen consumption,²⁴⁸ increased cytotoxicity toward helminthic targets,²⁵¹ and release more LTC₄ after physiologic stimulation.¹²¹ Activation of eosinophils, *in vitro*, with inflammatory mediators such as platelet activating factor (PAF), as well as long-term culture with cytokines (e.g., IL-3, IL-5, and GM-CSF), has been associated with a decrease in eosinophil density.^{236,255} Two possible explanations may account for the enhanced responsiveness of hypodense eosinophils. The first is that hypodense eosinophils frequently co-migrate to the same density as neutrophils in metrizamide or Percoll gradients, thus making it difficult to separate these two cell types. Neutrophils could, therefore, enhance the responsiveness of eosinophils through cell-cell interaction. For example, total LTC₄ produced by a mixture of eosinophils and neutrophils was found to be greater than the amount produced by either cell type alone.²⁵⁶ However, other studies assessing the possibility of neutrophils enhancing eosinophil responsiveness have been negative.^{257,258} Secondly, hypodense eosinophils have been shown to express a greater number of receptors for IgG, IgE, CD44, complement, and the p55 subunit of the IL-2 receptor when compared with normodense cells,^{248,259,260,261} which may explain their enhanced responsiveness to stimuli. However, the surface expression of numerous other receptors does not differ between normodense and hypodense eosinophils, with some populations (e.g., CD18) even showing decreased expression in hypodense cells.²⁶² Furthermore, normodense eosinophils from patients with an eosinophilia have enhanced effector function compared with eosinophils from normal individuals. It is possible, therefore, that the formation of low-density eosinophils results from the migration of normodense eosinophils from the bone marrow to the circulation, whereupon they become activated by elevated systemic factors. Another scenario may be that the association between hypodensity and activation is coincidental, with the less dense cells being immature. This heterogeneity in eosinophils has not received significant attention in recent years, likely due to changes in purification techniques for eosinophils. Although early studies generated eosinophils purified by density gradients, using Percoll, for example, by far the most common approach in modern studies is negative selection by immunomagnetic bead separation.²⁶³ Immunomagnetic separation of eosinophils has the advantage of greatly enhancing the purity of eosinophils, but reveals little regarding hypodense subpopulations.

EOSINOPHIL TISSUE ACCUMULATION

Eosinophils migrate to the gastrointestinal tract during their normal development,^{235,264,265} and possibly in response to environmental factors as part of a role in innate defense against parasites. The mechanisms involved in the selective tissue recruitment of eosinophils across the vascular endothelium and into tissues in allergic reactions occur sequentially in four well-defined steps. These include (1) the tethering of the eosinophil to the luminal surface of the vascular endothelium during normal transport through the blood vessel, (2) rolling of the eosinophil along the luminal surface of the activated endothelium in a reversible manner, (3) firm adhesion of the eosinophil to endothelial cells, and (4) transmigration of the eosinophil through the endothelium into target tissues (Fig. 8.11). A further, less understood, step in eosinophil trafficking in the tissues is the *in situ* differentiation of circulating committed Eo/B precursors. Most migration through endothelium occurs at post-capillary venules.

Each of these steps is controlled by a complex network of chemotactic factors and adhesion molecules, which collectively direct the movement of the eosinophil into the tissues. For eosinophils, L-selectin and $\alpha 4$ integrin are thought to be important in tethering and rolling, and $\alpha 4$ and $\beta 2$ (CD18) integrins mediate firm adhesion. The transmigration step is primarily regulated by $\beta 2$ integrins as well as C-C chemokines such as CCL11/eotaxin. Cytokines and chemokines are elaborated by surrounding tissues to modulate the transmigration of eosinophils into tissues. Many of these mechanisms appear to be controlled at the level of the T-cell response to antigen (allergen)-presenting cells, and the subsequent release of cytokines and chemokines which in turn regulate the activity of eosinophils.

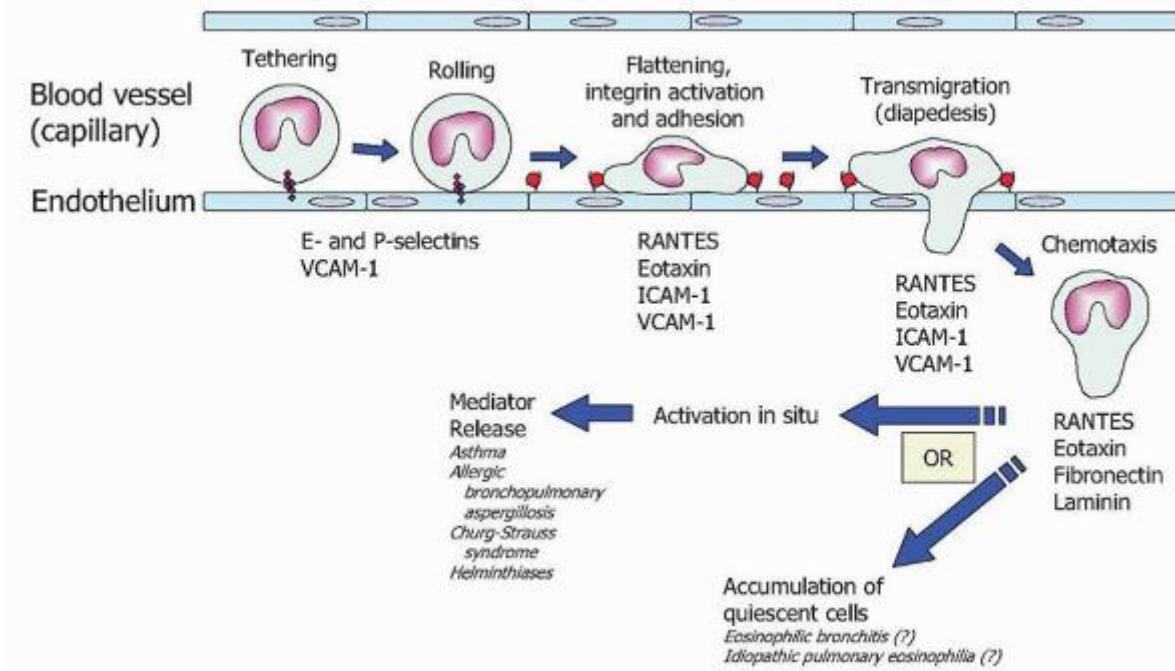

FIGURE 8.11. Eosinophil tethering, rolling, adhesion, transmigration, and chemotaxis in response to inflammatory signals in tissues. During chemotaxis, eosinophils may either become activated in response to local inflammation and release mediators, as in asthma and other related conditions, or they accumulate in tissues in the apparent absence of mediator release.

P.174

Tethering and Rolling

Our knowledge of the mechanisms involved in eosinophil interactions with the endothelium extends primarily from *in vitro* assays of leukocyte adhesion to cultured human umbilical vein endothelial cells (HUVEC) both in stable and under flow conditions. Antibodies specific for adhesion molecules have been applied in this system and have identified critical regulatory molecules required for adhesion and transmigration of eosinophils. Tethering and rolling of eosinophils on HUVEC cells under flow conditions are regulated by L-selectin (CD62L) expressed on the eosinophil surface interacting with E- and P-selectins (CD62E and CD62P) on endothelial cells.²⁶⁶ Selectins are characterized by a lectin-binding domain, which is involved in the initial anchoring of inflammatory cells to the venular endothelium. This interaction is enhanced after the release of inflammatory mediators from these cells as well as neighboring tissues. Once tethered, eosinophils roll until they become stimulated by a chemoattractant stimulus (indicating local inflammation), which induces activation of $\alpha 4$ integrin receptors on the leukocyte. In addition, rolling appears to facilitate the subsequent adherence and transmigration of eosinophils into tissues. Eosinophils also express PSGL-1 and the integrins $\alpha 4\beta 1$ (VLA-4) and $\alpha 4\beta 7$, which are involved in cell rolling.²⁶⁶ Eosinophil integrins bind to target sites in the endothelium, primarily ICAM-1 (CD54) and VCAM-1 (CD106), through their Mac-1 (a $\beta 2$ integrin, also known as CR3 or CD11b/CD18) and VLA-4 ($\alpha 4\beta 1$ integrin) receptors, respectively. The constitutive expression of VLA-4 ($\alpha 4\beta 1$ integrin) is limited to a small number of leukocytes, including eosinophils, monocytes, basophils, and T-cells, suggesting that regulated expression of its ligand, VCAM-1, on endothelial cells may be important in selective recruitment of these cells.²⁶⁷

Adhesion

The firm adhesion of eosinophils involves the interaction of $\alpha 4$ and $\beta 2$ integrins with the endothelial layer. Specifically, eosinophils adhere to TNF α -, IL-1 β -, and LPS-activated HUVECs through CR3/ICAM-1 and VLA-4/VCAM-1 interactions.^{267,268,269,270,271} Other adhesion molecules that may contribute to this process are LFA-1, VLA-6 ($\alpha 4\beta 1$), $\alpha 4\beta 7$ integrin, p150,95, and CD11d. Eosinophils exhibit differential binding properties through VCAM-1 and ICAM-1, which are dependent on their activation status. Freshly prepared unstimulated eosinophils preferentially bind to endothelial VCAM-1 via VLA-4 ($\alpha 4\beta 1$) rather than $\beta 2$ to ICAM-1.^{230,272} Once activated, eosinophil preference for VCAM-1 shifts to that of endothelial ICAM-1 via $\beta 2$ integrins.^{230,273,274} and²⁷⁵ During extravasation (diapedesis) into tissues, the eosinophil becomes

progressively more activated upon contact with extracellular matrix proteins and other stimulated cells. Tissue eosinophils from an antigen challenge model express increased CD11, CD69, and ICAM-1.²⁷⁶ Eosinophil binding in tissues switches to ICAM-1 and the CS-1 region of tissue fibronectin.^{170,266,273} The change in the activation status is also confirmed by the changes in the expression of cell surface molecules seen as the eosinophil goes through tissue. Eosinophils recovered from bronchoalveolar lavage (BAL) express increased ICAM-1, Mac-1, CD69, and decreased L-selectin, suggesting an activated state.²⁴⁷

Cytokines such as IL-4 and IL-13 have been shown to upregulate eosinophil adhesion, primarily through up-regulation of VCAM-1 on endothelial cells.^{277,278} The effects of IL-4 and IL-13 are mediated through Jak3 and the nuclear transcription factor STAT-6.^{279,280} Interestingly, a decrease in tissue eosinophilia has been observed in allergen-challenged STAT-6^{-/-} mice, in spite of high levels of VCAM-1 expression.²⁸⁰ This difference was thought to be due to decreased expression of CCR3 in eosinophils, which is directly controlled by STAT-6.²⁸¹ Results from STAT-6^{-/-} mice would suggest that IL-4 and IL-13 also have a role in the induction of CCR3 on eosinophils and T-cells. These findings underline the importance of cytokine and chemokine cross-talk in the generation of blood eosinophilia and tissue diapedesis.

The switch to ICAM-1-mediated adhesion and transmigration may be associated with facilitation of eosinophil entrance into the tissue. Increased β 1 expression (VCAM-associated) has been shown to slow eosinophil migration compared with ICAM-1/ β 2.²⁸² It is important to note that anti-VLA-4 antibodies may not prevent eosinophil migration into tissue if ICAM-1 or P-selectin sites are the first targets for activated eosinophils.²⁶⁶

P.175

IL-5 also up-regulates eosinophil, but not neutrophil, adhesion to unstimulated endothelium, offering a selective pathway of eosinophil adhesion.⁶⁴ IL-5 has been shown to activate transendothelial migration of eosinophils through ICAM-1 via decreased β 1 and increased β 2 integrin expression.²⁸³ Similarly, stimulation of eosinophil CCR3 with a chemokine such as CCL11/eotaxin, which can be released from endothelial cells, also increases β 2 integrin expression, resulting in preferential binding to ICAM-1.²⁸⁴ Thus, numerous cytokines and chemokines have been shown to enhance eosinophil adhesion to endothelium.

Complement proteins are also important in eosinophilic trafficking in tissues. Complement-mediated inflammation, as seen with parasite infection, is associated with the release of C3a and C5a. C3a increases binding of eosinophil to endothelium but does not increase migration; however, C5a increases both adhesion and migration.²⁸⁵ VCAM-1 and ICAM-1 are involved in complement-mediated binding and migration of eosinophils, as this process is blocked by the application of anti- α 4 and β 2 antibodies. These findings illustrate the importance of adhesion molecules VCAM-1 and ICAM-1 in the complement-mediated pathway of anaphylaxis and host defense.

Other more general inflammatory cytokines, such as IL-1 and TNF α , are also released by inflamed tissues and have significant effects on eosinophil migration.²⁶⁶ Message encoding both IL-1 and TNF α is increased in the airways of symptomatic as opposed to nonsymptomatic asthmatics,²⁸⁶ and IL-1 is increased in tissues from sites of cutaneous allergy.²⁸⁷ Antibodies to IL-1 have been shown to decrease the expression of VCAM-1 and ICAM-1 in endothelial cells.²⁸⁸ Mice deficient in IL-1 expression (IL-1^{-/-}) have decreased eosinophil rolling, adhesion, and transmigration.²⁸⁹ TNF α has also been shown to increase expression of endothelial ICAM-1, VCAM-1, P-selectin, and E-selectin, causing increased eosinophil rolling and adhesion.^{290,291,292} In addition, TNF^{-/-} mice show decreased eosinophil adhesion and migration into tissue, similar to IL-1^{-/-} mice.²⁹³ These factors may have important roles in allergic asthma where preferential accumulation of eosinophils is a feature of atopic (IgE-dependent) inflammatory conditions.

Transmigration and Chemotaxis

Once eosinophils adhere to vascular endothelium, they commence diapedesis whereby they emerge out of the capillaries and traverse the adjacent connective tissue en route to the focus of the inflammatory response. Eosinophils move through the endothelium by extending lamellipodia in the form of a uropod, thus leading to lamellar motion.²⁶⁶ For cells to move, there must be increased binding forward via the uropod and release of binding to the rear. Changes in the binding affinity for adhesion molecules and extracellular matrix proteins are thought to contribute to cell movement on a substratum. A gradient in binding affinity of eosinophil VLA-4 to fibronectin has been demonstrated,²⁹⁴ where increased adherence at the leading edge of the cell is followed by de-adherence at the rear of the cell, allowing the cell to move on. Cytokines and chemokines also influence the binding of eosinophils to tissue surfaces, such as GM-CSF which increases the binding affinity of VLA-4 to VCAM-1 or CS-1,²⁹⁵ and CCL11/eotaxin which stimulates the reverse reaction.²⁸⁴ CCL11/eotaxin induces cytoskeletal changes via mitogen-activated protein kinases (MAPK),²⁶⁶ Rho guanosine triphosphatases (GTPases),

and Rho kinase.^{296,297} Eosinophil chemotaxis may be inhibited by CXCL9 (monokine induced by interferon γ , Mig), a factor that inhibits eotaxin-induced chemotaxis.^{298,299} Other chemokines or chemotactic factors, such as CCL5/RANTES, CCL7/monocyte chemoattractant protein-3 (MCP-3) and C5a, may also alter β 1 integrin affinity in eosinophils.^{273,300} The balance of these factors determines the rate of eosinophil migration.

Although cytokines (e.g., IL-3, IL-5, and GM-CSF) are essential for the development and proliferation of eosinophils, they are likely to play an immunomodulatory role in priming eosinophils for better chemotactic responses to target tissue sites. The most potent eosinophil chemoattractants include PAF, LTD₄, C5a, IL-2, and C-C chemokines such as CCL11/eotaxin and CCL5/RANTES (regulated upon activation, normal T-cell expressed and secreted).^{86,301} C-C chemokines appear to be essential for inducing the specific migration of eosinophils to inflamed sites. Several distinct families of chemokines have been identified, and the CCR3-binding family in particular plays a crucial role in generating tissue eosinophilia due the nearly exclusive expression of CCR3 in eosinophils.²³⁰ This family of chemokines consists of CCL11/eotaxin (1, 2, and 3), CCL5/RANTES, CCL7, CCL8, CCL12 (MCP-2, 3, and 5), and CCL3/macrophage inhibitory protein (MIP)-1 α . Chemokines binding CCR3 may be selective for granulocytes such as eosinophils and basophils, as neutrophils do not express this receptor. CCL11/eotaxin is the only chemokine with potent chemoattractant effects on eosinophils, making it a key ligand for the CCR3 family.^{301,302} CCR3 chemokines are produced by endothelial cells, epithelial cells, parasympathetic nerves, T-cells, macrophages, fibroblasts, and eosinophils, among other tissue sources.^{45,303,304}

Basal expression of CCL11/eotaxin in the gut is elevated compared with other tissues in the normal animal.³⁰⁵ During allergen-induced eosinophilia, CCL11/eotaxin expression is further increased within tissues.³⁰⁶ Some synergism exists between IL-5 and CCL11/eotaxin, as IL-5 stimulation enhances the eosinophil response to CCL11/eotaxin both in vitro and in vivo.^{307,308} In order to define the specific role of CCL11/eotaxin in inflammation, CCL11/eotaxin gene-knockout (Eo^{-/-}) mice have been deployed.^{235,309} These mice produce IL-5 normally, and thus continue to develop blood eosinophilia similar to their wild-type heterozygotes. However, Eo^{-/-} mice do not develop tissue eosinophilia. Thus, the primary role of CCR3 appears to be involved in the homing of circulating eosinophils to target tissues expressing CCL11/eotaxin.

Additional chemokines of the CCR3 family have been shown to exert important effects in situations where CCL11/eotaxin may not be necessarily essential to the response.^{266,310} Each chemokine appears to have a unique role in the timing and location of tissue eosinophilia. Peripheral blood levels and cultured mononuclear cells from patients with allergic dermatitis produce increased levels of CCL5/RANTES, CCL2/MCP-1, and CCL3/MIP-1 α compared with nonallergic controls.³¹¹ Similarly to CCL11/eotaxin, IL-5-stimulated eosinophils have an increased affinity for CCL5/RANTES. However, unlike CCL11/eotaxin, CCL5/RANTES was specifically associated with exacerbations of eosinophilic bronchitis, thought to be provoked by viral infection. Infections with respiratory syncytial virus (RSV) leading to eosinophilia have been correlated with increased CCL5/RANTES, CCL2/MCP-1, and CCL3/MIP-1 α expression.^{312,313} Children with asthma have large increases in eosinophil-associated MBP, CCL5/RANTES, and CCL3/MIP-1 α in their nasal secretions during naturally acquired viral infections.³¹⁴ Therefore, the apparently broader range of effects of CCL5/RANTES, CCL3/MIP-1 α , and CCL2/MCP-1 may also increase the range of eosinophil activity in disease, even though all of these bind specifically to CCR3 on eosinophils.

Other factors are also produced in mucosal tissues, which are moderately or strongly chemotactic for eosinophils. These include bacterial products (e.g., endotoxin and the tripeptide f-Met-Leu-Phe [fMLF]), the anaphylatoxin complement factor, C5a, opsonized particles (which exert their effect via complement [CR1, CR3] and Fc γ RII receptors), and other cytokines (IL-4, CXCL8/IL-8, and possibly IL-13). In addition, the lipid-derived mediators, leukotriene B₄ (LTB₄) and PAF, which are elevated in allergic responses and induce eosinophil respiratory burst and degranulation at higher doses,^{39,239,315,316} are also eosinophilotactic. Eosinophil cytokines IL-3, IL-5, and GM-CSF are able to enhance the chemotactic ability of each of these factors. Although PAF antagonists are not sufficient at preventing eosinophilic inflammation in allergy,

P.176

treatment of allergic individuals with leukotriene modifiers has been effective at reducing eosinophil numbers and inhibiting eosinophil activation.³¹⁷

EOSINOPHILS AND ALLERGIC DISEASE

The association between eosinophils and allergic disease has been known for many years. Eosinophils are a feature of allergic and nonallergic asthma,²⁶⁵ and large numbers of eosinophils and eosinophil granule products are found in and around the bronchi in asthma patients.^{19,318,319,320,321} and ³²² The gastrointestinal tract is a natural homing site for eosinophils, however, excessive eosinophilia and active secretion in various compartments of the gut result in disease

states such as eosinophilic esophagitis, gastroesophageal reflux disease (GERD), or inflammatory bowel disease (IBD).²⁶⁴ Patients with atopic dermatitis also show strong evidence of eosinophil presence and mediator release.^{323,324} and³²⁵

Eosinophils and Asthma

There is a strong correlation between the presence of bronchial hyperresponsiveness (a cardinal clinical feature of asthma) and eosinophilia, particularly activated eosinophils.^{233,319,326} Challenge of the airways with inhaled allergen induces local airway inflammation characterized by influx of both eosinophils and neutrophils. In the late phase of the response, eosinophils are a predominant feature.^{326,327} and³²⁸ A transient peripheral blood eosinophilia may also occur following these challenges.³²⁶ Challenges with low molecular weight occupational compounds such as toluene diisocyanate have also been associated with eosinophilia.³²⁹ Even nonatopic asthma, which appears to lack an IgE-mediated immune response, shows similar increases in airway eosinophils.^{329,330}

Eosinophils in the airways may be assessed using bronchial biopsy, bronchoalveolar lavage (BAL), or induced sputum. The use of fiberoptic bronchoscopy with biopsy is considered the gold standard for acquiring the best appreciation of eosinophil involvement in asthma.^{331,332} A consistent finding in asthmatic airways is the presence of increased numbers of activated eosinophils or their release products, which correlate broadly with the severity of disease as reflected in symptoms, bronchial hyperreactivity, and lung function.^{330,333} Segmental allergen challenge of human subjects' bronchi induces increased eosinophils in the airways,^{327,328} that were positive for the early activation marker CD69³³⁴ and show up-regulation of integrins.³³⁵ Even in mild disease, there may be a significant increase in numbers of eosinophils in the airways of patients, and these are CD69-positive.^{330,336}

Eosinophil granule proteins are significantly associated with the incidence of allergy and allergic asthma. As mentioned previously, MBP is found in large amounts in the lung tissues of patients with status asthmaticus, suggesting widespread eosinophil recruitment and degranulation.¹⁹ The analysis of BAL samples from patients with asthma demonstrated that high concentrations of MBP correlate with the severity of bronchial hyperreactivity.⁸ Intratracheal instillation of MBP and EPO in a primate model provoked bronchoconstriction, and MBP enhanced airway responsiveness to inhaled methacholine.⁸ These physiologic effects of MBP are likely mediated by its cationic properties, inasmuch as treatment with polyanionic peptides such as polyglutamic acid reverse the effects of MBP.^{337,338} These studies suggest that eosinophil degranulation is a major feature of allergic asthma. However, whether degranulation from eosinophils is simply the result of eosinophil infiltration, or if it plays an important role in allergic disease, is yet to be determined.

Sputum analysis offers a noninvasive technique showing correlation of eosinophil numbers with clinical outcomes.^{339,340} and³⁴¹ Increases in sputum eosinophils correlate with the degree of airway responsiveness, asthma symptom scores, and asthma exacerbations.^{330,342,343} Monitoring eosinophilic inflammation using induced sputum samples has been suggested as an important adjunct to the clinical management of asthma beyond relying on lung function and symptoms alone.³⁴⁴ Conversely, a lack of eosinophils in sputum analysis appears to correlate with a lack of response to inhaled corticosteroids.³⁴⁵

The Eosinophil Controversy

Early studies on eosinophil function in the immune response suggested that eosinophils played an immunoprotective role in allergy. For example, eosinophils produce histaminase, which was thought to act by down-regulating mast-cell-mediated early phase responses to allergen.³⁴⁶ However, reports emerging in the latter part of the 20th century suggested that eosinophils had a destructive role in allergic and asthmatic airways, based on the discovery of intensely stained deposits of eosinophil MBP in the airways of individuals who died from fatal asthma.¹⁹ More recent studies then cast this concept back into doubt, including animal models of asthma (IL-5 gene knockouts and anti-IL-5-treated mice) and clinical trials using anti-IL-5, IL-12, and IFN γ .

Mouse Models of Airway Hyperresponsiveness

The roles of IL-5 and eosinophilia in mouse models became a concern. Depending on the protocol used for sensitization and challenge, it appeared that airway hyperresponsiveness could persist in mice in spite of treatment with an antibody to IL-5 and depletion of blood eosinophils. Animal models of asthma have utilized IL-5^{-/-} mice to determine the contribution of eosinophils to the pathogenesis of airway inflammation induced by allergens. One report showed that airway hyperresponsiveness was not affected in allergen-sensitized and challenged IL-5^{-/-} mice, although blood eosinophil numbers were significantly diminished.³⁴⁷ Studies using anti-IL-5 injections in mice generated similar observations.^{228,348} In contrast, using another allergen challenge model, increased blood and tissue IL-5 levels were evident in wild-type mice.³⁴⁹ These levels correlated with both blood and tissue eosinophilia and airway hyperresponsiveness. In the same study, IL-5^{-/-} mice did not mount a blood or tissue eosinophil response after allergen challenge, nor did they develop airway hyperresponsiveness.³⁴⁹ Restoring IL-5 expression in these animals via vaccinia virus encoding IL-5 reconstituted blood and

tissue eosinophilia with an associated development of airway hyperresponsiveness. In an inducible model of T-cell-specific transgenic expression of IL-5, mice produced severe skin lesions, gastrointestinal dysfunction, splenic enlargement, and airway hyperresponsiveness similar to symptoms associated with human eosinophilic disorders,³⁵⁰ supporting a crucial role for the eosinophil in tissue damage associated with allergy.

It appeared that airway hyperresponsiveness could develop during allergen challenge even though blood eosinophilia was lost. The answer to this dilemma may be in the persistence of tissue eosinophils even during IL-5 depletion. Although IL-5 is important in the differentiation and proliferation of eosinophils in the bone marrow, once they arrive in peripheral mucosal tissues, they may switch to an IL-5-independent mechanism of activation, and possibly recruitment, due to the strong down-regulatory effects of IL-5 on eosinophil IL-5 receptor expression.

The possibility of persistence of IL-5-independent tissue eosinophils has been implicated in results from $Eo^{-/-}$ mice. Despite developing blood eosinophilia, $Eo^{-/-}$ mice show reduced but not abolished tissue eosinophilia²⁴² with its associated eosinophil-mediated tissue damage following allergen challenge.³⁵¹ However, in IL-5 transgenic mice treated with recombinant CCL11/eotaxin-2, both IL-5 and CCL11/eotaxin-2 cooperatively

P.177

promote eosinophil accumulation in the blood and tissues, leading to increased IL-13 production and enhanced airway hyperresponsiveness during allergen challenge.²²⁹ Neither IL-5 nor CCL11/eotaxin on its own was able to induce these events. These studies indicate that there are distinct roles for eotaxin and IL-5 in eosinophil maturation, proliferation, and homing to target tissues. Thus, although IL-5 is critical for the maturation and proliferation of eosinophils in the bone marrow, eotaxin may be equally essential in a cooperative manner for movement and maintenance of eosinophilia in the tissues. Therefore, a key event in eosinophil-mediated inflammation leading to airway hyperresponsiveness may lie in the persistence of activated eosinophils in the tissue.

Studies in an eosinophil-knockout mouse, generated by linking the diphtheria toxin promoter to the gene expressing eosinophil peroxidase (the so-called "PHIL" mouse), indicate a key role for eosinophils in establishing airway hyperresponsiveness in an acute model of allergic inflammation.³⁵² In the PHIL mice, eosinophils were depleted in both blood and tissue compartments, and Th2-type airway inflammation and an asthmalike pathology was attenuated upon sensitization and challenge with ovalbumin. These responses were restored by reconstitution of eosinophils³⁵³ or a combination of eosinophils and antigen-specific T-cells.¹⁸⁸ Another study showed that GATA-1 promoter disruption in mice (generating the $\Delta db1$ -GATA lineage), which also leads to the ablation of eosinophils, had no effect on airway hyperresponsiveness to methacholine challenge in either acute or chronic models of allergic inflammation, but showed reduced mucus production and airway remodeling.^{216,354} In general, these studies show supportive data for a role for eosinophils in mediating Th2-type inflammatory responses, at least in the mouse model, but with some conflicting details. For example, the $\Delta db1$ -GATA mice did not show any significant differences in airway hyperresponsiveness following allergen sensitization and challenge, whereas PHIL mice exhibited a profound reduction in airway resistance upon challenge with methacholine.

Indeed, the appropriateness of the mouse as an animal model for investigating airway hyperresponsiveness has been brought into question. A major limitation of mouse models is that mouse eosinophils seem to be markedly deficient in their ability to undergo respiratory burst^{158,355} and degranulate *in vivo* or *in vitro* in response to any known eosinophil-specific agonists. As mentioned earlier, eosinophil degranulation appears to be a vital component of the symptoms associated with allergic airway disease, and the use of mice may be counterproductive in providing clues relating to a better understanding of the role of the eosinophil in airway hyperresponsiveness.

In conclusion, these findings have important implications for the treatment of asthmatic patients with antieosinophil therapies, such that more specific and targeted treatments may be needed to block either the recruitment or activation of eosinophils at sites of inflammation.

Antieosinophil Strategies in Human Asthma

Although eosinophils are closely associated with the clinical presentation of asthma and other atopic diseases, the evidence that this reflects a direct cause-and-effect relationship is still a subject of debate. The discovery of interleukin-5 in the 1980s as the most crucial cytokine in the regulation of growth and terminal differentiation of the eosinophil^{224,356} led to major pharmaceutical investments aimed at antagonizing IL-5 with a view to blocking the eosinophil influx into the tissue and presumably inhibiting its associated inflammatory sequelae. Animal models, particularly simian, pointed optimistically to such a possibility.³⁵⁷ However, clinical trials with a humanized anti-IL-5 monoclonal antibody, mepolizumab, concluded that targeting the eosinophil is far more complex than blocking its differentiation at the level of

the bone marrow and blood.^{358,359,360} As expected, a single intravenous injection of anti-IL-5 induced a profound reduction in peripheral blood eosinophils in patients for up to 16 weeks. However, in spite of the loss of eosinophils from the circulation, bronchial hyperresponsiveness to histamine persisted in these patients for up to 6 weeks after treatment. Based on these findings, the authors questioned the role of the eosinophil in the late-phase asthmatic response and bronchial hyperresponsiveness.

However, the study design and patient selection criteria may have been deficient in determining the success of mepolizumab in these reports.³⁶¹ Moreover, the measurement of eosinophils in sputum or airway fluids alone may not reflect the complete contribution of airway tissue eosinophils. Mepolizumab only depleted ~50% of bronchial tissue eosinophils in spite of its ability to eradicate blood and BAL fluid eosinophils.³⁶² Airway tissue eosinophils may be less dependent on IL-5 for their survival. The development and maturation of eosinophils can occur in situ in peripheral sites of inflammation. Eosinophil progenitors are released into the circulation to reach such tissue sites.²²⁰ Eosinophils can release GM-CSF in an autocrine fashion,^{42,47} a cytokine which is stored in association with eosinophil granules,⁵⁵ and can enhance tissue eosinophil maturation and prolong their survival in tissues. Autocrine GM-CSF stimulation of eosinophils bound to fibronectin, via $\alpha 4$ integrin, promoted eosinophil survival for 2 weeks.⁴⁷ Additionally, GM-CSF appears to have a strong role in inhibiting eosinophil apoptosis at the tissue level. Other eosinophil-derived and stored cytokines (e.g., IL-4⁵⁶ and IL-13^{167,363}) and chemokines (e.g., RANTES^{44,364}) may further amplify the inflammatory milieu. Eosinophils may enhance their own survival by directly stimulating CD4⁺ T-cells within tissue to produce IL-5.²⁴² Nasal explants from atopic patients were shown to survive ex vivo using similar mechanisms to promote extramedullary eosinophil maturation and survival.^{241,243} Lee et al. demonstrated that eosinophils, when instilled into the trachea of IL-5 knockout mice, not only survive in the absence of IL-5, but in concert with CD4⁺ T-cells, migrate back into lung, and reconstitute the asthma phenotype of wild-type antigen-challenged animals.³⁶⁵ Overall, although IL-5 is essential in the maturation and differentiation of eosinophils in the bone marrow,²¹² the recruitment to tissues and function within tissues may be IL-5-independent.

The position of eosinophils in the airways may also play a role. Patients with eosinophilic bronchitis have increased sputum and tissue eosinophils, but do not develop asthma.³⁶⁶ From histopathologic samples of patients with asthma, eosinophils can be found clustered around vagal nerve ganglia in the lung.¹⁸ As well, positive staining for extracellular eosinophil MBP has been detected in the vicinity of these nerves.¹⁸ In guinea pig models of antigen sensitization followed by challenge³⁶⁷ and antigen sensitization followed by virus infection,¹⁷ the release of MBP from eosinophils has been shown to cause M2 receptor dysfunction and hyperreactivity. This may be related to the increased number of eosinophils found in closer proximity to the parasympathetic nerves of sensitized guinea pigs compared to nonsensitized animals.³⁶⁸

In summary, despite uncertainty surrounding the specific role of eosinophils in asthma, significant correlations between numbers of activated airway eosinophils (and their released products) and disease severity have been provided in a large body of literature.^{9,360,369,370} and³⁷¹ More recently, targeting IL-5 has shown favorable results improving health outcomes in a subgroup of patients with eosinophilic asthma.^{372,373} Further studies will be essential for determining the precise role of the eosinophil in asthma.

Eosinophilic Esophagitis

Eosinophils are also associated with the pathogenesis of gastrointestinal disorders such as eosinophilic esophagitis (EE). Often patients undergoing biopsy for diagnosis of gastroesophageal reflux disease (GERD) have increased numbers of intraepithelial eosinophils,^{374,375} which appear to clear with effective antireflux

P.178

therapy.³⁷⁶ The condition of EE is described as a distinct clinical entity, although the feature of esophageal dysfunction is shared with GERD. The pathogenesis of EE has an allergic basis, and EE has been called asthma of the esophagus. Patients with EE present with increased gastroesophageal reflux, and also exhibit choking or food impaction. The clinical symptoms of EE respond well to antiasthma therapy such as systemic corticosteroids,³⁷⁷ topical corticosteroids,^{378,379,380} and³⁸¹ and montelukast.^{382,383} Despite therapy, EE appears to be chronic illness with the potential for relapses.³⁸⁴ Similar to asthma, a key stimulus for developing exacerbations of EE symptoms is not always food allergen, but inhaled aeroallergen.^{385,386} The mechanism of this surprising observation is not known, but may relate back to the shared embryonic origin of the gastrointestinal and respiratory tracts.

THE EFFECTOR ROLE OF THE EOSINOPHIL IN WORM INFECTIONS

There is a strong relationship between parasitic infection and eosinophilia. Infection with helminths is the most common cause of moderate to marked eosinophilia. Studies in the late 1970s demonstrated that eosinophils had the capacity to kill parasitic targets and led to the concept that eosinophils were immunoprotective.^{5,138}

As in allergic inflammation, the precise role of eosinophils in the immunopathologic changes associated with helminth infections remains ill-understood and rather controversial. Increases in the number of tissue and peripheral blood eosinophils, together with elevations in the levels of total and parasitic-specific IgE and mastocytosis, have been considered for a long time to be hallmarks of infection with parasitic worms,⁴ especially during their tissue migratory phases. Much has been published about the inimical role this cell may play in protection against helminths, but there is equally important evidence to suggest that their presence may be a reflection of their participation in the pathology of the disease rather than immunity to the parasitic metazoa.³⁸⁷ The original observation of Basten and Beeson⁷ that helminth-associated eosinophilia is T-cell-dependent was an important turning point in our current understanding of eosinophil-mediated inflammation in worm infections. The identification and subsequent cloning of GM-CSF, IL-3, and particularly IL-5 helped to explain the T-cell control of eosinophilic response both in terms of eosinophilopoiesis and differentiation as well as priming and activation of the mature cell. The question, however, remains as to why there is a selective increase of eosinophils and what their function is, both locally, and systematically, in infected subjects.

In Vitro and Mouse Parasitic Helminth Studies

Much has been published on the helminthocidal effects of human, primate, and rodent eosinophils against metazoan targets coated with either IgG, IgA, IgE, and/or complement components. In this context, a number of parasitic targets have been studied including schistosomula of *Schistosoma mansoni*, newborn larvae of *Trichinella spiralis*, larvae of *Nippostrongylus brasiliensis*, *Fasciola hepatica*, and others.^{8,388}

Eosinophils adhere readily to appropriately coated larvae and undergo exocytosis which results in the deposition of the basic and cytotoxic granule-associated proteins. On their own, these pre-formed products of eosinophils (including MBP, ECP, and EPO) have potent helminthocidal properties at low molar concentrations.⁸ The exogenous addition of a number of chemotactic agents, such as LTB₄, PAF, fMLF,^{389,390} and cytokines such as GM-CSF, IL-3 TNF- α , and IL-5³⁹¹ to eosinophil preparations enhances their cytotoxic capacity against parasitic larvae. In addition to killing worm larvae, eosinophils that adhere to schistosomula via IgG, IgE, or complement, generate substantial amounts of membrane phospholipid-derived mediators, especially LTC₄.³⁹² More recent studies have shown that in IL-5^{-/-} mice, skin implants containing parasites failed to eliminate larval forms of the organisms.³⁹³ The mechanism underlying larval expulsion was shown to be dependent on eosinophils as well as IgM, and the results suggested that the function of eosinophil granule proteins might be associated with disrupting parasitic larvae to allow processing by antigen-presenting cells, including the eosinophil itself. A recent study using the eosinophil-less PHIL mice demonstrated that infection of these mice with *Schistosoma mansoni* had no effect on traditional measures of disease in this model.³⁹⁴ However, these findings should be taken with caution as there are many differences in eosinophil functions between mice and humans, and specifically, mouse eosinophils are not as readily activated as their human counterparts.³⁵⁵

Helminthiasis in Humans and Nonhuman Primates

The precise regulatory and functional roles of eosinophils in human helminthiasis during the well-documented inflammatory reaction require urgent and extensive attention. In general, no clear evidence exists of direct contact between eosinophils and adult worms, although accumulation of eosinophils around helminthic parasites has been described. Eosinophil-rich granulomas surrounding dead fragments of skin-invading larvae of the skin-invading nematode *Strongyloides ratti* have been described in hyperimmune rats following challenge.³⁹⁵ Eosinophils were also found in close contact with the surface tegument of schistosomula of *S. haematobium* in the cutaneous tissue of immune monkeys, associated with the presence of a large number of dead larvae in eosinophil-rich sites.³⁸⁹ Similar observations were made in other host-parasite systems.⁸ Using appropriate antibodies, eosinophil-derived toxic proteins such as MBP have been identified on filarial worm targets in vivo³⁹⁰ and levels of blood ECP is elevated in patients with filariasis which may suggest the activation and degranulation of eosinophils.³⁹¹

CONCLUSIONS

The eosinophil is an enigmatic and fascinating cell that has intrigued biomedical scientists for more than a century. The precise function of this cell in allergic inflammation and asthma remains a matter of debate and requires further study in appropriately designed research projects. However, it is important to recognize that no single cell type, whether the eosinophil, T-cell, mast cell, neutrophil, or other lung cell, is on its own responsible for all aspects of the immunopathology and clinical sequelae of airway inflammation in asthma and related diseases. In recognition of this fact, the attention currently focused on the eosinophil is warranted and timely. This relates partially to the overwhelming evidence in favor of a potential effector role of the eosinophil in parasitic helminthic and allergic diseases, including asthma. Although the mechanisms of eosinophilia in association with allergic disease are not yet fully understood, they seem likely to be controlled at the level of the T-cell response to antigen and the subsequent elaboration of cytokines that exert both direct

and indirect effect on these inflammatory cells. The profile of cytokines generated in allergic reactions, such as the allergen-induced latephase response in the skin, nose, and lung, appears to conform to a Th2 profile, because mRNA expression of IL-4 and IL-5, but not IFN γ or IL-2, is expressed or up-regulated during these reactions. The release of IL-5 by Th2-type T-cells following stimulation with allergen may, therefore, be responsible for the eosinophilia of allergic disease. Thus, a complex network of T-cells, eosinophils, and other inflammatory cells as well as their cytokine products may participate in a cascade of events that leads to specific

P.179

accumulation of eosinophils in sites of allergic inflammation and asthma. Whether tissue damage, a feature of these disease conditions, is the consequence of the activation and exocytosis of these infiltrating cytotoxic cells and the release of their highly basic protein products, is yet to be demonstrated unequivocally.

REFERENCES

1. Rothenberg ME, Hogan SP. The eosinophil. *Annu Rev Immunol* 2006;24: 147-174.
2. Hogan SP, Rosenberg HF, Moqbel R, et al. Eosinophils: biological properties and role in health and disease. *Clin Exp Allergy* 2008;38:709-750.
3. Blanchard C, Rothenberg ME. Biology of the eosinophil. *Adv Immunol* 2009;101:81-121.
4. Kay AB, Moqbel R, Durham SR, et al. Leucocyte activation initiated by IgE-dependent mechanisms in relation to helminthic parasitic disease and clinical models of asthma. *Int Arch Allergy Appl Immunol* 1985;77:69-72.
5. Wardlaw AJ, Moqbel R. The eosinophil in allergic and helminth-related inflammatory responses. In: Moqbel R, ed. *Allergy and immunity to helminths. Common mechanisms or divergent pathways?* London: Taylor & Francis, 1992:154-186.
6. Spry CJF. Eosinophils. A comprehensive review and guide to the scientific and medical literature. Oxford: Oxford University Press, 1988:1-484.
7. Basten A, Beeson PB. Mechanism of eosinophilia. II. Role of the lymphocyte. *J Exp Med* 1970;131:1288-1305.
8. Gleich GJ, Adolphson CR. The eosinophilic leukocyte: structure and function. *Adv Immunol* 1986;39:177-253.
9. Wardlaw AJ, Moqbel R, Kay AB. Eosinophils: biology and role in disease. *Adv Immunol* 1995;60:151-266.
10. Gleich GJ, Loegering DA, Maldonado JE. Identification of a major basic protein in guinea pig eosinophil granules. *J Exp Med* 1973;137:1459-1471.
11. Hamann KJ, Barker RL, Ten RM, Gleich GJ. The molecular biology of eosinophil granule proteins. *Int Arch Allergy Appl Immunol* 1991;94:202-209.
12. Popken-Harris P, McGrogan M, Loegering DA, et al. Expression, purification, and characterization of the recombinant proform of eosinophil granule major basic protein. *J Immunol* 1995;155:1472-1480.
13. Popken-Harris P, Checkel J, Loegering D, et al. Regulation and processing of a precursor form of eosinophil granule major basic protein (ProMBP) in differentiating eosinophils. *Blood* 1998;92:623-631.
14. Mahmudi-Azer S, Velazquez JR, Lacy P, Denburg JA, Moqbel R. Immunofluorescence analysis of cytokine and granule protein expression during eosinophil maturation from cord blood-derived CD34 progenitors. *J Allergy Clin Immunol* 2000;105:1178-1184.
15. Shalit M, Sekhsaria S, Mauhorter S, Mahanti S, Malech HL. Early commitment to the eosinophil lineage by cultured human peripheral blood $\text{CD}34^+$ cells: messenger RNA analysis. *J Allergy Clin Immunol* 1996;98:344-354.
16. Abu-Ghazaleh RI, Gleich GJ, Prendergast FG. Interaction of eosinophil granule major basic protein with synthetic lipid bilayers: a mechanism for toxicity. *J Membr Biol* 1992;128:153-164.
17. Adamko DJ, Yost BL, Gleich GJ, Fryer AD, Jacoby DB. Ovalbumin sensitization changes the inflammatory response to subsequent parainfluenza infection. Eosinophils mediate airway hyperresponsiveness, M₂ muscarinic receptor dysfunction, and antiviral effects. *J Exp Med* 1999;190:1465-1478.
18. Costello RW, Schofield BH, Kephart GM, Gleich GJ, Jacoby DB, Fryer AD. Localization of eosinophils to airway nerves and effect on neuronal M₂ muscarinic receptor function. *Am J Physiol* 1997;273:L93-L103.

19. Filley WV, Holley KE, Kephart GM, Gleich GJ. Identification by immunofluorescence of eosinophil granule major basic protein in lung tissues of patients with bronchial asthma. *Lancet* 1982;2:11-16.
20. Moy JN, Gleich GJ, Thomas LL. Noncytotoxic activation of neutrophils by eosinophil granule major basic protein. Effect on superoxide anion generation and lysosomal enzyme release. *J Immunol* 1990;145:2626-2632.
21. Kita H, Abu-Ghazaleh RI, Sur S, Gleich GJ. Eosinophil major basic protein induces degranulation and IL-8 production by human eosinophils. *J Immunol* 1995;154:4749-4758.
22. Plager DA, Loegering DA, Checkel JL, et al. Major basic protein homolog (MBP2): a specific human eosinophil marker. *J Immunol* 2006;177: 7340-7345.
23. Ten RM, Pease LR, McKean DJ, Bell MP, Gleich GJ. Molecular cloning of the human eosinophil peroxidase. Evidence for the existence of a peroxidase multigene family. *J Exp Med* 1989;169:1757-1759.
24. Weiss SJ, Test ST, Eckmann CM, Roos D, Regiani S. Brominating oxidants generated by human eosinophils. *Science* 1986;234:200-203.
25. Mayeno AN, Curran AJ, Roberts RL, Foote CS. Eosinophils preferentially use bromide to generate halogenating agents. *J Biol Chem* 1989;264:5660-5668.
26. Thomas EL, Bozeman PM, Jefferson MM, King CC. Oxidation of bromide by the human leukocyte enzymes myeloperoxidase and eosinophil peroxidase. Formation of bromamines. *J Biol Chem* 1995;270:2906-2913.
27. van Dalen CJ, Kettle AJ. Substrates and products of eosinophil peroxidase. *Biochem J* 2001;358:233-239.
28. Gleich GJ, Loegering DA, Bell MP, Checkel JL, Ackerman SJ, McKean DJ. Biochemical and functional similarities between human eosinophil-derived neurotoxin and eosinophil cationic protein: homology with ribonuclease. *Proc Natl Acad Sci U S A* 1986;83:3146-3150.
29. Lehrer RI, Szklarek D, Barton A, Ganz T, Hamann KJ, Gleich GJ. Antibacterial properties of eosinophil major basic protein and eosinophil cationic protein. *J Immunol* 1989;142:4428-4434.
30. Domachowske JB, Dyer KD, Adams AG, Leto TL, Rosenberg HF. Eosinophil cationic protein/RNase 3 is another RNase A-family ribonuclease with direct antiviral activity. *Nucleic Acids Res* 1998;26:3358-3363.
31. Rosenberg HF, Domachowske JB. Eosinophils, eosinophil ribonucleases, and their role in host defense against respiratory virus pathogens. *J Leukoc Biol* 2001;70:691-698.
32. Young JD, Peterson CG, Venge P, Cohn ZA. Mechanism of membrane damage mediated by human eosinophil cationic protein. *Nature* 1986;321:613-616.
33. Durack DT, Sumi SM, Klebanoff SJ. Neurotoxicity of human eosinophils. *Proc Natl Acad Sci U S A* 1979;76:1443-1447.
34. Fredens K, Dahl R, Venge P. The Gordon phenomenon induced by the eosinophil cationic protein and eosinophil protein X. *J Allergy Clin Immunol* 1982;70:361-366.
35. Hamann KJ, Ten RM, Loegering DA, et al. Structure and chromosome localization of the human eosinophil-derived neurotoxin and eosinophil cationic protein genes: evidence for intronless coding sequences in the ribonuclease gene superfamily. *Genomics* 1990;7:535-546.
36. Rosenberg HF, Dyer KD, Tiffany HL, Gonzalez M. Rapid evolution of a unique family of primate ribonuclease genes. *Nat Genet* 1995;10:219-223.
37. Domachowske JB, Dyer KD, Bonville CA, Rosenberg HF. Recombinant human eosinophil-derived neurotoxin/RNase 2 functions as an effective antiviral agent against respiratory syncytial virus. *J Infect Dis* 1998;177:1458-1464.
38. Ackerman SJ, Liu L, Kwatia MA, et al. Charcot-Leyden crystal protein (galectin-10) is not a dual function galectin with lysophospholipase activity but binds a lysophospholipase inhibitor in a novel structural fashion. *J Biol Chem* 2002;277:14859-14868.
39. Giembycz MA, Lindsay MA. Pharmacology of the eosinophil. *Pharmacol Rev* 1999;51:213-339.
40. Hamann KJ, Douglas I, Moqbel R. Eosinophil mediators. In: Busse WW, Holgate ST, eds. *Asthma and rhinitis*. Oxford: Blackwell Scientific Publications, 2000:394-428.
41. Lacy P, Moqbel R. Immune effector functions of eosinophils in allergic airway inflammation. *Curr Opin Allergy Clin Immunol* 2001;1:79-84.

42. Moqbel R, Hamid Q, Ying S, et al. Expression of mRNA and immunoreactivity for the granulocyte/macrophage colony-stimulating factor in activated human eosinophils. *J Exp Med* 1991;174:749-752.
43. Kita H, Ohnishi T, Okubo Y, Weiler D, Abrams JS, Gleich GJ. Granulocyte/macrophage colony-stimulating factor and interleukin 3 release from human peripheral blood eosinophils and neutrophils. *J Exp Med* 1991;174:745-748.
44. Lacy P, Mahmudi-Azer S, Bablitz B, et al. Rapid mobilization of intracellularly stored RANTES in response to interferon- γ in human eosinophils. *Blood* 1999;94:23-32.
45. Lacy P, Moqbel R. Eosinophil cytokines. *Chem Immunol* 2000;76:134-155.
46. Hamid Q, Barkans J, Meng Q, et al. Human eosinophils synthesize and secrete interleukin-6, in vitro. *Blood* 1992;80:1496-1501.
47. Anwar AR, Moqbel R, Walsh GM, Kay AB, Wardlaw AJ. Adhesion to fibronectin prolongs eosinophil survival. *J Exp Med* 1993;177:839-843.
48. Wong DT, Weller PF, Galli SJ, et al. Human eosinophils express transforming growth factor α . *J Exp Med* 1990;172:673-681.
49. Wong DT, Elovic A, Matossian K, et al. Eosinophils from patients with blood eosinophilia express transforming growth factor β 1. *Blood* 1991;78: 2702-2707.
50. Desreumaux P, Janin A, Colombel JF, et al. Interleukin 5 messenger RNA expression by eosinophils in the intestinal mucosa of patients with coeliac disease. *J Exp Med* 1992;175:293-296.
51. Broide DH, Paine MM, Firestein GS. Eosinophils express interleukin 5 and granulocyte macrophage-colony-stimulating factor mRNA at sites of allergic inflammation in asthmatics. *J Clin Invest* 1992;90:1414-1424.
52. Chu VT, Frohlich A, Steinhauser G, et al. Eosinophils are required for the maintenance of plasma cells in the bone marrow. *Nat Immunol* 2011;12: 151-159.
53. Beil WJ, Weller PF, Tzizik DM, Galli SJ, Dvorak AM. Ultrastructural immunogold localization of tumor necrosis factor- α to the matrix compartment of eosinophil secondary granules in patients with idiopathic hypereosinophilic syndrome. *J Histochem Cytochem* 1993;41:1611-1615.
54. Dubucquoi S, Desreumaux P, Janin A, et al. Interleukin 5 synthesis by eosinophils: association with granules and immunoglobulin-dependent secretion. *J Exp Med* 1994;179:703-708.
55. Levi-Schaffer F, Lacy P, Severs NJ, et al. Association of granulocyte-macrophage colony-stimulating factor with the crystalloid granules of human eosinophils. *Blood* 1995;85:2579-2586.
56. Moqbel R, Ying S, Barkans J, et al. Identification of messenger RNA for IL-4 in human eosinophils with granule localization and release of the translated product. *J Immunol* 1995;155:4939-447.
57. Levi-Schaffer F, Barkans J, Newman TM, et al. Identification of interleukin-2 in human peripheral blood eosinophils. *Immunology* 1996;87:155-161.
58. Lacy P, Levi-Schaffer F, Mahmudi-Azer S, et al. Intracellular localization of interleukin-6 in eosinophils from atopic asthmatics and effects of interferon γ . *Blood* 1998;91:2508-2516.
59. Gauvreau GM, O'Byrne PM, Moqbel R, et al. Enhanced expression of GM-CSF in differentiating eosinophils of atopic and atopic asthmatic subjects. *Am J Respir Cell Mol Biol* 1998;19:55-62.
60. Velazquez JR, Lacy P, Mahmudi-Azer S, et al. Interleukin-4 and RANTES expression in maturing eosinophils derived from human cord blood \Rightarrow progenitors. *Immunology* 2000;101:419-425.
61. Egesten A, Calafat J, Knol EF, Janssen H, Walz TM. Subcellular localization of transforming growth factor- α in human eosinophil granulocytes. *Blood* 1996;87:3910-3918.
62. Bandeira-Melo C, Gillard G, Ghiran I, Weller PF. EliCell: a gel-phase dual antibody capture and detection assay to measure cytokine release from eosinophils. *J Immunol Methods* 2000;244:105-115.
63. Moqbel R, Lacy P. Exocytotic events in eosinophils and mast cells. *Clin Exp Allergy* 1999;29:1017-1022.
64. Lindau M, Nusse O, Bennett J, Cromwell O. The membrane fusion events in degranulating guinea pig eosinophils. *J Cell Sci* 1993;104:203-210.

65. Hartmann J, Sceppek S, Lindau M. Regulation of granule size in human and horse eosinophils by number of fusion events among unit granules. *J Physiol (Lond)* 1995;483:201-209.
66. Sceppek S, Lindau M. Exocytotic competence and intergranular fusion in cord blood-derived eosinophils during differentiation. *Blood* 1997;89:510-517.
67. Sceppek S, Moqbel R, Lindau M. Compound exocytosis and cumulative degranulation by eosinophils and its role in parasitic killing. *Parasitol Today* 1994;10:276-278.
68. Newman TM, Tian M, Gomperts BD. Ultrastructural characterization of tannic acid-arrested degranulation of permeabilized guinea pig eosinophils stimulated with GTP- γ -S. *Eur J Cell Biol* 1996;70:209-220.
69. McLaren DJ, Mackenzie CD, Ramalho-Pinto FJ. Ultrastructural observations on the in vitro interaction between rat eosinophils and some parasitic helminths (*Schistosoma mansoni*, *Trichinella spiralis* and *Nippostrongylus brasiliensis*). *Clin Exp Immunol* 1977;30:105-118.
70. Mahmudi-Azer S, Downey GP, Moqbel R. Translocation of the tetraspanin CD63 in association with human eosinophil mediator release. *Blood* 2002;99:4039-4047.
71. Dvorak AM, Furitsu T, Letourneau L, Ishizaka T, Ackerman SJ. Mature eosinophils stimulated to develop in human cord blood mononuclear cell cultures supplemented with recombinant human interleukin-5. Part I. Piecemeal degranulation of specific granules and distribution of Charcot-Leyden crystal protein. *Am J Pathol* 1991;138:69-82.
72. Erjefält JS, Andersson M, Greiff L, et al. Cytolysis and piecemeal degranulation as distinct modes of activation of airway mucosal eosinophils. *J Allergy Clin Immunol* 1998;102:286-294.
73. Melo RC, Spencer LA, Perez SA, Ghiran I, Dvorak AM, Weller PF. Human eosinophils secrete preformed, granule-stored interleukin-4 through distinct vesicular compartments. *Traffic* 2005;6:1047-1057.
74. Lacy P, Stow JL. Cytokine release from innate immune cells: association with diverse membrane trafficking pathways. *Blood* 2011;118:9-18.
75. Melo RC, Spencer LA, Perez SA, et al. Vesicle-mediated secretion of human eosinophil granule-derived major basic protein. *Lab Invest* 2009;89:769-781.
76. Spencer LA, Melo RC, Perez SA, Bafford SP, Dvorak AM, Weller PF. Cytokine receptor-mediated trafficking of preformed IL-4 in eosinophils identifies an innate immune mechanism of cytokine secretion. *Proc Natl Acad Sci U S A* 2006;103:3333-3338.
77. Persson CG, Erjefalt JS. Eosinophil lysis and free granules: an in vivo paradigm for cell activation and drug development. *Trends Pharmacol Sci* 1997;18:117-123.
78. Fukuda T, Ackerman SJ, Reed CE, Peters MS, Dunnette SL, Gleich GJ. Calcium ionophore A23187 calcium-dependent cytolytic degranulation in human eosinophils. *J Immunol* 1985;135:1349-1356.
79. McLaren DJ, Ramalho-Pinto FJ, Smithers SR. Ultrastructural evidence for complement and antibody-dependent damage to schistosomula of *Schistosoma mansoni* by rat eosinophils in vitro. *Parasitology* 1978;77: 313-324.
80. Abu-Ghazaleh RI, Fujisawa T, Mestecky J, Kyle RA, Gleich GJ. IgA-induced eosinophil degranulation. *J Immunol* 1989;142:2393-2400.
81. Kita H, Abu-Ghazaleh RI, Gleich GJ, Abraham RT. Regulation of Ig-induced eosinophil degranulation by adenosine 3',5'-cyclic monophosphate. *J Immunol* 1991;146:2712-2718.
82. Monteiro RC, Hostoffer RW, Cooper MD, Bonner JR, Gartland GL, Kubagawa H. Definition of immunoglobulin A receptors on eosinophils and their enhanced expression in allergic individuals. *J Clin Invest* 1993;92: 1681-1685.
83. Kita H, Kaneko M, Bartemes KR, et al. Does IgE bind to and activate eosinophils from patients with allergy? *J Immunol* 1999;162:6901-6911.
84. Seminario MC, Saini SS, MacGlashan DW Jr, Bochner BS. Intracellular expression and release of Fc ϵ R1 α alpha by human eosinophils. *J Immunol* 1999;162:6893-6900.
85. Rot A, Krieger M, Brunner T, Bischoff SC, Schall TJ, Dahinden CA. RANTES and macrophage inflammatory protein 1 α induce the migration and activation of normal human eosinophil granulocytes. *J Exp Med* 1992;176: 1489-1495.
86. Alam R, Stafford S, Forsythe P, et al. RANTES is a chemotactic and activating factor for human eosinophils. *J Immunol* 1993;150:3442-3448.

87. Kita H, Weiler DA, Abu-Ghazaleh R, Sanderson CJ, Gleich GJ. Release of granule proteins from eosinophils cultured with IL-5. *J Immunol* 1992;149:629-635.
88. Daffern PJ, Pfeifer PH, Ember JA, Hugli TE. C3a is a chemotaxin for human eosinophils but not for neutrophils. I. C3a stimulation of neutrophils is secondary to eosinophil activation. *J Exp Med* 1995;181:2119-2127.
89. Kernen P, Wymann MP, von T, V, Deranleau DA, Tai PC, Spry CJ, Dahinden CA, Baggiolini M. Shape changes, exocytosis, and cytosolic free calcium changes in stimulated human eosinophils. *J Clin Invest* 1991;87:2012-2017.
90. Egesten A, Gullberg U, Olsson I, Richter J. Phorbol ester-induced degranulation in adherent human eosinophil granulocytes is dependent on CD11/CD18 leukocyte integrins. *J Leukoc Biol* 1993;53:287-293.
91. Dyer KD, Percopo CM, Xie Z, et al. Mouse and human eosinophils degranulate in response to platelet-activating factor (PAF) and lysoPAF via a PAF-receptor-independent mechanism: evidence for a novel receptor. *J Immunol* 2010;184:6327-6334.
92. Bartemes KR, McKinney S, Gleich GJ, Kita H. Endogenous platelet-activating factor is critically involved in effector functions of eosinophils stimulated with IL-5 or IgG. *J Immunol* 1999;162:2982-2989.
93. Kato M, Kimura H, Motegi Y, et al. Platelet-activating factor activates two distinct effector pathways in human eosinophils. *J Immunol* 2002;169: 5252-5259.
94. Rock KL, Kono H. The inflammatory response to cell death. *Annu Rev Pathol* 2008;3:99-126.
95. Kobayashi T, Kouzaki H, Kita H. Human eosinophils recognize endogenous danger signal crystalline uric acid and produce proinflammatory cytokines mediated by autocrine ATP. *J Immunol* 2010;184:6350-6358.
96. Lotfi R, Herzog GI, DeMarco RA, et al. Eosinophils oxidize damage-associated molecular pattern molecules derived from stressed cells. *J Immunol* 2009;183:5023-5031.
97. Hirai H, Tanaka K, Yoshie O, et al. Prostaglandin D2 selectively induces chemotaxis in T helper type 2 cells, eosinophils, and basophils via seven-transmembrane receptor CRTH2. *J Exp Med* 2001;193:255-261.
98. Janeway CA, Jr., Medzhitov R. Innate immune recognition. *Annu Rev Immunol* 2002;20:197-216.
99. Plotz SG, Lentschat A, Behrendt H, et al. The interaction of human peripheral blood eosinophils with bacterial lipopolysaccharide is CD14 dependent. *Blood* 2001;97:235-241.
100. Sabroe I, Jones EC, Usher LR, Whyte MK, Dower SK. Toll-like receptor (TLR)2 and TLR4 in human peripheral blood granulocytes: a critical role for monocytes in leukocyte lipopolysaccharide responses. *J Immunol* 2002;168: 4701-4710.
101. Nagase H, Okugawa S, Ota Y, et al. Expression and function of Toll-like receptors in eosinophils: activation by Toll-like receptor 7 ligand. *J Immunol* 2003;171:3977-3982.
102. Miike S, McWilliam AS, Kita H. Trypsin induces activation and inflammatory mediator release from human eosinophils through protease-activated receptor-2. *J Immunol* 2001;167:6615-6622.
103. Miike S, Kita H. Human eosinophils are activated by cysteine proteases and release inflammatory mediators. *J Allergy Clin Immunol* 2003;111:704-713.
104. Wada K, Matsuwaki Y, Yoon J, et al. Inflammatory responses of human eosinophils to cockroach are mediated through protease-dependent pathways. *J Allergy Clin Immunol* 2010;126:169-172.
105. Matsuwaki Y, Wada K, White TA, et al. Recognition of fungal protease activities induces cellular activation and eosinophil-derived neurotoxin release in human eosinophils. *J Immunol* 2009;183:6708-6716.
106. Kaneko M, Horie S, Kato M, Gleich GJ, Kita H. A crucial role for β 2 integrin in the activation of eosinophils stimulated by IgG. *J Immunol* 1995;155:2631-2641.
107. Yoon J, Ponikau JU, Lawrence CB, Kita H. Innate antifungal immunity of human eosinophils mediated by a β 2 integrin, CD11b. *J Immunol* 2008;181:2907-2915.
108. Söllner T, Whiteheart SW, Brunner M, Erdjument-Bromage H, Geromanos S, Tempst P, Rothman JE. SNAP receptors implicated in vesicle targeting and fusion. *Nature* 1993;362:318-324.
109. Brumell JH, Volchuk A, Sengelov H, et al. Subcellular distribution of docking/fusion proteins in neutrophils, secretory cells with multiple exocytic compartments. *J Immunol* 1995;155:5750-5759.

110. Ravichandran V, Chawla A, Roche PA. Identification of a novel syntaxin- and synaptobrevin/VAMP- binding protein, SNAP-23, expressed in non-neuronal tissues. *J Biol Chem* 1996;271:13300-13303.
111. Guo Z, Turner C, Castle D. Relocation of the t-SNARE SNAP-23 from lamellipodia-like cell surface projections regulates compound exocytosis in mast cells. *Cell* 1998;94:537-548.
112. Lacy P, Logan MR, Bablitz B, Moqbel R. Fusion protein vesicle-associated membrane protein 2 is implicated in IFN- γ -induced piecemeal degranulation in human eosinophils from atopic individuals. *J Allergy Clin Immunol* 2001;107:671-678.
113. Logan MR, Lacy P, Odemuyiwa SO, et al. A critical role for vesicle-associated membrane protein-7 in exocytosis from human eosinophils and neutrophils. *Allergy* 2006;61:777-784.
114. Logan MR, Lacy P, Bablitz B, Moqbel R. Expression of eosinophil target SNAREs as potential cognate receptors for vesicle-associated membrane protein-2 in exocytosis. *J Allergy Clin Immunol* 2002;109:299-306.
115. Erjefalt JS, Persson CG. New aspects of degranulation and fates of airway mucosal eosinophils. *Am J Respir Crit Care Med* 2000;161:2074-2085.
116. Neves JS, Perez SAC, Spencer LA, et al. Eosinophil granules function extracellularly as receptor-mediated secretory organelles. *Proc Natl Acad Sci U S A* 2008;105:18478-18483.
117. Zhu X, Munoz NM, Rubio N, et al. Quantitation of the cytosolic phospholipase A2 (type IV) in isolated human peripheral blood eosinophils by sandwich-ELISA. *J Immunol Methods* 1996;199:119-126.
118. Blom M, Tool AT, Wever PC, et al. Human eosinophils express, relative to other circulating leukocytes, large amounts of secretory 14-kD phospholipase A2. *Blood* 1998;91:3037-3043.
119. Weller PF, Lee CW, Foster DW, Corey EJ, Austen KF, Lewis RA. Generation and metabolism of 5-lipoxygenase pathway leukotrienes by human eosinophils: predominant production of leukotriene C4. *Proc Natl Acad Sci U S A* 1983;80:7626-7630.
120. Shaw RJ, Cromwell O, Kay AB. Preferential generation of leukotriene C4 by human eosinophils. *Clin Exp Immunol* 1984;56:716-722.
121. Shaw RJ, Walsh GM, Cromwell O, Moqbel R, Spry CJ, Kay AB. Activated human eosinophils generate SRS-A leukotrienes following IgG-dependent stimulation. *Nature* 1985;316:150-152.
122. Cowburn AS, Holgate ST, Sampson AP. IL-5 increases expression of 5-lipoxygenase-activating protein and translocates 5-lipoxygenase to the nucleus in human blood eosinophils. *J Immunol* 1999;163:456-465.
123. Cowburn AS, Sladek K, Soja J, et al. Overexpression of leukotriene C4 synthase in bronchial biopsies from patients with aspirin-intolerant asthma. *J Clin Invest* 1998;101:834-846.
124. Lam BK, Owen WF Jr, Austen KF, Soberman RJ. The identification of a distinct export step following the biosynthesis of leukotriene C4 by human eosinophils. *J Biol Chem* 1989;264:12885-12889.
125. Nasser SM, Lee TH. Products of 15-lipoxygenase: are they important in asthma? *Clin Exp Allergy* 2002;32:1540-1542.
126. Holtzman MJ, Pentland A, Baenziger NL, Hansbrough JR. Heterogeneity of cellular expression of arachidonate 15-lipoxygenase: implications for biological activity. *Biochim Biophys Acta* 1989;1003:204-208.
127. Bradding P, Redington AE, Djukanovic R, Conrad DJ, Holgate ST. 15-lipoxygenase immunoreactivity in normal and in asthmatic airways. *Am J Respir Crit Care Med* 1995;151:1201-1204.
128. Chu HW, Balzar S, Westcott JY, et al. Expression and activation of 15-lipoxygenase pathway in severe asthma: relationship to eosinophilic phenotype and collagen deposition. *Clin Exp Allergy* 2002;32:1558-1565.
129. Henderson WR, Harley JB, Fauci AS. Arachidonic acid metabolism in normal and hypereosinophilic syndrome human eosinophils: generation of leukotrienes B₄, C₄, D₄ and 15-lipoxygenase products. *Immunology* 1984;51: 679-686.
130. Lee T, Lenihan DJ, Malone B, Roddy LL, Wasserman SI. Increased biosynthesis of platelet-activating factor in activated human eosinophils. *J Biol Chem* 1984;259:5526-5530.
131. Cromwell O, Wardlaw AJ, Champion A, Moqbel R, Osei D, Kay AB. IgG-dependent generation of platelet-activating factor by normal and low density human eosinophils. *J Immunol* 1990;145:3862-388.

132. Burke LA, Crea AE, Wilkinson JR, Arm JP, Spur BW, Lee TH. Comparison of the generation of platelet-activating factor and leukotriene C4 in human eosinophils stimulated by unopsonized zymosan and by the calcium ionophore A23187: the effects of nedocromil sodium. *J Allergy Clin Immunol* 1990;85:26-35.
133. Sun FF, Czuk CI, Taylor BM. Arachidonic acid metabolism in guinea pig eosinophils: synthesis of thromboxane B2 and leukotriene B4 in response to soluble or particulate activators. *J Leukoc Biol* 1989;46:152-160.
134. Giembycz MA, Kroegel C, Barnes PJ. Platelet activating factor stimulates cyclo-oxygenase activity in guinea pig eosinophils. Concerted biosynthesis of thromboxane A2 and E-series prostaglandins. *J Immunol* 1990;144:3489-3497.
135. Dvorak AM, Morgan E, Schleimer RP, Ryeom SW, Lichtenstein LM, Weller PF. Ultrastructural immunogold localization of prostaglandin endoperoxide synthase (cyclooxygenase) to non-membrane-bound cytoplasmic lipid bodies in human lung mast cells, alveolar macrophages, type II pneumocytes, and neutrophils. *J Histochem Cytochem* 1992;40:759-769.
136. Bozza PT, Yu W, Penrose JF, Morgan ES, Dvorak AM, Weller PF. Eosinophil lipid bodies: specific, inducible intracellular sites for enhanced eicosanoid formation. *J Exp Med* 1997;186:909-920.
137. Bozza PT, Yu W, Cassara J, Weller PF. Pathways for eosinophil lipid body induction: differing signal transduction in cells from normal and hypereosinophilic subjects. *J Leukoc Biol* 1998;64:563-569.
138. Butterworth AE, Thorne KJ. Eosinophils and parasitic diseases. In: Smith H, Cook RM, eds. *Immunopharmacology of eosinophils*. London: Academic Press, 1993:119-150.
139. DeLeo FR, Quinn MT. Assembly of the phagocyte NADPH oxidase: molecular interaction of oxidase proteins. *J Leukoc Biol* 1996;60:677-691.
140. Bolscher BG, Koenderman L, Tool AT, Stokman PM, Roos D. NADPH:O₂ oxidoreductase of human eosinophils in the cell-free system. *FEBS Lett* 1990;268:269-273.
141. Someya A, Nagaoka I, Iwabuchi K, Yamashita T. Comparison of O₂^{•-}-producing activity of guinea-pig eosinophils and neutrophils in a cell-free system. *Comp Biochem Physiol B* 1991;100:25-30.
142. Yagisawa M, Yuo A, Yonemaru M, et al. Superoxide release and NADPH oxidase components in mature human phagocytes: correlation between functional capacity and amount of functional proteins. *Biochem Biophys Res Commun* 1996;228:510-506.
143. DeChatelet LR, Shirley PS, McPhail LC, Huntley CC, Muss HB, Bass DA. Oxidative metabolism of the human eosinophil. *Blood* 1977;50:525-535.
144. Yazdanbakhsh M, Eckmann CM, De Boer M, Roos D. Purification of eosinophils from normal human blood, preparation of eosinoplasts and characterization of their functional response to various stimuli. *Immunology* 1987;60:123-129.
145. Lacy P, Abdel Latif D, Steward M, Musat-Marcu S, Man SF, Moqbel R. Divergence of mechanisms regulating respiratory burst in blood and sputum eosinophils and neutrophils from atopic subjects. *J Immunol* 2003;170:2670-2679.
146. Carlyon JA, Abdel-Latif D, Pypaert M, Lacy P, Fikrig E. *Anaplasma phagocytophilum* utilizes multiple host evasion mechanisms to thwart NADPH oxidase-mediated killing during neutrophil infection. *Infect Immun* 2004;72:4772-4783.
147. Abo A, Boyhan A, West I, Thrasher AJ, Segal AW. Reconstitution of neutrophil NADPH oxidase activity in the cell-free system by four components: p67-phox, p47-phox, p21^{rac1}, and cytochrome b-245. *J Biol Chem* 1992;267:16767-16770.
148. Bokoch GM, Knaus UG. The role of small GTP-binding proteins in leukocyte function. *Curr Opin Immunol* 1994;6:98-105.
149. Groemping Y, Rittinger K. Activation and assembly of the NADPH oxidase: A structural perspective. *Biochem J* 2005;386:401-416.
150. Suh CI, Stull ND, Li XJ, et al. The phosphoinositide-binding protein p40phox activates the NADPH oxidase during FcγIIA receptor-induced phagocytosis. *J Exp Med* 2006;203:1915-1925.
151. Lapouge K, Smith SJ, Groemping Y, Rittinger K. Architecture of the p40-p47-p67phox complex in the resting state of the NADPH oxidase. A central role for p67phox. *J Biol Chem* 2002;277:10121-10128.
152. Massenet C, Chenavas S, Cohen-Addad C, et al. Effects of p47phox C terminus phosphorylations on binding interactions with p40phox and p67phox. Structural and functional comparison of p40phox and p67phox SH3 domains. *J Biol Chem* 2005;280:13752-13761.

153. Nisimoto Y, Motalebi S, Han CH, Lambeth JD. The p67phox activation domain regulates electron flow from NADPH to flavin in flavocytochrome b₅₅₈. *J Biol Chem* 1999;274:22999-23005.
154. Koga H, Terasawa H, Nunoi H, Takeshige K, Inagaki F, Sumimoto H. Tetratricopeptide repeat (TPR) motifs of p67phox participate in interaction with the small GTPase Rac and activation of the phagocyte NADPH oxidase. *J Biol Chem* 1999;274:25051-25060.
155. Didsbury J, Weber RF, Bokoch GM, Evans T, Snyderman R. rac, a novel ras-related family of proteins that are botulinum toxin substrates. *J Biol Chem* 1989;264:16378-16382.
156. Heyworth PG, Bohl BP, Bokoch GM, Curnutte JT. Rac translocates independently of the neutrophil NADPH oxidase components p47phox and p67phox. Evidence for its interaction with flavocytochrome b₅₅₈. *J Biol Chem* 1994;269:30749-30752.
157. Lacy P, Mahmudi-Azer S, Bablitz B, et al. Expression and translocation of Rac2 in eosinophils during superoxide generation. *Immunology* 1999;98:244-252.
158. Lacy P, Willetts L, Kim JD, et al. Agonist activation of F-actin-mediated eosinophil shape change and mediator release is dependent on Rac2. *Int Arch Allergy Immunol* 2011;156:137-147.
159. Petreccia DC, Nauseef WM, Clark RA. Respiratory burst of normal human eosinophils. *J Leukoc Biol* 1987;41:283-288.
160. Perkins RS, Lindsay MA, Barnes PJ, Giembycz MA. Early signalling events implicated in leukotriene B₄-induced activation of the NADPH oxidase in eosinophils: role of β , protein kinase C and phospholipases C and D. *Biochem J* 1995;310:795-806.
161. Mellor H, Parker PJ. The extended protein kinase C superfamily. *Biochem J* 1998;332 (Pt 2):281-292.
162. Rabe KF, Giembycz MA, Dent G, Barnes PJ. Activation of guinea pig eosinophil respiratory burst by leukotriene B₄: role of protein kinase C. *Fundam Clin Pharmacol* 1992;6:353-358.
163. van der BT, Kok PT, Blom M, et al. Transient exposure of human eosinophils to the protein kinase C inhibitors CGP39-360, CGP41-251, and CGP44-800 leads to priming of the respiratory burst induced by opsonized particles. *J Leukoc Biol* 1993;54:552-557.
164. Woerly G, Roger N, Loiseau S, Dombrowicz D, Capron A, Capron M. Expression of CD28 and CD86 by human eosinophils and role in the secretion of type 1 cytokines (interleukin 2 and interferon γ): inhibition by immunoglobulin A complexes. *J Exp Med* 1999;190:487-495.
165. Sabin EA, Kopf MA, Pearce EJ. *Schistosoma mansoni* egg-induced early IL-4 production is dependent upon IL-5 and eosinophils. *J Exp Med* 1996;184:1871-1878.
166. Piehler D, Stenzel W, Grahnert A, et al. Eosinophils contribute to IL-4 production and shape the T-helper cytokine profile and inflammatory response in pulmonary cryptococcosis. *Am J Pathol* 2011;179:733-744.
167. Woerly G, Lacy P, Younes AB, et al. Human eosinophils express and release IL-13 following CD28-dependent activation. *J Leukoc Biol* 2002;72:769-779.
168. Voehringer D, Reese TA, Huang X, Shinkai K, Locksley RM. Type 2 immunity is controlled by IL-4/IL-13 expression in hematopoietic non-eosinophil cells of the innate immune system. *J Exp Med* 2006;203:1435-1446.
169. Herz U, Lacy P, Renz H, Erb K. The influence of infections on the development and severity of allergic disorders. *Curr Opin Immunol* 2000;12:632-640.
170. Rothenberg ME, MacLean JA, Pearlman E, Luster AD, Leder P. Targeted disruption of the chemokine eotaxin partially reduces antigen-induced tissue eosinophilia. *J Exp Med* 1997;185:785-790.
171. Dixon H, Blanchard C, Deschoolmeester ML, Yuill NC, Christie JW, Rothenberg ME, Else KJ. The role of Th2 cytokines, chemokines and parasite products in eosinophil recruitment to the gastrointestinal mucosa during helminth infection. *Eur J Immunol* 2006;36:1753-1763.
172. Shi HZ, Humbles A, Gerard C, Jin Z, Weller PF. Lymph node trafficking and antigen presentation by endobronchial eosinophils. *J Clin Invest* 2000;105:945-953.
173. Spencer LA, Weller PF. Eosinophils and Th2 immunity: contemporary insights. *Immunol Cell Biol* 2010;88:250-256.
174. Lucey DR, Nicholson-Weller A, Weller PF. Mature human eosinophils have the capacity to express HLA-DR. *Proc Natl Acad Sci U S A* 1989;86:1348-1351.

175. Celestin J, Rotschke O, Falk K, et al. IL-3 induces B7.2 (CD86) expression and costimulatory activity in human eosinophils. *J Immunol* 2001;167:6097-6104.
176. Ohkawara Y, Lim KG, Xing Z, et al. CD40 expression by human peripheral blood eosinophils. *J Clin Invest* 1996;97:1761-1766.
177. Yamamoto H, Sedgwick JB, Vrtis RF, Busse WW. The effect of transendothelial migration on eosinophil function. *Am J Respir Cell Mol Biol* 2000;23:379-388.
178. Radke AL, Reynolds LE, Melo RC, Dvorak AM, Weller PF, Spencer LA. Mature human eosinophils express functional Notch ligands mediating eosinophil autocrine regulation. *Blood* 2009;113:3092-3101.
179. Corrigan CJ. T cells in asthma. In: Holgate ST, Busse WW, eds. *Inflammatory mechanisms in asthma*. New York: Marcel Dekker, 1998:343-359.
180. Wills-Karp M, Luyimbazi J, Xu X, Schofield B, Neben TY, Karp CL, Donaldson DD. Interleukin-13: central mediator of allergic asthma. *Science* 1998;282:2258-2261.
181. del P, V, De AB, Martin E, et al. Eosinophil as antigen-presenting cell: activation of T cell clones and T cell hybridoma by eosinophils after antigen processing. *Eur J Immunol* 1992;22:1919-1925.
182. Padigel UM, Lee JJ, Nolan TJ, Schad GA, Abraham D. Eosinophils can function as antigen-presenting cells to induce primary and secondary immune responses to *Strongyloides stercoralis*. *Infect Immun* 2006;74:3232-3238.
183. MacKenzie JR, Mattes J, Dent LA, Foster PS. Eosinophils promote allergic disease of the lung by regulating Th2 lymphocyte function. *J Immunol* 2001;167:3146-3155.
184. Shi HZ, Xiao CQ, Li CQ, et al. Endobronchial eosinophils preferentially stimulate T helper cell type 2 responses. *Allergy* 2004;59:428-435.
185. Sabin EA, Pearce EJ. Early IL-4 production by non- Th2 cells at the site of antigen deposition predicts the development of a T helper 2 cell response to *Schistosoma mansoni* eggs. *J Immunol* 1995;155:4844-4853.
186. Shinkai K, Mohrs M, Locksley RM. Helper T cells regulate type-2 innate immunity in vivo. *Nature* 2002;420:825-829.
187. Voehringer D, Shinkai K, Locksley RM. Type 2 immunity reflects orchestrated recruitment of cells committed to IL-4 production. *Immunity* 2004;20:267-277.
188. Jacobsen EA, Ochkur SI, Pero RS, et al. Allergic pulmonary inflammation in mice is dependent on eosinophil-induced recruitment of effector T cells. *J Exp Med* 2008;205:699-710.
189. Throsby M, Herbelin A, Pleau JM, Dardenne M. Th2 eosinophils in the murine thymus: developmental regulation and recruitment upon MHC class I-restricted thymocyte deletion. *J Immunol* 2000;165:1965-1975.
190. Tulic MK, Sly PD, Andrews D, et al. Thymic indoleamine 2,3-dioxygenase-positive eosinophils in young children: potential role in maturation of the naive immune system. *Am J Pathol* 2009;175:2043-2052.
191. Odemuyiwa SO, Ghahary A, Li Y, et al. Cutting edge: human eosinophils regulate T cell subset selection through indoleamine 2,3-dioxygenase. *J Immunol* 2004;173:5909-5913.
192. Tulic MK, Andrews D, Crook ML, et al. Changes in thymic regulatory T-cell maturation from birth to puberty: differences in atopic children. *J Allergy Clin Immunol* 2012;129:199-206.
193. Watanabe N, Wang YH, Lee HK, et al. Hassall's corpuscles instruct dendritic cells to induce Th1 regulatory T cells in human thymus. *Nature* 2005;436:1181-1185.
194. Jessup HK, Brewer AW, Omori M, et al. Intradermal administration of thymic stromal lymphopoietin induces a T cell- and eosinophil-dependent systemic Th2 inflammatory response. *J Immunol* 2008;181:4311-4319.
195. Munn DH, Zhou M, Attwood JT, et al. Prevention of allogeneic fetal rejection by tryptophan catabolism. *Science* 1998;281:1191-1193.
196. Mellor AL, Munn DH. IDO expression by dendritic cells: tolerance and tryptophan catabolism. *Nat Rev Immunol* 2004;4:762-774.
197. Uyttenhove C, Pilotte L, Theate I, et al. Evidence for a tumoral immune resistance mechanism based on tryptophan degradation by indoleamine 2,3-dioxygenase. *Nat Med* 2003;9:1269-1274.

198. Grohmann U, Fallarino F, Bianchi R, et al. A defect in tryptophan catabolism impairs tolerance in nonobese diabetic mice. *J Exp Med* 2003;198:153-160.
199. Gurtner GJ, Newberry RD, Schloemann SR, McDonald KG, Stenson WF. Inhibition of indoleamine 2,3-dioxygenase augments trinitrobenzene sulfonic acid colitis in mice. *Gastroenterology* 2003;125:1762-1773.
200. Mellor AL, Chandler P, Baban B, et al. Specific subsets of murine dendritic cells acquire potent T cell regulatory functions following CTLA4-mediated induction of indoleamine 2,3 dioxygenase. *Int Immunol* 2004;16:1391-1401.
201. Baban B, Hansen AM, Chandler PR, et al. A minor population of splenic dendritic cells expressing CD19 mediates IDO-dependent T cell suppression via type I IFN signaling following B7 ligation. *Int Immunol* 2005;17:909-919.
202. Munn DH, Sharma MD, Mellor AL. Ligation of B7-1/B7-2 by human α T cells triggers indoleamine 2,3-dioxygenase activity in dendritic cells. *J Immunol* 2004;172:4100-4010.
203. Grohmann U, Orabona C, Fallarino F, et al. CTLA-4-Ig regulates tryptophan catabolism in vivo. *Nat Immunol* 2002;3:1097-1101.
204. Astigiano S, Morandi B, Costa R, et al. Eosinophil granulocytes account for indoleamine 2,3-dioxygenase-mediated immune escape in human non-small cell lung cancer. *Neoplasia* 2005;7:390-396.
205. Samoszuk M. Eosinophils and human cancer. *Histol Histopathol* 1997;12:807-812.
206. Alkhabuli JO, High AS. Significance of eosinophil counting in tumor associated tissue eosinophilia (TATE). *Oral Oncol* 2006;42:849-850.
207. Yang D, Rosenberg HF, Chen Q, Dyer KD, Kurosaka K, Oppenheim JJ. Eosinophil-derived neurotoxin (EDN), an antimicrobial protein with chemotactic activities for dendritic cells. *Blood* 2003;102:3396-3403.
208. Yang D, Chen Q, Rosenberg HF, et al. Human ribonuclease A super-family members, eosinophil-derived neurotoxin and pancreatic ribonuclease, induce dendritic cell maturation and activation. *J Immunol* 2004;173:6134-6142.
209. Yang D, Chen Q, Su SB, et al. Eosinophil-derived neurotoxin acts as an alarmin to activate the TLR2-MyD88 signal pathway in dendritic cells and enhances Th2 immune responses. *J Exp Med* 2008;205:79-90.
210. Spry CJ. The natural history of eosinophils. In: Smith H, Cook RM, eds. *Immunopharmacology of eosinophils*. London: Academic Press, 1993:241-243.
211. Walle AJ, Parwaresch MR. Estimation of effective eosinopoiesis and bone marrow eosinophil reserve capacity in normal man. *Cell Tissue Kinet* 1979;12:249-255.
212. Denburg JA, Sehmi R, Saito H, Pil-Seob J, Inman MD, O'Byrne PM. Systemic aspects of allergic disease: bone marrow responses. *J Allergy Clin Immunol* 2000;106:S242-S246.
213. McNagny K, Graf T. Making eosinophils through subtle shifts in transcription factor expression. *J Exp Med* 2002;195:F43-F47.
214. Walsh JC, DeKoter RP, Lee HJ, et al. Cooperative and antagonistic interplay between PU.1 and GATA-2 in the specification of myeloid cell fates. *Immunity* 2002;17:665-676.
215. Du J, Stankiewicz MJ, Liu Y, et al. Novel combinatorial interactions of GATA-1, PU.1, and C/EBPepsilon isoforms regulate transcription of the gene encoding eosinophil granule major basic protein. *J Biol Chem* 2002;277:43481-43494.
216. Yu C, Cantor AB, Yang H, et al. Targeted deletion of a high-affinity GATA-binding site in the GATA-1 promoter leads to selective loss of the eosinophil lineage in vivo. *J Exp Med* 2002;195:1387-1395.
217. Inman MD, Sehmi R, O'Byrne P, Denburg JA. The role of the bone marrow in allergic disease. In: Denburg JA, ed. *Allergy and allergic diseases: the new mechanisms and therapeutics*. Totowa, NJ: Humana Press, 1998:85-102.
218. Dombrowicz D, Woerly G, Capron M. IgE receptors on human eosinophils. *Chem Immunol* 2000;76:63-76.
219. Ackerman SJ, Kephart GM, Habermann TM, Greipp PR, Gleich GJ. Localization of eosinophil granule major basic protein in human basophils. *J Exp Med* 1983;158:946-961.
220. Denburg JA. Bone marrow in atopy and asthma: hematopoietic mechanisms in allergic inflammation. *Immunol Today* 1999;20:111-113.
221. Foster PS. Allergic networks regulating eosinophilia. *Am J Respir Cell Mol Biol* 1999;21:451-454.

222. Hamelmann E, Gelfand EW. IL-5-induced airway eosinophilia—the key to asthma? *Immunol Rev* 2001;179:182-191.
223. Sutherland DR, Stewart AK, Keating A. CD34 antigen: molecular features and potential clinical applications. *Stem Cells* 1993;11:50-57.
224. Clutterbuck EJ, Hirst EM, Sanderson CJ. Human interleukin-5 (IL-5) regulates the production of eosinophils in human bone marrow cultures: comparison and interaction with IL-1, IL-3, IL-6, and GM-CSF. *Blood* 1989;73:1504-1512.
225. Dent LA, Strath M, Mellor AL, Sanderson CJ. Eosinophilia in transgenic mice expressing interleukin 5. *J Exp Med* 1990;172:1425-1431.
226. Tominaga A, Takaki S, Koyama N, et al. Transgenic mice expressing a B cell growth and differentiation factor gene (interleukin 5) develop eosinophilia and autoantibody production. *J Exp Med* 1991;173:429-437.
227. Foster PS, Hogan SP, Ramsay AJ, Matthaei KI, Young IG. Interleukin 5 deficiency abolishes eosinophilia, airway hyperreactivity, and lung damage in a mouse asthma model. *J Exp Med* 1996;183:195-201.
228. Corry DB, Folkesson HG, Warnock ML, et al. Interleukin 4, but not interleukin 5 or eosinophils, is required in a murine model of acute airway hyperreactivity. *J Exp Med* 1996;183:109-117.
229. Yang M, Hogan SP, Mahalingam S, et al. Eotaxin-2 and IL-5 cooperate in the lung to regulate IL-13 production and airway eosinophilia and hyperreactivity. *J Allergy Clin Immunol* 2003;112:935-943.
230. Bochner BS, Schleimer RP. Mast cells, basophils, and eosinophils: distinct but overlapping pathways for recruitment. *Immunol Rev* 2001;179:5-15.
231. Steinbach KH, Schick P, Trepel F, et al. Estimation of kinetic parameters of neutrophilic, eosinophilic, and basophilic granulocytes in human blood. *Blut* 1979;39:27-38.
232. Krause JR, Boggs DR. Search for eosinopenia in hospitalized patients with normal blood leukocyte concentration. *Am J Hematol* 1987;24:55-63.
233. Horn BR, Robin ED, Theodore J, Van Kessel A. Total eosinophil counts in the management of bronchial asthma. *N Engl J Med* 1975;292:1152-1155.
234. Winkel P, Statland BE, Saunders AM, Osborn H, Kupperman H. Within-day physiologic variation of leukocyte types in healthy subjects as assayed by two automated leukocyte differential analyzers. *Am J Clin Pathol* 1981;75:693-700.
235. Mishra A, Hogan SP, Lee JJ, Foster PS, Rothenberg ME. Fundamental signals that regulate eosinophil homing to the gastrointestinal tract. *J Clin Invest* 1999;103:1719-1727.
236. Rothenberg ME, Owen WF Jr, Silberstein DS, Soberman RJ, Austen KF, Stevens RL. Eosinophils cocultured with endothelial cells have increased survival and functional properties. *Science* 1987;237:645-647.
237. Rothenberg ME, Owen WF Jr, Silberstein DS, et al. Human eosinophils have prolonged survival, enhanced functional properties, and become hypodense when exposed to human interleukin 3. *J Clin Invest* 1988;81:1986-1992.
238. Silberstein DS, Austen KF, Owen WF Jr. Hemopoietins for eosinophils. Glycoprotein hormones that regulate the development of inflammation in eosinophilia-associated disease. *Hematol Oncol Clin North Am* 1989;3:511-533.
239. Dri P, Cramer R, Spessotto P, Romano M, Patriarca P. Eosinophil activation on biologic surfaces. Production of O₂^{•-} in response to physiologic soluble stimuli is differentially modulated by extracellular matrix components and endothelial cells. *J Immunol* 1991;147:613-620.
240. Mould AP, Wheldon LA, Komoriya A, Wayner EA, Yamada KM, Humphries MJ. Affinity chromatographic isolation of the melanoma adhesion receptor for the IIICS region of fibronectin and its identification as the integrin $\alpha 4\beta 1$. *J Biol Chem* 1990;265:4020-4024.
241. Simon HU, Yousefi S, Schranz C, Schapowal A, Bachert C, Blaser K. Direct demonstration of delayed eosinophil apoptosis as a mechanism causing tissue eosinophilia. *J Immunol* 1997;158:3902-3908.
242. Foster PS, Mould AW, Yang M, et al. Elemental signals regulating eosinophil accumulation in the lung. *Immunol Rev* 2001;179:173-181.
243. Cameron L, Christodoulopoulos P, Lavigne F, et al. Evidence for local eosinophil differentiation within allergic nasal mucosa: inhibition with soluble IL-5 receptor. *J Immunol* 2000;164:1538-1545.

244. Eidelman DH, Minshall E, Dandurand RJ, et al. Evidence for major basic protein immunoreactivity and interleukin 5 gene activation during the late phase response in explanted airways. *Am J Respir Cell Mol Biol* 1996;15:582-589.
245. Miyajima A, Kitamura T, Harada N, Yokota T, Arai K. Cytokine receptors and signal transduction. *Annu Rev Immunol* 1992;10:295-331.
246. Pazdrak K, Olszewska-Pazdrak B, Stafford S, Garofalo RP, Alam R. Lyn, Jak2, and Raf-1 kinases are critical for the antiapoptotic effect of interleukin 5, whereas only Raf-1 kinase is essential for eosinophil activation and degranulation. *J Exp Med* 1998;188:421-429.
247. Wardlaw AJ, Brightling C, Green R, Woltmann G, Pavord I. Eosinophils in asthma and other allergic diseases. *Br Med Bull* 2000;56:985-1003.
248. Winqvist I, Olofsson T, Olsson I, Persson AM, Hallberg T. Altered density, metabolism and surface receptors of eosinophils in eosinophilia. *Immunology* 1982;47:531-539.
249. Peters MS, Gleich GJ, Dunnette SL, Fukuda T. Ultrastructural study of eosinophils from patients with the hypereosinophilic syndrome: a morphological basis of hypodense eosinophils. *Blood* 1988;71:780-785.
250. Caulfield JP, Hein A, Rothenberg ME, et al. A morphometric study of normodense and hypodense human eosinophils that are derived in vivo and in vitro. *Am J Pathol* 1990;137:27-41.
251. Prin L, Capron M, Tonnel AB, Bletry O, Capron A. Heterogeneity of human peripheral blood eosinophils: variability in cell density and cytotoxic ability in relation to the level and the origin of hypereosinophilia. *Int Arch Allergy Appl Immunol* 1983;72:336-346.
252. Prin L, Charon J, Capron M, et al. Heterogeneity of human eosinophils. II. Variability of respiratory burst activity related to cell density. *Clin Exp Immunol* 1984;57:735-742.
253. Fukuda T, Dunnette SL, Reed CE, Ackerman SJ, Peters MS, Gleich GJ. Increased numbers of hypodense eosinophils in the blood of patients with bronchial asthma. *Am Rev Respir Dis* 1985;132:981-985.
254. Kloprogge E, de Leeuw AJ, de Monchy JG, Kauffman HF. Hypodense eosinophilic granulocytes in normal individuals and patients with asthma: generation of hypodense cell populations in vitro. *J Allergy Clin Immunol* 1989;83:393-400.
255. Owen WF Jr, Rothenberg ME, Silberstein DS, et al. Regulation of human eosinophil viability, density, and function by granulocyte/macrophage colony-stimulating factor in the presence of 3T3 fibroblasts. *J Exp Med* 1987;166:129-141.
256. Kloprogge E, de Leeuw AJ, de Monchy JG, Kauffman HF. Cellular communication in leukotriene C₄ production between eosinophils and neutrophils. *Int Arch Allergy Appl Immunol* 1989;90:20-23.
257. Kajita T, Yui Y, Mita H, et al. Release of leukotriene C₄ from human eosinophils and its relation to the cell density. *Int Arch Allergy Appl Immunol* 1985;78:406-410.
258. Hodges MK, Weller PF, Gerard NP, Ackerman SJ, Drazen JM. Heterogeneity of leukotriene C₄ production by eosinophils from asthmatic and from normal subjects. *Am Rev Respir Dis* 1988;138:799-804.
259. Capron M, Kusnierz JP, Prin L, et al. Cytophilic IgE on human blood and tissue eosinophils: detection by flow microfluorometry. *J Immunol* 1985;134:3013-3018.
260. Rand TH, Silberstein DS, Kornfeld H, Weller PF. Human eosinophils express functional interleukin 2 receptors. *J Clin Invest* 1991;88:825-832.
261. Matsumoto K, Appiah-Pippim J, Schleimer RP, Bickel CA, Beck LA, Bochner BS. CD44 and CD69 represent different types of cell-surface activation markers for human eosinophils. *Am J Respir Cell Mol Biol* 1998;18:860-866.
262. Hartnell A, Moqbel R, Walsh GM, Bradley B, Kay AB. Fcγ and CD11/CD18 receptor expression on normal density and low density human eosinophils. *Immunology* 1990;69:264-270.
263. Hansel TT, De Vries IJ, Iff T, et al. An improved immunomagnetic procedure for the isolation of highly purified human blood eosinophils. *J Immunol Methods* 1991;145:105-110.
264. Rothenberg ME, Mishra A, Brandt EB, Hogan SP. Gastrointestinal eosinophils. *Immunol Rev* 2001;179:139-155.
265. DeBrosse CW, Rothenberg ME. Allergy and eosinophil-associated gastrointestinal disorders (EGID). *Curr Opin Immunol* 2008;20:703-708.
266. Broide D, Sriramarao P. Eosinophil trafficking to sites of allergic inflammation. *Immunol Rev* 2001;179:163-172.

267. Bochner BS, Lusinskas FW, Gimbrone MA Jr, et al. Adhesion of human basophils, eosinophils, and neutrophils to interleukin 1-activated human vascular endothelial cells: contributions of endothelial cell adhesion molecules. *J Exp Med* 1991;173:1553-1557.
268. Walsh GM, Hartnell A, Moqbel R, et al. Receptor expression and functional status of cultured human eosinophils derived from umbilical cord blood mononuclear cells. *Blood* 1990;76:105-111.
269. Walsh GM, Mermod JJ, Hartnell A, Kay AB, Wardlaw AJ. Human eosinophil, but not neutrophil, adherence to IL-1-stimulated human umbilical vascular endothelial cells is $\gamma 4\beta 1$ (very late antigen-4) dependent. *J Immunol* 1991;146:3419-3423.
270. Dobrina A, Menegazzi R, Carlos TM, et al. Mechanisms of eosinophil adherence to cultured vascular endothelial cells. Eosinophils bind to the cytokine-induced ligand vascular cell adhesion molecule-1 via the very late activation antigen-4 integrin receptor. *J Clin Invest* 1991;88:20-26.
271. Weller PF, Rand TH, Goetz SE, Chi-Rosso G, Lobb RR. Human eosinophil adherence to vascular endothelium mediated by binding to vascular cell adhesion molecule 1 and endothelial leukocyte adhesion molecule 1. *Proc Natl Acad Sci U S A* 1991;88:7430-7433.
272. Matsumoto K, Sterbinsky SA, Bickel CA, Zhou DF, Kovach NL, Bochner BS. Regulation of $\alpha 4$ integrin-mediated adhesion of human eosinophils to fibronectin and vascular cell adhesion molecule-1. *J Allergy Clin Immunol* 1997;99:648-656.
273. Weber C, Katayama J, Springer TA. Differential regulation of $\beta 1$ and $\beta 2$ integrin avidity by chemoattractants in eosinophils. *Proc Natl Acad Sci U S A* 1996;93:10939-10944.
274. Ebisawa M, Bochner BS, Georas SN, Schleimer RP. Eosinophil transendothelial migration induced by cytokines. I. Role of endothelial and eosinophil adhesion molecules in IL-1 β -induced transendothelial migration. *J Immunol* 1992;149:4021-4028.
275. Shahabuddin S, Ponath P, Schleimer RP. Migration of eosinophils across endothelial cell monolayers: interactions among IL-5, endothelial-activating cytokines, and C-C chemokines. *J Immunol* 2000;164:3847-3854.
276. Georas SN, Liu MC, Newman W, Beall LD, Stealey BA, Bochner BS. Altered adhesion molecule expression and endothelial cell activation accompany the recruitment of human granulocytes to the lung after segmental antigen challenge. *Am J Respir Cell Mol Biol* 1992;7:261-269.
277. Schleimer RP, Sterbinsky SA, Kaiser J, et al. IL-4 induces adherence of human eosinophils and basophils but not neutrophils to endothelium. Association with expression of VCAM-1. *J Immunol* 1992;148:1086-1092.
278. Bochner BS, Klunk DA, Sterbinsky SA, Coffman RL, Schleimer RP. IL-13 selectively induces vascular cell adhesion molecule-1 expression in human endothelial cells. *J Immunol* 1995;154:799-803.
279. Kuperman D, Schofield B, Wills-Karp M, Grusby MJ. Signal transducer and activator of transcription factor 6 (STAT6)-deficient mice are protected from antigen-induced airway hyperresponsiveness and mucus production. *J Exp Med* 1998;187:939-948.
280. Akimoto T, Numata F, Tamura M, et al. Abrogation of bronchial eosinophilic inflammation and airway hyperreactivity in signal transducers and activators of transcription (STAT)6-deficient mice. *J Exp Med* 1998;187:1537-1542.
281. Matsukura S, Stellato C, Georas SN, et al. Interleukin-13 upregulates eotaxin expression in airway epithelial cells by a STAT6-dependent mechanism. *Am J Respir Cell Mol Biol* 2001;24:755-761.

P.180

282. Kuijpers TW, Mul EP, Blom M, et al. Freezing adhesion molecules in a state of high-avidity binding blocks eosinophil migration. *J Exp Med* 1993;178:279-284.
283. Werfel SJ, Yednock TA, Matsumoto K, Sterbinsky SA, Schleimer RP, Bochner BS. Functional regulation of $\beta 1$ integrins on human eosinophils by divalent cations and cytokines. *Am J Respir Cell Mol Biol* 1996;14:44-52.
284. Tachimoto H, Burdick MM, Hudson SA, Kikuchi M, Konstantopoulos K, Bochner BS. CCR3-active chemokines promote rapid detachment of eosinophils from VCAM-1 in vitro. *J Immunol* 2000;165:2748-2754.

285. DiScipio RG, Daffern PJ, Jagels MA, Broide DH, Sriramarao P. A comparison of C3a and C5a-mediated stable adhesion of rolling eosinophils in postcapillary venules and transendothelial migration in vitro and in vivo. *J Immunol* 1999;162:1127-1136.
286. Broide DH, Lotz M, Cuomo AJ, Coburn DA, Federman EC, Wasserman SI. Cytokines in symptomatic asthma airways. *J Allergy Clin Immunol* 1992;89:958-967.
287. Bochner BS, Charlesworth EN, Lichtenstein LM, et al. Interleukin-1 is released at sites of human cutaneous allergic reactions. *J Allergy Clin Immunol* 1990;86:830-839.
288. Hirata N, Kohrogi H, Iwagoe H, et al. Allergen exposure induces the expression of endothelial adhesion molecules in passively sensitized human bronchus: time course and the role of cytokines. *Am J Respir Cell Mol Biol* 1998;18:12-20.
289. Broide DH, Campbell K, Gifford T, Sriramarao P. Inhibition of eosinophilic inflammation in allergen-challenged, IL-1 receptor type 1-deficient mice is associated with reduced eosinophil rolling and adhesion on vascular endothelium. *Blood* 2000;95:263-269.
290. Walsh LJ, Trinchieri G, Waldorf HA, Whitaker D, Murphy GF. Human dermal mast cells contain and release tumor necrosis factor γ , which induces endothelial leukocyte adhesion molecule 1. *Proc Natl Acad Sci U S A* 1991;88:4220-4224.
291. Mackay F, Loetscher H, Stueber D, Gehr G, Lesslauer W. Tumor necrosis factor α (TNF- α)-induced cell adhesion to human endothelial cells is under dominant control of one TNF receptor type, TNF-R55. *J Exp Med* 1993;177:1277-1286.
292. Neumann B, Machleidt T, Lifka A, et al. Crucial role of 55-kilodalton TNF receptor in TNF-induced adhesion molecule expression and leukocyte organ infiltration. *J Immunol* 1996;156:1587-1593.
293. Broide DH, Stachnick G, Castaneda D, Nayar J, Sriramarao P. Inhibition of eosinophilic inflammation in allergen-challenged TNF receptor p55/p75- and TNF receptor p55-deficient mice. *Am J Respir Cell Mol Biol* 2001;24:304-311.
294. Masumoto A, Hemler ME. Multiple activation states of VLA-4. Mechanistic differences between adhesion to CS1/fibronectin and to vascular cell adhesion molecule-1. *J Biol Chem* 1993;268:228-234.
295. Sung KL, Li Y, Elices M, Gang J, Sriramarao P, Broide DH. Granulocyte-macrophage colony-stimulating factor regulates the functional adhesive state of very late antigen-4 expressed by eosinophils. *J Immunol* 1997;158:919-927.
296. Adachi T, Vita R, Sannohe S, et al. The functional role of rho and rho-associated coiled-coil forming protein kinase in eotaxin signaling of eosinophils. *J Immunol* 2001;167:4609-4615.
297. Muessel MJ, Scott KS, Friedl P, Bradding P, Wardlaw AJ. CCL11 and GM-CSF differentially use the Rho GTPase pathway to regulate motility of human eosinophils in a three-dimensional microenvironment. *J Immunol* 2008;180:8354-8360.
298. Fulkerson PC, Zimmermann N, Brandt EB, et al. Negative regulation of eosinophil recruitment to the lung by the chemokine monokine induced by IFN γ (Mig, CXCL9). *Proc Natl Acad Sci U S A* 2004;101:1987-1992.
299. Fulkerson PC, Zhu H, Williams DA, Zimmermann N, Rothenberg ME. CXCL9 inhibits eosinophil responses by a CCR3- and Rac2-dependent mechanism. *Blood* 2005;106:436-443.
300. Kitayama J, Mackay CR, Ponath PD, Springer TA. The C-C chemokine receptor CCR3 participates in stimulation of eosinophil arrest on inflammatory endothelium in shear flow. *J Clin Invest* 1998;101:2017-2024.
301. Jose PJ, Griffiths-Johnson DA, Collins PD, et al. Eotaxin: a potent eosinophil chemoattractant cytokine detected in a guinea pig model of allergic airways inflammation. *J Exp Med* 1994;179:881-887.
302. Rothenberg ME. Eotaxin. An essential mediator of eosinophil trafficking into mucosal tissues. *Am J Respir Cell Mol Biol* 1999;21:291-295.
303. Schall TJ. Biology of the RANTES/SIS cytokine family. *Cytokine* 1991;3:165-183.
304. Fryer AD, Stein LH, Nie Z, et al. Neuronal eotaxin and the effects of CCR3 antagonist on airway hyperreactivity and M2 receptor dysfunction. *J Clin Invest* 2006;116:228-236.
305. Zimmermann N, Hogan SP, Mishra A, et al. Murine eotaxin-2: a constitutive eosinophil chemokine induced by allergen challenge and IL-4 overexpression. *J Immunol* 2000;165:5839-5846.
306. Rothenberg ME, Luster AD, Lilly CM, Drazen JM, Leder P. Constitutive and allergen-induced expression of eotaxin mRNA in the guinea pig lung. *J Exp Med* 1995;181:1211-1216.

307. Collins PD, Marleau S, Griffiths-Johnson DA, Jose PJ, Williams TJ. Cooperation between interleukin-5 and the chemokine eotaxin to induce eosinophil accumulation in vivo. *J Exp Med* 1995;182:1169-1174.
308. Mould AW, Ramsay AJ, Matthaei KI, Young IG, Rothenberg ME, Foster PS. The effect of IL-5 and eotaxin expression in the lung on eosinophil trafficking and degranulation and the induction of bronchial hyperreactivity. *J Immunol* 2000;164:2142-2150.
309. Matthews AN, Friend DS, Zimmermann N, et al. Eotaxin is required for the baseline level of tissue eosinophils. *Proc Natl Acad Sci U S A* 1998;95:6273-6278.
310. Gonzalo JA, Lloyd CM, Wen D, et al. The coordinated action of CC chemokines in the lung orchestrates allergic inflammation and airway hyperresponsiveness. *J Exp Med* 1998;188:157-167.
311. Kaburagi Y, Shimada Y, Nagaoka T, Hasegawa M, Takehara K, Sato S. Enhanced production of CC-chemokines (RANTES, MCP-1, MIP-1 α , MIP-1 β , and eotaxin) in patients with atopic dermatitis. *Arch Dermatol Res* 2001;293:350-355.
312. Noah TL, Becker S. Chemokines in nasal secretions of normal adults experimentally infected with respiratory syncytial virus. *Clin Immunol* 2000;97:43-49.
313. Harrison AM, Bonville CA, Rosenberg HF, Domachowske JB. Respiratory syncytial virus-induced chemokine expression in the lower airways: eosinophil recruitment and degranulation. *Am J Respir Crit Care Med* 1999;159:1918-1924.
314. Teran LM, Seminario MC, Shute JK, et al. RANTES, macrophage-inhibitory protein 1 α , and the eosinophil product major basic protein are released into upper respiratory secretions during virus-induced asthma exacerbations in children. *J Infect Dis* 1999;179:677-681.
315. Palmblad J, Gyllenhammar H, Lindgren JA, Malmsten CL. Effects of leukotrienes and f-Met-Leu-Phe on oxidative metabolism of neutrophils and eosinophils. *J Immunol* 1984;132:3041-3045.
316. Kroegel C, Yukawa T, Dent G, Venge P, Chung KF, Barnes PJ. Stimulation of degranulation from human eosinophils by platelet-activating factor. *J Immunol* 1989;142:3518-3526.
317. Moqbel R. Leukotriene receptor antagonists in the treatment of asthma: implications for eosinophilic inflammation. *Can Respir J* 1999;6:453-457.
318. Dunnill MS. The pathology of asthma with special reference to changes in the bronchial mucosa. *J Clin Path* 1960;13:27-33.
319. Kim CK, Callaway Z, Kim DW, Kita H. Eosinophil degranulation is more important than eosinophilia in identifying asthma in chronic cough. *J Asthma* 2011;48:994-1000.
320. Grainge CL, Lau LC, Ward JA, et al. Effect of bronchoconstriction on airway remodeling in asthma. *N Engl J Med* 2011;364:2006-2015.
321. Selivanova PA, Kulikov ES, Kozina OV, Gereng EA, Freidin MB, Ogorodova LM. Morphological and molecular characteristics of "difficult" asthma. *J Asthma* 2010;47:269-275.
322. Turato G, Barbato A, Baraldo S, et al. Nonatopic children with multitrigger wheezing have airway pathology comparable to atopic asthma. *Am J Respir Crit Care Med* 2008;178:476-482.
323. Cheng JF, Ott NL, Peterson EA, et al. Dermal eosinophils in atopic dermatitis undergo cytolytic degeneration. *J Allergy Clin Immunol* 1997;99:683-692.
324. Simon D, Braathen LR, Simon HU. Eosinophils and atopic dermatitis. *Allergy* 2004;59:561-570.
325. Foster EL, Simpson EL, Fredrikson LJ, et al. Eosinophils increase neuron branching in human and murine skin and in vitro. *PLoS One* 2011;6:e22029.
326. Durham SR, Kay AB. Eosinophils, bronchial hyperreactivity and late-phase asthmatic reactions. *Clin Allergy* 1985;15:411-418.
327. Montefort S, Gratziau C, Goulding D, et al. Bronchial biopsy evidence for leukocyte infiltration and upregulation of leukocyte-endothelial cell adhesion molecules 6 hours after local allergen challenge of sensitized asthmatic airways. *J Clin Invest* 1994;93:1411-1421.
328. Lommatzsch M, Julius P, Kuepper M, et al. The course of allergen-induced leukocyte infiltration in human and experimental asthma. *J Allergy Clin Immunol* 2006;118:91-97.

329. Fabbri LM, Boschetto P, Zocca E, et al. Bronchoalveolar neutrophilia during late asthmatic reactions induced by toluene diisocyanate. *Am Rev Respir Dis* 1987;136:36-42.
330. Bentley AM, Menz G, Storz C, et al. Identification of T lymphocytes, macrophages, and activated eosinophils in the bronchial mucosa in intrinsic asthma. Relationship to symptoms and bronchial responsiveness. *Am Rev Respir Dis* 1992;146:500-506.
331. Wardlaw AJ. Eosinophils in the 1990s: new perspectives on their role in health and disease. *Postgrad Med J* 1994;70:536-552.
332. de BJ, Tillie-Leblond I, Tonnel AB, Jaubert F, Scheinmann P, Gosset P. Difficult asthma in children: an analysis of airway inflammation. *J Allergy Clin Immunol* 2004;113:94-100.
333. Kim CK, Kim SW, Kim YK, et al. Bronchoalveolar lavage eosinophil cationic protein and interleukin-8 levels in acute asthma and acute bronchiolitis. *Clin Exp Allergy* 2005;35:591-597.
334. Julius P, Luttmann W, Knoechel B, Kroegel C, Matthys H, Virchow JC Jr. CD69 surface expression on human lung eosinophils after segmental allergen provocation. *Eur Respir J* 1999;13:1253-1259.
335. Johansson MW, Kelly EA, Busse WW, Jarjour NN, Mosher DF. Up-regulation and activation of eosinophil integrins in blood and airway after segmental lung antigen challenge. *J Immunol* 2008;180:7622-7635.
336. Hartnell A, Robinson DS, Kay AB, Wardlaw AJ. CD69 is expressed by human eosinophils activated in vivo in asthma and in vitro by cytokines. *Immunology* 1993;80:281-286.
337. Gundel RH, Letts LG, Gleich GJ. Human eosinophil major basic protein induces airway constriction and airway hyperresponsiveness in primates. *J Clin Invest* 1991;87:1470-1473.
338. Costello RW, Evans CM, Yost BL, et al. Antigen-induced hyperreactivity to histamine: role of the vagus nerves and eosinophils. *Am J Physiol* 1999;276:L709-L714.
339. Gibson PG, Dolovich J, Denburg JA, Girgis-Gabardo A, Hargreave FE. Sputum cell counts in airway disease: a useful sampling technique. *Agents Actions Suppl* 1990;30:161-172.
340. Pizzichini E, Pizzichini MM, Efthimiadis A, et al. Indices of airway inflammation in induced sputum: reproducibility and validity of cell and fluid-phase measurements. *Am J Respir Crit Care Med* 1996;154:308-317.
341. Lex C, Ferreira F, Zacharasiewicz A, et al. Airway eosinophilia in children with severe asthma: predictive values of noninvasive tests. *Am J Respir Crit Care Med* 2006;174:1286-1291.
342. Green RH, Brightling CE, McKenna S, et al. Asthma exacerbations and sputum eosinophil counts: a randomised controlled trial. *Lancet* 2002;360:1715-1721.
343. Jayaram L, Pizzichini MM, Cook RJ, et al. Determining asthma treatment by monitoring sputum cell counts: effect on exacerbations. *Eur Respir J* 2006;27:483-494.
344. Petsky HL, Cates CJ, Lasserson TJ, et al. A systematic review and meta-analysis: tailoring asthma treatment on eosinophilic markers (exhaled nitric oxide or sputum eosinophils). *Thorax* 2012;67:199-208.
345. Bacci E, Cianchetti S, Bartoli M, et al. Low sputum eosinophils predict the lack of response to beclomethasone in symptomatic asthmatic patients. *Chest* 2006;129:565-572.
346. Zeiger RS, Colten HR. Histaminase release from human eosinophils. *J Immunol* 1977;118:540-543.
347. Hogan SP, Matthaai KI, Young JM, Koskinen A, Young IG, Foster PS. A novel T cell-regulated mechanism modulating allergen-induced airways hyperreactivity in BALB/c mice independently of IL-4 and IL-5. *J Immunol* 1998;161:1501-1509.
348. Nagai H, Yamaguchi S, Inagaki N, Tsuruoka N, Hitoshi Y, Takatsu K. Effect of anti-IL-5 monoclonal antibody on allergic bronchial eosinophilia and airway hyperresponsiveness in mice. *Life Sci* 1993;53:L243-L247.
349. Hogan SP, Koskinen A, Matthaai KI, Young IG, Foster PS. Interleukin-5-producing $\gamma\delta$ T cells play a pivotal role in aeroallergen-induced eosinophilia, bronchial hyperreactivity, and lung damage in mice. *Am J Respir Crit Care Med* 1998;157:210-218.
350. Lee NA, McGarry MP, Larson KA, Horton MA, Kristensen AB, Lee JJ. Expression of IL-5 in thymocytes/T cells leads to the development of a massive eosinophilia, extramedullary eosinophilopoiesis, and unique histopathologies. *J Immunol* 1997;158:1332-1344.

351. Hogan SP, Mishra A, Brandt EB, et al. A pathological function for eotaxin and eosinophils in eosinophilic gastrointestinal inflammation. *Nat Immunol* 2001;2:353-360.
352. Lee JJ, Dimina D, Macias MP, et al. Defining a link with asthma in mice congenitally deficient in eosinophils. *Science* 2004;305:1773-1776.
353. Walsh ER, Sahu N, Kearley J, et al. Strain-specific requirement for eosinophils in the recruitment of T cells to the lung during the development of allergic asthma. *J Exp Med* 2008;205:1285-1292.
354. Humbles AA, Lloyd CM, McMillan SJ, et al. A critical role for eosinophils in allergic airways remodeling. *Science* 2004;305:1776-1779.
355. Kita H. Eosinophils: multifaceted biological properties and roles in health and disease. *Immunol Rev* 2011;242:161-177.
356. Sanderson CJ. Interleukin-5, eosinophils, and disease. *Blood* 1992;79:3101-3109.
357. Egan RW, Athwahl D, Chou CC, et al. Pulmonary biology of anti-interleukin 5 antibodies. *Mem Inst Oswaldo Cruz* 1997;92 Suppl 2:69-73.
358. Leckie MJ, ten Brinke A, Khan J, et al. Effects of an interleukin-5 blocking monoclonal antibody on eosinophils, airway hyper-responsiveness, and the late asthmatic response. *Lancet* 2000;356:2144-2148.
359. Kips JC, O'Connor BJ, Langley SJ, et al. Effect of SCH55700, a humanized anti-human interleukin-5 antibody, in severe persistent asthma: a pilot study. *Am J Respir Crit Care Med* 2003;167:1655-1659.
360. Adamko D, Odemuyiwa SO, Moqbel R. The eosinophil as a therapeutic target in asthma: beginning of the end, or end of the beginning? *Curr Opin Pharmacol* 2003;3:227-232.
361. O'Byrne PM, Inman MD, Parameswaran K. The trials of interleukin-5, eosinophils and allergic asthma. *J Allergy Clin Immunol* 2001;108:503-508.
362. Flood-Page PT, Menzies-Gow AN, Kay AB, Robinson DS. Eosinophil's role remains uncertain as anti-interleukin-5 only partially depletes numbers in asthmatic airway. *Am J Respir Crit Care Med* 2003;167:199-204.
363. Schmid-Grendelmeier P, Altnauer F, et al. Eosinophils express functional IL-13 in eosinophilic inflammatory diseases. *J Immunol* 2002;169:1021-1027.
364. Ying S, Meng Q, Taborda-Barata L, et al. Human eosinophils express messenger RNA encoding RANTES and store and release biologically active RANTES protein. *Eur J Immunol* 1996;26:70-76.
365. Shen HH, Ochkur SI, McGarry MP, et al. A causative relationship exists between eosinophils and the development of allergic pulmonary pathologies in the mouse. *J Immunol* 2003;170:3296-3305.
366. Brightling CE, Bradding P, Symon FA, Holgate ST, Wardlaw AJ, Pavord ID. Mast-cell infiltration of airway smooth muscle in asthma. *N Engl J Med* 2002;346:1699-1705.
367. Evans CM, Fryer AD, Jacoby DB, Gleich GJ, Costello RW. Pretreatment with antibody to eosinophil major basic protein prevents hyperresponsiveness by protecting neuronal M₂ muscarinic receptors in antigen-challenged guinea pigs. *J Clin Invest* 1997;100:2254-2262.
368. Adamko DJ, Fryer AD, Bochner BS, Jacoby DB.  T lymphocytes in viral hyperreactivity and M₂ muscarinic receptor dysfunction. *Am J Respir Crit Care Med* 2003;167:550-556.
369. Wardlaw AJ, Moqbel R, Kay AB. Eosinophils and the allergic inflammatory response. In: Kay AB, ed. *Allergy and allergic diseases*. Oxford: Blackwell Scientific Publications, 1997:171-197.
370. Adamko D, Lacy P, Moqbel R. Mechanisms of eosinophil recruitment and activation. *Curr Allergy Asthma Rep* 2002;2:107-116.
371. Adamko DJ, Odemuyiwa SO, Vethanayagam D, Moqbel R. The rise of the phoenix: the expanding role of the eosinophil in health and disease. *Allergy* 2005;60:13-22.
372. Nair P, Pizzichini MM, Kjarsgaard M, et al. Mepolizumab for prednisone-dependent asthma with sputum eosinophilia. *N Engl J Med* 2009;360: 985-993.
373. Castro M, Mathur S, Hargreave F, et al. Reslizumab for poorly controlled, eosinophilic asthma: a randomized, placebo-controlled study. *Am J Respir Crit Care Med* 2011;184:1125-1132.

374. Seefeld U, Krejs GJ, Siebenmann RE, Blum AL. Esophageal histology in gastroesophageal reflux. Morphometric findings in suction biopsies. *Am J Dig Dis* 1977;22:956-964.
375. Ruchelli E, Wenner W, Voytek T, Brown K, Liacouras C. Severity of esophageal eosinophilia predicts response to conventional gastroesophageal reflux therapy. *Pediatr Dev Pathol* 1999;2:15-18.
376. Riddell RH. The biopsy diagnosis of gastroesophageal reflux disease, "carditis," and Barrett's esophagus, and sequelae of therapy. *Am J Surg Pathol* 1996;20 Suppl 1:S31-S50.
377. Khan S, Orenstein SR, Di LC, et al. Eosinophilic esophagitis: strictures, impactions, dysphagia. *Dig Dis Sci* 2003;48:22-29.
378. Arora AS, Perrault J, Smyrk TC. Topical corticosteroid treatment of dysphagia due to eosinophilic esophagitis in adults. *Mayo Clin Proc* 2003;78:830-835.
379. Teitelbaum JE, Fox VL, Twarog FJ, et al. Eosinophilic esophagitis in children: immunopathological analysis and response to fluticasone propionate. *Gastroenterology* 2002;122:1216-1225.
380. Schroeder S, Fleischer DM, Masterson JC, Gelfand E, Furuta GT, Atkins D. Successful treatment of eosinophilic esophagitis with ciclesonide. *J Allergy Clin Immunol* 2012;129:1419-1421.
381. Lu TX, Sherrill JD, Wen T, et al. MicroRNA signature in patients with eosinophilic esophagitis, reversibility with glucocorticoids, and assessment as disease biomarkers. *J Allergy Clin Immunol* 2012;129:1064-1075.
382. Attwood SE, Lewis CJ, Bronder CS, Morris CD, Armstrong GR, Whittam J. Eosinophilic oesophagitis: a novel treatment using Montelukast. *Gut* 2003;52:181-185.
383. Stumphy J, Al-Zubeidi D, Guerin L, Mitros F, Rahhal R. Observations on use of montelukast in pediatric eosinophilic esophagitis: insights for the future. *Dis Esophagus* 2011;24:229-234.
384. Helou EF, Simonson J, Arora AS. 3-yr-follow-up of topical corticosteroid treatment for eosinophilic esophagitis in adults. *Am J Gastroenterol* 2008;103:2194-2199.
385. Fogg MI, Ruchelli E, Spergel JM. Pollen and eosinophilic esophagitis. *J Allergy Clin Immunol* 2003;112:796-797.
386. Mishra A, Hogan SP, Brandt EB, Rothenberg ME. An etiological role for aeroallergens and eosinophils in experimental esophagitis. *J Clin Invest* 2001;107:83-90.
387. Finkelman FD, Pearce EJ, Urban JF Jr, Sher A. Regulation and biological function of helminth-induced cytokine responses. *Immunol Today* 1991;12: A62-A66.
388. Butterworth AE. Cell-mediated damage to helminths. *Adv Parasitol* 1984;23:143-235.
389. Hsu SY, Hsu HF, Penick GD, Hanson HO, Schiller HJ, Cheng HF. Immunoglobulin E, mast cells, and eosinophils in the skin of rhesus monkeys immunized with x-irradiated cercariae of *Schistosoma japonicum*. *Int Arch Allergy Appl Immunol* 1979;59:383-393.
390. Kephart GM, Gleich GJ, Connor DH, Gibson DW, Ackerman SJ. Deposition of eosinophil granule major basic protein onto microfilariae of *Onchocerca volvulus* in the skin of patients treated with diethylcarbamazine. *Lab Invest* 1984;50:51-61.
391. Spry CJ. Alterations in blood eosinophil morphology, binding capacity for complexed IgG and kinetics in patients with tropical (filarial) eosinophilia. *Parasite Immunol* 1981;3:1-11.
392. Moqbel R, Walsh GM, Nagakura T, et al. The effect of platelet-activating factor on IgE binding to, and IgE-dependent biological properties of, human eosinophils. *Immunology* 1990;70:251-257.
393. Herbert DR, Lee JJ, Lee NA, Nolan TJ, Schad GA, Abraham D. Role of IL-5 in innate and adaptive immunity to larval *Strongyloides stercoralis* in mice. *J Immunol* 2000;165:4544-45451.
394. Swartz JM, Dyer KD, Cheever AW, et al. *Schistosoma mansoni* infection in eosinophil lineage-ablated mice. *Blood* 2006;108:2420-2427.
395. Moqbel R. Histopathological changes following primary, secondary and repeated infections of rats with *Strongyloides ratti*, with special reference to tissue eosinophils. *Parasite Immunology* 1980;2:11-27.

WEBSITES

<http://www.annualreviews.org/doi/pdf/10.1146/annurev.immunol.24.021605.090720>

<http://apfed.org/drupal/drupal/index.php>

http://en.wikipedia.org/wiki/Eosinophil_granulocyte

<http://en.wikipedia.org/wiki/Eosinophilia>

Chapter 9 Mast Cells and Basophils: Ontogeny, Characteristics, and Functional Diversity

> Table of Contents > Part II - The Normal Hematologic System > Section 3 - Granulocytes and Monocytes > Chapter 9 - Mast Cells and Basophils: Ontogeny, Characteristics, and Functional Diversity

Chapter 9

Mast Cells and Basophils: Ontogeny, Characteristics, and Functional Diversity

A. Dean Befus

Kelly M. McNagny

Judah A. Denburg

INTRODUCTION

In 1965, Selye¹ reviewed the literature on two populations of basophilic leukocytes, namely mast cells and basophils. These cells have many similarities, but they also exhibit several intriguing differences. Recent contributions to the literature documenting advances made in our understanding of these cells, their development, contents, biosynthetic activities, activation, and functions in physiology and pathophysiology^{2,3,4,5,6,7} are helping us begin to understand the nature of their relationship in ontogeny and immunity,² and factors that govern their elicitation and contributions to a wide variety of inflammatory disorders, including allergic inflammation. Mast cells and basophils contain electron-dense cytoplasmic granules and stain metachromatically with selected basic dyes. They produce numerous inflammatory mediators, many—such as histamine—that are common to both cells, and others that are cell-specific. Both cells express a tetrameric isoform of the high-affinity receptor for immunoglobulin E (IgE) and are best known for their ability to release a plethora of factors and inflammatory mediators in response to receptor cross-linking. When the tetrameric high-affinity IgE receptor is cross-linked by sensitizing allergen or by anti-IgE antibodies, mast cells and basophils can be activated, mediator synthesis and secretion are induced, and gene expression altered, with consequences on many immune and inflammatory events.

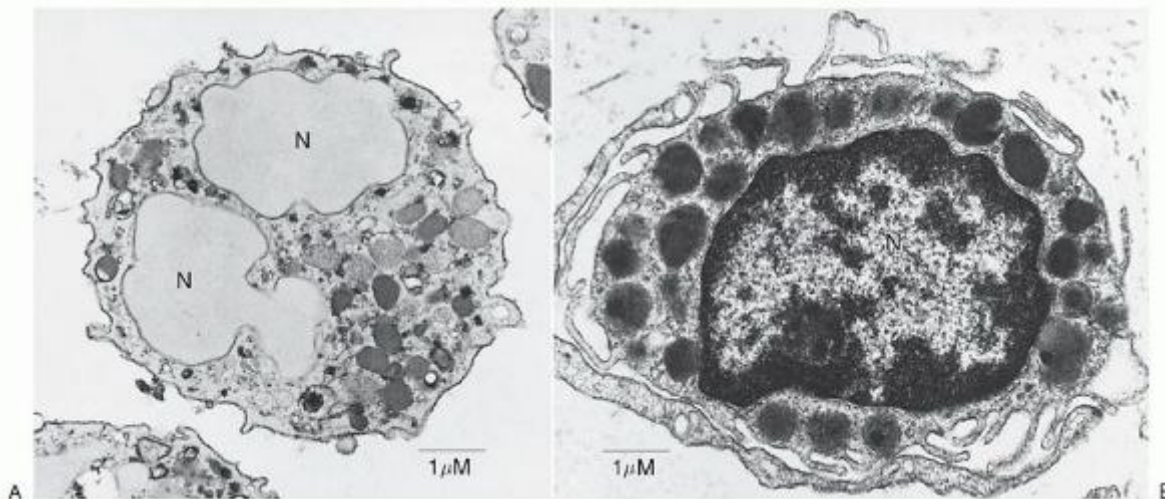

FIGURE 9.1. A. Basophils are “cells with the kinetics and natural history of granulocytes that mature in bone marrow, circulate in the blood, and retain certain characteristic ultrastructural features, even after migrating into the tissues during inflammatory or immunologic processes. The ultrastructure of mature basophils varies according to species but generally includes electron-dense cytoplasmic granules, prominent aggregates of cytoplasmic glycogen, and short, blunt, irregularly distributed plasma membrane processes. There is no convincing evidence that mature basophils, whether in the circulation or in the tissues, retain mitotic capability, or that basophils metamorphose into mast cells upon entering the

tissues.” (Galli SJ, Dvorak AM, Dvorak HF. *Prog Allergy* 1984;34:1-141). As shown in Figure 9.1A, human basophils are round and have irregular, short surface projections, cytoplasmic secretory granules, and aggregates of cytoplasmic glycogen. N, nucleus; bar, 1 μ m. (Reproduced with permission from the authors and Blackwell Science Ltd., Dvorak AM, Warner JA, Fox P, et al. Recovery of human basophils after FMLP-stimulated secretion. *Clin Exp Allergy* 1996; 26:281-294.)

B. Mast cells “ordinarily mature outside of the bone marrow or circulation, generally in the connective tissues or serous cavities. Cells in this lineage(s), wherever distributed, apparently retain at least limited or latent proliferative capacity... (l)mmature and mature granules of mast cells and basophils differ distinctively in ultrastructure. Mast cells also differ from basophils in lacking electron-dense aggregates of cytoplasmic glycogen, and in having a plasma membrane surface with uniformly distributed, thin, elongate folds and processes. Mast cell nuclei may appear bilobed in an individual photomicrograph, but they generally lack the pattern of peripherally condensed nuclear chromatin characteristic of basophils and other granulocytes.” (Galli SJ, Dvorak AM, Dvorak HF. *Prog Allergy*. Basophils and mast cells: morphologic insights into their biology, secretory patterns, and function. 1984;34:1-141). A human skin mast cell is shown with monolobed nucleus with partially condensed chromatin, numerous cytoplasmic granules containing crystalline structures and regularly distributed, narrow, thin surface projections. Bar, 1 μ m. (Reproduced with permission from the author and Springer-Verlag. Dvorak AM. Human mast cells. In: Beck F, Hild W, Kriz W, et al., eds. *Advances in anatomy, embryology and cell biology*. Leicester: Springer-Verlag, 1989;114:1-107.)

Classical ontogenic and ultrastructural descriptions for mast cells and basophils are shown in Figure 9.1 A,B; however, new information and emerging technologies have greatly expanded our understanding of the roles of basophils and mast cells in both innate and acquired immunity,^{2,4,8,9,10,11,12,13} notably including: (a) a burgeoning literature and controversy on basophil involvement as antigen-presenting cells in Th2 immune responses^{2,8,9,10,11,12,13}; (b) new insights into the role of gut microbiota and thymic stromal lymphopoietin (TSLP) in basophil hemopoiesis and in mast cell localization and function^{14,15}; (c) expression of the hemopoietic antigen, CD34, on mast cells involved in a variety of inflammatory reactions^{16,17,18}; (d) novel roles for mast cells in tissue remodeling, angiogenesis, and tumor growth^{19,20,21,22}; and (e) the capacity of mast cells to be derived from a compartment of multipotential hemopoietic progenitors, distinct from the myeloid lineage.^{23,24,25} In many ways the original statement by Ehrlich in 1879¹ that basophils are “blood mast

P.182

cells,” and the corollary, that mast cells are “tissue basophils,” although imprecise from a strictly developmental standpoint, is still of some value in thinking about the nature of these two cell types. The striking inverse relationship between the numbers of circulating basophils and the numbers of tissue mast cells has been used for decades to infer similarities in function.¹

This chapter provides an overview of the developmental biology of these two cell types, comparing and contrasting basophil and mast cell physiology, phenotype, activation, and function; lineage commitment and differentiation; and roles in innate and acquired immunity. Anticipated increases in the understanding of basophil and mast cell function will lead to effective new diagnostic and therapeutic strategies for the betterment of those suffering from allergic and other related diseases.

GENERAL MORPHOLOGY, MEDIATOR SECRETION, AND RECOVERY

Morphology

Histochemical staining of blood smears or cytocentrifuge preparations of enriched basophils or mast cells with Wright or May-Grünwald-Giemsa stain show many similarities in these cell types (Fig. 9.2 A,B). The cytoplasm of the cells generally stains pink, the nucleus is purplish or blue, and the cytoplasmic granules are dark blue to purple or even blackish. Basophils in peripheral blood or tissues range in size from 10 to 15 μ m, whereas mast cells in tissue sites may appear irregular in shape and up to 20 μ m in a long dimension. Ultrastructural analyses demonstrate many similarities between mast cells and basophils, but also identify some distinct differences (Fig. 9.1A,B).²⁶ In the blood, basophils are round, whereas in the tissues they can acquire various shapes. Mast cells can appear to be round, oval, or elongate-spindle shaped in the tissues. The surface of basophils exhibits blunt processes of variable shape and size, whereas mast cells often possess long fingerlike processes that extend from the surface. The nucleus of mast cells can be round or lobed, whereas that of the basophil is generally multilobed. Nucleoli are often not apparent or are absent from normal mast cells and basophils. Basophils have an abundance of condensed chromatin positioned at the periphery of the nucleus, whereas mast cells have little condensed chromatin, possibly reflecting their capacity for continued proliferation. The cytoplasm of normal mature mast cells has few mitochondria and a relatively inconspicuous Golgi apparatus; and ribosomes, rough endoplasmic reticulum, and aggregates of glycogen are rare. In normal basophils, mitochondria and aggregates of

glycogen are more abundant than in mast cells, but as with mast cells, Golgi apparatus, ribosomes, and rough endoplasmic reticulum are rare in normal basophils. The most prominent cytoplasmic elements in both cell types are the membrane-bound, electron-dense granules.

Basophils generally possess fewer granules than mast cells and the granules exhibit a more homogeneous ultrastructural morphology than those of mast cells. Basophil granules are often homogeneously electron-dense, although dense particles may be interspersed with membrane aggregates and whorls. Charcot-Leyden crystals can be formed in basophils as well. Mast cell granules may be homogeneously electron-dense or may exhibit electron-dense particles, membrane or complex scroll-like patterns, highly organized crystalline structures, or combinations of these. The relationship of these different granule patterns to the tissue site, phase in development, or mediator content is not clear. Interestingly, Dvorak has reported that mast cell granules, in addition to storing mediators, are also sites of RNA metabolism and protein synthesis activity. Mast cells produce 30 to 100 nm extracellular membrane vesicles of endocytic origin, called exosomes, that possess mRNA, microRNAs, proteins, and lipids, and have been shown to transfer these components to other cells and influence their functions.²⁷ Moreover, the composition and cell-to-cell communication functions of exosomes are influenced by activation of mast cells.²⁸ Basophils have not been shown to produce exosomes, but they do contain numerous electron-lucent vesicles of 50 to 70 nm that often have contents similar to granules. These may be associated with a form of mediator exocytosis (see below).

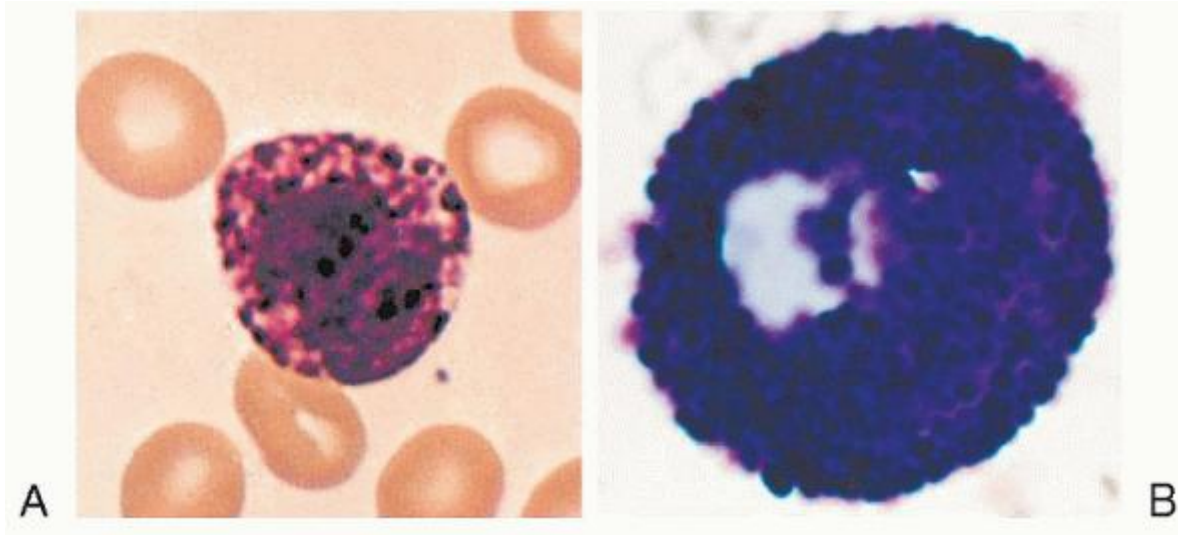

FIGURE 9.2. A. Human peripheral blood basophil stained with Wright's. (From Lee, Bithell, Foerster, et al., eds. Wintrobe's clinical hematology, 9th ed. Philadelphia, PA: Lea & Febiger, 1993.) B. Rat peritoneal mast cell stained with May-Grünwald-Giemsa.

Mast cells and basophils also contain rounded, non-membrane-bound, electron-dense structures called lipid bodies, a rich store of arachidonic acid. Lipid bodies increase in number during cell activation, and are thought to be derived from membrane catabolism and the rapid synthesis of lipid mediators such as the cyclooxygenase and lipoxygenase derivatives of arachidonic acid.²⁹

Mediator Secretion

Mast cells and basophils undergo distinct patterns of granule mediator secretion or synthesis, depending on the stimuli involved in their activation.^{26,30} Degranulation or regulated exocytosis, whereby granules or their contents are released, occurs following stimulation through the IgE receptor or numerous other receptors, such as those for fragments of the complement cascade. This degranulation can be extensive, involving the majority of the granules, or it can be more restricted. The numbers of granules involved appear to correlate with the proportion of the total cellular histamine that is released. The granules rapidly exhibit signs of swelling, then demonstrate membrane fusion with adjacent granules; interconnecting chains and channels form that ultimately fuse with the plasma membrane, creating pores or larger openings and subsequently granule contents or larger granule structures can be seen outside the cell. Prominent cytoplasmic microtubules can be seen close to the granules, and actin complexes appear outside the cell in association with granules or their contents. The process is generally similar for basophils. Electron-dense granules appear to evolve into electron-lucent vacuoles, many of which communicate with other vacuoles and the cell surface through pores within

5 to 10 minutes of activation. Apparently intact granules can be seen outside the cell. This degranulation does not lead to prominent cell death, and cells can recover and degranulate again.^{26,31}

Another form of secretion of stored mediators is piecemeal degranulation, involving production of small vesicles arising from granules that shuttle selected granule components to the extracellular milieu.³⁰ Piecemeal degranulation also occurs in both mast cells and basophils, as well as in eosinophils,^{26,32} and is the most prevalent morphologic expression of mast cell and basophil secretion in nonallergic inflammatory conditions in human biopsy material. It is postulated that intragranular vesiculotubular networks fuse with the plasma membrane, and discharge their granule contents to the extracellular space. This form of mediator secretion appears to be associated with secretion of selected mediators, rather than the entire contents of the granules. It has been reported in communications between mast cells and neurons

P.183

in the brain,³³ in psychosocial stress,³⁴ and in acute gastritis,³⁵ and may be a component of responses to Toll-like receptor (TLR) activation.⁴ In inflammatory reactions in which mast cell and basophil infiltration occurs, such as in cutaneous delayed hypersensitivity, piecemeal degranulation can occur. As with anaphylactic degranulation, piecemeal secretion is associated with the ability of mast cells to recharge their granules and function again.

Cytokines and chemokines are also secreted by mechanisms independent of degranulation, as are arachidonic acid metabolites, prostaglandins, and leukotrienes. Newly synthesized cytokines and chemokines can be secreted by a process called constitutive exocytosis. The pathways of secretion of arachidonic acid metabolites as well as those for exosome release are poorly known.

Recovery after Activation

Dvorak²⁶ summarized the evidence for the ability of mast cells and basophils to recover and regranulate following activation. During this process, mast cells and basophils appear to conserve membranes and other components and to resynthesize granule and other components, such as rough endoplasmic reticulum, Golgi, and microtubules. This recovery generally occurs within 1 to 2 days; whether death occurs by necrosis or apoptosis as a critical feature of mast cell or basophil activation in vivo needs to be more carefully evaluated.

ONTOGENY AND DEVELOPMENTAL BIOLOGY OF MAST CELLS AND BASOPHILS

The tissue mast cell and the blood basophil are not normally derived directly from a common progenitor, but share their origins from a CD34⁺ hemopoietic stem cell regulated closely by various marrow and tissue stromal factors (Fig. 9.3A, B). A unique role is played by CD34 itself—which can be found on some mast cell subpopulations, and is involved in mast cell migration as well as tissue inflammatory responses—in these processes.^{18,36} Recent evidence suggests that mast cells are derived from a separate, nonmyeloid lineage-committed progenitor,²³ and that, for the most part, basophils and mast cells have distinct ontogenic derivations and markers,²³ although evidence from leukemic cell lines raises the possibility of some lineage pathway commonalities.^{37,38} and ^{39,40} Phylogenetically, there appears to be an inverse relationship between the presence of basophils and mast cells, as well as supporting evidence for a “common origin” by analysis of the evolution of a mast cell progenitor from an ancestral leukocyte involved in innate immunity.^{1,2,41} Major advances in understanding human basophil and mast cell growth and differentiation have come from rodent models,^{14,42,43,44} which have recently included an appreciation of the pivotal roles played by epithelial factors such as TSLP, IL-33, IL-25, and receptors such as the TLRs^{45,46} in basophil, eosinophil, and mast cell differentiation.

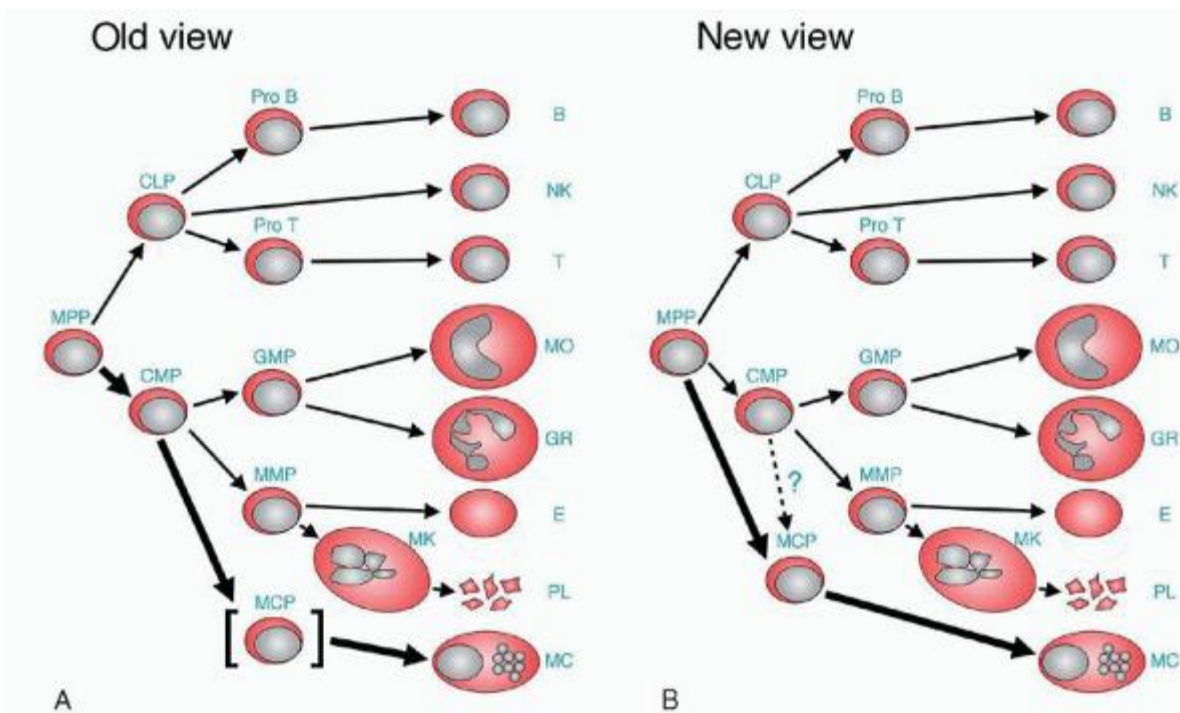

FIGURE 9.3. Change of lineage model of hematopoiesis. A. In the old view, the presence of mast cell committed progenitors (MCP) was not clear, but mast cells were considered to be the progeny of common myeloid progenitors (CMP) without convincing evidence. Therefore, MCP is put in brackets. B. In the new view proposed by Chen et al.²³ the presence of MCP is clear, and MCP is directly derived from multipotential progenitors (MPP). The thick line shows the main differentiation route from MPP to mast cell. CLP, common lymphoid progenitor; GMP, granulocyte/macrophage progenitor; Pro B, progenitor B cell; Pro T, progenitor T cell; B, B cell; NK, natural killer cell; T, T cell; MO, monocyte/macrophage; GR, granulocyte; E, erythrocyte; PL, platelet; MC, mast cell. (Reproduced with permission, Proc Natl Acad Sci U S A 2005;102:11129-11130 © 2005 National Academy of Sciences, U.S.A.⁷⁴).

Identification of the mast-cell hemopoietin and ligand, stem cell factor (SCF), and its receptor, c-kit (CD117), has provided a wealth of insight into the functional role of mast cells in a variety of processes. Mutations in either the ligand ("Steel" locus) or its receptor ("W" locus) render mice largely mast-cell-deficient, facilitating evaluation of the role of mast cells in a variety of animal models.^{47,48} Mast cells have thus been revealed to be key players not only in allergic inflammation but also in angiogenesis and tumor growth, tissue remodeling, graft tolerance, and some autoimmune diseases.^{19,20,21,22,49,50,51,52} However, inasmuch as mutations of the SCF/c-kit loci also affect other hematopoietic lineages and gut function, these studies must be interpreted with caution; novel studies with more selective mutations have suggested that some of the functions previously ascribed to mast cells might be artifacts of the "W" strains.^{53,54} Nonetheless, advances in isolation and analysis of mast cell and basophil populations^{3,9,10,11} have provided novel insights into their functions and transcriptional regulation of their hemopoietic development.

Mast Cell Growth and Differentiation

Rodent and human mast cells can be grown *in vitro* from lineage-committed, unipotent, or multipotent progenitors. Although

P.184

interleukin-3 (IL-3) is known to contribute to murine mast cell and to both human and rodent basophil development,^{55,56,57} it is SCF or c-kit ligand⁵⁸ which uniquely drives human mast cell differentiation, and not other cytokines that may help promote mast cell development in rodents, such as IL-3, IL-4, IL-9, IL-10,⁵⁹ and nerve growth factor (NGF).⁶⁰ SCF is produced by murine and human fibroblasts, epithelial cells, endothelial cells, and tumor cell lines,⁶¹ and must bind to c-kit to effect differentiation. Mutations in c-kit can result in mast cell deficiency *in vivo* and *in vitro* ("loss-of-function") or, alternately, in autonomous mast cell growth ("gain of function"), generally leading to autophosphorylation.⁶² The latter mutations, especially the D-816-V-associated mastocytosis (which can be transferred with similar consequences to the

mouse⁶²) have formed the basis of newly designed tyrosine kinase inhibitors in some proliferative mast cell and hypereosinophilic disorders.

Recently, it has been shown that both Th1 and Th2 cytokines (interferon-g [IFN-g], IL-4, and IL-5), the latter induced in rodents via TSLP and IL-25 or IL-33 acting in concert, induce a distinct population of multipotent mucosal progenitors (“nuocytes”)^{14,42,43,44,63} and thus may exert differential modulatory effects on SCF-dependent mast cell numbers in vitro and in vivo.⁶⁴ Table 9.1 lists cytokines, growth factors, transcription factors, and signaling molecules that regulate primate/human and rodent mast cell differentiation.^{51,65,66,67,68}

Mast Cell and Basophil Progenitors

In humans and in rodents, mast cell differentiation proceeds from an immature CD34⁺, CD38⁺, CD13⁺, c-kit⁺, FcεRI⁻, FcγRII/III⁺ cell, or, as recently shown, from a previously uncharacterized immature cell in mouse marrow.^{23,24,25} More specifically, a multipotent hemopoietic progenitor of both mucosal and serosal mast cell phenotypes can be identified, and is characterized as Lin⁻c-kit⁺Sca-1-Ly6c⁻FcεRI⁻CD27^{-β7+}T1/ST2⁺⁶⁹ (Fig. 9.4).

Mast cell differentiation, heterogeneity, abundance, and functional responses are also regulated in vitro and in vivo in rodents by CD34 itself and through the actions of several transcriptional and nucleosomal regulators such as PU.1, GATA factors, C/EBP factors, and MITF, as well as through M-Ras, and RabGEF1 type signaling molecules.^{39,66,68,70,71,72} Phenotypical alterations of mast cell populations can be governed by the tissue milieu, and they also exhibit switching and “trans-differentiation,”^{1,73} reflecting stochastic processes in progenitor differentiation. Primitive cord blood CD34⁺ c-kit⁺ progenitors may respond quite differently to hemopoietic cytokines than more mature FcεRI⁺, c-kit⁺ cells.^{23,74} Thus, tissue-dependent stages of progenitor commitment and of growth and differentiation signals may ultimately predict differences in mast cell phenotype in vivo.⁷⁵ Mast cell progenitors can be identified in blood, bone marrow, and various other tissues, especially in relation to mast-cell-inducing stimuli, such as viruses or nematodes.⁶⁹

Leukemic or other self-sustaining cell lines with basophilic or mast cell phenotype have also been used to study progenitors and immunophenotypic markers of lineage commitment.⁷⁶ Although these findings may represent aberrant pathways activated during malignant transformation, the recent identification of a novel antigenic marker of mast cells, basophils, and their progenitors,⁷⁷ and the presence in peripheral blood of basophilic cells that express mast cell proteases⁷⁸ have revived earlier postulates⁷⁹ that these cell types share some lineage characteristics under conditions of aberrant cell growth,^{37,38} although rodent eosinophil lineage-committed progenitors may not express basophil/mast cell-related proteases.⁸⁰

New and exciting information has emerged on the role of gut microbiota in regulating a TSLP-induced, IgE-dependent Th2 response, involving basophil progenitors in rodents, and in humans with hyper-IgE syndrome.¹² Profound decreases in gut flora lead to a B-cell driven overproduction of IgE with binding to its high-affinity receptor, and thus to increased marrow basophilopoiesis, with Th2 skewed inflammatory responses. Previous work on normal, atopic, or leukemic/mastocytotic human blood or marrow had identified pure or mixed basophil colonies in semisolid cultures,^{79,81,82} thus defining a basophil progenitor (termed “CFU-baso” or “CFU-baso/eo”).^{81,83} The phenotype and lineage commitment of the basophil progenitor, including recent controversial notions of possible lineage pathway commonalities with mast cells and/or megakaryocytes,^{84,85} are depicted in Figure 9.4.

TABLE 9.1 CYTOKINES AND OTHER FACTORS INVOLVED IN BASOPHIL AND MAST CELL GROWTH AND DIFFERENTIATION

Cytokine	Effect
GM-CSF	Basophil growth and differentiation; promotes in vivo basophilia and increases in circulating CFU-baso/eo (primates); basophil activation/survival; down-regulates human mast cell differentiation.
IL-3	Human basophil growth and differentiation; basophil activation/survival; promotes in vivo basophilia (in primates); mast cell differentiating activity in rodents.
IL-5	Primarily eosinophil, but also basophil growth and differentiation; basophil and eosinophil activation/survival.
TSLP/IL-33/IL-25	Co-factors in rodent nuocyte (multipotent mucosal progenitor) differentiation and tissue basophilic responses.
IL-4/IL-13	Produced by basophils with minimal activity on differentiation.

IL-9/IL-10/THPO	Co-factors in rodent mast cell phenotype switching.
TGF- β /IFN- α	Negative regulators of basophil differentiation.
SCF	Primary mast cell growth factors in mouse and rat; little known effect on basophil differentiation.
NGF	Induces mast cell hyperplasia (rodents), human mast cell line (HMC-1), and basophil-eosinophil differentiation in vitro.
RA	A mutation in the RA receptor allows for expression of basophil differentiation; may concurrently down-regulate human mast cell differentiation.
v-erb	Associated with the development of lethal mastocytosis in the rodent.
Fc γ RIIB	Down-regulates mast cell growth.
Stat5	An essential regulator in vivo of mast cell development.
IL-6/TNF/IFN- γ	May play a role in regulating phenotypic direction and lineage commitment of human basophils and mast cell subtypes.

GM-CSF, granulocyte-macrophage colony stimulating factor; INF, interferon; IL-, interleukin-; NGF, nerve growth factor; RA, retinoic acid; SCF, stem cell factor; TSLP, thymic stromal lymphopoietin; TNF, tumor necrosis factor.

Basophil Differentiation-inducing Cytokines

IL-3 is the main cytokine involved in human basophil growth and differentiation,⁸⁶ with some evidence for a co-factor role for TSLP. Granulocyte-macrophage colony stimulating factor (GM-CSF),^{79,81,82,87} IL-4,⁸⁸ IL-5,^{83,88} and SCF⁸⁹ may also play roles. A mutation in the retinoic acid (RA) receptor permits basophil differentiation; studies on basophil crisis in chronic myeloid leukemia and the in vitro suppressive effects of RA on basophil-eosinophil differentiation support this notion.⁹⁰ Cytokines and other factors that modulate basophil or mast cell differentiation are listed in Table 9.1.

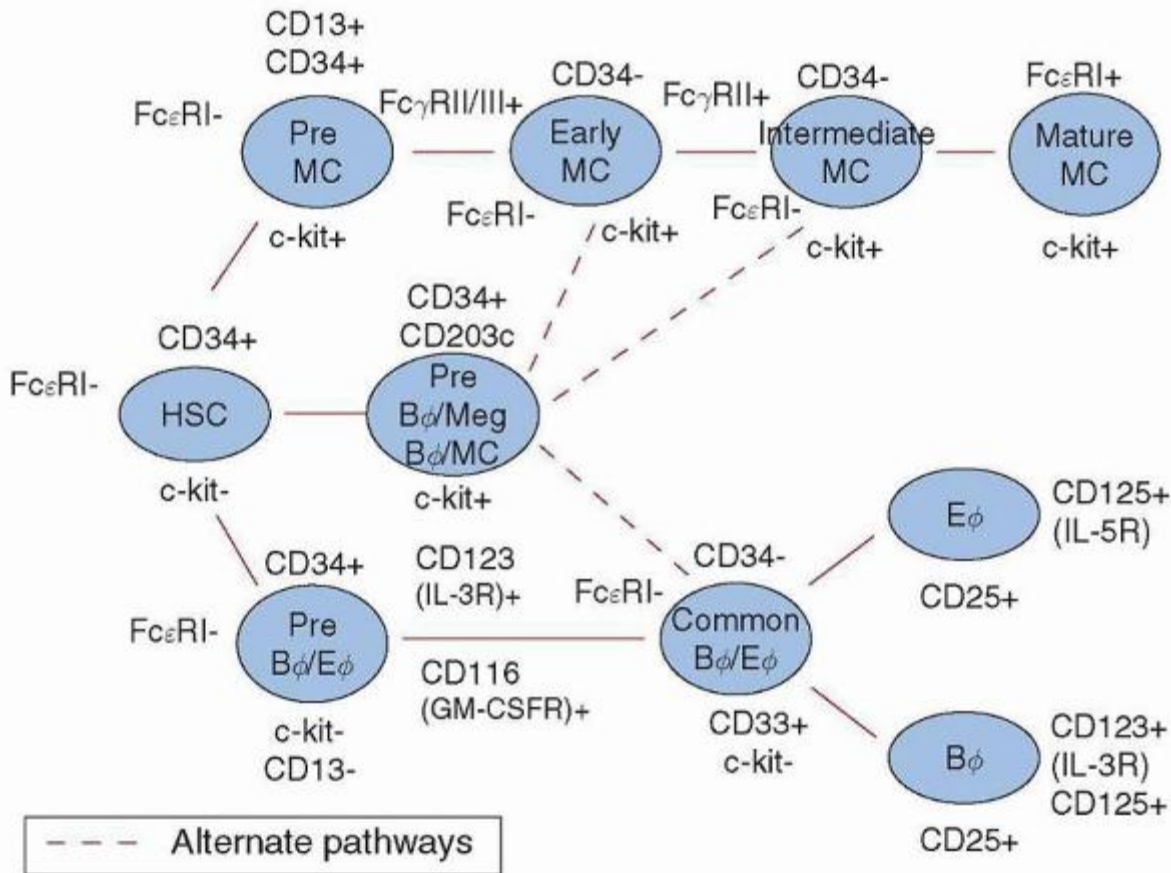

FIGURE 9.4. Mast cell and basophil ontogeny. An orderly sequence of differentiation is depicted, beginning with a primitive $CD34^+$, $Fc\epsilon RI^-$, $c-kit^-$ hemopoietic stem cell (HSC), and proceeding through various stages of commitment to either mast cell or basophil/eosinophil lineages. In reality, the differentiation process is stochastic, and multiple cytokines binding to their receptors permit specific, end-stage differentiation to proceed. For more detailed phenotypic analyses of basophil and mast cell progenitors, see Wang et al.³⁷

P.185

Clinical Relevance of Basophil and Mast Cell Differentiation

Allergic Diseases

The relationship to disease activity, severity, and response to therapy of fluctuations in numbers of human basophil-eosinophil, basophil-mast, or mast cell progenitors—including $CD34^+$ cell subpopulations—in the blood and bone marrow of patients with a variety of allergic disorders, including allergic rhinitis, nasal polyposis, asthma, atopic dermatitis, and drug allergies, has been extensively documented.^{59,91} Indeed, therapies targeting basophil-eosinophil progenitors with anti-IL-5 monoclonal antibodies have had some efficacy in causing maturation arrest of these shared lineages, accompanied by some clinical benefits, in patients with eosinophilic bronchitis and asthma^{92,93}; targeting of basophil or mast cell progenitors in these and some hematologic disorders may likewise prove to be effective treatments. For example, the IL-3R is expressed at high levels by basophil progenitors and subsets of dendritic cells; therefore, development of high-affinity monoclonal antibodies to this receptor would be predicted to dampen allergic disease.

It has been noted that up-regulated CD34 expression correlates closely with the development of allergic disease.⁹⁴ Although it is best known for its expression by early multipotent hematopoietic progenitors, CD34 is more selectively expressed by monopotent lineages associated with allergic disease (mast cell, eosinophil, and dendritic cell precursors⁹⁵); recent data suggest that CD34 enhances their capacity for migration to peripheral tissues.⁹⁶ Therefore, therapeutic antibodies targeting CD34 as an enhancer of migration may also prove to be an effective approach. Finally, because IgE

binding to FcεRI leads to basophilopoiesis and increased susceptibility to allergic disease,¹² blocking antibodies directed to IgE, IgE-producing B-cells, or the IgE receptor on basophils would also be predicted to be helpful therapeutically via a number of mechanisms. Given that deletion of the encoding genes for these receptors (IL-3R, CD34, and FcεRI) in mice has no apparent deleterious effects on development, therapies targeting these molecules would be predicted to be well tolerated.^{97,98,99}

Malignancies

In transient leukemias occurring in Down syndrome (trisomy 21), in various hematologic malignancies, as well as in megakaryoblastic leukemia, there is basophilic differentiation (which may also include mast cell proliferation) from leukemic cell progenitors. This could involve aberrant stimulation of basophil or mast cell progenitors by certain transcription factors that also regulate erythroid and megakaryocytic lineages, including GATA-1 to GATA-3.^{100,101} Embryonic stem cells or CD34⁺ progenitors transfected with GATA genes express varying degrees of erythroid/megakaryocytic and basophil/mast cell commitment,¹⁰⁰ whereas mice with mutations in the eosinophil-specific promoter of the GATA-1 gene completely lack eosinophils. Factors such as Gab-2, certain adaptor proteins,¹⁰² signaling molecules, Lyn, and SHP-1, or the flt3 ligand for this tyrosine kinase receptor, also can play important roles in basophil and mast cell differentiation.

Other hemopoietic malignancies also exhibit dysregulation of basophil and mast cell lineages, including chronic myeloid leukemia (CML), other myeloproliferative disorders and mast cell proliferative diseases (mastocytosis of various subtypes, urticaria pigmentosa, and mast cell leukemia). In the latter disorders, proliferation of mast cells occurs mainly in tissues, with immature or mature mast cells rarely circulating in blood (the aforementioned leukemia). However, higher numbers of both basophil and mast cell progenitors and changes in their regulatory factors can be documented^{79,103,104,105} in both mast cell disorders and leukemias. These observations underscore the capacity of hemopoietic malignancies to blur the normal differences that exist between basophil and mast cell lineages. The previously mentioned "gain of function" mutations in both juxtamembrane and intracellular domains of c-kit provide an explanation for many adult mast cell proliferative diseases, although such mutations are rarely found in the pediatric form of limited, skin-associated mastocytosis (urticaria pigmentosa). The biologic significance of increased numbers of mast cells in various hemopoietic and lymphatic malignancies, as well as in refractory anemias, may be related to acquisition in the leukemic clone of concomitant c-kit mutations.

Basophilia or basophil crisis heralding terminal blast crisis in CML is well known¹⁰³ and the fusion protein bcr-abl may be P.186

involved in basophil/mast cell lineage expression during this phase (see above). Hyperhistaminemia in CML and myeloproliferative disorders is related to increased numbers of basophils (and, possibly, mast cells)⁹⁰; indeed, blood basophilia and increases in basophil progenitors are poor prognostic indicators in CML.^{90,103} Such phenomena may relate to specific chromosomal abnormalities in forms of leukemia associated with basophilia or eosinophilia, for example, inversion of chromosome 16 (inv 16) associated with atypical eosinophils with mixed granulation; t(6;9) chromosomal translocation associated with basophilia and leukemia; trisomy 21; and several translocations associated with increased numbers of basophils in acute promyelocytic and other leukemias, such as t(15;17), del(5)(q31q35), and t(9;14).^{106,107} However, the precise relationship between specific chromosomal aberrations and basophil or mast cell differentiation in vivo is not clear. Recently and importantly, increases in blood basophils, presumably on the basis of increased basophilopoiesis, have been described in human hyper-IgE syndrome, associated with a DOCK8 polymorphism,¹⁰⁸ paralleling the rodent model.¹²

Apart from c-kit/SCF, whether other cytokines are involved in malignant basophil or mast cell proliferation in vivo is not known; for example, dysregulated cytokine genes such as those encoding IL-3, IL-4, IL-5, and GM-CSF in 5q-leukemias may play a role in phenotypic expression of leukemic cells. Detailed therapeutic approaches for hematologically based basophil and mast cell disorders is beyond the scope of this chapter, and is dealt with elsewhere in this book.

CHARACTERISTICS OF MAST CELLS AND BASOPHILS

Surface Phenotype and Activation

A wealth of information is available about the surface phenotype of mast cells and basophils (Table 9.2), including identification of receptors for immunoglobulins, complement components, cytokines and chemokines, arachidonic acid metabolites, e.g., CRTH2 (chemoattractant receptor-homologous molecule expressed on T-helper class 2 cells, also known as D prostanoid receptor 2 [DP2]), CD200, vitamin D, and ligands for TLR; as well as integrins and other molecules with or

without CD nomenclature.^{4,5,109,110,111} and ^{112,113,114,115,116} However, one must be cautious in making generalizations about surface receptor expression and mast cell/basophil phenotype given the heterogeneity of mast cells from various tissue sites and species, and the in vivo relevance of various mast cell and basophil-like cell lines.

One prominent difference between mast cells and basophils is that mature mast cells can express CD117 or c-kit (Table 9.2), whereas basophils do not. Another potentially important difference lies in expression of Fc receptors that provide key pathways for activation and modulation of function (Table 9.2 and 9.3). Although both mast cells and basophils express high-affinity receptors for IgE,^{117,118} mast cells can express the FcγR CD16, CD32, and CD64,^{119,120} but to date the only receptors for IgG that have been identified on basophils are FcγRIIA and B (CD32). Further investigation of Fcγ receptors on human mast cells and basophils will be important, because different receptors such as FcγRIIA and B and FcγRIII, can play distinct roles in mediator secretion and phagocytosis or endocytosis.¹²⁰ Mice deficient in FcγRIIB are highly sensitive to IgG-triggered mast cell degranulation through FcγRIII, and exhibit enhanced passive cutaneous anaphylaxis and elevated immunoglobulin levels in response to antigen stimulation.¹²¹ FcγRIIB down-regulates FcεRI signaling and is important in the regulation of mast cell and basophil activities.^{122,123} Interestingly, it has recently been shown that basophils and mast cells express a protease-sensitive, IL-3- or IL-4-inducible receptor for IgD that is distinct from receptors for

P.187

IgG, IgE, and IgA.¹²⁴ Activation of basophils via this IgD receptor has no effect on histamine secretion, but can induce release of antimicrobial peptides, IL-4, and B-cell activating factor.^{5,124}

TABLE 9.2 EXPRESSION OF SELECTED SURFACE MARKERS ON HUMAN MAST CELLS AND BASOPHILS

Marker	Mast Cells	Basophils
Fc Receptors	FcεRI ($\alpha\beta\gamma 2$); FcγRI, IIA, IIB, III (CD64, 32, 16)	FcεRI ($\alpha\beta\gamma 2$); FcγRIIA, IIB
Integrins	CD11c/18 ($\alpha X\beta 2$)	
B ₂ family		CD11a/18 ($\alpha L\beta 2$) CD11b/18 ($\alpha M\beta 2$) CD11c/18
B ₁ family	CD49c/CD29 ($\alpha 3B 1$) CD49d/CD29 ($\alpha 4B 1$) CD49e/CD29 ($\alpha 5B 1$)	CD49d/CD29 CD49e/CD29
Selectins	N/A	L, P, and E (CD62L, CD162, CD15s)
Chemokine receptors	CCR1,3,4,5,7 CXCR1,2,3,4,6	CCR1,2,3,7 CXCR2,4
Cytokine receptors	c-kit (CD117) IL-3Rα (CD123) IFNγR IL-1R, IL-10R IL-33R (ST2)	IL-2R (CD25) IL-3R2 (CD123) IL-3/5/GMRβ IL-18Rβ IL-33R
Cysteinyl leukotriene receptors	cysLT1,2	cysLT1,2

Prostaglandin receptors	CRTH ₂ EP1-3	CRTH ₂
Toll-like receptors	TLR2,3,4,6,9	TLR1,2,4,6,9
Other	CD200R3 Vitamin D receptor	CD200R3 2D7 antigen

TABLE 9.3 SELECTED MEDIATORS OF HUMAN MAST CELLS AND BASOPHILS^a

Marker	Cell Type	
	Mast Cells	Basophils
Histamine	+	+
Platelet-activating factor (PAF)	+	+
Nitric oxide	+	NK ^b
Proteoglycans	Heparin, chondroitin sulfates	Chondroitin sulfates
Arachidonic acid metabolites	LTB ₄ , LTC ₄ , PGD ₂ , PGF ₂ , thromboxane A ₂	LTB ₄ , LTC ₄
Proteinases	Tryptase, chymase, carboxypeptidase A, cathepsin G-like	
Cytokines/chemokines/growth factors	IL-1,2,3,4,5,6,8,10,11,13,16 TNF, LT, NGF, TGF- β , GM-CSF, RANTES (CCL5), MCP1 (CCL2), I-309 (CCL1), MIP1 α (CCL3), 1 β (CCL4), lymphotactin (XCL1), FGF, PDGFAB, VEGF, BDNF	IL-4, IL-13, MIP-1 α (CCL3)

^aMediators selected from more comprehensive lists published by others and recent updates (e.g., ^{4,5,131,132,149}).

^b NK, not known.

A number of other stimuli, including anaphylatoxins C3a and C5a, certain lectins, and the bacterial product formyl methionyl leucyl phenylalanine (fMLP) activate basophils and/or mast cells. Interestingly, polycationic substances such as compound 48/80 and numerous basic polypeptides including a spectrum of neuropeptides activate human skin mast cells, but not human mast cells from other sites, or human basophils.¹²⁵ Presently, the working model to explain these observations¹²⁵ is that human skin and rat peritoneal mast cells possess a binding site for these polycationic secretagogues, including neuropeptides such as substance P, which leads to activation of G_i-like G-protein and cell activation. This binding site appears to be distinct from the tachykinin NK1 receptor that has been associated with in vivo mast cell activation.¹²⁶ Neurogenic vasodilatation produced by an axonal reflex in human skin appears to involve mast cell activation by neuropeptides released from primary afferent nerves.¹²⁵ Mast cell-dependent neurogenic inflammation has been described in the respiratory and gastrointestinal tracts [e.g., ¹²⁷], and appears to be important in at least some inflammatory and infectious diseases. More recently, the relationship between mast cells and nerves has been emphasized in the intestine as a component of the gut-brain axis,¹²⁸ as well as in pain hypersensitivity¹²⁹ and hypoxia-ischemia injury in the immature brain.¹³⁰ Further work on bidirectional communications between mast cells and the nervous system will be enlightening.

Recently there has been great interest in activation of basophils and mast cells by several interleukins, chemokines, and other factors (Table 9.4).^{24,131,132} The significance of these pathways of basophil and mast cell activation in vivo in health or disease is becoming increasingly clear, particularly in chronic allergic and parasitic diseases, and in relation to commensal bacteria and particularly the gut microbiome.^{3,9,10,11,12,14,42,43,44,133,134} The CC chemokines appear to be important in basophil activation; however, there is less information for mast cells. SCF appears to be a specific stimulus for mast cells,

acting through the receptor CD117.¹³⁵ Redegeld et al. have made the intriguing observation that highly purified immunoglobulin light chain can sensitize mast cells for antigen-specific activation, providing a molecular mechanism for earlier observations of antigen-specific, but non-antibody-mediated mast cell activation. Additional research on the role of such stimuli for mast cells and/or basophils will shed light on the pathogenesis of inflammatory disorders such as inflammatory bowel disease, rheumatoid arthritis, and allergic airway diseases.^{136,137}

TABLE 9.4 FACTORS THAT ACTIVATE MEDIATOR SECRETION FROM HUMAN BASOPHILS AND MAST CELLS

Stimulation	Mast Cells Basophils	
FcεR and FcγR cross-linkage	+	+
Compound 48/80	SMC only	-
Basic polypeptides ^a (includes several neuropeptides)	SMC only	-
Anaphylatoxins (C3a C5a)	+	+
fMLP	-	+
Lectins (e.g., Concanavalin A)	+	+
Interleukins/chemokines (CC)/histamine releasing factors (HRF)	MIP-1α (CCL3) IL-1 SCF Ig light chain	MCP1(CCL-2), MCP2(CCL-8), MCP3(CCL-7), MIP-1α(CCL3), RANTES(CCL5), IL-8(CXCL8), HrHRF CTAPIII/NAP-2
TLR ligands	TLR2,3,4	TLR2
IL-33 increases cytokine production and secretion without degranulation. ¹⁴⁵		
TSLP stimulates Th2 cytokine production in mast cells. ^{15,147}		
CD200R binds CD200 and thereby inhibits mast cell degranulation and cytokine secretion. ¹⁴³		
SMC, human skin mast cells.		

^a Includes ACTH, mellitin, substance P, vasoactive intestinal polypeptide, neurotensin, bradykinin, etc.

Another intriguing difference between mast cells and basophils lies in their expression of selected integrin molecules (Table 9.2). Human basophils, but not mast cells, express CD11a/18, CD11b/18, and CD11c/18, which have as their complementary ligands, ICAM-1/2, C3bi, and fibrinogen, respectively. The latter are expressed on endothelial cells and appear to be involved in the migration of basophils into the tissues during inflammation. By contrast, mature mast cells and basophils express a repertoire of adhesion molecules designed to interact with the extracellular matrix components, which play significant roles in cell recruitment and activation. In particular, rodent basophils are readily distinguished from mast cells based on their selective expression of the collagen receptor, CD49b/29.¹³⁸

Recent focus on mast cells in innate immunity, including their expression of TLR and other molecules^{4,131,139,140} has markedly influenced our view of these cells. Basophils express a partially overlapping, but distinct, repertoire of these types of receptors,⁵ and thus must have roles in innate immunity distinct from mast cells. Similarly, although some exciting clues have been uncovered (e.g., ultraviolet B irradiation- and vitamin D receptor-dependent production of inflammation-depressing IL-10 by cutaneous mast cells¹⁴¹), much remains to be learned about the functions of many other surface molecules on mast cells and basophils, including the vitamin D receptor, CD200R,^{142,143} and receptors for IL-33^{144,145} and TSLP^{146,147} (see Table 9.2).

Mediators

Mast cells and basophils are storehouses of inflammatory mediators that can be released by IgE receptor activation and other stimuli and also synthesize several other mediators upon activation (Table 9.3 and 9.4). Mediators such as histamine, platelet-activating factor (PAF), arachidonic acid metabolites, and several proteinases have been extensively

studied and are important in the pathogenesis of inflammatory diseases and tissue injury and repair (e.g.,^{4,5,8,132,148}). A major distinction between the two cell types lies in the proteinases that are abundant in mast cells from humans and other species,^{149,150} but are not major markers of basophils. These proteinases include tryptases, chymases, carboxypeptidase A3, and dipeptidylpeptidase 1 (cathepsin C).¹⁴⁹ Indeed, proteinases are used as markers of human mast cell heterogeneity, with two major populations separated on their serine proteinase content, namely, those with tryptase only (MC_T) and those with both tryptase and chymase (MC_{TC}). A limited number of MC_C are also found. Recent work on proteinase-based mast cell heterogeneity in mice has established that even for one previously recognized phenotype, mucosal mast cells, there can be tissue-specific differences in proteinase expression, e.g., intestine versus airways.¹⁵⁰ Human basophils can express low levels of tryptases, but little or no chymase.¹⁵¹ In the mouse, mast cell proteinase 8 (MCP8) and MCP11 have been shown to be more abundant in basophils than mast cells; indeed, MCP8 has been targeted in two

P.188

strains of engineered mice to constitutively deplete basophils, or to deplete basophils in a conditional manner (e.g., diphtheria toxin-mediated⁷). Since initial observations in the 1980s, research on cytokine and chemokine production by mast cells and basophils has expanded rapidly (Table 9.3).^{132,152,153,154,155} Given that there is literature on cytokine expression in cells from in vivo sites, the relevance of many studies utilizing long-term in vitro cell lines must be viewed cautiously. Moreover, although expression of mRNA may be detected by sensitive methodologies, the actual quantities of the encoding proteins secreted by mast cells and/or basophils may range from small to relatively large; how this relates to levels produced by other cell types must be carefully evaluated. For example, basophils produce relatively large quantities of IL-4 and IL-13 (hundreds of picograms per 10⁶ cells) and are therefore considered to be important in vivo sources of these cytokines in selected settings. Mast-cell-derived chemotactic factors can be important components of host defenses induced by viruses as well as by cancer.^{154,155} Furthermore, the cytokine repertoire of mast cells includes a broad spectrum, representing those associated with both Th1 and Th2 phenotypes; it is likely, therefore, that in a given population of mast cells, cytokines are differentially expressed in individual cells or at different times, or that individual mast cells express several functionally distinct cytokines. In the latter case, control mechanisms may regulate production, secretion, and functions of individual cytokines. Most recent work suggests that cell type-specific regulation of cytokine expression can be under epigenetic control at the level of structural modifications in the DNA.¹⁵⁶

Inhibition of Basophil and Mast Cell Activation

Several antiallergic and anti-inflammatory drugs inhibit the release of histamine and other mediators, including cytokines and chemokines and arachidonic acid metabolites from human basophils and/or mast cells (Table 9.5).^{157,158} Although many of these drugs are valuable in the treatment of allergies and other inflammatory diseases, their mechanisms of action are diverse: none is mast cell- or basophil-specific, and the precise targets in vivo can be difficult to define. Furthermore, given the heterogeneity of mast cells at different tissue sites, and perhaps even at different times during the evolution of an inflammatory insult (e.g., initial injury, repair, chronic, or remodeling phases), agents may vary in the nature or extent of their modulatory effects on basophils and mast cells during the course of an inflammatory response or disease.

TABLE 9.5 INHIBITION OF MEDIATOR SECRETION FROM MAST CELLS AND BASOPHILS

Existing Drugs

β_2 Adrenergic agonists

Methylxanthines (nonselective phosphodiesterase inhibitors)

Antihistamines (H1-H4)

Sulfasalazine (or metabolites)

Corticosteroids

Cyclosporine A/Fk506

Ketotifen

Monoclonal antibodies (e.g., anti-IgE)

Sodium cromoglycate/nedocromil sodium (inhibit mast cells but not basophils)

Drugs in Development

Flavonoids (e.g., Quercetin)

Syk kinase inhibitors

Monoclonal antibodies to several biologic targets

Agonism of immunoreceptor tyrosine-based, inhibitory motifs (e.g., Fc γ RIIB, LILRB₄, MAFA; see text)

There are several promising advances in drug development targeting mast cells and basophils and their roles in allergic and other inflammatory processes. One such development has been with humanized monoclonal antibodies. For example, humanized monoclonal antibodies to IgE reduce IgE levels and decrease the density of high-affinity IgE receptors on mast cells and basophils, thus limiting sensitivity to allergens. Anti-IgE has been reported to be effective and safe in treatment of allergic asthma, rhinitis and peanut allergy,¹⁵⁹ and its use in other conditions is under investigation. Moreover, from this pioneering approach with humanized monoclonal antibodies, numerous other potential therapeutic targets are being explored, including, for example: IL-4, IL-5, IL-9, IL-13, and CCR3.^{160,161} Other promising targets for development of drugs that would inhibit mast cell and basophil function include: Syk kinase^{162,163}; the prostaglandin D₂ receptor, CRTH2^{164,165}; c-kit¹⁶⁶; and several inhibitory molecules expressed by mast cells and basophils that have in common immunoreceptor tyrosine-based inhibitory motifs (ITIM), such as Fc γ RIIB, leukocyte Ig-like receptor B4 (LILRB₄), sialic acidbinding immunoglobulin-like lectin 8 (Siglec-8), CD200R; and mast cell function associated antigen (MAFA).^{167,168,169,170} Other classes of compounds, such as the plant flavonoids have a variety of anti-inflammatory activities including the inhibition of mast cell and basophil functions (e.g.,^{171,172}).

Given their potency, and the plethora of functions of mast cell and basophil cytokines and chemokines, it is not surprising that these cells are a focus of study to modulate allergic and other inflammatory events. Furthermore, the postulate that distinct profiles of cytokines (Th1 and Th2) orchestrate these responses has stimulated studies of cytokine regulation of mast cell and basophil functions. As predicted by the Th1/Th2 paradigm, the Th1-associated cytokine IFN- γ and related IFN- α/β , inhibit mast cell degranulation and tumor necrosis factor (TNF) secretion.⁴ IFN- γ has no effect on basophil cytokine secretion, but IFN- α inhibits IL-4 and IL-13 secretion from human basophils, but has no effect on histamine or LTC₄ secretion.¹⁷³ Interestingly, the effects of IFN- γ on mast cell mediator secretion are dependent on exogenous or endogenous nitric oxide.^{4,174} TGF- β ₁ also inhibits histamine and TNF production by rat mast cells.¹⁷⁵ Furthermore, IL-10, often associated with Th2 responses, inhibits TNF and IL-6 production by mast cells.¹⁷⁶ but enhances their antigen-induced secretion of histamine.¹⁷⁷ This information, taken together with evidence that other mediators such as histamine and arachidonic acid metabolites^{178,179,180} and¹⁸¹ modulate mediator secretion, suggests that several basophil and mast cell mediators may have autocrineregulatory roles in inflammation.

BASOPHIL AND MAST CELL FUNCTIONS

Inflammatory Injury and Host Defenses

Investigations of the functions of basophils and mast cells have focused on their roles in allergic and other inflammatory disorders because of the highly visible symptoms of IgE-mediated allergic reactions, including life-threatening anaphylaxis. In turn, a great deal has been learned about some aspects of these cells, notably about their activation, inflammatory mediators, and regulation. Numerous drugs are available that inhibit many of their functions, and a wealth of novel approaches are emerging that will exploit numerous pathways to regulate allergic and other inflammatory responses. Nevertheless, several challenges remain, including perhaps the most obvious question: why do both basophils and mast cells exist, and what functions distinguish them?

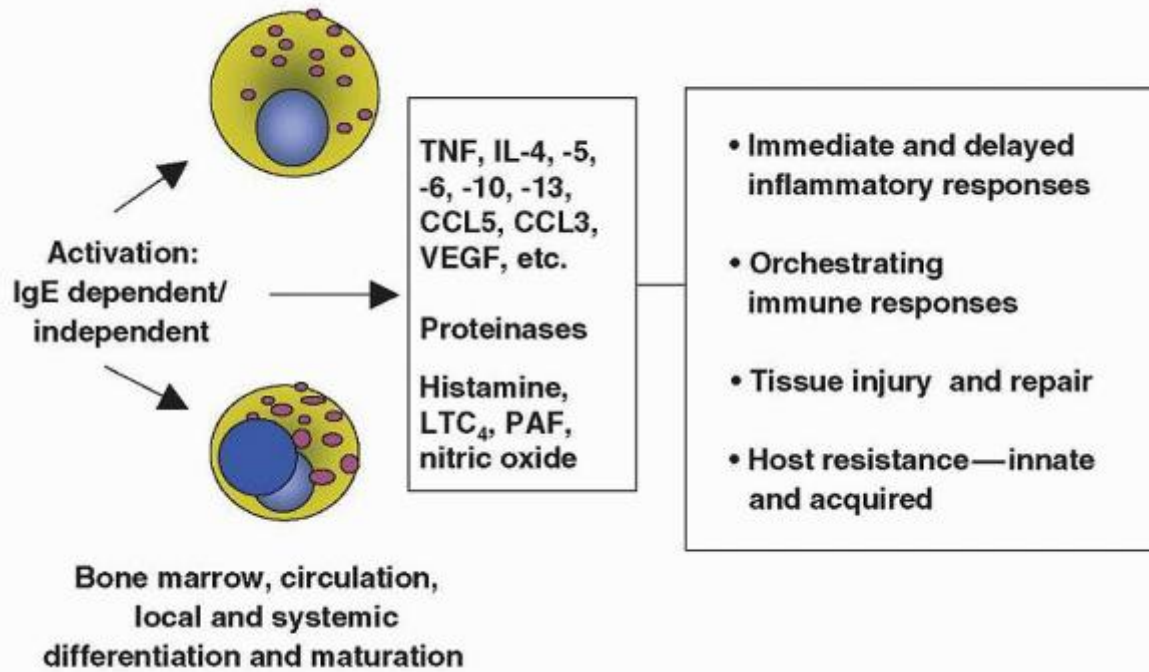

FIGURE 9.5. Summary of the activation of mast cells and basophils, the mediators they produce, and the spectrum of their actions in host defenses and tissue injury.

Basophils and mast cells are central players in allergic inflammation as they express high-affinity receptors for IgE and produce several mediators in common, each with potential to initiate inflammatory cascades and complex cellular and molecular networks involved in injury and repair (Fig. 9.5). In early phases of allergic responses, the pool of circulating mature basophils and the large tissue repository of mast cells are important. However, basophils and mast cells are not restricted to these sites, because under certain circumstances a large influx of basophils can occur into local tissues (e.g., cutaneous basophilic hypersensitivity¹⁸², asthma¹⁸³), and the numbers of mast cell progenitors in the circulation and in selected tissues can be increased.^{184,185}

The roles of basophils and mast cells in allergic inflammation differ with regard to some of the stimuli that are important for cell activation. Some mast cell populations respond to a number of basic secretagogues, including several neuropeptides, and given the close anatomical association between mast cells and nerves¹⁸⁶ and abundant evidence for their functional interdependence, it is likely that mast-cell-dependent neurogenic pathways are important. There is much less evidence to suggest that neurogenic inflammation is a major pathway in basophil-mediated reactions. It is intriguing that IgE receptors have recently been discovered on neurons,^{187,188} and although the clinical significance of this observation is currently unknown, the implications are considerable. For example, depending upon the distribution of IgE receptors on neurons in the CNS as well as peripherally, allergens could communicate directly with the nervous system and impact sensory pathways, central processing or efferent responses, as well as cognition and behavior. Such pathways might help explain associations between stress and depression and allergy.¹⁸⁹

Since the first reports of the role of mast cells in innate antimicrobial immunity,^{190,191} there has been great interest in expression and function of TLRs on mast cells^{131,132} and basophils.^{139,140} The signaling pathways employed by such receptors to induce mast cell and basophil activation and mediator secretion will be particularly enlightening with regard to selectivity of mediator secretion and cell functions.¹⁹² There is increasing evidence that the profiles of mediators produced by these pathways differ from those following IgE-mediated activation; knowledge of such differences will help elucidate the distinct roles of these two cell types in host defenses and inflammatory diseases (e.g.,¹⁹³).

The role of mast cells and basophils in the development and expression of adaptive immunity has also been an exciting area of new knowledge, albeit with some controversy.^{3,5,11,193} Both mast cells and basophils can enter draining lymph nodes^{194,195} and mast cells are well known to induce dendritic cell traffic to lymph nodes and dendritic cell priming.^{196,197} Indeed, mast cell activators and even synthetic mast cell granules are adjuvants of primary immune responses.^{198,199} Initial studies suggested that basophils could act as dendritic cells, especially in responses to protease-containing allergens eliciting a Th2 response, but this has been challenged.^{3,9,11} As outlined above, the use of W mutant mice that are naturally

deficient in mast cells has been a powerful tool to study mast cell functions, but recent work in two additional strains of mice engineered to be mast-cell-deficient (independent of mutations in *kit*) have raised some questions about the conclusions from earlier studies with *W* mutant mice regarding these functions.²⁰⁰ Mast cells are confirmed to be critical components in contact sensitivity reactions,²⁰¹ but their roles in at least some autoimmune responses have been questioned.⁵³ With new and powerful tools and models, the next few years promise to provide more clarity about the precise roles of mast cells and basophils in immunity.

The spectrums of mediators produced by mast cells and basophils have similarities and differences. Several mediators are common (histamine, LTC₄, PAF, and others, etc.), whereas the cytokine and proteinase profiles of the two cell types are distinct. Although the differences in proteinase content likely hold clues to the functional distinctions among the cell types and among mast cell subpopulations, knowledge of substrate specificities of mast cell proteinases is limited, and thus the functional significance remains to be fully clarified.^{149,202,203} It is intriguing that inhibitors of mast-cell-specific tryptase have promising effects in models of allergic asthma.¹⁴⁹ Furthermore, another function associated with mast cell tryptase-heparin complexes is the inhibition of the production of fibrin and clots through fibrinogen degradation at sites of inflammation.²⁰⁴ Knockout of mast cell proteinases has rapidly expanded our knowledge of some of the functions of these abundant and diverse enzymes. For example, mouse MCP4 has an anti-inflammatory effect in allergic asthma,^{205,206} but is proinflammatory in models of bullous pemphigoid.²⁰⁷ Mouse MCP4 and mast cell carboxypeptidase A3 are important in degradation of several animal toxins, e.g., snake, Gila monster and scorpion venom.²⁰⁸ Basophil-derived MCP11 induces microvascular leakage in mice, independent of mast cells.²⁰⁹ In the future, drugs designed to selectively activate or inhibit specific mast cell or basophil enzyme-substrate interactions will be of therapeutic value and also help distinguish between the roles of mast cells and basophils in allergic and other inflammatory cascades, such as between the early- and late-phase asthmatic responses to allergen.

Containment of Injury, Initiation of Repair, Remodeling, and Normal Function

Following initial insult and injury, the inflammatory response elaborates mediators and pathways that minimize the extent of

P.190

the tissue damage and begin repair processes. In addition to early activation, mast cell and basophil mediators are involved in these phases of the response (Fig. 9.6). Histamine, arachidonic acid metabolites, and several cytokines, particularly, IL-1, IL-6, IL-10, TNF, and TGF- β , have several effects on endothelial, epithelial, mesenchymal, and inflammatory cells. Such effects include influences on epithelial integrity and function, regulation of blood flow and vascular permeability, tissue edema, fibroblast proliferation, and biochemical phenotype, and others. The relationship between mast cell activation and fibroblasts and angiogenesis,^{19,20,21,22} in models of tissue repair and remodeling,⁵¹ has been studied,^{210,211} and it is obvious that the pathways involved are multifactorial. As experimental models are developed to address these questions, we will begin to understand the role of mast cells and basophils in this "containment and repair phase" of inflammatory injury.

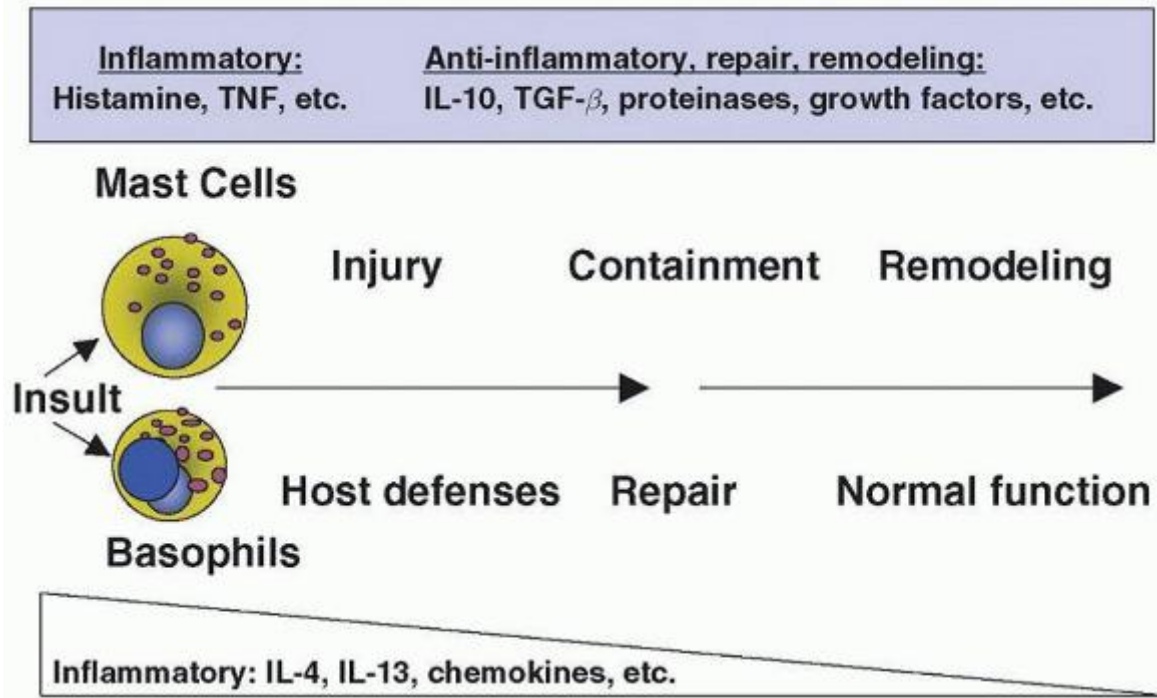

FIGURE 9.6. Model of activities of mast cells and basophils in the sequential responses of tissue injury, containment, repair, and remodeling.

Once the site of injury is contained and repair processes have begun, mast cells and perhaps basophils are likely to be involved in the remodeling of the tissues, and the return to normal function. The numerous proteinases of mast cells have distinct substrate specificities, and restructuring of the connective tissue, extracellular matrix in the local environment is very likely to be among their functions. Cytokines such as TGF- β , IL-1, and IL-6 that influence the activities of fibroblasts are likely to be important candidates for this remodeling phase in the responses to injury. Given the life span and normal distribution of mast cells and basophils, an attractive hypothesis is that basophils play a particularly important role in the injury phase, but their importance in the latter phases (containment and remodeling) is minimal. By contrast, mast cells are undoubtedly important in the injury phase, but also in the containment and remodeling phases. Given the plasticity of mast cell phenotypes, it may be that there is a general pattern of expression of functionally linked clusters of mast cell genes that, in a carefully orchestrated manner, facilitate the evolving roles of local mast cell populations in the three phases of injury, containment, and repair/remodeling.

Dynamic Equilibrium and Homeostasis

In addition to the evolving mast cell phenotype in the above sequence, some subsets of mast cells are involved in normal tissue homeostasis, such as neurogenic and endocrine responses.^{212,213,214} While these aspects of mast cell function are not well understood, there is a diverse literature on mast cell involvement in such processes as sexual behavior, implantation, parturition, neuroendocrine signaling, the hypothalamic-pituitary-adrenal axis, gastric acid secretion, bone metabolism, and myelopoiesis. Furthermore, given the prominent anatomical association between mast cells and the vasculature, and the effects of mast cell products on blood flow, permeability, and leukocyte adhesion and diapedesis in inflammation,²¹⁵ it is widely held that one normal physiologic role of mast cells is in the dynamic regulation of tissue perfusion and the chemical and cellular composition of extravascular spaces. To date, little direct evidence exists that basophils exhibit similar functions within tissues; rather, the basophil appears to be mostly involved in a rapid, circulating response with potential for recruitment to sites of injury.

REFERENCES

1. Selye H. The mast cells. Washington, DC: Butterworths, 1965.
2. Crivellato E, Nico B, Ribatti D. The history of the controversial relationship between mast cells and basophils. *Immunol Lett* 2011;141:10-17.

3. Sokol CL, Medzhitov R. Emerging functions of basophils in protective and allergic immune responses. *Mucosal Immunol* 2010;3:129-137.
4. Moon TC, St Laurent CD, Morris KE, et al. Advances in mast cell biology: new understanding of heterogeneity and function. *Mucosal Immunol* 2010;3:111-128.
5. Siracusa MC, Comeau MR, Artis D. New insights into basophil biology: initiators, regulators, and effectors of type 2 inflammation. *Ann N Y Acad Sci* 2011;1217:166-177.
6. Galli SJ, Borregaard N, Wynn TA. Phenotypic and functional plasticity of cells of innate immunity: macrophages, mast cells and neutrophils. *Nat Immunol* 2011;12:1035-1044.
7. Karasuyama H, Mukai K, Obata K, et al. Nonredundant roles of basophils in immunity. *Annu Rev Immunol* 2011;29:45-69.
8. Chirumbolo S. State-of-the-art review about basophil research in immunology and allergy: is the time right to treat these cells with the respect they deserve? *Blood Transfus* 2011;1-17.
9. Leslie M. Immunology. Mouse studies challenge rare immune cell's powers. *Science* 2010;329:1595.
10. Ohnmacht C, Schwartz C, Panzer M, et al. Basophils orchestrate chronic allergic dermatitis and protective immunity against helminths. *Immunity* 2010;33:364-374.
11. Hammad H, Plantinga M, Deswarte K, et al. Inflammatory dendritic cells—not basophils—are necessary and sufficient for induction of Th2 immunity to inhaled house dust mite allergen. *J Exp Med* 2010;207:2097-2111.
12. Hill DA, Siracusa MC, Abt MC, et al. Commensal bacteria-derived signals regulate basophil hematopoiesis and allergic inflammation. *Nat Med* 2012;18:538-546.
13. Wada T, Ishiwata K, Koseki H, et al. Selective ablation of basophils in mice reveals their nonredundant role in acquired immunity against ticks. *J Clin Invest* 2010;120:2867-2875.
14. Siracusa MC, Saenz SA, Hill DA, et al. TSLP promotes interleukin-3-independent basophil haematopoiesis and type 2 inflammation. *Nature* 2011;477:229-233.
15. Allakhverdi Z, Comeau MR, Jessup HK, et al. Thymic stromal lymphopoietin is released by human epithelial cells in response to microbes, trauma, or inflammation and potently activates mast cells. *J Exp Med* 2007;204:253-258.
16. Nielsen JS, McNagny KM. CD34 is a key regulator of hematopoietic stem cell trafficking to bone marrow and mast cell progenitor trafficking in the periphery. *Microcirculation* 2009;16:487-496.
17. Blanchet MR, Maltby S, Haddon DJ, et al. CD34 facilitates the development of allergic asthma. *Blood* 2007;110:2005-2012.
18. Drew E, Merzaban JS, Seo W, et al. CD34 and CD43 inhibit mast cell adhesion and are required for optimal mast cell reconstitution. *Immunity* 2005;22:43-57.
19. Coussens LM, Raymond WW, Bergers G, et al. Inflammatory mast cells up-regulate angiogenesis during squamous epithelial carcinogenesis. *Genes Dev* 1999;13:1382-1397.
20. Soucek L, Lawlor ER, Soto D, et al. Mast cells are required for angiogenesis and macroscopic expansion of Myc-induced pancreatic islet tumors. *Nat Med* 2007;13:1211-1218.
21. Gounaris E, Erdman SE, Restaino C, et al. Mast cells are an essential hematopoietic component for polyp development. *Proc Natl Acad Sci U S A* 2007;104:19977-19982.
22. Maltby S, Khazaie K, McNagny KM. Mast cells in tumor growth: angiogenesis, tissue remodelling and immune-modulation. *Biochim Biophys Acta* 2009;1796:19-26.
23. Chen CC, Grimbaldston MA, Tsai M, et al. Identification of mast cell progenitors in adult mice. *Proc Natl Acad Sci U S A* 2005;102:11408-11413.
24. Gurish MF, Boyce JA. Mast cells: ontogeny, homing, and recruitment of a unique innate effector cell. *J Allergy Clin Immunol* 2006;117:1285-1291.
25. Franco CB, Chen CC, Drukker M, et al. Distinguishing mast cell and granulocyte differentiation at the single-cell level. *Cell Stem Cell* 2010;6:361-368.
26. Dvorak AM. Ultrastructural studies of human basophils and mast cells. *J Histochem Cytochem* 2005;53:1043-1070.

27. Valadi H, Ekstrom K, Bossios A, et al. Exosome-mediated transfer of mRNAs and microRNAs is a novel mechanism of genetic exchange between cells. *Nat Cell Biol* 2007;9:654-659.
 28. Eldh M, Ekstrom K, Valadi H, et al. Exosomes communicate protective messages during oxidative stress; possible role of exosomal shuttle RNA. *PLoS One* 2010;5:e15353.
 29. Melo RC, D'Avila H, Wan HC, et al. Lipid bodies in inflammatory cells: structure, function, and current imaging techniques. *J Histochem Cytochem* 2011;59:540-556.
 30. Lacy P, Stow JL. Cytokine release from innate immune cells: association with diverse membrane trafficking pathways. *Blood* 2011;118:9-18.
 31. Xiang Z, Block M, Lofman C, et al. IgE-mediated mast cell degranulation and recovery monitored by time-lapse photography. *J Allergy Clin Immunol* 2001;108:116-121.
 32. Melo RC, Perez SA, Spencer LA, et al. Intraorganular vesiculotubular compartments are involved in piecemeal degranulation by activated human eosinophils. *Traffic* 2005;6:866-879.
 33. Wilhelm M. Neuro-immune interactions in the dove brain. *Gen Comp Endocrinol* 2011;172:173-180.
 34. Vicario M, Guilarte M, Alonso C, et al. Chronological assessment of mast cell-mediated gut dysfunction and mucosal inflammation in a rat model of chronic psychosocial stress. *Brain Behav Immun* 2010;24:1166-1175.
 35. Caruso RA, Parisi A, Crisafulli C, et al. Intraepithelial infiltration by mast cells in human *Helicobacter pylori* active gastritis. *Ultrastruct Pathol* 2011;35:251-255.
 36. Drew E, Huettner CS, Tenen DG, et al. CD34 expression by mast cells: of mice and men. *Blood* 2005;106:1885-1887.
 37. Wang J, Qi JC, Konecny P, et al. Hemopoietic cells with features of the mast cell and basophil lineages and their potential role in allergy. *Curr Drug Targets Inflamm Allergy* 2003;2:293-302.
 38. Sperr WR, Hauswirth AW, Valent P. Tryptase a novel biochemical marker of acute myeloid leukemia. *Leuk Lymphoma* 2002;43:2257-2261.
 39. Iwasaki H, Mizuno S, Arinobu Y, et al. The order of expression of transcription factors directs hierarchical specification of hematopoietic lineages. *Genes Dev* 2006;20:3010-3021.
 40. Arinobu Y, Iwasaki H, Gurish MF, et al. Developmental checkpoints of the basophil/mast cell lineages in adult murine hematopoiesis. *Proc Natl Acad Sci U S A* 2005;102:18105-18110.
 41. Crivellato E, Ribatti D. The mast cell: an evolutionary perspective. *Biol Rev Camb Philos Soc* 2010;85:347-360.
- P.191
42. Ziegler SF, Artis D. Sensing the outside world: TSLP regulates barrier immunity. *Nat Immunol* 2010;11:289-293.
 43. Saenz SA, Taylor BC, Artis D. Welcome to the neighborhood: epithelial cell-derived cytokines license innate and adaptive immune responses at mucosal sites. *Immunol Rev* 2008;226:172-190.
 44. Taylor BC, Zaph C, Troy AE, et al. TSLP regulates intestinal immunity and inflammation in mouse models of helminth infection and colitis. *J Exp Med* 2009;206:655-667.
 45. Reece P, Thanendran A, Crawford L, et al. Maternal allergy modulates cord blood hematopoietic progenitor Toll-like receptor expression and function. *J Allergy Clin Immunol* 2010;doi:10.1016/j.jaci.2010.11.006.
 46. Nagai Y, Garrett KP, Ohta S, et al. Toll-like receptors on hematopoietic progenitor cells stimulate innate immune system replenishment. *Immunity* 2006;24:801-812.
 47. Kitamura Y, Tsujimura T, Jippo T, et al. Regulation of development, survival and neoplastic growth of mast cells through the c-kit receptor. *Int Arch Allergy Immunol* 1995;107:54-56.
 48. Grimbaldston MA, Chen CC, Piliponsky AM, et al. Mast cell-deficient W-shash c-kit mutant Kit W-sh/W-sh mice as a model for investigating mast cell biology in vivo. *Am J Pathol* 2005;167:835-848.
 49. Lee DM, Friend DS, Gurish MF, et al. Mast cells: a cellular link between auto-antibodies and inflammatory arthritis. *Science* 2002;297:1689-1692.

50. Secor VH, Secor WE, Gutekunst CA, et al. Mast cells are essential for early onset and severe disease in a murine model of multiple sclerosis. *J Exp Med* 2000;191:813-822.
51. Heissig B, Rafii S, Akiyama H, et al. Low-dose irradiation promotes tissue revascularization through VEGF release from mast cells and MMP-9-mediated progenitor cell mobilization. *J Exp Med* 2005;202:739-750.
52. Lu LF, Lind EF, Gondek DC, et al. Mast cells are essential intermediaries in regulatory T-cell tolerance. *Nature* 2006;442:997-1002.
53. Feyerabend TB, Weiser A, Tietz A, et al. Cre-mediated cell ablation contests mast cell contribution in models of antibody- and T cell-mediated autoimmunity. *Immunity* 2011;35:832-844.
54. Bennett JL, Blanchet MR, Zhao L, et al. Bone marrow-derived mast cells accumulate in the central nervous system during inflammation but are dispensable for experimental autoimmune encephalomyelitis pathogenesis. *J Immunol* 2009;182:5507-5514.
55. Lantz CS, Boesiger J, Song CH, et al. Role for interleukin-3 in mast-cell and basophil development and in immunity to parasites. *Nature* 1998;392:90-93.
56. Denburg JA. Bone marrow in atopy and asthma: hematopoietic mechanisms in allergic inflammation. *Immunol Today* 1999;20:111-113.
57. Wright HV, Bailey D, Kashyap M, et al. IL-3-mediated TNF production is necessary for mast cell development. *J Immunol* 2006;176:2114-2121.
58. Mitsui H, Furitsu T, Dvorak AM, et al. Development of human mast cells from umbilical cord blood cells by recombinant human and murine c-kit ligand. *Proc Natl Acad Sci U S A* 1993;90:735-739.
59. Mwamtemi HH, Koike K, Kinoshita T, et al. An increase in circulating mast cell colony-forming cells in asthma. *J Immunol* 2001;166:4672-4677.
60. Matsuda H, Coughlin MD, Bienenstock J, et al. Nerve growth factor promotes human hemopoietic colony growth and differentiation. *Proc Natl Acad Sci U S A* 1988;85:6508-6512.
61. Galli SJ, Tsai M, Wershil BK. The c-kit receptor, stem cell factor, and mast cells. What each is teaching us about the others. *Am J Pathol* 1993;142:965-974.
62. Zappulla JP, Dubreuil P, Desbois S, et al. Mastocytosis in mice expressing human Kit receptor with the activating Asp816Val mutation. *J Exp Med* 2005;202:1635-1641.
63. Neill DR, Wong SH, Bellosi A, et al. Nuocytes represent a new innate effector leukocyte that mediates type-2 immunity. *Nature* 2010;464:1367-1370.
64. Kulka M, Metcalfe DD. High-resolution tracking of cell division demonstrates differential effects of TH1 and TH2 cytokines on SCF-dependent human mast cell production in vitro: correlation with apoptosis and Kit expression. *Blood* 2005;105:592-599.
65. Alcaide P, Jones TG, Lord GM, et al. Dendritic cell expression of the transcription factor T-bet regulates mast cell progenitor homing to mucosal tissue. *J Exp Med* 2007;204:431-439.
66. Kalesnikoff J, Rios EJ, Chen CC, et al. RabGEF1 regulates stem cell factor/c-Kit-mediated signaling events and biological responses in mast cells. *Proc Natl Acad Sci U S A* 2006;103:2659-2664.
67. Shelburne CP, McCoy ME, Piekorz R, et al. Stat5 expression is critical for mast cell development and survival. *Blood* 2003;102:1290-1297.
68. Ito T, Nishiyama C, Nishiyama M, et al. Mast cells acquire monocyte-specific gene expression and monocyte-like morphology by overproduction of PU.1. *J Immunol* 2005;174:376-383.
69. Rodewald HR, Dessing M, Dvorak AM, et al. Identification of a committed precursor for the mast cell lineage. *Science* 1996;271:818-822.
70. Cantor AB, Iwasaki H, Arinobu Y, et al. Antagonism of FOG-1 and GATA factors in fate choice for the mast cell lineage. *J Exp Med* 2008;205:611-624.
71. Walsh JC, DeKoter RP, Lee HJ, et al. Cooperative and antagonistic interplay between PU.1 and GATA-2 in the specification of myeloid cell fates. *Immunity* 2002;17:665-676.

72. Kitamura Y. MITF and SgIGSF: an essential transcription factor and its target adhesion molecule for development and survival of mast cells. *Novartis Found Symp* 2005;271:4-11.
73. Nakano T, Sonoda T, Hayashi C, et al. Fate of bone marrow-derived cultured mast cells after intracutaneous intraperitoneal and intravenous transfer into genetically mast cell-deficient W/W^v mice. Evidence that cultured mast cells can give rise to both connective tissue type and mucosal mast cells. *J Exp Med* 1985;162:1025-1043.
74. Kitamura Y, Ito A. Mast cell-committed progenitors. *Proc Natl Acad Sci U S A* 2005;102:11129-11130.
75. Moon TC, Yoshimura T, Parsons T, et al. Microenvironmental regulation of inducible nitric oxide synthase expression and nitric oxide production in mouse bone marrow-derived mast cells. *J Leukoc Biol* 2012;91:581-590.
76. Kirshenbaum AS, Akin C, Goff JP, et al. Thrombopoietin alone or in the presence of stem cell factor supports the growth of KIT(CD117)^{low}/MPL(CD110)⁺ human mast cells from hematopoietic progenitor cells. *Exp Hematol* 2005;33:413-421.
77. Buhning HJ, Simmons PJ, Pudney M, et al. The monoclonal antibody 97A6 defines a novel surface antigen expressed on human basophils and their multipotent and unipotent progenitors. *Blood* 1999;94:2343-2356.
78. Li L, Li Y, Reddel SW, et al. Identification of basophilic cells that express mast cell granule proteases in the peripheral blood of asthma, allergy, and drug-reactive patients. *J Immunol* 1998;161:5079-5086.
79. Denburg JA, Richardson M, Telizyn S, et al. Basophil/mast cell precursors in human peripheral blood. *Blood* 1983;61:775-780.
80. Iwasaki H, Mizuno S, Mayfield R, et al. Identification of eosinophil lineage-committed progenitors in the murine bone marrow. *J Exp Med* 2005;201:1891-1897.
81. Denburg JA, Telizyn S, Messner H, et al. Heterogeneity of human peripheral blood eosinophil-type colonies: evidence for a common basophil-eosinophil progenitor. *Blood* 1985;66:312-318.
82. Leary AG, Ogawa M. Identification of pure and mixed basophil colonies in culture of human peripheral blood and marrow cells. *Blood* 1984;64:78-83.
83. Denburg JA, Silver JE, Abrams JS. Interleukin-5 is a human basophilopoietin: induction of histamine content and basophilic differentiation of HL-60 cells and of peripheral blood basophil-eosinophil progenitors. *Blood* 1991;77:1462-1468.
84. Arock M, Schneider E, Boissan M, et al. Differentiation of human basophils: an overview of recent advances and pending questions. *J Leukoc Biol* 2002;71:557-564.
85. Dy M, Pacilio M, Arnould A, et al. Modulation of histidine decarboxylase activity and cytokine synthesis in human leukemic cell lines: relationship with basophilic and/or megakaryocytic differentiation. *Exp Hematol* 1999;27:1295-1305.
86. Valent P, Schmidt G, Besemer J, et al. Interleukin-3 is a differentiation factor for human basophils. *Blood* 1989;73:1763-1769.
87. Hutt-Taylor SR, Harnish D, Richardson M, et al. Sodium butyrate and a T lymphocyte cell line-derived differentiation factor induce basophilic differentiation of the human promyelocytic leukemia cell line HL-60. *Blood* 1988;71:209-215.
88. Denburg JA. Basophil and mast cell lineages in vitro and in vivo. *Blood* 1992;79:846-860.
89. Galli SJ, Zsebo KM, Geissler EN. The kit ligand, stem cell factor. *Adv Immunol* 1994;55:1-96.
90. Denburg JA, Wilson WEC, Bienenstock J. Basophil production in myeloproliferative disorders: increases during acute blastic transformation of chronic myeloid leukemia. *Blood* 1982;60:113-120.
91. Denburg JA, Telizyn S, Belda A, et al. Increased numbers of circulating basophil progenitors in atopic patients. *J Allergy Clin Immunol* 1985;76:466-472.
92. Menzies-Gow A, Flood-Page P, Sehmi R, et al. Anti-IL-5 (mepolizumab) therapy induces bone marrow eosinophil maturational arrest and decreases eosinophil progenitors in the bronchial mucosa of atopic asthmatics. *J Allergy Clin Immunol* 2003;111:714-719.
93. Nair P, Pizzichini MM, Kjarsgaard M, et al. Mepolizumab for prednisone-dependent asthma with sputum eosinophilia. *N Engl J Med* 2009;360:985-993.

94. Sehmi R, Howie K, Sutherland DR, et al. Increased levels of CD34⁺ hemopoietic progenitor cells in atopic subjects. *Am J Respir Cell Mol Biol* 1996;15:645-654.
95. Nielsen JS, McNagny KM. Novel functions of the CD34 family. *J Cell Sci* 2008;121:3683-3692.
96. Blanchet MR, Bennett JL, Gold MJ, et al. CD34 is required for dendritic cell trafficking and pathology in murine hypersensitivity pneumonitis. *Am J Respir Crit Care Med* 2011;184:687-698.
97. Hara T, Miyajima A. Function and signal transduction mediated by the interleukin 3 receptor system in hematopoiesis. *Stem Cells* 1996;14:605-618.
98. Dombrowicz D, Flamand V, Brigman KK, et al. Abolition of anaphylaxis by targeted disruption of the high affinity immunoglobulin E receptor alpha chain gene. *Cell* 1993;75:969-976.
99. Suzuki A, Andrew DP, Gonzalo JA, et al. CD34-deficient mice have reduced eosinophil accumulation after allergen exposure and show a novel crossreactive 90-kD protein. *Blood* 1996;87:3550-3562.
100. Martin DIK, Zon LI, Mutter G, et al. Expression of an erythroid transcription factor in megakaryocytic and mast cell lineages. *Nature* 1990;344:444-447.
101. Tsai F-Y, Orkin SH. Transcription factor GATA-2 is required for proliferation/survival of early hematopoietic cells and mast cell formation, but not for erythroid and myeloid terminal differentiation. *Blood* 1997;89:3636-3643.
102. Nishida K, Wang L, Morii E, et al. Requirement of Gab2 for mast cell development and KitL/c-Kit signaling. *Blood* 2002;99:1866-1869.
103. Soler J, O'Brien M, deCastro JT, et al. Blast crisis of chronic granulocytic leukemia with mast cell and basophil precursors. *Am J Clin Pathol* 1985;83:254-259.
104. Krishnan S, Mali RS, Ramdas B, et al. p85beta regulatory subunit of class IA PI3Kinase negatively regulates mast cell growth, maturation and leukemogenesis. *Blood* 2012;119:3951-3961.
105. Ishizaki T, Tamiya T, Taniguchi K, et al. miR126 positively regulates mast cell proliferation and cytokine production through suppressing Spred1. *Genes Cells* 2011;16:803-814.
106. Suda T, Suda J, Miura Y, et al. Clonal analysis of basophil differentiation in bone marrow cultures from a Down's syndrome patient with megakaryoblastic leukemia. *Blood* 1985;66:1278-1283.
107. Pearson MG, Vardiman JW, Le Beau MM, et al. Increased numbers of marrow basophils may be associated with a t(6;9) in ANLL. *Am J Hematol* 1985;18:393-403.
108. Engelhardt KR, McGhee S, Winkler S, et al. Large deletions and point mutations involving the dedicator of cytokinesis 8 (DOCK8) in the autosomal-recessive form of hyper-IgE syndrome. *J Allergy Clin Immunol* 2009;124:1289-1302.
109. Kostenis E, Ulven T. Emerging roles of DP and CRTH2 in allergic inflammation. *Trends Mol Med* 2006;12:148-158.
110. Feng C, Beller EM, Bagga S, et al. Human mast cells express multiple EP receptors for prostaglandin E2 that differentially modulate activation responses. *Blood* 2006;107:3243-3250.
111. Kay LJ, Yeo WW, Peachell PT. Prostaglandin E2 activates EP2 receptors to inhibit human lung mast cell degranulation. *Br J Pharmacol* 2006;147:707-713.
112. Wang XS, Lau HY. Prostaglandin E potentiates the immunologically stimulated histamine release from human peripheral blood-derived mast cells through EP1/EP3 receptors. *Allergy* 2006;61:503-506.
113. Zhang S, Cherwinski H, Sedgwick JD, et al. Molecular mechanisms of CD200 inhibition of mast cell activation. *J Immunol* 2004;173:6786-6793.
114. Kojima T, Obata K, Mukai K, et al. Mast cells and basophils are selectively activated in vitro and in vivo through CD200R3 in an IgE-independent manner. *J Immunol* 2007;179:7093-7100.
115. Yu C, Fedoric B, Anderson PH, et al. Vitamin D(3) signalling to mast cells: a new regulatory axis. *Int J Biochem Cell Biol* 2011;43:41-46.
116. Befus AD, Denburg JA. Basophilic leucocytes: mast cells and basophils. In: Greer JP, Foerster J, Rodgers GM, et al., eds. *Wintrobe's Clinical Hematology*. 12th ed. Baltimore, MD: Lippincott Williams & Wilkins, 2009:236-248.
117. Kraft S, Kinet JP. New developments in FcepsilonRI regulation, function and inhibition. *Nat Rev Immunol* 2007;7:365-378.

118. Wu LC. Immunoglobulin E receptor signaling and asthma. *J Biol Chem* 2011;286:32891-32897.
119. Tkaczyk C, Metcalfe DD, Gilfillan AM. Fc gamma RI and other Fc receptors on human mast cells. Alternative paradigms for the regulation of mast-cell activation. *Allergy Clin Immunol Int* 2002;14:109-116.
120. Nimmerjahn F, Ravetch JV. Fc gamma receptors: old friends and new family members. *Immunity* 2006;24:19-28.
121. Takai T, Ono M, Hikida M, et al. Augmented humoral and anaphylactic responses in Fc gamma RII-deficient mice. *Nature* 1996;379:346-349.
122. Kraft S, Novak N. Fc receptors as determinants of allergic reactions. *Trends Immunol* 2006;27:88-95.
123. Bruhns P, Fremont S, Daron M. Regulation of allergy by Fc receptors. *Curr Opin Immunol* 2005;17:662-669.
124. Chen K, Xu W, Wilson M, et al. Immunoglobulin D enhances immune surveillance by activating antimicrobial, proinflammatory and B cell-stimulating programs in basophils. *Nat Immunol* 2009;10:889-898.
125. Foreman J. Non-immunological stimuli of mast cells and basophil leucocytes. In: Foreman J, ed. *Immunopharmacology of Mast Cells and Basophils*. London: Academic Press, 1993:57-69.
126. Li WW, Guo TZ, Liang DY, et al. Substance P signaling controls mast cell activation, degranulation, and nociceptive sensitization in a rat fracture model of complex regional pain syndrome. *Anesthesiology* 2012;116:882-895.
127. Pothoulakis C, Castagliuolo I, LaMont JT. Nerves and intestinal mast cells modulate responses to enterotoxins. *News Physiol Sci* 1998;13:58-63.
128. Buhner S, Schemann M. Mast cell-nerve axis with a focus on the human gut. *Biochim Biophys Acta* 2012;1822:85-92.
129. Levy D, Kainz V, Burstein R, et al. Mast cell degranulation distinctly activates trigemino-cervical and lumbosacral pain pathways and elicits widespread tactile pain hypersensitivity. *Brain Behav Immun* 2012;26:311-317.
130. Jin Y, Silverman AJ, Vannucci SJ. Mast cells are early responders after hypoxia-ischemia in immature rat brain. *Stroke* 2009;40:3107-3112.
131. Marshall JS. Mast-cell responses to pathogens. *Nat Rev Immunol* 2004;4:787-799.
132. Galli SJ, Kalesnikoff J, Grimbaldeston MA, et al. Mast cells as "tunable" effector and immunoregulatory cells: recent advances. *Annu Rev Immunol* 2005;23:749-786.
133. Kuroda E, Antignano F, Ho VW, et al. SHIP represses Th2 skewing by inhibiting IL-4 production from basophils. *J Immunol* 2011;186:323-332.
134. Russell SL, Gold MJ, Hartmann M, et al. Early life antibiotic-driven changes in microbiota enhance susceptibility to allergic asthma. *EMBO Rep* 2012:440-447.
135. Saito H, Hatake K, Dvorak AM, et al. Selective differentiation and proliferation of hematopoietic cells induced by recombinant human interleukins. *Proc Natl Acad Sci U S A* 1988;85:2288-2292.
136. Groot KT, Thio M, Blokhuis BR, et al. Atopic and non-atopic allergic disorders: current insights into the possible involvement of free immunoglobulin light chains. *Clin Exp Allergy* 2009;39:33-42.
137. Redegeld FA, Wortel CH. IgE and immunoglobulin free light chains in allergic disease: new therapeutic opportunities. *Curr Opin Investig Drugs* 2008;9:1185-1191.
138. Bochner BS, Schleimer RP. Mast cells, basophils, and eosinophils: distinct but overlapping pathways for recruitment. *Immunol Rev* 2001;179:5-15.
139. Bieneman AP, Chichester KL, Chen YH, et al. Toll-like receptor 2 ligands activate human basophils for both IgE-dependent and IgE-independent secretion. *J Allergy Clin Immunol* 2005;115:295-301.
140. Komiya A, Nagase H, Okugawa S, et al. Expression and function of toll-like receptors in human basophils. *Int Arch Allergy Immunol* 2006;140(Suppl 1):23-27.
141. Biggs L, Yu C, Fedoric B, et al. Evidence that vitamin D(3) promotes mast cell-dependent reduction of chronic UVB-induced skin pathology in mice. *J Exp Med* 2010;207:455-463.
142. Gorczynski RM, Chen Z, Khatri I, et al. Graft-infiltrating cells expressing a CD200 transgene prolong allogeneic skin graft survival in association with local increases in Foxp3(+)Treg and mast cells. *Transpl Immunol* 2011;25:187-193.

143. Cherwinski HM, Murphy CA, Joyce BL, et al. The CD200 receptor is a novel and potent regulator of murine and human mast cell function. *J Immunol* 2005;174:1348-1356.
144. Cho KA, Suh JW, Sohn JH, et al. IL-33 induces Th17-mediated airway inflammation via mast cells in ovalbumin-challenged mice. *Am J Physiol Lung Cell Mol Physiol* 2012;302:L429-L440.
145. Oboki K, Ohno T, Kajiwara N, et al. IL-33 and IL-33 receptors in host defense and diseases. *Allergol Int* 2010;59:143-160.
146. Comeau MR, Ziegler SF. The influence of TSLP on the allergic response. *Mucosal Immunol* 2010;3:138-147.
147. Roan F, Bell BD, Stoklasek TA, et al. The multiple facets of thymic stromal lymphopoietin (TSLP) during allergic inflammation and beyond. *J Leukoc Biol* 2012;91.doi:10.1189/jlb.1211622.
148. Bradding P, Walls AF, Holgate ST. The role of the mast cell in the pathophysiology of asthma. *J Allergy Clin Immunol* 2006;117:1277-1284.
149. Trivedi NN, Caughey GH. Mast cell peptidases: chameleons of innate immunity and host defense. *Am J Respir Cell Mol Biol* 2010;42:257-267.
150. Xing W, Austen KF, Gurish MF, et al. Protease phenotype of constitutive connective tissue and of induced mucosal mast cells in mice is regulated by the tissue. *Proc Natl Acad Sci U S A* 2011;108:14210-14215.
151. Xia HZ, Kepley CL, Sakai K, et al. Quantitation of tryptase, chymase, Fc epsilon RI alpha, and Fc epsilon RI gamma mRNAs in human mast cells and basophils by competitive reverse transcription-polymerase chain reaction. *J Immunol* 1995;154:5472-5480.
152. Wakahara S, Fujii Y, Nakao T, et al. Gene expression profiles for Fc epsilon RI, cytokines and chemokines upon Fc epsilon RI activation in human cultured mast cells derived from peripheral blood. *Cytokine* 2001;16:143-152.
153. Nakajima T, Inagaki N, Tanaka H, et al. Marked increase in CC chemokine gene expression in both human and mouse mast cell transcriptomes following Fc epsilon receptor I cross-linking: an interspecies comparison. *Blood* 2002;100:3861-3868.
154. Oldford SA, Haidl ID, Howatt MA, et al. A critical role for mast cells and mast cell-derived IL-6 in TLR2-mediated inhibition of tumor growth. *J Immunol* 2010;185:7067-7076.
155. McAlpine SM, Issekutz TB, Marshall JS. Virus stimulation of human mast cells results in the recruitment of CD56 T cells by a mechanism dependent on CCR5 ligands. *FASEB J* 2012;26:1280-1289.
156. Monticelli S, Lee DU, Nardone J, et al. Chromatin-based regulation of cytokine transcription in Th2 cells and mast cells. *Int Immunol* 2005;17:1513-1524.
157. Marone G, Genovese A, Granata F, et al. Pharmacological modulation of human mast cells and basophils. *Clin Exp Allergy* 2002;32:1682-1689.
158. Peachell P. Regulation of mast cells by beta-agonists. *Clin Rev Allergy Immunol* 2006;31:131-142.
159. Kopp MV. Omalizumab: anti-IgE therapy in allergy. *Curr Allergy Asthma Rep* 2011;11:101-106.
160. Kearley J, Erjefalt JS, Andersson C, et al. IL-9 governs allergen-induced mast cell numbers in the lung and chronic remodeling of the airways. *Am J Respir Crit Care Med* 2011;183:865-875.
161. Catley MC, Coote J, Bari M, et al. Monoclonal antibodies for the treatment of asthma. *Pharmacol Ther* 2011;132:333-351.
162. MacGlashan D, Jr., Udem BJ. Inducing an anergic state in mast cells and basophils without secretion. *J Allergy Clin Immunol* 2008;121:1500-1506.
163. Sanderson MP, Gelling SJ, Rippmann JF, et al. Comparison of the anti-allergic activity of Syk inhibitors with optimized Syk siRNAs in Fc epsilon RI-activated RBL-2H3 basophilic cells. *Cell Immunol* 2010;262:28-34.
164. Royer JF, Schratl P, Carrillo JJ, et al. A novel antagonist of prostaglandin D2 blocks the locomotion of eosinophils and basophils. *Eur J Clin Invest* 2008;38:663-671.
165. Boehme SA, Franz-Bacon K, Chen EP, et al. Murine bone marrow-derived mast cells express chemoattractant receptor-homologous molecule expressed on T-helper class 2 cells (CRTh2). *Int Immunol* 2009;21:621-632.

166. Jeong HJ, Choi Y, Kim KY, et al. C-kit binding properties of hesperidin (a major component of KMP6) as a potential anti-allergic agent. *PLoS One* 2011;6:e19528.
167. Katz HR. Inhibition of pathologic inflammation by leukocyte Ig-like receptor B4 and related inhibitory receptors. *Immunol Rev* 2007;217:222-230.
168. Abramson J, Pecht I. Regulation of the mast cell response to the type 1 Fc epsilon receptor. *Immunol Rev* 2007;217:231-254.
169. Karra L, Levi-Schaffer F. Down-regulation of mast cell responses through ITIM containing inhibitory receptors. *Adv Exp Med Biol* 2011;716:143-159.
170. Yokoi H, Choi OH, Hubbard W, et al. Inhibition of FcepsilonRI-dependent mediator release and calcium flux from human mast cells by sialic acid-binding immunoglobulin-like lectin 8 engagement. *J Allergy Clin Immunol* 2008;121:499-505.
171. Chirumbolo S, Conforti A, Ortolani R, et al. Stimulus-specific regulation of CD63 and CD203c membrane expression in human basophils by the flavonoid quercetin. *Int Immunopharmacol* 2010;10:183-192.
172. Weng Z, Zhang B, Asadi S, et al. Quercetin is more effective than cromolyn in blocking human mast cell cytokine release and inhibits contact dermatitis and photosensitivity in humans. *PLoS One* 2012;7:e33805.
173. Chen YH, Bieneman AP, Creticos PS, et al. IFN-alpha inhibits IL-3 priming of human basophil cytokine secretion but not leukotriene C4 and histamine release. *J Allergy Clin Immunol* 2003;112:944-950.
174. Coleman JW. Nitric oxide: a regulator of mast cell activation and mast cell-mediated inflammation. *Clin Exp Immunol* 2002;129:4-10.
175. Bissonnette EY, Enciso JA, Befus AD. TGF-beta1 inhibits the release of histamine and tumor necrosis factor-alpha from mast cells through an autocrine pathway. *Am J Respir Cell Mol Biol* 1997;16:275-282.
176. Marshall JS, Leal-Berumen I, Nielsen L, et al. Interleukin (IL)-10 inhibits longterm IL-6 production but not preformed mediator release from rat peritoneal mast cells. *J Clin Invest* 1996;97:1122-1128.
177. Lin TJ, Befus AD. Differential regulation of mast cell function by IL-10 and stem cell factor. *J Immunol* 1997;159:4015-4023.
178. Gibbs BF, Levi-Schaffer F. H₄ receptors in mast cells and basophils: a new therapeutic target for allergy? *Front Biosci* 2012;17:430-437.
179. Bissonnette EY. Histamine inhibits tumor necrosis factor alpha release by mast cells through H2 and H3 receptors. *Am J Respir Cell Mol Biol* 1996;14:620-626.
180. Hogaboam CM, Bissonnette EY, Chin BC, et al. Prostaglandins inhibit inflammatory mediator release from rat mast cells. *Gastroenterology* 1993;104:122-129.
181. Abdel-Majid RM, Marshall JS. Prostaglandin E2 induces degranulation-independent production of vascular endothelial growth factor by human mast cells. *J Immunol* 2004;172:1227-1236.
182. Dvorak AM, Dvorak HF. Cutaneous basophil hypersensitivity—a twenty-year perspective, 1970 to 1990. In: Foreman J, ed. *Immunopharmacology of Mast Cells and Basophils*. London: Academic Press, 1993:153-180
183. Schroeder JT, Lichtenstein LM, Roche EM, et al. IL-4 production by human basophils found in the lung following segmental allergen challenge. *J Allergy Clin Immunol* 2001;107:265-271.
184. Hallgren J, Gurish MF. Mast cell progenitor trafficking and maturation. *Adv Exp Med Biol* 2011;716:14-28.
185. Collington SJ, Williams TJ, Weller CL. Mechanisms underlying the localisation of mast cells in tissues. *Trends Immunol* 2011;32:478-485.
186. Stead RH, Colley EC, Wang B, et al. Vagal influences over mast cells. *Auton Neurosci* 2006;125:53-1.
187. Andoh T, Kuraishi Y. Expression of Fc epsilon receptor I on primary sensory neurons in mice. *Neuroreport* 2004;15:2029-2031.

188. van der Kleij H, Charles N, Karimi K, et al. Evidence for neuronal expression of functional Fc (epsilon and gamma) receptors. *J Allergy Clin Immunol* 2010;125:757-760.
189. Van Lieshout RJ, Bienenstock J, MacQueen GM. A review of candidate pathways underlying the association between asthma and major depressive disorder. *Psychosom Med* 2009;71:187-195.
190. Echtenacher B, Mannel DN, Hultner L. Critical protective role of mast cells in a model of acute septic peritonitis. *Nature* 1996;381:75-77.
191. Malaviya R, Ikeda T, Ross E, et al. Mast cell modulation of neutrophil influx and bacterial clearance at sites of infection through TNF-alpha. *Nature* 1996;381:77-80.
192. Gilfillan AM, Tkaczyk C. Integrated signalling pathways for mast-cell activation. *Nat Rev Immunol* 2006;6:218-230.
193. Abraham SN, St John AL. Mast cell-orchestrated immunity to pathogens. *Nat Rev Immunol* 2010;10:440-452.
194. Charles N, Hardwick D, Daugas E, et al. Basophils and the T helper 2 environment can promote the development of lupus nephritis. *Nat Med* 2010;16:701-707.
195. McLachlan JB, Hart JP, Pizzo SV, et al. Mast cell-derived tumor necrosis factor induces hypertrophy of draining lymph nodes during infection. *Nat Immunol* 2003;4:1199-1205.
196. Shelburne CP, Nakano H, St John AL, et al. Mast cells augment adaptive immunity by orchestrating dendritic cell trafficking through infected tissues. *Cell Host Microbe* 2009;6:331-342.
197. de Vries VC, Pino-Lagos K, Nowak EC, et al. Mast cells condition dendritic cells to mediate allograft tolerance. *Immunity* 2011;35:550-561.
198. McLachlan JB, Shelburne CP, Hart JP, et al. Mast cell activators: a new class of highly effective vaccine adjuvants. *Nat Med* 2008;14:536-541.
199. St John AL, Chan CY, Staats HF, et al. Synthetic mast-cell granules as adjuvants to promote and polarize immunity in lymph nodes. *Nat Mater* 2012;11: 250-257.
200. Katz HR, Austen KF. Mast cell deficiency, a game of kit and mouse. *Immunity* 2011;35:668-670.
201. Dudeck A, Dudeck J, Scholten J, et al. Mast cells are key promoters of contact allergy that mediate the adjuvant effects of haptens. *Immunity* 2011;34:973-984.
202. Huang C, De Sanctis GT, O'Brien PJ, et al. Evaluation of the substrate specificity of human mast cell tryptase beta I and demonstration of its importance in bacterial infections of the lung. *J Biol Chem* 2001;276:26276-26284.
203. Karlson U, Pejler G, Froman G, et al. Rat mast cell protease 4 is a betachymase with unusually stringent substrate recognition profile. *J Biol Chem* 2002;277:18579-18585.
204. Prieto-Garcia A, Zheng D, Adachi R, et al. Mast cell restricted mouse and human tryptase.heparin complexes hinder thrombin-induced coagulation of plasma and the generation of fibrin by proteolytically destroying fibrinogen. *J Biol Chem* 2012;287:7834-7844.
205. Waern I, Jonasson S, Hjoberg J, et al. Mouse mast cell protease 4 is the major chymase in murine airways and has a protective role in allergic airway inflammation. *J Immunol* 2009;183:6369-6376.
206. Sugimoto K, Kudo M, Sundaram A, et al. The alphavbeta6 integrin modulates airway hyperresponsiveness in mice by regulating intraepithelial mast cells. *J Clin Invest* 2012;122:748-758.
207. Lin L, Bankaitis E, Heimbach L, et al. Dual targets for mouse mast cell protease-4 in mediating tissue damage in experimental bullous pemphigoid. *J Biol Chem* 2011;286:37358-37367.
208. Akahoshi M, Song CH, Piliponsky AM, et al. Mast cell chymase reduces the toxicity of Gila monster venom, scorpion venom, and vasoactive intestinal polypeptide in mice. *J Clin Invest* 2011;121:4180-4191.
209. Yamagishi H, Mochizuki Y, Hamakubo T, et al. Basophil-derived mouse mast cell protease 11 induces microvascular leakage and tissue edema in a mast cell-independent manner. *Biochem Biophys Res Commun* 2011;415:709-713.
210. Garbuzenko E, Nagler A, Pickholtz D, et al. Human mast cells stimulate fibroblast proliferation, collagen synthesis and lattice contraction: a direct role for mast cells in skin fibrosis. *Clin Exp Allergy* 2002;32:237-246.

211. Monument MJ, Hart DA, Befus AD, et al. The mast cell stabilizer ketotifen fumarate lessens contracture severity and myofibroblast hyperplasia: a study of a rabbit model of posttraumatic joint contractures. *J Bone Joint Surg Am* 2010;92:1468-1477.
212. Befus D. Reciprocal interactions between mast cells and the endocrine system. In: Freier S, ed. *The Neuroendocrine-immune Network*. Boca Raton, FL: CRC Press, 1990:39-52.
213. Maurer M, Theoharides T, Granstein RD, et al. What is the physiological function of mast cells? *Exp Dermatol* 2003;12:886-910.
214. Silverman AJ, Asarian L, Khalil M, et al. GnRH, brain mast cells and behavior. *Prog Brain Res* 2002;141:315-325.
215. Gaboury JP, Niu XF, Kubes P. Nitric oxide inhibits numerous features of mast cell-induced inflammation. *Circulation* 1996;93:318-326.

Chapter 10 Monocytes, Macrophages, and Dendritic Cells

> Table of Contents > Part II - The Normal Hematologic System > Section 3 - Granulocytes and Monocytes > Chapter 10 - Monocytes, Macrophages, and Dendritic Cells

Chapter 10

Monocytes, Macrophages, and Dendritic Cells

Matthew Collin

Derralynn A. Hughes

Annette Plüddemann

Siemon Gordon

INTRODUCTION

Monocytes, macrophages, and dendritic cells (DCs) constitute a group of myeloid cells which share common hematopoietic origins and express related functions in host homeostasis and innate and acquired immunity. They develop in hematopoietic organs, enter the circulation, and are widely distributed throughout almost all tissues. They express a variable capacity for migration, phagocytosis, antigen presentation, and secretion.

Study of this family of cells, initially known as the reticuloendothelial system (RES), and later as the mononuclear phagocyte system (MPS), is undergoing rapid change, with recent emphasis on cellular heterogeneity and differentiation, compounded by complex modulation of their phenotype within tissues. As a result of their specialized functions, the fields of macrophage and DC immunobiology have diverged to a great extent. Our goal in this chapter is to re-integrate these divisions, to emphasize their related properties and variations on a common theme. While much remains unknown concerning their life history and properties in situ, there is a considerable body of detail now available from studies in cell culture and in experimental animals, especially in the mouse, which may not necessarily reflect their behavior in humans. In this chapter, we summarize their cellular and molecular properties and emphasize studies in humans, drawing attention where possible to clinically relevant functions and pathogenic mechanisms. While primarily aimed at hematologists, this chapter highlights the major populations present in the

P.194

tissues, both normally and in a range of inflammatory, infectious, metabolic, and neoplastic diseases.

A BRIEF HISTORY^{1,2,3} and ^{4,5,6,7}

The award of the Nobel Prize in 1908 to Elie Metchnikoff, shared with Paul Ehrlich, established the macrophage as a specialized phagocyte, distinct from the microphage (neutrophil) and an important part of the inflammatory cellular response to foreign bodies and infection. There was still considerable confusion between monocytes and lymphocytes, based on morphology and histology alone. Electron microscopy in the 1950s (such as the work of Marchesi and Florey) characterized the ultrastructure of monocytes, their diapedesis and the pleomorphic appearance of macrophages in tissues. The precursor-product studies of Ebert and Florey and the migration studies of Volkman and Gowans helped to clarify the distinctions between these mononuclear cells. Recent reviews by Cavaillon^{2,3} cover the origins, the first half of

the 20th century, and the emergence of the RES in detail. During this time the importance of mycobacterial infection of monocytes and macrophages was a popular research topic: for example, in the significant work of Florence Sabin.

In the 1960s Zanvil Cohn and James Hirsch turned from their studies on granulocytes and defined the endocytic and cellular properties in culture of mouse macrophages that had been isolated from the peritoneal cavity. Together with Ralph van Furth and a group of investigators, they established the classification of macrophage-related cells as members of the MPS. A series of influential international Leiden conferences reviewed and published progress of research in the field from the late 1960s to the early 1990s.

During the 1950s and 1960s George Mackaness described the antigen-dependent but nonspecific activation of macrophages by cell-mediated protective immune responses to intracellular pathogens such as BCG and *Listeria monocytogenes*. This association of macrophages with T lymphocytes had profound implications for acquired immunity. The search for accessory cells responsible for antigen specific activation of T helper lymphocytes led to the discovery of DC, by Ralph Steinman and Zanvil Cohn⁸ in 1973. The unique role of DCs in antigen presentation, later shown by others to depend on the Major Histocompatibility Antigen complex, forms a bridge between innate and adaptive immunity and was recognized by part of the Nobel Prize for Medicine and Physiology in 2011.

Macrophages and DCs are both considered to be components of the MPS, although significant debate remains concerning their exact relationship and derivation in the steady state and inflammation. Derivatives of macrophages and DCs form an abundant component of the organized structures known as granulomata, as shown by Walter Spector. Although they are a prominent feature of important chronic infectious diseases such as tuberculosis the nature of their interactions with T lymphocytes and their precise functions are still unclear.

Other milestones of macrophage research include the discovery and exploitation of growth factors for macrophages and other hematopoietic cells, notably by Donald Metcalf; the identification of cytokines such as tumor necrosis factor (TNF) by Anthony Cerami and Lloyd Old, that play an important role and provide a therapeutic target in diseases such as rheumatoid arthritis; and the recognition by Russell Ross of the central role of monocytes that adhere to the walls of large arteries and give rise to lipid-laden macrophages in atherosclerosis. In addition, Marcel Bessis recognized the hematopoietic importance of macrophages in erythroblastic islands, although the full implications of his discovery remain to be explored.

The DC field has gained increasing momentum since the 1970s. The discovery of toll-like receptors (TLRs), C-type lectins, and other pathogen-associated molecular pattern recognition systems were key events in understanding how DCs and macrophages distinguish self from nonself. The contributions of Jules Hoffman and Bruce Beutler to this area were also recognized in the 2011 Nobel Prize. Another important breakthrough was the isolation of distinct precursors of DCs and macrophages through the work of several groups including Frederic Geissmann, Marcus Manz, Ken Shortman, Miriam Merad, and Michel Nussenzweig. More recently, the genetic control and specialized functions of distinct DC subsets have been documented in both mouse and humans. Unique pathways of ontogeny have also been described for special members of the MPS including osteoclasts, epidermal Langerhans cells, and microglia of the brain.

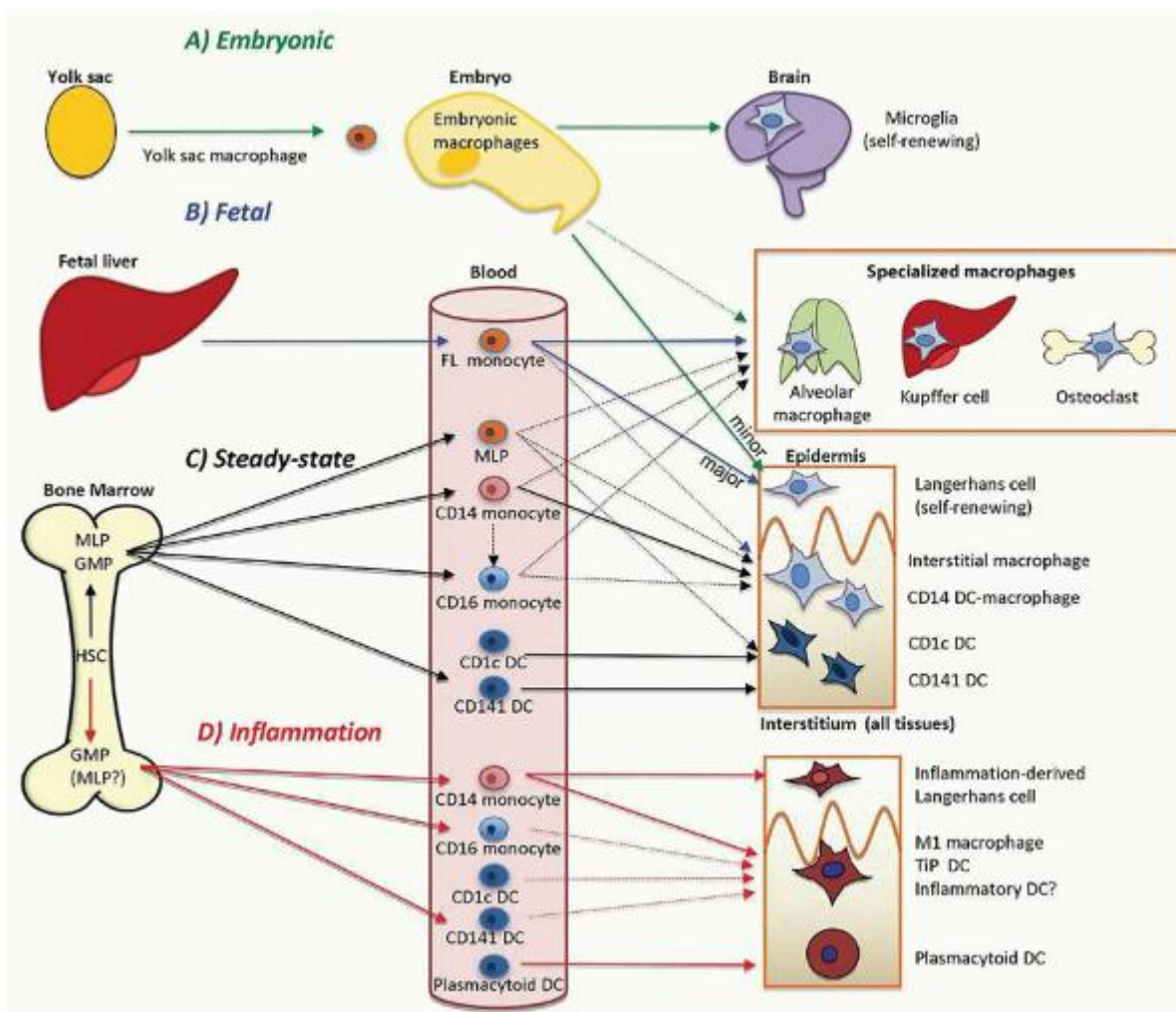

FIGURE 10.1. Summary of the main pathways of monocyte, macrophage, and dendritic cell (DC) development in human tissue during embryogenesis, fetal development, adult steady state, and inflammation. **A: Embryonic.** Yolk sac macrophages are the first hematopoietic cells to appear. Studies in mice indicate that these cells migrate through the mesoderm prior to vasculogenesis, proliferating and colonizing all the tissues of the embryo. Lineage tracing indicates that 100% of microglia arise from the yolk sac, becoming isolated in the developing brain by closure of the blood-brain barrier. They are maintained in adult life by local proliferation. **B: Fetal.** In models derived from lineage tracing in mice, hematopoiesis in the liver gives rise to the first monocytes, which circulate widely and dilute the contribution of yolk sac macrophages in almost all tissue sites. Residual yolk sac contribution of approximately 10% is detectable in the Langerhans cells of the epidermis; the other 90% are fetal liver-derived and become locally self-renewing in adult life. Tissue macrophages and specialized populations of macrophages: alveolar, Kupffer, and osteoclasts, may also derive from fetal liver monocytes, at least initially. **C: Adult steady-state hematopoiesis,** arising from multi-lymphoid progenitors (MLP) capable of differentiating into monocytes, DCs, lymphoid cells, and granulocyte-macrophage progenitors (GMP), contributes a wide variety of cells with macrophage and DC potential into the blood. These include circulating CD34+ MLP, classical CD14+ and nonclassical CD16+ monocytes, CD1c+ myeloid DCs, CD141+ myeloid DCs, and plasmacytoid DCs. The contribution of these steady state blood components to macrophage homeostasis in a wide range of tissues, in addition to those illustrated, has not been rigorously defined. CD34+ precursors and both subsets of monocytes potentially contribute to tissue macrophages in interstitial and specialized sites. CD14+ monocytes and CD16+ monocytes are closely related to CD14+ interstitial DCs, while CD1c+ and CD141+ blood DCs both have phenotypically similar interstitial DC counterparts. CD34+ precursors also have the potential to form tissue DCs. Plasmacytoid DCs do not migrate into the tissues in the steady state. **D: Inflammation.** Upregulation of myelopoiesis under conditions of stress is likely to involve expansion of GMP production of monocytes, myeloid DCs, and plasmacytoid DCs. Multiple inflammatory signals potentially recruit all peripheral blood populations to the tissues. Classical CD14+ monocytes are the most significant component giving rise to inflammatory activated “M1” macrophages and TNF/i-NOS-producing DCs (Tip-DCs) in a range of tissues. This may include

the CNS (pathway not shown for simplicity here). Langerhans cells are also replaced by inflammatory classical monocytes in desquamating epidermal inflammation. Myeloid DCs may be directly recruited to give inflammatory DCs, and infiltration with plasmacytoid DCs is well documented.

In the following section, we summarize general and specialized features of monocytes, macrophages, and DCs, collectively termed mononuclear phagocytes (MPs). Figure 10.1 illustrates a comprehensive overview of human MP differentiation and distribution, to be discussed in detail in subsequent sections.

FUNCTIONAL PROPERTIES

Cellular Morphology^{9,10}

Aspects of mononuclear cell differentiation and morphology in situ and ex vivo are illustrated in Figures 10.1, 10.2, 10.3 and 10.4 and summarized in Table 10.1.

P.195

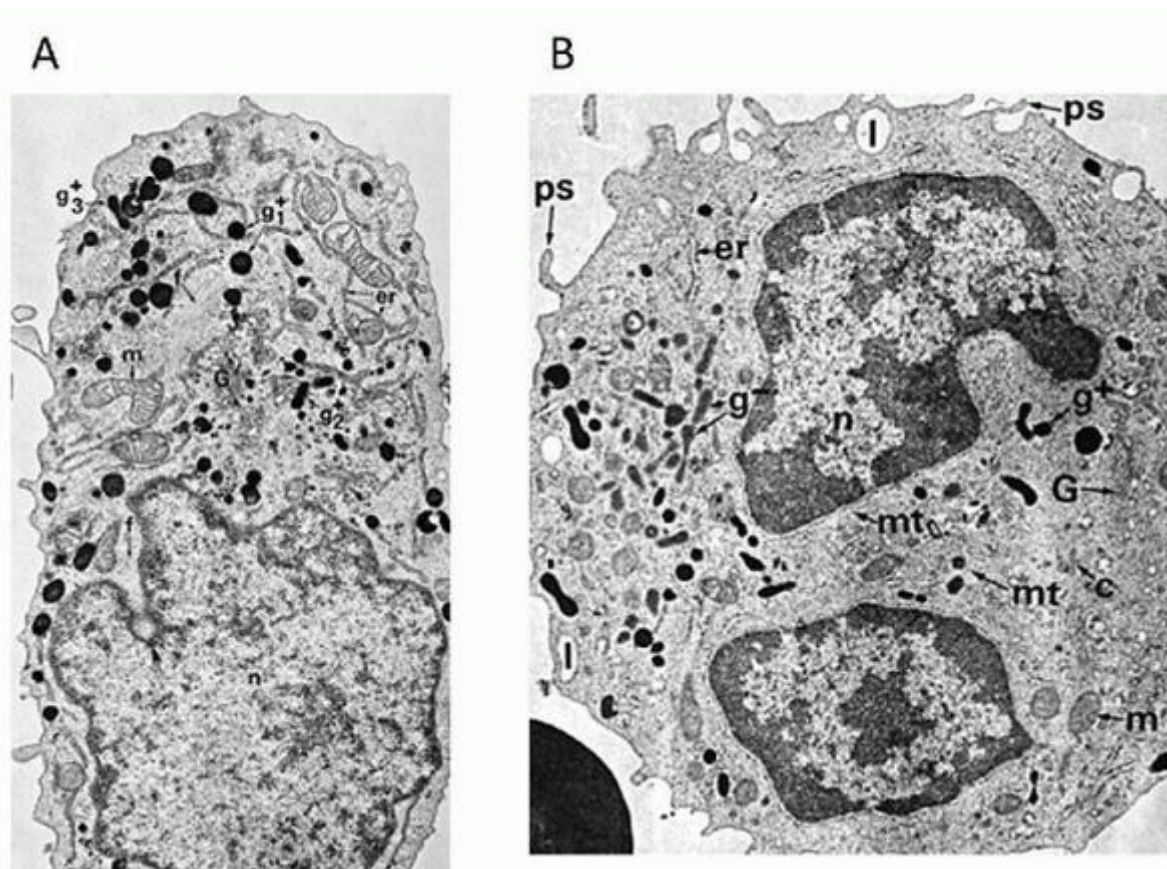

FIGURE 10.2. Ultrastructure of promonocyte and monocyte. A: Electron micrograph of a promonocyte from human bone marrow stained for peroxidase. The nucleus (n), situated at one end of the cell, exhibits an irregular outline and deep indentation. The cytoplasm contains a number of cytoplasmic organelles. Peroxidase reactivity is demonstrable throughout the rough endoplasmic reticulum (er), Golgi complex (G), and all cytoplasmic granules (g^+_1 , g^+_2 , g^+_3). Apparently, all granules mature from the earliest forms, which are spherical and dense (g^+_1), with a homogeneous matrix, to more condensed and elongated forms (g^+_2), and then to dumbbell forms (g^+_3). The Golgi complex (G) is composed of several stacks of cisternae and occupies a large area adjacent to the nucleus. Bundles of filaments (f) are prominent in the cytoplasm and are believed to be useful in characterizing the cell as a monocyte form. Several mitochondria (m) are also seen $\times 18,000$. B: Electron micrograph of a normal human monocyte examined for peroxidase. In the nucleus (n), the chromatin is more condensed than in earlier forms, is mainly peripheral in distribution, and is interrupted at the nuclear pores. The voluminous cytoplasm (c) contains a full complement of organelles associated with protein synthesis and export of secretory granules. Peroxidase is present in only some of the granules (g^+), but others (g^-), as well as the

endoplasmic reticulum (er) and Golgi complex (G), now lack the reaction product. At this stage, the two kinds of granules are approximately equal in number and similar in size and shape, ranging from 90 to 450 nm in length and from spherical or rodlike to dumbbell in shape. Microtubules (mt) radiate from the cell center, where a centriole can be seen adjacent to the Golgi complex (G). The moderately abundant endoplasmic reticulum has a more peripheral distribution than in the promonocyte, and modest numbers of mitochondria (m) are present. Numerous pseudopodia (ps) extend from the cell surface. The peripheral lacunae (l) represent a tangential section through surface irregularities $\times 16,200$. From Nicholls BA, Bainton DF: Differentiation of human monocytes in bone marrow and blood. Sequential formation of two granule populations. *Lab Invest* 1973;29:27-40, with permission.

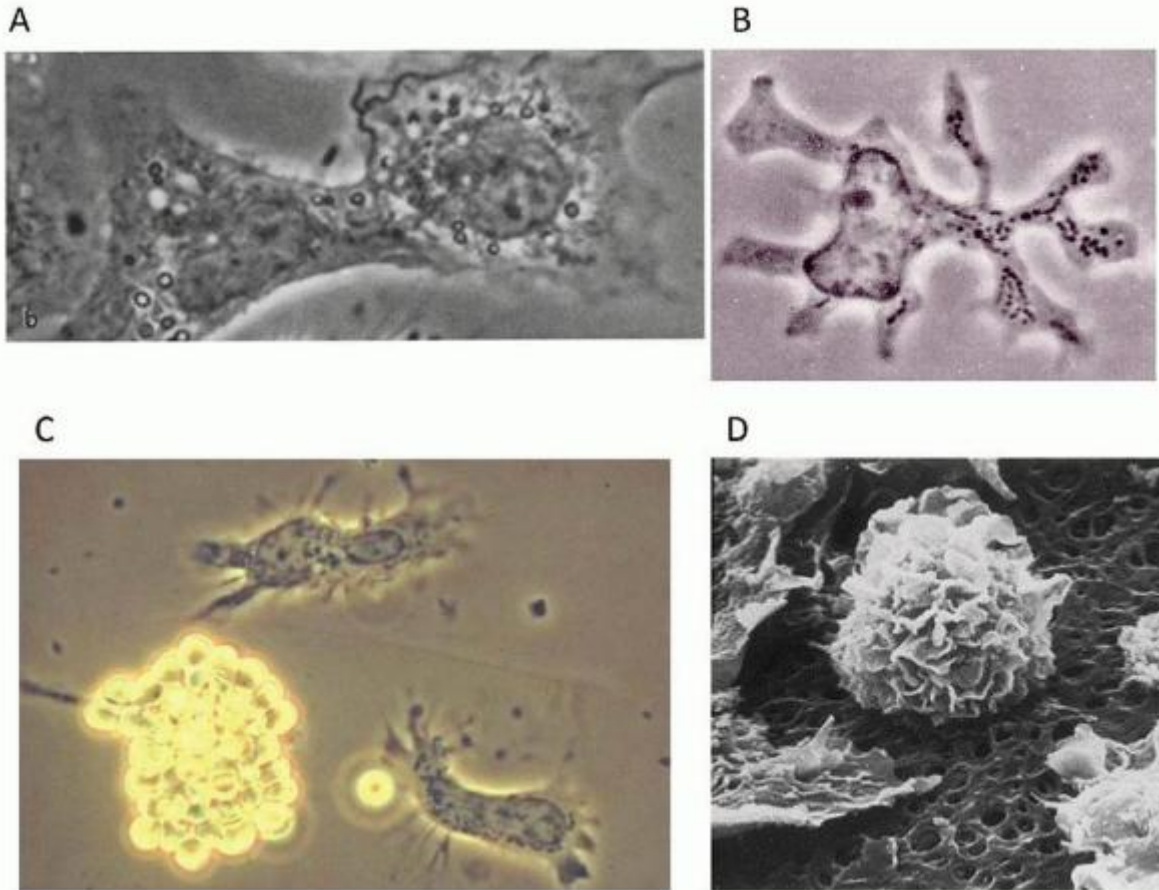

FIGURE 10.3. Morphology of mouse mononuclear phagocytes. A: Mouse peritoneal macrophages in culture on cover glasses undergo cell fusion shortly after addition of UV-irradiated Sendai virus. Note cytoplasmic bridge formation in nascent homokaryon. Phase contrast microscopy reveals characteristic nuclear morphology, rudimentary nucleoli, and extensive phase-lucent and phase-dense vesicles. Plasma membrane shows spreading of organelle-poor cell periphery with ruffling. From Gordon S, Cohn Z. Macrophage-melanocyte heterokaryons. I. Preparation and properties. *J Exp Med* 1970;131:981-1003, with permission. B,C: Phase contrast micrograph of dendritic cell isolated by Steinman and Cohn from mouse spleen. B: Note extensive dendrites, euchromatin nucleus, and mitochondria-rich cytoplasm, a feature of their high motility. C: Note lack of resetting of DCs with antibody-coated sheep erythrocytes, compared with macrophages in the same preparation, one of the features which allowed separation and their distinction. From Steinman RM, Cohn ZA. Identification of a novel cell type in peripheral lymphoid organs of mice. I. Morphology, quantitation, tissue distribution. *J Exp Med* 1973;1142-1162, with permission. D: Scanning electron microscopy of human alveolar macrophages cultured on cellulose membrane in a biphasic cell culture system. Note characteristic rounded appearance with extensive ruffles. From Wallaert B, Fahy O, Tscopoulos A, Gosset P, Tonnel AB. Experimental systems for mechanistic studies of toxicant induced lung inflammation. *Toxicol Lett* 2000;112-113:157-163, with permission.

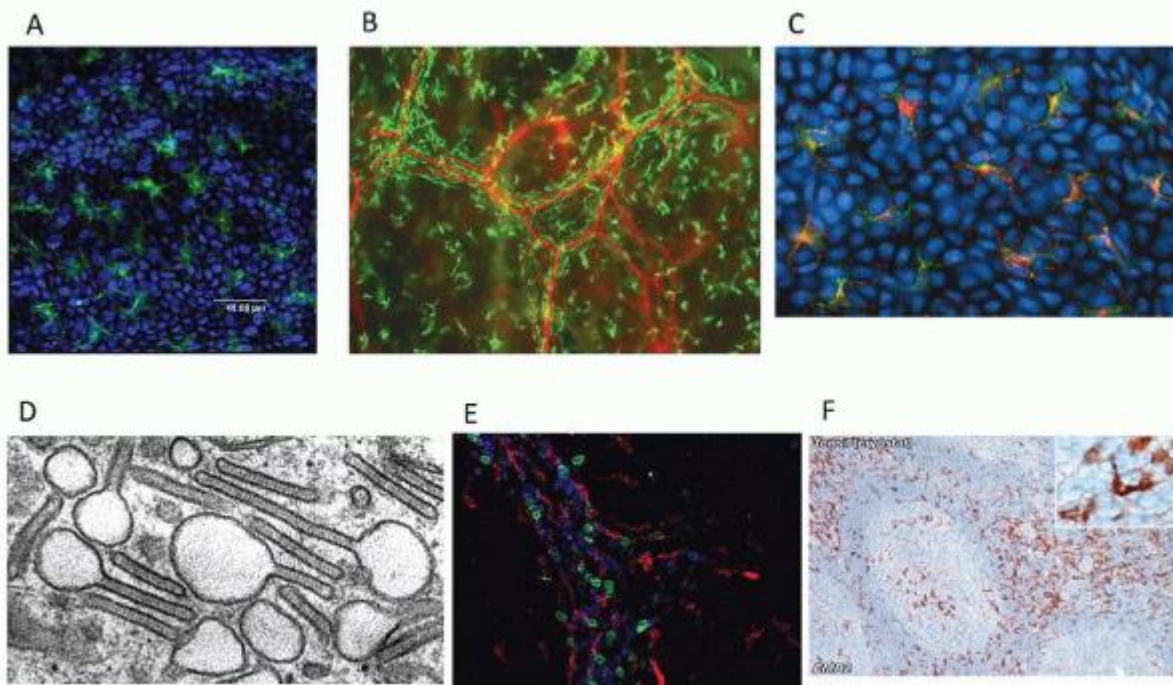

FIGURE 10.4. Mononuclear phagocytes in human skin and thymus. A: Epidermis: CD1a⁺ Langerhans cells. B: Dermis/interstitium Lyve-1⁺ macrophages and CD31⁺ endothelium. C: Epidermis: Langerhans cells express langerin and MHCII, which co-localize. D: Electron micrograph of Birbeck granules. E: Dermis: Triple labeling shows CD11c (DCs, green), XIIIa (macrophages, red) and CD3 (T cells, blue). F: Thymic macrophages and DCs express EMR2. Photomicrograph D from Romani N, Clausen BE, Stoitzner P. Langerhans cells and more: langerin expressing cell subsets in the skin. Immunol Rev 2010;234(1):120-141, with permission. Other images from M. Collin, N. Romani and T. Marafioti.

TABLE 10.1 SELECTED PROPERTIES OF HUMAN MONONUCLEAR PHAGOCYTES

Properties	Functions
A. Monocytes	
Low level in blood (~1-4%)	
Subpopulations:	
Classical (~90%) CD14 ^{hi} CD16 ^{var}	Phagocytosis, secretion, inflammation
Nonclassical (~10%) CD14 ^{mod/dim} CD16 ^{hi}	Patrolling, intravascular
Migration/adhesion:	
CCR2 ⁺ (classical)	Recruitment by inflammation, infection, immune stimulation
CX ₃ CR ₁ , variable	
CD11b ⁺	
CD11c ⁺	
LFA-1 (nonclassical)	
Recognition, endocytosis, phagocytosis:	
Opsonic receptors, e.g., FcR, CR	Clearance
Nonopsonic receptors, e.g., TLR, CD36, Lectins	Humoral immunity
Cytosolic sensors	Innate immunity, homeostasis
	Inflammasome activation

Biosynthesis: varied secretion:

Myeloperoxidase (MPO), Lysozyme

Respiratory burst (RB)

Cytokines

Leukotrienes

Tissue factor

Link to acquired immunity

Antimicrobial

Microbial killing

Cell activation, regulation

Inflammation

Procoagulant

Differentiation/modulation:

Precursor for macrophages and DCs

Inflammation, T cell activation

B. Macrophages

Widely distributed: Lymphohemopoietic tissues as resident and recruited populations

Local and systemic homeostasis

Trophic functions—inflammation and repair

Variable life span

Heterogeneous phenotype

Sessile (mainly)

Endocytosis and phagocytosis:

Opsonic (Fc, CR)

Nonopsonic recognition (SR, Lectins)

CD163, CD71, folate receptors

Clearance, digestion, host defense

Humoral immunity

Defense and homeostasis

Uptake hemoglobin-haptoglobin, transferrin, B12

Sensing (TLR, cytosolic)

Innate immunity

Regulatory receptors, e.g., TREMs, EMR2, GPCR

Potentiate responses

Biosynthesis and secretion:

Pro- and anti-inflammatory cytokines

E.g., IL-1, TNF, IL-6, IL-12, IL-18, IL-10, TGF- β

Neutral proteinases, enzymes

Low-molecular-weight mediators: RB, nitric oxide, prostanoids

Trophic and cytotoxic

Inflammation, repair

Innate immunity

Tissue catabolism

Defense and inflammation

Modulation:

Classical (M1) and alternative activation (M2)

Regulation of cellular immunity

Immune interactions:

Expression of MHCII and costimulatory molecules

Activation/suppression of primed T cells

Adaptive immune regulation

C. Myeloid Dendritic cells (mDC)

Minor population in blood, lymph tissues

Sentinel cells

Short to medium-lived

Bridge innate to adaptive immunity or tolerance

Subsets described, varied antigen markers

Motile	Migration
Chemokine receptors, e.g., CCR7	
Transient adhesion	
Endocytosis and phagocytosis	Antigen capture
Two-stage maturation/activation:	Induced by LPS, other ligands, e.g., TLR
Loss endocytosis, macropinocytosis, phagocytosis	Processing, direct and cross-presentation to naive lymphocytes
Intracellular MHCII redistributed to surface	
Limited digestion, capture peptides DM	
Specialized endosomal compartment (multivesicular bodies, Birbeck granules)	
CD1d expression	Lipid antigen presentation
Cytosolic sensors	Nucleic acid recognition
Costimulatory molecules	Activation and inhibition of APC functions
TLR, PRR-dependent cytokine production, e.g., IL-12, IL-18	Activation, regulation of tissue activation

D. Plasmacytoid Dendritic Cells (pDCs)

Minor, blood, tissue
 Short-lived, labile
 Mixed phenotype markers, e.g., CD123 (IL-3R); TLR3, 7, 9; Siglec H (mouse), RLR, helicases

Biosynthesis, secretion:

Type I interferon+ Antiviral responses
 IL-1, interleukin-1; MPO, Myeloperoxidase; RLRs, RIG-I-like receptor; PRRs, pattern recognition receptors; TGF- β , tumor growth factor- β ; TNF, tumor necrosis factor; TLR, Toll-like receptors; LFA-1, Lymphocyte function-associated antigen 1; APC, antigen presenting cell; MHCII, major histocompatibility complex Class II.

P.197

P.198

Monocytes are rounded cells, 10 to 15 μ m in size, with oval, kidney-shaped, or indented nuclei, a rim of heterochromatin, and mostly euchromatic nucleoplasm. Their cytoplasm is relatively abundant, compared with nonactivated lymphocytes, containing myeloperoxidase+ and rudimentary lysozyme+ granules, nonspecific esterases, and lysosomes. Scanning electron microscopy reveals extensive surface folds. They adhere readily to native and artificial substrates by a range of adhesion receptors, flattening out and spreading in characteristic fried egg or stellate shape with fine plasma membrane processes. They respond slowly to chemotactic gradients in vitro, compared with neutrophils.

Macrophages are larger, rounded (e.g., in alveolar space, peritoneal cavity), or stellate, with two or more processes, sticky and sluggish though motile, and with extensive, dynamic plasma membrane processes and filopodia. Podosomes have

been observed. The cytoplasm of cultured cells has a well-developed centrosome, with an organized cytoskeleton, and is rich in synthetic organelles and endocytic vesicles, often containing debris and residues of phagocytosis in abundant lysosomes. They lose their peroxidase granules as monocytes mature in culture. Macrophages love lining up along surface irregularities on culture substrata and usually keep their distance from one another in culture; inflammatory stimuli cause aggregation. Occasional binucleate cells arise by failure of cytokinesis; macrophage fusion can be observed "spontaneously," especially on selected substrates, or after exposure to serum lipids or cytokines such as interleukin (IL)-4.

DCs in the blood are smaller than monocytes and may be found in the "lymphoid" gates on flow cytometry analyses. In the tissues, they are smaller than macrophages and less extensively arborized with multiple short processes. During migration through the afferent lymph they mature into "veiled cells" with extensive macropinocytic processes. In lymph nodes they are highly motile and transit rapidly between T cells until a cognate antigen interaction is detected by the T cell. In vitro they are lightly or nonadherent compared with monocytes or macrophages, a property that was exploited in their original isolation from mouse spleen.

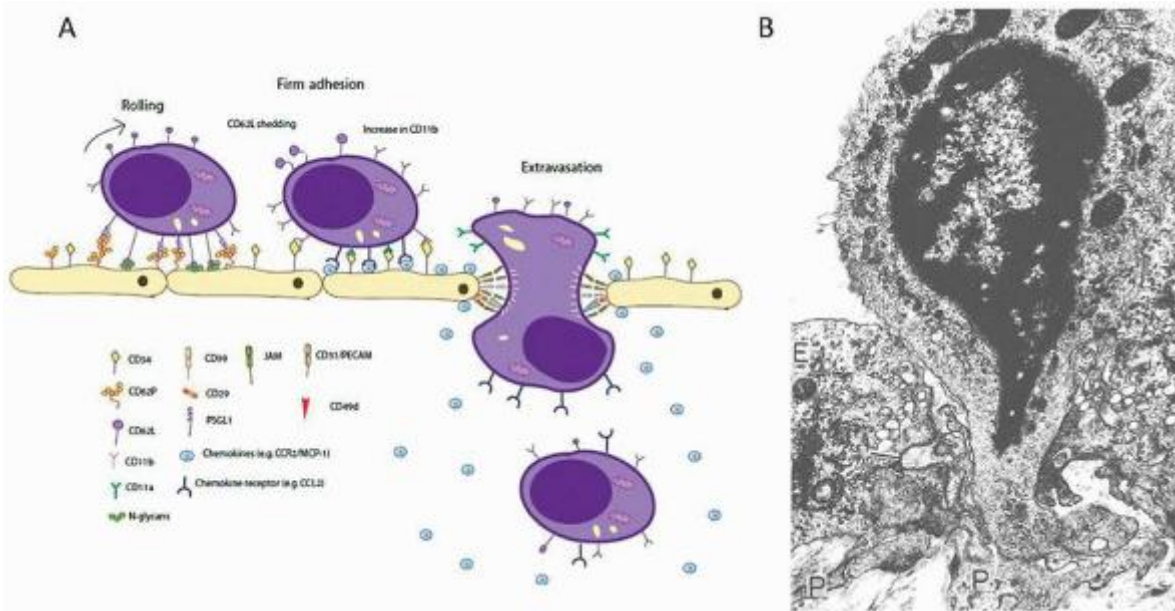

FIGURE 10.5. (A) Recruitment. Stages of monocyte adherence to endothelium and diapedesis, induced by inflammatory stimuli. The model is mainly based on the recruitment of neutrophils, with which it shares many features, although monocyte-specific chemokines, receptors, and adhesion ligands exist, especially in constitutive and noninfectious, metabolic forms of inflammation. Figure provided by S. Yona. (B) Monocyte diapedesis. Electron micrograph from collection of H. Florey.

Chemotaxis, Migration, and Adhesion

See Figures 10.5 and 10.6A. Selected antigen markers and receptors are listed in Tables 10.2 and 10.3.

Chemotaxis of MPs to inflammatory sites is stimulated by factors such as complement component C5a, N-formylated oligopeptides, fragments of fibronectin, elastin, and collagen; and by secreted proteins called chemokines. Stimulation by chemotactic factors results in increased integrin affinity and therefore binding to the endothelium at the same time as formation of lamellipodia and actin polymerization, resulting in cell movement. Chemokines are divided into subclasses on the basis of the spacing of the N-terminal cysteine residues. CCL#, CXCL#, CL#, and CX3CL# refer to four families of chemokine ligands, in which # denotes the identifying number, C denotes a cysteine, and X denotes a noncysteine amino acid. CC chemokines are responsible for attracting monocytes and lymphocytes, directing traffic of leukocytes under steady state conditions; whereas inflammatory chemokines are expressed by circulating leukocytes and other cells only upon activation. In the mouse two subsets, classical (Ly6C⁺ analogous to human CD14⁺⁺CD16⁻) and nonclassical monocytes (Ly6C^{lo, human} CD14^{dim}CD16⁺) express different chemokine receptors, especially CCR1, CCR2, and CX3CR1 (fractalkine receptor). Under conditions of inflammation, monocytes are recruited to tissues by CCL2 (MCP-1), CCL3 (MIP1a), and CCL5 (RANTES) acting through CCR1, CCR2, and CCR5. These inflammatory monocytes are able to

differentiate into macrophages or DCs that appear to play important roles in the initiation of immune responses. The signals that drive steady state recruitment have not been solved but are independent of CCR1, CCR2, and CCR5.

Monocytes and macrophages adhere to other cell types, including lymphocytes and vascular endothelial cells, and to extracellular matrix components, e.g., fibronectin and laminin, using specific cell surface adhesion receptors.

Inflammatory macrophages and DCs originate from the migration and differentiation of circulating monocytes into virtually all tissues, contributing to

P.199

P.200

the pathophysiology of many human diseases including atherogenesis and other inflammatory diseases. The origin of steady state tissue macrophages and DCs is much less certain, as discussed below. It is likely that blood monocytes and blood DCs contribute, but circulating hematopoietic progenitor cells may also give rise to tissue leukocytes.

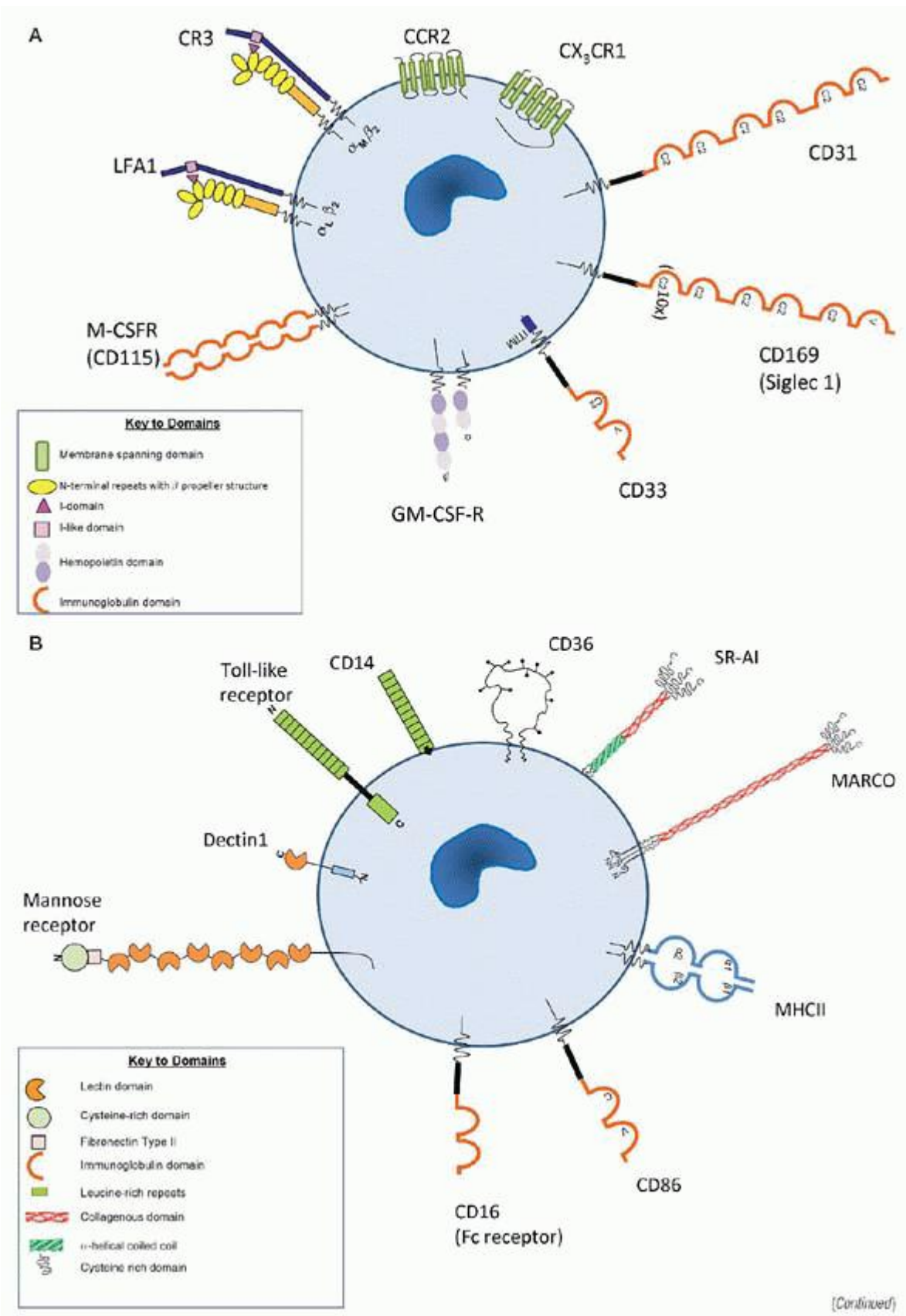

FIGURE 10.6. Selected macrophage plasma membrane receptors. (A) Growth, differentiation, adhesion and migration. (B) Recognition and sensing.

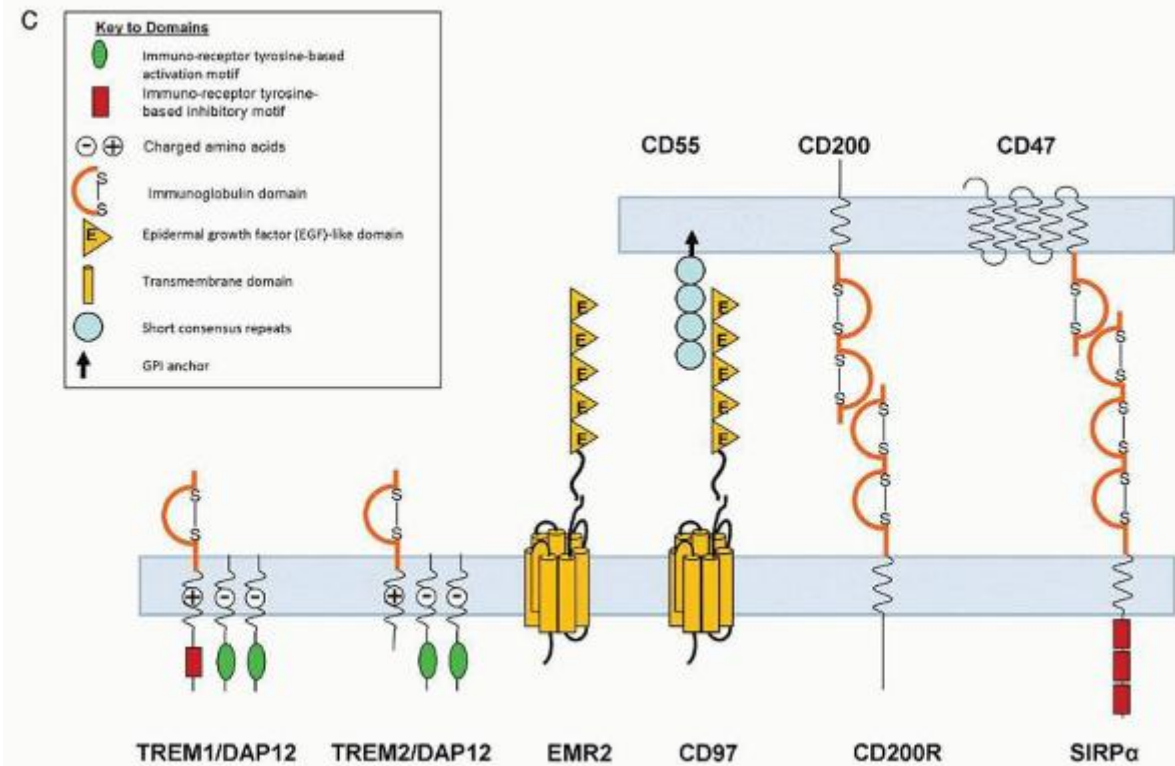

FIGURE 10.6. Selected macrophage plasma membrane receptors. (C) Potentiation and negative regulation.

Three families of cell surface glycoproteins mediate most cell adhesion: integrins, immunoglobulin-related molecules, and selectins. Integrins are large heterodimeric glycoproteins classified in subfamilies according to the common beta subunit; beta 1 (CD49/cd29) or VLA, beta 2 (CD11/CD18), beta 3 (cytoadhesion), and beta 7 are the most relevant. Integrins recognize Ig-related molecules such as intercellular adhesion molecule-1 (ICAM-1), ICAM-2, and vascular cell adhesion molecule (VCAM). Selectins (L-selectin, E-selectin, and P-selectin) recognize oligosaccharides, e.g., Sialyl Le^x. CD44 and CD36 are structurally unrelated but important adhesion molecules which bind to hyaluronic acid and thrombospondin. Macrophage entry into tissues is a multistep process involving both adhesion and transendothelial migration. The process involves monocyte tethering and rolling on the surface of activated endothelial cells mediated mainly by activated selectins; firm adhesion is mediated by VCAM-1 and ICAM-1 on the endothelium, binding to β 1 and β 2 integrins expressed on leukocytes. Subsequently, monocytes transmigrate the endothelium.

The dynamic complexity of adhesion receptor utilization in chronic inflammatory processes such as atherosclerosis is exemplified by the following studies. Analysis of integrin, immunoglobulin-related, and selectin expression on blood monocytes, in vitro differentiated macrophages, and alveolar macrophages reveals monocyte expression of β 1 (CD29), α 4, α 5, α 6, β 2 (CD18), CD11a, CD11b, and CD11c subunits, but not α V (CD51). Some expression of CD41b (IIb) and CD61 (β 3) has been detected. The Ig-related molecules CD54 (ICAM-1), ICAM-2, and CD58 (LFA-3) are expressed, as well as L-selectin and the carbohydrate ligands Le^x (CD15) and sialyl Le^x. CD44 and CD36 are strongly positive. Alveolar macrophages exhibit lower expression of α 4, α 6, β 2, CD11a, CD11b, L-selectin, Le^x, and sialyl Le^x. ICAM-2 and CD36 are absent, whereas expression of α 3, but not of CD11c, is higher. Similar results were obtained with in vitro differentiated macrophages. The profile of adhesion receptors expressed as monocytes differentiate into macrophages varies according to tissue location and the disease state. For example, endothelium overlying human atherosclerotic lesions and fatty streaks expresses high levels of E- and P-selectins, ICAM-1, and VCAM-1. Selectin deficiency reduces atherosclerosis, and genetic mutation of ICAM-1 or VCAM-1 reduces atherosclerosis in mice. Oxidized LDL leads to endothelial dysfunction, leading to expression of adhesion molecules and recruitment of monocytes into the subendothelial space. Ox-LDL is taken up by macrophages via scavenger receptors such as SR-A1, SR-A2, and LOX-1, which are themselves implicated in local macrophage adhesion. CD36, a multifunctional membrane receptor present on MPs and other cells, functions as a scavenger receptor for oxidized phospholipids. On macrophages, CD36 interaction with oxidized LDL triggers a pro-inflammatory and pro-atherogenic response involving activation of src-family kinases, MAP kinases, and Vav family guanine nucleotide exchange factors and results in ligand internalization, foam cell formation, and inhibition of migration.

Macrophage adhesion molecules also have an important role in homotypic cell fusion, forming osteoclasts and multinucleated giant cells associated with chronic inflammation. Progress has recently been made in identifying molecules involved in macrophage fusion. Signaling processes mediated by DAP12 and STAT6 induce a fusion-competent status. Chemotaxis through CCL2, cell-cell adhesion mediated by E-cadherin, exposure of phosphatidylserine, lipid recognition by CD36, purinergic receptors, and cytoskeletal rearrangement dependent on RAC1 are prerequisites for successful macrophage fusion.

P.201

TABLE 10.2 SELECTED ANTIGEN MARKERS EXPRESSED BY HUMAN MONONUCLEAR PHAGOCYTES

	Antigen	Ligand/Comment
Monocytes:	CD14	LPS, TLR
	CD16 ^{+/-}	FcR γ
	CD115	CSF-1
	CD45	Leukocyte common, phosphatase
	CD11b	Complement receptor
	CD11c ^{+/-}	Complement receptor
	CD11a	LFA-1—patrolling monocytes
	CD163	Haptoglobin-hemoglobin complex
	CD36	OxLDL
	SLAN ^{+/-}	6-SulfoLacNAc
	CX ₃ CR ₁	Fractalkine
	MHCII	Peptides
	CD4	
Macrophages	CD115	CSF-1
	CD68	Endosomal pan-macrophage, DC osteoclasts
	CD312 (EMR2)	Myeloid adhesion GPCR (also monocytes, DCs, neutrophils)
	CD169	Siglec-1 (sialoadhesin), macrophage subsets, e.g., marginal zone, subcapsular sinus
	CD206	MMR, alternative activation
	fXIIIa	
mDCs:	CD115	CSF-1, IL-34
	CD116	GM-CSF
	CD135	Flt-3L
	CD11c	Not unique to DCs
	CD1a, c (BDCA-1), d	Major subset
	MHCII ^{hi}	
	CD83, 80, 86	Costimulatory molecules

	CD205 (Dec205)	Lectin-like
	CD206	MMR
	CD209 (DC-SIGN)	Interstitial DCs, not unique
	CD141 (BDCA-3, thrombomodulin)	Minor subset—cross presenting (widely expressed)
	Langerin	Mannosylated and sulfated glycans
	CD103 ($\alpha_E\beta_7$ Integrin)	Gut DCs tolerogenic
pDCs:	CD123 (IL-3R)	
	CD303 (BDCA-2)	Type II C-type lectin
	CD304 (Neuropilin-1; BDCA-4)	
	(Siglec H-member mouse CD33 family)	
	CD2	Lymphoid antigen
	CD7	Lymphoid antigen

CSF-1, colony stimulating factor-1; GM-CSF, granulocyte-macrophage colony stimulating factor-1; TLR, Toll-like receptors; LPS, lipopolysaccharide; MMR, macrophage mannose receptor; OxLDL, oxidized low-density lipoprotein; BDCA, blood dendritic cell antigen.

The regulation of DC function is intimately linked to migration. At sites of antigen contact, myeloid or “classical” DCs are found in immature forms with high expression of pattern recognition receptors (PRRs) and endocytic activity, but low surface expression of MHC and costimulatory molecules. Migration and maturation are believed to occur in the steady state, but are massively increased by local inflammatory stimuli mediated by TLR agonists, cytokines, and other danger signals. DC migration from tissue sites to afferent lymphatics is integrin-independent and driven by chemokine gradients of CCL19 and CCL21 acting through CCR7. Recent studies show that these chemokines decorate the endothelium of afferent lymphatics. The passive drainage of fluid through afferent lymphatics may also play a part in the migration of DCs towards lymph nodes. Within the node, similar chemokine gradients position DCs in the T cell areas, where they upregulate antigen-bearing MHC molecules and costimulatory antigens. Antigen uptake declines and morphological changes ensue, including the extension of dendrites. Myeloid and plasmacytoid DCs also enter the lymph nodes directly from the bloodstream, where they undergo a parallel process of maturation. In the later stages of immune activation, monocyte-derived DCs also reach the lymph nodes by direct recruitment from the blood or via inflamed tissues.

TABLE 10.3 SELECTED PLASMA MEMBRANE PATTERN RECOGNITION RECEPTORS (PRRs) EXPRESSED BY HUMAN MONONUCLEAR PHAGOCYTES

Receptor	Ligand	Comment
FcR	Immunoglobulins	Phagocytosis, ADCC
CD11b/18	Complement, other	Phagocytosis, myeloid adhesion
CD163	Haptoglobin-hemoglobin complex	
CD14	LPS	TLR complex
TLR (various)	Microbial, endogenous	
Siglec-1 (CD169)	Sialylated glycoconjugates	Subset macrophages
DC-SIGN (CD209)	Mannose, fucose, GlcNAc	
Dectin-1 CLEC-1	β -glucan	Fungal infection

Dectin-2	High mannose	Th17 activation
Langerin	Mannosyl and sulfated glycans	Abundant in Birbeck granules
Mincle	C-type lectin-like	Binds mycobacterial cord factor
CLEC-9A (DNGR-1)	Actin	Cross-presentation
TAM (Tyro3, Axl, MER)	Gas6, ProtS	Apoptotic cell uptake
SR-A	Polyanions, ApoA1, LPS, LTA <i>Neisseria</i> proteins	Endocytosis, adhesion
MARCO	LPS, <i>Neisseria</i> proteins	Innate immunity, phagocytosis, adhesion
CD36	OxLDL, phosphatidylserine	Adhesion, apoptotic cell clearance, fusion of macrophages
TIM(1-4)	Phosphatidylserine	Apoptotic cell uptake
CD300a	Phosphatidylserine	Apoptotic cell uptake
EMR2	Chondroitin sulfate B	Adhesion GPCR
CD97	CD55	Adhesion GPCR

TLR, toll-like receptor; ADCC, antibody-dependent cell-mediated cytotoxicity; GPCR, G protein-coupled receptor; LPS, lipopolysaccharide; DC-SIGN, dendritic cell-specific intercellular adhesion molecule-3-grabbing non-integrin; OxLDL, oxidized low-density lipoprotein; LTA, lipoteichoic acid; TIM, T-cell immunoglobulin mucin; EMR2, epidermal growth factor-like module-containing mucin-like hormone receptor 2.

P.202

Recognition: Plasma Membrane Antigen Markers, Sensors, and Regulators

See Figures 10.6, 10.7, 10.8, 10.9, 10.10, 10.11 and 10.12 and Tables 10.1, 10.2 and 10.3.^{26,27,28,29,30,31} and ^{32,33,34,35,36,37}

Monocytes and macrophages express a range of opsonic and nonopsonic plasma membrane and endosomal receptors to recognize foreign and modified self-ligands. These include activatory (ITAM cytoplasmic motif) and inhibitory (ITIM motif) Fc receptors, receptors for complement-derived ligands, TLRs, lectins, and scavenger receptors, as well as receptors for other humoral ligands, for example, collectins and pentraxins. Monocytes also express CD14, a GPI-linked receptor for LPS, which is downregulated upon cell maturation in culture. Resting monocytes do not express class A scavenger receptor I/II, which is upregulated on macrophages during maturation, but do express MARCO,

P.203

a related SR, and CD36, another promiscuous adhesion molecule also present on platelets and endothelial cells. The lectins include Dectin-1, the receptor for fungal β -glucan, expressed by monocytes, macrophages, neutrophils, and DCs; the mannose receptor, a multilectin with distinct carbohydrate recognition domains for GlcNAc, mannosyl, and fucosyl ligands on microbes and selected host molecules; and a cysteine-rich domain which recognizes endogenous sulfated sugars. Other mannose binding lectins include DC-SIGN and Dectin-2; galectin is a receptor for galactosyl recognition. Additional plasma membrane receptors include CD163, an SR-like molecule that recognizes haptoglobin - hemoglobin complexes, and which is induced by glucocorticoids. Additional SR, not shown, are present on endothelial cells, which also express SR-A. Apart from the scavenger receptors, several other receptors can recognize apoptotic cells, e.g., the Tyro3, Axl, and Mer (TAM) receptors, which recognize Gas 6 and Protein S ligands. Several TIM molecules and CD300A bind phosphatidyl serine, another ligand for apoptotic cell recognition.

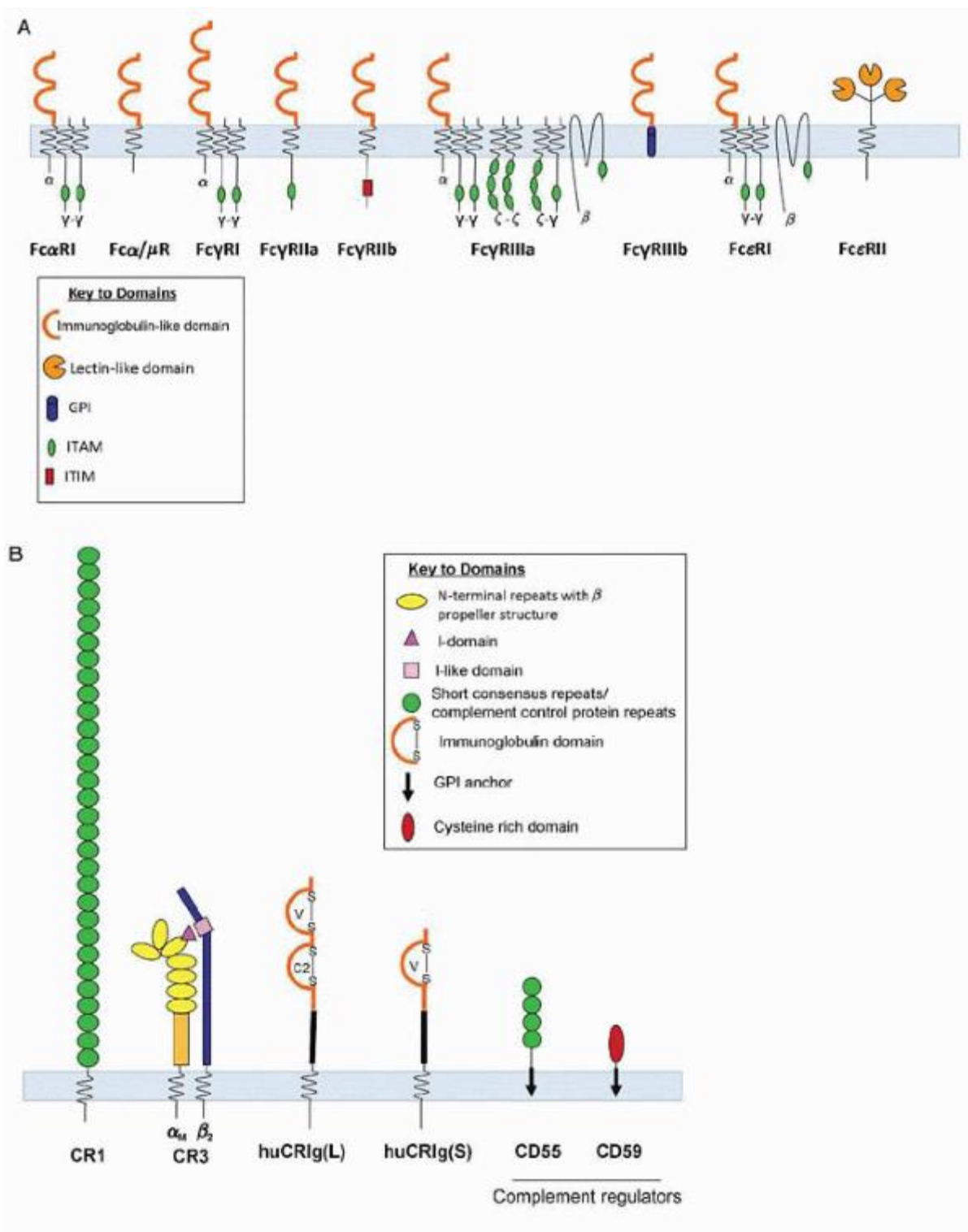

FIGURE 10.7. A: Fc receptors of human macrophages show diversity for Ig class ligands and signaling. See references for further details. B: Macrophage receptors for complement recognition and regulation.

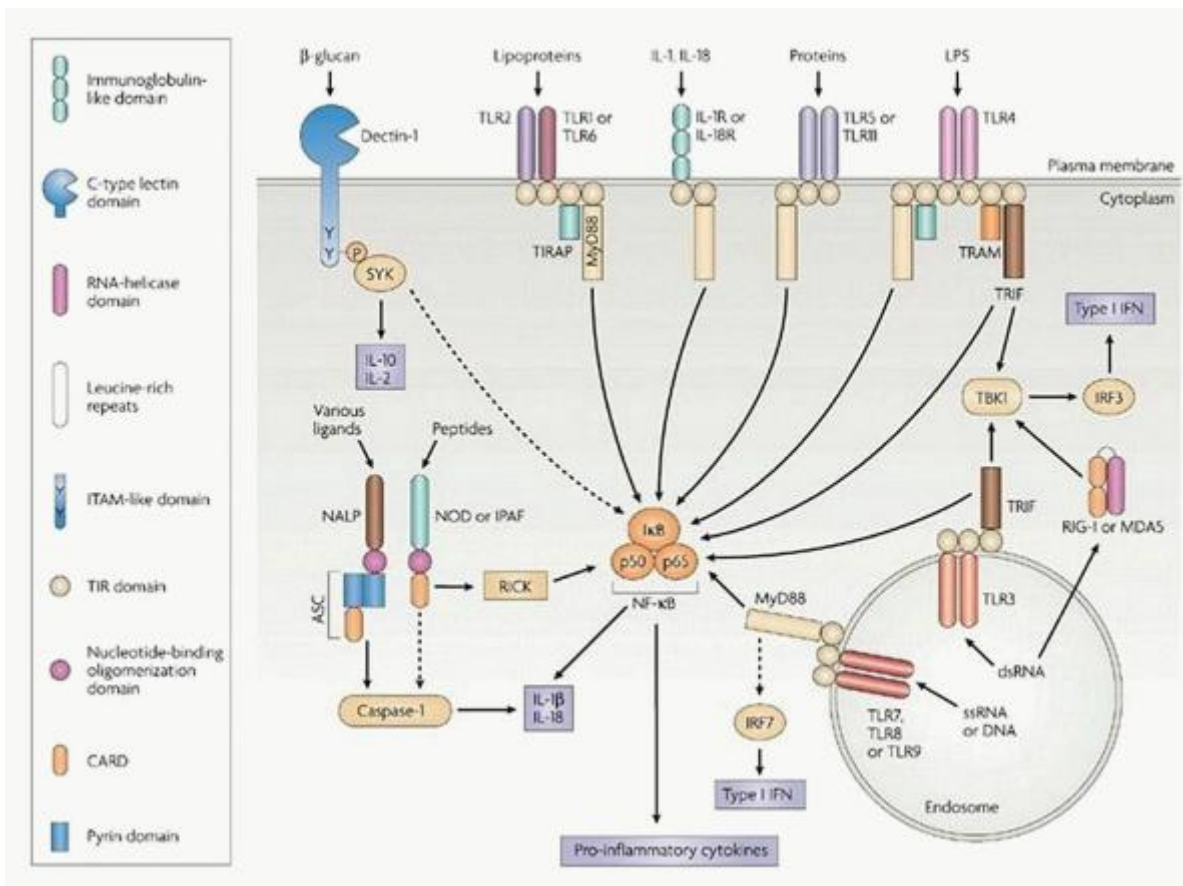

FIGURE 10.8. Cooperation of Toll-like receptor signals and Dectin-1 (with cytosolic inflammasome activation and type I interferon) in innate immune defense. From Trinichieri G, Sher A. Cooperation of Toll-like receptor signals in innate immune defense. *Nat Immunol Rev* 2007;7:179-190, with permission.

In common with monocytes and macrophages, DCs are equipped with an array of PRRs, which can detect evolutionary-conserved pathogen-associated molecular patterns (PAMPs), including proteins, lipids, carbohydrates, and nucleic acids. The PRRs encompass families of membrane-bound TLRs and C-type lectin receptors (CLRs), such as Langerin, MMR, DC-205, DC-LAMP, DC-SIGN, Dectin-1, and DCIR. The PRRs also include cytosolic NOD-like receptors (NLRs), RIG-I-like receptors (RLRs), and helicase nucleic acid receptors, as discussed further below. Human DCs are equipped with multiple CD1 antigens for the recognition of bacterial lipid antigens (notably CD1a and CD1c) and a range of receptors for complement (CD11b and CD11c) and coagulation proteins (CD141: thrombomodulin).

The SIGLEC family of leukocyte plasma membrane molecules interacts with sialylated glycoconjugates, and members are variably expressed on myeloid cells of different species, including macrophages and plasmacytoid DCs. Siglec-1 (sialoadhesin, CD169) has been implicated in binding of hematopoietic cells, including lymphocytes.

The murine macrophage plasma membrane antigen marker F4/80 is part of a small family of seven transmembrane adhesion GPCR which includes CD97 and EMR2, more broadly expressed on myeloid cells. EMR2 is a useful immunocytochemical marker for human tissue macrophages, as well as neutrophils, in which it potentiates a range of cellular functions. The TREM family also modulates myeloid cell responses; TREM-2, for example, associates with DAP-12 as one of several signaling partners. Counterreceptors include the negative receptor pair CD200/CD200R.

Genetic polymorphisms have been described for a range of the above surface molecules; for example, TLR mediating pro-inflammatory signaling and Fc receptors, which mediate important functions such as phagocytosis, antibody-dependent cytotoxicity, and immunomodulation.

Cytosolic Recognition and Inflammasome Activation

See Figures 10.8 and 10.9.^{38,39,40,41}

This topic has benefited enormously from the study of auto-inflammatory syndromes associated with rare genetic

P.204

disorders, and their dramatic amelioration by IL-1 antagonists. Inflammasomes are protein complex platforms which are required for the activation of inflammatory caspases and the maturation of their pro-inflammatory cytokines including IL-1 β and IL-18. They are constructed around several proteins, including NLRP3, NLRC4, AIM2, and NLRP6, and recognize inflammatory signals arising from receptors for PAMPs, damage-associated molecules (DAMPs), and sterile particulates, such as uric acid crystals. Recognition of immune signals by one of several families of receptors results in direct activation of caspase-1 and caspase-5, secretion of potent pro-inflammatory cytokines, and a form of cell death called pyroptosis. PRRs of innate immune cells can be classified into phagocytic and sensor PRRs and, in addition to the plasma membrane receptors described above, include intracellular TLRs, retinoic acid-inducible gene I-like receptors (RLRs), and nucleotide-binding oligomerization domain-like receptors (NLRs). Inflammasome-mediated processes are important during microbial infections and also in regulating both metabolic processes and mucosal immune responses. For example, the NLRP3 inflammasome has

P.205

been demonstrated to be involved in antibacterial, viral, fungal, and parasitic immune responses. On infection with influenza A, endosomal TLR7 recognizes viral RNA and induces transcription of the NLRP3 inflammasome components. Selected bacteria have been shown to allow the cytoplasmic entry of flagellin, the NLRC4 ligand, leading to activation of the NLRC4 pathway. Some inflammasome activators are exogenous particles, e.g., silica and asbestos, whose uptake by pulmonary macrophages activates NLRP3 inflammasome-dependent caspase activation, cytokine, and cellular reactive oxygen species release, contributing to silicosis or asbestosis. Inflammasomes have also been implicated in metabolic pathologies with activation of caspase-1 by NLRP3 in adipose tissue, resulting in inhibition of insulin signaling, expression of TNF- α , and induction of CD4 T helper cells. However, a protective role for activated inflammasomes in age-related macular degeneration has also been proposed, since lack of NLRP3 or IL-18 exacerbates choroidal neovascularization.

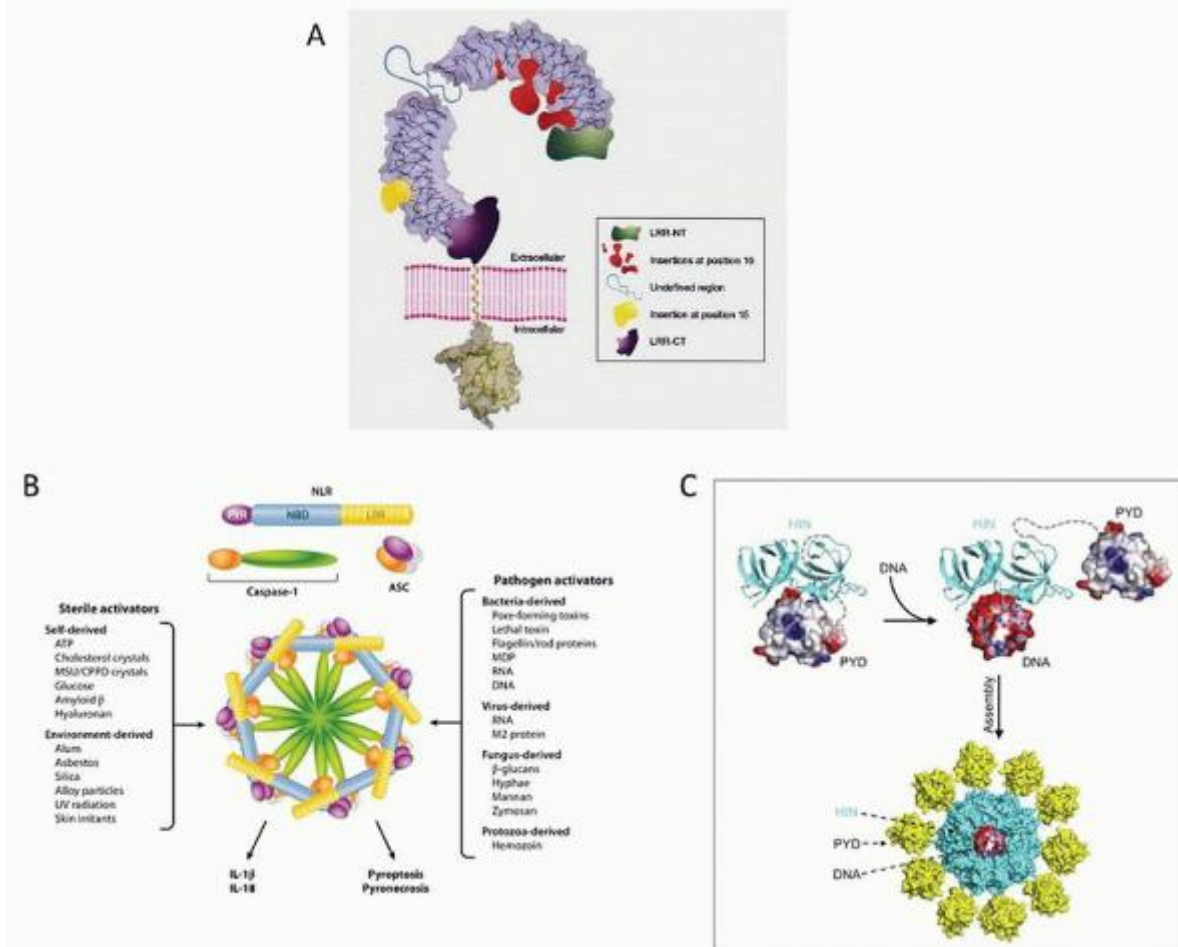

FIGURE 10.9. Models of inflammasome structure. A: A Toll-like receptor (TLR). TLRs are integral membrane glycoproteins with an N-terminal ectodomain and a single transmembrane domain. The ectodomain of a TLR7, TLR8, and TLR9 family member is depicted, with the leucine-rich repeat (LRR) solenoid shown with a gray molecular surface, and the N- and C-terminal flanking regions shown in green and purple, respectively. An undefined region present in TLR7, TLR8, and TLR9, but not in the other TLRs, is shown as a light blue string. Insertions within LRRs at position 10 are indicated in red and might contribute to the formation of the pathogen-associated molecular pattern (PAMP) binding site. An insert at position 15 is indicated in yellow. Also shown is a cartoon of the transmembrane domain (presumed to be a single α -helix), followed by a molecular surface representation of the TLR1 Toll-IL-1 and IL-18 receptor (TIR) domain. From Bell JY, Mullen GE, Leifer CA, Mazzoni A, Davies DR, Segal DM. Leucine-rich repeats and pathogen recognition in Toll-like receptors. *Trends Immunol* 2003;24:528-533, with permission. B: Activators of the inflammasome. Sterile activators include host- and environment-derived molecules, and pathogen-associated activators include PAMPs derived from bacteria, viruses, fungi, and protozoa. Assembly of the NLRs, ASC, and caspase-1 leads to the formation of a pentad- or heptamer structure: the inflammasome. Activation of the inflammasome leads to maturation and secretion of IL-1 β and IL-18, as well as inflammatory cell death, by either pyroptosis or pyronecrosis. ASC, apoptosis-associated speck-like protein containing a caspase recruitment domain; CPPD, calcium pyrophosphate dihydrate; MDP, muramyl dipeptide; MSU, monosodium urate; NLR, nucleotide-binding domain, leucine-rich repeat containing; PAMP, pathogen-associated molecular patterns. From Davis BK, Wen H, Ting JP. The inflammasome NLRs in immunity, inflammation, and associated diseases. *Annu Rev Immunol* 2011;29:707-735. C: Electrostatic attraction underlies innate dsDNA recognition by the HIN domains. Both oligonucleotide/oligosaccharide binding folds and the linker between them engage the dsDNA backbone. An autoinhibited state of AIM2 is activated by DNA that liberates the PYD domain. DNA serves as an oligomerization platform for the inflammasome assembly. From Jin T, Perry A, Jiang J, et al. Structures of the HIN domain: DNA complexes reveal ligand binding and activation mechanisms of the AIM2 inflammasome and IFI16 receptor. *Immunity* 2012;36(4):561-571, with permission.

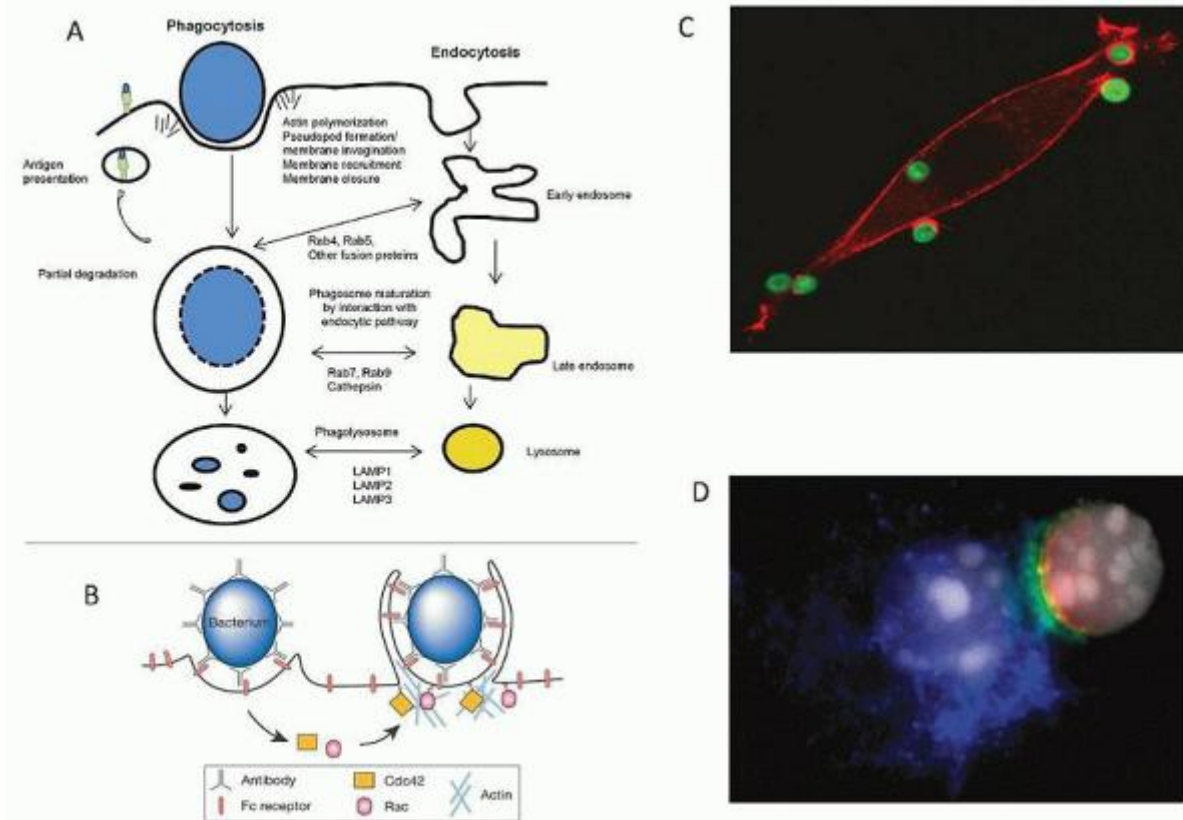

FIGURE 10.10. A: Phagocytosis and endocytosis pathways. Particulates are taken up by actin-dependent sequential maturation processes, involving membrane fusion and fission, which intersect with the endocytic pathway at several stages. Cytosolic small guanosine triphosphatases (rabs) determine organelle-specific interactions. Membrane is recycled to the plasma membrane, with processed antigen. Progressive acidification and delivery of lysosomal hydrolases result in terminal degradation. Compartment membranes express marker proteins such as LAMP1; the pan-macrophage CD68 antigen is associated with late endosomes and lysosomes. B: Schematic representation of FcR-mediated uptake of a

bacterium by a zipper-like mechanism, initiating actin assembly. Modified from Conner SD, Schmid SL. Regulated portals of entry into the cell. *Nature* 2003;422(6927):37-44. C: Dectin-1 transfected fibroblast taking up unopsonized zymosan (yeast wall particle) through β -glucan recognition, to initiate a phagocytic cup. (Courtesy of G. Brown.) D: Uptake of *Pneumocystis carinii* via Dectin-1. Contact zone resembles phagocytic synapse described by Goodridge et al.³⁰

Intracellular detection of nucleic acids by DCs is very sophisticated. TLR3, TLR7, and TLR9 cooperate with a large family of helicases, RLRs, and DNA sensors in the recognition of single- and double-stranded nucleic acids. Ligation of these receptors leads to rapid phenotypic maturation, activation of antigen-presenting capacity, and cytokine release; plasmacytoid DCs, for example, release abundant type 1 interferon in response to viral infection.

Endocytosis and Phagocytosis

See Figures 10.10 and 10.11.^{42,43,44,45} and ^{46,47} and ⁴⁸

Monocytes and macrophages are able to internalize and ingest soluble and particulate ligands, including apoptotic cells and micro-organisms, with variable efficiency. Surface molecules which mediate receptor-mediated endocytosis, apart from those listed above, include transferrin (CD71) and folate receptors. Macrophages are able to internalize the equivalent of their surface in 20 minutes; and a series of fusions and fissions, assisted by small GTP-ases, result in membrane retrieval, receptor recycling to the cell surface, or cargo delivery from endosomes to lysosomes for digestion. Phagosome formation and fusion result in formation of phagolysosomes. Fc receptor-mediated uptake depends on circumferential engagement of the target ligands by pseudopodia, a zipper-like process, and ingestion depends on the actin cytoskeleton. Complement-mediated uptake proceeds by a distinct “sinking” mechanism. Underwood and colleagues have described formation of a phagocytic synapse in the uptake of yeast particles

P.206

by Dectin-1, which has a hemi-ITAM in its cytoplasmic domain, by a syk- and CARD9-dependent pathway. Uptake is associated with acidification, to promote digestion of all macromolecules.

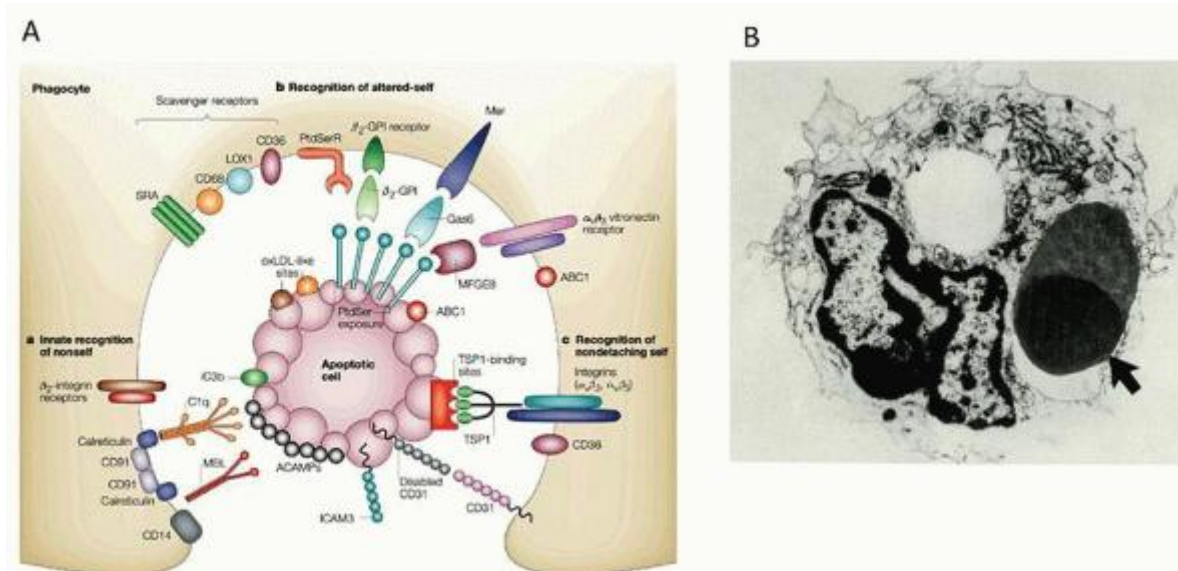

FIGURE 10.11. A: Phagocytic receptors for apoptotic cell phagocytosis. Macrophages and immature myeloid dendritic cells (mDCs) express multiple receptors for direct or opsonic binding, e.g., mannose binding lectin (MBL) or milk fat globulin (mFGE8). Phosphatidylserine (PS) exposed on the outer surface of the apoptotic cell can be recognized by a range of receptors, including TIM4, TIM1 and CD300A (not shown). Discrimination of nonself and altered-self may involve combinations of different phagocyte receptors. Apoptotic cell uptake results in an antiinflammatory response (e.g., release of transforming growth factor- β and prostaglandin E2), but has also been implicated in cross-presentation by DCs. From Savill J, Dransfield I, Gregory C, Haslett C. A blast from the past: clearance of apoptotic cells regulates immune responses. *Nat Rev Immunol* 2002;2:965-975, with permission. **B:** Thymic macrophage with apoptotic thymocyte in phagocytic vacuole. The vast majority of thymocytes never leave the thymus, undergo apoptosis, and are rapidly removed by macrophages ($\times 4,500$).

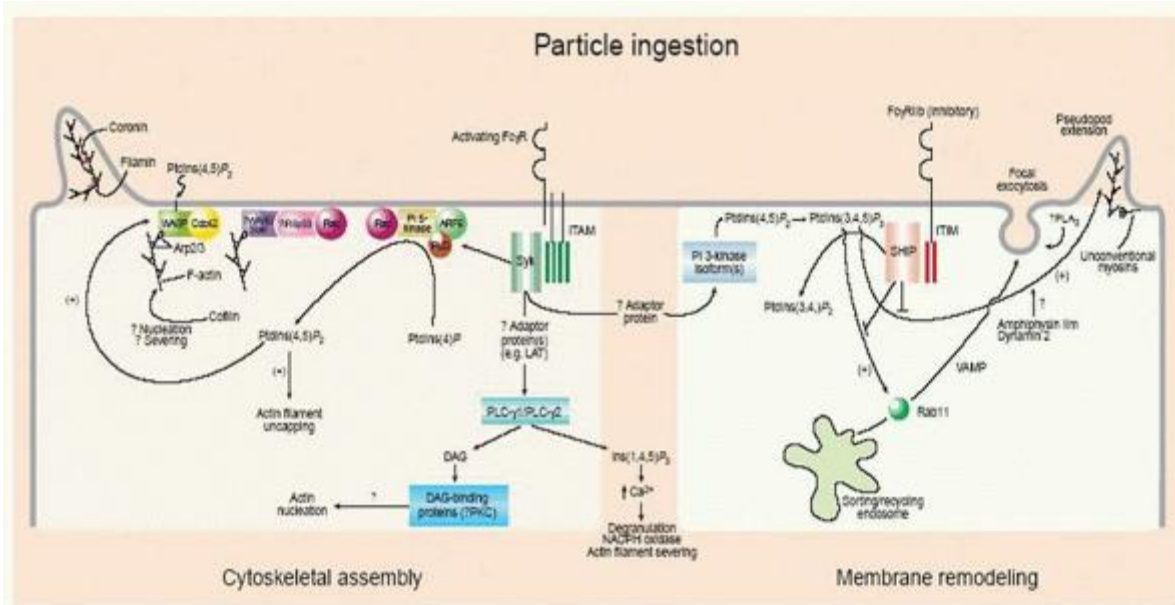

FIGURE 10.12. Plasma membrane remodeling, cytoskeletal assembly, and cytoplasmic signaling associated with Fc receptor-mediated particle ingestion. From Greenberg S. Diversity in phagocytic signalling. *J Cell Sci* 2001;114(Pt 6):1039-1040, with permission.⁴⁴

Endocytosis by DCs follows special pathways that preserve antigens for presentation on MHC molecules. Most DCs are competent to present externally acquired antigen to maturing MHC class II dimers in the late endosomes. A complex pathway involving invariant chain and HLA-DM maintains MHC class II in an open configuration for peptide binding. A subset of DCs is competent at cross-presenting externally acquired antigen to Class I MHC. These

P.207

DCs are characterized by high expression of CD141 in humans and CD8 in mice. They also possess a unique chemokine receptor XCR1 and lectin CLEC9A (DNGR-1) with actin as ligand; and they express a high level of TLR3. Specialized biochemical machinery allows these cells to transfer exogenous antigen to the endogenously loaded MHC class I presentation pathway.

Autophagy is an analogous process by which macrophages and DCs surround damaged cytoplasmic organelles with membrane for delivery to lysosomes, especially after microbial infection. Several components involved in this process have been identified and some have been implicated in genetic predisposition to inflammatory bowel disease. This is also thought to be a key process in antigen presentation of cytosolic antigens to MHC class I.

Signaling and Gene Expression

See Figures 10.8, 10.9, and 10.12.^{49,50,51} and ⁵²

A range of signaling pathways have been characterized in myeloid cells following on receptor ligation and collaboration, which differ depending on the cell type involved. These include sequential phosphorylation/dephosphorylation by kinases and phosphatases, the assembly and disassembly of protein complexes, and redistribution of molecules including phosphoinositides and lipid metabolites from cytoplasm to the plasma membrane as well as to the nucleus. The adaptor proteins for TLR-signaling include MyD-88, TRIF, and TIRAP/MAL. Signaling pathways that are particularly well characterized include MAP kinase activation, classical and alternative NFκB activation, and GPCR activation, e.g., by leukotrienes. Actin assembly and disassembly play a prominent role in cell migration and phagocytosis, as well as secretion. Gene expression depends on dynamic changes in chromatin conformation, binding and release of transcription complexes, and epigenetic modifications of DNA as well as histones by methylation and acetylation. Recent studies have begun to compare transcription by monocytes, macrophages, and DCs in considerable detail, including microRNA analysis. Translational modifications include glycosylation, prenylation and other lipid modifications, and ubiquitination, which determine protein turnover and export, as well as biosynthetic quality control. Current high throughput sequencing and microarray and proteomic analysis is set to transform our knowledge of cell functions and differences as well as of

similarities among monocytes, macrophages, and DCs. We include a few recent references of useful resources in a fast-moving field.

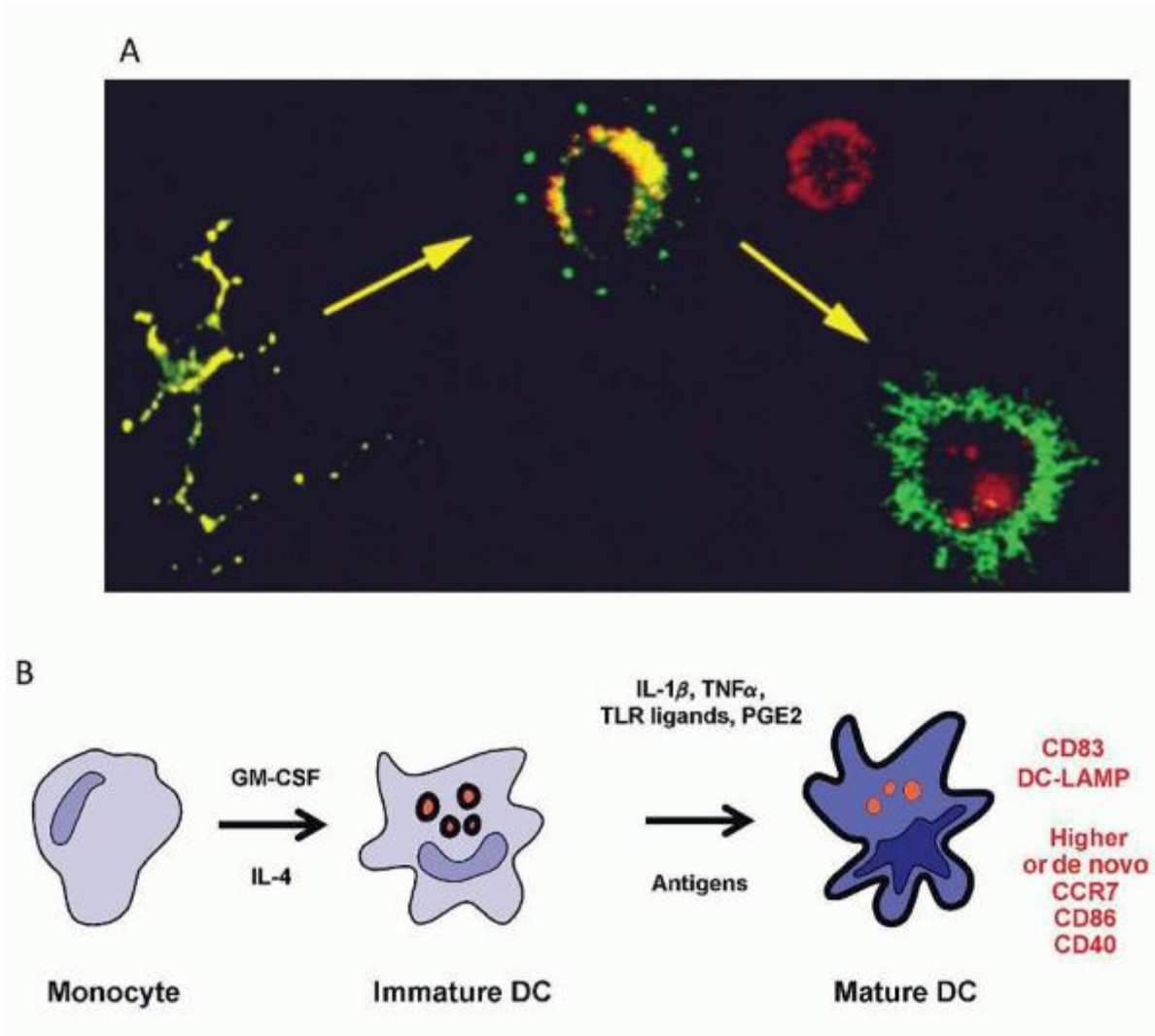

FIGURE 10.13. Maturation/activation of dendritic cells (DCs) leads to acquisition of APC function. A: DC maturation ex vivo. Langerhans cells upon explantation from mouse skin undergo “spontaneous” maturation with redistribution of MHCII from an intracellular compartment to the cell surface. (Courtesy of Ira Mellman and Ralph Steinman.) B: One of the first systems to produce large numbers of human dendritic cells from blood monocytes; the added cytokines and other maturation stimuli influence the function of the DCs. Based on studies by Lanzavecchia, Sallusto, Romani, Schuler, Bhardwaj, and their colleagues.

Antigen Presentation

See Figure 10.13.^{6,53}

The capacity of macrophages and DCs to present antigens to T cells was first recognized in classical experiments describing the requirement for “accessory” cells in order to generate lymphocyte proliferation and antibody production in response to antigens *in vitro*. Accessory cell function is now known to encompass antigen uptake, processing, and presentation as peptide bound to MHC molecules. Both macrophages and DCs are able to perform this function, but DCs are superior. Indeed, DCs were first described in the mouse spleen by Steinman and colleagues and differentiated from macrophages by their lack of adherence, characteristic morphology, and ability to stimulate the proliferation of naive T cells with approximately 100-fold greater potency than macrophages.

The ability to take up, process, and present antigens, to migrate through tissues, and to prime naive T cell responses are defining DC characteristics. Immature DCs bear Fc receptors, C-type lectin-like receptors, scavenger receptors, and

complement receptors.⁵⁴ Antigen is acquired and directed to endosomal compartments containing MHC, rather than being degraded in lysosomes.

In vivo depletion models have confirmed that efficient T cell priming is dependent upon DCs, but not macrophages.

P.208

The superior ability of DCs in T cell priming is linked to high expression of MHC (signal 1), costimulatory molecules (signal 2), secretion of polarizing factors (signal 3), and imprinting instructions (signal 4).

MP function is often described as bridging innate and adaptive immunity. Antigen presentation frequently involves recruitment of NK cells and other innate lymphocytes to amplify and polarize immunity. Thus the invariant MHC molecules CD1a, CD1c, and CD1d are prominent markers of human DCs and have a critical function in presenting lipoproteins to innate lymphocytes. A number of complex and phylogenetically ancient soluble molecules also enhance cooperation between innate and adaptive immunity; these include pentraxins, high mobility group proteins, and heat shock proteins.

Secretion

See Figures 10.14 and 10.15.^{55,56} and ^{57,58}

Macrophages are highly active secretory cells, producing a great variety of molecules when stimulated, some of which are listed in Table 10.4. These include enzymes such as lysozyme; neutral proteinases (urokinase, collagenase, and elastase); and inhibitors such as alpha1-antitrypsin, complement proteins, a range of cytokines (IL-1 β , TNF- α , IL-6, type 1 interferon, IL10, IL-12 family, and transforming growth factor- β [TGF- β]), growth factors (e.g., CSF-1 and GM-CSF), and chemokines. Low molecular products include reactive oxygen species, reactive nitrogen species and arachidonate metabolites. Secretion can be induced by TLR, Fc receptor, or Dectin-1 stimulation. The secretory mechanism of IL-1 β release depends on inflammasome and caspase activation. Jenny Stow has studied the secretory pathway of TNF and other cytokines.^{58a} Macrophage activation by innate, cytokine, and phagocytic stimuli profoundly influences their secretory activity, as discussed further below.

The lysozyme secretory pathway has not been defined. In culture it is secreted constitutively by monocyte-derived macrophages; in vivo it is markedly upregulated by granuloma formation, as in BCG infection and sarcoidosis; extraordinary levels enter the blood and urine in monocytic leukemia.

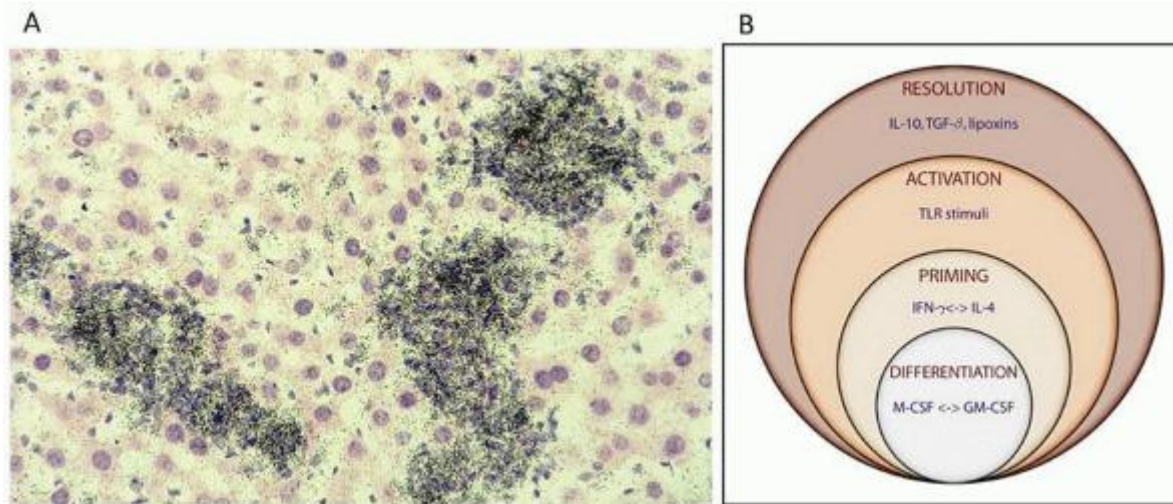

FIGURE 10.14. A: BCG-induced granulomata in mouse liver. In situ hybridization reveals intense lysozyme mRNA expression in macrophage-rich granulomata. Sinusoids display weaker expression by trafficking monocytes and activated Kupffer cells. (Courtesy of S. Keshav.) B: Paradigm of macrophage activation. The development into fully activated macrophages can be divided into successive stages. During a first phase the recruited monocytes mature into macrophages. The balance of macrophage-colony stimulating factor (M-CSF), granulocyte-macrophage-colony stimulating factor (GM-CSF), retinoic acids, and lipoproteins determine substantial differences in the phenotype of the mature macrophage. During recruitment, monocytes are exposed to cytokines, inducing a second phase of priming. During the third phase of activation, macrophages reach a mature functional phenotype in response to toll-like receptor (TLR) and

opsonic stimuli. The final phase of deactivation and/or resolution allows clearance of debris and expression of general repair functions, regulated by interleukin-10 (IL-10), tumor necrosis factor- β (TGF- β), and antiinflammatory mediators such as nucleotides, lipoxins, and glucocorticoids.⁶⁸

Many other questions remain, relating to the control of secretion by macrophage populations in situ. Degranulation is less of a feature than in granulocytes. Many plasma membrane glycoproteins such as CD163 and TNF receptors are shed into the circulation by proteolytic cleavage, but the biological significance is unclear in many cases. CD14 may be an exception, since it can be incorporated into the membrane of other cells. Macrophage products may provide biomarkers for underlying chronic inflammatory and storage disorders, such as plasma chitotriosidase in Gaucher's disease, and angiotensin converting enzyme in sarcoidosis.

Macrophage secretion, though considerably lower than other sources such as hepatocytes, may be significant within a confined local environment. Thus macrophage neutral proteinases, peptidases, and their inhibitors are able to contribute to inflammation and repair, and activate and regulate the plasma cascades of complement, coagulation, fibrinolysis, and the generation of kinins. Finally, macrophages release important products of digestion, including salvaged iron in various forms, as well as acid hydrolases after phagocytosis under particular circumstances.

DC secretion is important for the polarization and imprinting of T cells, following TCR ligation (signal 1) and costimulation (signal 2). Polarizing signals (signal 3) include IL-12 for the initiation of TH1 responses, IL-4 for generation of TH2 cells, and IL-23 for TH-17 cells. Mature DCs also provide homing instructions to activated T cells in order to navigate the T cells to the tissue from which the DCs originated. The exact mechanism of this "signal 4" is not clear, but upregulation of skin-targeting receptors CLA and CCR10 or gut targeting receptors α 4 β 7 and CCR9 endows T cells with specific tissue homing properties. It has been shown that DCs possess the enzymes to metabolize sunlight-induced vitamin D3 into the active form 1,25-dihydroxyvitamin D3, which induces CCR10 on T cells and concomitantly suppresses gut-homing receptors α 4 β 7 and CCR9.

P.209

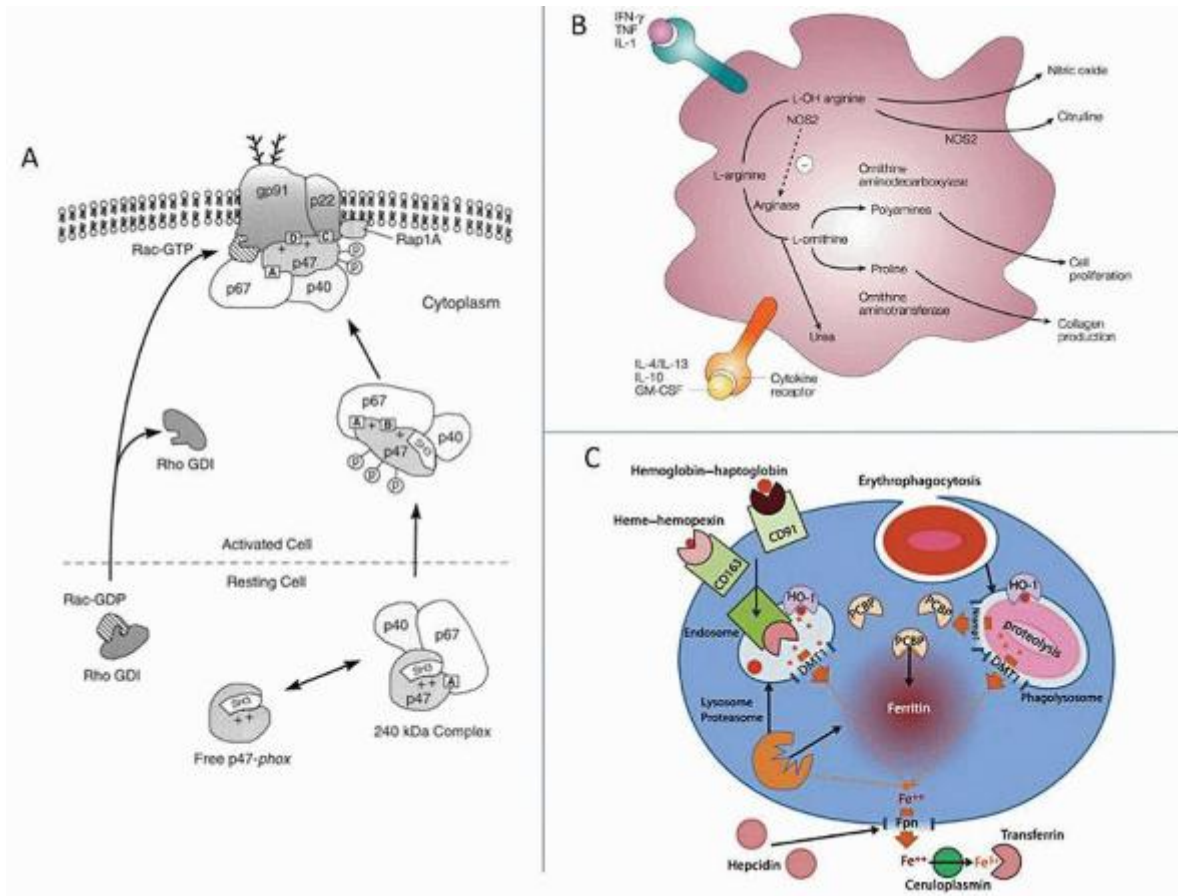

FIGURE 10.15. A: Schematic representation of NADPH oxidase activation and assembly. Following stimulation of resting phagocytes, cytoplasmic subunits form a complex at the plasma membrane which converts oxygen to highly reactive oxygen radicals, the respiratory burst. From De Leo FR, Ulman KV, Davis AR, Jutila KL, Quinn MT. Assembly of the human neutrophil NADPH oxidase involves binding of p67phox and flavocytochrome b to a common functional domain in p47phox. *J Biol Chem* 1996;271:17013-17020, with permission.⁵⁵ B: The role of nitrogen metabolism in macrophage function. Interferon- γ (IFN γ) enhances the activity of nitric oxide synthase 2 (NOS2) to generate nitric oxide, and inhibits arginase. IL-4 and IL-13 promote arginine-dependent formation of L-ornithine and ultimately fibroblast proliferation and collagen production. From Gordon S. Alternative activation of macrophages. *Nat Rev Immunol* Jan 2003;3(1):23-35, with permission.¹³³ C: Flow of iron in macrophages. Macrophages take up iron through erythrophagocytosis of damaged or senescent erythrocytes. Macrophages can also scavenge heme and hemoglobin, usually complexed with hemopexin and haptoglobin, and endocytosed by CD163 and CD91 for proteolysis to release heme. Heme is degraded by HO-1 to release iron, which is exported to the cytoplasm by DMT1 and possibly by Nramp1. Cytoplasmic chaperones of the poly(rC)-binding protein (PCBP) family deliver iron for storage in ferritin. Alternatively, iron may also be delivered by an unknown carrier to ferroportin (Fpn) for export. When demand for iron is high, ferritin is degraded by lysosomes or proteasomes, and the released ferrous iron is exported through ferroportin. Iron export is controlled by extracellular hepcidin through its ability to induce endocytosis and proteolysis of ferroportin. The ferroxidase ceruloplasmin oxidizes iron to its ferric form and facilitates iron export and loading onto the carrier protein transferrin. From Ganz T. Macrophages and systemic iron homeostasis. *J Innate Immun* 2012;4(5-6):446-453, with permission.¹²⁵

Antimicrobial Activity

See Figure 10.15.^{55,58}

The respiratory burst of human neutrophils and activated monocytes/macrophages has been well studied as a result of the inborn errors that give rise to chronic granulomatous disease (Fig. 10.15A). The components which assemble to form the NADPH oxidase include a novel cytochrome, and the various targets of mutation have been defined. The burst of oxygen consumption gives rise to superoxide anions, singlet oxygen, hydroxyl radicals, and hydrogen peroxide, which, in combination with myeloperoxidase and halides (the Klebanoff reaction), gives rise to enhanced oxidative power. The role of ion channels in the initial alkalinization associated with the respiratory burst remains controversial. Glutathione and other intracellular reducing mechanisms provide protection against injury.

The role of the inducible nitric oxidase in humans is unresolved; in mice the NADPH oxidase and i-NOS together account for almost all the microbicidal activity of myeloid leukocytes. In mouse macrophages the metabolism of arginine is strongly regulated by the Th1/2 cytokines.

The cationic antimicrobial peptides such as cathelicidins are produced by various cells, including neutrophils and some but not all monocytes and tissue macrophages; by contrast, lysozyme requires additional damage to the microbial wall, e.g., by complement, for microbicidal lysis. Although neutrophil extracellular traps (NETS) are now established as antimicrobial mechanisms of neutrophils, this has not been documented in activated human monocytes/macrophages, a likely counterpart.

A role has been proposed for potent neutral proteinases such as elastase in microbial killing, as well as degradation.

P.210

TABLE 10.4 SELECTED SECRETION PRODUCTS OF MACROPHAGES

Proteins	Product	Comment
Enzymes	Lysozyme	Bulk product
	Urokinase type plasminogen activator	Regulated by inflammation
	Collagenase	Regulated by inflammation
	Elastase	Also inhibitors
	Metalloproteinases	All components and regulators

	Complement	Alternative activation
	Arginase	Induced glucocorticoids, granulomas
	Angiotensin converting enzyme	Gaucher's disease, lysosomal storage
	Chitotriosidase	All classes (mainly intracellular)
	Acid hydrolases	
Inhibitors	TIMP	
Chemokines	Many C-C, C-X-C, CX ₃ C-, e.g., MCP, Rantes, IL-8	Initiates acute and chronic recruitment of myeloid and lymphoid cells
Cytokines	IL-1 β , TNF- α	Pro and anti-inflammatory, also antagonists, e.g. IL-1Ra
	IL-6, IL-10, IL-12, IL-17, IL-18, IL-23	Pro and anti-inflammatory, also antagonists, e.g. IL-1Ra
	Type I interferon	Autocrine and paracrine amplification
Apolipoproteins	Apolipoprotein E	Local source, bone marrow origin after adoptive transfer
Growth/differentiation factors	TGF- β	Also other family members (activins), fibrosis
	M-CSF	
	GM-CSF	Myeloid growth and differentiation
	FGF	Fibrosis
	PDGF	Repair
	VEGF	Angiogenesis
Opsonins	Fibronectin, Pentraxin (PTX3)	Also uncharacterized receptor on M ϕ
Soluble receptors	Mannose receptor	Soluble mannose receptor
Cationic peptides	Defensins	Subpopulations and species variation
Lipids	Procoagulant	Initiation clotting
	Arachidonate metabolites:	Pro- and anti-inflammatory mediators
	Prostaglandins	
	Leukotrienes	
	Thromboxanes	
	Resolvins and maresins	
Metabolites	Reactive oxygen intermediates	
	Reactive nitrogen intermediates	
	Heme breakdown (bile pigments)	
	Iron, B12 binding protein	
	Vit. D metabolites	

GM-CSF, granulocyte-macrophage-colony stimulating factor; IL, interleukin; M-CSF, macrophage-colony stimulating factor; TNF- α , tumor necrosis factor- α ; TIMP, tissue inhibitor of metalloproteinase; MCP, monocyte chemoattractant protein-1; FGF, fibroblast growth factor; PDGF, platelet-derived

growth factor; VEGF, vascular endothelial growth factor.

Inflammation and Repair^{59,60} and ⁶¹

Monocytes and macrophages play central roles in the generation and resolution of inflammatory responses. The function of DCs is less obvious, although steady state populations may be required to maintain tolerance in the periphery.

Upon stimulation, monocytes and macrophages are able to initiate, amplify, regulate, and terminate inflammation and repair. This depends on their integrated recognition of microbes and modified host components, uptake, signaling by NFκB and other pathways, altered gene expression, and secretion of a host of mediators, including pro- and antithrombotic agents. Apart from the products listed above, they generate both pro- and anti-inflammatory prostaglandins, thromboxanes, and leukotrienes; recent studies by Serhan and colleagues have described potent resolvins and maresins, implicated in resolution and repair. They orchestrate granulocyte and lymphocyte recruitment, contribute to coagulation and thrombolysis, modulate endothelial cells, and regulate angiogenesis. Macrophage-derived urokinase plays an important role in fibrinolysis, through the generation of plasmin; the UPA receptor and PA inhibitor-1 help to localize and regulate plasmin generation. Interactions with neutrophils are particularly important in acute inflammation and with T and B lymphocytes and their products in chronic inflammation. Poor degradation of particulates within macrophage lysosomes is a driver of chronicity, through altered and persistent protein synthesis and secretion of host degrading enzymes, and through pathologic fibrosis. Once local defenses are breached, the systemic consequences include metabolic and endocrine effects, as well as fever and anorexia via the nervous system. The balance between activation and inhibition of macrophage activation is influenced by a range of amplifying and negative regulators.

Monocyte Subsets

See Figure 10.16.^{62,63,64,65} and ⁶⁶

Monocytes may be divided into two or more subsets based on the expression of phenotypic properties and differentiation potential. The major “classical” subset in humans expresses high CD14 and variable CD16 and comprises 90% of circulating monocytes.

P.211

The remaining 10% express high CD16 and moderate CD14 and are known as “nonclassical.” This is a useful basis to approach monocyte heterogeneity; but casual inspection of the CD14 vs. CD16 flow cytometry plot shows that it is difficult to draw distinct boundaries between the two subsets, and some authorities recognize a third CD14+CD16+ population known as “intermediate” at the knee of the population. Confusion still arises over whether the CD14+CD16+ double positive cells are closer to the classical or nonclassical group.

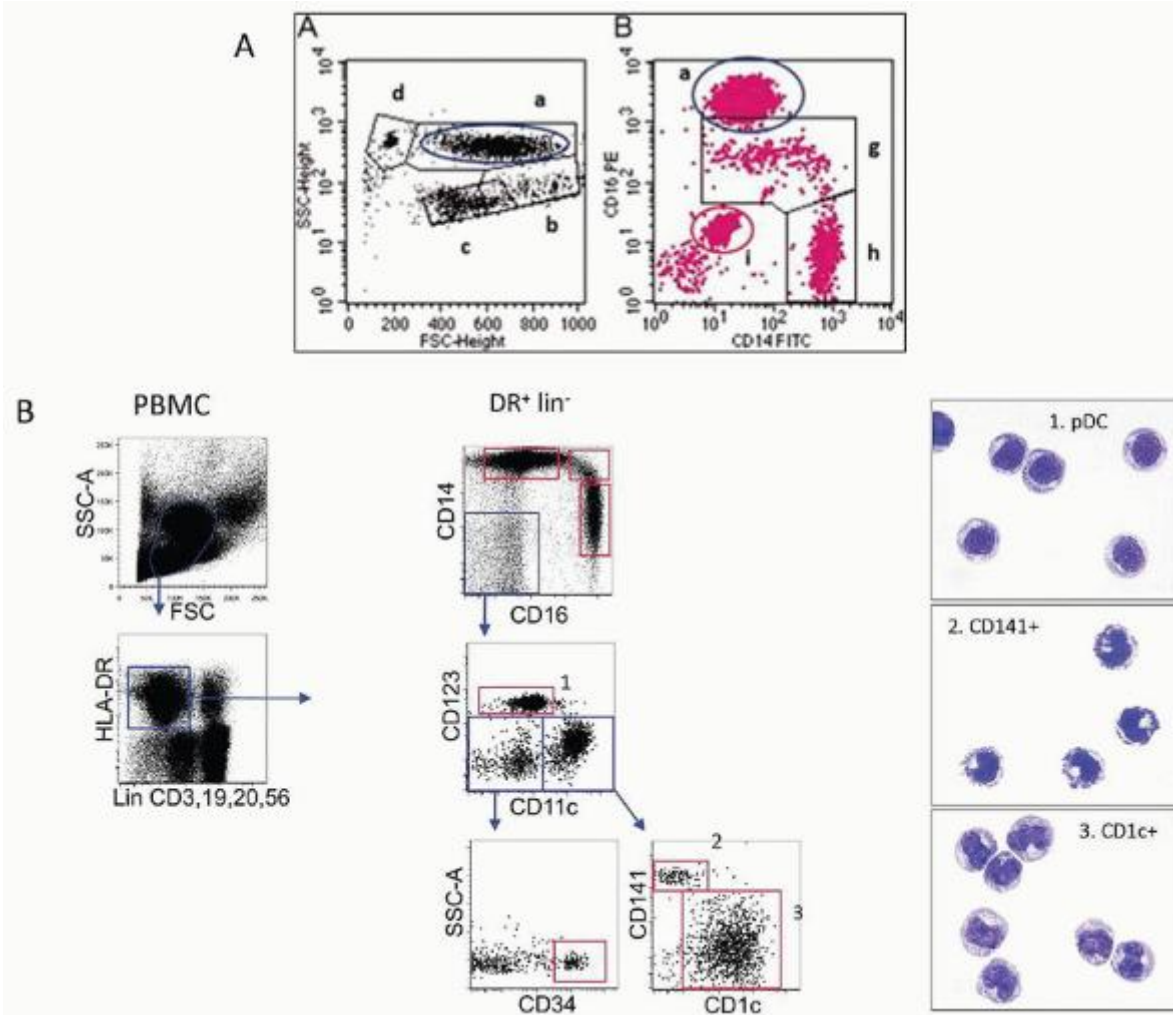

FIGURE 10.16. FACS analysis of human blood leukocytes to distinguish monocytes from granulocytes. A: Stained cells were analyzed with scatter gates around monocytes and granulocytes (a and b in A). The CD14 and CD16 histogram (B) demonstrates CD16-positive neutrophils (a) and CD16-negative eosinophils (i). A representative example is shown: (a) granulocytes, (b) monocytes, (c) lymphocytes, (d) beads, (g) CD14⁺CD16⁺ monocytes, (h) CD14⁺CD16⁻ monocytes, and (i) eosinophilic granulocytes. From Heimbeck I, Hofer TP, Eder C, et al. Standardized single-platform assay for human monocyte subpopulations: Lower CD14⁺CD16⁺⁺ monocytes in females. *Cytometry A* 2010;77:823-830, with permission.⁶⁴ B: Schema for isolating human blood DCs from gradient purified PBMC (peripheral blood mononuclear cells). SSC, side scatter; FSC, forward scatter; Lin, lineage. HLA-DR⁺ lin⁻ contains all monocyte and DC subsets and includes CD34⁺ progenitors. Gate 1 plasmacytoid DCs; Gate 2 CD141⁺ myeloid DCs; Gate 3 CD1c⁺ myeloid DCs; CD34⁺ progenitors are found in the CD11c⁻ CD123⁻ gate. Note the basophilic cytoplasm and perinuclear lucency of plasmacytoid DCs (1), the more activated membrane appearance of CD141⁺ DCs (2), and the heterochromatin with prominent nucleoli of CD1c⁺ DCs (3).

Classical and nonclassical monocytes differ in a number of important properties (see Table 10.1). Most notably, the classical monocyte expresses CCR2 and is rapidly recruited in a CCR2-dependent fashion to sites of inflammation in animal models. Although this seems straightforward, it is apparent that CCR2 signaling is actually required for monocytes to leave the BM and the precise role of this chemokine receptor in recruitment from blood to tissue therefore remains unsolved. The nonclassical cell bears CX3CR1 and is found in contact with the endothelium, where it is said to perform a “patrolling” function. Deletion of the ligand CX3CL1 (fractalkine) in mice reduces the survival of nonclassical monocytes and their recruitment to the spleen during bacterial sepsis. This function is not exclusive, as classical monocytes also show dependence upon CX3CR1 signaling. Monocytes also express CCR1 and CCR5. Recruitment through these molecules may result in a more chronic inflammatory phenotype and is implicated in atherosclerosis, rheumatoid arthritis, and multiple sclerosis.

Historically, there has been confusion over the status of the nonclassical monocyte, and in many publications it is referred to as the CD16+ “dendritic cell.” The two terms are synonymous and

P.212

there is only a single discrete population of myeloid cells bearing CD16 in the mononuclear compartment of human blood. Inclusion of CD16+ monocytes in the DC lineage reflects a number of properties of these cells, including higher expression of MHC class II and costimulatory molecules CD80 and CD86. A subset of CD16+ monocytes also expresses SLAN (6-sulfoLacNAc). Gene expression analysis indicates that SLAN+ and SLAN- monocytes are equivalent, but a case has been made for a specialized role of “SLAN-DC” in host defense.

Automated blood counters most likely recognize the classical CD14+ monocyte with its larger size and granularity and may enumerate the smaller nonclassical populations as lymphocytes. Clinical hematology pays little heed to the separation of monocyte subsets, in spite of a wealth of information indicating differential modulation of one or the other in disease states.

Macrophage Activation, Regulation, and the M1 M2 Paradigm

See Figure 10.14.^{67,68,69,70,71,72,72a}

The concept of macrophage activation became an important issue following the studies by George Mackaness and colleagues, who demonstrated enhanced antimicrobial resistance of mice, associated with altered macrophage effector functions, after infection by BCG and *Listeria monocytogenes*. Subsequently, this effect of cell-mediated immunity to intracellular bacteria was shown to be due to interferon- γ (IFN γ), released by activated CD4 T helper 1 cells and by NK cells. Microbial constituents such as LPS further enhance macrophage inflammatory and antimicrobial activities, but since these TLR ligands are also able to induce distinct changes in macrophages directly, in the absence of IFN γ , we have chosen to term this innate activation. The scavenger receptor MARCO is a marker of innate activation of macrophages.

Studies by many groups have catalogued IFN γ -induced changes in macrophage gene expression, induction of MHC II and costimulatory molecules, and secretion of pro-inflammatory cytokines such as TNF- α and of reactive oxygen and nitrogen metabolites. We prefer the term classical activation, also widely known as M1 polarization, to describe the cellular program evoked by the priming stimulus (IFN γ) with or without a secondary microbial ligand. The role of IFN γ , IL12, their receptors, and STAT 1 in classical activation, initially discovered in mouse studies, has been confirmed in inborn errors in humans by Casanova, Holland, Gallin, and others. Recent studies by Udalova and colleagues have drawn attention to the role of INF-regulatory proteins 4, 5 in regulating macrophage activation.

The concept of alternative (M2) activation arose from studies of mouse peritoneal macrophages treated with IL-4, which induced distinct activation activities such as upregulation of mannose receptors, in contrast to IFN γ , a selective downregulator. Other markers in the mouse include induction of Arginase1, instead of i-NOS, as part of a distinctive gene signature. This was shown to be due to TH2-derived cytokines, IL-4 or IL-13, acting through their specific surface receptors, and signaling and transcription factors, mainly STAT6. DNA-specific demethylation has been shown to play a critical role in alternative activation. These cytokines derive from innate and acquired sources, especially during parasitic and allergic inflammation, and also regulate the cellular response to TH1 stimuli. Currently, we are defining the effects of TH-2 cytokines on human macrophages, and testing their relevance to disease in human tissues. Recent studies have demonstrated unexpected homeostatic functions of IL-4 in thermoregulation and metabolism. IL-13 has been implicated in fibrosis.

Other types of M2 activation include Fc receptor-stimulated alteration of IL10/IL12 ratios, to induce a distinct form of regulatory macrophages, described in mice by David Mosser and colleagues. IL-10 is primarily a negative counter of M1 activation and its potential to produce inflammatory injury in tissue. Additional anti-inflammatory mediators in macrophages include TGF- β , prostaglandin E, induced, for example, by macrophage uptake of apoptotic cells; surface CD200-CD200 receptor and SIRP alpha-CD47 interactions; and cytoplasmic inhibitors such as the SOCS proteins. Glucocorticosteroids are potent inhibitors of macrophage activation.

Microarray and proteomic studies, in vitro and ex vivo, are helping to define the remarkable plasticity of macrophage phenotype, which needs further study in situ, at the level of cell populations and individual cells. Pathogens are able to manipulate macrophage activation mechanisms for their own benefit, in a dynamic interplay with infected and neighboring host cells.

Dendritic Cell Functional Subsets⁷³

In recent years it has become clear that different subsets of DCs are equipped with functional specializations that influence their interactions with antigen and other immune cells. Human and mouse DCs fall into two principal categories, myeloid or “classical” (in mice) and plasmacytoid. These terms originally arose from morphology and surface markers: blood myeloid DCs have a pale-staining monocytoid morphology and also bear CD11c, in common with monocytes; plasmacytoid DCs are more basophilic, reflecting their secretory capacity, and may express a number of lymphoid markers including CD2 and CD7. All human DCs and monocyte subsets express CD4, but none express CD8, unlike the mouse. Myeloid DCs consist of at least one major subset, marked by CD1c and a minor subset expressing CD141 (BDCA-3; thrombomodulin).

Plasmacytoid DCs (pDCs) are found in several mammalian species and perform unique antiviral functions through the expression of PRRs for viral nucleic acids (TLR3, TLR7 and TLR9, RLRs, and HELICASES) and the capacity to synthesize large quantities of IFN α rapidly when challenged. Depletion of pDCs in animal models does not attenuate initial responses to viral infection as much as might be anticipated by their kinetics of response, but rather limits the formation of robust antiviral memory. Human blood pDCs are labile and do not survive well *ex vivo*.

Myeloid DCs (mDCs) are an important component of human blood, although conspicuously absent from the mouse. The properties of CD1c+ mDCs are similar to the so-called classical or conventional DCs isolated from mouse spleen in that they phagocytose external antigens, mature through expression of CD83 and costimulatory molecules CD80 and CD86, and are capable of priming naive CD4+ T cells to proliferate.

CD1c+ myeloid DCs are also found in epithelial tissues including skin, gut, liver, and lung. In the tissues they usually express CD1a, CD205 (DEC205), and CD206 (macrophage mannose receptor), but do not bear CD14 or DC-SIGN (DC209). It seems likely from comparison of gene expression profiles that blood CD1c+ DCs give rise to analogous cells in the tissues. In the steady state, these cells are distinct from monocytes, but differentiation of monocytes in the presence of GM-CSF and IL-4 leads to rapid expression of CD1a and myeloid DC-like features.

Myeloid DCs with similar surface phenotype constitute the bulk of DCs found in the T cell areas of lymph nodes (interdigitating cells), but it has been difficult to dissect in humans whether these cells are predominantly derived by migration from the tissues or recruitment from the blood.

CD141+ marks a specialized DC subset that has superior cross-presenting capacity and potential to interact with CD8+ T cells. Recent comparative transcriptomic and functional analyses have shown that these DCs are related to the CD8+ DCs of mouse lymphoid tissue. They are present at very low frequency—approximately 0.1% of mononuclear cells—but their potency in cross-presentation assays suggests they may play a key role in

P.213

immunity to viral infection, tumors, and extracellular pathogens. In some analyses, as discussed above, CD16+ nonclassical monocytes are considered to be a subset of myeloid DCs.

The specialization of each DC subset is determined by functional adaptations at many levels. A particular repertoire of PRRs focuses interactions with certain pathogens; thus TLR2/4 is prominent on myeloid DCs, TLR3 is found highly expressed on cross-presenting DCs, and pDCs have abundant TLR7/9. Characteristic C-type lectins are also displayed by DCs with different functions, most notably langerin on the epidermal Langerhans cell, DC-SIGN on interstitial DCs, and CLEC9A on cross-presenting myeloid DCs. Antigen processing and presentation pathways are adapted to drive MHC I or MHC II-restricted responses in the context of the appropriate polarizing cytokines. For example, cross-presenting DCs that are specialized for interaction with viruses have abundant nucleic acid receptors, cross-presenting capacity, and biased stimulation of TH1 and CD8 responses.

DISTRIBUTION OF MONONUCLEAR PHAGOCYTES

In the following section we describe the distribution of MPs in different tissue compartments of the adult, emphasizing humans where possible, but drawing on information obtained in the mouse with the antigen F4/80 marker, as appropriate. Macrophage and DC generation and turnover depend on growth factors and transcriptional regulators and will be described in detail below, except for osteoclasts, discussed in this section.

Blood^{74,75}

MPs are found in almost all tissues. The human blood mononuclear cell compartment has been almost exhaustively investigated and is the most readily accessible and clinically relevant tissue.

A recommended FACS analysis of human blood leukocytes to distinguish monocytes from granulocytes is illustrated in Figure 10.16A. A schema for classifying blood monocytes and DCs is shown in Figure 10.16B. All monocytes and DCs express MHC class II HLA-DR molecules. B cells, activated T cells, and NK cells also bear MHC class II antigens, so the most useful starting point is to identify HLA-DR⁺ lineage cells. Lineage markers are a cocktail of antibodies that usually include a minimum of CD19/20 (B cells), CD3 (T cells), and CD56 (NK cells). Circulating hematopoietic progenitors also express HLA-DR and may be excluded by adding CD34 to the lineage cocktail.

HLA-DR⁺ lineage cells defined in this way comprise approximately 10% of all peripheral blood mononuclear cells. Ninety percent of these cells are monocytes and approximately 10% DCs. Monocytes comprise a major fraction of classical CD14⁺ cells (90%) and a minor CD16⁺ nonclassical fraction as discussed previously.

The DCs of human blood comprise 10% of HLA-DR⁺ lineage cells and 2% to 3% of total mononuclear cells. Plasmacytoid DCs are the major component and myeloid DCs a smaller component comprising 30% to 40% of blood DCs. A common way to separate these two groups is by differential expression of CD123 (IL-3R) and CD11c (alpha X integrin), respectively. Plasmacytoid DCs are also marked by CD303 (a C-type lectin) and CD304 (neuropilin-1), antigens also known as BDCA-2 and BDCA-4. Human myeloid DCs are mainly CD1c⁺ while a small fraction (10% to 20%) expresses CD141. CD1c⁺ is an invariant class I molecule identified by BDCA-1 antibody and is a reliable marker of tissue and lymphoid DCs in many sites. CD141 (thrombomodulin) is more widely expressed and finds utility only in identifying DCs within the hierarchy of markers already described.

Bone Marrow (See Figs. 10.1, 10.17 and 10.18)^{76,77,78,79} and ⁸⁰

Both developing monocytes and mature macrophages supporting hematopoiesis are found within the bone marrow microenvironment in normal bone marrow. Macrophages are large cells with a large amount of cytoplasm and small nuclei, and are often surrounded by plasma cells, lymphocytes, or maturing erythroid cells. Their cytoplasm is often ruffled and vacuolated and contains phagocytosed debris. Hematopoietic stem cells are found in specific areas near osteoblast-lineage cells at the endosteum. Macrophages are important components of the hematopoietic stem cell niche and interact with both osteoblasts and mesenchymal stem cells to retain hematopoietic stem cells within the bone marrow. G-CSF mobilization depletes endosteal macrophages that support osteoblast function, resulting in reduced endosteal osteoblasts, as well as suppression of bone formation and factors required for stem cell retention and renewal with consequent mobilization of stem cells into peripheral blood.

The appearance of hematopoietic cell clusters in bone marrow has been known for many years. Studies by Paul Crocker and colleagues in the mouse identified F4/80⁺ mature stromal macrophages at the center of such clusters with differentiating hematopoietic cells. They described the presence of a novel sialic acid-recognition macrophage adhesion receptor, sialoadhesin (Siglec-1, CD169), which was concentrated at the sites of contact with developing granulocytes (Fig. 10.18). Similar stromal macrophages were found within hematopoietic clusters in human bone marrow (Fig. 10.17). The function of CD169 or other divalent cation-dependent stromal macrophage adhesion molecules is not understood, but specific depletion of CD169⁺ macrophages as opposed to monocytes is sufficient to induce progenitor egress in the mouse.

Lymphoid Organs (See Fig. 10.19)⁸¹

Macrophages and DCs form important components of lymphoid tissue. Macrophages play carefully choreographed roles in the induction of immune responses. In the subcapsular spaces of lymph nodes, CD169⁺ macrophages are positioned to capture antigen from afferent lymph and transport it to B cells in the follicles. This function is one of many examples of monocyte and macrophages providing direct help to B cells through presentation of intact antigen and elaboration of maturation and class-switching factors including BAFF and APRIL. Surrounding the follicles, a capsule of marginal zone macrophages is specialized to engulf apoptotic B cells that fail to receive survival stimuli and achieve maturation in the germinal centers. Macrophages also occupy the medulla and splenic red pulp. Here they provide niches for plasma cells. In the spleen the sinus-lining macrophages play a key role in the uptake of senescent red cells.

DCs are classically found as “interdigitating cells” of the perifollicular T cell regions and splenic white pulp. Lineage tracing studies now show that these are a mixture of migratory myeloid DCs arriving from the periphery and blood-derived cells recruited directly to the node. During inflammation their number increases manyfold and is augmented by plasmacytoid DCs and monocyte-derived inflammatory DCs. Live cell imaging shows dynamic and complex interactions between DCs and T cells in these regions.

Follicular DCs are a unique population of antigen-storing cells that are mesenchymal in origin and do not express typical leukocyte markers, but are rich in complement and Fc receptors. They have a complex arborizing structure and are found

scattered in the germinal centers where they attract B cells by CXCL13 signaling. Their function has been linked to the preservation of opsonized intact antigen and promotion of B cell memory responses.

P.214

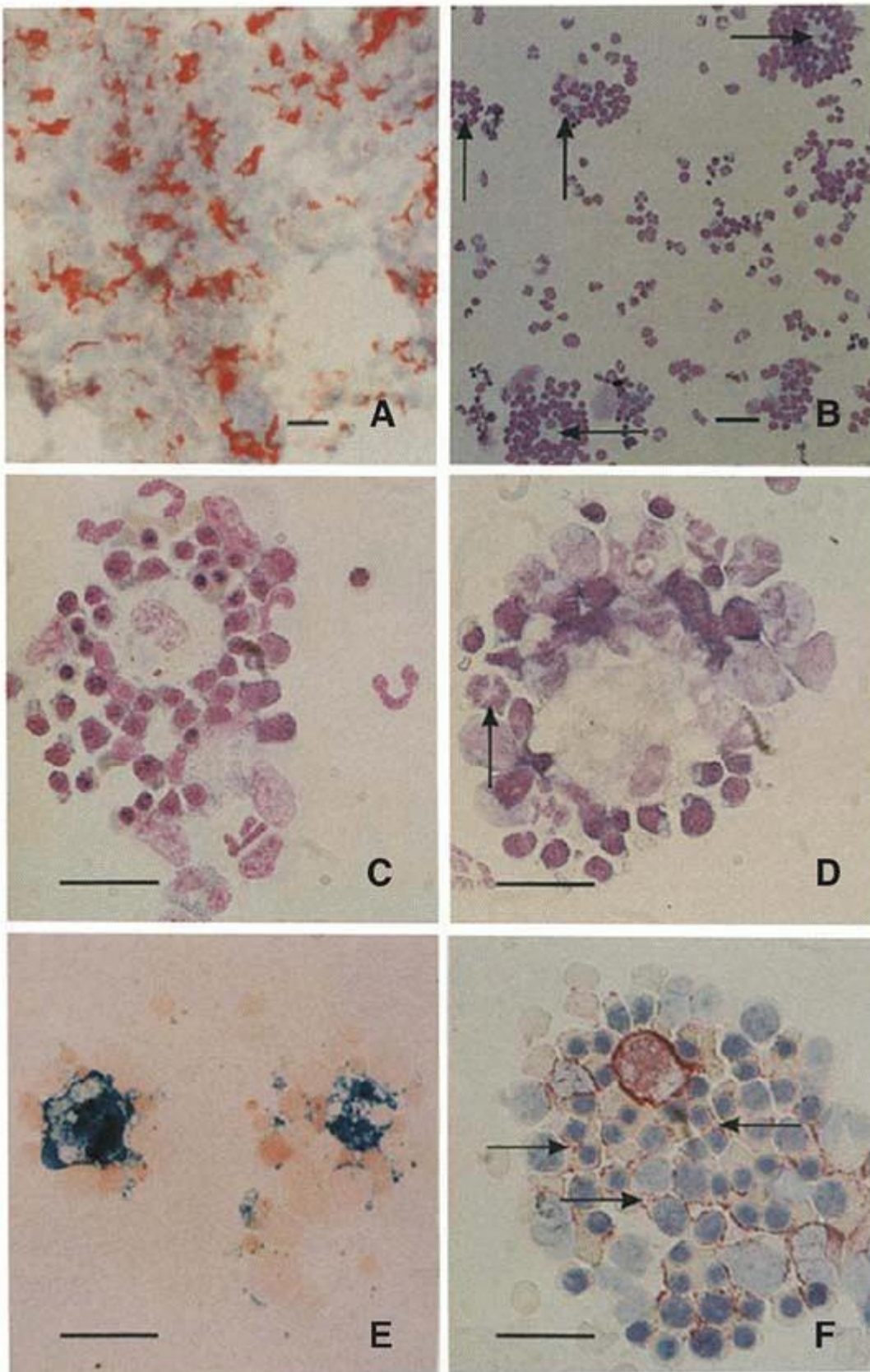

FIGURE 10.17. A: Stromal macrophages in human marrow associate with developing hematopoietic cells in islands/clusters. Immunocytochemical staining with antimacrophage monoclonal antibody Y-1/82A of marrow section

reveals a network of arborizing stromal macrophages uniformly distributed throughout the marrow interstitium (alkaline phosphatase-anti-alkaline phosphatase [APAAP] stain; hematoxylin counterstain). B: Marrow cells depleted of red cells and other single cells are enriched for cell clusters, most of which are erythroid clusters with a central stromal macrophage (arrows; Giemsa). C: Isolated erythroid cluster with intermediate and late normoblasts surrounding a central stromal macrophage (Giemsa). D: Isolated mixed cluster with both myeloid and erythroid cells attached to a central stromal macrophage. A dividing cell (arrow) is seen (Giemsa). E: Isolated erythroid clusters from a pathologic marrow sample show intense staining for hemosiderin of stromal macrophages with cellular processes extending between attached erythroblasts (Perl acid ferrocyanide reaction; counterstain neutral red). F: Immunocytochemical stain with antibody Y1/82A of isolated erythroid cluster. Both the stromal macrophage cell body and processes (arrows) between attached erythroblasts are visible (APAAP stain; hematoxylin counterstain). Bar = 50 μ m. From Lee SH, Crocker PR, Westaby S, et al. Isolation and immunocytochemical characterization of human bone marrow stromal macrophages in hemopoietic clusters. *J Exp Med* 1988;168:1193-1198, with permission.⁷⁹

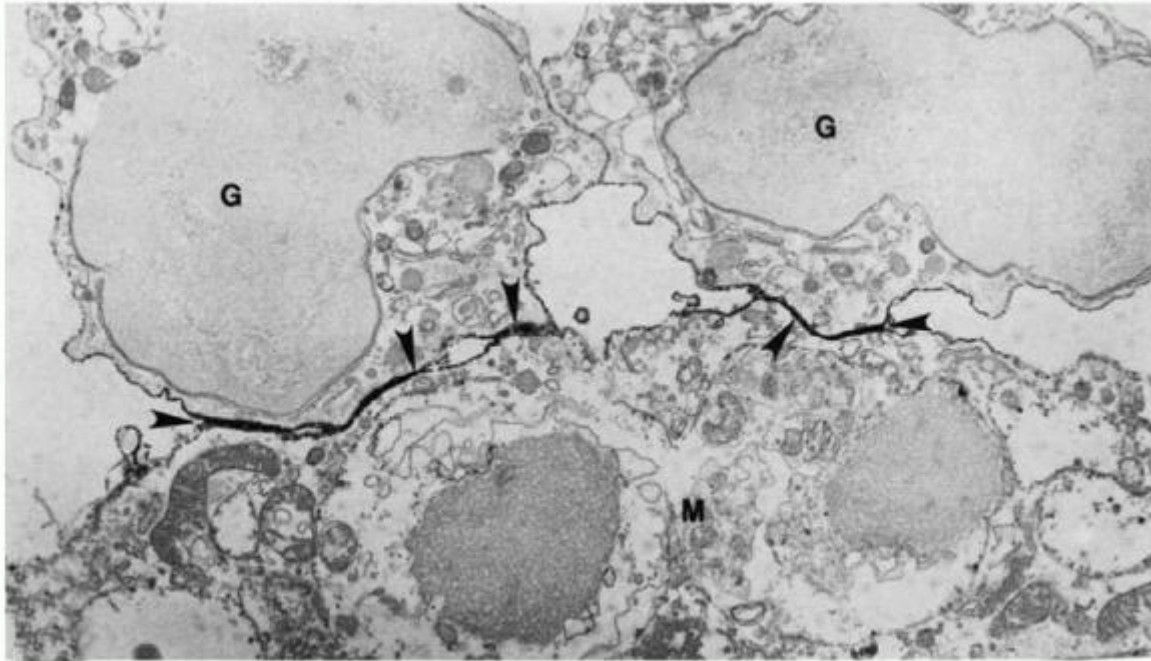

FIGURE 10.18. Ultrastructural localization of CD169 (siglec-1, sialoadhesin) in mouse macrophage-hematopoietic cell clusters. Immunoelectronmicroscopy with monoclonal antibody to CD169 shows concentration of CD169 at contacts between macrophages (M) and developing granulocytic cells (G). CD169 was diffusely localized at the contact zones between macrophages and erythroblasts (not shown). (See Crocker PR, Werb Z, Gordon S, Bainton DF. Ultrastructural localization of a macrophage-restricted sialic acid binding hemagglutinin, SER, in macrophage-hematopoietic cell clusters. *Blood* 1990;76(6):1131-1138, for further details.)

P.215

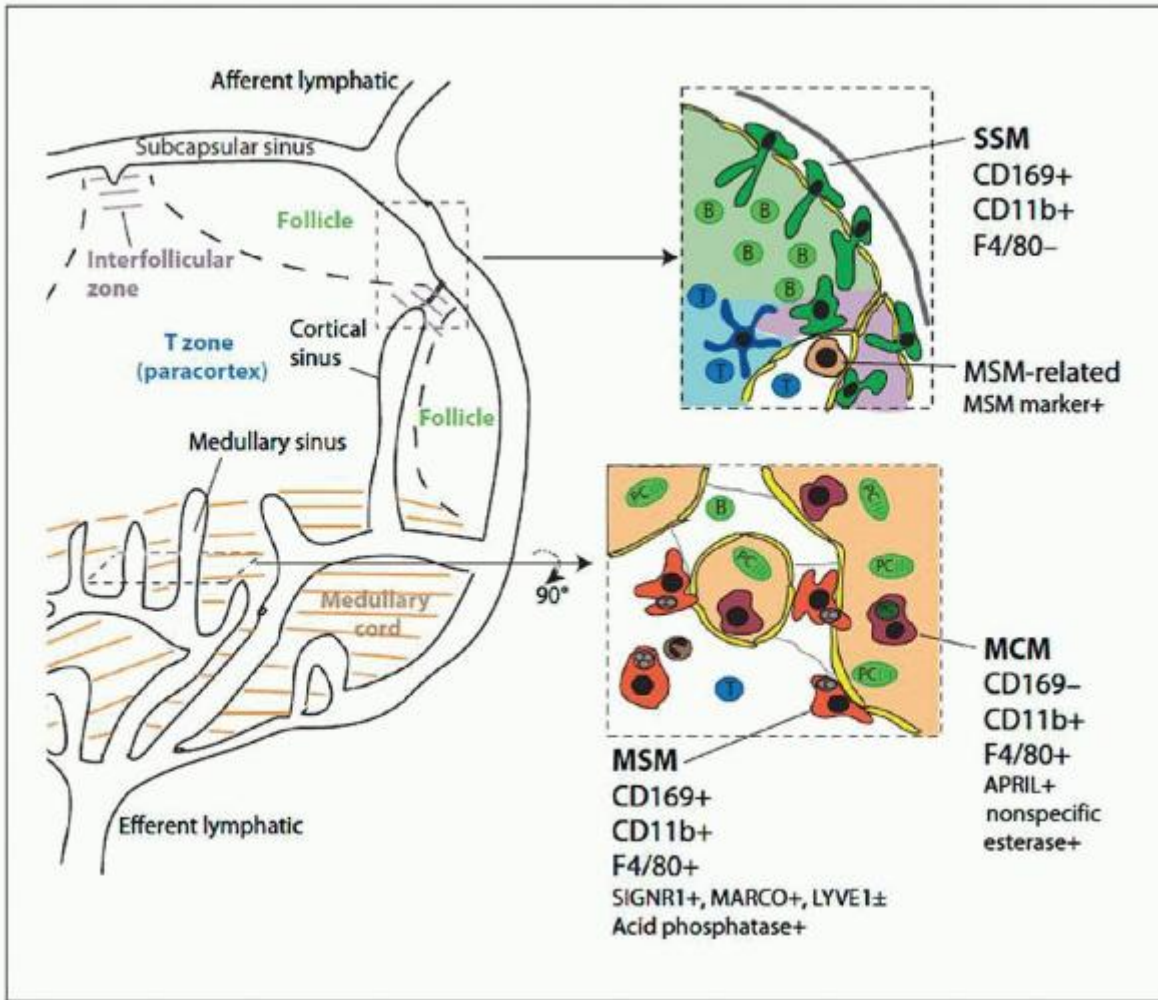

FIGURE 10.19. Schematic of mouse lymph node showing major zones and lymphatic sinuses with macrophage subsets (subcapsular sinus [SCS] macrophages [SSM], medullary sinus macrophages [MSM], and medullary cord macrophages [MCM]). Boxed regions are enlarged on the right. Upper box: SCS and interfollicular region with follicle shown in green shading, T zone in blue, and interfollicular region in purple. Lower box: medullary region in cross-section showing medullary cords in light brown. Sinuses are shown in white and sinus-lining lymphatic endothelial cells are yellow. Their CD169, CD11b, and F4/80 phenotype is summarized. A DC is shown in dark blue (upper) and a polymorphonuclear cell in brown (lower). Reticular fibers within medullary sinuses are in gray. B, B cell; PC, plasma cell; T, T cell. From Gray EE, Cyster JG. Lymph node macrophages. *J Innate Immun* 2012;4(5-6):424-436, with permission.

DCs and macrophages are also found in the thymus. DCs are critical in the positive selection of T cells in the cortex while macrophages in the medulla remove apoptotic debris resulting from negative selection to remove autoreactive T cells.

Spleen (See Fig. 10.20)^{82,83,84,85}

In the mouse, histological examination of the spleen reveals a marginal zone (MZ) between the hematopoietic red pulp (RP) and lymphoid white pulp (WP), constituting an interface between the circulation and resident lymphoid tissue. The white pulp contains CD68+F4/80- cells, macrophages as well as DCs, which can be induced to migrate into the white pulp in response to antigenic stimulation. The MZ contains an inner CD169+ F4/80- metallophilic population and an outer population of phagocytic MARCO+ SIGNR-1+ macrophages. A subset of metallophilic macrophages also expresses ligands for the cysteine-rich N-terminus of the mannose receptor (CD206), which itself functions as a receptor for sulfated sugars, targeting captured glycoconjugates to the marginal zone. The MARCO scavenger receptor and SIGNR1 lectin (counterpart of human DC-SIGN) are important in the clearance of apoptotic cells and avoidance of immunization by autoantigens. Depletion of MZM leads to enhanced phagocytosis of apoptotic cells by RP macrophages, an inflammatory response, and in mice, acceleration of autoimmune disease and increased susceptibility to certain pathogens including *Listeria monocytogenes*.

Red pulp macrophages are strongly F4/80+ CD206+ and are involved in clearance of senescent erythrocytes and granulocytes and in iron turnover. They have also been implicated in a tolerogenic function. The red pulp can also serve as reservoir for mobilization of monocytes to peripheral sites of injury, and contributes to hematopoiesis in the normal mouse.

Humans lack the characteristic features of MZ found in rodents; studies by Steiniger, Crocker, and colleagues have identified an interfollicular region with CD169+ cells which may fulfill a parallel function. Martinez-Pomares and colleagues found that CD68+ macrophages in the red pulp of human spleen are distinct from MR+ cells, which are present in venous sinuses, and coexpress ligands for the MR cysteine-rich domain, as well as the Lyve-1 antigen.

Given these striking species differences, it is difficult at present to attribute particular immunological functions to specialized macrophages and DCs in human spleen, comparable to the role attributed to CD169+ MZ cells in specific interactions with lymphocytes, including CD8+ T cells.

Nonlymphoid (Interstitial) Tissues

Analysis of the leukocyte content of human tissues and lymphoid organs has been a preoccupation of pathology for more than a century but only recently have modern multiparameter tools and functional studies been applied to elucidate the complexity of resident and inflammatory cells in these sites. Interstitial tissues such as the dermis are rich in leukocytes, blood vessels, and lymphatics. Most tissues contain a macrophage or histiocyte component, myeloid DCs, predominantly CD4+ effector memory lymphocytes,

P.216

and mast cells. Plasmacytoid DCs, NK cells, and B cells are not usually found in uninflamed tissue.

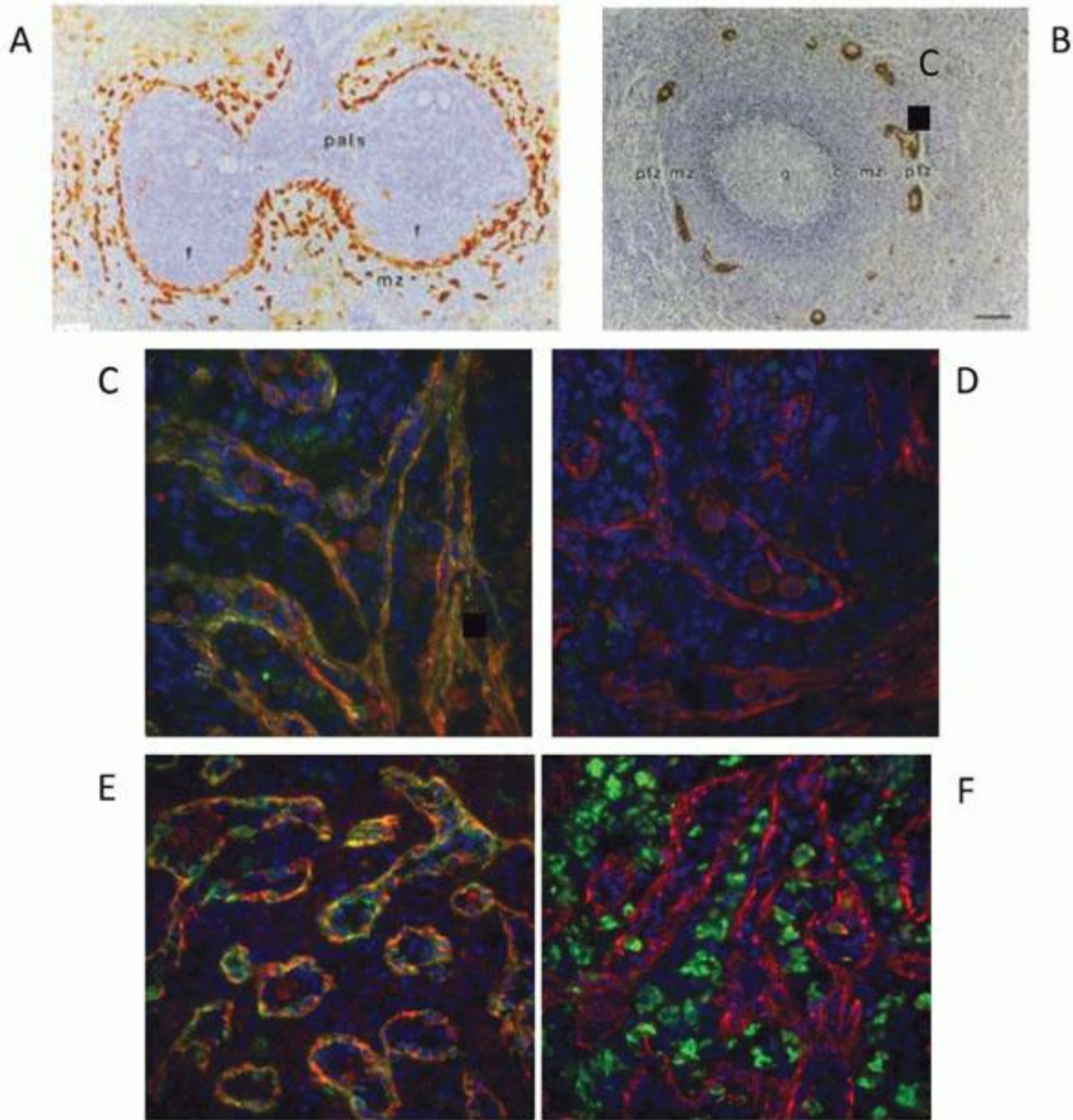

FIGURE 10.20. Species and antigen expression differences of splenic macrophages. A, B: Human and rat spleens differ markedly in marginal zone structure. A: Rat spleen demonstrates CD169 antigen on marginal metallophilic macrophages (monoclonal antibody ED3). B: CD169+ macrophages form sheaths around capillaries in the perifollicular region of the human spleen. From Steiniger B, Barth P, Herbst B, Hartnell A, Crocker PR. The species-specific structure of microanatomical compartments in the human spleen: strongly sialoadhesin-positive macrophages occur in the perifollicular zone, but not in the marginal zone. *Immunology* 1997;92(2):307-316, with permission. C-F: Mannose receptor and cysteine-rich domain ligands in the human spleen do not co-localize with CD68+ macrophages. From Martinez-Pomares L, Hanitsch LG, Stillion R, Keshav S, Gordon S. Expression of mannose receptor and ligands for its cysteine-rich domain in venous sinuses of human spleen. *Lab Invest* Oct 2005;85(10):1238-1249, with permission. C, D: MR- and CR ligands co-localize in venous sinuses of splenic red pulp. Fluorescent labeling of CR ligands (in green) and MR (in red) in the presence or absence of SO4-4-GalNAc demonstrates that there is a perfect co-localization of the MR and ligands for the CR in venous sinuses. E, F: MR is present in Lyve-1+ cells lining venous sinuses in human spleen. MR-specific fluorescent labeling in human spleen (in red) does not co-localize with CD68-specific labeling (in green, [right]), but co-localizes with Lyve-1-specific labeling (in green, [left]).

Tissue macrophages and DCs were originally recognized as histiocytes—literally “tissue cells.” Early studies with intravital dyes and carbon particles, combined with light and electron microscopy, revealed the presence of phagocytic histiocytes in all tissues of the body, typically underlying the basement membranes of epithelia, even in the absence of inflammation.

The distinction between macrophages and DCs arrived much later. Quite accurately, as it has since emerged, macrophages were said to be “fixed” in the tissues and had little propensity to migrate to draining lymph nodes. Common evidence of this is seen

P.217

in the survival of tattoo pigment in resident human dermal macrophages with little evidence of diffusion over the course of many decades. Dermal macrophages also have a half-life of more than 1 year after hematopoietic stem cell transplantation, in contrast to DCs, which are replaced within weeks. This property can also be recapitulated in vitro by their inability to leave explanted tissue fragments, in contrast with DCs and resident T cells. Interstitial macrophages in the dermis are laden with melanin and are also known as melanophages. Macrophages are scattered throughout the interstitium, while DCs are found mainly in the perivascular sheaths and close to the basement membrane of epithelia.

Human tissue macrophages and DCs both express CD45 leukocyte antigen, HLA-DR, CD68, EMR2, and CD11b. The best markers for macrophages are FXIIIa, LYVE-1, and CD163; they also express CD14 and DC-SIGN at low level. The major population of tissue DCs are CD1c+ myeloid DCs analogous to the CD1c+ DCs found in human blood. These express higher amounts of HLA-DR and are specifically identified by CD11c and CD1c.⁸⁶ In addition, fascin and CD1a have been used but are less reliable markers. A previous erroneous assignment of FXIIIa as a DC marker has led to significant confusion in the field. FXIIIa positive “dermal dendrocytes” are elongated branching cells that are now known to be macrophages. They often expanded in chronic inflammatory conditions by the recruitment of monocyte-derived cells. In addition to resident interstitial macrophages and CD1c+ DCs, there exists a minor population of CD14+ cells that have previously been described as “interstitial DCs.” These are mobile and migrate in vitro, but gene expression analysis links them to monocytes and macrophages rather than the DC lineage. In common with macrophages they express CD14, DC-SIGN, and FXIIIa. Plasmacytoid DCs are not found in resting tissues, and CD141+ myeloid DCs can be isolated by flow cytometry but are rare and difficult to observe in situ.⁸⁷ In the gut there is evidence for an additional CD103+ DC involved in tolerance in both mice and humans. Although research studies clearly delineate the difference between macrophages and DCs, routine diagnostic immunopathology does not differentiate between these cells.

Specialized Populations of Mononuclear Phagocytes⁴³

Kupffer Cells

Kupffer cells are abundant sinus-lining macrophages of the liver, sharing clearance functions with endothelial cells. Macrophage cytokines such as IL-6 play an important role in induction of acute phase proteins, such as C reactive protein, serum amyloid protein (SAP), complement, and fibrinogen, in humans. The resident Kupffer cells become tolerant to LPS delivered by the portal system and may represent an entry site to pathogens; the host depends on newly recruited monocytes to mount an effective antimicrobial response.

Gastrointestinal Macrophages and Dendritic Cells^{31,87,88}

The gut contains an abundant population of macrophages in the body. The lamina propria is rich in macrophages and DCs throughout the intestine; the microbial flora, especially in the colon, may be sampled, captured, and transported into lymph and the portal circulation. Macrophages and DCs take up and digest apoptotic epithelial cells, contributing to tolerance of food antigens. They also contribute to epithelial integrity and barrier functions, in part dependent on TLR-dependent responses to symbionts. The macrophage phenotype in the small intestine is downregulated by TGF- β and IL-10, interacting with a range of innate and adaptive T lymphocytes. Peyer's patches contain M cells, specialized for antigen uptake. In mice and humans, a specialized population of CD103+ gut DCs is thought to play a role in tolerance.

The peritoneal cavity of the mouse provides an accessible source of resident, inflammatory, and immunologically activated macrophages for experimentation; much of our knowledge of macrophage immunobiology derives from studies on peritoneal macrophages.

Alveolar Macrophages (See Fig. 10.3D)^{89,90}

Alveolar macrophages from humans accumulate inhaled particles and pollutants and often contain poorly degradable cigarette residues. The cells express a range of phagocytic receptors, take up and metabolize surfactant molecules, and secrete abundant lysozyme, among other products. Alveolar macrophages often suppress inflammation and immune

responses. Within the lung interstitium, a full complement of macrophages, myeloid DCs, and monocyte-derived cells are found similar to other interstitial tissue sites. These are anatomically and phenotypically distinct from alveolar macrophages.

Microglia^{31,91,92}

In the mouse, microglia derive from yolk sac macrophages during development, removing apoptotic neurons as they enter the neutrophil; they adapt within days to their neuroparenchymal environment. Their arborized morphology varies in different regions of the brain. Their functions in the absence of inflammation or degeneration remain mysterious. Microglia differ in their phenotype from the perivascular, meningeal, and choroidal macrophages. The response of microglia to excitotoxin injury, amyloid deposits, inflammation, and infection includes striking changes in morphology, recruitment of blood monocytes, and local proliferation. The blood-brain barrier controls entry of other resting and activated white blood cells and of soluble molecules from the systemic circulation.

Langerhans Cells (See Figs. 10.4 and 10.13A)^{86,92,93,94,95,96} and ^{97,98,99}

The Langerhans cell of human epidermis furnished a critical paradigm of MP biology. Originally described as a nerve cell by Paul Langerhans in 1868, a series of studies by Stingl and others in the 1970s confirmed its leukocyte origin and expression of MHC class II molecules. Subsequent studies developed a specific antigen marker, the C-type lectin Langerin, a component of Birbeck granules. The study of skin explants then revealed the striking property of this DC to round up and migrate out of the epidermis where it became a potent immunostimulatory cell akin to the “veiled cells” of afferent lymph. In this way it was conceived that resident myeloid-derived cells would function as sentinels of the immune system by capturing and transporting exogenous antigen to lymph nodes, where they would differentiate into antigen-presenting cells. This concept remains a cornerstone of DC biology. Paradoxically, the role of LCs in immunity remains a subject of debate. Mice lacking LCs have very few defects in immunity, although recent evidence points towards a role in maintaining TH17-directed resistance to *Candida*.

The dermis contains heterogeneous populations of macrophages and DCs and may represent an important source of APCs draining to regional lymph nodes.

Osteoclasts (See Fig. 10.21)^{100,101,102,103}

Early studies by Loutit, for example, demonstrated that osteoclasts derived from circulating monocytes; many subsequent studies established that *in vitro* culture in CSF-1 and RANK

P.218

ligand could generate multinucleated osteoclasts able to resorb living bone. Fusion with mononuclear precursors occurs throughout life, and survival of osteoclasts is believed to be dependent upon continued replenishment by fusion. They share many properties with, but differ from, multinucleated macrophage giant cells present in granulomata, e.g., in tuberculosis and schistosomiasis.

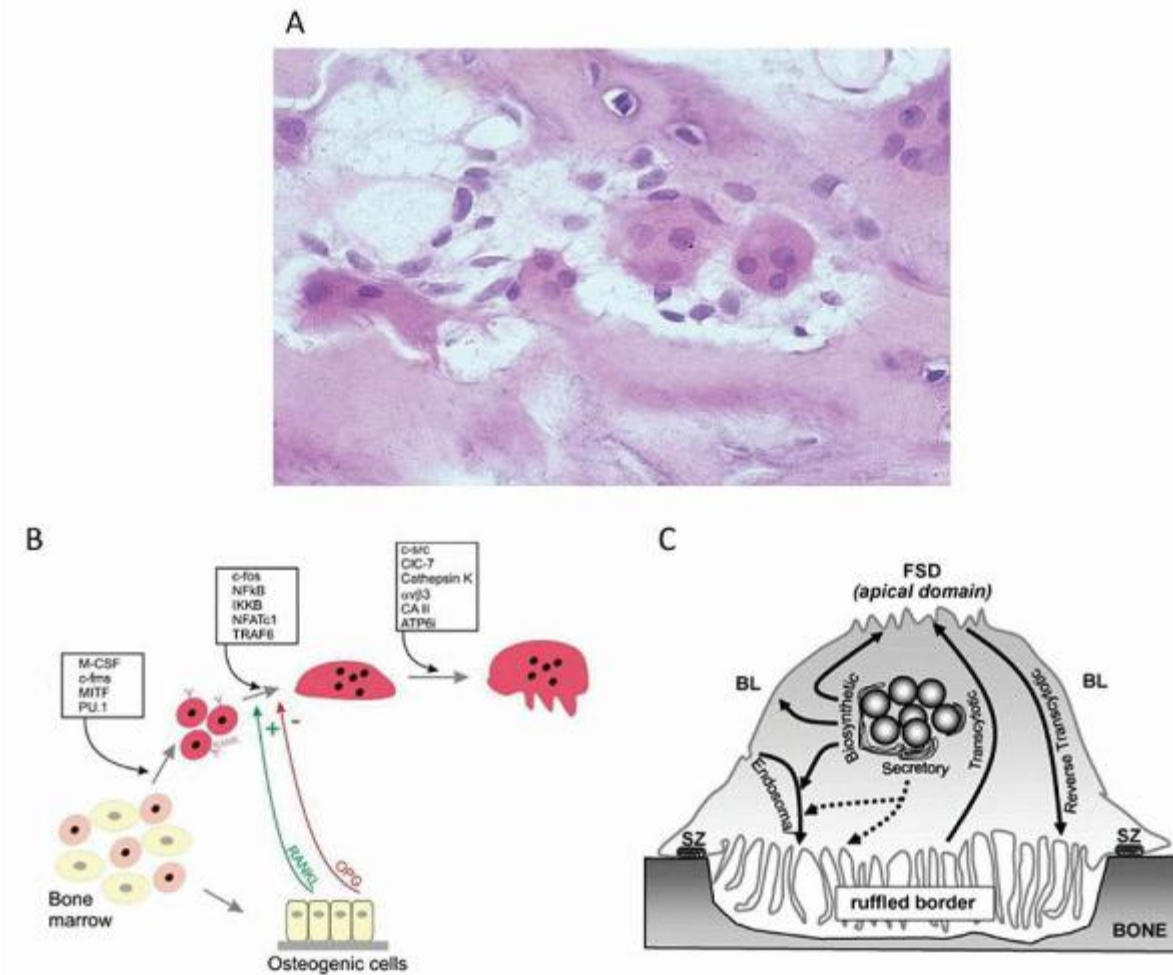

FIGURE 10.21. Morphology, differentiation, and function of osteoclasts. A: Light micrograph to illustrate appearance of osteoclasts in situ. B: Osteoclasts differentiate from myeloid stem cells via macrophage-colony-forming units (CFU-M). The exact point at which definitive commitment into osteoclasts along the differentiation pathway occurs is currently unknown. The mononuclear precursors fuse to form terminally differentiated multinuclear osteoclasts. From Vaananen HK, Laitala-Leinonen T. Osteoclast lineage and function. *Arch Biochem Biophys* 2008;473(2):132-138, with permission. C: Vesicular trafficking pathways in osteoclasts. The ruffled border is formed as a consequence of trafficking of vesicles in the endosomal pathway and therefore has characteristics of a late endosomal membrane. A distinct biosynthetic pathway may also contribute to the formation of the ruffled border. Degradation products from the resorption process are removed from the resorption lacuna by a transcytotic pathway and released at the FSD, which exhibits characteristics of an apical membrane. Recently, a reverse pathway from the FSD to the ruffled border has been identified. BL, basolateral domain; FSD, functional secretory domain; SZ, sealing zone. From Coxon FP, Taylor A. Vesicular trafficking in osteoclasts. *Semin Cell Dev Biol* 2008;19(5):424-433, with permission.

One of the three principal cell types present in bone, osteoclasts are giant multinucleated cells arising from the monocyte-macrophage-DC common progenitor. (Bone also contains mononucleated macrophages which lack the special features of osteoclasts.) Osteoblasts, on the other hand, are of mesenchymal origin, having the function of bone formation; and osteocytes arise from mature osteoblasts that, having once deposited the bone matrix, remain trapped in it, becoming quiescent cells. Osteoclasts are unique bone-resorbing cells. In histological sections, they appear attached to the bone matrix, in small depressions caused by bone resorption, "Howship's lacunae." They are derived from the fusion of mononuclear cells, resulting in polykaryons containing 4 to 50 nuclei up to 100 micrometers in diameter which can resorb large areas of tissue using an extracellular lysosomal compartment. Proteolytic enzymes required to digest the organic components of the bone tissue are secreted from a specialized ruffled border segregated from the extracellular fluid by an adhesion area.

In 1981 Marks and Walker demonstrated the peripheral blood origin of osteoclasts in a parabiosis experiment connecting normal and osteopetrotic mice. Subsequent *in vitro* work

P.219

has shown that multinuclear osteoclasts can be derived from differentiation of CFU-M in culture. Osteoclasts in turn promote mobilization of hematopoietic progenitors from the bone marrow by degrading endosteal components. The antigenic phenotype of human fetal osteoclasts has been compared with that of human tissue macrophages and macrophage-derived giant cells. Osteoclasts express a subset of macrophage-associated antigens including CD13, CD15A, CD44, CD45, CD54 (ICAM-1), CD71 (transferrin receptor), and CD68. Antigens expressed on macrophages and macrophage polykaryons, but not on osteoclasts, include CD1 a,b,c, CD18, CD14, CD31, CD36, CD37, CD39, and CD43 antigens; and less strong expression of CD16 (FcRIII), CD25 (IL-2 receptor), CD32 (FcRII), CD35 (C3b receptor), and HLA-DR by macrophage giant cells. The presence of some macrophage-associated antigens on osteoclasts is consistent with their common origin; however, the differences in antigenic phenotype suggest that their pathways of development and differentiation are not identical.

Macrophage-colony stimulating factor (CSF-1) promotes the differentiation of a common CSF-1 receptor expressing progenitor into populations of monocytes, macrophages, DCs, and bone-resorbing osteoclasts. Mutations of the *Csf-1* locus in the osteopetrotic mouse (*op/op*) results in the loss of osteoclast differentiation. However, while mononuclear macrophages are generated in the presence of M-CSF alone, culture with M-CSF plus RANKL (receptor activator of nuclear factor kappa B ligand) is required for cell-cell fusion and generation of multinuclear osteoclasts using various adhesion molecules, such as E-cadherin. RANKL, also known as TNF ligand superfamily member 11, TNF-related activation-induced cytokine (TRANCE), osteoprotegerin ligand, and osteoclast differentiation factor, is a protein that in humans is encoded by the *TNFSF11* gene and found in both a membrane-bound form expressed on preosteoblastic/stromal cells and a soluble form. RANKL mRNA is most highly expressed in bone and bone marrow, but also found in lymphoid tissues including lymph node, thymus, spleen, fetal liver, and Peyer's patches; whereas RANK mRNA is highly expressed by bone marrow-derived osteoclast progenitors and by mature osteoclasts *in vivo*. OPG, osteoprotegerin, is a soluble, decoy receptor belonging to the TNF receptor superfamily which inhibits osteoclast differentiation and activity by binding to RANKL.

RANKL stimulation regulates osteoclastogenesis positively through NFATc1 and AP1TRAF6 (TNF receptor activated factor 6), which is recruited by binding of RANKL and activates MAP kinases and I κ B, leading to the nuclear translocation of transcription factors such as c-fos, c-jun, ATF2 (activating transcription factor 2), and nuclear factor-kappaB (NF-kappaB), that drive the expression of osteoclast-specific genes. Deficiency of RANKL in mice results in the abrogation of bone resorption, which leads to lack of bone marrow and the absence of tooth eruption. In bone marrow macrophage cultures, RANKL treatment results in production and secretion of sphingosine 1 phosphate, a factor which has a dual role in triggering a negative loop in osteoclasts in response to RANKL, and stimulating migration and survival of osteoblasts.

The transcription factor PU.1 drives the expression of the *c-fms* gene, encoding the tyrosine kinase receptor of M-CSF as well as of the receptor RANK. PU.1 is essential for the initial commitment to osteoclast differentiation. PU.1-deficient mice are characterized by the absence of osteoclasts and macrophages, and PU.1 expression increases as marrow macrophages differentiate into osteoclasts. PU.1 also interacts with another transcription factor that distinguishes osteoclast and macrophage differentiation, Mitf-E (microphthalmia-associated transcription factor-E). This is a basic-loop-helix-leucine zipper which occurs in two forms, Mitf-A and Mitf-E. Mitf-A is expressed in macrophages and osteoclasts at similar levels, whereas Mitf-E increases during osteoclast differentiation by increasing transcription of *ctsk* and *acp5*, encoding cathepsin k and tartrate resistant acid phosphatase.

Cell fusion is controlled via the regulator DC-STAMP, which itself was originally isolated by a cDNA subtractive screen between osteoclasts and macrophages. In DC-STAMP-deficient mice the expression of osteoclast differentiation markers is normal; however, the multinucleation of osteoclasts is completely absent. *Bcl6* has been demonstrated to bind directly to the DC-STAMP promoter, becoming dissociated upon RANKL stimulation. Lack of *Bcl6* results in increased osteoclast differentiation and osteopenia.

Bone cell development does not occur in isolation. Many of the molecules involved in osteoclastogenesis are also immune system regulators and there is considerable bone-immune system interaction. RANKL has a function in the immune system, where it is expressed by T helper cells and is thought to be involved in DC maturation. It was shown to be a DC survival factor and is involved in the regulation of T cell-dependent immune response. A subset of T lymphocytes, named osteoclastogenic TH cells, which are able to induce osteoclast differentiation through IL-17, have also been identified. Other studies have demonstrated a positive relationship between bone density and fat mass, possibly through the

adipokine leptin, which is produced by adipocytes increasing osteoblast proliferation and differentiation, inhibiting osteoclast differentiation.

Adipose Tissue

Figure 10.22 illustrates some of the transcription factors associated with macrophage specialization in different tissue environments such as adipose tissue, and in different functions, including infection.

The co-localization of macrophages and adipocytes has attracted interest in adipokine functions and metabolic regulation. Bone marrow-derived mesenchymal stem cells differentiate to the osteogenic and adipogenic lineages. As bone volume decreases with age, osteoporosis is accompanied by an increase in adipose tissue, implying a relationship between the adipogenic process and bone loss.

Genitourinary Tract

The mouse kidney contains interstitial macrophages associated with the tubular epithelium and the juxta-glomerular complex, perhaps part of erythropoietin and renin homeostasis. The glomerular tuft does not contain F4/80+ macrophages, which line Bowman's capsule. Mesangial cells are F4/80-, but express mannose receptors. The bladder has a population of macrophages which penetrate its transitional epithelium. The ovary and testis contain prominent macrophage populations which fluctuate with the reproductive cycle, e.g., during follicular atresia, and the removal of apoptotic sperm. The uterus contains specialized Hofbauer macrophages, and the placenta and umbilical cord provide specialized fetal progenitors and macrophage populations.

Endocrine Organs

F4/80+ macrophages are present in the anterior and posterior pituitary, thyroid, adrenal, and pancreas; they may play an unrecognized role in hormone homeostasis.

Cardiovascular Systems¹⁰⁴

Healthy large blood vessels and the normal heart do contain interstitial macrophages, but the accumulation of lipid serves to

P.220

recruit monocytes to the intima, atheromatous plaque formation, thrombosis, and vascular occlusion.

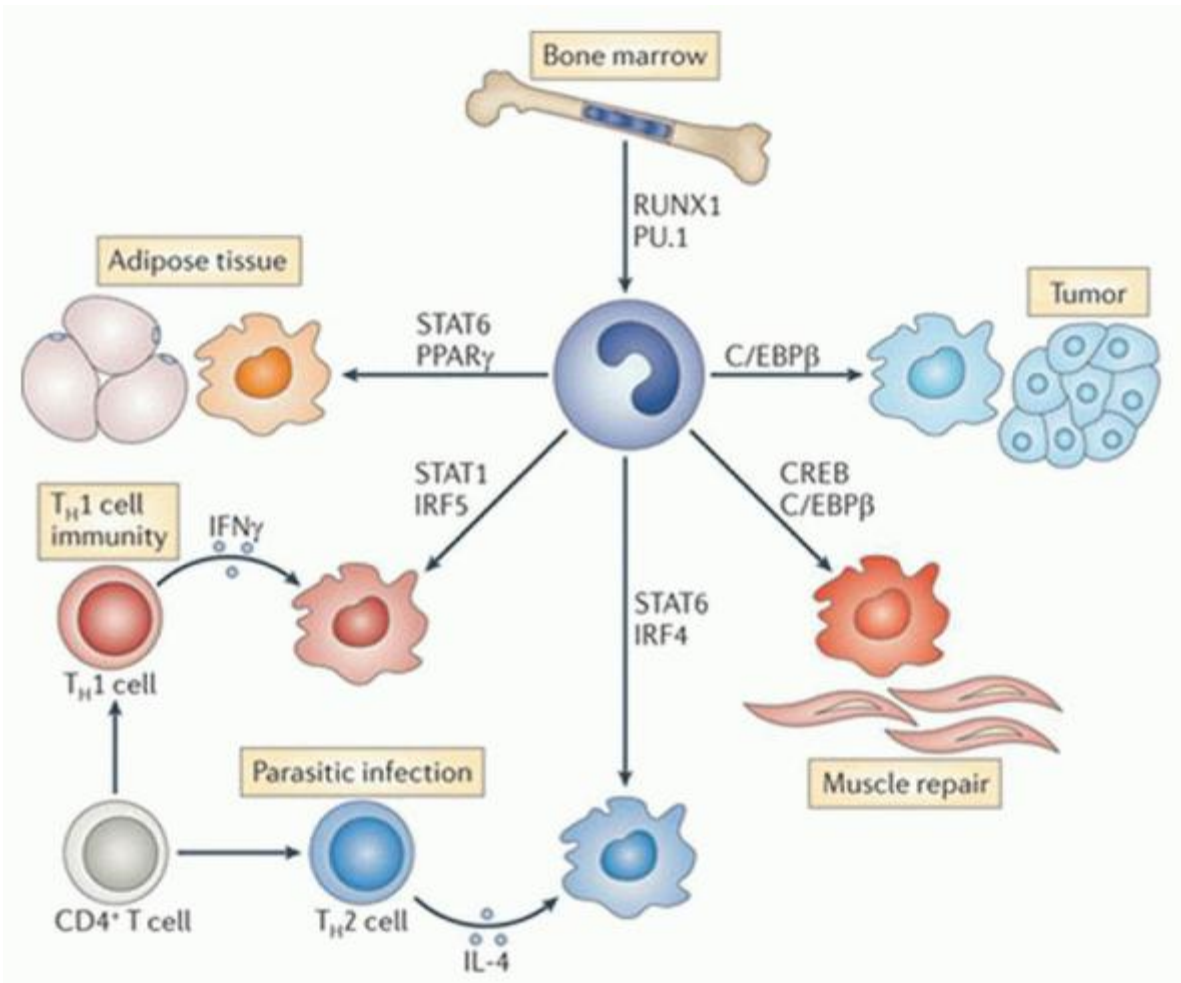

FIGURE 10.22. Transcription factors associated with different polarized populations of macrophages. C/EBP β , CCAAT/enhancer-binding protein- β ; CREB, cAMP-responsive element-binding protein; IFN γ , interferon- γ ; IL-4, interleukin-4; IRF, interferon-regulatory factor; PPAR γ , peroxisome proliferator-activated receptor- γ ; RUNX1, Runt-related transcription factor 1; STAT, signal transducer and activator of transcription; TH, T helper. From Lawrence T, Natoli G. Transcriptional regulation of macrophage polarization: enabling diversity with identity. *Nat Rev Immunol* 2011;11(11):750-761, with permission.

Muscle and Connective Tissue

Macrophages are present throughout these tissues. In muscle they play a part in the hematopoietic and metabolic response to exercise, as well as to tissue injury and repair (Fig. 10.22), catabolism, and wasting syndromes.

DEVELOPMENT AND RENEWAL

(See Fig. 10.1.)

Yolk Sac Macrophages^{105,106}

The earliest hematopoietic cells are yolk sac macrophages. It has recently been demonstrated in mice by lineage tracing studies that these colonize the ectodermal and mesodermal tissues late in embryogenesis, prior to the onset of definitive hematopoiesis in the fetal liver. A striking finding is that 100% of microglia and 10% of Langerhans cells remain derived from this early wave of primitive macrophage invasion. Yolk sac does not appear to contribute to other macrophage populations in interstitial tissues; rather these and the bulk of Langerhans cells arise from a second wave of immigration by fetal liver monocytes. Once seeded in the tissues, it is likely that these cells are postmitotic and renewed by blood-borne precursors at an extremely slow rate.

Renewal of Steady-state Macrophages in the Adult^{21,91,107,108,109,110} and¹¹¹

Conventional wisdom suggests that tissue macrophages are replaced by circulating monocytes, although it appears that

P.221

this dogma arose through extrapolation of models of inflammatory monocyte recruitment. Several attempts have been made to dissect which monocyte subset is more likely to give rise to tissue macrophages, but the rate of renewal is sufficiently slow that adoptive transfer and parabiosis experiments (experimental joining of the circulation of two animals) produce only very subtle signals in the tissues. These findings are in keeping with the very slow renewal of tissue macrophages following hematopoietic stem cell transplantation in humans. A small pool of monocytes may be mobile enough to traffic in and out of tissues as evidenced by the minor population of CD14+ cells present in human interstitial sites, but these appear to equilibrate only very slowly with tissue macrophages, if indeed they serve any precursor function at all. Lineage tracing experiments now indicate that tissue macrophages may arise through intermediates that do not express lysozyme, thus excluding the majority of monocytes. These findings resonate with the observation in humans that tissue macrophages are retained for many years after the generation of blood monocytes has failed because of genetic disorders of hematopoiesis. Current efforts to understand this paradox are focusing on circulating hematopoietic progenitors that occupy most tissue sites and potentially contribute directly to tissue macrophage homeostasis.

MACROPHAGE DEVELOPMENT IN THE MOUSE³¹

Our knowledge of the origin, differentiation, and tissue distribution of macrophage lineage cell types depends on experimental studies in the mouse using genetic and immunological methods. The monoclonal antibody F4/80 was used to detect a sensitive and fixation-stable plasma membrane antigen present in many mature macrophages. This made it possible to identify F4/80- progenitors by their ability to give rise to F4/80+ progeny by day 4. The first F4/80+ macrophages in the mouse embryo were detected in the yolk sac at day 8 to 9, together with nucleated erythroid cells. Fetal liver showed increasing numbers of F4/80+ monocytes and stellate macrophages in clusters with erythroblasts undergoing definitive erythropoiesis; the clusters reached a peak at day 12 to 14, declining by day 15 as hematopoiesis moved to the spleen and then the bone marrow by day 17/18 before birth. By a week after birth, the stellate macrophages appeared to remain as isolated early Kupffer cells, no longer in clusters with erythroid cells and no longer containing the remnants of phagocytosed erythroid nuclei. Maturation after birth included the appearance of CD169+ metallophilic macrophages in the developing marginal zone of the spleen between 2 and 4 weeks. This antigen, also known as sialoadhesin or siglec-1, closely related to, if not identical with, MOMA-1, recognizes sialylated ligands on erythroid and myeloid cells.

Further studies documented expression of F4/80 in a wide range of tissues in adult mice, normally and in a range of disease models. Subsequent studies with F4/80 knockout mice identified a role for the antigen in peripheral tolerance in the anterior chamber of the eye. The human counterpart, EMR1, has not been suitable for immunocytochemical detection of macrophages or DCs, but the EMR2 antigen, expressed by monocytes, macrophages, DCs, and neutrophils, provides a promising alternative.

Local Proliferation^{73,107,108,111}

One general distinction between monocytes and macrophages and cells of the DC lineage in the steady state is that monocytes and macrophages are generally nondividing cells, while blood and tissue DCs include small proportions of cells in S/M/G2 by DNA content analysis and Ki-67 staining. In mice, and probably also in humans, Langerhans cells and microglia undergo sufficient proliferation to maintain numbers independently of blood-borne precursors in the steady state. Following hematopoietic stem cell transplantation, this is sufficient to enable recipient LCs to survive independently of the donor bone marrow. However, observations in humans suggest that LCs are more labile and become donor-derived by 3 months. A postmortem study of human microglia suggested that recipient microglia persist several years after hematopoietic transplantation.

It should be noted that the observation of cycling cells is not sufficient to conclude that a population is self-renewing, however; and DC populations, although completing a small number of cell divisions in situ, appear to be rapidly replenished by bone marrow-derived precursors in human transplantation, parabiosis, and adoptive transfer models. Historical studies in which the appearance of pulsed tritiated thymidine was presented as evidence of relatively rapid renewal of tissue macrophages from the bone marrow should be interpreted with caution in the light of local proliferation, more precise definitions of phenotypes, and experimental systems with fewer variables.

Monocyte and Dendritic Cell Hematopoiesis^{112,113,114,115}

In contrast with macrophage populations which appear largely static, monocytes and DCs are continually produced by the bone marrow. Inflammatory monocytes have an estimated half-life of several days; nonclassical monocytes and DCs are

likely to live a little longer, although this has not been accurately measured in humans. According to conventional models, monocytes arise from hematopoietic stem cells via common myeloid and granulocyte-macrophage progenitors. In the mouse, further stages of differentiation have been mapped by clonogenic assays and adoptive transfer. GMP are said to lose granulocyte potential, giving rise to monocytes and DCs via a macrophage-dendritic progenitor (MDP). The MDP has the potential to give rise to monocytes and to a common DC progenitor (CDP). Plasmacytoid DCs arise directly from CDPs, while a committed "pre-DC" forms the classical and cross-presenting myeloid DCs. No such intermediates have been found in humans. It has been shown that GMPs can form macrophages and DCs but many studies have also found that committed lymphoid progenitors retain monocyte and DC potential. Indeed, state of the art transcriptomic mapping of human hematopoiesis, while confirming the proximity of monocytes to granulocytes, places the DC lineage adrift between myeloid and lymphoid signatures. A full discussion of the hematopoietic hierarchy is beyond the scope of this chapter, but these studies raise questions about the classical split between myeloid and lymphoid hematopoiesis, somewhat confounding the myeloid-biased model of murine DC differentiation. One significant problem in understanding the differences between human monocyte and DC hematopoiesis is that the factors that control steady state DC differentiation are poorly understood, and many assays claiming to show in vitro differentiation of DCs may simply be examining inflammatory monocyte-derived DCs. At the time of writing, it has been possible to generate cells resembling 14+ monocytes, pDCs, and CD141+ DCs in vitro, but not CD16+ monocytes or CD1c+ myeloid DCs.

Regulation by Soluble Factors^{46,92,116}

A number of soluble mediators play a part in monocyte and DC differentiation, although many have been verified only in mouse models or human in vitro studies. Standard colony forming assays in which erythroid, granulocyte, and macrophage colonies may be detected by morphology contain SCF, IL-3, GM-CSF, G-CSF, and Epo. M-CSF, FLT-3L, and TPO have all been added to enhance the production of monocytes or DCs, but their effects are pleiotropic and have not been resolved in detail. M-CSF, FLT-3L, and TPO are all steady state cytokines present in normal plasma and widely produced by stromal tissues. Receptors for M-CSF (CD115) and FLT-3L (CD135) are present on monocytes and circulating DCs and may play a role in enhancing both the generation and functional capacity of mature cells. In mice, osteoclast generation, Langerhans cell differentiation, and the formation of microglia are all dependent upon signaling through the M-CSF receptor, while DC generation is critically dependent upon FLT-3. Recently, IL-34, an alternate ligand for CD115, has emerged as a critical cytokine in the differentiation of microglia and LC. All monocytes and DCs express receptors for GM-CSF (CD116). Quantities of this cytokine are much more limited in the steady state, and although lymphoid DCs develop normally in GM-CSF deficient mice, recent experiments show that nonlymphoid tissue DCs are depleted. Production by epithelial surfaces appears to be important, since antibodies to GM-CSF in humans cause dysfunction of alveolar macrophages, leading to pulmonary alveolar proteinosis (PAP). There is considerable interest in the use of growth factors to augment production or activity of monocytes and DCs, particularly in the field of vaccination and cancer therapy. Clinical trials of GM-CSF and FLT-3L have been performed. One of the difficulties in the interpretation of results is that the expansion of immature precursors may have immunosuppressive effects by inducing populations with properties similar to those attributed to myeloid suppressor cells. GM-CSF as a local adjuvant may have more promise; and the only FDA-licensed DC therapy "Provenge" uses a GM-CSF conjugated immunogen.

Regulation by Transcription Factors^{4,71,117,118,119}

Recent work in mice and also humans has defined the transcription factors associated with macrophage, monocyte, and DC differentiation. Macrophage development requires PU.1 and Myb and is interrupted by defects of Ikaros and GFI1. DCs are dependent upon PU.1, IRF2, IRF4, and IRF8, and a recently described zDC. Ikaros and GFI1 deletion probably also affect DC development. Many of these transcription factors control the development

P.222

of monocytes, but this is not always reported. Specific factors are required for the development of pDC (E2-2) and CD8+ cross-presenting DCs (Batf3, Id2). Analysis of genetic defects in human DC deficiency was recently reported. Ikaros and IRF8 mutations prevent the formation of monocytes and DCs. GATA-2 mutation interrupts mononuclear cell development, leading to a late-onset loss of DCs.

Trafficking of Blood-borne Precursors to Quiescent Tissues^{62,87}

It has recently been recognized that nonlymphoid tissues contain myeloid DC populations and CD14+ monocyte-like cells similar to those found in peripheral blood. The tissue counterparts of CD1c+ DCs, CD141+ DCs, and classical CD14+ monocytes appear more mature than their blood relatives, implying that each blood subset gives rise to a corresponding tissue cell. In the mouse a few selected DC populations are monocyte-derived in the steady state, notably the CD11b+

CX3CR1+ resident mononuclear cell of mouse lamina propria, which is derived from a classical monocyte. The role of patrolling nonclassical monocytes in steady state tissue homeostasis remains unclear. Although these cells are anatomically apposed to the endothelium and more mature in phenotype than classical monocytes, they do not appear to contribute quantitatively to homeostasis in the tissues.

Inflammatory Recruitment^{67,74,104}

Both classical and nonclassical monocytes are recruited during inflammation. In mouse *in vivo* models, nonclassical cells are recruited more quickly, but classical monocytes are quantitatively more important. Classical monocytes can differentiate into inflammatory TiP DC/M1 macrophages in the tissues and replace microglia and Langerhans cells after an inflammatory insult. A great variety of infection models in mice have confirmed the role of CCR2 and classical monocytes in the response to and resolution of infection. These include mycobacteria, *Listeria*, *Toxoplasma*, *Cryptococcus*, *Aspergillus*, and influenza. Classical monocytes are clearly implicated in the sterile inflammation of atherosclerosis and in the response of humans to myocardial infarction. Granulomata provide an intriguing opportunity to examine this by intravital microscopy, as shown by Germain and colleagues. Earlier studies showed that mycobacterial granulomata depend on TNF- α and the type 3 complement receptor, CD11b/CD18. The presence of multinucleated giant cells, products of macrophage fusion, in tuberculous (Langhans giant cells) and schistosome egg granulomata has long attracted attention of pathologists. Their formation by IL-4, for example, depends on surface glycoproteins such as CD36 and DAP12, and of lipids of microbial and host origin. Notably, granulomata are produced by persistent, poorly degraded pathogens and foreign bodies, rather than viruses, which can also induce syncytia. It would be useful to compare epithelioid and giant cell phenotypes in different organs such as the liver (BCG), lung (schistosome eggs), and intestine (Crohn's disease), as well as by the same causal agent in different tissues, e.g., tuberculosis.

In the mouse, local macrophage proliferation has been reported during infection with helminths stimulating Th2-type responses. It remains to be determined how significant this is quantitatively and whether these mechanisms occur in humans under similar conditions.

Monocyte-derived Macrophages and Dendritic Cells⁴⁶

A great deal of human research has focused on the generation of DC and macrophage-like cells from peripheral blood monocytes. The major drawback of these models is that they recreate inflammatory conditions and probably bear little or no relationship to the origin and differentiation of steady state macrophages and DCs, which are really distinct cells with very different provenances. However, the true value of studying monocyte-derived cells is now being put into context by many emerging *in vivo* studies of inflammatory monocyte-derived macrophages and DCs which play important roles in immunity.

A vast array of different antigen-presenting cells may be derived from monocytes *in vitro*, and it is clear that macrophages form in the presence of M-CSF, IL-10, and serum, while a potent DC can be derived using IFN α or GM-CSF. The addition of TFG- β causes monocyte-derived DCs to express langerin and resemble a Langerhans cell. It is likely that *in vitro* phenotypes bear some relationship to cells present in different inflammatory contexts, although experimental data to support this are hard to find.

MONONUCLEAR PHAGOCYTES IN MEDICINE

Transplantation¹²⁰

Allogeneic organ and stem cell transplantation is an important modality of clinical therapy that generates a unique immunological problem because of differences between donor and recipient major or minor histocompatibility antigens. Allograft rejection and graft-versus-host disease are mediated by T cells primed to recognize histocompatibility antigens. DCs are likely to play an important role in the initiation of alloreactive T cell responses. Tissue macrophages may also exacerbate or modulate this process, and recruited inflammatory monocytes contribute to effector responses and immunopathology.

Allograft Rejection

Solid organs including the heart, kidney, and liver contain tissue macrophages and DCs that contribute to the sensitization of recipient T cells and the activation of rejection mechanisms. Broadly speaking, the density of antigen-presenting cells within a tissue correlates with the strength of rejection reactions and is in the order skin > lung/gut > liver > heart/kidney. Conditioning a transplanted organ to deplete donor DCs results in enhanced allograft survival, and methods to optimize this may present therapeutic opportunities. More recent allograft experiments using inducible depletion of DCs or antibodies have confirmed this finding.

Graft-versus-Host Disease

Conversely to solid organs in which donor DCs and macrophages may trigger rejection, the dominant immune response in hematopoietic stem cell transplantation is between donor T cells and recipient antigen-presenting cells. The role of recipient BM-derived cells was first demonstrated by the blood-lymph filtering experiments of Sprent and colleagues. Attenuation of recipient antigen-presenting capacity has since been shown to ameliorate GVHD, suggesting that recipient DCs are essential for the initiation of GVHD, at least in models dependent upon alloreactive CD8⁺ T cells recognizing directly presented minor histocompatibility antigen. Many studies have confirmed this finding and shown that donor DCs serve mainly to augment continuing GVHD responses. Support for potential therapeutic targeting of DCs was provided by a demonstration that anti-CD83 antibodies could delay GVHD in a xeno-transplant model. However, more recent experiments have shown that complete ablation of recipient DCs in inducible depletion models fails to prevent GVHD. Another interesting manipulation was the expansion of recipient

P.223

monocytes by M-CSF injection, resulting in less GVHD. Expansion of myeloid suppressor cells or tolerogenic DCs has been mooted as the explanation.

In human bone marrow transplantation, it was noted that alemtuzumab (anti-CD52) might attenuate GVHD not only by depleting donor T cells, but also by removing recipient APC including monocytes and blood DCs but not their tissue counterparts or Langerhans cells. Several studies have shown those recipient DCs are rapidly lost after transplantation. Recipient Langerhans cells survive for a month or so but are eventually replaced even in the absence of GVHD and are unlikely to constitute a reservoir of persistent recipient histocompatibility antigen. Interstitial tissue macrophages are the most long-lived antigen-presenting cells in humans and may promote chronic GVHD responses. In haplo-identical transplantation, ablation of recipient DCs by donor NKs has been suggested to play a role in the relatively low risk of GVHD experienced by these patients. Depletion or modulation of cutaneous DCs by UV light has also been suggested as a useful form of localized prophylactic therapy for GVHD. The mechanisms underlying chronic GVHD are more obscure. From a simple perspective, the delayed onset of chronic GVHD suggests a greater dependence on donor-derived APC and indirect rather than direct routes of antigen presentation. The difference between acute and chronic GVHD might be explained by a transition from CD8-mediated pathology to a CD4-dominated response to tissuespecific antigens.

Efferent Pathway

Recruitment of inflammatory monocytes also plays a role in the effector phase of organ rejection and GVHD. Injection of iron nanoparticles has been used as a means to demonstrate infiltration of rejecting organs by inflammatory monocytes. A high density of macrophages in GVHD biopsies has also been shown to correlate with poor outcome. Selective ablation of monocytes by inducible genetic systems or administration of M-CSFR antibodies attenuates both processes and offers the potential of a new means of controlling allograft rejection in humans. Further work is required to dissect the pathways of differentiation and the precise roles of recruited monocytes infiltrating during organ rejection or GVHD.

Macrophages and Dendritic Cells in Hematopoietic Disorders

Disorders of Production: Monocyte and Dendritic Cell Deficiency^{107,109,117}

While specific defects of lymphocyte development, granulocyte differentiation, and function are well known, primary disorders involving loss of monocytes, DCs, and macrophages have been described only relatively recently. GATA-2 mutation causes a syndrome known as DC, monocyte, B, and NK lymphocyte (DCML) deficiency. This is characterized by a failure of mononuclear cell development, resulting in immunodeficiency to intracellular pathogens, viruses, and tumors, and evolves to myelodysplasia and leukemia. It has also been described as "monoMAC" to reflect the link between monocytopenia and Mycobacterium avium infection. IRF8 mutation, CXCR4 mutation, E2-2 mutation, and several other genes have also been shown to lead to deficiency of DCs and monocytes. Although these affect very small numbers of patients, they provide fascinating insights into the genetic regulation of DC and monocyte development.

Histiocytoses^{121,122}

The histiocytoses are a group of disorders characterized by the accumulation of abnormal DCs or macrophages. A recent Histiocyte Society classification attempts to correlate each disorder with the transformation of a normal physiological counterpart: Langerhans cell, DC, or macrophage.

Langerhans cell histiocytosis (LCH) is the most prevalent and best characterized. LCH cells are CD1a⁺, Langerin⁺, and S100⁺. Their characterization as abnormal LCs was initially suggested by the demonstration of Birbeck granules under EM.

Although LCH is “epidermotropic” in the skin, it occurs in many other organs where LCs are not normally found and therefore represents a significant dysregulation of LC homeostasis. In the steady state, epidermal LCs are self-renewing, but LCH cells probably derive from classical monocytes, along a pathway described for inflammatory generation of LCs. Gene expression profiling confirms that LCH cells are much more immature compared with epidermal LCs, and recent genetic analysis has strikingly revealed that approximately two-thirds of cases harbor mutated BRAF (V600E).

The other histiocytoses, Erdheim Chester disease (ECD), juvenile xanthogranuloma (JXG), and Rosai-Dorfman disease/sinus histiocytosis with massive lymphadenopathy (RDD/SHML), are much rarer. These are classically described as more macrophagelike and express CD68 and CD14; JXG is also typically Factor XIIIa+. Although at the cellular level LCH appears quite distinct from any of these macrophage-like disorders, a firm link between LCH and ECD has recently been established by the finding that two-thirds of ECD cases also have mutated BRAF. This unexpected observation suggests that LCH and ECD are two facets of the same pathology, as had been suggested by the occasional finding of both in the same patient. However, neither the precursor cell nor the mechanisms that control its differentiation are established. In the same publication it was demonstrated that JXG and RDD do not share mutated BRAF and should perhaps be considered distinct.

Another distinct entity is hemophagocytic lymphohistiocytosis (HLH, or “hemophagocytic syndrome”). This extreme inflammatory disorder shows a spectrum of activity, from a familial neonatal presentation to an apparently sporadic secondary disorder occurring in adulthood. Nearly all cases of HLH are now thought to derive from a defect in NK- or CD8-mediated cytotoxicity. In the familial cases, very clear defects in cytotoxicity mechanisms have been found, including mutations in perforin. Sporadic, late occurrences are often perceived as “secondary” to uncontrolled viral infection with EBV, but are likely to represent a manifestation of more subtle, possibly polygenic, variations in cytolytic mechanisms. In all cases, the inability to control viral replication leads to uncontrolled immune activation with a cytokine storm, massive elevation of ferritin and sCD25, and widespread macrophage activation, leading to phagocytic destruction of the hematopoietic tissue.

Disorders of Destruction

In spite of its importance, the recognition and destruction mechanisms of normal senescent erythrocytes remain unclear, with complement, lectins, and possibly antibody-dependent Fc receptors all implicated. Apoptotic cell recognition and clearance have been described above.

Splenic macrophages play a prominent role in immune destructive processes, including immune thrombocytopenic purpura (ITP) and autoimmune hemolytic anaemia (AIHA), using Fc receptor and complement-mediated uptake of opsonized platelets and red cells. In other autoimmune disorders, phagocytosis of apoptotic cells and antigen presentation by DCs and macrophages may be critical in initiating T cell-mediated cytotoxicity. M2 macrophages are particularly efficient at scavenging self-tissues following injury through receptors like the MR and scavenger receptor A, and may contribute to autoimmune disease.

P.224

Lysosomal Storage Diseases^{123,124}

Lysosomal storage disorders (LSDs) are a heterogeneous group of diseases arising from genetic deficiency of a catabolic lysosomal enzyme. Disorders are classified according to the accumulated substrate and consequent phenotype. Sphingolipid accumulation in macrophages involved in the digestion of effete hematological cells occurs in patients with Gaucher disease (β -glucocerebrosidase deficiency), the most common LSD. The accumulation of glucosylceramide and its deacetylated form glucosylsphingosine leads to intracellular lipid accumulation and the formation of foamy macrophages known as Gaucher cells. Patients with genotypes conferring very low residual glucocerebrosidase activity confer neuronopathic disease, in which microglia are also affected.

Gaucher cells accumulate in sheets and have voluminous cytoplasm. Boven et al. demonstrated that Gaucher cells expressed common macrophage markers including CD68, CD14, and HLA-class II, and have a phenotype of M2 macrophages (CD163, IL-1RA, and CCL-18). Other lysosomal storage disorders exhibiting foamy macrophages are Fabry disease, GM1 gangliosidosis, and Wolman/cholesterol ester storage disorder. In Niemann-Pick A and B the macrophages have a distinctly blue appearance and are described as sea blue histiocytes. Macrophages with identical appearances to Gaucher cells by light microscopy (pseudo-Gaucher cells) have been demonstrated in the bone marrow trephines of patients with other disorders with high cellular turnover, including multiple myeloma, Hodgkin lymphoma, NHL, chronic

myeloid leukemia (CML), myelodysplastic and common B-ALL, and nonmalignant hematological conditions, including thalassemia and sickle cell disease.

Hemochromatosis, Macrophages, and Iron^{57,125,126,127}

Bone marrow and “reticuloendothelial” macrophages in the liver and spleen are responsible for the majority of iron storage outside the red cell mass or “erythron.” Iron is acquired by uptake of transferrin through receptor-mediated endocytosis of the transferrin receptor (CD71). Iron-laden macrophages can be easily observed in conditions of iron overload such as genetic hemochromatosis and multiple transfusions. These appear brown with “hemosiderin” in unstained sections and blue with Perl's stain, a specific preparation for visualizing iron. In health, most iron is stored as intracellular ferritin, but this may be released into the circulation during acute phase responses. The highest ferritin levels (>10,000) are seen in HLH, where there is widespread extreme macrophage activation.

Osteoclast Disorders^{128,129} and¹³⁰

Disorders of osteoclast function or number illustrate their pivotal role in bone mineralization. Compromise of osteoclast function results in osteoporosis, whereas in the Paget disease-like disorders, osteoclast overactivity results in abnormal bone remodeling brought about by waves of bone resorption and reformation. A number of genes relevant to the various clinical patterns of osteopetrosis have been identified. Loss-of-function mutations explain about 70% of cases. Mutant TCIRG1, CLCN7, OSTM1, and PLEKHM1, which are involved in the trafficking of acidic vesicles in osteoclasts, are found in autosomal recessive osteopetrosis. Mutations in the OSTM1 gene results in a severe form of autosomal recessive osteopetrosis, whereas an intermediate form is caused by a mutation in PLEKHM1. Gain-of-function mutation in LRP5 results in autosomal dominant osteopetrosis type I; autosomal dominant osteopetrosis type II is caused by loss-of-function mutations in CLCN7. The etiology of failure of osteoclast formation in vivo (osteoclast-poor osteopetrosis), is unknown, but may be related to mutations in the osteoclast growth factors M-CSF and RANKL, or their receptors.

Paget's disease occurs in a number of forms and severities. Juvenile Paget's disease is caused by loss-of-function mutations in the gene for OPG (TNFRSF11B), resulting in undetectable OPG and elevation of RANKL. It can be treated by reconstituting OPG. Classic Paget's disease of bone (PDB) is associated with mutations in SQSTM1 (p62). p62 functions as a scaffold protein with multiple domains to integrate kinase-activated and ubiquitin-mediated signaling pathways with the IL receptor and TNF receptor family members, especially RANK. The severe Paget-like disorders, early-onset PDB, familial expansile osteolysis, and expansile skeletal hyperphosphatasia, are all associated with mutations in the signal peptide region of the RANK gene, TNFRSF11A. The clinical symptoms in these diseases are similar, and all include early tooth loss and deafness; however, there is significant interindividual variation, suggesting environmental and epigenetic involvement.

Infection^{26,36}

Monocytes, macrophages, and DCs play an important role in all infectious processes as part of the recognition of pathogens, hematopoietic, and immunological responses; mobilization and delivery of mononuclear and myeloid cells to local sites of infection; destruction or otherwise of invading microbes; and the orchestration of systemic reactions of the host, such as fever, and cardiovascular and metabolic responses. We have learned much from the study of model systems in transgenic mice, detailed observation of the natural history of infectious disease in humans, and the experiments of nature, the inborn errors of metabolism and their resistance or susceptibility to infection. In turn, the great variety of microbiome commensal and pathogenic organisms and their invasion and evasion strategies have taught us a great deal about the cellular and molecular properties of these myeloid cells and their interactions with other elements of the hematopoietic system. Here we can only illustrate this rich field by bringing out a few principles and raising questions relevant to hematology.

MPs play a role in the initiation and subsequent reactions to acute as well as chronic infection by bacteria, viruses, fungi, protozoa, and multicellular parasites. Apart from their well-established role in intracellular pathogen entry, killing, and persistence, e.g., tuberculosis, they contribute to the host's innate and adaptive immune response to extracellular bacteria, e.g., streptococci, and to facultative intracellular organisms such as *Listeria* and *Neisseria meningitidis*. Microbes exploit MP receptors' usage, and cytokine dysregulation is a common feature of infection. Macrophages play a devastating role in the inflammatory storm of acute sepsis, as well as the lethal complications of antiretroviral treatment after mixed infection by HIV-1 and tuberculosis, the immune reconstitution inflammatory syndrome. MPs express plasma membrane and cytosolic inhibitors as well as amplifiers, to regulate inflammation and tissue injury: for example, the TREM family of myeloid enhancers of proinflammatory responses, and the CD200/CD200R pair, a downregulator of TLR, NLR, and inflammasome activation. Focal macrophage-rich destructive inflammatory lesions are characteristic of granulomata, by known or unidentified microbes, e.g., Crohn's disease. Malaria results in diffuse intravascular pathology and hematological

dyscrasia, as monocytes and sinus-lining macrophages ingest parasitized erythrocytes, and accumulate pigment residues. Polarization of macrophages by TH1 and TH2 cytokines has been outlined above. Depending on the outcome of host-pathogen interaction, macrophages contribute to latency and immunosuppression.

Granulomatous Disorders

These include a range of infectious and autoimmune conditions of genetic origin, such as CGD (NADPH oxidase), Blau syndrome (NOD), or the combination of genetic predisposition and poorly

P.225

characterized environmental factors (Crohn's disease). Here we restrict our discussion to granuloma annulare and sarcoidosis.

Granuloma Annulare

This is a relatively common benign inflammatory condition of the dermis and subcutaneous tissue of unknown etiology. Histological analysis of dermal papules and annular plaques reveals foci of palisaded granulomatous inflammation around "necrobiotic" collagen. Fifty percent of patients have IgM and C3 in vessels. It may be associated with diabetes, HIV, EBV, or lymphoma.

Sarcoidosis

Sarcoidosis is an idiopathic granulomatous disease in which collections of chronic inflammatory cells form nodules in multiple organs, most commonly lungs or lymph nodes. Sarcoidosis may be asymptomatic or chronic or may progress to life-threatening organ fibrosis. The pathogenesis involves exposure to an undescribed antigen in a host with genetic susceptibility, resulting in nonnecrotizing granulomatous inflammation. There is a prominent Th1 cell-mediated immune response characterized by IFN γ and TNF- α with increased macrophage and CD4 helper T cell activation, but suppression of responses to other antigenic challenges. Patients with sarcoidosis exhibit increased risk for malignancy, including lung cancer and lymphoma.

Tumor-associated Macrophages^{68,131,132,133}

Interactions with trophic and immunosuppressive host cells promote the emergence and perhaps metastasis of neoplastic disease. Some cancers attract macrophages through CSF-1, and stimulate their local growth and angiogenic properties, in part through alternative activation of macrophage. IL-6 plays a direct role in the establishment of myelomas; macrophage-derived growth factors may also contribute to asbestos-induced mesothelioma. In addition, tumors evoke the recruitment of myeloid-derived suppressor cells and immature granulocytes and monocytes, which downregulate antitumor T cell responses.

Macrophages have been found to be more abundant in the bone marrow of patients with multiple myeloma, a malignant proliferation of plasma cells, than in healthy controls. Macrophage contact upregulates antiapoptotic proteins, and prevents chemotherapy-induced death in plasma cells. Higher numbers of infiltrating tumor-associated macrophages (TAMs) are associated with tumor invasion, lymph node metastasis, and advanced disease in colorectal cancer. Poor prognosis is conferred by the presence of large numbers of TAMs in other cancers such as sinonasal melanoma, and predicts an inferior outcome to hormonal therapy in prostate cancer.

Metabolic Disease

Atherosclerosis is now well recognized as a modified form of inflammation in which monocytes and macrophages are major drivers of plaque formation and thrombosis. As circulating cells they interact with platelets and adhere to endothelium or exposed vessel wall constituents. They take up and accumulate lipids through their scavenger receptors, become foam cells, and either remain in the intima, or migrate to the media to interact with smooth muscle. A characteristic feature is death in situ, although cells can also emigrate from the vessel wall, as shown in experimental models. Metalloproteinases are involved in vulnerable plaque rupture, and pro- and anticoagulant balance contributes to local thrombosis and embolism. Of course, monocytes are part of the host response to infarcts, leading to repair and fibrosis; depletion of monocyte recruitment via anti-MCP-1 antibody has been achieved experimentally.

Recent attention to the role of macrophages in obesity has grown; they associate with adipocytes, and cytokines from both cell types have been implicated in cell activation and lipolysis. The role of macrophages in diabetes has been somewhat neglected; they are present in the pancreas in early stages of beta cell damage, and both DCs and macrophages have been implicated in autoimmune recruitment and activation, resulting in islet inflammation and beta cell destruction.

Macrophages are also involved in the complications of diabetes resulting from hyperglycemia and the generation and clearance of advanced glycosylation end (AGE) products, via AGE receptors.

CONCLUSION¹²⁴

We have compared the properties of three monocyte-derived sublineages, macrophages, DCs, and osteoclasts, which express many genes in common, although specialization of function is also clear. Further studies are required to identify osteoclast progenitors in yolk sac, fetal liver, bone marrow, and blood, comparable to what has been done with DCs, to establish branch points during differentiation, as well as common precursors. Comprehensive *ex vivo* and *in vitro* microarray, RNA sequencing, and proteomic analysis will help, but there are many variables of maturation, modulation, and culture, as well as species, that make such comparisons difficult. RNA-mediated silencing of transcription factors will assist this analysis, in mouse and human deficiency syndromes. The recent application of induced pluripotent stem cell (iPS) technology to Gaucher disease is a stunning illustration of how immortal macrophages and other differentiated cell types can be generated from fibroblasts or monocyte-derived macrophages from individual patients.

Even within each sublineage, modulation within cell populations among individual cells needs to be defined, not only for a few selected cytokines but also for a much larger group of stimuli, including activation, deactivation, and regulation. In particular, the roles of local tissue microenvironments, perhaps due to stromal cell heterogeneity, as well as hormones and microbial constituents, need clarification.

The application of FACS and immunocytochemistry to cells *in situ*, *ex vivo*, and *in vitro* needs to be extended; suitable antibodies are needed for further tissue analysis, especially in humans. Monocytic mononuclear cell populations may contain minor populations of distinct precursors and unrelated lineages. To deal with genetic variation among humans, it will be helpful to study individual subjects sequentially during different stages of a disease.

Disease-specific biomarkers and signatures for blood monocytes, sera, or other body fluids could provide considerable diagnostic and prognostic value.

With regard to the role of MPs in hematology, it is important to remember that apart from the fact that they are themselves part of the hematopoietic system, these cells play a still poorly understood role in trophic functions for other hematopoietic and nonhematopoietic cells; hence the importance of considering their contribution to all disease processes. Improved noninvasive tests, and standardization of more complex assays of their function, are urgently required. Improved imaging methods, based on NMR and PET, for example, with antibodies, iron oxide tracers, and particles, should provide fresh insight into bone marrow, spleen, and lymph node function in health and disease.

ACKNOWLEDGMENTS

SG would like to thank the Stellenbosch Institute for Advanced Study (STIAS) for a visiting fellowship in November 2012, during which this chapter was completed.

P.226

REFERENCES

1. Beutler B. How mammals sense infection: from endotoxin to the toll-like receptors. Nobel Lectures 2012. http://www.nobelprize.org/nobel_prizes/medicine/laureates/2011/beutler-lecture.html; Accessed on 5 February 2013
2. Cavaillon JM. The historical milestones in the understanding of leukocyte biology initiated by Elie Metchnikoff. *J Leukoc Biol* 2011;90(3):413-424.
3. Cavaillon JM. Sir Marc Armand Ruffer and Giulio Bizzozzero: the first reports on efferocytosis. *J Leukoc Biol* Epub 2012 Sep 14.
4. Geissmann F, Gordon S, Hume DA, Mowat AM, Randolph GJ. Unravelling mononuclear phagocyte heterogeneity. *Nat Rev Immunol* 2010;10(6): 453-460.
5. Gordon S. Elie Metchnikoff: father of natural immunity. *Eur J Immunol* 2008;38(12):3257-3264.
6. Moberg CL. An appreciation of Ralph Marvin Steinman (1943-2011). *J Exp Med* 2011;208:2337-2342.
7. Steinman RM, Moberg CL. Zanvil Alexander Cohn 1926-1993. *J Exp Med* 1994;179(1):1-30.
8. Steinman RM, Cohn ZA. Identification of a novel cell type in peripheral lymphoid organs of mice. I. Morphology, quantitation, tissue distribution. *J Exp Med* 1973;137(5):1142-1162.

9. Gordon S. Macrophage heterogeneity and function: biomedical and life sciences collection. London: Henry Stewart Talks Limited, 2012.
10. Nichols BA, Bainton DF. Differentiation of human monocytes in bone marrow and blood. Sequential formation of two granule populations. *Lab Invest* 1973;29(1):27-40.
11. Braunersreuther V, Zernecke A, Arnaud C, et al. Ccr5 but not Ccr1 deficiency reduces development of diet-induced atherosclerosis in mice. *Arterioscler Thromb Vasc Biol* 2007;27(2):373-379.
12. Broxmeyer HE, Cooper S, Hangoc G, Gao JL, Murphy PM. Dominant myelopoietic effector functions mediated by chemokine receptor CCR1. *J Exp Med* 1999;189(12):1987-1992.
13. Charo IF, Ransohoff RM. The many roles of chemokines and chemokine receptors in inflammation. *N Engl J Med* 2006;354(6):610-621.
14. Eis V, Luckow B, Vielhauer V, et al. Chemokine receptor CCR1 but not CCR5 mediates leukocyte recruitment and subsequent renal fibrosis after unilateral ureteral obstruction. *J Am Soc Nephrol* 2004;15(2):337-347.
15. Gao JL, Wynn TA, Chang Y, et al. Impaired host defense, hematopoiesis, granulomatous inflammation and type 1-type 2 cytokine balance in mice lacking CC chemokine receptor 1. *J Exp Med* 1997;185(11):1959-1968.
16. Gautier EL, Jakubzick C, Randolph GJ. Regulation of the migration and survival of monocyte subsets by chemokine receptors and its relevance to atherosclerosis. *Arterioscler Thromb Vasc Biol* 2009;29(10):1412-1418.
17. Gerard C, Frossard JL, Bhatia M, et al. Targeted disruption of the beta-chemokine receptor CCR1 protects against pancreatitis-associated lung injury. *J Clin Invest* 1997;100(8):2022-2027.
18. Helming L, Gordon S. Molecular mediators of macrophage fusion. *Trends Cell Biol* 2009;19(10):514-522.
19. Kaufmann A, Salentin R, Gemsa D, Sprenger H. Increase of CCR1 and CCR5 expression and enhanced functional response to MIP-1 alpha during differentiation of human monocytes to macrophages. *J Leukoc Biol* 2001;69(2):248-252.
20. Leuschner F, Dutta P, Gorbатов R, et al. Therapeutic siRNA silencing in inflammatory monocytes in mice. *Nat Biotechnol* 2011;29(11):1005-1010.
21. Massberg S, Schaerli P, Knezevic-Maramica I, et al. Immunosurveillance by hematopoietic progenitor cells trafficking through blood, lymph, and peripheral tissues. *Cell* 2007;131(5):994-1008.
22. Pellegatti P, Falzoni S, Donvito G, Lemaire I, Di Virgilio F. P2X7 receptor drives osteoclast fusion by increasing the extracellular adenosine concentration. *FASEB J* 2011;25(4):1264-1274.
23. Taylor PR, Martinez-Pomares L, Stacey M, Lin HH, Brown GD, Gordon S. Macrophage receptors and immune recognition. *Annu Rev Immunol* 2005;23:901-944.
24. Thomas S, Baumgart DC. Targeting leukocyte migration and adhesion in Crohn's disease and ulcerative colitis. *Inflammopharmacology* 2012;20(1):1-18.
25. Zhang J, Alcaide P, Liu L, et al. Regulation of endothelial cell adhesion molecule expression by mast cells, macrophages, and neutrophils. *PLoS One* 2011;6(1):e14525.
26. Areschoug T, Plüddemann A, Gordon S. Innate immunity against bacteria. In: Kaufmann SH, Rouse T, Sacks DL, eds. *The immune response to infection*. Washington, DC: ASM Press, 2011:209-223.
27. Bell JK, Mullen GE, Leifer CA, Mazzone A, Davies DR, Segal DM. Leucine-rich repeats and pathogen recognition in Toll-like receptors. *Trends Immunol* 2003;24(10):528-533.
28. Brown GD. Dectin-1: a signalling non-TLR pattern-recognition receptor. *Nat Rev Immunol* 2006;6(1):33-43.
29. Crocker PR, McMillan SJ, Richards HE. CD33-related siglecs as potential modulators of inflammatory responses. *Ann N Y Acad Sci* 2012;1253:102-111.
30. Goodridge HS, Reyes CN, Becker CA, et al. Activation of the innate immune receptor Dectin-1 upon formation of a "phagocytic synapse." *Nature* 2011;472(7344):471-475.
31. Gordon S, Hamann J, Lin HH, Stacey M. F4/80 and the related adhesion-GPCRs. *Eur J Immunol* 2011;41(9):2472-2476.
32. Janeway CA, Jr., Medzhitov R. Innate immune recognition. *Annu Rev Immunol* 2002;20:197-216.
33. Kawai T, Akira S. The roles of TLRs, RLRs and NLRs in pathogen recognition. *Int Immunol* 2009;21(4):317-337.

34. Nakahashi-Oda C, Tahara-Hanaoka S, Shoji M, et al. Apoptotic cells suppress mast cell inflammatory responses via the CD300a immunoreceptor. *J Exp Med* 2012;209(8):1493-1503.
35. Netea MG, Wijmenga C, O'Neill LA. Genetic variation in Toll-like receptors and disease susceptibility. *Nat Immunol* 2012;13(6):535-542.
36. Pluddemann A, Mukhopadhyay S, Gordon S. Innate immunity to intracellular pathogens: macrophage receptors and responses to microbial entry. *Immunol Rev* 2011;240(1):11-24.
37. Trinchieri G, Sher A. Cooperation of Toll-like receptor signals in innate immune defence. *Nat Rev Immunol* 2007;7(3):179-190.
38. Davis BK, Wen H, Ting JP. The inflammasome NLRs in immunity, inflammation, and associated diseases. *Annu Rev Immunol* 2011;29:707-735.
39. Jin T, Perry A, Jiang J, et al. Structures of the HIN domain:DNA complexes reveal ligand binding and activation mechanisms of the AIM2 inflammasome and IFI16 receptor. *Immunity* 2012;36(4):561-571.
40. Khare S, Luc N, Dorfleutner A, Stehlik C. Inflammasomes and their activation. *Crit Rev Immunol* 2010;30(5):463-487.
41. Strowig T, Henao-Mejia J, Elinav E, Flavell R. Inflammasomes in health and disease. *Nature* 2012;481(7381):278-286.
42. Conner SD, Schmid SL. Regulated portals of entry into the cell. *Nature* 2003;422(6927):37-44.
43. Gordon S. Macrophages and phagocytosis. In: Paul WE, ed. *Fundamental immunology*, 7th ed. Philadelphia, PA: Lippincott, Williams and Wilkins, 2012:547-569.
44. Greenberg S. Diversity in phagocytic signalling. *J Cell Sci* 2001;114 (Pt 6):1039-1040.
45. Ravichandran KS. Beginnings of a good apoptotic meal: the find-me and eat-me signaling pathways. *Immunity* 2011;35(4):445-455.
46. Sallusto F, Lanzavecchia A. Efficient presentation of soluble antigen by cultured human dendritic cells is maintained by granulocyte/macrophage colony-stimulating factor plus interleukin 4 and downregulated by tumor necrosis factor alpha. *J Exp Med* 1994;179(4):1109-1118.
47. Savill J, Dransfield I, Gregory C, Haslett C. A blast from the past: clearance of apoptotic cells regulates immune responses. *Nat Rev Immunol* 2002;2(12):965-975.
48. Stuart LM, Ezekowitz RA. Phagocytosis: elegant complexity. *Immunity* 2005;22(5):539-550.
49. Alam MM, O'Neill LA. MicroRNAs and the resolution phase of inflammation in macrophages. *Eur J Immunol* 2011;41(9):2482-2485.
50. Gautier EL, Shay T, Miller J, et al. Gene-expression profiles and transcriptional regulatory pathways that underlie the identity and diversity of mouse tissue macrophages. *Nat Immunol* 2012;13(11):1118-1128.
51. Hume DA. Applications of myeloid-specific promoters in transgenic mice support in vivo imaging and functional genomics but do not support the concept of distinct macrophage and dendritic cell lineages or roles in immunity. *J Leukoc Biol* 2010;89(4):525-538.
52. Miller JC, Brown BD, Shay T, et al. Deciphering the transcriptional network of the dendritic cell lineage. *Nat Immunol* 2012;13(9):888-899.
53. Kapsenberg ML. Dendritic-cell control of pathogen-driven T-cell polarization. *Nat Rev Immunol* 2003;3(12):984-993.
54. Trombetta ES, Mellman I. Cell biology of antigen processing in vitro and in vivo. *Annu Rev Immunol* 2005;23:975-1028.
55. De Leo FR, Ulman KV, Davis AR, Jutila KL, Quinn MT. Assembly of the human neutrophil NADPH oxidase involves binding of p67phox and flavocytochrome b to a common functional domain in p47phox. *J Biol Chem* 1996;271(29):17013-17020.
56. Dinarello CA. Interleukin-1 in the pathogenesis and treatment of inflammatory diseases. *Blood* 2011;117(14):3720-3732.
57. Evstatiev R, Gasche C. Iron sensing and signalling. *Gut* 2012;61(6):933-952.
58. Nathan C. Secretory products of macrophages: twenty-five years on. *J Clin Invest* 2012;122(4):1189-1190.

- 58a. Manderson AP, Kay JG, Hammond LA, Brown DL, Stow JL. Subcompartments of the macrophage recycling endosome direct the differential secretion of IL-6 and TNF α . *J. Cell Biol* 2007;178:57-69.
59. Banchereau J, Pascual V, O'Garra A. From IL-2 to IL-37: the expanding spectrum of anti-inflammatory cytokines. *Nat Immunol* 2012;13(10):925-931.
60. Monticelli S, Sallusto F. Negative regulators take center stage. *Nat Immunol* 2012;13(8):719-720.
61. Murray PJ, Smale ST. Restraint of inflammatory signaling by interdependent strata of negative regulatory pathways. *Nat Immunol* 2012;13(10):916-924.
62. Cros J, Cagnard N, Woollard K, et al. Human CD14dim monocytes patrol and sense nucleic acids and viruses via TLR7 and TLR8 receptors. *Immunity* 2010;33(3):375-386.
63. Gordon S, Taylor PR. Monocyte and macrophage heterogeneity. *Nat Rev Immunol* 2005;5(12):953-964.
64. Heimbeck I, Hofer TP, Eder C, et al. Standardized single-platform assay for human monocyte subpopulations: lower CD14+CD16++ monocytes in females. *Cytometry A* 2010;77(9):823-830.
65. Shi C, Pamer EG. Monocyte recruitment during infection and inflammation. *Nat Rev Immunol* 2011;11(11):762-774.
66. Ziegler-Heitbrock L, Ancuta P, Crowe S, et al. Nomenclature of monocytes and dendritic cells in blood. *Blood* 2010;116(16):e74-e80.
67. Egen JG, Rothfuchs AG, Feng CG, Winter N, Sher A, Germain RN. Macrophage and T cell dynamics during the development and disintegration of mycobacterial granulomas. *Immunity* 2008;28(2):271-284.
68. Gordon S, Martinez FO. Alternative activation of macrophages: mechanism and functions. *Immunity* 2010;32(5):593-604.
69. Karp CL, Murray PJ. Non-canonical alternatives: what a macrophage is 4. *J Exp Med* 2012;209(3):427-431.
70. Krausgruber T, Blazek K, Smallie T, et al. IRF5 promotes inflammatory macrophage polarization and TH1-TH17 responses. *Nat Immunol* 2011;12(3):231-238.
71. Lawrence T, Natoli G. Transcriptional regulation of macrophage polarization: enabling diversity with identity. *Nat Rev Immunol*. 2011;11(11):750-761.
72. Satoh T, Takeuchi O, Vandenberg A, et al. The Jmjd3-Irf4 axis regulates M2 macrophage polarization and host responses against helminth infection. *Nat Immunol* 2010;11(10):936-944.
- 72a. Martinez FO, Helming L, Milde R, et al. Genetic programs expressed in resting and IL-4 alternatively activated mouse and human macrophages: similarities and differences. *Blood*. 2013. [Epub ahead of print].
73. Naik SH, Sathe P, Park HY, et al. Development of plasmacytoid and conventional dendritic cell subtypes from single precursor cells derived in vitro and in vivo. *Nat Immunol* 2007;8(11):1217-1226.
74. Auffray C, Sieweke MH, Geissmann F. Blood monocytes: development, heterogeneity, and relationship with dendritic cells. *Annu Rev Immunol* 2009;27:669-692.
75. Sallusto F, Zielinski CE, Lanzavecchia A. Human Th17 subsets. *Eur J Immunol* 2012;42(9):2215-2220.
76. Chow A, Lucas D, Hidalgo A, et al. Bone marrow CD169+ macrophages promote the retention of hematopoietic stem and progenitor cells in the mesenchymal stem cell niche. *J Exp Med* 2011;208(2):261-271.
77. Crocker PR, Morris L, Gordon S. Adhesion receptors involved in the erythroblastic island. *Blood Cells* 1991;17(1):83-91; discussion 91-86.
78. Crocker PR, Werb Z, Gordon S, Bainton DF. Ultrastructural localization of a macrophage-restricted sialic acid binding hemagglutinin, SER, in macrophage-hematopoietic cell clusters. *Blood* 1990;76(6):1131-1138.
79. Lee SH, Crocker PR, Westaby S, et al. Isolation and immunocytochemical characterization of human bone marrow stromal macrophages in hemopoietic clusters. *J Exp Med* 1988;168(3):1193-1198.
80. Winkler IG, Sims NA, Pettit AR, et al. Bone marrow macrophages maintain hematopoietic stem cell (HSC) niches and their depletion mobilizes HSCs. *Blood* 2010;116(23):4815-4828.
81. Gray EE, Cyster JG. Lymph node macrophages. *J Innate Immun* 2012;4 (5-6):424-436.

82. Den Haan JMM, Kraal G. Innate immune functions of macrophage subpopulations in the spleen. *J Innate Immunol* 2012;4(5-6):437-445.
83. Martinez-Pomares L, Gordon S. CD169+ macrophages at the crossroads of antigen presentation. *Trends Immunol* 2011;33(2):66-70.
84. Martinez-Pomares L, Hanitsch LG, Stillion R, Keshav S, Gordon S. Expression of mannose receptor and ligands for its cysteine-rich domain in venous sinuses of human spleen. *Lab Invest* 2005;85(10):1238-1249.
85. Steiniger B, Barth P, Herbst B, Hartnell A, Crocker PR. The species-specific structure of microanatomical compartments in the human spleen: strongly sialoadhesin-positive macrophages occur in the perifollicular zone, but not in the marginal zone. *Immunology* 1997;92(2):307-316.
86. Zaba LC, Fuentes-Duculan J, Steinman RM, Krueger JG, Lowes MA. Normal human dermis contains distinct populations of CD11c+BDCA-1+ dendritic cells and CD163+FXIIIa+ macrophages. *J Clin Invest* 2007;117(9):2517-2525.
87. Haniffa M, Shin A, Bigley V, et al. Human tissues contain CD141hi cross-presenting dendritic cells with functional homology to mouse CD103+ non-lymphoid dendritic cells. *Immunity* 2012;37(1):60-73.
88. Jaensson E, Uronen-Hansson H, Pabst O, et al. Small intestinal CD103+ dendritic cells display unique functional properties that are conserved between mice and humans. *J Exp Med* 2008;205(9):2139-2149.
89. Mason R, Austyn J, Brodsky F, Gordon S. Monoclonal antimacrophage antibodies: human pulmonary macrophages express HLA-DR (Ia-like) antigens in culture. *Am Rev Respir Dis* 1982;125(5):586-593.
90. Wallaert B, Fahy O, Tscopoulos A, Gosset P, Tonnel AB. Experimental systems for mechanistic studies of toxicant induced lung inflammation. *Toxicol Lett* 2000;112-113:157-163.
91. Kennedy DW, Abkowitz JL. Kinetics of central nervous system microglial and macrophage engraftment: analysis using a transgenic bone marrow transplantation model. *Blood* 1997;90(3):986-993.
92. Wang Y, Szretter KJ, Vermi W, et al. IL-34 is a tissue-restricted ligand of CSF1R required for the development of Langerhans cells and microglia. *Nat Immunol* 2012;13(8):753-760.
93. de Witte L, Nabatov A, Pion M, et al. Langerin is a natural barrier to HIV-1 transmission by Langerhans cells. *Nat Med* 2007;13(3):367-371.
94. Klechevsky E, Morita R, Liu M, et al. Functional specializations of human epidermal Langerhans cells and CD14+ dermal dendritic cells. *Immunity* 2008;29(3):497-510.
95. Lenz A, Heine M, Schuler G, Romani N. Human and murine dermis contain dendritic cells. Isolation by means of a novel method and phenotypical and functional characterization. *J Clin Invest* 1993;92(6):2587-2596.
96. Mc Dermott R, Ziyhan U, Spehner D, et al. Birbeck granules are subdomains of endosomal recycling compartment in human epidermal Langerhans cells, which form where langerin accumulates. *Mol Biol Cell* 2002;13(1):317-335.
97. Nestle FO, Zheng XG, Thompson CB, Turka LA, Nickoloff BJ. Characterization of dermal dendritic cells obtained from normal human skin reveals phenotypic and functionally distinctive subsets. *J Immunol* 1993;151(11): 6535-6545.
98. Romani N, Clausen BE, Stoitzner P. Langerhans cells and more: langerin-expressing dendritic cell subsets in the skin. *Immunol Rev* 2010;234(1): 120-141.
99. Romani N, Ebner S, Flacher V, et al., eds. Langerhans cells—dendritic cells of the epidermis and other epithelia. In: Saeland S, ed. *Recent advances in skin immunology*. Research Signpost, Kerala, India, 2008:27.
100. Athanasou NA. The osteoclast—what's new? *Skeletal Radiol* 2011;40(9): 1137-1140.
101. Athanasou NA, Quinn J. Immunophenotypic differences between osteoclasts and macrophage polykaryons: immunohistological distinction and implications for osteoclast ontogeny and function. *J Clin Pathol* 1990;43(12):997-1003.
102. Miyamoto T. Regulators of osteoclast differentiation and cell-cell fusion. *Keio J Med* 2011;60(4):101-105.
103. Vaananen HK, Laitala-Leinonen T. Osteoclast lineage and function. *Arch Biochem Biophys* 2008;473(2):132-138.
104. Woollard KJ, Geissmann F. Monocytes in atherosclerosis: subsets and functions. *Nat Rev Cardiol* 2010;7(2):77-86.
105. Ginhoux F, Greter M, Leboeuf M, et al. Fate mapping analysis reveals that adult microglia derive from primitive macrophages. *Science* 2010;330(6005):841-845.

106. Schuster C, Vaculik C, Fiala C, et al. HLA-DR+ leukocytes acquire CD1 antigens in embryonic and fetal human skin and contain functional antigen-presenting cells. *J Exp Med* 2009;206(1):169-181.
107. Bigley V, Haniffa M, Doulatov S, et al. The human syndrome of dendritic cell, monocyte, B and NK lymphoid deficiency. *J Exp Med* 2011;208(2):227-234.
108. Collin MP, Hart DN, Jackson GH, et al. The fate of human Langerhans cells in hematopoietic stem cell transplantation. *J Exp Med* 2006;203(1):27-33.
109. Hambleton S, Salem S, Bustamante J, et al. IRF8 mutations and human dendritic-cell immunodeficiency. *N Engl J Med* 2011;365(2):127-138.
110. Haniffa M, Ginhoux F, Wang XN, et al. Differential rates of replacement of human dermal dendritic cells and macrophages during hematopoietic stem cell transplantation. *J Exp Med* 2009;206(2):371-385.
111. Merad M, Manz MG, Karsunky H, et al. Langerhans cells renew in the skin throughout life under steady-state conditions. *Nat Immunol* 2002;3(12): 1135-1141.
112. Doulatov S, Notta F, Laurenti E, Dick JE. Hematopoiesis: a human perspective. *Cell Stem Cell* 2012;10(2):120-136.
113. Fogg DK, Sibon C, Miled C, et al. A clonogenic bone marrow progenitor specific for macrophages and dendritic cells. *Science* 2006;311(5757):83-87.
114. Geissmann F, Manz MG, Jung S, Sieweke MH, Merad M, Ley K. Development of monocytes, macrophages, and dendritic cells. *Science* 2010;327(5966):656-661.
115. Novershtern N, Subramanian A, Lawton LN, et al. Densely interconnected transcriptional circuits control cell states in human hematopoiesis. *Cell* 2011;144(2):296-309.
116. Greter M, Helft J, Chow A, et al. GM-CSF controls nonlymphoid tissue dendritic cell homeostasis but is dispensable for the differentiation of inflammatory dendritic cells. *Immunity* 2012;36(6):1031-1046.
117. Collin M, Bigley V, Haniffa M, Hambleton S. Human dendritic cell deficiency: the missing ID? *Nat Rev Immunol* 2011;11(9):575-583.
118. Meredith MM, Liu K, Kamphorst AO, et al. Zinc finger transcription factor zDC is a negative regulator required to prevent activation of classical dendritic cells in the steady state. *J Exp Med* 2012;209(9):1583-1593.
119. Schulz C, Gomez Perdiguero E, Chorro L, et al. A lineage of myeloid cells independent of Myb and hematopoietic stem cells. *Science* 2012;336(6077):86-90.
120. Qi F, Adair A, Ferenbach D, et al. Depletion of cells of monocyte lineage prevents loss of renal microvasculature in murine kidney transplantation. *Transplantation* 2008;86(9):1267-1274.
121. Badalian-Very G, Vergilio JA, Fleming M, Rollins BJ. Pathogenesis of Langerhans cell histiocytosis. *Annu Rev Pathol Epub* 2012 Aug 6.
122. Risma K, Jordan MB. Hemophagocytic lymphohistiocytosis: updates and evolving concepts. *Curr Opin Pediatr* 2012;24(1):9-15.
123. Pastores GM, Weinreb NJ, Aerts H, et al. Therapeutic goals in the treatment of Gaucher disease. *Semin Hematol* 2004;41(4 Suppl 5):4-14.
124. Panicker LM, Miller D, Park TS, et al. Induced pluripotent stem cell model recapitulates pathologic hallmarks of Gaucher disease. *Proc Natl Acad Sci U S A* 2012;109(44):18054-18059.
125. Ganz T. Macrophages and systemic iron homeostasis. *J Innate Immun* 2012;4(5-6):446-453.
126. Jacolot S, Yang Y, Paitry P, Ferec C, Mura C. Iron metabolism in macrophages from HFE hemochromatosis patients. *Mol Genet Metab* 2010;101(2-3):258-267.
127. Pietrangelo A, Caleffi A, Corradini E. Non-HFE hepatic iron overload. *Semin Liver Dis* 2011;31(3):302-318.
128. Lacey DL, Boyle WJ, Simonet WS, et al. Bench to bedside: elucidation of the OPG-RANK-RANKL pathway and the development of denosumab. *Nat Rev Drug Discov* 2012;11(5):401-419.
129. Michou L, Brown JP. Genetics of bone diseases: Paget's disease, fibrous dysplasia, osteopetrosis, and osteogenesis imperfecta. *Joint Bone Spine* 2011;78(3):252-258.
130. Coxon FP, Taylor A. Vesicular trafficking in osteoclasts. *Semin Cell Dev Biol* 2008;19(5):424-433.

131. Kalinski P, Edington H, Zeh HJ, et al. Dendritic cells in cancer immunotherapy: vaccines or autologous transplants? *Immunol Res* 2011;50(2-3):235-247.
132. Gordon S, Cohn Z. Macrophage-melanocyte heterokaryons. I. Preparation and properties. *J Exp Med* 1970;131(5):981-1003.
133. Gordon S. Alternative activation of macrophages. *Nat Rev Immunol* 2003;3(1):23-35.

Section 4 - The Lymphocytes

Chapter 11 Lymphocytes and Lymphatic Organs

> Table of Contents > Part II - The Normal Hematologic System > Section 4 - The Lymphocytes > Chapter 11 - Lymphocytes and Lymphatic Organs

Chapter 11

Lymphocytes and Lymphatic Organs

Frixos Paraskevas

LYMPHOCYTES: HISTORICAL PERSPECTIVE

In the early part of the 20th century, the main debate about the nature and function of the lymphocyte centered around its relationship to cells of the connective tissue and cells of inflammatory exudate. Lymphocytes were considered capable of transforming into granulocytes, monocytes, macrophages, fibroblasts, and other cells. Although Marschalko,¹ Downey,² Maximow,³ and Bloom⁴ believed that lymphocytes gave rise to plasma cells, the scientific evidence for these assumptions was lacking; and Rich (1936) suggested that "The complete ignorance of the function of this cell is one of the most humiliating and disgraceful gaps in all medical knowledge."⁵ The first conclusive evidence that antibodies are formed in the lymph nodes (LNs) was presented in 1935 by McMaster and Hudack,⁶ but it took another decade to prove that lymphoid cells in LNs were the cells that contained antibody.^{7,8} This discovery tipped the balance in favor of the lymphocytic theory of antibody production.⁹

In parallel with these studies, the classic work of Fagraeus brought strong indirect evidence of the relationship of plasma cells to antibody production.¹⁰ The demonstration with immunofluorescence techniques by Coons et al. of the presence of antibodies in plasma cells is a landmark in the long debate on the origin of antibodies and the function of plasma cells.^{11,12} The question whether plasma cells arise from lymphocytes was answered later by the elegant ultrastructural studies of Harris et al., who by means of electron microscopy demonstrated the gradual change of a lymphocyte to an antibody-forming plasma cell.^{13,14,15}

Lymphocytes are a heterogeneous population of cells which differ greatly in terms of origin, life span, preferred areas of settlement within the lymphoid organs, surface structure, molecular markers, and function.¹⁶

Certain morphologic characteristics, such as size, granularity, and nucleocytoplasmic ratio, distinguish a variety of lymphocyte populations, but provide no clues to identification of their lineage and function. A precise and quantitative method used in clinical laboratories is based on detection of certain glycoproteins displayed on the membrane of lymphocytes known as markers. Two discoveries have helped in the dissemination of routine application of lymphocyte marker analysis in clinical medicine, the development of monoclonal antibodies and the invention of flow cytometry.

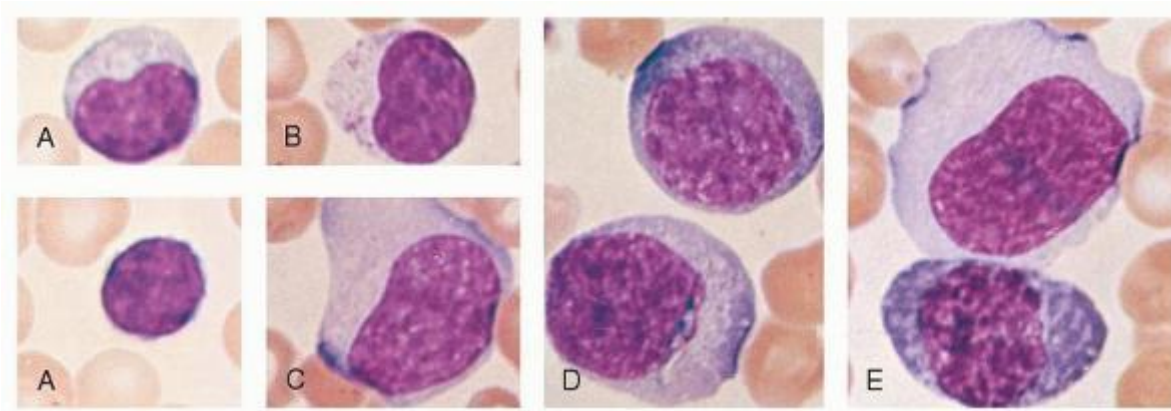

FIGURE 11.1. Morphologic heterogeneity of human peripheral blood lymphocytes. A: Giemsa-stained blood smears: Small and large lymphocytes. B: Large granular lymphocyte with azurophilic granules. C: Atypical lymphocyte. D: Lymphocytes resembling plasma cells (plasmacytoid) from the blood of a patient with viral pneumonia. E: One atypical lymphocyte and one plasmacytoid lymphocyte from peripheral blood.

LYMPHOCYTES

Light Microscopy

Most blood lymphocytes are small (10 μm or smaller) but larger forms are common (Fig. 11.1A). Some of the large lymphocytes are known as large granular lymphocytes and contain azurophilic granules in their cytoplasm (Fig. 11.1B).^{17,18} The dimensions of the cells vary according to the method of preparation. In blood smears stained with Romanovsky dyes, the nucleus is deep purple-blue, usually round or slightly indented, composed of dense aggregates of chromatin. Nucleoli are not visible in Giemsa stained smears with ordinary techniques, although a nucleolus may be seen in wet smears and histologic sections. The cytoplasm forms a narrow rim in small lymphocytes, but it may be abundant in larger cells. The cytoplasm is moderately basophilic and usually is devoid of granules, but larger cells may contain several bright reddish-violet (azurophilic) granules that differ from the granules of myeloid cells because they are not positive in oxidase or peroxidase reactions. By phase contrast microscopy, a well-defined centrosome can be observed adjacent to the nucleus and because it is somewhat rigid, it may cause an indentation in the nucleus. Transitional forms between lymphocytes and plasma cells are often seen in the blood of patients with viral infections (Fig. 11.1C-E). These cells are variously known as lymphocytoid plasma cells or plasmacytoid lymphocytes and represent morphologic stages of differentiation of antigenically stimulated lymphocytes.

Flow Cytometry

Flow cytometry, invented in the 1960s, has been used for diagnosis, staging, and evaluation of patients with hematologic malignancies and has contributed to identification and characterization

P.228

of cell populations. With the advent of one- and two-color flow cytometers, two major lymphocyte lineages were identified, comprising the humoral arm (B cell) and the cellular arm (T cell) of immunity. The characterization of the cells on the basis of their phenotype provided a more reliable platform than morphology for accurate diagnosis and evaluation of residual disease. The new technology, using 12- to 18-color analysis of the patient's blood or other body fluids, brought an unprecedented resolution, which identified multiple subpopulations of T cells, i.e., follicular helper T cells, Th-17 cells and regulatory T cells. Flow cytometry helped our understanding of certain functions of the immune system such as cell cycle analysis, immune deficiencies, the nature of leukemia/lymphoma, and detection of apoptosis induced by various concentrations of gamma secretase inhibitor, N-(3,5-Difluorophenacetyl)-¹-Alanyl-Sphenylglycine T-butyl ester (DAPT), and signaling by Notch 1, recognized as the cell fate signaling molecule.

Electron Microscopy

The small lymphocyte is 6 to 9 μm in size, with a smooth bilaminar cytoplasmic membrane that contains only a few microvilli, except in the area of the uropod in motile cells (Fig. 11.2).¹⁹ The scanty cytoplasm of small lymphocytes shows a remarkable absence of organelles. The Golgi apparatus is small, usually found near the nuclear notch, and one or two centrioles are often seen. No organized endoplasmic reticulum is observed, although careful scrutiny may reveal one or

two profiles. Many ribosomes are evident, occasionally in clusters, and typical mitochondria are common, but lysosomes containing enzymes characteristic of these organelles are sparse. Dense bodies of unknown significance may also be seen occasionally. The cytoskeleton consists of occasional microtubules in the cytoplasm and microfilaments adjacent to the cell membrane. The nucleus is enveloped by a membrane consisting of two layers which fuse at the site of nuclear pores, while abundant dense heterochromatin forms aggregates close to the membrane, but less often in the center of the body of the nucleus. These aggregates are separated by interchromatinic spaces which contain smaller bits of chromatin aggregates, particles resembling ribosomes, fibrils, and usually a nucleolus.

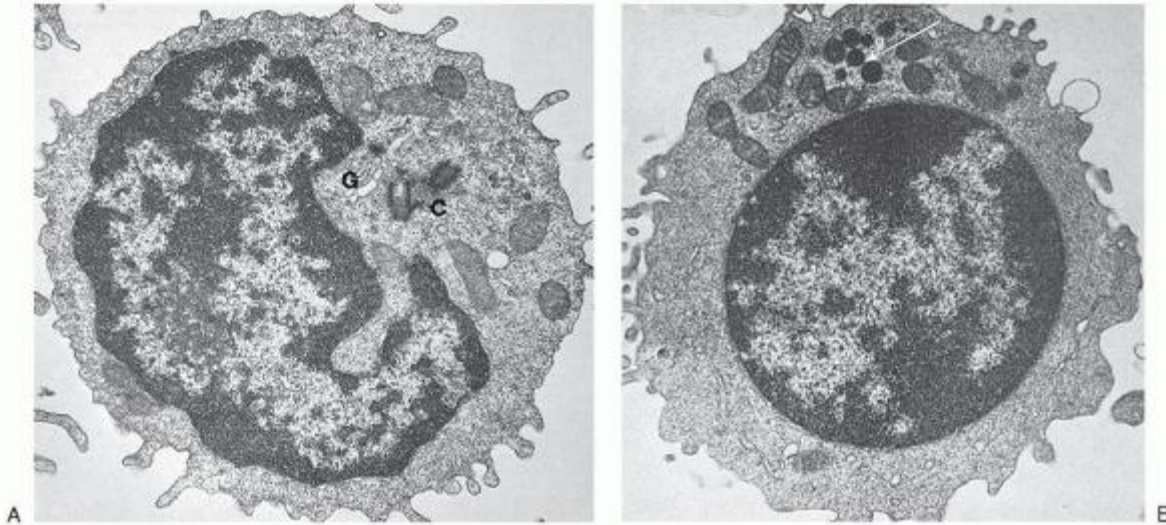

FIGURE 11.2. Ultrastructure of normal peripheral blood lymphocytes. A: A typical resting lymphocyte. The nucleus contains primarily heterochromatin in aggregates along the nuclear membrane. The nucleolus in lymphocytes is usually small. In the cytoplasm, the ribosomes are dispersed, but occasionally, a few short strands of rough endoplasmic reticulum are visible. The mitochondria are well developed, and the centrioles (C), longitudinally sectioned in this illustration, show evidence that the cell is ready to enter mitosis on triggering. The Golgi apparatus (G) is small ($\times 24,000$). B: This lymphocyte contains granules (arrow) and is likely to correspond to the large granular lymphocyte variety. The cytoplasm is abundant and filled with ribosomes with a few strands of endoplasmic reticulum ($\times 12,000$). (From Zucker-Franklin D, Greaves MF, Grossi CF. Atlas of blood cells, 2nd ed. Philadelphia, PA: Lea & Febiger, 1988, with permission.)

The medium lymphocyte is larger (6 to 8 μm) because of an increase in the amount of cytoplasm and a Golgi apparatus which is more developed than in the small lymphocyte. The cytoplasm contains numerous polyribosomes and a few strands of endoplasmic reticulum parallel to the nuclear membrane. Lymphoblasts are usually larger cells (8 to 12 μm) with scarce cisternae of endoplasmic reticulum, a nucleus with loose chromatin, and a giant nucleolus that has a reticulated appearance and occupies as much as one third of the nuclear area. Lymphocytes carry the normal diploid number of 44 autosomes and two sex chromosomes.

Scanning Electron Microscopy

By scanning electron microscopy, the human peripheral blood lymphocytes can be seen to be of two broad categories on the basis of their cell surface²⁰; one population has a fairly smooth surface, whereas the other is covered by numerous microvilli (described as "hairy") (Fig. 11.3). The smooth cells correspond to thymus-derived, or T lymphocytes, whereas the one with the microvilli is bone marrow-derived or B lymphocyte. The surface features of the lymphocyte depend on the functional state of the cells as well as the methods used for preparation of the cells.²¹ All lymphocytes develop villi if they are stimulated by mitogens or after crossing the high endothelial cells of LN venules, but recover their smooth surface when they reach their respective home microenvironment. Therefore the smooth cell surface is likely associated with resting lymphocytes, whereas microvilli appear following environmental stimuli that interact with cell-surface receptors and may help lymphocytes to interact with target substrates.

B cells with characteristic thin cytoplasmic projections, i.e., hairy, are positive for tartrate-resistant acid phosphatase (TRAP), and by immunophenotyping they are shown to be positive for CD-103, CD-25, and CD-11c.

Malignancy of this B cell subpopulation has a typical clonal pattern and is known as hairy cell leukemia (HCL), an indolent B cell lymphoproliferative disease, characterized by splenomegaly and pancytopenia.²²

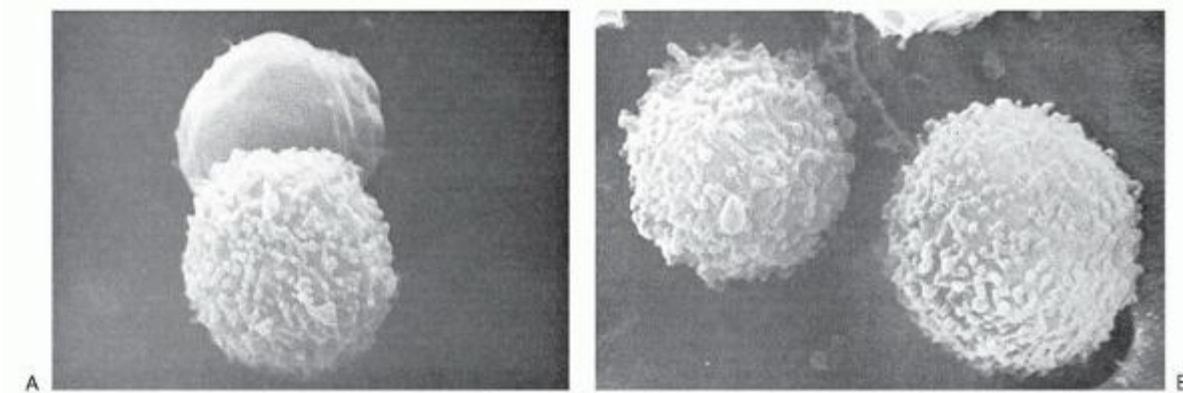

FIGURE 11.3. Heterogeneity of human lymphocytes by scanning electron microscope. A: A smooth and villous lymphocyte thought to correspond to that of T and B lymphocytes, respectively. The appearance of the lymphocytes, however, depends on the method of preparation; both lymphocytes are smooth when they rest in their microenvironments ($\times 14,500$). B: Two villous cells in a preparation depleted of T cells ($\times 14,500$). (From Zucker-Franclin D, Greaves MF, Grossi CF. Atlas of blood cells, 2nd ed. Philadelphia, PA: Lea and Feibiger 1988, with permission).

Lymphocyte Locomotion

The motile lymphocyte may extend cytoplasmic projections, 12.5 to 200 nm wide and up to 0.8 μm in length, and moves with an average speed of 20 $\mu\text{m}/\text{minute}$. Its motility increases with the state of activation; thus lymphoblasts demonstrate greater locomotion compared to small lymphocytes. Locomotion is enhanced by stimuli inducing blast transformation, and the trailing edge of the mobile lymphocyte, the “uropod,” is associated not only with locomotion, but with a variety of interactions with lymphocytes, macrophages, and other cells.²³ (Fig. 11.4)

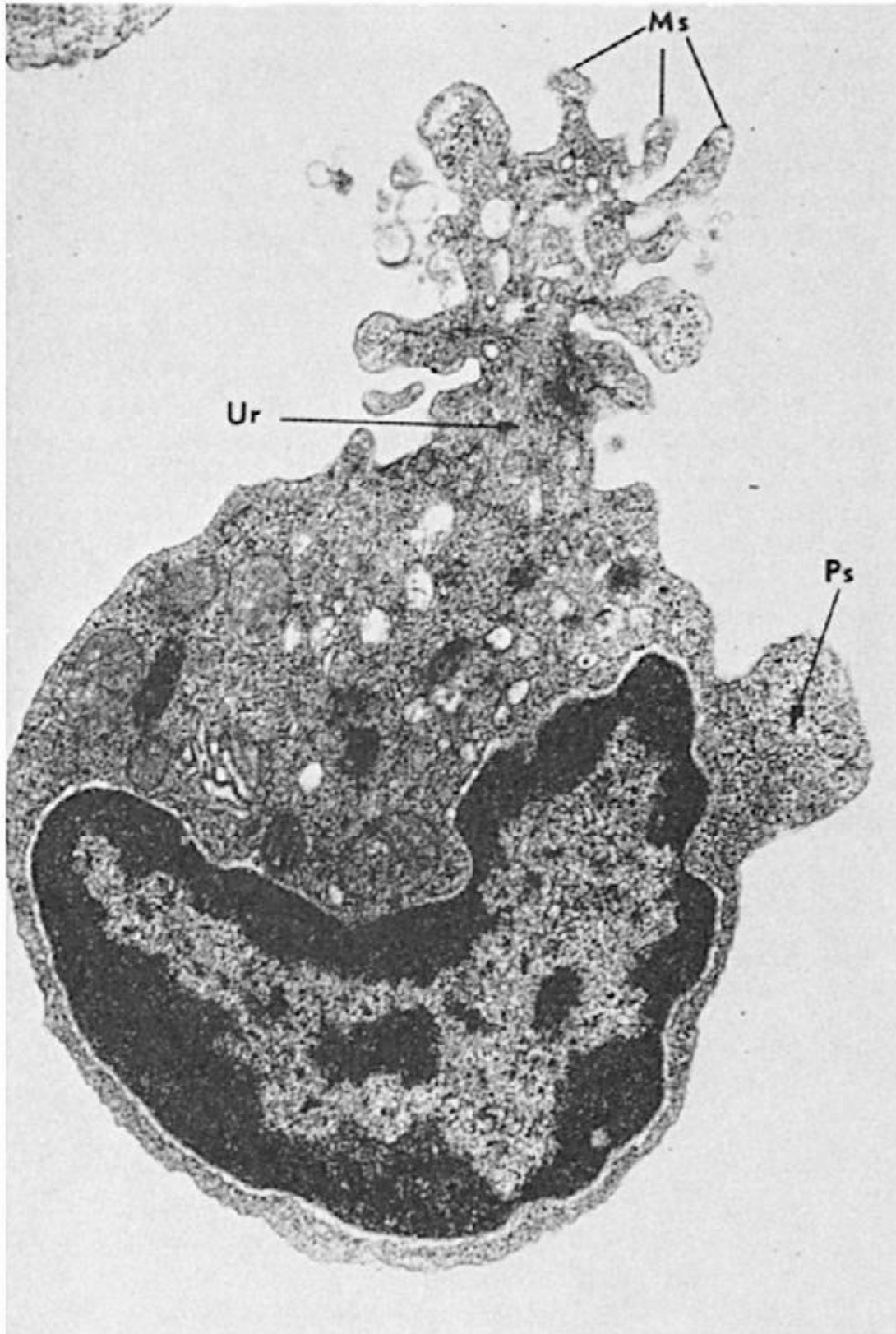

FIGURE 11.4. Lymphocyte locomotion. The lymphocyte assumes the characteristic handmirror configuration. The nucleus occupies the front, and part of the cytoplasm forms a tail or uropod (Ur), which displays an elaborate pattern of microspikes (Ms). A small pseudopod (Ps) on the side contains only ribosomes. (From Rosenstreich DI, Shevach E, Green I,

et al. The uropodbearing lymphocyte of the guinea pig. Evidence for thymic origin. *J Exp Med* 1972;135:1037, with permission.)

The T lymphocytes adhere to macrophages, forming clusters or rosettes, and their mobility is regulated by their lamellipodia and filopodia.²⁴ A stable cluster forms only when macrophages and lymphocytes are exposed to antigen and the T lymphocytes within the clusters are stimulated into proliferative activity. In general, the uropod formation is a morphologic expression of lymphocyte activation as measured by DNA synthesis. The locomotion of lymphocytes is strikingly different from that of other cells, since they move forward in a steady manner, maintaining a hand mirror shape, whereas myeloblasts express a wriggling worm-like locomotion, and the cells of the monocytic series change shape and direction continuously. Locomotion of the lymphocytes is an important function regulated by the Krupel-like transcription factors which regulate other important functions, such as trafficking and differentiation.²⁵ Although the uropod is characteristic of T lymphocytes, the B lymphocytes also form uropods after stimulation with anti-immunoglobulin antibodies²⁶ and the formation by surface immunoglobulin (Ig) of caps, which eventually are endocytosed. The uropod therefore serves not only in cell mobility but also as a site for endocytosis of foreign substances, and ultrastructurally contains practically all cytoplasmic organelles, including the Golgi apparatus, mitochondria, microfilaments, and microtubules. It has been shown that an important protein in T cell motility, known as Kidins-220, is expressed in high concentration in the T cell uropod associated with intercellular adhesion molecule-3 (ICAM-3).²⁷ The enzyme kinase-D, which interacts with Kidin-220, regulates the motility and migration of the T cell, essential for its response to foreign antigens.

PLASMA CELLS

Plasma cells are the progeny of lymphocytes and morphologically are easily distinguished from other cell types (Fig. 11.5) by their spherical or ellipsoid shape and their size, which ranges from 5 to 30 μm . The cytoplasm is abundant and basophilic, usually deep blue, and may have a granular character. There is a well-defined perinuclear clear zone that contains the Golgi apparatus. The nucleus is small in relation to the cell size, round or oval, eccentrically placed, and contains dense masses of chromatin.

By electron microscopy, the plasma cell membrane and the nucleus appear to be similar to those of the lymphocyte, but their cytoplasm is characterized by a well-developed rough endoplasmic reticulum (Fig. 11.6A) that fills most of the cytoplasmic space, except for a clear area in the perinuclear zone which

P.230

contains the Golgi apparatus. The endoplasmic reticulum consists of lamellae arranged in a variety of patterns but usually as parallel convolutions. Their inner surfaces are smooth and form the walls of spaces (cisternae) that are filled with amorphous products of varying density. The outer aspects of the lamellae are rough because of attached ribosomes, and a few mitochondria may be seen.

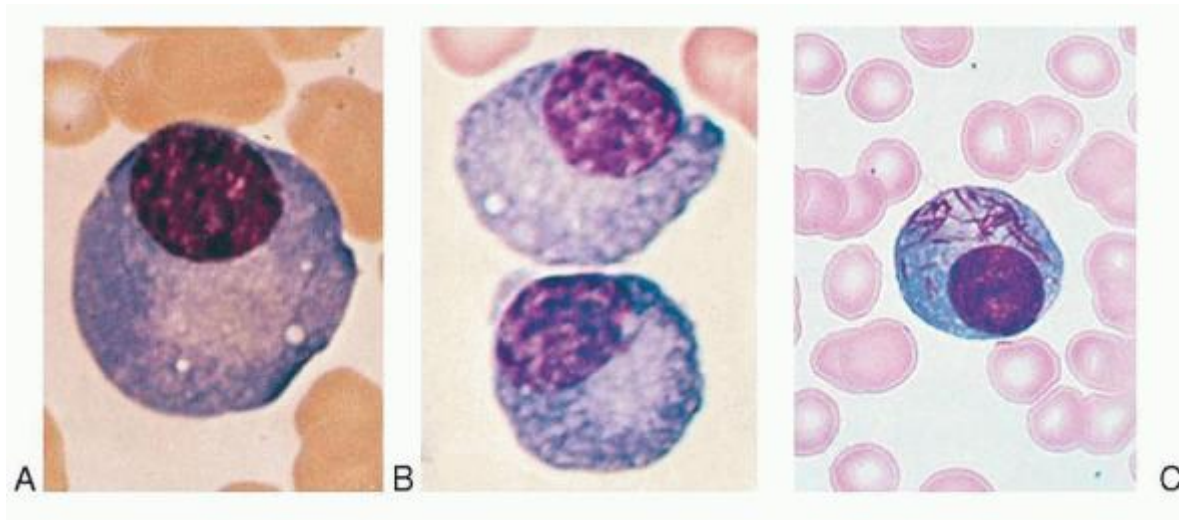

FIGURE 11.5. Plasma cells. A: Normal plasma cell. B: Plasmacytes with vacuoles from the bone marrow of a patient with infection and arthritis. C: Needle type of inclusions in plasma cell. (C used with permission of the American Society of

Hematology Slide Bank, 3rd ed., 1990.)

The morphology of plasma cells shown by electron microscopy as described above is the most typical, but intermediate forms exist which resemble small lymphocytes,¹⁴ with a scant amount of cytoplasm and an unusually well-developed rough endoplasmic reticulum (Fig. 11.6B). Such intermediate cells (Fig. 11.1C-E) are common in the blood of patients with plasma cell dyscrasias or immunologic diseases characterized by hypergammaglobulinemia. Similar cells have been observed in the blood of patients with viral infections (Turk cells),¹⁹ including infectious mononucleosis, as well as in the blood of apparently healthy individuals. Alternatively, immature plasma cells may have an appearance more akin to that of phytohemagglutinin (PHA)-transformed lymphocytes, with large and leptochromatic nuclei and cytoplasm containing a simple endoplasmic reticulum, but many ribosomes and polyribosomes, demonstrating that it is often difficult to draw sharp cytologic dividing lines. Other plasma cells may contain vacuoles or needle-type inclusions in the cytoplasm (Fig. 11.5C).

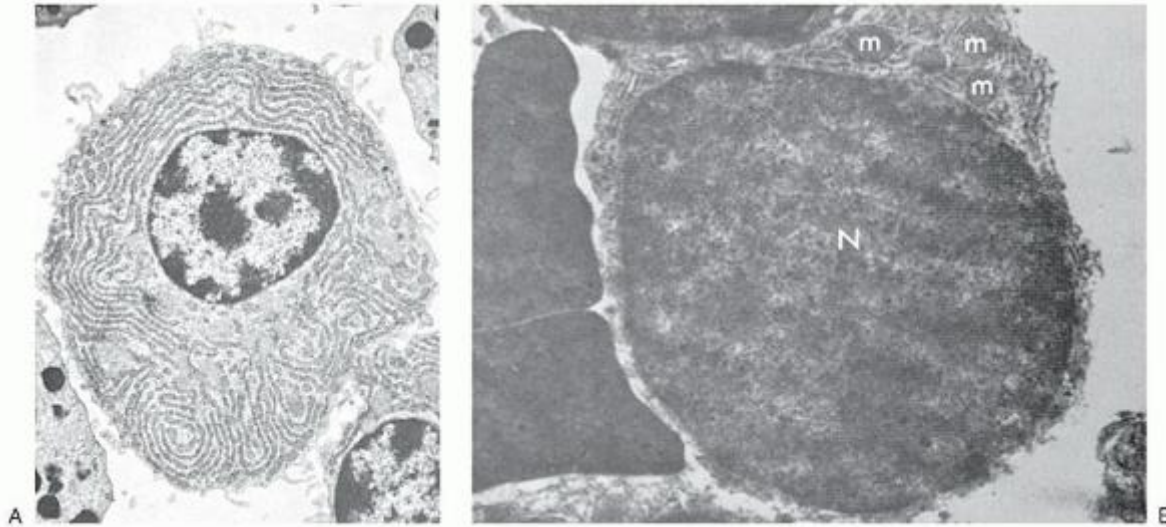

FIGURE 11.6. Electron micrographs of a plasma cell and an intermediate form. A: Typical plasma cell has cytoplasm filled with endoplasmic reticulum ($\times 6,000$). B: A lymphocytoid plasma cell with scant amounts of cytoplasm filled with endoplasmic reticulum and a few mitochondria (m) ($\times 9,900$). N, nucleus. (From Maldonado JE, Kyle RA, Brown AL, et al. "Intermediate" cell types and mixed cell proliferation in multiple myeloma: electron microscopic observations. *Blood* 1966;27:212-226, with permission.)

PRIMARY LYMPHOID ORGANS

The cells of the immune system originate in the primary lymphoid organs, which in humans are the bone marrow and the thymus, and during their life span settle in the secondary lymphoid organs, i.e., spleen, LNs, and Peyer patches (PPs) of the gut and the Waldeyer ring (tonsils and adenoids). This division provides the anatomic basis for the two fundamental stages of lymphocyte differentiation, i.e., the antigen-independent stage in primary lymphoid organs and the antigen-dependent stage in the secondary.

The primary lymphoid organs develop first in ontogeny, while the secondary organs provide the proper microenvironment for antigen-dependent differentiation of lymphocytes from immature precursors. Immunocompetent lymphocytes are released from the primary organs and home to specific areas of the secondary lymphoid organs.

The secondary lymphoid organs provide an optimal microenvironment for attracting antigen-specific lymphocytes directing the terminal stages of lymphocyte differentiation activated by antigens.

P.231

Bone Marrow

A detailed account of the histologic features and function of bone marrow is given in Chapter 5. Here we concentrate on the contribution of bone marrow in lymphopoiesis as a "primary lymphoid organ." The bone marrow occupies the medullary cavities of bones throughout the skeleton. It is the major hematopoietic organ in humans and supports

differentiation of all blood cells,²⁸ although in some cases this differentiation is not always complete. T lymphocytes and monocytes, for example, reach their final stages of maturation in locations outside the bone marrow.

The bone marrow is divided into an extravascular compartment, which is the site of hematopoiesis, and a vascular compartment, composed of wide venous blood vessels known as sinuses. These vessels receive blood from the nutrient artery and the periosteal capillary network. The sinuses are radially disposed in the bone marrow and eventually open into larger, centrally located sinuses that exit through the same foramina used by the nutrient arteries. The walls of the venous sinuses consist of an endothelial layer, a basement membrane, and the adventitia. The endothelial cells are flat, with tapering ends, and contain the usual organelles and therefore are endowed with endocytic activity.

The adventitial cells have broad sheet-like processes that form a reticulum, the interstices of which are occupied by the hematopoietic cells. Under certain circumstances, the adventitial cells become swollen because of an increased fat content, and the gross appearance of the marrow turns from red to yellow. In conditions of increased demand on the hematopoietic process, the fatty adventitial cells decrease in size, allowing an expansion of the hematopoietic compartment. The adventitial cells are related to the reticular cells found in the splenic cords and are therefore called adventitial reticular cells.

The hematopoietic compartment displays specific cellular arrangements of hematopoietic cells. Megakaryocytes lie close to the adventitial cells and deliver platelets directly into the sinuses through apertures in the sinus walls. Erythrocytes are produced near the sinuses, forming erythroblastic islets, while granulocytopoiesis takes place at a distance from the sinus wall in a diffuse pattern or sometimes in distinct clusters or sheets.

Available evidence obtained through labeling techniques suggests that new lymphocytes are formed at the periphery of the bone marrow and move toward the center in a centripetal fashion.

The lymphocyte progenitors are enriched with a polymphocyte population which contains progenitors for B cells and natural killer (NK) cells, which are CD122⁺ and under defined culture conditions can mature toward B or NK lineage. The B cells are generated from hematopoietic stem cells (HSCs), which migrate from the subendosteal region toward the center of the cavity.

These stem cells differentiate toward several cell lines as a result of signals received from bone marrow-adherent cells that create microenvironments known as niches that support hematopoiesis. The bone marrow stromal cells can be identified by their phenotype, i.e., CD105, CD90, CD184, and class MHC II.²⁹ HSCs interact with the osteoblasts of the bone, which may contribute to the creation of the hematopoietic niche³⁰ and support the development of hematopoietic colonies as a result of secretion of a variety of cytokines.³¹

The development of an in vitro culture system³² facilitated the identification of the growth and differentiation factors necessary for B cell lymphopoiesis, while animal studies defined five stages of B cell differentiation downstream from the common lymphocyte progenitor (CLP) cell: (a) pre-pro-B cell, (b) pro-B cell, (c) pre-B cell, (d) immature B cell and (e) mature B cell. The CLP is the first cell which is irreversibly committed to B or T cell differentiation, but the terminal stages of B cell differentiation, within bone marrow niches, require the availability of certain growth and differentiation factors such as Ikaros,³³ which acts as a factor of lineage competency and facilitates both myeloid and lymphoid development programs.³⁴

Immediately after commitment to the B lineage, precursors become dependent on SDF1 chemokine and its receptor CXCR4, as shown with the earliest identifiable B cell precursor populations in the bone marrow, where their development in CXCL12 (SDF1)^{-/-}, but not in IL7^{-/-}, embryos is severely disrupted.³⁵

The SDF-1 and its receptor are the first example of a chemokine and its receptor responsible for specific biologic activities of the B cell precursors in the earliest B lineage stages.³⁵ Other important molecules for the function of B cells are the early B cell factor (EBF) and the FLT3 ligand, essential at the pre-pro-B and pro-B stages and the chemokine ligand CXCL12 (known as stromal cell-derived factor-1, SDF1).³⁶

The B cell growth after pro-B cell is regulated by interleukin-7 (IL7) (which is essential for the development of B cells).³⁷ The chemokine CXCL12, which binds to its receptor CXCR4 of stromal cell, guides and retains B cells to appropriate secondary lymphoid organs.³⁸ Newly synthesized lymphocytes are discharged into the circulation and have been found singly or in small groups near the sinusoidal walls. Some of them are in transit through the wall of the sinus, which suggests that B lymphocytes are not stored in the bone marrow except for brief periods of time before they are released into the circulation. Histologically, no lymphoid follicles are distinguishable in normal bone marrow, which resembles the red pulp of the spleen with vascular sinuses and reticular meshwork formed by the adventitial cells or the cordal reticular cells,

respectively. The bone marrow circulation, however, is closed while the circulation of the red pulp is partially open, and there is no endothelial continuity between the arteries and the veins.

Thymus

Ontogeny and Histology

The thymus is a lymphoepithelial organ situated in the superior mediastinum^{39,40} which consists of two lobes that are divided into lobules forming the basic anatomic units of the thymus. The thymus is covered by a fibrous capsule from which fibrous bands (trabeculae) penetrate the parenchyma, dividing it into lobules. Histologically, the lobules have two distinct regions (Fig. 11.7), (1) a peripheral region named the cortex which is divided into the outermost or subcapsular cortex, and the inner or deep cortex, and (2) a central region named the medulla. In hematoxylin-eosin-stained sections, the cortex appears dark blue to purple because of the predominance of lymphocytes (80% to 85%), whereas the medulla appears eosinophilic because of the predominance of the epithelial cells. These anatomic divisions correspond to functionally distinct microenvironments that support specific phases of thymocyte differentiation. The subcapsular or superficial cortex contains large, actively dividing blasts with many mitotic figures, while the deep cortex is composed principally of nondividing small thymocytes.

The medulla contains predominantly medium-sized thymocytes. The relationships between the thymocytes in each compartment and the mechanisms underlying thymocyte differentiation are discussed in detail in Chapter 13.

The embryologic origin of the thymus has been under dispute for more than 30 years⁴¹. According to one view, the thymic primordium arises from the third pharyngeal pouch (endoderm) as well as the pharyngeal crest (ectoderm)⁴²; while another study supported exclusively an endodermal origin,⁴³ which alone contributes to the formation of the thymus.⁴⁴

The pharyngeal pouches are transient embryonic structures and their formation requires the paired box gene 1 (PAX 1) and 9 (PAX 9) as well as the fibroblastic growth factor-8 (FGF8). They develop in an anterior to posterior sequence and are separated from each other by pharyngeal arches. Each endodermal primordium contains precursors for one thymic lobe and one parathyroid gland. It is surrounded by a capsule of mesenchymal cells derived from cells of the neural crest, which supports the growth

P.232

and development of the primordium, and under their guidance it separates into a thymus and pharynx.

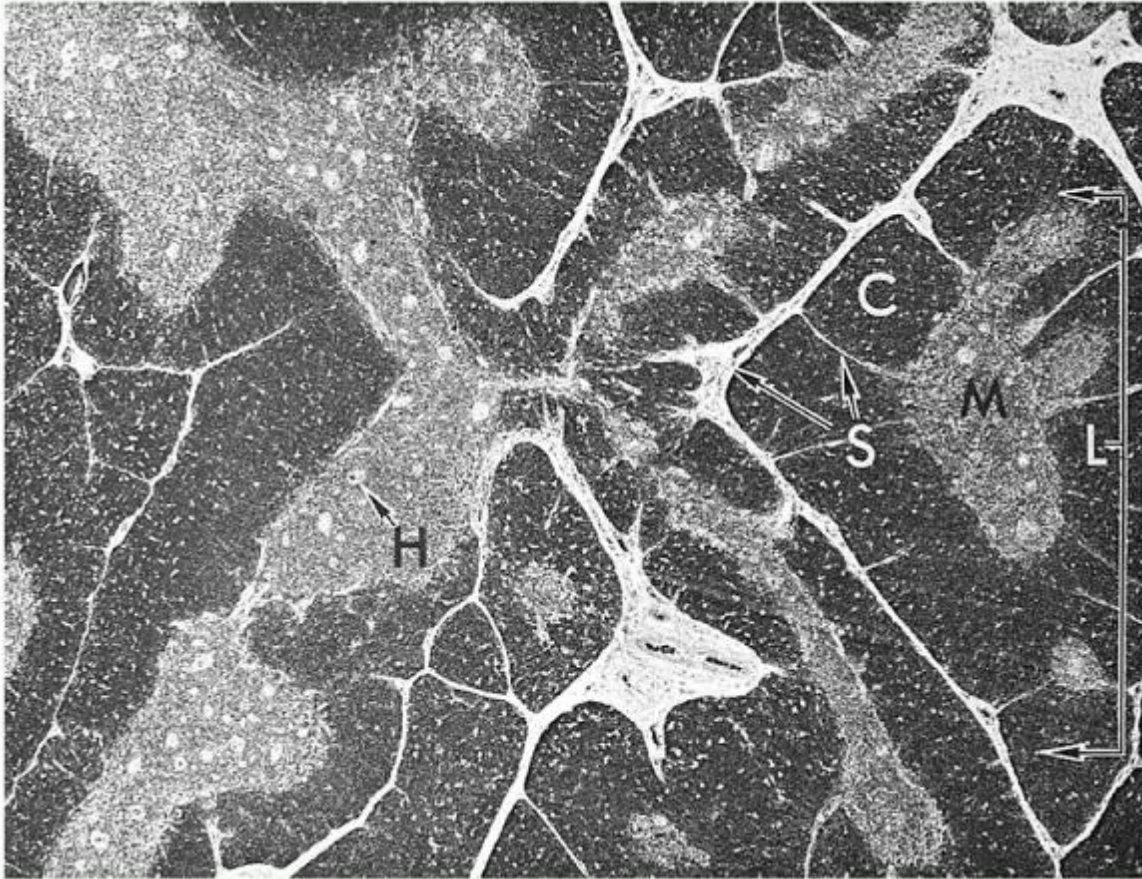

FIGURE 11.7. Histology of thymus shows lobules (L) consisting of cortex (C) and medulla (M). H, Hassall corpuscles; S, septa (trabeculae).

The development of the thymus proceeds through several stages: (a) positioning, i.e., determination of the place where the organ rudiment will develop; (b) growth and patterning, i.e., generation of distinct regions in the growing rudiment; and (c) differentiation, i.e., separation of distinct cell types that have been developed. The function of the homeobox A3 (HOXA3) is necessary to identify the third pouch, which forms the thymus and may control the position of the mitral rudiment.⁴⁴ Mice lacking *Hoxa3* are athymic and have no parathyroids, since the third pouch endoderm cannot differentiate appropriately. The expression of PAX1 in all pharyngeal pouches requires two other genes such as the eyes absent gene (EYA1) and the sine oculus-related homeobox1 homologue (SIX1).⁴⁵ Functional evidence that the endoderm alone forms a fully functional thymus was obtained through ectopic transplantation of isolated endoderm tissue grafted under the kidney capsule.⁴⁶ Normally, the structures of the original tubular epithelium, one on each side, descend into the anterior superior mediastinum where they fuse, forming the mature organ with two lobes. At this stage, the thymus is triangular, with the base resting on the pericardium and the apex pointing toward the neck.

Once the anlage is formed, the function of the WHN (winged helix nude; now known as FOXP1) gene is required for the completion of thymic structure and function.^{47,48} The nude locus gene encodes the FOXP1 transcription factor, of the forked/winged/helix family. It contains a DNA-binding domain and a strongly acidic transcriptional activation domain, which is functionally indispensable. Mutations affect the DNA-binding domain or the C-terminal transcriptional activation domain and are associated with athymia and hairlessness because the gene regulates the keratinization of hair.

The neural crest contributes to the formation of several glands, including the perivascular mesenchyme of the thymus.⁴⁹ The neural crest cells migrate into the thymus early in development, surrounding the epithelial rudiments and are closely associated with the developing thymocytes. They form the connective tissue capsule and trabecular septa that penetrate the parenchyma, dividing it into lobules, and likely provide extracellular matrix into the cortex and medulla, such as hyaluronan, collagen, and fibronectin, which may be important for the presentation of growth factors to the thymocytes. Hyaluronan is the ligand of CD44, and their interactions are important in the early stages of human thymus development.⁵⁰ The undifferentiated epithelial cells are large, with dispersed chromatin, short, blunt cytoplasmic

processes, and sparse tonofilaments. As the cell matures, the amount of cytoplasm decreases and long dendritic processes form, which permit tight junctions between adjacent cells and the formation of the epithelial framework, within the interstices of which T-lymphocyte differentiation takes place.

Migrating lymphoid progenitors initiate a symbiotic relationship with the epithelial cells and contribute to the organization of the thymic microenvironments. Whereas prothymocytes (i.e., immature T cells) regulate induction of the cortical microenvironment,⁵¹ the mature thymocytes, i.e., T cell receptors (TCR)+ organize thymic medullary epithelial cells.⁵² E-cadherin plays an important role at this stage because it mediates interactions that shape the cortical and medullary thymic microenvironments which are architecturally distinct.⁵³

Heterotypic interactions important for thymocyte proliferation occur between epithelial cells, which express the E-cadherin, and the double-negative T lymphocytes, which express the ligand of E-cadherin, i.e., CD103 or $\alpha\epsilon\beta_7$ integrin.⁵⁴

The thymic anlage is permeated by blood vessels, which also contribute to a well-organized medullary epithelial compartment, even in the absence of CD3⁺ mature thymocytes (i.e., in Rag2^{-/-} mice). Medullary epithelial cells arranged as cuffs around vessels of intermediate size affect the development of the thymic microenvironment.⁵⁵

Addition of keratinocyte growth factor, a member of the fibroblast growth factor family secreted from mesenchymal cells, results in the expansion of the medullary epithelial compartment in the Rag2^{-/-} mice.⁵⁶ These data emphasize the fact that the growth and maintenance of a functional thymic microenvironment is a highly complex process and is maintained by stimuli from all structural components. The RELB gene encodes a subunit of the nuclear factor- κ B complex, critical for the coordination of several aspects in the development and organization of medullary epithelial cells and dendritic cells.

Overexpression of CD40L on thymocytes disrupts the thymic architecture and the epithelial differentiation, with loss of cortical epithelial cells, expansion of the medullary compartment, and infiltration of the capsule with a mixture of CD3⁺ cells, B cells, and macrophages.⁵⁷ These findings point out that regulation of normal development of the thymus is a highly complex process, delicately regulated by multiple cellular interactions and soluble factors released as a result of these interactions.

The medullary epithelium expresses several molecules, considered tissue specific such as parathyroid hormone, thyroglobulin, insulin, and respiratory epithelium. This may represent a "promiscuous" gene expression or a "mosaic" of epithelial differentiation,⁵⁸ which may be the basis for the establishment of self-tolerance. This view is supported by the demonstration that the AIRE gene, which is defective in autoimmune polyendocrinopathy candidiasis ectodermal dystrophy (APECED), is expressed by medullary thymic epithelial cells (TECs).⁵⁹

AIRE (auto immune regulator) is a DNA-binding nuclear protein with a putative DNA-binding domain named SAND (Sp100, Aire-1, NucP41/75, DEAF-1) and four LXXLL nuclear receptor-binding motifs. The structure of AIRE suggests that its function is that of a transcription regulator^{60,61} which interacts with CREB-binding protein (CBP), a property that mediates its transcriptional regulation property.⁶² It also contains a proline-rich region, known to be expressed by several transcription factors which mediate interactions with SH3 domains.

The LXXLL motif binds coactivators to nuclear receptors and activates transcription of target genes by nuclear receptors. AIRE plays a vital role in preventing autoimmunity; and mutations in this molecule cause a recessive inherited disease known as APECED or autoimmune polyendocrinopathy syndrome type-1 (APS-1). APECED at the beginning is presented as mucocutaneous candidiasis early in childhood with eventual destruction of endocrine organs and the appearance of Addison disease, hypoparathyroidism, and type I diabetes.⁶³ AIRE is expressed in medullary

P.233

epithelial cells, testes, and cells of dendritic lineage.⁶⁴ It has been suggested that AIRE may induce transcription of genes specific to other tissues that are promiscuously expressed in the TECs.⁶⁵

It promotes the expression by TECs of self antigens from other tissues facilitating the removal of thymocytes with self-reactive T cell receptors.^{66,67}

Recently, a second thymus has been identified in the neck of mice with typical cortical and medullary structures.⁶⁸ The cervical thymus is structurally the same as the thoracic thymus, consisting of cortex and medulla and containing double-positive (CD4⁺/CD8⁺) and single-positive (CD4⁺/CD8⁻ and CD4⁻/CD8⁺) thymocytes expressing TCR/CD3 complexes. The cervical thymus is fully functional, because it could supply T cells to athymic (nude) mice, correcting their immune deficiency.

This unexpected discovery poses a number of questions for experimental work done with thymectomized animals over the past 45 years.⁶⁹ Perhaps the cervical thymus is too small to be relevant and its cellularity is only 1/500th of the thoracic thymus.⁷⁰

Work done with thymectomized animals suggest that the role of the thymus in autoimmune disease may have to be reconsidered.⁷¹

Nonlymphoid Cells

Thymic Epithelial Cells

The thymic rudiment is populated by epithelial cells which are distinguished anatomically as cortical and medullary. Lack of *Hoxa3* has an impact on the early phases of thymic organogenesis from the third pharyngeal pouch.⁷² *Foxn1* is expressed in epithelial progenitors of cortical and medullary compartments and regulates the differentiation of TECs during embryonic and adult life. In *Pax9* null mice, the thymic anlage develops as an ectopic polyp-like structure, and expression of the *Foxn1*, a marker of thymic epithelium, is markedly reduced. Expression, however, of the *Tcrb* genes is readily detectable in the mutant thymus, but the TCR gamma chain is not detectable.⁷³ The forkhead transcription factor *Foxn1* is indispensable for TEC development and function, acting as a master regulator of the epithelial programs of the thymus.⁷⁴

Overexpression of *Foxn1* attenuates the decline of thymocyte numbers and frequency of early thymic progenitors, and histologic studies reveal that structural alterations associated with thymic involution are diminished in aged *Foxn1* transgenic mice.⁷⁵

Deletion of *Pax1* results in thymic hypoplasia as a result of defective organogenesis of the thymus, while *Pax9* causes marked thymic hypoplasia because of defective cellular migration to thymic rudiments. In *Pax9* null mice the thymic anlage develops as an ectopic polyp-like structure in the larynx, expresses *Whn/Foxn1*, the markers of thymic epithelium, but fails to perform the normal caudo-ventral movement to the upper mediastinum, and the TCR- γ chain is not detectable.⁷³ Loss of *Foxn1* function, on the other hand, results in a more complex phenotype known collectively as the "nude" mouse.

The "nude" mouse has been an important "experiment" of nature that has provided important insights of the function of the thymus.

Abnormal thymic development is associated with defective keratinization, as seen in the nude mouse,⁷⁶ and although the early stages of development proceed normally, including normal mediastinal migration, the subsequent rudiment of the thymus does not develop as a result of failure of its colonization by lymphoid progenitors.⁷⁷

It is generally accepted that organogenesis of the thymus is completed in two distinct steps. During the first stage, endodermal elements of the third pharyngeal pouch migrate to the mediastinum and form the thymic rudiment. In the second stage the *Foxn1* transcription factor drives differentiation of multipotential progenitors to the thymic cell lineage. In the absence of *Foxn1* function, the cells of the rudiment resemble respiratory epithelium in their phenotype and organizational features.⁷⁴ As shown in nude mice, T cell development and selection require expression of the forkhead transcription factor *Foxn1* regulated by Wnt glycoproteins secreted by epithelial cells and thymocytes. In the absence of their function, epithelial cell morphogenesis is defective and lymphoid precursors are not attracted to the thymic primordium. The Wnt molecules therefore provide regulatory signals critical for thymic function.⁷⁸

The glycoproteins Wnt bind to glycosaminoglycans of the extracellular matrix, cell-surface receptors of the Frizzled (Fz) family, and members of receptors related to low density-lipoprotein receptors. Through regulation of *Foxn1* function the Wnt proteins contribute importantly in the development of TECs.

The epithelial cells in the cortex and medulla have a common progenitor as shown by clonal analysis,⁷⁹ and these progenitors still exist in the thymus after birth.⁸⁰

Ultrastructurally, the epithelial cells are highly heterogeneous, probably reflecting their divergent origins (see Chapter 13). In the past, the epithelial cells have been referred to by a variety of designations, such as reticular, syncytial, epithelioid, and squamoid (Fig. 11.8). The characteristic features that distinguish them from other cells in the thymic parenchyma are the presence of tonofilaments and desmosomes. The tonofilaments are filamentous structures approximately 3.0 nm in diameter and 0.1 to 3.0 μ m in length which often form bundles and are located close to the nucleus. Desmosomes are detected at the junctions of the dendritic processes of adjacent epithelial cells. Their oval nuclei have evenly distributed chromatin and prominent nucleoli. The epithelial cells joined by desmosomes form a continuous meshwork that surrounds the trabeculae, the blood vessels and the inner surface of the capsule. Between the epithelial sheath and the

supporting scaffolding of the trabeculae and blood vessels there forms a kind of a continuous basement membrane or meshwork, which is distinct from the basement membrane of the capillaries and separates the epithelial meshwork from the cavernous spaces filled with thymocytes.

The cortical epithelial cells do not have secretory granules and probably do not participate in the secretion of thymic hormones. Such interactions are regulated by products of genes of the major histocompatibility complex. Indeed, the presence on epithelial cells of class I and II molecules in mice and humans has been demonstrated.

The distribution of class II antigens is typically dendritic in the cortex, but is confluent in the medulla. MHC II levels, as well as the percentages and cycling status of TEC populations expressing MHC II, were not static during postnatal development, suggesting

P.234

quantitative flexibility in presenting signals to the developing thymocytes.⁸¹

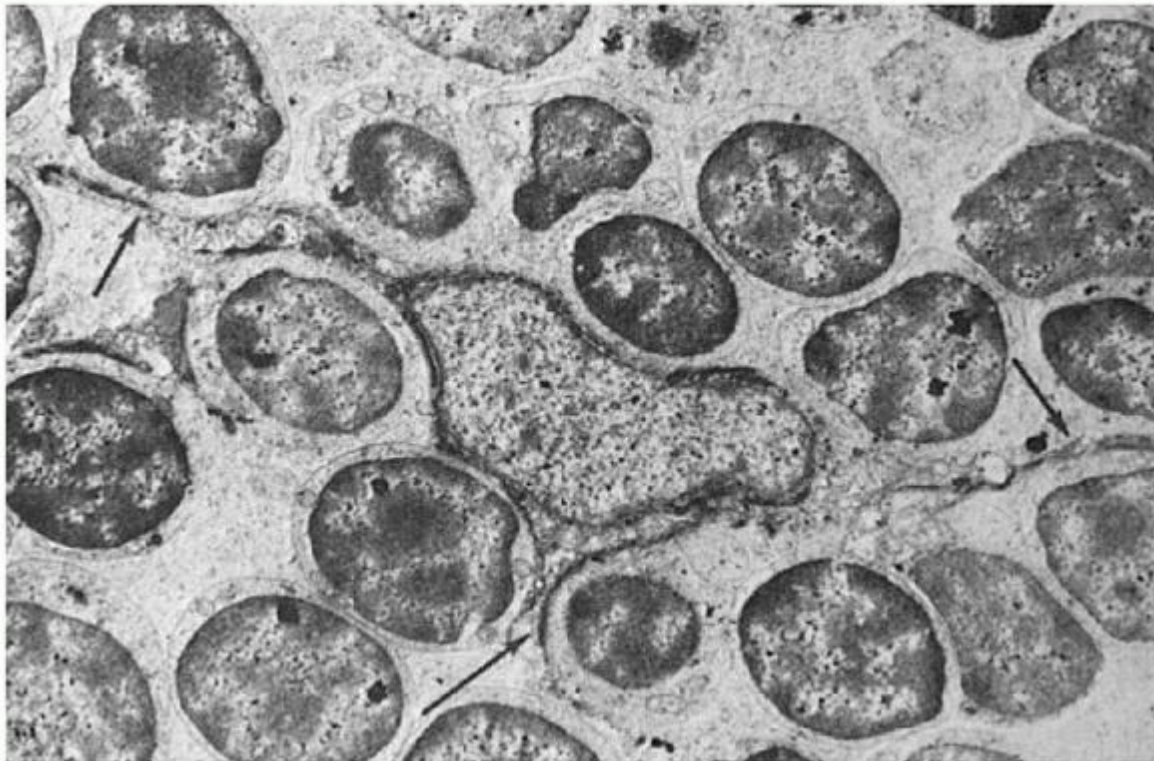

FIGURE 11.8. Ultrastructure of the thymus. An epithelial dendritic cell at center (E) extends long cytoplasmic processes (arrows). Note the intimate contact between the epithelial cell and the surrounding thymocytes ($\times 4,400$). (From Bloodworth JMB Jr, Hiratsuka H, Hickey RC, Wu J. Ultrastructure of the human thymus, thymic tumors, and myasthenia gravis. *Pathol Annu* 1975;10:329, with permission.)

The class II antigens are of higher density than the class I antigens in cortical epithelial cells, but they are of the same high density in the medullary epithelium. Using immunohistochemical techniques and electron microscopy, investigators have shown that these molecules are of epithelial origin because they are located on cells containing desmosomes and tonofilaments.

The thymocyte-epithelial cell interaction in the outer cortex results in the formation of lymphoepithelial complexes known as nurse cells (TNC) (Fig. 11.9). TNCs are located within the corticomedullary junction to express cytokeratins five and eight (K5 and K8) and the transcription factor Trp-63. The phenotype suggests that the TNCs play an important role in thymocyte selection and may also be involved in the maintenance of thymic epithelia.⁸² They are composed of large clusters of lymphocytes surrounded by cell membrane and appear to reside within the cell body of an epithelial cell. Their significance in T cell differentiation is discussed in Chapter 13.

The epithelial cells of the medulla do not have long dendritic processes and are known as epithelioid or spatulate epithelial cells. They are more pleomorphic and contain dark granular inclusions that may have secretory functions. Another variety of epithelial cells, known as squamoid, is found exclusively in the medulla. These cells probably give rise to Hassall corpuscles and contain dense bundles of tonofilaments and masses of keratohyalin.

The Hassall corpuscles, first described more than 150 years ago,⁸³ are solid or cystic, and their origin is highly disputed. Hammar suggested that Hassall corpuscles arise as solid structures through the tight apposition of as many as 20 to 50 epithelial cells in a concentric fashion, but degenerative changes in the centrally located cells produce the cystic forms. The cavity of the cystic forms of these corpuscles is lined by epithelial cells with villous projections, and sometimes it is filled with debris and degenerated cells. In some solid corpuscles, keratinization is prominent and is similar to that of the skin.

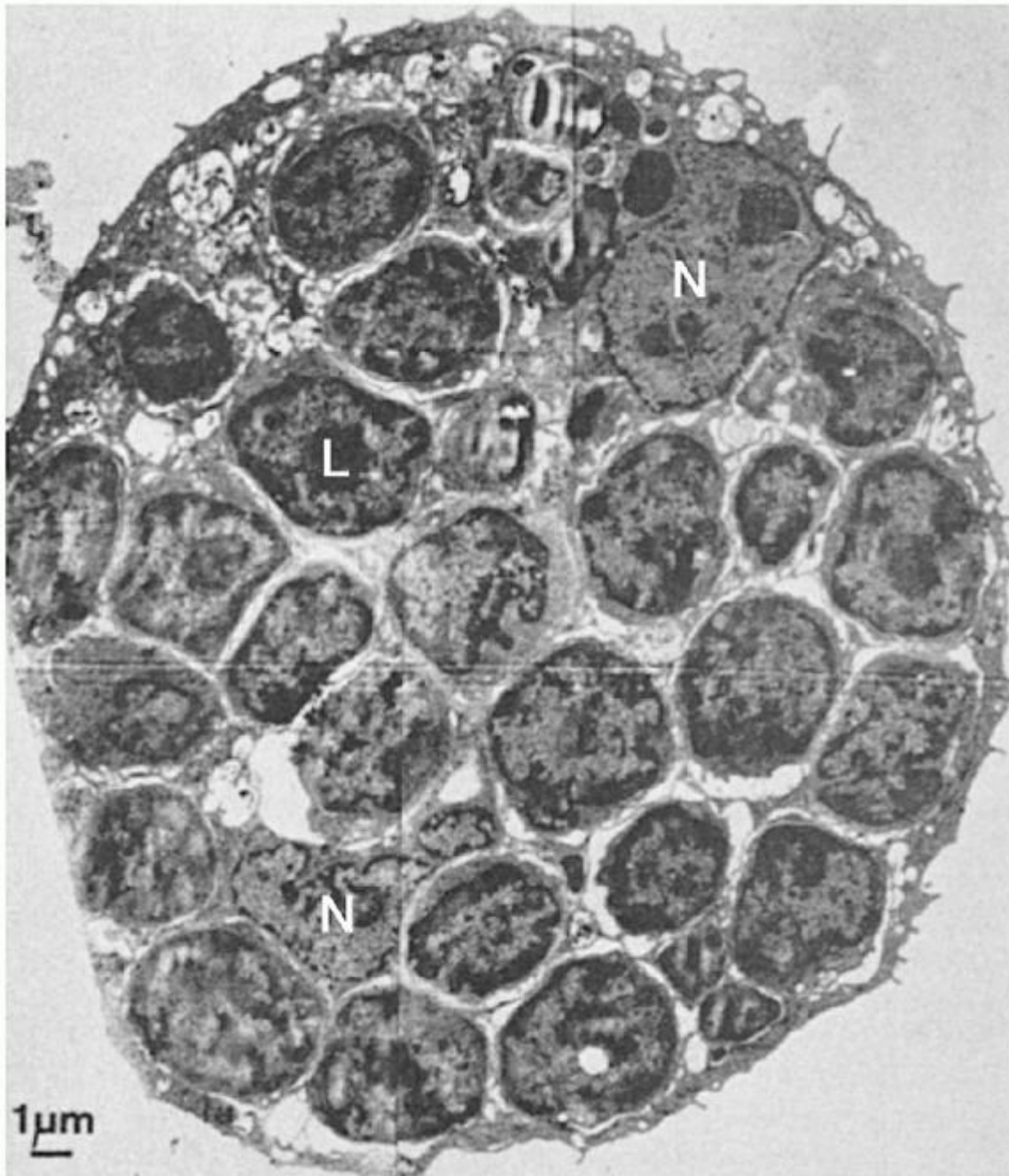

FIGURE 11.9. A typical large nurse cell containing many thymocytes (L) and two epithelial nuclei (N). Between the internalized thymocytes are cytoplasmic vesicles and tonofilaments. Some nurse cells contain thymocytes in mitosis.

(From Wekerle H, Ketelsen UP, Ernst M. Thymic nurse cells. Lymphoepithelial cell complexes in murine thymuses: morphologic and serologic characterization. *J Exp Med* 1980;151:925, with permission.)

Monoclonal antibodies specific for high-molecular-weight keratins that react with terminally differentiated epithelial cells of the skin also bind to Hassall corpuscles.^{39,84} Epithelial cells of the deep cortex are phenotypically different from those in the medulla, which undergo terminal keratinocyte differentiation. Hassall corpuscles are not the epithelial cell graveyard as previously thought, but contribute actively to important immunoregulatory functions. They secrete thymic stromal lymphopoietin (TSLP), which regulates CD4⁺ T cell homeostasis through activation of thymic dendritic cells (TDCs) (see below) and induces proliferation and differentiation of CD4⁺/CD25⁺/Foxp3⁺ regulatory T cells from CD4⁺/CD25⁻ thymocytes.⁸⁵

Macrophages

Macrophages are found throughout the thymus: among thymocytes, in capsular and septal connective tissues, and in the perivascular space. Some macrophages are surrounded by thymocytes and form rosette-like structures. Thymic macrophages direct thymocyte maturation, but appear to be involved also in the disposal of many thymocytes dying within the thymus. Macrophages are more prominent in involuted thymuses after stress or steroid hormone treatment, rendering the histologic picture of a starry sky.

Lymphocyte phagocytosis is found in the germinal center (GC), a site that also is characterized by high proliferative activity.

Interdigitating Dendritic Cells

A third population of nonlymphoid cells in the corticomedullary junction is known as interdigitating dendritic cells or thymic dendritic cells (TDCs). They contain an irregularly shaped nucleus and clear cytoplasm, but they lack the Birbeck granules characteristic of Langerhans cells (LCs) and their phenotype and origin apparently varies.

Specialized dendritic cells (DCs) within the thymus are crucial for deletion of autoreactive T cells. The question of whether these cells arise from intrathymic precursors with T cell potential has been hotly debated, and the regulatory pathways as well as the signals that direct their development remain unclear.⁸⁶ Some are CD8a⁺-derived from a common precursor with T cells and therefore are lymphoid-related and the granulocyte-macrophage colony-stimulating factor is not required for their development (in contrast to the myeloid DCs), and they need functional Ikaros transcription factors for their maturation.⁸⁷ In humans, pluripotent stem cells, which leave the bone marrow to migrate to the thymus, have the potential to develop into T cells and DCs.⁸⁸ The question whether these cells arise from intrathymic precursors with T cell potential has been hotly debated, and the regulatory pathways and signals that direct their development remain unclear.⁸⁹

Other thymic DCs express the CD116/CD8 phenotype (i.e., the Langerhans cells in other tissues) and originate from DC precursors.⁹⁰ Their differentiation is driven by factors produced by TECs as well as Hassall corpuscles.⁹¹ Another pathway of TDC differentiation is from double-negative thymocytes (i.e., CD4⁻/CD8⁻) stimulated, in the presence of IL7, by IL18 produced by TECs.⁹²

Thymic stromal cells produce the IL7-like lymphopoietin, TSLP, that acts through appropriate receptors on dendritic cells carrying self-peptide-MHC complexes inducing expansion of CD4⁺ T cells. TSLP is also produced by epithelial cells in tonsillar crypts and other mucosal tissues, and thus may exert a homeostatic mechanism on CD4⁺ T cells, through dendritic cell activation not only within the thymus, but in other mucosal lymphoid tissues as well.

P.235

Myoid Cells

Myoid cells are striated muscle cells seen in many lower vertebrates and are found in the medulla of the thymus. Their origin has not been documented but it is believed to originate from mesenchymal or epithelial cells to which they are attached by desmosomes.

They contain muscle proteins, including myosin, desmin, acetylcholine receptors, and numerous intracytoplasmic filaments arranged in haphazard fashion.

Their presence in human fetal thymuses has been documented and plays a role in T cell differentiation, maturation, and protection of thymocytes from apoptosis.⁹³

Lymphoid Cells

Lymphoid cells constitute 80% to 85% of the cortical and 15% of the medullary cells. The outer cortex lymphocytes are large blast cells with dark blue cytoplasm that proliferate actively. They are the immediate descendants of bone marrow-derived prothymocytes, which enter the thymus and migrate to the subcapsular cortex. As they mature, they move into the deeper cortex, which is occupied by small nondividing thymocytes. The medullary thymocytes are of medium size and are considered emigrant cells, although this fact has not been proven conclusively. The recruitment, migration, and differentiation of lymphocytes and the relationship between subcapsular, deep cortical, and medullary thymocytes are discussed in Chapter 13.

Thymic Vasculature

The thymic anlage initially is avascular and is penetrated by vessels at approximately 12 to 14 weeks of gestation. The thymic arteries are branches of the inferior thyroid, internal mammary, and pericardial phrenic arteries; they enter the thymus and pass down to the medulla, branching into arterioles which penetrate into the deep cortex.

Capillaries that arise from the arterioles run toward the subcapsular cortex, where they anastomose and turn inward toward the medulla, eventually forming venules.⁹⁴ The vessels are ensheathed with epithelial cells and connective tissue that is continuous with the capsule.

Histologically, a number of layers can be distinguished from the lumen of the blood vessels outward which constitute the blood-thymus barrier: (a) endothelium; (b) vascular basement membrane; (c) mesenchymal perivascular connective tissue space occupied by collagen fibers; (d) fibroblasts, macrophages, and other cells; (e) epithelial basement membrane; and (f) epithelial cell syncytium. The mesenchymal interstitial space is probably formed in the early stages of development when the TECs envelop the blood vessels; it is considered extraparenchymal. The tightness of the barrier has been tested with particulate and protein tracers. It is tight in the cortex, mainly because of the impermeability of the endothelial junctions. Traces of protein transported by plasmalemmal vesicles of the endothelial cells which are released on the parenchymal front are removed rapidly by macrophages along the interstitial spaces of the vessels and are prevented from coming into contact with the thymocytes. This barrier, however, is incomplete in the medulla, especially along the site of thymocyte migration through the wall of venules.⁹⁵ The fact that antigens are detected in the thymus indicates that the "barrier" has leaks, although experimental tracers have never reached the cortical parenchyma. This arrangement of the vasculature and the epithelial sheaths separates the thymus into the intraparenchymal compartment, composed of the lymphoepithelial complex and the extraparenchymal compartment composed of the blood vessels and the surrounding interstitial space.

Involution

Beginning at puberty, the thymus undergoes a gradual process of involution, characterized by loss of the cortical lymphocytes and atrophy of epithelial cells and their replacement by fat originating from mesenchymal cells present in the connective tissues along the vasculature and capsule. More than 50% of the thymus is replaced by adipose tissue by the age of 40 to 45 years, but the fat is still contained in the extraparenchymal compartment, separated from the remaining lymphoepithelial complex by the epithelial basement membrane and the sheet of epithelial cells. The age-related involution may be influenced by stress and other factors.

Thymic involution starting at puberty has been associated with use of sex hormones. This hypothesis, however, has been challenged, since morphometric studies have shown that thymic involution actually starts early in life,⁹⁶ as the potential of intrathymic progenitors to maintain the level of mature thymocytes starts to decrease at that time.⁹⁷

With a rise of sex hormone concentration there is a decline in the production of growth hormone and many of its effects in the periphery are mediated by insulin growth factor-I induction.⁹⁸ A slow rate of thymic activity is maintained throughout life with complete but slow renewal of T cells,⁹⁹ but the changes of the thymic tissue are quantitative rather than qualitative. At the molecular level thymic involution is linked with the expression of JAGGED-1 protein in T cells¹⁰⁰ together with Delta protein. The gene of this protein is a member of the Delta/Serrate/Lag2 (DSL) genes which regulate Notch signaling implicated in regulation of T cell activation and differentiation. Expression of JAGGED-1 on T cells interferes with Notch signaling and induces premature involution as a result of apoptosis of TECs. In contrast to chronic involution which is a result of aging, the thymus undergoes acute involution as a result of stress, which is mediated by adrenal corticosteroids. Injections of glucocorticoids eliminate as much as 75% of the thymocytes within 2 to 3 days, affecting both the cortex and the medulla, but the effects are more pronounced in the cortex. Most of the cortical thymocytes are cortisone sensitive, whereas the medullary thymocytes are cortisone resistant. As a result of acute stress the lymphocytes undergo pyknotic changes, fragmentation of the nuclei, and eventually a decrease in size; subsequently they are phagocytosed by macrophages.

Recovery takes place within 8 to 10 days and is marked by an early increase in mitotic activity in the subcapsular cortex.

Pathology of Human Thymus

Myasthenia Gravis

In some of the patients with myasthenia gravis, the thymus shows an increase in the number of medullary epithelial cells containing thymic hormones and development of follicles with GCs composed of B cells and many plasma cells,¹⁰¹ i.e., histologic changes which are typical of reactive peripheral lymphoid organs. These follicles are located outside the epithelial basement membrane, predominantly in the medulla, and are surrounded by many Hassall corpuscles; but the cause of these histopathologic lesions is unknown. Antibodies against the acetylcholine receptor, in the neuromuscular junction, play an important role in the pathogenesis of myasthenia gravis; and it is intriguing that this receptor, or a structurally similar antigen, has been detected on thymic cells.¹⁰² Patients with myasthenia gravis have circulating antibodies reacting in culture with the striations of myoid cells from animal and human thymuses, as well as muscle cells expressing acetylcholine receptors.¹⁰³ These are the "myasthenogenic" factors in the blood of the patients, which in mice induce many characteristic features of the disease, i.e., reduced amplitudes of the miniature endplate potentials and a reduction of the number of acetylcholine receptors available for binding of bungarotoxin

P.236

up to 38% to 54%. Approximately 10% to 15% of patients with myasthenia gravis have thymomas, but these histologic changes are not characteristic of myasthenia gravis, since they have been observed in patients with other diseases such as endocrinopathies, i.e., Addison disease and thyrotoxicosis; and autoimmune diseases, such as systemic lupus erythematosus.

Similar lesions have been identified in thymuses from patients with multiple sclerosis, supporting a well-documented fact that the thymus and the brain share some antigens such as the Thy-1 antigen (CD90).

Dysplasia. The thymus of patients with severe combined immunodeficiency disease is characterized by scant lymphocytes with reduced numbers of epithelial cells.

Thymomas. Tumors of the thymus are epithelial, lymphocytic, or consist of a mixture of both cellular elements; while others are mixtures of ductal and glandular structures mixed with epithelial cells. These cases are thought to imitate the early ontogenetic stages of the thymic anlage and support the view of the double origin of the thymic epithelium. Thymic lymphomas that appear as mediastinal masses are associated with acute T cell leukemia in children who bear the phenotype of cortical thymocytes in the early stages of their development. The diagnosis of primary thymic epithelial tumors has been controversial, because of the difficulties in their histopathologic classification and prognostication of their clinical behavior. A new histologic classification has recently been proposed by the World Health Organization (WHO),¹⁰⁴ which provides an improved platform over pre-existing classifications for clinical practice in relation to assessment and treatment of the patients.

SECONDARY LYMPHOID ORGANS

Lymph Nodes

Ontogeny

The fundamental concepts of lymphoid organ neogenesis were generated approximately 100 years ago, and the ontogeny of the secondary lymphoid organs, i.e., lymph nodes (LN), Peyer patches (PP), and spleen is highly complex (reviewed in Refs. 105-107). The evolution of their development generated structures, the lymphoid organs of the immune system, to fit their function, i.e., as defenders of the integrity of "self." This of course requires enhancement of their "sensitivity of antigen recognition" in order to facilitate activation and differentiation of antigen-specific cells, to be followed by the activation and deployment of the defence mechanisms of the body. The LN and PP develop from the budding of a group of cells from large vessels of lymph sacs which are penetrated by connective tissue and lymphatic vessels interconnecting with other vessels forming a network; this is regulated by the PROX1 gene which is expressed on lymphatic endothelial cells and is required for budding and sprouting of the lymphatic endothelium¹⁰⁸. The budding occurs in one spot in the anterior cardinal veins of the neck and generates a lymph sac, which gives rise to the lymphatics of the neck, thorax, heart, lungs, and forelegs regulated by the PROX1 gene.¹⁰⁹ After the development of the lymphatics, circulating CD45⁺ CD4⁺ CD3⁻ hematopoietic progenitor cells from the liver provide the signals for the induction of LNs and PPs. Lymphotoxin (LT) is essential for the formation of LNs and PPs, as shown in mice rendered deficient in LT by gene targeting,¹¹⁰ and in the white

pulp of the spleen normal segregation of B and T cells does not occur. Both phenotypes of T cells, i.e., CD4⁺CD8⁻ and CD4⁻CD8⁺ are present in a normal ratio.

Lymphocytes positive for immunoglobulin-M are present in increased numbers in both the spleen and peripheral blood. These findings suggest that LT is essential in the normal development of peripheral lymphoid organs.¹¹¹ Lymphocytes positive for immunoglobulin M are present in increased numbers in both the spleen and peripheral blood. The membrane-bound LT forms heterotrimers, i.e., LT-1-2, which bind to the LT receptor (LT-R). The LT-1-2 triggers expression of kinase NIK, which induces the nuclear transcription factor κ -B and initiates an alternative pathway for its activation, which plays a pivotal role in innate and adaptive immunity.¹¹² The interaction of LT 1-2 with its receptor LTR constitutes a major pathway in the development of the architecture and the function of the secondary lymphoid organs¹¹³ for adaptive immune responses. These findings document the crucial roles of LT- and LT-R in building and maintaining the architecture of lymphoid organs and ensuring the function of the immune response against invading pathogens.

Chronic inflammation, autoimmunity, or cancer may interfere with the development of secondary lymphoid organs; and the maintenance of their microarchitecture depends on interactions of cells of hematopoietic and nonhematopoietic origin, as well as the chemokines CXCR5 and CCR7.^{114,115}

The chemokines CCL12 and CCL19, which bind to chemokine receptor CCR7, and the CXCL13, which binds to receptor CXCR5, are important for the colonization of lymphoid organs by T and B lymphocytes and antigen-presenting cells.¹¹⁴ The enzyme IKK kinase limits gene activation in inflammatory responses, and downregulates signaling by the transcription factor NF- κ B. Upon completion of the connective tissue skeleton the first cells which colonize the LN in mice express the CD4⁺CD3⁻ phenotype, and after stimulation with IL-2, differentiate to NK cells, or, depending on the combination of cytokines, will give rise to antigen-presenting cells. The precursors of these cells are CD45⁺/CD4⁺/CD3⁻ and IL7 R⁺ residing in the liver.¹¹⁶

Their development requires the function of the RORC gene¹¹⁷ as well as the Id2 gene, which regulates LN and PP development in mice.¹¹⁸ Development of LNs depends also on signaling from TNFSF11, known also as RANKL or TRANCE,¹¹⁹ a member of the TNF family of cytokines. This protein is involved in the development of secondary lymphoid organs and regulation of homeostasis of the immune system. Mice deficient in Trance lack LNs (although the PPs are normal), and the development of the bone marrow is defective because of the absence of osteoclasts.

Another genetic defect of the development of the primary lymphoid organs is alymphoplasia, (aly/aly),¹²⁰ and mice with this defect have a mutation in nuclear factor- κ B inducing kinase Nik, now known as Map3k14. The Map3k14 mutation causes disruption of the architecture of the thymus, affecting the TECs¹²¹ and aly/aly mice show decreased numbers of CD25⁺ CD4⁺ T cells in the spleen.¹²² Mutation of the alymphoplasia, ("aly" or Map3k14) gene results in the complete absence of LNs and PPs and well-defined lymphoid follicles in the spleen. Development of lymphoid follicles rich in B cells requires the function of the B-lymphocyte chemoattractant BLC (CXCL13) and its receptor CXCR5, which stimulate homing of B lymphocytes to the follicles. BLC induces upregulation of lymphotoxin alpha-1 beta-2, which promotes follicular DC development and BLC expression, establishing a positive feedback loop.

Histology

The LNs are ovoid structures ranging in size from a few millimeters to more than a centimeter. They are particularly common at the base of extremities, in the retroperitoneum, the mediastinum, and along blood vessels. A fibrous capsule surrounds the LN, and trabeculae penetrate the parenchyma, forming a supporting meshwork, while blood vessels enter and leave the LN through the hilum. Histologically, two regions can be distinguished, a peripheral cortex and a central medulla. The cortex is subdivided into the superficial cortex, located immediately beneath the capsule, and the deep cortex or paracortex, which is located toward the center of the node (Fig. 11.10). The function of the LN is best understood by considering the reticulum and the cellular compartment.

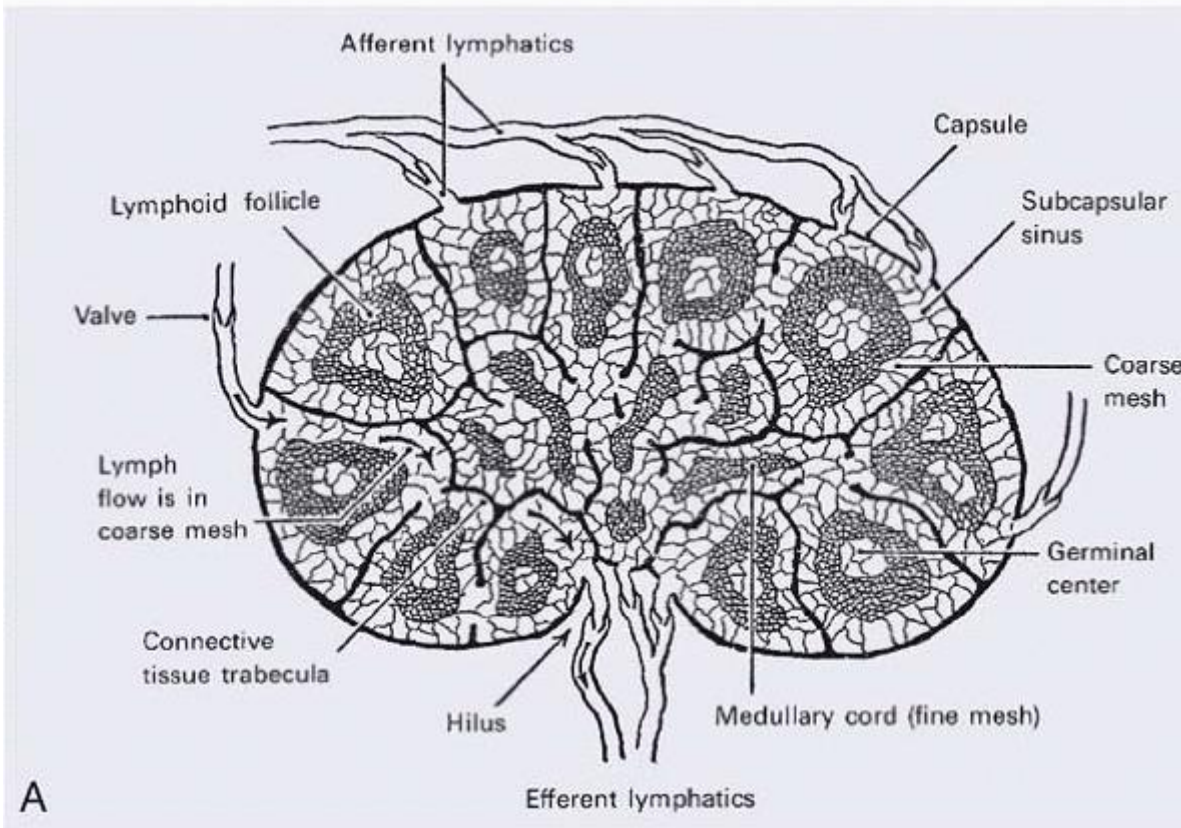

A

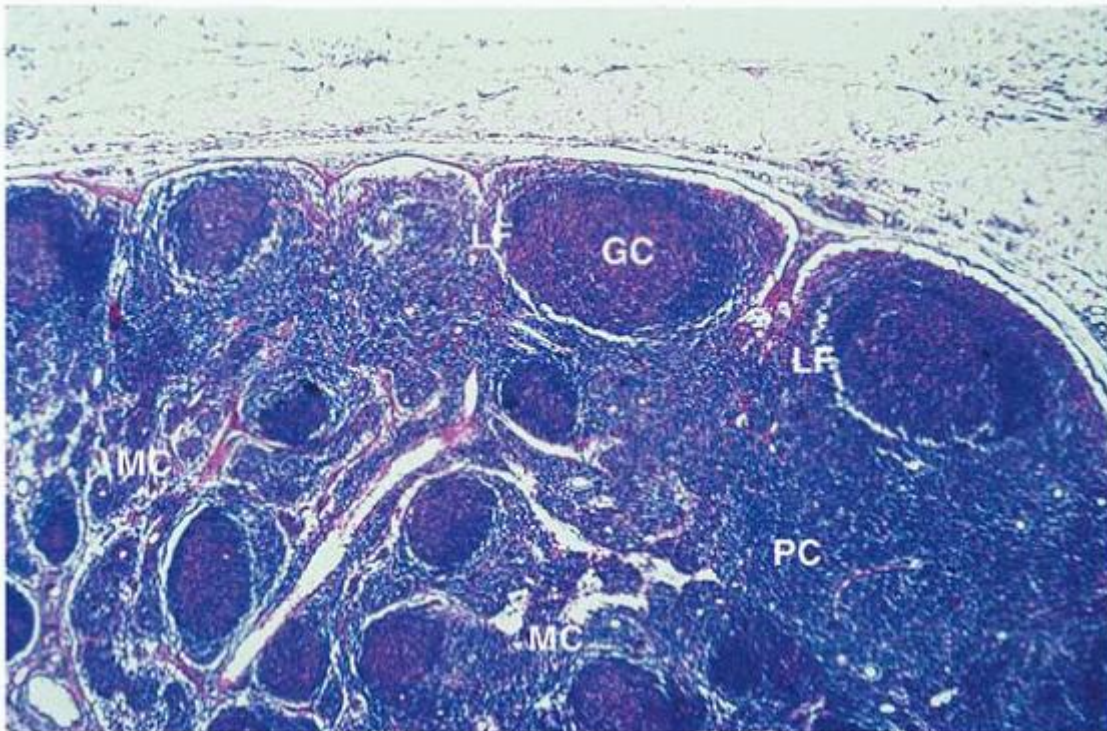

B

FIGURE 11.10. Lymph node. A: Drawing of a lymph node. B: Cross section of a normal lymph node. GC, germinal centers; LF, lymphocytic follicles; MC, medullary cords; PC, paracortical lymphoid areas.

Reticulum

The basic framework of the LN is composed of trabeculae made of bundles of collagen and a few elastic fibers.^{123,124} This fibrous reticulum is argyrophilic when silver impregnation techniques are applied, forming a closely knit sponge-like framework, with the fibers branching frequently and anastomosing freely with each other. The fibers surround the sinuses and penetrate the dense lymphatic tissue and are ensheathed by two kinds of cells (Fig. 11.11). On the side bordering the dense lymphoid tissue, the fibrous reticulum is covered by thin elongated cells that have been identified as fibroblasts or fibroblastic reticulum cells. They have large nuclei and endoplasmic reticulum in their cytoplasm. Cytoplasmic processes join similar processes of adjacent cells forming a continuous cellular sheath (cellular reticulum), which separates the fibrous reticulum from the dense lymphoid tissue. On the side bordering the sinuses, which are lined by littoral or endothelial cells, the fibrous reticulum is lined by flat endothelial cells with multiple vesicles and fibers which cross the sinuses and divide the lumen into smaller interconnecting compartments (Fig. 11.12).

The fibrous trabeculae provide mechanical support for the sinuses and slow the flow of the lymph, enhancing the opportunities for phagocytosis by macrophages which are present along their course as well as covering the sinus wall. The sinuses which follow the fibrous trabeculae originate from a foramen on the inner wall of the subcapsular sinus where afferent lymphatics terminate. Viewed from this perspective, the reticulum divides the LN into two distinct spaces. One consists of conventional vascular channels, with a rapid flow, facilitating lymphocyte traffic. The other space is lined with fibroblasts, the flow is slow, and the lumen is tightly packed with lymphocytes and other cells.

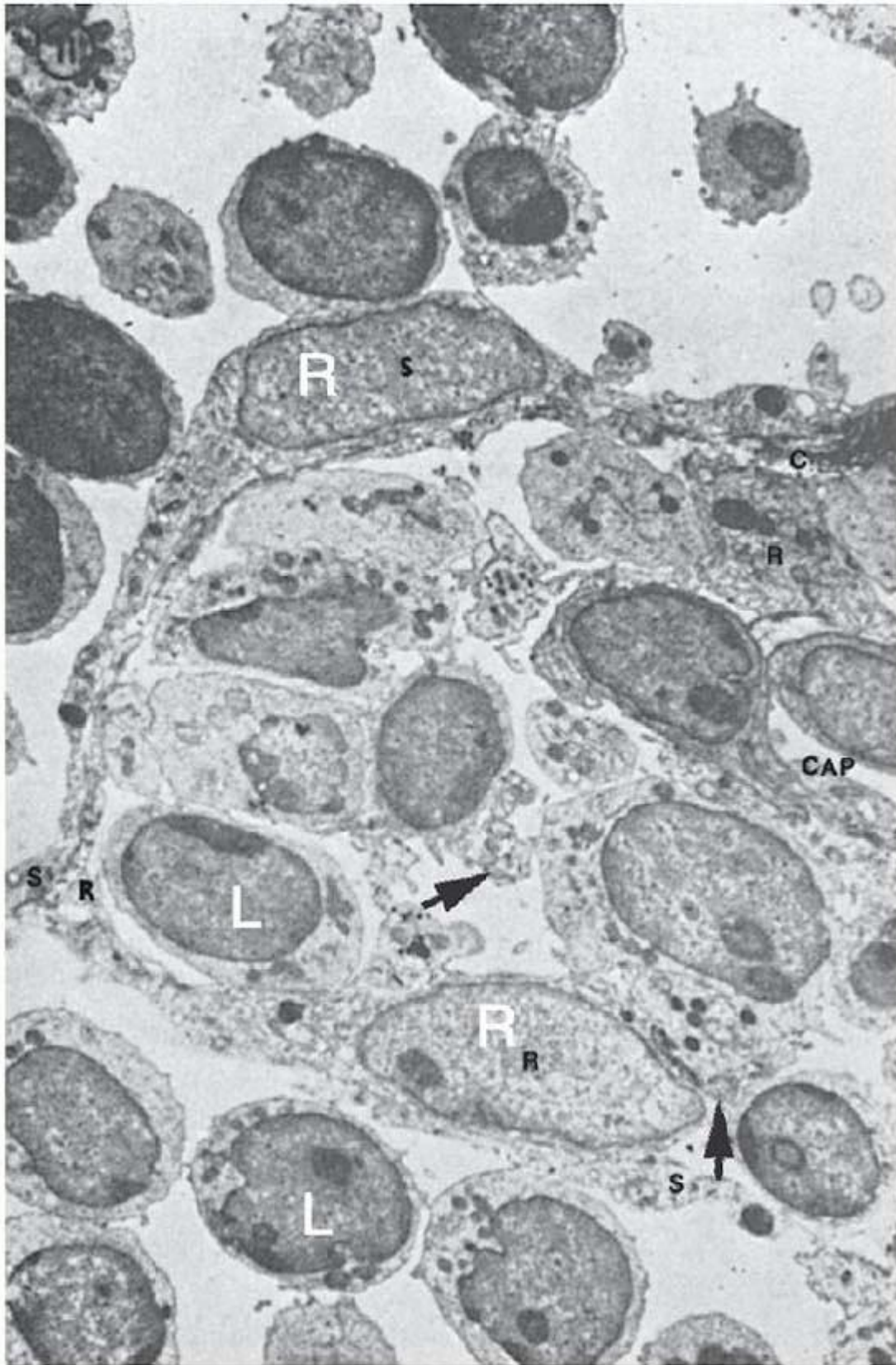

FIGURE 11.11. Ultrastructure of a lymph node. The area in the center and to the right is occupied by dense lymphoid tissue with many lymphoid cells. It is separated from the sinus (upper area, left, and below) by flat endothelial cells lining

the sinus (s), bulky reticular cells (R) bordering the dense lymphoid tissue, and collagenous fibers (c) between the two cellular layers. Arrows indicate collagenous fibers traversing the dense lymphoid tissue. Cap, blood capillary. (From Clark SL Jr. The reticulum of lymph nodes in mice studied with the electron microscope. *Am J Anat* 1962;110:217, with permission.)

Cellular interactions of the immune responses take place in this compartment and both communicate through pores in the inner wall of the subcapsular sinus.

Cellular Compartments

The most abundant cells in the LN are the lymphocytes, arranged in clusters known as follicles which occupy the region beneath the capsule known as the cortex. A follicle composed of uniform small lymphocytes is known as the primary follicle and one containing pale, lightly stained, blast-like cells with a euchromatic nucleus in its center is the secondary follicle. The central zone of the secondary follicle is called the germinal center (GC) and is the hallmark of antigenic stimulation. In the secondary follicles, the lymphocytes surrounding the GC constitute the mantle or crescent. The name germinal center was given by Flemming in 1884 because he considered them as "breeding grounds for the generation of lymphocytes."¹²⁵ Later Hellman called them "reaction centers," and considered them important in the induction of immunity.¹²⁶ In the areas between the follicles the lymphocytes are distributed diffusely (the diffuse cortex), and the region which separates the cortex from the medulla is known as the deep cortex or paracortex, occupied predominantly by tightly packed T lymphocytes. The histologic arrangement of lymphocytes in the LN corresponds to distinct functions performed by separate classes of lymphocytes (Fig. 11.13). The follicles are occupied by B lymphocytes and are sites of intense activity during antibody responses (Chapters 12 and 14).

P.238

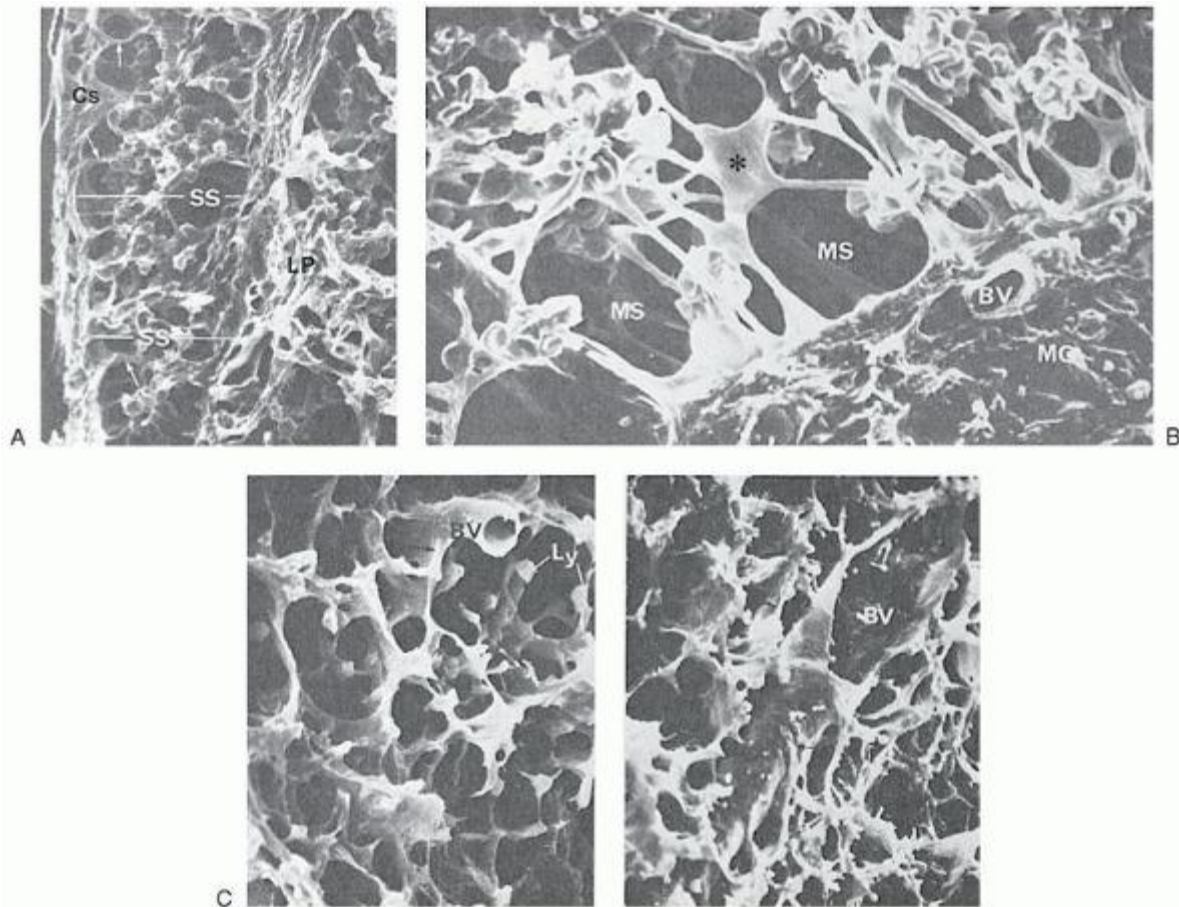

FIGURE 11.12. Ultrastructure of a lymph node. A: Subcapsular sinus (SS) traversed by trabeculae (arrows) stretches between the capsule (Cs) and the parenchyma (LP) ($\times 600$). B: Medullary sinus (MS) with medullary cord (MC) and a

meshwork of trabeculae (asterisk). ($\times 1,900$). C: Lymphoid parenchyma and the meshwork of trabeculae (arrows) separating intercommunicating cavernous spaces normally occupied by lymphocytes (Ly). (left, $\times 1,100$; right, $\times 1,600$). BV, blood vessel. (From Luk SC, Nopajarooyri C, and Simon GT. The architecture of the normal lymph node and hemolymph node. A scanning and transmission electron microscopic study. *Lab Invest* 1973;29:258, with permission.)

The GC is occupied by two types of lymphoid cells, the centroblasts (noncleaved), which are large activated B lymphocytes, and the centrocytes (cleaved), which are small lymphocytes originating from centroblasts. The centroblasts are located at the bottom of the GC (dark zone), while the centrocytes are located at the upper part (apical zone). The role of the GC in the maturation of the antibody response is discussed in Chapter 12.

The GCs contain a subpopulation of centroblasts which express a phenotype characteristic of Burkitt cells¹²⁷ and a subset of $CD4^+ CD45RO^+ CD57^+$ T cells¹²⁸ which belong to the Th-2 subset, important for the initiation of T-B cell interactions in antibody formation. A large number of B lymphocytes die by apoptosis, and are subsequently disposed of by phagocytic macrophages known as tingible body macrophages.

The mantle of the follicle is composed of small lymphocytes that morphologically appear identical, but phenotypically and functionally are heterogeneous. A small number of lymphocytes, not yet antigenically stimulated, are immunologically competent and express both IgM and IgD; and a third population are longlived memory B cells, which are recirculating and express IgG or IgA. B lymphocytes of the mantle are $CD5^+$ and their relationship to $CD5^+$ -B cells is discussed in Chapter 12.

The paracortex and diffuse cortex constitute the T cell compartment of the LN, which undergoes histologic changes during cell-mediated immunity. Sometimes the paracortex contains nodules formed after an immune response, consisting of interdigitating DCs and T cells.¹²⁹ The B cells in these clusters are selected in an antigen dependent, MHC restricted fashion and become responsive to soluble, polyclonal helper factors. Cross sections of paracortex stained with special stains show a set of concentric rings, which form barriers or walls separating vascular spaces in between, where the lymph flows (Fig. 11.14). This structure constitutes the paracortical cord,¹³⁰ with its center in the high endothelial venule (HEV) (see description later in this section). In the medulla, the cells are arranged in cords (medullary cords) composed of lymphocytes, macrophages, and plasma cells.

Lymphocytes exit the HEV through an interendothelial route and emerge into the perivenular channels (PVCs), which is the space between the abluminal side of the endothelium and the surrounding pericytes. The channels are bounded by pericytes or fibroblastic reticular cells (FRCs), which circumscribe the HEV with at least two layers of overlapping cells. The flow of lymphocytes through the PVCs is rate limiting because the PVC around the HEV is extremely narrow, and lymphocytes must distend the channel to pass through it. As they emerge from the PVCs, the lymphocytes enter a space packed densely with cells known as the corridor. The corridors accommodate two lymphocytes side by side and their walls consist of reticular fibers enclosed by FRCs, which leave narrow spaces surrounding the fibers named the conduit. The corridors allow cellular interactions between slowly

P.239

moving T cells that sample antigens presented by stationary DCs, "shaking hands much like the receiving line at a wedding."¹³¹ The conduit, on the other hand, is a specialized system where fluid carries soluble factors important for the immune functions of the lymphocytes. The corridor space, where flow is slow, is separated from the sinuses, where flow is fast, by the reticular fibers and the endothelium of the sinuses.

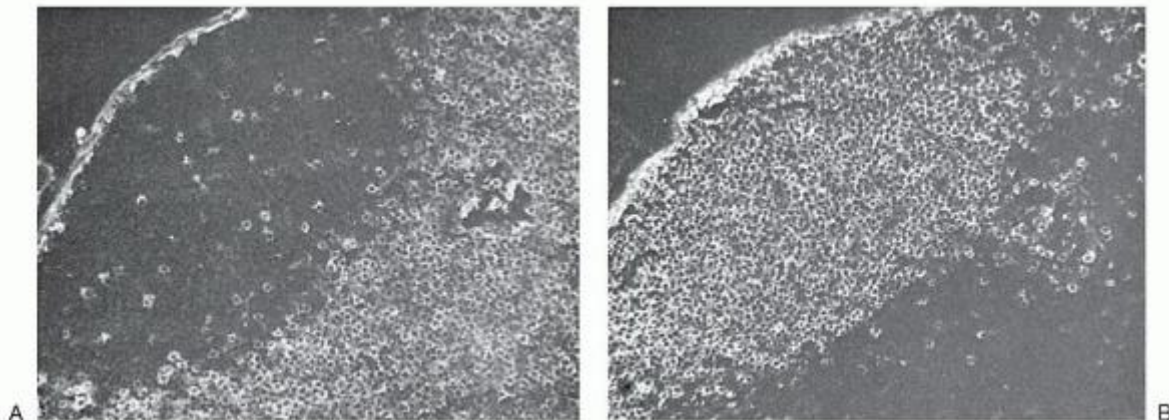

FIGURE 11.13. B- and T cell-dependent areas of the lymph node. A frozen section of a mouse lymph node was examined by immunofluorescence with an anti-immunoglobulin antiserum (A) or an antiserum to T cells (B). A: Only the follicle fluoresces (B cell-dependent area). B: The paracortex fluoresces brightly (T cell-dependent area), whereas the follicle remains dark except for a few scattered fluorescent T cells. These are $CD4^+$ helper T cells, which migrate to the germinal center because they express the chemokine receptor CXCR5 and are attracted to its ligand, BCA-1 chemokine released from cells in the follicle (see Lymphocyte Homing and Recirculation). (From Weissman IL, Weiryke R, Butcher EC, et al. The lymphoid system. Its normal architecture and the potential for understanding the system through the study of lymphoproliferative diseases. *Hum Pathol* 1978;9:25-45 with permission.)

Dendritic Cells

The functions of lymphocytes are predicated by their interactions with other cells, such as macrophages and dendritic cells (DCs). Macrophages are found in large numbers in the walls of the sinuses and in the dense lymphoid regions. They remove by phagocytosis within minutes foreign substances which are found in the phagolysosomes of medullary macrophages. Macrophages therefore contribute in an important way to the filtering functions of LNs, since as they capture and destroy infectious agents and foreign material by phagocytosis, they process it for presentation to the T lymphocytes. Antigen presentation is also mediated by the nonphagocytic dendritic cells,¹³² a name which vividly describes their morphology, i.e., long arborizing cytoplasmic processes or dendrites (from the Greek dendron which means “tree”), extending for long distances from the cell body.

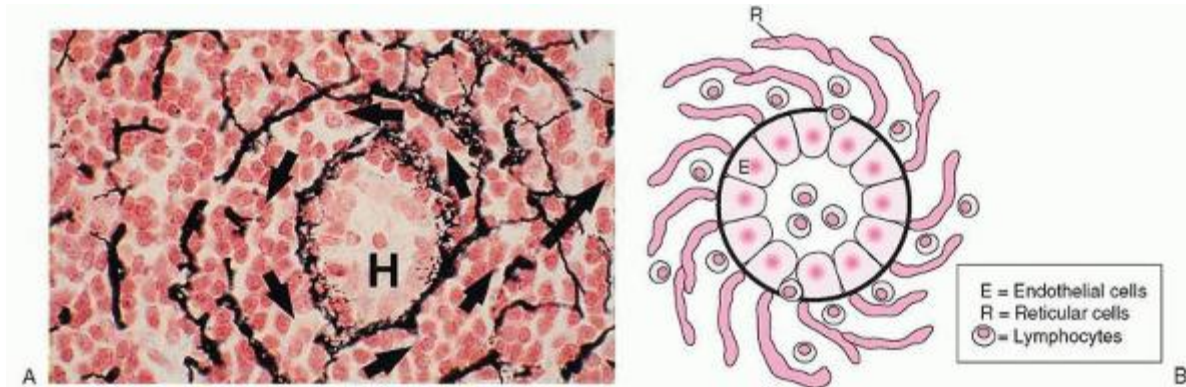

FIGURE 11.14. Cross section of a paracortical cord showing the corridor, outlined by reticular fibers stained by Gomoristain. A: The corridor encircles the high endothelial venule in the center (H). B: The drawing represents an “idealized” cross section of panel A. (Courtesy of Drs. Gretz, Anderson, and Shaw. From Gretz JE, Anderson AO, Shaw S. Cords, channels, corridors, and conduits: critical architectural elements facilitating cell interactions in the lymph node cortex. *Immunol Rev* 1997;156:11-24, with permission.)

Within the LN there are two distinct populations of DCs: one resides in the follicles, known as a follicular DC (FDC), and the second in the paracortex, known as interdigitating DC (IDC). Their origins, functions, and cellular associations are distinct, i.e., while FDCs are autochthonous, the IDCs are immigrants arriving from remote parts of the body using the routes of the lymphatic vessels. The FDCs of the follicles have an irregularly shaped nucleus with long, beaded cytoplasmic processes. They are not phagocytic, but retain the captured antigen for prolonged periods, in the form of immune complexes. FDCs therefore function as the arbiters of life or death for emerging centrocytes, based, respectively, on the high or low affinity of their receptor for antigen (see Chapters 12 and 14). They also have been implicated in the generation of memory lymphocytes and the maintenance of antibody production. Two types of FDCs have been described, one with filiform and one with beaded dendrites.¹³³ The FDCs through adhesion molecules expressed on their surface, i.e., the intercellular adhesion molecule-1 (ICAM1) (CD54) and the vascular cell adhesion molecule-1 (VCAM1) (CD106), interact with their respective “ligands,” LFA1 (CD11a/CD18 or L2 integrin) and VLA4 (CD49d)

P.240

on the surface of the B cells.¹³⁴ The FDC network is disrupted in angioimmunoblastic lymphadenopathy, acquired immunodeficiency syndrome, and Hodgkin lymphoma¹³⁵; and as a result, lack of appropriate handling of foreign antigens is reflected in the clinical consequences for these patients. Electron microscopic studies of the primary follicles detected reticulum cells with little or no evidence of phagocytic activity making contact with neighboring cells by very tight adhesions or desmosomes.¹³⁶ These “reticulum cells” are stellate in shape, have long cytoplasmic processes and are

probably of mesenchymal origin. The FDC of the germinal center probably originates from the reticulum cells of the primary follicle and is not ensheathed by collagenous fibers like the fibroblastic reticulum cell.

The Interstitial Dendritic Cells (IDC) are located in the paracortex and extend numerous cytoplasmic processes that surround T cells. They are not phagocytic, but carry antigen from the periphery for presentation to T cells in the paracortex of the LNs. Tight junctions between IDC and T lymphocyte have been detected by electron microscopy and become particularly prominent after stimulation with antigens that elicit strong cell-mediated immunity. Their cytoplasm is electron lucent and contains lysosome-like vesicles and tubular structures extending to the periphery of the cell. The IDCs are surrounded by clusters of T cells around the endothelial venules of the paracortical nodules. Antigen-specific T lymphocytes around the B cell follicles, form prominent nodules, known as "composite nodules," and are detected in dermatopathic lymphadenitis, a condition characterized by large numbers of DCs migrating from the areas of inflamed skin. Similar changes are also seen in regional LNs, draining areas of T cell lymphomas involving the skin.

In ontogeny the dendritic cell system develops slowly, and as a result during neonatal life the body depends primarily on innate immunity.¹³⁷ The traffic of DCs is regulated by cytokines, i.e., IL1, TNF- α , and chemokines; and regardless of their origin, immature DCs express the chemokine receptor-6 (CCR6), which binds the chemokine macrophage inflammatory protein MIP-3 alpha (CCL20). The CCR6, which is constitutively expressed by keratinocytes, is also the only known receptor for MIP-3 a, a CC chemokine chemotactic for lymphocytes and dendritic cells. The CCR6 is expressed on memory T cells and on B cells, and therefore chemotaxis by MIP-3 alpha is limited to these cells. The defensins are a group of vertebrate antimicrobial peptides (AMPs) with microbicidal and immune regulatory functions. In spite of their conservation across the vertebrate lineage ranging from bony fish to human, the evolutionary origin of these molecules remains unsolved. The defensins produced by mucosal membranes after microbial infection bind also to CCR6 and thus attract DCs to submucosal areas.

In response to antigenic stimulation at the initiation of the immune response, vascular growth is necessary in the draining lymph nodes and is reflected in the growth of the endothelial cells of the venules, growth which is concomitantly associated with increased cell entry into the LN. The CD11c⁺ DCs optimize the microenvironment of the draining lymph node by increasing the levels of vascular endothelial growth factor (VEGF) which induces endothelial cell proliferation.^{138,139} Maintenance of lymphatic vessels, as well as the growth and maturation of new vessels, is regulated by the function of tyrosine kinases, which thus may be used as an attractive target for inhibition of lymphangiogenesis in cancers.¹⁴⁰ The cellularity of the lymph nodes and the maintenance of a functional HEV status in adult mice relies largely on lymphotoxin-beta (LT-beta) receptor signaling, which may be reduced by a blockade of the receptor in adult mice.¹⁴¹ Another factor which influences the cellularity of the lymph node is the movement of small lymphocytes across the postcapillary venules. This movement modifies the structure of the endothelium, evidenced by intravenously injected small thymocytes which trigger migration of small numbers of lymphocytes.¹⁴² The CD40-CD40 ligand may also play a role for their emigration.

Detached DCs downregulate CCR6 and upregulate chemokine receptor CCR7, known to regulate homing as well as retention of T cells, which allows the now mobile DCs to move toward the lymphatic vessels in response to its ligand SLC.

The barrier to their migration, imposed by the basement membrane of the skin (collagen IV), is brought down by the matrix metalloproteinase-9, released by DCs with specificity to collagen IV. DCs cross the abluminal side of the lymphatic vessels, probably with the involvement of P-glycoprotein, and eventually enter LNs. In the lymphatic vessels, they are known as veiled cells because of their morphology (i.e., large lamellipodia veils), which like sails propel them forward. DCs are divided into different subsets based on their biologic functions, with plasmacytoid DCs (pDCs) and conventional DCs (cDCs) being two major populations. They both derive from bone marrow precursors of myeloid- or lymphoid-origin and enter the LN from the afferent lymphatic vessel into the subcapsular sinus to reach the T cell areas. The CCL21 is the ligand for CCR7 cells and regulates homing to, as well as retention of, T cells in the LNs. The CCL21 binds to the surface of DCs via its heparin-binding domain, which explains why T cells leave LNs more rapidly in the absence of DCs.

These data suggest that DCs attracted by SLC and MIP-3 α (or ELC), both of them ligands of the CCR7 receptor, regulate T cell homeostasis in LNs.¹⁴³ In the T cell areas, they are known as IDCs, as their elaborate long cytoplasmic processes interdigitate between T cells. IDCs present to T cells the antigens they have captured in the periphery, initiating an immune response (see Chapter 14). The lymphatic vascular system plays an important role in the regulation of tissue fluid homeostasis, immune surveillance, and growth and maturation of new vessels, as well as maintenance of existing lymphatic vessels, the functions of which are regulated by tyrosine kinases.

Growth factors of the vascular endothelial cell family (VEGF) control lymphangiogenesis and activate VEGF-specific receptors, of which VEGFR3 (FLT4), VEGFC, and VEGFD have been implicated in the regulation of lymphatic development.

Both are processed after synthesis and form mature dimers of the VEGF domain. Both bind with high affinity to VEGFR2 and VEGFR3 expressed on endothelial cells. The VEGFR3 is a receptor tyrosine kinase with seven extracellular Ig-like domains and a cytoplasmic tyrosine kinase domain.¹⁴⁰ The growth of the endothelial cells of the high endothelial venules is regulated by VEGF, secreted by CD11c⁺ dendritic cells,¹³⁹ and optimizes the microenvironment for the immune response. VEGF binds to VEGF receptors on endothelial cells, triggering the tyrosine kinase pathway leading to angiogenesis. Lymph node endothelial cell proliferation is dependent on VEGF, and DCs are associated with increased lymph node VEGF levels. DC-induced endothelial cell proliferation and increased VEGF levels are mediated by DC-induced recruitment of blood-borne cells. Vascular growth in the draining lymph node includes the growth of endothelial cells in the high endothelial venules associated with increased entry of cells into the lymph node. Existing evidence suggests that the endothelial cell in the draining lymph node is induced by DCs as part of a program that optimizes the microenvironment for the ensuing immune response.

The importance of the lymphatic vessels in fluid and cellular homeostasis provides opportunities for developing inhibitors to target tyrosine kinases and thus affect lymphatic vessel functions or even lymphangiogenesis in the chemotherapy of malignancies. Afferent lymphatics pierce the capsule and empty into a subcapsular sinus, which gives rise to cortical sinuses and often runs along the trabeculae through the cortex to the medulla. At this point they become medullary sinuses which eventually become the efferent lymphatic vessels that leave the LN at the hilum. The artery enters the LN at the hilum, gives rise to arterioles that reach the cortex along the trabeculae and finally split into a rich network of capillaries. The capillaries empty into venules that

P.241

extend from the cortex to the medullary cords and eventually exit from the hilum as veins. The venules which give rise to capillaries possess unique endothelial cells that are tall and cuboidal and therefore contrast with the endothelial linings of other venules that usually are low or flat. The HEVs (Figs. 11.15 and 11.16) are the sites of lymphocyte crossing from the blood into the lymphatic circulation and homing to the paracortex, which results in marked reduction of the cellularity of the lymph node.

Lymphotoxin signaling, which controls the expression of GlcNAc-6-O sulfotransferase-1 and -2, binds to the lymphotoxin-B receptor and generates signals required for the homeostatic control of HEV differentiation and function.¹⁴¹ The LT, through its LT receptor, plays crucial roles in building and maintaining the architecture of lymphoid organs and ensures an adapted immune response against invading pathogens. Induction of inhibitors, such as antagonist antibodies or decoy receptors, may be used in chronic inflammation, autoimmunity, cell death, or cancer, i.e., disorders that occur when the LT/LTR system malfunctions. Two types of high endothelial cells are distinguished, one having abundant cytoplasm, and their luminal surface is covered by a coat of filamentous and granular material 1.5 nm in thickness. By electron microscopy, on the basis of the content of their polyribosomes, one cell is lighter and one darker and intensely pyroninophilic. Their cytoplasm contains numerous microtubules which radiate from the centriole and multiple dense bodies which probably are related to lysosomes and function as storage sites for glycoproteins used for the formation of the cellular coat. A striking morphologic feature of these cells is their large Golgi complex with many vesicles which are associated with actively secreting cells not seen in endothelial cells. Indeed, these cells secrete chemokines, which direct the transendothelial migration of lymphocytes in HEVs (see section Lymphocyte Homing and Recirculation). Their bulky nucleus protrudes into the lumen and contains a well-developed reticulated nucleolus, both characteristics of a metabolically highly active cell. Acid hydrolase activity and nonspecific esterases that are not present in other endothelia have been detected in these cells, as well as a peculiar ability to switch to anaerobic metabolism.

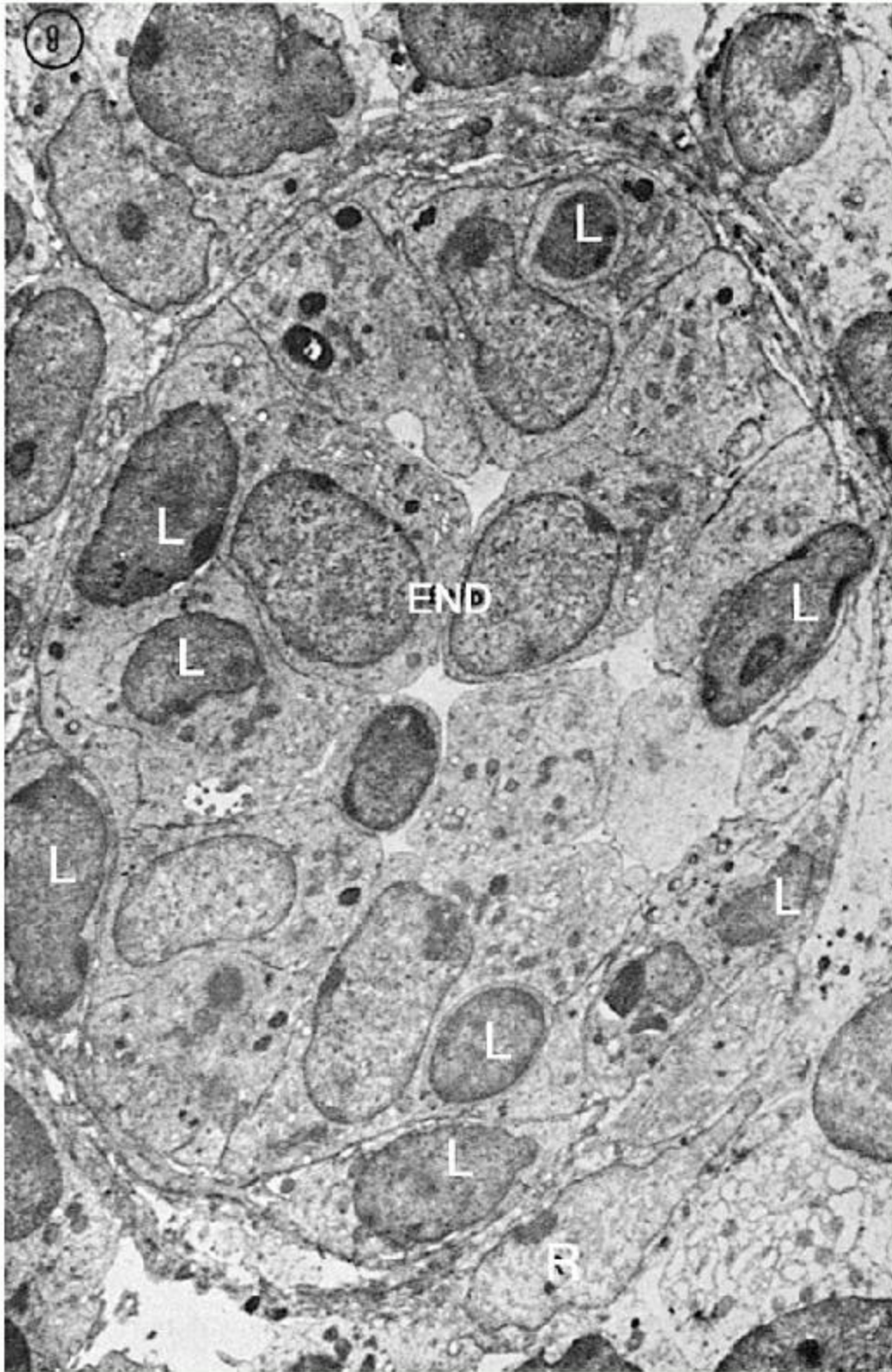

FIGURE 11.15. A postcapillary venule is practically occluded by tall endothelial cells (End). Some lymphocytes (L) are crossing the wall of the high endothelial venule and enter the lymph node. The wall is surrounded by reticular cells (R) ($\times 4,500$). (From Clark SJL Jr. The reticulum of lymph nodes in mice studied with the electron microscope. *Am J Anat* 1962;110:217, with permission.)

The metabolic activity of the endothelial cells is influenced by the number of circulating T lymphocytes. In congenitally athymic mice or in normal mice following neonatal thymectomy or chronic thoracic duct drainage, i.e., conditions with no lymphocyte migration through the HEV wall, the endothelium is flat and has lost its pyroninophilia,¹⁴² but infusion of lymphocytes reconstitutes the normal morphologic appearance of the HEV. Some evidence also has implicated the dendritic cells as playing a regulatory role in determining the morphology and metabolic activity of the endothelial cells.¹⁴³

The HEVs are surrounded by layers of sheaths that derive from cytoplasmic plates of reticular cells linked to the fibrous reticulum of the LN. These sheaths may regulate the passage of lymphocytes to the LN while limiting fluid leakage and providing vascular support (Fig. 11.14B). When Marchesi and Gowans¹⁴⁴ originally identified the HEVs as the site for lymphocyte migration, they thought that lymphocytes cross the HEV wall by penetrating the cytoplasm of the high endothelial cells. This crossing is now recognized as an artifact because all lymphocytes that appeared on electron microscopic sections to be surrounded by endothelial cells were in fact outside of these cells when evaluated with tracer studies. Thus the lymphocytes migrate across the HEV wall by insinuating themselves between endothelial cells.^{145,146} The interactions of lymphocytes and the HEV during homing and recirculation are described in the section Transendothelial Migration.

Morphologic Changes during the Immune Response

Antigens enter the LN via the afferent lymphatics, which empty into the subcapsular sinus, percolating through the parenchyma. They are deposited in two areas of the LN, the medulla¹⁴⁷ and the cortex, and are associated with the membranes of FDCs.¹⁴⁸

Antibody facilitates follicular localization since intense proliferative activity is observed in the center of the follicles after immunization and large pyroninophilic cells are seen in the GCs of draining LNs within 72 hours.¹⁴⁹ These cells have been given various names, such as immunoblasts, a term introduced

P.242

originally by Dameshek,¹⁵⁰ or germinoblasts. In order to avoid confusion with gonadal cells, however, they were renamed centroblasts. The blast is a large cell (larger than 10 μm) and has a nucleus with loose chromatin and a giant reticulated nucleolus that may occupy as much as one half of the nuclear area. The Golgi apparatus is moderately developed and contains many free polyribosomes but only few cisternae of endoplasmic reticulum. As the endoplasmic reticulum becomes more abundant, these cells are known as plasmablasts.¹⁵¹ At this stage their nucleus possesses clumps of heterochromatin and a moderate-sized nucleolus. Free polyribosomes are still present and the cisternae of the endoplasmic reticulum do not fill the cytoplasm entirely.

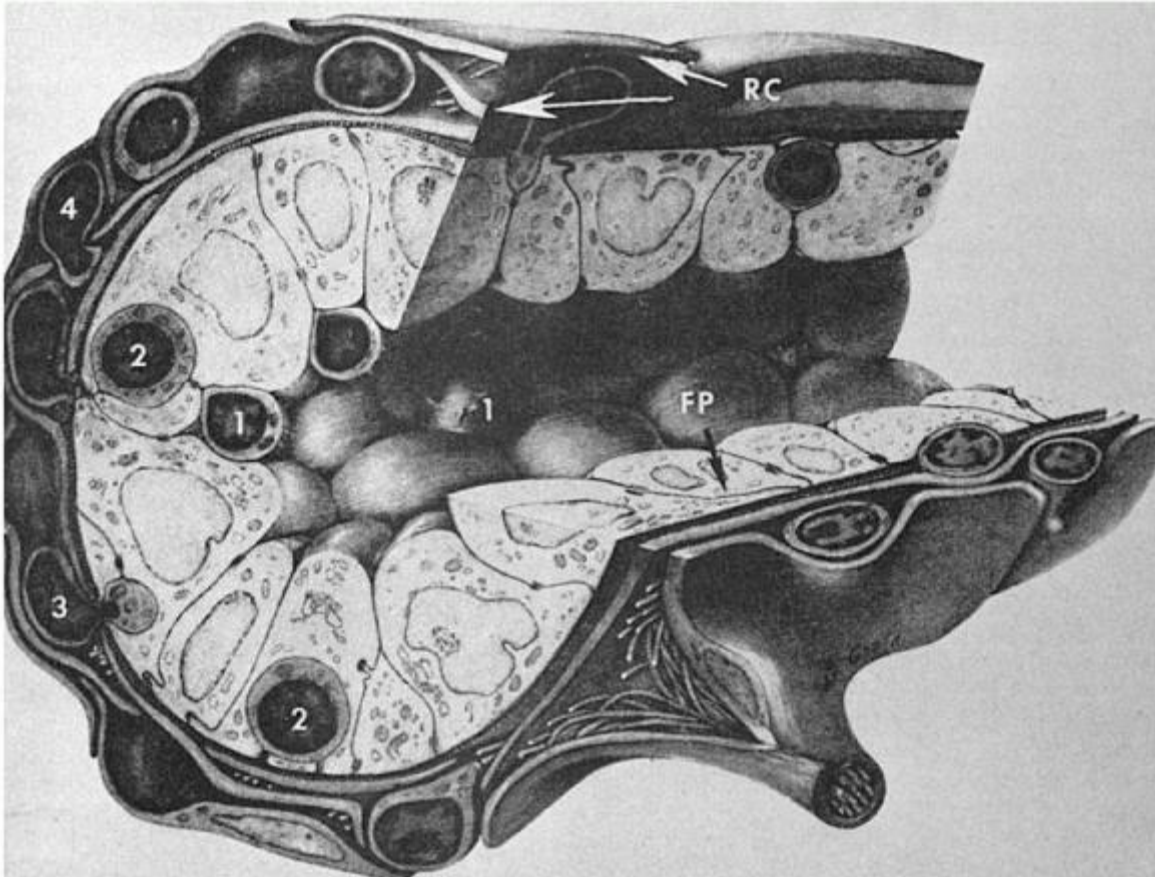

FIGURE 11.16. Lymphocytes crossing the high endothelial venule (HEV). Lymphocyte migration is shown in successive stages (1-4). After attachment to the luminal surface of an endothelial cell (1), the lymphocytes insinuate between endothelial cells (2) and cross the basement membrane (3) and a sheath of reticular cells (RC) surrounding the HEV (4). The endothelial cells are attached to the neighboring cells by junctional complexes and to the perivascular sheaths by foot processes (FP). (From Anderson AO, Anderson ND. Lymphocyte emigration from high endothelial venules in rat lymph nodes. *Immunology* 1976;31:455, with permission.)

By day five there is an increase of the number of tingible body macrophages, i.e., macrophages which contain engulfed apoptotic nuclei (Körper of Flemming) and have phagocytosed nuclear debris of lymphocytes (the graveyard theory).¹⁵² Because of their intense basophilic cytoplasm, the immunoblasts (or centroblasts) demarcate a histologic area known as the dark zone (also known as the basal or lower zone because it is located in the area of the GC that is toward the interior of the LN).¹⁵³ As they become more mature (immunocytes, centrocytes), they occupy the light zone, also called the upper zone because it is located above the dark zone toward the capsule. Further differentiation gives rise to plasma cells, which are detected in small numbers in the GCs. Kinetic studies with H-3 thymidine, which allows studies of lymphocyte turnover, provide evidence of the origin of mature lymphocytes (centrocytes) from GC immature cells (centroblasts) which then disseminate beyond the GC confines.¹⁵⁴

The formation of GCs depends on T lymphocyte function¹⁵⁵; The GCs become the home of B cell blasts which display a unique phenotype characterized by lack of membrane IgD.

The role therefore of T lymphocyte in the life of the B lymphocyte stretches from the early stages of building the GCs to helping later in antibody formation by mature B cells. The significance of the GC reaction is discussed in Chapter 14. Antigenic stimulation drives the differentiation of B cells into plasma cells,¹⁵⁶ seen in the medullary cords by day 3 or 4 after immunization, as well as the proliferative activity reflected in the increase of pyroninophilic blast cells in the paracortex.

Lymph Node Functions

The LNs are dynamic structures, with their cells being constantly on the move, and their functions may be considered in two broad categories: as efficient mechanical filters due to an exquisite arrangement of a reticular meshwork, and as

masters of phagocytosis with macrophages strategically located in the sinuses. Failure of filtration and phagocytic functions by the LN results in loss of control of infectious agents and spread of the disease.

The immune function of the LNs is carried out by lymphocytes, which activate humoral and cell-mediated immunity, following complex interactions between dendritic cells or macrophages, as antigen-presenting cells and T or B cells. To this effect LNs provide a suitable microenvironment, that includes the HEV, which controls lymphocyte homing and recirculation, stromal cells, and distinct domains occupied by IDC and FDC in the cortex. The LNs therefore are important sites for activation of the effector mechanisms of immunity, i.e., humoral and cell-mediated immune responses. The effector cells of both responses are exported to remote sites for effective control of the infection.

Spleen

The orphan homeobox gene-11 HOX11, now known as TLX1, regulates expression of the spleen,¹⁵⁷ as shown in Tlx1 mice, which lack the spleen while other secondary lymphoid organs develop normally. Although the spleen is considered a secondary lymphoid organ, it serves several other functions unrelated to the immune system and affects all blood cells throughout their life span.¹⁵⁸ It provides the microenvironment for the final differentiation of reticulocytes, platelets, and monocytes, and is the reservoir for erythrocytes and granulocytes and removes aged or deformed red blood cells. The spleen of human adults has a unique reservoir of multilineage adult stem cells, that express the developmental transcription factor TLX1. In contrast to hematopoietic stem cells, TLX1 spleen stem cells hold potentially broader therapeutic applications because they are less lineage restricted.

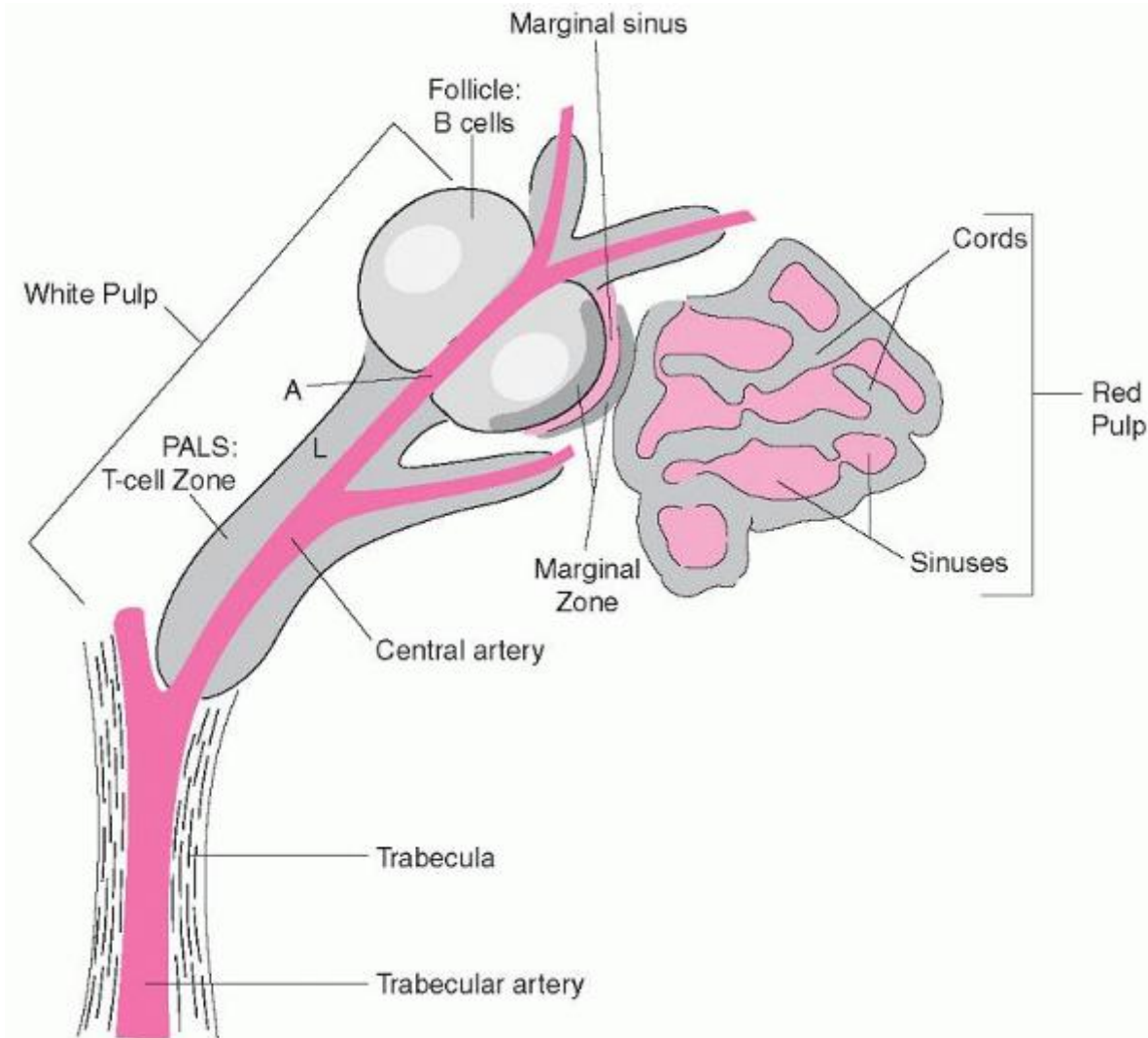

FIGURE 11.17. Drawing of the splenic structure and circulation. PALS, periarteriolar lymphatic sheath.

The spleen is covered by a connective tissue capsule which is several millimeters thick,¹⁵⁹ and in humans it contains only a few muscle cells and is not capable of marked contractions. The internal surface of the capsule is the point of origin of an

extensive network of trabeculae that divides the organ into communicating compartments, with a sponge-like appearance and spaces containing the parenchyma, or pulp tissue. The capsule is indented on the medial surface where the blood vessels, lymphatics, and nerves enter and leave. Histologic studies show two kinds of parenchyma: one is stained dark blue to purple because of the predominance of small lymphocytes (the white pulp), and the second is red because of the predominance of blood-filled sinuses (the red pulp) (Figs. 11.17 and 11.18).

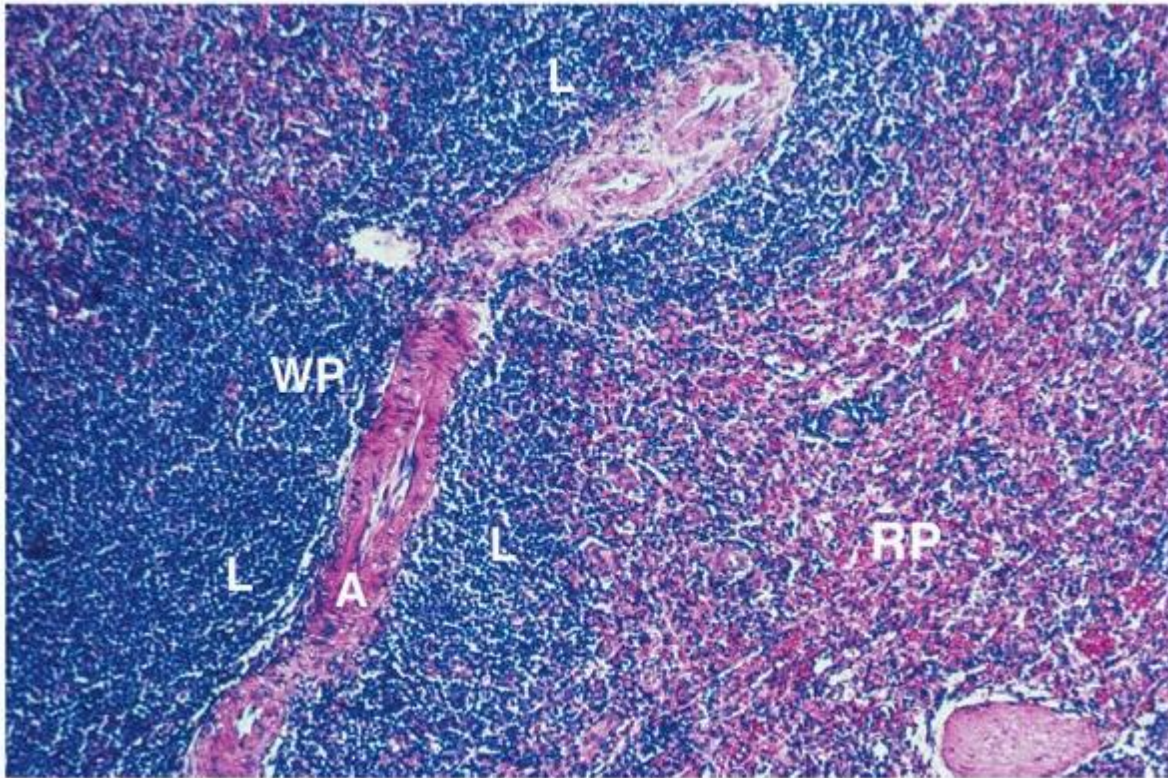

FIGURE 11.18. Section of the spleen. White pulp (WP): Lymphocytes (L) packed around an arteriole (A). Red pulp (RP) surrounds the white pulp and consists mainly of sinuses, the cords, and cordal spaces.

P.243

White Pulp

The white pulp is the main lymphatic tissue of the spleen and surrounds the blood vessels (Figs. 11.19 and 11.20); it is composed of the supporting reticulum, the free cells, and the blood vessels. The splenic artery branches into trabecular arteries (central arteries), muscular vessels that can alter blood flow by their contraction and relaxation, which follow the trabeculae and periodically give off branches (Fig. 11.20). The reticulum is a scaffolding made of reticular fibers secreted from spindle shaped reticular cells, with conspicuous microfilaments in their cytoplasm, a prominent endoplasmic reticulum, and a nucleus which contains finely dispersed chromatin. It provides support for free cells and blood vessels, runs circumferentially around the central artery, and becomes particularly pronounced in the periphery of the white pulp, where the reticular cells extend concentric sheets of membranes^{160,161} (Fig. 11.19A). The central artery gives off secondary branches that radiate through the white pulp with different destinations, some terminating before they reach the edges of the white pulp, while others terminate in the marginal zone (MZ) or extend even further into the red pulp. In the human spleen, some branches curve back from the red pulp to form a delicate network around lymphatic follicles located at the periphery of the white pulp.

The predominant cell type of the white pulp is the lymphocyte, which occupies the interstices of the sponge-like meshwork of the reticulum, forming two histologically distinct arrangements. The central artery is surrounded by tightly packed lymphocytes which follow the artery, becoming eventually a diffuse thin sheath as the artery divides into small arterioles known as the periarteriolar lymphatic sheath (PALS) (Figs. 11.18 and 11.19A). The PALS is divided into the central and peripheral areas, the former consisting of tightly packed T lymphocytes and interdigitating cells, seen in the T

dependent area, or paracortex of the LN. The PALS in the human spleen is not continuous, and at intervals the arteriole runs across a follicle but subsequently re-enters the T cell region,¹⁶² where T lymphocytes usually are found in intimate contact with the interdigitating cells. The periphery of the PALS lacks the interdigitating cells and contains B and T lymphocyte collections known as follicles and blast-like cells in the germinal center (GC) of the secondary follicle.

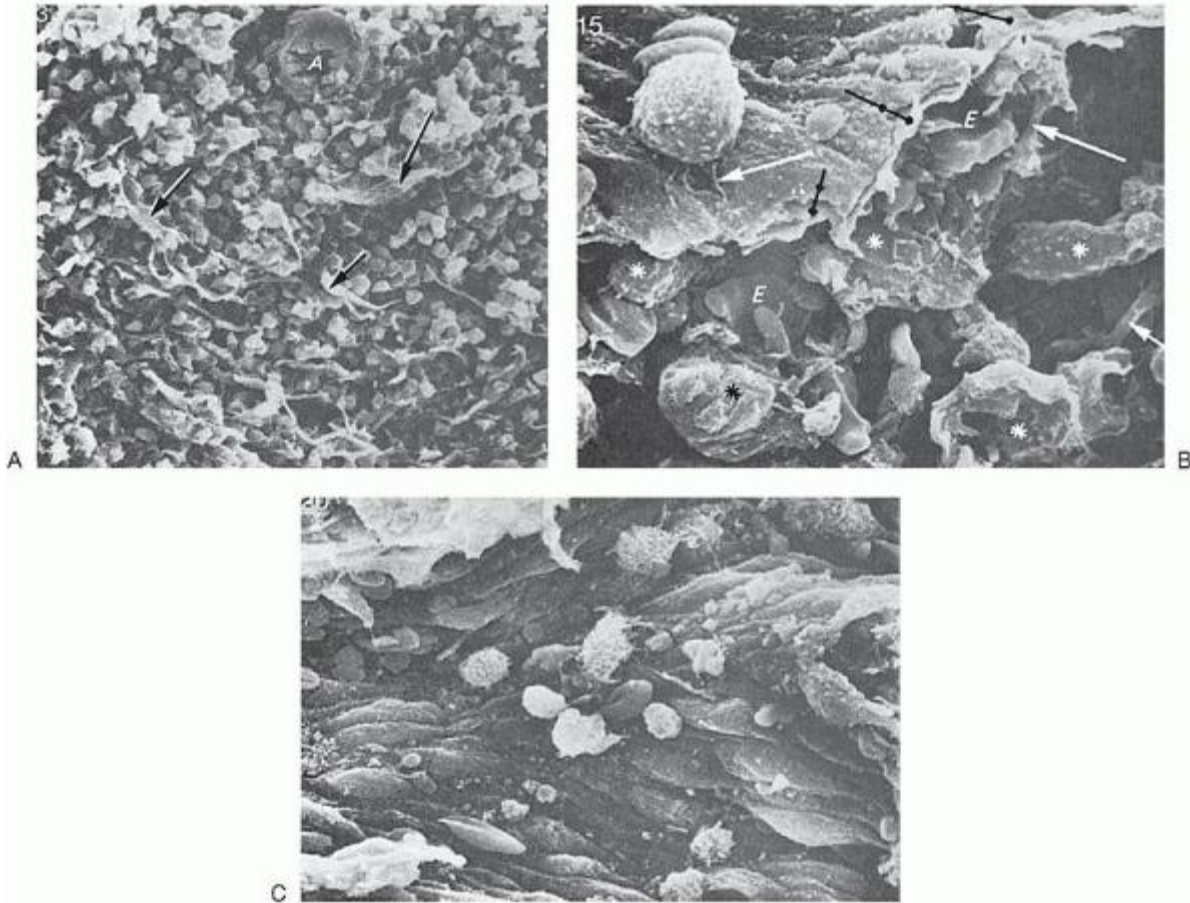

FIGURE 11.19. Ultrastructure of the spleen by scanning electron microscopy. A: Periarteriolar lymphatic sheath with a central artery (A). Tightly packed lymphocytes lie between fibers and reticular cells (arrows) that run circumferentially around the artery. B: Lumen of a sinus at upper left has elongated endothelial lining cells. The cord below contains bulky reticular cells (asterisks) and fibers (white arrows). Some erythrocytes (E) are visible in the cordal spaces. The large cell in the lumen of the sinus is probably a macrophage with several thin cytoplasmic strands (arrow). The beaded black lines at the cut edge of the sinus identify its adventitial layer (terminal bead) and its endothelial layer (subterminal bead). C: Lumen of a sinus that bifurcates to the right. The elongated endothelial cells are in close apposition without any visible gaps. (From Weiss L. A scanning electron microscopic study of the spleen. *Blood* 1974;43:665, with permission.)

Small lymphocytes surrounding the GCs constitute the mantle zone which separates the MZ from the GC, which histologically is divided into a dark zone, occupied by large pyroninophilic blasts with high mitotic activity, and a light zone with more mature cells.

The light zone, which faces the MZ, has an abundance of characteristic FDCs that are present also in the nodules of the LN. They are large with unusually shaped nuclei, poor in heterochromatin, and their cytoplasmic extensions are thin sheets rather than dendrites. The FDCs are not phagocytic but retain foreign substances on their membranes for long periods. No FDC

P.244

is located in the central section of PALS, and their presence in the mantle of the nodules, facing the MZ, places them in a strategic location to capture foreign substances entering the spleen. Foreign antigens are localized first in the MZ and then cross the marginal sinus to lodge in the mantle of the nodules, forming a crescentic cap. The nodules of the peripheral

section of PALS constitute the B-dependent regions of the spleen. The segregation of the two major lymphocyte populations within distinct settlements of the secondary lymphoid organs seems to be determined by the nature of their underlying neighbors.

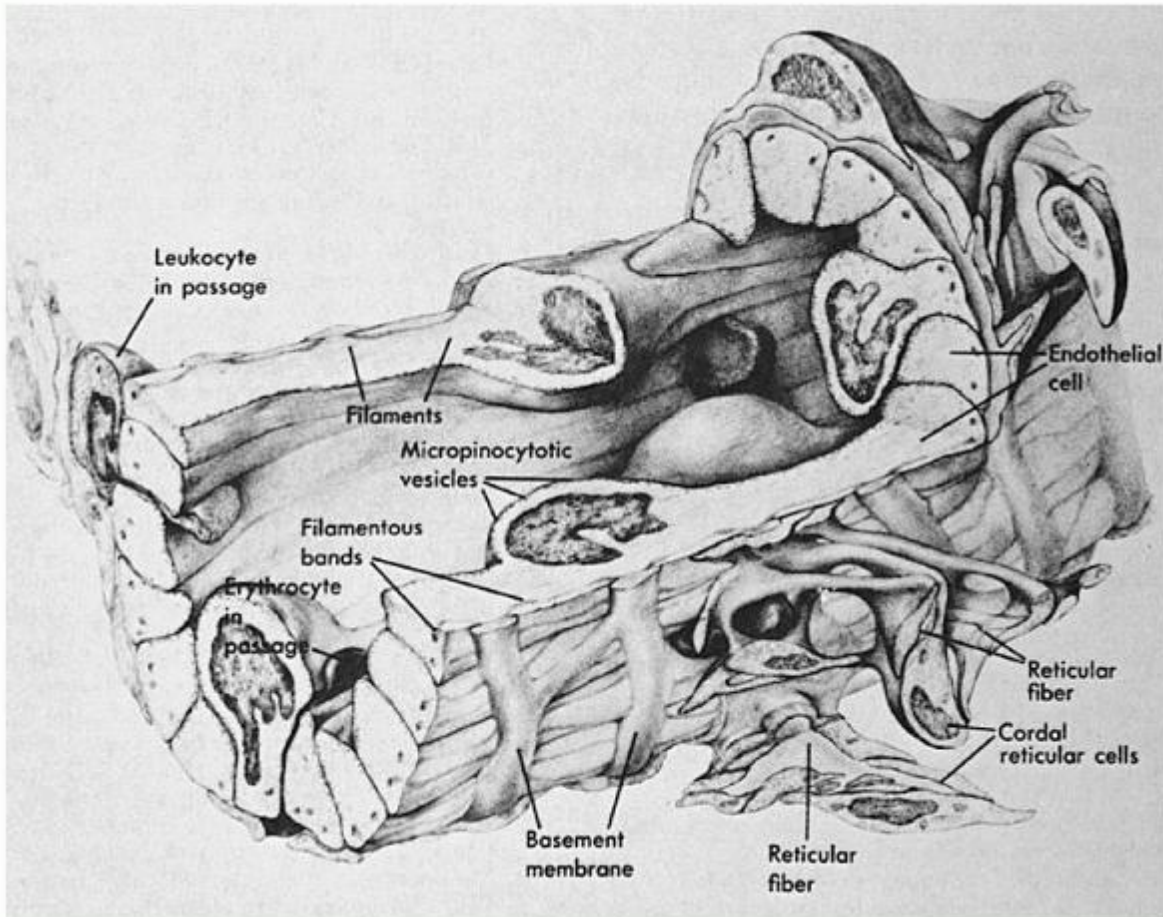

FIGURE 11.20. A human splenic sinus. The elongated lining cells run parallel to the axis of the sinus. The vessel is supported by cordal reticular cells and fibers and a fenestrated basement membrane consisting of heavy fibrous strands running circumferentially and lighter longitudinal strands. Thus, the circular bands, like the hoops of a barrel, hold the endothelial cells (staves of the barrel) tightly. (From Weiss L. The spleen. In: Weiss L, ed. Cell and tissue biology. Baltimore, MD: Urban and Schwarzenberg, 1988, with permission.)

Marginal Zone

MZ is the part of the parenchyma that lies between the white pulp and red pulp (Figs. 11.17 and 11.18). This area of the spleen comes in contact with large quantities of circulating blood as many arterial vessels terminate in this region and some of them, with funnel-shaped orifices, empty their contents into the interstices of the MZ, which, unlike the red pulp, has no sinuses. In rodents a marginal sinus separates the MZ from the white pulp, but the human spleen lacks a marginal sinus. Some authors suggest that the marginal sinus may be functionally equivalent to the postcapillary venule, which in rodents is the site at which lymphocytes enter the splenic parenchyma.

The lymphocytes entering the marginal sinus have multiple microvilli with which they establish contacts with reticular cells as they find their way toward their microenvironments, and once they reach their destination the microvilli disappear. The marginal sinus does not have the tall endothelial cells that direct traffic in the LNs and some authors speculate that this function is performed by splenic macrophages located in the marginal sinus. These cells have distinct phagocytic and morphologic properties which distinguish them from macrophages in other locations of the spleen, including the ability to bind lymphocytes.¹⁶³

Marginal Zone Lymphocytes: Functions and Lymphomas

In the human spleen, the MZ contains clusters of B cells and macrophages in the vicinity of the periphery of the white pulp. These cells differ from naive B cells in morphology, phenotype, and genotype, i.e., they are large with pale cytoplasm and an irregular nucleus; they express IgD-, CD5-, CD10-, and CD23-; and they have mutated their Ig-V genes.^{164,165} On the basis of their VH gene rearrangements, the MZ B cells are heterogeneous memory cells; and in terms of response to antigens they are divided into three categories: one B cell responds to T cell-dependent antigens and two respond to T cell-independent antigens such as lipopolysaccharide (type-1)¹⁶⁶ or bacterial capsular polysaccharides (type-2).¹⁶⁴ The B cells originate from precursors in the bone marrow and settle in the lymphoid organs, where they mature, giving rise to two morphologically and functionally distinct subsets: (a) follicular B cells and (b) MZ B cells.¹⁶⁷ The follicular B cells are small in size, express low levels of IgM but high levels of IgD, and recirculate; while the B cells of the MZ of the spleen are of medium size, with high expression of IgM and low IgD.

On the basis of cell-surface markers, maturation of B cells in the periphery proceeds through three transitional stages. The MZ B cells arise from an intermediate CD23⁺ stage¹⁶⁸ and respond rapidly to certain antigens brought by blood.¹⁶⁷ Activation of B cells is triggered by the signaling molecule Notch 2, which preferentially is expressed at the mature stage.¹⁶⁹ Notch 2 is preferentially expressed in mature B cells and is indispensable for marginal zone B lineage development, migration,¹⁷⁰ and localization in the marginal zone.¹⁷¹ An intriguing concept for the development of MZ B cells suggests that their development depends on signal strength from self antigens¹⁷² and is independent of exogenous antigens.¹⁷³

Some B cells in lymph nodes have a similar phenotype and morphology as the MZ B cells and are known as nodal-MZ B cells or monocytoid B cells. The splenic MZ B cells and nodal B cells rearrange the same VH-3 family of genes, suggesting that both of these B cell populations are closely related.¹⁷⁴ There is other evidence, however, that the monocytoid B cells are distinct from the MZ B cells on the basis of their phenotype, i.e., lack of IgM and IgD expression from most of them, and polyclonal Ig gene rearrangements with lack of somatic mutations.¹⁷⁵ However, the occurrence of hypermutation in the MZ B cells has been challenged, because the activation-induced cytidine deaminase (AID) (see Chapter 14), the enzyme that is essential for somatic hypermutation and class-switch recombination, is not detected in MZ B cells.¹⁷⁶ The splenic MZ B cell subpopulation may mutate their Ig genes as a result of recognition of self-lipids presented by the CD1 of NK T cells.^{177,178} Another intriguing finding which may shed some light on the origin and nature of the MZ B cells is that the BCR of the MZ B cells is "polyreactive",¹⁷⁸ but these results from experimental animals may not necessarily apply to humans.¹⁷⁹ The CD27 B cells of human spleens are detected in the periphery of the follicles corresponding to the mantle, but these cells are not present exclusively in the spleen, and most likely CD27 expression is associated with memory B cells.¹⁸⁰

B-cell neoplasms with cells strikingly similar in morphologic, phenotypic, and cytogenetic characteristics have been detected in different anatomic locations, i.e., spleen, lymph nodes, and extranodal locations.^{181,182} Variations detected by mutational analysis are considered as evidence that these lymphomas originate from different subsets of marginal cells.¹⁸³ More recent studies of MZ B cell lymphomas utilizing complementary DNA microarray analysis identified the expression of three genes which may distinguish splenic MZ lymphoma, FOXK2, SETX, and CD40.¹⁸⁴ Furthermore, the evidence that mucosal-associated lymphomas preferentially disseminate to the spleen is considered evidence of the relationship of these cells to the splenic MZ cell.¹⁸⁵

Red Pulp

As seen in histologic sections the red pulp consists of sinuses and cords,^{186,187} which are composed of a meshwork of reticular fibers and cells. The reticular cells are large, extend membranous processes into the interstices (Figs. 11.17, 11.18, and 11.19),

P.245

and contact those of adjacent cells, forming cavernous spaces. The large reticular cell sheets have microfilaments that endow them with the capacity to retract and extend, and thus determine the available space and regulate blood flow. These cordal spaces receive blood directly from the arterial vessels, as the central artery gives off many branches which terminate in slender, straight, nonanastomosing arterioles that enter the cords of the red pulp but not the sinuses. Some of the arterioles divide into arterial capillaries which are enveloped by a sheath of phagocytic cells. These sheaths were called ellipsoids, but now are called periarterial macrophage sheaths, which in the human spleen is not well developed. The periarterial macrophage sheath functions as a major source of phagocytic cells and also may regulate blood flow. The cords represent a unique vascular space, with regulation by the cordal reticular cells of its flow, which removes old or damaged red cells.

The red pulp sinuses are tortuous vascular channels 35 to 40 μm in diameter, lined with an endothelium consisting of elongated tapered cells arranged with their long axes parallel to that of the vessel (Fig. 11.19B,C).

The endothelial cells have three distinctive morphologic features: (a) micropinocytotic vesicles, (b) loosely organized cytoplasmic filaments, and (c) tightly organized filaments along the basal side, which provide the cell with rigidity and contractility. Slit-like gaps between the endothelial cells allow the passage of blood cells from the cordal spaces into the lumen; but the slits never exceed 0.2 to 0.5 μm in width, which cannot be enlarged since the intra-endothelial filaments run parallel to the slits and restrict their opening.¹⁸⁸ Although normal red blood cells are flexible and capable of passing through the slits, the presence of rigid inclusions, such as Heinz bodies, interferes with their passage.

The basement membrane is not continuous, but consists of a network of reticular fibers that resemble a roll of chicken wire. Fibers running circumferentially (annular fibers) are thick and are joined by thinner fibers that run longitudinally (Fig. 11.20). The network is connected to the reticulum of the cords and some reticular cells are in close contact with the wall of the sinuses. Through the fenestrations of this network blood cells pass from the cords to the sinuses. Adventitial cells cover the sinus wall from the cordal side and contribute to blood flow regulation by covering or exposing the interendothelial slits.

The short description of the splenic circulation emphasizes its complexity as well as its importance and explains the fact that it has been the subject of debate for a long time. It is believed that the circulation is closed, with endothelial continuity from the arteries to the sinuses and veins. Others believe that the circulation is open, i.e., the arteries empty their blood into the MZ and red pulp cords, and the blood percolates through the cavernous spaces of the cords and finally crosses the wall of the sinuses through the interendothelial slits.

According to this view, although the circulation is anatomically open, it is functionally closed. This issue has not been resolved, but it is likely that both types of pathways exist. In keeping with this last hypothesis is the finding that the largest amount of blood passes through the spleen as rapidly as it does through other organs, but a smaller portion of blood has a considerably slower rate of flow.

Morphologic Changes of the Immune Response

Within 24 hours of antigenic stimulation, an accumulation of polymorphonuclear leukocytes is detected in the red pulp,¹⁵¹ and large pyroninophilic blast cells are first seen 3 to 4 days later in the PALS, which then migrate toward the periphery.

Proplasmacytes, which is the next stage of maturation, have an abundant endoplasmic reticulum and a few remaining free ribosomes, findings that differentiate this stage of development from mature plasma cells. They eventually reach the cords of the red pulp and are found even within the sinuses. When viewed by electron microscopy, the most immature blasts, known as immunoblasts or plasmablasts, have a large nucleus, a prominent nucleolus, and an increase in the number of ribosomes; but no organized endoplasmic reticulum is evident and they mature to plasma cells in GCs which are well developed by the end of the first week.

Immunologic Functions of the Spleen

The two most important immunologic functions of the spleen are phagocytosis and the development of the effector mechanisms of humoral and cell-mediated immunity.¹⁸⁹

The labyrinthine structure of the spleen is ideal for the effective removal of invading microorganisms by phagocytes that come to reside in the spaces of the reticulum.

Phagocytosis is facilitated by opsonization, i.e., coating of bacteria with complement, antibody, or both. Although the phagocytic function of the spleen is well recognized, its contribution to humoral or cell-mediated immunity in humans has generated considerable controversy.^{190,191} Originally it was reported that children who had splenectomy for congenital hemolytic anemia acquired an increased incidence of overwhelming fatal infections, but not all subsequent studies yielded results that confirmed these findings.

Splenectomy for hematologic disorders apparently has far more serious consequences than splenectomy for trauma. The incidence of overwhelming sepsis in the former cases is 24.8% compared to a 1.45% incidence for the latter group.¹⁹² In humans, the loss of the spleen compromises the immune system and its ability to form antibody,¹⁹³ and postsplenectomy antibody synthesis by peripheral blood lymphocytes is impaired.¹⁹⁴

Against the evidence cited above of the importance of the spleen for defense against infections, Hox11 $-/-$ mice without spleen have no major defect in antiviral immunity except for some delay in antibody response by 1 to 2 days.¹⁹⁵

LYMPHOCYTE HOMING AND RECIRCULATION

Homing to Secondary Lymphoid Organs

Migration of leukocytes across the vascular endothelium is a complex multistep process which involves different types of endothelia for different leukocytes, as well as a variety of adhesion molecules. When B and T lymphocytes complete their maturation in the bone marrow and thymus respectively (primary lymphoid organs), they are still naive, i.e., they have not yet encountered antigenic stimulation. The migration patterns of naive lymphocytes differ from those of the activated (or memory) lymphocytes. Naive lymphocytes enter the secondary lymphoid organs (homing) and settle in specific (T-dependent or T-independent) compartments.

Subsequently they use the blood and lymphatic circulation as traffic routes and migrate between secondary lymphoid organs without any specific preference (recirculation).

Antigen-activated or memory lymphocytes migrate specifically to sites where they have encountered antigen. Thus memory T lymphocytes tend to accumulate in extranodal tissues where they have previously been antigenically stimulated. These lymphoid accumulations are sometimes called tertiary lymphoid tissues and are associated with epithelial surfaces such as the gut, respiratory tree, and sites of inflammation in the skin and synovium. In some of these accumulations, however, there are also small numbers of naive lymphocytes.

Homing of lymphocytes to the spleen takes place through blood sinusoids in the MZ, but in regional LNs antigen triggers accumulation of antigen-specific memory T lymphocytes by two fundamentally distinct routes of entry.¹⁹⁶

The first is by crossing the HEV, primarily followed by the naive lymphocytes; the second is by crossing flat endothelium, a P.246

route followed by the activated T lymphocytes. HEVs are abundant in the T cell-dependent areas of the LN and are used as entry sites for both T and B lymphocytes.^{197,198,199,200} HEVs are found in lymph nodes and other extranodal locations, such as PPs, tonsils, adenoids of the pharynx, appendix, and lymphocyte aggregates of the stomach and small intestine. The best HEV marker currently available is a carbohydrate epitope recognized by the monoclonal antibody MECA-79.²⁰¹

Crossing HEVs by lymphocytes involves interaction of leukocytes with endothelia in three steps (a) tethering and rolling, (b) integrin activation and arrest or tight adhesion, and (c) transendothelial migration (Fig. 11.21).

Tethering and Rolling

Blood flow "rolls" the lymphocyte over the endothelial cells, establishing loose and transient contacts with them. This tethering and rolling over the vascular endothelium in the HEV, is mediated by L-selectin (CD62L), previously known as LECAM-1 (Leukocyte-Endothelial Cell Adhesion Molecule 1), LAM-1, SELL, or MEL14. It is expressed on lymphocytes and interacts with its counterreceptor on HEV cells. In order for L-selectin to mediate primary adhesion (i.e., rolling), it must be located on the tips of the microvilli^{202,203} of HEV in peripheral LNs. Homing of naive lymphocytes to secondary lymphoid organs or the PPs of the gut requires L-selectin interaction with integrin, but it is not required for activated T lymphocytes which lack expression of L-selectin.²⁰⁴ The L-selectin is important for lymphocyte adhesion to HEV as shown in gene knockout mice and with antibodies which block lymphocyte migration to LN by 99%.²⁰⁵

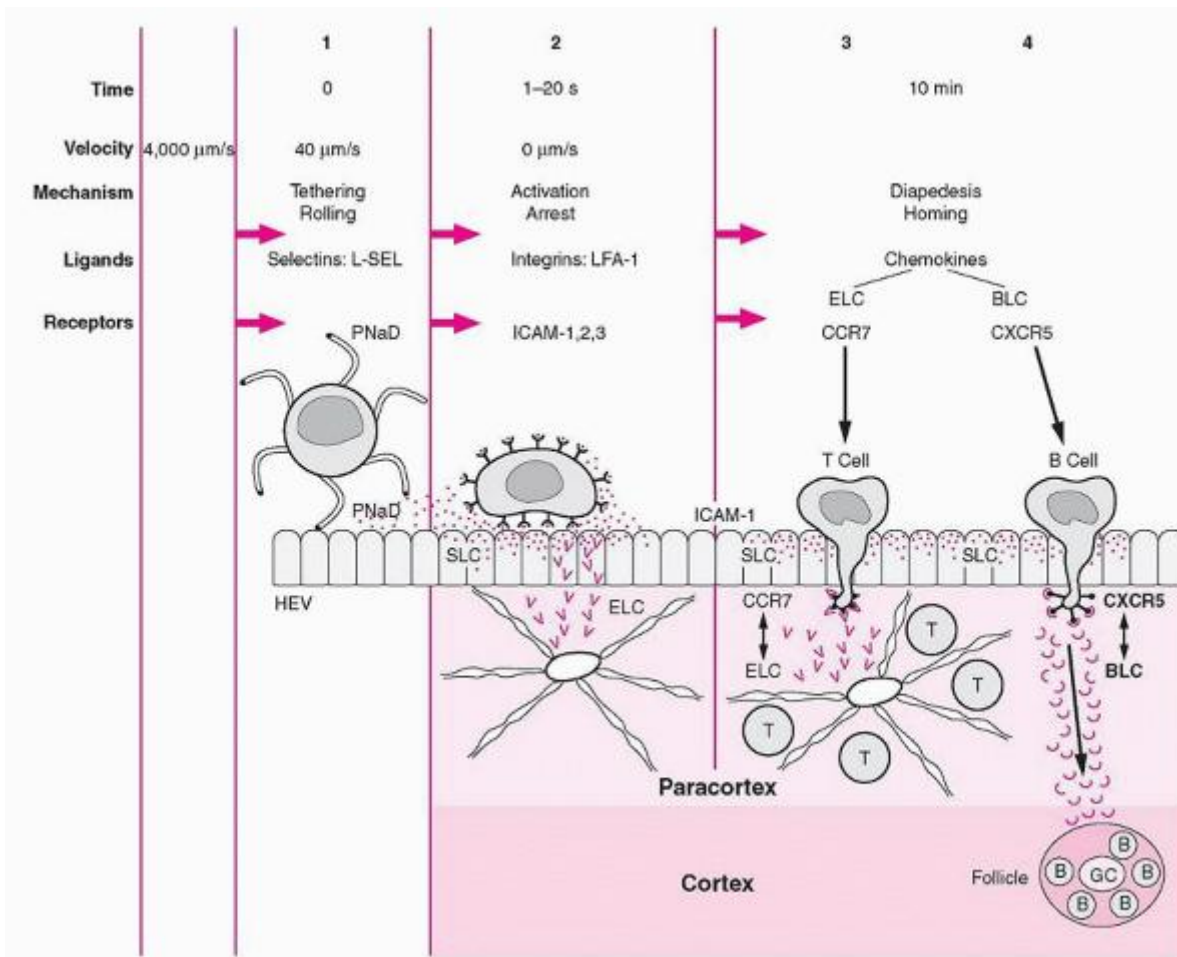

FIGURE 11.21. Homing of T and B lymphocytes to peripheral lymph nodes. 1. Rolling: Lymphocytes entering the high endothelial venule (HEV) slow down as a result of interaction of the L-selectin (L-SEL) (lymphocytes) with its ligand, the peripheral node addressin (PNad) on endothelial cells. 2. Arrest: Secondary lymphoid tissue chemokine (SLC), constitutively produced by HEV cells, activates integrin $\alpha_1\beta_2$ (CD11a/CD18) and tightly adheres lymphocyte to the endothelial surface. 3. Diapedesis: SLC (produced by HEV cells) and Epstein-Barr virus-induced molecule-1 ligand chemokine (ELC) (produced by dendritic cells and transcytosed to the surface) act on appropriate receptors (CCR7) and attract T (stronger) and B (weaker) cells that insinuate themselves through the endothelial cells. 4. Home settling: Entering the node, T cells settle in the paracortex (ELC production), while B cells and a few antigenically experienced CD4⁺ T cells move on, being attracted by another chemokine, B-lymphocyte chemoattractant (BLC) (or BCA-1), acting on both of them, expressing the receptor CXCR5 to settle in the follicles. Gc, germinal center; ICAM, intercellular adhesion molecule; INT, integrin.

Rolling by L-selectin requires its linkage to cytoskeletal proteins such as actinin, vinculin, and talin through its carboxy terminal eleven amino acids.²⁰⁶ This enables leukocytes to reduce speed and sense chemoattractants which activate firm adhesion.

At higher shear the average lifetime of rolling tethers is much longer as a result of the elongation of the microvillus tethers P.247

which stabilize leukocyte rolling over a wide range of shear forces.²⁰⁷ For efficient rolling the ligand for L-selectin needs to carry three critical structural elements: sialic acid, fucose, and sulfate. Monoclonal antibodies specific for sialyl- 6-sulfate of Lewis X oligosaccharide inhibit almost completely the binding of L-selectin to human HEVs. Examination of the adhesion requirements of the three selectin members has clearly shown that the L-selectin prefers carbohydrate 6-sulfation to tyrosine sulfation, which is the preference of the E-selectin.²⁰⁸

Molecules carrying L-selectin-binding saccharides are known as vascular addressins, but some of them are secreted proteins and do not participate in lymphocyte trafficking, like the glycosylation cell adhesion molecule-1 (GlyCAM-1). The lymphocyte trafficking is basically a physiologic multimolecular adhesion cascade, which involves lymphocyte endothelial recognition mediated by the alpha-4 integrins as a “bridge” between selectin and beta-2 integrin, although it may involve only preactivated alpha-4 integrins. At the present time the nature of the macromolecule which carries the epitope detected by the monoclonal antibody MECA79, known as peripheral node addressin (PNad), which defines an HEV-specific carbohydrate epitope, remains elusive.^{209,210} Biochemical and genetic evidence implies that, for the synthesis of sulfated glycan moieties, sulfation precedes sialylation, which is followed by 1,3 fucosylation, required for an L-selectin ligand. With targeted deletion of the FucT-VII locus, which encodes an 1,3 fucosyltransferase expressed in HEVs, there is an 80% to 90% reduction of short-term lymphocyte homing. However, some other work suggests that although sulfate on the epitope is required for L-selectin binding, neither sialic acid²¹¹ nor fucose²¹² are directly involved in the binding. Sulfate groups are required for optimal L-selectin binding, because if the sialyl Lewis-X (i.e., “sialyl”-2-3-galactopyranosyl-1-4-N acetylglucosamine-“1-3-fuco-pyranosyl”) is modified with sulfate, it generates a critically important L-selectin recognition determinant.

The most important sulfate modification is known as “sialyl 6-sulfo Lewis X,” i.e., sialyl Lewis X with sulfation of GlcNAc on the sixth position.²¹¹ Sulfation is catalyzed by a member of the GlcNAc-6-O-sulfotransferases (Glc-N-Ac-6-STs) family, which has five members.^{213,214} L-selectin-mediated leukocyte rolling is extremely fast and jerky in nature.²¹⁵ This is probably due to endothelial chemokines juxtaposed to endothelial L-selectin ligands.²¹⁶ Rolling leukocyte is of a jerky nature probably as a result of detachment of the cell from its binding site followed by binding to another ligand downstream. The endothelial chemokines CCR7 and CXCK5 are G-protein-coupled receptors (GPCRs), or SLC/ELC and BCA-1, respectively. It is hypothesized that clusters of GPCR around L-selectin prevent the association of multiple L-selectin molecules necessary for stabilization of L-selectin contacts.

The sulfated/sialylated-O-linked oligosaccharides recognized by L-selectin are displayed on sialomucin core proteins. One of them is endomucin, which is expressed on HEVs of the lymph nodes but also on endothelial cells of other vessels. One of the sialomucins is endomucin, which is decorated with carbohydrate chains reactive with L-selectin, and its isoform-a is expressed on PNad of HEVs. Appropriately modified by glycotransferases and sulfotransferases, it can function as a ligand for L-selectin.^{217,218}

The P-selectin glycoprotein ligand-1 (PSGL-1), a mucin-like glycoprotein detected on various leukocytes, is a ligand for P-selectin, but it also binds to L-selectin and E-selectin.

PSGL-1 is a heavily glycosylated sialomucin expressed on most leukocytes and has dual function, as a selectin ligand for leukocytes rolling on vascular selectins expressed in inflammation, and as a facilitator of resting T cells homing into lymphoid organs.²¹⁸

Flow cytometric analyses show that the endothelial cells from the cremaster muscle bound L-selectin in a PSGL-1-independent manner. These results provide evidence for the existence of an L-selectin ligand distinct from PSGL-1 in inflammation and indicate that such a ligand is expressed on endothelial cells, promoting neutrophil rolling in vivo.

The enzymes fucosyltransferase (FucT)-IV and FucT-VII confer the L-selectin binding activity.²¹⁹

Integrin Activation and Lymphocyte Arrest

In preparation for transendothelial migration, lymphocytes need to adhere firmly to the endothelial cells. Arrest is achieved by activation of LFA-1 (L-2) integrin, which interacts with ICAM1 or ICAM2. On resting lymphocytes the LFA-1 exists in an inactive form; but within less than a second, it is activated by chemokines constitutively expressed on lymphoid tissues (“lymphoid chemokines”).^{220,221} and ²²² These are the secondary lymphoid tissue chemokine (SLC) or CCL21,^{223,224} and the Epstein-Barr virus-induced molecule-1 ligand chemokine, ELC, or CCL19, also called MIP-3.²²⁵

SLC induces arrest of naive T cells to ICAM-1²²⁶ with sixfold higher efficiency for naive than for memory T cells.²²⁷ The arrest is pertussis toxin-sensitive, implying that the signaling mechanism is mediated through G-proteins. The ELC shares the same binding specificity with SLC, but its role is less obvious. ELC transcripts are restricted to nonendothelial cells in the perivascular area of the paracortex,²²⁸ and is brought to the luminal surface of the HEV by transcytosis, where it is able to participate in LFA-1 activation and arrest of the lymphocytes through the same receptor CCR7 as the SLC.²²⁹ Integrin activation and affinity is regulated by conformational changes of their extracellular domains²³⁰ and these changes occur through extension of the genu, followed by separation of the stalks that lead to the high-affinity conformation (see details of integrin structure and activation in Chapter 14).

Transendothelial Migration

SLC induces strong chemotaxis for T cells and to a lesser extent for B cells²²³ and their entry to the secondary lymphoid organs, which requires the expression of CCR7, its high-affinity receptor, as shown in mice with Plt mutation (paucity of LN T cells).

These mice lack SLC lymphocytes which cannot enter through HEVs, and as result the structure of the paracortical areas is severely disorganized. The Slc gene in mice is located on chromosome-4,²³¹ which corresponds to human chromosome 9p13 where CCL21 (SLC) is located. Furthermore, T cells lacking the SLC receptor (CCR7) have a markedly reduced ability to enter LNs and PPs. In CCR7-deficient mice the homing of B cells into secondary lymphoid organs is not disturbed, and the arrest of B cells on HEVs takes place in the absence of SLC, indicating that other chemotactic activities regulate entry of B cells into secondary LNs. Lymphocyte entry into LNs may also be mediated by 1 (CXCL12) which is recognized by the CXCR4 receptor expressed on resting T and B cells.

However, this interaction is not important for T cells as CXCR4-deficient mice have normal T cell areas. The redundancy of the mechanisms for B cell homing explains the normal B cell homing in plt mice, as well as on CXCL12- and CXCR4-deficient mice.

Transgenic mice that do not produce SLC in the normal anatomic locations but have SLC expression directed to the pancreas under the control of the insulin promoter II have collections of CD4⁺ and CD8⁺ cells near the center of the islets and only a few scattered B cells surrounding them.²³² In older mice, these clusters in the islets develop stromal reticulum, seen in LNs and vascular endothelium with morphology of HEVs. B cells as follicular-like clusters without GCs merge with the T cell areas, which demonstrates the important role of SLC in LN neogenesis.

Once naive lymphocytes have crossed the HEV, chemokines direct the lymphocytes to their compartmental homing, i.e., T lymphocytes to the paracortex and B lymphocytes to the follicles.

P.248

SLC is expressed not only on HEVs, but also by stromal cells within the T cell areas of LNs, spleen, and PPs. A second ligand for CCR7 is ELC, which is also expressed in T cell areas and is made by macrophages and the DCs of the paracortex. In vitro, the SLC and ELC attract T cells effectively and B cells weakly. In conclusion, SLC and ELC chemokines bind to their receptor CCR7 and stimulate the T cells' crossing of the HEV, while B cells cross the HEV by more than one chemokine/receptor system (Fig. 11.21).

Once inside the LN, T cells are attracted to the follicles by chemokine CXCL13 (BLC, BCA-1, B cell-attracting chemokine-1), which binds to the receptor CXCR5 (or BLR-1, Burkitt lymphoma receptor-1). The CXCR5 is expressed by mature as well as by activated B cells and in addition by CD4⁺-activated T cells. Antigen-activated CD4⁺ T cells downregulate CCR7 and upregulate CXCR5; and this CD4⁺ T cell subset, in contrast to naive T cells that stay in the paracortex, travel with B cells to the follicles. This explains the results of fluorescent antibody, which detects small numbers of scattered T cells within the GC (Fig. 11.13A), which induce strong antibody responses in culture with B cells.²³³ CXCR5-deficient mice show defective follicular localization of B cells. BLC is expressed constitutively by FDC in lymphoid follicles of LNs and other secondary lymphoid organs, and in BLC-deficient mice there are severe defects in the development of secondary lymphoid organs. Histologically, B cells are not organized in follicles but form a ring around the T cell areas.²³⁴ The importance of BLC for the organization of B cells into follicles was shown by the ectopic expression of BLC in pancreatic islets, where B lymphocytes but not T cells accumulate in these sites.²³⁵ The organization of primary follicles requires an FDC network, which is strongly dependent on LT-1 and LT-2 and TNF expressed on B cells.²³⁶

In conclusion, for proper formation of follicles and localization of B lymphocytes, two ligand-receptor systems are mandatory: TNF and the LT-1 and LT-2 ligand and their receptor LTR, as well as the BLC ligand and its receptor CXCR5.

Signaling for Lymphocyte Homing

Cells receive a multitude of stimuli which may be chemical (such as cytokines and growth factors) or physical (such as mechanical stresses or adhesion to extracellular matrix or other cells). These stimuli influence their function by affecting intracellular signaling pathways, and often involve cell-surface receptors or other molecules that function through activation of the Rho family of small GTPases. Rho GTPases control multiple cellular processes, including actin and microtubule dynamics, gene expression, cell cycle and polarity, and membrane transport; and they bind to numerous downstream effectors diverting signaling pathways appropriately.

The integrin activation pathway involves intracellular signaling mediated by the Ras homologous A protein (Rho-A), which is a guanosine triphosphate-binding protein.^{237,238} Rho-A activation depends on the cytoplasmic tail of ICAM1, but the exact mechanism of activation remains unknown. Activation of Ras stimulates a cascade of activations initiated with the

phosphorylation of the mitogen-activated protein kinase and phospholipase-C, which in turn activates protein kinase-C and mobilizes Ca^{2+} from intracellular sources.

Activation of PI-3 kinase by chemokine stimulation activates in turn phospholipase D and initiates actin rearrangements and vesicular trafficking.^{239,240,241} There are several PI-3 kinase isoforms and cytokines which affect cell migration by altering the isoform of activated PI-3 kinase, which in cooperation with DOCK2 activates homing of T and B lymphocytes.²⁴²

DOCK2 is a hematopoietic cell-specific protein of the CDM family and is indispensable for lymphocyte chemotaxis. Dock2-deficient mice (*Dock2*^{-/-}) exhibit migration defects of T and B lymphocytes but not of monocytes, and response to chemokines results in several abnormalities including T lymphocytopenia, atrophy of lymphoid follicles, and loss of marginal-zone B cells. DOCK-2 is a member of the CDM protein family, which regulates cell motility and cytokine production in mammalian hematopoietic cells through the activation of Rac and plays a pivotal role in the modulation of the immune system.²⁴³ It is also expressed in lymphoma cells such as follicular lymphoma and diffuse large B cell lymphoma. DOCK2 is the mammalian homologue of the CED-5 protein family in *Caenorhabditis elegans* and activates Rac which in turn regulates actin cytoskeleton and therefore cell mobility. DOCK2 mediates migration of lymphocytes, independently of PI-3 kinase; and its intracellular signals result in reorganization of the cytoskeleton, causing cells to send out pseudopodia and move along the chemoattractant gradient. Transendothelial migration occurs rapidly, and within minutes lymphocytes reach the basement membrane and move toward the cell-cell junctions. Adhesive contacts with the endothelium are modulated so that the cell is not immobilized, but this may result from a decrease of activation signals.

Dendritic Cell Migration

The traffic of DCs is regulated by cytokines (IL1, TNF- α), chemokines, and defensins; but regardless of their origin, immature DCs express the chemokine receptor-6 (CCR6), which binds the chemokine MIP-3 (CCL20). The ligand for CCR6 (i.e., MIP-3) is constitutively expressed by keratinocytes and provides homing signals for the positioning of LC to the suprabasal layer of epidermis.²⁴⁴

In mucosal surfaces, such as in the intestinal mucosa, the CCR6 functions as a mucosa-specific regulator of humoral immunity and lymphocyte homeostasis and attracts immature DCs to submucosal areas.²⁴⁵ CCR6 binds a family of antimicrobial peptides known as defensins, which constitute one of the first lines of host defense. For example, the human beta-defensins (hBD), such as hBD-2 and -3 have anti-HIV activity.

The defensins are detected throughout evolution, in fungi and flowering plants as well as in invertebrates and vertebrates. They are cysteine-rich, cationic peptides with the ability to kill a broad range of microorganisms including bacteria, yeast, and viruses, and thus they are a strong component of the arsenal in innate immunity.

The antigen-presenting cell required for induction of primary immune responses in skin are the LCs. Following activation by a foreign antigen, their level of MHC class II antigen and their accessory cell activity are increased; they migrate to regional lymph nodes, where they stimulate T cells. One of the earliest manifestations of LC activation is the accumulation of increased amounts of IL-1-beta mRNA within 15 minutes after exposure to antigens such as contact allergens in vivo. LCs are connected physically with keratinocytes through homotypic interactions mediated by E-cadherin, which is downregulated by inflammatory or allergic stimuli and results in "maturation" and detachment of LCs.²⁴⁶ The migration of antigen-bearing LCs, from the skin to draining lymph nodes is mediated by TNF- α and CD40-CD40 ligand interactions critical for Ag presentation to T cells in eliciting an immune response.²⁴⁷ Their interaction is mediated by the ligand of 6C-kine, known also as Exodus-2/6 C-kine secondary lymphoid tissue chemokine/T cell activator protein-4. Another potent stimulator of T cell migration is the macrophage inflammatory protein MIP-3, which binds to the CC chemokine receptor-7 (CCR7). These chemokines are expressed in lymphoid organs and the 6C-kine has been localized to high endothelial venules and lymphatic endothelium. It is therefore likely that they may play an important role in the homing of dendritic cells to lymphoid tissues.²⁴⁸

The barrier to their migration, imposed by the basement membrane of the skin (collagen IV), is brought down by the matrix metalloproteinase-9, released by LCs with specificity for collagen IV.²⁴⁹ LCs cross the abluminal side of the lymphatic vessels,

P.249

probably with the involvement of P-glycoprotein, and eventually enter LNs. In the lymphatic vessels they are known as veiled cells on the basis of their morphology (i.e., large lamellipodia veils), which like sails propel them forward. Attracted by SLC and MIP-3 (or ELC), both of them ligands of the CCR7 receptor, they enter the LN from the afferent lymphatic

vessel into the subcapsular sinus to reach the T cell areas.²⁵⁰ In the T cell areas, they are known as IDCs, as their elaborate long cytoplasmic processes interdigitate between T cells. IDCs present to T cell antigens they have captured in the periphery, initiating an immune response (see Chapter 14).

Special Homing Pathways

Homing to the Skin

Memory lymphocytes tend to return to the type of tissue where they have encountered the antigen.²⁵¹ Lymphocytes that entered the afferent lymphatics from the skin have a distinct phenotype and express a marker called cutaneous lymphocyte-associated antigen (CLA),²⁵² which binds to E-selectin.^{253,254} E-selectin is induced on dermal endothelial cells in the delayed type of hypersensitivity and in chronically inflamed skin.

Other molecules also mediate strong adhesion of memory T cells to skin, such as VLA (Very Late Antigen-4, or CDw49d) interacting with VCAM1, and the integrin alpha-3 beta-11 with the extracellular matrix component epiligrin, an interaction which may be involved in cutaneous inflammation.²⁵⁵ T lymphocytes may penetrate the epidermis using E-cadherin, a member of a group of single-pass transmembrane proteins which mediate specific cell-cell interactions with their extracellular regions, while the intracellular region is associated with the actin cytoskeleton.²⁵⁶

Homing to the Gut

Lymphoid cells in the gut are found in three areas: (a) well-organized collections known as Peyer patches, which are secondary lymphoid organs; (b) in the lamina propria underlying the intestinal epithelium; and (c) interspersed between epithelial cells (after penetration of the basement membrane) known as intraepithelial lymphocytes (IEL).

Naive lymphocytes home to PPs, whereas memory cells home to extralymphoid sites, i.e., the intestinal lamina propria, because of variation in the expression of highly specialized homing receptors. Expression of the ligand of L-selectin and MADCAM1 (mucosal addressin cellular adhesion molecule-1) is weak in the HEV of the PPs; and therefore neither set of these molecules alone is capable of mediating tethering and rolling to initiate integrin activation, but their cooperation allows naive lymphocytes to enter the PPs. The endothelium of the lamina propria, on the other hand, is negative for the ligand of L-selectin but strong for MADCAM1 expression; and as a result naive lymphocytes are unable to use the L-selectin pathway, and since the expression of $\alpha_E\beta_7$ is weak, they cannot use this pathway either in order to initiate rolling. This is the reason that naive lymphocytes are blocked from normally infiltrating the lamina propria.

On the other hand, memory lymphocytes, although they lack L-selectin and cannot use this set of molecules to enter PPs, have a strong expression of $\alpha_E\beta_7$ and are able to initiate rolling to enter the lamina propria. One may assume that this an expression of the wisdom of nature to allow only memory, i.e., activated lymphocytes, already well-equipped for defense, to enter areas with infectious foci. Some of the lymphocytes are able to penetrate the basement membrane of the intestinal epithelium and settle between enterocytes to become IELs. The IELs interact with the intestinal epithelium through an integrin known as the human mucosal lymphocyte molecule, now shown to be the $\alpha_E\beta_7$ integrin.^{257,258}

The $\alpha_E\beta_7$ integrin is expressed in approximately 2% to 6% of blood T cells, a memory subset which is negative for CLA-1 and L-selectin²⁵⁹ and is induced by transforming growth factor- β .²⁶⁰ The same cytokine is also known to trigger a class switch of IgM⁺ B cells to IgA, which is the predominant Ig class produced by the gut lymphocytes. It is of interest that MADCAM1, a gut mucosal addressin, contains an IgA-like domain.²⁶¹

Homing to Inflammatory Sites

Lymphocytes are known to accumulate in sites of chronic inflammation and tissues with active autoimmune mechanisms. The phenotype of these lymphocytes indicates that they are activated, and therefore antigenically stimulated.²⁵¹ Cytokines produced from macrophages, such as interferon- γ and TNF- α , regulate lymphocyte traffic to inflammatory sites. Accumulation of lymphocytes at chronic inflammation sites involves several adhesion molecules such as LFA-1 and α_4 integrins, as well as E-selectin and VCAM1. Chemoattractants such as MIP-1 β enhance binding of CD8⁺ T cells,²⁶² whereas RANTES selectively attracts memory T cells.²⁶³ The MPC-1 is a major lymphocyte chemoattractant (in addition to its strong activity on monocytes),²¹⁶ which explains the mixed composition of cellular infiltrates, rich in lymphocytes and monocytes, in sites of chronic and autoimmune inflammatory reactions. MCP-1 is present in abundance in areas of antigenic challenge and autoimmune diseases.²⁶⁴ The data suggest that -C-C chemokines provide the triggering signal for the integrin-independent tight adhesion of lymphocytes to endothelia for emigration to inflammatory sites.

Homing to Other Sites

In bone marrow transplantation the hemopoietic progenitors use the $\alpha_4\beta_1$ -V CAM1 to home to bone marrow,²⁶⁵ as well as interactions involving P-selectin with PSGL-1, the P-selectin ligand.²⁶⁶ Lymphocyte homing to tonsils is mediated by L-

selectin and CD34,²⁶⁷ whereas the attachment of lymphocytes to brain microvasculature is mediated by the sulfoglucuronosyl paragloboside, a ligand for L-selectin.²⁶⁸ Integrin adhesion receptors mediate cell-cell and cell-extracellular matrix interactions, which control cell morphology, migration, differentiation, and tissue integrity.

Integrin heterodimers, such as $\alpha 4\beta 1$ and $\alpha 5\beta 1$ are considered to generate distinct signal transduction mechanisms.

The Significance of Lymphocyte Homing and Recirculation

It is estimated that as many as 5×10^6 lymphocytes/second leave the blood and cross HEVs in the body. The process of rolling and sticking to the HEV takes 1 to 20 seconds and the transendothelial passage approximately 10 minutes.²⁶⁹ From in situ microscopic observations of PPs, the velocity of the lymphocyte before contact with the HEV is approximately 4,000 $\mu\text{m}/\text{second}$, and rolling effectively reduces this to approximately 40 $\mu\text{m}/\text{second}$.²⁰⁶ Thus, rolling increases the chances for firm adhesion, but at the same time the cell may escape if proper triggering for activation of integrin mechanisms fails to be initiated. Triggering mechanisms involve G-protein-linked chemoattractant receptors and their ligands, and they can bring about integrin activation within 1 to 3 seconds after contact for tight adhesion. Homing and recirculation are not random, but the result of active interactions determined by the phenotypes of the HEV cells and the lymphocytes. Homing to specific microenvironments of the secondary lymphoid organs is developmentally acquired, carried out under the guidance of chemokines,²⁷⁰ and influenced by the cellular composition of the microenvironments (i.e., IDCs vs. FDCs).

Chemokines mediate entry of lymphocytes into lymphatic tissues, and sphingosine 1-phosphate (S1P) promotes localization of

P.250

lymphocytes to the vasculature. Both signals are sensed through G protein-coupled receptors (GPCRs).

When lymphocytes are antigenically stimulated, the pattern of migration is modified and antigen-specific lymphocytes are directed to particular tissues so that they may influence more effectively various aspects of the immune response. This ultimately is the significance of lymphocyte recirculation reflected in the difference between naive and antigenically experienced lymphocytes. Immune responses within various microenvironments^{271,272} are all under the control of the chemokines. Knowledge of the mechanisms of chemokine regulation will allow the development of therapeutic strategies to control inflammatory diseases.²⁷³

P.251

REFERENCES

1. Marschalko T von. Ueber die sogenannten plasmazellen; ein beitrag zur kenntniss der herkunft der entzündlichen infiltrationszellen. Arch Derm Syph 1895;30:241.
2. Downey H. The origin and structure of the plasma cells of normal vertebrates, especially of the cold blooded vertebrates, and the eosinophils of the lung of Amblystoma. Folia Haematol 1911;11:275.
3. Maximow A. Untersuchungen über blut und bindegewebe. VIII. Die zytologischen eigenschaften der fibroblasten, reticulanzellen und lymphozyten des lymphoiden gewebes ausserhalb des organismus ihre genetischen wechselbeziehungen und prospektiven entwicklungspotenzen. Arch Mikroskop Anat 1923;97:283.
4. Bloom W. Relationships between lymphocytes, monocytes and plasma cells. Folia Haematol (Leipzig) 1928;37:63.
5. Rich AR. Inflammation in resistance to infection. Arch Pathol 1936;22: 228-254.
6. McMaster PD, Hudack SS. The formation of agglutinins within lymph nodes. J Exp Med 1935;61:783-805.
7. Dougherty TF, Chase JH, White A. The demonstration of antibodies in lymphocytes. Proc Soc Exp Biol Med 1944;57:295-298.
8. Harris TN, Grimm E, Mertens E, et al. The role of the lymphocyte in antibody formation. J Exp Med 1945;81:73-83.
9. Ehrlich WE, Harris TN. The site of antibody formation. Science 1945;101: 28-31.
10. Fagraeus A. Antibody production in relation to the development of plasma cells. In vivo and in vitro experiments. Acta Med Scand 1948;204(Suppl): 1-122.

11. Coons AH, Leduc EH, Conolly JM. Studies on antibody production. I. A method for the histochemical demonstration of specific antibody and its application to a study of the hyperimmune rabbit. *J Exp Med* 1955;102:49-61.
12. Leduc EH, Coons AH, Conolly JM. Studies on antibody production. II. The primary and secondary responses in the popliteal lymph node of the rabbit. *J Exp Med* 1955;102:61-82.
13. Gudat FG, Harris TN, Harris S, et al. Studies on antibody producing cells. I. Ultrastructure of 19s and 7s antibody-producing cells. *J Exp Med* 1970;132:448-474.
14. Harris TN, Hummeller K, Harris S. Electron microscopic observations on antibody producing lymph node cells. *J Exp Med* 1966;123:161-172.
15. Hummeller K, Harris TN, Tomasini N, et al. Electron microscopic observations on antibody producing cells in lymph and blood. *J Exp Med* 1966;124:255-262.
16. De Boer RJ, Perelson AS, Ribeiro RM. Modelling deuterium labelling of lymphocytes with temporal and/or kinetic heterogeneity. *R Soc Interface* 2012 Apr 18. Epub ahead of print.
17. Bessis M. *Living blood cells and their ultrastructure*. New York: Springer-Verlag, 1973.
18. Grossi CE, Greaves MF. Normal lymphocytes. In: Zucker-Franklin D, ed. *Atlas of blood cells. Function and pathology*, 2nd ed. Philadelphia, PA: Lea & Febiger, 1988.
19. Bessis M, Thiery JP. Electron microscopy of human white blood cells and their stem cells. *Int Rev Cytol* 1961;12:199-241.
20. Polliack A, Lampen N, Clarkson BD, et al. Identification of human B and T lymphocytes by scanning electron microscopy. *J Exp Med* 1973;138:607-624.
21. Dwyer JM. Identifying and enumerating human T and B lymphocytes: a review of techniques, problems, and progress in clinical studies. *Prog Allergy* 1976;21:178-260.
22. Riccioni R, Galimberti S, Petrini M. Hairy Cell Leukemia. *Curr Treat Options Oncol* 2007;8:129-134.
23. Soriano SF, Hons M, Schumann K et al. In vivo analysis of uropod function during physiological T cell trafficking. *J Immunol* 2011;187:2356-2364.
24. Heasman SJ, Ridley AJ. Multiple roles for RhoA during T cell transendothelial migration. *Small GTPases* 2010;1:174-179.
25. Hart GT, Hogquist KA, Jameson SC. Kruppel-like factors in lymphocyte biology. *J Immunol* 2012;188:521-526.
26. Sánchez-Madrid F, Serrador JM. Bringing up the rear: defining the roles of the uropod. *Nat Rev Mol Cell Biol* 2009;10:353-359.
27. Jean-Mairet RM, Lopez-Menendez C, Sanchez-Ruiloba L, et al. The neuronal protein Kidins 220/ARMS associates with ICAM-3 and other uropod components and regulates T cell motility. *Eur J Immunol* 2001;41:1035-1046.
28. Lichtman MA. The ultrastructure of the hemopoietic environment of the marrow: a review. *Exp Hematol* 1981;9:392-410.
29. Campioni D, Moretti S, Ferrari L, et al. Immunophenotypic heterogeneity of bone marrow-derived mesenchymal stromal cells from patients with hematologic disorders: correlation with bone marrow microenvironment. *Hematologica* 2006;91:364-368.
30. Taichman RS. Blood and bone: two tissues whose fates are intertwined to create the hematopoietic stem-cell niche. *Blood* 2005;105:2631-2639.
31. Taichman RS, Reilly MJ, Emerson SG. Human osteoblasts support human hematopoietic progenitor cells in in vitro bone marrow cultures. *Blood* 1996;87:518-524.
32. Whitlock CA, Witte ON. Long-term culture of B lymphocytes and their precursors from murine bone marrow. *Proc Nat Acad Sci U S A* 1982;79:3608-3612.
33. Yoshida T, Ng SY-M, Zuinga-Pflucker JC, et al. Early hematopoietic lineage restrictions directed by Ikaros. *Nat Immunol* 2006;7:382-391.
34. John LB, Ward AC. The Ikaros gene family: transcriptional regulators of hematopoiesis and immunity. *Mol Immunol* 2011;48:1272-1278.

35. Egawa T. The earliest stages of B cell development require a chemokine stromal cell derived factor/pre-B cell growth-stimulating factor. *Immunity* 2001;15:323-334.
36. Sitnicka E. Complementary signaling through flt3 and interleukin-7 receptor α is indispensable for fetal and adult B cell genesis. *J Exp Med* 2003;198:1495-1506.
37. vanFreedon-Jeffrey V. Lymphopenia in interleukin (IL)-7 gene-deleted mice identifies IL-7 as a non-redundant cytokine. *J Exp Med* 1995;181:1519-1526.
38. Ma O, Jones D, Sprigner TA. The chemokine receptor CXCR4 is required for the retention of B lineage and granulocytic precursors within the bone marrow environment. *Immunity* 1999;10:463-471.
39. Haynes BF. The human thymic microenvironment. *Adv. Immunol.* 1984;36:87-142.
40. Weiss L. The thymus. In: Weiss L, ed. *Cell and tissue biology*. Baltimore, MD: Urban and Schwarzenberg, 1988.
41. Hollander G, Gill J, Zukleys S, et al. Cellular and molecular events during early thymus development. *Immunol Rev* 2006;209:28-46.
42. Varga I, Pospisilova V, Jablonska-Mestanova V, et al. The thymus: picture review of human thymus prenatal development. *Bratisl Lek Listy* 2011;112:368-376.
43. LeDouarin NM, Jotereua FV. Tracing of cells of the avian thymus through embryonic life in interspecific chimeras. *J Exp Med* 1975;142:17-40.
44. Blackburn CC, Manley NR. Developing a new paradigm for thymus organogenesis. *Nat Rev Immunol* 2004;4:278-288.
45. Manley NR, Richi ER, Blackburn CC, et al. Structure and function of the thymic microenvironment. *Front Biosci* 2011;17:2461-2477.
46. Gordon J, Wilson VA, Blair NF, et al. Functional evidence of a single endodermal origin for the thymic epithelium. *Nat Immunol* 2004;5:546-553.
47. Nehls M, Pfeifer D, Schorpp M, et al. New member of the winged-helix protein family disrupted in mouse and rat nude mutations. *Nature* 1994;372:103-107.
48. Schuddekopf K, Schorpp M, Boehm T. The whn transcription factor encoded by the nude locus contains an evolutionarily conserved and functionally indispensable activation domain. *Proc Natl Acad Sci U S A* 1996;93: 9661-9664.
49. Dupin E, Creuzet S, Le Douarin NM The contribution of the neural crest to the vertebrate body. *Adv Exp Med Biol* 2006;119:589-596
50. Patel D D, Hale LP, Whichard LP, et al. Expression of CD-44 molecules and CD-44 ligands during human thymic fetal development: expression of CD-44 isoforms is developmentally regulated. *Int Immunol* 1995;7:277-286.
51. Hollander GA, Wong B, Nichogiannopoulou A, et al. Developmental control point in induction of thymic cortex regulated by a subpopulation of prothymocytes. *Nature* 1995;373:350-353.
52. Ritter MA, Boyd RL. Development in the thymus: it takes two to tango. *Immunol Today* 1993;14:462-469.
53. Muller KM, Leudecker CJ, Udey MC, et al. Involvement of E-cadherin in thymus organogenesis and thymocyte maturation. *Immunity* 1997;6:257-264.
54. Kutlesa S, Wessels JT, Speiser A, et al. E-cadherin-mediated interactions of thymic epithelial cells with CD103+ thymocytes lead to enhanced thymocyte cell proliferation. *J Cell Sci* 2002;115:4505-4515.
55. Anderson M, Anderson SK, Farr AG. Thymic vasculature: organizer of the medullary epithelial compartment? *Int Immunol* 2000;12:1105-1110.
56. Erickson M, Morkowski S, Lehar S, et al. Regulation of thymic epithelium by keratinocyte growth factor. *Blood* 2002;100:3269-3278.
57. Dunn RJ, Leudecker CJ, Haugen HS, et al. Thymic overexpression of CD40 ligand disrupts normal thymic epithelial organization. *J Histochem Cytochem* 1997;45:129-147.
58. Farr AG, Dooley JL, Erickson M. Organization of thymic medullary epithelial heterogeneity: implications for mechanisms of epithelial differentiation. *Immunol Rev* 2002;189:20-27.
59. Bjorses P, Aaltonen J, Horelli-Kuitunen N, et al. APECED: a new clue to auto-immunity. *Hum Mol Genet* 1998;7:1547-1553.

60. Kumar PG, Laloraya M, Wang C-Y, et al. The autoimmune regulator (AIRE) is a DNA-binding protein. *J Biol Chem* 2001;276:41357-41364.
61. Su MA, Anderson MS. Aire: an update. *Curr Opin Immunol* 2004;16:746-752.
62. Tao Y, Kupfer R, Stewart BJ, et al. AIRE recruits multiple transcriptional components to specific genomic regions through tethering to nuclear matrix. *Mol Immunol* 2006;43:335-345.
63. Pitkaenen J, Peterson P. Autoimmune regulator: from loss of function to auto-immunity. *Genes Immun* 2003;4:12-21.
64. Kogawa K, Nagafuchi S, Katsuta H, et al. Expression of AIRE gene in peripheral monocyte/dendritic cell lineage. *Immunol Lett* 2002;80:195-198.
65. Klein L, Kyewski B. "Promiscuous" expression of tissue antigens in the thymus: a key to T cell tolerance and autoimmunity? *J Mol Med* 2002;78:483-494.
66. Anderson MS, Venanzi ES, Chen Z, et al. The cellular mechanism of Aire control of T cell tolerance. *Immunity* 2005;23:227-239.
67. Hughes AL, Friedman R. A cross-tissue expression and evolution of genes controlled by the Aire transcription factor. *Genomics* 2006;88:462-467.
68. Terszowski G, Muller SM, Bleul CC, et al. Evidence for a functional second thymus in mice. *Science* 2006;312:284-287.
69. Miller JF. Immunological function of the thymus. *Lancet* 1961;2:748-749.
70. Miller JFAP. Investigating a second thymus in mice. *Science* 2006;312: 1597-1598.
71. von Boehmer H. Thoracic thymus, exclusive no longer. *Science* 2006;312: 206-207.
72. Corbeaux T, Hess I, Swann JB, et al. Thymopoiesis in mice depends on a Foxn1-positive thymic epithelial cell lineage. *Proc Natl Acad Sci U S A* 2010;107:16613-16618.
73. Hetzer-Egger C, Scharp M, Haas-Assenbaum A, et al. Thymopoiesis requires Pax9 function in thymic epithelial cells. *Eur J Immunol* 2002;32:1175-1181.
74. Nowell CS, Bredenkamp N, Tetélin S, et al. Foxn1 regulates lineage progression in cortical and medullary thymic epithelial cells but is dispensable for medullary sublineage divergence. *PLoS Genet* 2011;7:11.
75. Zook EC, Krishack PA, Zhang S et al. Overexpression of Foxn1 attenuates age-associated thymic involution and prevents the expansion of peripheral CD4 memory T cells. *Blood* 2011;24:5723-5731.
76. Mecklenburg L, Nakamura M, Sundberg JP, et al. The nude mouse skin phenotype: the role of Foxn1 in hair follicle development and cycling. *Exp Mol Pathol* 2001;71:171-178.
77. Bleul CC, Boehm T. Chemokines define distinct microenvironments in the developing thymus. *Eur J Immunol* 2000;30:3171-3379.
78. Balcirunaite G, Kellar MP, Balcirunaite E, et al. Wnt glycoproteins regulate the expression of Foxn1, the gene defective in nude mice. *Nat Immunol* 2002;3:1102-1108.
79. Rossi SW, Jenkinson WE, Anderson G, et al. Clonal analysis reveals a common progenitor for thymic cortical and medullary epithelium. *Nature* 2006;441:988-990.
80. Bleul CC, Corbeaux T, Reuter P, et al. Formation of a functional thymus initiated by a postnatal epithelial progenitor cell. *Nature* 2006;441:992-996.
81. van Ewijk W. Immunohistology of lymphoid and non-lymphoid cells in the thymus in relation to T lymphocyte differentiation. *Am J Anat* 1984;170: 311-330.
82. Hendrix TM, Chilukuri RV, Martinez M, et al. Thymic nurse cells exhibit epithelial progenitor phenotype and create unique extracytoplasmic membrane space for thymocyte selection. *Cell Immunol* 2010;261:81-92.
83. Hassal AH. The microscopic anatomy of the human body in health and disease. London: Samuel Highly Publications, 1849.
84. Lobach DF, Searce RM, Haynes BF. The human thymic microenvironment: phenotypic characterization of Hassall's bodies with the use of monoclonal antibodies. *J Immunol* 1985;134:250-257.

85. Watanabe N, Wang Y-H, Kyre Lee H, et al. Hassall's corpuscles instruct dendritic cells to induce CD4⁺ CD25⁺ regulatory T cells in human thymus. *Nature* 2005;436:1181-1185.
86. Wu L, Li CL, Shortman K. Thymic dendritic cell precursors: relationship to the T lymphocyte lineage and phenotype of the dendritic cell progeny. *J Exp Med* 1996;184:903-911.
87. Shortman K, Vremec D, Corcoran LM, et al. The linkage between T cell and dendritic cell development in the mouse thymus. *Immunol Rev* 1998;165: 39-46.
88. Spits H, Blom B, Jaleco AC, et al. Early stages in the development of human T, natural killer and thymic dendritic cells. *Immunol Rev* 1998;165:75-86.
89. Moore AJ, Sarmiento J, Mohtashami M, et al. Transcriptional priming of intrathymic precursors for dendritic cell development. *Development* 2012;139:373-384.
90. Ardavin C, Martinez del Hoyo G, Martin P, et al. Origin and differentiation of dendritic cells. *Trends Immunol* 2001;22:691-700.
91. Savchenko AS, Hasegawa G, Naito M. Development and maturation of thymic dendritic cells during human ontogeny. *Cell Tissue Res* 2006;325:455-460.
92. Ito H, Esashi E, Akiyama T, et al. IL-18 produced by thymic epithelial cells induces development of dendritic cells with CD-11b in the fetal thymus. *Intern Immunol* 2006;18:1253-1263.
93. Le Panse R, Berrih-Aknin S. Thymic myoid cells protect thymocytes from apoptosis and modulate their differentiation: implication of the ERK and Akt signaling pathways. *Cell Death Differ* 2005;12:463-472.
94. Bearman RM, Bensch KG, Levine GD. The normal human thymic vasculature: an ultrastructural study. *Anat Rec* 1975;183:485-497.
95. Henry L, Durrant TE, Anderson G. Pericapillary collagen in the human thymus: implications for the concept of the "blood-thymus" barrier. *J Anat* 1992;181:39-46
96. Steinmann GG. Changes in the human thymus during aging. *Curr Top Pathol* 1986;75:43-48.
97. Min H, Montecino-Rodriguez E, Dorshkind K. Reduction in the developmental potential of intrathymic T cell progenitors with age. *J. Immunol* 2004;173:245-251.
98. Montecino-Rodriguez D, Min H, Dorshkind K. Reevaluating current models of thymic involution. *Sem Immunol* 2005;17:356-361.
99. Shanker A. Is thymus redundant after adulthood? *Immunol Lett* 2004;91: 79-86.
100. Beverly LJ, Ascano JM, Capobianco AJ. Expression of JAGGED 1 in T lymphocytes results in thymic involution by inducing apoptosis of thymic stromal epithelial cells. *Genes Immun* 2006;7:476-486.
101. Tridente G. Immunopathology of the human thymus. *Semin Hematol* 1985;22:56-67.
102. Leite MI, Waters P, Vincent A Diagnostic use of autoantibodies in myasthenia gravis. *Autoimmunity* 2010;43:371-379.
103. Kao I, Drachman DB. Thymic muscle cell bear acetylcholine receptors: possible relation to myasthenia gravis. *Science* 1977;195:74-75.
104. Okumura M, Miyoshi S, Fujii Y, et al. Clinical and functional significance of WHO classification of human thymic epithelial neoplasms. *Am J Surg Pathol* 2001;25:103-110.
105. Fu YX, Chaplin DD. Development and maturation of secondary lymphoid tissues. *Ann Rev Immunol* 1999;17:399-433.
106. Cupedo T, Kraal G, Megius RE. The role of CD45⁺CD4⁺CD3⁻ cells in lymphoid organ development. *Immunol Rev* 2002;189:41-50.
107. Drayton DL, Liao S, Mounzer RH, et al. Lymphoid organ development: from ontogeny to neogenesis. *Nat Immunol* 2006;7:344-353.
108. Kefer F, Adams RH. Lymphatic endothelial differentiation: start out with Sox—carry on with Prox. *Genome Biol* 2008;9:243.
109. Wigle JT, Harvey N, Detman M, et al. An essential role for Prox1 in the induction of the lymphatic endothelial cell phenotype. *EMBO J* 2002;21: 1505-1513.

110. Mounzer RH, Svendsen OS, Baluk P, et al. Lymphotoxin- α contributes to lymphangiogenesis. *Blood* 2010;116:2173-2182.
111. Ware CF, Van Arsdale TL, Crow PD, et al. The ligands and receptors of the lymphotoxin system. *Curr Top Microbiol Immunol* 1995;198:175-218.
112. Weih F, Cosemano J. Regulation of secondary lymphoid organ development by the nuclear factor- κ B signal transduction pathway. *Immunol Rev* 2003;195:91-105.
113. Remouchamps C, Boutaffala L, Ganef C, Dejardin E. Biology and signal transduction pathways of the lymphotoxin- α β /LT β R system. *Cytokine Growth Factor Rev* 2011;22:301-310.
114. Ohl L, Henning G, Krautwald S, et al. Cooperating mechanisms of CXCR5 and CCR7 in development and organization of secondary lymphoid organs. *J Exp Med* 2003;197:1199-1204.
115. Müller G, Höpken UE, Lip M. The impact of CCR7 and CXCR5 on lymphoid organ development and systemic immunity. *Immunol Rev* 2003;195: 117-135.
116. Mebius RE, Miyamoto T, Christensen J, et al. The fetal liver counterpart of adult common lymphoid progenitors gives rise to all lymphoid lineages, CD45⁺CD4⁺CD3⁻ cells, as well as macrophages. *J Immunol* 2001;166: 6593-6601.
117. Kurebayashi S, Ueda E, Sakaue M, et al. Retinoid-related orphan receptor gamma (ROR gamma) is essential for lymphoid organogenesis and controls apoptosis during thymopoiesis. *Proc Natl Acad Sci U S A* 2000;97: 10132-10137.
118. Yokota Y, Mansowi A, Mori S, et al. Development of peripheral lymphoid organs and natural killer cells depends on the helix-loop-helix inhibitor Id2. *Nature* 1999;397:702-706.
119. Hess E, Duheron V, Decossas M, et al. RANKL induces organized lymph node growth by stromal cell proliferation. *J Immunol* 2012;188:1245-1254.
120. Tamura C, Nakazawa M, Kasahara M et al. Impaired function of dendritic cells in alymphoplasia (aly/aly) mice for expansion of CD25⁺CD4⁺ regulatory T cells. *Autoimmunity* 2006;39:445-453.
121. Konishi J, Iwabuchi K, Iwabuchi C, et al. Thymic epithelial cells responsible for impaired generation of NK-T thymocytes in alymphoplasia mutant mice. *Cell Immunol* 2000;206:26-35.
122. Karrer U, Althage A, Odermatt B, et al. Immunodeficiency of alymphoplasia mice (aly/aly) in vivo: structural defect of secondary lymphoid organs and functional B cell defect. *Eur J Immunol* 2000;10:2799-2807.
123. Clark SL Jr. The reticulum of lymph nodes in mice studied with the electron microscope. *Am J Anat* 1962;110:217-257.
124. Luk SC, Nopajaroonsri C, Simon GT. The architecture of the normal lymph node and hemolymph node. A scanning and transmission electron microscopic study. *Lab Invest* 1973;29:258-265.
125. Flemming W. Studien über regeneration der Gewebe. I. Die Zellvermehrung in den Lymphdrüsen und verwandten Organen und ihr Einfluss auf deren Bau. *Arch Mikrosk Anat* 1884;24:50.
126. Hellman T. Studien über das lymphoide Gewebe. Die Bedeutung der Sekundärfollikel. *Beiträge Pathol Anat Allgem Pathol* 1921;68:333.
127. Gregory CD, Tursz T, Edwards CF, et al. Identification of a subset of normal B cells with a Burkitt's lymphoma (BL)-like phenotype. *J Immunol* 1987;139:313-318.
128. Bowen MB, Butch AW, Parvin CA, et al. Germinal center T cells are distinct helper-inducer T cells. *Hum Immunol* 1991;31:67-75.
129. Inaba K, Witmer MD, Steinman RM. Clustering of dendritic cells, helper T lymphocytes, and histocompatible B cells during primary antibody responses in vitro. *J Exp Med* 1984;160:858-876.
130. Kelly RH. Functional anatomy of lymph nodes: the paracortical cords. *Int Arch Allergy Appl Immunol* 1975;48:836-849.
131. Gretz JE, Anderson AO, Shaw S. Cords, channels, corridors and conduits: critical architectural elements facilitating cell interactions in the lymph node cortex. *Immunol Rev* 1997;156:11-24.
132. Bancereau J, Briere F, Cause C, et al. Immunobiology of dendritic cells. *Annu Rev Immunol* 2000;18:767-811.
133. Szakal AK, Kosco MH, Tew JG. Microanatomy of lymphoid tissue during humoral immune responses: structure function relationships. *Annu Rev Immunol* 1989;7:91-109.

134. Freedman AS, Munro JM, Rice GE, et al. Adhesion of human B cells to germinal centers in vitro involves VLA-4 and ICAM-1. *Science* 1990;249: 1030-1033.
135. Alavaikko MJ, Hansmann ML, Nebendahl C, et al. Follicular dendritic cells in Hodgkin's disease. *Am J Clin Pathol* 1991;95:194-200.
136. Cyster JG, Ansel KM, Eklund EH, et al. Follicular stromal cells and lymphocyte homing to follicles. *Immunol. Rev* 2000;176:181-193.
137. Dakic A, Shao Q-x, D'Amico AD, et al. Development of the dendritic cell system during mouse ontogeny. *J Immunol* 2004;172:1018-1027.
138. Achen MG, Stacker SA. The vascular endothelial growth factor family: proteins which guide the development of the vasculature. *Int J Exp Pathol* 1998;79:255-265.
139. Webster B, Eklund EH, Agle LM, et al. Regulation of lymph node vascular growth by dendritic cells. *J Exp Med* 2006;203:1903-1913.
140. Williams SP, Karnezis T, Achen MG, Stacker SA). Targeting lymphatic vessel functions through tyrosine kinases. *Angiogenesis Res* 2010;11:2-13.
141. Browning JL, Allaire N, Ngam-ek A, et al. Lymphotoxin-B receptor signaling is required for the homeostatic control of HEV differentiation and function. *Immunity* 2005;23:539-550.
142. Goldschneider I, McGregor DD. Migration of lymphocytes and thymocytes in the rat. I. The route of migration from blood to spleen and lymph nodes. *J Exp Med* 1968;127:155-168.
143. Wendland M, Willenzon S, Kocks J, et al. Lymph node T cell homeostasis relies on steady state homing of dendritic cells. *Immunity* 2011;23:945-945.
144. Marchesi VT, Gowans JL. The migration of lymphocytes through the endothelium of venules in lymph nodes: an electron microscope study. *Proc R Soc (Biol)* 1964;159:283-290.
145. Anderson AO, Anderson ND. Lymphocyte emigration from high endothelial venules in rat lymph nodes. *Immunology* 1976;31:731-748.
146. Lippert DN, Wilkins JA. Glia maturation factor gamma regulates the migration and adherence of human T lymphocytes. *BMC Immunol* 2012 Apr 18;13:21. Epub ahead of print.
147. Nossal GJV, Abbot A, Mitchell J. Antigens in immunity. XIV. Electron microscopic radioautographic studies of antigen capture in the lymph node medulla. *J Exp Med* 1968;127:263-276.
148. Nossal GJV, Abbot A, Mitchell J, et al. Antigens in immunity. XV. Ultrastructural features of antigen capture in primary and secondary lymphoid follicles. *J Exp Med* 1968;127:277-290.
149. Stein H, Gerdes J, Mason DY. The normal and malignant germinal center. *Clin Haematol* 1982;11:531-559.
150. Dameshek W. "Immunoblasts" and immunocytes. An attempt at a functional nomenclature. *Blood* 1963;21:243-245.
151. Movat HZ, Fernando NVP. The fine structure of the lymphoid tissue during antibody formation. *Exp Mol Pathol* 1965;4:155-188.
152. Swartzendruber DC, Congdon CC. Electron microscope observations on tingible body macrophages in mouse spleen. *J Cell Biol* 1963;19:641-646.
153. Mori M, Ishi Y, Onoé T. Studies on the germinal center. I. Ultrastructural study of germinal centers in human lymph nodes with correspondence to the zonal differentiation. *J Reticuloendothel Soc* 1969;6:140-157.
154. Hanna MG Jr. An autoradiographic study of the germinal center in spleen white pulp during early intervals of the immune response. *Lab Invest* 1964;13:95-104.
155. Jacobson EB, Caporale LH, Thorbecke GJ. Effect of thymus cell injections on germinal center formation in lymphoid tissues in nude (thymusless) mice. *Cell Immunol* 1974;13:416-430.
156. Nossal GJV, Makela O. Autoradiographic studies on the immune response. I. The kinetics of plasma cell proliferation. *J Exp Med* 1962;115:209-230.
157. Roberts CWM, Shutter JR, Korsmeyer SJ. Hox11 controls the genesis of the spleen. *Nature* 1994;368:747-749.
158. Lewis SM. The spleen—mysteries solved and unresolved. *Clin Haematol* 1983;12:363-373.

159. Weiss L. The spleen. In Weiss L. ed. Cell and tissue biology. Baltimore, MD Urban and Schwarzenberg, 1988.
160. Weiss L. A scanning electron microscopic study of the spleen. *Blood* 1974;43:665-691.
161. Weiss L. The structure of the normal spleen. *Semin Haematol* 1965;2: 205-228.
162. Steiniger B, Rüttinger L, Barth PJ. The three-dimensional structure of human splenic white pulp compartment. *J Histochem Cytochem* 2006;51:655-663.
163. Lyons AB, Parish CR. Are murine marginal-zone macrophages the splenic white pulp analog of high endothelial venules? *Eur J Immunol* 1995;25: 3165-3172.
164. Spencer J, Perry ME, Dunn-Walters DK. Human marginal-zone B cells. *Immunol Today* 1998;19:421-426.
165. Tierens A, Delabie J, Michiels L, et al. Marginal-zone B cells in the human lymph nodes and spleen show somatic hypermutations and display clonal expansion. *Blood* 1999;93:226-234.
166. MacLennan ICM, Liu YJ. Marginal zone B cells respond to both polysaccharide antigens and protein antigens. *Res Immunol* 1991;142:436.
167. Martin BG, Kearney JF. Marginal-zone B cells. *Nat Rev Immunol* 2002;2: 3232-3335.
168. Srivastava B, Quinn WJ, Hazard K, et al. Characterization of marginal zone B cell precursors. *J Exp Med* 2005;202:1225-1234.
169. Saito T, Chiba S, Ichikawa M, et al. Notch 2 is preferentially expressed in mature B cells and indispensable for marginal zone B lineage development. *Immunity* 2003;18:675-685.
170. Girkontaite I, Missy K, Sakk V, et al. B cells, regulation of lymphocyte motility and immune responses. *Nat Immunol* 2001;2:855-862.
171. Cinamon G, Matloubian M, Lesneski MJ, et al. Sphingosine1-phosphate receptor-1 promotes B cell localization in the splenic marginal zone. *Nat Immunol* 2004;5:713-720.
172. Dammers PM, Kroese FGM. Recruitment and selection of marginal zone B cells is independent of exogenous antigens. *Eur J Immunol* 2005;35: 2089-2099.
173. Wen L, Brill-Dashoff J, Shinton SA, et al. Evidence of marginal-zone B cell positive selection in spleen. *Immunity* 2005;23:297-308.
174. Camacho FI, García JF, Sánchez-Verde L et al. Unique phenotypic profile of monocytoid B cells: differences in comparison with the phenotypic profile observed in marginal zone B cells and so-called monocytoid B cell lymphoma. *Am J Pathol* 2001;158:1363-1369.
175. Stein K, Hummel M, Korlujhn P, et al. Monocytoid B cells are distinct from splenic marginal zone cells and commonly derive from unmutated naïve B cells and less frequently from postgerminal center B cells by polyclonal transformation. *Blood* 1999;94:2800-2808.
176. Willenbrock K, Jungnickel B, Hansmann M-L, et al. Human splenic marginal zone B cells lack expression of activation-induced cytidine deaminase. *Eur J Immunol* 2005;35:3002-3007.
177. Weller S, Reynaud C-A, Weill J-C. Splenic marginal B cells in humans: where do they mutate their Ig receptor. *Eur J Immunol* 2005;35:2789-2792.
178. Kanayama N, Cascalho M, Ohmari H. Analysis of marginal zone B cell development in the mouse with limited B cell diversity: role of the antigen receptor signals in the recruitment of B cells to the marginal zone. *J Immunol* 2005;174:1438-1445.
179. Steiniger B, Timphus E-M, Jacob R, et al. CD27+ B cells in human lymphatic organs—reevaluating the splenic marginal zone. *Immunology* 2005;116: 429-442.
180. Steiniger B, Timpus E-M, Barth PJ. The splenic marginal zone in humans and rodents: an enigmatic compartment and its inhabitants. *Histochem Cell Biol* 2006;126:641-648.
181. Dierlamm J, Pittaluga S, Wlodarska I, et al. Marginal zone B cell lymphomas of different sites share similar cytogenetic and morphologic features. *Blood* 1996;87:299-307.
182. Berger F, Felman P, Thieblemont C, et al. Non-MALT marginal B cell lymphomas: a description of clinical presentation and outcome in 124 patients. *Blood* 2000;95:1950-1956.

183. Tierens A, Delabie J, Pittaluga S, et al. Mutational analysis of the rearranged immunoglobulin heavy chain genes of marginal zone cell lymphomas indicates an origin from different marginal zone B lymphocyte subsets. *Blood* 1998;91:2381-2386.
184. Ruiz-Ballesteros E, Molleje M, Rodriguez A, et al. Splenic marginal zone lymphoma: proposal of a new diagnostic and prognostic marker identical after tissue and cDNA microarray analysis. *Blood* 2005;106:1831-1838.
185. Du MQ, Peng HZ, Degan A, et al. Preferential dissemination of B cell gastric mucosa-associated lymphoid tissue (MALT) lymphoma to the splenic marginal zone. *Blood* 1997;90:4071-4077.
186. Chen LT, Weiss L. Electron microscopy of the red pulp of human spleen. *Am J Anat* 1972;134:425-457.
187. Weiss L. The red pulp of the spleen: structural basis of blood flow. *Clin Haematol* 1983;12:375-393.
188. Chen LT, Weiss L. The role of the sinus wall in the passage of erythrocytes through the spleen. *Blood* 1973;41:529-537.
189. Lockwood CM. Immunological functions of the spleen. *Clin Haematol* 1983;12:449-465.
190. Bohnsack JF, Brown EJ. The role of the spleen in resistance to infection. *Annu Rev Med* 1986;37:49-59.
191. Dickerman JD. Bacterial infection and the asplenic host: a review. *J Trauma* 1976;16:662-668.
192. Singer DB. Postsplenectomy sepsis. *Perspect Pediatr Pathol* 1973;1:285-311.
193. Hosea SW, Berch CG, Brown EJ, et al. Impaired immune response of splenectomized patients to polyvalent pneumococcal vaccine. *Lancet* 1981;1: 804-807.
194. Drew PA, Kirrow GK, Ferante A, et al. Alterations in immunoglobulin synthesis by peripheral blood mononuclear cells from splenectomized patients with and without splenic regrowth. *J Immunol* 1984;132:191.
195. Karrer U, Althage A, Odermatt B, et al. On the key role of secondary lymphoid organs in antiviral immune responses studied in alymphoplastic (aly/aly) and spleenless (Hox11^{-/-}) mutant mice. *J Exp Med* 1997;185:2157-2170.
196. Picker LJ, Butcher EC. Physiological and molecular mechanisms of lymphocyte homing. *Annu Rev Immunol* 1992;10:561-591.
197. Kim CH. The greater chemotactic network for lymphocyte trafficking: chemokines and beyond. *Curr Opin Hematol* 2005;12:298-304.
198. Sackstein R. The lymphocyte homing receptors: gatekeepers of the multistep paradigm. *Curr Opin Hematol* 2005;12:444-450.
199. Ebert LM, Schaerli P, Moser B. Chemokine-mediated control of T cell traffic in lymphoid and peripheral tissues. *Mol Immunol* 2005;42:799-809.
200. Mora JR, van Andrian VH. T cell homing specificity and plasticity: new concepts and future challenges. *Trends Immunol* 2006;27:235-243.
201. Streeter PR, Rouse BT, Butcher EC. Immunohistologic and functional characterization of a vascular addressin involved in lymphocyte homing into peripheral lymph nodes. *J Cell Biol* 1988;107:1853-1862.
202. von Andrian UH, Hasslen SR, Nelson RD, et al. A central role for microvillous receptor presentation in leukocyte adhesion under flow. *Cell* 1995;82: 989-999.
203. Berlin C, Bargatze RF, Campbell JJ, et al. alpha 4 integrins mediate lymphocyte attachment and rolling under physiologic flow. *Cell* 1995;80:413-422.
204. Bargatze RF, Jutila MA, Butcher EC. Distinct roles of L-selectin and integrins alpha 4 beta 7 and LFA-1 in lymphocyte homing to Peyer's patch-HEV in situ: the multistep model confirmed and refined. *Immunity* 1995;3:99-108.
205. Arbonés ML, Ord DC, Ley K, et al. Lymphocyte homing and leukocyte rolling and migration are impaired in L-selectin-deficient mice. *Immunity* 1994;1:247-260.
206. Pavalko FM, Walker DM, Graham L, et al. The cytoplasmic domain of L-selectin interacts with cytoskeletal proteins via α -actinin: receptor positioning in microvilli does not require interaction with α -actinin. *J Cell Biol* 1995;129:1155-1164.
207. Chen S, Springer TA. An automatic braking system that stabilizes leukocyte rolling by an increase in selectin bond number with shear. *J Cell Biol* 1999;144:185.

208. Kanamori A, Kojima N, Uchimura K, et al. Distinct sulfation requirements of selectins disclosed using cells that support rolling mediated by all three selectins under shear flow. L-selectin prefers carbohydrate 6-sulfation to tyrosine sulfation, whereas P-selectin does not. *J Biol Chem* 2002;277:32578-32586.
209. Vestweber D, Blanks JE. Mechanisms that regulate the function of the selectins and their ligands. *Physiol Rev* 1999;79:181-213.
210. Lowe JB. Glycosylation in the control of selectin counter-receptor structure and function. *Immunol Rev* 2002;186:19-36.
211. Hemmerich S, Butcher EC, Rosen SD. Sulfation-dependent recognition of high endothelial venules (HEV)-ligands by L-selectin and MECA 79, an adhesion-blocking monoclonal antibody. *J Exp Med* 1994;180:2219-2226.
212. Maly P, Thall AD, Petryniak CE, et al. The α -(1,3) fucosyltransferase Fuc-TVII controls leukocyte trafficking through an essential role in L-, E-, and P-selectin ligand biosynthesis. *Cell* 1996;86:643-653.
213. Kawashima H, Petryniak B, Hiraoka N, et al. N-acetylglucosamine-6-Osulfotransferases 1 and 2 cooperatively control lymphocyte homing through L-selectin ligand biosynthesis in high endothelial venules. *Nat Immunol* 2005;6:1096-1104.
214. Uchimura K, Ganguet J-M, Singer MS, et al. A major class of L-selectin ligands is eliminated in mice deficient in two sulfotransferases expressed in high endothelial venules. *Nat Immunol* 2005;6:1105-1113.
215. Warnock RA, Askari S, Butcher EC, et al. Molecular mechanisms of lymphocyte homing to peripheral lymph nodes. *J Exp Med* 1998;187:205-216.
216. Grabovsky V, Dwir O, Alon R. Endothelial chemokines destabilize L-selectin mediated lymphocyte rolling without inducing selectin shedding. *J Biol Chem* 2002;227:20640-20650.
217. Kanda H, Tanaka T, Matsumoto M, et al. Endomucin, a sialomucin expressed in high endothelial venules, supports L-selectin-mediated rolling. *Intern Immunol* 2004;16:1265-1274.
218. Samulowitz V, Kuhn A, Brachtendorf G, et al. Human endomucin distribution pattern, expression on high endothelial venules, and decoration with the MECA-79 epitope. *Am J Pathol* 2002;160:1669-1681.
219. Martinez M, Joffraud M, Giraud S, et al. Regulation of PSGL-1 interactions with L-selectin, P-selectin, and E-selectin: role of human fucosyltransferase-IV and VII. *J Biol Chem* 2005;280:5378-5390.
220. Butcher EC, Picker LJ. Lymphocyte homing and homeostasis. *Science* 1996;272:60-66.
221. Ebnet K, Kaldjian EP, Anderson AO, et al. Orchestrated information transfer underlying leukocyte endothelial interactions. *Annu Rev Immunol* 1996;14:155-177.
222. Alon R, Feigelson S. From rolling to arrest on blood vessels: leukocyte tap dancing on endothelial integrin ligands and chemokines at subsecond contacts. *Sem Immunol* 2002;14:93-104.
223. Gunn MD, Tangemann K, Tam C, et al. A chemokine expressed in lymphoid high endothelial venules promotes the adhesion and chemotaxis of naïve T lymphocytes. *Proc Natl Acad Sci U S A* 1998;95:258-263.
224. Nagira M, Imai T, Yoshida R, et al. A lymphocyte-specific CC chemokine, secondary lymphoid tissue chemokine (SLC), is a highly efficient chemoattractant for B cells and activated T cells. *Eur J Immunol* 1998;28:1516-1523.
225. Campbell JJ, Butcher EC. Chemokines in tissue-specific and microenvironment-specific lymphocyte homing. *Curr Opin Immunol* 2000;12:336-341.
226. Campbell JJ, Hendrick J, Zlotnic A, et al. Chemokines and the arrest of lymphocytes under flow conditions. *Science* 1998;279:381-384.
227. Tangemann K, Gunn MD, Giblin P, et al. A high endothelial cell-derived chemokine induces rapid, efficient, and subset-selective arrest of rolling T lymphocytes on a reconstituted endothelial substrate. *J Immunol* 1998;161:6330-6337.
228. Ngo VN, Tang HL, Cyster JG. Epstein-Barr virus-induced molecule 1 ligand chemokine is expressed by dendritic cells in lymphoid tissues and strongly attracts naïve T cells and activated B cells. *J Exp Med* 1998;188:373-386.
229. Backevold ES, Yamanaka T, Palframan RT, et al. The CCR7 ligand ELC (CCL19) is transcytosed in high endothelial venules and mediate T cell recruitment. *J Exp Med* 2001;193:1105-1111.
230. Kinashi T. Intracellular signalling controlling integrin activation in lymphocytes. *Nat Rev Immunol* 2005;5:546-559.

231. Nakano H, Mori S, Yonekawa H, et al. A novel mutant gene involved in T-lymphocyte-specific homing into peripheral lymphoid organs on mouse chromosome 4. *Blood* 1998;91:2886-2895.
232. Fan L, Reilly CR, Luo Y, et al. Cutting edge: ectopic expression of the chemokine TCA4/SLC is sufficient to trigger lymphoid neogenesis. *J Immunol* 2000;164:3955-3959.
233. Schaerli P, Willmann K, Lang AB, et al. CXC chemokine receptor 5 expression defines follicular homing T cells with B cell helper function. *J Exp Med* 2000;192:1553-1562.
234. Ansel KM, Ngo VN, Hyman PL, et al. A chemokine-driven positive feedback loop organizes lymphoid follicles. *Nature* 2000;406:309-314.
235. Luther SA, Lopez T, Bai W, et al. BCL expression in pancreatic islets causes B cell recruitment and lymphotoxin-dependent lymphoid neogenesis. *Immunity* 2000;12:471-481.
236. Ngo VN, Korner H, Gunn MD, et al. Lymphotoxin alpha/beta and tumor necrosis factor are required for stromal cell expression of homing chemokines in B and T cell areas of the spleen. *J Exp Med* 1999;189:403-412.
237. Wittchen ES, van Buul JD, Burridge K, et al. Trading spaces: Rap, Rac, and Rho as architects of transendothelial migration. *Curr Opin Hematol* 2005;12:14-21.
238. Zhang Z, Vuori K, Wang H, et al. Integrin activation by R-ras. *Cell* 1996;85:61-69.
239. Sotsios Y, Ward SG. Phosphoinositide kinase: a key biochemical signal for cell migration in response to chemokines. *Immunol Rev* 2000;177:217-235.
240. Ward SG. T lymphocytes on the move: chemokines, PI-3 kinase and beyond. *Trends Immunol* 2006;27:80-87.
241. Toker A. Phosphoinositide 3-kinases-a historical perspective. *Subcell Biochem* 2012;58:95-110.
242. Nombela-Arrieta C. Differential requirements for DOCK2 and phosphoinositide-3-kinase-gamma during T and B lymphocyte homing. *Immunity* 2004;21:429-441.
243. Wang L, Nishihara H, Kimura T, et al. DOCK2 regulates cell proliferation through Rac and ERK activation in B cell lymphoma. *Biochem Biophys Res Commun* 2010;395:111-115.
244. Romani N, Ratzinger G, Pfaller K, et al. Migration of dendritic cells into lymphatics. The Langerhans cell example: routes, regulation, and relevance. *Int Rev Cytol* 2001;207:237-270.
245. Cook DN, Prosser DM, Foster R, et al. CCR6 mediates dendritic cell localization, lymphocyte homeostasis, and immune responses in mucosal tissue. *Immunity* 2000;12:495-503.
246. Schwarzenberger K, Udey MC. Contact allergens and epidermal proinflammatory cytokines modulate Langerhans cell E-cadherin expression in situ. *J Invest Dermatol* 1996;106:553-558.
247. Moodycliffe AM, Schreedhar V, Ullrich SE, et al. CD40-CD40 ligand interactions in vivo regulate migration of antigen bearing dendritic cells from the skin to draining lymph nodes. *J Exp Med* 2000;191:2011-2020.
248. Kellerman SA, Hudak S, Oldham ER, et al. The CC chemokine receptor-7 ligands 6-Ckine and macrophage inflammatory protein-3-beta are potent chemoattractants for in vitro- and in vivo-derived dendritic cells. *J Immunol* 1999;162:3859-3864.
249. Kobayashi Y, Matsumoto M, Kotani M, et al. Possible involvement of matrix metalloproteinase-9 in Langerhans cell migration and maturation. *J Immunol* 1999;163:5989-5993.
250. Cyster JG. Chemokines and the homing of dendritic cells to the T cell areas of lymphoid organs. *J Exp Med* 1999;189:447-450.
251. Mackay CR. Migration pathways and immunologic memory among T lymphocytes. *Semin Immunol* 1992;4:51-58.
252. Mackay CR, Marston WL, Dudler L, et al. Tissue-specific migration pathways by phenotypically distinct subpopulations of memory T cells. *Eur J Immunol* 1992;22:887-895.
253. Berg EL, Yoshino T, Rott LS, et al. The cutaneous lymphocyte antigen is a skin lymphocyte homing receptor for the vascular lectin endothelial cell-leukocyte adhesion molecule-1. *J Exp Med* 1991;174:1461-1466.
254. Picker LJ, Kishimoto TK, Smith CW, et al. ELAM-1 is an adhesion molecule for skin-homing T cells. *Nature* 1991;349:796-799.

255. Cotran RS, Gimbrone MA Jr, Bevilacqua MP, et al. Induction and detection of a human endothelial activation antigen in vivo. *J Exp Med* 1986;164:661-666.
256. Wayner EA, Gil SG, Murphy GF, et al. Epiligrin, a component of epithelial basement membranes, is an adhesive ligand for $\alpha E\beta 7$ positive T lymphocytes. *J Cell Biol* 1993;121:1141-1152.
257. Cerf-Bensussan N, Bègue B, Gagnon J, et al. The human intraepithelial lymphocyte marker HML-1 is an integrin consisting of $\alpha E \beta 7$ subunit associated with a distinctive α chain. *Eur J Immunol* 1992;22:273-277.
258. Cepek KL, Parker CM, Madara JL, Brenner MB. Integrin $\alpha E \beta 7$ mediates adhesion of T lymphocytes to epithelial cells. *J Immunol* 1993;150:3459-3470.
259. Picker LJ, Terstappen LW, Rott LS, et al. Differential expression of homing-associated adhesion molecules by T cell subsets in man. *J Immunol* 1990;145:3247-3255.
260. Parker CM, Cepek KL, Russell GJ, et al. A family of $\beta 7$ integrins on human mucosal lymphocytes. *Proc Natl Acad Sci* 1992;89:1924-1928.
261. Briskin MJ, McEvoy LM, Butcher EC. MAdCAM-1 has homology to immunoglobulin and mucin-like adhesion receptors and to IgA1. *Nature* 1993;363:461-464.
262. Tanaka Y, Adams DH, Hubscher S, et al. T cell adhesion induced by proteoglycan-immobilized cytokine MIP-1 β . *Nature* 1993;361:79-82.
263. Schall TJ, Bacon K, Toy KJ, et al. Selective attraction of monocytes and T lymphocytes of the memory phenotype by cytokine RANTES. *Nature* 1990;347:669-671.
264. Miller MD, Krangel MS. Biology and biochemistry of the chemokines: a family of chemotactic and inflammatory cytokines. *Crit Rev Immunol* 1992;12:17-46.
265. Papayannopoulou T, Craddock C, Nakamoto B, et al. The VLA4/VCAM-1 adhesion pathway defines contrasting mechanisms of lodgment of transplanted murine hemopoietic progenitors between bone marrow and spleen. *Proc Natl Acad Sci U S A* 1995;92:9647-9651.
266. Zannettino AC, Berndt MC, Butcher C, et al. Primitive human hematopoietic progenitors adhere to P-selectin (CD62P). *Blood* 1995;85:3466-3477.
267. Puri KD, Finger EB, Gaudernack G, et al. Sialomucin CD34 is the major L-selectin ligand in human tonsil high endothelial venules. *J Cell Biol* 1995;131:261-270.
268. Kanda T, Yamawaki M, Ariga T, et al. Interleukin 1 β up-regulates the expression of sulfoglucuronosyl paragloboside, a ligand for L-selectin, in brain micro-vascular endothelial cells. *Proc Natl Acad Sci U S A* 1995;92:7897-7901.
269. Smith ME, Ford WL. The recirculating lymphocyte pool of the rat: a systemic description of the migratory behavior of recirculating lymphocytes. *Immunology* 1983;49:83-94.
270. Förster R, Schubel A, Breitfeld D, et al. CCR7 coordinates the primary immune response by establishing functional microenvironments in secondary lymphoid organs. *Cell* 1999;99:23-33.
271. Butcher EC, Williams M, Youngman K, et al. Lymphocyte trafficking and regional immunity. *Adv Immunol* 1999;72:209-253.
272. Shaniel C, Rolinck AG, Melchers F. Attractions and migrations of lymphoid cells in the organization of humoral immune responses. *Adv Immunol* 2001;78:111-168.
273. Gerard C, Rollins BJ. Chemokines and disease. *Nat Immunol* 2001;2: 108-115.

Chapter 12 B Lymphocytes

> Table of Contents > Part II - The Normal Hematologic System > Section 4 - The Lymphocytes > Chapter 12 - B Lymphocytes

Chapter 12

B Lymphocytes

Frixos Paraskevas

ONTOGENY

Pluripotential stem cells give rise to all hematopoietic lineages, undergoing asymmetric division, i.e., one daughter cell follows a pathway of differentiation, whereas the other remains as a self-renewing stem cell. Depending on their interaction with the appropriate stromal cells, as well as growth and differentiation factors, stem cells differentiate into various lineages including B and T lymphocytes. Their differentiation is guided by the type of stromal elements to which they are exposed; i.e., in the thymic microenvironment they develop as T cells, whereas in contact with bone marrow-derived stromal cells they develop as B lymphocytes or myeloid cells. Multiple checkpoints ensure proper differentiation of precursor to mature B lymphocytes, and several have been found disrupted in patients with primary immunodeficiency. The differentiation of the B cell involves critical processes divided into two periods; the first from stem cell to immature Ig-M⁺ B cell is antigen-independent, while the second period from immature B cell to plasma cell is antigen-dependent. The first period is subdivided into two stages: from stem cell to progenitor B (pro-B) cell and from pro-B cell to immature Ig⁺ B cell. Differentiation has been studied in animals and humans with cells obtained from different stages of development (embryonic as well as adult) and with cells from patients with lymphoproliferative disorders, which are considered “frozen windows” of normal differentiation. This approach, however, is not accepted universally because evidence from acute leukemias suggests the existence of some degree of asynchronous maturation with phenotypes not found normally.¹

STEM CELL TO PROGENITOR B CELL

See Figure 12.1

Transcriptional Regulation

Hematopoiesis is coordinated by several genes that orchestrate multiple cell interactions which release growth and differentiation factors.² More than eight specific cell lineages have been identified which differentiate from pluripotent stem cells, guided through a well-defined hierarchical sequence to mature functional cells.³

During fetal life lymphopoiesis takes place in the yolk sac and liver and after birth in the bone marrow.⁴ “Master” genes regulate differentiation of lineages through transcription factors which activate target genes, progressively narrowing their differentiation potential to specific lineages,³ and which coordinate the various stages of lymphocytic development.^{5,6,7,8} A common progenitor gives rise to separate myeloid and lymphoid progenitors, and the latter to lymphocytic lineages B, T, natural killer (NK), and dendritic cells (DC).

Normal development of lymphopoiesis depends on the Ikaros family of transcription factors, which regulate lymphocytic development. The Ikaros gene (IKZF1) encodes a zinc finger protein (ZFP), which is a transcription factor expressed by B and T cells at different stages of differentiation (except plasma cells).⁹

A long-standing goal of molecular biology has been the construction of DNA-binding proteins for the control of gene expression by using the classical Cys2-His2 design of a ZFP, ideally suited for such purposes; and it was adopted for discriminating genes with closely related DNA sequences.¹⁰ The classical ZFs are one of the most common protein domains in higher eukaryotes widely used in zinc finger nucleases (ZFN) and are currently used in human clinical trials with an aim of therapeutic gene editing. ZFPs are nucleases designed to cut at specific DNA sequences and are becoming powerful tools in gene targeting to replace a gene within a genome by homologous recombination (HR), or to permanently modify plant and mammalian genomes, including the human genome. They were developed and used in *Drosophila*, rats, and zebra fish to generate modified organisms with genotargeted mutations and/or deletions.

This brief review emphasizes the point that Ikaros is a master regulator of gene expression and chromatin remodeling, and its biologic roles include regulation of the development and function of the immune system and overall even the hematopoietic differentiation.

The Ikaros^{-/-} mice have a complete block of B-cell differentiation, with lack of pro-B and precursor B (pre-B) cells in fetal liver and bone marrow. The Ikaros gene generates eight protein isoforms by alternative splicing and some of them bind, through the N-terminal ZFP motif, to DNA sequences which contain GGGGA core motifs. This family of DNA-binding proteins, restricted to lymphocytes, are highly conserved in humans and mice and regulate the expression of other genes. They are localized in the nucleus of most primitive hematopoietic stem cell subsets, particularly at two stages: (a) long-term self-renewing stem cells and (b) multipotent progenitors, which are not self-renewing, but able to differentiate into lymphoid-committed progenitors.¹¹ The isoforms detected in hematopoietic stem cells differ from those detected in lymphoid progenitors, but all of them share two C-terminal zinc fingers that mediate their self-association, forming multiple heteromeric complexes. Other members of the Ikaros family (i.e., Aiolos and Helios) encode transcription factors that form multimeric complexes with Ikaros.¹²

The Ikaros gene is required not only for the early stages of lymphocytic differentiation but also for late stages, especially in T-cell maturation. It exerts multiple regulatory functions by recruiting repressor complexes, or what are known as

chromatin remodeling machines, an unconventional function of transcription factors. IKAROS is also needed for the maintenance of B cells by regulating BCR signaling, and importantly overall it acts as a master regulator of hematopoietic differentiation and as a tumor suppressor in acute lymphoblastic leukemia (ALL), especially forms of the disease associated with poor prognosis.¹³

The transcription factor PU.1 acts at the pluripotent level of myeloid-lymphoid progenitors, and its expression maintains the hematopoietic progenitor pool by supporting the generation of the earliest lymphoid and myeloid progenitors.¹⁴

It regulates early B-cell development by activating the IL7R α gene, rendering B-cell progenitors responsive to appropriate differentiation signals, and thus promoting differentiation to the pro-B-cell stage. Among the three main B-cell populations, B-1, B-2 (follicular), and marginal zone B cells, PU.1 directs differentiation toward the B-2 subpopulation¹⁵ and enhances the activity of other transcription factors, i.e., the interferon (IFN)-regulatory factor. The B-1 and B-2 B cells which are involved in innate and adaptive immune responses, respectively, arise from distinct progenitors.¹⁶

The TCF3 (previously E2A) gene is important for lymphocytic differentiation encoding two proteins, E12 and E47 of the basic helix-loop-helix family by differential splicing. The proteins encoded by TCF3 bind uniquely to the DNA of B cells as homodimers¹⁷ and are essential for the coordination of Ig gene

P.253

rearrangements;¹⁸ therefore in their absence B-cell differentiation is blocked before entrance into the pro-B-cell stage. The basic region mediates DNA binding, whereas the HLH domain is required for protein dimerization. The E12 targets the genes of the early B-cell factor (EBF)¹⁹ and the Pax5,²⁰ directing differentiation along B lineage while it blocks myeloid differentiation.

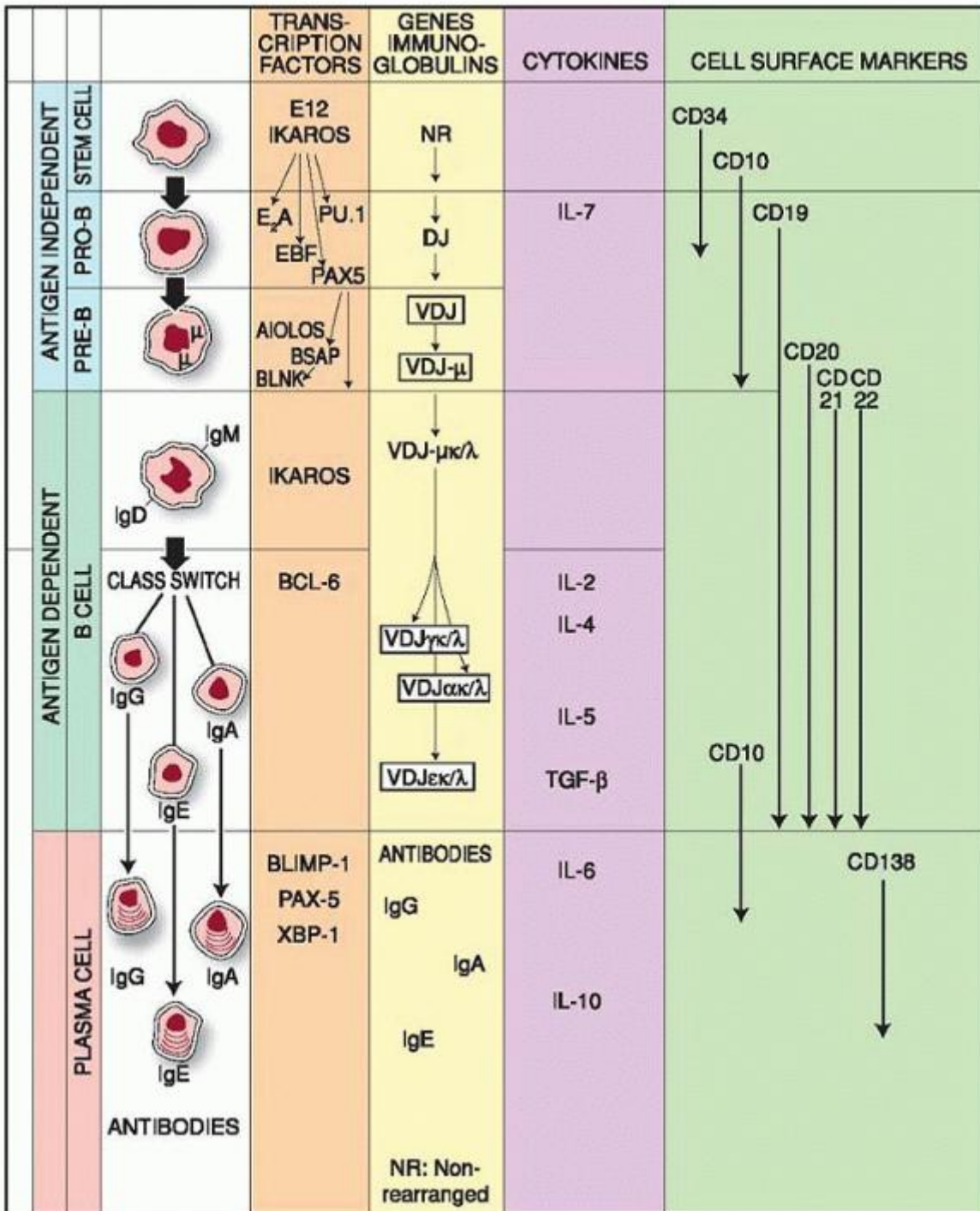

FIGURE 12.1. B-cell differentiation. The first stage of B-cell development takes place in the bone marrow. Normal development of lymphopoiesis depends on the Ikaros family of transcription factors, which form multimeric complexes with other members, i.e., Aiolos and Helios. These complexes are known as chromatin remodeling machines, and their targets induce a second wave of transcription factors, i.e., PU.1, E2A, EBF, PAX5, etc. Their targets are a third set of genes, forming BSAP that acts on the adaptor protein BLNK (SLP-65). Targets of BSAP are the genes for CD-19, V-preB, and λ5, i.e., markers distinctly of the B-cell lineage. BLNK regulates the transition from pro-B to pre-B, whereas PAX5 is needed for V(D) J recombination. This stage of development is independent of exposure to antigen and is followed by an antigen-dependent stage that unravels in the peripheral lymphoid organs. Antigen receptors, i.e., Igs, expressed on their surface interact with antigen and helper T cells, and trigger B-cell differentiation (plasma cells) and antibody secretion. Class switching generates distinct classes of antibodies suitable to dispose antigens in the various microenvironments, i.e.,

inside the body as well as on body surfaces.

The Pax5 is exclusively expressed in the stage between pro-B cell and mature B cell.²⁰ The B-cell-specific activator protein, BSAP/ PAX5, is a paired domain DNA-binding protein expressed in the developing nervous system, testis, and in all B-lineage cells, except terminally differentiated plasma cells. BSAP regulates transcription of several genes expressed in B cells and also the activity of the 3'-IgH enhancer and targets the genes of CD19, VPREB1, the gene transcribing for the lambda light chain, and several intronic sites of the C4B gene. The Pax5 gene regulates the V(D)J Ig heavy-chain gene rearrangements after the first DJ-H rearrangement,²¹ which generates the pro-B-cell population. Mice deficient for Pax5 have a pre-B-1 cell population which do not express CD19 or Ig- α and to a lesser extent Ig- β , V-preB, and lambda-5. These cells proliferate normally in vitro on stromal cells in the presence of interleukin IL7 and carry out D-J rearrangements of both IgH chain alleles. Removal of IL7 from the cultures inhibits differentiation to surface Igm expressing B cells. Transplantation of Pax5-deficient pre-B I clones into Rag-deficient hosts leads to full reconstitution of the thymus with D(H)J(H) rearrangements and normal positive and negative selection of CD4⁻CD8⁻ and CD4⁺CD8⁺ thymocytes and the development of normal, mature CD4⁺ and CD8⁺ T-cell compartments in the peripheral lymphoid tissues.

The target for BSAP is the adaptor protein B-cell linker protein (BLNK) which is linked with surface IgM by CMTM7, a tetra-spanning membrane protein, co-localized with clathrin and sIgM on the plasma membrane. The linking of sIgM with BLNK, a pivotal adaptor protein in the signal transduction, results in its recruitment to the vicinity of the tyrosine kinase Syk and initiation of signal transduction. This culminates in MAP kinase activation as well as other downstream signaling proteins, i.e., PLC- γ_2 , Bruton tyrosine kinase (Btk), etc.²² The BSAP regulation of BLNK gene expression controls also the pro-B to pre-B transition and mediates the constitutive signaling of the pre-B cell receptor (pre-BCR) in cell proliferation, growth factor responsiveness, and V(D)J recombination. BSAP diverts differentiation of a common myeloid/lymphoid progenitor to lymphocytic differentiation as a result of its ability to suppress the response of the progenitor cell to myeloid growth factors,²³ and represses genes inappropriately expressed at the pro-B-cell stage.²⁴

Essential for early B-lymphocyte development is the EBF which regulates the expression of Ig- α (mb-1) and Ig- β (B-29) coreceptors. Isolated human EBF factor binds to Ig- α and Ig- β promoters, and EBF-deficient mice lack Ig- α and Ig- β transcripts in pro-B cells.^{25,26} EBF activates transcription of B-cell-specific genes and initiates necessary events such as gene activation of other transcriptional regulators (i.e., Pax5) that direct the early stages of B-cell lymphopoiesis.²⁷ Mutations of E2A or EBF arrest B-cell development at a stage earlier than that of PAX5, because recombinase expression is blocked and expression of pre-BCR, λ_5 , and V-preB genes is inhibited.²⁷ The three transcription factors PAX5, TCF3 (E2A), and EBF form a cross-regulatory network with the TCF3 gene being the most potent B-cell regulator, essential for expression of PAX5 and EBF, which in turn is needed for expression of E47. Collectively, the targets of IKZF1 are the genes of the transcription factors TCF3 (E2A), PU.1, EBF, and PAX5, all of which regulate stages of B-cell differentiation before the expression of Ig genes. It has been shown however, that the TCF3 gene plays a central role for some aspects in subsequent stages of B-cell lymphopoiesis.²⁸ TCF3 (E2A) proteins are required for the interleukin IL7-dependent expansion of pro-B cells and their progression to the pre-B-cell stage and even later, for the regulation of rearrangements of the IgK gene and heavy-chain isotype switching.^{29,30,31} TCF3 encodes proteins that enhance hypermutation by recruiting AID to the Ig loci²⁹ and is essential in promoting pre-B- and B-cell survival.³⁰

CELL INTERACTIONS IN EARLY B-CELL DEVELOPMENT

Study of B-cell differentiation has become feasible with the development of long-term bone marrow culture techniques. This approach has helped to define the cells that are essential for the development of B cells and the factors that support B-cell growth and differentiation. The bone marrow stroma makes a critical contribution to hematopoietic differentiation and the term stroma is used in a collective sense to include a variety of cells, such as adventitial reticular cells, adipocytes, fibroblasts, and endothelial cells of the sinuses.³² The stroma includes also the extracellular matrix, composed of various fibrous proteins, glycoproteins, and heparan sulfate, effective in binding cytokines.

Granulocyte-macrophage colony-stimulating factor can bind to marrow stromal glycosaminoglycans and be presented to hematopoietic stem cells. Stroma cells have been isolated from adult bone marrow³³ or fetal bone marrow after removal of adherent cells (i.e., macrophages, endothelial cells). Stroma cells have the morphology of an adventitial/reticular/fibroblast cell, which expresses several adhesion molecules. They support, in cultures, differentiation of fetal bone marrow cells (CD34⁺, CD19⁻)³⁴ toward B-cell lineage, i.e., with loss of CD34 and acquisition of CD19 and the V-pre-B protein.

Several adhesion molecules have been implicated in the mediation of interactions between B-cell progenitors and stroma cells. Critical among them are vascular cell adhesion molecule-1 (VCAM1) on stroma cells and very late antigen-4 (VLA-4) on B-cell progenitors.^{33,35} The CD34 is expressed not only on stem cells,³⁶ but also on stroma cell precursors³⁷ and

endothelial cells,³⁸ and thus mediates interactions with its counterreceptor, L-selectin expressed on progenitor cells. Among cytokines with a wide range of functions is IL7, which acts in an early stage of common lymphoid progenitors (CLP, B/T/NK), mediates growth and differentiation of lymphocytes in the bone marrow, and plays a critical role in B-cell development.³⁹ IL7 maintains B-cell differentiation programs open; and although in the absence of IL7 the differentiation of T/NK proceeds normally, B-cell differentiation is arrested since IL7 modulates EBF expression, which activates target genes that are specific for B-cell differentiation programs.⁴⁰

In mice lacking IL-7R the recombination process comes to a halt, because normally it is the IL-7R which targets V_H segments to the recombinase complex; and furthermore, aberration in the expression of Pax5, a gene with pivotal importance in B-cell development and regulation, is associated with B-cell malignancies.⁴¹ Even though the block from IL7 deficiency is after the pro-B cell stage, these cells have certain abnormalities, such as failure to upregulate terminal deoxynucleotidyl transferase (TdT) and the high-affinity IL-7R chain.⁴² The net result of IL7 deficiency is lack of expression of the μ -chain and the pre-BCR, events that normally promote the advancement from pro-B-cell to pre-B-cell stage. Stimulation of proliferation and expression of the μ -chain follows distinct signaling pathways, because the Y449F mutation in the cytoplasmic region of the $I7\alpha$ chain, which abrogates proliferation induced by IL7, does not block μ -chain expression.⁴³ In the absence of IL7, the thymic stroma lymphopoietin (TSLP) (see Chapter 11) assumes a host of functions, i.e., regulation of the development of IgM^+ B cells from IgM^- precursors, the promotion of B-cell and Th-2 differentiation of naive $CD4^+$ T cells, and the activation of NK T cells, basophils, and other innate immune cells at the initial stage of inflammation.

TSLP affects B cell maturation and activation and may also influence differentiation and development of T regulatory T (Treg) cells.⁴⁴ Human X-linked severe immunodeficiency results from mutations of the γ chain, a common subunit for several cytokine receptors (i.e., IL2, IL4, IL7, IL9, and IL15). The patients lack T and NK cells but have normal or even elevated B cells,⁴⁵ and normal numbers of B cells are detected in patients with mutations of the $IL7R\alpha$ chain.⁴⁶ The IL7 exerts changes in gene expression, which effect differentiation of pro-B cells to pre-B cells, especially in concert with other growth factors of stromal cells.⁴⁷ It synergizes with FMS-like tyrosine kinase 3 ligand (FLT3LG) and induces strong expansion of fetal B cells in vitro.⁴⁸ IL7R has been detected on human B-cell progenitors, with a pro-B-cell phenotype, which lack expression of CD19 and clonogenic capacity,⁴⁹ are $CD34^+$, have messenger RNAs (mRNAs) for CD79B, RAG1, PAX5, and are TdT⁺. The $IL7R-\alpha^-/CD19^-/CD34^+$ cells do not differentiate in short-term cultures into pro-B cells, therefore the expression of IL7R- α defines an entry into a stage characterized by upregulation of multiple B-lymphoid-associated markers. Single adult human $CD34^+ CD38^- CD7^-$ cells cultured over a murine fetal liver adherent cell line supplied with IL7, FLT3LG, and IL3 differentiate into B cells, NK cells, myeloid cells, and DC.⁵⁰

B-lineage development therefore is based on a complex, interconnected network of genetic programs which provide lineage commitment and specification.^{8,51}

The CXCR4 chemokine receptor is detected in $CD34^+$ hematopoietic progenitors⁵² committed to B-cell development,⁵³ and its ligand is the stromal cell-derived factor-1 (SDF1 or PBSF, now known as CXCL12).⁵⁴ The CXCL12 chemokine orchestrates rapid revascularization of injured, ischaemic, and regenerating tissues via the CXC chemokine receptors CXCR4 and CXCR7. The CXCL12 induces intracellular actin polymerization in lymphocytes, a process that is thought to be a prerequisite for cell motility. Expression of CXCR4 on $CD34^+$ BM cells is one of the phenotypic alterations for committed lymphoid progenitors and allows discrimination of lymphoid progenitors from myeloid progenitors. Since $CD34^+CXCR4^+$ cells are differentiated from $CD34^+CXCR4^-$ cells, multipotential progenitors located in the BM are likely to be negative for CXCR4 expression.

CXCR4 is also known as fusin and acts as a coreceptor for human immunodeficiency virus (HIV) which infects host cells, but CXCL12 blocks the entry of HIV to T cells.⁵³ The $CD34^+CXCR4^-$ bone marrow cells generate myeloid and lymphoid progenitors, while the $CD34^+CXCR4^+$ cells, although they give rise to B cells and T cells, lack the potential for myeloid, erythroid, megakaryocytic, and mixed colony-forming progenitors. CXCR4 therefore defines B-lineage committed progenitors more accurately than other commonly used markers and is expressed earlier than IL7R or TdT.

PRO-B CELL TO Ig^+ B CELL

The early development of B cell differentiation is divided into two stages, the pro-B and the pre-B cells. In pro-B cells the first rearrangement involves the D_H to J_H segments of the immunoglobulin heavy chain ($IGH@$). With the completion of this step, the V_H to D_H-J_H rearrangement begins and if it is productive, an H chain is formed which binds a surrogate light chain (SLC) forming the pre-BCR. Further signaling by the pre-BCR stimulates proliferation followed by light chain rearrangement. $IGK@$ light chain rearrangement begins before the rearrangement of the $IGL@$ light-chain genes. These

epigenetic changes regulate the transition to the B cell stage, characterized by rearrangements of the light-chain genes with the kappa light chain preceding the rearrangement of the lambda chain gene.

Molecular definition of the stages of early B-cell development identified cells with μ H chains in the cytoplasm without L chains and no mature IgM molecules on the cell surface,⁵⁵ followed by phenotypic markers or Ig gene rearrangement.⁵⁶ Single-cell polymerase chain reaction analysis and Ig gene rearrangements allowed a more precise identification of B-lineage commitment and definition of the stages which characterize the transition from stem cells to pro-B-cell stage and B-cell development (Fig. 12.1). The pro-B cell stage in B cell development is followed by the pre-B cell, which may be divided into pre-B-I and pre-B-II stages.

Clones of pre-B I cells carry characteristic D(H)J(H) rearrangements on both IGH@ chain alleles. However removal of IL7 from the tissue cultures does not induce B-cell differentiation in B cells expressing surface IgM.

When the Ig gene rearrangements reach their final stage, IgM is expressed on the cell surface and differentiation reaches the end of the immature B lymphocyte stage. Three sets of genes regulate the transition from the pro-B-cell to the pre-B-cell stage, with expression of the complete Ig molecule on the surface of the B cell. One set includes RAG1 and RAG2 genes, and a third gene encodes the SLC which is composed of the proteins from the VPRED1 and λ 5 genes.

The proteins from two other genes, CD79A (mb1, PSMB5; IGB) and CD79B (CD79B; IGB) CD79B; IGB, form the coreceptor. These

P.254

genes support the expression of IgM on the surface of the B cell, the BCR repertoire, and allelic exclusion (i.e., expression of only one of the two alleles). The rearrangements of the Ig genes start with the joining of a D to J_H segment in the pro-B cells, which proliferate in contact with stromal elements and express the SLC linked to a gp30 protein, sometimes referred to as the surrogate heavy chain of the pro-B-cell complex.^{57,58} and ⁵⁹ SLC expression is required to establish immunoglobulin heavy chain allelic exclusion during early B-cell development and is easily detected on mouse pro-B cells but difficult to detect on human pro-B cells.^{58,59} The SLC consists of two noncovalently associated proteins, VPRED1 and λ 5 (Fig. 12.2), encoded by genes located on chromosome 22, where the λ -chain genes are also located.^{60,61} The VPRED1 and λ 5 proteins have several unusual features that distinguish them from conventional light chains. The VPRED1 protein is composed of 102 amino acids with homology to a conventional V domain and both have atypical sequences which target them to the endoplasmic reticulum (ER).⁶²

However, whereas the conventional V domain has a total of nine beta strands, including a sequence encoded by a J segment, the VPRED1 has no sequence similar to the J segment and is shorter by one strand, the β 7 strand, and its C-terminal portion has no homology to any other known protein. The N-terminal end of the λ 5 protein is unique, with only marginal sequence homologies to conventional domains. The C-terminal end of the λ 5 protein has an Ig-like fold, homologous to the conventional λ -chain C domain. This is followed by a sequence with marginal homology to the Ig structures and an extra β -strand that is homologous to the J region of the conventional V λ domains. Unique regions and Ig-like domains of the VPRED1 and lambda-5 proteins control the folding and assembly of SLC,⁶² which associates with the μ -chain to form the pre-BCR. The C-1 domain of the μ -H chain in the pre-BCR is protected from improper folding by the hsp-70 protein BiP, which retains the μ -H chain in the ER.⁶³ The protection from improper folding of CH-1 is taken over by the C- λ 5 protein at a later stage as long as the CH-1 is associated with the VPRED1 as SLC.⁶⁴ SLC escorts the μ -H chain to the surface of the cell, although not all μ -H chains can pair with the SLC, since some V segments have structural features that prevent their association. At this point, the RAG1, RAG2, and DNTT (TDT)TdT genes are turned off, securing allelic exclusion and thus preventing further rearrangements at the other allele.⁶⁵ The λ -5 chain of the pre-BCR represents the C domain of the conventional L chain of BCR, and has 85% homology with the C- λ domain, while the VPRED1 is the equivalent to the VL domain.⁶⁶ The SLC is linked by a disulfide bond to the μ _H chain through the C μ -1, i.e., the first constant domain,⁶⁷ and its role in the formation of the pre-BCR is dual. The C domain of λ -5 protein interacts with C μ -1 and the VPRED1 (and part of λ 5) with the V_H domain of the μ _H chain.⁶⁸ This last interaction is likely to be the first step in the selection of the B-cell repertoire⁶⁷ as the pre-BCR induces asymmetric divisions of pre-B cells.⁶⁹ In contact with pre-BCR ligands on stromal cells, i.e., heparin sulfate⁷⁰ or galectin-1,⁷¹ the SLC mediates receptor aggregation, signaling, and internalization, as well as transition from pro-B cells to pre-B cells.⁷² Pre-B-cell signals induce proliferative activity of pre-B cells, allelic exclusion of the heavy-chain locus, and activation of the light-chain loci preparing for V(D)J recombination.⁷³

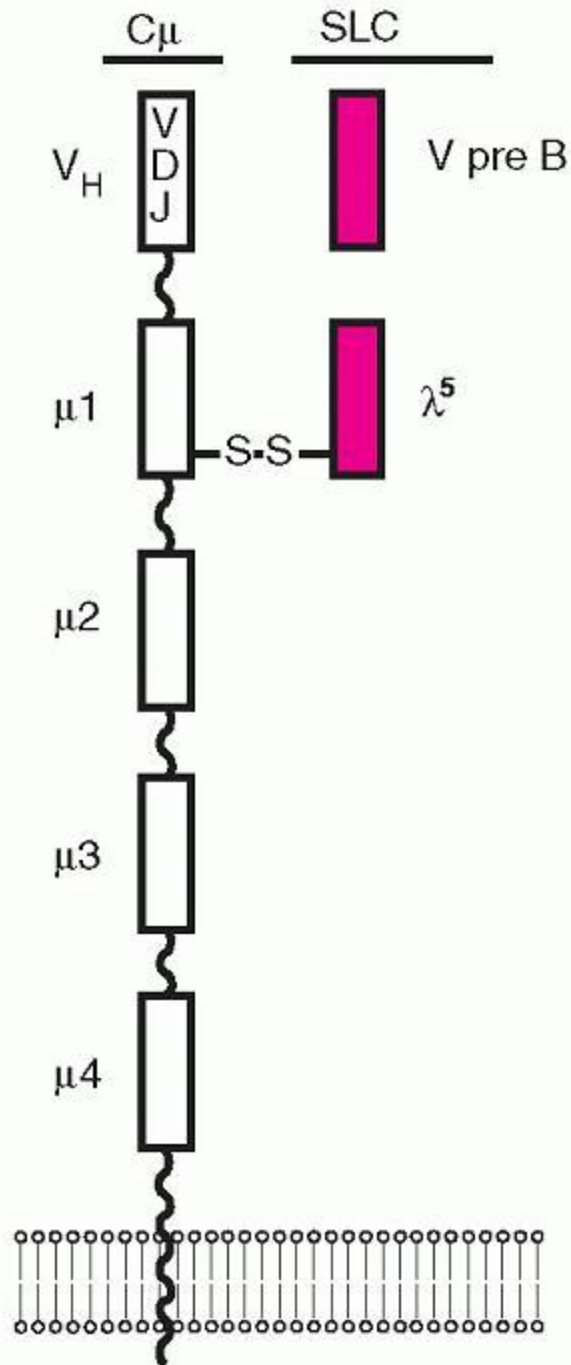

FIGURE 12.2. The structure of the pre-B-cell receptor. The pre-B-cell receptor is composed of the μ chain and a surrogate light chain that consists of two components, the λ^5 and the V-preB. The μ chain is linked by disulfide bond to the λ^5 component, whereas the V-preB is noncovalently attached. It is not yet clear whether the surrogate light chain can be expressed on the surface without the μ chain.

Productive rearrangement of the L chain completes induction of the IgM molecule expressed on the B cell surface, and marks the transition to the immature B-cell stage. The strong proliferative capacity of the pre-B cells was analyzed in Pax5^{-/-} mice, which showed that the pre-B cell has an extensive renewal capacity, multipotency, and the ability to reconstitute recipient animals with lymphoid and myeloid lineages.⁷⁴

Signaling is transmitted by the CD79A/CD79B partners of the pre-BCR, which is linked to several protein tyrosine kinases, i.e., Bruton's tyrosine kinase [BTK], SYK, ITK, BLNK, and phosphoinositide 3-kinase (PI-3K).⁷⁵ Ligand binding causes

aggregation of the pre-BCR, resulting in endocytosis of pre-BCR, loss of cell surface expression, and accumulation of pre-BCR within membrane lipid microdomains.

The pre-BCR signaling achieves two important outcomes for subsequent differentiation of the B cell: activation of MAP kinases, which block apoptosis usually triggered by the engagement of CD24;⁷⁶ and downregulation of RAG1/RAG2 expression to turn V(D)J recombination off, so that allelic exclusion is accomplished.⁷⁷ The RAG1/RAG2 proteins are still expressed on active proliferating cells of the pre-BI stage, but are silenced during the pre-BII stage. Because the cell has achieved its objectives (i.e., survival and allelic exclusion), it reactivates the V(D)J recombination machinery to allow rearrangements of the conventional κ/λ chains, to be able to form the complete IgM molecule and thus enter the immature B-cell stage.

Existing epigenetic mechanisms prioritize expression of single heavy and light chain alleles (allelic exclusion) in order to maintain monoallelic expression of both genes in a single B cell,⁷⁸ maintaining at the same time single specificity of the B cell receptor. At a later stage of B cell development, additional mechanisms contribute to prioritizing expression of single IGH@ and IGL@ alleles to help maintain the monoallelic expression of Ig.

The nontranscribed allele is in close association with heterochromatin, and the transcription factor IKZF1 initiates the silencing of transcription of the lambda-5 gene through a direct effect on the promoter.⁷⁹ Individual B lymphocytes normally express immunoglobulin (Ig) proteins derived from single Ig heavy chain (H) and light chain (L) alleles. At later stages of B cell development, additional mechanisms may contribute in prioritizing expression of single IGH@ and IGL@ alleles. The importance of pre-BCR signaling for progression from pro-B-cell to pre-B-cell stages and beyond is emphasized by the fact that deficiencies of any component of the pre-BCR or downstream signaling molecules blocks developmental progression of B cells at the pro-B or pre-B stage.⁸⁰ Targeting the genes for VPRED1,⁸¹ $\lambda 5$,⁸² or exons of the μ -chain blocks B-cell differentiation at the pro-B to pre-B-cell stage.⁸³ In mice with $\lambda 5$ -deficiency the expression of VPRED1 is normal, which excludes an essential role for pro-B and pre-B

P.255

cell receptors in VPRED1 regulation.⁸⁴ Similarly, in a patient with agammaglobulinemia, mutations in both $\lambda 5$ /IGLL1 genes were associated with agammaglobulinemia and reduced numbers of B cells.⁸⁵

The SLC is not detected on the surface or in the cytoplasm of a subpopulation of self-reactive cells found in germinal centers⁸⁶ and circulation.⁸⁷ B cells having a VPRED1 sequence in their BCR and RAG mRNA have also been described in normal human tonsils and the joints of patients with rheumatoid arthritis.^{88,89} The pre-B cell signaling that terminates pre-B cell expansion and induces Ig L-chain rearrangement is transmitted by Bruton's tyrosine kinase and the BLNK (Src homology-2 domain), which contains a leukocyte-specific phosphoprotein of 65 kD.⁹⁰ The V-region of a pre-B receptor and $\lambda 5$ proteins of the pre-BCR are invariant, but each contains unique evolutionarily conserved non-Ig sequences (unique regions or URs) attached to the Ig sequences.⁹¹ The URs interrupt the SLC complex and may be considered equivalent to the CDR3 of the Ig L chain which participates in antigen binding.⁹² The transcription factors that are most active and are specifically upregulated at this stage are TCF3, EBF1, PAX5, and IRF4.⁹³ The pre-BCR not only switches on the Ig genes, it appears to select preferentially those that provide μ H chains of a higher quality, i.e., with a higher potential to assemble with Ig L chains.⁹⁴

In conclusion, the pre-BCR plays a major role in the expansion of pre-B cells, allelic exclusion, repertoire selection, activation of V(D)J recombination, and developmental progression to IgM⁺ B cells.⁷³ Multiple checkpoints ensure proper differentiation of precursor and mature B lymphocytes. Many of these checkpoints have been found disrupted in patients with primary immunodeficiency; and it still remains unclear how B cells are affected, as 11 critical processes in B cell differentiation have been identified.

IMMUNOGLOBULIN GENES

Among the early successes of investigations in recombinant DNA, was the characterization of the Ig genes. There are three loci for the heavy chains and two for the light chains (κ , λ). The gene for the human heavy chain is located on chromosome-14,⁹⁵ the C(κ) gene on chromosome-2,⁹⁶ and the C- λ on chromosome-22.^{97,98} Separate genes encode the V and C domains of the Ig molecule. The human heavy-chain genes are not completely linked and the C μ gene is the closest to the Vdj segments.

At the 3' end of the H chain locus, there are two copies of a γ - γ - ϵ - α unit (Fig. 12.3). One of the duplicated ϵ -sequences is a pseudogene ($\psi\epsilon$) in which the CH1 and CH2 domains have been deleted. The genome contains a third closely homologous ϵ -related sequence, a "processed" pseudogene found on chromosome-9. These kinds of pseudogenes probably are

products of a reverse transcription from RNA and then are inserted at locations in the genome that are unrelated to the original locus. A γ -related pseudogene lacking the switch region is present between the two γ - ϵ - α duplications. The recombination events occur in a region on the 5' side of the C_H coding sequences.

This region contains repetitive DNA sequences and has been known as the switch region (S) sequence. Within the switch regions occur the recombination breakpoints during isotype switch (see Chapter 14). Usually the stimuli for switch recombination, like IL4 and CD40, promote transcription across the S regions to produce switch junctions, one retained in the chromosome while the other is found in a circular DNA (see Chapter 14).

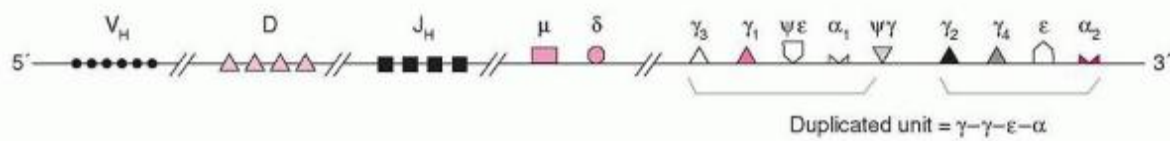

FIGURE 12.3. Human immunoglobulin heavy-chain gene locus. The heavy-chain gene locus contains the μ and δ genes close to the J_H genes, whereas the remaining heavy-chain genes are farther downstream in two clusters from duplications. See text.

V_H -D- J_H GENES

The heavy chain of the IgM molecule is encoded by four sets of DNA: variable (V_H), diversity (D), joining (J_H), and the constant (C- μ) genes.

A V_H gene encodes the first 95 or 96 amino acids of a V domain but the exact number of V_H genes is not known; it is estimated, however, to be 100 to 200. Of the available V_H genes only a portion are functional, and an even smaller portion is available for rearrangement.^{99,100} The V_H genes constitute seven families based on their homology at the DNA level and are known as V_{H1} to V_{H7} . Most V_H genes are polymorphic, but the degree of variation is usually small.¹⁰¹ The V_H segment encodes the hydrophobic leader sequence, the three framework regions, and the two complementarity-determining regions (CDR).

The name D gene, or segment, was proposed to indicate the diversity of an antibody at positions after amino acid 99 to the beginning of the J segment,¹⁰² which spans the third CDR. The D segments are located in chromosome band 14q32, with the major locus between V_H and J_H loci and several D segments interspersed within the V_H segments, sandwiched between signal sequences (see later). The CDR-3 is encoded by the 3' end of the V_H segment, the D gene segment, and the D- J_H junctional area. There are approximately 30 D segments grouped in seven families, and each one spans approximately 70 kb, with a promoter on its 5' end that allows initiation of transcription when Ig genes at the pre-B-cell stage start rearrangements. The first rearrangement produces a DJ_H complex, which together with the μ gene, encodes a protein known as $D\mu$ protein. There are six functional J_H genes and three pseudogenes, each J_H gene encoding the 3' end of CDR-3 and the fourth framework region.

V (D) J RECOMBINATION: FORMATION OF THE CODING AND SIGNAL JOINTS

Next to the V, D, and J genes are conserved sequences of seven nucleotides (heptamers), which are attached to the 3' side of the V segments, the 5' side of the J segments, and on both sides of the D segments (Fig. 12.4). The heptamer is followed by 12 or 23 nonconserved base pairs (bp) (spacers), followed by another sequence of 9 bp (nonamers), which may diverge from the consensus sequence. This noncoding sequence is known as the recombination signal sequence (RSS).

Recombination signal sequences for V(D)J joining consist of a conserved heptamer (CACAGTG) and a nonamer (ACAAAAACC) separated by a spacer of a constant length of 12 or 23 bp. The presence of three consecutive A residues in the nonamer is necessary for efficient recombination, and the nucleotides flanking the A-rich core should be other than A residues, so that the border of the A-stretch is precisely defined. This may be important when the recombinase measures the distance between the heptamer and the nonamer to satisfy the 12/23-bp spacer rule.¹⁰³

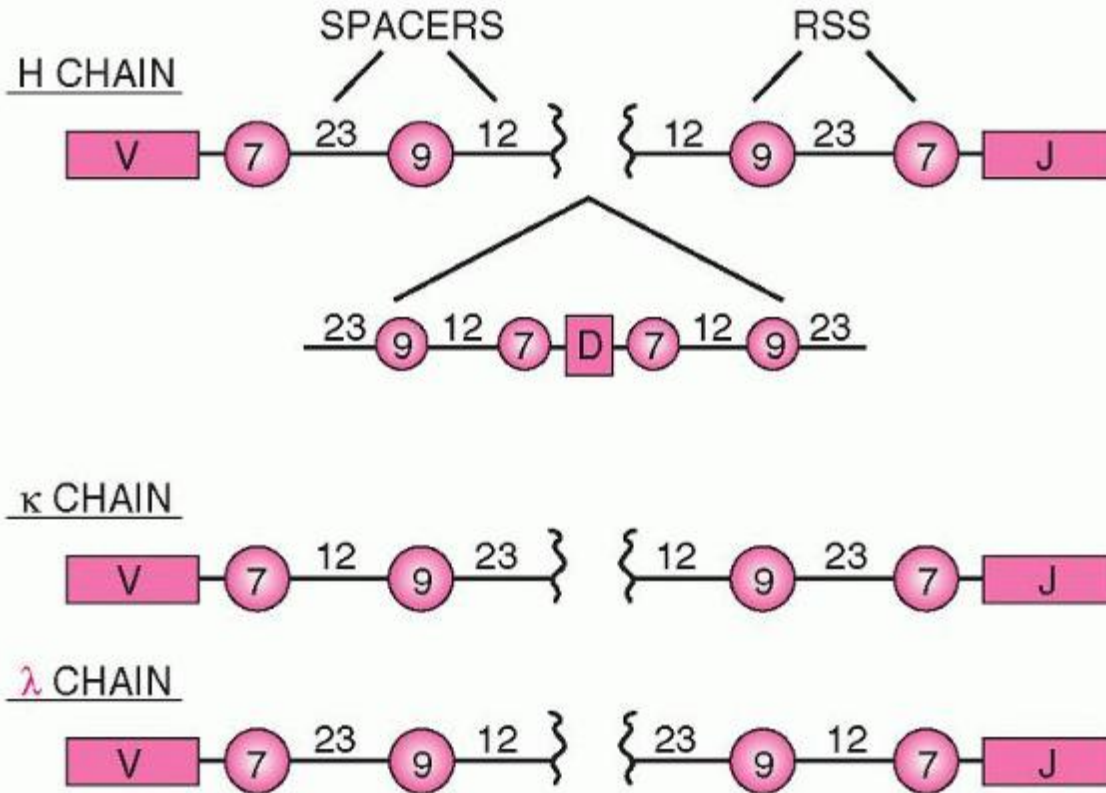

FIGURE 12.4. Recombination signal sequences (RSS) and heptamer/nonamer spacing sequences. The coding sequences of the immunoglobulin genes are flanked by a 7-nucleotide sequence (heptamer), which is followed by either 12 or 23 nucleotides, which in turn are followed by a 9-nucleotide sequence (nonamer) and again by a 23- or 12-nucleotide spacer. This order allows rearrangements only between a segment in which the 7/9 sequences are separated by a 12-mer spacer and another segment in which they are separated by a 23-mer spacer. This is known as the 12/23 rule.

The 12-bp spacer corresponds to one turn of the DNA α -helix, whereas the 23-bp spacer corresponds to two turns. This way, the recombining segments are juxtaposed on the same side of the DNA helix, so that they can be recognized by the enzymes of the recombination machinery.^{104,105} Joining of the various segments is limited between an RSS with a 12-bp spacer and one with 23 bp¹⁰⁶ (the 12/23 rule). Recombination follows strictly the 12/23 rule of spacers, which prevents inappropriate recombination, i.e., a V_H segment joining directly to a J_H segment, as both of them have a 23-bp spacer between their heptamers and nonamers.¹⁰⁶ The pattern of the RSS at each locus is uniform. For example, in the Ig locus, all V_k segments have next to their heptamers a 12-bp spacer, whereas all J_k segments have a 23-bp spacer. This prevents accidental joining of two V_k or J_k segments. The RSS sequences are the only ones that are required for recombination, whereas the coding sequences (V, D, or J) can be replaced by other DNA while the joining still occurs if the 12/23 rule is satisfied. During recombination, two new structures are formed: the joining of the coding sequences (coding joint), which is imprecise, and the joining of the RSS (signal joint), which is precise.

The V(D)J recombination (Fig. 12.5) is mediated by two enzymes known as RAG proteins,¹⁰⁷ the RAG1 and RAG2, which are not related to other proteins. Their expression normally is limited to immature B and T cells, even after the expression of surface antigen receptor, until the receptor is cross-linked. Deficiency of RAG proteins in mice^{108,109} or humans¹¹⁰ results in SCID. The RAG2 is divided into an N-terminal (core) domain and a C-terminal (non-core) domain. The core domain is necessary and sufficient for carrying out the V(D)J recombination. The C terminus of RAG2 contains a PHD finger motif, usually present in chromatin-associated proteins. The PHD (Plant Homeodomain) is encoded by many genes, including RAG2, and recognizes or “reads” the gene status of expression for histone H-3, lysine-4, and DNA damage, i.e., histone modifications, and as a result is known as a chromatin reader. The PHD finger of RAG2 modulates V(D)J recombination,¹¹¹ and mutations of RAG2 at this site result in immunodeficiencies. Tetramers of the RAG1/RAG2 proteins initiate the V(D)J recombination, which proceeds in three steps.^{112,113,114,115} The RAG1 binds to the nonamer, which acts as an anchoring platform, while the heptamer stabilizes the complex in the presence of RAG2. The recognition by RAG proteins of the RSS is assisted by sequence-nonspecific DNA-binding proteins, HMG1/2 (high-motility group), which enhance binding and

cleavage. In the RAG1/RAG2 complex, the RAG2 C terminus probably interacts directly with histones and stabilizes the RAG1/RAG2 complex.¹¹⁶ This interaction, which requires Mg^{2+} , may bring the recombinase to specific signal sequences which may be required for the postcleavage phase of the recombination. HMGB proteins bind to DNA through two DNA-binding domains known as HMG-box-A and -B.¹¹⁷ Each consists of 80 amino acids interacting with the minor groove of the DNA. Box-A bends distorted DNA structures, whereas box-B bends severely linear DNA sequences. Mutations in HMGB proteins block synaptic complex formation, or possibly recognize distorted DNA structures induced initially by RAG1/RAG2 binding. Their binding stabilizes the formation of the synaptic complex and thus promotes the DNA cleavage.¹¹⁸ The recognition by RAG proteins of the RSS is assisted by sequence-nonspecific DNA-binding proteins, HMG $\frac{1}{2}$, which enhance binding and cleavage. During the first step of V(D)J recombination, the RSSs are recognized by the recombinase and are brought in juxtaposition, forming the synaptic complex, which is composed of a dimer of RAG-2 and at least a trimer of RAG1.¹¹⁹ In the second step the recombinase nicks the phosphoester bond between the last nucleotide of the coding sequence and the first nucleotide of the RSS (Fig. 12.5, Panel 1). The precise mechanism of the hydrolysis of the phosphate ester bond is not known. The nicking reaction requires the physiologic divalent cation Mg^{2+} . The cleavage leaves blunt phosphorylated signal ends and hairpin sealed coding ends (Fig. 12.5, Panels 2 and 3), which are formed between the 3'-OH of the coding sequence (top strand) and the central phosphorus atom of the phosphate group between the coding sequence and the RSS of the opposite strand (the lower strand in Fig. 12.5). Formation of the hairpin requires significant bending of one or both DNA strands (Fig. 12.5, Panel 4). In the third step, the hairpin must be nicked open, so that the two coding ends form the coding joint. Opening of the hairpin may be done by a DNA repair complex¹²⁰ or by RAG proteins themselves.¹²¹ Because the nicking may not be exactly in the center of the hairpin, the opening creates an overhang in one strand formed by the nucleotides from the other strand (Fig. 12.5, Panels 5 and 6). These are known as P-nucleotides, which are coming from the opposite or complementary end of the hairpin or palindrome (from the Greek palindromicos, meaning successive movement forward and backward, like the piston of an engine). As a result, they have an inverse complementary relationship with the adjacent coding end. Most of the coding ends detected in normal lymphoid precursors have 3' overhangs.¹²² TdT adds nucleotides known as N-nucleotides (nongermline) to the strand with the missing nucleotides (Fig. 12.5, Panels 7 and 8). Disruption of TdT drastically lowers junctional insertions. In fetal and neonatal periods, the N insertions are low or absent as a result of the developmental regulation of TdT. The alterations in the coding joint as a result of P- and N-nucleotides are the basis for junctional diversity (Fig. 12.5, Panel 9).

The RAG proteins continue to be bound to the signal and coding ends in a four-end complex, known as a cleaved signal complex, at least while the coding ends are still processed. The RSSs are highly conserved among vertebrates, from sharks to humans. The three heptamer nucleotides closest to the recombination site are the most important, whereas mutations at other heptamer positions still allow recombination. Variations in the position of RSS may influence the use of gene segments IGK@ vs. IGL@.

The RSS joint is assumed to be lost by being converted to reactive, broken DNA, disposed of in the next cell division (deletional recombination). However, the existence of inverted segments of DNA in these loci indicates that sometimes signal joints are retained in the chromosome (inversional recombination), a mechanism that restores chromosomal integrity. The fate of the signal joint has taken an unexpected direction as a result of findings indicating that the RAG proteins perform genetic transposition

P.257

(i.e., act as transposases).^{123,124} The name given to the enzyme indicates its function, i.e., transposing or inserting pieces of DNA in a new location. The transposase MuA of the bacteriophage Mu is the best characterized in this class of enzymes, consisting of a tetramer in which two of the subunits nick the two ends of the Mu genome, while the other two catalyze the transfer of the ends into the target DNA. These reactions are important in the transmission of drug resistance among bacteria and the integration of retroviruses, such as HIV and others, into the genome. In fact the active site of MuA exhibits a striking similarity to the HIV integrase. It is interesting that the RAG1/2 act as tetramers in V(D)J recombination and resemble the HIV integrase responsible for inserting DNA copies of the viral genome into the cellular chromosomes. There are also similarities between the mechanisms of transposition and V(D)J recombination, suggesting that the RAG proteins may be members of the retroviral integrase superfamily.¹²⁵ Hairpins during V(D)J recombination are the targets of the RAG-mediated transposition. Notable differences, however, exist in the nick-cleavage mechanisms between the two.¹²⁶ Transposition of RSS in various positions, targeted to DNA, results in branched molecules.^{127,128} The high Mg^{2+} concentration prevailing in mammals, however, results in removal of transposed DNA by disintegration. No transposition in vivo has been reported as yet, probably because it is suppressed by GTP

P.258

and the C terminus of the RAG2 protein.^{129,130} Active transposition events are detrimental to the host because of the mutagenic potential of genomic rearrangements.

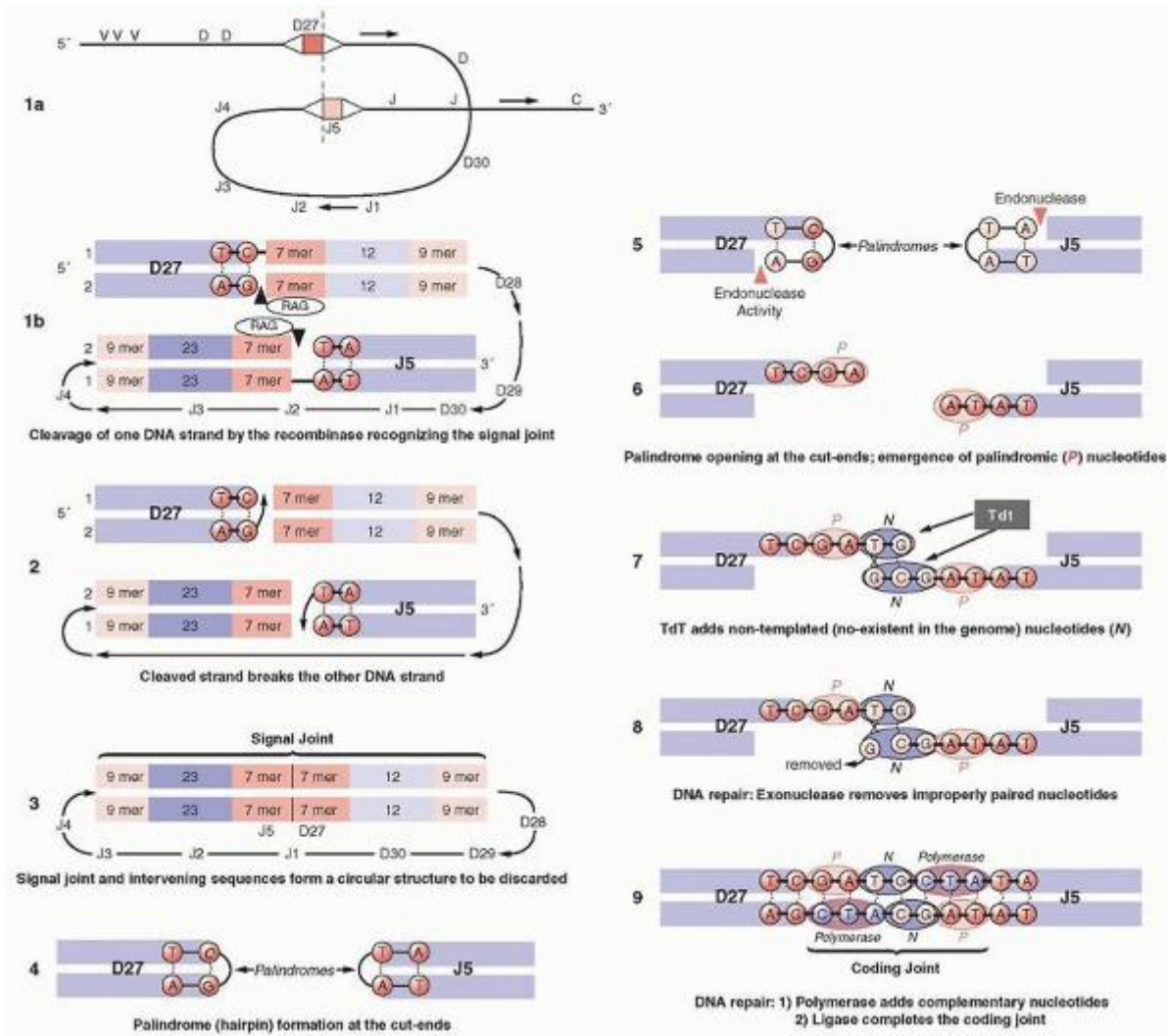

FIGURE 12.5. V(D)J recombination. Shown in this figure is the recombination of two hypothetical segments, D27 and J5. The recombination begins with recombination-activating gene-1 (RAG-1) and RAG-2 recognizing the heptamers and monomers (see text) (Panel 1). They cut out one strand at the junction between the heptamer and the coding sequence. The other strand is severed by a nucleophile attack from the cut end (Panel 2). The two blunt ends of the heptamers form the signal joint (Panel 3), while a hairpin seals the cut coding ends (Panel 4). The hairpin is nicked open either by the RAG proteins or by a ubiquitous DNA double-strand repair complex (Panels 5 and 6). The opening is usually asymmetric and creates overhangs, with the nucleotides at the end of the overhang being complementary because they derive from the complementary opposite strand. These are known as palindromic (P) nucleotides (Panels 5 and 6) (from the Greek palindromicos, meaning moving forward and backward in succession). The double DNA strand breaks of the coding joint receive nucleotides from the function of TdT (nongermline nucleotides) known as N-nucleotides (Panel 7). Improperly paired nucleotides are removed (Panel 8), and the coding joint is completed with the addition of missing nucleotides (Panel 9). The P- and N-nucleotides added to the coding joint constitute the junctional diversity.

As a result of these recent insights into the nature of V(D)J recombination and the function of RAG1/2, the question of the fate of the signal joint becomes very important. Signal joints have been found to be cleaved quite efficiently.¹²⁸ In vitro experiments showed that transposition is targeted not to a particular DNA sequence, but to structural features, such as hairpins, inverted repeats, supercoiling of DNA forming cruciform structures, and generally distorted DNA structures.^{131,132} In vitro experiments demonstrating transposition were performed with only the core part of RAG1/2; it is conceivable that other parts of the molecule exert an inhibitory effect on this potential function of RAG1/2. Although the in vitro

experimental evidence suggests that there is a bias toward transposition, there is no evidence that this occurs *in vivo*, as it severely compromises genomic stability in the lymphocytes. On the other hand, lymphoid malignancies are associated with chromosomal translocations, many of which involve the Ig or T-cell receptor (TCR) loci and potentially may be mediated by the V(D)J recombinase.¹³³

DNA REPAIR MECHANISMS

Cleavage of DNA is always potentially dangerous, and although the recombinase function is essential for the integrity and normal function of the immune system, it is, at the same time, perilous. The V(D)J recombination, as well as class switch recombination, are necessary processes, but they demand double-strand DNA breakage. As vital as these two processes are for survival, the DNA double-strand break (DSB) is a threat to survival and it does occur in viral infections and malignancies. If genetic integrity is to be maintained, the DNA breaks need to be repaired.¹³⁴ Although nature has developed a highly complex repair mechanism, it is, however, efficient. Double-strand breaks generate an alarm mechanism, based on the transduction of signals from the sensors to the transducers and eventually to the effectors for the DNA repair job. An important sensor is the MRN complex, consisting of a nuclease (Mre-11) and the chromosome protein (RAD50), which maintain chromosomal structure and protein NBN.^{135,136,137} RAD50 and NBN are recruited rapidly to DSB sites for processing broken ends. MRN transduces the early signals to a kinase, the main transducer, known as ATM (ataxia telangiectasia mutated), which rapidly phosphorylates various substrates needed in the repair pathway. ATM belongs to a family of proteins known as PI-3-K-like protein kinases (PIKK), with five members, while an additional protein is the catalytic subunit of the DNA-PK kinase. Four of the PIKKs are involved in the DNA damage response: DNA-PK, ATM, ATR, and SMG1. ATM is the first to be recruited to DSBs, where it is activated by MRN, probably as a result of changes in chromatin configuration; it then phosphorylates and activates several DNA repair and cell cycle checkpoint proteins, *i.e.*, the histone λ H2AX and NBN, required for recruiting other ATM targets.

ATM initiates a pathway that activates NF- κ B (associated with cellular survival), as well as phosphorylates BID, which plays an anti-apoptotic role.

The DNA-PK (DNA-dependent protein kinase) complex consists of a catalytic subunit (DNA-Pkcs) and a DNA-binding complex called Ku, which binds altered DNA structures such as double-strand breaks, nicks, or hairpin loops. Recombination of broken DNA strands occurs either between strands that have long stretches of homology (HR) or between DNA strand breaks, without relying on the presence of considerable homology between them. This recombination is known as nonhomologous end joining (NHEJ).¹³⁸ Mutations in this system result in the accumulation of V(D)J-specific double-strand breaks, indicating a defective repair mechanism, which causes SCID. A new gene has been added to those already known that regulate double-strand DNA break repairs. It was named ARTEMIS (now known as DCLRE1C),¹³⁹ after the Greek goddess who was the protector of small children and animals.¹⁴⁰ It belongs to the superfamily of metallo- β -lactamase enzymes and is now called DNA cross-link repair K (DCLRE1C).¹⁴¹ It is involved in the nonhomologous end joining pathway, a DNA repair process used by eukaryotic cells,^{142,143} as well as in the repair of broken DNA ends from the V(D)J recombinase activity.

The repair requires that the hairpin in the coding joint is opened by the DNA-PK-DCLRE1C protein complex.^{141,144} In such a complex, DCLRE1C acquires endonuclease activity, which it does not possess by itself.¹⁴⁴ DCLRE1C has been shown to be mutated in patients with SCID, expressing radiosensitivity.¹³⁸ Patients with hypomorphic mutations in DCLRE1C have not only immunodeficiency, but also a predisposition to lymphoma.¹⁴⁴

RAG1 AND RAG2 PROTEINS

The evolutionary origin of the RAG proteins has been controversial. Up to now it was accepted that the RAG genes originated from a horizontal gene transfer of a transposon, *i.e.*, a mobile DNA element, and therefore are related to transposases, as discussed earlier.

Recently, however, two genes in sea urchins (Echinodermata) were detected that bear structural similarities to the RAG proteins.¹⁴⁵ Echinodermata are an earlier evolutionary stage of chordates, to which vertebrates and humans belong. It is therefore possible that RAG proteins may have arisen very early in evolution and acquired their present-day function early in vertebrate evolution.

Both RAG proteins are required for V(D)J recombination, because lack of function of either one leads to SCID.^{146,147} A region that retains the recombinase activity is known as the core and has been used for studies *in vitro*. For RAG1, the core is located in the sequence 384-1,008 from a total of 1,040 amino acids, and for RAG2 in amino acids 1 to 383 of a total of 527. The core of RAG2 contains six repeats, each consisting of an antiparallel β -sheet, formed by four β -strands. The repeats are arranged in a circular formation like blades of a propeller,¹⁴⁷ a structure that is known to mediate protein-

protein interactions. The C-terminal quarter of RAG2 consists of a plant homeodomain fold, which is found in proteins with chromatin-binding properties.¹⁴⁸

Mutational analysis of the RAG proteins has provided some clues about structure-function relations. The catalytic properties of the proteins have similarities with members of the retroviral integrase superfamily¹³² and require divalent metal ions for their function—a requirement that is characteristic of some nucleases, the functions of which depend on acidic amino acids. Indeed, in RAG1, several acidic amino acids are critical for both nicking and hairpin formation, without affecting the DNA binding.¹⁴⁹ For RAG1, the N terminus is important for activity,¹⁴⁹ and the binding of RAG1 directly to DNA is supported by basic residues of RAG2.¹⁵¹ Deletion of the C-terminal region of RAG2 results in a reduction of the number of B and T cells.¹⁵² The plant homeodomain of RAG2 regulates differential access to sites of recombination, and although it is dispensable for D/J_H recombination, it is essential for the V_H/DJ_H step.¹⁵³

SOMATIC HYPERMUTATION

The primary importance of somatic hypermutation (SHM) is related to affinity maturation, i.e., the increase of the affinity of antibodies following repeated antigenic stimulations.¹⁵⁴ However, a wider scope of hypermutation is to provide a better defense

P.259

against hypermutating microorganisms. Many pathogens such as Trypanosoma, Neisseria, influenza virus, and HIV evade the immune system by variations of the antigens of their coat (antigenic variation). Accordingly, SHM is the adaptation of the B cell in response to hypermutating microorganisms.¹⁵⁵ SHM introduces mutations in the V gene at the rate of about 10³ mutations/base pair/cell division, i.e., 10⁶-fold higher than spontaneous mutations of somatic cells. At this rate genomic integrity can be maintained only if the SHM specifically targets the Ig genes. However, it has been suggested that SHM is not a mechanism specific for the Ig genes but it may occur in other genes. Perhaps the apparent preference for the Ig genes may be due to their higher density of certain hot spots,¹⁵⁶ and SHM appears to target preferentially certain hot spots, such as the short DNA motif DGYW.

HUMAN HEAVY- AND LIGHT-CHAIN GENE LOCI

The heavy and light chains of the Ig molecule are assembled from a large collection of preexisting gene segments by the lymphoid-specific RAG1 and RAG2 proteins. The RAG proteins cooperate to make double-strand breaks at specific recognition sequences (recombination signal sequences) or RSS.¹⁵⁷ The recombination takes place between one RSS with 12-bp spacer (12-signal) and one with a 23-bp spacer (23-signal) and this arrangement is called the 12/23 rule. In the presence of the metal ion Mn²⁺, a single signal sequence supports double-strand cleavage, whereas Mg-2⁺ requires two signal sequences.¹⁵⁷ The two light-chain isotypes, κ (kappa) and λ (lambda), comprise approximately 60% and 40% of all Igs, respectively, and consist of a V domain and a C domain of approximately 107 residues each in length. The V domain is encoded by the V and J segments, the former encoding the first 95 to 96 residues and the latter encoding the remaining 12 to 13. There is a single C-κ gene, and several C-λ genes. The κ locus contains approximately seventy-six V-κ segments grouped into six families, and five J-κ segments, but no d segments. The λ-locus contains 10 families of V-λ segments, a high number of pseudogenes, and several C-λ genes, each preceded by a single J-λ segment.

One of the consequences of the imprecision of the V(D)G recombination is a change in the reading frame at the junction between the two gene segments, causing the segments to join out of phase, so that the triplet reading frame for translation is not preserved. In this case the rearrangement results in V(D) J combinations with numerous stop codons which interrupt the translation. Recombination may be nonproductive or productive; when the junction lies within a codon, the resulting amino acid is encoded by nucleotides from both gene segments involved. It is estimated that only one in three recombination attempts are productive, but the imprecision in the joints between variable gene segments increases their diversity by at least 100-fold. Difference in mRNA stability allows pro-B cells to distinguish between productive and nonproductive Ig gene rearrangements.

The Ig gene rearrangements follow a certain sequence of the various loci and use only some of the available gene segments (allelic exclusion), which indicates that there are regulatory mechanisms underlying the process of rearrangement. For the IgG molecule the IGH@ gene is rearranged first and forms a complete V gene from three individual segment clusters, i.e., V, D, and J. One of the D segments joins a J_H segment forming the D-J_H complex and in the next step, which is regulated by the D_μ protein, the V segment joins the complex. A D-J_H rearrangement has also been found sometimes in T cells. The D_μ protein, which lacks a V_H segment, is encoded by the D-J_H complex and the constant gene of the μ-heavy chain and may be expressed on the membrane of the cell with an SLC. Expression of D_μ protein prevents further V_H-to-DJ_H rearrangement, or the rearrangements are diverted to another pathway such as κ-chain

rearrangements, which are accelerated. Completion of the μ -chain inhibits further rearrangements by the opposite allele (known as allelic exclusion).¹⁵⁸ Completion of the μ -chain rearrangement is followed by rearrangements of the IGH@ gene, and if both κ alleles fail to rearrange productively, the IGL@ gene is rearranged (Fig. 12.6). However, this hierarchical order of Ig gene rearrangements has been challenged, because examination of B cells at different stages of early development shows that the heavy and light-chain genes rearrange independently.¹⁵⁹ At the end of its early developmental stage, the B cell emerges with the expression on its surface of a unique antigen receptor consisting of IgM accompanied by two accessory molecules, CD79A and CD79B.¹⁶⁰

REGULATION OF V(D)J RECOMBINATION

Initiation of rearrangements by the recombinase requires that the gene must be accessible, i.e., the locus must be able to act as a template for the recombinase. In cells competent for rearrangement it was found that J_{κ} and V_H genes have already been transcribed, but these RNAs, named germline or sterile transcripts, are incapable of encoding the protein. Several possibilities may exist to explain this finding, and since inactive genes are not accessible to the recombinase, it is possible that the altered structure of the chromatin allows the recombinase to recognize the RSS. Alternately, the enhancers may establish altered chromatin regions where both the recombinase and the transcription machinery have access; this is known as the accessibility hypothesis.^{104,161} Enhancers and promoters function as accessibility control elements (ACEs), which regulate V(D)J recombination. Enhancers maintain an open chromatin state in multiple embryonic tissues independent of their activity level. Regions of nonprotein coding genomic DNA bind protein transcription factors (TFs) and thus direct the expression of target genes. The enhancer of the IgM heavy chain (E_{μ}) is located within the intron between the J_H segments and the C_{μ} gene and is associated with matrix attachment regions (MAR), which improve production of the protein by recombination.¹⁶² Transcriptional regulation by enhancers is fundamental to the evolutionary diversity of metazoans as well as their embryonic development. The regulation of a gene is an exceedingly complex process controlled by interacting proximal and distal DNA elements usually placed in a cis configuration, proximal to the basal promoter where the general transcription machinery assembles. A promoter is always located in close proximity to the 5'-end of a gene and is necessary, but not sufficient, for its transcription, while enhancers or silencers are distant elements.

Enhancers are thought to be composed of binding sites for transcription factors (TF), which upon recruitment to the enhancer loop over the promoter and activate the transcription of the target gene. There are three additional enhancers within the Ig heavy-chain locus, and one of them (DQ52) competes more efficiently in conferring accessibility to the JH region. Interaction between DQ52 and E_{μ} is likely responsible for ordered rearrangement, i.e., D to J_H followed by V_H -to- DJ_H complex.¹⁶³ The κ -light chain intronic enhancer is active only in mature B cells and plasmacytomas, and its stage restriction is dictated by a single motif that binds the transcription of nuclear factor- κ B (NF- κ B), which recognizes a 10-bp motif. The NF- κ B consists of two subunits and the DNA-binding function is mediated by the smaller one. The enhancers for the Ig transcription lie in the vicinity of the C- α gene and κ locus. The enhancer between the J_{κ} and C_{κ} genes becomes transcriptionally active in the transition from the pre-B to B-cell stage.¹⁶⁴ The matrix attachment regions are regions rich in AT

P.260

and demarcate regions of chromatin that undergo base unpairing and other regions that mediate binding of topoisomerase II. This regional division of chromatin may also be regulated from a distance by trans-acting factors, which bind to specific motifs within the enhancer or promoter. Despite the promiscuity and redundancy of regulatory sequences, transcription is still specific for tissue lineage and even stage of development. Several transcription factors and other signals lead to changes in expression levels, yet no clear model exists to explain the complexity of transcriptional regulation. The clear result is that disruption of the TCF3 and EBF1 transcription factors results in blocking of B-cell development at a stage before Ig heavy-chain gene rearrangements.

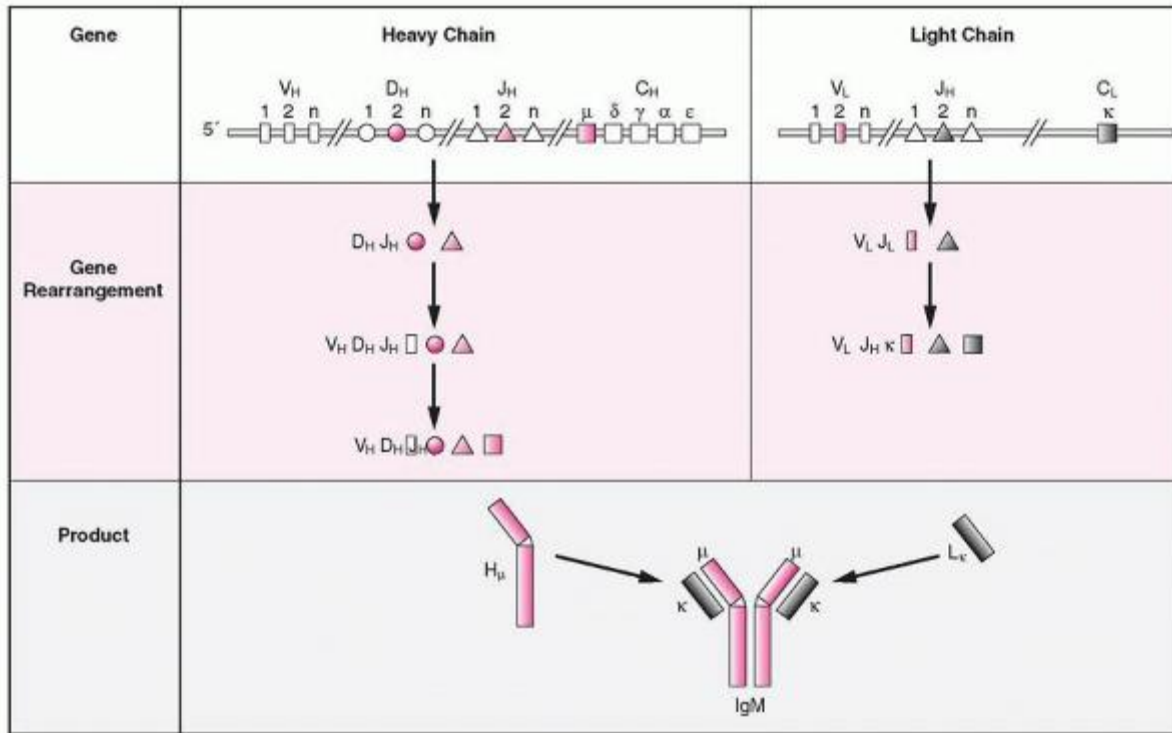

FIGURE 12.6. Heavy-chain immunoglobulin (Ig) M and kappa light-chain rearrangement. With the completion of the V(D)J recombination of the μ chain and the formation of a complete μ H chain, the LK chain rearranges, and, if successful, it forms the complete IgMK molecule. If both κ alleles rearrange unsuccessfully, the λ gene rearranges. If successful, an IgM λ molecule is formed. If both λ genes cannot rearrange successfully, the cell dies by apoptosis.

BCR V GENE REPERTOIRE

Certain aspects of the study of the Ig V gene repertoire and the Ig gene rearrangement have found wide applications in clinical medicine.¹⁶⁵ The total number of V genes defines the available repertoire. However, not all genes are equally functional, and as a result, the repertoire which is usually expressed is biased, because some of the V genes are expressed with a significantly higher frequency than would be expected if all had an equal chance for rearrangement. This biased expression affects all V, D, and J gene segments; thus the J_{H4} segment (one of the existing six), on the basis of equal opportunity among all five segments, should be detected in 17% of B cells, yet it is found in 32% of B clones from fetal liver and in 42% of pre-B-cell ALL. The bias of the expressed repertoire shows striking association with certain diseases. For example, the V_{H4-21} , a member of the V_{H4} family, is found in cold agglutinins.¹⁶⁶ Preferential expression of certain V_H segments is also detected in ALL clones. In ALL the frequency of N-nucleotide additions differs in children less than 3 years of age (12.5%) compared with children greater than 3 years old (89%).¹⁶⁷ Because in fetal B lymphocytes the frequency of N-nucleotide additions is low, it is suggested that the transforming event in the younger age group probably occurred during fetal life.

In chronic lymphocytic leukemia (CLL), the use of V genes is also restricted, and the same is true in non-Hodgkin lymphomas. It is interesting that in certain cases of follicular lymphoma, the V genes not only have undergone somatic mutations, but also continue to do so during the course of the disease, suggesting that the malignant clone is responsive to an antigen.^{168,169} Somatic mutations, as expected, have also been detected in multiple myeloma, because the malignancy derives from an advanced stage of differentiation of B cells.¹⁷⁰ This brief summary emphasizes the fact that defects in V(D)J recombination¹⁷¹ are associated with human diseases such as loss of RAG1/RAG2 function, which results in SCID. In certain autosomal recessive diseases, hypersensitivity to DNA-damaging agents results in chromosomal breaks and rearrangements, with an increased incidence for development of leukemia and other malignancies. They have been classified as DNA repair disorders and include AT, Fanconi anemia, xeroderma pigmentosum, and Bloom syndrome (see later). Genomic instability is most often linked to DNA repair deficiencies, which suggests that evaluation of deficiencies in repair mechanisms in pluripotent human stem cells should be a necessary step prior to their clinical and research use. The DNA repair pathways and repair capacities in pluripotent cells are more heterogeneous than those of differentiated cell lines. In mice the SCID mutation, an autosomal recessive mutation, results in the absence of B and T cells as a result of

impairment of the V(D)J recombination. Both lymphoid and nonlymphoid SCID cells are hypersensitive to killing by ionizing radiation because of a DNA double-strand base-repair

P.261

defect. It is rather important that a human gene on chromosome 8q11 has been identified that restores V(D)J recombination, double-strand base repairs, and normal resistance to irradiation in SCID cells.^{172,173} V(D)J recombination is necessary for immune diversity and survival, but this objective can be achieved only through DSBs which threaten genomic stability. The complexity of the recombinase function is matched by complex DNA repair machinery. Disorders related to V(D)J recombination may be considered in two categories: those related to the first step (cleavage) and those related to the second step (cleavage repair).¹⁷⁴

THE MUTATION IN SEVERE COMBINED IMMUNODEFICIENCY

Two fundamental processes operate in V(D)J recombination, i.e., double-strand breaks during the gene rearrangements, followed by DNA repair. The SCID mutation in mice¹⁷⁵ is associated with lack of mature lymphocytes and agammaglobulinemia. SCID T cells have long P-nucleotide sequences and accumulate hairpins at the TRD@ coding ends. In addition to the lack of rearrangements, there is an inability to repair damage from irradiation. In mice the SCID mutation is located on chromosome 16, and since human chromosome 8 can complement mouse SCID defects, it has been assumed that the SCID defect for humans should be in chromosome 8, although human chromosome 8 is not associated with any known immunodeficiency or DNA repair diseases. The gene, however, for the DNA polymerase- δ , is in chromosome 8p11-12. Mutated RAG genes have been detected in nine patients from seven families.¹⁷⁶ Recombination activity was undetectable with mutations in the RAG core domains, and in four patients there was a complete B-cell differentiation arrest between the pre-BI and pre-BII stages.

V(D)J RECOMBINATION: DNA CLEAVAGE

Two types of RAG1 and RAG2 gene inactivations have been identified in mice. The first type results in the inactivation of the recombinase so that V(D)J recombinations cannot be initiated,^{108,109} and as result the mice have no mature T and B lymphocytes, although there is an increase of immature lymphocytes in the lymphoid organs. The second type of mutation consists of a single conservative amino acid substitution in both proteins. It does not affect the initiation of V(D)J recombination, but severely impairs the coding and signal joint formation.^{177,178} The mutant enzymes are defective in hairpin opening in vitro and the formation of the coding joint in vivo. This evidence indicates that the RAG proteins, in addition to their cleavage function, are important for the formation of the joints; therefore, they must remain associated with the postcleavage complex to achieve opening of the hairpin.

In severe combined immune deficiency (SCID), approximately 20% of the patients lack both T and B lymphocytes, but have normal NK cell counts;¹⁷⁹ some of these patients have RAG1 or RAG2 gene mutations,¹¹⁰ while others have increased radiosensitivity of their bone marrow cells and fibroblasts (RS-SCID).¹⁸⁰ The RAG2 structure consists of two globular domains separated by a hinge of approximately 60 amino acids. The largest domain which is enzymatically active has 350 residues and includes the previously described core region of RAG2. This domain forms a β -propeller with six blades arranged in a circle from a center. The β -propellers are made of 4 to 10 β -sheet units (blades) circularly arranged around a central tunnel, and have probably evolved by duplication and fusion of a rudimentary repetitive unit. The beta-propeller fold is phylogenetically widespread and able to support a variety of functions such as catalysis, ligand binding and transport, regulation, and protein binding. Interestingly, it appears that the beta-propeller topology is also compatible with strikingly diverse sequences. Amongst this diversity there are three large groups of proteins with related sequences and very important cellular and intercellular regulatory functions. The WD-40 repeat proteins have a variety of functions, such as signal transduction, transcription regulation, cell cycle control, autophagy, and apoptosis. The YWTD proteins and the Kelch repeats interact directly with the actin-binding protein LASP1 in membrane ruffles at the tips of pseudopodia, where both proteins are necessary for pseudopodial elongation. A common characteristic among the proteins of these families is the internal repeats of 40 to 45 residues. The β -propellers are widely utilized in nature as recognition modules, and the well-conserved β -propeller fold exhibits a high degree of functional diversity, which is probably accomplished through variations in the surface properties of the proteins.¹⁸¹ The β -propeller fold shows a high degree of functional diversity, probably accomplished through variations in the surface properties of the proteins. It is present in some integrins and other proteins which are known to mediate protein-protein interactions. Six out of seven mutations so far described in RAG2 in humans are clustered on one side of the propeller. This side is involved in interactions between RAG1 and RAG2 which are critical for functional activity. Two of these mutants (C41W and M285R) reduce the interaction

between RAG1 and RAG2 in vitro but no DNA-binding activity of the complex was detected.¹⁸² This is consistent with the hypothesis that RAG2 stabilizes the RAG1/RAG2 complex.¹⁸³

OMENN SYNDROME

Omenn syndrome (OS) is an inherited disorder characterized by absence of circulating B cells, infiltration of the skin and intestine with activated oligoclonal T lymphocytes (HLA-D⁺), eosinophilia, and elevated serum IgE.¹⁸⁴

The immunologic hallmark of OS is the expansion and activation of an oligoclonal population of autoreactive T cells. These cells should be controlled rapidly by immunosuppressive agents.¹⁸⁵ The patient has diffuse erythroderma, lymphadenopathy, hepatosplenomegaly, protracted diarrhea, and failure to thrive. The T cells are activated, secrete Th-2 types of cytokines,¹⁸⁶ and express oligoclonal expansion of TRB@ chains with VDJ junction similarities, suggesting a common antigenic specificity with possible autoimmune proliferation and a critical defect in the development of lymphocytes.¹⁸⁷ The hallmarks of OS are expansion and activation of an oligoclonal population of autoreactive T cells, skin erythroderma, and elevated IgE in the absence of circulating B cells.¹⁸⁸ The syndrome expresses clinical symptoms and signs which define an inflammatory condition associated with various genetic defects.¹⁸⁸ The patients have activated oligoclonal T cells, and it appears that genes other than those directly involved in V(D)J recombination may play a role in the pathogenesis of OS. Omenn-like features are associated with mutations of genes involved in the maturation steps of lymphoid cells and not those directly regulating V(D)J recombination.¹⁸⁸

OS is characterized by a cellular infiltrate of the skin, gut, liver, and spleen and a resemblance to graft-versus-host-like disease. The V(D)J recombination process is impaired but not abolished and leads to the generation of a few T cells which expand in the periphery and infiltrate target organs such as skin and gut, resulting in severe erythroderma and colitis, supporting the evidence that Omenn is an inflammatory condition.

Inherited mutations in RAG1 and RAG2 genes have been reported^{189,190} in a series of 20 patients with OS, and were shown to result in partial V(D)J recombinase activity.¹⁹¹ Because similar mutations have been detected in patients with T/B SCID, it has been suggested that an additional factor exists in OS to account for the different clinical picture, such as an autoantigen or an external antigen that drives T-cell activation. In a 5-week-old girl with

P.262

Omenn-like SCID, the RAG1 gene had a mutation with deletion of nucleotide (631 del-T),¹⁹⁰ and as a result the N-terminal region of RAG1 protein was deleted by a premature stop codon. The patient had a high number of T cells with almost a polyclonal TCR gene rearrangement, but there were no B cells and hardly detectable Ig gene rearrangements. The truncated RAG1 protein apparently could still support TCR, but not Ig gene rearrangements. This suggests that the N terminus of RAG1 is specifically involved in Ig V(D)J rearrangements. Another case of OS was reported with a mutation in the DCLRE1C (ARTEMIS) gene,¹⁹² a mutated maternal allele, and as a result the DCLRE1C protein was not functional as endonuclease, lacking the hairpin opening activity in a V(D)J recombination assay. In a cohort of nine patients with OS, only two of the nine had RAG mutations,¹⁹³ but the cause of OS in seven other patients remains unknown.

All patients, however, expressed restricted TCR-V and B cell repertoire, which might have occurred in response to infections. Missense mutations in RAG1 (p.Arg474Cys and p.Leu506Phe) result in reduced RAG activity with idiopathic CD4⁺ T lymphocytopenia (ICL) and reduction of T and B cells, but no evidence of autoimmunity or infections. It is therefore likely that RAG mutations are associated with conditions such as severe immune defects or even an almost normal condition.

V(D)J RECOMBINATION: DNA REPAIR

A double-strand break (DSB) is one of the most significant of DNA lesions which threatens cell integrity, but the cells have developed an exquisite repair machinery to maintain genomic stability. Immune diversity, which is a function vital for the survival of an organism, has to cross the dangerous path of DSBs.¹⁹⁴ The body uses the nonhomologous machinery to repair the damage caused by the recombinase,¹⁹⁵ and the major mechanism for repair in mammalian cells is nonhomologous end joining. Five proteins operate in nonhomologous end joining; three of them form the DNA-PK complex (KU70/XRCC6, KU80/XRCC5, PRKDC), the XRCC4, and the DNA ligase IV.¹⁹⁶ The Ku protein is an autoantigen that induces autoantibodies in patients with scleroderma, polymyositis, or systemic lupus erythematosus. Two proteins, the XRCC6 (KU70) and XRCC5 (KU80), form a stable heterodimer, which binds DNA ends regardless of sequence composition. The heterodimer forms a complex with a third component, the DNA-PK complex, which phosphorylates many DNA-binding proteins, including transcription factors c-Jun and p53. However, the most efficiently phosphorylated substrates are those close to DSBs, including the Ku components of the DNA-PK complex, which appears to regulate the

nonhomologous end joining process which is the main function of the DNA-PK complex. Mice that are defective in Ku proteins have SCID,^{197,198} and in general the defects in the DSB repair machinery are associated with immune deficiencies.¹⁹⁹

ATAXIA TELANGIECTASIA

AT is an autosomal recessive disorder characterized by immunodeficiency, progressive cerebellar ataxia, oculocutaneous telangiectasias, clinical radiosensitivity, chromosomal instability, and elevated risk for development of lymphoid malignancies. AT is due to deficiency of a protein kinase that mediates repair to double-strand breaks generated during metabolic processes or from DNA-damaging agents.¹³⁷ One of the hallmarks of AT is the generation of aberrant rearrangements during V(D)J recombination, such as translocations, large chromosomal deletions, and inversions. A protein kinase known as ATM mediates repairs of DSB by phosphorylating and activating several repair proteins.^{135,137}

Immunodeficiency affects both T and B cells and there is a decrease of serum IgA. The AT cells display γ -irradiation sensitivity, a cell cycle checkpoint control (i.e., inability to arrest at the G₁-S and S-phase checkpoints), and a G₂-M arrest. AT cells have also a DNA repair defect,²⁰⁰ i.e., they can rejoin DNA at the DSB efficiently. The defect is localized on a protein member of the PI-3K family of kinases with serine-threonine protein kinase activity,²⁰¹ which phosphorylates a number of proteins involved in the mechanisms of damage repair (i.e., p53 and CHK).^{202,203}

NIJMEGEN BREAKAGE SYNDROME

Nijmegen breakage syndrome is a rare autosomal disorder with clinical features overlapping with those of AT. The patients have defective humoral and cellular immunity, radiosensitivity, chromosomal instability, and predisposition to cancer.²⁰³

The patients have recurrent bacterial sinopulmonary infections, hypogammaglobulinemia, and impaired antibody responses to antigens. The cells from the patients have defects at some checkpoints of the cell cycle.²⁰⁴ The defective protein is NBN (nibrin or NBS1), which shows homology with the protein Xrs-2, involved in DNA repair response in yeast.

BLOOM SYNDROME

Bloom syndrome (BS) is a rare autosomal recessive disorder with immunodeficiency, genomic instability, and predisposition to cancer. It presents with a variable clinical picture including respiratory infections, chronic lung disease, and low IgM levels. Affected individuals show sun sensitivity on the face and infertility.²⁰⁵ BS is caused by mutations in the BLM gene, located in chromosome 15 at 15q26.1, which encodes the BLM protein,²⁰⁶ a member of the helicase subfamily. It displays ATP- and Mg²⁺-dependent 3'-5'-DNA helicase activity. It is a member of the BASC (BRCA-1-associated genome surveillance complex) family, which includes ATM and NBN, which are defective in Nijmegen syndrome.

DEFECTS OF LIGASES

There are multiple DNA ligases in higher organisms and a point mutational change in DNA ligase-1, which does not abolish the activity of the enzyme. It was found in an individual who experienced recurrent sinopulmonary infections leading to bronchiectasis.²⁰⁷ The patients display pancytopenia and microcephaly and the V(D)J recombination shows mildly impaired fidelity, which may result in oncogenesis.¹⁷⁴ In bacterial and viral infections a severe form has been reported with a SCID presentation, evolving into an Epstein-Barr virus (EBV)-induced lymphoma.²⁰⁷

XERODERMA PIGMENTOSUM

Xeroderma pigmentosum is a rare disorder associated with sun sensitivity, high risk of cutaneous malignancy in sun-exposed areas, and immunodeficiency in some patients.²⁰⁸ Some aspects of immunosuppression associated with xeroderma pigmentosum are due to defects in the DNA repair machinery. The patients have impaired NK cell cytotoxicity.

GENETIC DEFECTS OF B-CELL DEVELOPMENT

Signaling during B-Cell Development

After the V_H-to-DJ_H rearrangement of the IGH@ gene, the cytoplasmic μ -chain pairs with the SLC and traffics to the cell surface in association with the signal-transducing chains CD79A and

P.263

CD79B to form the pre-B-cell complex. Signaling for the transition from pre-B cells to Ig⁺ B cells requires the immunoreceptor tyrosine-based activation motif (ITAM) of the cytoplasmic domains of the CD79A and CD79B chains, because inactivation of ITAMs by mutation blocks the transition to the Ig⁺ B-cell stage.²⁰⁹ Deficiency of CD79B chain by

gene targeting abolishes formation of the CD79A-CD79B dimer and blocks assembly of the SLC. As a result, the differentiation of B cells is arrested at the pro-B-cell stage.²¹⁰

Interactions of pro-B and pre-B cells with stromal elements are necessary for progression through the early stages of B-cell development, but a ligand for the pre-BCR has not yet been identified and it is conceivable that the receptor may be signaling constitutively. It is apparent that the presence of ITAM motifs and the concentration of signaling molecules around them are the critical factors in determining progression through the early stages of B-cell development. Pro-B cells are able to become pre-B cells in the absence of the μ -H chain as long as the CD79A/CD79B chains are aggregated and thus can recruit sufficient numbers of signaling molecules around their ITAMs.²¹¹ Furthermore, signaling by other molecules unrelated to pre-BCR, such as EBV latent protein-2A (LMP-2A), can drive pro-B- to pre-B-cell transition. LMP-2A protein with ITAM motifs in its cytoplasmic region, spanning the membrane twelve times, possesses constitutively its own signaling activity in nontransformed cells.²¹² Phosphorylation of these motifs recruits SYK and SRC kinases and thus bypasses the normal checkpoints of B-cell development. Of all the signaling molecules assembled around the cytoplasmic tail of the pre-BCR complex, the CD79A and CD79B chains' ITAMs act as docking sites for SYK kinase and trigger its activation, which is important for the transition from pro-B- to pre-B cell.²¹³ An important signaling function is provided by the adaptor protein BLNK, which acts as a scaffolding to link BTK (and other molecules) to downstream signaling molecules. In *Blnk*^{-/-} mice the transition from the pro-B- to the pre-B-cell stage is blocked,²¹⁴ and a similar defect has been detected in a patient with deficiency of BLNK, which blocks B-cell development.²¹⁵ SYK kinase deficiency is more effective than BLNK deficiency in arresting B-cell development.

Signaling Defects

Failure of B-cell development may result from defects in signaling through the pre-BCR. These experiments of nature have helped in delineating the molecular mechanisms of early B-cell development.⁸⁰ Immune deficiencies resulting from arrest of B-cell development are usually associated clinically with recurrent bacterial infections, laboratory findings of markedly reduced numbers of B cells, and hypogammaglobulinemia. Of all the patients, 85% have mutations in BTK, whereas the remaining 15% constitute a heterogeneous group with defects of various signaling molecules.

Defects of λ -5 Genes

The SLC is formed from two components: the BPREF1 and the lambda 5 (λ 5). In humans there is one VPREF1 gene and three immunoglobulin lambda-like (lambda 5) genes (IGLL1, IGLL3P and IGLL2P).²¹⁶ A boy with mutations in both alleles of the λ -5 genes expressed recurrent infections, hypogammaglobulinemia, and lack of B cells at an early age. The patient had three base-pair changes in a single allele and alterations within exon-3. Changes in codons 131 and 140 were silent, whereas that in codon 142 resulted in the replacement of proline, which in this place is highly conserved, by leucine (P142L).⁸⁵ The boy at 9 years of age had 0.1% CD19⁺ cells in the blood, but these cells were of the mature phenotype. In contrast to this patient, mice that are deficient in λ -5 have a leaky block at the pro-B-cell stage and still maintain 10 to 20% of the B cells.

Defects of CD79A

While screening several patients with defects of B-cell development, one 2-year-old girl was identified with an A-to-G substitution in the splice-acceptor site preceding exon 3 of Ig α ,²¹⁷ resulting in CD79A transcripts that were aberrant, because most of them had no exon 3. The patient showed failure to thrive, had diarrhea in the first month of life, and, later, had bronchitis and neutropenia. She had severe hypogammaglobulinemia and absent B cells. The block of B-cell development was at the pro-B-cell stage.

Defects of the μ Heavy Chain

Defects in μ H have been associated with agammaglobulinemia in individuals from two families. The defects consist of a large deletion of a 75- to 100-kb segment, including D, JH, and μ genes, or a base-pair substitution in the alternative splice site, with inhibition of the synthesis of the membrane form of Ig.²¹⁸ Mutations of the μ -H chain with agammaglobulinemia should be distinguished from X-linked agammaglobulinemia, because the disease from μ -H mutations can occur in females. Another report described a female patient with a cytosine insertion at the beginning of the CH-1 exon of the μ gene, which resulted in premature codon and absence of the μ -H chain.²¹⁹

Defects of B-cell Linker Protein

The gene for human BLNK is located on the long arm of chromosome 10 at 10q23.22. The BLNK is an adapter protein which, after phosphorylation by SYK, recruits several signaling molecules (i.e., PLCG2, VAV1, CBL, and BTK). A 20-year-old man with absent B cells and hypogammaglobulinemia was found to have two base-pair alterations: One of them did not change the amino acid (proline), but the second which was an A-to-T substitution, affected the position of the splice-

donor site for intron-1, approximately 20 bp downstream from the first alteration. The second defect resulted in a marked decrease of the BLNK transcripts and BLNK protein.²¹⁵ The patient had recurrent infections, undetectable serum Ig, and at the age of 20 years less than 0.01% of CD19⁺ cells in the blood. Mice with Blnk deficiency have only a leaky block of B-cell differentiation at the pro-B-cell stage; and in humans, mutations of λ -5 or BLNK cause a profound block of B-cell differentiation.

BRUTON AGAMMAGLOBULINEMIA

In 1952 Bruton described a male child with hypogammaglobulinemia and early onset of bacterial infections,²²⁰ later found to be inherited in an X-linked pattern that became known as X-linked agammaglobulinemia.²²¹ The constellation of findings consisted of very low serum Ig levels (i.e., for IgG approximately 10% of the normal control), no antibody production after immunization, markedly decreased B cells (0.3% of normal levels), and no germinal centers.²²² The genetic defect was located in the midportion of the long arm of the X chromosome (i.e., Xq22).²²³ There are several variants of the disease in relation to immunologic function and clinical heterogeneity.²²⁴ The product of this gene was identified as an SRC protein tyrosine kinase (PTK) that was called Bruton tyrosine kinase or BTK,^{225,226} and more than 400 mutations have been characterized to date.²²⁷ BTK is essential to BCR signaling and the BTK protein and the mRNA are significantly overexpressed in CLL compared with normal B cells. Although BTK is not always constitutively active in CLL cells, BCR or CD40 signaling is accompanied by effective activation of this pathway.

BTK is a member of the BTK-Tec family of PTKs, which includes BTK, TEC, ITK, TXK, and BMX.²²⁸ In the C-terminal end the BTK contains the catalytic SH-2 domain, and next to it lies the SH-3 domain, which associates with phosphorylated tyrosines

P.264

in other signaling molecules. The SH-2 is followed by one SH-3 domain, which binds proline-rich sequences in protein-protein interactions, and next is a T-ec homology (T-H) domain, which contains the Zn²⁺-binding BTK motif and a proline-rich stretch. At the N terminus is the pleckstrin homology (PH) domain, which binds with high-affinity phosphatidylinositol-3,4,5-triphosphate (PIP₃) and is responsible for the translocation of BTK to the membrane. BTK occupies a central position in BCR signaling and regulation of lineage development and is linked to multiple downstream signaling pathways through BLNK (also known as SH2 domain-containing leukocyte protein [SLP-65]). BLNK functions as a scaffolding protein and binds to the SH2 domain of BTK.²²⁹ It connects Syk to BTK and links BTK to downstream signaling molecules, like PLCG2, a linkage essential for Ca²⁺ signals.²³⁰ BTK also associates with Wiskott-Aldrich syndrome protein via the SH₃ domain; this is the reason that in XLA patients with defective BTK, the collagen-induced tyrosine phosphorylation of Wiskott-Aldrich syndrome protein in platelets is reduced.²³¹ Different regions of BTK are critical for its activation and signal transduction, that is, the PH domain binds to Ca²⁺-dependent (α , β -I, β -II) and Ca²⁺-independent isoforms of protein kinase C (PKC) (ϵ and ζ), to I-P₃,²³² and to heterotrimeric G proteins.²³³ Sequential phosphorylations of regulatory tyrosines by the BCR-associated Src kinases activate BTK, such as the phosphorylation of Tyr551 in the kinase domain or Tyr 223 in the SH-3 domain.^{234,235}

In SRC kinases, negative regulation is mediated by the Tyr-527 in their C-terminal region, but BTK has no equivalent residue, and it is likely that such a function is mediated by the recently identified inhibitor of BTK (I-BTK). I-BTK binds to the PH domain and downregulates Btk function, such as Ca²⁺ mobilization and NF- κ B activation.²³⁶

BTK is a bidirectional regulator with the capacity to deliver survival or apoptotic signals, depending on the expression of surface receptors and the stage of the cell differentiation.^{237,238} The molecular mechanism of BTK function in XLA is still not quite clear. Mutations of BTK gene, i.e., deletions, insertions, or substitutions,²³⁹ produce variable degrees of immunodeficiency, whether in the kinase domain²²⁶ or in other domains.

Evidence from the bone marrow of XLA patients shows that there is an expansion of pro-B cells, whereas the numbers of more mature B cells are negligible.²⁴⁰ Based on the expression of VPBEB1, the pre-BI cells are SLC-positive, and a number of them are large in size and cycling, whereas the pre-BII cells are SLC-negative. It appears that BTK blocks normal B-cell maturation at a point just before that stage (i.e., it interferes with the transition of pro-B cells to pre-BI stage).²⁴⁰ Some patients express an inactive form of BTK and have a more severe form of XLA than those expressing no BTK molecule.²⁴¹

EARLY STAGES OF B-CELL DEVELOPMENT

The study of phenotypes of B-cell precursors in normal adult bone marrow is hampered by the relative paucity of these cells. Therefore, some investigators have resorted to the study of leukemias, under the assumption that they accurately reflect normal B-cell development. Because aberrant phenotypes in acute leukemias have been identified, suggesting

asynchronous antigen expression, the validity of the results from such an approach has been challenged.^{1,242} Studies which used normal adult bone marrow²⁴³ or fetal bone marrow and fetal liver^{244,245} as a source of B-cell precursors in cultures or after injection in SCID mice have shown that B lymphocytes derive from cells expressing high levels of CD34.^{246,247}

The development of B cells can be separated into three stages according to phenotype: (a) pre-B cells (which includes pro-B cells and pre-B cells), (b) immature B cells, and (c) mature B cells (Fig. 12.1). Markers defining the first stage are CD19; occasionally some other promiscuous markers, such as CD2 or CD7, are detected, but probably the best marker is the SLC, a hallmark of a B cell, which may be detected by a monoclonal antibody. Entrance into the immature B-cell stage is defined by the expression on the surface of the cell of IgM, with antisera not only for μ chains but also for κ or λ light chains. This indicates that the μ chain is associated with a light chain and not with the SLC, and therefore the Ig gene rearrangements are complete. The immature B-cell stage is characterized by expression of only IgM without IgD. Functionally, this is important because the former phenotype defines a cell that is vulnerable to tolerogenic stimuli, indicative of its immaturity. At this stage the cell expresses other markers, such as CD10 at high density. The mature B-cell stage is simply identified by coexpression of IgD as well as other markers such as CD20, CD21, and CD22.

Another useful phenotypic marker for precursors of B cells is the nuclear enzyme TdT,²⁴⁸ which is a DNA polymerase catalyzing the elongation of polynucleotide chains without template,²⁴⁹ and which adds N-nucleotides at the DNA cleavage site during V(D)J recombination. CD24 is also expressed at a very early stage and at a higher density compared to mature slgM^+ B lymphocyte.²⁵⁰ The expression of the CD2 has been detected on biphenotypic ALL cells and also on their normal counterparts in human fetal hematopoietic tissues,^{251,252} but whether they represent common T- and B-lineage progenitors remains to be seen. Pre-B cells have been detected during fetal life, first in the liver (by 8 weeks) and later in the bone marrow (by 12 weeks).^{253,254} In the liver they are mixed among other myeloid cells next to liver parenchyma in extrasinusoidal areas.²⁵⁵ The small pre-B cell, the immediate precursor of the immature B cells, starts to express slgM by the end of the first trimester, and in adults the pre-B cells are present in the bone marrow, where they constitute 0% to 7% of the nucleated cells but rarely are noted in the peripheral lymphoid organs.

During the last phase of pre-B cell development, expression of CD34 and TdT disappears, CD10 is downregulated, and the cell expresses first CD22 and later CD20. Before its appearance on the cell surface, the CD22 is detected in the cytoplasm very early during development. It is identical to the surface CD22 and is B-lineage-restricted.²⁵⁶ The receptors for Fc are not present on pre-B cells, but receptors for C3b have been detected in some large pre-B cells and in approximately 40% of the small pre-B cells.²⁵⁷

MATURE B LYMPHOCYTES

The expression of slgM is the hallmark of B lymphocytes, which early in life are mostly CD5^+ and settle in the primary lymphoid follicles. By 13 weeks most of the B cells are IgM^+IgD^+ , but later IgG or IgA are added. This phenotype of fetal B cells persists until birth and is converted to the adult phenotype during the first few months of life. By 10 weeks of age practically all B cells in the spleen are IgM^+IgD^+ , whereas in the bone marrow only 30% to 40% coexpress the two isotypes. Maturation of B lymphocytes is associated with a change in the density of the two isotypes from $\text{IgM}^{\text{high}}\text{IgD}^+$ eventually to $\text{IgM}^{\text{low}}\text{IgD}^{\text{high}}$. New markers appear on B lymphocytes with the expression of IgM (Fig. 12.1), such as the CD21 which is present in more than 90% of the cells, as well as the C3d/EBV receptor. Activation triggers loss of CD21 and CD22, while CD23 is expressed and is upregulated by IL4.²⁵⁸ The EBV nuclear antigen-2 (EBNA-2)²⁵⁹ is downregulated by interferon- γ . Expression of CD24 decreases with B-cell maturation and in combination with the expression of CD45, it can be used to identify the mature stage of B cells, and it is useful in B-cell neoplasias.²⁶⁰ CD45 expression varies with B-cell maturation and is low in the most immature precursors in the bone marrow. It is upregulated as normal B-cell differentiation progresses and then declines at the terminal stages of differentiation as plasma cells become negative for CD45.²⁶¹

P.265

Probably the most important application of the B cell phenotype is in B-cell malignancies such as leukemias and lymphomas, which arise in distinct stages of differentiation. An attempt to incorporate the immunophenotype into the traditional morphologic features resulted in the revised classification of well-defined disease entities²⁶² by the World Health Organization.²⁶³

SURFACE IMMUNOGLOBULIN

Surface Ig on the surface of B lymphocytes serves as the receptor for antigen and is identified most commonly with the use of fluorochrome-conjugated anti-Ig antisera. The first Ig to appear on B lymphocytes is IgM, which is composed of only

one subunit, in contrast to the secreted pentameric form of membrane IgM (mIgM), containing two H and two L chains. The second isotype to appear is IgD, which is present either as a complete four-chain molecule or as a half-molecule. IgD is present in the serum in very low concentrations and it is not known to have a role in humoral responses, by tuning finely the BCR for its binding with the antigen.²⁶⁴ The ratio of secreted Ig to mIg increases with maturation from resting B cells to plasma cells. The transmembrane and secreted forms are encoded by the same gene. There are two polyadenylation sites for transcription termination; one is 3' to the last exon of the constant chain and the second is 3' to the second transmembrane exon (Fig. 12.7). Termination at the first site results in loss of the transmembrane exons and production of the secreted form, whereas polyadenylation at the second site produces the membrane form of Ig.

Each B lymphocyte contains on the average 50,000 to 100,000 molecules of Ig, although the density of sIg varies among individual B cells.²⁶⁵ The mIg is distributed on the surface in small clusters, including the microvilli^{266,267}; in human B lymphocytes the clusters are separated from each other by a few thousand angstroms of bare membrane, indicating restriction in the free distribution of mIg. In the mouse the clusters are interconnected by strands composed of a few molecules forming a lacy continuous network. When examined at 4°C in the fluorescent microscope with fluorescein-conjugated anti-Ig antibodies, the mIg appears distributed as a ring, and the increase in temperature to 37°C prompts the formation of clusters (patching) that move rapidly toward one pole of the cell, forming a cap²⁶⁸ (Figs. 12.8 and 12.9). Shortly after the formation of the cap, changes in cell shape occur accompanied by cell movement. The cell pushes out a projection located opposite to the cap, which corresponds to the membrane ruffles noted on scanning electron microscopic analysis²⁶⁹ (Fig. 12.10).

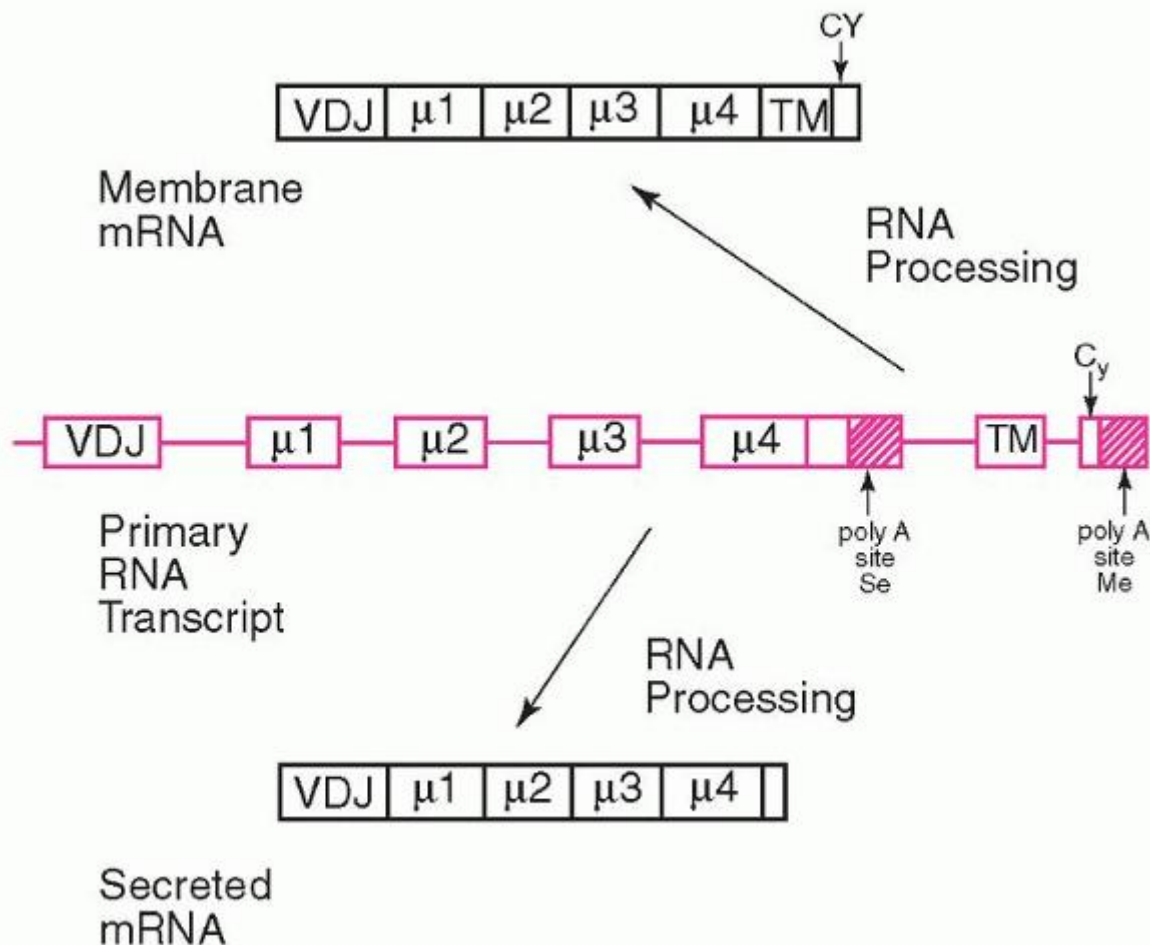

FIGURE 12.7. Expression of membrane versus secreted immunoglobulin (Ig) depends on alternative processing of the primary RNA transcript. There are two polyadenylation (poly A) sites, one for secreted (Se) and one for membrane (Me) forms. $C\mu 1$ - $C\mu 4$ are the exons of IgM. Cy, cytoplasmic region; mRNA, messenger RNA; TM, transmembrane region.

After the formation of the cap, a constriction under the cap encircles the cell and the cell takes the shape of a hand mirror, with the cap occupying the area of the uropod with numerous microvilli. A dense band of microfilaments is collected

under the constriction which separates the cell body from the uropod, and the area opposite the cap contains the cell organelles and the nucleus.²⁷⁰

The majority of human B lymphocytes cannot form a cap because the Ig clusters on the surface of the cell are widely separated from each other. Capping requires energy provided by the respiratory chain and glycolysis and is not affected by cell motility, which is complete in many B cells before any amoeboid movement is noticed.²⁷⁰

Colchicine, which disrupts microtubules, has no effect on capping and only a slight effect is noted with cytochalasin B, which disrupts the microfilaments; but the combination of these drugs inhibits mIg capping. Calcium, which plays an important role in contractile systems, is also involved in mIg capping.^{270,271} The fate of the complexes in the cap has been studied morphologically using autoradiography, electron microscopy, and measurements of radioactivity. The bulk of the complexes is internalized (endocytosed) in the presence of adequate antibody. Endocytosed material is catabolized within the lysosomes, and small fragments are released into the culture medium. With the completion of endocytosis, the B lymphocyte remains free of mIg until it is resynthesized to the original level in 24 hours.

BCR COMPLEX: STRUCTURE AND SIGNALING

The surface Ig (sIg) of the B lymphocyte, or BCR, forms a complex with several components assembled into two structurally and functionally distinct modules: an antigen-recognition module (sIg) and a signal-transducer module which is the heterodimer of the CD79A/CD79B polypeptide chains (Fig. 12.11).^{272,273,274}

The BCR is an antigen-specific receptor which transmits signals regulating activation, growth, and differentiation. Since the cytoplasmic tails of both heavy chains of mIgM consist of three amino acids, the mIgM is not suitable for signal transduction; as a result this function is undertaken by two other proteins, associated with the mIgM BCR: CD79A with a 61-residue cytoplasmic tail and the CD79B with a 48-residue tail. The cytoplasmic domain of the CD79A and CD79B proteins initiate their internalization by a signal from the first cytoplasmic tyrosine residue, Y-176 of the CD79A and Y-195 of CD79B. The genes encoding these proteins are also known as mb-1 and B-29, respectively. The transmembrane region of C μ is a highly conserved portion of the Ig molecule between species and isotypes and provides the site which binds the CD79A/CD79B heterodimer. The conserved amino acids are not all hydrophobic, but contain several hydrophilic residues; and its amphipathic nature indicates that mIg forms complexes with other proteins. These proteins carry in their cytoplasmic tails a sequence motif of six conserved and precisely distributed amino acids (tyrosines and negatively charged amino acids) over a sequence of 26 residues.

The motif named immunoreceptor tyrosine-based activation motif, or ITAM,²⁷⁵ is found in γ , δ , ϵ , ζ , and ϵ chains of CD3 and Fc receptors. The ITAMs are sequences in multiple receptor chains, and in TCR they mediate signal transduction following phosphorylation of the two tyrosines in the ITAM, which activates the SRC family kinase Lyn, but not SYK. In mice the B-lymphocyte accessory molecule Cd79a (I- α), which is encoded by the B cell-specific gene Cd79a (mb-1), Cd79b (Ig- β) and the

P.266

P.267

membrane-bound immunoglobulin (mIg) form the B-cell receptor (BCR). Cd79a and Cd79b form a heterodimer which, upon antigen binding and receptor clustering, initiates and controls BCR intracellular signaling, ultimately triggering an effector response. The signaling capacity of Cd79a is contained within its immunoreceptor tyrosine-based activation motif (ITAM), which is also a key component for intracellular signaling initiation in other immune cell-specific receptors and is required in Syk-dependent integrin signaling. Following the binding of the ligand by the BCR, the ITAMs transmit activation signals initiating proliferation and differentiation of the B cell. However, the ITAMs also transmit what have been called tonic signals, which have a role in B cell development and survival;²⁷⁶ but the molecular mechanism for their induction is not known. The CD79A and CD79B genes are active only in the B lineage and are expressed before the assembly of the V gene. In cells from multiple myeloma, however, only the CD79B is expressed and that prevents expression of Ig in plasma cells. The expression of surface Ig requires the complete assembly of the Ig with the CD79A/CD79B heterodimers, which explains the lack of detection of mIg on plasma cells;²⁷⁷ and indeed, the transfection of plasma cells with the CD79A gene results in expression of sIg.²⁷⁸ A patch of polar amino acids within the transmembrane region of C μ signals the retention of IgM within the ER until the CD79A/CD79B heterodimer associates with IgM for transportation to the cell surface.

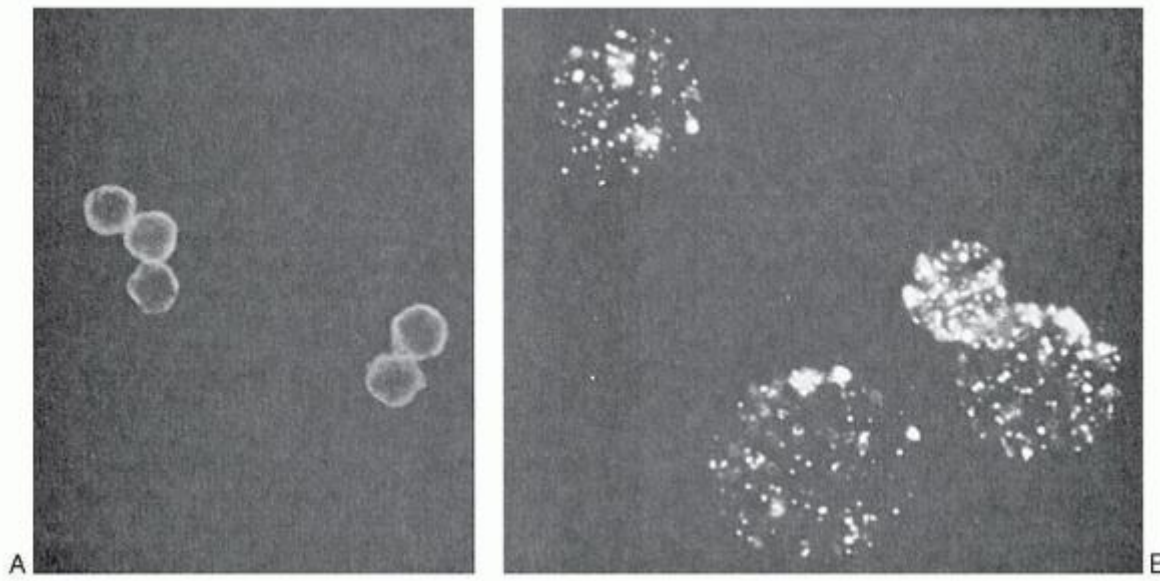

FIGURE 12.8. Demonstration of surface immunoglobulin (Ig) by immunofluorescence on B lymphocytes. Viable normal B lymphocytes treated with anti-IgM antiserum at 4°C present a staining pattern of a uniform ring around the periphery of the cell (A) or discrete patches uniformly dispersed over the cell surface (B). (From Zucker-Franklin D, Greaves MF, Grossi CF. Atlas of blood cells, 2nd ed. Philadelphia, PA: Lea & Febiger, 1988, with permission.)

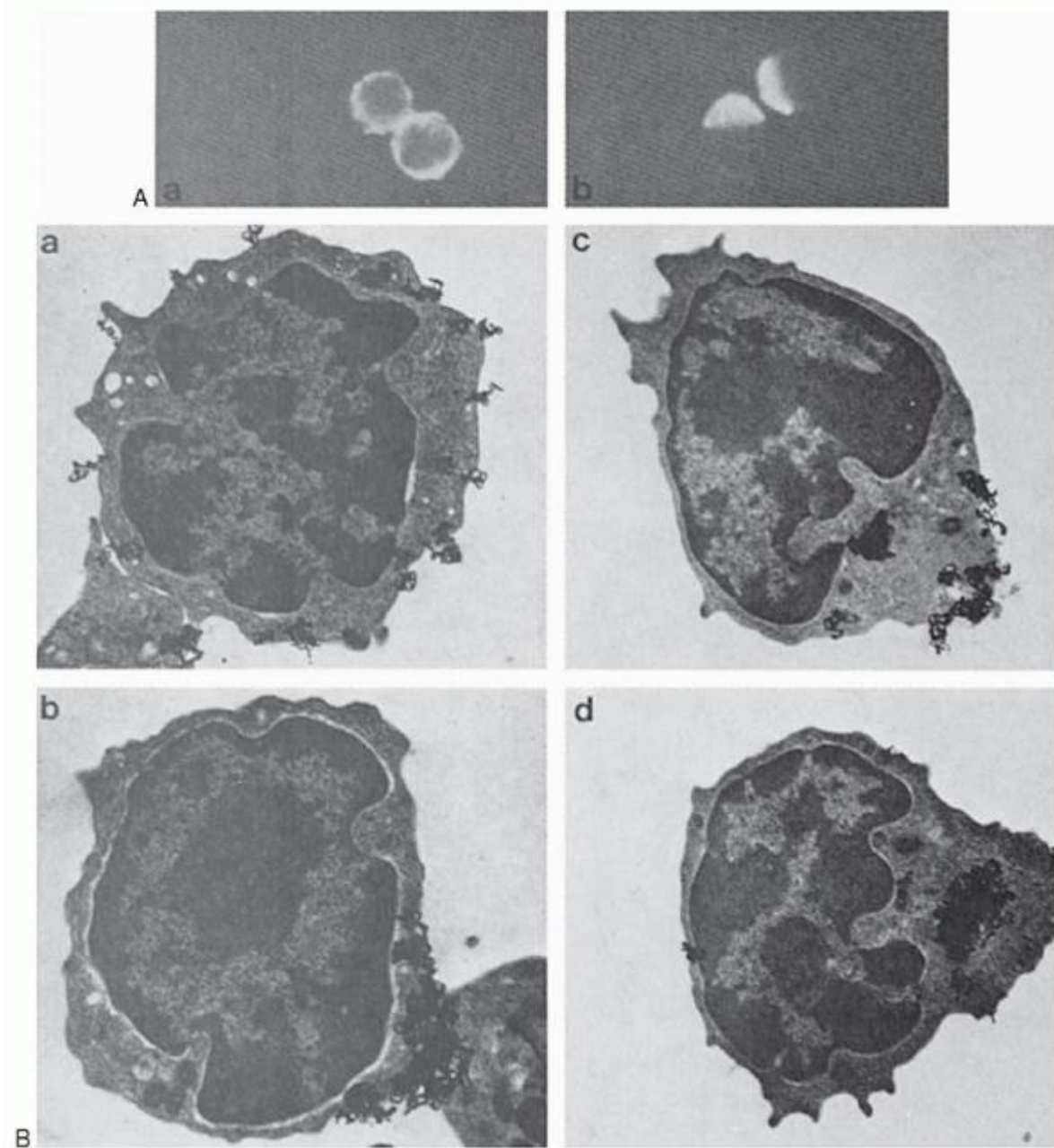

FIGURE 12.9. Redistribution of surface immunoglobulin (Ig). A: Mouse B lymphocytes treated with fluorescein-conjugated anti-mouse Ig antibody. a: Surface Ig is uniformly distributed around the cell (ring pattern). This pattern is seen only if the cell is kept at 0°C. b: Warming the cell to room temperature causes redistribution of the Ig so that it occupies only one pole (cap pattern). (From Taylor RB, Duffus WP, Raff MC, de Petris S. Redistribution and pinocytosis of lymphocyte surface immunoglobulin molecules induced by anti-immunoglobulin antibody. *Nature* 1971;233:225, with permission. Copyright (c)1971 Macmillan Magazines Limited.) B: Mouse B lymphocytes treated with rabbit anti-mouse Ig-conjugated with iodine-125 were examined by high-resolution radioautography. a: At the ultrastructural level, Ig is distributed around the entire surface of the cell, if it is maintained at 4°C. b: Surface Ig accumulates to one of the poles of the cell (uropod), forming a cap when it is warmed at 37°C. c and d: The cap is eventually endocytosed. (From Unanue ER, Perkins WD, Karnovsky MJ. Ligand-induced movement of lymphocyte membrane macromolecules. I. Analysis by immunofluorescence and ultrastructural radioautography. *J Exp Med* 1972;136:885-906. Reproduced by copyright permission of the Rockefeller University Press.)

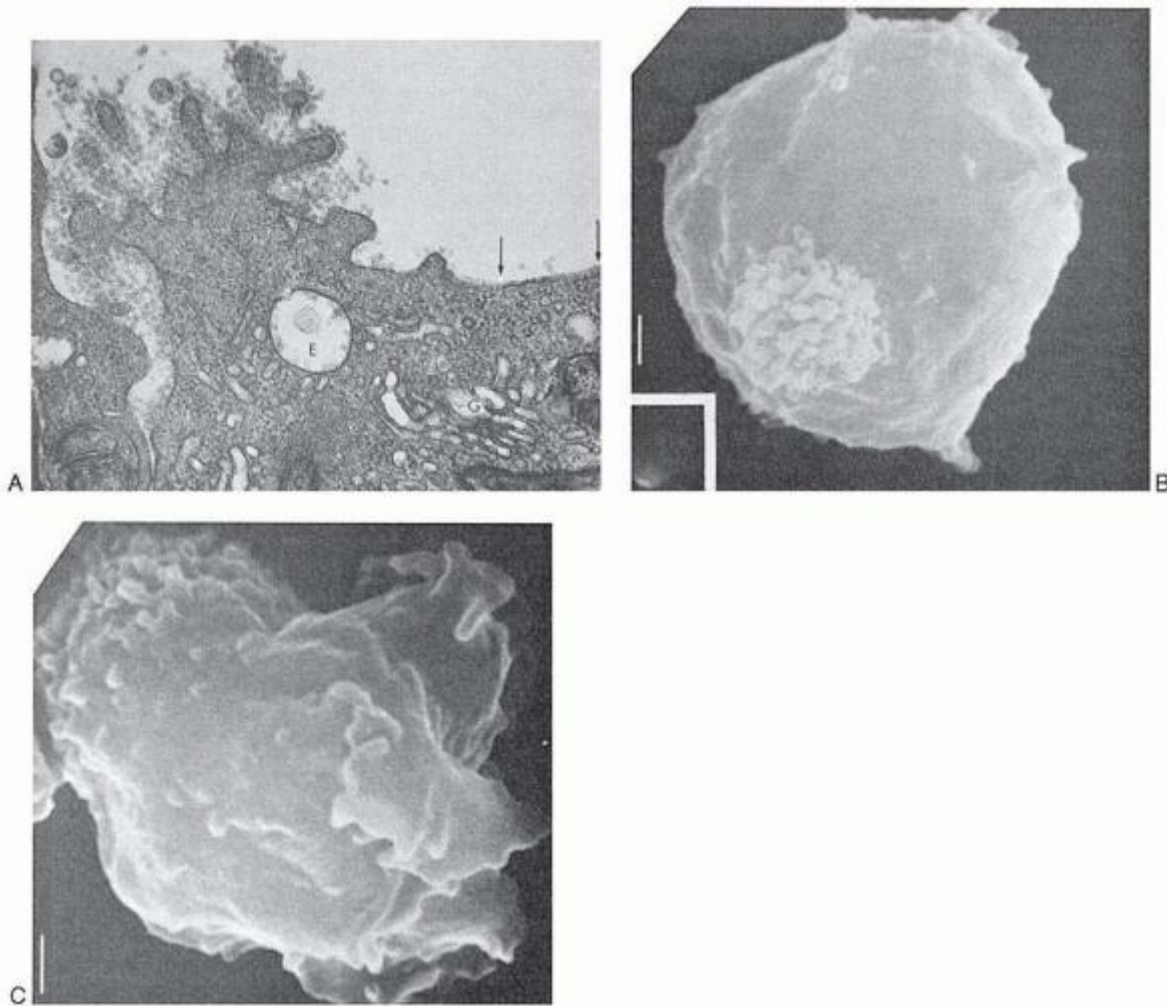

FIGURE 12.10. Ultrastructure of a cap. A: Anti-immunoglobulin (Ig) labeled with hemocyanin in mouse spleen. B lymphocyte is heavily concentrated in the uropod around short microvilli. Some of the capped Ig has been endocytosed (E). The label in the cap is densely packed, whereas the adjacent areas are clear of label (arrows). (From Karnovsky MJ, Unanue ER, Leventhal M. Ligand-induced movement of lymphocyte membrane macromolecules. II. Mapping of surface moieties. *J Exp Med* 1972;136:907-930. Reproduced by copyright permission of the Rockefeller University Press.) B: A cell with a tightly packed cap with smooth surface in the remaining body. C: The cap is separated by a constriction from the rest of the body, which shows intense membrane ruffling. G, Golgi apparatus. (B and C from Karnovsky MJ, Unanue E. Cell surface changes in capping studied by correlated fluorescence and scanning electron microscopy. *Lab Invest* 1978;39:554-564, with permission.)

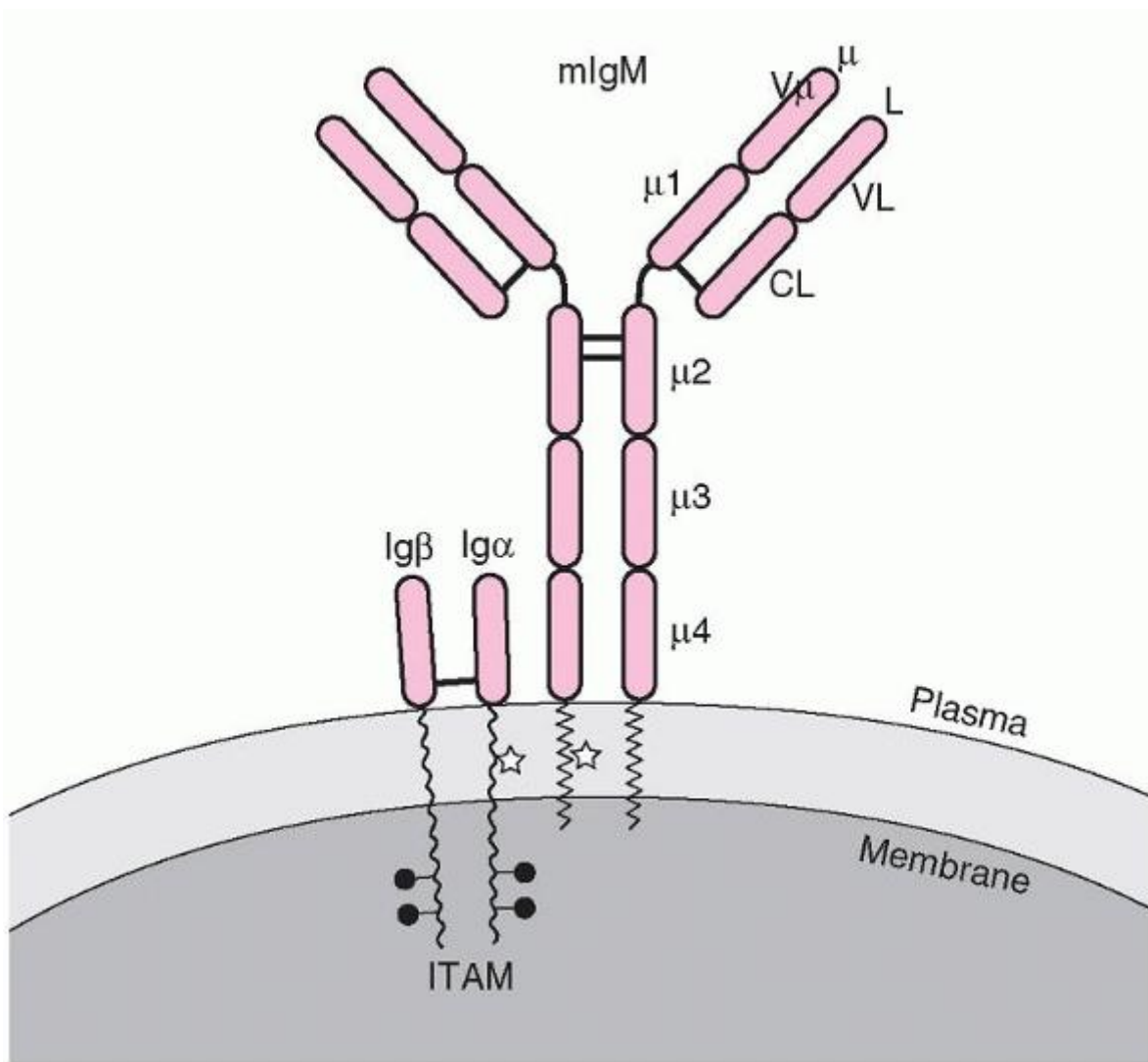

FIGURE 12.11. The B-cell receptor (BCR). The surface immunoglobulin (Ig) (two heavy and two light chains) constitutes the antigen-specific component of BCR, which is associated noncovalently with a heterodimer consisting of two chains, Ig α and Ig β . This heterodimer constitutes the signal transduction component. The Ig α chain associates with the H chains through ionic interactions. ITAM, immunoreceptor tyrosine-based activation motif; mIgM, membrane immunoglobulin M. The functional B-cell receptor is a complex consisting of IgM with one CD79A/CD79B heterodimer on each side.²⁷⁹ New P.268

evidence, however, indicates that each IgM molecule is associated with only one CD79A/CD79B heterodimer (Fig. 12.11).²⁸⁰ If this model is correct, the question remains whether both chains are linked to IgM, or whether only CD79A binds to both heavy chains and CD79A-BCR forms oligomers with additional molecules of the same isotype.

B-CELL RECEPTOR AND LIPID RAFTS

Ligand binding changes the orientation of the BCR molecules so that their ITAMs become more accessible to phosphorylation, which causes signal spreading restricted to BCRs of the same isotype.²⁸⁰ Lipid rafts are dynamic assemblies of proteins and lipids that float freely within the liquid-disordered bilayer of cellular membranes, but can also cluster to form larger, ordered platforms which regulate membrane function in eukaryotic cells.²⁸¹ These early events of BCR reorganization provide a mechanism for detecting low concentrations of antigens, thus increasing the threshold of activation. Cross-linking of BCR by multivalent antigen leads to a series of morphologic and molecular events that are interrelated, i.e., BCR aggregation and its loading to lipid rafts, signaling, and finally internalization and antigen presentation.

In the resting state the BCR floats on the cell membrane as monomer, but at the time of signal spreading it forms oligomers which are carried on specialized membrane microdomains referred to as lipid rafts. Lipid rafts are estimated to represent 30% to 40% of the cell surface in lymphocytes and have a role in B-cell activation as platforms for BCR signaling and might also act in antigen trafficking. Lipid rafts are an important component of B-cell signaling, since they facilitate the regulation of the BCR during B cell development by B-cell coreceptors.²⁸² Their size varies from submicroscopic dimensions which contain only a few hundred phospholipid molecules and four to ten protein molecules. Cross-linking of the BCR with antigen enhances its transfer to lipid rafts,^{281,282,283,284} while the pre-BCR which is constitutively located on lipid rafts generates a calcium signal.⁷⁵ Lipid rafts are also preferential sites of formation of prion proteins and β -amyloid associated with Alzheimer's disease.²⁸⁵

The mechanism of their action is not clear, but it is believed that they act as molecular sorting machines, coordinating signal transduction pathways. It is rather intriguing that they serve as portals of entry for various pathogens and toxins, such as HIV-1. In this case the raft microdomains mediate the mechanisms of the fusion of HIV-1 with the host cell. Lipid rafts are enriched in cholesterol and glycosphingolipids with saturated fatty acid side chains consisting of GM-1 gangliosides, and are resistant to solubilization in nonionic detergents at low temperatures. Most proteins are excluded from the lipid rafts, except proteins modified by saturated fatty acids such as acylated Src kinases and the α -subunits of trimeric G proteins. They facilitate BCR signaling by co-localizing signaling molecules, i.e., LYN, FYN, and BLK, members of the SRC family of kinases, but also by excluding molecules that inhibit BCR signaling such as CD22. Furthermore, in anergic or tolerized B cells, the BCR is unable to enter lipid rafts, indicating that inclusion of BCR within these microdomains is an absolute requirement for initiation of signaling.²⁸⁶ Similarly, localization of BCR within the rafts occurs only in mature, but not immature, B cells.²⁸⁷ The translocation of the BCR into lipid rafts is independent of any signaling initiated by the receptor and does not require actin cytoskeleton polymerization or the CD79A/CD79B complex.²⁸⁸ Lipid rafts facilitate not only activation but also apoptosis, because cross-linking of CD24, a glycosylphosphatidylinositol-anchored protein that is downregulated during B-cell differentiation, induces apoptosis via a lipid raft signaling system.²⁸⁹ CD24 cross-linking brings some BCR within the lipid rafts, activating LYN kinase. EZR (EZBIN) is a member of the ezrin-radixin-moesin (ERM) family, is dephosphorylated by BCR, and is detached from the actin as well as from lipid rafts, resulting in greater coalescence of lipid rafts and more effective B-cell activation.²⁹⁰ B cells are not only antibody-producing cells, but in addition are antigen-processing and -presenting cells. For this function they interact with antigen-specific T cells to receive T cell help.²⁹¹ Antigen captured by B cells induces BCR cross-linking, translocation into lipid rafts, where it is phosphorylated, promoting BCR internalization mediated by clathrin associated with the rafts. This is followed by BCR cross-linking, antigen internalization, which is diverted to the endocytic pathway for further processing and presentation to T cells.²⁸⁴

The B cell antigen receptor and the T cell receptor have no inherent kinase activity and, like other multichain immune recognition receptors (MIRRs), they are associated with members of the SRC family kinases to initiate signaling spatially organized by the lipid rafts and regulated by clathrin.

The CD21/CD19 complex coreceptor markedly enhances BCR activation, stabilizes the residence of BCR within the rafts, and thus prolongs B-cell activation.²⁹² In contrast, the FCGR2, which inhibits B-cell activation, destabilizes BCR-raft association.²⁹³ After translocation of BCR (or other immune receptors) onto lipid rafts, the rafts appear to form clusters, i.e., clustered rafts,²⁸¹ which increases the range of their diameters from hundreds of nanometers to micrometers. Clustering results from cross-linking of receptors located on separate rafts and eventually from the linking of rafts with linker proteins. In addition, cytosolic proteins that have been associated with the cytoplasmic domains of receptors residing on a raft may also contribute to the bridging of individual lipid rafts to form larger conglomerates. Cytoskeletal components are also linked to activated receptors and their reorganization bridges clustered rafts.

Continuation of raft clustering eventually leads to the formation of the synapse, a highly ordered membrane structure in which immune receptors, signaling molecules, and cell adhesion molecules are clustered.²⁹⁴ Synapse formation is a highly organized structure with a cluster of immune receptors in the center ringed by adhesion molecules and several signaling molecules and cytoskeletal components on the cytoplasmic side.

The formation of a synapse was first described in T cells, but it has now been detected on B cells,²⁹⁵ suggesting that this is a unique mechanism associated with foreign antigen capturing for processing and handling by the immune system to secure a cellular response. When DC capture the antigen, they trigger the formation of the synapse on B cells and during the close encounter between B cell and DC around the synapse, the B cell samples and gathers antigen for internalization and processing. Internalization of the antigen and signaling are two interrelated and inseparable events mediated by lipid rafts.^{282,296} B cells with deficiency of expression of the SRC kinases, which normally initiate B-cell signaling, fail to internalize the receptor, and as a result, targeting of antigen to MHC-II peptide-loading compartment is also disrupted.²⁹⁷ Internalization of BCR occurs when clathrin, which is associated with the rafts, is phosphorylated on its tyrosine after BCR

cross-linking.²⁹³ When lipid rafts are disrupted by the expression of LMP2A protein of the EBV or by reagents that sequester cholesterol, the internalization of the antigen does not occur.^{298,299}

Expression of LMP2A therefore not only inhibits BCR function, but generates a ligand-independent cellular activation signal, which provides a molecular switch for different EBV life cycle stages and thus contributes to EBV-associated lymphoproliferative disorders.

P.269

B-CELL RECEPTOR SIGNALING

The most important structural elements of signaling molecules for the initiation of B-cell activation and differentiation are the ITAM motifs of the CD79A/CD79B heterodimer and the PTKs associated with the complex (Fig. 12.12). The ITAM is characterized by a sequence of 26 amino acids, D/E-X₇-D/E-X₂-YXXL/I-X₆(7)-YXXL/I, with six of them being conserved (X = any amino acid). Critical for signaling are the two tyrosines (Y), and one or both of them are phosphorylated when the BCR is engaged by antigen. Some evidence suggests that activation of B cells may be triggered not only by the tyrosine-based activation motif (ITAM), but by a critical non-ITAM tyrosine 204 residue that is conserved in evolution.³⁰⁰

BCR signaling is a highly complex process,^{213, 301, 302} but for the sake of understanding, we divide the interactions somewhat arbitrarily into three major pathways: (a) initial interactions, (b) phosphoinositide pathways, and (c) the ras pathway.

INITIATION PATHWAY

BCR has no intrinsic protein tyrosine kinase (PTK) activity but uses several distinct families of cytoplasmic PTKs. Three distinct types of PTKs are activated on BCR engagement: (a) the SRC-PTKs (LYN, BLK, and FYN), (b) SYK, and (c) BTK.³⁰¹ Activation of LYN is one of the earliest events in BCR-induced signaling, which is constitutively acylated and, as a result, localizes in the cell membrane. It is responsible for the initial phosphorylation of the ITAMs of CD79A and CD79B. The kinase activity of LYN is regulated by phosphorylation of a carboxy-terminal regulatory tyrosine by the kinase CSK³⁰³ and dephosphorylation by the phosphatase CD45.³⁰⁴ LYN has one SH-3 domain on its N terminus, followed by one SH-2 domain and the kinase domain in the C terminus. SH-2 domains bind phosphorylated tyrosines, whereas the SH-3 domains bind proline-rich sequences. BCR engagement triggers dephosphorylation of Tyr-508 by the CD45 phosphatase, whereas Tyr394 within the catalytic domain is rapidly phosphorylated. SYK kinase is recruited to the phosphorylated ITAMs of CD79A and CD79B, and is phosphorylated by LYN or by an autophosphorylation mechanism.³⁰⁵

Activation of SYK is a critical event in BCR signaling and for recruitment of BLNK, or SLP-65, a linker protein with a major scaffolding function connecting several downstream signaling molecules.³⁰⁶ BLNK assembles macromolecular complexes that include PLCG2, VAV, BTK, and additional linker proteins GRB2 and NCK1.^{307,308}

Phosphorylation of five tyrosine residues of BLNK is required for coordination of the assembly of multimolecular complexes. BTK belongs to the TEC family of kinases and differs in several aspects from the SRC kinases (i.e., it is not myristoylated, does not contain a negative regulatory phosphorylation site in the C terminus, and has a pleckstrin homology domain [PH] in the N terminus). BTK function is regulated by phosphorylation of the Tyr551, which is essential for BTK participation in signal transduction.²³⁴ BTK also interacts with phosphatidylinositol-3,4,5-tri-phosphate (PIP3), an interaction required for recruitment of BTK to the cell membrane.³⁰⁹ Because PIP3 is generated from activated PI3 kinase, BTK is targeted to the membrane after PI3 kinase activation, where it could be phosphorylated by LYN or SYK.

GENERATION OF PHOSPHOINOSITIDES

Hydrolysis of inositol-containing phospholipids is mediated by the lipid metabolizing enzymes PLCG2 and PIK3CA. There are several pathways leading to activation of PLCG2 in B cells.³¹⁰ BLNK associated with PLCG2 (which is the main isoform in B cells) brings it to an appropriate position for activation by SYK kinase. On the other hand, BTK also contributes to PLCG2 activation because B cells from XLA patients show a profound reduction of IP3 production on BCR engagement.³¹¹ PIP₃, the product of PIK3CA activation, binds to the PH domain of PLCG2, thus providing another pathway for PLCG2 activation. PLCG2 activation leads to hydrolysis of phospholipids, generating IP₃ and DAG (diacylglycerol). IP₃ binds to appropriate receptors on the ER, leading to Ca²⁺ release from internal stores.

PIK3CA is activated by at least two pathways and a prominent substrate for tyrosine phosphorylation is the product of the oncogene CBL. BCR engagement phosphorylates p12-CBL, which is then associated with the 85-kDa component of PIK3CA.³¹² A second pathway is through the CD19/CD21 coreceptor complex.^{313,314} BCR stimulation phosphorylates the

two YXXM motifs of CD19, which then bind the SH-2 domain of the p85 regulatory subunit of PIK3CA. Enhanced phosphorylation occurs when the CD19/CD21 complex binds C3d fragments. Furthermore, the proline-rich region of the p85 subunit binds to SH-3 domains of LYN and FYN, further enhancing PIK3CA activation.

Ca²⁺ binds to calmodulin and promotes calmodulin-dependent protein kinase activation and calcineurin, a serine-threonine-specific protein phosphatase. Calcineurin directly dephosphorylates the NFAT family of transcription factors.^{315,316} DAG1, (diacylglycerol), one of the two second messengers produced by PLCG2 gene activation, activates cPKC. One target of PKC on B cells is MARCKS, (Myristoylated Alanine-Rich C- Kinase Substrate) that regulates actin reorganization. Elevation Ca²⁺ also activates a number of other transcription factors, such as NF-κB and ATF2. Phosphoinositides generated by PIK3CA bind to AKT1(PKB) kinase, an evolutionarily conserved kinase across species.³¹⁷ AKT1 is the product of an oncogene transduced by the acute transforming retrovirus (Akt8). The viral and cellular oncogenes encode a serine-threonine protein kinase consisting of a C-terminal kinase domain and an N-terminal PH domain. Mutations of the PH domain block AKT1 activation by growth factors or phosphoinositides. AKT1 activation is also mediated by the serine/threonine kinase PDK1 (Pyruvate Dehydrogenase Kinase 1), which is stimulated by PIP₃ and phosphorylates AKT1 on Thr308. AKT1 inhibits glycogen synthase kinase 3 (GSK3), which destabilizes MYC and cyclin D, both required for cell cycle progression. A combination of various AKT1 activation effects plays a role for its transforming and oncogenic potential. Some of its multiple effects include transcriptional regulation of gene expression, inhibition of apoptosis, cell cycle regulation, insulin-induced metabolic signals, endocytosis, etc.

THE RAS PATHWAY

BCR cross-linking leads to an increase of the guanosine triphosphate (GTP)-bound ras and its accumulation in the membrane under BCR. RAS is a guanine nucleotide-binding protein, which cycles between a guanosine diphosphate (GDP)-bound (inactive) and a GTP-bound (active) state. The proteins of the RAS family are proto-oncogenes, which, on mutation, accumulate in the GTP-bound state in human tumors. On activation of B lymphocytes, Ras is rapidly converted to the GTP-bound state. The cycle between GDP and GTP binding is controlled by guanine nucleotide exchange factors (GEFs) that promote the transition from a GDP- to a GTP-bound state. This is reversed by guanosine triphosphatase (GTPase)-activating proteins, which stimulate GTPase activity of Ras and result in hydrolysis of GTP to GDP. The balance between GEFs and GTPase-activating proteins regulates RAS activity.³¹⁸ The most likely pathway of ras activation is through the adapter protein SHC1, which is phosphorylated after

P.270

BCR engagement. SHC1 binds to a second adapter protein GRB2, which in turn binds to SOS, a nucleotide exchange factor.

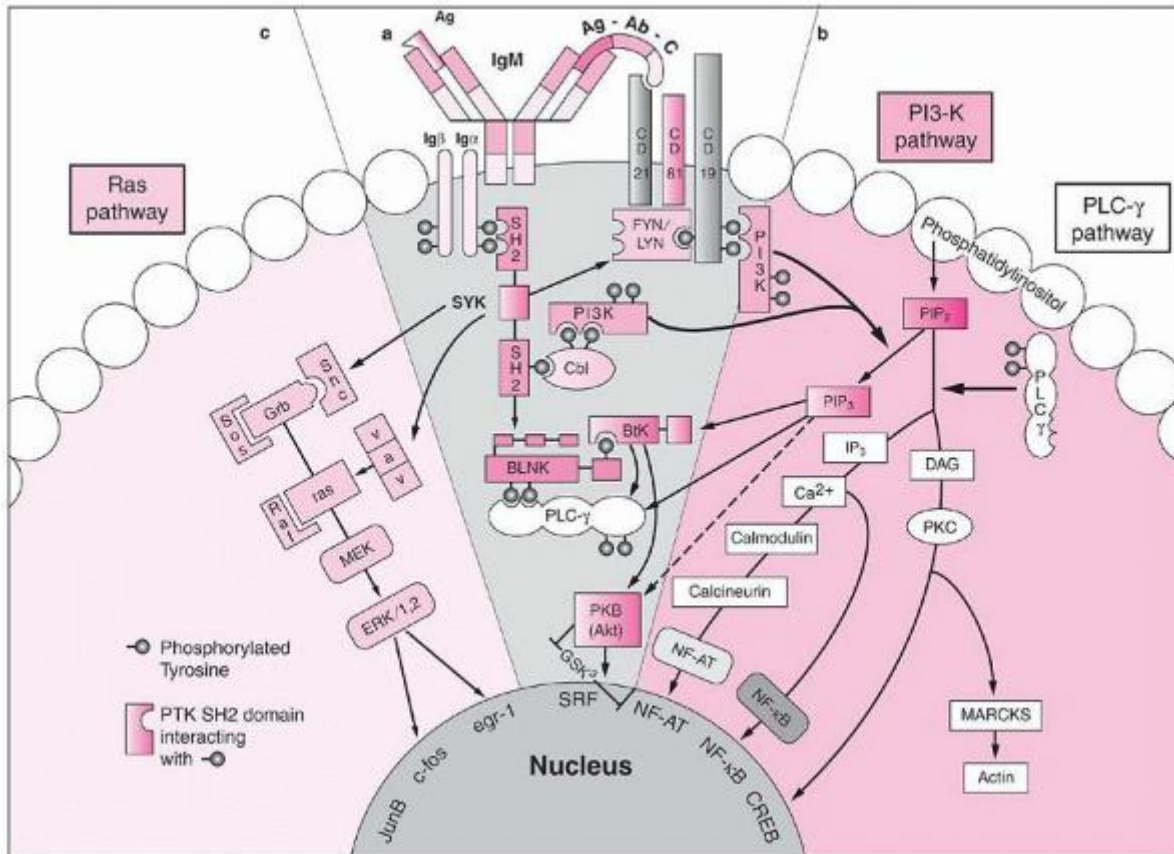

FIGURE 12.12. B-cell activation. Signal transduction initiated by the engagement of the B-cell receptor (BCR) is a highly complex process. For better understanding, it is divided arbitrarily into three main signaling pathways: (a) initiation: with the assembly by adapter proteins such as BLNK (B-cell linker protein), Cbl, and others of signaling protein tyrosine kinase (PTK) complexes such as Src (Lyn, Fyn), Syk, and Btk; (b) inositol phosphatides generation by the activation of PI3K and PLC- γ ; (c) the ras/Erk pathway assembled by adapter proteins Grb, Shc, and Sos. These pathways carry the signals downstream to other signaling molecules Akt, calcineurin, and Erk/1,2, and to activation of transcription factors nuclear factor-AT (Nfat), NF- κ B, Creb, c-fos, etc.

This multimolecular complex is associated with the membrane.^{319,320} A guanine nucleotide exchanger protein, VAV, which is a GEF in the Rho family of GTPases, is recruited to the phosphorylated Tyr-341 and Tyr-345 of SYK through its SH-2 domain and is subsequently phosphorylated.³²¹ These RAS-like proteins are molecular switches that are active in the GTP-bound state and can promote site-specific actin polymerization to create alterations in plasma membrane structures such as filopodia and lamellipodia. VAV has a Dbl homology domain, which has the GEF activity, a PH domain (binds phosphoinositides), an SH-2 domain, and two SH-3 domains. The PH domain of VAV uses PIP₃ for recruitment to the cell membrane. VAV may also be recruited to the membrane by binding to Tyr-391 of CD19. A negative regulator of the RAS pathway is CBL, which competes for the binding to SOS. CBL (Casitas b-lineage lymphoma) is the cellular homolog of v-Cbl, part of the transforming gene of the Cas-NS1 retrovirus, a murine virus, capable of causing pre-B-cell lymphomas. It contains a proline-rich region (residues 481 to 688), a leucine zipper motif (residues 855 to the C terminus), and multiple potential SH-2-binding motifs. It binds to PTKs such as FYN, ZAP70, and BTK, to the adapter molecule GRB2, and to PI-3K.³²² In B-cell signaling, CBL binds to BLNK through its SH-2 domain and inhibits association of PLCG2 phosphorylation.³²³

Binding of SOS and CBL to GRB2 is mutually exclusive, because the proline-rich domains of these proteins compete for the same SH-3 domain of GRB2. A group of signal transduction pathways is characterized by successive phosphorylations of serine/threonine kinases. This group consists of a mitogen-activated protein kinase (MAPK), a MAPK kinase (MAPKK), and a MAPKK kinase (MAPKKK). RAS-GTP phosphorylates RAF1, which is the MAPKKK of this cascade. RAF1 phosphorylates and activates MAP2K1 (MEK1) and MAP2K2 (MEK2), which in turn phosphorylates MAPK3 (ERK1) and MAPK1 (ERK2). Phosphorylated ERKs form dimers and are translocated to the nucleus, where they phosphorylate transcription factors c-fos and JUN members of the ETS family.

ADAPTER MOLECULES: PLASTICITY AND DIVERSITY OF SIGNALING

Adapter proteins possess domains that mediate protein-protein or protein-lipid interactions, but they have no enzymatic activity. Two groups of adapter proteins can be identified: transmembrane adapter proteins and cytosolic adapter proteins (CAPs). In general, adapter proteins assemble multimolecular signaling complexes and direct their formation to specific cellular locations.^{324,325,326} and ³²⁷ At the initial stages of B-cell activation, LYN, SYK, and

P.271

BTK kinases are activated. A transmembrane adapter protein, PAG (phosphoprotein associated with glycosphingolipid-enriched microdomains), links Lyn to the kinase that phosphorylates the C-terminal tyrosine for LYN activation. The CAP adapter protein BLNK (or SLP-65, SH-2 containing Linker Protein of 65 kDa) connects BTK to SYK and brings PLCG2 on the lipid rafts. There are inhibitors for adapter proteins, such as I-BTK, which binds to the pleckstrin domain of BTK and negatively regulates its activation. BLNK, which connects several important molecules to BCR for the initial stage of signaling, is indispensable for LMP2A (latent membrane protein), a constitutively activated EBV protein in infected B cells. LMP2A signaling can substitute for the signaling of BCR and maintains survival of EBV-infected B cells, leading to infectious mononucleosis or Burkitt lymphoma. The CAP BLNK is clearly required for the translocation of PLCG2 from the cytosol to the plasma membrane and its subsequent activation. BLNK (SLP-65) is essential in pre-B-cell development and, with BTK, induces cell proliferation.

B-CELL SIGNALING BY ACCESSORY STRUCTURES

Many other cell surface molecules participate in B-cell signaling. The coreceptor complex CD19/CD21 activates the CD19-associated PTKs, which induce phosphorylation of tyrosine residues on CD19 motifs.³²⁸ These then become potential SH2-binding sites for PI3 kinase, which generates phosphoinositides. Recruitment of PI3K to CD19 requires phosphorylation of Tyr484 and Tyr515. Activation of PI3K generates PIP-3, which functions to localize BTK to the plasma membrane, where it is phosphorylated and activated by SRC and SYK kinases. BCR activation of BTK is dependent on CD19 expression, whereas activation of LYN and SYK is not.³²⁹ PLC activation generates DAG, which activates PKC and 1,4,5-triphosphate, which increases cellular Ca^{2+} . CD22 is associated with BCR, which on engagement phosphorylates some of the six tyrosines of CD22. This in turn leads to recruitment of PTPN6 (SHP-1) via its SH-2 domain to CD22.³³⁰ CD22 contains ITAMs and four immunoreceptor tyrosine-based inhibition motifs (ITIMs) in the cytoplasmic region. PI3K and PLCG1 associate with CD22 through the YXXM motif recognized by the N-terminal SH-2 domain of the p85 subunit of PI3K, whereas the protein tyrosine phosphatase PTPN6 (SHP-1) binds to ITIMs. As a result of multiple ITIMs, CD22 is probably a negative regulator of B cell activation. (For more details, see CD22 in Appendix A.)

INTERLEUKIN-4

Although several cytokines act on B cells, the action of IL4 was first demonstrated on B lymphocytes, and on these cells IL4 evokes the strongest reactions. IL4 binds to a transmembrane receptor and results in cross-linking with another protein termed common gamma chain (γ c), which is shared by other cytokines.^{331,332,333} Mutations in the γ c chain results in X-linked SCID, an inherited disease with profound suppression of cell-mediated and humoral immunity.^{334,335} IL4 binding induces phosphorylation of a substrate of 170 kDa designated as 4PS, which is unique because no other cytokine except IL13 binding phosphorylates a similar substrate. However, insulin and insulin growth factor-1 result also in 4PS phosphorylation. 4PS is structurally similar to insulin receptor substrate-1 (IRS-1). The gene for 4PS has been cloned and is called IRS2. IRS1/2 contains more than 20 potential tyrosine phosphorylation sites and 30 potential threonine/serine phosphorylation sites. The tyrosine phosphorylation sites bind with high affinity to cellular proteins possessing SH-2 domains and thus act as docking sites for several signal-transducing proteins such as PI3 kinase and growth factor receptor-bound protein-2 (GRB2). Mutational analysis has mapped a region of the IL4R between amino acids 437 and 557, which is important for IRS1 phosphorylation and therefore signal transduction.³³⁶ This region contains a single tyrosine, is shared by the IL4 receptor (IL4R) and the insulin receptor, and is known as the I4R motif.

Although the insulin receptor and IL4R have many similarities, they have an important difference. The insulin receptor is a receptor tyrosine kinase, whereas the IL4R and γ c are not, but are associated with nonreceptor PTKs. Association of IL4R and γ c activates kinases associated with IL4R, which then phosphorylates the tyrosine in the I4R motif. This allows 4PS to bind to the IL4R and to be phosphorylated by the kinases associated with the IL4R. The phosphorylated motif I4R interacts with the PTB domain of IRS1/2. PTB domains are found in adapter proteins, such as SHC, and bind phosphopeptides.

IRS1/2 becomes phosphorylated as a result of interaction with the IL4R α receptor and binds to the p85 subunit of PI3K, which as an adapter links IRS1/2 to the catalytic subunit p110. PI3K is activated as a result of conformational changes, acts on phosphatidylinositol of the cell membrane, and transfers phosphate groups from adenosine triphosphate to the D₃ position of inositol-generating PIP₃ and phosphatidylinositol 3,4-bisphosphate. The phosphoinositides act on downstream

kinases (i.e., PKC and AKT1) that make important contributions to cell survival. Activation of the IRS1/2 signaling proteins is associated with activation of the RAS/MAPK pathway (see "The RAS Pathway"). IL4R is also associated with the Janus kinases (or JAKs).^{337,338} The α chain binds to JAK1, whereas the γ chain binds to JAK3. The receptors bind to these kinases through their membrane-proximal domains, which are known as box 1 and box 2 motifs and have some similarity among cytokine receptors.

The sequence of residues 557 and 657 of the α -chain (known as the gene-regulation domain) is critical for expression of IL4-responsive genes. It contains three conserved Tyr residues (Y575, Y603, and Y631), which can potentially be phosphorylated and thus be able to associate with SH-2 domains. IL4 utilizes the STAT6 member of the transcription factor family known as STATs (signal transducers and activators of transcription). IL4-responsive genes include class II HLA, CD23, germline Ig ϵ and γ -1 chains, and IL4R α chains.

Engagement of IL4R results in the activation of JAK1 and JAK3, which phosphorylate tyrosines of the cytoplasmic region of the receptor. STAT6 binds through its SH-2 domains to the phosphorylated tyrosines and becomes itself phosphorylated at its C terminus by the activated JAK kinases. The phosphorylated STAT6 dimerizes and binds to promoters of the IL4-responsive genes.³³⁹ (For more on IL4 see Chapter 14.)

INTERLEUKIN-5

The α chain of IL5R is a type-I membrane protein of 415 amino acids, its extracellular region comprising three sets of fibronectin type III domains, whereas the intracellular domain does not contain sequences of tyrosine kinase but shows homology with a part of the actin-binding domain of β -spectrin.³⁴⁰ It also has a region rich in prolines conserved among receptors of other cytokines (e.g., IL3, granulocyte-macrophage colony-stimulating factor receptor or CD116; see Appendix A).

A second β -chain is important for signal transduction but it does not contribute to IL5 binding. A membrane-proximal region contains a conserved box-1/box-2 motif that is responsible for the interaction with JAK2, and the distal domain is responsible for the activation of the RAS-related pathways. IL5 signaling increases BTK activity.

P.272

INTERLEUKIN-6

IL6 is a pleiotropic cytokine that, among many other functions, is involved in terminal differentiation of B cells.^{341,342} The extracellular region of the IL6R consists of one constant region domain of the Ig superfamily and two fibronectin type III domains, which have four conserved cysteine residues and a motif containing two tryptophans and two serines. This motif is located in a groove between the two fibronectin domains. The intracellular domain is short and is not involved in signal transduction. Associated with the IL-6R is a protein known as gp130, which dimerizes when IL6 binds to the IL6R. The gp130 protein is shared by other cytokine receptors and initiates signal transduction. Homodimerization of gp130 induces activation of JAK kinases, which are associated with the membrane-proximal region of gp130, also known as box-1. This leads into phosphorylation of a tyrosine in the distal part of gp130 (box-3), resulting in binding through an SH-2 domain of the transcription factor STAT3, previously known as acute phase response factor or APRF. JAK kinases activate STAT3 by phosphorylation.

Another nuclear target for gp130 signaling is the transcription factor NF-IL6 with a leucine zipper motif. This factor is inducible in hepatocytes and monocytes by IL6 and other cytokines and mediates the expression of IL6-inducible genes. NF-IL6 has a consensus sequence for MAP kinase, suggesting that it is activated through this pathway, which is RAS-dependent. (For further details, see Chapter 14.)

CD 40

CD40 is a member of the tumor necrosis factor receptor family, which interacts with its ligand, CD154, expressed on T cells. (See "CD40 and CD40 Ligand [CD154]"; Appendix A.) Signal transduction by CD40 is mediated by certain proteins that bind to its cytoplasmic region and are known as TRAFs (tumor necrosis factor receptor activation factor) (see Appendix A: CDs). Engagement of CD40 by its ligand activates the SRC kinases LYN and FYN and BTK. Signaling follows the RAS pathway via the nucleotide exchanging factor SOS, leading to MAPK8 (JNK) and MAPK1 (ERK) activation. The functional outcome of CD40 depends on the state of activation of B cells and the intensity of stimulation. On naive B cells it induces proliferation and Ig production, but on memory cells it induces apoptosis. CD40 activation induces homotypic adhesion of B cells mediated by CD54 (intercellular adhesion molecule-1)-CD11/CD18 (ITGB2 or LFA-1), or CD23-CD21. The functional

outcomes depend on the type of TRAFs that are associated with CD40. For example, trimers of TRAF2 mediate apoptosis, whereas trimers of TRAF6 or TRAF5 mediate proliferation.³⁴³ Germinal-center formation and Ig class switch are hallmarks of T-cell-dependent responses, and TRAF6 plays a role in class switch (see Chapter 14).

POLYCLONAL ACTIVATION

Certain substances can activate B lymphocytes independently of their antigenic specificity. The response to these substances involves all B-cell clones, and for this reason these substances became known as polyclonal B-cell activators (PBAs).

PBAs are primarily microbial cell constituents such as lipopolysaccharide (LPS), purified protein derivative, staphylococcal protein A, streptolysin O, pneumococcal polysaccharide III, a water-soluble antigen from *Nocardia*, EBV, dextrans, etc.

PBAs can be categorized on the basis of their effect on B lymphocytes; some promote only B-cell proliferation, whereas others in addition stimulate Ig secretion.

LPS has been used experimentally as PBA for several years, but only recently was its receptor shown to be the CD14 molecule.³⁴⁴ LPS binding to CD14 is enhanced in the presence of a plasma protein, LPS-binding protein.³⁴⁵ CD14 is expressed primarily on monocytes and granulocytes. Its structure, function, and role in human disease have been reviewed.³⁴⁶

MORPHOLOGIC CHANGES ASSOCIATED WITH B-CELL DIFFERENTIATION

Plasma Cell

Elegant studies of morphologic differentiation in immunized animals at the ultrastructural level were performed by Harris et al., who isolated individual cells involved in antibody synthesis³⁴⁷ (Fig. 12.13). These authors showed that antibody production is detected while the cell still retains a lymphocytic morphology and contains no ER. These cells can be differentiated from inactive lymphocytes by the abundance of free polyribosomes and a large nucleolus. A spectrum of cells that actively secrete antibody can be ranked according to the size and development of the ER.^{348,349,350,351} and ³⁵²

During early differentiation, the ER is scarce and unorganized. Later, the lamellae increase in length and become parallel, until they fill the entire cytoplasm and give rise to its onion-skin appearance. The Golgi apparatus increases concomitantly. No dividing line exists that distinguishes the cells that make IgM from those that make IgG antibody, although a preponderance of IgM producers with lymphocytic morphology and of IgG producers with plasmacytic morphology is noted.³⁴⁸

The name plasma cell was first used by Waldeyer in 1875.³⁵³ His description, however, included several types of cells; and in 1881 Unna³⁵⁴ redefined the cells as he observed them in a case of lupus, emphasizing the characteristic basophilia of the cytoplasm (granuloplasm). In a subsequent report³⁵⁵ containing pictures of methyl green- and pyronin-stained cells, several cells are identified easily as characteristic plasma cells. In 1895, Marschalko took issue with Unna's description and emphasized that the appearance of the nucleus with its characteristic arrangement of angular chromatin blocks and its eccentric position within the cell are to be used as stringent criteria for the identification of plasma cells.³⁵⁶ The characteristic nuclear morphology was given the name radkern by Pappenheim. Early analytic reviews of plasma cells were provided by Downey³⁵⁷ and later by Michels.³⁵⁸ In those early years, whether the plasma cell was a normal constituent of tissues was the subject of considerable debate. Its origin was disputed, but several prominent investigators believed that it originated from lymphocytes.

The modern period of plasma cell study originated in 1937 with the clinical observations of Bing and Plum, who noted the close association of hyperglobulinemia and the presence of plasma cells.³⁵⁹ Subsequent studies in hyperimmunized rabbits were carried out by Bjornboe and Gormsen,³⁶⁰ who demonstrated that antibody production correlated with massive plasma cell proliferation in the spleen. In his doctoral thesis, Fagraeus³⁶¹ left little doubt about the importance of plasma cells in antibody formation. Differences among animals in their capacity to produce antibody could be related to differences in the number of plasma cells, particularly immature plasma cells. Fagraeus thought that mature plasma cells had "passed the stage of their greatest functional intensity."

Indisputable evidence in favor of antibody production by plasma cells was provided by Coons, who introduced the powerful technique of immunofluorescence to immunology.^{362,363} Plasma cells containing antibody were detected in the red pulp of the spleen, the medullary cords of the lymph nodes, and the focal granulomata of immunized animals.

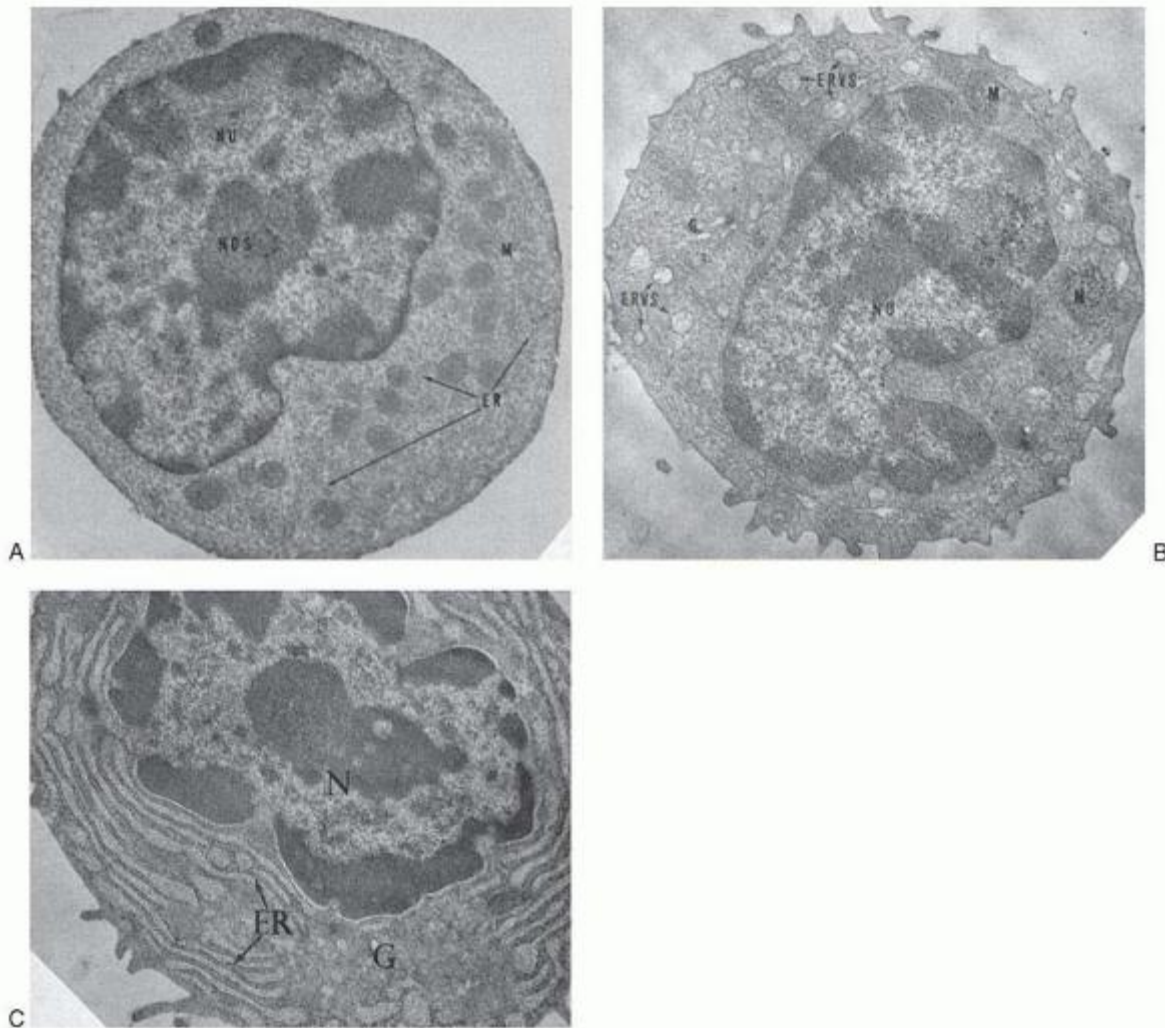

FIGURE 12.13. Morphology of antibody production. Terminal B-cell differentiation (antigen-dependent) is characterized morphologically by the gradual increase of the amount of cytoplasm and, concomitantly, the appearance of strands and eventually well-organized endoplasmic reticulum. A: An antibody-producing lymphoid cell with sparse endoplasmic reticulum (ER). (From Harris TN, Hummeler K, Harris S. Electron microscopic observations on proteins such as BLNK (B-cell linker protein), Cbl, et al. of signaling protein tyrosine antibody-producing lymph node cells. *J Exp Med* 1966;123:161-172, with permission.) B: Endoplasmic reticulum (ERVS) is slightly distended, containing amorphous material. (From Hummeler K, Harris TN, Tomassini N, et al. Electron microscopic observations on antibody-producing cells in lymph and blood. *J Exp Med* 1966;124:255-262, with permission.) C: Mature plasma cell displaying well-organized ER and distinct Golgi apparatus (G). (From Gudat FG, Harris TN, Harris S, Hummeler K. Studies on antibody-producing cells. I. Ultrastructure of 19S and 7S antibody-producing cells. *J Exp Med* 1970;132:448-474, with permission.) M, mitochondrion; N, nucleus; NOS, nucleolus; NU, nucleus. (Figures A, B, and C reproduced from *J Exp Med*, as cited, by copyright permission of the Rockefeller University Press.)

Excellent detailed descriptions of the morphology and ultrastructure of plasma cells have been published.^{364,365} The plasma cell is round or oval, with an eccentrically located nucleus and chromatin arranged in pyramidal blocks against the nuclear membrane, giving the characteristic “cartwheel” appearance (Fig. 12.14). The cytoplasm is intensely basophilic because of the high content of ribonucleoprotein. Certain plasma cells stain red to violaceous rather than blue, and are known as flaming plasma cells, a name coined by Undritz. This coloration is attributed to the accumulation within the ER cisternae of Ig with a high carbohydrate content. Electron microscopic studies revealed that the nucleus is surrounded by a double membrane. The outer membrane is covered with ribonucleoprotein particles and is continuous with the cytoplasmic ER. The Golgi is well developed and consists of vesicles and tubules. The centrosome lies next to the nucleus, surrounded by the Golgi apparatus. Several microtubules radiate from the centriole. Many prominent mitochondria are scattered between the ER lamellae. A striking ultrastructural feature of the plasma cell is the rich and well-organized ER. It

consists of membranes studded on one side with ribosomal particles and arranged in parallel arrays. In the mature plasma cell, the ER fills the entire cytoplasm. The cisternae are sometimes distended with granular or homogeneous material, giving rise to cytoplasmic inclusions known as Russell bodies.³⁶⁶ The Russell bodies are composed of Ig,^{366,367} although sometimes Ig cannot be demonstrated,³⁶⁸ and it was suggested that these inclusions are

P.274

not made from Ig aggregates. Alternatively, the Ig is condensed to such a degree that it cannot be penetrated by the dyes. Russell bodies sometimes are detected within the nucleus (intranuclear inclusions). Under certain circumstances, the plasma cell contains large quantities of a homogeneous material that distends the cell and stains gray or sometimes red as in the flaming cells. These cells, called thesaurocytes,³⁶⁹ reveal, under electron microscopic analysis, dilation of the ER cisternae³⁷⁰ (Fig. 12.15). The flaming cell likely represents an early stage of the thesaurocyte in terms of storage of synthesized Ig.^{371,372} Two lines of evidence suggest that these forms are the result of disturbances in the secretion of Ig. In nonsecretory myelomas, the cells often are similar to thesaurocytes,³⁷³ or flaming plasma cells.³⁷⁴ Mott cells, which are considered plasma cells with multiple Russell bodies, may also result from a complete or partial block in the secretion of Ig, causing localized distention of ER cisternae.³⁷⁵

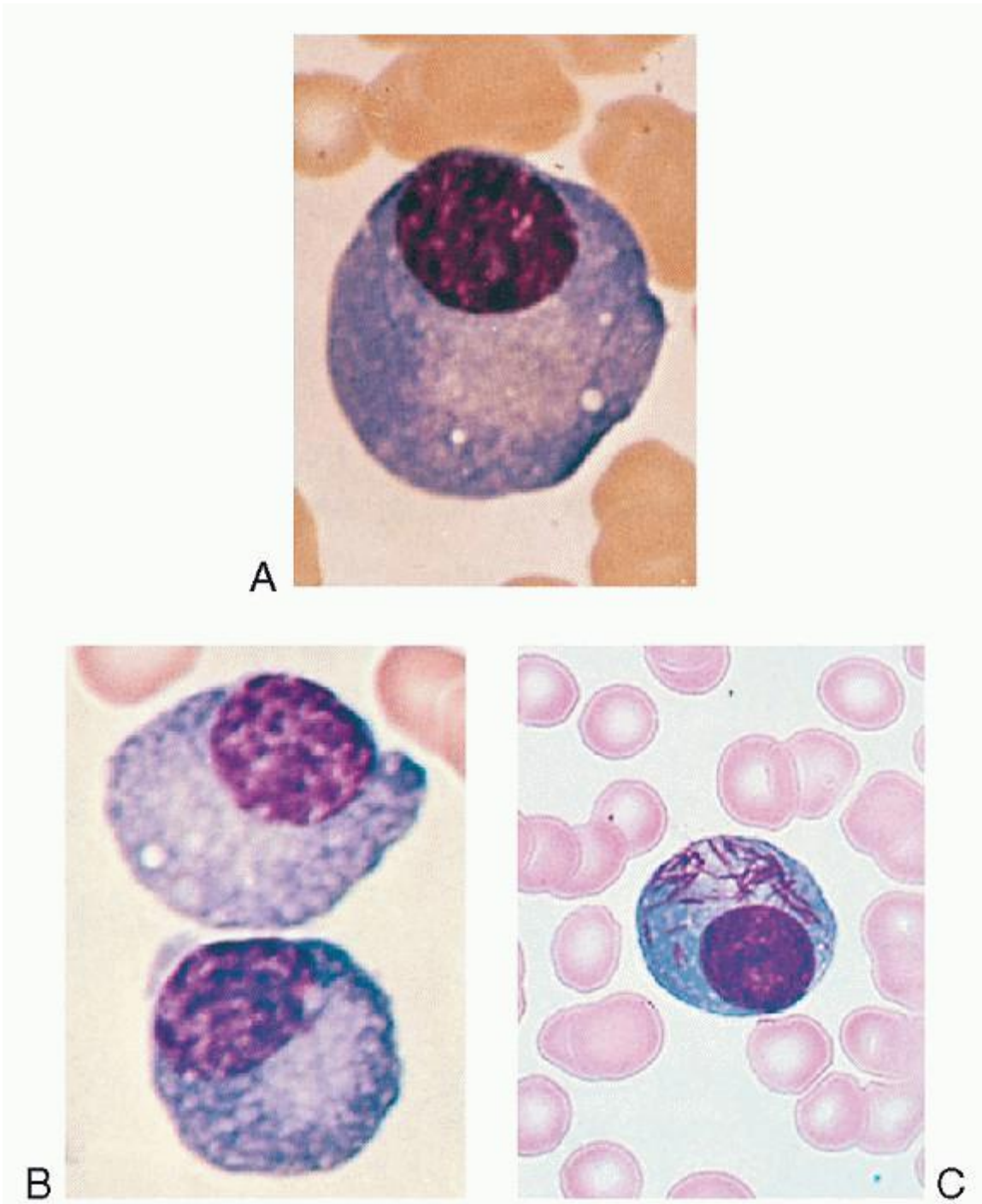

FIGURE 12.14. Plasma cells. A: Normal. B, C: Plasmacytes with vacuoles from the bone marrow of a patient with infection and arthritis.

The most immature plasma cell is the plasmablast, with a nucleus which has evenly dispersed chromatin and a large nucleolus. The ER is sparse and the cytoplasm is filled with clusters of polyribosomes. As the cell matures the chromatin forms clumps and the ER becomes more abundant and well organized. As the lymphocytes mature into plasma cells, they pass through intermediate stages, which are seen in the blood of patients with plasma cell dyscrasias or immunologic diseases characterized by hypergammaglobulinemia. Similar cells sometimes are encountered in the blood of patients with viral infections (Turk cells), including infectious mononucleosis. The intermediate forms have blue cytoplasm with abundant ER, but not as much as the mature plasma cells. Some intermediate forms resemble the less mature transformed lymphocytes with simple ER and many ribosomes and polyribosomes.

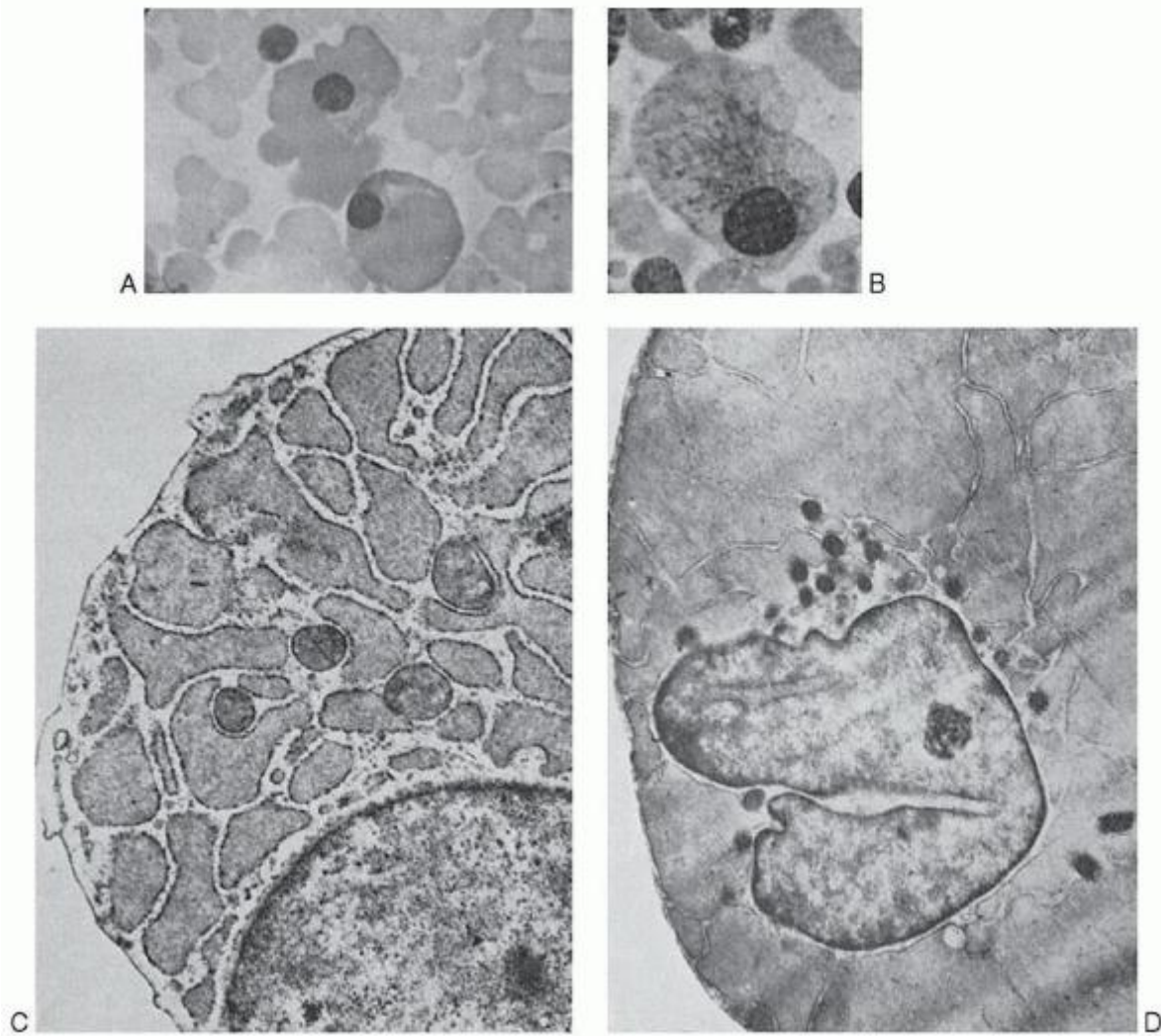

FIGURE 12.15. Unusual forms of plasma cells. Under certain circumstances related to immunoglobulin (Ig) secretion, the cisternae of endoplasmic reticulum are distended as a result of the accumulation of Ig. Plasma cells with accumulation of a homogeneous material that sometimes stains pink or red on Giemsa preparations (thesaurocytes). A, B: Giemsa stain of bone marrow from two patients with IgA myeloma. C, D: Ultrastructure of thesaurocytes with different degrees of distention of the cisternae of the endoplasmic reticulum. (From Bessis M, Breton-Gorius J, Binet JL. Étude comparée du plasmacytome et du syndrome de Waldenström. *Nouv Rev Fr Hematol* 1963;3:159, with permission.)

By the time the lymphocyte evolves into plasma cells, certain surface molecules such as the BCR, the major histocompatibility complex class II, CD19, and CD20 are downregulated; while other molecules such as syndecan-1 (CD138) and CD38 are expressed on the surface of plasma cells. The differentiation of lymphocyte to plasma cells requires the transcription factor PRDM1 (BLMP1), which is a transcriptional repressor.³⁷⁶ PRDM1 represses MYC transcription, which explains the cessation of the cell cycle in plasma cells, and also represses PAX5, which is required for lineage commitment of B-cell development and for isotype switching in germinal centers. Downregulation of PAX5 is necessary for the development of antibody-producing cells, because it represses XBP1, J-chain, and Ig heavy-chain gene transcription.³⁷⁷ PRDM1 promotes plasmacytic differentiation by extinguishing the expression of genes that are important for BCR signaling, germinal-center function, and proliferation, but allowing the expression of XBP1 (X-box binding protein). XBP1 is the only transcription factor required specifically for terminal differentiation of B lymphocytes to plasma cells.³⁷⁸ XBP1 is a basic region leucine zipper protein essential for the growth of hepatocytes and has been implicated in the proliferation of malignant plasma cells.³⁷⁹

P.275

A small subpopulation of germinal-center cells in the light zone express PRDM1, which functions upstream from XBP1.³⁸⁰

These cells have survived the selection and are probably destined to become plasma cells. PRDM1, a germinal-center-restricted transcriptional repressor, inhibits BCL6, required for germinal-center function. A negative feedback loop operates in the germinal centers between PRDM1 and BCL6, the expression of which blocks PRDM1 expression and plasma cell differentiation irreversibly (see also Chapter 14).

MOLECULAR AND ULTRASTRUCTURAL ASPECTS OF IMMUNOGLOBULIN BIOSYNTHESIS

Heavy and light chains are synthesized separately, the H chain on large 270S to 300S polyribosomes composed of 16 to 20 subunits, and the L chains on smaller 190S to 200S polyribosomes composed of 7 to 8 subunits. The size of these polysomes is such as to suggest synthesis of each chain as a single unit. Under normal conditions the L chains may be synthesized in slight excess. After completion of separate synthesis of H and L chains, intramolecular folding and assembly of the individual chains begins on nascent proteins and continues into the cisternae of the ER. Depending on the Ig class, the assembly begins with the formation of the H-L half-molecules, two of which then combine to form a complete Ig monomer. Alternatively, two H chains combine to form H₂, followed by H₂L, suggesting that the final H₂-L₂ structure may be reached by several pathways.³⁸¹ Assembly of H chains is restricted between chains of the same class, so that dimers between different H chain isotypes are not formed in cells expressing both. In most instances, polymeric Ig, such as IgM and IgA (9S, 11S, 13S), are assembled intracellularly from their constituent subunits.

The attachment of core oligosaccharides to the N-glycosylation acceptor site begins on the ribosome, but glycosylation is completed in the Golgi apparatus, where the polypeptides are transported from the ER.³⁸² The Golgi apparatus is also the site of final processing of the carbohydrate,³⁸³ and where the molecule is attached to membrane and then packaged into vesicles for secretion or incorporation into the plasma membrane.³⁸³ This mechanism of secretion is a form of reverse pinocytosis. Disruption of the traffic of the vesicles containing Ig inhibits Ig secretion.

The carbohydrate moiety may facilitate the secretion of Ig by the cell, although this effect depends on the Ig class and the amount of Ig synthesized. For some classes, such as IgM, Ig secretion is blocked when glycosylation is inhibited. H chains that have not bound to L chains form complexes with an H chain-binding protein (BiP).^{384,385} BiP prevents transportation of H chains to the Golgi complex until they become associated with the L chains that displace BiP. The presence of such complexes provides an explanation for the lack of secretion of μ chains in pre-B cells when L chains are not available. In contrast to the normal situation, free H chains are secreted in certain lymphomas (H chain disease).^{386,387} In these disorders, the H chains have a large deletion involving the CH-1 domain,³⁸⁸ which explains how these mutant chains can be secreted, i.e., complexes with BiP can be formed only through the CH-1 domain.^{389,390} Although the synthesis of L chains and H chains takes only 30 and 60 seconds, respectively, the addition of carbohydrates and the process of secretion take at least another 30 minutes. An adult synthesizes approximately 2.3 g of Ig daily,³⁹¹ and most Ig-synthesizing cells contain one type of H chain and one type of L chain,³⁹² but a few cells (usually <1%) contain more than one type of H chain, usually μ and γ .

Antibody first appears in the perinuclear cisternae³⁹³ and eventually is detected in the rest of the ER^{394,395} (Fig. 12.16). Activation of the ER cisternae is gradual, because not all of them within the same cell contain antibody at any one moment. Antibody is found in association with the ribosomes of ER and is not detected outside the ER cisternae. In most immature blasts with a sparse or nonexistent ER, antibody is present in the cytoplasm, synthesized on polyribosomal clusters. Not only the intracellular distribution but also the rate of synthesis increases with time; and Ig, in some cases, distends the cisternae, forming large spheric masses reminiscent of Russell bodies. Not all plasma cells contain antibody during the primary response. In the first 2 to 3 days after immunization, most of the plasma cells contain Ig that has no antibody activity.³⁹⁶ Antibody-containing plasma cells appear later in the response and throughout plasmacytic differentiation, the Golgi apparatus always contains antibody.

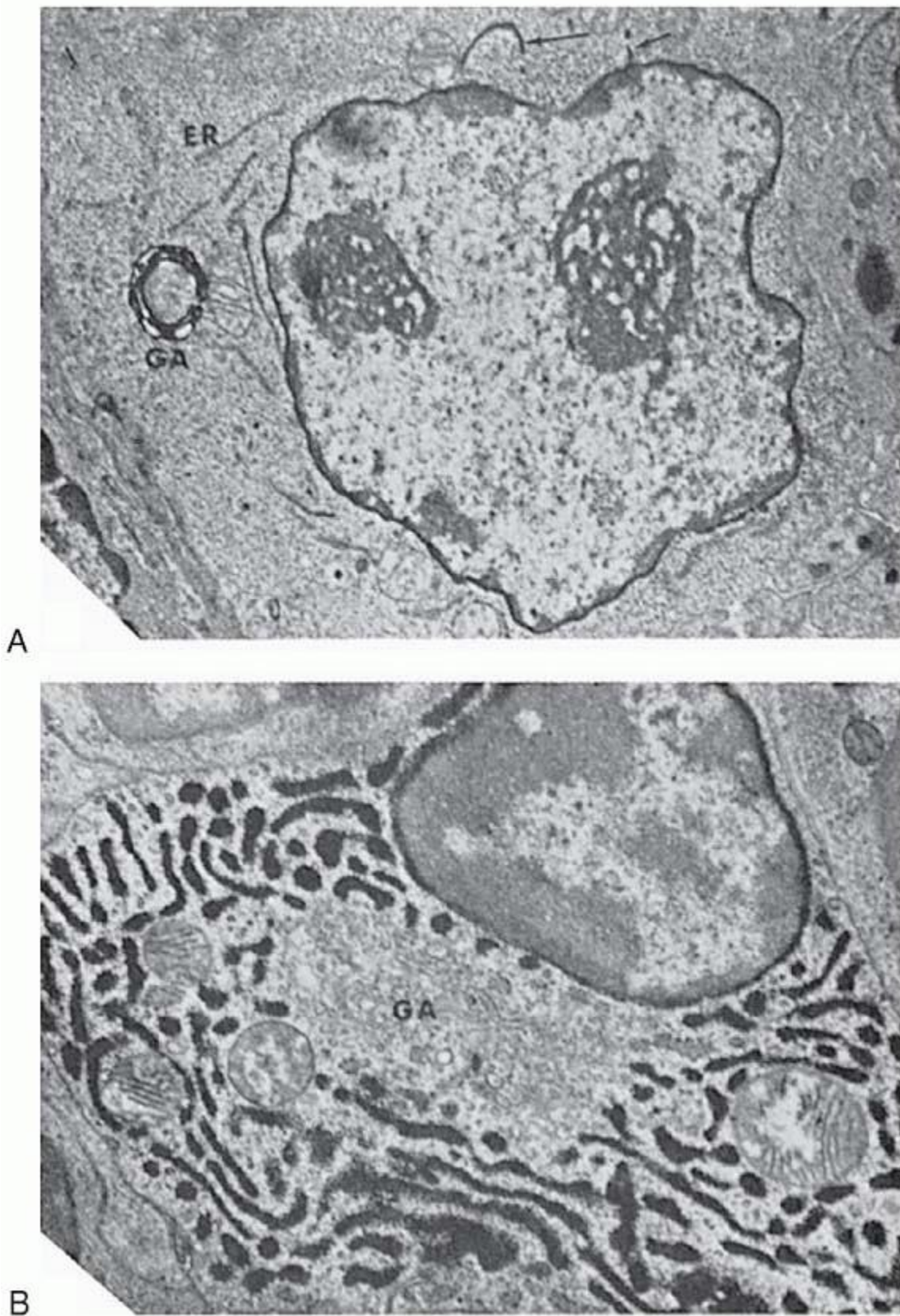

FIGURE 12.16. Ultrastructural localization of antibody. A: An immature plasma cell demonstrates antibody primarily in the perinuclear area. Antibody is also detected in the few strands of endoplasmic reticulum (ER, arrows) and the Golgi (GA)

apparatus. B: Plasma cell with well developed endoplasmic reticulum filled with antibody. Both cells were isolated from rabbits immunized with peroxidase. For the intracellular localization of the antiperoxidase antibody, the cells were treated with peroxidase before incubation with diaminobenzidine. (From Leduc EH, Avrameas S, Bouteille M. Ultrastructural localization of antibody in differentiating plasma cells. *J Exp Med* 1968;127:109-118. Reproduced by copyright permission of the Rockefeller University Press.)

B-CELL ACTIVATION AND DIFFERENTIATION

Malignancies arise from one cell; therefore they are monoclonal and inherit a unique Ig rearrangement.¹⁰⁶ The new technology of gene profiling enables identification of the genes that are activated

P.276

and very likely it is characteristic of each stage in the life of the B cell. This technology has already been applied on normal B cells to characterize their genetic profile in various functional states. Gene profiling inspects activation and gene transcription of hundreds or thousands of genes, providing a global genomic view.³⁹⁷ In contrast to gene sequencing (structural genomics), gene profiling is considered a new field of functional genomics.

Serial analysis of gene expression (SAGE) uses gene-specific 14-bp sequence tags for enumeration of genes expressed in a cell.³⁹⁸ In the new methods, DNA fragments from individual genes are placed on a solid support in an ordered array. Total cellular mRNA isolated from cells is used to generate, by reverse transcription, cDNA probes tagged by radioactivity or fluorescence. The cDNA probes are then applied to the arrays for hybridization with the DNA on the array. The hybridization results are quantitated by phosphor imagers for radioactive probes, or by scanning confocal microscopy for fluorescent probes. In one commonly used microarray system, oligonucleotides are produced by in situ synthesis in a technique called photolithography and are hybridized by fluorescent cDNA probes.^{399,400} In another technique, PCR products from cDNA clones are spotted onto coated glass slides.⁴⁰¹ In this technique, two cDNA probes from different samples, labeled with different fluorochromes (usually Cy3 or Cy5), are applied on the microarray simultaneously for hybridization. The expression for each gene is evaluated by the ratio of the fluorescence, and interpretation of the data uses algorithms. Various analytical tools are available, but no single tool is better than others. Their use may well depend on the experimental design and the questions asked.^{402,403}

One approach uses hierarchical clustering,⁴⁰⁴ and this algorithm begins by clustering pairs of genes with the most similar patterns of expression, eventually building larger and larger clusters. Clustering may be unsupervised (i.e., the arrangement of gene expression follows predefined parameters built into the algorithm). In supervised clustering, the investigator introduces other parameters such as clinical data. Several algorithms have been designed for data analysis, and more than one may be necessary for the analysis.

Three B-cell functional states were evaluated in an experimental model: naive B cells, B cells activated in vitro by a foreign antigen (hen egg lysozyme, HEL), and B cells tolerant against self. In this case B cells were obtained from transgenic mice (i.e., expressing HEL from birth); therefore, the B cells have developed tolerance against HEL as for any other natural self-antigen.^{405,406} The results show that the naive or resting state is maintained by several inhibitory genes, whereas activation is associated with loss of expression of some of the inhibitory genes rather than the induction of genes that regulate entry into the cell cycle. B cells tolerant to "self" are characterized by increasing expression of more inhibitory genes at the same time that they maintain the expression of the basal inhibitory gene profile.

Some other data reveal that the gene profile of in vitro activated B cells differs from that of germinal-center B cells, where they are activated by T cells.³⁹⁷ Germinal-center B cells differ from naive B cells in the expression of hundreds of genes.⁴⁰⁷ The function of signaling molecules has been studied by inactivation of the appropriate gene, but repercussions from changes in the expression of other genes cannot be heard. An attempt was made to provide an answer to this question from the effect of reduction of the function of PI3K or BTK to other genes. Reduced function of PI3K or BTK significantly affected 5% of BCR-dependent gene expression.⁴⁰⁸ The data also suggested that PI3K acts through BTK in regulating genes that are critical for determining entry into the cell cycle. By hierarchical clustering it has been possible to identify groups of genes that are characteristic of a lineage or a specific stage of differentiation or proliferation (i.e., germinal-center B cells), and each group of genes defines a signature of a cell type or of a function, etc.

Plasma cells, which represent the end stage of B-cell differentiation, were found to have 1,476 known genes, which were differently expressed compared to B cells.⁴⁰⁹ A number of factors characteristic of terminal differentiation (i.e., related to RNA polymerase I) were downregulated, while a number of transcription factors were maintained (e.g., AP-1, NFAT, and NF- κ B). Two genes specific for factors associated with neuronal cell positioning, reeling and neuropilin-1, were unexpectedly expressed and their role in plasma cell life remains to be determined.

B-CELL MALIGNANCIES

A large body of data has already been collected in the short period since this technology was developed for large-scale application, and the findings in B-cell malignancies hold a number of unexpected results.⁴¹⁰ Diffuse large B-cell lymphomas (DLBCLs) have been shown to have two different gene profiles.⁴¹⁰ In one group of patients, the cells had a germinal-center gene profile, whereas in the second group, the lymphoma cells showed a profile of mitogenically activated B cells, and these two groups differ in several genes. DLBCL with the germinal-center B-cell profile has retained the hypermutation machinery, but the second group resembling mitogenically activated B cells has not.⁴¹¹ The germinal-center B-like DLBCL also resembles closely follicular lymphoma.⁴¹² On the basis of sharing some gene expressions with a small population of germinal-center B cells, as well as with plasma cells, it has been suggested that the activated B-like DLBCL may arise from a cell in its transition to becoming a plasma cell.

Another important finding is the possibility that B-CLL, which phenotypically has been separated into two groups on the basis of CD38 expression, may actually be one genomic disease with two variants.⁴¹³ A small number of <30 genes may, however, be able to distinguish cases with IgV-mutated versus -unmutated profiles.⁴¹⁴ Furthermore, the gene profiles have indicated that in the majority of cases, the cells are related to memory B cells rather than naive B cells or B cells of any other category. This may not be unexpected, because the somatic hypermutation machinery is active in CLL and could play a role in intraclonal diversification development.⁴¹⁵ Microarray gene profiling has been used to identify B-CLL cases with cells resistant to apoptosis after DNA damage. Thirteen of 16 genes were found that were specific for resistant B-CLL cells.⁴¹⁶ A study of mantle cell lymphoma also detected resistance to apoptosis gene profiling. The FADD (Fas-Associated Death Domain) gene, a key gene associated with Fas-mediated apoptosis, was downregulated 10-fold in this lymphoma.⁴¹⁷

In multiple myeloma, the profiling suggests a classification into four subgroups.^{418,419} Group 1 patients (MM1) have a gene profile similar to MGUS (Monoclonal Gammopathy of Unknown Significance), whereas the patients in the MM4 group have poor prognosis, with a gene profile similar to myeloma cell lines. Numerous unexplained genes with unknown function have been detected, so that only 10% of all these genes have matched entries in the database Expressed Sequence Tags.⁴²⁰

The origin of Hodgkin and Reed-Sternberg (HRS) cells has remained elusive, and recently, strong evidence has been presented that in most cases with this disease, the cell is of B-lineage origin and only rarely originates from a T cell.⁴²¹ Identification of gene profiling demonstrated that the HRS cell expresses a distinct gene profile regardless of its B- or T-cell derivation. The gene profile is similar to that of EBV-transformed B cells or cell lines from large cell lymphomas, with features of in vitro-activated B cells.⁴²² Among the genes specifically identified in HRS are a cluster of genes for transcription factors (i.e., GATA3, MSC/ABF-1, NR2F1/EAR-3, and NFE2L3/NRF3). Downregulation of several genes that are active in B cells was identified. Several of these genes are positively regulated by the transcription factor

P.277

PAX5 (see "Stem Cell to Progenitor B [Pro-B] Cell"). However, the PAX5 gene is still expressed in HRS cells, and therefore the loss of B-cell-specific gene expression remains unknown.⁴²³

BTK mutations influence the expression of other genes in EBV-transformed cell lines and, in the absence of functional BTK, 11 genes were identified that were induced more than 1.9-fold.⁴²⁴ Microarray gene profiling has been applied to develop a molecular predictor of survival after chemotherapy for DLBCL. The study used 17 genes to construct a predictor of overall survival.⁴²⁵ Four gene groups were identified and clustered within individual signatures. The proliferation signature was the best predictor for adverse outcome. Signatures identifying good prognosis were the lymph node signature, encoding extracellular matrix, and the connective tissue growth factor, which promotes fibrosis and synthesis of extracellular matrix. Some of these genes are linked to histologic or other lymph node reactions, known already for their favorable prognosis. For example, the lymph node signature is associated with expression of genes that are also expressed in macrophages and NK cells, presumed to indicate a cellular antitumor response. The other favorable signature is the major histocompatibility complex class II gene expression.

B-CELL SUBPOPULATIONS

A subpopulation of B cells can be detected on the basis of expression of the CD5 antigen ordinarily present on T cells. The CD5 antigen (formerly T1 or Leu1) is a 67,000-dalton gp detected on all normal T cells,^{426,427} on a small subpopulation of normal B cells,⁴²⁸ and on all cells from patients with CLL.^{429,430} and⁴³¹ The CD5 B cells possess unique properties, i.e., they are phenotypically identical to CD5⁻ B cells,⁴³² but they are larger; in mice they have 10 times more mIgM with λ chains, which is expressed only rarely in mice. The CD5⁺ B cells are present in high numbers in fetal and neonatal life (50% of all IgM⁺ B cells), but they progressively diminish in number after birth and are present in small numbers in secondary

lymphoid organs in adult life.^{433,434} and ⁴³⁵ At birth most of the B cells in cord blood are CD5⁺,⁴³⁴ but they constitute less than 10% to 30% of B cells in adult spleen, lymph nodes, and peripheral blood. Their proliferative capacity is high and as a result, they give rise spontaneously to cell lines that demonstrate MYC amplification.⁴³⁶ Presently there are two views regarding the origin of the CD5⁺ subpopulation. According to one of them, the CD5⁺ cells (also known as B1a) belong to a lineage of B cells distinct from the conventional B lymphocytes (CD5⁻).^{437,438} and ⁴³⁹

The CD5⁺ (B-1) cells develop early in ontogeny and, in the adult, predominate in peritoneal and pleural cavities and are self-replenished; that is, they do not arise from undifferentiated progenitors. Progenitors of CD5⁺ cells are present in fetal liver and omentum but not adult bone marrow, whereas conventional B-cell progenitors are present in fetal liver and adult bone marrow. According to the second hypothesis, the B-1 cells derive from conventional B cells,^{440,441} based on in vitro evidence of stimulation of conventional B cells with anti-IgM antibodies and IL6, which generated the B-1 phenotype.⁴⁴²

B-1 cells may have different antibody repertoires (e.g., have few N-region insertions in their rearranged V genes), and the V_H repertoire is biased toward V gene families proximal to J_H, whereas in adult B cells it is more randomized.

Perhaps the most controversial aspect is the production of autoantibodies. In NZB mice (New Zealand Black), a strain well-known for autoimmune phenomena, the CD5⁺ B cells are increased in number and spontaneously secrete IgM autoantibodies.⁴⁴³ Increased numbers of CD5⁺ B cells are found in patients with rheumatoid arthritis,^{444,445} Sjögren syndrome,⁴⁴⁶ and progressive systemic sclerosis,⁴⁴⁷ but not in patients with systemic lupus erythematosus.⁴⁴⁷ Numbers of CD5⁺ B cells are also increased after bone marrow transplantation.⁴⁴⁸ In 95% of patients with B-cell CLL, the leukemic cells express the CD5 antigen,^{429,430,449} which is also detected on cells from other B-cell lymphomas, the CD5⁺ B cells from normal subjects,^{450,451} or from patients with CLL.⁴⁵² The CD5⁺ B-cell subpopulation may therefore play an important role in the development of B-cell repertoire related to natural immunity, which develops in the absence of an encounter with exogenous antigens. Certain V genes are selectively expressed in CD5⁺ B cells, and those are not changed by somatic hypermutations normally observed in CD5⁻ B cells responding to exogenous antigens. The marginal zone B lymphocytes share many phenotypic characteristics with B-1 cells and, like them, develop in response to T-independent type-2 antigens. The B-2 repertoire is selected by self-antigen and therefore tends to be autoreactive. Selection into the B-1a population is favored during fetal life because TdT is not expressed during this period; therefore, the repertoire is limited in its specificity range. This dangerous repertoire is kept under control by the CD5-mediated negative signaling, thus preventing inappropriate activation. On the other hand, this repertoire is useful because the B-1 cell specificities are directed against several pathogens and are important in mucosal immunity.⁴⁵³

REFERENCES

1. Hurwitz CA, Loken MR, Graham ML, et al. Asynchronous antigen expression in B lineage acute lymphoblastic leukemia. *Blood* 1988;72:299-307.
2. Metcalf D. Hematopoietic regulators: redundancy or subtlety? *Blood* 1993;82:3515-3523.
3. Orkin SH. Diversification of haematopoietic stem cells to specific lineages. *Nat Rev Genet* 2000;1:57-64.
4. Shivdasani RA, Orkin SH. The transcriptional control of hematopoiesis. *Blood* 1996;87:4025-4039.
5. Busslinger M. Transcriptional control of early B cell development. *Ann Rev Immunol* 2004;22:55-79.
6. Rothenberg EV, Pant R. Origins of lymphocyte developmental programs: transcription factor evidence. *Semin Immunol* 2004;16:277-238.
7. Medina KL, Singh H. Genetic networks that regulate B lymphopoiesis. *Curr Opin Hematol* 2005;12:203-209.
8. Hagman J, Lukin K. Transcription factors drive B cell development. *Curr Opin Hematol* 2006;18:127-134.
9. Sellars M, Kastner P, Chan S. Ikaros in B cell development and function. *World J Biol Chem* 2011;2:132-139.
10. Klug A. The discovery of zinc fingers and their development for practical applications in gene regulation and genome manipulation. *Q Rev Biophys* 2010;43:1-21.
11. Klug CA, Morrison SJ, Masek M, et al. Hematopoietic stem cells and lymphoid progenitors express different Ikaros isoforms, and Ikaros is localized to heterochromatin in immature lymphocytes. *Proc Natl Acad Sci U S A* 1998;95:657-662.
12. Kelley CM, Ikeda T, Korpally J, et al. Helios, a novel dimerization partner of Ikaros, expressed in the earliest hematopoietic progenitors. *Curr Biol* 1998;8:508-515.
13. Payne KJ, Dovat S. Ikaros and tumor suppression in acute lymphoblastic leukemia. *Crit Rev Oncog* 2011;16:3-12.

14. Iwasaki H, Somoza C, Shigematsu H, et al. Distinctive and indispensable roles of PU.1 in maintenance of hematopoietic stem cells and their differentiation. *Blood* 2005;106:1590-1600.
15. Ye M, Ermakova O, Graf T. PU.1 is not strictly required for B cell development and its absence induces a B-2 to B-1 cell switch. *J Exp Med* 2005;202: 1411-1422.
16. Montecino-Rodriguez E, Dorshkind K. B-1 B cell development in the fetus and adult. *Immunity* 2012;36:13-21.
17. Markus M, Benezra R. Two isoforms of protein disulfide isomerase alter the dimerization status of E2A proteins by a redox mechanism. *J Biol Chem* 1999;274:1040-1049.
18. Riley RL, Blomberg BB, Frasca D. B cells, E2A, and aging. *Immunol Rev* 2005;205:30-47.
19. Kee BL, Murre C. Induction of early B cell factor (EBF) and multiple lineage genes by the basic helix-loop-helix transcription factor E12. *J Exp Med* 1998;188:699-713.
20. Nera K-P, Kohonen P, Narvi E, et al. Loss of Pax-5 promotes plasma cell differentiation. *Immunity* 2006;24:283-293.
21. Zhang Z, Espinoza CR, Yu Z, et al. Transcription factor Pax-5 (BSAP) trans-activates the RAG-mediated V_H- to DJ_H rearrangement of immunoglobulin genes. *Nat Immunol* 2006;7:616-624.
22. Miyazaki A, Yogosawa S, Murakami A, et al. Identification of CMTM7 as a transmembrane linker of BLNK and the B-cell receptor. *PLoS One* 2012;7(2):e31829. Epub 2012
23. Chiang MY, Monroe JG. BSAP/Pax-5A expression blocks survival and expansion of early myeloid cells implicating its involvement in maintaining commitment to the B lymphocyte lineage. *Blood* 1999;94:3621-3632.
24. Delogu A, Schebesta A, Sun Q, et al. Gene expression by Pax5 in B cells is essential for blood cell homeostasis and is reversed in plasma cells. *Immunity* 2006;24:269-281.
25. Kerblad P, Rosberg M, Leanderson T, et al. The B29 (immunoglobulin beta-chain) gene is a genetic target for early B-cell factor. *Mol Cell Biol* 1999;19:392-401.
26. Gisler R, Jacobsen SEW, Sigvardsson M. Cloning of human early B-cell factor and identification of target genes suggest a conserved role in B-cell development in man and mouse. *Blood* 2000;96:1457-1464.
27. Hagman J, Luken K. Early B-cell factor "pioneers" the way for B cell development. *Trends Immunol* 2005;26:455-461.
28. Kee BL, Quong MW, Durre C. E2A proteins: essential regulators at multiple stages of B-cell development. *Immunol Rev* 2000;175:138-149.
29. Schoetz V, Cervelli M, Wang Y-D, et al. E2A expression stimulates Ig hypermutation. *J Immunol* 2006;177:395-400.
30. Lazorchak A, Jones ME, Zhuang Y. New insights into E-protein function in lymphocyte development. *Trends Immunol* 2005;26:334-338.
31. Lazorchak AS, Wojciechowski J, Dai M, Zhuang Y. E2A promotes the survival of precursor and mature B lymphocytes. *J Immunol* 2006;177:2495-2504.
32. Dorshkind K. Regulation of hematopoiesis by bone marrow stromal cells and their products. *Annu Rev Immunol* 1990;8:111-137.
33. Moreau I, Duvert V, Caux C, et al. Myofibroblastic stromal cells isolated from human bone marrow induce the proliferation of both early myeloid and B-lymphoid cells. *Blood* 1993;82:2396-2405.
34. Pribyl JAR, Le Bien TW. Interleukin-7 independent development of human B cells. *Proc Natl Acad Sci U S A* 1996;93:10348-10353.
35. Ryan DH, Nuceie BL, Abboud CN, et al. Vascular cell adhesion molecule-1 and the integrin VLA-4 mediate adhesion of human B-cell precursors to cultured bone marrow adherent cells. *J Clin Invest* 1991;88:995-1004.
36. Simmons DL, Satherthwaite AB, Tenen DG, et al. Molecular cloning of a cDNA encoding CD34, a sialomucin of human hematopoietic stem cells. *J Immunol* 1992;148:267-271.
37. Simmons PJ, Toroh-Storb B. CD34 expression by stromal precursors in normal human adult bone marrow. *Blood* 1991;78:2848-2853.
38. Lin G, Finger E, Gutierrez-Ramos JC. Expression of CD34 in endothelial cells, hematopoietic progenitors and nervous cells in fetal and adult mouse tissue. *Eur J Immunol* 1995;25:1508-1516.

39. von Freeden-Jeffrey U, Vieira P, Lucian LA, et al. Lymphopenia in interleukin IL-7 gene-deleted mice identified IL-7 as a non-redundant cytokine. *J Exp Med* 1995;181:1519-1526.
40. Treiber T, Mandel EM, Pott S, et al. Early B cell factor 1 regulates B cell gene networks by activation, repression, and transcription-independent poisoning of chromatin. *Immunity* 2010;32:714-725
41. O'Brien P, Morin P Jr, Ouellette RJ, Robichaud GA. The Pax-5 gene: a pluripotent regulator of B-cell differentiation and cancer disease. *Cancer Res* 2011;71:7345-7350.
42. Wei C, Zeff R, Goldschneider I. Murine pro-B cells require IL-7 and its receptor complex to up-regulate IL-7R α terminal deoxynucleotidyl transferase, and μ expression. *J Immunol* 2000;164:1961-1970.
43. Corcoran AE, Smart FM, Cowling RJ, et al. The interleukin-7 receptor alpha chain transmits distinct signals for proliferation and differentiation during B lymphopoiesis. *EMBO J* 1996;15:1924-1932.
44. Zhang Y, Zhou B. Functions of thymic stromal lymphopoietin in immunity and disease. *Immunol Res* 2012;52(3):211-223.
45. Noguchi M, Yi H, Rosenblatt HM, et al. Interleukin-2 receptor γ chain mutation results in X-linked severe combined immunodeficiency in humans. *Cell* 1993;73:147-157.
46. Puel A, Ziegler SF, Buckley RH, et al. Defective IL-7R expression in T-B+NK+ severe combined immunodeficiency. *Nat Genet* 1998;20:394-397.
47. Dittel BN, Le Bien TW. The growth response to IL-7 during normal B cell ontogeny is restricted to B-lineage cells expressing CD34. *J Immunol* 1995;154:58-67.
48. Namikawa R, Muench MO, de Vries JE, et al. The FLK2/FLT3 ligand synergizes with interleukin-7 in promoting stromal cell-independent expansion and differentiation of human fetal pro-B cells in vitro. *Blood* 1996;87:1881-1890.
49. Ryan DH, Nuccie BL, Ritterman I, et al. Expression of interleukin-7 receptor by lineage-negative human bone marrow progenitors with enhanced lymphoid proliferative potential and B-lineage differentiation capacity. *Blood* 1997;89:929-940.
50. Hao Q-L, Zhu J, Price MA, et al. Identification of a novel human multi-lymphoid progenitor in cord blood. *Blood* 2001;97:3683-3690.
51. Medina KL, Singh H. Genetic networks that regulate B lymphopoiesis. *Curr Opin Hematol* 2005;12:203-209.
52. Deichmann MR, Kronenwett R, Haas R. Expression of the human immunodeficiency viruses type-1, coreceptors CXCR4 (fusin, LESTR) and CKR-5 in CD34+ hematopoietic progenitor cells. *Blood* 1997;89:3522-3528.
53. Ishii T, Nishihara M, Ma F, et al. Expression of stromal cell-derived factor-1/pre-B cell growth-stimulating factor receptor, CXC chemokine receptor-4, on CD34+ human bone marrow cells is a phenotypic alteration for committed lymphoid progenitors. *J Immunol* 1999;163:3612-3620.
54. Bleul CC, Farzan M, Choe H, et al. The lymphocyte chemoattractant SDF-1 is a ligand for LESTR/fusin and blocks HIV-1 entry. *Nature* 1996;382:829-833.
55. Raff MC, Megson M, Owen JJT, et al. Early production of intracellular IgM by B lymphocyte precursors in the mouse. *Nature* 1976;259:224-226.
56. Osmond DG, Rolink A, Melchers F. Murine B lymphopoiesis: towards a unified model. *Immunol Today* 1998;19:65-68.
57. Meffre E, Fougereau M, Argenson JN, et al. Cell surface expression of surrogate light chain (ψ L) in the absence of μ on human pro-B cell lines and normal pro-B cells. *Eur J Immunol* 1996;26:2172-2180.
58. Sanz E, de la Hera A. A novel anti-VpreB antibody identifies immunoglobulin surrogate receptors on the surface of human pre-B cells. *J Exp Med* 1996;183:2693-2698.
59. Lemmers B, Gauthier L, Guelpa-Fonlupt V, et al. The human (Ψ + μ -) pro-B complex: cell surface expression and biochemical structure of a putative transducing receptor. *Blood* 1999;93:4336-4346.
60. Mattei MG, Fumoux F, Roeckel N, et al. The human pre-B specific λ -like cluster is located in the 22q11.2-22q12.3 region distal to the Ig κ locus. *Genomics* 1991;9:544-546.
61. Karasuyama H, Rolink A, Melahers F. Surrogate light chain in B cell development. *Adv Immunol* 1996;63:1-41.

62. Minegishi Y, Hendershot LM, Conley ME. Novel mechanisms control the folding and assembly of $\lambda 5/14.1$ and V pre-B to produce an intact surrogate light chain. *Proc Natl Acad Sci U S A* 1999;96:3041-3046.
63. Hendershot LM, Kearney JF. A role for human heavy chain binding protein in the developmental regulation of immunoglobulin transport. *Mol Immunol* 1998;25:585-595.
64. Melchers F. Fct for life in the immune system? Surrogate L chain tests H chains that test L chains. *Proc Natl Acad Sci U S A* 1999;96:2571-2573.
65. Grawunder U, Leu TM, Schatz DG, et al. Down-regulation of RAG1 and RAG2 gene expression in pre-B cells after functional immunoglobulin heavy chain rearrangement. *Immunity* 1995;3:601-608.
66. Burrows PD, Stephan RP, Wang Y-H, et al. The transient expression of pre-B receptors governs B cell development. *Semin Immunol* 2002;14:343-349.
67. Karasuyama H, Rolink A, Melchers F. Surrogate light chain in B cell development. *Adv Immunol* 1996;61:1-41.
68. Gauthier L, Lemmers B, Guelpa-Fonlupt V, et al. μ -Surrogate light chain, physicochemical interactions of the human pre-B cell receptor: implications for VH repertoire selection and cell signaling at the pre-B cell stage. *J Immunol* 1999;162:41-50.
69. Bradl H, Jack HM. Surrogate light chain-mediated interaction of a soluble pre-B cell receptor with adherent cell lines. *J Immunol* 2001;167:6403-6411.
70. Bradl H, Wittmann J, Milius D, et al. Interaction of murine precursor B cell receptor with stromal cells is controlled by the unique tail of lambda 5 and stroma cell associated heparin sulfate. *J Immunol* 2003;171:2338-2348.
71. Gauthier L, Rossi B, Roux F, et al. Galectin-1 is a stromal cell ligand of the pre-B cell receptor (BCR) implicated in synapse formation between pre-B and stromal cells and in the pre-BCR triggering. *Proc Natl Acad Sci U S A* 2002;99:13014-13019.
72. Bannish G, Fuentes-Panana EM, Cambier JC, et al. Ligand-independent signaling functions for the B lymphocyte antigen receptor and their role in positive selection during B lymphopoiesis. *J Exp Med* 2001;194:1583-1596.
73. Geier JK, Schlissel MS. Pre-BCR signals and the control of Ig gene rearrangements. *Semin Immunol* 2006;18:31-39.
74. Shaniel C, Gottar M, Roosnek E, et al. Extensive in vivo self-renewal, long term reconstitution capacity, and hematopoietic multipotency of Pax5-deficient precursor B-cell clones. *Blood* 2000;99:2760-2766.
75. Guo B, Kato RM, Garcia-Lloret M, et al. Engagement of the human pre-B cell receptor generates a lipid raft-dependent calcium signaling complex. *Immunity* 2000;13:243-253.
76. Taguchi T, Kiyokawa N, Mimori K, et al. Pre-B cell antigen receptor-mediated signal inhibits CD24-induced apoptosis in human pre-B cells. *J Immunol* 2003;170:252-260.
77. Melchers F, ten Boekel E, Yamagami T, et al. The roles of pre-B and B cell receptors in the stepwise allelic exclusion of mouse IgH and L chain gene loci. *Semin Immunol* 1999;11:307-317.
78. Skok J, Brown K, Azura V, et al. Nonequivalent nuclear location of immunoglobulin alleles in B lymphocytes. *Nat. Immunol* 2001;2:848-854.
79. Sabbattini P, Lundgren M, Georgiou A, et al. Binding of Ikaros to the $\lambda 5$ promoter silences transcription through a mechanism that does not require heterochromatin formation. *EMBO J* 2001;20:2812-2822.
80. Conley ME, Rohrer J, Rapalus L, et al. Defects in early B-cell development: comparing the consequences of abnormalities in pre-B cell signaling in the human and the mouse. *Immunol Rev* 2000;178:75-90.
81. Mundt C, Licence S, Shimizu T, et al. Loss of precursor B cell expansion but not allelic exclusion in VpreB1/VpreB2 double-deficient mice. *J Exp Med* 2001;193:435-445.
82. Kitamura D, Kudo A, Shaal S, et al. A critical role of $\lambda 5$ protein in B cell development. *Cell* 1992;69:823-831.
83. Kitamura D, Roes J, Kuhn R, et al. A B cell-deficient mouse by targeted disruption of the membrane exon of the immunoglobulin μ chain gene. *Nature* 1991;350:423-426.
84. Stephan RP, Elgavish E, Karasuyama H, et al. Analysis of V-pre B expression during B lineage differentiation in $\lambda 5$ -deficient mice. *J Immunol* 2001;167:3734-3739.

85. Minegishi Y, Coustan-Smith E, Wang YH, et al. Mutations in the human lambda 5/14.1 gene result in B cell deficiency and agammaglobulinemia. *J Exp Med* 1998;187:71-77.
86. Wang Y-H, Namura J, Faye-Petersen OM, et al. Surrogate light chain production during B cell differentiation: differential intracellular versus cell surface expression. *J Immunol* 1998;161:1132-1139.
87. Meffre E, Chiorazzi M, Nussenzweig MC. Circulating human B cells display a unique antibody repertoire. *J Immunol* 2001;167:2151-2156.
88. Meffre E, Papavasiliou F, Cohen P, et al. Antigen receptor engagement turns off the V(D)J recombination machinery in human tonsil B cells. *J Exp Med* 1998;188:765-772.
89. Meffre E, Davis E, Schiff C, et al. Circulating human B cells that express surrogate light chains and edited receptors. *Nat Immunol* 2000;1:207-213.
90. Kersseboom R, Ta VB, Zijlstra AJE, et al. Bruton's tyrosine kinase and SLP-65 regulate pre-B cell differentiation and the induction of Ig light chain gene rearrangement. *J Immunol* 2006;176:4543-4552.
91. Guloglu FB, Bajor E, Smith BP, Roman CAJ. The unique region of surrogate light chain component $\lambda 5$ is a heavy chain-specific regulator of precursor B cell receptor signaling. *J Immunol* 2005;175:358-366.
92. Lanig H, Bradl H, Jack HM. Three-dimensional modeling of a pre-B cell receptor. *Mol Immunol* 2004;40:1263-1272.
93. van Zelm MC, van der Burg M, de Ridder D, et al. Ig gene rearrangement steps are initiated in early human precursor B cell subsets and correlate with specific transcription factor expression. *J Immunol* 2005;175:5912-5922.
94. Kawano Y, Yoshikawa S, Minegishi Y, Karasuyama H. Pre-B cell receptor assesses the quality of IgH chains and tunes the pre-B cell repertoire by delivering differential signals. *J Immunol* 2006;177:2242-2249.
95. Watson CT, Breden F. *Genes Immun* May 2012. The immunoglobulin heavy chain locus: genetic variation, missing data, and implications for human disease. [Epub ahead of print.]. doi:10.1038/gene.2012.12.
96. Lefranc MP. Nomenclature of the human immunoglobulin genes. *Curr Protoc Immunol* May 2001;Appendix-1:Appendix 1P.
- P.278
97. Erikson J, Martinis J, Croce CM. Assignment of the genes for human λ immunoglobulin chains to chromosome 22. *Nature* 1981;294:173-175.
98. McBride OW, Heiter PA, Hollis GF, et al. Chromosomal location of human kappa and lambda immunoglobulin light chain constant region genes. *J Exp Med* 1982;155:1480-1490.
99. Tomlison IM, Walter G, Marks ID, et al. The repertoire of human germline VH sequences reveals about fifty groups of VH segments with different hypervariable loops. *J Mol Biol* 1992;227:776-798.
100. Matsuda F, Shin EK, Nagaoka H, et al. Structure and physical map of 64 variable segments in the 3' 0.8-megabase region of the human immunoglobulin heavy-chain locus. *Nat Genet* 1993;3:88-94.
101. Pascual V, Capra JD. Human immunoglobulin heavy-chain variable region genes: organization, polymorphism, and expression. *Adv Immunol* 1991;49:1-74.
102. Schilling J, Clevinger B, Davie JM, et al. Amino acid sequence of homogeneous antibodies to dextran and DNA rearrangements in heavy-chain V-region gene segments. *Nature* 1980;283:35-40.
103. Akamatsu Y, Tsurushita N, Nagawa F, et al. Essential residues in V(D)J recombination signals. *J Immunol* 1994;153:4520-4529.
104. Sleckman BP, Gorman JR, Alt FW. Accessibility control of antigen-receptor variable region gene assembly: role of cis-acting elements. *Annu Rev Immunol* 1996;14:459-481.
105. Gellert M. Recent advances in understanding V(D)J recombination. *Adv Immunol* 1997;64:39-64.
106. Tonegawa S. Somatic generation of antibody diversity. *Nature* 1983;302: 575-581.
107. Frugmann SD, Lee AI, Shockett PE, et al. The RAG proteins and V(D)J recombination: complexes, ends, and transposition. *Ann Rev Immunol* 2000;18: 495-527.

108. Mombaerts P, Iacomini J, Johnson RS, et al. RAG1-deficient mice have no mature B and T lymphocytes. *Cell* 1992;68:869-877.
109. Shinkai Y, Ruthven G, Lam K-P, et al. RAG2-deficient mice lack mature lymphocytes owing to inability to initiate V(D)J rearrangement. *Cell* 1992;68: 855-867.
110. Schwarz K, Gauss GH, Ludwig L. RAG mutations in human B cell-negative SCID. *Science* 1996;274:97-99.
111. Elkin SK, Ivanov D, Ewalt M, et al. A PHD finger motif in the C terminus of RAG2 modulates recombination activity. *J Biol Chem* 2005;280: 28701-28710.
112. Bailin T, Mo X, Sadofsky MJ. A RAG1 and RAG2 tetramer complex is active in cleavage in V(D)J recombination. *Mol Cell Biol* 1999;19:4664-4671.
113. Eastman QM, Leu TMJ, Schatz DG. Initiation of V(D)J recombination in vitro obeying the 12/23 rule. *Nature* 1996;380:85-88.
114. Hiom K, Gellert M. Assembly of a 12/23 paired signal complex: a critical control point in V(D)J recombination. *Mol Cell* 1998;1:1011-1019.
115. Hiom K, Gellert M. A stable RAG1-RAG2-DNA complex that is active in V(D)J recombination. *Cell* 1997;88:65-72.
116. West KL, Singha NC, Deloannes P, et al. A direct interaction between the RAG2 C terminus and the core histones is required for efficient V(D)J recombination. *Immunity* 2005;23:203-212.
117. Bergeran S, Madathiparambil T, and Swanson PC. Both high mobility group (HMG)-boxes and the acidic tail of HMGB1 regulate recombination-activating gene (RAG)-mediated recombination signal synopsis and cleavage in vitro. *J Biol Chem* 2005;280:31314-31324.
118. Dai Y, Wong B, Yen-Y-M, et al. Determinants of HMBG proteins required to promote RAG1/2-recombination signal sequence complex assembly and catalysis during V(D)J recombination. *Mol Cell Biol* 2005;25:4413-4425.
119. Mundy CL, Patenge N, Matthews AGW, Oettinger MA. Assembly of the RAG1/RAG2 synoptic complex. *Mol Cell Biol* 2002;22:69-77.
120. Paul TT, Gellert M. Nbs1 potentiates ATP-driven DNA unwinding and endonuclease cleavage by the Mre11/Rad 50 complex. *Genes Dev* 1999;13:276-288.
121. Besmer E, Mansilla-Soto J, Cassard S, et al. Hairpin coding and opening is mediated by RAG1 and RAG2 proteins. *Mol Cell* 1998;2:817-828.
122. Schatz DG, Swanson PC. V(D)J recombination: mechanisms of initiation. *Annu Rev Genet* 2011;45:167-202.
123. Swanson PC. A RAG-1/RAG-2 tetramer supports 12/23-regulated synopsis, cleavage, and transposition of V(D)J recombination signals. *Mol Cell Biol* 2002;22:7790-7801.
124. Hiom K, Melek M, Gellert M. DNA transposition by the RAG1 and RAG2 proteins: a possible source of oncogenic translocations. *Cell* 1998;94:463-470.
125. Brandt VL, Roth DB. V(D)J recombination: how to tame a transposase. *Immunol Rev* 2004;200:249-260.
126. Gellert M. V(D)J recombination: RAG proteins repair factors and regulation. *Annu Rev Biochem* 2002;71:101-132.
127. Melek M, Gellert M. Rag 1/2-mediated resolution of transposition intermediates: two pathways and possible consequences. *Cell* 2000;101:625-633.
128. Neiditch MB, Lee GS, Huye Le, et al. The V(D)J recombinase efficiently cleaves and transposes signal joints. *Mol Cell* 2002;9:871-878.
129. Tsai C-L, Schatz DG. Regulation of RAG-1/RAG2-mediated transposition by GTP and the C-terminal region of RAG2. *EMBO J* 2003;22:1922-1930.
130. Elkin SK, Matthews AG, Oettinger MA. The C-terminal portion of RAG2 proteins against transposition in vitro. *EMBO J* 2003;22:1931-1938.
131. Neiditch MB, Lee GS, Landree MA, et al. The RAG transposase can capture and commit to target DNA before or after donor cleavage. *Mol Cell Biol* 2001;21:4302-4312.
132. Lee GS, Neiditch MB, Sinden RR, et al. Targeted transposition by the V(D)J recombinase. *Mol Cell Biol* 2002;22:2068-2077.

133. Roth DB, Craig NL. VDJ recombination: a transposase goes to work. *Cell* 1998;94:411-414.
134. Casali P, Pal Z, Xu Z, Zan H. DNA repair in antibody somatic hypermutation. *Trends Immunol* 2006;27:313-321.
135. Shiloh Y. The ATM-mediated DNA-damage response: taking shape. *Trends Biochem Sci* 2006;31:402-410.
136. Xu Y. DNA damage: a trigger of innate immunity but a requirement for adaptive immune homeostasis. *Nat Rev Immunol* 2006;6:261-270.
137. Wen J, Cerosaletti K, Schultz KG et al. NBN Phosphorylation regulates the accumulation of MRN and ATM at sites of DNA double-strand breaks *Oncogene* 2012;443 (Epub)
138. Burma S, Chen BPC, Chen DJ. Role of non-homologous end joining (NHEJ) in maintaining genomic integrity. *DNA Repair (AMST)* 2006;5:1042-1048.
139. Moshous D, Callebaut I, de Chasseval R, et al. Artemis, a novel DNA double strand break repair/V(D)J recombination protein mutated in human severe combined immune deficiency. *Cell* 2001;105:177-186.
140. Brandt VL, Roth DB. Artemis: guarding small children and, now, the genome. *J Clin Invest* 2003;111:315-316.
141. Ma Y, Pannicke U, Schwartz K, et al. Hairpin opening and overhang processing by an Artemis/DNA-dependent protein kinase complex in non-homologous end joining and V(D)J recombination. *Cell* 2002;108:781-794.
142. Lieber MR. The biochemistry and biological significance of non-homologous DNA end joining: an essential repair process in multicellular eukaryotes. *Genes Cells* 1999;4:77-85.
143. Chu G. Double strand break repair. *J Biol Chem* 1997;272:24097-24100.
144. Moshous D, Pannetier C, de Chasseval R, et al. Partial T and B lymphocyte immunodeficiency and predisposition to lymphoma in patients with hypomorphic mutations in Artemis. *J Clin Invest* 2003;111:381-387.
145. Fugman SD, Messier C, Novack LA, et al. An ancient evolutionary origin of the Rag 1/2 gene locus. *Proc Natl Acad Sci U S A* 2006;103:3728-3733.
146. Schlissel MS. Does Artemis end the hunt for hairpin-opening activity in V(D)J recombination? *Cell* 2002;109:1-4.
147. Callebaut I, Moron JP. The V(D)J recombination activating protein RAG-2 consists of six-bladed propeller and a PHD finger-like domain, as revealed by sequence analysis. *Cell Mol Life Sci* 1998;54:880-891.
148. Aravind L, Koonin EV. Cleaning non-trivial structural-functional and evolutionary information about proteins by iterative database searches. *J Mol Biol* 1999;187:1023-1040.
149. Landree MA, Wibbenmeyer JA, Roth DB. Mutational analysis of RAG-1 and RAG-2 identifies three catalytic amino acids in RAG-1 critical for both cleavage steps and V(D)J recombination. *Genes Dev* 1999;13:3059-3069.
150. McMahan CJ, Difilippantonio MJ, Rao N, et al. A basic motif in the N-terminal region of RAG-1 enhances V(D)J recombination activity. *Mol Cell Biol* 1997;17:4544-4552.
151. Fugmann SD, Schatz DG. Identification of basic residues in RAG-2 critical for DNA binding by the RAG-1-RAG-2 complex. *Mol Cell* 2001;8:899-910.
152. Akamatsu Y, Monroe R, Dudley DD, et al. Deletion of the RAG-2 C-terminus leads to impaired lymphoid development in mice. *Proc Natl Acad Sci U S A* 2003;100:1209-1214.
153. Kirch SA, Rathbun GA, Oettinger MA. Dual role of RAG-2 in V(D)J recombination: catalysis and regulation of ordered Ig gene assembly. *EMBO J* 1998;17:4881-4886.
154. Carsetti Rosado WW, Wardmann H. Peripheral development of B cells in mouse and man. *Immunol. Rev* 2004;197:179-191.
155. Longo NS, Lipsky PE. Why do B cells mutate their immunoglobulin receptors? *Trends Immunol* 2006;27:374-380.
156. Odegard VH, Schatz DG. Targeting of somatic hypermutation. *Nat Rev Immunol* 2006;6:537-583
157. Jones JM, Gellert M. The taming of a transposon: V(D)J recombination and the immune system. *Immunol Rev* 2004;200:233-248.
158. Kilamura D, Rajewsky K. Targeted disruption of μ chain membrane exon causes loss of heavy-chain allelic exclusion. *Nature* 1992;356:154-156.

159. Ehlich A, Schaal S, Gu H, et al. Immunoglobulin heavy and light chain genes rearrange independently at early stages of B cell development. *Cell* 1993;72:695-704.
160. Reth M, Hombach J, Wienands J, et al. The B-cell antigen receptor complex. *Immunol Today* 1991;12:196-201.
161. Sen R, Oltz E. Genetic and epigenetic regulation of IgH gene assembly. *Curr Opin Immunol* 2006;18:237-242.
162. Harraghy N, Buceta M, Regamey A, et al. Using matrix attachment regions to improve recombinant protein production. *Methods Mol Biol* 2012;801: 93-110.
163. Kottman AH, Zevnik B, Welte M, et al. A second promoter and enhancer element within the immunoglobulin heavy chain locus. *Eur J Immunol* 1994;24:817-821.
164. Atchison ML, Perry RP. The role of the κ enhancer and its binding factor NF- κ B in the developmental regulation of κ gene transcription. *Cell* 1987;48:121-128.
165. Stewart AK, Schwartz RS. Immunoglobulin V regions and the B cell. *Blood* 1994;83:1717-1730.
166. Pascual V, Victor K, Spellerberg M, et al. VH restriction among human cold agglutinins. The VH4-21 gene segment is required to encode anti-I and anti-I specificities. *J Immunol* 1992;149:2337-2344.
167. Wasserman R, Galili N, Ito Y, et al. Predominance of fetal type DJH joining in young children with B precursor lymphoblastic leukemia as evidence of an in utero transforming event. *J Exp Med* 1992;176:1577-1581.
168. Friedman DF, Cho EA, Goldman J, et al. The role of clonal selection in the pathogenesis of an autoreactive human B cell lymphoma. *J Exp Med* 1991;174:525-537.
169. Zelenetz AD, Chen TT, Levy R. Clonal expansion in follicular lymphoma occurs subsequent to antigenic selection. *J Exp Med* 1992;176:1137-1148.
170. Bakkus MH, Heirman C, Van Riet I, et al. Evidence that multiple myeloma Ig heavy chain VDJ genes contain somatic mutations but show no intraclonal variation. *Blood* 1992;80:2326-2335.
171. Schwarz K, Bartram CR. V(D)J recombination pathology. *Adv Immunol* 1996;61:285-326.
172. Banga SS, Hall KT, Sandhu AK, et al. Complementation of V(D)J recombination defect and x-ray sensitivity of SCID mouse cells by human chromosome-8. *Mutat Res* 1994;315:239-247.
173. Komatsu K, Kubota N, Gallo M, et al. The SCID factor on human chromosome-8 restores V(D)J recombination in addition to double-strand break repair. *Cancer Res* 1995;55:1774-1779.
174. O'Driscoll M, Jeggo P. Immunological disorders and DNA repair. *Mutat Res* 2002;509:109-126.
175. Bosma GC, Custer RP, Bosma MJ. A severe combined immunodeficiency mutation in the mouse. *Nature* 1983;301:527-530.
176. Noordzi J, deBruin-Bersteeg S, Verhaik NS, et al. The immunophenotypic and immunogenotypic B-cell differentiation arrest in bone marrow of RAG-deficient SCID patients corresponds to residual recombination activities of mutated RAG patients. *Blood* 2002;100:2145-2152.
177. Schultz HY, Landree MA, Qiu J-X, et al. Joining-deficient RAG-1 mutants block V(D)J recombination in vivo and hairpin opening in vitro. *Mol Cell* 2001;7:65-75.
178. Qiu J, Kale SB, Schultz HY, et al. Separation of function mutants reveal critical roles for RAG-2 in both cleavage and joining steps of V(D)J recombination. *Mol Cell* 2001;7:77-87.
179. Fisher A, Cavazzana-Calvo M, De Saint Basile G, et al. Naturally occurring primary deficiencies of the immune system. *Annu Rev Immunol* 1997;15: 93-124.
180. Nicolas N, Moshous D, Papadopoulos D, et al. A human severe combined immunodeficiency (SCID) condition with increased sensitivity to ionizing radiation and impaired V(D)J rearrangements defines a new DNA recombination/repair deficiency. *J Exp Med* 1998;188:627-634.
181. Stevens TJ, Paoli M. RCC1-like repeat proteins: a pangenomic, structurally diverse new superfamily of beta-propeller domains. *Proteins* 2008;70: 378-387.
182. Villa A, Santagata S, Bozzi F, et al. Partial V(D)J recombination activity leads to Omenn syndrome. *Cell* 1998;93:885-896.

183. Mo X, Bailin T, Sadofsky MJ. RAG1 and RAG2 cooperate in specific binding to the recombination signal sequence in vitro. *J Biol Chem* 1999;274: 7025-7031.
184. Omenn GS. Familial reticuloendotheliosis with eosinophilia. *N Engl J Med* 1965;273:427.
185. Lev A, Simon AJ, Amarglio N, et al. Selective clinical and immune response of the oligoclonal autoreactive T cells in Omenn patients after cyclosporin A treatment. *Clin Exp Immunol* 2012;167:338-345.
186. Schandene L, Ferster A, Mascart-Lemone F, et al. T helper 2-like cells and therapeutic effects of interferon gamma in combined immunodeficiency with hypereosinophilia (Omenn's syndrome). *Eur J Immunol* 1993;23:56-60.
187. Rieux-Laucat F, Bahadoran P, Brousse N, et al. Highly restricted human T cell repertoire in peripheral blood and tissue-infiltrating lymphocytes in Omenn's syndrome. *J Clin Invest* 1998;102:312-321.
188. Marrella V, Maina V, Villa A. Omenn syndrome does not live by V(D)J recombination alone. *Curr Opin Allergy Clin Immunol* 2011;11:525-531.
189. Wada T, Takei K, Kudo M, et al. Characterization of immune function and analysis of RAG gene mutation in Omenn syndrome and related disorders. *Clin Exp Immunol* 2000;119:148-155.
190. Noordzig JG, Verkaik NS, Hartwig NG, et al. N-terminal truncated human RAG-1 protein can direct T cell receptor but not immunoglobulin gene arrangements. *Blood* 2000;96:203-209.
191. Corneo B, Moshous D, Güngör T, et al. Identical mutations in RAG-1 or RAG-2 genes leading to defective V(D)J recombinase activity can cause either T-B-severe combined immune deficiency or Omenn syndrome. *Blood* 2001;97:2772-2776.
192. Ege M, Ma Y, Manfras B, et al. Omenn syndrome due to ARTEMIS mutations. *Blood* 2005;105:4179-4186.
193. Gennery AR, Hodges E, Williams AP, et al. Omenn's syndrome occurring in patients without mutations in recombination activating genes. *Clin Immunol* 2005;116:246-256.
194. Jeggo PA, Concannon P. Immune deficiency and genomic stability: opposite goals but similar paths. *J Photochem Photobiol* 2001;65:88-96.
195. Lieber MR. The mechanism of double-strand DNA break repair by the nonhomologous DNA end-joining pathway. *Annu Rev Biochem* 2010;79:181-211.
196. Jeggo PA. DNA breakage and repair. *Adv Genet* 1998;38:185-218.
197. Blunt T, Finnie NJ, Taccioli GE, et al. Defective DNA-dependent protein kinase activity is linked to V(D)J recombination and DNA repair defects associated with murine SCID mutation. *Cell* 1995;80:813-823.
198. Nussenzweig MC, Li GC. Requirement for Ku80 in growth and immunoglobulin V(D)J recombination. *Nature* 1996;382:551-555.
199. Gennery AR, Cant AJ, Jeggo PA, et al. Immunodeficiency associated with DNA repair defects. *Clin Exp Immunol* 2000;121:1-7.
200. Jeggo PA, Carr AM, Lehmann AR. Splitting the ATM: distinct repair and checkpoint defects in ataxia-telangiectasia. *Trends Genet* 1998;14:312-316.
201. Savitsky K, Bar-Shira A, Gilad S, et al. A single ataxia telangiectasia gene with a product similar to PI-3 kinase. *Science* 1995;268:1749-1753.
202. Khanna KK, Keating KE, Kozlov S, et al. ATM associates with and phosphorylates p53: mapping the region of interaction. *Nat Genet* 1998;20:398-400.
203. Matsuoka S, Huang M, Elledge SJ. Linkage at ATM to cell cycle regulation by the Chk-2 protein kinase. *Science* 1998;282:1893-1897.
204. van der Burgt I, Chrzanowska KH, Smeets D, et al. Nijmegen breakage syndrome. *J Med Genet* 1996;33:153-156.
205. German J. Bloom syndrome: a Mendelian prototype of somatic mutational disease. *Medicine* 1993;72:393-406.
206. Amor-Gueret M. Bloom syndrome, genomic instability and cancer: the SOS-like hypothesis. *Cancer Lett* 2006;236:1-12.
207. Enders A, Fisch P, Schwartz K, et al. A severe form of human combined immunodeficiency due to mutations in DNA ligase IV. *J Immunol* 2006;176:5060-5068.

208. Caspari AA, Fleisher TA, Kraemer KH. Impaired interferon production and natural killer cell activation in patients with the skin cancer prone disorder, xeroderma pigmentosum. *J Clin Invest* 1993;92:1135-1142.
209. Papavasiliou F, Jankovic M, Suh H, et al. The cytoplasmic domains of the immunoglobulin Iga and Igb can independently induce the precursor B cell transition and allelic exclusion. *J Exp Med* 1995;182:1389-1394.
210. Kurosaki T. Functional dissection of BCR signaling pathways. *Curr Opin Immunol* 2000;12:276-281.
211. Nagata K, Nakamura T, Kitamura F, et al. The Ig α /Ig β heterodimer on μ -negative pro-B cells is competent for transducing signals to induce early B cell differentiation. *Immunity* 1997;7:559-570.
212. Caldwell RG, Wilson JB, Anderson SJ, et al. Epstein-Barr virus LMP2A drives B cell development and survival in the absence of normal B cell receptor signals. *Immunity* 1998;9:405-411.
213. Kurosaki T. Genetic analysis of B cell receptor signaling. *Annu Rev Immunol* 1999;17:555-592.
214. Pappu R, Cheng AM, Li B, et al. Requirement for B cell linker protein (BLNK) in B cell development. *Science* 1999;286:1949-1954.
215. Minegishi Y, Rohrer J, Coustan-Smith E, et al. An essential role for BLNK in human B cell development. *Science* 1999;286:1954.
216. Chang H, Dmitrovsky E, Hieter PA, et al. Identification of three new Ig lambda-like genes in man. *J Exp Med* 1986;163:425-435.
217. Minegishi Y, Coustan-Smith E, Rapalus L, et al. Mutations in Ig- α (CD 79-a) result in a complete block of B-cell development. *J Clin Invest* 1999;104:1115-1121.
218. Yel L, Minegishi Y, Coustan-Smith E, et al. Mutations in the mu heavy chain in patients with agammaglobulinemia. *N Engl J Med* 1996;335:1486-1493.
219. Schiff C, Lemmers B, Deville A, et al. Autosomal primary immunodeficiencies affecting human bone marrow B-cell differentiation. *Immunol Rev* 2000;178:91-98.
220. Bruton OC. Agammaglobulinemia. *Pediatrics* 1952;9:722.
221. Janeway CA, Apt L, Gitlin D. Agammaglobulinemia. *Trans Assoc Am Physicians* 1953;66:200.
222. Siegal FP, Pernis B, Kunkel HG. Lymphocytes in human immunodeficiency states: a study of membrane-associated immunoglobulins. *Eur J Immunol* 1971;1:482.
223. Parolini O, Hejtmancik JF, Allen RC, et al. Linkage analysis and physical mapping near the gene for X-linked agammaglobulinemia at Xq22. *Genomics* 1993;15:342-349.
224. Conley ME, Parolini O, Rohrer J, et al. X-linked agammaglobulinemia: new approaches to old questions based on the identification of the defective gene. *Immunol Rev* 1994;138:5-21.
225. Tsukada S, Saffran DC, Rawlings DJ, et al. Deficient expression of a B cell cytoplasmic tyrosine kinase in human X-linked agammaglobulinemia. *Cell* 1993;72:279-290.
226. Vetrie D, Verechovsky I, Sideras P, et al. The gene involved in X-linked agammaglobulinemia is a member of the src family of protein-tyrosine kinases. *Nature* 1993;361:226-233.
227. Conley ME, Mathias D, Treadaway J, et al. Mutations of Btk in patients with presumed X-linked agammaglobulinemia. *Am J Hum Genet* 1998;62: 1034-1043.
228. Desiderio S. Role of Btk in B cell development and signaling. *Curr Opin Immunol* 1997;9:534-540.
229. Tsukada S, Baba Y, Watanabe D. Btk and BLNK in B cell development. *Adv Immunol* 2001;77:123-162.
230. Kurosaki T, Tsukada S, et al. BLNK: connecting Syk and Btk to calcium signals. *Immunity* 2000;12:1-5.
231. Gross BS, Wilde JI, Quek L, et al. Regulation and function of WASp in platelets by the collagen receptor, glycoprotein VI. *Blood* 1999;94:4166-4176.
232. Salim K, Bottomley MJ, Querfurth E, et al. Distinct specificity of the recognition of phosphoinositides by the pleckstrin homology domains of dynamin and Bruton's tyrosine kinase. *EMBO J* 1996;15:6241-6250.
233. Jiang Y, Ma W, Wan Y, et al. The G protein G α 12 stimulates Bruton's tyrosine kinase and a ras GAP through a conserved PH/BM domain. *Nature* 1998;395:808-813.

234. Kurosaki T, Kurosaki M. Transphosphorylation of Bruton's tyrosine kinase on tyrosine 551 is critical for B cell antigen receptor function. *J Biol Chem* 1997;272:15595-15598.
235. Sutterthwaite AB, Li Z, Witte ON. Btk function in B cell development and response. *Semin Immunol* 1998;10:309-316.
236. Liu W, Quinto I, Chen X, et al. Direct inhibition of Bruton's tyrosine kinase by IBtk, a Btk binding protein. *Nat Immunol* 2001;2:939-946.
237. Uckun FM. Bruton's tyrosine kinase (BTK) as a dual-function regulator of apoptosis. *Biochem Pharmacol* 1998;56:683-691.
238. Islam TC, Smith CIE. The cellular phenotype conditions Btk for cell survival or apoptosis signaling. *Immunol Rev* 2000;178:49-63.
239. Vihinen M, Brandeau O, Branden LJ, et al. BTK base, mutation database for X-linked agammaglobulinemia (XLA). *Nucleic Acids Res* 1998;26:242-247.
240. Nomura K, Kanegane H, Karasuyama H, et al. Genetic defect in human X-linked agammaglobulinemia impedes a maturational evolution of pro-B cells into a later stage of pre-B cells in the B cell differentiation pathway. *Blood* 2000;96:610-617.
241. Rawlings DJ, Witte ON. Bruton's tyrosine kinase is a key regulator of B-cell development. *Immunol Rev* 1994;138:105-119.
242. Ross CW, Stoolman LM, Schuitzer B, et al. Immunophenotypic aberrancy in adult acute lymphoblastic leukemia. *Am J Clin Pathol* 1990;94:590-599.
243. Loken MR, Shah VO, Dattilio KL, et al. Flow cytometric analysis of human bone marrow. II. Normal B lymphocyte development. *Blood* 1987;70: 1316-1324.
244. Ryan D, Kossover S, Mitchell S, et al. Subpopulations of common acute lymphoblastic leukemia antigen-positive lymphoid cells in normal bone marrow identified by hematopoietic differentiation antigens. *Blood* 1986;68:417-425.
245. Uckun FM, Ledbetter JA. Immunobiologic differences between normal and leukemic human B-cell precursors. *Proc Natl Acad Sci U S A* 1988;85: 8603-8607.
246. DiGiusto D, Chen S, Combs J, et al. Human fetal bone marrow early progenitors for T, B, and myeloid cells are found exclusively in the population expressing high levels of CD34. *Blood* 1994;84:421-432.
247. Pontvert-Delucq S, Breton-Gorius J, Schmitt C, et al. Characterization and functional analysis of adult human bone marrow cell subsets in relation to B-lymphoid development. *Blood* 1993;82:417-429.
248. Janossy G, Bollum, FJ, Bradstock KF, et al. Terminal transferase-positive human bone marrow cells exhibit the antigenic phenotype of common acute lymphoblastic leukemia. *J Immunol* 1979;123:1525-1529.
249. Bollum FJ. Terminal deoxynucleotidyl transferase as a hematopoietic cell marker. *Blood* 1979;54:1203-1215.
250. Duperray C, Boiron JM, Boucheix C, et al. The CD24 antigen discriminates between pre-B and B cells in human bone marrow. *J Immunol* 1990;145:3678-3683.
251. Uckun FM. Regulation of human B-cell ontogeny. *Blood* 1990;76:1908-1923.
252. Uckun FM, Muraguchi A, Ledbetter JA, et al. Biphenotypic leukemic lymphocyte precursors in CD2+CD19+ acute lymphoblastic leukemia and their putative normal counterparts in human fetal hematopoietic tissues. *Blood* 1989;73:1000-1015.
253. Hokland P, Rosenthal P, Griffin JD, et al. Purification and characterization of fetal hematopoietic cells that express the common acute lymphoblastic leukemia antigen (CALLA). *J Exp Med* 1983;157:114-129.
254. Gathings WE, Lawton AR, Cooper MD. Immunofluorescent studies of the development of pre-B cells, B lymphocytes and immunoglobulin isotype diversity in humans. *Eur J Immunol* 1977;7:804-810.
255. Kamps WA, Cooper MD. Microenvironmental studies of pre-B and B cell development in human and mouse fetuses. *J Immunol* 1982;129:526-531.
256. Boue DR, LeBien TW. Expression and structure of CD-22 in acute leukemia. *Blood* 1988;71:1480-1486.
257. Tedder TF, Fearon DT, Bartland GL, et al. Expression of C3b receptors on human B cells and myelomonocytic cells but not natural killer cells. *J Immunol* 1983;130:1668-1673.

258. Defrance T, Aubry JP, Rousset F, et al. Human recombinant interleukin 4 induces Fc epsilon receptors (CD-23) on normal human B lymphocytes. *J Exp Med* 1987;165:1459-1467.
259. Wang F, Gregory CD, Rowe M, et al. Epstein-Barr virus nuclear antigen 2 specifically induces expression of the B-cell activation antigen CD-23. *Proc Natl Acad Sci U S A* 1987;84:3452-3456.
260. Lavabre-Bertrand T, Duperray C, Brunet C, et al. Quantification of CD-24 and CD-45 antigens in parallel allows a precise determination of B-cell maturation stages: relevance for the study of B-cell neoplasias. *Leukemia* 1994;8:402-408.
261. Caldwell CW, Patterson WP. Relationship between CD-45 antigen expression and putative stages of differentiation in B-cell malignancies. *Am J Hematol* 1991;36:111-115.
262. Harris NL, Jaffe ES, Stein H, et al. A revised European-American classification of lymphoid neoplasms: a proposal from the International Lymphoma Study Group. *Blood* 1994;84:1361-1392.
263. Jaffe ES, Harris NL, Stein H, et al, eds. WHO classification of tumors. Pathology and genetics of tumors of haematopoietic and lymphoid tissues. Lyon, France: IARC Press, 2001.
264. Geisberger R, Lamers M, Achatz G. The riddle of the dual expression of IgM and IgD. *Immunology* 2006;118:429-437.
265. Scher I, Sharrow SO, Wistar R Jr, et al. B-lymphocyte heterogeneity: ontogenetic development and organ distribution of B-lymphocyte populations defined by their density of surface immunoglobulin. *J Exp Med* 1976;144:494-506.
266. de Petris S, Raff MC. Distribution of immunoglobulin on the surface of mouse lymphoid cells as determined by immunoferritin electron microscopy. Antibody induced, temperature-dependent redistribution and its implications for membrane structure. *Eur J Immunol* 1972;2:523-535.
267. Lejonc RJ, Gourdin MF, Mannoni P, et al. The surface morphology of human B lymphocytes as revealed by immunoelectron microscopy. *J Exp Med* 1975;141:392-410.
268. Taylor RB, Duffus WP, Raff MC, de Petris S. Redistribution and pinocytosis of lymphocyte surface immunoglobulin molecules induced by anti-immunoglobulin antibody. *Nature* 1971;233:225.
269. Karnovsky MJ, Unanue ER. Cell surface changes in capping studied by correlated fluorescence and scanning electron microscopy. *Lab Invest* 1978;39:554-564.
270. Srinivas A, Tsourkas PK, Raychaudhuri S. Monte Carlo study of B-cell receptor clustering mediated by antigen crosslinking and directed transport. *Cell Mol Immunol* 2011;8:255-264.
271. Braun J, Unanue ER. B lymphocyte biology studied with anti-Ig antibodies. *Immunol Rev* 1980;52:3-28.
272. Cambier JC, Bedzyk W, Campbell K, et al. The B-cell antigen receptor: structure and function of primary, secondary, tertiary and quaternary components. *Immunol Rev* 1993;132:85-106.
273. van Noesel CJ, van Lier RA. Architecture of the human B-cell antigen receptors. *Blood* 1993;82:363-373.
274. Pleiman CM, D'Ambrosio D, Cambier JC. The B-cell antigen receptor complex: structure and signal transduction. *Immunol Today* 1994;15:393-399.
275. Cambier JC. Antigen and Fc receptor signaling. The awesome power of the immunoreceptor tyrosine-based activation motif (ITAM). *J Immunol* 1995;155:3281-3285.
276. Monroe JG. ITAM-mediated tonic signalling through pre-BCR and BCR complexes. *Nat Rev Immunol* 2006;6:283-294.
277. Paraskevas F, Lee S-T, Israels LG. Absence of γ -globulin receptors on mouse plasmacytoma cells. *Nature* 1970;227:395-396.
278. Hombach J, Tsubata T, Leclercq L, et al. Molecular components of the B cell antigen receptor complex of class IgD differ partly from those of IgM. *Nature* 1990;343:760-762.
279. Schamel WWA, Reth A. Monomeric and oligomeric complexes of the B cell antigen receptor. *Immunity* 2000;13:5-14.
280. Treanor B. B cell receptor: from resting state to activate. *Immunology* 2012;10:1365-2012.
281. Simons K, Ehehalt R. Cholesterol, lipid rafts, and disease. *J Clin Invest* 2002;110:597-603.
282. Pierce SK. Lipid rafts and B cell activation. *Nat Rev Immunol* 2002;2:96-105.
283. Aman MJ, Ravichandran KS. A requirement for lipid rafts in B cell receptor induced Ca²⁺ flux. *Curr Biol* 2000;10:293-396.

284. Cheng PC, Dykstra ML, Mitchell RN, et al. A role for lipid rafts in B cell antigen receptor signaling and antigen targeting. *J Exp Med* 1999;190:1549-1560.
285. Fantini J, Garmy N, Mahfoud R, et al. Lipid rafts: structure, function and role in HIV, Alzheimer's and prion diseases. *Expert Rev Mol Med* 2002;4:1-22.
286. Weintraub BC, Jun JE, Bishop AC, et al. Entry of B cell receptor into signaling domains is exhibited in tolerant B cells. *J Exp Med* 2000;191:1443-1448.
287. Chung JB, Boumeister MA, Monroe JG. Cutting edge: differential sequestration of plasma membrane-associated B cell antigen receptor in mature and immature B cells into glycosphingolipid-enriched domains. *J Immunol* 2001;166:736-740.
288. Cheng PC, Brown BK, Song W, et al. Translocation of the B cell antigen receptor into lipid rafts reveals a novel step in signaling. *J Immunol* 2001;166:3693-3701.
289. Suzuki T, Kiyokawa K, Taguchi T, et al. CD24 induces apoptosis in human B cells via the glycolipid-enriched membrane domains/rafts-mediated signaling system. *J Immunol* 2001;166:5567-5577.
290. Gupta N, Wollscheid B, Watts JD, et al. Quantitative proteomic analysis of B cell lipid rafts reveals that ezrin regulates antigen receptor-mediated lipid raft dynamics. *Nat Immunol* 2006;7:625-633.
291. Germain RN. MHC-dependent antigen processing and peptide presentation: providing ligands for T lymphocyte activation. *Cell* 1994;76:287-299.
292. Cherukuri A, Cheng PC, Sohn HW, et al. The CD19/CD21 complex functions to prolong B cell antigen receptor signaling from lipid rafts. *Immunity* 2001;14:169-179.
293. Dykstra M, Cherukuri A, Pierce SK. Rafts and synapses in the spatial organization of immune cell signaling cascades. *J Leukoc Biol* 2001;70:699-707.
294. Bromley SK, Burack WR, Johnon KG, et al. The immunological synapse. *Annu Rev Immunol* 2001;19:375-396.
295. Batista FD, Iber D, Neuberger MS. B cells acquire antigen from target cells after synapse formation. *Nature* 2001;411:489-494.
296. Di Fiore PP, De Camilli P. Endocytosis and signaling: an inseparable partnership. *Cell* 2001;106:1-4.
297. Wagle NM, Cheng P, Kim J, et al. B-lymphocyte signaling receptors and the control of class II antigen processing. *Curr Top Microbiol Immunol* 2000;245:101-126.
298. Dykstra ML, Longnecker R, Pierce SK. Epstein-Barr virus coopts lipid rafts to block signaling and antigen transport functions of BCR. *Immunity* 2001;14:57-67.
299. Stoddart A, Dykstra ML, Brown BK, et al. Lipid rafts unite signaling cascades with clathrin to regulate BCR internalization. *Immunity* 2002;17:451-462.
300. Patterson HCK, Kraus M, Kim Y-M, et al. The B cell receptor promotes cell activation and proliferation through a non-ITAM tyrosine in the Ig α cytoplasmic domain. *Immunity* 2006;25:55-65.
301. De Franco AL. The complexity of signaling pathways activated by the BCR. *Curr Opin Immunol* 1997;9:296-308.
302. Reth M, Wienands J. Initiation and processing of signals from the B cell antigen receptor. *Annu Rev Immunol* 1997;15:453-479.
303. Hata AH, Sabe H, Kurosaki T, et al. Functional analysis of Csk in signal transduction through the B-cell antigen receptor. *Mol Cell Biol* 1994;14: 7306-7313.
304. Yanagi S, Sugawara H, Kurosaki M, et al. CD45 modulates phosphorylation of both autophosphorylation and negative regulatory tyrosines of Lyn in B cells. *J Biol Chem* 1996;271:30487-30492.
305. Kurosaki T, Takata M, Yamanashi Y, et al. Syk activation by the Src family tyrosine kinase in B cell receptor signaling. *J Exp Med* 1994;179:1725.
306. Chiu CW, Dalton M, Ishiai M, et al. BLNK: molecular scaffolding through cis-mediated organization of signaling proteins. *EMBO J* 2002;21:6472-6521.
307. Fu C, Turck C, Kurosaki T, et al. BLNK: a central linker protein in B cell activation. *Immunity* 1998;9:93-103.
308. Yablonski D, Weiss A. Mechanisms of signaling by the hematopoietic-specific adaptor proteins, SLP-76 and LAT and their B cell counterpart BLNK/SLP65. *Adv Immunol* 2001;79:93-128.

309. Li Z, Wahl MI, Equinea A, et al. Phosphatidylinositol 3-kinase activates Bruton's tyrosine kinase in concert with Src family of kinases. *Proc Natl Acad Sci U S A* 1997;94:13820-13825.
310. Falasca M, Logan SK, Lehto VP, et al. Activation of phospholipase C γ by PI-3 kinase-induced PH domain-mediated membrane targeting. *EMBO J* 1998;17:414-422.
311. Fluckiger A-C, Li Z, Kato RM, et al. Btk/Tec kinases regulate sustained increases in intracellular Ca $^{2+}$ following B-cell receptor activation. *EMBO J* 1998;17:1973-1985.
312. Kim TJ, Kim Y-T, Pillai S. Association of activation phosphatidylinositol 3-kinase with p129cbl in antigen receptor-ligated B cells. *J Immunol* 1995;270:27504-27509.
313. Tuveson DA, Carter RH, Soltoff SP, et al. CD19 of B cells as a surrogate kinase insert region to bind phosphatidylinositol 3-kinase. *Science* 1993;260: 986-989.
314. Marshall AJ, Niro H, Yun TJ, et al. Regulation of B-cell activation and differentiation by the phosphatidylinositol 3-kinase and phospholipase C γ pathways. *Immunol Rev* 2000;176:30-46.
315. Rao A, Luo C, Hogan PG. Transcription factors of the NFAT family: regulation and function. *Annu Rev Immunol* 1997;15:707-747.
316. Dolmetsch RE, Lewis RS, Goodnow CC, et al. Differential activation of transcription factors induced by Ca $^{2+}$ response amplitude and duration. *Nature* 1997;386:855-858.
317. Chan TO, Rittenhouse SE, Tsichlis PN. ATK/PKB and other D-3 phosphoinositide-regulated kinases: kinase activation by phosphoinositide-dependent phosphorylation. *Annu Rev Biochem* 1999;68:965-1044.
318. Genot E, Cantrell DA. Ras regulation and function in lymphocytes. *Curr Opin Immunol* 2000;12:289-294.
319. Harmer SL, de Franco AL. Shc contains two Grb2 binding sites needed for efficient formation of complexes with SOS in B lymphocytes. *Mol Cell Biol* 1997;17:4087-4095.
320. Lankester AC, van Schijndel GM, Rood PM, et al. B cell antigen receptor crosslinking induces tyrosine phosphorylation and membrane translocation of a multimeric Shc complex that is augmented by CD-19 co-ligation. *Eur J Immunol* 1994;24:2818-28253
321. Deckert M, Tartare-Deckert S, Couture C, et al. Functional and physical interactions of Syk family kinases with the Vav proto-oncogene product. *Immunity* 1996;5:591-604.
322. Deckert M, Elly C, Altman A, et al. Coordinated regulation of the tyrosine phosphorylation of Cbl by Fyn and Syk tyrosine kinases. *J Biol Chem* 1998;273:8867-8874.
323. Yasuda T, Maeda A, Kurosaki M, et al. Cbl suppresses B cell receptor-mediated phospholipase C (PLC)- γ 2 binding. *J Exp Med* 2000;191:641-650.
324. Leo A, Schraven B. Adapters in lymphocyte signaling. *Curr Opin Immunol* 2001;13:307-316.
325. Kelle ME, Chan AC. Regulation of B-cell function by linker proteins. *Curr Opin Immunol* 2000;12:267-275.
326. Kurosaki T. Regulation of B-cell signal transduction by adapter proteins. *Nat Rev Immunol* 2002;2:354-363.
327. Leo A, Wienands J, Baier G, et al. Adapters in lymphocyte signaling. *J Clin Invest* 2002;109:301-309.
328. Tedder TF, Zhou L-J, Engel P. The CD19/CD21 signal transduction complex of B lymphocytes. *Immunol Today* 1994;15:437-442.
329. Buhl AM, Cambier JC. Phosphorylation of CD19 Y484 and Y515 and linked activation of phosphatidylinositol 3-kinase are required for B cell antigen receptor-mediated activation of Bruton's tyrosine kinase. *J Immunol* 1999;162:4438-4446.
330. Tedder TF, Tuscano J, Sato S, et al. CD22, a B lymphocyte-specific adhesion molecule that regulates antigen receptor signaling. *Annu Rev Immunol* 1997;15:481-504.
331. Nelms K, Kiegan AD, Zamorano J, et al. The IL-4 receptor: signaling mechanisms and biological functions. *Annu Rev Immunol* 1999;17:701-738.
332. Keegan AD, Nelms K, Wang LM, et al. Interleukin 4 receptor: signaling mechanisms. *Immunol Today* 1994;15:423-432.
333. Russell SM, Keegan AD, Harada N, et al. Interleukin-2 receptor gamma chain: a functional component of the interleukin-4 receptor. *Science* 1993;262:1880-1883.

334. Leonard WJ, Shores EW, Love PE. Role of the common cytokine receptor- γ chain in cytokine signaling and lymphoid development. *Immunol Rev* 1994;137: 97-114.
335. Voss SD, Hong R, Sondel PM. Severe combined immunodeficiency, interleukin-2 (IL-2), and the IL-2 receptor: experiments of nature continue to point the way. *Blood* 1994;83:626-635.
336. Keegan AD, Nelms K, White M, et al. An IL-4 receptor region containing an insulin receptor motif is important for IL-4-mediated IRS-1 phosphorylation and cell growth. *Cell* 1994;76:811-820.
337. Ihle JN, Witthuhn BA, Quelle FW, et al. Signaling through the hematopoietic cytokine receptors. *Annu Rev Immunol* 1995;13:369-398.
338. Schindler C, Darnell JE Jr. Transcriptional responses to polypeptide ligands: the JAKSTAT pathway. *Annu Rev Biochem* 1995;64:621-651.
339. Nakanishi K, Yoshida N, Kishimoto T, et al. Essential role of Stat-6 in IL-4 signaling. *Nature* 1996;380:627-630.
340. Takatsu K, Takaki S, Hitoshi Y. Interleukin-5 and its receptor system: implications in the immune system and inflammation. *Adv Immunol* 1994;57:145-190.
341. Kishimoto T, Akira S, Narazaki M, et al. Interleukin-6 family of cytokines and gp130. *Blood* 1995;86:1243-1254.
342. Akira S, Yoshida K, Tanaka T, et al. Targeted disruption of the IL-6 related genes: gp130 and NF-IL-6. *Immunol Rev* 1995;148:221-253.
343. Grammer AC, Lipsky PE. CD-40-mediated regulation of immune responses by TRAF-dependent and TRAF-independent signaling mechanisms. *Adv Immunol* 2001;76:61-178.
344. Wright SD, Ramos RA, Tobias PS, et al. CD-14, a receptor for complexes of lipopolysaccharide (LPS) and LPS binding protein. *Science* 1990;249: 1431-1433.
345. Schumann RR, Leong SR, Flagg GW, et al. Structure and function of lipopolysaccharide binding protein. *Science* 1990;249:1429-1431.
346. Ulevitch RJ. Recognition of bacterial endotoxins by receptor-dependent mechanisms. *Adv Immunol* 1993;53:267-289.
347. Gudat FG, Harris TN, Harris S, et al. Studies on antibody-producing cells. III. Identification of young plaque-forming cells by thymidine-3H labeling. *J Exp Med* 1971;134:1155-1169.
348. Gudat FG, Harris TN, Harris S, et al. Studies on antibody-producing cells. II. Appearance of 3H-thymidine-labeled rosette-forming cells. *J Exp Med* 1971;133:305-320.
349. Gudat FG, Harris TN, Harris S, et al. Studies on antibody-producing cells. I. Ultrastructure of 19S and 7S antibody-producing cells. *J Exp Med* 1970;132:448-474.
350. Harris TN, Hummeler K, Harris S. Electron microscopic observations on antibody-producing lymph node cells. *J Exp Med* 1966;123:161-172.
351. Hummeler K, Harris TN, Tomassini N, et al. Electron microscopic observations on antibody-producing cells in lymph and blood. *J Exp Med* 1966;124:255-262.
352. Bosman C, Feldman JD, Pick E. Heterogeneity of antibody-forming cells. An electron microscopic analysis. *J Exp Med* 1969;129:1029-1044.
353. Waldeyer W. Ueber Bindegewebezellen. *Arch Mikroskop Anat* 1875;11:176.
354. Unna PG. Ueber plasmazellen Insbesondere bei Lupus. *Monatsschr Prakt Dermatol* 1881;12:296.
355. Unna PG. Die Herkunft der Plasmazellen. *Virchows Arch Pathol Anat Physiol Klin Med* 1913;214:320.
356. v. Marschalko T. Ueber die sogenannten Plasmazellen, ein Beitrag zier Kenntniss der Herkunft der entzündlichen Infiltrationszellen. *Arch Derma Syph* 1895;30:241.
357. Downey H. The origin and structure of the plasma cells of normal vertebrates, especially of the cold blooded vertebrates, and the eosinophils of the lung of *Amblystoma*. *Folia Haematol (Frankf)* 1911;11:275.
358. Michels N. The plasma cell. *Arch Pathol* 1931;11:775.
359. Bing J, Plum P. Serum proteins in leucopenia. *Acta Med Scand* 1937;92:415.

360. Bjorneboe M, Gormsen H. Experimental studies on the role of plasma cells as antibody producers. *Acta Pathol Microbiol Scand* 1943;20:649.
361. Fagraeus A. Antibody production in relation to the development of plasma cell. In vivo and in vitro experiments. *Acta Med Scand (Suppl)* 1948;204:1.
362. Coons AH, Leduc EH, Connolly JM. Studies on antibody production. I. A method for the histochemical demonstration of specific antibody and its application to a study of the hyperimmune rabbit. *J Exp Med* 1955;102:49.
363. Leduc EH, Coons AH, Connolly JM. Studies on antibody production. II. The primary and secondary responses in the popliteal lymph node of the rabbit. *J Exp Med* 1955;102:61.
364. Bessis M. *Living blood cells and their ultrastructure*. New York: Springer-Verlag, 1973.
365. Murphy MJ, Hay JB, Morris B, et al. Ultrastructural analysis of antibody synthesis in cells from lymph and lymph nodes. *Am J Pathol* 1972;66:25-42.
366. Blom J, Mansa B, Wilk A. A study of Russell bodies in human monoclonal plasma cells by means of immunofluorescence and electron microscopy. *Acta Pathol Microbiol Scand [A]* 1976;84:335-349.
367. Matthews JB. The immunoglobulin nature of Russell bodies. *Br J Exp Pathol* 1983;64:331-335.
368. Hsu SM, Hsu PL, McMillan PN, et al. Russell bodies: a light and electron microscopic immunoperoxidase study. *Am J Clin Pathol* 1982;77:26-31.
369. Paraskevas F, Heremans J, Waldenström J. Cytology and electrophoretic pattern in γ 1A (β 2A) myeloma. *Acta Med Scand* 1961;170:575-589.
370. Bessis M, Breton Gornis J, Binet JL. Etude comparee du plasmocytome et du syndrome de Waldenstrom. *Nouv Rev Fr Hematol* 1963;3:159.
371. Maldonado JE, Brown AL Jr, Bayrd ED, et al. Ultrastructure of the myeloma cell. *Cancer* 1966;19:1613-1627.
372. Maldonado JE, Bayrd ED, Brown AL Jr. The flaming cell in multiple myeloma. A light and electron microscopy study. *Am J Clin Pathol* 1965;44:605-612.
373. Mabry RJ, Shelburne J, Cohen HJ. In vitro kinetics of immunoglobulin synthesis and secretion by nonsecretory human myeloma cells. *Blood* 1977;50:1031-1038.
374. Forssman O, Nilsson G. A case of myeloma with flaming plasma cells but no significant M-compound in serum or urine. *Acta Med Scand* 1967;181:33-36.
375. Alanen A, Pira U, Lassila O, et al. Mott cells are plasma cells defective in immunoglobulin secretion. *Eur J Immunol* 1985;15:235-242.
376. Shaffer AL, Lin K-I, Kuo TC, et al. Blimp-1 orchestrates plasma cell differentiation by extinguishing the mature B cell gene expression program. *Immunity* 2002;17:51-62.
377. Lin KI, Angelin-Duclos C, Kuo TC, et al. Blimp-1-dependent repression of Pax5 is required for differentiation of B cells to IgM secreting plasma cells. *Mol Cell Biol* 2002;22:4771-4780.
378. Reinold AM, Iwakoshi NN, Manis J, et al. Plasma cell differentiation requires the transcription factor XBP-1. *Nature* 2001;412:300-307.
379. Wen XY, Stewart AK, Sooknanan RR, et al. Identification of c-myc promoter-binding protein and X-box binding protein 1 as interleukin-6 target genes in human multiple myeloma cells. *Int J Oncol* 1999;15:173-178.
380. Angelin-Duclos C, Cattoretti G, Lin K-I, et al. Commitment of B lymphocytes to a plasma cell fate is associated with Blimp-1 expression in vivo. *J Immunol* 2000;165:5462-5471.
381. Baumal R, Scharff MD. Synthesis, assembly and secretion of mouse immunoglobulin. *Transplant Rev* 1973;14:163-183.
382. Schenkein I, Uhr JW. Immunoglobulin synthesis and secretion. I. Biosynthetic studies of the addition of the carbohydrate moieties. *J Cell Biol* 1970;46:42-51.
383. Vitetta ES, Uhr JW. Synthesis, transport, dynamics and fate of cell surface Ig and alloantigens in murine lymphocytes. *Transplant Rev* 1973;14: 50-75.

384. Bole DG, Hendershot LM, Kearney JF. Posttranslational association of immunoglobulin heavy chain binding protein with nascent heavy chains in nonsecreting and secreting hybridomas. *J Cell Biol* 1986;102:1558-1566.
385. Haas IG, Wabl M. Immunoglobulin heavy chain binding protein. *Nature* 1983;306:387-389.
386. Franklin EC, Lowenstein J, Bigelow B, Meltzer M. Heavy chain disease. A new disorder of serum γ -globulins. Report of the first case. *Am J Med* 1964;37:332.
387. Seligmann M, Mihaesco E, Preud'homme JL, et al. Heavy chain diseases: current findings and concepts. *Immunol Rev* 1979;48:145-167.
388. Franklin EC, Frangione B. The molecular defect in a protein (CRA) found in gamma-1 heavy chain disease, and its genetic implications. *Proc Natl Acad Sci U S A* 1971;68:187-191.
389. Hendershot L, Bole D, Kohler G, et al. Assembly and secretion of heavy chains that do not associate post-translationally with immunoglobulin heavy chain-binding protein. *J Cell Biol* 1987;104:761-767.
390. Hendershot L, Bole D, Kearney JF. The role of immunoglobulin heavy chain binding protein in immunoglobulin transport. *Immunol Today* 1987;8:11.
391. Waldmann TA, Strober W. Metabolism of immunoglobulins. *Prog Allergy* 1969;13:1-110.
392. Bernier GM, Cebra JJ. Frequency distribution of α , γ , κ and λ polypeptide chains in human lymphoid tissues. *J Immunol* 1965;95:246-253.
393. Leduc EH, Avrameas A, Bouteille M. Ultrastructural localization of antibody in differentiating plasma cells. *J Exp Med* 1968;127:109-118.
394. Miller HR, Avrameas S, Ternynck T. Intracellular distribution of antibody in immunocytes responding to primary challenge with horseradish peroxidase. *Am J Pathol* 1973;71:239-260.
395. Miller HR, Avrameas S, Ternynck T. Intracellular distribution of antibody in immunocytes responding to secondary challenge with horseradish peroxidase. *Am J Pathol* 1973;71:261-278.
396. Bernard J, Jeannesson P, Thiernes N, et al. Subpopulations of Ig-secreting cells induced by peroxidase immunization: discrimination according to antibody storage and secretion. *Immunology* 1979;36:719-727.
397. Staudt LM, Brown PO. Genomic views of the immune system. *Annu Rev Immunol* 2000;18:829-859.
398. Velculescu VE, Zhang L, Vogelstein B, et al. Serial analysis of gene expression. *Science* 1995;270:484-487.
399. Pease AC, Solas D, Sullivan EJ, et al. Light-generated oligonucleotide arrays for rapid DNA sequence analysis. *Proc Natl Acad Sci U S A* 1994;91: 5022-5026.
400. Lockhart DJ, Dong H, Byrne MC, et al. Expression monitoring by hybridization to high-density oligonucleotide arrays. *Nat Biotechnol* 1996;14: 1675-1680.
401. Hedge P, Qi R, Abernathy K, et al. A concise guide to cDNA microarray analysis. *Biotechniques* 2000;29:548-562.
402. Ermolaeva O, Rastogi M, Pruitt KD, et al. Data management and analysis for gene expression arrays. *Nat Genet* 1998;20:19-23.
403. Sherlock G. Analysis of large-scale gene expression data. *Curr Opin Immunol* 2000;12:201-205.
404. Eisen MB, Spellman PT, Brown PO, et al. Cluster analysis and display of genome-wide expression patterns. *Proc Natl Acad Sci U S A* 1998;95: 14863-14868.
405. Glynne R, Ghandour G, Rayner J, et al. B-lymphocytes quiescence, tolerance and activation as viewed by global gene expression profiling on microarrays. *Immunol Rev* 2000;176:216-246.
406. Glynne RJ, Watson SR. The immune system and gene expression microarrays: new answers to old questions. *J Pathol* 2001;195:20-30.
407. Ma C, Staudt LM. Molecular definition of the germinal center stage of B-cell differentiation. *Philos Trans R Soc Lond B Biol Sci* 2001;356:83-89.
408. Fruman DA, Ferl GZ, An SS, et al. Phosphoinositide 3-kinase and Bruton's tyrosine kinase regulate overlapping sets of genes in B lymphocytes. *Proc Natl Acad Sci U S A* 2002;99:359-364.

409. Underhill GH, George D, Bremer EG, et al. Gene expression profiling reveals a highly specialized genetic program of plasma cells. *Blood* 2003;100: 4013-4021.
410. Staudt LM. Gene expression profiling of lymphoid malignancies. *Annu Rev Med* 2002;53:303-318.
411. Lossos IS, Alizadeh AA, Eisen MB, et al. Ongoing immunoglobulin somatic mutation in germinal center B cell-like but not in activated B cell-like diffuse large cell lymphomas. *Proc Natl Acad Sci U S A* 2000;97:10209-10213.
412. Alizadeh AA, Eisen MB, Davis RE, et al. Distinct types of diffuse large B-cell lymphoma identified by gene expression profiling. *Nature* 2000;403:503-511.
413. Rosenwald A, Alizadeh AA, Widhopf GF, et al. Relation of gene expression phenotype to immunoglobulin mutation genotype in B cell chronic lymphocytic leukemia. *J Exp Med* 2001;194:1639-1647.
414. Klein U, Tu Y, Stolovitzky GA, et al. Gene expression profiling of B cell chronic lymphocytic leukemia reveals a homogeneous phenotype related to memory B cells. *J Exp Med* 2001;194:1625-1638.
415. Gurrieri C, McGuire P, Zan H, et al. Chronic lymphocytic leukemia B cells can undergo somatic hypermutation and intracлонаl immunoglobulin VHDJH gene diversification. *J Exp Med* 2002;196:629-639.
416. Vallat L, Magdelenat H, Merle-Beral H, et al. The resistance of B-CLL cells to DNA damage-induced apoptosis defined by DNA microarrays. *Blood* 2003;101:4598-45606.
417. Hofmann W-K, de Vos S, Tsukasaki K, et al. Altered apoptosis pathways in mantle cell lymphoma detected by oligonucleotide microarray. *Blood* 2001;98:787-794.
418. Zhan F, Hardin J, Kordsmeier B, et al. Global gene expression profiling of multiple myeloma, monoclonal gammopathy of undetermined significance, and normal bone marrow plasma cells. *Blood* 2002;99:1745-1757.
419. Zhan F, Tian E, Bremm K, et al. Gene expression profiling of human plasma cell differentiation and classification of late-stage B-cell development. *Blood* 2003;101:1128-1140.
420. Claudio JO, Masih-Khan E, Tang E, et al. A molecular compendium of genes expressed in multiple myeloma. *Blood* 2002;100:2175-2186.
421. Küppers R, Rajewsky K. The origin of Hodgkin and Reed/Sternberg cells in Hodgkin's disease. *Annu Rev Immunol* 1998;16:471-493.
422. Küppers R, Klein U, Schwering I, et al. Identification of Hodgkin and Reed-Sternberg cell-specific genes by gene expression profiling. *J Clin Invest* 2003;111:529-537.
423. Schwering I, Bräuninger A, Klein U, et al. Loss of the B-lineage-specific gene expression program in Hodgkin and Reed-Sternberg cells of Hodgkin lymphoma. *Blood* 2003;101:1505-1512.
424. Islam TC, Lindvall J, Wennborg A, et al. Expression profiling in transformed human B cells: influence of Btk mutations and comparison to B cell lymphomas using filter and oligonucleotides. *Eur J Immunol* 2002;32:982-993.
425. Rosenwald A, Wright G, Chan WC, et al. The use of molecular profiling to predict survival after chemotherapy for diffuse large-B-cell lymphoma. *N Engl J Med* 2002;346:1937-1947.
426. Ledbetter JA, Evans RL, Lipinski M, et al. Evolutionary conservation of surface molecules that distinguish T lymphocyte helper/inducer and cytotoxic/suppressor subpopulations in mouse and man. *J Exp Med* 1981;153:310-323.
427. Ledbetter JA, Rouse RV, Micklem HS, et al. T cell subsets defined by expression of Lyt-1,2,3 and Thy-1 antigens. Two-parameter immunofluorescence and cytotoxicity analysis with monoclonal antibodies modifies current views. *J Exp Med* 1980;152:280-295.
428. Caligaris-Caplo F, Gobbi M, Bofill M, et al. Infrequent normal B lymphocytes express features of B-chronic lymphocytic leukemia. *J Exp Med* 1982;155:623-628.
429. Bousmell L, Coppin H, Pham D, et al. An antigen shared by a human T cell subset and B cell chronic lymphocytic leukemic cells. Distribution on normal and malignant lymphoid cells. *J Exp Med* 1980;152:229-234.
430. Martin PJ, Hansen JA, Siadak AW, et al. Monoclonal antibodies recognizing normal human T lymphocytes and malignant human B lymphocytes: a comparative study. *J Immunol* 1981;127:1920-1923.

431. Royston I, Majda JA, Baird SM, et al. Human T cell antigens defined by monoclonal antibodies: the 65,000-dalton antigen of T cells (T-65) is also found on chronic lymphocytic leukemia cells bearing surface immunoglobulin. *J Immunol* 1980;125:725-731.
432. Gadol N, Ault KA. Phenotypic and functional characterization of human Leu-1 (CD5) B cells. *Immunol Rev* 1986;93:23-34.
433. Antin JH, Emerson SG, Martin P, et al. Leu-1+ (CD-5+) B cells. A major lymphoid subpopulation in human fetal spleen: phenotypic and functional studies. *J Immunol* 1986;136:505-510.
434. Hardy RR, Hayakawa K. Development and physiology of Ly-1B and its human homolog, Leu-1 B. *Immunol Rev* 1986;93:53-79.
435. Hayakawa K, Hardy RR. Development and function of B-1 cells. *Curr Opin Immunol* 2000;12:346-353.
436. Herzenberg LA, Stall AM, Lalor PA, et al. The Ly-1 B cell lineage. *Immunol Rev* 1986;93:81-102.
437. Braun J, Citri Y, Baltimore D, et al. B-Ly1 cells: immortal Ly-1+ B lymphocyte cell lines spontaneously arising in murine splenic cultures. *Immunol Rev* 1986;93:5-21.
438. Herzenberg LA, Kantor AB. B-cell lineages exist in the mouse. *Immunol Today* 1993;14:79-83.
439. Kantor AB, Herzenberg LA. Origin of murine B cell lineages. *Annu Rev Immunol* 1993;11:501-538.
440. Hardy RR, Hayakawa K. CD-5 B cells, a fetal B cell lineage. *Adv Immunol* 1994;55:297-339.
441. Haughton G, Arnold LW, Whitmore AC, et al. B-1 cells are made, not born. *Immunol Today* 1993;14:84-87.
442. Wortis HH. Surface markers, heavy chain sequences and B cell lineages. *Int Rev Immunol* 1992;8:235-246.
443. Rabin E, Cong YZ, Wortis HH. Loss of CD-23 is a consequence of B-cell activation. Implications for the analysis of B-cell lineages. *Ann NY Acad Sci* 1992;651:130-142.
444. Hayakawa K, Hardy RR, Honda M, et al. Ly-1 B cells: functionally distinct lymphocytes that secrete IgM autoantibodies. *Proc Natl Acad Sci U S A* 1984;81:2494-2498.
445. Plater-Zyberk C, Maini RN, Lam K, et al. A rheumatoid arthritis B cell subset expresses a phenotype similar to that in chronic lymphocytic leukemia. *Arthritis Rheum* 1985;28:971-976.
446. Dauphinee M, Tovar Z, Talal N. B cells expressing CD-5 are increased in Sjögren's syndrome. *Arthritis Rheum* 1988;31:642-647.
447. Hardy RR, Hayakawa K, Shimizu M, et al. Rheumatoid factor secretion from human Leu-1+ B cells. *Science* 1987;236:81-83.
448. Kipps TJ. The CD-5 B cell. *Adv. Immunol* 1989;47:117-185.
449. Ault KA, Antin JH, Ginsburg D, et al. Phenotype of recovering lymphoid cell populations after marrow transplantation. *J Exp Med* 1985;161: 1483-1502.
450. Caligaris-Cappio F, Janossy G. Surface markers in chronic lymphoid leukemias of B cell type. *Semin Hematol* 1985;22:1-12.
451. Casali P, Notkins AL. Probing the human B-cell repertoire with EBV: poly-reactive antibodies and CD-5+ B lymphocytes. *Annu Rev Immunol* 1989;7: 513-535.
452. Stoeber ZM, Wakai M, Tse DB, et al. Production of autoantibodies by CD-5 expressing B lymphocytes from patients with chronic lymphocytic leukemia. *J Exp Med* 1989;169:255-268.
453. Berland R, Wortis HH. Origins and functions of B-1 cells with notes on the role of CD-5. *Annu Rev Immunol* 2002;20:253-300.

Chapter 13 T Lymphocytes and Natural Killer Cells

> Table of Contents > Part II - The Normal Hematologic System > Section 4 - The Lymphocytes > Chapter 13 - T Lymphocytes and Natural Killer Cells

Chapter 13

T Lymphocytes and Natural Killer Cells

Frixos Paraskevas

MORPHOLOGY

The T lymphocyte under routine staining procedures (Giemsa or Wright) is 5 to 8 μm in diameter, with a high nucleocytoplasmic ratio. The nucleus is purple with densely packed chromatin, and the cytoplasm forms a narrow light-blue rim.

By transmission electron microscopy, the nucleus shows shallow indentations with dense heterochromatin along the nuclear membrane and euchromatin occupying most of the remaining nuclear surface. One or two nucleoli are visible (Fig. 13.1). The cytoplasm shows a few organelles, such as mitochondria and a small Golgi apparatus. By scanning electron microscopy, the surface of the T lymphocytes is either smooth or shows short microvilli, depending on the method of preparation as well as the state of activation.^{1,2}

Some T lymphocytes present in normal subjects are characterized by a highly indented nucleus and are known as cerebriform mononuclear cells.³ These cells are not detected in T-lymphocyte-depleted fractions and constitute approximately 3% to 4% of the unfractionated T lymphocytes. They possess scanty cytoplasm, and the degree of their nuclear indentation is expressed as a nuclear contour index (nuclear perimeter/area).⁴ Their structural similarity to the cells present in cutaneous T-cell lymphomas suggests that they represent the normal equivalent of Sézary cells, which are derived from T lymphocytes.

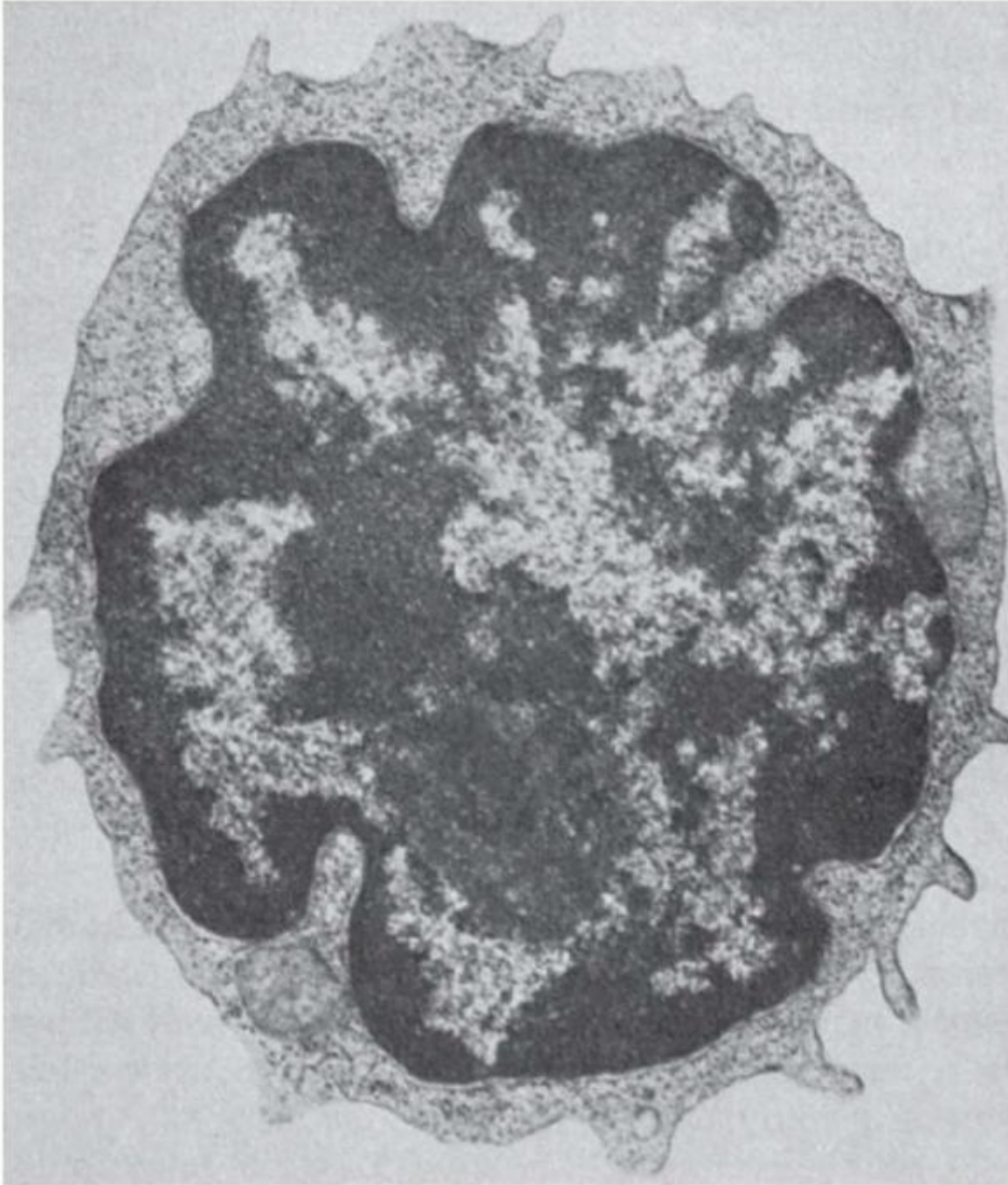

FIGURE 13.1. Ultrastructure of T-cells. The normal T-cell has a small rim of cytoplasm with only a few organelles. Nucleus shows dense heterochromatin. (From Zucker-Franklin D, Greaves MF, Grossi CE. Atlas of blood cells, 2nd ed. Philadelphia: Lea & Febiger, 1988, with permission.)

ONTOGENY OF THYMIC MICROENVIRONMENT

The thymic anlage develops from epithelial structures of the third branchial complex (Fig. 13.2). Neural crest cells (Hoxa3-positive) invade the epithelial cluster to form the thymic rudiment. Several studies support the view that the cortical and medullary epithelia originate from a common precursor, and, in the early stages, the epithelium co-expresses markers that are later segregated to the cortical or medullary compartments. After completion of thymic organogenesis, the cortical epithelia are cytokeratin-8⁺, whereas medullary epithelia are cytokeratin-5⁺,⁵ except for a small subpopulation in the corticomedullary junction, which is cytokeratin 5⁺/8⁺.⁵ Furthermore, neoplastic human thymomas often express both cortical and medullary epithelial markers.⁶

The best evidence of the origin of thymic epithelia from a common progenitor is the identification by monoclonal antibodies of a cell that generates in vivo the thymic microenvironment.^{7,8} The monoclonal antibody MTS24 detects a glycoprotein with mucinlike characteristics and a peptide backbone.⁷ The antigen is detected during the early embryonic stages in the anterior

P.280

endodermal epithelium, the pharyngeal endoderm, and a portion of intermediate mesoderm, which develops the urogenital epithelium. The MTS24⁺ cells are positive for major histocompatibility complex (MHC) class II and express cytokeratin-5 and cytokeratin-8, which are markers of the medullary and cortical epithelium, respectively. Highly purified MTS24 cells, inserted under the kidney capsule, are able to develop into a complete thymus and, furthermore, provide the complete milieu necessary for T-cell development.

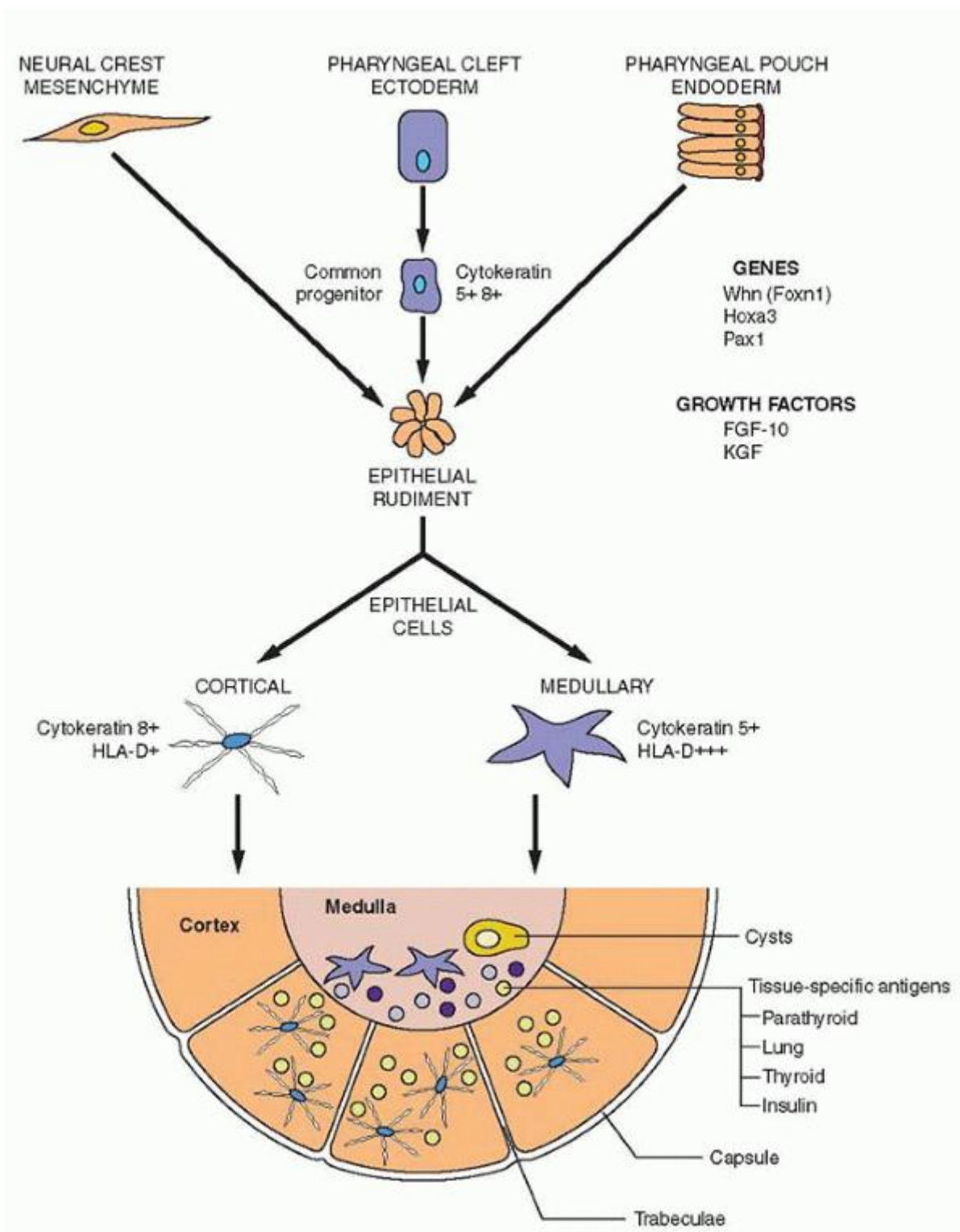

FIGURE 13.2. Morphogenesis of thymus. Elements from the third pharyngeal cleft form the epithelial rudiment, joined by mesenchymal cells from the neural crest. The common epithelial progenitor differentiates into cortical and medullary epithelium under the influence of the mesenchyme. The presence of endodermal cysts and tissue-specific “antigens” and “organoids” suggests some contribution from the endoderm. FGF, fibroblast growth factor; KGF, keratinocyte growth factor.

Because primordial epithelial cells normally need the cooperation of mesenchymal cells for thymus organogenesis,⁹ it is conceivable that, in the case of the ectopically placed MTS24 cells, this is provided by comparable cellular elements from

the kidney capsule. The MTS24 antibody completely blocks T-cell development in fetal thymic organ cultures, supporting the conclusion that the molecule recognized by the MTS24 antibody regulates normal epithelial function. During this early stage in the development of the thymus, the cell interactions are regulated by a number of transcription factors, such as HOXA3 and PAX1 which are part of cluster A on chromosome 7 and encode a DNA-binding transcription factor which may regulate gene expression, morphogenesis, and differentiation.^{10,11} An important step in our understanding of the genetic control of thymic development came from the study of the “nude” mouse and the cloning of the gene that confers the nude phenotype, designated Whn, for Winged h n,¹² more recently renamed Foxn1. The Foxn1 gene encodes a transcription factor with a DNA-binding domain of the forkhead/winged helix class. The defect responsible for the nude phenotype is a single base pair deletion in the third exon of the Foxn1 gene. It results in hair loss, the arrest of the thymic epithelial cell expansion, and inability to attract the hematopoietic precursors into the epithelial rudiment.^{13,14} Formation of the epithelial primordium is not affected by the loss of Whn function, but subsequent differentiation of the primitive epithelial precursors into subcapsular, cortical, and medullary epithelial cells is arrested¹⁵ and the epithelial rudiment becomes cystic.

In normal development, the epithelial rudiment is invaded by mesenchymal cells from the neural crest,¹⁶ which stimulate epithelial progenitor differentiation into cortical and medullary subpopulations.^{8,17,18,19} These mesenchymal-epithelial interactions are mediated by growth factors and their receptors, such as the fibroblast growth factor 10 (FGF10) and its specific receptor, FGFR2IIIb, on thymic epithelial cells. Deficiency of either the factor or the receptor results in severe thymic hypoplasia.^{20,21} When immature lymphoid cells begin to arrive in the thymic rudiment, another wave of cellular interactions takes place between the developing lymphoid cells and the stromal epithelial cells. This second stage of thymic development establishes thymic microenvironments conducive to thymocyte differentiation and repertoire selection. Further differentiation and maturation are under the regulation of interactions with thymocytes. Experiments in animals and experiments of nature in humans (disease processes) have clearly shown the symbiotic relationship between epithelial cells and lymphocytes. Prothymocytes regulate differentiation of cortical epithelial cells,²² whereas mature thymocytes organize the medullary microenvironment.^{23,24,25}

The epithelial cells in the cortex and medulla differ by ultrastructure, by immunophenotype, and by functional characteristics. Ultrastructurally, three subsets have been detected on the basis of cytoplasmic processes, secretory organelles, and desmosome connections.²⁶ Type I cells, located in the cortex, have stellate cytoplasmic processes and make contact with their neighbors, forming a syncytium. Type II cells are found in the medulla, are voluminous with many secretory intracellular vesicles, and have short cytoplasmic processes. Type III cells are rare, may contain vacuoles (pseudocysts), and are located in the medulla.

Six clusters of thymic epithelial staining (CTES) have been identified: type 1 epithelium (CTES II)²⁷ produces thymic hormones, type II (pale), type III (CTES III) of intermediate electron lucency, and type IV (dark with oval nuclei) are in the cortex proper. These cells extend fine cytoplasmic processes, establishing contacts with neighboring cells, and are connected by desmosomes forming a syncytium, the interstices of which are filled with thymocytes. Some tend to engulf up to 20 to 40 thymocytes in a lymphoepithelial cluster, known as nurse cells, detected in human thymus^{28,29} (Chapter 11, Fig. 11.9). The internalized thymocytes are located within caveolae lined by plasma membranes. The lack of penetration by certain dyes indicates that the nurse cells are not an artifact, are completely sealed from the rest of the thymus, and may play a role in T-cell selection. Their formation is not dependent on interactions of T-cell receptors (TCRs) with MHC because they are present in knockout mice deprived of TCR- $\alpha\beta$.³⁰

A better understanding of the thymocyte-epithelial cell interdependence for survival came from experiments with a variety of TCR-transgenic mice.³¹ The final organization of the cortical and medullary epithelium depends on interactions of the TCR on the thymocytes with ligands on stromal cells. Thymocytes expressing a transgenic TCR that triggers strong positive selection, resulting only in maturation of CD4⁺/CD8⁻ T-cells, lose the normal reticular pattern of cortical epithelial cells, and the epithelium in the medulla forms small scattered groups of cells surrounded by macrophages and dendritic cells.³²

Several other transgenic models demonstrated that maintenance of a balance among positive selection (PS), negative selection (NS), and nonselection is necessary to preserve normal compartmentalization and architectural integrity of the thymic epithelia.^{33,34} It is the diversity of signals emanating from these physiologic processes within the thymus during thymocyte maturation that are critical for the maintenance of epithelial organization. These signals are generated from the endogenously rearranged TCRs, which regulate positive and NS. In addition to thymocytes, the thymic vasculature is also an important epithelial organizer.³⁵ In Rag2^{-/-} mice, the medullary epithelium forms cuffs around intermediate-sized vessels, particularly the post-capillary venules. This anatomic arrangement may have important functional implications. The medullary epithelial cells have been linked to NS and tolerance induction^{36,37} and³⁸ and are therefore strategically

located around the post-capillary venules, where the concentration of autoantigens would be high. The possible functional importance of this peculiar anatomic arrangement of the medullary epithelium is also suggested from the detection of several molecules and structures considered to be tissue-specific within the medulla (i.e., parathyroid hormone, thyroglobulin, insulin, and even organized epithelial "organoids" with ultrastructural features of respiratory epithelium and thyroid follicles).³⁹ The ectopic location of these molecules and structures is supported by the detection of the expression of the appropriate genes.³⁹ It has also been postulated that, because these "ectopic" tissues within the medulla have their origin from primordial endoderm, the precursors of the epithelial cells in the medulla also may arise from pharyngeal endoderm. Further support of this view comes from the histologic appearance of medulla in athymic mice, in which further differentiation of these cells fails and the epithelium remains in the primordial condition of endodermal cysts.

Whereas epithelial development depends on FGF, its functional integrity is maintained by other growth factors contributed by the mesenchyme. The keratinocyte growth factor (KGF), a member of the FGF family, is a paracrine growth factor produced by mesenchymal cells. It acts on epithelial cells that express a splice variant of FGF (i.e., FGFR2IIIb). In fetal thymic organ cultures, exogenous KGF expands the medullary epithelium, and in Rag^{-/-} animals deprived of thymocytes, which normally produce KGF, the administration of KGF restores the normal medullary epithelial architecture.⁴⁰

The architectural integrity of the thymus is maintained throughout life, but eventually it atrophies with age.⁴¹ Changes
P.281

in signals between epithelial cells and thymocytes may determine thymic involution.⁴² Stat3 has been identified as an important signaling molecule between epithelial and mesenchymal cells in the thymic microenvironment.⁴³ Stat3 gene disruption in mice results in severe thymic atrophy and enhanced susceptibility of the thymus to environmental stress, such as glucocorticoids or γ -irradiation.

The extracellular matrix (ECM) is an important component of thymic stroma after the cells and certain interactions between differentiating thymocytes and thymic epithelial cells are mediated by ECM proteins that influence intrathymic migration events and thymocyte differentiation.⁴⁴ The ECM consists primarily of fibers of collagens, reticulin, glycosaminoglycans, and glycoproteins, including laminin and fibronectin.

Heterotrimeric laminin molecules consist of at least 15 naturally occurring isoforms, which are formed by five α , three β , and three γ subunits. In the human thymus, laminin with α_2 -chains (LN-2/4) or α_5 -chains (LN-10/11) are detected in the subcapsular epithelium and blood vessels.⁴⁵ The CD4⁻/CD8⁻ (double negative) thymocytes are located in the subcapsular area by strong attachment to LN-10/11 through their $\alpha_6\beta_1$ integrin. The CD4⁺/CD8⁺ (double positive) thymocytes, however, lose their capacity to adhere to LN-10/11 and move down to the cortex.

The interactions between thymocytes and stroma facilitate intrathymic migration and regulate positioning of the developing thymocytes to appropriate microenvironments during differentiation. The ECM proteins support the growth of thymocytes and epithelial cells and facilitate cell-cell interaction, especially migration of thymocytes in and out of nurse cells. Receptors for ECM proteins are highest in the double-negative precursors but gradually decrease with maturation.

T-CELL PROGENITORS

The T-cell progenitors in fetal life derive from the liver, whereas in adult life, they come from the bone marrow. The difference in stem cell origin has implications in subsequent lymphoid development, apparently as a result of precommitment or restriction of developmental options at the level of stem cell.⁴⁶ Human thymus becomes fully differentiated by approximately the 15th week of gestation (i.e., approximately 7 to 8 weeks after colonization of the thymic rudiment). These early migrants contribute to the development of the thymic microenvironment.

Cells with the CD34⁺/CD38^{weak}/CD90⁺ phenotype contain T-cell progenitors when they grow in fetal thymic organ cultures. In human adult bone marrow, CD34⁺/CD38⁺/HLA-DR⁺ stem cells have the potential to differentiate toward lymphoid and myeloid lineages.⁴⁷ These cells are CD45RA⁺, lack Thy1 (CD90) antigen, and may represent an intermediate oligopotent stem cell with T-cell-reconstituting ability.⁴⁸ By phenotype, there are three subpopulations in the bone marrow, which can differentiate to T-cells in the thymus: CD34⁺/CD2⁺, CD34⁺/CD7⁺, and CD34⁺/CD2⁺/CD7⁺ and all three are negative for CD3/CD4/CD8.⁴⁹ The thymus is populated by hematopoietic multipotent progenitors from the bone marrow.⁵⁰

Experiments with transgenic mice have shown that disruption of the zinc finger protein Zbtb1, resulted in a T(-)B⁺NK⁻ SCID phenotype.⁵¹ In knockout mice for Zbtb1 protein differentiation of common lymphoid progenitors is inhibited and it is associated with expanded populations of bone marrow hematopoietic stem cells and multipotent and early lymphoid

lineages⁵¹ corresponding to a common lymphoid progenitor subset.⁵² The most primitive thymocytes are Lin⁻, c-Kit^{high}, L-selectin⁺, TdT⁺, and RAG1⁺, a phenotype similar to progenitor population in the bone marrow which sustains the adult thymus.⁵³

Recruitment involves the chemokines CCL21 (or SLC, secondary lymphoid tissue chemokine) and CCL25 produced by the fetal thymus, which attract CD4⁻/CD8⁻/CD25⁻/CD44⁺ thymocytes.⁵⁴ At the site of entry P-selection of the thymic vascular endothelium binds arrests precursors expressing the P-selectin ligand (rolling). Chemokine CCL25 from endothelial cells activates precursors through the CCR9 receptor, and intercellular adhesion molecule-1 (ICAM-1) and vascular cell adhesion molecule-1 (VCAM-1) of the endothelial cells bind the cells firmly through the integrins $\alpha_4\beta_2$ and $\alpha_4\beta_1$, respectively.⁵⁵ The multipotent T-cell progenitors entering the thymus trigger Notch activation, which is critical for T-cell development (see below) for later stages of TCR-dependent selection within the thymus as well as during peripheral T-cell differentiation.⁵⁵ There is some overlap of regulatory programs between those required for T-cell specification and those needed for stem cell maintenance or self-renewal, such as Notch pathway, GATA3, IKZF1 (IKAROS), and SPI1 (PU.1).⁵⁶ The genes that need to be turned on for a successful entrance in the early stage of T-cell development include RAG1 and RAG2 and CD3G and CD3E of the pre-TCR and TCR. Although certain options of differentiation are eliminated relatively early after T-cell lineage commitment, others such as differentiation into dendritic cells and natural killer (NK) cells remain through some stages of the T-cell development. The B-cell potential is lost early within the thymus probably as a result of Notch signaling. Additional factors, such as GATA3 (T-cell-specific among the hematopoietic cells), TCF3 (E2A), shared with B lineage and even non-T-cell-specific such as RUNX1 and IKZF1 are also used in T-cell development.

NOTCH AND T-CELL COMMITMENT

Signaling through the Notch receptor is a key factor for T-cell commitment.^{57,58,59} and ⁶⁰ Notch plays a pivotal role in determining T-/B-lineage choice, and signaling through Notch drives commitment of lymphoid precursors to T lineage.^{61,62} and ⁶³ Notch belongs to a family of conserved proteins that function as cell-surface receptors and direct regulators of gene transcription.⁶⁴ It was first isolated as a gene involved in chromosomal translocations with the TRB@ gene in a subset of cases of human T-cell acute lymphoblastic leukemia. The extracellular domain of Notch contains a variable number of tandem epidermal growth-factor-like repeats and three Lin/Notch repeats, which function for ligand binding and Notch activation.⁶⁵ The intracellular region contains six Cdc10/ankyrin repeats characteristic of protein-protein interactions and essential for signal transduction. The Notch protein initially is synthesized as a single-polypeptide chain, but, as a result of proteolytic processing, it is split into two parts. The extracellular region is separated and forms a noncovalent heterodimer with the remaining portion consisting of the transmembrane and the cytoplasmic regions.

Ligands for Notch are Delta, Serrate, and several other molecules corresponding to these two classes. In general, those homologous to Delta are referred to as Delta, and those homologous to Serrate are called Serrate or Jagged.⁶⁵ These ligands are transmembrane proteins with an extracellular domain with a variable number of epidermal growth-factor-like repeats and the unique domain for this family, the DSL (Delta/Serrate Lag-2) domain, which mediates binding to Notch and activation. Which of the two groups of ligands is important for lineage commitment remains controversial.⁶⁶ In cells of the immune system, there are two Notch receptors, NOTCH1 and NOTCH2, and four signals.⁶⁷ The pleiotropic signaling by Notch regulates differentiation, proliferation, and cell death, but it is not yet clear which function most precisely determines cell fate and ultimately directs T-cell commitment.⁶⁸ With Notch inactivation, the double-negative T-cells diminish in the thymus, whereas B-cell precursors increase, probably from a more efficient production of B-cells within the thymus.⁶⁹ On the other hand, transgenic expression of Notch in the bone marrow permits the accumulation of CD4⁺/CD8⁺ T-cells. The NOTCH1 functional role seems to

P.282

be in developmental specification, driving T-cell precursors at the expense of B-cell precursors and perhaps directing the choice of a common precursor between these two fates. Notch is also needed for later stages for TRB@ gene rearrangements, PS, and CD4/CD8 lineage choices.⁵⁶

PHENOTYPIC DIFFERENTIATION

The first migrants from the bone marrow to the thymus settle in the corticomedullary junction and are large dividing cells expressing CD34⁺/CD45RA⁺, CD2⁺, and CD7⁺, with the TCR genes in the germline configuration (Fig. 13.3). The new immigrants potentially are able to differentiate to other lineages, such as NK-cells, dendritic cells, and monocytes. The CD34⁺ cells then co-express other markers such as CD38 and CD71 (transferrin receptor) associated with proliferating cells, and a portion of them are CD10⁺. They are subdivided into three categories, double negative-1 (DN-1), DN-2, and DN-3, depending on the expression of CD44 and CD25.^{70,71} Recruitment involves interactions between P-selectin

expressed by thymic endothelium and P-selectin glycoprotein ligand-1 detected on the bone marrow progenitor cells.⁷² Upon arrival they migrate to the subcapsular cortex (DN-3 cells), where they acquire expression of CD1A and CD4 and CD8, and as a result become double positive (DP). In the cortex they are submitted to PS (vide infra) and those considered "useful" return back to the medulla, and they are separated into two distinct phenotypes, CD4⁺ and CD8⁺ single-positive (SP) cells. These migrations across the thymic parenchyma are mediated by several chemokine receptors, CXCR4, CCR7, and CCR9. Adherence of thymocytes to epithelial cells is also mediated by CD2 and the lymphocyte function molecule-3 (LFA3, CD58), ICAM, and LFA1. The SP thymocytes are submitted to another screening in the medulla. Those with high-affinity TCR against self-antigens are deleted (NS). After this checkpoint, the surviving thymocytes exit the thymus for the secondary lymphoid organs. Emigration of thymocytes requires the sphingosine-1-phosphate receptor 1 (S1P-1).

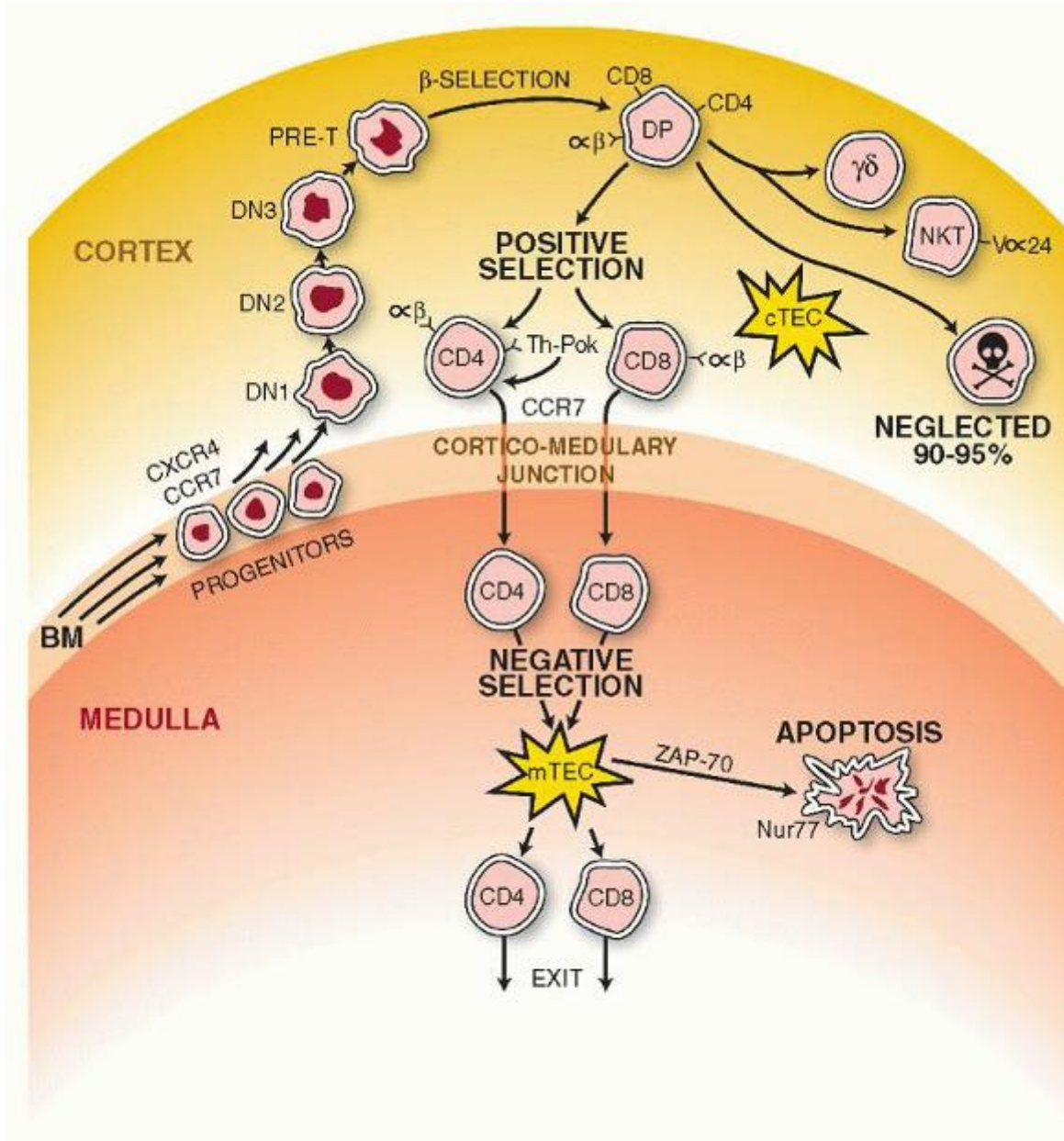

FIGURE 13.3. The first migrants from the bone marrow arrive and settle in the corticomedullary junction. They lack expression of CD4 and CD8 and are known as double negatives (DN). These new immigrants begin to move to the outer cortex and, depending on certain markers, are distinguished in three stages: DN1, DN2, and DN3. The migration is supported through interactions between P-selectin (thymic epithelium) and its ligand (progenitor cells). In the outer cortex they become double positive (DP) (i.e., CD4⁺/CD8⁺), and at the DN3 stage, undergo gene rearrangements with expression of the T-cell receptor (TCR)-β gene (β selection). Signals provided by the CCR-7 chemokine receptor guide the positively selected thymocytes that have already separated into the CD4 or CD8 lineages back to the medulla. A final

screening for the “affinity” of their TCR binding to autoantigens takes place in the medulla (NS). It is triggered by contacts of their TCR with tissue-restricted self-antigens (TRAs) on medullary thymic endothelial cells (mTECs). Promiscuous gene expression (pGE), for autoantigens, regulated by the AIRE gene (see text for details), controls central tolerance. The thymic medullary epithelium ultimately allows survival of the “useful,” and it ignores the “useless” and “destroys” the harmful¹²⁸. Exit of mature T-cells from the thymus is regulated by the G-protein-coupled receptor sphingosine-1-phosphate receptor 1 (S1P-1) as well as the very late antigen (VLA-) and lymphotoxin- β receptor.

In the process of differentiation, CD34 is progressively lost, whereas the intensity of CD7 decreases. Myeloid and NK-cells have been detected in various in vitro systems arising from thymocytes,^{73,74} and the thymic microenvironment is able to support myeloid differentiation.

Evidence of direct cellular communication between various thymic cells was provided by the demonstration of the existence of gap junctions formed by connexin 43 between two epithelial cells or between epithelial cells and thymocytes.⁷⁵

Of the cytokines that have been implicated in T-cell differentiation, interleukin-7 (IL7) is essential.⁷⁶ It is produced constitutively by epithelial cells, and it induces proliferation of DN thymocytes⁷⁷ or maintains their viability.⁷⁸ CD34⁺ thymocytes cultured with IL7 start to express CD8 and CD4 but remain CD3 and TCR negative, indicating that other stimuli from stromal cells are essential for generating CD3⁺/CD4⁺/CD8⁺ cells. IL7 also induces Tcrb gene rearrangements.⁷⁹ Mice genetically deficient in IL7 receptor have a profound reduction of T and B lymphocytes, and thymocyte development is blocked at a very early stage before the induction of CD25 and Tcrb gene rearrangements.⁸⁰ IL7 regulation is tightly coordinated during T-cell maturation within the thymus for thymocyte survival, as IL7 is essential for post-selection expansion of positively selected thymocytes.⁸¹

Other cytokines, such as IL1, IL2, and IL4, have also been shown to play some role in thymocyte differentiation.⁷⁶ The thymus is continuously colonized by hematopoietic progenitors that have the genes for the Tcr in germline configuration. Approximately 100 to 1,000 such progenitors enter the thymus daily, and it takes approximately 3 weeks to undergo complete differentiation to mature functional and self-tolerant T-cells.

The biologic processes within the thymus are highly complex, but for a better understanding, we divide them, somewhat arbitrarily, into three areas: (a) lineage determination i.e., TCR- $\alpha\beta$ versus TCR- $\gamma\delta$, (b) separation of the two main T-cell subsets, i.e., CD4 versus CD8, and (c) selection for survival of those cells with a TCR able to recognize foreign antigens, i.e., PS and elimination of those possessing autoreactive configurations, i.e., NS. Understanding of these events will be facilitated by a prior description of the genes encoding the Tcrs.

T-CELL RECEPTOR GENES

Knowledge of the structure and patterns of expression of the various TCR genes is essential to our understanding of antigen recognition by T-cells. The TCR gene, “a needle in the haystack,” was isolated by the technique of subtractive hybridization.⁸² Four human and murine TCR genes have been identified: α (TRA@, Tcra),⁸³ β (TRB@, Tcrb),⁸⁴ γ (TRG@, Tcrg), and δ (TRD@, Tcrd)^{85,86} (Fig. 13.4).

The TRA@ gene is located on chromosome 14 (bands q11-12),⁸⁷ as is the immunoglobulin (Ig) gene (band q32). Rearrangement involving the region of the chromosome containing TRA@ has been detected in patients with T-cell malignancies.^{88,89} The TRD@ gene is located on chromosome 14 within the TRA@ gene.⁹⁰ The TRB@ and TRG@ genes are located on chromosome 7.^{91,92} Translocations and inversions of chromosomes 14 and 7 are

P.283

often seen in association with ataxia telangiectasia, probably involving fragile sites that normally are used during the TCR gene rearrangements.

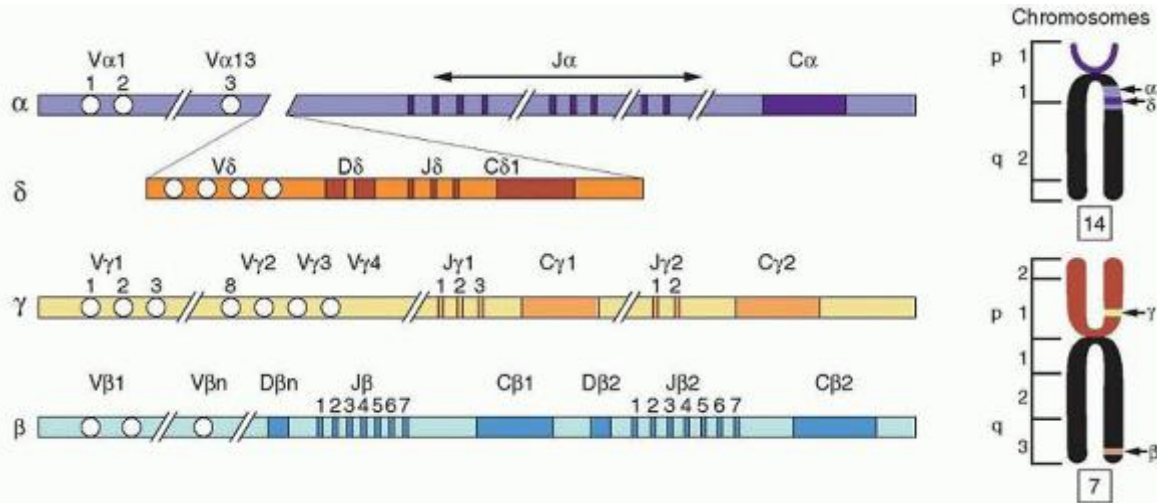

FIGURE 13.4. Organization of the genes for human T-cell receptor chains (see text for details). (Adapted from Kronenberg M, Siu G, Hood LE, et al. The molecular genetics of the T-cell antigen receptor and T-cell antigen recognition. *Annu Rev Immunol* 1986;4:529-591; and Raulet DH. The structure, function, and molecular genetics of the γ/δ T-cell receptor. *Annu Rev Immunol* 1989;7:175-207.)

All TCR genes display an overall organization similar to that of the Ig genes. They are composed of variable (V) and constant (C) genes. The V gene is made of three segments (V, J, and D) in the TRB@ and TRD@ genes, but only two segments (V and J) in the TRA@ and TRG@ genes.⁸⁶ Each V gene family is divided into subfamilies like the Ig V genes, on the basis of sequence similarity (more than 75%). In humans, the TCR gene group consists of one C- α gene,⁹³ two C- β genes,⁹⁴ two C- γ genes, and one C- δ gene. With the exception of the C- γ gene, which is composed of three exons, all of the genes have four exons. The TRD@ locus is located between the C- α and J- α gene segments. Diversity of the TCR genes is generated through rearrangements, with each of the V and J segments and the D segment, in the case of TRB@ and TRD@ genes, forming the complete V gene. The TCR genes, however, contain a large number of J segments as compared to the Ig genes.

Associated with the C- α gene are approximately 50 V α and 61 J α segments that spread over 100 kb of DNA. The β -chain (TRB@) gene complex is located on chromosome six, spans 600 kb⁹⁵ and incorporates 57 V- β segments. Each of the two C- β genes possesses a set of J- β segments and one D- β segment. The V- β segments are all located upstream from the two clusters of C- β genes. During rearrangements, when a V- β segment forms a VDJ complex, the transcript is committed to using the same C- β segment genes. The TRG@ gene locus contains two C- γ genes, each associated with its own set of J- γ segments. There are approximately 14 V- γ segments, all located upstream separately from the two C γ -J γ clusters. The C- δ gene complex lies between the V and J segments of the TRA@ gene complex and contains eight V- δ , three D- δ , and three J- δ segments. The TCR gene segments, as are the Ig gene segments, are flanked by heptamer-spacer-nonamer sequences, which serve as recognition sites for the recombinase, the enzyme that initiates V(D)J recombination which is regulated by the RAG1 and RAG2 genes for both T- and B-cells. The RAG1/RAG2 proteins act in a lineage-specific manner; i.e., Ig genes are assembled only in B-cells and TCR genes only in T-cells. The recombinations are also developmentally regulated. For T-cells the β genes are recombined before TRA@ genes and for B-cells the IGH@ gene is recombined before IGL@. These differences are explained by differential accessibility of V genes during development. Accessibility for V(D)J recombination is usually accompanied by germline transcription at antigen receptor loci.⁹⁶ Two mutually exclusive T-cell lineages have been identified on the basis of TCR: $\alpha\beta$ and $\gamma\delta$.

Transcription increases the recombination of J (α) segments located within several kilobases of a promoter and prevents the activation of downstream promoters.⁹⁷ The mechanism of V(D)J recombination has been described in detail in Chapter 12.

The mechanisms generating diversity are combinatorial associations of different V, D, and J segments and combinatorial pairing of TCR protein. However in contrast to the Ig genes, fewer V segments are available to the TCR genes. The diversity of the TCR is mainly junctional, i.e., a result of additions of nucleotides at the DNA cleavage site. Additions that depend on the template are known as P nucleotides, whereas random additions are called N nucleotides, added by terminal deoxynucleotidyl transferase (TdT) (see Chapter 12). TdT is not expressed during fetal life and in TdT knockout mice, the T-cell repertoire is of fetal type (i.e., less diverse). TdT is expressed only in immature lymphocytes and is responsible for the transition from fetal to adult repertoire by contributing significantly to the lymphocyte antigen receptor repertoire. A

striking difference between Ig and TCR is the lack of somatic hypermutations, which is very important in generating high-affinity antibodies in the germinal centers (Chapter 11). Assembly of V segments of TRB@, TRG@, and TRD@ genes occurs during the DN stage. If the β -chain rearranges successfully, it forms a heterodimer with the pre-T α (PTA) chain and differentiates along the T- $\alpha\beta$ lineage entering the DP phenotype stage.

TCR gene rearrangements occur in two discrete stages of thymocyte development: first during the DN stage with the TRD@ gene rearranging first, followed by the TRG@ and TRB@ genes and the TRA@ gene rearranging during the DP stage. During the TRB@ gene rearrangement, a D- β segment joins a J- β segment and as with the IGH@ gene rearrangement, a V- β joins the D β -J β complex. If the rearrangement is not productive the cell may have one more chance at rearranging a second C- β cluster inasmuch as there are two C- β segments each with its own D and J segments.

PRE-T-CELL RECEPTOR AND T-CELL- $\alpha\beta$, T-CELL- $\gamma\delta$ LINEAGES

The decision in choosing a TCR- $\gamma\delta$ versus a TCR- $\alpha\beta$ lineage is made by any one of three proposed models. According to one mechanism each lineage starts from a separate precursor

P.284

(stochastic or independent pathway), and a second model proposes that there is a common precursor for both lineages (instructive pathway). The third model (competitive pathway) postulates that rearrangements for the genes of the lineages start concurrently and those finishing successfully first determine the fate of the cell. Some evidence appears to support a variant of the stochastic model.⁹⁶ It is agreed that the TRD@ gene rearrangement occurs in thymocytes that can adopt either one of the $\gamma\delta$ or $\alpha\beta$ fates, but activation of the TRA@ gene rearrangement during the DP stage seals the fate of the T-cell for the $\alpha\beta$ lineage.

Determination of lineage is regulated by transcription factors that act on promoters and enhancers and make appropriate genes accessible to the recombinase.^{97,98} Another regulatory mechanism involves the pre-TCR. At this stage of T-cell development, the TCR- β chain forms a heterodimer with the PTA chain and the complex is referred to as pre-TCR.⁹⁹ The PTA is a 33-kd type I transmembrane protein of the Ig superfamily, with a single Ig-like domain. Two cysteines form the intrachain disulfide bond, whereas a third cysteine just above the transmembrane region forms the disulfide bridge with the TCR- β chain.¹⁰⁰ The human PTA gene is located on the short arm of chromosome 6, in the vicinity of the HLA locus. The PTA chain is not essential for CD3 expression, but has a major role in TCR- $\alpha\beta$ versus TCR- $\gamma\delta$ commitment. It generates large numbers of CD4⁺/CD8⁺ T-cells with productive TCR- β rearrangements and directs these cells to the TCR- $\alpha\beta$ lineage.¹⁰¹ At the DN-3 stage, thymocytes undergo extensive DNA rearrangements at the TRB@, TRG@, and TRD@ gene loci and make a choice for selection, between the TCR- $\alpha\beta$ and TCR- γ receptors. Expression of the TCR- β chain in combination with the pre-TCR- α chain results in a process known as β selection, which leads to rearrangements of the TRA@ genes and formation of the complete TCR- $\alpha\beta$. If the TRD@ or TRG@ genes are rearranged, the cells follow the TCR- $\gamma\delta$ lineage ($\gamma\delta$ selection).^{102,103} and ¹⁰⁴

The selection for TCR- β is initiated at a stage phenotypically characterized by expression of CD4⁺/CD8 $\alpha^+\beta^-$.¹⁰⁵ The productive V- β gene rearrangement in one allele prevents rearrangements of the second allele, a process called allelic exclusion that is regulated by the pre-TCR. Signaling by the pre-TCR requires the CD-3 chains γ , ϵ , ζ , and η , and the LCK kinase,¹⁰⁶ which is associated with the CD3- ϵ and - γ chains and is indispensable for the pre-TCR function. Other functions mediated by pre-TCR signaling are cell survival and phenotypic changes. Pre-TCR promotes thymocyte survival, whereas signaling by TCR induces apoptosis.^{107,108} Because pre-TCR is expressed on DN T-cells, the antiapoptotic function of pre-TCR is crucial for their survival and differentiation of DN T-cells into the DP stage when the TCR is needed for positive or NS.

Both receptors follow initially similar signaling pathways, such as tyrosine phosphorylation and so forth, but in the apoptotic pathway, they diverge at the level of Fas ligand (FasL) induction, which requires induction of Nur-77 and transcription factors from the nuclear factor of activated T-cells (NFAT). These factors can be induced only by the TCR- $\alpha\beta$ but not by the pre-TCR. The PTA possesses a palmitoyl moiety that spontaneously targets the PTA chain to the cell membrane (lipid rafts).¹⁰⁹ This may offset the requirements for a ligand because the pre-TCR from such a location is able to signal constitutively. Signaling through pre-TCR results in expression of certain transcription factors required for the differentiation of precursors to $\alpha\beta$ T-cells, i.e., β selection (see above). Some of these factors are the E-proteins of the basic helix-loop-helix transcription activators required for expression of CD4, TCR- α and TCR- β chains and so forth.¹¹⁰

CD4/CD8 LINEAGE COMMITMENT

The DP thymocyte (CD4⁺/CD8⁺) differentiates into two phenotypically and functionally distinct lineages of αβ T-cells: CD4⁺ and CD8⁺. The TCR of the CD4⁺ cells interacts with peptides bound to class II MHC molecules, whereas the TCR of the CD8⁺ cells recognizes peptide-class I MHC complexes. The CD4 and CD8 proteins are not clonally distributed and are known as coreceptors because they recognize the same ligands as the TCR.¹¹¹ The mechanism by which the separation of the lineages from DP thymocytes is achieved remains unresolved.^{112,113}

According to one theory, known as instructive, thymocytes carrying an MHC class I restricted TCR differentiate to CD8⁺ lineage, whereas engagement of TCR with class II MHC induces commitment to CD4. An alternative model, known as stochastic (or selective), accepts that the DP thymocytes are already committed randomly to a lineage; they make a choice that is unrelated to the MHC specificity of their TCR. Data collected from a variety of approaches do not agree with any particular mechanism in lineage commitment. The instructive model proposes that the CD4 or CD8 transduces differentiation-specific signals, but no lineage-specific signals have ever been identified.

It is also possible that the cytoplasmic region of CD4 directs CD4 lineage commitment. A chimeric construct, for example, made of the cytoplasmic region of CD4 and the extracellular and transmembrane region of CD8a supported the development of cells with the CD4⁺/CD8a⁻ phenotype but with a class I restricted TCR.¹¹⁴ CD4 is preferentially associated with its cytoplasmic tail with the tyrosine kinase LCK. Therefore, CD4 is likely to deliver stronger signals than the coengagement of TCR and CD8.^{115,116}

The strength of signal model suggests that strong signals dictated by the frequency of the available ligand induce CD4 differentiation, whereas weak signals induce CD8. Another aspect of signaling that was evaluated was the duration of signals as an important parameter. When the interaction is limited to a few hours, the cells become CD8⁺, but exposure for longer periods of time results in CD4⁺ lineage commitment.¹¹⁷ Accordingly, TCR of a DP thymocyte initiates down-regulation of CD8 and produces a CD4⁺/CD8⁻ intermediate cell. At this stage, the duration of signaling determines the final outcome. That is, short signaling produces CD8⁺ T-cells, whereas persistence of signaling in the CD4⁺/CD8⁻ intermediate cell causes CD4⁺ differentiation.¹¹⁸ Variation of LCK function seems to be the single most important parameter in CD4/CD8 lineage decision. Constitutively active LCK promotes CD4 differentiation, even in the presence of class I MHC-restricted TCR. When, on the other hand, LCK is catalytically inactive, all thymocytes including those with class II MHC-restricted TCR, become CD8⁺.^{119,120} In the absence of LCK, cross-linking of CD3 induces CD8 differentiation.¹²¹ The LCK-dependent regulation of lineage commitment is not only phenotypic, but also functional, because the class II MHC-restricted CD8⁺ cells behave as killer cells, whereas the class I restricted CD4⁺ cells up-regulate CD40 ligand, a function characteristic of helper T-cells.¹¹⁹ Signaling initiating from LCK is channelled through the Ras-Erk pathway.¹²²

The various experimental approaches used in these studies make it clear that the signals required for CD4 differentiation are promiscuous, which is believed to indicate that CD-4 differentiation is a default pathway.¹²³ The multiplicity of the models entertained and the ambiguity of some of the results are also a testimony that the precise mechanism of T-cell lineage commitment remains still elusive and certainly complex.^{113,124}

More recently a new transcription factor Th-POK (T-helper-inducing POK factor) was found to be necessary and sufficient for CD4 lineage commitment and absence of Th-POK results in the development of CD8⁺ T-cells.¹²⁵ The existence of this factor was suspected as a result of studies of the spontaneous recessive mutant mouse with helper deficient cells (i.e., CD4⁺ T-cells).¹²⁶ Th-POK belongs to the POK family of transcription factors characterized by two motifs, a regulatory POZ/BTB domain (for interaction with other transcription factors) and a Zn finger DNA-binding domain.

In summary, LCK is a key regulator, but other signals originating from the TCR in the absence of a coreceptor or in the

absence of a significant recruitment of LCK provide sufficient SRC activity for a response. Such signals depend on the nature of the peptides involved in positive versus NS, which is linked to lineage selection.¹²¹ Although the prevailing opinion accepts that lineage commitment and the selection of thymocytes with useful TCRs are linked, some of the models proposed point to the opposite.¹²⁷ The latest view that CD4/CD8 lineage commitment is transcriptionally regulated will put an end to this question hotly debated for a long time.

POSITIVE AND NEGATIVE SELECTION

The random nature of rearrangements of TCR genes generates specificities directed not only against foreign antigens, but also against self-antigens. Self-reactive T-cells are harmful if they have the opportunity of exiting the thymus. Mechanisms have therefore been developed that allow the thymus to “select the useful, neglect the useless and destroy the harmful.”¹²⁸ The time for selection appears to begin at the DP stage when the TCR is expressed at low levels.^{129,130,131} and

¹³² The TCR of the thymocytes recognizes self-peptides presented by the MHC molecules. It has been widely accepted that the options for each DP thymocyte are determined by some fine qualities and properties of the TCR and MHC-peptide (pMHC) ligand interaction. If the affinity of interaction is “weak,” the cell is positively selected, whereas a T-cell with high affinity is negatively selected.¹³³

Cells with TCRs that cannot bind with sufficient avidity are neglected and die by apoptosis, whereas in the positively selected cell the expression of RAG, which encodes the proteins regulating V(D)J recombination and the PTCRA (pre-T-cell receptor) gene are turned off and expression of CD4 and CD8 are partially down-regulated. At this stage the cell moves from the cortex to the medulla, one of the coreceptors is re-expressed and the cell lineage is defined.^{122,134} Signaling by LCK regulates positive and NS and in its absence the selection mechanisms are compromised.¹³⁵ LCK interacts with the coreceptors CD4 and CD8 through two cysteines in the cytoplasmic region of each co-receptor and two cysteines in LCK.¹³⁶

The binding of TCR to the ligand induces phosphorylation of the three immunoreceptor tyrosine-based activation motifs (ITAMs) of the ζ -chain and the single ITAM in each of the CD3 ϵ -, δ -, and γ -chains. The ζ -chain is constitutively associated in thymocytes with the ZAP70 kinase, suggesting that a low level of activation takes place continuously.¹³⁷ The fate of the immature thymocyte depends on the type of APC that it encounters in the various histologic compartments of the thymus. The cortical thymic epithelial cells usually mediate PS,^{138,139} and the medullary hematopoietic cells mediate NS,¹⁴⁰ although under certain circumstances they may also contribute to PS.¹⁴¹ Interactions among thymocytes may also support PS if the selecting thymocyte carries MHC class II molecules.¹⁴² In this case the α -chain of the TCR, and particularly the highly diverse CDR3 loop of the α -chain, plays an important regulatory role.¹⁴³ Signals provided by the CCR7 chemokine receptor¹⁴⁴ guide the positively selected thymocyte to the medulla. The CCR7 signals provide guidance for the selected thymocyte through the corticomedullary maze, in preparation of the central tolerance in the medulla prior to their exit to the periphery.¹⁴⁴ An important selective force in these cellular interactions is the strength of the interaction, which determines the outcome. Strong interactions lead to deletion, whereas intermediate strength induces PS. This may explain the increase of PS following blocking of CD28/B7 interactions.¹⁴⁵ Removal of strong self-reactive cells is the sole purpose of the NS. Such clones potentially may initiate autoimmunity if they exit to the periphery. An estimated 2,000 to 3,000 tissue-specific antigens are expressed in human or murine medullary thymic endothelial cells (mTECs),^{146,147} i.e., 5% to 10% of the known mouse genes, in addition to their normal tissue expression. About 500 of these genes may be AIRE (autoimmune regulator) -dependent. Using hen egg lysozyme as reporter for the insulin promoter, it was shown that the expression of the antigen in the thymic stroma is necessary and sufficient for deletion.¹⁴⁸

Expression of tissue-restricted self-antigens (TRAs) by mTECs is the result of promiscuous gene expression (pGE) by the mTECs.¹⁴⁶ Some of the genes are expressed by both mTECs and cortical thymic endothelial cells (cTECs; pool 1), whereas others are expressed only by mTECs (pool 2), and finally others are expressed only in the more mature mTECs (i.e., strongly positive for MHC class II; pool 3). Depending on the stage of differentiation of mTECs, two models have been proposed for pGE: (a) in the developmental, or progressive restriction model, pGE is detected in immature and perhaps pluripotent progenitor cells and (b) in the terminal differentiation model, pGE is mutated in mTECs of a mature phenotype.¹⁴⁹ The pGE is regulated by AIRE, the gene mutated in the rare autoimmune disorder known as autoimmune polyglandular syndrome type 1 (APS-1).¹⁵⁰

AIRE has a nuclear localization signal and several potential DNA-binding and protein interaction domains. In cooperation with transcription factor CREB-binding protein it transactivates the transcription of other genes, although it is still a mystery how as a single molecule it controls the transcription of such an array of genes.

The pGE has been conserved across species barriers during evolution as a study recently with human pure populations of thymic cTECs and mTECs has shown.¹⁵¹ The AIRE gene showed the highest enrichment in mTECs and the promiscuously over-expressed genes are those remarkably well conserved among species. A set of 443 genes have been detected overexpressed in mTECs (comparable to 555 in mouse). This is an underestimate as most were detected by polymerase chain reaction. These genes show no preference for any chromosome. Another interesting aspect is the finding of clustering of nonhomologous genes. This clustering has been suggested to result from the juxtaposition during evolution of genes involved in the formation of a particular tissue. Because the promiscuously expressed genes do not all share such a function, the clustering is the result of epigenetic mechanisms of regulation. They become accessible to mTECs as a result of belonging to the same “gene neighborhood.” pGE not only is sufficient for self-tolerance, but also likely has been essential for survival of the species inasmuch as infertility as a result of gonad-specific autoimmunity is highly prevalent in APS-1¹⁵² and in Aire^{-/-} mice.¹⁵³ In addition to genetic control, self-tolerance may also be regulated by epigenetic mechanisms. The lymphotoxin β receptor (LT β R) directs the three-dimensional organization of mTECs,¹⁵⁴ and TRAF6, a cytoplasmic adaptor molecule, which does not bind to LT β R, was still shown to direct mTEC development.^{155,156}

Self-tolerance is mediated primarily by NS or clonal deletion,¹⁵⁷ but some of the self-reactive T-cells are submitted to nondeletional central tolerance and give rise to immunosuppressive CD4⁺ T-cells, also known as natural regulatory T-cells (T reg) cells.¹⁵⁸ T reg cells are T-cells with medium to high affinity for self-antigens. However, they escape NS and are positively selected by a subset of dendritic cells that have been educated by a thymic stromal lymphopoeitin produced by Hassall corpuscles.¹⁵⁹ Other evidence, on the other hand, indicates that CD4⁺ T reg cells are positively selected by thymic epithelial cells expressing self-antigens but not by bone-marrow-derived dendritic cells.¹⁶⁰ ZAP70 is indispensable for positive and NS because both processes are abrogated in ZAP70-deficient mice.¹⁶¹

The SRC-like adaptor protein (SLAP) down-regulates the TCR expression during the DP stage of development and rescues T-cell development in the absence of ZAP70. Overall, SLAP acts as a

P.286

negative regulator and probably “marks” activated receptors for retention and degradation.¹⁶² The main downstream signaling pathway for PS is the Ras/map kinase (MAPK) cascade.¹⁶³ TCR signaling alone is not sufficient to induce selection for survival or death.¹⁶⁴ CD2 expression exerts a strong influence on the TCR repertoire. In the absence of CD2, the thymocytes with high affinity for peptide MHC escape NS.¹⁶⁵ CD2 also influences pre-TCR function in the usage of V α genes, which is substantially altered in CD2-deficient mice.

The costimulatory interaction of CD40/CD40L is a master regulator of NS, usually acting in the regulation of the ligands of other costimulatory molecules, such as CD80 and CD86.¹⁶⁶ CD40 may also induce other co-stimuli required for thymocyte deletion, such as CD54 (ICAM-1), FASL, or tumor necrosis factor (TNF).^{167,168} and ¹⁶⁹ These molecules could regulate NS separately or in combination with CD5 and CD28. The CD28 costimulatory molecule engaged with TCR signals thymocytes to undergo apoptosis or maturation, depending on the intensity of costimulation.¹⁷⁰

Stimulation of maturation of DP thymocytes follows activation of the extracellular signal-regulated kinase ERK/MAPK pathway and up-regulation of the antiapoptotic protein BCL2. Apoptosis is triggered with the expression of the Nur77 family of transcription factors and occurs only if TCR engagement is accompanied by costimulation. Ca²⁺ fluxes in mature T lymphocytes regulate proliferation, differentiation, and survival. Some of the functions of Ca²⁺ are mediated by the Ca²⁺-dependent phosphatase calcineurin. The function of calcineurin is disrupted by cyclosporin A and FK506. Both of these substances form complexes with cellular proteins, termed immunophilins, that bind and sequester calcineurin. Cyclosporin A and FK-506 block the initial steps of PS.^{171,172} On the other hand, intracellular chelators reduce deletion,¹⁷³ which suggests that interference of Ca²⁺ fluxes and function exerts several effects on the selection process.

All signaling pathways end up targeting regulation of transcription factors, and various studies have examined the roles of NFAT and nuclear factor- κ B (NF- κ B), but only members of the Nur-77 family have been clearly shown to be involved in the process of selection, with a major role in apoptosis of massive numbers of thymocytes.¹⁷⁴ It has been estimated that 90% to 95% of thymocytes die inside the thymus, and the appearance of very large numbers of dead cells on histologic sections is the reason that histopathologists called the thymus the “graveyard” of T-cells. The timing of positive versus NS has been difficult to define. NS was believed to occur relatively late because the TCR affinity increases with time, and it is the high affinity of TCR that triggers NS.

THE CELLS AND MOLECULES IN THE SELECTION OF THYMOCYTES

Hematopoietic components of the thymic stroma are radiosensitive, whereas the epithelial components are radioresistant. These differences allowed the construction of chimeric thymuses (i.e., thymuses composed of epithelial and hematopoietic elements with a different MHC background). These experiments indicated that the thymic cortical epithelium is responsible for PS.¹⁷⁵ The hematopoietic stromal cells, on the other hand, are potent inducers of NS. The cortical epithelial cells have weak MHC expression and the developing DP thymocytes at that stage have low TCR expression; as a result, the interactions are only of low avidity, required by positive. Similarly, the hematopoietic cells in the corticomedullary junction express MHC molecules at higher density, and the T-cells have up-regulated their TCRs. As a result, the interactions in this anatomic location are appropriate for NS. The concentration of the peptide may also play a role in the selection process. thymocyte bearing a TCR specific for class-I-peptide complex is positively selected if the peptide it carries is in a low concentration and is killed if the peptide concentration is high.¹⁷⁶ However, the weak interactions required for PS and the strong interactions operating in NS can also be provided by the half-life of the pMHC complex (i.e., short half-life for positive and long half-life for NS).

The original question of affinity versus concentration was better answered with manipulation of the pMHC. PS is driven by peptides with varying affinities; however, by increasing the concentration of the peptide, even low-affinity ligands can positively select.¹⁷⁷ It has been argued that the recognition of self-peptides in PS must be relatively degenerate. In other

words, a single pMHC can trigger the PS of multiple thymocytes;¹⁷⁸ therefore, the peptide recognition during PS is cross-reactive.¹⁷⁹ This apparent degeneracy of the peptide binding to TCR is the result of a significant contribution to the binding by the MHC molecule.¹⁸⁰

Other parameters of a pMHC complex, such as the conformation¹⁸¹ and the concentration¹⁸² of the peptide, contribute to the repertoire selection. Despite the evidence that each pMHC complex selects more than one TCR, the large diversity of the fully developed T-cell repertoire depends on a large number of pMHCs¹⁸³ as well as on the quantity and quality of the stromal cells.¹⁸⁴ Peptide diversity during the selection seems to have a greater effect on negative than on PS. In thymus organ cultures, testing with a diverse array of peptides, the addition of 1% of dendritic cells reduced the number of CD4⁺ T-cells selected by 80% compared to that of the controls in the absence of dendritic cells. Thus, the quantity and quality of the selecting stromal cells have a significant impact on the selected repertoire by multiple peptides.¹⁸⁴ At the end of the selection process, mature T lymphocytes exit the thymus and home to the secondary lymphoid organs (see Chapter 11). There are two types of TCR- $\alpha\beta$ T-cells, the CD4⁺ (T helper cell) and the CD8⁺ (cytotoxic T-cell) and one TCR- $\gamma\delta$ cell.

THE α/β T-CELL RECEPTOR COMPLEX

The TCR complex is composed of two components: one is unique in each T-cell and is involved in antigen recognition (ligand binding) and the second component is the same in all T-cells and is involved in signal transduction leading to T-cell activation.^{185,186} and ¹⁸⁷

THE MAJOR HISTOCOMPATIBILITY COMPLEX-PEPTIDE COMPLEX

The $\alpha\beta$ receptor is formed by two chains, α and β (Fig. 13.5), each consisting of a constant domain, C- α and C- β , and a variable domain, V- α and V- β . The V- α domain is encoded by two gene segments, V- α and J- α , and is homologous to the V domain of the Ig heavy chain (IGH@). The V- β domain is formed by three polypeptides, V- β , D, and J- β . The constant domains correspond to the Ig C domains, but there are certain differences. The C- α -C- β interface is highly polar, whereas that of CL-CH1 is hydrophobic. C- β has a large loop, which extends out to the side of the domain. It has been proposed that it may interact with the coreceptors. The C- α domain has several structural deviations from the C-type Ig domain.

The V domains are very similar to the V domains of an antibody molecule. They contribute to the formation of the TCR-combining site, which is made up of hypervariable loops or complementarity-determining regions CDR 1, 2, and 3 from the α - and β -chains and another loop termed HV-4, which exhibits some hypervariability. The CDR1 and CDR2 are formed by the V segments, which are less polymorphic in the TCR than in IGH@ because fewer V segments are available for TCR, whereas the CDR3 is polymorphic as

P.287

a result of the larger number of J segments available for β -chain contributing to CDR3.

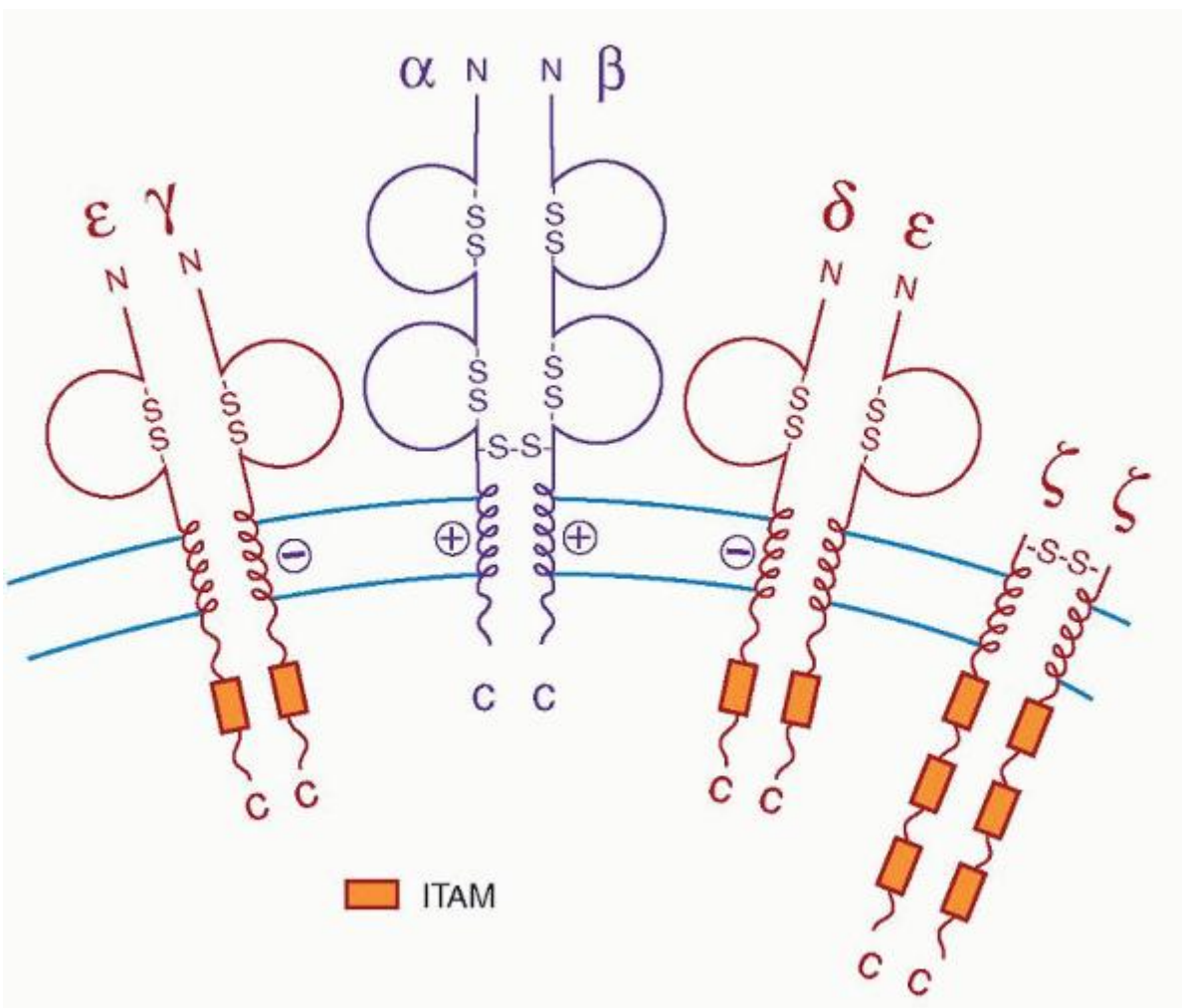

FIGURE 13.5. T-cell receptor complex. The T-cell receptor complex consists of two components: ligand binding (antigen recognition) and signal transduction. The antigen recognition component consists of two polypeptide chains, α and β . Because of their short intracytoplasmic tails, they cannot link themselves to the signal transduction cascade. The signal transduction component consists of the CD3 proteins γ , δ , and ϵ , members of the immunoglobulin superfamily, and two other proteins forming either a homodimer (two ζ proteins) or a heterodimer (ζ - ϵ). The γ -, δ -, and ϵ -chains have one immunoreceptor tyrosine-based activation motif each, and the ζ -chain has three. See text for details.

The loops of V- β that form the expected antigen-binding site of the TCR are similarly placed as in the IGH@ V region. The chains are linked by a disulfide bond, and the heterodimer is anchored to the cell membrane by the transmembrane region, ending in the cytoplasm by a short (three- to five-amino acid) cytoplasmic tail. Crystallization of the TCR shows that it resembles the Fab fragment of the Ig molecule.¹⁸⁷ However, the TCR- $\alpha\beta$ is extensively glycosylated with up to seven N-linked sites distributed between the α - and β -chains. The combining site is usually flat, similar to antiprotein antibodies and consistent with the TCR's function of binding to the generally flat, undulating surface of the pMHC.¹⁸⁸ The diversity of the CDR3 is much higher, implying that the function of CD-3 is in peptide discrimination, whereas CDR1 and 2 interact with more conserved structural elements of the MHC. The TCR contains many more J segments and thus are able to increase V- $J\alpha$ and V-D- $J\beta$ junctional diversity in the CDR3.¹⁸⁹ The residues of the TCR that contact the pMHC are always in the apices of the CDR (i.e., for CDR1 α , residues 27 to 30; for CDR2 α , residues 50 to 52; for CDR1 β residues 27 to 30; and for CDR2 β residues 52 and 53).

The TCR interacts with peptides bound to MHC molecules (Fig. 13.6). The aminoterminal domains, α_1 and α_2 of the MHC class I heavy chain, form the binding site for the peptide. The site consists of a floor of eight strands of antiparallel β -pleated sheets, which support two α helices, one contributed by the α_1 domain and the other by the α_2 domain aligned in an antiparallel orientation. The floor of the groove is supported by two Ig domains from below; one is the α_3 domain of the heavy chain and the other the β_2 -microglobulin. This arrangement forms a groove, on the floor of which lies the peptide from an antigen to be presented to the TCR. Some of the residues of the peptide are exposed above the groove

and interact directly with the TCR, whereas others point to the floor of the groove. Depressions in the floor of the groove, known as pockets A through F, interact with some side chains of the bound peptide.¹⁹⁰

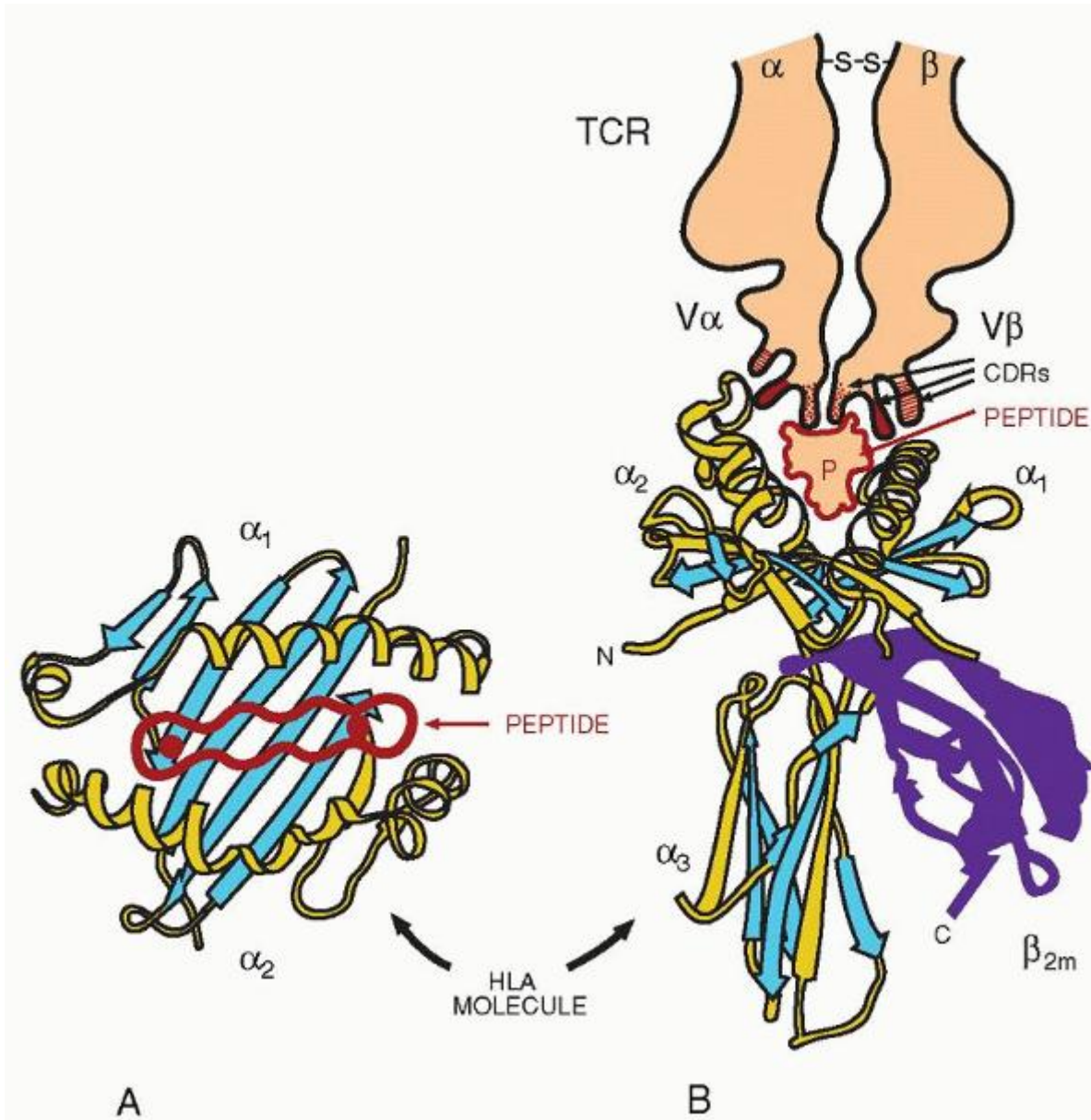

FIGURE 13.6. T-cell receptor (TCR) interaction with HLA/peptide complex. Crystallographic studies of the HLA class II molecule have shown that the two variable domains (α_1 and α_2) form a groove that binds the peptide that is released as a result of antigen processing. The peptide groove is formed by the helices of the α_1 and α_2 domains (A). Binding of the peptide is mediated through anchor amino acids near both ends of the peptide (in A). The TCR binds to both the major histocompatibility complex molecule and the peptide. The complementarity-determining region (CDR) 3 of both the α - and β -chains interacts with amino acids of the peptide, whereas the CDR1 and CDR2 interact with the major histocompatibility complex molecule (B).

For HLA-B27, the side chain of the C-terminal of the bound peptide sits deep in the F pocket, whereas the N-terminal forms strong hydrogen bonds with the hydroxyl groups of conserved amino acids at the end of the groove.¹⁹¹ (For details of interaction with the pMHC, see Chapter 14.) For crystallization of TCR-pMHC, the peptide was attached covalently through a linker to the amino terminus of the β -chain of an MHC class II molecule¹⁹² or covalently connected to the amino terminus of the β -chain of the TCR¹⁹³ and thus tethered to the MHC groove. Such approaches provided stable complexes of HLA-DR1 and HLA-DR4 that permitted their crystallization. Several TCR-pMHCs have been analyzed to clarify the contributions of V α for the buried surface area (i.e., the interface between TCR and the pMHC). The contribution of V α is on the average 57% and that of the V β 43%.¹⁹⁴ The orientation of the TCR over the pMHC is diagonal rather than

orthogonal.¹⁹⁵ It is more likely that the TCR turns around the MHC molecule by approximately 35° and varies also in its roll in a range of 19° (range 30°).¹⁹⁶ As shown by x-ray crystallography, with 2.5 angstrom resolution, of a complex of human $\alpha\beta$ -TCR bound to a complex of HLA-A2/HTLV-1 Tax peptide, (HTLV = human T-cell leukemia virus), the initiation of T-cell signaling is favored by a diagonal binding position of the TCR with the supramolecular assembly. This form of interaction of the TCR with its target is in striking contrast to antibody molecules, which use different binding positions even with the same antigen. The diagonal approach of the TCR, to the MHC/peptide complex, evolved to facilitate the initiation of T-cell signaling, inasmuch as the same MHC-bound antigen can be recognized by different TCRs. Unlike antibody molecules, which bind even to the same antigen by many different binding geometries, the TCRs interact with the MHC/peptide complex with a diagonal binding mode. The diagonal binding

P.288

geometry has implications for the mechanism of initiation of T-cell signaling, because it places the TCR in a orientation that facilitates the positioning of the CDR1 and CDR2 loops over the α_1/α_2 helices of MHC class I, and the α_1/β_1 helices for class II molecules. The V α domain is critical in setting up these orientations facilitating the read-out of the peptide sequence. Thus the CDR1 and CDR2 interactions of V α are conservative¹⁸⁶ and provide the basic affinity of the TCR. The CDR3 loop is primarily positioned for contact of the peptide in the peptide-binding groove whereas the V β interaction is more variable in the C-terminal half of the peptide. The contribution of the individual CDR loops to the interaction varies. CDR1 β and CDR2 β actually contribute little or nothing to the interaction whereas the CDR3 loops are centrally located and usually dominate the interactions.¹⁹⁴ The contribution of the peptide to the interactions with the TCR varies and usually, two to five side chains of the peptide make direct contact with the TCR. These contact points, known as hot spots, are peptide residues that bulge out of the groove which is more prominent and sometimes profound as in MHC class I.¹⁹⁷ In the interactions of MHC class II with the TCR, the contributions of the peptide side chains are more uniformly dispersed and the peptides are slightly deeper in the MHC binding groove.¹⁹⁷ No single contact dominates the TCR-pMHC interactions, as is often observed in the antigen-antibody interactions. A small number of amino acids dominate the energy landscape in antigen-antibody interaction, as shown by somatic mutations that result in higher-affinity binding.¹⁹⁸ Based on these considerations, it appears likely that the CDR1 and CDR2 loops interacting with the helices of the MHC are responsible for PS, and the CDR3 loops probably play a more important role in NS. As an extension of these considerations in delineating the roles of V-region loops of the TCR, the CDR1 and CDR2 loops provide the basic affinity in the interaction, whereas the CDR3 provides the specificity.¹⁹⁴ The residues of the peptide that protrude highest from the groove provide the basis for discrimination of peptide and for altering affinity or half-life of the TCR-pMHC interaction.

An important point that came out of these crystallographic studies is the role of the water that fills the TCR-pMHC interfaces. This water provides additional complementarity by filling the cavities in the interface, and some of these molecules mediate contact between TCR and pMHC.¹⁹⁹ Overall, the consistent feature of TCR-pMHC interaction is that the peptide contributes a smaller portion of the binding interface (21% to 34%) and a smaller proportion of contacts (26% to 47%) than the MHC. The central positions of the peptide play the critical role and those define the peptides as agonists, partial agonists, and antagonists.²⁰⁰ The binding of TCR to the pMHC results in T-cell activation and usually there is a broad correlation among affinity, half-life, and the functional outcomes.²⁰¹ Mutational analysis of the role of the centrally located residues indicates that in some systems, the biologic activity increases,²⁰² yet in others, the peptide is converted from an agonist to an antagonist;²⁰³ nevertheless the affinities of the pMHC for TCR change only marginally.

Contacts on certain hot spots are very sensitive in changing the functional read-out but are not based on changes in the affinity of binding or half-life differences in the TCR-pMHC complexes. It has been argued that affinities usually have been measured in isolated TCR-pMHC complexes, and true affinity measurements may require the presence of coreceptors and signaling components and need to be measured with cellular assays.²⁰³

Because changes in the TCR-pMHC complementarity interface are important for triggering biologic reactions, the conformational changes that have been observed in the TCR-complex crystal structures have been considered for initiation of signaling, but their role is not clear.²⁰⁴ Conformational changes contribute to an increase in the binding of a number of other peptides (i.e., an expansion of the repertoire).²⁰⁵

PEPTIDE-MAJOR HISTOCOMPATIBILITY COMPLEX INTERACTION: THE CORECEPTORS

The TCR is not alone in its interaction with the pMHC but is associated with coreceptors (i.e., CD4, CD8, and the CD3 chains). The monomorphic CD3 γ -, δ -, ϵ -, and ζ -chains, together with the $\alpha\beta$ heterodimer form the TCR complex. The CD4 or CD8 act as assistants to the TCRs in the helper or cytotoxic function of the cells, respectively. Therefore they have been known as coreceptors.¹¹¹ In the current model, the CD4 binds to the same MHC II as the TCR of the CD4⁺ T-cell and

similarly the CD8 binds to the same MHC I as the TCR of the CD8⁺ T-cell. The binding of the coreceptors occurs with another site of the MHC molecule than that involved in the TCR binding. The TCR binds to the pMHC surface at an angle of 45° to 80° relative to the axis of the two α -helices of MHC,²⁰⁶ which excludes the possibility for direct association of the coreceptors with the TCR that binds the same pMHC. One possibility is that the coreceptors could be linked with TCR in the cytoplasm through signaling molecules (i.e., ZAP70 and LCK).²⁰⁷ Another possibility is that the coreceptor associated with a TCR binds to a different pMHC to which a second TCR binds forming a pseudodimer.²⁰⁸

The CD8 acts as a dimer that includes either two α -chains or one α - and one β -chain, whereas CD4 is a monomer with four Ig-like domains. Both CD8 chains consist of an Ig-like V domain and a long mucinlike stalk. The Ig-like domain binds to the α 3 domain of MHC,²⁰⁹ forming also some hydrogen bonds with the α 2 domain and the β 2M-chain, away from the peptide interface. In CD4, only the fourth Ig-like domain binds directly to pMHC. The ternary complex (TCR-pMHC-CD4/CD8) within the T-cell-APC interface of the immunologic synapse (IS) has a V shape²¹⁰ (Fig. 13.7). Although the CD8 α stalk is longer than the CD8 β chain, even in its full extension, it reaches only 50 to 60 Å, which is not long enough to traverse the distance of approximately 100 Å to the TCR-pMHC complex. As a result, the TCR-pMHC has to tilt for the CD-8 to reach the MHC. The stalk of the CD8 chains is heavily glycosylated and changes in glycosylation (which occur after T-cell activation) result in a decrease of binding to MHC.²¹¹ The coreceptors enhance TCR signaling by strengthening the stability of the TCR-pMHC complex.²¹² The V-shaped ternary complex accepts that the coreceptors bind to the same pMHC as the TCR,²¹⁰ whereas the CD-3 components probably lie inside the "open angle" of the V-shaped structure (Fig. 13.7). Such an arrangement makes possible the association of signaling molecules, such as ZAP-70, LCK, and SRC kinases, with CD4 and CD8. With this topologic model, direct interaction of the coreceptors with TCR is not likely as was previously indicated.²¹³

The CD2 binds to CD58 (LFA-3) in humans based on electrostatic complementarity, with the CD2 surface heavily populated by basic residues, whereas the CD58 is acidic. The interactions span approximately 134 Å, very similar to that of TCR-pMHC. Therefore, the CD2/CD58 interaction in the contact zone between T-cell and the APC, would facilitate the scanning of pMHC by TCR and lower the threshold for TCR triggering in vitro and T-cell activation in vivo.²¹⁴

CD28 and CTLA4 (CD152) are type I membrane proteins consisting of one moderately to heavily glycosylated V Ig-like domain and are expressed as disulfide-linked homodimers. Their counterreceptors B7-1 (CD80) and B7-2 (CD86) consist of two Ig-like domains, a membrane-proximal C-2 type, and a membrane-distal V-type. B7-2 binds C-28 more effectively than CTLA4 and as a result, enhances costimulatory effects when CD28 and CTLA4 are co-expressed. In contrast, B7-1 binds preferentially CTLA4, and its inhibitory effect would not be affected in the presence of CD28. Delayed expression of B7-1 on APCs appears to be timed to enhance the inhibitory function of

P.289

CTLA4. The CTLA4 periodic arrays of crystal lattices enhance the avidity of interaction, whereas the CD28/B7-2 interaction does not have this potential. As a result, during an immune response the CD28/B7-2-activating complexes are 10,000-fold less stable than the inhibitory complexes formed later by CTLA4/B7-1.²¹⁵

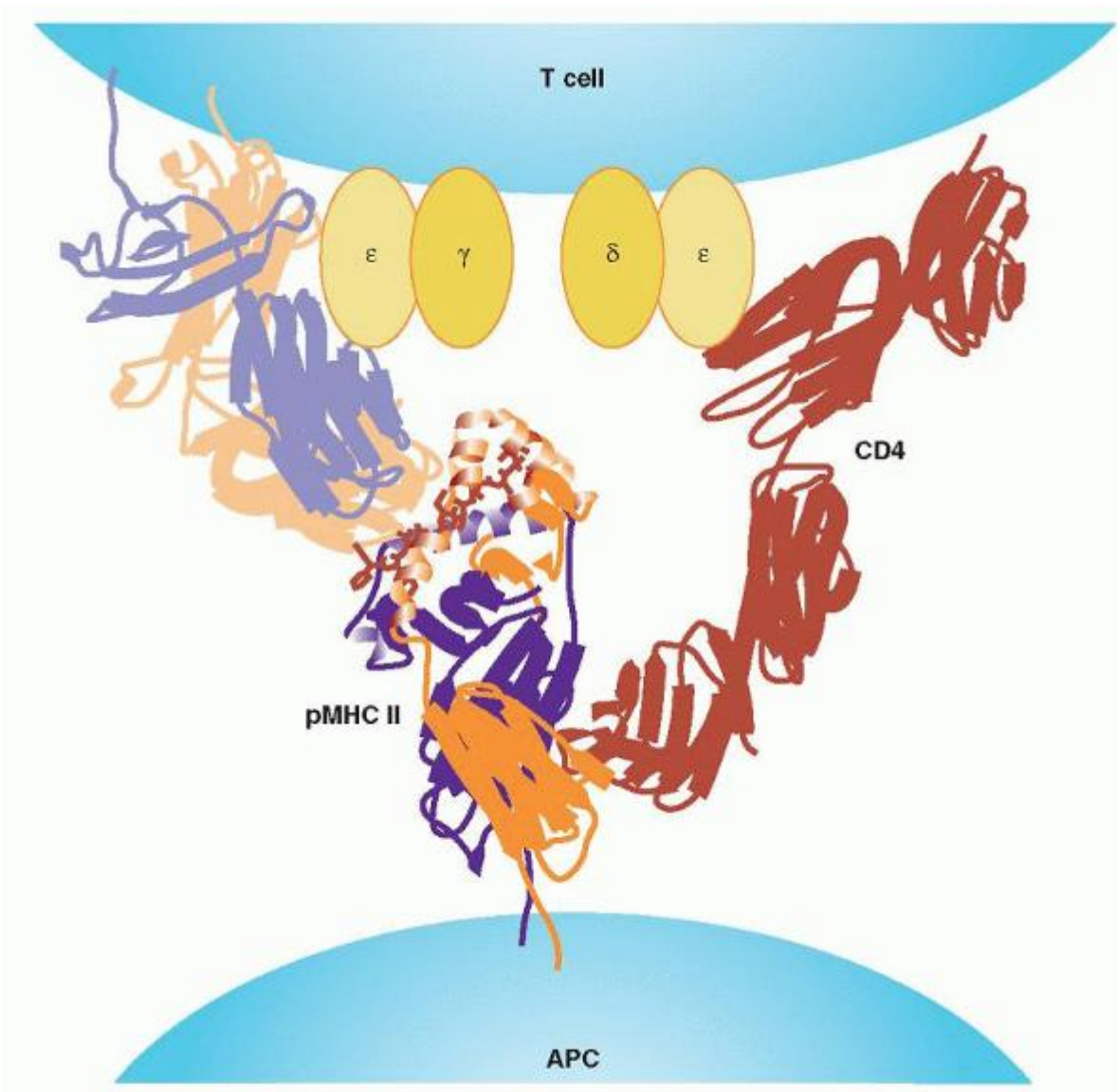

FIGURE 13.7. T-cell receptor (TCR) major histocompatibility complex (MHC) coreceptor interaction. The CD4 and CD8 are coreceptors of the TCR (i.e., “assistants” in the interaction of TCR with peptide-MHC complex [pMHC]). In this function, the N-terminal domain of CD4 (D1) makes contact with the $\alpha 2$ and $\beta 2$ domains of MHC II. In the CD8, the CD8 α subunit of the CD8 $\alpha\beta$ heterodimer contributes the binding energy, interacting with both the $\alpha 2$ and $\alpha 3$ domains of pMHC I, and CD8 β binds only to $\alpha 3$. Therefore, both coreceptors recognize different sites of MHC from the TCR. The length of each receptor is not long enough to reach the MHC binding site, traversing alongside the TCR-MHC complex. It is proposed that TCR-MHC has to tilt for the coreceptor to reach the MHC, forming a V-shaped ternary complex. The CD3 components of the TCR (γ , δ , ϵ) probably are located inside the V-shaped structure. APC, T-cell-antigen presenting cell. (Courtesy of Dr. G. F. Gao.)

THE T-CELL RECEPTOR: SIGNAL TRANSDUCTION COMPONENT

The TCR- $\alpha\beta$ is accompanied by five other polypeptide chains, collectively known as CD3 proteins: γ , δ , ϵ , ζ , and η . They form disulfide-linked heterodimers, such as $\gamma\delta$, $\epsilon\delta$, $\zeta\epsilon$, or a homodimer $\zeta\zeta$ ²¹⁶ (Fig. 13.5). The γ , δ , and ϵ proteins show a significant degree of similarity to one another and consist of an Ig-like domain similar to a C domain, with an intrachain disulfide bond. The extracellular region of the ζ -chain is only nine amino acids long and contains the only cysteine of the molecule, which forms the disulfide bond with another ζ chain or with an ϵ -chain. In the transmembrane region, the γ , δ , and ϵ proteins have a negatively charged amino acid complementary to a positively charged amino acid of the transmembrane region of the TCR- $\alpha\beta$ chains. The cytoplasmic regions of γ -, δ -, and ϵ -chains are long, ranging from 40 to 80 amino acids, whereas that of the ζ -chain is longer with 113 amino acids. The ϵ -chain is a splice variant of the ζ -chain

and like a heterodimer with the ζ -chain, exists only in a small number of T-cells. The CD3 proteins have a dual mission in the function of the TCR: escort the receptor to the cell membrane and mediate the signals generated by the TCR-pMHC complex. The complex is assembled in the endoplasmic reticulum, transported to the Golgi apparatus, and then transferred to the plasma membrane. The numbers of the ζ -chain are the rate limiting of the synthesis of the other chains because, although it is synthesized at only 10% of the level of the other chains, it regulates the degradation of a vast majority of the newly synthesized α , β , or CD3 components within 4 hours of their synthesis. The remaining nondegraded chains are long lived and form the complete TCR-CD3 complexes with a limiting role by the ζ -chain. The TCR-CD3 complex lacking the ζ -chain, migrates through the endoplasmic reticulum and Golgi apparatus intact and it is then transported to the lysosomes, where it is degraded. A lysosome-targeting motif has been identified in the δ - and γ -chains and consists of a dileucine-based motif (DKQTLL) and tyrosine-based motif²¹⁷ in the carboxy terminal region. In the completed complex the TCR α -chain pairs with CD3 δ - and ϵ -chains, and the TCR β -chain pairs with CD3 γ and ϵ . The ζ -chain joins the TCR and the CD3 chains in the last stage of the assembly. The topology of the TCR-CD3 complex is shown in Figure 13.5. Two TCR $\alpha\beta$ heterodimers are associated with one each of $\gamma\epsilon$ and $\delta\epsilon$ heterodimers and one $\zeta\zeta$ homodimer. The signal transduction function of the CD3 proteins is based on the presence of one ITAM in each of the γ , δ , and ϵ proteins and three in the ζ -chain. An ITAM consists of two YXXY/L sequences separated by six to eight amino acids and in the one-letter code for amino acids: Y = tyrosine, X = any amino acid, and L = leucine).²¹⁸

Phosphorylation of the tyrosines turns the ITAM motifs into docking sites for protein tyrosine kinases, which bind to the ITAM through their SH2 domain (see below). An important protein tyrosine kinase in T-cell activation is the ZAP70, which is recruited to the ITAM motifs of the ζ -chain. The multiplicity of ITAM motifs in the cytoplasmic tails of the CD3 proteins results in signal amplification and increases the sensitivity of the TCR to ligand stimulation. Triplication of a single ITAM motif significantly enhances Ca^{2+} mobilization, association with ZAP70 and transcriptional activity in the NFAT complex involved in IL2 gene regulation.²¹⁹ Cross-linking of a single isolated ITAM results in approximately threefold induction in NFAT-regulated activity and cross-linking of a triplicated motif results in an approximately eightfold increase in NFAT-regulated activity (i.e., comparable to intact ζ -chain).

CORECEPTORS TO T-CELL RECEPTOR: CD4 AND C-8 CD4

CD4 is the characteristic marker of $\alpha\beta$ T-cells with helper activity and cytokine secretion. The molecule consists of four Ig-like domains, (D-1 to D-4), with domains D-1 and D-3 similar to a V domain and D-2 and D-4 similar to C domains (C-2 type), but with patches of sequences similar to the V domain. In D-1 and D-3 domains, the nine β strands form two β sheets, linked by a disulfide bond. The domains are linearly arranged, forming a rod with limited flexibility.²²⁰ The binding of CD4 to MHC II molecules and to HIVgp120-envelop protein was studied by mutational analysis. The binding is mediated by a sequence within the D1 domain of two β strands, C'C'', that form a ridge (residues 35 to 46).²²¹ Phe-43 within this sequence is critical for binding to gp120, as well as for CD4 coreceptor function²²² because it provides the major binding energy, whereas the surrounding charged amino acids facilitate specificity.²²³ Crystal structure of the D1/D2 domains from CD4 complexed with class II molecule shows that the CD4 N-terminal V domain is directed and reaching into the two membrane-proximal domains of the MHC II molecule.²²⁴ Both TCR and CD4 are tilted rather than vertically oriented, forming a V-shaped CD4-pMHCII-TCR ternary complex (Fig. 13.7).

In this complex, the antigen-binding groove of pMHC II is no longer parallel to the cell surface but makes an approximately 45° angle with the membrane. However, despite the V shape of the ternary complex, the membrane-proximal domains of each of the components are all roughly vertical, including domain 4 of CD4 and the α_2 and β_2 domains of pMHC II as well as the C- β domain of TCR. Only the C- α domain of TCR hangs almost parallel above the membrane with its lengthy stalk bridging the space.

The extracellular fragment of CD4 crystallizes as a dimer associated via the D-4 domains.²²⁵ The CD4 dimers are associated with superdimers or dimers of dimers of the MHC II molecules²²⁷ and each CD4 molecule of the CD4 dimer interacts with one dimer of MHC II. X-ray crystallography of several MHC class II molecules revealed a structure described as a dimer of heterodimers, or a superdimer. This discovery led to the hypothesis that the MHC class II molecule may interact with the TCR and CD4 as an α/β -2 superdimer, potentially providing more stable and stimulatory interactions than can be provided by the simple $\alpha\beta$ heterodimer alone and indeed oligomers of CD4 have been extracted from isolated lymphocytes.²²⁶

Amino acid substitutions in the faces of the MHC II molecules that participate in the formation of the superdimers block activation of CD4⁺ T-cells, implying that superdimer formation is a prerequisite for T-cell activation.²²⁷ Stable binding of the T-cell to MHC II requires oligomerization of CD4, facilitated by the D3/D4 domains. Existing evidence suggests that CD4,

once it binds to one MHC II molecule, forms tetramers or even larger oligomers and cross-linked lattices²²⁸ a process influenced not only by MHC II but also by the TCR.

When CD4 and TCR co-localize for interaction with the same pMHC II molecule, the CD4 brings p56^{lck}, associated with its short cytoplasmic tail to the site of immune recognition. This may constitute one of the main contributions of CD4 to TCR signaling.²²⁹

CD8

The CD8 consists of an Ig-like ectodomain, a membrane-proximal stalk (or hinge) region, a transmembrane region, and a cytoplasmic region. The Ig-like domain is involved in the binding to MHC, as shown by crystallographic evidence²³⁰ and mutational analysis.²³¹ The CDR loops of the A and B strands of the CD8 α molecule contact the α_2 , α_3 , and β_2 -M domains of MHC I.²³² The β -subunit of the CD8 interacts only with the α_3 domain, whereas the α -subunit interacts with the α_2 and α_3 domains.²³³ In these interactions, the α_3 domain is shifted for better accommodation of the CD8 binding.²⁰⁹ Multiple contacts between the coreceptor and MHC I promote the functional contributions of the coreceptor to T-cell activation.¹⁹⁵ CD8 enhances cytotoxic T lymphocyte (CTL) activation by promoting the stability of interaction between the APC and the T-cell.²³⁴

The α -chain of the CD8 is associated with the p56^{lck}, which is brought closer to the ZAP70 kinase associated with the TCR, a role that has also been assigned to the CD4 coreceptor. The contributions therefore of both coreceptors in ligand recognition and enhancement of TCR signaling are multiple and involve facilitation of TCR clustering, stabilization of the TCR-pMHC complex, and promotion of signaling by bringing together signaling molecules attached separately on the cytoplasmic tails of the TCR and coreceptors.²³⁵ The availability of pMHC tetramers has encouraged studies on the function of CD4 and CD8 coreceptors in TCR binding to pMHC. The CD4 is critical for signal transduction with pMHC tetramers,^{236,237} and ²³⁸ but the CD8 coreceptor also contributes to the initial phase of interaction (binding), the duration of interaction (stability), and the delivery of signal transduction.^{239,240} The final result of CD8 function depends on an epitope of the CD8 involved in the interactions, which are more pronounced with low-affinity ligands. Blockade of CD8- β may affect TCR-C-8 rather than CD8-MHC interaction. The CD8 β is more efficient than CD8- α for association with the TCR.²⁴¹

An important function of the coreceptors in TCR-mediated activation is the demonstration that CD4 and CD8 associate with LAT (linker for activation of T-cells), a 36- to 38-kD membrane-associated adaptor protein, that plays a central role in TCR signaling.^{242,243} As a result of LAT association with surface coreceptors and coengagement of the TCR with the coreceptors, LAT is phosphorylated and recruits downstream signaling molecules.²⁴⁴ In conclusion, the contribution of the coreceptors in TCR signaling results from (a) the physical approximation of the LCK, which is associated with the coreceptors; (b) phosphorylation of the ITAMs of the CD3 chains of TCR; (c) recruitment of ZAP70; and (d) phosphorylation of LAT, also associated with the coreceptors. Individual TCR molecules are probably associated with either LCK or with LAT.²⁴⁴

T-CELL RECEPTOR AND T-CELL ACTIVATION

Topology of Immune Recognition

The $\alpha\beta$ -TCR recognizes short peptides (i.e., eight to ten residues long) for class I-restricted TCRs or 13 to 25 amino acids for class II restricted TCRs. However, approximately only nine amino acids contact the TCR. The peptide is held by the MHC molecule embedded in a groove formed by the α_1 - α_2 domains of MHC I or by the α_1 - β_1 domains of the MHC II (see Chapter 14). Interaction of TCRs initiates signal transduction leading to transcription of genes encoding cytokines in CD4⁺ T-cells or assembling and mobilizing the lytic machinery in CD8⁺ T-cells for killing cells infected by viruses, transformed to a malignant state, or being "strangers," such as in transplanted tissues. The crystal structure of $\alpha\beta$ -TCR has been solved and, for several of them in complex with their cognate pMHC ligand.^{193,195,196,245,246,247} The data support the docking model of the TCR ligand interaction, in which the TCR approaches the peptide held on an MHC platform. In this model, the V α domain of the TCR is closest to the N-terminal residues of the peptide, whereas the V β domain of the TCR is closest to the C-terminal end of the peptide. In this orientation, the TCR V β domain contacts the MHC I α_1 domain, whereas the TCR V α domain interacts with the α_2 of MHC I. The TCR orientation relative to the long axis of the MHC platform varies between 45° and 80° (i.e., the angle formed between a line passing through the centers of the V α and V β domains of the TCR and a second line defined by the peptide on the MHC platform).²⁴⁸ The peptides in all MHC I structures have their N- and C-termini anchored into two fixed pockets approximately 20 Å apart in the MHC I platform. Longer peptides usually bulge in the center. In MHC II, the peptides assume an extended conformation, and the middle portion is smooth and concaves away from the TCR. Residues 1 and 5 of the peptide (p-1, p-5) in MHC II point toward the TCR and are critical in TCR

recognition. The coreceptors bind to the same pMHC ligand as the TCR, but the binding of the coreceptor is independent of the TCR binding and is severalfold weaker.^{229,249}

The TCR, the pMHC, and the coreceptor form a ternary complex that assumes a V shape with the pMHC II at the apex and the TCR and CD4 as the two arms.

Overall, the data from crystallized complexes of TCR with pMHC suggest that TCR docking on the MHC platform involves residues that are conserved within the CDR1 and CDR2 of the TCR and provide a basal level of stabilizing energy in the formation of the complex.²⁵⁰ Variations within the CDR3 α and CDR3 β loops affect the way the TCRs footprint on the pMHC surface.

Lipid Rafts and the Immunologic Synapse

A model for T-cell activation proposes that a naive or resting T-cell needs to cross several stages to achieve full activation.²⁵¹ During the first stage, which lasts a few seconds, contacts need to be established by adhesion molecules that overcome charge repulsions between cells. In the next stage, active cytoskeletal

P.291

rearrangements bring together accessory molecules and the TCR and concomitantly exclude unligated molecules, such as CD45 (a protein tyrosine phosphatase) as well as CD43. CD43 is a highly glycosylated protein with strong repulsive forces forming a thick glycocalyx “cloud” approximately 45 nm thick around the cells. The distance spanned between the TCR and the MHC-Ag complex is a mere 15 nm; in order for the TCR to sample the complex, it is mandatory that the area of contact between TCR and MHC is clear from interfering tall molecules, such as CD43 and CD45. This process takes minutes. On the other hand, the fundamental signaling units consisting of several molecules, are “loaded” on a lipid raft that is sustained by the cytoskeleton, a process that takes hours. Lipid rafts in evolution are conserved structures that gather receptors involved in signaling in various cell types.^{252,253,254} and ²⁵⁵ The lipid rafts are cholesterol-dependent microdomains, resistant to solubilization in nonionic detergents at low temperatures.²⁵⁶ The lipids contained within the cellular plasma membrane include glycerophospholipids, glycosphingolipids, and sterols. Rafts consist of sphingolipids and cholesterol, which can move through the more liquid-disordered phase of the membrane containing glycerophospholipids.²⁵⁷ Because of their consistency, lipid rafts have also been referred to as glycosphingo-lipid-enriched membrane microdomains or GEMs. Lipid rafts are anchored by filamentous actin and actin polymerization causes their coalescence.

Phosphatidylinositol-4,5 biphosphate (PIP2) activates proteins involved in actin-membrane interactions, such as binding of the ezrin-radixin-moesin family to CD44, a protein broadly expressed on detergent-resistant membranes. Detergent-resistant membranes are presumed to be isolated rafts. PIP2 activates actin nucleation and polymerization of raft domains. Raft size is poorly understood because they cannot be visualized by light microscopy without clustering.²⁵⁸ In resting T-cells, the TCR and GM1 are homogeneously distributed. Cross-linking, however, produces large enough aggregates to be visualized using epifluorescence microscopy. Fluorescence resonance energy transfer is sensitive to distances on the order of a few nanometers. Because fluorescence resonance energy transfer was detected between glycosylphosphatidylinositol (GPI)-anchored transferrin receptors interacting with natural ligands, it was concluded that rafts exist but that they are smaller than 70 nm in diameter.²⁵⁸ Others could not find microdomains enriched in GPI-anchored proteins or GM1. Some MHC II molecules loaded with a select set of peptides are detected on microdomains made up of tetraspan proteins, such as CD9, CD63, CD81, or CD82.²⁵⁶ These tetraspan microdomains are recognized by CDw78 antibody (mAb FN1), which originally was believed to recognize an epitope of HLA-class II molecules.

A central feature of lipid rafts is that they allow for the lateral segregation of proteins within the plasma membrane. This provides a mechanism for compartmentalization of signaling components within the membrane, concentrating certain components in lipid rafts and excluding others (Fig. 13.8). Proteins with GPI linkage, such as CD14, CD16, CD48, and CD58, are associated with the outer leaflet of lipid rafts. Cytoplasmic proteins, on the other hand, associate with the inner leaflet of lipid rafts through acylation. Most of the SRC signaling proteins are acylated and raft associated. The vast majority of transmembrane proteins are excluded from rafts constitutively and cannot be induced to partition into rafts on cross-linking.

Some proteins important in T-cell activation, such as LAT, CD4, and CD8, reside on rafts. Other proteins reside constitutively outside the rafts but, when activated, become translocated to rafts. The multichain immune recognition receptor family is an example.^{259,260} Translocation into rafts after ligand binding appears to be immediate, occurring within seconds of engagement of the receptors, and is selective. For example, CD45, α_4 integrin, and IL1 receptor are excluded

from rafts and do not translocate into rafts, even on cross-linking.^{261,262} The transmembrane domains of the receptors appear to have a significant influence on translocation, as exchange or mutation of the transmembrane regions

P.292

alters the translocation properties of the receptors. Translocation of the receptor into the lipid rafts does not need actin reorganization. However, stable residency into the rafts depends on interaction with actin cytoskeleton. The constitutive presence of receptors in rafts may be related to their role in cell survival. For example, the pre-TCR is constitutively associated with rafts and, with its signaling, instructs lineage commitment. TCR/CD28 is excluded from rafts in immature thymocytes and signaling leads to apoptosis.²⁵³

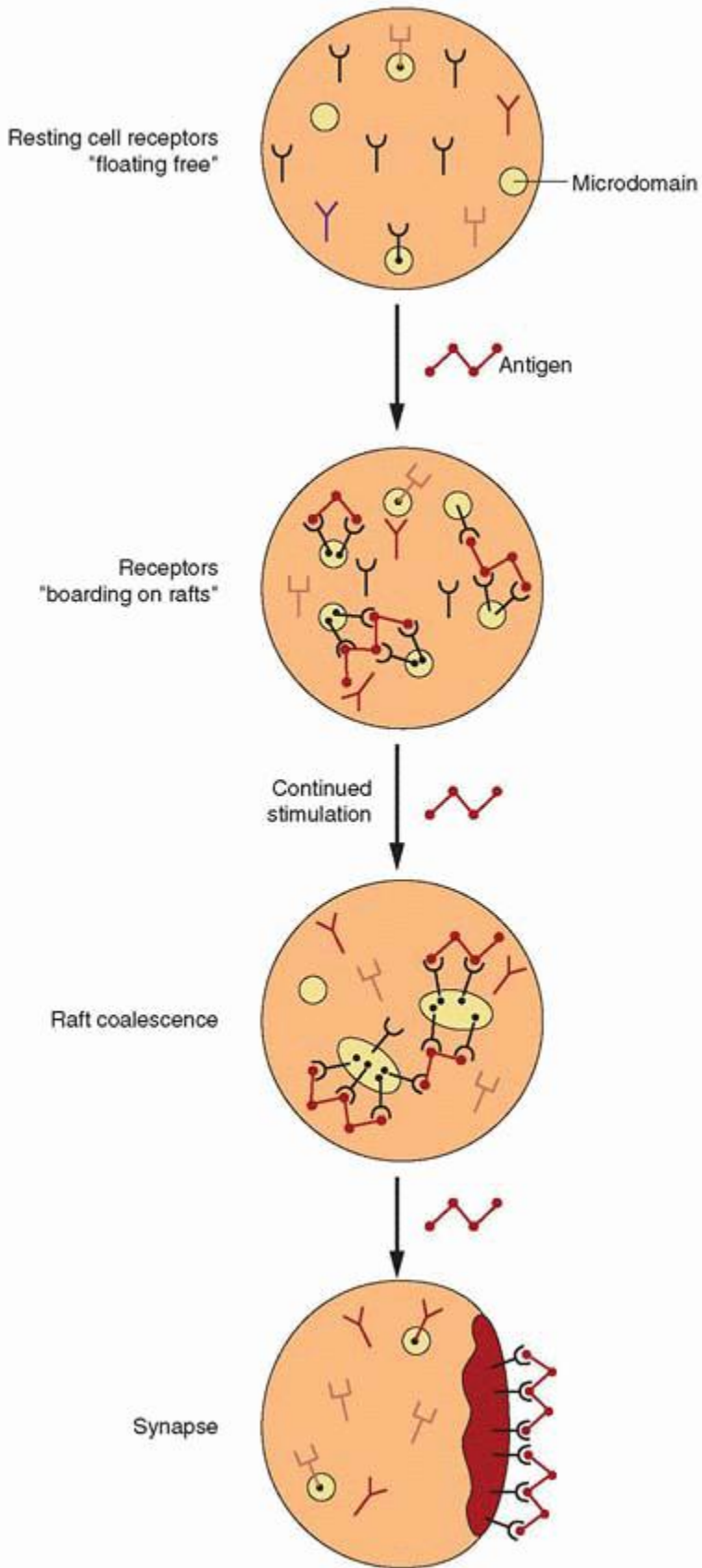

FIGURE 13.8. Rafts: elementary units of the immunologic synapse? In the resting state, the multichain immune recognition receptors (MIRR; i.e., T-cell receptor, B-cell receptor, etc.) "float" free on the lipid membrane, or transiently, some may

get on board on certain membrane “microdomains,” also known as “lipid rafts.” Interaction with a multivalent ligand aggregates several receptors that accumulate within the rafts, forming multimolecular clusters. On prolonged exposure to the ligand, the MIRR clusters result in raft coalescence with the formation of a large aggregate, the immunologic synapse. Cytoskeletal reorganization from multichain immune recognition receptor and chemokine signaling promotes immunologic synapse formation. (Adapted from a model proposed by Dykstra M, Cherukuri A, Sohn HW et al. Location is everything: lipid rafts and immune cell signaling. *Annu Rev Immunol* 2003;21:457-481.)

In addition to their role in signaling, lipid rafts serve as platforms for B-cell receptors (BCRs) to transport bound antigen for processing and presentation. The internalization of BCRs with captured antigen is initiated from rafts.

Retention of receptors in rafts is a mechanism for augmentation of cell activation. The CD19/CD21 complex is excluded from rafts, but its colligation with BCRs by antigen-antibody-complement complexes causes translocation of BCR and CD19/CD21 complex into rafts, where the complex prolongs the retention of BCR within the rafts.²⁶³

T-cell activation causes rearrangement of the actin cytoskeleton and polarization of the cell toward the site of activation, such as the APC. This polarization is reflected by re-orientation of the microtubule-organizing center (MTOC) toward the APC.^{264,265} The TCR is clustered together with associated molecules (CD4, CD8, CD2, CD28, etc.), a process known as capping. Capping depends on actin reorganization regulated by phosphoinositides, which activate Vav (a guanosine diphosphate-guanosine triphosphate [GTP] exchange factor) and the Wiskott-Aldrich syndrome protein (WASP). In patients with Wiskott-Aldrich syndrome, WASP is lacking or markedly reduced, and they have defects in actin polymerization, capping, and antigen-induced proliferative responses.²⁶⁶ WASP regulates the Arp2/3 complex, which mediates actin branching and polymerization.

PIP3 is a strong activator of Vav, which is targeted to detergent-resistant membranes after TCR activation. In Vav-deficient mice, the capping is severely disrupted, and T-cell proliferation is reduced. Raft aggregation is disrupted by the negative regulator of T-cell activation, Cblb (Casitas B-cell lymphoma-b), which is a molecular adaptor and part of the ubiquitin ligation machinery involved in the degradation of phosphorylated proteins. Cblb inhibits TCR clustering and sustained tyrosine phosphorylation. In Cblb-deficient mice, TCR/CD3 stimulation alone can activate receptor clustering without the need for CD28 costimulation.²⁶⁷

Immunologic Synapse

The TCR interactions with pMHC take place in an intercellular junction between the T-cell and the APC. In this junction, signal 1 (TCR) and signal 2 (costimulation) are processed. This interface reveals a dramatic reorganization of signaling components, forming what is called the IS, a term borrowed from Sherrington's turn-of-the-century definition of the interconnections of neurons as synapses (from the Greek *synapsis*, meaning joining, linking, connecting).²⁶⁸ The IS relays information across the cell junction in both directions²⁶⁹ organized into two major compartments. The central supramolecular activation cluster (cSMAC), enriched in TCRs and CD28 and the peripheral supramolecular activation cluster (pSMAC), which contains the LFA1 molecule and talin²⁷⁰ (Fig. 13.9). On the side of the APC, correspondingly, the cSMAC contains the pMHC and CD80 (ligand for CD28) and the pSMAC contains the ICAM-1 (counterreceptor for LFA1) and CD58, ligand for CD2. The IS develops over a period of minutes after interactions of the T-cell and the APC. Formation of the synapse depends on an intact cytoskeleton.²⁷¹ T-cell activation is accompanied by a dynamic reorganization of cortical actin with increase of filamentous actin. These cytoskeletal changes are accompanied by progressive morphologic changes of the T-cells, which first become round, followed by spreading of the cell.²⁷² In the absence of antigen, the T-cell maintains its motility, continues to crawl around the APC and may even leave for another partner. Some receptors on the APC may convey a “danger signal” for the T-cell to pay particular attention and explore the APC in search of antigen.²⁷³

In the first stage, the contact is antigen-independent and is mediated by CD28 on the T-cell and CD80/CD-86 on the APC, which are more abundant ($>10^4$) than the pMHC (approximately 100 to 200). The CD28 affinity for CD80 is at least two orders of magnitude above that determined for the TCR-pMHC interaction. These interactions of CD28 preceding the TCR encounters are actually contrary to the original definition of the costimulatory function of CD28, believed to parallel or even follow TCR signaling.

The second stage of IS formation is antigen-dependent and the T-cell extends large cytoplasmic, pulsatile protrusions toward the APC.^{274,275} Tyrosine phosphorylated Vav-1 and tyrosine phosphorylated LCP2 (SLP76) assemble with the p21-activated kinase (PAK1) via the adaptor protein NCK1.^{276,277} and ²⁷⁸

The T-cell-APC complex is stabilized in the third stage, which is regulated by increases of intracellular Ca^{2+} . By the end of the third phase, SMAC is in place with all the receptors and the signaling molecules, held together with clusters of GEMs (lipid rafts) on the surface and an elaborate cytoskeleton scaffolding underneath.

The kinetics of the IS from its early beginnings are coordinated and organized by the cytoskeleton.²⁷¹ The TCR-pMHC can only interact at a distance of 15 nm, which is significantly below the thick glycocalyxes of the two cells that separate their membranes by a 50-to 100-nm distance. Adhesion molecules, such as L-selectin, located on the tip of microvilli, may very well initiate the T-cell-APC interaction, until LFA1, lying on flat surfaces of the membrane, is released from its inhibitory state by activating signals delivered by chemokines. These signals also result in the formation of myosin II thick filaments, which disrupt and pull the thick network of polymerized actin away. In this clearing, new actin polymerization pushes forward new filopodia and lamellipodia (i.e., the cell becomes motile). Now that the T-cell is polarized, the long interfering molecules of the glycocalyx, such as CD43 and CD45, are pulled to the rear end, or uropod, of the cell.

In the meantime, activated high-affinity LFA1 released from inhibition stabilizes the contact area between the cells, moving laterally and forming strong bonds with ICAM-1 across the cell junction.²⁷⁹ In the membrane clearing created and stabilized by LFA1 adhesion, the TCRs sample MHC on the APC surface for complementary peptides. It has been noted that paradoxically, a large cluster of TCRs has been pulled to the rear of the cell, but through the mediation of myosin II is brought to the front, reinforcing the frontal cluster.²⁸⁰ Nascent IS is further stabilized by TCR links with the cytoskeleton. These links are mediated by some of the components of CD3 (i.e., ζ -chain), which, through its phosphorylated ITAMs, induces actin polymerization.

If pMHCs are present on the APC surface, the T-cell stops moving.^{275,281} The central area of T-cell closest to the APC includes the bulk of the TCRs, which are surrounded by integrins farther away.^{270,282}

The final arrangement defines the mature IS or the bull's eye²⁷⁰ (i.e., the cSMAC, a central area 1 to 3 μ m in diameter that contains TCR, CD28, and C-2), surrounded by pSMAC, an adhesion ring that contains the LFA1 and talin. Formation of mature IS with APCs (instead of artificial lipid bilayers) shows that the TCR signaling precedes the completion of the mature IS.²⁸³ Bull's eye IS also has been observed with CD8⁺ T-cells during recognition and killing of target cells.²⁸⁴ Granule secretion occurs after the MTOC polarization in cSMAC, where membrane fusion occurs. Cellular functions between T-cells and the target cells have been demonstrated by transmission and scanning electron microscopy several years ago. These junctions are followed by disruption and blebbing of the target cell membrane.²⁸⁵

Synapses with dendritic cells are formed even in the absence of antigen or MHC.^{286,287} Encounters with dendritic cells are relatively short as compared to B-cells.²⁸⁸ This may be due to chemokine secretion by dendritic cells, which stimulate T-cell

P.293

P.294

migration. There also seem to be other differences between dendritic cells and B-cells, such as the length of time of the encounter, which is short for dendritic cells but longer for B-cells. The role of the dendritic cell in the formation of IS is active with full involvement of its cytoskeleton, whereas the B-cell remains passive and the T-cell makes the major contribution.²⁸⁹ The functional consequences of the formation of a mature IS are believed to be primarily related to polarized secretion^{290,291} and signaling.²⁹² IS may help to retain secreted substances close to the targeted cell. Although this is true for the synapses formed by killer lymphocytes such as the CD8⁺ cytotoxic T-cell or the NK-cell, it may not apply to the CD4⁺ T-cell, which uses the APC to pull the trigger for its activation. In this case, the IS concentrates crucial molecules, such as CD28, that provide costimulatory signals and enhance TCR-mediated signaling.^{293,294}

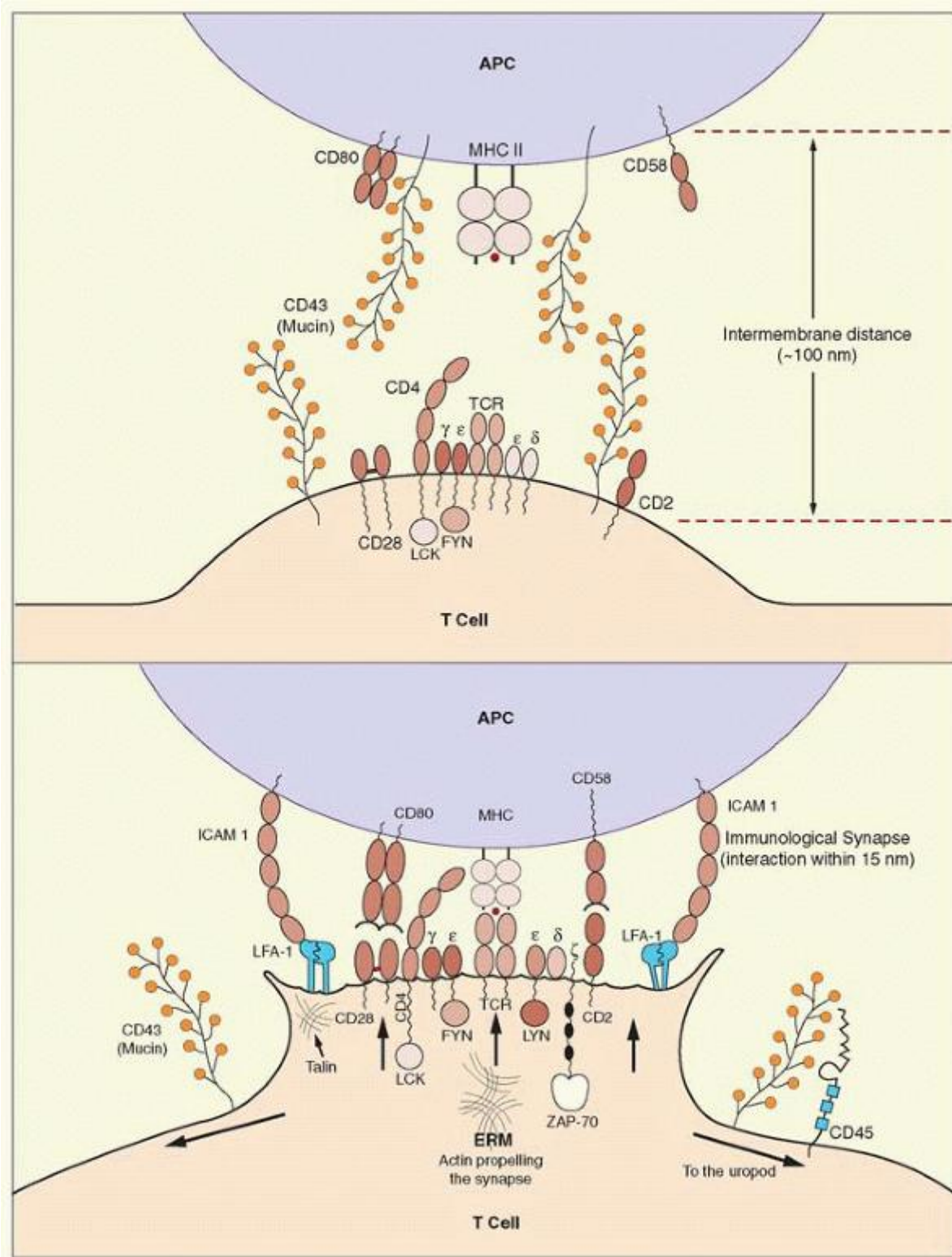

FIGURE 13.9. The structure of the immunologic synapse. The immunologic synapse is formed between T-cell and an antigen-presenting cell (APC; in the case of the CD4⁺ T-cell) or with a target cell (in the case of the CD81 T-cell). Immunologic synapse formation is a multistep process. A thick glycocalyx on both cells, made predominantly from the mucin molecule CD43, comes in conflict with the approaching T-cell and APC. This distance (50 to 100 nm) is too long for the T-cell receptor (TCR) peptide-major histocompatibility complex (MHC), which interacts at 15 nm. The integrin lymphocyte function molecule (LFA)-1 and its counterreceptor, intercellular adhesion molecule (ICAM), which interact at 40 nm, may bring the cells for an initial contact. More important, chemokine signaling that activates heterotrimeric G

proteins activates myosin II, and the cortical cytoskeleton collapses, disanchoring CD43 by the ERM (ezrin/radixin/moesin) adaptor proteins. With loss of the cell rigidity, a new F-actin network creates a pseudopod that propels the leading edge of the T-cell toward the APC. This approach at an intercellular distance of 15 nm prevents CD43 re-entry in the central area of T-cell-APC contact. Concomitantly, talin (a large cytoskeletal protein with attachment to integrins) maintains LFA-1 immobilized in a ring around the central part of the synapse. Although LFA-1/ICAM-1 interacts initially at a distance of 40 nm (extended LFA-1 form), after activation it assumes a bent form (high affinity) that brings the cell membranes closer ("ratchet"-like effect). Multiple other adhesion molecules of low affinity, such as between CD2 and CD58, contribute to the alignment of the two cell surfaces at a 15-nm distance, allowing the TCR to sample the small numbers of peptide-MHC ("proofreading"). The final mature immunologic synapse ("bull's eye") consists of a central supramolecular activation cluster and the peripheral integrin-rich zone. (From Dustin ML, Cooper JA. The immunological synapse and the actin cytoskeleton: molecular hardware for T cell signaling. *Nat Immunol* 2000;1:23-29; and Delon J, Stelon S, Germain RN, et al. Imaging of T-cell interactions with antigen-presenting cells in culture and in intact lymphoid tissue. *Immunol Rev* 2002;189:51-63.)

T-cell Receptor Signaling

Two models have been proposed for sustained T-cell signaling: (a) serial engagement (migration), when the T-cell migrates from one APC to the next and thus renews its signaling capacity;²⁸⁸ and (b) signaling based on formation of IS. Both models achieve similar results but require different molecular mechanisms. The mature IS forms a specialized mode of signaling and enables T-cells to remain responsive to antigen while still with the initial APC. For a better understanding of the complexities of signaling, we organize it into three phases: (a) initiation, (b) generation of phosphoinositides, and (c) the Ras pathway (Fig. 13.10, Table 13.1).

Initiation Phase of Signaling

Signaling is initiated by activation of LCK, which is regulated by two tyrosines: Tyr 394 in the activation loop and Tyr 505 in the C-terminus. LCK is kept inactive or "closed" by two intramolecular bonds: One is between Tyr 505, which is phosphorylated by the C-terminal SRC, Csk, and binds to the SH2 domain of LCK; a second bond is formed between the SH3 domain of LCK and a sequence connecting the SH2 and the kinase domains. For activation of LCK, the Tyr 505 needs to be dephosphorylated by CD45, a protein tyrosine phosphatase,²⁹⁵ whereas Tyr 394 is autophosphorylated and activates the kinase domain. The large-size CD45 isoforms are excluded from the IS,^{296,297} but some move back to cSMAC adjacent to the TCRs.²⁹⁸ LCK, recruited by CD4, is maintained in the activated state by CD28²⁹⁴ and phosphorylates the ITAMs of the ζ -chain of TCR in a sequential and ordered manner, establishing thresholds of T-cell activation.²⁹⁹ This mechanism determines whether a sufficient number of tyrosines are phosphorylated for full activation and supports the kinetic proofreading model of T-cell activation, which examines the relationship between kinetics of TCR-ligand interaction and intensities of T-cell activation.^{300,301,302} and ³⁰³

ZAP70 is recruited to the phosphorylated ITAMs of the ζ -chain and in turn activates the adaptor protein LAT, which then is localized in the rafts. LAT has a short extracellular and long intracellular region and possesses a central position in T-cell activation because it assembles other adaptor molecules and signaling proteins.

There are two groups of adaptor proteins: transmembrane adaptor proteins and cytosolic adaptor proteins.³⁰⁴ LAT (a transmembrane adaptor protein) is located in the rafts and is phosphorylated by ZAP70. As a result, it recruits PLCG1, phosphoinositide 3-kinase (PI3-K), IL-2-inducible T-cell kinase (ITK), adaptor proteins GRB2 and GADS (GRAP2), and, indirectly, Vav and LCP2 (SLP76).^{242,305,306} LCP2 is a cytosolic adaptor protein that has three protein-binding motifs and plays an essential role in signaling pathways required for IL2 secretion.³⁰⁷ It is expressed on thymocytes, T-cells, mast cells, NK-cells, and platelets. Through Gads, it binds indirectly to LAT after TCR ligation. So LAT and LCP2 function as mutually dependent intermolecular scaffolds, together recruiting crucial signaling regulators to sites of raft aggregation. In mice deficient in LCP2 (or LAT), thymocyte development is arrested at the stage at which the TCR β -chain is coupled to the pre-T α -chain. LCP2 recruits ITK to lipid rafts and allows for optimal phosphorylation of PLCG1, which also associates with ZAP70.

Phosphoinositide Metabolism

Phosphoinositides are produced by the action of PLCG1 and PI3-K. PLCG1 binds to LAT and is activated as a result of phosphorylation of multiple tyrosines by ZAP70. PLCG1 hydrolyzes inositol phospholipids generating diacylglycerol and inositol (1,4,5)-triphosphate (IP₃).

Diacylglycerol contributes to activation of protein kinase C (PKC), whereas IP₃ increases Ca²⁺ released from intracellular sources. There are multiple isoforms of PKC serine kinases, which are regulated by Ca²⁺, diacylglycerol, phospholipids, the classic PKC (α , β , γ), and the novel PKC (δ , ϵ , ζ , and θ).³⁰⁸ PKC- θ is recruited to the plasma membrane and is the only

isoform detected in cSMAC together with TCR.³⁰⁹ The PKC- θ targets are activation of the NF- κ B, production of IL2, regulation of integrin function, and control of the cytoskeleton through association with Vav. Both Ca²⁺ and PKC synergize in the increase in transcriptional activity of NFAT. Ca²⁺ acts through calcineurin, a calmodulin-dependent phosphatase that contributes to induction or function of NFAT.

The PI3-K produces phosphatidylinositol 3,4,5-triphosphate (PI-3,4,5-P₃), which acts as a second messenger. It binds to proteins that contain a pleckstrin homology domain and recruits them to the inner leaflet of the cell membrane.³¹⁰ PI3-K overall is involved in survival and cytoskeletal signaling processes and is essential for adhesion signals. Important targets for PI3-K products are the GTPases, Rac and Rho, stimulated by GEF (guanine nucleotide exchange) proteins promoting transition from the inactive guanosine-diphosphate-bound state to the active GTP-bound conformation. Rac and Rho regulate several functions in the life of the T-cell, and during T-cell activation, they regulate cytoskeletal rearrangements. The PI-3,4,5-P₂ product of PI3-K is converted to PI-3,4-P₂ by the phosphatidylinositol-5 phosphatase (SHIP). This product binds to the pleckstrin homology domain of the protein kinase B or AKT.

AKT moves to the nucleus, where it acts on several substrates regulating cell survival, NF- κ B activation, metabolism, and energy generation.³¹¹ It also regulates transcription factors (i.e., NFAT and the Forkhead family), promoting cell survival and progression through the cell cycle. All signals from PI3-K products are eventually terminated by the inositol phosphatase SHIP.

The Ras Pathway

The adaptor protein GRB2 is a bifunctional molecule having an SH2 domain with which it binds to phosphorylated tyrosines of LAT, whereas its SH3 domain binds other proteins that have proline-rich sequences. These proteins are cytosolic, but through association with LAT, they are translocated to the membrane.³⁰⁵ GRB2 functions in many cells and associates with a large number of proteins.³¹² In T-cells it is associated with the proline-rich domain of SOS, the mammalian homolog of the *Drosophila* "son of Sevenless" protein, which is a critical activator of the small G protein RAS.³¹³ The GRB2-SOS binding is also mediated by another small linker protein, SHC, and CBL binding to GRB2 inhibits activation.

The Ras pathway activates Erk kinase and MAPK. MAPK pathway may induce integrin activation, and, in reverse, the integrin may induce the MAPK pathway through PI3-K. There are other bidirectional signaling pathways that, in general, send signals to the nucleus and activate membrane molecules by a feedback pathway.

P.295

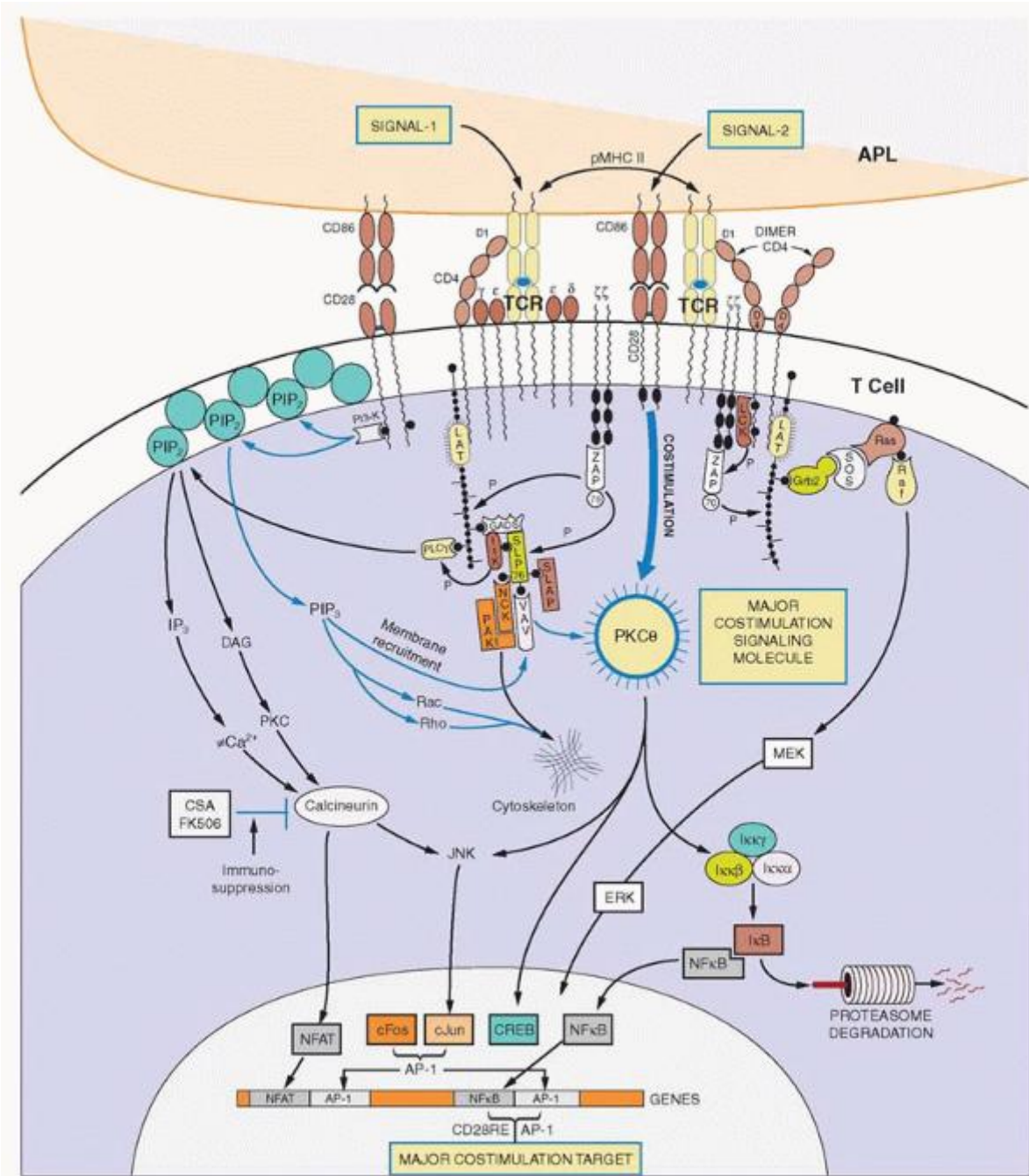

FIGURE 13.10. T-cell activation. T-cells are activated by two signals: signal 1 is delivered by the T-cell receptor (TCR) interacting with peptide-major histocompatibility complex (pMHC), and signal 2, or costimulatory signal, by CD28 interacting with CD80/CD86. A number of adaptor proteins (i.e., proteins acting as scaffolding) assemble a supramolecular signaling complex. Foremost among them are LAT (linker for activated T-cells) and SLP-76 (SH₂-domain-containing leukocyte-specific phosphoprotein of 76 kD). LAT expression is limited to T-cells, natural killer (NK) cells, platelets, and mast cells and is not expressed on B-cells or monocytes. LAT is a membrane adaptor protein as compared to SLP-76, which is cytoplasmic. Engagement of TCR activates Lck, which is associated with the coreceptor (CD4 or CD8). Lck phosphorylates ZAP-70 (ζ-chain-associated protein). ZAP-70 in turn phosphorylates LAT, which at this point makes the transition between proximal and downstream signaling events initiated by TCR. LAT is also associated with the coreceptor, competing in the binding with Lck. LAT and Lck are linked to individual coreceptors, rather than both of them being linked to the same molecule. LAT as an adaptor protein is a scaffolding that is associated with several downstream molecules: phospholipase (PLC)-γ generates phosphoinositides and increases Ca²⁺, which activate protein kinase C (PKC) and calcineurin, respectively. Another cluster is formed with Gads (Grb-related protein), SLP-76, Vav, and so forth that regulates the

cytoskeleton together with the PIP₃ product of phosphoinositide-3-kinase (PI3-K). The other signaling pathway linked to LAT is through the Ras activation, linking to the activation of MAPK/ERK kinase (MEK) and extracellular signal-regulated kinase (ERK). A central position in T-cell signaling is occupied by the novel PKC isoform, PKC θ , which is selectively expressed in T lymphocytes and is recruited to the immunologic synapse. It induces essential activation signals for interleukin-2 synthesis in cooperation with calcineurin. It is a master inducer of NF κ B activation and its translocation to the nucleus. PI3-K associated with CD28 generates PIP₃ that recruits Vav and PKC θ to the membrane. APC, antigen-presenting cell; DAG, diacylglycerol; SLPP, serum lipophosphoprotein. (Important information from Bosselut R, Zhang W, Ashe JM, et al. Association of the adaptor molecule LAT with CD4 and CD8 co-receptors identifies a new co-receptor function in T cell receptor signal transduction. *J Exp Med* 1999;190:1517-1525; Myung PS, Boerthe NJ, Koretzky GA. Adapter proteins in lymphocyte antigen-receptor signaling. *Curr Opin Immunol* 2000;12:256-266; Koretzky GA, Myzeng PS. Positive and negative regulation of T cell activation by adaptor proteins *Nat Rev Immunol* 2001;1:95-107, and Cantrell DA. T-cell antigen receptor signal transduction. *Immunology* 2002;105:369-374.)

P.296

TABLE 13.1 T-CELL RECEPTOR- $\alpha\beta$ ACTIVATION MACHINERY

Receptors/Ligands	Antigen Recognition	Signal Transduction	Adhesion	Ligand/Counterreceptors
α/β	+	-	-	Major histocompatibility peptide complex ^a
$\epsilon/\gamma-\epsilon/\delta$	-	+	-	—
ζ/ϵ	-	+	-	—
CD4	-	+	-	HLA class II
CD8	-	+	-	HLA class I
CD2	-	+	+	CD58 (LFA-3)
CD28/CTLA-4	-	+	-	CD80/CD86
CD40L	-	+	-	CD40
CD11a/CD18 (LFA-1)	-	+	+	CD54 (intercellular adhesion molecule-1)

HLA, human leukocyte antigen; LFA, lymphocyte function molecule.

^a See text for details.

T-cell Activation and the Cytoskeleton

The cytoskeleton plays an important role in IS formation and T-cell activation. T-cells polarize toward their target, focusing the signaling on the secretory apparatus at the APC or target cell. Cytochalasin, which disrupts the cytoskeleton assembly, blocks T-cell activation. Actin dynamics are controlled by a biphasic model at the IS. TCR engagement initiates actin solubilization through changes in the phosphorylation of ezrin, radixin, and moesin that allow certain molecules to move away from the points of contact with APC.³¹⁴ With the formation of new actin filaments, LFA-1 is anchored and stabilizes the adhesion between T-cell and APC.³¹⁵ Polarization of the MTOC requires TCR and involves members of the Rho family of GTPases CDC42, ATK1 (RAC), and RHO.

Disruption of the Rho family members disrupts the proliferation, differentiation, migration, and effector functions and even survival of T-cells.^{272,316} CDC42, as with all members of the Rho family of GTPases, functions as a binary switch regulated by nucleotide binding. When CDC42 binds GTP, it is converted from the inactive to the active form and binds effector molecules with high affinity. One of its important substrates is the WASP gene. Mutations are responsible for the clinical manifestations of Wiskott-Aldrich syndrome (i.e., thrombocytopenia, eczema, and recurrent infections). T-cells from Wiskott-Aldrich syndrome patients lack microvilli and have an abnormal cell shape. Mutants with inactive CDC42 prevent efficient conjugation of T-cells with APC. In contrast, T-cells with constitutively active CDC42 mutants form

extensive filopodia rich in F-actin, which interfere with the formation of IS because CDC42 accumulates in the T-cell-APC contact area. Activation of WASP is achieved by a complex formed by LCP2 (SLP76) adaptor protein, VAV, and NCK (phosphorylated by ZAP70). In this trimolecular complex, LCP2 binds VAV, which converts CDC42-guanosine diphosphate to the GTP form. CDC42-GTP binds to the GTPase binding domain of WASP. At the same time, the NCK binds by its SH3 domain to the polyproline sequence of WASP. These interactions release WASP from its autoinhibitory state and enable it to activate the Arp2/3 complex for actin-branching polymerization.^{317,318,319} and ³²⁰ Other studies suggest that WASP may not be the critical or even the sole regulator of actin polymerization, but other molecules, such as its homolog WASP, are involved. However, mice with a WASP deficient in the VCA domain have defects in T-cell development.³²¹

A significant contribution to the T-cell interaction with the APC is made by the ERM cytoskeletal proteins (i.e., ezrin-radixin-moesin).³²² These proteins act as linkers between cortical actin and plasma membrane, connecting the F-actin to cytoplasmic tails of several transmembrane proteins (i.e., ICAMs, CD43, FAS, etc.). In the resting T-cell, the plasma membrane is rigid because of the thick actin network kept by phosphorylated moesin. With TCR engagement, moesin is dephosphorylated, the actin network “thaws,” and the proteins linked to the cytoskeleton are freed to move. The tall ones, CD43, are “squeezed” out of the narrow junction between the T-cell and APC.³²³ At the same time, new F-actin networks create pseudopod extensions for contact with the APC. Moesin in the back of the cell is rephosphorylated and keeps the excluded molecules actively out of the IS. CD43 and other molecules that are excluded from the uropod form a cluster called the distal pole complex. This cluster may not be simply a negative contributor to T-cell activation by collecting tall molecules interfering in the formation of the IS, but it has its own signaling mechanism in some aspects of T-cell activation, such as cytokine secretion.³²⁴

Regulation of T-cell Activation: Costimulation and Inhibition

T-cell activation depends on signals delivered by the TCR engaged with pMHC. However, additional signaling is needed, and this function is known as costimulation. Costimulatory signals are delivered to the T-cell through the CD-28 molecule reacting with ligands (counterreceptors) on APCs (i.e., CD80 [B7-1] and CD86 [B7-2]). These receptors do not act independently but modify the responses mediated by TCR. The CD28 consists of one Ig-like domain of V-type, whereas the two ligands contain two Ig domains, one V-type and one C-type. CD28 is constitutively expressed on T-cells (all CD4⁺ and approximately 50% of CD8⁺).

Another receptor, the CTLA4 (CD152), shares approximately 30% identity with CD28; it is not detected in naive T-cells but is induced after T-cell activation.

Both CD28 and CTLA4 share the same ligands. In costimulation, the critical event is up-regulation of the B7 molecules on the surface of the APCs.³²⁵ The major role of CD28 function is to stimulate cell cycle progression and prevent apoptosis. It also enhances production of various cytokines, such as IL1, IL2, IL4, IL5, and interferon (IFN)- γ , and plays a fundamental role in Th1-Th2 differentiation. CD28/B7 interactions also play a critical role in B-cell stimulation. The importance of CD28/B7 interaction was established in transplantation. The importance of the CD28/B7 costimulation pathway was established with studies in transplantation in mice in which blockade of the pathway by CTLA4-Ig prolonged cardiac graft survival and prevented development of vascular lesions associated with chronic rejection.³²⁶ Another costimulatory receptor homologous to CD28 and CTLA4, termed ICOS (inducible costimulator), is a disulfide-linked homodimer.³²⁷ ICOS lacks the extracellular motif present in CD28, which is implicated in binding with the B7 molecules. It is an inducible molecule expressed in activated, but not resting, T-cells. ICOS augments T-cell proliferative responses and cytokine secretion, particularly IL10.³²⁸ The ligand for ICOS (ICOS-L or B7h) is a B7-like molecule expressed constitutively on B-cells and macrophages. Costimulation by ICOS promotes germinal center reaction and isotype switching. ICOS and CD28 regulate Th2 responses, but whereas CD28 is critical in the priming stage to induce Th-2 differentiation, ICOS plays a role in regulating Th2 effector functions.³²⁹ Activation of the ICOS pathway of costimulation initiates acute and chronic graft rejection, which indicates that the ICOS costimulatory pathway also regulates Th1 responses.³³⁰

P.297

CD4 T-CELL DIFFERENTIATION

Activated naive CD4⁺ helper T-cells (Th), in response to signals from TCR engagement with pMHC, proliferate and differentiate into cytokine-secreting effector cells, which have been distinguished into two major categories.³³¹ Th1 cells produce primarily IFN- γ , IL2, and TNF- β , whereas Th2 cells secrete IL4, IL5, IL6, IL10, and IL13. Both types of cells produce IL3, TNF- α , and granulocyte-macrophage colony-stimulating factor. Once the initial stimulus from TCR is received, the cells proliferate in response to the autocrine growth factor IL2. At this stage, they are called pT helper cells (pTh) because they

have not yet differentiated enough to secrete cytokines. Both Th1 and Th2 cells derive from a single precursor, and several factors regulate their differentiation.^{332,333} and ³³⁴ The Th1 cells induce predominantly inflammatory immune reactions and control intracellular bacterial infections (cellular immunity). They are also associated with some autoimmune diseases. The Th2 cells provide defense against extracellular pathogens, regulating the humoral antibody-mediated immune response. They are also the mediators of allergic reactions.

Th1 versus Th2 differentiation takes place in two stages. During the first stage, the activation signals delivered by TCR pre-condition the naive T-cell for one or the other pathway of differentiation. In the second stage, final development of effector cells is dependent on IL12 or IL4 (Fig. 13.11).

Transcriptional Regulation

In the early stages of Th cell differentiation, TCR stimulation activates a number of downstream signaling pathways. Differential signaling of MAPKs, PKC, and calcineurin pre-conditions Th cells toward one or the other pathway in the absence of cytokines from the environment.³³⁵ A number of parameters related to antigenic stimulation and costimulation influence the final outcome. Low doses of antigen or low affinity of binding favor Th2 development, whereas large doses of antigen or high affinity of binding support predominantly Th1 differentiation. Costimulatory signals modulate the outcome. CD28 ligation favors Th2 development, perhaps by enhancing IL4 production³³⁶ or by direct activation of signal transducer and activator of transcription 6 (STAT6).³³⁷

The CD40/CD40L interactions selectively induce Th1 cells, but this is the result of the production of IL12 from APCs.³³⁸ During the early stage of Th activation, key genetic and epigenetic events take place that lead to accessibility and activation of specific genes. Expression of certain transcription factors is critical in the early regulation of differentiation.^{339,340}

Th1 Regulation

The most prominent factor for Th1 differentiation is IL12. In naive T-cells, the IL12 receptor is not functional but is induced by IFN- α/β . Binding of IL12 to its receptor induces phosphorylation of Janus kinases JAK2 and TYK2, which phosphorylate STAT4. STAT4 translocates to the nucleus and activates target genes. The GTPase RAC2, which is selectively expressed on Th1 cells, activates the IFN- γ promoter via NF- κ B and MAPK.³⁴¹ During the early Th1 polarizing signaling, the key transcription factor for Th1 development is T-bet (for box expressed in T-cells) induced in naive T-cells.^{342,343} T-bet transactivates IFN- γ promoter, induces chromatin remodeling of the gene that encodes INF- γ ,³⁴⁴ and induces expression of the β_2 subunit of the IL12 receptor.³⁴³ The importance of T-bet in Th1 differentiation is underscored by the susceptibility of T-bet knockout mice to challenge with *Leishmania major*³⁴⁵ and their predisposition to allergic disease.

Th2 Regulation

The key transcription factor for Th2 differentiation is GATA3,³³⁹ induced in the early stages of Th2 signaling. GATA refers to a family of transcription factors, important regulators of T-cell development. STAT6 activation enhances expression of GATA3. GATA3 induces expression of another Th2-specific factor, MAF. MAF is a basic region/leucine-zipper transcription factor that binds to and transactivates the IL4 promoter.^{346,347}

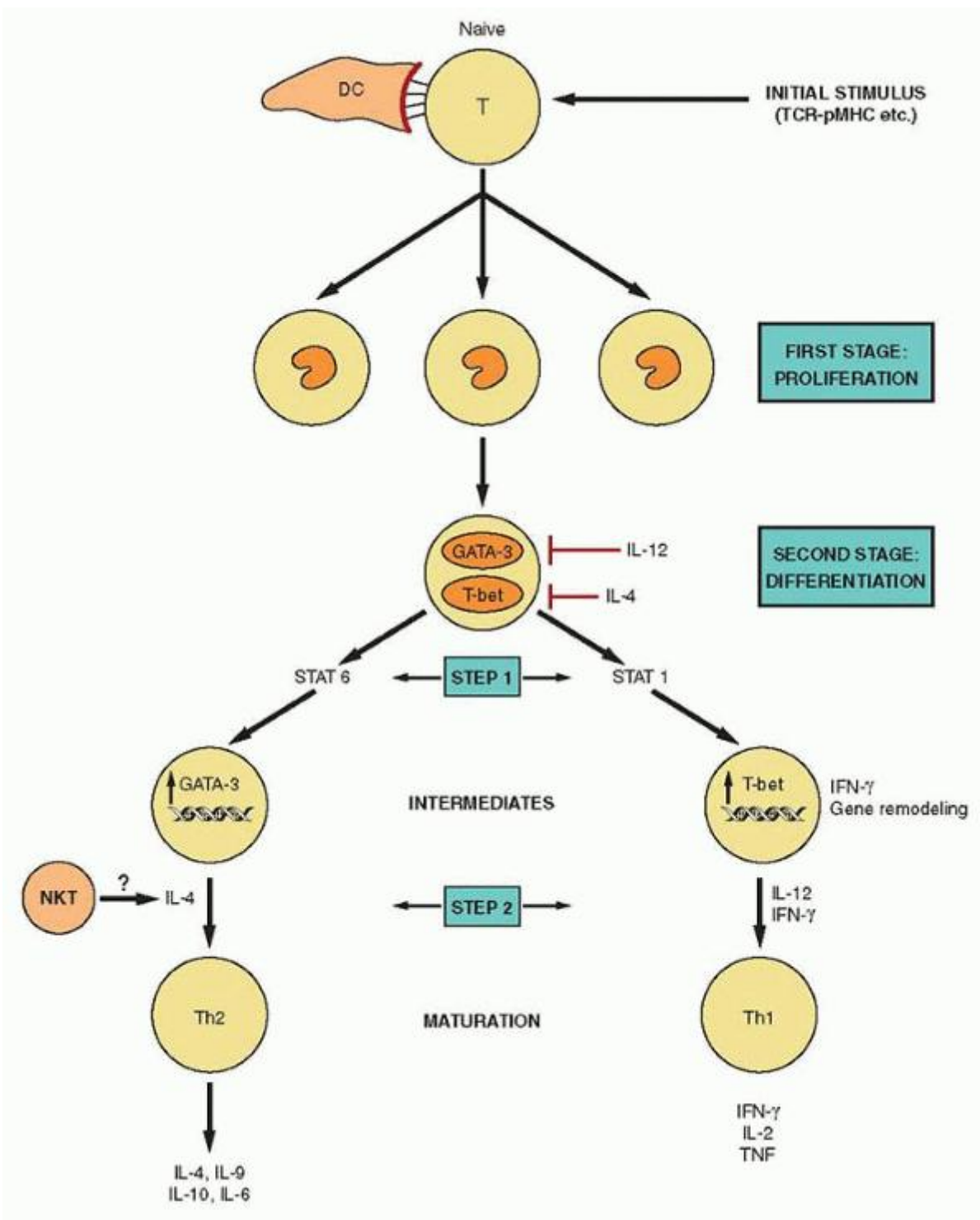

FIGURE 13.11. CD4⁺ T-cell differentiation. After their differentiation in the thymus into the two main lineages, CD4⁺ and CD8⁺, the CD4⁺ or Th cells differentiate further in the peripheral lymphatic organs into effector cells with distinct patterns of cytokine secretion. The initial stimulus is delivered by the T-cell receptor (TCR) and results in the proliferation of the naive T-cell. These activated T-cells (pTh) have only a limited potential of interleukin (IL)-2 secretion, and they acquire the propensity to respond to additional signals for further differentiation. Primary stimuli via the TCR (dose of antigen, intensity and duration of TCR triggering) influence downstream signaling (Ca²⁺, protein kinase C, map kinase, etc.) that regulates transcription factor expression. Expression of GATA-3 leads to Th2, whereas T-bet leads to Th1 differentiation. In the second stage, exposure to cytokines (i.e., IL-4 or IL-12/interferon [IFN]-γ) drives the final steps of differentiation to the Th1 or Th2 pattern of cytokine secretion. NKT, natural killer T-cell; TNF, tumor necrosis factor. (Adapted from Noble A.

Review article: molecular signals and genetic reprogramming in peripheral T-cell differentiation. *Immunology* 2000;101:289-299; Murphy KM, Reiner SL. The lineage decisions of helper T cells. *Nat Rev Immunol* 2002;2:933-944; and Diehl S, Rincón M. The two faces of IL-6 on Th1/Th2 differentiation. *Mol Immunol* 2002;39:531-536.)

Epigenetic Modification of Cytokine Genes

Detailed description of these early events is beyond the scope of this brief review. The reader is referred to reviews of the topic.^{339,348} Transcriptionally inactive gene loci have a condensed chromatin with DNA tightly packed around the nucleosomes. For gene transcription, "open" chromatin is associated with acetylated histones and hypomethylation of DNA. Accessibility of IL4 and IFN- γ genes is initiated promptly after TCR and CD28 activation, but for sustained transcription, STAT6 or STAT4 signaling, and induction, GATA3 and T-bet are required. Within the first few days of Th1 and Th2 differentiation, signs of accessibility of the cytokine gene loci are observed in Th-activated cells. These signs are hypersensitivity to DNAase I and DNA demethylation.

P.298

Maturation of Th1/Th2 Cells

The IL12 and IL4 play a major role in the maturation of Th1 and Th2 cells, respectively. IL12 and IL18 act synergistically to produce IFN- γ from terminally differentiating Th1 cells. IL23 is composed of the p40 subunit of IL12 paired with the IL23 α -chain related to one of the chains of IL12. It binds to IL12 β -chain but interacts with its own IL23R. It activates STAT4 and may act during the induction of Th1 and the production of IFN- γ in cooperation with IL18. The IL27 is produced by APCs and induces proliferation of naive T-cells. It acts together with IL12 in promoting IFN- γ production and is the ligand for the T-cell cytokine receptor in the early development of Th1 cells.³⁴⁹ Th2 maturation is promoted by IL21, which is produced from Th2 cells, and specifically inhibits IFN- γ production and decreases responsiveness of T-cells to IL12, thus amplifying Th2 development.³⁵⁰

IL6 produced by several types of cells, especially APCs, activates transcription by NFAT, leading to production of IL4, which promotes Th2 differentiation. However IL6 also inhibits Th1 development because it up-regulates the suppression of cytokine signaling (SOCS)-1. SOCS, also known as STAT-induced STAT inhibitor, belongs to a family of regulators of cytokine production. SOCS1 inhibits IFN- γ production and the development of Th1 cells. Thus, IL6 plays a dual role in Th1/Th2 differentiation through induction of IL4 and SOCS1.³⁵¹ IL10 has also been reported to promote Th2 differentiation, but its main effect is in suppressing Th1 cells.

Another cytokine with double regulatory function is IL18. IL18 is produced from macrophages and synergizes with IL12 for IFN- γ production from NK-cells and T-cells. In collaboration with IL2, it promotes Th1 differentiation in activated T-cells.³⁵² Overproduction of both cytokines induces severe inflammatory disorders. In addition to its function as a Th1 inducer and as a proinflammatory cytokine, under certain experimental conditions, IL18 stimulates Th2 cell differentiation, increase of IgE, and allergic manifestations.³⁵³ The role of dendritic cells in humans is not clear as the production of cytokines varies depending on signals received from T-cells.

CD8 T-CELL DIFFERENTIATION

CD8⁺ T-cells produce primarily type 1 cytokines because CD8⁺ T-cells have no requirement for STAT4 signaling via IL12 to develop into Tc1 effectors. The Tc1/Tc2 regulation is mediated by transforming growth factor (TGF)- β with IL4 promoting Tc1 development and cytotoxicity in the presence of TGF- β .³⁵⁴ There is some kind of cross-regulation between CD4⁺ and CD8⁺ T-cells. CD8⁺ T-cells produce relatively high levels of IFN- γ and as a result, enhance Th1 immunity. On the other hand, Th2-cell-derived IL4 stimulates development of Tc2 cells in allergic states.

GENOMIC VIEW OF TYPE 1 AND TYPE 2 DIFFERENTIATION

Application of the new technology of gene expression by gene microarrays on polarized type 1 and type 2 CD4 and CD8 T-cells identified similarities in the broad pattern of gene expression in both CD4 and CD8 T-cells for type 1 and type 2 polarization, but differences were also identified between the two lineages.³⁵⁵ Large numbers of apoptosis-related genes were expressed, particularly in Th1 cells, which correlates with the propensity of these cells to undergo activation-induced cell death.³⁵⁶ A large number of cytokine and growth factor genes are preferentially expressed by either type Th1 or type Th2 cells. Th2 cells resemble Tc2 cells in their cytokine gene profile. Differences are also noted in genes involved in synthesis of cell migration molecules, such as CCR1, CXCR4, and β_7 integrin in Th2 cells and α_4 integrin in Th1 cells. This is something that should be expected because the two Th populations home to different locations.³⁵⁷

THE TH1—TH2 PARADIGM

T lymphocytes constitute a diversified population. Of the two CD4⁺ T-cells, the Th2 activates the B-cells for antibody production and the second, CD4⁺ the Th1, activates macrophages for cell-mediated immunity. The first provides defense against extracellular and helminthic infections. The second acts against intracellular bacterial infections, fungi, and protozoa (Fig. 13.12).

Th1 cells coordinate the activation of macrophages and constitute the most important cellular defense mechanism against intracellular pathogens. Macrophage activation is mediated by IFN- γ , the principal cytokine produced by Th1 cells. Macrophages activated by IFN- γ rapidly kill susceptible intracellular bacteria. They produce TNF- α , which synergizes with IFN- γ . IFN- γ has been used successfully as adjunct to chemotherapy in the treatment of leprosy, tuberculosis, and atypical mycobacteriosis. In induction of Th1 immunity, IL12 is rapidly produced by infected macrophages, which activates NK-cells and stimulates production of IFN- γ , which subsequently induces Th1 differentiation. However, overproduction of IL12, by a positive feedback mechanism triggered by IFN- γ , results in inflammatory responses.³⁵⁸ IL12 production is inhibited by IL10.

There is compelling evidence that the Th1 cells have an essential role in protection from mycobacterial infection. Mice deficient in IL4, a major Th2 cytokine, have a normal response to *Mycobacterium tuberculosis*, whereas increased production of IL4

P.299

correlates with disease progression.³⁵⁹ Mice infected acutely with *M. tuberculosis* are protected by adoptive transfer of Th1 cells with a tenfold reduction in bacterial counts, whereas recipients of Th2 cells suffer from weight loss and lung fibrosis.³⁶⁰

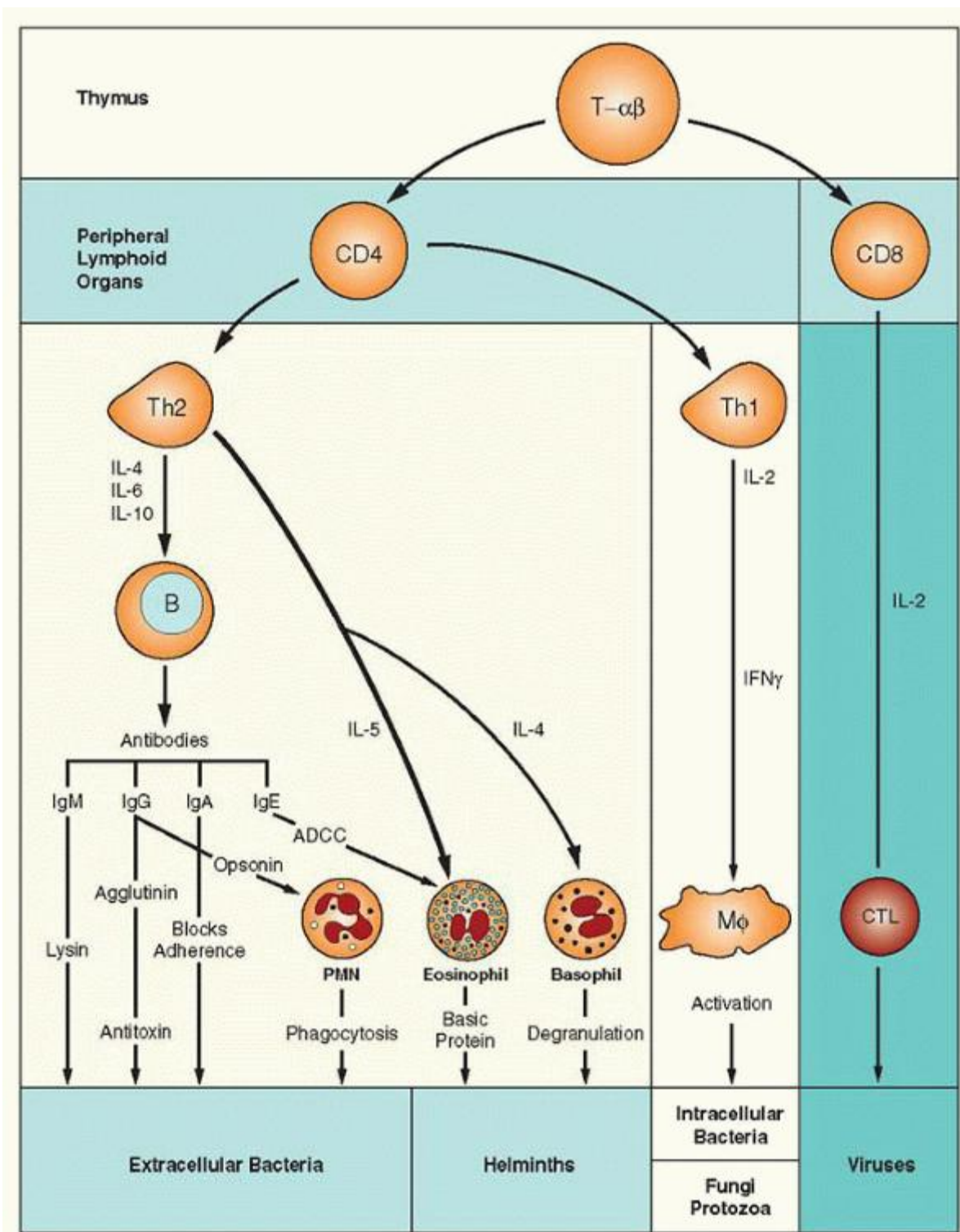

FIGURE 13.12. Th1 and Th2 cells and effector mechanisms against pathogens. See text for details. ADCC, antibody-dependent cell-mediated cytotoxicity; CTL, cytotoxic T lymphocyte; IFN, interferon; Ig, immunoglobulin; IL, interleukin; PMN, polymorphonuclear cells.

Leishmanial disease currently affects some 12 million people in 88 countries. The annual incidence is approximately 2 million new cases. Experimental studies have clearly documented that Th1 response is associated with restriction of the disease and cure, whereas a Th2 response is associated with progressive systemic disease. Balb/c mice are susceptible to Leishmania infection because they are unable to generate a Th1 response, whereas C57Bl/6 mice are resistant to the

infection as a result of strong Th1 response. In Balb/c mice, the draining lymph nodes show elevated transcripts for IL4 but not for IFN- γ .³⁶¹

The most critical unifying effect able to induce resistance has been the successful attenuation of IL4 expression in the draining lymph node of infected susceptible animals during the first 24 hours of infection. The extent of IL12 responsiveness is also a critical determinant for the development of a curative immune response because it induces a Th1 response.³⁶²

Another example of the importance of a balanced Th1/Th2 response is related to the allergic inflammation.³⁶³ The pathophysiologic mechanisms of asthma seem to be based on dysregulation of the Th1/Th2 balanced response with a preponderance of Th2 cytokines. Asthma affects 8% to 10% of the population in the United States and is the leading cause of hospitalization among children younger than 15 years of age, causing an exorbitant financial burden on society. Th2-dominant responses stimulate antibody-mediated responses, activate mast cells and elicit tissue eosinophilia (i.e., the predominant response in the asthmatic airway).³⁶⁴ IL13 is one of the Th2 cytokines, and overexpression of IL13 in transgenic mice induces an inflammatory response with an infiltrate rich in eosinophils and macrophages. Furthermore, it causes airway fibrosis, mucous metaplasia, and airway hyperresponsiveness.³⁶⁵ It is likely that asthma is the result of a dysregulated mucosal immune system and pathologic T-cell response in genetically susceptible individuals.³⁶⁶

CD8⁺ T LYMPHOCYTES

The CD8⁺ T lymphocyte is one of the two professional cytotoxic lymphocytes, the other being the NK-cell. The CD8⁺ T lymphocytes, also known as CTLs, differ from NK-cells in the basic mechanism of target recognition. CTL expresses an $\alpha\beta$ -TCR, recognizing processed peptides presented by MHC class I molecules (pMHC), whereas the NK-cell cytotoxicity is regulated by the C-lectin type of NK-cell receptors (CD94) or members of the killer cell Ig-like receptors (KIRs), which recognize class I HLA allotypes rather than pMHC.³⁶⁷

Two fundamentally different groups of methods of evaluation of target cell lysis have been developed: one evaluates disruption of cell membrane and release of tracers incorporated into the target, and the other evaluates DNA fragmentation resulting from apoptotic nuclear damage. In the first category, the most widely used method has been the release of radioactive chromium, ⁵¹Cr, preloaded into the target.³⁶⁸ More sensitive techniques using fluorescent impermanent dyes have been developed. DNA fragments released from the nuclei are harvested, and a "ladder" pattern is identified.³⁶⁹ Direct comparisons of the cytotoxic potency of different cell populations cannot be made by these methods because the target cell death is not linearly related to the cytotoxic input. Usually, the number of cytotoxic cells required to achieve a given level of target cell lysis is expressed in lytic units, which are inversely related to the effector cell number.

Activation of Cytotoxic T Lymphocytes

For the CTL to become an active effector, the precursor cell must be stimulated by antigen to undergo proliferation and differentiation.³⁷⁰ The activation or priming results from the interaction of the naive CD8⁺ T-cell with professional APCs. Granules are not always visible before activation, but the killing machinery (i.e., perforin, granzymes, and FasL) is delivered immediately upon priming.^{371,372} The granule by electron microscopy is 0.5 to 1.0 μm in diameter and is heterogeneous in its structure.³⁷³ The core is homogeneous and sometimes it is surrounded by double membranes containing the perforin enclosed by a thin membrane.³⁷⁴ Multiple small vesicles surround the core toward the periphery of the granule. Depending on the preponderance of these two components, granules have been distinguished as type I (dominated by the cores) or type II (with dominant multivesicular component but no cores), and other granules in terms of content are intermediate between types I and II. The granules are similar to late endosomes and have the properties of two usually separate organelles: those of the secretory type and those of the lysosomes.³⁷⁵ Similarities with lysosomes include the acidic pH, the mannose-6-phosphate receptor (MPR), and the lysosomal marker, lysosome-associated membrane protein. Endocytic components carrying CD3/TCR, CD8, and MHC molecules reach the perforin-containing granule and are displayed in the outer leaflet of the membrane.

GRANULE CONTENTS

Perforin (Cytolysin)

Perforin is a 65- to 75-kD glycoprotein with patchy homology to C9 complement component. It is synthesized as an inactive precursor, which is cleaved to yield a 60-kD active form.³⁷⁶ The protein consists of two regions: one has homology to complement proteins (C₆ to C₉), and the other is a C-2 domain related to Ca²⁺-binding proteins.³⁷⁷ The C-terminal portion is cleaved by proteolytic enzymes activating the C-2 domains for phospholipid binding.³⁷⁸ The N terminal is involved in interaction with the membrane and polymerization. However, the central portion contains four membrane-

spanning domains, potentially capable of forming amphipathic α helices of β sheets. At the carboxy terminal, a short peptide (propeptide with a bulky glycan attached) is removed, and the remaining perforin monomer undergoes conformational changes in the presence of Ca^{2+} , inserting itself in the membrane. Interaction with other perforin monomers forms the polyperforin pores.^{379,380} and ³⁸¹ At least three to four monomers are needed to form a functional channel, whereas 10 to 20 aggregated monomers are needed to produce a pore visible by electron microscopy.

Granulysin

Granulysin is a member of the saposin^{382,383} family of lipid-binding proteins, related functionally to defensins and other bacterial peptides, but is structurally different. It is active against Gram-positive and Gram-negative bacteria, fungi, and parasites. It disrupts artificial liposomes, damages mitochondria, and activates caspase 9 to induce apoptosis. It probably plays an important role in innate and acquired antimicrobial defenses. It kills extracellular *M. tuberculosis* and decreases their viability inside the cell.³⁸⁴

Granzymes

Granzymes are serine proteases of the chymotrypsin family.^{385,386} The crystal structure of granzyme B has been solved, and its structural similarity with chymotrypsin has been verified.³⁸⁷ On the basis of the gene structure, proteolytic specificity, and biologic function, these enzymes are divided into three subfamilies. They are produced as proenzymes, with an acidic inactivating peptide. During their transport through the endoplasmic reticulum and Golgi apparatus, they are processed so that they are targeted to the secretory pathway. The activation peptide is removed by dipeptidyl peptidase I (DPPI), and a sequence motif interacts with

P.300

proteoglycan in the granule to maintain proper conformation for activation. Granzyme B has a unique specificity among mammalian serine proteases in that it requires aspartic acid as P1 amino acid (i.e., the cleavage leaves a carboxy-terminal aspartic acid). Granzymes are highly positively charged proteins at neutral pH and form complexes with proteoglycans in the granule and extracellularly with polyanionic components.

Calreticulin

Calreticulin is a Ca^{2+} storage protein and carries a sequence that retains it in the endoplasmic reticulum. It co-localizes with perforin and is released together with perforin, which binds to the P-domain of calreticulin. Calreticulin functions as a chaperone protein for perforin and protects the CTL during biogenesis of the granules.³⁸⁸ Fragments of individual calreticulin domains used in lytic assays showed that the Ca^{2+} -binding C-domain, which does not bind perforin, has the strongest capacity for inhibitory activity.³⁸⁹ Lysis, however, is independent of calreticulin's ability to sequester Ca^{2+} . It is suggested that calreticulin stabilizes membranes and thus prevents polyperforin pore formation.

Other Components

Chondroitin sulfate proteoglycans are negatively charged and are exocytosed during target lysis. They probably regulate delivery of the positively charged granzymes.³⁹⁰ The multivesicular domain of the granule is rich in MPR, which is normally absent in mature lysosomes but present in early endosomes.

The DPPI (cathepsin C) is a lysosomal cysteine protease responsible for post-translational processing in the generation of activated myeloid and lymphoid granule serine proteases.

TARGET CELL LYSIS

Secretory Synapse

As we have seen with the CD4 T lymphocyte, recognition of the antigenic determinants by TCR is associated with the formation of the IS. In the synapse, the SMAC is organized by TCR and adhesion molecules. CTL also forms a synapse with the target cells, and within the synapse, there is a defined secretory domain.³⁹¹ LFA-1 and talin form an outer ring of adhesion proteins with a distinct secretory domain in the center and separate from the cluster of the TCR and signaling molecules.³⁹² Electron microscopy shows granules at the point of degranulation. The CTL acquires the hand-mirror configuration during its movement, with the nucleus leading in the front and cytoplasmic organelles trailing behind. The Golgi is apposed tightly to the membrane at the point of contact and the organelles appear to be "streaming" toward the contact site. Confocal microscopy shows that the granules initially cluster behind the MTOC and then go around the MTOC to reach the secretory domain. Intimate interdigitations are visible over a large area, but a thin extracellular space separates the two cells that are held together by gap junctions³⁹³ (Fig. 13.13). Gap junctions exist normally between cells in various tissues and probably serve the function of cellular communication. The nucleus moves away and the granules

take up position next to the area of adherence with the target. Confocal microscopy identifies regions of the secretory synapse where granules are secreted between LCK and talin or CD11a (Fig. 13.9). The granules stream around the nucleus along microtubules and accumulate behind the MTOC and the Golgi apparatus. Then they move around the Golgi and reach the synapse, where secretion occurs between the adhesion ring and the signaling domain. They fuse with the membrane within 4 minutes after contact with the target.³⁹⁴

This fusion marks the beginning of the Ca^{2+} -dependent second stage characterized by striking intracellular changes. The most remarkable of these changes is the re-orientation of the MTOC, which, together with the Golgi, takes a position facing the area of contact with the target.^{395,396} and ³⁹⁷ The Ca^{2+} requirements for lysis may also be due to the Ca^{2+} dependency of the MTOC re-orientation that is a prerequisite for CTL killing.³⁹⁸ Granules attach to and then move along microtubules toward the MTOC and finally are secreted at the MTOC. Disruption of microtubules by certain drugs severely impairs killing.³⁹⁷

For the last stage of granule secretion, a GTP-binding protein, RAB27A, is critical for moving the granules from the MTOC to the synapse.³⁹⁹ In a rare autosomal recessive disease known as Griscelli syndrome, RAB27A is defective. These patients have albinism because melanocytes require RAB27A to secrete melanosomes. WASP, which activates the Arp2/3 complex for actin polymerization, is also required for cytotoxicity.³⁹⁹

Lymphocyte-mediated killing can be confined to two pathways: the perforin-granzyme-mediated and the Fas-mediated pathways.⁴⁰⁰ Independent of the importance of the contribution of each pathway in target cell lysis, the fact is that lysis absolutely requires exocytosis of granules and their contents. Exocytosis requires signaling from PI3-K and ERK. The importance of exocytosis is emphasized by markedly decreased cytotoxicity of CTLs and NK-cells in Griscelli syndrome (a rare autosomal recessive disorder characterized by partial albinism and the ashen mouse). The ashen mice have a profound decrease of cytotoxicity, even though they have normal FASL expression and FASL cytotoxicity.⁴⁰¹ Patients with Griscelli syndrome and the ashen mouse have a loss of function mutation in the RAB27A gene that abrogates the expression of RAB27A GTPase (one of approximately 50 GTPases). RAB27A affects the functions of the dense granules of platelets, melanosomes of melanocytes, and secretory lysosomes of CTLs. In platelets, RAB27A regulates secretion only of the dense granules. Increase of Ca^{2+} is critical for cytotoxicity, which results from extracellular sources, because it does not occur if extracellular Ca^{2+} is removed.⁴⁰²

The Role of Perforin

Perforin was the name given to a protein within the granules that perforates the cell membrane and opens pores, which originally were believed to be the cause of lysis and cell death. The C-terminal domain of perforin is the Ca^{2+} -binding site that initiates the insertion of the molecule into cell membrane.³⁷⁸ The insertion is mediated by exposure of several aspartate residues after cleavage of the C-terminus to yield a 60-kD active form. These residues are presumed to become approximated in three dimensions and bind Ca^{2+} , and the molecule becomes highly reactive for lipids from exposure of amphipathic domains. Some data suggest that perforin actually is inserted into the lipid bilayer with the help of a receptor. NK-cells release a lysolipid, the platelet-activating factor, which binds to its receptor and forms a bridge between the platelet-activating factor receptor and perforin.⁴⁰³

At 37°C, perforin inserts into the membrane, and approximately 20 perforin monomers form a tubular structure (16 nm wide) with a torus in the upper ring,⁴⁰⁴ similar to that formed by the C9 component of complement (Fig. 13.14). Purified perforin causes cell lysis but not the DNA fragmentation and condensation associated with apoptosis, which is a hallmark of target cell lysis by CTLs.⁴⁰⁵ Furthermore, nuclear changes occur before cell membrane damage.⁴⁰⁶ Targeting cell death requires the combined action of perforin and granule-associated granzymes. However, mice deficient in perforin suffer more serious consequences of lack of or diminished cytolytic functions⁴⁰⁷ as compared to mice deficient in granzymes A and B.⁴⁰⁸ It has been assumed that granzymes enter passively through perforin pores (Fig. 13.15). Large pores that allow passive diffusion of the granzymes are formed only with large concentrations of perforin. The pore size formed by small concentrations of perforin does not permit diffusion of

P.301

proteins larger than 8 kD. However, even under these conditions, granzymes (32 to 65 kD) have access to the cytosol, although evidently not by direct diffusion through perforin pores. A lysin from *Listeria monocytogenes* also permits granzyme access to cytosol even in the absence of any measurable plasma membrane damage.⁴⁰⁹

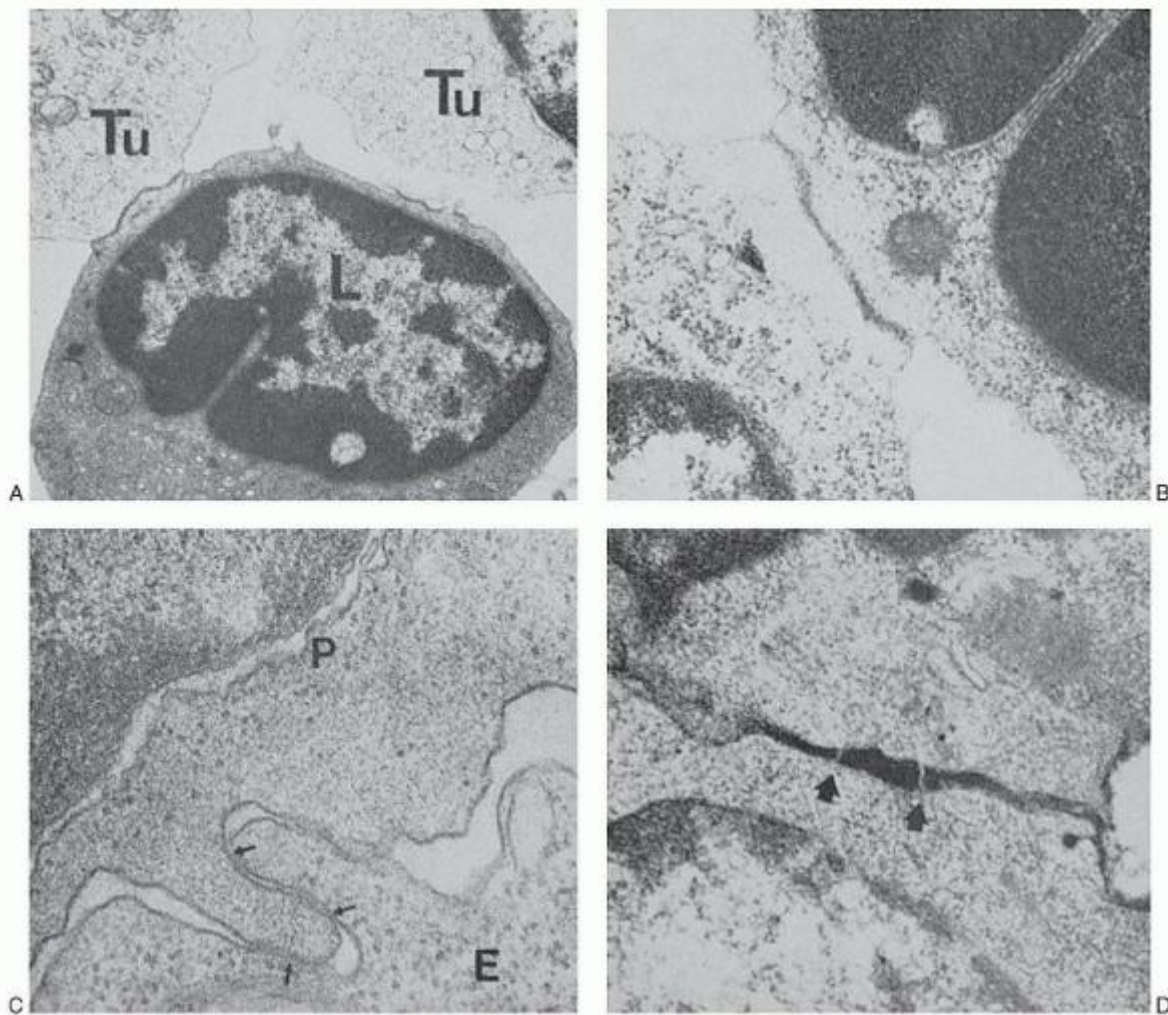

FIGURE 13.13. Interaction between a cytotoxic T-cell and its target. A-C: Cytotoxic T-cell attaches to its target over broad areas of the cell membrane. The formation of the conjugate involves interdigitations of microvilli between the two cells. D: Lanthanum nitrate fills the gap between cytotoxic T lymphocyte and its target and reveals junctions (arrows) that stretch between the two cells. The function of these junctions remains unknown. E, EL-4 tumor cell; L, lymphocyte; P, peritoneal exudate cell (i.e., cytotoxic T-cell); Tu, tumor. (A, B, and D from Grimm E, Price Z, Bonavida B. Studies on the induction and expression of T cell-mediated immunity. VIII. Effector-target junctions and target cell membrane disruption during cytolysis. *Cell Immunol* 1979;46:77-99; C from Kalina M, Berke G. Contact regions of cytotoxic T lymphocyte-target cell conjugates. *Cell Immunol* 1976;25:41-51, with permission.)

The entrance of granzyme B into the cell at low perforin concentrations is suggested to occur, probably as a result of endocytosis ("facilitated access" hypothesis). Perforin endocytosed together with granzyme disrupts the endocytic pathway and releases granzyme for delivery to the nucleus. Support for this interpretation comes from the observation that brefeldin, which interferes with redistribution of proteins out of the endosomal system, inhibited perforin-induced release of granzyme B, blocked its translocation to the nucleus, and inhibited cell death.⁴⁰⁹ Granzyme B is therefore able to enter into the interior of the cell autonomously in the absence of perforin. However, apoptotic death does not occur unless perforin is added.⁴¹⁰ Granzyme binds to MPR, when it is trafficking within the cell at the time of synthesis but also on the surface of the target cell.⁴¹¹ However, MPR is not critical for transportation of granzyme B within the target cell because cells lacking MPR are still subject to apoptosis by granzyme B, which enters the cell by constitutive fluid-phase micropinocytosis^{412,413} or some other, probably specific, receptor.

Endocytosis follows the binding to the receptor, and the granzyme B is detected first within Rab5-positive endocytic vesicles and subsequently in Rab5-negative, novel endocytic compartments that are not identifiable by any of the known endocytic markers.⁴¹⁴ The granzyme B is released to the cytoplasm by a second signal provided by perforin or replication deficient adenovirus (Ad2). From the cytoplasm, the granzyme B reaches the nucleus, initiating the apoptotic pathway.

The localization in the nucleus occurs before the nuclear events of apoptosis, suggesting that nuclear translocation of the granzyme B transmits an apoptotic signal that is communicated to the nucleus.⁴¹⁵

P.302

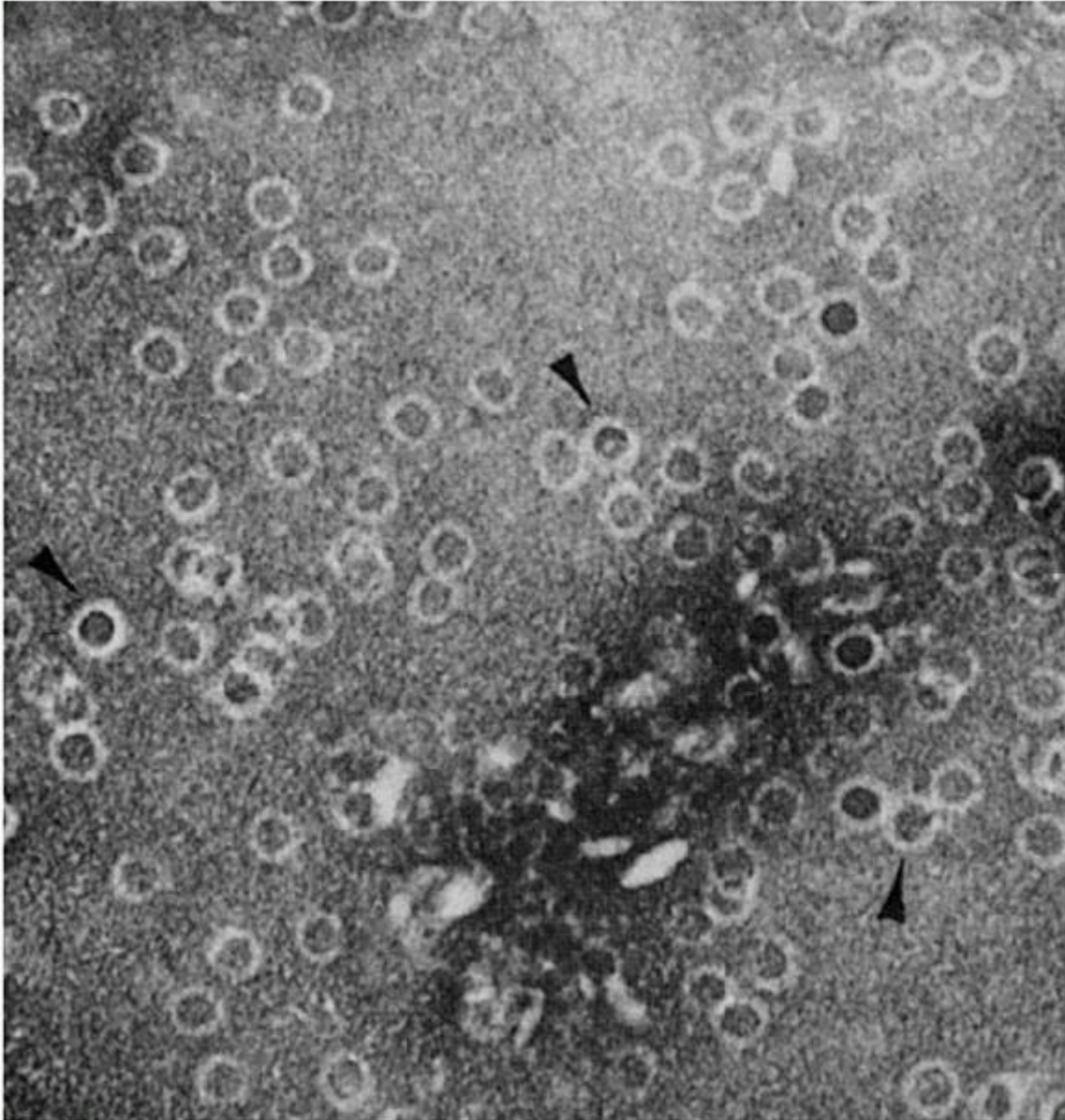

FIGURE 13.14. Lesions (arrows) inflicted on its target by cytotoxic T lymphocytes. Cytotoxic T lymphocytes form punched-out lesions on the membrane of the target similar to those formed by complement. (From Dennert G, Podack ER. Cytolysis by H-2-specific T killer cells. Assembly of tubular complexes on target membranes. *J Exp Med* 1983;157:1483-1495, with permission.)

The Role of Granzymes

Independent of the role played by each of the constituents of the granules, it is absolutely clear that exocytosis is crucial for target cell death. In T-cells, the granules are synthesized when the cells receive activation signals, whereas in NK-cells, the granules are preformed. At least four granzymes are present ubiquitously in human cytotoxic cells (i.e., A, G, H, and K). After their synthesis, the granzymes undergo post-translational modifications and as a result assume an active

conformation. First, the signal peptide is removed and subsequently, a short propeptide which for granzymes A and B is DPPI a cysteine aminopeptidase that can activate several serine proteases.⁴¹⁶ Subsequently they are glycosylated and then sorted by MPR in the Golgi apparatus on the way to the granules.⁴¹⁷ Granzyme B is a serine protease originally defined as an aspartase because it cleaves aspartic acid in the P1 position and is the only granzyme with the preference for proteolytic cleavage of aspartate residues. In this respect, it has a specificity similar to caspases and has an extended substrate specificity with nine amino acids making contact with the substrate. The first substrate of biologic significance of granzyme B was found to be a member of the caspase family.⁴¹⁸ Cleavage of target cell caspases⁴¹⁹ results in the activation of the cellular apoptotic cascade (Fig. 13.16).

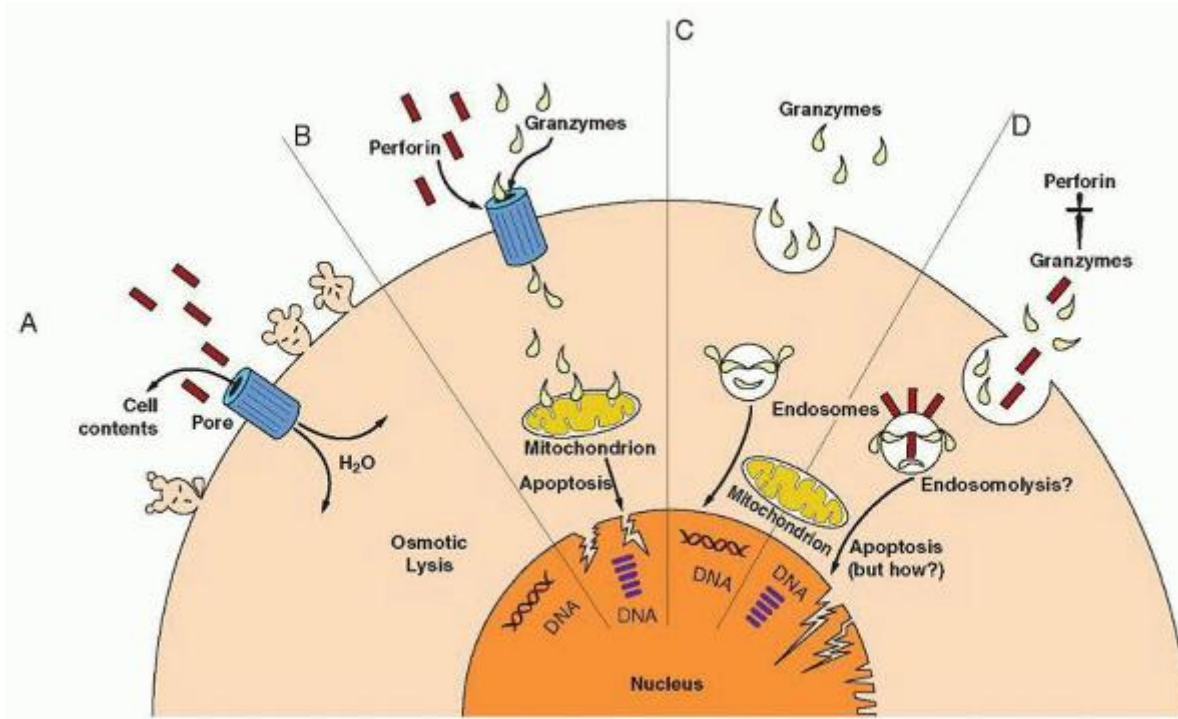

FIGURE 13.15. What is the role of perforin in cell lysis? The perforin lesion used to be considered the cause of cell death by osmotic lysis (as with complement) (A). When the granzymes were implicated in the cause of cell death by the apoptotic pathway, it was believed that the pores of perforin allow the entrance of the granzymes into the cell (B). Granzymes, however, can still enter the cell without perforin, but by themselves, they cannot cause cell death (C). Because granzymes enter the cell by endocytosis and are within endocytic vesicles, it is argued that perforin is needed to release them in the cytosol by punching holes in the vesicles (endosomolytic mechanism; D). At this point, it is known that cytotoxic T lymphocytes kill their targets, and for this function, they need at least two of the contents of the granules: the granzymes and the perforin. The exact mechanism, however, is still strongly debated.

Granzyme B activates apoptosis by two distinct pathways: i.e., by directly cleaving its substrates, caspase 3 or caspase 8,⁴²⁰ or by a caspase-independent pathway through mitochondria. Mitochondrial factors enhance extramitochondrial caspase activation and play a central role in the execution of apoptosis, involving disruption of electron transport, energy metabolism, production of reactive oxygen radicals, and the release of apoptotic proteins, such as cytochrome-c.^{421,422}

BCL2 can rescue cells from granzyme-B-mediated cell death, specifically blocking the pathways that operate directly through mitochondrial perturbations. BCL2 suppresses the mitochondrial pathway because it prevents loss of mitochondrial membrane depolarization and inhibits the release of cytochrome c and apoptosis-inducing factor into the cytosol.⁴²³ The mitochondrial apoptotic pathway is triggered by direct cleavage of BID (BH-3 interacting domain)⁴²⁴; it results in translocation of BID to mitochondria, where it interacts with its receptors, BAX (BCL2-associated X protein) and BAK (BCL2-antagonist killer) triggering cytochrome-c release. Cytochrome c then activates apoptosome, which in turn activates caspase 9 and ultimately caspase 3.⁴²⁵ BCL2 apparently blocks granzyme-B-induced apoptosis by acting at an upstream point of the granzyme B pathway, i.e., blocking the translocation of the granzyme to the nucleus.⁴²⁶

Granzyme A

Granzyme A is a tryptase and induces caspase-independent cell death. It concentrates in the nucleus of the targeted cells and degrades histone H1 into small fragments.⁴²⁷ Histone H1 plays

P.303

a critical role in chromatin hypercondensation, which protects genomic DNA from endonuclease digestion. Histone digestion provides a mechanism for unfolding compacted chromatin and facilitating endogenous DNAase access to DNA during T-cell granule-mediated apoptosis. Another target for granzyme A is protein HMG2 (high-mobility group protein 2). HMG2 is a nonhistone protein that binds to the internucleosomal linker region of DNA and to core histones and is involved in critical steps in DNA replication and transcription. It binds preferentially to distorted DNA and unwinds damaged DNA for its repair. It facilitates the assembly of higher-order nucleoprotein structures by bending and looping DNA or by stabilizing underwound DNA. However, the HMG2 is cleaved by granzyme A and thus opens up chromatin and blocks the de novo transcription required for cellular repair responses. Opening up chromatin probably contributes to the observed synergy of granzyme A with granzyme B in the induction of oligonucleosomal DNA fragmentation during CTL lysis.⁴²⁸ Both granzyme A and B directly cleave lamin B,⁴²⁹ a member of the lamin family of proteins that maintain the integrity of the nuclear envelope.

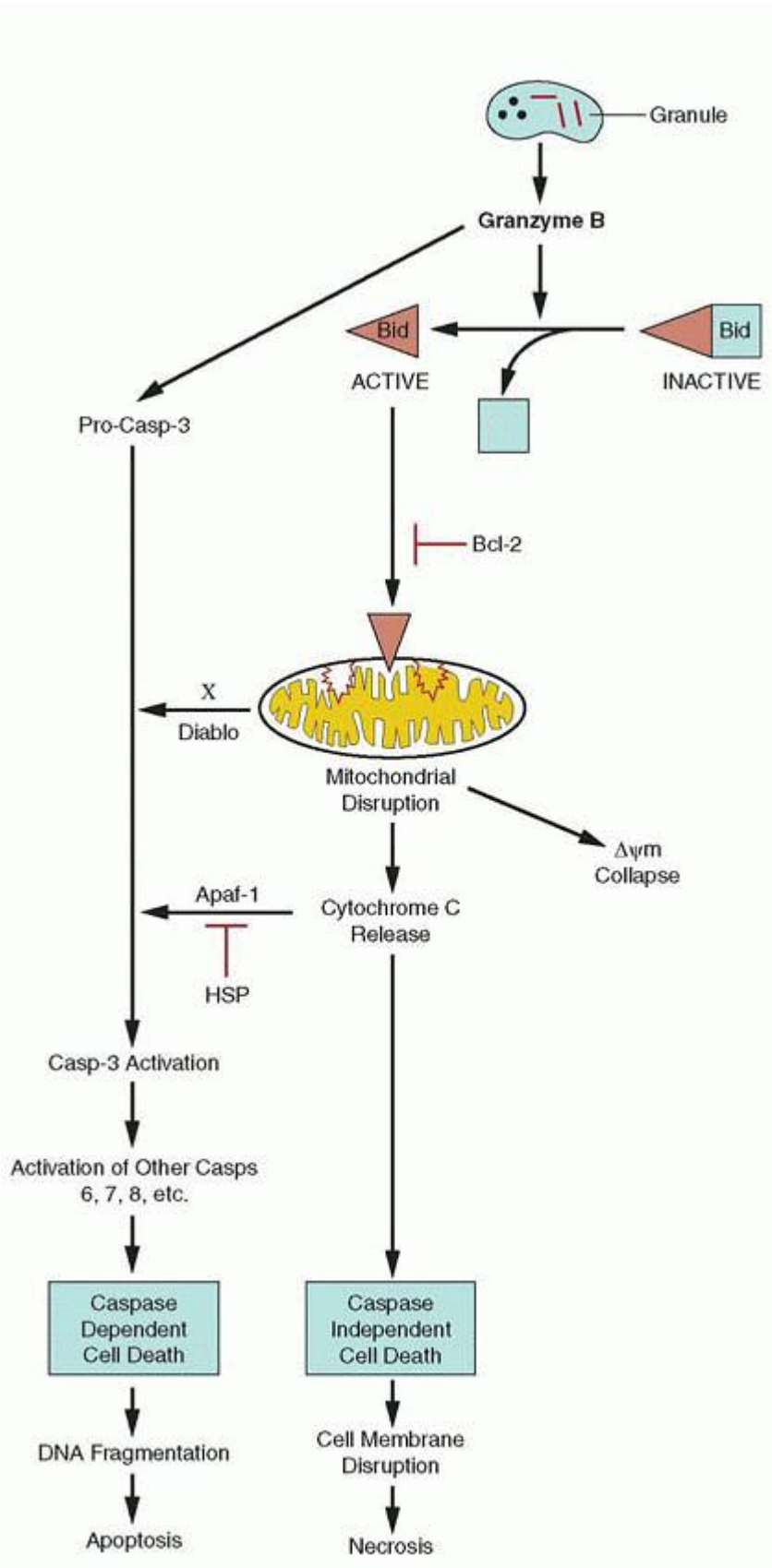

FIGURE 13.16. Cytotoxic T-lymphocyte killing of target cells. The cytotoxic T-lymphocyte killing of its targets is mediated by both the granzyme(s) (Gr), especially GrB, and the perforin, and because both of them share the same intracellular

residence (i.e., the granule), the killing mechanism is known as the granule exocytosis mechanism. GrB activates caspase (Casp)-3, either directly or, most likely, in vivo by cleavage of the proapoptotic member of the Bcl2 family, Bid. The active Bid acts on the mitochondrion and causes opening of the permeability transition (PT) pore of the inner mitochondrial membrane that causes (or is the result of) the collapse of the $\Delta\Psi_m$ (mitochondrial transmembrane potential). $\Delta\Psi_m$ normally results from the asymmetric distribution of protons and other ions on both sides of the inner mitochondrial membrane. It is essential for normal mitochondrial function. $\Delta\Psi_m$ disruption occurs before cells exhibit nuclear DNA fragmentation or aberrant exposure of phosphatidyl serine on the outer cell membrane; therefore, it constitutes probably the earliest common event of the apoptotic cascade. Mitochondrial disruption activates a factor not yet well identified (X) and contributes to amplification of activation of Casp-3 and other Casps subsequently (Casp-6, -7, -8, -9, -10). The factor X may be Diablo (direct inhibitor of apoptosis protein-binding protein), which facilitates processing of Casps through inhibition of inhibitor of apoptosis proteins. The Bid pathway of Casp-3 activation provides a greater lethal threshold of amplification of activation of Casps than the direct GrB activation. In addition to the Casp-dependent pathway (apoptosis), disruption of mitochondria by GrB-activated Bid leads to cell death by necrosis. HSP, heat-shock protein. (From Kroemer G, Zamzami N, Snesin SA, et al. Mitochondrial control of apoptosis. *Immunol Today* 1997;18: 44-51; Heibein JA, Barry M, Molyca B, et al. Granzyme B-induced loss of mitochondrial inner membrane potential [$\Delta\Psi_m$] and cytochrome c release are caspase independent. *J Immunol* 1999;163:4683-4693; Sutton VR, Davis JE, Cancilla M, et al. Initiation of apoptosis by granzyme B requires direct cleavage of bid, but not direct granzyme B-mediated caspase activation. *J Exp Med* 2000;192:1403-1413; and Barry M, Bleackley RC. Cytotoxic T lymphocytes: all roads lead to death. *Nat Rev Immunol* 2002;2:401-409.)

Granzyme A bound to proteoglycans, has been detected in the blood of patients with viral diseases and rheumatoid arthritis.⁴³⁰ In complexes with proteoglycans, it is protected against inactivation by protease inhibitors such as α_2 -macroglobulin and others. However, its role in the blood in these conditions remains unknown. The entry of granzyme A into the nucleus requires the signal from perforin and once inside the nucleus, it binds to insoluble factors because it does not leak out even after the nuclear membrane is permeabilized.⁴³¹

Death Receptor Pathway

Cytotoxic lymphocytes use two pathways for killing their targets: the exocytosis pathway (perforin-granzyme) and a death receptor pathway. Although there are multiple receptors on the cell surface that can initiate an apoptotic cascade, they converge at one point downstream to a common final pathway. The point of confluence is the adaptor molecule FADD (fas-associated death domain). These alternate apoptotic pathways may be considered as the FADD pathway.⁴³² The pathways that converge to FADD are initiated by FAS (CD95), physiologically the most important receptor in the family of TNF receptors. FADD binds and recruits caspase-8, which stands at the apex of the cascade of all caspases⁴³³ and forms the DISC (death-inducing signaling complex).⁴³⁴ Caspase-8 may target the mitochondria through BID or caspase 3, depending on the cell type.^{435,436}

In the FADD pathway, the FASL is not stored even in activated cells, and as a result, it requires the induction of a new ligand after TCR stimulation, which requires 1 to 2 hours after stimulation. The half-life of the ligand is long (2 to 3 hours), and the CTL can kill innocent bystanders (as long as they express the appropriate receptor, FAS) without the need for TCR signaling.⁴³⁷ In this respect, the FADD pathway is much more promiscuous than the perforin pathway. The death receptor pathway is important for CD4⁺ Th1 cells.⁴³⁸

Membrane Morphology of Target Cell Lysis

In the early stages of cell death induced by CTL, plasma membrane components are translocated to intracellular membrane structures, including nuclear envelope and mitochondria. Membrane-bound perforin and the granzymes are internalized at the same time, and it is postulated that, subsequently, perforin releases the granzymes to the cytosol by an endosomolytic action for activation of the caspase pathway (Figs. 13.15 and 13.16). In the early stage, the target does not undergo extensive permeabilization during perforin-dependent CTL lysis.

The first detectable change in the target-cell-surface morphology consists of the formation of small dilatations of the surface

P.304

microvilli, forming small vesicles that eventually expand into large blebs even before ⁵¹Cr release can be detected. Some of the detached vesicles attach to neighboring CTLs, suggesting that they carry some target-specific antigens on their surface (Fig. 13.17).

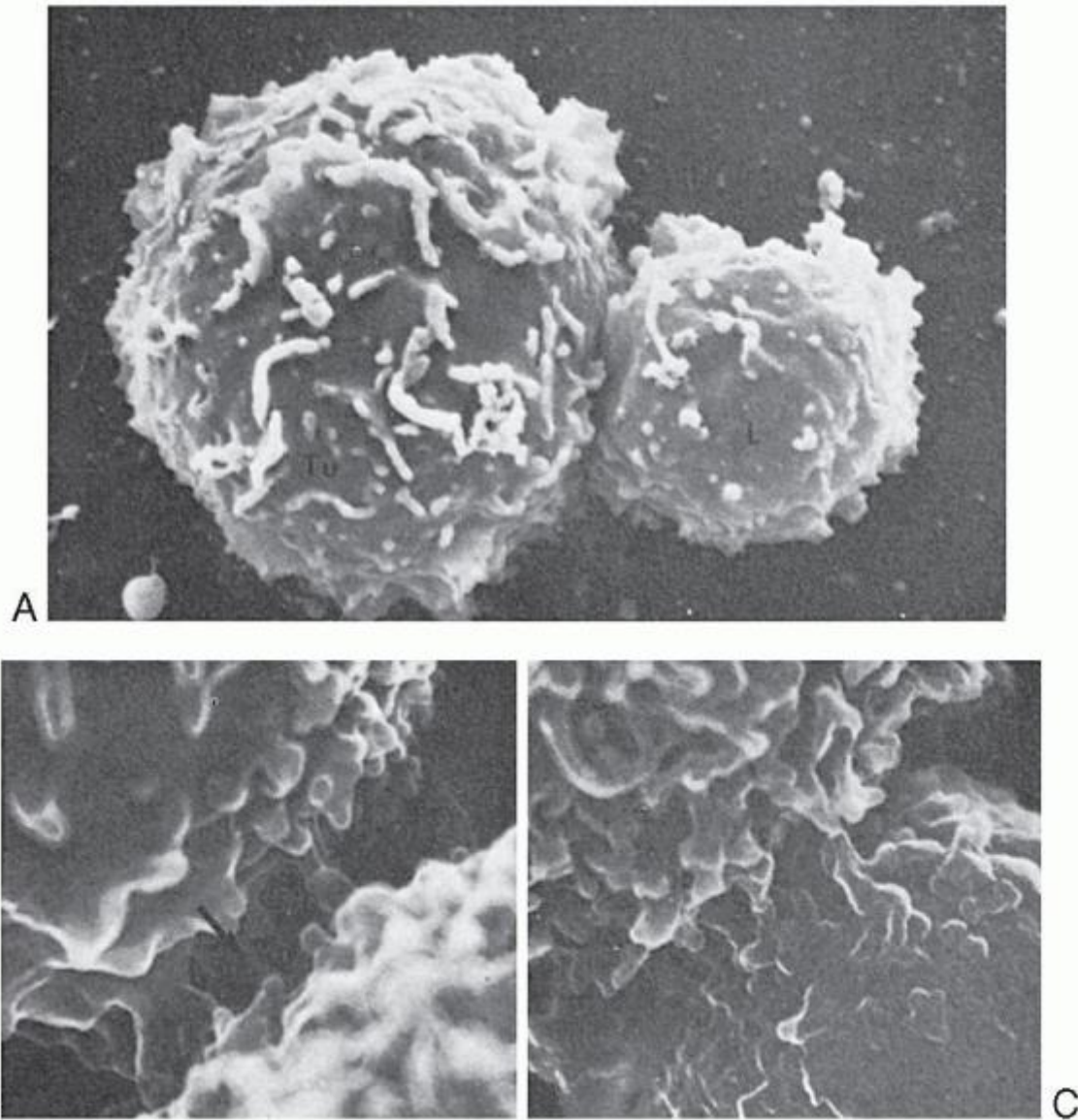

FIGURE 13.17. Cytotoxic T-lymphocyte-target cell interaction. A-C: Scanning electron microscopy of the formation of the killer cell synapses. Intimate contact is established between the microvilli of the two cells. Compare with the electron microscopic view in Figure 13.13. (B and C from Kalina M, Berke G. Contact regions of cytotoxic T lymphocyte-target cell conjugates. *Cell Immunol* 1976;25:41-51; and A from Grimm E, Price Z, Bonavida B. Studies on the induction and expression of T cell-mediated immunity. VIII. Effector-target junctions and target cell membrane disruption during cytolysis. *Cell Immunol* 1979;46:77-99, with permission.)

THE FUNCTION OF CYTOTOXIC T LYMPHOCYTES

Deficiencies of Granule Contents

Virus-specific cytotoxic CD8⁺ T-cells (CTL) are induced during viral infections (Fig. 13.12) and lyse infected cells during the eclipse phase, i.e., before infectious virus is generated. They kill virus-infected cells before new viral antigens can be detected on the surface of infected cells with antibodies.⁴³⁹ Fas deficiency has no effect on the role of viral clearance, but elimination of both Fas and perforin leads to uncontrolled infection.⁴⁴⁰ Normal mice easily survive a high inoculum (10^6 PFU) of the ectromelia virus, a murine-specific poxvirus. However, perforin-deficient mice succumb with a dose as small as 10 PFU.

Perforin deficiency in mice is associated with increased susceptibility to a variety of infections by viruses, protozoa, (plasmodium, *Trypanosoma cruzi*) and bacteria (i.e., mycobacteria, salmonella, chlamydia, listeria, etc.).⁴⁴¹ Defense

involves not only cytolytic mechanisms but also cytokines (i.e., IFN- γ , TNF, etc.), as well as microbicidal molecules. In the experimental model of lymphocytic choriomeningitis virus infection in mice, a nonlytic viral infection, perforin-dependent cytotoxicity is crucial in the control of the acute stage.⁴⁴² During the chronic stage of this infection, perforin down-regulates CD8⁺ T-cell expansion and prevents immunopathology.⁴⁴³ In perforin-deficient mice, however, the lack of this immunoregulatory control results in expansion of CD8⁺-activated T-cells, with approximately 50% of the animals dying within 2 to 4 weeks as a result of the immunopathologic damage from uncontrollable CD8⁺ proliferation and activation. Infusion of normal CD8⁺ T-cells fully reverses pathology and the associated mortality. This example clearly differentiates between defense and immunopathology, which normally is averted from an “exocytosis”-mediated mechanism of regulation of CD8⁺ cytolytic cells.

In another model involving the *lpr/lpr* mice, which are deficient in the Fas receptor, deficiency of perforin markedly accelerates the spontaneous lymphoproliferative disease, which normally occurs at a slower pace in these mice. This evidence also supports the notion that perforin plays a role in immune regulation, prevention of immunopathology, and autoimmunity. Recently a homozygous loss of function defect in the human perforin gene has been detected that is associated with several clinical manifestations, mainly due to uncontrolled T-cell and macrophage activation with overproduction of inflammatory cytokines. The syndrome is known as familial hemophagocytic lymphohistiocytosis (FHL).⁴⁴⁴ The disease is mapped in chromosome 10q21-22 (i.e., the location of the perforin gene). Overall, the incidence of the mutation is approximately 20% in all FHL patients. For the development of FHL syndrome, a viral infection or a defect of an additional pathway that controls lymphocyte homeostasis is required. Perforin-deficient mice, for reasons unknown at the present time, do not develop symptomatology similar to human FHL. Mice deficient in granzyme B lose the ability to induce DNA fragmentation, even though perforin causes membrane damage. Deficiency of both granzymes A and B causes susceptibility to ectromelia infection,⁴⁴⁵ although cytotoxic lymphocytes with the same deficiency and inability to cause DNA fragmentation are still able to exert a potent antitumor effect.⁴⁴⁶

DPPI, also known as cathepsin (CTSC), is a lysosomal cysteine protease expressed in most tissues, and in CTLs, it is found in the secretory compartment. It belongs to the papain superfamily of proteases and shares similarities to lysosomal cysteine proteases cathepsins B, H, and L. Granzymes A and B become enzymatically active only after cleavage of the N-terminal dipeptide by DPPI and are stored in the lysosomal granules in the active form along with perforin. DPPI knockout mice resemble the perforin-deficient mice: Both fail to cause apoptosis. DPPI deficiency results in failure to activate the granzymes, whereas perforin deficiency fails to deliver the granzymes into target cells.^{447,448} Deficiency of DPPI has been detected in humans with Papillon-Lefèvre syndrome, which is characterized by keratosis palmoplantaris with periodontopathia.⁴⁴⁹ There is premature tooth loss due to periodontal disease and thickening of the skin.

Graft versus Host and Graft versus Leukemia Reactions

Lymphocyte cytotoxicity has been implicated in graft versus host disease after allogeneic bone marrow transplantation, with contribution to the pathogenesis by both the perforin and Fas pathways.^{450,451} and ⁴⁵² It is agreed that cytotoxic lymphocytes contribute to the development of the disease, but there is no agreement about the underlying mechanism. The graft versus leukemia effect, however, seems to be mediated predominantly by the perforin pathway.

Granzyme Inhibitors

An important characteristic of the function of cytotoxic cells is that they successfully avoid the damaging effect of the lethal weapons they deliver to kill their targets. As a matter of fact, the CTLs, after a successful hit, disengage and are directed against another target.

P.305

Some recent observations provided a molecular explanation for their protection from “suicide.” The effector cells contain a potent inhibitor of granzyme B, known as proteinase inhibitor 9.^{453,454} The inhibitor is a serpin, is found in both the cytoplasm and the nucleus, and forms tight complexes with granzyme B but does not inhibit most of the caspases. Serpins are a large family of intracellular and extracellular protease inhibitors. Many viruses encode serpins that block caspases, the enzymes of apoptosis. Inhibitors of granzyme B can be encoded by several viruses. Best described is the poxvirus-encoded cytokine response modifier A (Crm A). Overexpression of Crm A in target cells inhibits CTL-mediated killing, but predominantly through a Fas-mediated pathway. Crm A inhibits granzyme B and several caspases. With several of the steps of CTL cytotoxicity now understood, therapeutic interventions are possible for several of the steps of lymphocyte cytotoxicity in a number of human conditions.

Apoptosis

Despite the wealth of information on the mechanism of this important pathway, there are several areas that are not well understood. Perforin has an indispensable role in the delivery of granzyme B, but certainly not simply as a pore-forming molecule. Granzymes, on the other hand, induce the nuclear changes affecting the DNA (i.e., by apoptosis), but even if they enter the cell in the absence of perforin, they cannot be translocated to the nucleus without perforin.⁴⁵⁵ The mechanism of granzyme delivery by perforin is not clear. It has been postulated that intracellular delivery of granzymes is through an endosomolytic mechanism.⁴⁵⁶ Translocation of a fluorescent probe from the target cell membrane to interior membranes, including the nuclear envelope and mitochondria, is supportive of this prediction.⁴⁵⁷

The relationship of the roles of perforin and granzymes in cytotoxicity was examined in the *gld/gld* (FasL/FasL) mice, which have a FasL deficiency and therefore cannot have Fas-mediated cytotoxicity. The additional deficiency of granzyme B in *gld/gld* mice (i.e., mice with the phenotype GrB *gld/gld*) leads to CTLs with residual cytotoxicity, which can only be perforin-dependent. This can be concluded also from the fact that perforin^{-/-} *gld/gld* CTLs have no residual cytotoxicity.⁴⁵⁸ It is reasonable to conclude that the cytotoxicity, which is independent of granzyme B, is normally partially accounted for by a Fas pathway and partially by a second perforin-dependent mechanism. Finally, inhibitors of caspases block the Fas death pathway, but in CTL granule exocytosis, the target cell lysis is not detectably blocked, although the accompanying apoptotic nuclear damage is efficiently blocked. Thus, caspase inhibitors prevent the hallmark phenotype of apoptosis without affecting cell death, as evidenced by lysis.⁴⁵⁹ At this point, not all the roads used by the CTL that may lead to cell death have been fully explored.

Regulatory T-cells

T reg cells constitute about 5% to 10% of the peripheral CD4⁺ T-cells and express the characteristic phenotype CD4⁺/CD25⁺ (the α -chain of the IL2 receptor). They are also CTLA4⁺ (costimulatory molecule cytotoxic T-lymphocyte antigen-4) and GITR⁺ (glucocorticoid-induced TNF receptor family-related protein).¹⁵⁸ Differentiation of CD4⁺ T reg cells is mediated by interactions of CD4⁺ thymocytes with stromal cells. Some thymocytes acquire MHC II molecules,⁴⁶⁰ which are derived from APCs.⁴⁶¹ T reg cells are enriched in autoreactive cells,⁴⁶² but are resistant to deletion by NS, as compared to conventional CD4⁺ thymocytes.⁴⁶³ The TCRs of T reg cells are of relatively high affinity for autoantigens, and this may facilitate their reactivation in the periphery by self-antigens. However, their affinity is still below the level required to trigger NS. These fundamental differences between the TCRs of T reg cells and the other thymocytes, in terms of specificity (MHC II vs. peripheral tissue antigens), affinity, and the nature of the selecting cell, provides an additional mechanism of protection against autoimmunity (i.e., active peripheral suppression in addition to central tolerance). Selection of T reg cells is mediated by the bone-marrow-derived APCs and not the epithelial cells.⁴⁶⁴ It has been suggested that the TCR affinities of T reg cells are just below the deletion level, permitting them to follow a unique differentiative pathway with regulatory function.⁴⁶⁵ The development and function of natural T reg cells depends on the transcription factor FOXP3, which encodes a new member of the forkhead/winged helix family of transcription factors.⁴⁶⁶ Mutations of the human gene FOXP3 is the cause of the IPEX syndrome (immune dysregulation polyendocrinopathy enteropathy and X-linked syndrome),⁴⁶⁷ an X-linked immunodeficiency syndrome associated with autoimmunity involving multiple endocrine organs, inflammatory bowel disease, and atopic dermatitis. TGF- β maintains a central role in the generation and function of T reg cells.⁴⁶⁸ CD4⁺/CD25⁺ T reg cells may arise from CD4⁺/CD25⁻ T-cells following stimulation of TCR and costimulation with TGF- β .⁴⁶⁹ Once they exit the thymus, the T reg cells depend for their survival, preservation, and function on dendritic cells, which present them with autoantigens.⁴⁷⁰ The continuous exposure to self-antigens will maintain the T reg cells in a state of activation.

A portion of T reg cells arising in the thymus are “anergic,” i.e., in a state of partial or total unresponsiveness.⁴⁷¹ Anergy may follow TCR stimulation without subsequent costimulation. Anergic T-cells are unable to produce IL2 and induce a proliferative response. Naturally arising anergic T-cells upon stimulation suppress effector T-cells but are prone to apoptosis, probably as a result of a continuous antigenic stimulation from self-antigens. Anergic T-cells exert their suppressor function by targeting APCs. The APC brings the anergic-suppressive cell into proximity with the target T-cell, forming a tricellular complex and setting the stage for a T-T-cell interaction.⁴⁷² T-T-cell interaction is the foundation for induction and spreading of the anergic state, otherwise known as infectious tolerance.

$\gamma\delta$ T-CELLS

Commitment to $\gamma\delta$ T-cell lineage takes place in the thymus as discussed earlier in this chapter. (See “T-Cell- $\alpha\beta$ versus T-Cell- $\gamma\delta$ ” and “The Pre-T-cell Receptor.”)

Rearrangements of the human γ and δ genes appear to occur in a developmentally ordered fashion.⁴⁷³ Initially the $\gamma\delta$ TCR repertoire is small inasmuch as it involves rearrangements of a small number of V segments and as a result the junctional diversity is limited.

In human embryos between 8.5 and 15.0 weeks of gestation, the most common V fragments are V δ 2 joined to D δ 3 and V γ 1-8 or V γ 9 with J γ 1. These cells are referred to as the V δ 2 cells. Rearrangements after birth at approximately 4 to 6 months of age involve the joining of other $\gamma\delta$ segments such as V δ 1 to D δ 1 and D δ 2 and the V γ 1 family with the J γ 2 cluster. Postnatally in the thymus, the V δ 2 subset represents 15% and the V δ 1 85% of the $\gamma\delta$ cells, and these proportions remain relatively constant throughout adult life.

It has, however, been questioned whether two distinct subsets of $\gamma\delta$ T-cell subsets exist, or one V9V2 T-cell population exerts multiple effector functions.⁴⁷⁴ Although intrinsic or genetic factors generate $\gamma\delta$ T-cell subsets, extrinsic or environmental factors act further to shape and select specific clones. An enormous selective pressure is exerted on the development of $\gamma\delta$ T-cells throughout life to produce populations of cells that express antigen receptors that are encoded by specific gene segments. The predominance in adult human blood of the V δ 2 to V γ 9 population is explained by such antigen-mediated expansion. These expansions create oligoclonal populations due to selection pressures from environmental microbes and certain edible plants. In contrast to the V γ 2/V δ 2

P.306

(V γ 2 is the same as V γ 9) T-cells which are a major circulating population, the V δ 1 cells account for the vast majority of the $\gamma\delta$ T-cells in tissues such as intestine and spleen.⁴⁷⁵

$\gamma\delta$ T-cell Receptor: Structure and Antigen Recognition

Antigen recognition by the $\gamma\delta$ TCR resembles recognition by antibodies.⁴⁷⁶ The V and C domains are organized into "Ig folds" (i.e., approximately seven β strands packed face to face in two antiparallel β sheets, constrained by intradomain disulfide bonding). The V regions are subdivided into framework and hypervariable regions, which have three CDRs. The orientations of V γ and V δ are similar to the relative orientations between the V domains in the Fab Ig fragment or the $\alpha\beta$ TCR. However, the CDR3 of V δ is diverse in length and composition (8 to 21 amino acids), a range similar only to the IGH@ (3 to 25). Furthermore the CDR3 loops of the $\gamma\delta$ TCR protrude above the rest of the molecule creating clefts between them; these strikingly distinguish them from the equivalent loops of the $\alpha\beta$ TCR, which are flat and bind to pMHC, and from the antibodies that bind large proteins.⁴⁷⁷

The $\gamma\delta$ TCR exists as a complex with the CD3 polypeptide chains and recognizes antigens with a wide distribution, by a mechanism fundamentally different from that of $\alpha\beta$ TCRs; i.e., antigen is not processed and there is no MHC restriction.^{476,477,478} and ⁴⁷⁹ Examples of nonprotein substances are pyrophosphates and alkyl-amines found in bacteria, plant, or animal cells,^{480,481} and ⁴⁸² and bacterial and mammalian homologs of heat-shock protein 60 kD (HSP-60).⁴⁸³ Human peripheral blood V γ 2V δ 2 cells are present in large numbers in lepromatous lesions reactive with monoalkyl compounds of mycobacterial cell walls. The most potent compound is monoethylphosphate, which stimulates cytotoxic activity of these cells and the phosphate group is very important in their recognition by the $\gamma\delta$ TCR. Alkyl-amines, derived from plant food products or from bacteria also stimulate V γ 9V δ 2⁺ T-cells⁴⁸² and the aminobiphosphonates that inhibit osteoclastic bone resorption, particularly in cancer patients, can also stimulate V γ 9V δ 2 cells.⁴⁸⁴ The V γ 9⁺ T-cells respond to superantigens, such as staphylococcal enterotoxin A.⁴⁸⁵ Some mucosal $\gamma\delta$ T-cells interact with MHC-encoded proteins, MICA and MICB,⁴⁸⁶ through the NKG2D C-type lectin receptor.⁴⁸⁷ MICA and MICB class I molecules identify stressed cells and have a very restricted pattern of expression, primarily limited to intestine. MICA and MICB do not present peptides because the peptide-binding groove is of limited size.⁴⁸⁸ These molecules may function in innate immunity as important targets for V δ 1⁺ cells for elimination of stressed cells.⁴⁷⁵ Some V δ 1⁺ cells recognize the nonpolymorphic CD1C member of the CD1 family of molecules, expressed on APCs, that presents lipid and glycolipid foreign antigens to T-cells.⁴⁸⁹ These $\gamma\delta$ cells activated in response to CD1C produce IFN- γ and direct $\alpha\beta$ T-cells to Th1 differentiation. Furthermore they are cytotoxic, express granulysin, and they could lyse infected dendritic cells via the perforin pathway and kill released bacteria by granulysin. Therefore their role is significant in host defense before antigen-specific T-cells have differentiated.⁴⁹⁰

Direct recognition of CD1C may represent a bridge between innate and adaptive immunity in a similar fashion to recognition of CD1D by murine and human NK⁺ $\alpha\beta$ T-cells,⁴⁹¹ which polarize T-cells to a Th2 phenotype. The CD1C-restricted $\gamma\delta$ T-cells promote the maturation of myeloid-derived dendritic cells, which are able to present antigens to CD4⁺ T-cells. This function of $\gamma\delta$ T-cells is important because they stimulate rapid accumulation of mature dendritic cells,⁴⁹² early during microbial invasion; at the same time they secrete IL12 to drive T-cell polarization to the Th1 type.

$\gamma\delta$ T-cell Function

The recognition of antigens by the $\gamma\delta$ TCR is more akin to that of antibodies and does not need antigen processing and presentation. The V δ 1 and V δ 2 cells are believed to represent separate lineages with different developmental pathways and tissue distribution.⁴⁹³ Most of the $\gamma\delta$ T-cells with intraepithelial localization are V δ 1, whereas the V δ 2, about 5% of all T-cells, are detected in the peripheral blood. The V γ 9/V δ 2 T-cells release proinflammatory chemokines⁴⁹⁴ and provide protection against mycobacteria by directly killing infected macrophages⁴⁹⁵ as well as extracellular bacteria by granulysin and perforin.⁴⁹⁶

Persistent chronic disease correlates with a decline or disappearance of mycobacteria-reactive $\gamma\delta$ T-cells.⁴⁹⁷ This contributes to the prevention of chronic inflammatory disease by directly killing activated macrophages.⁴⁹⁸ This function of $\gamma\delta$ T-cells may be facilitated by the expression of CCR5, the receptor for the chemokine RANTES (MIP-1 α) produced by macrophages.⁴⁹⁹ The evidence of a role of $\gamma\delta$ cells against cancer is still circumstantial.⁵⁰⁰ Their mucosal localization plays an immunoregulatory role in IL10-mediated low-dose oral tolerance induction, but not in the induction of systemic tolerance.⁵⁰¹ In nonobese diabetic mice with spontaneous insulinitis and diabetes, administration of insulin intranasally induces IL10 secreting suppressor $\gamma\delta$ T-cells.⁵⁰²

In patients with rheumatoid arthritis⁵⁰³ or in collagen-induced arthritis, $\gamma\delta$ T-cells accumulate in the synovium, their role depending on the stage of the disease.⁵⁰⁴ The $\gamma\delta$ T-cells in defense, immune regulation, and surveillance, are critical in their role as a "sentinel" between innate and adaptive immunity.⁵⁰⁵

A population of TCR- $\gamma\delta$ cells resides within the intestinal epithelium and these intraepithelial lymphocytes may have an extrathymic origin (bone marrow),⁵⁰⁶ express a CD8 $\alpha\alpha$ homodimer⁵⁰⁷ and are important in maintaining self-tolerance.⁵⁰⁸ These TCR- $\gamma\delta$ lymphocytes are "educated" by thymic stroma and are dendritic in morphology.⁵⁰⁹

NATURAL KILLER CELLS: MORPHOLOGY, CYTOCHEMISTRY, AND SURFACE MARKERS

NK cells originally described on a functional basis according to their capability of killing certain tumor cells in the absence of prior stimulation are of hematopoietic origin. They are a discrete population of cytolytic lymphocytes implicated in several activities *in vivo*, such as activity against tumor cells, resistance to viral infections, and regulation of hematopoiesis.^{510,511} NK-cells are a heterogeneous population with respect to phenotype and target specificity. Although the majority of the CD-56⁺ NK-cells are CD-3⁺, small numbers of CD-45⁺ cells have been detected and large granular lymphocyte (LGL) leukemias with the same phenotype have been reported.⁵¹² LGLs are large cells with pale blue cytoplasm and a high cytoplasmic-to-nuclear ratio with azurophilic granules. These cells constitute 2% to 6% of the peripheral white cells and approximately 10% to 15% of the peripheral blood lymphocytes. They are larger than the typical lymphocytes (10 to 12 μ m) with a larger amount of cytoplasm that contains peroxidase-negative granules (Fig. 13.18). The α -naphthyl acetate esterase distribution is diffuse, similar to that found in monocytes, and is different from the dotlike pattern of T lymphocytes. LGLs do not adhere to surfaces and have no phagocytic activity. Ultrastructurally, they are heterogeneous in terms of size and the density of the granule matrix.⁵¹³ The granules are located next to the Golgi apparatus, which also contains several smooth membranes and coated vesicles. The granules have an electron-dense center surrounded by a layer of lesser opacity. Like the granules of CTL, the NK-cell granules contain perforin and granzymes, both important for their cytotoxic function⁵¹⁴ and may be present in various forms, such as smooth or coated, depending on the stage of cell activation. LGLs are phenotypically and functionally heterogeneous (i.e., CD56⁺/CD3⁺/CD8⁺) and 80% to 90% of them

P.307

are CD16⁺ and others CD57⁺/CD3⁺/CD8⁺/TCR- $\alpha\beta$ ⁺. Both populations are cytolytic, but the CD57⁺ cells are T (or NK-like) cells that are non-MHC restricted. The CD56⁺ population is sometimes known as NK-LGL, whereas the CD57⁺ population is known as T-LGL and both are CD2⁺ and CD7⁺. The separation of the two cell types is not absolute, and we often detect an intermediate cell population that is CD56⁺/CD57⁺. The relationship of these cells to those expressing only one of the two markers is not known. Clonal diseases have been described from both the NK-LGL and T-LGL lineages with distinct clinical syndromes.

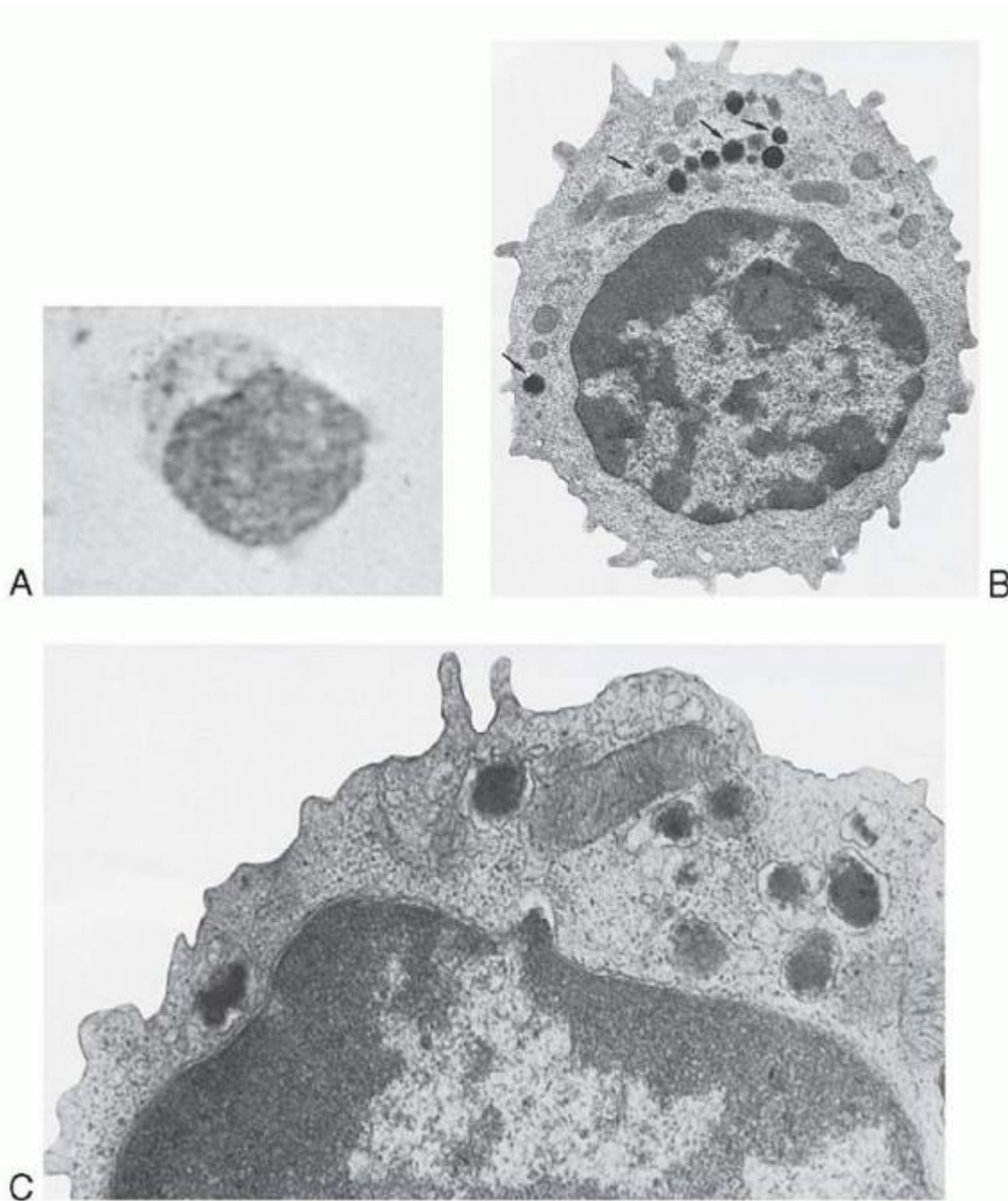

FIGURE 13.18. Natural killer cell morphology and ultrastructure. A: Natural killer cell is characterized by large amounts of pale blue cytoplasm and the presence of azurophilic granules. B: By electron microscopy, the granules in the cytoplasm appear heterogeneous in terms of size and density (arrows). A few scattered mitochondria are present. C: The granule consists of an electron-dense center that contains the perforin and may be enclosed by a thin membrane. Surrounding the core is a layer of lesser opacity containing the granzymes. The granules of the cytotoxic cells are probably derived from two separate organelles—those of secretory granules and those of lysosomes—and are sometimes called granulosomes. (From Zucker-Franklin D, Greaves MF, Grossi CE. Atlas of blood cells, 2nd ed. Philadelphia: Lea & Febiger, 1988, with permission.)

Ontogeny of Natural Killer Cells

Phenotypic Studies

The presence on NK-cells of some markers (CD2, CD7) characteristic of T-cells raised the question of common ontogenetic origins between these two lymphocytes. However, interference with T-cell development, as in athymic or severe

combined immunodeficiency (SCID) mice⁵¹⁵ or in mice with targeted disruptions of RAG, has no impact on NK-cell development. It is conceivable that the two lineages derive from a common progenitor with separation of their developmental pathways.

Some evidence for a common T/NK precursor has been obtained^{516,517} and relates to expression of cytoplasmic CD3 γ , δ , and ϵ . Cytoplasmic expression of CD3 γ , δ , and ϵ proteins has been detected in fetal NK-cells,⁵¹⁸ and overexpression of CD3 ϵ blocks T/NK-cell development without affecting other hematopoietic lineages.⁵¹⁹ Based on the expression of CD56 progenitors of NK-cells have been identified in the thymus within the triplenegative (TN) thymocyte population⁷⁴ and a common T/NK-cell precursor was detected among the CD-34⁺ TN population.⁵²⁰ The common progenitor has a CD45/CD5 phenotype and becomes an NK-committed cell with loss of the capacity for T-cell differentiation with the expression of CD56. The common precursor is present among TN thymocytes that are CD34⁺ and become CD34⁻ as the cell is committed to NK lineage. NK-cell differentiation requires a combination of stem cell factor, IL7, and IL2 in the presence of a stromal feeder layer. Precursors of NK-cells, that can differentiate into DP (CD4⁺/CD8⁺) thymocytes, have also been identified in fetal thymuses of mice⁵²¹ if they remain in contact with the thymic stroma, or into NK-cells if they are removed from the thymic microenvironment. This again supports the notion that the thymus is not essential for NK-cell development. The common T- and NK-cell progenitor in fetal mouse thymus is CD117⁺/CD44⁺/CD25⁻/NK1.1⁺ and shows commitment to NK lineage with loss of CD117 expression.⁵²² The overall scheme of differentiation in fetal mouse thymus suggests that multipotent precursors entering the thymus first lose B-lymphoid potential as they up-regulate NK1.1 and commit to a T/NK lineage. Then CD25 is up-regulated, CD117 is down-regulated, and cells commit to T- and NK-cell lineages, respectively.

Bone marrow is also an important location of NK-cell progenitors which are CD34⁺/CD7⁺ and differentiate to mature NK-cells either in the presence⁵²³ or absence of stromal cells.^{524,525} and ⁵²⁶ The progenitors express CD34 and CD7 and cytokines such as stem cell factor, IL2, and IL7 are essential, for their differentiation.

Cytolytic activity against NK-cell targets is detected at the time of CD56 expression. Mature NK-cells can be stimulated by IL2 for further enhancement of cytotoxic activity, increase of cytotoxic granule content, expression of adhesion molecules, and acquisition of properties attributed to lymphokine-activated killer cells. Other cytokines, such as IL7 and IL12, have similar effects, albeit to a lesser degree than IL2. The common lymphocyte precursor in the bone marrow with the CD-34⁺/CD-10⁺/CD-45RA⁺ phenotype is able to develop into NK-cells in vitro.⁵²⁷ Uncommitted hematopoietic progenitors are CD-34⁺/CD-38⁻, but up-regulation of CD38 indicates enrichment of cells committed to a particular hematopoietic lineage. CD34⁺/CD38²⁺ progenitors in fetal thymus develop into T-cells, but CD34⁺/CD382⁺ progenitors in fetal liver have no T-cell precursor activity. This population has no TRD@ rearrangements and no pre-TCR- α chain expression and develops in vitro into NK-cells through an intermediate stage of CD3⁻/NKR-1⁺/CD34⁻/CD56⁻.^{528,529} A similar NKR-1⁺/CD56⁻ population has been detected in cord blood and develops into mature CD56⁺ NK-cells in the presence of IL12.⁵³⁰

Natural Killer Cell Functional Studies

The cytokine environment regulates NK-cell maturation for the two distinct human NK-cell populations, one producing IFN- γ and the second IL13. IL-4 regulates the size of the IL13 population primarily by inducing their proliferation, whereas IL12 has minimal effects on the proliferation of IFN- γ + NK-cells. Cells with the CD161⁺ (NKR-P1)/CD56⁻ phenotype produce IL13 but not IFN- γ and have no perforin-mediated cytotoxicity.⁵³¹ CD161 is encoded by the NK-gene complex including CD69 and CD94. The CD161⁺CD56⁻ cells produce IL13 and differentiate to phenotypically mature IFN- γ - producing cells in the presence of IL12 and feeder cells. As cells mature they pass through an intermediate stage of IL13⁺/IFN- γ + NK-cells and eventually acquire the mature irreversible phenotype IFN- γ +/IL13⁻ CD56⁺.⁵³² The molecular defect of X-linked SCID conclusively demonstrated that cytokines are critical for T- and NK-cell development.^{533,534} These X-SCID patients present with a severe block of T- and NK-cell development, whereas normal or even elevated numbers of B-cells are

P.308

present. The cause of the disease is the lack of the common γ c-chain shared by several interleukin receptors (i.e., IL2, IL4, IL7, IL9, and IL15). The most important among these interleukins is IL7, which promotes development of human thymocytes (and, in the mouse, B lymphocytes also). Deficiency of Jak3, a tyrosine kinase associated with the γ c-chain, also blocks NK-cell development.⁵³⁵ Other data suggest a critical role for IL15.^{536,537} Of the transcription factors, the Ikaros family is required for transcriptional regulation of NK-cell development.^{538,539}

Natural Killer Cell Receptors

NK-cells are one of the important cellular components of innate immunity, with the mission to defend the body immediately against pathogens or in the early stages of tumor development. As a consequence, the recognition molecules

or receptors of the NK-cells are displayed on the cell surface without the need of assembly, i.e., rearrangements from multiple DNA segments after the antigenic encounter.^{540,541,542,543,544} and ⁵⁴⁵ Another important difference from other receptors such as BCRs or TCRs is that NK receptors do not directly recognize pathogens or their products but the quantitative change of MHC molecules induced as a result of the infection. In humans, three distinct families of genes have been defined that encode for receptors of HLA class I molecules. One family belongs to the Ig superfamily and is composed of KIRs. The second family is structurally Ig-like, named Ig-like transcripts (ILTs). ILTs are expressed mainly on B, T, and myeloid cells, but some members are also present on NK-cells. They are also called LIRs for leukocyte Ig-like receptors. The third family consists of C-type lectin receptors. C-type lectins are a superfamily with homologous modular carbohydrate recognition domains (CRDs) that bind carbohydrates in a Ca^{2+} -dependent manner.⁵⁴⁶ The proteins of this family of NK receptors form group V outside of a total of seven groups. The C-type lectin receptors, however, have structural differences from the other (more than 200) members of the superfamily, and it has been proposed that it be renamed as a new family of C-type lectin-like NK-receptor domains.⁵⁴⁷ The human lectin-like receptor gene complex is on chromosome 12p13.1 and the genes for the Ig-like receptors are in chromosome 19g13.4.

The Leukocyte Immunoglobulin-like Receptors

NK cells express Ig-like receptors, known as “KIRs”, shown to be involved in regulation of adaptive cytotoxic T-cell responses.

The KIRs have two or three Ig-like domains and hence are designated KIR2D or KIR3D receptors, respectively⁵⁴⁸ (Fig. 13.19 and Table 13.2). The cytoplasmic domains of the KIRs can be either long (L) or short (S), corresponding to their function, either inhibitory or activating, respectively. The inhibitory receptors contain one or two immunoreceptor tyrosine-based inhibitory motifs, or ITIMs (I/V/L/S)-X-Y-XX-(L/V) (where X denotes any amino acid).⁵⁴⁹ When tyrosine (Y) is phosphorylated, it recruits and activates SHP-1 phosphatase, leading to inhibition of signaling. Activating receptors do not signal directly but must associate noncovalently (via a salt bridge linking the transmembrane regions) with other signaling adaptor molecules that have ITAMs in their cytoplasmic domain (consensus sequence, -Y-X-X-L-X₆₋₈-YXXL/I).⁵⁵⁰ NK-cells express three ITAM-bearing transmembrane proteins: ζ , Fc ϵ R1 γ , and DAP12. The first two are present as homodimers or heterodimers, whereas DAP12 is exclusively a disulfide homodimer. (The KIRs in the CD designation are known CD158a-m and CD158z. See Table 13.2 and Appendix A for details.)

A fundamental difference between recognition by KIRs and TCRs is that the KIRs recognize more than one MHC allele. They do this by recognizing conserved residues within the polymorphic regions of MHC, whereas TCR recognizes the polymorphic residues. In addition, KIRs display a precise specificity for a particular MHC allotype. This is achieved by variations in single amino acids of KIR molecules.⁵⁵¹

The ligands for KIRs are alleles of all three MHC class I molecules, HLA-A, HLA-B, and HLA-C, which can confer protection from lysis by NK-cells. Generally, KIR3D receptors recognize HLA-A and -B, whereas KIR2D receptors recognize HLA-C alleles. A number of techniques have been used to study the binding and specificity of the receptors. No other molecule is necessary for binding except the HLA alleles.^{552,553} and ⁵⁵⁴ Crystal structures of some KIR receptors with their ligands have been solved. The KIR2DL2 in complex with HLA-Cw3 and peptide shows that KIR binds in nearly orthogonal orientation across the α 1 and α 2 helices of HLA-Cw3. It contacts positions 7 and 8 of the peptide, but most contacts are between the KIR and conserved HLA-C residues.⁵⁵⁵

Allotypic specificity is determined by the interaction between Lys44 of KIR2DL2 and Asn80 of the HLA-Cw3. In general, the peptides play a minimal role in the interaction, a point that strikingly distinguishes TCR-MHC from the KIR-MHC interactions.⁵⁵⁶ LIR-1 is a member of the LIR family (LIR-1 to LIR-8) expressed on monocytes, B-cells, dendritic cells, and some NK-cells. LIRs have two to four extracellular Ig-like domains and ITIMs in the cytoplasmic region; therefore, engagement with MHC molecules protects target cells from lysis. The first amino terminal domain of LIR-1 binds to the nonpolymorphic α 3 domain of MHC I, an interaction that is more similar to that of CD4 with the MHC II than to that of KIRs. LIR-1 also recognizes the human cytomegalovirus protein UL-18, which has a structure similar to MHC I and associates even with β_2 -microglobulin and host peptides. LIR-1 binds to this human cytomegalovirus protein with an affinity that is more than 1,000-fold higher than the host MHC I. This mechanism illustrates an example of viral subversion of host defenses and protection of infected cells from lysis⁵⁵⁷ because the binding of LIR-1 to UL-18 sends an inhibitory signal.

C-type Lectin-like Receptors

The members of the C-type lectin-like receptor family are either homodimers (the large murine family Ly-49A-W, CD69, and NKR-P1) or heterodimers, which consist of an invariant chain CD94 and a second subunit from the NKG2 family members A, B, C, and E.⁵⁵⁸ The function of the heterodimeric proteins depends on the cytoplasmic regions of the variant

chains (i.e., whether long [NKG2A,B] or short [NKG2C,E], corresponding to inhibitory or activating functions, respectively). The inhibitory subunits have one pair of ITIMs in the cytoplasmic region, whereas the activating subunits associate with the ITAM-containing adaptor molecule DAP12. The NKG2D (KLRK1) protein forms a homodimer (does not pair with CD94) and is an activating receptor. Each subunit is composed of an extracellular C-type lectin-like domain known also as an NK-receptor domain or NKD. The NKD, however, binds proteins and not carbohydrates, which are the ligands for the classical C-type lectins, and furthermore, their structure differs from the classical C-type lectins.⁵⁵⁹ C-type lectin-like NK-receptor domains include other important molecules of innate immunity, macrophage mannose receptor, collectins (i.e., pulmonary surfactants), and so forth. The ligands for CD94/NKG2 proteins are the nonclassical HLA-E molecule, which binds peptides from the leader sequence of the HLA-A, -B, -C, and -G molecules.^{560,561} Expression of HLA-E depends on the presence of the signal peptides, thus providing a safe strategy for NK-cells to monitor the presence of polymorphic HLA molecules⁵⁶² because absence of HLA-E would indicate absence of some of the HLA-A, -B, or -C. HLA-E is also capable of binding the signal sequence of heat-shock protein HSP60. HSP60 is present in all living cellular organisms⁵⁶³ and serves as a mitochondrial chaperone. HSP60 levels are increased in response to stress stimuli (i.e., temperature increase, nutrient deprivation, exposure to toxic chemicals, inflammation, etc.). HSP60 protects these cells from harmful stimuli, but at the

P.309

same time, the HLA-E/HSP60 peptide is not recognized by the inhibitory receptor, CD94/NKG2A, and these cells are eliminated by NK-cell activation.⁵⁶⁴

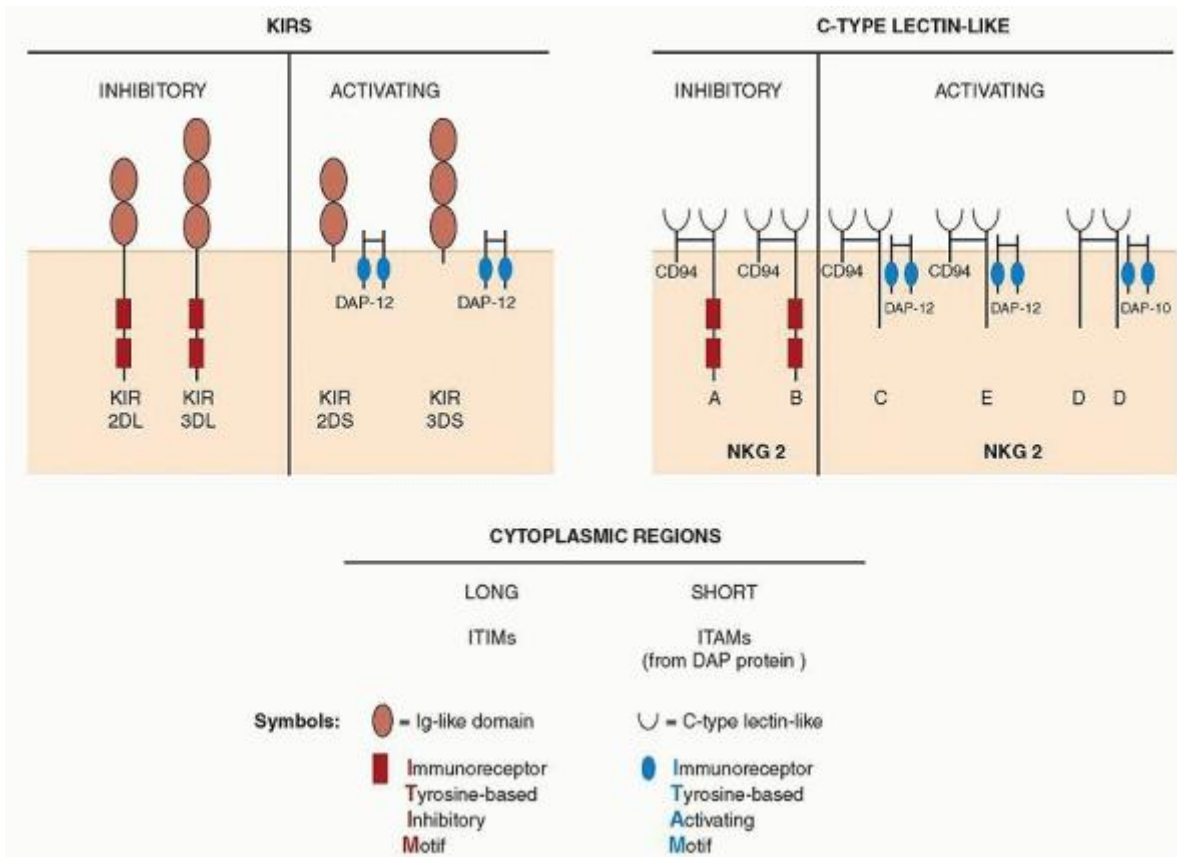

FIGURE 13.19. Natural killer (NK) cell receptors. The NK-cell receptors in humans structurally belong to two different families: one family has immunoglobulin (Ig) domains in the extracellular region and are known as killer Ig receptors (KIRs) and the other family has a C-type lectin-like domain. The C-type lectin domain recognizes oligosaccharides (and sometimes polypeptides), but the binding is directly mediated by Ca^{2+} , hence the term C-type lectin. However, the NK-cell receptors with the C-type fold lack the Ca^{2+} -ligating elements and thus have been termed C-type lectin-like. (See Kogelberg H, Feizi T. New structural insights into lectin-type proteins of the immune system. *Curr Opin Struct Biol* 2001;11:635-643.) The NK-cell receptors in both families are functionally divided into inhibitory and activating. The labyrinthine jargon of the NK-cell receptors becomes simpler with the acquaintance of some rules: The inhibitory KIRs have either two or three Ig domains in the extracellular region (i.e., 2D or 3D) and a long or short cytoplasmic tail (i.e., 2DL

or 2DS and 3DL or 3DS). Those with long cytoplasmic tails are inhibitory, whereas those with short tails are activating. Thus, the receptor KIR 2DL is an inhibitory receptor with two Ig domains, whereas the receptor KIR 3DS is an activating receptor with three Ig domains. (See more details in text and in Table 13.2.)

In humans the ligands for the NKG2D receptor are the MHC class I-related molecules MICA and MICB, which are up-regulated in virally infected cells and many tumors.^{565,566} They are minimally expressed in normal tissues but up-regulated in stressed cells.⁵⁶⁷ MICA is composed of two structural domains: one in the form of a platform formed by α_1/α_2 and the second in the form of a C-type Ig-like α_3 domain.⁵⁶⁸ The NKG2D receptor binds orthogonally to the MICA platform in a way similar to the docking of TCR on pMHC (see above).⁵⁶⁹ For signaling, it uses the adaptor protein DAP10, which has no ITAMs but contains the sequence YINM and propagates signaling through PI3-kinase and is thus less susceptible to the SHP-1-coupled receptors. The NKG2D receptor in mice (Kirk1) may associate with another adaptor protein, DAP12 (also known as KARAP), which recruits protein tyrosine kinases.⁵⁷⁰ Through DAP12, it can activate ZAP70 or SYK protein kinases through the ITAM of DAP12 and the p85 subunit of PI3-K. Thus depending on the availability of the adaptor partners, NKG2D may mediate costimulation in T-cells and/or activation in NK-cells.⁵⁷⁰ Furthermore, the functional outcomes of NKG2D stimulation depend on ligand density, cytokines, or the presence of inhibitory ligands.⁵⁷¹ Another family of ligands for NKG2D contains proteins that bind the UL16 cytomegalovirus protein, known as UL16-binding proteins (ULBP).^{572,573} The ULBP possess α_1 and α_2 domains but differ from MIC and MHC I in lacking the α_3 domain, and they are GPI-anchored proteins without β_2M protein. Binding to the NKG2D receptor has been demonstrated by blocking of ULBP binding by anti-NKG2D antibodies.⁵⁷⁴ The presence on NK-cells of receptors that recognize infected or abnormal (malignant) cells provides a new platform for developing strategies for immunotherapy of malignancy.⁵⁷⁵

The major breakthrough in the regulation of NK-cell function came with the formulation of the “missing self” hypothesis^{576,577} (Fig. 13.20). This hypothesis states that NK-cells can recognize and selectively lyse targets that fail to express self-MHC I antigens. The validity of the hypothesis has been demonstrated in multiple in vivo and in vitro systems as summarized.⁵⁷⁶ The basic premise is that when appropriate MHC I molecules are expressed, lysis of the target is inhibited, but when the target is deficient in MHC I expression, the target is lysed. Specific inhibitory receptors engaged with normal MHC I molecules prevent activating receptors to kill the target. Cells that have lost a normal MHC I expression (“missing self”; i.e., tumors or infected cells) are unable to deliver an inhibitory signal to NK-cells and

P.310

become susceptible to lysis. Cells susceptible to lysis by NK-cells as a result of deficiency of MHC I molecules could be protected by transfection of MHC I alleles. This experiment provided formal demonstration of the validity of the missing self hypothesis. However, NK-cells under persistent stimulatory signals, below the level of full activation, become hyporesponsive or “anergic” (i.e., chronic stimulation induces loss or responsiveness to NK-cells [disarming model]).^{578,579} Another possibility (arming model) assumes that MHC class I inhibitory receptors induce functional maturation and in their absence the NK-cells remain immature (i.e., hyporesponsive).

TABLE 13.2 NATURAL KILLER CELL RECEPTORS AND CD DESIGNATION

A	KIRs	B	LIRs/ILTs
CD158a	KIR2DL1	CD85a	LIR3 (ILT5)
CD158 b1/b2	KIR2DL2/L3	CD85b	ILT8
CD158c	KIR2DS6	CD85c	LIR8
CD158d	KIR2DL4	CD85d	LIR2 (ILT4)
CD158 e1/e2	KIR3DL1/S1	CD85e	LIR4 (ILT6)
CD158f	KIR2DL5	CD85f	ILT11
CD158g	KIR2DS5	CD85g	ILT7
CD158h	KIR2DS1	CD85h	LIR7 (ILT1)
CD158i	KIR2DS4	CD85i	LIR6
CD158j	KIR2DS2	CD85j	LIR1 (ILT2)

CD158k	KIR3DL2	CD85k	LIR5 (ILT3)
CD158z	KIR3DL7	CD85l	ILT9
		CD85m	ILT10

Note: See also Figure 13.20 for structural classification. (Designations were assigned during the seventh HLADA Workshop, Harrogate, UK, June 2000.)

ILT, immunoglobulin-like transcript; KIR, killer cell immunoglobulin-like receptor; LIR, leukocyte immunoglobulin-like receptor.

From Mason D. CD antigens 2001. *Immunology* 2001;103:401-406, with permission.

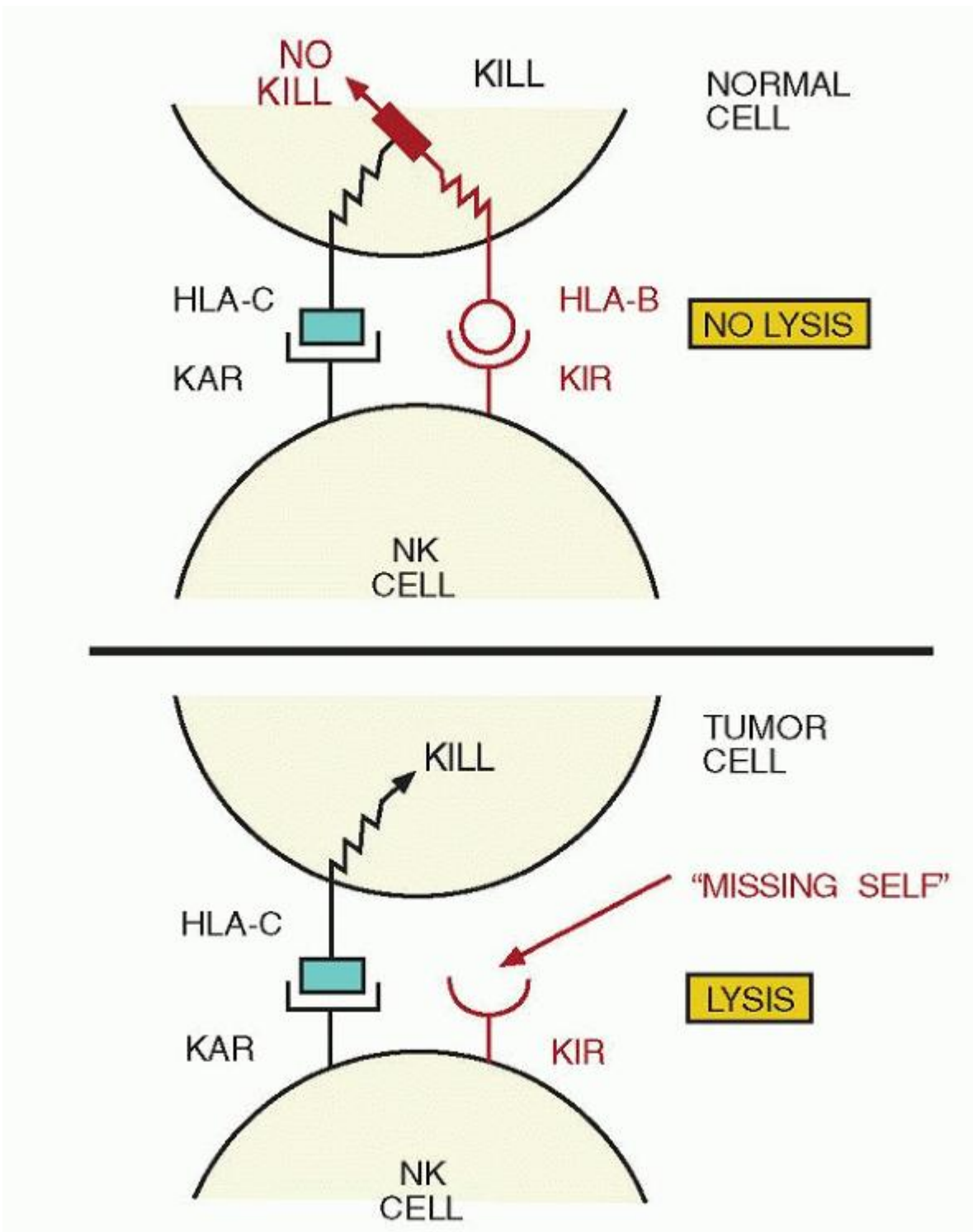

FIGURE 13.20. Natural killer (NK) cell cytotoxicity: the missing self. NK-cell cytotoxicity is a delicate balance between activating receptors and inhibitory receptors. Both (whether of the immunoglobulin SF or C-type lectin) have HLA class I specificity, although some receptors recognize nonmajor histocompatibility complex molecules. The presence of activating receptors against normal cells causes no problem as long as the NK-cells possess at least one inhibitory receptor, the signal of which is always dominant. However, with alterations of the structure of a class I molecule or complete loss of the molecule, the binding of the inhibitory receptor is abolished and the activating signal remains unopposed. This is the essence of the missing self hypothesis. KAR, killer-activating receptor; KIR, killer Ig receptor. (From Kärre K. How to recognize a foreign submarine. *Immunol Rev* 1997;155:5-9.)

The effector functions of the NK-cell receptors are controlled by the transmembrane and cytoplasmic regions. The inhibitory receptors have ITIMs in their cytoplasmic tails and recruit SHP-1 phosphatase. Activating receptors have a short cytoplasmic region, but for signaling, they borrow the function of ITAMs by associating with adaptor molecules such as DAP12 (TYROBP). Association is mediated by a positively charged residue of the receptor and an oppositely charged (i.e., aspartate) residue of the adaptor.⁵⁸⁰ Further research into the regulation of NK-cell function by the NK receptors is expected to expose new initiatives for investigating tumor immunosurveillance^{581,582} and autoimmunity.⁵⁸³ In hematology specifically, the manipulation of receptor-ligand interactions may help in allogeneic bone marrow transplantation to prevent leukemia relapse and graft versus host disease.^{584,585} and ⁵⁸⁶

Cytotoxicity of Natural Killer Cells

Two major mechanisms are used by NK-cells to kill target cells and both require contact with their targets. One pathway involves proteins released from granules by the process of exocytosis such as perforin (see section "Cytotoxic T Lymphocytes") or serine proteases, the granzymes with various substrate specificities. The other pathway involves engagement of death receptors (e.g., FAS/CD95) on target cells, with their cognate ligands (FASL) on NK-cells.⁵⁸⁷ Engagement of the NK-cell with its targets is mediated by the NK-cell receptors (see above).

Natural Resistance

NK-cells are one of the main effectors of innate immunity. Their role against viral infections has been well documented.⁵⁸⁸ NK-cells selectively lyse virally infected cells but spare noninfected cells. The mechanism of natural resistance against viral infections may involve direct lysis of the infected cells or production of TNF- α , which stimulates NK-cell activity. A patient with selective deficiency of NK-cells has been described who had life-threatening viral infections.⁵⁸⁹ NK-cells also play a role against certain intracellular parasites, such as *Toxoplasma gondii*. Production of TNF- α and IL12 activates NK-cells for production of IFN- γ , which is important for macrophage activation in the defense against intracellular parasites.⁵⁹⁰

Regulation of Adaptive Immunity

NK-cells enhance responses of B- and T-cells during the early stages of an immune response. As a result of stimulation by IL12, produced by macrophages in response to infectious agents, NK-cells produce large amounts of IFN- γ .⁵⁹¹ IFN- γ acts on macrophages and enhances their antigen-presenting function by increasing expression of class II antigens. IFN- γ is important in directing T-cell differentiation to Th1 cytokine responses. Induction of predominantly Th1 responses leads to enhancement of cell-mediated immunity. Finally IFN- γ activates macrophages enhancing their microbicidal function.

Natural Killer Cells: Malignancies and Bone Marrow Transplantation

NK-cells provide surveillance against tumor cells and virus-infected cells.⁵⁶⁵ In patients with X-linked lymphoproliferative disease⁵⁹² or deficient NK activity,⁵⁹² there is a high incidence

P.311

of cancer.⁵⁹³ Nude mice are T-cell deficient, but have normal NK activity, and no increased susceptibility for development to malignancies. There is a positive correlation between NK-cell activity and survival time without metastasis in patients with solid tumors.⁵⁹⁴ Decrease of NK-cell activity has been detected in patients with malignant lymphoma, in patients before relapse of leukemia, and also in women with breast cancer and metastasis to regional lymph nodes. Acceptance of organ grafts in the F1 progeny of inbred strains of mice results from the fact that the F1 animals express co-dominantly the class I antigens from both parents, and therefore, the F1 T-cells recognize them as self but reject bone marrow stem cells from either parent.^{595,596} This is known as hybrid resistance mediated by NK-cells but not T-cells.

After bone marrow transplantation the NK-cells engraft during the first few weeks.^{597,598} In one third of the patients after autologous or allogeneic bone marrow transplantation, a minor NK subpopulation (CD56⁺/CD16⁻) was markedly expanded (up to 40% of peripheral blood lymphocytes).⁵⁹⁹ NK activity helps the acceptance of the graft by controlling viral infections, eliminating leukemic cells, or stimulating hematopoiesis.⁵⁹³

Regulation of Hematopoiesis

Existing evidence suggests that NK-cells exert both inhibitory and stimulatory effects on hemopoietic progenitors. These effects are mediated predominantly by the release of cytokines from NK-cells rather than by cytotoxicity.

Strong evidence exists that an increase in the number of LGLs is associated with anemia or granulocytopenia. NK-cells inhibit in vitro granulocytopenia in the granulocyte-macrophage colony-forming cell assay.⁶⁰⁰ NK-cells also exert a promoting effect on hematopoiesis, however, and the net effect may actually depend on the stage of maturation of the progenitor cells.⁶⁰¹

In some patients with neutropenia, there is an increase of NK-like cells in the bone marrow but not in the peripheral blood.

These cells can be identified only by immunophenotyping.⁶⁰²

Decidual Natural Killer Cells

A unique subset of CD56^{bright} NK-cells accumulates in the maternal decidua in direct contact with fetal trophoblasts.⁶⁰³ These NK-cells are not derived from peripheral blood and produce IL8 and interferon-inducible protein-10 chemokines. They secrete a variety of angiogenic factors, induce vascular growth in the decidua, and possess low or even inefficient cytotoxic abilities and overall orchestrate developmental processes in the fetal-maternal interface.

Natural Killer Cell Proliferations

Artificially five to seven times the normal number (250 to 450/ μ l), is believed to represent a lymphoproliferative disease of LGL if it persists for longer than 3 months.⁶⁰⁴ Some of the most common clinical presentations are fever, infections, neutropenia, anemia, and thrombocytopenia. Mortality was associated with moderately elevated counts of LGLs (2,000 to 3,000/ μ l) and very high counts (more than 7,000/ μ l), which indicates that LGL proliferations are, in general highly heterogeneous.

Cytogenetic abnormalities have been detected, and in LGL cases that are CD57⁺ (and therefore express TCRs), rearrangements of TRB@ genes are detected in most of the cases.⁶⁰⁵ Because these cases are also associated with widespread involvement of several organs, such as the spleen, liver, and bone marrow, the term LGL leukemia has been proposed. The predominant phenotype of the LGL is CD57⁺ (HNK-1⁺)/CD3⁺ and these patients often have rheumatoid arthritis, neutropenia, and splenomegaly, a combination resembling Felty syndrome. Anemia and thrombocytopenia are not uncommon, and serologically, rheumatoid factor, antinuclear antibodies, hypergammaglobulinemia, and immune complexes are detectable.

Two major subtypes have been distinguished in terms of clinical presentation and the phenotype of the cells.^{606,607} and ⁶⁰⁸ The LGLs in type A, also known as T-LGLs, are CD57⁺/CD3⁺/CD8⁺/CD2⁺, and those in type B, also known as NK-LGLs, are CD56⁺/CD3⁺/CD8⁺/CD2⁺. Patients with T-LGL (CD57⁺) often may have neutropenia (84%), rheumatoid arthritis, and autoantibodies. However, these clinical and serologic findings in patients with T-LGL could not be confirmed in other studies.⁶⁰⁹ NK-LGL leukemias are observed in younger patients and run an aggressive course.⁶¹⁰ The most characteristic clinical presentation is hepatosplenomegaly and involvement of the gastrointestinal system with ascites. The course of the disease is acute, and often the patients die within 1 to 2 months after diagnosis.

NATURAL KILLER T-CELLS

Natural killer T-(NKT) cells have been identified as a novel lymphocyte lineage, which, in humans expresses the cell-surface marker CD161 (NKR-PIA) structurally related to several other proteins encoded by the NK-gene complex, including CD94, NKG2, and CD69.⁶¹¹ Because α -glycosphingolipids are not detected in mammals, the α -Gal-Cer probably mimics self-antigens that are recognized by NKT-cells.

The NKT-cells express an invariant V α -14 receptor (V α -14i TCP), which is used only by the NKT-cells but not by T-cells. The expression of an invariant TCR suggests that the selection is mediated by a monomorphic rather than polymorphic MHC molecule.⁶¹² The NKT-cells are selected from DP CD4⁺/CD8⁺ thymocytes expressing CD1D.⁶¹³ Their thymic CD4⁺CD8⁺ V α 14i precursors, recognize endogenous CD1D-associated glycolipids on other CD4⁺CD8⁺ thymocytes and are selected to undergo a maturation program involving sequential expression of CD44 and NK-related markers such as NK1.1.⁶¹⁴ After their selection, the V α 14i precursors are exported and acquire the NKT phenotype in the periphery.⁶¹⁵ They migrate to the liver and from there to sites of inflammation responding to stimuli, i.e., chemokines and glycolipids. They have a surface phenotype characteristic of recently activated or memory T-cells, even when the cells are obtained from cord blood,⁶¹⁶ consistent with the postulated autoreactivity of the NKT-cells.

Inhibitory receptors prevent unchecked autoreactivity for CD1D DCs.⁶¹⁷ The NKT-cells expressing V α 24 in their TCR play a critical role in immune responses, inhibition of tumor development, and protection from autoimmune disease development.^{618,619} These cells have cytolytic function and rapidly induce cytokines after stimulation and activate other cells (i.e., NK-cells, T-cells, B-cells, and macrophages).

In humans the CD4⁺ V α 24i cells preferably produce IL-4, which is believed to regulate Th1/Th2 differentiation,^{620,621} but the Th1 versus Th2 polarization is more complex and depends on additional factors such as the number of antigenic stimulations with a shift to Th2 after multiple challenges.^{622,623} Th2 cytokine prevents the development of type I diabetes in mice with genetic predisposition,⁶²⁴ as well as allergic encephalomyelitis in another strain susceptible to the

development of this disease.⁶²⁵ In experimental autoimmune diseases that develop spontaneously, there is a direct correlation between the development of the disease and the decline of V α -14 cells.⁶²⁶

Selective reduction of V α 24 cells has also been shown in patients with systemic sclerosis,⁶²⁷ systemic lupus erythematosus, rheumatoid arthritis,⁶²⁸ and type I diabetes.⁶²⁹ Stimulation of NKT-cells by α -Gal-Cer in animals triggers secretion of large amounts of cytokines (IFN- γ , IL4, IL2, IL5, etc.).⁶³⁰ The fact remains, however, that NKT-cells promote Th2 responses and suppress Th1-dominant autoimmunity.⁶³¹

P.312

Others have found that NKT-cells are not critical in the IL12-mediated rejection of tumors,⁶³² and it appears that the conflicting results in the literature about the role of NKT in tumor responses are due to complex factors, including the types of tumors and their microenvironment, and functionally different subsets of NKT-cells.⁶³³ NKT-cells have been implicated in protective immunity against several pathogens, i.e., mycobacteria⁶³⁴ and malaria parasites.⁶³⁵ In conclusion, NKT-cells are phenotypically and functionally heterogeneous, endowed with cytolytic and cytokine secretion functions and regulation of several functions of the immune response that are related to host defenses against infections, autoimmunity, and tumor immunity.

They have been called “nonconformist” and “unconventional” because they are suited to get involved in such a great variety of homeostatic disequilibrium conditions of the host.

Th17 CD4⁺ Cells

Effector CD4⁺ T-cells develop in response to cytokines elicited from cells activated during an immune response. as in the development of Th1 and Th2. Another CD4 T-cell lineage known as Th17, represents an additional CD4⁺ T-cell effector cell, characterized by a distinct profile of effector cytokines such as IL17, IL17F, and IL6.⁶³⁶ In the absence of IFN- γ and IL4, IL23 induces naive precursors to differentiate to Th17 cells.⁶³⁷ TGF- β is critical for up-regulation of the IL23 receptor, thus conferring responsiveness to IL23.⁶³⁸ IL6 probably is also needed in cooperation with TGF- β for Th17 cell development from naive T-cells.⁶³⁹ Others, however, have shown that TGF- β alone is a critical factor for differentiation of IL17-producing effector cells.⁶⁴⁰ The role of IL23 may be important for stabilizing the Th17 phenotype in chronic inflammation⁶⁴¹ and control of certain pathogen-induced diseases not covered by Th1 and Th2.⁶⁴²

REFERENCES

1. Pollack A, Lampen N, Clarkson BD, et al. Identification of human B and T lymphocytes by scanning electron microscopy. *J Exp Med* 1973;138:607-624.
2. Pollack A, Hammerling U, Lampen N, et al. Surface morphology of murine B and T lymphocytes: a comparative study by scanning electron microscopy. *Eur J Immunol* 1975;5:32-39.
3. van der Loo EM, Gossen J, Meijer CJ. Morphological aspects of T cell subpopulations in human blood: characterization of the cerebriform mononuclear cells in healthy individuals. *Clin Exp Immunol* 1981;43:506-516.
4. Meijer CJ, van der Loo EM, van Vloten WA, et al. Early diagnosis of mycosis fungoides and Sezary's syndrome by morphometric analysis of lymphoid cells in the skin. *Cancer* 1980;45:2864-2871.
5. Klug DB, Carter C, Drouch E, et al. Interdependence of cortical thymic epithelial cell differentiation on T-lineage commitment. *Proc Natl Acad Sci U S A* 1998;95:11822-11827.
6. Schleup M, Wilcox N, Ritter MA, et al. Myasthenia gravis thymus: clinical, histological and culture correlations. *J Autoimmun* 1988;1:445-467.
7. Gill J, Malin M, Hollander GA, et al. Generation of complete thymic microenvironment by MTS24+ thymic epithelial cells. *Nat Immunol* 2002;3:635-642.
8. Bennett AR, Farley A, Blair NF, et al. Identification and characterization of thymic epithelial progenitor cells. *Immunity* 2002;16:803-814.
9. Suniara RK, Jenkinson EJ, Owen JJ. An essential role for thymic mesenchyme in early T cell development. *J Exp Med* 2000;191:1051-1056.
10. Manley NR, Cappechi MR. The role of Hoxa-3 in mouse thymus and thyroid development. *Development* 1995;121:1989-2003.

11. Su DM, Manley NR. Hoxa3 and Pax1 transcription factors regulate the ability of fetal thymic epithelial cells to promote thymocyte development. *J Immunol* 2000;164:5753-5760.
12. Nehls M, Pfeifer D, Schorp PM, et al. New member of the winged-helix protein family disrupted in mouse and rat nude mutations. *Nature* 1994;372:103-107.
13. Itoi M, Kawamoto H, Katsura Y, et al. Two distinct steps of immigration of hematopoietic progenitors into the early thymus anlage. *Int Immunol* 2001;13:1203-1211.
14. Blackburn CC, Augustine CL, Li R, et al. The nu gene acts cell-autonomously and is required for differentiation of thymic epithelia progenitors. *Proc Natl Acad Sci U S A* 1996;93:5742-5746.
15. Nehls M, Kyewski B, Messerle M, et al. Two genetically separable steps in the differentiation of thymic epithelium. *Science* 1996;272:886-889.
16. Bockman DE, Kirby ML. Dependence of thymus development on derivatives of neural crest. *Science* 1984;223:498-500.
17. Anderson G, Jenkinson EJ. Lymphostromal interactions in thymic development and function. *Nat Rev Immunol* 2001;1:31-40.
18. Manley NR. Thymus organogenesis and molecular mechanisms of thymic epithelial cell differentiation. *Semin Immunol* 2000;12:421-428.
19. Blackburn CC, Manley NR, Palmer DB, et al. One for all and all for one: thymic epithelial stem cells and regeneration. *Trends Immunol* 2002;23:391-395.
20. Ohuchi H, Hori Y, Yamasaki M, et al. FGF10 acts as a major ligand for FGF receptor 2IIIb in mouse multi-organ development. *Biochem Biophys Res Commun* 2000;277:643-649.
21. Revest JM, Suniara RK, Kerr K, et al. Development of the thymus requires signaling through the fibroblast growth factor receptor r2-iiib. *J Immunol* 2001;167:1954-1961.
22. Hollander CA, Wong B, Nichogiannopoulou A, et al. Developmental control point in induction of thymic cortex regulated by a subpopulation of prothymocytes. *Nature* 1995;373:350-353
23. Van Ewijk W, Shores EW, Singer A. Crosstalk in the mouse thymus. *Immunol Today* 1994;16:214-217.
24. Ritter MA, Boyd RL. Development in the thymus: it takes two to tango. *Immunol Today* 1993;14:462-469.
25. Suhr CD, Ernst B, Sprent J. Growth of epithelial cells in the thymic medulla is under the control of the mature T cells. *J Exp Med* 1992;176:611-616.
26. Van Ewijk W. T-cell differentiation is influenced by thymic microenvironments. *Annu Rev Immunol* 1991;9:591-615.
27. Boyd RL, Tucek CL, Godfrey DI, et al. The thymic microenvironment. *Immunol Today* 1993;14:445-459.
28. van Vliet E, Melis M, van Ewijk W. Immunohistology of thymic nurse cells. *Cell Immunol* 1984;87:101-109.
29. Kyewski BA. Thymic nurse cells possible sites of T cell selection. *Immunol Today* 1986;7:374-379.
30. Mombaerts P, Clarke AR, Rudnicki MA, et al. Mutations in T-cell antigen receptor genes α and β block thymocyte development at different stages. *Nature* 1992;360:225-231.
31. Goverman J, Brabb T, Huseby ES, et al. TCR signaling regulates thymic organization: lessons from TCR-transgenic mice. *Immunol Today* 1997;18:204-208.
32. Brabb T, Huseby ES, Morgan TM, et al. Thymic stromal organization is regulated by the specificity of T cell receptor/major histocompatibility complex interactions. *Eur J Immunol* 1997;27:136-146.
33. Matechak EO, Kileen N, Hedrick SM, et al. MHC class II-specific T cells can develop in the CD8 lineage when CD4 is absent. *Immunity* 1996;4:337-347.
34. Hogquist KA, Jameson SC, Heath WR, et al. T cell receptor antagonist peptides induce positive selection. *Cell* 1994;76:17-27.
35. Anderson M, Anderson SK, Farr AG. Thymic vasculature: organizer of the medullary epithelial compartment? *Intern Immunol* 2000;12:1105-1110.
36. Schonrich G, Momburg F, Hammerling GJ, et al. Anergy induced by thymic medullary epithelium. *Eur J Immunol* 1992;22:1687-1691.

37. Hoffmann MW, Allison J, Miller JF. Tolerance induction by thymic medullary epithelium. *Proc Natl Acad Sci U S A* 1992;89:2526-2530.
38. Klein L, Klein T, Ruther U, et al. CD4 T cell tolerance to human C reactive protein, an inducible serum protein is mediated by medullary thymic epithelium. *J Exp Med* 1998;188:5-16.
39. Farr AG, Dooley JL, Erickson M. Organization of thymic medullary epithelial heterogeneity: implications for mechanisms of epithelial differentiation. *Immunol Rev* 2002;189:20-27.
40. Erickson M, Morkowski S, Lehar S, et al. Regulation of thymic epithelium by keratinocyte growth factor. *Blood* 2002;100:3269-3278.
41. Mackall CL, Gress RE. Thymic aging and T cell regeneration. *Immunol Rev* 1997;160:91-102.
42. Mackall CL, Punt JA, Morgan P, et al. Thymic function in young/old chimeras: substantial thymic regenerative capacity despite irreversible age-associated thymic involution. *Eur J Immunol* 1998;28:1886-1893.
43. Sano S, Takahuma Y, Sugawara T, et al. Stat3 in thymic epithelial cells is essential for postnatal maintenance of thymic architecture and thymocyte survival. *Immunity* 2001;15:261-273.
44. Savino W, Villa-Verde DM, Lannes-Vieira J. Extracellular matrix proteins in intrathymic T-cell migration and differentiation? *Immunol Today* 1993;14:158-161.
45. Kutlesa A, Siler U, Speiser A, et al. Developmentally regulated interactions of human thymocytes with different laminin isoforms. *Immunology* 2002;105:407-418.
46. Shortman K, Wu L. Early T lymphocyte progenitors. *Annu Rev Immunol* 1996;14:29-47.
47. Huang S, Terstappen LWMM. Lymphoid and myeloid differentiation of single human CD34⁺HLA-DR⁺CD38⁻ hematopoietic stem cells. *Blood* 1994;83:1515-1526.
48. Galy AHM, Cen D, Travis M, et al. Delineation of T-progenitor cell activity within the CD34⁺ compartment of adult bone marrow. *Blood* 1995;85:270-278.
49. Tjønnefjord GE, Veiby OP, Steen R, et al. T lymphocyte differentiation in vitro from adult human pre-thymic CD34⁺ bone marrow cells. *J Exp Med* 1993;177:1531-1539.
50. Ikuta K, Uchida N, Friedman J, et al. Lymphocyte development from stem cells. *Annu Rev Immunol* 1992;10:759-783.
51. Weerkamp F, Baert MR, Dik WA, et al. Human thymus contains multipotent progenitors with T/B lymphoid, myeloid, and erythroid lineage potential. *Blood* 2006;107:3131-3137.
52. Krueger A, Garbe AI, von Boehmer H. Phenotypic plasticity of T cell progenitors upon exposure to Notch ligands. *J Exp Med* 2006;203:1977-1983.
53. Perry SS, Weiner RS, Kauro T, et al. Primitive lymphoid progenitors in bone marrow, with T lineage reconstituting potential. *J Immunol* 2006;177:2880-2887.
54. Liu C, Veno T, Kuse S. The role of CCL-21 in recruitment of T-precursor cells to fetal thymi. *Blood* 2005;105:31-39.
55. Scimone ML, Aifantis I, Apostolou I, et al. A multistep adhesion cascade for lymphoid progenitor cell homing to the thymus. *Proc Nat Acad Sci U S A* 2006;103:7006-7011.
56. Rothenberg EV, Taghon T. Molecular genetics of T cell differentiation. *Annu Rev Immunol* 2005;23:601-649.
57. Harman BC, Jenkinson EJ, Anderson G. Entry into the thymic microenvironment triggers Notch activation in the earliest migrant T cell progenitors. *J Immunol* 2003;170:1299-1303.
58. Anderson G, Pongracz J, Parnell S, et al. Notch ligand-bearing thymic epithelial cells initiate and sustain Notch signaling in thymocytes independently of T cell receptor signaling. *Eur J Immunol* 2001 Nov;31(11):3349-3354.
59. Deftos ML, Bevan MJ. Notch signaling in T cell development. *Curr Opin Immunol* 2000;12:166-172.
60. Allman D, Aster JC, Pear WS. Notch signaling in hematopoiesis and early lymphocyte development. *Immunol Rev* 2002;187:75-86.
61. Allman D, Punt JA, Izon DJ, et al. An invitation to T and more: Notch signaling in lymphopoiesis. *Cell* 2002;109:S1-S11.
62. Mumm JS, Kopan R. Notch signaling: from the outside in. *Dev Biol* 2000;228:151-165.

63. Koch U, Lacombe TA, Holland D, et al. Subversion of the T/B lineage decision in the thymus by lunatic fringe-mediated inhibition of Notch-1. *Immunity* 2001;15:225-236.
64. Milner LA, Bigas A. Notch as a mediator of cell fate determination in hematopoiesis: evidence and speculation. *Blood* 1999;93:2431-2448.
65. Rebay I, Fleming RJ, Rehon RG, et al. Specific EGF repeats of Notch mediate interactions with Delta and Serrate: implications for Notch as a multifunctional receptor. *Cell* 1991;67:687-699.
66. Jaleco AC, Neves H, Hooijberg E, et al. Differential effects of Notch ligands Delta-1 and Jagged-1 in human lymphoid differentiation. *J Exp Med* 2001;194:991-1002.
67. Artavanis-Tsakonas S, Rand MD, Lake RJ. Notch signaling: cell fate control and signal integration in development. *Science* 1999;284:770-776.
68. Robey E. Regulation of T cell fate by notch. *Annu Rev Immunol* 1999;17: 283-295.
69. Wilson A, MacDonald HR, Radtke F. Notch-1 deficient common lymphoid precursors adopt a B cell fate in the thymus. *J Exp Med* 2001;194:1003-1012.
70. Ladi E, Yin X, Chtanova T, et al. Thymic microenvironments for T cell differentiation and selection. *Nat Immunol* 2006;7:338-343.
71. Takahama Y. Journey through the thymus: stromal guides for T-cell development and selection. *Nat Rev Immunol* 2006;6:127-135.
72. Rossi FMV, Corbel SY, Merzaban JS, et al. Recruitment of adult thymic progenitors is regulated by P-selectin and its ligand PSGL-1. *Nat Immunol* 2006;6:626-634.
73. Marquez C, Trigueros C, Fernandez E, et al. The development of T and non-T cell lineages from CD34⁺ human thymic precursors can be traced by the differential expression of CD44. *J Exp Med* 1995;181:475-483.
74. Sánchez MJ, Spits H, Lanier LL, et al. Human natural killer cell committed thymocytes and their relation to the T cell lineage. *J Exp Med* 1993;178:1857-1866.
75. Alves LA, Campos de Carvalho AC, Cirne Lima EQ, et al. Functional gap junctions in thymic epithelial cells are formed by connexin 43. *Eur J Immunol* 1995;25:431-437.
76. Carding SR, Hayday AC, Bottomly K. Cytokines in T-cell development. *Immunol Today* 1991;12:239-245.
77. Groh V, Fabbi M, Strominger JL. Maturation or differentiation of human thymocyte precursors in vitro? *Proc Natl Acad Sci U S A* 1990;87:5973-5977.
78. Suda T, Zlotnik A. IL-7 maintains the T cell precursor potential of CD3-CD4-CD8-thymocytes. *J Immunol* 1991;146:3068-3073.
79. Muegge K, Vila MP, Durum SK. Interleukin-7: a cofactor for V(D)J rearrangement of the T cell receptor β gene. *Science* 1993;261:93-95.
80. Perschon JJ, Morrissey PJ, Grabstein KH, et al. Early lymphocyte expansion is severely impaired in interleukin 7 receptor deficient mice. *J Exp Med* 1994;180:1955-1960.
81. Munitic I, Williams JA, Yang Y, et al. Dynamic regulation of IL-7 receptor expression is required for normal thymopoiesis. *Blood* 2004;104:4165-4172.
82. Davis MM, Chien YH, Gascoigne NR, et al. A murine T cell receptor gene complex: isolation, structure and rearrangement. *Immunol Rev* 1984;81:235-258.
83. Yoshikai Y, Clark SP, Taylor S, et al. Organization and sequences of the variable, joining and constant region genes of the human T-cell receptor α -chain. *Nature* 1985;316:837-840.
84. Davis MM. Molecular genetics of the T cell-receptor beta chain. *Annu Rev Immunol* 1985;3:537-560.
85. Brenner MB, Strominger JL, Krangel MS. The $\gamma\delta$ T cell receptor. *Adv Immunol* 1988;43:133-192.
86. Raulat DH. The structure, function, and molecular genetics of the $\gamma\delta$ T cell receptor. *Annu Rev Immunol* 1989;7:175-207.
87. Caccia N, Bruns GA, Kirsch IR, et al. T cell receptor α chain genes are located on chromosome 14 at 14q11-14q12 in humans. *J Exp Med* 1985;161:1255-1260.

88. Hecht F, Morgan R, Hecht BK, et al. Common region on chromosome 14 in T-cell leukemia and lymphoma. *Science* 1984;226:1445-1447.
89. Williams DL, Look AT, Melvin SL, et al. New chromosomal translocations correlate with specific immunophenotypes of childhood acute lymphoblastic leukemia. *Cell* 1984;36:101-109.
90. Griesser H, Champagne E, Tkachuk D, et al. The human T cell receptor α - δ locus: a physical map of the variable, joining and constant region genes. *Eur J Immunol* 1998;18:641-644.
91. Isobe M, Erikson J, Emanuel BS, et al. Location of gene for β subunit of human T-cell receptor at band 7q35, a region prone to rearrangements in T cells. *Science* 1985;228:580-582.
92. Le Beau MM, Diaz MO, Rowley JD, et al. Chromosomal localization of the human T cell receptor β -chain genes. *Cell* 1985;41:335.
93. Hayday AC, Diamond DJ, Tanigawa G, et al. Unusual organization and diversity of T cell receptor α -chain genes. *Nature* 1985;316:828-832.
94. Sims JE, Tunnacliffe A, Smith WJ, et al. Complexity of human T-cell antigen receptor β -chain constant- and variable-region genes. *Nature* 1984;312:541-545.
95. Caccia N, Kronenberg M, Saxe D, et al. The T cell receptor beta chain genes are located on chromosome 6 in mice and chromosome 7 in humans. *Cell* 1984;37:1091-1099.
96. MacDonald AW, Wilson A. The role of the T-cell receptor (TCR) in $\alpha\beta/\gamma\delta$ lineage commitment: clues from intracellular TCR staining. *Immunol Rev* 1998;165:87-94.
97. Krangel MS, Hernandez-Munain C, Lauzirica P, et al. Developmental regulation of V(D)J recombination at the TCR α/δ locus. *Immunol Rev* 1998;165:131-147.
98. Sleckman BP, Bassing CH, Barden CG, et al. Accessibility control of variable region gene assembly during T-cell development. *Immunol Rev* 1998;165:121-130.
99. Groettrup M, Ungewiss K, Azogui O, et al. A novel disulfide-linked heterodimer on pre-T cells consists of the T cell receptor β chain and a 33 kd glycoprotein. *Cell* 1993;75:283-294.
100. von Boehmer H, Fehling HJ. Structure and function of the pre-T cell receptor. *Annu Rev Immunol* 1997;15:433-452.
101. von Boehmer H, Aifantis I, Azogui O, et al. Crucial function of the pre-T-cell receptor (TCR) in TCR β selection, TCR β allelic exclusion and $\alpha\beta$ versus $\gamma\delta$ lineage commitment. *Immunol Rev* 1998;165:111-119.
102. Borowski C, Martin C, Gounari F, et al. On the brink of becoming a T cell. *Curr Opin Immunol* 2002;14:200-206.
103. Haks MC, Lefebvre JM, Lauritzen JP, et al. Attenuation of $\gamma\delta$ TCR signaling efficiently diverts thymocytes to the $\alpha\beta$ lineage. *Immunity* 2005;22:595-606.
104. Taghon T, Yui MA, Pant R, et al. Developmental and molecular characterization of emerging β - and $\gamma\delta$ -selected pre-T cells in the adult mouse thymus. *Immunity* 2006;24:53-64.
105. Blom B, Verschuren MCM, Heemskerk MHM, et al. TCR gene rearrangements and expression of the pre-T cell receptor complex during human T-cell differentiation. *Blood* 1999;93:3033-3043.
106. von Boehmer H, Aifantis I, Feinberg J, et al. Pleiotropic changes controlled by the pre-T-cell receptor. *Curr Opin Immunol* 1999;11:135-142.
107. Steff A-M, Trop S, Maira M, et al. Opposite ability of pre-TCR and $\alpha\beta$ TCR to induce apoptosis. *J Immunol* 2001;166:5044-5050.
108. Murga C, Barber DF. Molecular mechanisms of pre-T cell receptor-induced survival. *J Biol Chem* 2002;277:39156-39162.
109. Saint-Ruf C, Panigada M, Azogui O, et al. Different initiation of pre-TCR and $\gamma\delta$ TCR signaling. *Nature* 2000;406:524-527.
110. Michie AM, Zuniga-Pflucker JC. Regulation of thymocyte differentiation: pre-TCR signals and β -selection. *Semin Immunol* 2002;14:311-323.
111. Janeway CA Jr. The T cell receptor as a multicomponent signaling machine: CD4/CD8 coreceptors and CD45 in T cell activation. *Annu Rev Immunol* 1992;10:645-674.

112. Singer A, Bosselut R, Bhandoola A. Signals involved in CD4/CD8 lineage commitment: current concepts and potential mechanisms. *Semin Immunol* 1999;11:273-281.
113. Germain RN. T-cell development and the CD4-CD8 lineage decision. *Nat Rev Immunol* 2002;2:309-322.
114. Itano A, Salmon P, Kioussis D, et al. The cytoplasmic domain of CD4 promotes the development of CD4 lineage T cells. *J Exp Med* 1996;183:731-741.
115. Veillette A, Bookman M, Horak E, et al. The CD4 and CD8 T cell surface antigens are associated with the internal membrane tyrosine-protein kinase p56lck. *Cell* 1988;55:301-308.
116. Wiest D, Yuan L, Jefferson J, et al. Regulation of T cell receptor expression in immature CD4⁺CD8⁺ thymocytes by p56lck tyrosine kinase: basis for differential signaling by CD4 and CD8 in immature thymocytes expressing both coreceptor molecules. *J Exp Med* 1993;178:1701-1712.
117. Yasumoto K, Doyle C, Kiele L, et al. The duration of antigen receptor signaling determines CD4⁺ versus CD8⁺ T-cell lineage fate. *Nature* 2000;404:506-510.
118. Bosselut R, Fergenbaum L, Sharrow SO, et al. Strength of signaling by CD4 and CD8 coreceptor tails determines the number but not the lineage direction of positively selected thymocytes. *Immunity* 2001;14:483-494.
119. Hernandez-Hoyos G, Sohn SJ, Rothenberg EV, et al. Lck activity controls CD4/CD8 T cell lineage commitment. *Immunity* 2000;12:313-322.
120. Sohn SJ, Forbush KA, Pan XC, et al. Activated p56lck directs maturation of both CD4 and CD8 single positive thymocytes. *Blood* 2001;166:2209-2217.
121. Basson MA, Bommhardt U, Mee PJ, et al. Molecular requirements for lineage commitment in the thymus—antibody-mediated receptor engagement reveal a central role for Lck in lineage decisions. *Immunol Rev* 1998;165:181-195.
122. Bommhardt U, Basson MA, Krummrei U, et al. Activation of the extracellular signal-related kinase/mitogen-activated protein kinase pathway discriminates CD4 versus CD8 lineage commitment in the thymus. *J Immunol* 1999;163:715-722.
123. Cibotti R, Punt JA, Dash KS, et al. Surface molecules that drive T cell development in vitro in the absence of thymic epithelium and in the absence of lineage-specific signals. *Immunity* 1997;6:245-255.
124. Chan S, Correia-Neves M, Benoist C, et al. CD4/CD8 lineage commitment: matching fate with competence. *Immunol Rev* 1998;165:195-207.
125. He X, Kappes DJ. CD4/CD8 lineage commitment: light at the end of the tunnel? *Curr Opin Immunol* 2006;18:135-142.
126. He X, He X, Dave VP, et al. The zing finger transcription factor Th-POK regulates CD4 versus CD8 T-cell lineage commitment. *Nature* 2005;433:826-833.
127. Keefe R, Dave V, Allman D, et al. Regulation of lineage commitment distinct from positive selection. *Science* 1999;286:1149-1153.
128. von Boehmer H, Teh HS, Kisielow P. The thymus selects the useful, neglects the useless and destroys the harmful. *Immunol Today* 1989;10:57-61.
129. Bevan MJ. In thymic selection, peptide diversity gives and takes away. *Immunity* 1997;7:175-178.
130. Amsen D, Kruisbeek AM. Thymocyte selection: not by TCR alone. *Immunol Rev* 1998;165:209-229.
131. Anderson G, Hare KJ, Jenkinson EJ. Positive selection of thymocytes: the long and winding road. *Immunol Today* 1999;20:463-468.
132. Jamieson S, Hogquist KA, Bevan MJ. Positive selection of thymocytes. *Annu Rev Immunol* 1995;13:93-126.
133. Sprent J, Webb SR. Function and specificity of T cell subsets in the mouse. *Adv Immunol* 1987;41:39-133.
134. Jamieson SC, Bevan MJ. T cell selection. *Curr Opin Immunol* 1998;10:214-219.
135. Trobridge PA, Forbush KA, Levin SD. Positive and negative selection of thymocytes depends on Lck interaction with the CD4 and CD8 coreceptors. *J Immunol* 2001;166:809-818.
136. Turner JM, Brodsky MH, Irving BA, et al. Interaction of the unique N-terminal region of the tyrosine kinase p56lck with the cytoplasmic domains of CD4 and CD8 is mediated by cysteine motifs. *Cell* 1990;60:755.

137. Van Oers NSC, Kileen N, Weiss A. ZAP-70 is constitutively associated with tyrosine phosphorylated TCR in murine thymocytes and lymph node T cells. *Immunity* 1994;1:675-685.
138. Anderson G, Owen JJ, Moore NC, et al. Thymic epithelial cells provide unique signals for positive selection of CD4⁺ CD8⁺ thymocytes in vitro. *J Exp Med* 1994;179:2027-2031.
139. Capone M, Romagnoli P, Beemann F, et al. Dissociation of thymic positive and negative selection in transgenic mice expressing major histocompatibility complex class I molecules exclusively on thymic cortical epithelial cells. *Blood* 2001;97:1336-1342.
140. Brocker T, Riedinger M, Karjalainen K. Targeted expression of major histocompatibility complex (MHC) class II molecules demonstrates that dendritic cells can induce negative, but not positive selection of thymocytes in vivo. *J Exp Med* 1997;185:541-550.
141. Martinic MM, Rulicke T, Althage A, et al. Efficient T cell repertoire selection in tetraparental chimeric mice independent of thymic epithelial MHC. *Proc Natl Acad Sci U S A* 2003;100:1861-1866.
142. Choi EY, Jung KC, Park HJ, et al. Thymocyte-thymocyte interaction for efficient positive selection and maturation of CD4 T cells. *Immunity* 2005;23:387-396.
143. Ferreira C, Furmanski A, Millrain M, et al. TCR- α CDR3 loop audition regulates positive selection. *J Immunol* 2006;177:2477-2485.
144. Kurobe H, Liu C, Ueno T, et al. CCR7-dependent cortex-to-medulla migration of positively selected thymocytes is essential for establishing central tolerance. *Immunity* 2006;24:165-177.
145. Vacchio MS, Williams JA, Hodes RJ. A novel role for CD28 in thymic selection: elimination of CD28/B7 interactions increases positive selection. *Eur J Immunol* 2005;35:418-425.
146. Derbinski J, Gabler J, Brors B, et al. Promiscuous gene expression in thymic epithelial cells is regulated at multiple levels. *J Exp Med* 2005;202:33-45.
147. Siggs OM, Makaroff LE, Listen A. The why and how of thymocyte negative selection. *Curr Opin Immunol* 2006;18:175-183.
148. Liston A, Lesage S, Gray DH, et al. Genetic lesions in T-cell tolerance and thresholds for autoimmunity. *Immunol Rev* 2005;204:87-101.
149. Kyewski B, Klein L. A central role for central tolerance. *Annu Rev Immunol* 2006;24:571-606.
150. Pitkanen J, Peterson P. Autoimmune regulator: from loss of function to auto-immunity. *Genes Immunol* 2003;4:12-21.
151. Gotter J, Brors B, Hergenroth M, et al. Medullary epithelial cells of the human thymus express a highly diverse selection of tissue-specific genes colocalized in chromosomal clusters. *J Exp Med* 2003;199:155-166.
152. Vogel A, Strassburg CP, Obermayer-Straub P, et al. The genetic background of autoimmune polyendocrinopathy-candidiasis-ectodermal dystrophy and its autoimmune disease components. *J Mol Med* 2002;80:201-211.
153. Boehmer HV, Aifantis I, Gounarri F, et al. Thymic selection revisited: how essential is it? *Immunol Rev* 2003;191:62-78.
154. Boehm T, Scheu S, Pfeffer K, et al. Thymic medullary epithelial cell differentiation, thymocyte emigration and the control of autoimmunity require lymphoepithelial cross talk via LT β R. *J Exp Med* 2003;198:757-769.
155. Akiyama T, Maeda S, Yamane S, et al. Dependence of self-tolerance on TRAF6-directed development of thymic stroma. *Science* 2005;308:248-251.
156. Derbinski J, Kyewski B. Linking signaling pathways, thymic integrity and autoimmunity. *Trends Immunol* 2005;26:503-506.
157. Starr TK, Jameson SC, Hogquist KA. Positive and negative selection of T cells. *Annu Rev Immunol* 2003;21:139-176.
158. Sakaguchi S. Naturally arising CD4⁺ regulatory T cells or immunologic self-tolerance and negative control of immune responses. *Annu Rev Immunol* 2004;22:531-562.
159. Liu Y-J. A unified theory of central tolerance in the thymus. *Trends Immunol* 2006;27:215-221.

160. Rebot J, Romagnoli PK, van Meerwijk JPM. Against ligands expressed by thymic epithelium enhance positive selection of regulatory T lymphocytes from precursors with a normally diverse TCR repertoire. *J Immunol* 2006;177:1101-1107.
161. Negishi I, Motoyama N, Nakayama K, et al. Essential role for ZAP-70 in both positive and negative selection. *Nature* 1995;376:435-438.
162. Sosinowski T, Kileen N, Weiss N. The Src-like adaptor protein downregulates the T cell receptor on CD4+CD8+ thymocytes and regulates positive selection. *Immunity* 2001;15:457-466.
163. Alberola-Ila J, Hernandez-Hojos G. The Ras/MAPK cascade and the control of positive selection. *Immunol Rev* 2003;191:79-96.
164. Page DM, Kane LP, Allison JP, et al. Two signals are required for negative selection of CD4⁺CD8⁺ thymocytes. *J Immunol* 1993;151:1868-1880.
165. Sasada T, Reinherz EL. A critical role for CD2 in both thymic selection events and mature T cell function. *J Immunol* 2001;166:2394-2403.
166. Li R, Page DM. Requirement for a complex array of costimulators in the negative selection of autoreactive thymocytes in vivo. *J Immunol* 2001;166:6050-6057.
167. Dautigny N, Le Campion A, Lucas B. Timing and casting for actors of thymic negative selection. *J Immunol* 1999;162:1294-1302.
168. Page DM. Cutting edge: thymic selection and autoreactivity are regulated by multiple coreceptors involved in T cell activation. *J Immunol* 1999;163:3577-3581.
169. Kishimoto H, Sprent J. Several different cell surface molecules control negative selection of medullary thymocytes. *J Exp Med* 1999;190:65-74.
170. McKean DJ, Huntoon CJ, Bell MP, et al. Maturation versus death of developing doublepositive thymocytes reflects competing effects on Bcl-2 expression and can be regulated by the intensity of CD28 costimulation. *J Immunol* 2001;166:3468-3475.
171. Wang CR, Hashimoto K, Kubo S, et al. T cell receptor-mediated signaling events in CD4+CD8+ thymocytes undergoing thymic selection: requirement of calcineurin activation for thymic positive selection but not negative selection. *J Exp Med* 1995;181:927-941.
172. Urdahl KB, Pardoll DM, Jenkins MK. Cyclosporin A inhibits positive selection and delays negative selection in $\alpha\beta$ TCR transgenic mice. *J Immunol* 1994;152:2853-2862.
173. Kane LP, Hedrick SM. A role for calcium influx in setting the threshold for CD3⁺CD8⁺ thymocyte negative selection. *J Immunol* 1996;156:4594-4601.
174. Zhou T, Cheng J, Yang P, et al. Inhibition of Nur77/Nurr1 leads to inefficient clonal deletion of self-reactive T cells. *J Exp Med* 1996;183:1879-1892.
175. Benoist C, Mathis D. Positive selection of the T cell repertoire: where and when does it occur? *Cell* 1989;58:1027-1033.
176. Sebzda E, Wallace VA, Mayer J, et al. Positive and negative thymocyte selection induced by different concentrations of a single peptide. *Science* 1994;263:1615-1618.
177. Liu C-P, Crawford F, Marrack P, et al. T cell positive selection by a high density, low affinity ligand. *Proc Natl Acad Sci U S A* 1998;95:4522-4526.
178. Ignatowicz L, Rees W, Pacholczyk R, et al. T cells can be activated by peptides that are unrelated in sequence to their selecting peptide. *Immunity* 1997;7:179-186.
179. Hu Q, Bazemore-Walker CR, Girao C, et al. Specific recognition of thymic self-peptides induces the positive selection of cytotoxic T lymphocytes. *Immunity* 1997;7:221-231.
180. Ignatowicz L, Kappler J, Marrack P. The repertoire of T cells shaped by a single MHC/peptide ligand. *Cell* 1996;86:521-529.
181. Barton GM, Beers C, de Roos P, et al. Positive selection of self-MHC-reactive T cells by individual peptide-MHC class II complexes. *Proc Natl Acad Sci U S A* 2002;99:6937-6942.

182. Lee D-S, Ahn C, Ernst B, et al. Thymic selection by a single MHC/peptide ligand: autoreactive T cells are low affinity cells. *Immunity* 1999; 10:83-92.
183. Surh CD, Lee D-S, Fung-Leung W-P, et al. Thymic selection by a single MHC/peptide ligand produces a semidiverse repertoire of CD4⁺ T cells. *Immunity* 1997;7:209-219.
184. Anderson G, Partington KM, Jenkinson EJ. Differential effects of peptide diversity and stromal cell type in positive and negative selection in the thymus. *J Immunol* 1998;161:6599-6603.
185. Bentley GA, Mariuzza RA. The structure of the T cell antigen receptor. *Annu Rev Immunol* 1996;14:563-590.
186. Garcia KC, Teyton L, Wilson IA. Structural basis of T cell recognition. *Annu Rev Immunol* 1999;17:369-397.
187. Fields BA, Mariuzza RA. Structure and function of the T-cell receptor: insights from X-ray crystallography. *Immunol Today* 1996;17:330-336.
188. Madden D. The three-dimensional structure of peptide-MHC complexes. *Annu Rev Immunol* 1995;13:587-622.
189. Davis MM, Bjorkman PJ. T-cell antigen receptor genes and T-cell recognition. *Nature* 1988;334:395-402.
190. Bjorkman PJ, Saper MA, Samraoui B, et al. Structure of the human class I histocompatibility antigen HLA-A2. *Nature* 1987;329:506-512.
191. Madden D, Gorga J, Strominger J, et al. The structure of HLA-B27 reveals nonamer selfpeptides bound in an extended conformation. *Nature* 1991;353:321-325.
192. Kozono H, White J, Clements J, et al. Production of soluble MHC class II proteins with covalently bound single peptides. *Nature* 1994;369:151-154.
193. Hennecke J, Carfi A, Wiley DC. Structure of a covalently stabilized complex of a human $\alpha\beta$ T-cell receptor, influenza HA peptide and MHC class II molecule, HLA-DR1. *EMBO J* 2000;19:5611-5624.
194. Rudolph MG, Wilson IA. The specificity of TCR/pMHC interaction. *Curr Opin Immunol* 2002;14:52-65.
195. Garboczi DN, Ghosh P, Utz U, et al. Structure of the complex between human T-cell receptor, viral peptide and HLA-A2. *Nature* 1996;384:134-141.
196. Reinherz EL, Tan K, Tang L, et al. The crystal structure of a T cell receptor in complex with peptide and MHC class II. *Science* 1999;286:1913-1921.
197. Speir JA, Stevens J, Joly E, et al. Two different highly exposed, bulged structures for an unusually long peptide bound to rat MHC class I TR1-Aa. *Immunity* 2001;4:81-92.
198. Braden BC, Goldman ER, Marinzza RA, et al. Anatomy of an antibody molecule: structure, kinetics, thermodynamics and mutational studies of the antilysozyme antibody D1.3. *Immunol Rev* 1998;163:45-57.
199. Hennecke J, Wiley DC. Structure of a complex of the human $\alpha\beta$ -T cell receptor HA1.7, influenza HA peptide, and MHC class II cross-restriction and alloreactivity. *J Exp Med* 2002;195:571-581.
200. Sloan-Lancaster J, Allen PM. Altered peptide ligand-induced partial T cell activation: molecular mechanisms and role in T cell biology. *Annu Rev Immunol* 1996;14:1-27.
201. Davis MM, Boniface JJ, Reich Z, et al. Ligand recognition by alpha beta T cell receptors. *Annu Rev Immunol* 1998;16:523-544.
202. Udaka K, Wiesmuller KH, Kienle S, et al. Self-MHC restricted peptides recognized by an alloreactive T lymphocyte clone. *J Immunol* 1996;157:670-678.
203. Sykulev Y, Vugmeyster Y, Brunmark A, et al. Peptide antagonism and T cell receptor interactions with peptide MHC complexes. *Immunity* 1998;9:475-483.
204. Garcia KC. Molecular interactions between extracellular components of the T-cell receptor signaling complex. *Immunol Rev* 1999;172:73-85.
205. Garcia KC, Degano M, Pease LR, et al. Structural basis of plasticity in T cell receptor recognition of a self peptide-MHC antigen. *Science* 1998;279:1166-1172.
206. Hennecke J, Wiley DC. T cell receptor-MHC interactions up close. *Cell* 2001;104:1-4.

207. Thome M, Germain V, Di Santo JP, et al. The p56lck SH2 domain mediates recruitment of CD8/p56lck to the activated T cell receptor/CD3/zeta complex. *Eur J Immunol* 1996;26:2093-2100.
208. Irvine DJ, Purbhoo MA, Krogsgaard M, et al. Direct observation of a single ligand recognition by T cells. *Nature* 2002;419:845-849.
209. Gao GF, Jacobsen BK. Molecular interactions of coreceptor CD8 and MHC class I: the molecular basis for functional coordination with the T-cell receptor. *Immunol Today* 2000;21:630-636.
210. Gao GF, Rao Z, Bell JI. Molecular coordination of $\alpha\beta$ T-cell receptors and coreceptors CD8 and CD4 in their recognition of peptide-MHC ligands. *Trends Immunol* 2002;23:408-413.
211. Moody AM, Chui D, Reche PA, et al. Developmentally regulated glycosylation of the CD8 alpha beta coreceptor stalk modulates ligand binding. *Cell* 2001;107:501-512.
212. van der Merwe PA, Davis SJ. Molecular interactions mediating T cell antigen recognition. *Annu Rev Immunol* 2003;21:659-684.
213. Vignali DA, Vignali KM. Profound enhancement of T cell activation mediated by the interaction between the TCR and the D3 domain of CD4. *J Immunol* 1999;162:1431-1439.
214. Bachmann MF, Barner M, Kopf M. CD2 sets quantitative thresholds in T cell activation. *J Exp Med* 1999;190:1383-1392.
215. Collins AV, Brodie DW, Gilbert RJC, et al. The interaction properties of costimulatory molecules revisited. *Immunity* 2002;17:201-210.
216. Clevers H, Larcon B, Wileman T, et al. The T cell receptor/CD3 complex: a dynamic protein ensemble. *Annu Rev Immunol* 1998;16:629-662.
217. Letourneur F, Klausner RD. A novel di-leucine motif and a tyrosine based motif independently mediate lysosomal targeting and endocytosis of CD3 chains. *Cell* 1992;69:1143-1157.
218. Cambier JC. Antigen and Fc receptor signaling. The awesome power of the immunoreceptor tyrosine based activation motif (ITAM). *J Immunol* 1995;155:3281-3285.
219. Irving BA, Chan AC, Weiss A. Functional characterization of a signal transducing motif present in the T cell antigen receptor ζ chain. *J Exp Med* 1993;177:1093-1103.
220. Brady RL, Barclay AN. The structure of CD4. *Curr Top Microbiol Immunol* 1996;205:1-18.
221. König R, Clury S, Germain RN. The structural basis of CD4-MHC class II interactions: coreceptor contributions to T cell receptor antigen recognition and oligomerization-dependent signal transduction. *Curr Top Microbiol Immunol* 1996;205:19-46.
222. Tachibana M, Siddiqi MA, Ikegami Y, et al. Coreceptor function of mutant human CD4 molecule without affinity to gp120 of human immunodeficiency virus. *J Biol Chem* 2000;275:20288-20294.
223. Wang J-H, Reinherz EL. Structural basis of cell-cell interactions in the immune system. *Curr Opin Struct Biol* 2000;10:656-661.
224. Wang J-H, Meijers R, Xiong Y, et al. Crystal structure of the human CD4 N-terminal two-domain fragment complexed to a class II MHC molecule. *Proc Natl Acad Sci U S A* 2001;98:10799-10804.
225. Lynch GW, Sloane AJ, Raso V, et al. Direct evidence of native CD4 oligomers in lymphoid and monocytoid cells. *Eur J Immunol* 1999;29:2590-2602.
226. Cherry RJ, Wilson KM, Triantafilou K, et al. Detection of dimers of human leukocyte antigen (HLA)-DR on the surface of living cells by single-particle fluorescence imaging. *J Cell Biol* 1998;140:71-79.
227. Lindstedt R, Monk N, Lombardi G, et al. Amino acid substitutions in the putative MHC class II "dimer of dimers" interface inhibit CD4⁺ T cell activation. *J Immunol* 2001;166:800-808.
228. Sakihama T, Smolyar A, Reinherz EL. Molecular recognition of antigen involves lattice formation between CD4, MHC class II and TCR molecules. *Immunol Today* 1995;16:581-587.
229. Xiong Y, Kern P, Chang H-C, et al. T cell receptor binding to a pMHCII ligand is kinetically distinct from and independent of CD4. *J Biol Chem* 2001;276:5659-5667.

230. Gao GF, Tormo J, Gerth UC, et al. Crystal structure of the complex between human CD8 alpha and HLA-A2. *Nature* 1997;387:630-634.
231. Connolly JM, Hansen TH, Ingold AL, et al. Recognition by CD8 on cytotoxic T lymphocytes is ablated by several substitutions in the same class I molecule. *Proc Natl Acad Sci U S A* 1990;87:2137-2141.
232. Giblin PA, Leahy DJ, Mennone J, et al. The role of charge and multiple faces of the CD8-alpha/alpha homodimer is binding to major histocompatibility complex class I molecules—support for a bivalent model. *Proc Natl Acad Sci U S A* 1994;91:1716-1720.
233. Devine L, Sun JR, Barr MR, et al. Orientation of the Ig domains of the CD8 alpha beta relative to MHC class I. *J Immunol* 1999;162:846-851.
234. Sun J, Leahy DJ, Kavathas PB. Interaction between CD8 and major histocompatibility complex (MHC) class I mediated by multiple contact surfaces that include $\alpha 2$ and $\alpha 3$ domains of MHC class I. *J Exp Med* 1995;182: 1275-1280.
235. König R. Interactions between MHC molecules and co-receptors of the TCR. *Curr Opin Immunol* 2002;14:75-83.
236. Hamad AR, O'Herrin SM, Lebowitz MS, et al. Potent T cell activation with dimeric peptide-major histocompatibility complex class II ligand: the role of CD4 coreceptor. *J Exp Med* 1998;188:1633-1640.
237. Crawford F, Kozono H, White J, et al. Detection of antigen-specific T cells with multivalent soluble class II MHC covalent peptide complexes. *Immunity* 1998;8:675-682.
238. Boniface JJ, Rabinowitz JD, Wulfig C, et al. Initiation of signal transduction through the T cell receptor requires the multivalent engagement of peptide/MHC ligand. *Immunity* 1998;9:459-466.
239. Campanelli R, Palernio B, Garbelli S, et al. Human CD8 co-receptor is strictly involved in MHC-peptide tetramer-TCR binding and T cell activation. *Intern Immunol* 2002;14:39-44.
240. Daniels MA, Jameson SC. Critical role for CD8 in T cell receptor binding and activation by peptide/major histocompatibility complex multimers. *J Exp Med* 2000;191:335-345.
241. Kwan Lim GE, McNeill L, Whitley K, et al. Co-capping studies reveal CD8/TCR interactions after capping CD8 beta polypeptides and intracellular associations of CD8 with p56(lck). *Eur J Immunol* 1998;28:745-754.
242. Zhang W, Sloan-Lancaster J, Kitchen J, et al. LAT: the ZAP-70 tyrosine kinase substrate that links T cell receptor to cellular activation. *Cell* 1998; 92:83-92.
243. Finco TS, Kadlecsek T, Zhang W, et al. LAS is required for TCR-mediated activation of PLC- $\gamma 1$ and the Ras pathway. *Immunity* 1998;9:617-626.
244. Bosselut R, Zhang W, Ashe JM, et al. Association of the adaptor molecule LAT with CD4 and CD8 coreceptors identifies a new coreceptor function in T cell receptor signal transduction. *J Exp Med* 1999;190:1517-1525.
245. Garcia KC, Degano M, Stanfield RL, et al. An $\alpha\beta$ T cell receptor structure at 2.5 Å and its orientation in the TCR-MHC complex. *Science* 1996;274:209-219.
246. Ding YH, Smith KJ, Garboczi DN, et al. Two human T cell receptors bind in a similar diagonal mode to the HLA-A2/Tax peptide complex using different TCR amino acids. *Immunity* 1998;8:403-411.
247. Teng MK, Smolyar A, Tse AG, et al. Identification of a common docking topology with substantial variation among different TCR-peptide-MHC complexes. *Curr Biol* 1998;8:409-412.
248. Wang J-H, Reinherz EL. Structural basis of T cell recognition of peptides bound to MHC molecules. *Mol Immunol* 2001;38:1039-1049.
249. Wyer JR, Wilcox BE, Gao GF, et al. T cell receptor and co-receptor CD8 $\alpha\alpha$ bind peptide-MHC independently and with distinct kinetics. *Immunity* 1999;10:219-225.
250. Mazza G, Housset D, Piras C, et al. Glimpses at the recognition of peptide-MHC complexes by T cell antigen receptors. *Immunol Rev* 1998;163:187-196.
251. Shaw AS, Dustin ML. Making T cell receptor go the distance: a topological view of T cell activation. *Immunity* 1997;6:361-369.
252. Simons K, Toomre D. Lipid rafts and signal transduction. *Nat Rev Mol Cell Biol* 2000;1:31-41.

253. Cherukuri A, Dykstra ML, Pierce SK. Floating the raft hypothesis: lipid rafts play a role in immature cell activation. *Immunity* 2001;14:657-660.
254. Langlet C, Bernard A-M, Drevot P, et al. Membrane rafts and signaling by the multichain immune recognition receptors. *Curr Opin Immunol* 2000;12:250-255.
255. Brown DA, London E. Structure and function of sphingolipid- and cholesterol-rich membrane rafts. *J Biol Chem* 2000;275:17221-17224.
256. Brown DA, London E. Functions of lipid rafts in biological membranes. *Annu Rev Cell Dev Biol* 1998;14:111-136.
257. Morley SCP, Bierer BE. The actin cytoskeleton, membrane lipid microdomains and T cell signal transduction. *Adv Immunol* 2001;77:1-43.
258. Varma R, Mayer S. GPI-anchored proteins are organized in submicron domains at the cell surface. *Nature* 1998;394:798-801.
259. Vogt AB, Spindeldreher S, Kropshofer H. Clustering MHC-peptide complexes prior to their engagement in the immunological synapse: lipid raft and tetraspan microdomains. *Immunol Rev* 2002;189:136-151.
260. Dykstra M, Cherukuri A, Sohn HW, et al. Location is everything: lipid rafts and immune cell signaling. *Annu Rev Immunol* 2003;21:457-481.
261. Cheng PC, Cherukuri A, Dykstra ML, et al. Floating the raft hypothesis: the roles of lipid rafts in B cell antigen receptor function. *Semin Immunol* 2001;13:107-114.
262. Janes PW, Ley SC, Magee AI, et al. The role of lipid rafts in T cell antigen receptor (TCR) signaling. *Semin Immunol* 2000;12:23-34.
263. Cherukuri A, Cheng PC, Sohn HW, et al. The CD19/CD21 complex functions to prolong B cell antigen receptor signaling from lipid rafts. *Immunity* 2001;14:169-179.
264. Lowin-Kropf B, Shapiro VS, Weiss A. Cytoskeletal polarization of T cells is regulated by an immunoreceptor tyrosine-based activation motif-dependent mechanism. *J Cell Biol* 1998;140:861-871.
265. Harder T. Raft membrane domains and immunoreceptor functions. *Adv Immunol* 2001;77:45-92.
266. Snapper SB, Rosen FS. The Wiskott-Aldrich syndrome protein (WASP): roles in signaling and cytoskeletal organization. *Annu Rev Immunol* 1999;17:905-929.
267. Chiang YJ, Kole HK, Brown K, et al. Cbl-b regulates the CD28 dependence of T cell activation. *Nature* 2000;403:216-220.
268. Sherrington CS. *The integrative action of the nervous system*. New York: C Scribner's sons, 1906.
269. Bromley S, Burack WR, Johnson KG, et al. The immunological synapse. *Annu Rev Immunol* 2001;19:375-396.
270. Monks CR, Freiberg BA, Kupfer H, et al. Three dimensional segregation of supramolecular activation clusters in T cells. *Nature* 1998;395:82-86.
271. Dustin ML, Cooper JA. The immunological synapse and the actin cytoskeleton: molecular hardware for T cell signaling. *Nat Immunol* 2000;1:23-29.
272. Acuto O, Cantrell D. T cell activation and the cytoskeleton. *Annu Rev Immunol* 2000;18:165-184.
273. Matzinger P. An innate sense of danger. *Semin Immunol* 1998;10:399-415.
274. Donnadieu E, Bismuth G, Trautman A. Antigen recognition by helper T cells elicits a sequence of distinct changes of their shape and intracellular calcium. *Curr Biol* 1994;4:584-595.
275. Negulescu PA, Krasieva TB, Khan A, et al. Polarity of T cell shape, motility and sensitivity to antigen. *Immunity* 1996;4:421-430.
276. Tuosto L, Michel F, Acuto O. p95vav associates with tyrosine phosphorylated SLP-76 in antigen stimulated T cells. *J Exp Med* 1996;184:1161-1166.
277. Wu J, Motbo DG, Koretzky GA, et al. Vav and SLP-76 interact and functionally cooperate in IL-2 gene activation. *Immunity* 1996;4:593-602.

278. Wardenburg JP, Pappu R, Bu JY, et al. Regulation of PAK activation and the cell cytoskeleton by the linker protein SLP-76. *Immunity* 1998;9:607-616.
279. Sedwik CE, Morgan MM, Jusino L, et al. TCR, LFA-1 and CD28 play unique and complementary roles in signaling T cell cytoskeletal reorganization. *J Immunol* 1999;162:1367-1375.
280. Wüfling C, Davis MM. A receptor/cytoskeletal movement triggered by costimulation during T cell activation. *Science* 1998;282:2266-2269.
281. Dustin M, Bromely SK, Kan Z, et al. Antigen receptor engagement delivers a stop signal to migrating T lymphocytes. *Proc Natl Acad Sci U S A* 1997;94:3909-3913.
282. Grakoui A, Bromley SK, Sumen C, et al. The immunological synapse: a molecular machine controlling T cell activation. *Science* 1999;285:221-227.
283. Lee KH, Holderf AD, Dristin ML, et al. T cell receptor signaling precedes immunological synapse formation. *Science* 2002;295:1539-1542.
284. Stinchcombe JC, Bossi G, Booth S, et al. The immunological synapse of CTL contains a secretory domain and membrane bridges. *Immunity* 2001;15:751-761.
285. Liepins A, Foanes RB, Lifter J, et al. Ultrastructural changes during T-lymphocytemediated cytolysis. *Cell Immunol* 1997;28:109-124.
286. Revy P, Sospedra M, Barbour B, et al. Functional antigen independent synapses formed between T cells and dendritic cells. *Nat Immunol* 2001;2:925-931.
287. Kondo T, Cortese I, Markovic-Plese S, et al. Dendritic cells signal T cells in the absence of exogenous antigen. *Nat Immunol* 2001;2:932-938.
288. Gunzer M, Schafer A, Borgmann S, et al. Antigen presentation in extracellular matrix: interactions of T cells with dendritic cells are dynamic, short lived, and sequential. *Immunity* 2000;13:323-332.
289. Wulfig C, Sjaastad MD, Davis MM. Visualizing the dynamics of T cell activation: intracellular adhesion molecule 1 migrates readily to the T cell/B cell interface and acts to sustain calcium levels. *Proc Natl Acad Sci U S A* 1998;95:6302-6307.
290. Davis SJ, van der Merwe PA. The immunological synapse: required for T cell receptor signaling or directing effector function. *Curr Biol* 2001;11:R289-R290.
291. van der Merwe PA, Davis SJ. Immunology. The immunological synapse—a multitasking system. *Science* 2002;295:1479-1480.
292. van der Merwe PA. Formation and function of the immunological synapse. *Curr Opin Immunol* 2002;14:293-298.
293. Bromley SK, Iaboni A, Davis SJ, et al. The immunological synapse and CD28-CD80 interactions. *Nat Immunol* 2001;2:1159-1166.
294. Holdorf AD, Lee KH, Burack WR, et al. Regulation of Lck activity by CD4 and CD28 in the immunological synapse. *Nat Immunol* 2002;3:259-264.
295. Mustelin T, Coggeshall KM, Altman A. Rapid activation of T cell tyrosine protein kinase pp56lck by the CD45 phosphotyrosine phosphatase. *Proc Natl Acad Sci U S A* 1989;86:6302-6306.
296. van der Merwe PA, Davis SJ, Shaw AS, et al. Cytoskeletal polarization and redistribution of cell surface molecules during T cell antigen recognition. *Semin Immunol* 2000;12:5-21.
297. Leupen O, Zaru R, Laroche T, et al. Exclusion of CD45 from T cell receptor signaling area in antigen-stimulated T lymphocytes. *Curr Biol* 2000;10: 277-280.
298. Johnson KG, Bromley SK, Dustin ML, et al. A supramolecular basis for CD45 regulation during T cell activation. *Proc Natl Acad Sci U S A* 2000;97:10138-10143.
299. Kersh EN, Shaw AS, Allen PM. Fidelity of T cell activation through multistep T cell receptor ζ phosphorylation. *Science* 1998;281:572-575.
300. Kersh GJ, Allen PM. Essential flexibility in the T-cell recognition of antigen. *Nature* 1996;380:495-498.

301. McKeethan TW. Kinetic proofreading in T cell receptor signal transduction. *Proc Natl Acad Sci U S A* 1995;92:5042-5046.
302. Rabinowitz JD, Beeson C, Lyons DS, et al. Kinetic discrimination in T cell activation. *Proc Natl Acad Sci U S A* 1996;93:1401-1405.
303. Lanzavecchia A, Iezzi G, Viola A. From TCR engagement to T cell activation: a kinetic view of T cell behavior. *Cell* 1999;96:1-4.
304. Leo A, Wienandz, Baier G, et al. Adapters in lymphocyte signaling. *J Clin Invest* 2002;109:301-309.
305. Samelson LE. Signal transduction mediated by the T cell antigen receptor: the role of adapter proteins. *Annu Rev Immunol* 2002;20:371-394.
306. Sims TN, Dustin ML. The immunological synapse. *Immunol Rev* 2002;186: 100-117.
307. Koretzky GA, Myung PS. Positive and negative regulation of T cell activation by adaptor proteins. *Nat Rev Immunol* 2001;1:95-107.
308. Meller H, Parker PJ. The extended protein kinase C superfamily. *Biochem J* 1998;332:281-292.
309. Isakov N, Altman A. Protein kinase C (θ) in T cell activation. *Annu Rev Immunol* 2002;20:761-794.
310. Cantrell DA. T cell antigen receptor signal transduction. *Immunology* 2002;105:369-374.
311. Jones RG, Parsons M, Bonnard M, et al. Protein kinase B regulates T lymphocyte survival nuclear factor kappa B activation and Bcl-X (L) levels in vivo. *J Exp Med* 2000;191:1721-1734.
312. Koretzky GA. The role of Grb2-associated proteins in T-cell activation. *Immunol Today* 1997;18:401-406.
313. Egan SE, Gidding BW, Brooks MW, et al. Association of SOS Ras exchange protein with Grb2 is implicated in tyrosine kinase signal transduction and transformation. *Nature* 1993;363:45-51.
314. Delon J, Kaibuchi K, Germain RN. Exclusion of CD43 from the immunological synapse is mediated by phosphorylation-regulated relocation of cytoskeletal adaptor moesin. *Immunity* 2001;15:691-701.
315. Cannon JL, Burkhardt JK. The regulation of actin remodeling during T-cell-APC conjugate formation. *Immunol Rev* 2002;186:90-99.
316. Henning S, Cleverly S. Small GTPases in lymphocyte biology: Rho proteins take center stage. *Immunol Res* 1999;20:29-42.
317. Abdul-Manan N, Aghazadeh B, Liu GA, et al. Structure of Cdc42 in complex with the GTPase-binding domain of the "Wiskott-Aldrich syndrome" protein. *Nature* 1999;399:379-383.
318. Higgs HN, Pollard TD. Activation by Cdc 42 and PIP(2) of Wiskott-Aldrich syndrome protein (WASp) stimulates actin nucleation by Arp2/3 complex. *J Cell Biol* 2000;150:1311-1320.
319. Prehoda KE, Scott JA, Dyché Mullins R, et al. Integration of multiple signals through cooperative regulation of N-WASP-Arp2/3 complex. *Science* 2000;290:801-806.
320. Thrasher AJ. WASp in immune system organization and function. *Nat Rev Immunol* 2002;2:635-646.
321. Zhang J, Shi F, Badour K, et al. WASp verpolin homology, cofilin homology, and acidic region domain-mediated actin polymerization is required for T cell development. *Proc Natl Acad Sci U S A* 2002;99:2240-2245.
322. Das V, Nal B, Roumier A, et al. Membrane-cytoskeleton interactions during the formation of the immunological synapse and subsequent T-cell activation. *Immunol Rev* 2002;189:123-135.
323. Delon J, Stoll S, Germain RN. Imaging of T-cell interactions with antigen presenting cells in culture and in intact lymphoid tissue. *Immunol Rev* 2000;189:51-63.
324. Cullinan P, Sperling AI, Burkhardt JK. The distal pole complex: a novel membrane domain distal to the immunological synapse. *Immunol Rev* 2002;189:111-122.
325. Lenschow DJ, Walunas TL, Bluestone JA. CD28/B7 system of T cell costimulation. *Annu Rev Immunol* 1996;14:233-258.
326. Larsen CP, Elwood ET, Alexander DZ, et al. Long-term acceptance of skin and cardiac allografts after blocking CD40 and CD28 pathways. *Nature* 1996;381:434-438.

327. Beier KC, Hutloff A, Dittrich AM, et al. Induction, binding specificity and function of human ICOS. *Eur J Immunol* 2000;30:3707-3717.
328. Carreno BM, Collins M. The B7 family of ligands and its receptors: new pathways for costimulation and inhibition of immune response. *Annu Rev Immunol* 2002;20:29-53.
329. Gonzalo JA, Tian J, Delaney T, et al. ICOS is critical for T helper cell-mediated lung mucosal inflammatory responses. *Nat Immunol* 2001;2:597-604.
330. Özkaynak E, Gao W, Shemmeri N, et al. Importance of ICOS-B7RP-1 costimulation in acute and chronic allograft rejection. *Nat Immunol* 2001;2:591-596.
331. Mosmann TR, Cherwinski H, Bond MW, et al. Two types of murine helper T cell clones. I. Definition according to profiles of lymphokine activities and secreted proteins. *J Immunol* 1986;136:2348-2357.
332. Constant SL, Bottomly K. Induction of Th1 and Th2 CD4⁺ T cell responses: the alternative responses. *Annu Rev Immunol* 1997;15:297-322.
333. Noble A. Molecular signals and genetic programming in peripheral T-cell differentiation. *Immunology* 2000;101:289-299.
334. Murphy KM, Reiner SL. The lineage decisions of helper T cells. *Nat Rev Immunol* 2002;2:933-944.
335. Noble A, Thomas MJ, Kemeny DM. Early Th1/Th2 cell polarization in the absence of IL-4 and IL-12: T cell receptor signaling regulates the response to cytokines in CD4 and CD8 T cells. *Eur J Immunol* 2001;31:2227-2235.
336. Rugilson IC, Sperling AI, Fields PE, et al. CD28 costimulation promotes the production of Th2 cytokines. *J Immunol* 1997;158:658-665.
337. Oki S, Otsuki N, Kohsaka T, et al. STAT-6 activation and Th2 cell proliferation driven by CD28 signals. *Eur J Immunol* 2000;30:1416-1424.
338. Howland KC, Ausubel LJ, London CA, et al. The roles of CD28 and CD40 ligand in T cell activation and tolerance. *J Immunol* 2000;164:4465-4470.
339. Löhning M, Richter A, Radbruch A. Cytokine memory of T helper thymocytes. *Adv Immunol* 2002;80:115-181.
340. Ho I, Glimcher LH. Transcription: tantalizing times for T cells. *Cell* 2002;109:S109-S120.
341. Li B, Yu H, Zheng W, et al. Role of guanosine triphosphate Rac2 in T helper 1 cell differentiation. *Science* 2000;288:2219-2222.
342. Szabo SJ, Kim ST, Costa GL, et al. A novel transcription factor, T-bet, directs Th1 lineage commitment. *Cell* 2000;100:655-669.
343. Afkarian M, Sedy J, Yang J, et al. T-bet is a STAT-1-induced regulator of IL-12R expression in naïve CD4⁺ T cells. *Nat Immunol* 2002;3:549-557.
344. Mullen AC, High FA, Hutchins AS, et al. Role of T-bet in commitment of TH1 cells before IL-12 dependent selection. *Science* 2001;292:1907-1910.
345. Szabo SJ, Sullivan BM, Stemmann C, et al. Distinct effects of T-bet in TH1 lineage commitment and IFN-gamma production in CD4 and CD8 T cells. *Science* 2002;295:338-342.
346. Ho IC, Hodge MR, Rooney JW, et al. The proto-oncogene c-maf is responsible for tissue specific expression of interleukin-4. *Cell* 1996;85:973-983.
347. Kim JI, Ho IC, Grusby MJ, et al. The transcription factor c-Maf controls the production of interleukin-4 but not other Th2 cytokines. *Immunity* 1999;10:745-751.
348. Arni O, Rao A. T cell differentiation: a mechanistic view. *Curr Opin Immunol* 2000;12:654-659.
349. Chen Q, Ghilardi N, Wang H, et al. Development of Th1-type of immune responses requires the type I cytokine receptor TCCR. *Nature* 2000;407:916-920.
350. Wurster AL, Rogers VL, Satoskar AR, et al. Interleukin-21 is a T helper (Th) cell 2 cytokine that specifically inhibits differentiation of naïve Th cells into interferon γ -producing Th1 cells. *J Exp Med* 2002;196:969-977.
351. Diehl S, Rincon M. The two faces of IL-6 on Th1/Th2 differentiation. *Mol Immunol* 2002;39:531-536.

352. Nakanishi K, Yoshimoto T, Tsutsui H, et al. Interleukin-18 regulates both Th1 and Th2 responses. *Annu Rev Immunol* 2001;19:423-474.
353. Yoshimoto T, Mizutani H, Tsutsui H, et al. IL-18 induction of IgE: dependence on CD4⁺ T cells, IL-4 and STAT-6. *Nat Immunol* 2000;1:132-137.
354. Erard F, Garcia-Sanz JA, Moriggl R, et al. Presence or absence of TGF-beta determines IL-4-induced generation of type 1 or type 2, CD8 T cell subsets. *J Immunol* 1999;162:209-214.
355. Chtanova T, Kemp RA, Sutherland APR, et al. Gene microarrays reveal extensive differential gene expression in both type 1 and type 2 cells. *J Immunol* 2001;167:3057-3063.
356. Rogge L, Bianchi E, Biffi M, et al. Transcript imaging of the development of human T helper cells using oligonucleotide arrays. *Nat Genet* 2000;25:96-101.
357. Sallusto F, Mackay CR, Lanzavecchia A. The role of chemokine receptors in primary, effector, and memory immune responses. *Annu Rev Immunol* 2000;18:593-620.
358. Altare F, Durandy A, Lammas D, et al. Impairment of mycobacterial immunity in human interleukin-12 receptor deficiency. *Science* 1998;280: 1432-1435.
359. van Crevel R, Caryadi E, Preyers F, et al. Increased production of interleukin 4 by CD4⁺ and CD8⁺ T cells from patients with tuberculosis is related to the presence of pulmonary cavities. *J Infect Dis* 2000;181:1194-1197.
360. Wangoo A, Sparer T, Brown IN, et al. Contribution of Th1 and Th2 cells to protection and pathology in experimental models of granulomatous lung disease. *J Immunol* 2001;166:3432-3439.
361. Lolbach W, Laskay T. The host response to Leishmania infection. *Adv Immunol* 2000;74:275-317.
362. Romani L, Puccetti P, Bistoni F. Interleukin-12 in infectious diseases. *Clin Microbiol Rev* 1997;10:611-636.
363. Wills-Karp M. Immunologic basis of antigen-induced airway hyperresponsiveness. *Annu Rev Immunol* 1999;17:255-281.
364. Elias JA, Lee CG, Zheung T, et al. New insights into the pathogenesis of asthma. *J Clin Invest* 2003;111:291-297.
365. Zhu Z, Homer RJ, Wang Z, et al. Pulmonary expression of interleukin-13 causes inflammation, mucus hypersecretion, subepithelial fibrosis, physiologic abnormalities and eotaxin production. *J Clin Invest* 1999;103:779-788.
366. Neurath MF, Finotto S, Glimcher LH. The role of Th1/Th2 polarization in mucosal immunity. *Nat Med* 2002;8:567-573.
367. Trowsdale J. Genetic and functional relationships between MHC and NK receptor genes. *Immunity* 2001;15:363-374.
368. Sanderson CJ. The uptake and retention of chromium by cells. *Transplantation* 1976;21:526-529.
369. Matzinger P. The JAM test. A simple assay for DNA fragmentation and cell death. *J Immunol Methods* 1991;145:185-192.
370. Mescher MF. Molecular interactions in the activation of effector and precursor cytotoxic T lymphocytes. *Immunol Rev* 1995;146:179-210.
371. Bossi G, Griffiths GM. Degranulation plays an essential part in regulating cell surface expression of Fas ligand in T cells and natural killer cells. *Nat Med* 1999;5:90-96.
372. Blott EJ, Bossi G, Clark R, et al. Fas ligand is targeted to secretory lysosomes via proline-rich domain in its cytoplasmic tail. *J Cell Sci* 2001;114:2405-2416.
373. Peters PJ, Borst J, Oorschot V, et al. Cytotoxic T lymphocyte granules are secretory lysosomes, containing both perforin and granzymes. *J Exp Med* 1991;173:1099-1109.
374. Tschopp J, Nabholz M. Perforin-mediated target lysis by cytolytic T lymphocytes. *Annu Rev Immunol* 1990;8:279-302.
375. Peters PJ, Geuze HJ, Van der Donk HA, et al. A new model for lethal hit delivery by cytotoxic T lymphocytes. *Immunol Today* 1990;11:28-32.
376. Smith MJ, Kelly JM, Sutton VR, et al. Unlocking the secrets of cytotoxic granule proteins. *J Leuk Biol* 2001;70:18-29.
377. Nalefski EA, Falke JJ. The C2 domain calcium-binding motif: structure and functional diversity. *Protein Sci* 1996;5:2375-2390.

378. Vellner R, Zvelebil MJ, Hopkins J, et al. Perforin is activated by proteolytic cleavage during biosynthesis which reveals a phospholipid-binding C2 domain. *EMBO J* 1997;16:7287-7296.
379. Tschopp J, Schafer S, Masson D, et al. Phosphoryl choline acts as a calcium dependent receptor molecule for lymphocyte perforin. *Nature* 1989;337:272-274.
380. Young JD, Hengartner H, Podack ER, et al. Purification and characterization of a cytolytic pore-forming protein from granules of cloned lymphocytes with natural killer activity. *Cell* 1986;44:849-859.
381. Liu C-C, Walsh CM, Young JD-E. Perforin: structure and function. *Immunol Today* 1995;16:194-201.
382. Pena SV, Hanson DA, Carr BA, et al. Processing, subcellular localization and function of 519 (granulysin), a human late T cell activation molecule with homology to small, lytic, granule proteins. *J Immunol* 1997;158:2680-2688.
383. Krensky AM. Granulysin: a novel antimicrobial peptide of cytolytic T lymphocytes and natural killer cells. *Biochem Pharmacol* 2000;59:317-320.
384. Stenger S, Hanson DA, Teitelbaum R, et al. An antimicrobial activity of cytolytic T cells mediated by granulysin. *Science* 1998;282:121-125.
385. Smyth MJ, O'Connor MD, Trapani JA. Granzymes: a variety of serine protease specificities encoded by genetically distinct subfamilies. *J Leuk Biol* 1996;60:555-562.
386. Trapani JA. Dual mechanisms of apoptosis induction by cytolytic lymphocytes. *Int Rev Cytol* 1997;182:111-192.
387. Waugh SM, Harris JL, Fletterick B, et al. The structure of the pro-apoptotic protease granzyme B reveals the molecular determinants of its specificity. *Nat Struct Biol* 2000;7:762-765.
388. Andrin C, Pinkoski MJ, Burns K, et al. Interaction between a Ca^{2+} binding protein calreticulin and perforin, a component of the cytotoxic T-cell granules. *Biochemistry* 1998;37:10386-10394.
389. Fraser SA, Karimi R, Michalak M, et al. Perforin lytic activity is controlled by calreticulin. *J Immunol* 2000;164:4150-4155.
390. Calvin JP, Spaeny-Dekking LH, Wang B, et al. Apoptosis induced by granzyme glycosaminoglycan complexes: implications for granule-mediated apoptosis in vivo. *J Immunol* 1999;162:5345-5350.
391. Bossi G, Trambas C, Booth S, et al. The secretory synapse: the secrets of a serial killer. *Immunol Rev* 2002;189:152-160.
392. Grimm E, Price Z, Bonavida B. Studies on the induction and expression of T cell mediated immunity. VIII Effector-target junctions and target cell membrane disruption during cytolysis. *Cell Immunol* 1979;46:77-79.
393. Yanelli JR, Sullivan JA, Mandell GL, et al. Reorientation and fusion of cytotoxic T lymphocyte granules after interaction with target cells as determined by high resolution cinemicrography. *J Immunol* 1986;136:377-382.
394. Geiger B, Rosen D, Berke G. Spatial relationships of microtubule-organizing centers and the contact area of cytotoxic T lymphocyte and target cells. *J Cell Biol* 1982;95:137-143.
395. Kupfer A, Singer SJ. Cell biology of cytotoxic and helper T cell functions: immunofluorescence microscopic studies of single cells and cell couples. *Annu Rev Immunol* 1989;7:309-337.
396. Kupfer A, Dennert G. Reorientation of the microtubule-organizing center and the Golgi apparatus in cloned cytotoxic lymphocytes triggered by binding to lysable target cells. *J Immunol* 1984;133:2762-2766.
397. Kupfer A, Dennert G, Singer SJ. The reorientation of the Golgi apparatus and the microtubule-organizing center in the cytotoxic effector cell is a prerequisite in the lysis of bound target cells. *J Mol Cell Immunol* 1985;2:37-49.
398. Menasche G, Pastural E, Feldmann J, et al. Mutations in RAB27A cause Griscelli syndrome associated with haemophagocytic syndrome. *Nat Genet* 2000;25:173-176.
399. Orange JS, Ramesh N, Remold-O'Donnell E, et al. Wiskott-Aldrich syndrome protein is required for NK cell cytotoxicity and colocalizes with actin to NK cell-activating immunologic synapse. *Proc Natl Acad Sci U S A* 2002;99:11351-11356.
400. Kagi D, Ledermann B, Bürke K, et al. Molecular mechanisms of lymphocyte-mediated cytotoxicity and their role in immunological protection and pathogenesis in vivo. *Annu Rev Immunol* 1996;14:207-232.
401. Haddad EK, Uri X, Hammer JA III, et al. Defective granule exocytosis in Rab27a deficient lymphocytes from Ashen mice. *J Cell Biol* 2001;152:835-842.

402. Gray LS, Grarra JR, Sullivan JA, et al. Spatial and temporal characteristics of the increase in intracellular Ca^{2+} induced in cytotoxic T lymphocytes by cellular antigen. *J Immunol* 1988;141:2424-2430.
403. Berthou C, Bourge JF, Zhang Y, et al. Interferon- γ -induced membrane PAF-receptor expression confers tumor cell susceptibility to NK perforin-dependent lysis. *Blood* 2000;95:2329-2336.
404. Dourmaskin RR, Deteix P, Simone CB, et al. Electron microscopic demonstration of lesions of target cell membranes associated with antibody-dependent cellular cytotoxicity. *Clin Exp Immunol* 1980;42:554-560.
405. Duke RC, Persecchini PM, Chang S, et al. Purified perforin induces target cell lysis but not DNA fragmentation. *J Exp Med* 1989;170:1451-1456.
406. Shi L, Kam CM, Powers JC, et al. Purification of three cytotoxic lymphocyte granule serine proteases that induce apoptosis through distinct substrate and target cell interactions. *J Exp Med* 1992;176:1521-1529.
407. Bhakdi S, Tranum-Jensen J. Alpha-toxin of staphylococcus aureus. *Microbiol Rev* 1991;55:733-751.
408. Ebnet KM, Hausmann M, Lehmann-Grube F, et al. Granzyme A-deficient mice retain potent cell-mediated cytotoxicity. *EMBO J* 1995;14:4230-4239.
409. Browne KA, Blink E, Sutton VR, et al. Cytosolic delivery of granzyme B by bacterial toxins: evidence that endosomal disruption, in addition to trans-membrane pore formation, is an important function of perforin. *Mol Cell Biol* 1999;19:8604-8615.
410. Shi L, Mai S, Israels S, et al. Granzyme B (GraB) autonomously crosses the cell membrane and perforin initiates apoptosis and GraB nuclear localization. *J Exp Med* 1997;185:855-866.
411. Motyka B, Korbitt G, Pinkoski MJ, et al. Mannose-6-phosphate/insulin-like growth factor II receptor is a death receptor for granzyme B during cytotoxic T cell-induced apoptosis. *Cell* 2000;103:491-500.
412. Trapani JA, Sutton VR, Thia KYT, et al. A clathrin/dynamin- and mannose-6-phosphate receptor-independent pathway for granzyme B-induced cell death. *J Cell Biol* 2003;160:223-233.
413. Griffiths GM. Endocytosing the death sentence. *J Cell Biol* 2003;160:155-156.
414. Pinkoski MJ, Hobman M, Heibein JA, et al. Entry and trafficking of granzyme B in target cells during granzyme B-perforin-mediated apoptosis. *Blood* 1998;92:1044-1054.
415. Trapani JA, Jans P, Smyth MJ, et al. Perforin-dependent nuclear entry of granzyme B precedes apoptosis, and is not a consequence of nuclear membrane dysfunction. *Cell Death Differ* 1998;5:488-496.
416. Smyth JA, McGuire MJ, Thia KYT. Expression of recombinant human granzyme B. *J Immunol* 1995;154:6299-6305.
417. Griffiths GM. Protein sorting and secretion during CTL killing. *Semin Immunol* 1997;9:109-115.
418. Darmon AJ, Nicholson DW, Bleakley RC. Activation of apoptotic protease CPP32 by cytotoxic T-cell-derived granzyme B. *Nature* 1995;377:446-448.
419. Andrade F, Roy S, Thornberry N, et al. Granzyme B directly and efficiently cleaves several downstream caspase substrates: implications for CTL-induced apoptosis. *Immunity* 1998;8:451-460.
420. Barry M, Bleakley RC. Cytotoxic T lymphocytes: all roads lead to death. *Nat Rev Immunol* 2002;2:401-409.
421. Heibein JA, Barry M, Motyka B, et al. Granzyme B induced loss of mitochondrial inner membrane potential ($\Delta\Psi_m$) and cytochrome c release are caspase independent. *J Immunol* 1999;163:4683-4693.
422. MacDonald G, Shi L, van de Velde C, et al. Mitochondria-dependent and -independent regulation of granzyme B induced apoptosis. *J Exp Med* 1999;189:131-144.
423. Susin SA, Zamzami N, Castedo M, et al. Bcl-2 prevents the release from mitochondria of an apoptogenic protease. *J Exp Med* 1996;184:1331-1334.
424. Sutton VR, Davis JE, Cancilla M, et al. Initiation of apoptosis by granzyme B requires direct cleavage of Bid, but not direct granzyme B-mediated caspase activation. *J Exp Med* 2000;192:1403-1413.
425. Alimonte JB, Shi L, Baijal PK, et al. Granzyme B induces BID-mediated cytochrome c release and mitochondrial permeability transition. *J Biol Chem* 2001;276:6974-6982.
426. Jans DA, Sutton VR, Jans P, et al. BCL-2 blocks perforin-induced nuclear translocation of granzymes concomitant with protection against the nuclear events of apoptosis. *J Biol Chem* 1999;274:3953-3961.

427. Zhang D, Pasternack MS, Beresford PJ, et al. Induction of rapid histone degradation by the cytotoxic T lymphocyte protease granzyme A. *J Biol Chem* 2001;276:3683-3690.
428. Fan Z, Beresford PJ, Zhang D, et al. HMG2 interacts with the nucleosome assembly protein SET and is a target for the cytotoxic T-lymphocyte protease granzyme A. *Mol Cell Biol* 2002;22:2810-2820.
429. Zhang D, Beresford PJ, Greenberg AH, et al. Granzymes A and B directly cleave lamins and disrupt the nuclear lamina during granule-mediated cytolysis. *Proc Natl Acad Sci U S A* 2001;98:5746-5751.
430. Spaeny EHA, Kamp AM, Froelich CJ, et al. Extracellular granzyme A, complexed to proteoglycans, is protected against inactivation by protease inhibitors. *Blood* 2000;95:1465-1472.
431. Jans DA, Briggs LJ, Jans P, et al. Nuclear targeting of the serine protease granzyme A (fragmentin-1). *J Cell Sci* 1998;111:2645-2654.
432. Russell JH, Ley TJ. Lymphocyte-mediated cytotoxicity. *Annu Rev Immunol* 2002;20:323-370.
433. Juo P, Kuo CJ, Yuan J, et al. Essential requirement for caspase-8/FLICE in the initiation of the Fas-induced apoptotic cascade. *Curr Biol* 1998;8: 1001-1008.
434. Kischkel FC, Hillbardt S, Behrman I, et al. Cytotoxicity-dependent APO-1 (Fas/CD95)-associated proteins form a death-inducing signaling complex (DISC) with the receptor. *EMBO J* 1995;14:5579-5588.
435. Waterhouse NJ, Trapani JA. CTL: caspases terminate life, but that's not the whole story. *Tissue Antigens* 2002;59:175-183.
436. Fesik SW. Insights into programmed cell death through structural biology. *Cell* 2000;103:273-282.
437. Wang R, Rogers AM, Ratliff TL, et al. CD95-dependent bystander lysis caused by CD4+ T helper 1 effectors. *J Immunol* 1996;157:2961-2968.
438. Ju ST, Cui H, Panka DJ, et al. Participation of target Fas protein in apoptosis pathway induced by CD4⁺ Th1 and CD8⁺ cytotoxic T cells. *Proc Natl Acad Sci U S A* 1994;91:4185-4189.
439. Zinkernagel RM, Althage A. Antiviral protection by virus-immune cytotoxic T cells: infected target cells are lysed before infectious virus progeny is assembled. *J Exp Med* 1997;145:644-651.
440. Parra B, Lin MD, Stohlman SA, et al. Contributions of Fas-Fas ligand interactions to the pathogenesis of mouse hepatitis virus in the central nervous system. *J Virol* 2000;74:2447-2450.
441. Harty JT, Tvinnereim AR, White DW. CD8⁺ T cell effector mechanisms in resistance to infection. *Annu Rev Immunol* 2000;18:275-308.
442. Kügi D, Ledermann B, Bucki K, et al. Cytotoxicity mediated by T cells and antiviral killer cells is greatly impaired in perforin deficient mice. *Nature* 1994;369:31-37.
443. Matloubian M, Suresh M, Glass A, et al. A role for perforin in downregulating T-cell responses during chronic viral infection. *J Virol* 1999;73:2527-2536.
444. Stepp SE, Dufourcq-Lagelouse R, Le Deist F, et al. Perforin gene defects in familial hemophagocytic lymphohistiocytosis. *Science* 1999;286:1957-1959.
445. Müllbacher A, Waring P, Hla RT, et al. Granzymes are the essential downstream effector molecules for the control of primary virus infections by cytolytic leukocytes. *Proc Natl Acad Sci U S A* 1999;96:13940-13955.
446. Davis JE, Smyth MJ, Trapani JA. Granzyme A and B-deficient killer lymphocytes are defective in eliciting DNA fragmentation but retain potent in vivo antitumor capacity. *Eur J Immunol* 2001;31:39-47.
447. Podack ER. How to induce involuntary suicide: the need for dipeptidyl peptidase I. *Proc Natl Acad Sci U S A* 1999;99:8312-8314.
448. Pham CTN, Ley TJ. Dipeptidyl peptidase I is required for the processing and activation of granzymes A and B in vivo. *Proc Natl Acad Sci U S A* 1999;96:8627-8632.
449. Toomes C, Janies J, Wood AJ, et al. Loss-of-function mutation in the cathepsin c gene result in periodontal disease and palmoplantar keratosis. *Nat Genet* 1999;23:421-424.

450. Graubert TA, Di Persio JF, Russel JH, et al. Perforin granzyme-dependent and -independent mechanisms are both important for the development of graft-versus-host disease after murine bone marrow transplantation. *J Clin Invest* 1997;100:904-911.
451. Baker MB, Riley RL, Podack ER, et al. Graft-versus-host disease associated lymphoid hypoplasia and B cell dysfunction is dependent upon donor T cell-mediated Fas-ligand function, but not perforin function. *Proc Natl Acad Sci U S A* 1997;94:1366-1371.
452. Braun MY, Lewin B, French L, et al. Cytotoxic T cell deficient in both functional Fas ligand and perforin show residual cytolytic activity yet lose their capacity to induce lethal acute graft-versus-host disease. *J Exp Med* 1996;183:657-661.
453. Sun J, Bird CH, Sutton V, et al. A cytosolic granzyme B inhibitor related to the viral apoptotic regulator cytokine response modifier A is present in cytotoxic lymphocytes. *J Biol Chem* 1996;271:27802-27809.
454. Bird CH, Sutton VR, Sun J, et al. Selective regulation of apoptosis: the cytotoxic lymphocyte serpin proteinase inhibitor 9 protects against granzyme B-mediated apoptosis without perturbing the Fas cell death pathway. *Mol Cell Biol* 1998;18:6387-6398.
455. Trapani JA, Smyth MJ. Functional significance of the perforin/granzyme cell death pathway. *Nat Rev Immunol* 2002;2:735-747.
456. Froelich CJ, Dixit VM, Yang X. Lymphocyte granule-mediated apoptosis: matters of viral mimicry and deadly proteases. *Immunol Today* 1998;19:30-36.
457. Kawasaki Y, Saito T, Shirota-Someya Y, et al. Cell death-associated trans-location of plasma membrane components induced by CTL. *J Immunol* 2000;164:4641-4648.
458. Shestra S, Russel JH, Ley TJ. Mechanism responsible for granzyme B-independent cytotoxicity. *Blood* 1997;89:4085-4091.
459. Henkart PA, Williams MS, Zacharchuk CM, et al. Do CTL kill target cells by inducing apoptosis? *Semin Immunol* 1997;9:135-144.
460. Sharrow SO, Matheson BJ, Singer A. Cell surface appearance of unexpected host MHC determinants on thymocytes from radiation bone marrow chimeras. *J Immunol* 1981;126:1327-1335.
461. Hudrisier D, Bongrand P. Intercellular transfer of antigen-presenting cell determinants onto T cells, molecular mechanisms and biological significance. *FASEB J* 2002;16:477-486.
462. Romagnoli P, Hudrisier D, vanMeerwijk JPM. Preferential recognition of self-antigens despite normal thymic deletion of CD4⁺CD25⁺ regulatory T cells. *J Immunol* 2002;168:1644-1648.
463. van Santen HM, Benoist C, Mathis D. Number of T reg cells that differentiate does not increase upon encounter of agonist ligand on thymic epithelial cells. *J Exp Med* 2004;200:1221-1230.
464. Romagnoli P, Hudrisier D, van Meerwijk JPM. Molecular signature of recent thymic selection events on effector and regulatory CD4⁺ T lymphocytes. *J Immunol* 2005;175:5751-5758.
465. Coutinho A, Caramalho I, Seixas E, et al. Thymic commitment of regulatory T cells is a pathway of TCR-dependent selection that isolates repertoires, undergoing positive or negative selection. *Curr Top Microbiol Immunol* 2005;293: 43-71.
466. Bruknow ME, Jeffery EW, Hjerrild KA, et al. Disruption of a new forkhead/winged-helix protein, scurf, results in the fatal lymphoproliferative disorder of surfy mouse. *Nat Genet* 2001;27:68-73.
467. Chatila A, Blueser F, Ho N, et al. JM2 encoding a fork head-related protein is mutated in X-linked autoimmunity-allergic dysregulation syndrome. *J Clin Invest* 2000;106:R75-R81.
468. Gorelik L, Flavell RA. Transforming growth factor- β in T-cell biology. *Nat Rev Immunol* 2002;2:46-53.
469. Zheng SG, Wang JH, Gray JD, et al. Natural and induced CD4⁺ CD25⁺ cells educate CD4⁺ CD25⁻ cells to develop suppressive activity: the role of IL-2, TGF- β , and IL-10. *J Immunol* 2004;172:5213-5221.
470. Yamazaki S, Iyoda T, Tarbell K, et al. Direct expansion of functional CD25⁺ DC4⁺ regulatory T cells by antigen-processing dendritic cells. *J Exp Med* 2003;198:235-247.

471. Takahashi T, Kuniyasu Y, Toda M, et al. Immunologic self-tolerance maintained by CD25⁺ CD4⁺ naturally energetic and suppressive T cells: induction of autoimmune disease by breaking their anergic/suppressive state. *Intern Immunol* 1998;10:1969-1980.
472. Vendetti S, Chai J-G, Dyson J, et al. Anergic T cells inhibit the antigen-presenting function of dendritic cells. *J Immunol* 2000;165:1175-1181.
473. McVay LD, Cardig SR, Bottomly K, et al. Regulated expression and structure of T cell receptor gamma delta transcript in human thymic ontogeny. *EMBO J* 1991;10:83-88.
474. Bottino C, Tambussi G, Ferrini S, et al. Two subsets of human T lymphocytes expressing $\gamma\delta$ antigen receptor are identifiable by monoclonal antibodies directed to two distinct molecular forms of the receptor. *J Exp Med* 1988;168:491-505.
475. Falini B, Flenghi S, Pileri P, et al. Distribution of T cells bearing different forms of the T cells receptor γ/δ in normal and pathological human tissues. *J Immunol* 1989;143:2480-2488.
476. Hayday AC. $\gamma\delta$ cells: a right time and a right place for a conserved third way protection. *Annu Rev Immunol* 2000;18:975-1026.
477. Allison TJ, Garboczi DN. Structure of $\gamma\delta$ T cell receptors and their recognition on nonpeptide antigens. *Mol Immunol* 2001;38:1051-1061.
478. Carding SR, Egan PJ. $\gamma\delta$ T cells: functional plasticity and heterogeneity. *Nat Rev Immunol* 2002;2:336-345.
479. Born W, Cody C, Jones-Carson J, et al. Immunoregulatory functions of $\gamma\delta$ T cells. *Adv Immunol* 1999;71:77-144.
480. Constant P, Davodeau F, Peyrat MA, et al. Stimulation of human gamma delta T cells by non-peptide mycobacterial ligands. *Science* 1994;264:267-270.
481. Tanaka Y, Morita CT, Tanaka Y, et al. Natural and synthetic non-peptide ligands for human $\gamma\delta$ T cells. *Nature* 1995;375:155-158.
482. Buckowski JF, Monita CT, Brenner MB. Human $\gamma\delta$ T cells recognize alkyl-amines derived from microbes, edible plants, tea: implications for innate immunity. *Immunity* 1999;11:57-65.
483. O'Brien RL, Fu Y, Cranfill R, et al. Heat-shock protein Hsp-60-reactive $\gamma\delta$ cells: a large, diversified T-lymphocyte subset with highly focused specificity. *Proc Natl Acad Sci U S A* 1992;89:4348-4352.
484. Fleisch H. Biphosphonates. Pharmacology and use in the treatment of tumor-induced hypercalcemic and metastatic bone disease. *Drugs* 1991;42: 919-944.
485. Morita CT, Li H, Lamphear JG, et al. Superantigen recognition by $\gamma\delta$ T cells: SEA recognition site for human V γ 2 T cell receptors. *Immunity* 2001;14: 331-344.
486. Groh V, Steinle A, Bauer S, et al. Recognition of stress-induced MHC molecules by intestinal epithelial $\gamma\delta$ T cells. *Science* 1998;279:1737-1740.
487. Bauer S, Groh V, Wu J, et al. Activation of NK cells and T cells by NKG2D, a receptor for stress-induced MICA. *Science* 1999;285:727-729.
488. Li P, Willie ST, Bauer S, et al. Crystal structure of the MHC class I homolog MIC-A, a $\gamma\delta$ T cell ligand. *Immunity* 1999;10:557-584.
489. Beckman EM, Melian A, Behar SM, et al. CD1c restricted responses of mycobacteriaspecific T cells. Evidence for antigen presentation by a second member of the human CD1 family. *J Immunol* 1996;157:2795-2803.
490. Spada FM, Grant EP, Peters PJ, et al. Self-recognition of CD1 by γ/δ T cells: implications for innate immunity. *J Exp Med* 2000;191:937-948.
491. Exley M, Garcia J, Balk SP, et al. Requirements for CD1d recognition by human invariant V α 24 CD4-CD8- T cells. *J Exp Med* 1997;186:109-120.
492. Leslie DS, Vincent MS, Spada FM, et al. CD1-mediated γ/δ T cell maturation of dendritic cells. *J Exp Med* 2002;196:1575-1584.
493. De Rosa SC, Mitra DK, Watanabe N, et al. V δ 1 and V δ 2 $\gamma\delta$ T cells express distinct surface markers and might be developmentally distinct lineages. *J Leukoc Biol* 2001;70:518-526.

494. Cipriani B, Borsellino G, Poccia F, et al. Activation of C-C β -chemokines in human peripheral blood $\gamma\delta$ T cells by isopentenyl pyrophosphate and regulation by cytokines. *Blood* 2000;95:39-47.
495. Dieli F, Troye-Blomberg M, Ivanyi J, et al. V γ 9/V γ 2 T lymphocytes reduce viability of intracellular *Mycobacterium tuberculosis*. *Eur J Immunol* 2000;30:1512-1519.
496. Dieli F, Troye-Blomberg M, Ivanyi J, et al. Granulysin-dependent killing of intracellular and extracellular *Mycobacterium tuberculosis* by V γ 9/V δ 2 T lymphocytes. *J Infect Dis* 2001;184:1082-1085.
497. Li B, Bassiri H, Rossman MD, et al. Involvement of Fas/Fas-ligand pathway of activation-induced cell death of mycobacteria-reactive human $\gamma\delta$ T cells: a mechanism for the loss of $\gamma\delta$ T cells in patients with pulmonary tuberculosis. *J Immunol* 1998;161:1558-1567.
498. Carding SR, Egan PJ. The importance of $\gamma\delta$ T cells in the resolution of pathogen-induced inflammatory immune responses. *Immunol Rev* 2000;173:98-108.
499. Glatzel A, Wesch D, Schiemann F, et al. Patterns of chemokine receptor expression on peripheral blood $\gamma\delta$ T lymphocytes: strong expression of CCR5 is a selective feature of V δ 2/V γ 9 $\gamma\delta$ T cells. *J Immunol* 2002;168:4920-4929.
500. Ferrarini M, Ferrero E, Dagna L, et al. Human $\gamma\delta$ T cells: a non-redundant system in the immune-surveillance against cancer. *Trends Immunol* 2002;23:14-18.
501. Wells H. Studies on the chemistry of anaphylaxis III. Experiments with isolated proteins, especially those of the hen's egg. *J Infect* 1911;9:147-151.
502. Hänninen A, Harrison LC. $\gamma\delta$ T cells as mediators of mucosal tolerance: the autoimmune diabetes model. *Immunol Rev* 2000;173:109-119.
503. Holoshitz J. Activation of $\gamma\delta$ T cells by mycobacterial antigens in rheumatoid arthritis. *Microbes Infect* 1999;1:197-202.
504. Peteman GM, Spencer G, Sperling AI, et al. Role of $\gamma\delta$ T cells in murine collageninduced arthritis. *J Immunol* 1993;151:6546-6558.
505. De Libero G. Sentinel function of broadly reactive human $\gamma\delta$ T cells. *Immunol Today* 1997;18:22-26.
506. Saito H, Kanamori Y, Takemori T, et al. Generation of intestinal T cells from progenitors residing in gut cryptopatches. *Science* 1998;280:275-278.
507. Cheroutre H. Starting at the beginning: new perspectives on the biology of mucosal T cells. *Annu Rev Immunol* 2004;22:217-246.
508. Locke NR, Stankovic S, Funda DP, et al. TCR $\gamma\delta$ intraepithelial lymphocytes are required for self-tolerance. *J Immunol* 2006;176:6553-6559.
509. Lewis JM, Girardi M, Roberts SJ, et al. Selection of the cutaneous intraepithelial $\gamma\delta$ ⁺ T cell repertoire by a thymic stromal determinant. *Nat Immunol* 2006;7:843-850.
510. Lodoen MB, Lanier LL. Natural killer cells as an initial defence against pathogens. *Curr Opin Immunol* 2006;18:391-398.
511. Trinchieri G. Biology of natural killer cells. *Adv Immunol* 1989;47:187-376.
512. Gentile TC, Uner AH, Hutchison RE, et al. CD3⁺, CD56⁺ aggressive variant of large granular lymphocyte leukemia. *Blood* 1994;84:2315-2321.
513. Grossi CE, Cadoni A, Zicca A, et al. Large granular lymphocytes in human peripheral blood: ultrastructural and cytochemical characterization of the granules. *Blood* 1982;59:277-283.
514. Caulfield JP, Hein A, Schmidt RE, et al. Ultrastructural evidence that the granules of human natural killer cell clones store membrane in a nonbilayer phase. *Am J Pathol* 1987;127:305-316.
515. Garni-Wagner BA, Witte PL, Tutt MM, et al. Natural killer cells in the thymus. Studies in mice with severe combined immune deficiency. *J Immunol* 1990;144:796-803.
516. Lanier LL, Spits H, Phillips JH. The developmental relationship between NK cells and T cells. *Immunol Today* 1992;13:392-395.
517. Spits H, Lanier LL, Phillips JH. Development of human T and natural killer cells. *Blood* 1995;85:2654-2670.

518. Phillips JH, Hori T, Nagler A, et al. Ontogeny of human natural killer (NK) cells: fetal NK cells mediate cytolytic function and express cytoplasmic CD3 ϵ , δ proteins. *J Exp Med* 1992;175:1055-1066.
519. Wang B, Biron C, She J, et al. A block in both early T lymphocyte and natural killer cell development in transgenic mice with high-copy numbers of the human CD3 gene. *Proc Natl Acad Sci U S A* 1994;91:9402-9406.
520. Sánchez MJ, Muench MO, Roncarolo MG, et al. Identification of a common T/natural killer cell progenitor in human fetal thymus. *J Exp Med* 1994;180:569-576.
521. Rodewald HR, Moingeon P, Lucich JL, et al. A population of early fetal thymocytes expressing Fc γ RII/III contains precursors of T lymphocytes and natural killer cells. *Cell* 1992;69:139-150.
522. Carlyle JR, Zuniga-Pflücker JC. Lineage commitment and differentiation in the fetal mouse. *Immunol Rev* 1998;165:63-74.
523. Miller JS, Alley KA, McGlave P. Differentiation of natural killer (NK) cells from human primitive marrow progenitors in a stroma-based long-term culture system: identification of a CD34+7+ NK progenitor. *Blood* 1994;83: 2594-2601.
524. Lotzová E, Savary CA, Champlin RE. Genesis of human oncolytic natural killer cells from primitive CD34+CD33- bone marrow progenitors. *J Immunol* 1993;150:5263-5269.
525. Silva MR, Hoffman R, Srour EF, et al. Generation of human natural killer cells from immature progenitors does not require marrow stromal cells. *Blood* 1994;84:841-846.
526. Shibuya A, Nagayoshi K, Nakamura K, et al. Lymphokine requirement for the generation of natural killer cells from CD34+ hematopoietic progenitor cells. *Blood* 1995;85:3538-3546.
527. Galy A, Travis M, Cen D, et al. Human T, B, natural killer, and dendritic cells arise from a common bone marrow progenitor subset. *Immunity* 1995;3: 459-473.
528. Jaleco AC, Blom B, Res P, et al. Fetal liver contains committed NK progenitors of CD34+ cells into T cells. *J Immunol* 1997;159:694-702.
529. Spits H, Blom B, Jaleco AC, et al. Early stages in the development of human T, natural killer and thymic dendritic cells. *Immunol Rev* 1998;165:75-86.
530. Bennett IM, Zatzepina O, Zanai L, et al. Definition of a natural killer NKRP-1A/CD56-/CD16- functionally immature human NK cell subset that differentiates in vitro in the presence of interleukin 12. *J Exp Med* 1996;184:1845-1856.
531. Zamai L, Ahmad M, Bennett IM, et al. Natural killer (NK) cell-mediated cytotoxicity: differential use of TRAIL and Fas ligand by immature and mature primary human NK cells. *J Exp Med* 1998;188:2375-2380.
532. Loza MJ, Perussia B. Final steps in natural killer cell maturation: a model for type 1-type 2 differentiation? *Nat Immunol* 2001;2:917-924.
533. Voss SD, Hong R, Sondel PM. Severe combined immunodeficiency, interleukin 2 (IL-2) and IL-2 receptor: experiments of nature continue to point the way. *Blood* 1994;83:626-635.
534. Di Santo JP, Colucci F, Guy-Grand D. Natural killer and T cells of innate and adaptive immunity: lymphoid compartments with different requirements for common γ chain-independent cytokines. *Immunol Rev* 1998;165:29-38.
535. Park SY, Saijo K, Takahashi T, et al. Developmental defects of lymphoid cells in Jak3 kinase-deficient mice. *Immunity* 1995;3:771-782.
536. Mrozek E, Anderson PK, Caligiuri MA. Role of interleukin-15 in the development of human CD56+ natural killer cells from CD34+ hematopoietic progenitor cells. *Blood* 1996;87:2632-2640.
537. Prizanov IJ, Bennett M, Kumar V. IL-15 can substitute for the bone marrow microenvironment in the differentiation of natural killer cells. *J Immunol* 1996;157:4282-4285.
538. Wang J-H, Nichogiannopoulou A, Wu L, et al. Selective defects in the development of the fetal and adult lymphoid system in mice with an Ikaros null mutation. *Immunity* 1996;5:537-549.
539. Williams NS, Klem J, Puzanov IJ, et al. Natural killer cell differentiation: insights from knockout and transgenic mouse models and in vitro systems. *Immunol Rev* 1998;165:47-61.
540. Long E. Regulation of immune responses through inhibitory receptors. *Annu Rev Immunol* 1999;17:875-904.

541. Sawicki MW, Dimasi N, Natarajan K, et al. Structural basis of MHC class I recognition by natural killer cell receptors. *Immunol Rev* 2001;181:52-65.
542. Natarajan K, Dimasi N, Wang J, et al. Structure and function of natural killer cell receptors: multiple molecular solutions to self, nonself discrimination. *Annu Rev Immunol* 2002;20:853-885.
543. Lanier LL. NK cell receptors. *Annu Rev Immunol* 1998;16:359-393.
544. Borrego F, Kabat J, Kim DK, et al. Structure and function of major histocompatibility complex (MHC) class I specific receptors expressed on human natural killer (NK) cells. *Mol Immunol* 2002;38:637-660.
545. Moretta L, Biassoni R, Bottino C, et al. Human NK cells and their receptors. *Microbes Infect* 2002;4:1539-1544.
546. Drickamer K. Ca²⁺-dependent carbohydrate-recognition domains in animal proteins. *Curr Opin Struct Biol* 1993;3:393-400.
547. Weiss WI, Taylor ME, Drickamer K. The C-type lectin superfamily. *Immunol Rev* 1998;163:19-34.
548. André P, Biassoni R, Colonna M, et al. New nomenclature for MHC receptors. *Nat Immunol* 2001;2:661.
549. Billadeau DD, Leibson PJ. ITAMs versus ITIMs: striking a balance during cell regulation. *J Clin Invest* 2002;109:161-168.
550. Lanier LL. On guard-activating NK cell receptors. *Nat Immunol* 2001;2:23-27.
551. Boyington JC, Brooks AG, Sun PD. Structure of the killer cell immunoglobulinlike receptors and their recognition of the class I MHC molecules. *Immunol Rev* 2001;181:66-78.
552. Wagtmann N, Rajagopalan S, Winter CC, et al. Killer cell inhibitory receptors specific for HLA-C and HLA-B identified by direct binding and by functional transfer. *Immunity* 1995;3:801-809.
553. Fan QR, Garboczi DN, Winter CC, et al. Direct binding of a soluble natural killer cell inhibitory receptor to a soluble human leukocyte antigen-Cw4 class I major histocompatibility complex molecule. *Proc Natl Acad Sci U S A* 1996;93:7178-7183.
554. Mandelboim O, Reyburn HT, Sheu EG, et al. The binding site of NK receptors on HLAC molecules. *Immunity* 1997;6:341-350.
555. Boyington JC, Motyka SA, Schuck P, et al. Crystal structure of an NK cell immunoglobulin-like receptor in complex with its class I MHC ligand. *Nature* 2000;405:537-552.
556. Fan QR, Long EO, Wiley DC. Crystal structure of the human natural killer cell inhibitory receptor KIR2DL1-HLA-Cw4 complex. *Nat Immunol* 2001;2: 452-460.
557. Chapman TL, Heikeman AP, Bjorkman PJ. The inhibitory receptor LIR-1 uses a common binding interaction to recognize class I MHC molecules and the viral homolog v L18. *Immunity* 1999;11:603-613.
558. Lopez-Bodet M, Perez-Villar JJ, Carretero M, et al. Structure and function of the CD94 C-type lectin receptor complex involved in recognition of HLA class I molecules. *Immunol Rev* 1997;155:165-174.
559. Boyington JC, Riaz AN, Patamewenu A, et al. Structure of CD94 reveals a novel C-type lectin fold: implications for the NK cell-associated CD94/NKG2 receptors. *Immunity* 1999;10:75-82.
560. Borrego F, Ulbrecht M, Weiss EH, et al. Recognition of human histocompatibility leukocyte antigen (HLA)-E complexed with HLA class I signal sequence-derived peptides by CD94/NKG2 confers protection from natural killer cell-mediated lysis. *J Exp Med* 1998;187:813-818.
561. Brand VM, Allan DS, O'Callaghan CA, et al. HLA-E binds to natural killer cell receptors C94/NKG2A, B, and C. *Nature* 1998;391:795-799.
562. Brand VM, Allan DSJ, Wilson D, et al. TAP- and tapasin-dependent HLA-E surface expression correlates with the binding of an MHC class I leader peptide. *Curr Biol* 1997;8:1-10.
563. Michaëlsson J, Texeira de Matos C, Achour A, et al. A signal peptide derived from hsp60 binds HLA-E and interferes with CD94/NKG2a recognition. *J Exp Med* 2002;196:1403-1414.
564. Long EO, Rajagopalan S. Stress signals activate natural killer cells. *J Exp Med* 2002;196:1399-1402.
565. Hayakawa Y, Smyth MJ. NKG2D and cytotoxic effector function in tumor immune surveillance. *Semin Immunol* 2006;18:176-185.

566. Deng L, Mariuzza RA. Structural basis for recognition of MHC and MHC-like ligands by natural killer cell receptors. *Semin Immunol* 2006;18: 159-166.
567. Vetter CS, Groh V, Thor Straten P, et al. Expression of stress-induced MHC class I related chain molecules on human melanoma. *J Invest Dermatol* 2002;118:600-605.
568. Li P, Morris DL, Williox BE, et al. Complex structure of the activating immunoreceptor NKG2D and its MHC class I-like ligand MICA. *Nat Immunol* 2001;2:443-451.
569. Li P, Willie ST, Bauer S, et al. Crystal structure of the MHC class I homolog MIC-A, a gamma delta T cell ligand. *Immunity* 1999;10:577-584.
570. Gilfillan S, Ho EL, Cella M, et al. NKG2D recruits two distinct adaptors to trigger NK cell activation and costimulation. *Nat Immunol* 2002;3:1150-1155.
571. Upshaw JL, Leibson PJ. NKG2D-mediated activation of cytotoxic lymphocytes: unique signaling pathways and distinct functional outcomes. *Semin Immunol* 2006;18:167-175.
572. Radaev S, Rostro B, Brooks AG, et al. Conformational plasticity revealed by the cocrystal structure of NKG2D and its class I MHC-like ligand ULBP3. *Immunity* 2001;15:1039-1049.
573. Cosman D, Mullberg J, Sutherland CL. ULPs, novel MHC class I-related molecules bind to CMV glycoprotein UL16 and stimulate NK cytotoxicity through the NKG2D receptor. *Immunity* 2001;14:123-133.
574. Sutherland CL, Chalupny NJ, Cosman D. The UL16-binding proteins, a novel family of MHC class I-related ligands for NKG2D, activate natural killer cell functions. *Immunol Rev* 2001;181:185-192.
575. Sentman CL, Barber MA, Barber A, et al. NK cell receptors as tools in cancer immunotherapy. *Adv Cancer Res* 2006;95:249-292.
576. NK Cells. MHC class I antigens and missing self. *Immunol Rev* 1997;115. (Several papers devoted to "missing self hypothesis.")
577. Karre K. How to recognize a foreign submarine. *Immunol Rev* 1997;155:5-9.
578. Raulet DH. Missing self recognition and self tolerance of natural killer (NK) cells. *Semin Immunol* 2006;18:145-150.
579. Raulet DH, Vance RE. Self-tolerance of natural killer cells. *Nat Rev Immunol* 2006;6:520-531.
580. Campbell KS, Colonna M. DAP12: a key accessory protein for relaying signals by natural killer cell receptors. *Int J Biochem Cell Biol* 1999;31:631-636.
581. Smyth MJ, Godfrey DI, Trapani JA. A fresh look at tumor immunosurveillance and immunotherapy. *Nat Immunol* 2001;16:359-366.
582. Fuchs A, Colonna M. The role of NK cell recognition of nectin and nectin-like protein in tumor immunosurveillance. *Semin Cancer Biol* 2006;16:359-366.
583. Yen JH, Moore BE, Nakajima T, et al. MHC class I-recognizing receptors are disease risk genes in rheumatoid arthritis. *J Exp Med* 2001;193:1-10.
584. Farag SS, Fehninger TA, Ruggeri L, et al. Natural killer cell receptors: new biology and insights into the graft-versus-leukemia effect. *Blood* 2002;100:1935-1947.
585. Murphy WJ, Koh CY, Raziudolin A, et al. Immunobiology of natural killer cells and bone marrow transplantation: merging of basic and preclinical studies. *Immunol Rev* 2001;181:279-289.
586. Ruggeri L, Capanni M, Urbani E. Effectiveness of donor natural killer cell alloreactivity in mismatched hematopoietic transplants. *Science* 2002;295:2097-3100.
587. Smyth MJ, Cretney E, Kelly JM, et al. Activation of NK cell cytotoxicity. *Mol Immunol* 2005;42:501-510.
588. See DM, Khemka P, Sahl L, et al. The role of natural killer cells in viral infections. *Scand J Immunol* 1997;46:217-224.
589. Biron CA, Byron KS, Sullivan JL. Severe herpes virus infections in an adolescent without natural killer cells. *N Engl J Med* 1989;320:1731-1735.
590. Gazzinelli RT, Hieny S, Wynn TA, et al. Interleukin 12 is required for the T-lymphocyte-independent induction of interferon gamma by an intracellular parasite and induces resistance in T-cell-deficient hosts. *Proc Natl Acad Sci U S A* 1993;90:6115-6119.

591. Trinchieri G. Interleukin-12: a proinflammatory cytokine with immunoregulatory functions that bridge innate resistance and antigen-specific adaptive immunity. *Annu Rev Immunol* 1995;13:251-276.
592. Sullivan JL, Byron KS, Brewster FE, et al. Deficient natural killer cell activity in Xlinked lymphoproliferative syndrome. *Science* 1980;210:543-545.
593. Strayer DR, Carter WA, Mayberry SD, et al. Low natural cytotoxicity of peripheral blood mononuclear cells in individuals with high familial incidences of cancer. *Cancer Res* 1984;44:370-374.
594. Whiteside TL, Herberman RB. The role of natural killer cells in human disease. *Clin Immunol Immunopathol* 1989;53:1-23.
595. Yu YY, Kumar V, Bennett M. Murine natural killer cells and marrow graft rejection. *Annu Rev Immunol* 1992;10:189-213.
596. Cudkowicz G, Hochman PS. Do natural killer cells engage in regulated reactions against self to ensure homeostasis? *Immunol Rev* 1979;44:13-41.
597. Ault KA, Antin JH, Ginsburg D, et al. Phenotype of recovering lymphoid cell populations after marrow transplantation. *J Exp Med* 1985;161: 1483-1502.
598. Reittie JE, Gottlieb D, Heslop HE, et al. Endogenously generated activated killer cells circulate after autologous and allogeneic marrow transplantation but not after chemotherapy. *Blood* 1989;73:1351-1358.
599. Jacobs R, Stoll M, Stratmann G, et al. CD16CD56+ natural killer cells after bone marrow transplantation. *Blood* 1992;79:3239-3244.
600. Hansson M, Beran M, Andersson B, et al. Inhibition of in vitro granulopoiesis by autologous allogeneic human NK cells. *J Immunol* 1982;129:126-132.
601. Matera L, Santoli D, Garbarino G, et al. Modulation of in vitro myelopoiesis by LGL: different effects on early and late progenitor cells. *J Immunol* 1986;136:1260-1265.
602. Picker LJ, Furst A, Robingson SH, et al. Immunoarchitecture of the bone marrow in neutropenia: increased HNK-1+ cells define a subset of neutropenic patients. *Am J Hematol* 1987;25:29-41.
603. Hanna J, Goldman-Wohl D, Hamani Y, et al. Decidual NK cells regulate key developmental processes at the human fetal-maternal interface. *Nat Med* 2006;12:1065-1074. Online publication.
604. Pandolfi F, Loughran TP Jr, Starkebaum G, et al. Clinical course and prognosis of the lymphoproliferative disease of granular lymphocytes. A multicenter study. *Cancer* 1990;65:341-348.
605. Loughran TP Jr, Kadin ME, Starkebaum G, et al. Leukemia of large granular lymphocytes: association with clonal chromosomal abnormalities and auto-immune neutropenia, thrombocytopenia, and haemolytic anemia. *Ann Intern Med* 1985;102:169-175.
606. McKenna RW, Arther DC, Gajl-Peczalska KJ, et al. Granulated T cell lymphocytosis with neutropenia: malignant or benign chronic lymphoproliferative disorder? *Blood* 1985;66:259-266.
607. Rambaldi A, Pelicci PG, Allavena P, et al. T cell receptor β chain gene rearrangements in lymphoproliferative disorders of large granular lymphocytes/natural killer cells. *J Exp Med* 1985;162:2156-2161.
608. Loughran TP Jr, Starkebaum G. Large granular lymphocyte leukemia. Report of 38 cases and review of the literature. *Medicine* 1987;66:397-405.
609. Chan WC, Link S, Mawle A, et al. Heterogeneity of large granule lymphocyte proliferations: delineation of two major subtypes. *Blood* 1986;68:1142-1153.
610. Scott CS, Richards SJ. Classification of large granular lymphocyte (LGL) and Nk-associated (NKa) disorders. *Blood Rev* 1992;6:220-233.
611. Loughran TP Jr. Clonal diseases of large granular lymphocytes. *Blood* 1993;82:1-14.
612. Sun T, Brody J, Koduru P, et al. Study of the major phenotype of large granular T-cell lymphoproliferative disorder. *Am J Clin Pathol* 1992;98:516-521.

613. Imamura N, Kusunoki Y, Kawa-Ha K, et al. Aggressive natural killer cell leukaemia/lymphoma: report of four cases and review of the literature. Possible existence of a new clinical entity originating from the third lineage of lymphoid cells. *Br J Haematol* 1990;75:49-59.
614. Godfrey DI, MacDonald HR, Kronenberg M, et al. NKT cells: what's in a name. *Nat Rev Immunol* 2004;4:231-237.
615. Brossay L, Chioda M, Burdin N, et al. CD1d-mediated recognition of an α -galactosylceramide by natural killer T cells is highly conserved through mammalian evolution. *J Exp Med* 1998;188:1521-1528.
616. Taniguchi M, Harada M, Kojo S, et al. The regulatory role of V α 14 NKT cells in innate and acquired immune response. *Annu Rev Immunol* 2003;21:483-513.
617. Prochorec-Sobieszek M. Advances in diagnosis and treatment of large granular lymphocyte syndrome. *Curr Opin Hematol* 2010 Oct. 21 (Epub ahead of print)
618. MacDonald HR. CD1d-glycolipid tetramers: a new toll to monitor natural killer T cells in health and disease. *J Exp Med* 2000;192:F15-F19.
619. Coles MC, Raulet DH. NK1.1+ T cells in the liver arise in the thymus and are selected by interactions with class I molecules on CD4+CD8+ cells. *J Immunol* 2000;164:2412-2418.
620. Kronenberg M, Gapin L. The unconventional lifestyle of NKT cells. *Nat Rev Immunol* 2002;2:557-568.
621. van der Vliet HJJ, Nishi N, de Gruijl TD, et al. Human natural killer T cells acquire a memory-activated phenotype before birth. *Blood* 2000;95:2440-2442.
622. Dark SH, Banlagha K, Lee D, et al. Unaltered phenotype, tissue distribution and function of V α 14+ NKT cells in germ-free mice. *Eur J Immunol* 2000;30:620-625.
623. Ikarashi Y, Mikami R, Bendelac A, et al. Dendritic-cell maturation overrules H-2Dmediated natural killer T (NKT)-cell inhibition. Critical role for B7 in CD1d-dependent NKT-cell interferon- γ production. *J Exp Med* 2001;194:1179-1186.
624. van der Vliet HJJ, Molleng JW, van Blomberg BME, et al. The immunoregulatory role of CD1d-restricted natural killer T cells in disease. *Clin Immunol* 2004;112:8-23.
625. Yu KOA, Porcelli SA. The diverse functions of CD1d-restricted NKT cells and their potential for immunotherapy. *Immunol Lett* 2005;100:42-55.
626. Gumperz JE, Miyake S, Yamamura T, et al. Functionally distinct subsets of CD1drestricted NKT cells revealed by CD1d tetramer staining. *J Exp Med* 2002;195:625-636.
627. Lee PT, Banlagha K, Teyton L, et al. Distinct functional lineages of human V α 24 natural killer T cells. *J Exp Med* 2002;195:637-641.
628. Burden N, Brossay L, Kronenberg M. Immunization with α -galactosyl ceramide polarized CD1-reactive NKT cells towards Th2 cytokine synthesis. *Eur J Immunol* 1999;29:2014-2225.
629. Singh N, Hong S, Scherer DC, et al. Cutting edge: activation of NKT cells by CD1d and α -galactosylceramide directs conventional T cells to the acquisition of a Th2 phenotype. *J Immunol* 1999;163:2373-2377.
630. Hong S, Wilson MT, Serizawa I, et al. The natural killer T cell ligand α -galactosylceramide prevents autoimmune diabetes in non-obese diabetic mice. *Nat Med* 2001;7:1052-1056.
631. Singh AK, Wilson MT, Hong S, et al. Natural killer T cell activation protects mice against experimental autoimmune encephalomyelitis. *J Exp Med* 2001;194:1801-1811.
632. Mieza MA, Itoh T, Cui JQ, et al. Selective reduction of V α 14+ NKT cells associated with disease development in autoimmune-prone mice. *J Immunol* 1996;156:4035-4040.
633. Sumida T, Sakamoto A, Murata H, et al. Selective reduction of T cells bearing invariant V α 24J α Q antigen receptor in patients with systemic sclerosis. *J Exp Med* 1995;182:1163-1168.
634. Kojo S, Adachi Y, Keeno H, et al. Dysfunction of T cell receptor AV24AJ18+, BV21+ double negative regulatory natural killer T cells in autoimmune diseases. *Arthritis Rheum* 2001;44:1127-1138.
635. Wilson SB, Kent SC, Horton HF, et al. Multiple differences in gene expression in regulatory V α 24J α Q T cells from identical twins discordant for type I diabetes. *Proc Natl Acad Sci U S A* 2002;97:7411-7416.

636. Linsen L, Somers V, Stinissen P. Immunoregulation of autoimmunity by natural killer T cells. *Hum Immunol* 2005;66:1193-1202.
637. Kaer Van L. Regulation of immune responses by CD1d-restricted natural killer T cells. *Immunol Res* 2004;30:139-153.
638. Hammond KJL, Kronenberg M. Natural killer T cells: natural or unnatural regulators of autoimmunity. *Curr Opin Immunol* 2003;15:683-689.
639. Smyth MJ, Crowe NV, Hayakawa Y, et al. NKT cells—conductors of tumor immunity? *Curr Opin Immunol* 2002;14:165-171.
640. Terabe M, Matsui S, Noben-Trauth N, et al. NKT cell-mediated repression of tumor immunosurveillance by IL-13 and the IL-4R-STAT6 pathway. *Nat Immunol* 2000;1:515-520.
641. Moodycliffe AM, Clydesdale C, Ullrich SE. Immune suppression and skin cancer development: regulation by NKT cells. *Nat Immunol* 2000;1:521-525.
642. Park S-H, Kyin T, Bendelac A, et al. The contribution of NKT cells, NK cells, and other γ -chain-dependent non-T, non-B cells to IL-12 mediated rejection of tumors. *J Immunol* 2003;170:1197-1201.

Chapter 14 Effector Mechanisms in Immunity

> Table of Contents > Part II - The Normal Hematologic System > Section 4 - The Lymphocytes > Chapter 14 - Effector Mechanisms in Immunity

Chapter 14

Effector Mechanisms in Immunity

Frixos Paraskevas

MAJOR HISTOCOMPATIBILITY COMPLEX

The function of the immune system is under genetic control¹ and molecular genetic studies have helped to elucidate the mechanism of gene regulation of immune functions.² The genes that regulate immune functions are found in the chromosomal region of the major histocompatibility complex (MHC) involved in defining histocompatibility for transplantation, and these antigens have been given specific names in different species, i.e., human leukocyte antigens (HLAs) in humans and histocompatibility-2 or H2 in the mouse.

The HLA complex extends approximately over 4,000 kilobases (kb) on the short arm of chromosome 6, i.e., 6p21-3, whereas the H2 complex is located on chromosome 17 and occupies a segment that is halfway between the centromere and the telomere. Approximately 180 genes have been located within the HLA region and the number grows constantly with the increase in sensitivity and sophistication of techniques of molecular biology.

The complex is divided into three regions: (a) the class I region occupies the most distal (telomeric) end of the short arm of the chromosome and spans approximately 1.8 megabases (Mb); (b) the class II region (approximately 1 Mb) occupies the most centromeric end of the chromosome; and (c) the class III region is between the other two regions² (Fig. 14.1).

Class I Region

Of the polymorphic class I genes HLA-A, HLA-B, and HLA-C, the HLA-B is the most centromeric and HLA-A is the most telomeric; the HLA-C is between the two but closest to HLA-B. There are several nonclassical class I or Ib genes that include HLA-E, HLA-F, HLA-G, HLA-H, HLA-I, HLA-J, HLA-K, and HLA-L, as well as several pseudogenes and gene fragments.^{2,3,4,5} Pseudogenes give products that do not associate with β_2 microglobulin (β_2m), probably as a result of deleterious mutations, and the gene fragments are not expressed because the genes are severely disrupted. In the human MHC class I region, which spans 1.8 Mb from the MICB gene to the HLA-F gene at the telomeric end of the HLA region, there are 118 genes (73 known and 45 new genes), i.e., one gene for every 15.2 kb. The G+C content on average is 45.8%⁶ and contains three classical HLA class I genes, HLA-A, HLA-B, and HLA-C; three nonclassical class I genes, HLA-E, HLA-F, and HLA-G; and two of the nonclassical MHC class I chain-related (MIC) genes MICA and MICB. The class I region also contains 50 non-HLA genes. A number of diseases including Behçet syndrome, ankylosing spondylitis, ulcerative colitis, Takayasu arteritis, and Hashimoto thyroiditis, are associated with a particular class I allele. The large-scale genomic sequencing has greatly facilitated the clarification of gene organization and identification, as well as mapping of the disease-susceptible genes.⁷ A total of 758 microsatellite repeats have been identified consisting of two, three, four, or five nucleotides. They can be used as markers for mapping the exact location of the disease that is associated with the HLA genes. Class I genes

are composed of eight coding sequences or exons that are separated by noncoding sequences or introns. Of the eight exons that correspond to the domains of the protein the first encodes the hydrophobic N-terminal precursor or leader sequence and the second, third, and fourth exons encode the three extracellular domains. A fifth exon encodes the hydrophobic transmembrane segment and the basic residues that act as an anchor. The sixth and seventh exons are small, coding for the cytoplasmic domain of the molecule. The second and third exons are the most polymorphic whereas the fourth exon is the most conserved.

Class II Region

The MHC class II molecule consist of two chains, α and β , each having two extracellular domains $\alpha 1$, $\alpha 2$ and $\beta 1$, $\beta 2$ and a transmembrane domain, which anchors the molecule to the cell membrane.⁵ A peptide-binding groove formed by the $\alpha 1$ and $\beta 1$ domains of the molecule presents the foreign peptides to $CD4^+$ lymphocytes. The nonclassic molecules are detected in internal membranes such as lysosomes. The human class II molecules were originally defined by mixed lymphocyte cultures and because participation of class I, HLA-A, HLA-B, and HLA-C was excluded, the new region was called HLA-D and its specificities were defined with serological reagents obtained from multiparous women. The HLA-D (DR) is located on the centromeric (left) side of the HLA-B and consists of three subregions which in the direction of the telomere are HLA-DP, HLA-DQ, HLA-DR. The genes of the class II region have a 40% G, C content with only one gene for every 25 kb, i.e., much lower in density than class I (15.2/kb) or class III (14.3/kb) regions. The α chain is composed of five exons and the β chain consists of six exons. The sequence of the α chain contains five regions: i.e., (a) signal sequence, (b) $\alpha 1$ domain, (c) $\alpha 2$ domain, (d) transmembrane region and cytoplasmic tail, and (e) an untranslated 3' region. By comparison with murine class II genes, considerable gene expansion has apparently taken place in the evolution of human MHC. Many more α and β chains are in the human class II region and the DR molecule is homologous to the murine E molecule whereas the human DQ molecule is homologous to the murine A molecule.

The genes encoding the α and β chains of class II molecule are designated A and B, respectively, and a DR contains one A gene, three B genes, and pseudogenes.⁸ The α chain can associate with two different β chains to give two different molecules. In the DQ and DP subregions, only one set of genes (A and B) is expressed, and the genes in the other set are pseudogenes. Not all class II molecules that are encoded by these genes are polymorphic. For example, the DR α chain is not polymorphic, and the DP α shows only limited polymorphism.

Within the class II region, several genes encode proteins that are related to antigen processing. Two of them, PSMB9 and PSMB8 (previously known as LMP2 and LMP (for large multifunctional protease), are subunits of the proteasome that cleaves peptides from antigens that are present in the cytoplasm to be transported and loaded on class I molecules.⁹

Also close to these genes are the TAP1 and TAP2 genes (transporters associated with antigen presentation), which encode the proteins that transport the peptides from cytosol across the endoplasmic reticulum (ER) membrane to be loaded on class I.¹⁰ The DR subregion has several haplotypes. The DRA gene is the most telomeric of all class II genes.

The DQ subregion has two pairs of DQ genes, but one of them is nonfunctional. The DP also has two pairs of genes, but only one is expressed, and the others are pseudogenes. Within the class II region are the genes for the nonclassical molecules DMA and DMB, which are distantly related to classical loci (approximately 30% amino acid identity) and must have duplicated from them at an early stage. There are no polymorphic variations in humans in the DM gene. The DN and DO genes, as does DM, may play a role in peptide editing.¹¹

P.314

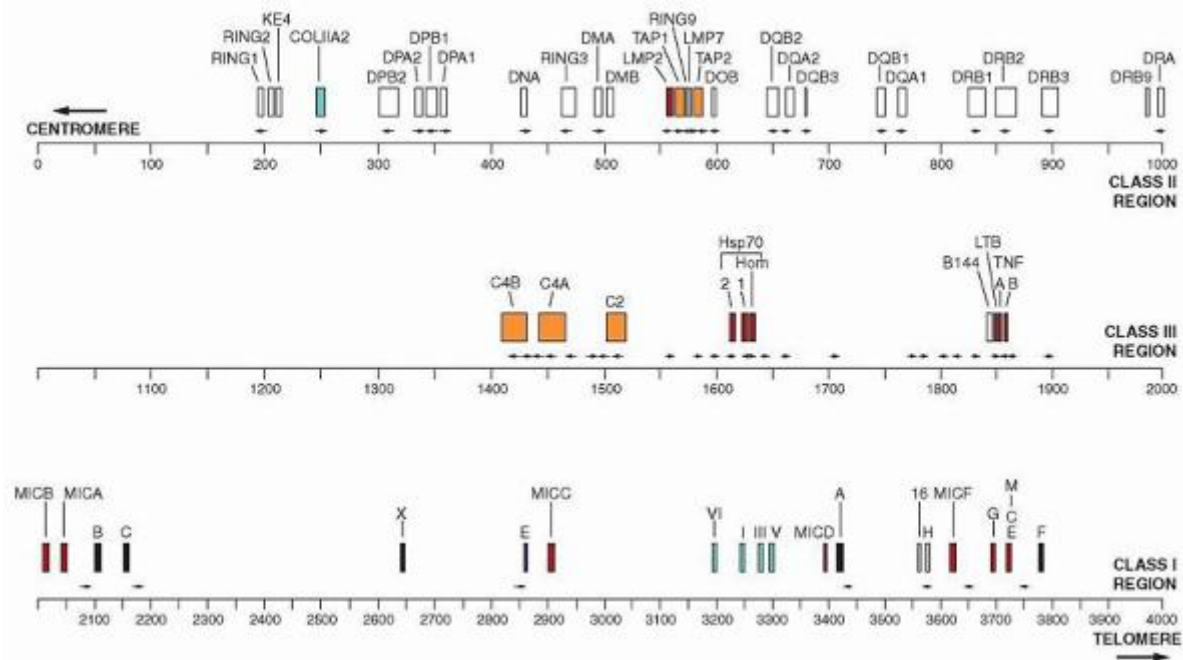

FIGURE 14.1. The human major histocompatibility complex contains genes that are grouped in three regions. Closest to the centromere is the class II region, followed by the class III region, and finally the class I region. Within the class II region are proteasome genes and TAP-1 and TAP-2 genes. The class II genes are located from the centromere in the order DP, DQ, and DR. The class III region contains genes of the complement system heat-shock protein 70, tumor necrosis factor- α , and tumor necrosis factor- β . The class I region contains the genes for the α chain of the HLA-A, HLA-B, and HLA-C molecules and the genes that encode the newly discovered class Ib molecules, such as HLA-E, HLA-F, HLA-G, HLA-H.

Other genes in the class II region are antigen-processing genes. They constitute a cluster of four genes. Two of them, TAP1 and TAP2, are adenosine triphosphate (ATP)-binding cassette (ABC) transporters (for structure and function, see section “Antigen Processing and Presentation”). The proteasome genes, PSMB9 and PSMB8, are both members of the catalytic subunit of proteasome (see section “Antigen Processing and Presentation”).

Class III Region

The class III genes encode proteins that do not participate in antigen presentation, such as the genes of certain components of the classical and alternative complement pathways (C4, C2, and B), as well as the genes of tumor necrosis factor TNFA and TNFB, HSP70 and the 21-hydroxylase-producing gene (CYP21A2). Telomeric to the class III region is a group of genes that encode the proteins involved in inflammation or infection, such as the tumor necrosis factor (TNF)- α , TNF- β (LTA), and LTB cytokines. It has been proposed that this region should be named the class IV region.¹²

The genes of class I and class II regions are present in multiple alleles or, in other words, alternate forms that are defined by distinct DNA sequences. The combination of all HLA-I and HLA-II alleles is known as the haplotype. Because the HLA genes are expressed co-dominantly, each individual therefore inherits two haplotypes. Each class I locus has several alleles, and, according to an adopted nomenclature, each allele is defined by its locus, an asterisk, and a four-digit number. The number that defines the allele relates to the serologically defined antigen that is detected on a molecule that is synthesized by the allele (first two digits) and allows discrimination between closely related alleles (last two digits). For example, the B27 locus has at least seven identifiable alleles, which are defined as HLA-B*2701 through HLA-B*2707.

Major Histocompatibility Complex Class II Molecules

Class II molecules are encoded by the MHC genes HLA-A, HLA-B, and HLA-C. Another group of molecules that are structurally homologous to the class I molecules (44% to 82%) has been detected. These molecules are known as class I-b¹³ to distinguish them from the classical class-I molecules that are now called class I-a. Some of the class I-b molecules are encoded by the MHC-linked genes, HLA-E, HLA-F, and HLA-G, whereas others, such as CD1 and certain CTMV genes, are encoded by non-MHC genes. The MHC class II molecule is a heterodimer consisting of an alpha (α) and a beta (β) chain both encoded by the MHC, whereas the class-I molecule is a heterodimer consisting of an α -chain and the β 2m of 12 kD¹⁴ (Fig. 14.2). The α chain is divided into three extracellular domains, α_1 , α_2 , and α_3 . Except for the domain that is most distal to the membrane (α_1), the other two consist of a loop that is formed by a disulfide bond. The transmembrane portion

consists of hydrophobic residues and terminates in five amino acids, including three arginines (Arg) and one lysine (Lys) that anchor the molecule to the membrane. The variable residues are clustered in seven sequences,¹⁵ three of which are in the α_1 domain and four of which are in the α_2 domain. The α_3 domain is highly conserved. Amino acids 223, 227, and 229 in the α_3 domain are critical for interaction with CD8.¹⁶

The structure of β_2m consists of one Ig domain with one disulfide bond and is highly homologous between species and homologous to the CH₃ domain of human Ig and to the α_3 domain of the class I molecule to which it is noncovalently associated.

The L chain plays an important role in the transport of the α chain, because cells that are derived from patients with Burkitt lymphoma, who are unable to synthesize β_2m , do not express

P.315

HLA antigens. All three extracellular domains of the α chain are in contact with β_2m .¹⁷

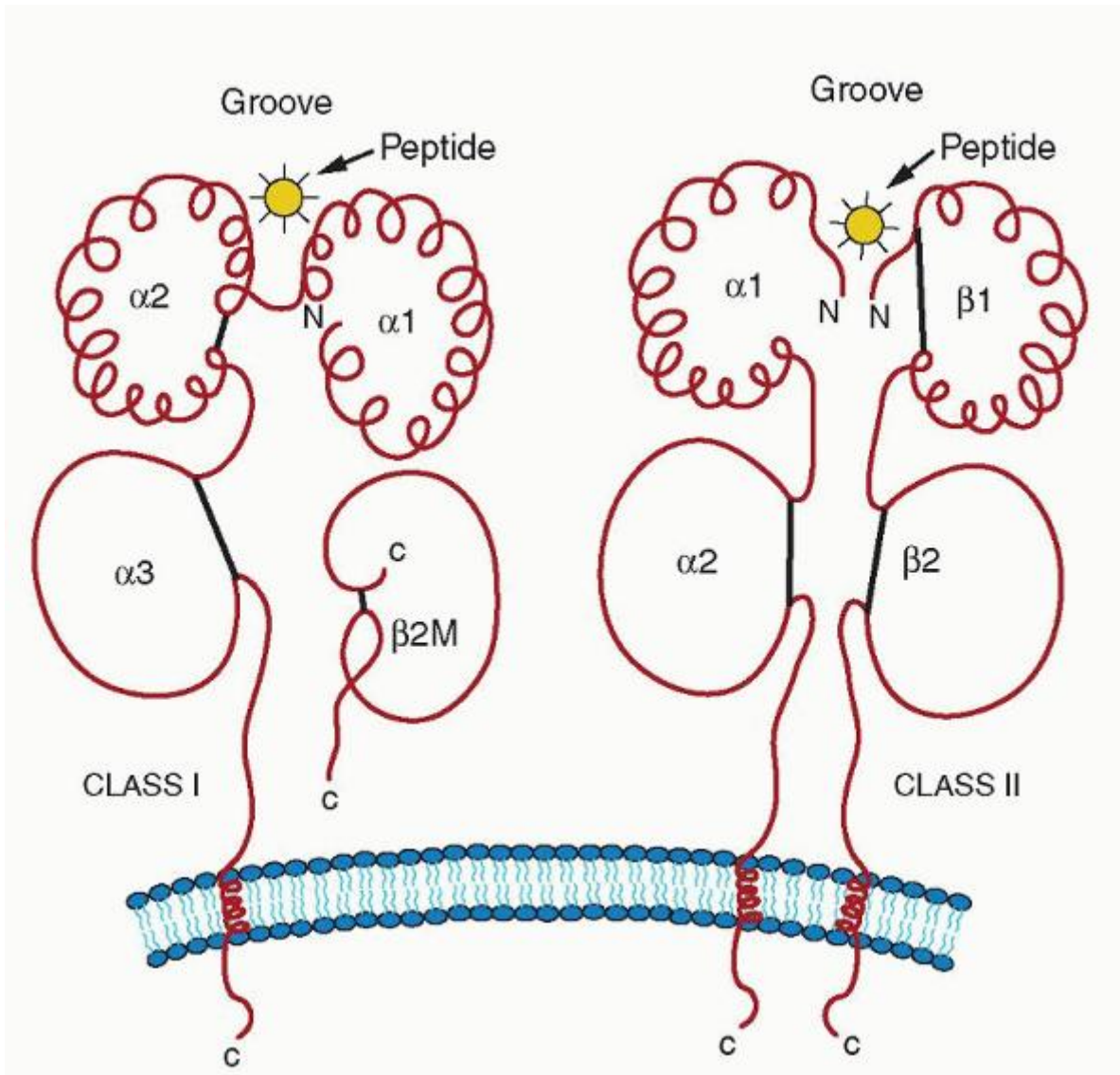

FIGURE 14.2. Structure of class I and class II major histocompatibility complex molecules. The class I molecule is a heterodimer of a heavy chain or α chain and a noncovalently associated light chain, β_2 microglobulin (β_2m). The α chain consists of three domains: the N terminal α_1 , followed by α_2 and an immunoglobulinlike α_3 domain. The β_2m protein is homologous to the CH₃ immunoglobulin domain, located underneath the α_1 domain. The class II molecule is a heterodimer of two chains, α and β . The N-terminal polymorphic domain from each chain forms the peptide groove.

β_2m is present on all cells, and small amounts are shed into body fluids. Because of its low molecular weight, it is filtered out rapidly by the glomeruli, but it is re-absorbed from the kidney tubules and then catabolized. In patients with kidney diseases in whom tubular function is impaired, increased amounts of β_2m are detected in the urine. It is also found in increased quantities in the serum and in other fluids from individuals with certain malignancies, such as lymphomas and myelomas.

The crystallographic structure of HLA class I markedly helped the understanding of the function of the molecule.¹⁸ β_2m and the α_3 domain form the base that supports the α_1 and α_2 domains. Each of the α_1 and α_2 domains consists of four antiparallel β strands and one α helix. This structure is similar to that of the class II molecule shown in Figure 14.3. Seeing them from the top, the way the T-cell receptor (TCR) does, the juxtaposition of the two domains isolates a longitudinal cavity, which is commonly known as the groove, which is 30 Å long and 12 Å wide in the middle. Its floor consists of the β -pleated sheets of the α_1 and α_2 domains ("intramolecular dimer"), and the side walls are two α helices, one each from the α_1 and α_2 domains. The MHC I groove tapers at both ends to a width of approximately 5 Å and then is blocked completely by bulky amino acid side chains (Tyr84 and Trp167), which are conserved in virtually all class I MHCs.¹⁷ It is lined by a series of pockets (A to F), which are sites of interaction with the peptide.

The polymorphism of the class I molecule is particularly concentrated in the groove,¹⁹ and yet certain residues are strongly conserved among virtually all class I molecules. These residues surround, on the left and right ends of the groove, the first and last pockets (A and F), which bind the N terminus and C terminus of the peptide, respectively. The other pockets line the central portion of the groove and are also involved in peptide binding.²⁰ Many of the MHC side chains that contribute to the formation of the pockets are polymorphic, and, as a result, the architecture of the pockets varies among the class I molecules. In some molecules, a bulky side chain may block a pocket that is open in another molecule. In other molecules, a smaller polymorphic amino acid may extend the size of the pocket.²¹ This may explain the fact that there are sequence restrictions on the final residue of the peptides.²² A given groove can bind hundreds or even thousands of different peptides, which are identical or homologous at only a few side-chain positions.^{22,23} Side chains from the MHC residues protrude into the groove from the α helices and the β sheet and form an irregular surface along the length of the groove, so that side pockets extend out from the main cavity.²⁴

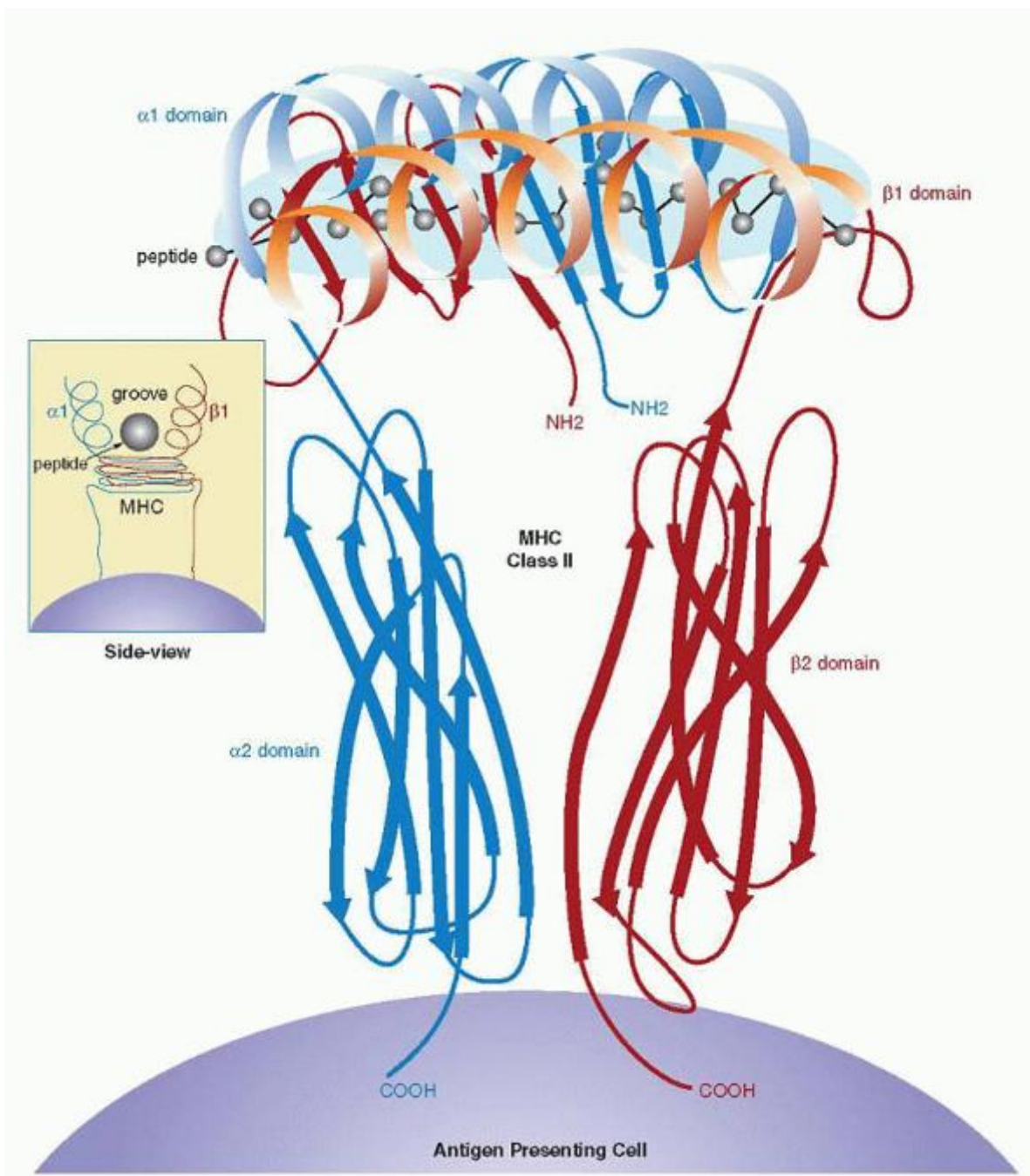

FIGURE 14.3. Drawing of a major histocompatibility complex (MHC) class II molecule-peptide complex. The MHC class II molecule forms a groove with walls that are made by α helices from the $\alpha 1$ and $\beta 1$ domains and a floor by β -pleated sheets formed by antiparallel β strands from each chain. The peptide is usually long (15 to 25 residues) and projects from both ends, which are not closed (as with MHC class I molecules).

A class I molecule usually accommodates within the groove peptides that are nine amino acids long and that bind with an affinity that is 100- to 1,000-fold higher than longer or shorter peptides. The binding of the peptides is mediated by certain amino acids that are known as anchor residues (sequence-dependent binding). The set of anchor residues that binds to a certain MHC molecule is known as a sequence motif. It allows the identification of peptides within a complex immunogen that are likely to bind to class I MHC. Hydrogen bonds between the peptide and conserved MHC I side chains provide stability to the peptide binding, which is sequence-independent.²⁵ A prominent kink or arch is found approximately one third of the way from the N terminus, which lifts the peptide up, away from the main floor.

The arch that is formed by the peptide contributes to the antigenic specificity of the complex, despite the fact that 73% to 83% of the peptide surface is buried by the MHC in the complex. A number of side chains that do not affect the binding of the peptide to the MHC contribute strikingly to the TCR binding (flag side chains).²⁶ Antigenic specificity is provided not only by the flag side chains, but also by the conformational flexibility of the

P.316

peptide. Peptides that differ in length are usually accommodated by buckling at the center of the cleft.

In many different peptides, the flag side chains are prominently exposed at the surface of the complex and provide TCR with a direct access to the antigenic identity of the bound peptide. The upward-pointing orientation of flag side chains, such as P1 and P4, is conserved in many different HLA-A2-peptide complexes. Some peptides are sandwiched between the MHC and the TCR and make contact with both molecules.

In conclusion, the requirements to satisfy the vast and exquisite specificity of the TCR are provided by the peptide-MHC complex, which is formed with only a small number of nonvariable MHC molecules. The peptide binding is contributed to peptide-MHC complex formation by sequence-dependent binding and is supplemented by sequence-independent interactions of the primary anchor side chains in specific MHC pockets. These interactions, although constraining the conformation of class I-bound peptides at both ends, leave the center relatively free to adopt a conformation that optimizes the secondary anchor and other interactions with the MHC molecule. The MHC molecule is a remarkable tool with which evolution has achieved so much by so little.

Class II Molecules

The second group of MHC genes, the class II genes, encode glycoproteins that regulate cell interactions in the immune response. The genes reside in the D region of the MHC in humans and in the I region of the MHC in the mouse. The class II proteins are also referred to as Ia antigens (immune response antigens). They are not as widely distributed as the class I molecules. They are found in high concentrations on B lymphocytes and on a subpopulation of macrophages, as well as on dendritic cells (DCs). On T cells, small quantities are detectable under conditions that are associated with T-cell activation in vitro or during the course of certain diseases. However, human T cells may acquire Ia antigens from other cells, and murine T lymphocytes acquire Ia antigens passively from macrophages.²⁷ A variety of cell types expresses Ia antigens in response to interferon (IFN)- γ including vascular endothelial cells,²⁸ melanoma cells, and brain astrocytes.

The human class II molecule is a heterodimer of two noncovalently linked proteins, an α chain (34 kDa) and a β chain (29 kDa).²⁹ Each chain can be divided into four domains, two of which form the extracellular region in each chain, and the third and fourth correspond to the transmembrane segment and the intracellular part of the chain, respectively. With the exception of the α_1 domain, the other three domains (α_2 , β_1 , and β_2) are loops that are formed by disulfide bonds. The α_2 and β_2 domains are homologous to the Ig constant domain. The human DR, DQ, and DP β chains and the DQ α chains are polymorphic, and only the DR α chains and DP α chains seem to be invariant (Ii).

The assembly and expression of class II molecules involves a third chain that is known as Ii (CD74),³⁰ which is encoded by a gene on chromosome 5. Complementary DNA clones have been isolated, and the amino acid sequence indicates that the Ii chain is a type II transmembrane protein; that is, the N terminal is inside the cell. When synthesized in the absence of MHC class II molecules, the Ii chain exists as a trimer or even as a hexamer.³¹ The complex of the Ii chain with the class II α and β chains is a nonamer that consists of a core of three Ii chains, each one associated with an α and β class II dimer.³²

However, a peptide from the N terminal two thirds of the I chain, which is known as a class II associated invariant chain peptide (CLIP), inhibits the binding of the antigenic peptides to the class II molecule.³³ The assembly of the class II Ii chain complex occurs in the ER. Class II α/β dimers that are formed in the absence of the Ii chain are poorly expressed on the cell surface and remain in the ER, as they cannot maintain their normal folded structure. In the assembly of multimeric proteins, certain ER-associated proteins stabilize the partially folded subunits, thus preventing aggregation. These proteins are known as chaperons.³⁴

Another ER-resident protein that associates with class II chains is calnexin.³⁵ The class II molecule is transported to the Golgi apparatus and enters the endosomal-lysosomal system, where it is loaded with an antigenic peptide on its way to cell surface expression³⁶ (see section "Processing Antigen for Class II Presentation").

The polymorphism of the class II molecule is localized in the α_1 and β_1 domains. HLADR, HLA-DQ, and HLA-DP have three hypervariable regions in their β_1 domains, whereas the α_1 domain of HLA-DQ has only one hypervariable region.³⁷ The CD4 molecule interacts with amino acids 134 to 148 of the β_2 domain.^{38,39}

The crystallographic structure of the HLA-DR1 molecule reveals similarities with the structure of the HLA class I molecule.⁴⁰ The α_1 and β_1 domains form the peptide-binding groove (Fig. 14.3). As with the class I molecule, the floor is the β -pleated sheet, and the walls are the α helices from the α and β chains. The first two hypervariable regions are found on the floor, whereas the third hypervariable region is on the α helix of the β chain. The class II groove can accommodate longer peptides (10 to 25 residues), because, in contrast to the class I groove, it is open on both ends.⁴¹ Long peptides, which range from 15 to 25 residues, can bind in an extended conformation, projecting out of both ends of the groove. This contrasts with class I peptide binding, in which mostly nonamers bind with extended, but kinked, conformations, and the N and C termini of the peptides are bound to groove pockets. In class I molecules, the residues at the end of the groove are conserved, imposing tight binding for the peptides, but in the class II molecules, conserved residues are located at different intervals along the groove, making the peptide-binding side chain independent. The peptides in class II bind through the central region, and their N- and C-terminal ends protrude from the open ends of the groove.⁴⁰

Evidence from crystallographic studies indicates that the class II molecules exist as tetramers on the cell surface.⁴² Therefore, the geometry of the TCR-MHC peptide interaction places the complementarity-determining region (CDR)-3 loops of the $V\alpha$ and $V\beta$ chains of TCR in contact correspondingly with the N- and C-terminal ends of the peptide, whereas the CDR-1 and CDR-2 loops are in contact with the β_1 and α_1 domains. Ligand-induced dimerization of receptors is a general feature for cell activation and involves most of the known receptors.

MAJOR HISTOCOMPATIBILITY COMPLEX MOLECULES: NONCLASSICAL

Class I: Human Leukocyte Antigen-E, Human Leukocyte Antigen-F, and Human Leukocyte Antigen-G

The nonclassical class I HLA molecules are HLA-E, HLA-F, and HLA-G, and are also known as class Ib, to distinguish them from class Ia (HLA-A, HLA-B, and HLA-C). They constitute one group of the class Ib molecules, the other being the CD1 molecules, a non-MHC-linked group with genes that are located in chromosome 1. Class Ib molecules show limited polymorphism, and although their tissue expression is low, they play a significant role as molecules of antigen recognition.^{42,43} They form heterodimers with β_2m and have conserved key residues that interact with CD8.

Human Leukocyte Antigen-E

The structure of HLA-E is similar to that of the class Ia molecules,⁴⁴ with the β_2 and CD8 interaction sites being conserved.
P.317

The size of the HLA-E groove is structurally similar to that of the classical molecules. It preserves the crucial positions within the groove, of certain residues that determine the preference for binding the peptide. Peptides occupy all the pockets and as a result the HLA-E keeps the peptide tightly bound. The secure fastening of the peptides reinforces the favorable selection of a specific peptide.⁴⁵

The leader peptides of class Ia HLA molecules enter the cytosol after they are cleaved from the coding sequence and are then transported to the inside of the ER by the TAP transporter, to be loaded onto HLA-E.⁴⁶ Detection of HLA-E on the cell surface of $CD56^+CD16^+$ natural killer (NK) cells can be achieved accurately with HLA-E tetramers⁴⁷ (further information regarding HLA-tetramers can be found in Appendix A). The tetramers react with the CD94/NKG2A receptors, and HLA-E is a major ligand for this inhibitory receptor on NK cells⁴⁸ (see Chapter 13). Recognition of HLA-E by this receptor inhibits activation of NK cells and thus protects cells from being killed by the cytotoxic NK cells.⁴⁹ Because HLA-E is expressed with the leader peptides of MHC class I molecules, its presence on the cell surface sends signals to surveilling NK cells that there is no "missing self," that is, an absence of MHC class I molecules, and thus protects cells from being killed by NK cells. Rare $CD8^+$ T cells have been detected that bind HLA-E directly through the TCR.⁵⁰ Subversion of the protective mechanism that is conferred by HLA-E has been demonstrated with cytomegalovirus (CMV).

The leader peptide of the CMV glycoprotein gpUL40 is the same as the class Ia leader peptides, and, as a result, it binds to HLA-E.⁵¹ Although CMV down-regulates MHC class I expression on infected cells, thus rendering them susceptible to lysis by NK cells ("missing self"), it concomitantly up-regulates HLA-E, thus inhibiting lysis. This mechanism represents an escape route for CMV.

Another example of subversion of HLA-E function is the binding of heat-shock protein, HSP60, signal peptide.⁵² HSP60 is present in all normal cells and in eukaryotic cells and serves as a mitochondrial chaperon. Stress stimuli, such as heat, nutrient deprivation, toxic chemicals, and inflammation, up-regulate HSP60. Binding of the HSP60 signal peptide to HLA-E results in loss of its recognition by the CD94/NKG2A receptor and renders stressed cells susceptible to NK-cell lysis.

Human Leukocyte Antigen-F

The structure of HLA-F is not known in great detail, but some predictions have been made based on the known structure of HLA-E and the sequence analysis of HLA-F.⁴³ HLA-F tetramers stain monocytes and bind to Ig-like transcript (ILT) 2 and ILT4.^{47,53} ILT molecules, also known as leukocyte Ig-like receptors, are structurally and functionally related. They recognize HLA class I allotypes, rather than individual peptide-MHC complexes, and are expressed on monocytes, macrophages, and DCs. HLA-F is retained intracellularly, empty, but reaches cell surface after acquisition of its ligand.⁵⁴

Human Leukocyte Antigen-G

HLA-G shows limited polymorphism, restricted tissue distribution, and low levels of expression and therefore belongs to the nonclassical MHC molecules. In the HLA-G gene, all of the regulatory elements of HLA class I genes are missing, thus suggesting that its expression and distribution are uniquely regulated.⁵⁵ HLA-G is expressed strongly in extravillous cytotrophoblasts, endothelial cells of fetal vessels, and in other tissues, such as the thymus. It is not detected in syncytiotrophoblasts. Messenger RNA (mRNA) of HLA-G is detected in peripheral blood T and B cells, keratinocytes, fetal liver, and other cells.⁵⁶ Tetrameric complexes of HLA-G bind to monocytes, especially the CD16⁺ subpopulation, and react with ILT2 and ILT4 receptors, but they do not bind T, B, or NK cells.^{47,57}

The HLA-G gene transcribes six different transcriptional isoforms, membrane bound and soluble forms.⁵⁶ The complete transmembrane isoform HLA-G1 consists of three extracellular domains, whereas isoforms HLA-G2, HLA-G3, and HLA-G4 have one or two domains.

The peptide-binding pocket residues determine the specificity of the molecule. The isoforms HLA-G2 and HLA-G3 lack the α_2 domain and, as a result, do not bind peptides. They also do not bind the CD8 molecule and are therefore unable to present peptides. The HLA-G molecule has an antigen-presenting potential, but, because of the limited diversity of the peptides and its low polymorphism, the function of the molecule is rather restricted. However, it may still be sufficient, considering the limited species of viruses that infect the placenta.⁵⁶

Other than antigen-presenting functions, HLA-G may be more important for its role during pregnancy. HLA-G exerts inhibitory functions by several mechanisms. First, it binds directly to CD94/NKG2A, which is an inhibitory receptor^{58,59}; second, it binds to receptor KIR2DL4 on all NK cells that inhibit lysis of cells that express HLA-G⁶⁰; third, the leader peptide of HLA-G binds to HLA-E, which interacts with the inhibitory receptor CD94/NKG2A. HLA-G is strongly expressed in the placenta, and these inhibitory mechanisms are important for the protection of the fetus.

Class II: Human Leukocyte Antigen-DM and Human Leukocyte Antigen-DO

Human Leukocyte Antigen-DM

There are two nonclassical II proteins with their genes within the class II region, HLA-DM, with two genes, HLA-DMA and HLA-DMB on the centromeric site of TAP and PSMB genes. DMA and DMB encode the α and β chains of the DM molecule,⁶¹ which is detected in all class II expressing cells and is up-regulated by IFN- γ , together with classical class II molecules. Class II molecules associate with the li chain after they enter the ER and form nonameric complexes ($\alpha\beta li$)₃. Through the CLIP, the li chain prevents class II molecules from binding peptides within the ER (see details in the following discussion). The heterodimer DM is formed in the ER, and, by the time class II molecules pass through the endosomal system on the way to the cell surface, the DM protein has already arrived there by a multivesicular system that is known as the MHC class II compartment (MIIC). It is retained in MIIC by a tyrosine (Tyr)-based targeting motif (YTPL) that is located in the cytoplasmic tail of the β chain. DM transiently binds directly to the HLA class II-CLIP complex⁶² and induces the release of CLIP, whereas DM remains associated with the class II molecule until the peptide to be loaded has been found and is safely in place within the groove.⁶³

DM rescues empty HLA-II molecules from denaturation and loss of their peptide-binding capacity. Both HLA-II and DM are in an "acidic" environment, and conformational changes of both molecules seem to facilitate their interaction.⁶⁴

Another important function of the DM molecule after the removal of CLIP and maintenance of an intact three-dimensional structure of the class II molecule is the editing of peptide loading. Editing implies a selection, from a variety of available peptides, of a good peptide, which is defined by the stability of its interactions within the groove.⁶⁵ Intrinsic stability is determined by multiple hydrogen bonds between the peptide backbone and the conserved residues of the binding groove and by the anchor side chains and the specificity pockets.⁶⁶ The mechanism of the ultimate release of DM from HLA-II is not clear. It appears that DM binds more stably to an empty HLA-II than to one that contains a peptide.⁶⁷

Human Leukocyte Antigen-DO

The genes that encode the α and β chains of the DO molecule are similar to the class II genes. The DO proteins have a more

restricted distribution and are detected in B cells, DCs, a melanoma cell line, and cortical and medullary epithelial cells in the thymus.⁶⁸ Upon completion of its synthesis, DO associates with DM, and the tetramer is transported mainly to lysosomes, in which most of it is localized.^{69,70} The lysosomes that contain DO also contain class II molecules. Loading of peptides to class II is slower in the presence of DMDO tetramers, suggesting that DO is a negative regulator of DM function,⁷¹ and overexpression of DO results in accumulation of MHC class II-CLIP complexes at the cell surface. The regulation of peptide presentation by DO limits only one of the mechanisms of antigen uptake—that is, by free fluid phase—whereas membrane Ig-mediated uptake is augmented.⁷²

Major Histocompatibility Complex Class I Chain-Related Genes and Proteins

A distinct family of genes, the last and final to be detected within the MHC class I region, is known as MIC.⁷³ MICC, MICD, and MICE are in close proximity to HLA-E, HLA-A, and HLA-F, respectively. MICE and MICG are between HLA-G and HLA-F, and MICF is centromeric to HLA-G. MICC, MICE, MICF, and MICG are pseudogenes. MICA and MICB are unusually large genes (11 to 13 kb) compared to an average of 3.5 kb for HLA-A to HLA-G genes. However, their overall genomic structure parallels those of the other MHC genes and of the Ig superfamily genes in general, in which distinct functional domains are encoded by separate exons. The crystal structure of MICA shows that the molecule has a general configuration of a class I molecule, that is, a membrane proximal Ig-like C-type domain, and an α_3 domain that, with two distal α_1 and α_2 domains, together form an eight-stranded antiparallel β -pleated sheet bordered at the edges by two α helices.⁷⁴ The groove is less spacious than that of class Ia molecules, i.e., 10 Å within the first four β strands and 7 Å across the second four β strands (compared with >18 Å of classical MHC-I and 14.4 Å for CD-1). The most striking finding is that the groove is oriented down toward the membrane,⁷⁵ so that the whole molecule appears as a wilting flower.⁷⁶ Another major difference from other MHC molecules is the lack of β_2 m binding, due to restructuring of the interface of binding, which ablates the interaction.⁷⁶ The surprising findings about the structure of these proteins were matched by equally surprising findings about their function. The MIC proteins are recognized by the $\gamma\delta$ T cell, especially the V δ -1 cell, but not by the $\alpha\beta$ T cells.⁷⁷

In addition, MICA is the ligand for NKG2-D activating receptor of NK and $\gamma\delta$ T cells, triggering cytolytic responses against epithelial tumors that express MIC-A.⁷⁸ NKG2-D is the most common NK-cell receptor that is known, but it may require a synergistic action by a TCR.⁷⁹ The polymorphic residues are concentrated in the α_2 domain,⁷⁴ which apparently is re-oriented after binding with the ligand NKG2-D.⁸⁰ This ligand-induced re-positioning of the MICA molecule brings the α_1 - α_2 platform with the same polymorphic residues in contact with the NKG2-D receptor. This receptor-induced conformational change is probably facilitated by the coil of the α_1 to α_3 domains.

A number of disease associations have been detected with MIC alleles, such as ankylosing spondylitis, Behçet syndrome, psoriasis vulgaris, and Kawasaki disease. MICA and MICB are up-regulated under stress and in many gastrointestinal tumors. Pancreatic carcinomas express MICs, and their level in the serum of patients is elevated.⁸¹ Soluble MIC unimpairs NKG2-D-mediated immunity (see Chapter 13); i.e., it interferes with T- $\gamma\delta$ cells and NK cells.⁸² In summary, the MICA and MICB polymorphic HLA-like molecules present several unresolved enigmas. Their distribution is relatively restricted to epithelial and endothelial tissues (not on T or B cells) keratinocytes as well as monocytes⁸³ and their expression is associated with some form of stress. In spite of their polymorphism, they are recognized by $\gamma\delta$ T cells in a genetically unrestricted manner.

CD1 System: Genes and Proteins

One of the first monoclonal antibodies, which was made after the discovery of hybridoma technology,⁸⁴ was specific for a protein that later was given the first number, CD1, when the CD nomenclature was introduced at the First International Workshop on Human Leukocyte Differentiation Antigens, which was held in Paris in 1982.

The CD1 family consists of four proteins, CD1a, CD1b, CD1c, and CD1d that are encoded by genes CD1A, CD1B, CD1C, CD1D, and CD1E, which is not transcribed. The genes are located on chromosome 1q22-23, and the proteins that they encode have significant homology to MHC class I and II proteins. They are divided into group 1, which contains CD1a, CD1b, CD1c, and CD1e and group 2, which contains CD1d.

CD1 molecules represent an ancient family of antigen-presenting molecules, and the fact that they are homologous to the MHC molecules suggests that both evolved from a common ancestor with subsequent diversification. CD1 consists of three extracellular domains, α_1 , α_2 , and α_3 . The α_1 domain has minimal, if any, homology to MHC I, whereas with the other two, homology is approximately 35%, which is still far below the average of 70% between different class I proteins.

All CD1 proteins are transmembrane and associate with β_2m , which is necessary for folding and membrane expression.⁸⁵ The crystal structure of mouse CD1d1 shows a remarkable similarity in overall shape to MHC class I proteins.⁸⁶ The α_1 and α_2 domains form a groove with β -pleated sheets that is different from that of the MHC molecules, with three channels, A, C, and F', and a distinct tunnel, which is designated T'.

Another difference between CD1 and MHC is that the CD1 groove is formed by hydrophobic residues, so it is unlikely to form hydrogen bonds with the peptide; furthermore, it is also closed at both ends as well as covered for much of its length.

A complex of CD1b with ligands has been crystallized, and its structure has been solved⁸⁷. The total volume of the groove (220 Å³) and the four interconnected channels are occupied by the two alkyl groups necessary for stable ligand binding.

Mycobacterial mycolates, which are large molecules that play a crucial role in the survival of mycobacteria in the intracellular environment, have been the first characterized ligands for CD1b.⁸⁸ Lipids with three alkyl groups, such as triacylglycerols that are found in atherosclerotic plaques, are presented by CD1, are expressed on macrophages of the atherosclerotic lesions, and activate T cells.⁸⁹ The role of this mechanism in the formation and evolution of such lesions remains to be determined. The CD1 molecules are antigen-presenting molecules for lipids: i.e., bacterial as well as self-glycosphingolipids.⁹⁰ The CD1d molecule presents a number of endogenous glycolipids, tumor-derived lipids as well as nonlipid molecules to NKT cells.⁹¹ The presentation of these molecules has immunopotentiating effects that might be of some utility for the treatment and prevention in certain disorders. The CD1 molecules mediate T- (or NKT-) cell activation, following antigen presentation by CD1-expressing DCs.⁹² Endotoxin binding to TLR4 receptor induces CD1 expression on DCs, promoting T-cell activation.⁹²

UL-16-binding Proteins

The UL-16-binding proteins (ULBP) are novel class I-related surface proteins whose identification was based on their ability to bind the UL-16 glycoprotein of the human CMV.⁹³ The family has three members, ULBP1, ULBP2, and ULBP3, and their genes are located on chromosome 6q25 and not within the MHC complex. However, sequence alignments show clearly that the ULBPs belong to the MHC class I family. The ULBP proteins are glycosyl phosphatidyl inositol (GPI)-linked, do not have the α_3 domain of class I MHC, and do not associate with β_2m . Expression of ULBPs or the MICs on target cells confers susceptibility to NK-cell killing. The ULBP

P.319

transduces signals that override the negative signal generated by an inhibitory receptor. ULBP messages are expressed by a variety of cells, tissues, and tumors. The ULBPs are ligands for the homodimeric NKG2-D C-type lectin receptor,^{94,95} which is expressed not only on NK cells, but also on T cells and activated macrophages.⁹⁶ The cytoplasmic domain of NKG2-D is short, and, as a result, signaling is delivered by the DAP-10 adaptor protein that is associated with NKG2-D (see Chapter 13). DAP-10 binds to the p85 subunit of phosphoinositide 3-kinase (PI3K) and adaptor Grb2, transmitting downstream signals from NKG2-D through Janus kinase 2 and Akt activation pathways.⁹⁵ NKG2-D delivers co-stimulatory signals to T cells,⁷⁹ stimulates proliferation, and induces increased production of cytokines and other activation-associated molecules.⁹⁴ UL-16 mediates an additional evasive function of the human CTMV by inhibiting MICB expression, because it binds directly to MICB, causing its intracellular retention.⁹⁷ Metalloproteases mediate proteolytic shedding of ULBP2 from tumor cells, which interferes with NKG2-D-mediated cytotoxicity and thus may facilitate tumor escape from immunosurveillance.⁹⁸

Furthermore, soluble ULBP proteins down-regulate NKG2-D expression on NK cells, further interfering with NK-cell-mediated attack on cancer cells.⁹⁹

ORIGINS OF THE MAJOR HISTOCOMPATIBILITY COMPLEX

The human MHC is close to 4 Mb long, with approximately 180 to 200 genes, which traditionally has been divided into three regions: starting from the centromere to the telomere, class II, class III, and class I. During evolution, genetic events, such as insertions, duplications, deletions, inversions, conversions, and translocations, have introduced modifications, but the conserved genes have escaped identification with ancestral chromosomal regions. Genes that arose within a species by duplication are termed paralogous genes, and the chromosomal segment that contains the duplicated genes is termed the paralogous region. In the late 1990s, it was realized that three other chromosomes, 1, 9, and 19, have genes that are organized in the same manner as the MHC.^{100,101}

Some gene families, such as NOTCH and PBX, are represented in all four chromosomal paralogous regions, whereas others are represented in only two or three. Two hypotheses have been proposed for the explanation of these observations: (a)

All four paralogous regions arose from large-scale chromosomal duplication^{102,103}; and (b) the paralogous regions arose from independent duplications of genes, which were brought into proximity by selective forces (the functional clustering hypothesis).¹⁰⁴ It is possible that chromosomal duplication may have played a primary role, and functional clustering may have played only a minor one.

The hypothesis proposes that the “block duplication” that generated the four paralogous regions took place before the emergence of jawed vertebrates. Because all vertebrates have four paralogous regions, the duplication from one ancestral region must have occurred twice. It is postulated that the first occurred before the emergence of jawless fishes, which have two paralogous groups, and the second occurred before the emergence of jawed vertebrates. In the vertebrates, the gene order within each region is poorly conserved, probably as a result of structural rearrangements over the 500 million years since the second duplication. The hypothesis of “block duplication” draws severe criticism from others, who have data from phylogenetic analyses of individual gene families that are considered to be inconsistent with this hypothesis.¹⁰⁵

Class Ia genes cluster with class Ib genes but have risen independently by gene duplication from classical genes.

Furthermore, the polymorphism of MHC molecules is localized within the peptide-binding region. Within this region, the number of nonsynonymous nucleotide substitutions (amino acid-altering) far exceed the synonymous (silent or neutral) substitutions, whereas the opposite is true of the rest of the molecule. Because the synonymous substitutions are almost neutral, it is evident that polymorphism is supported by a form of natural selection, which favors peptide-binding region diversity. Other genomic evidence from *Xenopus laevis* (frog) indicates that, in this amphibian, there are class I, II, and III genes, which are linked.¹⁰⁶ Similarly, in cartilaginous fish (sharks), the most primitive organisms with a MHC, the gene structures and sequence variations are impressively similar to those in humans. Sharks also share with humans the MHC class I and class II linkage¹⁰⁷ that is common to all amphibian, bird, and mammalian species.¹⁰⁸ The proposed primordial MHC (proto-MHC) consists of the linkage group class I-PSMB9-PSMB8-TAP2-BRD2-RXR-class I and several genes that are involved in the preparation of class I presentation, that is, PSMB8 and PSMB9 (for proteasome) and TAP2 for peptide transporter. It is likely that, with further genomic sequencing analyses and phylogenetic tree analyses, the nature and composition of the proto-MHC will be determined. For many years, the HLA haplotype has been considered to be the most important genetic marker of susceptibility to many diseases. It has been found that the strongest disease associations are with alleles at multiple loci rather than with individual alleles. The expression of alleles from multiple loci has been called the ancestral haplotype (AH). AHs are conserved genomic sequences that are separated by recombination hotspots. For example, the 8.1 AHs (A1, CW7, B8, CHA0, DR3, and DQ2) are associated with multiple immunologic diseases.^{109,110} No single gene predisposes to all diseases, but different regions of 8.1 AH are associated with diseases such as insulin-dependent diabetes, systemic lupus erythematosus (SLE), gluten-sensitive enteropathy, dermatitis herpetiformis, common variable immunodeficiency and IgA deficiency. The AH 8.1 is also associated with rapid loss of CD4⁺ T cells and impaired survival after human immunodeficiency virus (HIV) infection. The precise immunologic mechanisms that give rise to such diverse diseases are not completely known. The AH 8.1 also affects the balance of cytokines with low interleukin (IL)-2 and IFN- γ and normal IL-4 production, with a bias toward the T-helper cell (TH) 2 type of immune responses.

ANTIGEN PROCESSING AND PRESENTATION

Antigen-presenting Cells

The development of humoral and cell-mediated immunity depends on complex cellular interactions that involve lymphocytes and nonlymphoid cells. Activation of lymphocytes by antigen requires its processing and presentation by another cell that is commonly known as an antigen-presenting cell (APC; Table 14.1). Macrophages promptly capture foreign substances, and antigen processing and presentation were first demonstrated there. Other APCs are the DCs (see section “Dendritic Cells”) and B lymphocytes.

Processing Antigens for Class I Presentation

Antigen processing begins in the cytoplasm with an ATP-dependent, proteolytic machine that is known as a proteasome, which is highly conserved from yeast to mammals.^{111,112,113,114,115} Most of the MHC class I presented peptides are generated outside the endosomes and lysosomes, and the energy required is supplied by ATP. The proteolytic subunit of the proteasome is a large cylindrical structure of 20S, which is arranged in four stacked rings. Based on structural analysis, the 20S proteasome is composed of two types of sequences, α and β . The two central rings of the 20S proteasome are composed of seven distinct, but homologous, β subunits,

which surround a central chamber in which proteolysis occurs (Fig. 14.4). The other two outer rings are made of α subunits, which form openings from which substrates enter and leave. Isolated subunits have no proteolytic activity, therefore the subunits must assume a precise conformation in the β ring to be active. It has been determined that the proteolytic mechanism depends on the hydroxyl group of the N-terminal threonine (Thr) of the β subunits. This mechanism of proteolysis by the proteasome is distinct from that of any other known protease. The function of the α subunits may be related to the formation of a scaffolding for the self-assembly of the β rings,¹¹⁶ as well as facilitation of the entry of the substrates.

TABLE 14.1 ANTIGEN-PRESENTING CELLS

	B Cell	Macrophage	Dendritic Cell
Antigen uptake	+++ Surface immunoglobulin (antigen-specific)	+++ Phagocytosis	+++
Major histocompatibility complex expression	Constitutive +++ to ++++	Inducible - to +++	Constitutive ++++
Co-stimulatory activity	Inducible - to +++	Inducible - to +++	Constitutive ++++
Antigen presented	Toxins Viruses Bacteria	Extracellular and vesicular bacteria	Viruses “Allergens?”
Location	Lymphoid tissues Peripheral blood	Wide body distribution	Wide body distribution Epithelia

+++ , strong; +++++, very strong; -, negative.

From Janeway CA Jr, Travers P. Immunobiology. The immune system in health and disease. New York: Garland, 1994, with permission.

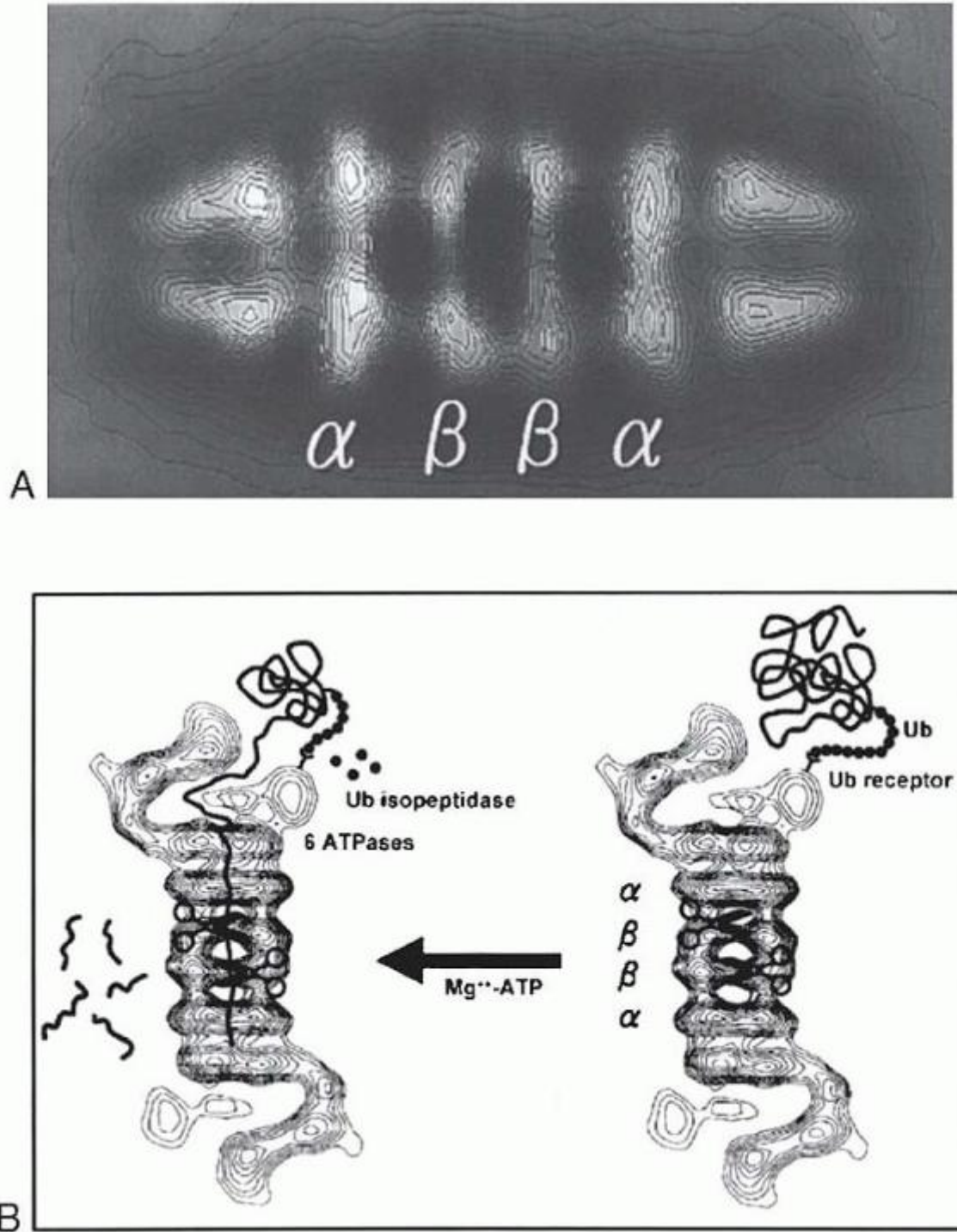

FIGURE 14.4. The proteasome. A: The 26S proteasome consists of a central unit (20S proteasome) composed of seven α and seven β subunits, arranged in four rings in the order $\alpha\beta\beta\alpha$. The central unit performs the catalytic functions. On each side of the central cylinder is a regulatory unit. B: Proteins to be degraded are first coupled to ubiquitin (Ub), which binds to an appropriate receptor in the regulatory unit that directs the protein to the central canal (“digestive tract”) of the proteasome. ATP, adenosine triphosphate. (From Tanaka K, Tanahashi N, Tsurumi C, et al. Proteasomes and antigen processing. *Adv Immunol* 1997;64:1-38, with permission.)

The 20S (650-kDa) proteasome is capped on each side by a 19S (700-kDa) regulatory complex to form the 26S (2,000-kDa) proteasome^{113,115} with proteolytic activity. Each 19S cap contains approximately 20 distinct subunits. It has been known as

PA700 proteasome activator, because, in the presence of ATP, it associates with the 20S particle and stimulates peptidase activity. In the absence of P700, the 20S particle cannot degrade ubiquitinated proteins. At least six of the P700 subunits are putative ATPases and account for the ATP requirements in proteasome-mediated proteolysis. These ATPases have one or two nucleotide-binding domains (NBDs) (“AAA modules”) and function as chaperons in diverse cellular processes. The size of the 19S regulatory complex, or antechamber, is $\sim 59 \text{ nm}^3$ and is large enough to retain unfolded proteins in a “ready to eat” state before they enter the “execution chamber.”¹¹⁷ The 26S proteasome has a dumbbell shape, with the 20S proteasome as a cylinder in the center and the two PA700 V-shaped subunits attached on each end. IFN- γ induces expression of three β -type subunits, two of them encoded by genes, PSMB8 and PSMB9, within the class II region, and a third one, PSMB10 (MECL1), which is encoded outside the MHC.¹¹⁸ IFN- γ also down-regulates three of the normally constitutively expressed subunits. The net result of IFN- γ stimulation is the exchange of three constitutive β subunits by those that are IFN- γ -inducible and that are incorporated into the 20S proteasome.¹¹⁹ This function of IFN- γ changes the activity of the immunoproteasome.

Another regulatory complex, PA28 (11S), a 200-kDa conical structure, also forms a cap at either end of the 20S proteasome¹²⁰ and stimulates multiple peptidase activities with faster kinetics. The PA8 consists of two components, α and β , which are structurally related to the Ki antigen, a nuclear antigen that is detected by autoantibodies in patients with SLE. Ki antigen is now renamed PA28 γ . The PA28 at the two ends of the 20S proteasome consists of a heterohexameric complex with alternating α and β subunits. PA28 proteasome is not involved in the initial cleavage of proteins but, rather, degradation of polypeptides of intermediate size. It is thought to work after the initial action of the 26S proteasome.

P.321

How from a long polypeptide or a protein, the specific peptide that precisely fits to the groove of the MHC is generated is a tantalizing question. These specific peptides are embedded within the polypeptide chain and in order to be extracted, two precise cuts are needed, one at the N terminal (start) and one at the C terminal (end). The importance of proteasomes for the generation of MHC class I-restricted peptides is widely recognized.^{121,122}

Antigen processing in the cytoplasm does not generate the final product in exactly one step. The view that proteasome makes the C-terminal cut is favored by several studies.^{123,124} According to this view, the proteasome releases intermediates with a precisely cut C-terminal end but with an extended N-terminal end. Proteasome cleaves peptides on the carboxyl side of basic and hydrophobic residues of substrates. This specificity satisfies an important requirement for the binding of peptide to the MHC class I groove; that is, basic and hydrophobic residues normally serve in anchoring the peptide in the groove. In addition, the C terminally cut peptides are also more efficiently transported by the TAP transporter.

N-terminal trimming is necessary to produce the antigenic peptide and may occur by aminopeptidases in the ER.¹²⁵ It is estimated that the 26S proteasome generates an antigenic peptide from an intact protein with an efficiency of one peptide for every 20 molecules that are degraded.¹²⁶ The peptides generated are 3 to 22 residues long, but only 20% are in the range that is favored for high-affinity binding (8 to 10 residues).¹²⁷ The crystal structure of the proteasome has revealed that the distance between active Thr residues of adjacent β subunits is approximately 28 Å. This distance determines the length of the generated peptides.

The ubiquitin proteolytic pathway has a crucial role in the degradation of short-lived and regulatory proteins that are important in a variety of cellular processes. Proteolytic cleavage by the proteasome requires the conjugation of the substrate by ubiquitin.^{128,129} The ubiquitin (8.5 kDa) is one of the most conserved proteins in evolution and is activated to a high-energy thioester bond at its C terminal by an activating enzyme, E1. After activation, one of several E2 enzymes (ubiquitin carrier proteins) transfers ubiquitin to an E3 protein (ubiquitin protein ligase) to which the substrate protein is specifically bound. This E3 protein covalently attaches ubiquitin to the substrate, at which it binds to ϵ -NH₂ groups of an internal Lys residue. This step is repeated until a polyubiquitin chain is formed, which serves as a recognition marker to the 26S proteasome. After degradation, ubiquitin molecules are released to participate in another cycle of proteolysis.¹³⁰ Substrates linked to ubiquitin may have different fates within the cell, depending on to which residue of the ubiquitin they are attached.¹³¹ Substrates linked to lysine 48 (K48) usually are directed for proteolysis, whereas K63-linked proteins signal several other, nonproteolytic intracellular pathways, such as kinase activation, protein trafficking, ribosomal protein synthesis, and others.

Rescue of proteins from degradation is mediated by de-ubiquitinating proteases or ubiquitinating specific proteases, the majority of which are cysteine proteases.¹³² These enzymes remove the (poly)ubiquitin from proteins, before their translocation into the catalytic chamber of the proteasome.¹³³

The proteasome exhibits three distinct peptidase activities that are associated with β subunits. One is chymotrypsinlike because it hydrolyzes peptides after a large hydrophobic residue, a second is trypsinlike because it cleaves after basic residues, and a third hydrolyzes after acidic residues. Occupancy of the chymotryptic site by a peptide substrate allosterically activates cleavages by the postacidic site, which in turn inhibits the chymotryptic site. By these cycles of activation-inhibition, the proteins are cleaved in pieces and are propagated for further fragmentation by other active sites.

Peptide Transport

Peptides that are generated by the proteasome must be transported across the ER membrane to meet the MHC class I molecules at which they are synthesized (Fig. 14.5).^{134,135,136} and ¹³⁷ The first indication that peptides are actively transported to the interior of the ER came from the study of mutant cell lines that had low MHC class I expression and could not present antigen, although their capacity to synthesize the molecules was intact. In the absence of peptides, the class I molecule cannot maintain its quaternary structure, folds up, and is incapable of moving along the constitutive pathway to the cell surface. Two genes have been identified within the MHC complex that encode the transporters of cytosolic peptides.¹³⁸ They are called transporters associated with antigen presentation (TAPs). Transfection of these genes to the mutant lines that were mentioned previously corrected their defect in antigen presentation. Profound defects in MHC class I-restricted antigen presentation were detected in humans lacking TAP2¹³⁹ and in mutant mice lacking Tap1.¹⁴⁰

The TAP proteins are members of the ABC family that is found in prokaryotes and eukaryotes.¹⁴¹ In mammals, the ABC proteins are grouped into four subfamilies: the glycoproteins, the cystic fibrosis transmembrane conductance regulators, the peroxisomal membrane proteins, and the TAP proteins. From the genomic structure of the human TAP1 and TAP2 genes, it is predicted that the TAP1 protein has 10 transmembrane-spanning segments. The sixth segment is joined to the seventh and the eighth is joined to the ninth by hydrophilic cytoplasmic segments.¹³⁴ The NBD, which is located in the cytoplasm, is large and consists of several modules. Two are involved in nucleotide binding (Walker motifs), and three others are hydrophilic. The direction of transport varies.

P.322

Some members (such as P-glycoprotein) transport their substrates away from the NBD, and others transport their substrates toward the NBD. The TAP proteins are functional only as heterodimers and are located in the ER and the cis-Golgi.¹⁴² In addition to the ATP-binding site,¹⁴³ a peptide-binding site is formed by both subunits.¹⁴⁴ Peptide binding is ATP-independent, but its transport is ATP-dependent.¹⁴⁵ It is of interest that peptides with 7 to 12 residues and a C terminus are transported more efficiently, and those are precisely the requirements for optimal binding by the class I MHC molecule.¹⁴⁶ Because peptides are usually rapidly degraded in the cytoplasm, it is suggested that they may be carried from the proteasome to the TAP proteins by chaperon proteins, such as those of the HSP70 family. Genes that encode such proteins have been found in the MHC region.¹⁴⁷ Peptide binding to TAP precedes its translocation across the ER membrane, and TAP acts as a peptide channel permitting the diffusion of peptides across the membrane. Most data, however, are consistent with the transporter function, that is, binding followed by translocation. ATP binding releases the peptide as a result of conformational changes of the NBD.

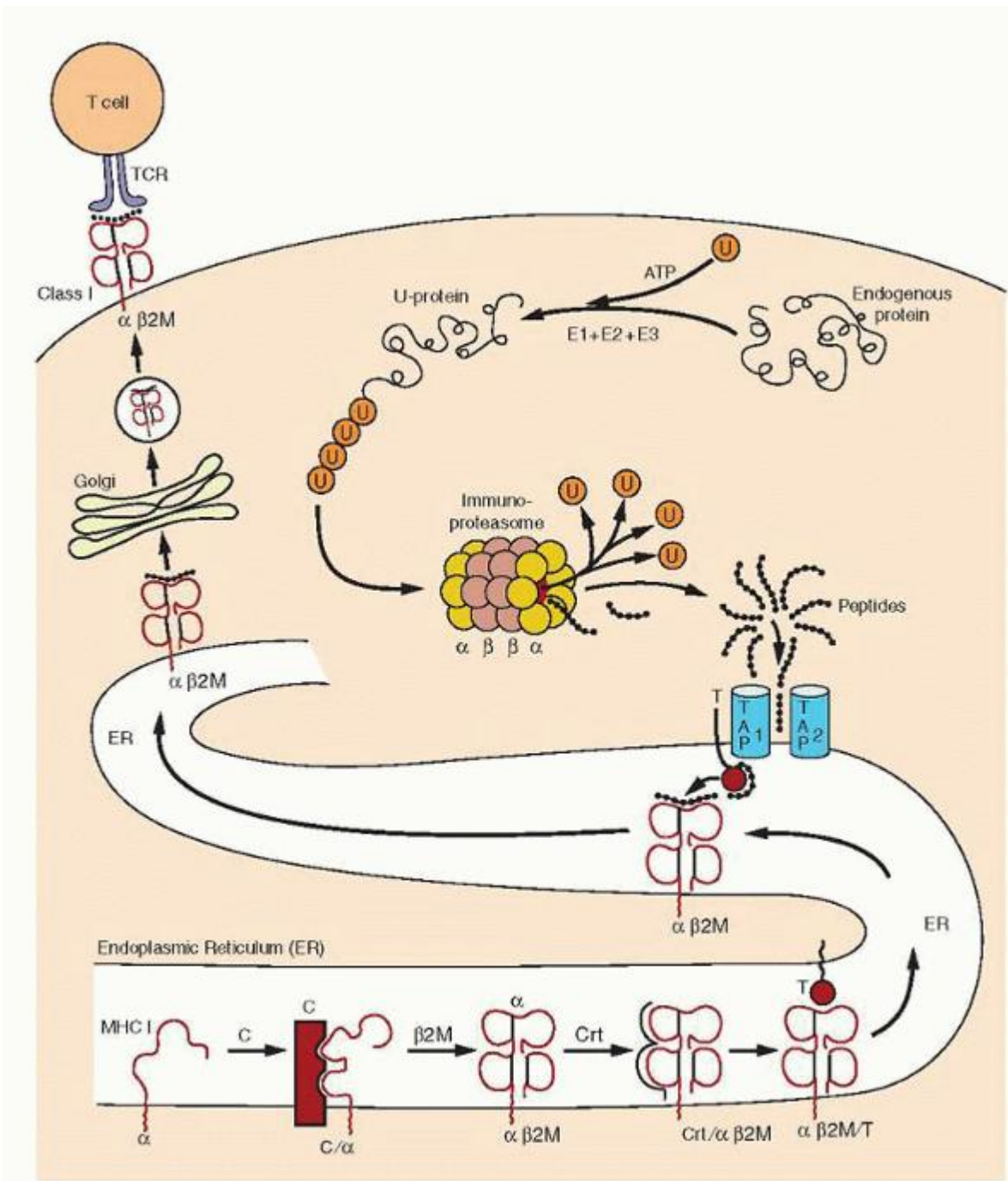

FIGURE 14.5. Processing and presentation for major histocompatibility complex (MHC) class I. Peptides (approximately 8 to 10 amino acids long) are generated by proteolysis within the proteasome. The protein to be degraded is first ubiquitinated. Ubiquitin (U) is attached by a covalent bond to the ϵ -NH₂ group of a lysine residue by an enzyme complex. The peptides are carried across the membrane of the endoplasmic reticulum (ER) by the transporter associated with antigen presentation (TAP) to be loaded on the groove of MHC class I molecules. The nascent α chain of MHC retains its proper conformation by calnexin (C) and after the addition of the β 2 microglobulin (β 2m) chain by calreticulin (Crt). When the peptide passes inside the ER and lands on the MHC groove, with the help of tapasin (T), calreticulin is relieved from its chaperon duties, because the peptide stabilizes the MHC conformation. ATP, adenosine triphosphate; TCR, T-cell receptor.

An important question related to class I antigen presentation is the mechanism by which viral proteins or tumor antigens, which are synthesized within the ER, are targeted to the cytosol to be handled by the processing machinery. There is an ER retrograde pathway that transports proteins from the ER to the cytosol.¹⁴⁸ Until these proteins are assembled and folded

properly, they are retained within the ER by calnexin or calreticulin. Misfolded or aberrant proteins are released for proteasomal degradation.¹⁴⁹ However, the ER possesses proteolytic activity, that is, aminopeptidases that may also process N terminally extended precursors of antigenic peptides for loading to MHC class I molecules.

Assembly and Loading of Class I Molecules

The size restriction for peptides to bind to class I molecules is 8 to 10 residues. The restriction is imposed by the structure of the MHC class I groove, which is closed at the two ends. The class I α chain and β_2m are synthesized on membrane-associated ribosomes and are inserted co-translationally into the ER through a specialized structure known as the translocon. N-Glycosylation takes place in the ER during the translocation process. HLA-A, HLA-B, and HLA-C have a single N-glycosylation site. The ER chaperon, BiP, a HSP70 homolog, interacts with proteins during this stage and, through ATP regulation, provides the energy that is required for the movement of the protein through the ER membrane. BiP binds with free HLA heavy (H) chains.¹⁵⁰ Calnexin is the most important chaperon and binds to newly synthesized free class I α chain,^{151,152} but not to the heterodimer (Fig. 14.5).

Calnexin is a transmembrane lectin and binds to N-linked glycans that bear a single glucose after removal by glycosidases of the extra glucose residues. How calnexin facilitates folding is not known, but the glucose is removed by a glycosidase II and calnexin is released. If the MHC class I molecule has not achieved its proper folding, a second glycosylation cycle follows with another attempt at refolding. Removal of calnexin permits the MHC class I molecule to leave the ER. Another chaperon that has been detected by some studies is calreticulin, which is a soluble homolog of calnexin.¹⁵³ Both recognize Asn-linked glycans bearing a terminal glucose residue, an intermediate in oligosaccharide maturation present on incompletely folded ER glycoproteins. The successive addition and removal of this glucose residue results in cyclical calnexin or calreticulum interactions with substrate proteins until they are correctly folded and assembled. Calreticulin promotes folding of HLA class I molecules to a state in which at low temperatures they spontaneously acquire peptide-binding capacity.¹⁵³

The TAP heterodimeric proteins transport the cytosolic peptides that are generated by the proteasome across the ER membrane. They bind to MHC class I molecules through an additional component that is called tapasin (TAP-associated glycoprotein).¹⁵⁴ Tapasin is a transmembrane glycoprotein that has an ER retention signal in the cytoplasmic region. The gene that encodes tapasin is in the centromeric end of the human MHC region. Tapasin probably forms a bridge between TAP and MHC class I molecules¹⁵⁵ (Fig. 14.5). However, tapasin also stabilizes class I molecules in the absence of peptides by occupying the groove, a function that is performed by the Ii chain in class II MHC molecules. In addition, tapasin is involved in peptide loading¹⁵⁶ and also influences the peptide selection.¹⁵⁷

An additional molecule that associates with MHC class I molecules at the assembly stage is ERp57, an enzyme that ensures the correct formation of intrachain and interchain disulfide bonds.¹⁵⁸ ERp57 is a thiol-dependent reductase and a cysteine (Cys) protease. As a protease, it may play a role in the trimming of peptides, because it remains attached to the complex until the time of the peptide loading.

The order and kinetics of the assembly of the various components of the loading complex is as follows^{159,160}: H chain β_2m heterodimers can be recovered within 4 minutes after translation, and the peptide joins 2 minutes later. Shortly after the synthesis of the H chain, one disulfide bond forms in the α_2 domain, and a second forms in the α_3 domain. Disulfide bond formation is necessary for β_2m binding and peptide loading. The β_2m is required for physical support of the peptide-binding groove.

Calnexin may be bound to a nascent H chain, but calnexin dissociates as β_2m binds to the H chain, and calreticulin is taken up by the heterodimer. The other half of the complex is being assembled in the meantime; that is, TAP forms a complex with tapasin, and both are joined by calnexin and ERp57. When the two halves of the final complex join together, calnexin dissociates, and the final loading complex is complete. Loading of the peptide at this point releases the MHC class I- β_2m heterodimer for the secretory pathway to reach the cell membrane. Presentation of certain proteins such as those derived from viruses is presented very rapidly to CD8⁺ T cells. It was proposed that antigenic peptides originate from defective ribosomal products (DRiP hypothesis)¹⁶¹ from a specialized machinery consisting of immunoribosomes.¹⁶²

Presentation of Exogenous Antigen by Major Histocompatibility Complex Class I Molecules

The class I MHC system evolved to identify cells that bear peptides that derive mostly from infectious agents. The vast majority of peptides that are presented by MHC I derive from proteins that are synthesized by the cell's own ribosomes. The proteins or polypeptides that generate these peptides are referred to as endogenous, whereas peptides that derive from proteins or micro-organisms that are phagocytosed are termed exogenous. It has been widely accepted that endogenous antigens trigger a CD8⁺ class I-restricted response, whereas exogenous antigens activate CD4⁺ class II-restricted cells. However, several examples over the years have detected class I-restricted CD8⁺ T-cell responses with dead

phagocytosed viruses, bacteria, transplants, dead cells, and others, which were handled by the immune system as exogenous antigens and were targeted to the endocytic system.¹⁶³ This has been known as cross-priming, which was originally described in mice that were immunized with cells that expressed minor histocompatibility antigens. Today, it is also known as cross-presentation. Hepatitis B surface antigen, given by the exogenous route and submitted to efficient endolysosomal processing, can lead to peptide-loaded MHC class I molecules.¹⁶⁴ Sometimes peptides derived from internalized particulate material have access to ER or peripheral phagosomes with membrane contributions from the ER, which then are loaded to MHC class I molecules.¹⁶⁵ Cross-presentation also occurs by “immunoproteasomes,” i.e., proteasomes enriched in proteasome proteolytic subunits (PSMB9 and PSMB9) by the action of INF- γ .¹⁶⁶ The

P.323

nicotinamide adenine dinucleotide phosphate (NADPH) oxidase, NOX2, maintains an alkaline milieu of the phagosomes of DC predisposing to peptide presentation rather than protein degradation, which occurs by proteases in the highly acidified lysosomes of neutrophils.

Cross-presentation by APCs of antigens that are chaperoned by HSP (heat-shock proteins) is described by Shrivastava et al.¹⁶⁷ HSPs are highly conserved peptide-binding molecules that control the folding of proteins and prevent their aggregation. HSP70 that is complexed with a variety of synthetic peptides is taken up by APCs and elicits CD8⁺ T-cell class I-restricted antitumor cytolytic responses.¹⁶⁸ The HSP-peptide complexes are internalized by a receptor-mediated mechanism and are subsequently processed by a proteasome and TAP-dependent mechanism or through the endosomal route.¹⁶⁹ This is a highly efficient mechanism whereby antigens that follow an exogenous route induce strong CD8⁺ responses against tumors or viruses.¹⁷⁰ Peptides that are introduced into the cytosol induce a strong class I-restricted response only if they are chaperoned by HSP, but not alone.¹⁷¹ Receptors for HSP have been detected on CD11b⁺ cells,¹⁷² and, recently, the receptor for all HSPs was identified to be the CD91 protein¹⁷³ (see Appendix A). The CD91 is receptor for α_2 -macroglobulin and, with calreticulin, binds and stimulates uptake of apoptotic cells¹⁷⁴; together, they act as receptors for the collectin family and regulate the clearance of organs in the removal of apoptotic cells and cell debris.¹⁷⁵ It is postulated that HSP-peptide complexes that are given by the exogenous route might be used in the future to elicit protective immunity against cancer or viruses.¹⁷⁶

Although macrophages, DCs, and B cells have been reported to be able to mediate cross-presentation, the evidence collectively suggests that the most important cell is a DC. Interactions between CD4 and CD8 T cells that interact with the same APC are apparently needed.¹⁷⁷ Cross-priming is involved, predominantly in response to virus infection, cancer cells, and histoincompatible tissues. Although cross-priming is associated with an immune response, depending on the nature of the antigen (e.g., normal healthy cellular antigens), cross-presentation leads to the opposite of the immune response: cross-tolerance.

Antigen Processing for Class II Presentation

Biosynthesis of Major Histocompatibility Complex Class II Molecules

Expression of class II MHC molecules is restricted mainly to certain cell types, such as macrophages, DCs, and B lymphocytes. However, MHC class II molecules can be induced in other cells by IFN- γ . Regulation of MHC class II molecule expression occurs at the level of transcription. Many factors that regulate their expression are DNA binding and are ubiquitously expressed.¹⁷⁸ An important mediator is the MHC class II trans-activator molecule (CIITA), which is not a direct DNA-binding molecule and is detected in cells that express class II molecules constitutively or after induction with IFN- γ . CIITA is essential for the activation of MHC class II promoters that have the SXY regulatory module, i.e., a module consisting of certain motifs known as S, X, and Y boxes,¹⁷⁹ as well as for the expression of the Ii chain and HLA DM molecules. The MHC class II molecules and Ii chain are co-translationally inserted into the membrane of the ER through a signal peptide. The Ii is a type II membrane protein: the NH₂ terminus is on the cytosolic face of the ER and rapidly forms trimers through interactions of its luminal sequences.¹⁸⁰ It also associates with three MHC class II molecules, added sequentially, forming nonamers.³⁶ A central region of the Ii, which is termed CLIP, occupies the peptide-binding region of MHC class II and prevents peptide loading to MHC class II in the ER. Furthermore, the MHC class II-Ii association conceals a motif that retains Ii into the ER, and, as a result, the nonamer complex moves to the Golgi apparatus.¹⁸¹ Leucine (Leu) signals in Ii bind the AP-1 and AP-2 adaptors,¹⁸² but more than one sorting mechanism probably exists, depending on the cell type. The MHC class II-Ii complexes are targeted to late endosomes,^{183,184} possibly with an intermediate stopover, on the cell membrane or on the early endosome. Permanent localization in the early endosomes (by exchanging the cytoplasmic tail of Ii with that of transferrin receptor) blocks class II presentation, indicating that late endosomes or

lysosomes provide the appropriate milieu for class II presentation.¹⁸⁵ The CLIP has also been shown to mediate interaction of the Ii chain with MHC class I molecules.¹⁸⁶

Generation of Antigenic Peptides for Class II Major Histocompatibility Complex Presentation

Proteolytic breakdown of exogenous antigen in the endocytic pathway is essential for peptide loading. Specific uptake involves endocytosis and phagocytosis, mediated by various receptors in different cells, such as the B-cell receptor (BCR) in B cells and mannose receptors and Fc receptors in macrophages. The mannose receptor recognizes patterns of carbohydrates on the surface of the cell wall of infectious agents, and this increases dramatically the efficiency of class II-mediated presentation by DCs (Fig. 14.6).

The endocytic route that is taken by endocytosed foreign material consists of a complex network of compartments that vary in morphology, physiochemical properties, and content. Three major regions, however, can be distinguished: the early endosomes, with slightly acidic pH, are barely proteolytic; the late endosomes are more acidic and contain some components that are classically used as markers of lysosomal compartments, LAMP1 and LAMP2, and the lysosomes that have a low pH and are rich in hydrolytic enzymes. This route is intersected by another route that originates in the trans-Golgi network (TGN). This route is taken by molecules that come out of the ER, and, depending on specific signals such as dileucine or mannose 6-phosphate, they follow the secretory pathway on the way to the cell membrane or secretion. Foreign antigens that enter the endocytic pathway are subject to gradual proteolysis, which may generate peptides that are suitable for receptive MHC class II molecules.¹⁸⁷ Antigens follow different routes in the endocytic pathway, and antigen processing is different.¹⁸⁸ "Exit tracks" from the endocytic pathway join the constitutive secretory pathway for reaching the membrane. Proteolytic activities along the endocytic pathway are acquired progressively.

Acidification is an important factor for protein unfolding, and, as the pH decreases progressively, it influences several steps in the processing of incoming antigens and in peptide loading, such as protease activity, MHC class II molecule aggregation, peptide receptivity, and function of chaperons HLA-DM and HLA-DO.

Antigen processing is carried out primarily by proteases, and most of the lysosomal proteases are known as cathepsins. The final peptide that is suitable for loading onto MHC class II molecules is prepared by the action of the protease alone or with the assistance of the MHC molecule. A protease-guided initial step breaks down large proteins into smaller polypeptide chains, which may be partially accessible to MHC class II molecules. At this point, MHC class II-guided processing allows the protease to trim down unnecessary protrusions outside the binding site.¹⁸⁹

Several proteases exist within the endocytic system, endoproteases and exoproteases, and some cooperation between them is anticipated.¹⁹⁰ It appears that the first key protease is a Cys endopeptidase that cleaves after Asn residues.¹⁹¹ Once this enzyme takes the first step, other enzymes complete the digestion for the generation of peptides.

P.324

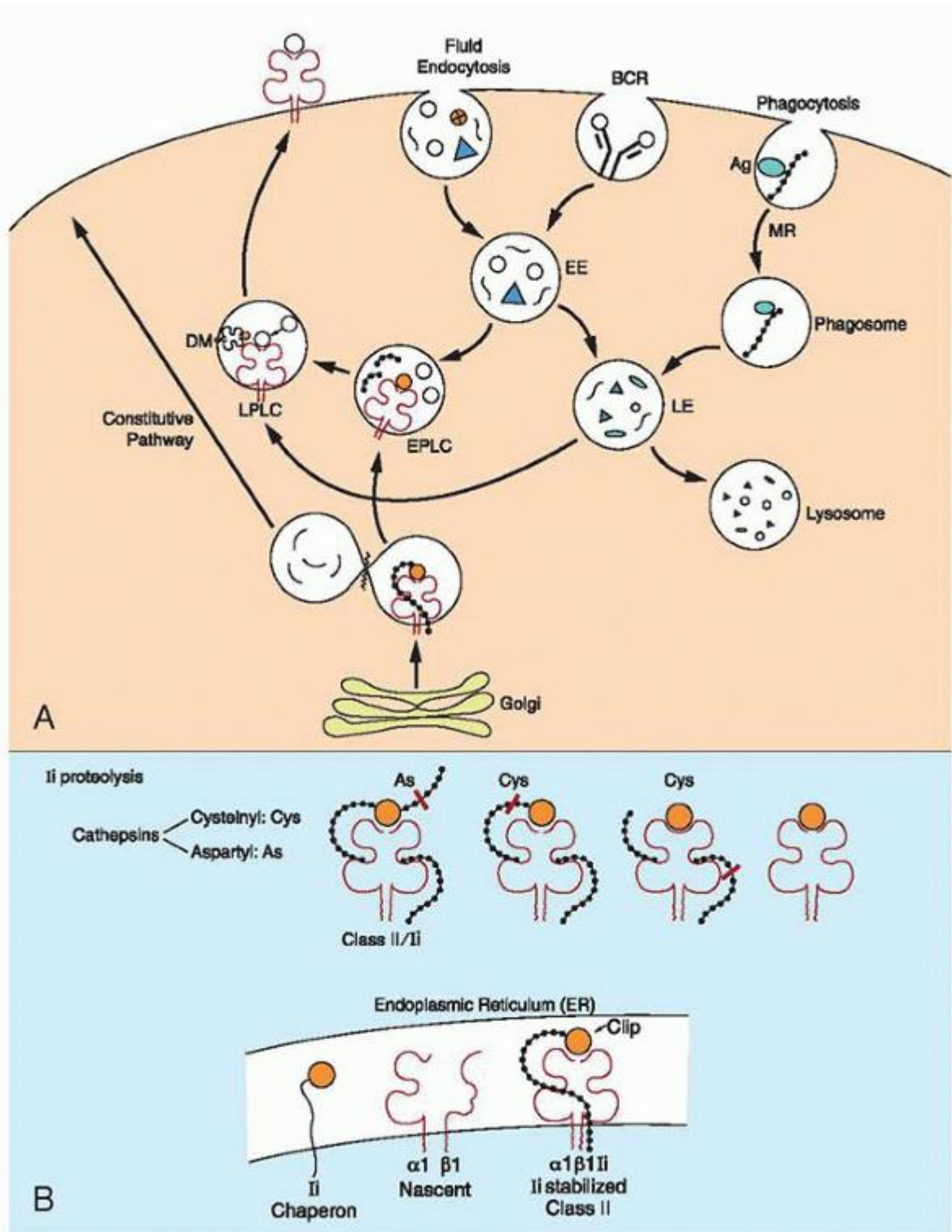

FIGURE 14.6. Processing and presentation for major histocompatibility complex (MHC) class II. Pathogens or their products are captured by phagocytic or dendritic cells and are carried to the interior of the cell enclosed within endocytic vesicles. A: Endocytosis is mediated through the mannose receptor (MR) or the B-cell receptor (BCR), or, depending on the method of entrance, they end up within typical phagosomes or early endosomes (EEs). The endocytic pathway is relatively complex, which is reflected in changes of their composition and pH. There is a dramatic morphologic change from a simple vesicle to multilamellar and multivesicular compartments that are known as MHC class II compartments. The endocytosed material is targeted to vesicles with class II MHC: early peptide loading compartment (EPLC) and late peptide loading compartment (LPLC). Their conformation and groove are maintained by the invariant (Ii) chain in EPLC and HLA-DM in

LPLC. The MHC class II molecule is synthesized in the endoplasmic reticulum (ER), and its conformation is stabilized by the chaperon protein Ii chain. A region of Ii termed class II-associated invariant chain peptide (CLIP) occupies the groove and prevents the collapse of MHC class II molecules. MHC class II molecules and Ii exist as nonamers. The complex moves out of the ER, passes through the Golgi apparatus, and reaches the EPLC, where the Ii chain is proteolytically destroyed but CLIP remains in the groove. Exchange of CLIP with the antigenic peptide is catalyzed by the nonclassical HLA-DM protein. In the last step of this long and tortuous path, the MHC class II-peptide complex is delivered to the plasma membrane by the EPLC vesicle, where it interacts with the appropriate T-cell receptor on CD4⁺ T cells. B: Proteolysis of the Ii chain is mediated by cathepsins, which cleave at a cysteine or aspartic acid residue. LE, late endosome.

Peptide Loading on the Major Histocompatibility Class II Molecule

As indicated earlier, the MHC class II molecule arrives in the endocytic system as a nonamer with the Ii chain. The CLIP region of Ii is inserted in the peptide-binding groove and prevents interaction with ER-resident proteins or other proteins on the way to the endosomes. CLIP also keeps the MHC class II molecule stable until the time of peptide loading. The precise location of the peptide loading within the endocytic system has been debated for a long time. Electron microscopic studies demonstrate that the MHC class II molecule is found throughout the endosomal pathway, including mannose 6-phosphate-positive late endosomes and in late endosomes and lysosomes, a compartment that is rich in MHC II but negative for the mannose 6-phosphate receptor, which is known as MIIC.¹⁹² This compartment consists of vesicles 200 to 300 nm in diameter with heterogeneous morphology, such as multivesicular, multilamellar, and tubulovesicular. Various functional stages of MIICs are distinguished on the basis of the Ii detection; for example, in some of them the intact Ii chain is detected, in others only the aminoterminal region is detected, and, in still others the Ii chain is absent. Loss of the Ii chain is associated with a change from multivesicular to multilamellar MIIC.¹⁹³ Another endocytic compartment, known as the CIIV (for class II vesicles), from a B-cell line, is similar to MIIC. Both are considered to be sites for peptide loading. The MIIC compartment is set aside from the remaining endosomal vesicles, and several endocytic markers are absent. These vesicles receive newly synthesized MHC class II molecules by virtue of the targeting motif of the Ii chain. Once they arrive, the Ii targeting motif is removed (C-terminal region), and the MHC II-Ii complex is retained within the MIIC for prolonged periods of time.^{193a} The MIIC is particularly abundant in DCs which are the professional APCs.

The first step in the peptide loading is the digestion of the Ii chain in the MHC class II-Ii chain nonamer complex (Fig. 14.6). The carboxyterminal region of Ii is cleaved by a protease that releases an MHC class II-Ii trimer.¹⁹⁴ Ii degradation occurs in an orchestrated fashion until only the CLIP remains attached to the MHC class II molecule. Proteolysis proceeds in two stages, and, for proteolysis of the second intermediate, different cathepsins are used in different APCs. Of the lysosomal enzymes, cathepsin S plays an essential role in the degradation of Ii in B cells and DCs, and its absence has major consequences for the onset of humoral immune responses.¹⁹⁰ Cathepsin L, on the other hand, is expressed on thymic epithelial cells.¹⁹⁵

Removal of CLIP from the peptide-binding groove and subsequent loading with antigenic peptide is catalyzed by the nonclassical class II HLA-DM, which binds directly to MHC class II-CLIP complex,⁶¹ near the N terminus of MHC class II.¹⁹⁶ It is thought that the DM induces a transitional “open” state to the MHC class II groove that releases CLIP. This occurs by disruption of a few hydrogen bonds between MHC class II and CLIP.¹⁹⁷ It is intriguing that HLA-DM does not interact with MHC class II that is associated with intact Ii chain.

The HLA-DO molecule is a negative regulator of HLA-DM, and, when it is overexpressed, it results in an accumulation of MHC-CLIP complexes.

MHC class II-peptide complexes are transported to the cell surface by vesicles, the movement of which depends on the cytoskeletal elements. MIIC transport is microtubule-dependent.¹⁹⁸ Microtubules are assembled from $\alpha\beta$ tubulin heterodimers in the microtubule organizing center and extend toward the periphery. A large family of motor proteins, known as kinesins, mediate transport of vesicles of the secretory pathway, cytotoxic granules, lysosomes, and the like. On microtubules, kinesin transports vesicles toward the positive end of the microtubule (the end away from the microtubule organizing center, toward the cell periphery). Another group of proteins, dynein, creates motion toward the negative end of the microtubule.¹⁹⁹ Thus, dynein is important to keep vesicles around the nucleus, because inhibition of its function shuttles all the vesicles to the cell membrane. How and when the vesicular movement is regulated is unknown. In monocytes, IL10 triggers positioning of MIIC in the cell, but in B cells, the BCR performs this function. The signal for kinesin to transport the mature MIIC—i.e., the MIIC that is loaded with the peptide—to the cell surface is unknown. It is also intriguing that only MHC class II-peptide complexes are detected on the cell surface, not the other contents of the MIIC vesicle.

Antigen Presentation by CD1

CD1 was first identified in human cortical thymocytes but later was detected on other cells, such as on antigen-presenting DCs, and CD1a is expressed on Langerhans cells (LCs), which are specialized DCs in the epidermis.²⁰⁰ CD1c is detected on a subset

P.325

of peripheral blood B cells and B cells of the marginal zone, and CD1d is expressed in intestinal epithelia and in a wide variety of hematopoietic cells. The members of the CD1 family are antigen-presenting molecules, and, after their synthesis, they must first reach an appropriate vesicular compartment for peptide loading on the way to the cell surface. There are striking differences in the intracellular distribution of the CD1 isoforms.^{201,202} CD1a is found mainly on the cell surface but also in early endosomes^{203,204} and in LCs that are present in the Birbeck granules. Together with CD1d, CD1b accumulates in the late endosomes and lysosomes, whereas CD1c is found in the early endosomes (transferrin receptor-positive). The ratio between surface expression and intracellular concentration also varies among the isoforms. The differential expression of the isoforms is regulated by a Tyr-based motif in the intracellular region that is present in all isoforms except CD1a.^{205,206} This sequence, YXXZ (Y, Tyr; X, any amino acid; and Z, an amino acid with bulky side chains), interacts with a member of the cytosolic adaptor proteins AP-1 through AP-4.²⁰⁷ AP-2 is positioned in the TGN and mediates delivery from the TGN to the endosomal-lysosomal system, whereas AP-2 is localized in the plasma membrane, where it directs proteins to clathrin-coated pits that lead to the entrance into the endocytic pathway. The AP-3 is implicated in the sorting of proteins from the TGN to endosomes and lysosomes. The AP proteins determine the specificity of destination for the CD1 molecules, but the binding to a specific AP member is determined by the residues that surround the Tyr-based motif.²⁰⁸ The YXXZ motif is essential for localization in the endosomal and lysosomal compartments, because mutations that are introduced into the sequence inhibit presentation of mycobacterial glycolipids to T cells.²⁰⁹ Although the YXXZ motif predicts the final destination, it does not indicate the route that is to be followed. The CD1d first follows a direct route from the ER to the cell surface, where, through the YXXØ motif (Ø, phenylalanine), it binds to AP-2. It is subsequently internalized and is directed to the MIIC compartment.²⁰⁹ MIIC overlaps considerably with lysosomes and may represent a fusion product between endosomes and lysosomes. CD1d is associated with the li chain, which directs CD1d to the same compartment independently of the Tyr-based motif.²⁰⁹ The li chain needs to be degraded by cathepsin S to allow loading of the CD1d and to be directed to the cell membrane.^{210,211}

The antigens that are presented by CD1 molecules are lipids and glycolipids (Fig. 14.7). Mycolic acids are a class of long chain, branched, free fatty acids and constitute the predominant component of the thick outer layer of the mycobacterial cell wall. They confer the acid-fast staining property on mycobacteria. They contain approximately 80 carbon atoms and are known to be required for mycobacterial survival. In addition to mycolic acids, two glycolipids, lipoarabinomannan (LAM) and lipomannan, are large molecules that contain 20 to 100 glycosyl residues and are also presented by CD1 molecules.²¹² Other antigens include selected phosphatidylinositol mannosides and glycosylated mycolates, including glucose monomycolate.

Mycobacteria are taken up by phagocytosis and reside within nonacidified phagosomes (due to a paucity in the vacuolar H⁺ ATPase). Therefore, they are restricted in their capacity to fuse with late endosomes and lysosomes. The macrophage mannose receptor that has been implicated in glycolipid uptake by APC²¹³ is absent from mycobacterial phagosomes.

The mechanism of distribution of various mycobacterial antigens to the subcellular compartments is not well understood. LAM has been found in late endosomes and lysosomes, either by being released from the phagosome or after uptake from the extracellular environment by the mannose receptor.²¹³ Nevertheless, mycobacterial antigens are distributed throughout the endocytic system after their release from the phagosome.^{214,215} Antigens that are released from phagocytosed mycobacteria reach various compartments of the endocytic lysosomal system, where all CD1 isoforms, that is, CD1a, CD1b, and CD1c, gain access to mycobacterial glycolipids at these different sites (Fig. 14.8). CD1a and CD1c sample the antigens in phagosomes that are arrested in the early endosomal stage, whereas CD1b samples antigens in phagosomes that are arrested in the late mature phagolysosome stage. The CD1 molecule binds the lipid antigens by accommodating the first two lipid tails within the hydrophobic groove, whereas the hydrophilic caps (sugars) are exposed to the solvent and contact the TCR directly.²¹⁶ The buried surface of the groove, as determined from crystallographic studies, is 1,400 Å, which could optimally accommodate a lipid with 32 carbons. However, some of the antigens that are presented by CD1 are 44 carbons long, and the mycolic acids are 80 carbons long. Presentation of large lipids takes hours (trafficking to late endosomes), whereas the same antigens with shorter chains are presented rapidly but inefficiently from the cell membrane.²¹⁷ DCs specialize in the presentation of lipids with long alkyl chains, whereas nonprofessional APCs present preferentially short chain glycolipids. The acidic environment of the late endosomes and lysosomes is an

important factor in the interaction of the large lipid antigens with the groove. The properties of the CD1b protein are dramatically altered in an acidic pH to facilitate the interaction with its ligands. There is a reversible unfolding of the α -helical portions of CD1 in an acidic pH, which permits the direct binding of the hydrophobic portions of the molecule, thus burying the alkyl chains.^{218,219} The depth, enclosed nature, and hydrophobicity of the interior of the CD1 groove is well adapted to carry out antigen presentation of lipids and amphipathic glycolipids, for which the hydrophobic component is sequestered within the groove, whereas the carbohydrates are left outside to interact with the TCR.

APC alters the structure of glycolipids by removing terminal glycosyl residues from certain glycolipids, resulting in the exposure of epitopes that are reactive with TCR.²²⁰ Glycosylation also generates new antigens, as is the case of glycosylation of mycolic acids during mycobacterial infections, with the use of glucose from the host and a mycobacterial enzyme.²²¹ Glycolipid processing generates a large variety of lipid ligands for presentation by CD1 proteins.²²²

In addition to bacterial glycolipids (i.e., LAM) and glucose monomycolate, CD1b molecules recognize self-glycosphingolipids, such as GM1 ganglioside.²²³ Several of these gangliosides can bind to CD1b, and, in striking contrast to bacterial glycolipids, the self-glycolipids bind on the cell surface without the need of the late endosome and lysosome acidified environment.²²⁴ Five or more oligosaccharide groups are required to stimulate TCR recognition with a large component of the ligand that is exposed. Apparently, these gangliosides act as blockers to prevent harmful autoreactivity. The number of these autoreactive T cells increases in multiple sclerosis.²²³

CD1 System in Microbial Immunity

The protective value of CD1-mediated immunity is currently under intensive investigation.^{225,226,227} The CD1⁺ cells correlate with the level of immunity to *Mycobacterium leprae* and are present in the lesion tenfold more abundantly in the tuberculoid form (immunologically responsive) than in the lepromatous form (immunologically unresponsive). Low numbers of CD1⁺ cells correlate with low granulocyte-macrophage colony-stimulating factor (GM-CSF) levels and high IL10 levels, which inhibits GM-CSF secretion. GM-CSF is a key differentiating factor for mature CD83⁺ DCs.^{218,228} CD1-restricted T cells contribute to intracellular bacterial infections, such as *M. tuberculosis*, based on high levels of IFN- γ secretion and strong cytolytic activity.

The CD1 isoforms broadly survey the endocytic system over pathways that are distinct from those of MHC class I and MHC class II molecules, and, furthermore, they are restricted to presentation of an important class of antigens, lipids, that are not covered by the MHC molecules. Among them, CD1c is particularly

P.326

P.327

important, because it is expressed on LCs (in the absence of CD1b) and B cells (without CD1a or CD1b).²²⁹

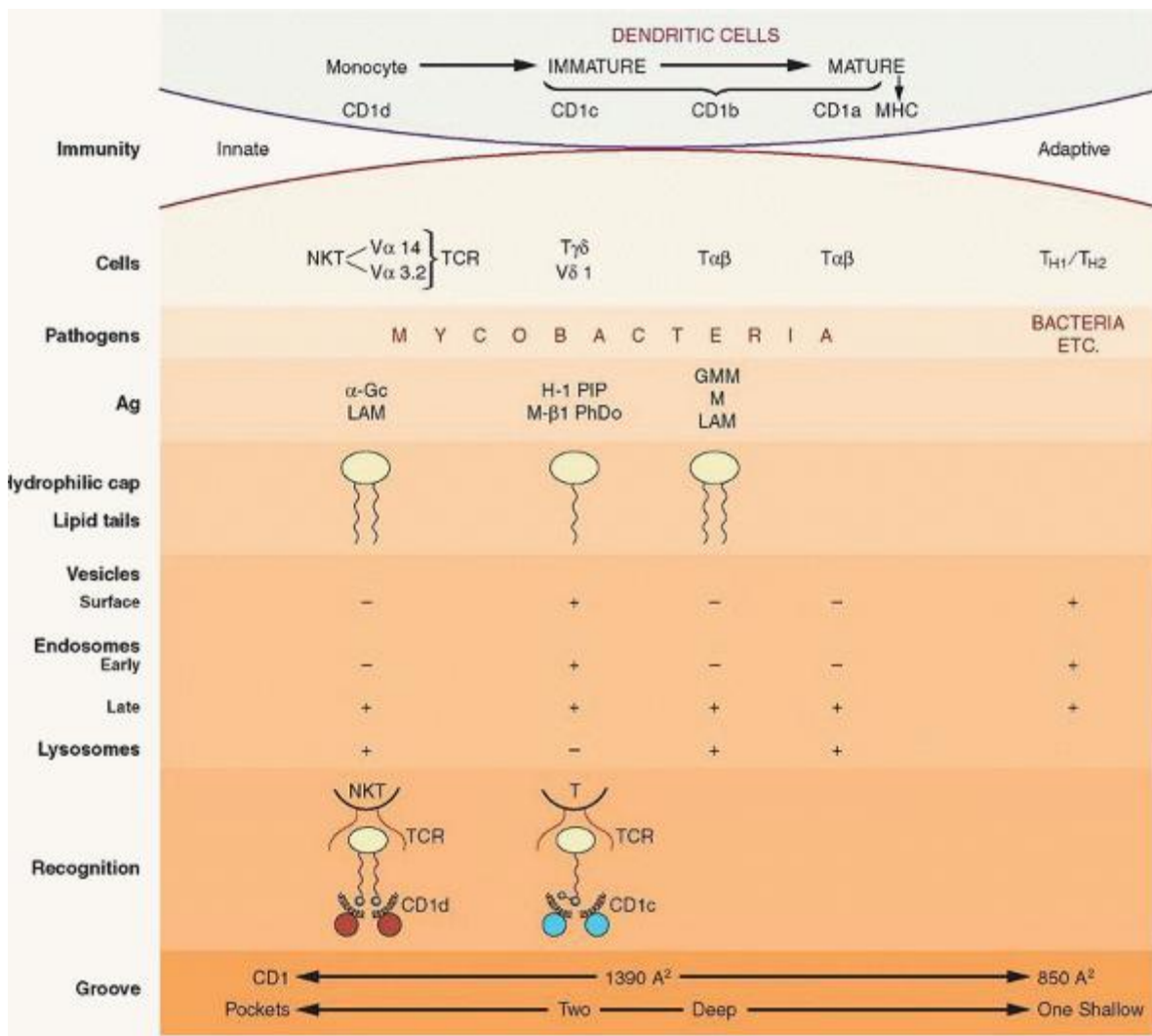

FIGURE 14.7. Microbial glycolipid presentation to T cells. The CD1 molecule, an orphan family of major histocompatibility complex (MHC)-like molecules, presents long carbon-chain glycolipids from mycobacteria and other similar pathogens, to natural killer T cells (NKT), T-cell receptor (TCR)- $\gamma\delta$, and TCR- $\alpha\beta$ cells, linking innate and adaptive immunity. The CD1 molecules are expressed in various compartments of the endocytic system, providing a broad surveying mechanism for the detection of intracellular mycobacterial infections. Localization of CD1 molecules depends on endosomal targeting sequences for loading of glycolipids. The glycolipids in general consist of a hydrophilic head of carbohydrate molecules and one or two lipid tails. The head interacts with the TCR, whereas the lipid tails are accommodated within the large groove of the CD1 molecules, penetrating into two deep pockets. Ag, antigen; α -Gc, α -galactosylceramide; GMM, glucose monomycolate; H-1 PIP, hexosyl-1-phosphoisoprenoid; LAM, lipoarabinomannan; M- β 1-PhDo, mannosyl- β 1-phosphodolichols.

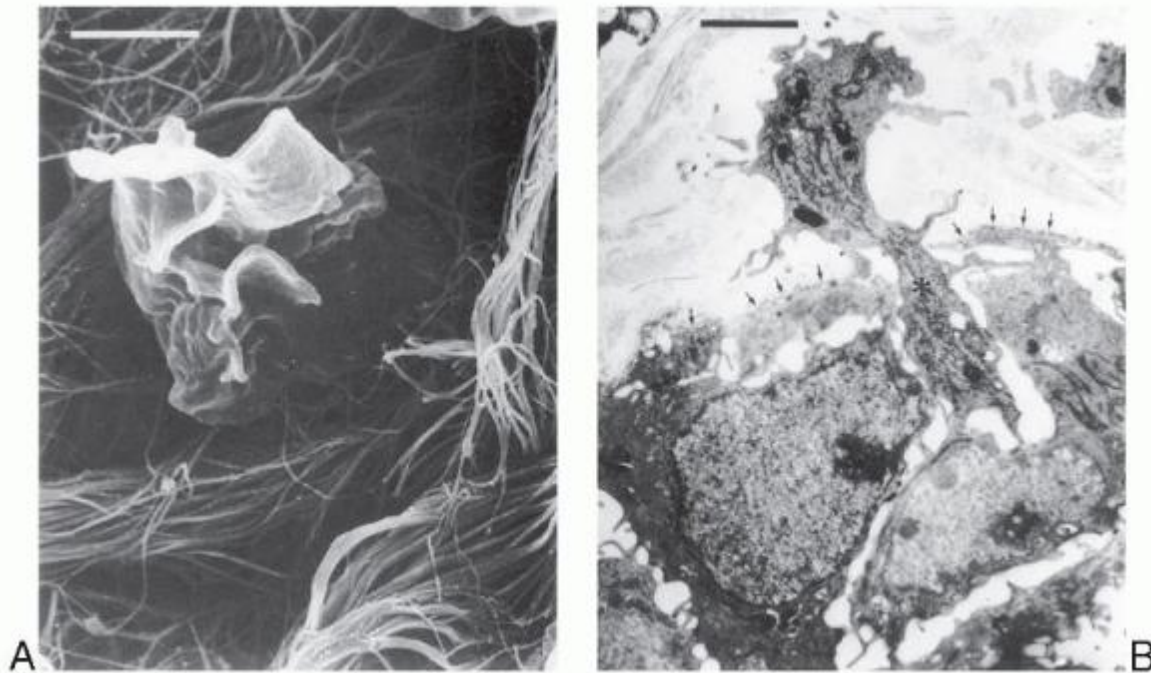

FIGURE 14.8. Migration of dendritic cells. A: A Langerhans cell, migrating through the labyrinthine space of the dermis, guided by chemokine signals that are received by its chemokine receptors. B: The Langerhans cell penetrates into the dermis through a hole (between the two groups of arrows) in the basement membrane (asterisk). (From Romani N, Ratzinger G, Pfaller K, et al. Migration of dendritic cells into lymphatics—the Langerhans cell example: routes, regulation and relevance. *Int Rev Cytol* 2001;207:237-270, with permission.)

DENDRITIC CELLS

DCs, as their name indicates, are characterized by their long and elaborate cytoplasmic branching processes (the Greek word dendron means “tree”). The adaptive immune system, under evolutionary pressures, developed cells with exquisite specific receptors for sensing components of pathogens, so as to be able to generate molecular and cellular effector mechanisms for their elimination. Sensing of the pathogens or their products requires their breakdown (processing) and presentation by cells of the innate immunity. Foremost among the APCs are the DCs.^{230,231,232} DCs are a highly heterogeneous group that resides in most peripheral tissues at sites at which the body interfaces with the environment (i.e., skin, intestine, respiratory mucosa). Although DCs, as do other hematopoietic cells, ultimately derive from bone marrow progenitors, partially differentiated precursors are outside the bone marrow, such as peripheral blood, cord blood, and thymus. Such progenitors that are exposed *in vivo* to bacterial or inflammatory products, cytokines, and the like, differentiate to more mature cells with DC morphology and function. This large plasticity of DC development has created confusing and sometimes contradictory results. Basically, there are two lines of differentiation from stem cells, one along myeloid lineage and another along lymphoid lineage, thus the generation of two prevailing terms: myeloid DC and lymphoid DC. DC precursors circulate in the peripheral blood with a monocytic phenotype $CD14^+CD11c^+CD13^+$. These cells, cultured *in vivo* in the presence of GM-CSF and IL4, give rise to the DCs that are considered as myeloid DCs. However, the same precursors cultured with fibroblasts differentiate to macrophages.²³³ IL6 that is released from fibroblasts in contact with the monocytic precursors up-regulates the macrophage colony-stimulating factor receptors. This switches differentiation to macrophages by an autocrine mechanism, based on the secreted macrophage colony-stimulating factor. Progenitors from cord blood that are considered lymphoid, with the potential to differentiate into NK cells, could give rise *in vitro* to phenotypically and functionally potent DCs under stimulation with various cytokines.²³⁴ *In vitro* studies may not represent the normal *in vivo* pathways of differentiation, but they nevertheless provide evidence that, *in vivo* also, partially differentiated cells of different lineages may choose a DC differentiation pathway when they are exposed to appropriate conditions. The stimuli for DC differentiation vary widely, from inflammatory microbial products²³⁵ to simply crossing endothelial barriers. DCs that develop within the thymus are $CD8^+$ and are considered to be of lymphoid origin. However, it has been documented that even myeloid DCs can express CD8, so CD8 expression does not define lineage origin.^{236,237} Origin from lymphoid precursors was suggested by unique DCs known as plasmacytoid T cells or plasmacytoid monocytes. These cells have a typical plasma cell-like morphology; lack expression of myeloid markers; and

are CD11c-, CXCR3⁺, and L-selectin (CD62L)⁺. DCs are heterogeneous with respect to their phenotype, anatomic distribution, and function.

Functionally, DCs have been distinguished into two groups, DC1 and DC2; the former derive from myeloid monocytes (pre-DC1), and the second derive from a plasmacytoid DC precursor (pre-DC2).²³⁸ This separation correlates with functional differentiation. Myeloid DCs from monocytes that are activated by the CD40 ligand (CD40L) produce large amounts of IL-12 and induce preferentially T_H1 development. Lymphoid DC2s from plasmacytoid precursors produce lower amounts of IL12 and preferentially induce TH2 development.^{239, 240} Another study, however, reached opposite conclusions,²⁴¹ suggesting that the two DCs represent two separate evolutionary traits. The pre-DC1s express the Toll-like receptor (TLR)-2 and TLR4, and preDC2s express TLR7 and TLR9.²⁴²

Pre-DC1s are strongly positive for mannose receptor and rapidly produce large amounts of proinflammatory cytokines, such as TNF- α , IL6, and IL12, in response to ligands of TLR2-bacterial glycoproteins. Pre-DC2s produce IFN- γ in response to ligands of TLR9-bacterial DNA.²⁴³ The origin, response to stimuli, and pathways of differentiation of DCs vary greatly, depending on conditions that are still poorly understood.

The precursors of DCs from bone marrow progenitors move to the periphery as immature DCs and take position at crucial sites of potential entry of pathogens. Once they capture antigens and are exposed to stimuli, they mature and migrate to regional lymphoid organs to present antigens and to activate the adaptive immune responses by presenting antigens that are brought from the periphery. DCs are the professional APCs in immunity.

Migration of Dendritic Cells

DCs are cells that are continuously on the move from the moment they come out of the bone marrow to settle in various organs and tissues as immature DCs. In these locations, they are easily exposed to antigens and invading pathogens, and, now as mature activated DCs, they migrate to the lymphoid organs. Each of these pathways is orchestrated by distinct sets of molecules and receptors, foremost among them being the chemokines and their receptors.

Circulating monocytes and immature DCs express receptors for inflammatory chemokines (CXCR1, CCR1, CCR2, and CCR5), as well as receptors for bacterial and complement chemoattractants (receptor for N-formyl-methionyl-leucyl-phenylalanine-R and C5a-R),²⁴⁴ and, in response to such mediators, they develop into DCs.²⁴⁵ The crossing of the blood wall by DC precursors is mediated by a DC-specific adhesion molecule that is known as DC-specific intercellular adhesion molecule-3 (ICAM3) grabbing nonintegrin (DC-SIGN or CD209). DC-SIGN is a novel cell surface C-type lectin that is expressed on DCs, binds ICAM3, and mediates interactions between DCs and T cells.²⁴⁶ The extracellular region of DC-SIGN has a C-terminal, C-type carbohydrate recognition domain, particularly for mannose. DC-SIGN interacts with ICAM2 on the endothelial cells and establishes shear-resistant contacts with blood vessel walls for the transmigration of the DCs.²⁴⁷ The DC-SIGN-ICAM2 interaction is involved in the bloodborne DC precursor exit into peripheral tissues and in tissue mature DCs to peripheral lymphoid tissues. In the skin and epithelia of lung, intestine, and so on, immature DCs are exposed to stimuli that trigger their maturation, such as cytokines (TNF- α and IL1) and microbial products (e.g., lipopolysaccharide, LPS).

The mature DCs change to a new phenotype (MHC II³⁺, costimulatory and adhesion molecules positive) and acquire new migratory capacity. As a result, they migrate to the T-cell areas of the regional lymph nodes. DCs first down-regulate CCR1 and CCR5 (receptors for macrophage inflammatory protein [MIP]-1 α and MIP-1 β), up-regulate CCR7, and become responsive to secondary lymphoid tissue chemokine (SLC) and Epstein-Barr virus-induced molecule 1 ligand chemokine (ELC), the ligands for CCR7.^{248,249} Maturing DCs first move from their interstitial location to afferent lymphatic capillaries, where SLC is secreted from the endothelial cells and is carried to draining lymph nodes. The migratory pathways of the LCs, the DCs of the epidermis, provide a vivid example of the exquisite regulation of DC migration (Fig. 14.8).²⁵⁰

The LC precursors, CD11⁺ and CD1a⁺,²⁰⁰ are recruited into dermis, depending on the selectin expression of the dermal blood vessels.²⁵¹ These cells express the CCR6 receptor, which binds the inflammatory chemokine MIP-3 α (CCL-20), which is produced by keratinocytes of the epidermis.^{252,253} The LCs remain in the suprabasal layer, physically connected to neighboring keratinocytes by homotypic interactions that are mediated by E-cadherin, which is expressed by keratinocytes and LCs. Concomitantly, the CCR6 is down-regulated and the CCR7 is up-regulated, which

P.328

allows the LCs to move toward the lymphatic vessels in response to SLC. The basement membrane of the skin, however, stands as a barrier to their migration. LCs penetrate the lamina densa, which consists of type IV collagen and is digested by

the matrix metalloproteinase of LCs. They cross the dermis and reach the abluminal side of the vessels. Entry into the lymphatic vessel is poorly understood, but P-glycoprotein may be involved.

LCs are carried by the lymph and acquire morphology that is known as a veiled cell as a result of their broad sail-like membranous sheets. Entering the lymph node, they settle in the dependent areas in response to SLC (CCL21) and ELC (MIP-3 β , CCL19), ligands for the CCR7 receptor. SLC is produced by the endothelial cells of the high endothelial venule, and ELC is produced by DCs or other cells in the paracortex.²⁵⁴ The LCs that settle in the paracortex are known as interdigitating dendritic cells (IDCs).

Accumulation of DCs around tumors follows the same mechanisms and depends fully on the interaction between chemokines released by tumors and the appropriate receptors on DCs²⁵⁵.

Dendritic Cell Functions

DCs are best known for their efficient antigen presentation function. They capture antigens and pathogens, which they internalize and process for antigen presentation. DCs use a variety of receptors to take in antigens, such as receptors for Fc and complement, macrophage-scavenger receptors, mannose receptors, and DEC-205. However, of all the receptors that the DCs use to endocytose pathogens, the best studied is the DC-SIGN receptor that binds to HIV.²⁵⁶ HIV is not endocytosed by the DC, but the DC-SIGN binds to gp120 envelope glycoprotein, and the DC transfers the HIV to the lymphoid organs, where it enhances infection of T cells that express CD4 and chemokine coreceptors. DCs are efficient APCs for the class II-restricted pathway, but endocytosed antigens can also be diverted to the class I-restricted pathway. This is known as cross-priming or cross-presentation (see section "Presentation of Exogenous Antigen by Major Histocompatibility Complex Class I Molecules"). Immature DCs are crucial for this mechanism of presentation.

Interaction with pathogens by immature DCs not only prepares naive T cells for priming, it also activates immature DCs for maturation. This is mediated by signaling receptors, such as the Toll-like receptors of innate immunity (i.e., TLR2, which is involved in response to Gram-positive bacterial components, or TLR4, which interacts with LPS in response to Gram-negative bacteria). An interesting example of the diversity of responses to a single bacterial protein by immature DCs is the bacterial cell wall protein OmpA (from *Klebsiella pneumoniae*). This protein triggers maturation signaling of immature DCs through the TLR2 receptor, endocytosis via a receptor-dependent mechanism, and cross-priming of antigen-specific CD8⁺ T cells (in the absence of CD4⁺ T-cell help).²⁵⁷

DCs, however, are not simply antigen-delivering cells for lymphocytes. They play a key role in the maintenance of T and B lymphocyte pools in the absence of exogenous antigen. For T cells, this function depends on the high density of MHC class II molecules.²⁵⁸ It is postulated that the MHC class II molecules display self-peptides, and the interaction generates and transmits signals that are sufficient for the survival of T cells and could be traced from the cell surface to the nucleus (increase of IL12R β_2 chain and IFN- γ mRNA). Contact between DCs and naive T cells in the absence of antigen is established by the interaction of DC-SIGN (DCs) and the ICAM3 (T cells).²⁴⁶ This strong interaction allows the establishment of interactions with other adhesion molecules to form the immunologic synapse. These synapses are antigen-independent and induce local Tyr phosphorylation, small Ca²⁺ responses, and long-term survival.²⁵⁹

DCs can regulate differentiation of naive B cells. In the initiation of the antibody response, a three-cell interaction takes place among T, B, and D cells with various combinations of cell-surface-expressed molecules. This gives time to B cells to process and present peptide through the class II MHC molecules, for a cognate T- and B-cell interaction.²⁶⁰ DCs directly modulate growth and differentiation of B cells and enhance IgG and IgA secretion by 30- to 300-fold, and through IL2 production stimulate IgM production. IL2 is a key cytokine that is produced early after DC stimulation by maturation signals.²⁶¹

Dendritic Cells in Human Disease

DCs accumulate in the joints of rheumatoid arthritis patients and within psoriatic plaques, which express high levels of CD1b and CD1c, and are active stimulators of autologous T-cell proliferation. In contact allergy, hapten-modified proteins are processed by LCs that migrate to draining lymph nodes and initiate immune responses. A similar pathway is taken by DCs in the respiratory airways that capture and process inhaled antigens in asthma. The DCs are significantly higher in asthmatics. Targeting DCs may be an important new therapeutic approach for asthma.

In human parasitic infections, immature DCs can phagocytose the organism and restrain parasite replication in dermal infiltrates.

The role of DCs as potentiators and initiators of antiviral immune responses is well documented, especially in stimulating recall of cytotoxic T lymphocyte responses. Nevertheless, viruses still survive within DCs and subvert the immune response by down-regulation of MHC class I molecule expression, induction of immunosuppressive cytokines (IL10), or down-

regulation of immunostimulatory cytokines (IL12). In the pathogenesis of HIV disease, the DCSIGN acts as a dendritic-specific HIV-1-binding protein that does not need a coreceptor and promotes binding and transmission of HIV-1 to T cells rather than entry to DCs. The virus is retained in an infectious state but is not allowed to enter the DC. DC-SIGN literally presents HIV to T cells in a nonprocessed infectious form. Various carcinomas display a heavy infiltrate of DCs with high MHC class II molecule expression that is associated with better prognosis. DCs have been used in trials in cancer therapy. Prospects for future successful DC immunotherapy are promising.²⁶² T-cell immunity can be induced, even in patients with advanced stage IV melanoma, by vaccination with antigen-pulsed mature monocyte-derived DCs.²⁶³ When the DCs are loaded with MHC class II molecule-binding melanoma peptides, strong tumor-specific T_H1 responses were elicited.

In a large body of literature regarding animal models, DCs that were loaded with tumor-associated antigens were able to induce antitumor immunity.²⁶⁴ Measurements of CD8⁺ T cells by using MHC tetramers help quantify antigen-specific responses.²⁶⁵

Langerhans Cells

LCs were first observed in the epidermis by Langerhans and can be identified only by means of special stains that make use of the affinity of the cell for heavy-metal ions or the uptake by the cell of L-dopa, dopamine, and noradrenaline.²⁶⁶ The demonstration of a formalin-resistant and sulfhydryl-dependent ATPase is a reliable and specific technique for identifying LCs. Their ultrastructure was first described by Birbeck et al.,²⁶⁷ who also described a characteristic granule that bears Birbeck's name.

LCs constitute 3% to 8% of all cells in the epidermis and are present in all parts of the skin, esophagus, and cervix; they are not found in the cornea, trachea, stomach, or bladder. In humans, the number of LCs per unit of skin varies between 40,000 and 100,000/cm². Their precursors originate in the bone marrow, and in the mature stage they are located in the suprabasal layers of the skin, within the epidermis, where they can be distinguished from keratinocytes on the basis of absent desmosomes and tonofilaments and from melanocytes by the absence of melanosomes.

P.329

The long dendritic processes form a continuous network. The nucleus is irregular and lobulated. The cytoplasm is clear and contains microfilaments and multivesicular bodies, as well as the unique Birbeck granule, which is rod-shaped with periodic striations, giving it the appearance of a zipper. LCs are present in the dermal lymphatics, the marginal sinus, and the paracortex of draining lymph nodes, which suggests that these cells are mobile (see the previous discussion).

Mature LCs express a granule-associated antigen, E-cadherin,²⁶⁸ and HLA-D antigens. Ultraviolet irradiation depletes the skin of LCs and blocks the induction of contact sensitivity.

Veiled Cells

Veiled cells are present in the afferent lymph and resemble LCs.²⁶⁹ Their name derives from the possession of long, actively moving processes or veils that are approximately 100 nm thick. The veils do not contain organelles, and their movement must therefore be generated at a distance. Their nucleus is highly convoluted, and the cytoplasm contains bundles of microfilaments. Only approximately 4% of veiled cells contain a Birbeck granule, but all possess a large vacuole under the cell surface. They elicit a strongly positive response when they are tested for ATPase, and they resemble LC in the content of other enzymes. They are not actively phagocytic, but they possess Fc receptors.

After contact sensitization, Langerhans-like cells appear in the dermal lymphatics, and an increase in the number of veiled cells in the lymph that drain the area is noted. Once they are in the lymph node, most veiled cells localize in the T-cell-dependent areas, where they may function as interdigitating cells. Some veiled cells enhance the response of T lymphocytes to mitogens. Their function possibly consists of transporting antigens into the paracortical area, where they present them to T lymphocytes. Thus, a cellular chain for antigen transport exists in which more than one cell type takes part. Starting from the floor of the subcapsular sinus, antigen is localized first in cells that have the appearance of LCs, but, in deeper regions of the cortex, a second cell with morphologic characteristics of veiled cells has been identified.²⁷⁰ These two cells are similar to the cells that are known to migrate from skin areas to the paracortex.²⁷¹

Interdigitating Dendritic Cells

The T-cell-dependent areas of the lymphoid organs contain substantial numbers of DCs that are known as IDCs.²⁶⁹ They have a clear cytoplasm and an irregularly shaped nucleus and extend long dendritic processes to contact T cells. They

express MHC class II antigens but do not express receptors for the Fc fragment of Ig and complement. IDCs are positive for CD83 and the S100b protein (cytoplasm). The name usually is reserved to describe cells that lack Birbeck granules.

Many common features are shared by IDCs and DCs from other compartments (e.g., skin and splenic white pulp). This led to the view that a single DC system exists in which the peripheral nonlymphoid organs' DCs migrate to the T-cell-dependent areas and become IDCs.²⁷² This has been shown by labeling DCs that are isolated from the spleen of mice and injecting them into footpads. The labeled cells migrated to the periarteriolar sheath of the spleen or the paracortex of the lymph node.²⁷³ DCs from skin that is painted with hapten migrate within 24 hours to the lymph nodes.²⁷⁴

Similarly, Leishmania parasites that are injected into the skin are found within IDCs in the T-cell areas of the lymph nodes, probably as a result of uptake of the parasites by skin DCs that migrated to the lymph nodes to become IDCs.²⁷⁵ In patients with skin allergies, one finds Birbeck granules in some IDCs of local lymph nodes. Also, the T-cell areas stain strongly for CD12, a marker that is expressed on LCs. This evidence supports the notion that LCs migrate from areas of the skin to the T-cell areas of regional lymph nodes. Transportation of antigen from the periphery to lymph nodes is not only characteristic of the skin DC but is also a function that is performed by intestinal DCs and other DCs in the periphery.

Follicular Dendritic Cells

Follicular dendritic cells (FDCs) are found in the follicles and germinal centers (GCs) of lymph nodes and were identified by a distinct dendritic pattern of antigen localization in the follicles. Antigen trapping in the follicles requires antibody with an intact Fc fragment and complement. The antigen that is so trapped persists for long periods, in contrast to the antigen that is captured by the medullary macrophages. Cytologically, the FDCs have an irregular nucleus, a narrow rim of cytoplasm, and filiform dendrites, giving the cell a sunburstlike pattern. On their surface, they express Fc and C3 receptors and MHC class II antigens.

Electron microscopic studies have identified two FDC types: FDCs with filiform dendrites, which mature to FDCs with beaded dendrites.²⁷⁶ After secondary immunization, FDCs form spherical particles called iccosomes (immune complex-coated bodies; Fig. 14.9). The iccosomes are formed through interactions of the two FDC types. One cell binds immune complexes, and the second cell, with beaded dendrites, binds to the areas of the complexes. Thus, the bead becomes coated with the complexes and the cytoplasmic membrane of the first FDC that carries the complexes. At this stage, the bead is filled with immune complexes and is subsequently detached as iccosomes that are dispersed among the cells of a developing GC. This process constitutes what is called the alternative antigen presentation pathway,²⁷⁶ to distinguish it from the more conventional antigen capture and presentation.

Antigen complexes are poor immunogens because they deliver a down-regulatory signal to the B cell that is related to the phosphorylation of the immune receptor Tyr-based inhibitory motif on the B-cell Fc receptor. However, the FDC strongly expresses FcR, and it is conceivable that, as FDC binds to complexes, it limits the available Fc on the complexes for binding to the FcR on B cells. FDC also delivers co-stimulatory signals to B cells, probably through complement-derived fragments, C3dg and C3d, which are associated with the FDC-bound complexes. Complement fragments bind on B cells to complement receptor 2 (CR2, CD21), which is a member of the CD19/CD21/CD81 (TAPA1) complex, a coreceptor of the B-cell antigen receptor (see Chapter 12).²⁷⁷ Thus, the FDC-associated complexes colligate the antigen BCR and the CD19/CD21/CD81 coreceptor, providing two signals for B-cell stimulation.

The CD21 exists in two isoforms, one long and one short. FDCs selectively express the long isoform of CD21, whereas the short molecule is expressed by B cells. CD21 on FDC most likely participates in binding of complexes. The FDC-dependent B-cell stimulation is enhanced by IL2.

FDC traps and retains large numbers of retroviral particles,²⁷⁸ which markedly alter the function of FDC and the anatomy of the follicle. Infected FDC brings the virus and CD4⁺ T cells together, promoting their infectivity. The antigen presentation function of the FDCs is lost, and, eventually, the cells are destroyed.

There are two views on the origin of FDCs: one proposes a hematopoietic origin, whereas the other proposes a mesenchymal/fibroblast origin. FDCs have a fibroblastic morphology and express certain molecules, such as vimentin and desmin, which are found in mesenchymal tissues. FDCs are also found in areas of chronic inflammation.²⁷⁹ As yet there is no convincing evidence for either theory. For the time being, FDCs continue to be defined as the cells in the follicles of lymphoid organs that have the property to trap complexes of Ig and antigen. The reticulum cells within the GCs were thought to be different from those in the mantle, but, by ultrastructural studies, DCs in GCs and those of the mantle zone (or primary follicles) are considered to be of the same family.²⁸⁰

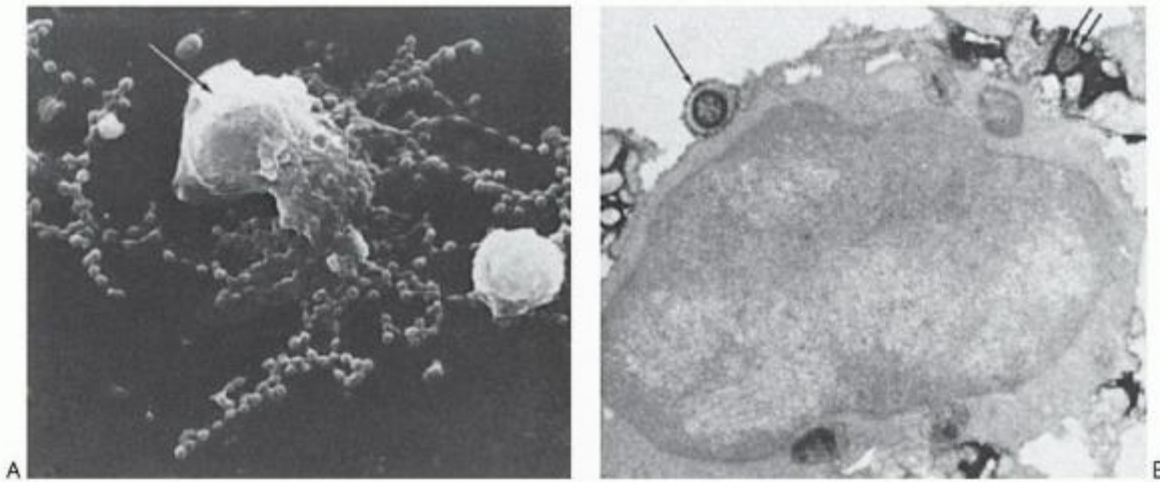

FIGURE 14.9. Follicular dendritic cell and iccosomes. A: Scanning electron micrograph that illustrates a follicular dendritic cell (arrow) with beaded dendrites. Each dendrite contains several iccosomes. B: Transmission electron micrograph of a lymphocyte from the germinal center with two iccosomes in contact with its surface (arrows). (From Szakal AK, Kosco MH, Tew JG. A novel *in vivo* follicular dendritic cell-dependent iccosome-mediated mechanism for delivery of antigen to antigen-processing cells. *J Immunol* 1988;140:341-353, with permission.)

T-B-CELL INTERACTIONS

Immune responses are regulated by the dose and the localization of antigen.²⁸¹ Furthermore, for T and B lymphocytes that need to collaborate, recognition of antigen by their antigen receptors is not sufficient to activate them, but a second signal (co-stimulation) is required. T lymphocytes are in the paracortical areas, and the most abundant APCs in the paracortex are the IDCs.

The complexity of the mechanisms that are involved in activation of naive T cells *in vivo* was elucidated with TCR transgenic T cells.²⁸² When antigen is injected in the absence of an adjuvant, T-cell activation does not take place or is too small in intensity and short in duration and therefore is nonproductive. DCs, which are interspersed in the tissues behind the physical barriers of the body, are Nature's adjuvants, and although they are immature, they are still phagocytic and able to capture pathogens or their products. Under these conditions and with stimulation by inflammatory cytokines, DCs transform into mature DCs, and although they may have lost their phagocytic capacity, they have acquired two new important properties. First, they change their chemokine receptors to migrate to the T-cell areas of the draining lymph nodes. In addition, they acquire co-stimulatory molecules (CD80 and CD86), adhesion molecules (CD48 and CD58), and class II MHC molecules that are loaded with peptides from newly internalized antigens expressed on the cell membrane. In addition to these molecular immunologic changes, morphologic signs of their activated state become apparent, with long cytoplasmic dendrites reaching out between T cells. This morphologic appearance contributed to their name as IDCs. Inflammatory cytokines, such as TNF- α , that are released from activated macrophages contribute to the activation of DCs^{283,284} and up-regulate CD40 expression on DCs,²⁸⁵ which further promotes interaction with CD40L⁺ T cells.²⁸⁶

Activated DCs lead to significant immune responses, whereas immature DCs can be tolerogenic, as has been shown with healthy human volunteers. Immature DCs inhibit CD8⁺ T-cell immunity to viral peptide-specific IL10-producing T cells.²⁸⁷ In contrast, mature DCs (triggered by a mixture of macrophage products, such as IL1 β , IL6, TNF- α , and prostaglandin E₂) induce functionally superior CD8⁺ T cells and polarize CD4 T cells toward IFN- γ production.

Maturation stimuli direct co-stimulatory molecules and MHC class II-peptide complexes to membrane microdomains ("lipid rafts"), where they are able to interact more efficiently with the CD28 and TCR as the DCs and T cells form the immunologic synapse (see Chapter 13).^{288,289} This is the first cognate interaction, which takes place between DCs and T cells in the paracortical area and results in full activation of T cells (Fig. 14.10). Co-stimulatory signaling amplifies the TCR signaling as much as 100-fold, as T cells respond to lower doses of antigen (~100-fold lower dose). The co-stimulatory pathway up-regulates bcl-xL and prevents Fas-mediated apoptosis of newly activated T cells. Co-stimulation enhances production of IL2 from activated T cells and induces expansion of antigen-specific T cells.

The factors that drive these two processes are the levels of MHC class II-peptide complexes and, therefore, the TCR stimulation and the intensity of co-stimulation; both are related to the stability of the synapse.^{290,291,292} Recurrent and sustained exposures to antigen and to polarizing cytokines are essential for differentiation of CD4⁺ T cells.²⁹³ Early withdrawal of antigenic stimulation arrests differentiation, even in the continued presence of cytokines. For TH1 differentiation, prolonged signaling is required to induce appropriate epigenetic modifications to maintain high levels of T-bet expression (Chapter 13, see section “TH1 and TH2 Differentiation”).

An important aspect of T-cell differentiation involves antigen selection of a TCR-restricted repertoire. This was clearly shown in the immune response against pigeon cytochrome C, in which the specificity is determined by the CDR3 of the TCR α chain. Of eight preferred CDR3 features that are rapidly selected early during the response, only one (TCR- α 93 glutamic acid) existed to any significant extent before immunization. This TCR restriction and clonal dominance is antigen-driven and is propagated by expansion of one or a few clones from the postthymic repertoire.

This selective T-cell expansion for effector and memory function takes place in the T-cell zone, before the GC reaction. Inflammatory cytokines, particularly IL1 or TNF- α , also mediate some of these effects through CD28 co-stimulation by up-regulating expression of CD80 and CD86 on DCs.

After the peak of clonal expansion, the number of antigenspecific T cells falls owing to cell death, which may occur via Fas-dependent or activation-induced cell death. For the antibody response to continue, T and B cells, which are specific for different

P.331

P.332

epitopes of the same antigen, must move from their separate locations to meet. Of the surviving activated T cells, most of them move out of the lymph node as memory T cells, but a small portion migrates to the edges of the paracortex next to the follicle, and B cells also move to the same location.^{294,295}

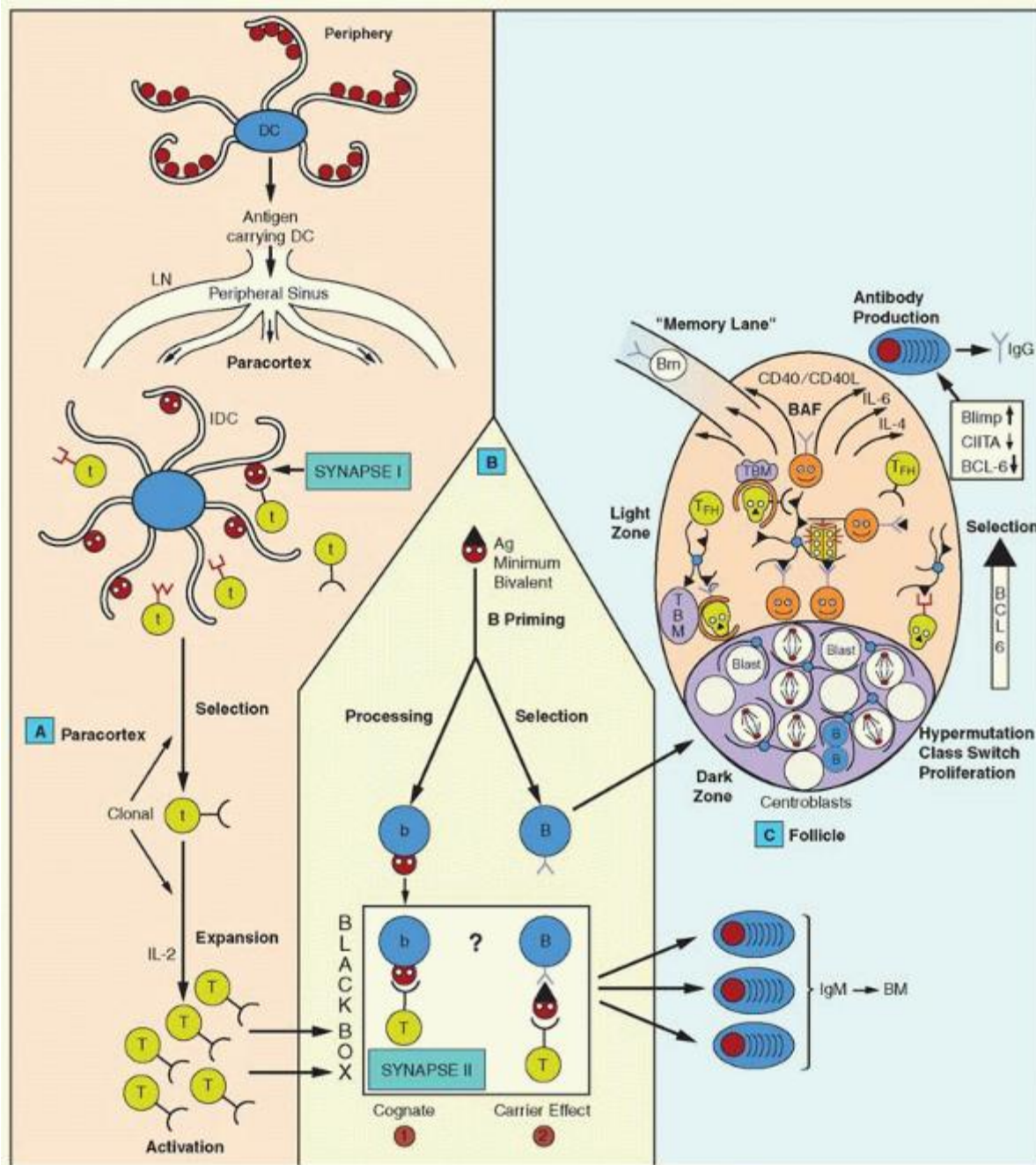

FIGURE 14.10. Chance and necessity: the germinal center reaction. Antigen (Ag) captured in the periphery by dendritic cells (DCs) is brought to the regional lymph nodes to be presented to naive T cells (t) (synapse I). Clonally selected naive T cells become activated by interleukin (IL)-2 (T). They up-regulate the CXCR5 receptor, respond to BLC chemokine that is secreted from follicular cells, and move toward or even inside the follicle. In the border between the paracortex and the mantle of the follicle, they interact with B cells. The interactions are not yet well characterized in vivo. Some B cells process antigen and may present it to T cells that are selected by DCs (synapse II) (1). B cells may have been selected by the same antigen but for a different epitope. B and T cells may bind to the same immunogen but on different epitopes (“carrier effect”; synapse II) (2). Synapse II promotes differentiation of plasma cells that secrete immunoglobulin (Ig) M. B cells move inside the follicle to the pole that is adjacent to the T-cell zone (dark zone) and begin intensive proliferation. They are Ig-negative and are called centroblasts. B cells undergo mutations in the V gene at a high rate (somatic hypermutation) and change their IgM to another Ig class (class switch). When proliferation subsides, centroblasts move to the center of the germinal center—i.e., the light zone—and are known as centrocytes (Ig-positive). Their B-cell receptor (BCR) is submitted to the scrutiny of antigen-antibody complexes on dendrites of DCs of the densely populated light zone. In most centrocytes, somatic hypermutations have decreased or destroyed the affinity of their BCR and enter the pathway

for apoptosis. Their corpses are removed by macrophages known as tingible body macrophages (TBM). If the affinity is increased, they are given the green light for survival and growth (BAFF, IL-6, IL-4, CD40-CD40L). Surviving cells have higher affinity than their predecessors (affinity maturation). They receive signals from germinal center DCs or follicular T-helper cells (TFH). Depending on the instructions that are received, some centrocytes go down memory lane, whereas others become plasma cells. Two genes are most influential in the regulation of germinal center reaction: B-cell lymphoma 6 (BCL-6) in the early phase represses all genes that regulate the second state; the B-lymphocyte-induced maturation protein-1 (Blimp-1) is released from repression when BCL-6 is down-regulated by high-affinity BCR signals. Blimp-1 regulates plasma cell differentiation. b, naive B cell; B, primed, antigen-specific B cell; BAF, B-cell activating factor of the TNF family; BM, bone marrow; CIITA, major histocompatibility complex class II trans-activator molecule; IDC, interdigitating dendritic cell.

Chemokines and their receptors are the main regulators of primary immune responses, setting the stage for the main players as well as orchestrating their performance. CCR7 is the most important for organizing the appropriate microenvironment to make the initial interaction possible.²⁹⁶ As multiple cells contribute to an immune response, change in the chemokine receptor program regulates the second stage in the cell interactions for antibody synthesis. CCR7 is the receptor for chemokines SLC (6CKine, exodus2, and CCL21) and ELC (MIP-3 β , exodus3, and CCL19). SLC is secreted by the cells of high endothelial venules and mediates the crossing of T cells to the lymph nodes. ELC is secreted by stromal cells of the paracortex and attracts naive T cells to settle within the T-cell areas (see Chapter 11). DCs in the peripheral tissues up-regulate CCR7 expression as part of their maturation and are guided to the paracortical areas. The CXCR5 is the receptor for chemokine BLC (CXCL13), which is secreted by stromal cells in the follicles and attracts B cells that cross the high endothelial venules to settle in the follicular area. Activated CD4⁺ T cells up-regulate CXCR5 and migrate to the follicles.^{297,298,299,300,301} Whether the T-cell-B-cell interaction takes place on the paracortical side²⁹⁵ or the follicular side²⁹⁴ of the T-cell-B-cell border is not clear. The fact is that the two cells physically interact (second cognate interaction), forming a synapse by adhesion molecules and supported by co-stimulatory molecules, including the inducible costimulator (ICOS) on activated T cells and its counterreceptor B7-h on B cells.³⁰²

GERMINAL CENTER REACTION

Interaction of B cells with activated T cells initiates their proliferation and migration into the area within the primary follicle, which is now called the secondary follicle. Some of the activated B cells differentiate at the edge of the T-cell zone into plasma cells, secreting IgM and migrating to the medullary cords and on to the bone marrow. Plasma cell differentiation in this area could also be induced in a T-cell-independent way, especially from antigens known as T-cell-independent antigens. The IgM antibody is part of the early phase of antibody production.³⁰³ The remaining antigen-specific B cells are recruited within the follicle and rapidly expand to form the germinal centers.³⁰⁴ GCs are formed as a result of the expansion of one or a small number of B cells and are therefore monoclonal or oligoclonal. The expanding population of B cells fills the FDC network,³⁰⁵ and although T cells facilitate their formation, GCs may be formed in the absence of T-cell signals for certain antigens.³⁰⁶ Multiple steps of mutation and selection are the main driving forces in the formation of the GCs, and recirculation of positively selected centrocytes is quite unlikely.³⁰⁷ CD27 is important for GC formation by two distinct mechanisms. T cells support formation of GC as a result of interaction of CD28 (T cells) with CD27 (B cells) (centroblast expansion) and, in addition, CD27⁺ T cells may be interacting with CD70 on B cells.³⁰⁸ The GCs are oligoclonal and with a cell cycle time of the dividing B cells of approximately 6 hours, the number of accumulating blasts within 3 days is of the order of 1 to 1.5×10^4 . During this exponential growth, the small recirculating B cells are excluded and are pushed aside to form the familiar mantle that surrounds the GC. By the time the B blasts finish their exponential growth, they have filled the FDC network that is close to the T-cell zone, which is known as the dark zone, and the B blasts are known as centroblasts. Centroblasts are Ig⁻ and give rise to nondividing Ig⁺ cells, which are known as centrocytes, which occupy the center of the follicle or the light zone. The light zone has been divided into an apical (FDC CD23²⁺) and a basal component (FDC CD23⁻; Fig. 14.11).

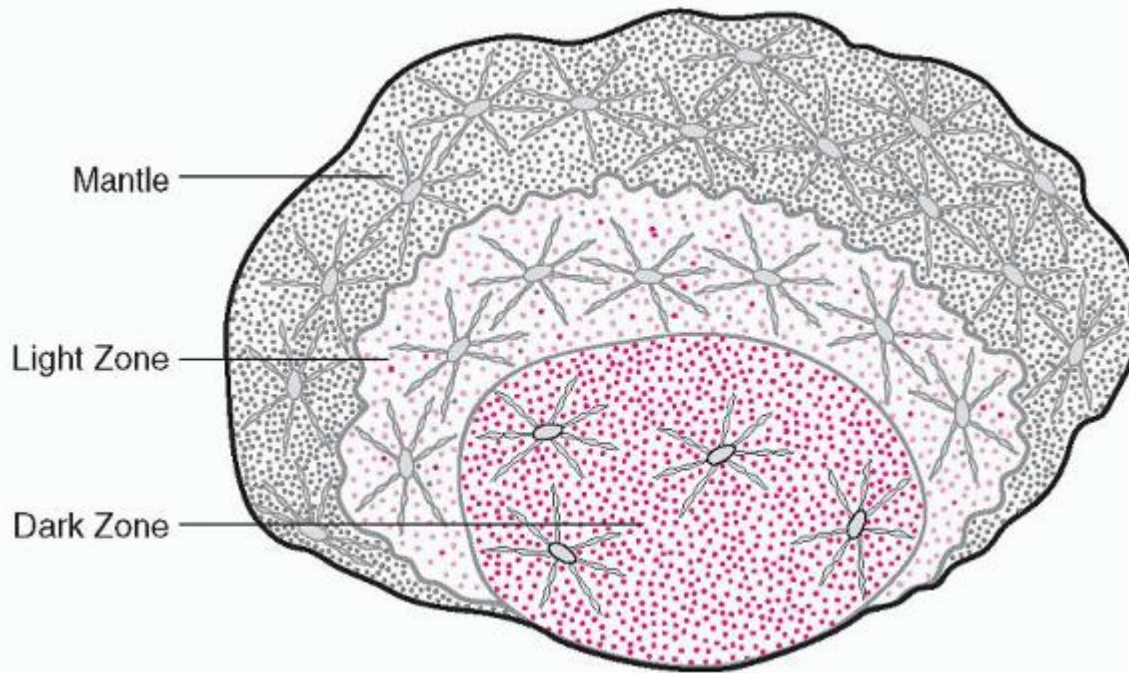

FIGURE 14.11. The germinal center. Dark zone, centroblasts in cell cycle. Light zone, strong expression of CD23 on dense follicular dendritic cell (FDC) network. Mantle, loose FDC network.

Several important events for the life of B cells take place in the GCs: clonal expansion, somatic hypermutation (SHM) resulting in affinity maturation, Ig class switch, and generation of memory B cells and plasma cells. All naive B cells express the CXCR5 receptor for chemokine CXCL13 (BCA-1, B-cell attractant [chemokine 1]), which is secreted constitutively by cells within the DC network in the follicular area. Furthermore, the DC-specific chemokine CD-CK1 (CCL18, also known as PARC) preferably attracts CD38⁺ mantle-zone B cells toward the FDC and may well provide the initiation signal for the formation of GCs.³⁰⁹ Responsiveness to the CXCL13 is also shown by a minor subpopulation of memory CD4⁺ T cells that express the CXCR5 receptor for the CXCL13 chemokine and, as a result, are attracted to the follicles; they are known as follicular T-helper cells (T_{FH}).^{297,298} The expression of CXCR5 is transient and occurs during T-cell activation but before their proliferation. The CXCR5⁺ T cells constitute only a minor proportion of peripheral T cells. They also express the CC-chemokine receptor 7 (CCR7) and L-selectin (CD62L), allowing a steady-state re-circulation through secondary lymphoid organs.²⁹⁹ Several molecules expressed on T_{FH} cells mediate help to B cells, but crucial among them are CD40L (CD40 ligand or CD154) and ICOS (inducible T-cell co-stimulator), which interact with CD40 and the ICOS-ligand (ICOS-L), respectively, on B cells. Another important molecule of T_{FH} is SAP (its name derives from its association with an activation molecule known as SLAM [CD150], or signaling lymphocytic activation molecule). A significant member of TFH undergoes apoptosis, as shown by gene expression profiling.³⁰⁰

The FDCs are strongly positive for CD21 and CD23 and form a dense network in the light zone. In the dark zone, they are weakly positive for CD21 and negative for CD23, and they form a light network. The FDCs express the long isoform of CD21, which is the only specific marker for human FDCs, whereas the B cells express only the short isoform. FDCs trap immune complexes and present antigen to B cells, although the B cells can undergo somatic mutation and memory cell formation, even in the absence of complexes,³¹⁰ probably by other signals that are received from FDCs, which support B cells in the immune response in several ways. Engagement of CD21 in the BCR by complement in the antigen-antibody complexes augments the stimulation that is delivered by FDCs.³¹¹ Furthermore, engagement of the FcγRIIB on DCs diverts binding of the complexes from the same receptor on B cells. FcγRIIB is an inhibitory receptor, and, thus, by trapping the complexes, the FDCs protect B cells from inhibition.³¹¹

There is cross-talk between FDC progenitors and B cells, because B-cell signals contribute to FDC maturation and network development. LT-α, LT-β, and TNF-α from B cells, and TNFR-1

P.333

expression by some nonbone-marrow-derived cells lead to FDC cluster formation in the lymphoid organs.³¹²

Because FDCs have no phagocytic activity and do not synthesize MHC class II molecules, they are unable to present peptides that are complexed with the MHC after processing of internalized antigens. However, there are two other ways that FDCs perform their antigen-presenting function. Cytochemically, antigen has been detected on FDCs along filiform or beaded dendrites. The beads, like pearls on a string, are particles that contain the immune complexes called iccosomes (immune complex-coated body), which are usually detected in the early phase of the formation of the GCs.²⁷⁶

Complement in the complexes binds to CD21 on FDC and delivers a crucial signal that dramatically augments the B-cell stimulation resulting from binding of the antigen to BCR. FDCs have no phagocytic activity and do not synthesize MHC class II molecules, and therefore they are unable to process antigen for presentation.³¹³ MHC class II, however, has been detected on the surface of FDCs in the form of microvesicles that contain MHC class II molecules and other antigens that are foreign to the FDC.³¹⁴ These vesicles are exosomes that are enriched in MHC class II molecules and members of the tetraspan family (i.e., CD37, CD53, CD63, CD81, and CD82; see Appendix A). The exosomes derive from multivesicular endosomes that are released by B cells with specificity for attachment to DCs and the ability to stimulate CD4⁺ T cells.^{315,316} This is an interesting example of cell communication, antigen processing, and presentation for T-cell activation. FDCs therefore have a dual mission for B-cell response within the GCs: antigen processing and presentation to B cells, and promotion of B-cell differentiation and isotype switching.^{317,318}

In addition to FDCs, T cells have a critical role in GC formation, primarily for the late stages of GC reaction and not during the initial development.^{319,320} GCs that are induced in the absence of T cells are of short duration, and the V genes of the antibodies do not undergo hypermutation. The GCs abort dramatically at the time when T cells normally select the high-affinity B cells.³¹⁹ The demise of the GCs at this point is a fail-safe mechanism to prevent autoreactive B cells from escaping into the periphery, with development of autoimmunity.

In the dark zone, lymphocytes are densely packed, and only fine FDC processes penetrate this area. The FDCs in the dark zone are CD23⁻ and only weakly CD21⁺. The centroblasts are in rapid cell cycle and do not increase in number, but they give rise to a progeny of centrocytes that are nondividing and express surface Ig. Centrocytes are located in the light zone and are CD21 strongly positive and CD23 moderately to strongly positive. In this stage of the evolution of the GC, the B cell is selected for survival or death, based on the affinity of the antigen receptor as the cell emerges from changes induced by hypermutation (see the following discussion).

B Cells in Germinal Centers: Struggle for Survival

Proliferation of B cells in the GCs is stimulated by antigen, but different mechanisms regulate the proliferation in the two GC zones, dark versus light. The paucity of T cells in the dark zone suggests that this early, expansive B-cell phase is supported by strong stimulatory signals from complement-containing immune complexes, FDC-B-cell cognate interactions, and soluble factors from FDCs.³²¹ In the light zone, T_{FH} cells play a more important role and, although the density of FDCs is much higher, some FDCs are inhibitory for B-cell activation. GCs develop within 4 to 6 days after primary immunization, and centroblasts in the dark zone continue to maintain a high output of centrocytes for 7 to 14 days and undergo SHM that results in antigen receptor diversification.

The decision between life or death, a process known as selection, takes place within the light zone as the B cell emerges from the dark zone. The mechanism of selection is not yet clear, but antigen that is trapped on FDCs is used to “test” the affinity of the BCR of the centrocytes. A key determinant for selection is the CDR3, which has a major contribution to diversity and affinity of the receptor. Structurally identical receptors are handled differently if variations in CDR3 exist between them, and such variations drive the selection process.³²² The vast majority of these random mutations is deleterious to antigen binding and destroys or diminishes the affinity of the BCR that existed when the antigen-specific B blast entered the dark zone from the paracortex-follicular border. These cells are negatively selected and are diverted to apoptosis.

Other cells have acquired autoreactivity, and these cells receive no signals from FDCs and therefore die from “neglect.”³²³ Of the cells in which BCR expresses reactivity with antigen, some emerge from the mutational process with high affinity, and only those are positively selected to achieve affinity maturation. Affinity maturation was discovered 42 years ago³²⁴ but remained poorly understood until somatic diversification of BCR genes in the GCs was demonstrated.³²⁵ Affinity maturation signifies the increase of the affinity of antibodies between those that are produced early after primary immunization (low affinity) and those that are produced 2 weeks after immunization or, better, after secondary immunization (high affinity). Affinity maturation is associated with somatic diversification that occurs during hypermutation. As shown by studies in mice, the D and J regions of the H chain (16 amino acids long) of the antibodies that are synthesized 7 days after immunization have no residue changes that could be attributed to mutations. However, by 14 days the antibodies carry somatic mutations that have resulted in increase of the affinity.³²⁶ Positive selection of these high-affinity antibodies constitutes affinity maturation.

Survival of the Fittest

One of the puzzling phenomena related to the life of B cells after their release from the bone marrow is the fact that approximately 70% of them do not reach maturation and die. B-cell survival and maturation relies on the delivery of signals, most importantly through BCR, and survival depends on a mechanism of positive selection.³²⁷ The immature B cells that leave the bone marrow undergo a progressive maturation process that takes the cell through three stages, known as transitional stage type 1 (T1), type 2 (T2), and type 3 (T3).³²⁸ T1 cells are IgM^{hi}, IgD⁻, CD23⁻, and CD21^{lo}, and T2 cells are IgM^{hi}, IgD^{hi}, CD23⁺, and CD21^{hi}.³²⁹

Although the location and mechanism by which this huge number of B cells perish have not been identified, it is possible that a prime location is the light zone, in which the mechanism of cell death is by apoptosis as a result of a BCR that is incapacitated by hypermutation.

B cells require and receive multiple signals from different cells and molecules for survival. The cognate interaction between FDCs and B cells provides signals through antigen presentation (albeit weak), as well as through several receptor-ligand pair interactions, such as ICAM-lymphocyte function-associated antigen-1, vascular cell adhesion molecule-1-very late antigen-4, and CD23-CD21.³³⁰

In addition, DC stimulates B-cell proliferation and Ig synthesis, which are mediated by the CD137-ligand system.³³¹ CD137 is a member of the TNF receptor family that is expressed by FDCs and stimulates the CD137 ligand-expressing B cells by reverse signaling.

Germinal Center B Cell

An important B-cell survival factor that is known as the B-cell activation factor member of the TNF family (BAFF or TNFSF13B) promotes maturation of B cells and prolongs their survival and, under certain conditions, B-cell growth.^{332,333} BAFF forms a trimerlike TNF, like other members of the family, but its unique

P.334

feature is the presence of two Mg²⁺ ions. The gene for TNFSF13B (BAFF) is located in human chromosome 13q32-34, a location that is frequently involved in translocations in Burkitt lymphoma. BAFF exists as a membrane-bound form and as a soluble form. It is closely related (approximately 50% similarity) to another TNF family member, a proliferation-inducing ligand (APRIL). Both BAFF and APRIL bind to two receptors, B-cell maturation antigen (TNFRSF17) and transmembrane activator, and calcium modulator and cyclophilin ligand interactor (TNFRSR13B or TACI), with high affinity, but preferences by the ligands have been detected,³³⁴ with BAFF being associated more often with TACI than with TNFRSF17.³³⁵ A third receptor, called BAFFR (TNFSF13C), selectively binds BAFF and not APRIL. However, a basic amino acid sequence close to the NH2 terminus of APRIL binds to proteoglycans in the extracellular matrix or cells and produces its oligomerization. It is probably an APRIL-specific receptor.³³⁶ TNFSF17 (previously known as BCMA), TNFRSF13B, and TNFSF13C (BAFFR) are located on human chromosomes 16p13.1, 17p.11.2, and 22q13.1-13.3, respectively.

Structural analyses of the three receptors and the phenotypes of mice that are deficient in each one have shown that TNFSF13B (BAFF) transmits the survival signal to transitional cells through the TNFRSF13C (BAFFR) and not through TNFRSF17 (BCMA) or TNFRSF13B (TACI).³³⁷ All three receptors are devoid of death domains, and BAFFR is devoid of TNF-receptor-associated factor (TRAF)-binding domains. TRAFs are adaptor proteins that mediate transmission of downstream signaling in the activation of nuclear factor kappa B (NFκB) and mitogen-activated protein kinase (MAPK) pathways. TNFRSF17 (BCMA) however, activates NFκB through binding of TRAF5 or TRAF6, but not TRAF2.³³⁸

NFκB is associated with a strong antiapoptotic function that regulates the end stages of B-cell maturation, Ig class switching, GC organization, and other processes.^{339,340,341} In the absence of the TRAF-binding domain, TNFRSF13C (BAFFR) uses the C-terminal sequence for survival signaling. Replacement of the last C-terminal amino acids results in loss of BAFFR function and of peripheral blood B cells in mice (strain A/WySn).³⁴²

The mechanism of action of TNFSF13B (BAFF) is not stimulation of B-cell proliferation but promotion of survival, probably by increasing BCL2 expression.³⁴³ Loss of signaling by NFκB blocks up-regulation of BCL2. Mice that are deficient in Rel and Rela, which are members of the NFκB family of transcription factors, have a block of B-cell maturation and are similar to mice that lack Tnfsf13b or Tnfrsf13c. BCL2 expression rescues these mice from B-cell deficiency.³⁴⁴ TNFSF13B acts on the T2 transitional stage of B-cell maturation and on marginal-zone B lymphocytes. In mice that are transgenic for Tnfsf13B, the T2 and marginal-zone compartments of B cells are enlarged. The effect of TNFSF13B on various transitional stages of B cells is regulated by different downstream mediators, but mainly by up-regulation of the antiapoptotic genes A1 and

BCLXL in marginal-zone cells. The net result is a proportional increase in the survival of the cells that traverse each stage.³⁴⁵

TNFSF13B and TNFSF13 (APRIL) regulate B-cell survival and activation,³⁴⁶ and disturbances of their function may lead to important disorders such as autoimmunity^{347,348} and malignancies.^{348,349}

Patients with SLE, rheumatoid arthritis, and Sjogren syndrome have elevated levels of TNFSF13B in their sera^{350,351} as well as in their synovial fluids,³⁵² suggesting that TNFSF13B plays a role in autoimmunity. B cells with strong self-reactivity, however, are deleted before they express TNFSF13B receptor,³⁵³ a mechanism that provides protection against B-cell autoimmunity. TNFSF13B is produced by malignant B cells and is an essential autocrine survival factor in B-cell malignancies.³⁴⁹ Myeloma cells express TNFSF13B and TNFSF13 at levels higher than normal B cells and also co-express TNFSF13B receptor and TNFRSF13B (TACI), thus promoting their survival and proliferation.³⁵⁴

In some of these patients, the TNFSF13B and TNFSF13 have been found in the serum in the form of active heterotrimers.³⁵⁵ The pathogenetic relationship between these two members of the TNF family and the levels of various autoantibodies was shown by the fact that their levels were correlated with titers of the autoantibodies in Sjogren syndrome, such as the levels of Ig, rheumatoid factor, and anti-skin-sensitizing antibody.³⁵⁶

Chronic infection may lead to sustained release of TNFSF13B and emergence of autoreactivity. TNFSF13B therefore appears to be critically involved in certain antibody-mediated autoimmune diseases. Most studies have concentrated on the roles of TNFSF13B and TNFSF13 on B cells. However TNFSF13 also acts on T-cell survival by a mechanism that involves up-regulation of BCL2³⁵⁷ and TNFSF13B; although it does not appear to deliver a typical survival signal, it nevertheless acts on T-cell co-stimulation.³⁵⁸

TNFSF13 is up-regulated in many tumors (colon, prostatic carcinoma) and promotes tumor growth,³⁵⁹ but a soluble form of TNFRSF17 and TNFRSF13B counteracts the action of TNFSF13 and inhibits tumor growth.³⁶⁰ The enhancement by TNFSF13 of tumor growth may be due to up-regulation of BCL2 or signals that are delivered by inflammatory cells in the neighborhood of the growing tumors by cells, such as monocytes (which express TNFSF13), that provide optimal conditions for growth of some tumors, such as Burkitt lymphoma.³⁶¹

The tumor-promoter function of TNFSF13 contrasts to functions of many other TNF-related ligands. The difference in the level of expression of TNFSF13 between normal and neoplastic cells is dramatic. Because adenocarcinoma cells lack any detectable expression of TNFRSF17 or TNFRSF13B, it is likely that another TNFSF13 receptor exists in these tumors. Because TNFSF13B and TNFSF13 promote the survival of B cells and the development of autoimmunity, the inflammatory milieu of an autoimmune reaction supplies paracrine signals for the development of malignancies on an autoimmune background,³³⁵ a connection that was identified clinically many years ago.³⁶²

Follicular T-Helper and Germinal-center B Cells

The CD4⁺CD45RO⁺ recently activated T cells in the blood cross into the lymph nodes, and, because they have down-regulated CCR7 and have acquired instead the CXCR5 receptor, they respond to the call from DCs in the GCs, that is, to chemokine CXCL13 (BLC and BCA-1).²⁹⁷ In the GCs, they become known as T_{FH} cells. In this location, TFH cells express high levels of CD40L, a co-stimulatory molecule that is required for B-cell activation and Ig class switching, as well as for the induction of ICOS (inducible co-stimulator). CD28 is required for naive T cells to differentiate into effector GC T cells and for subsequent primary antibody response. Secondary B-cell responses and continuous B-cell activation depend on the CD28 homolog, ICOS; that is, T-cell help is delivered for B cells in an orderly sequence of interactions.³⁶³ The importance of ICOS for sustained B-cell proliferation is reflected in the Icos-deficient mice that have no GCs after secondary immunizations.

Memory T_H cells, after repeated antigenic challenges, emerge with restricted V-region genes and preferred CDRs that confer peptide specificity.³⁶⁴ The memory T cell acquires a functional potential of cytokine secretion early in the primary response, but the delivery of these functions is highly regulated and complex.

T-cell memory is an "operational property of the whole animal or immune system,"³⁶⁵ and, under this broad definition, the requirements for its maintenance and the delivery of specialized functions, although precisely regulated, depend on complex microenvironmental influences.

B-cell proliferation and differentiation are down-regulated by cytotoxic T-lymphocyte-associated protein-4 (CTLA4), a negative regulator for B-cell proliferation. CTLA4 is sequestered in a late or post-Golgi endosomal compartment and is available for rapid delivery to the cell surface, where it interacts with B7 ligands.³⁶⁵ Interaction with B7 causes phosphorylation of one of

the Tyr-containing sequences of CTLA4 that binds the SRC homology 2 (SH2) domain of the Syk phosphatase. Syk dephosphorylates signaling molecules in the vicinity of TCR, dampening or inhibiting completely the TCR signaling pathway.³⁶⁶

CD40 and CD40 Ligand (CD154) Interactions

CD40 and CD40L (CD154) are members of the TNF superfamily and play a crucial role in T-dependent and T-independent humoral immune responses. The CD40 gene is localized in chromosome 20q12-13.2. CD40 is homologous to the TNF receptor, and CD40L is homologous to TNF. (For details of the structure and expression of CD40 and CD154 (CD40L), see Appendix A).

CD40 is expressed on DCs and B cells, and CD154 is expressed on T cells. The CD40-CD154 interaction is critical for T-cell activation and development of the T_H1 and T_H2 responses.^{367,368} The extracellular region contains four Cys-rich domains, and the intracellular region contains distinct sites for binding the adaptor proteins, TRAF1, TRAF2, TRAF3, TRAF5, and TRAF6, and a separate site for direct binding of JAK3 (the Janus family of protein Tyr kinases).

CD40 engagement delivers signals along two broad pathways: TRAF-dependent and TRAF-independent. TRAFs are adaptor proteins that link the receptor to signaling molecules and mediate specific biologic responses. The specific functional outcomes of CD40 engagement extend to a huge territory of cell biology in general and of B cells specifically, such as clonal expansion, activation, chemokine and cytokine secretion and responsiveness, Ig production, and Ig class switch.

The reader is referred to the reviews that were cited previously. The functions that are induced by CD40 engagement are the result of activation of several transcription factors, more importantly, NF κ B, AP-1, and c-AMP response element. Ligation of CD40 on B cells results in proliferation or apoptosis, depending on the differentiation state of the B cell, particularly by linking to different TRAF adaptor molecules. CD40 induces homotypic adhesion between B cells through expression of lymphocyte function-associated antigen-1-ICAM1, or CD23-CD21. The same molecules can also mediate interactions between B cells and T cells or DCs.

Important contributions of CD40-CD154 interactions in humoral immunity are the regulation of APC functions, GC formation, Ig synthesis, and Ig class switch.³⁶⁹ A central role in several of these functions of CD40 is played by the duration of expression of the ligand of CD40 by the T cells.³⁷⁰ Some memory T cells have pre-formed CD154 that can be rapidly expressed on the surface after T-cell activation.

Expression of CD154 for a limited time allows B cells to terminally differentiate and secrete antibody. T_H1 -differentiated cells express CD154 for >3 days and suppress antibody production, whereas activated T_H2 memory cells express CD154 for <12 hours and allow antibody to be produced.³⁷⁰ Expression of CD154 on T cells is reciprocally regulated by cytokines; although IL12 sustains CD154 expression, IL4 represses CD154 expression. It is clear now that prolonged engagement of CD40 inhibits secretion of Ig.³⁷¹

Multimers of TRAF3 and TRAF5 mediate the signals for T-dependent humoral responses.

Signaling events from CD40 engagement without TRAF involvement are still unclear. CD40 ligation leads to phosphorylation of several protein Tyr kinases, such as LYN, BLK, BTK, and SYK. JAK3 binds directly to CD40, but the role of signaling by this pathway remains controversial. BTK leads to expression of CD80 and CD86 after CD40 ligation.

In general, signaling through TRAFs seems to be more important for the CD40-mediated functions.

IMMUNOGLOBULIN CLASS SWITCH

Class or isotype switch refers to the change of the H chain of the antibody molecule by the constant domains of another H chain class. When the antibody changes to another Ig class, it still retains the entire L chain and the V domains of the H chain. In other words, the antibody retains the same specificity for antigen but changes all effector functions that are determined by the H chain domains, such as complement fixation and phagocytosis.³⁷² The change involves a recombination of H chain alleles that results in deletion of DNA. It is called switch recombination, because it occurs between the switch (S) regions. Class switch affects all Ig classes except IgD, which has no S region of its own and is co-expressed with IgM by termination of transcription and RNA processing. Switch recombination occurs in mature B cells after exposure to antigen, T-dependent or -independent; simply by T-cell signals alone in the absence of antigen (i.e., CD40 and CD40L); or by cytokines. Transcription initiates within the promoter of the intronic (I) exon, proceeds through the S region, and terminates in the 3' end of the C_H allele, at the poly (A) site of secreted or membrane C_H allele (Fig. 14.12).

A unique sequence 5' to each I exon determines the selectivity of the switch recombination, acting as the site for binding of a series of regulatory proteins that are expressed after activation. The I region targets class switching to specific S regions that initiate transcription,³⁷³ and an intact I region is required for recombination. The factors that initiate recombination confer accessibility of the switch recombinase to the C_H locus (accessibility model).³⁷² Basically, what accessibility means is that the gene that undergoes switching must be transcriptionally active and therefore accessible. Although accessibility allows transcription, which is targeted to a specific S region to be initiated, it is not the only operating mechanism in class-switch recombination (CSR).³⁷⁴

Understanding of CSR took an unexpected turn with the discovery that CSR and SHM are mediated by the same or similar mechanisms.^{375,376,377} An enzyme known as activation-induced cytidine deaminase (AID) is an RNA-editing enzyme that is induced after cell activation.³⁷⁸ RNA editing is a post-translational modification of RNA. The type of editing that occurs in mammalian cells involves deamination of a base, which converts it to

P.336

another base (e.g., cytidine to uridine or adenosine to inosine). Usually, the editing enzyme is associated with other proteins, forming an editing complex or editosome. AID is structurally similar to the RNA-editing enzyme, APOBEC-1, which deaminates deoxycytidine. APOBEC1 is involved in editing of the mRNA for apolipoprotein-B, generating a new mRNA that encodes a protein, which is an essential component of chylomicron. B-cell activation is important for the induction of CSR recombinase and the selection of the target S region. Both of these events are absolute requirements for CSR.

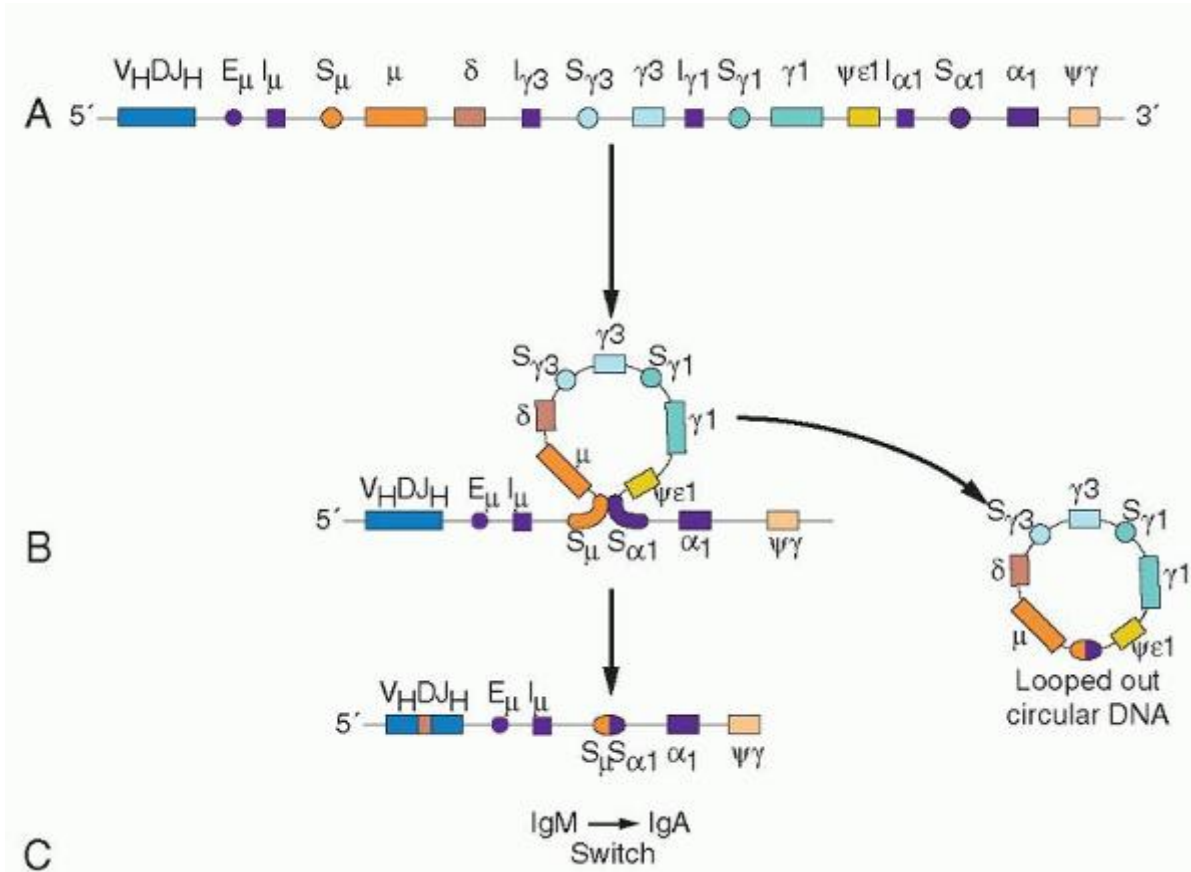

FIGURE 14.12. Class-switch recombination (CSR). In CSR, the surface immunoglobulin (Ig) M of the B cells is replaced by an Ig of another class. The IgM gene, which is located in the variable region of the heavy chain (VH) proximal end of the constant region of the light chain (CH) gene cluster (A) is replaced in that position by a gene of another class. In the 5' side of each CH gene is the S region (switch; A), followed by a specific intronic (I) promoter, which regulates cytokine-induced transcription of the target gene. The intronic enhancer (E_μ) makes S_μ accessible for recombination with other downstream S regions ("accessibility model"). Beyond accessibility, an enzyme known as activation-induced deaminase (AID; Fig. 14.13) is involved in CSR. The contribution of AID is not yet clarified, but AID deficiency in mice blocks CSR

completely, although germinal center reaction is still intact. The S region of the new Ig gene is brought in juxtaposition to $S\mu$, and the intervening sequence is looped out (B). The new CH is brought in next to the VH (C). The new Ig has the same specificity (VH) but possesses different biologic functions that are dictated by the CH.

Activation of the B cell usually occurs through BCR or CD40/CD40L or a cytokine. CSR has always been considered highly dependent on CD40L, and IgG, IgA, and IgE production is severely impaired in the X-linked hyper-IgM (HIGM) syndrome (see section "Hyper-IgM Syndrome"). The CSR activation through CD40/CD40L is T-cell-dependent, because CD40 signaling depends on its ligation by the CD40L that is expressed on T cells. Viral glycoproteins and bacterial LPSs can stimulate IgG and IgA production in the absence of CD40L-expressing T cells. A more physiologic T-independent CSR is induced by DCs through BAFF and APRIL.³⁷⁹

Cytokines direct switching for certain Ig classes; IL4 directs switching to IgG4 and IgE, whereas IFN- γ antagonizes some of the effects of IL4 on germline transcription. TGF- β increases IgA transcripts followed by IgA switching.

The S region is removed by splicing, leaving the 5'-I_HC_H-3' germline RNA. Upstream (i.e., 5') of the I exons are sequences that are considered as sites of cytokine action, which generate DNAase-hypersensitive sites to be used for germline transcription.

For example, IL4, which is a switch factor for IgE, binds to the IL4 receptor and activates the Jak kinases. The Jak kinases induce the signal transducer and activator of transcription (STAT)6, which binds to IL4-responsive elements found upstream of the IgE gene and switch on for IgE transcription.

The S regions used for CSR consist of tandemly repetitive units with many palindromic, that is, inverted, repeats. Therefore, CS recombinase may recognize the secondary structure of the S region DNA rather than the primary sequence. In this respect, it differs from V(D)J recombinase, which targets consensus heptamer and nonamer sequences around the V, D, and J segments. In CSR, the germline transcripts and AID are not sufficient to induce class switch, as was originally thought,³⁸⁰ but transacting factors may play a role.^{374,381} These trans-acting factors are thought to act as docking proteins that recruit AID to the S regions.^{382,383} and ³⁸⁴

The initial event in CSR is a double-strand break (DSB) and produces 3' or 5' overhangs. If, for example, the class switch is between the IgM constant gene and the IgA-1 constant gene (Fig. 14.12) the CSR brings the IgA heavy-chain gene close to the V (V_HDJ_H) gene. Thus, after the IgM/IgA class switch, the IgA antibody has the same specificity as the IgM. The intervening DNA sequence between the $S\mu$ and $S\alpha$ regions forms a circular structure that is looped out.³⁷⁶ The circular DNA that is looped out includes the I promoter of the target S region, which is driven by specific cytokine stimulation before the CSR. This I promoter is still active in the looped-out DNA and directs production of transcripts, termed circular transcripts, which depend on the expression of AID. Circular transcripts may be used as a hallmark of active CSR⁴⁰⁸ and were detected in the majority of patients (14 of 20) with CLL. This indicates that some cells of the clone are able to differentiate in vivo along the pathway that induces CSR³⁸⁵ by stimuli provided from bystander immune cells. The DSB repair machinery is recruited to repair the DNA breaks. Because the S regions are heterogeneous in nature, the joining of the DNA is completed by the nonhomologous end-joining (NHEJ) system. Mutations in the NHEJ system inhibit class switch.³⁸⁶

NHEJ is a process that rejoins DNA breaks with the use of little or no homology. There are five proteins that operate in NHEJ: KU86 (XRCC5), and DNA-dependent protein kinase (DNAPK). DNA-PK consists of a catalytic subunit (DNA-PK_{CS}) and a DNA-binding component that is called Ku, itself a heterodimer of 70- and 80-kDa polypeptides. The protein kinase activity of DNA-PK is activated when Ku binds to altered DNA structures, such as DSB, nicks, or hairpin loops.³⁸⁷ The discovery of the mechanism of CSR is a major advance in our understanding of the complexity of mechanisms that are used by the immune system in the diversification of genetic information to meet the needs and challenges caused by pathogens,^{376,388,389} and it is even more intriguing that the same machinery used for CSR is also used for a second diversification mechanism that takes place in the GCs, SHM.^{375,376,390}

SOMATIC HYPERMUTATION

The first diversification of genetic information in B lymphocytes takes place in the bone marrow during B-cell development. It involves the building of a BCR by random selection of a few DNA segments that are joined by V(D)J recombination. The assembly of these segments constitutes the combinatorial diversity (CD). CD is enhanced further by the addition during the repair of the cut ends of the DNA of palindromic and nongermline nucleotides that generate another level of diversity, the junctional diversity. (See Chapter 12, Fig. 12.5.)

When the IgM⁺ B lymphocyte moves out of the bone marrow to the real world of the secondary lymphoid organs, it finds itself ill-prepared to meet the existing challenges. It further diversifies its BCR during the evolution of the immune

response within the GCs by two additional mechanisms: antibody CSR and SHM. Both of these pathways of diversification use similar mechanisms, with a prominent role played by an enzyme known as AID, which functions as a deaminase and is induced after cell activation. Although the same enzyme, AID, functions in both CSR and SHM, different domains of AID mediate each of these two processes.³⁹¹ Mutations in the N-terminal region of AID causes SHM deficiency and CSR is retained, whereas changes in the C terminal cause loss of CSR activity but not SHM. In addition to its enzymatic activity, AID acts as a docking platform by its C terminus that is specific for CSR.³⁹² Under conditions of stimulation of murine splenic B lymphocytes (e.g., LPS or IL4, which do not induce SHM), large numbers of mutations were detected in the 3' subregion of the S μ region.³⁹⁰ The S μ mutations are independent of the CSR, because they are detected in the S μ of switched and unswitched alleles. These mutational changes of S μ have been considered similar to the mutations that are introduced by SHM during B-cell activation in the GCs.³⁹³ Comparison of the amino acid sequence of L chains from mouse myeloma proteins with the sequence of the same gene from bone marrow B cells (germline) confirmed that the amino acid differences occurred as a result of mutations.³⁹⁴ SHM is the mechanism by which the affinity of antibodies increases after antigen stimulation, a phenomenon that was discovered in the late 1960s and has been known as affinity maturation.

The mutations are largely confined to the V domains^{395,396} and occur in the framework regions as well as the hypervariable regions. They also tend to occur on some residues (hotspots) more often than on others. Hotspots of SHM overlap with the CDRs, which contact the antigen directly. However, the SHM mechanism does not seem to target a specific sequence, because SHM has even been detected in other molecules, such as the BCL6 gene,³⁹⁷ CD79A (Ig α), and CD79B (Ig β) genes,³⁹⁸ and CD95,³⁹⁹ or even in completely artificial sequences that are inserted into an IGK α transgene.⁴⁰⁰ Mutations are introduced in the variable region of the Ig genes at a rate of $\sim 10^{-3}$ mutations per base pair per division, which is 10^6 -fold higher than spontaneous mutation rate in somatic cells. Comparison of the mutability of triplets shows that some are targeted more often than others. For each of the triplets, one can calculate an expected ratio of replacement (R) to silent (S)

P.337

mutations. For example, in triplets that encode glycine (Gly), six of the nine possible nucleotide substitutions result in an amino acid replacement mutation that gives an R:S value of 2 (6/3). In the case of histidine, eight of nine possible substitutions generate an amino acid exchange, and the ratio is 8 (8:1). Evolution has selected for CDRs in which the codon usage leads to a high ratio of R:S mutations. Those are mutations that are likely to affect the antibody-binding site, and the R:S value in the CDR is used as a marker for affinity maturation. No specific targeting mechanism is likely to exist. SHM assisted by AID may occur in other genomic locations,⁴⁰¹ and it is not specific for the Ig genes. Accordingly, AID and the SHM machinery may be a genomewide mutator.⁴⁰² The Ig genes seem to be more highly mutated than the rest of the genome during the affinity maturation process in the GCs. In addition, they are more highly transcribed and have a higher density of DGYW hotspots than other genes.

The process of SHM occurs during the period in which the B cell undergoes a high rate of divisions (approximately one every 6 hours); this period is observed in the dark zone of GCs and is also linked to transcription, with which it is positively correlated.⁴⁰³ GCs have been considered the centers of hypermutation,⁴⁰⁴ although in lymphotoxin- α -deficient mice that lack GCs, mutations can still be induced with strong antigenic stimulations.⁴⁰⁵ The nature of the signals that are necessary for SHM is not well understood. CD40/CD40L interaction is important for the development of GCs and for proliferative activity, both of which are requirements for SHM. Under conditions in vitro that allow SHM to take place, three signals have been identified to be required: signals from anti-Ig, anti-CD40, and anti-CD38.⁴⁰⁶

With the use of several phenotypic markers, the B lymphocytes have been separated into different groups that represent different stages of B-cell differentiation. The majority of the B cells in humans expresses IgM (as much as 90%) and can be distinguished into IgM⁺/IgD⁺, IgM⁺/IgD⁻, and IgM⁻/IgD⁻ groups.

The IgM⁺/IgD⁺ do not carry mutations, except for a subpopulation that expresses CD27.⁴⁰⁷ IgM⁺/IgD⁺ B cells are newly released from bone marrow and are considered still antigenically inexperienced. The two other groups, IgM⁺/IgD⁻ and IgM⁻/IgD⁻, have mutations and therefore belong to their post-GC lymphocytes.⁴⁰⁸

Mechanism of Hypermutation

The hypermutation domain—the region in which mutations occur—spans 1.5 to 2.0 kb downstream of the Ig promoter (Fig. 14.12). The frequency of the mutations increases in the 5'-to 3'-direction, peaks over the V(D)J recombination site, and then decreases toward the J-C junction. The 5' boundary near the promoter is sharp, but the 3' boundary near the enhancer region is less well defined. The I enhancer is the only sequence in the Ig gene cluster that is irreplaceable and

must be in the correct orientation. The need for the enhancer provides the explanation of the strong correlation of SHM with the transcription process. The mutation rate is 10^{-3} to 10^{-4} base pairs per generation, that is, six orders of magnitude higher than the spontaneous mutations.³²⁶ The mutations are usually point mutations, but insertions, deletions, or duplications also occur.^{408,409} Although mutations are limited within the boundaries of 1.5 to 2.0 kb, they tend to exhibit a characteristic nucleotide substitution preference, which affects not only the primary sequence but also secondary structures, such as hairpin loops, which are encoded by palindromic motifs. In spite of these preferences, the sequence of the V gene itself does not initiate the mutation, because artificial substrates hypermutate successfully.⁴¹⁰

Two steps have been considered important for SHM: (a) DNA cleavage, which results in DSBs and (b) DSB repair, which is done by an error-prone mechanism.⁴¹¹ It is recognized that (a) DSBs occur in hypermutating sequences (hotspots), (b) they are coupled to transcription, (c) they depend on the presence of the Ig enhancer, and (d) they correlate with the appearance of nearby mutations.^{412,413} The DSBs are restricted to cells that have completed or almost completed DNA replication and need to be repaired before the end of cell division. In eukaryotes, there are two DNA repair mechanisms, homologous and NHEJ, each of which is used in distinct phases of the cell cycle. The NHEJ is used in the G₁ to S phase, and the homologous recombination is used in the late S to G₂ phase.

In V(D)J recombination, the DNA breaks occur in the G₁ phase and are repaired by the NHEJ that is activated in the same period of the cell cycle. SHM occurs during the G₂ phase,⁴¹⁴ when a sister chromatid is present, and homologous recombination is active, whereas NHEJ occurs in the absence of such a template. The precise phase of the cell cycle for introduction of mutations, however, is not yet agreed on, because they have also been detected during the G₁ phase.⁴¹⁵ For SHM, the AID is necessary, because AID deficiency impairs SHM. The relationship of AID to the DSBs is not clear, and AID probably makes no contribution to their generation,⁴¹⁶ because, according to some evidence, AID acts after their occurrence.⁴¹² Furthermore, DSBs occur with the same frequency in rearranged and germline genes, and yet SHM is preferentially attracted to the rearranged genes,⁴¹⁷ which suggests that DSBs do not express any functional affinity for AID attraction. AID has landed on the stage of SHM only recently, evokes considerable wonder, and attracts massive attention. AID's activity is well understood, but its role in SHM remains elusive.⁴¹⁸

Another approach in the search for answers for the SHM mechanism concentrates on polymerases.⁴¹⁹ Most mutations in SHM are point mutations, but deletions, insertions, or duplications of DNA segments are also common. These changes are recognized as the signature for a DNA polymerase (pol) and are considered as strong evidence against an SHM mechanism that invokes a basemodifying enzyme or chemical DNA modification. Based on these arguments, the SHM could be the result of a DNA polymerase with poor discriminatory capacity for bases. Such a polymerase could be one of the Y family of DNA polymerases—pol ζ, pol ε, pol ι, pol κ⁴²⁰—that are specialized for bypassing DNA lesions (translesional polymerases). Some of these polymerases have been implicated in SHM.^{421,422,423} and ⁴²⁴

Pol ε is significantly error-prone when it copies normal DNA and makes, on average, several more mistakes than a stringent polymerase.⁴²⁴ Patients with a null mutation of POLH (pol ε) present a variant form of xeroderma pigmentosum with a propensity for skin malignancies.⁴²⁵ These sloppy polymerases have the capacity to bypass a DNA lesion, which may otherwise bring the DNA replication to a halt and the cell to its death. However, during the replication of normal DNA, they are notoriously unfaithful in the selection of bases.

AID may function in signaling processes or in editing key molecules in B-cell differentiation in the GCs (see section “Hyper-IgM Syndrome”), at the mRNA level, or by direct alteration of the target V gene, at the level of the RNA transcript. However, some recent results point out another pathway that is opened to AID in CSR and SHM. AID, as mentioned earlier, is a deaminase that converts deoxycytosine (dC) to deoxyuracil (dU; Fig. 14.13A-C). This conversion takes place during transcription of target genes and affects only the nontemplate DNA strand that is exposed as single-stranded DNA during the elongation reaction. This evidence supports once more the direct relationship of transcription and mutations that are linked by the deamination function of AID.⁴²⁶ As a result of this function, AID creates a dU/deoxyguanosine (dG) mismatch or lesion in the DNA, which needs to be repaired. A major mechanism in the resolution of the lesion is excision of the uracil, which can be accomplished by several enzymes, one of them being a uracil-DNA glycosylase (UNG).⁴²⁷ UNG is the major DNA glycosylase in the mouse that processes programmed dU/dG lesions in the Ig genes.⁴²⁸ If the dU that is created by AID is removed by UNG, an abasic site (AP) is generated (Fig. 14.13D).

P.338

If the base excision repair (BER) mechanism arrives first, ahead of the replication fork, a nick or a gap is created, which is filled quickly by the high-fidelity pol δ or pol ε, and no mutations take place. However, if the replication fork wins the race to the lesion, the high-fidelity polymerases are stalled (Fig. 14.13E), and an error-prone polymerase, such as pol ζ, pol ε, or

pol ι , places a base across from the AP site. If the polymerase continues its error-prone function, it introduces many more errors, that is, mutations.⁴²⁹ In mice that are deficient for UNG, the class switch is markedly impaired. This indicates that the AP that is created from removal of dU by the UNG is essential for CSR. The generation of double DNA breaks follows through interference with BER assembly by the CSR machinery.

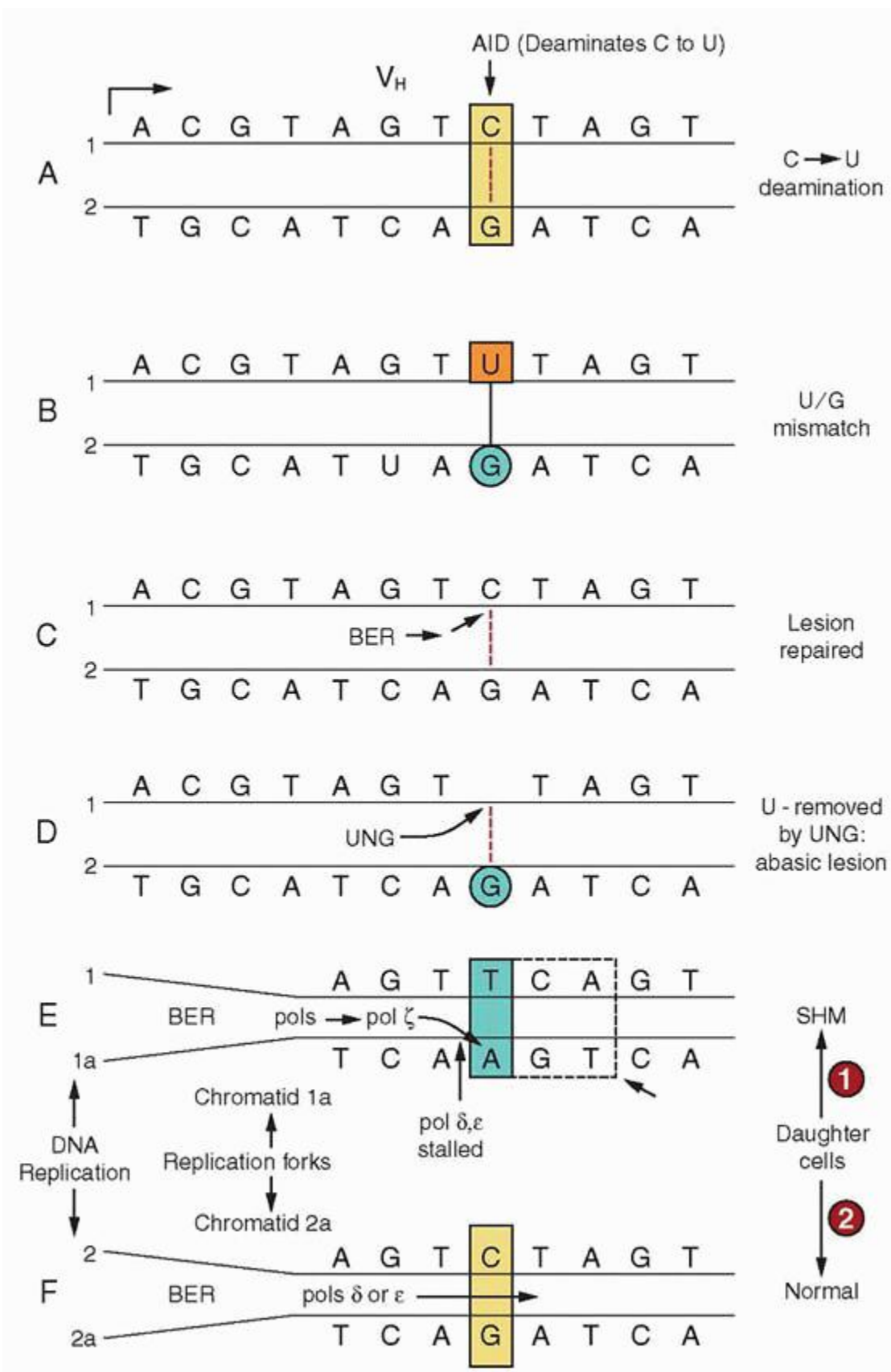

FIGURE 14.13. Somatic hypermutation. The immunoglobulin M of B cells is of low affinity and has been selected before exposure to antigen. The need to improve the affinity is satisfied by another round of B-cell receptor diversification in the

germinal centers, after exposure to antigen. In the dark zone of the germinal centers, mutations are introduced in the V gene at a rate 1 million times faster than natural mutations; thus it is called somatic hypermutation (SHM; see the text for details). During SHM, double-strand breaks occur in the DNA, as well as rapid gene transcription. Furthermore, for SHM, the immunoglobulin gene promoter is essential, as is an enzyme, activation-induced deaminase (AID). AID removes the NH₂ group of deoxycytosine (dC) (A), forming deoxyuracil (dU) (B). The change generates a dU/deoxyguanosine (dG) mismatch (B). The lesion may be repaired by the base excision repair (BER) (C), and mutation is prevented. However, dU may be removed by another enzyme, uracil-DNA glycosylase (UNG). In this case, the DNA strand remains in one spot that is unoccupied by any base (abasic lesion) (D). High-fidelity DNA polymerases (pols) (i.e., δ or ϵ) are stalled at the abasic lesions, and a promiscuous error-prone pol (i.e., ζ or ϵ) takes over. It usually places a deoxyalanine (dA) on the sister chromatid, opposite to the abasic lesion (E). The positioning of thymidine (T) opposite dA repairs the lesion, but pol continues over the lesion (translesional ppls), altering the bases downstream. This generates a cluster of mutations that are close to the dU excision. As a result, one of the daughter cells is normal (F), whereas the other (with the abasic lesion) has mutational changes (E). VH, variable region of the heavy chain.

The function of AID involves introduction of potentially mutagenic changes,⁴³⁰ which have been detected in various experimental systems' non-Ig genes. Ubiquitous and constitutive expression of AID in transgenic mice causes T-cell lymphomas, with TCRs and Myc genes expressing several mutations.⁴³¹ These mutations preferentially occurred in hypermutation hotspots, and were biased toward G-C pairs, which is an AID sequence preference. AID also induces MYC-IGH@ translocations in B cells lacking p53 tumor suppressor.⁴³² AID activity in these experiments indicates that under certain circumstances it may induce chromosomal translocations.

In contrast to normal B cells, in B-CLL cells AID transcripts have been detected constitutively even though the cases were classified as unmutated.⁴³³ However, when B-CLL cases with Richter's transformation were examined, AID expression and SHM activity were higher than in nontransforming B-CLL.⁴³⁴ The oncogenic potential of AID has been verified in transgenic mice that develop T-cell lymphomas.⁴³¹

In conclusion, the AID appears to be important for somatic diversification of Ig genes, but the question remains whether AID can unite all the gene changes, such as SHP, CSR, and gene conversion,⁴³⁵ required in life, or if AID needs more than one other aid.⁴³⁶ To this point, it is interesting that AID deaminates dC on single-stranded DNA, but it requires the action of RNase.⁴³⁷ As of today, this is the latest aid that comes to AID's help.

GENOMIC VIEW OF GERMINAL CENTER REACTION

The study of the GC reaction by conventional, morphologic, and functional methods has provided a clear picture of the central position of the GC in the differentiation of B cells and the function of humoral immunity. Microarray technology carries our understanding to the last frontier,⁴³⁸ the genes that are involved in initiation and evolution of the reaction. Findings by this approach confirm what is known: the naive, antigenically inexperienced B cell does not divide and does not make Ig but is poised to respond to antigen. Indeed, naive B cells express genes that are inhibitory of proliferation (CDKN1A, also known as WAF1), as well as growth expression (BIN1 and BOK) genes. They also express mRNA for early-response genes (JUN and ZFP36L2, also known as ERF2), CCND1 (cyclin D1), and CCND2 (cyclin D2) that function during the transition from G₁ to S phase.

The change from naive B cell to centroblast is as striking at the gene level as it is with the techniques that have been used thus far. The centroblast expresses the vast majority of proliferation-associated genes, as well as those that regulate the cell cycle and mitosis. One of the unexpected results was the lack of expression of c-myc proto-oncogene, which is known to be associated with cell proliferation. Genes that regulate apoptosis are up-regulated, whereas antiapoptotic genes (BCL2) are down-regulated. Studies of gene expression do not detect significant differences between centrocytes and centroblasts, although these two populations have distinct functional characteristics. It is suggested that one of the two populations may be heterogeneous. The light zone contains detectable subpopulations by phenotype or by the expression of transcription factors.

In general, the global gene profile of naive B cells is that of suppression, actively maintained by notable inhibitors of signal transduction.⁴³⁹ However, the GC B cell is characterized by a proliferation signature, which includes activation of genes that participate in various stages of cell cycle, such as cyclin, cyclin-dependent kinase (cdk), and CDC2, which drive cells through the G₂ and M phases. Additionally, other genes that organize the mitotic spindle are also activated.⁴⁴⁰ Somewhat atypical is the lack of MYC expression, a gene known for its proliferative function. Lack of MYC expression⁴³⁸ is reflected by the down-regulation of

sets of genes involved in energy metabolism that are transcriptionally regulated by MYC.

The lack of MYC function may be due to the expression of the human homolog to the mouse MXD3 (MAD3) gene, which forms dimers with MYC and thus blocks its function as a transcriptional activator.

The GC B cells are thus poised to undergo apoptosis, which takes place extensively in the light zone, after hypermutation. Well-known antiapoptotic genes, such as BCL2 and BCL2L1 (BCL-XL), which are targeted by the NFκB transcription factor, are poorly expressed. Not only are antiapoptotic genes suppressed, but expression of proapoptotic genes, such as BIK (member of the BCL2 family), constitute part of the GC B-cell signature.

The BCL6 gene is highly expressed during the GC reaction that promotes the differentiation within GCs but is down-regulated during plasmacytic differentiation.⁴⁴¹ Mice that are deficient in Bcl6 fail to develop GCs and are deficient in affinity maturation, with a reduction in antibody responses. BCL6 represses CD40L-induced and NFκB-dependent gene transcription of B7-1, a co-stimulatory molecule that is essential for T-cell-B-cell interactions.⁴⁴² Mice that are deficient in Bcl6 not only cannot develop GCs, their memory B cells also have no VH mutations.⁴⁴³ Because Bcl6 appears to be a major promoter of GC reaction, the question that is raised is what are the signals that oppose Bcl6 signaling and bring GC reaction to a halt. The BCR signaling opposes BCL6 transcription,⁴⁴⁴ probably directing BCL6 degradation by proteasomes as a result of its phosphorylation by MAPKs.⁴⁴⁵ The hypermutated high-affinity BCRs interact in the light zone with antigen, and the signals that are generated are sufficiently strong to phosphorylate BCL6, leading to its degradation and bringing GC reaction to a halt. Important molecules that have been kept suppressed, such as B lymphocyte-induced maturation protein 1 (PRDM1 or BLIMP1), initiate plasma cell differentiation (see the following discussion). With BCL6 degradation, PRDM1, a major plasma cell differentiation factor, is up-regulated and completes the end stage of the GC reaction.

POST-GERMINAL CENTER DIFFERENTIATION

After somatic diversification in the dark zone, the centroblast moves into the light zone as a centrocyte-expressing surface Ig that has undergone SHM. The centrocytes are submitted to the selection procedure by antigen that is carried on the dendrites of the dense FDC network in the light zone. The majority of centrocytes is destined to die, because the mutational changes are detrimental to affinity and avidity. Loss or diminished binding to antigen leads to programmed cell death, and those dead centrocytes are rapidly removed by macrophages, which are now called tingible body macrophages. Some of the centrocytes may be recycled once more through the dark zone for further clonal expansion, diversification, and selection.

This recycling provides, once more, the opportunity for reaching the highest affinity peak. In the light zone, the selection process separates the fittest B cells (high affinity) for survival and the unfit (poor or no affinity) for death (negative selection). Positive and negative selection may work in concert, so that, among the positively selected high-affinity B cells, those with autoreactivity are deleted⁴⁴⁶ by apoptosis, because overexpression of BCL2 in B cells allows the survival of autoreactive B cells.⁴⁴⁷ The products of several genes participate in the regulation of the selection processes. The protein tyrosine kinase Lyn plays a rate-limiting role in BCR triggering through phosphorylation of CD22, an inhibitory molecule that recruits SHP-1 to the BCR-CD22 complex.⁴⁴⁸ The transcription factor Aiolos maintains B cells at low reactivity levels, because, in mice that are deficient in Aiolos, there is an increase of serum Igs, autoantibody production, and the development of B-cell lymphomas.⁴⁴⁹

CD21 appears to be necessary for the survival of GC B cells with high-affinity BCRs. CD21 is a complement receptor (CR2) and, as a component of the CD19/CD21/CD81 coreceptor, mediates the binding of complement-containing immune complexes to B cells and provides a survival signal for B cells.⁴⁵⁰ The CD19/CD21 coreceptor is a major regulator of B-cell function in humoral immunity, for fine tuning of signals that are received by the BCR.⁴⁵¹ Simultaneous ligation of BCR and the CD19-CD21 complex (i.e., with antigen-antibody-complement complexes) significantly lowers the threshold of antigen that is required to trigger B-cell activation by antigen alone through the BCR. (See Chapter 12, Fig. 12.12.)

The centrocyte that has been positively selected is poised for commitment to one of the two pathways of differentiation: memory B cell or plasma cell, depending on whether the normally delivered signals are properly received.

Memory B Cells

Centrocytes can be diverted to the memory B-cell pool by positive signals or by the lack of negative signals. The CD40/CD40L interaction or IL4 stimulation⁴⁵² belongs to the first category. The apoptotic pathway that normally deletes centrocytes belongs to the second category. Apoptosis normally deletes centrocytes that have emerged from the dark zone with nonfunctional or low-affinity receptors. Interference, therefore, with the apoptotic pathway blocks negative selection and results in accumulation of heavily mutated B cells that bring forward a "bad" memory of the primary

response. Thus, overexpression of BCL2, an antiapoptotic protein, interferes with negative selection and diverts centrocytes to the memory pool.⁴⁵³ Similarly, the lymphoproliferative mutation that incapacitates the FAS receptor results in accumulation of heavily mutated B cells.⁴⁵⁴ These changes disrupt the anatomic organization of lymphatic organs with the development of autoimmune lymphoproliferative disease.

Memory B cells are long-lived and do not secrete antibody until they are challenged again. In such a secondary antigenic challenge, they respond to much smaller doses of antigen, expand clonally, and produce 7 to 10 times more antibody than the antigen-inexperienced B cells.⁴⁵⁵ Memory B cells have undergone an Ig class switch, and expression of Ig classes can be used for their classification, as well as for the classification of other markers, such as CD27⁴⁵⁶ or CD148.⁴⁵⁷

The mechanism that maintains the memory B-cell pool is unknown. Antigen is not required to keep them alive, and, according to an hypothesis that has some appeal, B-cell memory (and, for that matter, T-cell memory) is maintained by idiotypic-anti-idiotypic interactions between B cells.⁴⁵⁸ Such interactions take place between B cells that have been antigenically stimulated, therefore their BCR carries distinct idiotypes that are specific for this clone. These idiotypes are structures (protein sequences) within the antigen-binding site that are specific for this particular BCR. Other B cells that respond to these idiotypes express a BCR with anti-idiotypic properties. Interaction between idiotypic cells (memory cells for the primary antigen) and antiidiotypic B cells, according to this hypothesis, stimulates enough proliferative activity to maintain the B-cell memory pool. Such interactions may also link and maintain T-cell memory within a pan-lymphocyte idiotypic-anti-idiotypic web.

Plasma Cells

The purpose of the B cell's life is to make antibodies after it reaches maturity, a stage of differentiation that is characterized morphologically by the development of an elaborate ER and functionally by the synthesis of Ig that is released extracellularly. Since the detection and description of the plasma cell (see Chapter 11), clinicians and scientists have become quite familiar with the

P.340

morphology, ultrastructure, and physiology of the plasma cell. The new techniques of molecular biology and genomics identify the genes that bring about this spectacular morphologic and functional transformation (Fig. 14.14).

The earliest signs of the plasma cell differentiation are detected within the GCs when the positively selected centrocytes choose one of the two pathways that are available to them. A small number of centrocytes express a partial plasma cell phenotype CD138 (syndecan-1); the transcription factor PRDM1 (BLIMP1); and down-regulation of BCL6 and PAX5.^{459,460} These precursors exit the GCs and migrate to the bone marrow, where they develop into plasma cells, secreting high-affinity antibodies. They are probably

P.341

the same cells that are detected on bone marrow smears,⁴⁶¹ surviving with signals that are delivered by marrow stromal cells,⁴⁶² and are able to secrete antibody in the absence of antigen for several months.⁴⁶³ These post-GC plasma cells should be distinguished from pre-GC plasma cells that secrete IgM antibody, which are generated in the early stage of the primary response.

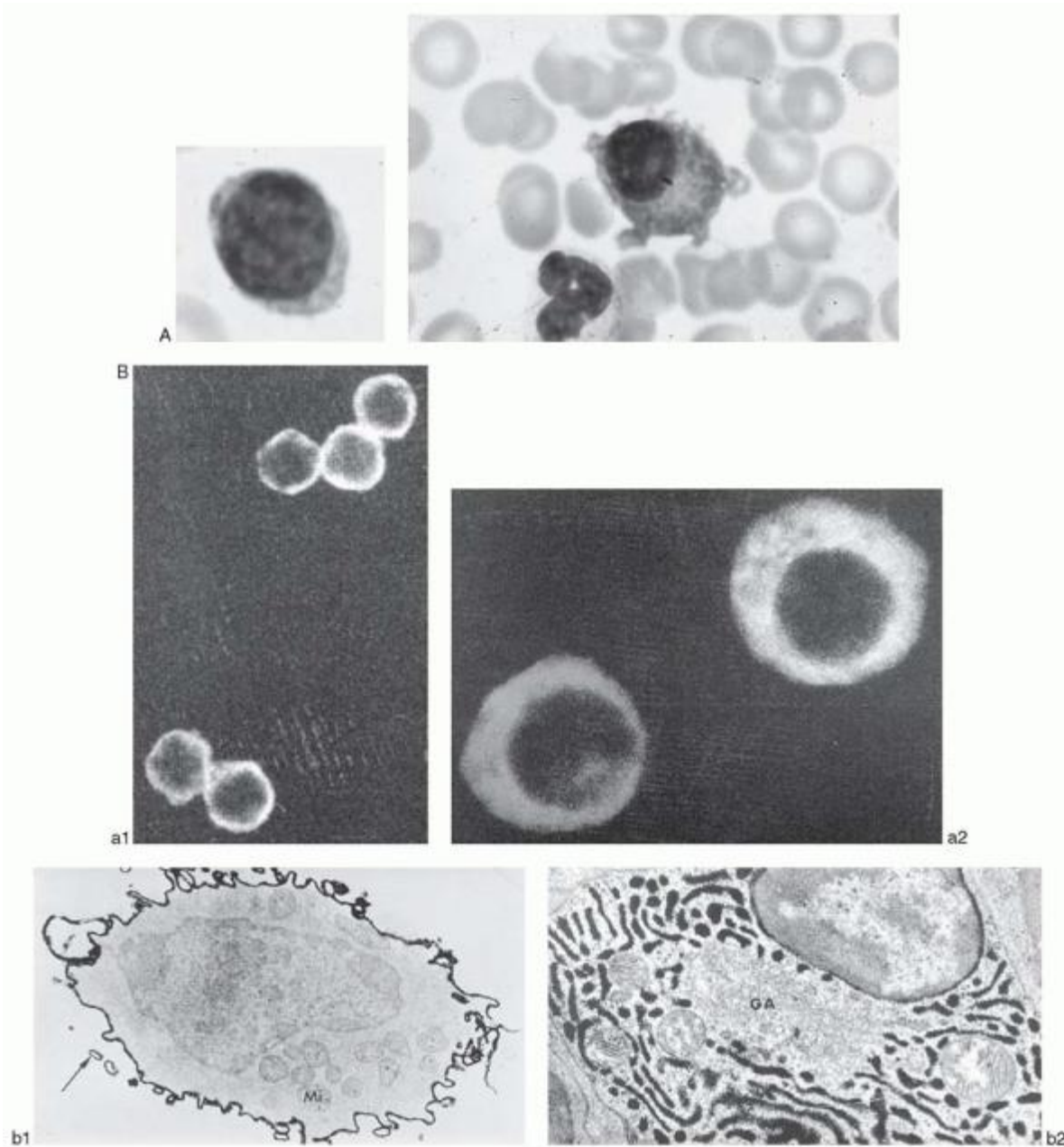

FIGURE 14.14. Lymphocytes and plasma cells. Morphologic and functional differences between lymphocyte and plasma cells. A: Morphology: routine staining. B: Immunoglobulin production and expression: B-cell surface versus plasma cell intracellular immunoglobulin. a: Fluorescence. b: High-resolution autoradiography. GA, Golgi apparatus; Mi, mitochondrion.

IL6 is particularly effective in driving high-affinity B lymphocytes to plasma cell differentiation.⁴⁶⁴ Before the acquisition by B cells of plasma cell characteristics, the cell loses expression of MHC class II molecules, CD19, CD20, CD22, and CD45,⁴⁶⁵ and up-regulates CD38 (the highest density of all stages during B-cell development) and CD138 (or syndecan-1).⁴⁶⁶ CD38 is a transmembrane type II protein (i.e., NH₂ terminal intracellular), which is the ectoenzyme nicotinamide adenine dinucleotide (NAD⁺), converting NAD⁺ to adenosine diphosphate ribose (glycohydrolase activity; see Appendix, CD38). CD138 binds to hepatocyte growth factor, which is produced by mesenchymal cells and stimulates myeloma cell growth (see Appendix, CD138). Among transcription factors, PAX5 is down-regulated, whereas PRDM1 is up-regulated.⁴⁵⁹

The BCL6 proto-oncogene exerts a negative effect on plasma cell differentiation, because it suppresses genes that are critical in the promotion of their differentiation. BCL6 is a pox virus zinc finger (POZ)/zinc finger (ZF) protein, which contains six Krüppel-type ZF motifs at the terminal end and a POZ motif at the N-terminal end. Therefore, it belongs to the POZ domain and Krüppel-like family (POK) of proteins.⁴⁶⁷

The ZF proteins contain cysteines and histidines that are spaced at regular intervals with a zinc atom that is coordinated between two cysteines and two histidines. ZF proteins are folded in nine loops, with an Ii Leu and a Tyr or Phe that is located in each loop and is important for the DNA binding. The zinc binds to the consensus core sequence TTCCT (A/C) GAA that is found in several BCL6 target genes, but it also mediates protein-protein interactions, notably with class II histone deacetylases (HDACs), JUN transcription factor, and the like. The POZ domain is a protein-protein interaction motif that is conserved in evolution and is found in many transcription factors, oncogenic proteins, ion-channel proteins, and so on. POZ proteins are involved in critical cellular processes, such as development, oncogenesis, apoptosis, and transcription. The most common property of the POZ domain is repression of transcription, based on its ability to recruit the HDAC.

Histone acetylation is mediated by a histone acetyltransferase complex. Acetylation destabilizes the nucleosomal structure by neutralizing the positively charged Lys residues of the N-terminal tail domain of core histone and increases the accessibility of DNA to transcriptional regulatory proteins.^{468,469} Therefore, acetylation plays an important role in the regulation of gene expression and in DNA replication and repair. Deacetylation has the opposite effect. There are two classes of enzymes that deacetylate histones: Class I (HDAC1, HDAC2, HDAC3, and HDAC8) is detected in yeasts and similar organisms, and class II (HDAC4, HDAC5, HDAC6, HDAC7, HDAC9, and HDAC10) is detected in vertebrates. BCL6 recruits class II HDAC4, HDAC5, and HDAC7, forming complexes through the N-terminal POZ domain and the C-terminal ZF region.⁴⁷⁰ BCL6, lacking four of the six ZF proteins, loses entirely its ability to recruit the HDACs. It is likely that this interaction exerts the transcriptional repression of BCL6.⁴⁷¹ Several genes are targets for BCL6, such as CD40, IL4, PRDM1 (BLIMP1), CD80 (B7- 1), and CCND2 (cyclin D2; Fig. 14.15). Point mutations of CREBZF (ZF) indicate that ZF-3, ZF-4, ZF-5, and ZF-6 abolish DNA binding and the ability of BCL6 to bind to its cognate cis element. BCL6 represses genes that are activated by STAT6 or NFκB,⁴⁴⁶ thus regulating IL-4 signaling and IgE production. BCL6 competes with STAT6 for the same DNA-binding sites and thus inhibits specific STAT6-dependent gene transcription. Bcl6^{-/-} mice have dysregulation of IgE production and develop type T_H2 inflammation of the heart and lungs.^{441,442}

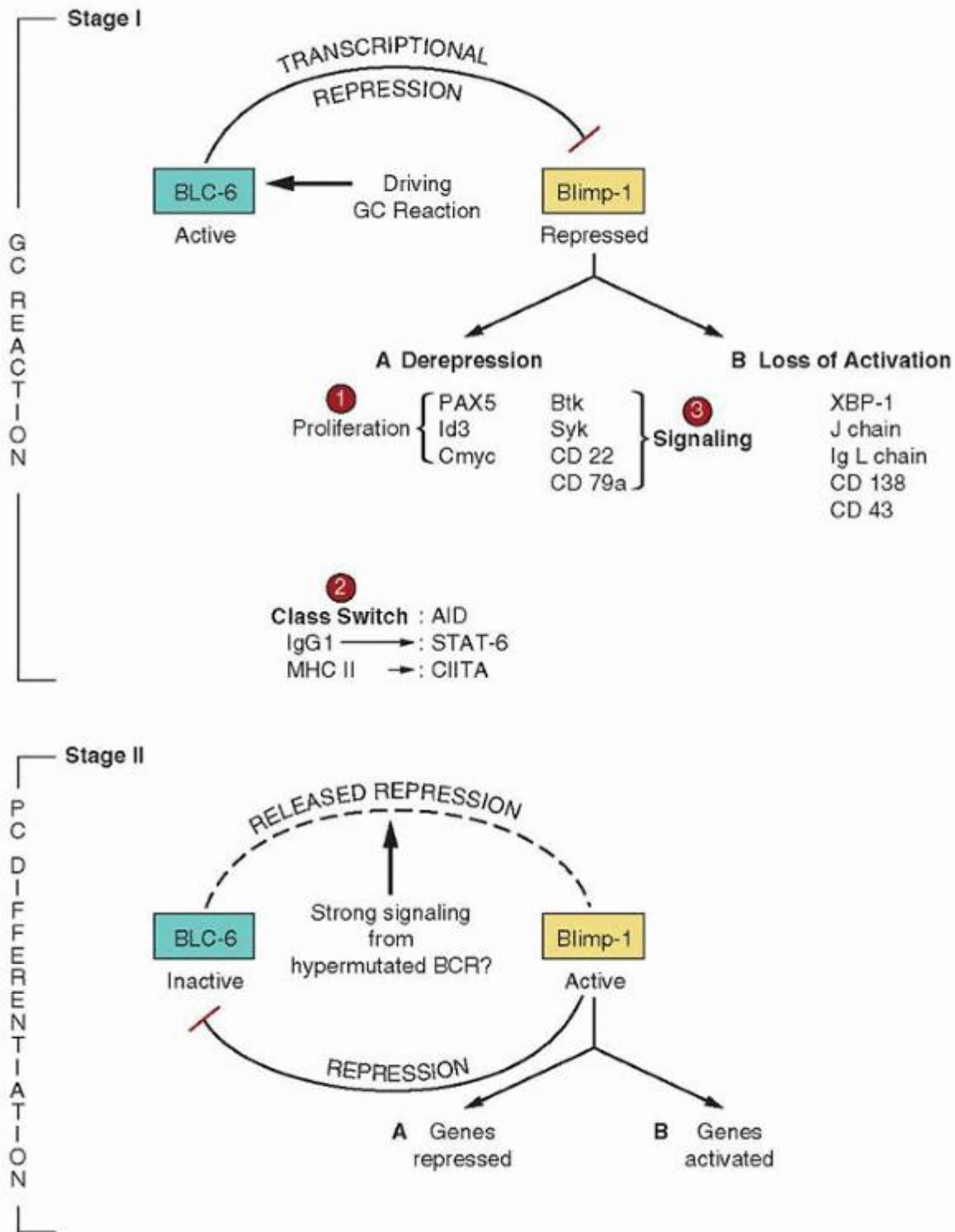

FIGURE 14.15. Gene regulation of germinal center (GC) reaction. Several genes, by their expression or repression, contribute to the molecular and cellular processes that take place within the GCs. More than any others, two genes virtually conduct the GC orchestra: B-cell lymphoma 6 (BCL-6) and B-lymphocyte-induced maturation protein-1 (Blimp-1). BCL-6 is a repressor gene that is identified in diffuse large B-cell lymphomas. It represses several genes and, importantly, Blimp-1 (stage I). As a result, BCL-6 releases from repression all genes that are normally repressed by Blimp-1 (A). The net result is “activation” of genes for proliferation (1), class switch (2), somatic hypermutation, and signaling B-cell molecules (3). BCL-6 is down-regulated, probably by strong signals that are delivered by hypermutated high-affinity B-cell receptors (BCRs; stage II). Loss of BCL-6 function releases Blimp-1 from repression. Genes that are active during the first stage I are

now repressed, whereas genes that are important for plasma cell (PC) differentiation are activated, such as XBP-1 and immunoglobulin L chain. Thus, the GC reaction and the generation of antibodies are finely tuned, basically by a repressor loop between the two master genes BCL-6 and Blimp-1. AID, activation-induced deaminase; CIITA, major histocompatibility complex class II trans-activator molecule; MHC II, major histocompatibility complex class II; STAT, signal transducer and activator of transcription.

Suppression of STAT3 by BCL6 blocks plasma cell differentiation through inhibition of PRDM1⁴⁷² (Fig. 14.15). This function of BCL6 is, at least partially, critical in the role of BCL6 in B-cell differentiation, the block of terminal plasma cell differentiation to maintain proliferation and hypermutation for affinity maturation (i.e., maintenance of GC reaction). BCL6's function is curtailed by signals from high-affinity BCRs that are initiated from interactions with antigen in the light zone. If BCL6 function achieves constitutive independence through chromosomal translocations, it may lead to B-cell lymphomas. When BCL6 is down-regulated, it releases suppression of PRDM1, a transcriptional repressor that is important for plasma cell differentiation. The genes that are repressed by Blimp are shown in Figure 14.15. Several of the biologic characteristics of plasma cells are explained by the repressor function of PRDM1 (BLIMP1). PRDM1 represses MYC and inhibits proliferation⁴⁷³ and also represses the PAX5 gene, releasing XBP1 from PAX5 repression, which is needed for plasma cell formation.⁴⁷⁴ PRDM1 also releases PAX5-mediated inhibition of H chain and J chain⁴⁷⁵ synthesis.

Plasma cells have lost the antigen-presenting function of their parent B cells. This is due to loss of MHC class II expression as a

P.342

result of repression of the gene that encodes the CIITA, which is required for MHC II expression in B cells.⁴⁷⁶

PRDM1 (BLIMP1) is the master regulator gene of the plasma cell differentiation program. Genes that are regulated by it are direct targets or are regulated by other PRDM1 target genes. Its basic function is repression of transcription, which is active or passive. Factors that act as passive repressors interfere with transcriptional activators by competing with their binding site on the promoter or by binding directly to the activation domain of the activator. In active repression, the repressors interact directly with the components of the transcription machinery or recruit co-repressors, such as the HDACs. PRDM1 is an active repressor that is associated directly with HDACs and carries them to the promoters it binds.⁴⁷⁷ HDACs bring alterations in the chromatin structure, which underlines the basic mechanism of PRDM1 function. Another co-repressor for this gene is a complex of the Groucho family proteins.⁴⁷⁸

GENETIC DEFECTS OF CLASS-SWITCH RECOMBINATION

The interaction between CD40L (CD154), expressed on activated T cells and CD40 on B cells, is required for terminal B-cell differentiation. Signaling through CD40 leads to B-cell proliferation and its rescue from apoptosis. Mutations of CD40LG result in the X-linked syndrome that is characterized by lack of GCs in lymphoid organs and the inability of B cells to undergo switch recombination; as a result IgG, IgA, IgE are absent or markedly decreased.⁴⁷⁹ Men who are affected with HIGM syndrome are susceptible to bacterial infections but also experience *Pneumocystis carinii* pneumonia and *Cryptosporidium* intestinal infections, usually observed in T-cell deficiencies.⁴⁸⁰ Lack of interaction between T cells and macrophages leads to defective macrophage activation, probably the basis for opportunistic infections.^{481,482} Some patients with HIGM1 syndrome have a few IgM⁺/IgD⁺ B cells that express CD27, a memory B-cell marker and have SHM. HIGM1 is due to mutations in the gene that encodes CD40L (CD40LG).⁴⁸³

Carriers of HIGM1 are considered to be asymptomatic, because expression of CD40L, even in only a small fraction of T cells, is sufficient for effective immunity. A female carrier has been described with HIGM1 syndrome as a result of extreme lyonization of the normal X chromosome.⁴⁸⁴ This patient was the sister of a boy who was affected with HIGM1 syndrome, and only 5% of T cells were CD40L⁺.

A second HIGM syndrome with autosomal recessive inheritance (HIGM2) has normal CD40L but does not undergo CSR *in vitro* in the presence of CD40 agonists.⁴⁸⁵ CD40 gene sequence and CD40 expression are normal. The defect of HIGM2 is linked to chromosome 12p13, where the AICDA gene also maps. Patients with mutation of AID lack CSR and SHM and have lymph node hyperplasia with giant GCs.⁴⁸⁶ The cells in these GCs are proliferating B cells that co-express IgM, IgD, and CD38, a phenotype that was previously described as characteristic of the GC founder cell subset.⁴⁸⁷ Some mutations are predicted to lead to truncated forms of AID by generating stop codons; other missense mutations are localized within the putative cytidine deaminase catalytic region of the protein. The phenotype of HIGM2 is similar to the phenotype of mice with deficiency of AID.⁴⁸⁸

In a group of 13 patients with HIGM syndrome and normal CD40L, all patients had AID mutations, five of them with a missense mutation of Arg112 His, which indicates that Arg112 is the hotspot for mutations.⁴⁸⁹ Levels of IgG, IgA, and IgE were undetectable, and SHM was impaired, which shows that AID is indispensable in CSR and SHM. Another group of 14 patients of French Canadian descent from Quebec, Canada, had a C-to-T transition in codon 112, resulting in the substitution of Arg with Cys. These patients inherited the genetic defect from a common founder.⁴⁹⁰ In contrast to HIGM1 syndrome, patients with HIGM2 have bacterial, but not opportunistic infections.

Mutations of the AICDA gene do not account for all cases of autosomal recessive HIGM1 syndrome. Mutations in the CD40 gene, which lead to lack of CD40 expression, cause an autosomal recessive form of immunodeficiency with HIGM, which is characterized by lack of CSR, impaired memory B lymphocytes and defective SHM (HIGM3).⁴⁹¹ One patient was detected at 4 months of age with severe respiratory distress because of *P. carinii* infection. Two other patients experienced recurrent respiratory infections early in life.

CYTOKINES IN B-CELL DIFFERENTIATION

The structure and function of the main cytokines that are involved in B-cell differentiation and their receptors are briefly described here. Some of the cytokines have similar structural features and have been divided into two groups, type I and type II.

Type I cytokines consist of four α helices (A, B, C, and D) that are connected by long loops. If the molecule is viewed in the direction from the NH₂ to the COOH terminal, the orientation of the A and B helices is up, and the orientation of the C and D helices is down (i.e., up-up-down-down). Depending on the length of the helix, they are distinguished as short chain or long chain. Cytokines with short chains include IL2, IL3, IL4, IL5, IL7, IL9, IL13, IL15, and SCF, and those with long chains include erythropoietin, thrombopoietin, IL6, IL11, leukemia inhibitory factor (LIF), and oncostatin. Only the short chain cytokines have β -sheet structures in the AB and CD loops. There are intrachain disulfide bonds to maintain the overall tertiary structure, but the number varies; for example, IL2 has one disulfide bond and IL4 has three. The sequences in helices A and D are the most conserved in evolution, and these helices make contacts with the receptors. The receptors of the cytokines that are discussed here have a characteristic cytokine-binding domain (CBD) that consists of two fibronectin type III (FnIII) domains. The N terminal contains four conserved cysteines that form two disulfide bonds and the membrane-proximal conserved sequence WSXWS (Trp-Ser-X-Trp-Ser, where X is any amino acid). The cytokine receptors use several signaling pathways. Briefly described here is the JAK-STAT pathway, which mediates most of the cytokine effects.

The biologic properties of the ILs described here are listed in Table 14.2.

Jaks and Signal Transducers and Activators of Transcription

The Janus family of kinases, which is known as JAK (“just another kinase”), has been given the name of the Roman god, Janus, the god of gates and doorways and the god of all beginnings and endings, who had two faces. JAKs also have two tandem domains, a kinase, and a pseudokinase.⁴⁹² Each molecule consists of seven homology domains, which are termed JAK homology (JH) domains. JH1 is the catalytic domain and has the features of a TYR kinase domain, whereas the N terminal binds to cytokine receptors. Mutation of the conserved LYS in subdomain II that binds ATP abrogates kinase activity. JAKs are apparently interdependent in their function, because they form homo- or heterodimers with other members of the family when the receptors with which they associate form homo- or heterodimers. Certain domains are used as cytokine receptor-specific binding sites. For example, JAK1 uses JH7 and JH6 for binding to IL2RB and IL4RA, but the binding to IFN α R β L and IL10RA requires another domain.⁴⁹³ The Jak-3 kinase is rapidly phosphorylated by IL2 and binds to the γ c chain through the JH6 and JH7 domains, whereas the JAK1 associates with the β chain.

P.343

TABLE 14.2 BIOLOGIC ACTIVITIES OF CYTOKINES

		Effects on:		
Cytokine	Produced	B Cells	T Cells	Macrophages
IL-2	T _H 1	Growth	Growth	—
IL-4	T _H 2	Growth	Growth	Activation

		↑ Major		
		histocompatibility	complex activation	
		↑ Immunoglobulin E		
IL-5	T _H 2	Differentiation	—	—
		↑ Immunoglobulin A		
IL-6	T _H 2	Growth	Costimulation	—
		Differentiation		

IL, interleukin; T_H, T helper cell; ↑, increased.

STATs are latent cytosolic transcription factors with an acronym that accurately reflects the speed of their activation and the urgency of their biologic function, in agreement with the STAT (“at once”) order for immediate action in clinical medicine and emergency rooms. There are seven known mammalian STAT proteins that were conserved in evolution from primitive eukaryotes to humans.⁴⁹⁴ The important structural features of STATs are the SH2 (SRC homology 2) domain and the DNA-binding domain.⁴⁹⁵ The SH2 domain is used to bind to phosphorylated TYR and is used for their dimerization. After phosphorylation of their single TYR (Y-P), they form homodimers or heterodimers, based on the interaction of the Y-P with the SH2 domain of another molecule of a similar or different STAT. Dimerization unmasks a nuclear localization signal that permits STATs to enter the nucleus and bind to DNA.⁴⁹⁵ STATs must take six steps for the full expression of their function: (a) bind to Y-P, (b) become phosphorylated themselves, (c) dimerize, (d) translocate to the nucleus, (e) bind to DNA, and (f) participate in gene transcription. STATs bind to Y-P of cytokine receptors or Y-P of a STAT that is already bound to the receptor or directly to a JAK.

The DNA-binding domain in the C terminal in some STATs contains a SER whose phosphorylation is important for transcriptional activity. JAKs and STATs constitute an important signaling pathway for cytokines. All IFNs and cytokines activate one or more STATs. Because there are more cytokines than STATs, it is not possible for each cytokine to have its own STAT. However, cytokines form groups that share the same STATs. For some STATs that are activated by many cytokines (STAT3, STATA, and STAT5B), their unique actions cannot be mediated by STATs alone, but require a combination of other transcription factors. In addition to transcription regulation, some STATs recruit other signaling components. STAT4 and STAT5 are two of the most important STATs in the STAT pathway, primarily because of their role in TH cell differentiation. STAT3 and STAT1 have a primary role in the function of IL5 and IFN-γ, respectively, in defense against infectious agents.⁴⁹⁶

Interleukin-2 and Interleukin-2 Receptor

IL2 and IL2R were the first to be isolated, and, although IL2 was originally thought to be only a T-cell growth factor, subsequent studies demonstrated that it acted on several types of cells, including B cells and NK cells.⁴⁹⁷ IL2 belongs to the short-chain four-α-helical bundles. IL2R consists of a complex of three polypeptide chains: the IL2RA, IL2RB, and γc (common) chains. The γc chain is shared by receptors of several ILs, such as IL4, IL7, IL9, and IL15.

IL2RA binds IL2 with low affinity (dissociation constant $K_D = 10^{-8}$), whereas, in association with IL2RB, it forms an intermediate-affinity complex ($K_D = 10^{-9}$), and all three subunits form the high-affinity receptor ($K_D = 10^{-11}$). The IL2RB subunit has two pairs of conserved cysteines that are close to the N-terminal end and the sequence WSXWS in the membrane-proximal end of the extracellular region, which is characteristic of type I cytokine receptors.

The intracellular region has the Box1-, Ser (S)-, acidic (A)-, and proline (H)-rich regions. The extracellular region of the γc chain has an N-terminal domain with two pairs of cysteines, and the second membrane-proximal domain contains the highly conserved WSXWS motif. The α and β subunits are expressed only on lymphocytes, but, after activation, they are also expressed on macrophages. The γc chain is detected in several other hematopoietic cells.⁴⁹⁸

The contributions of each of the three chains to IL2 binding are not quite clear. The α chain is necessary to form, with the other two chains, the high-affinity IL2R, whereas the γc chain contributes three loops from the extracellular region (including two of the cysteines) to the IL2 and IL7 binding.⁴⁹⁹ IL2 expresses lectin properties and binds to the β chain in a Ca²⁺-independent manner to oligomannosidic N-glycans (5 to 6 mannose residues). It is proposed that by this mechanism IL2 links the β chain of IL2R with CD23.⁵⁰⁰ The β and γc chains are certainly the signal-transducing components of the IL2R. Signaling through the IL2R follows several paths to the nucleus (Fig. 14.16). One pathway is

the RAS-MAPK cascade that is initiated by the phosphorylation of the Shc adaptor protein.⁴⁹⁷ A second is the PI3K activation, and a third one is through the JAK-STATs.

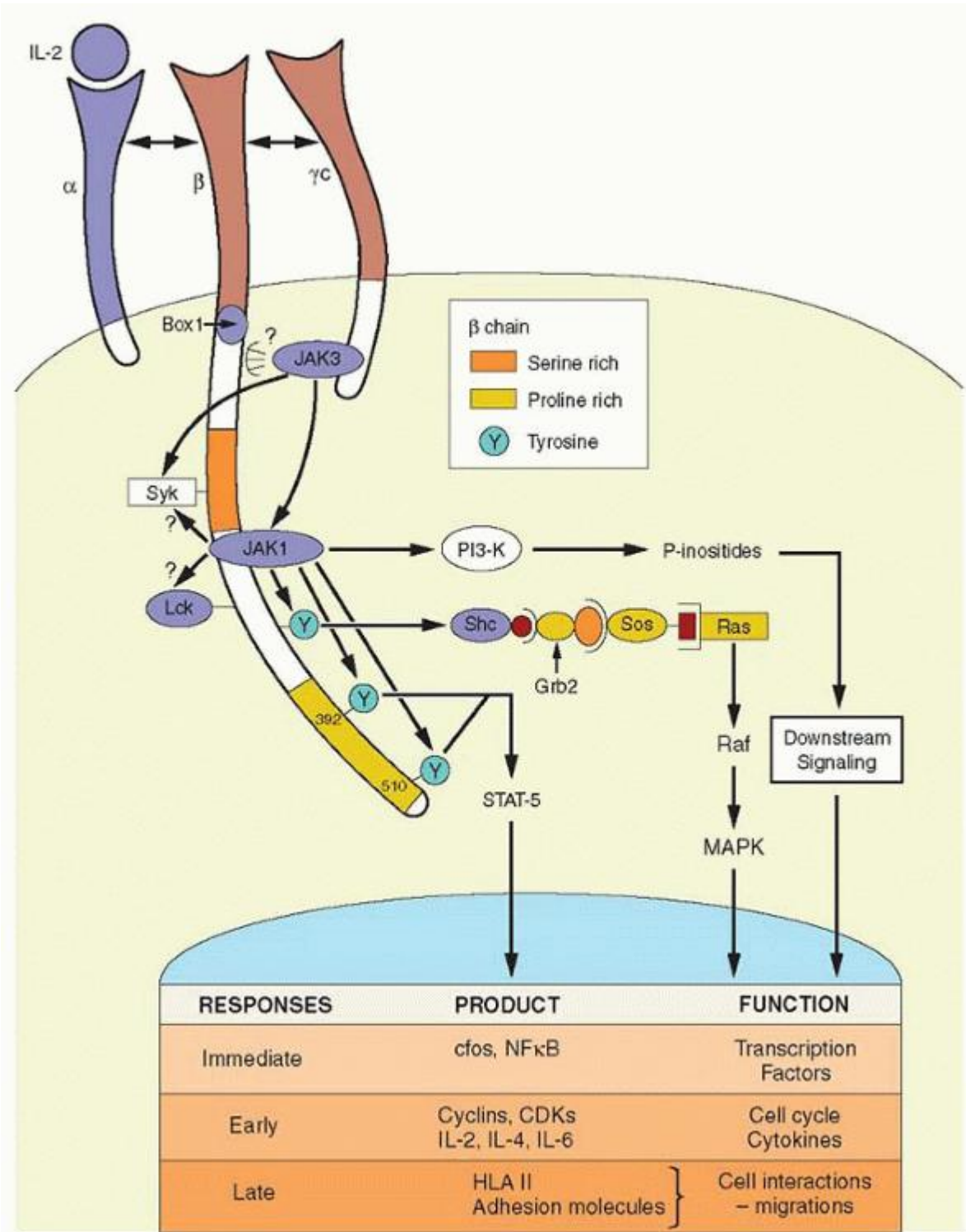

FIGURE 14.16. Interleukin (IL)-2 signaling. The IL-2 receptor complex consists of three polypeptide chains: α , β , and γ . High-affinity binding of IL-2 requires all three chains. The β chain is associated with Jak 1 kinase, Src kinases (e.g., Lck), and Syk. Jak 1 phosphorylates tyrosines of the C-terminal region of the β chain, which become docking sites for signal transducer and activator of transcription 5 (STAT-5). One of them links to the adaptor protein Shc, which connects to the Ras pathway and mitogen-activated protein kinase (MAPK) activation. Jak 1 also connects with phosphoinositide 3-kinase

(PI3K) and the downstream signaling that is mediated by phosphoinositides. Jak-3 is associated with the γ c chain and probably with β chain. It probably activates Jak 1 and Syk. IL-2 and IL-2R signaling induces multiple and prolonged T-cell responses, such as immediate responses, transcription factors that activate genes for cell cycle, and cytokine release. Later induction of integrins supports T-cell migration and interactions with other cells. IL-2 was the first cytokine to be discovered and retains a commanding role in the regulation of several aspects in T-cell life. NF- κ B, nuclear factor- κ B.

The A region of the β chain is associated with members of the SRC family and PI3K. The H region mediates activation of the JAK family of TYR kinases that activate STATs.⁵⁰¹ The most membrane-proximal TYR (Y) 338 is involved in the phosphorylation of the adaptor protein, SHC1, which is linked to the RAS pathway. The two membrane-distal TYR Y322 and Y510 associate the β chain with the JAK1 kinase,⁵⁰² which interacts with the PI3K. This pathway leads to maximal T-cell proliferation.⁵⁰³ IL2 and several others are associated with the JAK-STAT signal transduction pathway. The JAK3 kinase is rapidly activated by IL2, and, through the JH7 and JH6 domains, it binds to the γ c chain,⁵⁰⁴ whereas JAK1 is associated with the β chain.⁵⁰⁵ Understanding the mechanism of T-cell progression through the cell cycle has been advanced by the discovery of rapamycin, a potent immunosuppressant.⁴⁹⁷ Rapamycin is a macrocyclic lactone that is derived from the filamentous bacterium *Streptomyces hygroscopicus*⁵⁰⁶ and has structural similarities to another powerful immunosuppressant, FK506, or tacrolimus. Both substances bind to a family of intracellular receptors, FK506-binding proteins (FKBPs), which are peptidyl-prolyl isomerases; that is, they catalyze the cis-trans interconversion of peptide bonds that contain proline. The complexes of FK506 and FKBP in T cells inhibit calcineurin, a Ca^{2+} -regulated Ser-Thr phosphatase, which plays a crucial role in the activation of gene transcription by IL2. However, the rapamycin-FKBP complexes do not bind to calcineurin but to another protein that is called the target of rapamycin (TOR).⁵⁰⁷ This protein is expressed in *Saccharomyces cerevisiae*, and it provides resistance to the potent antifungal action of rapamycin.

The protein TOR is apparently needed for the transition of T cells from G_1 to S phase. Transition of the cell from G_1 to S phase is regulated by G_1 cyclins and their associated cdk, which assure the orderly progression from G_1 to S phase. IL2 stimulates the synthesis of three cyclins, D2, E, and A.⁵⁰⁸ These cyclins form complexes with CDKs, which sequentially (D2-complexes followed by E-complexes and then A-complexes) lead the cell from G to S phase. Rapamycin affects the assembly and function of all three cyclin-CDK complexes. The D2-complexes function by phosphorylating their substrate, the retinoblastoma protein, which normally is phosphorylated at a low level and restricts the G_1 -to-S transition. The function of cyclin-CDK complexes is regulated by another set of proteins called kinase-inhibitory proteins (KIPs),⁵⁰⁹ which bind and inhibit the kinase activities of the cyclin-CDK complexes. The IL-2R delivers a signal for KIP down-regulation, whereas rapamycin prevents the IL2-induced reduction of KIP.

The TOR protein regulates the p70^{56K} protein, which is present in mammalian cells, and, as a protein kinase, phosphorylates various intracellular substrates that are involved in protein synthesis and cell cycle control. T-cell activation by antigen induces within the first 30 minutes a number of transcription factors (e.g., FOS, NFAT, and NF κ B; immediate response). These factors in turn activate the transcription of cytokine genes, such as IL2, IFN- γ , IL4, and IL5 (early response). IL2 stimulates T-cell clonal expansion and dictates proliferation of antigen-selected T cells. Antigenic stimulation induces IL2R's expression and secretion of IL2 and other cytokines.⁴⁹⁸ Cross-linking of surface Ig leads to IL2R expression on B cells and responsiveness to IL2. IL2 stimulates proliferation of B cells and Ig secretion and mediates the switch from the membrane form to the secretory form of the μ chain, allowing formation of pentameric IgM molecules. Therefore, IL2 is critical for primary immune responses that are characterized by the production of IgM antibodies. IL2 stimulates secretion of other cytokines, such as IL4, IL5, and IFN- γ , preparing the stage for isotype switch and the maturation of the antibody response. Antigen activation of T cells initiates a series of waves of gene activation that is coordinated by TCR signaling and IL2 secretion, with the expansion of the role of T-cell cytokines in B-cell proliferation, antibody secretion, affinity maturation, and class switch (late response).

X-linked Severe Combined Immunodeficiency

The γ c chain gene of the IL2R is located in chromosome Xq13, which is also the locus for X-linked SCID. X-linked SCID patients are phenotypically identical: T^- , B^+ , and NK^- .⁵¹⁰ Of a large group of patients with SCID, γ c deficiency accounted for 42%, and Jak-3 deficiency accounted for approximately 6% of the cases.⁵¹¹ This form of SCID is associated with severe defects in T-cell development and lack of peripheral T and NK cells. Patients have severe persistent infections of the upper respiratory and gastrointestinal tracts by CTMV, fungal, and bacterial pathogens and require bone marrow transplantation to survive. B-cell levels are normal or elevated in the T^- , B^+ , and NK^- SCID cases. With the exception of two large deletions, the γ c mutations are missense mutations involving one or a few nucleotides. Five mutational hotspots have been identified in exons that encode part of the extracellular domain.⁵¹² In patients with autosomal SCID, a single amino acid substitution, Y100C, in the JH7 domain of JAK3 prevents the interaction of JAK3 with the receptor.⁵¹³

Interleukin-4 and Interleukin-4 Receptor

The IL4 is one of the small four-helix bundle cytokines with four α helices, A, C, B, and D, two end-to-end long loops, and a short β sheet that is packed against the B and D helices.⁵¹⁴ It has biologic activity that is species-specific, in spite of the fact that the main binding residues are conserved.

IL4 is a pleiotropic cytokine that is produced by CD4⁺ T_H2 cells, NKT cells, $\gamma\delta$ T cells, basophils, and mast cells, and it is essential for T_H2 differentiation (see Chapter 13). IL4 binds with high affinity to the IL4RA, and this complex recruits the γ c chain (Fig. 14.17). IL4 binding induces a conformational change in the receptor, forming a structural mosaic in the binding interface. The interacting residues are grouped into three clusters,⁵¹⁵ with the first two clusters consisting of a nucleus of polar groups that are surrounded by hydrophobic side chains. They have been compared to the avocado fruit, in which a nucleus is enveloped by an oily shell. The first cluster is around Glu9, and the second cluster is around Arg88 of IL4 and Asp72 of the IL4RA.

The third cluster steers and accelerates the binding of the IL4 with the receptor.⁵³⁹ The first and second clusters show cooperativity and additive properties, which reinforce the binding to higher affinity.⁵¹⁶ IL4R consists of a complex of two proteins, IL4RA and the γ c chain. The IL4RA has two FnIII domains. The N terminal (D1) has the conserved disulfide bonds of an Ig fold, whereas the second domain (D2) has no disulfide bonds; both have unique structural features.⁵¹⁷ A membrane-proximal WSXWS domain maintains the favorable conformation for cytokine binding. The cytoplasmic region has the box 1 motif (prolinerich) and an acidic region that is adjacent to box 1 that interacts with SRC TYR kinases. Ligand binding causes heterodimerization of the α and γ c chains and activation of JAK1, JAK2, and JAK3 kinases,⁵¹⁸ the first two associating with IL4RA and the last associating with γ c.

Activation of Tyr kinases that are associated with the IL-4R leads to phosphorylation of the five tyrosines of the cytoplasmic region of IL4RA,⁵¹⁴ which function as docking sites for SRC kinases. The functions of IL4RA are mediated by distinct domains in the cytoplasmic region. The first, most membrane-proximal domain contains the Y497 (Y1), which interacts with the IL4 phosphotyrosine substrate (4PS), a 180-kDa protein related to insulin receptor substrate 1 (IRS1) that is phosphorylated and generates proliferative signals.⁵¹⁹ It is interesting that 4PS was found to be homologous to a cytoplasmic protein, which is used as a substrate for the insulin receptor. Insulin binding to the insulin receptor results in rapid autophosphorylation of the receptor, which is a

P.345

receptor protein kinase. The receptor subsequently phosphorylates cytoplasmic substrates that link to downstream signaling pathways. One such major substrate of the insulin receptor is the IRS1. 4PS, which is homologous to IRS1, has been called IRS2.⁵²⁰ IRS1 and -2 bind to the sequence (⁴⁸⁸PL-[X] 4 NPXYXSXSD⁵⁰²) around Y497 of the IL4R, which is highly homologous to a sequence in the cytoplasmic regions of the insulin receptor, and of the insulin growth factor-1 receptor, both of which activate IRS1 and -2. This sequence is critical for transducing signals through the insulin receptor and IL4RA and was termed the insulin IL4 receptor or I4R motif (Fig. 14.17). The IRS2 has a phosphotyrosine-binding domain, which binds to the I4R motif of the IL4RA and insulin receptor. IRS1 and -2 become phosphorylated when they bind to phosphorylated IL4RA and act as a docking site for several SH2-domain-containing signaling molecules. Among such signaling molecules are the PI3K that generates phosphoinositides, which in turn activate Akt and protein kinase C (PKC), which are important in cell growth and survival.

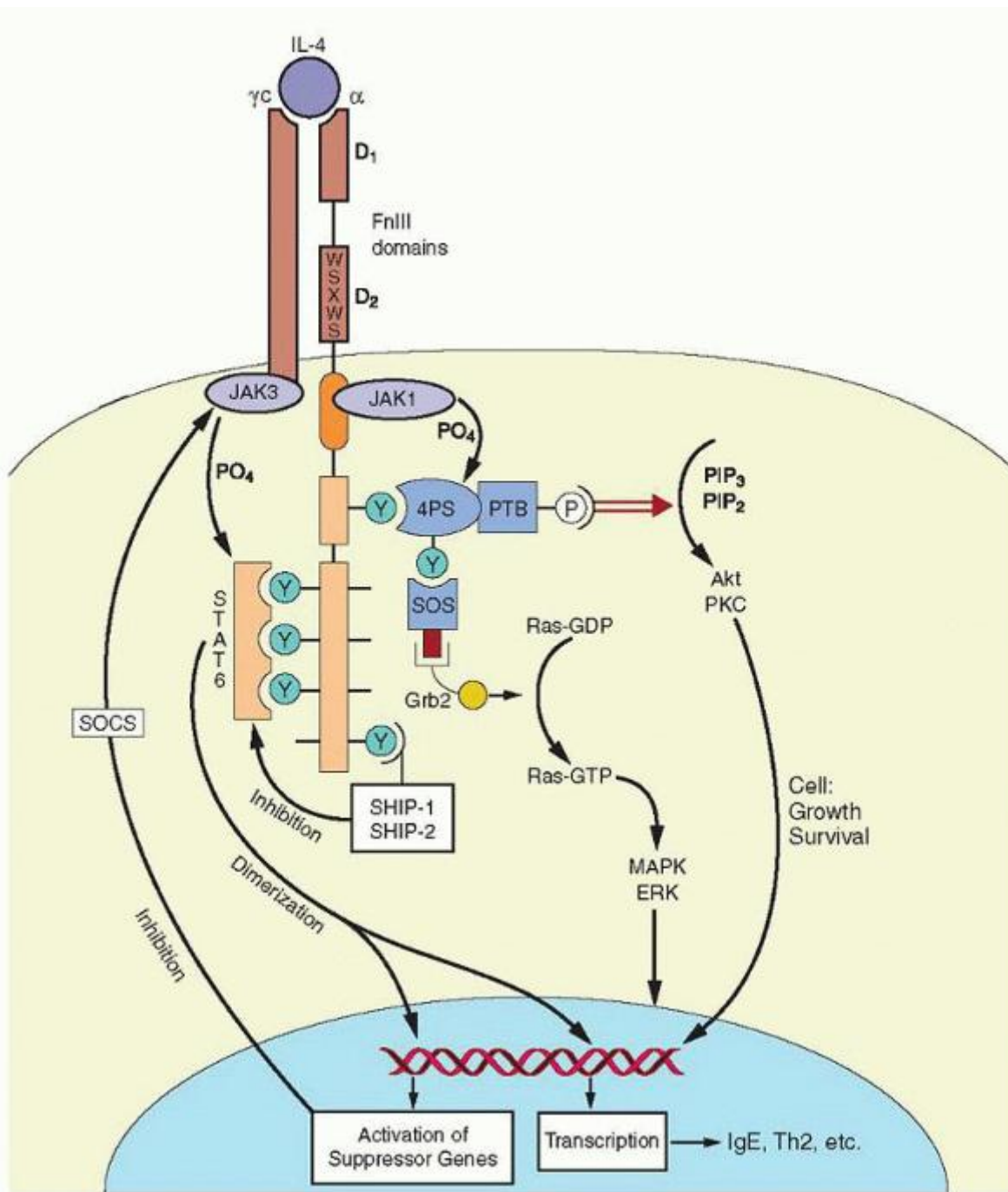

FIGURE 14.17. Interleukin (IL)-4 signaling. IL-4 binds to a receptor, which consists of two chains, α and γ c. The α receptor has two extracellular fibronectin III domains (Fn; D1 and D2), with features of a cytokine receptor homology domain, which is seen in type I cytokine receptors. D2 is characterized by the WSXWS motif (amino acid letter code: W is tryptophan, S is serine, and X is any amino acid) that is implicated in folding and transport of the receptor. The binding of IL-4 to the α chain is mediated by three discrete clusters. Two of them are known as avocado clusters because they consist of a central core of polar groups that is surrounded by a hydrophobic (oily) shell. The third cluster is dominated by electrostatic interactions and stabilizes the complex. The α chain associates with Jak-1 and the γ c chain with Jak-3. Distinct domains of the cytoplasmic tail of the α chain mediate the multiplicity of IL-4 function. A unique feature in the IL-4R α chain is its association with a protein known as IL-4 phosphotyrosine substrate (4PS), which links to phosphoinositide 3-kinase (PI3K) and downstream signaling for cell growth and survival. 4PS also connects to the Ras pathway for mitogen-activated protein kinase (MAPK) activation. 4PS binds to a unique sequence of IL-4R α that is shared by the insulin receptor. In the insulin receptor, this motif binds a protein-linking signaling pathway, which is known as insulin receptor

substrate 1 (IRS-1). 4PS of the IL-4R α is homologous to IRS-1 and has been called IRS-2. Jak-3 phosphorylates tyrosines of the α chain that are used by the signal transducer and activator of transcription 6 (STAT-6) for binding. This phosphorylation is regulated by SHIP phosphatases, which are associated with the C-terminal part of the α chain. STAT-6 induces the suppressor proteins, suppressors of cytokine signaling (SOCSs), which inhibit Jak-3 activation. GTP, guanosine triphosphate; PTB, phosphotyrosine-binding domain.

The adaptor protein Shc binds to the phosphorylated IL4RA chain and links through GRB2 to RAS pathway activation. STAT6 is the primary STAT that is activated by IL4 stimulation, leading to expression of IL4-responsive genes. STAT6 plays an important role in IL4-induced responses, and, for IL4 signaling to be maintained, STA-6 undergoes continuous cycling.⁵²¹ When STAT6 is deactivated in the nucleus, it is exported back to the cytoplasm, where it becomes available for another cycle of phosphorylation and reactivation. STAT6 (together with STAT4) is the most important STAT in the immune response to sepsis, mainly because of its role in T_H differentiation. STAT6 is essential for T_H2 differentiation on activation by IL4.

The phosphorylated C-terminal immunoreceptor tyrosinebased inhibitory motif of the IL4RA acts as docking site for SHP-1 and SHP-2 phosphotyrosine phosphatases. The former is expressed primarily in hematopoietic tissues, whereas the latter is expressed in several other tissues. Another phosphatase, SHIP, regulates the PI3K signaling pathways.

The JAK-STAT pathway is also subject to regulation by a family of newly discovered suppressor proteins termed suppressors of cytokine signaling (SOCSs).⁵²² There are four members in the SOCS family: SOCS1, SOCS2, SOCS3, and CIS (cytokineinducible SH2-containing protein). The SOCS proteins have an SH2 domain in the center, an N-terminal-variable region, and a region of homology at the C terminus, which is termed the SOCS box, with a unique sequence and an unknown function. Five families (20 members) have been identified with a sequence that is homologous to the SOCS box, but the rest of their structure is different.⁵²³ SOCS proteins are not constitutively present in the cells but are induced only after cytokine stimulation. The mechanism of their action is different among the members of the family. SOCS1 binds to the catalytic domain of JAK2 kinase, whereas CIS competes with signaling molecules, such as STATs, for binding to STAT binding sites.⁵²⁴ SOCS1 and SOCS3 inhibit IL4-dependent STAT6 activation by binding to JAK1.^{525,526}

IL4 activates the RAS-MAPK pathway through interaction of IRS2 with the GRB2 protein. The RAS pathway, and other small guanosine triphosphatases (GTPases) that are related to RAS, are regulated by the RAS GTPase activating protein, which activates the GTPase activity of RAS. Down-regulation of RAS is controlled by a molecule termed IL-four receptor interacting protein, which binds to the IL4R motif of IL4RA and, through RAS GTPase activating protein, inactivates the RAS GTP active form.

Functions of Interleukin-4 in T-cell-B-cell Interactions

IL4 plays a central role in differentiation of naive T cells to T_H2 cells capable of producing IL4, IL5, IL10, and IL13 (see Chapter 13). Thus, IL4, through T_H2 differentiation, controls humoral immunity. IL4 increases MHC class II expression in B cells, DCs, and macrophages, thus enhancing their class II antigen presentation, and up-regulates the CD23 expression of B cells. IL4 promotes activation and viability of B cells. A major role of IL4 in B-cell function is in the class switch, as it induces the switch to IgG1, IgG3, IgG4, and, most important, IgE. In this respect, it plays a major role in allergic reactions and protection against helminthic infestations.

The mechanism of promotion of CSR by IL4 is through up-regulation of AID.⁵²⁷ AID is required for CSR and hypermutation (see section "Immunoglobulin Class Switch"). CD45 has recently been defined as a Janus phosphatase,⁵²⁸ which negatively regulates IgE CSR in human B cells through inhibition of IL4-induced (plus anti-CD40) IgE germline transcription.

Interleukin-5 and Interleukin-5 Receptor

IL5 was originally described as a T-cell-replacing factor or B-cell growth factor 2. It affects the terminal differentiation of B cells and is a single polypeptide of a total of 134 amino acids with a molecular weight of 30 to 40 kDa.⁵²⁹ Its tertiary structure reveals

P.346

two domains with a cytokine fold (four α helices and two β sheets), as is seen in GM-CSF, IL2, and IL4. The IL5 gene is found on chromosome 5.

The IL5 receptor is expressed on B cells, eosinophils, and certain cell lines. It consists of an α chain and a β chain. The β_c chain is shared by GM-CSF and IL3 receptors and is functionally analogous to other common chains that are shared by several cytokines, such as the gp130 of the IL6 family and the common γ chain of the IL2 receptor family. The β_c chain

consists of 880 amino acids with four extracellular domains that are related to the FnIII domains, a single region, and the intracellular region.⁵³⁰ The four extracellular domains consist of seven β strands (A through G), which form two cytokine receptor modules. The membrane proximal module contains the recognition contact sites for the α chain.⁵³¹ The membrane proximal cytoplasmic region shows similarities to the sequences of box 1 and box 2 of other receptors and serves in recruitment of members of the family of JAKs. The cytoplasmic region also contains several TYR residues that are phosphorylated after cytokine binding. Binding of the cytokine induces dimerization of the receptor through free Cys that is present in the α subunit and in the first domain of the β_c chain. The disulfide bonds that are formed involve the α chain of one receptor with the β_c chain of the second receptor and vice versa. Dimerization is essential for the Tyr phosphorylation of the receptors. Because the β_c chain is shared by different cytokines, there are sites that are specific for shared interactions.

Detailed studies of the function of IL5 on mouse B cells have concluded that IL5 stimulates production of IgM, IgG1, and IgA, and induces IgA production; therefore, it acts on B cells that are committed to IgA secretion. IL5 synergizes with IL4 in augmenting IgM secretion of human B cells and with IL2 for IgG, IgG, and IgA secretion. The effects of IL5 are detected on activated B lymphocytes.

IL5 plays a unique role in the production, activation, and localization of eosinophils,⁵³² which are seen in patients with asthma and helminthic infestations. IL5 is detected in some patients with severe exacerbations of asthma,⁵³³ and it is conceivable that exacerbations are associated with activation of T cells that secrete IL-5. Local expression of IL5 was detected by in situ hybridization in mucosal bronchial biopsies, which was correlated with the number of infiltrating eosinophils.⁵³⁴

Interleukin-6 and Interleukin-6 Receptor

IL6 is a cytokine with pleiotropic activities that is produced by a great variety of cells (Table 14.3) and plays a central role in immunity and inflammation. IL6 induces (a) terminal differentiation and Ig secretion of B cells; (b) growth promotion of B cells, plasma cells, and myeloma cells; (c) support of colony formation by stem cells; (d) induction of acute-phase response (APR) proteins; (e) differentiation and activation of T cells and macrophages; and (f) neural differentiation. It is also involved in the pathology of several diseases, such as rheumatoid arthritis, proliferative glomerulonephritis, and multiple myeloma. At least 11 different activities are known, with an equal number of acronyms; these turned out to be mediated by the same molecule, which was called IL6. IL6 is a member of a family of structurally and functionally related cytokines that includes IL11, LIF, oncostatin M (OSM), ciliary neurotrophic factor (CNTF), and cardiotrophin-1. Redundancy of function is a result of the sharing of the signal-transducing component of gp130.

IL6 is a glycoprotein that belongs to the long chain, four- α -helical bundle of cytokines^{535,536} and binds to the IL6R-gp130 complex (see the following discussion) but, in addition, has the intriguing property of a lectin that interacts with a trisaccharide (HNK-1 or CD57)⁵³⁷ (see Appendix, CD57). CD57 is a sulfated trisaccharide that is carried by N-glycans, that is, complex polysaccharides. It has been identified in the nervous system as a major target of peripheral neuropathies in patients with lymphomas.

TABLE 14.3 INTERLEUKIN-6 PRODUCTION

Producing Cell Inducer

B cells	IL-4, IL-1, and TNF- α
T cells	Phytohemagglutinin and tissue plasminogen activator
Macrophages	IL-6, interferon- γ , granulocyte-macrophage colony-stimulating factor, IL-1, and LPS
Endothelial cells	LPS, interferon- γ , IL-1, IL-4, and TNF- α
Fibroblasts	IL-1, TNF- α , and LPS
Keratinocytes	IL-1, IL-4, and phorbol myristate acetate
Osteoblasts	IL-1, TNF- α , and LPS
Kupffer cells	IL-1, TNF- α , and LPS

IL, interleukin; LPS, lipopolysaccharide; TNF, tumor necrosis factor.

IL6R consists of an extracellular region with one Ig-like domain (C2-type) and two FnIII domains, which form the CBD, which is characteristic of the class I cytokine receptors. The first FnIII domain has two disulfide bonds, whereas the second

has the sequence WSXWS.⁵³⁸ IL6 binds to the IL6R-gp130 complex by three contact sites. Site one is located in the loop that connects helices A and B of the IL6 and interacts with the D2 domain of IL6R. Site two is located at the C terminus of helix D of IL6, and interacts with the D2 domain of gp130.⁵³⁹ A third site interacts with the N-terminal Ig-like domain (D1) of gp130. gp130 is the signal transduction component of the IL6-gp130 complex, because the cytoplasmic region of IL6R is short.^{540,541,542}

The gp130 protein has an extracellular region that consists of six domains. D2 and D3 have the features that are characteristic of the CBD of class I cytokine receptors. D1 is an Ig-like domain, whereas D4 to D6 are FNIII domains. IL6 induces the formation of a hexamer that consists of two molecules each of IL6, IL6R, and gp130. The crystal structure of gp130 shows that the uncomplexed receptor assumes an L-shaped quaternary structure with limited flexibility.⁵⁴³ gp130 associates with other cytokines, such as OSM, LIF, and CNTF. The crystal structure shows that there is little domain reorientation of the ligand-binding domains, indicating that the overall structure is adaptable to bind multiple cytokines.⁵⁴³ The gp130 protein also has an N-glycan that carries the HNK-1 epitope,⁵⁴⁴ which interacts with IL6. The lectin activity of the IL6 is necessary for the initial signal transduction.⁵⁴⁴

Binding of IL6 to the IL6R-gp130 complex triggers signal transduction, which follows two pathways: the SRC protein tyrosine kinases and the JAKs⁵⁴⁵ (Fig. 14.18). Activated JAKs phosphorylate several TYR (Y) residues of the gp130 cytoplasmic region, which then become docking sites for signaling molecules that possess SH2 domains.^{546,547} The second membrane-proximal Y recruits the SHP-2 phosphatase, leading to the activation of MAPK. Activation of the SRC kinase, HCK, phosphorylates adaptor molecules that link to the GRB2, SOS, RAS pathway to MAPK activation.⁵⁴⁸ This pathway mediates proliferative signaling and, at the same time, through activation of SHP-2 phosphatase, dephosphorylates PYK2 and blocks dexamethasone-induced apoptosis of myeloma cells.⁵⁴⁹

Any of the four most distal TYR residues mediates STAT3 activation. The STAT3 structure is similar to that of other STATs: an N-terminal tetramerization domain, a central DNA-binding domain, a conserved SH2 domain (which binds to the cytokine receptor or another STAT molecule for dimerization), followed by a conserved Y and a C-terminal transactivation domain. STAT3 is the major STAT in IL6 signaling.⁵⁵⁰ IL6 signaling is down-regulated by SOCS1 (see the previous discussion), which is induced via activation of STAT3.⁵⁵¹ Another mechanism of IL6R

P.347

down-regulation involves endocytosis of gp130, after IL6 binding. It is mediated by a dileucine motif after phosphorylation of a SER residue in the cytoplasmic tail of the gp130 protein⁵⁵² (Fig. 14.18).

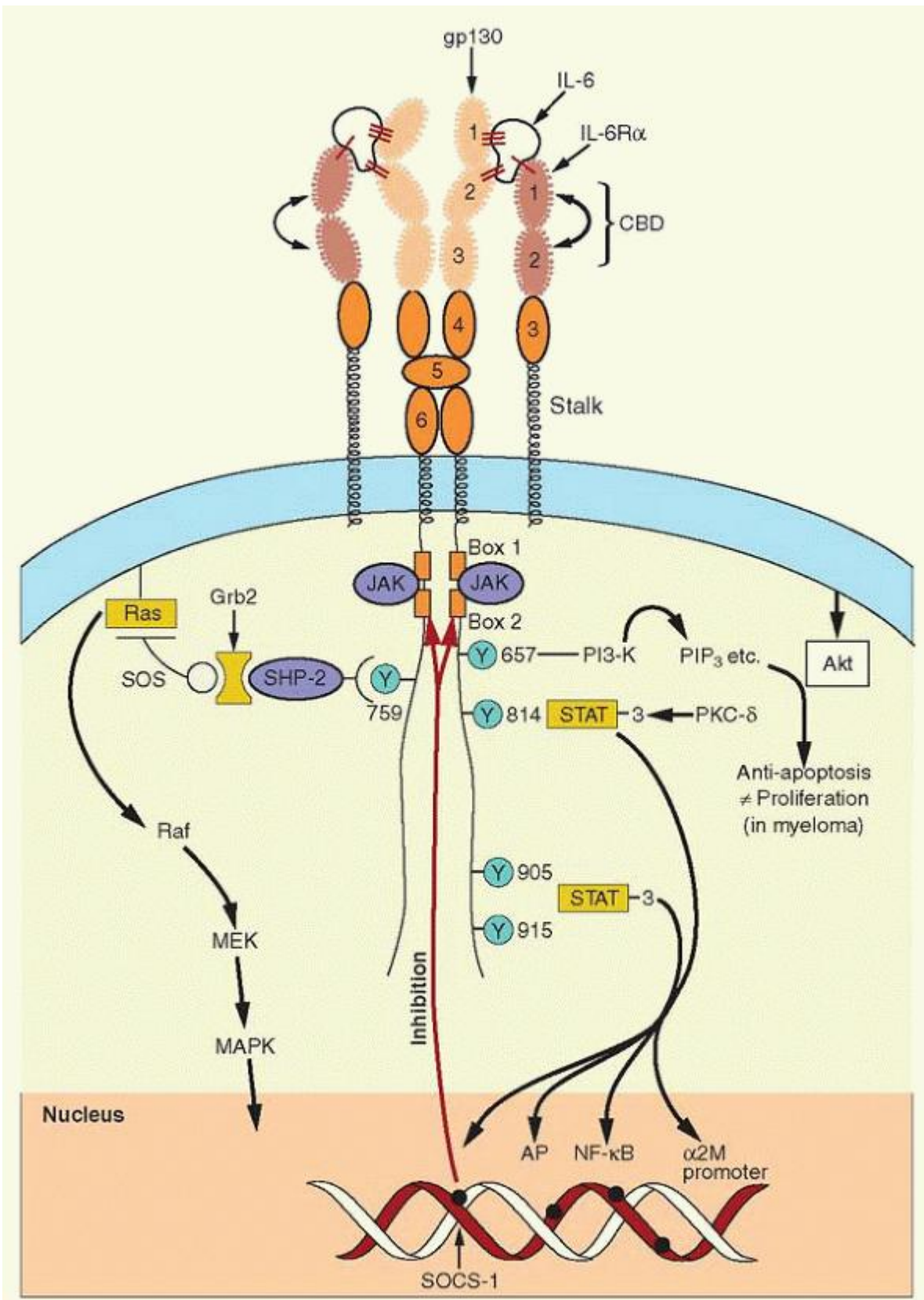

FIGURE 14.18. Interleukin (IL)-6 and IL-6 receptor (IL-6R) signaling. The IL-6 binds first to IL-6R α (site I). This binary complex forms a composite site that is termed site II, which interacts with the cytokine-binding domain (CBD) of gp130 (which includes domains D2 and D3), forming a trimolecular complex. Recruitment of site III on the immunoglobulinlike activation domain (IGD; i.e., D1 of the gp130) results in the formation of higher-order activation complexes (i.e., a hexamer), which is

fully active (gene transcription). High-affinity binding to the N-terminal domains of gp130 (D1 to D3) is not sufficient for receptor activation. The membrane-proximal (D4 to D6) domains of gp130 are necessary for activation, as they facilitate appropriate spacing (especially D5) of the cytoplasmic components of gp130. gp130 is the signaling component of the complex and recruits Jak-1 and Jak-2 kinases, with Jak-1 having an essential role. Jaks bind to box 1 and box 2 of the membrane-proximal cytoplasmic regions. The N-terminal domain of Jaks comprises a 4.1-ezrin-radixin-moesin domain, which is crucial to link Jak with the receptor. Proteins 4.1 is a large family of proteins that link the membrane of the cell with the cytoskeleton. Jaks phosphorylate tyrosines (Y), which then act as docking sites for signal transducer and activator of transcription (STAT) 3 factors. On dimerization, STAT-3 is translocated to the nucleus, binding to DNA through its DNA-binding domain. STAT-3 is phosphorylated on serines by PKC- δ kinase. Phosphoinositide 3-kinase (PI3-K) is recruited on phosphorylated tyrosine 657. The other important signaling pathway involves activation of SHP-2 phosphatase, which interacts with Grb2-SOS adaptor proteins and leads to Ras activation and the ERK1/2-mitogenactivated protein kinase (MAPK) cascade. STAT-binding sites are in close proximity with binding sites of other transcription factors. MEK, mitogen-activated extracellular signal-regulated kinase; PIP, phosphatidylinositol phosphate.

Interleukin-6 in T- and B-cell Interaction and Myeloma

On T cells, IL6 acts as an activation, growth, and differentiation factor. It can replace co-stimulatory signals from APCs to stimulate IL2 secretion and T-cell proliferation (Table 14.4). IL6 is the most important growth factor for B cells (normal and malignant). It is a potent stimulator of terminal B-cell differentiation and antibody formation. The role of IL6 in multiple myeloma has been extensively studied.⁵⁵³ It is involved in proliferation of plasmablasts and differentiation into mature plasma cells, acting by an autocrine or paracrine mechanism. In addition to its proliferative activity, it blocks the apoptotic pathway (see the previous discussion). The gp130 protein is activated sometimes in the absence of direct ligand binding, i.e., independent of IL6R and IL6. IFN- α induces tyrosine phosphorylation of gp130 in myeloma cell lines that are responsive to IL6.⁵⁵⁴ The question is raised whether receptor cross-talk may be a common theme in the biology of multiple myeloma. The human herpes virus (HHV)-8 is associated with all forms of Kaposi sarcoma (KS) as well as primary effusion lymphoma. It is found in the lymph nodes of a high proportion of patients with multicentric Castleman disease, a polyclonal plasmacytosis that is characterized by hyperplastic lymphadenopathy.^{555,556} IL6 is present at elevated levels in KS and multicentric Castleman disease lesions, and IL6 promotes the growth of KS cells in culture. HHV-8 encodes a homolog of human IL-6 that is known as viral interleukin-6 (vIL6), which acts as a mitogenic factor and induces intracellular signaling that is generally the same as IL6. vIL6 induces receptor dimerization and forms complexes with IL6R and gp130.^{557,558} Signaling by vIL6 may be dependent or independent of the IL6RA.

TABLE 14.4 INTERLEUKIN-6 FUNCTIONS

Target	Function
B cells	Production of IgM, IgG, IgA Growth of plasma cells
T cells	Activation Growth Differentiation
Hematopoietic progenitors	Induce progression from G ₀ to G ₁ phase Enhance survival Stimulate proliferation Enhance megakaryopoiesis Macrophage differentiation
Hepatocytes	Acute-phase protein synthesis
Skin	Stimulates proliferation of keratinocytes
Blood vessels	Increase permeability
Neuronal cells	Proliferation of astrocytes

Survival of cholinergic neurons

Ig, immunoglobulin.

One of the most striking responses to injury and inflammation is the APR. APR consists of alterations in several serum proteins that are known as acute-phase proteins (APPs), which are synthesized mainly by the liver. The response involves more than 1,000-fold increases in C-reactive protein and serum amyloid A and moderate increases in fibrinogen, α -1 antitrypsin, complement factor B, and others. The biosynthesis of these proteins takes place in the liver and is regulated by a factor that was known as hepatocytes stimulating factor, which later was shown to be IL6. Several other cytokines, such as IL1, TNF- α , IL11, and TGF- β , are also capable of inducing APP from the liver. In addition to induction of APP, other systemic responses are associated with APR, such as fever and release of ACTH. These responses are also mediated through IL6.

IL6 has multiple other effects, such as bone remodeling, proliferation of keratinocytes, increase of endothelial cell permeability, and proliferation of astrocytes.

P.348

Interleukin-10 and Interleukin-10 Receptor

The search for a product of T_H2 cells that would inhibit proliferation, effector function, and even development of T_H1 cells resulted in the discovery of a factor that inhibited cytokine synthesis. This cytokine synthesis inhibitory factor was called IL10. It is produced by T_H2 clones and inhibits the synthesis of IFN- γ from the T_H1 clones.⁵⁵⁹

The primary structure of IL10 was determined from a complementary DNA that was isolated from T_H2 cells. It has four α helices and is expressed as a noncovalent dimer.⁵⁶⁰ The IL10 gene is located on chromosome 1. It expresses strong homology to an open reading frame in the Epstein-Barr virus genome.

In addition to T cells, IL10 is produced by macrophages in response to LPS, by B cells, especially after Epstein-Barr virus transformation,⁵⁶¹ and by keratinocytes, especially after exposure to ultraviolet light.

IL10 strongly stimulates proliferation of B cells, especially after cross-linking of CD40 by anti-CD40 antibody,⁵⁶² and this effect is synergistically enhanced by IL4. IL10 induces B-cell differentiation that is activated by anti-CD40 antibodies, with the production of large amounts of IgM, IgG, and IgA antibodies. This activity is antagonized by IL4 but is enhanced by TGF- β , especially for IgA secretion.⁵⁶³ In general, the effects of IL4 and IL10 on proliferation and differentiation of B cells account for much of the noncontact help that is provided during T-cell-B-cell interactions in antibody responses. As a suppressor cytokine of cell proliferation and cytokine response, IL10 plays an important role in tolerating exogenous antigens, especially in immunotherapy of allergy.⁵⁶⁴ It selectively inhibits the CD28-mediated co-stimulatory pathway and, as a result, inhibits T-cell responses that are initiated by engagement of a small number of TCRs, a situation that is critically dependent on CD28 co-stimulation. Blocking of CD28 co-stimulation depends on inhibition of CD28 tyrosine phosphorylation, which is the initial step in co-stimulation by CD28. IL10 regulates cyclo-oxygenase-2 expression and reduces production of prostaglandins that act directly on cyclo-oxygenase-2 expression or through regulation of inflammatory cytokines.⁵⁶⁵

IMMUNOGLOBULIN STRUCTURE

Antibodies are Igs that are produced by B cells in response to foreign antigens; therefore, they have the property of binding specifically to the antigen that triggered their production. Igs constitute the fraction of plasma proteins, originally defined as γ -globulins, because they were located behind the α - and β -globulins, as a result of their slow electrophoretic mobility. When it was shown that these γ -globulins are products of cells of the immune system, they were given the name immunoglobulins.

Antibodies have two fundamental properties for defense against pathogens: they bind specifically to the antigen that is responsible for their induction by one part of their molecule and then dispose the captured antigen with the cooperation of other molecules (complement) or cells (phagocytes) of the immune system.

Primary Structure: One Polypeptide from Two Genes

One of the most revolutionary hypotheses in the recent history of molecular biology was proposed for the structure of the antibody molecule: the Ig molecule is encoded by two different sets of genes.⁵⁶⁶ The C-terminal region is encoded by one gene that is selected from a small group of genes, whereas the N-terminal region is encoded by two or three genes that

are selected from a large number (hundreds) of genes. The Ig molecule consists of two short or light (L) chains and two long or heavy (H) chains, which are held together by disulfide bonds.

The two L chains are of equal length, each consisting of 214 amino acids. The H chains vary in length; the shortest is the γ 1 chain, which is made of 446 amino acids, and the longest is the μ chain, which is made of 567 amino acids. A striking feature of the primary structure of H and L chains is the considerable variation at the N-terminal end of the chains, compared to a significant degree of homology at the C-terminal end. The former region is known as the variable or V region and the latter as the constant or C region. In L chains, the V region of the light chain (V_L) constitutes one half of the chain (amino acids 1 to 107), and the remaining part of the chain is the constant (C_L) region of the light chain. The L chains are encoded by a V and a J allele (N-terminal half) and a C allele (C-terminal half). For L chains, the V allele contributes amino acids 1 to 95, and the J allele contributes the remaining 13 amino acids. The V region of the H chains is encoded by three alleles, V_H , J_H , and D (see Chapter 12). For the V_H region, the V_H allele encodes amino acids 1 to 94, and the remaining amino acids are encoded by the D_H and J_H genes. The rest of the chain is divided into three constant regions, C_{H1} , C_{H2} , and C_{H3} , for IgG, IgA, and IgD, and four constant regions for IgM and IgE.

Within the V regions are three short stretches of amino acid sequences that show extreme variability and are therefore known as hypervariable regions. Hypervariable regions contain amino acids that are in contact with the antigen, and, in the primary structure of the molecule, these regions are separated by long stretches of less variable amino acid sequences. However, these hypervariable regions are in close proximity to each other when the molecule assumes its functional tertiary structure. Amino acid sequences that are not part of the hypervariable regions form the framework regions and constitute 80% of the V region.

Secondary Structure: Immunoglobulin Fold

Results from crystallographic studies confirm that the Ig polypeptide chain is folded back and forth on itself in opposite directions (antiparallel), forming a sheet, which is known as the β -pleated sheet, and is arranged as a sandwich (or β barrel), with a hydrophobic center. This is known as the Ig fold (Fig. 14.19). Each strand bends in a hairpin fashion when it changes direction. Almost all bends contain a Gly that is highly conserved.

Tertiary Structure: Immunoglobulin Domain

The intrachain disulfide bonds divide each chain into globular structures of approximately 100 to 110 amino acids that are known as domains. The IgG molecule has four V-region domains, one C_L per L chain and three C_H per H chain. Considerable homology exists among the V domains and among all the C domains. The degree of homology suggests that domains originated from one primordial gene and evolved independently rather than as a group comprising a single H chain. Each Fab fragment (see the following discussion) has four domains: the V_L and V_H interact to form the V module, and the C_L and C_{H1} interact to form the C module. Each domain is made of two β -pleated sheets (x and y), one consisting of three, the other of four, antiparallel strands that are labeled A through G. In each of the two V domains, there are two additional strands that are called C' and C'' . The sheets are held together by one li disulfide bond and by interactions between the strands A-B-E and D for the C modules and C-C-F and G for the V module. The hypervariable regions correspond to the hairpin loops that link the strands as they turn around to run in the opposite direction, which are called complementarity-determining regions (CDRs) (Fig. 14.19). Each V domain has three CDRs, for a total of six in the V module. They are known, in sequence order along the polypeptide chain, as L1, L2, and L3 for the V_L domain, and H1, H2, and H3 for the V_H domain. The length of each CDR varies considerably, both as a function of usage of the V allele, mainly affecting CDR1 and -2, and as a consequence of junctional diversity, i.e., additions of amino acids during V(D)J recombination that affect the CDR3 (see Chapter 12). All six CDRs contribute to the formation of each combining site. Because of their positioning in the free end of the

P.349

V module, they are endowed with some mobility, which may be important for binding with the antigen. In the Fab fragment, they form a cavity that is 15 Å long, 6 Å wide, and 6 Å deep. The strands correspond to conserved sequences that are known as framework (FR) sequences. Each V domain has four conserved FR sequences, FR1 through FR4. The Ig fold is not unique to the Ig molecule but is also found in other molecules, such as the $\alpha\beta$ and $\gamma\delta$ TCRs; the class I and class II MHC molecules; the CD2, CD3, CD4, and CD8; and the β_{2m} , which represents a free domain. Several other proteins have Ig-like domains that form the Ig superfamily.

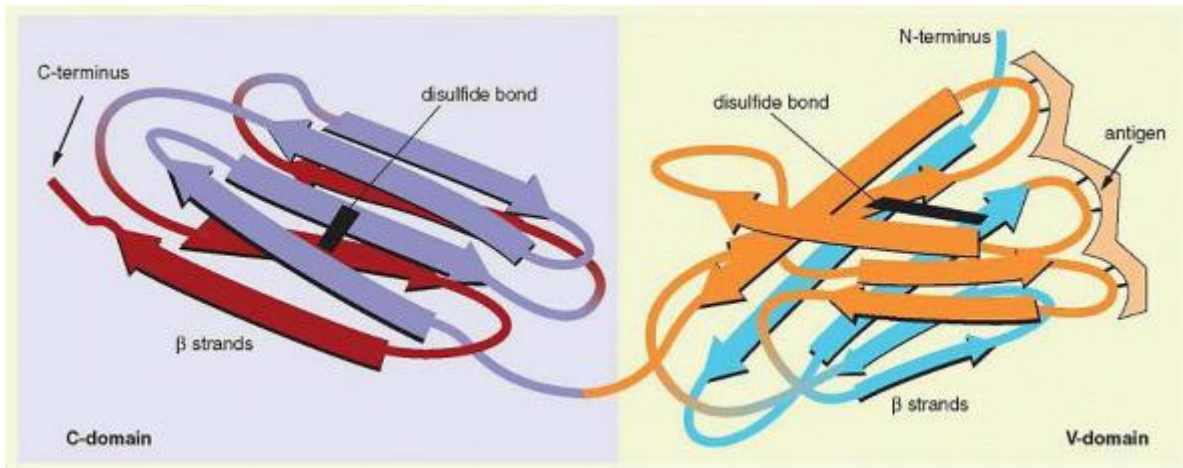

FIGURE 14.19. Tertiary structure of a light chain that depicts the variable (V) and constant (C) domains. Each domain is composed of two sheets that are formed by strands of polypeptide chains that possess the basic β -pleated structure. In each sheet, the strands run in alternating directions (antiparallel). The strands are shown as broad arrows, pointing in an N-terminal-to-C-terminal direction. The strands that belong to the same sheet are blank or hatched. Stretches of polypeptide chains that connect the strands form loops. Three of these loops in the V domain include the complementarity-determining regions (CDR), which are involved in antigen binding. The strands are identified by letters, A to G, starting from the N-terminal end. The V domain contains two additional strands C' and C'' (which are not shown in the diagram as broad arrows). Interactions between the VL and VH sheets contribute to the formation of a cylindrical V module that contains the antigen combining site. The black bars represent the disulfide bonds.

Quaternary Structure: Immunoglobulin Monomer

The Ig molecule consists of four polypeptide chains, which are held together by disulfide bonds and noncovalent interactions⁵⁶⁷ (Fig. 14.20). Two of the chains have a molecular weight of 53 kDa (IgG) or 75 kDa (IgM) and are known as H chains. The other two chains have a molecular weight of 22.5 kDa and are known as L chains. The former determine the major Ig class of the molecule: IgG, IgM, IgA, IgD, and IgE. The respective H chains are designated by Greek letters: γ (IgG), μ (IgM), α (IgA), δ (IgD), and ϵ (IgE). Within each class are subclasses: four for IgG (1, 2, 3, and 4), two for IgM, and two for IgA. The H chains are distinguished by isotypes to identify antigenic determinants that are shared by all individuals of a given species. Humans have 10 loci for constant region genes and, therefore, 10 isotypes that correspond to the total number of what otherwise are known as subclasses: $\mu 1$, $\mu 2$, δ , $\gamma 1$, $\gamma 2$, $\gamma 3$, $\gamma 4$, $\alpha 1$, $\alpha 2$, and ϵ . There are only two types of L chains, kappa (κ) and lambda (λ). The L chains of the λ type exist in four isotypes ($\lambda 1$, $\lambda 2$, $\lambda 3$, and $\lambda 4$). Any given Ig molecule has two κ chains or two λ chains but never one of each type. The κ -to- λ ratio varies between species: in humans it is 70:30, whereas in the mouse it is 95:5.

The hinge region is located between C_{H2} and C_{H3} and is rich in proline residues. Cysteines form the inter-heavy chain disulfide bonds. Because of its unique amino acid sequence, this region does not fold well and thus becomes susceptible to enzymatic attack. The hinge region also affects the flexibility of the molecule and other properties, such as complement binding. IgM and IgE have no hinge region but instead have an extra C domain.

Disulfide bonds are important because they maintain the association of the four chains and divide the Ig molecule into functional domains. The H and L chains are held together by interchain disulfide bonds. Each L chain is attached to the H chain by one disulfide bond, with the exception of human IgA2, which contains no disulfide bond between H and L chains. The disulfide bond is formed between C-terminal cysteine of the κ chain or the penultimate cysteine in the λ chain and the cysteine that is closest to the middle of the H chain.

The two half-molecules are held together by interchain disulfide bonds between the two H chains. The number of these bonds varies among classes: the IgG1 molecule has two, whereas IgG3 possesses 15. Disulfide bonds exist within each chain (intrachain). All L chains have two bonds, and all γ and α chains have four bonds; μ , δ , and ϵ chains have five bonds. Because the cysteines that form the intrachain bonds are separated by 40, or even 70, amino acids, the bond can be formed only if the two cysteines are brought into apposition by looping the intervening sequence. The regularity of the distribution of the intrachain disulfide bonds formed the basis of the domain hypothesis, in which the Ig molecule is separated into distinct functional regions.⁵⁶⁸

Carbohydrate Moiety

Carbohydrate chains are of variable length and shape. The number of these chains varies among isotypes: 2 in IgG molecules, 10 in IgM molecules, 16 in IgA molecules, and 12 in IgE molecules. The carbohydrate chains are attached to the C_{H2} domain, forming a bond between the first carbon of asparagines and the sugar N-acetylglucosamine (GlcNAc). Procedures that interfere with the glycosylation of the α and ε chains prevent the secretion of IgA and IgE molecules.

Enzymatic Fragments

Treatment of the Ig molecule with papain generates three fragments. Two of these fragments are identical; each contains one antigen-binding site and thus they are known as Fab (fragment antigen binding).⁵⁶⁹ The third piece, which is known as Fc (fragment crystallizable), mediates fixation of Ig molecules to skin and other cells (macrophages and lymphocytes), fixes complement,

P.350

and mediates transport of the Ig molecule across the placenta. Digestion of the Ig molecule with pepsin yields one large piece, with a molecular weight of 100 kDa. This divalent fragment, which is known as F(ab)₂, consists of two Fab fragments, each capable of binding antigen. The Fc fragment is digested by pepsin into small peptides (Fig. 14.21).

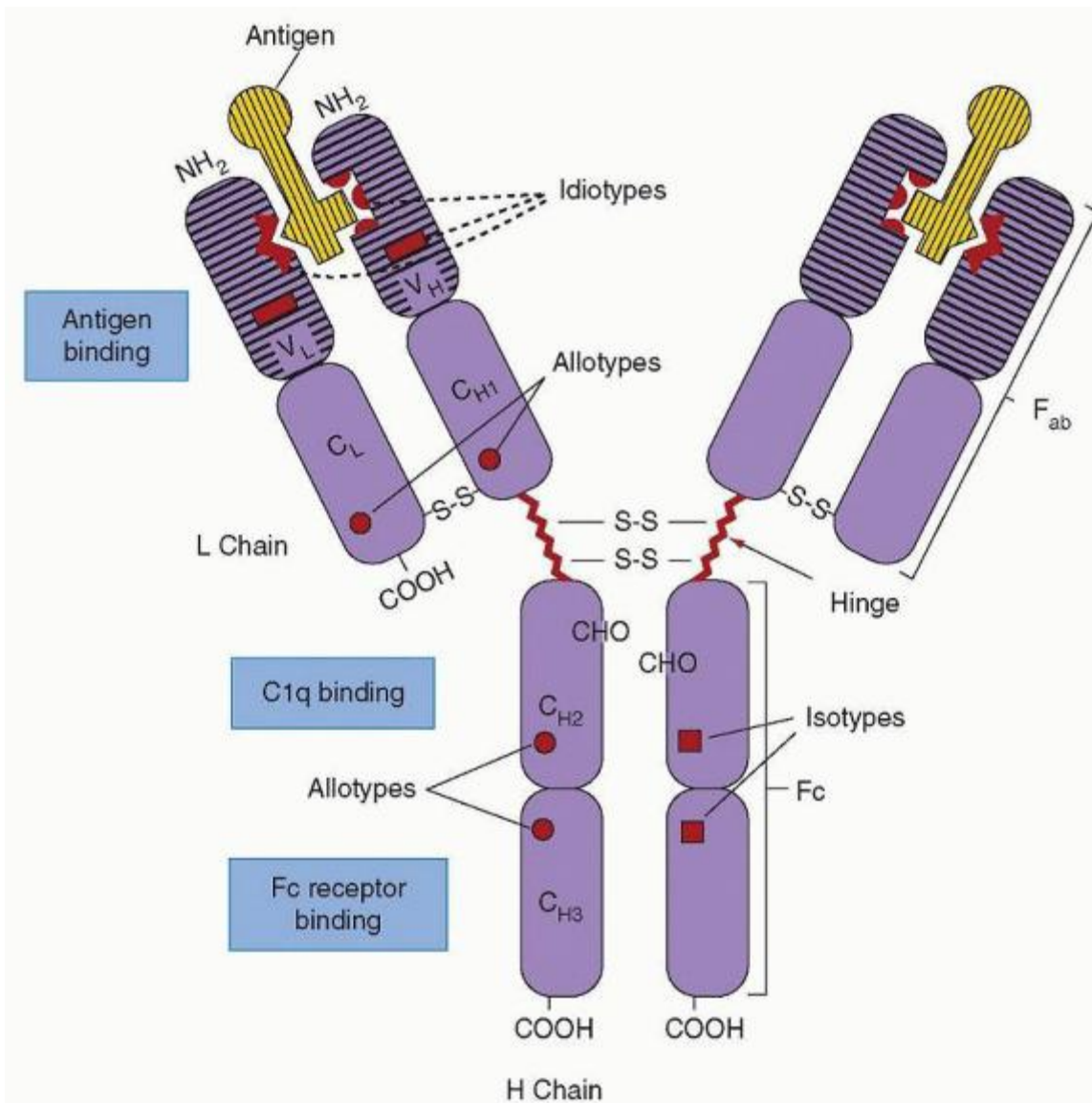

FIGURE 14.20. Basic arrangement of the polypeptide chains, the enzymatic fragments, and their domain structure of the immunoglobulin G molecule. Locations for structures that are defined as idiotypes, allotypes, and isotypes are shown, as

well as the position of the carbohydrate (CHO). Various domains are shown on the left side.

Combining Site

The antigen-combining site is located near the tip of the two arms on the Y-shaped Ig molecule.^{570,571} The size of the combining site was determined initially by Kabat, using antidextran antibodies that reacted with oligosaccharides of different lengths. Maximal inhibition of the binding was obtained with an oligosaccharide that consisted of six isomaltohexose molecules. The structure of the combining site has also been studied by means of affinity labeling. With this technique, the hapten is linked to a chemical group that interacts with the amino acids that are closest to those that form the combining site. This method helped demonstrate that H and L chains participate in the formation of the combining site. The antigen-binding V module may be viewed as a stable, packed FR structure with six superimposed flexible CDRs. Molecular biologists have now constructed hybrid genes that combine FR and CDR from different Igs. Upon transfection to lymphoid cell lines, these genes produced antibodies with the specificity of the CDR donor.⁵⁷²

Idiotypes and Allotypes

Antibodies and myeloma proteins possess determinants that are characteristic for each antibody or myeloma protein and are known as individually specific antigenic determinants or idiotypes. Idiotypes can be detected by means of antisera. Some anti-idiotypic antibodies detect determinants that are restricted to a single Ig (individual, or private, IdI), and other antibodies detect determinants that are present in antibodies or myeloma proteins other than those that are used for immunization (public, or cross-reactive, IdX). Idiotypic determinants, which are known as idiotopes, have also been classified according to their location in relation to the combining site: α -idiotopes are located outside of the combining site; β -idiotopes are close to the site, so that the binding of the anti-idiotypic antibody interferes with the binding of the antigen; and γ -idiotopes are formed by the site itself.⁵⁷³

In addition to CDR, the idiotope-determining region (IDR) can be defined, not on the basis of amino acid sequence variability, but as a surface-variable structure that is complementary to a structure on the V region of another Ig molecule. Although all CDRs are also IDRs, the partial overlap between these two kinds of regions suggests that IDRs outnumber CDRs.⁵⁷³ IDRs, therefore, are functionally involved in antigen recognition, as well as in recognizing and being recognized by other Ig molecules. This functional attribute of IDR is central to the network theory of immune regulation of Jerne.^{574,575}

Allotypes are allelic variants of Ig polypeptide chains that segregate in Mendelian fashion in outbred populations. Allotypes that vary by one or a few amino acids are simple allotypes, whereas those that are characterized by greater differences are complex allotypes. In humans, Ig allotypes have been well characterized for all subclasses of the IgG (γ) H chains (Gm allotypes), for IgA (α) H chains (Am allotypes), and for the κ chains (Km allotypes). The H chain allotypes of different H chain isotypes are inherited together as a group, which is sometimes referred to as a haplotype.⁵⁷⁶

IMMUNOGLOBULIN FUNCTION

Immunoglobulin G

IgG is the major Ig in humans and constitutes approximately three fourths of the total Ig (Table 14.5). The serum concentration varies from 8 to 16 g/L in adults, but the intravascular pool accounts for less than one half the total body IgG; approximately 55% is found

P.351

widely distributed within the extravascular space. The total body content is in excess of 1 g/kg of body weight. IgG molecules have a half-life of 21 days and therefore have the longest lifespan.

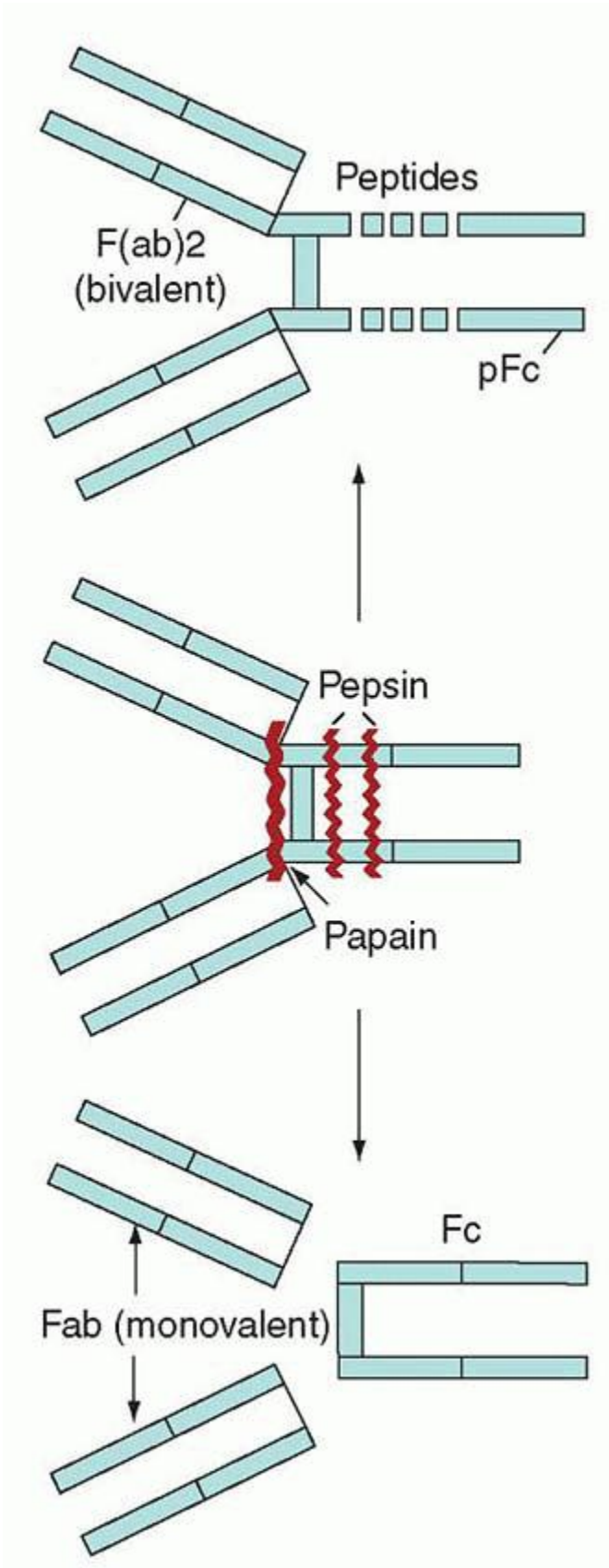

FIGURE 14.21. Proteolytic fragmentation of the immunoglobulin G molecule by papain and pepsin. Papain hydrolyzes the molecule to the N-terminal side of the interchain disulfide bonds and releases three fragments of approximately equal

size, two Fab and one Fc. Pepsin acts on the C-terminal side of the disulfide bonds and forms one large divalent fragment (F[ab']₂); the Fc is fragmented to small peptides and one larger fragment known as pFc'.

The four isotypic subclasses of IgG molecules are distributed as follows: IgG1, 66%; IgG2, 23%; IgG3, 7%; and IgG4, 4%. These antigenic differences are the result of variations in amino acid sequences of the carboxy-terminal parts of the γ chains. All four types of molecules are found in any given normal serum, but individual molecules contain only a single type of γ chain. The IgG subclasses carry numbers of disulfide bonds that are arranged in different ways. The hinge region is also strikingly different among the subclasses; the longest is in IgG3 and supports certain functions of the Fc fragment.

Biologic Properties

Most of the antibodies that are found in secondary antibody responses to antigen are IgGs. IgG is selectively transferred across the placenta, thereby giving a measure of protection to the newborn⁵⁷⁷ (Table 14.5).

Some biologic properties of IgG proteins, and particularly those that are mediated by the Fc fragment, are distinctly subclass-specific. IgG1 and IgG3 react most readily with C1q, the first component of complement, and therefore activate complement most efficiently. IgG2 is less reactive, and intact IgG4 proteins are completely unreactive. The binding of Fc to macrophage and granulocyte Fc receptors is most efficient with IgG1 and IgG3, and this reaction is important in the process of opsonization. Anti-Ig antibodies (rheumatoid factors) react most readily with IgG1, IgG2, and IgG4 proteins and not at all with IgG3 proteins. IgG3, on the other hand, has a tendency to aggregate,⁵⁷⁸ a property that probably is also responsible for the affinity of the molecule for C1q. Aggregation of IgG3 may lead to clinically significant hyperviscosity states, especially in patients with IgG3 myeloma. In addition, IgG3 is selectively retained in the sera of some patients who have generalized hypogammaglobulinemia.

TABLE 14.5 PROPERTIES OF IMMUNOGLOBULINS

Properties	IgM	IgG	IgA	IgD	IgE
Subclasses	2	4	2	—	—
Molecular weight (kDa)	950	150	150 to 300	185	190
Heavy chain	μ	γ	α	δ	ϵ
Light chain	κ, λ	κ, λ	κ, λ	κ, λ	κ, λ
Percent carbohydrates	10-12	4	10	12	12
Survival ($t_{1/2}$ days)	5	21	6	3	
Complement fixation					
Classical	+++	+	-	-	-
Alternative	-	-	+	+	+
Cross placenta	-	+	-	-	-
External secretions	+	+	+++	-	+
Cytophilic for:					
Macrophages	\pm	+++	-	-	-
Mast cells	-	\pm	-	-	+++
Serum concentration (g/L)	1.5	11.0	2.4	0.03	<0.005
Percent of total Ig	5	80	15	-	-

Ig, immunoglobulin; +, weak; +++, strong; -, negative; \pm , borderline.

Some antibody activities are subclass-specific. Thus, anti-Rh antibodies are usually IgG1 or IgG3; antifactor VIII antibodies are often restricted to IgG4, and other antibodies, such as antidextran and antilevan, have been found to be IgG2.

Immunoglobulin A

The IgA class of antibodies can be divided into two separate systems of Ig.⁵⁷⁹ One system, IgA1, provides IgA antibodies for the circulation and the internal secretions, such as the aqueous humor of the eye, the cerebrospinal fluid, and the synovial, amniotic, pleural, and peritoneal fluids. These IgA antibodies probably are synthesized by nonmucosal lymphoid tissues. The other system, IgA2, is found in external secretions, such as saliva, tears, bile, and colostrum, as well as secretions of the respiratory tract, the gastrointestinal tract, the seminal vesicles, the cervix, and the urinary tract. The IgA of external secretions is, for the most part, not derived from the blood but is produced locally by plasma cells that are situated in proximity to the epithelial mucosa. It is the predominant Ig in external secretions, although smaller amounts of IgM and IgG also may be found.

In the serum, 85% of IgA molecules are monomers, with a molecular weight of 170 kDa and a sedimentation coefficient of 7S; 9S, 11S, and 13S polymers make up the remainder. Approximately 1% is secretory IgA (sIgA); this percentage increases in association with a variety of mucosal inflammatory diseases. The serum concentration of IgA is in the range of 2 to 3 g/L, with a half-life of 6 days. Monomeric IgA is composed of two H (α) and two L chains. The α chains of IgA1 and IgA2 subclasses are strikingly different in the hinge region. Certain bacterial proteases cleave IgA1, but not IgA2, into Fab and Fc fragments. These IgA1 proteases are

P.352

exquisitely specific. In the IgA2 subclass, the H and L chains are not held together by a disulfide bond.

sIgA is a large molecule with a molecular weight of 390 to 400 kDa. It consists of two IgA molecules that form a dimer and two additional non-Ig components, which are known as the J chain and the secretory component (SC).⁵⁸⁰ The J chain joins two IgA molecules through a disulfide bond to form a dimer, whereas the SC is the extracellular part of the polymeric Ig receptor (pIgR), which remains attached to IgA after trans-epithelial crossing (Fig. 14.22).⁵⁸¹ The epithelial cells in the glands and basolateral crypts of the gastrointestinal and upper respiratory tracts produce the full-length (100-kDa) pIgR located in the nonserosal surface of the epithelial cells. It consists of five V-type Ig-like domains in the extracellular region, a transmembrane, and a 103-amino acid intracellular region. Binding of polymeric IgA (pIgA) to the first extracellular domain of the pIgR is followed by endocytosis and transcytosis across the epithelial cell.⁵⁸² The initial step is through clathrin-coated pits and requires two cytoplasmic tyrosines of pIgR and phosphorylation of serine 726. The endocytosed complex is delivered first to RAB⁺ basolateral early endosomes and then on to RAB17⁺ common recycling endosome. In this compartment, the complex is sorted and directed to the apical plasma membrane.

The IgA dimer is released on the luminal side of the epithelial cell, with the extracellular portion of the pIgR (i.e., the SC) still attached, forming the sIgA.^{583,584} During transcytosis, disulfide bonds form between pIgR and pIgA. The J chain is essential for the transport of IgA, and expression of the J chain by plasma cells is particularly critical for the overall function of sIgA in mucosal surfaces.⁵⁸⁵ A disulfide bond between the J chain and the IgA monomer is sufficient for IgA dimerization. IgA polymers are also formed that retain high affinity for free SC. The SC protects the IgA from intracellular digestion by proteolytic enzymes. The SC is more efficient than IgR in providing protection because, as a result of its carbohydrates, it is able to anchor the sIgA to mucus within infected areas, in contrast to the random distribution of pIgR. Furthermore, pIgR can be used by some bacteria (e.g., *Streptococcus pneumoniae*) to gain access to the transcytosis pathway. The IgA transport system is unique in that, in contrast to other pathways, it does not lead to degradation of its ligand, the IgA molecule. The IgA and the asialo glycoprotein transport of hepatocytes occupy the same compartment inside the cell, yet each follows distinct pathways subsequently.

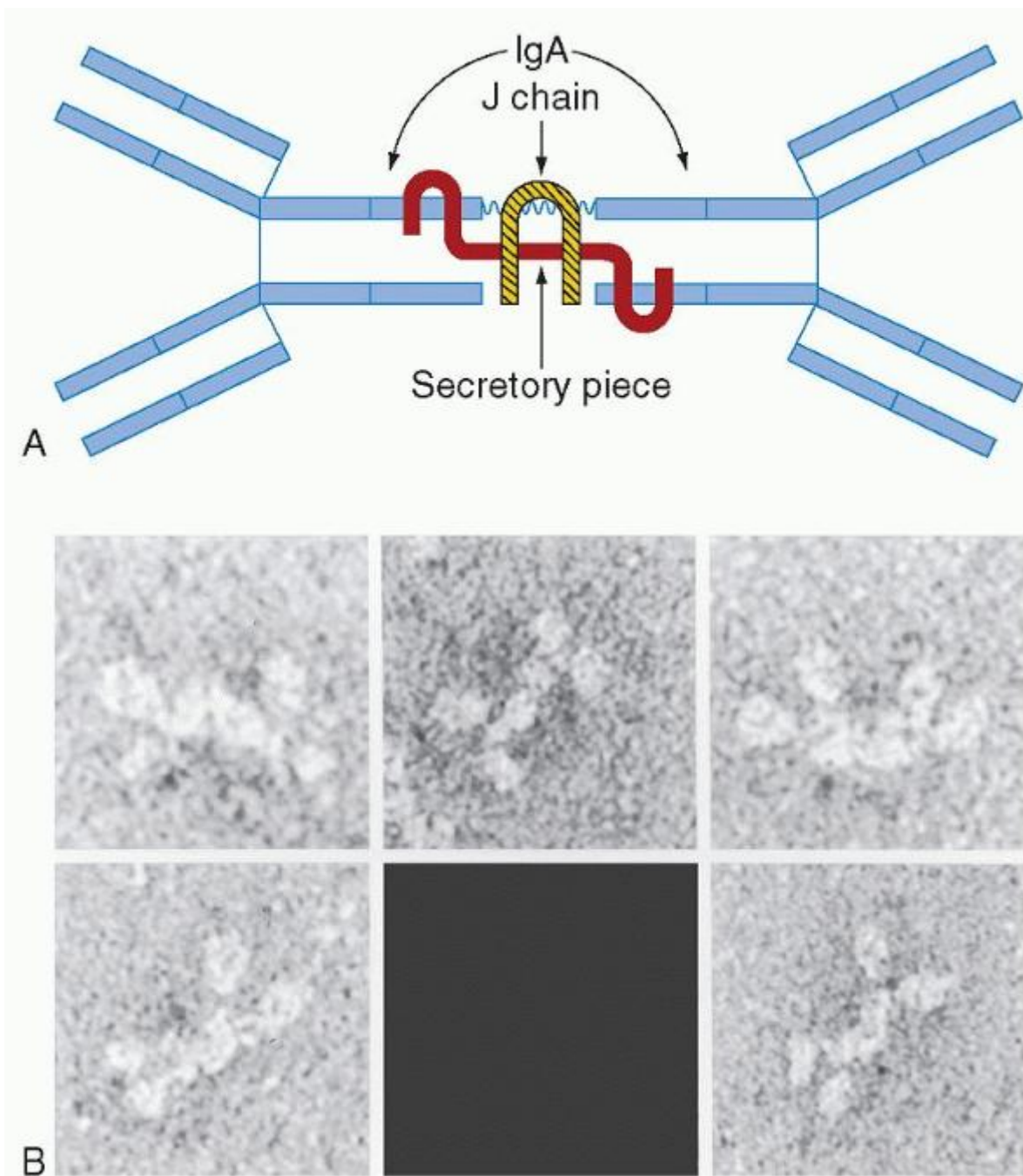

FIGURE 14.22. A: Dimer of immunoglobulin A (IgA). The J chain is linked through disulfide bonds with the C α 3 domains of the monomers. The secretory piece attaches through disulfide bonds to the Fc fragments of the monomers. B: IgA dimers. (Courtesy of Dr. K. H. Roux.)

Biologic Properties

Although IgA is incapable of fixing complement or acting as an opsonin, the sIgA molecule, together with complement and lysozyme, is capable of killing *Escherichia coli*. IgA does not activate complement, except in its aggregated form and even then it activates complement only through the alternate pathway. Like other Igs, sIgA is capable of blocking bacterial adherence to mucosal surfaces, thereby preventing colonization. It may also act as a blocking antibody to reagenic reactions on mucosal surfaces and may prevent the absorption of antigenic molecules from the lumen of the gut.

Surprisingly, most IgA-deficient individuals appear to be fairly healthy and not overly susceptible to upper respiratory tract infections. IgA antibodies against intrinsic factor have been reported in the gastric secretions of patients with pernicious anemia. It has been proposed that IgA may serve as a carrier of antigens from the blood to the mucosal sites, providing an

explanation of how antigens find their way into external secretions through the SC transport system. Perhaps the mucosal synthesis of IgA makes it particularly suitable for removal of dietary and microbial antigens that are absorbed from the gut. More recently, receptors for the Fc portion of IgA were identified on peripheral and alveolar macrophages, lymphocytes, and neutrophils.⁵⁸⁶ Through such receptors, IgA participates in antibody-dependent, cell-mediated cytotoxicity reactions.

Immunoglobulin M

IgM antibodies are proteins with a molecular weight of 850 kDa that sediment predominantly at 18S to 19S but also at 22S, 26S, and 35S (Table 14.5). Because of their size, IgM molecules are referred to as macroglobulins. Their rate of synthesis is only 1/20 of that of IgG, whereas their fractional catabolic rate is two to three times that of IgG, which accounts for the relatively short survival (half-life of 5 days) and low serum levels (0.8 to 3.0 g/L) of IgM.

IgM macromolecules are composed of five identical subunits called IgM monomers, each of which consists of two μ (H) chains and two L chains (Fig. 14.23A). The L chains may be κ or λ and are identical to those of other Ig. The H chains, on the other hand, have some unique structural features. Whereas human γ chains vary in length from 446 to 450 amino acid residues, μ chains contain in excess of 500 residues and have a correspondingly higher molecular weight of approximately 70 kDa. In addition, μ chains appear to consist of a variable region and four constant regions, in contrast to the three constant regions of γ chains. Similar to γ chains, however, each region (constant and variable) contains a loop of approximately 60 amino acids with an internal disulfide bridge that is flanked on either side by approximately 20 amino acids. Carbohydrates account for 10.7% of the molecule by weight and are distributed over five sites within the constant region: one within the Fd region, one in the hinge region, two within Fc, and one near the COOH terminus. They affect the conformation and other properties of the molecule but do not contribute directly to antibody specificity. Two subclasses of IgM (IgM1 and IgM2) have been identified on the basis of antigenic differences within the μ chain.

In the intact IgM molecule, five monomers are assembled in a star-shaped configuration, with the carboxy terminal (Fc pieces) being joined at the center through disulfide bonds, whereas the antigen-binding sites (Fab pieces) extend toward the periphery.

P.353

The molecule appears to have a great deal of rotational freedom, and, although it is bound to particulate antigen, it may take on the appearance of a staple or a spider (Fig. 14.23B), with its legs (Fab pieces) extending toward the plane of the antigen (a cell surface) and its body consisting of closely linked Fc fragments that protrude from the center, thus making it ideally suited for complement fixation (Fig. 14.24).

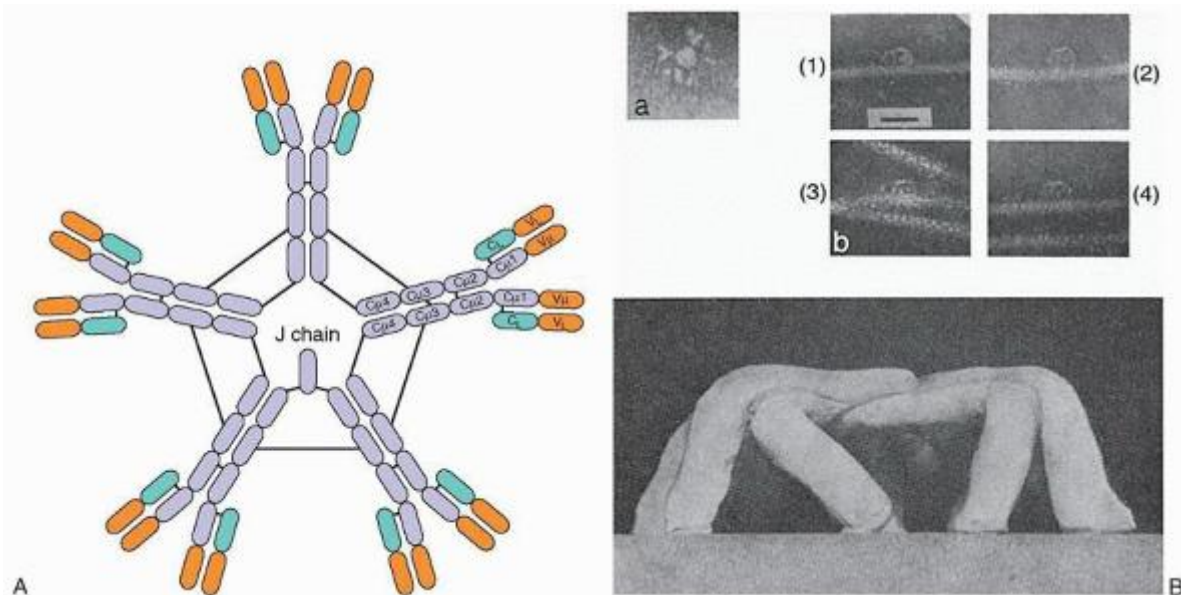

FIGURE 14.23. A: Immunoglobulin M (IgM) pentameric molecule. The IgM molecule is composed of five subunits that are held together through disulfide bonds. In the polymerization of the subunits, the J chain is involved. (From Roitt IM, Brostoff J, Male DK. Immunology, 2nd ed. St. Louis: Mosby, 1989, with permission.) B: By electron microscopy, the IgM

molecule appears star-shaped (a). When it is bound to antigen, such as the flagellum of *Salmonella*, it assumes the crab or staple form (b: 1-4), a model of which is shown in c. (From Feinstein A, Munn EA. Conformation of the free and antigen-bound IgM antibody molecules. *Nature* 1969;224:1307-1309, with permission.)

Because the IgM molecule consists of five subunits, each with two antigen-combining sites, there are 10 combining sites per IgM pentamer. A single J chain has been found attached to the IgM pentamer by disulfide bridges. IgM monomers do not have J chains.

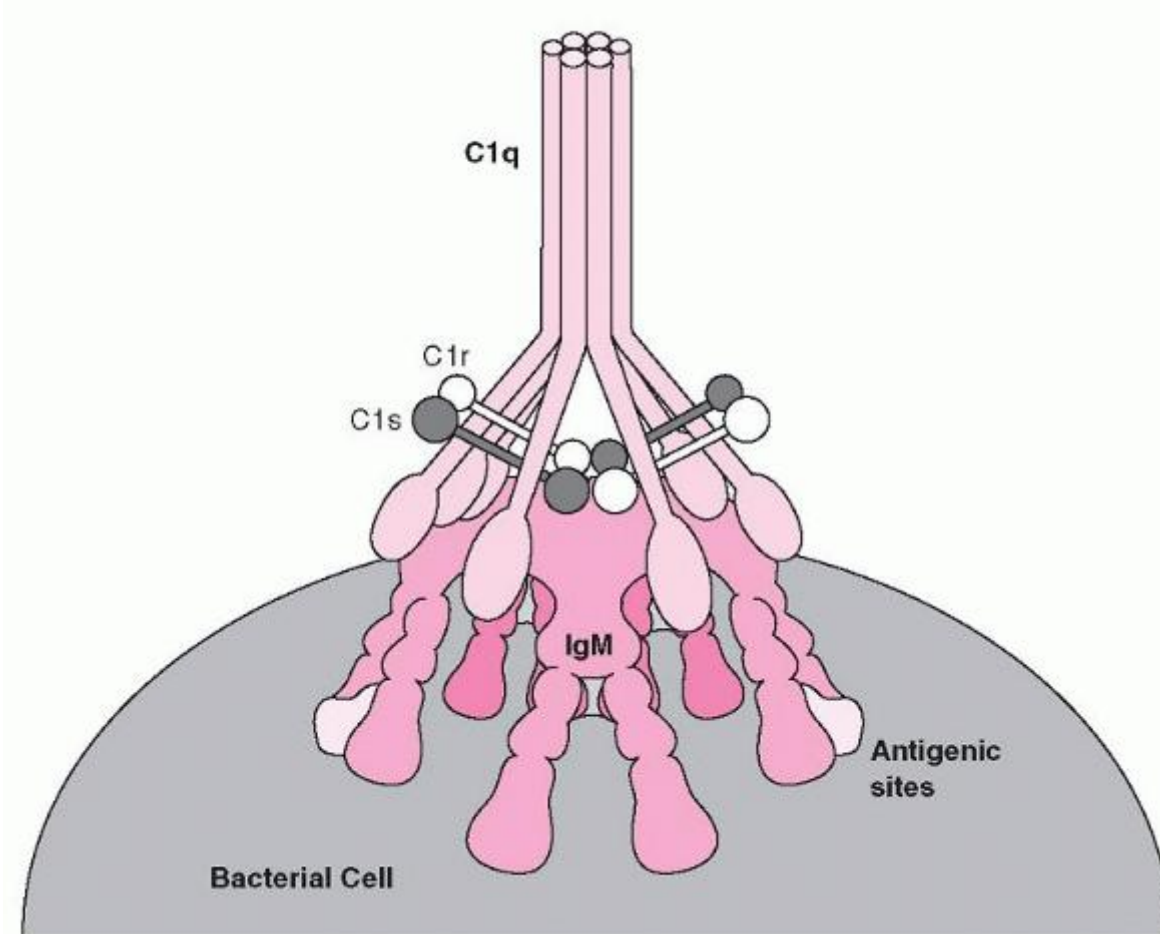

FIGURE 14.24. Immunoglobulin M (IgM)-C1 esterase interaction. On the surface of pathogens, IgM assumes the staple (as seen sideways) or crab conformation. Whereas the Fabs touch the surface of a pathogen, or immune complexes deposited on tissues, the Fc fragments form a plateau on which C1q finds space to touch down with the heads of the arms. The C1r-C1s tetramer weaves between the arms as a necklace. Recognition of patterns by C1q creates a conformational shakeup, which is transmitted to the catalytic domains of C1r, which is activated. In turn, C1r activates the C1s, which performs the esterase functions of the whole complex, C1 esterase.

Biologic Properties

Macroglobulins are restricted mostly to the intravascular pool. Little if any IgM crosses the placental barrier, and the amount that is present at birth is almost entirely of fetal origin. Detectable levels of IgM may be synthesized by the human fetus by as early as the 20th week of gestation, but high levels of IgM at birth usually are indicative of intrauterine sepsis.

On cell surfaces, a single molecule of IgM readily fixes complement, whereas antibody doublets are required for fixation of complement by IgG. IgG is efficient at 4°C and 37°C, however, whereas IgM is inefficient at the lower temperature. Binding of C1q to IgM has been assigned to both C μ 3 and C μ 4 domains. Mutations that involve a single amino acid in the C μ 3 domain abolishes complement fixation.

Specific macrophage receptor sites for the Fc region of IgM have been described in animal systems. Such receptors may play a critical role in the process of phagocytosis of immune complexes.

IgM antibodies are the first to be produced in a primary immune response, to be replaced subsequently by IgG antibodies. However, certain types of antibody responses remain mostly IgM, including those against LPS and the heterophil (Forssman) antigens. Wassermann antibodies, isohemagglutinins, cold agglutinins, and antibodies to the O antigens of Gram-negative bacteria are usually IgM.

Immunoglobulin M Monomer

IgM monomer (7S IgM) is the predominant Ig on the B-cell surface. Naturally occurring 7S to 8S IgM monomers also have been identified in normal sera, and higher concentrations of monomers occur in association with various diseases, including SLE, Waldenström macroglobulinemia and other hypergammaglobulinemic states, congenital rubella, and immune deficiency disorders, such as ataxia telangiectasia and dysgammaglobulinemia. In some

P.354

instances, IgM monomers possess antibody activity against blood-group substances or cell nuclei (antinuclear factors). IgM monomers may be related to more primitive Ig and appear to be synthesized as such, rather than to represent an in vivo or in vitro breakdown product of IgM.

Immunoglobulin D

IgD is found in low concentration (3 to 400 mg/L) in normal serum. It consists of two H (δ) chains and two L (κ or λ) chains, has a molecular weight of 180 kDa, and sediments at 7S. It appears to be catabolized rapidly (half-life 2.8 days), is confined largely to the intravascular space, and does not cross the placental barrier. The IgD has three constant region domains and an unusual hinge region, which is strikingly different from the hinge regions of other Ig. It is longer than the γ_1 , γ_2 , and α_2 hinges and has a highly charged C-terminal half. Its unusual structure makes it extremely susceptible to proteolytic cleavage. IgD is a major surface Ig of peripheral blood lymphocytes.

IgD plays an important role as antigen receptor in B-cell activation. It is expressed during certain periods of B-cell differentiation. IgD may function as an antigen receptor that is capable of triggering antibody production, whereas binding of antigen to IgM leads to tolerance. Both receptors, however, are capable of inducing proliferation and differentiation of B lymphocytes.

Immunoglobulin E

Reaginic antibodies, which mediate acute and sometimes lifethreatening allergic reactions in atopic patients, belong to this distinct class of Igs.^{586a} IgE molecules also have two H (ϵ) chains and two L chains. They have a molecular weight of 200 kDa and a sedimentation coefficient of 8.2S, and they contain 12% carbohydrate. The ϵ chains are approximately the same size as the μ chains, with four constant region domains totaling approximately 550 amino acids. Each molecule has 15 half-cysteines, eight of which form intrachain disulfide bonds within the four constant domains. The formation of two interchain H-H bonds between two noncomplementary regions, that is, between C ϵ 1 and C ϵ 2 and between C ϵ 2 and C ϵ 3, is unique to ϵ chains. Carbohydrates are found throughout the chains. All six oligosaccharide units are N linked to Asn. The survival of IgE molecules in the serum is shorter than that of any other Ig (half-life 2.4 days), and their serum concentration is in the range of 0.1 to 0.7 mg/L, with a mean of 0.3 mg/L. Higher concentrations may be found in the sera of patients who have asthma, hay fever, eczema, Wiskott-Aldrich syndrome, and helminthic infestations. IgE-forming plasma cells are found most commonly in the respiratory, gastric, and intestinal mucosa and in the regional lymph nodes, but a few are noted in the spleen and in other lymph nodes. Thus, IgE, like IgA, is classified as an slg.

Biologic Properties

IgE antibodies are capable of sensitizing basophils and mast cells. The Fc portion of the IgE molecule fits into specific receptor sites on the cell surface. When bivalent or multivalent antigens bind at least two adjacent IgE molecules, the mast cell or basophil is triggered to degranulate, thereby releasing vasoactive substances, especially histamine and slow-reacting anaphylaxis substances, which are responsible for such clinical manifestations as wheal-and-flare reactions, bronchospasm, small-vessel dilation, and shock. Reduction of the disulfide bonds destroys the ability of the molecule to bind to the Fc receptor, and heating of the IgE at 56°C inactivates its cytotropic activity. This inactivation is associated with loss of antigenic determinants in the C ϵ 3 and C ϵ 4 domains, suggesting that these regions are important for binding to the receptor.

J Chain

The J (joining) chain has been detected in association with polymeric forms of serum and slgA, as well as with the IgM pentamer.⁵⁸⁰ This chain has a molecular weight of 15 kDa. It is attached to IgA or IgM polymers by disulfide linkages. It is

not detectable by antisera while the polymers are in their native state, but it becomes readily accessible if the polymers are dissociated. In contrast to the secretory piece, J chains are produced by plasma cells and appear to play a key role in the process of polymerization of Ig, serving as a clasp or zipper to fasten the last two monomeric components of a plg together.

The complete amino acid sequence has been inferred from cloned genomic DNA. The chain is larger than previously determined, containing 137 amino acids. Many cysteine residues are scattered throughout the molecule. Of the 137 amino acids in mouse and human J chains, 106 are identical (77%). This characteristic, plus the fact that the C-terminal regions of the μ and α chains are also conserved, suggests that the polymerization of Ig molecules has been conserved in evolution, probably because they confer advantages in defense mechanisms in that they aggregate complex pathogens more effectively.

COMPLEMENT

The name complement was introduced by Paul Ehrlich and J. Morgenroth, because it was thought to complete the activity of the antibodies from which it could be distinguished by its particular properties. It is now recognized that complement represents a multimolecular system and is activated by three different pathways, the classical, the alternate, and the lectin, with the final lytic or effector function being carried out by a common pathway. This final common pathway leads to the formation of the membrane attack complex (MAC).

Classical Pathway

The classical pathway is initiated by two functional units: the recognition unit, which consists of three proteins, C1q, C1r, and C1s; and the activation unit, which consists of C2, C3, and C4⁵⁸⁷ (Fig. 14.25). The MAC is activated by the classical pathway by the generation of three complex enzymes with proteolytic activity, the formation of which requires the association of two or more proteins.⁵⁸⁸ Not all Ig classes are capable of binding to C1q; IgG1 and IgG 3 bind readily, whereas IgG4 does not bind at all. Complement binding to the IgG subclasses is determined by the flexibility of the hinge that prevents steric interference between Fab and C1q binding. IgG3, with the longest hinge region, is the most efficient of all IgG subclasses. Exposure of the C1q-binding site of IgM molecules is optimal when the molecule assumes the staple configuration as it binds to the antigen (Fig. 14.24). This site is hidden in the native form of IgM by the closeness of the subunits. IgM has the strongest binding ability because one C1q molecule that is bound to one IgM antibody is capable of lysing an erythrocyte, whereas two IgG molecules in close proximity are required to achieve the same effect. Ig antibodies that are bound to independent epitopes can activate the complement cascade in this way. Depending on the epitope density, activation occurs when at least 800 IgG molecules bind to the cell. For this reason, IgM antibodies are considerably more efficient lysins.

Step 1: C1 Esterase (C1)

C1 esterase is a complex that is assembled from three proteins: C1q (recognition subunit), C1r, and C1s (catalytic complex).⁵⁸⁹

C1q: Recognition Unit of C1s

All activators of the complement cascade recognize the C1q, which consists of a total of 18 polypeptide chains, six of each of the

P.355

three different types, A, B, and C.^{590,591,592} All polypeptide chains are equal in length, and each is comprised of a short N-terminal region that is involved in the formation of A-B and C-C interchain disulfide bonds. It is followed by collagenlike sequences, which consist of repeating triplets X-Y-Gly, a collagenlike motif (X is often a proline; Y is usually hydroxyproline or hydrolysine). These sequences are not found in human serum proteins but are present in collagen fibrils. At the beginning, three heterotrimers (each consisting of A, B, and C polypeptide chains) associate, forming a stalk. Because of the interruption of the collagen sequence, the

P.356

triplets dissociate into six radiating arms (Fig. 14.26A). At the C-terminal end, each arm ends in a globular head, which consists of heterotrimers of protein domains known as C1q modules. When viewed by electron microscopy, the C1q resembles a bouquet of flowers (Fig. 14.26B).

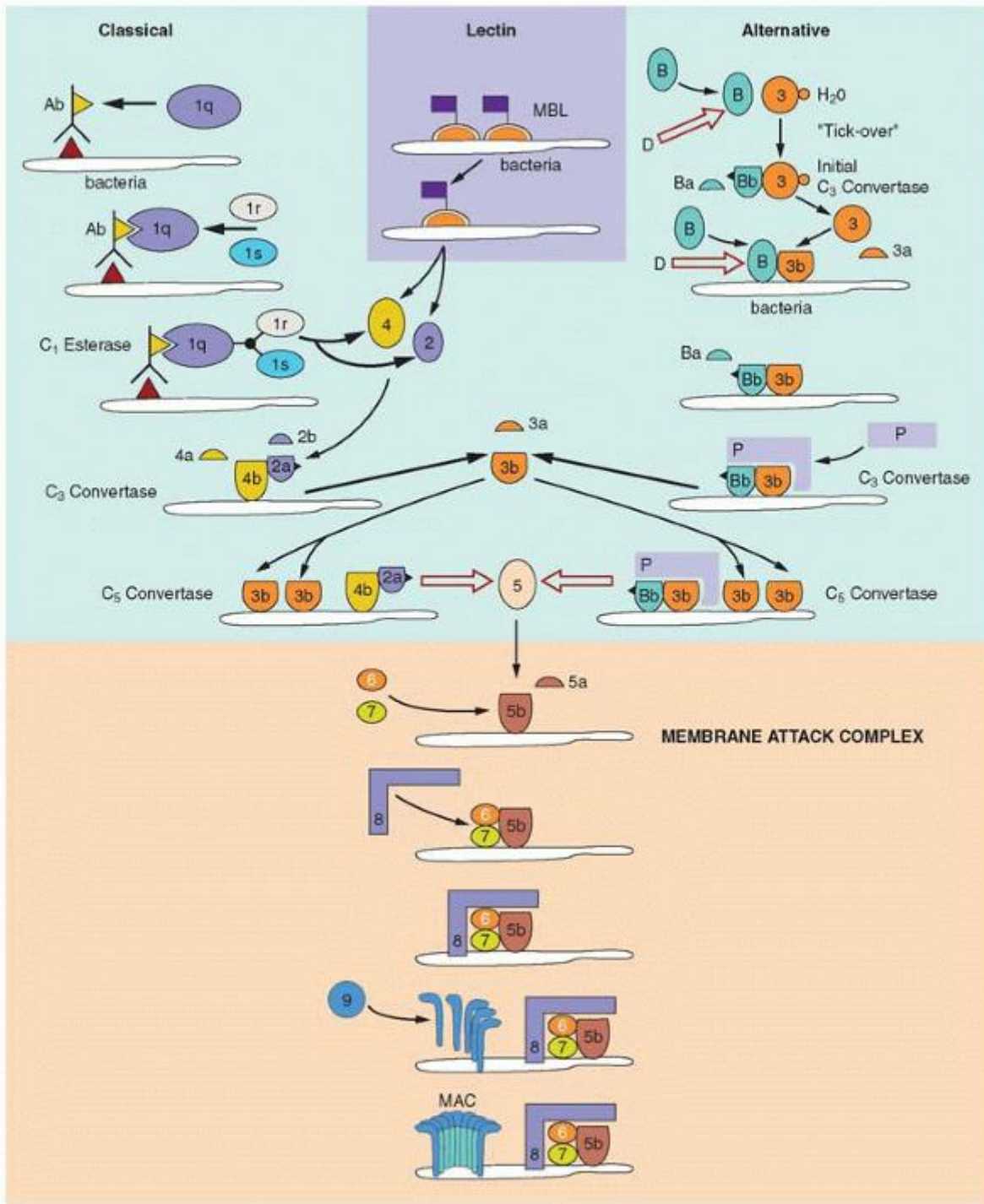

FIGURE 14.25. The complement (C) pathways. The hemolytic function of the C is activated by three pathways, which converge to the same final common pathway (see the text for details). The classical pathway uses C1q as the recognition molecule, which generates sequentially three enzymatic functions: C1 esterase, C3 convertase, and C5 convertase. The alternative pathway initiates activation by a “tick-over” mechanism in the absence of antibody and again generates similar enzymatic functions as the classical pathway. The lectin pathway is triggered by a receptor, mannose-binding lectin (MBL), which, through carbohydrate binding, activates the MBL-associated serine protease (MASP) esterases. A MASP cleaves C4 and C2, generating the same C3 convertase as the classical pathway, which it joins at this point. All pathways converge to the same membrane attack complex (MAC) pathway, which they initiate by cleaving C5.

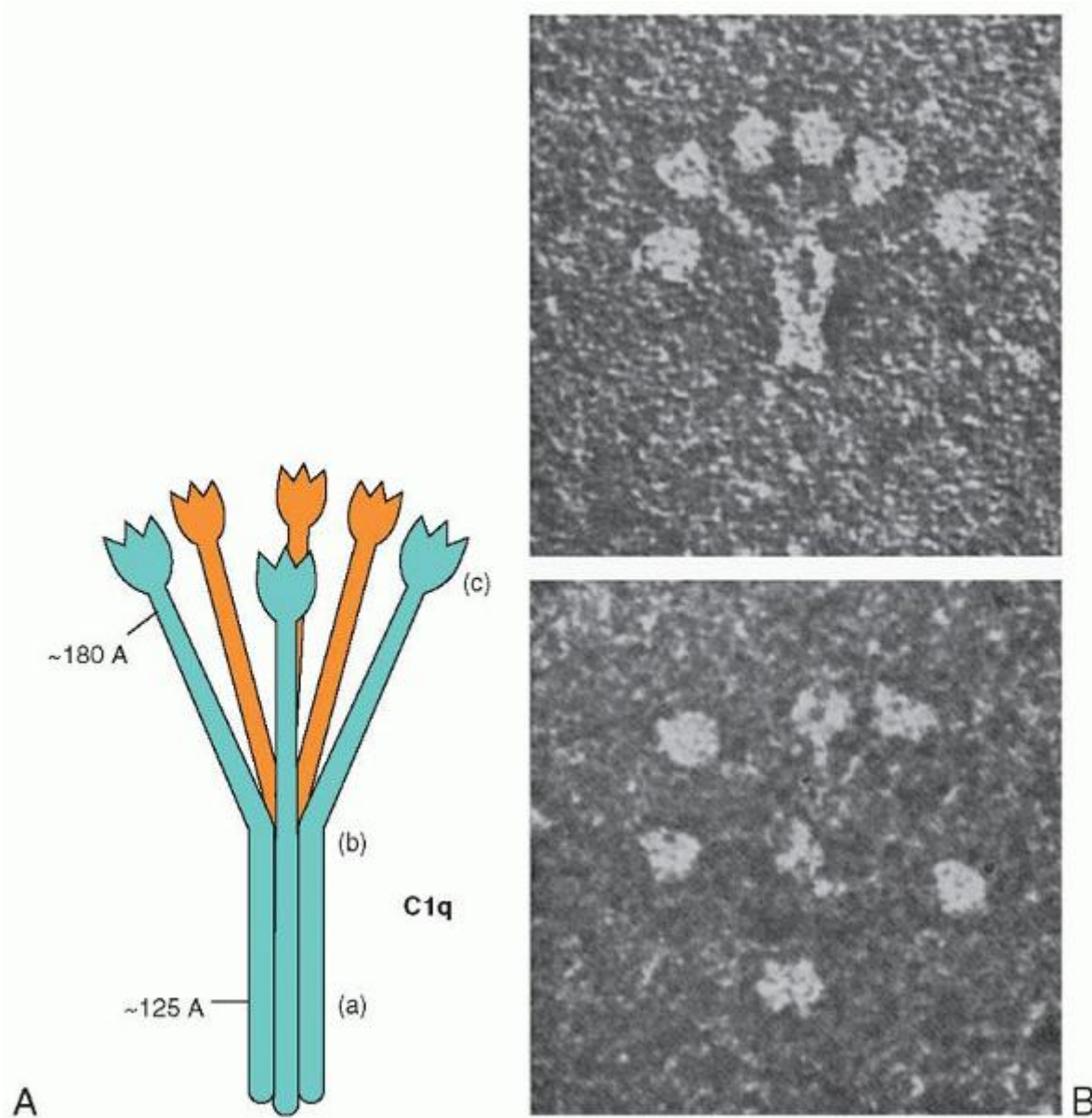

FIGURE 14.26. A: C1q molecule. Each of the six subunits is made of three polypeptide chains that form a triple helical strand. The N-terminal ends have a collagenlike structure and are packed together, forming a central stalk (a); halfway, they bend and separate from each other (b) to end at the C-terminal end in a globular domain (c) that binds to the immunoglobulin. B: Electron micrographs of the C1q molecule (upper) and bird's eye view (lower). (From Knobel H, Villiger W, Isliker H. Chemical analysis and electron microscopy studies of human C1q prepared by different methods. *Eur J Immunol* 1975;5:78-82.)

Modules of the C1

gC1q Module. Most of the C1 activators, such as immune complexes, β -amyloid fibrils, and HIV, are recognized by the globular heads of C1q.⁵⁹³ Each head is composed of trimers of the gC1q domain, which is detected not only in C1q but also in type VIII and type X collagens and several other proteins.⁵⁹⁰ The gC1q modules bear structural features that are seen in members of the TNF family.⁵⁹⁴

CUB Module: C1r-C1s Uegf Bone Morphogenetic Protein-1 Module. The acronym CUB was given from the detection of this module for the first time in the sea urchin protein, Uegf, and the human bone morphogenetic protein-1. The CUB modules of C1r and C1s surround the single epidermal growth factor (EGF) module and a pair of complement control protein (CCP) modules. CUB modules are detected in proteins that are involved in developmental processes. They contain four cysteine residues, forming two disulfide bonds, except the N-terminal CUB module of C1r and C1s, which has only two cysteines.

Epidermal Growth Factor Module: Epidermal Growth Factorlike. EGF-like modules are detected in diverse proteins that are involved in processes such as blood coagulation and cell adhesion. They have six cysteines that form three disulfide bonds. In C1r and C1s, the EGF module has characteristic consensus sequences with residues Asp and Asn that are hydroxylated and are involved in Ca^{2+} binding.

Complement Control Protein Module. The CCP module is detected in complement receptors and other CCPs. Their consensus sequence consists of aromatic and hydrophobic residues and four cysteines. The crystal structure has been solved and shows six β strands around a hydrophobic core.⁵⁹⁵ The modules are ellipsoidal with the β strands aligned along their long axis, with N and C termini at opposite ends.

Serum Protease Domain

The target bonds in the substrates for cleavage by the C1 esterase have one Arg residue. Indicative of its trypsinlike enzymatic specificity is the Asp residue that is found close to the substrate-binding site. Arginyl bonds, such as Arg-isoleucine (Ile), are the targets in the autoactivation of C1r and in the activation of C1s by C1r. Arg-containing bonds are also cleaved in C4 and C2 by the active C1s. C1s esterase activity is expressed only by the multimolecular complex, which is a tetramer that is formed by two C1r and two C1s. Therefore, the enzymatic activity depends on protein-protein interactions among the four components of the esterase, which are facilitated by Ca^{2+} .⁵⁹⁶ Ca^{2+} brings together one CUB and one EGF module to form a compact structure.⁵⁹⁷ During the formation of the tetramer, interactions are flexible to allow a single C1r to cleave the neighboring and the distant C1s.⁵⁹⁸

C1r and C1s

The C1r and C1s are single polypeptide chains of approximately 85 kDa, with a SER protease activity. In the proenzyme form, they are single glycoproteins, which are activated by cleavage of a single Arg-Ile bond, forming a two-chain active enzyme. They are composed of two CUB modules,⁵⁹⁹ an EGF-like module, two CCP modules, and a C-terminal chymotrypsinlike SER protease domain (Fig. 14.27).

Assembly of C1 Esterase

The first enzymatic activity of the C cascade is assembled from five components, one C1q, two C1r, and two C1s (Fig. 14.27). The C1r-C1s tetramer, in isolation, is a linear structure, with the C-terminal domains responsible for the catalytic function and the N-terminal domain involved in the Ca^{2+} -dependent protein interactions. In the linear form, the two C1r catalytic domains are in the center, whereas those of the C1s are at the two ends. In the assembly of the C1 esterase, which is the first enzymatic activity of the classical complement cascade, the linear tetramer assumes a compact figure-eight conformation. In this configuration, all four catalytic domains of C1r and C1s are brought into juxtaposition under the cone that is formed by the arms of the C1q. The proteininteraction domains are located outside the arms of C1q.^{600,601}

Activation of C1 esterase occurs upon recognition by the globular heads of C1q of pattern target sites (e.g., antibody bound to pathogen surfaces and immune complexes). This binding generates transient conformational changes, which activate C1r by disrupting the C1r homodimer. Activated C1r in turn breaks an Arg-Ile bond, activating C1s.⁵⁹⁶ These transient "earthquakes" do not bring about the collapse of the elaborate C1 esterase edifice, because C1r and C1s are associated tightly with the C1q collagen arms by the CUB-EGF modules that were discussed previously.

C1s is a highly specific enzyme, but, within the mechanical constraints that are imposed by the superstructure of the whole assembly, it requires some degree of freedom of mobility for its interaction with the substrate. These requirements are provided by the CCP modules, especially CCP-2, which is linked by a flexible hinge to the CCP-1 module. This allows CCP-2 to act as a handle and a spacer, to amplify the shift that is required for the serine protease domain.^{595,601}

C1q-binding Proteins

In addition to its function in C activation, C1q binds to other proteins that are sometimes called receptors, mediating other C1q functions.^{602,603} There are two types of surface proteins that bind to C1q. One binds to the collagenous portion of C1q (cC1q

P.357

receptor), and the other binds to the globular heads (gC1q receptor). Some of these proteins are transmembrane, whereas others are intracellular, such as calreticulin (CALR) and the gC1q-binding protein (gC1qR, now known as C1QBP). The C1q structure bears similarity to the proteins of the collectin family, which includes the mannose-binding lectin (MBL), the pulmonary surfactant protein A, and conglutinin. However, the collectins are C-type lectins and bind carbohydrates, whereas the heads of C1q recognize protein patterns on immune complexes.

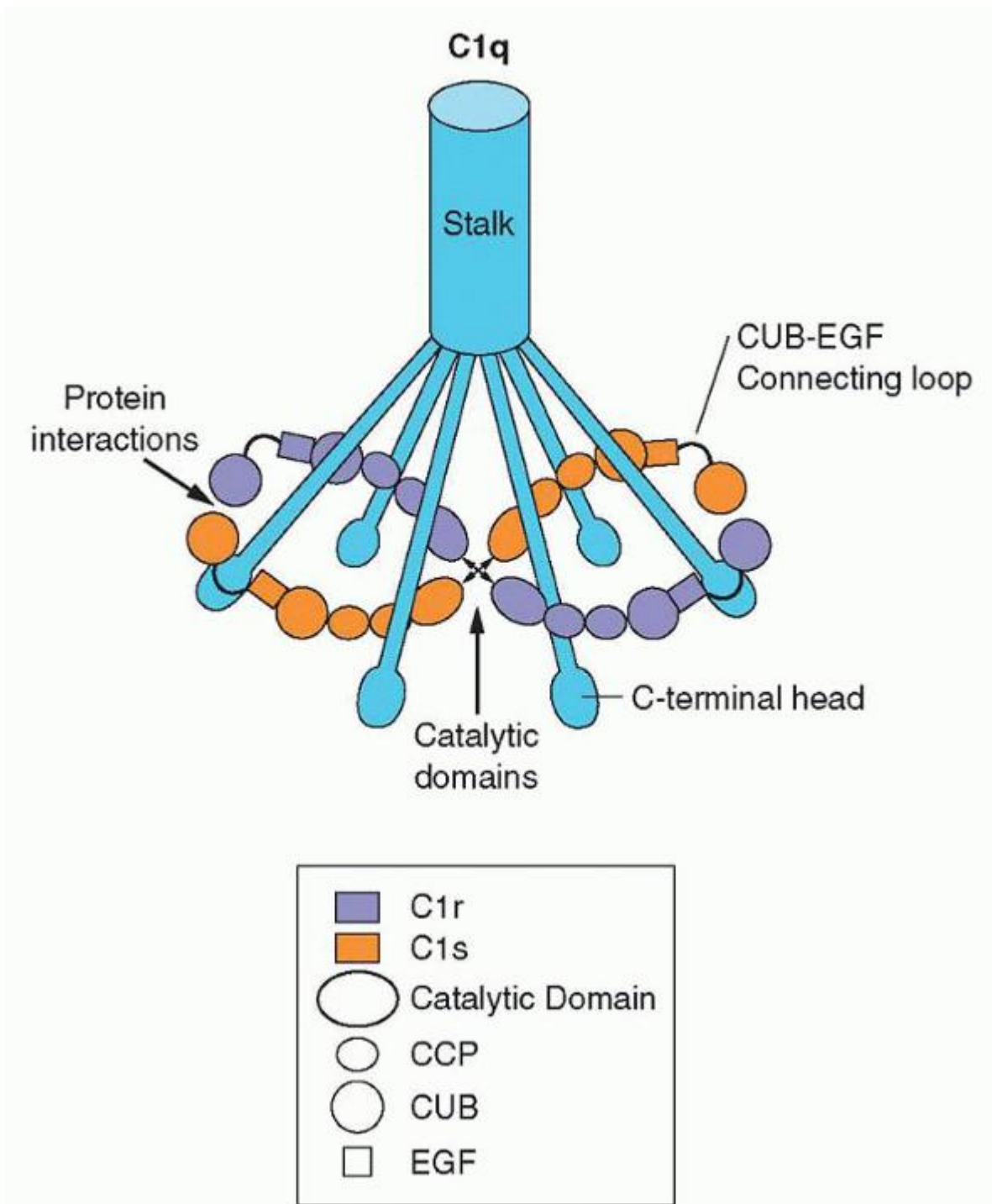

FIGURE 14.27. C1 esterase assembly. The C1 esterase is a complex that consists of one C1q molecule (recognition component) and a tetramer of two C1r and two C1s. The tetramer in isolation assumes a linear form: C1s-C1r-C1r-C1s. It weaves among the arms of the C1q in a necklacelike way and assumes a figure eight. This arrangement allows access of the catalytic domain of the C1 in the zymogen form to be in contact with the active catalytic domain of C1r for C1s to be activated. Both C1rs have access to both C1s. The flexibility of the tetramer allows changes in their relative position, so that the active C1s sites have access to C4 and C2 for their cleavage and formation of the C4a-C2b C3 convertase. The CUB and EGF modules of C1r are connected by a flexible loop and form a high-affinity Ca^{2+} -binding site that is involved in the interaction with C1s. The CUB-EGF pair interacts with the C1q arm. When the heads of C1q interact with a pattern of sites on the surface of a target, a conformational stress that is transmitted through the arms of C1q triggers the C1r catalytic domain and results in its activation. CCP, complement control protein.

The term C1qR has been used loosely, sometimes without hard evidence that the receptor triggers cell signaling that leads to some cellular functions.⁶⁰³ The gC1qR is expressed on myeloid cells⁶⁰⁴ and microglial cells,⁶⁰⁵ in which it mediates chemotaxis and phagocytosis, and in platelets,⁶⁰⁶ modulating their function in injured vascular sites. Calreticulin is a Ca^{2+} -binding protein that is located primarily in the ER of most nucleated cells. It has been found that calreticulin binds C1q and therefore qualifies as cC1qR, but the significance of this interaction remains elusive.

Step 2: C4 and C2 Complex: C3 Convertase

C3 convertase is formed by the interaction of two fragments from the C4 and C2 components of complement. Complement component 4 circulates in the blood as a disulfide-linked heterotrimer that consists of α (93 kDa), β (75 kDa), and γ chains (33 kDa). C3 and C5 components share a similar structure that is considered to be evolutionarily derived from one ancestral gene. The C3 and C4 components share an internal thioester bond, which is formed between a cysteine and a glutamine, which are two residues apart.⁶⁰⁷

C4 is synthesized as a single polypeptide chain but is later hydrolyzed, giving rise to the three constituent chains. C1s activates C4 by splitting the α chain, releasing the C4a fragment from the N-terminal end of the chain. The thioester bond, which is normally hidden in the C4b fragment, is exposed, reacts with an NH_2 or OH group of the surrounding molecules (Fig. 17.28), and deposits C4b on the surface of potential targets for C attack.

C2 is a single chain protein of approximately 100 to 110 kDa, with a distinct structure that consists of three globular regions: three N-terminal CCP domains, a single von Willebrand factor (vWF) domain in the center, and a serine protease domain in the C terminus.⁶⁰⁸ CCP modules are highly compact structures, folding independently into a β barrel (e.g., two interacting antiparallel β sheets), that form an ellipsoid structure. Loops that connect the β strands protrude from the module and may function as the ligand-binding sites. The vWF type A module consists of five parallel β strands and a short antiparallel strand that form a central twisted core, which is surrounded by seven amphipathic α helices.⁶⁰⁹ Cleavage of C2 by C1s occurs in the N-terminal region of the vWF domain, which results in the generation of two fragments, a larger (70-kDa) C2a, consisting of most of vWF and SP domains, and a smaller (30-kDa) C2b fragment (CCP-1, CCP-2, and CCP-3). Fragmentation of C2 exposes a C4b-binding site that is located on the C2b fragment, which interacts with C4b. C4b-C2a complex formation depends on Mg^{2+} ions, which are coordinated by residues in the metal ion-binding MIDAS (metal-ion-dependent adhesion site) motif of the vWF modules, which is also present in several integrins (see Appendix A, CD61). By electron microscopy, the C2a fragment appears as a two-lobed structure that links the C4b and C3b fragments in the final C5 convertase (see the following discussion). The C4b-C2a complex is a Ser esterase with an esterolytic activity and with the C3 as the natural substrate.⁶¹⁰

Step 3: C3b-C4b-C2a Complex: C5 Convertase

C3 Component

The C3 component of complement is the most abundant in the serum (1.2 mg/ml) and occupies the most critical position in all three C cascades. The prevailing hypothesis is that a gene that was common for all three components, C3, C4, and C5, originated from an ancestral α_2 -macroglobulin gene. Subsequent duplication formed the C4 and C3-C5 genes, and a second duplication formed separate C3 and C5 genes.

C3 comprises an α chain (110 kDa) and a β chain (75 kDa), which are connected covalently by a single disulfide bond. It is synthesized as a single protein and is modified post-translationally by a furinlike enzyme, which removes a sequence of four arginines.⁶¹¹

Another disulfide bond within the α chain connects the N and C terminals (Fig. 14.28). C3 convertase cleaves the α chain at a site that is close to the N terminus, generating two fragments: a small C3a (9 kDa) and a large C3b (176 kDa). The C3b consists of the remaining α chain, which is linked by the disulfide bond to the intact β chain. Cleavage of the α chain of C3 by the C3 convertase exposes the thioester bond, which, in the intact molecule, is well protected within a pocket in the α chain, with a half-life of 231 hours. In the metastable C3b fragment, the bond is exposed, with a half-life of 60 microseconds. These differences strikingly express the extraordinary reactivity of the thioester bond for certain groups on the cell surfaces. The thioester bond participates in a chemical transacylation reaction that results in the attachment of C3b on OH or NH_2 groups on cell surfaces, complex carbohydrates, or immune complexes that are within a radius of 600 Å from the point at which it was generated. Attachment of C3b is not

P.358

discriminatory between self- and nonself-surfaces but is regulated by CCPs (see the following discussion). The selection, however, of the OH groups on the sites of binding is quite restricted.⁶¹² C3b expresses multiple sites for binding to other

complement proteins, which determine its fate. C3b is deposited on and around the C4b-C2a complex, binding through the thioester bond. The deposition produces an enzyme with a change in the specificity from C3 to C5, generating the C5 convertase.⁶¹³ C3b is also deposited on other previously deposited C3b molecules, forming C3b-C3b dimers. The C3b-C4b and C3b-C3b form high-affinity binding sites for C5 and probably, the role of these dimers is to hold the substrate in a rigid position for efficient cleavage of C5. It also appears that the C3b-C3b-IgG complexes function as better precursors of convertases than monomeric C3b.

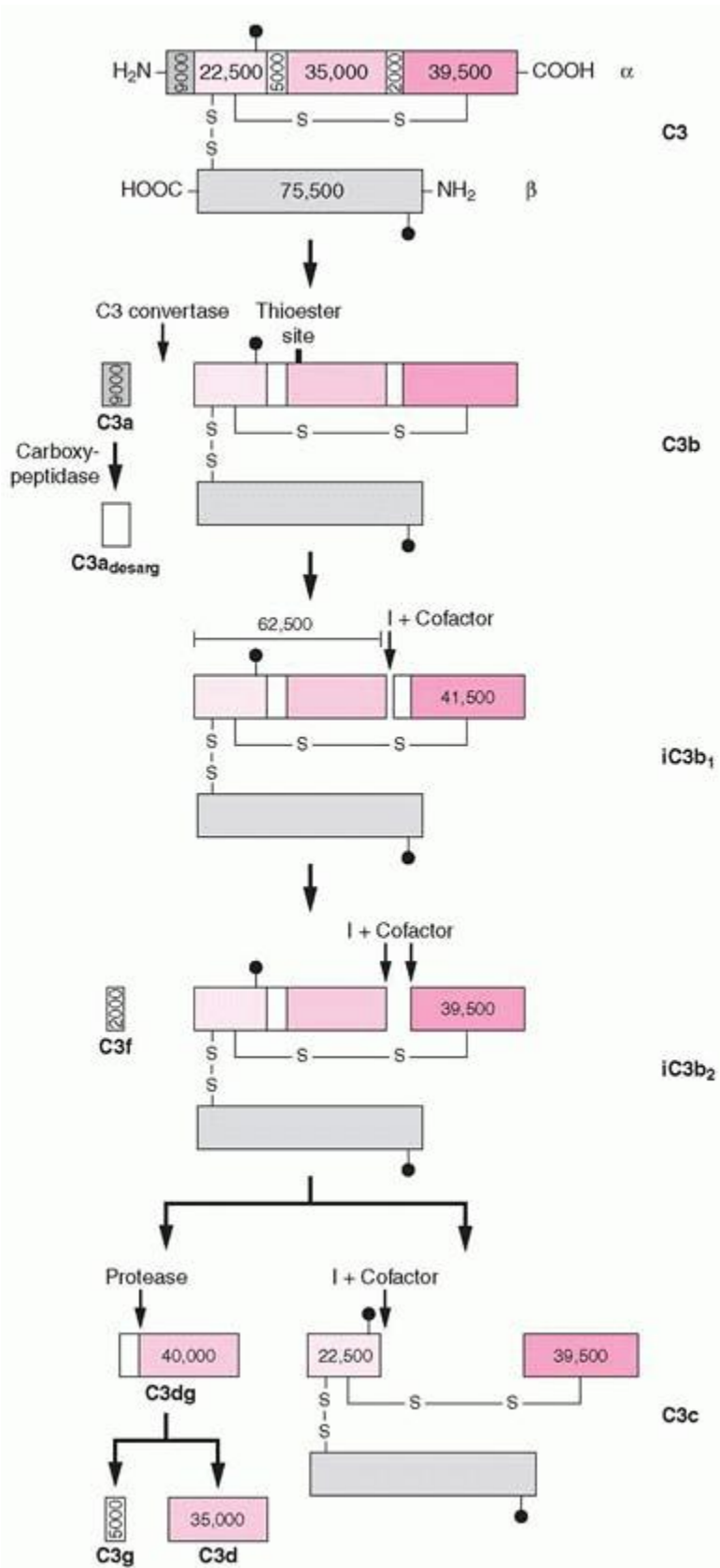

FIGURE 14.28. C3 degradation. The C3 component not only contributes to the classical pathway in the formation of the C5 convertase, it also, as a result of fragmentation, provides parts of its molecule for other important functions. For example,

C3a serves as an anaphylatoxin, C3b serves as a ligand for the CR1 receptor (CD35), C3d serves as a ligand for CR2 receptor (CD21), iC3b serves as a ligand for CR3 receptor (lymphocyte-function-associated antigen-1 integrin, CD11b/CD18) and for CD11c/CD18 integrin. (Courtesy of Dr. J. D. Lambris. From Sahu A, Lambris JD. Structure and biology of complement protein C3, a connecting link between innate and acquired immunity. *Immunol Rev* 2001;180:35-48, with permission.)

C3 Fragmentation

C3 is fragmented by several enzymes that generate a variety of functionally active fragments (Fig. 14.28). The activation of C3 by the C3 convertase cleaves the peptide bond between residues 726 and 727 (Arg-Ser) and generates a small C3a (9 kDa) and a large C3b (176 kDa) fragment. C3a is the N terminal of the α chain that functions as anaphylatoxin. C3b consists of the remaining α chain (α') and the entire β chain, which are linked by the disulfide bond. C3b is inactivated by further proteolysis by factor I and one of the co-factors. The first cleavage occurs between residues 1,281 to 1,282 of the α' chain and generates the inactivated C3b or iC3b₂, which is the ligand for CD11b-CD18 integrin (see Appendix A). A second cleavage by factor I separates a small fragment C3f (2 kDa) from the α' chain and yields another inactivated C3b or iC3b₂. Factor I, with CR1 or factor H as co-factor, cleaves the α chain once more, at residues 932 and 933, to yield C3dg and C3c. The C3dg fragment is a ligand for CD21 (CR2), a component of the coreceptor complex CD19-CD21-CD81 on B cells (see Chapter 12). C3dg is cleaved by a protease into C3g and C3d fragments.

Alternate Pathway

The alternate complement pathway represents an important natural defense mechanism that is independent of the immune response (Fig. 14.25). Activation of the alternative pathway involves three components: C3, B factor, and D factor. Polysaccharides (zymosan), bacterial products, aggregated human IgA, cobra venom factor, and many other substances are activators of the alternative C cascade. The mechanisms that initiate this pathway have been the subject of much debate. The enzyme that cleaves C3 contains C3b as one of its components, which is the product of a previous C3 cleavage. The origin of the first C3b becomes a puzzling problem. Normally, the C3 continuously generates a low level of a functionally C3b-like form by a "tick-over" mechanism. The mechanism for the tick-over is not a proteolytic process, but involves the spontaneous hydrolysis of the thioester bond by H₂O and the formation of a metastable C3 (H₂O). The hydrolysis occurs *in vitro* at 37°C at a rate of 0.005% per minute.⁶¹⁴ The C3 (H₂O) is an uncleaved C3 molecule and yet has the conformation and function of a C3b in the presence of Mg²⁺, which provides a site for binding of the B factor.

Factor B

Factor B (90 kDa) has a similar structure to C2: it consists of three CCP modules, a vWF type A module, and a serine protease domain that are all connected by short amino acid sequences. By electron microscopy, it appears as a three-lobed structure, presumably with each module corresponding to one of the lobes.

Factor D

Factor D is a Ser protease with only one known substrate, factor B. The single Arg²³³-Lys²³⁴ bond of factor B becomes susceptible to the enzymatic activity of factor D only when it forms an Mg²⁺-dependent complex with C3b. It is the only enzyme in blood that is able to catalyze this reaction and is therefore absolutely required for alternative-pathway activation.

P.359

The concentration of factor D in the blood is 1.8 ± 0.4 $\mu\text{g/ml}$, the lowest of any complement protein, which makes factor D the limiting factor in the activation of the alternative pathway. It is a single chain protein (24 kDa) and is structurally similar to pancreatic serine proteases. It circulates in blood in a zymogen or profactor form⁶¹⁵ converted to the mature enzyme as a result of conformational changes. However, this first step generates a "resting" enzyme because of an inhibitory sequence loop, which prevents its activation. The active enzyme conformation is induced after binding to the substrate in a second step.

Factor D has a structure that is similar to other members of the serine proteases: the polypeptide chain is folded into two antiparallel β barrels. Each barrel consists of six β strands with the same topology in all members.⁶¹⁶ Efficient catalysis requires three amino acids, Asp¹⁰², His⁵⁷, and Ser¹⁹⁵, forming the "catalytic triad," and the positioning of the three residues is crucial for the synergistic action that is required for hydrolysis of the target bond. In the bottom of the substrate specificity pocket is an Asp residue, which places factor D in the category of the trypsin subfamily of serine proteases and cleaves an Arg-Lys bond of its single natural substrate, factor B.

Properdin

Properdin is one of six plasma glycoproteins that collectively comprise the alternative pathway of complement. It was first described by Pillemer et al.⁶¹⁷ as a novel plasma protein that activated complement in the absence of immune complexes. Properdin consists of a single chain (53 kDa), which by electron microscopy appears as a rodlike structure that forms cyclic dimers, trimers, and tetramers.⁶¹⁸ The monomer consists of an N-terminal region of no known homology, followed by six thrombospondin type 1 repeats (TSRs) of approximately 60 amino acids.⁶¹⁹ Repeats of this type have been identified in the cell adhesion molecule thrombospondin and in a variety of other proteins, including thrombospondin types 1 and 2 (TSP-1 and TSP-2), C6 through C9, and the circumsporozoite protein of malaria parasites.⁶²⁰

Removal of TSR5 prevents binding to C3b and sulfatide, whereas, with the removal of TSR4, properdin is unable to stabilize the C3b-Bb complex but is still able to bind C3b and sulfatide,^{621,622} while it exists only as a monomer or a dimer. Absence of TSR3 does not affect any of the functions of properdin, including the formation of the polymers. TSR5 is important for polymer formation, because, in its absence, no cyclic polymers are detected. Properdin, as does thrombospondin, binds sulfated glycoconjugates and sulfatide with especially high affinity when it is activated. Properdin significantly contributes to linking innate and adaptive immunity. It is synthesized by endothelial cells, especially under turbulent blood flow conditions,⁶²³ and mRNA has been detected in neutrophils, monocytes, and T cells. In response to chemoattractants C5a or IL8, neutrophils discharge their properdin content promptly, as well as C3 and factor B, which they store within their granules. Factor D is supplied locally by blood, which completes the list of the components that are essential for activation of the alternative pathway. T cells and monocytes participate in the process, because they also secrete properdin, factor B, and C3. Activation-produced fragments C3d and iC3b are essential B-cell activation factors,⁶²⁴ thus linking with the adaptive immune system.

Activation of the Alternate Complement Pathway

In the presence of Mg^{2+} , C3 (H_2O ; also referred to as iC3) binds factor B, which is cleaved by factor D into a large Bb and a small Ba fragment (Fig. 14.25). The Bb forms a complex with the iC3, which is termed the initial C3 convertase. Although the iC3-Bb complex is destroyed on host surfaces by factor H and factor I (see the following discussion), C3b fragments that are deposited on foreign surfaces associate with factor B in the presence of Mg^{2+} . The C3b-B complex activates factor D, which cleaves factor B into Bb and Ba fragments. The distinction between activator and nonactivator surfaces is not clear. An activator surface is one that allows binding of factor B to C3b in preference of factor H (see the following discussion), thus activating the alternative pathway, and the opposite is true for nonactivators. Nonactivators can be converted to activators by removing sialic acid. A widely used activator is cobra venom factor, which binds to factor B and forms a stable C3 convertase. The factor is functionally analogous to C3b but is related structurally to C3c. It is used to deplete serum of C3 in a variety of experimental situations and is resistant to inactivation by factors H and I.

The C3b-Bb is stabilized by the serum protein properdin, which amplifies the cleavage and deposition of more C3b molecules^{625,626} to form the C5 convertase. The serine protease activity of the C3b-Bb complex, which is located in the Bb component, accelerates deposition of C3b fragments (C3b amplification), a unique feature of the alternative pathway, on and around the C3b-Bb complex. Some will form C3b-C3b dimers, which have a high affinity for C5 self-amplified C5 convertase⁶²⁶ and switch cleavage from C3 to C5, thus initiating the formation of the cytolytic C5b-9 complex. As the activation continues, at the outer ring of this circle, monomeric C3bs form more C3 convertases with factor B, which in turn deposits a new crop of C3bs, forming a new generation of C3b-C3b dimers, that is, C5 convertases. These cycles of successive outward deposition of C3 and C5 convertase activities continue until all surfaces are covered or the supply of individual components is exhausted.

Lectin Complement Pathway

The lectin pathway is an important humoral mechanism of innate immunity. It is activated by pattern-recognition receptors, such as MBL, which interacts with carbohydrates⁶²⁷ (Fig. 14.25).

MBL is a member of the collectin family, which includes the lung surfactant proteins, SP-A and SP-D, and a protein that is localized in the hepatic cell cytosol, CL-L1. Collectins are composed of a C-terminal lectin domain (carbohydrate recognition domain) and a neck region that connects to the collagenlike region, followed by a short cross-linking region that contains two to three cysteines. The neck region forms an α -helical coiled-coil structure, which initiates the formation of a trimer. In blood, MBL is found as multimers (i.e., dimers to hexamers). MBL is a C-type lectin, as it requires Ca^{2+} for binding to a carbohydrate ligand.

Associated with MBL are four serine proteases that are known as MBL-associated serine proteases (MASPs): MASP1, MASP2, MASP3,^{628,629} and sMAP or MAP-19, a truncated form of MASP2. MASP2 and sMAP are encoded by a single gene, but two different mRNAs are generated by alternative splicing.⁶³⁰ All MASP proteases have a modular structure that is

identical to C1r-C1s: a CUB domain, an EGF-like domain, a second CUB domain, two CCP domains, and a serine protease domain. The serine protease domain is homologous to the chymotrypsinogen family. An Asp residue in the substrate specificity pocket indicates trypsinlike substrate specificity. MASP's association with MBL is mediated by the CUB-EGF domain and is Ca^{2+} dependent.⁶³⁰ The MASP proteases are activated when MBL binds to conserved pathogen-associated sugar arrays that form molecular patterns, which are shared by broad classes of pathogens.⁶³¹

When MASP is activated, it cleaves C4 and C2, and the C4b fragment binds covalently to the microbial surface or the lectin itself and becomes the focus for C2 binding and activation. The remaining cascade is identical to that of the classical pathway (Fig. 14.25).

MBL binds mannose-acetyl glucosamine or GlcNAc, which are also ligands for other types of GlcNAc-binding lectins, which are termed ficolins and are present in the serum. Ficolins contain

P.360

collagenlike and fibrinogenlike domains. They bind to GlcNAc through the fibrinogenlike domain. They are associated with MASPs and sMAP and have the capacity to activate the lectin complement pathway.⁶³² In the serum, there are two types of ficolins, which are named L-ficolin and H-ficolin (Hakata antigen).^{633,634}

The recognition that is mediated by MBL and ficolins in complement activation is detected as far back in evolution as the ascidians, our closest invertebrate relatives. It indicates that the complement pathway has been important in innate immunity since before the evolution of adaptive immune systems in jawed vertebrates.

Membrane Attack Complex

C5

C5 (191 kDa) consists of two polypeptide chains, α (115 kDa) and β (75 kDa). C5 convertase selectively cleaves an Arg-Leu bond^{74,75} of the α chain, generating C5a, a potent leukocyte chemotactic peptide that consists of 74 amino acids and has considerable structural homology with C3a and C4a, the other two anaphylatoxins. The remaining larger fragment, C5b, in its nascent state constitutes the nucleus for the MAC. It possesses a metastable binding site with specificity for C6. By electron microscopy, C5 has the shape of a heart or of an ellipse, but the heart-shaped form is related to the elliptical type by rotation.⁶³⁵ The binding sites for C6 and C7 are located in the α chain of C5b. Interaction with C5b involves the C terminus of C6, specifically the C6c fragment that consists of two factor I modules (FIMs).

C6

C6 is a single polypeptide chain (104 kDa), which, by trypsin digestion, can be separated into an N-terminal region (C6a) with some homology to C8 and C9 and a C-terminal region (C6b) with homology to factor H and factor I. Several disulfide bonds separate discrete segments of C6, which is structurally homologous to a variety of other proteins. Overall, the primary sequence is a patchwork, with several modules that are involved in protein-protein interactions (Fig. 14.29). Starting from the N terminus, there are several domains: two tandem TSP-1s, a class A low-density lipoprotein receptor (LDLR), an extended central segment that is referred to as the membrane attack complex perforin (MACPF) domain with homology to perforin, an EGF, a third TSP-1, two CCPs, and two FIMs, which are related to those in the H chain of the complement control factor I.⁶³⁶ The FIMs are specific C5-binding modules, and yet they are not absolutely necessary, probably because other hydrophobic interactions also contribute to the C5 and C6 interactions. As devices that facilitate C5 and C6 interactions, FIMs make a greater contribution to the classical pathway in which C5b density is not as high as it is in the alternative pathway, because fewer C5bs are formed in the classical pathway, and C5b half-life is shorter.⁶³⁷

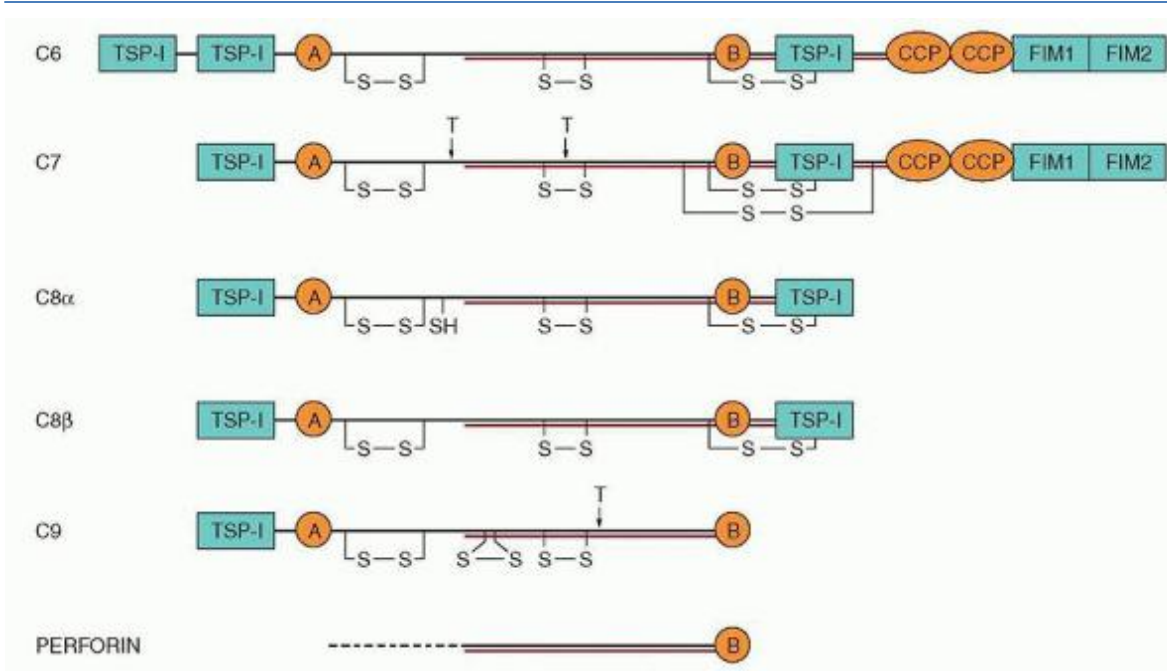

FIGURE 14.29. Structural organization of the C6 through C9 complement components. The last five complement components (C6 through C9) are structurally and genetically related proteins and form the membrane attack complex family. They all have a similar modular structure. In the middle of each molecule is a sequence-designated membrane attack complex perforin to emphasize its similarity with perforin. Membrane attack complex perforin is the portion of the molecule that is inserted in the membrane to form the pore. C8 γ is the sixth component, which is not modular and differs structurally from the others. It is considered that the perforin gene gave rise first to the C9 gene, which evolved in retrograde, followed by the appearance of the genes for the other proteins. The modules in the C6 and C7, which are not shared by C8 and C9 (i.e., complement control protein [CCP] and factor I module [FIM]) are used to interact with C5. A, low-density lipoprotein receptor class A; B, low-density lipoprotein receptor class B (or epidermal growth factor precursor module); TSP-1, thrombospondin 1.

The secondary structure of C6 is a mixture of α helices and β sheets. The α helices reside in MACPF, which is free of disulfide bonds. By transmission electron microscopy, C6 appears as a sickle.

C7

C7 is a single polypeptide (97 kDa), which, like C6, is a mosaic of several modules that are found in other proteins. Starting from the N terminus, C7 has one TSP1, one LDLR type A (LDLRA), a second TSP1, two CCPs, and two FIMs. Its secondary structure is high in β sheets (38%), and, by electron microscopy, it appears as a flexible elongated molecule (151-59-43 Å).⁶³⁸ The three components C5-C6-C7 in a fluid phase form rosettes as a consequence of radial aggregation. However, the complexes on a phospholipid area insert themselves, anchoring by the stalk, whereas the Cys-rich segments fasten the complex for the assembly of the MAC. The C5b-7 complex does not traverse the phospholipid membrane and does not cause lysis. The long flexible stalk of C7 provides greater surface area for interaction within the membrane.

P.361

C8

The C8 component consists of three chains: α (64 kDa), β (64 kDa), and γ (22 kDa), all being encoded by separate genes. The C8 α and C8 γ are linked by a single disulfide bond, and the C8 α -C8 β heterodimer is associated noncovalently with C8 β through a binding site on the C8 α chain.⁶³⁹ The α chain interacts with C9, directs the insertion into the membrane of the first C9 in the formation of MAC, and interacts with lipids, thus becoming accessible to MAC formation. Note that together with the membrane protein CD59, they inhibit MAC formation in homologous cells and protect them from lysis.

The C8 β chain has three binding sites for C8 α , the C5b-7 complex, and membrane lipids. For binding of C8 β to the C8 α - γ complex, the N-terminal TSP1, LDLRA, and the MACPF segment are most important, and, furthermore, they mediate the incorporation of C8 into the MAC.⁶⁴⁰

The C8 α and β chains are structurally related and are members of the MAC family, whereas the C8 γ chain is a member of the lipocalin family, which is unrelated to the MAC family.⁶⁴¹ The lipocalins are widely distributed proteins that are involved in the transport of small lipophilic substances, such as retinol and pheromones, but C8 does not bind retinol. They all share the same folding pattern, which is known as the lipocalin fold. Strikingly, C8 γ is the only protein from a different family among the 35 proteins of the complement system. Furthermore, C8 γ is not absolutely required for the expression of C8 activity by the α and β chains, but it enhances their function.⁶⁴² The crystal structure of C8 γ has been solved and confirms its lipocalin fold and, furthermore, identifies its structural relationship to the neutrophil gelatinase, a protein that is released from the granules of activated neutrophils.⁶⁴³ Overall, it forms a calyx with a distinct large hydrophobic cavity at the base of the calyx for ligand binding.

C9

Complement component C9 is a single polypeptide chain (71 kDa) that has a modular structure that is similar to that of the other members of the MAC family: an N-terminal TSP1; an LDLR-A; the extended central sequence MACPF, which is homologous to perforin⁶⁴⁴; and an EGF module in the C-terminal end. C9 is endowed with the capacity to polymerize spontaneously in a circular fashion and to create tubules.

Membrane Attack Complex Formation

The C5b-7 complex binds to the cell membrane, and, although it inflicts no harm on the cell, it marks it for subsequent assault by C8 (Fig. 14.25). The C5b-8 complex appears foliaceous by electron microscopy, with branched structures radiating from the central pedicle, but, on smaller phospholipid vesicles, C5b-8 monomers appear as long rodlike structures that are 250 Å wide.⁶⁴⁵ The C8 α chain mediates binding and self-polymerization of C9 to form MAC.⁶⁴⁶ The N-terminal TSP1 and LDLRA modules are the principal binding sites for C9 with the cooperative function of MACPF domain. MACs are heterogeneous in size, probably as a result of their composition, and the number of the C9 subunits may vary from 1 to 18, whereas all other components contribute only one molecule.⁶⁴⁷

The final molecular weight of the MAC therefore varies between 66 and 1,850 kDa. The average C9 binding capacity per C8 molecule is 15.4 molecules. C9 polymerizes spontaneously, but the C5b-8-induced rate of C9 polymerization is 10,000-fold greater. Self-associating C9 complexes develop new antigenic determinants that are not present in the monomer. C9 is inserted into the membrane through its C-terminal region, and disulfide bonds stabilize the complex. Electron microscopically, the polymerized C9 appears as a cylinder that extends 120 Å above the cell surface. The extracellular hydrophilic end terminates in an annulus that is 30 Å thick, with an inner diameter of approximately 100 Å⁶⁴⁵ (Fig. 14.30). The C5b-8 is attached firmly to the C9 cylinder and actually extends 160 to 180 Å above the annulus. The annulus, which is seen with computer-assisted programs, appears to be made of whorls⁶⁴⁸ (Fig. 14.30).

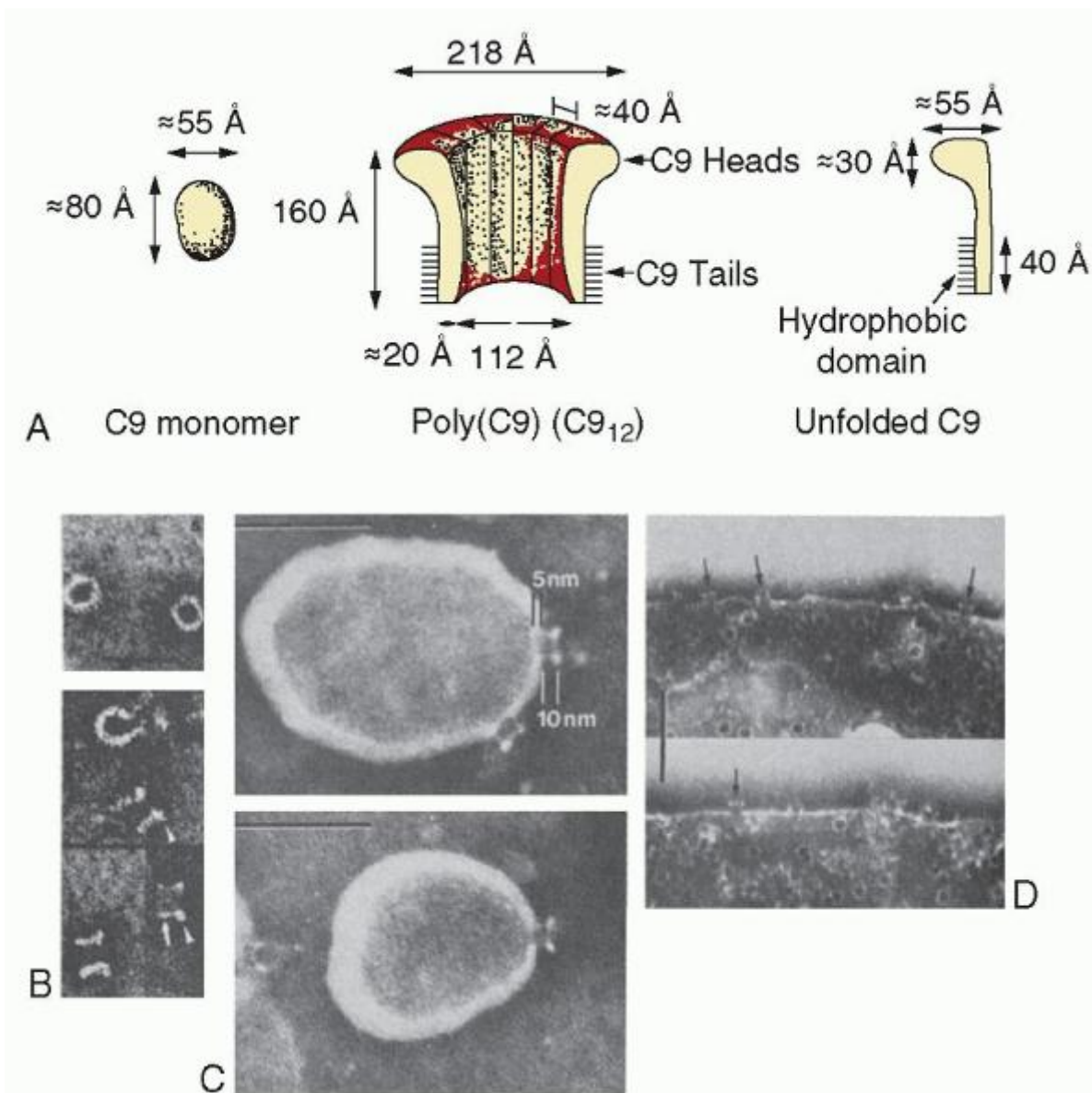

FIGURE 14.30. A: C9 molecule in its monomeric form, folded (left) or unfolded (right) and in its polymerized form (center) as a tubular structure that is seen on cell membranes. B: Poly C9 as ring structures (top view) or tubules (side view). (Courtesy of Dr. E. R. Podack. From Podack ER, Tschopp J. Polymerization of the ninth component of complement (C9): formation of poly(C9) with a tubular ultrastructure resembling the membrane attack complex of complement. *Proc Natl Acad Sci U S A* 1982;79:574-578.) C: Lipid vesicle with a typical cylinder that is formed from polymerization of C9 (side view). The cylinder penetrates the wall and protrudes to the outside, above the surface of the vesicle. D: Lesions that are induced by complement on sheep red blood cell membranes clearly show cylindric structures of the membrane attack complex and its penetration into the membrane (arrows). (Courtesy of Dr. S. Bhakdi. From Bhakdi S, Tranum-Jensen J. Molecular nature of the complement lesion. *Proc Natl Acad Sci U S A* 1978;75:5655-5659.)

Because the height of the monomeric C9 is only 80 \AA , and the poly C9 cylinder is 160 \AA , the C9 must be unfolding and must transform into a rodlike structure. Thus, the formation of the cylinder by polymerization of C9 molecules involves the transformation of a hydrophilic C9 monomer into an amphiphilic C9 polymer.

The N-terminal part of C9 does not participate directly in polymerization and is located in the upper rim of the cylinder.⁶⁴⁸ The MACPF domain traverses across the thickness of the cell membrane, forming the wall of the cylinder. The C terminal part of C9 returns back up near the rim, indicating that polymerization transforms a straight ellipsoid C9 into a U shape.⁶⁴⁹

C9 aligns with other molecules side by side, like staves of a barrel forming a volutelike structure (i.e., a capital of an Ionianstyle Greek column). Not all agree with the cylinder model of MAC. Others suggest that MAC proteins cause a distortion of the phospholipid bilayer, thus creating "leaky patches."⁶⁵⁰

REGULATION OF COMPLEMENT ACTIVATION

A large number of proteins, known as complement control proteins, are involved in the regulation of complement activation (Table 14.6). This complex regulatory system is best understood

P.362

if we consider the stages of complement activation that are regulated or whether CCPs exist in fluids versus cellular surfaces. CCPs exert regulation mainly by accelerating dissociation of the convertases, a function that is known as decay-accelerating activity (DAA), or by acting as co-factors to the serine protease factor I, a function that is known as co-factor activity (CA). Some regulators are able to serve as both decay accelerators and co-factors, such as factor H, C4-binding protein (C4bp), and complement receptor 1 (CD35).

TABLE 14.6 REGULATORY PROTEINS OF COMPLEMENT

Factor	Location	Function
Initiation step		
C1 inhibitor	Serum	Inactivates C1r and C1s
Amplification step		
Factor I	Serum	Fragmentation of C3b and C4b
Membrane cofactor protein	Membrane	Cofactor for factor I in degradation of C3b Prevents C3 convertase formation
Decay-accelerating factor	Membrane	Dissociates preformed C3 and C5 convertases
C4 binding protein	Serum	Accelerates decay of C4b as cofactor for factor I Impairs uptake of factor B by C3
Factor H	Serum	Cofactor for factor I in C3b cleavage Promotes cleavage of C3b Impairs uptake of factor B by C3b
Complement receptor 1	Membrane	Displaces Bb from C3b
Properdin	Serum	Stabilizes C3 convertases
Membrane attack		

S protein	Serum	Blocks fluid-phase membrane attack complex
CD59	Membrane	Blocks membrane attack complex on cells

Adapted from Liszewski MK, Farries TC, Lublin DM, et al. Control of the complement system. *Adv Immunol* 1996;61:201-283.

Control of the Initiation Step

C1 Inhibitor

C1 inhibitor (C1 INH) is a heavily glycosylated α -globulin with a molecular weight of 105 kDa. It is synthesized in the liver and by blood monocytes. Its gene is located on chromosome 11. C1 INH belongs to the superfamily of serpin proteins (serine protease inhibitors).⁶⁵¹ The inhibitor possesses a site that is structurally similar to the substrate, and, when a protease binds to this site and cleaves a peptide bond, it forms a covalent bond that results in a stable complex between the inhibitor and the enzyme. C1 INH inhibits activation of the classical and alternative pathways. It binds to C1r and C1s, forming stable complexes that prevent them from acting as an esterase. It also binds to the C1r-C1s complex and causes rapid dissociation of the C1 esterase. In the alternative pathway, it prevents factor B from binding to immobilized C3b. Cleavage of factor B by factor D is markedly inhibited when C3b is incubated with C1 INH.⁶⁵² A genetically inherited deficiency of C1 INH is manifested by recurrent acute attacks of circumscribed edema. Hereditary angioneurotic edema (HAE) may cause death from laryngeal edema. The mortality rate that is associated with this condition has been reduced with androgen therapy. This disease assumes two forms. In most (85%) cases (type 1 HAE), the inhibitor is present in reduced concentrations, whereas in the second form (type 2 HAE), it is present in normal concentrations, but is biologically inactive.

Control of C3 and C5 Convertases

The C3 convertase cleaves C3 to C3b and C3a, whereas the C5 convertase cleaves C5 and initiates the final stage that ends with the formation of MAC. These amplification steps are regulated by seven proteins: three of them are present in the serum (C4BP, factor H, and factor I), and four are cell membrane proteins [MCP, decay-accelerating factor (DAF or CD55), CR1, and CR2]. The overall function of these proteins is to prevent formation of the two convertases on self cells. Except for factor I, all other proteins belong to a structurally related family of proteins that is known as the complement control proteins. The genes are clustered on the long arm of chromosome 1q32.

A striking structural feature that is common to these proteins is the multiple homologous cysteine-rich domains, a 60 amino acid sequence referred to as CCP repeats.⁶⁵³ The CCP module or repeat has four li cysteines, an li tryptophan and highly conserved prolines, glycines and hydrophobic residues.⁶⁵⁴ The number of CCP domains are 30 in CR1, 20 in factor H and 4 in CD55. The 60 amino acid unit represents an ancestral domain that gave rise to the complement genes through duplication and splicing. The CCP domains are found in other complement proteins, such as C1r, C1s, C2, and factor B, as well as in noncomplement proteins, such as IL-2 receptor, haptoglobin, and coagulation factor XIII. Each CCP domain has a hydrophobic core that is interlaced with β strands connected by protruding loops, possessing a privileged position for interactions with other proteins. The control of the convertases is achieved by two mechanisms: (a) by dissociating the convertase to its individual components (DAA) and (b) by proteolytic degradation of C4b or C3b components as a result of the CA of the RCA proteins that act as co-factors for the serine protease, factor I. Some proteins have DAA and CA activity in the serum (C4BP, factor H) or cell surface (CR1), whereas others possess only one activity for the C4b and C3b components.

Regulators on Cell Surfaces

Membrane Co-factor Protein (CD46)

The extracellular region of membrane co-factor protein (MCP) consists of four CCP domains that contain the binding site for C3b and C4b and a region that is rich in serines, threonines, and prolines. The serine, threonine, and proline region is O-glycosylated and provides protection from proteolysis. A portion of this region may be removed by alternative splicing, which generates two of the four MCP isoforms. Two alternate forms of cytoplasmic regions contribute to the formation of another two MCP isoforms. MCP is present in almost all cells examined, except for red blood cells. Sites for C3b binding are in CCP2, CCP3, and CCP4 domains. The C3b and C4b binding sites have residues that bind to both complement

components as well as others that are specific for each component.⁶⁵⁵ MCP acts as co-factor for the serine protease factor I for inactivation of C4b that is deposited on self-tissues.⁶⁵⁶ MCP in the maternal-fetal interface protects the fetal tissue from attack by the maternal complement. It is found on the inner membrane of the spermatozoa and may play a role in protecting the sperm against C3b deposition. MCP is a receptor for several pathogens. The measles virus binds to an extended surface of MCP that encompasses the area from the top of CCP1 to the bottom of CCP2.⁶⁵⁷ The measles virus binding to CD46 is more like that of polio virus to its receptor: a wider open area that is flexibly hinged between CCP1 and CCP2 domains.⁶⁵⁸ This leaves the virus still exposed to immune attack. It contrasts with the narrow, recessed binding site or canyon in the case of HIV and rhinoviruses.⁶⁵⁹ The

P.363

M protein of *Streptococcus pyogenes*,⁶⁶⁰ which causes serious suppurative skin infections (e.g., cellulitis, necrotizing fasciitis), binds directly to CCP3 and CCP4 domains at a site that is distinct from the C3b-binding site. MCP mediates adherence of group A streptococci to keratinocytes.⁶⁶¹ HHV-6 also uses CD46 as a receptor and binds to CCP2 and CCP3.⁶⁶²

Decay-accelerating Factor (CD55)

DAF contains four CCP domains and is attached to the membrane by a GPI anchor. Its molecular weight is between 70 and 80 kDa, depending on its glycosylation. Soluble forms exist in body fluids that may arise from the action of a phospholipase on the membrane form. It is expressed on all hematopoietic cells, endothelial and epithelial cells, and cells of the gastrointestinal, genitourinary, and central nervous systems. Erythrocytes possess approximately 3,000 DAF molecules, and, among the lymphoid cells, the NK cells appear to be deficient in DAF. Neutrophil activation results in enhanced expression of DAF (from 10,000 to 20,000 molecules per cell). It is present in a soluble form in many body fluids, including plasma, tears, saliva, urine, synovial fluid, and cerebrospinal fluid.

DAF accelerates the decay of C3 convertase for the classical and alternative pathways but prevents its formation (Fig. 14.31). Regulation by DAF involves separate sites for the two convertases as well as common sites for both.⁶⁶³ For the alternative C3 convertase, DAF acts on the type A domain (vWF type A domain) of the Bb component.⁶⁶⁴ Classical C3 convertase is regulated by a site that is located in the CCP2-CCP3 domain junction, which consists of three consecutive lysines and a hydrophobic patch.^{665,666} DAF is used as receptor by many pathogens, such as several types of echoviruses, enteroviruses, and *E. coli*. It constitutes a functional component of the LPS receptor complex.⁶⁶⁷ CD55 is the ligand (counterreceptor?) of CD97, the prototype of a large seven-span transmembrane family (as many as 2,000 members) with variable numbers of EGF domains and sequence homology to the G-protein-coupled peptide hormone receptors.^{668,669} CD97 is associated with inflammation and is detected in malignancies.

Complement Receptor 1

Receptors for complement components or their breakdown products are expressed on many cells and tissues. They mediate various effector functions listed in Table 14.7. Some of the functions of complement receptors that are related to the regulation of complement activation are briefly reviewed. The complement receptor type one (CR1, C3b/C4b receptor, CD35) was the first to be discovered as the receptor for immune adherence, a fundamental event in the initiation of the immune response. It is a polymorphic membrane protein of 190 to 280 kDa composed of 2,039 residues and present on all peripheral blood cells except platelets, NK cells, and most T cells.⁶⁷⁰ CR1 is expressed on kidney podocytes and FDCs. Cell membrane expression of CR1 is up-regulated by chemotactic peptides, such as C5a, endotoxin, and cytokines. Blood cells at resting state express only 5% to 10% of the total cellular CR1 at the plasma membrane, whereas the remaining CR1 is found intracellularly. The red blood cells express 100 to 400 receptors per cell, and the leukocytes have 10,000 to 50,000 receptors per cell. However, because the number of red cells is approximately 1,000 times more than white cells, they possess more than 85% of the total CR1 that is available in the blood.

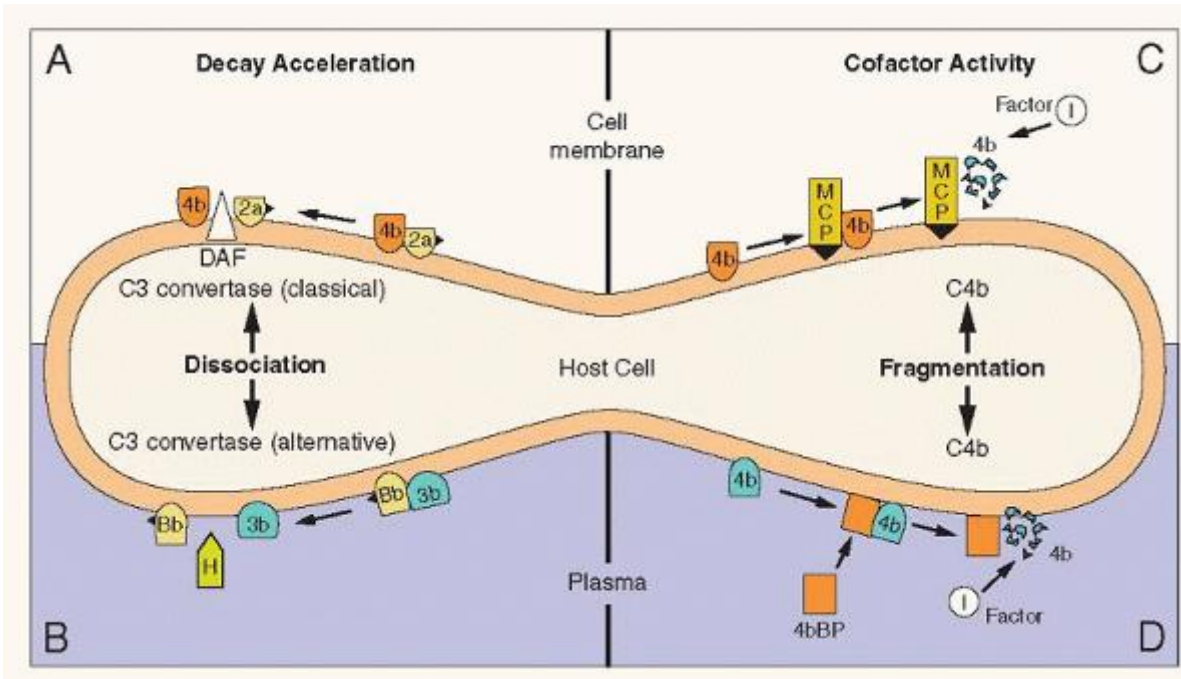

FIGURE 14.31. A, B: Decay activity on cell surfaces. A: Decay-accelerating factor (DAF, CD55) is a GP I-anchored protein, which dissociates formed C3 convertase complex, as well as prevents its formation. B: Factor H is a serum protein that expresses DA activity by attacking C3 convertases on self surfaces. It binds to the C3b-Bb complex and displaces factor B irreversibly. C, D: Co-factor activity. C: Membrane co-factor protein (MCP, CD46) is a cell membrane protein, which contains binding sites for C3b and C4b. It acts as co-factor for factor I to cleave both proteins. It is also the measles virus receptor. D: The C4b-binding protein (C4BP) is a serum protein that acts as a co-factor for factor I for cleaving C4b.

TABLE 14.7 CELLULAR DISTRIBUTION AND FUNCTION OF RECEPTORS FOR COMPLEMENT COMPONENTS

Receptor	Cell Type	Functions
C1q	Neutrophils	Respiratory burst
	Monocytes	—
	B cells	—
	Null cells	Enhanced antibody-dependent cell-mediated cytotoxicity
CR1	Macrophages	Enhanced phagocytosis
	Neutrophils	Same as macrophages
	B cells	—
	T cells	—
	Red blood cells	—
	Eosinophils	—
	Epithelial cells: kidney	—
CR2	B cells	Activation
CR3	Similar to CR1	Similar to CR1
Factor H	B cells	Secretion of factor I
	Monocytes	Respiratory burst

	Neutrophils	—
C5a	Mast cells	Histamine release
	Neutrophils	Chemotaxis, increased adhesiveness Enhancement of CR1 expression
	Macrophages	—
C3a/C4a	Mast cells	Histamine release

From Fearon DT, Wong WW. Complement ligand-receptor interactions that mediate biological responses. *Ann Rev Immunol* 1983;1:243, with permission.

CR1 contains 30 CCP domains with three sites for C4b binding and two sites for C3b binding. The CCP15 domain is critical for C4b binding and, together with the CCP16 domain, is required for C3b binding.⁶⁷¹ The CCP domains are arranged in larger domains that are known as long homologous repeats, with each one containing seven CCPs. It is likely that this arrangement facilitates the binding of CR1 with clusters of its ligands. There are four allotypes of CR1 (A through D). CR1, one of the most versatile RCAs, possesses DAA and CA, which are restricted to reducing the complement activity on cells that have absorbed immune complexes. The DAA of CD35 is mediated by CCP1 to CCP3 domains for the classical and alternative pathways.⁶⁷² In the classical pathway, CR1 inhibits the uptake of C2 by C4b as well as displaces C2a from C4b2a C3 convertase and from C4b2a3b C5 convertase. It also promotes the cleavage of C4b to C4c and C4d by factor I and the

cleavage of C3b to iC3b (ligand of CR3) and C3dg (ligand of CR2) by factor I. In the alternative pathway, the CR1 impairs uptake of factor B by C3b and displaces Bb from C3bBb C3 convertase. Complexes that are bound to erythrocytes are eliminated in the spleen. Conversion of C3b to fragments leads to binding of the complexes to macrophages and monocytes that possess CR3 or to lymphoid follicular areas in which all three CR are expressed.

The CR1 has the capacity to inhibit complement activation on cells and tissues other than those in which it is expressed (extrinsic protection), whereas DAF and MCP protect only the cells on which they are expressed (intrinsic protection). CR1 facilitates phagocytosis which in the absence of other ligands does not occur with resting neutrophils or monocytes. However, activation of these cells up-regulates CR1 expression and alters its function, so that phagocytosis of C3b-coated particles may occur. Soluble human CR1 inhibits complement-dependent tissue damage and reduces inflammatory responses.

Regulators in Body Fluids

Factor H

Factor H is a soluble glycoprotein that is present in blood at concentrations of 0.3 to 0.5 mg/L. It is a single polypeptide chain of 150 kDa with a highly elongated shape. It is composed of 1,213 amino acids that are assembled in 20 CCP domains. Factor H synthesis in the liver and in other extrahepatic sites (myeloblasts) is regulated by IL6.⁶⁷³

The main functions of factor H are (a) binding to the α chain of C3b, blocking the amplification cycle in the alternative pathway (tick-over), and preventing the generation of C3 convertase, C3bBb; (b) binding to the C3bBb enzyme and irreversibly displacing the Bb component (DA activity); and (c) acting as co-factor for factor I and enhancing its affinity for C3b. By these three activities, factor H prevents formation of the C5 convertase and, thus, the generation of MACs by the alternative pathway. Factor H possesses an impressive number of discriminatory functional sites. Its 20 CCP domains and its long and flexible structure allow factor H to scan a large surface area. The affinity of factor H for C3b is affected by the properties of the cell or tissue surface. Carbohydrate-rich polymers that are found on yeast and bacterial cells prevent binding of factor H to C3b, thus enabling the complement activation to react against these pathogens. Removal of sialic acid from sheep erythrocytes prevents binding of factor H to C3b and allows activation of complement.

Factor H binds to polyanions and blocking of this site enhances its affinity for C3b.⁶⁷⁴ The propensity of factor H to bind on polyanions, such as heparin on host tissues, may function as a protective mechanism against the alternative complement pathway.⁶⁷⁵ The discriminatory ability of factor H depends on its differential binding to various types of surfaces to which C3b has been initially deposited (Fig. 14.32). The nonactivating surfaces have sialic acid and other negatively charged glycosaminoglycans to which factor H binds through domain CCP20. The same domain is important for binding within approximately 30 Å from the C3d attachment site, indicating that the binding sites of factor H for polyanion and C3d

overlap.⁶⁷⁶ It is possible that discrimination by factor H occurs by a joint recognition of C3 and polyanions. The CCP11 to CCP20 domains are important for binding to activator surfaces,⁶⁷⁷ but the DAA or CA varies among these CCPs, depending on the nature of the surface on which C3b has been deposited. It appears that factor H uses different CCP domains, individually or in combinations, for recognition of C3, host, or foreign tissues. The CCP1 to CCP4 domains are used to bind intact C3b, the CCP6 to CCP10 domains are used for binding C3c within the C3b, and the CCP16 to CCP20 domains are used for the C3d part of the C3b.⁶⁷⁸

Recently, single-base mutations or base pair deletions have been demonstrated in sporadic and familial cases of hemolytic uremic syndrome (HUS).⁶⁷⁹ HUS is characterized by microangiopathic hemolytic anemia, thrombocytopenia, and acute renal failure in affected individuals and is classified as diarrheal (D+ HUS) or nondiarrheal (D- HUS) and as sporadic or familial.

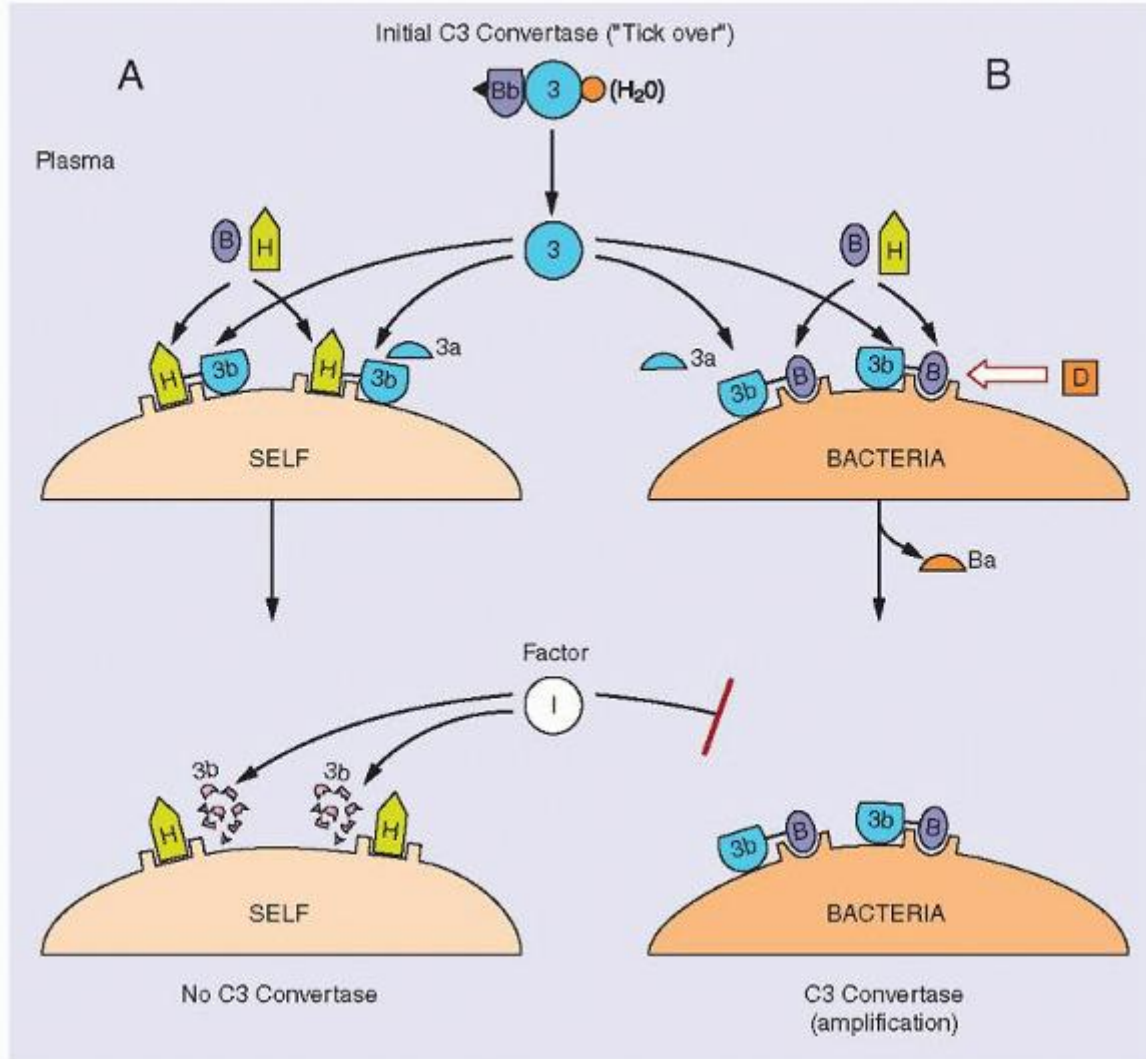

FIGURE 14.32. Self-/nonself-discrimination by factor H. A: Factor H prevents alternative complement activation by blocking the amplification cycle of the alternative pathway. It enhances its affinity to C3b as a result of binding to certain polyanions (negatively charged glycosaminoglycans) on self surfaces. Binding to C3b invites factor I to fragment C3b (cofactor activity). B: On pathogen surfaces, factor B expresses a higher affinity to deposited C3b and, with a lack of appropriate carbohydrate ligand for factor H, forms the alternative C3 convertase.

A set of 12 missense mutations in the CCP domains between CCP16 through CCP20 is associated with HUS. Nine of them are in CCP20 and are inferred to lead to a functional defect.⁶⁸⁰ The positions of these mutations correspond to basic residues that are involved in binding to heparin. It is suggested that these mutations interfere with the normal function of factor H to bind to sulfated glycosaminoglycans and to prevent the activation of the alternative complement pathway.

These experiments of nature strongly imply that the host-versus-foreign discrimination by factor H resides in CCP20 and is lost by these mutations.⁶⁸¹ Lack of host recognition results in uncontrolled complement activation and, eventually, renal failure.

Mice that are deficient in factor H develop membranoproliferative glomerulonephritis as a result of uncontrolled activation of the alternative complement pathway.⁶⁸² Factor H consists of several members; factor-H-like protein 1 (FHL-1) or reonectin, shares the complement regulatory functions with factor H and interacts with heparin. It contains the first seven of 20 CCP domains of factor H and has four unique residues that are attached to the terminal end.⁶⁸³ Both factor H and FHL-1 are synthesized by the same gene, but their transcripts are differentially regulated. They are produced by the liver, monocytes, and neuronal cells. Other members of the family are factor-H-related (FHR) proteins 3 and 4 (FHR-3 and FHR-4)⁶⁸⁴ which bind to C3b and particularly to C3d fragment.⁶⁸⁵

C4B-binding Protein

The C4b-binding protein (C4BP) is a regulator of the classical complement pathway C3 convertase. C4BP possesses CA and DAA. It consists of eight subunits that radiate from a central core in a spiderlike formation (Fig. 14.33). The peripheral end of each subunit is capable of binding one C4 molecule. Each of the seven

P.365

subunits known as α chains has a molecular weight of 75 kDa, and the eighth subunit, known as a β chain, is 45 kDa. They are flexible, 33 nm in length, and are linked together by disulfide bonds near the carboxy termini. In addition to the most common form of C4BP, $\alpha_7:\beta_1$, there are two other minor forms, $\alpha_7:\beta_0$ and $\alpha_6:\beta_1$. The α chains are composed of 549 amino acids divided into eight CCP domains, with 58 residues left in the C terminus to form the disulfide bond with the other α chains in the core region. The β chains have three CCP domains and are attached by a disulfide bond in a similar way to the α chains. The genes for C4BP are within the gene cluster of the other RCA proteins. The C4b binding site is localized in the CCP1 and CCP2 domains of the α chain, in a cluster of positively charged amino acids.⁶⁸⁶ The same region is also important for binding to heparin, Bordetella pertussis, and the M-protein of *S. pyogenes*, *Neisseria gonorrhoeae*, and *E. coli*.

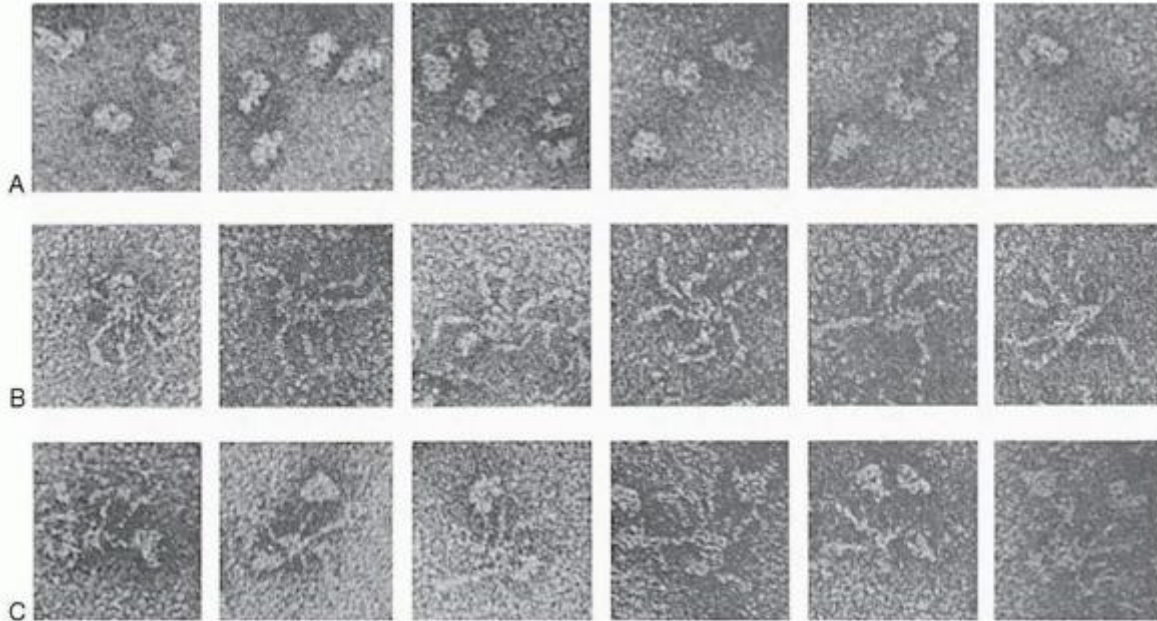

FIGURE 14.33. Electron micrographs of the C4b (A) and the C4b-binding protein (B) that form complexes with C4b (C). (Courtesy of Dr. B. Dahlback. From Dahlback B, Smith CA, Muller-Eberhard HJ. Visualization of human C4b-binding protein and its complexes with vitamin K-dependent protein S and complement protein C4b. Proc Natl Acad Sci U S A 1983;80:3461-3465, with permission.)

C4BP is synthesized in the liver under stimulation of IL6 and TNF- α and is present in the blood at a concentration of 0.2 mg/L. The mechanism of control of the classical pathway by C4BP depends on the binding to C4b and the displacement of C2a from the C4b2a convertase (DAA), as well as its function as a co-factor for cleavage of C4b by factor I. Dissociation of

C2a from the classical pathway C3 convertase destroys its activity and prevents rebinding of the C2a to C4b. C4BP acts also as co-factor for cleavage of C3b by factor I.⁶⁸⁷

Protein S binds with high affinity to the β chain of C4BP.⁶⁸⁸ Protein S of the coagulation pathway is a vitamin-K-dependent anticoagulant protein. It acts as the co-factor for activated protein C that inactivates factor Va and is also the direct inhibitor of factor Xa. The concentration of free protein S is determined by the concentration of C4BP, as 50% or more of protein S is bound to C4BP. Protein S that is bound to C4BP is unable to participate in the anticoagulant protein C system. It is critical that the balance between free and C4BP-bound protein S is maintained stable, because lack of free protein S leads to thrombosis. Protein-S-bound C4BP is probably localized on negatively charged surfaces that are found in platelets and apoptotic cells. Conditions with elevated C4BP (autoimmune diseases) may be associated with increased clotting tendency as a result of increased binding of protein S to C4BP.

Factor I

Factor I is a serine protease that mediates proteolytic degradation of C3b, iC3b, and C4b only if a co-factor binds to the substrate to promote the binding of the enzyme. These co-factors for C3 and C4 degradation on host cells are MCP (Fig. 14.31), and, to a lesser extent, CR1, whereas in plasma the co-factors are C4BP and factor H (Figs. 14.31 and 14.32). Factor I is constitutively active and essential for control of the fluid and cellular complement reactions. Genetic deficiency of factor I leaves the generation of C3 convertases uncontrolled, leading to incapacitation of the complement system as a result of the continuous low-level conversion of C3. Fragmentation by factor I of C3 and C4 determines the specificity of their derivatives for CR1, CR2, and CR3. Factor I is a two-chain disulfide-linked protein that is synthesized from a single-chain precursor. The H chain is 50 kDa, and the L chain is 38 kDa in molecular mass and has the Ser esterase domain. The H chain is composed of three different types of modules that are derived from different gene superfamilies. One module, which is also found in C6 and C7, is from members of the follistatin family of the extracellular matrix, a second type is a scavenger-receptor cysteine-rich module, and the third type are two LDLR-A modules.

The only known substrates for factor I are C3b and C4b. C3b is cleaved at Arg¹³⁰³-Ser¹³⁰⁴ and Arg¹³²⁰-Ser¹³²¹. For this cleavage, the co-factors are factor H, MCP, and CR1. C4BP acts as a co-factor for cleavage of C4b and C3b. C4b is cleaved at Arg¹³³⁶-Asn¹³³⁷. In general, for C3b and C4b and all subsequent fragments, factor I acts on the C-terminal side of an Arg.

Control of the Membrane Attack Complex Assembly

Protein S

Protein S is identical to vitronectin (serum spreading factor). It is a 75- to 80-kDa protein that is synthesized from a single polypeptide chain that is subsequently cleaved to give the mature polypeptide as a single or double chain protein. At the NH₂ terminus, there is a somatomedin B domain (containing eight cysteines) followed by a linear sequence, which contains the RGD sequence

P.366

that is responsible for the binding of integrins. Two domains of the S protein have homology to hemopexin. The C terminus is rich in basic residues that mediate the binding of S protein with sulfated polysaccharides.

Protein S binds to the metastable C5b-7 complex and prevents the formation of MAC. Because MAC in the process of its formation can be inserted on any cell membrane, the most important function of S protein is the protection of the cells of the body that may be attacked by MAC as innocent bystanders. Protein S acts through its heparin-binding site, which prevents the polymerization of C9. The protein S is important in cell matrix interactions, and, through its multiple binding sites, it participates in several other functions of adherence, phagocytosis, the coagulation cascade in which it interacts with thrombin.

Clusterin (Cytolysis Inhibitor)

Clusterin is an 80-kDa protein composed of two chains (α and β). The gene is located on chromosome 8p21-p12. It is present in a variety of tissues and in the serum at concentrations of 35 to 105 $\mu\text{g/L}$. It forms complexes with lipoproteins and binds to C7, C8b, and C9, to inhibit MAC formation.⁶⁸⁹

Clusterin is involved in several other poorly understood functions. It has been found to be up-regulated in injured tissues and in Alzheimer's disease, as well as in tissues undergoing apoptosis.

Control of Deposited MAC: CD59

CD59 is an 18- to 20-kDa protein that inhibits MAC formation.⁶⁹⁰ It has been known by a variety of other names, such as homologous restriction factor 20, membrane inhibitor of reactive lysis, and protectin. It is a GPI-anchored protein and is widely distributed in human tissues and most body fluids (see the following discussion). CD59 expression is lacking in patients with paroxysmal nocturnal hemoglobinuria (PNH).

Conclusion

The RCA proteins exert several important functions in the regulation of complement activity: (a) they prevent complement activation in the blood (factor H and C4BP); (b) they interfere with the assembly and function of convertase activity on cell membranes (DAF and MCP), protecting the cells of the body from complement attack; (c) they transport and clear immune complexes (CR1); and (d) they mediate transmembrane and intracellular trafficking (CR1) and transmembrane signaling (CR2).

The CCP units that are characteristic of the members of the proteins of the RCA gene cluster are present also in C1r, C6, C7, factor B, properdin, and noncomplement proteins, such as coagulation factor XIII and IL2 receptor. The 60 amino acid unit represents an ancestral domain that gave rise to the complement genes through duplication and splicing with domains from the serine protease gene family.

ANAPHYLATOXINS

Activation of the complement cascade leads to the release of important inflammatory factors that are known as anaphylatoxins: the C3a, C4a, and C5a molecules. Their amino acid sequence varies from 74 to 78 residues. The cysteines are conserved in all anaphylatoxins and form three disulfide bonds that stabilize the conformation and form the core of the molecule. The C terminus forms the active site, with the C-terminal Arg being essential for function. Under physiologic conditions, the molecule is folded or compact.

The C-terminal end protrudes from the core and is considered to be the active site of the molecule that mediates biologic activities. Removal of the last Arg (C5a desArg) results in a loss of spasmogenic activity, but the chemotactic and other neutrophil activation functions are retained. The N-terminal region of C5a binds to its high-affinity receptor on neutrophils, which spans the membrane seven times with the N terminus on the extracellular side.⁶⁹¹ It belongs to the rhodopsin family of receptors, the members of which are linked to G proteins. Binding of C5a to its receptor on neutrophils induces a variety of responses, depending on its concentration, such as chemotaxis, granule secretion, up-regulation of adhesion molecules, changes of cytoskeleton, and activation of NADPH oxidase.

All anaphylatoxins are cleaved rapidly in the serum by carboxypeptidase-N, an enzyme that removes the C-terminal Arg that is found on all three anaphylatoxins. The main biologic function of anaphylatoxins is related to their ability to increase vascular permeability as a result of mast-cell degranulation. Anaphylatoxins also cause serious lung injury because of their capacity to recruit and sequester leukocytes in the pulmonary circulation. Anaphylatoxins also mediate production of oxygen and nitrogen-derived radicals, leukocyte margination, release of granule-associated proteolytic enzymes and capillary leakage, all components of an inflammatory response.

COMPLEMENT COMPONENT DEFICIENCIES

C1 Esterase Inhibitor: Hereditary Angioneurotic Edema

HAE is an autosomal dominant disease that afflicts persons of all races with no sex predominance.⁶⁹² It manifests as recurrent attacks of intense, massive localized edema without pruritus and in the absence of any identifiable initiating event. Gastrointestinal and respiratory systems are most commonly involved with upper airways symptoms, including risk of asphyxiation. There are two types of HAE: type 1 (80% to 85% of cases) caused by decreased production of C1 INH and type 2 (15% to 20%) caused by a functionally impaired C1 INH (C1 esterase inhibitor).

C1 INH belongs to the same family as α 1-antitrypsin; antithrombin IFN- γ and IL6 stimulate its synthesis and release from the liver and monocytes. The main function of C1 INH is prevention of autoactivation of the complement cascade. It also inactivates coagulation factors XIIa, XIIf, and XIId and activated kallikrein. The mechanism of action involves formation of irreversible covalent bonds with the substrates.

Under physiologic conditions, small quantities of factor XII are autoactivated to factor XIIa and trigger the contact system, which cleaves prekallikrein to kallikrein; this cleaves kininogen, generating excessive release of kinins especially bradykinin. This pathway normally is blocked by C1 INH, which inhibits factor XIIa. In the absence of the normal control function of C1 INH, not only is factor XIIa not inhibited, but kallikrein also generates plasmin from plasminogen, activating factor XIIa for more kallikrein as well as activation of the C1 esterase.

Deficiency of Other Early Complement Components

Homozygous deficiencies of the early components of the classical pathway are associated with SLE,⁶⁹³ and the severity of the associated disease is greatest with C1q deficiency. This is caused by failure of C1q synthesis or synthesis of a dysfunctional molecule. C4 deficiency is associated with early onset of severe SLE. C2 deficiency is the most common homozygous complement deficiency in whites; C3 deficiency is associated with recurrent pyogenic infections, and deficiency of factor H has been associated with membranoproliferative glomerulonephritis.

P.367

Paroxysmal Nocturnal Hemoglobinuria: Deficiencies of Decay-accelerating Factor (CD55) or Clustering (CD59), or Both

PNH is an acquired hematopoietic stem cell disorder, which is manifested by intravascular hemolysis, venous thrombosis, aplastic anemia, myelodysplasia, and leukemia. The defect is the result of somatic mutations that consist of deletions, insertions, or point mutations of the PIGA (phosphatidyl inositol glycan complementation class A) gene, which is involved in the synthesis of GPI.^{694,695}

The GPI anchor consists of three components: (a) phosphoethanolamine (PEA), (b) a glycan core formed by three mannose molecules and one GlcNAc, and (c) PI.

Glycosyl Phosphatidyl Inositol Biosynthesis

GPI synthesis involves multiple steps and takes place in the ER (Fig. 14.34). Initially, GlcNAc is attached to PI, by the GPI-N-acetyltransferase, a complex enzyme that is composed of at least six proteins encoded in genes located on the short arm of the X chromosome:^{696,697,698} and ⁶⁹⁹ PIGA, PIGH, PIGC, PIGQ, PIGP, and DPM (dolichol phosphate mannose).

In humans, there is only one PEA, which is added to the third mannose. PIGO is responsible for such a reaction, and its function is stabilized by PIGF. PIGN is involved in the addition of PEA to the first mannose. Once the synthesis of GPI is complete, it is transferred to the protein by a transamidase complex. This complex consists of PIGK (GPI8), a small protein that is a protease, and PIGT (GPI16), PIGS (GPI17), and GPAA1-GAA1 proteins.⁷⁰⁰ These proteins interact physically with each other, but PIGT is the most important for the stability of the complex. The protein to have the GPI attached is first processed by removing the N-terminal leader peptide. The protein bound on the luminal side by a C-terminal peptide is translocated to the transamidase complex in the presence of the BiP chaperon. The C-terminal peptide of the protein is removed, and the transamidase complex attaches the GPI through the ethanolamine head to the newly exposed C terminal (ω site). This C-atom is linked to the amino group of PEA, which is attached to the third mannose by an amide bond.

Paroxysmal Nocturnal Hemoglobinuria: Immunopathology

The biochemical defect of PNH occurs in the first step of GPI synthesis and results from mutations in the PIGA gene. Because PIGA is on the X chromosome, one mutational event is sufficient to cause the disease.^{701,694} Cell proteins that are anchored by GPI are missing from PNH hematopoietic cells, and some of the clinical manifestations are due to loss of GPI-anchored proteins. Lack of CD55 alone is not responsible for the hemolytic component of the disease, because individuals with the Inab phenotype in which CD55 is absent have only slightly increased sensitivity. CD59, which binds to C3 and prevents binding and subsequent polymerization of C9, accounts for the intravascular hemolysis and, possibly, thrombosis in PNH.⁷⁰²

In addition to hemolysis, thrombosis is an important manifestation of PNH. Thrombosis is probably caused by the release of microparticles from platelets with procoagulant activity, such as particles that are rich in factor Va, factor Xa, and the prothrombinase complex. Endothelial cells are stimulated to express tissue factor and may contribute to thrombosis. Furthermore, lack of the urokinase plasminogen activator receptor (uPAR CD87), a GPI-anchored protein, is absent. Normally, it binds urokinase on the surface of granulocytes and monocytes, converting plasminogen to plasmin-initiating fibrinolysis and its lack may promote thrombosis. An important, albeit still unanswered, question is the relationship of PNH to bone marrow aplasia or myelodysplasia and the development of acute myelogenous leukemia. Normal stem cells from patients with PNH show diminished proliferative potential in vitro compared to mutant PNH CD34⁺ stem cells.⁷⁰³ The PNH clone with a proliferative advantage expands and dominates the normal cells. It has been suggested that PNH is expressed only when normal hematopoiesis is impaired and when the PNH clone dominates hematopoiesis. This is supported by some evidence that a tiny proportion of PIGA progeny exists in normal individuals.⁷⁰⁴

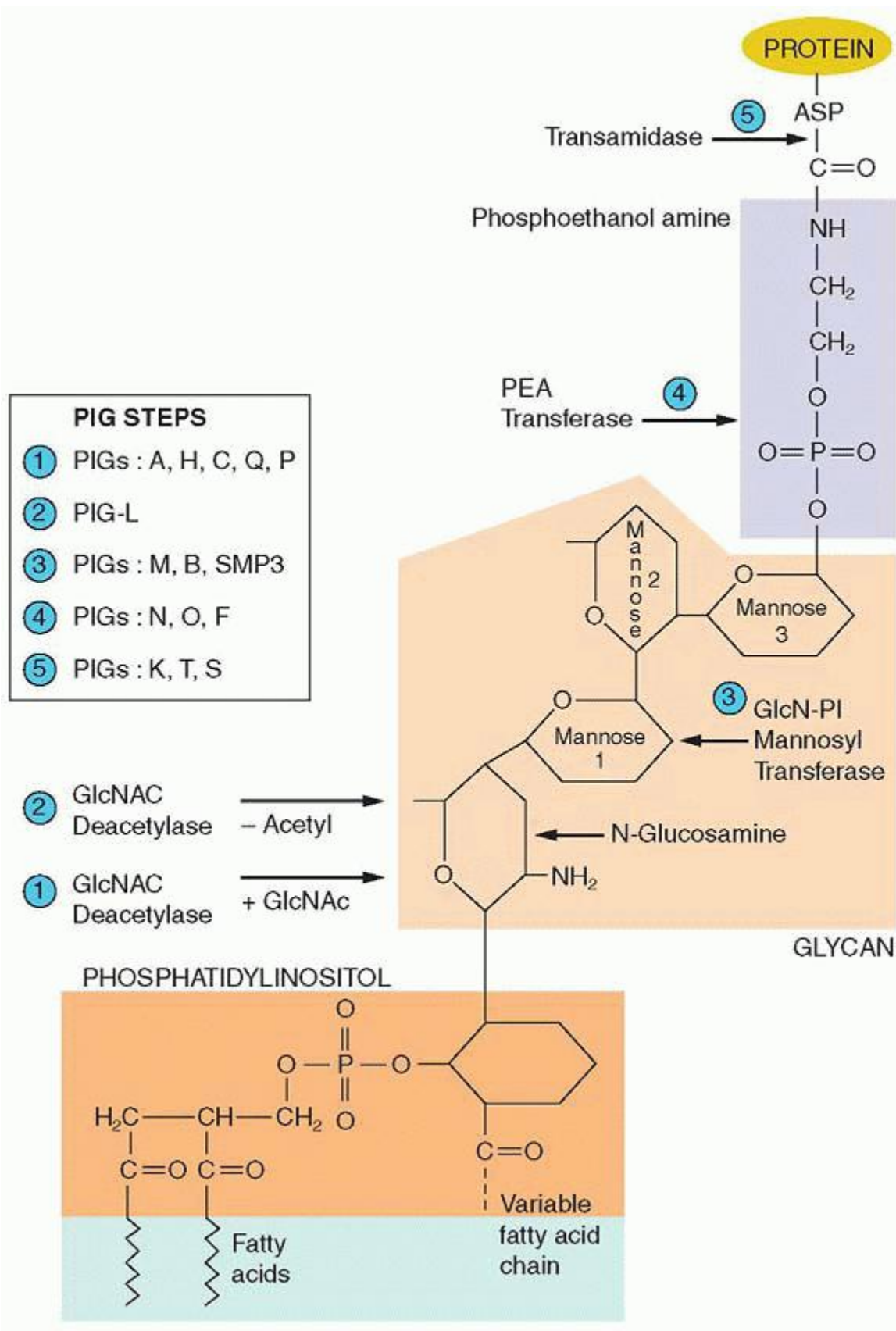

FIGURE 14.34. Biosynthesis of glycosyl phosphatidyl inositol (GPI). GPI consists of three components: (a) phosphatidyl inositol (PI), (b) glycan (made of one N-glucosamine and three mannose molecules), and (c) one phosphoethanolamine

(PEA). GPI anchored is synthesized in the endoplasmic reticulum and to proteins, expressing a signal that is encoded in the C-terminal sequence. The signal sequence is cleaved to expose the GPI attachment site (ω site). The first of several steps (1) in GPI biosynthesis attaches N-acetyl glucosamine (GlcNAc) to PI, by the enzyme GlcNAc transferase. The acetyl group is removed in the second step (2) by a deacetylase. Subsequently, three mannose (M) molecules are added by different mannose transferases (3) (attachment bonds differ), and, finally, the PEA molecule is attached by a PEA transferase. The attachment of the completed GPI to the protein is mediated by a transamidase complex. The first enzyme, GlcNAc transferase, is a complex of at least five gene products (see the text for details). Phosphatidyl inositol glycan complementation class A (PIG-A) performs the catalytic function of the enzyme, and mutations in this gene result in paroxysmal nocturnal hemoglobinuria.

Deficiencies of Terminal Complement Components

Deficiencies of the terminal complement components, such as C7, have been detected in several countries, whereas C6 has been detected primarily in blacks in the United States and in South Africa, and the majority of C9 deficiencies have been found in

P.368

Japan.^{693,705,706} and ⁷⁰⁷ C6 deficiency has been defined as quantitatively zero C6 (C6Q0) or subtotal C6 (C6SD), when C6 is structurally abnormal but hemolytically active.⁷⁰⁸

Deficiencies are due to single-base deletions or mutations that lead to premature stop codons. In C6 deficiency there is a tendency for mutations in exon 6⁷⁰⁷ with defects in an area that is adjacent to a sequence that contains seven Gs and a string of six Ts.⁷⁰⁹ Carboxy terminally truncated C6, which results in a shorter dysmorphic, but functionally active, molecule, has been detected in South African families.⁷¹⁰ Complement component C6 deficiency is associated with *Neisseria* infections often being recurrent.⁷¹¹

Infections with serogroup B are the major problems in these patients; these infections limit the usefulness of the available vaccine, which is not directed against this group. Other infections have also been detected in homozygous C6 deficiency, such as SLE, Still disease, and glomerulosclerosis.⁷¹²

THE COMPLEMENT SYSTEM

The origins of the complement system, i.e., the C3 and a protein similar to B factor, can be traced to sea urchins.^{634,713,714} The scidians (sea squirts), or tunicates, occupy an intermediary position between invertebrates and vertebrates.

Two lectins that correspond to mammalian MBL, ficolins, two mannan-binding lectin serine proteases (MASP), the C3 and its receptor the B factor, have been identified in ascidians. These findings indicate that a lectinlike pathway precedes the development of the classical pathway, which seems to emerge only at the stage of cartilaginous fishes at the same time as the appearance of the adaptive immunity. Mannose-binding protein-associated serine protease-2 (MASP2), is an enzyme which in humans is encoded by the MASP2 gene involved in the complement system. MASP2 is very similar to the C-1s molecule, of the classical complement pathway, and they are thought to have a common evolutionary ancestor. When the carbohydrate-recognizing heads of MBL bind to specifically arranged mannose residues on the surface of a pathogen, MASP2 is activated to cleave complement components C4 and C2 into C4a, C4b, C2a, and C2b.

REFERENCES

1. Benacerraf B, Germain RN. The immune response genes of the major histocompatibility complex. *Immunol Rev* 1978;38:70-119.
2. Campbell RD, Trowsdale J. Map of the human MHC. *Immunol Today* 1993;14:349-352.
3. el Kahloun A, Chauvel B, Mauvieux V, et al. Localization of seven new genes around the HLA-A locus. *Hum Mol Genet* 1993;2:55-60.
4. Geraghty DE, Koller BH, Hansen JA, et al. The HLA class I gene family includes at least six genes and twelve pseudogenes and gene fragments. *J Immunol* 1992;149:1934-1946.
5. Doxiadis GG, Hoof I, de Groot N, et al. Evolution of HLA-DRB genes. *Mol Biol Evol*. Epub 2012.
6. Shiina T, Tamiya G, Oka A, et al. Genome sequencing analysis of the 1.8 Mb entire human MHC class I region. *Immunol Rev* 1999;167:193-199.

7. Shiina T, Tamiya G, Oka A, et al. Molecular dynamics of MHC genesis unraveled by sequence analysis of the 1,796,938-bp HLA class I region. *Proc Natl Acad Sci U S A* 1999;96:13282-13287.
8. Beck S, Trowsdale J. Sequence organization of the class II region of the human MHC. *Immunol Rev* 1999;167:201-210.
9. Groettrup M, Soza A, Kuckelkorn U, et al. Peptide antigen production by the proteasome: complexity provides efficiency. *Immunol Today* 1996;17:429-435.
10. Monaco JJ. Genes in the MHC that may affect antigen processing. *Curr Opin Immunol* 1992;4:7073.
11. Kropshofer H, Hammerling GJ, Vogt AB. How HLA-DM edits the MHC class II peptide repertoire: survival of the fittest? *Immunol Today* 1997;18:77-82.
12. Gruen JR, Weissman SM. Evolving views of the major histocompatibility complex. *Blood* 1997;90:4252-4265.
13. Shawar SM, Vyas JM, Rodgers JR, et al. Antigen presentation by major histocompatibility complex class I-b molecules. *Annu Rev Immunol* 1994;12: 839-880.
14. Wilson IA, Fremont DH. Structural analysis of MHC class I molecules with bound peptide antigens. *Semin Immunol* 1993;5:75-80.
15. Lopez de Castro JA, Barbosa JA, Krangel MS, et al. Structural analysis of the functional sites of class I HLA antigens. *Immunol Rev* 1985;85:149-168.
16. Salter RD, Benjamin RJ, Wesley PK, et al. A binding site for the T-cell coreceptor CD8 on the $\alpha 3$ domain of HLA-A2. *Nature* 1990;345:41-46.
17. Saper MA, Bjorkman PJ, Wiley DC. Refined structure of the human histocompatibility antigen HLA-A2 at 2.6 Å resolution. *J Mol Biol* 1991;219:277-319.
18. Bjorkman PJ, Saper MA, Samraoui B, et al. Structure of the human class I histocompatibility antigen, HLA-A2. *Nature* 1987;329:506-512.
19. Hedrick PW, Whittam TS, Parhaml P. Heterozygosity at individual amino acid sites: extremely high levels for HLA-A and -B genes. *Proc Natl Acad Sci U S A* 1991;88:5897-5901.
20. Madden DR, Gorga JC, Strominger JL, et al. The structure of HLA-B27 reveals nonamer self-peptides bound in an extended conformation. *Nature* 1991;353:321-325.
21. Garrett TPJ, Saper MA, Bjorkman PJ, et al. Specificity pockets for the side chains of peptide antigens in HLA-Aw68. *Nature* 1989;342:692-696.
22. Engelhard VH. Structure of peptides associated with MHC class I molecules. *Curr Opin Immunol* 1994;6:13-23.
23. Rotzschke O, Falk K. Origin, structure and motifs of naturally processed MHC class II ligands. *Curr Opin Immunol* 1994;6:45-51.
24. Young AC, Zhang W, Sacchettini JC, et al. The three-dimensional structure of H-2Db at 2.4 Å resolution: implications for antigen-determinant selection. *Cell* 1994;76:39-50.
25. Madden DR. The three-dimensional structure of peptide-MHC complexes. *Annu Rev Immunol* 1995;13:587-622.
26. Bowness P, Allen RL, McMichael AJ. Identification of T cell receptor recognition residues for a viral peptide presented by HLA B27. *Eur J Immunol* 1994;24:2357-2363.
27. Lee ST, Paraskevas F. Macrophage-T cell interactions. II. The uptake by T cells of fragments bearing Ia determinants released from macrophages. *Cell Immunol* 1979;48:1-14.
28. Pober JS, Gimbrone MA Jr, Cotran RS, et al. Ia expression by vascular endothelium is inducible by activated T cells and by human γ -interferon. *J Exp Med* 1983;157:1339-1353.
29. Kappes D, Strominger JL. Human class II major histocompatibility complex genes and proteins. *Annu Rev Biochem* 1988;57:991-1028.
30. Dixon AM, Stanley BJ, Matthews EE, et al. Invariant chain transmembrane domain trimerization: a step in MHC class II assembly. *Biochemistry* 2006;45: 5228-5234.
31. Marks MS, Blum JS, Cresswell P. Invariant chain trimers are sequestered in the rough endoplasmic reticulum in the absence of association with HLA class II antigens. *J Cell Biol* 1990;111:839-855.

32. Roche PA, Marks MS, Cresswell P. Formation of a nine-subunit complex by HLA class II glycoproteins and the invariant chain. *Nature* 1991;354:392-394.
33. Riberdy JM, Newcomb JR, Surman MJ, et al. HLA-DR molecules from an antigen-processing mutant cell line are associated with invariant chain peptides. *Nature* 1992;360:474-477.
34. Craig EA. Chaperones: helpers along the pathways to protein folding. *Science* 1993;260:1902-1903.
35. Anderson KS, Cresswell P. A role for calnexin (IP-90) in the assembly of class II MHC molecules. *EMBO J* 1994;13:675-682.
36. Cresswell P. Assembly, transport, and function of MHC class II molecules. *Annu Rev Immunol* 1994;12:259-293.
37. Marsh SG, Bodmer JG. HLA class II nucleotide sequences, 1992. *Hum Immunol* 1992;35:1-17.
38. Konig R, Huang LY, Germain RN. MHC class II interaction with CD4 mediated by a region analogous to the MHC class I binding site for CD8. *Nature* 1992;356:796-798.
39. Cammarota G, Scheirle A, Takacs B, et al. Identification of a CD4 binding site on the β 2 domain of HLA-DR molecules. *Nature* 1992;356:799-801.
40. Stern LJ, Brown JH, Jardetzky TS, et al. Crystal structure of the human class II MHC protein HLA-DR1 complexed with an influenza virus peptide. *Nature* 1994;368:215-221.
41. Chicz RM, Urban RG, Lane WS, et al. Predominant naturally processed peptides bound to HLA-DR1 are derived from MHC-related molecules and are heterogeneous in size. *Nature* 1992;358:764-768.
42. Jardetzky TS, Brown JH, Gorga JC, et al. Three-dimensional structure of a human class II histocompatibility molecule complexed with superantigen. *Nature* 1994;368:711-718.
43. O'Callaghan CA, Bell JH. Structure and function of human MHC class Ib molecules HLA-E, HLA-F and HLA-G. *Immunol Rev* 1998;163:129-138.
44. O'Callaghan CA, Tormo J, Willcox BE, et al. Structural features impose tight peptide binding specificity in non-classical MHC molecule HLA-E. *Mol Cell* 1998;1:531-541.
45. Miller JD, Weber DA, Ibegbu C, et al. Analysis of HLA-E peptide-binding specificity and contact residues in bound peptide required for recognition by CD94/NKG2. *J Immunol* 2003;171:1369-1375.
46. Braud VM, Allan DS, Wilson D, et al. TAP and tapasin-dependent HLA-E surface expression correlates with the binding of an MHC class I leader peptide. *Curr Biol* 1998;8:1-10.
47. Allan DSJ, Lepin EJM, Braud VM, et al. Tetrameric complexes of HLA-E, HLA-F, and HLA-G. *J Immunol Methods* 2002;268:43-50.
48. Lee N, Llano M, Carretero M, et al. HLA-E is a major ligand for the natural killer inhibitory receptor CD94/NKG2A. *Proc Natl Acad Sci U S A* 1998;95:5199-5204.
49. Borrego F, Ulbrecht M, Weiss EH, et al. Recognition of human histocompatibility leukocyte antigen (HLA-E) complexed with HLA class I signal sequence derived peptides by CD94/NKG2 confers protection from natural killer cell-mediated lysis. *J Exp Med* 1998;187:813-818.
50. Garcia P, Llano M, de Heredia AB, et al. Human T cell receptor-mediated recognition of HLA-E. *Eur J Immunol* 2002;32:936-944.
51. Tomasec P, Braud VM, Richards C, et al. Surface expression of HLA-E, an inhibitor of natural killer cells, enhanced by human cytomegalovirus gpUL40. *Science* 2000;287:1031-1033.
52. Michaëlson J, Teixeira de Matos C, Achour A, et al. A signal peptide derived from hsp-60 binds HLA-E and interferes with CD94/NKG2A recognition. *J Exp Med* 2002;196:1403-1414.
53. Lepin EJ, Bastin JM, Allan DS, et al. Functional characterization of HLA-F and binding of HLA-F tetramers to ILT2 and ILT4 receptors. *Eur J Immunol* 2000;30:3552.
54. Wainwright SD, Siro PA, Holmes CH. HLA-F is a predominantly empty, intracellular, TAP-associated MHC class Ib protein with a restricted expression pattern. *J Immunol* 2000;164:319-328.
55. Le Bouteiller P, Lenfant F. Antigen-presenting function(s) of the non-classical HLA-E, -F, and -G class I molecules: the beginning of a story. *Res Immunol* 1996;147:301-313.

56. Le Bouteiller P, Blaschitz A. The functionality of HLA-G is emerging. *Immunol Rev* 1999;167:233-244.
57. Allan DSJ, Colonna M, Lanier LL, et al. Tetrameric complexes of human histocompatibility leukocyte antigen (HLA)-G bind to peripheral blood myelomonocytic cells. *J Exp Med* 1999;189:1149-1155.
58. Pende D, Sivori S, Accame L, et al. HLA-G recognition by human natural killer cells. Involvement of CD94 both as inhibitory and as activated receptor complex. *Eur J Immunol* 1997;27:1875-1880.
59. Navarro F, Llano M, Bellon T, et al. The ILT2 (LIR1) and CD94/NKG2A NK cell receptors respectively recognize HLA-G1 and HLA-E molecules coexpressed on target cells. *Eur J Immunol* 1999;29:277-283.
60. Rajagopalan S, Long EO. A human compatibility leukocyte antigen (HLA)-G-specific receptor expressed on all natural killer cells. *J Exp Med* 1999;189: 1093-1099.
61. Alfonso C, Karlsson L. Nonclassical MHC class II molecules. *Annu Rev Immunol* 2000;18:113-142.
62. Sanderson F, Thomas C, Neefjes J, et al. Association between HLA-DM and HLA-DR in vivo. *Immunity* 1996;4:87-96.
63. Kropshofer H, Hammerling GJ, Vogt AB. The impact of non-classical MHC proteins HLA-DM and HLA-DO on loading of MHC class II molecules. *Immunol Rev* 1999;172:267-278.
64. Ullrich HJ, Döring K, Grüneberg U, et al. Interaction between HLA-DM and HLA-DR involves regions that undergo conformational changes at lysosomal pH. *Proc Natl Acad Sci U S A* 1997;94:13163-13168.
65. Kropshofer H, Vogt AB, Moldenhauer G, et al. Editing of the HLA-DR peptide repertoire by HLA-DM. *EMBO J* 1996;15:6144-6154.
66. Sant AJ, Beeson C, McFarland B, et al. Individual hydrogen bonds play a critical role in MHC class II peptide interactions: implications for the dynamic aspects of class II trafficking and DM-mediated peptide exchange. *Immunol Rev* 1999;172:239-253.
67. Kropshofer H, Arndt SO, Moldenhauer G, et al. HLA-DM acts as a molecular chaperone and rescues empty HLA-DR molecules at lysosomal pH. *Immunity* 1997;6:293-302.
68. Douek DC, Altman DM. HLA-DO is an intracellular class II molecule with distinctive thymic expression. *Int Immunol* 1997;9:335-364.
69. Liljedahl M, Kuwana T, Fung-Leung WP, et al. HLA-DO is a lysosomal resident which requires association with HLA-DM for efficient intracellular transport. *EMBO J* 1996;15:4817-4824.
70. Kropshofer H, Vogt AB, Thery C, et al. A role for HLA-DO as a co-chaperone of HLA-DM in peptide loading of MHC class II molecules. *EMBO J* 1998;17:2971-2981.
71. Van Ham SM, Tjin EP, Lillemeijer BF, et al. HLA-DO is a negative modulator of HLA-DM-mediated MHC class II peptide loading. *Curr Biol* 1997;7: 950-957.
72. Alfonso C, Liljedahl M, Wingvist O, et al. The role of H2-O and HLA-DO in major histocompatibility complex class II-restricted antigen processing and presentation. *Immunol Rev* 1999;172:255-266.
73. Bahram S. MIC genes: from genetics to biology. *Adv Immunol* 2001;76:1-60.
74. Li P, Willie ST, Bauer S, et al. Crystal structure of the MHC class I homolog MIC-A, a gamma delta T cell ligand. *Immunity* 1999;10:577-584.
75. Strong RK. Class (I) will come to order—not. *Nat Struct Biol* 2000;7:173-176.
76. Stephens HAF. MICA and MICB genes: can the enigma of their polymorphism be resolved? *Trends Immunol* 2001;22:378-385.
77. Groh V, Rhinehart R, Secrist H, et al. Broad tumor-associated expression and recognition of tumor derived $\gamma\delta$ T cells of MICA and MICB. *Proc Natl Acad Sci U S A* 1999;96:6879-6884.
78. Bauer S, Groh V, Wu J, et al. Activation of NK cells and T cells by NKG2D, a receptor for stress-inducible MICA. *Science* 1999;285:727-732.
79. Groh V, Rhinehart R, Randolph-Habecker J, et al. Costimulation of CD8+ $\alpha\beta$ T cells by NKG2D via engagement by MIC induced on virus-infected cells. *Nat Immunol* 2001;2:255-260.
80. Li P, Morris DL, Willcox BE, et al. Complex structure of the activating immunoreceptor NKG2D and its MHC class I-like ligand MICA. *Nat Immunol* 2001;2:443-451.

81. Marten A, vonLilienfeld-Toal M, Buchler MW, Schmidt J. Soluble MIC is elevated in the serum of patients with pancreatic carcinoma diminishing gamma delta T cell cytotoxicity. *Int J Cancer* 2006;119:2359-2365.
82. Salih HR, Goehlsdorf D, Steinle A. Release of MICB molecules by tumor cells: mechanism and soluble MICB in sera of cancer patients. *Hum Immunol* 2006;67:188-195.
83. Zwirner NW, Dole K, Stastny P. Differential surface expression of MICA by endothelial cells, fibroblasts, keratinocytes and monocytes. *Hum Immunol* 1999;60:323-330.
84. McMichael A, Pilch JR, Galfre G, et al. A human thymocyte antigen defined by a hybrid myeloma monoclonal antibody. *Eur J Immunol* 1979;9:205-210.
85. Sugita M, Porcelli SA, Brenner MB. Assembly and retention of CD1b heavy chains in the endoplasmic reticulum. *J Immunol* 1997;159:2358-2365.
86. Zeng Z, Castano AR, Segelke BW, et al. Crystal structure of mouse CD1: an MHC-like fold with a large hydrophobic binding groove. *Science* 1997;277:339-345.
87. Godola SD, Caccai NR, Harlos K, et al. Structure of human CD1b with bound ligands and 2.3 Å, a maze for alkyl chains. *Nat Immunol* 2002;3:721-726.
88. Beckman EM, Porcelli SA, Morita CT, et al. Recognition of a lipid antigen by CD1-restricted $\alpha\beta$ T cells. *Nature* 1994;372:691-694.
89. Melian A, Geng YJ, Sukhova GK, et al. CD1 expression in human atherosclerosis—a potential mechanism for T cell activation by foam cells. *Am J Pathol* 1999;155:775-786.
90. DeLibero G, Mori L. How T cells recognize lipid antigens. *FEBS Lett* 2006;580: 5580-5587.
91. Brutkiewicz RR. CD1d ligands: the good, the bad and the ugly. *J Immunol* 2006;177:769-775.
92. Moody DB. TLR gateways to CD1 function. *Nat Immunol* 2006;7:811-817.
93. Cosman D, Mullberg J, Sutherland CL, et al. ULBPs, novel MHC class I related molecules, bind to CMV glycoprotein UL16 and stimulate NK cytotoxicity, through the NKG2D receptor. *Immunity* 2001;14:123-133.
94. Kubin M, Cassiano L, Chalupny J, et al. ULBP1, 3, 3: novel MHC class I-related molecules that bind to human cytomegalovirus glycoprotein UL16, activate NK cells. *Eur J Immunol* 2001;31:1428-1437.
95. Sutherland CL, Chalupny NJ, Schooley K, et al. UL16-binding proteins, novel MHC class I-related proteins, bind to NKG2D and activate multiple signaling pathways in primary NK cells. *J Immunol* 2002;168:671-679.
96. Diefenbach A, Jamieson AM, Liu SD, et al. Ligands for the murine NKG2D receptor: expression by tumor cells and activation of NK cells and macrophages. *Nat Immunol* 2000;1:119-126.
97. Wu J, Chalupny NJ, Manley TJ, et al. Intracellular retention of the MHC class I related chain B ligand of NKG2D by the human cytomegalovirus UL16 glycoprotein. *J Immunol* 2003;170:4196-4200.
98. Waldhauer I, Steinle A. Proteolytic release of soluble UL-16-binding protein 2 from tumor cells. *Cancer Res* 2006;66:2520-2526.
99. Song H, Kim JK, Cosman D, Choi I. Soluble ULBP suppresses natural killer cell activity via down-regulating NKG2D expression. *Cell Immunol* 2006;239: 22-30.
100. Flajnik MF, Kasahara M. Comparative genomics of the MHC: glimpses into the evolution of the adaptive immune system. *Immunity* 2001;15:351-362.
101. Parham P. Virtual reality in the MHC. *Immunol Rev* 1999;167:5-15.
102. Kasahara M. The chromosomal duplication model of the major histocompatibility complex. *Immunol Rev* 1999;167:17-32.
103. Abi-Rached L, McDermott MF, Pontarotti P. The MHC big bang. *Immunol Rev* 1999;167:33-44.
104. Hughes AL. Phylogenetic tests of the hypothesis of block duplication of homologous genes on human chromosomes 6, 9 and 1. *Mol Biol Evol* 1998;15:854-870.
105. Yeager M, Hughes AL. Evolution of the mammalian MHC: natural selection, recombination and convergent evolution. *Immunol Rev* 1999;167:45-58.

106. Flajnik MF, Ohta Y, Namikawa-Yamada C, et al. Insight into the primordial MHC from studies in ectothermic vertebrates. *Immunol Rev* 1999;167:59-67.
107. Hashimoto K, Okamura K, Yamaguchi H, et al. Conservation and diversification of MHC class I and its related molecules in vertebrates. *Immunol Rev* 1999;167:81-100.
108. Kaufman J, Jacob J, Shaw I, et al. Gene organization determines evolution of function in the chicken MHC. *Immunol Rev* 1999;167:101.
109. Price P, Witt C, Allcock R, et al. The genetic basis for the association of the 8.1 ancestral haplotype (A1, B8, DR3) with multiple immunopathological diseases. *Immunol Rev* 1999;167:257-274.
110. Dawkins R, Leelayuwat C, Goudieri S, et al. Genomics of the major histocompatibility complex: haplotypes, duplication, retroviruses and disease. *Immunol Rev* 1999;167:275-304.
111. York IA, Rock KL. Antigen processing and presentation by the class I major histocompatibility complex. *Annu Rev Immunol* 1996;14:369-396.
112. Tanaka K, Tanahashi N, Tsurumi C, et al. Proteasomes and antigen processing. *Adv Immunol* 1997;64:1-38.
113. Coux O, Tanaka K, Goldberg AL. Structure and functions of the 28S and 26S proteasomes. *Annu Rev Biochem* 1996;65:801-847.
114. Shastri N, Schwab S, Serwold T. Producing nature's gene-chips: the generation of peptides for display by MHC class I molecules. *Annu Rev Immunol* 2002;20:463-493.
115. Rock KL, York IA, Saric T, et al. Protein degradation and the generation of MHC class I-presented peptides. *Adv Immunol* 2002;80:1-70.
116. Zwickl P, Kleinz J, Baumeister W. Critical elements in proteasome assembly. *Nat Struct Biol* 1994;1:765-770.
117. Pickart CM, Cohen RE. Proteasomes and their kin: proteases in the machine age. *Nat Rev Mol Cell Biol* 2004;5:177-182.
118. Monaco JJ, Nandi D. The genetics of proteasomes and antigen processing. *Annu Rev Genet* 1995;29:729-754.
119. Tanaka K, Kasahara M. The MHC class I ligand-generating system: role of immunoproteasomes and the interferon- γ -inducible proteasome activator PA28. *Immunol Rev* 1998;163:161-176.
120. Dubiel W, Pratt G, Ferrel K, et al. Purification of an 11S regulator of the multicatalytic protease. *J Biol Chem* 1992;267:22369-22377.
121. Ferrington DA, Gregerson DS. Immunoproteasomes: structure, function, and antigen presentation. *Prog Mol Biol Transl Sci* 2012;109:75-112.
122. Goldberg AL, Cascio P, Saric T et al. The importance of the proteasome and subsequent proteolytic steps in the generation of antigenic peptides. *Mol Immunol* 2002;39:147-64.
123. Craiu A, Akopian T, Goldberg A, et al. Two distinct proteolytic processes in the generation of a major histocompatibility complex class I-presented peptide. *Proc Natl Acad Sci U S A* 1997;94:10850-10855.
124. Cascio P, Hilton C, Killelev AF, et al. 26S proteasomes and immunoproteasomes produce mainly N-extended versions of an antigenic peptide. *EMBO J* 2000;20:2357-2366.
125. Paz P, Brouwenstijn N, Perry R, et al. Discrete proteolytic intermediates in the MHC class I antigen processing pathway and MHC I-dependent peptide trimming in the ER. *Immunity* 1999;11:241-251.
126. Ben Shahan S, Komlos A, Nadav E, et al. 26S proteasome-mediated production of an authentic major histocompatibility class I-restricted epitope from an intact protein substrate. *J Biol Chem* 1999;274:2963-2972.
127. Yewdell JW, Bennick JR. Cut and trim: generating MHC class I peptide ligands. *Curr Opin Immunol* 2001;13:13-18.
128. Schwartz AL, Ciechanover A. The ubiquitin-proteasome pathway and pathogenesis of human diseases. *Annu Rev Med* 1999;50:57-74.
129. Pickard CM, Cohen RE. Proteasome and their kin: proteases in the machine age. *Nat Rev Mol Cell Biol* 2004;5:177-187.
130. Pickard CM, Eddins MJ. Ubiquitin: structures, functions, mechanisms. *Biochim Biophys Acta* 2004;1695:55-72.

131. Pickard CM, Fushman D. Polyubiquitin chains: polymeric protein signals. *Curr Opin Chem Biol* 2004;8:610-616.
132. Renatus M, Parrado SG, D'Arcy AD, et al. Structural bases of ubiquitin recognition by the deubiquitinating proteases USP2. *Structure* 2006;14:1293-1302.
133. Hu M, Pingwei Li, Song L, et al. Structure and mechanism of the proteasome associated deubiquitinating enzyme USP14. *EMBO J* 2005;24:3747-3756.
134. Momburg F, Hämmerling GJ. Generation of TAP-mediated transport of peptides for major histocompatibility complex class I molecules. *Adv Immunol* 1998;68:191-256.
135. Koch J, Guntrum R, Taupe R. Exploring the minimal functional unit of the transporter associated with antigen processing. *FEBS Lett* 2005;579: 4413-4416.
136. Yewdell JW, Reits E, Neefjes J. Making sense of mass destruction: quantitating MHC class I antigen presentation. *Nat Rev Immunol* 2003;3:952-961.
137. Keusekotten K, Leonhardt RM, Ehses S, Knittler MR. Biogenesis of functional antigen peptide transporter TAP requires assembly of pre-existing TAP1 with newly synthesized TAP2. *J Biol Chem* 2006;281:17545-17551.
138. Townsend A, Trowsdale J. The transporters associated with antigen presentation. *Semin Cell Biol* 1993;4:53-61.
139. de la Salle H, Hanau D, Fricker D, et al. Homozygous human TAP peptide transporter mutation in HLA class I deficiency. *Science* 1994;265:237-241.
140. Van Kaer L, Ashton-Rickardt PG, Ploegh HL, et al. TAP1 mutant mice are deficient in antigen presentation, surface class I molecules, and CD4₊ T cells. *Cell* 1992;71:1205-1214.
141. Higgins CF. ABC transporters: from microorganisms to man. *Annu Rev Cell Biol* 1992;8:67-113.
142. Kleijmeer MJ, Kelly A, Geuze HJ, et al. Location of MHC-encoded transporters in the endoplasmic reticulum and cis-Golgi. *Nature* 1992;357:342-344.
143. Muller KM, Ebensperger C, Tampe R. Nucleotide binding to the hydrophilic Cterminal domain of the transporter associated with antigen processing (TAP). *J Biol Chem* 1994;269:14032-14037.
144. Androlewicz MJ, Cresswell P. Human transporters associated with antigen processing possess a promiscuous peptide-binding site. *Immunity* 1994;1: 7-14.
145. Androlewicz MJ, Anderson KS, Cresswell P. Evidence that transporters associated with antigen processing translocate a major histocompatibility complex class I-binding peptide into the endoplasmic reticulum in an ATP-dependent manner. *Proc Natl Acad Sci U S A* 1993;90:9130-9134.
146. Schumacher TN, Kantesaria DV, Heemels MT, et al. Peptide length and sequence specificity of the mouse TAP1/TAP2 translocator. *J Exp Med* 1994;179:533-540.
147. Sargent CA, Dunham I, Trowsdale J, Campbell RD. Human major histocompatibility complex contains genes for the major heat shock protein HSP70. *Proc Natl Acad Sci U S A* 1989;86:1968-1972.
148. Wang Y, Chen D, Androlewicz MJ. The role of endoplasmic reticulum-associated protein degradation in MHC class I antigen processing. *Immunol Rev* 1999;172:67-72.
149. Plemper RK, Wolf DH. Retrograde protein translocation: eradication of secretory proteins in health and disease. *Trends Biochem Sci* 1999;24:266-270.
150. Kleizen B, Braakman I. Protein folding and quality control in the endoplasmic reticulum. *Curr Opin Cell Biol* 2004;16:343-349.
151. Williams DB. Beyond lectins: the calnexin/calreticulum chaperone system of the endoplasmic reticulum. *J Cell Sci* 2006;119:615-623.
152. Cresswell P, Bangia N, Dick T, et al. The nature of MHC class I peptide loading complex. *Immunol Rev* 1999;172:21-28.
153. Culina S, Lauvau G, Gubler B, vanEnder PM. Calreticulin promotes folding of functional human leukocyte antigen class I molecules in vitro. *J Biol Chem* 2004;279:54210-54215.
154. Ortmann B, Copeman J, Lehner PJ, et al. A critical role for tapasin in the assembly and function of multimeric MHC class I-TAP complexes. *Science* 1997;277:1306-1309.

155. Sadasivan B, Lehner PJ, Ortmann B, et al. Roles of calreticulin and a novel glycoprotein, tapasin, in the interaction of MHC class I molecules with TAP. *Immunity* 1996;5:103-114.
156. Li S, Paulsson KM, Sjögren H-O, et al. Peptide-bound major histocompatibility complex class I molecules associate with tapasin before dissociation from transporter associated with antigen processing. *J Biol Chem* 1999;274:8649-8654.
157. Peh CA, Burrows SR, Barnden M, et al. HLA-B27-restricted antigen presentation in the absence of tapasin reveals polymorphism in mechanisms of HLA class I peptide loading. *Immunity* 1998;8:531-542.
158. Morrice NA, Powis SJ. A role for the thiol dependent reductase ERp57 in the assembly of MHC class I molecules. *Curr Biol* 1998;8:713-716.
159. Solheim JC. Class I MHC molecules: assembly and antigen presentation. *Immunol Rev* 1999;172:11-19.
160. Diedrich G, Bangia N, Pan M, et al. A role for calnexin in the assembly of the MHC class I loading complex in the endoplasmic reticulum. *J Immunol* 2001;166:1703-1709.
161. Yewdell JW, Anton LC, Bennink JR, et al. Defective ribosomal products (DRiPS). A major source of antigenic peptides for MHC class I molecules? *J Immunol* 1996;157:1823-1826.
162. Yewdell JW, Nicchitta CV. The DRiP hypothesis decennial: support, controversy, refinement and extension. *Trends Immunol* 2006;27:370-373.
163. Yewdell JW, Norbury CC, Bennink JR. Mechanisms of exogenous antigen presentation by MHC class I molecules in vitro and in vivo: implications for generating CD8+ T cell responses to infectious agents, tumors, transplants and vaccines. *Adv Immunol* 1999;73:1-77.
164. Reimann J, Shirmbeck R. Alternative pathways for processing exogenous and endogenous antigens that can generate peptides for MHC class I-restricted presentation. *Immunol Rev* 1999;172:131-152.
165. Ackerman AL, Kyritsis C, Tempe R, Cresswell P. Access of soluble antigens to the endoplasmic reticulum can explain cross-presentation by dendritic cells. *Nat Immunol* 2005;6:107-113.
166. Palmowski MJ, Gileadi V, Salio M, et al. Role of immunoproteasomes in crosspresentation. *J Immunol* 2006;177:983-990.
167. Shrivastava P. Interaction of heat shock proteins with peptides and antigen presenting cells: chaperoning of the innate and adaptive immune responses. *Annu Rev Immunol* 2002;20:395-425.
168. Blachere NE, Li Z, Chandawarkar RY, et al. Heat shock protein-peptide complexes, reconstituted in vitro, elicit peptide-specific cytotoxic T lymphocyte response and tumor immunity. *J Exp Med* 1997;186:1315-1322.
169. Castellino F, Boucher PE, Eichelberg K, et al. Receptor-mediated uptake of antigen/heat shock protein class I antigen presentation via two distinct processing pathways. *J Exp Med* 2000;191:1957-1964.
170. Suto R, Srivastava PK. A mechanism for the specific immunogenicity of heat shock protein-chaperoned peptides. *Science* 1995;269:585-588.
171. Binder RJ, Blachere NE, Srivastava PK. Heat shock protein-chaperone peptides but not free peptides introduced into the cytosol are presented efficiently by major histocompatibility complex I molecules. *J Biol Chem* 2001;276: 17163-17171.
172. Binder RJ, Harris ML, Menoret A, et al. Saturation, competition and specificity in interaction of heat shock proteins (hsp) gp96, hsp90 and hsp70 with CD11b+ cells. *J Immunol* 2000;165:2582-2587.
173. Basu S, Binder RJ, Ramalingam T, et al. CD91 is a common receptor for heat shock proteins gp96, hsp90, hsp70, and calreticulin. *Immunity* 2001;14: 303-313.
174. Ogden CA, de Cathelineau A, Hoffmann PR, et al. C1q and mannose binding lectin engagement of cell surface calreticulin and CD91 initiates macropinocytosis and uptake of apoptotic cells. *J Exp Med* 2001;194:781-795.
175. Vancivier RW, Ogden CA, Fadok VA, et al. Role of surfactant proteins A, D and C1q in the clearance of apoptotic cells in vivo and in vitro: calreticulin and CD91 as a common collectin receptor complex. *J Immunol* 2002;169:3978-3986.
176. Srivastava PK, Menoret A, Basu S, et al. Heat shock proteins come of age: primitive functions acquire new roles in an adaptive world. *Immunity* 1998;8:657-665.

177. Heath WR, Carbonne FR. Cross-presentation, dendritic cells, tolerance, and immunity. *Annu Rev Immunol* 2001;19:47-64.
178. Boss JM. Regulation of transcription of MHC class II genes. *Curr Opin Immunol* 1997;9:107-113.
179. van den Elsen PJ, Holling TM, Kuipers HF, van der Stoep N. Transcriptional regulation of antigen presentation. *Curr Opin Immunol* 2004;16:67-75.
180. Cresswell P. Invariant chain structure and MHC class II function. *Cell* 1996;84:505-507.
181. Schutze MP, Peterson PA, Jackson MR. An N-terminal double-arginine motif maintains type II membrane proteins in the endoplasmic reticulum. *EMBO J* 1994;13:1696-1705.
182. Rodionov DG, Bakke O. Medium chains of adaptor complexes AP-1 and AP-2 recognize leucine-based sorting signals from the invariant chain. *J Biol Chem* 1998;273:6005-6008.
183. Geuze HJ. The role of endosomes and lysosomes in MHC class II functioning. *Immunol Today* 1998;19:282-287.
184. Neefjes J. CIIV, MIIC and other compartments for MHC class II loading. *Eur J Immunol* 1999;29:1421-1425.
185. Bakke O, Nordeng TW. Intracellular traffic to compartments for MHC class II peptide loading: signals for endosomal and polarized sorting. *Immunol Rev* 1999;172:171-187.
186. Powis SJ. CLIP-region mediated interaction of invariant chain with MHC class I molecule. *FEBS Lett* 2006;580:3112-3116.
187. Villadangos JA. Presentation of antigens by MHC class II molecules: getting the most out of them. *Mol Immunol* 2001;38:329-346.
188. Fernandes DM, Vidard L, Rock KL. Characterization of MHC class II-presented peptides generated from an antigen targeted to different endocytic compartments. *Eur J Immunol* 2000;30:2333-2343.
189. Villadangos JA, Ploegh HL. Proteolysis in MHC class II antigen presentation: who's in charge? *Immunity* 2000;12:233-239.
190. Villadangos JA, Bryant RAR, Deussing J, et al. Proteases involved in MHC class II antigen presentation. *Immunol Rev* 1999;172:109-120.
191. Antoniou AN, Blackwood SL, Mazzeo D, et al. Control of antigen presentation by a single protease cleavage site. *Immunity* 2000;12:391-398.
192. Stern LJ, Potolicchio I, Santambrogio L. MHC class II compartment subtypes: structure and function. *Curr Opin Immunol* 2006;18:64-69.
193. Wubbolts R, Neefjes J. Intracellular transport and peptide loading of MHC class II molecules: regulation by chaperones and motors. *Immunol Rev* 1999;172:189-208.
- 193a. Pieters J. MHC class II restricted antigen processing and presentation. *Adv Immunol* 2000;75:159-208.
194. Bryant PW, Lennon-Dumenil A-M, Fiebiger E, et al. Proteolysis and antigen presentation by MHC class II molecules. *Adv Immunol* 2002;80:71-114.
195. Nakagawa TY, Reidensky AY. The role of lysosomal proteinases in MHC II mediated antigen processing and presentation. *Immunol Rev* 1999;172:121-129.
196. Doebele RC, Busch R, Scott HM, et al. Determination of the HLA-DM interaction site on HLA-DR molecules. *Immunity* 2000;13:517-527.
197. Mosyak L, Zaller DM, Wiley DC. The structure of HLA-DM, the peptide exchange catalyst that loads antigen onto class II MHC molecules during antigen presentation. *Immunity* 1998;9:377-383.
198. Matteoni R, Kreis TE. Translocation and clustering of endosomes and lysosomes depends on microtubules. *J Cell Biol* 1998;105:1253-1265.
199. Wubbolts R, Fernandez-Borja M, Jordens I, et al. Opposing motor activities of kinesin and dynein mediate bi-directional transport of MHC class II containing vesicles. *J Cell Sci* 1998;112:785-795.
200. Ito T, Inaba M, Inaba K, et al. A CD1a+/CD11c+ subset of human blood dendritic cells is a direct precursor of Langerhans cells. *J Immunol* 1999;163:1409-1419.

201. Briken V, Jackman RM, Watts GF, et al. Human CD1b and CD1c isoforms survey different intracellular compartments for the presentation of microbial lipid antigens. *J Exp Med* 2000;192:281-287.
202. Sugita M, Grant EP, van Donselaar E, et al. Separate pathways for antigen presentation by CD1 molecules. *Immunity* 1999;11:743-752.
203. Manolova V, Hirabayashi Y, Mori L, et al. CD1a and CD1b surface expression is independent from de novo synthesized glycosphingolipids. *Eur J Immunol* 2003;33:29-37.
204. Schaible UE, Hagens K, Fischer K, et al. Intersection of group I CD1 molecules and mycobacteria in different intracellular compartments of dendritic cells. *J Immunol* 2000;164:4843-4852.
205. Jackman RM, Stenger S, Lee A, et al. The tyrosine containing cytoplasmic tail of CD1b is essential for its efficient presentation of bacterial antigens. *Immunity* 1998;8:341-351.
206. Chiu YH, Jayawardena J, Weiss A, et al. Distinct subsets of CD1d-restricted T cells recognize self-antigens loaded in different cellular compartments. *J Exp Med* 1999;189:103-110.
207. Robinson MS, Bonifacino JS. Adaptor-related proteins. *Curr Opin Cell Biol* 2001;13:444-453.
208. Bonifacino JS, Dell'Angelica EC. Molecular bases for the recognition of tyrosine based sorting signals. *J Cell Biol* 1999;145:923-926.
209. Jayawardena-Wolf J, Benlogha K, Chiu Y-H, et al. CD1d endosomal trafficking is independently regulated by an intrinsic CD1d-encoded tyrosine motif and by the invariant chain. *Immunity* 2001;15:897-908.
210. Riese RJ, Shi G-P, Villadangos J, et al. Regulation of CD1 function and NK1-1 T cell selection and maturation by cathepsin S. *Immunity* 2001;15:909-919.
211. Moody DB, Porcelli SA. CD1 trafficking: invariant chain gives a new twist to the tale. *Immunity* 2001;15:861-865.
212. Sugita M, Moody DR, Jackman RM, et al. CD1—a new paradigm for antigen presentation and T cell activation. *Clin Immunol Immunopathol* 1998;87:8-14.
213. Prigozy TI, Sieling PA, Clemens D, et al. The mannose receptor delivers lipoglycan antigens to endosomes for presentation to T cells by CD1b molecules. *Immunity* 1997;6:187-197.
214. Briken V, Moody DB, Porcelli SA. Diversification of CD1 proteins: sampling the lipid content of different cellular compartment. *Semin Immunol* 2000;12:517-525.
215. Beatty WL, Rhoades ER, Ulrich HJ, et al. Trafficking and release of mycobacterial lipids from infected macrophages. *Traffic* 2000;1:235-247.
216. Moody DB, Besra GS, Wilson IA, et al. The molecular basis of CD1-mediated presentation of lipid antigens. *Immunol Rev* 1999;172:285-296.
217. Moody DB, Briken V, Cheng TY, et al. Lipid length controls antigen entry into endosomal and non-endosomal pathways for CD1b presentation. *Nat Immunol* 2002;3:435-442.
218. Porcelli SA, Modlin RL. The CD1 system: antigen-presenting molecules for T cell recognition of lipids and glycolipids. *Annu Rev Immunol* 1999;17: 297-329.
219. Ernst W, Maher J, Cho S, et al. Molecular interaction of CD1b with lipoglycan antigens. *Immunity* 1998;8:331-340.
220. Prigozy TI, Nardenko O, Qasba P, et al. Glycolipid antigen processing for presentation by CD1d molecules. *Science* 2001;291:664-667.
221. Moody DB, Reinhold BB, Reinhold VN, et al. Uptake and processing of glycosylated mycolates for presentation of CD1b-restricted T cells. *Immunol Lett* 1999;65:85-91.
222. Moody DB, Besra GS. Glycolipid targets of CD1-mediated T-cell responses. *Immunology* 2001;104:243-251.
223. Shamshiev A, Donda A, Carena I, et al. Self glycolipids as T cell autoantigens. *Eur J Immunol* 1999;29:1667-1675.
224. Shamshiev A, Donda A, Prigozy TI, et al. The ab T cell response to selfglycolipids shows a novel mechanism of CD1b loading and a requirement to complex oligosaccharides. *Immunity* 2000;13:255-264.
225. Park S-H, Bendelac A. CD1-restricted T-cell responses and microbial infection. *Nature* 2000;406:788-792.

226. Jackman RM, Moody DB, Porcelli SA. Mechanisms of lipid antigen presentation by CD1. *Crit Rev Immunol* 1999;19:49-63.
227. Gumperz JE, Brenner MB. CD1-specific T cells in microbial immunity. *Curr Opin Immunol* 2001;13:471-478.
228. Descher CC, Brenner MB. CD1 antigen presentation and infectious disease. *Contrib Microbiol* 2003;10:164-182.
229. Sugita M, van der Wel N, Rogers RA, et al. CD1c molecules broadly survey the endocytic system. *Proc Natl Acad Sci U S A* 2000;97:8445-8450.
230. Bell D, Young JW, Bancereau J. Dendritic cells. *Adv Immunol* 1999;72:255-324.
231. Bancereau J, Briere F, Coux C, et al. Immunobiology of dendritic cells. *Annu Rev Immunol* 2000;18:767-811.
232. Guermonprez P, Valladeau J, Zitrogel L, et al. Antigen presentation and T cell stimulation by dendritic cells. *Annu Rev Immunol* 2002;20:621-667.
233. Chomarat P, Banchereau J, Davoust J, et al. IL-6 switches the differentiation of monocytes from dendritic cells to macrophages. *Nat Immunol* 2000;1:510-514.
234. Canque B, Camus S, Dalloul A, et al. Characterization of dendritic cell differentiation pathways from cord blood, CD34+CD7+CD45RA+ hematopoietic progenitor cells. *Blood* 2000;96:3748-3756.
235. Randolph GJ, Inaba K, Robiani DF, et al. Differentiation of phagocytic monocytes into lymph nodes dendritic cells in vivo. *Immunity* 1999;11:753-761.
236. Merad M, Fong L, Bogenberger J, et al. Differentiation of myeloid dendritic cells into CD8a-positive dendritic cells in vivo. *Blood* 2000;96:1865-1872.
237. Traver D, Akashi K, Manz M, et al. Development of CD8a positive dendritic cells from a common myeloid progenitor. *Science* 2000;290:2152-2154.
238. Rissoan M-C, Soumelis V, Kadowaki N, et al. Reciprocal control of T helper cell and dendritic cell differentiation. *Science* 1999;283:1183-1186.
239. Ito T, Amakawa R, Inaba M, et al. Differential regulation of human blood dendritic cell subsets by IFNs. *J Immunol* 2001;166:2961-2969.
240. Arpinati M, Green CL, Heinfeld S, et al. Granulocyte-colony stimulating factor mobilizes T helper 2-inducing dendritic cells. *Blood* 2000;95:2484-2490.
241. Cella M, Fchette F, Lanzavecchia A, et al. Plasmacytoid dendritic cells activated by influenza virus and CD40L drive a potent Th1 polarization. *Nat Immunol* 2000;1:305-310.
242. Liu Y-J, Kanzler H, Coumelis V, et al. Dendritic cell lineage, plasticity and crossregulation. *Nat Immunol* 2001;2:585-589.
243. Hemmi H, Takeuchi O, Kawai T, et al. Toll-like receptor recognizes bacterial DNA. *Nature* 2000;408:740-745.
244. Sallusto F, Lanzavecchia A. Understanding dendritic cell and T-lymphocyte traffic through the analysis of chemokine receptors. *Immunol Rev* 2000;177:134-140.
245. Randolph GJ, Beaulieu S, Lebecque S, et al. Differentiation of monocytes into dendritic cells in a model of transendothelial trafficking. *Science* 1998;282: 480-483.
246. Geitjtenbeek TBH, Torensma R, van Vliet SJ, et al. Identification of DC-SIGN, a novel dendritic cell-specific ICAM-3 receptor that supports primary immune responses. *Cell* 2000;100:575-585.
247. Geitjtenbeek TBH, Krooshoop DJEB, Bleijs DA, et al. CD-SIGN-ICAM-2 interaction mediates dendritic cell trafficking. *Nat Immunol* 2000;1:353-357.
248. Sozzani S, Allavena P, D'Amico G, et al. Differential regulation of chemokine receptors during dendritic cell maturation: a model for their trafficking properties. *J Immunol* 1998;161:1083-1086.

249. Dieu M-C, Vanbervliet B, Vicari A, et al. Selective recruitment of immature and mature dendritic cells by distinct chemokines expressed in different anatomic sites. *J Exp Med* 1998;188:373-386.
250. Romani N, Ratzinger G, Pfaller K, et al. Migration of dendritic cells into lymphatics—the Langerhans cell example: routes, regulation and relevance. *Int Rev Cytol* 2001;207:237-270.
251. Robert C, Fuhlbrigge RC, Kieffer JD, et al. Interaction of dendritic cells with skin endothelium: a new perspective on immunosurveillance. *J Exp Med* 1999;189:627-635.
252. Charbonnier AS, Kohrgruber N, Kriehuber E, et al. Macrophage inflammatory protein 3 is involved in the constitutive trafficking of epidermal Langerhans cells. *J Exp Med* 1999;190:1755-1767.
253. Dieu-Nosjean MC, Massacrier C, Homey B, et al. Macrophage inflammatory protein-3 alpha is expressed at inflamed epithelial surfaces, and is the most potent chemokine known in attracting Langerhans cell precursors. *J Exp Med* 2000;192:705-718.
254. Cyster JG. Chemokines and the homing of dendritic cells to the T cell areas of lymphoid organs. *J Exp Med* 1999;189:447-450.
255. Alavena P, Sica A, Vecchi A, et al. The chemokine receptor switch paradigm and dendritic cell migration: its significance in tumor tissues. *Immunol Rev* 2000;177:141-149.
256. Geijtenbeek TBH, Kwon DS, Torensma R, et al. DC-SIGN, a dendritic cell specific HN-1-binding protein that enhances trans-infection of T cells. *Cell* 2000;100:587-597.
257. Jeannin P, Rinno T, Goetsch L, et al. OmpA targets dendritic cells, induces their maturation and delivers antigen into MHC class I presentation pathway. *Nat Immunol* 2000;1:502-509.
258. Kondo T, Cortese I, Markovic-Plese S, et al. Dendritic cells signal T cells in the absence of exogenous antigen. *Nat Immunol* 2001;2:932-938.
259. Revy P, Sospedra M, Barbour B, et al. Functional antigen-independent synapses formed between T cells and dendritic cells. *Nat Immunol* 2001;2: 925-931.
260. MacPherson G, Kushnir N, Wikes M. Dendritic cells, B cells and the regulation of antibody synthesis. *Immunol Rev* 1999;172:325-334.
261. Grannuci F, Vizzardelli C, Pavelka N, et al. Inducible IL-2 production by dendritic cells revealed by global gene expression analysis. *Nat Immunol* 2001;2:882-888.
262. Fong L, Engleman EG. Dendritic cells in cancer immunotherapy. *Annu Rev Immunol* 2000;18:245-273.
263. Thurner B, Haendle I, Röder C, et al. Vaccination with Mage-3A1 peptide-pulsed mature, monocyte-derived dendritic cells expands specific cytotoxic T cells and induces regression of some metastases in advanced stage IV melanoma. *J Exp Med* 1999;190:1669-1678.
264. Gilboa E. The makings of a tumor rejection antigen. *Immunity* 1999;11:263-270.
265. Bancereau J, Schuler-Thurner B, Palucka AK, et al. Dendritic cells as vectors for therapy. *Cell* 2001;106:271-274.
266. Silberberg-Sinakin I, Baer RL, Thorbecke GJ. Langerhans cells: role in contact hypersensitivity and relationship to lymphoid dendritic cells and to macrophages. *Immunol Rev* 1980;53:203-232.
267. Birbeck MS, Breathnach AS, Everall JD. An electron microscope study of basal melanocytes and high-level clear cells (Langerhans cells) in vitiligo. *J Invest Dermatol* 1961;37:51-63.
268. Tang A, Amagai M, Granger LG, et al. Adhesion of epidermal Langerhans cells to keratinocytes mediated by E-cadherin. *Nature* 1993;361:82-85.
269. Balfour BM, Drexhage HA, Kamperdijk EW, et al. Antigen-presenting cells, including Langerhans cells, veiled cells and interdigitating cells. *Ciba Found Symp* 1981;84:281-301.
270. Szakal AK, Kosco MH, Tew JG. A novel in vivo follicular dendritic cell-dependent iccosome-mediated mechanism for delivery of antigen to antigenprocessing cells. *J Immunol* 1988;140:341-353.
271. Hoefsmit EC, Duijvestijn AM, Kamperdijk EW. Relation between Langerhans cells, veiled cells, and interdigitating cells. *Immunobiology* 1982;161:255-265.
272. Steinman RM. The dendritic cell system and its role in immunogenicity. *Annu Rev Immunol* 1991;9:271-296.

273. Fossum S. Lymph-borne dendritic leucocytes do not recirculate, but enter the lymph node paracortex to become interdigitating cells. *Scand J Immunol* 1988;27:97-105.
274. van Wilsem EJ, Breve J, Kleijmeer M, et al. Antigen-bearing Langerhans cells in skin draining lymph nodes: phenotype and kinetics of migration. *J Invest Dermatol* 1994;103:217-220.
275. Moll H, Fuchs H, Blank C, Rollinghoff M. Langerhans cells transport *Leishmania major* from the infected skin to the draining lymph node for presentation to antigen-specific T cells. *Eur J Immunol* 1993;23:1595-1601.
276. Szakal AK, Kosco MH, Tew JG. Microanatomy of lymphoid tissue during humoral immune responses: structure function relationships. *Annu Rev Immunol* 1989;7:91-109.
277. Tew JG, Wu J, Qin D, et al. Follicular dendritic cells and presentation of antigen and costimulatory signals to B cells. *Immunol Rev* 1997;156:39-52.
278. Burton GF, Masuda A, Heath SL, et al. Follicular dendritic cells (FDC) in retroviral infection: host/pathogen perspectives. *Immunol Rev* 1997;156:185-197.
279. Lindhout E, van Eijk M, van Pel M, et al. Fibroblast-like synoviocytes from rheumatoid arthritis patients have intrinsic properties of follicular dendritic cells. *J Immunol* 1999;162:5949-5956.
280. Cyster JG, Ansel KM, Reif K, et al. Follicular stromal cells and lymphocyte homing to follicles. *Immunol Rev* 2000;176:181-193.
281. Zinkernagel RM, Ehl S, Aichele P, et al. Antigen localization regulates immune responses in a dose- and time-dependent fashion: a geographical view of immune reactivity. *Immunol Rev* 1997;156:199-209.
282. Pape KA, Kearney ER, Khoruts A, et al. Use of adoptive transfer of T-cellantigen-receptor-transgenic T cells for the study of T-cell activation in vivo. *Immunol Rev* 1997;156:67-78.
283. Roake JA, Rao AS, Morris PJ, et al. Dendritic cell loss from nonlymphoid tissues after systemic administration of lipopolysaccharide, tumor necrosis factor, and interleukin 1. *J Exp Med* 1995;181:2237-2247.
284. De Smedt T, Pajak B, Muraille E, et al. Regulation of dendritic cell numbers and maturation by lipopolysaccharide in vivo. *J Exp Med* 1996;184:1413-1424.
285. McLellan AD, Sorg RV, Williams LA, et al. Human dendritic cells activate T lymphocytes via a CD40:CD40 ligand-dependent pathway. *Eur J Immunol* 1996;26:1204-1210.
286. Lenschow DJ, Walunas TL, Bluestone JA. CD28/B7 system of T cell costimulation. *Annu Rev Immunol* 1996;14:233-258.
287. Dhodapkar MV, Steinman RM, Drasevsky J, et al. Antigen-specific inhibition of effector T cell function in humans after injection of immature dendritic cells. *J Exp Med* 2001;193:233-238.
288. Turley SJ, Inaba K, Garrett WS, et al. Transport of peptide-MHC class II complexes in developing dendritic cells. *Science* 2000;288:522-527.
289. Monks CR, Freiberg BA, Kupfer H, et al. Three-dimensional segregation of supramolecular activation clusters in T cells. *Nature* 1998;395:82-86.
290. Lanzavecchia A, Sallusto F. Dynamics of T lymphocyte responses: intermediates, effectors, and memory cells. *Science* 2000;290:92-97.
291. Lanzavecchia A, Sallusto F. Antigen decoding by T lymphocytes: from synapses to fate determination. *Nat Immunol* 2001;2:487-492.
292. Lanzavecchia A, Sallusto F. Regulation of T cell immunity by dendritic cells. *Cell* 2001;106:263-266.
293. Bejenoff M, Wurtz O, Guerder S. Repeated antigen exposure is necessary for the differentiation, but not the initial proliferation of naïve CD4+ T cells. *J Immunol* 2002;168:1723-1729.
294. Garside P, Ingulli E, Merica RR, et al. Visualization of specific B and T lymphocyte interactions in the lymph node. *Science* 1998;281:96-99.
295. MacLennan ICM, Gulbranson-Judge A, Toellner K-M, et al. The changing preference of T and B cells for partners as T-dependent antibody responses develop. *Immunol Rev* 1997;156:53-66.

296. Förster R, Schubel A, Breitfeld D, et al. CCR7 coordinates the primary immune response by establishing functional microenvironments in secondary lymphoid organs. *Cell* 1999;99:23-33.
297. Breitfeld D, Ohl L, Kremmer E, et al. Follicular B helper T cells express CXC chemokine receptor 5, localize to B cell follicles and support immunoglobulin production. *J Exp Med* 2000;192:1545-1551.
298. Schaerli P, Willemann K, Lang AB, et al. CXC chemokine receptor 5 expression defines follicular homing T cells with B cell helper function. *J Exp Med* 2000;192:1553-1562.
299. Vinuesa CG, Tangye SG, Moser B, Mackay CR. Follicular B helper T cells in antibody responses and autoimmunity. *Nat Rev Immunol* 2005;5:853-865.
300. Marinova E, Han S, Zheng B. Human germinal center T cells are unique Th cells with high propensity for apoptosis induction. *Int Immunol* 2006;18:1337-1345.
301. Jenkins MK, Khoruts A, Ingulli E, et al. In vivo activation of antigen-specific CD4+ T cells. *Annu Rev Immunol* 2001;19:23-45.
302. Kopf M, Coyle AJ, Schmitz N, et al. Inducible costimulator protein (ICOS) controls T helper cell subset polarization after virus and parasite infection. *J Exp Med* 2000;192:53-62.
303. Baumgarth N. A two-phase model of B cell activation. *Immunol Rev* 2000;176:171-180.
304. McHeyser-Williams LJ, Driver DJ, McHeyser-Williams MG. Germinal center reaction. *Curr Opin Immunol* 2001;8:52-59.
305. Camacho SA, Kosco-Vilbois MH, Berek C. The dynamic structure of the germinal centre. *Immunol Today* 1998;19:511-514.
306. deVinuesa CG, Cook MC, Ball J, et al. Germinal centers without T cells. *J Exp Med* 2000;191:485-494.
307. Meyer-Hermann ME, Maini PK. Cutting edge: back to "one way" germinal centers. *J Immunol* 2005;174:2489-2493.
308. Xiao Y, Hendricks J, Langerak P, et al. CD27 is acquired by primed B cells at the centroblast stage and promotes germinal center formation. *J Immunol* 2004;172:7432-7441.
309. Lindhout E, Vissers JLM, Hartgers FC, et al. DC-CK1 is expressed by germinal center dendritic cells and attracts CD38-negative mantle zone B lymphocytes. *J Immunol* 2001;166:3284-3289.
310. Hannum LG, Haberman AM, Anderson SM, et al. Germinal center initiation, variable gene region hypermutation and mutant B cell selection without detectable immune complexes on follicular dendritic cells. *J Exp Med* 2000;192:931-942.
311. Tew JG, Wu J, Fakher M, et al. Follicular dendritic cells: beyond the necessity of T cell help. *Immunol Today* 2001;22:361-367.
312. Gonzalez M, Mackay F, Browning JL, et al. The sequential role of lymphotoxin and B cells in the development of splenic follicles. *J Exp Med* 1998;187: 997-1007.
313. van Nierop K, de Groot C. Human follicular dendritic cells: function, origin, and development. *Sem Immunol* 2002;14:251-257.
314. Denzer K, van Eijk M, Kleijmeer MJ, et al. Follicular dendritic cells carry MHC class II-expressing microvesicles at their surface. *J Immunol* 2000;165: 1259-1265.
315. Escola JM, Kleijmeer MJ, Stoorvogel W, et al. Selective enrichment of tetraspan proteins on the internal vesicles of multivesicular endosomes and on exosomes secreted by human B lymphocytes. *J Biol Chem* 1998;273:20121-20127.
316. Hammond C, Denzin LK, Pan M, et al. The tetraspan protein CD82 is a resident of MHC class II compartments where it associates with HLA-DR, -DM and -DO molecules. *J Immunol* 1998;161:3282-3291.
317. Debois B, Barthélémy C, Durand I, et al. Toward a role of dendritic cells in the germinal center reaction: triggering of B cell proliferation and isotype switching. *J Immunol* 1999;162:3428-3436.
318. Dubois B, Bridon J-M, Fayette J, et al. Dendritic cells directly modulate B cell growth and differentiation. *J Leuk Biol* 1999;66:224-230.
319. Garcia de Vineusa C, Cook CM, Ball J, et al. Germinal centers without T cells. *J Exp Med* 2000;191:485-493.
320. Lentz VM, Manser T. Germinal centers can be induced in the absence of T cells. *J Immunol* 2001;167:15-20.

321. Hollowood K, Goodlad JR. Germinal center cell kinetics. *J Pathol* 1998;185: 229-233.
322. Xu JL, Davis MM. Diversity in the CDR3 region of V(H) is sufficient for most antibody specificities. *Immunity* 2000;13:37-45.
323. Pulendran B, van Driel R, Nossal GJV. Immunological tolerance in germinal centers. *Immunol Today* 1997;18:27-32.
324. Eisen HN, Siskind GW. Variations in affinities of antibodies during the immune response. *Biochemistry* 1964;3:996-1008.
325. Tonegawa S. Somatic generation of antibody diversity. *Nature* 1983;302: 575-581.
326. Berek C, Berger A, Apel A. Maturation of the immune response in germinal centers. *Cell* 1991;67:1121-1129.
327. Levine MH, Haberman AM, Sant'Angelo DB, et al. A B-cell receptor-specific selection step governs immature to mature B cell differentiation. *Proc Natl Acad Sci U S A* 2000;97:2743-2748.
328. Allman D, Lindsley RC, DeMuth W, et al. Resolution of three nonproliferative immature splenic B cell subsets reveals multiple selection points during peripheral B cell maturation. *J Immunol* 2001;167:6834-6840.
329. Loder FB, Mutchler RJ, Ray CJ, et al. B cell development in the spleen takes place in discrete steps and is determined by the quality of B cell receptor-derived signals. *J Exp Med* 1999;190:75-89.
330. Koopman G, Keehnen RMJ, Lindhout E, et al. Adhesion through LFA-1 (CD11a/CD18)-ICAM-1 (CD54) and the VLA-4 (CD49d)-VCAM-1 (CD106) pathways prevents apoptosis of germinal center B cells. *J Immunol* 1994;152: 376-377.
331. Pauly S, Broll K, Wittmann M, et al. CD137 is expressed by follicular dendritic cells and costimulates B lymphocyte activation in germinal centers. *J Leukoc Biol* 2002;72:35-42.
332. Mackay F, Schneider P, Rennert P, et al. BAFF and APRIL: a tutorial on B cell survival. *Annu Rev Immunol* 2003;21:231-264.
333. Waldschmidt TJ, Noelle RJ. Long live the mature B cell—a BAFFing mystery resolved. *Science* 2001;293:2012-2014.
334. Marsters SA, Yan M, Pitti RM, et al. Interaction of the TNF homologues Bly and APRIL with the TNF receptor homologues BCMA and TACI. *Curr Biol* 2000;10:785-788.
335. Ware CF. APRIL and BAFF connect autoimmunity and cancer. *J Exp Med* 2000;192:F35-F37.
336. Ingold K, Zumsteg A, Tardivel A, et al. Identification of proteoglycans as the APRIL-specific binding partners. *J Exp Med* 2005;201:1375-1383.
337. Schiemann B, Gommermann JL, Vora K, et al. An essential role for BAFF in the normal development of B cells through a BCMA-independent pathway. *Science* 2001;293:2111-2114.
338. Shu HB, Johnson H. B cell maturation protein is a receptor for the tumor necrosis factor family member TALL-1. *Proc Natl Acad Sci U S A* 2000;97:9156-9161.
339. Li Q, Verma IM. NF- κ B regulation in the immune system. *Nat Rev Immunol* 2002;2:725-734.
340. Kalled SL. Impact of the BAFF/BR3 axis on B cell survival, germinal center maintenance and antibody production. *Semin Immunol* 2006;18:290-296.
341. Vora KA, Wang LC, Rao SP, et al. Cutting edge: germinal centers formed in the absence of B cell-activating factor belonging to the TNF family exhibit impaired maturation and function. *J Immunol* 2003;171:547-551.
342. Thompson JS, Bixler SA, Qian F, et al. BAFF-R, a newly identified TNF receptor that specifically interacts with BAFF. *Science* 2001;293:2108-2111.
343. Batten M, Groom J, Cachero TG, et al. BAFF mediates survival of peripheral immature B lymphocytes. *J Exp Med* 2000;192:1453-1465.
344. Grossman M, O'Reilly LA, Gugasyan R, et al. The anti-apoptotic activities of Rel and Rel A required during B-cell maturation involve the regulation of Bcl2 expression. *EMBO J* 2000;19:6351-6360.
345. Hsu BL, Harless SM, Lindsley RC, et al. Cutting edge: B Lys enables survival of transitional and mature B cells through distinct mediators. *J Immunol* 2002;168:5993-5996.
346. Schneider P. The role of APRIL and BAFF in lymphocyte activation. *Curr Opin Immunol* 2005;17:282-289.
347. Kalled SL. The role of BAFF in immune function and implications for autoimmunity. *Immunol Rev* 2005;204:43-54.

348. Tangye SG, Bryant VL, Cuss AK, Good KL. BAFF, APRIL and human B cell disorders. *Sem Immunol* 2006;18:305-317.
349. Mackay F, Tangye SG. The role of the BAFF/APRIL system in B cell homeostasis. *Curr Opin Pharmacol* 2004;4:347-354.
350. Groom J, Kalled SL, Cutler AH, et al. Association of BAFF/BLys overexpression and altered B cell differentiation with Sjögren's syndrome. *J Clin Invest* 2002;109:59-68.
351. Cheema GS, Roschke V, Hilbert DM, et al. Elevated serum B lymphocyte stimulator levels in patients with systemic immune-based rheumatic diseases. *Arthritis Rheum* 2001;44:1313-1319.
352. Tan SM, Xu D, Roschke V, et al. Local production of B lymphocyte stimulator protein and APRIL in arthritic joints of patients with inflammatory arthritis. *Arthritis Rheum* 2003;48:982-992.
353. Brink R. Regulation of B cell self-tolerance by BAFF. *Semin Immunol* 2006;18: 276-283.
354. Novak AJ, Darce JR, Arendt BK, et al. Expression of BCMA, TACI and BAFF-R in multiple myeloma: a mechanism for growth and survival. *Blood* 2004;103:689-694.
355. Roschke V, Snosnovtseva S, Ward CD, et al. BLys and APRIL from biologically active heterotrimers, that are expressed in patients with systemic immune-based rheumatic diseases. *J Immunol* 2002;169:4314-4321.
356. Marriette X. The level of BLYS (BAFF) correlates with the titer of autoantibodies in human Sjogren's syndrome. *Ann Rheum Dis* 2003;62:168-171.
357. Stein JV, Lopez-Fraga M, Elustondo FA, et al. APRIL modulates B and T cell immunity. *J Clin Invest* 2002;109:1587-1598.
358. Huard B, Schneider P, Mareri D, et al. T cell costimulation by the TNF ligand BAFF. *J Immunol* 2001;167:6225-6231.
359. Hahne M, Kataoka T, Schröter M, et al. APRIL, a new ligand of the tumor necrosis factor family, stimulates tumor cell growth. *J Exp Med* 1998;188: 1185-1190.
360. Rennert P, Schneider P, Cachero TG, et al. A soluble form of B cell maturation antigen, a receptor for the tumor necrosis factor family member APRIL, inhibits tumor cell growth. *J Exp Med* 2000;192:1677-1683.
361. Levens JM, Gordon J, Gregory CD. Microenvironmental factors in the survival of human B-lymphoma cells. *Cell Death Differ* 2000;7:59-69.
362. Goldenberg G, Paraskevas F, Israels LG. The association of rheumatoid arthritis with plasma cell and lymphocytic neoplasms. *Arthritis Rheum* 1969;12:569-579.
363. Walker LSK, Wiggett HE, Gaspal FMC, et al. Established T cell-driven germinal center B cell proliferation is independent of CD28 signaling but is tightly regulated through CTLA-4. *J Immunol* 2001;170:91-98.
364. McHeyzer-Williams LJ, Panus JF, Mikszta JA, et al. Evolution of antigen-specific T cell receptors in vivo: pre-immune and antigen-driven selection of preferred complementarity-determining regions 3 (CDR3) motifs. *J Exp Med* 1999;189:1823-1838.
365. Dutton RW, Bradley LM, Swain SL. T cell memory. *Annu Rev Immunol* 1998;16: 201-223.
366. Waterhouse P, Marengere LEM, Mittrücker HW, et al. CTLA-4, a negative regulator of T-lymphocyte activation. *Immunol Rev* 1996;153:183-207.
367. Grewal IS, Flavell RA. CD40 and CD154 in cell-mediated immunity. *Annu Rev Immunol* 1998;16:111-135.
368. Grammer AC, Lipsky PE. CD40-mediated regulation of immune responses by TRAF-dependent and TRAF-independent signaling mechanisms. *Adv Immunol* 2001;76:61-178.
369. Grewal IS, Flavell RA. The CD40 ligand. At the center of the immune universe? *Immunol Res* 1997;16:59-70.
370. Lee BO, Haynes L, Eaton SM, et al. The biological outcome of CD40 signaling is dependent on the duration of CD40 ligand expression: reciprocal regulation by interleukin (IL)-4 and IL-12. *J Exp Med* 2002;196:693-704.
371. Randall TD, Heath AW, Santo-Argumedo L, et al. Arrest of B lymphocyte terminal differentiation by CD40 signaling: mechanism for lack of antibodysecreting cells in germinal centers. *Immunity* 1998;8:733-742.
372. Stavnezer J. Antibody class switching. *Adv Immunol* 1996;61:79-146.
373. Lorenz M, Jung S, Radbruch A. Switch transcripts in immunoglobulin class switching. *Science* 1995;267:1825-1828.

374. Snapper CM, Marcu KB, Zelazowski P. The immunoglobulin class switch: beyond accessibility. *Immunity* 1997;6:217-223.
375. Honjo T, Kinoshita K, Muramatsu M. Molecular mechanism of class switch recombination: linkage with somatic hypermutation. *Annu Rev Immunol* 2002;20:165-196.
376. Kinoshita K, Honjo T. Linking class-switch recombination with somatic hypermutation. *Nat Rev Mol Cell Biol* 2001;2:493-503.
377. Dudley DD, Chaudhuri J, Bassing CH, Alt FW. Mechanism and control of V(D) J recombination versus class switch recombination: similarities and differences. *Adv Immunol* 2005;86:43-112.
378. Muramatsu M, Honjo T. Complex layers of genetic alteration in the generation of antibody diversity. *Trends Immunol* 2001;22:66-68.
379. Litinski MB, Nardelli B, Hilbert DM, et al. DCs induce CD40-independent immunoglobulin class switching through Bly S and APRIL. *Nat Immunol* 2002;3:822-829.
380. Manis JP, Tian M, Alt FW. Mechanism and control of class-switch recombination. *Trends Immunol* 2002;23:31-39.
381. Shanmugam A, Shi MJ, Yauch L, et al. Evidence for class-specific factors in immunoglobulin isotype switching. *J Exp Med* 2000;191:1365-1380.
382. Ma L, Wortis H, Kenter AL. Two new isotype specific switching factors detected for Ig class switching. *J Immunol* 2002;168:2835-2846.
383. Starnezer J. Molecular processes that regulate class switching. *Curr Top Microbiol Immunol* 2000;245:127-168.
384. Kinoshita K, Harigai M, Fagarasan S, et al. A hallmark of active class switch recombination: transcripts directed by I promoters on looped-out circular DNAs. *Proc Natl Acad Sci U S A* 2001;98:12620-12623.
385. Cerutti A, Zan H, Kim EC, et al. Ongoing in vivo immunoglobulin class switch DNA recombination in chronic lymphocytic leukemia B cells. *J Immunol* 2002;169:6594-6603.
386. Rolink A, Melchers F, Andersson J. The SCID but not the RAG-2 gene product is required for S- μ -S- ϵ heavy-chain class switching. *Immunity* 1996;5: 319-330.
387. Jeggo PA. DNA breakage and repair. *Adv Genet* 1998;38:185-218.
388. Kenter AL. Class-switch recombination: after the dawn of AID. *Curr Opin Immunol* 2003;15:190-198.
389. Hu Y, Ericsson I, Torseth K, et al. A combined nuclear and nucleolar localization motif in activation-induced cytidine deaminase (AID) controls immunoglobulin class switching. *J Mol Biol* 2013 Jan 23;425(2):424-43.
390. Nagaoka H, Muramatsu M, Yamamura N, et al. Activation induced deaminase (AID)-directed hypermutation in the immunoglobulin S μ region: implication of AID involvement in a common step of class switch recombination and somatic hypermutation. *J Exp Med* 2002;195:529-534.
391. Sinkura R, Ito S, Begum NA, et al. Separate domains of AID are required for somatic hypermutation and class-switch recombination. *Nat Immunol* 2004;5:707-712.
392. Durandy A, Peron S, Taubenheim N, Fischer A. Activation-induced cytidine deaminase: structure-function relationship as based on the study of mutants. *Hum Mutat* 2006;27:1185-1191.
393. Wagner SD, Neuberger MS. Somatic hypermutation of immunoglobulin genes. *Annu Rev Immunol* 1996;14:441-457.
394. Bernard O, Hozumi N, Tonegawa S. Sequences of mouse immunoglobulin light chain gene before and after somatic changes. *Cell* 1978;15:1133-1144.
395. Kim S, Davis M, Sinn E, et al. Antibody diversity: somatic hypermutation of rearranged VH genes. *Cell* 1981;27:573-581.
396. Lebeque SG, Gearhart PJ. Boundaries of somatic mutation in rearranged immunoglobulin genes: 5' boundary is near the promoter and 3' boundary is \approx 1 kb from V(D)J gene. *J Exp Med* 1990;172:1717-1727.
397. Peng HZ, Du MQ, Koulis A, et al. Nonimmunoglobulin gene hypermutation in germinal center B cells. *Blood* 1999;93:2167-2172.
398. Gordon MS, Kanegai CM, Doern JR, et al. Somatic hypermutation of the B cell receptor genes B29 (Ig β , CD79b) and mb1 (Ig α , CD79a). *Proc Natl Assoc Adv Sci U S A* 2003;100:4126-4131.

399. Müschen M, Re D, Jungnickel B, et al. Somatic mutation of the CD95 gene in human B cells as a side-effect of the germinal center reaction. *J Exp Med* 2000;192:1833-1839.
400. Klotz EL, Kackett J Jr, Storb U. Somatic hypermutation of an artificial test substrate within an Ig kappa transgene. *J Immunol* 1998;161:782-790.
401. Odegard VH, Schatz DG. Targeting of somatic hypermutation. *Nat Rev Immunol* 2006;6:573-583.
402. Wang CL, Harper RA, Wabl M. Genome-wide somatic hypermutation. *Proc Natl Acad Sci U S A* 2004;101:7352-7356.
403. Bachl J, Carlson C, Gray-Schopfer V, et al. Increased transcription levels induce higher mutation rates in a hypermutating cell line. *J Immunol* 2001; 166:5051-5057.
404. Malennan I. The center of hypermutation. *Nature* 1999;354:352-353.
405. Matsumoto M, Lo SF, Carruthers CJL, et al. Affinity maturation without germinal centers in lymphotoxin- α -deficient mice. *Nature* 1996;382:462-466.
406. Bergthorsdottir S, Gallagher A, Jainandunsing S, et al. Signals that initiate somatic hypermutation of B cells in vitro. *J Immunol* 2001;166:2228-2234.
407. Klein U, Goossens T, Fischer M, et al. Somatic hypermutation in normal and transformed human B cells. *Immunol Rev* 1998;162:261-280.
408. Wilson P, Liu Y-J, Bancereau J, et al. Amino acid insertions and deletions contribute to diversity the human Ig repertoire. *Immunol Rev* 1998;162:143-151.
409. Goossens T, Klein U, Küppers R. Frequent occurrence of deletions and duplications during somatic hypermutation: implications of oncogene translocations and heavy chain disease. *Proc Natl Acad Sci U S A* 1998;95:2463-2468.
410. Neuberger MS, Ehrenstein MR, Klex N, et al. Monitoring and interpreting the intrinsic features of somatic hypermutation. *Immunol Rev* 1998;162: 107-116.
411. Brenner S, Milstein C. Origin of antibody variation. *Nature* 1966;211:242-243.
412. Papavasiliou FN, Schatz DC. The activation-induced deaminase functions in a postcleavage step of the somatic hypermutation process. *J Exp Med* 2002;195:1193-1198.
413. Kong Q, Maizels N. DNA breaks in hypermutating immunoglobulin genes: evidence of a break-and-repair pathway of somatic hypermutation. *Genetics* 2001;158:369-378.
414. Papavasiliou FN, Schatz DG. Cell cycle-regulated DNA double-strand breaks in somatic hypermutation of immunoglobulin genes. *Nature* 2000;408:216-221.
415. Faili A, Aoufouchi S, Gueranger Q, et al. AID-dependent somatic hypermutation occurs as a DNA single-strand event in the BL2 cell line. *Nat Immunol* 2002;3:815-821.
416. Bross L, Muramatsu M, Kinoshita K, et al. DNA double-strand breaks: prior to but not sufficient in targeting hypermutations. *J Exp Med* 2002;195: 1187-1192.
417. Jacobs H, Bross L. Towards an understanding of somatic hypermutation. *Curr Opin Immunol* 2001;13:208-218.
418. Chua KF, Alt FW, Manis JP. The function of AID in somatic mutation and class switch recombination: upstream or downstream of DNA breaks. *J Exp Med* 2002;195:F37-F41.
419. Weill JC, Bertoci B, Foili A, et al. Ig gene hypermutation: a mechanism is due. *Adv Immunol* 2002;80:183-202.
420. Ohmori H, Friedberg EC, Fuchs RP, et al. The Y family of DNA polymerases. *Mol Cell* 2001;8:7-8.
421. Zeng X, Winter D, Kasmer K, et al. DNA polymerase eta is an A-T mutator in somatic hypermutation of immunoglobulin variable genes. *Nat Immunol* 2001;2:537-541.
422. Faili A, Aoufouchi S, Flatter E, et al. Induction of somatic hypermutation in immunoglobulin genes is dependent on DNA polymerase iota. *Nature* 2002;419:944-947.
423. Diaz M, Verkoczy LK, Flaznik MF, et al. Decreased frequency of somatic hypermutation and impaired affinity maturation but intact germinal center formation in mice expressing antisense RNA to DNA polymerase zeta. *J Immunol* 2001;167:327-335.

424. Matsuda T, Bebenek K, Masutani C, et al. Low fidelity DNA synthesis by human DNA polymerase ϵ . *Nature* 2000;404:1011-1013.
425. Masutani C, Kusumoto R, Yamada A, et al. The human XPV (xeroderma pigmentosum variant) gene encodes human polymerase ϵ . *Nature* 1999;399:700-704.
426. Ramiro AR, Staropoulos P, Jancovic M, et al. Transcription enhances AID mediated cytidine deamination by exposing single stranded DNA on the nontemplate strand. *Nat Immunol* 2003;4:452-456.
427. Lindahl T, Barnes DE. Repair of endogenous DNA damage. *Cold Spring Harb Symp Quant Biol* 2001;65:127-133.
428. Rada C, Williams GT, Nilsen H, et al. Immunoglobulin isotype switching is inhibited and somatic hypermutation perturbed in UNG-deficient mice. *Curr Biol* 2002;12:1738-1755.
429. Storb U, Stavnezer J. Immunoglobulin genes: generating diversity with AID and UNG. *Curr Biol* 2002;12:R725-R727.
430. deYebenes VG, Ramiro AR. Activation-induced deaminase: light and dark sides. *Trends Mol Med* 2006;12:432-437.
431. Okazaki IM, Hiai H, Kakazu N, et al. Constitutive expression of AID leads to tumorigenesis. *J Exp Med* 2003;197:1173-1181.
432. Ramiro AR, Jancovic M, Callen E, et al. Role of genomic instability and p53 in AID-induced c-myc-Igh translocations. *Nature* 2006;440:105-109.
433. Oppezio P, Dighiero G. What do somatic hypermutation and class switch recombination teach us about chronic lymphocytic leukemia pathogenesis? *Curr Top Microbiol Immunol* 2005;294:71-89.
434. Kotani A, Okazaki I-M, Muramatsu M, et al. A target selection of somatic hyper-mutations is regulated similarly between T and B cells upon activation-induced cytidine deaminase expression. *Proc Natl Acad Sci U S A* 2005;102:4506-4511.
435. Fugmann SD, Schatz DG. One AID to unite them all. *Science* 2002;295: 1244-1245.
436. Honjo T. Does AID need another aid? *Nat Immunol* 2002;3:800-801.
437. Bransteitter R, Sneed LJ, Allen S, Pham P. First AID (activation-induced cytidine deaminase) is needed to produce high affinity isotype-switched antibodies. *J Biol Chem* 2006;281:16833-16836.
438. Klein U, Tu Y, Stolovitzky GA, et al. Transcriptional analysis of the B cell germinal center reaction. *Proc Natl Acad Sci U S A* 2003;100:2639-2644.
439. Glynne R, Ghandour G, Rayner J, et al. B-lymphocyte quiescence, tolerance and activation as viewed by global gene expression profiling on microarrays. *Immunol Rev* 2000;176:216-246.
440. Shaffer AL, Rosenwald A, Hurt EM, et al. Signatures of the immune response. *Immunity* 2001;15:375-385.
441. Schaffer AL, Yu X, He Y, et al. BCL-6 represses genes that function in lymphocyte differentiation, inflammation, and cell cycle control. *Immunity* 2000;13:199-212.
442. Niu H. The protooncogene BCL-6 in normal and malignant B cell development. *Hematol Oncol* 2002;20:155-166.
443. Toyama H, Okada S, Hatano M, et al. Memory B cells without somatic hypermutation are generated from BCL-6-deficient cells. *Immunity* 2002;17:329-339.
444. Allman D, Jain A, Dent A, et al. BCL-6 expression during B-cell activation. *Blood* 1996;87:5257-5268.
445. Niu H, Ye BH, Dalla-Favera R. Antigen receptor signaling induces MAP-kinase mediated phosphorylation and degradation of the BCL-6 transcription factor. *Genes Dev* 1998;12:1953-1961.
446. Manser T, Tumas-Brundage KM, Casson LP, et al. The roles of antibody variable region hypermutation and selection in the development of the memory B-cell compartment. *Immunol Rev* 1998;162:182-196.
447. Haude S, Notides E, Manser T. Bcl-2 obstructs negative selection of autoreactive, hypermutated antibody V regions during memory B cell development. *Immunity* 1998;8:189-198.
448. Cornall RG, Cyster JG, Hibbs ML, et al. Polygenic autoimmune tracts: Lyn, CD22, and SHP-1 are limiting elements of a biochemical pathway regulating BCR signaling and selection. *Immunity* 1998;8:497-508.
449. Wong JH, Avitahl N, Carriapa A, et al. Aiolos regulated B cell activation and maturation to effector state. *Immunity* 1998;9:543-553.

450. Fischer MB, Georg S, Shen L, et al. Dependence of germinal center B cells on expression of CD21/CD35 for survival. *Science* 1998;280:582-585.
451. Tedder TF, Inaoki M, Sato S. The CD19-CD21 complex regulates signal transduction thresholds governing humoral immunity and autoimmunity. *Immunity* 1997;6:107-118.
452. Zhang X, Li L, Jung J, et al. The distinct roles of T cell derived cytokines and a novel follicular dendritic cell-signaling molecule 8D6 in germinal center B cell differentiation. *J Immunol* 2001;167:49-56.
453. Smith KGC, Light A, O'Reilly LA, et al. Bcl-2 transgene expression inhibits apoptosis in the selection of memory B cells and bone marrow antibody-forming cells. *J Exp Med* 2000;191:475-484.
454. Takahashi YT, Ohta H, Takemori T. Fas is required for clonal selection in germinal centers and the subsequent establishment of the memory B cell repertoire. *Immunity* 2001;14:181-192.
455. McHeyzer-Williams MG, Ahmed R. B cell memory and the long-lived plasma cell. *Curr Opin Immunol* 1999;11:172-179.
456. Klein U, Kuppers R, Rajewsky K. Evidence of a large compartment of IgM expressing memory B cells in humans. *Blood* 1997;89:1288-1298.
457. Tangye SG, Liu YJ, Aversa G, et al. Identification of functional human splenic memory B cells by expression of CD148 and CD27. *J Exp Med* 1998;188:1691-1703.
458. Nayak R, Mitra-Kaushik S, Shaila MS. Perpetuation of immunological memory: a relay hypothesis. *Immunology* 2001;102:387-395.
459. Calame KL, Lin KI, Tunyaplin C. Regulatory mechanisms that determine the development and function of plasma cells. *Annu Rev Immunol* 2003;21: 205-230.
460. Angelin-Duclos C, Cattoretti G, Lin KI, et al. Commitment of B lymphocytes to a plasma cell fate is associated with blimp-1 expression in vivo. *J Immunol* 2000;165:5462-5471.
461. O'Conner BP, Cascalho M, Noelle RJ. Short-lived and long-lived bone marrow plasma cells are derived from a novel precursor population. *J Exp Med* 2002;195:737-745.
462. Merville P, Dechanet J, Desmouliere A, et al. Bcl-2+ tonsillar plasma cells are rescued from apoptosis by bone marrow fibroblasts. *J Exp Med* 1996;183: 227-236.
463. Slifka MK, Ahmed R. Long-lived plasma cells: a mechanism for maintaining persistent antibody production. *Curr Opin Immunol* 1998;10:252-258.
464. Kawano MM, Mihara K, Huang N, et al. Differentiation of early plasma cells on bone marrow stromal cells requires interleukin-6 for escaping apoptosis. *Blood* 1995;85:487-494.
465. Morrison AM, Nutt SL, Thevenin C, et al. Loss- and gain-of-function mutations reveal an important role of BSAP (Pax5) at the start and end of B cell differentiation. *Semin Immunol* 1998;10:133-142.
466. Calame KL. Plasma cells: finding new light at the end of B cell development. *Nat Immunol* 2001;2:1103-1108.
467. Mascle X, Albagli O, Lemerrier C. Point mutations in BCL-6 DNA-binding domain reveal distinct roles for the six zinc fingers. *Biochem Biophys Res Commun* 2003;300:391-396.
468. Strahl BD, Allis CD. The language of covalent histone modifications. *Nature* 2000;403:41-45.
469. Struhl K. Histone acetylation and transcriptional regulatory mechanisms. *Genes Dev* 1998;12:599-606.
470. Lemerrier C, Brocard MP, Puvion-Dutilleul F, et al. Class II histone deacetylases are directly recruited by BCL-6 transcriptional repressor. *J Biol Chem* 2002;277:22045-22052.
471. Lee SC, Battaro A, Insel RA. Activation of terminal B cell differentiation by inhibition of histone deacetylation. *Mol Immunol* 2003;39:923-932.
472. Reljic R, Wagner SD, Peakman LJ, et al. Suppression of signal transducer and activator of transcription 3-dependent B lymphocyte terminal differentiation by BCL-6. *J Exp Med* 2000;192:1841-1847.
473. Lin Y, Wong K, Calame K. Repression of c-myc transcription by Blimp-1, an inducer of terminal B cell differentiation. *Science* 1997;276:596-599.

474. Lin KI, Angelin Duclos C, Kuo T-C, et al. Blimp-1-dependent repression of Pax-5 is required for differentiation of B cells to IgM secreting plasma cells. *Mol Cell Biol* 2002;22:4771-4780.
475. Rinkenberger JL, Wallin JJ, Johnson KW, et al. An interleukin-2 signal relieves BSAP (Pax5)-mediated repression of the immunoglobulin J chain gene. *Immunity* 1996;5:377-386.
476. Piskurich JF, Lin KI, Lin Y, et al. BLIMP-1 mediates extinction of major histocompatibility class II transactivator expression in plasma cells. *Nat Immunol* 2000;1:526-532.
477. Yu J, Angelin-Duclos C, Greenwood J, et al. Transcriptional repression of Blimp-1 (PRD1-BF1) involves recruitment of histone deacetylase. *Mol Cell Biol* 2000;20:2592-2603.
478. Ben B, Chee KJ, Kim TH, et al. PRD1-BFI/Blimp-1 repression is mediated by corepressors of the Groucho family of proteins. *Genes Dev* 1999;13:125-137.
479. Kroczek RA, Graf D, Brugnani D, et al. Defective expression of CD40 ligand on T-cells causes "X-linked immunodeficiency with hyper-IgM (HIGM1)." *Immunol Rev* 1994;138:39-59.
480. Notorangelo LD, Duse M, Ugaglio AG. Immunodeficiency with hyper-IgM (HIM). *Immunodeficiency Rev* 1992;3:101-121.
481. Wiley JA, Harmsen AG. CD40 ligand is required for resolution of *Pneumocystis carinii* pneumonia in mice. *J Immunol* 1995;155:3525-3529.
482. Noelle RJ. CD40 and its ligand in host defense. *Immunity* 1996;4:415-419.
483. Weller S, Faili A, Garcia C, et al. CD40-CD40L independent Ig gene hypermutation suggests a second B cell diversification pathway in humans. *Proc Natl Acad Sci U S A* 2001;98:1166-1170.
484. de Saint Basile G, Tabone M-D, Durandy A, et al. CD40 ligand expression deficiency in a female carrier of the X-linked hyper-IgM syndrome as a result of X chromosome lyonization. *Eur J Immunol* 1999;29:367-373.
485. Callard RE, Smith SH, Herbert J, et al. CD40 ligand (CD40L) expression and B cell function in agammaglobulinemia with normal or elevated levels of IgM (HIM). Comparison of X-linked, autosomal recessive and non-Xlinked forms of the disease, and obligate carriers. *J Immunol* 1994;153: 3295-3306.
486. Revy D, Muto T, Levy Y, et al. Activation-induced cytidine deaminases (AID) deficiency causes the autosomal recessive form of the hyper-IgM syndrome (HIGM2). *Cell* 2000;102:565-575.
487. Durandy A, Honjo T. Human genetic defects in class-switch recombination (hyper-IgM syndromes). *Curr Opin Immunol* 2001;13:543-548.
488. Muramatsu M, Kinoshita K, Faragasan S, et al. Class switch recombination and hypermutation require activation-induced cytidine deaminase (AID), a potential RNA editing enzyme. *Cell* 2000;102:553-563.
489. Zhu Y, Nonoyama S, Morio T, et al. Type two hyper-IgM syndrome caused by mutation in activation-induced cytidine deaminase. *J Med Dent Sci* 2003;50: 41-46.
490. Minegishi Y, Lavoie A, Cunningham-Rundles C, et al. Mutations in activation induced cytidine deaminase in patients with hyper IgM syndrome. *Clin Immunol* 2000;97:203-210.
491. Ferrari S, Giliani S, Inalaco A, et al. Mutations of CD40 gene cause an autosomal recessive form of immunodeficiency with hyper IgM. *Proc Natl Acad Sci U S A* 2001;98:12614-12619.
492. Kisseleva T, Bhattacharya S, Braunstein J, et al. Signaling through the JAK/STAT pathway: recent advances and future challenges. *Gene* 2002; 285:1-24.
493. Usacheva A, Kotenko S, Witte MM, et al. Two distinct domains within the Nterminal region of Janus kinase 1 interact with cytokine receptors. *J Immunol* 2002;169:1302-1308.
494. Hoey T, Brusby MJ. STATs as mediators of cytokine-induced responses. *Adv Immunol* 1999;71:145-162.
495. Vinkemeier U, Moarefi I, Darnell JE, et al. Structure of the amino-terminal protein interaction domain of STAT-4. *Science* 1998;279:1048-1052.
496. Scott MJ, Godshall CJ, Cheadle WG. JAKs, STATs, cytokines and sepsis. *Clin Diag Lab Immunol* 2002;9:1153-1159.
497. Karnitz LM, Abraham RT. Interleukin-2 receptor signaling mechanisms. *Adv Immunol* 1996;61:147-197.
498. Sugamura K, Asao H, Kondo M, et al. The interleukin-2 receptor γ chain: its role in the multiple cytokine receptor complexes and T cell development in XSCID. *Annu Rev Immunol* 1996;14:179-205.

499. Olosz F, Malek TR. Three loops of the common γ chain ectodomain required for the binding of interleukin-2 and interleukin-7. *J Biol Chem* 2000;275:30100-30105.
500. Zanetta JP, Alonso C, Michalski JC. Interleukin-2 is a lectin that associates its receptor with the T-cell receptor complex. *Biochem J* 1996;318:49-53.
501. Fujii H, Ogasawara K, Otsuka H, et al. Functional dissection of the cytoplasmic subregions of the IL-2 receptor β chain in primary lymphocyte populations. *EMBO J* 1998;17:6551-6557.
502. Friedman MC, Migone T-S, Russel SM, et al. Different interleukin 2 receptor β chain tyrosines couple to at least two signaling pathways and synergistically mediate interleukin 2-induced proliferation. *Proc Natl Acad Sci U S A* 1996;93:2077-2082.
503. Migone TS, Rodig S, Cacalano NA, et al. Functional cooperation of the interleukin-2 receptor β chain and Jak1 in phosphatidylinositol 3-kinase recruitment and phosphorylation. *Mol Cell Biol* 1998;18:6416-6422.
504. Chen M, Cheng A, Chen Y-Q, et al. The amino terminus of JAK3 is necessary and sufficient for binding to the common γ chain and confers the ability to transmit interleukin 2-mediated signals. *Proc Natl Acad Sci U S A* 1997;94: 6910-6915.
505. Zhu M-L, Berry JA, Russel SM, et al. Delineation of the regions of interleukin-2 (IL-2) receptor β chain important for association of Jak1 and Jak3. *J Biol Chem* 1998;273:10719-10725.
506. Sigal NH, Dumont FJ. Cyclosporin A, FK-506, and rapamycin: pharmacologic probes of lymphocyte signal transduction. *Annu Rev Immunol* 1992;10:519-560.
507. Brown EJ, Albers MW, Shin TB, et al. A mammalian protein targeted by G1-arresting rapamycin-receptor complex. *Nature* 1994;369:756-758.
508. Ajchenbaum F, Ando K, DeCaprio JA, et al. Independent regulation of human D type cyclin gene expression during G1 phase in primary human T lymphocytes. *J Biol Chem* 1993;268:4113-4119.
509. Polyak K, Lee MH, Erdjument-Bromage H, et al. Cloning of p27Kip1, a cyclindependent kinase inhibitor and a potential mediator of extracellular antimitogenic signals. *Cell* 1994;78:59-66.
510. Noguchi M, Nakamura Y, Russel SM, et al. Interleukin-2 receptor γ chain: a functional component of the interleukin-7 receptor. *Science* 1993;263:1877-1880.
511. Buckley RH, Schiff RI, Schieff SE, et al. Human severe combined immunodeficiency: genetic, phenotypic, and functional diversity in one hundred eight infants. *J Pediatr* 1997;130:378-387.
512. Cacalano N, Johnston JA. Interleukin-2 signaling and inherited immunodeficiency. *Am J Hum Genet* 1999;65:287-293.
513. Cacalano M, Migone TS, Bazan F, et al. Autosomal SCID caused by a point mutation in the N-terminus of Jak3: mapping of the Jak3-receptor interaction domain. *EMBO J* 1999;18:1549-1558.
514. Mueller TD, Zhang JL, Sebald W, et al. Structure, binding, and antagonists in the IL-4/IL-13 receptor family. *Biochem Biophys Acta* 2002;1592:237-250.
515. Hage T, Sebald W, Reinemer P. Crystal structure of the interleukin-4/receptor α chain complex reveals a mosaic binding interface. *Cell* 1999;97:271-281.
516. Zhang JL, Simeonowa I, Wang Y, et al. The high-affinity interaction of human IL-4 and the receptor α chain is constituted by two independent binding clusters. *J Mol Biol* 2002;315:399-407.
517. Bork P, Holm L, Sander C. The immunoglobulin fold. Structural classification, sequence patterns and common core. *J Mol Biol* 1994;242:309-320.
518. Nelms K, Keegan AD, Zamorano J, et al. The IL-4 receptor: signaling mechanisms and biologic functions. *Annu Rev Immunol* 1999;17:701-738.
519. Reichel M, Nelson BH, Greenberg PD, et al. The IL-4 receptor alpha-chain cytoplasmic domain is sufficient for activation of JAK-1 and STAT-6 and the induction of IL-4 specific gene expression. *J Immunol* 1997;158:5860-5867.
520. Sun XJ, Wong LM, Zhang Y, et al. Role of IRS-2 in insulin and cytokine signaling. *Nature* 1995;377:173-177.
521. Andrew RP, Erickson MB, Cunningham CM, et al. Analysis of the life cycle of STAT-6. Continuous cycling of STAT-6 is required for IL-4 signaling. *J Biol Chem* 2002;277:36563-36569.
522. Starr R, Hilton DJ. SOCS: suppressors of cytokine signaling. *Int J Biochem Cell Biol* 1998;30:1081-1085.

523. Hilton DJ, Richardson RT, Alexander WS, et al. Twenty proteins containing a Cterminal SOCS box form five structural classes. *Proc Natl Acad Sci U S A* 1998;95:114-119.
524. Alexander WS, Starr R, Metcalf D, et al. Suppressors of cytokine signaling (SOCS): negative regulators of signal transduction. *J Leukoc Biol* 1999;66: 588-592.
525. Hague SJ, Harbor PC, Williams BRG. Identification of critical residues required for suppression of cytokine signaling-specific regulation of interleukin-4 signaling. *J Biol Chem* 2000;275:26500-26506.
526. Losman JA, Chen XP, Hilton D, et al. SOCS-1 is a potent inhibitor of IL-4 signal transduction. *J Immunol* 1999;162:3770-3774.
527. Zhou C, Saxon A, Zhang K. Human activation-induced cytidine deaminase is induced by IL-4 and negatively regulated by CD45: implication of CD45 as a Janus kinase phosphatase in antibody diversification. *J Immunol* 2003;170:1887-1893.
528. Sasaki JI, Sasaki T, Matsumoto W, et al. CD45 is a JAK phosphatase and negatively regulates cytokine receptor signaling. *Nature* 2001;40:349-354.
529. Takatsu K, Takaki S, Hitoshi Y. Interleukin-5 and its receptor system: implications in the immune system and inflammation. *Adv Immunol* 1994;57:145-190.

P.370

530. Bagley CJ, Woodcock JM, Stomski FC, et al. The structural and functional basis of cytokine receptor activation: lessons from the common β subunit of the granulocyte-macrophage colony-stimulating factor, interleukin-3 (IL-3), and IL-5 receptors. *Blood* 1997;89:1471-1482.
531. Woodcock JM, Bagley CJ, Zacharakis B, et al. A single tyrosine residue in the membrane-proximal domain of the granulocyte-macrophage colony-stimulating factor, interleukin (IL)-3, and IL-5 receptor common β -chain is necessary and sufficient for high affinity binding and signaling by all three ligands. *J Biol Chem* 1996;271:25999-26006.
532. Sanderson CJ. Interleukin-5, eosinophils, and disease. *Blood* 1992;79:3101-3109.
533. Corrigan CJ, Haczku A, Gemou-Engesaeth V, et al. CD4 T-lymphocyte activation in asthma is accompanied by increased serum concentrations of interleukin-5. Effect of glucocorticoid therapy. *Am Rev Respir Dis* 1993;147:540-547.
534. Hamid Q, Azzawi M, Ying S, et al. Expression of mRNA for interleukin-5 in mucosal bronchial biopsies from asthma. *J Clin Invest* 1991;87:1541-1546.
535. Bravo J, Heath JH. Receptor recognition by gp130 cytokines. *EMBO J* 2000;19:2399-2411.
536. Somers W, Stahl M, Seehra JS. 1.9 Å crystal structure of interleukin 6: implications for a novel mode of receptor dimerization and signaling. *EMBO J* 1997;16:989-997.
537. Cebo C, Durier V, Lagant P, et al. Function and molecular modeling of the interaction between human interleukin 6 and its HNK-1 oligosaccharide ligands. *J Biol Chem* 2002;277:12246-12252.
538. Cole AR, Hall NE, Trentlein HR, et al. Disulfide bond structure and N-glycosylation sites of the extracellular domain of the human interleukin-6 receptor. *J Biol Chem* 1999;274:7207-7215.
539. Özbek S, Gröntzinger J, Krebs B, et al. The membrane proximal cytokine receptor domain of the human interleukin-6 receptor is sufficient for ligand binding but not for gp130 association. *J Biol Chem* 1998;273:21374-21379.
540. Kurth I, Horsten U, Pflanz S, et al. Importance of the membrane-proximal extracellular domains for activation of the signal transducer glycoprotein 130. *J Immunol* 2000;164:273-282.
541. Kalai M, Montero-Julian FA, Grötzing J, et al. Analysis of the hIL-6/hIL-6-R binding interface at the amino acid level: proposed mechanisms of interaction. *Blood* 1997;89:1319-1333.
542. Kurth I, Horsten U, Pflanz S, et al. Activation of the signal transducer glycoprotein 130 by both IL-6 and IL-11 requires two distinct binding epitopes. *J Immunol* 1999;162:1480-1487.
543. Bravo J, Staunton D, Heath JH, et al. Crystal structure of a cytokine-binding region of gp130. *EMBO J* 1998;17:1665-1674.

544. Cebo C, Vergoten G, Zanetta J-P. Lectin activities of cytokines: functions and putative carbohydrate-recognition domains. *Biochem Biophys Acta* 2002;1572: 422-434.
545. Taga T, Kishimoto T. GP130 and the interleukin-6 family of cytokines. *Annu Rev Immunol* 1997;15:797-819.
546. Chow DC, He XL, Snow AL, et al. Structure of an extracellular gp130 cytokine receptor signaling complex. *Science* 2001;291:2150-2155.
547. Heinrich PC, Behrmann I, Haan S, et al. Principles of IL-6-type cytokine signalling and its regulation. *Biochem J* 2003;374:1-20.
548. Schaeffer M, Schneiderbauer M, Weidler S, et al. Signaling through a novel domain of gp130 mediates cell proliferation and activation of Hck and Erk kinases. *Mol Cell Biol* 2001;21:8068-8081.
549. Chouhan D, Hideshima P, Pandey P, et al. RAFTK/PYK2-dependent and independent apoptosis in multiple myeloma cells. *Oncogene* 1999;18:6733-6740.
550. Levy DE, Lee CK. What does Stat-3 do? *J Clin Invest* 2002;109:1143-1148.
551. Narazaki M, Fujimoto M, Matsumoto T, et al. Three distinct domains of SSI-1/SOCS-1/JAB protein required for its suppression of interleukin 6 signaling. *Proc Natl Acad Sci U S A* 1998;95:13130-13134.
552. Gibson RM, Schiemann W, Prichard LB, et al. Phosphorylation of human gp130 at Ser-782 adjacent to the di-leucine internalization motif. Effects on expression and signaling. *J Biol Chem* 2000;275:22574-22582.
553. Lauta VM. A review of the cytokine network in multiple myeloma. Diagnostic, prognostic and therapeutic implications. *Cancer* 2003;97:2440-2452.
554. French JD, Walters DK, Jelinek DF. Transactivation of gp130 in myeloma cells. *J Immunol* 2003;170:3717-3723.
555. Castleman B, Iverson L, Menendez VP. Localized mediastinal lymph node hyperplasia resembling thymoma. *Cancer* 1956;9:822-830.
556. Keller AR, Hochholzer L, Castleman B. Hyaline-vascular and plasma-cell types of giant lymph node hyperplasia of the mediastinum and other locations. *Cancer* 1972;29:670-683.
557. Li H, Wang H, Nicholas J. Detection of direct binding of human herpesvirus 8-encoded interleukin-6 (IL-6) to both gp130 and IL-6 receptor (IL-6R) and identification of amino acid residues of vIL-6 important for IL-6R-dependent and independent signaling. *J Virol* 2001;75:3325-3334.
558. Li H, Nicholas J. Identification of amino acid residues of gp130 signal transducer and gp80 α receptor subunit that are involved in ligand binding and signaling by human herpesvirus 8-encoded interleukin 6. *J Virol* 2002;76: 5627-5636.
559. Mosmann TR. Properties and functions of interleukin-10. *Adv Immunol* 1994;56:1-26.
560. Moore KW, de Waal Malefyt R, Coffman RL, et al. Interleukin-10 and the interleukin-10 receptor. *Annu Rev Immunol* 2001;19:683-765.
561. Burdin N, Peronne C, Banchereau J, et al. Epstein-Barr virus transformation induces B lymphocytes to produce human interleukin 10. *J Exp Med* 1993;177:295-304.
562. Rousset F, Garcia E, Defrance T, et al. Interleukin 10 is a potent growth and differentiation factor for activated human B lymphocytes. *Proc Natl Acad Sci U S A* 1992;89:1890-1893.
563. Defrance T, Vanbervliet B, Briere F, et al. Interleukin 10 and transforming growth factor β cooperate to induce anti-CD40-activated naive human B cells to secrete immunoglobulin A. *J Exp Med* 1992;175:671-682.
564. Akdis CA, Blaser K. Mechanisms of interleukin-10-mediated immune suppression. *Immunology* 2001;103:131-136.
565. Berg DJ, Zhang J, Lauricella DM, et al. IL-10 is a central regulator of cyclooxygenase-2 expression and prostaglandin production. *J Immunol* 2001;166: 2674-2680.
566. Dreyer WJ, Bennett JC. The molecular basis of antibody formation: a paradox. *Proc Natl Acad Sci U S A* 1965;54:864-869.
567. Edelman GM, Gall WE. The antibody problem. *Annu Rev Biochem* 1969;38: 415-466.
568. Edelman GM, Cunningham BA, Gall WE, et al. The covalent structure of an entire gG immunoglobulin molecule. *Proc Natl Acad Sci U S A* 1969;63:78-85.

569. Porter RR. The hydrolysis of rabbit g-globulin and antibodies with crystalline papain. *Biochem J* 1959;73:119.
570. Amit AG, Mariuzza RA, Phillips SE, et al. Three-dimensional structure of an antigen-antibody complex at 2.8 Å resolution. *Science* 1986;233:747-753.
571. Capra JD, Edmundson AB. The antibody combining site. *Sci Am* 1977;236:50-59.
572. Jones PT, Dear PH, Foote J, et al. Replacing the complementarity-determining regions in a human antibody with those from a mouse. *Nature* 1986;321:522-525.
573. Kieber-Emmons T, Kohler H. Towards a unified theory of immunoglobulin structure-function relations. *Immunol Rev* 1986;90:29-48.
574. Jerne NK. The somatic generation of immune recognition. *Eur J Immunol* 1971;1:1-9.
575. Jerne NK. Towards a network theory of the immune system. *Ann Immunol (Paris)* 1974;125C:373-389.
576. Review of the notation for the allotypic and related markers of human immunoglobulins. *J Immunol* 1976;117:1056-1058.
577. Morell A, Skvaril F, van Loghem E, et al. Human IgG subclasses in maternal and fetal serum. *Vox Sang* 1971;21:481-492.
578. Capra JD, Kunkel HG. Aggregation of g-G3 proteins: relevance to the hyper-viscosity syndrome. *J Clin Invest* 1970;49:610-621.
579. Mestecky J, McGhee JR. Immunoglobulin A (IgA): molecular and cellular interactions involved in IgA biosynthesis and immune response. *Adv Immunol* 1987;40:153-245.
580. Mostov KE. Transendothelial transport of immunoglobulins. *Annu Rev Immunol* 1994;12:63-84.
581. Johansen FE, Braathen R, Brandtzaeg P. Role of the J chain in secretory immunoglobulin formation. *Scand J Immunol* 2000;52:240-248.
582. Rojas R, Apodaca G. Immunoglobulin transport across polarized epithelial cells. *Nat Rev Mol Cell Biol* 2002;3:944-955.
583. Phalipon A, Corthesy B. Novel functions of the polymeric receptor: well beyond transport of immunoglobulins. *Trends Immunol* 2003;24:55-58.
584. Norderhaug IN, Johanssen FE, Schjerven H, et al. Regulation of the formation and external transport of secretory immunoglobulins. *Crit Rev Immunol* 1999;19:481-508.
585. Johansen FN, Braathen R, Brandtzaeg P. The J chain is essential for polymeric Ig receptor-mediated epithelial transport of IgA. *J Immunol* 2001;167:5185-5192.
586. Kaetzel CS. Polymeric Ig receptor: defender of the fort or Trojan Horse? *Curr Biol* 2001;11:R35-R38.
- 586a. Ishizaka K. Human reaginic antibodies. *Annu Rev Med* 1970;21:187-200.
587. Muller-Eberhard HJ. Molecular organization and function of the complement system. *Annu Rev Biochem* 1988;57:321-347.
588. Reid KB, Porter RR. The proteolytic activation systems of complement. *Annu Rev Biochem* 1981;50:433-464.
589. Reid KB, Day AJ. Structure-function relationships of the complement components. *Immunol Today* 1989;10:177-180.
590. Kishore U, Reid KBM. C1q: structure, function, and receptors. *Immunopharmacology* 2000;49:159-170.
591. Arlaud GJ, Gaboriaud C, Thielens NM, et al. Structural biology of C1: dissection of a complex molecular machinery. *Immunol Rev* 2001;180:136-145.
592. Arlaud GJ, Gaboriaud C, Thielens NM, et al. Structural biology of C1 complex of complement unveils the mechanisms of its activation and proteolytic activity. *Mol Immunol* 2002;39:383-394.
593. Tacnet-Delorme P, Chevallier S, Arlaud GJ. Beta amyloid fibrils activate the C1 complex of complement under physiological conditions. Evidence for a binding site for A beta on the C1q globular regions. *J Immunol* 2001;167:6374-6381.
594. Shapiro L, Scherer PE. The crystal structure of a complement-1q family protein suggests an evolutionary link to tumor necrosis factor. *Curr Biol* 1998;8:335-338.

595. Gaboriaud C, Rossi V, Bally V, et al. Crystal structure of the catalytic domain of human complement C1s: a serine protease with a handle. *EMBO J* 2000;19:1755-1765.
596. Budayova-Spano M, Lacroix MB, Thielens NM, et al. The crystal structure of the zymogen catalytic domain of the complement protease C1r reveals that a disruptive mechanical stress is required to trigger activation of the C1 complex. *EMBO J* 2002;21:231-239.
597. Thielens NM, Enrie K, Lacroix M, et al. The N-terminal CUB-epidermal growth factor module pair of human complement C1r binds Ca²⁺ with high affinity and mediates Ca²⁺-dependent interaction with C1s. *J Biol Chem* 1999;274:9149-9159.
598. Lőrincz Z, Gal P, Dobo J, Czeh S, et al. The cleavage of two C1s subunits by a single active C1r reveals substantial flexibility of the C1s-C1r-C1r-C1s tetramer in the C1 complex. *J Immunol* 2000;165:2048-2051.
599. Bork P, Beckmann G. The CUB domain. A widespread module in developmentally regulated proteins. *J Mol Biol* 1993;231:539-545.
600. Arlaud GJ, Gaboriaud C, Thielens NM, et al. Structural biology of C1. *Biochem Soc Trans* 2002;30:1001-1006.
601. Arlaud GJ, Gaboriaud C, Thielens NM, et al. Structural biology of C1: dissection of a complex molecular machinery. *Immunol Rev* 2001;180:136-145.
602. Eggleton P, Reid KBM, Tenner AJ. C1q—How many functions? How many receptors? *Trends Cell Biol* 1998;8:428-431.
603. Eggleton P, Tenner AJ, Reid KBM. C1q receptors. *Clin Exp Immunol* 2000;120: 406-412.
604. Leigh LEA, Ghebrehwet B, Perera TPS, et al. C1q mediated chemotaxis by human neutrophils: involvement of gC1qR and G-protein signaling mechanisms. *Biochem J* 1998;330:247-254.
605. Webster SD, Park M, Fonseca MI, et al. Structural and functional evidence of microglial expression of C1qRp, the C1q receptor that enhances phagocytosis. *J Leukoc Biol* 2000;65:109-116.
606. Peerschke EIB, Ghebrehwet B. Human blood platelet gC1qR/p33. *Immunol Rev* 2001;180:56-64.
607. Tack BF. The β -Cys- γ -Glu thioester bond in human C3, C4, and α 2-macroglobulin. *Springer Semin Immunopathol* 1983;6:259-282.
608. Jenkins PV, Pasi KJ, Perkins SJ. Molecular modeling of ligand and mutation sites of the type A domains of human von Willebrand factor and their relevance to von Willebrand's disease. *Blood* 1998;91:2032-2044.
609. Hinselwood J, Perkins SJ. Metal-dependent conformational changes in a recombinant vWF-A domain from human factor B: a solution study by circular dichroism, Fourier transform infrared, and ¹H NMR spectroscopy. *J Mol Biol* 2000;298:135-147.
610. Arlaud GJ, Volanakin JE, Thielens NM, et al. The atypical serine proteases of the complement system. *Adv Immunol* 1998;69:249-307.
611. Sahu A, Lambris JD. Structure and biology of complement protein C3, a connecting link between innate and acquired immunity. *Immunol Rev* 2001;180:35-48.
612. Sahu A, Kozel TR, Pangburn MK. Specificity of the thioester-containing reactive site of human C3 and its significance to complement activation. *Biochem J* 1994;302:429-436.
613. Pangburn MK, Rawal N. Structure and function of complement C5 convertase enzymes. *Biochem Soc Trans* 2002;30:1006-1010.
614. Pangburn MK, Schreiber RD, Muller-Eberhard HJ. Formation of the initial C3 convertase of the alternative complement pathway. Acquisition of C3b-like activities by spontaneous hydrolysis of the putative thioester in native C3. *J Exp Med* 1981;154:856-867.
615. Jing H, Macon KJ, Moore D, et al. Structural basis of profactor D activation: from a highly flexible zymogen to a novel self-inhibited serine protease, complement factor D. *EMBO J* 1999;18:804-814.
616. Volanakis JE, Narayana SVL. Complement factor D, a novel serine protease. *Protein Sci* 1996;5:553-564.
617. Pillemer L, Blum L, Lepow IH, et al. The properdin system and immunity. I. Demonstration and isolation of a new serum protein, properdin, and its role in immune phenomena. *Science* 1954;120:279-285.

618. Pangburn MK. Analysis of the natural polymeric forms of human properdin and their functions in complement activation. *J Immunol* 1989;142: 202-207.
619. Smith CA, Pangburn MK, Vogel C-W, et al. Molecular architecture of human properdin, a positive regulator of the alternative pathway of complement. *J Biol Chem* 1984;259:4582-4588.
620. Goundis D, Reid KBM. Properdin, the terminal complement components, thrombospondin, and circumsporozoite protein of malaria parasites contain similar sequence motifs. *Nature* 1988;335:82-85.
621. Higgins JMG, Wiedemann H, Timpl R, et al. Characterization of mutant forms of recombinant human properdin lacking single thrombospondin type I repeats. *J Immunol* 1995;155:5777-5785.
622. Perdikoulis MV, Kishore U, Reid KBM. Expression and characterization of the thrombospondin type I repeats of human properdin. *Biochem Biophys Acta* 2001;1548:265-277.
623. Bongrazio M, Pries AR, Zakrewicz A. The endothelium as physiological source of properdin: role of wall shear stress. *Mol Immunol* 2003;39:669-675.
624. Schwaeble WJ, Reid KBM. Does properdin crosslink the cellular and the humoral immune response? *Immunol Today* 1999;20:17-21.
625. Xu Y, Narayana SVL, Volanakis JE. Structural biology of the alternative pathway convertase. *Immunol Rev* 2001;180:123-135.
626. Rawal N, Pangburn MK. Structure/function of C5 convertases of complement. *Int Immunopharmacol* 2001;1:415-422.
627. Petersen SV, Thiel S, Jensenius JC. The mannan-binding lectin pathway of complement activation: biology and disease association. *Mol Immunol* 2001;38: 133-149.
628. Dahl MR, Thiel S, Matsushita M, et al. A new mannan-binding lectin associated serine protease, MASP-3, and its association with distinct complexes of the MBL complement activation pathway. *Immunity* 2001;15:1-10.
629. Thielens NM, Cseh S, Thiel S, et al. Interaction properties of human mannan binding lectin (MBL)-associated serine proteases-1 and -2 MBL-associated serine proteases-1 and -2, MBL-associated protein 19 and MBL. *J Immunol* 2001;166:5068-5077.
630. Stover CM, Thiel S, Thelen M, et al. Two constituents of the initiation complex of the mannan-binding lectin activation pathway of complement are encoded by a single structural gene. *J Immunol* 1999;162:3481-3490.
631. Jack DL, Klein NJ, Turner MW. Mannose-binding lectin: targeting the microbial world for complement attack and opsonophagocytosis. *Immunol Rev* 2001;180:86-99.
632. Matsushita M, Fujita T. Ficolins and the lectin complement pathway. *Immunol Rev* 2001;180:78-85.
633. Matsushita M, Kuraya M, Hamasaki N, et al. Activation of the lectin complement pathway by H-ficolin (Hakata antigen). *J Immunol* 2002;168:3502-3506.
634. Fujita T. Evolution of the lectin-complement pathway and its role in innate immunity. *Nat Rev Immunol* 2002;2:346-353.
635. Di Scipio RG. Formation and structure of the C5b-7 complex of the lytic pathway of complement. *J Biol Chem* 1992;267:17087-17094.
636. Haefliger J-A, Tschopp J, Vial N, Jenne DE. Complete primary structure and functional characterization of the sixth component of the human complement system. *J Biol Chem* 1989;264:18041-18051.
637. Di Scipio RG, Linton SM, Rushmere NK. Function of the factor I modules (FIMs) of human complement component C6. *J Biol Chem* 1999;274: 31811-31818.
638. Di Scipio RG, Chakravarti DN, Muller-Eberhard HJ, et al. The structure of human complement component C7 and the C5b-7 complex. *J Biol Chem* 1988;263: 549-560.
639. Sodetz JM. Structure and function of C8 in the membrane attack sequence of complement. *Curr Top Microbiol Immunol* 1989;140:19.
640. Musingarimi P, Plumb ME, Sodetz JM. Interaction between the C8 alpha-gamma and C8 beta subunits of human complement C8: role of the C8 beta N-terminal thrombospondin type 1 module and membrane attack complex/perforin domain. *Biochemistry* 2002;41:11255-11260.

641. Schreck SF, Parker C, Plumb ME, et al. Human complement protein C8 γ . *Biochem Biophys Acta* 2000;1482:199-208.
642. Parker CL, Sodetz JM. Role of the human C8 subunits in complement-mediated bacterial killing: evidence that C8 γ is not essential. *Mol Immunol* 2002;39:453-458.
643. Ortlund E, Parker CL, Schreck SF, et al. Crystal structure of human complement protein C8 gamma at 1.2 Å resolution reveals a lipocalin fold and a distinct ligand binding site. *Biochemistry* 2002;41:7030-7037.
644. Shinkai Y, Takio K, Okumura K. Homology of perforin to the ninth component of complement (C9). *Nature* 1988;334:525-527.
645. Tschopp J, Podack ER, Muller-Eberhard HJ. Ultrastructure of the membrane attack complex of complement: detection of the tetramolecular C9 polymerized complex C5b-8. *Proc Natl Acad Sci U S A* 1982;79:7474-7478.
646. Scibek JJ, Plumb ME, Sodetz JM. Binding of human complement C8 to C9: role of the N-terminal modules in the C8 alpha subunit. *Biochemistry* 2002;41:14546-14551.
647. Müller-Eberhardt HJ. Membrane attack complex of complement. *Annu Rev Immunol* 1986;4:503-528.
648. Di Scipio RG, Berlin C. The architectural transition of human complement component C9 to poly (C9). *Mol Immunol* 1999;36:575-585.
649. Di Scipio RG. The size, shape, and stability of complement component C9. *Mol Immunol* 1993;30:1097-1106.
650. Esser AF. Big MAC attack: complement proteins cause leaky patches. *Immunol Today* 1991;12:316-318.
651. Davis AE 3rd. C1 inhibitor and hereditary angioneurotic edema. *Annu Rev Immunol* 1988;6:595-628.
652. Juang H, Wagner E, Zhang H, et al. Complement 1 inhibitor is a regulator of the alternative complement pathway. *J Exp Med* 2001;194:1609-1616.
653. Liszewski MK, Farries TC, Lublin DM, et al. Control of the complement system. *Adv Immunol* 1996;61:201-283.
654. Kirkitadze MD, Barlow PN. Structure and flexibility of the multiple domain proteins that regulate complement activation. *Immunol Rev* 2001;180: 146-161.
655. Liszewski MK, Leung M, Cui W, et al. Dissecting sites important for complement regulatory activity in membrane cofactor protein (MCP;CD46). *J Biol Chem* 2000;275:37692-37701.
656. Barilla-La Barca ML, Liszewski MK, Lambris JD, et al. Role of membrane cofactor protein (CD46) in regulation of C4b and C3b deposited on cells. *J Immunol* 2002;168:6298-6304.
657. Casanovas JM, Larvie M, Stehle T. Crystal structure of two CD46 domains reveals an extended measles virus-binding surface. *EMBO J* 1999;18: 2911-2922.
658. Manchester M, Nanche D, Stehle T. CD46 as a measles receptor: form follows function. *Virology* 2000;274:5-10.
659. Manchester M, Liszewski MK, Atkinson JP, et al. Multiple isoforms of CD46 (membrane cofactor protein) serve as receptors for measles virus. *Proc Natl Acad Sci U S A* 1994;91:2161-2165.
660. Okada N, Liszewski MK, Atkinson JP, et al. Membrane cofactor protein (CD46) is a keratinocyte receptor for the M protein of the group A streptococcus. *Proc Natl Acad Sci U S A* 1995;92:2489-2493.
661. Giannakis E, Jokiranta TS, Ormsy RJ, et al. Identification of the Streptococcal M protein binding site on membrane cofactor protein (CD46). *J Immunol* 2002;168:4585-4592.
662. Greenstone HL, Santoro F, Lusso P, et al. Human herpesvirus 6 and measles virus employ distinct CD46 domains for receptor function. *J Biol Chem* 2002;277:39112-39118.
663. Brodbeck WG, Kuttner-Kondo L, Mold C, et al. Structure/function studies of human decay-accelerating factor. *Immunology* 2000;101:104-111.
664. Hourcade DE, Mitchell L, Kuttner-Kondo LA, et al. Decay-accelerating factor (DAF), complement receptor 1 (CR1), and factor H dissociate the complement AP C3 convertase (C3bBb) via sites on the type A domain of Bb. *J Biol Chem* 2002;277:1107-1112.
665. Williams P, Chaudry Y, Goodfellow IG, et al. Mapping CD55 function. The structure of two pathogen-binding domains at 1.7 Å. *J Biol Chem* 2003;278:10691-10696.

666. Uhrinova S, Lin F, Ball G, et al. Solution structure of a functionally active fragment of decay-accelerating factor. *Proc Natl Acad Sci U S A* 2003;100: 4718-4723.
667. Hane H, Ulmer AJ, El-Samalouti VT, et al. Decay-accelerating factor (DAF/CD55) is a functional active element of the LPS receptor complex. *J Endotoxin Res* 2001;7:227-231.
668. McKnight AJ, Gordon S. The EGF-TM7 family: unusual structures at the leukocyte surface. *J Leukoc Biol* 1998;63:271-280.
669. Lea S. Interactions of CD55 with non-complement ligands. *Biochem Soc Trans* 2002;30:1014-1019.
670. Krych-Goldberg M, Atkinson JP. Structure-function relationships of complement receptor type 1. *Immunol Rev* 2001;180:112-122.
671. Smith BO, Mallin RL, Krych-Goldberg M, et al. Structure of the C3b binding site of CR1 (CD35), the immune adherence receptor. *Cell* 2002;108:769-780.
672. Krych-Goldberg M, Hauhart RE, Subramanian VB, et al. Decay accelerating activity of complement receptor type 1 (CD35). *J Biol Chem* 1999;274: 31160-31168.
673. Schlaf G, Demberg T, Beisel N, et al. Expression and regulation of complement factor H and I in rat and human cells: some critical notes. *Mol Immunol* 2001;38:231-239.
674. Meri S, Pangburn MK. Discrimination between activators and nonactivators of the alternative pathway of complement: regulation via a sialic acid/polyanion binding site on factor H. *Proc Natl Acad Sci U S A* 1990;87:3982-3986.
675. Meri S, Pangburn MK. Regulation of alternative pathway complement activation by glycosaminoglycans: specificity of the polyanion binding site on factor H. *Biochem Biophys Res Commun* 1994;198:52-59.
676. Hellwage J, Jokiranta TS, Friese MA, et al. Complement C3b/C3d and cell surface polyanions are recognized by overlapping binding sites on the most carboxy-terminal domain of complement factor H. *J Immunol* 2002;169: 6935-6944.
677. Pangburn MK, Pangburn KLW, Koistinen V, et al. Molecular mechanisms of target recognition in an innate immune system: interactions among factor H, C3b, and target in the alternative pathway of human complement. *J Immunol* 2000;164:4742-4751.
678. Jokiranta TS, Hellwage J, Koistinen V, et al. Each of the three binding sites of factor H interacts with a distinct site on C3b. *J Biol Chem* 2000;275: 27657-27662.
679. Richards A, Buddles MR, Denne RL, et al. Factor H mutations in hemolytic uremic syndrome cluster in exons 18-20, a domain important for host cell recognition. *Am J Hum Genet* 2001;68:485-490.
680. Perkins SJ, Goodship THJ. Molecular modeling of the C-terminal domains of factor H of human complement: a correlation between haemolytic uraemic syndrome and a predicted heparin binding site. *J Mol Biol* 2002;316: 217-224.
681. Pangburn MK. Localization of the host recognition functions of complement factor H at the carboxyl-terminal: implications for hemolytic uremic syndrome. *J Immunol* 2002;169:4702-4706.
682. Pickering MC, Cook HT, Warren J, et al. Uncontrolled C3 activation causes membranoproliferative glomerulonephritis in mice deficient in complement factor H. *Nat Genet* 2002;31:424-428.
683. Zipfel PF, Jokiranta TS, Hellwage J, et al. The factor H protein family. *Immunopharmacology* 1999;42:53-60.
684. Friese MA, Hellwage J, Jokiranta TS, et al. FHL-1/reconectin and factor H: two human complement regulators which are encoded by the same gene are differently expressed and regulated. *Mol Immunol* 1999;36:809-818.
685. Hellwage J, Sakari T, Jokiranta TS, et al. Functional properties of complement factor H-related proteins FHR-3 and FHR-4: binding to the C3d region of C3b and differential regulation by heparin. *FEBS Lett* 1999;462:345-352.
686. Blom AM, Kask L, Dahlbäck B. Structural requirements for the complement regulatory activities of C4BP. *J Biol Chem* 2001;276:27136-27144.
687. Blom AM, Kask L, Dahlbäck B. CCP1-4 of the C4b-binding protein α -chain are required for factor I mediated cleavage of complement factor C3b. *Mol Immunol* 2003;39:547-556.
688. Nelson RM, Long GL. Solution-phase equilibrium binding interaction of human protein S with C4b-binding protein. *Biochemistry* 1991;30:2384-2390.

689. Tschopp J, Chonn A, Hertig S, et al. Clustering, the human apolipoprotein and complement inhibitor, binds to complement C7, C8 β , and the b domain of C9. *J Immunol* 1993;151:2159-2165.
690. Farkas I, Baranyi L, Ishikawa Y, et al. CD59 blocks not only the insertion of C9 into MAC but inhibits ion channel formation by homologous C5b-8 as well as C5b-9. *J Physiol* 2002;539(2):537-545.
691. Gerard C, Gerard NP. C5A anaphylatoxin and its seven transmembranesegment receptor. *Annu Rev Immunol* 1994;12:775-808.
692. Nzeako UC, Frigas E, Tremaine WJ. Hereditary angioedema. *Arch Intern Med* 2001;161:2417-2429.
693. Morgan PB, Walport MJ. Complement deficiency and disease. *Immunol Today* 1991;12:301-306.
694. Rosse WF, Ware RE. The molecular basis of paroxysmal nocturnal hemoglobinuria. *Blood* 1995;86:3277-3286.
695. Johnson RJ, Hillmen P. Paroxysmal nocturnal haemoglobinuria: nature's gene therapy. *Mol Pathol* 2002;55:145-152.
696. Ikezawa H. Glycosylphosphatidylinositol (GPI)-anchored proteins. *Biol Pharm Bull* 2002;25:409-417.
697. Watanabe R, Inoue N, Westfall B, et al. The first step of glycosylphosphatidylinositol biosynthesis is mediated by a complex of PIG-A, PIG-H, PIG-C and GPI-1. *EMBO J* 1998;17:877-885.
698. Kinoshita T, Inoue N. Dissecting and manipulating the pathway for glycosylphosphatidylinositol-anchor biosynthesis. *Curr Opin Chem Biol* 2000;4: 632-638.
699. Eisenhaber B, Maurer-Stroh S, Novatchkova M, et al. Enzymes and auxiliary factors for GPI lipid anchor biosynthesis and post-translational transfer to proteins. *BioEssays* 2003;25:367-385.
700. Ohishu K, Inoue N, Kinoshita T. PIG-S and PIG-T, essential GPI anchor attachment to proteins, form a complex with GAA1 and GPI8. *EMBO J* 2001;20: 4088-4098.
701. Hall C, Richards SJ, Hillmen P. The glycosylphosphatidylinositol anchor and paroxysmal nocturnal haemoglobinuria/aplasia model. *Acta Haematol* 2002;108:219-230.
702. Rosse WF. New insights into paroxysmal nocturnal hemoglobinuria. *Curr Opin Hematol* 2001;8:61-67.
703. Chen R, Nagarajan S, Prince G, et al. Impaired growth and elevated Fax receptor expression in PIGA+ stem cells in primary paroxysmal nocturnal hemoglobinuria. *J Clin Invest* 2000;106:689-696.
704. Young NS, Maciejewski JP. Genetic and environmental effects in paroxysmal nocturnal hemoglobinuria: this little PIG-A goes "Why? Why? Why?" *J Clin Invest* 2000;106:637-641.
705. Orren A. Molecular mechanisms of complement component C6 deficiency; a hypervariable exon 6 region responsible for three of six reported defects. *Clin Exp Immunol* 2000;119:255-258.
706. Fernie BA, Orren A, Sheehan G, et al. Molecular basis of C7 deficiency. *J Immunol* 1997;159:1019-1026.
707. Orren A, O'Hara AM, Morgan BP, et al. An abnormal but functionally active complement component C9 protein found in an Irish family with subtotal C9 deficiency. *Immunology* 2003;108:384-390.
708. Hobart MJ, Fernie BA, Fijen KA, et al. The molecular basis of C6 deficiency in the western Cape, South Africa. *Hum Genet* 1998;103:506-512.
709. Zhu Z-B, Atkinson TP, Hovanky KT, et al. High prevalence of complement component C6 deficiency among African-Americans in the south-eastern United States. *Clin Exp Immunol* 2000;119:305-310.
710. Würzner R, Hobart MJ, Fernie BA, et al. Molecular basis of subtotal complement C6 deficiency. A carboxy-terminally truncated but functionally active C6. *J Clin Invest* 1995;95:1877-1883.
711. Orren A, Potter PC, Cooper R, et al. Deficiency of the sixth component of complement and susceptibility to Neisseria meningitis infections. Studies in ten families and five isolated cases. *Immunology* 1987;62:249-253.
712. Dragon-Durey MA, Fremaux-Bacchi V, Blouin J, et al. Restricted genetic defects underlie human complement C6 deficiency. *Clin Exp Immunol* 2003;132:87-91.
713. Smith LC, Clow LA, Terwilliger DP. The ancestral complement system in sea urchins. *Immunol Rev* 2001;180:16-34.
714. Smith LC, Azumi K, Nonaka M. Complement systems in invertebrates. The ancient alternative and lectin pathways. *Immunopharmacology* 1999;42:107-120.

Section 5 - Hemostasis

Chapter 15 Megakaryocytes

> Table of Contents > Part II - The Normal Hematologic System > Section 5 - Hemostasis > Chapter 15 - Megakaryocytes

Chapter 15

Megakaryocytes

Amy E. Geddis

Megakaryocytes are large polyploid cells within the bone marrow that produce circulating platelets. Platelets are small anucleate cells that play an essential role in hemostasis, both serving to plug holes in blood vessels and initiate coagulation. To function in this role, platelets have unique properties, including the ability to adhere to injured blood vessels and to other platelets, undergo dramatic shape change, release granules containing vasoactive and thrombogenic substances, and modulate the phospholipid content of their external membrane. Platelets also release agents that promote wound healing. Based on the adult blood volume (5 L), the number of platelets per microliter of blood ($\sim 2 \times 10^5$), and their circulatory half-life (10 days), it can be calculated that each day an adult human produces 1×10^{11} platelets, although in times of increased demand, platelet production can rise tenfold or more. The process of megakaryocyte and platelet formation is complex and only partially understood. This chapter discusses the molecular mechanisms underlying the development of megakaryocytes and platelets, as well as disease states that have illuminated our understanding of megakaryopoiesis.

HISTORICAL PERSPECTIVE

Platelets were described by Addison in 1841 as “extremely minute ... granules” in clotting blood¹ and were termed platelets (blutplättchen) by Bizzozero, who also observed their adhesive qualities as “increased stickiness when a vascular wall is damaged.”² The same elements were identified by microscopic examination of blood smears by Osler and Schaefer and by Hayem in the late nineteenth century.^{3,4} Duke, a student of James Homer Wright's, associated low platelet counts, or thrombocytopenia, with clinical bleeding that could be corrected by transfusion.⁵

Megakaryocytes are rare polyploid cells within the bone marrow, representing approximately 0.05% of nucleated cells. Although Howell coined the term megakaryocyte as early as 1890, it was not until 1906 that James Homer Wright put forth the hypothesis that blood platelets are derived from the cytoplasm of megakaryocytes,^{6,7} and the basic elements of thrombopoiesis were established. Many years later in the early 1990s, c-Mpl, the cellular homolog of the v-Mpl (myeloproliferative leukemia retrovirus) oncogene, was identified and proposed to be a hematopoietic growth factor receptor.^{8,9,10} and¹¹ Shortly thereafter, thrombopoietin (TPO) was cloned based on its properties of binding to and stimulating growth of c-Mpl-bearing cells; subsequent characterization of the cytokine revealed it to be the major growth factor promoting megakaryopoiesis.^{12,13,14,15} The availability of TPO was a major step forward in megakaryocyte and platelet biology as it facilitated expansion of megakaryocytes for further study as well as dissection of the signaling pathways regulating megakaryocyte proliferation and survival.

This chapter focuses primarily on mammalian species. However, it is worth noting that in nonmammalian vertebrates, such as fish and birds, the hemostatic equivalent of platelets is served by nucleated thrombocytes,¹⁶ and polyploid megakaryocytes are not present. The purpose of megakaryocyte polyploidization in the process of platelet development is not understood but it is speculated that this allows for increased expression of the proteins that are needed for the production of large numbers of platelets.¹⁷

MEGAKARYOPOIESIS AND THE HEMATOPOIETIC STEM CELL

Megakaryocytes, like cells of all blood lineages, are derived from the hematopoietic stem cell (HSC). HSCs are also very rare cells within the bone marrow, estimated to represent approximately 0.01% of total nucleated cells. Identified in 1961 by Till and McCullough,¹⁸ key properties of HSCs include the capacity for prolonged quiescence, self-renewal, and ultimately expansion and differentiation into the total diversity of blood cell types. Although megakaryocytes are terminally differentiated cells, they share a number of characteristics with HSCs.¹⁹ For example, both megakaryocytes and HSCs express the integrins CD41 (integrin $\alpha 2b$) and CD61 (integrin $\beta 3$). The integrin $\alpha 2b\beta 3$ complex forms a fibrinogen receptor that is one of the defining markers of the megakaryocyte lineage, but is now known to be expressed much earlier in hematopoiesis, including on HSCs.^{20,21} and²² In addition, expression of integrin $\beta 3$ in association with integrin αv identifies a population of cells with enhanced long-term repopulating activity in transplantation assays.²² Several

transcription factors share key roles in both HSC and megakaryocyte development, including SCL/TAL1, RUNX1, GATA, and ETS family members (discussed below). Strikingly, even the global transcriptional profiles of HSCs and early megakaryocytic/erythroid progenitors (MEPs) are highly similar.²³

In addition to similarities in cell surface protein and gene expression patterns, both HSCs and megakaryocytes require TPO for their growth and survival. The importance of TPO and its receptor c-Mpl for the function of HSCs was suspected when knockout mice, lacking either TPO or c-Mpl, were noted to be deficient in progenitors of all hematopoietic lineages. Transplantation experiments in mice confirmed that in the absence of an intact TPO-c-Mpl axis, HSCs are unable to compete with wild-type cells, either due to reduced numbers or expansion potential, although the mice do not develop bone marrow failure.^{24,25,26,27,28} In humans, mutations that eliminate c-Mpl function are the basis of congenital amegakaryocytic thrombocytopenia (CAMT). Children with CAMT are born with isolated thrombocytopenia and a paucity of megakaryocytes, but typically progress to trilineage bone marrow failure within the first decade of life, providing evidence of an essential and nonredundant role of TPO for the HSC.²⁹

TPO has been demonstrated to contribute to both HSC quiescence and expansion in various experimental settings. In mice, the absence of TPO or c-Mpl leads to acceleration of HSC cell cycling and eventual HSC exhaustion, suggesting that TPO is required for HSC quiescence and self-renewal.³⁰ One potential mechanism

P.372

by which TPO enhances HSC quiescence is by up-regulation of cyclin-dependent kinase inhibitors.^{30,31} In addition, TPO affects the interactions between the HSC and the bone marrow niche. HSCs are maintained in a quiescent state through interactions with TPO-producing osteoblasts.³¹ Although both outside-in and inside-out signaling, TPO triggers a conformational change of integrin $\alpha\beta3$ to its high-affinity state, and binding of $\alpha\beta3$ to its extracellular ligand within the niche results in phosphorylation of tyrosine 747 (Y747) of the integrin $\beta3$ tail, which cooperates with TPO signals to inhibit cell cycling and maintain HSC long-term repopulating activity.³²

TPO can also promote HSC expansion. In vitro, single cell experiments demonstrated that TPO supports the survival of HSCs, and in addition promotes their proliferation if either stem cell factor (SCF) or interleukin (IL)-3 is also present.³³ TPO also cooperates with vascular endothelial growth factor (VEGF) through an autocrine mechanism; TPO increases VEGF expression in primitive murine hematopoietic cells through induction of hypoxia-inducible factor (HIF)-1 α , and TPO in conjunction with VEGF promotes proliferation of hematopoietic progenitors.³⁴ In human embryonic stem cell models, the combination of TPO and VEGF enhances the generation of CD34⁺ cells.³⁵ In addition to HIF-1 α , TPO increases the expression and function of HOX family members. TPO-induced p38 MAPK enhances HOXB4 expression, a homeobox factor that promotes HSC expansion.^{36,37} TPO-induced MAPK also leads to phosphorylation of MEIS1 which binds to and facilitates nuclear translocation of HOXA9.³⁸ As with HOXB4, disruption of HOXA9 in animal models also leads to HSC defects.³⁹ Finally, Lnk, an adaptor protein that modulates TPO-induced STAT5, AKT, and p38 MAPK signaling, negatively regulates self-renewal of HSCs. Lnk-deficient HSCs are hypersensitive to TPO and have enhanced long-term repopulating activity due to increased self-renewal.⁴⁰ Although the mechanisms remain incompletely understood, clinical studies are examining the possible applications for TPO-receptor agonists in expanding HSCs in patients with acquired aplastic anemia with promising preliminary results.⁴¹

MEGAKARYOCYTE DEVELOPMENT

In current models of hematopoiesis, the HSC can either undergo symmetric divisions, resulting in self-renewal, or asymmetric divisions, in which the daughter cells become progressively committed to a specific hematopoietic lineage. Lineage commitment is marked by characteristic gene expression patterns and modulated by hematopoietic cytokines (Fig. 15.1). Specific multipotent and megakaryocytic progenitors can be defined using semi-solid colony assays. More recent strategies have used fluorescence-activated cell sorting approaches to identify progenitors and committed cells prospectively based on cell surface protein expression patterns^{42,43} (Table 15.1). The earliest multipotent progenitor that has been isolated is the committed myeloid progenitor, which gives rise to the colony-forming-unitgranulocyte-erythroid-macrophage-megakaryocyte (CFU-GEMM). From the CFU-GEMM arises a bipotential progenitor with both megakaryocytic and erythroid potential, the MEP.^{44,45,46} and⁴⁷ Identified within the CD34⁺CD38^{low} cell population of progenitor cells,⁴⁶ murine MEPs have been further defined as existing within the CD150⁺CD9^{lo}endoglin^{lo} fraction of Lin⁻cKit⁺IL7R α ⁻Fc γ RII/III^{lo}Sca1⁻ cells.^{48,49} Megakaryocyte-lineage-committed progenitors in contrast were included in the CD150⁺CD9^{hi}endoglin^{lo} fraction. The most primitive committed megakaryocytic cell is the megakaryocytic burst-forming unit, which resembles a small lymphocyte and forms a colony of 40 to 500 cells in semi-solid assays. The megakaryocytic colony-forming unit (CFU-MK) is a more mature progenitor that will form a colony of 3 to 50 cells in semi-solid assays.

Whereas all megakaryocytic progenitors can be recognized by staining for CD41 and, in murine cells, acetylcholinesterase, only CFU-MK express HLA-DR. Though this represents the classical model of megakaryocytic differentiation, it has been proposed that an alternative pathway exists in which the MEP can arise directly from the HSC.⁵⁰

Precursors that are committed to the megakaryocyte lineage undergo further maturation before they are capable of platelet production. As they differentiate, megakaryocytes express specific cell surface proteins, become polyploid, develop a complex cytoplasm containing granules and a system of demarcation membranes, and ultimately form proplatelet processes (Fig. 15.2). Historically, the developmental stages of megakaryocytes have been described based on morphologic criteria including the quality and quantity of the cytoplasm and the size, lobulation, and chromatin pattern of the nucleus. Thus, cells can be categorized as promegakaryoblasts and stage I megakaryoblasts, stage II promegakaryocytes, stage III mature megakaryocytes, and stage IV megakaryocytes preparing to release platelets from their cytoplasm. Stage I megakaryocytes account for approximately 25% of all megakaryocyte lineage cells in a normal marrow. They are 6 to 24 μm in diameter and contain a relatively large, minimally indented nucleus (2 to 4 N) with loosely organized chromatin and multiple nucleoli and scant basophilic cytoplasm containing a small Golgi complex, a few mitochondria and α -granules, and abundant free ribosomes. Although the cytoplasm is scant, the demarcation membrane system (DMS) that is characteristic of more mature cells has already begun to form. This early, proliferative megakaryocytic cell is also sometimes termed a megakaryoblast and, in rodent hematopoiesis, is characterized by intense staining for acetylcholinesterase. Stage II megakaryocytes also represent approximately 25% of marrow megakaryocytes. They measure 14 to 30 μm in diameter, with a lobulated nucleus of 8 to 64 N and more abundant polychromatic cytoplasm. Ultrastructurally, the cytoplasm contains more abundant α -granules and organelles, and the DMS begins to expand at this stage of development. The remaining 50% of morphologically recognizable megakaryocytes in the marrow are stage III/IV megakaryocytes. These cells are very large (40 to 60 μm in diameter) with abundant mature cytoplasm. The DMS is prominent, and the multilobulated nucleus becomes more compact and is often eccentrically placed. Stage IV megakaryocytes may display proplatelet processes. It has been calculated that it takes approximately 72 hours for stage III and stage IV cells to develop from stage I megakaryocytes.

Starting in early megakaryocytes, expression of characteristic cell surface proteins, including integrin $\alpha 2\text{b}\beta 3$ and GPIb/IX, becomes functionally important. Integrin $\alpha 2\text{b}\beta 3$ is an integral transmembrane protein that acts as a receptor for fibrinogen. Of the two subunits, only integrin $\alpha 2\text{b}$ is megakaryocyte lineage specific. Loss of integrin $\alpha 2\text{b}\beta 3$ leads to Glanzmann thrombasthenia due to failure of the defective platelets to engage fibrinogen during aggregation. The two subunits of integrin $\alpha 2\text{b}\beta 3$ are synthesized in the endoplasmic reticulum and form a Ca^{2+} -dependent complex immediately on translation, a step necessary for membrane expression. Subsequently, the α -subunit is cleaved into heavy and light chains and modified with carbohydrate before transfer to the cell surface, demarcation, and α -granule membranes.^{51,52} Megakaryocytes and platelets contain approximately twice the amount of integrin $\alpha 2\text{b}\beta 3$ in granules as is present on the cell surface, the granule compartment serving as a mobilizable pool that is exteriorized on platelet activation.

The GPIb/IX complex is developmentally expressed only slightly later than integrin $\alpha 2\text{b}\beta 3$ and forms a receptor for von Willebrand factor (vWF).²¹ Although known for its role in binding vWF, GPIb α also is an important structural component in platelets through its interaction with the cytoskeletal protein filamin A. Filamin A, in turn, promotes clustering and activation of GPIb, thus regulating its function in platelet aggregation.^{53,54} Absence of

P.373

the GPIb/IX complex results in Bernard-Soulier syndrome (BSS), an autosomal recessive macrothrombocytopenia with severe platelet dysfunction; mutations of filamin A are also associated with macrothrombocytopenia but GPIb surface expression is normal.⁵⁵ Except for minor expression in endothelial cells,⁵⁶ GPIb is a megakaryocyte-specific protein. GPV is also expressed in complex with GPIb and GPIX in a 2:2:1 (Ib:IX:V) stoichiometric ratio^{57,58}; however, GPV is not required for the function of the GPIb/V/IX complex in binding vWF. Genetic elimination of GPV has little effect on platelet adhesion⁵⁹ and no mutations of GPV have been associated with BSS.⁶⁰ Rather, GPV appears to function as a target of thrombin, possibly playing a role in platelet activation.^{61,62}

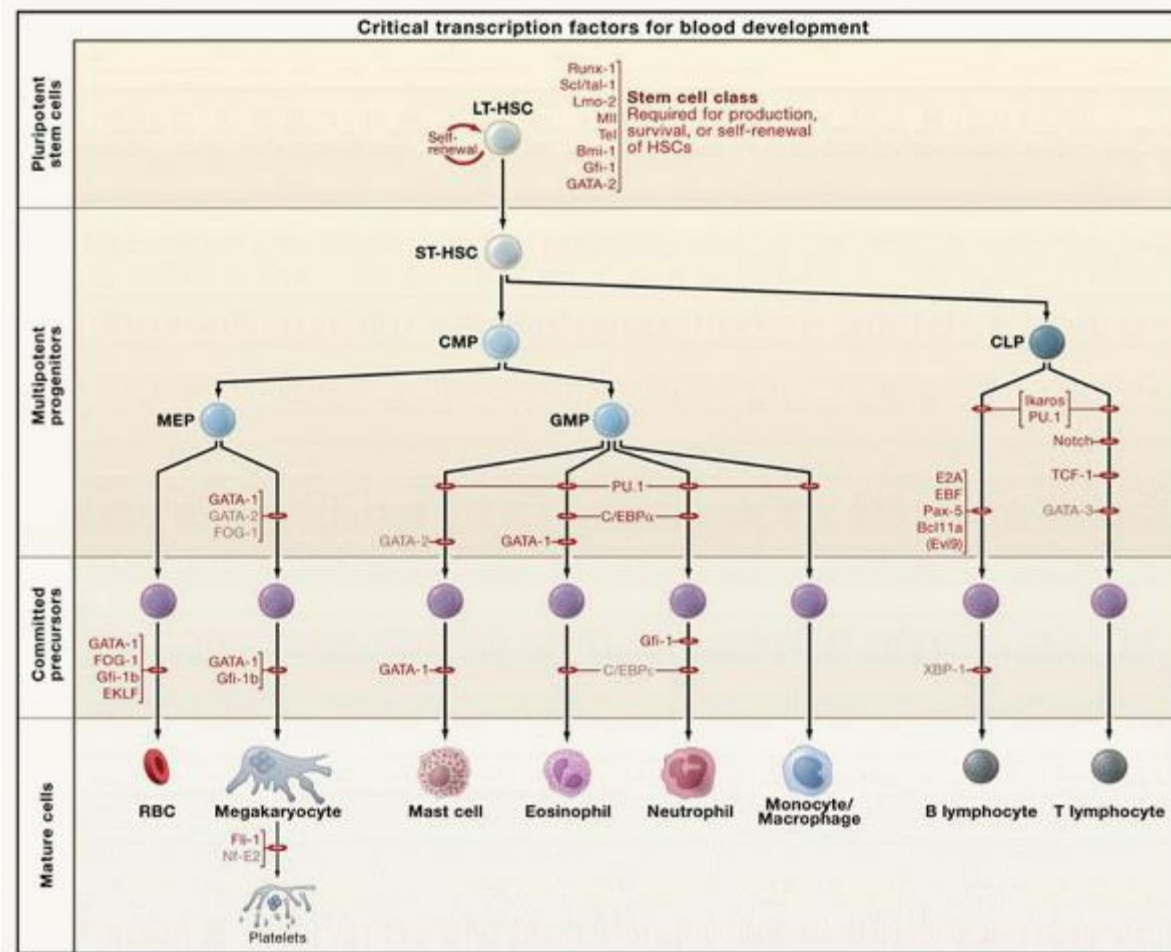

FIGURE 15.1. Hematopoietic cell development. Transcription factors regulate the differentiation of the HSC to produce committed progenitors and mature blood cells. The MEP is a bipotential precursor that gives rise to both erythroid and megakaryocytic lineages. Whereas GATA1 and FOG1 are required for both erythropoiesis and megakaryopoiesis, EKLF favors red cell development and FLI1 promotes megakaryopoiesis. With permission from Orkin SH, Zon LI. Hematopoiesis: an evolving paradigm for stem cell biology. Cell 2008;132:631-644.

TABLE 15.1 CELL SURFACE MARKERS CHARACTERISTIC OF MEGAKARYOCYTE DEVELOPMENT

Cell Surface Antigen Markers During Megakaryopoiesis

Stage	Sca	CD117	CD34	CD38	CD150	CD41	CD42	CD9
HSC	+	+	-/+	-/+	+	+	-	lo
CMP	-	+	+	+	+	+	-	lo
MEP	-	+	+	lo	+	+	-	lo
CFUMK	-	-	-	-	-	+	+	+
MK	-	-	-	-	-	+	+	+

P.374

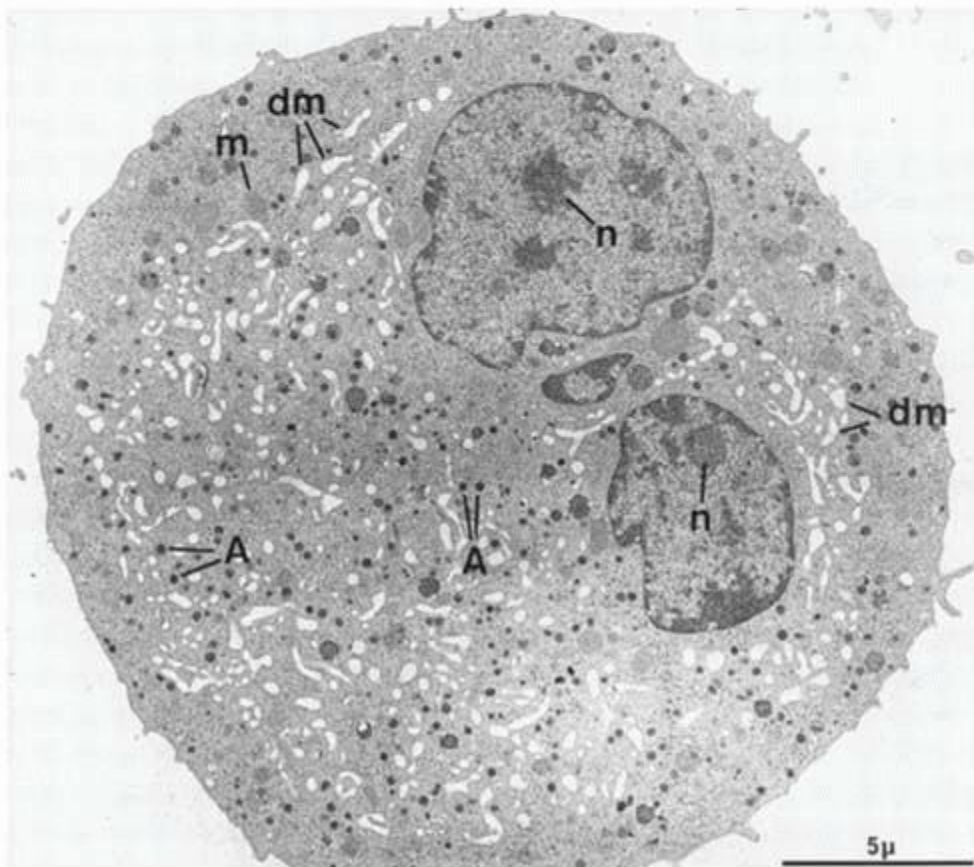
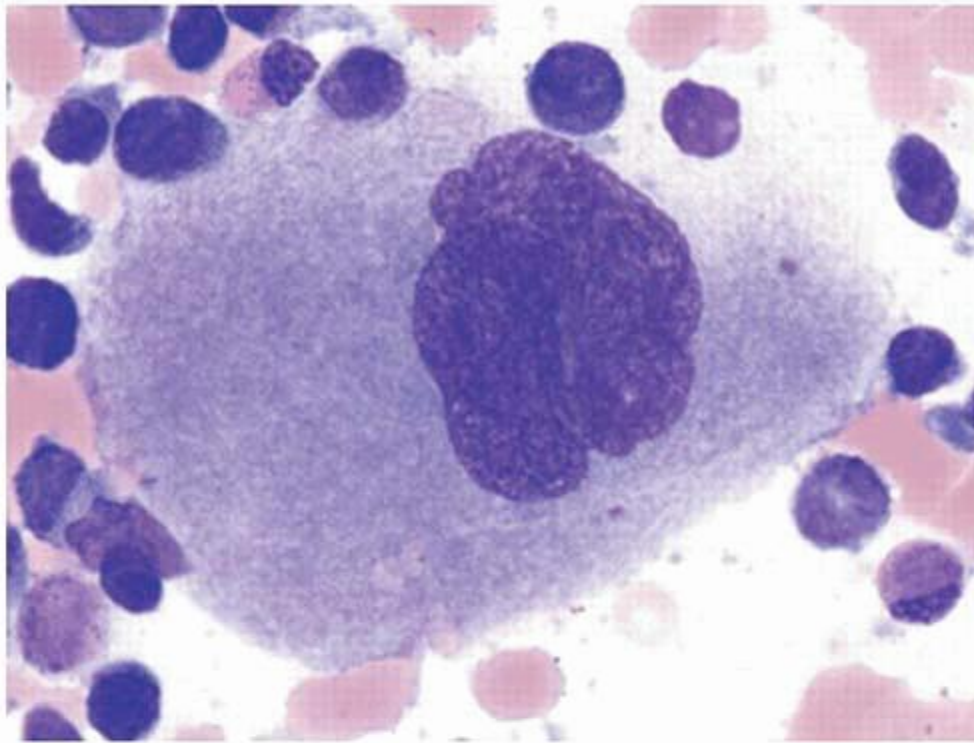
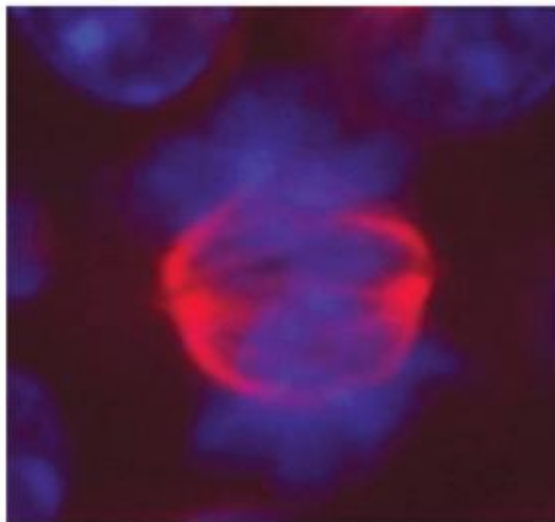

FIGURE 15.2. Mature megakaryocytes (A) Bone marrow megakaryocyte visualized by Wright's stain. Note the multilobated nucleus. (B) Electron micrograph of a mature megakaryocyte, showing cytoplasmic alpha granules (A), mitochondria (m),

and demarcation membranes (dm). There appear to be separate nuclei with nucleoli (n), but these represent two lobes of a single nucleus visible in this section.

One of the most characteristic and intriguing features of megakaryocyte maturation is the development of polyploidy. As they mature, megakaryocytes switch from mitotic cell cycling to endomitosis, or DNA replication in the absence of nuclear or cytoplasmic division (Fig. 15.3). Endomitosis begins late in stage I megakaryoblasts, after sufficient diploid cell divisions have occurred to expand the number of megakaryocytic precursor cells, and is completed by the end of stage II megakaryocyte development.^{63,64} This carefully controlled process (i.e., cells are polyploid, rather than aneuploid) results in cells containing DNA content from 8 to 128 times the normal chromosomal complement in a single, highly lobated nucleus. Endomitosis is not simply the absence of mitosis, but rather an aborted mitosis.⁶⁵ The cell-cycle kinetics of endomitotic cells is also unusual, characterized by a short G₁ phase, a normal or modestly prolonged DNA synthesis phase, a short G₂ phase, and a very short endomitosis phase.⁶⁶ During the latter, megakaryocytic chromosomes condense, the nuclear membrane breaks down, and centromeres form mitotic spindles on which the replicated chromosomes assemble. However, after initiation of anaphase with chromosomal separation and cleavage furrow formation, the furrow regresses, the spindle dissociates, and the megakaryocyte re-enters the G₁ phase as a polyploid cell.^{65,67} Attempts at biochemical analysis of this process have come from leukemic cell lines and normal cultured megakaryocytes. Hypotheses for the mechanisms triggering polyploidy in megakaryocytes have included deficiencies of cyclin B, altered cytoskeletal dynamics, a defect of the chromosomal passenger proteins, and malfunction of the contractile ring. Early interest focused on the M-phase cyclin-dependent kinase cyclin B-cdc2. Also termed mitosis-promoting factor, the amount of cyclin B and the activity of the cyclin B-cdk1 complex rise through the cell cycle until mitosis, where they fall abruptly due to proteosomal degradation of cyclin B. As the major departure from normal cell-cycle behavior in megakaryocytes occurs during the M phase, it was proposed that endomitosis might result from impaired activation of cyclin B-cdc2 kinase, as suggested in several cell line models.^{68,69} and ⁷⁰ However, results from normal murine and human megakaryocytes argue for normal mitotic kinase activity during endomitosis. Using TPO to expand primary megakaryocytes in vitro, two groups have demonstrated the presence of functional cyclin B and cdc2 in endomitotic megakaryocytes^{65,71} as well as a normal metaphase checkpoint mechanism.⁷² Although the combined deletion of cyclin D1, D2, and D3 in mouse models did not specifically affect megakaryocytes,⁷³ deletion of cyclin E did impair megakaryopoiesis as well as trophoblast development,⁷⁴ suggesting that cyclin E plays a role in endomitosis.

Endomitosis in Megakaryocytes



Diploid cell

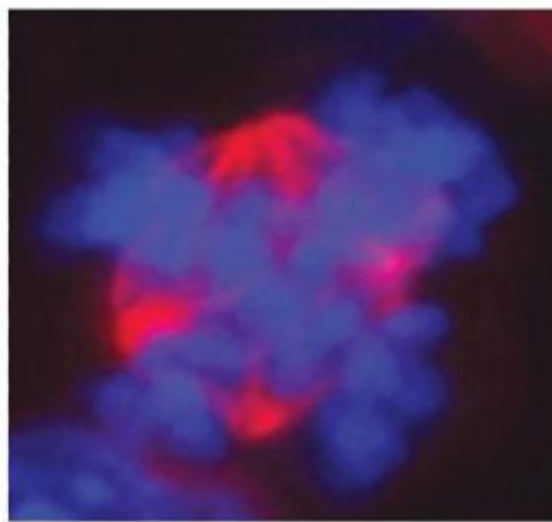

Polyploid cell

FIGURE 15.3. Endomitosis in megakaryocytes. (A) Mitosis in a megakaryocytic precursor: chromatids (blue) are arranged in a single metaphase plate, microtubules (red) form a bipolar spindle. (B) Endomitosis: chromatids are arranged in two

metaphase plates and the spindle is multipolar.

Alterations in regulation of the microtubule cytoskeleton have also been proposed as fundamental in triggering endomitosis. Stathmin is a microtubule-depolymerizing protein that is important for the regulation of the mitotic spindle. As cells enter mitosis, the microtubule-depolymerizing activity of stathmin decreases, allowing microtubules to polymerize and assemble into a mitotic spindle. Reactivation of stathmin in the later stages of mitosis is necessary for the disassembly of the mitotic spindle and the exit from mitosis. Interfering with stathmin expression disrupts the normal mitotic spindle and leads to aberrant mitotic exit.⁷⁵ Thus it has been hypothesized that alterations in stathmin expression underlie endomitosis in megakaryocytes. In support of this view, expression of stathmin is decreased in higher ploidy megakaryocytes,⁷⁶ and studies in the erythroleukemia cell line K562 show that inhibition of stathmin expression enhances polyploidy, whereas overexpression of stathmin inhibits the transition from a mitotic cycle to an endomitotic cycle and reduces formation of multipolar mitotic spindles.^{76,77} Whether down-regulation of stathmin leads to polyploidization in megakaryocytes or is a result of it is not known. Proper activation and localization of

P.375

the chromosomal passenger proteins have also been examined as a potential point of departure from the mitotic cell cycle in megakaryocytes. These proteins, including INCENP, survivin, and Aurora Kinase B, form a complex that localizes to the centrosome prior to anaphase and then shifts to the microtubules of the midbody and cleavage furrow.⁷⁸ Elimination of individual members of the passenger protein complex in organisms as diverse as *Drosophila* and mammals leads to the abrogation of proper cell division and the formation of a cellular syncytium containing a large nuclear mass.^{79,80} and⁸¹ Work in cell lines initially suggested that megakaryocytes might be deficient in survivin or Aurora kinase B.^{82,83} However, subsequent examination of primary megakaryocytes revealed that Aurora kinase B as well as associated passenger proteins are active and appropriately localized in both diploid and polyploid megakaryocytes.⁸⁴ Further observation of endomitosis by live cell microscopy demonstrated that endomitotic megakaryocytes assemble cleavage furrows that begin to contract and then regress; this fact suggests that the "defect" in endomitosis is beyond anaphase and involves the function of the contractile ring in cytokinesis.^{85,86} Confocal microscopy confirmed poor localization of RhoA and the actin/myosin complex to the cleavage furrow in endomitotic megakaryocytes. In support of the role of RhoA in endomitosis, expression of Ect2 and GEF-H1, guanine exchange factors that activate RhoA during cytokinesis, is decreased in polyploidizing cells, and forced overexpression of Ect2 and GEF-H1 blocks endomitosis.⁸⁷ Recent work indicates that nonmuscle myosin IIB heavy chain, whose expression is controlled by Runx1, is also down-regulated during megakaryocyte maturation, and that loss of myosin IIB expression inhibits the return of 4 N cells to the diploid state.⁸⁸ It is likely that there are multiple alterations in the cell cycle of megakaryocytes that are involved in the process of endomitosis.

Another important aspect of megakaryocyte maturation is the development of the DMS. Initially described more than 30 years ago,⁸⁹ what begins as invaginations of the plasma membrane ultimately becomes a highly branched interconnected system of channels that course through the cytoplasm. The use of electron-dense tracers indicated that the DMS is in open communication with the extracellular space,^{52,89,90} in comparison with the rough endoplasmic reticulum which is contiguous with the nuclear membrane. Over the 72 hours it takes for stage III and stage IV cells to develop from stage I megakaryocytes, the DMS grows by approximately 25-fold. The mature DMS contains phosphatidyl inositol-4,5-P₂ (PI-4,5-P₂), a phospholipid that is usually associated with the plasma membrane, and PI-4,5-P₂ promotes actin polymerization by activating Rho-like guanosine triphosphatases (GTPases) and Wiskott-Aldrich syndrome (WASp) family proteins.⁹¹ The purpose of the DMS has been disputed for nearly 20 years⁹²; initially, it was thought to compartmentalize the cytoplasm of the mature megakaryocyte into platelet territories, which ultimately fragment into mature platelets along the cleavage planes so formed, but recent evidence suggests that the DMS provides the necessary membrane required for the formation of proplatelet processes and may promote actin polymerization.⁹¹

Two specific types of granules are characteristic of mature megakaryocytes and platelets. The more abundant α -granules first begin to form adjacent to the Golgi apparatus as 300- to 500-nm round or oval organelles in stage I and II cells. α -Granules contain multiple proteins with functions in coagulation and angiogenesis. Three distinct compartments are recognized in α -granules: (a) a central electron-dense nucleoid containing fibrinogen, platelet factor 4 (PF4), β -thromboglobulin, transforming growth factor (TGF)- β 1, vitronectin, multimerin, and tissue-type plasminogen activator; (b) a relatively lucent peripheral zone containing tubules and vWF (an arrangement akin to Weibel-Palade bodies found in endothelial cells); and (c) the granule membrane containing many of the critical platelet receptors for cell rolling (P-selectin, also termed CD62p), firm adhesion (gpIb/V/IX), and aggregation ($\alpha_{IIb}\beta_3$ integrin). In platelets, proteins present in α -granules arise from de novo megakaryocyte synthesis (e.g., gpIb/V/IX, gpIV, $\alpha_{IIb}\beta_3$ integrin, vWF, P-selectin, β -

thromboglobulin, and platelet-derived growth factor), nonspecific pinocytosis of environmental proteins (e.g., albumin and IgG), or cell surface membrane receptor-mediated uptake from the environment (e.g., fibrinogen, fibronectin, and factor V).^{93,94} Dense granules are less numerous and contain the vasoconstrictive 5-hydroxytryptamine, the nonmetabolic pool of adenosine triphosphate and adenosine diphosphate (ADP), calcium, and magnesium, and they have a fundamental role in hemostasis. Although α -granules contain multiple proteins with opposing functions, proteins with specific functions may be released selectively in response to certain agonists. For example, ADP and PAR1 stimulate the release of angiogenic factors such as VEGF, whereas thromboxane A2 and PAR4 stimulate the release of antiangiogenic factors such as endostatin.^{95,96} Therefore, current models propose differential secretion of granule contents in response to different agonists, although the mechanisms by which this selectivity is achieved are still unclear.

Throughout megakaryocyte development, the cytoplasm acquires a rich network of microfilaments and microtubules. Toward stages III and IV, these proteins accumulate in the cell periphery, creating an organelle-poor peripheral zone. Biochemically, the megakaryocyte cytoskeleton is composed of actin, α -actinin, filamin, nonmuscle myosin, β 1 tubulin, talin, and spectrin. Spectrin plays an important role in stabilizing the DMS and proplatelet processes.⁹⁷ β 1 tubulin is expressed exclusively in megakaryocytes and platelets and is critical for proplatelet formation; over 90% of microtubules in the mature megakaryocyte are composed of the β 1 isoform.^{98,99} At the onset of proplatelet formation, blunt pseudopodia are formed, and β 1-tubulin-containing microtubules assemble into thick bundles below the plasma membrane¹⁰⁰ (Fig. 15.4). The pseudopodia elongate, bend, and branch to form proplatelets, and the microtubules form bidirectional linear arrays with terminal loops composed of 8 to 12 microtubule coils at the proplatelet tips.¹⁰¹ Dynein powers microtubule sliding and proplatelet elongation, whereas actin and myosin are involved in proplatelet bending and branching.^{100,102} Granules and organelles such as mitochondria traffic on these microtubule "tracks" to accumulate within the tips that will ultimately be released to become circulating platelets.¹⁰³ The coiled microtubules at the proplatelet tip become the marginal band that maintains the discoid shape of the platelet.^{100,104} RanBP10 binds to microtubules and functions as a GEF for Ran, stabilizing microtubules and facilitating granule transport.^{105,106} Remodeling of the megakaryocyte cytoskeleton is essential for proplatelet formation, and mutations affecting cytoskeletal proteins, including regulators of actin (WASp), filamin A, β 1-tubulin, and nonmuscle myosin heavy chain IIA form the basis of several of the inherited thrombocytopenia syndromes.^{55,107,108,109}

Platelets are derived from the megakaryocyte cytoplasm. It has been estimated that each megakaryocyte gives rise to 1,000 to 5,000 platelets^{110,111} and¹¹² before the residual nuclear material is engulfed and eliminated by marrow macrophages.¹¹³ Stage IV megakaryocytes are wholly engaged in platelet formation. Careful microscopic studies have localized marrow megakaryocytes to the abluminal surface of sinusoidal endothelial cells. Fully mature megakaryocytes develop cytoplasmic processes constricted at platelet-sized intervals that extend through the endothelial barrier into the sinusoidal lumen, where platelets are released.¹¹⁴ It is likely that both integrin-mediated cell-cell interactions and extracellular matrix degradation are required for this process.^{115,116} and¹¹⁷ It is also possible that the final stages of megakaryocyte fragmentation occur in the lung, at least for some megakaryocytes. Howell and Donahue reported in 1939 that platelet levels in pulmonary venous blood exceed those found in the pulmonary artery, suggesting platelet production in the lung.¹¹⁸ Whether this represents the migration and fragmentation of intact megakaryocytes in

P.376

the lung or merely the final size reduction of large fragments of megakaryocyte cytoplasm that are also released into the blood¹¹⁹ is not clear. Lung megakaryocytes have been characterized by Slater et al., who believe they contribute substantially to blood platelet production.¹²⁰ However, in preclinical studies of TPO, Kaushansky et al. did not detect any denuded megakaryocyte nuclei in the lungs of mice which at the time of sacrifice had platelet counts as high as 4 million/mm³.¹²¹ One study found that dog lungs contain 2.5 megakaryocytes/cm² tavassoli¹²²; extrapolation of these data would suggest that human lungs contain approximately 6,000 megakaryocytes, only enough to account for a small proportion (<0.1%) of daily platelet production. Moreover, cultured megakaryocytes can form functional platelets in vitro by generating proplatelets in the absence of endothelial surfaces or the pulmonary circulation,¹⁰⁰ and the release of proplatelet fragments into bone marrow sinusoids has been visualized in living mice.¹²³ Thus, the role of pulmonary bed platelet production remains controversial.

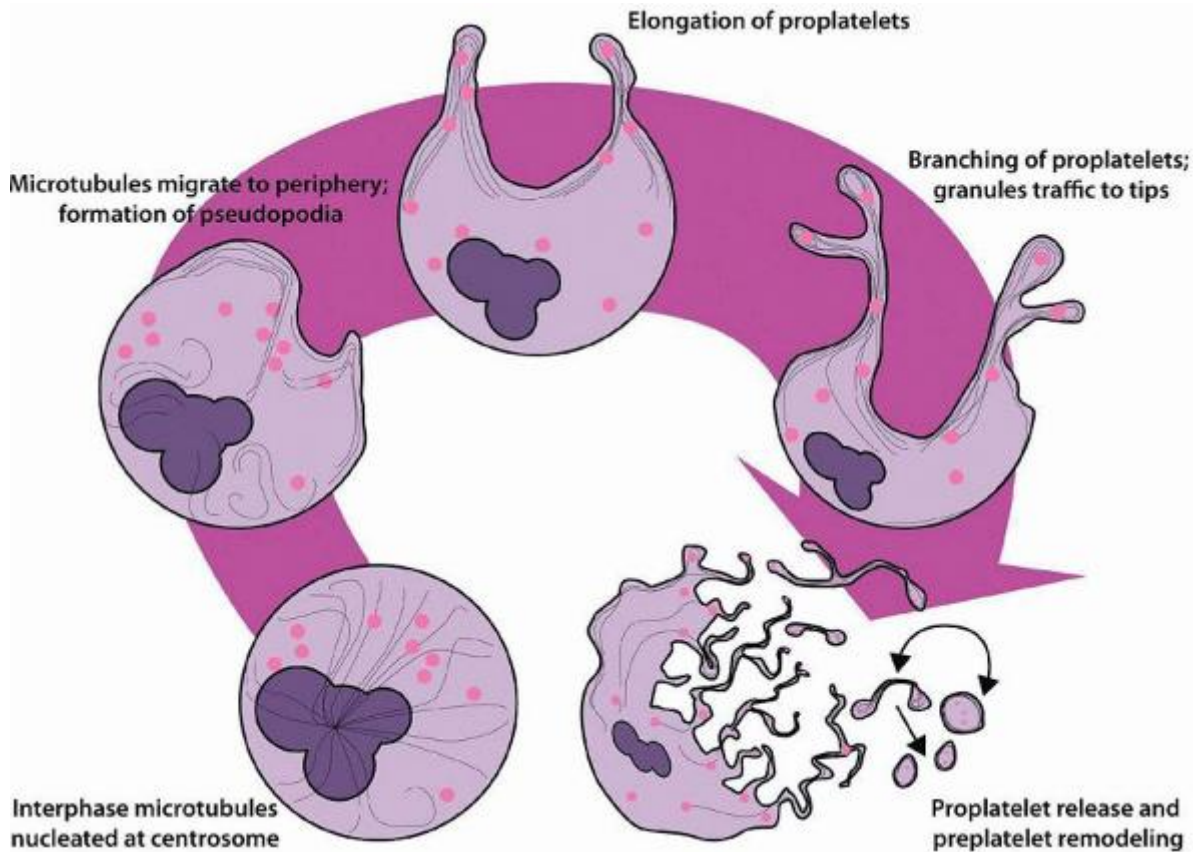

FIGURE 15.4. Proplatelet formation in mature megakaryocytes. Noncentrosomal microtubules migrate to the cell periphery where they form bundles. Pseudopodia form and elongate into proplatelet processes, and the microtubules form bidirectional tracks within the processes that terminate in coiled ends. Granules and other organelles traffic along the microtubules and accumulate in the tips. Proplatelet processes are released and continue to remodel in the circulation, alternating between barbell-shaped proplatelets and large preplatelets, before the proplatelets finally divide into individual platelets.

Notably, the proplatelets and platelets released in experimental models are larger than typical circulating platelets. In addition, it has long been recognized that patients with disorders of increased platelet production, such as immune thrombocytopenia, have relatively large circulating platelets. Thus, it has been proposed that once released into the circulation, these larger platelet precursors undergo further remodeling.^{124,125,126} Using an *in vitro* model, Thon et al. demonstrated that platelet precursors shift back and forth between two morphologic states, discoid preplatelets and barbell-like proplatelets.¹²⁶ Spectrin stabilizes the bridge between the ends of the barbell form.⁹⁷ Furthermore, these precursor platelets can be observed to divide or undergo fission. Shear forces in the circulation likely contribute to the cleavage of barbell-shaped proplatelets into individual platelets, although it has been postulated that mechanisms similar to those driving cell separation in cytokinesis may also be involved.

Programmed cell death represents not only the end of the megakaryocyte life cycle and proteins that regulate the intrinsic apoptosis pathway influence megakaryocyte survival. Apoptosis has also been proposed to play a role in megakaryocyte functions such as proplatelet formation. Early studies found that focal activation of caspases accompanies megakaryocyte maturation and overexpression of Bcl2 inhibits proplatelet formation, suggesting that localized apoptosis is required for platelet shedding.¹²⁷ However, a recent study found that targeted deletion of caspase 9, the initiator caspase in the intrinsic apoptotic pathway, has no effect on proplatelet formation.¹²⁸ Additional data support the alternative hypothesis that inhibition of apoptosis in mature megakaryocytes is necessary for proplatelet formation. In mouse models, targeted loss of Bcl-xL in megakaryocytes leads to caspase activation and failure of proplatelet formation and release of morphologically abnormal, large platelets.¹²⁹ Whereas isolated loss of Bcl-xL primarily affects mature megakaryocytes at the point of proplatelet formation, combined deletion of Bcl-xL

and Mcl-1 has even more profound effects, with severe impairment of megakaryopoiesis in embryos lacking both apoptotic regulators.¹³⁰ In addition, Bcl-xL inhibits apoptosis in circulating platelets. Mutation or pharmacologic inhibition of Bcl-xL leads to reduced platelet life span in mice.^{129,131} Apoptosis of aged platelets is mediated by Bak and Bax, whose activity is normally controlled by Bcl-xL; genetic deletion of Bak and Bax prolongs platelet survival and renders platelets resistant to the effects of Bcl-xL inhibition.¹²⁹ Mutations of Bcl-xL or Mcl-1 have not been described in humans; however, a proapoptotic mutation of cytochrome c has been identified in a family with autosomal dominant thrombocytopenia.¹³²

TRANSCRIPTIONAL REGULATION OF MEGAKARYOPOIESIS

Several themes are emerging in models of transcriptional regulation of hematopoietic differentiation that are relevant to the discussion of megakaryopoiesis. Lineage priming refers to the concept that the HSC is competent to express multiple genetic programs and lineage choice is the consequence of progressive silencing of alternative possibilities.^{133,134} Similarly, anticipatory regulation refers to the concept that differentiation-associated transcription factors are already bound at target promoters in HSCs, allowing for low-level expression that increases with differentiation.²³ Thus, as previously discussed, several transcription factors associated with megakaryocytes, as well as other lineages, are also expressed at low levels in HSCs, as well as in bipotential megakaryocytic/erythroid cells. As cells start to differentiate, lineage-specific transcription factors promote their own expression while suppressing factors that would favor other cell types, thus reinforcing lineage choice. For example, GATA1 activates its own promoter to increase its expression, and simultaneously inhibits PU.1, favoring megakaryocytic/erythroid differentiation, whereas in other cells, PU.1 might dominate, repressing the megakaryocytic/erythroid program and favoring myelopoiesis.^{135,136,137} Transcription factors do not act in isolation, however, but are typically present as components of cross-regulatory multiprotein complexes; their function may vary depending on the other factors that are present.

Recent studies have identified five core transcription factors, SCL/TAL1, GATA1, GATA2, RUNX1, and FLI1, as the promoters of hematopoietic genes in primary megakaryocytes. Genes next to regions bound by all five factors were highly enriched for known regulators of megakaryocytic differentiation or function.¹³⁸ Additional factors of importance in megakaryopoiesis include NF-E2, FOG1, HOX family proteins, GFI-1b, and c-Myb. Mutant forms of several of these factors or their downstream targets have been found in inherited thrombocytopenia syndromes or leukemias. In addition, there is emerging recognition of the role of noncoding RNAs in megakaryocytic differentiation.

SCL/TAL1: Stem cell leukemia/T-cell acute lymphoblastic leukemia gene 1, or SCL/TAL1, is a basic helix-loop-helix transcription factor that is essential for early hematopoietic specification as well as definitive differentiation of the erythroid and megakaryocyte lineages.¹³⁹ Loss of Scl/Tal1 expression in adult mice leads to defects in megakaryocyte cytoplasmic maturation and thrombocytopenia.^{140,141} In addition, progenitor cells from Scl/Tal1-deficient mice are unable to generate megakaryocytes *in vitro*.^{142,143} Among the transcriptional targets of SCL/TAL1 important for megakaryopoiesis are NF-E2 and MEF2C. Scl/Tal1 directly binds regulatory elements of Mef2C in megakaryocytic cells, and the platelet phenotype of Mef2C-knockout mice is similar to that of Scl/Tal1-deficient animals.¹⁴⁴ In human CD34⁺ hematopoietic progenitor cells, expression of MEF2C increases with megakaryocytic differentiation.¹⁴⁵ SCL/TAL1 has multiple partners, including E2A and LMO2. E2A binds canonical DNA elements called E-boxes represented by the motif CANNTG. E-boxes are frequently found along with GATA-binding motifs within the regulatory elements of erythroid and megakaryocytic cells.^{146,147} LMO2 is a LIM domain containing protein that forms a multiprotein complex with GATA1, SCL/TAL1, E2A, and another LIM domain protein LDB1^{146,148,149} and ¹⁵⁰; the complex is critical for early hematopoietic specification.^{139,148,151} LDB1 can self-associate to form oligomers and may bind multiple GATA1 molecules simultaneously, thus facilitating long-range interactions between GATA-bound sites.^{152,153} and ¹⁵⁴

GATA1: GATA1 is a zinc finger transcription factor critical in both erythroid and megakaryocytic development, with target genes including HBB (encoding β -globin), ALAS1, BCL2L1, NFE2, GP1BB, and GP9. Gata1 deficiency in mouse models leads to arrest of erythroid maturation at the proerythroblast stage and severe anemia,¹⁵⁵ as well as defects in megakaryocyte maturation with hyperproliferation of low ploidy cells, impaired endomitosis and formation of the DMS, and release of large hypogranulated platelets.^{156,157} GATA-binding motifs (T/A)GATA(A/G) are found in the regulatory elements of nearly all erythroid and megakaryocytic genes.^{158,159} Furthermore, the co-occurrence of ETS and GATA motifs was significantly associated with expression of the megakaryocytic program over the erythroid program.¹⁶⁰ GATA1 can function either as a transcriptional activator or repressor, depending on its binding partners. GATA1 contains two zinc fingers; the C-terminal zinc finger is responsible for high-affinity DNA binding, whereas the N-terminal finger stabilizes the interaction and binds to the co-factor FOG1.¹⁶¹ In addition to FOG1,¹⁶² GATA1 has interactions with other megakaryocytic core factors, including RUNX1 and FLI1.^{163,164,165} FOG1 contains 9 zinc fingers, 4 of which mediate interactions with GATA1.¹⁶⁶ In mouse models, deletion of FOG1 results in a more severe defect in megakaryopoiesis than does deletion of Gata1,^{167,168} supporting the

conclusion that although GATA1 is required for erythroid lineage commitment, FOG1 is required for specification of both erythroid and megakaryocytic progenitors.¹⁶⁸ The interaction of GATA1 with FOG1 and PU.1 is mutually exclusive,¹⁶⁹ thus GATA1 bound by FOG1 may be protected from repression by PU.1, favoring megakaryocytic/erythroid differentiation. Posttranslational modification of GATA1 by SUMOylation of amino acid K137 also disrupts FOG1 binding.¹⁷⁰ FOG1 can promote the function of GATA1 either as an activator or repressor of transcription. FOG1 contains an N-terminal nucleosome remodeling and histone deacetylase complex (NuRD) recruitment domain,¹⁷¹ and can thus bind transcriptional repressors such as HDAC1 and HDAC2. Knockin mice expressing FOG1 mutated within its NuRD domain exhibited thrombocytopenia and anemia, suggesting that FOG1 function in megakaryopoiesis is mediated at least in part through recruitment of NuRD.¹⁷² Although association with NuRD was linked with both gene activation and repression, NuRD binding by FOG1 was shown to repress the mast cell program in megakaryocytic/erythroid cells.¹⁷³ In humans, X-linked inheritance of mutations of GATA1 involving the N-zinc finger, abrogating interaction with FOG1, leads to macrothrombocytopenia and dyserythropoiesis^{174,175,176,177} and ¹⁷⁸ (Fig. 15.5). In Down syndrome, acquired mutations within exon 2 of GATA1 result in alteration of the translational start site and production of a shortened species, GATA1S. GATA1S binds DNA and interacts with FOG1, but lacks the N-terminal activation domain and has a reduced transactivation potential.¹⁷⁹ GATA1S is nearly always present in children with Down syndrome who develop transient abnormal myelopoiesis and megakaryoblastic leukemia and is thought to be an early event in the initiation of leukemogenesis.^{180,181}

GATA2: Closely related to GATA1, GATA2 is an essential transcription factor for HSCs, MEPs, and megakaryocytes, but becomes down-regulated in mature erythroid cells.^{182,183,184} and ¹⁸⁵ GATA2 expression is down-regulated to a lesser extent during

P.378

megakaryopoiesis,^{186,187} and overexpression of GATA2 favors megakaryopoiesis in cell lines.¹⁸⁸ In maturing cells, expression of GATA2 is repressed by GATA1, reinforcing the differentiation program.¹⁸⁹ Thus, in experimental models, deletion of GATA1 is accompanied by overexpression of GATA2.¹⁹⁰ GATA1 and GATA2 have homologous zinc fingers, interact with FOG1, and bind overlapping sets of genes.^{191,192} However, in general, GATA1 and GATA2 have opposite effects at target genes, either activating or repressing transcription. The exchange of GATA2 for GATA1 at regulatory elements during differentiation is referred to as the GATA switch.¹⁹³ Using an in vitro model of megakaryocyte maturation, Dore et al. recently found that as many as 30% of sites occupied by GATA2 are occupied instead by GATA1 in differentiated cells.¹⁶⁰ In contrast to GATA1 which is on the X-chromosome, GATA2 is on chromosome 3 and GATA2 mutations have not been described in human disease.

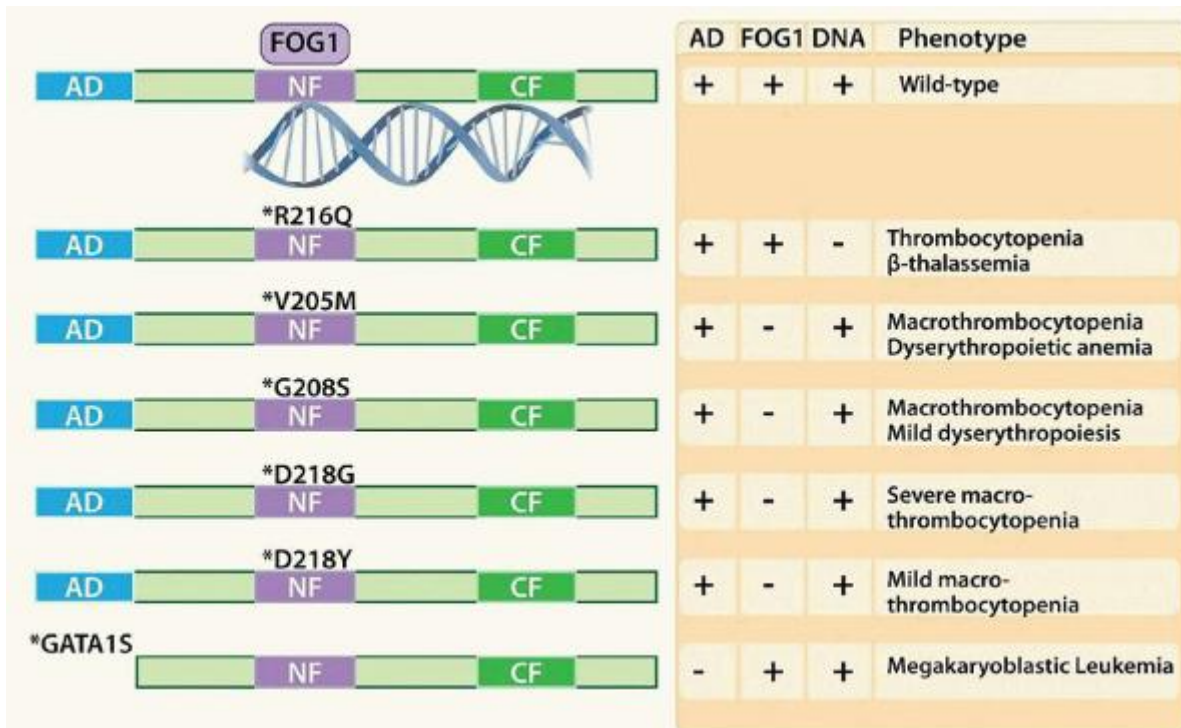

FIGURE 15.5. GATA1 mutations associated with human disease. Wild-type GATA1 contains an activation domain (AD) and

two zinc fingers (NF and CF) that mediate DNA binding. FOG1 interacts with the amino-terminal zinc finger (NF). Mutations in the N-finger have been discovered in males with macrothrombocytopenia and impaired erythropoiesis, either due to disruption of FOG1 binding or, in the case of R216Q, impaired DNA binding. In Down syndrome, mutations that lead to loss of the AD (GATA1S) promote the development of transient myeloproliferative disorder and megakaryoblastic leukemia.

RUNX1: RUNX1 is a heterodimeric transcription factor of the Runt-domain family, consisting of core-binding factor α -2 (CBFA2) that binds DNA and CBF- β , which does not directly bind DNA.¹⁹⁴ Although RUNX1 is critical for emergence of the HSC during embryogenesis, in the adult it is dispensable for maintenance of stem cells but required for megakaryopoiesis.¹⁹⁵ In cell line and animal models, overexpression of RUNX1 induces megakaryocytic differentiation, whereas RUNX1 deficiency results in proliferation of immature megakaryocytes and thrombocytopenia.^{163,195,196} Mutations leading to haploinsufficiency of RUNX1 cause familial thrombocytopenia with defective megakaryocyte maturation and a striking predisposition to myeloid leukemias.¹⁹⁷ Targets of RUNX1 in megakaryopoiesis include c-Mpl.¹⁹⁸ RUNX family members frequently cooperate with co-factors such as CCAAT box/enhancer-binding protein (C/EBP) α , ETS family members, p300/CBP, and c-Myb.^{199,200} In vitro models have demonstrated cooperation of RUNX1 with GATA1 and ETS family members in the activation of megakaryocytic target genes.^{163,165,201,202} RUNX1 and GATA1 also modulate the activity of the cyclin-dependent kinase positive transcription elongation factor (P-TEFb), thus affecting transcriptional elongation²⁰³; induction of megakaryocytic differentiation correlates with P-TEFb activity.²⁰⁴

NF-E2: NF-E2 is a heterodimeric transcription factor containing a p45 leucine-zipper subunit and a p18 subunit MafG. NF-E2 binds DNA through Maf-recognition elements, but p45 is required for transcriptional activation.²⁰⁵ NF-E2 is essential for the final differentiation of megakaryocytes and for platelet formation, as p45^{-/-} mice are severely thrombocytopenic ($\leq 5\%$ the normal platelet count) despite increased numbers of megakaryocytes.^{206,207} Several target genes of NF-E2 have been identified, including TUBB1 (encoding β 1-tubulin), CASP12 (caspase 12), TBXAS1 (thromboxane A synthase-1), RAB27B, and 3β -HSD 3β -hydroxysteroid dehydrogenase, a mediator of autocrine biosynthesis of estradiol within megakaryocytes.^{99,208,209,210} and²¹¹ Intriguingly, ectopic expression of 3β -HSD in NF-E2-deficient megakaryocytes rescues proplatelet formation.²¹² Platelets in NF-E2^{-/-} mice are spherocytic, due to loss of the integrity of the marginal band, normally comprised of β 1-tubulin.²⁰⁸ NF-E2 is itself a target of GATA1 and SCL/TAL1.¹⁴¹

Homeobox Genes: The homeobox genes, which include HOX and non-HOX genes, play key roles in body pattern development, and they are also expressed in adult HSC and play pivotal roles in their proliferation. In hematopoietic progenitors, TPO promotes expression of HOXB4 as well as nuclear localization of HOXA9 through up-regulation of its co-factor MEIS1.^{37,38} In addition to HOXA9, MEIS1 can interact with PBX1b and PBX2, and the

P.379

complex of MEIS1 and PBX up-regulates megakaryocytic gene expression in cooperation with GATA1 and ETS.²¹³ Meis1^{-/-} mice have a severe abnormality of megakaryopoiesis and lack CD41⁺ cells in the fetal liver.^{214,215} Although its function in megakaryocytes is not understood, mutations of HOXA11 are associated with the congenital thrombocytopenia syndrome amegakaryocytic thrombocytopenia with radioulnar synostosis (ATRUS).²¹⁶

FLI1, KLF1, and c-Myb: Several changes in gene expression accompany the divergence of bipotential MEPs to committed megakaryocytic or erythroid cells. The ETS family member FLI1, in conjunction with SCL and GATA2, controls HSC specification²¹⁷; however, it is also critical for formation of the vasculature and for megakaryopoiesis.^{218,219,220} and²²¹ FLI1 cooperates with GATA1^{222,223} and regulates many genes important for terminal megakaryocytic maturation.^{222,224} Expression of FLI1 influences cell fate decisions in the MEP; increased expression of FLI1 favors megakaryocyte development, whereas FLI1 expression decreases in erythroid cells. In mouse models, loss of Fli1 suppresses megakaryopoiesis, whereas overexpression of Fli1 promotes megakaryocyte development while suppressing erythropoiesis.^{218,225,226} Conversely, KLF1 (or EKLF), a target of GATA1, is up-regulated in erythroid-committed progenitors, but inhibits megakaryopoiesis.^{227,228,229} FLI1 and KLF1 inhibit each other's activity directly through protein-protein interaction,²²⁹ and this cross-antagonism has been suggested to reinforce lineage choice between megakaryocytes and erythroid cells.¹⁶⁸ Indeed, selective disruption of Klf1 in mouse models leads to anemia with thrombocytosis,²³⁰ whereas targeted deletion of Fli1 enhances erythropoiesis.²³¹ Other transcription factors have been identified that act in the MEP, including GFI-1b and c-Myb. Growth factor independence-1B (GFI-1b) is a transcriptional repressor that is essential for both erythropoiesis and megakaryopoiesis.^{232,233} GFI-1b is expressed in the bipotent MEP and inhibits the expression of the TGF- β receptor III (TGFB3) gene. This disrupts TGF- β /smad2 signaling which otherwise restrains proliferation and differentiation of erythro-megakaryocytic progenitors.²³⁴ The c-Myb gene encodes for a basic helix turn helix transcription factor composed of three functional domains: a DNA binding domain at the N terminus, a central transactivation domain,

and a C-terminal negative regulatory domain. c-Myb has critical roles both during early hematopoiesis and in differentiating cells.^{235,236} Down-regulation of c-Myb accompanies megakaryocytic differentiation, and hypomorphic c-Myb expression increases megakaryopoiesis at the expense of erythropoiesis.^{236,237} Silencing of c-Myb in human CD34⁺ progenitor cells in vitro is associated with loss of KLF1 and LMO2 (<http://bloodjournal.hematologylibrary.org/content/116/22/e99.full>, ref 22) expression and results in commitment toward the monomacrophage and megakaryocyte lineages whereas erythroid differentiation is strongly impaired.²³⁸

Recently, the role of noncoding RNAs has been recognized in hematopoiesis and megakaryocyte differentiation.^{239,240,241} MicroRNAs (miRNAs) are a class of approximately 22-nucleotide noncoding RNAs that have been highly conserved during evolution and modulate protein expression by degrading mRNA or repressing translation. There are over 400 human miRNAs, and several of them have been implicated in megakaryopoiesis using profiling, knockdown, or overexpression assays. In megakaryocytes, miR-155 expression is reduced as cells differentiate toward megakaryocytes, and overexpression of miR-155 inhibits megakaryopoiesis in in vitro and mouse models, potentially by targeting Meis1 and Ets1 transcripts.^{242,243} and ²⁴⁴ In contrast, miR-150 levels increase during megakaryocyte differentiation, but not in erythroid cells.²³⁹ miR-150 targets c-Myb expression. Down-regulation of c-Myb promotes megakaryocytic differentiation at the expense of erythroid cells.²³⁶ TPO induces expression of miR-150, providing another mechanism by which it influences megakaryopoiesis.²⁴⁵ Additional regulatory miRNAs with potential roles in megakaryopoiesis include miR-34a which when overexpressed in CD34⁺ cells increases megakaryocyte colony formation, and miR-27a which targets the Runx1 transcript.^{246,247}

CYTOKINES IN MEGAKARYOPOIESIS

The identification of TPO and its receptor c-Mpl was a major advance in the study of megakaryocytes. The term thrombopoietin was first coined in 1958 to describe the putative primary regulator of platelet production²⁴⁸; the anticipated factor was also referred to as megakaryocyte growth and development factor (MGDF). Over the four decades following its description, evidence both for and against the existence of TPO as a distinct entity was presented.^{249,250} Although not appreciated at the time, a major insight into megakaryocyte biology was provided in 1986 when Françoise Wendling et al. described a murine retrovirus, myeloproliferative leukemia virus, which induced a vast expansion of hematopoietic cells.²⁵¹ The responsible viral oncogene was characterized in 1990,¹¹ and its cellular homolog c-mpl was cloned in 1992.¹⁰ Based on the presence of two copies of the hematopoietic cytokine receptor motif, it was immediately apparent that c-mpl encoded a growth factor receptor. However, its ligand was not known. Using three distinct strategies, four separate groups were able to clone the complementary DNA for the corresponding hormone and reported their results in 1994.^{12,13,14} and ¹⁵ The gene for this c-Mpl ligand was mapped to human chromosome 3q26-28, spans 6 to 8 kb, consists of seven exons, and encodes a predicted 36-kD polypeptide.^{252,253} and ²⁵⁴ The recombinant and naturally occurring cytokines migrate as 70-kD proteins, indicating substantial posttranslational modification, a conclusion verified by the finding of six sites of N-linked carbohydrate and many sites of O-linked carbohydrate.²⁵⁵ Based on its biologic activities, the c-Mpl ligand was termed thrombopoietin (TPO).¹²¹

TPO bears a striking homology to erythropoietin (EPO), the primary regulator of erythropoiesis, within the amino terminal half of the predicted polypeptide.^{12,13,14} and ¹⁵ The two proteins are more closely related than any other two cytokines within the hematopoietic cytokine family, sharing 20% identical amino acids, an additional 25% conservative substitutions, and identical positions of three of the four cysteine residues. However, unlike any of the other cytokines in the family, TPO contains a 181-residue carboxyl terminal extension, which bears homology to no known protein. Two functions have been assigned to this region: it prolongs the circulatory half-life of the cytokine and it aids in the secretion of TPO from cells that normally synthesize it.^{256,257} and ²⁵⁸

The biologic activities of TPO are consistent with a primary role in megakaryopoiesis. Incubation of marrow cells from mice, rats, dogs, nonhuman primates, and humans with TPO leads to an impressive stimulation of megakaryocyte growth in both suspension and semi-solid culture.^{12,121,259,260} Compared to cultures initiated with other hematopoietic growth factors with promegakaryocytic activity such as IL-3, kit ligand (KL), IL-6, IL-11, or leukemia inhibitory factor (LIF), marrow cells grown in TPO contain greater numbers of megakaryocytes, and the cells are larger and more highly polyploid. When administered to animals or humans, TPO stimulates platelet production in a log-linear manner to levels tenfold higher than baseline^{14,256,261,262,263} and ²⁶⁴ without affecting the peripheral blood red or white cell counts. However, perhaps unexpectedly, the number of erythroid and myeloid progenitors and mixed myeloid progenitors in marrow and spleen were also increased in some studies,^{265,266} an effect that is especially impressive when the cytokine is administered to animals after myelosuppressive therapy^{265,267,268} and probably due to the synergy between TPO and the other hematopoietic cytokines circulating at high levels in this condition.

In the hopes of treating patients with thrombocytopenia, a number of clinical trials were conducted with recombinant TPO, using either recombinant human TPO (rHuTPO) or a truncated

P.380

and pegylated form (PEG-MGDF); however, the development of antibodies to PEG-MGDF that cross-reacted with endogenous TPO halted further development of these first-generation agents.²⁶⁹ As an alternative strategy, second-generation agents, the TPO-receptor agonists, were designed that can stimulate c-Mpl but bear little homology to the native protein. These agents include peptibodies that bind the extracellular domain of c-Mpl (Romiplostim) as well as small molecules that bind within the transmembrane domain of c-Mpl at a site distinct from TPO.²⁷⁰ Phase 3 studies have demonstrated the efficacy and safety of TPO-receptor agonists in adults with chronic immune thrombocytopenia,^{271,272} and additional clinical indications are under investigation.

The biologic effects of TPO in vitro and of its administration in vivo strongly suggest that the cytokine plays an important role in hematopoiesis. Based on genetic studies, it is now clear that TPO is the primary regulator of thrombopoiesis. Genetic elimination of c-mpl or tpo in mice leads to profound thrombocytopenia due to a greatly reduced number of megakaryocyte progenitors and mature megakaryocytes and the reduced ploidy of the remaining megakaryocytes.^{24,253} The human disease related to deficiency of c-Mpl is CAMT. In CAMT, autosomal recessive inheritance of nonsense or missense mutations of MPL results in loss of TPO responsiveness.^{273,274,275} Both mice and humans with c-Mpl deficiency also have a HSC defect, with humans developing overt marrow failure. Restoration of Mpl expression in Mpl-deficient mice using transcriptionally targeted vectors results in restoration of the HSC pool and correction of thrombocytopenia.²⁷⁶ Although tpo-knockout mice phenocopy c-mpl-deficient animals, mutations eliminating TPO expression have not been described in humans.

TPO levels in the plasma are primarily regulated by platelet mass, although there is evidence for additional regulation at the level of gene transcription and protein translation. In most experimental and natural cases of thrombocytopenia, plasma concentrations of TPO vary inversely with platelet counts, rising to maximal levels within 24 hours of the onset of profound thrombocytopenia.^{277,278} and ²⁷⁹ TPO is produced at a constant rate by the liver, and to a minor extent the kidney, and once in the circulation its uptake and degradation (and, hence, the level remaining in the blood to affect megakaryopoiesis) are determined by the mass of c-Mpl receptors present on platelets and megakaryocytes.^{279,280,281,282,283} In this way, when platelet levels are high, more TPO is removed from the circulation and there is a compensatory reduction of megakaryopoiesis. Conversely, thrombocytopenia, particularly thrombocytopenia due to decreased platelet production, is associated with increased plasma TPO levels that stimulate megakaryopoiesis (Fig. 15.6). Although TPO expression by the liver is not regulated by thrombocytopenia, other stimuli can enhance TPO production. For example, IL-6 increases TPO expression through enhanced hepatic transcription, accounting for the thrombocytosis that is observed in clinical states of inflammation.^{284,285} In addition, transcription of TPO in marrow stromal cells has been shown to increase in states of thrombocytopenia and platelet proteins such as CD40 ligand, platelet-derived growth factor, fibroblast growth factor, TGF- β , PF4, and thrombospondin may also modulate TPO production from marrow stromal cells.^{280,286,287,288} and ²⁸⁹ The human TPO gene 5' flanking region lacks a TATA box or a CAAT motif and directs transcription initiation at multiple sites over a 50-nucleotide region.²⁹⁰ Reporter gene analysis in a hepatocyte cell line identified an ETS2 transcription factor-binding motif responsible for high-level expression of the gene. Subsequent studies, though failing to confirm ETS factor interaction, identified binding of the C/EBP- δ .²⁹¹ The 5' flanking region also includes binding sites for specificity protein-1, activator protein-2 (AP-2), and nuclear factor- κ B (NF- κ B),²⁵² although the contribution of these transcription factors to TPO gene expression, either under steady-state or stimulated conditions, has yet to be defined.

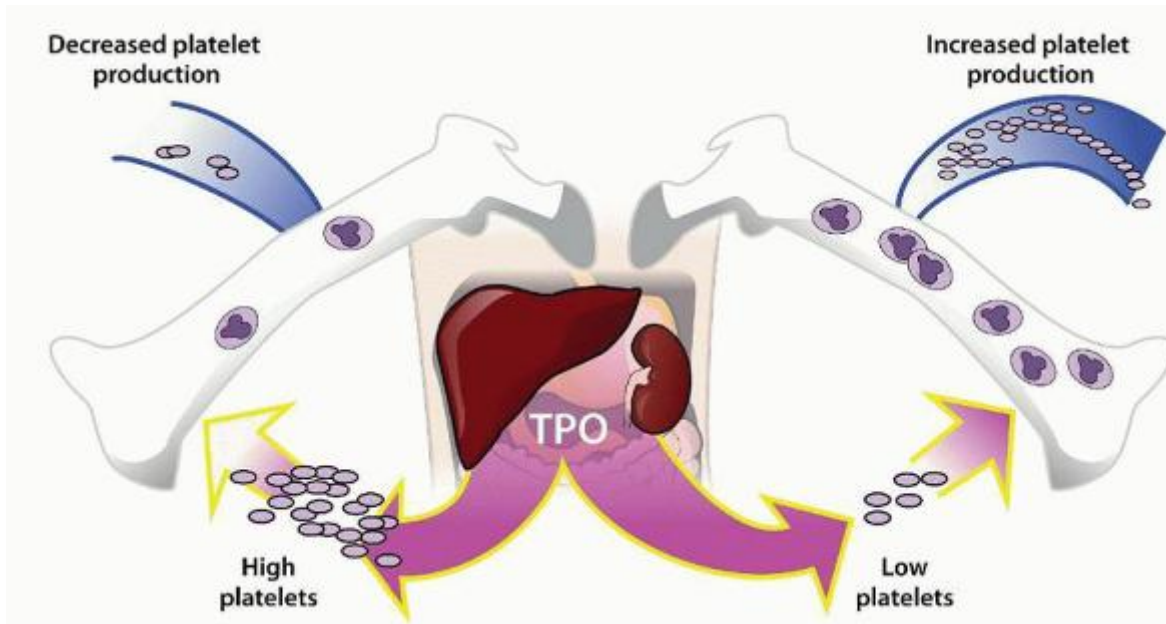

FIGURE 15.6. Regulation of plasma TPO levels. TPO is produced at a steady-state level by the liver, and to a lesser extent by the kidney. Plasma TPO is bound and internalized by c-Mpl receptors on circulating platelets, reducing the amount that reaches the bone marrow to stimulate megakaryopoiesis. In states of thrombocytopenia, more TPO reaches the marrow and thus platelet production is increased. When platelet levels are high, little TPO is available to stimulate megakaryopoiesis and platelet production decreases.

Although TPO is critically important for megakaryopoiesis, it is not essential, as mice lacking either the cytokine or its receptor retain approximately 10% of normal levels of megakaryocytes and platelets.^{292,293} Thus, other cytokines can support megakaryopoiesis. Prior to the discovery of TPO, it was known that IL-3, granulocyte-macrophage colony-stimulating factor (GM-CSF), and the c-KL (also called stem cell factor or steel factor) support the proliferation of megakaryocyte progenitors in plasma-containing cultures.^{294,295,296,297} and²⁹⁸ IL-3 is a 25- to 30-kD protein produced primarily by T lymphocytes.²⁹⁹ The mature human polypeptide contains 133 amino acids, but significant amounts of N-linked carbohydrate modification account for the larger-than-expected relative molecular mass (M_r) of the cytokine. GM-CSF is an 18- to 30-kD protein also produced by T lymphocytes, but endothelial cells, monocytes, and fibroblasts also produce the protein and, like IL-3, GM-CSF is highly modified with both N-linked and O-linked carbohydrate.³⁰⁰ Although the two polypeptides display essentially no primary sequence homology, their tertiary structures

P.381

are highly related,^{301,302} and the receptors for the two cytokines share a common subunit.³⁰³ However, the physiologic relevance of IL-3 and GM-CSF for thrombopoiesis is uncertain because their administration to mice or humans has only minimal effects on platelet production, and the genetic elimination of either cytokine has no impact on megakaryopoiesis, even in combination with the elimination of other thrombopoietic cytokines.^{304,305}

In contrast to the hematopoietic cytokine family, KL is more closely related to other hematopoietic proteins that use protein tyrosine kinase receptors, such as macrophage colony-stimulating factor and the flt-3 ligand (FL).³⁰⁶ Nevertheless, KL has been shown to stimulate megakaryocyte colony growth when used in combination with other cytokines.^{259,298,307} Moreover, genetic elimination of c-kit reduces megakaryocyte production and the rebound thrombocytosis that occurs after immunosuppressive therapy.^{308,309} and³¹⁰ In addition to early hematopoietic cells, KL also acts on primitive cells of the melanogenic and germ cell systems.^{311,312,313,314,315} and³¹⁶ KL is a dimeric protein composed of two identical noncovalently linked polypeptides; the soluble form monomer contains 165 residues,³¹⁷ derived by proteolytic cleavage of a membrane-bound form of the molecule.³¹⁸ The membrane-bound form is actually more active than the soluble cytokine because cell survival and proliferation signals derived from the former are prolonged in receptor-bearing cells.³¹⁹ Moreover, a naturally occurring mutant allele of the gene (Sl^d), which allows production of the soluble but not the membrane-bound form of KL, results in a phenotype nearly identical to deletion of the entire locus.³²⁰

In the late 1980s and early 1990s, three molecules related by use of a common receptor subunit were characterized that display effects on megakaryocyte production. IL-6, cloned by several groups using multiple assays (hepatocyte growth,

myeloma cell growth, immunoglobulin secretion, and antiviral activity), was found to enhance megakaryocyte maturation. IL-6 is a 26-kD polypeptide widely produced in response to inflammatory stimuli from T-cells, fibroblasts, macrophages, and stromal cells.³²¹ The mature protein is composed of 184 amino acids, contains two disulfide bonds, and displays both N-linked and O-linked carbohydrate modification. Although IL-6 alone does not affect *in vitro* megakaryopoiesis, it augments the number of megakaryocyte colonies obtained in the presence of IL-3 or KL.³²² In such culture systems, IL-6 primarily exerts a differentiating effect, as its levels correlate with megakaryocyte size and ploidy in long-term marrow cultures, and its neutralization reduces these parameters.^{323,324} The administration of IL-6 to mice, dogs, or humans results in a modest thrombocytosis.^{322,324,325,326,327} and³²⁸ However, genetic elimination of IL-6 does not significantly affect basal platelet production³²⁹; furthermore, studies may be confounded by the effect of IL-6 on TPO transcription.²⁸⁵

IL-11 and leukemia inhibitory factor (LIF) also act in synergy with IL-3 or KL to augment megakaryocyte formation. IL-11 is a 23-kD polypeptide initially cloned from a gibbon marrow stromal cell line as an activity that supported the proliferation of an IL-6-responsive myeloma cell line.^{330,331} LIF was initially cloned as a human IL that induced DA-1 cells to proliferate (hence its alternate name, HILDA) or induced leukemic M1 cells to differentiate.^{332,333} LIF displays a wide range of activities³³⁴ including effects on the liver (initiates the acute-phase response), neurons (induces an adrenergic to cholinergic switch), adipocytes (inhibits lipoprotein lipase), and embryonic cells (maintains pluripotentiality). As do IL-6 and IL-11, LIF enhances megakaryocyte maturation *in vitro*.^{335,336} Moreover, IL-6 and IL-11 were also found to augment the effects of IL-3 and KL on the proliferation of primitive hematopoietic cells, suggesting that these cytokines augment megakaryocyte development at multiple levels. Consistent with these *in vitro* findings, the administration of either recombinant IL-11 or LIF to rodents, nonhuman primates, or humans produces a modest thrombocytosis.^{333,337,338,339,340} and³⁴¹ However, genetic elimination of either LIF or the IL-11 receptor has no obvious effect on thrombopoiesis.^{342,343}

Although EPO is considered generally specific for erythrocytes, significant evidence supports its activity in megakaryocytes. EPO and TPO, as well as their receptors, are closely related,^{10,11} and¹² and they display synergy in stimulating the growth of progenitors of both lineages.^{259,344,345} However, despite this similarity there is no promiscuity between the receptors and EPO does not stimulate c-Mpl.³⁴⁶ When the wild-type human EPOR or a mutant human gain-of-function EPOR gene was knocked into the mouse EpoR locus, the mice expressing wild-type EPOR, which is hypofunctional due to reduced affinity of the human receptor for mouse EPO, were not only anemic but also thrombocytopenic.³⁴⁷ Expression of the active EPOR, in contrast, only led to erythrocytosis, perhaps due to down-regulation of endogenous TPO. The synergy between EPO and TPO may in part reflect stimulation of a common progenitor, but some studies support the activity of EPO in committed megakaryocytes.³⁴⁸

Additional factors have been found to influence megakaryopoiesis, including the chemokine SDF-1 and the transmembrane protein Notch. Stromal-derived factor-1 (SDF-1) is the ligand for the 7-transmembrane G-protein-coupled chemokine receptor CXCR4 and it is known to enhance HSC homing to the marrow.³⁴⁹ Several avenues have provided evidence that SDF-1 is important in megakaryopoiesis. CXCR4 is expressed on developing megakaryocytes,³⁴⁹ and mice lacking either SDF-1 or CXCR4 have a deficiency in CFU-MK compared with controls.^{350,351} Infusion of SDF-1 can increase platelet production in *tpo*^{-/-} or *c-Mpl*^{-/-} mice.³⁵² CXCR4 is the target of miR146a, and *in vitro* studies in which miR146a was overexpressed resulted in silencing of CXCR4 and impaired megakaryocytic cell proliferation.³⁵³ Some authors have found that SDF-1 acts together with TPO to enhance proliferation of CFU-MK³⁵⁴; however, its efficacy in mice lacking an intact TPO-MPL axis indicates it also has activity that is independent of TPO. SDF-1 enhances adhesion of integrin $\alpha 2\beta 3$ -positive progenitors to fibrinogen and vitronectin and may promote the migration of megakaryocytic progenitors to the vascular niche for platelet formation.^{352,355,356}

Notch signaling is complex, as there are four single-pass transmembrane Notch receptors (Notch1-4) and five transmembrane ligands (Delta-like-1/3/4, Jagged-1/2). Notch signaling is initiated when the extracellular portion of a Notch receptor binds one of its cognate ligands, resulting in proteolytic cleavage that releases the intracellular domain of Notch from the membrane, allowing it to translocate to the nucleus and stimulate gene transcription. Although previously recognized for its role in T-cell development, Notch has more recently been shown to specify megakaryocyte development from hematopoietic stem and progenitor cells.³⁵⁷ Murine hematopoietic progenitors, cultured in the absence of cytokines on stroma expressing DL1, underwent megakaryocytic differentiation, whereas the same cells cultured on control stroma gave rise to erythroid and granulocyte-macrophage cells.³⁵⁸ Conversely, under megakaryocytic culture conditions, the presence of stromal cells expressing DL4 inhibited the later stages of megakaryocytic maturation without affecting earlier aspects of differentiation.³⁵⁹ The pathways are only partially understood; however, DL1 has been shown to cooperate with HOXB4 in promoting HSC expansion³⁶⁰; because TPO promotes HOXB4 expression,³⁷ this provides an opportunity for synergy between Notch and TPO signaling. In addition, both Notch and TPO signaling result in activation of PI3K and Akt, another potential synergy that would promote megakaryopoiesis.^{361,362}

In addition to positive regulators of megakaryopoiesis, several substances have been shown to inhibit megakaryocyte development. TGF- β is a family of five isoforms, all disulfide-linked homodimers each containing 112 residues.³⁶³ TGF- β 1 is the predominant type of TGF found in hematopoietic tissues; platelet α -granules are a particularly rich source of this cytokine. TGFs are inhibitors of hematopoiesis in general, but particularly of megakaryocyte development.^{364,365,366,367} and³⁶⁸ The two best understood TGF- β growth inhibitory effects are exerted on cell-cycle

P.382

progression. After binding to one of five TGF receptors, two pathways that block cell-cycle progression are activated: pRb is hypophosphorylated,³⁶⁹ antagonizing the effects of G₁-phase cyclin-dependent kinases, and the cell-cycle inhibitor p27 is upregulated, again halting cell-cycle progression at the level of S phase.^{370,371} It should be noted that TGF- β is not inhibitory only for megakaryopoiesis; rather, the cytokine appears to reduce hematopoiesis at many levels.^{372,373} and³⁷⁴ In contrast to its effects on cell proliferation, evidence has been presented that TGF- β might enhance megakaryocyte differentiation by enhancing expression of the cell-cycle inhibitor p15^{Ink},³⁷⁵ an effect that may be due to autocrine production of the cytokine. Additional platelet granule proteins found to inhibit megakaryocyte development include the chemokine PF4³⁷⁶ and β -thromboglobulin.³⁷⁷ PF4 is a CXC chemokine, but unlike SDF-1 it does not act through a G protein-coupled CXCR; instead it forms a tetramer and binds to glycosaminoglycans on cell surfaces and to negatively charged domains of several membrane receptors.^{378,379} PF4 secreted by marrow megakaryocytes may act in a paracrine fashion to down-regulate megakaryopoiesis by binding to lipoprotein receptor-related protein-1 (LRP1).³⁸⁰ Although not demonstrated in megakaryocytes, LRP1 is required for growth inhibition in response to TGF- β in vascular cells,³⁸¹ providing a potential mechanistic link between PF4 and TGF- β . Finally, interferon (IFN)- α inhibits megakaryopoiesis, and its use leads to modest to severe thrombocytopenia in a significant number of patients undergoing therapy for chronic hepatitis.^{382,383} Multiple mechanisms are responsible for the inhibitory effect of IFN- α on megakaryopoiesis, including a direct inhibitory effect of IFN- α on growth-factor-induced proliferation pathways. For example, IFN- α augments double-stranded RNA-activated protein kinase activity, inhibiting translation initiation factor-2 and implicating reduction of the growth-factor-induced protein synthesis necessary for cytokine response.³⁸⁴ Other investigators have reported that the functionally similar cytokine IFN- γ induces expression of the cell-cycle inhibitor p27^{kip1}, arresting cells in G₀/G₁.³⁸⁵ Wang et al. demonstrated that IFN- α induces a suppressor of the cytokine signaling-1 (SOCS1)-based feedback mechanism that negatively regulates TPO signaling.³⁸⁶ Consistent with these findings, TPO-receptor agonists have been used to ameliorate the thrombocytopenia resulting from IFN- α therapy in patients with hepatitis.³⁸⁷ Thus, in addition to the multiple positive mediators of megakaryopoiesis, several cytokines block the process and can lead to thrombocytopenia.

SIGNAL TRANSDUCTION PATHWAYS IN MEGAKARYOCYTES

c-Mpl is a typical hematopoietic receptor containing two cytokine receptor homology domains (marked by the distinctive WSXWS sequence motif), a transmembrane domain, and a cytoplasmic domain that mediates intracellular signaling. The extracellular domain is N-glycosylated, enhancing receptor secretion and cell surface expression.³⁸⁸ c-Mpl is secreted onto the cell surface as a pre-formed but inactive homodimer. Although c-Mpl does not have intrinsic tyrosine kinase activity, it associates with a cytoplasmic tyrosine kinase, Janus kinase (JAK)2 (Fig. 15.7). JAK2 binds to a short motif (termed box1) adjacent to the transmembrane domain of the receptor.^{389,390} Upon binding of TPO to its extracellular domain, c-Mpl undergoes a conformational change that brings the cytoplasmic tails of the receptor and the associated JAK2 closer together, initiating JAK2 kinase transactivation and downstream signaling events.³⁹¹ Experimental manipulation of the receptor has identified three different states of the receptor, inactive, partially active, and active, related by receptor subunit rotation.^{392,393} The state of the receptor depends in part on an amphipathic KWQFP motif at the junction between the transmembrane and cytoplasmic domains; deletion of this sequence experimentally results in a gain of function, in which the mutant receptor can signal in the absence of TPO.³⁹⁴ Naturally occurring mutations within the transmembrane domain (e.g., c-Mpl Ser505Asn, Trp508Ser, and Trp515Leu) also result in a constitutively active receptor and are associated with myeloproliferative disease.^{395,396,397} In addition, small molecule TPO-receptor agonists such as Eltrombopag bind to the transmembrane domain and may promote receptor activation through this type of allosteric mechanism.²⁷⁰ Following ligation, both c-Mpl and the bound TPO are then internalized through endocytosis, limiting the duration of signaling.^{398,399} Whereas a portion of the internalized receptor is degraded in the proteasome, a fraction is also recycled to the cell surface where it can again interact with TPO and participate in signaling.^{400,401} Enhanced proteosomal degradation and reduced receptor maturation and recycling of c-Mpl occurs in cells bearing the constitutively active Jak2 Val617Phe, present in the majority of patients with the myeloproliferative disease polycythemia vera (PV), leading to reduced surface expression of the receptor.^{402,403}

Janus family kinases are critical to megakaryopoiesis. Four JAK kinases have been identified in hematopoietic cells: JAK1, JAK2, JAK3, and TYK2.³⁸⁹ Of the cytokines that affect megakaryopoiesis, IL-3 activates JAK2⁴⁰⁴; IL-6, IL-11, and LIF activate JAK1, JAK2, and TYK2 (although JAK1 is most important)⁴⁰⁵; and TPO leads to JAK2 and TYK2 phosphorylation (although JAK2 is most important).^{406,407,408} and ⁴⁰⁹ Moreover, even members of the receptor tyrosine kinase family that affect megakaryopoiesis, such as KL or FL, activate JAK kinases.^{410,411} Phosphorylation of JAKs leads to their activation, which, in turn, leads to phosphorylation of a number of substrates, including the receptors themselves and reversibly tethered signaling molecules. One of the best studied families of secondary signaling molecules is the signal transducers and activators of transcriptions (STATs); these latent transcription factors dock at P-Tyr residues of cytokine receptors and are phosphorylated by JAKs, and, once so modified, P-STATs dimerize, translocate to the nucleus, and bind to specific genetic elements altering transcription. Both P-Tyr and P-Ser modifications are required to fully activate STATs.^{412,413} Of the cytokines affecting megakaryocyte development, IL-3 and GM-CSF activate STAT5⁴¹⁴; IL-6, IL-11, and LIF activate STAT3^{415,416}; and TPO activates both STAT3 and STAT5.^{417,418,419,420} Among the known targets of the STATs known to play an important role in megakaryocytic cell survival and proliferation are Bcl-X_L and c-myc,^{421,422} and ⁴²³ with STAT1 displaying generally inhibitory effects on cell cycling and STAT3 and STAT5 displaying the opposite effect.⁴²⁴ Phosphorylation of tyrosine residues on c-Mpl by JAK2 creates docking sites for additional signaling intermediates via SRC homology 2 (SH2) domains, including the guanine nucleotide exchange factor Vav, adapter proteins such as Shc and the Gabs, and the phosphatase SHP2. Phosphorylation of JAK2 itself provides additional docking sites, providing binding sites for p85 α and the adaptor protein Lnk.^{425,426} These interactions modulate signaling, activating the RAS-RAF-MAPK and PI3K-AKT pathways, or in the case of Lnk, down-regulating JAK2.^{40,425}

The RAS-RAF-MAPK pathway is critical in megakaryopoiesis.

Activation of MAPK in cell lines promotes megakaryocytic differentiation, and MAPK pathway inhibitors block polyploidization and megakaryocyte maturation in primary cells.^{356,427,428,429,430,431,432} MAPKs are approximately 40-kD Ser/Thr kinases that are highly conserved in all eukaryotic cells from yeast to humans. At least six signaling cascades classified as MAPK pathways have been identified^{433,434} and have been found to mediate cell proliferation, survival, apoptosis, or differentiation. At present, three classes of MAPKs have been identified in megakaryocytes: extracellular stimulus response kinase (ERK) 1 and ERK2 (also termed p44 and p42, respectively); c-jun N-terminal kinase (JNK); and p38 kinase.^{435,436} and ⁴³⁷ MAPK activation requires phosphorylation both on threonine and tyrosine residues present on

P.383

specific motifs (Thr-Xaa-Tyr). Receptors that activate MAPKs do so by activating Ras and initiating a kinase cascade. Thus, for c-Mpl, the adapter molecule Shc is recruited to the tyrosinephosphorylated receptor cytoplasmic domain, which is then phosphorylated by JAK2. Phospho-Shc then recruits the adapter protein Grb2, which activates the guanine nucleotide exchange factor SOS, which then charges Ras with GTP, thereby activating it. Active Ras, in turn, leads to the activation of an MAPK kinase kinase such as Raf-1, which phosphorylates an MAPK kinase such as MEK, which then phosphorylates MAPKs including ERK1 and ERK2. Because cells contain numerous MAPK kinase kinases and MAPK kinases, the potential for cross-talk between different MAPK pathways is large; this potential is reduced considerably through scaffolding proteins that sequester only the corresponding MAPK kinase kinase, MAPK kinase, and MAPK.^{438,439} Virtually every cytokine affecting megakaryocytes activates ERK1 and ERK2.^{411,430,440,441} and ⁴⁴² Alternate pathways to MAPK activation have also been described in platelets,⁴⁴³ and integrin engagement in fibroblasts affects the cellular localization of ERK1/2, exerting a profound effect on its capacity to signal.⁴⁴⁴ Blockade of ERK1 and ERK2 has been shown to reduce cell proliferation in c-Mpl receptor-bearing cell lines and both cell proliferation and the generation of highly polyploid cells in megakaryocytic progenitors,⁴³¹ but, curiously, to enhance proliferation of more primitive megakaryocytic progenitors from cord blood.⁴⁴⁵ The molecular targets of active MAPKs in megakaryocyte progenitors that mediate the effect of ERK1 and ERK2 on cell survival, proliferation, and differentiation are presently a topic of intense research; most studies in other cell systems suggest that ERK affects nuclear transcription factors, such as c-jun, c-myc, and the ets family member Elk-1,^{446,447} which then modulate activity of the cell-cycle machinery. For example, stimulation of ERK1 and ERK2 leads to increased levels of cyclin D in fibroblasts.⁴⁴⁸ The strength and duration of MAPK activation may be important in whether the cell responds by proliferation or differentiation. Transient or acute MAPK activation that occurs in the cell cytoplasm (minutes to hours) is typical of cell-cycle progression and proliferation, whereas sustained MAPK activation into the nucleus (lasting many hours or several days) is characteristic of cell-cycle arrest and differentiation.^{449,450} Activation of the Ras-like small GTPase Rap1 activates the MAPK kinase kinase B-Raf and leads to a sustained activation of ERK1/2 in cell lines.⁴⁵¹ The Rap1 ERK signaling pathway responds to Src kinases and cAMP via activation of PKA and is linked to cell receptors via adaptor and scaffold proteins such as c-Cbl and CrkL. MAPKs also act on additional kinases, including the 90

kD ribosomal S6 kinase and the NF- κ B activator AP-1.^{446,452} Despite their apparent importance, a requirement for either Raf-1 or B-Raf in megakaryopoiesis has not been proven in mouse models.^{453,454} Although TPO activates JNK and p38 in c-Mpl-bearing cells, primary megakaryocytes, and platelets,^{443,455} less is known of their effects on megakaryocyte development.

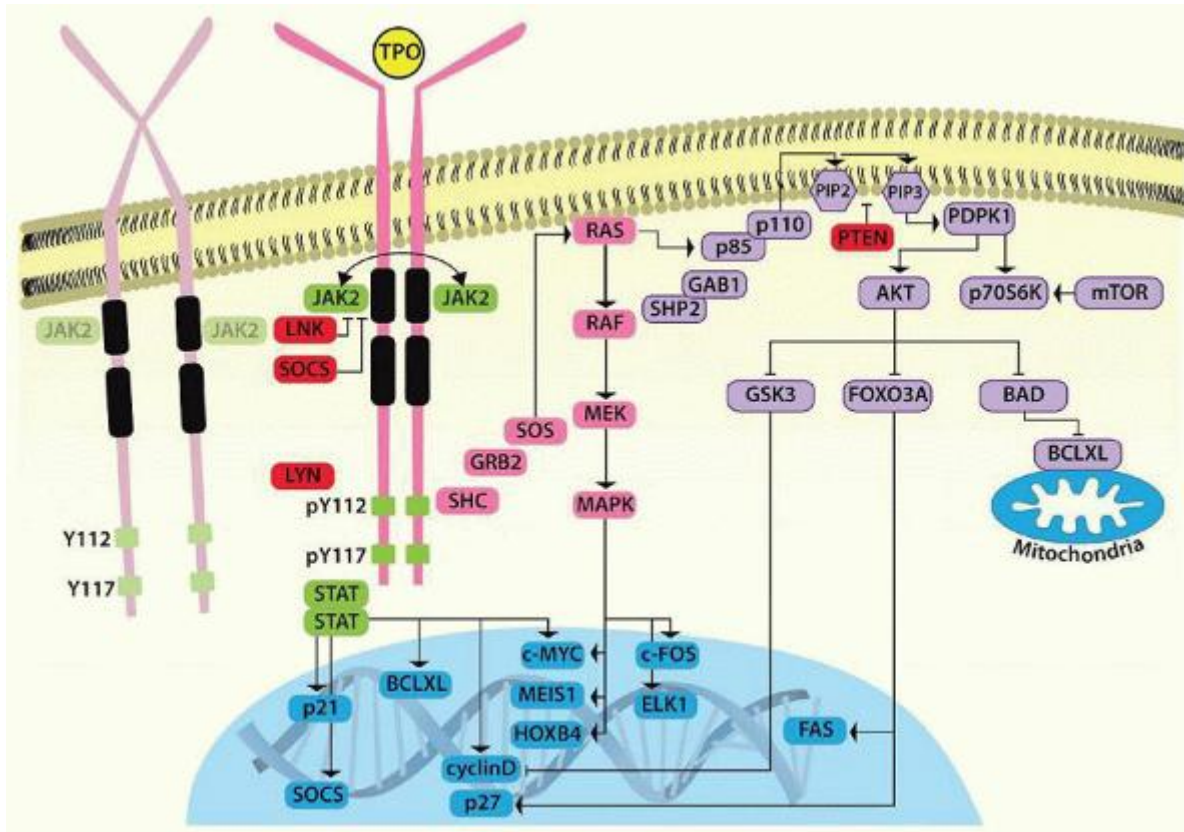

FIGURE 15.7. Representative pathways in TPO signaling. TPO binds to the homodimeric c-Mpl, leading to a conformational change that leads to transactivation of the associated JAK2 molecules. Active JAK2 then phosphorylates tyrosine residues on the receptor, including Y112 and Y117, which form docking sites for SH2-domain-containing proteins and adaptors. JAK2 phosphorylates STATs 3 and 5, which form homodimers and translocate to the nucleus where they activate transcription. Formation of a complex between SHC, SOS, and GRB2 leads to activation of the RAS/RAF/MAPK pathway. Engagement of p85 through adaptor proteins in conjunction with RAS activation leads to activation of PI3K and its downstream effectors. Negative regulators of TPO signaling, including SOCS, Lnk, Lyn, and PTEN, are shown in red.

P.384

The PI3K pathway also has a critical role in megakaryopoiesis and is activated in response to multiple cytokines, including TPO, IL-3, GM-CSF, KL, and IL-6.^{355,362,411,440,456,457,458,459,460} and ⁴⁶¹ PI3K is a heterodimeric lipid kinase composed of a 110-kD kinase (p110) and an 85-kD (p85) regulatory subunit. PI3K activity is initiated by the engagement of the two SRC homology 2 domains of p85, either by a phosphorylated cytokine receptor (usually in the context of a YXXM or YVAC motif)^{462,463} and ⁴⁶⁴ or an adapter molecule,^{456,457,465,466} and ⁴⁶⁷ resulting in conformational changes allowing activation of p110 and relocation of the kinase to the lipid membrane.⁴⁶⁸ Although p85 interacts directly with some hematopoietic cytokine receptors, the mechanism by which it is activated in TPO signaling is not clear; it may involve interaction with an adaptor molecule.^{457,469} Once in proximity to its membrane lipid substrates and its coactivator, membrane-bound activated Ras,⁴⁷⁰ active PI3K then generates PI 4,5 phosphate (PIP2) and PI 3,4,5 phosphate (PIP3), and pleckstrin homology (PH) domain-containing proteins are recruited to these phospholipids to initiate signaling cascades. Lipid phosphatases, including SRC homology 2-containing inositol phosphatase (SHIP2)^{471,472} and ⁴⁷³ and PTEN,^{474,475} negatively regulate PI3K signaling.

Central to the PI3K signaling cascade is 3-phosphoinositide-dependent protein kinase-1, also known as PDK1. PDK1 is recruited to PIP2 and PIP3 in the cell membrane through its PH domain where it can interact with its effector substrates

including Akt, ribosomal protein p70 S6 kinase (p70S6K), and PKC. Akt is a serine-threonine kinase with multiple targets that have roles in cell survival and growth. TPO promotes phosphorylation and activation of Akt which is blocked by inhibitors of PI3K, and inhibition of PI3K in cell line models as well as in primary megakaryocytes leads to reduced cell survival and proliferation; furthermore, expression of a constitutively active Akt restores proliferation and survival in the presence of PI3K inhibitors.³⁶² Akt promotes cell survival by phosphorylation of the proapoptotic protein Bad. Phosphorylated Bad binds to protein 14-3-3 and is thus targeted for proteolysis, removing its inhibitory effect on the pro-survival protein Bcl-X_L.^{476,477,478} GSK-3 β is also phosphorylated by Akt, leading to inhibition of GSK-3 β activity and enhanced survival and proliferation.^{479,480} Forkhead family members, including FOXO3a, are also phosphorylated by Akt, preventing their translocation to the nucleus where they promote cell-cycle arrest and apoptosis by induction of p27, Bim, Fas ligand, and GADD45. TPO promotes down-regulation of p27 in megakaryocytic cells through a PI3K/Akt/FOXO3a pathway.⁴⁸¹

In addition, PI3K and Akt signaling activate the mammalian target of rapamycin (mTOR) through inhibition of the GTPase TSC2 and subsequent activation of the small GTP-binding protein Rheb.^{482,483} mTOR is a serine-threonine kinase and a member of the PI3K-related kinase family that functions in the regulation of cell size and cell-cycle progression. mTOR controls the phosphorylation status of proteins involved in initiating translational control, including p70S6K and eukaryotic translation initiation factor 4E-binding protein (4E-BP). Multiple signaling pathways converge on p70S6K and it has multiple sites of inducible phosphorylation; however, phosphorylation by PDK1 and mTOR are essential for its activity.⁴⁸⁴ The Ras-MAPK pathway also modulates mTOR activity. TPO induces activation of the mTOR/p70S6K pathway in megakaryocytes, and inhibition of mTOR signaling by rapamycin leads to reduced proliferation of megakaryocytic progenitors and, in some studies, megakaryocyte polyploidization and maturation.^{485,486,487} mTOR signaling may be particularly important in neonatal megakaryopoiesis.⁴⁸⁸

Although JAK2 has been studied the most, other tyrosine kinases are activated by TPO and play a role in megakaryopoiesis. The src family kinase Lyn is activated in TPO-stimulated megakaryocytes.⁴⁸⁹ Mutagenesis experiments identified tyrosine 112 of c-Mpl as critical for Lyn activation.⁴⁹⁰ Unlike JAK2, Lyn negatively regulates megakaryocytic proliferation and differentiation, possibly through inhibition of MAPK and Akt signaling, and lyn^{-/-} mice show increased megakaryopoiesis.^{490,491}

In vivo, megakaryocytes are affected both by soluble cytokines and activation of adhesive receptors in the marrow microenvironment⁴⁹²; similarly, focal adhesion kinase (FAK) activation in platelets requires the co-stimulation of growth factor receptors and integrins. In megakaryocytic cell lines, TPO stimulates phosphorylation of FAK.⁴⁹³ Targeted deletion of Fak in a mouse model resulted in enhanced megakaryopoiesis, with increased numbers of megakaryocytic progenitors, mature megakaryocytes, and circulating platelets. Fak^{-/-} megakaryocytes were impaired in their ability to activate Lyn in response to TPO, but in contrast showed increased activation of MAPK and Akt,⁴⁹³ reminiscent of megakaryocytes from Lyn^{-/-} mice and suggesting that FAK plays a role in the activation of Lyn.

As should be clear from the previous discussion, the megakaryocyte (and probably all hematopoietic cells) uses multiple molecular pathways to affect cell survival and proliferation. Recent work with c-Mpl has helped to clarify the nature and teleology behind this seeming redundancy. Phosphorylation of the penultimate tyrosine residue in the cytoplasmic domain of c-Mpl leads to Shc, STAT3, and STAT5 activation.⁴¹⁹ Moreover, MAPK activation is also thought to emanate from the distal half of the receptor.⁴³⁰ Nevertheless, a truncated form of c-Mpl bearing neither of these regions continues to modestly activate STAT5, MAPK, and PI3K in a TPO-dependent manner,⁴¹⁹ and introduction of a similarly truncated receptor into the germline in place of the full-length receptor affords the resultant mice a normal steady-state platelet count throughout life.⁴⁹⁴ However, these mice do not respond properly to stress; compared with normal mice, platelet recovery after immune-mediated or chemotherapy-induced thrombocytopenia is substantially delayed. Thus, the seeming redundancy in cytokine signaling appears to reflect a capacity of the cell to grade the TPO response into steady-state and emergency thrombopoiesis. A similar conclusion regarding signaling via STAT5 in erythropoiesis has been presented.⁴⁹⁵

The signaling cascades initiated by TPO are of limited duration. Multiple mechanisms exist to govern this process. As discussed above, following initiation of signaling, the ligated c-Mpl is internalized and degraded.^{398,399} and⁴⁰⁰ Another mechanism of feedback inhibition of cytokine receptor signaling is mediated by STAT-mediated induction of SOCS proteins.⁴⁹⁶ At present, five members of this STAT-induced family of signaling proteins have been found to inhibit signaling, either by directly blocking JAK kinase function or by competing for binding to phosphotyrosine receptor-signaling sites with secondary signaling mediators. Hence, when STAT is activated, it ultimately feeds back to inhibit JAK2 signaling. This mechanism can also account for receptor cross-talk (i.e., the ability of one cytokine signal to negatively affect another), because SOCS proteins induced by one receptor can interact with others.^{385,497} The SH2-domain-containing adaptor protein Lnk also binds to and negatively regulates JAK2 that has been phosphorylated in response to TPO. In the absence of Lnk, mice exhibit thrombocytosis and over time develop a myeloproliferative disorder.^{425,426,498}

Naturally occurring mutations that disrupt regulation of JAK2 are associated with the development of myeloproliferative disorders and leukemia.

CLINICAL DISORDERS OF MEGAKARYOPOIESIS

A number of disorders of megakaryopoiesis, including congenital thrombocytopenias and thrombocythemias, as well as acquired myeloproliferative disorders and leukemias, involve mutation of transcription factors and signaling molecules that have been discussed in this chapter as having a role in megakaryocyte

P.385

development (Table 15.2). A brief review of several instructive disorders follows.

TABLE 15.2 GENETIC MUTATIONS IN SELECTED INHERITED PLATELET DISORDERS

Gene	Function	Gain/Change of Function	Loss of Function
MPL	TPO receptor	ET, PMF	CAMT
TPO	Growth factor	ET	
JAK2	Tyrosine kinase	PV, ET, PMF	
HOXA11	Transcription factor		ATRUS
RUNX1	Transcription factor		FDP-PMM
FLI1	Transcription factor		PTS
GATA1	Transcription factor	DS-TMD, DS-AMKL	XLT, XLTT
OTT/MAL	Fusion protein, transcription factor	AMKL	
GPIb/GPIX	Adhesive receptor	Platelet-type VWD	BSS
FLNA	Cytoskeletal protein		Macrothrombocytopenia
MYH9	Cytoskeletal protein		MYH9-related disease
WASp	Cytoskeletal protein		WAS
TUBB1	Cytoskeletal protein		Macrothrombocytopenia
NBEAL2	Vesicle trafficking		GPS
AP3	Vesicle trafficking		HPS
CYCS	Apoptosis regulator	AD thrombocytopenia	

ATRUS, amegakaryocytic thrombocytopenia with radioulnar synostosis; BSS, Bernard-Soulier syndrome; CAMT, congenital amegakaryocytic thrombocytopenia; DS-AMKL, Down syndrome, acute megakaryoblastic leukemia; DS-TMD, Down syndrometransient myeloproliferative disorder; ET, essential thrombocythemia; FDP-PMM, familial platelet disorder with predisposition to myeloid malignancy; GPS, gray platelet syndrome; HPS, Hermansky Pudlak syndrome; PMF, primary myelofibrosis; PTS, Paris-Trousseau syndrome; PV, polycythemia vera; vWD, von Willebrand disease; WAS, Wiskott-Aldrich syndrome; XLT, X-linked thrombocytopenia; XLTT, X-linked thrombocytopenia with thalassemia.

CAMT: CAMT is the quintessential defect of megakaryocyte production, resulting from homozygous or compound heterozygous mutations of MPL encoding c-Mpl.⁴⁹⁹ The clinical course of CAMT confirms the critical role of TPO in both megakaryocytes and HSCs. Although children with CAMT are typically born with isolated thrombocytopenia and deficiency of megakaryocytes, over time they develop pancytopenia and bone marrows performed later in their course will show a severe depletion of megakaryocytes and trilineage hypocellularity.⁵⁰⁰ In addition, children with CAMT are at risk to develop clonal disease including myelodysplastic syndrome (MDS) or leukemia.⁵⁰¹ Serum TPO levels are highly elevated

due to the absence of receptor-mediated uptake.²⁷⁴ Whereas the majority of described mutations are in exons 1 to 3 of MPL, mutations have been described throughout the coding sequence. Mutations that result in complete disruption of the receptor (type I) are associated with an earlier onset of marrow failure (median age 22 months), whereas mutations that encode amino acid substitutions that result in partial receptor function (type II) are associated with transient improvement in platelet counts and a later onset of marrow failure (median age 48 months).⁵⁰⁰

TAR and ATRUS: As in CAMT, thrombocytopenia with absent radii (TAR) also presents at birth with thrombocytopenia, but affected infants have the characteristic finding of bilateral absent radii. Additional skeletal and nonskeletal defects are frequent, including lower extremity, cardiac, renal, and gastrointestinal abnormalities.⁵⁰² Unlike CAMT, thrombocytopenia in TAR tends to improve over the first 2 years of life, and children do not usually develop other cytopenias. TAR remains enigmatic with an incomplete understanding of its genetic etiology, and current evidence suggests a complex pattern of inheritance. Platelets from young patients with thrombocytopenia have impaired responses to TPO and impaired megakaryocyte differentiation, but TPO signaling is restored in platelets from adults.⁵⁰³ No defects in THPO (the gene for TPO), MPL, or JAK2 have been identified.^{504,505} and ⁵⁰⁶ A large study involving 30 patients with TAR identified a common interstitial microdeletion of 200 kb on chromosome 1q21.1 including several candidate genes.⁵⁰⁷ However, in approximately 75% of the patients, the deletion was inherited from an unaffected parent, suggesting that a second genetic change must be co-inherited in order for the phenotype to be expressed. The treatment of thrombocytopenia in TAR is largely supportive, as platelet counts typically improve with age.

ATRUS shares features with both CAMT and TAR. Thrombocytopenia is present at birth, and like TAR, there are radial abnormalities, in this case bilateral fusion of the proximal radius and ulna. However, platelet counts do not improve with age and similar to CAMT, most affected children develop bone marrow failure. Autosomal dominant inheritance of a mutation in the HOX family member HOXA11 was reported in two unrelated families with ATRUS^{216,508}; it is intriguing that mice lacking expression of HOXA11 show skeletal abnormalities but lack a hematologic phenotype.⁵⁰⁹ Additional patients with clinical features of ATRUS have been reported who do not have identifiable mutations in HOXA11,^{510,511} suggesting other loci may also be involved.

RUNX1: Reflecting the role of RUNX1 in hematopoiesis and megakaryocyte development, autosomal dominant mutations resulting in haploinsufficiency of RUNX1 are found in the familial platelet disorder with a propensity for myeloid malignancy (FPD-PMM).^{197,512} In FPD-PMM platelets are normal in size and thrombocytopenia is typically moderate, but bleeding may be more prominent than expected due to associated platelet dysfunction. The major complication of this disorder is not bleeding but the development of myelodysplasia or leukemia. The rate of myeloid malignancies in affected individuals ranges between 20% and

P.386

65% and peaks at the fourth decade of life. T-cell malignancies have been reported as well.⁵¹³ Heterozygous mutations of RUNX1 described in this disorder range from substitutions or large deletions and most commonly affect the RUNX homology domain; although most result in haploinsufficiency, some mutations may have a dominant negative effect. Additional acquired mutations in RUNX1 or karyotypic abnormalities are frequently detected in the malignant clone at the time of acute myeloid leukemia/MDS diagnosis.

GATA1: As discussed above, GATA1 is essential for differentiation of both erythrocytes and megakaryocytes; thus, mutations affecting this transcription factor are associated with red cell abnormalities as well as thrombocytopenia. GATA1 mutations are associated with several phenotypes, including X-linked thrombocytopenia (XLT) with dyserythropoiesis, X-linked thrombocytopenia with thalassemia (XLTT), and rarely congenital erythropoietic porphyria.⁵¹⁴ All mutations described to date are within the N-terminal zinc finger of GATA1; mutations altering the interaction of GATA1 and its co-factor FOG1 are associated with XLT, whereas mutations altering the interaction of GATA1 and DNA are associated with XLTT. Features suggestive of a GATA1 mutation include X-linked recessive inheritance, macrothrombocytopenia, "gray platelets" with deficient alpha granules, red cell abnormalities including dyserythropoiesis or thalassemia, and hyperproliferation of megakaryocytes in the bone marrow. Although inheritance is X-linked, a mild phenotype due to skewed X-inactivation in female family members has been described.⁵¹⁵

FLI1: Although no specific FLI1 mutations have been described in patients with inherited thrombocytopenia, in Paris-Trousseau syndrome there is deletion of the terminal portion of chromosome 11q (11q23), and within the critical deleted region are several genes important to megakaryopoiesis, most notably ETS and FLI1.²¹⁸ Affected infants may have severe thrombocytopenia, congenital heart defects, and neurologic abnormalities.⁵¹⁶ Platelets are normal in size, but Romanovsky staining or electron microscopy reveals abnormal giant alpha granules and may show deficiency of dense

granules.^{517,518} Over time platelet counts improve and can reach near-normal levels, but a bleeding tendency that is out of proportion to the degree of thrombocytopenia frequently remains. Multiple genes are deleted; however, thrombocytopenia in Paris-Trousseau syndrome can be traced to the hemizygous loss of FLI1.⁵¹⁹

Macrothrombocytopenias: Giant platelet disorders include BSS and MYH9-related disease, although other thrombocytopenias are also characterized by large platelets. BSS is an autosomal recessive macrothrombocytopenia with significant platelet dysfunction due to the deficiency of GPIb, the platelet receptor for vWF. GPIb is composed of four subunits, encoded by four separate genes: GPIBA, GPIBB, GP5, and GP9. To date, mutations in BSS have been found in GPIBA, GPIBB, and GP9. Although BSS is classically inherited in an autosomal recessive fashion, the Bolzano mutation (c.515C>T transition in the GPIBA gene) is associated with mild macrothrombocytopenia in the heterozygous state.⁵²⁰ The mechanism of macrothrombocytopenia in BSS has been attributed at least in part to the interaction of GPIb with filamin A, a dimeric scaffolding protein.⁵²¹ This interaction may be critical for maintaining the platelet shape, as platelets from Flna- knockout mice are large and fragile despite normal GPIb expression.⁵²² Macrothrombocytopenia associated with mutation of FLNA has also been described in X-linked periventricular nodular heterotopia.⁵⁵ Gain-of-function mutations of GPIb are also associated with thrombocytopenia, due to inappropriate binding of platelets to vWF and consumption. This disorder resembles type 2B von Willebrand disease and is called platelet-type von Willebrand disease.⁵²³ In contrast to BSS, MYH9-related disease is inherited as an autosomal dominant disorder, and MYH9-related disease is also associated with progressive sensorineural deafness, nephropathy, and cataracts. Prior to discovery of the underlying gene defect, affected patients were diagnosed with various disorders, including May-Hegglin anomaly, Sebastian syndrome, Ebstein syndrome, and Fechtner syndrome.^{108,524,525} MYH9 encodes the heavy chain of myosin IIA, which is active in the organization of the DMS and in proplatelet formation.^{526,527} and ⁵²⁸ Review of the peripheral blood smear may reveal Dohle-like bodies within neutrophils, which represent the abnormal precipitated myosin.

Wiskott-Aldrich Syndrome: Wiskott-Aldrich syndrome is caused by mutations involving the WASp, which is a hematopoietic-specific regulator of actin polymerization encoded on the X-chromosome.¹⁰⁷ The full syndrome is manifested by microthrombocytopenia and impaired T-cell function, with eczema, frequent viral and bacterial infections, autoimmune phenomena, and predisposition to lymphoma.⁵²⁹ Mutations that only partially impair WASp function are associated with a less severe clinical course, typically X-linked microthrombocytopenia in the absence of significant immunodeficiency.⁵³⁰ This has been called X-linked thrombocytopenia or XLT, but it must be distinguished from XLT related to GATA1 mutations.

Granule Disorders: The study of disorders involving platelet α -granules (gray platelet syndrome) or dense granules (Hermansky Pudlak syndrome) has provided insights into the cellular mechanisms involved in granule formation in the megakaryocyte. Gray platelet syndrome (GPS) is characterized by thrombocytopenia with large platelets that appear pale on the peripheral blood smear due to a deficiency of α -granules. Families with X-linked disease are likely to have GATA1 mutations that can phenotypically resemble GPS (see above).⁵³¹ Recently, mutations in NBEAL2 (neurobeachin-like 2) were identified as the genetic cause of autosomal recessive GPS.^{532,533,534} The function of NBEAL2 is not understood but it is a member of a family of proteins that are involved in vesicular trafficking. In Hermansky Pudlak syndrome, defects in the biogenesis and trafficking of lysosome-related organelles, including melanosomes and platelet dense granules, underlie the hypopigmentation and bleeding manifestations characteristic of the disorder. At least seven mutations in human disease, as well as additional mutants in mouse models have been described, involving members of multiprotein complexes that function to regulate formation of, and cargo recruitment into, membrane-bounded transport carriers (AP-3), in the tethering and regulation of fusion between endosomal compartments (HOPS), and the intracellular positioning and movement of late endocytic organelles (HOPS and BLOC-3).⁵³⁵ Both α - and dense granules are deficient in gunmetal mice, in which mutation of Rab geranylgeranyl transferase disrupts membrane remodeling and granule packaging⁵³⁶; the human mutation has not been identified.

BCR/ABL-Negative Myeloproliferative Disorders: BCR/ABL-negative myeloproliferative disorders include PV, essential thrombocythemia (ET), and primary myelofibrosis (PMF). Acquired activating mutations in JAK2, typically Val617Phe but rarely alternative exon 12 mutations, can be found in most patients with PV, and nearly half of those with ET or PMF.^{537,538} and ^{539,540,541} Activating mutations in the transmembrane domain of c-Mpl, including Trp515Leu or Trp515Lys, are also found in a small proportion of patients with PMF and ET.⁵⁴² JAK2 contains two Jak homology domains: JH1, which represents the active kinase domain, and JH2, which lacks kinase activity and negatively regulates JH1.^{543,544} The Val617Phe mutation within JH2 disrupts this negative regulation.⁵⁴⁵ In addition, JAK2 Val617Phe is not downregulated normally by Lnk.⁴⁹⁸

In addition to these acquired conditions, familial thrombocytopenia has also been linked to inherited mutations that alter TPO signaling. The mutation Ser505Asn within the transmembrane domain of c-Mpl was identified in a large Japanese

family with thrombocytosis, and the mutant c-Mpl was shown to confer cytokine independence in a Ba/F3 cell line.³⁹⁵

Mutations

P.387

leading to overproduction of TPO have also been identified in families with thrombocytosis. The TPO gene displays an unusual 5' untranslated region structure. Unlike the majority of genes that initiate translation of the encoded polypeptide from the first ATG codon present in the mRNA, TPO translation initiates at the eighth ATG codon, located within the third exon of the full-length transcript.²⁵² Moreover, the eighth ATG is embedded in the short open reading frame (ORF) of the seventh ATG, a particularly inefficient circumstance for translation initiation.⁵⁴⁶ As such, little TPO protein is produced for any given amount of mRNA. Although it is not yet certain whether this molecular arrangement has physiologic consequences (i.e., if it can be differentially regulated), mutation of the TPO gene in noncoding sequences can lead to enhanced translation efficiency and thrombocytosis.⁵⁴⁷ Four pedigrees of familial, autosomal dominant thrombocytosis have been linked to mutations in the region surrounding the initiation codon. In two families, a single mutation in different nucleotides of the intron 3 splice donor sequence results in alternate splicing of the primary TPO transcript, eliminating the seventh and eighth ATG codons, and in the creation of a new amino terminus by the fusing of the fifth ORF with the TPO coding sequence. This novel TPO mRNA is efficiently translated, resulting in supraphysiologic levels of cytokine production and polyclonal expansion of thrombopoiesis.⁵⁴⁸ In another mutant TPO allele, the deletion of a single nucleotide within the seventh ORF leads to its fusion with the TPO coding sequence and to now-enhanced translation of TPO from the seventh ATG codon.⁵⁴⁹ Finally, another mutation within the seventh ORF leads to its premature termination, preventing its interference with translation initiation from the usual eighth initiation codon⁵⁵⁰ and again enhancing TPO production.

Transient Myeloproliferative Disorder and Acute Megakaryoblastic Leukemia: Approximately 10% to 20% of infants with Down syndrome develop transient myeloproliferative disease (TMD), in which immature megakaryoblasts accumulate in the liver, bone marrow, and peripheral blood. Although almost indistinguishable from acute megakaryoblastic leukemia (AMKL), this disorder undergoes spontaneous remission in most cases.⁵⁵¹ However, approximately 30% of children with a history of TMD go on to develop AMKL within 3 years. Certainly an extra copy of chromosome 21, which contains the gene *RUNX1*, predisposes these children to megakaryocytic proliferative disorders, although the exact role of trisomy 21 is unclear. However, acquired mutations of *GATA1*, resulting in the production of *GATA1S*, have been detected in the majority of Down syndrome patients with TMD and AMKL and represent an early step in leukemic transformation.⁵⁵² Note that *GATA1* mutations are not found in children with AMKL in the absence of Down syndrome, suggesting an important interaction between *GATA1S* and trisomy 21. Instead, a translocation between chromosomes 1 and 22, resulting in the fusion protein *OTT-MAL*, has been detected in AMKL occurring in children without Down syndrome.^{553,554} Expression of the *OTT-MAL* fusion protein in a conditional knockin mouse model led to expansion of multipotent myeloid progenitors, enhanced self-renewal of megakaryocytic progenitors, extramedullary hematopoiesis, and eventual development of AMKL.⁵⁵⁵ Further studies showed that expression of *OTT-MAL* activates *RBPJ*, which normally serves as a transcriptional coactivator of Notch, thus deregulating Notch signaling. The activation of *RBPJ*-mediated transcription by *OTT-MAL* is required for the growth of AMKL cells derived from leukemic animals.⁵⁵⁵

REFERENCES

1. Addison W. On the colourless corpuscles and on the molecules and cytoblasts in the blood. *London Med Gaz* 1841;NS30:144-152.
2. Bizzozero G. Ueber einer neuen formbestandtheil des blutes und dessen rolle bei der thrombose und der blutegerinnung. *Virchow's Arch Pathol Anat Physiol* 1882;90:261-332.
3. Osler W, Schaefer EA. Uber einige im blute vorhandene bacterienbildende massen. *Centr Med Wissensch* 1873;11:577-578.
4. Hayem G. Recherches sur l'evolution des hematies dans le sang de l'homme, et des vertebres. *Arch Physiol (deuxieme serie)* 1878;5:692-734.
5. Duke W. The relation of blood platelets to hemorrhagic disease. Description of a method for determining the bleeding time and the coagulation time and report of 3 cases of hemorrhagic disease relieved by transfusion. *JAMA* 1910;55:1185-1192.
6. Wright J. The origin and nature of the blood plates. *Boston Med Surg J* 1906;23:643-645.
7. Wright J. The histogenesis of blood platelets. *J Morphol* 1910;21:117-130.

8. Wendling F, Tambourin P. The oncogene V-MPL, a putative truncated cytokine receptor which immortalizes hematopoietic progenitors. *Nouv Rev Fr Hematol* 1991;33:145-146.
9. Vigon I, Florindo C, Fichelson S, et al. Characterization of the murine Mpl proto-oncogene, a member of the hematopoietic cytokine receptor family: molecular cloning, chromosomal location and evidence for a function in cell growth. *Oncogene* 1993;8:2607-2615.
10. Vigon I, Mornon JP, Cocault L, et al. Molecular cloning and characterization of MPL, the human homolog of the v-mpl oncogene: identification of a member of the hematopoietic growth factor receptor superfamily. *Proc Natl Acad Sci U S A* 1992;89:5640-5644.
11. Souyri M, Vigon I, Penciolelli JF, et al. A putative truncated cytokine receptor gene transduced by the myeloproliferative leukemia virus immortalizes hematopoietic progenitors. *Cell* 1990;63:1137-1147.
12. de Sauvage FJ, Hass PE, Spencer SD, et al. Stimulation of megakaryocytopoiesis and thrombopoiesis by the c-Mpl ligand. *Nature* 1994;369:533-538.
13. Lok S, Kaushansky K, Holly RD, et al. Cloning and expression of murine thrombopoietin cDNA and stimulation of platelet production in vivo. *Nature* 1994;369:565-568.
14. Bartley TD, Bogenberger J, Hunt P, et al. Identification and cloning of a megakaryocyte growth and development factor that is a ligand for the cytokine receptor Mpl. *Cell* 1994;77:1117-1124.
15. Sohma Y, Akahori H, Seki N, et al. Molecular cloning and chromosomal localization of the human thrombopoietin gene. *FEBS Lett* 1994;353:57-61.
16. Ratnoff OD. The evolution of hemostatic mechanisms. *Perspect Biol Med* 1987;31:4-33.
17. Raslova H, Roy L, Vourc'h C, et al. Megakaryocyte polyploidization is associated with a functional gene amplification. *Blood* 2003;101:541-544.
18. Till JM, McCulloch EA. A direct measurement of the radiation sensitivity of normal mouse bone marrow cells. *Radiat Res* 1961;14:213-222.
19. Huang H, Cantor AB. Common features of megakaryocytes and hematopoietic stem cells: what's the connection? *J Cell Biochem* 2009;107:857-864.
20. Mikkola HK, Fujiwara Y, Schlaeger TM, et al. Expression of CD41 marks the initiation of definitive hematopoiesis in the mouse embryo. *Blood* 2003;101:508-516.
21. Debili N, Robin C, Schiavon V, et al. Different expression of CD41 on human lymphoid and myeloid progenitors from adults and neonates. *Blood* 2001;97:2023-2030.
22. Umemoto T, Yamato M, Shiratsuchi Y, et al. CD61 enriches long-term repopulating hematopoietic stem cells. *Biochem Biophys Res Commun* 2008;365:176-182.
23. Novershtern N, Subramanian A, Lawton LN, et al. Densely interconnected transcriptional circuits control cell states in human hematopoiesis. *Cell* 2011;144:296-309.
24. Alexander WS, Roberts AW, Nicola NA, et al. Deficiencies in progenitor cells of multiple hematopoietic lineages and defective megakaryocytopoiesis in mice lacking the thrombopoietic receptor c-Mpl. *Blood* 1996;87:2162-2170.
25. Kimura S, Roberts AW, Metcalf D, et al. Hematopoietic stem cell deficiencies in mice lacking c-Mpl, the receptor for thrombopoietin. *Proc Natl Acad Sci U S A* 1998;95:1195-1200.
26. Murone M, Carpenter DA, de Sauvage FJ. Hematopoietic deficiencies in c-mpl and TPO knockout mice. *Stem Cells* 1998;16:1-6.
27. Solar GP, Kerr WG, Zeigler FC, et al. Role of c-mpl in early hematopoiesis. *Blood* 1998;92:4-10.
28. Abkowitz JL, Chen J. Studies of c-Mpl function distinguish the replication of hematopoietic stem cells from the expansion of differentiating clones. *Blood* 2007;109:5186-5190.
29. Ballmaier M, Germeshausen M, Krukemeier S, et al. Thrombopoietin is essential for the maintenance of normal hematopoiesis in humans: development of aplastic anemia in patients with congenital amegakaryocytic thrombocytopenia. *Ann N Y Acad Sci* 2003;996:17-25.

30. Qian H, Buza-Vidas N, Hyland CD, et al. Critical role of thrombopoietin in maintaining adult quiescent hematopoietic stem cells. *Cell Stem Cell* 2007;1:671-684.
31. Yoshihara H, Arai F, Hosokawa K, et al. Thrombopoietin/MPL signaling regulates hematopoietic stem cell quiescence and interaction with the osteoblastic niche. *Cell Stem Cell* 2007;1:685-697.
32. Umemoto T, Yamato M, Ishihara J, et al. Integrin- α v β 3 regulates thrombopoietin-mediated maintenance of hematopoietic stem cells. *Blood* 2012;119:83-94.
33. Sitnicka E, Lin N, Priestley GV, et al. The effect of thrombopoietin on the proliferation and differentiation of murine hematopoietic stem cells. *Blood* 1996;87:4998-5005.
34. Kirito K, Fox N, Komatsu N, et al. Thrombopoietin enhances expression of vascular endothelial growth factor (VEGF) in primitive hematopoietic cells through induction of HIF-1 α . *Blood* 2005;105:4258-4263.
35. Srivastava AS, Nedelcu E, Esmaeli-Azad B, et al. Thrombopoietin enhances generation of CD34+ cells from human embryonic stem cells. *Stem Cells* 2007;25:1456-1461.
36. Antonchuk J, Sauvageau G, Humphries RK. HOXB4-induced expansion of adult hematopoietic stem cells ex vivo. *Cell* 2002;109:39-45.
37. Kirito K, Fox N, Kaushansky K. Thrombopoietin stimulates HoxB4 expression: an explanation for the favorable effects of TPO on hematopoietic stem cells. *Blood* 2003;102(9):3172-3178.
38. Kirito K, Fox N, Kaushansky K. Thrombopoietin induces HOXA9 nuclear transport in immature hematopoietic cells: potential mechanism by which the hormone favorably affects hematopoietic stem cells. *Mol Cell Biol* 2004;24:6751-6762.
39. Lawrence HJ, Helgason CD, Sauvageau G, et al. Mice bearing a targeted interruption of the homeobox gene HOXA9 have defects in myeloid, erythroid, and lymphoid hematopoiesis. *Blood* 1997;89:1922-1930.
40. Seita J, Ema H, Ooehara J, et al. Lnk negatively regulates self-renewal of hematopoietic stem cells by modifying thrombopoietin-mediated signal transduction. *Proc Natl Acad Sci U S A* 2007;104:2349-2354.
41. Olnes MJ, Scheinberg P, Calvo KR, et al. Eltrombopag and improved hematopoiesis in refractory aplastic anemia. *N Engl J Med*. 2012;367(1):11-19.
42. Akashi K, Traver D, Miyamoto T, et al. A clonogenic common myeloid progenitor that gives rise to all myeloid lineages. *Nature* 2000;404:193-197.
43. Pronk CJ, Rossi DJ, Mansson R, et al. Elucidation of the phenotypic, functional, and molecular topography of a myeloerythroid progenitor cell hierarchy. *Cell Stem Cell* 2007;1:428-442.
44. McDonald TP, Sullivan PS. Megakaryocytic and erythrocytic cell lines share a common precursor cell. *Exp Hematol* 1993;21:1316-1320.
45. Hunt P. A bipotential megakaryocyte/erythrocyte progenitor cell: the link between erythropoiesis and megakaryopoiesis becomes stronger. *J Lab Clin Med* 1995;125:303-304.
46. Debili N, Coulombel L, Croisille L, et al. Characterization of a bipotent erythro-megakaryocytic progenitor in human bone marrow. *Blood* 1996;88:1284-1296.
47. Vannucchi AM, Paoletti F, Linari S, et al. Identification and characterization of a bipotent (erythroid and megakaryocytic) cell precursor from the spleen of phenylhydrazine-treated mice. *Blood* 2000;95:2559-2568.
48. Ng AP, Kauppi M, Metcalf D, et al. Characterization of thrombopoietin (TPO)-responsive progenitor cells in adult mouse bone marrow with in vivo megakaryocyte and erythroid potential. *Proc Natl Acad Sci U S A* 2012;109:2364-2369.
49. Clay D, Rubinstein E, Mishal Z, et al. CD9 and megakaryocyte differentiation. *Blood* 2001;97:1982-1989.
50. Adolfsson J, Mansson R, Buza-Vidas N, et al. Identification of Flt3+ lymphomyeloid stem cells lacking erythro-megakaryocytic potential a revised road map for adult blood lineage commitment. *Cell* 2005;121:295-306.
51. Duperray A, Berthier R, Chagnon E, et al. Biosynthesis and processing of platelet GPIIb-IIIa in human megakaryocytes. *J Cell Biol* 1987;104:1665-1673.
52. Breton-Gorius J, Reyes F. Ultrastructure of human bone marrow cell maturation. *Int Rev Cytol* 1976;46:251-321.
53. Feng S, Lu X, Kroll MH. Filamin A binding stabilizes nascent glycoprotein I α trafficking and thereby enhances its surface expression. *J Biol Chem* 2005;280:6709-6715.

54. Feng S, Resendiz JC, Lu X, et al. Filamin A binding to the cytoplasmic tail of glycoprotein Ibalph α regulates von Willebrand factor-induced platelet activation. *Blood* 2003;102:2122-2129.
55. Nurden P, Debili N, Coupry I, et al. Thrombocytopenia resulting from mutations in filamin A can be expressed as an isolated syndrome. *Blood* 2011;118:5928-5937.
56. Wu G, Essex DW, Meloni FJ, et al. Human endothelial cells in culture and in vivo express on their surface all four components of the glycoprotein Ib/IX/V complex. *Blood* 1997;90:2660-2669.
57. Hickey MJ, Hagen FS, Yagi M, et al. Human platelet glycoprotein V: characterization of the polypeptide and the related Ib-V-IX receptor system of adhesive, leucine-rich glycoproteins. *Proc Natl Acad Sci U S A* 1993;90: 8327-8331.
58. Li CQ, Dong JF, Lanza F, et al. Expression of platelet glycoprotein (GP) V in heterologous cells and evidence for its association with GP Ib α in forming a GP Ib-IX-V complex on the cell surface. *J Biol Chem* 1995;270: 16302-16307.
59. Kahn ML, Diacovo TG, Bainton DF, et al. Glycoprotein V-deficient platelets have undiminished thrombin responsiveness and do not exhibit a Bernard-Soulier phenotype. *Blood* 1999;94:4112-4121.
60. Lopez JA, Andrews RK, Afshar-Kharghan V, et al. Bernard-Soulier syndrome. *Blood* 1998;91:4397-4418.
61. Ramakrishnan V, DeGuzman F, Bao M, et al. A thrombin receptor function for platelet glycoprotein Ib-IX unmasked by cleavage of glycoprotein V. *Proc Natl Acad Sci U S A* 2001;98:1823-1828.
62. Moog S, Mangin P, Lenain N, et al. Platelet glycoprotein V binds to collagen and participates in platelet adhesion and aggregation. *Blood* 2001;98: 1038-1046.
63. Feinendegen LE, Odartchenko N, Cottier H, et al. Kinetics of megakaryocyte proliferation. *Proc Soc Exp Biol Med* 1962;111:177-182.
64. Ebbe S, Stohlman F Jr. Megakaryocytopoiesis in the Rat. *Blood* 1965;26: 20-35.
65. Vitrat N, Cohen-Solal K, Pique C, et al. Endomitosis of human megakaryocytes are due to abortive mitosis. *Blood* 1998;91:3711-3723.
66. Odell TT Jr, Jackson CW. Polyploidy and maturation of rat megakaryocytes. *Blood* 1968;32:102-110.
67. Geddis AE, Fox NE, Tkachenko E, et al. Endomitotic megakaryocytes that form a bipolar spindle exhibit cleavage furrow ingression followed by furrow regression. *Cell Cycle* 2007;6:455-460.
68. King RW, Jackson PK, Kirschner MW. Mitosis in transition. *Cell* 1994;79: 563-571.
69. Zhang Y, Wang Z, Ravid K. The cell cycle in polyploid megakaryocytes is associated with reduced activity of cyclin B1-dependent cdc2 kinase. *J Biol Chem* 1996;271:4266-4272.
70. Matsumura I, Tanaka H, Kawasaki A, et al. Increased D-type cyclin expression together with decreased cdc2 activity confers megakaryocytic differentiation of a human thrombopoietin-dependent hematopoietic cell line. *J Biol Chem* 2000;275:5553-5559.
71. Carow CE, Fox NE, Kaushansky K. Kinetics of endomitosis in primary murine megakaryocytes. *J Cell Physiol* 2001;188:291-303.
72. Roy L, Coullin P, Vitrat N, et al. Asymmetrical segregation of chromosomes with a normal metaphase/anaphase checkpoint in polyploid megakaryocytes. *Blood* 2001;97:2238-2247.
73. Kozar K, Ciemerych MA, Rebel VI, et al. Mouse development and cell proliferation in the absence of D-cyclins. *Cell* 2004;118:477-491.
74. Geng Y, Yu Q, Sicinska E, et al. Cyclin E ablation in the mouse. *Cell* 2003;114:431-443.
75. Rubin CI, Atweh GF. The role of stathmin in the regulation of the cell cycle. *J Cell Biochem* 2004;93:242-250.
76. Rubin CI, French DL, Atweh GF. Stathmin expression and megakaryocyte differentiation: a potential role in polyploidy. *Exp Hematol* 2003;31:389-397.
77. Iancu-Rubin C, Nasrallah CA, Atweh GF. Stathmin prevents the transition from a normal to an endomitotic cell cycle during megakaryocytic differentiation. *Cell Cycle* 2005;4:1774-1782.
78. Adams RR, Carmena M, Earnshaw WC. Chromosomal passengers and the (aurora) ABCs of mitosis. *Trends Cell Biol* 2001;11:49-54.

79. Li F, Ackermann EJ, Bennett CF, et al. Pleiotropic cell-division defects and apoptosis induced by interference with survivin function. *Nat Cell Biol* 1999;1:461-466.
80. Fraser AG, James C, Evan GI, et al. *Caenorhabditis elegans* inhibitor of apoptosis protein (IAP) homologue BIR-1 plays a conserved role in cytokinesis. *Current Biol* 1999;9:292-301.
81. Speliotes EK, Uren A, Vaux D, et al. The survivin-like *C. elegans* BIR-1 protein acts with the Aurora-like kinase AIR-2 to affect chromosomes and the spindle midzone. *Mol Cell* 2000;6:211-223.
82. Katayama H, Ota T, Morita K, et al. Human AIM-1: cDNA cloning and reduced expression during endomitosis in megakaryocyte-lineage cells. *Gene* 1998;224:1-7.
83. Kawasaki A, Matsumura I, Miyagawa J, et al. Downregulation of an AIM-1 kinase couples with megakaryocytic polyploidization of human hematopoietic cells. *J Cell Biol* 2001;152:275-287.
84. Geddis AE, Kaushansky K. Megakaryocytes express functional Aurora-B kinase in endomitosis. *Blood* 2004;104:1017-1024.
85. Geddis AE, Kaushansky K. Endomitotic megakaryocytes form a midzone in anaphase but have a deficiency in cleavage furrow formation. *Cell Cycle* 2006;5:538-545.
86. Lordier L, Jalil A, Aurade F, et al. Megakaryocyte endomitosis is a failure of late cytokinesis related to defects in the contractile ring and Rho/Rock signaling. *Blood* 2008;112:3164-3174.
87. Gao Y, Smith E, Ker E, et al. Role of RhoA-specific guanine exchange factors in regulation of endomitosis in megakaryocytes. *Dev Cell* 2012;22:573-584.
88. Lordier L, Bluteau D, Jalil A, et al. RUNX1-induced silencing of non-muscle myosin heavy chain IIB contributes to megakaryocyte polyploidization. *Nat Commun* 2012;3:717.
89. Behnke O. An electron microscope study of the megakaryocyte of the rat bone marrow. I. The development of the demarcation membrane system and the platelet surface coat. *J Ultrastruct Res* 1968;24:412-433.
90. Bentfeld-Barker ME, Bainton DF. Ultrastructure of rat megakaryocytes after prolonged thrombocytopenia. *J Ultrastruct Res* 1977;61:201-214.
91. Schulze H, Korpál M, Hurov J, et al. Characterization of the megakaryocyte demarcation membrane system and its role in thrombopoiesis. *Blood* 2006;107:3868-3875.
92. Radley JM, Haller CJ. The demarcation membrane system of the megakaryocyte: a misnomer? *Blood* 1982;60:213-219.
93. Harrison P, Savidge GF, Cramer EM. The origin and physiological relevance of alpha-granule adhesive proteins. *Br J Haematol* 1990;74:125-130.
94. Camire RM, Pollak ES, Kaushansky K, et al. Secretable human platelet-derived factor V originates from the plasma pool. *Blood* 1998;92:3035-3041.
95. Battinelli EM, Markens BA, Italiano JE Jr. Release of angiogenesis regulatory proteins from platelet alpha granules: modulation of physiologic and pathologic angiogenesis. *Blood* 2011;118:1359-1369.
96. Chatterjee M, Huang Z, Zhang W, et al. Distinct platelet packaging, release, and surface expression of proangiogenic and antiangiogenic factors on different platelet stimuli. *Blood* 2011;117:3907-3911.
97. Patel-Hett S, Wang H, Begonja AJ, et al. The spectrin-based membrane skeleton stabilizes mouse megakaryocyte membrane systems and is essential for proplatelet and platelet formation. *Blood* 2011;118:1641-1652.
98. Wang D, Villasante A, Lewis SA, et al. The mammalian beta-tubulin repertoire: hematopoietic expression of a novel, heterologous beta-tubulin isotype. *J Cell Biol* 1986;103:1903-1910.
99. Lecine P, Italiano JE Jr, Kim SW, et al. Hematopoietic-specific beta 1 tubulin participates in a pathway of platelet biogenesis dependent on the transcription factor NF-E2. *Blood* 2000;96:1366-1373.
100. Italiano JE Jr, Lecine P, Shivdasani RA, et al. Blood platelets are assembled principally at the ends of proplatelet processes produced by differentiated megakaryocytes. *J Cell Biol* 1999;147:1299-1312.
101. Patel-Hett S, Richardson JL, Schulze H, et al. Visualization of microtubule growth in living platelets reveals a dynamic marginal band with multiple microtubules. *Blood* 2008;111:4605-4616.

102. Patel SR, Richardson JL, Schulze H, et al. Differential roles of microtubule assembly and sliding in proplatelet formation by megakaryocytes. *Blood* 2005;106:4076-4085.
103. Richardson JL, Shivdasani RA, Boers C, et al. Mechanisms of organelle transport and capture along proplatelets during platelet production. *Blood* 2005;106:4066-4075.
104. Italiano JE Jr, Bergmeier W, Tiwari S, et al. Mechanisms and implications of platelet discoid shape. *Blood* 2003;101:4789-4796.
105. Schulze H, Dose M, Korpál M, et al. RanBP10 is a cytoplasmic guanine nucleotide exchange factor that modulates noncentrosomal microtubules. *J Biol Chem* 2008;283:14109-14119.
106. Kunert S, Meyer I, Fleischhauer S, et al. The microtubule modulator RanBP10 plays a critical role in regulation of platelet discoid shape and degranulation. *Blood* 2009;114:5532-5540.
107. Jin Y, Mazza C, Christie JR, et al. Mutations of the Wiskott-Aldrich Syndrome Protein (WASP): hotspots, effect on transcription, and translation and phenotype/genotype correlation. *Blood* 2004;104:4010-4019.
108. Seri M, Cusano R, Gangarossa S, et al. Mutations in MYH9 result in the May-Hegglin anomaly, and Fechtner and Sebastian syndromes. The May-Hegglin/Fechtner Syndrome Consortium. *Nat Genet* 2000;26:103-105.
109. Kunishima S, Kobayashi R, Itoh TJ, et al. Mutation of the beta1-tubulin gene associated with congenital macrothrombocytopenia affecting microtubule assembly. *Blood* 2009;113:458-461.
110. Thiery JP, Bessis M. Mechanism of platelet genesis; in vitro study by cinemicrophotography. *Rev Hematol* 1956;11:162-174.
111. Harker LA, Finch CA. Thrombokinetics in man. *J Clin Invest* 1969;48: 963-974.
112. Stenberg PE, Levin J. Mechanisms of platelet production. *Blood Cells* 1989;15:23-47.
113. Radley JM, Haller CJ. Fate of senescent megakaryocytes in the bone marrow. *Br J Haematol* 1983;53:277-287.
114. Tavassoli M, Aoki M. Localization of megakaryocytes in the bone marrow. *Blood Cells* 1989;15:3-14.
115. Leven RM, Yee T. Collagenase production by guinea pig megakaryocytes in vitro. *Exp Hematol* 1990;18:743-747.
116. Tablin F, Castro M, Leven RM. Blood platelet formation in vitro. The role of the cytoskeleton in megakaryocyte fragmentation. *J Cell Sci* 1990;97 (Pt 1):59-70.
117. Leven RM, Tablin F. Extracellular matrix stimulation of guinea pig megakaryocyte proplatelet formation in vitro is mediated through the vitronectin receptor. *Exp Hematol* 1992;20:1316-1322.
118. Howell WH, Donahue DD. The production of blood platelets in the lungs. *J Exp Med* 1937;65:177-203.
119. Tong M, Seth P, Penington DG. Proplatelets and stress platelets. *Blood* 1987;69:522-528.
120. Slater DN, Trowbridge EA, Martin JF. The megakaryocyte in thrombocytopenia: a microscopic study which supports the theory that platelets are produced in the pulmonary circulation. *Thromb Res* 1983;31:163-176.
121. Kaushansky K, Lok S, Holly RD, et al. Promotion of megakaryocyte progenitor expansion and differentiation by the c-Mpl ligand thrombopoietin. *Nature* 1994;369:568-571.
122. Kaufman RM, Airo R, Pollack S, et al. Circulating megakaryocytes and platelet release in the lung. *Blood* 1965;26:720-731.
123. Junt T, Schulze H, Chen Z, et al. Dynamic visualization of thrombopoiesis within bone marrow. *Science* 2007;317:1767-1770.
124. Schwertz H, Koster S, Kahr WH, et al. Anucleate platelets generate progeny. *Blood* 2010;115:3801-3809.
125. Schwertz H, Weyrich AS. Platelet precursors display bipolar behavior. *J Cell Biol* 2010;191:699-700.
126. Thon JN, Montalvo A, Patel-Hett S, et al. Cytoskeletal mechanics of proplatelet maturation and platelet release. *J Cell Biol* 2010;191:861-874.
127. De Botton S, Sabri S, Daugas E, et al. Platelet formation is the consequence of caspase activation within megakaryocytes. *Blood* 2002;100:1310-1317.
128. White MJ, Schoenwaelder SM, Josefsson EC, et al. Caspase-9 mediates the apoptotic death of megakaryocytes and platelets, but is dispensable for their generation and function. *Blood* 2012;119(18):4283-4290.

129. Josefsson EC, James C, Henley KJ, et al. Megakaryocytes possess a functional intrinsic apoptosis pathway that must be restrained to survive and produce platelets. *J Exp Med* 2011;208:2017-2031.
130. Debrincat MA, Josefsson EC, James C, et al. Mcl-1 and Bcl-xL co-ordinately regulate megakaryocyte survival. *Blood* 2012;119(24):5850-5858.
131. Mason KD, Carpinelli MR, Fletcher JI, et al. Programmed anuclear cell death delimits platelet life span. *Cell* 2007;128:1173-1186.
132. Morison IM, Cramer Borde EM, Cheesman EJ, et al. A mutation of human cytochrome c enhances the intrinsic apoptotic pathway but causes only thrombocytopenia. *Nat Genet* 2008;40:387-389.
133. Akashi K. Lineage promiscuity and plasticity in hematopoietic development. *Ann N Y Acad Sci* 2005;1044:125-131.
134. Orkin SH, Zon LI. Hematopoiesis: an evolving paradigm for stem cell biology. *Cell* 2008;132:631-644.
135. Galloway JL, Wingert RA, Thisse C, et al. Loss of gata1 but not gata2 converts erythropoiesis to myelopoiesis in zebrafish embryos. *Dev Cell* 2005;8: 109-116.
136. Rhodes J, Hagen A, Hsu K, et al. Interplay of pu.1 and gata1 determines myelo-erythroid progenitor cell fate in zebrafish. *Dev Cell* 2005;8:97-108.
137. Burda P, Laslo P, Stopka T. The role of PU.1 and GATA-1 transcription factors during normal and leukemogenic hematopoiesis. *Leukemia* 2010;24: 1249-1257.
138. Tijssen MR, Cvejic A, Joshi A, et al. Genome-wide analysis of simultaneous GATA1/2, RUNX1, FLI1, and SCL binding in megakaryocytes identifies hematopoietic regulators. *Dev Cell* 2011;20:597-609.
139. Shivdasani RA, Mayer EL, Orkin SH. Absence of blood formation in mice lacking the T-cell leukaemia oncoprotein tal-1/SCL. *Nature* 1995;373:432-434.
140. Hall MA, Curtis DJ, Metcalf D, et al. The critical regulator of embryonic hematopoiesis, SCL, is vital in the adult for megakaryopoiesis, erythropoiesis, and lineage choice in CFU-S12. *Proc Natl Acad Sci U S A* 2003;100:992-997.
141. McCormack MP, Hall MA, Schoenwaelder SM, et al. A critical role for the transcription factor Scl in platelet production during stress thrombopoiesis. *Blood* 2006;108:2248-2256.
142. Mikkola HK, Klintman J, Yang H, et al. Haematopoietic stem cells retain long-term repopulating activity and multipotency in the absence of stem-cell leukaemia SCL/tal-1 gene. *Nature* 2003;421:547-551.
143. Schlaeger TM, Mikkola HK, Gekas C, et al. Tie2Cre-mediated gene ablation defines the stem-cell leukemia gene (SCL/tal1)-dependent window during hematopoietic stem-cell development. *Blood* 2005;105:3871-3874.
144. Gekas C, Rhodes KE, Gereige LM, et al. Mef2C is a lineage-restricted target of Scl/Tal1 and regulates megakaryopoiesis and B-cell homeostasis. *Blood* 2009;113:3461-3471.
145. Fuhrken PG, Chen C, Apostolidis PA, et al. Gene Ontology-driven transcriptional analysis of CD34+ cell-initiated megakaryocytic cultures identifies new transcriptional regulators of megakaryopoiesis. *Physiol Genomics* 2008;33:159-169.
146. Wadman IA, Osada H, Grutz GG, et al. The LIM-only protein Lmo2 is a bridging molecule assembling an erythroid, DNA-binding complex which includes the TAL1, E47, GATA-1 and Ldb1/NLI proteins. *EMBO J* 1997;16:3145-3157.
147. Vyas P, McDevitt MA, Cantor AB, et al. Different sequence requirements for expression in erythroid and megakaryocytic cells within a regulatory element upstream of the GATA-1 gene. *Development* 1999;126:2799-2811.
148. Li L, Jothi R, Cui K, et al. Nuclear adaptor Ldb1 regulates a transcriptional program essential for the maintenance of hematopoietic stem cells. *Nat Immunol* 2011;12:129-136.
149. Li L, Lee JY, Gross J, et al. A requirement for Lim domain binding protein 1 in erythropoiesis. *J Exp Med* 2010;207:2543-2550.
150. Wilkinson-White L, Gamsjaeger R, Dastmalchi S, et al. Structural basis of simultaneous recruitment of the transcriptional regulators LMO2 and FOG1/ZFPM1 by the transcription factor GATA1. *Proc Natl Acad Sci US A* 2011;108:14443-14448.
151. Warren AJ, Colledge WH, Carlton MB, et al. The oncogenic cysteine-rich LIM domain protein rbtn2 is essential for erythroid development. *Cell* 1994;78:45-57.

152. Cross AJ, Jeffries CM, Trehella J, et al. LIM domain binding proteins 1 and 2 have different oligomeric states. *J Mol Biol* 2010;399:133-144.
153. Soler E, Andrieu-Soler C, de Boer E, et al. The genome-wide dynamics of the binding of Ldb1 complexes during erythroid differentiation. *Genes Dev* 2010;24:277-289.
154. Song SH, Hou C, Dean A. A positive role for NLI/Ldb1 in long-range betaglobin locus control region function. *Mol Cell* 2007;28:810-822.
155. Fujiwara Y, Browne CP, Cunniff K, et al. Arrested development of embryonic red cell precursors in mouse embryos lacking transcription factor GATA-1. *Proc Natl Acad Sci U S A* 1996;93:12355-12358.
156. Shivdasani RA, Fujiwara Y, McDevitt MA, et al. A lineage-selective knockout establishes the critical role of transcription factor GATA-1 in megakaryocyte growth and platelet development. *EMBO J* 1997;16:3965-3973.
157. Vyas P, Ault K, Jackson CW, et al. Consequences of GATA-1 deficiency in megakaryocytes and platelets. *Blood* 1999;93:2867-2875.
158. Orkin SH. GATA-binding transcription factors in hematopoietic cells. *Blood* 1992;80:575-581.
159. Weiss MJ, Orkin SH. GATA transcription factors: key regulators of hematopoiesis. *Exp Hematol* 1995;23:99-107.
160. Dore LC, Chlon TM, Brown CD, et al. Chromatin occupancy analysis reveals genome-wide GATA factor switching during hematopoiesis. *Blood* 2012;119:3724-3733.
161. Martin DI, Orkin SH. Transcriptional activation and DNA binding by the erythroid factor GF-1/NF-E1/Eryf 1. *Genes Dev* 1990;4:1886-1898.
- P.388
162. Tsang AP, Visvader JE, Turner CA, et al. FOG, a multitype zinc finger protein, acts as a cofactor for transcription factor GATA-1 in erythroid and megakaryocytic differentiation. *Cell* 1997;90:109-119.
163. Elagib KE, Racke FK, Mogass M, et al. RUNX1 and GATA-1 coexpression and cooperation in megakaryocytic differentiation. *Blood* 2003;101:4333-4341.
164. Huang H, Yu M, Akie TE, et al. Differentiation-dependent interactions between RUNX-1 and FLI-1 during megakaryocyte development. *Mol Cell Biol* 2009;29:4103-4115.
165. Xu G, Kanezaki R, Toki T, et al. Physical association of the patient-specific GATA1 mutants with RUNX1 in acute megakaryoblastic leukemia accompanying Down syndrome. *Leukemia* 2006;20:1002-1008.
166. Fox AH, Liew C, Holmes M, et al. Transcriptional cofactors of the FOG family interact with GATA proteins by means of multiple zinc fingers. *EMBO J* 1999;18:2812-2822.
167. Tsang AP, Fujiwara Y, Hom DB, et al. Failure of megakaryopoiesis and arrested erythropoiesis in mice lacking the GATA-1 transcriptional cofactor FOG. *Genes Dev* 1998;12:1176-1188.
168. Mancini E, Sanjuan-Pla A, Luciani L, et al. FOG-1 and GATA-1 act sequentially to specify definitive megakaryocytic and erythroid progenitors. *EMBO J* 2012;31:351-365.
169. Sugiyama D, Tanaka M, Kitajima K, et al. Differential context-dependent effects of friend of GATA-1 (FOG-1) on mast-cell development and differentiation. *Blood* 2008;111:1924-1932.
170. Lee HY, Johnson KD, Fujiwara T, et al. Controlling hematopoiesis through sumoylation-dependent regulation of a GATA factor. *Mol Cell* 2009;36: 984-995.
171. Hong W, Nakazawa M, Chen YY, et al. FOG-1 recruits the NuRD repressor complex to mediate transcriptional repression by GATA-1. *EMBO J* 2005;24:2367-2378.
172. Miccio A, Wang Y, Hong W, et al. NuRD mediates activating and repressive functions of GATA-1 and FOG-1 during blood development. *EMBO J* 2010;29:442-456.
173. Gregory GD, Miccio A, Bersenev A, et al. FOG1 requires NuRD to promote hematopoiesis and maintain lineage fidelity within the megakaryocyticerythroid compartment. *Blood* 2010;115:2156-2166.

174. Nichols KE, Crispino JD, Poncz M, et al. Familial dyserythropoietic anaemia and thrombocytopenia due to an inherited mutation in GATA1. *Nat Genet* 2000;24:266-270.
175. Mehaffey MG, Newton AL, Gandhi MJ, et al. X-linked thrombocytopenia caused by a novel mutation of GATA-1. *Blood* 2001;98:2681-2688.
176. Freson K, Devriendt K, Matthijs G, et al. Platelet characteristics in patients with X-linked macrothrombocytopenia because of a novel GATA1 mutation. *Blood* 2001;98:85-92.
177. Freson K, Matthijs G, Thys C, et al. Different substitutions at residue D218 of the X-linked transcription factor GATA1 lead to altered clinical severity of macrothrombocytopenia and anemia and are associated with variable skewed X inactivation. *Hum Mol Genet* 2002;11:147-152.
178. Del Vecchio GC, Giordani L, De Santis A, et al. Dyserythropoietic anemia and thrombocytopenia due to a novel mutation in GATA-1. *Acta Haematol* 2005;114:113-116.
179. Wechsler J, Greene M, McDevitt MA, et al. Acquired mutations in GATA1 in the megakaryoblastic leukemia of Down syndrome. *Nat Genet* 2002;32: 148-152.
180. Greene ME, Mundschau G, Wechsler J, et al. Mutations in GATA1 in both transient myeloproliferative disorder and acute megakaryoblastic leukemia of Down syndrome. *Blood Cells Mol Dis* 2003;31:351-356.
181. Crispino JD. GATA1 mutations in Down syndrome: implications for biology and diagnosis of children with transient myeloproliferative disorder and acute megakaryoblastic leukemia. *Pediatr Blood Cancer* 2005;44:40-44.
182. Tsai FY, Keller G, Kuo FC, et al. An early haematopoietic defect in mice lacking the transcription factor GATA-2. *Nature* 1994;371:221-226.
183. Tsai FY, Orkin SH. Transcription factor GATA-2 is required for proliferation/survival of early hematopoietic cells and mast cell formation, but not for erythroid and myeloid terminal differentiation. *Blood* 1997;89: 3636-3643.
184. Ling KW, Ottersbach K, van Hamburg JP, et al. GATA-2 plays two functionally distinct roles during the ontogeny of hematopoietic stem cells. *J Exp Med* 2004;200:871-882.
185. Dorfman DM, Wilson DB, Bruns GA, et al. Human transcription factor GATA-2. Evidence for regulation of preproendothelin-1 gene expression in endothelial cells. *J Biol Chem* 1992;267:1279-1285.
186. Chou ST, Khandros E, Bailey LC, et al. Graded repression of PU.1/Sfp1 gene transcription by GATA factors regulates hematopoietic cell fate. *Blood* 2009;114:983-994.
187. Terui K, Takahashi Y, Kitazawa J, et al. Expression of transcription factors during megakaryocytic differentiation of CD34+ cells from human cord blood induced by thrombopoietin. *Tohoku J Exp Med* 2000;192:259-273.
188. Ikonomi P, Rivera CE, Riordan M, et al. Overexpression of GATA-2 inhibits erythroid and promotes megakaryocyte differentiation. *Exp Hematol* 2000;28:1423-1431.
189. Grass JA, Boyer ME, Pal S, et al. GATA-1-dependent transcriptional repression of GATA-2 via disruption of positive autoregulation and domain-wide chromatin remodeling. *Proc Natl Acad Sci U S A* 2003;100:8811-8816.
190. Li Z, Godinho FJ, Klusmann JH, et al. Developmental stage-selective effect of somatically mutated leukemogenic transcription factor GATA1. *Nat Genet* 2005;37:613-619.
191. Ko LJ, Engel JD. DNA-binding specificities of the GATA transcription factor family. *Mol Cell Biol* 1993;13:4011-4022.
192. Merika M, Orkin SH. DNA-binding specificity of GATA family transcription factors. *Mol Cell Biol* 1993;13:3999-4010.
193. Bresnick EH, Lee HY, Fujiwara T, et al. GATA switches as developmental drivers. *J Biol Chem* 2010;285:31087-31093.
194. Speck NA, Stacy T, Wang Q, et al. Core-binding factor: a central player in hematopoiesis and leukemia. *Cancer Res* 1999;59:1789s-1793s.
195. Ichikawa M, Asai T, Saito T, et al. AML-1 is required for megakaryocytic maturation and lymphocytic differentiation, but not for maintenance of hematopoietic stem cells in adult hematopoiesis. *Nat Med* 2004;10:299-304.
196. Growney JD, Shigematsu H, Li Z, et al. Loss of Runx1 perturbs adult hematopoiesis and is associated with a myeloproliferative phenotype. *Blood* 2005;106:494-504.
197. Song WJ, Sullivan MG, Legare RD, et al. Haploinsufficiency of CBFA2 causes familial thrombocytopenia with propensity to develop acute myelogenous leukaemia. *Nat Genet* 1999;23:166-175.

198. Heller PG, Glembotsky AC, Gandhi MJ, et al. Low Mpl receptor expression in a pedigree with familial platelet disorder with predisposition to acute myelogenous leukemia and a novel AML1 mutation. *Blood* 2005;105:4664-4670.
199. Zhang DE, Hetherington CJ, Meyers S, et al. CCAAT enhancer-binding protein (C/EBP) and AML1 (CBF alpha2) synergistically activate the macrophage colony-stimulating factor receptor promoter. *Mol Cell Biol* 1996;16:1231-1240.
200. Martensson A, Xie XQ, Persson C, et al. PEBP2 and c-myb sites crucial for lambda5 core enhancer activity in pre-B cells. *Eur J Immunol* 2001;31: 3165-3174.
201. Goldfarb AN. Megakaryocytic programming by a transcriptional regulatory loop: a circle connecting RUNX1, GATA-1, and P-TEFb. *J Cell Biochem* 2009;107:377-382.
202. Pencovich N, Jaschek R, Tanay A, et al. Dynamic combinatorial interactions of RUNX1 and cooperating partners regulates megakaryocytic differentiation in cell line models. *Blood* 2011;117:e1-14.
203. Jiang H, Peterlin BM. Differential chromatin looping regulates CD4 expression in immature thymocytes. *Mol Cell Biol* 2008;28:907-912.
204. Elagib KE, Mihaylov IS, Delehanty LL, et al. Cross-talk of GATA-1 and P-TEFb in megakaryocyte differentiation. *Blood* 2008;112:4884-4894.
205. Mosser EA, Kasanov JD, Forsberg EC, et al. Physical and functional interactions between the transactivation domain of the hematopoietic transcription factor NF-E2 and WW domains. *Biochemistry* 1998;37:13686-13695.
206. Shivdasani RA, Orkin SH. Erythropoiesis and globin gene expression in mice lacking the transcription factor NF-E2. *Proc Natl Acad Sci U S A* 1995;92:8690-8694.
207. Levin J, Peng JP, Baker GR, et al. Pathophysiology of thrombocytopenia and anemia in mice lacking transcription factor NF-E2. *Blood* 1999;94: 3037-3047.
208. Schwer HD, Lecine P, Tiwari S, et al. A lineage-restricted and divergent betatubulin isoform is essential for the biogenesis, structure and function of blood platelets. *Curr Biol* 2001;11:579-586.
209. Kerrigan SW, Gaur M, Murphy RP, et al. Caspase-12: a developmental link between G-protein-coupled receptors and integrin alphaIIb beta3 activation. *Blood* 2004;104:1327-1334.
210. Deveaux S, Cohen-Kaminsky S, Shivdasani RA, et al. p45 NF-E2 regulates expression of thromboxane synthase in megakaryocytes. *EMBO J* 1997;16:5654-5661.
211. Tiwari S, Italiano JE, Barral DC, et al. A role for Rab27b in NF-E2-dependent pathways of platelet formation. *Blood* 2003;102(12):3970-3979.
212. Nagata Y, Yoshikawa J, Hashimoto A, et al. Proplatelet formation of megakaryocytes is triggered by autocrine-synthesized estradiol. *Genes Dev* 2003;17:2864-2869.
213. Okada Y, Nagai R, Sato T, et al. Homeodomain proteins MEIS1 and PBXs regulate the lineage-specific transcription of the platelet factor 4 gene. *Blood* 2003;101:4748-4756.
214. Hisa T, Spence SE, Rachel RA, et al. Hematopoietic, angiogenic and eye defects in Meis1 mutant animals. *EMBO J* 2004;23:450-459.
215. Azcoitia V, Aracil M, Martinez AC, et al. The homeodomain protein Meis1 is essential for definitive hematopoiesis and vascular patterning in the mouse embryo. *Dev Biol* 2005;280:307-320.
216. Thompson AA, Woodruff K, Feig SA, et al. Congenital thrombocytopenia and radio-ulnar synostosis: a new familial syndrome. *Br J Haematol* 2001;113:866-870.
217. Pimanda JE, Ottersbach K, Knezevic K, et al. Gata2, Fli1, and Scl form a recursively wired gene-regulatory circuit during early hematopoietic development. *Proc Natl Acad Sci U S A* 2007;104:17692-17697.
218. Hart A, Melet F, Grossfeld P, et al. Fli-1 is required for murine vascular and megakaryocytic development and is hemizygotously deleted in patients with thrombocytopenia. *Immunity* 2000;13:167-177.
219. Kawada H, Ito T, Pharr PN, et al. Defective megakaryopoiesis and abnormal erythroid development in Fli-1 gene-targeted mice. *Int J Hematol* 2001;73:463-468.
220. Spyropoulos DD, Pharr PN, Lavenburg KR, et al. Hemorrhage, impaired hematopoiesis, and lethality in mouse embryos carrying a targeted disruption of the Fli1 transcription factor. *Mol Cell Biol* 2000;20:5643-5652.

221. Liu F, Walmsley M, Rodaway A, et al. Fli1 acts at the top of the transcriptional network driving blood and endothelial development. *Current Biol* 2008;18:1234-1240.
222. Wang X, Crispino JD, Letting DL, et al. Control of megakaryocyte-specific gene expression by GATA-1 and FOG-1: role of Ets transcription factors. *EMBO J* 2002;21:5225-5234.
223. Eisbacher M, Holmes ML, Newton A, et al. Protein-protein interaction between Fli-1 and GATA-1 mediates synergistic expression of megakaryocyte-specific genes through cooperative DNA binding. *Mol Cell Biol* 2003;23:3427-3441.
224. Pang L, Xue HH, Szalai G, et al. Maturation stage-specific regulation of megakaryopoiesis by pointed-domain Ets proteins. *Blood* 2006;108:2198-2206.
225. Athanasiou M, Clausen PA, Mavrothalassitis GJ, et al. Increased expression of the ETS-related transcription factor FLI-1/ERGB correlates with and can induce the megakaryocytic phenotype. *Cell Growth Differ* 1996;7:1525-1534.
226. Athanasiou M, Mavrothalassitis G, Sun-Hoffman L, et al. FLI-1 is a suppressor of erythroid differentiation in human hematopoietic cells. *Leukemia* 2000;14:439-445.
227. Crossley M, Tsang AP, Bieker JJ, et al. Regulation of the erythroid Kruppel-like factor (EKLF) gene promoter by the erythroid transcription factor GATA-1. *J Biol Chem* 1994;269:15440-15444.
228. Frontelo P, Manwani D, Galdass M, et al. Novel role for EKLF in megakaryocyte lineage commitment. *Blood* 2007;110:3871-3880.
229. Starck J, Cohet N, Gonnet C, et al. Functional cross-antagonism between transcription factors FLI-1 and EKLF. *Mol Cell Biol* 2003;23:1390-1402.
230. Siatecka M, Sahr KE, Andersen SG, et al. Severe anemia in the Nan mutant mouse caused by sequence-selective disruption of erythroid Kruppel-like factor. *Proc Natl Acad Sci USA* 2010;107:15151-15156.
231. Starck J, Weiss-Gayet M, Gonnet C, et al. Inducible Fli-1 gene deletion in adult mice modifies several myeloid lineage commitment decisions and accelerates proliferation arrest and terminal erythrocytic differentiation. *Blood* 2010;116:4795-4805.
232. Osawa M, Yamaguchi T, Nakamura Y, et al. Erythroid expansion mediated by the Gfi-1B zinc finger protein: role in normal hematopoiesis. *Blood* 2002;100:2769-2777.
233. Garcon L, Lacout C, Svinartchouk F, et al. Gfi-1B plays a critical role in terminal differentiation of normal and transformed erythroid progenitor cells. *Blood* 2005;105:1448-1455.
234. Randrianarison-Huetz V, Laurent B, Bardet V, et al. Gfi-1B controls human erythroid and megakaryocytic differentiation by regulating TGF-beta signaling at the bipotent erythro-megakaryocytic progenitor stage. *Blood* 2010;115:2784-2795.
235. Mucenski ML, McLain K, Kier AB, et al. A functional c-myb gene is required for normal murine fetal hepatic hematopoiesis. *Cell* 1991;65:677-689.
236. Emambokus N, Vegiopoulos A, Harman B, et al. Progression through key stages of haemopoiesis is dependent on distinct threshold levels of c-Myb. *EMBO J* 2003;22:4478-4488.
237. Mukai HY, Motohashi H, Ohneda O, et al. Transgene insertion in proximity to the c-myb gene disrupts erythroid-megakaryocytic lineage bifurcation. *Mol Cell Biol* 2006;26:7953-7965.
238. Bianchi E, Zini R, Salati S, et al. c-myb supports erythropoiesis through the transactivation of KLF1 and LMO2 expression. *Blood* 2010;116:e99-110.
239. Lu J, Guo S, Ebert BL, et al. MicroRNA-mediated control of cell fate in megakaryocyte-erythrocyte progenitors. *Dev Cell* 2008;14:843-853.
240. Alemdehy MF, Erkeland SJ. MicroRNAs: key players of normal and malignant myelopoiesis. *Curr Opin Hematol* 2012;19(4):261-267.
241. Opalinska JB, Bersenev A, Zhang Z, et al. MicroRNA expression in maturing murine megakaryocytes. *Blood* 2010;116:e128-138.
242. O'Connell RM, Rao DS, Chaudhuri AA, et al. Sustained expression of microR-NA-155 in hematopoietic stem cells causes a myeloproliferative disorder. *J Exp Med* 2008;205:585-594.

243. Georgantas RW 3rd, Hildreth R, Morisot S, et al. CD34+ hematopoietic stem-progenitor cell microRNA expression and function: a circuit diagram of differentiation control. *Proc Natl Acad Sci U S A* 2007;104:2750-2755.
244. Romania P, Lulli V, Pelosi E, et al. MicroRNA 155 modulates megakaryopoiesis at progenitor and precursor level by targeting Ets-1 and Meis1 transcription factors. *Br J Haematol* 2008;143:570-580.
245. Barroga CF, Pham H, Kaushansky K. Thrombopoietin regulates c-Myb expression by modulating micro RNA 150 expression. *Exp Hematol* 2008;36: 1585-1592.
246. Navarro F, Gutman D, Meire E, et al. miR-34a contributes to megakaryocytic differentiation of K562 cells independently of p53. *Blood* 2009;114: 2181-2192.
247. Ben-Ami O, Pencovich N, Lotem J, et al. A regulatory interplay between miR-27a and Runx1 during megakaryopoiesis. *Proc Natl Acad Sci U S A* 2009;106:238-243.
248. Kelemen E, Cserhati I, Tanos B. Demonstration and some properties of human thrombopoietin in thrombocythaemic sera. *Acta Haematol* 1958;20:350-355.
249. McDonald TP. Thrombopoietin: its biology, purification, and characterization. *Exp Hematol* 1988;16:201-205.
250. Hill RJ, Leven RM, Levin FC, et al. The effect of partially purified thrombopoietin on guinea pig megakaryocyte ploidy in vitro. *Exp Hematol* 1989;17: 903-907.
251. Wendling F, Varlet P, Charon M, et al. MPLV: a retrovirus complex inducing an acute myeloproliferative leukemic disorder in adult mice. *Virology* 1986;149:242-246.
252. Chang MS, McNinch J, Basu R, et al. Cloning and characterization of the human megakaryocyte growth and development factor (MGDF) gene. *J Biol Chem* 1995;270:511-514.
253. Gurney AL, Carver-Moore K, de Sauvage FJ, et al. Thrombocytopenia in c-mpl-deficient mice. *Science* 1994;265:1445-1447.
254. Foster DC, Sprecher CA, Grant FJ, et al. Human thrombopoietin: gene structure, cDNA sequence, expression, and chromosomal localization. *Proc Natl Acad Sci U S A* 1994;91:13023-13027.
255. Hoffman RC, Andersen H, Walker K, et al. Peptide, disulfide, and glycosylation mapping of recombinant human thrombopoietin from ser1 to Arg246. *Biochemistry* 1996;35:14849-14861.
256. Harker LA, Marzec UM, Hunt P, et al. Dose-response effects of pegylated human megakaryocyte growth and development factor on platelet production and function in nonhuman primates. *Blood* 1996;88:511-521.
257. Linden HM, Kaushansky K. The glycan domain of thrombopoietin enhances its secretion. *Biochemistry* 2000;39:3044-3051.
258. Muto T, Feese MD, Shimada Y, et al. Functional analysis of the C-terminal region of recombinant human thrombopoietin. C-terminal region of thrombopoietin is a "shuttle" peptide to help secretion. *J Biol Chem* 2000;275: 12090-12094.
259. Broudy VC, Lin NL, Kaushansky K. Thrombopoietin (c-mpl ligand) acts synergistically with erythropoietin, stem cell factor, and interleukin-11 to enhance murine megakaryocyte colony growth and increases megakaryocyte ploidy in vitro. *Blood* 1995;85:1719-1726.
260. Zeigler FC, de Sauvage F, Widmer HR, et al. In vitro megakaryocytopoietic and thrombopoietic activity of c-mpl ligand (TPO) on purified murine hematopoietic stem cells. *Blood* 1994;84:4045-4052.
261. Kaushansky K. The mpl ligand: molecular and cellular biology of the critical regulator of megakaryocyte development. *Stem Cells* 1994;12(Suppl 1): 91-96; discussion 96-97.
262. Bassler RL, Rasko JE, Clarke K, et al. Thrombopoietic effects of pegylated recombinant human megakaryocyte growth and development factor (PEGHuMGDF) in patients with advanced cancer. *Lancet* 1996;348:1279-1281.
263. Vadhan-Raj S, Murray LJ, Bueso-Ramos C, et al. Stimulation of megakaryocyte and platelet production by a single dose of recombinant human thrombopoietin in patients with cancer. *Ann Intern Med* 1997;126:673-681.
264. Arnold JT, Daw NC, Stenberg PE, et al. A single injection of pegylated murine megakaryocyte growth and development factor (MGDF) into mice is sufficient to produce a profound stimulation of megakaryocyte frequency, size, and ploidy. *Blood* 1997;89:823-833.

265. Kaushansky K, Broudy VC, Grossmann A, et al. Thrombopoietin expands erythroid progenitors, increases red cell production, and enhances erythroid recovery after myelosuppressive therapy. *J Clin Invest* 1995;96:1683-1687.
266. Farese AM, Hunt P, Boone T, et al. Recombinant human megakaryocyte growth and development factor stimulates thrombocytopoiesis in normal nonhuman primates. *Blood* 1995;86:54-59.
267. Akahori H, Shibuya K, Ozai M, et al. Effects of pegylated recombinant human megakaryocyte growth and development factor on thrombocytopenia induced by a new myelosuppressive chemotherapy regimen in mice. *Stem Cells* 1996;14:678-689.
268. Neelis KJ, Dubbelman YD, Qingliang L, et al. Simultaneous administration of TPO and G-CSF after cytoreductive treatment of rhesus monkeys prevents thrombocytopenia, accelerates platelet and red cell reconstitution, alleviates neutropenia, and promotes the recovery of immature bone marrow cells. *Exp Hematol* 1997;25:1084-1093.
269. Li J, Yang C, Xia Y, et al. Thrombocytopenia caused by the development of antibodies to thrombopoietin. *Blood* 2001;98:3241-3248.
270. Kuter DJ. Biology and chemistry of thrombopoietic agents. *Semin Hematol* 2010;47:243-248.
271. Kuter DJ, Bussel JB, Lyons RM, et al. Efficacy of romiplostim in patients with chronic immune thrombocytopenic purpura: a double-blind randomised controlled trial. *Lancet* 2008;371:395-403.
272. Cheng G, Saleh MN, Marcher C, et al. Eltrombopag for management of chronic immune thrombocytopenia (RAISE): a 6-month, randomised, phase 3 study. *Lancet* 2011;377:393-402.
273. Ihara K, Ishii E, Eguchi M, et al. Identification of mutations in the c-mpl gene in congenital amegakaryocytic thrombocytopenia. *Proc Natl Acad Sci U S A* 1999;96:3132-3136.
274. Ballmaier M, Germeshausen M, Schulze H, et al. c-mpl mutations are the cause of congenital amegakaryocytic thrombocytopenia. *Blood* 2001;97: 139-146.
275. van den Oudenrijn S, Bruin M, Folman CC, et al. Mutations in the thrombopoietin receptor, Mpl, in children with congenital amegakaryocytic thrombocytopenia. *Br J Haematol* 2000;110:441-448.
276. Heckl D, Wicke DC, Brugman MH, et al. Lentiviral gene transfer regenerates hematopoietic stem cells in a mouse model for Mpl-deficient aplastic anemia. *Blood* 2011;117:3737-3747.
277. Wendling F, Maraskovsky E, Debili N, et al. cMpl ligand is a humoral regulator of megakaryocytopoiesis. *Nature* 1994;369:571-574.
278. Nichol JL, Hokom MM, Hornkohl A, et al. Megakaryocyte growth and development factor. Analyses of in vitro effects on human megakaryopoiesis and endogenous serum levels during chemotherapy-induced thrombocytopenia. *J Clin Invest* 1995;95:2973-2978.
279. Emmons RV, Reid DM, Cohen RL, et al. Human thrombopoietin levels are high when thrombocytopenia is due to megakaryocyte deficiency and low when due to increased platelet destruction. *Blood* 1996;87:4068-4071.
280. McCarty JM, Sprugel KH, Fox NE, et al. Murine thrombopoietin mRNA levels are modulated by platelet count. *Blood* 1995;86:3668-3675.
281. Kuter DJ, Rosenberg RD. The reciprocal relationship of thrombopoietin (c-Mpl ligand) to changes in the platelet mass during busulfan-induced thrombocytopenia in the rabbit. *Blood* 1995;85:2720-2730.
282. Stoffel R, Wiestner A, Skoda RC. Thrombopoietin in thrombocytopenic mice: evidence against regulation at the mRNA level and for a direct regulatory role of platelets. *Blood* 1996;87:567-573.
283. Fielder PJ, Gurney AL, Stefanich E, et al. Regulation of thrombopoietin levels by c-mpl-mediated binding to platelets. *Blood* 1996;87:2154-2161.
284. Hollen CW, Henthorn J, Koziol JA, et al. Elevated serum interleukin-6 levels in patients with reactive thrombocytosis. *Br J Haematol* 1991;79: 286-290.
285. Kaser A, Brandacher G, Steurer W, et al. Interleukin-6 stimulates thrombopoiesis through thrombopoietin: role in inflammatory thrombocytosis. *Blood* 2001;98:2720-2725.
286. Solanilla A, Dechanet J, El Andaloussi A, et al. CD40-ligand stimulates myelopoiesis by regulating flt3-ligand and thrombopoietin production in bone marrow stromal cells. *Blood* 2000;95:3758-3764.

287. Sungaran R, Chisholm OT, Markovic B, et al. The role of platelet alpha-granular proteins in the regulation of thrombopoietin messenger RNA expression in human bone marrow stromal cells. *Blood* 2000;95:3094-3101.
288. Guerriero A, Worford L, Holland HK, et al. Thrombopoietin is synthesized by bone marrow stromal cells. *Blood* 1997;90:3444-3455.
289. Sungaran R, Markovic B, Chong BH. Localization and regulation of thrombopoietin mRNA expression in human kidney, liver, bone marrow, and spleen using in situ hybridization. *Blood* 1997;89:101-107.
290. Kamura T, Handa H, Hamasaki N, et al. Characterization of the human thrombopoietin gene promoter. A possible role of an Ets transcription factor, E4TF1/GABP. *J Biol Chem* 1997;272:11361-11368.
291. Dordelmann C, Telgmann R, Brand E, et al. Functional and structural profiling of the human thrombopoietin gene promoter. *J Biol Chem* 2008;283:24382-24391.
292. Alexander WS, Roberts AW, Maurer AB, et al. Studies of the c-Mpl thrombopoietin receptor through gene disruption and activation. *Stem Cells* 1996;14(Suppl 1):124-132.
293. Carver-Moore K, Broxmeyer HE, Luoh SM, et al. Low levels of erythroid and myeloid progenitors in thrombopoietin- and c-mpl-deficient mice. *Blood* 1996;88:803-808.
294. Quesenberry PJ, Ihle JN, McGrath E. The effect of interleukin 3 and GM-CSA-2 on megakaryocyte and myeloid clonal colony formation. *Blood* 1985;65: 214-217.
295. Williams N, Sparrow R, Gill K, et al. Murine megakaryocyte colony stimulating factor: its relationship to interleukin 3. *Leuk Res* 1985;9:1487-1496.
296. Kaushansky K, O'Hara PJ, Berkner K, et al. Genomic cloning, characterization, and multilineage growth-promoting activity of human granulocyte-macrophage colony-stimulating factor. *Proc Natl Acad Sci U S A* 1986;83: 3101-3105.
297. Segal GM, Stueve T, Adamson JW. Analysis of murine megakaryocyte colony size and ploidy: effects of interleukin-3. *J Cell Physiol* 1988;137:537-544.
298. Briddell RA, Bruno E, Cooper RJ, et al. Effect of c-kit ligand on in vitro human megakaryocytopoiesis. *Blood* 1991;78:2854-2859.
299. Yang YC, Ciarletta AB, Temple PA, et al. Human IL-3 (multi-CSF): identification by expression cloning of a novel hematopoietic growth factor related to murine IL-3. *Cell* 1986;47:3-10.
300. Wong GG, Witek JS, Temple PA, et al. Human GM-CSF: molecular cloning of the complementary DNA and purification of the natural and recombinant proteins. *Science* 1985;228:810-815.
301. Diederichs K, Boone T, Karplus PA. Novel fold and putative receptor binding site of granulocyte-macrophage colony-stimulating factor. *Science* 1991;254:1779-1782.
302. Feng Y, Klein BK, Vu L, et al. ¹H, ¹³C, and ¹⁵N NMR resonance assignments, secondary structure, and backbone topology of a variant of human interleukin-3. *Biochemistry* 1995;34:6540-6551.
303. Lopez AF, Eglinton JM, Gillis D, et al. Reciprocal inhibition of binding between interleukin 3 and granulocyte-macrophage colony-stimulating factor to human eosinophils. *Proc Natl Acad Sci U S A* 1989;86:7022-7026.
304. Chen Q, Solar G, Eaton DL, et al. IL-3 does not contribute to platelet production in c-Mpl-deficient mice. *Stem Cells* 1998;16(Suppl 2):31-36.
305. Scott CL, Robb L, Mansfield R, et al. Granulocyte-macrophage colony-stimulating factor is not responsible for residual thrombopoiesis in mpl null mice. *Exp Hematol* 2000;28:1001-1007.
306. Lyman SD, James L, Vanden Bos T, et al. Molecular cloning of a ligand for the flt3/flk-2 tyrosine kinase receptor: a proliferative factor for primitive hematopoietic cells. *Cell* 1993;75:1157-1167.
307. Avraham H, Vannier E, Cowley S, et al. Effects of the stem cell factor, c-kit ligand, on human megakaryocytic cells. *Blood* 1992;79:365-371.
308. Arnold J, Ellis S, Radley JM, et al. Compensatory mechanisms in platelet production: the response of Sl/Sld mice to 5-fluorouracil. *Exp Hematol* 1991;19:24-28.
309. Ebbe S, Phalen E, Stohlman F Jr. Abnormalities of megakaryocytes in S1-S1d mice. *Blood* 1973;42:865-871.

310. Hunt P, Zsebo KM, Hokom MM, et al. Evidence that stem cell factor is involved in the rebound thrombocytosis that follows 5-fluorouracil treatment. *Blood* 1992;80:904-911.
311. Fleischman RA. From white spots to stem cells: the role of the Kit receptor in mammalian development. *Trends Genet* 1993;9:285-290.
312. Morrison-Graham K, Takahashi Y. Steel factor and c-kit receptor: from mutants to a growth factor system. *Bioessays* 1993;15:77-83.
313. Broudy VC. Stem cell factor and hematopoiesis. *Blood* 1997;90:1345-1364.
314. Sieber-Blum M, Zhang JM. Growth factor action in neural crest cell diversification. *J Anat* 1997;191(Pt 4):493-499.
315. Rossi P, Sette C, Dolci S, et al. Role of c-kit in mammalian spermatogenesis. *J Endocrinol Invest* 2000;23:609-615.
316. Driancourt MA, Reynaud K, Cortvrindt R, et al. Roles of KIT and KIT LIGAND in ovarian function. *Rev Reprod* 2000;5:143-152.
317. Langley KE, Bennett LG, Wypych J, et al. Soluble stem cell factor in human serum. *Blood* 1993;81:656-660.
318. Cheng HJ, Flanagan JG. Transmembrane kit ligand cleavage does not require a signal in the cytoplasmic domain and occurs at a site dependent on spacing from the membrane. *Mol Biol Cell* 1994;5:943-953.
319. Miyazawa K, Williams DA, Gotoh A, et al. Membrane-bound Steel factor induces more persistent tyrosine kinase activation and longer life span of c-kit gene-encoded protein than its soluble form. *Blood* 1995;85: 641-649.
320. Flanagan JG, Chan DC, Leder P. Transmembrane form of the kit ligand growth factor is determined by alternative splicing and is missing in the Sld mutant. *Cell* 1991;64:1025-1035.
321. Kishimoto T. The biology of interleukin-6. *Blood* 1989;74:1-10.
322. Ishibashi T, Kimura H, Shikama Y, et al. Interleukin-6 is a potent thrombopoietic factor in vivo in mice. *Blood* 1989;74:1241-1244.
323. Kimura H, Ishibashi T, Uchida T, et al. Interleukin 6 is a differentiation factor for human megakaryocytes in vitro. *Eur J Immunol* 1990;20:1927-1931.
324. Williams N, De Giorgio T, Banu N, et al. Recombinant interleukin 6 stimulates immature murine megakaryocytes. *Exp Hematol* 1990;18:69-72.
325. Asano S, Okano A, Ozawa K, et al. In vivo effects of recombinant human interleukin-6 in primates: stimulated production of platelets. *Blood* 1990;75:1602-1605.
326. Carrington PA, Hill RJ, Stenberg PE, et al. Multiple in vivo effects of interleukin-3 and interleukin-6 on murine megakaryocytopoiesis. *Blood* 1991;77:34-41.
327. Burstein SA, Downs T, Friese P, et al. Thrombocytopoiesis in normal and sublethally irradiated dogs: response to human interleukin-6. *Blood* 1992;80:420-428.
328. Zeidler C, Kanz L, Hurkuck F, et al. In vivo effects of interleukin-6 on thrombopoiesis in healthy and irradiated primates. *Blood* 1992;80:2740-2745.
329. Bernad A, Kopf M, Kulbacki R, et al. Interleukin-6 is required in vivo for the regulation of stem cells and committed progenitors of the hematopoietic system. *Immunity* 1994;1:725-731.
330. Paul SR, Bennett F, Calvetti JA, et al. Molecular cloning of a cDNA encoding interleukin 11, a stromal cell-derived lymphopoietic and hematopoietic cytokine. *Proc Natl Acad Sci U S A* 1990;87:7512-7516.
331. Du X, Williams DA. Interleukin-11: review of molecular, cell biology, and clinical use. *Blood* 1997;89:3897-3908.
332. Gough NM. Molecular genetics of leukemia inhibitory factor (LIF) and its receptor. *Growth Factors* 1992;7:175-179.
333. Metcalf D, Nicola NA, Gearing DP. Effects of injected leukemia inhibitory factor on hematopoietic and other tissues in mice. *Blood* 1990;76:50-56.
334. Hilton DJ. LIF: lots of interesting functions. *Trends Biochem Sci* 1992;17: 72-76.
335. Debili N, Masse JM, Katz A, et al. Effects of the recombinant hematopoietic growth factors interleukin-3, interleukin-6, stem cell factor, and leukemia inhibitory factor on the megakaryocytic differentiation of CD34+ cells. *Blood* 1993;82:84-95.

336. Metcalf D, Hilton D, Nicola NA. Leukemia inhibitory factor can potentiate murine megakaryocyte production in vitro. *Blood* 1991;77:2150-2153.
337. Neben TY, Loebelenz J, Hayes L, et al. Recombinant human interleukin-11 stimulates megakaryocytopoiesis and increases peripheral platelets in normal and splenectomized mice. *Blood* 1993;81:901-908.
338. Yonemura Y, Kawakita M, Masuda T, et al. Effect of recombinant human interleukin-11 on rat megakaryopoiesis and thrombopoiesis in vivo: comparative study with interleukin-6. *Br J Haematol* 1993;84:16-23.
339. Hangoc G, Yin T, Cooper S, et al. In vivo effects of recombinant interleukin-11 on myelopoiesis in mice. *Blood* 1993;81:965-972.
340. Farese AM, Myers LA, MacVittie TJ. Therapeutic efficacy of recombinant human leukemia inhibitory factor in a primate model of radiation-induced marrow aplasia. *Blood* 1994;84:3675-3678.
341. Gordon MS, McCaskill-Stevens WJ, Battiato LA, et al. A phase I trial of recombinant human interleukin-11 (neumega rhIL-11 growth factor) in women with breast cancer receiving chemotherapy. *Blood* 1996;87:3615-3624.
342. Escary JL, Perreau J, Dumenil D, et al. Leukaemia inhibitory factor is necessary for maintenance of haematopoietic stem cells and thymocyte stimulation. *Nature* 1993;363:361-364.
343. Nandurkar HH, Robb L, Tarlinton D, et al. Adult mice with targeted mutation of the interleukin-11 receptor (IL11Ra) display normal hematopoiesis. *Blood* 1997;90:2148-2159.
344. Papayannopoulou T, Brice M, Farrer D, et al. Insights into the cellular mechanisms of erythropoietin-thrombopoietin synergy. *Exp Hematol* 1996;24: 660-669.
345. Metcalf D, Di Rago L, Mifsud S. Synergistic and inhibitory interactions in the in vitro control of murine megakaryocyte colony formation. *Stem Cells* 2002;20:552-560.
346. Geddis AE, Kaushansky K. Cross-reactivity between erythropoietin and thrombopoietin at the level of Mpl does not account for the thrombocytosis seen in iron deficiency. *J Pediatr Hematol Oncol* 2003;25:919-920; author reply 920.
347. Huang X, Pierce LJ, Chen GL, et al. Erythropoietin receptor signaling regulates both erythropoiesis and megakaryopoiesis in vivo. *Blood Cells Mol Dis* 2010;44:1-6.
348. Tange T, Miyazaki H. Synergistic effects of erythropoietin and interleukin-6 on the in vitro proplatelet process formation of rat megakaryocytes. *Pathol Int* 1996;46:968-976.
349. Wang JF, Liu ZY, Groopman JE. The alpha-chemokine receptor CXCR4 is expressed on the megakaryocytic lineage from progenitor to platelets and modulates migration and adhesion. *Blood* 1998;92:756-764.
350. Nagasawa T, Hirota S, Tachibana K, et al. Defects of B-cell lymphopoiesis and bone-marrow myelopoiesis in mice lacking the CXC chemokine PBSF/SDF-1. *Nature* 1996;382:635-638.
351. Zou YR, Kottmann AH, Kuroda M, et al. Function of the chemokine receptor CXCR4 in haematopoiesis and in cerebellar development. *Nature* 1998;393:595-599.
352. Avecilla ST, Hattori K, Heissig B, et al. Chemokine-mediated interaction of hematopoietic progenitors with the bone marrow vascular niche is required for thrombopoiesis. *Nat Med* 2004;10:64-71.
353. Labbaye C, Spinello I, Quaranta MT, et al. A three-step pathway comprising PLZF/miR-146a/CXCR4 controls megakaryopoiesis. *Nat Cell Biol* 2008;10:788-801.
354. Hodohara K, Fujii N, Yamamoto N, et al. Stromal cell-derived factor-1 (SDF-1) acts together with thrombopoietin to enhance the development of megakaryocytic progenitor cells (CFU-MK). *Blood* 2000;95:769-775.
355. Majka M, Janowska-Wieczorek A, Ratajczak J, et al. Stromal-derived factor 1 and thrombopoietin regulate distinct aspects of human megakaryopoiesis. *Blood* 2000;96:4142-4151.
356. Mazharian A, Watson SP, Severin S. Critical role for ERK1/2 in bone marrow and fetal liver-derived primary megakaryocyte differentiation, motility, and proplatelet formation. *Exp Hematol* 2009;37:1238-1249 e5.
357. Bigas A, Espinosa L. Hematopoietic stem cells: to be or Notch to be. *Blood* 2012;119:3226-3235.
358. Mercher T, Cornejo MG, Sears C, et al. Notch signaling specifies megakaryocyte development from hematopoietic stem cells. *Cell Stem Cell* 2008;3:314-326.

359. Poirault-Chassac S, Six E, Catelain C, et al. Notch/Delta4 signaling inhibits human megakaryocytic terminal differentiation. *Blood* 2010;116:5670-5678.
360. Watts KL, Delaney C, Humphries RK, et al. Combination of HOXB4 and Delta-1 ligand improves expansion of cord blood cells. *Blood* 2010;116:5859-5866.
361. Cornejo MG, Mabalala V, Sykes SM, et al. Crosstalk between NOTCH and AKT signaling during murine megakaryocyte lineage specification. *Blood* 2011;118:1264-1273.
362. Geddis AE, Fox NE, Kaushansky K. Phosphatidylinositol 3-kinase is necessary but not sufficient for thrombopoietin-induced proliferation in engineered Mpl-bearing cell lines as well as in primary megakaryocytic progenitors. *J Biol Chem* 2001;276:34473-34479.
363. Daopin S, Piez KA, Ogawa Y, et al. Crystal structure of transforming growth factor-beta 2: an unusual fold for the superfamily. *Science* 1992;257: 369-373.
364. Ishibashi T, Miller SL, Burstein SA. Type beta transforming growth factor is a potent inhibitor of murine megakaryocytopoiesis in vitro. *Blood* 1987;69:1737-1741.
365. Kuter DJ, Gminski DM, Rosenberg RD. Transforming growth factor beta inhibits megakaryocyte growth and endomitosis. *Blood* 1992;79:619-626.
366. Han ZC, Bellucci S, Wan HY, et al. New insights into the regulation of megakaryocytopoiesis by haematopoietic and fibroblastic growth factors and transforming growth factor beta 1. *Br J Haematol* 1992;81:1-5.
367. Jackson H, Williams N, Westcott KR, et al. Differential effects of transforming growth factor-beta 1 on distinct developmental stages of murine megakaryocytopoiesis. *J Cell Physiol* 1994;161:312-318.
368. Han ZC, Bellucci S, Shen ZX, et al. Glycosaminoglycans enhance megakaryocytopoiesis by modifying the activities of hematopoietic growth regulators. *J Cell Physiol* 1996;168:97-104.
369. Laiho M, DeCaprio JA, Ludlow JW, et al. Growth inhibition by TGF-beta linked to suppression of retinoblastoma protein phosphorylation. *Cell* 1990;62:175-185.
370. Polyak K, Kato JY, Solomon MJ, et al. p27Kip1, a cyclin-Cdk inhibitor, links transforming growth factor-beta and contact inhibition to cell cycle arrest. *Genes Dev* 1994;8:9-22.
371. Weinberg RA. The retinoblastoma protein and cell cycle control. *Cell* 1995;81:323-330.
372. Ohta M, Greenberger JS, Anklesaria P, et al. Two forms of transforming growth factor-beta distinguished by multipotential haematopoietic progenitor cells. *Nature* 1987;329:539-541.
373. Keller JR, Mantel C, Sing GK, et al. Transforming growth factor beta 1 selectively regulates early murine hematopoietic progenitors and inhibits the growth of IL-3-dependent myeloid leukemia cell lines. *J Exp Med* 1988;168:737-750.
374. Dybedal I, Jacobsen SE. Transforming growth factor beta (TGF-beta), a potent inhibitor of erythropoiesis: neutralizing TGF-beta antibodies show erythropoietin as a potent stimulator of murine burst-forming unit erythroid colony formation in the absence of a burst-promoting activity. *Blood* 1995;86: 949-957.
375. Teofili L, Martini M, Di Mario A, et al. Expression of p15(ink4b) gene during megakaryocytic differentiation of normal and myelodysplastic hematopoietic progenitors. *Blood* 2001;98:495-497.
376. Gewirtz AM, Calabretta B, Rucinski B, et al. Inhibition of human megakaryocytopoiesis in vitro by platelet factor 4 (PF4) and a synthetic COOH-terminal PF4 peptide. *J Clin Invest* 1989;83:1477-1486.
377. Abgrall JF, Han ZC, Sensebe L, et al. Inhibitory effect of highly purified human platelet beta-thromboglobulin on in vitro human megakaryocyte colony formation. *Exp Hematol* 1991;19:202-205.
378. Suvarna S, Espinasse B, Qi R, et al. Determinants of PF4/heparin immunogenicity. *Blood* 2007;110:4253-4260.
379. Greinacher A, Gopinadhan M, Gunther JU, et al. Close approximation of two platelet factor 4 tetramers by charge neutralization forms the antigens recognized by HIT antibodies. *Arterioscler Thromb Vasc Biol* 2006;26:2386-2393.
380. Lambert MP, Wang Y, Bdeir KH, et al. Platelet factor 4 regulates megakaryopoiesis through low-density lipoprotein receptor-related protein 1 (LRP1) on megakaryocytes. *Blood* 2009;114:2290-2298.

381. Huang SS, Ling TY, Tseng WF, et al. Cellular growth inhibition by IGFBP-3 and TGF-beta1 requires LRP-1. *FASEB J* 2003;17:2068-2081.
382. Fattovich G, Giustina G, Favarato S, et al. A survey of adverse events in 11,241 patients with chronic viral hepatitis treated with alfa interferon. *J Hepatol* 1996;24:38-47.
383. Dusheiko G. Side effects of alpha interferon in chronic hepatitis C. *Hepatology* 1997;26:112S-121S.
384. Jaster R, Tschirch E, Bittorf T, et al. Interferon-alpha inhibits proliferation of Ba/F3 cells by interfering with interleukin-3 action. *Cell Signal* 1999;11: 769-775.
385. Kuniyasu H, Yasui W, Kitahara K, et al. Growth inhibitory effect of interferon-beta is associated with the induction of cyclin-dependent kinase inhibitor p27Kip1 in a human gastric carcinoma cell line. *Cell Growth Differ* 1997;8:47-52.
386. Wang Q, Miyakawa Y, Fox N, et al. Interferon-alpha directly represses megakaryopoiesis by inhibiting thrombopoietin-induced signaling through induction of SOCS-1. *Blood* 2000;96:2093-2099.
387. McHutchison JG, Dusheiko G, Shiffman ML, et al. Eltrombopag for thrombocytopenia in patients with cirrhosis associated with hepatitis C. *N Engl J Med* 2007;357:2227-2236.
388. Fox NE, Chen R, Hitchcock I, et al. Compound heterozygous c-Mpl mutations in a child with congenital amegakaryocytic thrombocytopenia: functional characterization and a review of the literature. *Exp Hematol* 2009;37: 495-503.
389. Ihle JN, Kerr IM. Jaks and Stats in signaling by the cytokine receptor super-family. *Trends Genet* 1995;11:69-74.
390. Pezet A, Buteau H, Kelly PA, et al. The last proline of Box 1 is essential for association with JAK2 and functional activation of the prolactin receptor. *Mol Cell Endocrinol* 1997;129:199-208.
391. Remy I, Wilson IA, Michnick SW. Erythropoietin receptor activation by a ligand-induced conformation change. *Science* 1999;283:990-993.
392. Matthews EE, Thevenin D, Rogers JM, et al. Thrombopoietin receptor activation: transmembrane helix dimerization, rotation, and allosteric modulation. *FASEB J* 2011;25:2234-2244.
393. Staerk J, Defour JP, Pecquet C, et al. Orientation-specific signalling by thrombopoietin receptor dimers. *EMBO J* 2011;30:4398-4413.
394. Staerk J, Lacout C, Sato T, et al. An amphipathic motif at the transmembranecytoplasmic junction prevents autonomous activation of the thrombopoietin receptor. *Blood* 2006;107:1864-1871.
395. Ding J, Komatsu H, Wakita A, et al. Familial essential thrombocythemia associated with a dominant-positive activating mutation of the c-MPL gene, which encodes for the receptor for thrombopoietin. *Blood* 2004;103:4198-4200.
396. Abe M, Suzuki K, Inagaki O, et al. A novel MPL point mutation resulting in thrombopoietin-independent activation. *Leukemia* 2002;16:1500-1516.
397. Pikman Y, Lee BH, Mercher T, et al. MPLW515L is a novel somatic activating mutation in myelofibrosis with myeloid metaplasia. *PLoS Med* 2006;3:e270.
398. Dahlen DD, Broudy VC, Drachman JG. Internalization of the thrombopoietin receptor is regulated by 2 cytoplasmic motifs. *Blood* 2003;102:102-108.
399. Hitchcock IS, Chen MM, King JR, et al. YRRL motifs in the cytoplasmic domain of the thrombopoietin receptor regulate receptor internalization and degradation. *Blood* 2008;112(6):2222-2231.
400. Saur SJ, Sangkhae V, Geddis AE, et al. Ubiquitination and degradation of the thrombopoietin receptor c-Mpl. *Blood* 2010;115:1254-1263.
401. Royer Y, Staerk J, Costuleanu M, et al. Janus kinases affect thrombopoietin receptor cell surface localization and stability. *J Biol Chem* 2005;280: 27251-27261.
402. Moliterno AR, Hankins WD, Spivak JL. Impaired expression of the thrombopoietin receptor by platelets from patients with polycythemia vera. *N Engl J Med* 1998;338:572-580.
403. Pecquet C, Diaconu CC, Staerk J, et al. Thrombopoietin receptor down-modulation by JAK2 V617F: restoration of receptor levels by inhibitors of pathologic JAK2 signaling and of proteasomes. *Blood* 2012;119(20):4625-4635.

404. Silvennoinen O, Witthuhn BA, Quelle FW, et al. Structure of the murine Jak2 protein-tyrosine kinase and its role in interleukin 3 signal transduction. *Proc Natl Acad Sci USA* 1993;90:8429-8433.
405. Guschin D, Rogers N, Briscoe J, et al. A major role for the protein tyrosine kinase JAK1 in the JAK/STAT signal transduction pathway in response to interleukin-6. *EMBO J* 1995;14:1421-1429.
406. Drachman JG, Griffin JD, Kaushansky K. The c-Mpl ligand (thrombopoietin) stimulates tyrosine phosphorylation of Jak2, Shc, and c-Mpl. *J Biol Chem* 1995;270:4979-4982.
407. Miyakawa Y, Oda A, Druker BJ, et al. Recombinant thrombopoietin induces rapid protein tyrosine phosphorylation of Janus kinase 2 and Shc in human blood platelets. *Blood* 1995;86:23-27.
408. Sattler M, Durstin MA, Frank DA, et al. The thrombopoietin receptor c-MPL activates JAK2 and TYK2 tyrosine kinases. *Exp Hematol* 1995;23:1040-1048.
409. Drachman JG, Millett KM, Kaushansky K. Thrombopoietin signal transduction requires functional JAK2, not TYK2. *J Biol Chem* 1999;274: 13480-13484.
410. Deberry C, Mou S, Linnekin D. Stat1 associates with c-kit and is activated in response to stem cell factor. *Biochem J* 1997;327(Pt 1):73-80.
411. Linnekin D. Early signaling pathways activated by c-Kit in hematopoietic cells. *Int J Biochem Cell Biol* 1999;31:1053-1074.
412. Wen Z, Zhong Z, Darnell JE Jr. Maximal activation of transcription by Stat1 and Stat3 requires both tyrosine and serine phosphorylation. *Cell* 1995;82:241-250.
413. Decker T, Kovarik P. Serine phosphorylation of STATs. *Oncogene* 2000;19:2628-2637.
414. Azam M, Erdjument-Bromage H, Kreider BL, et al. Interleukin-3 signals through multiple isoforms of Stat5. *EMBO J* 1995;14:1402-1411.
415. Zhong Z, Wen Z, Darnell JE Jr. Stat3: a STAT family member activated by tyrosine phosphorylation in response to epidermal growth factor and interleukin-6. *Science* 1994;264:95-98.
416. Nakajima K, Yamanaka Y, Nakae K, et al. A central role for Stat3 in IL-6-induced regulation of growth and differentiation in M1 leukemia cells. *EMBO J* 1996;15:3651-3658.
417. Bacon CM, Tortolani PJ, Shimosaka A, et al. Thrombopoietin (TPO) induces tyrosine phosphorylation and activation of STAT5 and STAT3. *FEBS Lett* 1995;370:63-68.
418. Pallard C, Gouilleux F, Benit L, et al. Thrombopoietin activates a STAT5-like factor in hematopoietic cells. *EMBO J* 1995;14:2847-2856.
419. Drachman JG, Kaushansky K. Dissecting the thrombopoietin receptor: functional elements of the Mpl cytoplasmic domain. *Proc Natl Acad Sci U S A* 1997;94:2350-2355.
420. Miyakawa Y, Oda A, Druker BJ, et al. Thrombopoietin induces tyrosine phosphorylation of Stat3 and Stat5 in human blood platelets. *Blood* 1996;87: 439-446.
421. Lecine P, Algarte M, Rameil P, et al. Elf-1 and Stat5 bind to a critical element in a new enhancer of the human interleukin-2 receptor alpha gene. *Mol Cell Biol* 1996;16:6829-6840.
422. Curiel RE, Lahesmaa R, Subleski J, et al. Identification of a Stat-6-responsive element in the promoter of the human interleukin-4 gene. *Eur J Immunol* 1997;27:1982-1987.
423. Socolovsky M, Nam H, Fleming MD, et al. Ineffective erythropoiesis in Stat5a(-/-)5b(-/-) mice due to decreased survival of early erythroblasts. *Blood* 2001;98:3261-3273.
424. Horvath CM. STAT proteins and transcriptional responses to extracellular signals. *Trends Biochem Sci* 2000;25:496-502.
425. Tong W, Lodish HF. Lnk inhibits Tpo-mpl signaling and Tpo-mediated megakaryocytopoiesis. *J Exp Med* 2004;200:569-580.
426. Bersenev A, Wu C, Balcerak J, et al. Lnk controls mouse hematopoietic stem cell self-renewal and quiescence through direct interactions with JAK2. *J Clin Invest* 2008;118:2832-2844.

427. Whalen AM, Galasinski SC, Shapiro PS, et al. Megakaryocytic differentiation induced by constitutive activation of mitogen-activated protein kinase kinase. *Mol Cell Biol* 1997;17:1947-1958.
428. Melemed AS, Ryder JW, Vik TA. Activation of the mitogen-activated protein kinase pathway is involved in and sufficient for megakaryocytic differentiation of CMK cells. *Blood* 1997;90:3462-3470.
429. Racke FK, Lewandowska K, Goueli S, et al. Sustained activation of the extra-cellular signal-regulated kinase/mitogen-activated protein kinase pathway is required for megakaryocytic differentiation of K562 cells. *J Biol Chem* 1997;272:23366-23370.
430. Rouyez MC, Boucheron C, Gisselbrecht S, et al. Control of thrombopoietin-induced megakaryocytic differentiation by the mitogen-activated protein kinase pathway. *Mol Cell Biol* 1997;17:4991-5000.
431. Rojnuckarin P, Drachman JG, Kaushansky K. Thrombopoietin-induced activation of the mitogen-activated protein kinase (MAPK) pathway in normal megakaryocytes: role in endomitosis. *Blood* 1999;94:1273-1282.
432. Miyazaki R, Ogata H, Kobayashi Y. Requirement of thrombopoietin-induced activation of ERK for megakaryocyte differentiation and of p38 for erythroid differentiation. *Ann Hematol* 2001;80:284-291.
433. Cobb MH, Goldsmith EJ. How MAP kinases are regulated. *J Biol Chem* 1995;270:14843-14846.
434. Robinson MJ, Cobb MH. Mitogen-activated protein kinase pathways. *Curr Opin Cell Biol* 1997;9:180-186.
435. Kramer RM, Roberts EF, Striffler BA, et al. Thrombin induces activation of p38 MAP kinase in human platelets. *J Biol Chem* 1995;270:27395-27398.
436. Nadal F, Levy-Toledano S, Grelac F, et al. Negative regulation of mitogen-activated protein kinase activation by integrin α IIb β 3 in platelets. *J Biol Chem* 1997;272:22381-22384.
437. Barry OP, Kazanietz MG, Pratico D, et al. Arachidonic acid in platelet microparticles up-regulates cyclooxygenase-2-dependent prostaglandin formation via a protein kinase C/mitogen-activated protein kinase-dependent pathway. *J Biol Chem* 1999;274:7545-7556.
438. Schaeffer HJ, Catling AD, Eblen ST, et al. MP1: a MEK binding partner that enhances enzymatic activation of the MAP kinase cascade. *Science* 1998;281:1668-1671.
439. Whitmarsh AJ, Cavanagh J, Tournier C, et al. A mammalian scaffold complex that selectively mediates MAP kinase activation. *Science* 1998;281: 1671-1674.
440. Boulton TG, Stahl N, Yancopoulos GD. Ciliary neurotrophic factor/leukemia inhibitory factor/interleukin 6/oncostatin M family of cytokines induces tyrosine phosphorylation of a common set of proteins overlapping those induced by other cytokines and growth factors. *J Biol Chem* 1994;269:11648-11655.
441. Okuda K, Sanghera JS, Pelech SL, et al. Granulocyte-macrophage colony-stimulating factor, interleukin-3, and steel factor induce rapid tyrosine phosphorylation of p42 and p44 MAP kinase. *Blood* 1992;79:2880-2887.
442. Yamada M, Komatsu N, Okada K, et al. Thrombopoietin induces tyrosine phosphorylation and activation of mitogen-activated protein kinases in a human thrombopoietin-dependent cell line. *Biochem Biophys Res Commun* 1995;217:230-237.
443. Ezumi Y, Uchiyama T, Takayama H. Thrombopoietin potentiates the protein-kinase-C-mediated activation of mitogen-activated protein kinase/ERK kinases and extracellular signal-regulated kinases in human platelets. *Eur J Biochem* 1998;258:976-985.
444. Aplin AE, Stewart SA, Assoian RK, et al. Integrin-mediated adhesion regulates ERK nuclear translocation and phosphorylation of Elk-1. *J Cell Biol* 2001;153:273-282.
445. Fichelson S, Freyssonier JM, Picard F, et al. Megakaryocyte growth and development factor-induced proliferation and differentiation are regulated by the mitogen-activated protein kinase pathway in primitive cord blood hematopoietic progenitors. *Blood* 1999;94:1601-1613.
446. Chen RH, Sarnecki C, Blenis J. Nuclear localization and regulation of erk- and rsk-encoded protein kinases. *Mol Cell Biol* 1992;12:915-927.
447. Marais R, Wynne J, Treisman R. The SRF accessory protein Elk-1 contains a growth factor-regulated transcriptional activation domain. *Cell* 1993;73: 381-393.

448. Lavoie JN, L'Allemain G, Brunet A, et al. Cyclin D1 expression is regulated positively by the p42/p44MAPK and negatively by the p38/HOGMAPK pathway. *J Biol Chem* 1996;271:20608-20616.
449. Marshall CJ. Specificity of receptor tyrosine kinase signaling: transient versus sustained extracellular signal-regulated kinase activation. *Cell* 1995;80: 179-185.
450. Murphy LO, Blenis J. MAPK signal specificity: the right place at the right time. *Trends Biochem Sci* 2006;31:268-275.
451. Garcia J, de Gunzburg J, Eychene A, et al. Thrombopoietin-mediated sustained activation of extracellular signal-regulated kinase in UT7-Mpl cells requires both Ras-Raf-1- and Rap1-B-Raf-dependent pathways. *Mol Cell Biol* 2001;21:2659-2670.
452. Kim KW, Kim SH, Lee EY, et al. Extracellular signal-regulated kinase/90-KDA ribosomal S6 kinase/nuclear factor-kappa B pathway mediates phorbol 12-myristate 13-acetate-induced megakaryocytic differentiation of K562 cells. *J Biol Chem* 2001;276:13186-13191.
453. Kamata T, Pritchard CA, Leavitt AD. Raf-1 is not required for megakaryocytopoiesis or TPO-induced ERK phosphorylation. *Blood* 2004;103:2568-2570.
454. Kamata T, Kang J, Lee TH, et al. A critical function for B-Raf at multiple stages of myelopoiesis. *Blood* 2005;106:833-840.
455. Nagata Y, Nishida E, Todokoro K. Activation of JNK signaling pathway by erythropoietin, thrombopoietin, and interleukin-3. *Blood* 1997;89: 2664-2669.
456. Lecoq-Lafon C, Verdier F, Fichelson S, et al. Erythropoietin induces the tyrosine phosphorylation of GAB1 and its association with SHC, SHP2, SHIP, and phosphatidylinositol 3-kinase. *Blood* 1999;93:2578-2585.
457. Miyakawa Y, Rojnuckarin P, Habib T, et al. Thrombopoietin induces phosphoinositol 3-kinase activation through SHP2, Gab, and insulin receptor substrate proteins in BAF3 cells and primary murine megakaryocytes. *J Biol Chem* 2001;276:2494-2502.
458. Lev S, Givol D, Yarden Y. Interkinase domain of kit contains the binding site for phosphatidylinositol 3' kinase. *Proc Natl Acad Sci U S A* 1992;89:678-682.
459. Craddock BL, Welham MJ. Interleukin-3 induces association of the protein-tyrosine phosphatase SHP2 and phosphatidylinositol 3-kinase with a 100-kDa tyrosine-phosphorylated protein in hemopoietic cells. *J Biol Chem* 1997;272:29281-29289.
460. Sattler M, Salgia R, Durstin MA, et al. Thrombopoietin induces activation of the phosphatidylinositol-3' kinase pathway and formation of a complex containing p85PI3K and the protooncprotein p120CBL. *J Cell Physiol* 1997;171:28-33.
461. Al-Shami A, Naccache PH. Granulocyte-macrophage colony-stimulating factor-activated signaling pathways in human neutrophils. Involvement of Jak2 in the stimulation of phosphatidylinositol 3-kinase. *J Biol Chem* 1999;274:5333-5338.
462. Rottapel R, Turck CW, Casteran N, et al. Substrate specificities and identification of a putative binding site for PI3K in the carboxy tail of the murine Flt3 receptor tyrosine kinase. *Oncogene* 1994;9:1755-1765.
463. Damen JE, Cutler RL, Jiao H, et al. Phosphorylation of tyrosine 503 in the erythropoietin receptor (EpR) is essential for binding the P85 subunit of phosphatidylinositol (PI) 3-kinase and for EpR-associated PI 3-kinase activity. *J Biol Chem* 1995;270:23402-23408.
464. Klinghoffer RA, Duckworth B, Valius M, et al. Platelet-derived growth factor-dependent activation of phosphatidylinositol 3-kinase is regulated by receptor binding of SH2-domain-containing proteins which influence Ras activity. *Mol Cell Biol* 1996;16:5905-5914.
465. Rother KI, Imai Y, Caruso M, et al. Evidence that IRS-2 phosphorylation is required for insulin action in hepatocytes. *J Biol Chem* 1998;273: 17491-17497.
466. Nishida K, Yoshida Y, Itoh M, et al. Gab-family adapter proteins act downstream of cytokine and growth factor receptors and T- and B-cell antigen receptors. *Blood* 1999;93:1809-1816.
467. Wickrema A, Uddin S, Sharma A, et al. Engagement of Gab1 and Gab2 in erythropoietin signaling. *J Biol Chem* 1999;274:24469-24474.

468. Rameh LE, Cantley LC. The role of phosphoinositide 3-kinase lipid products in cell function. *J Biol Chem* 1999;274:8347-8350.
469. Jung AS, Kaushansky A, Macbeath G, et al. Tensin2 is a novel mediator in thrombopoietin (TPO)-induced cellular proliferation by promoting Akt signaling. *Cell Cycle* 2011;10:1838-1844.
470. Rodriguez-Viciana P, Warne PH, Dhand R, et al. Phosphatidylinositol-3-OH kinase as a direct target of Ras. *Nature* 1994;370:527-532.
471. Huber M, Helgason CD, Damen JE, et al. The src homology 2-containing inositol phosphatase (SHIP) is the gatekeeper of mast cell degranulation. *Proc Natl Acad Sci U S A* 1998;95:11330-11335.
472. Aman MJ, Lamkin TD, Okada H, et al. The inositol phosphatase SHIP inhibits Akt/PKB activation in B cells. *J Biol Chem* 1998;273:33922-33928.
473. Liu Q, Sasaki T, Kozieradzki I, et al. SHIP is a negative regulator of growth factor receptor-mediated PKB/Akt activation and myeloid cell survival. *Genes Dev* 1999;13:786-791.
474. Stambolic V, Suzuki A, de la Pompa JL, et al. Negative regulation of PKB/Akt-dependent cell survival by the tumor suppressor PTEN. *Cell* 1998;95:29-39.
475. Cantley LC, Neel BG. New insights into tumor suppression: PTEN suppresses tumor formation by restraining the phosphoinositide 3-kinase/AKT pathway. *Proc Natl Acad Sci U S A* 1999;96:4240-4245.
476. Zha J, Harada H, Yang E, et al. Serine phosphorylation of death agonist BAD in response to survival factor results in binding to 14-3-3 not BCL-X(L). *Cell* 1996;87:619-628.
477. del Peso L, Gonzalez-Garcia M, Page C, et al. Interleukin-3-induced phosphorylation of BAD through the protein kinase Akt. *Science* 1997;278: 687-689.
478. Datta SR, Dudek H, Tao X, et al. Akt phosphorylation of BAD couples survival signals to the cell-intrinsic death machinery. *Cell* 1997;91:231-241.
479. Soda M, Willert K, Kaushansky K, et al. Inhibition of GSK-3 β promotes survival and proliferation of megakaryocytic cells through a β -catenin-independent pathway. *Cell Signal* 2008;20:2317-2323.
480. Ono M, Matsubara Y, Shibano T, et al. GSK-3 β negatively regulates megakaryocyte differentiation and platelet production from primary human bone marrow cells in vitro. *Platelets* 2011;22:196-203.
481. Nakao T, Geddis AE, Fox NE, et al. PI3K/Akt/FOXO3a pathway contributes to thrombopoietin-induced proliferation of primary megakaryocytes in vitro and in vivo via modulation of p27(Kip1). *Cell Cycle* 2008;7:257-266.
482. Inoki K, Li Y, Xu T, et al. Rheb GTPase is a direct target of TSC2 GAP activity and regulates mTOR signaling. *Genes Dev* 2003;17:1829-1834.
483. Garami A, Zwartkruis FJ, Nobukuni T, et al. Insulin activation of Rheb, a mediator of mTOR/S6K/4E-BP signaling, is inhibited by TSC1 and 2. *Mol Cell* 2003;11:1457-1466.
484. Magnuson B, Ekim B, Fingar DC. Regulation and function of ribosomal protein S6 kinase (S6K) within mTOR signalling networks. *Biochem J* 2012;441:1-21.
485. Drayer AL, Olthof SG, Vellenga E. Mammalian target of rapamycin is required for thrombopoietin-induced proliferation of megakaryocyte progenitors. *Stem Cells* 2006;24:105-114.
486. Raslova H, Baccini V, Loussaief L, et al. Mammalian target of rapamycin (mTOR) regulates both proliferation of megakaryocyte progenitors and late stages of megakaryocyte differentiation. *Blood* 2006;107:2303-2310.
487. Guerriero R, Parolini I, Testa U, et al. Inhibition of TPO-induced MEK or mTOR activity induces opposite effects on the ploidy of human differentiating megakaryocytes. *J Cell Sci* 2006;119:744-752.
488. Liu ZJ, Italiano J Jr, Ferrer-Marin F, et al. Developmental differences in megakaryocytopoiesis are associated with up-regulated TPO signaling through mTOR and elevated GATA-1 levels in neonatal megakaryocytes. *Blood* 2011;117:4106-4117.
489. Lannutti BJ, Shim MH, Blake N, et al. Identification and activation of Src family kinases in primary megakaryocytes. *Exp Hematol* 2003;31:1268-1274.

490. Lannutti BJ, Drachman JG. Lyn tyrosine kinase regulates thrombopoietin-induced proliferation of hematopoietic cell lines and primary megakaryocytic progenitors. *Blood* 2004;103:3736-3743.
491. Lannutti BJ, Minear J, Blake N, et al. Increased megakaryocytopoiesis in Lyn-deficient mice. *Oncogene* 2006;25:3316-3324.
492. Slayton WB, Wainman DA, Li XM, et al. Developmental differences in megakaryocyte maturation are determined by the microenvironment. *Stem Cells* 2005;23:1400-1408.
493. Hitchcock IS, Fox NE, Prevost N, et al. Roles of focal adhesion kinase (FAK) in megakaryopoiesis and platelet function: studies using a megakaryocyte lineage specific FAK knockout. *Blood* 2008;111:596-604.
494. Luoh SM, Stefanich E, Solar G, et al. Role of the distal half of the c-Mpl intracellular domain in control of platelet production by thrombopoietin in vivo. *Mol Cell Biol* 2000;20:507-515.
495. Socolovsky M, Fallon AE, Wang S, et al. Fetal anemia and apoptosis of red cell progenitors in Stat5a^{-/-}5b^{-/-} mice: a direct role for Stat5 in Bcl-X(L) induction. *Cell* 1999;98:181-191.
496. Hilton DJ. Negative regulators of cytokine signal transduction. *Cell Mol Life Sci* 1999;55:1568-1577.
497. Begley CG, Nicola NA. Resolving conflicting signals: cross inhibition of cytokine signaling pathways. *Blood* 1999;93:1443-1447.
498. Bersenev A, Wu C, Balcerek J, et al. Lnk constrains myeloproliferative diseases in mice. *J Clin Invest* 2010;120:2058-2069.
499. Ballmaier M, Germeshausen M. Congenital amegakaryocytic thrombocytopenia: clinical presentation, diagnosis, and treatment. *Semin Thromb Hemost* 2011;37:673-681.
500. King S, Germeshausen M, Strauss G, et al. Congenital amegakaryocytic thrombocytopenia: a retrospective clinical analysis of 20 patients. *Br J Haematol* 2005;131:636-644.
501. Maserati E, Panarello C, Morerio C, et al. Clonal chromosome anomalies and propensity to myeloid malignancies in congenital amegakaryocytic thrombocytopenia (OMIM 604498). *Haematologica* 2008;93:1271-1273.
502. Greenhalgh KL, Howell RT, Bottani A, et al. Thrombocytopenia-absent radius syndrome: a clinical genetic study. *J Med Genet* 2002;39:876-881.
503. Fiedler J, Strauss G, Wannack M, et al. Two patterns of thrombopoietin signaling suggest no coupling between platelet production and thrombopoietin reactivity in thrombocytopenia-absent radii syndrome. *Haematologica* 2012;97:73-81.
504. Ballmaier M, Schulze H, Cremer M, et al. Defective c-Mpl signaling in the syndrome of thrombocytopenia with absent radii. *Stem Cells* 1998;16(Suppl 2):177-184.
505. Ballmaier M, Schulze H, Strauss G, et al. Thrombopoietin in patients with congenital thrombocytopenia and absent radii: elevated serum levels, normal receptor expression, but defective reactivity to thrombopoietin. *Blood* 1997;90:612-619.
506. Letestu R, Vitrat N, Masse A, et al. Existence of a differentiation blockage at the stage of a megakaryocyte precursor in the thrombocytopenia and absent radii (TAR) syndrome. *Blood* 2000;95:1633-1641.
507. Klopocki E, Schulze H, Strauss G, et al. Complex inheritance pattern resembling autosomal recessive inheritance involving a microdeletion in thrombocytopenia-absent radius syndrome. *Am J Hum Genet* 2007;80:232-240.
508. Thompson AA, Nguyen LT. Amegakaryocytic thrombocytopenia and radio-ulnar synostosis are associated with HOXA11 mutation. *Nat Genet* 2000;26:397-398.
509. Boulet AM, Capecci MR. Multiple roles of Hoxa11 and Hoxd11 in the formation of the mammalian forelimb zeugopod. *Development* 2004;131: 299-309.
510. Castillo-Caro P, Dhanraj S, Haut P, et al. Proximal radio-ulnar synostosis with bone marrow failure syndrome in an infant without a HOXA11 mutation. *J Pediatr Hematol Oncol* 2010;32:479-485.
511. Yoshida H, Hashii Y, Okuda T, et al. A case of congenital bone marrow failure with radio-ulnar synostosis. *Int J Hematol* 2010;91:331-332.
512. Liew E, Owen C. Familial myelodysplastic syndromes: a review of the literature. *Haematologica* 2011;96:1536-1542.

513. Preudhomme C, Renneville A, Bourdon V, et al. High frequency of RUNX1 biallelic alteration in acute myeloid leukemia secondary to familial platelet disorder. *Blood* 2009;113:5583-5587.
514. Ciovacco WA, Raskind WH, Kacena MA. Human phenotypes associated with GATA-1 mutations. *Gene* 2008;427:1-6.
515. Tubman VN, Levine JE, Campagna DR, et al. X-linked gray platelet syndrome due to a GATA1 Arg216Gln mutation. *Blood* 2007;109:3297-3299.
516. Grossfeld PD, Mattina T, Lai Z, et al. The 11q terminal deletion disorder: a prospective study of 110 cases. *Am J Med Genet A* 2004;129:51-61.
517. Krishnamurti L, Neglia JP, Nagarajan R, et al. Paris-Trousseau syndrome platelets in a child with Jacobsen's syndrome. *Am J Hematol* 2001;66: 295-299.
518. White JG. Platelet storage pool deficiency in Jacobsen syndrome. *Platelets* 2007;18:522-527.
519. Raslova H, Komura E, Le Couedic JP, et al. FLI1 monoallelic expression combined with its hemizygous loss underlies Paris-Trousseau/Jacobsen thrombopenia. *J Clin Invest* 2004;114:77-84.
520. Noris P, Perrotta S, Bottega R, et al. Clinical and laboratory features of 103 patients from 42 Italian families with inherited thrombocytopenia derived from the monoallelic Ala156Val mutation of GPIIb/IIIa (Bolzano mutation). *Haematologica* 2012;97:82-88.
521. Nakamura F, Pudas R, Heikkinen O, et al. The structure of the GPIIb-filamin A complex. *Blood* 2006;107:1925-1932.
522. Jurak Begonja A, Hoffmeister KM, Hartwig JH, et al. FlnA-null megakaryocytes prematurely release large and fragile platelets that circulate poorly. *Blood* 2011;118:2285-2295.
523. Othman M. Platelet-type von Willebrand disease: a rare, often misdiagnosed and underdiagnosed bleeding disorder. *Semin Thromb Hemost* 2011;37:464-469.
524. Seri M, Pecci A, Di Bari F, et al. MYH9-related disease: May-Hegglin anomaly, Sebastian syndrome, Fechtner syndrome, and Epstein syndrome are not distinct entities but represent a variable expression of a single illness. *Medicine (Baltimore)* 2003;82:203-215.
525. Seri M, Savino M, Bordo D, et al. Epstein syndrome: another renal disorder with mutations in the nonmuscle myosin heavy chain 9 gene. *Hum Genet* 2002;110:182-186.
526. Balduini A, Pallotta I, Malara A, et al. Adhesive receptors, extracellular proteins and myosin IIA orchestrate proplatelet formation by human megakaryocytes. *J Thromb Haemost* 2008;6:1900-1907.
527. Eckly A, Strassel C, Freund M, et al. Abnormal megakaryocyte morphology and proplatelet formation in mice with megakaryocyte-restricted MYH9 inactivation. *Blood* 2009;113:3182-3189.
528. Chen Z, Shivdasani RA. Regulation of platelet biogenesis: insights from the May-Hegglin anomaly and other MYH9-related disorders. *J Thromb Haemost* 2009;7(Suppl 1):272-276.
529. Ochs HD. The Wiskott-Aldrich syndrome. *Semin Hematol* 1998;35:332-345.
530. Notarangelo LD, Mazza C, Giliani S, et al. Missense mutations of the WASP gene cause intermittent X-linked thrombocytopenia. *Blood* 2002;99:2268-2269.
531. Balduini CL, De Candia E, Savoia A. Why the disorder induced by GATA1 Arg216Gln mutation should be called "X-linked thrombocytopenia with thalassemia" rather than "X-linked gray platelet syndrome". *Blood* 2007;110:2770-2771; author reply 2771.
532. Kahr WH, Hinckley J, Li L, et al. Mutations in NBEAL2, encoding a BEACH protein, cause gray platelet syndrome. *Nat Genet* 2011;43:738-740.
533. Gunay-Aygun M, Falik-Zaccai TC, Vilboux T, et al. NBEAL2 is mutated in gray platelet syndrome and is required for biogenesis of platelet alpha-granules. *Nat Genet* 2011;43:732-734.
534. Albers CA, Cvejic A, Favier R, et al. Exome sequencing identifies NBEAL2 as the causative gene for gray platelet syndrome. *Nat Genet* 2011;43:735-737.
535. Di Pietro SM, Dell'Angelica EC. The cell biology of Hermansky-Pudlak syndrome: recent advances. *Traffic* 2005;6:525-533.

536. Detter JC, Zhang Q, Mules EH, et al. Rab geranylgeranyl transferase alpha mutation in the gunmetal mouse reduces Rab prenylation and platelet synthesis. *Proc Natl Acad Sci U S A* 2000;97:4144-4149.
537. James C, Ugo V, Le Couedic JP, et al. A unique clonal JAK2 mutation leading to constitutive signalling causes polycythaemia vera. *Nature* 2005;434: 1144-1148.
538. Baxter EJ, Scott LM, Campbell PJ, et al. Acquired mutation of the tyrosine kinase JAK2 in human myeloproliferative disorders. *Lancet* 2005;365: 1054-1061.
539. Levine RL, Wadleigh M, Cools J, et al. Activating mutation in the tyrosine kinase JAK2 in polycythemia vera, essential thrombocythemia, and myeloid metaplasia with myelofibrosis. *Cancer Cell* 2005;7:387-397.
540. Kralovics R, Passamonti F, Buser AS, et al. A gain-of-function mutation of JAK2 in myeloproliferative disorders. *N Engl J Med* 2005;352: 1779-1790.
541. Zhao R, Xing S, Li Z, et al. Identification of an acquired JAK2 mutation in polycythemia vera. *J Biol Chem* 2005;280:22788-22792.
542. Pardanani AD, Levine RL, Lasho T, et al. MPL515 mutations in myeloproliferative and other myeloid disorders: a study of 1182 patients. *Blood* 2006;108:3472-3476.
543. Lindauer K, Loerting T, Liedl KR, et al. Prediction of the structure of human Janus kinase 2 (JAK2) comprising the two carboxy-terminal domains reveals a mechanism for autoregulation. *Protein Eng* 2001;14:27-37.
544. Saharinen P, Vihinen M, Silvennoinen O. Autoinhibition of Jak2 tyrosine kinase is dependent on specific regions in its pseudokinase domain. *Mol Biol Cell* 2003;14:1448-1459.
545. Lee TS, Ma W, Zhang X, et al. Structural effects of clinically observed mutations in JAK2 exons 13-15: comparison with V617F and exon 12 mutations. *BMC Struct Biol* 2009;9:58.
546. Morris DR, Geballe AP. Upstream open reading frames as regulators of mRNA translation. *Mol Cell Biol* 2000;20:8635-8642.
547. Cazzola M, Skoda RC. Translational pathophysiology: a novel molecular mechanism of human disease. *Blood* 2000;95:3280-3288.
548. Wiestner A, Schlemper RJ, van der Maas AP, et al. An activating splice donor mutation in the thrombopoietin gene causes hereditary thrombocythaemia. *Nat Genet* 1998;18:49-52.
549. Kondo T, Okabe M, Sanada M, et al. Familial essential thrombocythemia associated with one-base deletion in the 5'-untranslated region of the thrombopoietin gene. *Blood* 1998;92:1091-1096.
550. Ghilardi N, Wiestner A, Skoda RC. Thrombopoietin production is inhibited by a translational mechanism. *Blood* 1998;92:4023-4030.
551. Zipursky A. Transient leukaemia—a benign form of leukaemia in newborn infants with trisomy 21. *Br J Haematol* 2003;120:930-938.
552. Gurbuxani S, Vyas P, Crispino JD. Recent insights into the mechanisms of myeloid leukemogenesis in Down syndrome. *Blood* 2004;103:399-406.
553. Ma Z, Morris SW, Valentine V, et al. Fusion of two novel genes, RBM15 and MKL1, in the t(1;22)(p13;q13) of acute megakaryoblastic leukemia. *Nat Genet* 2001;28:220-221.
554. Mercher T, Busson-Le Coniat M, Nguyen Khac F, et al. Recurrence of OTTMAL fusion in t(1;22) of infant AML-M7. *Genes Chromosomes Cancer* 2002;33:22-28.
555. Mercher T, Raffel GD, Moore SA, et al. The OTT-MAL fusion oncogene activates RBPJ-mediated transcription and induces acute megakaryoblastic leukemia in a knockin mouse model. *J Clin Invest* 2009;119:852-864.

Chapter 16 Platelet Structure and Function in Hemostasis and Thrombosis

> Table of Contents > Part II - The Normal Hematologic System > Section 5 - Hemostasis > Chapter 16 - Platelet Structure and Function in Hemostasis and Thrombosis

Chapter 16

Platelet Structure and Function in Hemostasis and Thrombosis

Susan S. Smyth

PLATELET STRUCTURE

Structural and Functional Anatomy

Light Microscopy

Light microscopy of Wright-stained smears (Fig. 16.1) reveals platelets as small, anucleate (i.e., lacking a nucleus) fragments with occasional reddish granules, measuring approximately 2 μm in diameter with a volume of approximately 8 fl^1 and exhibiting considerable variation in size and shape. Platelets released from the marrow under "conditions of stress" such as thrombocytopenia and termed stress platelets are large and often beaded in shape, whereas young platelets, recently released from the marrow, are termed reticulated in reference to their RNA content and in analogy to young red cell reticulocytes.²

Electron Microscopy and Subcellular Features

Platelets exist in two distinct forms, resting and activated, with the resting state marked by baseline metabolic activity and the activated form resulting from agonist stimulation (e.g., response to thrombin). By scanning electron microscopy, circulating resting blood platelets appear as flat discs with smooth contours, rare spiny filopodia (Fig. 16.2), and random openings of a channel system, the surface-connected canalicular system (SCCS), which invaginates throughout the platelet and is the conduit by which granule contents exocytose after stimulation.^{3,4} Although the platelet is anucleate, transmission electron microscopy reveals a complex surface and a cytoplasm packed with a number of different subplatelet structures and organelles that are essential to the maintenance of normal hemostasis (Figs. 16.3 and 16.4). Initial descriptions of platelet anatomy stem from studies employing transmission electron microscopy; and platelet structure is classified into four general areas: the platelet surface, membranous structures, cytoskeleton, and granules.

Platelet Surface

Plasma Membrane

The platelet plasma membrane separates intra- from extracellular regions and, in thin sections, exhibits a typical 20-nm-thick trilaminar structure⁵ whose overall appearance does not differ from that of other blood cells.⁶ The platelet membrane is exceptionally complex in composition, distribution, and function, incorporating a number of glycoproteins (GPs) and lipids into its phospholipid bilayer and integrating a variety of extra- and intraplatelet events such as permeability, agonist stimulation, and platelet adhesion, activation/secretion, and aggregation.

The lipid composition of the membrane is distributed in an asymmetric manner, with neutral species located mainly in the outer layer, and anionic forms, such as phosphatidylserine (PS), concentrated on the inner side.⁷ This sequestration of PS, which promotes plasma coagulation by contributing to the prothrombinase complex,⁸ on the inner side of the membrane may account for the fact that resting platelets are essentially nonreactive in terms of thrombin generation.⁹ On the other hand, activated platelets make a major contribution to thrombin formation through the interactions of factors Xa and Va and prothrombin on their surface.^{9,10} The plasma membrane also contains sodium and calcium adenosine triphosphatase (ATPase) pumps, which are important for maintaining ionic homeostasis.¹¹

Platelet Membranous Systems

Platelets have features of muscle-related cells in terms of their high content of actin and their contractile response during activation. Similar muscle-like qualities are found in the two membranous systems of platelets, the SCCS and the dense tubular system, which resemble transverse tubules and sarcotubules, respectively.¹²

Surface-connected Canalicular System

The SCCS, also called the open canalicular system, is fenestrated and contiguous with the surface plasma membrane.^{3,13,14} The SCCS has several prominent functional roles: first, as an internal reservoir of membrane to facilitate platelet spreading and filopodia formation after adhesion;¹⁵ and second, as a storage reservoir for membrane GPs, such as $\alpha_{\text{IIb}}\beta_3$ (GPIIb-IIIa), that increase on the platelet surface after activation.¹⁶ The system also provides a route for granule release during the secretory phase of platelet activation⁴ and serves as a route of ingress and egress for molecules as they translocate between the plasma and the platelet.

Dense Tubules

Unlike the SCCS, the dense tubular system is a closed-channel system consisting of narrow, membrane-limited tubules, approximately 40 to 60 nm in diameter.¹⁷ It contains residual smooth endoplasmic reticulum from the megakaryocyte.^{18,19} Peroxidase,^{20,21} and ²² glucose 6-phosphatase,²³ acetylcholinesterase (in cat, rat, and mouse but not human platelets or megakaryocytes),²⁴ adenylate cyclase, and Ca^{2+} - and Mg^{2+} -activated ATPases²⁵ have been cytochemically demonstrated in the dense tubular system.

This channel system is involved in the regulation of intracellular calcium transport because it has been reported to selectively bind, sequester, and release divalent cations after activation.²⁵

P.390

The dense tubular system is also the site of prostaglandin (PG) synthesis in platelets.^{26,27}

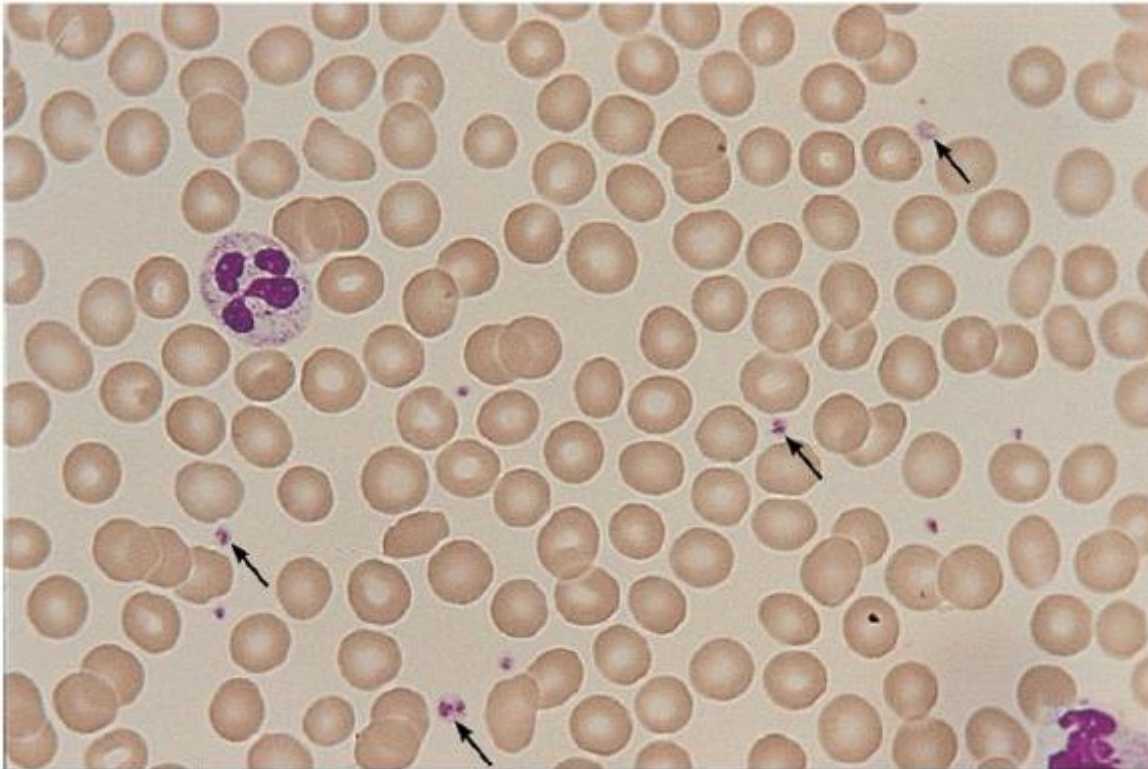

FIGURE 16.1. A human peripheral blood smear stained with Wright-Giemsa. Platelets, indicated by arrows, are interspersed between erythrocytes and a few leukocytes. The pale, grayish-blue cytoplasm contains purple-red granules. Original magnification of 35-mm slide $\times 100$.

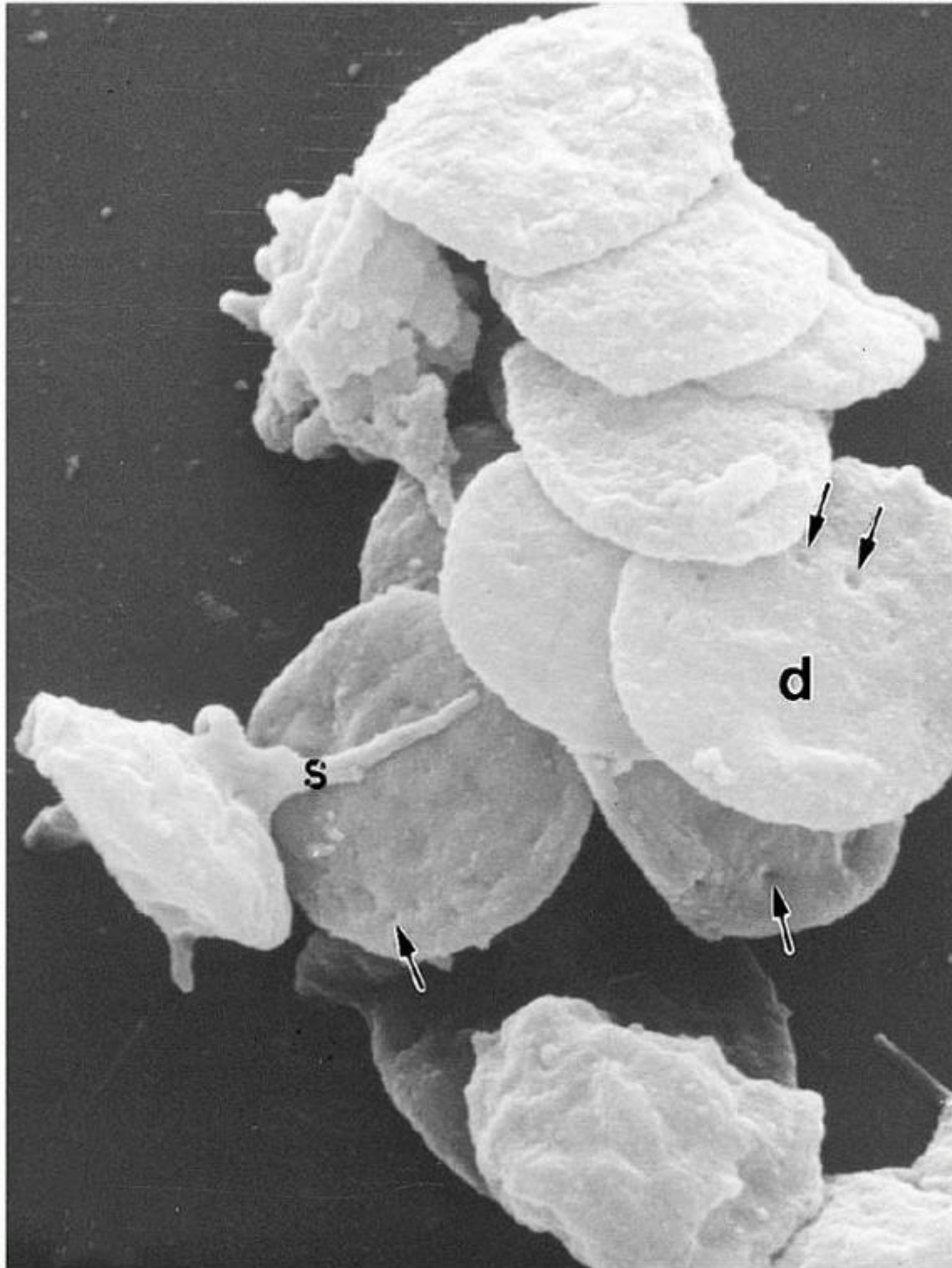

FIGURE 16.2. Scanning electron micrograph of unstimulated human platelets. Most are discoid (d) in shape. Many surface indentations, indicated by arrows, are present; these correspond to openings of the surface-connected canalicular system to the external milieu. Magnification $\times 15,000$. (Data from Stenberg PE, Shuman MA, Levine SP, Bainton DF. Optimal techniques for the immunocytochemical demonstration of β -thromboglobulin, platelet factor 4, and fibrinogen in the alpha granules of unstimulated platelets. *Histochem J* 1984;16:983-1001.)

Platelet Cytoskeleton

(See additional cytoskeleton information in the section "Role of the Cytoskeleton in Platelet Function.")

The shape of platelets and their ability to contract and spread depend on an organized cytoskeleton.²⁸ The cytoskeleton can direct platelet shape change, send out extracellular extensions, collect and then extrude secretory granules, and affect surface reactivity (Fig. 16.5). These varied functions are performed by three distinct structures: first, the membrane skeleton, which buttresses the inner side of the plasma membrane; second, the mass of actin and intermediate filaments, which fills the cytoplasm; and third, the circumferential microtubule band, which encircles the substance of the platelet to produce the resting disk-like form.^{15,28} Three different protein filaments/tubules contribute to the overall network: 5- to 6-nm-diameter microfilaments of actin,^{29,30} 10- to 12-nm intermediate filaments of desmin and vimentin,^{31,32} and 25-nm microtubules composed mainly of tubulin.^{33,34} and ³⁵ Together, these filaments, depending on the activation state of the platelet, comprise 30% to 50% of total platelet protein.

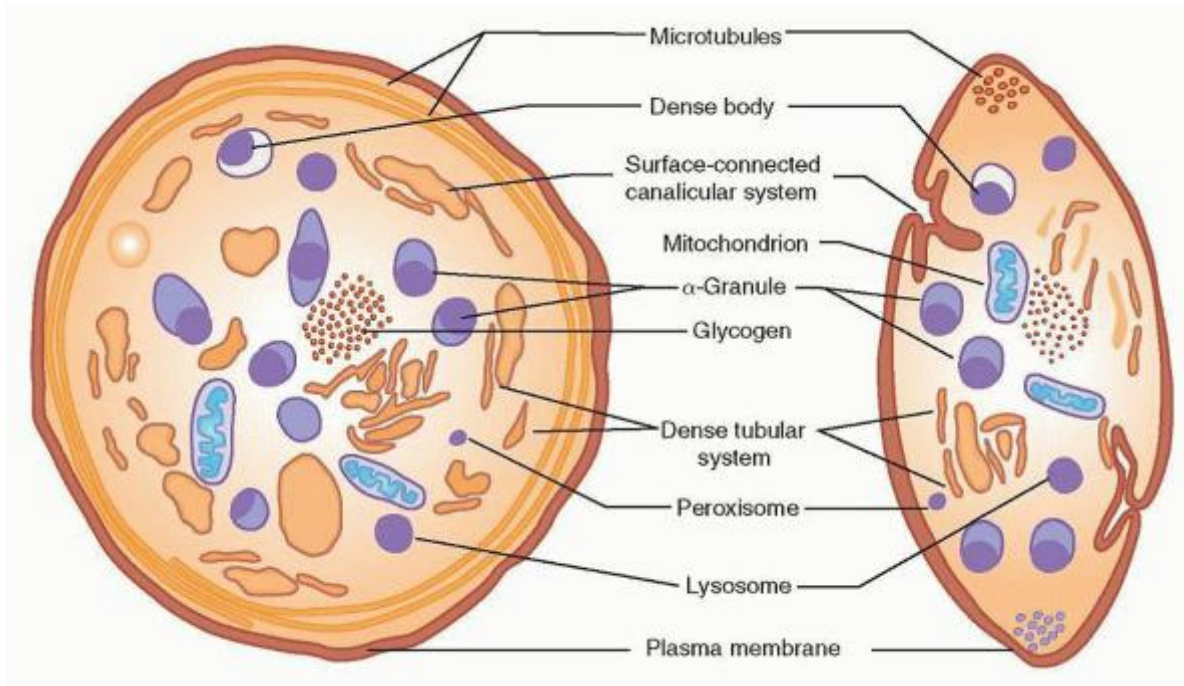

FIGURE 16.3. Diagram of a human platelet displaying components visible by electron microscopy and cytochemistry. In addition to membranous components (plasma membrane, surface-connected canalicular system, and dense tubular system), mitochondria, microtubules, and glycogen, four types of storage organelles are identified: α -granules, dense bodies, lysosomes, and microperoxisomes. Whereas the first two can be identified morphologically, microperoxisomes and lysosomes are recognizable only by cytochemical stains. (From Bentfeld-Barker ME, Bainton DF. Identification of primary lysosomes in human megakaryocytes and platelets. *Blood* 1982;59:472-481, with permission.)

Membrane Skeleton

The membrane skeleton was first described more than 30 years ago by electron microscopy^{36,37} and then analyzed biochemically by detergent lysis in Triton X-100.^{28,38} The membrane skeleton contains short actin filaments that connect surface receptors with the bulk of cytoplasmic actin filaments.²⁹ Filamin-A, a component of the membrane cytoskeleton, links the cytoplasmic domain of GPIIb α with actin filaments and also binds integrins. Other components of the membrane skeleton include structural and signaling molecules such as spectrin, talin, migfilin, Src, and small GTPase family members (Table 16.1).^{15,28} Through tight regulation, the interactions of these proteins allow platelets to sense and to respond to environmental cues.

Cytoplasmic Actin and Intermediate Filaments

The bulk of the platelet cytoskeleton consists of a large amount of actin ($M_r = 42,000$) that comprises approximately 25% of total platelet protein.³⁹ Other platelet cytoskeletal proteins, such as tropomyosin and α -actinin, are present in lower amounts (2% to 5% of total platelet protein).^{40,41,42} and ⁴³ The actin exists in soluble, monomeric (G-actin), and filamentous (F-actin) forms and connects to both the membrane skeleton and the microtubules.¹⁵ In resting platelets, approximately 40% of actin is in microfilaments, which are dispersed throughout the cytoplasm and obscured by their small size and the

many other subplatelet structures present, such as granules.⁴⁴ The intermediate filaments are more stable, resistant structures, rich in vimentin, that appear to bear tension within the cytoplasm.³²

Platelet stimulation results in profound changes in cytoskeletal organization. Morphologically, platelets rapidly lose their discoid shape, become rounded, and extend filopodia.^{45,46} With the

P.391

rise in intracellular calcium, the proportion of F-actin increases rapidly to 60% or 70%.⁴⁶ Actin monomers polymerize into filaments at platelet peripheries,^{45,47} and bundles of new filaments form to fill developing filopodia.^{48,49} and⁵⁰ Phosphorylation of myosin light chain results in binding of myosin to actin,^{51,52,53} providing the tension required for granule centralization and retraction of filopodia.⁵⁴ Additional proteins, such as talin and surface $\alpha_{IIb}\beta_3$, join the developing electron-dense actin filaments, and the structure is remodeled through the action of an associated calciumdependent protease, calpain.⁵⁵ The sum of these events in platelet function is critical because the combination of various additions, rearrangements, and remodeling steps underpins shape change and spreading (filopodia and lamellipodia formation), along with platelet secretion and clot retraction.

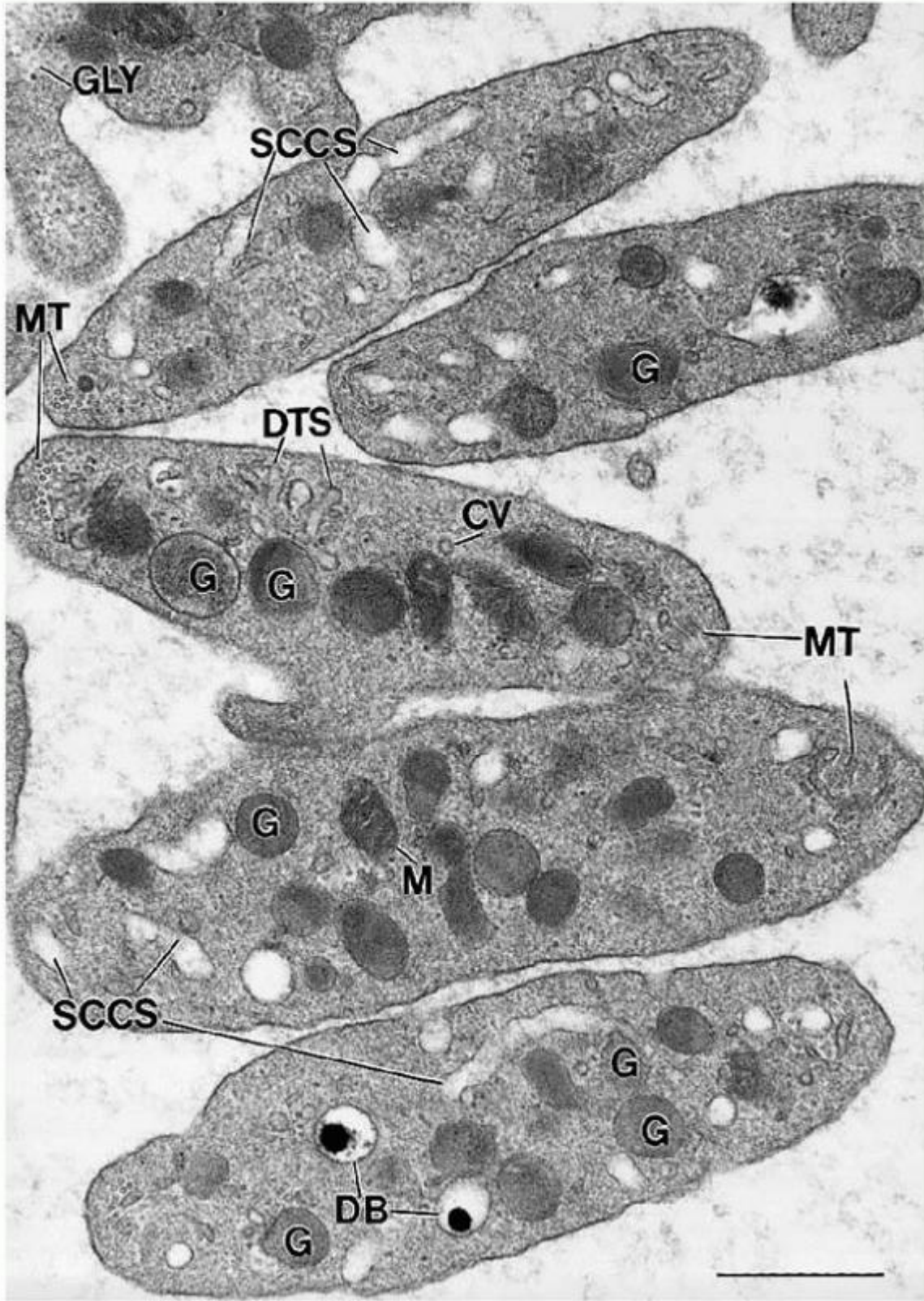

FIGURE 16.4. Ultrastructure of unstimulated human platelets. Membranous organelles, including the surface-connected canalicular system (SCCS) and dense tubular system (DTS), and cytoplasmic organelles, including mitochondria (M), α -granules (G), dense bodies (DB), coated vesicles (CV), and glycogen (GLY), are visualized at the ultrastructural level. Microtubules (MT) are present as cross-sectional and longitudinal profiles at the poles of the discoid platelets.

Magnification $\times 46,000$. Bar = $0.5 \mu\text{m}$.

Microtubules

A circumferential microtubule band that supports the discoid form of the platelet^{33,34} is made of two nonidentical subunit proteins (α - and β -tubulin), associated with microtubule-associated proteins. The 25-nm-diameter microtubule coil lies adjacent to, but does not touch, the plasma membrane.⁵⁶ Platelet microtubules comprise 13 protofilaments of $\alpha\beta$ tubulin dimers and are primarily polymerized in unstimulated platelets. Platelet activation results in microtubule disassembly and then reassembly; such alterations in the marginal microtubule bundle result in platelet shape changes.⁵⁶ Microtubules appear to be key determinates of platelet size⁵⁷ and may be disorganized in giant platelet disorders.⁵⁸

Platelet Granules and Organelles

Platelets possess secretory granules and mechanisms for cargo release to amplify responses to stimuli and influence the surrounding environment. Platelet granule structures include α - and dense granules, lysosomes, and peroxisomes. α -Granules and the dense bodies are the main secretory granules that release cargo (e.g., fibrinogen and adenosine diphosphate [ADP]) upon platelet activation.



FIGURE 16.5. Human platelet cytoskeletons prepared by simultaneous fixation and lysis in Triton X-100 detergent. Single actin filaments, indicated by short arrows, course throughout the platelet cytoplasm. Clusters of filaments, indicated by

long arrows, also are present. Note the microtubule coils at the platelet peripheries (arrowheads). Magnification $\times 30,000$. (From Boyles J, Fox JEB, Phillips DR, Stenberg PE. Organization of the cytoskeleton in resting, discoid platelets: preservation of actin filaments by a modified fixation that prevents osmium damage. *J Cell Biol* 1985;101:1463-1472, with permission.)

Platelet granule secretion begins with a dramatic increase in platelet metabolic activity, set off by a wave of calcium release and marked by increased adenosine triphosphate (ATP) production.⁵⁹ After platelet stimulation by agonists, a “contractile ring” develops around centralized granules,^{5,6} the granules fuse with the surface membranes, and then they extrude their contents.⁶⁰ The molecular events underlying platelet granule release involve many of the same proteins and processes observed in other systems of membrane docking, fusion, and extrusion.^{61,62} Granule secretion in platelets is a graded process that depends on the number, concentration, and nature of the original stimulus/stimuli, either strong (e.g., thrombin and collagen) or weak (e.g., ADP and epinephrine).⁶²

α -Granules

α -Granules, with a cross-sectional diameter of approximately 300 nm and numbering approximately 50 per platelet, are the predominant platelet granules.⁶³ They are approximately spherical in shape, with an outer membrane enclosing two distinct intragranular zones that vary in electron density. The larger, electron-dense region is often eccentrically placed and consists of a nucleoid material that is rich in platelet-specific proteins such as β -thromboglobulin.⁶⁴ The second zone, of lower electron density, lies in the periphery adjacent to the granule membrane and contains tubular structures with adhesive GPs such as von Willebrand factor (vWF) and multimerin,

P.392

along with factor V.^{65,66,67} Platelets take up plasma proteins and store them in their α -granules.^{68,69,70} Select α -granule proteins are discussed below and listed in Table 16.2.

TABLE 16.1 MAJOR PLATELET CYTOSKELETAL PROTEINS

Protein	Molecular Weight	Principal Known Function
Actin	42,000	Major protein constituent of microfilaments; 30% of platelet protein; F-actin binds myosin.
Myosin II	500,000	Binds actin; phosphorylation of light chains contracts microfilaments; 4% of platelet protein.
Talin	235,000	Interacts with α -actinin, vinculin; 2% of platelet protein.
Vinculin	130,000	Interacts with talin; links to actin.
α -Actinin	102,000	Dimer forms a gel with F-actin; promotes actin polymerization.
Actin-binding protein (filamin 1)	260,000	Cross-links actin filaments; links membrane skeleton with glycoprotein Ib-IX complex.
Gelsolin	91,000	Caps and severs actin filaments.
Thymosin β_4	5,000	Binds 1:1 with G-actin monomer and inhibits its polymerization.
Profilin	15,200	Binds 1:1 with G-actin and inhibits its polymerization; adds adenosine triphosphate.
Tropomyosin	28,000	Binds groove on certain F-actins.
Caldesmon	80,000	Regulates actomyosin ATPase and actin bundling.
Myosin light chain kinase	105,000	Phosphorylates myosin, activates its ATPase, and causes contraction.

Calmodulin 17,000 Binds four Ca^{2+} ; activates myosin light chain kinase.
ATPase, adenosine triphosphatase.

Three proteins, β -thromboglobulin, PF4, and thrombospondin, are synthesized in megakaryocytes and highly concentrated in α -granules. The first two, β -thromboglobulin and PF4, show homology in amino acid sequence and share the additional features of localization in the dense nucleoid of α -granules, heparin-binding properties, and membership in the CXC family of chemokines.^{14,71,72,73} and ⁷⁴ Together, they constitute approximately 5% of total platelet protein, and they can serve as useful markers for platelet activation in serum or plasma.^{75,76} Thrombospondin may comprise up to 20% of the total platelet protein released in response to thrombin, and likely participates in multiple biologic processes.^{77,78}

vWF is also synthesized by megakaryocytes and is present in the tubular structures of the α -granule peripheral zone, similar to its localization within Weibel-Palade bodies of vascular endothelial cells.^{66,79} Factor V and multimerin, a factor V/Va-binding protein,^{67,80} co-localize with vWF in platelets but not in endothelial cells. Fibrinogen is also found in α -granules, but is incorporated actively from plasma and not synthesized by megakaryocytes.⁶⁹ In fact, small amounts of virtually all plasma proteins, such as albumin, immunoglobulin G (IgG), fibronectin, and β -amyloid protein precursor, may be taken up into the platelet α -granules.^{79,81,82} and ⁸³ α -Granules also contain many growth factors, including platelet-derived growth factor, transforming growth factor- β_1 (TGF- β_1), and vascular endothelial growth factor. These signaling molecules may contribute to the mitogenic activity of platelets.^{84,85} A role for platelet α -granule proteins in angiogenesis has been recently reported. Both pro- (e.g., VEGF) and antiangiogenesis proteins (e.g., endostatin) are stored within α -granules. How populations of angiogenesis regulatory proteins may be selectively compartmentalized and released from platelets is an area of active investigation.^{86,87,88,89} and ⁹⁰ Likewise, the activation and functions of platelet-derived TGF- β_1 in cardiac fibrosis and other conditions have been described.^{91,92}

Platelet α -granules serve as an important reservoir for $\alpha_{\text{IIb}}\beta_3$ that contributes significantly to the surface fibrinogen receptors present on activated platelets.^{93,94,95} The α -granule membrane protein, P-selectin (granule membrane protein-140) is translocated to the plasma membrane after platelet activation.^{96,97} Finally, a number of additional proteins have been located to the surface of α -granules alone, including CD9, platelet endothelial cell adhesion molecule-1 (PECAM-1), Rap 1b, GPIb-IX-V, and osteonectin^{98,99} and ¹⁰⁰ (Table 16.2).

The platelets and megakaryocytes of patients with gray platelet syndrome have decreased numbers of α -granules and reduced levels of some proteins. It is proposed that there is incorrect targeting of α -granule proteins to the α -granule in the megakaryocyte in this disease.^{101,102}

Dense Bodies

Dense bodies, numbering approximately five per platelet, are exceptionally electron-dense and easily distinguished by electron microscopy because of their distinctive “bull’s-eye” appearance.^{103,104} With an approximate diameter of 250 nm, these granules contain a large reservoir of ADP, a critical agonist for platelet activation that amplifies the effect of other stimuli.¹³² In addition to this nonmetabolic pool of ADP, the dense bodies are rich in ATP, pyrophosphate, calcium, and serotonin (5-hydroxytryptamine), with lesser amounts of guanosine triphosphate (GTP), guanosine diphosphate (GDP), and magnesium.⁷⁴ The adenine nucleotides are synthesized and segregated by megakaryocytes, whereas serotonin is incorporated into dense granules from the plasma by circulating platelets.^{133,134,135} There is more ADP than ATP in dense bodies, and both can lead to adenosine monophosphate (AMP). In turn, AMP can be dephosphorylated to adenosine or cyclized to produce cyclic AMP, an inhibitor of the platelet-stimulatory response. The dense granule membrane contains P-selectin and granulophysin.¹³⁶

Lysosomes

Lysosomes are small, acidified vesicles, approximately 200 nm in diameter,¹⁰⁵ that contain acid hydrolases with pH optima of 3.5 to 5.5, including β -glucuronidase, cathepsins, aryl

P.393

sulfatase, β -hexosaminidase, β -galactosidase, heparitinase, and β -glycerophosphatase. Additional proteins found in lysosomes include cathepsin D and lysosome-associated membrane proteins (LAMP-1/LAMP-2), which are expressed on the plasma membrane after activation).^{106,107} Lysosomal constituents are released more slowly and incompletely (maximally, 60% of the granules) than α -granules or dense-body components after platelet stimulation, and their release also requires stronger agonists such as thrombin or collagen.

TABLE 16.2 MAJOR PLATELET GRANULAR CONSTITUENTS SECRETED WITH ACTIVATION

α -Granule Protein	Comments	Amount/ 10^9 Platelets	Concentration in Platelets >Plasma
Coagulant Proteins			
Fibrinogen	Critical ligand for aggregation	140 μ g	3 \times conc. platelets >plasma
Factor V	Critical cofactor for coagulation	4 μ g	30 \times conc. platelets >plasma
Platelet-Specific Proteins			
Platelet factor 4	Marker for platelet activation	12 μ g	20,000 \times conc. platelets >plasma
β -Thromboglobulin	Marker for activation	10-20 μ g	20,000 \times conc. platelets >plasma
Mitogenic and Angiogenic Factors			
Platelet-derived growth factor	Smooth muscle mitogen	30-100 ng	
Transforming growth factor- β	Complex activation pathway; binds thrombospondin		
Vascular endothelial growth factor	Relatively high concentrations in platelets		
Adhesive Glycoproteins and α-Granule Membrane-Specific Proteins			
Thrombospondin	Multiple complexes	40 μ g	20,000 \times conc. platelets >plasma
von Willebrand factor (vWF)	Role in adhesion	0.3 μ g	100 \times conc. platelets >plasma
Multimerin	Binds factor V; resembles vWF-binding factor VIII; has RDG sequence		
P-selectin	Mediates platelet-leukocyte binding	20,000 copies on activated platelets	
Dense Granule Constituent			
Constituent	Comments	Concentration in Granules (nmol/mg Dense Granule Protein)	Percent Secreted
Adenosine diphosphate	Highly concentrated; a critical mediator of aggregation	630	95% secreted with platelet activation
Adenosine triphosphate		440	40% released with activation
Calcium		2,630	70% secreted with activation
Serotonin		100	95% released with activation

conc., concentration.

Note: A number of additional elements are released or secreted from within the platelet. For example, α -granules also contain the major platelet surface glycoproteins (GPs) GPIIb-IIIa and GPIb-IX along with albumin and immunoglobulin G, adhesive glycoproteins (fibronectin, vitronectin), fibrinolytic components (α_2 -antiplasmin, plasminogen activator), and coagulation-related proteins (high-molecular-weight kininogen, α_2 -macroglobulin). In addition, dense granules contain guanosine triphosphate/guanosine diphosphate and high concentrations of pyrophosphate, phosphate, and magnesium, much of which is secreted with activation. A number of additional proteins are present, some released and some retained in the platelet cytosol, such as a subunit of factor XIII, amyloid β -protein precursor, protease nexin I, and tissue factor pathway inhibitor.

Organelles: Microperoxisomes, Coated Vesicles, Mitochondria, and Glycogen

Peroxisomes are rare, small (90 nm in diameter) granules, demonstrable with alkaline diaminobenzidine as a result of their catalase activity.¹⁰⁸ The structure may participate in the synthesis of platelet-activating factor.¹⁰⁹

Mitochondria in platelets are similar, with the exception of their smaller size, to those in other cell types. There are approximately seven per human platelet, and they serve as the site for the actions of the respiratory chain and the citric acid cycle.¹¹⁰ Glycogen is found in small particles or in masses of closely associated particles, playing an essential role in platelet metabolism.¹¹¹

Platelet Biochemistry and Metabolism

Composition

The platelet is composed of approximately 60% protein, 15% lipid, and 8% carbohydrate by dry weight. Platelet minerals include magnesium, calcium, potassium, and zinc. Platelets contain substantial amounts of vitamin B₁₂, folic acid, and ascorbic acid.¹¹² The concentrations of sodium and potassium within the platelet are 39 and 138 mEq, respectively.¹¹³ This gradient against plasma, apparently distributed in two discrete metabolic compartments, is maintained by an active ion pump, which derives energy from a membrane ATPase of the ouabain-sensitive, Na⁺/K⁺-dependent type.¹¹⁴

Unstimulated platelets maintain a low cytoplasmic Ca²⁺ concentration (~100 to 500 nmol/L) by limiting Ca²⁺ transport from plasma and promoting active efflux of this ion from the cell.¹¹⁵ Two pools of calcium are present in platelets: a rapidly turning over cytosolic pool regulated by a sodium-calcium antiporter in the plasma membrane and a more slowly exchanging pool regulated by Ca²⁺/Mg⁺-ATPase and sequestered in the dense tubular system.¹¹⁶ Platelets are therefore able to transport calcium from the cytosol by moving it against a gradient into the extracellular space or by sequestration in the dense tubular system.

P.394

Energy Metabolism and Generation of ATP

There are several similarities between the energy metabolism of the platelet (Fig. 16.6) and that of skeletal muscle. Both involve active glycolysis and the synthesis and use of large amounts of glycogen,¹¹⁷ and in both, the major mediator of intracellular energy use is an actomyosin-like ATPase. The platelet, like muscle, is metabolically adapted to expend large amounts of energy rapidly during aggregation, the release reaction, and clot retraction.

The major energy source for the platelet is glucose, which is rapidly taken up from the plasma (Fig. 16.6, Step 1). Under basal conditions, 40% to 50% of the absorbed glucose is used to provide energy for synthetic functions or is converted into glycogen. Electron microscopy reveals prominent masses of glycogen in some platelets. The glycolytic pathway with its regulatory enzymes (phosphorylase, pyruvate kinase, hexokinase, phosphofruktokinase, and glyceraldehyde 3-phosphate dehydrogenase),¹¹⁷ the citric acid cycle, the pentose phosphate shunt, and the NAD-NADH (nicotinamide adenine dinucleotide-nicotinamide adenine dinucleotide [reduced form]) system are all active in the platelet. Ninety-eight percent of platelet pyruvate is converted to lactate, which leaves the platelet.¹¹⁸ and ^{119,120} In addition to glycolysis, platelets contain enzymes for oxidative phosphorylation and fatty acid oxidation (Fig. 16.6, Step 2).^{121,122}

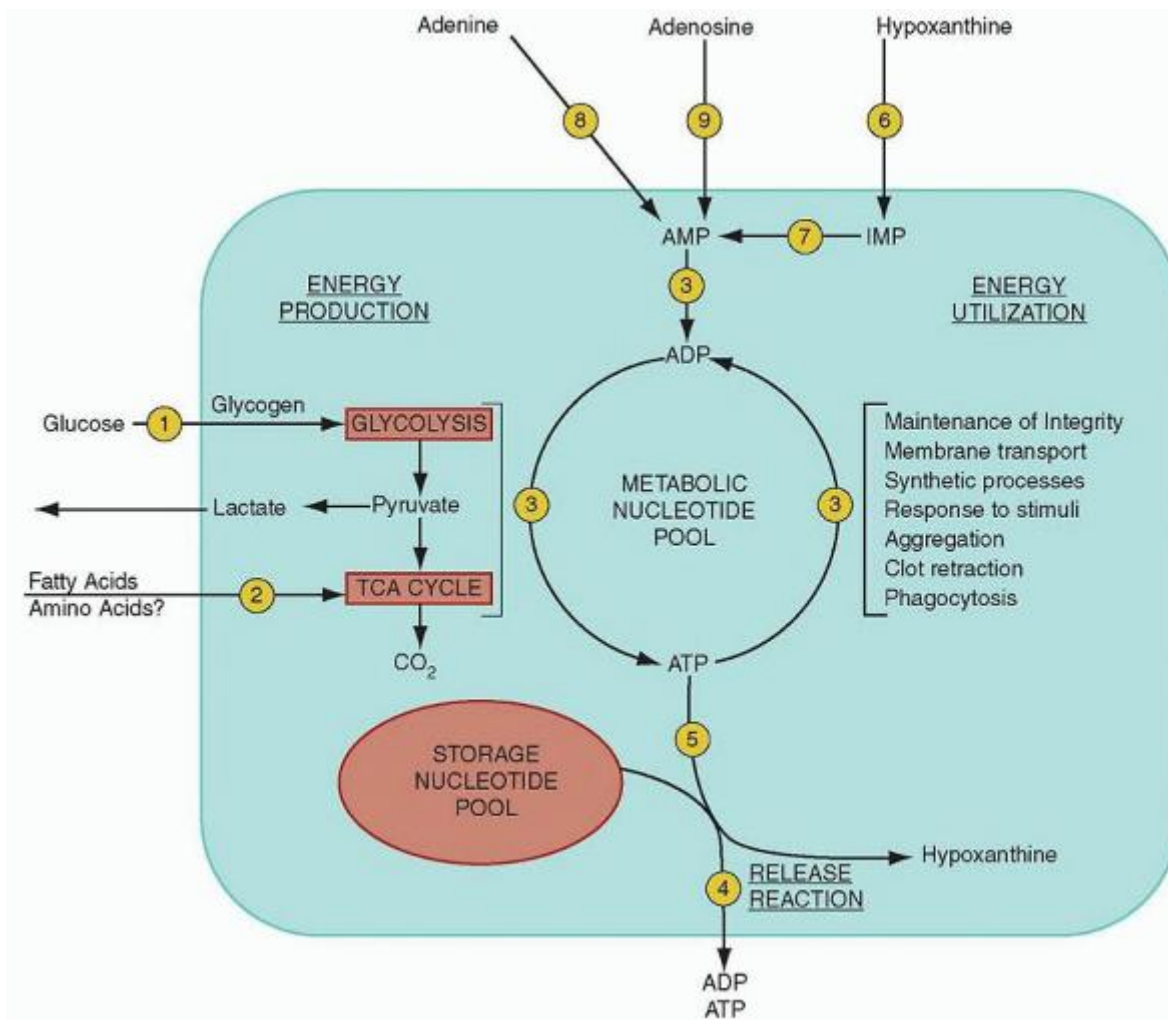

FIGURE 16.6. Simplified scheme of platelet energy metabolism. Platelet energy is derived from the metabolism of glucose and, to a lesser extent, from the metabolism of fatty acids. Energy is provided in approximately equal amounts by glycolysis and the citric acid cycle. The platelet energy reserve is provided by the metabolic pool of platelet nucleotides that is in a state of continuous turnover. This energy is used for the maintenance of the platelets' structural integrity and in the reactions accompanying the response of platelets to stimuli. The granule-bound storage (nonmetabolic) nucleotide pool is discharged during the release reaction. ADP, adenosine diphosphate; AMP, adenosine monophosphate; ATP, adenosine triphosphate; IMP, inosine monophosphate. (Adapted from Hirsh J, Doery JCG. Platelet function in health and disease. *Prog Hematol* 1972;7:185-234.)

ATP production in platelets is affected greatly by the suspending medium, chelating agents, and in vitro manipulation of platelets. In plasma, oxidative ATP production by unstimulated platelets is predominant, and all ATP formed by oxidative phosphorylation may be the product of β -oxidation of fatty acids;¹²³ glycogen turnover, the hexose monophosphate shunt, and the citric acid cycle are virtually inactive.¹²⁰ Glycolysis is capable of completely compensating for reduced ATP production when oxidative phosphorylation is inhibited. Platelet stimulation by agents that induce aggregation and release is associated with a marked increase in metabolic activity involving glycogenolysis,¹²⁴ as well as with glycolysis and oxidation to varying degrees.^{117,125}

The total amounts of ATP synthesized by the two pathways are approximately equal because of the greater ATP yield per mole of glucose provided by oxidation.^{118,122} ATP energy is used in unstimulated platelets to maintain homeostatic levels of H^+ , K^+ , Na^+ , and Ca^{2+} .^{126,127}

Nucleotide Metabolism and the Nonmetabolic Role for ADP

Adenine nucleotides constitute 90% of free platelet nucleotides and are partitioned into at least two different pools, which undergo minimal interchange (Fig. 16.6).⁹⁷ The metabolic or

cytoplasmic pool makes up 40% of total adenine nucleotides; it is used for the maintenance of various energy-consuming cell functions and is retained during platelet release. In large part made up of ATP, this pool is constantly turning over, as revealed by the rapid incorporation of ^{14}C -adenine and ^{32}P -phosphate into ATP. In unstimulated platelets, the relative concentrations of metabolic AMP, ADP, and ATP are maintained by the enzyme adenylate kinase (Fig. 16.6, Step 3).¹²⁸

The storage pool, which is present in the dense bodies, contains approximately two-thirds of the total platelet nucleotides, mainly in the form of ADP and ATP.¹²⁹ It is metabolically inactive, does not rapidly incorporate exogenous adenine or phosphate, and equilibrates slowly with the metabolic pool.¹³⁰ Nucleotides in this pool are extruded from the platelet during the release reaction (Fig. 16.6, Step 4) and cannot be replenished after release. ATP hydrolysis is required for conversion of G-actin to F-actin, and the resultant ADP becomes associated with F-actin; this small percentage of platelet ADP bound to actin constitutes one-third of the nucleotide compartment.¹³¹ Perhaps as much as 40% of all ATP produced is used during the process of actin treadmilling,¹³² and as much as 7% is used in the turnover of the phosphoinositides PIP and PIP₂.¹³³

The ATP that is broken down to provide energy for the release reaction is not rephosphorylated; rather, it is irreversibly degraded to hypoxanthine (Fig. 16.6, Step 5), which diffuses out of the cell.¹²⁸ This reaction also proceeds slowly in stored normal platelets.¹⁷⁰ Hypoxanthine in the plasma may be reincorporated slowly into metabolic AMP by the salvage pathway (Fig. 16.6, Steps 6 and 7).^{129,134} Platelet stimulation results in marked activation of ATP-producing pathways.¹³⁵ The steady-state level of ATP decreases and hypoxanthine accumulates. In addition, a transient but greatly increased uptake of phosphate by platelets occurs.¹³⁶ Although ATP-requiring processes are activated by platelet stimulation, it is unknown whether or how these are coupled to signal processing in platelets.

Lipid Composition and Metabolism and the Generation of Arachidonic Acid

Phospholipids constitute 80% of total platelet lipid, with neutral lipids and glycolipids comprising the remainder.¹³⁷ The five major phospholipids identified in human platelets are phosphatidylcholine (PC, 38% of total phospholipids), phosphatidylethanolamine (PE, 27%), sphingomyelin (17%), PS (10%), and phosphatidylinositol (PI, 5%).⁸ Studies of platelet subcellular fractions reveal that 57% of total human platelet phospholipids are present in the plasma membrane.¹³⁸ Most of the negatively charged phospholipids (i.e., PE, PI, and PS) are contained in the inner leaflet,^{138,139} and ¹⁴⁰ an asymmetric arrangement that prevents inappropriate coagulation by sequestering the phospholipids that accelerate plasma coagulation (mainly PS) away from the platelet surface. This asymmetry collapses when platelets are activated.¹⁴¹ These same phospholipids (i.e., PS and PE, which interact with coagulation proteins) redistribute with platelet activation and are thereby exposed on the surface to function in promoting clot formation.¹⁴² The asymmetric distribution of phospholipids on the platelet surface appears to be maintained by one or more membrane scramblase enzymes; and a "floppase" has been proposed to reverse the phospholipid asymmetry with activation.

Almost all platelet fatty acids are esterified in phospholipids, leaving only trace amounts in the free form. Platelet phospholipids are enriched in arachidonate, the precursor of prostaglandins, at their "sn-2" position.¹⁴³ After agonist stimulation, phospholipase A₂ activity rises, and arachidonic acid is released from membrane phospholipids, predominantly PC.^{144,145,146} After release, arachidonic acid is oxygenated to form the cyclic endoperoxide intermediate, PGH₂, by cyclo-oxygenase-1, which leads to TxA₂ formation.¹⁴³ The lipoxygenase pathway accounts for a small proportion of arachidonate metabolism, producing mainly 12-HETE (12-hydroxyeicosatetraenoic acid).

Neutral lipids, mainly cholesterol, make up approximately 28% of total platelet lipids. Cholesterol is a major constituent of platelet membranes and is also present in the platelet cytoskeleton.¹⁴⁷ It is synthesized by megakaryocytes but not by platelets. Finally, neutral glycolipids, gangliosides, and ceramides have been detected in platelets.¹⁷⁹

Platelet Microparticles and Kinetics

Microparticles

Platelet microparticles are tiny structures rich in surface PS that are generated during platelet activation and can contribute significantly to the acceleration by platelets of plasma coagulation, specifically factor Xa and thrombin generation.¹⁴⁸ The composition of microparticles varies with the agonist or stimulus (C5b-9, ionophore A23187, thrombin, tissue factor, shear) involved in their formation,^{149,150} and have been found to bind factors Xa, VIII, and Va, along with protein S.^{151,152} Physiologically, microparticles appear to be an important contributor to procoagulant activity as their defect in patients is associated with clinical bleeding.^{153,154}

Platelet Heterogeneity

The normal platelet count varies between 150,000 and 400,000/ μl , and normal platelet size (mean platelet volume) varies between 7.5 and 10.5 fl. Platelets are released into the blood from long proplatelet extensions of megakaryocytes.¹⁵⁵

Young platelets, that is, those recently released by megakaryocytes, are larger and more dense, and undergo remodeling in circulation, in part by shedding some of their surface components. Macrothrombocytopenias may reflect a disturbance in the steps of platelet production,¹⁵⁶ and the properties of large platelets may reflect unique attributes of platelets recently released from the marrow or proplatelets produced under conditions of accelerated or abnormal production.

Platelet Distribution and Survival Kinetics

Labeling

Platelets labeled with ⁵¹Cr (chromate) have been used to estimate platelet lifespan in humans at 8 to 12 days,¹⁵⁷ and the method has been widely validated.¹⁵⁸ Other methods reported for platelet labeling include ¹¹¹In (indium) chelated with 8-hydroxyquinoline and ³²P-labeled diisopropylfluorophosphate, ⁶⁸Ga (gallium).¹⁵⁹ Platelet labeling is not commonly used for clinical evaluations, but all of the published studies give the same approximate values for distribution and survival.

Distribution

Approximately one-third of the total platelet mass appears to pool in the spleen. The splenic pool exchanges freely with the platelets in the peripheral circulation. Transfusion of ⁵¹Cr-labeled platelets into normal subjects results in approximately two-thirds remaining in the circulation—in contrast to nearly 100% in splenectomized patients.^{160,161} In addition, administration of epinephrine, which evacuates platelets from the spleen, increases the peripheral platelet count 30% to 50%.¹⁶² Platelet counts in asplenic patients are not affected by epinephrine. Some studies suggest that the splenic pool consists of the youngest, largest platelets. The mechanism of splenic sequestration has been hypothesized to result from a longer transit time through the splenic cords (which platelets enter because of their small size) or from binding to the reticular and endothelial cells of the spleen.¹⁶³ Pathophysiologic states can result in 80% to 90% of platelets being sequestered in the spleen, resulting in thrombocytopenia. Release of platelets from the lungs after intracardiac administration of epinephrine has been reported.¹⁶⁴ Also, platelet counts rise after

P.396

vigorous exercise, and this rise is not affected by splenectomy.¹⁶⁵ This nonsplenic pool represents approximately 16% of the total platelet mass.

Life Span

Platelet life span, based on the time required to clear labeled platelets from the circulation, has been estimated to be 8 to 12 days in humans. In steady state, when platelet production equals destruction, platelet turnover has been estimated at 1.2 to 1.5 $\times 10^{11}$ cells per day.^{160,166} Recommendations for estimation of platelet lifespan have been published by the Panel on Diagnostic Application of Radioisotopes in Hematology, International Committee for Standardization in Hematology,¹⁶⁶ and multiple models for analysis of platelet lifespan have been proposed.¹⁶⁷ As discussed above, platelets may be removed from circulation by pooling in the spleen,¹⁶¹ the liver, and the lung.¹⁶⁴

Platelet life span is regulated by Bcl-2 proteins.^{168,169} Platelet Bcl-x(L) is required for survival by suppressing Bak. Bak activation results in classic apoptosis pathways that result in mitochondrial damage, caspase activation, and PS exposure. Platelets from Bak-deficient animals live longer than normal,¹⁶⁹ indicating a predetermined program of platelet death.

Interactions beyond Platelets: The Coagulation System

Platelet Interactions with the Plasma Coagulation System

Activated platelets accelerate thrombin generation. The production of factor Xa and thrombin is the result of the coagulation “cascade” in which a series of successive calcium-dependent complexes is generated by the extrinsic and intrinsic pathways.¹⁷⁰ The complex development occurs primarily on phospholipid surfaces.^{171,172} Soluble Xa binds avidly to Va on the surface of activated platelets, indicating that the surface of activated platelets is likely a major site for coagulation reactions.¹⁷³ The precise elements involved in “platelet-based coagulation” remain to be elucidated. Platelet-bound VIIIa may serve as a binding site for IXa and, in addition to factor Va, the effector cell protease receptor-1 (EPR-1) has been identified as a factor Xa-binding site. An additional receptor(s) for IXa may also exist. Whether specific receptors for VIIIa and Va exist or if they bind to exposed PS is not entirely established. Unlike factor V, it is not clear if factor VIII is present within resting, unactivated platelets. Platelets do not appear to take up significant amounts of plasma vWF with bound factor VIII—a clear difference from their active uptake of plasma fibrinogen.⁷⁰

Thrombin can activate factor XI, particularly on platelet surfaces or in the presence of proteoglycans.^{174,175} In this instance, traces of thrombin, generated through tissue factor from sites of cellular injury, activate plasma factor XI (bound to platelets through the presence of prothrombin itself), which, in turn, activates plasma factor IX and leads to a subsequent dramatic increase in thrombin production.^{176,177} and ¹⁷⁸ Such a sequence of events is favored by the presence of platelets that protect any surfacebound reactants from soluble inhibitors. The process may also conserve a small amount of initial thrombin by linking it to immobilized protein substrates, away from plasma inhibitors.¹⁷⁸ The data are consistent with the clinical observation that the amount of platelet factor XI, rather than plasma factor XI, determines the bleeding severity in deficient patients, and the information explains how factor XI can be activated regardless of other contact factors.^{179,180}

This work illustrates that platelets play a multifaceted role in coagulation and emphasizes the fundamental difference between resting platelets with no ability to accelerate coagulation and agonist-activated platelets, which are intensely active participants. Both intact platelets and platelet microparticles may contribute to these processes. Regardless of the exact mechanisms involved, the binding of any coagulation factor to a high-affinity binding site on the platelet plasma membrane concentrates that factor locally and can orient it with respect to other factors. Also, multiple studies show that platelet surface-bound coagulation proteins are generally protected from their usual plasma inhibitors.¹⁸¹ Finally, such binding (e.g., factor Xa to activated platelets) can facilitate the rapid delivery of a potent coagulant and potential agonist to a site of vessel injury, where it may be most valuable in hemostasis.

Platelet Forms of Plasma Proteins

Three factors (factor V, fibrinogen, and vWF) found in platelet α -granules contribute significantly to coagulation (Table 16.3). Platelets have particularly large amounts of fibrinogen, which they do not synthesize, and lesser amounts of vWF, which they do. The origin of FV appears to be a combination of incorporation from plasma and de novo synthesis in megakaryocytes. The bulk of FV (20% of total factor V in blood) is located in the α -granules, and the thrombin-activated form, factor Va, is the major secreted platelet phosphoprotein.^{182,183} The distinct and critical role of FV in hemostasis is underscored by the findings in two kindreds of factor V Quebec, in which a selective defect in α -granule factor V (plasma factor V is nearly normal), probably due to excessive granule-based proteolysis, is accompanied by a severe bleeding diathesis.^{184,185} Platelet fibrinogen constitutes up to 10% of total platelet protein.^{186,187} Platelet vWF is present in relatively large amounts in α -granules, and may play a role in platelet adherence to subendothelium.¹⁸⁸

Other Platelet-associated Coagulation Factors

The numerous platelet proteins that participate in plasma coagulation are listed in Table 16.3. Several additional plasma coagulation factors are associated with platelets, along with a variety of coagulation inhibitors as noted in the following. FXIII is contained in the cytosol and is not organelle-associated; it is a fully active subunit of plasma factor XIII. FXIII makes up 50% of the total amount of factor XIII activity in blood. It has been suggested that it provides a subunit for plasma factor XIII.¹⁸⁹ High-molecular-weight kininogen is present in α -granules and is secreted and expressed on the platelet plasma membrane after thrombin activation.¹⁹⁰ Platelets contain 2.5% of protein S found in whole blood. This protein is synthesized in megakaryocytes, stored in α -granules, and released from platelets on thrombin stimulation.¹⁹¹ Additionally, platelet-dense granules contain polyphosphate at a concentration of approximately 130 mM,¹⁹² which is released upon platelet activation. Polyphosphate, a highly anionic polymer, activates the contact pathway, heightens Va activation, and accelerates thrombin generation.^{193,194} Polyphosphates also incorporate into fibrin clots and may alter clot structure.¹⁹⁴

Protease Inhibitors

All known plasma protease inhibitors¹⁹⁵ are also localized to platelet α -granules. These include α_1 -protease inhibitor, α_2 -macroglobulin, C1 inhibitor, α_2 -antiplasmin, plasminogen activator inhibitor-1, lipoprotein-associated coagulation inhibitor, protease nexin I (thrombin inhibitor), and protease nexin II (factors IXa and XIa inhibitors).

Clot Retraction

When whole blood is placed in a glass tube and simply left to clot for several hours at ambient temperature, clear serum is expressed from the bulk of the fibrin-red cell mass as platelets exert their global contractile potential.¹⁹⁶ Clot retraction in vitro requires the major surface integrin $\alpha_{IIb}\beta_3$ (or GPIIb-IIIa)¹⁹⁷ and

P.397

contractile proteins actin and myosin, including the non-muscle myosin heavy chain IIA.¹⁹⁸ Integrin activation by talin is required for clot retraction,¹⁹⁹ However, beyond these broadly based studies, relatively few additional details are available to translate this dramatic laboratory event into a physiologic mechanism.

TABLE 16.3 PLATELET-ASSOCIATED COAGULATION FACTORS

Protein	Amount Present	Subcellular Localization	Mechanism of Release or Exposure	Proposed Function
Fibrinogen				
Total	5-25 mg/10 ¹¹ platelets ^a			
Surface-associated	0.3-10.0 mg/10 ¹¹ platelets ^{b, c}	Adsorbed to platelet	Not released	Platelet aggregation by adenosine diphosphate
Intracellular	3-7 mg/10 ¹¹ platelets ^a	Membrane α -granules	Secretion	Platelet aggregation by thrombin
Factor V	0.25-0.77 mg/10 ¹¹ platelets ^b	α -Granules	Secretion	Receptor for factor Xa
von Willebrand factor	10-64 units/10 ¹¹ platelets	α -Granules	Secretion	Platelet adhesion
Factor XI	1.2-6.1 units/10 ¹¹ platelets ^a	Platelet membrane	Unknown	Initiation of intrinsic coagulation
Factor XIII	50% of the total in blood ^a	Cytosol	Not released	α Subunit of factor XIII
High-molecular-weight kininogen	60 μ g/10 ¹¹ platelets ^d	α -Granules	Secretion	Contact activation of coagulation

^aQuantitation by bioassay.

^bQuantitation by radioimmunoassay.

^cQuantitation by electroimmunodiffusion.

^dQuantitation by competitive enzyme-linked immunosorbent assay.

PLATELET ADHESION AND ACTIVATION

Primary hemostasis and arterial thrombosis are the results of a complex series of cell-cell, cell-protein, and protein-protein reactions that involve platelets, leukocytes, endothelium, subendothelial matrix, and plasma proteins, such as fibrinogen, vWF, and others. The consequences of arterial thrombosis include such events as myocardial infarction (MI), unstable angina, and stroke. These clinicopathologic entities and their associated cellular physiologic mechanisms that are outlined in this chapter, collectively account for the largest cause of morbidity and mortality in the Western world.

Platelet adhesion to exposed subendothelium is a complex multistep process that involves a diverse array of adhesive ligands (vWF, collagen, fibronectin, thrombospondin, and perhaps laminin) and surface receptors (GPIb/V/IX, GPVI, integrins $\alpha_{IIb}\beta_3$, $\alpha_2\beta_1$, $\alpha_5\beta_1$, and $\alpha_6\beta_1$).^{200,201,202,203} The specific ligand/receptor players in primary platelet adhesion are largely dependent on the arterial flow conditions present.²⁰⁴ As such, in larger arteries and veins, platelet adhesion to the vessel wall is thought to involve fibrillar collagen, fibronectin, and laminin. There are at least 25 forms of collagen, and several of these are present in the blood vessel wall, while one (type IV) is present in the subendothelial basement membrane.^{205,206} In high shear conditions, platelet tethering is dependent on the unique shear-dependent interaction between GPIb/V/IX and subendothelial vWF, derived either from plasma or released by endothelial cells and/or platelets.²⁰⁷ A tether forms between GPIb and vWF that either halts platelet movement or reduces it such that other interactions can proceed. Subsequent interactions are mediated by GPVI binding to glycineproline-hydroxyproline sites on

collagen and perhaps to exposed laminin.²⁰⁷ The interaction of GPVI with collagen strongly activates platelets such that integrins, including $\alpha_2\beta_1$ and $\alpha_{IIb}\beta_3$ (GPIIb-IIIa), can engage in high-affinity interactions with ligands.

Following initial platelet adhesion, subsequent platelet-platelet interactions are initially mediated by two receptors, GPIb/V/IX and $\alpha_{IIb}\beta_3$, and their respective contributions are dependent on the flow conditions present. In high shear stress conditions, GPIb/V/IX receptor and vWF ligand action are predominant, with fibrinogen playing a stabilizing role. At low shear conditions, fibrinogen is thought to be the primary ligand supporting platelet plug formation through its interaction with $\alpha_{IIb}\beta_3$, although thrombus formation can take place in the absence of vWF and fibrinogen, so other ligands may also be involved.²⁰⁸

Platelet Glycoprotein Ib Complex-von Willebrand Factor Interaction and Signaling

The interaction of the platelet GPIb "complex" (the polypeptides GPIb α , GPIb β , GPIX, and GPV) with its primary ligand, vWF, is the receptor-ligand pairing that initiates platelet adhesion followed by a cascade of events leading to pathologic thrombosis or physiologic hemostasis. A unique aspect of this receptor-ligand interaction is that it requires the presence of high arterial shear rates to take place, thus explaining the predisposition of platelet-rich "white clots" in the arterial circulation over clots found in the venous circulation, with its relatively lower shear forces, in which clot formation takes place independent of the GPIb complex.

The GPIb complex consists of four transmembrane subunits, each of which is a member of the leucine-rich repeat protein superfamily that participates in cell-matrix interactions throughout nature. Each of the four subunits contains one or more tandem, 24-amino acid leucine-rich repeats flanked by conserved disulfide loop structures at both the N and C termini of the repeats.²⁰⁹ GPIb α is covalently associated with the GPIb β chain through disulfide linkage of cysteine residues, and both of these chains are noncovalently associated with GPIX in a 1:1 ratio and with GPV in a 2:1 ratio (Fig. 16.7). GPIb contains multiple O-linked carbohydrate groups with sialic acid residues. The complex appears as a long rod with globular domains by electron microscopy and is predicted to extend far out from the platelet surface, a feature which may make it sensitive to shear-induced conformational changes.²¹⁰

vWF is a large, multimeric GP that circulates in plasma and is also found in platelets and the Weibel-Palade bodies of endothelial cells. Mature vWF is a 2,050-amino acid subunit that is

P.398

disulfide linked into large multimers. It contains three adjacent A domains in the N-proximal half of the peptide that collectively regulate the adhesion of platelets to subendothelial matrix. In this respect, the A₁ and A₃ domains bind to different matrix collagens, whereas the A₁ domain contains the binding site for the GPIb complex.²¹¹ The A₁ domain is the primary role player in platelet adhesion, because this part of the molecule is believed to change its conformation in response to immobilization and high shear forces, thus making it a high-affinity ligand for the GPIb complex receptor.^{212,213}

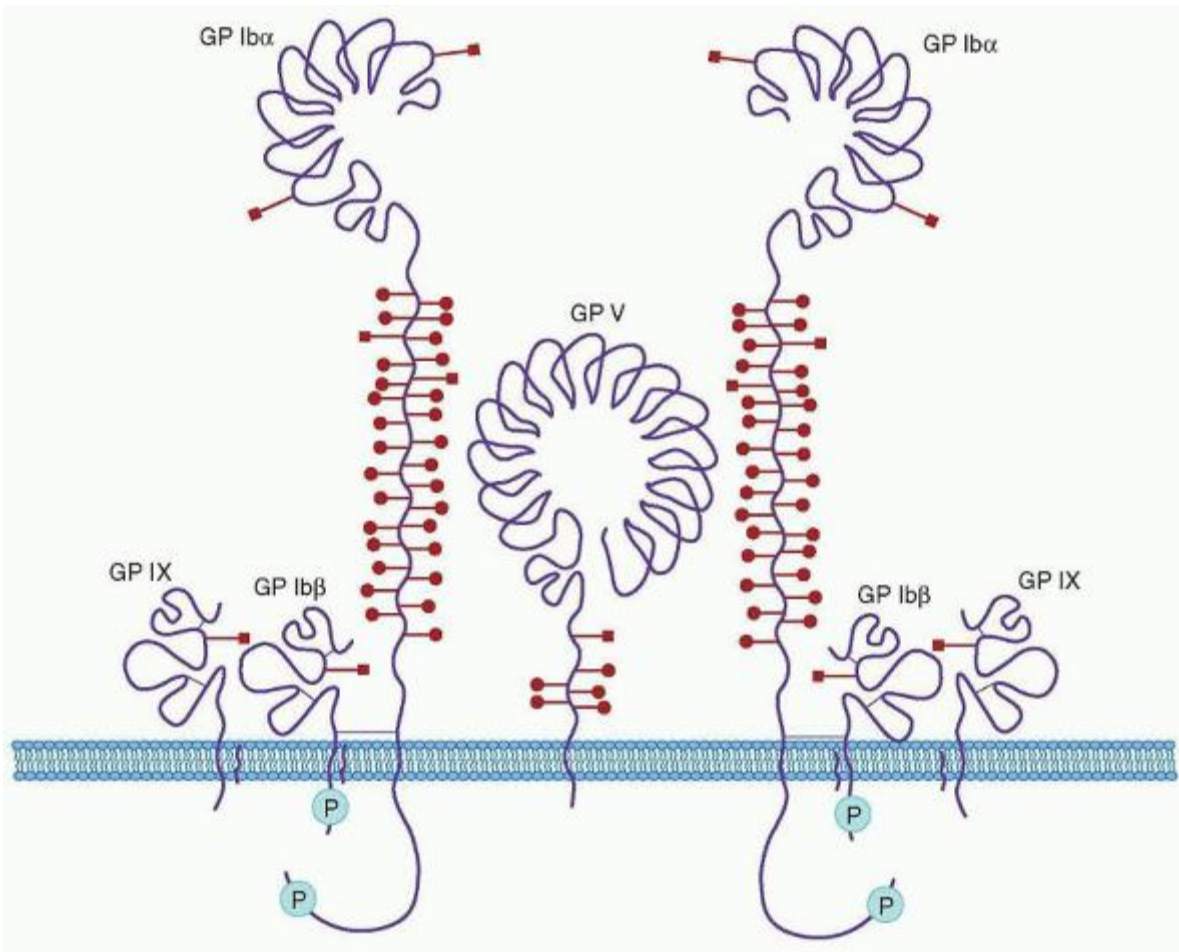

FIGURE 16.7. Glycoprotein (GP) Ib complex. GPIb α Disulfide linked to GPIb β is noncovalently associated with GPIX and GPV in the ratio of 2:2:2:1. Phosphorylation sites within the cytoplasmic tails of GPIb α (Ser 609) and GPIb β (Ser 166) are indicated by a circled P. (From Berndt MC, Shen Y, Dopheide SM, et al. The vascular biology of the GP Ib-IX-V complex. *Thromb Haemost* 2001;86:180, with permission.)

The binding site for vWF is present in the N-terminal 282 residues of GPIb. Important to the interactions are a cluster between residues Asp 252 and Arg 293 containing sulfated tyrosine residues and important anionic residues, a disulfide loop between Cys 209 and Cys 248, and an N-terminal flanking sequence of the leucine-rich repeats (LRG). Mutations involving single amino acid residues within these LRGs account for some cases of the congenital bleeding disorder Bernard-Soulier syndrome, in which the GPIb complex binds poorly, or not at all, to vWF. The crystal structure of the N terminus of GPIb α in complex with the A1 domain of vWF reveals an elongated complex with interactions of the globular A1 domain with the concave face of GPIb α .^{214,215}

Unlike other receptors, GPIb does not require platelet activation for its interactions with vWF. In vitro, the interactions of vWF and binding with the GPIb complex occur with generally very low affinity in the absence of shear. The presence of the vancomycinlike antibiotic ristocetin or viper venom proteins, such as botrocetin, promotes the interactions. Mobilization may uncoil vWF to promote interactions with GPIb.²⁰⁴ The addition of shear, in a parallel-plate flow system, results in platelet interaction with subendothelial vWF that occurs in a biphasic fashion.²¹⁶ Likewise, the rate of translocation of platelets from blood to the endothelial cell surface, which is dependent, increases linearly up to wall shear rates of $1,500 \text{ s}^{-1}$, whereas the translocation rate remains relatively constant with the wall shear rate between $1,500$ and $6,000 \text{ s}^{-1}$. Thus, the presence of shear is important for promoting the interactions between the GPIb complex and vWF. Studies of real-time thrombus formation in the absence of platelet GPIb complex and in blood from individuals with severe (type 3) von Willebrand disease²¹⁷ indicate that GPIb and vWF interaction are required for platelet surface interaction at high shear rates ($>1,210 \text{ s}^{-1}$), whereas GPIb deficiency results in poor platelet adhesion at lower shear.

Shear accelerates thrombus formation likely by promoting this receptor-ligand interaction.

Glycoprotein Ib Complex Interaction with Thrombin and Other Molecules

The GPIb complex serves as an α -thrombin binding site on platelets,²¹⁸ although the physiologic relevance of the interactions is not clear. The density of GPIb complexes ($\sim 20,000$ /platelet) far exceeds the number of thrombin binding sites reported on platelets ($\sim 6,000$ /platelet). Both exosites I and II of thrombin have been implicated in the interactions. Two independently solved crystal structures had significant differences.^{219,220} Involvement of exosite I could have important ramifications for thrombin activity, as most substrates need to bind exosite 1 to be efficiently cleaved. Thrombin binding may influence vWF interactions, although this has not been definitively established. Thrombin is also capable of cleaving GPV near the surface to release a soluble fragment.

P.399

Studies have identified interaction of the GPIb complex with ligands other than vWF. These include a study of a reversible association of GPIb with P-selectin, which is examined in more detail in the section "Platelets and Endothelium." The interaction of platelet GPIb with the neutrophil adhesion receptor $\alpha M\beta 2$ (Mac-1) is discussed in the section "Platelets and White Blood Cells." Additionally, GPIb reportedly interacts with high-molecular-weight kininogen, factor XII, and factor XI.

Glycoprotein Ib Complex Signaling

When the GPIb complex interacts with its vWF ligand under conditions of elevated shear stress, signals are initiated that activate integrin $\alpha_{IIb}\beta_3$.^{221,222} The pathways involved lead to (a) elevation of intracellular calcium; (b) activation of a tyrosine kinase signaling pathway that incorporates nonreceptor tyrosine kinases such as Src, Fyn, Lyn, and Syk, phospholipase C $\gamma 2$, and adaptor proteins such as SHC, LAT, and SLP-76; (c) inside-out signaling through the $\alpha_{IIb}\beta_3$ integrin followed by platelet aggregation; and (d) activation of protein kinase C (PKC), protein kinase G (PKG), and phosphoinositide 3-kinase (PI3K). Other downstream players and events that play roles after GPIb receptor occupancy include: a) the homodimeric signaling protein 14-3-3 and calmodulin, (b) receptor cross-linking, and (c) the immunoreceptor tyrosine-based activation motif (ITAM)-containing proteins Fc γ receptor IIA (Fc γ RIIA) and Fc receptor (FcR) γ chain. Signaling through the GPIb complex can release ADP and generate thromboxane A $_2$ generation,²¹² which in turn activate integrin $\alpha_{IIb}\beta_3$.

Binding sites for 14-3-3 have been identified in the cytoplasmic domains of GPIb α , GPIb β , GPIX, and GPV, and yeast two-hybrid studies documented in vivo interaction between 14-3-3 ζ and both GPIb α and - β .²²³ Phosphorylation of Ser 166 of the 14-3-3 consensus sequence in the GPIb β cytoplasmic domain is required to permit high-affinity 14-3-3 binding.^{223,224} The GPIb complex appears to physically associate with the 14-kDa FcR γ -chain²²⁵ and with the 40-kDa Fc γ RIIA receptor.²²⁶ Both of these proteins contain nonidentical, but similar ITAM domain sequences and may play roles in signaling by GPIb. The lipid kinase PI3K has been found to play a role in GPIb-IX mediated activation of $\alpha_{IIb}\beta_3$ by participation in complex formation with the GPIb and 14-3-3.²²⁷ Thus, once vWF binds to GPIb-V-IX, signaling complexes form in the vicinity of the GPIb α cytoplasmic tail consisting of cytoskeletal proteins such as 14-3-3 ζ as well as signaling proteins like Src and PI 3-kinase. This process leads to Syk activation, protein tyrosine phosphorylation, and recruitment of other cytoplasmic proteins with pleckstrin homology domains that can support interactions with 3-phosphorylated phosphoinositides and ultimately activation of integrin $\alpha_{IIb}\beta_3$.^{228,229}

Platelet-Collagen Interaction and Signaling

Collagens, one of the most thrombogenic substances in vessels, are very important activators of platelets in the vascular subendothelium and vessel wall, and thus are prime targets for therapeutic intervention in patients experiencing a pathologic arterial thrombotic event such as MI or stroke. Platelets have two major surface receptors for collagen, the immunoglobulin superfamily member GPVI and the integrin $\alpha_2\beta_1$. The former is considered to be the primary player in platelet adhesion, initiating signaling and subsequent platelet activation. In addition to these two surface receptors, the GPIb complex can also be considered an indirect collagen receptor because its subendothelial vWF ligand essentially acts as a bridging molecule between platelets and collagen by fixing itself to the latter, which, in turn, acts as scaffolding for the multimers. Collagen adhesion also results in indirect activation of the protease-activated receptor 1 via MMP-1. Other molecules, such as CD 36, may also sustain collagen interactions.

Glycoprotein VI Receptor

The GPVI receptor, a member of the IgG superfamily,^{230,231,232} is expressed in platelets in close association with the 14-kDa FcR γ -chain, which serves as the signaling subunit for GPVI.^{233,234} The receptor exists as a dimer in stable association with the FcR γ -chain. Expression of GPVI on mouse platelets appears to be dependent on FcR γ -chain expression, and the latter has also been found to be critical for collagen-mediated platelet activation.²³⁴

GPVI has two Ig C2 loops, and the N-terminal loop likely contains the collagen-binding domain.²³⁰ The crystal structure indicates that the GPVI dimers assume a parallel orientation of the collagen-binding domains to fit the helix structure of collagen.²³⁵

GPVI is the main receptor involved in collagen-mediated platelet activation.^{236,237} and ²³⁸ Studies of mice lacking platelet GPVI show that they lose collagen-induced platelet activation due to a defect in platelet adhesion.²³⁹ Thus, GPVI appears to serve as the initial receptor involved in platelet adhesion, and it activates integrin binding. GPVI alone supports adhesion to insoluble collagens, and works with $\alpha_2\beta_1$ to promote platelet adhesion to soluble collagen microfibrils. GPVI can also be engaged by collagen-related peptides (arranged in triple helical structures with sequences similar to collagen) and the snake venom convulxin, which elicit signals through GPVI.

$\alpha_2\beta_1$ Receptor

The first platelet collagen receptor identified was the integrin $\alpha_2\beta_1$ receptor, also known as platelet GPIa/IIa and lymphocyte VLA-2.²⁴⁰ In all α subunits of integrins, seven tandem repeats are localized to the N-terminal end and folded into a sevenbladed β -propeller structure.²⁴¹ The α_2 subunit also contains an I domain between the second and third repeats that includes a metal coordination site for Mg^{2+} that is critical for interaction with collagen.²³⁰ As with other integrins, activation increases the affinity between $\alpha_2\beta_1$ and collagen.²⁴² Currently, $\alpha_2\beta_1$ is believed to mediate stable adhesion following GPIb- and GPVI-initiated interactions with vWF and collagen, respectively.

Platelet-Collagen Signaling

When compared to vWF, collagen is a more efficient substrate when it comes to supporting stable platelet adhesion and thrombus formation. The fact that initial platelet tethering to collagen under high shear flow first requires interaction between vWF and platelet GPIb serves to underscore the importance of the two major collagen receptors, GPVI and $\alpha_2\beta_1$, in promoting platelet adhesion and activation under shear conditions.

Many of the early signaling events that follow GPVI stimulation have been characterized. Synergism between GPVI pathways and those related to other adhesion receptors such as GPIb-V-IX and soluble agonists released by activated platelets are likely necessary for the full repertoire of platelet-collagen signaling. Exposure of platelets to collagen surfaces likely results in GPVI clustering that in turn triggers the tyrosine phosphorylation of the FcR γ chain.²³³ GPVI signaling may also be influenced by its association with glycolipid-enriched microdomains (GEMS, membrane rafts) in the plasma membrane.²⁴³ The GPVI/FcR γ -chain complex leads to platelet activation through a pathway that has many aspects in common with signaling by immune receptors, such as the Fc receptor family (of which Fc γ RIIA is the lone family member found in platelets) and the B- and T-cell antigen receptors (Fig. 16.8). Immunoreceptors like the Fc receptors and the FcR γ chain all have the ITAM (immunoreceptor tyrosine-based activation motif) in common. Tyrosine phosphorylation of the ITAM by Lyn and Fyn of the Src family of tyrosine kinases takes place after activation of GPVI. The phosphorylated Src kinase, in turn, leads to activation of the tyrosine kinase Syk after its autophosphorylation.²⁴⁴ Syk then initiates a downstream signaling

P.400

cascade involving the LAT and SLP-76 adapter proteins, which leads to formation of a signaling complex by virtue of its multiple phosphorylation sites that also act as docking sites, leading to recruitment of additional proteins to the plasma membrane.²⁴⁵ The signaling complex activates cytosolic second messenger-producing enzymes PI3K and phospholipase C γ 2, facilitated by tyrosine phosphorylated LAT.²⁴⁶ PI3K leads to the generation of PI3,4P₂ and PI3,4,5P₃ (PIP₃), and this, in turn, supports recruitment of proteins to the membrane signalosome complex with specific pleckstrin homology (PH) domains, including a member of the Tec kinase family, Btk, along with PIC γ 2.^{247,248} Syk is critical for collagen-mediated platelet activation through the GPVI/FcR γ -chain complex, and knockout mouse studies have shown that absence of this enzyme leads to loss of phosphorylation of LAT, the adapter SLP-76, and PIC γ 2.^{248,249}

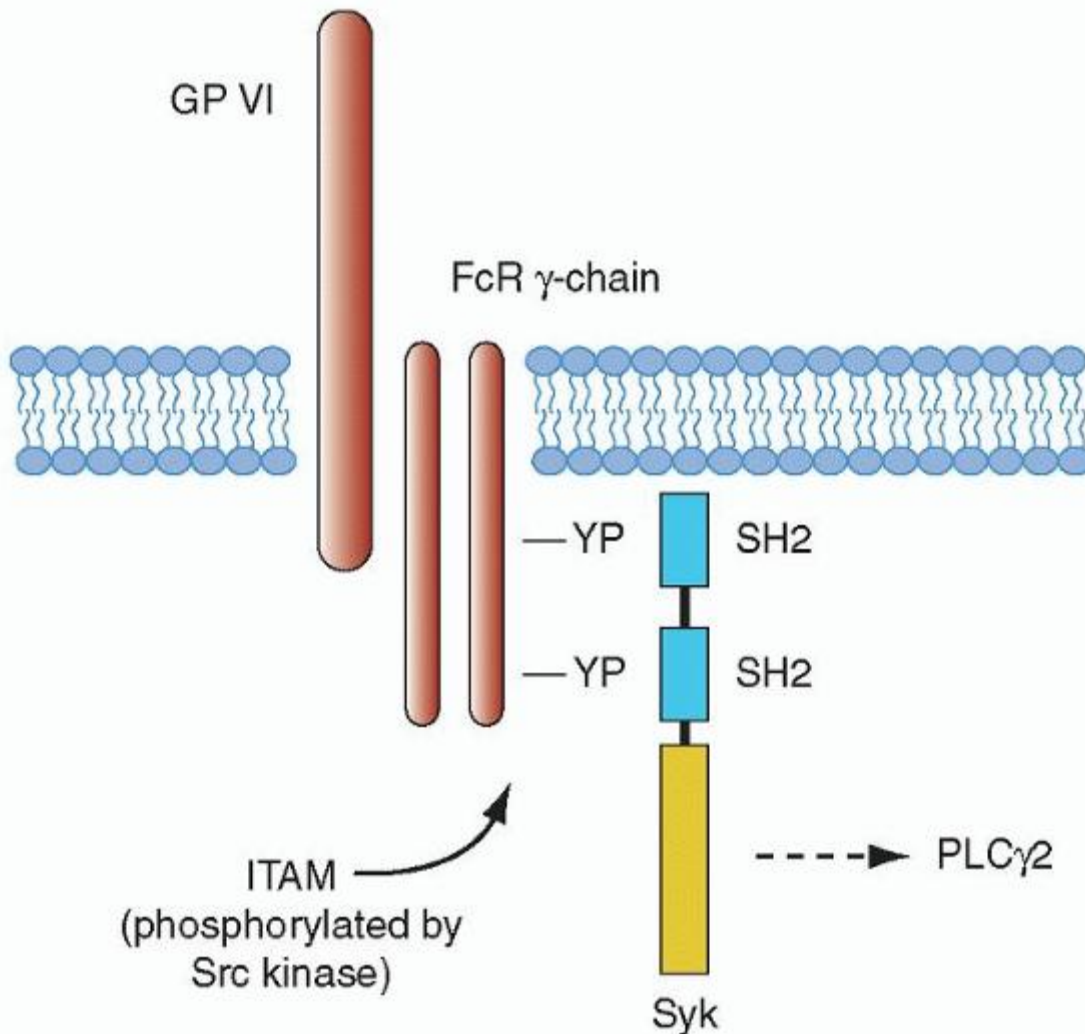

FIGURE 16.8. Collagen activates platelets through the same pathway as an immune receptor. Cross-linking of the glycoprotein (GP) VI/Fc receptor (R) γ chain leads to tyrosine phosphorylation of the immunoreceptor tyrosine-based activation motif (ITAM) sequence, enabling recruitment of the tyrosine kinase (Syk) through its tandem Src-homology 2 (SH2) domains. This leads to autophosphorylation and subsequent activation of Syk, which in turn leads to tyrosine phosphorylation of phospholipase Cy2 (PLC γ 2). A large number of proteins are implicated in the regulation of PLC γ 2, as discussed in the text. YP, phosphotyrosine. (From Watson SP. Collagen receptor signaling in platelets and megakaryocytes. *Thromb Haemost* 1999;82:367, with permission.)

PLC γ 2 plays a critical role in aggregation and secretion responses to collagen, as demonstrated in PLC γ 2 knockout mice.^{250,251} The major role of PLC isoforms is concerned with the generation of the second messengers inositol 1,4,5-triphosphate and 1,2-diacylglycerol (DAG), which participate in intracellular calcium homeostasis and activation of many isoforms of PKC. The former process culminates in a robust calcium signal that promotes efficient platelet activation, via $\alpha_2\beta_1$ as well as $\alpha_{IIb}\beta_3$. Along with the proteins noted above, PI3K and its associated second messenger pathway also play a very important role in the regulation of PLC γ 2 through activation of other signaling proteins such as protein kinase B (also known as Akt).²⁵² Platelets contain several isoforms of Akt that are important for normal platelet function and thrombus formation along with granule secretion. Other downstream events include activation of Rap1 and Pyk2.^{251,252,253} and ^{254,255}

In addition to GPVI, the $\alpha_2\beta_1$ receptor also propagates signaling. The use of $\alpha_2\beta_1$ -selective ligands has demonstrated calcium-dependent spreading and tyrosine phosphorylation of several proteins when interaction with platelets takes place, including Src, Syk, SLP-76, PLC γ 2, p38 MAP kinase, ILK, Rac, and PAK.²⁵⁶

Physiologic Inhibition of Platelet Adhesion

Negative regulation of platelets is essential to set the stimulus threshold for thrombus formation, determine final clot size and stability, and prevent uncontrolled thrombosis. The mechanisms behind the negative regulation of platelet activation are described later in the chapter, and in this respect, roles of players such as nitric oxide and prostacyclin have been well characterized. Platelet activation can also be inhibited by signaling through the adhesion molecule PECAM-1 (CD31).^{257,258,259,260} Expressed on a number of blood cells and endothelial cells, PECAM has a wide array of regulatory functions in processes such as apoptosis and cell activation. Following homophilic interactions and/or clustering, PECAM-1 is tyrosine phosphorylated in its cytoplasmic tail ITIM domain (immunoreceptor tyrosine-based inhibition motif) by Src family kinases, and this engenders recruitment of tyrosine, serine/threonine, or lipid phosphatases with resultant kinase-dependent signaling inhibition.²⁵⁸ Phosphorylation of PECAM-1 recruits and activates the SH2 domain-containing protein-tyrosine phosphatase, SHP-2.²⁶⁰ Studies suggest that the PECAM-1/SH-2 complex functions to counteract platelet activating, most particularly for collagen by inhibiting GPVI/ FcR γ chain signaling.²⁶⁰ However, PECAM-1 has also been observed to attenuate G-protein mediated signaling by thrombin and other agonists. The Src family kinase Lyn also inhibits platelet activation by GPVI, and appears to do so independently of PECAM.²⁶¹ Other platelet proteins with ITIM-domains that also inhibit platelet function include carcinoembryonic antigen cell adhesion molecule 1 (CECAM1) and G6B.²⁶²

Platelet Thrombin (Protease-activated) Receptors and Signaling

PARs are G-protein-coupled receptors that use a unique mechanism to convert an extracellular protein cleavage event into an intracellular activation signal. In this case, the ligand is already part of the receptor per se, by virtue of the fact that it is represented by the amino acid sequence SFLLRN (residues 42 through 47) and is unmasked as a new amino terminus after thrombin cleaves the peptide bond between Arg 41 and Ser 42. This “tethered ligand” then proceeds to irreversibly dock with the body of its own receptor to effect transmembrane signaling, as shown in Figure 16.9.

Thrombin signaling in platelets is mediated, at least in part, by four members of a family of G-protein-coupled PARs (PAR-1, -2, -3, and -4) (see previous section for a discussion of the GPIb complex as a thrombin receptor).²⁶³ Human platelets express PAR-1 and PAR-4, and activation of either is sufficient to trigger platelet aggregation.^{264,265} Mouse platelets express PAR-3 and PAR-4.²⁶⁶ PAR-1, -3, and -4 can be activated by thrombin, whereas PAR-2 can be activated by trypsin, tryptase, and coagulation factors VIIa and Xa. Presumably, other proteases are capable of recognizing the active sites of these receptors and can thus also trigger PAR signaling.

PAR-1 is the prototype family member and was the first to be cloned and characterized in the human and hamster.²⁶⁴ A synthetic peptide that mimics the PAR-1-tethered ligand (SFLLRN) is capable of functioning as an agonist by activating the receptor independent of cleavage of the 41-residue N-terminal exodomain.

The mechanism by which G-protein-coupled receptors, such as PAR-1, signal through the G proteins is shown in Figure 16.10. PAR-1 is capable of coupling to members of the G12/13, Gq, and Gi/z families and thus is connected to a significant number of intracellular signaling pathways. The α subunits of G12 and G13 are believed to be involved in mediating platelet shape change,²⁶⁷ and downstream signaling mediators include Rho family members, among others. The α subunit of Gq is needed for platelet secretion and aggregation and participates in activation of PIC β that leads to calcium mobilization and PKC activation.²⁶⁸ The α

P.401

subunit of Gz is a Gi family member that has been speculated to play an epinephrinelike role in human platelets through inhibition of adenylate cyclase.²⁶⁹

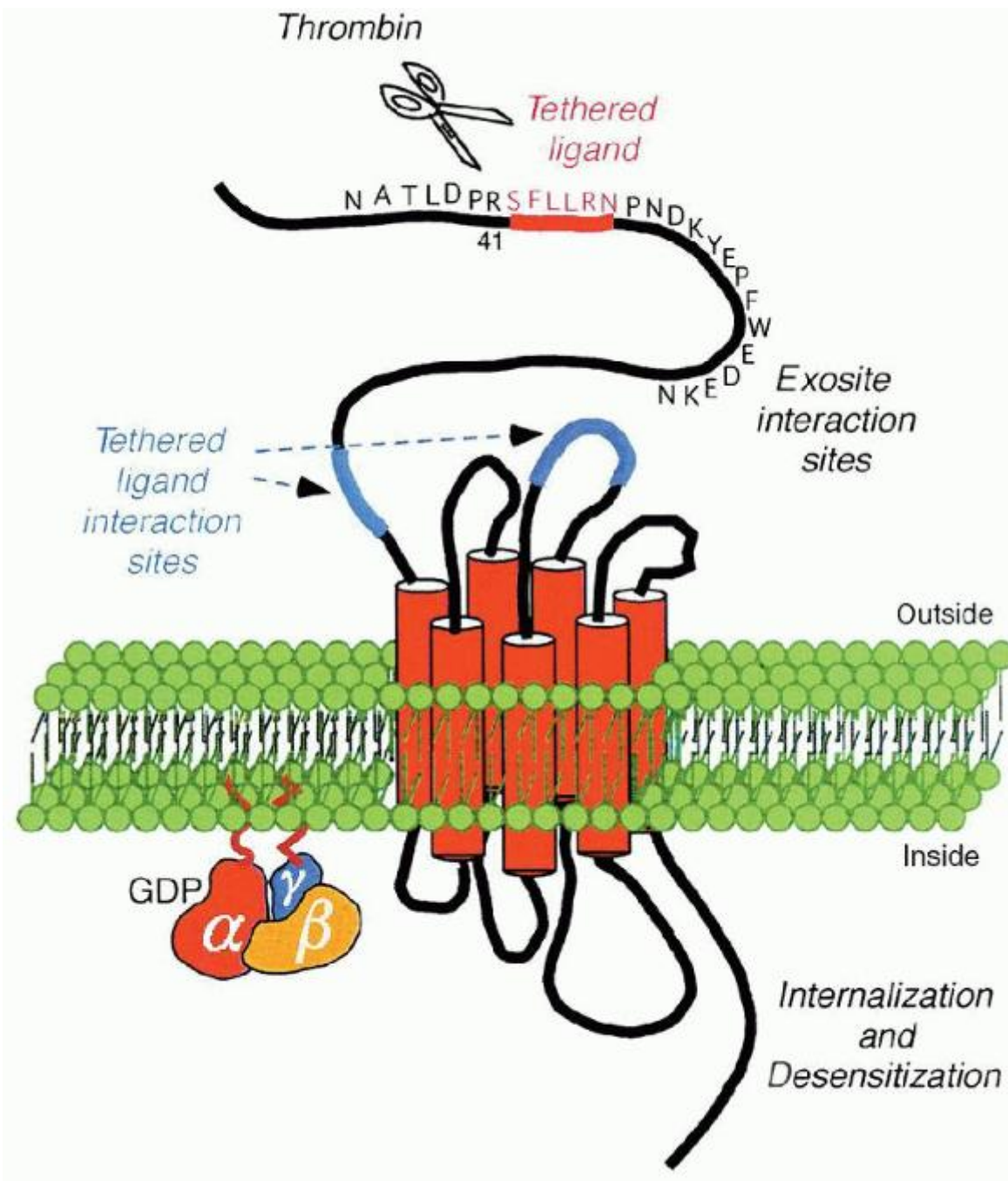

FIGURE 16.9. Structure and features of PAR-1. Cleavage of PAR-1 by thrombin between arginine 41 and serine 42 exposes a new N terminus that serves as a tethered ligand. Activation of PAR-1 is followed by a rapid burst of signaling before the receptor is desensitized and, in some cases, cleared from the cell surface. (From Brass LF. Thrombin and platelet activation. *Chest* 2003;124:18S-25S.)

The β - γ subunit counterparts of G proteins involved in PAR signaling are involved in a plethora of activities, including activation of protein kinases, channels, and lipid-modifying enzymes, such as PI3K, which provide attachment for multiple signaling protein complexes close to the inner leaflet of the cell membrane, potentially through surface "hot spots."²⁷⁰ Thus, this vast network of signaling pathways mediated through several G-protein families is in keeping with the pleiotropic roles that thrombin has been shown to exhibit in cellular homeostasis, which extends beyond platelet activation to include endothelial cells, leukocytes, smooth muscle cells, and T lymphocytes, along with physiologic processes such as tissue injury, inflammation, angiogenesis, and embryonic development.

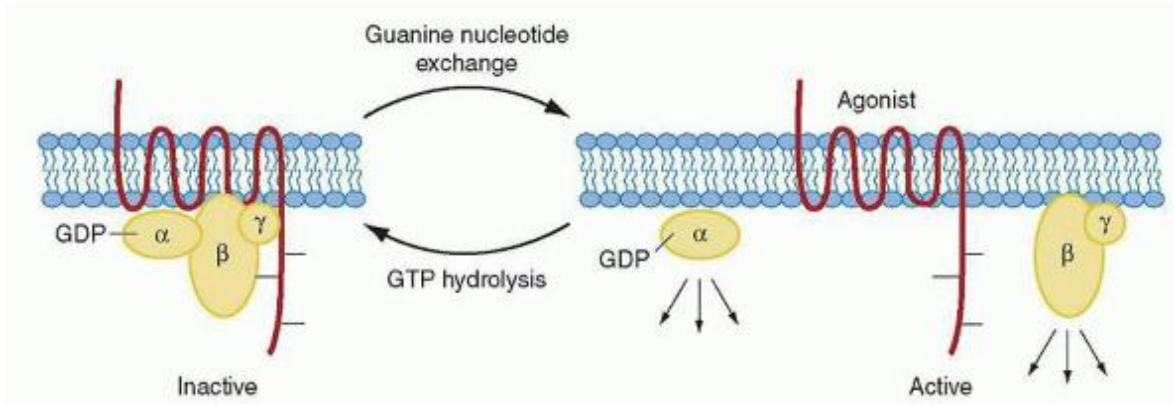

FIGURE 16.10. Signaling through G proteins and G-protein-coupled receptors. Agonist binding to the receptor causes the exchange of guanosine triphosphate (GTP) for guanosine diphosphate (GDP) on the guanine nucleotide-binding site of the G-protein α subunit. This causes the dissociation of $G\alpha$ from $G\beta\gamma$, both of which can activate intracellular effectors and ion channels. (From Brass LF. Molecular basis of platelet activation. In: Hoffman R, Benz EJ, Shattil SJ, et al., eds. Hematology: basic principles and practice. New York: Churchill-Livingstone, 2000:1754, with permission.)

Physiologic differences exist between PAR-1 and PAR-4 on human platelets. PAR-1 appears to mediate a substantial portion of thrombin signaling and appears to be most efficient at mediating platelet activation at low concentrations of thrombin, whereas PAR-4 can function in the absence of PAR-1, but only at high thrombin concentrations. The rate of platelet activation through PAR-4 is significantly slower and more sustained than that through PAR-1.^{271,272} Given the importance of this system with respect to normal hemostasis, PAR-4 may serve as a redundant, backup receptor to PAR-1, or it may serve as an important receptor for one or more proteases other than thrombin.

Once activated, PAR-1 is rapidly uncoupled from signaling and internalized into the cell.²⁷³ It is then transported to lysosomes and degraded.^{268,269} Platelets presumably have no need for a thrombin receptor recycling mechanism, because once activated, they are irreversibly incorporated into blood clots. Conversely, in cell lines with characteristics similar to megakaryocytes, new protein synthesis is needed for recovery of PAR-1 signaling,²⁷⁴ and in endothelial cells, sensitivity to thrombin is maintained by delivery of naive PAR-1 to the cell surface from a preformed intracellular pool.²⁷⁵

Subsequent studies employing PAR3 and PAR4 knockout mice have also demonstrated defective thrombus formation under high shear conditions *in vivo*, suggesting the possible existence of shear-based functional differences between protease-activated receptors.^{276,277}

Platelet ADP (Purinergetic) Receptors and Signaling

Evidence that ADP plays an important role in both the formation of the platelet plug and the pathogenesis of arterial thrombosis has been accumulating since its initial characterization in 1960 as a factor derived from red blood cells that influences platelet adhesion.²⁷⁸ ADP is present in high (molar) concentrations in platelet-dense granules and is released when platelet stimulation takes place with other agonists, such as collagen; thus, ADP serves to further amplify the biochemical and physiologic changes associated with platelet activation and aggregation. Inhibitors of this ADP-associated aggregation include commonly used clinical agents, including ticlopidine, clopidogrel, prasugrel, and ticagrelor, proven to be very effective antithrombotic drugs.^{278,279}

Platelet P2Y₁ and P2Y₁₂ and P2X₁ Receptors

Adenine nucleotides interact with P2 receptors that are ubiquitous among different cell types and have been found to regulate a wide range of physiologic processes. They are divided into two groups, the G-protein-coupled superfamily named P2Y and the ligand-gated ion channel superfamily termed P2X.²⁸⁰ Two G-protein-coupled

P.402

(P2Y) receptors contribute to platelet aggregation. The P2Y₁ receptor initiates aggregation through mobilization of calcium stores, and the P2Y₁₂ receptor is coupled to inhibition of adenylate cyclase and is essential for a full aggregation response to ADP with stabilization of the platelet plug. P2X₁ is a third purinergetic receptor present in platelets that may largely recognize ATP.

The P2Y₁ receptor was first cloned in 1993 from a chick brain complementary DNA library.²⁸¹ The P2Y₁ receptor has 373 amino acid residues and the prototype structure of a G-protein-coupled receptor. It is distributed in various tissues such as heart, blood vessels, testis, and ovary.²⁸⁰ P2Y₁ couples to G_{αq}, and platelets from mice deficient in P2Y₁ are unable to change shape or aggregate in response to ADP²⁸²; likewise, platelets from mice lacking G_{αq} do not aggregate to ADP.²⁸³ After the characterization of P2Y₁, it became clear that a second platelet ADP receptor had to exist that was responsible for the inhibition of cAMP production by ADP^{284,285} and that was the target for antithrombotic drugs (at the time, ticlopidine and clopidogrel) that interfered with ADP-activation. The P2Y₁₂ receptor was cloned in 2001 from human and rat platelet complementary DNA libraries using *Xenopus* oocytes.²⁸⁶ The receptor indeed showed the ability to display ADP-mediated inhibition of platelet cyclic AMP (cAMP) formation that was not blocked by P2Y₁ antagonists.

Inhibition of either of the P2Y₁ or P2Y₁₂ receptors is sufficient to block ADP-mediated platelet aggregation, and coactivation of both receptors is therefore necessary, through the G proteins G_q and G_i, respectively, for ADP to activate and aggregate the platelet (Fig. 16.11).²⁸⁷ A series of studies involving the use of selective P2Y₁ and P2Y₁₂ receptor antagonists, a cAMP inhibitor, gene targeting, and G_q and G_i protein agonists that would theoretically activate the two main G-protein pathways associated with ADP stimulation (see below) has led to the conclusion that signaling events downstream of both receptors are needed to elicit full activation.

Studies done with platelets from patients who manifest defective P2Y₁₂, along with experiments involving the study of P2Y₁ receptor function in platelet-rich plasma that has high fibrinogen concentrations, indicate that the P2Y₁ receptor has roles in activation and aggregation in addition to shape change. Platelet shape change is dependent on two separate G signaling pathways, a G_q-linked release of calcium from internal stores, and a G₁₂/G₁₃ link to activation of Rho kinases and Rho guanine nucleotide exchange factors that activate small G proteins.²⁸⁸ The primary role of the P2Y₁₂ receptor in platelet activation and aggregation is to amplify and complete the aggregation response to ADP.^{284,285} Individuals with congenital defects in P2Y₁₂ display a mild to moderate bleeding diathesis. Platelets from P2Y₁₂-deficient mice aggregate poorly, or not at all, in response to ADP, display a shift in the dose-response curves for collagen and thrombin, and lack ADP-induced repression of cAMP levels.²⁸⁹ The bleeding time of homozygous knockouts was markedly prolonged compared with near normal results in heterozygotes.²⁹⁰ Current data indicated that the P2Y₁ receptor elicits a transient platelet response (manifested by a rise in cytoplasmic calcium, shape change, and reversible aggregation), and the P2Y₁₂ receptor, via inhibition of adenylyl cyclase, amplifies the ADP response. The central role of the P2Y₁₂ receptor in the formation and stabilization of thrombi has been demonstrated by the therapeutic efficacy of antithrombotic drugs that are antagonists.^{282,283}

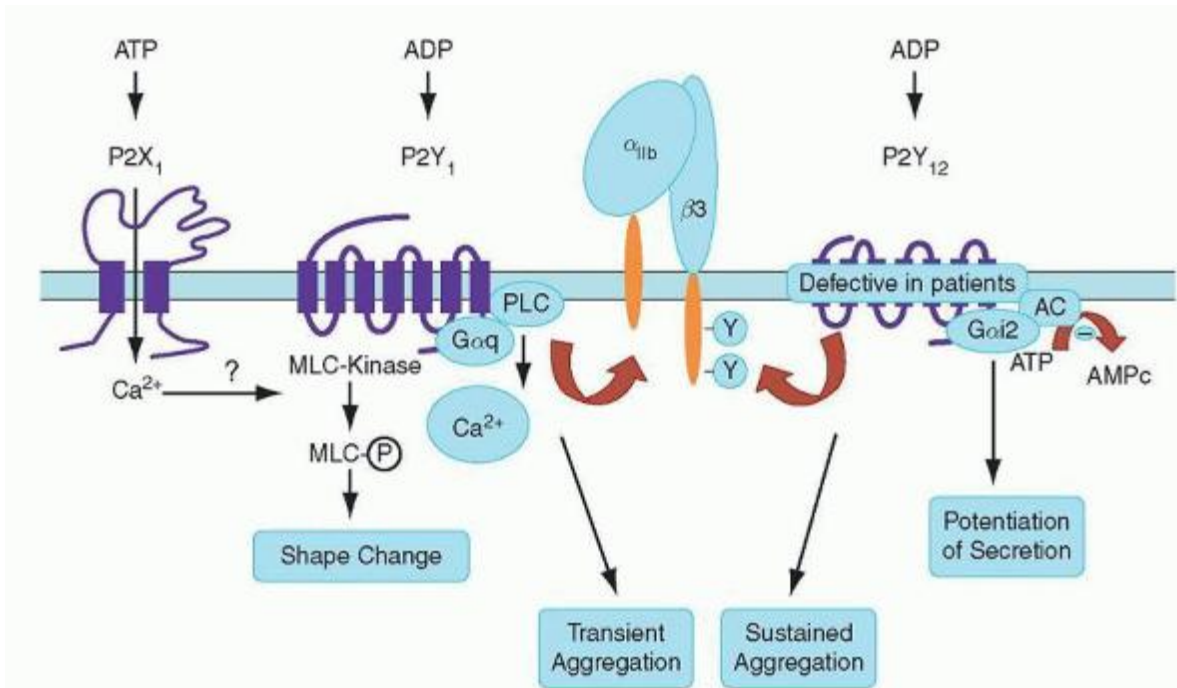

FIGURE 16.11. Current view of the interplay between the platelet P2 receptors. Two G-protein-coupled receptors are involved in adenosine diphosphate (ADP)-induced platelet aggregation, P2Y₁ and P2Y₁₂. The former is responsible for intracellular calcium mobilization, shape change, and transient aggregation, whereas the latter is coupled to adenylate

cyclase (AC) inhibition and is responsible for amplification of platelet aggregation and potentiation of platelet secretion. Both receptors are required for normal platelet response to ADP. A P2X receptor is also present on platelets and is responsible for rapid calcium influx. It therefore synergizes with the P2Y₁ receptor. Both the P2Y₁₂ and P2X₁ receptors have been shown to play key roles in platelet activation and aggregation under high shear stress conditions. ATP, adenosine triphosphate; cAMP, cyclic adenosine monophosphate; MLC, myosin light chain; P, phosphorylated; PLC, phospholipase C; Y, phosphotyrosine. (Modified from Gachet C. ADP receptors of platelets and their inhibition. *Thromb Haemost* 2001;86:227, with permission.)

The P2X₁ is an ATP-gated ion channel known to mediate rapid and selective permeability to cations. On platelets, the P2X₁ receptor has been shown to mediate fast calcium entry stimulated by ADP,²⁹¹ although ATP may be the physiologically relevant agonist. P2X₁ is a 399-amino acid protein composed of two transmembrane domains, intracellular N and C termini, and an extracellular loop with 10 conserved cysteine residues.²⁸⁰ At least three P2X subunits are required to constitute a membrane pore. A study of P2X₁-deficient mice has further indicated that this receptor contributes to the thrombosis of small arteries.²⁹² Conversely, increased systemic thrombosis has been reported in mice overexpressing the human P2X₁ receptor.²⁹³

ADP Receptor Signaling

Although considered a weak agonist in comparison to collagen or thrombin, ADP clearly plays an important role in thrombus stabilization, likely by contributing to the recruitment of

P.403

additional platelets to growing thrombi. Aggregation is often reversible when platelets are stimulated by ADP alone. In addition, low concentrations of ADP serve to amplify the effects of both strong and weaker agonists, the latter including serotonin and adrenaline, among others. As noted in the preceding paragraphs, ADP signal transduction downstream from the P2Y₁ receptor leads to a transient rise in free cytoplasmic calcium as a result of mobilization from internal stores, and this is followed by a secondary store-mediated influx, while a concomitant inhibition of adenylate cyclase is initiated by ADP stimulation of the P2Y₁₂ receptor (Fig. 16.11). The G-protein family member responsible for signaling through P2Y₁ to PICβ is G_q, whereas the member responsible for signaling through P2Y₁₂ to inhibit adenylate cyclase is G_i. While ADP-mediated platelet activation via the P2Y₁ receptor incorporates the G_q-dependent PLC-β second messenger pathway, the P2Y₁₂ receptor mediates its postoccupancy signaling through G_i-dependent PI3 kinase activation and subsequent repression of cAMP levels. In addition to the PI3K role, several groups have reported a role for Rap1b in P2Y₁₂ signal transduction. Rap1b is a small GTPase that is highly expressed in platelets, and its ADP-stimulated increased activation is abolished by P2Y₁₂ antagonists and G_i knockout mice.²⁹⁴ Rap1b, in turn, is an important intermediate in activation of platelet integrins.²⁹⁵ P2Y₁₂ activation has been found to play an important role in activation of α_{IIb}β₃. Using P2Y₁₂ knockout mice, Andre et al. noted that platelets activated with PAR-4 or ADP were defective in binding soluble fibrinogen relative to wild-type mice.²⁹⁰

Platelet Activation by Soluble Agonists

α₂-Adrenergic Receptors and Epinephrine

Epinephrine is unique among platelet agonists because it is considered to be capable of stimulating secretion and aggregation, but not cytoskeletal reorganization responsible for shape change. Platelet responses to epinephrine are mediated through α₂-adrenergic receptors,^{296,297} and these responses have been found to vary among individuals, with some donors with otherwise normal platelets manifesting delayed or absent responses.²⁹⁸ The α_{2A}-adrenergic receptor couples to G_{ai} members, most notably G_{αz} in platelets. Epinephrine synergizes with other agonists, although whether ADP or thromboxane is necessary for epinephrine's actions is not entirely clear. Epinephrine may mediate sympathetic stimulation of platelets.

Arachidonic Acid, Thromboxane A₂, and Thromboxane Receptors

After platelet stimulation by a number of agonists, arachidonic acid is generated directly by phospholipase A from its membrane phospholipid precursors (PC, PS, and PI) and indirectly by PLC generation of DAG followed by DAG lipase action. Most platelet agonists are believed to activate this pathway. Three known eicosanoid subsets of biochemical compounds are known to be derived from the formation of arachidonic acid—the prostanoids, leukotrienes, and epoxides. The prostanoids are formed by the cyclo-oxygenase pathway and include endoperoxides and thromboxanes along with prostaglandins. The leukotrienes are formed by the lipoxygenase pathway and the epoxides by the cytochrome

P450 epoxygenase pathway. Although all three of these pathways are present in platelets, most arachidonic acid ends up being metabolized to thromboxane A₂ (TxA₂).²⁹⁹

TxA₂ is produced in platelets from arachidonic acid through the generation of PGH₂ by the enzyme cyclo-oxygenase, which is irreversibly inhibited by aspirin through acetylation of a serine residue near its C terminus.^{300,301} PGH₂ is the parent compound for both biologically active prostaglandins, such as PGE₂ and PGI₂, and TxA₂. The former two compounds act to inhibit platelet activation by generating intracellular cAMP, whereas TxA₂ activates platelets. Although prostaglandin and thromboxane pathways can be present in the same cell, platelets primarily synthesize thromboxane, and endothelial cells mainly synthesize prostaglandins such as PGI₂, which acts as a local vasodilator and thus indirectly opposes platelet activation and vasoconstriction.³⁰¹

Like ADP and epinephrine, TxA₂ is also capable of activating nearby platelets after its release into plasma. It has a very short half-life of 30 seconds before its conversion to the inactive metabolite thromboxane B₂ prevents widespread platelet activation beyond the vicinity of thrombus formation.³⁰² Both arachidonic acid and analogs of TxA₂ have been found to activate and aggregate platelets by mediating shape change and phosphorylation of signaling enzymes, such as PLCβ, PKC, and so forth.³⁰³ The thromboxane receptor (TP) is a member of the seven-transmembrane G-protein-coupled receptor family and has been localized to the plasma membrane. Two isoforms of the receptor have been identified in platelets—TPα and TPβ—and they activate platelets through the G_q pathway to PLCβ and G₁₂/G₁₃ to myosin light chain phosphorylation through activation of Rho kinase.³⁰³ In addition, the α receptor is associated with activation of adenylate cyclase that leads to generation of cAMP, known to inhibit platelet activation, whereas the β receptor inhibits adenylate cyclase activation after its stimulation.

Coordination between Platelet Adhesion Events and Soluble Agonist Stimulation in Thrombus Growth

The mechanism by which soluble agonists coordinate their actions with platelet adhesion-related processes is an important consideration in the context of the steps required to facilitate thrombus growth.³⁰⁴ The application of advanced imaging techniques for visualizing individual platelets and thrombus development in live animals has dramatically improved understanding of the underlying mechanisms.^{305,306} Depending on the type and degree of vessel injury, exposure of collagen and generation of thrombin appear to serve as initiators of thrombus formation. Thrombus propagation appears to be a dynamic process, with platelets adhering and separating from the core. The bulk of the data supports a role for soluble mediators, such as ADP, in the additional accumulation of platelets within the growing thrombus. Rapid blood and high shear exert complex prothrombotic properties (e.g., by enhancing GPIb adhesions) and antithrombotic properties (e.g., by clearing soluble mediators). Within the platelet, initial platelet/vessel wall interactions characterized by contact between platelet GPIb and matrix vWF result in subsequent conformational changes in α_{IIb}β₃. Costimulation of platelets by these adhesion events and soluble agonist receptors may then potentiate and sustain early activation signals initiated by the early GPIb/vWF/α_{IIb}β₃. The costimulation may then lead to arrest of platelets. Once platelets are in close contact, molecules on the surface of one platelet can interact directly with those on an adjacent platelet. These contact-dependent events can promote or inhibit platelet functions.³⁰⁴ Major receptor pairs that amplify signaling include the Eph receptor tyrosine kinase and its ephrin ligands, semaphoring 4D, which reinforces signaling downstream of GPVI. Several adhesion/junction receptors participate in contact-dependent signaling, including PECAM-1, CEACAM1, ESAM, and JAM-A, and the bulk of the evidence indicates that they limit platelet activation and thrombus growth. Platelets also express connexins, which appear to form functional pores in closely attached platelets, but their function remains to be established definitively.³⁰⁷

Physiologic Inhibition of Platelet Activation

One of the many remarkable features of platelets is their ability to remain in a physiologic resting state and resist becoming activated while navigating the heart, arterial, and venous circulations.

P.404

Indeed, the pathologic consequences associated with widespread inappropriate platelet activation are life- and limb-threatening in the settings of well-characterized clinical disorders, such as thrombotic thrombocytopenic purpura and heparin-induced thrombocytopenia. The mechanisms responsible for maintaining the fine balance of keeping platelets in a resting state until they encounter a genuine need to undergo adhesion, activation, and aggregation at the site of vascular injury are nearly as diverse as those responsible for mediating these physiologic phenomena.

Some general mechanisms involved in physiologic inhibition of platelet activation include phenomena such as (a) generation of negative-regulating molecules by the platelet (e.g., cAMP), endothelium (e.g., PGI₂, nitric oxide [NO], heparan sulfate), and at distant sites (e.g., antithrombin); (b) barrier of endothelial cells that prevents direct contact of

circulating platelets with collagen; (c) ecto-ADPase (CD39) expression by endothelial cells that metabolizes ADP secreted from platelets; (d) tendency for blood flow to wash away unbound thrombin and other soluble mediators from the site of platelet plug formation; (e) brief half-life of certain key platelet activators such as TxA_2 ; (f) tight regulation of the affinity state of receptors such as $\alpha_{\text{IIb}}\beta_3$; (g) downregulation of signaling receptors to limit their actions; and (h) inhibitory pathways mediated by ITIM-containing and/or contact-dependent adhesion receptors, such as PECAM, CECAM-1, JAM-A, and potentially others.³⁰⁸ Some of the physiologic and biochemical phenomena related to inhibition of platelet activation are described in the following.

Receptor Downregulation and Desensitization

Signaling through G-protein-coupled receptors present on the surface of platelets is limited by their phosphorylation, which triggers desensitization, that is, uncoupling from G proteins, and internalization via Claritin-mediated endocytosis. G-protein kinases and β -arrestin are central to these processes.³⁰⁹ In addition, G-protein-coupled receptors interact with a myriad of other molecules that finely tune their signaling, including regulators of G-protein signaling (RGS)³¹⁰ and GPCR-associated sorting proteins.³¹¹

Inhibitory Prostaglandins

Generation of the prostaglandins from arachidonic acid metabolism, such as PGI_2 and PGE_2 (at high concentrations), results in inhibition of platelet activation and aggregation, and counterbalances the actions of thromboxanes derived from the same pathway. While PGI_2 and PGD_2 inhibit platelet function at low doses, PGE_2 displays a biphasic response, and inhibits platelet function only at higher concentrations, likely via the EP4 receptor. The inhibitory effects are mediated via G-protein-coupled receptors (IP and EP receptors, respectively) that couple to the α subunits of G_s to regulate adenylate cyclase-mediated generation of cAMP. cAMP levels in platelets are also governed by the activity of phosphodiesterase, the enzyme responsible for cAMP metabolism. This enzyme activity is inhibited by drugs such as the weak antiplatelet agent dipyridamole, the bronchodilator theophylline, and sildenafil, used to treat erectile dysfunction in men.

Raising cAMP levels causes a number of specific changes in platelet function, mediated in large part by activation of protein kinase A (PKA). Targets for PKA include vasodilator-stimulated phosphoprotein (VASP), the IP_3 receptor, which reduces intracellular calcium mobilization, $\text{G}\alpha_{13}$, and the cytoplasmic domain of $\text{GPIIb}\beta$. Phosphorylation of the IP_3 receptor reduces intracellular calcium mobilization, whereas $\text{G}\alpha_{13}$ phosphorylation downregulates TxA_2 signaling. Phosphorylation of $\text{GPIIb}\beta$ may reduce platelet activation through its increased interaction with the 14-3-3 ζ protein. Other targets include small G proteins of the Rho family, filamin, myosin light chain, VASP, and Rap1b.³¹² The net effect is inactivation of signaling pathways and modulation of actin cytoskeletal dynamics to block adhesion, granule release, and aggregation.

Nitric Oxide

NO is generated by endothelial cells and platelets from L-arginine in response to shear stress forces and other platelet agonists, such as thrombin and ADP. The bulk of the evidence suggests that at high concentrations NO functions to inhibit platelet activation through the cyclic guanosine monophosphate (cGMP) second messenger generated by guanylate cyclase activation.³¹³ Elevations in cGMP, by modulating phosphodiesterase activity, can raise intraplatelet cAMP. Paradoxically, low levels of NO may elicit platelet activation pathways. Endothelial NO synthase activity is enhanced during platelet activation, presumably as an additional means for limiting platelet aggregation.

Other Inhibitory Processes of Platelet Activation

Increasingly, a number of surface receptors are being identified that negatively regulate platelet signaling.³⁰⁸ Among these include the immunoglobulin (Ig)-immunoreceptor tyrosine-based inhibitory motif (ITIM) superfamily members, PECAM-1, CECAM-1, and G6b-B. While the ITIM members clearly suppress immunoreceptor tyrosine-based activation motif (ITAM)-associated Fc γ receptor IIa and glycoprotein VI (GPVI)/FcR γ -chain signaling pathways in platelets, they also appear to have broader effects at multiple levels on platelet function.

Platelet Secretion

The extent of secretion of α -, dense-, and lysosomal-granule contents is dependent on the strength of the agonist, occurs in association with platelet activation, and is one of the many downstream consequences mediated by the activation and transport to the internal leaflet of the plasma membrane of PKC. In turn, release of cargo, such as ADP, vWF, fibrinogen, and calcium ions, enhances activation and aggregation. To date, over 300 proteins have been identified that are released by platelets and may alter the local environment and have important downstream consequences.

The strongest responses a platelet can mount to agonist stimulation include activation, secretion, and aggregation. The granule secretory (release) phase is most readily documented in vitro by the “secondary wave” that denotes a second surge of aggregation activity of a fixed number of platelets in response to release of proaggregatory granule contents. These platelets are exposed to an agonist under the controlled in vitro conditions associated with platelet aggregation studies, in which clinical defects in primary hemostasis due to platelet perturbations are further characterized. The secondary wave is typically seen best when the agonist is a weaker one, such as epinephrine, or is a relatively lower concentration of another relatively weak agonist, ADP. These two agonists require both cyclo-oxygenase activity and a primary wave of aggregation to induce secretion at low calcium concentrations.³¹⁴

Several studies suggest that the mechanism by which platelet granules (vesicles) fuse with the cell membrane to release their granule contents involves soluble N-ethylmaleimide-sensitive factor (NSF) attachment protein (SNAP) receptor (SNARE) complexes that are formed between vesicle-associated membrane proteins (VAMPs; v-SNAREs), and proteins in the target membranes (different members of the syntaxin, SNAP, and vesicle-associated membrane protein [VAMP] gene families; t-SNAREs) in a lock-and-key form of docking.^{61,315} These SNARE complexes are crucial for membrane trafficking and fusion events such as secretion and

P.405

exocytosis. In platelets, the specific isoforms VAMP-2, VAMP-3, and VAMP-8 form SNARE complexes with platelet syntaxin 2, 4, and SNAP-23 to mediate platelet secretion.^{61,315} A number of SNARE regulators, such as members of the Munc family, Doc2 α , and tomosyn, regulate SNARE function. Simultaneous with the exocytosis of platelet granules, it is apparent that there is also inward (centripetal) movement of other intracellular contents, and this may play a role in transporting proaggregatory proteins away from the membrane surface and thus serve as another counterbalancing mechanism for limiting the extent of thrombus formation. Examples of this phenomenon include the internalization of fibrinogen from the surface of activated platelets, along with $\alpha_{IIb}\beta_3$ receptors from the surface of resting and activated platelets, as noted earlier.³¹⁶

PLATELET AGGREGATION: $\alpha_{IIb}\beta_3$ RECEPTOR AND ITS SIGNALING MECHANISMS

Platelet aggregation is a complex phenomenon that is the end result of a series of adhesion- and activation-related processes. The molecular mechanisms involved in platelet aggregation continue to be an area of very active research that also periodically reminds us that there is still much to be characterized about this important aspect of platelet function. Essential components of this process include an agonist, calcium, and the adhesive proteins fibrinogen and vWF. Divalent cations, such as calcium and magnesium, are required for platelet aggregation in trace amounts, and these alter the specificity of the integrin $\alpha_{IIb}\beta_3$ for its ligands. Fibrinogen and vWF play dominant roles in platelet aggregation through binding to $\alpha_{IIb}\beta_3$, and also by the ability of the former to generate polymerized fibrin as support for the platelets in a thrombus. The multivalent nature of fibrinogen and vWF allows them to cross-link platelets on binding to $\alpha_{IIb}\beta_3$ on stimulated platelets to initiate platelet aggregation.

The molecular basis of integrin signaling that occurs in platelet $\alpha_{IIb}\beta_3$ is an integral part of thrombus formation and is important in understanding this process. GPIIb (α_{IIb}) and GPIIIa (β_3) were identified as the abnormal proteins present in patients with Glanzmann thrombasthenia in the 1970s.^{316,317} They represent the most abundant receptor on the platelet surface. Like all integrin receptors, this complex is composed of noncovalently linked subunits. Each subunit is encoded by separate genes on the long arm of chromosome 17. Both subunits consist of a large extracellular domain and very short cytoplasmic domains, and together they form a heterodimer. Within their combined extracellular domains is the ligand-binding pocket, with surrounding subunit domains conferring specificity. Equally important are the short cytoplasmic domains critical for transmembrane signaling. These domains act to regulate the affinity of the receptor, transmit intracellular signaling, and anchor the receptor to the cytoskeletal elements.³¹⁸

The signaling pathways of $\alpha_{IIb}\beta_3$ are complex and have been extensively studied. Central concepts of the signaling pathway include inside-out signaling, which involves the processes termed affinity and avidity modulation,^{318,319,320,321} and outside-in signaling, in which messages are transmitted to the inside of the platelet via the events occurring outside the membrane through $\alpha_{IIb}\beta_3$ activation. Primary platelet agonists such as ADP, thrombin, and matrix proteins collagen and vWF affect platelet aggregation through a process known as inside-out signaling. This term denotes an integrin property that involves the binding action of agonists and extracellular matrix ligands to their receptors, leading to activation of numerous platelet functions, including the conformational change of $\alpha_{IIb}\beta_3$ to a high-affinity state, referred to as affinity modulation. The relative contribution of soluble and extracellular matrix stimuli to inside-out signaling likely varies with flow conditions and other factors related to vascular perturbation. For example, GPIb/V/IX function is most relevant under

high shear stress conditions such as those associated with arterioles and capillaries and in stenotic arteries. One of the effects of inside-out signaling on $\alpha_{IIb}\beta_3$ is exposure of the fibrinogen-binding site through signal transduction involving the cytoplasmic domains (Figs. 16.12 and 16.13). The process involves a cascade of intracellular pathways that converge on Rap1, the Rap1-adaptor molecule RIAM, talin, and kindlin. The association between subunit cytoplasmic tails, and likely also the integrin subunit transmembrane domains, maintains the $\alpha_{IIb}\beta_3$ complex in a resting, nonadhesive conformation. Likewise, talin appears to be “auto-inhibited” in resting cells. Inside-out signals release talin auto-inhibition to expose a FERM domain in the talin head. This domain interacts with the integrin β subunit cytoplasmic domains, which causes separation of the integrin tails with consequent changes in the extracellular domains to increase $\alpha_{IIb}\beta_3$ affinity. Activation of $\alpha_{IIb}\beta_3$ also requires kindlin-3, an adaptor protein that interacts with a distinct site on β_3 integrin tails. The precise relationship between talin and kindlin remains to be elucidated.³²²

The crystal structure of the $\alpha_{IIb}\beta_3$ headpiece provides evidence that the receptor can assume different conformations, and complexes of the receptor with the drugs eptifibatide and tirofiban have been reported.³²³ Two major conformational changes of $\alpha_{IIb}\beta_3$ have been reported—headpiece extension and domain swing-out—both of which may enhance integrin ligand binding.³²⁴ Thiol-disulfide exchange may also influence $\alpha_{IIb}\beta_3$ activation.

Avidity modulation, the less dominant action, acts to cluster the $\alpha_{IIb}\beta_3$ heterodimers into oligomers through lateral diffusion.^{325,326} These conversions are critical in allowing $\alpha_{IIb}\beta_3$ to engage soluble adhesive ligands. These ligands contain the classical integrin-recognition sequence RGD, Arg-Gly-Asp, which acts as a bridge between adjacent platelets, allowing aggregation to proceed. In addition, more $\alpha_{IIb}\beta_3$ translocates to the platelet surface membrane from the degranulating α -granule pool, where additional receptors are stored. These changes facilitate irreversible binding to fibrinogen.

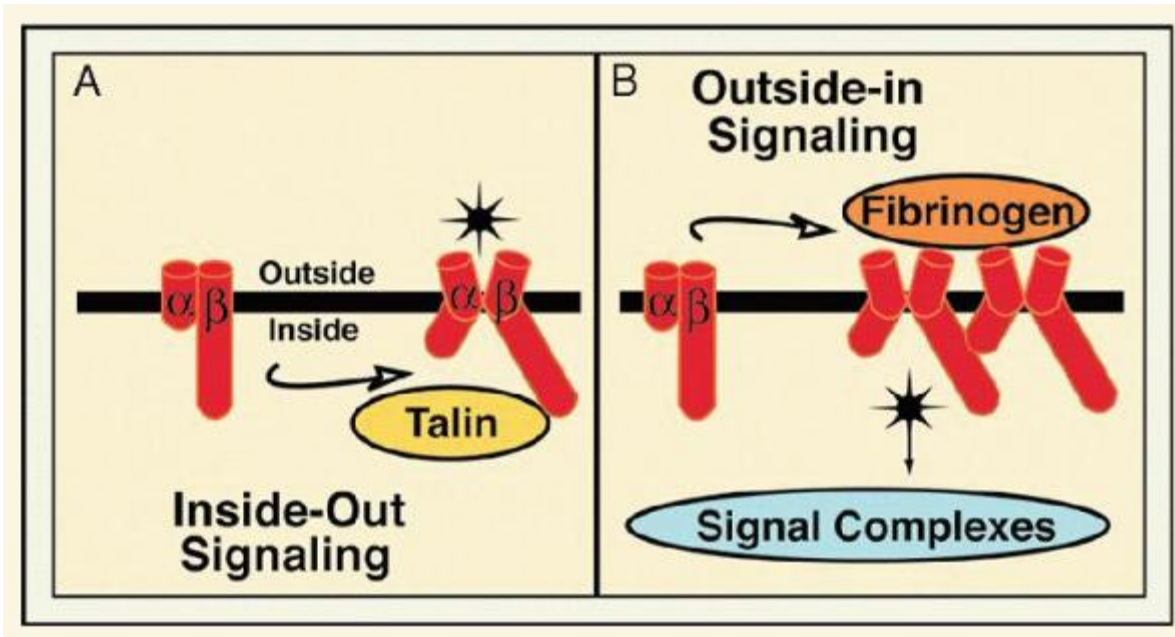

FIGURE 16.12. Integrin activation is bidirectional and reciprocal. The $\alpha_{IIb}\beta_3$ complex equilibrates between resting and activated states, the resting state predominating in unstimulated platelets and the activated state in stimulated platelets. Conversion from resting to activated does not imply a single, abrupt change but rather a series of coordinated and linked conformational transitions. A: Inside-out signaling. Agonist-dependent intracellular signals stimulate the interaction of key regulatory ligands (such as talin) with integrin cytoplasmic tails (in this case the β_3 tail). This leads to conformational changes in the extracellular domain that result in increased affinity for adhesive ligands such as fibrinogen, von Willebrand factor (vWF), and fibronectin. Plasma fibrinogen and vWF support platelet aggregation at low and high shear rates, respectively, by bridging $\alpha_{IIb}\beta_3$ receptors on adjacent platelets. Studies in mice deficient in fibrinogen and vWF indicate that plasma fibronectin can also promote thrombus initiation, growth, and stability at high shear rates. B: Outside-in signaling. Extracellular ligand binding, initially reversible, becomes progressively irreversible and promotes integrin clustering and further conformational changes that are transmitted to the cytoplasmic tails. This results in the recruitment and/or activation of enzymes, adaptors, and effectors to form integrin-based signaling complexes. (From Shattil SJ, Newman PJ. Integrins: dynamic scaffolds for adhesion and signaling in platelets. *Blood* 2004;104:1606-1615.)

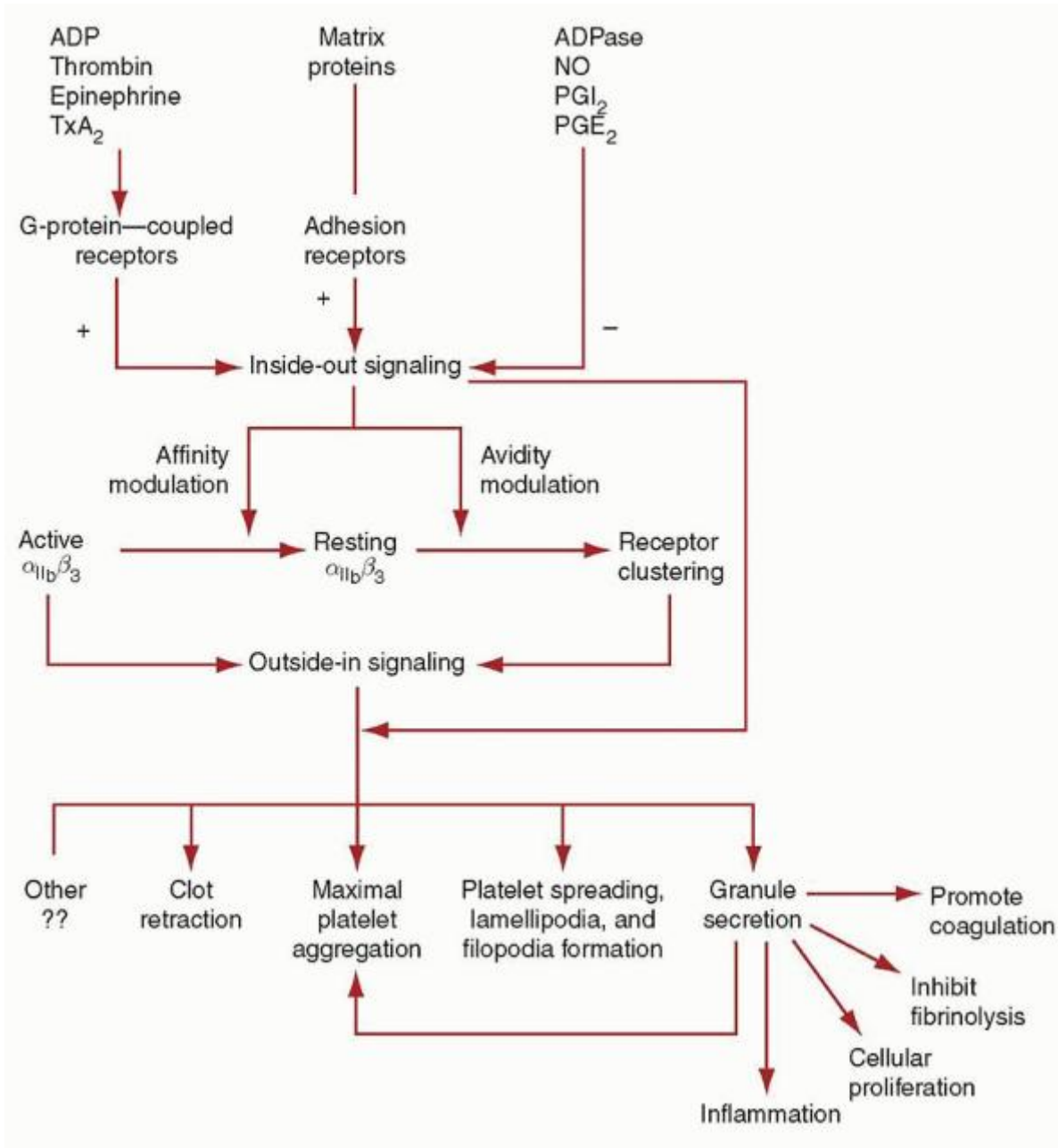

FIGURE 16.13. Schematic illustration of $\alpha_{IIb}\beta_3$ receptor regulation via inside-out and outside-in signaling. ADP, adenosine diphosphate; ADPase, adenosine 5'-diphosphatase; NO, nitric oxide; PGE_2 , prostaglandin E_2 ; PGI_2 , prostacyclin; TxA_2 , thromboxane A_2 . (From Casserly IP, Topol EJ. Glycoprotein IIb/IIIa antagonists—from bench to practice. *Cell Mol Life Sci* 2002;59:481, with permission.)

After ligand binding occurs, a multitude of intracellular signals are generated that are collectively referred to as outside-in signaling. This “contact-dependent signaling” determines the extent to which platelets will spread on a vascular matrix and how resistant to detachment they are.^{318,325} Outside-in signaling occurs in a discrete pattern in which ligand binding initiates integrin clustering and assembly of a “nascent” signaling complex proximal to the $\alpha_{IIb}\beta_3$ cytoplasmic tails, and this is followed by the growth of a larger “actin-based” signaling complex. It can be envisioned that the nascent complex is characterized temporally by (a) activation of Src kinases bound to the β_3 cytoplasmic tail by fibrinogen engaging and facilitating integrin clustering, then (b) recruitment and activation of Syk by Src, then (c) Src and/or Syk phosphorylation of various substrates including adaptor proteins SLP-76 and c-Cbl along with the Rac GTPase Vav; and these substrates in

turn act by participating in signaling to the actin cytoskeleton. As the nascent complex assembles, many additional proteins are recruited that can influence actin reorganization, including Rac, the adaptor Nck, PAK, PI3-kinase, and VASP, an actin-bundling protein. All these signaling events during platelet aggregation are further supported by release of granules induced by the binding of adhesive proteins to the extracellular domain of β_3 . This complex series of events serves as a determinant of the final clot size. Once full spreading and aggregation of platelets occurs, usually within several minutes, focal adhesion kinase is phosphorylated.³²⁶ The PI3K system is activated once $\alpha_{IIb}\beta_3$ is engaged, leading to generation of D3 phosphoinositides. These proteins act to prevent the depolymerization of the actin cytoskeleton, with the result that the platelet aggregate is stabilized. The end result of this outside-in signaling is a stable platelet clot. Not only does the $\alpha_{IIb}\beta_3$ receptor have important roles with respect to platelet function, it affects coagulation and may influence inflammatory processes as well.

Antithrombotic agents that act on the $\alpha_{IIb}\beta_3$ receptor have had a significant impact on clinical outcomes of patients with acute coronary syndromes (ACS) and those requiring percutaneous coronary interventions (PCI).³²⁷ The three parental agents used in the United States are the chimeric monoclonal antibody abciximab, the cyclic heptapeptide (based on the RGD sequence) eptifibatid, and the synthetic nonpeptide tirofiban. Disappointing clinical trial results were seen with the oral $\alpha_{IIb}\beta_3$ inhibitors used for longer term indications, and this even includes an increased all-cause mortality rate. The reasons for these results are not entirely known.

ROLE OF THE CYTOSKELETON IN PLATELET FUNCTION

(See additional cytoskeleton structure information in the section on platelet structure earlier in the chapter.)

Once an agonist has interacted with its platelet membrane receptor and triggered second messenger formation, a key event in platelet activation and subsequent aggregation is the transition of the platelet's shape from the discoid appearance associated with its circulating, resting state to the amorphous, amebalike

P.407

appearance with multiple pseudopodial projections that denote its activation state and readiness to participate in platelet plug formation. The platelet cytoskeleton and its associated signaling proteins are responsible for mediating shape change associated with activation, spreading, secretion, and aggregation. This cytoskeleton is associated with at least 14 different structural proteins that function interdependently as a single unit but can be seen as consisting of three major functional units: (a) a cytoplasmic network consisting mainly of actin, (b) a meshwork of proteins immediately proximal to the cytoplasmic leaflet of the platelet membrane referred to as the membrane skeleton (because they contain surface-associated proteins such as the GPIb complex), and (c) the microtubule coil that encircles the platelet to contribute to its resting, discoid state.

Transmembrane receptors such as GPIb participate in anchoring the platelets to extracellular matrix in the arterial subendothelium through their extracellular domains, while their cytoplasmic domains are almost simultaneously associating with membrane skeletal proteins in response. In doing so, these surface receptors are providing sites at which tension can be generated by intracellular contractile elements that subsequently lead to shape change and activation of signaling proteins.

The cytoplasmic network consists of actin filaments and their associated proteins, referred to as intermediate filaments. In resting platelets, approximately half of the actin is structurally filamentous in nature, and this fraction increases to approximately three-fourths during platelet activation.⁴⁶ During this process, the actin filaments are reorganized into longer filaments after their initial breakdown into smaller units. Simultaneously, myosin is phosphorylated by myosin light chain kinase and then associates with F-actin, with the resultant filament then attaching itself to the α subunit of the GPIb complex through filamin.^{328,329} These filaments are also anchored at sites called focal adhesions, where the tyrosine kinase Fak becomes activated after platelet stimulation. Focal adhesions assemble around the $\alpha_{IIb}\beta_3$ integrin on its conformational change (activation) and so play a very important role in signaling pathways associated with platelet activation by drawing together membrane receptors, the cytoskeleton, and signaling phosphoproteins, such as members of the Src family, PI3K, and Syk, into close physical proximity.³³⁰ Other platelet integrin receptors, such as $\alpha_2\beta_1$, also organize focal adhesions after binding to their respective extracellular ligands.

It was noted in the section on GPIb complex signaling that phosphorylation of Ser 166 in the cytoplasmic domain of the GPIb complex β chain has been observed to be mediated by cAMP-associated activation of PKA and that this phosphorylation reduced interaction of GPIb β and the signaling molecule, 14-3-3 ζ . The phosphorylation of GPIb β has also been demonstrated to have a direct inhibitory effect on actin polymerization.³³¹

The membrane skeleton consists of actin, filamin-A, talin, vinculin, spectrin, cortactin, α -actinin, and several membrane GPs, as noted previously. Filamin-A (previously termed actin-binding protein), a 280-kDa elongated dimer, serves as a scaffold for many proteins, including GPIIb α and is important to the latter's signaling and expression, and together they control platelet size. After platelet activation, cytoskeletal proteins, in particular filamin and talin, are preferentially cleaved by calpains, which are calcium-dependent proteases. Calpain-mediated cleavage of the β 3 tail of $\alpha_{IIb}\beta_3$ may modulate its functions.

The marginal microtubule band maintains a platelet discoid shape and appears to be an essential intermediate in the microtubule-driven process of proplatelet formation and platelet release.³³¹ This single microtubule polymer is wound in 8 to 12 coils in the cytoplasmic periphery and is located just beneath the plasma membrane. About 90% of β -tubulin in the marginal band is of the divergent, megakaryocyte (MK)/platelet-restricted β 1 isoform. β 1-tubulin-null mice show reduced proplatelet formation, thrombocytopenia, and platelet spherocytosis.³³²

PLATELET-CELL INTERACTIONS

Platelets and Endothelium

The mechanisms behind platelet interaction with vWF, collagen, and other subendothelial matrix molecules exposed as a result of damaged endothelium have been well studied and described in earlier sections of this chapter. In addition to these platelet-subendothelial interaction paradigms, platelets (like neutrophils) roll on intact, activated endothelium *in vivo* and then reversibly adhere to it in a process that is dependent on endothelial cell expression of P-selectin.^{333,334} This sequence of molecular interactions is a well-controlled multistep process involving platelet tethering and interaction of platelet P-selectin glycoprotein ligand-1 (PSGL-1) or GPIIb α with endothelial P-selectin ("rolling"), followed by subsequent "firm adhesion" to the vascular wall mediated through β_3 integrins. Platelets rolling on activated endothelium can be inhibited by both anti-P-selectin and anti-GPIIb α antibodies. GPIIb α and PSGL-1 have structural similarities, including similar ligand-binding domains, and both are present on platelets and may interact with P-selectin. Endothelial P-selectin is rapidly expressed on the surface in response to inflammatory stimuli by translocating from membranes of storage granules (Weibel-Palade bodies) to the plasma membrane within seconds.

Along with endothelial P-selectin, vWF expressed on activated venous endothelium promotes platelet adhesion and translocation.³³⁵ When released along the endothelial surface as ultralarge vWF, platelets adhere like beads on a string. Platelets are released by cleavage of vWF by the metalloprotease, a disintegrin-like metalloproteinase with thrombospondin repeats-13 (ADAMTS13), that proteolyzes vWF within the A2 domain under conditions of increased shear stress. Dysfunction in ADAMTS13 function underlies thrombotic thrombocytopenic purpura (TTP). In the absence of ADAMTS13, the platelet beads along the endothelial cells coalesce to form thrombi.

Firm platelet adhesion to intact endothelial cells following rolling is a process dependent on $\alpha_{IIb}\beta_3$ bridging to endothelium that involves endothelial receptors such as $\alpha_v\beta_3$ and intercellular adhesion molecule-1 interacting with platelet-bound fibrinogen, fibronectin, and vWF.^{335,336,337} This firm adhesion is strengthened by inflammatory cytokines, such as RANTES, and additional receptor pairs, such as CD40-CD40L.

Platelets and White Blood Cells

Platelets contribute to leukocyte rolling and extravasation, which are two well-characterized steps involved in the translocation of the latter cell from the circulation to sites of infection.³³⁸ Leukocytes are also capable of tethering and rolling on adherent and activated platelets by interacting with P-selectin expressed on the platelet surface, and they will subsequently display extravasation mediated by activation of Mac-1.³³⁹ The α subunits of certain integrins, such as Mac-1, have been found to contain "insert" (I) domains, homologous to the A₁ domain of vWF. This observation has taken on added interest since it has been shown that Mac-1 is capable of binding to the GPIIb complex and that this interaction requires the I domain of Mac-1 and the leucine-rich repeat region of GPIIb α . The Mac-1-GPIIb complex interaction may be important to initiate and propagate inflammation associated with the progression of atherosclerotic, purely thrombotic, or atherothrombotic processes.

Mac-1 has also been found to associate with other receptors of the platelet membrane, including the junctional adhesion molecule-3 (JAM-3), intercellular adhesion molecule-2 (ICAM-2), fibrinogen bound to $\alpha_{IIb}\beta_3$, and high-molecular-weight kininogen bound to GPIIb α .³⁴⁰ During this adhesive process, the association of platelet membrane PSGL-1 and Mac-1 stimulates the

P.408

release of inflammatory cytokines from platelets, which in turn induces inflammatory cascades in monocytes. This

integrin-, selectin-, and cytokine-based set of coordinated reactions linking neutrophils, platelets, and monocytes leads to circulating activated platelets and platelet-white cell aggregates that promote formation of atherosclerotic lesions.

ROLE OF PLATELETS IN SYSTEMIC DISORDERS

Inflammation and Immunity

The binding of platelets to leukocytes influences important white cell effector responses, such as cell activation, signaling associated with integrin activation, chemokine synthesis, and so forth. Thus, it has become clear that inflammation is capable of leading to local thrombosis, and thrombosis is capable of initiating and propagating inflammation. Leukocyte interactions with platelets result in immediate events, including activation of adhesion receptors, reactive oxygen species generation, and thrombin formation, but also in delayed responses such as alterations in gene expression and protein synthesis. The molecules regulated by platelet adhesion include cyclo-oxygenase 2 and tissue factor expression. Platelets and leukocytes participate in transcellular metabolism of arachidonic acid to generate novel mediators that either cell type alone could not generate. Platelets also stimulate the formation of neutrophil extracellular traps (nets) composed of DNA and proteases. Nets trap and kill bacteria and may also form scaffolds for thrombus formation. Platelets can also promote class switching of B cells through CD40L. The interactions of platelets with leukocytes may regulate the development of intimal hyperplasia, inflammatory lung and bowel disease, and arthritis.

Platelets in Atherogenesis

Atherosclerosis is the major cause of vascular occlusive disorders such as coronary artery disease, stroke, and peripheral arterial disease. Many of the molecular players mediating leukocyte-endothelium interactions that underscore the development of atherosclerosis have also been found to play important roles coordinating leukocyte attachment and transmigration across layers of platelets adherent to injured vascular intima. Animal models have recently provided strong evidence linking platelets to early events of atherogenesis. An atherosclerosis mouse model lacking α_{IIb} exhibited substantial reduction in atherosclerotic lesion formation.³⁴¹ The importance of P-selectin in atherosclerosis lesion formation has been well described.^{342,343} Platelet adhesion has been found to activate endothelial cell nuclear factor- κ B and its regulated genes, many of which play key roles in platelet-leukocyte-endothelium-extracellular matrix molecular events that support inflammatory and proatherogenic phenotypes. This includes events that contribute to lesion maturation such as smooth muscle cell and fibroblast proliferation and promotion of collagen synthesis, among others. Inhibition of COX-1, an enzyme with expression restricted to platelets, in turn inhibits lesion formation in an atherosclerosis mouse model.^{344,247} Another atherosclerosis mouse model demonstrates that prolonged antibody blockade of GPIIb α leads to reduced arterial leukocyte accumulation in carotid arterial intima and subsequent reduced atherosclerosis lesion formation.³⁴⁵ vWF may also have a role in atherogenesis.³⁴⁶

In contrast to animal data, conclusions regarding the role of human platelets in atherogenesis are not nearly as extensive. Mouse data cannot be unequivocally applied to humans, because mouse platelets differ from human with respect to expression levels of certain surface receptors. Systemic platelet activation in humans has been described in a variety of atherosclerosis disease presentations. Antiplatelet agents do not obviously influence disease progression when applied in the secondary disease prevention setting in humans in which atherosclerosis is likely advanced, as opposed to the possibly preventable progression of early lesions that are present before an initial atherosclerosis clinical event.³⁴⁷

Platelets in Atherothrombosis

The interior of intact atherosclerotic plaques is rich in components that are highly thrombogenic (e.g., collagen types I and III, fibrinogen/fibrin, thrombospondin), and the luminal surface is relatively nonthrombogenic. In contrast to these observations, the thrombotic response to plaque disruption is dynamic. In this respect, thrombosis, repeat thrombosis, and thrombolysis, along with embolization, all occur simultaneously in many patients with acute coronary syndrome, and this is considered responsible for intermittent flow obstructions.³⁴⁸ The initial flow obstruction is acknowledged as being due to platelet aggregation, but subsequent fibrin stabilization is important to the longevity of the early and fragile platelet thrombus.³⁴⁹ As a result of reduced flow caused by the platelet thrombus at the plaque rupture site, an erythrocyte- and fibrin-rich thrombus may form and propagate up and down the artery in both directions.³⁴⁸ There is evidence that alteration of the endothelium such as may occur with early atherogenesis (particularly when under the influence of atherosclerosis risk factors) or plaque disruption may cause the endothelium to generate more mediators that enhance constriction, such as endothelin-1, and fewer mediators that enhance dilation, such as PGI₂ and NO.

Platelets in Vessel Integrity and Development

Platelets are essential to maintain the integrity of the vasculature, although the mechanisms are unknown. Platelets store a number of barrier stabilizing cytokines and growth factors which may be released constitutively or in a stimulus-

dependent manner, including sphingosine-1-phosphate (S1P) is essential for barrier function, ADP, serotonin, VEGF, and thrombospondin. Platelets recruit and promote the differentiation of bone marrow-derived and circulating endothelial progenitor cells, which may contribute to the vessel response to injury. Finally, platelets regulate lymphangiogenesis through interactions between platelet C-type, lectin-like receptor 2 (CLEC-2) expressed by platelets and podoplanin on lymphatic endothelial cells. Disruptions in these interactions in mice result in severe lymphatic vascular defects.

REFERENCES

1. Frojmovic MM, Panjwani R. Geometry of normal mammalian platelets by quantitative microscopic studies. *Biophys J* 1976;16:1071-1089.
2. Robinson MS, Harrison C, Mackie IJ, et al. Reticulated platelets in primary and reactive thrombocytosis. *Br J Haematol* 1998;101:388-395.
3. Behnke O. Electron microscopic observations on the membrane systems of the rat blood platelet. *Anat Rec* 1967;158:121-138.
4. White JG. Electron microscopic studies of platelet secretion. *Prog Hemost Thromb* 1974;2:49-98.
5. White JG, Clawson GC. Overview article: biostructure of blood platelets. *Ultrastruct Pathol* 1980;1:533-558.
6. White JG. Anatomy and structural organization of the platelet. In: Colman RW, Hirsh J, Marder VJ, Salzman EW, eds. *Hemostasis and thrombosis. Basic principles and clinical practice*, 2nd ed. Philadelphia: JB Lippincott, 1987:537-554.
7. Bevers EM, Comfurius JP, van Rijn JL, et al. Generation of prothrombin-converting activity and the exposure of phosphatidylserine at the outer surface of platelets. *Eur J Biochem* 1982;122:429-437.
8. Schick PK. The organization of aminophospholipids in human platelet membranes: selective changes induced by thrombin. *J Lab Clin Med* 1978;91: 802-811.
9. Miletich JP, Jackson CM, Majerus PW. Properties of the factor Xa binding site on human platelets. *J Biol Chem* 1978;253:6908-6916.
10. Scandura JM, Ahmad S, Walsh PN. A binding site expressed on the surface of activated human platelets is shared by factor X and prothrombin. *Biochemistry* 1996;35:8890-8902.
11. Simons ER, Greenberg-Spersky SM. Transmembrane non-covalent cation gradients. In: Holmsen H, ed. *Platelet responses and metabolism*, 3rd ed. Boca Raton, FL: CRC Press, 1987:31-49.
12. White JG. Is the canalicular system the equivalent of the muscle sarcoplasmic reticulum? *Hemostasis* 1975;4:185-191.
13. White JG, Clawson CC. The surface-connected canalicular system of blood platelets—a fenestrated membrane system. *Am J Pathol* 1980;101:353-364.
14. Stenberg PE, Shuman MA, Levine SP, Bainton DF. Redistribution of alpha granules and their contents in thrombin-stimulated platelets. *J Cell Biol* 1984;98:748-760.
15. Cramer EM. Platelets and megakaryocytes: anatomy and structural organization. In: Colman RW, Hirsh J, Marder VJ, et al., eds. *Thrombosis and hemostasis. Basic principles and clinical practice*, 4th ed. Philadelphia: Lippincott Williams & Wilkins, 2001:411-428.
16. Kieffer N, Guichard J, Breton-Gorius J. Dynamic redistribution of major surface receptors after contact-induced platelet activation and spreading: an immuno-electron microscopic study. *Am J Pathol* 1992;40:57-73.
17. Behnke O. The morphology of blood platelet systems. *Ser Haematol* 1970;3:3-16.
18. Behnke O. An electron microscope study of the rat megakaryocyte. II. Some aspects of platelet release and microtubules. *J Ultrastruct Res* 1969;26: 111-129.
19. Daimon T, Gotoh Y. Cytochemical evidence of the origin of the dense tubular system in the mouse platelet. *Histochemistry* 1982;76:189-196.
20. Breton-Gorius J, Guichard J. Ultrastructural localization of peroxidase activity in human platelets and megakaryocytes. *Am J Pathol* 1972;66:277-286.
21. Breton-Gorius J. The value of cytochemical peroxidase reactions at the ultra-structural level in hematology. *Histochem J* 1980;12:127-137.
22. White JG. Interaction of membrane systems in blood platelets. *Am J Pathol* 1972;66:295-312.

23. Nichols BA, Setzer PY, Bainton DF. Glucose-6-phosphatase as a cytochemical marker of endoplasmic reticulum in human leukocytes and platelets. *J Histochem Cytochem* 1984;32:165-171.
24. Tranum-Jensen J, Behnke O. Acetylcholinesterase in the platelet-megakaryocyte system. II. Structural localization in megakaryocytes of the rat, mouse, and cat. *Eur J Cell Biol* 1981;24:281-286.
25. Cutler L, Rodan G, Feinstein MB. Cytochemical localization of adenylate cyclase and of calcium ion, magnesium ion-activated ATPases in the dense tubular system of human blood platelets. *Biochim Biophys Acta* 1978;542:357-371.
26. Gerrard JM, White JG, Rao GHR, Townsend E. Localization of platelet prostaglandin production in the platelet dense tubular system. *Am J Pathol* 1976;83:283-298.
27. Gerrard JM, White JG, Peterson DA. The platelet dense tubular system: its relationship to prostaglandin synthesis and calcium flux. *Thromb Haemost* 1978;40:224-231.
28. Fox JEB. Platelet cytoskeleton. In: Colman RW, Hirsh J, Marder VJ, et al., eds. *Thrombosis and hemostasis. Basic principles and clinical practice*, 4th ed. Philadelphia: Lippincott Williams & Wilkins, 2001:429-446.
- P.409
29. Fox JEB, Boyles JK, Reynolds CC, Phillips DR. Actin filament content and organization in unstimulated platelets. *J Cell Biol* 1984;98:1985-1991.
30. White JG. Arrangements of actin filaments in the cytoskeleton of human platelets. *Am J Pathol* 1984;117:207-217.
31. Tablin F, Taube D. Platelet intermediate filaments: detection of a vimentin like protein in human and bovine platelets. *Cell Motil Cytoskeleton* 1987;8:61-67.
32. Muzbek L, Adany R, Glukhova MA, Frid MG. The identification of vimentin in human blood platelets. *Eur J Cell Biol* 1987;43:501-504.
33. Sixma JJ, Molenaar I. Microtubules and microfibrils in human platelets. *Thromb Diath Haemorrh* 1966;16:153-162.
34. Behnke O. Further studies on microtubules. A marginal bundle in human and rat thrombocytes. *J Ultrastruct Res* 1965;13:469-477.
35. Castle AG, Crawford N. Platelet microtubule subunit proteins. *Thromb Haemost* 1979;42:1630-1633.
36. White JG. The submembrane filaments of blood platelets. *Am J Pathol* 1969;56:267-277.
37. Hartwig JH, DeSisto M. The cytoskeleton of the resting human blood platelet: structure of the membrane skeleton and its attachment to actin filaments. *J Cell Biol* 1991;112:407-425.
38. Fox JEB, Boyles JK, Berndt MC, et al. Identification of a membrane skeleton in platelets. *J Cell Biol* 1988;106:1525-1538.
39. Fox JEB, Reynolds CC, Morrow JS, Phillips DR. Spectrin is associated with membranebound actin filaments in platelets and is hydrolyzed by the Ca^{2+} -dependent protease during platelet activation. *Blood* 1987;69:537-545.
40. Niederman R, Pollard T. Human platelet myosin. II. In vitro assembly and structure of myosin filaments. *J Cell Biol* 1975;67:72-92.
41. O'Halloran T, Beckerle MC, Burrig K. Identification of talin as a major cytoplasmic protein implicated in platelet activation. *Nature* 1985;317:449-451.
42. Kotliansky VE, Gneushev GN, Glukhova MA, et al. Identification and isolation of vinculin from platelets. *FEBS Lett* 1984;165:26-30.
43. Schollmeyer JV, Rao GHR, White JG. An actin-binding protein in human platelets. Interactions with alpha-actinin on gelation of actin and the influence of cytochalasin B. *Am J Pathol* 1978;93:433-446.
44. Nachmias VT. Cytoskeleton of human platelets at rest and after spreading. *J Cell Biol* 1980;86:795-802.
45. Jennings LK, Fox JEB, Edwards HH, Phillips DR. Changes in the cytoskeletal structure of human platelets following thrombin activation. *J Biol Chem* 1981;256:6927-6932.
46. Carlsson L, Markey F, Blikstad I, et al. Reorganization of actin in platelets stimulated by thrombin as measured by the DNase I inhibition assay. *Proc Natl Acad Sci U S A* 1979;76:6376-6380.

47. Dingus J, Hwo S, Bryan J. Identification by monoclonal antibodies and characterization of human platelet caldesmon. *J Cell Biol* 1986;102:1748-1757.
48. Casella JF, Flanagan MD, Lin S. Cytochalasin D inhibits actin polymerization of actin filaments formed during platelet shape change. *Nature* 1981;293:302-305.
49. Hartwig JH. Mechanism of actin rearrangements mediating platelet activation. *J Cell Biol* 1992;118:1421-1442.
50. Karlsson R, Lassing I, Hoglund AS, Lindberg U. The organization of microfilaments in spreading platelets: a comparison with fibroblasts and glial cells. *J Cell Physiol* 1984;121:96-113.
51. Fox JEB, Phillips DR. Role of phosphorylation in mediating the association of myosin with the cytoskeletal structures of human platelets. *J Biol Chem* 1982;257:4120-4126.
52. Nachmias VT, Kavalier J, Jacobowitz S. Reversible association of myosin with the platelet cytoskeleton. *Nature* 1985;313:70-72.
53. Hathaway DR, Adelstein RS. Human platelet myosin light chain kinase requires the calcium-binding protein calmodulin for activity. *Proc Natl Acad Sci U S A* 1979;76:1653-1657.
54. Pollard TD, Fujiwara K, Handin R, Weiss G. Contractile proteins in platelet activation and contraction. *Ann NY Acad Sci* 1977;283:218-236.
55. Fox JEB, Reynolds CC, Phillips DR. Calcium-dependent proteolysis occurs during platelet activation. *J Biol Chem* 1983;258:9973-9979.
56. Behnke O, Zelander T. Substructure in negatively stained microtubules of mammalian blood platelets. *Exp Cell Res* 1967;43:236-243.
57. Thon JN, Macleod H, Begonja AJ. Microtubule and cortical forces determine platelet size during vascular platelet production. *Nat Commun* 2012;3:852
58. White JG, Sauk JJ. The organization of microtubules and microtubule coils in giant platelet disorders. *Am J Pathol* 1984;116:514-522.
59. Verhoeven AJM, Mommersteeg ME, Akkerman JWN. Quantification of energy consumption in platelets during thrombin-induced aggregation and secretion: tight coupling between platelet responses and the increment in energy consumption. *Biochem J* 1984;221:777-786.
60. White JG. Exocytosis of secretory organelles from blood platelets incubated with cationic polypeptides. *Am J Pathol* 1972;69:41-53.
61. Lemons PP, Chen D, Bernstein AM, et al. Regulated secretion in platelets: identification of elements of the platelet exocytosis machinery. *Blood* 1997;90:1490-1500.
62. Blair P, Flaumenhaft R. Platelet alpha-granules: basic biology and clinical correlates. *Blood Rev* 2009;23:177-189
63. Harrison P, Cramer EM. Platelet alpha granules. *Blood Rev* 1993;7:52-65.
64. Holt JC, Niewiarowski S. Biochemistry of alpha granule proteins. *Semin Hematol* 1985;22:151-168.
65. White JG. Tubular elements in platelet granules. *Blood* 1968;32:148-156.
66. Cramer EM, Meyer D, Menn RL, Breton-Gorius J. Eccentric localization of von Willebrand factor in an internal structure of platelet alpha-granule resembling that of Weibel-Palade bodies. *Blood* 1985;66:710-713.
67. Hayward CP, Furmaniak-Kazmierczak E, Cieutat AM, et al. Factor V is complexed with multimerin in resting platelet lysates and colocalizes with multimerin in platelet alpha-granules. *J Biol Chem* 1995;270:19217-19226.
68. Zucker-Franklin D. Endocytosis by human platelets: metabolic and freeze-fracture studies. *J Cell Biol* 1981;91:706-715.
69. Harrison P, Wilbourn B, Debili N, et al. Uptake of plasma fibrinogen into the alpha granules of human megakaryocytes and platelets. *J Clin Invest* 1989;84(4):1320-1324.
70. Handagama PJ, George JN, Shuman MA, et al. Incorporation of a circulating protein into megakaryocyte and platelet granules. *Proc Natl Acad Sci U S A* 1987;84(3):861-865.
71. Sander HJ, Slot JW, Bouma BN, et al. Immunocytochemical localization of fibrinogen, platelet factor 4, and beta thromboglobulin in thin frozen sections of human blood platelets. *J Clin Invest* 1983;72(4):1277-1287.

72. Hegyi E, Nakeff A. Ultrastructural localization of platelet factor 4 in rat megakaryocytes and platelets by gold-labeled antibody detection. *Exp Hematol* 1989;17(3):223-228.
73. Walz A, Dewald B, von Tschanner V, Baggiolini M. Effects of the neutrophilactivating peptide NAP-2, platelet basic protein, connective tissue-activating peptide III and platelet factor 4 on human neutrophils. *J Exp Med* 1989;70:1745-1758.
74. Rollins BJ. Chemokines. *Blood* 1997;90:909-922.
75. Rucinski B, Niewiarowski S, James P, et al. Antiheparin proteins secreted by human platelets: purification and characterization and radioimmunoassay. *Blood* 1979;53:47-58.
76. Kaplan KL, Nossel HL, Drillings M, Lesznik G. Radioimmunoassay of platelet factor 4 and β -thromboglobulin: development and application to studies of platelet release in relation to human platelet factor 4. *Thromb Res* 1977;11:673-681.
77. Baenziger NL, Brodie GN, Majerus PW. A thrombin-sensitive protein of human platelet membranes. *Proc Natl Acad Sci U S A* 1971;68:240-243.
78. Bornstein P. The thrombospondins: structure and regulation of expression. *FASEB J* 1992;6:3290-3300.
79. Wencel-Drake JD, Painter RG, Zimmerman TS, Ginsberg MH. Ultrastructural localization of human platelet thrombospondin, fibrinogen, fibronectin, and von Willebrand factor in frozen thin section. *Blood* 1985;74:929-938.
80. Chiu HC, Schick P, Colman RW. Biosynthesis of coagulation factor V by megakaryocytes. *J Clin Invest* 1985;75:339-348.
81. George JN. Platelet immunoglobulin G: its significance for the evaluation of thrombocytopenia and for understanding the origin of α -granule proteins. *Blood* 1990;76:859-870.
82. Li QX, Berndt MC, Bush AI, et al. Membrane-associated forms of the β A4 amyloid protein precursor of Alzheimer's disease in human platelet and brain: surface expression on the activated human platelet. *Blood* 1994;84:133-142.
83. Schmaier AH, Dahl LD, Hasan AA, et al. Factor IXa inhibition by protease nexin-2/amyloid beta-protein precursor on phospholipid vesicles and cell membranes. *Biochemistry* 1995;34:1171-1179.
84. Assoian RK, Komoriya AK, Meyers CA, et al. Transforming growth factor- β in human platelets: identification of a major storage site, purification, and characterization. *J Biol Chem* 1983;258:7155-7163.
85. Mohle R, Green D, Moore MA, et al. Constitutive production and thrombin-induced release of vascular endothelial growth factor by human megakaryocytes and platelets. *Proc Natl Acad Sci U S A* 1997;94:663-667.
86. Italiano J, Richardson JL, Patel-Hett S, et al. Angiogenesis is regulated by a novel mechanism: pro- and antiangiogenic proteins are organized into separate platelet alpha granules and differentially released. *Blood* 2008;111:1227-1233.
87. Battinelli EM, Markens BA, Italiano JE Jr. Release of angiogenesis regulatory proteins from platelet alpha granules: modulation of physiologic and pathologic angiogenesis. *Blood* 2011;118:1359-1369.
88. Klement GL, Yip TT, Cassiola F. Platelets actively sequester angiogenesis regulators. *Blood* 2009;113:2835-2842.
89. Chatterjee M, Huang Z, Zhang W. Distinct platelet packaging, release, and surface expression of proangiogenic and antiangiogenic factors on different platelet stimuli. *Blood* 2011;117:3907-3911.
90. Ma L, Perini R, McKnight. Proteinase-activated receptors 1 and 4 counter-regulate endostatin and VEGF release from human platelets. *Proc Natl Acad Sci U S A* 2005;102:216-220.
91. Meyer A, Wang W, Qu J. Platelet TGF- β 1 contributions to plasma TGF- β 1, cardiac fibrosis, and systolic dysfunction in a mouse model of pressure overload. *Blood* 2012;119:1064-1074.
92. Ahamed J, Burg N, Yoshinaga K. In vitro and in vivo evidence for shear-induced activation of latent transforming growth factor-beta1. *Blood* 2008;112:3650-3660.
93. Suzuki H, Nakamura S, Itoh Y, et al. Immunocytochemical evidence for the translocation of α -granule membrane glycoprotein IIb/IIIa (integrin $\alpha_{IIb}\beta_3$) of human platelets to the surface membrane during the release reaction. *Histochemistry* 1992;97:381-388.
94. Cramer EM, Savidge GF, Vainchenker W, et al. Alpha-granule pool of glycoprotein IIb-IIIa in normal and pathologic platelets and megakaryocytes. *Blood* 1990;75:1220-1227.

95. Wencel-Drake JD, Plow EF, Kunicki TJ, et al. Localization of internal pools of membrane glycoproteins involved in platelet adhesive responses. *Am J Pathol* 1986;124:324-334.
96. Stenberg PE, McEver RP, Shuman MA, et al. A platelet alpha-granule membrane protein (GMP-140) is expressed on the plasma membrane after activation. *J Cell Biol* 1985;101:880-886.
97. Metzelaar MJ, Heijnen HFG, Sixma JJ, Nieuwenhuis HK. Identification of a 33-Kd protein associated with the α -granule membrane (GMP33) that is expressed on the surface of activated platelets. *Blood* 1992;79:372-379.
98. Cramer EM, Berger G, Berndt MC. Platelet α -granule and plasma membrane share two new components: CD9 and PECAM-1. *Blood* 1994;84:1722-1730.
99. Berger G, Masse JM, Cramer EM. Alpha-granule membrane mirrors the platelet plasma membrane and contains the glycoproteins Ib, IX, and V. *Blood* 1996;87:1385-1395.
100. Breton-Gorius J, Clezardin P, Guichard J, et al. Localization of platelet osteonectin at the internal face of the alphagranule membranes in platelets and megakaryocytes. *Blood* 1992;79:936-941.
101. Rosa JP, George JN, Bainton DF, et al. Gray platelet syndrome. Demonstration of alpha granule membranes that can fuse with the cell surface. *J Clin Invest* 1987;80:1138-1146.
102. Cramer EM, Vainchenker W, Vinci G, et al. Gray platelet syndrome: immunoelectron microscopic localization of fibrinogen and von Willebrand factor in platelets and megakaryocytes. *Blood* 1985;66:1309-1316.
103. Fukami MH, Salganicoff L. Human platelet storage granules—a review. *Thromb Haemost* 1977;38:963-974.
104. McNicol A, Israels SJ. Platelet dense granules: structure, function and implications for hemostasis. *Thromb Res* 1999;95:1-13.
105. White JG. Platelet secretory granules and associated proteins. *Lab Invest* 1993;68:497-498.
106. Febbraio M, Silverstein RL. Identification and characterization of LAMP-1 as an activation-dependent platelet surface glycoprotein. *J Biol Chem* 1990;265:18531-18537.
107. Silverstein RL, Febbraio M. Identification of lysosome-associated membrane protein-2 as an activation-dependent platelet surface glycoprotein. *Blood* 1992;80:1470-1478.
108. de Duve C. Biochemical studies on the occurrence, biogenesis, and life history of mammalian peroxisomes. *J Histochem Cytochem* 1973;21:941-948.
109. Van den BH, de Vet EC, Zomer AS. The role of peroxisomes in ether lipid synthesis. Back to the roots of PAF. *Adv Exp Med Biol* 1996;416:33-41.
110. Akkerman JWN, Gorter G, Soons H, Holmsen H. Close correlation between platelet responses and adenylate energy charge during transient substrate depletion. *Biochim Biophys Acta* 1983;760:34-42.
111. Holmsen H, Farstad M. Energy metabolism. In: *Platelet responses and metabolism*, vol. 2. Boca Raton, FL: CRC Press, 1987:245-282.
112. Weiss HJ, Kelly A, Herbert V. Vitamin B₁₂ and folate activity in normal human platelets. *Blood* 1968;31:258-262.
113. Cooley MH, Cohen P. Potassium transport in human blood platelets. *J Lab Clin Med* 1967;70:69-79.
114. Brass LF. The effect of Na⁺ on Ca²⁺ homeostasis in unstimulated platelets. *J Biol Chem* 1984;259:12571-12575.
115. Enouf J, Bredoux R, Bourdeau N, Levy-Toledano S. Two different Ca²⁺ transport systems are associated with plasma and intracellular human platelet membranes. *J Biol Chem* 1987;262:9293-9297.
116. Karpatkin S, Charnatz A, Langer RM. Glycogenesis and glyconeogenesis in human platelets. Incorporation of glucose, pyruvate, and citrate into platelet glycogen, glycogen synthetase and fructose 1,6 diphosphatase activity. *J Clin Invest* 1970;49:140-149.
117. Akkerman JWN. Regulation of glycolytic flux in human platelets: relationship between energy produced by glyco(genol)ysis and energy consumption. *Biochim Biophys Acta* 1978;541:241-250.
118. Karpatkin S. Studies on human platelet glycolysis. Effect of glucose, cyanide, insulin, citrate, and agglutination and contraction on platelet glycolysis. *J Clin Invest* 1967;46:409-417.
119. Karpatkin S, Charnatz A. Heterogeneity of human platelets. III. Glycogen metabolism in platelets of different sizes. *Br J Haematol* 1970;19:135-143.

120. Akkerman JWN. Regulation of carbohydrate metabolism in platelets. A review. *Thromb Haemost* 1978;39:712-724.
121. Cohen P, Derksen A, Bosch H. Pathways of fatty acid metabolism in human platelets. *J Clin Invest* 1970;49:128-139.
122. Doery JCG, Hirsh J, Cooper I. Energy metabolism in human platelets: interrelationship between glycolysis and oxidative metabolism. *Blood* 1970;36: 159-168.
123. Holmsen H, Farstad M. Energy metabolism. In: Holmsen H, ed. *Platelet responses and metabolism*, vol. 2: receptors and metabolism. Boca Raton, FL: CRC Press, 1987:245-254.
124. Gear ARL, Schneider W. Control of platelet glycogenolysis; activation of phosphorylase kinase by calcium. *Biochim Biophys Acta* 1975;392:111-120.
125. Marcus AJ. Pathways of oxygen utilization by stimulated platelets and leukocytes. *Semin Hematol* 1979;16:188-195.
126. Simons ER, Greenberg-Sepersky SM. Transmembrane monovalent cation gradients. In: Holmsen H, ed. *Platelet responses and metabolism*, vol. 3: response metabolism relationships. Boca Raton, FL: CRC Press, 1987:31-50.
127. Dean WL. Structure, function, and subcellular localization of a human platelet Ca^{2+} -ATPase. *Cell Calcium* 1989;10:289-297.
128. Holmsen H, Day HJ, Storm E. Adenine nucleotide metabolism of blood platelets. VI. Subcellular localization of nucleotide pools with different functions in the platelet release reaction. *Biochim Biophys Acta* 1969;186:254-266.
129. Holmsen H, Salganicoff L, Fukami MH. Platelet behaviour and biochemistry. In: Ogston D, Bennett P, eds. *Haemostasis: biochemistry, physiology, and pathology*. London: Wiley-Liss, 1977:239-319.
130. Reimers HJ, Packham MA, Mustard JF. Labeling of the releasable adenine nucleotides of washed human platelets. *Blood* 1977;49:89-99.
131. Holmsen H. Energy metabolism and platelet responses. *Vox Sang* 1981;40:1-7.
132. Daniel JL, Molish IR, Robkin L, Holmsen H. Nucleotide exchange between cytosolic ATP and F-actin-bound ADP may be a major ATP-utilizing process in unstimulated platelets. *Eur J Biochem* 1986;156:677-684.
133. Verhoeven AJM, Tysnes OB, Aarbakke GM, et al. Turnover of the phosphomonoester groups of polyphosphoinositol lipids in unstimulated platelets. *Eur J Biochem* 1987;166:3-9.
134. Rivard GE, McLaren JD, Brunst RF. Incorporation of hypoxanthine into adenine and guanine nucleotides by human platelets. *Biochim Biophys Acta* 1975;381:144-156.
135. Akkerman JWN, Verhoeven AJM. Energy metabolism and function. In: Holmsen H, ed. *Platelet responses and metabolism*, vol. 3: response-metabolism relationships. Boca Raton, FL: CRC Press, 1987:69-99.
136. Verhoeven AJM, Tysnes OB, Horvli O, et al. Stimulation of phosphate uptake in human platelets by thrombin and collagen. Changes in specific ^{32}P -labeling of metabolic ATP and polyphosphoinositides. *J Biol Chem* 1987;262: 7047-7052.
137. Schick PK. Platelet and megakaryocyte lipids. In: Colman RW, Hirsh J, Marder VJ, et al., eds. *Hemostasis and thrombosis: basic principles and clinical practice*, 4th ed. Philadelphia: Lippincott Williams & Wilkins, 2001:521-534.
138. Perret B, Chap HJ, Douste-Blazy L. Asymmetric distribution of arachidonic acid in the plasma membrane of human platelets: a determination using purified phospholipases and a rapid method for membrane isolation. *Biochim Biophys Acta* 1979;556:434-446.
139. Schick PK, Kurica KB, Chacko GK. Location of phosphatidylethanolamine and phosphatidylserine in the human platelet plasma membrane. *J Clin Invest* 1976;57:1221-1226.
140. Bevers EM, Comfurius P, Zwaal RF. Changes in membrane phospholipid distribution during platelet activation. *Biochim Biophys Acta* 1983;736:57-66.
141. Sims PJ, Wiedmer T. Unraveling the mysteries of phospholipid scrambling. *Thromb Haemost* 2001;86:266-275.
142. Comfurius P, Williamson P, Smeets EF, et al. Reconstitution of phospholipid scramblase activity from human blood platelets. *Biochemistry* 1996;35: 7631-7634.
143. Marcus AJ. The role of lipids in platelet function: with particular reference to the arachidonic acid pathway. *J Lipid Res* 1976;9:793-826.
144. Clark JD, Schievella AR, Nalefski EA, Lin LL. Cytosolic phospholipase A2. *J Lipid Mediat Cell Signal* 1995;12:83-117.

145. Riendeau D, Gray J, Weech PK, et al. Arachidonyl trifluoromethyl ketone, a potent inhibitor of 85-kDa phospholipase A2, blocks production of arachidonate and 12-hydroxyeicosatetraenoic acid by calcium ionophore-challenged platelets. *J Biol Chem* 1994;269:15619-15624.
146. Dennis EA. The growing phospholipase A2 superfamily of signal transduction enzymes. *Trends Biochem Sci* 1997;22:1-2.
147. Schick PK, Tuszyński GP, Woort PWV. Human platelet cytoskeletons: specific content of glycolipids and phospholipids. *Blood* 1983;61:163-166.
148. Barry OP, FitzGerald GA. Mechanisms of cellular activation by platelet microparticles. *Thromb Haemost* 1999;82:794-808.
149. Sims PJ, Faioni EM, Wiedmer T, Shattil SJ. Complement proteins C5b-9 cause release of membrane vesicles from the platelet surface that are enriched in the membrane receptor for coagulation factor Va and express prothrombinase activity. *J Biol Chem* 1988;263:18205-18212.
150. Thiagarajan P, Tait JF. Collagen-induced exposure of anionic phospholipid in platelets and platelet-derived microparticles. *J Biol Chem* 1991;266: 24302-24307.
151. Dahlback B, Wiedmer T, Sims PJ. Binding of anticoagulant vitamin K dependent protein S to platelet-derived microparticles. *Biochemistry* 1992;31:12769-12777.
152. Gilbert GE, Sims PJ, Wiedmer T, et al. Platelet-derived microparticles express high affinity receptors for factor VIII. *J Biol Chem* 1991;266:17261-17268.
153. Sims PJ, Wiedmer T, Esmon CT, et al. Assembly of the platelet prothrombinase complex is linked to vesiculation of the platelet plasma membrane. Studies in Scott syndrome: an isolated defect in platelet procoagulant activity. *J Biol Chem* 1989;264:17049-17057.
154. Weiss HJ. Scott syndrome: a disorder of platelet coagulant activity. *Semin Hematol* 1994;31:312-319.
155. Thon JN, Italiano JE. Platelets: production, morphology and ultrastructure. *Handb Exp Pharmacol* 2012;210:3-22.
156. Thon JN, Italiano JE Jr. Does size matter in platelet production? *Blood* 2012;120:1552-1561.
157. Aster RH. The study of platelet kinetics with ⁵¹Cr-labeled platelets. In: Paulus JM, ed. *Platelet kinetics*. Amsterdam: North-Holland, 1971:317-323.
158. Kummer H, Von Muhlenen A, Laissue J. Survival of labeled and non-labeled platelets in the lethally irradiated dog: an evaluation of the ⁵¹Cr-chromium method. *Helv Med Acta* 1969;35:226.
159. Welch MJ, Thakur ML, Coleman RE, et al. Gallium-68 labeled red cells and platelets: new agents for positron tomography. *J Nuclear Med* 1977;18: 558-562.
160. Harker LA, Finch CA. Thrombokinetics in man. *J Clin Invest* 1969;48: 963-974.
161. Aster RH. Pooling of platelets in the spleen: role in the pathogenesis of "hypersplenic" thrombocytopenia. *J Clin Invest* 1966;45:645-657.
162. Shulman NR, Watkins SP Jr, Itscoitz SB, Students AB. Evidence that the spleen retains the youngest and hemostatically most effective platelets. *Trans Assoc Am Physicians* 1968;81:302-313.
163. Weiss L. A scanning electron microscopic study of the spleen. *Blood* 1974;43:665-691.
164. Bierman HR, Kelly KH, Cordes FL, et al. The release of leukocytes and platelets from the pulmonary circulation by epinephrine. *Blood* 1952;7:683.
165. Freedman M, Altszuler N, Karpatkin S. Presence of a nonsplenic platelet pool. *Blood* 1977;50:419-425.
166. Recommended methods for radioisotope platelet survival studies: by the Panel on Diagnostic Application of Radioisotopes in Hematology, International Committee for Standardization in Hematology. *Blood* 1977;50:1137-1144.
167. Lotter MG, Heyns AD, Badenhorst PN, et al. Evaluation of mathematic models to assess platelet kinetics. *J Nuclear Med* 1986;27:1192-1201.
168. Josefsson EC, White MJ, Dowling MR. Platelet life span and apoptosis. *Methods Mol Biol* 2012;788:59-71.
169. Mason KD, Carpinelli MR, Flethcer JI. Programmed anuclear cell death delimits platelet life span. *Cell* 2007;128:1173-86.

170. Davie EW, Ratnoff OD. Waterfall sequence for intrinsic blood clotting. *Science* 1964;145:1310-1312.
171. Mann KG, Bopvill EG, Srishnaswamy S. Surface-dependent reactions of the vitamin K-dependent enzyme complexes. *Blood* 1991;76:1-16.
172. Walsh PN. Platelet coagulant activities and hemostasis: a hypothesis. *Blood* 1974;43:597-605.
173. Miletich JP, Jackson CM, Majerus PW. Interaction of coagulation factor Xa with human platelets. *Proc Natl Acad Sci U S A* 1977;74:4033-4036.
174. Gailani D, Broze GJ Jr. Factor XI activation in a revised model of blood coagulation. *Science* 1991;253:909-912.
175. Naito K, Fujikawa K. Activation of human blood coagulation factor XI independent of factor XII. Factor XI is activated by thrombin and factor XIa in the presence of negatively charged surfaces. *J Biol Chem* 1991;266:7353-7358.
176. Walsh PN, Griffin JH. Contributions of human platelets to the proteolytic activation of blood coagulation factors XII and XI. *Blood* 1981;57:106-118.
177. Sinha D, Seaman FS, Walsh PN. Role of calcium ions and the heavy chain of factor XIa in the activation of human coagulation factor IX. *Biochemistry* 1987;26:3768-3775.
178. Baglia FA, Badellino KO, Ho DH, et al. A binding site for the kringle II domain of prothrombin in the apple I domain of factor XI. *J Biol Chem* 2000;275:31954-31962.
179. Rapaport SI, Proctor RR, Patch MJ, Yettra M. The mode of inheritance of PTA deficiency: evidence for the existence of a major PTA deficiency and a minor PTA deficiency. *Blood* 1961;18:149-155.
180. Shirk RA, Konkle BA, Walsh PN. Nonsense mutation in exon V of the factor XI gene does not abolish platelet factor XI expression. *Br J Haematol* 2000;111:91-95.
181. Walsh PN, Sinha D, Kueppers F, et al. Regulation of factor XIa activity by platelets and alpha I-protease inhibitor. *J Clin Invest* 1987;80:1578-1586.
182. Chesney CM, Pifer D, Colman RW. Subcellular localization and secretion of factor V from human platelets. *Proc Natl Acad Sci U S A* 1981;78:5180-5184.
183. Rand MD, Kalafatis M, Mann KG. Platelet coagulation factor Va: the major secretory phosphoprotein. *Blood* 1994;83:2180-2190.
184. Tracy PB, Giles AR, Mann KG, et al. Factor V (Quebec): a bleeding diathesis associated with a qualitative platelet factor V deficiency. *J Clin Invest* 1984;74:1221-1228.
185. Hayward CP, Cramer EM, Kane WH, et al. Studies of a second family with the Quebec platelet disorder: evidence that the degradation of the α -granule membrane and its soluble contents are not secondary to a defect in targeting proteins to α -granules. *Blood* 1997;89:1243-1253.
186. Louache F, Debili N, Cramer E, et al. Fibrinogen is not synthesized by human megakaryocytes. *Blood* 1991;77:311-316.
187. Nachman RL, Marcus AJ, Zucker-Franklin D. Immunological studies of proteins associated with subcellular fractions of normal human platelets. *J Lab Clin Med* 1967;69:651-668.
188. Jenkins CS, Phillips DR, Clemetson KJ, et al. Platelet membrane glycoproteins implicated in ristocetin-induced aggregation. Studies of the proteins on platelets from patients with Bernard-Soulier syndrome and von Willebrand's disease. *J Clin Invest* 1976;57:112-124.
189. Kappelmayer J, Bacsko B, Birinyi L, et al. Consecutive appearance of coagulation factor XIII subunit A in macrophages, megakaryocytes, and liver cells during early human development. *Blood* 1995;86:2191-2197.
190. Schmaier AH, Smith RM, Purdon AD, et al. High molecular weight kininogen: localization in unstimulated and activated platelets; and activation by platelet calpain(s). *Blood* 1986;67:119-130.
191. Schwarz HP, Heeb MJ, Wencel-Drake JD, Griffin JH. Identification and quantitation of protein S in human platelets. *Blood* 1985;66:1452-1455.
192. Smith SA, Mutch NJ, Baskar D. Polyphosphate modulates blood coagulation and fibrinolysis. *Proc Natl Acad Sci U S A* 2006;103:903-908.

193. Müller F, Mutch NJ, Schenk WA. Platelet polyphosphates are proinflammatory and procoagulant mediators in vivo. *Cell* 2009;139:1143-1156.
194. Morrissey JH, Choi SH, Smith SA. Polyphosphate: an ancient molecule that links platelets, coagulation, and inflammation. *Blood* 2012;119:5972-5979.
195. Schmaier AH, Dahl LD, Rozemuller AJM, et al: Protease nexin-2/amyloid β protein precursor. A tight-binding inhibitor of coagulation factor IXa. *J Clin Invest* 1993;92:2540-2545.
196. Pollard TD, Fujiwara K, Handin R, Weiss G. Contractile proteins in platelet activation and contraction. *Ann NY Acad Sci* 1977;283:218.
197. Rooney MM, Farrell DH, van Hemel BM, et al. The contribution of the three hypothesized integrin-binding sites in fibrinogen to platelet-mediated clot retraction. *Blood* 1998;92:2374-2381.
198. Léon C, Eckly A, Hechler B. Megakaryocyte-restricted MYH9 inactivation dramatically affects hemostasis while preserving platelet aggregation and secretion. *Blood* 2007;110:3183-3191.
199. Haling JR, Monkley SJ, Critchley DR. Talin-independent integrin activation is required for fibrin clot retraction by platelets. *Blood* 2011;117:1719-1722.
200. Bergmeier W, Hynes RO. Extracellular matrix proteins in hemostasis and thrombosis. *Cold Spring Harb Perspect Biol* 2012;4
201. Varga-Szabo D, Pleines I, Nieswandt B. Cell adhesion mechanisms in platelets. *Arterioscler Thromb Vasc Biol* 2008;3:403-412.
202. Nuytens BP, Thijs T, Deckmyn H. Platelet adhesion to collagen. *Thromb Res* 2011;127:S26-S29.
203. Ruggeri ZM, Mendolicchio GL. Adhesion mechanisms in platelet function. *Circ Res* 2007;100:1673-1685.
204. Ruggeri ZM. Platelet adhesion under flow. *Microcirculation* 2009:58-83.
205. Barnes MJ, Farndale RW. Collagens and atherosclerosis. *Exp Gerontol* 1999;34:513-525.
206. Varga-Szabo D, Pleines I, Nieswandt B. Cell adhesion mechanisms in platelets. *Arterioscler Thromb Vasc Biol* 2008;28:403-412.
207. Clemetson KJ. Platelets and primary haemostasis. *Thromb Res* 2012;129: 220-224.
208. Ni H, Yuen PS, Papalia JM, et al. Plasma fibronectin promotes thrombus growth and stability in injured arterioles. *Proc Natl Acad Sci U S A* 2003;100:2415-2419.
209. Roth GJ. Developing relationships: arterial platelet adhesion, glycoprotein Ib, and leucine-rich glycoproteins. *Blood* 1991;77:5-19.
210. López JA. The platelet glycoprotein Ib-IX complex. *Blood Coagul Fibrinolysis* 1994;5:97-119.
211. Ruggeri ZM. Structure and function of von Willebrand factor. *Thromb Haemost* 1999;82:576-584.
212. Miyata S, Goto S, Federici AB, et al. Conformational changes in the A1 domain of von Willebrand factor modulating the interaction with platelet glycoprotein Ib α . *J Biol Chem* 1996;271:9046-9053.
213. Siedlecki CA, Lestini BJ, Kottke-Marchant KK, et al. Shear-dependent changes in the three-dimensional structure of human von Willebrand factor. *Blood* 1996;88:2939-2950.
214. Uff S, Clemetson JM, Harrison T. Crystal structure of the platelet glycoprotein Ib (alpha) N-terminal domain reveals an unmasking mechanism for receptor activation. *J Biol Chem* 2002;277:35657-35663.
215. Huizinga EG, Tsuji S, Romijn, RA. Structures of glycoprotein Ibalpha and its complex with von Willebrand factor A1 domain. *Science* 2002;297: 1176-1179.
216. Savage B, Saldivar E, Ruggeri ZM. Initiation of platelet adhesion by arrest onto fibrinogen or translocation on von Willebrand factor. *Cell* 1996;84: 289-297.
217. Tsuji S, Sugimoto M, Miyata S, et al. Real-time analysis of mural thrombus formation in various platelet aggregation disorders: distinct shear-dependent roles of platelet receptors and adhesive proteins under flow. *Blood* 1999;94:968-975.
218. Ruggeri ZM, Zarpellon A, Roberts JR. Unravelling the mechanism and significance of thrombin binding to platelet glycoprotein Ib. *Thromb Haemost* 2010;104:894-902.

219. Celikel R, McClintock RA, Roberts JR. Modulation of alpha-thrombin function by distinct interactions with platelet glycoprotein Ibalpha. *Science* 2003;301:218-221.
220. Dumas JJ, Kumar R, Seehra J. Crystal structure of the Gplbalpha-thrombin complex essential for platelet aggregation. *Science* 2003;301:222-226.
221. Berndt MC, Shen Y, Dopheide SM, et al. The vascular biology of the glycoprotein Ib-IX-V complex. *Thromb Haemost* 2001;86:178-188.
222. Moake JL, Turner NA, Stathopoulos NA, et al. Shear-induced platelet-aggregation can be mediated by vWF released from platelets, as well as by exogenous large or unusually large vWF multimers, requires adenosine-diphosphate, and is resistant to aspirin. *Blood* 1988;71:1366-1374.
223. Calverley DC, Kavanagh TJ, Roth GJ. Human signaling protein 14-3-3ζ interacts with platelet glycoprotein Ib subunits Ibα and Ibβ. *Blood* 1998;91: 1295-1303.
224. Feng S, Christodoulides N, Resendiz JC, et al. Cytoplasmic domains of Gplbα and Gplbβ regulate 14-3-3ζ binding to Gplb/IX/V. *Blood* 2000;95:551-557.
225. Falati S, Edmead CE, Poole AW. Glycoprotein Ib-V-IX, a receptor for von Willebrand factor, couples physically and functionally to the Fc receptor γ-chain, Fyn, and Lyn to activate human platelets. *Blood* 1999;94:1648-1656.
226. Torti M, Bertoni A, Canobbio I, et al. Rap1B and Rap2B translocation to the cytoskeleton by von Willebrand factor involves FcγII receptor-mediated protein tyrosine phosphorylation. *J Biol Chem* 1999;274:13690-13697.
227. Munday AD, Berndt MC, Mitchell CA. Phosphoinositide 3-kinase forms a complex with platelet membrane glycoprotein Ib-IX-V complex and 14-3-3ζ. *Blood* 2000;96:577-584.
228. Canobbio I, Balduini C, Torti M. Signalling through the platelet glycoprotein Ib-V-IX complex. *Cell Signal* 2004;16:1329-1344.
229. Du X. Signaling and regulation of the platelet glycoprotein Ib-IX-V complex. *Curr Opin Hematol* 2007;14:262-269.
230. Clemetson KJ, Clemetson JM. Platelet collagen receptors. *Thromb Haemost* 2001;86:189-197.
231. Clemetson JM, Polgar J, Magnenat E, et al. The platelet collagen receptor glycoprotein VI is a member of the immunoglobulin superfamily closely related to FcαR and the natural killer receptors. *J Biol Chem* 1999;274:29019-29024.
232. Jandrot-Perrus M, Busfield S, Lagrue AH, et al. Cloning, characterization, and functional studies of human and mouse glycoprotein VI: a platelet-specific collagen receptor from the immunoglobulin superfamily. *Blood* 2000;96:1798-1807.
233. Tsuji M, Ezumi Y, Arai M, Takayama H. A novel association of Fc receptor γ-chain with glycoprotein VI and their co-expression as a collagen receptor in human platelets. *J Biol Chem* 1997;272:23528-23531.
234. Nieswandt B, Bergmeier W, Schulte V, et al. Expression and function of the mouse collagen receptor glycoprotein VI is strictly dependent on its association with the FcRγ chain. *J Biol Chem* 2000;275:23998-24002.
235. Horii K, Kahn ML, Herr AB. Structural basis for platelet collagen responses by the immune-type receptor glycoprotein VI. *Blood* 2006;108:936-942.
236. Kehrel B, Wierwille S, Clemetson KJ, et al. Glycoprotein VI is a major collagen receptor for platelet activation: it recognizes the platelet-activating quaternary structure of collagen, whereas CD36, glycoprotein IIb/IIIa, and von Willebrand factor do not. *Blood* 1998;91:491-499.
237. Kato K, Kanaji T, Russell S, et al. The contribution of glycoprotein VI to stable platelet adhesion and thrombus formation illustrated by targeted gene deletion. *Blood* 2003;102:1701-1707.
238. Massberg S, Gawaz M, Gruner S, et al. A crucial role of glycoprotein VI for platelet recruitment to the injured arterial wall in vivo. *J Exp Med* 2003;197:41-49.
239. Nieswandt B, Brakebusch C, Bergmeier W, et al. Glycoprotein VI but not α₂β₁ integrin is essential for platelet interaction with collagen. *EMBO J* 2001;20:2120-2130.
240. Staatz WD, Rajpara SM, Wayner EA, et al. The membrane glycoprotein Ia-IIa (VLA-2) complex mediates the Mg⁺⁺-dependent adhesion of platelets to collagen. *J Cell Biol* 1989;108:1917-1924.
241. Springer TA. Folding of the N-terminal, ligand-binding region of integrin α-subunits into a β-propeller domain. *Proc Natl Acad Sci U S A* 1997;94: 65-72.

242. Jung SM, Moroi M. Signal-transducing mechanisms involved in activation of the platelet collagen receptor integrin $\alpha_2\beta_1$. *J Biol Chem* 2000;275: 8016-8026.
243. Locke D, Chen H, Liu Y, et al. Lipid rafts orchestrate signaling by the platelet receptor glycoprotein VI. *J Biol Chem* 2002;277:18801-18809.
244. Watson SP, Asazuma N, Atkinson B, et al. The role of ITAM- and ITIM-coupled receptors in platelet activation by collagen. *Thromb Haemost* 2001;86: 276-288.
245. Clements JL, Lee JR, Gross B, et al. Fetal hemorrhage and platelet dysfunction in SLP-76-deficient mice. *J Clin Invest* 1999;103:19-25.
246. Gross BS, Melford SK, Watson SP. Evidence that phospholipase C-2 interacts with SLP-76, syk, lyn, LAT and the Fc receptor γ -chain after stimulation of the collagen receptor glycoprotein VI in human platelets. *Eur J Biochem* 1999;263:612-623.
247. Bobe R, Wilde JI, Maschberger P, et al. Phosphatidylinositol 3-kinase-dependent translocation of phospholipase C γ 2 in mouse megakaryocytes is independent of Bruton's tyrosine kinase translocation. *Blood* 2001;97:678-684.
248. Pasquet JM, Gross B, Quek L, et al. LAT is required for tyrosine phosphorylation of phospholipase C γ 2 and platelet activation by the collagen receptor GPVI. *Mol Cell Biol* 1999;19:8326-8334.
249. Gross B, Lee JR, Clements JL, et al. Tyrosine phosphorylation of SLP-76 is downstream of Syk following stimulation of the collagen receptor GPVI in platelets. *J Biol Chem* 1999;274:5963-5971.
250. Pasquet JM, Bobe R, Gross B, et al. A collagen-related peptide regulates phospholipase C γ 2 via phosphatidylinositol 3-kinase in human platelets. *Biochem J* 1999;342:171-177.
251. Gratacap M-P, Payrastra B, Viala C, et al. Phosphatidylinositol 3,4,5-trisphosphate-dependent stimulation of phospholipase C- γ 2 is an early key event in Fc γ RIIA-mediated activation of human platelets. *J Biol Chem* 1998;273:24314-24321.
252. Barry FA, Gibbins JM. Protein kinase B is regulated in platelets by the collagen receptor glycoprotein VI. *J Biol Chem* 2002;277:12874-12878.
253. Onoue S, Matsui T, Aoki Y. Self-assembled micellar formulation of chafuroside A with improved anti-inflammatory effects in experimental asthma/COPD-model rats. *Eur J Pharm Sci* 2012;45:184-189.
254. Wang Z, Holly SP, Larson MK. Rap1b is critical for glycoprotein VI-mediated but not ADP receptor-mediated $\alpha_2\beta_1$ activation. *J Thromb Haemost* 2009;7:693-700.
255. Bernardi B, Guidetti GF, Campus F. The small GTPase Rap1b regulates the cross talk between platelet integrin $\alpha_2\beta_1$ and integrin $\alpha_{IIb}\beta_3$. *Blood* 2006;107:2728-2735.
256. Inoue O, Suzuki-Inoue K, Dean WL, et al. Integrin $\alpha_2\beta_1$ mediates outside-in regulation of platelet spreading on collagen through activation of Src kinases and PLC- γ 2. *J Cell Biol* 2003;160:769-780.
257. Patil S, Newman DK, Newman PJ. Platelet endothelial cell adhesion molecule-1 serves as an inhibitory receptor that modulates platelet responses to collagen. *Blood* 2001;97:1727-1732.
258. Cicmil M, Thomas JM, Leduc M, et al. Platelet endothelial cell adhesion molecule-1 signaling inhibits the activation of human platelets. *Blood* 2002;99:137-144.
259. Jones CI, Moraes LA, Gibbins JM. Regulation of platelet biology by platelet endothelial cell adhesion molecule-1. *Platelets* 2012;23:331-335.
260. Newman PJ, Newman DK. Signal transduction pathways mediated by PECAM-1: new roles for an old molecule in platelet and vascular cell biology. *Arterioscler Thromb Vasc Biol* 2003;23:953-964.
261. Ming Z, Hu Y, Xiang J. Lyn and PECAM-1 function as interdependent inhibitors of platelet aggregation. *Blood* 2011;117:3903-3906.
262. Jones CI, Barrett NE, Moraes LA. Endogenous inhibitory mechanisms and the regulation of platelet function. *Methods Mol Biol* 2012;788:341-366.
263. Coughlin SR. How the protease thrombin talks to cells. *Proc Natl Acad Sci U S A* 1999;96:11023-11027.

264. Vu T-KH, Hung DT, Wheaton VI, Coughlin SR. Molecular cloning of a functional thrombin receptor reveals a novel proteolytic mechanism of receptor activation. *Cell* 1991;64:1057-1068.
265. Xu WF, Andersen H, Whitmore TE, et al. Cloning and characterization of human protease-activated receptor 4. *Proc Natl Acad Sci U S A* 1998;95:6642-6646.
266. Kahn ML, Nakanishi-Matsui M, Shapiro MJ, et al. Protease-activated receptors 1 and 4 mediate activation of human platelets by thrombin. *J Clin Invest* 1999;103:879-887.
267. Klages B, Brandt U, Simon MI, et al. Activation of G12/G13 results in shape change and rho/rho kinase-mediated myosin light chain phosphorylation in mouse platelets. *J Cell Biol* 1999;144:745-754.
268. Offermanns S, Toombs CF, Hu YH, Simon MI. Defective platelet activation in G $\alpha(q)$ -deficient mice. *Nature* 1997;389:183-186.
269. Yang J, Wu J, Kowalska MA, et al. Loss of signaling through the G protein, Gz, results in abnormal platelet activation and altered responses to psychoactive drugs. *Proc Natl Acad Sci U S A* 2000;97:9984-9989.
270. Lin Y, Smrcka AV. Understanding molecular recognition by G protein $\beta\gamma$ subunits on the path to pharmacological targeting. *Mol Pharmacol* 2011;80: 551-557.
271. Shapiro MJ, Weiss EJ, Faruqi TR, Coughlin SR. Protease-activated receptors 1 and 4 are shut off with distinct kinetics after activation by thrombin. *J Biol Chem* 2000;275:25216-25221.
272. Covic L, Gresser AL, Kuliopulos A. Biphasic kinetics of activation and signaling for PAR1 and PAR4 thrombin receptors in platelets. *Biochemistry* 2000;39:5458-5467.
273. Lefkowitz RJ, Pitcher J, Krueger K, Daaka Y. Mechanisms of β -adrenergic receptor desensitization and resensitization. *Adv Pharmacol* 1998;42: 416-420.
274. Hoxie JA, Ahuja M, Belmonte E, et al. Internalization and recycling of activated thrombin receptors. *J Biol Chem* 1993;268:13756-13763.
275. Hein L, Ishii K, Coughlin SR, Kobilka BK. Intracellular targeting and trafficking of thrombin receptors: a novel mechanism for resensitization of a G protein-coupled receptor. *J Biol Chem* 1994;269:27719-27726.
276. Sambrano GR, Weiss EJ, Zheng YW, et al. Role of thrombin signalling in platelets in haemostasis and thrombosis. *Nature* 2001;413:74-78.
277. Weiss EJ, Hamilton JR, Lease KE, Coughlin SR. Protection against thrombosis in mice lacking PAR3. *Blood* 2002;100:3240-3244.
278. Bhavaraju K, Mayanglambam A, Rao AK, et al. P2Y₁₂ antagonists as anti-platelet agents. *Curr Opin Drug Discov Devel.* 2010;13:497-506.
279. Michelson AD. New P2Y₁₂ Antagonists. *Curr Opin Hematol.* 2009;16: 371-377, 279.
280. Ralevic V, Burnstock G. Receptors for purines and pyrimidines. *Pharmacol Rev* 1998;50:413-492.
281. Webb TE, Simon J, Krishek BJ, et al. Cloning and functional expression of a brain G-protein-coupled ATP receptor. *FEBS Lett* 1993;324:219-223.
282. Fabre JE, Nguyen M, Latour A. Decreased platelet aggregation, increased bleeding time and resistance to thromboembolism in P2Y₁-deficient mice. *Nat Med* 1999;5:1199-1202.
283. Offermanns S, Toombs CF, Hu YH. Defective platelet activation in G $\alpha(q)$ -deficient mice. *Nature* 1997;389:183-186.
284. Daniel JL, Dangelmaier C, Jin J, et al. Molecular basis for ADP-induced platelet activation. I. Evidence for three distinct ADP receptors on human platelets. *J Biol Chem* 1998;273:2024-2029.
285. Hechler B, Eckly A, Ohlmann P, et al. The P2Y₁ receptor, necessary but not sufficient to support full ADP-induced platelet aggregation, is not the target of the drug clopidogrel. *Br J Haematol* 1998;103:858-866.
286. Hollopeter G, Jantzen HM, Vincent D, et al. Identification of the platelet ADP receptor targeted by antithrombotic drugs. *Nature* 2001;409:202-207.
287. Jin J, Kunapuli SP. Coactivation of two different G protein-coupled receptors is essential for ADP-induced platelet aggregation. *Proc Natl Acad Sci U S A* 1998;95:8070-8074.

288. Paul BZ, Daniel JL, Kunapuli SP. Platelet shape change is mediated by both calcium-dependent and -independent signalling pathways. *J Biol Chem* 1999;274:28293-28300.

P.410

289. Foster CJ, Prosser DM, Agans JM, et al. Molecular identification and characterization of the platelet ADP receptor targeted by thienopyridine anti-thrombotic drugs. *J Clin Invest* 2001;107:1591-1598.

290. Andre P, Delaney SM, LaRocca T, et al. P2Y₁₂ regulates both platelet adhesion/activation, thrombus growth and thrombus stability in injured arteries. *J Clin Invest* 2003;112:398-406.

291. MacKenzie A, Mahaut-Smith MP, Sage SO. Activation of receptor-operated cation channels via P2X₁ not P2₇ purinoceptors in human platelets. *J Biol Chem* 1996;271:2879-2881.

292. Hechler B, Lenain N, Marchese P, et al. A role of the fast ATP-gated P2X₁ cation channel in thrombosis of small arteries in vivo. *J Exp Med* 2003;198: 661-667.

293. Oury C, Kuijpers MJ, Toth-Zsomboki E, et al. Overexpression of the platelet P2X₁ ion channel in transgenic mice generates a novel prothrombotic phenotype. *Blood* 2003;101:3969-3976.

294. Woulfe D, Jiang H, Mortensen R, et al. Activation of Rap1B by G_i family members in platelets. *J Biol Chem* 2002;277:23382-23390.

295. Chrzanowska-Wodnicka M, Smyth SS. Rap1b is required for normal platelet function and hemostasis in mice. *J Clin Invest* 2005;115:680-687.

296. Regan JW, Nakata H, DeMarinis RM, et al. Purification and characterization of the human platelet α_2 -adrenergic receptor. *J Biol Chem* 1986;261: 3894-3900.

297. Kobilka BK, Matsui H, Kobilka TS, et al. Cloning sequencing and expression of the gene coding for the platelet α_2 -adrenergic receptor. *Science* 1987;238: 650-656.

298. Scrutton MC, Clare KC, Hutton RA, Bruckdorfer KR. Depressed responsiveness to adrenaline in platelets from apparently normal human donors: a familial trait. *Br J Haematol* 1981;49:303-314.

299. Smith WL. The eicosanoids and their biochemical mechanisms of action. *Biochem J* 1989;259:315-324.

300. Smith JB, Willis AL. Aspirin selectively inhibits prostaglandin production in human platelets. *Nature* 1971;231:235-237.

301. Roth GJ, Calverley DC. Aspirin, platelets, and thrombosis: theory and practice. *Blood* 1994;83:885-898.

302. FitzGerald GA. Mechanisms of platelet activation: thromboxane A₂ as an amplifying signal for other agonists. *Am J Cardiol* 1991;68:11B-15B.

303. Smyth SS, Woulfe DS, Weitz JI. 2008 Platelet Colloquium Participants. G-protein-coupled receptors as signaling targets for antiplatelet therapy. *Arterioscler Thromb Vasc Biol* 2009;29:449-457.

304. Brass LF, Wannemacher KM, Ma P. Regulating thrombus growth and stability to achieve an optimal response to injury. *J Thromb Haemost* 2011;9:66-75.

305. Bellido-Martin L, Chen V, Jasuja R. Imaging fibrin formation and platelet and endothelial cell activation in vivo. *Thromb Haemost* 2011;105:776-782.

306. Furie B, Furie BC. Mechanisms of thrombus formation. *N Engl J Med* 2008;359:938-949.

307. Brass LF, Stalker TJ. Minding the gaps—and the junctions, too. *Circulation* 2012;125:2414-2416.

308. Jones CI, Barrett NE, Moraes LA. Endogenous inhibitory mechanisms and the regulation of platelet function. *Methods Mol Biol* 2012;788:341-366.

309. Magalhaes AC, Dunn H, Ferguson SS. Regulation of GPCR activity, trafficking and localization by GPCR-interacting proteins. *Br J Pharmacol* 2012;165:1717-1736.

310. Kach J, Sethakorn N, Dulin NO. A finer tuning of G-protein signaling through regulated control of RGS proteins. *Am J Physiol Heart Circ Physiol* 2012;303:H19-H35.

311. Smolenski A. Novel roles of cAMP/cGMP-dependent signaling in platelets. *J Thromb Haemost* 2012;10:167-176.
312. Gkaliagkousi E, Ritter J, Ferro A. Platelet-derived nitric oxide signaling and regulation. *Circ Res* 2007;101:654-662.
313. Li Z, Xi X, Gu M. A stimulatory role for cGMP-dependent protein kinase in platelet activation. *Cell* 2003;112:77-86.
314. Banga HS, Simons ER, Brass LF, Rittenhouse SE. Activation of phospholipases A and C in human platelets exposed to epinephrine: role of glycoproteins IIb/IIIa and dual role of epinephrine. *Proc Natl Acad Sci U S A* 1986;83: 9197-9201.
315. Ren Q, Ye S, Whiteheart SW. The platelet release reaction: just when you thought platelet secretion was simple. *Curr Opin Hematol* 2008;15:537-541.
316. Phillips DR, Agin PP. Platelet membrane defects in Glanzmann's thrombasthenia: evidence for decreased amounts of two major glycoproteins. *J Clin Invest* 1977;60:535-545.
317. Nurden AT, Caen JP. An abnormal platelet glycoprotein pattern of three cases of Glanzmann's thrombasthenia. *Br J Haematol* 1974;253:253-260.
318. Shattil SJ, Newman PJ. Integrins: dynamic scaffolds for adhesion and signaling in platelets. *Blood* 2004;104:1606-1615.
319. Shattil SJ. Signaling through platelet integrin IIb β_3 : inside-out, outside-in, and sideways. *Thromb Haemost* 1999;82:318-325.
320. Kim M, Carman CV, Springer TA. Bidirectional transmembrane signaling by cytoplasmic domain separation in integrins. *Science* 2003;301:1720-1725.
321. Calderwood DA. Integrin activation. *J Cell Sci* 2004;117:657-666.
322. Shattil SJ, Kim C, Ginsberg MH. The final steps of integrin activation: the end game. *Nat Rev Mol Cell Biol* 2010;11:288-300.
323. Xiao T, Takagi J, Collier BS. Structural basis for allostery in integrins and binding to fibrinogen-mimetic therapeutics. *Nature* 2004;432:59-67.
324. Collier BS, Shattil SJ. The GPIIb/IIIa (integrin $\alpha_{IIb}\beta_3$) odyssey: a technology-driven saga of a receptor with twists, turns, and even a bend. *Blood* 2008;112:3011-3025.
325. Bennett JS, Zsigmond S, Vilaire G, et al. The platelet cytoskeleton regulates the affinity of the integrin $\alpha_{IIb}\beta_3$ for fibrinogen. *J Biol Chem* 1999;274: 25301-25307.
326. Kucik DF. Rearrangement of integrins in avidity regulation by leukocytes. *Immunol Res* 2002;26:199-206.
327. Collier BS. Platelet GPIIb/IIIa antagonists: the first anti-integrin receptor therapeutics. *J Clin Invest* 1997;99:1467-1471.
328. Fox JE. Identification of actin-binding protein as the protein linking the membrane skeleton to glycoproteins on platelet plasma membranes. *J Biol Chem* 1985;260:11970-11977.
329. Ezzell RM, Kenney DM, Egan S, et al. Localization of the domain of actin-binding protein that binds to membrane glycoprotein Ib and actin in human platelets. *J Biol Chem* 1988;263:13303-13309.
330. Bertagnolli ME, Beckerle MC. Regulated membrane-cytoskeleton linkages in platelets. *Ann NY Acad Sci* 1994;714:88-100.
331. Kenney DM, Linck RW. The cytoskeleton of unstimulated blood platelets: structure and composition of the isolated marginal microtubular band. *J Cell Sci* 1985;78:1-22.
332. Schwer HD, Lecine P, Tiwari S, et al. A lineage-restricted and divergent β -tubulin isoform is essential for the biogenesis, structure and function of blood platelets. *Curr Biol* 2001;11:579-586.
333. Kansas GS. Selectins and their ligands: current concepts and controversies. *Blood* 1996;88:3259-3287.
334. Frenette PS, Johnson RC, Hynes RO, Wagner DD. Platelets roll on stimulated endothelium in vivo: an interaction mediated by endothelial P-selectin. *Proc Natl Acad Sci U S A* 1995;92:7450-7454.
335. Andre P, Denis CV, Ware J, et al. Platelets adhere to and translocate on von Willebrand factor presented by endothelium in stimulated veins. *Blood* 2000;96:3322-3328.

336. Bombeli T, Schwartz BR, Harlan JM. Adhesion of activated platelets to endothelial cells: evidence for a GPIIb/IIIa-dependent bridging mechanism and novel roles for endothelial intercellular adhesion molecule 1 (ICAM-1), $\alpha_v\beta_3$ integrin, and GPIb α . *J Exp Med* 1998;187:329-339.
337. Frenette PS, Moyna C, Hartwell DW, et al. Platelet-endothelial interactions in inflamed mesenteric venules. *Blood* 1998;91:1318-1324.
338. McEver RP. Adhesive interactions of leukocytes, platelets, and the vessel wall during hemostasis and inflammation. *Thromb Haemost* 2001;86:746-756.
339. Diacovo TG, Roth SJ, Buccola JM, et al. Neutrophil rolling, arrest, and transmigration across activated, surface adherent platelets via sequential action of P-selectin and the β_2 -integrin CD11b/CD18. *Blood* 1996;88:146-157.
340. Totani L, Evangelista V. Platelet-leukocyte interactions in cardiovascular disease and beyond. *Arterioscler Thromb Vasc Biol* 2010;30:2357-2361.
341. Massberg S, Schurzinger K, Lorenz M, et al. Platelet adhesion via glycoprotein IIb integrin is critical for atheroprogession and focal cerebral ischemia: an in vivo study in mice lacking glycoprotein IIb. *Circulation* 2005;112:1180-1188.
342. Dong ZM, Chapman SM, Brown AA, et al. The combined role of P- and E-selectins in atherosclerosis. *J Clin Invest* 1998;102:145-152.
343. Burger PC, Wagner DD. Platelet P-selectin facilitates atherosclerotic lesion development. *Blood* 2003;101:2661-2666.
344. Belton OA, Duffy A, Toomey S, Fitzgerald DJ. Cyclooxygenase isoforms and platelet vessel wall interactions in the apolipoprotein E knockout mouse model of atherosclerosis. *Circulation* 2003;108:3017-3023.
345. Massberg S, Gawaz M, Gruner S, et al. A critical role of platelet adhesion in the initiation of atherosclerotic lesion formation. *J Exp Med* 2002;196:887-896.
346. Methia N, Andre P, Denis CV, et al. Localized reduction of atherosclerosis in von Willebrand factor-deficient mice. *Blood* 2001;98:1424-1428.
347. Gawaz M, Langer H, May AE. Platelets in inflammation and atherogenesis. *J Clin Invest* 2005;115:3378-3384.
348. Falk E. Coronary thrombosis: pathogenesis and clinical manifestations. *Am J Cardiol* 1991;68(Suppl B):28B-35B.
349. Falk E. Advanced lesions and acute coronary syndromes: a pathologist's view. In: Fuster V, ed. *Syndromes of atherosclerosis: correlations of clinical imaging and pathology*. Armonk, NY: Futura, 1996:81-104.

Chapter 17 Platelet Function in Hemostasis and Thrombosis

> Table of Contents > Part II - The Normal Hematologic System > Section 5 - Hemostasis > Chapter 17 - Platelet Function in Hemostasis and Thrombosis

Chapter 17

Platelet Function in Hemostasis and Thrombosis

David C. Calverley

PLATELET ADHESION AND ACTIVATION

Primary hemostasis and arterial thrombosis are the results of a complex series of cell-cell, cell-protein, and protein-protein reactions that involve platelets, leukocytes, endothelium, subendothelial matrix, and plasma proteins, such as fibrinogen, von Willebrand factor (vWF), and others. The consequences of arterial thrombosis include such events as myocardial infarction (MI), unstable angina, and stroke. These clinicopathologic entities and their associated cellular physiologic mechanisms that are outlined in this chapter collectively account for the largest cause of morbidity and mortality in the Western world.

Platelet adhesion to exposed subendothelium is a complex multistep process that involves a diverse array of adhesive ligands (vWF, collagen, fibrinogen/fibrin, fibronectin, thrombospondin, laminin, and vitronectin) and surface receptors (gpIb/V/IX, gpVI, integrins $\alpha_{IIb}\beta_3$, $\alpha_2\beta_1$, $\alpha_5\beta_1$, and $\alpha_6\beta_1$).^{1,2,3,4,5,6,7,8,9,10,11,12} and ¹³ The specific ligand/receptor players in primary platelet adhesion are largely dependent on the arterial flow conditions present.^{5,14} As such, in larger arteries and

veins, platelet adhesion to the vessel wall is thought to involve fibrillar collagen, fibronectin, and laminin. There are at least 25 forms of collagen, and several of these are present in the blood vessel wall, whereas one (type IV) is present in the subendothelial basement membrane.¹⁵ In the high-shear conditions present in smaller arteries, platelet tethering is dependent on the unique shear-dependent interaction between gpIb/V/IX and subendothelial vWF. The subsequent rapid platelet deceleration allows for other ligand-receptor interactions such as collagen and $\alpha_2\beta_1$ that have slower binding kinetics and take on the role of mediating firm platelet adhesion. A metalloprotease, ADAMTS13, cleaves vWF; this cleavage prevents the accumulation of ultrahigh-molecular-weight multimers that would otherwise cause spontaneous platelet clumping and arterial thrombosis.

Following initial platelet adhesion, subsequent platelet-platelet interaction (aggregation) is mediated by two receptors, gpIb/V/IX and $\alpha_{IIb}\beta_3$, and their respective contributions are dependent on the flow conditions present. In high-shear stress conditions, gpIb/V/IX receptor and vWF ligand action are predominant, with fibrinogen playing a stabilizing role. At low-shear conditions, fibrinogen is thought to be the primary ligand supporting platelet plug formation through its interaction with $\alpha_{IIb}\beta_3$. It has been shown that thrombus formation can take place in the absence of vWF and fibrinogen, and this supports the idea that a third ligand directed to the $\alpha_{IIb}\beta_3$ receptor may also exist *in vivo*.¹⁶

Platelet Glycoprotein Ib Complex-von Willebrand Factor Interaction and Signaling

It has long been recognized that the interaction of the platelet glycoprotein (gp) Ib “complex” (including the single-chain polypeptides gpIb α , gpIb β , gpIX, and gpV) with its primary ligand, vWF, is the receptor-ligand pairing that initiates platelet adhesion followed by a cascade of events leading to pathologic thrombosis or physiologic hemostasis. A unique aspect of this receptor-ligand interaction is that it requires the presence of high arterial shear rates to take place, thus explaining the predisposition of platelet-rich “white clots” in the arterial circulation over clots found in the venous circulation, with its relatively lower shear forces, in which clot formation takes place independent of the gpIb complex.

Using a parallel-plate flow cytometer, platelet interaction with subendothelial vWF has been characterized as occurring in a biphasic fashion.¹⁷ In this respect, the rate of translocation of platelets from blood to the endothelial cell surface increased linearly up to wall shear rates of $1,500 \text{ s}^{-1}$, whereas the translocation rate remained relatively constant with the wall shear rate between $1,500$ and $6,000 \text{ s}^{-1}$. This ability to mediate translocation or rolling of the platelet on vWF is contingent on the gpIb complex, and mammalian cells expressing either the full complex or a complex lacking the gpV subunit were able to roll onto vWF in a gpIb α -chain-dependent manner.^{18,19}

It is clear that arterial thrombus formation is contingent on both the presence of high wall shear rates and interaction between the gpIb complex and vWF. Studies involving the endpoint of realtime thrombus formation that involved comparison of blood from both patients with Bernard-Soulier syndrome (which lacks platelet gpIb complex) and severe (type 3) von Willebrand disease versus normal blood led to the conclusion that gpIb and vWF interaction was required for platelet surface interaction at high shear rates ($>1,210 \text{ s}^{-1}$), whereas normal thrombus formation at lower shear rates ($<340 \text{ s}^{-1}$) was possible with blood deficient in either gpIb or vWF.²⁰ In normal blood, thrombus formation was accelerated as shear rate increased, and this served to verify the unique shear flow dependence of this receptor-ligand interaction.

The gpIb complex consists of four transmembrane subunits, each of which is a member of the leucine-rich repeat protein superfamily that participates in cell-matrix interactions throughout nature. Each of the four subunits contains one or more tandem, 24-amino acid leucine-rich repeats flanked by conserved disulfide loop structures at both the N and C termini of the repeats.²¹ gpIb α is covalently associated with the gpIb β chain through disulfide linkage of cysteine residues, and both of these chains are noncovalently associated with gpIX in a 1:1 ratio and with gpV in a 2:1 ratio^{22,23} and ²⁴ (Fig. 17.1).

vWF is a large multimeric glycoprotein that circulates in plasma and is also found in platelets and the Weibe-Palade bodies of endothelial cells. Mature vWF is a 2,050-amino acid subunit that is disulfide linked into large multimers. It contains three adjacent A domains in the N-proximal half of the peptide that collectively regulate the adhesion of platelets to subendothelial matrix. In this respect, the A₁ and A₃ domains bind to different matrix collagens, whereas the A₁ domain contains the binding site for the gpIb complex.²⁵ The A₁ domain is the primary role player in platelet adhesion, because this part of the molecule is believed to change its conformation in response to immobilization and high-shear forces, thus making it a high-affinity ligand for the gpIb complex receptor.^{26,27} It has also been suggested that shear stresses may induce conformational changes in the gpIb complex that may be important in increasing its affinity for vWF.²⁸ Through the simultaneous binding of collagen and platelets, vWF can serve as a molecular bridge between platelets and the subendothelial matrix mediating platelet adhesion to the vessel wall. Thus by associating with matrix proteins vWF mediates rapid and reversible platelet adhesion that promotes the rolling of these cells along the surface of vascular injury.

To further add to the mystery behind the mechanism of shear dependence in gplb-vWF interaction, in vitro activation of vWF and binding to the gplb complex occur with generally very low affinity without shear, whereas this shear-free binding exhibits high affinity in the presence of the vancomycinlike antibiotic ristocetin, and viper venom proteins, such as botrocetin. It is interesting that studies incorporating anti-gplb α and anti-vWF domain A₁ antibodies have suggested that ristocetin and botrocetin each

P.412

appear to use different receptor and ligand-binding sites to facilitate the vWF-gplb complex interaction.^{29,30} and ³¹

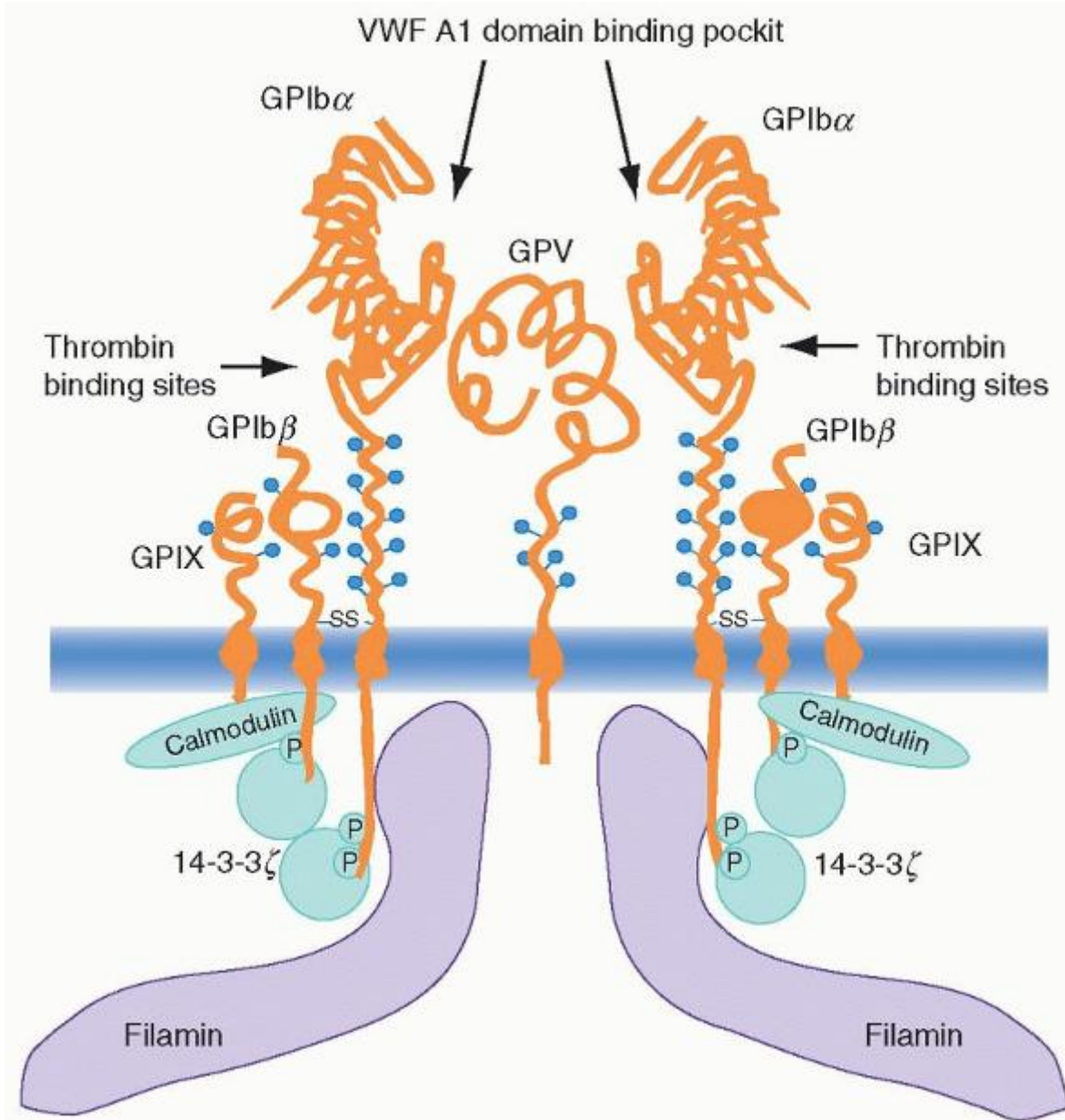

FIGURE 17.1. Schematic illustration of the glycoprotein (GP) Ib/V/IX complex and associated proteins. The N-terminal domain of GPIb α contains binding sites for von Willebrand factor (vWF) and thrombin. The cytoplasmic domain of GPIb α contains the phosphorylation-dependent 14-3-3 binding sites, and also the binding site for filamin that links GPIb-IX to the actin cytoskeleton underlying the membrane. The cytoplasmic domain of GPIb β is phosphorylated by protein kinase A (PKA) and this phosphorylation is required for 14-3-3 binding. The membrane proximal region in the cytoplasmic domain of GPIb β and GPIX contains calmodulin-binding sites. From Du, X. Signaling and regulation of the platelet glycoprotein Ib-IX-V complex. *LWW, Curr Opin Hematol* 2007;14:262, Figure 2, with permission.

The binding interaction between vWF and gplb appears to involve at least three distinct regions within the N-terminal 282 residues of gplb. Each of these regions appears to be responsible for either direct binding to vWF or modulating its affinity for the ligand.³² In this respect, one region (His 1 to Glu 282), which includes a cluster between residues Asp 252 and Arg 293 containing sulfated tyrosine residues and important anionic residues, appears to be predominantly responsible for vWF-gplb complex interaction in the presence of botrocetin over ristocetin.^{33,34} and ³⁵

The second region contains the disulfide loop between Cys 209 and Cys 248 along with two naturally occurring mutations (Gly 233 to Val and Met 239 to Val) and two additional mutation sites identified in the laboratory (Asp 235 to Val and Lys 237 to Val) that can individually lead to expression of the pseudo- or platelettype von Willebrand disease phenotype.³⁰ This disorder is associated with a gain-of-function gplb α on platelets that adheres to vWF in the presence of lower concentrations of ristocetin (0.3 to 0.5 mg/ml) than are required for the wild-type phenotype (1.5 g/ml). It is analogous to type 2B von Willebrand disease, in which high-molecular-weight vWF multimers are absent from the plasma, and similar gain-of-function mutations have been localized to the Cys 509 to Cys 695 disulfide loop of vWF exon 28.

The third region includes the N-terminal flanking sequence of the leucine-rich repeat (LRG) motifs and the LRGs themselves. Mutations involving single amino acid residues within these LRGs account for some cases of the congenital bleeding disorder, Bernard-Soulier syndrome, in which the gplb complex binds poorly or not at all to vWF. Evidence using mammalian Chinese hamster ovary cells expressing loss-of-function proteins and anti-gplb α monoclonal antibodies has suggested that the more N-terminal LRGs may play a more direct role in interaction with vWF.³⁶

Glycoprotein Ib Complex Interaction with Thrombin

Recent studies have examined the potential role of the gplb complex in thrombin-mediated platelet activation. The physiologic significance of the interaction of thrombin with the complex has remained relatively controversial. gplb α contains a well-characterized high-affinity binding site for thrombin, and thrombin is also capable of cleaving gpV near the surface to release a soluble fragment.³⁷

Recent studies have suggested that a relationship exists between thrombin binding to the gplb complex and cleavage of the seven-transmembrane G-protein-coupled protease-activated thrombin receptor, protease-activated receptor (PAR)-1 (see section "Platelet Thrombin [Protease-Activated] Receptors and Signaling"), and that accelerated coagulation on the surface of a developing thrombus is a downstream consequence of thrombin-gplb interaction because of enhanced phospholipid exposure.^{38,39} These studies support a procoagulant role of this thrombin-gplb pairing and this activity also plays an important role in the generation of platelet microparticles.^{40,41} In contrast, studies using gpV-null mice have suggested that the gpV subunit may act as a negative regulator of thrombin-mediated platelet activation, whereas data from another study suggest that thrombin-gplb interaction leads to conformational changes in thrombin that reduce its cleavage of fibrinogen.^{42,43}

The phenotype of a gplb α knockout mouse has been reported and was similar in many ways to human Bernard-Soulier syndrome.⁴⁴ This mouse was then capable of having the wild-type phenotype restored by a human gplb α transgene. Future use of this mouse model might be helpful toward further elucidation of the physiologic role of platelet gplb complex interaction with thrombin.⁴⁵ In the meantime, the current data extend further support for a role for the gplb complex as a thrombin receptor on platelets, whereas, recent insights notwithstanding, elucidation of the downstream consequences of that interaction with respect to platelet activation and thrombus formation will remain the subject of further investigation.

Studies have focused on interaction of the gplb complex with activated intact endothelium through ligands other than vWF adherent to subendothelial matrix. These include a study of a reversible association of gplb with endothelial cell P-selectin, which is examined in more detail in the section, "Platelets and Endothelium." The interaction of platelet gplb with the neutrophil adhesion receptor Mac-1 is discussed in the section, "Platelets and White Blood Cells." These interactions may contribute more to inflammatory responses than platelet thrombus formation. The dependence of fibrin-associated platelet procoagulant activity on both the gplb complex and vWF has also been documented.⁴⁶

Glycoprotein Ib Complex Signaling

For some time, controversy surrounded the question of whether the gplb/V/IX complex signals. This was likely a result of variations in experimental strategies that involve differences with respect to vWF preparations, the use of conformational modulators in experimental work such as botrocetin, cell lines used, and other causes. It is reasonable to assume that the receptor is capable of signaling, although a lot of questions remain to be answered, and the many molecules that are known to participate in the process remain to be assembled into a defined pathway.

When the gplb complex interacts with its vWF ligand under conditions of elevated shear stress, there is abundant evidence that signaling pathways are activated that lead to (a) elevation of intracellular calcium; (b) activation of a tyrosine kinase signaling

P.413

pathway that incorporates nonreceptor tyrosine kinases such as Src, Fyn, Lyn, and Syk, phospholipase C (PIC) γ 2, and adaptor proteins such as SHC, LAT, and SLP-76; (c) GTPase activating protein; (d) tyrosine phosphatases (PTP-1B and SHPTP10); (e) inside-out signaling through the $\alpha_{IIb}\beta_3$ integrin followed by platelet aggregation³²; and (f) activation of protein kinase C (PKC), protein kinase G (PKG), and phosphoinositide 3-kinase (PI3K). vWF binding also up-regulates integrin $\alpha_{IIb}\beta_3$ affinity indirectly through stimulation of adenosine diphosphate (ADP) secretion.³³ Other downstream players and events that play roles after gplb receptor occupancy include (a) the homodimeric signaling protein 14-3-3 and calmodulin, (b) receptor cross-linking, and (c) the immunoreceptor tyrosine-based activation motif (ITAM)-containing proteins Fc γ receptor IIA (Fc γ RIIA) and Fc receptor (FcR) γ chain. In addition to the above-mentioned components, the effect of shear force itself on gplb signaling, including the affinity and number of bonds between vWF and gplb, play potentially important roles as well.^{34,35}

Evidence has also been presented suggesting that indirect mechanisms may also be involved in gplb signaling, that are linked to ADP release and/or thromboxane A₂ (TxA₂) generation.^{33,34} The increase in intracellular calcium prompted by vWF-gplb interaction promotes dense granule secretion of ADP, which then activates integrin $\alpha_{IIb}\beta_3$ through the P2Y₁ and P2Y₁₂ purinergic receptors (see the section on "Platelet P2Y₁ and P2Y₁₂ Receptor Roles in ADP-Mediated Activation" later in the chapter).

14-3-3 ζ is among the 10 isoforms of the 14-3-3 family of proteins that is named according to its electrophoretic gel migration position. Functionally, this family has a wide range of activities, including participating as a DNA damage, cell-cycle checkpoint protein, regulation of PKC activity, formation of heterotrimers with the signaling kinase Raf and the guanosine triphosphate exchange factor Ras, and so forth.^{47,48} and ⁴⁹ Binding sites for 14-3-3 have been identified in the cytoplasmic domains of gplb α , gplb β , gplX, and gpV. In this respect, peptide fragments corresponding to overlapping cytoplasmic sequences of the four subunits demonstrated binding in vitro, whereas yeast two-hybrid studies documented in vivo interaction between 14-3-3 ζ and both gplb α and - β .^{50,51} Site-directed mutagenesis and protein-binding experiments confirmed the need for phosphorylation of Ser 166 of the 14-3-3 consensus sequence in the gplb β cytoplasmic domain to permit high-affinity 14-3-3 binding.^{51,52} Findings that have evolved in lieu of the above observations include the binding of fibrinogen to mammalian-cell-transfected $\alpha_{IIb}\beta_3$ in response to vWF binding to co-transfected gplb-IX that was inhibited when the 14-3-3-binding domain was deleted from the gplb-IX transfectant.⁵³ Also, the lipid kinase PI3K has been found to play a role in this gplb-IX dependence of $\alpha_{IIb}\beta_3$ activation through its participation in complex formation with the gplb complex and 14-3-3.⁵⁴ The reason for these associations would be to regulate, in short order, the formation of inositols phosphorylated in the 3-position within the reorganizing cytoskeleton in response to platelet activation (see section "Role of the Cytoskeleton in Platelet Function").³²

Many adhesion receptors initiate signaling through cross-linking, and there is evidence to suggest that the gplb complex may also use this mechanism. The gpV subunit surface expression on platelets is roughly half that of the other three subunits (12,000 vs. 25,000 copies per cell). It has also been suggested that two or more gplb α subunits cluster into a complex with the other glycoprotein subunits.⁵⁵ The fact that there is one gpV subunit available in this complex for every two of the other subunits, and that both actin-binding protein (ABP or filamin; a membrane skeleton protein that associates with gplb α ; see later in the chapter) and 14-3-3 exist as dimers, lends support to the concept of a complex consisting of a pair of gplb α -gplb β -gplX trimers joined noncovalently by a single gpV monomer (Fig. 17.1).

Several studies document a physical association of the gplb complex with the 14-kDa Fc γ -chain⁵⁶ and with the 40-kDa Fc γ RIIA receptor,⁵⁷ suggesting that platelet activation may also occur through gplb-mediated triggering of Src-family-kinase phosphorylation.^{58,59} Both of these proteins contain nonidentical but similar ITAM domain sequences. The Fc γ -chain forms a complex with the gpVI monomer and plays an essential role in collagen-mediated platelet activation, as reviewed in the next section. The Fc γ RIIA receptor is a member of the immunoglobulin (Ig) superfamily and is without a clearly defined physiologic role in platelets. Occupancy of this receptor by the C-terminal Fc domains of immunoglobulin leads to platelet activation, and this is blocked by anti-gplb α antibodies, whereas signaling through vWF is also blocked with anti-Fc γ RIIA antibodies.^{57,60} Both ITAM-containing receptors can be coimmunoprecipitated with gplb,^{56,60} and both have very similar signaling pathways that involve the tyrosine kinase Syk and PIC γ 2.^{61,62} and ⁶³ Although the physical proximities of these three players have recently become apparent, the nature and significance of any physiologic

relationships that exist between the gpIb complex and these two ITAM receptors with respect to vWF-dependent platelet activation remains unclear.

Shear flow studies have demonstrated an important role for calcium signals that in turn promote $\alpha_{\text{IIb}}\beta_3$ activation necessary for stable platelet adhesion to vWF (34,35). This phenomenon occurs independently of extracellular calcium and is thought to involve $\alpha_{\text{IIb}}\beta_3$ -mediated calcium release from intracellular stores. One proposed mechanism to explain this observation involves signaling pathways such as those used by ITAM-bearing receptors, because the enzyme and adaptor protein components used in both $\alpha_{\text{IIb}}\beta_3$ and ITAM signaling are very similar. These components are likely to be important in the positive feedback loop linking $\alpha_{\text{IIb}}\beta_3$ activation and calcium flux under high shear, which in turn promotes the efficient conversion of translocating platelets into firmly adhesive cells.⁶⁴

Once vWF binds to gpIb-V-IX , signaling complexes form in the vicinity of the $\text{gpIb}\alpha$ cytoplasmic tail consisting of cytoskeletal proteins such as 14-3-3 ζ as well as signaling proteins such as Src and PI 3-kinase. This process leads to Syk activation, protein tyrosine phosphorylation, and recruitment of other cytoplasmic proteins with Pleckstrin homology domains that can support interactions with 3-phosphorylated phosphoinositides.^{65,66,67,68} and ⁶⁹

Platelet-Collagen Interaction and Signaling

Collagens are very important activators of platelets in the vascular subendothelium and vessel wall, and thus are prime targets for therapeutic intervention in patients experiencing a pathologic arterial thrombotic event such as MI or stroke. Platelets have two major surface receptors for collagen, the integrin $\alpha_2\beta_1$ and the immunoglobulin superfamily member gpVI . In addition to binding collagen with high affinity, $\alpha_2\beta_1$ binds laminins, E-cadherins, matrix metalloproteins, C1q, echovirus, and rotavirus. In addition to these two surface receptors, the gpIb complex can also be considered an indirect collagen receptor because its subendothelial vWF ligand essentially acts as a bridging molecule between platelets and collagen by fixing itself to the latter, which, in turn, acts as scaffolding for the multimers.

Collagen supports platelet adhesion through interaction with the integrin surface receptor $\alpha_2\beta_1$, although this interaction alone does not support platelet activation.⁷² Laboratory evidence suggests that gpVI and the 14-kDa $\text{FcR}\gamma$ -chain signaling subunit ($\text{FcR}\gamma$ chain) with which gpVI forms a complex are both required for collagen-mediated platelet adhesion and activation.^{61,69,70,71,72,73,74,75,76,77,78,79,80} and ⁸¹ Thus platelet adhesion to collagen is a multistep process. Once exposed to an injured vascular wall, vWF adheres to subendothelial collagen and undergoes a conformational change allowing its A1 domain to bind to GP1b/V/IX under high-shear flow conditions. This rapidly formed bond is quickly broken and re-established and this leads to the platelet rolling along the vascular wall. This

P.414

in turn slows down the platelet and allows the signaling receptor GPVI to bind collagen, more specifically the repeating sequence Gly-Pro-Hyp (where Hyp is hydroxyproline). Both receptors can signal but the role of GPVI is considered predominant in this respect.⁸² A series of signaling events then leads to the inside-out signaling activation of $\alpha_2\beta_1$ and interaction of this receptor with collagen is stable and allows the platelet to form a high-affinity strong adhesive bond with the vessel wall.

The above notwithstanding, of many receptors studied only $\alpha_2\beta_1$ and GPVI have a defined role in platelet-collagen interactions although, in spite of extensive studies, their relative importance with respect to both adhesion and activation continues to be debatable. Problems associated with the isolation of collagen from extracellular matrices and possible but poorly understood differences between human *ex vivo* and mouse *in vivo* experimental systems explain these ongoing unresolved issues.⁸²

$\alpha_2\beta_1$ Receptor

The platelet collagen receptor to be first identified and characterized was the integrin $\alpha_2\beta_1$ receptor, also known as gpIa/IIa , and on lymphocytes as VLA-2 .⁸³ Integrins are a family of α - β heterodimers on the surface of cells that carry out diverse interactions between the cell surface and its environment that ultimately lead to changes in cell behavior in response to the ligand-receptor interaction. In all α subunits of integrins, seven tandem repeats are localized to the N-terminal end and folded into a seven-bladed β -propeller structure.⁸⁴ The α_2 subunit also contains an I domain between the second and third repeats that includes a metal coordination site for Mg^{2+} that is critical for interaction with collagen.⁸⁵ Similar domains are found on the β subunit, although less is known about these, and it appears that the interaction of $\alpha_2\beta_1$ with collagen involves only the I domain of α_2 . The β_1 subunit exhibits a cysteine-rich domain containing CGXC sequences that is close to the membrane surface. This region has protein disulfide isomerase activity responsible for regulating

conformational changes of the β_1 subunit (which, in turn, alters α_2 conformation, increasing its avidity for collagen) in response to inside-out signaling through the cytoplasmic domain.^{86,87}

Glycoprotein VI Receptor

Although the gpVI receptor was identified on the surface of platelets in 1982, its role in collagen-mediated platelet activation was not appreciated until much later.⁸⁸ The human and murine genes were cloned and characterized, and gpVI was found to be a member of the immunoglobulin superfamily.^{81,87,89,90} The expression of gpVI in platelets is very closely associated with that of the 14-kDa FcR γ -chain, which also serves as the signaling subunit for gpVI.^{91,92} Expression of gpVI on mouse platelets appears to be dependent on FcR γ -chain expression, and the latter has also been found to be critical for collagen-mediated platelet activation.^{76,92} gpVI has two Ig C2 loops, and the N-terminal loop likely contains the collagen-binding domain.⁸² It appears that gpVI has a requirement for the quaternary structure of collagen to be in a triple-helical conformation for the two to associate.⁹³

Following the cloning of gpVI, mouse knockout studies have suggested GPVI may be the primary receptor involved in collagen-mediated platelet activation.^{94,95} and⁹⁶ Further studies have enabled the collagen-binding site on gpVI to be characterized.⁹⁷

Studies incorporating collagen-related peptides (arranged in triple helical structures with sequences similar to collagen) and the snake venom convulxin as agonists have been shown to signal by clustering gpVI molecules on the surface.^{73,78,98} However, the idea of gpVI receptor clustering as a platelet activation mechanism applicable to collagen is tempered by consideration of the theoretically much greater distances that would exist between adjacent gpVI-binding sites along fibrillar collagen compared with the larger, noncovalently linked structures of convulxin, in which gpVI-binding site distribution is much different.⁹⁹

Platelet-Collagen Signaling

When compared to vWF, collagen is a more efficient substrate when it comes to supporting stable platelet adhesion and thrombus formation. The fact that initial platelet tethering to collagen under high-shear flow first requires interaction between vWF and platelet gpIb serves to underscore the importance of the two major collagen receptors, $\alpha_2\beta_1$ and gpVI, in promoting platelet adhesion and activation under shear conditions.

Many of the early signaling events that follow gpVI stimulation have been characterized, although synergism between these gpVI mediators and those related to other adhesion receptors such as gpIb-V-IX and soluble agonists released by activated platelets further complicates full elucidation of the players and pathways associated with platelet-collagen signaling.

The gpVI signaling pathway has been found to be essential for collagen-mediated platelet activation, and mouse platelet studies have shown a central role for this receptor in promoting platelet-collagen interaction.^{61,100} Integrin $\alpha_2\beta_1$ also contributes to platelet adhesion through amplification of signals from gpVI.^{101,102} As noted in the last section, exposure of platelets to collagen surfaces is thought to result in gpVI clustering that in turn triggers the tyrosine phosphorylation of the FcR γ chain.⁹¹ gpVI signaling may be influenced by its association with glycolipid-enriched microdomains (membrane rafts) in the plasma membrane, although it is unclear whether gpVI is constitutively associated with the rafts or is recruited.^{103,104} The gpVI/FcR γ -chain complex leads to platelet activation through a pathway that has many aspects in common with signaling by immune receptors, such as the FcR receptor family (of which Fc γ RIIA is the lone family member found in platelets) and the B- and T-cell antigen receptors (Fig. 17.2). Much of what we know about gpVI signaling has been based on earlier work related to immune-receptor signaling.^{105,106}

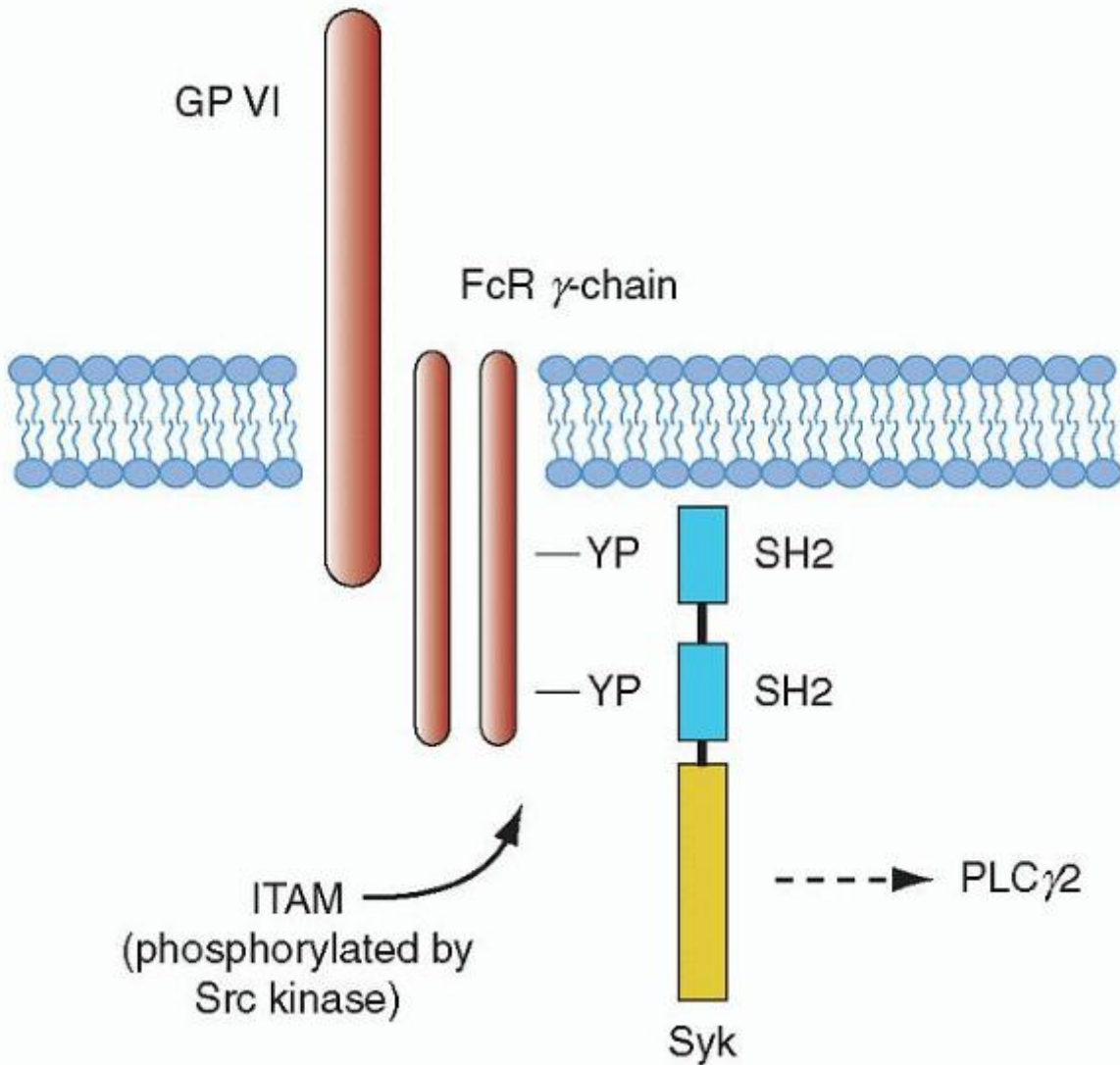

FIGURE 17.2. Collagen activates platelets through the same pathway as an immune receptor. Cross-linking of the glycoprotein (gp) VI/Fc receptor (R) γ chain leads to tyrosine phosphorylation of the immunoreceptor tyrosine-based activation motif (ITAM) sequence, enabling recruitment of the tyrosine kinase (Syk) through its tandem Src-homology 2 (SH2) domains. This leads to autophosphorylation and subsequent activation of Syk, which in turn leads to tyrosine phosphorylation of phospholipase C γ 2 (PLC γ 2). A large number of proteins are implicated in the regulation of PLC γ 2, as discussed in the text. YP, phosphotyrosine. From Watson SP. Collagen receptor signalling in platelets and megakaryocytes. *Thromb Haemost* 1999;82:367, with permission.

P.415

Immunoreceptors such as the FcRs and the FcR γ chain all have the ITAM in common. Tyrosine phosphorylation of the ITAM by Lyn and Fyn of the Src family of tyrosine kinases takes place after activation of gpVI. The phosphorylated Src kinase, in turn, leads to activation of the tyrosine kinase Syk after its autophosphorylation.¹⁰⁷ Syk then initiates a downstream signaling cascade involving the LAT and SLP-76 adapter proteins, which leads to formation of a signaling complex by virtue of its multiple phosphorylation sites that also act as docking sites, leading to recruitment of additional proteins to the plasma membrane.¹⁰⁸ Transport to the signaling complex and activation of the cytosolic second messenger-producing enzymes PI3K and PLC γ 2 is also facilitated by tyrosine phosphorylated LAT.¹⁰⁹ PI3K leads to the generation of PI3,4P3 and PI3,4,5P3 (PIP3), and this, in turn, supports recruitment of proteins to the membrane signalosome complex with specific plekstrin homology (PH) domains including a member of the Tec kinase family, Btk,

along with PLC γ 2.^{110,111} Syk is critical for collagen-mediated platelet activation through the gpVI/FcR γ -chain complex, and knockout mouse studies have shown that absence of this enzyme leads to loss of phosphorylation of LAT, the adapter SLP-76, and PLC γ 2.^{61,111,112}

Adapters such as LAT are modular proteins without enzyme activity that support protein-protein interaction. Many adapter proteins appear to participate in the regulation of PLC γ 2. These proteins appear to come together in T lymphocytes along with PLC γ 1 to form a LAT/SLP-76 signalosome that is essential for activation of PLC γ 2.¹⁰⁶ SLP-76 is thought to be especially important among adapters in the regulation of PLC γ 2, because its loss results in reduced phosphorylation of PLC γ 2.^{112,113}

Along with the adapter proteins noted above, PI3K and its associated second messenger pathway also play a very important role in the regulation of PLC γ 2 through activation of other signaling proteins such as protein kinase B (PKB) (also known as Akt).^{114,115} One of the two PKB isoforms, PKB β (Akt2), is important for normal platelet function and thrombus formation and leads to impaired alpha and dense granule secretion along with impaired $\alpha_{IIb}\beta_3$ activation when absent.¹¹⁵ Integrin-linked kinase (ILK) is another PI3K downstream effector that interacts with β_1 and β_3 integrin subunit cytoplasmic tails and is considered important in the bidirectional signaling of $\alpha_2\beta_1$ and $\alpha_{IIb}\beta_3$.^{396,397} It may also be playing a role in regulating PKB.³⁹⁴ Using PI3K inhibitors such as wortmannin and LY294002, studies have demonstrated significantly reduced PLC γ 2 activation through gpVI.^{116,117} and¹¹⁸ These inhibitors have also been shown to block platelet activation through the Fc γ RIIA immunoreceptor, and this demonstrates an additional similarity between signaling pathways of this receptor and the FcR γ chain.¹¹⁹

PLC γ 2 is known to play a critical role in aggregation and secretion responses to collagen, as demonstrated in PLC γ 2 knockout mice and in other studies.^{63,120,121} The major role of PLC isoforms is concerned with the generation of the second messengers inositol 1,4,5-triphosphate and 1,2-diacylglycerol (DAG), which participate in intracellular calcium homeostasis and activation of many isoforms of PKC. The former process culminates in a robust calcium signal that promotes efficient platelet activation. The PKC isoforms make possible the regulatory serine/threonine phosphorylation events needed for activation of $\alpha_2\beta_1$ as well as $\alpha_{IIb}\beta_3$, and interaction of these two integrins with their ligands facilitates a second round of signaling that includes some of the same molecules downstream of gpVI, such as Syk, SLP-76, and PLC γ 2.¹²²

Recent research has led to increased knowledge about $\alpha_2\beta_1$ receptor signaling. The use of $\alpha_2\beta_1$ -selective ligands has demonstrated calcium-dependent spreading and tyrosine phosphorylation of several proteins when interaction with platelets takes place, including Src, Syk, SLP-76, PLC γ 2, p38 MAP kinase, ILK, Rac, and PAK.^{117,123,124} It appears likely that only GPVI and GPIb/V/IX are able to bind collagen and vWF, respectively, without prior platelet activation. Once activation starts, $\alpha_2\beta_1$ and $\alpha_{IIb}\beta_3$ are able to bind their respective ligands as well.

Other Platelet Adhesion Receptors

Other adhesive proteins present in the extracellular matrix and involved in the interaction between platelets and the subendothelium include fibronectin, thrombospondin, laminin, and vitronectin. Fibronectin is stored in platelet α granules and secreted upon thrombin-mediated platelet activation. Thrombospondin is also stored in platelet α granules. It interacts with fibrinogen, fibrin, fibronectin, and collagen on the platelet membrane and its release during platelet activation might relate to its capability to overcome the antithrombotic activity of physiologic nitric oxide (NO). Laminin is a large glycoprotein and can amplify platelet activation through GPVI binding. Recent data suggest that laminin may also interact with vWF and the GPIb/V/IX complex thereby supporting platelet adhesion under high-shear flow conditions.¹²⁵ The extracellular adhesive protein vitronectin can bind to platelet receptor $\alpha_{IIb}\beta_3$ or the integrin $\alpha_v\beta_3$ and appears to be functionally similar to fibronectin.

Physiologic Inhibition of Platelet Adhesion

Negative regulation of platelets is essential to set the stimulus threshold for thrombus formation, determine final clot size and stability, and prevent uncontrolled thrombosis. The mechanisms behind the negative regulation of platelet activation are described later in the chapter, and in this respect, roles of players such as NO and prostacyclin have been well characterized. Platelet activation and aggregation can also be inhibited by signaling through the platelet endothelial cell adhesion molecule (PECAM)-1 (CD31).^{126,127} This molecule is expressed on a number of blood cells and endothelial cells and has a wide array of regulatory functions in processes such as apoptosis and cell activation. It becomes tyrosine phosphorylated following platelet stimulation by a diverse set of agonists, which suggests that it has a negative feedback role in this setting. Its main ligand is itself, so it has been proposed that interactions between platelet and endothelial PECAM-1 might serve to restrict thrombus growth through the signaling mechanisms below; this is supported by studies involving PECAM-1-knockout mice.^{128,129}

Following homophilic interactions and/or clustering, PECAM-1 is tyrosine phosphorylated in its cytoplasmic-tail ITIM domain (immunoreceptor tyrosine-based inhibition motif) by Src family kinases, and this engenders recruitment of tyrosine, serine/threonine, or lipid phosphatases with resultant kinase-dependent signaling inhibition.^{127,130} The net result is reduced total platelet tyrosine phosphorylation, calcium mobilization, and signaling through PI3K.¹²⁷ ITIM-mediated signaling inhibition through the ITAM domain is not the only mechanism by which PECAM-1 dampens platelet adhesion, because low-density lipoprotein and thrombin-dependent signaling pathways also appear to be downregulated by PECAM-1.^{127,130} Negative effects have also been documented with gplb signaling and platelet FcγRIIA-mediated responses.^{131,132}

Von Willebrand factor multimer size and thus also vWF activity is mainly regulated by the metalloprotease ADAMTS13 and recently other factors have been found to cleave vWF including plasmin and leukocyte proteases.^{133,134} ADAMTS13 cleaves released large vWF multimers into smaller fragments. Different circumstances can induce vWF unfolding thereby exposing the ADAMTS13 cleavage site. These include high-shear flow conditions, denaturing agents such as urea, and mutations seen in von Willebrand disease type 2A. In contrast, reduced ADAMTS13 activity may lead to insufficient vWF processing causing a prothrombotic state such as thrombotic thrombocytopenic purpura (see Chapter 48).

P.416

Platelet Thrombin (Protease-activated) Receptors and Signaling

PARs are G-protein-coupled receptors that use a unique mechanism to convert an extracellular protein cleavage event into an intracellular activation signal. In this case, the ligand is already part of the receptor per se, by virtue of the fact that it is represented by the amino acid sequence SFLLRN (residues 42 through 47) and is unmasked as a new amino terminus after thrombin cleaves the peptide bond between Arg 41 and Ser 42. This “tethered ligand” then proceeds to dock irreversibly with the body of its own receptor to effect transmembrane signaling, as shown in Figure 17.3.

Thrombin signaling in platelets is mediated, at least in part, by four members of a family of G-protein-coupled PARs (PAR-1, -2, -3, and -4; see previous section for a discussion of the gplb complex as a thrombin receptor).¹³⁵ Human platelets express PAR-1 and PAR-4, and activation of either is sufficient to trigger platelet aggregation.^{136,137} Mouse platelets express PAR-3 and PAR-4.¹³⁸ PAR-1, -3, and -4 can be activated by thrombin, whereas PAR-2 can be activated by trypsin, tryptase, and coagulation factors VIIa and Xa but not thrombin.^{139,140} and ¹⁴¹ Presumably, other proteases are capable of recognizing the active sites of these receptors and can thus also trigger PAR signaling.

PAR-1 is the prototype family member and was the first to be cloned and characterized in the human and hamster.^{136,142} A synthetic peptide that mimics the PAR-1-tethered ligand (SFLLRN) is capable of functioning as an agonist by activating the receptor independent of cleavage of the 41-residue N-terminal exodomain.

The mechanism by which G-protein-coupled receptors, such as PAR-1, signal through the G proteins is shown in Figure 17.4. PAR-1 is capable of coupling to members of the G_{12/13}, G_q, and G_{i/z} families and thus is connected to a significant number of intracellular signaling pathways. The α subunits of G₁₂ and G₁₃ are believed to be involved in mediating rearrangement of the actin cytoskeleton and platelet shape change,¹⁴³ and downstream signaling mediators include Rho family members, among others. The α subunit of G_q is needed for platelet secretion and aggregation and participates in activation of PICβ that leads to calcium mobilization and PKC activation.^{144,145} The α subunit of G_z is a G_i family member that has been speculated to play an epinephrinelike role in human platelets through inhibition of adenylate cyclase.^{34,146}

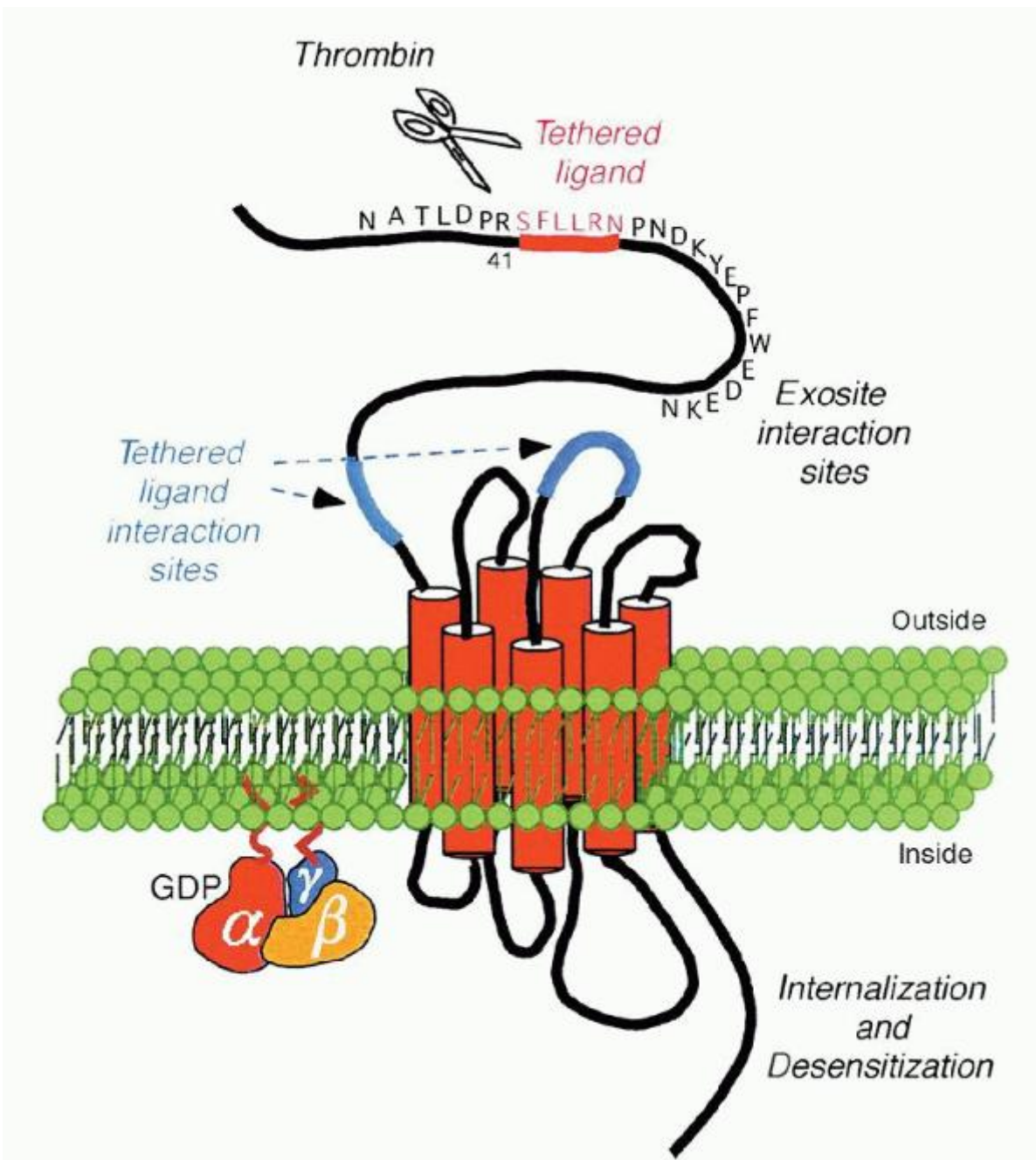

FIGURE 17.3. Structure and features of PAR-1. Cleavage of PAR-1 by thrombin between arginine 41 and serine 42 exposes a new N terminus that serves as a tethered ligand. Activation of PAR-1 is followed by a rapid burst of signaling before the receptor is desensitized and, in some cases, cleared from the cell surface. From Brass LF. Thrombin and platelet activation. *Chest* 2003;124:18S-25S, with permission.

The β - γ subunit counterparts of G proteins involved in PAR-1 signaling are involved in a plethora of activities, including activation of protein kinases, channels, and lipid-modifying enzymes, such as PI3K, which provides attachment for multiple signaling protein complexes close to the inner leaflet of the cell membrane.^{147,148} and ¹⁴⁹ Thus, this vast network of signaling pathways mediated through several G-protein families is in keeping with the pleiotropic roles that thrombin has been shown to exhibit in cellular homeostasis, which extends beyond platelet activation to include endothelial cells, leukocytes, smooth muscle cells, and T lymphocytes, along with physiologic processes such as tissue injury, inflammation, angiogenesis, and embryonic development.⁴⁵

Once activated, PAR-1 is rapidly uncoupled from signaling and internalized into the cell.^{150,151} and ¹⁵² It is then transported to lysosomes and degraded.^{151,153,154} and ¹⁵⁵ Platelets presumably have no need for a thrombin-receptor recycling

mechanism, because once activated, they are irreversibly incorporated into blood clots. Conversely, in cell lines with characteristics similar to megakaryocytes (MKs), new protein synthesis is needed for recovery of PAR-1 signaling^{151,153} and, in endothelial cells, sensitivity to thrombin is maintained by delivery of naïve PAR-1 to the cell surface from a preformed intracellular pool.¹⁵³

Physiologic differences exist between PAR-1 and PAR-4 on human platelets. When antibodies to the thrombin interaction site of PAR-1 are used, platelet activation is blocked at low, as opposed to high, thrombin concentrations.^{154,155} Antibodies that blocked PAR-4 alone had no effect on thrombin-mediated platelet activation. If both receptors were blocked, platelet activation was blocked at both low and high thrombin concentrations,¹³⁸ and so PAR-1 appears to be most efficient at mediating platelet activation at low concentrations of thrombin, whereas PAR-4 functions in the absence of PAR-1 but only at high thrombin concentrations. Because PAR-1 is capable of mediating platelet activation at low thrombin concentrations, the exact role of PAR-4 in human platelet function remains speculative. It has been shown that the rate of platelet activation through PAR-4 is significantly slower and more sustained than that through PAR-1.^{45,156,157} Given the importance of this system with respect to normal hemostasis, PAR-4 may serve as a redundant backup receptor to PAR-1, or it may serve as an important receptor for one or more proteases other than thrombin.

Initial studies addressing the role of thrombin in promoting platelet thrombus formation employing ex vivo perfusion systems pointed toward its importance at low- to intermediate-shear rates (100 to 650 s⁻¹), but not at higher shear rates (>2,600 s⁻¹).^{158,159} Subsequent studies employing PAR3 and PAR4 knockout mice have also demonstrated defective thrombus formation under high-shear conditions in vivo, although suggesting the possible existence of shear-based functional differences between PARs.^{160,161}

Platelet ADP (Purinergic) Receptors and Signaling

Evidence that ADP plays an important role in both formation of the platelet plug and the pathogenesis of arterial thrombosis has been accumulating since its initial characterization in 1960 as a factor derived from red blood cells that influences platelet

P.417

adhesion.^{161,162} ADP is present in high (molar) concentrations in platelet-dense granules and is released when platelet stimulation takes place with other agonists, such as collagen; thus, ADP serves to amplify further the biochemical and physiologic changes associated with platelet activation and aggregation. Inhibitors of this ADP-associated aggregation include commonly used clinical agents such as clopidogrel that have proven to be very effective antithrombotic drugs.^{163,164}

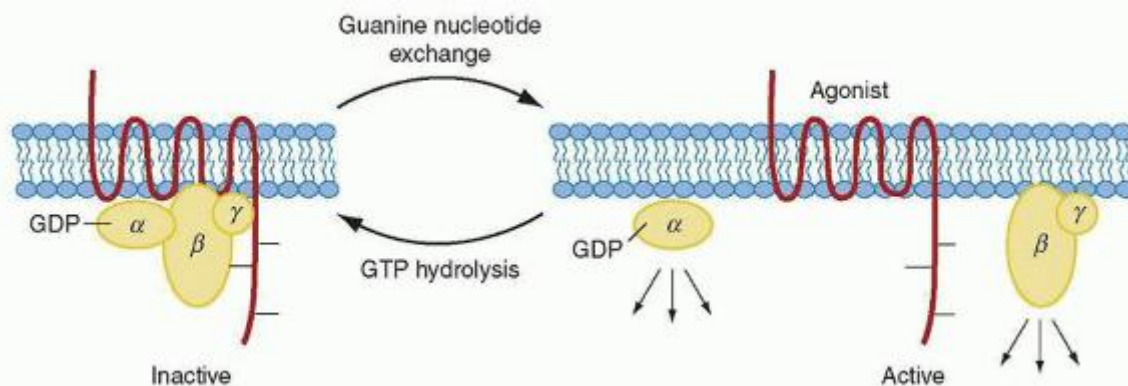

FIGURE 17.4. Signaling through G proteins and G-protein-coupled receptors. Agonist binding to the receptor causes the exchange of guanosine triphosphate (GTP) for guanosine diphosphate (GDP) on the guanine nucleotide-binding site of the G-protein α subunit. This causes the dissociation of $G\alpha$ from $G\beta\gamma$, both of which can activate intracellular effectors and ion channels. From Brass LF. Molecular basis of platelet activation. In: Hoffman R, Benz EJ, Shattil SJ, et al., eds. Hematology: basic principles and practice. New York: Churchill-Livingstone, 2000:1754, with permission.

Adenine nucleotides interact with P2 receptors that are ubiquitous among different cell types and have been found to regulate a wide range of physiologic processes. They are divided into two groups, the G-protein-coupled or “metabotropic” superfamily named P2Y and the ligand-gated ion channel or “ionotropic” superfamily termed P2X.¹⁶⁵ Two G-protein-coupled (P2Y) receptors contribute to platelet aggregation. The P2Y₁ receptor initiates aggregation through

mobilization of calcium stores, and the P2Y₁₂ receptor is coupled to inhibition of adenylate cyclase and is essential for a full aggregation response to ADP with stabilization of the platelet plug. P2X₁ is a third ADP receptor present in platelets and has been shown to contribute to aggregation in response to collagen. Both the P2Y₁₂ and P2X₁ receptors have been shown to play key roles in platelet activation and aggregation under flow conditions characterized by high-shear stress.^{166,167}

The P2Y₁ receptor was first cloned in 1993 from a chick brain complementary DNA library.^{168,169} and ¹⁷⁰ Messenger RNA was later found in MK-like cell lines, such as HEL and K562, along with human platelets.¹⁷¹ It was also established that the purported agonist effects of purified triphosphate nucleotides were, in fact, due to their transformation into diphosphate analogs by the ectonucleotidases present at the cell surface of the platelets and brain capillary endothelial cells being studied.^{171,172} The P2Y₁ receptor has 373 amino acid residues and the prototype structure of a G-protein-coupled receptor. It is distributed in various tissues such as heart, blood vessels, testis, and ovary.¹⁶⁵

After the characterization of P2Y₁, it became clear that a second platelet ADP receptor had to exist which was responsible for the inhibition of cAMP production by ADP that, in turn, was unaffected by blocking P2Y₁.^{173,174,175,176,177} and ¹⁷⁸ The P2Y₁₂ receptor was cloned in 2001 from human and rat platelet complementary DNA libraries using *Xenopus* oocytes.¹⁷⁹ The receptor indeed showed the ability to display ADP-mediated inhibition of platelet cyclic AMP (cAMP) formation that was not blocked by P2Y₁ antagonists. The receptor has been localized to certain regions of the brain, such as the substantia nigra and thalamus, in addition to platelets.¹⁷⁹

Platelet P2Y₁ and P2Y₁₂ Receptor Roles in ADP-Mediated Activation

Even at high concentrations ADP is a weak activator of PIC. Thus its role in platelet activation is based more on its ability to activate other pathways. Inhibition of either of the P2Y₁ or P2Y₁₂ receptors is sufficient to block ADP-mediated platelet aggregation, and co-activation of both receptors is therefore necessary, through the G proteins G_q and G_i, respectively, for ADP to activate and aggregate the platelet (Fig. 17.5).¹⁸⁰ A series of studies involving the use of selective P2Y₁ and P2Y₁₂ receptor antagonists, a cAMP inhibitor, gene targeting, and G_q and G_i protein agonists that would theoretically activate the two main G-protein pathways associated with ADP stimulation (see below) has led to the conclusion that a signaling event downstream from G_i is required for the conformational change and subsequent aggregation associated with the α_{IIb}β₃ receptor.^{176,178,180,181,182,183,184,185} and ¹⁸⁶

Studies done with platelets from patients who manifest defective P2Y₁₂, along with experiments involving the study of P2Y₁ receptor function in platelet-rich plasma that has high fibrinogen concentrations, have demonstrated that the P2Y₁ receptor has roles in activation and aggregation in addition to shape change, and that it is fully capable of mounting an aggregation response which is nonetheless transient in nature.^{176,187,188} The P2Y₁ receptor is an absolute requirement for ADP-mediated aggregation based on knockout mouse studies, the demonstration that platelets can become refractory to ADP due to desensitization of the P2Y₁ receptor, and the observation that adrenaline (which activates the G protein G_i that mediates inhibition of adenylate cyclase) does not restore aggregation in the presence of P2Y₁ selective antagonists.^{183,184,185,186,187} and ¹⁸⁸ Platelet shape change is dependent on two separate G signaling pathways, a G_q-linked release of calcium from internal stores, and a G₁₂/G₁₃ link to activation of Rho kinases and Rho guanine nucleotide exchange factors that activate small G proteins.^{143,189,190} The primary role of the P2Y₁₂ receptor in platelet activation and aggregation is to amplify and complete the aggregation response to ADP as well as to other agonists.^{173,174,175,176} and ¹⁷⁷ In the presence of a high ADP concentration, the receptor is also capable of mediating partial platelet aggregation on its own in P2Y₁ and G_q knockout mice, thus proving that α_{IIb}β₃ conformational change followed by aggregation can actually take place in the absence of calcium mobilization and PKC activation.^{184,190} In general terms, it appears that P2Y₁₂ is responsible for acting as an ADP co-stimulus receptor in the presence of low concentrations of other agonists, such as collagen, thrombin, chemokines, or IgG, whereas the P2Y₁ receptor has a specific role early in platelet activation.^{191,192} and ¹⁹³ Another role for the P2Y₁₂ receptor is the potentiation of platelet secretion.^{194,195} Because of its central role in the formation and stabilization of thrombi, the P2Y₁₂ receptor is a well-established target of antithrombotic drugs such as clopidogrel.^{194,196}

Platelets from P2Y₁₂-deficient mice aggregate poorly or not at all in response to ADP display a shift in the dose-response curves for collagen and thrombin and lack ADP-induced repression of cAMP levels.¹⁹⁷ The bleeding time of homozygous knockouts was markedly prolonged compared with near-normal results in heterozygotes.¹⁹⁸

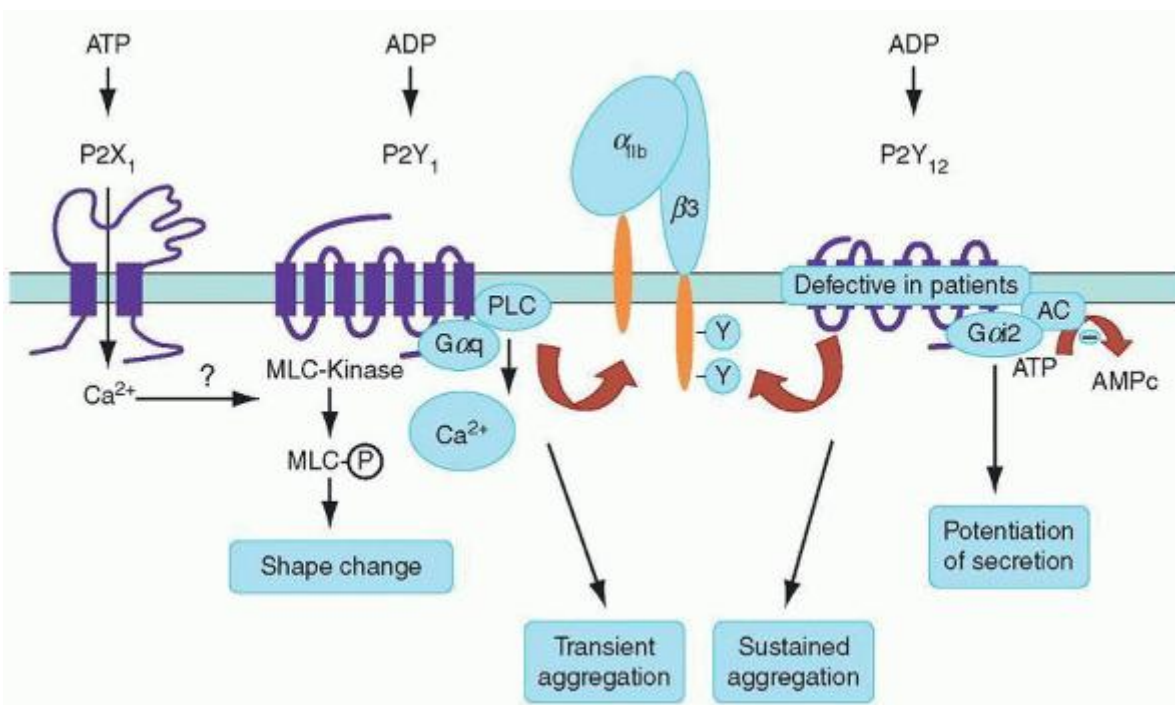

FIGURE 17.5. Current view of the interplay between the platelet P2 receptors. Two G-protein-coupled receptors are involved in adenosine diphosphate (ADP)-induced platelet aggregation, P2Y₁ and P2Y₁₂. The former is responsible for intracellular calcium mobilization, shape change, and transient aggregation, whereas the latter is coupled to adenylate cyclase (AC) inhibition and is responsible for amplification of platelet aggregation and potentiation of platelet secretion. Both receptors are required for normal platelet response to ADP. A P2X receptor is also present on platelets and is responsible for rapid calcium influx. It therefore synergizes with the P2Y₁ receptor. Both the P2Y₁₂ and P2X₁ receptors have been shown to play key roles in platelet activation and aggregation under high-shear stress conditions. ATP, adenosine triphosphate; cAMP, cyclic adenosine monophosphate; MLC, myosin light chain; P, phosphorylated; PLC, phospholipase C; Y, phosphotyrosine. Modified from Gachet C. ADP receptors of platelets and their inhibition. *Thromb Haemost* 2001;86:227, with permission.

P2X₁ Receptor

P2X₁ was first discovered in platelets using polymerase chain reaction of transcripts from platelets and MK-like cell lines.^{199,200,201} and ²⁰² This third platelet P2 receptor is an ATP-gated ion channel (as are all other P2X receptors thus far discovered) and is known to mediate rapid and selective permeability to cations. On platelets, the P2X₁ receptor has been shown to mediate fast calcium entry stimulated by ADP.²⁰³ P2X₁ is a 399-amino acid protein composed of two transmembrane domains, intracellular N and C termini, and an extracellular loop with 10 conserved cysteine residues.¹⁶⁵ At least three P2X subunits are required to constitute a membrane pore, and these receptors are typically expressed on excitable cells, such as neurons.

Despite the fact that activation of the P2X₁ receptor alone cannot induce platelet aggregation, it contributes to aggregation in response to collagen.^{204,205} The role of P2X₁ in platelet function seems to be particularly relevant under flow conditions characterized by high-shear stress.^{205,206} and ²⁰⁷ A study of P2X₁-deficient (P2X₁^{-/-}) mice has further indicated that this receptor contributes to the thrombosis of small arteries. P2X₁^{-/-} mice display resistance to the localized arterial thrombosis of mesenteric arterioles triggered by laser-induced vessel wall injury and to the acute systemic thromboembolism induced by infusion of a mixture of collagen and adrenaline.²⁰⁵ Conversely, increased systemic thrombosis has been reported in mice overexpressing the human P2X₁ receptor.²⁰⁸

ADP Receptor Signaling

ADP is considered a weak agonist compared with collagen or thrombin, for example. Aggregation is typically reversible when platelets are stimulated by ADP alone. In addition, low concentrations of ADP serve to amplify the effects of both strong and weaker agonists, the latter including serotonin and adrenaline, among others.^{136,137} As noted in the preceding paragraphs, ADP signal transduction downstream from the P2Y₁ receptor leads to a transient rise in free cytoplasmic calcium as a result of mobilization from internal stores, and this is followed by secondary-store-mediated influx, whereas a

concomitant inhibition of adenylate cyclase is initiated by ADP stimulation of the P2Y₁₂ receptor (Fig. 17.5). The G-protein family member responsible for signaling through P2Y₁ to PICβ is G_q, whereas the member responsible for signaling through P2Y₁₂ to inhibit adenylate cyclase is G_i. The G_i family member associated with P2Y₁₂ appears to be primarily G_{i2} inasmuch as G_{i2} knockout mice have an impaired response to ADP and those lacking G_{i3α} and G_{zα} do not.^{209,210} and ²¹¹ ADP also induces a rapid influx of calcium from the external media through ligand-gated calcium channels.^{212,213} Although partial platelet aggregation without shape change can be seen in P2Y₁ and G_q knockout mice in the presence of high ADP concentrations, the fact that aggregation is not seen at lower concentrations suggests that the G_q-dependent PICβ pathway leading to phosphoinositide hydrolysis and PKC activation is necessary to mobilize calcium after ADP stimulation and is essential for full platelet aggregation to take place in response to ADP.^{144,184,214,215}

Although ADP-mediated platelet activation via the P2Y₁ receptor incorporates the G_q-dependent PIC-β second messenger pathway, the P2Y₁₂ receptor mediates its post-occupancy signaling through G_i-dependent PI3 kinase activation and subsequent repression of cAMP levels. In addition to the PI3K role, several groups have reported a role for Rap1B in P2Y₁₂ signal transduction. Rap1B is a small GTPase that is highly expressed in platelets, and its ADP-stimulated increased activation is abolished by P2Y₁₂ antagonists and G_i knockout mice.^{216,217} and ²¹⁸ Rap1B activation through other receptors such as FcγRIIA and gpVI also appears to have a P2Y₁₂ component.^{217,218} Evidence suggests that ADP-induced Rap1B activation lies downstream of PI3K, because PI3K inhibitors have been shown to inhibit Rap1B activation, although evidence differs as to which isoform is involved.^{216,218}

The same G_i-protein-associated signaling pathway used by platelet ADP receptors has been found to act in a synergistic fashion when it is triggered either through other platelet receptors, or through key downstream players triggered by other receptors, such as PICγ2.^{219,220} It has been suggested that concomitant signaling through the G proteins and tyrosine kinases of other receptor pathways may potentially be seen as a general mechanism in

P.419

which ADP contributes to efficient platelet activation and aggregation.^{191,221} For example, ADP in platelets has been proposed to be an important co-factor of PI3 kinase activation that is stimulated through the PAR-1 thrombin receptor.²²² It is interesting that there is a difference in the ability of ADP to potentiate aggregation through the two platelet thrombin receptors (PAR-1 and PAR-4), in that PAR-1 is more dependent on secreted ADP acting through P2Y₁₂ than PAR-4.^{223,224} Collagen-induced platelet aggregation is similarly facilitated by P2Y₁₂.^{225,226} and ²²⁷

ADP has been implicated as an important co-factor of platelet activation seen in the settings of experimental cross-linking of the FcγRIIA immunoreceptor and in patients with heparin-induced thrombocytopenia.²²⁸ The latter is a disorder in which platelet activation and often serious thrombotic sequelae take place as a consequence of administration of the anticoagulant heparin or low-molecular-weight heparin. In susceptible patients, an autoantibody is generated by the immune system that is directed to a complex on the platelet membrane formed by the heparin molecule and platelet factor 4. The Fc portion of the autoantibody is then capable of activating the platelet through its interaction with the FcγRIIA receptor. Activation of PI3K has been shown to be a central player in these two settings.

P2Y₁₂ activation has been found to play an important role in activation of α_{IIb}β₃. Using P2Y₁₂ knockout mice, Andre et al. noted that platelets activated with PAR-4 or ADP were defective in binding soluble fibrinogen relative to wild-type mice.²⁰¹ Similarly, in humans it has been observed that P2Y₁₂ antagonists such as clopidogrel inhibit P-selectin expression and platelet-leukocyte conjugate formation, whereas aspirin does not.²²⁹

Platelet Activation by Soluble Agonists

α₂ Adrenergic Receptors and Epinephrine

Epinephrine is unique among platelet agonists because it is considered to be capable of stimulating secretion and aggregation, but not cytoskeletal reorganization responsible for shape change. Furthermore, generation of the key signaling enzyme PIC through epinephrine stimulation appears to be dependent on TxA₂ and can thus be blocked with aspirin.²³⁰ It is interesting, however, that epinephrine stimulation in the presence of aspirin is still capable of leading to the conformational change in the α_{IIb}β₃ receptor that precedes fibrinogen binding and platelet aggregation.^{231,232} Similarly, the thrombin inhibitor hirudin has been found to block epinephrine-associated aggregation of washed platelets in one study, suggesting that an element of thrombin co-stimulation of platelets may be necessary to enhance the effects of epinephrine.²³³ In low doses epinephrine is thought to prime platelets for activation with other agonists and the resulting stimulation is stronger than with either agonist alone.

Platelet responses to epinephrine are mediated through α_2 -adrenergic receptors,^{234,235} and these responses have been found to vary among individuals, with some donors with otherwise normal platelets manifesting delayed or absent responses.²³⁶ Potentiation is typically attributed to cAMP formation inhibition.

Arachidonic Acid, Thromboxane A₂, and Thromboxane Receptors

After platelet stimulation by a number of agonists, arachidonic acid is generated directly by phospholipase A from its membrane phospholipid precursors (PC, PS, and PI) and indirectly by PIC generation of DAG followed by DAG lipase action. Most platelet agonists are believed to activate this pathway. Three known eicosanoid subsets of biochemical compounds are known to be derived from the formation of arachidonic acid: the prostanoids, leukotrienes, and epoxides. The prostanoids are formed by the cyclo-oxygenase pathway and include endoperoxides and thromboxanes along with prostaglandins. The leukotrienes are formed by the lipoxygenase pathway and the epoxides by the cytochrome P450 epoxygenase pathway. Although all three of these pathways are present in platelets, most arachidonic acid ends up being metabolized to TxA₂.²³⁷

TxA₂ is produced in platelets from arachidonic acid through the generation of PGH₂ by the enzyme cyclo-oxygenase, which is irreversibly inhibited by aspirin through acetylation of a serine residue near its C terminus.^{238,239} PGH₂ is the parent compound for both biologically active prostaglandins, such as PGE₂ and PGI₂, and TxA₂. The former two compounds act to inhibit platelet activation by generating intracellular cAMP, whereas TxA₂ activates platelets. Although prostaglandin and thromboxane pathways can be present in the same cell, platelets primarily synthesize thromboxane, and endothelial cells mainly synthesize prostaglandins such as PGI₂, which acts as a local vasodilator and thus indirectly opposes platelet activation and vasoconstriction.²³⁹

Like ADP and epinephrine, TxA₂ is also capable of activating nearby platelets after its release into plasma. It has a very short half-life of 30 seconds before its conversion to the inactive metabolite thromboxane B₂ prevents widespread platelet activation beyond the vicinity of thrombus formation.^{240,241} Both arachidonic acid and analogs of TxA₂ have been found to activate and aggregate platelets by mediating shape change and phosphorylation of signaling enzymes, such as PIC β , PKC, and so forth.^{242,243} Signaling events associated with stimulation of the TxA₂ receptor (TxR) farther downstream from PIC β and PKC include activation of p38 mitogen-activated protein kinase and the small heat-shock protein hsp27.²⁴⁴

The TxR is a member of the seven-transmembrane G-proteincoupled receptor family and has been localized to the plasma membrane. The receptor is coupled to the α subunits of the G_q and G₁₂/G₁₃ members of the G-protein family.^{245,246} and ²⁴⁷ One isoform of the receptor has been cloned from placenta (TxR α) and the other from endothelium (TxR β). Both are found in platelets, and platelet activation through the G_q pathway has been found to activate PIC β and G₁₂/G₁₃ regulates myosin light-chain phosphorylation through activation of Rho kinase.^{245,246,248} In addition, the α receptor is associated with activation of adenylate cyclase that leads to generation of cAMP, known to inhibit platelet activation, whereas the β receptor inhibits adenylate cyclase activation after its stimulation.²⁴⁸ Because TxA₂ is a net agonist, the effects of PIC β activation must somehow outweigh those of adenylate cyclase activation, or MK and platelet TxR β receptor expression levels may outweigh those of TxR α receptor expression levels.²⁴⁸ TxR knockout mice have a prolonged bleeding time, do not aggregate in response to TxA₂ agonists, and show delayed aggregation with collagen.²⁴⁹

Coordination between Platelet Adhesion Events and Soluble Agonist Stimulation in Thrombus Growth

The mechanism by which soluble agonists coordinate their actions with platelet adhesion-related processes is an important consideration in the context of the steps required to facilitate thrombus growth.²⁵⁰ The constraint imposed by blood flow on these prothrombotic processes represents the primary means by which platelet adhesion and activation are negatively regulated. These arterial high-shear forces have complex effects on platelet-vWF matrix interactions that are both pro- and antithrombotic in nature. Rapid blood flow also has complex and poorly characterized effects on the formation and clearance of soluble agonists such as TxA₂.

One model to explain these relationships incorporates intraand intercellular calcium signaling phenomena as a central unifying process.²⁵⁰ In this model the initial platelet/vessel wall interaction is characterized by contact between platelet gpIb and matrix vWF with subsequent early platelet $\alpha_{1b}\beta_3$ conformational change, all leading to weak platelet activation. Co-stimulation of platelets by these adhesion events and soluble agonist receptors is

P.420

then needed to potentiate and sustain activation signals initiated by the early gpIb/vWF/ $\alpha_{1b}\beta_3$ interactions, and this co-stimulation leads to deceleration and arrest of platelet movement as the nidus of the thrombus develops. Platelet intracellular calcium is proposed to be the primary second messenger mediating these events, based on evidence

suggesting an inverse correlation between calcium flux and platelet translocation behavior under flow conditions.²⁵¹ Intercellular calcium-related signaling between platelets is then thought to lead to ADP release at the site of contact between platelets, which in turn sustains these $\alpha_{IIb}\beta_3$ -derived calcium signals by a P2Y₁₂-linked signaling mechanism.²⁵²

Physiologic Inhibition of Platelet Activation

One of the many remarkable features of platelets is their ability to remain in a physiologic resting state and resist becoming activated while navigating the heart, arterial, and venous circulations, and splenic microcirculation for an average of 10 days. Over this time, platelets can be expected to remain in a quiescent state while they encounter high-shear forces, what must be frequent collisions with other circulating cells as well as normal endothelium, and relatively profound turbulence associated with arterial branch points and diseased yet physically intact arteries and arterioles. Indeed, the pathologic consequences associated with widespread inappropriate platelet activation are life- and limb-threatening when associated with well-characterized clinical disorders such as thrombotic thrombocytopenic purpura and heparin-induced thrombocytopenia. The mechanisms responsible for maintaining the fine balance of keeping platelets in a resting state until they encounter a genuine need to undergo adhesion, activation, and aggregation at the site of vascular injury are almost as diverse as those responsible for mediating these physiologic phenomena.

Some general mechanisms involved in physiologic inhibition of platelet activation include phenomena such as (a) generation of negative-regulating molecules by the platelet (e.g., cAMP), endothelium (e.g., PGI₂, NO, heparan sulfate), and at distant sites (e.g., antithrombin); (b) direct contact of circulating platelets with collagen prevented by a barrier of endothelial cells; (c) generation of an ecto-ADPase (CD39) by endothelial cells that will metabolize ADP secreted from activated platelets and thus is intended to limit further activation; (d) tendency for blood flow to wash away unbound thrombin from the site of platelet plug formation and hence limit the extent of clot formation; (e) brief half-life of certain key platelet activators such as TxA₂; (f) ability to alter the conformation of a receptor such that it is then able to interact with a specific proaggregatory ligand, as happens with $\alpha_{IIb}\beta_3$ and plasma fibrinogen; and (g) the ability to inactivate switched-on receptors associated with activation through biochemical modification such as phosphorylation or their removal from the platelet surface.

Biochemical modification leads to receptor desensitization and occurs with G-protein-coupled receptors present on the surface of platelets, with the notable exception of PAR-1 because thrombin requires an intact N terminus to activate the receptor.²⁵³ Desensitization of G-protein-coupled receptors is normally mediated through phosphorylation of serine and threonine residues associated with the cytoplasmic side of the receptor by G-protein-coupled receptor kinases.²⁵⁴ The role of phosphorylation of these residues is to uncouple them from their G proteins and then lay the groundwork for internalization of the receptor through the binding of arrestin proteins.^{255,256} Some of the physiologic and biochemical phenomena related to inhibition of platelet activation are described in the following.

Inhibitory Prostaglandins

PGE₂ and PGI₂, along with PGE₁, are examples of prostaglandins generated through the arachidonic acid pathway that inhibit platelet activation and aggregation, which are processes mediated in part by other prostaglandins and thromboxanes derived from the same pathway. The inhibitors carry this out through G-protein-coupled receptors that regulate adenylate-cyclase-mediated generation of cAMP, which in turn activates PKA (or A kinases). PKA then goes on to inhibit other proteins that mediate platelet reactivity through phosphorylation.

The receptors of prostaglandins believed to increase cAMP levels in platelets such as PGI₂ have been described as being coupled to the α subunits of G_s. Conversely, most platelet agonists suppress cAMP formation by inhibiting adenylate cyclase via one or more of the G_i family members that are expressed in platelets.²⁵⁷ In addition to these considerations, cAMP levels in platelets are also governed by the activity of phosphodiesterase, the enzyme responsible for cAMP metabolism. This enzyme activity is inhibited by drugs such as the weak antiplatelet agent dipyridamole, the bronchodilator theophylline, and sildenafil, used to treat erectile dysfunction in men.

Raising cAMP levels causes a number of specific changes in platelet function. These include limitation of phosphoinositide hydrolysis, which is believed to occur through blockade of the inositol 1,4,5-triphosphate receptor and inhibition of the resynthesis of the phosphatidylinositol 4,5-bisphosphate precursor of DAG formation. There is also a smaller increase in the cytosolic free Ca²⁺ concentration in response to agonists and an accelerated uptake of Ca²⁺ into the dense tubular system.^{258,259,260} and ²⁶¹ The targets through which cAMP and PKA reduce platelet reactivity are incompletely understood. They include ABP (filamin), myosin light chain, VASP, and Rap1B. Another PKA substrate is the β subunit of the gplb complex, and this phosphorylation may in turn reduce platelet activation through its increased interaction with the 14-3-3 ζ protein.^{51,52} The 14-3-3 family of proteins exists as homodimers and modulates effector pathways in diverse cell types through interaction with key signaling enzymes.⁴⁸

Plekstrin and Protein Kinase C Inhibition

PKC is an important serine-threonine kinase with protean effector manifestations in platelet signaling. PKC is the receptor for the lipid second messenger DAG, and is a key enzyme in the signaling events that follow activation of receptors coupled to PLC. PKC isozymes phosphorylate multiple cellular proteins at serine and threonine residues. PKC is actually a family of structurally related molecules, and platelets contain at least the α , β , δ , ϵ , ϵ , θ , and perhaps ζ and λ isozymes.²⁶²

Once activated, PKC appears to mediate individual roles that, in some respects, may be considered contradictory in nature. These include positive effects such as mediating secretion and aggregation, as well as negative effects that can be observed when platelets are incubated with phorbol esters before agonist stimulation. Under these circumstances, the agonist effector-mediated responses are reduced or do not occur, particularly if they are mediated by effectors downstream from phosphoinositide hydrolysis, and this phenomenon may represent a form of negative feedback.^{263,264} and²⁶⁵ This is speculated as possibly being due to a shorter duration of signaling for calcium release.²⁶⁶

Several platelet proteins are known PKC substrates, and these include plekstrin (P47), myosin light chain (P20), ABP, and the α subunits of the G proteins G_z , G_{12} , and G_{13} . The precise role of plekstrin in platelets is unknown, although its first and last 100 residues are homologous with domains in molecules with roles in signal transduction. These so-called plekstrin homology domains are speculated to play roles in protein-protein interactions, and so phosphorylated plekstrin may have a role in the negative regulation of PKC. One study suggests that phosphorylated plekstrin may be accomplishing negative regulation of PKC through inhibiting phosphoinositide hydrolysis and the activity of the lipid kinase, PI3K.²⁶⁷ Reduced activity of PI3K leads to reduced phosphorylation of PI-4,5-P2 to PI-3,4,5-P3, a molecule that, in turn, is involved in the activation of the PKC isoforms.²⁶⁸

P.421

Other Inhibitory Processes of Platelet Activation

The $\alpha_{IIb}\beta_3$ receptor on the surface of activated and resting platelets along with the fibrinogen that binds to stimulated platelets expressing the activated form of $\alpha_{IIb}\beta_3$ have been observed to undergo rapid internalization into MK and platelet α -granules.^{269,270} and²⁷¹ It has been speculated that this may represent a mechanism by which platelets not involved in clot formation may be able to return to a resting state.²⁷² The in vivo evidence supporting this unique platelet-inhibitory process is included in a paper describing the transfusion of plasma into an afibrinogenemic patient followed by the demonstration that platelet fibrinogen could be restored faster than new platelets could be produced in the bone marrow.²⁷³

NO is generated by endothelial cells and platelets from L-arginine in response to shear stress forces and other platelet agonists, such as thrombin and ADP. This molecule works to inhibit platelet activation through the cyclic guanosine monophosphate second messenger generated by guanylate cyclase activation. Endothelial NO synthase activity is enhanced during platelet activation, presumably as an additional means for limiting platelet aggregation.

Platelet Secretion

The extent of secretion of α -, dense-, and lysosomal-granule contents is dependent on the strength of the agonist, occurs in association with platelet activation, and is one of the many downstream consequences mediated by the activation and transport to the internal leaflet of the plasma membrane of PKC. Granule contents that are involved in enhancing activation and aggregation of both their own and other platelets in the vicinity include ADP, vWF, fibrinogen, and calcium ions. Platelets contain three types of granules: dense granules contain agonists that amplify platelet activation, α granules contain proteins that enhance adhesion, and lysosomal granules contain glycosidases and proteases with largely unknown function.

The strongest response a platelet can mount to agonist stimulation includes activation, secretion, and aggregation. The granule secretory (release) phase is most readily documented in vitro by the "secondary wave" that denotes a second surge of aggregation activity of a fixed number of platelets in response to release of proaggregatory granule contents. These platelets are exposed to an agonist under the controlled in vitro conditions associated with platelet aggregation studies in which clinical defects in primary hemostasis due to platelet perturbations are further characterized. The secondary wave is typically seen best when the agonist is a weaker one, such as epinephrine, or is a relatively lower concentration of another relatively weak agonist, ADP. These two agonists require both cyclo-oxygenase activity and a primary wave of aggregation to induce secretion at low calcium concentrations.²⁷⁴

Although platelets are anucleate, they contain mRNA and are capable of synthesizing a restricted group of proteins mainly related to inflammation and apoptosis.^{275,276} In addition to this, vesicles are secreted from the membranes of stimulated platelets referred to as platelet microparticles that are enriched with specific membrane proteins which make them significantly procoagulant in settings such as heparin-induced thrombocytopenia, peripheral artery disease, and MI.²⁷⁷

Several studies suggest that the mechanism by which platelet granules (vesicles) fuse with the cell membrane to release their granule contents involves soluble N-ethylmaleimide-sensitive factor attachment protein (SNAP) receptor (SNARE) complexes that are formed between vesicle-associated membrane proteins (VAMPs; v-SNAREs) and proteins in the target membranes (different members of the syntaxin, SNAP-25, and VAMP gene families; t-SNAREs) in a lock-and-key form of docking.^{278,279} Many lines of evidence show that these SNARE complexes are crucial for membrane trafficking and fusion events such as secretion and exocytosis. There is evidence that suggests the specific isoforms VAMP-3 and VAMP-8 form SNARE complexes with platelet syntaxin 4 and that these specific complexes mediate platelet secretion.^{279,280}

Simultaneous with the exocytosis of platelet granules, it is apparent that there is also inward (centripetal) movement of other intracellular contents, and this may play a role in transporting proaggregatory proteins away from the membrane surface and thus serve as another counterbalancing mechanism for limiting the extent of thrombus formation. Examples of this phenomenon include the internalization of fibrinogen from the surface of activated platelets, along with gpIIb/IIIa receptors from the surface of resting and activated platelets, as noted earlier.²⁷²

PLATELET AGGREGATION: $\alpha_{IIb}\beta_3$ RECEPTOR AND ITS SIGNALING MECHANISMS

Platelet aggregation is a complex phenomenon that is the end result of a series of adhesion- and activation-related processes. The molecular mechanisms involved in platelet aggregation continue to be an area of very active research that also periodically reminds us that there is still much to be characterized about this important aspect of platelet function. Essential components of this process include an agonist, calcium, and the adhesive proteins, fibrinogen and vWF. Divalent cations, such as calcium and magnesium, are required for platelet aggregation in trace amounts, and these alter the specificity of the integrin $\alpha_{IIb}\beta_3$ for its ligands.²⁸⁰ Fibrinogen and vWF play dominant roles in platelet aggregation through binding to $\alpha_{IIb}\beta_3$ and also by the ability of the former to generate polymerized fibrin as support for the platelets in a thrombus.^{281,282} The multivalent nature of fibrinogen and vWF allows them to cross-link platelets on binding to $\alpha_{IIb}\beta_3$ on stimulated platelets to initiate platelet aggregation.

The molecular basis of integrin signaling that occurs in platelet $\alpha_{IIb}\beta_3$ is an integral part of thrombus formation and is important in understanding this process. gpIIb (α_{IIb}) and gpIIIa (β_3) were identified as the abnormal proteins present in patients with Glanzmann thrombasthenia in the 1970s.^{283,284} They represent the most abundant receptor on the platelet surface. Like all integrin receptors, this complex is composed of noncovalently linked subunits. Each subunit is encoded by separate genes on the long arm of chromosome 17. Both subunits consist of a large extracellular domain and very short cytoplasmic domains, and together they form a heterodimer. Within their combined extracellular domains is the ligand-binding pocket, with surrounding subunit domains conferring specificity.²⁸⁵ Equally important are the short cytoplasmic domains critical for transmembrane signaling. These domains act to anchor the receptor to the cytoskeletal elements.^{286,287,288}

The signaling pathways of gp $\alpha_{IIb}\beta_3$ are complex and have been extensively studied. Despite this, the terminal effector molecules affecting activation remain unknown. Central concepts of the signaling pathway include inside-out signaling, which involves the processes termed affinity and avidity modulation,^{271,290} and outside-in signaling in which messages are transmitted to the inside of the platelet via the events occurring outside the membrane through $\alpha_{IIb}\beta_3$ activation. Regarding the former, a major knowledge gap exists with respect to how second messengers effect functional changes in $\alpha_{IIb}\beta_3$. As examples, PKC, PI3-kinase, and Rap 1b have been implicated as intermediates in inside-out signaling, but identity of the effector molecules remains to be determined.^{250, 291} Current knowledge regarding these complex pathways has been recently reviewed and is summarized in Figures 17.6 and 17.7.^{285,286,292}

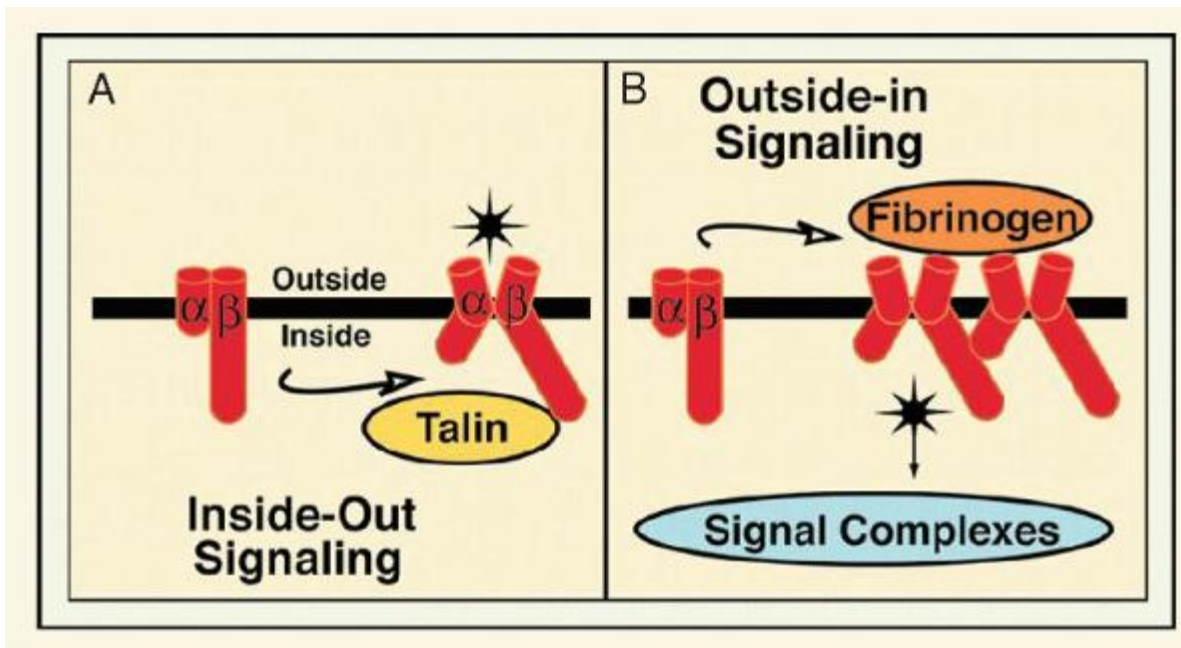

FIGURE 17.6. Integrin activation is bidirectional and reciprocal. The $\alpha_{IIb}\beta_3$ complex equilibrates between resting and activated states, the resting state predominating in unstimulated platelets and the activated state in stimulated platelets. Conversion from resting to activated does not imply a single abrupt change but rather a series of coordinated and linked conformational transitions. A: Inside-out signaling. Agonist-dependent intracellular signals stimulate the interaction of key regulatory ligands (such as talin) with integrin cytoplasmic tails (in this case the β_3 tail). This leads to conformational changes in the extracellular domain that result in increased affinity for adhesive ligands such as fibrinogen, von Willebrand factor (vWF), and fibronectin. Plasma fibrinogen and vWF support platelet aggregation at low and high shear rates, respectively, by bridging $\alpha_{IIb}\beta_3$ receptors on adjacent platelets. Studies in mice deficient in fibrinogen and vWF indicate that plasma fibronectin can also promote thrombus initiation, growth, and stability at high shear rates. B: Outside-in signaling. Extracellular ligand binding, initially reversible, becomes progressively irreversible and promotes integrin clustering and further conformational changes that are transmitted to the cytoplasmic tails. This results in the recruitment and/or activation of enzymes, adaptors, and effectors to form integrin-based signaling complexes. From Shattil SJ, Newman PJ. Integrins: dynamic scaffolds for adhesion and signaling in platelets. *Blood* 2004;104:1606-1615, with permission.

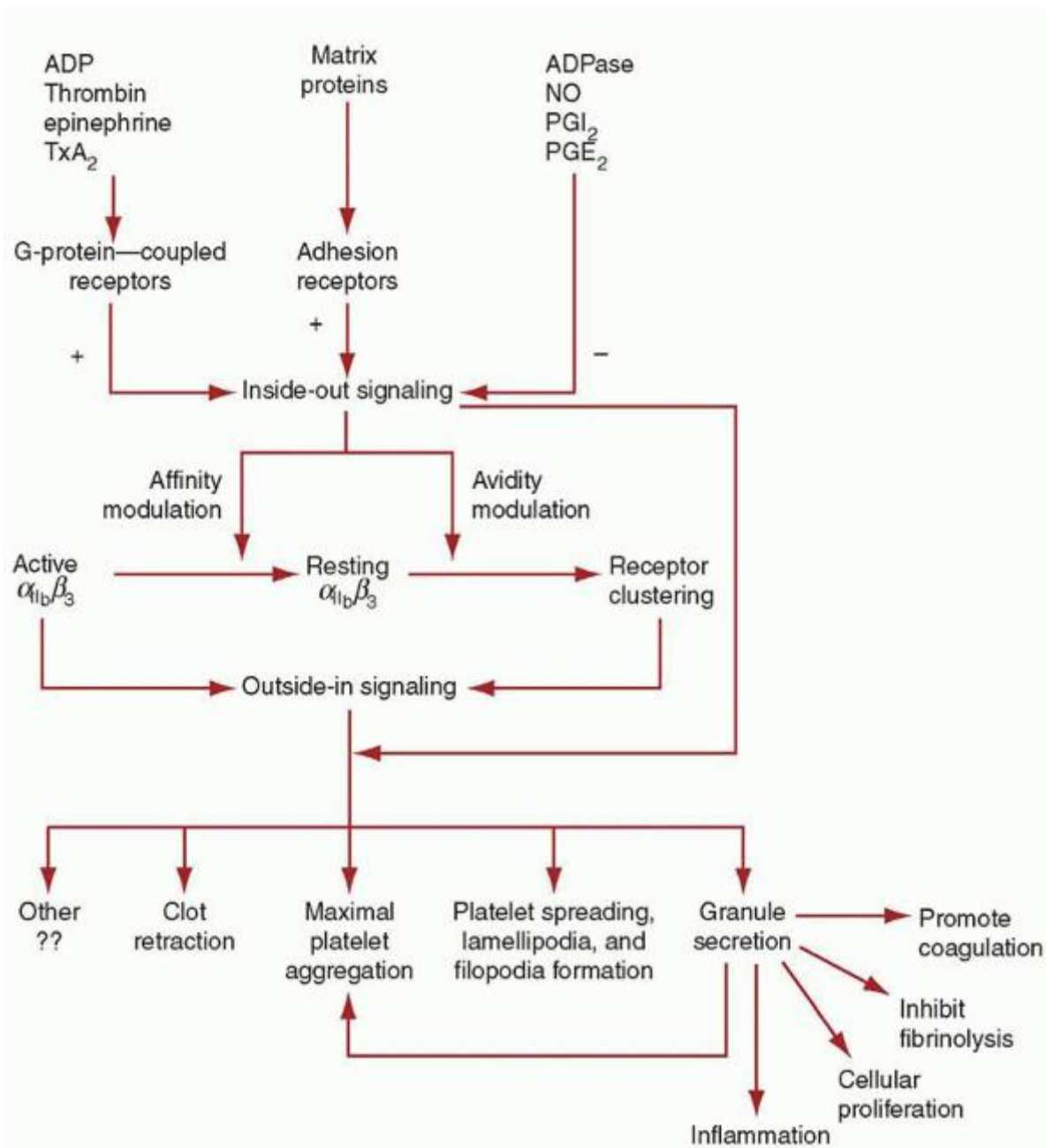

FIGURE 17.7. Schematic illustration of $\alpha_{IIb}\beta_3$ receptor regulation via inside-out and outside-in signaling. ADP, adenosine diphosphate; ADPase, adenosine 5'-diphosphatase; NO, nitric oxide; PGE_2 , prostaglandin E_2 ; PGI_2 , prostacyclin; TxA_2 , thromboxane A_2 . From Casserly IP, Topol EJ. Glycoprotein IIb/IIIa antagonists—from bench to practice. *Cell Mol Life Sci* 2002;59:481, with permission.

Normally, undisturbed endothelium possesses nonthrombogenic properties that can inactivate activated coagulation factors, increase blood flow, inhibit platelet aggregation, and modulate fibrinolysis. Substances that inhibit platelet activation released by the endothelium include PGI_2 , NO, and ADPase. In addition, platelets release PGE_2 that acts to prevent its own activation. These molecules act via the Gs protein pathway that stimulates protein kinases to modulate various enzymes involved in platelet receptor $\alpha_{IIb}\beta_3$ activation (see later).²⁹² They may also act to phosphorylate and inactivate various protein receptor agonists.^{293,294}

Primary platelet agonists such as ADP, thrombin, and matrix proteins collagen and vWF affect platelet aggregation through a process known as inside-out signaling. This term denotes an integrin property that involves the binding action of agonists and extracellular matrix ligands to their receptors, leading to activation of numerous platelet functions, including the conformational change of $\alpha_{IIb}\beta_3$ to a high-affinity state, referred to as affinity modulation. The relative contribution of

soluble and extracellular matrix stimuli to inside-out signaling likely varies with flow conditions and other factors related to vascular perturbation. For example, gplb/v/IX function is most relevant under high-shear stress conditions such as those associated with arterioles and capillaries and in stenotic arteries. Ligand binding is initially reversible and later becomes irreversible in nature.²⁹⁵ Therefore, one of the effects of inside-out signaling on $\alpha_{IIb}\beta_3$ is exposure of the fibrinogen-binding site through signal transduction involving the cytoplasmic domains (Fig. 17.6).^{293,296} Various regulatory intracellular or transmembrane proteins participate

P.423

in this process. Overall, the data provide strong evidence that association between subunit cytoplasmic tails and possibly also between integrin subunit transmembrane domains works to maintain the $\alpha_{IIb}\beta_3$ complex in a resting nonadhesive conformation, and disruption of this state causes separation of the tails with consequent changes in the extracellular domains to increase $\alpha_{IIb}\beta_3$ affinity.^{297,298} Evidence currently suggests that any role for extracellular or transmembrane molecules in affinity modulation is secondary to $\alpha_{IIb}\beta_3$ regulation by intracellular proteins, in particular a 270-kDa dimer named talin that interacts with the integrin cytoplasmic tails.²⁹⁹ The complexity of the mechanisms by which inside-out signaling trigger $\alpha_{IIb}\beta_3$ activation is significant.^{200,201}

Talin is a large protein that has been implicated as a trigger of integrin activation and binds to two sites in the β_3 cytoplasmic tail: the NPLY sequence in the midsegment of the cytoplasmic tail and a sequence in the membrane proximal region.³⁰² Its binding to the latter region may follow the former and may trigger separation of β_3 from the α_{IIb} cytoplasmic tail resulting in activation. Other proteins bind to the NPLY sequence and whether these function as coactivators or suppressors remains to be determined (Chapter 115, ref 303,304). Talin must also be activated to accomplish this and multiple activation pathways have been described.

Avidity modulation, the less dominant action, acts to cluster the $\alpha_{IIb}\beta_3$ heterodimers into oligomers through lateral diffusion.^{305,306} These conversions are critical in allowing $\alpha_{IIb}\beta_3$ to engage soluble adhesive ligands. These ligands contain the classical integrin-recognition sequence RGD, Arg-Gly-Asp, which acts as a bridge between adjacent platelets allowing aggregation to proceed.³⁰⁷ In addition, more $\alpha_{IIb}\beta_3$ translocates to the platelet surface membrane from the degranulating α -granule pool, where additional receptor is stored. These changes facilitate irreversible binding to fibrinogen. An important role for tyrosine kinase- and phosphatase-associated phosphorylation-dephosphorylation in integrin activation exists as assessed by the blockade of fibrinogen binding and platelet aggregation by enzyme inhibitors.^{308,309}

After ligand binding occurs, a multitude of intracellular signals are generated that are collectively referred to as outside-in signaling. This "contact-dependent signaling" determines the extent to which platelets will spread on a vascular matrix and how resistant to detachment they are.^{310,311} Outside-in signaling occurs in a discrete pattern in which ligand binding initiates integrin clustering and assembly of a "nascent" signaling complex proximal to the $\alpha_{IIb}\beta_3$ cytoplasmic tails, and this is followed by the growth of a larger "actin-based" signaling complex. It can be envisioned that the nascent complex is characterized temporally by (a) activation of Src kinases bound to the β_3 cytoplasmic tail by fibrinogen engaging and facilitating integrin clustering, then (b) recruitment and activation of Syk by Src, then (c) Src and/or Syk phosphorylation of various substrates including adaptor proteins SLP-76 and c-Cbl along with the Rac GTPase Vav, and these substrates in turn act by participating in signaling to the actin cytoskeleton.²⁹² As the nascent complex assembles, many additional proteins are recruited that can influence actin reorganization, including Rac, the adaptor Nck, PAK, PI3-kinase, and VASP, an actin-bundling protein.²⁹² All these signaling events during platelet aggregation are further supported by release of granules induced by the binding of adhesive proteins to the extracellular domain of β_3 . This complex series of events serves as a determinant of the final clot size.

Activation of $\alpha_{IIb}\beta_3$ by agonists is very rapid and the platelet can become fully competent to bind fibrinogen/vWF via the receptor within seconds after its initial encounter with agonist. Once full spreading and aggregation of platelets occurs, usually within several minutes, focal adhesion kinase is phosphorylated.^{312,313} and ³¹⁴ The PI3K system is activated once $\alpha_{IIb}\beta_3$ is engaged, leading to generation of D3 phosphoinositides.³¹⁵ These proteins act to prevent the depolymerization of the actin cytoskeleton, with the result that the platelet aggregate is stabilized.³¹⁶ The end result of this outside-in signaling is a stable platelet clot.

In addition to outside-in signaling, following binding of fibrinogen to $\alpha_{IIb}\beta_3$ one or more of a number of other events can be postulated to occur that facilitate platelet aggregation. These include the formation of a dimeric fibrinogen bridge between $\alpha_{IIb}\beta_3$ receptors on adjacent platelets, conformational changes in bound fibrinogen and/or occupied $\alpha_{IIb}\beta_3$, and additional interactions of bound receptor with cytoskeletal elements.^{317,318,319} and ³²⁰

Although fibrinogen is the dominant ligand, other RGD-containing peptides also bind to $\alpha_{IIb}\beta_3$ including vWF, collagen, fibronectin, and vitronectin. Because vWF binds to GPIb/V/IX it is close to $\alpha_{IIb}\beta_3$ which may facilitate their interaction. Thus $\alpha_{IIb}\beta_3$ may also play a role in platelet adhesion particularly in stabilizing cell-matrix interactions.³²¹ Other platelet membrane proteins have also been shown to associate with $\alpha_{IIb}\beta_3$ including CD9 and Gas6³²² and these may play a role in modulating $\alpha_{IIb}\beta_3$ function.

Not only does the $\alpha_{IIb}\beta_3$ receptor have important roles with respect to platelet function, it affects coagulation and the inflammatory process as well. It acts to promote the formation of the prothrombinase complex³²³ and mediates the adhesion of leukocytes to the platelet membrane and endothelium (i.e., vascular inflammation).^{324,325,326} and ³²⁷ This receptor may also have a role in cell proliferation. In this respect, antagonists to $\alpha_V\beta_3$ or to both $\alpha_{IIb}\beta_3$ and $\alpha_V\beta_3$ significantly inhibited intimal hyperplasia after vascular injury in all but 1 of at least 12 animal studies.³²⁸

Platelet Aggregation and Arterial Shear Flow

Until relatively recently platelet aggregation was considered to be comparatively straightforward involving just $\alpha_{IIb}\beta_3$ interacting with fibrinogen as described in the preceding paragraphs. With the recent ability to analyze in vivo platelet aggregate formation in realtime, though, it has become apparent that this process is much more complex than previously thought. Platelet aggregation now appears to represent a series of adhesion reactions involving multiple receptors and adhesive ligands such as vWF, fibrinogen, and fibronectin with the contribution of individual receptor-ligand interactions dependent on prevailing blood flow conditions. It has been postulated that at least three distinct mechanisms can initiate aggregation with each mechanism working over a specific arterial shear range in vivo.³²⁹ Under low-shear conditions ($<1,000\text{ s}^{-1}$) the predominant mechanism is thought to involve fibrinogen and $\alpha_{IIb}\beta_3$ exclusively and this occurs independent of GPIb/vWF interaction.³³⁰ Subsequent stimulation by locally generated soluble agonists induces platelet shape change and an increase in $\alpha_{IIb}\beta_3$ affinity for fibrinogen. At shear rates between 1,000 and 10,000 s^{-1} platelet-platelet interactions become more vWF dependent with roles for both GPIb and $\alpha_{IIb}\beta_3$ in promoting platelet aggregates. Now a third mechanism initiating platelet aggregation has been identified that occurs when shear rates are very high ($>10,000\text{ s}^{-1}$) and it is interesting that this mechanism does not require platelet activation or the adhesive function of $\alpha_{IIb}\beta_3$ and is mediated by GPIb/vWF bonds.^{286,331} This finding that nonactivated platelets can form large aggregates under very high shear may have important implications behind the mechanism of pathologic thrombus formation in stenosed arteries.

Integrin $\alpha_{IIb}\beta_3$ Antagonists

Antithrombotic agents that act against the $\alpha_{IIb}\beta_3$ receptor are extensive and represent a targeted therapy against the most prevalent platelet surface receptor. They have had a significant impact on clinical outcomes of patients with acute coronary syndromes (ACSs) and those requiring percutaneous coronary interventions (PCIs).

Although many anti- $\alpha_{IIb}\beta_3$ agents have been developed, only a small number are currently approved for clinical use.

Examples

P.424

of approved parenteral agents with various mechanisms of action include the chimeric monoclonal antibody abciximab, the synthetic peptide eptifibatide, and the synthetic nonpeptide tirofiban.

Coller reported on the first mouse monoclonal antibody directed against the $\alpha_{IIb}\beta_3$ receptor,³³² and abciximab was subsequently developed. Abciximab is thought to block access of large molecules to the receptor by steric hindrance and/or conformational effects rather than interacting directly with the arginine-glycine-aspartic acid-binding site of gpIIb/IIIa.²⁸⁵ Within minutes of receiving the standard bolus dose, $\sim 90\%$ of $\alpha_{IIb}\beta_3$ receptors are bound.³³³ Abciximab then slowly dissociates for up to 4 hours, and platelet function can be abnormal for up to 7 days after infusion.³³⁴

Eptifibatide is a synthetic cyclic heptapeptide based on an RGD sequence that blocks all RGD-recognizing integrin receptors. It binds to the ligand-binding pocket of the $\alpha_{IIb}\beta_3$ receptor such that it blocks its interaction with fibrinogen and vWF. It has a very rapid onset of action and a low affinity, leading to quick dissociation. It is approved for use in both the PCI and ACS settings.

Tirofiban is a synthetic nonpeptide tyrosine derivative that mimics the RGD recognition sequence.³³⁵ This agent also acts by blocking the ligand-binding region of the $\alpha_{IIb}\beta_3$ receptor such that it competitively inhibits platelet aggregation. Within minutes, it inhibits platelet aggregation, and it dissociates from the receptor within seconds. It is approved for use in ACS.

Numerous trials have been conducted to evaluate the efficacy of parenteral $\alpha_{IIb}\beta_3$ antagonists (Fig. 17.8).^{285,336} These trials evaluated the drugs in terms of 30-day post-intervention or event episodes of death or nonfatal MIs after PCI or ACS. With

>100,000 patients being evaluated in placebo-controlled trials, the absolute and relative risk reductions in PCI with the use of $\alpha_{IIb}\beta_3$ inhibitors were 2.9% and 34.0%, respectively. The benefit of the $\alpha_{IIb}\beta_3$ inhibitors among ACS patients is maximized in those undergoing PCI.³³⁷ This might relate to the relatively short time period between vessel injury and initiation of therapy. Correspondingly, the risk reductions provided by these agents in the medical management of ACS is more modest and the risk/benefit profile of currently available $\alpha_{IIb}\beta_3$ agents is substantially uncertain for patients with ACS who are not routinely scheduled for early revascularization.³³⁸ Among this particular population, benefit has been found to be highest in those with diabetes mellitus and/or elevated serum troponin levels reflecting microvascular obstruction and myocardial necrosis.^{339,340,341,342} and ³⁴³ Clopidogrel and anticoagulants have essentially curtailed the application of these agents in the non-PCI ACS setting.^{344,345}

After longer-term follow-up of 1 year, the evaluation of IIb/IIIa platelet inhibitor for stenting (EPISTENT) trial demonstrated a significant reduction in mortality after the use of abciximab in PCI. This effect has not been demonstrated with the other mentioned agents, although significantly fewer studies have been performed with them to date. A meta-analysis of the trials performed using tirofiban and eptifibatide in ACS showed no significant difference in mortality with these agents, but did show that there was a significant reduction in endpoints of death/MI, as well as death/MI/revascularization at 48- to 96-hour, 30-day, and 6-month followup periods.³⁴⁶

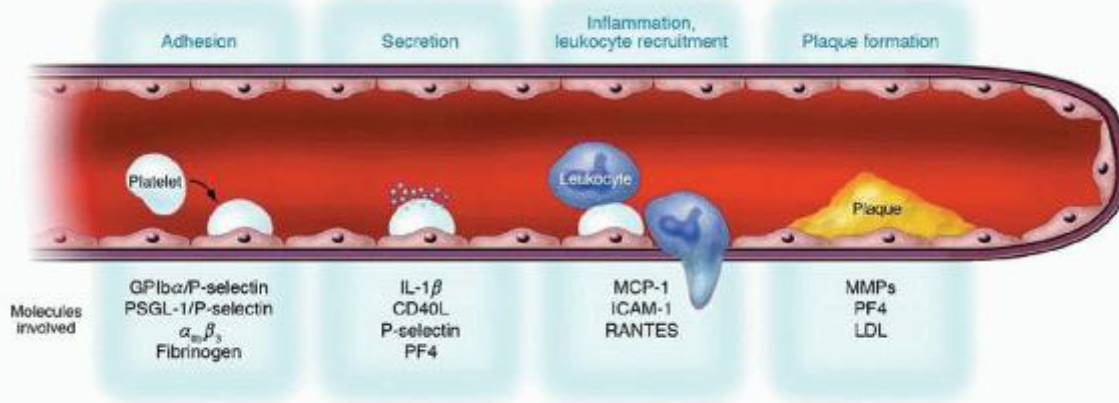

FIGURE 17.8. Hypothetical model of atherosclerosis triggered by platelets. Activated platelets roll along the endothelial monolayer via gpIb/P-selectin or PSGL-1/P-selectin. Thereafter, platelets firmly adhere to vascular endothelium via β_3 integrins, release proinflammatory compounds (IL-1 β , CD40L), and induce a proatherogenic phenotype of ECs (chemotaxis, MCP-1; adhesion, ICAM-1). Subsequently, adherent platelets recruit circulating leukocytes, bind them, and inflame them by receptor interactions and paracrine pathways, thereby initiating leukocyte transmigration and foam cell formation. Thus, platelets provide the inflammatory basis for plaque formation before physically occluding the vessel by thrombosis upon plaque rupture. From Gawaz M, Langer H, May AE. Platelets in inflammation and atherosclerosis. *J Clin Invest* 2005;115:3378-3384, with permission.

Disappointing clinical trial results have been seen with the oral $\alpha_{IIb}\beta_3$ inhibitors, and this even includes an increased all-cause mortality rate.^{347,348} This could be explained by possible subtherapeutic drug levels leading to platelet activation and/or inflammation. Another explanation is that these agents may leave the receptor activated as they dissociate away.³⁴⁹

ROLE OF THE CYTOSKELETON IN PLATELET FUNCTION

(See additional cytoskeleton structure information in Chapter 16 on platelet structure.)

Once an agonist has interacted with its platelet membrane receptor and triggered second messenger formation, a key event in platelet activation and subsequent aggregation is the transition of the platelet's shape from the discoid appearance associated with its circulating resting state to the amorphous amoebalike appearance with multiple pseudopodial projections that denote its activation state and readiness to participate in platelet plug formation. The platelet cytoskeleton and its associated signaling proteins are responsible for mediating shape change associated with activation, spreading, secretion, and aggregation. This cytoskeleton is associated with at least 14 different structural proteins that function interdependently as a single unit but can be seen as consisting of three major functional units: (a) a cytoplasmic network consisting mainly of actin, (b) a meshwork of proteins immediately proximal to the cytoplasmic leaflet of the platelet membrane referred to as the membrane skeleton (because it contains surface-associated proteins

such as the gplb complex), and (c) the platelet marginal band, which consists of a single peripheral microtubule coil that encircles the platelet to contribute to its resting discoid state.

Transmembrane receptors such as gplb participate in anchoring the platelets to extracellular matrix in the arterial subendothelium through their extracellular domains, whereas their cytoplasmic domains are almost simultaneously associating with membrane skeletal proteins in response. In doing so, these

P.425

surface receptors are providing sites at which tension can be generated by intracellular contractile elements that subsequently lead to shape change and activation of signaling proteins.

The cytoplasmic network consists of actin filaments and their associated proteins, referred to as intermediate filaments. In resting platelets, approximately half of actin is structurally filamentous in nature (with the rest present as globular monomeric G-actin), and this fraction increases to approximately three fourths during platelet activation.³⁵⁰ During this process, the actin filaments are reorganized into longer filaments after their initial breakdown into smaller units and this is thought to be regulated in part by an increase in phosphatidylinositol-4,5-bisphosphonate (PIP₂) that accompanies platelet activation. Simultaneously, myosin is phosphorylated by myosin light-chain kinase and then associates with F-actin, with the resultant filament then attaching itself to the α subunit of the gplb complex through ABP.^{351,352} These filaments are also anchored at sites called focal adhesions, where the tyrosine kinase Fak becomes activated after platelet stimulation. Focal adhesions assemble around the $\alpha_{IIb}\beta_3$ integrin on its conformational change (activation) and so play a very important role in signaling pathways associated with platelet activation by drawing together membrane receptors, the cytoskeleton, and signaling phosphoproteins such as members of the Src family, PI3K, and Syk into close physical proximity.³⁵³ Other platelet integrin receptors, such as $\alpha_2\beta_1$, also organize focal adhesions after binding to their respective extracellular ligands.

The membrane skeleton consists of actin, ABP, talin, vinculin, spectrin, cortactin, α -actinin, and several membrane glycoproteins, as noted in Chapter 16. ABP is a 250-kDa elongated dimer that associates with the cytoplasmic domain of the gplb α chain and acts to link the receptor to actin in the early stages of platelet activation, as noted in the previous paragraph. After platelet activation, calpain, the calcium-dependent protease, is activated in aggregating and spreading platelets and cleaves the link between ABP and gplb. Thus, ABP may be considered a prototype of sorts of membrane skeleton proteins that provides a good example of their important role in terms of interaction with second messengers and other signaling molecules that either may become activated or may act on their substrates after platelet stimulation.

The marginal microtubule band maintains platelet discoid shape and appears to be an essential intermediate in the microtubule-driven process of proplatelet formation and platelet release.⁹⁶ This single microtubule polymer is wound in 8 to 12 coils in the cytoplasmic periphery and is located just beneath the plasma membrane.³⁵⁴ About 90% of β -tubulin in the marginal band is of the divergent, MK/platelet-restricted β_1 isoform. β_1 -tubulin-null mice show reduced proplatelet formation, thrombocytopenia, and platelet spherocytosis.³⁵⁵

PLATELET-CELL INTERACTIONS

Platelets and Endothelium

The mechanisms behind platelet interaction with vWF, collagen, and other subendothelial matrix molecules exposed as a result of damaged endothelium have been well studied and described in earlier sections of this chapter. In addition to these platelet-subendothelial interaction paradigms, evidence has emerged that circulating unactivated platelets have the capacity (as do neutrophils) to roll on intact activated endothelium *in vivo* and then reversibly adhere to it in a process that is dependent on endothelial cell expression of P-selectin.^{356,357,358} and ³⁵⁹ This sequence of molecular interactions is a well-controlled multistep process involving platelet tethering and interaction of platelet P-selectin glycoprotein ligand-1 (PSGL-1) or gplb α with endothelial P-selectin ("rolling"), followed by subsequent "firm adhesion" to the vascular wall mediated through β_3 integrins. gplb α and PSGL-1 have structural similarities including similar ligand-binding domains. P-selectin is also expressed on the surface of activated platelets and is an α -granule component in resting platelets. Endothelial P-selectin is rapidly expressed on the surface in response to inflammatory stimuli by translocating from membranes of storage granules (Weibel-Palade bodies) to the plasma membrane within seconds.

As noted in an earlier section, there are multiple general mechanisms at play in inhibition of platelet activation that involve intact endothelium. It is increasingly recognized that inflammatory stimuli facilitate sustained platelet-endothelial interaction by perturbing these antiadhesion and activation mechanisms and increasing surface expression of endothelial molecules. Adhesion of platelets to inflamed endothelium involves a similar coordinated multistep process as occurs in

hemostasis and thrombosis, including platelet tethering, surface translocation, and firm adhesion.³⁶⁰ In atherosclerosis accumulation of modified oxidized lipoprotein particles in the setting of hyperlipidemia leads to surface expression of endothelial P- and E-selectin as well as endothelial vWF.^{360,361}

Along with endothelial P-selectin, it is not surprising that vWF expressed on activated venous endothelium has also been implicated in platelet adhesion and translocation.³⁶² The precise nature of the relationships between these two endothelial cell molecules and the platelet gplb complex, and the role different shear forces may play in determining which ligand gplb may preferentially associate with, remain to be determined. As noted in the section on "Platelet Aggregation and Arterial Shear Flow", aggregation is currently considered to consist of a series of adhesion reactions involving multiple receptors and adhesive ligands such as vWF, fibrinogen, and fibronectin with the contribution of individual receptor-ligand interactions dependent on prevailing blood flow conditions. Studies using intravital microscopy have confirmed that platelet-endothelium adhesion takes place even under high-shear stress *in vivo*.^{363,364} Platelets rolling on activated endothelium can be inhibited by both anti-P-selectin and anti-gplb α antibodies, and this suggests that platelet gplb/V/IX mediates platelet adhesion to both the subendothelial matrix and the intact endothelium.³⁶⁵ PSGL-1 on platelets has also been shown to mediate platelet rolling on the endothelial cell monolayer under high-shear stress.³⁶⁶

Platelet firm adhesion to intact endothelial cells following rolling is a process dependent on $\alpha_{IIb}\beta_3$ bridging to endothelium that involves endothelial receptors such as $\alpha_V\beta_3$ and intercellular adhesion molecule (ICAM)-1 interacting with platelet-bound fibrinogen, fibronectin, and vWF.^{325,358,367,386} This firm adhesion induces platelet surface P-selectin expression, and whether this selectin plays any role in their interaction with endothelium is unknown. The fact that P-selectin knockout mice have been observed to display impaired hemostasis suggests a potential role in this respect.³⁶⁹

Platelets and White Blood Cells

In addition to the participation of the gplb complex, selectins, and the β_3 integrin in the interaction between platelets and intact endothelium described above, these proteins along with the β_2 integrin receptor Mac-1 ($\alpha_M\beta_2$ or CD11b/CD18) participate in interactions between platelets and leukocytes.³⁷⁰ Platelets contribute to leukocyte rolling and extravasation, which are two well-characterized steps involved in the translocation of the latter cell from the circulation to sites of infection.³⁷¹ Normally, after interaction of endothelial cell P-selectin with leukocyte receptors such as PSGL-1, β_2 integrin activation on the leukocyte mediates increased adhesion to endothelium, followed by extravasation. Neutrophils are also capable of tethering and rolling on adherent and activated platelets through interactions between its P-selectin glycoprotein 1 and P-selectin expressed on the platelet surface, and they will subsequently display extravasation mediated by activation of Mac-1 and lymphocyte function-associated

P.426

antigen 1 ($\alpha_L\beta_2$) which are required to mediate stable leukocyte adhesion.^{372,373} and ³⁷⁴ The α subunits of certain integrins, such as Mac-1, have been found to contain "insert" (I) domains, homologous to the A1 domain of vWF. This observation has taken on added interest since it has been shown that Mac-1 is capable of binding to the gplb complex and that this interaction required the I domain of Mac-1 and the leucine-rich repeat region of gplb α .³⁷⁵ Mac-1 knockout mouse neutrophils were incapable of binding to isolated polypeptide fragments corresponding to the extracellular domain of gplb α (called glyocalicin). For this reason and others, the role of Mac-1-gplb complex interaction could turn out to be important with respect to initiating and propagating inflammation associated with the progression of atherosclerotic, purely thrombotic, or atherothrombotic processes.

Mac-1 has also been found to associate with other receptors of the platelet membrane, including the junctional adhesion molecule-3, ICAM-2, fibrinogen bound to $\alpha_{IIb}\beta_3$, and high-molecular-weight kininogen bound to gplb α .^{376,377,378,379} and ³⁸⁰ These associations have been characterized individually, however, their downstream signaling partners along with any coordinated actions that may exist between the ligand-receptor pairs *in vivo* remain to be determined. During this adhesive process, the association of platelet membrane PSGL-1 and Mac-1 stimulates the release of inflammatory cytokines from platelets, which in turn induces inflammatory cascades in monocytes.^{381,382} This integrin, selectin, and cytokine-based set of coordinated reactions linking neutrophils, platelets, and monocytes leads to circulating activated platelets and platelet-white cell aggregates that promote formation of atherosclerotic lesions.³⁸³

Role of Platelets in Inflammation

The growing list of pathophysiologic processes in which platelets have a proposed role is a reflection of the many different cell types with which they interact. These include endothelial cells, neutrophils, monocytes, dendritic cells, cytotoxic T lymphocytes, malaria-infected red cells, and various tumor cells. In addition to the mechanisms behind interaction of platelets with activated endothelium and white cells described in the last section, platelet activation induces a local

release of alpha granule contents containing various potent inflammatory substances that further enhance the inflammatory response and alter chemotactic, adhesive, and proteolytic properties of endothelial cells. These include chemokines CXCL4 (PF-4), CXCL7 (PBP, β -TG, CTAP-III, and NAP-2), and CCL5 (RANTES), platelet-derived growth factor, IL-1 β , CD40 ligand, TxA₂, leukotriene B₄, and platelet-activating factor.

The interaction between platelets, leukocytes, and the vascular wall can occur in various sequences.³⁸⁴ First, platelets can form aggregates with leukocytes that promote leukocyte recruitment either by activating leukocyte adhesion receptors or by directly serving as a bridging molecule between leukocytes and the endothelium. When adhered to the vessel wall, platelets can attract leukocytes by releasing chemoattractants and providing an adhesive surface for leukocyte adhesion. Thus platelets, leukocytes, and endothelial cells all become activated in a cascadelike fashion.

A key receptor-ligand interaction in these processes includes P-selectin and PSGL-1 (as noted above) that was initially found to be important in rolling interactions between leukocytes and the vessel wall and later found to be important in the recruitment of tissue factor bearing microparticles in thrombosis as well.^{385,386} Using apolipoprotein E-deficient mice, it has been shown that platelet P-selectin plays a critical role in atherosclerosis by promoting leukocyte recruitment on atherosclerosis-prone endothelium.³⁸⁷

A second key interaction involves platelet CD40 ligand, which is related to the tumor necrosis family, and CD40. Once on the activated platelet surface, CD40L increases release of attractants for neutrophils and monocytes, and triggers outside-in signaling by inducing $\alpha_{IIb}\beta_3$ phosphorylation and enhancing thrombus stability.^{388,389} High levels of soluble CD40L are released from platelets in response to thrombosis that then functions as a primary platelet agonist in an autocrine loop with $\alpha_{IIb}\beta_3$ as the primary agonist receptor.

ROLE OF PLATELETS IN ATHEROGENESIS AND ATHEROTHROMBOSIS

Atherosclerosis is the major cause of vascular occlusive disorders such as coronary artery disease, stroke, and peripheral arterial disease. Every year, more than 4 million patients are admitted to hospitals worldwide with ACS, more than 1.5 million of them in the United States.³⁹⁰ Peripheral arterial disease affects up to 12% of the general population and 20% of those older than age 70 years.³⁹¹ The instability associated with atherosclerotic plaque progression enhances vulnerability to disruption or ulceration, and this is associated with secondary deep vessel wall injury and thrombus formation.^{392,393} and³⁹⁴ Based on extensive laboratory and clinical experience, it is clear that platelet activation and aggregation play an integral role on two fronts: (a) in the cytokine-driven local inflammatory changes associated with plaque formation and growth, followed by (b) thrombus associated with plaque instability (Fig. 17.8).

Platelets in Atherogenesis

The importance of the role of both arterial wall and systemic inflammation in atherogenesis and its later clinical manifestations, along with the molecular interface between inflammation and thrombosis, have been the subject of much recent attention in the literature.^{395,396,397} An increased number of links between thrombosis and inflammatory mediators have been observed, and new roles for platelets in inflammation are becoming apparent.³⁹⁸

Many of the molecular players mediating leukocyte-endothelium interactions have also been found to play important roles coordinating leukocyte attachment and transmigration across layers of platelets adherent to injured vascular intima.^{375,399} In addition, the binding of platelets to leukocytes influences important whitecell effector responses, such as cell activation, signaling associated with integrin activation, chemokine synthesis, and so forth. Thus, it has become clear that inflammation is capable of leading to local thrombosis, and thrombosis is capable of initiating and propagating inflammation.

As noted in the section, "Platelets and Endothelium," platelet adhesion to intact endothelium (as opposed to exposed subendothelium following vascular injury) has been well characterized using intravital microscopy and atherosclerosis animal models, and in some cases, adhesion has been shown to occur even before detectable atherosclerotic lesions are manifested.^{400,401} Animal models have recently provided strong evidence linking platelets to early events of atherogenesis. An atherosclerosis mouse model lacking α_{IIb} exhibited substantial reduction in atherosclerotic lesion formation.⁴⁰² The importance of P-selectin in atherosclerosis lesion formation has been well described.^{403,404} and⁴⁰⁵ Platelet adhesion has been found to activate endothelial cell nuclear factor- κ B (NF- κ B) and its regulated genes, many of which play key roles in platelet-leukocyte-endothelium-extracellular matrix molecular events that support inflammatory and proatherogenic phenotypes. This includes events that contribute to lesion maturation such as smooth muscle cell and fibroblast proliferation and promotion of collagen synthesis, among others.^{406,407} and⁴⁰⁸ Inhibition of COX-1, an enzyme with expression restricted to platelets, in turn inhibited lesion formation in an atherosclerosis mouse model.⁴⁰⁹ Another atherosclerosis mouse model demonstrated that prolonged antibody blockade of gplb α leads to reduced arterial leukocyte accumulation in carotid arterial intima and subsequent reduced atherosclerosis lesion

formation.⁴⁰¹ This suggests that vWF may also have a role in atherogenesis.⁴¹⁰

In contrast to animal data, conclusions regarding the role of human platelets in atherogenesis are not nearly as extensive. Mouse data cannot be unequivocally applied to humans, because mouse platelets differ from human with respect to expression levels of certain surface receptors. Systemic platelet activation in humans has been described in a variety of atherosclerosis disease presentations. However, antiplatelet agents have not been found to influence disease progression when applied in the secondary disease-prevention setting in humans in which atherosclerosis is likely advanced, as opposed to the possibly preventable progression of early lesions that are present before an initial atherosclerosis clinical event.³⁶⁰ With respect to the role of NF- κ B noted in the preceding paragraph, one study of patients revealed a marked elevation of NF- κ B in those with unstable as compared to stable angina.⁴¹¹

Platelets in Atherothrombosis

The interior of intact atherosclerotic plaques is rich in components that are highly thrombogenic (e.g., collagen types I and III, fibrinogen/fibrin, thrombospondin), and the luminal surface is relatively nonthrombogenic. In contrast to these observations, the thrombotic response to plaque disruption is dynamic. In this respect, thrombosis, repeat thrombosis, and thrombolysis along with embolization all occur simultaneously in many patients with ACS, and this is considered responsible for intermittent flow obstructions.⁴¹² The initial flow obstruction is acknowledged as being due to platelet aggregation, but subsequent fibrin stabilization is important to the longevity of the early and fragile platelet thrombus.⁴¹³ As a result of reduced flow caused by the platelet thrombus at the plaque rupture site, an erythrocyte- and fibrinrich thrombus may form and propagate up and down the artery in both directions.⁴¹²

Normally blood flow is laminar with adjacent fluid layers traveling parallel to each other but at different velocities due to fluid drag exerted by the vessel wall and this leads to shear forces between adjacent fluid planes. However, at arterial branch points, curvatures, and areas of stenosis these flow profiles develop alterations leading to shear gradients, turbulence, flow separation, and eddy formation and these will influence atherogenesis. Progression of the lesion exacerbates these flow disturbances and so a dangerous cycle of shear-dependent atherosclerosis acceleration can occur.⁴¹⁴ The rate of fluctuation in blood flow has been quoted as the major parameter altering endothelial function and as such cell function responds to flow changes through a variety of mechanotransduction mechanisms.⁴¹⁵ These mechanosensory signaling mechanisms are very sensitive to changes in wall shear stress leading to alterations in cell morphology, gene expression profiles, and increased adhesiveness. Thus at high shear rates as occurs in stenosed atherosclerotic arteries ($>5,000 \text{ s}^{-1}$), shear will directly induce platelet activation and aggregation as noted in the section on "Platelet Aggregation and Arterial Shear Flow," and recent evidence suggests this can occur independently of ADP and TxA_2 which implies shear gradients can promote platelet deposition and initial thrombus growth even in the presence of aspirin and a P2Y_{12} inhibitor.⁴¹⁶

There is evidence that alteration of the endothelium such as may occur with early atherogenesis (particularly when under the influence of atherosclerosis risk factors) or plaque disruption may cause the endothelium to generate more mediators that enhance constriction, such as endothelin-1, and fewer mediators that enhance dilation, such as PGI_2 and NO.^{413,417,418,419} Coronary angioplasty data collected at the time of ACS have shown that transient vasoconstriction often accompanies plaque disruption or fissuring, and thrombosis.⁴²⁰ This vasoconstriction occurs with significant vessel wall damage and is dependent on both platelets and thrombin, with platelet dependence shown to be mediated by serotonin and TxA_2 .^{420,421}

ACKNOWLEDGMENTS

The author is grateful to Kandice Abrahamson for assistance with manuscript preparation.

REFERENCES

1. Agbanyo FR, Sixma JJ, de Groot PG, et al. Thrombospondin-platelet interactions. Role of divalent cations, wall shear rate, and platelet membrane glycoproteins. *J Clin Invest* 1993;92:288-296.
2. Hindriks G, Ijsseldijk MJ, Sonnenberg A, et al. Platelet adhesion to laminin: role of Ca^{2+} and Mg^{2+} ions, shear rate, and platelet membrane glycoproteins. *Blood* 1992;79:928-935.
3. Nievelstein PF, D'Alessio PA, Sixma JJ. Fibronectin in platelet adhesion to human collagen types I and III. Use of nonfibrillar and fibrillar collagen in flowing blood studies. *Arteriosclerosis* 1988;8:200-206.

4. Savage B, Saldivar E, Ruggeri ZM. Initiation of platelet adhesion by arrest onto fibrinogen or translocation on von Willebrand factor. *Cell* 1996; 84:289-297.
5. Savage B, Almus-Jacobs F, Ruggeri ZM. Specific synergy of multiple substrate -receptor interactions in platelet thrombus formation under flow. *Cell* 1998;94:657-666.
6. Bonnefoy A, Harsfalvi J, Pfliegler G, et al. The subendothelium of the HMEC-1 cell line supports thrombus formation in the absence of von Willebrand factor and collagen types I, III and VI. *Thromb Haemost* 2001;85:552-559.
7. Houdijk WP, Sakariassen KS, Nievelstein PF, Sixma JJ. Role of factor VIII-von Willebrand factor and fibronectin in the interaction of platelets in flowing blood with monomeric and fibrillar human collagen types I and III. *J Clin Invest* 1985;75:531-540.
8. Moroi M, Jung SM, Shinmyozu K, et al. Analysis of platelet adhesion to a collagen-coated surface under flow conditions: the involvement of glycoprotein VI in the platelet adhesion. *Blood* 1996;88:2081-2092.
9. Turitto VT, Weiss HJ, Zimmerman TS, Sussman II. Factor VIII/von Willebrand factor in subendothelium mediates platelet adhesion. *Blood* 1985;65:823-831.
10. Denis C, Methia N, Frenette PS, et al. A mouse model of severe von Willebrand disease: defects in hemostasis and thrombosis. *Proc Natl Acad Sci U S A* 1998;95:9524-9529.
11. Beumer S, IJsseldijk MJ, de Groot PG, Sixma JJ. Platelet adhesion to fibronectin in flow: dependence on surface concentration and shear rate, role of platelet membrane glycoproteins GP IIb/IIIa and VLA-5, and inhibition by heparin. *Blood* 1994;84:3724-3733.
12. Kroll MH, Hellums JD, McIntire LV, et al. Platelets and shear stress. *Blood* 1996;88:1525-1541.
13. Beumer S, Heijnen HF, IJsseldijk MJ, et al. Platelet adhesion to fibronectin in flow: the importance of von Willebrand factor and glycoprotein Ib. *Blood* 1995;86:3452-3460.
14. Sakariassen KS, Nievelstein PF, Coller BS, Sixma JJ. The role of platelet membrane glycoproteins Ib and IIb-IIIa in platelet adherence to human artery subendothelium. *Br J Haematol* 1986;63:681-691.
15. Barnes MJ, Farndale RW. Collagens and atherosclerosis. *Exp Gerontol* 1999;34:513-525.
16. Ni H, Yuen PS, Papalia JM, et al. Plasma fibronectin promotes thrombus growth and stability in injured arterioles. *Proc Natl Acad Sci U S A* 2003;100:2415-2419.
17. Savage B, Saldivar E, Ruggeri ZM. Initiation of platelet adhesion by arrest onto fibrinogen or translocation on von Willebrand factor. *Cell* 1996;84:289-297.
18. Fredrickson BJ, Dong JF, McIntire LV, Lopez JA. Shear-dependent rolling on von Willebrand factor of mammalian cells expressing the platelet glycoprotein Ib-IX-V complex. *Blood* 1998;92:3684-3693.
19. Cranmer SL, Ulsemer P, Cooke BM, et al. Glycoprotein (GP) Ib-IX-transfected cells roll on a von Willebrand factor matrix under flow. Importance of the GPIb/actin-binding protein (ABP-280) interaction in maintaining adhesion under high shear. *J Biol Chem* 1999;274:6097-6106.
20. Tsuji S, Sugimoto M, Miyata S, et al. Real-time analysis of mural thrombus formation in various platelet aggregation disorders: distinct shear-dependent roles of platelet receptors and adhesive proteins under flow. *Blood* 1999;94:968-975.
21. Roth GJ. Developing relationships: arterial platelet adhesion, glycoprotein Ib, and leucine-rich glycoproteins. *Blood* 1991;77:5-19.
22. Berndt MC, Gregory C, Kabral A, et al. Purification and preliminary characterization of the glycoprotein Ib complex in the human platelet membrane. *Eur J Biochem* 1985;151:637-649.
23. Du X, Beutler L, Ruan C, et al. Glycoprotein Ib and glycoprotein IX are fully complexed in the intact platelet membrane. *Blood* 1987;69:1524-1527.
24. Modderman PW, Admiraal LG, Sonnenberg A, von dem Borne AE. Glycoproteins V and Ib-IX form a noncovalent complex in the platelet membrane. *J Biol Chem* 1992;267:364-369.
25. Ruggeri ZM. Structure and function of von Willebrand factor. *Thromb Haemost* 1999;82:576-584.
26. Miyata S, Goto S, Federici AB, et al. Conformational changes in the A1 domain of von Willebrand factor modulating the interaction with platelet glycoprotein Ib α . *J Biol Chem* 1996;271:9046-9053.

27. Siedlecki CA, Lestini BJ, Kottke-Marchant KK, et al. Shear-dependent changes in the three-dimensional structure of human von Willebrand factor. *Blood* 1996;88:2939-2950.
28. Peterson DM, Stathopoulos NA, Giorgio TD, et al. Shear-induced platelet aggregation requires von Willebrand factor and platelet membrane glycoproteins Ib and IIb-IIIa. *Blood* 1987;69:625-628.
29. De Luca M, Facey DA, Favalaro EJ, et al. Structure and function of the von Willebrand factor A1 domain: analysis with monoclonal antibodies reveals distinct binding sites involved in recognition of the platelet membrane glycoprotein Ib-IX-V complex and ristocetin-dependent activation. *Blood* 2000;95:164-172.
30. Ward CM, Andrews RK, Smith AI, Berndt MC. Mocarhagin, a novel cobra venom metalloproteinase, cleaves the platelet von Willebrand factor receptor glycoprotein Ib α . Identification of the sulfated tyrosine/anionic sequence Tyr-276-Glu-282 of glycoprotein Ib α as a binding site for von Willebrand factor and α -thrombin. *Biochemistry* 1996;35:4929-4938.
31. Nishio K, Fujimura Y, Nishida S, et al. Antiplatelet glycoprotein Ib monoclonal antibody (OP-F1) totally abolishes ristocetin-induced von Willebrand factor binding, but has minimal effect on the botrocetin-induced binding. *Haemostasis* 1991;21:353-359.
32. Berndt MC, Shen Y, Dopheide SM, et al. The vascular biology of the glycoprotein Ib-IX-V complex. *Thromb Haemost* 2001;86:178-188.
33. Moake JL, Turner NA, Stathopoulos NA, et al. Shear-induced platelet-aggregation can be mediated by vWF released from platelets, as well as by exogenous large or unusually large vWF multimers, requires adenosine-diphosphate, and is resistant to aspirin. *Blood* 1988;71:1366-1374.
34. Mazzucato M, Pradella P, Cozzi MR, et al. Sequential cytoplasmic calcium signals in a 2-stage platelet activation process induced by the glycoprotein Ib α mechanoreceptor. *Blood* 2002;100:2793-2800.
35. Nesbitt WS, Kulkarni S, Giuliano S, et al. Distinct glycoprotein Ib/V/IX and integrin $\alpha_{IIb}\beta_3$ -dependent calcium signals cooperatively regulate platelet adhesion under flow. *J Biol Chem* 2002;277:2965-2972.
36. Marchese P, Murata M, Mazzucato M, et al. Identification of three tyrosine residues of glycoprotein Ib α with distinct roles in von Willebrand factor and α -thrombin binding. *J Biol Chem* 1995;270:9571-9578.
37. Dong JF, Hyun W, Lopez JA. Aggregation of mammalian cells expressing the platelet glycoprotein (GP) Ib-IX complex and the requirement for tyrosine sulfation of GP Ib α . *Blood* 1995;86:4175-4183.
38. Murata M, Ware J, Ruggeri ZM. Site-directed mutagenesis of a soluble recombinant fragment of platelet glycoprotein Ib α demonstrating negatively charged residues involved in von Willebrand factor binding. *J Biol Chem* 1991;266:15474-15480.
39. Miller JL, Cunningham D, Lyle VA, Finch CN. Mutation in the gene encoding the α chain of platelet glycoprotein Ib in platelet-type von Willebrand disease. *Proc Natl Acad Sci U S A* 1991;88:4761-4765.
40. Celikel R, McClintock RA, Roberts JR, et al. Modulation of alpha-thrombin function by distinct interactions with platelet glycoprotein Iba. *Science* 2003;301:218.
41. Dumas JJ, Kumar R, Seehra J, Somers WS, Mosyak L. Crystal structure of the GpIb α -thrombin complex essential for platelet aggregation. *Science* 2003;301:222.
42. Shen Y, Romo GM, Dong JF, et al. Requirement of leucine-rich repeats of glycoprotein (GP) Ib α for shear-dependent and static binding of von Willebrand factor to the platelet membrane GP Ib-IX-V complex. *Blood* 2000;95: 903-910.
43. Berndt MC, Phillips DR. Interaction of thrombin with platelets: purification of the thrombin substrate. *Ann NY Acad Sci* 1981;370:87-95.
44. Ware J, Russell S, Ruggeri ZM. Generation and rescue of a murine model of platelet dysfunction: the Bernard-Soulier syndrome. *Proc Natl Acad Sci U S A* 2000;97:2803-2808.
45. Coughlin SR. Protease-activated receptors in vascular biology. *Thromb Haemost* 2001;86:298-307.
46. Beguin S, Kumar R, Keularts I, et al. Fibrin-dependent platelet procoagulant activity requires GPIb receptors and von Willebrand factor. *Blood* 1999;93:564-570.
47. Robinson K, Jones D, Patel Y, et al. Mechanism of inhibition of protein kinase C by 14-3-3 isoforms. *Biochem J* 1994;299:853-861.

48. Muslin AJ, Tanner JW, Allen PM, Shaw AS. Interaction of 14-3-3 with signaling proteins is mediated by the recognition of phosphoserine. *Cell* 1996;84:889-897.
49. Morrison D. 14-3-3: modulators of signaling proteins? *Science* 1994;266:56-57.
50. Andrews RK, Harris SJ, McNally T, Berndt MC. Binding of purified 14-3-3 ζ signaling protein to discrete amino acid sequences within the cytoplasmic domain of the platelet membrane glycoprotein Ib-IX-V complex. *Biochemistry* 1998;37:638-647.
51. Calverley DC, Kavanagh TJ, Roth GJ. Human signaling protein 14-3-3 ζ interacts with platelet glycoprotein Ib subunits Ib α and Ib β . *Blood* 1998;91: 1295-1303.
52. Feng S, Christodoulides N, Resendiz JC, et al. Cytoplasmic domains of GpIb α and GpIb β regulate 14-3-3 ζ binding to GpIb/IX/V. *Blood* 2000;95:551-557.
53. Gu M, Xi X, Englund GD, et al. Analysis of the roles of 14-3-3 in the platelet glycoprotein Ib-IX-mediated activation of integrin $\alpha_{IIb}\beta_3$ using a reconstituted mammalian cell expression model. *J Cell Biol* 1999;147:1085-1096.
54. Munday AD, Berndt MC, Mitchell CA. Phosphoinositide 3-kinase forms a complex with platelet membrane glycoprotein Ib-IX-V complex and 14-3-3 ζ . *Blood* 2000;96:577-584.
55. Lopez JA. The platelet glycoprotein Ib-IX complex. *Blood Coagul Fibrinolysis* 1994;5:97-119.
56. Falati S, Edmead CE, Poole AW. Glycoprotein Ib-V-IX, a receptor for von Willebrand factor, couples physically and functionally to the Fc receptor γ -chain, Fyn, and Lyn to activate human platelets. *Blood* 1999;94:1648-1656.
57. Torti M, Bertoni A, Canobbio I, et al. Rap1B and Rap2B translocation to the cytoskeleton by von Willebrand factor involves Fc γ II receptor-mediated protein tyrosine phosphorylation. *J Biol Chem* 1999;274:13690-13697.
58. Canobbio I, Bertoni A, Lova P, et al. Platelet activation by von Willebrand Factor requires coordinated signaling through thromboxane A₂ and Fc γ IIA receptor. *J Biol Chem* 2000;276:26022-26029.
59. Wu Y, Suzuki-Inoue K, Satoh K, et al. Role of Fc receptor γ -chain in platelet glycoprotein Ib-mediated signaling. *Blood* 2001;97:3836-3845.
60. Sullam PM, Hyun WC, Szollosi J, et al. Physical proximity and functional interplay of the glycoprotein Ib-IX-V complex and the Fc receptor Fc γ RIIA on the platelet plasma membrane. *J Biol Chem* 1998;273:5331-5336.
61. Poole A, Gibbins JM, Turner M, et al. The Fc receptor γ -chain and the tyrosine kinase Syk are essential for activation of mouse platelets by collagen. *EMBO J* 1997;16:2333-2341.
62. Yanaga F, Poole A, Asselin J, et al. Syk interacts with tyrosine-phosphorylated proteins in human platelets activated by collagen and cross-linking of the Fc γ -IIA receptor. *Biochem J* 1995;311:471-478.
63. Blake RA, Schieven GL, Watson SP. Collagen stimulates tyrosine phosphorylation of phospholipase C- γ 2 but not phospholipase C- γ 1 in human platelets. *FEBS Lett* 1994;353:212-216.
64. Watson SP. Collagen receptor signaling in platelets and megakaryocytes. *Thromb Haemost* 1999;82:365-376.
65. Mazzucato M, Pradella P, Cozzi MR, et al. Sequential cytoplasmic calcium signals in a 2-stage platelet activation process induced by the glycoprotein Ib α mechanoreceptor. *Blood* 2002;100:2793-2800.
66. Kasirer-Friede A, Ware J, Leng LJ, et al. Lateral clustering of platelet GP Ib-IX complexes leads to up-regulation of the adhesive function of integrin $\alpha_{IIb}\beta_3$. *J Biol Chem* 2002;277:11949-11956.
67. Yap CL, Anderson KE, Hughan SC, et al. Essential role for phosphoinositide 3-kinase in shear-dependent signaling between platelet glycoprotein Ib/V/IX and integrin $\alpha_{IIb}\beta_3$. *Blood* 2002;99:151-158.
68. Feng S, Resendiz JC, Lu X, Kroll MH. Filamin binding to the cytoplasmic tail of glycoprotein Ib α regulates von Willebrand factor-induced platelet activation. *Blood* 2003;102:2122-2129.
69. Wu Y, Asazuma N, Satoh K, et al. Interaction between von Willebrand factor and glycoprotein Ib activates Src kinases in human platelets: the role of phosphoinositide 3-kinase. *Blood* 2003;101:3469-3476.
70. Moroi M, Jung SM. Platelet receptors for collagen. *Thromb Haemost* 1997;78:439-444.
71. Ryo R, Yoshida A, Sugano W, et al. Deficiency of P62, a putative collagen receptor, in platelets from a patient with defective collagen-induced platelet aggregation. *Am J Hematol* 1992;39:25-31.

72. Santoro SA, Walsh JJ, Staatz WD, Baranski KJ. Distinct determinants on collagen support $\alpha_2\beta_1$ integrin-mediated platelet adhesion and platelet activation. *Cell Regul* 1991;2:905-913.
73. Morton LF, Hargreaves PG, Farndale RW, et al. Integrin $\alpha_2\beta_1$ -independent activation of platelets by simple collagen-like peptides: collagen tertiary (triple-helical) and quarternary (polymeric) structures are sufficient alone for $\alpha_2\beta_1$ -independent platelet reactivity. *Biochem J* 1995;306:337-344.
74. Gibbins J, Asselin J, Farndale R, et al. Tyrosine phosphorylation of the Fc receptor γ -chain in collagen-stimulated platelets. *J Biol Chem* 1996;271:18095-18099.
75. Asselin J, Gibbins JM, Achison M, et al. A collagen-like peptide stimulates tyrosine phosphorylation of Syk and phospholipase C γ 2 in platelets independent of the integrin $\alpha_2\beta_1$. *Blood* 1997;89:1235-1242.
76. Gibbins JM, Okuma M, Farndale R, et al. Glycoprotein VI is the collagen receptor in platelets which underlies tyrosine phosphorylation of the Fc receptor γ -chain. *FEBS Lett* 1997;413:255-259.
77. Ichinohe T, Takayama H, Ezumi Y, et al. Cyclic AMP-insensitive activation of c-Src and Syk protein-tyrosine kinases through platelet membrane glycoprotein VI. *J Biol Chem* 1995;270:28029-28036.
78. Polgar J, Clemetson JM, Kehrel BE, et al. Platelet activation and signal transduction by convulxin, a C-type lectin from *Crotalus durissus terrificus* (tropical rattlesnake) venom via the p62/GPVI collagen receptor. *J Biol Chem* 1997;272:13576-13583.
79. Arai M, Yamamoto N, Moroi M, et al. Platelets with 10% of the normal amount of GPVI have an impaired response to collagen that results in a mild bleeding tendency. *Br J Haematol* 1995;89:124-130.
80. Ichinohe T, Takayama H, Ezumi Y, et al. Collagen-stimulated activation of syk but not c-src is severely compromised in human platelets lacking membrane glycoprotein VI. *J Biol Chem* 1997;272:63-68.
81. Clemetson JM, Polgar J, Magnenat E, et al. The platelet collagen receptor glycoprotein VI is a member of the immunoglobulin superfamily closely related to Fc α R and the natural killer receptors. *J Biol Chem* 1999;274:29019-29024.
82. Ruggeri ZM, Mendolicchio GL. Adhesion mechanisms in platelet function. *Circ Res* 2007;100:1673-1685.
83. Staatz WD, Rajpara SM, Wayner EA, et al. The membrane glycoprotein Ia-IIa (VLA-2) complex mediates the Mg⁺⁺-dependent adhesion of platelets to collagen. *J Cell Biol* 1989;108:1917-1924.
84. Springer TA. Folding of the N-terminal, ligand-binding region of integrin α -subunits into a β -propeller domain. *Proc Natl Acad Sci U S A* 1997;94:65-72.
85. Staatz WD, Rajpara SM, Wayner EA, et al. The membrane glycoprotein Ia-IIa (VLA-2) complex mediates the Mg⁺⁺-dependent adhesion of platelets to collagen. *J Cell Biol* 1989;108:1917-1924.
86. Lahav J, Gofer-Dadosh N, Luboshitz J, et al. Protein disulfide isomerase mediates integrin-dependent adhesion. *FEBS Lett* 2000;475:89-92.
87. Miura Y, Ohnuma M, Jung SM, Moroi M. Cloning and expression of the platelet-specific collagen receptor glycoprotein VI. *Thromb Res* 2000;98:301-309.
88. Clemetson KJ, McGregor JL, James E, et al. Characterization of the platelet membrane glycoprotein abnormalities in Bernard-Soulier syndrome and comparison with normal by surface-labeling techniques and high-resolution two-dimensional gel electrophoresis. *J Clin Invest* 1982;70:304-311.
89. Jandrot-Perrus M, Busfield S, Lagrue AH, et al. Cloning, characterization, and functional studies of human and mouse glycoprotein VI: a platelet-specific collagen receptor from the immunoglobulin superfamily. *Blood* 2000;96: 1798-1807.
90. Ezumi Y, Uchiyama T, Takayama H. Molecular cloning, genomic structure, chromosomal localization, and alternative splice forms of the platelet collagen receptor glycoprotein VI. *Biochem Biophys Res Commun* 2000;277:27-36.
91. Tsuji M, Ezumi Y, Arai M, Takayama H. A novel association of Fc receptor γ -chain with glycoprotein VI and their co-expression as a collagen receptor in human platelets. *J Biol Chem* 1997;272:23528-23531.
92. Nieswandt B, Bergmeier W, Schulte V, et al. Expression and function of the mouse collagen receptor glycoprotein VI is strictly dependent on its association with the FcR γ chain. *J Biol Chem* 2000;275:23998-24002.
93. Kehrel B, Wierwille S, Clemetson KJ, et al. Glycoprotein VI is a major collagen receptor for platelet activation: it recognizes the platelet-activating quaternary structure of collagen, whereas CD36, glycoprotein IIb/IIIa, and von Willebrand factor do not. *Blood* 1998;91:491-499.

94. Kato K, Kanaji T, Russell S, et al. The contribution of glycoprotein VI to stable platelet adhesion and thrombus formation illustrated by targeted gene deletion. *Blood* 2003;102:1701-1707.
95. Massberg S, Gawaz M, Gruner S, et al. A crucial role of glycoprotein VI for platelet recruitment to the injured arterial wall in vivo. *J Exp Med* 2003;197:41-49.
96. Schulte V, Rabie T, Prostedna M, et al. Targeting of the collagen-binding site on glycoprotein VI is not essential for in vivo depletion of the receptor. *Blood* 2003;101:3948-3952.
97. Smethurst PA, Joutsu-Korhonen L, O'Connor MN, et al. Identification of the primary collagen-binding surface on human glycoprotein VI by site-directed mutagenesis and by a blocking phage antibody. *Blood* 2004;103:903-911.
98. Chen JC, Diacovo TG, Grenache DG, et al. The α_2 integrin subunit-deficient mouse—a multifaceted phenotype including defects of branching morphogenesis and hemostasis. *Am J Pathol* 2002;161:337-344.
99. Nieswandt B, Schulte V, Bergmeier W, et al. Long-term antithrombotic protection by in vivo depletion of platelet glycoprotein VI in mice. *J Exp Med* 2001;193:459-469.
100. Nieswandt B, Brakebusch C, Bergmeier W, et al. Glycoprotein VI but not $\alpha_2\beta_1$ integrin is essential for platelet interaction with collagen. *EMBO J* 2001;20:2120-2130.
101. Kuijpers MJE, Schulte V, Bergmeier W, et al. Complementary roles of platelet glycoprotein VI and integrin $\alpha_2\beta_1$ in collagen-induced thrombus formation in flowing whole blood ex vivo. *FASEB J* 2003;17:U372-U394.
102. Kahn ML, Diacovo TG, Bainton DF, et al. Glycoprotein V-deficient platelets have undiminished thrombin responsiveness and do not exhibit a Bernard-Soulier phenotype. *Blood* 1999;94:4112-4121.
103. Ramakrishnan V, Reeves PS, DeGuzman F, et al. Increased thrombin responsiveness in platelets from mice lacking glycoprotein V. *Proc Natl Acad Sci U S A* 1999;96:13336-13341.
104. Locke D, Chen H, Liu Y, et al. Lipid rafts orchestrate signaling by the platelet receptor glycoprotein VI. *J Biol Chem* 2002;277:18801-18809.
105. Myung PS, Boerthe NJ, Koretzky GA. Adapter proteins in lymphocyte antigen-receptor signaling. *Curr Opin Immunol* 2000;12:256-266.
106. Tomlinson MG, Lin J, Weiss A. Lymphocytes with a complex: adapter proteins in antigen signaling. *Immunol Today* 2000;21:584-591.
107. Watson SP, Asazuma N, Atkinson B, et al. The role of ITAM- and ITIM-coupled receptors in platelet activation by collagen. *Thromb Haemost* 2001;86:276-288.
108. Clements JL, Lee JR, Gross B, et al. Fetal hemorrhage and platelet dysfunction in SLP-76-deficient mice. *J Clin Invest* 1999;103:19-25.
109. Gross BS, Melford SK, Watson SP. Evidence that phospholipase C-2 interacts with SLP-76, syk, lyn, LAT and the Fc receptor γ -chain after stimulation of the collagen receptor glycoprotein VI in human platelets. *Eur J Biochem* 1999;263:612-623.
110. Bobe R, Wilde JI, Maschberger P, et al. Phosphatidylinositol 3-kinase-dependent translocation of phospholipase Cy2 in mouse megakaryocytes is independent of Bruton's tyrosine kinase translocation. *Blood* 2001;97:678-684.
111. Pasquet JM, Gross B, Quek L, et al. LAT is required for tyrosine phosphorylation of phospholipase Cy2 and platelet activation by the collagen receptor GPVI. *Mol Cell Biol* 1999;19:8326-8334.
112. Gross B, Lee JR, Clements JL, et al. Tyrosine phosphorylation of SLP-76 is downstream of Syk following stimulation of the collagen receptor GPVI in platelets. *J Biol Chem* 1999;274:5963-5971.
113. Leo L, di Paola J, Judd BA, et al. Role of the adapter protein SLP-76 in GPVI-dependent platelet procoagulant responses to collagen. *Blood* 2002;100:2839-2844.
114. Barry FA, Gibbins JM. Protein kinase B is regulated in platelets by the collagen receptor glycoprotein VI. *J Biol Chem* 2002;277:12874-12878.
115. Woulfe D, Jiang H, Morgans A, et al. Defects in secretion, aggregation, and thrombus formation in platelets from mice lacking Akt2. *J Clin Invest* 2004;113:441-450.

116. Pasquet JM, Noury M, Nurden AT. Evidence that the platelet integrin $\alpha_{IIb}\beta_3$ is regulated by the integrin-linked kinase, ILK, in a PI3-kinase dependent pathway. *Thromb Haemost* 2002;88:115-122.
117. Stevens JM, Jordan PA, Sage T, Gibbins JM. The regulation of integrin-linked kinase in human platelets: evidence for involvement in the regulation of integrin $\alpha_2\beta_1$. *J Thromb Haemost* 2004;2:1443-1452.
118. Falet H, Barkalow KL, Pivniouk VI, et al. Roles of SLP-76, phosphoinositide 3-kinase, and gelsolin in the platelet shape changes initiated by the collagen receptor GPVI/Fc γ -chain complex. *Blood* 2000;96:3786-3792.
119. Pasquet JM, Bobe R, Gross B, et al. A collagen-related peptide regulates phospholipase C γ 2 via phosphatidylinositol 3-kinase in human platelets. *Biochem J* 1999;342:171-177.
120. Gratacap M-P, Payrastra B, Viala C, et al. Phosphatidylinositol 3,4,5-trisphosphate-dependent stimulation of phospholipase C- γ 2 is an early key event in Fc γ RIIA-mediated activation of human platelets. *J Biol Chem* 1998;273:24314-24321.
121. Wang D, Feng J, Wen R, et al. Phospholipase C γ 2 is essential in the functions of B cell and several Fc receptors. *Immunity* 2000;13:25-35.
122. Fujita H, Hashimoto Y, Russell S, et al. In vivo expression of murine platelet glycoprotein Ib α . *Blood* 1998;92:488-495.
123. Inoue O, Suzuki-Inoue K, Dean WL, et al. Integrin $\alpha_2\beta_1$ mediates outside-in regulation of platelet spreading on collagen through activation of Src kinases and PLC- γ 2. *J Cell Biol* 2003;160:769-780.
124. Sundaresan P, Farndale RW. Platelet p38 MAP kinase phosphorylation is required by $\alpha_2\beta_1$ through Src family kinases and protein phosphatases. *Platelets* 2003;13:361.
125. Inoue O, Suzuki-Inoue K, Ozaki Y. Redundant mechanism of platelet adhesion to laminin and collagen under flow: involvement of von Willebrand factor and glycoprotein Ib-IX-V. *J Biol Chem*. 2008;283(24):16279-16282.
126. Patil S, Newman DK, Newman PJ. Platelet endothelial cell adhesion molecule-1 serves as an inhibitory receptor that modulates platelet responses to collagen. *Blood* 2001;97:1727-1732.
127. Cicmil M, Thomas JM, Leduc M, et al. Platelet endothelial cell adhesion molecule-1 signaling inhibits the activation of human platelets. *Blood* 2002;99:137-144.
128. Albelda SM, Muller WA, Buck CA, Newman PJ. Molecular and cellular properties of PECAM-1 (endoCAM/CD31): a novel vascular cell-cell adhesion molecule. *J Cell Biol* 1991;114:1059-1068.
129. Falati S, Patil S, Gibbins J, et al. Opposing effects of P-selectin and PECAM-1 on arterial thrombus growth and stability in vivo. *J Thromb Haemost* 2003(Suppl 1):OC054.
130. Relou IAM, Gorter G, Ferreira IA, et al. Platelet endothelial cell adhesion molecule-1 (PECAM-1) inhibits low density lipoprotein-induced signaling in platelets. *J Biol Chem* 2003;278:32638-32644.
131. Rathore V, Stapleton MA, Hillery CA, et al. PECAM-1 negatively regulates GPIb/V/IX signaling in murine platelets. *Blood* 2003;102:3658-3664.
132. Thai LM, Ashman LK, Harbour SN, et al. Physical proximity and functional interplay of PECAM-1 with the Fc receptor Fc γ RIIa on the platelet plasma membrane. *Blood* 2003;102:3637-3645.
133. Bernardo A, Ball C, Nolasco L, Moake JF, Dong JF. Effects of inflammatory cytokines on the release and cleavage of the endothelial cell-derived ultra-large von Willebrand factor multimers under flow. *Blood*. 2004;104:100-106.
134. Raife TJ, Cao W, Atkinson BS, et al. Leukocyte proteases cleave von Willebrand factor at or near the ADAMTS13 cleavage site. *Blood*. 2009;114:1666-1674.
135. Coughlin SR. How the protease thrombin talks to cells. *Proc Natl Acad Sci U S A* 1999;96:11023-11027.
136. Vu T-KH, Hung DT, Wheaton VI, Coughlin SR. Molecular cloning of a functional thrombin receptor reveals a novel proteolytic mechanism of receptor activation. *Cell* 1991;64:1057-1068.
137. Xu WF, Andersen H, Whitmore TE, et al. Cloning and characterization of human protease-activated receptor 4. *Proc Natl Acad Sci U S A* 1998;95:6642-6646.
138. Kahn ML, Nakanishi-Matsui M, Shapiro MJ, et al. Protease-activated receptors 1 and 4 mediate activation of human platelets by thrombin. *J Clin Invest* 1999;103:879-887.

139. Molino M, Barnathan ES, Numerof R, et al. Interactions of mast cell tryptase with thrombin receptors and PAR-2. *J Biol Chem* 1997;272:4043-4049.
140. Camerer E, Røttingen JA, Iversen JG, Prydz H. Coagulation factors VII and X induce Ca^{2+} oscillations in Madin-Darby canine kidney cells only when proteolytically active. *J Biol Chem* 1996;271:29034-29042.
141. Camerer E, Huang W, Coughlin SR. Tissue factor- and Factor X-dependent activation of PAR2 by Factor VIIa. *Proc Natl Acad Sci U S A* 2000;97:5255-5260.
142. Rasmussen UB, Vouret-Craviari V, Jallat S, et al. cDNA cloning and expression of a hamster α -thrombin receptor coupled to Ca^{2+} mobilization. *FEBS Lett* 1991;288:123-128.
143. Klages B, Brandt U, Simon MI, et al. Activation of G12/G13 results in shape change and rho/rho kinase-mediated myosin light chain phosphorylation in mouse platelets. *J Cell Biol* 1999;144:745-754.
144. Offermanns S, Toombs CF, Hu YH, Simon MI. Defective platelet activation in G $\alpha(q)$ -deficient mice. *Nature* 1997;389:183-186.
145. Taylor S, Chae H, Rhee S-G, Exton J. Activation of the B1 isozyme of phospholipase C by α subunits of the Gq class of G proteins. *Nature* 1991;350:516-518.
146. Yang J, Wu J, Kowalska MA, et al. Loss of signaling through the G protein, Gz, results in abnormal platelet activation and altered responses to psychoactive drugs. *Proc Natl Acad Sci U S A* 2000;97:9984-9989.
147. Stoyanov B, Volinia S, Hanck T, et al. Cloning and characterization of a G protein-activated human phosphoinositide-3 kinase. *Science* 1995;269: 690-693.
148. Clapham DE, Neer EJ. G protein $\beta \gamma$ subunits. *Annu Rev Pharmacol Toxicol* 1997;37:167-203.
149. Leever SJ, Vanhaesebroeck B, Waterfield MD. Signalling through phosphoinositide 3-kinases: the lipids take centre stage. *Curr Opin Cell Biol* 1999;11:219-225.
150. Lefkowitz RJ, Pitcher J, Krueger K, Daaka Y. Mechanisms of β -adrenergic receptor desensitization and resensitization. *Adv Pharmacol* 1998;42:416-420.
151. Hoxie JA, Ahuja M, Belmonte E, et al. Internalization and recycling of activated thrombin receptors. *J Biol Chem* 1993;268:13756-13763.
152. Ishii K, Chen J, Ishii M, et al. Inhibition of thrombin receptor signaling by a G protein-coupled receptor kinase. Functional specificity among G protein-coupled receptor kinases. *J Biol Chem* 1994;269:1125-1130.
153. Hein L, Ishii K, Coughlin SR, Kobilka BK. Intracellular targeting and trafficking of thrombin receptors: a novel mechanism for resensitization of a G protein-coupled receptor. *J Biol Chem* 1994;269:27719-27726.
154. Hung DT, Vu TK, Wheaton VI, et al. Cloned platelet thrombin receptor is necessary for thrombin-induced platelet activation. *J Clin Invest* 1992;89:1350-1353.
155. Brass LF, Vassallo RJ, Belmonte E, et al. Structure and function of the human platelet thrombin receptor. Studies using monoclonal antibodies directed against a defined domain within the receptor N terminus. *J Biol Chem* 1992;267:13795-13798.
156. Shapiro MJ, Weiss EJ, Faruqi TR, Coughlin SR. Protease-activated receptors 1 and 4 are shut off with distinct kinetics after activation by thrombin. *J Biol Chem* 2000;275:25216-25221.
157. Covic L, Gresser AL, Kuliopulos A. Biphasic kinetics of activation and signaling for PAR1 and PAR4 thrombin receptors in platelets. *Biochemistry* 2000;39:5458-5467.
158. Fressinaud E, Sakariassen KS, Rothschild C, et al. Shear rate-dependent impairment of thrombus growth on collagen in nonanticoagulated blood from patients with von Willebrand disease and hemophilia A. *Blood* 1992;80:988-994.
159. Inauen W, Baumgartner HR, Bombeli T, et al. Dose and shear rate-dependent effects of heparin on thrombogenesis induced by rabbit aorta subendothelium exposed to flowing human blood. *Arteriosclerosis* 1990;10:607-615.
160. Sambrano GR, Weiss EJ, Zheng YW, et al. Role of thrombin signalling in platelets in haemostasis and thrombosis. *Nature* 2001;413:74-78.
161. Weiss EJ, Hamilton JR, Lease KE, Coughlin SR. Protection against thrombosis in mice lacking PAR3. *Blood* 2002;100:3240-3244.

162. Gaarder A, Jonsen L, Laland S, et al. Adenosine diphosphate in red cells as a factor in the adhesiveness of human blood platelets. *Nature* 1961;192:531-532.
163. Savi P, Herbert JM. Pharmacology of ticlopidine and clopidogrel. *Haematologica* 2000;85:73-77.
164. Humphries RG. Pharmacology of AR-C69931MX and related compounds: from pharmacological tools to clinical trials. *Haematologica* 2000;85:66-72.
165. Ralevic V, Burnstock G. Receptors for purines and pyrimidines. *Pharmacol Rev* 1998;50:413-492.
166. Turner NA, Moake JL, McIntire LV. Blockade of adenosine diphosphate receptors P2Y₁₂ and P2Y₁ is required to inhibit platelet aggregation in whole blood under flow. *Blood* 2001;98:3340-3345.
167. Remijn JA, Wu YP, Jeniga EH, et al. Role of ADP receptor P2Y₁₂ in platelet adhesion and thrombus formation in flowing blood. *Arterioscler Thromb Vasc Biol* 2002;22:686-691.
168. Webb TE, Simon J, Krishek BJ, et al. Cloning and functional expression of a brain G-protein-coupled ATP receptor. *FEBS Lett* 1993;324:219-223.
169. Léon C, Vial C, Cazenave JP, Gachet C. Cloning and sequencing of a human cDNA encoding endothelial P2Y₁ purinoceptor. *Gene* 1996;171:295-297.
170. Ayyanathan K, Webb TE, Sandhu AK, et al. Cloning and chromosomal localization of the human P2Y₁ purinoceptor. *Biochem Biophys Res Commun* 1996;218:783-788.
171. Léon C, Hechler B, Vial C, et al. The P2Y₁ receptor is an ADP receptor antagonized by ATP and expressed in platelets and megakaryoblastic cells. *FEBS Lett* 1997;403:26-30.
172. Hechler B, Vigne P, Léon C, et al. ATP derivatives are antagonists of the P2Y₁ receptor: similarities with the platelet ADP receptor. *Mol Pharmacol* 1998;53:727-733.
173. Daniel JL, Dangelmaier C, Jin J, et al. Molecular basis for ADP-induced platelet activation. I. Evidence for three distinct ADP receptors on human platelets. *J Biol Chem* 1998;273:2024-2029.
174. Geiger J, Honig-Liedl P, Schanzenbacher P, Walter U. Ligand specificity and ticlopidine effects distinguish three human platelet ADP receptors. *Eur J Pharmacol* 1998;351:235-246.
175. Fagura MS, Dainty IA, McKay GD, et al. P2Y₁-receptors in human platelets which are pharmacologically distinct from P2Y_{ADP}-receptors. *Br J Pharmacol* 1998;124:157-164.
176. Hechler B, Eckly A, Ohlmann P, et al. The P2Y₁ receptor, necessary but not sufficient to support full ADP-induced platelet aggregation, is not the target of the drug clopidogrel. *Br J Haematol* 1998;103:858-866.
177. Jantzen HM, Gousset L, Bhaskar V, et al. Evidence for two distinct G-proteincoupled ADP receptors mediating platelet activation. *Thromb Haemost* 1999;81:111-117.
178. Léon C, Vial C, Gachet C, et al. The P2Y₁ receptor is normal in a patient presenting a severe deficiency of ADP-induced platelet aggregation. *Thromb Haemost* 1999;81:775-781.
179. Hollopeter G, Jantzen HM, Vincent D, et al. Identification of the platelet ADP receptor targeted by antithrombotic drugs. *Nature* 2001;409:202-207.
180. Jin J, Kunapuli SP. Coactivation of two different G protein-coupled receptors is essential for ADP-induced platelet aggregation. *Proc Natl Acad Sci U S A* 1998;95:8070-8074.
181. Jin J, Daniel JL, Kunapuli SP. Molecular basis for ADP-induced platelet activation. II. The P2Y₁ receptor mediates ADP-induced intracellular calcium mobilization and shape change in platelets. *J Biol Chem* 1998;273:2030-2034.
182. Savi P, Beauverger P, Labouret C, et al. Role of P2Y₁ purinoceptor in ADP-induced platelet activation. *FEBS Lett* 1998;422:291-295.
183. Fabre JE, Nguyen M, Latour A, et al. Decreased platelet aggregation, increased bleeding time and resistance to thromboembolism in P2Y₁-deficient mice. *Nat Med* 1999;5:1199-1202.
184. Léon C, Hechler B, Freund M, et al. Defective platelet aggregation and increased resistance to thromboembolism in purinergic P2Y₁ receptor null mice. *J Clin Invest* 1999;104:1731-1737.
185. Savi P, Pflieger M, Herbert JM. cAMP is not an important messenger for ADP-induced platelet aggregation. *Blood Coagul Fibrinolysis* 1996;7:249-252.

186. Daniel JL, Dangelmaier C, Jin J, et al. Role of intracellular signaling events in ADP-induced platelet aggregation. *Thromb Haemost* 1999;82:1322-1326.
187. Cattaneo M, Lecchi A, Randi AM, et al. Identification of a new congenital defect of platelet function characterized by severe impairment of platelet responses to adenosine diphosphate. *Blood* 1992;80:2787-2796.
188. Nurden P, Savi P, Heilmann E, et al. An inherited bleeding disorder linked to a defective interaction between ADP and its receptor on platelets. *J Clin Invest* 1995;95:1612-1622.
189. Paul BZ, Daniel JL, Kunapuli SP. Platelet shape change is mediated by both calcium-dependent and -independent signalling pathways. *J Biol Chem* 1999;274:28293-28300.
190. Bauer M, Retzer M, Wilde JI, et al. Dichotomous regulation of myosin phosphorylation and shape change by Rho-kinase and calcium in intact human platelets. *Blood* 1999;94:1665-1672.
191. Gachet C. ADP receptors of platelets and their inhibition. *Thromb Haemost* 2001;86:222-232.
192. Storey RF, Sanderson HM, White AE, et al. The central role of the P_{2T} receptor in amplification of human platelet activation, aggregation, secretion and procoagulant activity. *Br J Haematol* 2000;110:925-934.
193. Jarvis GE, Humphries RG, Roberston MJ, Leff P. ADP can induce aggregation of human platelets via both P_{2Y}₁ and P_{2T} receptors. *Br J Pharmacol* 2000;129:275-282.
194. Gachet C. ADP receptors of platelets and their inhibition. *Thromb Haemost* 2001;86:222-232.
195. Hechler B, Cattaneo M, Gachet C. The P₂ receptors in platelet function. *Semin Thromb Haemost* 2005;31:150-161.
196. Savi P, Labouret C, Delesque N, et al. P_{2Y}₁₂, a new platelet ADP receptor, target of clopidogrel. *Biochem Biophys Res Commun* 2001;283:379-383.
197. Foster CJ, Prosser DM, Agans JM, et al. Molecular identification and characterization of the platelet ADP receptor targeted by thienopyridine antithrombotic drugs. *J Clin Invest* 2001;107:1591-1598.
198. Andre P, Delaney SM, LaRocca T, et al. P_{2Y}₁₂ regulates both platelet adhesion/activation, thrombus growth and thrombus stability in injured arteries. *J Clin Invest* 2003;112:398-406.
199. Vial C, Hechler B, Léon C, et al. Presence of P_{2X}₁ purinoceptors in human platelets and megakaryoblastic cell lines. *Thromb Haemost* 1997;78:1500-1504.
200. Sun B, Li J, Okahara K, Kambayashi J. P_{2X}₁ purinoceptor in human platelets. Molecular cloning and functional characterization after heterologous expression. *J Biol Chem* 1998;273:11544-11547.
201. Scase TJ, Heath MF, Allen JM, et al. Identification of a P_{2X}₁ purinoceptor expressed on human platelets. *Biochem Biophys Res Commun* 1998; 242:525-528.
202. Clifford EE, Parker K, Humphreys BD, et al. The P_{2X}₁ receptor, an adenosine triphosphate-gated cation channel, is expressed in human platelets but not in human blood leucocytes. *Blood* 1998;91:3172-3181.
203. MacKenzie A, Mahaut-Smith MP, Sage SO. Activation of receptor-operated cation channels via P_{2X}₁ not P_{2T} purinoceptors in human platelets. *J Biol Chem* 1996;271:2879-2881.
204. Oury C, Toth-Zsamboki E, Thys C, et al. The ATP-gated P_{2X}₁ ion channel acts as a positive regulator of platelet responses to collagen. *Thromb Haemost* 2001;86:1264-1271.
205. Hechler B, Lenain N, Marchese P, et al. A role of the fast ATP-gated P_{2X}₁ cation channel in thrombosis of small arteries in vivo. *J Exp Med* 2003;198:661-667.
206. Cattaneo M, Marchese P, Jacobson KA, et al. New insights into the role of P_{2X}₁ in platelet function. *Haematologica* 2002;87:13-14.
207. Oury C, Sticker E, Cornelissen H, et al. ATP augments von Willebrand factor-dependent shear-induced platelet aggregation through Ca²⁺-calmodulin and myosin light chain kinase activation. *J Biol Chem* 279:26266-26273.
208. Oury C, Kuijpers MJ, Toth-Zsamboki E, et al. Overexpression of the platelet P_{2X}₁ ion channel in transgenic mice generates a novel prothrombotic phenotype. *Blood* 2003;101:3969-3976.
209. Murata T, Ushikubi F, Matsuoka T, et al. Altered pain perception and inflammatory response in mice lacking prostacyclin receptor. *Nature* 1997;388:678.

210. Yang J, Wu J, Kowalska MA, et al. Loss of signaling through the G protein, G_z, results in abnormal platelet activation and altered responses to psychoactive drugs. *Proc Natl Acad Sci U S A* 2000;97:9984.
211. Jantzen H-M, Milstone DS, Gousset L, Conley PB, Mortensen RM. Impaired activation of murine platelets lacking Galphai2. *J Clin Invest* 2001;108:477.
212. Sage SO, Rink TJ. Kinetic differences between thrombin induced and ADP induced calcium influx and release from internal stores in fura-2 loaded human platelets. *Biochem Biophys Res Commun* 1986;136:1124-1129.
213. Mahaut-Smith MP, Sage SO, Rink TJ. Rapid ADP evoked currents in human platelets recorded with the nystatin permeabilized patch technique. *J Biol Chem* 1992;267:3060-3065.
214. Yang X, Sun L, Ghosh S, Rao AK. Human platelet signaling defect characterized by impaired production of inositol-1,4,5-triphosphate and phosphatidic acid and diminished pleckstrin phosphorylation: evidence for defective phospholipase C activation. *Blood* 1996;88:1676-1683.
215. Gabbetta J, Yang X, Kowalska MA, et al. Platelet signal transduction defect with G α subunit dysfunction and diminished G α q in a patient with abnormal platelet responses. *Proc Natl Acad Sci U S A* 1997;94:8750-8755.
216. Woulfe D, Jiang H, Mortensen R, et al. Activation of Rap1B by G_i family members in platelets. *J Biol Chem* 2002;277:23382-23390.
217. Lova P, Paganini S, Sinigaglia F, et al. A G_i-dependent pathway is required for activation of the small GTPase Rap1B in human platelets. *J Biol Chem* 2002;277:12009-12015.
218. Larson MK, Chen H, Kahn ML, et al. Identification of P2Y₁₂-dependent and independent mechanisms of glycoprotein VI-mediated Rap1 activation in platelets. *Blood* 2003;101:1409-1415.
219. Nieswandt B, Bergmeier W, Eckly A, et al. Evidence for cross-talk between GPVI and G_i coupled receptors during collagen-induced platelet aggregation. *Blood* 2001;97:3829-3835.
220. Gratacap MP, Héroult JP, Viala C, et al. Fc γ RIIA requires a G_i-dependent pathway for an efficient stimulation of phosphoinositide 3-kinase, calcium mobilization, and platelet aggregation. *Blood* 2000;96:3439-3446.
221. Payrastre B, Gratacap MP, Trumel C, et al. ADP: an important cofactor of PI 3-kinase activation in human blood platelets. *Haematologica* 2000;85:32-36.
222. Trumel C, Payrastre B, Plantavid M, et al. A key role of adenosine diphosphate in the irreversible platelet aggregation induced by the PAR1-activating peptide through the late activation of phosphoinositide 3-kinase. *Blood* 1999;94:4156-4165.
223. Covic L, Singh C, Smith H, et al. Role of PAR4 thrombin receptor in stabilizing platelet-platelet aggregates as revealed by a patient with Hermansky-Pudlak syndrome. *Thromb Haemost* 2002;87:722-727.
224. Kim S, Foster C, Lecchi A, et al. Protease-activated receptors 1 and 4 do not stimulate G_i signaling pathways in the absence of secreted ADP and cause human platelet aggregation independently of G_i signaling. *Blood* 2002;99:3629-3636.
225. Foster CJ, Prosser DM, Agans JM, et al. Molecular identification and characterization of the platelet ADP receptor targeted by thienopyridine antithrombotic drugs. *J Clin Invest* 2001;107:1591-1598.
226. Quinton TM, Ozdener F, Dangelmaier C, et al. Glycoprotein VI-mediated platelet fibrinogen receptor activation occurs through calcium-sensitive and PKC-sensitive pathways without a requirement for secreted ADP. *Blood* 2002;99:3228-3234.
227. Jung SM, Moroi M. Platelet collagen receptor integrin $\alpha_2\beta_1$ activation involves differential participation of ADP-receptor subtypes P2Y₁ and P2Y₁₂ but not intracellular calcium. *Eur J Biochem* 2001;268:3513-3522.
228. Polgar J, Eichler P, Greinacher A, Clemetson KJ. Adenosine diphosphate (ADP) and ADP receptor play a major role in platelet activation/aggregation induced by sera from heparin-induced thrombocytopenia patients. *Blood* 1998;91:549-554.
229. Storey RF, Judge HM, Wilcox RG, et al. Inhibition of ADP-induced P-selectin expression and platelet-leukocyte conjugate formation by clopidogrel and the P2Y₁₂ receptor antagonist AR-C69931MX but not aspirin. *Thromb Haemost* 2002;88:488-494.
230. Siess W, Weber PC, Lapetina EG. Activation of phospholipase C is dissociated from arachidonate metabolism during platelet shape change induced by thrombin or platelet-activating factor: epinephrine does not induce phospholipase C activation or platelet shape change. *J Biol Chem* 1984;259:8286-8292.

231. Bennett JS, Vilaire G, Burch JW. A role for prostaglandins and thromboxanes in the exposure of platelet fibrinogen receptors. *J Clin Invest* 1981;68:981-987.
232. Peerschke EI. Induction of human platelet fibrinogen receptors by epinephrine in the absence of released ADP. *Blood* 1982;60:71-77.
233. Lanza F, Beretz A, Stierlé A, et al. Epinephrine potentiates human platelet activation but is not an aggregating agent. *Am J Physiol* 1988;255: H1276-H1288.
234. Regan JW, Nakata H, DeMarinis RM, et al. Purification and characterization of the human platelet α_2 -adrenergic receptor. *J Biol Chem* 1986;261: 3894-3900.
235. Kobilka BK, Matsui H, Kobilka TS, et al. Cloning sequencing and expression of the gene coding for the platelet α_2 -adrenergic receptor. *Science* 1987;238:650-656.
236. Scrutton MC, Clare KC, Hutton RA, Bruckdorfer KR. Depressed responsiveness to adrenaline in platelets from apparently normal human donors: a familial trait. *Br J Haematol* 1981;49:303-314.
237. Smith WL. The eicosanoids and their biochemical mechanisms of action. *Biochem J* 1989;259:315-324.
238. Smith JB, Willis AL. Aspirin selectively inhibits prostaglandin production in human platelets. *Nature* 1971;231:235-237.
239. Roth GJ, Calverley DC. Aspirin, platelets, and thrombosis: theory and practice. *Blood* 1994;83:885-898.
240. FitzGerald GA. Mechanisms of platelet activation: thromboxane A_2 as an amplifying signal for other agonists. *Am J Cardiol* 1991;68:11B-15B.
241. Hamberg M, Svensson J, Samuelsson B. Thromboxanes: a new group of biologically active compounds derived from prostaglandin endoperoxides. *Proc Natl Acad Sci U S A* 1975;72:2994-2998.
242. Gerrard JM, Carroll RC. Stimulation of protein phosphorylation by arachidonic acid and endoperoxide analog. *Prostaglandins* 1981;22:81-94.
243. Pulcinelli FM, Ashby B, Gazzaniga PP, Daniel JL. Protein kinase C activation is not a key step in ADP-mediated exposure of fibrinogen receptors on human platelets. *FEBS Lett* 1995;364:87-90.
244. Saklatvala J, Rawlinson L, Waller RJ, et al. Role for p38 mitogen-activated protein kinase in platelet aggregation caused by collagen or a thromboxane analogue. *J Biol Chem* 1996;271:6586-6589.
245. Offermanns S, Laugwitz KL, Spicher K, Schultz G. G proteins of the G12 family are activated via thromboxane A_2 and thrombin receptors in human platelets. *Proc Natl Acad Sci U S A* 1994;91:504-508.
246. Klages B, Brandt U, Simon MI, et al. Activation of G12/G13 results in shape change and Rho/Rho-kinase-mediated myosin light chain phosphorylation in mouse platelets. *J Cell Biol* 1999;144:745-754.
247. Raychowdhury MK, Yukawa M, Collins LJ, et al. Alternative splicing produces a divergent cytoplasmic tail in the human endothelial thromboxane A_2 receptor. *J Biol Chem* 1995;270:7011.
248. Hirata T, Ushikubi F, Kakizuka A, et al. Two thromboxane A_2 receptor isoforms in human platelets. Opposite coupling to adenylyl cyclase with different sensitivity to Arg60 to Leu mutation. *J Clin Invest* 1996;97:949-956.
249. Thomas DW, Mannon RB, Mannon PJ, et al. Coagulation defects and altered hemodynamic responses in mice lacking receptors for thromboxane A_2 . *J Clin Invest* 1998;102:1994.
250. Jackson SP, Nesbitt WS, Kulkarni S. Signaling events underlying thrombus formation. *J Thromb Haemost* 2003;1:1602-1612.
251. Nesbitt WS, Kulkarni S, Giuliano S, et al. Distinct glycoprotein Ib/V/IX and integrin $\alpha_{IIb}\beta_3$ -dependent calcium signals cooperatively regulate platelet adhesion under flow. *J Biol Chem* 2002;277:2965-2972.
252. Nesbitt WS, Giuliano S, Kulkarni S, et al. Intercellular calcium communication drives thrombus growth. *J Cell Biol* 2003;160:1151-1161.
253. Brass LF, Molino M. Protease-activated G protein-coupled receptors on human platelets and endothelial cells. *Thromb Haemost* 1997;78:234-241.
254. Premont RT, Ingles J, Lefkowitz RJ. Protein kinases that phosphorylate activated G protein-coupled receptors. *FASEB J* 1995;9:175-182.

255. Ferguson SS, Barak LS, Zhang J, Caron MG. G-protein-coupled receptor regulation: role of G-protein-coupled receptor kinesis and arrestins. *Can J Physiol Pharmacol* 1996;74:1095-1110.
256. Goodman OB, Krupnick JG, Santini F, et al. β -Arrestin acts as a clathrin adaptor in endocytosis of the β_2 -adrenergic receptor. *Nature* 1996;383: 447-450.
257. Brass LF. Molecular basis of platelet activation. In: Hoffman R, Benz EJ, Shattil SJ, et al., eds. *Hematology: basic principles and practice*, 3rd ed. New York: Churchill-Livingstone, 2000:1753-1770.
258. Cavallini L, Coassin M, Borean A, Alexandre A. Prostacyclin and sodium nitroprusside inhibit the activity of the platelet inositol 1,4,5-triphosphate receptor and promote its phosphorylation. *J Biol Chem* 1996;271:5545-5551.
259. Nishimura T, Yamamoto T, Komuro Y, Hara Y. Antiplatelet functions of a stable prostacyclin analog, SM-10906 are exerted by its inhibitory effect on inositol 1,4,5-triphosphate production and cytosolic Ca^{2+} increase in rat platelets stimulated by thrombin. *Thromb Res* 1995;79:307-317.
260. Lapetina EG. Incorporation of synthetic 1,2-diacylglycerol into platelet phosphatidylinositol is increased by cyclic AMP. *FEBS Lett* 1986;195:111-114.
261. de Chaffoy de Courcelles D, Roevens P, van Belle H. Agents that elevate platelet cAMP stimulate the formation of phosphatidylinositol 4-phosphate in intact human platelets. *FEBS Lett* 1986;195:115-118.
262. Abrams CS, Kazanietz MG. Platelet signalling: protein kinase C. In: Gresele P, Page C, Fuster V, Vermynen J, eds. *Platelets in thrombotic and non-thrombotic disorders*. Cambridge: Cambridge University Press, 2002:272.
263. Watson SP, Lapetina EG. 1,2 Diacylglycerol and phorbol ester inhibit agonist-induced formation of inositol phosphates in human platelets: possible implications for negative feedback regulation of inositol phospholipid hydrolysis. *Proc Natl Acad Sci U S A* 1985;82:2623-2626.
264. Zavoico GB, Halenda SP, Sha'afi RI, Feinstein MB. Phorbol myristate acetate inhibits thrombin-stimulated Ca^{2+} mobilization and phosphatidylinositol 4,5-bisphosphate hydrolysis in human platelets. *Proc Natl Acad Sci U S A* 1985;82:3859-3862.
265. MacIntyre DE, McHicol A, Drummond AH. Tumour-promoting phorbol esters inhibit agonist-induced phosphatidate formation and Ca^{2+} flux in human platelets. *FEBS Lett* 1985;180:160-164.
266. Connolly TM, Lawing WJ Jr, Majerus PW. Protein kinase C phosphorylates human platelet inositol trisphosphate 5'-phosphomonoesterase, increasing the phosphatase activity. *Cell* 1986;46:951-958.
267. Abrams CS, Wu H, Zhao W, et al. Pleckstrin inhibits phosphoinositide hydrolysis initiated by G-protein-coupled and growth factor receptors: a role for pleckstrin's PH domains. *J Biol Chem* 1995;270:14485-14492.
268. Nakinishi H, Brewer KA, Exton JH. Activation of the ζ isozyme of protein kinase C by phosphatidylinositol 3,4,5-trisphosphate. *J Biol Chem* 1993;268:13-16.
269. George JN. Platelet immunoglobulin G: its significance for the evaluation of thrombocytopenia and for understanding the origin of α -granule proteins. *Blood* 1990;76:859-870.
270. Handagama P, Scarborough RM, Shuman MA, Bainton DF. Endocytosis of fibrinogen into megakaryocyte and platelet α -granules is mediated by $\alpha_{IIb}\beta_3$ (glycoprotein IIb-IIIa). *Blood* 1993;82:135-138.
271. Wencel-Drake JD. Plasma membrane GPIIb-IIIa: evidence for a cycling receptor pool. *Am J Pathol* 1990;136:61-70.
272. Wencel-Drake JD, Boudignon-Proudhon C, Dieter MG, et al. Internalization of bound fibrinogen modulates platelet aggregation. *Blood* 1996;87:602-612.
273. Harrison P, Wilbourn BR, Cramer EM, et al. The influence of therapeutic blocking of $\alpha_{IIb}\beta_3$ on platelet α -granule fibrinogen. *Br J Haematol* 1992;82:721-728.
274. Banga HS, Simons ER, Brass LF, Rittenhouse SE. Activation of phospholipases A and C in human platelets exposed to epinephrine: role of glycoproteins IIb/IIIa and dual role of epinephrine. *Proc Natl Acad Sci U S A* 1986;83:9197-9201.
275. Denis MM, Tolley ND, Bunting M, et al. Escaping the nuclear confines: signal-dependent pre- mRNA splicing in anucleate platelets. *Cell* 2005;122:379.
276. Weyrich A, Dixon DA, Pabla R, et al. Signal-dependent translation of a regulatory protein, Bcl-3, in activated human platelets. *Proc Natl Acad Sci U S A* 1998;95:5556.

277. van der Zee PM, Biro E, Ko Y, et al. P-selectin- and CD63- exposing platelet microparticles reflect platelet activation in peripheral arterial disease and myocardial infarction. *Clin Chem* 2006;52:657.
278. Lemons PP, Chen D, Bernstein AM, et al. Regulated secretion in platelets: identification of elements of the platelet exocytosis machinery. *Blood* 1997;90:1490-1500.
279. Bernstein AM, Whiteheart SW. Identification of a cellubrevin/vesicle associated membrane protein 3 homologue in human platelets. *Blood* 1999;93:571-579.
280. Polgár J, Chung S-H, Reed GL. Vesicle-associated membrane protein 3 (VAMP-3) and VAMP-8 are present in human platelets and are required for granule secretion. *Blood* 2002;100:1081-1083.
281. Carrell NA, Fitzgerald LA, Steiner B, et al. Structure of human platelet membrane glycoproteins IIb and IIIa as determined by electron microscopy. *J Biol Chem* 1985;260:1743-1749.
282. Weisel JW, Nagaswami C, Vilaire G, Bennett JS. Examination of the platelet membrane glycoprotein IIb-IIIa complex and its interaction with fibrinogen and other ligands by electron microscopy. *J Biol Chem* 1992;267: 16637-16643.
283. Phillips DR, Agin PP. Platelet membrane defects in Glanzmann's thrombasthenia: evidence for decreased amounts of two major glycoproteins. *J Clin Invest* 1977;60:535-545.
284. Nurden AT, Caen JP. An abnormal platelet glycoprotein pattern of three cases of Glanzmann's thrombasthenia. *Br J Haematol* 1974;253:253-260.
285. Casserly IP, Topol EJ. Glycoprotein IIb/IIIa antagonists—from bench to practice. *Cell Mol Life Sci* 2002;59:478-500.
286. Jackson, SP. The growing complexity of platelet aggregation. *Blood*, 2007;109:5087-5295.
287. Patil S, Jedsadayamata A, Wencel-Drake JD, et al. Identification of a talinbinding site in the integrin β_3 subunit distinct from the NPLY regulatory motif of post-ligand binding functions: the talin N-terminal head domain interacts with the membrane-proximal region of the β_3 cytoplasmic tail. *J Biol Chem* 1999;274:28575-28583.
288. Calderwood DA, Shattil SJ, Ginsberg MH. Integrins and actin filaments: reciprocal regulation of cell adhesion and signaling. *J Biol Chem* 2000;275: 22607-22610.
289. Shattil SJ. Signaling through platelet integrin IIb β_3 : inside-out, outside-in, and sideways. *Thromb Haemost* 1999;82:318-325.
290. Shattil SJ, Kashiwagi H, Pampori N. Integrin signaling: the platelet paradigm. *Blood* 1998;91:2645-2657.
291. Brass LF. The molecular basis for platelet activation. In: Hoffman R, Benz E, Shattil S, et al., eds. *Hematology: basic principles and practice*, 4th ed. New York: Churchill-Livingstone, 2005:1899-1914.
292. Shattil SJ, Newman PJ. Integrins: dynamic scaffolds for adhesion and signaling in platelets. *Blood* 2004;104:1606-1615.
293. Manganello JM, Djellas Y, Borg C, et al. Cyclic AMP-dependent phosphorylation of thromboxane A_2 receptor-associated $G\alpha_{13}$. *J Biol Chem* 1999;274:28003-28010.
294. Wang GR, Zhu Y, Halushka PV, et al. Mechanism of platelet inhibition by nitric oxide: in vivo phosphorylation of thromboxane receptor by cyclic GMPdependent protein kinase. *Proc Natl Acad Sci U S A* 1998;95:4888-4893.
295. Peerschke EI. Regulation of platelet aggregation by post-fibrinogen binding events. *Thromb Haemost* 1995;73:862-867.
296. O'Toole TE, Ylanne J, Culley BM. Regulation of integrin affinity states through an NPXY motif in the β subunit cytoplasmic domain. *J Biol Chem* 1995;270:8553-8558.
297. Vinogradova O, Vaynberg J, Kong X, et al. Membrane-mediated structural transitions at the cytoplasmic face during integrin activation. *Proc Natl Acad Sci U S A* 2004;101:4094-4099.
298. Kim M, Carman CV, Springer TA. Bidirectional transmembrane signaling by cytoplasmic domain separation in integrins. *Science* 2003;301:1720-1725.
299. Calderwood DA. Integrin activation. *J Cell Sci* 2004;117:657-666.
300. Calderwood DA, Ginsberg MH: Talin forges the links between integrins and actin. *Nat Cell Biol* 2003;5:694.
301. Han J, Lim CJ, Watanabe N, et al. Reconstructing and deconstructing agonistinduced activation of integrin $\alpha IIb\beta 3$. *Curr Biol* 2006;16:1796.

302. Wegener KL, Partridge AW, Han J, et al. Structural basis of integrin activation by talin. *Cell* 2007;128:171.
303. Kiema T, Lad Y, Jiang P, et al. The molecular basis of filamin binding to integrins and competition with talin. *Mol Cell* 2006;21:337.
304. Ma YQ, Qin J, Plow EF. Platelet integrin alpha(IIb)beta(3): activation mechanisms. *J Thromb Haemost* 2007;5:1345.
305. Bennett JS, Zigmond S, Vilaire G, et al. The platelet cytoskeleton regulates the affinity of the integrin $\alpha_{IIb}\beta_3$ for fibrinogen. *J Biol Chem* 1999;274: 25301-25307.
306. Kucik DF. Rearrangement of integrins in avidity regulation by leukocytes. *Immunol Res* 2002;26:199-206.
307. Bennett JS, Vilaire G. Exposure of platelet fibrinogen receptors by ADP and epinephrine. *J Clin Invest* 1979;64:1393-1401.
308. Jackson SP, Schoenwaelder SM, Yuan YP, et al. Non-receptor protein tyrosine kinases and phosphatases in human platelets. *Thromb Haemost* 1996;76:640-650.
309. Lerea KM, Tonks NK, Krebs EG, et al. Vanadate and molybdate increase tyrosine phosphorylation in a 50-kilodalton protein and stimulate secretion in electropermeabilized platelets. *Biochemistry* 1989;28:9286-9292.
310. Savage B, Shattil SJ, Ruggeri ZM. Modulation of platelet function through adhesion receptors. A dual role for glycoprotein IIb-IIIa mediated by fibrinogen and glycoprotein Ib-von Willebrand factor. *J Biol Chem* 1992;267: 11300-11306.
311. Prevost N, Woulfe D, Tognolini M, Brass LF. Contact-dependent signaling during the late events of platelet activation. *J Thromb Haemost* 2003;1: 1613-1627.
312. Law DA, Phillips DR. Glycoprotein IIb/IIIa in platelet aggregation and acute arterial thrombosis. In: Lincoff AM, Topol EJ, eds. *Platelet glycoprotein IIb/IIIa inhibitors in cardiovascular disease*. Totowa, NJ: Humana Press, 1999:35-66.
313. Naik MU, Naik UP. Calcium- and integrin-binding protein regulates focal adhesion kinase activity during platelet spreading on immobilized fibrinogen. *Blood* 2003;102:3629-3636.
314. Parsons JT. Focal adhesion kinase: the first ten years. *J Cell Sci* 2003;116:1409-1416.
315. Downes CP, Currie RA. Lipid signaling. *Curr Biol* 1998;8:R865-R867.
316. Kovacsovic TJ, Bachelot C, Toker A, et al. Phosphoinositide 3-kinase inhibitors spares actin assembly in activating platelets but reverses platelet aggregation. *J Biol Chem* 1995;270:11358-11366.
317. Gawaz MP, Loftus JC, Bajt ML, Frojmovic MM, Plow EF, Ginsberg MH. Ligand bridging mediates integrin alpha IIb beta 3 (platelet GPIIb-IIIa) dependent homotypic and heterotypic cell-cell interactions. *J Clin Invest* 1991;88:1128.
318. Zamarron C, Ginsberg MH, Plow EF. A receptor-induced binding site in fibrinogen elicited by its interaction with platelet membrane glycoprotein IIb-IIIa. *J Biol Chem* 1991;266:16193.
319. Frelinger 3rd AL, Lam SC, Plow EF, Smith MA, Loftus JC, Ginsberg MH. Occupancy of an adhesive glycoprotein receptor modulates expression of an antigenic site involved in cell adhesion. *J Biol Chem* 1988;263:12397.
320. Tuszynski GP, Kornecki E, Cierniewski C, et al. Association of fibrin with the platelet cytoskeleton. *J Biol Chem* 1984;259:5247.
321. Phillips DR, Jennings LK, Prasanna HR. Ca^{2+} -mediated association of glycoprotein G (thrombinsensitive protein, thrombospondin) with human platelets. *J Biol Chem* 1980;255:11629.
322. Brass LF, Jiang H, Wu J, Stalker TJ, Zhu L. Contact-dependent signaling events that promote thrombus formation. *Blood Cells Mol Dis* 2006;36:157.
323. Swords NA, Tracy PB, Mann KG. Intact platelet membranes, not platelet-released microvesicles, support the procoagulant activity of adherent platelets. *Arterioscler Thromb* 1993;13:1613-1622.
324. Henn V, Slupsky JR, Grafe M, et al. CD40 ligand on activated platelets triggers an inflammatory reaction of endothelial cells. *Nature* 1998;391:591-594.
325. Bombeli T, Schwartz BR, Harlan JM. Adhesion of activated platelets to endothelial cells: evidence for a GP-IIb/IIIa-dependent bridging mechanism and novel roles for endothelial intercellular adhesion molecule 1 (ICAM-1), $\alpha_v\beta_3$ integrin, and GPIb α . *J Exp Med* 1998;187:329-339.

326. Buttrum SM, Hatton R, Nash GB. Selectin-mediated rolling of neutrophils on immobilized platelets. *Blood* 1993;82:1165-1174.
327. Weber C, Springer TA. Neutrophil accumulation on activated, surface-adherent platelets in flow is mediated by interaction of Mac-1 with fibrinogen bound to $\alpha_{IIb}\beta_3$ and stimulated by platelet-activating factor. *J Clin Invest* 1997;100:2085-2093.
328. Smyth SS, Reis ED, Zhang W, et al. β_3 -Integrin-deficient mice but not P-selectin-deficient mice develop intimal hyperplasia after vascular injury: correlation with leukocyte recruitment to adherent platelets 1 hour after injury. *Circulation* 2001;103:2501-2507.
329. Maxwell MJ, Westein E, Nesbitt WS, et al. Identification of a 2-stage platelet aggregation process mediating shear-dependent thrombus formation. *Blood* 2007;109:566-567.
330. Chauhan AK, Kisucka J, Lamb CB, et al. von Willebrand factor and factor VIII are independently required to form stable occlusive thrombi in injured veins. *Blood* 2006;109:2424-2429.
331. Ruggeri ZM, Orje JN, Habermann R, et al. Activation-independent platelet adhesion and aggregation under elevated shear stress. *Blood* 2006;108:1903-1910.
332. Coller BS. A new murine monoclonal antibody reports an activation-dependent change in the conformation and/or microenvironment of the platelet glycoprotein IIb/IIIa complex. *J Clin Invest* 1985;76:101-108.
333. Tcheng JE, Ellis SG, George BS, et al. Pharmacodynamics of chimeric glycoprotein IIb/IIIa integrin antiplatelet antibody Fab 7E3 in high-risk coronary angioplasty. *Circulation* 1994;90:1757-1764.
334. Oscende JI, Fuster V, Lev EI, et al. Testing platelet activation with a shear-dependent platelet function test versus aggregation-based tests: relevance for monitoring long-term glycoprotein IIb/IIIa inhibition. *Circulation* 2001;103:1488-1491.
335. Hartman GD, Egbertson MS, Halczenko W, et al. Non-peptide fibrinogen receptor antagonists. Discovery and design of exosite inhibitors. *J Med Chem* 1992;35:4640-4642.
336. Bhatt DL, Topol EJ. Current role of platelet glycoprotein IIb/IIIa inhibitors in acute coronary syndromes. *JAMA* 2000;284:1549-1558.
337. Chew DP, Bhatt DL. Optimizing glycoprotein IIb/IIIa inhibition: lessons from recent randomized controlled trials. *Intern Med J* 2002;32:338-345.
338. Eikelboom JW, Hirsh J, Spencer FA, et al. Antiplatelet drugs: antithrombotic therapy and prevention of thrombosis, 9th ed: ACCP evidenced-based clinical practice guidelines. *Chest* 2012;141:e89S-e119S.
339. Bhatt DL, Topol EJ. Embolization as a pathological mechanism. In: Topol EJ, ed. *Acute coronary syndromes*, 2nd ed. New York: Marcel Dekker 2001:79-110.
340. Hamm CW, Heeschen C, Goldman B, et al. Benefit of abciximab in patients with refractory unstable angina in relation to serum troponin T levels. c7E3 Fab Antiplatelet Therapy in Unstable Refractory Angina (CAPTURE) study investigators. *N Engl J Med* 1999;340:1623-1629.
341. Hamm CW, Heeschen C, Goldmann BU, White HD. Benefit of tirofiban in high-risk patients with unstable angina identified by troponins in the PRISM trial. *Circulation* 1999;100:I-775.
342. Bhatt DL, Marso SP, Lincoff AM, et al. Abciximab reduces mortality in diabetics following percutaneous coronary intervention. *J Am Coll Cardiol* 2000;35:922-928.
343. Roffi M, Chew DP, Mukherjee D, et al. Platelet glycoprotein IIb/IIIa inhibitors reduce mortality in diabetic patients with non-ST-segment-elevation acute coronary syndromes. *Circulation* 2001;104:2767-2771.
344. Plosker GL, Lyseng-Williamson KA. Clopidogrel: a review of its use in the prevention of thrombosis. *Drugs* 2007;67:613.
345. Stone GW, McLaurin BT, Cox DA, et al. Bivalirudin for patients with acute coronary syndromes. *N Engl J Med* 2006;355:2203.
346. Kong DF, Califf RM, Miller DP, et al. Clinical outcomes of therapeutic agents that block the platelet glycoprotein IIb/IIIa integrin in ischemic heart disease. *Circulation* 1998;98:2829-2835.
347. Chew DP, Bhatt DL. Oral glycoprotein IIb/IIIa antagonists in coronary artery disease. *Curr Cardiol Rep* 2001;3:63-71.

348. Chew DP, Bhatt DL, Sapp S, Topol EJ. Increased mortality with oral platelet glycoprotein IIb/IIIa antagonists: a meta-analysis of phase III multicenter randomized trials. *Circulation* 2001;103:201-206.
349. Peter K, Schwarz M, Ylanne J, et al. Induction of fibrinogen binding and platelet aggregation as a potential intrinsic property of various glycoprotein IIb/IIIa (alphaIIb beta3) inhibitors. *Blood* 1998;92:3240.
350. Carlsson L, Markey F, Blikstad I, et al. Reorganization of actin in platelets stimulated by thrombin as measured by the DNase I inhibition assay. *Proc Natl Acad Sci U S A* 1979;76:6376-6380.
351. Fox JE. Identification of actin-binding protein as the protein linking the membrane skeleton to glycoproteins on platelet plasma membranes. *J Biol Chem* 1985;260:11970-11977.
352. Ezzell RM, Kenney DM, Egan S, et al. Localization of the domain of actin-binding protein that binds to membrane glycoprotein Ib and actin in human platelets. *J Biol Chem* 1988;263:13303-13309.
353. Bertagnolli ME, Beckerle MC. Regulated membrane-cytoskeleton linkages in platelets. *Ann NY Acad Sci* 1994;714:88-100.
354. Kenney DM, Linck RW. The cytoskeleton of unstimulated blood platelets: structure and composition of the isolated marginal microtubular band. *J Cell Sci* 1985;78:1-22.
355. Schwer HD, Lecine P, Tiwari S, et al. A lineage-restricted and divergent β -tubulin isoform is essential for the biogenesis, structure and function of blood platelets. *Curr Biol* 2001;11:579-586.
356. Kansas GS. Selectins and their ligands: current concepts and controversies. *Blood* 1996;88:3259-3287.
357. Frenette PS, Johnson RC, Hynes RO, Wagner DD. Platelets roll on stimulated endothelium in vivo: an interaction mediated by endothelial P-selectin. *Proc Natl Acad Sci U S A* 1995;92:7450-7454.
358. Frenette PS, Moyna C, Hartwell DW, et al. Platelet-endothelial interactions in inflamed mesenteric venules. *Blood* 1998;91:1318-1324.
359. Katayama T, Ikeda Y, Handa M, et al. Immunoneutralization of glycoprotein Ib α attenuates endotoxin-induced interactions of platelets and leukocytes with rat venular endothelium in vivo. *Circ Res* 2000;86:1031-1037.
360. Gawaz M, Langer H, May AE. Platelets in inflammation and atherogenesis. *J Clin Invest* 2005;115:3378-3384.
361. Wagner DD, Frenette PS. The vessel wall and its interactions. *Blood* 2008;111:5271-5281.
362. Andre P, Denis CV, Ware J, et al. Platelets adhere to and translocate on von Willebrand factor presented by endothelium in stimulated veins. *Blood* 2000;96:3322-3328.
363. Massberg S, Gruner S, Konrad I, et al. Enhanced in vivo platelet adhesion in vasodilator-stimulated phosphoprotein (VASP)-deficient mice. *Blood* 2004;103:136-142.
364. Massberg S, Enders G, Matos FC, et al. Fibrinogen deposition at the postischemic vessel wall promotes platelet adhesion during ischemia-reperfusion in vivo. *Blood* 1999;94:3829-3838.
365. Romo GM, Dong JF, Schader A, et al. The glycoprotein Ib-IX-V complex is a platelet counterreceptor for P-selectin. *J Exp Med* 1999;190:803-814.
366. Frenette PS, Denis CV, Weiss L, et al. P-Selectin glycoprotein ligand 1 (PSGL-1) is expressed on platelets and can mediate platelet-endothelial interactions in vivo. *J Exp Med* 2000;191:1413-1422.
367. D'Souza SE, Byers-Ward VJ, Gardiner EE, et al. Identification of an active sequence within the first immunoglobulin domain of intercellular cell adhesion molecule-1 (ICAM-1) that interacts with fibrinogen. *J Biol Chem* 1996;271:24270-24277.
368. Gardiner EE, D'Souza SE. A mitogenic action for fibrinogen mediated through intercellular adhesion molecule-1. *J Biol Chem* 1997;272:15474-15480.
369. Subramaniam M, Frenette PS, Saffari-pour S, et al. Defects in haemostasis in P-selectin-deficient mice. *Blood* 1996;87:1238-1242.
370. McEver RP. Adhesive interactions of leukocytes, platelets, and the vessel wall during hemostasis and inflammation. *Thromb Haemost* 2001;86:746-756.
371. Springer TA. Traffic signals for lymphocyte recirculation and leukocyte emigration: the multistep paradigm. *Cell* 1994;76:301-314.

372. Diacovo TG, Roth SJ, Buccola JM, et al. Neutrophil rolling, arrest, and transmigration across activated, surface adherent platelets via sequential action of P-selectin and the β_2 -integrin CD11b/CD18. *Blood* 1996;88:146-157.
373. Evangelista V, Manarini S, Sideri R, et al. Platelet/polymorphonuclear leukocyte interaction: P-selectin triggers protein-tyrosine phosphorylation-dependent CD11b/CD18 adhesion: role of PSGL-1 as a signaling molecule. *Blood* 1999;93:876-885.
374. Yang J, Furie BC, Furie B. The biology of P-selectin glycoprotein ligand-1: its role as a selectin counterreceptor in leukocyte-endothelial and leukocyte-platelet interaction. *Thromb Haemost* 1999;81:1-7.
375. Simon DI, Chen Z, Xu H, et al. Platelet glycoprotein Iba is a counterreceptor for the leukocyte integrin Mac-1 (CD11b/CD18). *J Exp Med* 2000;192:193-204.
376. Santoso S, Sachs UJ, Kroll H, et al. The junctional adhesion molecule 3 (JAM-3) on human platelets is a counterreceptor for the leukocyte integrin Mac-1. *J Exp Med* 2002;196:679-691.
377. Diacovo TG, deFougerolles AR, Bainton DF, Springer TA. A functional integrin ligand on the surface of platelets: intercellular adhesion molecule-2. *J Clin Invest* 1994;94:1243-1251.
378. Wright SD, Weitz JI, Huang AJ, et al. Complement receptor type three (CD11b/CD18) of human polymorphonuclear leukocytes recognizes fibrinogen. *Proc Natl Acad Sci U S A* 1988;85:7734-7738.
379. Altieri DC, Bader R, Mannucci PM, Edgington TS. Oligospecificity of the cellular adhesion receptor Mac-1 encompasses an inducible recognition specificity for fibrinogen. *J Cell Biol* 1988;107:1893-1900.
380. Chavakis T, Santoso S, Clemetson KJ, et al. High molecular weight kininogen regulates platelet-leukocyte interactions by bridging Mac-1 and glycoprotein Ib. *J Biol Chem* 2003;278:45375-45381.
381. Weyrich AS, Elstad MR, McEver RP, et al. Activated platelets signal chemokine synthesis by human monocytes. *J Clin Invest* 1996;97:1525-1534.
382. Neumann FJ, Marx N, Gawaz M, et al. Induction of cytokine expression in leukocytes by binding of thrombin-stimulated platelets. *Circulation* 1997;95:2387-2394.
383. Huo Y, Schober A, Forlow SB, et al. Circulating activated platelets exacerbate atherosclerosis in mice deficient in apolipoprotein E. *Nat Med* 2003;9: 61-67.
384. Lowenberg EC, Meijers JCM, Levi M. Platelet-vessel wall interaction in health and disease. *Netherlands J Med* 2010;68:242-251.
385. Falati S, Gross P, Merrill-Skoloff G, Furie BC, Furie B. Real-time in vivo imaging of platelets, tissue factor and fibrin during arterial thrombus formation in the mouse. *Nat Med*. 2002;8:1175-1181.
386. Falati S, Liu Q, Gross P, et al. Accumulation of tissue factor into developing thrombi in vivo is dependent upon microparticle P-selectin glycoprotein ligand 1 and platelet P-selectin. *J Exp Med*. 2003;197:1585-1598.
387. Li G, Sanders JM, Phan ET, Ley K, Sarembock IJ. Arterial macrophages and regenerating endothelial cells express P-selectin in atherosclerosis-prone apolipoprotein E-deficient mice. *Am J Pathol* 2005;167:1511-1518.
388. Henn V, Slupsky JR, Grafe M, et al. CD40 ligand on activated platelets triggers an inflammatory reaction of endothelial cells. *Nature* 1998;391:591-594.
389. Prasad KS, Andre P, He M, Bao M, Manganello J, Phillips DR. Soluble CD40 ligand induces β_3 integrin tyrosine phosphorylation and triggers platelet activation by outside-in signaling. *Proc Natl Acad Sci U S A* 2003;100:12367-12371.
390. American Heart Association. 1999 heart and stroke facts. Dallas, TX: American Heart Association, 1999.
391. Criqui MH, Fronek A, Barrett-Connor E, et al. The prevalence of peripheral artery disease in a defined population. *Circulation* 1985;71:510-515.
392. Falk E. Plaque rupture with severe pre-existing stenosis precipitating coronary thrombosis: characteristics of coronary atherosclerotic plaques underlying fatal occlusive thrombi. *Br Heart J* 1983;50:127-134.
393. Davies MJ, Thomas AC. Plaque fissuring: the cause of acute myocardial infarction, sudden ischaemic death, and crescendo angina. *Br Heart J* 1985;53:363-373.
394. Burke AP, Farb A, Malcolm GT, et al. Plaque rupture and sudden death related to exertion in men with coronary artery disease. *JAMA* 1999;281:921-926.

395. Ross R. Atherosclerosis—an inflammatory disease. *N Engl J Med* 1999; 340:115-126.
396. Libby P, Ridker PM, Maseri A. Inflammation and atherosclerosis. *Circulation* 2002;105:1135-1143.
397. Borissoff JI, Spronk HM, ten Cate H. The hemostatic system as a modulator of atherosclerosis. *N Engl J Med* 2011;364:1746-1760.
398. Libby P, Simon DI. Inflammation and thrombosis—the clot thickens. *Circulation* 2001;103:1718-1720.
399. Ostovsky L, King AJ, Bond S, et al. A juxtacrine mechanism for neutrophil adhesion on platelets involves platelet-activating factor and a selectin-dependent activation process. *Blood* 1998;91:3028-3036.
400. Theilmeier G, Michiels C, Spaepen E, et al. Endothelial von Willebrand factor recruits platelets to atherosclerosis-prone sites in response to hypercholesterolemia. *Blood* 2002;99:4486-4493.
401. Massberg S, Gawaz M, Gruner S, et al. A critical role of platelet adhesion in the initiation of atherosclerotic lesion formation. *J Exp Med* 2002;196:887-896.
402. Massberg S, Schurzinger K, Lorenz M, et al. Platelet adhesion via glycoprotein IIb integrin is critical for atheroprogession and focal cerebral ischemia: an in vivo study in mice lacking glycoprotein IIb. *Circulation* 2005;112:1180-1188.
403. Dong ZM, Chapman SM, Brown AA, et al. The combined role of P- and E-selectins in atherosclerosis. *J Clin Invest* 1998;102:145-152.
404. Dong ZM, Brown AA, Wagner DD. Prominent role of P-selectin in the development of advanced atherosclerosis in ApoE-deficient mice. *Circulation* 2000;101:2290-2295.
405. Burger PC, Wagner DD. Platelet P-selectin facilitates atherosclerotic lesion development. *Blood* 2003;101:2661-2666.
406. Mach F, Schonbeck U, Sukhova GK, et al. Reduction of atherosclerosis in mice by inhibition of CD40 signalling. *Nature* 1998;394:200-203.
407. Chi H, Messas E, Levine RA, et al. Interleukin-1 receptor signaling mediates atherosclerosis associated with bacterial exposure and/or a high-fat diet in a murine apolipoprotein E heterozygote model: pharmacotherapeutic implications. *Circulation* 2004;110:1678-1685.
408. Kirii H, Niwa T, Yamada Y, et al. Lack of interleukin-1 β decreases the severity of atherosclerosis in ApoE-deficient mice. *Arterioscler Thromb Vasc Biol* 2003;23:656-660.
409. Belton OA, Duffy A, Toomey S, Fitzgerald DJ. Cyclooxygenase isoforms and platelet vessel wall interactions in the apolipoprotein E knockout mouse model of atherosclerosis. *Circulation* 2003;108:3017-3023.
410. Methia N, Andre P, Denis CV, et al. Localized reduction of atherosclerosis in von Willebrand factor-deficient mice. *Blood* 2001;98:1424-1428.
411. Ritchie ME. Nuclear factor- κ B is selectively and markedly activated in humans with unstable angina pectoris. *Circulation* 1998;98:1707-1713.
412. Falk E. Coronary thrombosis: pathogenesis and clinical manifestations. *Am J Cardiol* 1991;68(suppl B):28B-35B.
413. Falk E. Advanced lesions and acute coronary syndromes: a pathologist's view. In: Fuster V, ed. *Syndromes of atherosclerosis: correlations of clinical imaging and pathology*. Armonk, NY: Futura, 1996:81-104.
414. Nesbitt WS, Mangin P, Salem HH, et al. The impact of blood rheology on the molecular and cellular events underlying arterial thrombosis. *J Mol Med* 2006;84:989-995.
415. Lehoux S, Tedgui A. Cellular mechanics and gene expression in blood vessels. *J Biomech* 2003;36:631-643.
416. Nesbitt WS, Westein E, Tovar-Lopez FJ, et al. A shear gradient-dependent platelet aggregation mechanism drives thrombus formation. *Nat Med* 2009;15:665-673.
417. Reddy KG, Nair RN, Sheehan HM, et al. Evidence that selective endothelial dysfunction may occur in the absence of angiographic or ultrasound atherosclerosis in patients with risk factors for atherosclerosis. *J Am Coll Cardiol* 1994;23:833-843.
418. Bogaty P, Hackett D, Davies G, et al. Vasoreactivity of the culprit lesion in unstable angina. *Circulation* 1994;90:5-11.
419. Yanagisawa M, Kurihara H, Kimura S, et al. A novel potent vasoconstrictor peptide produced by vascular endothelial cells. *Nature* 1988;332:411-415.

420. Fuster V. Mechanisms leading to myocardial infarction: insights from studies of vascular biology. *Circulation* 1994;90:2126-2146.

421. Willerson JT, Golino P, Eidt J, et al. Specific platelet mediators and unstable coronary artery lesions: experimental evidence and potential clinical implications. *Circulation* 1989;80:198-205.

Chapter 18 Blood Coagulation and Fibrinolysis

> Table of Contents > Part II - The Normal Hematologic System > Section 5 - Hemostasis > Chapter 18 - Blood Coagulation and Fibrinolysis

Chapter 18

Blood Coagulation and Fibrinolysis

Kathleen E. Brummel-Ziedins

Thomas Orfeo

Stephen J. Everse

Kenneth G. Mann

The opposing forces of fibrin clot formation and dissolution maintain hemostasis and preserve vascular function and integrity. Procoagulant events (platelet adhesion/activation, α -thrombin generation, and cross-linked fibrin clot formation) protect the vasculature from perforating injury and excessive blood loss in a process tightly regulated by plasma and cellular inhibition systems. Subsequent activation of the fibrinolytic system removes the clot, restores blood flow, and initiates tissue repair and regeneration. Hemostasis thus refers to multiple discrete processes that collectively culminate in preservation of vascular integrity. Circulating and adherent cells collaborate with plasma and cell membrane-associated proteins to carry out key roles in both pathways. Hemostasis is not a passive but a continuously active process in maintaining vascular integrity. With vascular perforation, focal interactions initiate procoagulant and fibrinolytic events and initiate tissue repair. Each process must operate in a cooperative fashion, or the entire system is compromised. Thus, balance between the procoagulant, anticoagulant, fibrinolytic, and antifibrinolytic processes is required to prevent extra vascular blood loss, or undesirable intravascular thrombosis.¹

Much of our knowledge of hemostasis has been gleaned and validated from observations of hemostatic and thrombotic pathology; however, much is still not well understood. Epidemiologic studies have expanded our knowledge about key factors that determine risk for venous and arterial thrombosis; however, vascular thrombosis is still the primary cause of death in the United States and Western Europe.² Thus, although the present information base is formidable, investigators continue to examine the processes that contribute to blood coagulation and fibrinolysis. The current concepts governing the roles of protein and cellular components, their structures, functions, and regulations are summarized in the following sections.

ESSENTIAL FEATURES OF COAGULATION

MacFarlane³ and Davie and Ratnoff⁴ provided the first integrated descriptions of the coagulation system. They proposed a "cascade" or "waterfall" sequence of events in which the reactions occur in a defined series leading to prothrombin activation and fibrin clot formation. Each reaction shares a similar mechanism in which an inactive zymogen is converted to an active enzyme. Although some facets of these initial descriptions are still valid, the emerging concept of coagulation and fibrinolysis centers on a complex network of highly interwoven collections of simultaneously occurring processes. Procoagulant, anticoagulant, and fibrinolytic processes occur with many positive and negative feedback loops regulating the processes. These overlapped reactions can be operationally described as five distinct phases: initiation of coagulation, propagation of α -thrombin formation, termination of the procoagulant response, elimination of the fibrin clot, and tissue repair and regeneration. The reactions involved in these five phases share several key features and the nomenclature used to describe the protein components of the reactions is similar.

The proteolytic enzymes and their zymogen precursors are mostly members of the serine protease family that includes chymotrypsin and trypsin with the zymogen and enzyme forms distinguished by an " α " to signify the active enzyme. For example, factor Xa is the active enzyme and factor X is the corresponding zymogen. Factor II, most commonly referred to as prothrombin, is the zymogen that upon activation becomes factor α IIa or α -thrombin. The non-zymogen procofactors factors V and VIII also share this nomenclature, in which the proteolytically activated fully functional cofactor forms are designated factors Va and VIIIa; conversely, the inactivated forms are designated with an "i" subscript (factor Va_i). The

protein cofactors that are cell associated, tissue factor and thrombomodulin, primarily exist in one form and designation. The mechanisms of the individual procoagulant reactions are likewise similar. In each case, a complex consisting of a serine protease, a cofactor protein and Ca^{2+} is assembled on a membrane surface. Each complex enzyme cleaves a zymogen to an enzyme.⁵ The progression from complex to complex results in amplification of product formation.⁶ In blood, the membrane surface is provided by platelets and by other circulating cells and microparticles. The vessel wall also contributes cofactors and membrane to support complex formation. The common features of these membrane-cofactor-protease complexes include target recognition, reaction amplification, regulation, and localization. The response to injury is rapid and ordinarily modulated to ensure a sufficient but not excessive response to the injury.

The initiation of the antihemorrhagic response occurs when the vascular wall is perforated and the antithrombotic nature of the vessel wall is overcome to achieve a prothrombotic state. Membrane surface and subcellular elements, including tissue factor, are presented and initiate the subsequent phases of coagulation. The assembly of the multicomponent procoagulant complexes on membrane surfaces triggers propagation of the coagulation response. The net result of the activities of these complexes (the intrinsic and extrinsic tenase and prothrombinase complexes) is an explosive local expression of α -thrombin. The initial burst of α -thrombin sustains the procoagulant response by activating circulating platelets, the procofactors V and VIII, and the zymogen factors VII and XI.^{7, 8,9,10,11,12,13,14,15} and¹⁶ Thrombin cleaves the fibrinopeptides from fibrinogen and activates factor XIII (to factor XIIIa),¹⁷ a protransglutaminase that, when activated, cross-links (to fXIIIa) and stabilizes the fibrin clot. Tight regulation by antithrombin (AT), tissue factor pathway inhibitor (TFPI), and the dynamic protein C system (thrombin-thrombomodulin) ensures that the response is appropriate to the stimulating injury. The thrombin-activatable fibrinolysis inhibitor (TAFI),^{18,19} a procarboxypeptidase zymogen, thrombin-activated as TAFIa, protects the fibrin clot by downregulating the fibrinolytic system. The propagation phase thus stems blood loss by producing a platelet-rich cross-linked fibrin clot.²⁰ Ultimately, inhibition of the procoagulant enzyme complexes by direct inhibition of the serine proteases and proteolytic inactivation of the cofactor proteins restores homeostasis by limiting coagulation to the site of vascular damage and preventing excessive clot formation.

The plasma proenzyme plasminogen is activated to plasmin by proteases associated with the vascular endothelial cells. Plasmin cleaves the cross-linked fibrin matrix to produce soluble peptides including D-dimer.^{21,22} The mechanism by which plasmin is generated is complex and involves several proteins with key roles throughout the hemostatic response. The solubilization and removal of the fibrin scaffolding of the hemostatic plug is coordinated with the processes of tissue repair and regeneration in part triggered by products of the processes. The extracellular matrix is degraded to allow for cell migration into the damaged area. Vascular cells repopulate the site and recreate the elements necessary to restore the vessel to its (relatively) previously unper-turbed state.

P.429

These steps occur rapidly and in a precise choreographed manner and must be localized to the site of injury. Localization presents challenges because the hemostatic response occurs under conditions of highly variable flow in vascular tubes of various diameters.²³ Localization is controlled on several levels. Endothelial cells actively inhibit coagulation by constitutively synthesizing various anticoagulants and platelet activation inhibitors. Furthermore, the surfaces of inactivated, undamaged blood and vascular cells are not conducive to the assembly and function of the procoagulant protein complexes. Thus, surface availability for procoagulant complex assembly is ordinarily limited by vascular pathology. The activated cell/damaged membrane surfaces may also provide for rapid transfer of intermediate products between complexes; such two-dimensional transfer of intermediates between complexes would increase the rates of complex formation and provide protection from the abundant plasma inhibitors. The essential features of the hemostatic response (recognition, amplification, regulation and localization) ensure that the response is localized to the injury, amplified appropriately according to the severity of the injury, and attenuated to block a systemic reaction.^{24,25}

In contrast to hemostasis, thrombosis is invoked by the presentation of intravascular tissue factor either by damaged endothelium or by an inflammatory cell. The resulting coagulation process is invoked, but in this instance results in the pathology of thrombosis. Vascular thrombotic occlusions composed of platelets and fibrin are significantly influenced by vascular architecture, vascular cell biology, and flow biophysics. In arterial thrombosis, high shear rates make platelet-rich clots (white clots) more apparent, while in the low shear venous circulation, fibrin-rich clots (red clots) are observed. However, it is likely that in both vascular environments, events similar to those associated with the hemostatic process occur.

OVERVIEW OF PROCOAGULANT PATHWAYS: PRIMARY (EXTRINSIC) AND ACCESSORY (INTRINSIC) PATHWAYS

Two procoagulant pathways have been identified which converge at the “intrinsic” fXase (fIXa•fVIIIa) complex (Fig. 18.1). The contact or “intrinsic” pathway is activated by the interaction of blood with a foreign surface. This pathway is activated by the factor XIIa-high-molecular-weight kininogen (HMWK)-prekallikrein complex in association with foreign surfaces including glass, dextran sulfate, or kaolin. The complex catalyst activates factor XI leading to the factor XIa-HMWK complex which activates fIX to fIXa. The “intrinsic” fXase rapidly cleaves fX to fXa.

Factor Xa is directly but less effectively produced by the “extrinsic” fXase, which is composed of plasma-derived fVIIa and tissue factor and expressed when the latter is exposed to blood. The “extrinsic” fXase also activates fIX to fIXa as the reaction progresses. The “extrinsic” fXase also activates fIX to fIXa as the reaction progresses, with suppression of the quaternary complex occurring by TFPI. The “intrinsic” fXase complex is kinetically superior and ultimately produces the majority of fXa.

Since bleeding pathology is not ordinarily associated with defects of the initiation protein complexes of the contact pathway, most investigations conclude that the “extrinsic” pathway is not the primary provider for hemostasis. The “intrinsic” pathway, however, has been implicated in some forms of thrombosis. The primary (“extrinsic”) and accessory (“intrinsic”) pathways, initiated by independent routes, both lead to the activation of factor IX and converge at the “intrinsic” fXase complex (Fig. 18.1). Regardless of the path, the outcome is the formation of the prothrombinase complex and thrombin generation. Each reaction of the primary pathway of coagulation involves the vitamin K-dependent zymogens and serine proteases, cofactor proteins, and Ca^{2+} ions assembled on membranes. The complexes display reaction rates 10^5 to 10^9 times greater than the respective serine proteases alone.⁵

Clinical laboratory tests differentiate between the pathways. The activated partial thromboplastin time (aPTT) initiates coagulation through the accessory pathway, whereas the prothrombin time (PT) assay initiates coagulation through the primary pathway.^{26,27} and ²⁸ The designations of primary and accessory pathways are based on clinical evidence of bleeding diseases. Deficiencies of proteins associated with the “intrinsic” or accessory pathway (factor XII, prekallikrein, and HMWK) exist but are not associated with abnormal bleeding events, even after surgical challenge.^{29,30} and ³¹ However, deficiencies of the protein components of the “extrinsic” or primary pathway (prothrombin and factors V, VII, VIII, IX, and X) can lead to severe bleeding diatheses.^{16,32,33,34} and ³⁵ Factor XI deficiency may also result in bleeding episodes subsequent to trauma or surgery.^{20,36} The role of the accessory pathway is therefore not clearly understood. Factor XI appears to play a role in coagulation,^{21,37} most likely unrelated to its activity in the “intrinsic” pathway, with the contribution of factor XI to hemostasis thought to be due to its activation by α -thrombin. Factor XIa then functions in the propagation phase of α -thrombin generation in association with the primary pathway.^{7,22}

Factor XII, prekallikrein, and HMWK are required for activity of the contact or accessory pathway and deficiencies are reported by the aPTT. Factor XII and prekallikrein are zymogens that are activated to serine proteases, while HMWK is a cofactor. The accessory pathway factors are hypothesized to play a role in disseminated intravascular coagulation (DIC) associated with the systemic inflammatory response syndrome,^{38,39} and may also be involved in the promotion of thrombus stability.^{5,24,40,41} The accessory pathway may also be important in cardiopulmonary bypass because of contact between blood components and synthetic surfaces.³⁹

The importance of the membrane component in coagulation was initially identified by kinetic studies of the prothrombinase complex. In the absence of the membrane surface, the cofactor (factor Va)-enzyme (factor Xa) interaction is relatively weak, with a dissociation constant (K_d) of 800 nmol/L.^{42,43,44} The factor Va-lipid interaction ($K_d = 3$ nmol/L) and factor Xa-lipid interaction ($K_d = 110$ nmol/L)⁴⁵ show higher affinity. However, all of the components must be present to generate the high-affinity factor Va-factor Xa- Ca^{2+} membrane complex, with a K_d of 1 nmol/L.⁴⁶ The fully assembled complex is stabilized through factor Va-factor Xa, factor Va-lipid, and factor Xa-lipid interactions.^{14,47,48} Similar properties have been observed for the fIXa/fVIIIa, TF/fVIIa, and Tm/fIIa complexes.⁴²

The primary pathway of coagulation is initiated or triggered by the interaction of circulating factor VIIa with its cofactor tissue factor.^{49,50,51} In general, the serine proteases associated with hemostasis circulate in their zymogen or inactive forms; however, low levels of circulating factor VIIa are present in blood.⁵² This factor VIIa binds to tissue factor expressed by pathology and initiates the procoagulant response. Free factor VIIa is a poor enzyme with virtually no proteolytic activity, but as a consequence is protected from interacting with the circulating inhibitors in the absence of tissue factor. Tissue factor, an integral membrane protein not normally expressed on vascular cell surfaces, is constitutively expressed on extravascular cellular surfaces^{53,54,55,56,57,58} and thus becomes exposed upon damage to the endothelial cell layer. Tissue factor is also expressed on peripheral blood cells and endothelial cells stimulated by inflammatory cytokines.^{59,60}

Upon interaction of plasma factor VIIa and the injury/pathology presented, tissue factor, the “extrinsic” fXase complex (factor VIIIa-tissue factor) is formed and initiates coagulation by

activating factors IX and X. Factor IXa forms a complex with its cofactor, factor VIIIa, to generate the intrinsic “fXase” complex, and factor Xa combines with factor Va to form the prothrombinase complex. The factor VIIIa-factor IXa complex more efficiently activates factor X to factor Xa, providing a robust source of the enzyme component (factor Xa) of the prothrombinase complex.

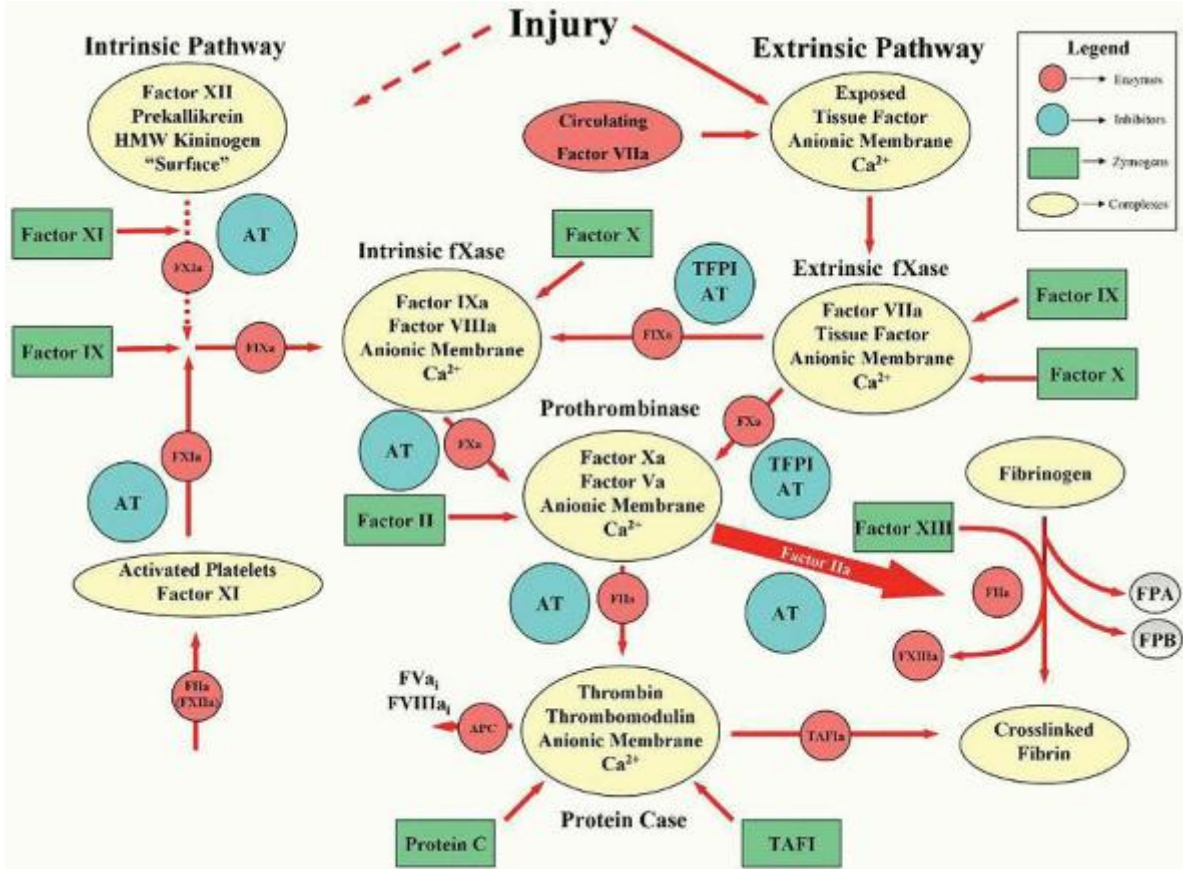

FIGURE 18.1. Overview of hemostasis. There are two pathways to initiate coagulation: the primary extrinsic pathway (shown on right) and the intrinsic (also called the contact pathway) (shown on left). The components of these multistep processes are illustrated as follows: enzymes (pink circles), inhibitors (blue circles), zymogens (green boxes), or complexes (cream ovals). The intrinsic pathway has no known bleeding etiology associated with it; thus, this path is considered accessory to hemostasis. On injury to the vessel wall, tissue factor, a membrane-bound cofactor, is exposed to circulating factor VIIa, forming the extrinsic fXase, a vitamin K-dependent complex. Factor IX and factor X are converted to the serine proteases factor IXa (FIXa) and factor Xa (FXa), which are the enzymatic components of the intrinsic fXase and the prothrombinase complexes, respectively. The combined actions of the intrinsic and extrinsic fXase and the prothrombinase complexes lead to an explosive burst of the enzyme thrombin (FIIa). In addition to its multiple procoagulant roles, thrombin also acts in an anticoagulant capacity when combined with the cofactor thrombomodulin in the protein Case complex. The product of the protein Case reaction, activated protein C (APC), inactivates the cofactors factors Va and VIIIa. The cleaved species, factors Va_i (FVa_i) and VIIIa_i (FVIIIa_i), no longer support the respective procoagulant activities of the prothrombinase and intrinsic fXase complexes. Once thrombin is generated through procoagulant mechanisms, thrombin cleaves fibrinogen (releasing fibrinopeptides A and B [FPA and FPB, respectively]) and activates factor XIII to form a cross-linked fibrin clot. Thrombin-thrombomodulin also activates thrombin-activatable fibrinolysis inhibitor (TAFI) that slows down fibrin degradation by plasmin. The procoagulant response is downregulated by the stoichiometric inhibitors tissue factor pathway inhibitor (TFPI) and antithrombin (AT). TFPI serves to attenuate the activity of the extrinsic fXase, the trigger of coagulation. AT directly inhibits thrombin, FIXa and FXa. The intrinsic pathway provides an alternate route for the generation of factor IXa. Thrombin has also been shown to activate factor XI. The fibrin clot is eventually degraded by plasmin, yielding soluble fibrin peptides (see Fig. 18.17). HMW, high molecular weight.

Deficiencies of the “intrinsic” fXase components factor VIIIa (hemophilia A) and factor IXa (hemophilia B) illustrate the significance of the factor IX activation by the fVIIa/TF complex and the enhanced rate of factor X activation by the intrinsic fXase and the inhibition of the extrinsic fXase by TFPI. Hemophilia A and B are detected using the aPTT. From inspection of Figure 18.1, it would appear activation of factor X by the “extrinsic” fXase should compensate for the lack of factor X activation by the “intrinsic” fXase in hemophilias A and B. However, this compensatory mechanism only occurs during clinical administration of supraphysiologic concentrations of recombinant factor VIIa during replacement therapy for hemophilia with inhibitors. The natural physiologic levels of factor VIIa are not able to provide sufficient levels of factor Xa to support normal coagulation. Factor Xa generation is suppressed to approximately one-half the level observed when factor X is the only substrate presented.^{61,62}

Factor IX, not factor X, appears to be the preferred substrate of the extrinsic fXase. In addition, factor IX α , the intermediate species in factor IX activation, is generated more rapidly in the presence of factor X. Factor IX α activation to the final product factor IXa occurs at a higher rate than factor IX activation, thereby providing a burst of factor IXa to form the intrinsic fXase complex. The low level of factor Xa generated by the tissue factor-factor VIIa complex most likely functions in the activation of factor IX. A model of extrinsic fXase behavior suggests

P.431

that factor IX is converted to factor IX α by the extrinsic fXase or factor Xa-phospholipid complex. Factor IX α is then rapidly converted to factor IXa by the extrinsic fXase.^{61,62} The factor VIIIa-factor IXa complex subsequently activates the major fraction of factor X to factor Xa and provides the enzyme component for the prothrombinase complex. Measurements of second-order rate constants for factor Xa generation by the intrinsic and extrinsic fXase complexes also support this model. The rate of factor Xa generation by the tissue factor-factor VIIa complex is 1/50th the rate of factor Xa generation by the factor VIIIa-factor IXa complex.^{61,62} and ⁶³ Both complexes thus have distinct roles in the procoagulant response.

In summary, the procoagulant response is triggered upon the interaction of factor VIIa with tissue factor, when the latter is exposed and/or expressed as a result of vascular perturbation. The extrinsic fXase generates low levels of factors IXa and Xa during the initiation phase of coagulation. Factor Xa-phospholipid complexes also assist in the activation of factor IX. Factor IXa combines with factor VIIIa on the membrane surface, and the intrinsic fXase accelerates factor Xa generation 50-fold over the extrinsic fXase. The burst of factor Xa overcomes circulating levels of factor Xa inhibitors and initiates maximal levels of prothrombinase complex activity. Prothrombinase activity subsequently leads to a burst of α -thrombin generation and propagation of the procoagulant response.^{61,62}

PROCOAGULANT PROTEINS: ACCESSORY PATHWAY FACTORS AND FACTOR XI

The procoagulant proteins that make up the intrinsic or accessory pathway consist of factor XII, plasma prekallikrein, HMWK, and factor XI. These proteins are responsible for the contact activation of blood coagulation. The physiologic role of the intrinsic pathway is not clearly understood, but does not appear to be essential for hemostasis because individuals deficient in factor XII, plasma prekallikrein, or HMWK do not manifest abnormal bleeding. Factor XI appears to play a more prominent role, unrelated to its activities in the intrinsic pathway, after activation by thrombin.^{7,37} Each of these proteins is described in terms of its gene structure and expression, biochemistry, activation, function, and regulation in regard to hemostasis.

Factor XII (Hageman Factor, Contact Factor)

Factor XII, or Hageman factor (HF), is the zymogen precursor of the serine protease factor XIIa. Factor XII is also known as contact factor for its role in the initiation of coagulation on contact with substances such as glass or kaolin. The contact pathway is the basis for the activated partial thromboplastin time clotting assay. Factor XII circulates in plasma at an average concentration of 40 $\mu\text{g/ml}$ (500 nmol/L)^{64,65} (Table 18.1). Increased levels of factor XII are seen in postmenopausal women using estrogen replacement therapy and during pregnancy. Animal studies also demonstrate enhanced expression of factor XII by estrogen and prolactin.^{66,67} and ⁶⁸ Since a deficiency of factor XII is not associated with any bleeding abnormality, its precise role in hemostasis is at present unknown. Studies show that mice lacking factor XII are protected against arterial thrombosis and stroke.^{40,41,69,70} This suggests that the intrinsic pathway of coagulation is essential for thrombus stability. The components of the contact pathway are also believed to provide a link between coagulation and inflammation,⁷¹ with the multifunctional cellular protein gC1q-R/p33 postulated to play a central bridging role between these two processes.⁷² Misfolded protein aggregates have been implicated in activating factor XII.⁷³

Gene Structure and Expression

Human factor XII is produced by a single gene located on chromosome 5 q33-qter^{74,75} (Table 18.2). The gene for factor XII spans approximately 12 kilobases (kb) and is composed of 13 introns and 14 exons.⁷⁶ The intron/exon gene structure is similar to the gene structures of tissue plasminogen activator (t-PA) and urokinase-type plasminogen activator (u-PA).⁷⁶ The promoter does not contain the CAAT or TATA sequences common in other genes, but it does contain two LF-A1 transcription elements characteristic of genes with liver-specific expression. The promoter also contains one estrogen-responsive element.^{76,77}

Biochemistry

Human factor XII is synthesized as a precursor protein with a 19-residue signal peptide. The mature factor XII molecule is a 596-amino acid single-chain β -globulin with a molecular weight of approximately 80 kDa.^{78,79,80,81,82} It circulates at a concentration of 40 $\mu\text{g/ml}$ (500 nmol/L) with a half-life ($t_{1/2}$) of 2 to 3 days (Table 18.1). The factor XII molecule is composed of two domains: an NH₂-terminal heavy chain and a COOH-terminal light chain. The heavy chain contains several domain structures: fibronectin type I and type II domains, two epidermal growth factor (EGF)-like domains, a kringle domain, and a proline-rich region (residues 277 to 330) (Fig. 18.2). The light chain contains the serine protease catalytic domain, a region homologous to the B-chain of the enzyme plasmin. The mature factor XII molecule contains approximately 17% carbohydrate. Glycosylation consists of an O-linked fucose at Thr⁹⁰ in the first EGF domain⁸³; N-linked carbohydrates at Asn²³⁰ and Asn⁴¹⁴ in the kringle and catalytic domains, respectively; and six O-linked carbohydrates in the proline-rich region.⁸⁴ The factor XII molecule also contains four zinc ion (Zn²⁺)-binding sites.⁸⁵ Zn²⁺ binding to factor XII likely induces a conformation change that promotes activation of factor XII associated with negatively charged surfaces.^{86,87} and ⁸⁸

Activation

Factor XII undergoes autoactivation on interaction with negatively charged surfaces such as glass, kaolin, dextran sulfate, ellagic acid, celite, or bismuth subgallate,^{89,90,91,92,93,94,95,96,97,98} and ⁹⁹ and on interaction with hydrophobic surfaces.¹⁰⁰ This is likely only an in vitro event triggered by the artificial surfaces used in studies of the contact pathway, although research is ongoing. Although factor XII associates with many physiologically relevant anionic surfaces, including negatively charged phospholipids,^{101,102,103} and ^{104,105,106,107,108,109,110,111,112} and ¹¹³ the autoactivation of factor XII induced by these surfaces in vitro does not appear to represent the mechanism for factor XII activation in vivo.¹¹⁴ Instead, factor XII is most likely activated by a cell membrane-associated proteinase.^{115,116} When factor XII, prekallikrein, and HMWK form a complex on anionic phospholipids of the cell membrane, prekallikrein is cleaved, forming the enzyme kallikrein. Kallikrein then activates factor XII (plasmin activates factor XII as well) via a single cleavage at Arg³⁵³-Val³⁵⁴ to generate an 80-kDa two-chain enzyme, α -factor XIIa (factor XIIa, α -HFa, or HFa), composed of an NH₂-terminal heavy chain (relative molecular weight [M_r] = 52,000) and a COOH-terminal light chain (M_r = 28,000) held together by a disulfide bond (Cys³⁴⁰-Cys⁴⁶⁷) (Fig. 18.2). This cleavage is essential for exposure of the active site in factor XIIa.¹¹⁷ Factor XIIa can then bind negatively charged surfaces and activate factor XI and prekallikrein.^{118,119} Two secondary cleavages can also occur on factor XII: one outside the disulfide bond (Arg³³⁴-Asn³³⁵) and one inside the disulfide loop (Arg³⁴³-Leu³⁴⁴), generating β -factor XIIa (FXII_f, HF_f).^{120,121,122} and ¹²³ β -Factor XIIa has no surface-binding capabilities but is able to activate prekallikrein.^{89,124,125}

P.432

TABLE 18.1 BIOCHEMICAL PROPERTIES OF BLOOD COAGULATION PROTEINS

Protein	Molecular Weight (Da)	Plasma Concentration		Carbohydrate (%)	Clinical Phenotype ^a		Functional Classification
		nmol/L	$\mu\text{g/ml}$		H	T	
Intrinsic pathway proteins							
Factor XII	80,000	500	40		2-317	-	
Prekallikrein	85/88,000	486	42		15		

High-molecular-weight kininogen	120,000	670	80		42	-
Low-molecular-weight kininogen	66,000	1,300	90		30	
Factor XI	160,000	30	5	2.5-3.3	5	±
Extrinsic pathway proteins						
Tissue factor	44,000					
Factor VII	50,000	100.5		0.25	13	+ ±
Factor VIIa	50,000		0.1	13		
Factor X	59,000	170	10	1.5	15	+
Factor Xa	48,000				3	
Factor IX	55,000	90	5	1	17	+
Factor IXa	45,000					
Factor V	330,000	20	6.6	0.5	13-25	+
B region	150,000				50	
Factor Va	180,000				8	
Factor VIII	280,000	0.7	0.2	0.3-0.5		+
Factor VIIIa	170,000					
von Willebrand factor	255,000 (monomer)	varies	10		10-15	
Prothrombin	72,000	1,400	100	2.5	8	+
α-Thrombin	37,000				5	
Fibrinogen	340,000	7,400	2,500		3-53	+ ±
Aα	66,500					
Bβ	52,000					
γ	46,500					
Factor XIII	320,000	93	30		9-10	+
A-chain	83,200					
B-chain	79,700				5	

+, presence of phenotype; -, absence of phenotype; ±, some individuals present with the phenotype and others do not; H, hemorrhagic disease/hemophilia; T, thrombotic disease/thrombophilia.

^aClinical phenotype: the expression of either H or T phenotype in deficient individuals.

Function

Factor XIIa is a serine protease that activates factor XI and prekallikrein by mechanisms dependent on anionic surfaces and the cofactor HMWK.^{118,126} Factor XIIa also activates the C1 component of the complement system.¹²⁷ In addition, factor XIIa downregulates the Fc receptor on monocytes and macrophages,¹²⁸ induces release of interleukin (IL)-1 and IL-6 from monocytes and macrophages,¹²⁹ and stimulates neutrophils.¹³⁰ Although these roles have no apparent impact on normal coagulation, factor XII/XIIa may be an important link between coagulation and inflammation (for review, see Ref. 131). Factor XIIa also activates plasminogen to plasmin, linking the contact pathway to fibrinolysis.¹³²

Regulation

C1 inhibitor is the major inhibitor of both factor XIIa and β-factor XIIa and irreversibly inhibits both enzymes.^{133,134,135} and ¹³⁶ Antithrombin and plasminogen activator inhibitor (PAI)-1 also inhibit factor XIIa.^{137,138} and ¹³⁹ Endothelial cells and eosinophils are reported to produce proteins that inhibit factor XII activation but not factor XIIa activity.^{140,141} and ¹⁴² Amyloid precursor protein likewise is reported to inhibit factor XII activation but not factor XIIa.¹⁴³

Plasma Prekallikrein (Fletcher Factor)

Plasma prekallikrein, or Fletcher factor, is the zymogen form of the enzyme kallikrein. Prekallikrein circulates in plasma at an average concentration of 42 µg/ml (486 nmol/L)^{144,145} (Table 18.1). Approximately 75% circulates in a noncovalent complex with HMWK,^{146,147} and the remaining 25% circulates as free prekallikrein. Like factor XII, prekallikrein is a component of the intrinsic or accessory pathway and serves as a link between coagulation and inflammation. Prekallikrein is also linked to fibrinolytic events. Plasma prekallikrein deficiency is rare and is not associated with

P.433

hemostatic defects except perhaps in deficient individuals with other cardiovascular risk factors.^{148,149}

TABLE 18.2 MOLECULAR GENETICS OF BLOOD COAGULATION PROTEINS

Protein	Molecular Weight (Da)	Gene Location: Chromosome	Gene Size (kb)	Gene Organization: No. of Exons	Messenger RNA Size (kb)	UNIPROT Accession Number^a
Intrinsic pathway proteins						
Factor XII		80,0005q33-qter	12		142.4	P00748
Prekallikrein		85/88,0004q34-35	30		152.4	P03952
High-molecular-weight kininogen		120,0003q26-qter	27		113.5	P01042
Low-molecular-weight kininogen		66,0003q26-qter				P01042
Factor XI		160,0004q35	23		152.1	P03951
Factor XII		80,0005q33-qter	12		142.4	P00748
Extrinsic pathway proteins						
Tissue factor		44,0001p21-22	12.4		62.3	P13726
Factor VII		50,00013q34-qter	12.8		92.5	P08709
Factor VIIa		50,000				
Factor X		59,00013q34-qter	27		81.5	P00742

Factor Xa	48,000				
Factor IX	55,000	Xq26.3-q27.1	33	82.8	P00740
Factor IXa	45,000				
Factor V	330,000	1q21-q25	80	256.8	P12259
B region	150,000				
Factor Va	180,000				
Factor VIII	280,000	Xq28	186	269.0	P00451
Factor VIIIa	170,000				
von Willebrand factor	255,000 (monomer)	12p-12pter	178	528.8	P04275
Prothrombin	72,000	1p11-q12	21	142	P00734
α -Thrombin	37,000				
Fibrinogen	340,000	4q23-q32	50		
A α	66,500		5.4	62.2	P02671
B β	52,000		8	81.9	P02675
γ	46,500		8.5	101.6	P02679
Factor XIII	320,000				
A-chain	83,200	6p24-p25	160	153.8	P00488
B-chain	79,700	1q31-q32.1	28	122.3	P05160

^a <http://www.uniprot.org>.

Gene Structure and Expression

The human prekallikrein gene is located on chromosome 4q34-35, close to the factor XI gene¹⁵⁰ (Table 18.2). The human plasma prekallikrein gene spans 30 kb and contains 15 exons and 14 introns.¹⁵¹ A total of 12 allelic variants have been identified in the 5' proximal promoter and in 7 of the exons. A common polymorphism (30% of the population) leads to an Asn124Ser replacement in the heavy chain of the apple 2 domain of prekallikrein. Two other polymorphisms in the coding region of the protein, His189Pro in the apple 3 domain of the heavy chain and His183Gln, were identified.¹⁵¹ Prekallikrein and factor XI are highly homologous, and both human and rat factor XI prekallikrein genes are located on chromosome 4, suggesting a gene duplication event from a common ancestor.¹⁵² Prekallikrein mRNA has been detected in human kidney, adrenal gland, placenta, and brain, but the liver is considered to be the major site of synthesis.^{153,154} and ¹⁵⁵

Biochemistry

Human plasma prekallikrein is synthesized as a precursor with a 19-amino acid signal peptide. The mature form of the protein, appearing as a doublet of 85 and 88 kDa when analyzed by sodium dodecyl sulfate-polyacrylamide gel electrophoresis (SDS-PAGE), is a single-chain fast γ -globulin of 619 amino acids (Table 18.1).^{132,156,157} Prekallikrein contains 15% carbohydrate with five N-linked sugar moieties.¹⁵³ Structurally, prekallikrein contains four tandem repeats, called apple domains, in the NH₂-terminal portion of the molecule (Fig. 18.2). Each apple domain consists of 90 to 91 amino acid residues including six to eight cysteines that are disulfide bonded to form the distinct domain structure.^{153,158} The apple 1 and apple 4 domains mediate the binding of prekallikrein to HMWK.^{159,160} The apple domains of prekallikrein are highly homologous to the apple domains of factor XI. Apple domains have been found only in these two proteins, lending support to a gene duplication event from a common ancestor.^{150,158} The COOH-terminal region of prekallikrein contains the catalytic site.

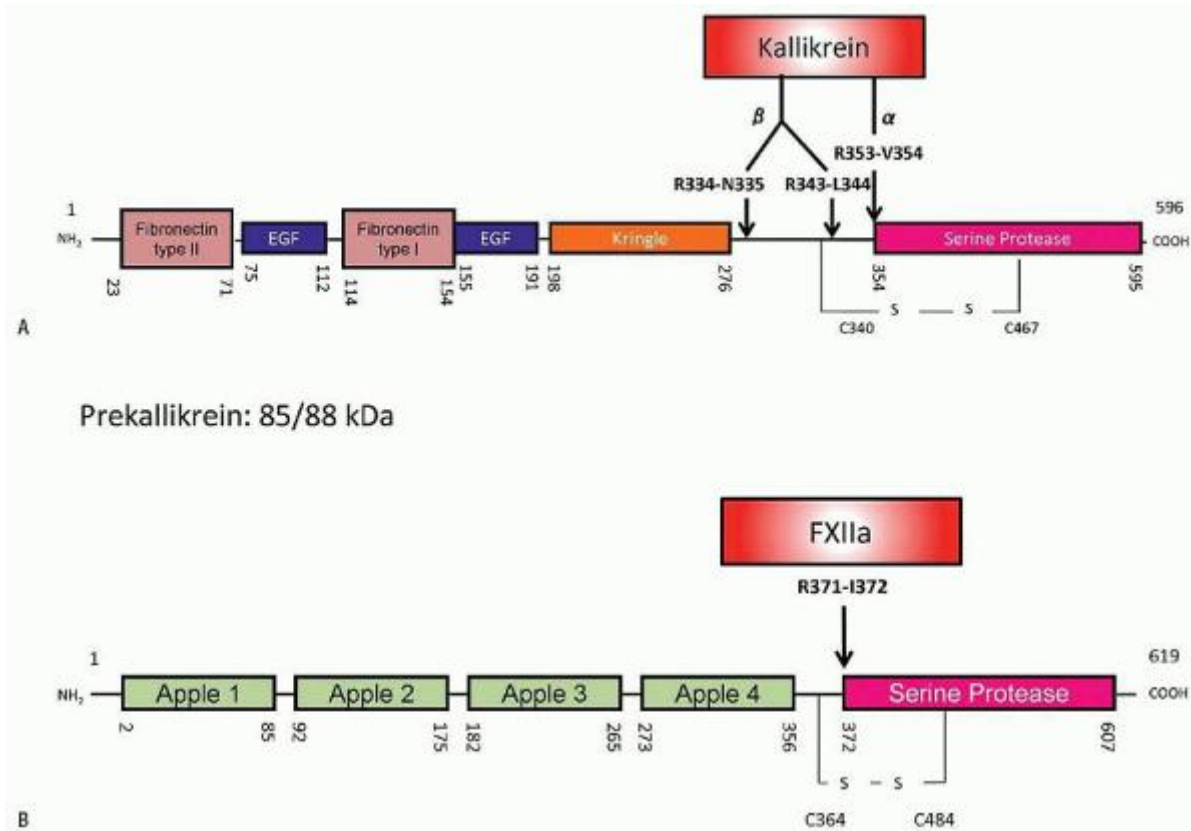

FIGURE 18.2. Schematic representation of the intrinsic pathway (contact) proteins. Factor XII (FXII), prekallikrein (PK), high-molecular-weight (HMW) kininogen, low-molecular-weight (LMW) kininogen, and factor XI (FXI) are shown with their various domains depicted as blocks. Activating proteases are placed in a box above the cleavage sites with the specific amino acid residues of the site shown directly underneath. Key interchain disulfide bonds (S-S) are included. For the kininogens, horizontal arrows indicate the amino acid residues defining heavy and light chain regions of the activated forms of the cofactors. Factor XI is illustrated as a monomer. EGF, epidermal growth factor.

Activation

Prekallikrein is activated by factor XIIa in complex with the cofactor HMWK on an anionic surface (Fig. 18.2). Prekallikrein is also activated by β -factor XII in the absence of a surface.¹⁶¹ The factor XIIa-HMWK complex or β -factor XII catalyzes the cleavage of the Arg³⁷¹-Ile³⁷² bond in prekallikrein. This cleavage is also reported to occur in the absence of factor XIIa when prekallikrein is bound to HMWK on the endothelial cell surface.^{115,162} The enzyme kallikrein is a two-chain molecule composed of an NH₂-terminal heavy chain ($M_r = 53,000$) containing the four apple domains and a COOH-terminal light chain ($M_r = 36,000$ or $33,000$) containing the active site.^{132,153,163,164}

Function

Kallikrein is a member of the trypsin family of serine proteases. In the presence of an appropriate anionic surface and the cofactor HMWK, kallikrein activates factor XII to factor XIIa and proteolyzes factor XIIa to β -factor XIIa. Kallikrein also undergoes autoproteolysis at Lys¹⁴⁰-Ala¹⁴¹ to yield β -kallikrein.^{165,166} Enzyme activity is significantly reduced on conversion of kallikrein to β -kallikrein.¹⁶⁴ Kallikrein cleaves HMWK at two sites to generate the vasoactive nonapeptide bradykinin.^{167,168} Bradykinin is a potent vasodilator and stimulates endothelial cell prostacyclin synthesis, resulting in hypotension.^{169,170} Kallikrein is also an activator of fibrinolytic zymogens and converts both plasminogen to plasmin and pro-u-PA to u-PA.^{132,171,172} In addition, kallikrein has been reported to activate neutrophils and stimulate elastase release as part of the hemostatic and inflammatory responses.¹⁷³

Regulation

C1 inhibitor and α_2 -macroglobulin are the major inhibitors of kallikrein.^{174,175} C1 inhibitor forms a 1:1 stoichiometric complex with kallikrein and abolishes its proteolytic and amidolytic activities.^{175,176,177} and ¹⁷⁸ α_2 -Macroglobulin inhibits the ability of kallikrein to generate bradykinin and partially inhibits amidolytic activity.¹⁷⁶ C1 inhibitor and α_2 -macroglobulin each inhibit equivalent amounts

P.435

of kallikrein in plasma, but C1 inhibitor acts much more rapidly and plays the major role in reducing kallikrein activity.¹⁷⁹ Antithrombin and antithrombin-heparin are slow inhibitors of kallikrein although the antithrombin-heparin-HMWK complex is an effective inhibitor.^{180,181} and ¹⁸² Protein C inhibitor also inhibits kallikrein.^{183,184} and ¹⁸⁵

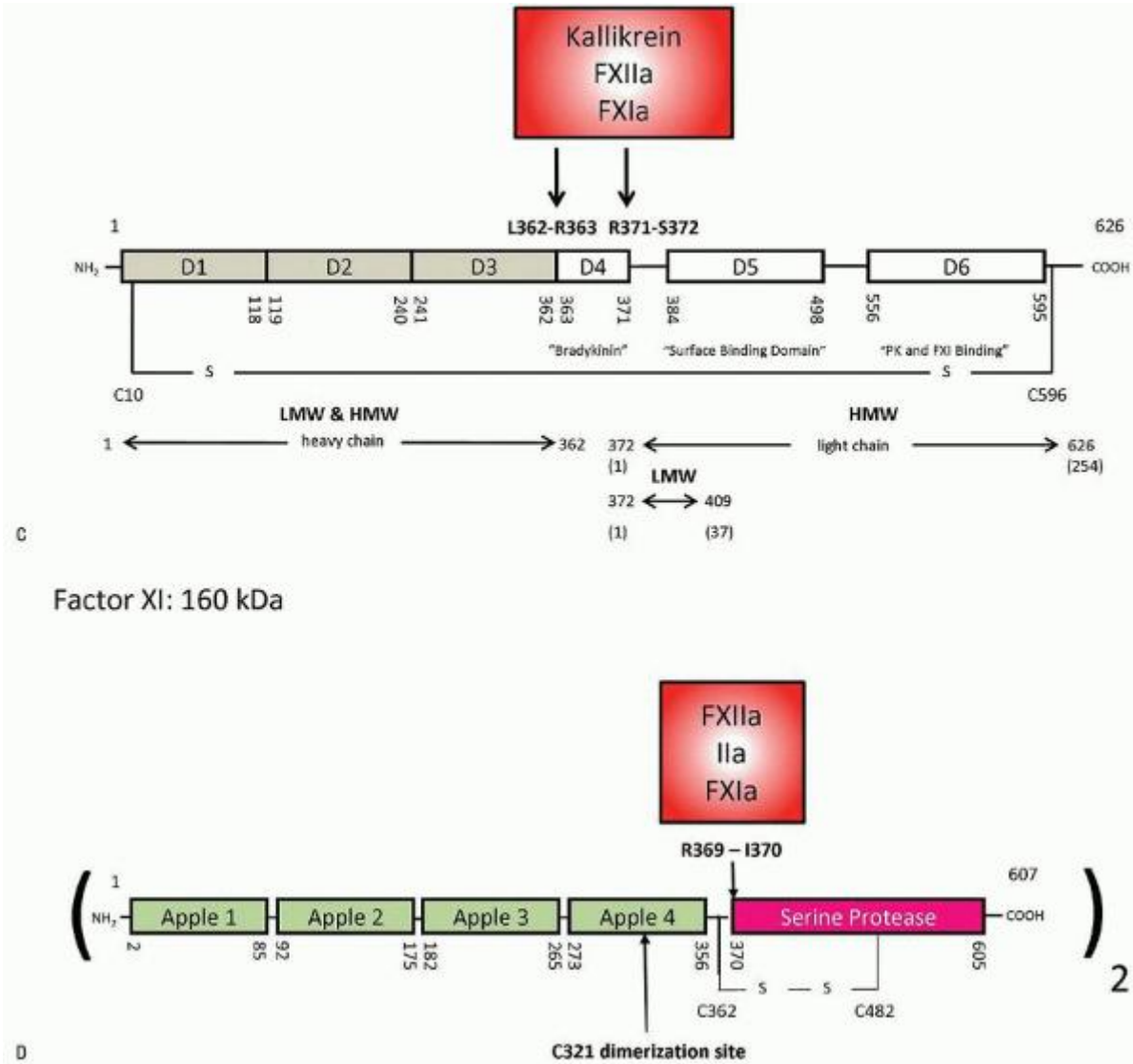

FIGURE 18.2. (continued)

FIGURE 18.2. (continued)

High-Molecular-Weight Kininogen (Fitzgerald Factor, Williams Factor)

HMWK, also known as Fitzgerald factor or Williams factor, circulates in plasma at an average concentration of 80 $\mu\text{g/ml}$ (670 nmol/L)^{186,187} (Table 18.1). HMWK acts as a cofactor for the activation of factor XII and prekallikrein and is the precursor of the vasoactive peptide bradykinin. A second form of kininogen, low-molecular-weight kininogen (LMWK), is also found in plasma. LMWK can be cleaved to yield bradykinin but has no procoagulant activity. LMWK circulates at an average concentration of 90 $\mu\text{g/ml}$ (1,300 nmol/L).¹⁸⁸ Deficiencies of HMWKs and LMWKs are rare and are not associated

with bleeding diatheses.¹⁸⁹ The major established function of the kininogens is to serve as a source of bradykinin and thereby to contribute to a number of vascular events regulated by bradykinin.¹⁹⁰

P.436

Gene Structure and Expression

The two forms of kininogen, HMWK and LMWK, are the products of a single gene^{191,192} located on chromosome 3q26-qter¹⁹³ (Table 18.2). The kininogen gene consists of 10 introns and 11 exons and spans 27 kb.¹⁹² The gene produces messenger RNAs (mRNAs) for the two different forms of kininogen by alternative splicing.¹⁹² HMWK and LMWK share the coding region of the first nine exons and the portion of exon 10 containing the bradykinin sequence and the first 12 amino acids following the COOH-terminal of bradykinin. Exon 10 also codes for a 56-kDa light chain unique to HMWK, whereas exon 11 codes for a 4-kDa light chain unique to LMWK. Human liver contains mRNAs for both HMWK and LMWK^{191,192}; only HMWK is expressed and secreted by human umbilical vein endothelial cells.¹⁹⁴ Estrogen administration¹⁹⁵ and pregnancy¹⁹⁶ increase HMWK levels. Conversely, progesterone treatment reduces kininogen gene expression and plasma kininogen levels.¹⁹⁷

Biochemistry

Human HMWKs and LMWKs are synthesized as precursor proteins containing 18 amino acid signal peptides. The mature form of HMWK is a 120-kDa single-chain α -globulin of 626 residues, whereas the LMWK form is a 66-kDa single-chain β -globulin composed of 409 residues.^{187,188,197} Glycosylation at a number of shared sites (Asn¹⁵¹, Asn¹⁸⁷, Asn²⁷⁶, and Asn³⁸³) and sites unique to HMWK (Thr⁵¹⁵, Thr⁵²¹, Thr⁵²⁸, Thr⁵³⁹, Thr⁵⁵³, Thr⁵⁵⁹, Thr⁵⁷⁵, and Thr⁶¹⁰) presumably accounts for the substantial increase over the masses predicted from the amino acid compositions (70,000 for HMWK and 46,000 for LMWK). The NH₂-terminal heavy chains (residues 1 to 362) of the two forms are identical and consist of three consecutive regions designated domains 1, 2, and 3 (D1, D2, and D3) (Fig. 18.2). Domain 1 has a low-affinity Ca²⁺-binding site.¹⁹⁸ Domains 2 and 3 share homology with cysteine protease inhibitors.¹⁹⁹ Both HMWK and LMWK are potent inhibitors of cysteine proteases such as calpain.^{200,201} Domain 3 also contains a cell-binding region^{202,203,204,205} and²⁰⁶ and is reported to inhibit α -thrombin activity^{203,205,207} and platelet activation.^{205,207,208} The central domain of both kininogens, domain 4 (D4), is the bradykinin region. Domain 4 also contains a cell-binding region²⁰⁹ and a region that inhibits α -thrombin activity.²¹⁰ The two forms of kininogen have different COOH-terminal light-chain regions. The light chain of LMWK (residues 372 to 409) consists of a single domain, domain 5_L (D5_L), with no known function. The light chain of HMWK (residues 372 to 626) is composed of two regions, domain 5_H (D5_H) and domain 6_H (D6_H). Domain 5_H contains additional cell-binding regions^{202,203,206,211,212} and mediates HMWK binding to anionic surfaces, heparin, and Zn²⁺.^{180,181,213,214} Domain 6_H has binding sites for prekallikrein and factor XI.^{215,216} and²¹⁷

Activation

Kallikrein, factor XIIa, and factor XIa cleave HMWK to release bradykinin (residues 363 to 371) (Fig. 18.2). Kallikrein also cleaves LMWK to release bradykinin. Bradykinin release from HMWK yields a two-chain protein composed of the heavy-chain (D1, D2, and D3) disulfide linked (Cys¹⁰-Cys⁵⁹⁶) to the light chain (D5_H and D6_H). This molecule retains procoagulant activity, binding to prekallikrein, factor XI, and anionic surfaces via light-chain interactions^{215,218,219} and induces apoptosis in endothelial cells.²²⁰

Function

The major role proposed for the kininogens is as a source of bradykinin. Bradykinin release provides a key vasoactive agent with a variety of roles and directly links the contact pathway to vascular repair processes. HMWK also functions as a nonenzymatic cofactor in the contact pathway of coagulation. HMWK binds anionic surfaces, prekallikrein, and factor XI, thus enhancing their activation by surface-associated factor XIIa. Although most studies of contact activation make use of artificial surfaces, cell membranes may provide appropriate sites for contact activation in vivo. Many cells contain kininogens and express kininogenbinding sites.^{187,194,221,222,223,224,225} and²²⁶ There is some evidence to support cell membrane-associated contact activation. Prekallikrein bound to HMWK on platelets or endothelial cells can result in the generation of kallikrein by a factor XIIa-dependent^{115,172} or -independent mechanism.¹¹⁵ However, factor XI bound to HMWK on the surface of platelets is not activated to factor XIa.²²⁷ HMWK and its cleaved form exert anticoagulant effects via their inhibitory action on platelet adhesion²²⁸ and aggregation.²²⁹

Factor XI (Plasma Thromboplastin Antecedent)

Factor XI, also known as plasma thromboplastin antecedent, circulates as a homodimer at an average concentration of 5 µg/ml (30 nmol/L)²³⁰ in complex with HMWK²³¹ (Table 18.1). Factor XI is also found in human platelets, and the platelet form accounts for approximately 0.5% of the factor XI antigen in blood.^{232,233,234,235} and ²³⁶ Factor XI is the zymogen precursor of the enzyme factor XIa. Unlike the other members of the accessory or contact pathway, factor XIa has an established role in coagulation as part of a positive feedback loop enhancing α-thrombin generation.^{7,16} Although rare in the general population (~1 in 100,000 individuals),²³⁷ factor XI deficiency is common in the Ashkenazi (European) Jewish population, with approximately 1 in 200 individuals affected by factor XI deficiency.^{238,239,240,241} and ²⁴² Factor XI deficiency can be associated with severe bleeding tendencies²⁴³ after injury or surgical trauma. Spontaneous hemorrhage is not common. Factor XI deficiency is unusual in that bleeding abnormalities vary considerably and range from a complete absence of symptoms to life-threatening hemorrhage.²⁴⁴ The severity of the bleeding complications is also not related to the severity of factor XI deficiency. Individuals with mild deficiency may experience severe hemorrhagic events, whereas individuals with severe deficiency may have no abnormal bleeding.^{238,240,242,245,246,247,248} and ²⁴⁹

Gene Structure and Expression

The gene for human factor XI is located on chromosome 4q35 and spans 23 kb (Table 18.2). The gene contains 14 introns and 15 exons.^{156,250} Although mRNA for human plasma factor XI has been found in liver, pancreas, and kidney,²⁵¹ evidence suggests that the primary site of synthesis is the liver: Plasma factor XI levels decrease in liver disease, and a patient with no history of factor XI deficiency developed a deficiency subsequent to a liver transplant from a factor XI-deficient donor.²⁵² Platelet factor XI is exclusively synthesized in the megakaryocyte.²⁵³ Human platelet factor XI lacks exon 5 and may be an alternative splicing product of the plasma factor XI gene or a product of a gene specific to megakaryocytes.²⁵³

There are three major types of genetic mutations associated with factor XI deficiency: (a) intronic point mutations that interrupt exon splicing^{240,254}; (b) exonic point mutations that lead to mutations in specific amino acids and result in premature polypeptide termination, disruption of dimerization, or reduced protein secretion^{240,254,255,256,257} and ²⁵⁸; and (c) nucleotide deletions that lead to decreased protein synthesis.^{259,260} Two specific exonic point mutations account for the majority of the cases of factor XI deficiency in the Ashkenazi Jewish population. An E117X mutation in exon 5 (type II mutation) introduces a stop codon and results in premature polypeptide termination. The type II mutation accounts for approximately 52% of the cases of factor XI deficiency in the Ashkenazi Jewish population. An F283L mutation in exon 9 (type III mutation) that accounts for 36% of the cases is believed to prevent intracellular dimer formation and protein secretion. These

P.437

mutations are less frequent in the general population.^{239,240,254,258} Approximately 150 mutations have been identified in the factor XI gene with four exhibiting founder effects in specific populations.²⁶¹

Biochemistry

Human factor XI is found in plasma and in platelets. The two forms of the protein are somewhat different and may have different functions as well. Plasma factor XI accounts for most of the factor XI antigen in the human system and is a disulfide-linked homodimer ($M_r = 160,000$), with approximately 5% of its mass made up by carbohydrate (Table 18.1). Each of the two identical polypeptide chains is synthesized with an 18-amino acid signal peptide. The mature polypeptide chain ($M_r = 80,000$) consists of 607 amino acid residues^{232,233} and ²³⁴ and has five potential glycosylation sites, although only Asn⁷², Asn¹⁰⁸, Asn⁴³², and Asn⁴⁷³ are glycosylated.²⁶² Exons 3 to 10 of the plasma factor XI gene encode four NH₂-terminal tandem sequences termed apple domains (apple 1 to apple 4, Fig. 18.2). The apple domains are homologous to the apple domains in human plasma prekallikrein.²⁶² Exons 11 to 15 encode the COOH-terminal catalytic domain. Human platelet factor XI lacks exon 5 and amino acids Ala⁹¹-Arg¹⁴⁴ in the NH₂-terminus of the apple 2 domain. The mature platelet polypeptide chain ($M_r = 55,000$) may form a disulfide-linked tetramer of identical subunits ($M_r = 220,000$) or may be disulfide linked to a platelet plasma membrane protein.^{233,246,253} Plasma factor XI circulates in complex with HMWK.²³¹ Formation of this complex, mediated by the apple 1 domain of factor XI, is required for factor XI to associate with anionic surfaces.²⁶³ The apple 1 domain also contains binding sites for α-thrombin²⁶⁴ and prothrombin.²⁴⁹ The apple 2, apple 3, or both domains mediate the binding of factor IX, the substrate of factor XIa.^{249,265,266,267} and ²⁶⁸ In addition to potentially mediating the factor XIa-factor IX interaction, the apple 3 domain contains binding sites for platelets and heparin.^{269,270} and ²⁷¹ The apple 4 domain contains the site (Cys³²¹) involved in the dimerization process. Dimerization is required for efficient intracellular processing and protein secretion.²⁵⁵ Factor XIa associates with a region of the apple 4 domain as well.²⁷² Polyphosphates have also been proposed as a natural cofactor for factor XI activation in plasma.^{273,274}

Activation

Plasma factor XI is cleaved at an internal Arg³⁶⁹-Ile³⁷⁰ bond to yield a disulfide-linked two-chain activated serine protease (Fig. 18.2). The factor XI homodimer yields two disulfide-linked heavy chains containing the apple domains and two light chains containing the active sites.^{275,276} and ²⁷⁷ Activation of factor XI can be accomplished by factor XIIa and α -thrombin and by autoactivation by factor XIa itself. Activation of factor XI by factor XIIa requires HMWK and an anionic surface. However, deficiencies of factor XII and HMWK do not result in bleeding diatheses, whereas factor XI deficiency is associated with hemorrhage. This suggests that factor XIIa-dependent activation of factor XI, a part of the contact pathway, is not likely to be the primary route of factor XIa generation in hemostasis. The physiologically relevant pathway for factor XI activation in coagulation is believed to involve α -thrombin.^{7,16,278} Factor XI in complex with HMWK binds to the platelet surface via the apple 3 domain.²⁶⁹ The rate of α -thrombin activation of factor XI on the platelet surface is greater than the rates of platelet-supported factor XIIa activation and factor XIa autoactivation.²⁷⁹ Although platelets appear to play a key role in providing the surface for factor XI activation, the precise mechanism of activation of platelet factor XI and its function remain unclear.²⁸⁰

Function

Subsequent to activation, factor XIa remains bound to the surface. Factor XIa is a trypsin-like serine protease that cleaves and activates factor IX in a Ca²⁺-dependent fashion.^{281,282} and ²⁸³ Factor IXa is the enzyme component of the intrinsic tenase complex that provides the burst of factor Xa necessary for normal coagulation. As part of a positive feedback loop, α -thrombin activates factor XI. In turn, factor XIa generates factor IXa, contributing to the high levels of factor Xa that ensure efficient α -thrombin generation.⁷ Factor XI as an antithrombotic target is being explored.^{284,285}

Regulation

Factor XIa is regulated by four serine protease inhibitors or serpins: antithrombin, α_1 -protease inhibitor, C1 inhibitor, and α_2 -antiplasmin.^{133,276,286,287,288,289,290,291,292,293,294,295} and ²⁹⁶ Factor XIa is also reported to be inhibited by PAI-1 and protein C inhibitor.^{139,297} In addition, platelets secrete several factor XIa inhibitors,^{298,299,300,301,302} including protease nexin-2 (PN2). PN2 is a truncated form of the Alzheimer's β -amyloid protein precursor and contains a Kunitztype serine protease inhibitor domain. Platelet-bound factor XIa is protected from inactivation by PN2²⁸¹; however, heparin enhances PN2 inactivation of factor XIa. Factor XIa bound to the surface of endothelial cells that secrete heparan sulfate glycosaminoglycans (GAGs) may be readily inactivated by PN2.³⁰³

PROCOAGULANT PROTEINS: VITAMIN K-DEPENDENT PROTEIN FAMILY

The first identification/description of vitamin K-dependent pro-teins was introduced by Henrik Dam et al. at the University of Copenhagen in the late 1920s.^{304,305} and ³⁰⁶ They demonstrated that chickens fed a lipid-free diet exhibited a hemorrhagic condition. The addition of alfalfa meal or a lipid extract of alfalfa prevented this condition. The active compound, 2-methyl-3-phytyl-1, 4-naphthoquinone (phyloquinone), was subsequently isolated from green plants. Further work performed by Doisy et al.³⁰⁷ in the 1930s showed that vitamin K activity in bacteria is also present as a series of menaquinones, 2-methyl-1,4-naphthoquinones substituted at the 3 position with an unsaturated polyisoprenoid chain. The Nobel Prize was awarded to Dam and Doisy in 1941 for their discovery of the fat-soluble vitamin K.

Simultaneously with the discovery of the vitamin, a naturally occurring antagonist, bishydroxycoumarin (dicumarol), was described. This naturally occurring vitamin K antagonist was identified as a toxic agent in spoiled sweet clover causing hemorrhage in cattle. The increase in clotting time was later identified as a function of decreased prothrombin time.³⁰⁸ This led to the synthesis of several oral anticoagulant analogs and coumarin derivatives, including warfarin.

Vitamin K is essential in the biosynthesis of functional clotting factors. It is the required cofactor for the enzyme catalyzing the conversion of 9 to 13 NH₂-terminal glutamic acid residues to γ -carboxy glutamic acid residues (Gla). The enzyme required for this conversion uses a reduced form of vitamin K.

This specific posttranslational modification allows the vitamin K-dependent proteins to interact with Ca²⁺ and a membrane surface to exert their effect. The modification was initially identified and characterized in bovine prothrombin.^{309,310,311} and ³¹² Gla residues were missing or present in decreased amounts in prothrombin isolated from cattle treated with coumarin derivatives. The vitamin K-dependent proteins present in plasma after treatment with anticoagulants lacked biologic activity due to decreased Ca²⁺-dependent phospholipid binding. Therefore, preventing the formation of Gla residues became a basis for anticoagulant therapy.

Recently, two cDNAs were identified that encode proteins with NH₂-terminal Gla domains.³¹³ Both appear to be integral membrane proteins but bear no other similarity to the vitamin K-dependent proteins beyond the Gla domain. Mineralized tissues

contain two proteins with Gla residues.³¹⁴ Gla has also been found as a component of the toxin peptides from the marine snail *Conus*.^{315,316} and³¹⁷ The biologic activity of the toxins has been found to depend on the Gla residue(s). The identification of Gla in invertebrates suggests that vitamin K has a much wider range of biologic functions than previously thought. Gas 6 is a novel member of the vitamin K-dependent family of proteins, and when bound to the receptor tyrosine kinase Axl has been shown to mediate cell survival. γ -Carboxylation of Gas 6 is necessary for its function.³¹⁸

The vitamin K-dependent proteins can be divided into two classes: procoagulant (factors II, VII, IX, and X; Fig. 18.3A) and anticoagulant (protein C, protein S, and protein Z; Fig. 18.3B). The vitamin K-dependent proteins are part of a family of serine proteinases (except for protein S and protein Z) related to the trypsin/chymotrypsin superfamily. Sequence homology exists between the proteins at both the gene and the protein level, possibly due to a common ancestral gene.^{319,320} Congenital deficiencies of factors II, VII, IX, and X are associated with bleeding tendencies, whereas protein C and protein S deficiencies are associated with thrombotic tendencies. These proteins are composed of separate domains, each of which is characterized by highly conserved regions that fold, independently from the rest of the molecule, into a characteristic three-dimensional shape. The domains of the vitamin K-dependent proteins are illustrated in Figure 18.3. NH₂-terminal Gla domains (containing from 9 to 13 Gla residues) are followed by either a kringle domain in factor II or an EGF-like domain (EGF) in factor VII, factor IX, factor X, protein C, protein S, and protein Z. Protein S contains a thrombin-sensitive region before the EGF domain. The active site is contained within the serine protease domain for factor II, factor VII, factor IX, factor X, and protein C and becomes functional on specific peptide bond cleavages. Protein S is not a serine protease precursor and instead contains a sex hormone-binding globulin-like domain in the COOH-terminus. Protein Z contains a "pseudo-catalytic domain" in the COOH-terminus and does not function as a serine protease enzyme.

Factor VII: 50 kDa

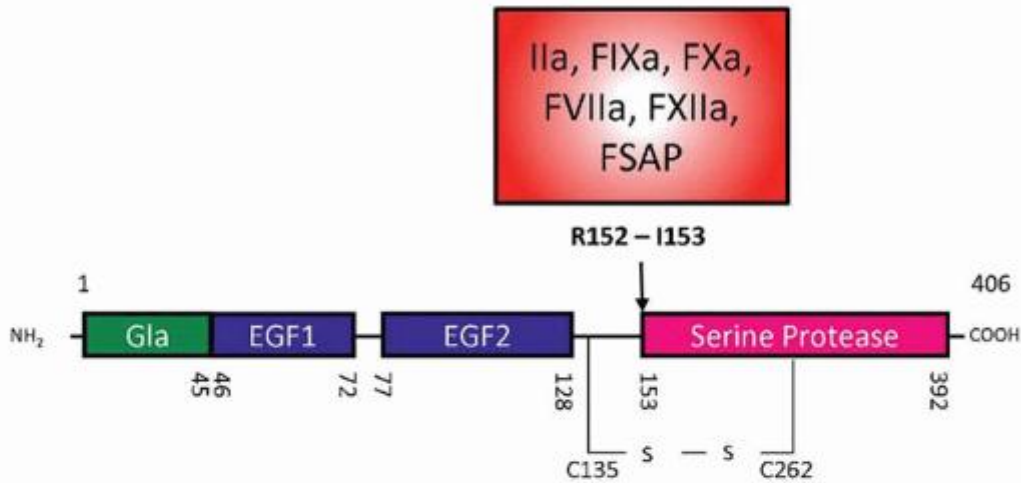

Factor IX: 55 kDa

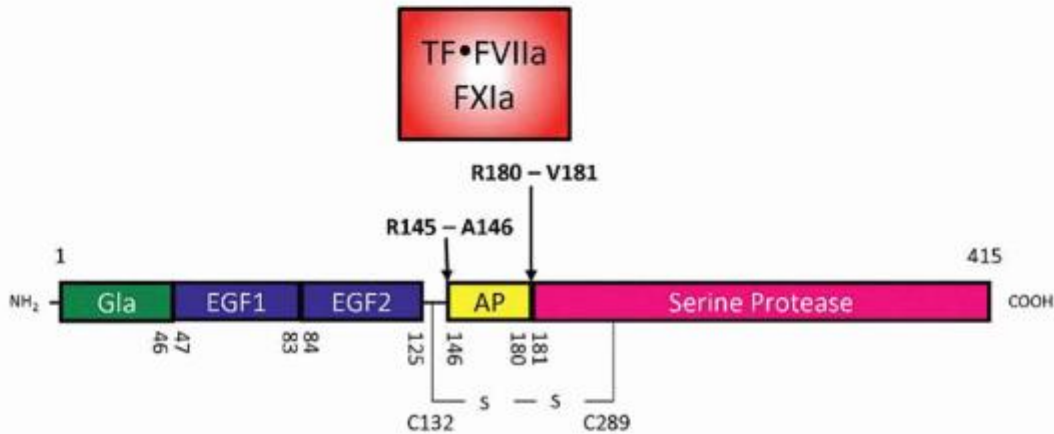
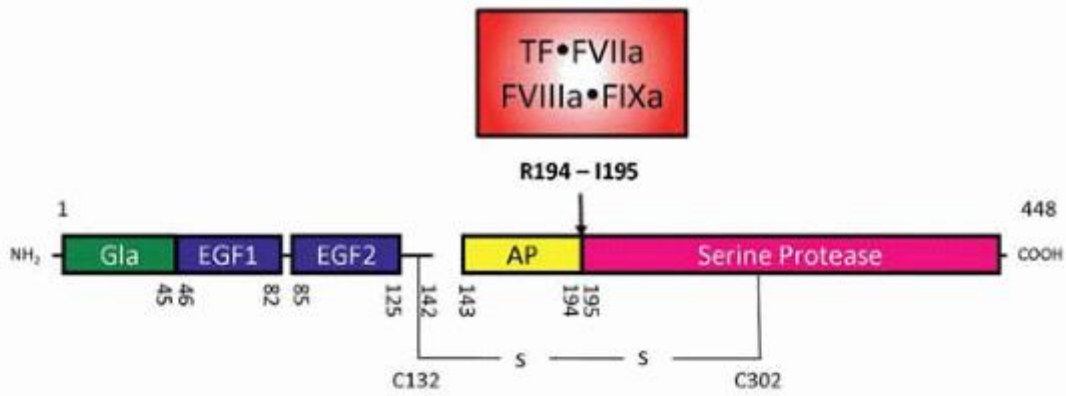
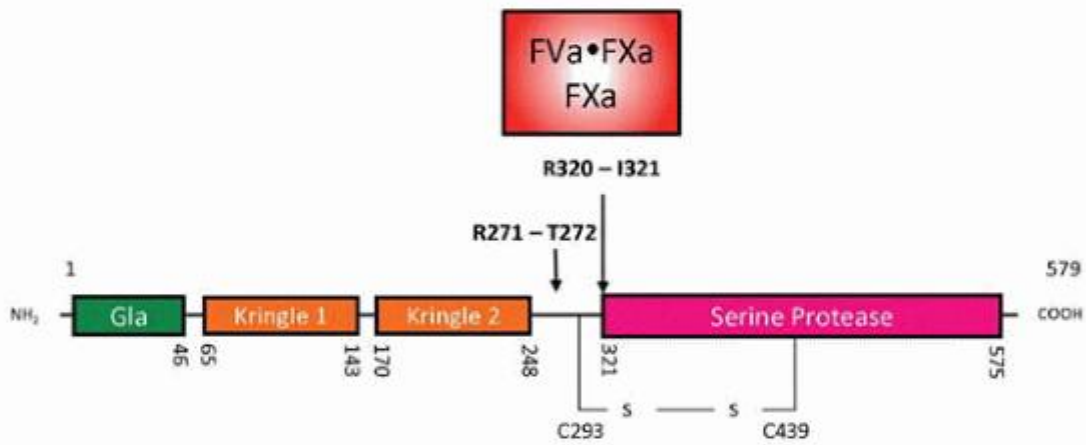

FIGURE 18.3. Schematic representation of the vitamin K-dependent proteins. The building blocks for these proteins include an NH₂-terminal Gla domain with 9 to 13 Gla residues followed by either an epidermal growth factor (EGF)-like domain in factor VII (FVII), factor IX (FIX), factor X (FX), protein C, protein S, and protein Z, or a kringle domain in prothrombin. Protein S contains a thrombin-sensitive region (TSR) before the EGF domain. Active sites are contained within the serine protease domain. Cleavage sites for the conversion of zymogens to their active forms are designated by arrows; activating proteases are placed in boxes above the arrows. Factor IX, factor X, and protein C are activated by proteolytic removal of an activation peptide (AP). Protein S is not a serine protease precursor and instead contains a sex hormone-binding globulin-like domain (SHGB) in the COOH-terminus. Protein Z also contains a “pseudo-catalytic domain” in the COOH-terminus and does not function as a serine protease. For reference, the molecular weight for each zymogen is listed, and disulfide bonds (-S-S-) critical to the integrity of the two-chain zymogens or active forms are presented. A: Panel illustrates the procoagulant vitamin K-dependent proteins factor VII, factor IX, factor X, and prothrombin. B: Panel illustrates the anticoagulant proteins, protein C, protein S, and protein Z. C: Structural ribbon diagram of factor IXa (PDB-ID: 1PFX). FSAP, factor VII-activating protease; TF, tissue factor; mIIa, meizothrombin.



Prothrombin: 72 kDa



A

Protein C: 62 kDa

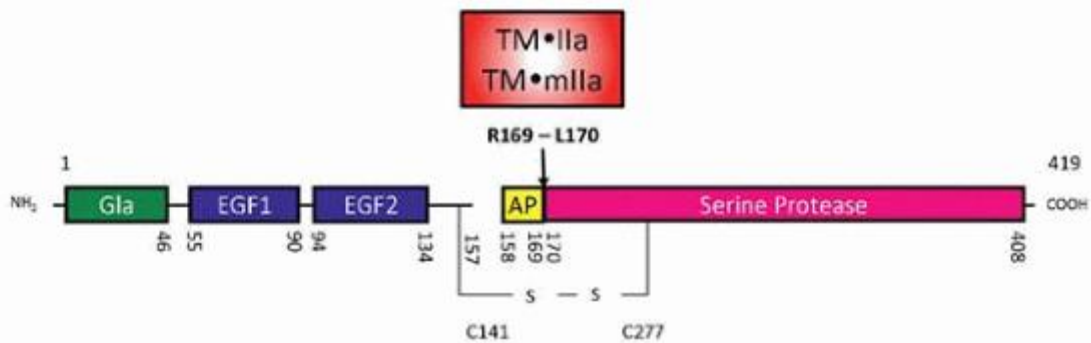
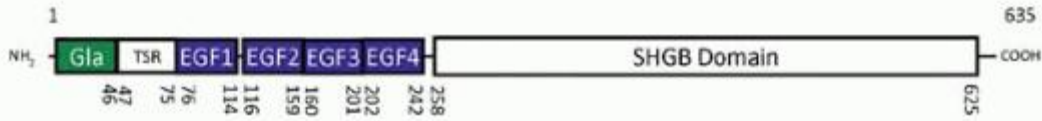

FIGURE 18.3. (Continued)

The synthesis of these proteins occurs primarily in the liver followed by secretion into circulation. However, recently, a functional prothrombin gene product has been found to be synthesized by human kidney cells.³²¹ The concentration of circulating zymogens in plasma varies 200-fold from 100 µg/ml for prothrombin to 0.5 µg/ml for factor VII (Table 18.1). Levels present in plasma can be affected by polymorphisms in the promoter or coding region^{322,323} and³²⁴ and aberrant levels are considered a risk factor for ischemic heart disease.³²⁵ Cholesterol and triglyceride levels have also been correlated with plasma concentrations of the vitamin K-dependent proteins.^{326,327} and³²⁸ Liver function in the synthesis of the clotting factors, dietary intake/adsorption of vitamin K, and drug interactions can affect individuals on anticoagulant therapy.^{329,330}

P.440

Protein S: 69 kDa



Protein Z: 62 kDa



B

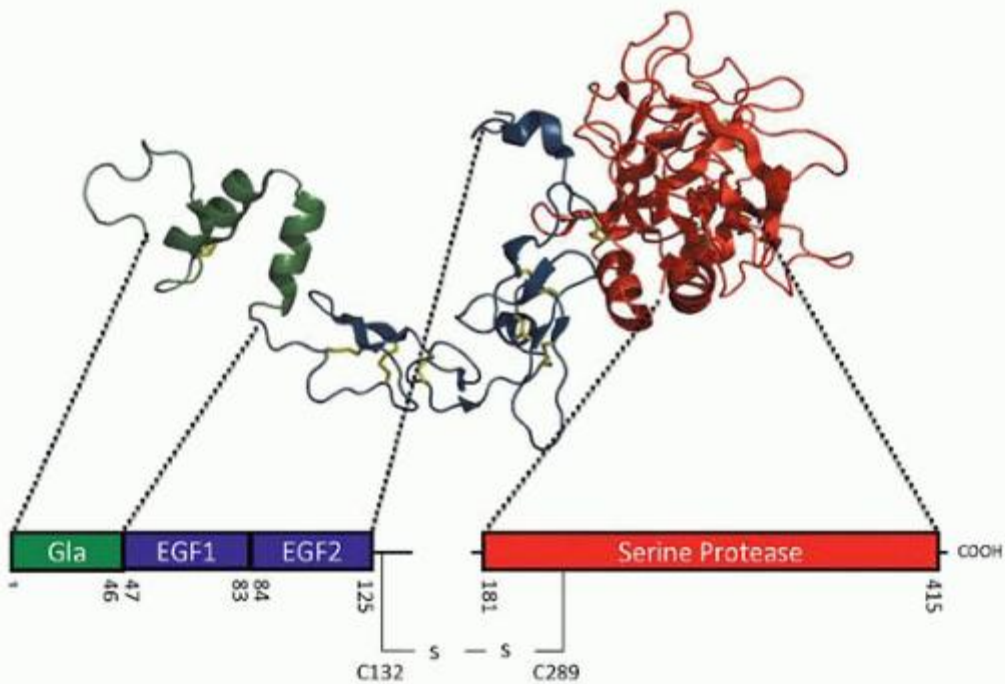

C

FIGURE 18.3. (Continued)

Clearance ($t_{1/2}$) of the vitamin K-dependent proteins varies from approximately 6 hours for factor VII to 2.5 days for prothrombin (Table 18.1). Once the zymogen is activated to its serine protease form, it is then inactivated by inhibitors and the complex cleared from the blood.

These activated forms of the vitamin K-dependent proteins are key components in the formation of the vitamin K-dependent coagulation complexes: the extrinsic tenase (factor VIIa-tissue factor); the intrinsic tenase (factor IXa-factor

VIIIa); prothrombinase (factor Xa-factor Va); and protein C (thrombin-thrombomodulin) (Fig. 18.4). When all the components for each complex are assembled on the appropriate membrane surfaces (e.g., activated platelets, monocytes, blood cells, or endothelium), the specific reactions occur with rates enhanced by 10^4 to 10^9 -fold over enzyme-substrate alone⁵ (Table 18.3). A simple calculation can illustrate the importance of the rate enhancements achieved through complex assembly (vitamin K-dependent serine protease-cofactor-membrane- Ca^{2+}): If a normal person takes 4 minutes for his or her blood to clot, then in the absence of membrane and cofactor, blood clot formation would take approximately 3.8 years.

Gene Structure and Expression

The family of vitamin K-dependent proteins is mainly synthesized in the liver by hepatocytes. Decreased levels of the vitamin

P.441

K-dependent proteins are indicators of liver dysfunction.^{333,334} Liver transplantation has been shown either to treat vitamin K deficiency³³⁵ or to bring about vitamin K deficiency.³³⁶ The genes encoding all of the vitamin K-dependent coagulation proteins have been sequenced and are seen in Table 18.2. The difference between the vitamin K-dependent protein genes and most other eukaryotic genes is that the 5'-flanking regions lack TATA boxes. Binding sites for liver-enriched or liver-specific (or both) transcription factors, which are important for hepatic expression of these proteins, are contained within the regulatory region of these genes. A common pentanucleotide motif that occurs in a similar location in the regulatory region of the genes encoding factor VII, factor IX, and factor X may be important in their possible coordinate expression.

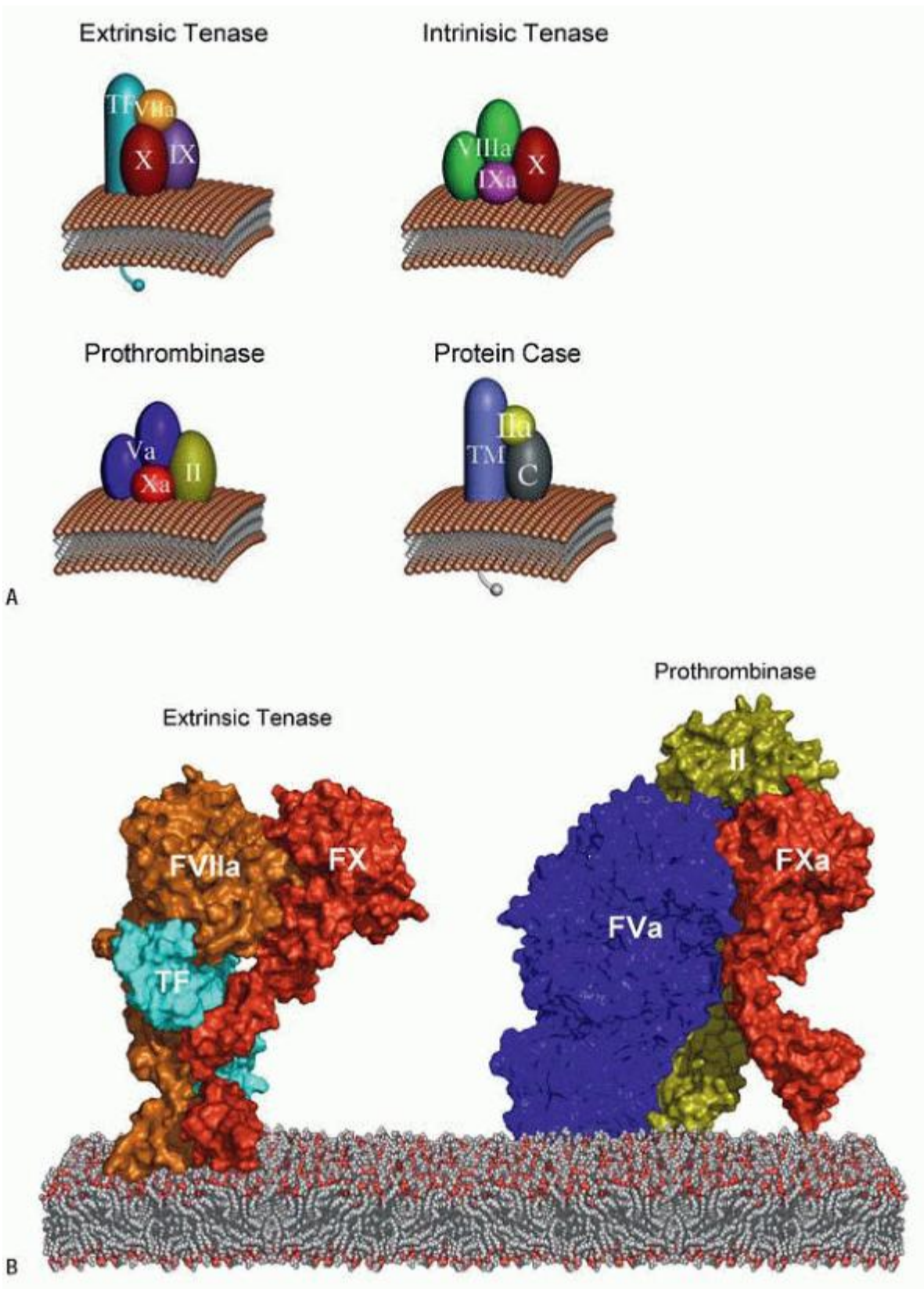

FIGURE 18.4. Vitamin K-dependent complexes. A: Three procoagulant complexes (extrinsic tenase, intrinsic tenase, and prothrombinase) and one anticoagulant complex (protein Case) are illustrated. Each membrane complex consists of a vitamin K-dependent serine protease (factor VIIa [VIIa], factor IXa [IXa], factor Xa [Xa], or thrombin [IIa]) and a soluble or cell surface-associated cofactor (factor VIIIa [heavy and light chain VIII_H and VIII_L], factor Va [heavy and light chain V_H and

V_I], tissue factor [TF], or thrombomodulin [TM]). Each serine protease is shown in association with the appropriate cofactor protein and zymogen substrate(s) on the membrane surface. The membrane serves as a scaffold for the coagulation reactants, enhancing the reaction rates by 10⁴- to 10⁹-fold. When vascular damage or inflammatory cytokine activation occurs, TF becomes exposed to flowing blood carrying low levels of factor VIIa. The formed extrinsic tenase complex activates the circulating serine protease zymogens factors IX and X. Factor IXa becomes the serine protease for the intrinsic tenase complex, which, with its cofactor factor VIIIa, activates factor X to its active protease form factor Xa. Factor Xa formed primarily from the intrinsic tenase combines with its cofactor factor Va to activate II to IIa on the prothrombinase complex. Cofactor regulation occurs when IIa released from the prothrombinase complex binds to endothelial cell surface protein TM to form the protein Case anticoagulant complex. This complex generates activated protein C, which then proteolytically inactivates factors Va and VIIIa. (From Mann KG. Coagulation explosion. Vermont Bus Graph 1997, with permission.) B: Structural models of extrinsic tenase³³¹ and prothrombinase.³³²

Posttranslational Processing

The vitamin K-dependent proteins are synthesized in the liver as preprozymogens in a process that requires a dietary intake of vitamin K. They are modified posttranslationally at glutamic acid (γ-carboxylation to form γ-carboxy glutamic acid)³¹⁰ and at aspartic acid and asparagine (β-hydroxylation to form erythro-β-hydroxy aspartic acid [Hya] and erythro-β-hydroxy asparagine [Hyn])^{79,337,338}; they are also modified by sulfation at tyrosine residues as well as the addition of sugar moieties (glycosylation).^{337,338} This high degree of posttranslational processing is necessary for the biologic activity of the mature vitamin K-dependent proteins.

P.442

TABLE 18.3 RATE ENHANCEMENT BY VITAMIN K-DEPENDENT COMPLEXES

Complex^a	Substrates	Fold Enhancement^b
FVIIa/TF/PCPS/Ca ²⁺	FIX	>1 × 10 ^{9c}
FVIIa/TF/PCPS/Ca ²⁺	FX	3 × 10 ⁴
FIXa/FVIIIa/PCPS/Ca ²⁺	FX	1 × 10 ⁹
FXa/FVa/PCPS/Ca ²⁺	FII	3 × 10 ⁵
FIIa/TM/PCPS/Ca ²⁺	PC	1 × 10 ⁵

F, factor; PC, phosphatidylcholine; PS, phosphatidylserine; TF, tissue factor; TM, thrombomodulin.

^a Complexes are assembled on membranes composed of PC and PS (3:1 molar ratio PC/PS).

^b Rate enhancement is derived from the ratio of catalytic efficiency [number of catalytic events per unit time/Michaelis constant (k_{cat}/K_m)] for the complex to the catalytic efficiency of the free serine protease for a given substrate.

^c No measurable activation of FIXa by FVIIa without TF and the membrane. The catalytic efficiency of the extrinsic tenase toward FIX is reduced relative to FX.

Proteolytic Maturation

The vitamin K-dependent proteins are synthesized in the liver as a single-chain precursor that contains a prepro sequence followed by the polypeptide region. The hydrophobic signal peptide (prepeptide) gets the protein to the endoplasmic reticulum, the first compartment in the secretory pathway. For the vitamin K-dependent proteins to become mature, the polypeptide is translocated out of the first compartment in the endoplasmic reticulum across the lipid bilayer into the lumen of the endoplasmic reticulum. The signal peptide is then removed by a signal peptidase. The propeptide, which plays a role in docking vitamin K-dependent carboxylase,³³⁹ is removed by an endoprotease. The release of the propeptide coincides with γ-carboxylation (Gla formation)³⁴⁰ (Fig. 18.5a). Removal of an internal di- or tripeptide in singlechain factor X and protein C occurs, which converts them to their mature two-chain zymogen form. Several studies

describe the endoproteinase that cleaves the propeptide and the internal bonds as furin/paired basic amino acid cleaving enzyme.^{341,342} and³⁴³

Carboxylation and Vitamin K-dependent Carboxylase

The γ -carboxylation reaction is catalyzed by the enzyme γ -glutamyl carboxylase. This enzyme is located in the rough endoplasmic reticulum and requires the reduced form of vitamin K, oxygen, and carbon dioxide.³¹¹ The carboxylation mechanism involves proton abstraction of the γ -hydrogen of the glutamate residues near the NH_2 -terminus of the nascent prepro protein (Fig. 18.5B). The generated carbanion at each glutamic acid residue then reacts with free CO_2 , forming γ -carboxy glutamic acid. It is this Gla region that mediates the Ca^{2+} -dependent binding of the protein to anionic phospholipid surfaces, thereby ensuring close proximity and interaction with other components of the coagulation sequence and with cell receptors for vitamin K-dependent ligands. Without vitamin K, the coagulation protein precursors continue to be synthesized but are not γ -carboxylated. In this form, they are still secreted into plasma but are nonfunctional.

The cDNA for the human γ -carboxylase gene was cloned and sequenced by Wu et al.³⁴⁴ The open reading frame predicts a molecular weight of approximately 87.5 kDa. Glycosylation of the carboxylase probably accounts for its decreased mobility on SDS-PAGE (94 kDa). Vitamin K-dependent carboxylase has been identified in many cell types.³⁴⁵ This supports the notion that vitamin K has a wide range of biologic functions.

The presence of vitamin K is essential to maintain the γ -carboxylation reaction. Vitamin K_1 (phylloquinone) is primarily found in leafy green vegetables and vegetable oils. Additional K activity may be provided by vitamin K_2 (menaquinones) synthesized by intestinal Gram-negative bacteria. Synthetic vitamin K_3 (menadione) has no intrinsic activity until it undergoes in vivo transformation to the active menaquinone form. These K vitamins are 2-methyl-1,4-naphthoquinones with repeating fivecarbon prenyl units at position 3. In vivo, vitamin K is recycled in a microsomal oxidation-reduction system for continued use in the γ -carboxylation reaction. To perform the γ -carboxylation reaction, vitamin K has to be present in its reduced hydroquinone form. As the precursor proteins are carboxylated, vitamin K is oxidized to the epoxide.³⁴⁶ The epoxide in the presence of 2, 3-epoxide reductase, using thiols as the reducing agent, yields the quinone form of vitamin K.³⁴⁷ A subsequent nicotinamide adenine dinucleotide phosphate- or nicotinamide adenine dinucleotidedependent quinone reductase reaction resynthesizes the hydroquinone form. The cycle can thus begin again.

One important target for anticoagulant therapy is the process required for the regeneration of reduced hydroquinone vitamin K. Anticoagulants that effectively block this reaction include warfarin (Coumadin), dicumarol, and phenprocoumon (Fig. 18.5B). These oral anticoagulants are structurally similar to the quinone form of vitamin K, thereby targeting the reductase enzyme and inhibiting the reduction to the requisite hydroquinone form. The affinity of the anticoagulants for the reductase enzymes determines the efficacy of the drug.^{12,348} In the United States, the most widely used oral anticoagulant warfarin (Coumadin) is also used as rat poison. It acts as a competitive inhibitor of oxidized vitamin K and interferes with its reduction. Without the regeneration of the reduced form of vitamin K, the vitamin K-dependent protein carboxylase is unable to convert glutamate to γ -carboxy glutamate. Thus, these drugs indirectly affect carboxylation and can be overcome with excess vitamin K. The level of competitive inhibition achieved in Coumadin therapy among individuals taking the same dose regimen is variable. Factors affecting the efficacy of treatment include liver function in the synthesis of the clotting factors, enhancement of effect from other medications, and dietary intake/adsorption of vitamin K.³⁴⁹ Therefore, proper monitoring of oral anticoagulant therapy is essential with frequently measured PT and corrected assay sensitivity using the international normalized ratio.^{350,351} Several lines of evidence indicate that vitamin K antagonists inhibit not only posttranslational modification on coagulation factors, but also the synthesis of functional extra hepatic vitamin K-dependent proteins potentially resulting in vascular calcification.^{352,353}

Hydroxylation

Hydroxylation in the context of vitamin K-dependent proteins refers to the addition of a hydroxyl group (-OH) to aspartic acid and asparagine residues present in the EGF-like domains. The EGF-1 domains of human factors IX and X, protein C, and protein S contain a homologous aspartic acid residue that is hydroxylated to form erythro- β -hydroxy aspartic acid (Hya).^{79,354,355} Protein S also contains asparagine residues in EGF-2 and EGF-4 domains that are hydroxylated to form erythro- β -hydroxy asparagine residues (Hyn).³⁵⁶ This posttranslational modification to Hya and Hyn occurs by a β -hydroxylase enzyme, a 2-oxo-glutarate-dependent dioxygenase.^{338,357} The mechanism of action involves the recognition of a consensus sequence Cys-X-Asp/Asn-X-X-X-Tyr/Phe-X-Cys-X-Cys.³⁵⁶ The reason for this modification to Hya and Hyn is unclear. No effect has been found on the overall fold of the EGF-1 domain, its affinity, or specificity for calcium.³⁵⁸ These modifications also appear to have no relevance to the biologic activity or macromolecular interactions of the vitamin K-dependent proteins.^{359,360}

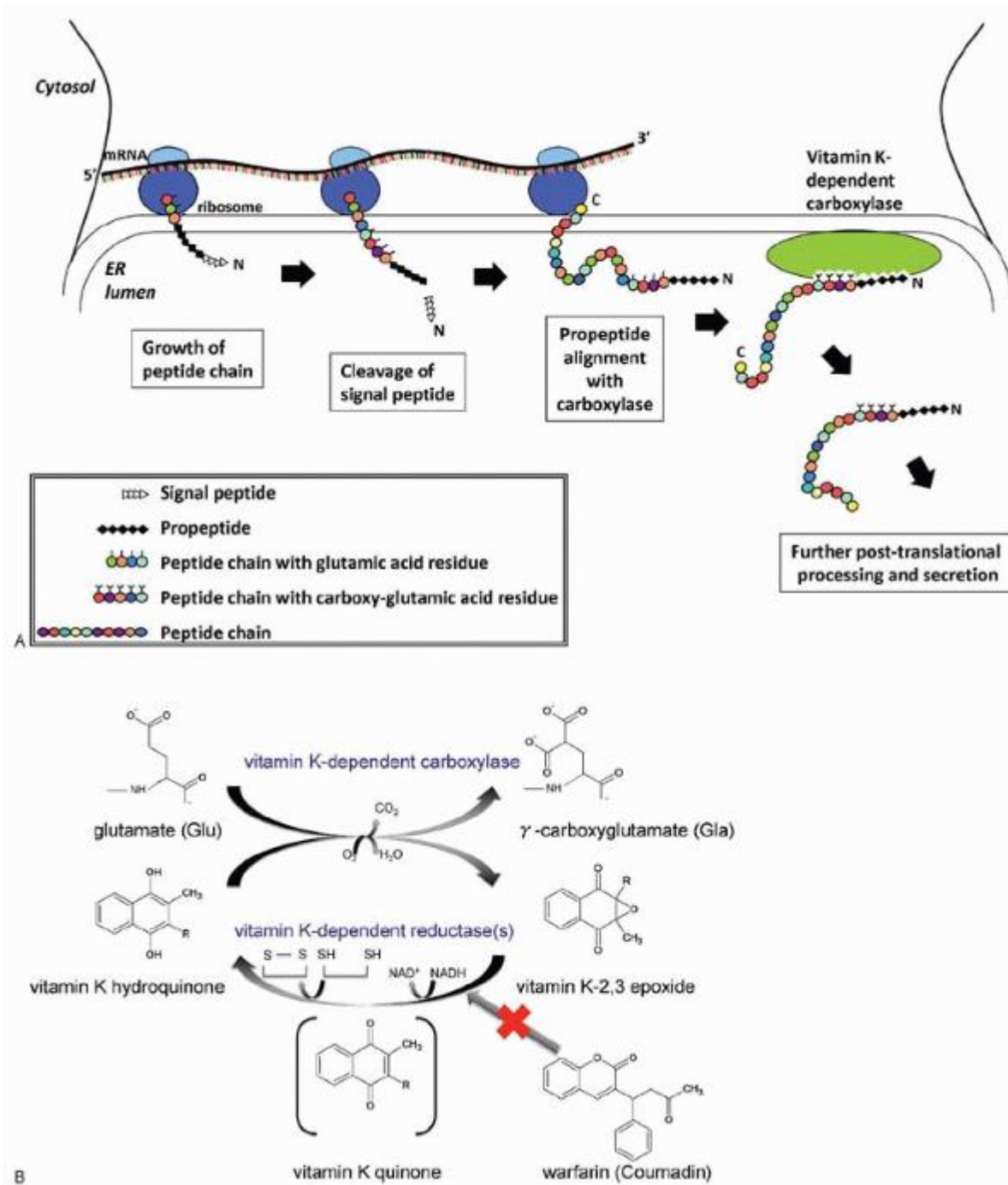

FIGURE 18.5. Vitamin K-dependent processes. A: Schematic representation of the synthesis and posttranslational carboxylation pathway of vitamin K-dependent proteins in the endoplasmic reticulum. (From Bovill EG, Malhotra OP, Mann KG. Mechanisms of vitamin K antagonism. Baillieres Clin Haematol 1990;3:555-581, with permission.) B: The mechanism of γ -carboxy glutamate (Gla) generation by a vitamin K-dependent reaction cycle is illustrated. The regeneration of vitamin K hydroquinone by the vitamin K-dependent reductases is inhibited by anticoagulants, as illustrated by Coumadin.

Glycosylation

The addition of a carbohydrate moiety as a posttranslational modification to proteins is referred to as glycosylation. The vitamin K-dependent proteins contain significant amounts of carbohydrate (Tables 18.1 and 18.4). Carbohydrate adducts on Asn, Ser, and Thr residues are found in key domains of these proteins, including the activation peptide of factor IX and factor X; the EGF domains in factor VII, factor IX, and protein Z; and the kringle domain in prothrombin. In most cases, the purpose of these modifications remains unknown. However, differences in the properties of the carbohydrate variants of protein C have been noted.^{361,362}

General Structure/Function Features

The vitamin K-dependent proteins, both procoagulant and anticoagulant, share a common protein domain structure. Each has a tripartite design: an NH₂-terminal γ-carboxy glutamic acid (Gla) domain, a linker region (kringle domains, EGF-like domains [EGF], or a thrombin-sensitive finger region, or all three), and a COOH-terminal domain usually consisting of a serine protease domain (factors II, VII, IX, and X and protein C) (Fig. 18.3). The Gla domain is involved in the Ca²⁺ ion-dependent binding of vitamin K-dependent proteins to anionic phospholipid membranes. The number of domains in the linker region is variable, and, in general, they are involved in protein-protein interactions. The COOH-terminal catalytic domain seen in factors II, VII, IX, and X and protein C is homologous to the pancreatic serine proteases, trypsin, and chymotrypsin. The nonsaline protease domain seen in protein S (a cofactor of activated protein C [APC]) is homologous to sex hormone-binding globulin.³⁶³ Protein Z is an enzymatically inactive homolog of factors VII, IX, and X and protein C.³⁶⁴ A separate review of the Gla, EGF, and serine protease domains is presented below.

TABLE 18.4 BIOCHEMICAL PROPERTIES OF HUMAN ANTICOAGULANT PROTEINS AND THEIR INHIBITORS

Protein	Plasma Concentration			Carbohydrate (%)	Clinical Phenotype ^a		Protein Family	Functional Classification
	Molecular Weight (Da)	nmol/L	Plasma t _{1/2} (days)		HT			
Protein C	62,000	65	4	0.33	23	+	VKD	Proteinase zymogen
Protein S	69,000	300	20	1.75	8	+	VKD	Inhibitor/cofactor
Protein Z	62,000	47	2.9	2.5		±	VKD	Cofactor
Thrombomodulin	100,000							Cofactor/modulator
α ₂ -Macroglobulin	735,000	2,700-4,000	2,000-3,000	0.002			Complement	Proteinase inhibitor
Tissue factor pathway inhibitor	40,000	1-4	0.1	6.4 × 10 ⁻⁴ -1.4 × 10 ⁻³			Kunitz	Proteinase inhibitor
Antithrombin	58,000	2,400	140	2.5-3.0			Serpin	Proteinase inhibitor
Heparin cofactor II	66,000	500-1,400	33-90	2.5	10		Serpin	Proteinase inhibitor
α ₁ -Proteinase inhibitor	53,000	28,000	1,500-3,500	6	12		Serpin	Proteinase inhibitor
C1 esterase	104,000	962	100	0.07	35		Serpin	Proteinase

inhibitor							inhibitor
Protein C inhibitor	57,00090	5	1	23	+	Serpin	Proteinase inhibitor

+, presence of phenotype; ±, some individuals present with phenotype and others do not; H, hemorrhagic disease/hemophilia; T, thrombotic disease/thrombophilia; VKD, vitamin K-dependent.

“Clinical phenotype: the expression of either H or T phenotype in deficient individuals.

The importance of each of the domains has been uncovered through studies from natural variants that occur in patients with either familial bleeding (i.e., factor IX deficiency/hemophilia B) or thrombotic disease (i.e., protein C deficiency). The situations that can cause a disease state are either deficiency in the level of protein present (cross-reactive material [CRM]-negative) or expressed protein that is present but nonfunctional (CRM⁺). Defects have diverse causes, including mutations that lead to amino acid substitutions in one or more domains, defects in posttranslational modifications, or mutations that introduce stop codons resulting in either no expression or expression of truncated proteins. In the case of combined vitamin K deficiency, a rare hereditary bleeding disorder,^{365,366} two studies have identified a missense mutation in the γ-carboxylase gene that results in a defective γ-glutamyl carboxylase and thus incomplete processing of the vitamin K-dependent proteins.^{367,368}

When a hemostatic disorder characterized by a dysfunctional protein (CRM⁺) is identified, it is through the combination of techniques including protein isolation, in vitro studies, and DNA technology that the root of the defect is elucidated. The importance of domains as functional units and of specific amino acid interactions can be uncovered using recombinant DNA technology. Single amino acid substitutions can be introduced into domains or entire domains removed to determine where the intra- and interprotein interactions take place. Structural information through nuclear magnetic resonance spectroscopy and x-ray crystallography provides amino acid assignments and tertiary structure, thus allowing for precise approaches to site-directed mutagenesis studies. The combination of all these techniques results in a map

P.445

of how the domains are aligned and interact. Further, using computational molecular dynamics, one can predict conformational changes associated with protein-protein, protein-ligand, and protein-surface interactions. Identifying residues directly involved in binding to membranes, metal ions, or small substrates can lead to new drug therapies.

The first x-ray crystal structure of a vitamin K-dependent protein was obtained by Tulinsky's laboratory for prothrombin fragment 1 (factor II, residues 1 to 155) in the presence³⁶⁹ and absence of calcium.^{370,371} These results provided information regarding the entire Gla domain, the connector peptide, and kringle 1. In the absence of calcium, only the connector peptide and the kringle can be visualized in the resulting x-ray crystal analysis. Prothrombin is the only vitamin K-dependent protein with a kringle domain. It is likely that organization of the polypeptide chains of the Gla domain is similar for all vitamin K-dependent proteins. To date, several other vitamin K-dependent protein structures have been elucidated^{372,373,374,375,376,377,378,379,380,381} and ³⁸² (see Table 18.5). Many studies on the individual vitamin K-dependent proteins have been conducted and are detailed under each protein subsection.

All the vitamin K-dependent proteins contain an NH₂-terminal Gla domain, and only factors II, VII, IX, and X and protein C contain a serine protease domain. Factors IX, X, and VII, protein C, and protein S contain EGF domains. Several recent reviews have been written on vitamin K-dependent proteins.^{383,384,385} and ³⁸⁶

TABLE 18.5 HIGHEST RESOLUTION X-RAY STRUCTURES OF HUMAN PROCOAGULANT, ANTICOAGULANT, FIBRINOLYTIC PROTEINS, AND THEIR INHIBITORS

Protein	Structure	Resolution (Å)	PDB Code
Procoagulant proteins			
Intrinsic pathway			
Factor XII	N/A		
Prekallikrein	Catalytic domain	1.4	2ANY
HMW kininogen	N/A		

LMW kininogen	N/A		
Factor XI	XI zymogen	2.9	2F83
	XIa + inhibitor	1.6	3BG8
Vitamin K-dependent			
Factor VII	VII zymogen (des Gla)	2.0	1JBU
	VIIa (des Gla)	1.7	1KLI
	VIIa + TF extracellular domain + inhibitor	1.7	2C4F
Factor IX	IXa (des Gla) + inhibitor	1.6	2WPJ
	Gla domain	1.5	1EDM
	IXa (porcine)	3.0	1PFX
Factor X	Xa β (des Gla)	1.8	2J4I
Factor II	Prethrombin 1	2.2	3NXP
	Prethrombin 2 + Fragment 2	1.90	3K65
	Meizothrombin (desF1)	2.1	3E6P
	α -IIa + inhibitor (small molecule)	1.2	2RM2
	α -IIa + inhibitor (hirudin fragment)	1.3	2CF8
Cofactors			
Tissue factor	Extracellular domain	1.7	2HFT
	VIIa + TF extracellular domain	1.8	2A2Q
Factor V	C2 domain	1.9	1CZT
	Va-inactive (bovine)	2.8	1SDD
Factor VIII	VIIIa	3.7	2R7E
VWf	A1 domain mutant	1.8	1IJB
	A2 domain	1.9	3GXB
	A3 domain	1.8	1ATZ
Anticoagulant proteins			
Dynamic inhibition			
Protein C	APC (des Gla)	2.8	1AUT
	Gla Domain of APC + PC receptor	1.6	1LQV
Protein S	N/A		
Protein Z	PZ + PZI	2.3	3F1S
Thrombomodulin	EGF 4-6 of thrombomodulin + IIa	2.3	1DX5
Proteinase inhibitors			
α_2 -macroglobin	MG2, TED & CUB domains	2.3	2P9R
TFPI	2nd Kunitz domain of TFPI + antibody	1.8	4DTG

Antithrombin	AT	2.8	2B4X
	Plasma α -AT	2.6	1E05
	Plasma β -AT	2.6	1E04
	AT + IIa + heparin	2.5	1TB6
	AT + IXa	1.7	3KCG
	AT + Xa	3.3	2GD4
Heparin cofactor II	Heparin cofactor II	2.4	1JMJ
	Heparin cofactor II + IIa	2.2	1JMO
α_1 -Proteinase inhibitor	α_1 -AT	2.0	1QLP
C1 Esterase inhibitor	Latent form	2.4	2OAY
Protein C inhibitor	PCI	2.0	2OL2
	PCI + IIa + heparin	1.6	3B9F
	PZI + PZ	2.3	3F1S
Protein Z-dependent inhibitor	MG2, TED, and CUB domains	2.3	2P9R
Proteins of clot formation			
Factor XIII	XIII zymogen	2.0	1EVU
	XIIIa	2.5	1FIE
Fibrinogen		2.9	3GHG
	Fragment E + IIa	3.7	2A45
	Alpha domain from fibrinogen-420	2.1	1FZD
Fibrin	D-dimer	2.3	1FZC
Fibrinolytic system			
Proteins			
Plasminogen	Catalytic domain	2.0	1QRZ
	Kringle 1 + inhibitor	2.1	1CEA
	Kringle 4	1.9	1PK4
t-PA	Single-chain + inhibitor (EGR-cmk)	3.3	1BDA
	Two-chain + inhibitor (benzamidine)	2.3	1RTF
u-PA	Two-chain + inhibitor	1.5	1C5L
	NH ₂ -terminal fragment + receptor + antibody	1.9	2FD6
Factor VII activating protease	N/A		
Inhibitors			
TAFI	TAFIa + inhibitor	2.5	3LMS
PAI-1	Latent form	1.8	1LJ5
	Active form	2.4	1DVM

PAI-2	Stabilized mutant	2.0	1BY7
α_2 -Antiplasmin		2.7	2R9Y

AT, antithrombin; HMW, high-molecular-weight; LMW, low-molecular-weight; N/A, Not currently available; PAI, plasminogen activator inhibitor; t-PA, tissue plasminogen activator; TAFI, thrombin-activatable fibrinolysis inhibitor; TFPI, tissue factor pathway inhibitor; u-PA, urokinase-type plasminogen activator.

Gla Domain

The Gla domain constitutes the first approximately 50 residues of the vitamin K-dependent proteins (Fig. 18.3). The negative charge elicited from the string of Gla residues (9 to 13) contributes to the binding to Ca^{2+} and the generation of the conformation required for binding to anionic phospholipid membranes. This surface in vivo is supplied by activated platelets or other blood cells in response to vascular damage through exposure of the internal face of their cell membranes where it is phosphatidylserine (PS)-rich.^{369,387} In vitro systems that attempt to mimic coagulation mainly use natural or synthetic preparations of PS and phosphatidylcholine, often at a 1:3 molar ratio. Studies have shown that PS exposure is crucial for cells to support the membrane-bound enzymatic reactions and that PS is more effective than other equally charged lipids.^{5,388,389} The striking degree of homology among the Gla domains of the vitamin K-dependent clotting factors suggests that the affinity of the calcium-Gla complexes for

P.446

P.447

phospholipids would also be very similar. However, this turns out not to be the case. The dissociation constants for binding to phosphatidylcholine and PS-containing vesicles vary, with K^d values in the range of 50 nmol/L for protein Z and protein S,³⁹⁰ 100 to 300 nmol/L for factor X and prothrombin,³⁹¹ 15 nmol/L for protein C,³⁹⁰ and 17,000 nmol/L for factor VII.^{390,392} A systematic analysis of the sequence/structural basis for these divergent membrane-binding properties is available.^{382,390}

The mode of interaction between the Gla domain-containing coagulation factors and biologic membranes has been difficult to study and is still a subject for debate. Two models of binding have been presented. One involves the bridging of calcium between specific Gla residues and the negative anionic phospholipid membrane components.^{392,393} A second model involves a major hydrophobic contribution to the membrane binding. X-ray crystallographic^{370,394,395} and³⁹⁶ and nuclear magnetic resonance studies³⁹⁷ have been conducted to elucidate the conformational changes, in the absence and presence of calcium, that occur on Gla domain binding to a lipid membrane. In the absence of calcium, the negatively charged Gla residues appear exposed to the solution, and the hydrophobic residues of the Gla domain are buried in its interior.³⁹⁷ On Ca^{2+} binding to the Gla domain, the conformation is altered to expose the hydrophobic residues, making possible their insertion into the lipid membrane. The hydrophobic patch in prothrombin fragment 1 surrounding the first pair of Gla residues was determined to be Phe⁴, Leu⁵, and Val⁸. Site-directed mutagenesis studies of protein C determined these residues (Phe⁴, Leu⁵, and Leu⁸) to be important in membrane interactions.^{398,399} and⁴⁰⁰ The actual mechanism of membrane binding is still under active investigation.

Epidermal Growth Factor Domain

The Gla domain is followed by two tandem EGF domains (EGF-1 and EGF-2) in factor VII, factor IX, factor X, and protein C and four EGF domains (EGF-1 to EGF-4) in protein S⁴⁰¹ (Fig. 18.3). The first EGF domain (EGF-1) contains the posttranslationally modified amino acid- β -hydroxy aspartic acid in the case of factors IX and X, and β -hydroxy asparagine in the case of protein S.^{337,354,356,402,403} and⁴⁰⁴ An EGF-like domain consists of 40 to 50 amino acids, including six cysteine residues involved in disulfide bond formation. The EGF domains have been evaluated by nuclear magnetic resonance spectroscopy.^{386,405,406,407,408} and⁴⁰⁹ The EGF-2 domains of factor Xa,³⁷⁸ factor VIIa,³⁸⁰ activated protein C,³⁸² and factor IXa⁴¹⁰ have been evaluated by x-ray crystallography. The EGF-like domains are found widely distributed in extracellular and membrane proteins. Proteins containing these domains are involved in blood coagulation, fibrinolysis, complement activation, and microfibril formation in connective tissue and in signal transduction.^{356,411,412} These domains are similar to the archetypal protein, EGF, which contains nine of these domains and is derived from a membrane-bound precursor.

The structure of the EGF-like domains is dominated by β sheets and β turns. Several point mutations in the EGF domain of factor IX have been identified that cause hemophilia B.⁴¹³ Calcium-binding sites have been identified in the NH₂-terminal EGF-like domains isolated from factors VII, IX, and X and proteins C and Z, with K_d values ranging from 1 to 5 mM. This Ca²⁺-binding site is functionally important because vitamin K-dependent proteins that have missense mutations in EGF-1 that disrupt the Ca²⁺-binding site have reduced biologic activity. In these proteins, the second EGF domain does not appear to bind calcium. The NH₂-terminal EGF domain of protein S does not appear to bind Ca²⁺.

The function of the EGF domain is still unclear. One hypothesis is that it serves as a spacer. A consistent elongation of the molecules of factors VII, IX, and X and protein C and protein S has been noted. The distance between the membrane-binding Gla domain and the serine protease domain is crucial to the placement of the active site in an appropriate position relative to the target peptide bond in its substrate.⁴¹⁴ Calcium binding serves a role in the function of these domains. For example, it has been proposed that for appropriate docking of factor VIIa to tissue factor, Ca²⁺ binding to the EGF domain is required.⁴¹⁵ Calcium binding to the EGF domains in non-vitamin K-dependent proteins has been observed in the Notch protein⁴¹⁶ and fibrillin.⁴¹⁷

Serine Protease Domain

The serine protease domain accounts for approximately one-half the mass of each protein. Peptide bond cleavage at specific sites converts the vitamin K-dependent zymogens to their active serine protease forms (Fig. 18.3). These enzymes are serine proteases in the same family as trypsin and chymotrypsin. The mechanism of proteolysis by chymotrypsin involves a catalytic triad, composed of Asp¹⁰², His⁵⁷, and Ser¹⁹⁵ (chymotrypsin numbering). The nucleophilic attack is carried out by the hydroxyl group of Ser¹⁹⁵ with the imidazole ring of His⁵⁷ taking up the liberated proton and the carboxylate ion of Asp¹⁰² stabilizing the developing charge. More extensive elements of structure (i.e., calcium-, membrane-, and cofactor-binding sites) are required for interactions of enzymes and substrates in the coagulation process.

The serine protease domains of all the Gla-containing factors show a high degree of sequence identity with each other and to trypsin and chymotrypsin, cleaving almost specifically at arginyl residues. However, unlike trypsin, which shows little specificity beyond the requirement for arginyl or lysyl residues at the cleavage site, the activated coagulation factors have extended substrate specificity pockets where only a small number of amino acid sequences are recognized by each activated factor. Despite a high degree of structural similarity between the protease domains of protein C and factors II, VII, IX, and X, each of these factors has a highly specific function in coagulation. Some of this discrimination may be mediated by surface loops and other domains away from the substrate-binding pocket that are not highly homologous.

Factor VII (Proconvertin, Convertin)

The vitamin K-dependent single-chain zymogen factor VII ($M_r = 50,000$), also known as proconvertin, circulates in plasma at a concentration of 0.5 $\mu\text{g/ml}$, or 10 nmol/L^{418,419} (Table 18.1). It is synthesized primarily in the liver. The activated two-chain serine protease form, factor VIIa, circulates in plasma at approximately 1% the concentration of its precursor, or 0.1 nmol/L.⁵² The mechanism for the initial activation of this zymogen is unclear. One recently identified candidate is the factor VII-activating protease (FSAP; see section on factor VII-activating protease). The function of factor VIIa is to serve as an initiator of the extrinsic pathway of coagulation when bound to its membrane cofactor, tissue factor. Factor VII has the shortest $t_{1/2}$ of all the clotting factor zymogens (~ 3 to 6 hours).⁴²⁰ Its activated form factor VIIa has a $t_{1/2}$ of 2.4 hours.^{421,422}

Factor VII deficiency is an autosomal recessive disorder with wide phenotypic and genotypic variability.^{423,424,425} and ⁴²⁶ Its incidence in the general population is approximately 1 in 500,000. In a large French-Canadian kindred, the incidence is approximately 1 in 335.⁴²⁷ Bleeding phenotypes can range from mild to severe and include bruising, epistaxis, postsurgical hemorrhage, and cerebral hemorrhage. Severe bleeding is most commonly associated with plasma factor VII levels that are $< 1\%$.⁴²⁸ Patients have prolonged PTs, and the final diagnosis is established by plasma factor VII coagulant activity (VII:C) using factor VII-deficient plasma and animal thromboplastins, immunologic quantitation of factor VII antigen, or both.^{419,429} Treatment of these individuals includes the use of fresh frozen plasma, prothrombin complex concentrates,⁴³⁰ factor VII concentrates (plasma-derived or

P.448

recombinant),⁴³¹ and liver transplantation.⁴³² Due to its short $t_{1/2}$ (~ 3 to 6 hours), therapy with factor VII concentrates is difficult. Recently, the use of recombinant factor VII as a safe and effective treatment for factor VII deficiency has been evaluated.^{433,434} and ⁴³⁵ During the last decade, supraphysiologic concentrations of recombinant factor VIIa have been used clinically for treatment of patients with hemophilia A or B (factor VIII or factor IX deficiency, respectively) and patients undergoing surgical procedures.^{436,437,438,439,440} and ⁴⁴¹ Recombinant factor VIIa has been suggested for treatment

of almost all bleeding disorders.⁴⁴² The mechanism of hemostasis by recombinant factor VIIa is not fully understood, although several hypotheses have been proposed.^{443,444,445,446}

Studies on the molecular basis for factor VII deficiency have led to the identification of several mutations in the factor VII gene. These mutations have been identified in the splice site,⁴⁴⁷ the promoter region,⁴⁴⁸ the EGF domain,⁴⁴⁹ and numerous single base pair (bp) mutations.^{450,451} For more detail, there is a factor VII mutation database available at europium.csc.mrc.ac.uk.⁴⁵² Factor VII deficiency in mice is not lethal at the embryonic stage, but factor VII^{-/-} neonates die from hemorrhage within the first days after birth.^{453,454}

Gene Structure and Expression

The factor VII gene is located on chromosome 13 band q34-qter, consists of nine exons, and spans 12.8 kb^{455,456,457} (Table 18.2). It is located approximately 2.8 kb upstream from the factor X gene. The mRNA encodes a 2.5-kb message.⁴⁵⁸ Alternative splicing of the factor VII gene yields two gene transcripts. One gene transcript contains eight segments as exons, and the second gene transcript contains nine segments as exons. The additional exon, which is unique among the vitamin K-dependent proteins, is in the prepro leader sequence. Factor VII mRNA expression is localized in the liver,⁴⁵⁹ where its expression is 6% of the factor X mRNA level.⁴⁶⁰ Extrahepatic synthesis of factor VII has been observed in human atherosclerotic vessels.⁴⁶¹ The 5'-flanking region of the factor VII gene contains binding sites for the liver-enriched transcription factor hepatic nuclear factor (HNF)-4.⁴⁶² Three potential activation peptide-1 binding sites are also contained in this region. Both genetic and epigenetic modifications in the promoter region of the factor VII gene have been shown to affect plasma factor VIIa levels.⁴⁶³

Biochemistry

Factor VII circulates in plasma as a single-chain zymogen of a molecular weight of 50,000.^{418,456,464,465} Its 406-amino acid structure consists of an NH₂-terminal Gla domain containing ten γ -carboxy glutamate residues, β -hydroxy aspartic acid at position 63,³⁵⁵ an aromatic residue-rich α -helical region, two EGF domains, and a serine protease domain (Fig. 18.3). The NH₂-terminus, along with the serine protease domain, is involved in the metal binding properties of the protein and its interaction with its cofactor tissue factor.^{466,467} and ⁴⁶⁸ The COOH-terminus of factor VII is important in its interactions with factor X.⁴⁶⁹ Structures of factors VII⁴⁷⁰ and VIIa³⁸¹ and the extrinsic tenase⁴⁷¹ have been determined and have been utilized in a variety of ways to enhance our understanding of this protein.

Activation

The single-chain zymogen factor VII is activated to its two-chain serine protease form, factor VIIa, through a single peptide bond cleavage between Arg¹⁵²-Ile¹⁵³ (Fig. 18.3). The resulting protease consists of an NH₂-terminal light chain (M_r = 20,000) containing the membrane-binding Gla domain (ten Gla residues), linked by a single disulfide bond between Cys¹³⁵-Cys²⁶² to a COOH-terminal heavy chain (M_r = 30,000) that contains the catalytic domain. A small amount of activated factor VII (10 to 100 pmol/L) already circulates in the cleaved active two-chain form.⁴⁷² This small portion of plasma factor VIIa has very poor catalytic efficiency in the absence of its cofactor, tissue factor.^{473,474} The cleavage of factor VII to factor VIIa is catalyzed by several proteases, including α -thrombin,⁸ factor IXa,⁴⁷⁵ factor Xa,⁸ autoactivation by factor VIIa,⁴⁷⁶ factor XIIa,⁴⁷⁷ and FSAP.⁴⁷⁸ The endothelial cell protein C receptor has been reported to bind factor VII and suppress its activation by factor Xa.⁴⁷⁹

Function

Factor VII is a crucial zymogen in blood coagulation and can bind to tissue factor with a subnanomolar K_d and become activated by a number of proteases. Once converted to its active serine protease form and bound to its cofactor, the integral membrane protein tissue factor, it forms the extrinsic tenase complex^{480,481} (Fig. 18.4). The enzyme complex is so named because it contains a protein, tissue factor, normally extrinsic to the plasma environment. The extrinsic tenase complex (factor VIIa-tissue factor-membrane surface-Ca²⁺) activates a fraction of the circulating vitamin K-dependent zymogens, factors IX and X, to their serine protease forms.^{45,482,483,484} Thus, it serves to initiate the formation of the intrinsic tenase (factor IXa-factor VIIIa-membrane-Ca²⁺) and the prothrombinase complexes (factor Xa-factor Va-membrane-Ca²⁺). In vitro studies have shown that the rate of activation by the extrinsic tenase complex is significantly greater (~100,000-fold) than the rate of substrate (factors IX and X) activation by the enzyme factor VIIa alone.^{485,486} Factor Xa bound to a membrane surface can activate additional factor VII in a positive feedback loop.^{8,487}

Regulation

Free factor VIIa, unlike other serine proteases of the coagulation cascade,⁴⁷⁴ is not readily inhibited by circulating protease inhibitors, including the antithrombin-heparin complex.^{488,489} This is most likely because of its poor catalytic efficiency when not bound to its cofactor tissue factor. However, when factor VIIa is bound to tissue factor, antithrombin-heparin

exhibits significant inhibition of factor VIIa.^{490,491} and ⁴⁹² Thus, regulation of tissue factor expression is the primary means to control factor VIIa activity. Paradoxically, in normal hemostasis, factor VII (10 nmol/L) is an effective competitor of factor VIIa (0.1 nmol/L) for binding to tissue factor. This competition downregulates the level of enzymatically active complex (factor VIIa-tissue factor), thus suppressing initiation of the clotting cascade. Once the extrinsic tenase complex (factor VIIa-tissue factor-Ca²⁺-membrane) activates factor X to factor Xa, tissue factor pathway inhibitor (TFPI) can form a quaternary complex (factor VIIa-tissue factor-factor Xa-TFPI) with no enzymatic activity⁴⁹³ (Fig. 18.6).

Factor IX (Plasma Thromboplastin Component, Christmas Factor, Hemophilia B Factor)

The zymogen factor IX is a single-chain vitamin K-dependent procoagulant glycoprotein synthesized in the liver, which has also been referred to as plasma thromboplastin component, Christmas factor, or hemophilia B factor. It circulates in plasma ($t_{1/2} = 24$ hours⁴⁹⁴) at a mean concentration of 5 µg/ml, or 90 nmol/L, with a relative molecular weight of 55,000⁴⁹⁵ (Table 18.1). In addition, there may be a pool of noncirculating factor IX, which is readily available to the intravascular space, systemically distributed and sequestered either to the endothelial surface⁴⁹⁶ or subendothelial components, specifically collagen IV.^{497,498} and ⁴⁹⁹ High levels of factor IX have been correlated with an increased risk of venous thrombosis.⁵⁰⁰

Deficiency of this glycoprotein, known as hemophilia B, is considered one of the most common inherited coagulation disorders. The factor IX gene, found on the X chromosome, is a

P.449

sex-linked recessive bleeding disorder that is found in males. The frequency of this disorder in the general population is approximately 1 in 30,000 males.^{495,501} It rarely affects females, but several cases have been identified involving a mutation on the factor IX gene.^{502,503} Acquired hemophilia can also occur due to the generation of autoantibodies.⁵⁰⁴ Many mutations, including large deletions, small deletions, point mutations, and missense mutations, have been identified in factor IX that appear to reduce activity in the presence of normal antigen levels (CRM⁺) or impair synthesis resulting in reduction of both activity and antigen (CRM⁻).^{505,506} Several specific cases and studies are noted: X translocation,⁵⁰⁷ links to factor V^{Leiden},⁵⁰⁸ population studies,^{509,510,511} and ⁵¹² and factor IX Denver.⁵¹³ The point mutation called factor IX Denver results in a 100-fold decrease in the binding affinity of factor IXa Denver for factor VIIIa ($K_d = 9.9$ nmol/L) compared to normal factor IXa.⁵¹³ Mutations in the EGF-1-like domain of factor IX, specifically at Gly⁴⁸, have also been identified in CRM⁺ individuals with hemophilia B.⁵¹⁴ Molecular insights into hemophilia B, as well as hemophilia A, have been formatted in reviews with references to accession numbers and locus identification.^{515,516}

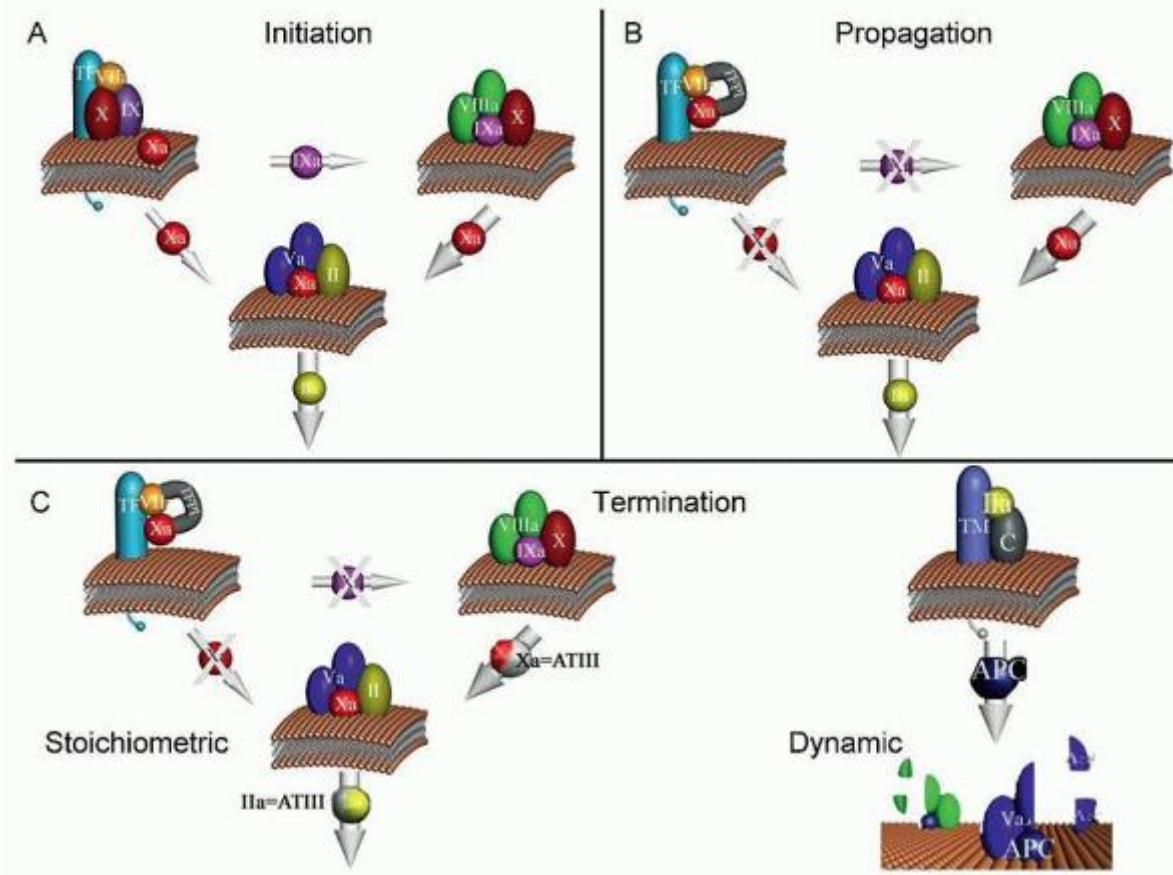

FIGURE 18.6. Regulation of the procoagulant response. Four vitamin K-dependent complexes are illustrated: the extrinsic tenase, the intrinsic tenase, prothrombinase, and protein Case. The procoagulant response is regulated by the stoichiometric inhibitors antithrombin (AT) and tissue factor pathway inhibitor (TFPI). AT inhibits thrombin, factor Xa, and factor IXa that are free in solution. TFPI inhibits both factor Xa and the factor VIIa-tissue factor (TF)-factor Xa complex. Activated protein C (APC) generated from the protein Case complex [thrombomodulin (TM)-thrombin (IIa)] inactivates FVa and FVIIIa by proteolysis of their heavy chains. PC, protein C. Panel A: initiation phase; Panel B: Propagation; Panel C: Termination. (Adapted from Mann KG. Coagulation explosion. Vermont Bus Graph 1997, with permission.)

Hemophiliacs experience prolonged bleeding episodes that can be life threatening and lead to chronic disabilities. The clinical presentation or phenotype is not homogeneous. Severe disease is associated with < 1% functional factor IX, moderate disease with 1% to 5%, and mild disease with 5% to 25%. Female carriers usually have approximately 20% to 50% functional factor IX. Traditionally, treatment for hemophilia B involves plasma-derived or recombinant factor IX.^{517,518} One problem with this therapy is the development of inhibitory antibodies. There is a North American Immune Tolerance Registry to study immune tolerance in hemophiliacs.⁵¹⁹ An alternative treatment in the last decade has been the use of recombinant factor VIIa at supraphysiologic concentrations (~90 µg/kg). These therapies eliminate the immediate danger of bleeding but do not constitute a cure for the patients. The potential for gene-based therapy for the treatment of hemophilia has become a new avenue for investigation.^{520,521,522} and ⁵²³ To date, transgene therapy has proved successful in animal models, and human trials have been initiated as well.^{524,525,526,527,528,529,530} and ^{531,532}

Gene Structure and Expression

The gene for factor IX is located on the X chromosome at position q26.3-27.1, near the factor VIII gene.^{533,534} and ⁵³⁵ The gene contains eight exons and seven introns and has an overall size of 33 kb.^{536,537} Five cis-acting elements have been identified in the promoter region of the factor IX gene.^{536,539} These include binding sites for transcription factor C/EBP,⁵⁴⁰ an HNF-1 binding site,⁵⁴¹ an HNF-4 binding site,⁵⁴² and a site for the D-box binding protein.⁵⁴³ Two essential age-regulatory elements, AE5' and AE3', have been identified in the 5' upstream region of the gene encoding factor IX in transgenic mice.⁵⁴⁴ Together, these elements identify the advancing age-associated increase in factor IX gene expression.

Single point mutations in the factor IX promoter region have been correlated with a rare form of hemophilia B termed hemophilia B Leyden.^{538,545,546} Hemophilia B Leyden is characterized by an altered developmental expression of blood

coagulation factor IX.⁵³⁸ These individuals have increasing levels of factor IX after puberty, or after administration of testosterone, resulting in decreased bleeding instances.^{547,548} Studies in mice support the role of androgen receptor binding to the factor IX promoter in regulating the developmental expression of factor IX.⁵⁴⁹

Biochemistry

The structure of human factor IX consists of 415 amino acids that are separated into a Gla domain (12 Gla residues), two tandem EGF domains (EGF-1 [residues 46 to 84] and EGF-2 [residues 85 to 127]), an activation peptide region, and a serine protease domain^{283,537,550} (Fig. 18.3). Glycosylation in the form of O-linked and N-linked oligosaccharides makes up 17% by weight of the factor IX protein—specifically, O-linked oligosaccharides at Ser⁵³ and Ser⁶¹ in the EGF-1 domain and O-linked and N-linked oligosaccharides at Asn¹⁵⁷, Asn¹⁶⁷, Thr¹⁵⁹, and Thr¹⁶⁹ in the activation peptide region.^{551,552,553} and ⁵⁵⁴ The Gla domains are crucial for binding to anionic lipid membranes through Ca²⁺ interactions. The x-ray crystal structure of human factor IX with Ca²⁺ has shown that EGF-1 binds a single Ca²⁺ with residues Asp⁴⁷, Gly⁴⁸, Gln⁵⁰, Asp⁶⁴, and Asp⁶⁵ functioning as the ligands.^{410,555} Hydrophobic

P.450

interactions⁵⁵⁶ and a salt bridge (Glu⁷⁸-Arg⁹⁴)⁵⁵⁷ between the carboxy end of EGF-1 and EGF-2 have also been identified.³⁷⁹ Ca²⁺ binding and hydrophobic interactions lock the domains in a manner that ensures biologic activity. Several point mutations in the EGF domain give rise to hemophilia B.⁴¹³

Activation

Factor IX activation to its serine protease form, factor IXa, is a two-stage process requiring sequential cleavages at Arg¹⁴⁵ and Arg¹⁸⁰, releasing a 35-residue activation peptide with an approximate molecular weight of 11,000^{558,559} (Fig. 18.3). Physiologic activators of factor IX are either tissue factor-factor VIIa (extrinsic tenase complex)^{482,560} or factor XIa.^{561,562} and ⁵⁶³ The first step in activation is the cleavage by its physiologic activators at the Arg¹⁴⁵-Ala¹⁴⁶ bond, resulting in factor IXa. This cleavage has been shown to be important in its affinity for its cofactor factor VIIIa⁵⁶⁴ and has been identified as a molecular defect in factor IX_{Chapel Hill}.⁵⁶⁵ The second step is cleavage at the Arg¹⁸⁰-Val¹⁸¹ bond, resulting in factor IXα β, the active form, also known as factor IXa. Both cleavages are required for full biologic activity of factor IXa.⁵⁵⁹ In vitro, factor IX has also been shown to be cleaved by factor Xa at Arg¹⁴⁵ on phospholipid membrane surfaces,⁶¹ producing the inactive precursor factor IXα and increasing the overall rate of factor IXa production by tissue factor-factor VIIa. Both cleavage sites, Arg¹⁴⁵ and Arg¹⁸⁰, have been identified as single point mutations in hemophilia B.⁵⁶⁶ The x-ray crystal structure of porcine factor IXa has also been solved.³⁷⁹

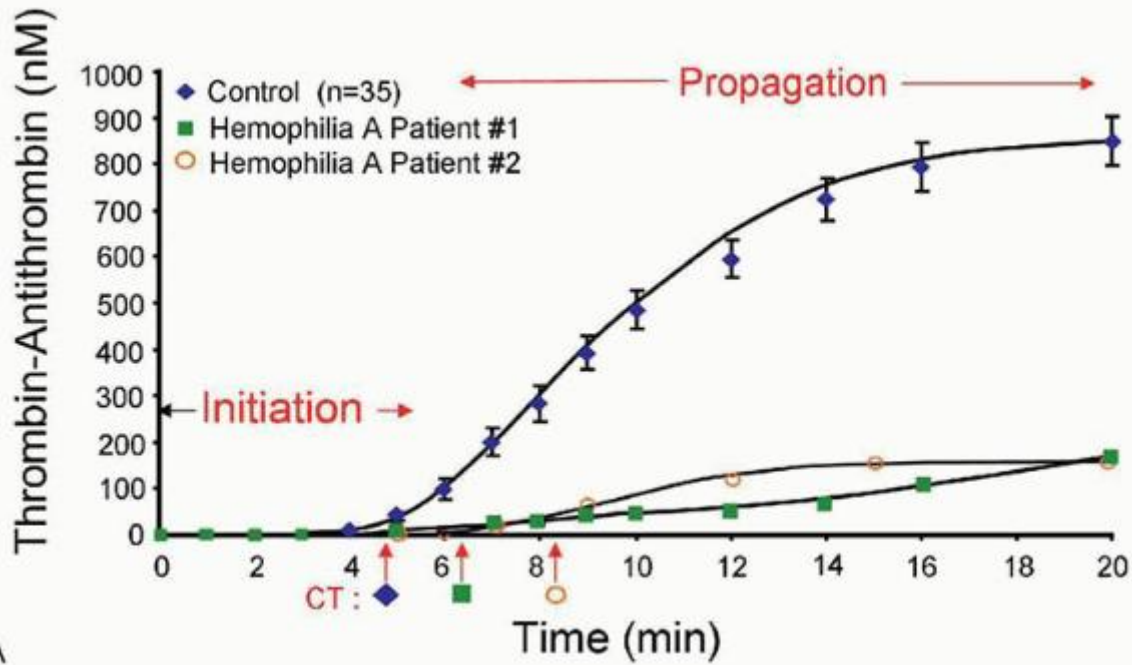

A

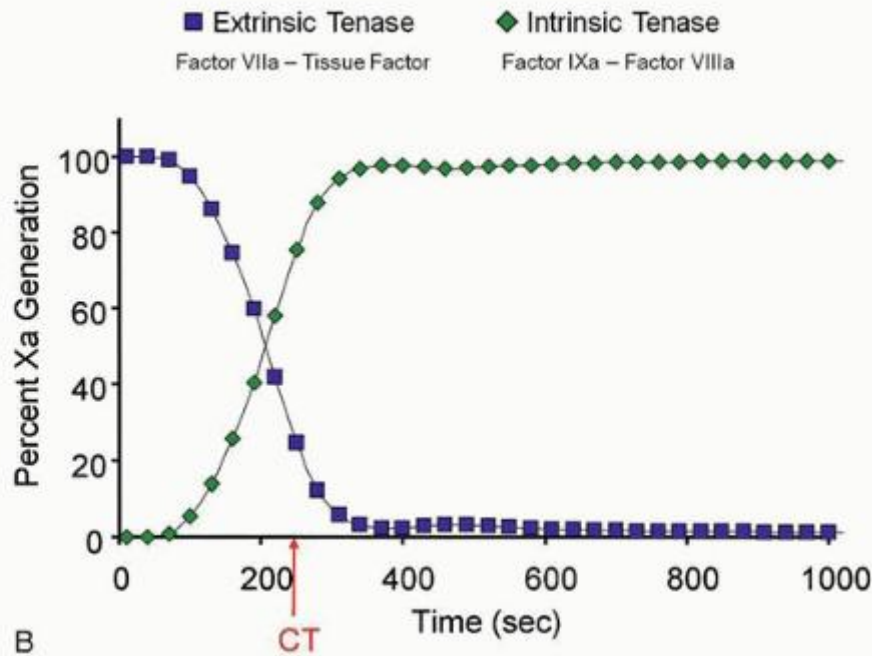

B

FIGURE 18.7. Profiles of thrombin and factor Xa generation. A: Empirical time course (x-axis: 0 to 20 minutes) of thrombin-antithrombin formation (y-axis: nmol/L thrombin-antithrombin complex) during whole blood coagulation initiated with 5 pmol/L tissue factor.⁵⁶⁹ Data represent means plus or minus standard error of the means for 35 individuals; thrombin-antithrombin levels reach maximum levels of 900 nmol/L (blue diamonds) in this group of normal individuals. Clot time (CT) is shown below with the symbols for each curve. Thrombin generation is divided into two phases: an initiation phase and a propagation phase. When two hemophilia A patients were studied (green squares, red circles), CT was delayed, and the propagation phase of thrombin generation was not present.^{446, 568} By not having factor VIIIa present, the intrinsic tenase complex is unable to generate the additional factor Xa that is required for the burst or propagation phase of thrombin generation. B: Computer simulation of the time course of factor Xa generation on activation of the factor VIIa-tissue factor pathway.⁵⁶⁷ Concentrations are expressed as the relative percentage of factor Xa produced by each catalyst at each time point. The factor Xa that is initially produced is via the extrinsic tenase complex. After CT, the majority of factor Xa generated is via the intrinsic Xase. The clot time represents the time point in the computer simulation at which

calculated thrombin levels are comparable to thrombin levels (~10 nmol/L) measured in clotting whole blood (see Fig. 18.11).

The active serine protease ($M_r = 45,000$) structure is composed of a heavy chain ($M_r = 28,000$) and a light chain ($M_r = 17,000$) covalently associated through a disulfide bond. Factor IXa forms the intrinsic tenase complex with its cofactor factor VIIIa, Ca^{2+} , and a membrane surface primarily supplied by platelets (Fig. 18.4). On formation of this complex, factor X is activated to its serine protease form, factor Xa. Factor IXa (the enzyme) alone without its cofactor (factor VIIIa) has poor amidolytic and proteolytic activity (10^7 -fold less activity).

Function

The main role for factor IXa in blood coagulation is to form the intrinsic tenase complex, which efficiently activates factor X to factor Xa. The complex is so named because the components, including the cofactor, are intrinsic to circulating blood, unlike tissue factor, the cofactor for the extrinsic tenase complex. Both complexes activate factor X to factor Xa. The extrinsic tenase complex (factor VIIa-tissue factor- Ca^{2+} -membrane) catalyzes the initial formation (picomolar amounts) of factor Xa, which ultimately participates in prothrombinase complex assembly and the resulting conversion of prothrombin to thrombin, allowing clot formation to occur. The intrinsic tenase complex (factor IXa-factor VIIIa- Ca^{2+} -membrane) generates the second burst of factor Xa that results in the propagation phase of the activation of prothrombin to thrombin (Fig. 18.7).⁵⁶⁷ The intrinsic tenase complex is kinetically more efficient than the extrinsic tenase complex in generating factor Xa. Factor Xa generation by tissue factor-factor VIIa occurs at

P.451

only 1/50th the rate of factor X activation by the factor IXa-factor VIIIa complex.^{61,62} and ⁶³ Without the intrinsic complex being formed, as occurs in situations like hemophilia A or B, factor Xa is not generated in levels sufficient to produce the propagation phase of thrombin generation (Fig. 18.7).^{446,568,569}

When the competitive substrates factors IX and X are simultaneously presented to the extrinsic tenase complex, factor IXa generation is increased, whereas factor Xa generation is suppressed.^{61,62} This occurs because the factor Xa initially produced cleaves factor IX at Arg¹⁴⁵, producing factor IX α . Factor IX α is a better substrate for factor VIIa-tissue factor than factor IX; the intermediate is converted to factor IX $\alpha\beta$ (factor IXa) by cleavage at Arg¹⁸⁰ by factor VIIa-tissue factor. This cooperative enzymatic action results in factor IX being an improved substrate for the extrinsic tenase complex, whereas factor X activation is suppressed.

Regulation

Plasma factor IXa is primarily inhibited by antithrombin⁵⁷⁰ (Fig. 18.6). In vitro experiments conducted on phospholipid vesicles and cell membranes showed that PN2/amyloid β -protein precursor (PN-2/APP) can also inhibit factor IXa.⁵⁷¹ Interestingly, an insect salivary protein, Prolixin-S, has been shown to inhibit factor IXa generation and the intrinsic tenase complex formation.⁵⁷²

One strategy to improve existing antithrombotic therapies has been to develop factor IXa inhibitors⁵⁷³—including the use of monoclonal antibodies that target factor IX/factor IXa^{574,575} or aptamers targeting factor IXa.^{576,577} Currently, problems exist in using direct thrombin inhibitors to regulate thrombin activity. Targeting the end product of an amplifying cascade results in a narrow window of therapeutic dose, which is difficult to achieve in clinical practice.^{578,579} and ⁵⁸⁰ The advantages of regulating events upstream (factor IX/factor IXa; the intrinsic tenase complex) as an approach to antithrombotic therapy would be to potentially produce a partial reduction in the magnitude of thrombin formation.^{581,582}

Factor X (Stuart Factor)

The zymogen factor X, or Stuart factor, is a vitamin K-dependent glycoprotein that is synthesized in the liver.^{560,583} It circulates in plasma at a mean concentration of 10 $\mu\text{g/ml}$ or 170 nmol/L, and has a $t_{1/2}$ of approximately 1.5 days^{494,584,585} (Table 18.1). In the Leiden Thrombophilia study, a population-based case control study on venous thrombosis, high levels of factor X alone predicted the risk of thrombosis but were not a risk factor for venous thrombosis when the levels of other vitamin K-dependent proteins were taken into account.⁵⁸⁶

Factor X deficiency is a rare autosomal recessive disorder with varied phenotype and genotype. Homozygous factor X deficiency has an incidence of 1 in 1 million in the general population.^{587,588} Whereas heterozygotes are often clinically asymptomatic, the most severely affected homozygous individuals exhibit extensive bleeding early in life. Multiple factor X deficiency cases have been identified, and the gene defects have been elucidated in individuals with bleeding tendencies^{589,590,591,592} and ^{593,594,595} and in an individual without a bleeding tendency,⁵⁹⁶ although mutations within the

catalytic domain are not always consistent with the phenotype of the individual.⁵⁹⁷ As with most deficiencies, the level of factor X expression is indicative of the bleeding response. When factor X levels are approximately 1%, bleeding can include hemarthrosis, soft tissue hemorrhage, and menorrhagia. With functional levels above 15%, bleeding is infrequent and usually mild. Acquired factor X deficiency is rare and is usually associated with lightchain amyloidosis.^{598,599} and ⁶⁰⁰ In amyloidosis, factor X is thought to be adsorbed onto extracellular amyloid fibrils, thereby decreasing the circulating factor X level and increasing bleeding. In these cases, replacement with factor X products is not as effective a therapy for deficiency because it is continuously removed from plasma. Treatment of bleeding from factor X deficiency can involve the administration of fresh frozen plasma or prothrombin complex concentrates. No sure venous or arterial thrombotic event has ever been reported in congenital factor X deficiency.⁶⁰¹

The importance of factor X generation is illustrated by transgenic mice with a total deficiency of factor X. Homozygous deficiency ($f^/-$) results in partial embryonic lethality with signs of massive bleeding.^{453,603} Those mice that survive to term die within 5 to 20 days from fatal neonatal bleeding. The lethality of factor X knockout genotype in mice supports the significance of factor X function in hemostasis.

Gene Structure and Expression

The gene for factor X spans 27 kb, is located on chromosome 13 bands q34-qter, and yields a 1.5-kb mRNA^{455,603,604} and ⁶⁰⁵ (Table 18.2). The gene for factor X is located near the gene for factor VII. Studies to elucidate the liver-specific expression of factor X have included the characterization of the human⁶⁰⁶ and murine factor X promoter.⁶⁰⁷ Using a hepatoma cell line that expresses factor X, the first 279 bp of the 5'-flanking sequence upstream from the first AUG proved to be sufficient to confer maximal promoter activity.⁶⁰⁶ From mutagenesis studies, two protein-binding sites within the 279-bp fragment were identified that are critical for promoter activity: CCAAT (at -120 to -116) and ACTTTG (at -56 to -51).⁶⁰⁶ Factor X also lacks a typical TATA box. In the human factor X promoter, the binding proteins HNF-4 (at -73),⁶⁰⁸ nuclear factor-Y (at -128),⁶⁰⁸ GATA-4 (GATA element at -96),⁶⁰⁹ and the Sp family of transcription factors I footprinted sites (at -165 and -195)⁶⁰⁹ have been identified as playing crucial roles in modulating the activity of the proximal promoter of factor X.

Biochemistry

Human factor X is a vitamin K-dependent glycoprotein of molecular weight 59,000 that circulates in plasma (10 µg/ml or 170 nmol/L) as a two-chain molecule composed of a disulfide-linked light chain ($M_r = 16,500$) and heavy chain ($M_r = 42,000$)^{610,611} (Table 18.1). Its structure contains an NH₂-terminal light chain consisting of a Gla domain (11 Gla residues), with a single β-hydroxy aspartic acid residue, and two EGF-like domains (EGF-1 and EGF-2) (Fig. 18.3). The COOH-terminal heavy chain consists of an activation peptide region and a catalytic (serine protease) domain. Most of the carbohydrate moieties (~15%) are located within the heavy chain⁵⁸⁴ in the activation peptide domain.⁶¹² Ca²⁺ binding in the first EGF domain has been proposed to enhance the structural rigidity of the factor X molecule.⁴⁰⁸ Numerous structures of factor Xa (des Gla)³⁷⁸ have been deposited in the Protein Data Bank, the majority of which are bound to inhibitors and have provided insight into specificity and function.⁶¹³

Activation

Factor X is activated to its serine protease form factor Xa through a cleavage of the activation peptide at Arg¹⁹⁴-Ile¹⁹⁵ (Arg⁵²-Ile⁵³ of the heavy chain) (Fig. 18.3). A 52-amino acid activation peptide is released with a relative molecular mass of 12,000. The resulting catalytic serine protease, factor Xa, has a molecular weight of 48,000 and is composed of a light chain ($M_r = 18,000$) and a disulfide-linked heavy chain ($M_r = 30,000$). The activation of factor X is catalyzed by factor VIIa-tissue factor (the extrinsic tenase complex)⁴⁸³ and factor IXa-factor VIIIa (the intrinsic tenase complex).⁶¹⁴ In vitro studies have determined that factor X has to be bound to the membrane before activation.^{45,615}

Function

The main function of factor Xa is to form the prothrombinase complex (factor Xa-factor Va-membrane-Ca²⁺) (Fig. 18.4).
Factor Xa

P.452

is the serine protease enzyme in the prothrombinase complex that catalytically activates prothrombin to thrombin, the key enzyme in blood coagulation. The prothrombinase complex activates prothrombin to thrombin 10⁵-fold faster than factor Xa alone.⁴² Factor Xa is a unique regulatory enzyme in that it is formed through both the extrinsic tenase and intrinsic tenase complexes (as mentioned in the section on Factor IX). During the initial stages of the hemostatic event, low levels of both factor Xa and factor IXa are generated. Once generated, the limited amounts of factor Xa produced by extrinsic tenase bind to available membrane sites and convert picomolar amounts of prothrombin to thrombin^{37,616,617}

(Fig. 18.7B). This thrombin then activates factor VIII⁶¹⁸ and factor V,⁶¹⁹ allowing the initial formation of the intrinsic tenase and prothrombinase complexes. Thus, the time period in which factor Xa directly generates picomolar amounts of thrombin is referred to as the initiation phase of blood coagulation. The burst or propagation phase of thrombin generation is then obtained from additional factor Xa generated via the intrinsic tenase complex (factor IXa-factor VIIIa-Ca²⁺-membrane) (Fig. 18.7). The intrinsic tenase complex activates factor X at a 50- to 100-fold higher rate than the extrinsic tenase complex.^{61,62} and ⁶³ This burst in factor Xa levels overcomes the levels of factor Xa inhibitors, such as TFPI, and achieves maximal prothrombinase activity and propagation of the procoagulant event.

There is evidence that factor Xa can also trigger intracellular signaling events by increasing endothelial cell cytosolic Ca²⁺ and the release of endothelial cell mitogens.⁶²⁰ Mitogenic activity toward smooth muscle cells⁶²¹ and lymphocytes⁶²² has also been identified. Both factor X and factor Xa have been shown to provoke PAR-2 dependent protective signaling responses in endothelial cells.⁶²³ An alternative initiation of factor X to factor Xa has been identified on stimulated cells of monocytic and myeloid differentiation involving the specific adhesive receptor Mac-1.⁶²⁴ A novel factor Xa receptor, effector cell protease receptor-1, has been identified on the surface of a monocytic cell line.⁶²⁵ A platelet factor Xa receptor has been described as important in mediating prothrombin binding via factor Xa binding to platelet factor Va.⁶²⁶

Regulation

Once assembled, the extrinsic tenase (factor VIIa-tissue factor-Ca²⁺-membrane) is rapidly inactivated along with its product factor Xa through the action of TFPI (Fig. 18.6). The factor Xa active site associates with the COOH-terminus of TFPI^{627,628} to localize the TFPI to the membrane. Once localized, the factor Xa-TFPI complex rapidly inactivates tissue factor-factor VIIa, forming a stable quaternary complex, tissue factor-factor VIIa-TFPI-factor Xa. The factor Xa-TFPI complex has been shown to be elevated in cancer patients.⁶²⁹

Factor Xa is also inhibited by antithrombin⁶³⁰ when not in complex with prothrombinase.^{631,632} Its inhibition is enhanced through the use of heparin, which increases the reactivity of antithrombin with its targets (i.e., factor Xa).

Because factor Xa is a major player in the coagulation cascade, it is a target for regulation by synthetic inhibitors in treating ischemic heart disease and cerebrovascular disease. Many studies are currently underway to develop a new class of antithrombotic agents that target factor Xa.^{633,634,635,636} and ^{637,638,639}

Factor II (Prothrombin)

Factor II, or prothrombin, is a single-chain vitamin K-dependent zymogen that, when activated, yields factor IIa (thrombin), the key enzyme in blood coagulation. The zymogen prothrombin (M_r = 72,000, 8% carbohydrate) is the most abundant of the vitamin K-dependent proteins and circulates in plasma at a mean concentration of 1.4 μmol/L or 100 μg/ml^{640,641} and ⁶⁴² (Table 18.1). Prothrombin is primarily synthesized in the liver with a t_{1/2} of approximately 2.5 days. Low levels of prothrombin expression have been identified in other tissues including brain, diaphragm, stomach, kidney, spleen, intestine, uterine, placental, and adrenal.^{643,644} Increased prothrombin levels have been associated with an increased risk of venous thrombosis.

Human prothrombin deficiency, first described by Quick in 1943,²⁷ is rare because of the autosomal nature of its expression. Prothrombin deficiencies are classified as either hypoprothrombinemia or dysprothrombinemia and occur due to genetic disorders affecting either transcriptional regulation or protein function.^{645,646} These disorders are characterized by variable pathologies extending from mild bruising to clinically severe bleeding.⁶⁴⁷ Homozygotes are characterized by severe bleeding, and heterozygotes either have mild bleeding or are asymptomatic. Prothrombin complex concentrates have been used for prophylaxis and bleeding episodes in individuals with prothrombin deficiency.⁴³⁰ The importance of α-thrombin to hemostasis is demonstrated in prothrombin-deficient mice, which experience embryonic and neonatal lethality.^{648,649} and ⁶⁵⁰

Gene Structure and Expression

The 21-kb human prothrombin gene is located on chromosome 11 bands p11-q12 and has been extensively studied.^{651,652,653,654} The prothrombin gene contains 14 exons and 13 introns⁶⁵² and is transcribed as a prepropeptide of 622 amino acids.^{653,654} The 43-amino acid propeptide mediates posttranslational processing to generate the mature protein of 579 amino acids. The promoter region of the prothrombin gene lacks a TATA box.

Many studies have been conducted on prothrombin gene polymorphisms to determine their relationships to thrombophilia. One common polymorphism is the G20210A transition in the 3'-untranslated region of the promoter. This mutation has been linked to familial thrombosis. The G20210A polymorphism of the prothrombin gene has been associated with elevated prothrombin levels and an increased risk for venous thrombosis.⁶⁵⁵ It is one of the most commonly identified genetic risk factors for thrombosis. An additional polymorphism, A19911G, in the prothrombin gene

has been identified that can modulate the risk of the G20210A polymorphism in developing deep vein thrombosis.⁶⁵⁶ Several reviews have been written on the influence of genetic polymorphisms (including the prothrombin G20210A) and the laboratory diagnosis of thrombophilia.^{657,658} and ⁶⁵⁹

Biochemistry

Initial observations about the structure/function relationship of the prothrombin molecule came about from the partial primary structures of bovine and human prothrombins. Subsequently, the complete primary structure of human prothrombin 2 (residues 272 to 579), which is the precursor of thrombin, was determined.⁶⁶⁰ Finally, the primary structure for bovine prothrombin⁶⁶¹ and human prothrombin⁶⁵⁴ were deduced from isolated cDNAs. The elucidated structure of human prothrombin is characterized by an NH₂-terminal Gla domain (residues 1 to 40 with 10 Gla residues), followed by two kringle domains (kringle 1, residues 65 to 143; kringle 2, residues 170 to 248) and the serine protease precursor domain (residues 272 to 579). Human prothrombin has three N-linked sugar chains—two in the first kringle domain and one in the catalytic domain.⁶⁶²

The first x-ray crystal structure of a blood coagulation protein fragment, bovine prothrombin kringle 1, was determined in Tulinsky's laboratory in 1986.³⁷¹ Kringles have been identified as common motifs in many plasma proteins, including prothrombin, plasminogen, t-PA, urokinase, factor XII, and apolipoprotein A.^{663,664} The kringle 1 domain contains four cysteine residues participating in two disulfide bonds. The role of the kringle 1 domain of prothrombin is still unclear, but it has been suggested that it is

P.453

involved with the interaction of prothrombin and factor Va in the prothrombinase complex.^{665,666} The NH₂-terminal Gla domain and the first kringle domain together are referred to as prothrombin fragment 1. The kringle 2 domain of human prothrombin, located in prothrombin fragment 2 (residues 156 to 271), is similar in sequence and presumably in structure. The kringle 2 domain also binds Ca²⁺ and appears to be the primary region in prothrombin that mediates the interaction of the prothrombin molecule with factor Va in the prothrombinase complex.^{667,668} This latter interaction has been suggested to initiate conformational changes that make reaction sites accessible for enzymatic cleavage of prothrombin.⁶⁶⁹ The sequence of the enzyme α -thrombin is contained within prothrombin 2 (residues 272 to 579).

Activation

Prothrombin is activated to the procoagulant α -thrombin by two cleavages: one at Arg²⁷¹-Thr²⁷² and another at Arg³²⁰-Ile³²¹ by the prothrombinase complex (factor Xa-factor Va-phospholipid membrane-Ca²⁺) (Fig. 18.3). Membrane-bound factor Va serves as the receptor for factor Xa, the catalytic serine protease. The rate of α -thrombin generation by prothrombinase is 3×10^5 -fold faster than the rate for factor Xa alone at potential physiologic concentrations of the proteins.⁴² Recent studies have indicated that the order of these two cleavages differs depending on the cell surface upon which prothrombinase is assembled.^{670,671}

On synthetic phospholipid vesicles, the activation of prothrombin by prothrombinase proceeds through an initial cleavage of prothrombin at Arg³²⁰-Ile³²¹, giving rise to meizothrombin, a twochain disulfide-linked molecule (Fig. 18.8; pathway A, cleavage at 1).⁶⁷² The probable mechanism involves meizothrombin dissociating from prothrombinase with a subsequent rebinding step and conversion to α -thrombin.^{672,673} Meizothrombin expresses some of the activities of α -thrombin. However, meizothrombin has impaired fibrinogen clotting ability compared to α -thrombin.⁶⁷⁴ Meizothrombin is subsequently cleaved at Arg²⁷¹-Thr²⁷² (Fig. 18.8; pathway A, cleavage at 2), yielding the NH₂-terminal half of the molecule, consisting of the Gla domain and two kringle domains (prothrombin fragment 1.2: residues 1 to 271) and α -thrombin. α -Thrombin consists of an NH₂-terminal 49-residue A-chain (residues 272 to 320) disulfide-linked to a COOH-terminal 259-residue B-chain (residues 321 to 579) containing the catalytic triad.

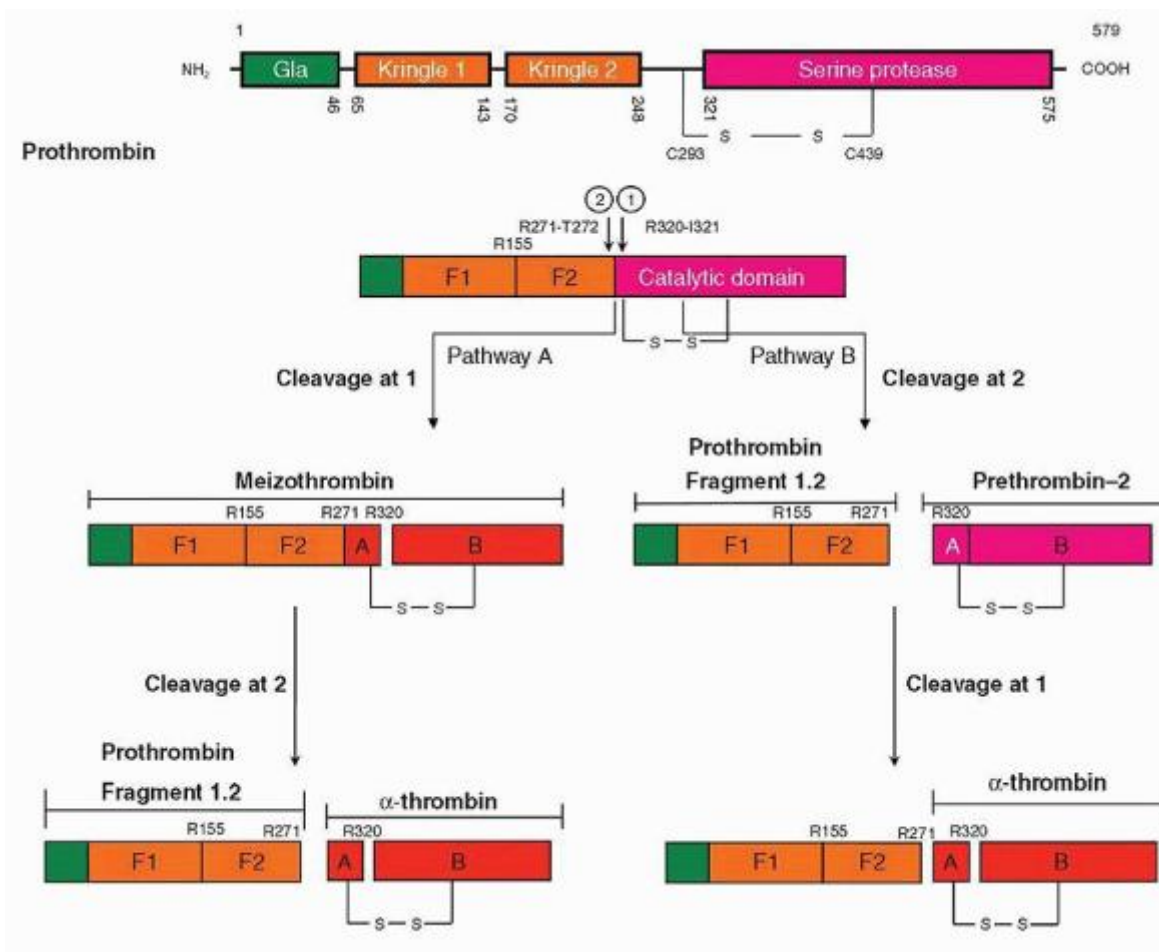

FIGURE 18.8. Schematic representation of the pathways for prothrombin activation. The generation of α -thrombin from its zymogen precursor prothrombin by factor Xa involves the cleavage of two peptide bonds. The reaction begins either via step 1 (cleavage at R³²⁰-I³²¹) or step 2 (cleavage at R²⁷¹-T²⁷²). Cleavage at 1 (R³²⁰), pathway A, produces meizothrombin. Meizothrombin is composed of a prothrombin fragment consisting of fragment 1 (F1, residues 1 to 155: Gla domain + kringle 1), fragment 2 (F2, residues 156 to 271: kringle 2), and residues 272 to 320 (A-chain) linked by a disulfide bond to the catalytic domain (B-chain). Subsequent cleavage at R²⁷¹ (cleavage at 2, pathway A) generates prothrombin fragment 1.2 (F1 and F2) and the disulfide-linked heterodimer α -thrombin (A- and B-chains). In pathway B cleavage occurs first at 2 (R²⁷¹), generating prothrombin fragment 1.2 (F1 and F2) and prethrombin-2. Subsequent cleavage at R³²⁰ produces the A- and B-chains of α -thrombin.

An alternative cleavage pathway occurs when factor Xa alone acts on prothrombin or when prothrombinase is assembled on washed platelets.⁶⁷⁰ In the presence of factor Xa, Ca²⁺, and an appropriate membrane surface, the initial cleavage occurs at Arg²⁷¹-Thr²⁷² and gives rise to prothrombin fragment 1.2 and prethrombin 2 (Fig. 18.8; pathway B, cleavage at 2). Cleavage at Arg³²⁰ in prethrombin 2 (Fig. 18.8; pathway B, cleavage at 2) yields α -thrombin. In contrast to the meizothrombin pathway, the prethrombin 2 intermediate appears not to dissociate from prothrombinase.⁶⁷⁵ Prothrombin fragment 1.2 remains noncovalently associated with α -thrombin. In vitro, α -thrombin is associated ($K_d = 10$ nmol/L) with prothrombin fragment 2,⁶⁷⁶ or the latter's precursor prothrombin fragment 1.2, or both.⁶⁷⁷ In contrast to other vitamin K-dependent proteins, the phospholipid-binding region is no longer covalently attached to the serine protease domain after prothrombin conversion to thrombin.

Thrombin and meizothrombin catalyze cleavage at Arg¹⁵⁵ of prothrombin, yielding a truncated molecule called prethrombin 1 (residues 156 to 579) that lacks the Gla domain. Thrombin can also cleave at Arg²⁸⁴, yielding a truncated α -thrombin species (residues 284 to 579), which is the form of thrombin found in commercial preparations.

The membrane surface that supports the prothrombinase complex in vivo has traditionally been assumed to be primarily provided by platelets, but can also be provided by other circulating blood cells, such as monocytes and lymphocytes, and by vascular endothelial cells.⁶⁷⁸ Since prothrombin activation on platelets proceeds through the prothrombin 2 pathway

and meizothrombin formation has been observed in clotting blood,^{671,679} it appears that prothrombin activation in blood involve both pathways. Prothrombin activation through the meizothrombin pathway has been reported to occur on the subpopulation of red blood cells that express phosphatidylserine on their surface.⁶⁷¹

P.454

Function

α -Thrombin can be considered the central enzyme in blood coagulation in that it contributes to reactions at all levels, allowing for the overall maintenance of vascular fidelity. Its main role is in stemming blood loss through fibrin clot formation.⁶⁸⁰ The series of events that leads up to and occurs after fibrin formation also involves protein activation by α -thrombin. This includes activation of platelets,⁶⁸¹ factor VII,⁸ factor V,⁶⁸² factor VIII,⁶⁸³ factor XI,⁷ and factor XIII.¹⁷ α -Thrombin activity also extends from the procoagulant process to anticoagulation and suppression of fibrinolytic reactions. For example, α -thrombin-thrombomodulin activates the anticoagulant protein, protein C,⁶⁸⁴ and the antifibrinolytic protein, TAFI.³⁶

Relatively minute concentrations of thrombin are generated during the initiation phase of blood coagulation, primarily due to the factor Xa generated from the extrinsic tenase complex (Fig. 18.7). These levels of thrombin, in the range of 0.5 to 2.0 nmol/L, have been shown to be sufficient for the initiation of rapid activation of platelets, factor XIII and factor V, and fibrin formation in an ex vivo whole blood model.⁵⁶⁹ All of these processes occur before the major burst of thrombin generation during the propagation phase of the reaction.

α -Thrombin's role continues into the tissue repair and remodeling phase that is necessary to regenerate damaged vascular tissue. α -Thrombin is a potent mitogen^{685,686} and stimulates cell division in macrophages,⁶⁸⁷ smooth muscle cells,⁶⁸⁸ and endothelial cells.⁶⁸⁹ α -Thrombin also appears to be involved in the growth and metastasis of tumors by promoting angiogenesis,^{690,691} possibly through vascular endothelial growth factor.⁶⁹² The roles that thrombin plays in coagulation and beyond are outlined in a recent review.⁶⁹³

Regulation

In vivo, the activity of the prothrombinase complex has to be tightly regulated to ensure that adequate but limited levels of α -thrombin are generated. If too much α -thrombin is continuously generated, localized clot formation can lead to occlusion or systemic thrombosis. Equally, if too little α -thrombin is generated, hemorrhagic conditions result. Two reaction systems, one covalent and one proteolytic, regulate α -thrombin generation. Antithrombin-heparin (or heparan sulfate) is a potent inhibitor of blood coagulation and inhibits both α -thrombin and factor Xa via covalent interactions.^{694,695} α -Thrombin also participates in its own downregulation by binding to thrombomodulin on the vascular cell surface and converting protein C to APC. This anticoagulant serine protease then cleaves factors Va and VIIIa. These cofactors for the vitamin K-dependent complexes are no longer available for ongoing reactions, thereby eliminating α -thrombin generation. In ex vivo models of blood coagulation, prothrombin levels and antithrombin appear to have the most significant impact on α -thrombin generation.⁶⁹⁶ Increased levels of antithrombin reduce α -thrombin generation by inhibiting α -thrombin activity and preventing positive feedback.⁶⁹⁶ Decreased levels of antithrombin allow for higher levels of prothrombin activation and prolongation of α -thrombin generation.⁶⁹⁶

PROCOAGULANT PROTEINS: PROCOAGULANT COFACTOR PROTEINS

There are two categories of cofactor proteins: the plasma-derived soluble procoagulant procofactors factors V and VIII (and their circulating carrier von Willebrand factor [vWF]), and the cell-associated coagulation cofactor, tissue factor. Factors V and VIII are highly homologous (40% identity), sharing many structural and functional similarities. Tissue factor is a single-chain transmembrane protein that is composed of extracellular, transmembrane, and cytoplasmic domains.

Tissue Factor (Tissue Thromboplastin, CD142, Coagulation Factor III)

Tissue factor, also known as tissue thromboplastin, CD142, and coagulation factor III, is a transmembrane protein that functions as a nonenzymatic cofactor for factor VIIa in the extrinsic tenase complex. In the absence of injury or stimulus, tissue factor is not ordinarily expressed on cellular surfaces in direct contact with circulating blood. Presentation of tissue factor to the circulation is the event that triggers the procoagulant primary pathway of coagulation (Fig. 18.1). There are no known mutations or deficiencies of human tissue factor, leading to the speculation that tissue factor is essential for life. In mice, inactivation of the tissue factor gene to create homozygous tissue factor-null mice proves to be lethal during embryonic development.^{697,698,699,700}

Gene Structure and Expression

The tissue factor gene is located on chromosome 1p21-22^{701,702} and spans 12.4 kb (Table 18.2). The gene contains five introns and six exons.⁷⁰³ Tissue factor expression can be induced in a number of cultured cell types. Fibroblasts express tissue factor on exposure to serum or mitogenic cytokines,^{704,705} as do vascular smooth muscle cells and keratinocytes.^{706,707} Monocytic cells and monocytes isolated from peripheral blood also express tissue factor when stimulated by bacterial endotoxin or other proinflammatory agents.^{706,707} The presence of these cells may be associated with DIC.⁷⁰⁸ In vitro, certain leukemic cell lines constitutively express low levels of tissue factor.^{709,710} and ⁷¹¹ Tissue factor expression by circulating and nonvascular cells plays key roles in cancer, sepsis, and perhaps atherosclerotic plaque formation.^{56,712,713,714,715} and ⁷¹⁶ However, tissue factor in the subendothelial cell layer is proposed to trigger coagulation on exposure to the circulation. Cultured vascular endothelial cells express tissue factor on stimulation by IL-1, tumor necrosis factor (TNF)- α , and bacterial endotoxin.^{706,707} In vivo, there is little or no detectable tissue factor expression on unstimulated endothelial cells. Certain conditions such as sepsis, placental villitis and graft rejection induce tissue factor expression on endothelial cells in vivo.^{708,717,718} and ⁷¹⁹ The mechanism governing tissue factor expression under nonpathologic conditions is presently unknown. Studies of transcriptional control of tissue factor expression in various cell lines have demonstrated that Sp1 sites are important in basal transcription of the tissue factor gene. EGR-1, activation peptide-1, and NF- κ β sites mediate tissue factor expression in response to pathologic stimulation.^{699,720,721,722,723} and ⁷²⁴

Biochemistry

Tissue factor is a single-chain glycoprotein ($M_r = 44,000$)⁷²⁵ of 261 or 263 amino acids (Table 18.1). It is synthesized with a signal peptide of 32 amino acids. The variability in protein size is due to heterogeneity at the NH₂-terminus.^{701,726,727} Tissue factor is a member of the class 2 cytokine receptor superfamily⁷²⁸ and a type I integral membrane protein. The type I designation refers to the location of the NH₂- and COOH-termini. The NH₂-terminus of tissue factor (residues 1 to 219) is extracellular, whereas the COOH-terminus of the protein is intracellular (residues 243 to 263). Tissue factor also contains a hydrophobic membrane-spanning domain (residues 220 to 242) (Fig. 18.9). This domain appears to function solely to anchor tissue factor in the membrane.⁷²⁹ The NH₂-terminal domain of tissue factor is composed of two fibronectin type III domains and is glycosylated at Asn¹¹, Asn¹²⁴, and Asn¹³⁷.⁷³⁰ X-ray crystal structures of tissue factor show that the two fibronectin type III domains are joined at an angle of approximately 120°.^{731,732,733,734,735} and ⁷³⁶ There are also two disulfide bonds (Cys⁴⁹-Cys⁵⁷

P.455

P.456

and Cys¹⁸⁶-Cys²⁰⁹) in the NH₂-terminal extracellular region.⁷³⁷ At least one of the disulfide bonds is required for tissue factor activity. Early studies suggested that glycosylation does not appear to play a key role in determining protein function^{730,738,739}; however, more recent work indicates that glycosylation⁷⁴⁰ and other posttranslational modifications^{741,742} play important roles in modulating tissue factor biological activities. The COOH-terminal cytoplasmic domain is quite short and contains a single cysteine residue (Cys²⁴⁵) that is linked to a palmitate or stearate fatty acyl chain via a thioester bond.⁷³⁷ The COOH-terminus also contains a serine that may be phosphorylated.⁷⁴³ The function of the COOH-terminus and the importance of these two modifications are not clear, as deletion of this domain has no significant effect on tissue factor procoagulant activity.⁷²⁹

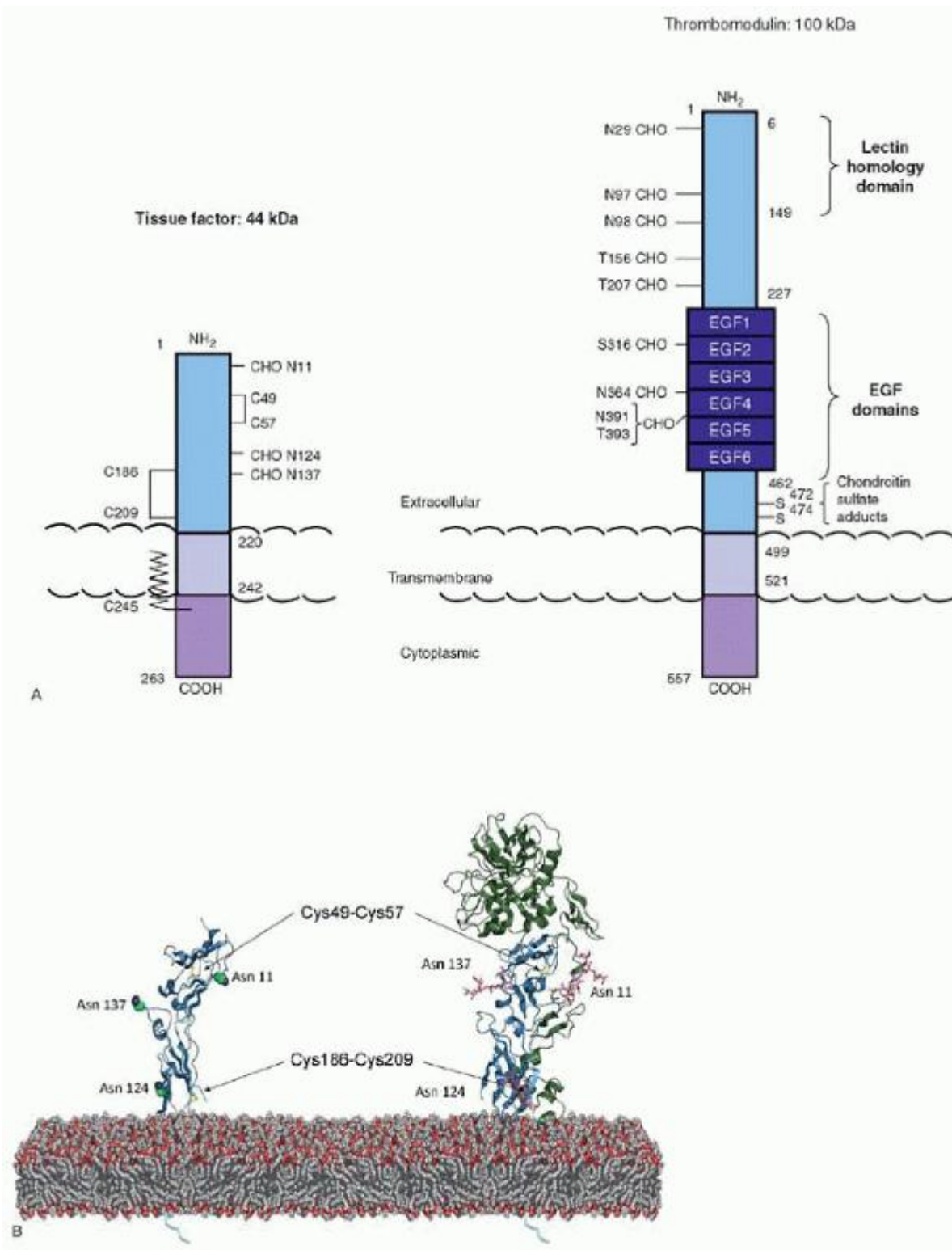

FIGURE 18.9. Transmembrane cofactors. A: Schematics of tissue factor and thrombomodulin. Tissue factor is composed of an extracellular domain (residues 1 to 219), a transmembrane domain (residues 220 to 242), and a cytoplasmic domain (residues 243 to 263). Two disulfide bonds (S-S) and the sites of the three carbohydrate moieties (CHO) are identified by amino acid residue. One cysteine (C²⁴⁵) contains a thiol ester linkage to a fatty acid. Tissue factor is the cofactor for factor VIIa in the extrinsic tenase complex and is exposed on the subendothelial surface after injury. Thrombomodulin is an endothelial cell surface glycoprotein composed of five distinct domains. The domain structures include a lectinlike domain (residues 6 to 149), a domain containing six epidermal growth factor (EGF)-like regions (residues 227 to 462), a small

extracellular domain rich in threonine and serine residues (two residues, S⁴⁷² and S⁴⁷⁴, have been identified as sites of chondroitin sulfate adducts), a membrane-spanning region (residues 499 to 521), and a cytoplasmic tail (residues 522 to 557). There are nine known glycosylation sites (CHO) on the thrombomodulin molecule. Thrombomodulin functions as the cofactor in the protein Case complex and assists in the generation of activated protein C. B: Structural ribbon diagram of tissue factor (blue) (PDB-ID: 2HFT)⁷³³ and tissue factor and factor VIIa (green) (PDB-ID: 1DAN).⁴⁷¹ The tissue factor carbohydrate side chains have been added to the structure.⁷⁴⁰

Function

The nonenzymatic cofactor tissue factor can bind either factor VII or factor VIIa in a Ca²⁺-dependent manner and form a highaffinity 1:1 complex. Once bound to tissue factor, the zymogen factor VII is rapidly converted to an active enzyme via limited proteolysis.⁷⁴⁴ The tissue factor-factor VIIa, or extrinsic tenase complex, activates factors IX and X. When tissue factor is exposed or expressed, or both, subsequent to vascular perturbation, low levels of circulating factor VIIa bind to tissue factor, and the extrinsic tenase triggers the procoagulant cascade. Factor VII bound to tissue factor is converted to factor VIIa, augmenting factors IXa and Xa generation. The primary role of the complex is to provide factor IXa and low levels of factor Xa, which serve to promote factor IXa production^{61,62} and^{63,487} and to directly catalyze the conversion of trace amounts of prothrombin to thrombin.

In the absence of tissue factor, factor VIIa is relatively inert. Once bound to tissue factor, the catalytic activity of factor VIIa is increased 20- to 100-fold with low-molecular-weight substrates^{476,745,746} and⁷⁴⁷ and approximately 10⁴-fold with its macromolecular substrates factors X and IX.^{745,747,748} Tissue factor alters the active site of factor VIIa, thus functioning as an allosteric activator of the enzyme.

Although the cofactor is necessary for enzymatic activity, complex formation between tissue factor and factor VIIa does not share the same requirements for an anionic phospholipid membrane surface as the other procoagulant complexes. The membrane dependency of the extrinsic tenase complex arises from membrane-mediated substrate delivery. Both factors X and IX bind to anionic membrane surfaces for efficient two-dimensional transfer to the extrinsic tenase.

An additional role for tissue factor-factor VIIa beyond its activation of the coagulation cascade involves triggering signaling through the G-protein-coupled, protease-activated receptor 2, which is relevant to inflammation and angiogenesis.^{749,750}

Regulation

Tissue factor activity is regulated by controlling its presentation. The common accepted source of functional tissue factor is through exposure of the subendothelium on vascular damage. However, there is controversy regarding the source and presentation of active tissue factor and whether functional tissue factor circulates in blood in healthy individuals or only in those with pathologies.^{751,752,753,754} Tissue factor function has been reported to be under the control of an allosteric disulfide bond.^{750,755,756} Once the tissue factor-factor VIIa complex is formed in the vicinity of an injury, the extrinsic tenase activity is then modulated by TFPI and antithrombin reduction of enzymatic activity.

Factor VIII (Antihemophilic Factor, Factor VIII:Antigen, Factor VIII:Coagulant)

Factor VIII, or antihemophilic factor, is a nonenzymatic procofactor that circulates in plasma in complex with the large multimeric protein vWF. Initially, factor VIII and vWF were thought to be a single entity, and early reports on factor VIII were actually measuring facets of vWF structure and function. The factor VIII protein is designated as factor VIII:Ag (antigen; VIII:Ag is vWF), and its procoagulant function is designated factor VIII:C (coagulant).⁷⁵⁷ Factor VIII circulates at an average concentration of 0.2 µg/ml (0.7 nmol/L; Table 18.1). The ratio of factor VIII to vWF is fairly constant and in the range of 1 molecule of factor VIII to 50 to 100 molecules of vWF monomeric units.^{758,759} vWF acts to regulate the plasma concentration of factor VIII. 1-Deamino-8-d-arginine vasopressin administration elicits an increase in the plasma concentration of vWF and, in turn, increases the plasma level of factor VIII.⁷⁶⁰ vWF also stabilizes factor VIII in plasma. Factor VIII in complex with vWF has a plasma t_{1/2} of approximately 12 hours, whereas factor VIII alone undergoes rapid clearance and has a t_{1/2} of approximately 2 hours.^{761,762,763} and⁷⁶⁴ Deficiency of factor VIII, or hemophilia A, is a well-characterized bleeding disorder linked to the X chromosome. Hemophilia A, therefore, occurs almost exclusively in males and occurs at a frequency of 1:5,000 to 1:10,000 males. Females with one abnormal factor VIII gene are unaffected carriers. The severity of bleeding in hemophilia A patients is correlated with the level of functional factor VIII in plasma.^{765,766} Approximately 50% to 60% of hemophilia A cases are severe, with factor VIII coagulant activity < 1% of normal. Severe hemophilia A is manifested in frequent episodes of spontaneous bleeding into joints, muscles, and internal organs. Factor VIII coagulant activity in the range of 1% to 5% of normal (25% to 30% of patients) results in moderate hemophilia A. In the moderate form, abnormal bleeding is generally linked to any trauma, including minor injury. The remaining patients have 6% to 30% of normal factor VIII activity and exhibit mild hemophilia A. In the mild form, factor VIII deficiency results in bleeding events only subsequent to significant trauma or surgery.⁷⁶⁷

Gene Structure and Expression

The factor VIII gene has been mapped to the long arm of the X chromosome in band q28.^{768,769,770,771,772} The factor VIII gene is 186 kb in length and contains 25 introns and 26 exons.^{9,770,773} The liver and spleen are thought to be the primary sites of factor VIII biosynthesis,^{774,775,776,777,778,779} and⁷⁸⁰ although factor VIII mRNA has been detected in other cell types as well.⁷⁸⁰

Biochemistry

Human factor VIII has a relative molecular weight in the range of 280,000 (Table 18.1). The heterogeneity in molecular weight is due to proteolysis of the protein in circulation or processing,⁸ or both. It is a glycoprotein of 2,351 amino acids that is synthesized as a precursor molecule with a 19-amino acid signal peptide.^{9,781} The sequence of factor VIII is highly homologous to factor V.⁷⁸² The procofactors factors VIII and V are organized into discrete structural domains. The NH₂-terminal heavy chains of both proteins contain the A1 and A2 domains (Fig. 18.10). The COOH-terminal light chains contain the A3, C1, and C2 domains. The heavy and light chains are separated by the B domain. The three A domains of factor VIII are homologous to each other and to the A domains of factor V and ceruloplasmin.^{781,782,782a} The C domains of factor VIII are homologous to each other and to the C domains of factor V. The C domains are also homologous to milk fat globule protein and the A-, C-, and D-chains of discoidin 1.^{784,785} The B domain of factor VIII is not homologous to the factor V B domain, nor do the B domains of either protein share homology with any known proteins.

The factor VIII molecule is secreted as a two-chain heterodimer as a result of intracellular proteolysis at the B-A3 junction (Arg¹⁶⁴⁹). Additional cleavages within the B-chain yield A1-A2-B fragments that are variable in length.^{786,787,788} and⁷⁸⁹ The B domain

P.457

P.458

(residues 741 to 1,649) contains 18 of the 25 potential N-linked glycosylation sites in factor VIII and is highly glycosylated. The murine factor VIII B-chain is also heavily glycosylated, suggesting that glycosylation of the B-chain may be important for protein expression or function, or both.⁷⁸⁹ The B domains of factors VIII and V are excised during activation of the proteins to generate the cofactor molecules factors VIIIa and Va.

Factor VIII: 280 kDa

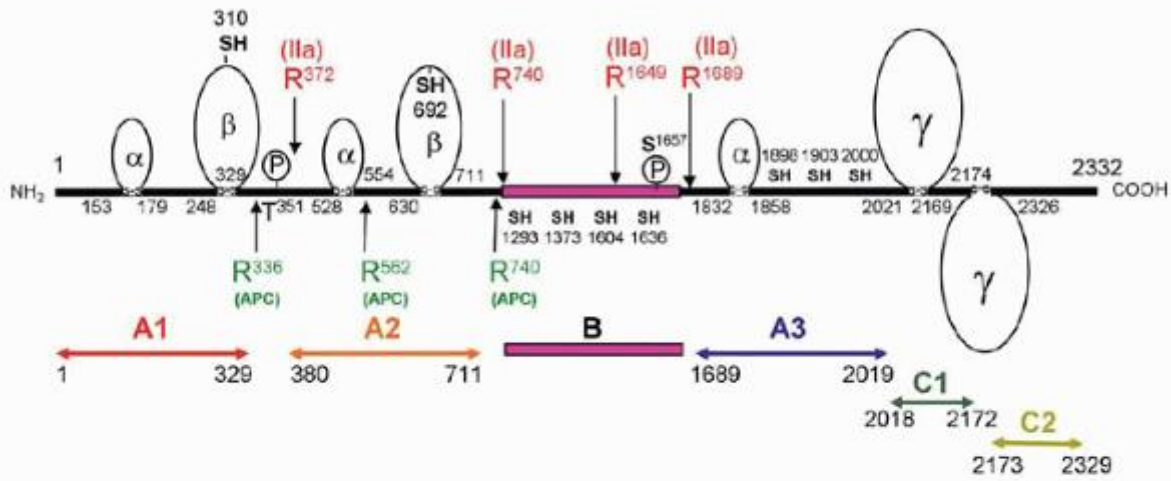

Factor V: 330 kDa

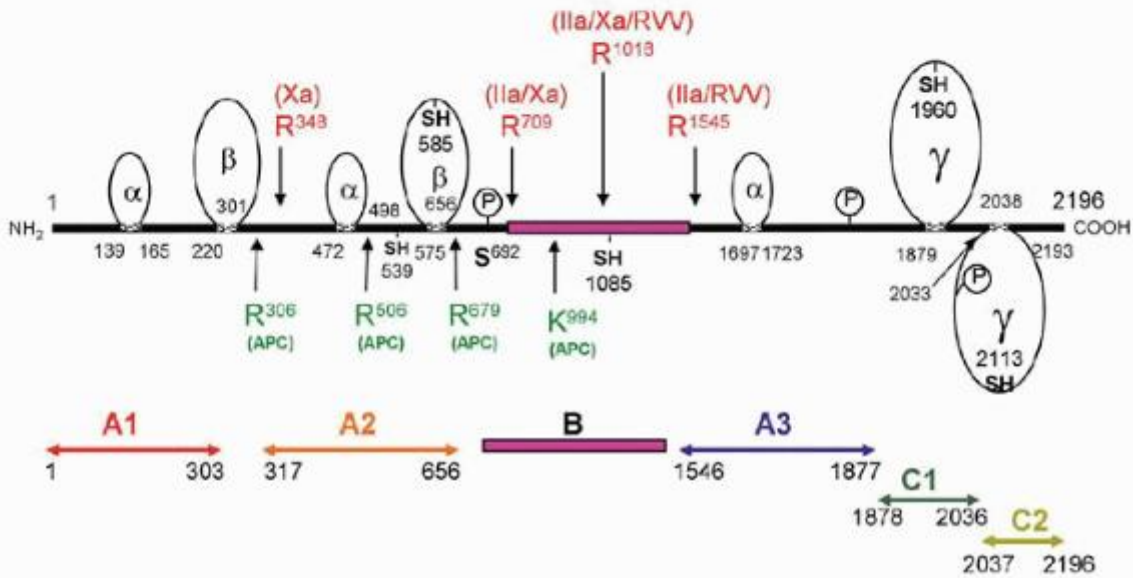

A

FIGURE 18.10. Soluble cofactors. A: Domain structures of the soluble cofactors factor VIII and factor V. The disulfide loop structures of factor VIII and factor V defining the α , β , and γ loops are illustrated as bubbles. α -Thrombin (IIa), activated protein C (APC), factor Xa, and Russell viper venom (RVV) cleavage sites are shown with vertical arrows. The linear domain structures (A1-A2-A3-C1-C2) are illustrated with horizontal arrows bracketed by the beginning and ending amino acid number. The B regions (factor V, residues 710 to 1,545; factor VIII, residues 741 to 1,649) are represented by the crosshatched regions. Phosphorylation sites are illustrated by a P inscribed in a circle and the phosphoamino acid, serine (S) or threonine (T), illustrated above or below it. Free cysteine thiols are represented by SH and identified by residue number. B: Crystal structures. Bovine factor Va des-A2 (PDB-ID: 1SDD)865 and human factor VIIIa (PDB-ID: 2R7E).⁷⁸³

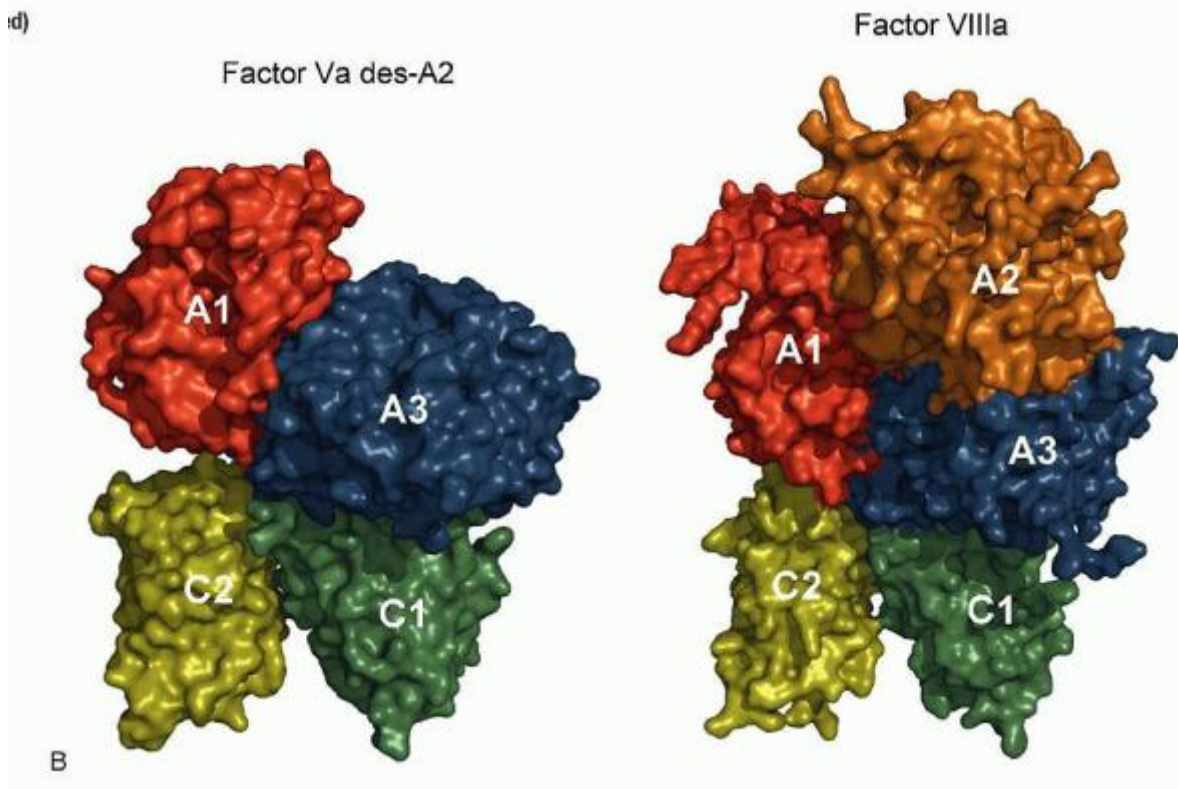

FIGURE 18.10. (Continued)

Factor VIII shares homology with the copper ion (Cu^+)-binding protein ceruloplasmin and contains a Cu^+ -binding site in the A1 domain.^{790,791} This site is important for protein function. A similar Cu^+ -binding site in the A3 domain does not appear to play a role in protein function.

Factor VIII also contains binding sites for vWF, anionic phospholipids, factor IXa, and, potentially, factor X. Factor VIII interaction with vWF requires the NH_2 - and COOH -termini of the factor VIII light chain (A3, C1, and C2 domains), although a specific vWF-binding site has been identified at residues 1,673 to 1,684 on the light chain.^{758,792,793} and ⁷⁹⁴ The vWF-binding site is removed from the factor VIII protein by α -thrombin cleavage at Arg¹⁶⁸⁹. A phospholipid-binding domain is located on the factor VIII C2 domain at residues 2,303 to 2,332.⁷⁹⁵ High-affinity factor IXa binding is mediated by the light chain of the factor VIII molecule. The A3 domain contains a high-affinity site for factor IXa localized at residues Glu¹⁸¹¹ to Lys^{1818, 796,797}. Residues 552 to 565 in the A2 domain of the factor VIII heavy chain may also play a role in factor VIII interaction with factor IXa.^{798,799} and ⁸⁰⁰ Mutations within this region have been documented in the hemophilia A mutation database.⁸⁰¹ Specifically, Ser558Phe, Val559Ala, Asp560Ala, and Gln565Arg have been described as CRM⁺ with defective activity resulting in mild hemophilia A. These residues have been shown to be essential for the catalytic efficiency of the factor VIIIa-factor IXa complex while not affecting the binding affinity between the two species.⁸⁰² A model of factor VIII based on the x-ray crystal structure of ceruloplasmin has been used to examine structure/function relationships in the factor VIII molecule.⁸⁰³ This approach has recently been expanded upon by using the x-ray structure of the C2⁸⁰⁴ domain to generate 10 hypothetical models of the intrinsic tenase complex.⁸⁰⁵ Based on homology between factor VIII and ceruloplasmin, the factor IXa binding sites in the A2 and A3 domains are likely located in close proximity on the same side of the factor VIII molecule. A factor X binding site may exist on the COOH -terminus of the factor VIII A1 domain.^{806,807}

Factor VIII also contains several tyrosine residues modified by the addition of sulfate.⁸⁰⁸ The tyrosine sulfate residues enhance α -thrombin cleavage of the procofactor.⁸⁰⁹ In addition, factor VIII contains biantennary complex-type sugar chains with blood group A or H, or both, determinants.⁸¹⁰

Function

The procofactor factor VIII is activated by α -thrombin to generate the cofactor factor VIIIa. Activation by α -thrombin involves cleavages at Arg³⁷² (the A1-A2 junction), Arg⁷⁴⁰ (the A2-B junction), and Arg¹⁶⁸⁹ in the light chain (Fig. 18.10). The resulting molecule contains three separate polypeptide chains: A light-chain region (A3-C1-C2) bound to the NH_2 region of the heavy chain (A1) in a Ca^{2+} -dependent manner and the noncovalently associated A2 region of the heavy chain. Once

formed, the cofactor factor VIIIa binds its serine protease enzyme factor IXa to form the Ca^{2+} - and membrane-dependent complex, the intrinsic tenase (Fig. 18.4). This complex is homologous to the prothrombinase complex. The intrinsic tenase complex catalyzes factor X conversion to factor Xa at a rate several orders of magnitude greater than the enzyme factor IXa alone.^{811,812} Factor Xa generated via the intrinsic tenase complex (factor IXa-factor VIIIa- Ca^{2+} -membrane) yields the propagation phase of α -thrombin generation by raising the factor Xa concentration approximately 100-fold over that achieved by the extrinsic tenase complex (Fig. 18.7B).⁵⁶⁷ Without formation of the intrinsic complex, as occurs in a situation like that of hemophilia A or B, factor Xa is not generated at a level sufficient to produce the propagation phase of α -thrombin generation (Fig. 18.7A).^{446,568,569}

Like the prothrombinase complex, the cofactor (factor VIIIa) interaction with the enzyme (factor IXa) in the presence of divalent cations and an anionic phospholipid surface is a highaffinity interaction with a K_d of 2 nmol/L. The interaction of factor IXa with phospholipid in the absence of its cofactor is of approximately 100-fold lower affinity.^{812,813}

Regulation

Factor VIIIa function is primarily regulated by dissociation of a fragment (residues 373 to 740) containing the A2 subunit from the heterotrimer. Once the A2 subunit is displaced, factor VIIIa

P.459

loses all cofactor function. Dissociation is spontaneous and occurs rapidly under physiologic conditions. Factor IXa stabilizes factor VIIIa, delaying dissociation of the heterotrimer and prolonging the transient activity of factor VIIIa.^{814,815} Factor VIIIa is also regulated by limited proteolysis. Factor IXa cleaves the factor VIIIa A1 subunit at Arg³³⁶ and eliminates factor VIIIa function.^{815,816} and ⁸¹⁷ In addition to factor IXa, the A1 subunit of factor VIIIa is cleaved by factor Xa and α -thrombin.^{11,808,815,818} APC is a key anticoagulant enzyme that likewise cleaves the A1 subunit at Arg³³⁶. APC also cleaves the factor VIIIa A2 subunit at Arg⁵⁶².^{11,819} The APC cleavages occur sequentially with the A1 cleavage first and the A2 cleavage second.⁸²⁰ Factor IXa protects factor VIIIa from APC cleavage at Arg⁵⁶²; however, protein S blocks the protective effect.⁸²¹ Although factor VIIIa is proteolytically inactivated by a number of enzymes, spontaneous dissociation is the key regulator of cofactor function.

Factor V (Labile Factor)

Factor V was first recognized as an unstable plasma component necessary for the generation of α -thrombin.²⁷ Factor V is a large single-chain glycoprotein that circulates in plasma at an average concentration of 6.6 $\mu\text{g/ml}$ (20 nmol/L) (Table 18.1). Factor V is also contained in the α -granules of human platelets, with approximately 18% to 25% of the total factor V present in platelets.⁸²² The identification, role in coagulation, and overall importance of factor V in hemostasis has been discussed in recent reviews.^{823,824} and ⁸²⁵

Congenital factor V deficiency, or parahemophilia, is an extremely rare disorder inherited in an autosomal recessive manner. Patients can exhibit severe bleeding diatheses. Although complete lack of factor V in humans does not appear to be lethal, factor V-deficient mice experience fatal hemorrhage in utero.⁸²⁶ Combined deficiencies of factors V and VIII have also been observed. Interestingly, combined cofactor deficiencies occur more commonly than factor V deficiency alone.^{827,828} Recently, the gene for ERGIC-53, a calcium-dependent lectin that serves as a glycoprotein-sorting receptor between the endoplasmic reticulum and the Golgi complex, has been linked to combined factors V and VIII deficiency.^{829,830} Mutations in this gene in patients with combined hemophilia have been described. Factor V deficiency becomes even more complex when platelet factor V is taken into consideration. Patients have been identified with normal functional levels of plasma factor V, but deficiencies of platelet factor V that result in bleeding disorders.^{822,831,832} and ⁸³³ Lack of platelet α -granules and their contents in storage pool disorders leads to deficiency of platelet factor V.^{831,832} Factor V^{Quebec} is an autosomal dominant bleeding disorder characterized by mild thrombocytopenia, normal levels of plasma factor V, and degraded platelet factor V with very low activity.^{822,833} A database on factor V mutation⁸³⁴ has been compiled by Dr. Hans L. Vos (Hemostasis and Thrombosis Research Center, Leiden University Medical Center, Leiden, The Netherlands; e-mail: h.l.vos@lumc.nl) and is available upon request.

Gene Structure and Expression

The human factor V gene is located on chromosome 1 bands q21-q25⁸³⁵ (Table 18.2). The gene spans approximately 80 kb and consists of 24 introns and 25 exons. Transcription and processing yield an mRNA species of 6.8 kb. The intron-exon structure of the factors V and VIII genes are quite similar, and the genes likely evolved from a common ancestor. The liver appears to be the primary site of factor V biosynthesis.^{782,836,837} While human megakaryocytes express factor V,^{838,839} and ⁸⁴⁰ platelet factor V is likely derived from circulating liver-derived plasma factor V^{841,842,843} and ⁸⁴⁴; however, the source of

platelet factor V has not been definitively determined.⁸⁴⁵ Bovine aortic endothelial cells⁸⁴⁶ and vascular smooth muscle cells⁸⁴⁷ also have been reported to express factor V.

Biochemistry

Human factor V ($M_r = 330,000$)^{848,849,850} and⁸⁵¹ is a single-chain glycoprotein of 2,196 amino acids derived from a precursor molecule with a signal peptide (Table 18.1 and Fig. 18.10). Factor V consists of an NH₂-terminal heavy chain (residues 1 to 709: A1-A2 domains), a central B domain (residues 710 to 1,545), and a COOH-terminal light chain (residues 1,546 to 2,196: A3-C1-C2 domains). The A domains are homologous to those found in factor VIII and plasma ceruloplasmin; the C domains are homologous to the slime mold protein discoidin.⁷⁸² Like factor VIII and ceruloplasmin, factor V is also a copper-binding protein.⁸⁵²

Factor V undergoes extensive posttranslational modification, including phosphorylation, sulfation, glycosylation, and formation of mixed disulfides between its five free cysteine residues and circulating thiols like cysteine and homocysteine.⁸⁵³ Phosphorylation occurs at sites in the heavy chain, B region, and light chain. Phosphorylation at Ser⁶⁹² affects the rate of inactivation of factor Va by APC.⁸⁵⁴ Factor V is sulfated at a number of sites in the heavy chain (Tyr⁶⁶⁵, Tyr⁶⁹⁶, and Tyr⁶⁹⁸), the B region (Tyr¹⁴⁹⁴, Tyr¹⁵¹⁰, and Tyr¹⁵¹⁵) and the light chain (Tyr¹⁵⁶⁵). The sulfation status of factor V has been related to its function.^{855,856} Carbohydrate accounts for 13% to 25% of the mass of factor V.⁸⁵⁷ The heavy chain has nine potential N-linked glycosylation sites. In the B region, 25 asparagine residues are candidates for modification with carbohydrate; carbohydrate accounts for approximately 50% of the mass of the B region. The light chain of factor V has three N-linked glycosylation sites. Differential glycosylation of Asn²¹⁸² in the C2 domain is reported to be responsible for the factor V1 and factor V2 variants observed in plasma. The two variants have slightly different molecular masses and charges.⁸⁵⁸ Factors Va1 and Va2 are distinguished by functional differences as well. Factor Va1 does not appear to bind to anionic phospholipid as efficiently as factor Va2 and is not as competent a cofactor in the prothrombinase complex as factor Va2.^{857,859,860} and⁸⁶¹ The presence of an oligosaccharide at Asn²¹⁸² apparently reduces the affinity of factor Va1 for the phospholipid surface and interferes with prothrombinase complex assembly and function. The COOH-terminal fragment of the factor Va light chain (residues 1,753 to 2,183) that contains the Asn²¹⁸² glycosylation site is one of the two regions that mediate membrane association.⁸⁶²

Several models of fragments of factor Va have been generated.^{863,864} The crystal structure of APC-inactivated bovine factor Va (factor Vai), which includes the A1 domain from the heavy chain and the entire light chain, showed a domain organization quite different from previous models of either factor V or factor VIII.⁸⁶⁵ Most notably, the structure places the C1 and C2 domains in a "side-by-side" orientation, in which both C domains can interact with the phospholipid surface. This model has been supported by biochemical experiments.⁸⁶⁶ Recently, homology models have been generated for the prothrombinase complex.⁸⁶⁷

Activation

The procofactor factor V does not bind factor Xa and is essentially completely inactive.⁴² Limited proteolysis of the factor V molecule yields the active cofactor factor Va. Factor Va functions as both a factor Xa receptor and a positive modulator of factor Xa catalytic potential in the prothrombinase complex. Rate enhancements of 300,000-fold derive from the participation of factor Va in the process of factor Xa activation of prothrombin.⁵⁸⁰

α -Thrombin is the primary catalyst of factor V activation in vivo. α -Thrombin cleaves factor V at Arg⁷⁰⁹, Arg¹⁰¹⁸, and Arg¹⁵⁴⁵,⁷⁸² (Fig. 18.10). The α -thrombin-generated form of factor Va is a heterodimer consisting of an NH₂-terminal heavy chain ($M_r = 105,000$ [A1-A2 domains]) linked noncovalently to a COOH-terminal light chain ($M_r = 73,000$ [A3-C1-C2 domains]).^{850,868,869,870} and⁸⁷¹ The association of the heavy and light chains of factor Va shows a divalent cation dependence. The B domain is excised during proteolysis.^{15,868,870}

P.460

Factor Xa cleaves factor V at Arg⁷⁰⁹, Arg¹⁰¹⁸, and Arg¹⁵⁴⁵, producing a factor Va molecule similar to the factor Va produced by α -thrombin cleavage.^{619,872} Factor Xa cleavage of factor V is less efficient than α -thrombin cleavage,^{619,872} although factor V released from stimulated platelets is partially activated and is more efficiently cleaved by factor Xa than plasma factor V.⁸⁷³

Other enzymes may also activate or partially activate factor V. Platelet calpain,⁸⁷⁴ cathepsin G, and human neutrophil elastase^{875,876} partially activate factor V. The fibrinolytic enzyme plasmin both activates and inactivates factor V.^{877,878} and

⁸⁷⁹ Plasmin cleavage and inactivation of factor V are hypothesized to play a role in hemorrhage subsequent to thrombolytic therapy by decreasing the level of factor Va cofactor activity.⁸⁸⁰

Function

Activation of the procofactor factor V yields the functional form factor Va. Factor Va acts as a cofactor for the serine protease factor Xa in the prothrombinase complex. Factor Va forms at least part of the receptor for factor Xa on platelets and serves to anchor factor Xa to the membrane surface.⁸²³ Factor Va stabilizes the prothrombinase complex and enhances prothrombin activation.^{5,682}

Factor Va Regulation and Factor V^{Leiden}

Factor Va is regulated by proteolytic inactivation by APC. An anionic membrane surface is required for complete cleavage and full inactivation of the cofactor; in the absence of phospholipid, factor Va cleavage is not complete, and the cofactor retains some activity. Protein S, a suggested cofactor for APC, only functions in the presence of a phospholipid bilayer as well. In the presence of a membrane surface, APC cleaves factor Va sequentially at three sites: Arg⁵⁰⁶, Arg³⁰⁶, and Arg⁶⁷⁹. Factor Va is initially cleaved at Arg⁵⁰⁶. Subsequently, the membrane-dependent cleavage at Arg³⁰⁶ results in complete loss of factor Va cofactor activity. An additional APC-mediated cleavage of factor Va fragments occurs at Arg⁶⁷⁹. Loss of cofactor activity coincides with dissociation of the A2 domain of APC-cleaved factor Va in a process similar to the spontaneous dissociation of factor VIIIa.^{881,882}

The importance of this regulatory mechanism is demonstrated by the “APC resistance” syndrome associated with factor V^{Leiden}.⁸⁸³ Individuals with factor V^{Leiden} have a G to A substitution at nucleotide 1,691 in the factor V gene that results in an Arg⁵⁰⁶→Gln mutation at the protein level.⁸⁸⁴ Factor Va^{Leiden} has normal cofactor activity as part of the prothrombinase complex. However, unlike normal factor Va, factor Va^{Leiden} is not readily inactivated by APC. The Arg⁵⁰⁶→Gln mutation hinders the first step in the sequential series of inactivating cleavages by APC. Factor Va^{Leiden} retains cofactor activity and continues to promote α-thrombin generation for an extended period of time. Inactivation of factor Va^{Leiden} by cleavage of the Arg³⁰⁶ bond occurs eventually but is markedly slower than normal factor Va.⁸⁸⁵ The prevalence of the factor V^{Leiden} mutation is approximately 5% in whites.⁸⁸⁶ Individuals heterozygous for factor V^{Leiden} have a sevenfold greater risk of thrombosis than normal individuals, whereas individuals homozygous for factor V^{Leiden} have an 80-fold greater risk of thrombosis.⁸⁸⁷ The risk of thrombosis in individuals with factor V^{Leiden} is also exacerbated by other genetic and acquired risk factors such as protein C or protein S deficiency, or both, and use of oral contraceptives.^{823,888} The effects of factor V^{Leiden} are of considerable interest, as factor V^{Leiden} is the most common prothrombotic risk factor yet identified.^{889,890} and ⁸⁹¹

von Willebrand Factor (von Willebrand Factor: Antigen, Ristocetin Cofactor, von Willebrand Factor Ristocetin: Cofactor)

vWF is a multifunctional protein with several key roles in coagulation. vWF circulates in plasma at an average concentration of 10 µg/ml⁸⁹² (Table 18.1) and is also contained in the α-granules of human platelets.⁸⁹³ ABO blood type has a significant influence on vWF levels, with individuals of types A, B, or AB blood having much higher levels of vWF than individuals with type O blood.^{894,895} vWF is also known for its role in ristocetin-induced platelet aggregation,^{896,897} which is the basis of clinical assays. vWF was first recognized as the missing or defective factor in a severe autosomal dominant bleeding disorder.^{898,899,900} and ⁹⁰¹ von Willebrand disease is fairly common and is estimated to occur in 1% to 2% of the general population.^{902,903,904} and ⁹⁰⁵ vWF is also an acute phase reactant; levels are elevated as a result of stress, pregnancy, or surgical trauma,^{906,907,908} and ⁹⁰⁹ and is a key player in hemostasis.⁹¹⁰

Gene Structure and Expression

The vWF gene is located on chromosome 12 band 12p-12pter and is 178 kb long with 51 introns and 52 exons^{911,912,913} (Table 18.2). A pseudogene with approximately 98% homology to the vWF gene has been mapped to chromosome 22.^{912,913} vWF is expressed only by endothelial cells and megakaryocytes.^{914,915} and ⁹¹⁶ vWF is stored in Weibel-Palade bodies in endothelial cells and in α-granules in platelets.^{917,918} and ⁹¹⁹ There are several regulatory elements that control vWF expression including GATA-binding consensus sequences in the promoter region.⁹²⁰ Endothelial cellspecific expression appears to be regulated by NF1 and Oct-1 binding sites.^{917,920,921,922} and ⁹²³ vWF expression is also regulated by complex signaling pathways that are directed by specific cellular environments.^{921,924,925} and ⁹²⁶ In addition, vWF plasma levels can be regulated through release of vWF from endothelial cell and platelet storage compartments. Platelet activation results in the release of vWF, and endothelial cell vWF release is induced by histamine and 1-deamino-8-d-arginine vasopressin.^{927,928} and ⁹²⁹

Biochemistry

vWF is a large adhesive glycoprotein that circulates in plasma as a heterogeneous mixture of disulfide-linked multimers. The biocycle of vWF comprises a series of steps ranging from regulated expression of the vWF gene in endothelial cells and megakaryocytes to its clearance from the blood.⁹³⁰ vWF is synthesized as a prepro molecule containing a 22-amino acid signal peptide, a propeptide of 741 amino acids, and the mature vWF protein of 2,050 amino acids.^{931,932,933,934,935} and⁹³⁶ The prepro vWF molecule is comprised of internally repeated A, B, C, and D domains arranged in the sequence D1-D2-D'-D3-A1-A2-A3-D4-B-C1-C2. The A repeats share homology with complement factor B, collagen type IV, chicken cartilage matrix protein, and the I domain of the integrin α -subunit.^{937,938} Portions of the C domains are homologous to sequences in procollagen and thrombospondin.⁹³⁹ Prepro vWF undergoes extensive posttranslational modification to yield the mature vWF protein lacking the D1 and D2 domains. The large vWF propolypeptide copurifies with factor VIII and vWF and is designated vWF antigen-II. The mature vWF monomer has a molecular weight of approximately 255,000 based on protein sequence and carbohydrate content.^{931,932,935,936,940} The disulfide-linked multimers range in size from dimers ($M_r = 600,000$) to extremely large multimers of 20 million D. vWF has binding sites for factor VIII, heparin, collagen, platelet glycoprotein (gp) Ib, and platelet gpIIb-IIIa.^{941,942,943,944,945,946,947,948,949,950,951,952,953} and⁹⁵⁴

Function

vWF has multiple functions in hemostasis. vWF stabilizes factor VIII and protects it from inactivation by APC,^{185,955} thus significantly prolonging factor VIII half-life in circulation.^{761,763,764} vWF is a structural protein and is part of the subendothelial matrix. vWF also acts as a bridge between platelets and promotes platelet aggregation. The primary platelet-binding site for vWF is the gpIb-IX-V receptor complex. gpIb-IX-V is an active receptor on

P.461

unstimulated platelets and serves to promote platelet aggregation and adhesion to vWF in the absence of platelet activation.⁴⁰⁰ This is likely a key element in the procoagulant response serving to recruit and localize platelets to the site of damage before the events that induce platelet activation.⁹⁵⁶ Subsequent platelet activation also induces expression of another receptor complex, gpIIb-IIIa. The gpIIb-IIIa complex recognizes a number of adhesive proteins including vWF. gpIIb-IIIa receptor binding of these adhesive proteins creates a strong network of platelets, other cells and matrix components.

Endothelial cells secrete vWF multimers, which are larger than those found circulating in plasma.⁹⁵⁷ The function of these large multimeric forms of vWF is to bind to and agglutinate blood platelets under high shear rates. These large multimers of vWF are degraded by a specific metalloprotease called a disintegrinlike and metalloprotease domain with thrombospondin in type I motifs (ADAMTS)-13.^{958,959,960} In familial and acquired thrombotic thrombocytopenic purpura, ultra-large vWF multimers are correlated to defective ADAMTS-13 activity.⁹⁶¹

PROCOAGULANT PROTEINS: THROMBIN (FACTOR IIa)

The enzyme α -thrombin, or factor IIa, is the central enzyme in blood coagulation and plays myriad roles in hemostasis²³ as well as roles in tissue repair, development, and pathogenic processes.^{649,687,962,963} and⁹⁶⁴ α -Thrombin is the most potent activator of circulating platelets, thus providing the requisite surface for procoagulant activities. α -Thrombin cleaves fibrinogen to generate the fibrin clot,^{680,965,966} and⁹⁶⁷ converts factor XIII to factor XIIIa to crosslink and stabilize the clot,^{17,968} and, in association with thrombomodulin, activates TAFI, which delays dissolution of the fibrin clot.^{36,969} α -Thrombin also acts directly and indirectly to amplify its own production. The procofactors V and VIII are activated by α -thrombin^{682,683,782,970} as are factor XI⁷ and, potentially, factor VII.⁸ In an analysis of a whole blood model of coagulation, a time course of α -thrombin generation and of the protein products of its catalytic activities illustrates that most procoagulant responses to α -thrombin occur during the initiation phase before fibrin formation (Fig. 18.11).⁵⁶⁹ Less than 0.2% of the final α -thrombin produced is required to achieve the activation of its primary substrates in blood. After fibrin clot formation, during the propagation phase, the bulk of α -thrombin is formed (~95%).

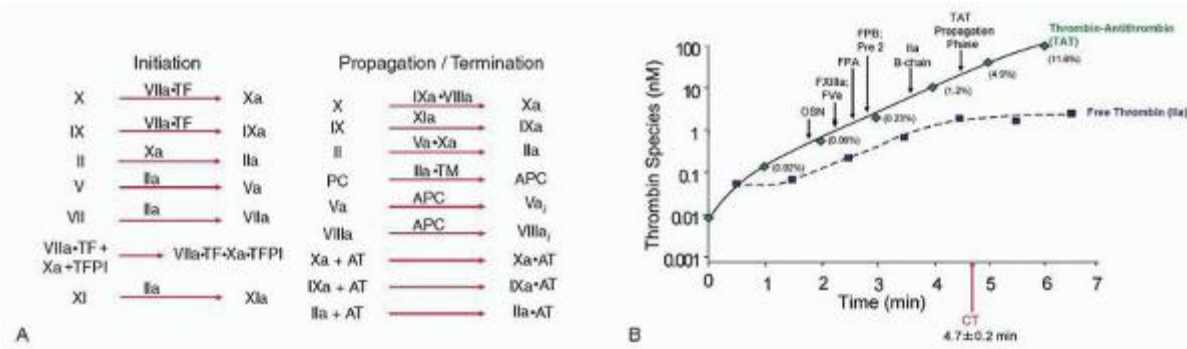

FIGURE 18.11. Initiation, propagation, and termination of thrombin generation and the procoagulant response. A: Low levels of thrombin are required to initiate clot formation (initiation phase) and trigger the coagulation cascade response (propagation phase). The enzymes, cofactors, and inhibitors act together to generate a hemostatic response that can be divided into an initiation phase and a propagation/termination phase. During the initiation phase, factors X and IX are converted to their respective serine proteases factor Xa and factor IXa; low levels of thrombin are subsequently generated by factor Xa. This thrombin then can activate platelets and the procofactors factors V and VIII, which stimulate further thrombin generation during the propagation phase. Thrombin generation is attenuated by shutting down the initiation phase by means of the stoichiometric inhibitor of the extrinsic tenase complex, tissue factor pathway inhibitor (TFPI), followed by antithrombin (AT), which directly inhibits thrombin and factors Xa and IXa. B: Time course of early thrombin-antithrombin (TAT) complex formation from whole blood coagulation of 35 individuals is presented: y-axis, TAT (solid line [green diamonds]) and free thrombin [dashed line (blue squares)] concentrations (nmol/L) are shown on a log scale; x-axis, time in minutes.⁵⁶⁹ Arrows indicate the time and TAT concentration at which each of the indicated events (osteonectin [OSN] release, a marker of platelet activation, factor XIII activation [fXIIIa], fibrinopeptide A [FPA] release, fibrinopeptide B [FPB] release, and prothrombin activation) has entered a phase of rapid activation. The percent of total TAT present at the point of activation is shown in parentheses. APC, activated protein C; CT, clot time; PC, protein C; TF, tissue factor. (From Brummel KE, Paradis SG, Butenas S, Mann KG. Thrombin functions during tissue factor induced blood coagulation. *Blood* 2002;100:148-152, with permission.)

In addition, α -thrombin also acts as a mitogen in a variety of cell types^{685,686,687,688} and^{689,971,972,973,974} and⁹⁷⁵; induces the release of cytokines,^{976,977,978,979} and⁹⁸⁰ vasoactive compounds,^{981,982} and⁹⁸³ and chemoattractants⁹⁸⁴ as part of the response to vascular damage; and stimulates events that initiate tissue repair.^{985,986,987} and^{988,989}

α -Thrombin acts to indirectly inhibit its own generation through the protein C anticoagulation pathway, a dynamic inhibitory system. α -Thrombin forms the protein Case complex with its cofactor thrombomodulin, and activates protein C to APC.^{893,990} APC cleaves factors Va and VIIIa, thus inhibiting prothrombinase and intrinsic tenase function and blocking α -thrombin formation. The binding of α -thrombin to thrombomodulin both produces a potent anticoagulant and alters α -thrombin reactivity. Once bound to thrombomodulin, α -thrombin no longer recognizes fibrinogen as a substrate and no longer acts in a procoagulant capacity.^{991,992}

α -Thrombin generation must be tightly regulated to ensure that localized, adequate levels of the enzyme are produced. Markedly decreased levels of α -thrombin due to hypoprothrombinemia or reduced α -thrombin activity due to genetic mutation (dysprothrombinemia) are often characterized by bleeding diatheses.^{993,994} Conversely, elevated levels of α -thrombin promote the risk of thrombosis. A G→A transition at nucleotide position 20210 (G20210A) in the 3'-untranslated region of the prothrombin gene results in elevated plasma levels of prothrombin⁶⁵⁵ and is strongly associated with venous thrombotic events.^{995,996,997} and⁹⁹⁸

Roles in Coagulation

On phospholipids, membrane activation to α -thrombin proceeds through the obligate intermediate meizothrombin. In contrast, on platelets, the reaction has been reported to proceed through prothrombin 2 (see Fig. 18.8).⁶⁷⁰

Most prothrombin activation to α -thrombin proceeds through the obligate intermediate meizothrombin. Both meizothrombin and α -thrombin possess catalytic activity and cleave a variety of

P.462

substrates. Although meizothrombin is a short-lived intermediate in the activation process, it appears to play several important roles in coagulation. Meizothrombin is a potent vasoactive agent and acts on the adrenergic receptor to induce

vascular constriction. The vasoactive potency of meizothrombin is five to seven times greater than that of α -thrombin.^{999,1000} However, the ability of meizothrombin to activate platelets and cleave fibrinogen is greatly reduced compared to that of α -thrombin.^{673,1001} These are major roles for α -thrombin in promoting an efficient and effective procoagulant response. α -Thrombin has long been recognized as the most potent platelet agonist.⁶⁸¹ α -Thrombin induces release of platelet α -granule contents, including a number of procoagulant and adhesive proteins,^{187,893,1002,1003,1004,1005,1006,1007,1008,1009} and ¹⁰¹⁰ and of adenosine diphosphate from the platelet-dense granules. α -Thrombin also triggers the translocation of anionic phospholipid to the outer leaflet of the platelet membrane. α -Thrombin thus provides a cross-linked platelet mesh and an anionic surface appropriate for procoagulant complex assembly and function.

In addition, α -thrombin generates and stabilizes the fibrin clot. α -Thrombin cleaves the Arg¹⁶-Gly¹⁷ bond in the A α -chain and the Arg¹⁴-Gly¹⁵ bond in the B β -chain of fibrinogen, releasing fibrinopeptide A (FPA) and fibrinopeptide B (FPB), respectively.⁶⁸⁰ FPA and FPB release allow formation of overlapping fibrin strands.^{965,966} and ⁹⁶⁷ α -Thrombin cleavage of the 37-residue NH₂-terminal activation peptide of factor XIII generates the transglutaminase factor XIIIa.^{17,968} Factor XIIIa cross-links and stabilizes the fibrin clot by catalyzing the formation of intermolecular γ -glutamyl ϵ -lysyl isopeptide bonds between fibrin molecules.¹⁷ TAFI, also known as plasma carboxypeptidase B or carboxypeptidase U, is likewise activated in an α -thrombin-dependent manner to provide activated TAFI (TAFIa).^{36,969} TAFIa has carboxypeptidase B-like activity and is a key link between the coagulation and fibrinolytic cascades. TAFIa prevents premature clot lysis by cleaving COOH-terminal lysine and arginine residues on fibrin, rendering it a less suitable cofactor in t-PA-dependent plasminogen activation.¹⁰¹¹ At elevated concentrations, TAFIa also directly inhibits plasmin and therefore clot lysis.¹⁰¹¹ In addition, TAFI is a substrate for factor XIIIa and is cross-linked to fibrin and incorporated into the fibrin clot.¹⁰¹² The α -thrombin-dependent processes involved in clot formation and stabilization likely occur simultaneously to generate a mature clot that effectively reduces blood loss.¹⁰¹³

α -Thrombin has other key roles in procoagulant events as well. α -Thrombin activates factor XI^{7,617} and the procofactors factor V, factor VIII,^{682,683,782,970} and potentially factor VII.⁸ Meizothrombin likewise is an efficient activator of factor XI¹⁰¹⁴ and possibly factor V.¹⁰¹⁵ Meizothrombin is thought to function to enhance α -thrombin generation by activating factor XI before its final processing to form α -thrombin.

Roles in Anticoagulation

Although α -thrombin is the central enzyme in the procoagulant response, it is also a key mediator of anticoagulant events as well.¹⁰¹⁶ When α -thrombin binds to the cell membrane-associated cofactor thrombomodulin, the reactivity of α -thrombin is altered. α -Thrombin bound to thrombomodulin no longer cleaves fibrinogen or acts as a procoagulant enzyme.^{991,992} Instead, the α -thrombin-thrombomodulin complex, or protein Case, cleaves protein C to generate the enzyme APC. APC is a potent anticoagulant and inactivates the cofactors factor Va and factor VIIIa.^{991,1017} α -Thrombin activation of platelets also induces the release of anticoagulant and inhibitory proteins from the α -granules.^{299,1018,1019} and ¹⁰²⁰

Roles in Tissue Repair and Regeneration

Tissue repair and regeneration is the final phase of the hemostatic response to injury. Subsequent to lysis of the fibrin clot, multiple cell types choreograph the restructuring of the damaged vasculature. Vascular permeability is increased, and inflammatory cells accumulate at the site of injury. Smooth muscle cells, fibroblasts, and endothelial cells migrate to the site and proliferate. Cellular differentiation, as well as production and remodeling of the extracellular matrix, restores the vascular tissue. α -Thrombin contributes to these processes through a variety of interactions with different cell types. α -Thrombin is a potent mitogen^{685,686,971,972,973} and ⁹⁷⁴ and stimulates proliferation of smooth muscle cells,^{686,688,975} macrophages,⁶⁸⁷ and endothelial cells.^{687,689} The mitogenic effects of α -thrombin are due to direct activation of cellular proliferation or α -thrombin-induced secretion of a variety of growth factors, or both. Platelet activation, an early event in the procoagulant response, results in the release of a plethora of α -granule proteins that regulate cell growth, vascular permeability, and chemotaxis.^{310,1021,1022,1023,1024,1025,1026,1027} and ¹⁰²⁸ α -Thrombin thus mediates multiple aspects of the hemostatic response to vascular injury from the formation and stabilization of the initial fibrin plug to the final stages of tissue repair and regeneration.

Thrombin Receptors

Many of the effects of α -thrombin on platelets and cells are elicited through α -thrombin interaction with receptor molecules in which α -thrombin binds to a receptor and initiates a signal transduction mechanism. The interaction between α -thrombin and the human platelet thrombin receptor, protease-activated receptor (PAR)-1, however, is characterized by a more unusual mechanism in which the receptor is also a substrate for α -thrombin.^{989,1029,1030} PAR-1 is a

425-amino acid transmembrane protein with a large NH₂-terminal extracellular domain.^{989,1030} α -Thrombin cleaves the extracellular region of the receptor at Arg⁴¹, producing a “tethered ligand.” The new NH₂-terminus binds back to and activates the receptor.^{989,1030} PAR-1 is also found on T lymphocytes, monocytes, and endothelial cells and mediates the α -thrombin-induced responses of these cells as well.

Two additional α -thrombin receptors homologous to PAR-1 have also been identified: PAR-3 and PAR-4. PAR-3 is expressed on human platelets and endothelial cells, although at much lower levels than PAR-1.¹⁰³¹ PAR-3 is required for normal α -thrombin-dependent platelet activation in mice,⁷³⁶ but in the human system, the role of PAR-3 appears to be primarily in cellular development. PAR-3 is expressed at high levels on human megakaryocytes, the precursor cells of platelets.⁷³⁶ PAR-4, however, is believed to act in combination with PAR-1 as a dual mechanism to elicit the multiple effects of α -thrombin on human platelets.

Structure/Function Relationships

In vivo, α -thrombin is derived from proteolytic cleavage of prothrombin by the prothrombinase complex (Figs 18.3 and 18.8). Cleavage of the Arg³²⁰-Ile³²¹ bond in prothrombin yields meizothrombin. Subsequent cleavage of the Arg²⁷¹-Thr²⁷² bond gives rise to fragment 1.2 and α -thrombin. Human α -thrombin cleaves its own NH₂-terminus at Arg²⁸⁴-Thr²⁸⁵ to generate a stable α -thrombin molecule. The initial form of human α -thrombin has an NH₂-terminal A-chain of 49 residues, whereas the autocatalytically generated stable protein has an A-chain of 36 residues. The COOH-terminal B-chain of α -thrombin has 259 amino acid residues including the catalytic triad residues His³⁶³, Asp⁴¹⁹, and Ser⁵²⁵.

α -Thrombin is subject to further degradation resulting in stable, degraded thrombin molecules with reduced reactivity.^{1032,1033} and ¹⁰³⁴ These degraded forms are designated β - and γ -thrombin. The degradation of α -thrombin may be autocatalytic or may be due to proteolysis by enzymes other than α -thrombin. Human β -thrombin is generated by cleavage at Arg³⁸² and Arg³⁹³, which deletes a segment of the α -thrombin B-chain.^{1035,1036} Cleavage of β -thrombin at Arg⁴⁴³ and Lys⁴⁷⁴ deletes an additional

P.463

segment of the B-chain and results in formation of γ -thrombin. β - and γ -thrombin retain some activity toward small peptide substrates,^{1000,1037} factor XIII,¹⁰³⁸ antithrombin,¹⁰³⁹ prothrombin,¹⁰⁴⁰ and factor XI.¹⁰⁴¹ However, both β - and γ -thrombin have no significant ability to cleave fibrinogen or protein C.^{640,1039,1042} These proteolyzed forms of α -thrombin have been identified as products of the blood clotting reaction in vivo,⁶⁷⁹ but their mechanism of production and function is unknown.

The stable form of human α -thrombin possesses at least five distinct binding sites for substrates, inhibitors, cofactors, apolar molecules, and sodium ions (Na⁺). The apolar binding site is located near the catalytic center of α -thrombin.¹⁰⁴³ The Na⁺ binding site is in the B-chain, in a cavity formed by three antiparallel β sheets, and appears to play a role in determining whether α -thrombin acts as a procoagulant or an anticoagulant. In the presence of Na⁺, α -thrombin recognizes fibrinogen as a substrate and acts as a procoagulant. In the absence of Na⁺, α -thrombin has increased specificity for protein C and functions in an anticoagulant capacity.^{1044,1045} The binding of Na⁺ therefore appears to mediate the dual nature of α -thrombin as both a procoagulant and an anticoagulant.

Exosite I, the fibrinogen-binding site, is an anion-binding, electropositive site distinct from, but acting in concert with, the active site of the α -thrombin molecule.¹⁰⁴⁵ In addition to fibrinogen, exosite I also recognizes the COOH-terminal domain of hirudin, the hirudin-like region of PAR-1, and the fifth and sixth EGF-like domains of thrombomodulin.¹⁰⁴⁵ Detailed information about exosite I is available from the x-ray crystal structure of the α -thrombin-hirudin complex. In solution, the COOH-terminal domain of hirudin is disordered.^{1046,1047} However, in the α -thrombin-hirudin complex, the COOH-terminus of hirudin inserts into the large groove in the α -thrombin molecule to interact with exosite I. Hirudin also inserts into the active site of α -thrombin.^{1048,1049} and ¹⁰⁵⁰ The high-affinity interaction ($K_d = 2 \times 10^{-14}$ mol/L) between α -thrombin and the inhibitor hirudin is thus stabilized by electrostatic, polar, and hydrophobic interactions.^{1048,1051}

Exosite II is a second electropositive, anion-binding site located on the opposite side of the α -thrombin molecule compared to exosite I. Exosite II recognizes the COOH-terminal region of the B-chain of thrombin and sulfated polysaccharides such as heparin and the chondroitin sulfate moiety of thrombomodulin.¹⁰⁴⁵

The active site of α -thrombin is responsible for mediating interactions with substrate molecules including fibrinogen, protein C, and antithrombin.¹⁰⁴⁵ The active site of α -thrombin is similar to the active sites of trypsin and chymotrypsin. However, unlike the relatively nonspecific pancreatic enzymes, α -thrombin also has secondary binding sites, exosites I and

II, that confer specificity to α -thrombin. For substrates such as fibrinogen, there may be multiple secondary binding sites.¹⁰⁵²

Regulation

α -Thrombin regulates its own production through complex formation with thrombomodulin and activation of protein C (Fig. 18.6). α -Thrombin enzymatic activity is mediated mainly by antithrombin-III. The inhibitory activity of antithrombin is potentiated *in vivo* by cell-expressed heparan sulfate GAGs or by pharmaceutical heparins.^{694,695} Antithrombin inhibits α -thrombin through formation of a covalent complex with the active site of α -thrombin.¹⁰⁵³ α -Thrombin-antithrombin (TAT) complexes are rapidly cleared from the circulation by the liver.¹⁰⁵⁴

α -Thrombin is also inhibited by α_2 -macroglobulin, a broad specificity proteinase inhibitor. α_2 -Macroglobulin does not appear to be a primary inhibitor of α -thrombin, but rather functions as a secondary inhibitor.¹⁰⁰⁰ Unlike antithrombin, α_2 -macroglobulin does not complex with the active site of its target enzymes. Enzymes in complex with α_2 -macroglobulin retain the ability to cleave small peptidyl substrates, although they are unable to cleave large substrates.¹⁰⁵⁵ α -Thrombin interaction with α_2 -macroglobulin involves limited proteolysis of α_2 -macroglobulin. Subsequent to cleavage, α_2 -macroglobulin undergoes a conformation change that traps the enzyme inside the α_2 -macroglobulin molecule.^{1056,1057} The α_2 -macroglobulin-enzyme complexes are rapidly cleared from circulation.^{1058,1059}

ANTICOAGULANT PROTEINS: DYNAMIC INHIBITORY SYSTEM

The protein C pathway provides a dynamic inhibitory system to regulate α -thrombin production.^{1060,1061,1062} The activity of this anticoagulant pathway is directly dependent on the level of α -thrombin production. The protein C activating complex, or protein Case, is a membrane-dependent multiprotein complex similar to the membrane-dependent procoagulant complexes (Figs. 18.4 and 18.6). The key proteins in the protein C pathway are α -thrombin, thrombomodulin, protein C, and protein S.

Protein C

Protein C, first identified as a thrombin inhibitory activity or autoproteolytic II-A,¹⁰⁶³ is the zymogen form of the enzyme APC. Protein C circulates at a concentration of 4 μ g/ml (65 nmol/L) with a $t_{1/2}$ of 8 to 10 hours^{1064,1065} and ¹⁰⁶⁶ (Table 18.4). The $t_{1/2}$ of protein C is markedly shorter than most other members of the vitamin K-dependent protein family and is the likely basis of the transient hypercoagulable state subsequent to administration of coumarin-based anticoagulants.^{1067,1068,1069,1070} and ¹⁰⁷¹ Homozygous protein C deficiency is associated with severe thrombotic tendencies and can result in fatal neonatal thrombotic events.¹⁰⁷² Heterozygous protein C deficiency is associated with increased risk of thrombosis.^{1073,1074} and ¹⁰⁷⁵ The mutation in factor V^{Leiden}, which blocks a key APC cleavage site in factor V^{Leiden}, is another defect leading to an alteration in the protein C anticoagulant pathway and predisposition to thrombosis.

Gene Structure and Expression

The protein C gene is located on chromosome 2 bands q14-q21 and spans 11 kb with eight introns and nine exons^{1076,1077} (Table 18.6). The promoter region contains HNF-1, HNF-3, and Sp1 binding sites that promote gene expression.^{1078,1079} HNF-3 is a liver-specific transcription factor.

Biochemistry

Protein C is synthesized in the liver as a single-chain polypeptide with a prepro sequence of 42 amino acids. The prepro protein is subsequently processed to remove the leader sequence and the dipeptide Lys¹⁵⁶-Arg¹⁵⁷. Thus, in plasma, most protein C circulates as a heterodimer consisting of a disulfide-linked (Cys¹⁴¹-Cys²⁷⁷) heavy and light chain.^{1080,1081,1082,1083,1084} and ¹⁰⁸⁵ However, approximately 5% to 10% of circulating protein C is the single-chain form.³⁶¹ The twochain form of human protein C ($M_r = 62,000$) is a 419-amino acid glycoprotein with approximately 23% carbohydrate (Table 18.4 and Fig. 18.3B). The NH₂-terminal light chain (residues 1 to 155; $M_r = 21,000$) contains the Gla domain (residues 6 to 29; nine Gla residues) and a hydrophobic region that connects the Gla domain to two EGF domains (residues 55 to 90 and 94 to 134). The COOH-terminal heavy chain (residues 158 to 419; $M_r = 41,000$) contains the serine protease domain. Residues 158 to 169 constitute the activation peptide domain. A β -hydroxy aspartate residue (Asp⁷¹) in the first EGF domain is required for Ca²⁺-dependent alterations in protein C. Ca²⁺ binding is mediated by the first EGF domain as well as the Gla domain and the serine protease

P.464

domain.^{354,398,402,1086,1087,1088,1089,1090} and ¹⁰⁹¹ Leu⁵ in the NH₂-terminus is important in mediating phospholipid binding.⁴⁰⁰ There are several glycosylation variants (Asn⁹⁷, Asn²⁴⁸, Asn³¹³, and Asn³²⁹) with two to four N-linked carbohydrate

chains.³⁶¹ The major forms, α -protein C and β -protein C, have four and three carbohydrate moieties, respectively. All the protein C carbohydrate variants can be activated, but appear to have different anticoagulant properties and rates of activation.¹⁰⁹² An x-ray crystal structure has been determined for Gla-domainless activated protein C.³⁸²

TABLE 18.6 MOLECULAR GENETICS OF HUMAN ANTICOAGULANT PROTEINS AND THEIR INHIBITORS

Protein	Molecular Weight (Da)	Gene Location: Chromosome	Gene Size (kb)	Gene Organization: No. of Exons	Messenger RNA Size (kb)	UNIPROT Accession Number^a
Protein C	62,000	2q14-q21	11	9	1.8 (1.6)	P04070
Protein S	69,000		80	15	3.5	P07225
Protein Z	62,000	13q34	14	9	—	P22891
Thrombomodulin	100,000	20p-12cen	3.7	Intronless	3.7	P07204
α_2 -Macroglobulin	735,000	12p12.3-p13.3	48	36	4.6	P01023
Tissue factor pathway inhibitor	40,000	2q31-32.1	85	9	1.4, 4.0	P10646
Antithrombin	58,000	1q23-q25	13.5	7	1.4	P01008
Heparin cofactor II	66,000	2q11	14	5	2.3	P05546
α_1 -Proteinase inhibitor	53,000	14q32.1	5	7	—	P01009
C1 esterase inhibitor	104,000	11q11.2-q13	17	8	—	P05155
Protein C inhibitor	57,000	14q32.1	11.5	5	—	P05154

^a <http://www.uniprot.org>.

Activation

Protein C is the zymogen form of the enzyme APC. Protein C is cleaved at the Arg¹⁶⁹-Leu¹⁷⁰ bond, releasing its activation peptide from the heavy chain to generate the active enzyme.^{1093,1094} The α -thrombin-thrombomodulin complex is likely the major physiologic activator of protein C.¹⁰⁹⁵ There are other activators as well. Plasmin activates and then inactivates protein C.^{1068,1096} Meizothrombin also binds thrombomodulin and can efficiently activate protein C.^{674,1097} Factor Xa has likewise been reported to bind to thrombomodulin and activate protein C¹⁰⁹⁸; however, this mechanism has not been confirmed in subsequent studies.^{1099,1100} More recently, glycosaminoglycans have been shown to potentiate factor Xa-mediated protein C activation.¹¹⁰¹ Copperhead snake venom also contains a protein C activator.¹¹⁰²

Function

APC is a serine protease with key anticoagulant functions. The most important anticoagulant role for the protein C pathway is the proteolytic inactivation of factor Va. APC inactivates factor Va via a series of proteolytic cleavages, thus inhibiting the generation of α -thrombin. APC also cleaves and inactivates factor VIIIa, although the spontaneous dissociation of the factor VIIIa A2 domain is the probable physiologic regulator of factor Xa generation. Full inactivation of factor Va by APC requires an anionic phospholipid surface, and the rates of APC inactivation of factors Va and VIIIa are enhanced by protein S.¹¹⁰³

APC also has a profibrinolytic effect. This effect is due to TAFI. TAFI is activated by the α -thrombin-thrombomodulin complex and acts to prolong clot lysis. APC cleavage of factor Va inhibits α -thrombin generation, thus reducing α -thrombin-thrombomodulin-mediated TAFI activation.¹¹⁰⁴ The prolongation of clot lysis by TAFIa likely contributes to the prothrombotic tendencies associated with factor V^{Leiden}.¹¹⁰⁵

The endothelial cell protein C receptor provides cell-specific binding sites for both protein C and APC.^{1106,1107} However, two other coagulation proteases, factors VIIa and Xa, have been shown to bind to this receptor.¹¹⁰⁸ Endothelial cell protein C receptor is downregulated by TNF- α .¹¹⁰⁷ Monocytes appear to express specific binding sites for APC that are distinct from endothelial cell protein C receptor.^{1109,1110} The cell-expressed binding sites may be important in the antiinflammatory

properties of APC.¹¹¹¹ APC blocks the septic shock response in animal models^{1112,1113} and has shown clinical success in severe sepsis patients.^{1114,1115} APC reduces the levels of inflammatory cytokines such as TNF- α .^{1113,1116} The antiinflammatory properties of APC are also due to inhibition of α -thrombin generation and, therefore, inhibition of the proinflammatory properties of α -thrombin.

Regulation

Protein C activation and APC activity are controlled on several levels. Inflammatory agents such as endotoxin, IL-1 β , transforming growth factor- β (TGF- β), and TNF- α regulate protein C activation on endothelial cells.^{1117,1118,1119,1120,1121,1122,1123,1124,1125} and¹¹²⁶ TNF- α is responsible for downregulation of thrombomodulin on the endothelial cell surface.^{1120,1123,1124,1125} and¹¹²⁶ There are multiple other factors that downregulate thrombomodulin as well. APC activity is regulated mainly by the protein C inhibitor or PAI-3.^{1127,1128} and¹¹²⁹

Protein S

Protein S is a vitamin K-dependent protein that is not a serine protease precursor. Protein S circulates at a plasma concentration of 20 μ g/ml (300 nmol/L)^{1130,1131} (Table 18.4). Approximately 40% of protein S circulates in the free form, and the remaining 60% circulates as a 1:1 complex with C4b-binding protein (C4bBP), a regulatory protein of the complement system.¹¹³⁰ Protein S is thought to function as a cofactor for APC in the inactivation of factors Va

P.465

and VIIIa.^{185,1132,1133,1134,1135,1136} and¹¹³⁷ Heterozygous deficiency of protein S increases the risk for developing thrombosis; however, the diagnosis is complicated.¹¹³⁸ The protein S cofactor effect is minimal, however, and does not correlate with the thrombotic pathologies manifested in protein S-deficient patients.^{1139,1140,1141,1142,1143,1144} and¹¹⁴⁵ Protein S has also been reported to inhibit prothrombin activation through several mechanisms.^{696,1146,1147} and¹¹⁴⁸ Although the precise function of protein S is not clear, protein S is important in anticoagulation.

Gene Structure and Expression

The gene for protein S is located on chromosome 3 and spans at least 80 kb^{1149,1150} (Table 18.6). The gene contains 15 exons and 14 introns.^{1149,1151,1152} A second copy of the protein S gene has also been identified; however, this second gene is likely a pseudogene.^{1153,1154} The pseudogene spans approximately 55 kb and differs from the protein S gene in that it lacks exon 1 and has multiple nucleotide substitutions. Protein S is synthesized in the liver^{1155,1156} and by a variety of other cell types including endothelial cells,^{1157,1158} and¹¹⁵⁹ osteoclasts,¹¹⁶⁰ and lymphoid cells.¹¹⁶¹ Protein S is also found in the α -granules of platelets.¹⁰¹⁹

Biochemistry

Protein S ($M_r = 69,000$) is a single-chain glycoprotein with approximately 8% carbohydrate and 11 Gla residues^{584,1162} (Table 18.4 and Fig. 18.3B). Protein S is synthesized with a signal sequence and propeptide region of 41 amino acids.^{1151,1152,1156,1163} The mature form of the protein has 635 amino acids and is organized into eight domains: An NH₂-terminal Gla domain (residues 1 to 45), an aromatic stack, a 29-residue thrombin-sensitive domain (residues 46 to 75), four EGF domains (residues 76 to 242), and a COOH-terminal domain homologous to the sex hormone-binding globulin and androgen-binding protein.^{1164,1165} The Gla domain and EGF domains mediate Ca²⁺ binding.¹¹⁶⁶ The Gla domain is also involved in interactions with phospholipid membranes.¹¹⁶⁷ C4bBP binds to the COOH-terminal sex hormone-binding globulin domain.^{1168,1169} Protein S reversibly self-associates in the absence of Ca²⁺.¹¹⁷⁰

Function

The precise function of protein S in the protein C inhibitory pathway is not clearly defined. Protein S enhances APC inactivation of factors Va and VIIIa in a phospholipid-dependent fashion.^{185,1132,1133,1134,1135,1136} and¹¹³⁷ The interaction between protein S and APC alters the structure of APC and moves the APC active site closer to the membrane surface.¹¹⁷¹ Protein S may also serve directly in an anticoagulant capacity. Protein S has been reported to bind to factor Xa,¹¹⁴⁷ factor VIII,¹¹⁷² and factor Va¹¹⁴⁶ to compete for prothrombinase-binding sites on the membrane surface^{696,1148} and to stimulate the inhibition of factor Xa by TFPI.^{1173,1174} These interactions serve to inhibit prothrombin activation in vitro.¹¹⁷⁵ The C4bBP-protein S complex may inhibit factor X activation as well.¹¹⁷⁶

Protein S also has additional potential roles outside of anticoagulation. Protein S interaction with T cells promotes T cell aggregation and proliferation and may serve to regulate inflammatory processes.¹¹⁷⁷

Regulation

α -Thrombin cleavage of protein S at Arg⁴⁹, Arg⁶⁰, or Arg⁷⁰ in the thrombin-sensitive domain inhibits the ability of protein S to act as a cofactor for APC.^{1136,1178,1179} and¹¹⁸⁰ Protein S activity is also regulated by interaction with C4bBP. The 1:1 complex between protein S and C4bBP neutralizes the anticoagulant capacity of protein S. Approximately 60% of plasma protein S circulates bound to C4bBP.

Protein Z

Protein Z, a vitamin K-dependent glycoprotein, is an enzymatically inactive homolog of factors VII, IX, and X, and protein C.³⁶⁴ Protein Z was first identified in bovine plasma by Prowse and Esnouf in 1977,¹¹⁸¹ and later in human plasma by Broze and Miletich in 1984.¹¹⁸² The name protein Z came about from its being the last of the vitamin K-dependent proteins to elute during anion exchange chromatography.¹¹⁸³ Protein Z circulates in plasma in a complex with protein Z-dependent protease inhibitor (ZPI).¹¹⁸⁴ This inhibitor, ZPI, has been identified as a 72-kDa member of the serpin superfamily.

Reports suggest that protein Z behaves as a negative acute-phase reactant.^{1185,1186} Protein Z levels have been found to be low in newborn infants^{1187,1188} and in individuals with DIC,¹¹⁸⁹ liver disease,¹¹⁹⁰ and amyloidosis.¹¹⁹¹ High plasma levels have been found in individuals on chronic hemodialysis and with idiopathic thrombocytopenic purpura.^{1192,1193} Protein Z levels also appear to be more susceptible to warfarin therapy than other vitamin K-dependent proteins.¹¹⁹⁴

Gene Structure and Expression

The gene for protein Z is located on chromosome 13 at band q34 (Table 18.6). It spans approximately 14 kb and consists of nine exons, including one alternative exon.³⁶⁴ The gene organization is similar to that of the other vitamin K-dependent proteins, factors VII, IX, and X, and protein C.

Homozygous and heterozygous protein Z-deficient mice showed no abnormalities in growth and development. Protein Z deficiency has been reported to be prothrombotic in nature in factor V^{Leiden} mice.¹¹⁹⁵ In general, evidence supports the anticoagulant role of the complex between protein Z and the serpin protein Z-dependent protease inhibitor (ZPI) and the thrombotic consequences of its deficiency.^{1196,1197} and¹¹⁹⁸ Protein Z-deficient mice crossed with factor V^{Leiden} mice did not have viable progeny. Several clinical studies identified diminished levels of plasma protein Z in patients with unidentified bleeding disorders.^{1219,1200} Protein Z has also been identified in liver disease¹¹⁹⁰ and atherosclerosis.¹²⁰¹

Biochemistry

Protein Z has a molecular weight of 62,000 and circulates in plasma at a mean concentration of $2.9 \pm 1.0 \mu\text{g/ml}$ ^{1182,1194} (Table 18.4). The plasma $t_{1/2}$ of protein Z is 2.5 days.¹¹⁹⁴ Structurally, protein Z is similar to factors VII, IX, and X, and protein C, containing a Gla domain (13 residues) and two EGF domains at its NH₂-terminus^{364,1202,1203} (Fig. 18.3B). However, like protein S, protein Z does not function as a protease. The COOH-terminus contains a region homologous to the catalytic domains present in the serine protease zymogens. The catalytic triad is not present in protein Z, except for the conserved Asp residue.^{1202,1203}

Function

Protein Z is a vitamin K-dependent protein that does not function as a serine protease enzyme. Protein Z circulates in plasma in complex with ZPI. The function of protein Z in vivo is still unclear to date.¹²⁰⁴ It has been reported that protein Z inactivates factor Xa by forming a Ca²⁺-dependent complex with factor Xa bound to phospholipid with the help of ZPI.¹¹⁸⁴ Factor IXa has also been reported to be a target for the protein Z/ZPI system.¹²⁰⁵ The overall importance of these protein Z/ZPI activities is unclear.¹¹⁹⁶ In vitro, protein Z has also been shown to have a weak interaction ($K_d = 8.9 \mu\text{mol/L}$) with thrombin that facilitates the binding of thrombin to phospholipid surfaces.¹²⁰⁶ It is also consumed, like all other coagulation factors and inhibitors, during the course of DIC.

P.466

Thrombomodulin

Thrombomodulin is a type 1 transmembrane protein constitutively expressed on the surface of vascular endothelial cells (Fig. 18.9). It is an essential that displays a range of antiinflammatory, anticoagulant, and antifibrinolytic properties.¹²⁰⁷ Thrombomodulin is a high-affinity receptor for α -thrombin and acts as a cofactor for the α -thrombin-dependent activation of protein C and TAFI. Thrombomodulin activity on the surface of endothelial cells is decreased by inflammatory cytokines and may contribute to the hypercoagulation characteristic of inflammatory states. Thrombomodulin is expressed widely during fetal development.¹²⁰⁸ Homozygous thrombomodulin-deficient mice die in utero before the formation of the cardiovascular system, suggesting a potential role for thrombomodulin in mammalian development.¹²⁰⁹

Gene Structure and Expression

The human thrombomodulin gene is located on chromosome 20 band p-12cen and spans 3.7 kb^{1210,1211} (Table 18.6). The gene is unusual in that it lacks introns.^{1212,1213} Thrombomodulin expression has been reported in a variety of cell types, including vascular endothelial cells,^{1214,1215} neutrophils,¹²¹⁶ monocytes,^{1217,1218} platelets,¹²¹⁹ synovial cells,¹²²⁰ and squamous epithelial cells.^{1221,1222} and¹²²³ Vascular expression is limited to endothelial cells. Thrombomodulin activity on the surface of endothelial cells is decreased by homocysteine, lipopolysaccharide, IL-1 β and TNF- α .^{1117,1118,1224,1225,1226} Many of these same inflammatory agents that downregulate thrombomodulin also upregulate tissue factor, contributing to the hypercoagulation associated with inflammation. Hypoxia also downregulates thrombomodulin expression.¹²²⁷ Likewise, thrombomodulin expression is decreased by glucose-modified albumin, which may provide a link to diabetic thrombotic complications.¹²²⁸ Conversely, dibutyl cyclic adenosine monophosphate, retinoic acid, shear stress, and increased temperature (42°C) upregulate thrombomodulin activity on endothelial cells.^{1229,1230,1231,1232} and¹²³³ Upregulation of thrombomodulin expression by TNF- α may involve a consensus sequence of a cyclic adenosine monophosphate response element in the 3'-untranslated region of the thrombomodulin gene.¹²³⁴ Increased thrombomodulin gene transcription due to elevated temperature is mediated by consensus sequence recognition sites for a heat shock element in the 5'-promoter region.¹²³³ Upregulation of thrombomodulin expression in response to elevated temperature may be a protective mechanism to compensate for the procoagulant effects of the inflammatory mechanism.

Biochemistry

Human thrombomodulin is synthesized with an 18-amino acid signal sequence followed by a 557-residue polypeptide chain of the mature protein.^{1210,1212,1213,1235} Thrombomodulin has five different domain structures: An NH₂-terminal domain having weak homology to lectins (residues 6 to 149) such as the asialoglycoprotein receptor,¹²³⁶ six EGF-like domains (residues 227 to 462), a 34-residue region rich in serine and threonine corresponding to potential O-linked glycosylation sites (residues 463 to 497), a 23-residue hydrophobic transmembrane region (residues 499 to 521), and a COOH-terminal domain (residues 522 to 557) containing several potential phosphorylation sites and one free cysteine residue (Cys⁵³⁶) (Fig. 18.9). The fifth and sixth EGF domains support α -thrombin association.¹²³⁸ The region required for efficient protein C activation extends from the linker region between EGF domains 3 and 4 through EGF-6.^{1238,1239,1240} and¹²⁴¹ Ser⁴⁷² and Ser⁴⁷⁴ in the serine- and threonine-rich region are potential sites for chondroitin sulfate addition.¹²⁴² The presence of chondroitin sulfate increases the affinity for α -thrombin more than 10-fold,¹²⁴³ thus increasing the ability of thrombomodulin to block fibrinogen cleavage and platelet activation by α -thrombin.^{1244,1245} The chondroitin sulfate moiety also enhances inactivation of α -thrombin by antithrombin^{1244,1246} and modulates the Ca²⁺ dependence of protein C activation.^{1243,1246} The O-linked sugar domain of thrombomodulin is required for APC generation on cellular surfaces. This domain is extended and rigid and rises approximately perpendicular to the membrane surface. The O-linked sugar domain likely functions to elevate α -thrombin from the membrane surface.¹²⁴⁷ The active site of α -thrombin bound to thrombomodulin is located approximately 65 Å from the membrane surface.¹²⁴⁸

Although no consensus sequence for internalization via coated pit-mediated endocytosis is found in thrombomodulin, coated and noncoated pit-mediated endocytosis has been observed.¹²⁴⁹ Internalization appears to be mediated by the NH₂-terminal lectin-like domain.¹²⁵⁰

Function

Thrombomodulin functions as a cofactor for α -thrombin in the activation of protein C and TAFI. Production of APC by the α -thrombin-thrombomodulin complex is approximately 1,000 times faster than by equivalent concentrations of protein C and thrombin. Once bound to thrombomodulin, α -thrombin's procoagulant activities are neutralized. The high-affinity α -thrombin-thrombomodulin interaction is mediated mainly by exosite I on the α -thrombin molecule. Exosite I also binds fibrinogen, and the interaction of α -thrombin with thrombomodulin therefore blocks fibrinogen binding and cleavage. In addition, thrombomodulin induces conformational changes in α -thrombin.^{1251,1252,1253,1254,1255} and¹²⁵⁶ Overall, the changes that occur on α -thrombin interaction with thrombomodulin reduce the ability of α -thrombin to generate fibrin, and to activate factor V and platelets,^{1257,1258} while increasing the rate of inactivation of α -thrombin by antithrombin.^{1259,1260} and¹²⁶¹ α -Thrombin-thrombomodulin, or protein Case, functions solely in an anticoagulant and antifibrinolytic capacity.

Regulation

There are several potential mechanisms of thrombomodulin regulation on the cell surface. Thrombomodulin expression is downregulated by endotoxin and inflammatory cytokines.¹¹²³ Shear stress, homocysteine, and hypoxia likewise downregulate thrombomodulin expression.^{1226,1227,1232,1262} α -Thrombin may also regulate thrombomodulin activity, although evidence is somewhat controversial. Thrombomodulin-dependent α -thrombin internalization has been

reported.^{1263,1264} and ¹²⁶⁵ However, the α -thrombin-thrombomodulin complex appears to be stable under some conditions.^{1017,1266} In addition, thrombomodulin activity can be regulated proteolytically, mainly by neutrophil elastase.^{1267,1268} Neutrophils decrease thrombomodulin activity via oxidation as well.¹²⁶⁹

ANTICOAGULANT PROTEINS: PROTEINASE INHIBITORS

Proteinases, enzymes that hydrolyze peptide bonds, are found in a wide array of biologic systems, including the blood coagulation process (clot formation and fibrinolysis), digestive system, apoptotic cascades, and the immune system. To keep these systems in balance between activation and inhibition, a complex system of proteinase inhibitors has evolved. In blood, proteinase inhibitors constitute a significant percentage of circulating proteins. In general, proteinases that activate the coagulation and fibrinolytic cascades have highly defined substrate specificities. Coagulation is kept in check through the action of several specific and broad-spectrum proteinase inhibitors. Specific clot formation inhibitors are antithrombin and TFPI. Fibrinolysis-specific

P.467

inhibitors are PAI-1 and α_2 -antiplasmin. Together, specific and broad-spectrum inhibitors function to localize, limit, and control hemostasis.

α_2 -Macroglobulin

α_2 -Macroglobulin is a nonspecific proteinase inhibitor that targets a broad spectrum of protease substrates.¹²⁷⁰ It is present in human plasma at concentrations ranging from 2 to 4 $\mu\text{mol/L}$ (2 to 3 mg/ml) (Table 18.4). α_2 -Macroglobulin can also be found at higher concentrations in extravascular fluids.¹²⁷¹ This protease inhibitor can be produced in a variety of cells including hepatocytes, fibroblasts, and macrophages.^{1058,1272} α_2 -Macroglobulin is also found in several species including the horseshoe crab.¹²⁷³

Reduced levels of serum α_2 -macroglobulin in humans have been observed in individuals with chronic obstructive lung disease¹²⁷⁴ and cancer metastasis.¹²⁷⁵ In humans, no absolute deficiency has been reported to date, leading to the suggestion that such a congenital deficiency is incompatible with survival. The inactivation of the mouse α_2 -macroglobulin gene results in viable mice that produce normal-sized litters but are more resistant to endotoxin challenge.¹²⁷⁶ In a later study, it was suggested that this phenotype in mice functions as a neutralizer of transforming growth factor- β and as an inducer of nitric oxide synthesis.¹²⁷⁷

Gene Structure and Expression

The gene encoding human α_2 -macroglobulin spans approximately 48 kb and consists of 36 exons and 35 introns¹²⁷⁸ (Table 18.6). It is located on chromosome 12p12.3-13.3.^{1279,1280} and ¹²⁸¹ The α_2 -macroglobulin gene is a single copy gene in the human genome. α_2 -Macroglobulin is synthesized in the liver as a pro- α_2 -macroglobulin, which contains a 23-residue signal peptide. Three transcription initiation sites, including a TATA box, a TATA-like structure (ATAAA), and a potential HP-1 binding site, have been identified in the liver.¹²⁷⁸

Biochemistry

Human α_2 -macroglobulin circulates in plasma as a tetramer with four identical single-chain subunits with an individual relative molecular weight of 180,000 and a total relative molecular weight of 735,000.^{1279,1282,1283} An unusual feature of this protein is that multiple forms may be found in various species and may appear only during acute-phase reactions.^{1058,1271,1272} A dimeric form termed pregnancy zone protein has been found in human plasma at peak levels during the last trimester. Therefore, this protein may be found in human plasma composed of either two or four identical subunits.^{1284,1285}

α_2 -Macroglobulin has a unique mechanism by which it achieves broad specificity.¹²⁸⁶ The initial step involves the "bait region" of α_2 -macroglobulin.¹⁰⁵⁷ This region consists of a 25-amino acid sequence that has sequence motifs appropriate for many proteases.¹²⁸⁷ After proteolysis in this bait region, α_2 -macroglobulin undergoes conformational changes that trap the proteinase inside the molecule.¹⁰⁵⁷ The crystal structure of human α_2 -macroglobulin displays a large central cavity capable of containing one or two average-sized proteases.¹²⁸⁸ These conformational changes have been referred to as a slow to fast transition.^{1056,1057} The active site of the substrate proteinase is not found in complex with the inhibitor. Studies have shown that the entrapped proteinase is no longer able to interact with macromolecular substrates, inhibitors, and antibodies, but still appears to retain its ability to react with small substrates and inhibitors.¹⁰⁵⁷ These complexes are rapidly cleared from the circulation by the endocytic α_2 -macroglobulin receptor also known as the lowdensity lipoprotein

receptor-related protein (LRP). This receptor is found on most mast cells and tissues. The proteinase inhibitor complex has an approximate $t_{1/2}$ of 2 to 5 minutes.¹⁰⁵⁸

Another important feature of α_2 -macroglobulin is the presence of a β -cysteinyl- γ -glutamyl thiol ester.^{1289,1290} Studies have shown that these thiol esters may directly react with small nucleophiles, such as ammonia or methylamine; induce a conformational change; and prevent proteinase binding.¹²⁹¹ The conformational changes associated with proteolysis of the bait region generate a thiol ester more susceptible to nucleophilic attack, with the result that surface Lys residues of the trapped proteinase can react with it and become covalently linked to α_2 -macroglobulin. Binding studies in vitro have identified specific high-affinity receptors for α_2 -macroglobulin-proteinase complexes on many cell types, including fibroblasts, macrophages, and hepatocytes.¹⁰⁵⁹

Function

One role for α_2 -macroglobulin is to inhibit a broad range of proteinases. It is distinctive in its capacity to inhibit members from each of four mechanistic classes of proteinases (serine, cysteine, and aspartic proteinases, and metalloproteinases). α_2 -Macroglobulin functions as a secondary inhibitor to serine proteinases in plasma by inhibiting thrombin, kallikrein, and plasmin.^{1292,1293} It may also be important in preventing thromboembolic events when there is a congenital deficiency of antithrombin or sepsis.^{1294,1295} α_2 -Macroglobulin also inhibits various growth factors and cytokines, including TGF- β ,¹²⁹⁶ IL-1 β ,¹²⁹⁷ IL-6,¹²⁹⁸ acidic fibroblast growth factor,¹²⁹⁹ basic fibroblast growth factor,¹²⁹⁹ TNF- α ,¹³⁰⁰ and IL-2.¹³⁰¹ Polymorphisms identified in α_2 -macroglobulin have been thought to play a role in Alzheimer disease.^{1302,1303} and ¹³⁰⁴ Overall, the biologic role of α_2 -macroglobulin in vivo is still being elucidated.

Tissue Factor Pathway Inhibitor

TFPI, formerly called extrinsic pathway inhibitor or lipoprotein-associated coagulation inhibitor, is a multivalent, Kunitz-type plasma proteinase inhibitor. TFPI modulates tissue factor-dependent coagulation in vivo by rapidly inhibiting the extrinsic tenase complex (factor VIIa-tissue factor) as soon as it is formed^{1305,1306} and ¹³⁰⁷ (Fig. 18.6). It circulates in plasma at approximately 0.1 $\mu\text{g}/\text{ml}$ ¹³⁰⁸ as a heterogeneous collection of partially proteolyzed forms^{1309,1310} and ¹³¹¹ (Table 18.4). Ninety percent of circulating TFPI is found associated with lipoproteins, primarily low-density lipoprotein.^{1310,1312,1313} Parenteral TFPI is cleared from the circulation primarily by the liver and has an unusually short $t_{1/2}$ (minutes) compared to other proteinase inhibitors.

Many reviews of TFPI have been published.^{1314,1315,1316,1317} and ¹³¹⁸ The importance of TFPI in blood coagulation has been best illustrated through transgenic mice that have a complete deficiency (-/-) of TFPI. This deficiency is incompatible with birth and survival.¹³¹⁹ However, this lethality in mice can be rescued by heterozygous or homozygous factor VII deficiency.¹³²⁰ This implies that diminishing the level of factor VII lessens the need for TFPI-mediated inhibition of the factor VIIa-tissue factor coagulation pathway during embryogenesis.¹³²⁰ When mice are generated that have a combined heterozygous TFPI deficiency and homozygous apolipoprotein E deficiency, they exhibit a greater atherosclerotic burden.¹³²¹ These observations suggest a role for TFPI in protection from atherosclerosis and as a potential regulator of thrombosis.

To date, there are no known human TFPI-deficient individuals described, which suggests that human embryos with TFPI^{-/-} genotype fail to develop. A role for TFPI in preventing thrombosis and other cardiovascular diseases is currently under intensive clinical and in vitro investigation.¹³²² One application for recombinant TFPI is in the area of sepsis in which patients frequently have reduced TFPI levels.^{1323,1324}

Gene Structure and Expression

The human TFPI gene has been localized to chromosome 2 bands q31-q32.1^{1325,1326} and ¹³²⁷ (Table 18.6). It spans 85 kb, over half of which

P.468

consists of the 5' noncoding region. The coding region is distributed over nine exons¹³²⁸; mature TFPI contains three Kunitz domains that are encoded on separate exons. The gene specifies a protein of 304 amino acids; the first 28 residues comprise a signal peptide. Two variants of TFPI (isoforms α and β) arising from alternative splicing have been identified; the variable region involves residues 210 to 251 of the primary gene product, spanning a large portion of the third Kunitz domain. TFPI is expressed constitutively by cultured endothelial cells, and its level of synthesis is hardly affected by endotoxin or inflammatory cytokines.^{1311,1329} TFPI is not expressed by hepatocytes. TFPI is found bound to low- and high-density lipoproteins located within platelets or noncovalently associated with endothelial cell heparin sulfate

proteoglycans.¹³⁰⁸ TFPI is catabolized in the liver and kidney by uptake/degradation via the low-density LRP or its homologs.¹³³⁰

Biochemistry

TFPI (M_r = 40,000) is a single-chain glycoprotein of the Kunitz proteinase inhibitor family.^{1331,1332} As isolated, the COOH-terminus of TFPI displays some degradation. Structurally, mature full-length TFPI (276 amino acids in the α isoform) consists of an acidic NH₂-terminal region, three tandem Kunitz-like serine protease inhibitor domains (K1 to K3), and a positively charged COOH-terminal region^{1330,1331} (Fig. 18.12). The tandem Kunitz domains are essential for the function of TFPI.¹³⁰⁸ The Kunitz 1 inhibitor domain (residues 26 to 76) binds factor VIIa-tissue factor. The second Kunitz domain (residues 97 to 147) of TFPI binds the factor Xa active site. The Kunitz 3 domain (residues 189 to 239) of TFPIα binds protein S, and the protein S mediated potentiation of factor Xa inhibition by TFPIα involves protein S-Kunitz 3 interaction.¹³³³ Heparin binds at two heparin-binding sites: a high-affinity site in the COOH-terminal basic region and a low-affinity site between Gly²¹² and Phe²⁴³ in the third Kunitz domain.^{627,628,1334}

Tissue factor pathway inhibitor (TFPI): 40 kDa

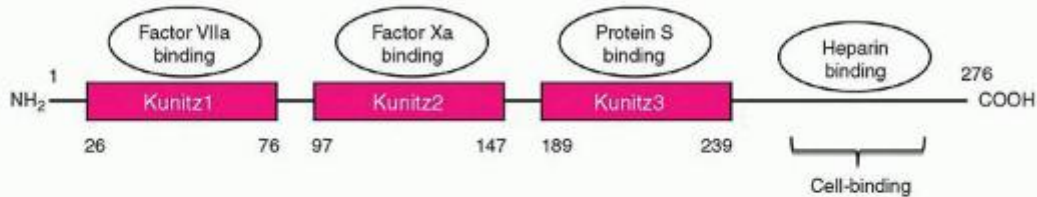

Antithrombin (AT): 58 kDa

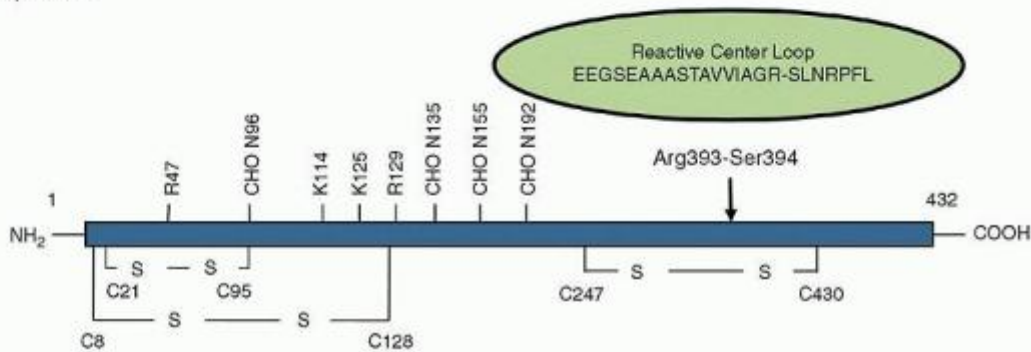

FIGURE 18.12. Soluble stoichiometric inhibitors. Tissue factor pathway inhibitor (TFPI) contains three Kunitz domains. TFPI inhibits the serine protease factor Xa (FXa) directly and tissue factor-factor VIIa complex in a factor Xa-dependent mechanism, shutting down the extrinsic pathway of coagulation. Kunitz 1 domain binds factor VIIa, Kunitz 2 domain binds factor Xa, and Kunitz 3 binds protein S, with this interaction reported to enhance the activity of TFPI.¹³³³ The COOH-terminus of TFPI contains a basic region, the cell-binding domain, which binds to heparin. Antithrombin (AT) contains two intrachain disulfide bonds (-S-S-) in its NH₂-terminus and one in its COOH-terminus with a carbohydrate-rich domain (CHO) in between. Asn¹³⁵ is not glycosylated in the β form of AT. The region of interaction between the active sites of target proteases and AT is illustrated as a circle (reactive center loop) above the reactive site bond R³⁹³-S³⁹⁴. Heparin binding occurs in the NH₂-terminus, involving interactions with residues R⁴⁷, K¹¹⁴, K¹²⁵, and R¹²⁹, and enhances the rate of inhibition of certain serine proteases.

TFPI contains three potential N-linked glycosylation sites (Asn¹¹⁷, Asn¹⁶⁷, and Asn²²⁸), with one or more of these oligosaccharides sulfated during expression by cultured endothelial cells.¹³³⁵ Two O-linked glycosylation sites have also been identified (Ser²⁰² and Thr²⁰³). A significant proportion of TFPI molecules in the blood is truncated to variable extents at the COOH-terminal end (some lacking most of the third Kunitz domain) and has compromised inhibitory activity.¹³³⁶ In

contrast, TFPI released by heparin infusion is full length and more active than the truncated forms.¹³³² The inhibitory activity of TFPI is enhanced by heparin.

P.469

The normal plasma concentration of TFPI is 0.1 µg/ml. TFPI α is found either associated with lipoproteins, such as low- and high-density lipoproteins or lipoprotein(a), complexed noncovalently to endothelial cell heparan sulfate proteoglycans¹³³⁷; or associated with endothelial cell surfaces via a glycosyl-phosphatidylinositol (GPI) anchor.^{1315,1316} On heparin administration, TFPI is released from endothelial cells, primarily microvascular, causing a two- to 10-fold increase in circulating TFPI levels.^{1332,1338,1339} TFPI release on heparin therapy is responsible for the observed elevation in PT and raises the possibility that a portion of the antithrombotic effect of the polysaccharide may be mediated by TFPI. GPI-anchored TFPI α is not released by heparin therapy and represents the largest in vivo pool of TFPI. A minor pool of TFPI (~10% of total TFPI in blood) is located within platelets and is released after dual stimulation by collagen and thrombin.¹⁰²⁰ TFPI β has Kunitz 1 and Kunitz 2 domains and a unique C-terminal region that contains a GPI-anchor sequence.¹³¹⁶

The qualitative and quantitative properties of TFPI can be altered both by the genotype of an individual and by environmental factors. This is illustrated by in vitro experiments in which factor V^{Leiden} is combined with reduced levels of TFPI. Factor V^{Leiden}, when combined with TFPI levels that are at the low end (50%) of the normal range, can produce an unregulated propagation phase of thrombin generation in a synthetic plasma system.¹³⁴⁰ In a control with normal factor V, the propagation phase of thrombin generation is attenuated substantially at the tissue factor concentrations used in this experiment (i.e., it is near threshold). With factor V^{Leiden} and low normal TFPI, the propagation phase of thrombin generation is equivalent to a situation in which the protein C regulatory system is totally dysfunctional. This observation suggests the risk of thrombotic pathology. An in vivo parallel to this in vitro experiment has been reported by Eitzman et al.,¹³⁴¹ who showed that factor V^{Leiden} (+/+) mice with reduced levels of TFPI (+/-) died of thrombosis.

Function

TFPI is the principal stoichiometric inhibitor of the extrinsic pathway (factor VIIa-tissue factor) of coagulation (Fig. 18.6). The extrinsic pathway generates low levels of the serine proteases, factor IXa (~1 pmol/L), and factor Xa (~10 pmol/L).⁵⁶⁷ As soon as the proteases are formed, factor Xa can activate prothrombin to generate thrombin, and factor IXa can combine with its cofactor factor VIIIa and form the intrinsic tenase complex to generate more factor Xa. This is followed by the formation of the prothrombinase complex (factor Xa-factor Va), which converts prothrombin to thrombin. The TFPI mechanism allows the factor VIIa-tissue factor complex to initiate factor Xa formation but then suppresses high levels of factor Xa product formation by this complex. TFPI is the principal regulator of the initiation phase of thrombin generation⁵⁶⁷ (Fig. 18.11).

The actual mechanism involves a rapid interaction between the second Kunitz domain of TFPI with the factor Xa active site; localization of the complex to the membrane surface is mediated by the Gla domain of factor Xa.^{628,1342,1343} Once surface bound, the factor Xa-TFPI complex rapidly inactivates tissue factor-factor VIIa. This complex formation depends on the binding of the first Kunitz domain of TFPI to the factor VIIa active site. These interactions together form a stable quaternary complex, tissue factor-factor VIIa-TFPI-factor Xa. Ethylenediaminetetraacetic acid (EDTA) can readily dissociate this inhibited quaternary complex. Protein S enhances TFPI α inhibition of factor Xa¹¹⁷³; although whether this affects TFPI α suppression of the factor VIIa-tissue factor complex is controversial.¹³⁴⁴

Inhibition of factor VIIa-tissue factor by TFPI is not completely dependent on the presence of factor Xa because the factor IXa-TFPI complex can also bind to and inhibit factor VIIa-tissue factor. However, the binding affinity of TFPI for factor IXa is significantly less than for factor Xa. The physiologic relevance of this route of inhibition is thus debatable because high plasma concentrations of TFPI are required. At normal plasma concentrations, this multicomponent interaction of TFPI allows basal function of the factor VIIa-tissue factor complex but inhibits it after more extensive activation occurs.

When combined with the stoichiometric inhibitor antithrombin, a synergistic regulatory effect of blood coagulation occurs by inducing kinetic "thresholds" such that the initiating tissue factor stimulus must achieve a significant magnitude to propel thrombin generation.¹³⁴⁵ Tissue factor concentrations below the threshold concentration are ineffective in promoting robust thrombin generation because of the cooperative influence of the inhibitors; concentrations in excess of the threshold yield robust and almost equivalent thrombin generation. In a similar fashion, TFPI and the dynamic protein C-thrombomodulin-thrombin system cooperate to provide a threshold-limited, synergistic inhibition of thrombin production.¹³⁴⁶ In this instance, TFPI slows the initiation phase, whereas the APC system reduces the availability of the cofactors factors Va and VIIIa, thereby shutting down the propagation phase of thrombin generation (Fig. 18.11).

Regulation

TFPI administered intravenously to rats and mice is cleared rapidly from the circulation by liver hepatocytes, which recognize its COOH-terminal region (third Kunitz domain and basic COOH-terminus).^{1347,1348} and ¹³⁴⁹ TFPI is cleared by the promiscuous endocytic receptor, low-density LRP. Several lines of evidence suggest that TFPI binding to heparin-like sites on the cell surface may precede its catabolism by LRP. In addition, TFPI appears to be important for factor Xa catabolism. TFPI-factor Xa complexes are cleared by a liver receptor that is distinct from LRP.

ANTICOAGULANT PROTEINS: SERINE PROTEASE INHIBITOR SUPERFAMILY (SERPIN)

Inhibitory serpins are irreversible covalent suicide protease inhibitors. These inhibitors target serine proteases, a family of proteolytic enzymes sharing common active site architectures and common catalytic mechanisms. Key features of these enzymes include a nucleophilic serine hydroxyl moiety that attacks the carbonyl group of the targeted bond and the formation of a transient acyl-enzyme intermediate between the enzyme and the NH₂-terminal part of the substrate polypeptide. In vivo, when a serpin successfully reacts with a protease, catalysis of serpin proteolysis is arrested at the acyl-enzyme stage, and the serpin-enzyme complex is cleared from the circulation by specific receptormediated processes. Members of this multigene inhibitor family include antithrombin, heparin cofactor II, α₁-proteinase inhibitor (also known as α₁-antitrypsin), C1 esterase inhibitor, protein C inhibitor, PAI-1, α₂-antiplasmin, protein Z-dependent protease inhibitor, and protease nexin-1. Plasminogen activator-1 and α₂-antiplasmin are discussed in detail in the section on Inhibitors of the Fibrinolytic System, and protein Z-dependent protease inhibitor is discussed briefly in the section on Protein Z. Serpins function in diverse physiologic processes including blood coagulation, fibrinolysis, complement activation, angiogenesis, apoptosis, inflammation, neoplasia, and viral pathogenesis^{1350,1351} and ¹³⁵² (Table 18.7). When a member of the serpin family is either deficient or dysfunctional, several biologic disorders are evidenced, including thrombosis,^{1353,1354} emphysema,¹³⁵⁵ lupus erythematosus,¹³⁵⁶ liver disease,¹³⁵⁷ and dementia.¹³⁵⁸

In the past two decades, advances have been made to further understand the mechanism of action of serpins.^{1053,1359,1360,1361,1362,1363,1364,1365,1366} and ^{1367,1368,1369,1370} Serpins in uncleaved states

P.470

(native or latent) and cleaved states have been crystallized.^{1367,1371,1372} Achievement of the first crystal structure for a serpin-protease complex (α₁-antitrypsin-trypsin)¹³⁷³ has confirmed the physical displacement of the tethered protease: The conformation of α₁-antitrypsin in the complex is superimposable with that of the isolated cleaved α₁-antitrypsin. The crystal structure also revealed that the translocated, tethered protease has undergone an overall 37% loss of structure with its catalytic site radically disrupted.

TABLE 18.7 SERPIN INHIBITORS

Serpin	System(s) Regulated	Target Protease(s)	Deficiency State
Antithrombin	Coagulation	Thrombin, FXa, FIXa, kallikrein ^a , FXIa, and FVIIa ^b	Thrombosis
Heparin cofactor II	Coagulation	Thrombin	Thrombosis in some individuals
Protein C inhibitor	Coagulation	APC, kallikrein	None reported
α ₁ -Proteinase inhibitor	Inflammation	Elastase	Pulmonary emphysema
	Tissue remodeling	Cathepsin G	—
	Coagulation	APC, FXIa, and FXa	—
Plasminogen activator inhibitor-1	Fibrinolysis	Tissue-type plasminogen activator, urokinase-type plasminogen activator	Bleeding

α_2 -Antiplasmin	Fibrinolysis	Plasmin	Bleeding
C1 esterase inhibitor	Complement	C1r, C1s	Angioedema
	Contact factors	FXIIa, kallikrein	—
	Coagulation	FXIa	—
Protease nexin-1	Coagulation	Thrombin	None reported

APC, activated protein C; F, factor.

^a Reaction also requires the presence of high-molecular-weight kininogen.

^b Antithrombin-heparin inhibits factor VIIa only when bound to tissue factor.

Inhibitory serpins share a similar backbone structure but expose a variable reactive site loop. This loop binds to the catalytic groove of the target proteases. Serpin specificity derives in part from the sequence of the reactive site loop and also from secondary binding sites.^{1374,1375} Initially, the reaction of a serpin and serine protease involves formation of a noncovalent Michaelis complex between the exposed reactive site loop and the protease active site. Exosite interactions between the two molecules, or in some cases, exosite binding of a cofactor, induce structural changes that increase the availability of the reactive site loop. Reversible complex formation is followed by reaction of the active site serine residue of the protease with the serpin "bait" peptide bond to form an acyl-enzyme intermediate. Trapping of this covalent complex between the reactive site loop and the protease appears to involve a process that both physically translocates the reactive loop-protease complex approximately 71 Å from the initial docking site and induces a general disordering of the protease's conformation with consequent loss of any further catalytic activity.¹³⁷³ The energy for translocation and structural alteration of the protease derives from the insertion of the proteolytically released reactive site loop of the serpin into β sheet A of its central core. A kinetic partitioning of serpin-protease reactions between stable inhibited complexes and mixtures of regenerated enzyme and proteolyzed serpin reflects the relative rates of reactive site loop insertion versus deacylation.¹³⁷⁶ A number of recent reviews have been written on the known serpin conformations and their biologic significance.^{1350,1377,1378,1379,1380,1381,1382,1383} and ¹³⁸⁴

Antithrombin

Antithrombin is a member of the serpin proteinase inhibitory family and circulates in blood as a single-chain glycoprotein²⁹⁶ (Table 18.4). Its $t_{1/2}$ is approximately 61 to 72 hours.^{1385,1386} Other names for antithrombin include antithrombin-heparin cofactor and heparin cofactor. Despite its name, antithrombin inhibits not only thrombin, but also many of the other enzymes in the coagulation pathway. Congenital antithrombin deficiency exhibits an autosomal dominant pattern of inheritance, with an incidence of 1:2,000 to 1:5,000.¹³⁸⁷ The complete absence of antithrombin is lethal. Individuals with this deficiency have partial expression of antithrombin and are prone to thromboembolic disease.¹³⁸⁸ Inherited deficiency is categorized by either quantitative defect with a reduction in antigen and activity (type I) or qualitative with reduced antithrombin functional activity and normal antigen levels (type II).¹³⁸⁹ These defects are caused by a variety of mutations that include insertions, deletions, and missense mutations.^{1390,1391,1392} Function can be compromised by mutations in the thrombin-binding domain or the heparin-binding domain. Unstable variants of antithrombin have been identified in families with severe episodic thrombotic disease. Acquired antithrombin deficiency occurs in patients with sepsis or severe traumatic shock.^{1393,1394} Therefore, studies are being conducted on the use of antithrombin as an agent for treating coagulation abnormalities associated with sepsis or other inflammation disorders.^{1395,1396}

Gene Structure and Expression

The gene encoding antithrombin is located on chromosome 1 in the q23-q25 region¹³⁹⁷ and spans 13.5 kb of genomic DNA¹³⁹⁸ (Table 18.6). The gene is composed of seven exons and six introns.¹³⁹⁸ The mechanisms underlying antithrombin gene expression are not well established. It is primarily expressed in the liver with low levels detected in the brain and kidney. Cis-acting elements and trans-acting factors have been identified that regulate constitutive expression of the human antithrombin gene.¹³⁹⁹

Biochemistry

Human antithrombin is a single-chain glycoprotein ($M_r = 58,000$) that circulates in blood at a concentration of approximately 140 $\mu\text{g/ml}$ (2.4 $\mu\text{mol/L}$).^{296,1400} It circulates as two glycoforms,

P.471

α and β variants, that contain identical polypeptide backbones but differ in carbohydrate content and heparin affinity.¹⁴⁰¹ The antithrombin α variant is the predominant form (~90%).¹⁴⁰² The structure of antithrombin α consists of 432 amino acid residues, with three disulfide bonds and four sialylated oligosaccharides at Asn⁹⁶, Asn¹³⁵, Asn¹⁵⁵, and Asn¹⁹² (Fig. 18.12). The carbohydrate residues account for 15% of the total mass.^{1402,1403,1404,1405} The antithrombin β variant is not glycosylated at Asn¹³⁵. Antithrombin β binds heparin more tightly than does antithrombin α and is observed to preferentially accumulate on the vessel wall when heparan sulfate proteoglycans are exposed.¹⁴⁰⁶ The reactive site peptide bond is Arg³⁹³-Ser³⁹⁴.

The first x-ray crystal structure of antithrombin that was determined was a cleaved form that diffracted to 3.2 Å resolution.¹⁴⁰⁷ Significant differences between structures of antithrombin and another serpin, α_1 -antitrypsin, were identified in the NH₂-terminal region that defines the heparin-binding site. Since then, several x-ray crystal structures of intact antithrombin have been solved to 2.6 to 3.0 Å.^{1408,1409} and ¹⁴¹⁰

Function

Antithrombin has a broad spectrum of inhibitory activity with most of its target proteases participating in the coagulation cascade. It is primarily an inhibitor of the serine protease thrombin as well as factor Xa, factor IXa, factor VIIa-tissue factor, factor XIa, factor XIIa, and plasma kallikrein.^{1411,1412} and ¹⁴¹³ Antithrombin plays a key role in maintaining hemostasis. Antithrombin also displays antiproliferative and antiinflammatory properties that primarily derive from its ability to inhibit thrombin. In addition, latent or cleaved forms of antithrombin have antiangiogenic activities.¹⁴¹⁴ Heparins and heparan sulfates potentiate these reactions and are used in the treatment of thrombosis.¹⁴¹⁵ When antithrombin is complexed with heparin, its rate of inhibition of several coagulation proteases is accelerated by up to 10,000-fold.

In general, binding of heparins to antithrombin improves its reactivities with proteases in two ways: (1) By inducing conformational changes in antithrombin, including better presentation both of the reactive center loop and of exosites on antithrombin that interact with target enzymes; and (2) by enabling a template effect, whereby binding of enzyme and antithrombin to the same heparin molecule improves the likelihood of the interaction.

The mechanism of inhibition involves reaction of the active site of the enzyme with a peptide loop structure (reactive center loop, Fig. 18.12) of the serpin to form a tight, equimolar (1:1) complex. Inactivation is suspected to proceed through covalent bond formation between antithrombin and the protease, followed by inactivating structural rearrangements of both antithrombin and the protease. However, the exact mechanism of inhibition of serine proteases by antithrombin is uncertain. In the case of factor Xa inhibition, crystallographic data indicate that heparin-induced conformational change in antithrombin permits contacts between antithrombin and the active site and two exosites of factor Xa.¹⁴¹⁶

Heparin Cofactor II (Leuserpin 2)

Heparin cofactor II, also called leuserpin 2, is a member of the serpin family.¹⁴¹⁷ Like antithrombin, heparin cofactor II inhibits thrombin in a reaction that is accelerated more than 1,000-fold by heparin.¹⁴¹⁸ However, heparin cofactor II is unique in that it is also stimulated by the proteoglycan dermatan sulfate. The plasma concentration of heparin cofactor II is 0.5 to 1.4 $\mu\text{mol/L}$ ^{1419,1420} (Table 18.4). Its plasma $t_{1/2}$ is approximately 2.5 days. The physiologic role of heparin cofactor II is uncertain at the present time. Low levels of thrombin-heparin cofactor II complexes are detected in normal plasma samples; elevated levels were detected in patients with DIC.¹⁴²¹ Although inherited deficiency of heparin cofactor II has been associated with thrombosis, this is not always the case.^{1422,1423} and ¹⁴²⁴ The incidence of heparin cofactor II deficiency in patients with thromboembolytic disorders appears to be similar to that in the normal population.¹⁴²⁵

Gene Structure and Expression

The gene encoding human heparin cofactor II, consisting of five exons and four introns, spans approximately 14 kb on chromosome 22 in the q11 region proximal to the breakpoint cluster region.^{1426,1427} The human heparin cofactor II gene is expressed exclusively in the liver and by a hepatoma-derived cell line.^{1428,1429}

Biochemistry

Human heparin cofactor II ($M_r = 66,000$) circulates as a singlechain protein of 480 amino acid residues that contains 10% carbohydrate.^{1419,1427,1428} It is glycosylated at Asn³⁰, Asn¹⁶⁹, and Asn³⁶⁸ and is sulfated at Tyr⁶⁰ and Tyr⁷³. It has three cysteines with no identified disulfide bonds. A cationic region of the molecule encompassing residues 163 to 194 constitutes the GAG binding site; dermatan sulfate and heparin bind to heparin cofactor II at nonidentical but overlapping

sites in this region.^{1430,1431} Residues Lys¹⁷³, Arg¹⁸⁴, Lys¹⁸⁵, Arg¹⁸⁹, Arg¹⁹², and Arg¹⁹³ have been specifically implicated in heparin binding.¹⁴³² The NH₂-terminal region of heparin cofactor II contains a cluster of acidic residues that are thought to interact with the positively charged GAG binding site.^{1433,1434} This “acidic” tail of heparin cofactor II contains two so-called hirudin domains—Glu⁵⁶AspAspAspTyrLeuAsp⁶² and Glu⁶⁹AspAspAspTyrIleAsp⁷⁵; in each, the Tyr residue is sulfated. It has been proposed that the NH₂-terminal “acidic” tail is constrained in the native structure through association with the highly cationic heparin-binding region. In the presence of GAG, the acidic region is displaced from the heparin-binding site, thus making it available for binding to the anion-binding exosite I of thrombin.¹⁴³⁵ However, crystallographic studies of heparin cofactor II indicate that the acidic tail of heparin cofactor II is flexible in the crystal and not associated with the heparin-binding site.¹³⁶⁷ Other functionally important regions of heparin cofactor II include a chemotactic peptide harbored between residues Asp⁴⁹ and Tyr⁶⁰ that is released by leukocyte proteases.¹⁴³⁶ Residues Phe⁴⁵⁶ to Ile⁴⁶⁰ constitute a pentapeptide recognition motif for the hepatic serpin-enzyme complex receptor that may be involved in clearance of heparin cofactor II-enzyme complexes.¹⁴³⁷

The domain of heparin cofactor II with homology to other serpins is at the COOH-terminus of the protein. It exhibits approximately 30% homology to antithrombin and other serpins. The reactive site peptide bond is Leu⁴⁴⁴-Ser⁴⁴⁵.¹⁴³⁸ This reactive center loop sequence is consistent for an inhibitor with specificity for proteases with a preference for nonpolar residues with relatively bulky side chains in the P1 position. Two such proteases, chymotrypsin and cathepsin G, do react with heparin cofactor II. Thrombin reactivity with heparin cofactor II is unusual because thrombin generally prefers substrates with arginine in the P1 position. Exosite binding interactions, such as that between the hirudin-like sequences of heparin cofactor II and exosite I of thrombin, compensate for the less than ideal structure of the P1 residue and allow thrombin to form a productive Michaelis complex with heparin cofactor II.^{1367,1439}

Function

The only coagulation enzyme inhibited by heparin cofactor II appears to be thrombin.¹⁴⁴⁰ However, the rate of thrombin inhibition by heparin cofactor II in the absence or presence of GAGs is significantly slower than by antithrombin under similar conditions. Considering that the plasma concentration of heparin

P.472

cofactor II is 25% to 50% that of antithrombin and that low levels of heparin cofactor II are not strongly associated with thrombosis,¹⁴⁴¹ the physiologic role of heparin cofactor II as a systemic thrombin inhibitor has been questioned. In vitro, heparin cofactor II inhibition of thrombin is stimulated by dermatan sulfate proteoglycans synthesized by fibroblasts and vascular smooth muscle cells.¹⁴⁴² Thus, heparin cofactor II may be uniquely suited to regulate extravascular thrombin in areas of vascular endothelium disruption, in which heparin cofactor II would be exclusively stimulated by dermatan sulfate in the subendothelial layers.¹⁴⁴³ In addition, heparin cofactor II may participate in regulation of acute inflammation and wound healing by harboring a peptide chemotactic for neutrophils and monocytes that is released by leukocyte proteolysis.¹⁴³⁶

Heparin cofactor II may also have a role in protection from thrombosis during pregnancy. Increased levels of dermatan sulfate in the maternal and fetal circulation¹⁴⁴⁴ along with increased levels of heparin cofactor II in pregnant women have been reported.^{1445,1446} Heparin cofactor II has also been reported to potentiate the activation of endothelial cells and promote angiogenesis.¹⁴⁴⁷

α_1 -Proteinase Inhibitor (α_1 -Antitrypsin)

α_1 -Proteinase inhibitor is the most abundant circulating inhibitor of the serpin family. It is a single-chain glycoprotein that circulates in blood at a concentration of 1.5 to 3.5 mg/ml with a relative molecular weight of 53,000^{1272,1448} (Table 18.4). It is synthesized predominantly in the liver and has a $t_{1/2}$ of 6 days.¹⁴⁴⁹ α_1 -Proteinase inhibitor is considered an acute-phase reactant.¹⁴⁵⁰

Deficiency in α_1 -proteinase inhibitor is a common autosomal recessive disorder (1:1,600 to 1:1,800) that can potentially be lethal.^{1451,1452} It is found associated with emphysema,¹³⁵⁵ liver cirrhosis,¹³⁵⁷ and hepatocellular carcinoma.¹³⁵⁷ Treatment for α_1 -proteinase inhibitor deficiency relies on infusions of human plasma-derived α_1 -proteinase inhibitor.¹⁴⁵³ Progress is under way to develop a therapy based on gene repair^{1454,1455} and¹⁴⁵⁶ or strategies to block aberrant conformational transitions.^{1452,1453,1457}

Gene Structure and Expression

The gene for α_1 -proteinase inhibitor is located on chromosome 14 band q32.1, is approximately 5 kb long,¹⁴⁵⁸ and contains seven exons and six introns^{1458,1459,1460} and¹⁴⁶¹ (Table 18.6). Uniquely, α_1 -antichymotrypsin, corticosteroid-binding

globulin, kallistatin, and protein C inhibitor also map to the same region on chromosome 14.^{1460,1462,1463} These genes are actively transcribed in the liver and cultured hepatoma cells. However, a few other cell types (macrophages and intestinal epithelial cells) express some of these serpin genes.¹⁴⁶⁴ Hepatocyte nuclear factor-1 α and hepatocyte nuclear factor-4 play important roles in expression of the α_1 -proteinase inhibitor gene in hepatic, intestinal, and pulmonary epithelial cells.¹⁴⁶⁵

Biochemistry

α_1 -Proteinase inhibitor is the most studied of the serpins, with high-resolution crystal structures achieved for the inhibitor by itself and in complex with a target protease.¹³⁷³ The 452-amino acid sequence for human α_1 -proteinase inhibitor shows two disulfide bridges and four glucosamine-based carbohydrate chains.^{1466,1467} The reactive site bond that is targeted by serine proteinases is between Met³⁵⁸ and Ser³⁵⁹.¹⁴⁶⁸ Studies using ¹³C nuclear magnetic resonance spectroscopy of the complex between human¹³C methionine-labeled α_1 -proteinase inhibitor and porcine pancreatic elastase have shown that a tetrahedral intermediate complex is formed during the serpin-proteinase interactions.¹⁴⁶⁹ The three-dimensional x-ray crystal structure of cleaved α_1 -proteinase inhibitor identified that for activity, α_1 -proteinase inhibitor requires the insertion of a single residue, Thr³⁴⁵, into β sheet A.¹⁴⁷⁰ This was supported by the x-ray crystal structures of α_1 -proteinase inhibitor complexed with synthetic peptides that correspond to the unprimed NH₂-terminal side of the active site loop.¹⁴⁷¹ The five-stranded β sheet A of α_1 -proteinase inhibitor undergoes conformational changes that facilitate and stabilize the insertion into sheet A of the reactive center loop after cleavage by its target serine proteases. The solution structure of α_1 -proteinase inhibitor has also been characterized by high-flux neutron scattering and by synchrotron x-ray scattering.¹⁴⁷²

Function

α_1 -Proteinase inhibitor can inhibit a wide range of serine proteases. Its primary physiologic target is the inhibition of neutrophil elastase to protect the elastin fibers of the lung. The role of α_1 -proteinase inhibitor in blood coagulation is minimal. It has been shown to inhibit factor XIa in vivo^{1473,1474} to be an important inhibitor of factor Xa in purified and plasma systems.⁶³⁰ APC complexes with α_1 -proteinase inhibitor have also been detected by enzyme-linked immunosorbent assay in patients with DIC.¹⁴⁷⁵ Inhibition by α_1 -proteinase inhibitor is heparin independent.

C1 Esterase Inhibitor

C1 esterase inhibitor is a member of the serpin proteinase inhibitor family that is present at 170 μ g/ml in blood¹⁴⁷⁶ (Table 18.4). It is predominantly synthesized in the liver. When complexed with a protease (e.g., factor XIa), it has a $t_{1/2}$ of 95 to 104 minutes.¹⁴⁷⁴ Targets for C1 esterase inhibitor are found in the complement cascade and the coagulation cascade.

Deficiency in C1 esterase inhibitor can result in hereditary angioedema¹⁴⁷⁷ and has been identified in a patient with lupus erythematosus.¹³⁵⁶ Cases of acquired C1 esterase inhibitor deficiency have been reported associated with splenic lymphoma.^{1478,1479} C1 esterase inhibitor-deficient mice show no obvious phenotypic abnormality,¹⁴⁸⁰ although, in conjunction with a bradykinin type 2 receptor knockout, diminished vascular permeability was observed.¹⁴⁸⁰ The C1 esterase inhibitor is used in the treatment of hereditary angioedema^{1481,1482} and sepsis.¹⁴⁸³ Its potential use in reducing ischemia reperfusion injury is being investigated.¹⁴⁸⁴

Gene Structure and Expression

The primary structure of human C1 esterase inhibitor was initially determined by peptide and DNA sequencing.¹⁴⁸⁵ The only proteolytic processing that occurs is that a 22-residue signal peptide required for secretion is cleaved. The C1 esterase inhibitor gene is located on chromosome 11, bands p11.2-q13¹⁴⁸⁵ (Table 18.6). The C1 esterase inhibitor gene consists of eight exons and seven introns and is approximately 17 kb in length.¹⁴⁸⁶ In vivo, androgens enhance expression of C1 esterase inhibitor. In vitro studies show that C1 esterase inhibitor mRNA and protein levels increase after stimulation with γ - and α -interferon, TNF- α , IL-6, and monocyte colony-stimulating factor.¹⁴⁸⁶

The molecular defects found associated with C1 esterase inhibitor deficiency include Alu repeat-mediated deletions, missense mutations, frame-shifts, stop codon mutations, promoter variants, splice site mutations, or deletions of a few amino acids.^{1487,1488} The clinical manifestation of this deficiency is predominantly angioedema.

Biochemistry

C1 esterase inhibitor is a single-chain glycoprotein containing 478 amino acid residues that circulates with an apparent molecular

P.473

mass of 104,000 when analyzed by SDS-PAGE. The amino acids account for only 51% of the apparent molecular mass of the circulating protein, with 35% of the remaining mass accounted for by carbohydrate moieties.¹⁴⁷⁶ Neutron scattering, x-

ray crystal structure determinations, ¹H nuclear magnetic resonance spectroscopy, and Fourier transform infrared spectroscopy have been used to study the structure of C1 esterase inhibitor, revealing a two-domain structure.^{1489,1490} and ¹⁴⁹¹ The NH₂-terminus, containing 113 amino acids, is heavily glycosylated with three N-linked and seven O-linked oligosaccharides. The COOH-terminus contains 365 amino acids with three N-linked oligosaccharides. When C1 esterase reacts with target proteases, the serpin undergoes changes in its whole secondary structure—not only the reactive site loop.

Function

C1 esterase inhibitor is a member of the serpin inhibitor family. It plays an important role in the regulation of the classic complement pathway, specifically as the sole regulator of the activities of C1r and C1s.¹⁴⁹² C1 esterase inhibitor's role in coagulation is mainly targeted to the contact activation pathway through the regulation of kallikrein,^{179,1493} factor XII,¹³⁴ factor XIIa,¹³⁶, and factor XIa.^{286,293,1426,1427,1494} Unlike other serpin inhibitors, such as antithrombin, protein C inhibitor, or PAI-1, the activity of C1 esterase inhibitor is not affected by heparin.¹⁴⁹⁵

Protein C Inhibitor (Plasminogen Activator Inhibitor-3)

Protein C inhibitor is a member of the serine proteinase inhibitor family. It is also known as PAI-3. Protein C inhibitor is considered nonspecific in that its targets range from procoagulant, anticoagulant, and fibrinolytic enzymes to plasma and tissue kallikreins, the sperm protease acrosin, and prostate-specific antigen.^{1496,1497} It circulates in blood at a concentration of 5 µg/ml^{1498,1499} (Table 18.4), and is cleared from the circulation with a t_{1/2} of 1 day. When in complex with a target (e.g., APC), it is cleared from circulation with a t_{1/2} of 20 minutes.¹⁵⁰⁰ Hereditary or acquired protein C inhibitor deficiency has not been documented to date.¹⁵⁰¹ A case control study of thrombophilia showed that high levels of protein C inhibitor might constitute a mild risk factor for venous thrombosis. Protein C inhibitor-deficient mice (-/-) show impaired spermatogenesis and male infertility.¹⁵⁰²

Gene Structure and Expression

The gene for protein C inhibitor has been mapped to chromosome 14 band q32.1 (Table 18.6). It is 11.5 kb in length and consists of five exons separated by four introns.^{1503,1504} The organization and location of this gene are similar to those of the genes for α₁-antitrypsin and α₁-antichymotrypsin, suggesting a common ancestor for these genes.^{1503,1505,1506} Human protein C inhibitor is mainly synthesized in the liver,¹⁴⁹⁹ but has also been identified in platelets and megakaryocytes,^{1507,1508} the kidney,¹⁵⁰⁹ and the testes, seminal vesicle, and prostate.¹⁵⁰⁹

Biochemistry

Human protein C inhibitor in blood has a relative molecular weight of 57,000.^{1498,1505} The mature protein contains 387 amino acids; a 19-amino acid signal peptide is present before secretion. Five potential N-linked glycosylation sites were found in the mature protein,¹⁵⁰⁵ and their roles in protein C inhibitor activity have been studied by mutational analysis.¹⁵¹⁰ The reactive site bond is located at Arg³⁵⁴-Ser³⁵⁵, and a stable 1:1 molar complex is formed between protein C inhibitor and its target proteinases. Protein C inhibitor binds heparin, and its activity is accelerated when in complex with heparin¹⁵¹¹; unlike other related heparin-binding serpins such as antithrombin, heparin cofactor II, and protease nexin, the primary heparin-binding site of protein C inhibitor is in the H helix, not the D helix.¹⁵¹² A recent crystal structure of this inhibitor provides a structural basis for understanding its multiple functions.¹⁵¹³

Function

Protein C inhibitor is a nonspecific inhibitor of serine proteinases and inhibits APC, thrombin, thrombin-thrombomodulin, factor Xa, u-PA,^{1514,1515} and ¹⁵¹⁶ and t-PA.^{1517,1518} The major target of protein C inhibitor, as its name suggests, is APC,^{1500,1519,1520} although from a kinetic point of view, the reaction with thrombin-thrombomodulin is the most favorable.¹⁵¹⁸ This is the physiologically most important inhibitor of APC. Protein C inhibitor has been shown to regulate TAFI activation by inhibiting the thrombin-thrombomodulin complex.¹⁵¹⁴ Its importance as a dual regulator of coagulation and fibrinolysis remains unresolved.¹⁵²¹ The importance of the regulation of APC by protein C inhibitor is evident by the use of this complex as a marker for detection of deep vein thrombosis.¹⁵²² Other targets for protein C inhibitor include human kallikrein,¹⁸³ factor XIa,¹⁸³ factor Xa, and thrombin. Because there are no documented patients with a deficiency to date, the actual function of protein C inhibitor in vivo is yet to be elucidated.

PROTEINS OF CLOT FORMATION

Early efforts to understand how blood clots form were directed at dissecting the vertebrate coagulation system and determining its components. This work revealed the central event in blood coagulation to be the conversion of soluble fibrinogen (factor I) to insoluble fibrin. Basically, this is accomplished when the coagulation enzyme thrombin (factor IIa)

removes small polar peptides (termed fibrinopeptides) from each fibrinogen molecule, forming fibrin. These fibrin molecules noncovalently interact with each other, forming a fibrin web. Fibrin stabilization is accomplished by the action of a second coagulation enzyme (factor XIIIa) that introduces numerous covalent cross-links between these fibrin molecules. The resulting fibrin web is able to capture platelets and red blood cells, effectively sealing the wound and stemming plasma loss.

Factor XIII (Fibrin Stabilizing Factor)

The first apparent suggestion of cross-linked fibrin by factor XIII came in 1923 from Barkan and Gaspar, who reported that fibrinogen preparations, when clotted in the presence of Ca^{2+} , generated clots that were insoluble in weak bases.^{1523,1524} Later, in the 1940s, work by Robbins,¹⁵²⁵ Laki and Lorand,¹⁵²⁶ and Lorand¹⁵²⁷ confirmed the presence of a serum factor that caused the transition to an insoluble clot and termed it fibrin stabilizing factor. It was not until 1963 that the International Committee on Blood Clotting Factors acknowledged fibrin stabilizing factor as a clotting factor and termed it factor XIII.¹⁵²⁸ Recommended terms and abbreviations for factor XIII have been established.¹⁵²⁴

Factor XIII functions as a transglutaminase that can form cross-linked amide bonds between specific glutamine and lysine residues on polypeptide chains. It plays an important role in hemostasis and thrombosis as well as participating in physiologic processes of cell proliferation and cell migration. Factor XIIIa has multiple substrates including fibrin(ogen), fibronectin, α_2 -plasmin inhibitor, collagen, vitronectin, vWF, actin, myosin, factor V, and thrombospondin.^{1529,1530,1531,1532,1533,1534,1535,1536} and ¹⁵³⁷ Recent reviews discuss the role of factor XIII in blood clotting,¹⁵³⁸ angiogenesis,¹⁵³⁹ cellular function,¹⁵⁴⁰ inflammation,¹⁵⁴¹ and cardiac and vascular diseases.¹⁵⁴²

Gene Structure and Expression

Plasma factor XIII circulates as a heterotetramer composed of two A-chains and two B-chains. The genes are located on different

P.474

chromosomes. The gene for the factor XIII A subunit is located on chromosome 6, bands p24-25,^{1543,1544} and spans approximately 160 kb¹⁵⁴⁵ (Table 18.2). The gene has 15 exons specifying a mature protein of 730 amino acids. The circulating product of the B subunit gene is a protein of 641 amino acids. The gene is located on chromosome 1, bands q31-32.1,¹⁵⁴⁶ spans approximately 28 kb, and has 12 exons¹⁵⁴⁷ (Table 18.2). Ten short homologous units, termed sushi or glycoprotein-1 domains, are coded for by exons 2 to 11 in the B subunit gene.^{1548,1549} Proteins associated with regulation of the complement system also contain sushi domains.^{1550,1551}

Factor XIII deficiency is autosomal recessive and is a rare bleeding disorder. It has a frequency in the general population of 1 in 2 million.^{1552,1553} The phenotype displays varying degrees of bleeding and is typically associated with the absence of cross-linking of fibrin monomers and impaired cross-linking of α_2 -antiplasmin inhibitor to fibrin.¹⁵⁵⁴ Mutations have been identified in both the A and B subunits,¹⁵⁵⁵ with the latter being the least common. Reviews by Loewy et al.¹⁵⁵⁴ and Ariens et al.¹⁵⁵⁶ describe the deficiency mutations and polymorphisms for both gene products that have been identified to date.

Five common polymorphisms in the A subunit have been identified. Three of these (Val34Leu, Pro564Leu, and Glu651Gln) have allele frequencies > 0.2. Adverse effects have not been associated with the Glu651Gln variation; however, young women with the Leu564/Leu⁵⁶⁴ genotype may be at increased risk of hemorrhagic stroke.¹⁵⁵⁷ The (Val34→Leu) polymorphism in the A subunit is found in approximately 25% of the population.¹⁵⁵⁸ This Val to Leu replacement takes place three amino acids away from the thrombin cleavage site at Arg³⁷-Gly³⁸.¹⁵⁵⁸ Due to its close proximity to the thrombin cleavage site, it has been postulated that this mutation might modulate factor XIII activation. Studies suggest that this polymorphism is a determining factor in arterial and venous thrombosis.^{1559,1560,1561,1562,1563} and ¹⁵⁶⁴ This polymorphism has been suggested to be associated with a protective effect against myocardial infarction.^{1559,1565} The Leu encoding allele occurs at a lower frequency in patients exhibiting myocardial infarction, deep vein thrombosis, and cerebral infarction. Studies also showed that the Leu³⁴ mutation accelerates factor XIII activation by thrombin and affects fibrin cross-linking.^{1566,1567,1568} and ¹⁵⁶⁹ This acceleration has been proposed to account for the wide reference range reported for factor XIII activity. A study by Undas et al.¹⁵⁷⁰ demonstrated in a bleeding time blood model that aspirin has a more pronounced effect on factor XIII activation when individuals are carriers of the Leu³⁴ allele. The mechanism underlying the lower risk for myocardial infarction observed in the Leu³⁴ carriers, despite faster factor XIII activation, is still unclear.

Biochemistry

There are two pools of factor XIII—a plasma pool and an intracellular platelet pool. Plasma factor XIII circulates as a 320-kDa A₂B₂ heterotetramer composed of two identical A-chains (M_r = 83.2 kDa) and two B-chains (M_r = 79.7 kDa)¹⁵⁷¹ (Table

18.1). The A- and B-chains associate noncovalently with an apparent binding constant of 0.4 $\mu\text{mol/L}$.¹⁵⁷² Plasma concentration of factor XIII is approximately 30 $\mu\text{g/ml}$ (94 nmol/L),¹⁵⁷³ with a reference interval in the population of 66% to 134%.¹⁵⁷⁴ The A subunit contains 730 residues, is not glycosylated, and contains three important functional sites: the catalytic site (Cys³¹⁴-His³⁷³-Asp³⁹⁶), a calcium-binding site, and the activation peptide.^{1575,1576} The A subunit is arranged into five distinct structural domains: The activation peptide (residues 1 to 37); the β sandwich (residues 38 to 184); the catalytic core (residues 185 to 515); barrel 1 (residues 516 to 628); and barrel 2 (629 to 730). The activation peptide of one A subunit limits access to the active site cysteine of the other A subunit of the dimer. The B subunit contains 641 residues, is glycosylated, and contains 10 sushi domain repeats.¹⁵⁴⁸ Each sushi domain repeat contains approximately 60 amino acids and is stabilized by two disulfide bonds. By electron microscopy, the B domain appears as strands that are thin, flexible, and kinked.¹⁵⁷⁷ The B-chain has no enzymatic activity and has been thought to function as a carrier of the A subunit.^{967,1578,1579}

Several x-ray crystal structures of the zymogen factor XIII A₂ subunit have been solved up to 2.0 Å.^{968,1580} These studies revealed a catalytic triad of Cys³¹⁴-His³⁷³-Asp³⁹⁶ similar in structure to that observed in cysteine proteases. Crystal structures of thrombin-activated factor XIII have been solved with¹⁵⁸¹ and without Ca²⁺.^{1582,1583} and¹⁵⁸⁴

The bone marrow is the primary site of synthesis for the plasma factor XIII A-chain.^{1585,1586} and¹⁵⁸⁷ Intracellular factor XIII is present in platelets, megakaryocytes, and monocytes as the 160-kDa A₂ homodimer.^{1588,1589,1590} and¹⁵⁹¹ The intracellular A₂ dimer, located in the cell cytosol, does not contain a leader sequence or carbohydrate, and its amino terminus is acetylated. How the A₂ dimer is transferred out of the cell and which cell type is the primary source of plasma A₂ are not clearly understood.¹⁵⁹² Secretion may be accomplished by the same pathway used by other nonclassically secreted proteins in blood, including fibroblast growth factor¹⁵⁹³ and the interleukins.¹⁵⁹⁴ Approximately 50% of the total potential factor XIII A-chain activity in human blood is found in platelets.¹⁵⁸⁸

During fibrin formation, platelet A₂ can be expressed on the platelet surface and plays an important role in fibrin cross-linking. Plasma factor XIII A-chains can also bind to thrombin-activated platelets.^{1595,1596} This binding is enhanced by thrombin cleavage of the A-chains as well as the thrombin-independent activation of the platelet. The association of the factor XIIIa molecule with the activated platelet surface allows it to participate at the platelet-fibrin interface, thereby stabilizing hemostatic plugs. The factor XIIIa binding site on platelets can be degraded by plasmin.¹⁵⁹⁵ The B subunit is solely synthesized in the hepatocyte^{1586,1597} and is secreted as a monomer.¹⁵⁹⁷ After being secreted, the A and B subunits associate, becoming an A₂B₂ tetrameric molecule in the blood.

Activation

Activation of the zymogen by thrombin occurs in the NH₂-terminus of the A-chains at Arg³⁷-Gly³⁸ and releases a 36-amino acid activation peptide from each of the A-chains¹⁵⁹⁸ (Fig. 18.13). Whether immediate dissociation of the activation peptide from the rest of the molecule is part of the activation process is not clear, because crystals of thrombin-activated FXIII showed no change in the location and conformation of the activation peptides.¹⁵⁸¹ This was also seen in the ion-bound structures,^{1582,1583} and¹⁵⁸⁴ in which the active site residues remained inaccessible to solvent and substrate. These combined results suggest that exposure of the catalytic residues is likely to occur on substrate binding.¹⁵⁵⁴ Calcium is required for factor XIIIa to expose its active site cysteine.^{1599,1600} and¹⁶⁰¹ Catalytic activity is expressed only after the A-chain dimer is dissociated from the B-chain through a Ca²⁺-dependent process after thrombin proteolysis.^{1578,1579} Fibrin and fibrinogen play important roles as cofactors in the dissociation of the B-chains from thrombin-cleaved factor XIII.^{1587,1593} The intracellular form of factor XIII only contains the A-chain; therefore, it does not require the dissociation of the B-chain, but it still requires a calcium-dependent thrombin proteolysis.

The process of factor XIII activation in whole blood has been correlated with fibrin formation,¹⁰¹³ while in hemophilia this coordination is disrupted.¹⁶⁰² This creates a carefully regulated system that has cross-linked polymers occurring as soon as fibrin is being formed. The rate of thrombin cleavage of plasma factor XIII has been shown to be greatly accelerated by the presence of fibrin polymers.^{1603,1604} This positive feedback network between thrombin, fibrin(ogen), and factor XIIIa ensures that a stable clot can form rapidly to maintain hemostasis.

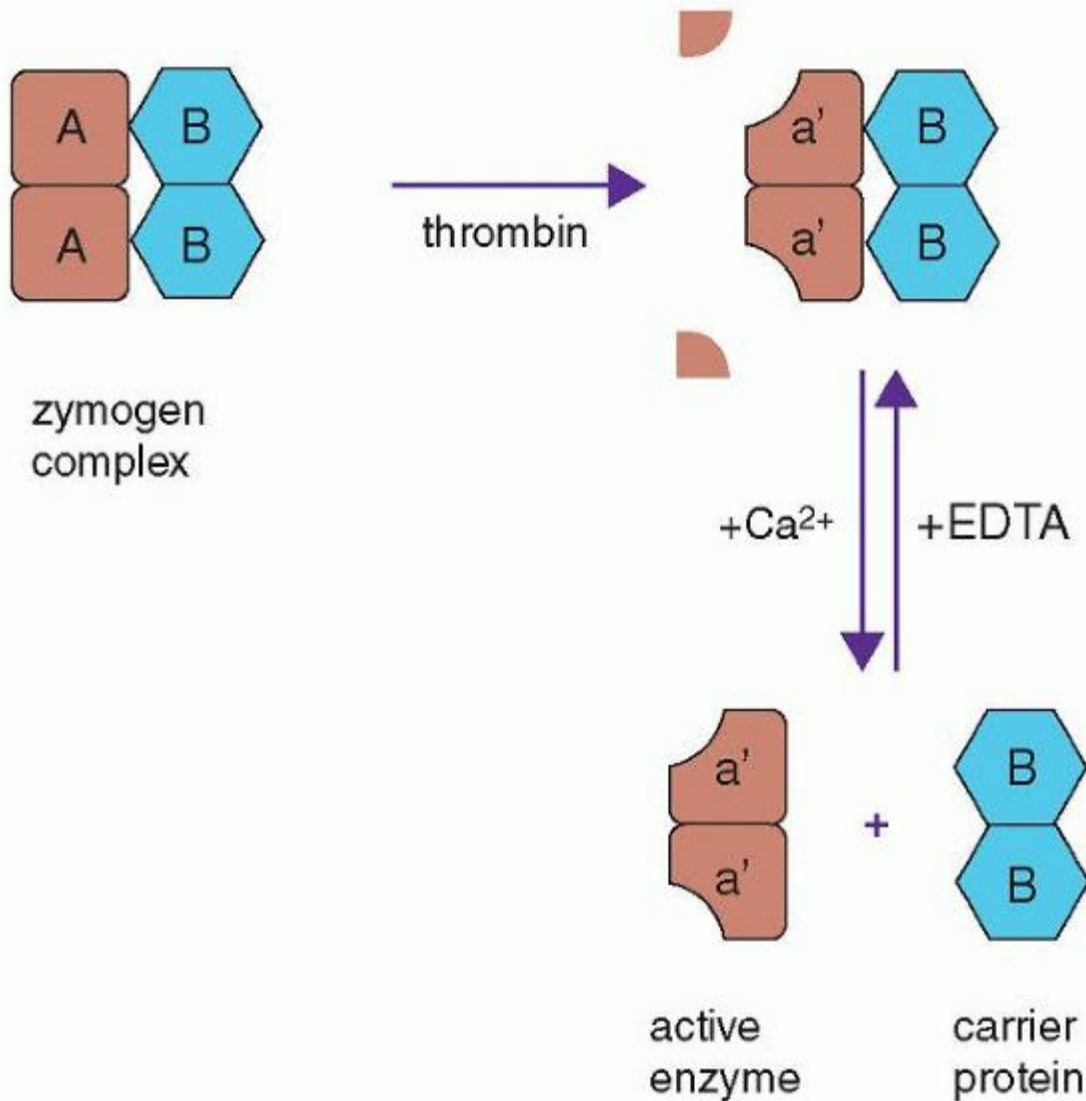

FIGURE 18.13. Activation of plasma factor XIII. The thrombin-catalyzed activation of plasma factor XIII (A_2B_2 ; 320,000 Da) occurs in two steps. In the first step, thrombin cleaves the ($R^{37}-G^{38}$) bond. This releases the activation peptides (residues 1 to 37) from the A-chains, producing the inactive intermediate a'_2B_2 . Fibrinogen interactions promote this event. In the second Ca^{2+} -dependent step, the B-chains dissociate from the a'_2B_2 intermediate, exposing the active site cysteine, Cys^{314} , of the a' subunits. These chains can re-associate in the presence of divalent cation chelators like ethylenediaminetetraacetic acid (EDTA). The enzyme a'_2 is now capable of catalyzing the formation of isopeptide bonds between glutamine residues and lysine residues of adjoining polypeptide chains. In this model, the a' -chains are oriented in such a way as to promote cross-linking of fibrin polymers in an antiparallel configuration.

Function

Activated factor XIII is essential for normal hemostasis and performs numerous functions in pathologic processes.^{1529,1554} Being a transglutaminase, activated factor XIII forms isopeptide bonds between the γ -carboxylamide and -amino groups of glutamyl and lysyl residues, respectively. Factor XIIIa is the only enzyme in the blood coagulation cascade that uses a cysteine for catalysis. To date, no known endogenous inhibitor has been described to regulate this important enzyme. Substrates for factor XIII include fibrin(ogen), fibronectin, α_2 -plasmin inhibitor, collagen, vitronectin, vWF, actin, myosin, factor V, and thrombospondin.^{1529,1530,1531,1532,1533,1534,1535,1536} and ¹⁵³⁷

Fibrin is the main physiologic substrate for factor XIIIa. The basic mechanism involves γ -chain dimerization and α -chain polymerization by creating isopeptide cross-links. The structural specificity for this reaction remains poorly defined. It

appears to reside within the primary amino acid sequence surrounding the surface-exposed glutamine residues.^{1605,1606} How clot stabilization occurs in fibrin formation is covered in the section on Polymerization (Fibrin Formation).

Fibrinogen (Factor I) and Fibrin

This section focuses on the gene structure, structure/function relationships, and regulation of fibrinogen and its insoluble counterpart fibrin. These topics, although extensively discussed within this section, have also been the subject of several comprehensive reviews,^{1607,1608,1609,1610} and¹⁶¹¹ as well as a 2000 New York Academy of Sciences symposium.¹⁶¹²

Fibrinogen is composed of six polypeptide chains (two A α -chains, two B β -chains, and two γ -chains); after posttranslational modification, the mature protein circulates in the blood with an average molecular weight of 340,000 Da (Table 18.1). The polypeptide chains are distributed into two symmetric halfmolecules, each containing one A α -, one B β -, and one γ -chain with the NH₂- and COOH-termini oriented in the same direction. The half-molecules are linked by noncovalent and disulfide bonds at their amino termini, yielding a linear arrangement of three nodular structures. The outside two domains, formed by the carboxyl-terminal regions of the B β - and γ -chains of fibrinogen, are designated D, whereas the central domain that contains the amino termini of all the chains is designated E. Between 1.7 and 5.0 g of fibrinogen is synthesized per day by the liver,^{1613,1614} with approximately 75% of this fibrinogen secreted into the plasma and the remainder distributed between the lymph and interstitial fluids.¹⁶¹⁴ This translates into a mean plasma level of 2.5 mg/ml with a normal t_{1/2} of 3 to 5 days.^{1615,1616} Fibrinogen is considered to be an acute-phase reactant, and as such, it is upregulated two to 10-fold in response to a variety of physiologic stresses including trauma, pregnancy, and tissue inflammation.¹⁶¹⁷

Fibrinogen has been found in the blood plasma of all vertebrates, including the most primitive vertebrate, the lamprey. Early phylogenetic work on fibrinogen began with protein sequences obtained for various fibrinopeptides.^{1618,1619} It was immediately obvious that although these peptides were exceptionally variable, certain features were conserved; without exception, they all contained an arginyl-glycine bond required for thrombin cleavage.¹⁶²⁰ Determination of the protein sequences for all three chains revealed that they were homologous and were evolved from a common ancestor.¹⁶²¹ The β - and γ -chains share the most identity (42%) in their COOH-terminal domains, although they share no homology with the C-terminal α -chain.^{1622,1623,1624} and¹⁶²⁵ In fact, the C-terminal α -chain varies greatly between species (molecular weight ranges from 60 to 120 kDa).

Sequence data, especially the detailed work determining intron/exon junctures, support the hypothesis that all three fibrinogen genes evolved from a common ancestor through a series of duplications that began approximately 1 billion years ago.^{1626,1627,1628,1629} and¹⁶³⁰ At this point, the ancestral gene duplicated to form both the A α -chain and a β/γ -chain precursor gene. Then, sometime before the last time lampreys and mammals shared a common ancestor (450 million years ago), the β/γ gene duplicated, forming today's β - and γ -chains. There is now a growing collection of proteins that share more than 30% sequence identity with both the β - and γ -chains, including α _c domains,^{1631,1632} and¹⁶³³ chicken cytotactin,¹⁶³⁴ mouse T-cell protein,¹⁶³⁴ sea cucumber,¹⁶³⁵ and scabrous gene product from the fruit fly.¹⁶³⁶

Gene Structure and Expression

The fibrinogen locus is composed of three closely linked genes (specifying the polypeptides A α , B β , and γ) found as single copies in a region of approximately 50 kb (bands q23 to q32) of chromosome 4.^{1637,1638,1639,1640,1641} and¹⁶⁴² (Table 18.2). Both the A α - and γ -chains are transcribed from the same DNA strand, whereas the B β -chain is transcribed from the opposing strand.¹⁶²⁶ The A α gene contains six exons, whereas the B β has eight and the γ -chain has 10.^{1643,1644} and¹⁶⁴⁵ The expression of all three genes appears to share a common regulatory mechanism, potentially via their 5'-flanking regions.^{1646,1647} and¹⁶⁴⁸ Therefore, expression for the three chains is coordinately controlled and, at least for the hepatocyte, results in almost equal levels of mRNA for each chain in the cell.^{1629,1641,1644,1649}

A single transcription initiation event at the promoter of each chain produces multiple mRNAs due to alternative polyadenylation site selection in all three chains, as well as alternative splicing for both A α - and γ -chains.^{1631,1650,1651} and¹⁶⁵² In the case of the γ -chain, normal processing results in a polypeptide chain ending at Val⁴¹¹ (human numbering); however, approximately 10% of the time during splicing, the last intron is retained as an exon, resulting in a new chain, γ' , which ends at Leu⁴²⁷.^{1641,1653} Sometimes the α -chain also fails to remove the last intron, producing a translated protein product that is 27-kDa larger.^{1631,1632} and^{1633,1654} The resulting larger form of fibrinogen is called fibrinogen-420 (1% to 2% of circulating human molecules), and the α -chain extension is called

$\alpha_E C$.¹⁶⁵⁵ Interestingly, this new domain shares as much sequence identity (~40%) with the COOH-terminal domain of the β - and γ -chains as the two share with each other.¹⁶⁵⁴

Common polymorphisms of the fibrinogen genes are associated with plasma fibrinogen concentrations as well as susceptibility to, or severity of, atherothrombotic disease.¹⁶⁵⁶ Epidemiologic studies have shown a strong association between two polymorphisms of the fibrinogen β -chain gene and fibrinogen plasma concentration.^{1657,1658} However, the majority of the studies did not find any relation with fibrinogen polymorphisms and cardiovascular disease.^{1657,1658} The effect of these polymorphisms and vascular disease still remains in question because environmental or intermediate conditions of the phenotype can influence the outcome. This supports the notion of individualized susceptibility to disease, which is determined by the genotype and environmental risk factors.

Afibrinogenemia

Inherited or congenital afibrinogenemia is an autosomal recessive disorder characterized by a total lack of fibrinogen in the plasma. This disorder, originally described in 1920, now affects more than 150 families, putting the estimated prevalence in the general population at approximately 1 in 1 million.^{1641,1659,1660} It is usually detected at birth with uncontrollable bleeding from the umbilical cord. The phenotype varies from mild to severe with some patients experiencing spontaneous intracranial hemorrhage and splenic rupture throughout life, as well as bleeding after minor trauma.^{1661,1662} It has been suggested that the presence of functional vWF, which allows platelet thrombus formation in the absence of fibrin, may be responsible for the phenotypic variation observed.^{1663,1664} Most patients respond well to replacement therapy.¹⁶⁶⁵ To date, 86% of all afibrinogenemia results from a truncation mutation in the fibrinogen A α gene.¹⁶⁵⁹

Investigation of the roles that both fibrinogen and fibrin play in vivo has been greatly enhanced by the creation of transgenic mice either lacking fibrinogen¹⁶⁶⁶ or expressing a modified form of fibrinogen.¹⁶⁶⁷ The fibrinogen-deficient mice (Fib A α ^{-/-}) were often able to survive to sexual maturity even though they had no immunologically detectable levels of any chain (A α , B β , γ) in circulation.¹⁶⁶⁶ As expected, plasma from these deficient mice was unable to clot in vitro even when combined with exogenous thrombin. In addition, the plasma did not support platelet aggregation in vitro. This is consistent with the view that fibrinogen bridges platelets via activated receptors (e.g., $\alpha_{IIb}\beta_3$).¹⁶⁶⁸ However, in vivo, these mice are able to form platelet thrombi and are often able to withstand spontaneous bleeding episodes.¹⁶⁶⁴ The resilience of the Fib A α ^{-/-} mice is probably due to the fact that all factors required for thrombin generation and platelet activation are present and that platelets have alternative ligands for their activated receptors that are capable of supporting adhesion and thrombus formation.¹⁶⁶⁰

Breeding experiments crossing fibrinogen-deficient mice with other mice deficient in a hemostatic factor are providing insights into the roles fibrinogen and fibrin play in vivo. For example, mice with combined deficiency in both fibrinogen and vWF were found to form stable thrombi, although platelet deposition was found to be delayed and unstable.¹⁶⁶⁴ However, crossbreeding plasminogen-deficient mice (Plg^{-/-}) with A α ^{-/-} mice eliminated many of the spontaneous pathologies^{1669,1670} (conjunctivitis, pulmonary lesions, terminal vessel thrombosis, ulceration, or prolapse of the rectum and wasting) normally associated with the Plg^{-/-} genotype, including death at 6 months. In addition, the delayed tissue repair observed in Plg^{-/-} mice after arterial challenge,¹⁶⁷¹ corneal damage,^{1672,1673} or skin incision were all corrected by the removal of fibrinogen. These data, in combination with other data not discussed here, support the concept that the physiologic role for the plasminogen activation system is fibrin lysis.¹⁶⁷⁴

Hereditary Dysfibrinogenemias

Like many of the other coagulation disorders, classic dysfibrinogenemias were frequently recognized by the mother when her child bled abnormally. These disorders are associated with prolonged thrombin times usually caused by a point mutation in one of the chains, but clinically, the patient presents with normal plasma fibrinogen concentrations. Hypofibrinogenemias, on the other hand, are associated with low plasma fibrinogen concentrations (< 1.5 mg/ml) due to a mutation(s) that can affect transcription, mRNA processing, translation, chain processing, and assembly, excretion, or stability of the mature protein.¹⁶⁷⁵ Hypofibrinogenemias can be classified into four groups according to the effect of the mutation: (a) mutations that affect intracellular processing, (b) retention in the endoplasmic reticulum, (c) intracellular assembly, and (d) A α -chain truncations.^{1661,1662,1675}

Dysfibrinogenemias can be divided into five groups based on their specific action: (a) mutations that impair or impede thrombin, (b) defects in the construction of protofibrils, (c) impaired lateral association of protofibrils, (d) defects in interactions with other substances, and (e) other unknown mechanisms.¹⁶⁷⁵ Thus, most common mutations are those that impede conversion of fibrinogen to fibrin by thrombin, which catalyzes the hydrolysis of the bonds between Arg α^{16} -Gly α^{17}

and Argβ¹⁴-Glyβ¹⁵, releasing FPA and FPB, respectively. The active site of thrombin is highly specific for an Arg in the P1 position as observed by the human variant replacement of Argα¹⁶ by His, which leads to delayed release of FPA¹⁶⁷⁶ or Cys, resulting in no release of FPA.^{1677,1678} In the case of Argβ¹⁴, only a Cys variant (fibrinogen Christchurch¹⁶⁷⁹) has been observed.

The identification of these mutations, originally through protein chemistry methods and now using DNA technology, has provided unique insights into the structural/function relationships of fibrinogen and fibrin. These mutants were originally gathered and published in the Index of Variant Human Fibrinogen,¹⁶⁸⁰ but with the advent of the Web, the material has been converted to a dynamic database (<http://www.geht.org>).¹⁶⁸¹ As of January 2012 (Release 37), 617 molecular abnormalities were present in the database, with 356 found in the Aα-chain (99 were Argα¹⁶ mutations), 82 in the Bβ-chain, and 176 in the γ-chain.

Biosynthesis

Pulse chase experiments in a human hepatic carcinoma line have shown that there is a large intercellular pool of both Aα- and γ-chains, but it is the Bβ-chain synthesis that limits assembly in the rough endoplasmic reticulum.^{1682,1683} However, in both chicken and rat hepatocytes, it seems to be the Aα-chain that limits fibrinogen assembly.^{1683,1684} Additionally, several extrahepatic sites of fibrinogen synthesis have been identified, including human cervical epithelial cells¹⁶⁸⁵ and lung alveolar epithelial cells.¹⁶⁸⁶ γ-Chain-only synthesis has been observed in vivo in the brain, lung, and bone marrow.^{1687,1688} A physiologic role remains to be determined.

A number of posttranslational modifications (Table 18.8) must occur after synthesis but before secretion. These include removal of the signal peptides from all three chains during or after passage across the membrane¹⁶⁸⁹; a biantennary carbohydrate (M_r ~ 2,500 Da) being added to Asnγ⁵² on the γ-chain much earlier than the Asnβ³⁶⁴ on the Bβ-chain^{1687,1690,1691,1692} and ¹⁶⁹³; and when synthesized, fibrinogen being fully phosphorylated (Serα³ and Ser3α⁴⁶)—but in its circulating form, only 20% to 30% of these sites remain phosphorylated.¹⁶⁹⁴ Additionally, the first residue on the Bβ-chain is also posttranslationally modified to form pyroglutamic acid, thus removing its free amino terminus.

Biochemistry and Activation

The fibrinogen molecule contains two copies of three separate polypeptide chains designated Aα, Bβ, and γ (Table 18.8). These

P.477

are arranged into two identical half-molecules in an elongated structure composed of three globules. In the central globule all six NH₂-termini of the polypeptides reside, and thus it has been referred to as the N-disulfide knot.^{1618,1695} There are 11 disulfide bonds in this region, three of which link the two half-molecules. Experiments in which one or more of the 29 intra- and interchain disulfides were removed or small deletions made have shown that for dimer formation both disulfide bonds and the noncovalent interactions of the amino termini are important.^{1696,1697,1698,1699} and ¹⁷⁰⁰ The common form of the Aα-chain contains 610 amino acid residues with an M_r of 66,500 D and two phosphorylation sites (Serα³ and Serα³⁴⁶), and thrombin cleavage of the Argα¹⁶-Glyα¹⁷ bond releases FPA. The Aα-chain of fibrinogen has sites appropriate for factor XIIIa-catalyzed formation of cross-links,¹⁷⁰¹ t-PA enhancement site (residues 148 to 160) found in fibrin,¹⁷⁰² as well as consensus integrin recognition sites (residues 95 to 98 and 572 to 575). The Bβ-chain is composed of 461 amino acids, displays an M_r of 52,000 Da and has a single glycosylation site (Asnβ³⁶⁴) and a Ca²⁺-binding site (residues 381 to 385). Thrombin cleavage of the Argβ¹⁴-Glyβ¹⁵ bond releases FPB. The γ-chain of fibrinogen is made up of 411 amino acids with an M_r of 46,500 D, is glycosylated at Asnγ⁵², and has a Ca²⁺-binding site (residues 318 to 324), a t-PA enhancement site (residues 320 to 324) in fibrin, and both donor (Glnγ³⁹⁸) and acceptor (Lysγ⁴⁰⁶) sites for cross-link formation.

TABLE 18.8 KEY FEATURES OF HUMAN FIBRINOGEN CHAINS

	Aα	αECBβ	γ	γ'
Total number of residues	610	236 461	411	427
Expression level (%)	98	2 100	90	10
Fibrinopeptide length	16	14		
Thrombin cleavage site	Arg ¹⁶ -Gly ¹⁷	Arg ¹⁴ -Gly ¹⁵		
Newly exposed N-termini	Gly ¹⁷ -Pro-Arg-Val	Gly ¹⁵ -His-Arg-Pro		

Cross-linking sites

Acceptor (Gln)	328, 366	398
Donor (Lys)	508-584	406
Number of calcium-binding sites?	1 2	1 1
Carbohydrate linkage site	667 364	52 52
Phosphorylation site	3, 346	

A comprehensive history of early fibrinogen and fibrin structure/function relationships can be found in an excellent review by Blomback.¹⁶¹² In the first recorded structural experiment, Bailey et al.¹⁷⁰³ placed both a concentrated solution of fibrinogen (which forms a viscous strand) and a fibrin thread in an x-ray beam. The resulting patterns were indistinguishable not only from each other, but also from the patterns of keratin and myosin. They all showed a characteristic 5.1 Å-repeat spacing that was later determined to be due to supercoiled α helices.¹⁷⁰⁴ Around this same time, a different physiochemical “picture” of fibrinogen was emerging. Techniques including electrophoresis, ultracentrifugation, viscosity measurements, and light scattering were coming into vogue and determined that fibrinogen was a prolate ellipsoid with a length between 500 and 700 Å, an axial ratio between 5 and 20 Å, and a molecular weight near 340 kDa.^{407,1705,1706} and ¹⁷⁰⁷

Hall and Slayter¹⁷⁰⁸ produced shadow-cast photographs of fibrinogen and observed three unconnected globules in a line. The center globule was the smallest, with a diameter of approximately 50 Å; the terminal globules were found to be of equivalent size, approximately 60 Å. The total molecule length was estimated to be 475 Å; thus, the connections between the globules were approximated to 150 Å, and Cohen¹⁷⁰⁹ suggested that these globules could be linked by α helices, which would explain the characteristic α -helix 5.1 Å-repeat spacing observed in the fiber diffraction. This trinodular structure has become known as the Hall and Slayter model of fibrinogen.

The reconstruction of fibrinogen from both enzymatic and chemical fragmentation products has allowed an exact picture of the structure and function of fibrinogen to emerge. Many fragments were subjected to protein sequencing, and the sequences reassembled until the whole structure was determined. These fragments also gave insights into the polymerization process as well as the shape of fibrinogen. Because plasmin is the natural protease for fibrin removal, it was the obvious choice for initial fragmentation. Nussenzweig et al.¹⁷¹⁰ characterized such a fibrinogen lysate that was chromatographed using a diethylaminoethyl cellulose column. The resulting peaks were denoted A through E, and it was determined that the pools D and E contained the bulk of the material, with an approximate mass ratio of 2:1. This coordinated well with the Hall and Slayter model in which pool E would represent the center globule and be called fragment E, and the terminal globules would be found in pool D and called fragment D.¹⁷¹¹ Thus, fibrinogen is a symmetric molecule, with a dyad axis drawn through fragment E.

Much effort has been expended in trying to crystallize fibrinogen. The first view was an 18-Å structure of a modified bovine fibrinogen,¹⁷¹² later refined to approximately 4 Å.¹⁷¹³ The modification was a partial proteolysis that predominantly removed the C-terminal α -chains. However, the density for the central domain was “poorly defined.” The first look at an unmodified fibrinogen was the 5.5-Å followed by 2.7-Å structures of chicken fibrinogen.^{1714,1715} Chicken fibrinogen was chosen as a target because it has the shortest α -chains that lack a series of repeated sequences found in most other species^{1633,1716,1717} (Fig. 18.14). This structure provided the first atomic resolution view of the central domain of fibrinogen, although the α domains were too disordered to allow the chain to be traced. A 35-kDa digestion product of fragment E (FE₅) was solved at 1.4 Å,¹⁷¹⁹ which correlates well with the observed fragment E region in the 2.7-Å chicken fibrinogen structure.

The first atomic resolution structure in the fibrinogen field was for a human recombinant γ -chain.¹⁷²⁰ As predicted, the fold of the γ -chain was unique and not represented in any of the structural databases.¹⁶²⁵ The next advance came with the 2.9-Å structure of human fragment D,¹⁷²¹ displaying the two globular β and γ domains forming the furrow. As expected, the β and γ COOH-terminal domains share the same fold^{1720,1722} and are

P.478

oriented approximately 130° apart. These observations have been confirmed in a structure of lamprey fragment D¹⁷²³ and a recombinant human fragment D.^{1724,1725} To date, a crystal structure of intact human fibrinogen has not been solved.

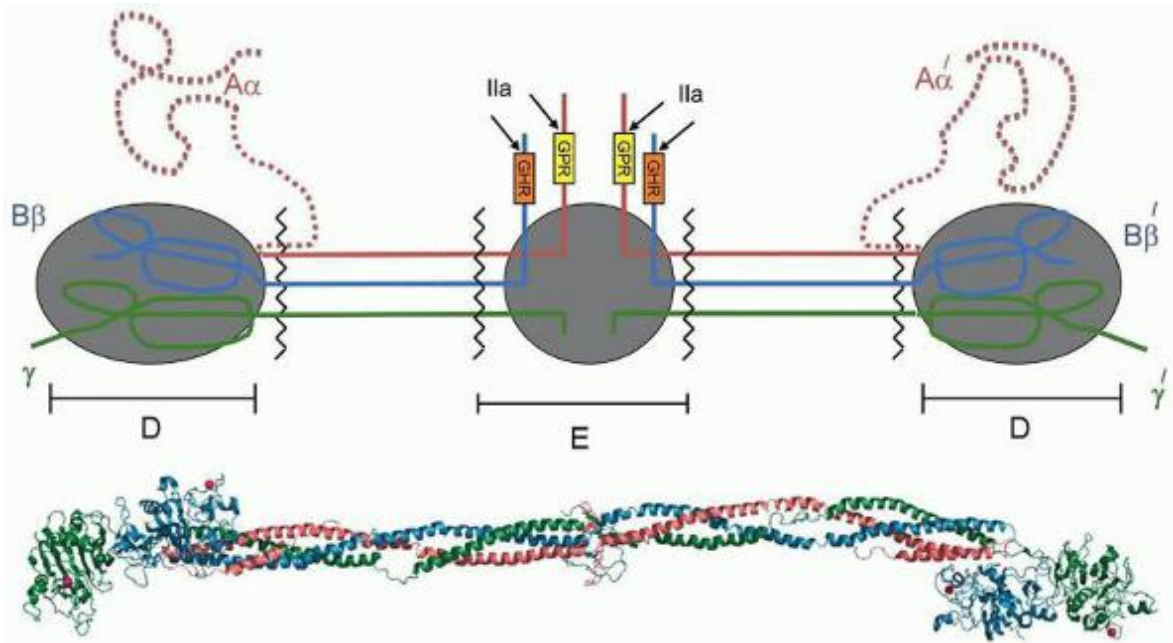

FIGURE 18.14. A schematic and crystal structure of human fibrinogen (PDB-ID: 3GHG). All six NH₂-termini are gathered together in the central or E domain.¹⁷¹⁸ Three chains [α -, β -, and γ -] extend out from this domain through coiled-coils in either direction forming the terminal or D domains. Thrombin (IIa) cleavage sites at the N-termini of the α and β are indicated, with the new N-termini that associate with “holes” in the D domains to form fibrin depicted in the boxes. Pink spheres indicate the four Ca²⁺ sites. Note that the carboxy termini of the α -chains are not visible in this structure.

Polymerization (Fibrin Formation)

The goal of a polymerization is to build a scaffold of sufficient mechanical strength to serve as a hemostatic plug. Interestingly, only 20% of a “clot” is actually protein—the remainder is solvent.¹⁷²⁶ In 1952, Ferry¹⁷²⁷ proposed a half-staggered overlap model to explain the polymerization process. This model can be expressed succinctly in terms of “knobs” and “holes”.¹⁶²¹ When thrombin removes the fibrinopeptides, it creates new amino termini on the α - and β -chains called knobs. Because the knobs are located in the central globule (fragment E) of the Hall and Slayter model, the holes for them to fit into must be present on the terminal domains (fragment D). To accommodate the half-staggered overlap model, the knobs on one molecule interact with holes in two different molecules. Reciprocally, a knob from each of these molecules fits into the holes on the first molecule’s fragment D. The binding sites of the α and β knobs were localized to the γ - and β -chains, respectively, using fragment D digested to different extents.¹⁷²⁸ To identify the polymerization hole in the γ -chain, recombinant γ -chain crystals were soaked in a solution containing a peptide mimic of the knob.¹⁷²² As was expected, the hole was preformed and contained a strong electronegative potential that was neutralized on the binding of the doubly positively charged peptide. The binding interaction was noncovalent and composed of only ionic and hydrogen bonds. Using laser tweezers, the strength of this interaction has been measured between 125 and 130 pN, which is the majority of the force holding fibrin polymer together at this early stage.¹⁷²⁹

The existence of a β -chain hole and that this hole binds the β -chain knob were confirmed with a double-D x-ray crystal structure in which peptide knobs for the α - and β -chains were present.¹⁷³⁰ As would be expected, the β -chain knob also binds with a combination of ionic and hydrogen bonds to the β -chain hole, though it contributes only 15 to 20 pN to the interaction.¹⁷²⁹ In another study using combinations of peptide knobs, it was determined that the β hole is not fully formed until the knob is present¹⁷³¹ and is much less discriminating in peptide acceptance.¹⁷³² This conformational change may be the basis for the acceleration of fibrin formation observed in the presence of the peptide ligand GHRP.^{1611,1728} No evidence has been found for an analogous mechanism with the γ hole; rather, the γ hole seems always ready to accept an α knob, though in the absence of an α knob, the β knob readily binds to both holes.¹⁷³¹ A single example of an α knob peptide (GPRVVE) has been observed occupying a β hole,¹⁷³³ but recent experiments using laser tweezers have demonstrated that this interaction is not physiologically relevant.¹⁷²⁹

The conversion of fibrinogen to fibrin can be separated into three congruent processes: (a) removal of the fibrinopeptides, (b) assembly, and (c) covalent stabilization. We examine each in depth in the following sections.

Fibrinopeptide Release

Many early investigators tried to determine the differences between fibrinogen and fibrin. Their molecular weights were identical, and fibrinogen was the more electronegative of the two.¹⁷³⁴ In the conversion of fibrinogen to fibrin, thrombin catalyzes the hydrolysis of Arg-Gly bonds, removing small, polar amino terminal pieces (fibrinopeptides) from the α - and β -chains.^{1735,1736} Cleavage of Arg α ¹⁶ by thrombin releases FPA and forms fibrin I. The release of two FPA peptides exposes a site in fragment E that aligns with a complementary site in fragment

P.479

D to form overlapping fibrils. Subsequent cleavage by thrombin at Arg β ¹⁴ releases FPB and leads to the formation of fibrin II, presumably increasing lateral aggregation of the protofibrils. FPA and FPB vary in length (between 13 and 21 amino acids in various mammals) and constitute < 2% of the total mass.¹⁷³⁷

Early studies in citrated plasmas or purified fibrinogen found that FPA and FPB are released at very different rates, with FPA being released first.^{1735,1738,1739} and ¹⁷⁴⁰ A sequential model for release has been postulated in which thrombin binds equally to both chains, but the presence of FPA hinders the release of FPB because thrombin is unable to undergo a required conformation change.^{1741,1742,1743} and ¹⁷⁴⁴ As the polymerization process proceeds, the FPB release rate continues to increase, suggesting that a polymerization-induced structure change facilitates its release.^{1741,1742,1745} When the fibrinogen to fibrin conversion is studied in a nonanticoagulated whole blood system, the pattern of fibrin formation based on fibrinopeptide release is different from that seen in citrated plasma or purified fibrinogen.¹⁰¹³

Bettelheim and Bailey¹⁷⁴⁶ first hypothesized that on FPA and FPB release these newly exposed amino termini (knobs) must be the principal contact sites during polymerization. In human fibrinogen, the α -chain knob, after FPA release, begins with the sequence GPRVV; whereas the β -chain, after FPB release, starts with GHRPL. Synthetic peptide GPR derivatives based on the β knob were found to bind to both fibrinogen and fragment D and inhibit fibrin monomer polymerization.¹⁷²⁸ Peptides based on the β knob also bound to both fibrinogen and fragment D but were unable to inhibit fibrin monomer polymerization. In analogous studies, venoms can be used to selectively remove only FPA without activating factor XIII, and fibrin will still form.^{1747,1748} Although it appears morphologically the same, this type of fibrin lacks the normal strength of fibrin.^{1749,1750} and ¹⁷⁵¹ Removal of only FPB (without FPA release) results in fibrin formation in lampreys,¹⁶²⁰ but human fibrinogen clots only if the temperature is maintained below 15°C.¹⁷⁵¹

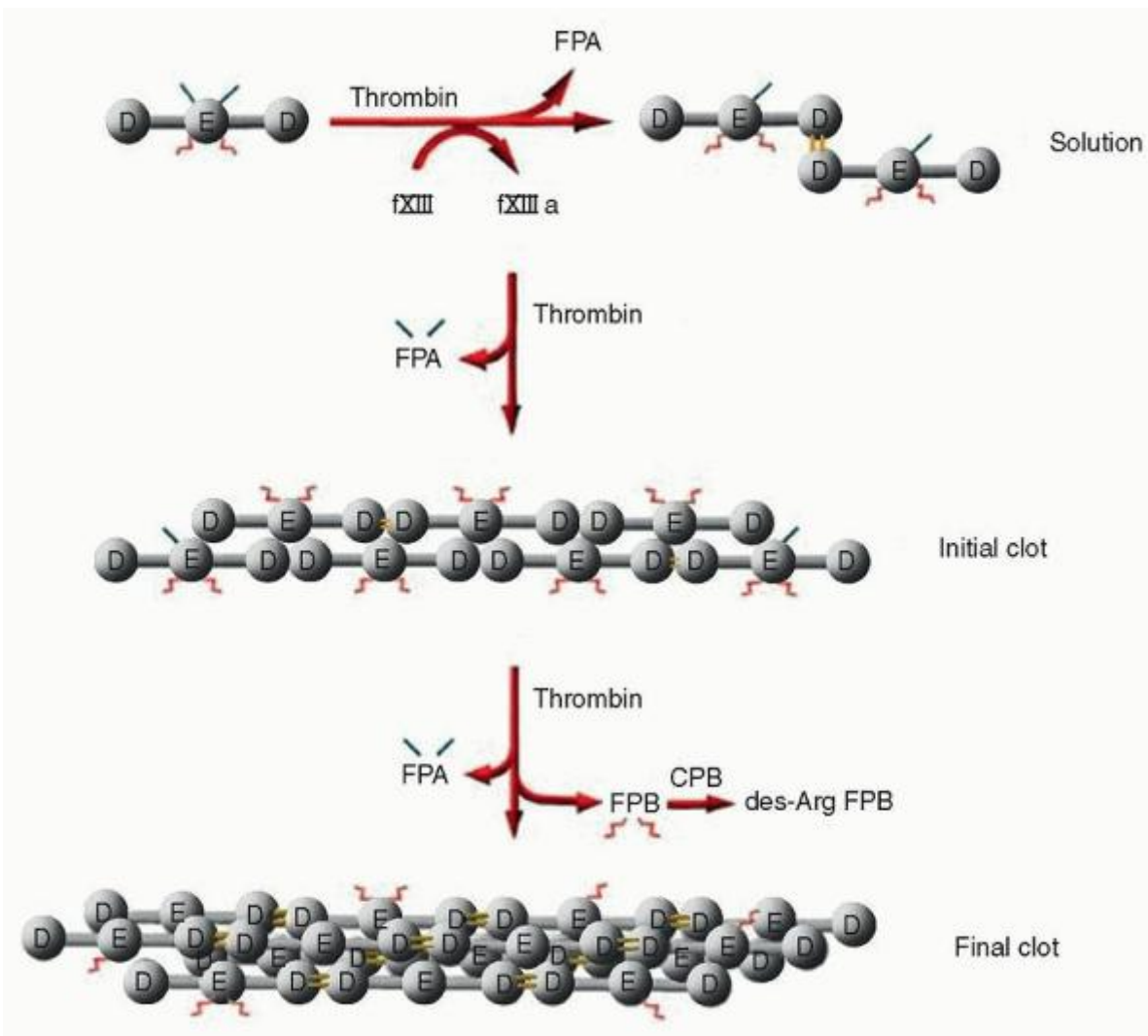

FIGURE 18.15. Schematic representation of whole blood fibrin formation. Thrombin at the beginning of clot formation simultaneously acts on fibrinogen (D-E-D) and factor XIII (fXIII). A portion (~40%) of fibrinopeptide A (FPA) is released from fibrinogen, and an initial clot is formed from the complementary overlap of the exposed sites between the E and D domains of adjacent molecules. Activated factor XIII (fXIIIa) simultaneously cross-links adjacent D domains (D=D). Thus, the initial soluble fibrin clot is composed of fibrinogen, fibrin, and γ - γ dimers (double yellow lines) with fibrinopeptide B (FPB) still attached. The initial clot is continuously acted on by thrombin, releasing the remaining FPA and some of the FPB to yield a final clot with the majority of FPB still attached. The released FPB is selectively acted on by a carboxypeptidase B-like enzyme (CPB) cleaving the carboxyl terminal arginine to produce des-Arg FPB. The significance of this cleavage is still unclear. (From Brummel KE, Butenas S, Mann KG. An integrated study of fibrinogen during blood coagulation. *J Biol Chem* 1999;274:22862-22870, with permission.)

Fibrin Assembly

The release of the FPAs from fibrinogen results in the formation of an intermediate termed fibrin monomer, which is all but indistinguishable from fibrinogen, and leads to the formation of the fibrin dimer through the noncovalent charge-charge (salt links) and hydrogen bonds between the knobs and the holes.¹⁷⁵² As fibrin monomers continue to be generated, the dimer elongates from both ends as a two-stranded molecule until it reaches approximately 30 monomers, when it becomes a protofibril.^{1738,1753,1754}

The second step in fibrin assembly is the lateral association of protofibrils into thicker fibrin fibers.^{1753,1754} These fibers are formed from the association of between 14 and 22 protofibrils.¹⁷⁵⁵ Because protofibrils, not dimers, are required for this step, it is believed that the forces involved in lateral association are weak and, therefore, only become "strong" in large numbers. Fragment D, specifically the β -chain, is likely responsible for this aspect of fiber growth.^{966,1756,1757} Clots are known to branch, although how this is accomplished is not clear. For example, perhaps a protofibril can attach and form a

link between two growing fibers,^{966,1608,1758} or perhaps this is the role for the C-terminal region of the α -chains.^{1759,1760} The presence or absence of carbohydrates also seems to affect branching.¹⁶⁹³

The description of fibrinogen activation and fibrin assembly has been based on studies using citrated plasmas, purified proteins, or both. To understand the *in vivo* process of fibrin formation, a system with nonanticoagulated blood has been used; in this experimental model, the pattern of fibrin formation based on fibrinopeptide release is different from systems using citrated plasma or purified fibrinogen¹⁰¹³ (Fig. 18.15). In this study, cleavage of FPA and subsequent clot formation occur just before the propagation phase of thrombin generation. At the point of visual clot formation, virtually all fibrinogen (and some product already cross-linked) disappears from the fluid phase of the reaction. Thus, the "clot" appears to be a mixture composed of fibrin I and fibrinogen. The insoluble material present in the fibrin clot is

P.480

virtually all cross-linked by factor XIIIa, whose activation is nearly simultaneous with FPA removal. Therefore, the transglutaminase factor XIIIa is available to cross-link the γ -chains of the initial fibrinogen/fibrin I clot. In purified systems, it has been observed that FPB removal precedes the cross-linking reaction. However, in the whole blood clotting model, the FPB antigen epitope is found associated with the β -chain after clot formation has occurred. FPB release proceeds at a slower rate than FPA release, occurs after γ - γ dimer formation, and only reaches approximately 38% of its theoretical maximum value. Doolittle and Pandi¹⁷⁶¹ have recently proposed that interaction of the β -knob with the β -hole generates a conformational change and exposes t-PA binding sites, which ultimately hasten a clot's removal.

Fibrin Cross-linking

To strengthen the "weak" (noncovalent) interactions holding the dimers and protofibrils together, factor XIII (a transglutaminase found circulating in the plasma) is activated to factor XIIIa by thrombin in the presence of Ca^{2+} to link the side chains of lysyl and glutamyl residues by isopeptide bonds. Thrombin activation of factor XIII activation has been shown to coincide with FPA release during the initiation phase of thrombin generation.^{569, 1013} The concentrations of thrombin (based on thrombin-antithrombin complex) needed for factor XIII activation, FPA release, and FPB release have been calculated to be 0.8 ± 0.3 nmol/L, 1.3 ± 0.4 nmol/L, and 1.7 ± 0.5 nmol/L, respectively.⁵⁶⁹

It has been proposed that as many as six cross-links can form between a fibrin monomer and its neighbors^{1762,1763} and that the presence of these cross-links increases the strength, chemical resistance to urea, and lysis by plasmin.^{1525,1526,1764,1765,1766,1767} and ¹⁷⁶⁸ Early in fibrin assembly, factor XIIIa has been shown to link Gln³⁹⁸ and Lys⁴⁰⁶ in reciprocal cross-links between adjacent C-terminal γ -chains.^{1532,1769} Once the majority of γ -chain crosslinks are inserted, then a much slower process begins to insert multiple cross-links between neighboring α -chains.¹⁷⁷⁰ Because each α -chain has two glutamyl acceptor sites and five potential lysine donor sites, a complex cross-linked network can result.¹⁷⁷¹ The result is cross-linked fibrin, which is more resistant to clot lysis.^{1768,1772} Factor XIIIa also covalently attaches α_2 -plasmin inhibitor (the principal fibrinolytic inhibitor) to α -chains in the clot, thereby increasing resistance to degradation.^{1773,1774}

Function

Fibrinogen functions in hemostasis to stem blood loss. It serves as a molecular bridge to support interplatelet aggregation, and it is the precursor of fibrin, which is the main component of the protein scaffolding of the forming hemostatic plug. Platelet aggregation critically depends on fibrinogen binding to activated platelets via the platelet fibrinogen receptor gpIIb-IIIa as well as fibrin adhesion. Fibrinogen/fibrin also regulates thrombin activity by interactions that include the proteolytic cleavage by thrombin of fibrinopeptides to form a fibrin clot and thrombin exosite binding to fibrin, which potentially limits the diffusion of thrombin and thereby regulates clot propagation. The structure, stability, and duration of the insoluble counterpart fibrin are controlled by an interplay between fibrin formation and fibrinolysis, which includes other molecular and cellular components. An important enzyme for the structure and stability of the fibrin clot is the transglutaminase factor XIIIa. Its function is to cross-link fibrin and other adhesive proteins including integrin receptors, providing a stable network. Once activated, the fibrinolysis inhibitor called TAFI functions to attenuate fibrinolysis by removing C-terminal lysines from fibrin. This appears to be critical in the stabilization of the fibrin clot by reducing the number of sites available for plasminogen binding, thus reducing the rate of plasmin generation with consequent prolongation of fibrin dissolution.^{1011,1775} TAFI has also been shown to play a role in the premature lysis of clots from hemophilic plasma.¹⁷⁷⁶

Fibrinogen is primarily recognized for its role in hemostasis but is also required for competent inflammatory reactions. Fibrinogen is an acute-phase reactant, with levels increasing during inflammation. During these situations, fibrinogen functions as a bridging molecule in cell-cell interactions. Fibrin and fibrinogen constitute a matrix that can allow for the modulation of cellular responses through a variety of different cell types, including endothelial cells, epithelial cells,

leukocytes, platelets, and fibroblasts. Cellular receptors that can bind fibrinogen and fibrin include the integrins $\alpha_{IIb}\beta_3$, $\alpha_v\beta_3$, and $\alpha_5\beta_1$, and the cellular adhesion molecules intercellular adhesion molecule-1 and vascular endothelial cadherin.

Although the function of fibrinogen and fibrin as a barrier to stemming blood loss through the dense fibrin network appears central to hemostasis, the findings from fibrinogen-deficient mice suggest that compensating mechanisms exist. Homozygous A α -chain-deficient mice are born with normal appearance and without elevated fetal mortality.¹⁶⁶⁶ These mice have no detectable levels of the A α -, B β -, and γ -chains in their blood.¹⁶⁶⁶ Therefore, the maintenance of hemostasis in these animals is most likely derived from normal thrombin generation and the support of platelet aggregation and adhesion by vWF.

Most clinical assays use fibrin formation as a means to assess hemostasis (PT and activated partial thromboplastin time). The formation of a visible fibrin clot occurs during the initiation phase of coagulation at very low levels of thrombin, approximately 3% to 5% of the total amount of thrombin produced.^{569,616} The majority of thrombin (~95%) is generated after clot formation during the propagation phase, which is overlooked when a fibrin endpoint assay is used.⁵⁶⁹ In congenital hemophilia A and B, only a slight prolongation of clot time is observed; the major impairment is in thrombin generation during the propagation phase of the reaction (Fig. 18.7).⁸⁸² Thus, most catalyst and thrombin formation is ignored using the current technology for evaluating clinical hemorrhagic risk or thrombosis. The survivability of the afibrinogenemic genotype in mice and male patients also supports this concept that critically important events are taking place beyond the endpoint of fibrin formation.

Regulation of Fibrin Lysis

The coagulation system prevents blood loss at the site of injury, filling one role in hemostasis. However, there must also exist mechanisms to limit the coagulation system and processes to remove a clot once it is no longer needed. This role is filled by the fibrinolytic system that uses elements from plasma, platelets, tissue, and other blood cells to regulate the degradation of fibrin. The main player is the zymogen plasminogen that on activation becomes plasmin, a serine protease, whose primary physiologic role is the degradation of the fibrin clot and extracellular matrix molecules. Even though the plasmin cleavage sites are similar for both fibrinogen and fibrin, we consider them separately for clarity.

Fibrinogenolysis

Marder^{1777,1778} proposed a scheme for fragmentation of fibrinogen based on his own detailed studies and the work of others.^{1779,1780} In the first step, fibrinogen is converted to fragment X ($M_r \sim 247,000$) by the removal of the C-terminal α -chain as well as the first 42 amino acids of the β -chain^{1781,1782} (Fig. 18.16). Fragment X remains clottable before it is split asymmetrically, forming fragment Y ($M_r \sim 150,000$), fragment D ($M_r \sim 88,000$), and some small detritus relating to the coiled-coil region. Finally, fragment Y is further split into fragment D and fragment E ($M_r \sim 50,000$), and some more detritus is released.

P.481

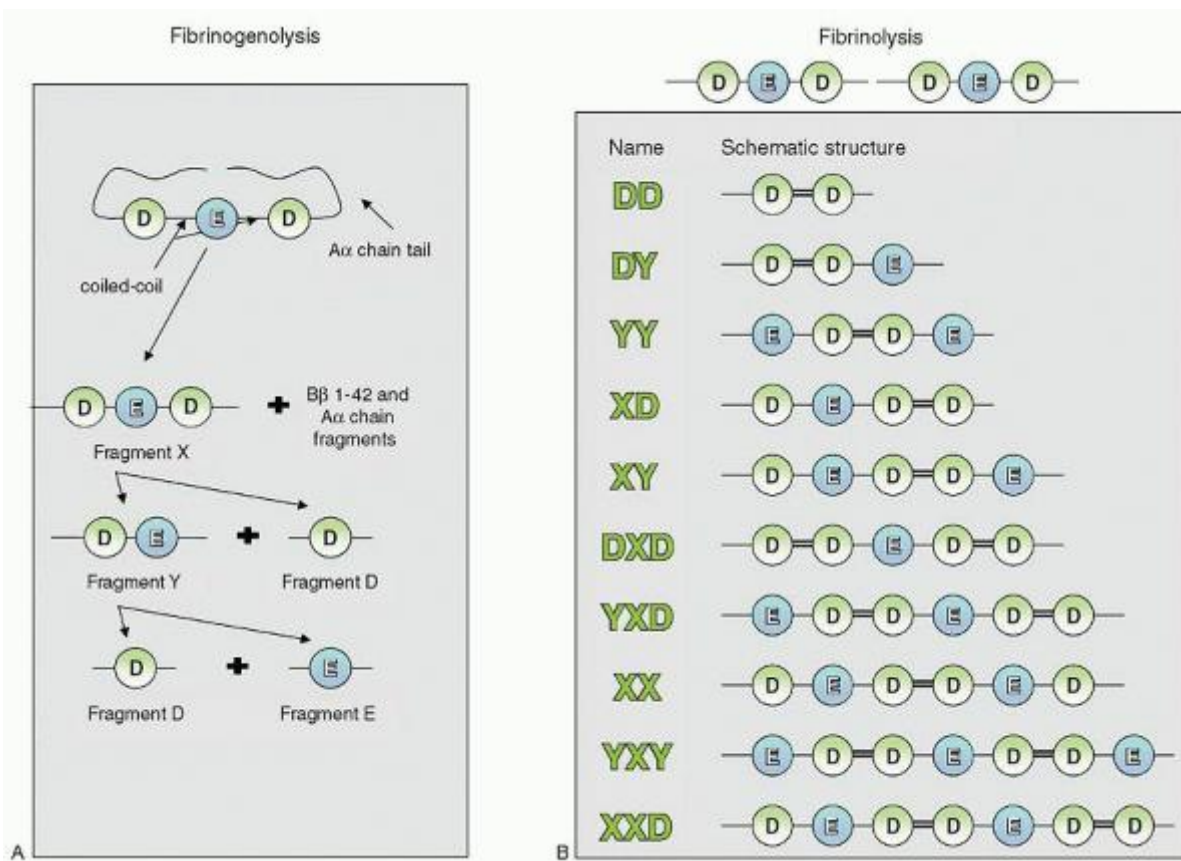

FIGURE 18.16. Fibrinogenolysis and fibrinolysis. A: Fibrinogen is represented as a trinodular structure (D-E-D domains). Each E domain and D domain is separated by a coiled-coil domain. The α -chain tail is shown as a line. Plasmin digests fibrinogen, yielding various fragments, the largest of which is fragment X. Fragment X contains the two D domains, the E domain, and the α -helical coiled-coils, but lacks the C-termini of the α -chains and the peptide β -chains. Fragment Y consists of the central E domain connected by the coiled-coil to one of the terminal D domains. Fragment Y can be further degraded by cleavage of the coiled-coil domain to release a second D domain and fragment E. B: The domain composition of the monomer units of degraded fibrin is indicated by the circles containing a D or an E. Intermolecular cross-links between the γ -chains are shown as thicker lines connecting the D regions. The structures of the various-sized fragments of cross-linked fibrin monomers resulting from plasmin proteolysis of fibrin are presented.

Fibrinolysis

Differences observed in the degradation products between fibrinogen and fibrin are due to the presence of the cross-links, not a change in the specificity of plasmin, which predominantly attacks the coiled-coil region between fragment E and fragment D. Degradation of cross-linked fibrin is much slower than fibrinogen, in large part because of the inaccessibility of the plasmin cleavage sites.^{1781,1783,1784} The first step in degrading cross-linked fibrin is the removal of the α -chains so that the coiled-coils are exposed. As the coiled-coils are cleaved, different-sized fragments are released.¹⁷⁸⁵ The smallest of these degradation products are double-D ($M_r \sim 180,000$), also known as D-dimer, a soluble fragment in which the two D fragments are linked by two isopeptide linkages, and a fragment with the stoichiometry D_2E (termed DY; $M_r \sim 235,000$), a double-D and a fragment E held in place by strong, noncovalent bonding.^{1786,1787} A large number of intermediate-sized fibrin degradation products arising from cleavages between the fragment D and fragment E regions are also generated (Fig. 18.16). The largest of these fragments is the XXD (two fragment Xs and a fragment D) with a mass in the range of 595 kDa. Some of these complexes (e.g., D-dimer) have been identified in the blood of patients with various thrombotic or thrombolytic disorders.

PROTEINS OF THE FIBRINOLYTIC SYSTEM

Clot formation is integrated with clot dissolution to maintain hemostasis. The biochemical mechanisms of clot dissolution center on fibrin-specific activation of plasminogen to plasmin. The key proteins involved are plasminogen, plasminogen activators (t-PA and u-PA), PAI-1, α_2 -antiplasmin, and TAFI (Fig. 18.17).

Plasminogen

Plasminogen is the inactive precursor of the enzyme plasmin, which is the primary catalyst of fibrin degradation. Hereditary plasminogen deficiency has been described as either a deficiency of plasminogen antigen and activity (type I), or as a normal antigen level but reduced activity (type II, dysplasminogenemia).¹⁷⁸⁸ Thrombophilia and ligneous conjunctivitis are clinical manifestations associated with homozygous deficiency; the impact of heterozygous deficiency remains in dispute. Homozygous plasminogen-deficient mice are viable but exhibit severe thrombosis with systemic fibrin deposition, and die prematurely.^{1789,1790}

P.482

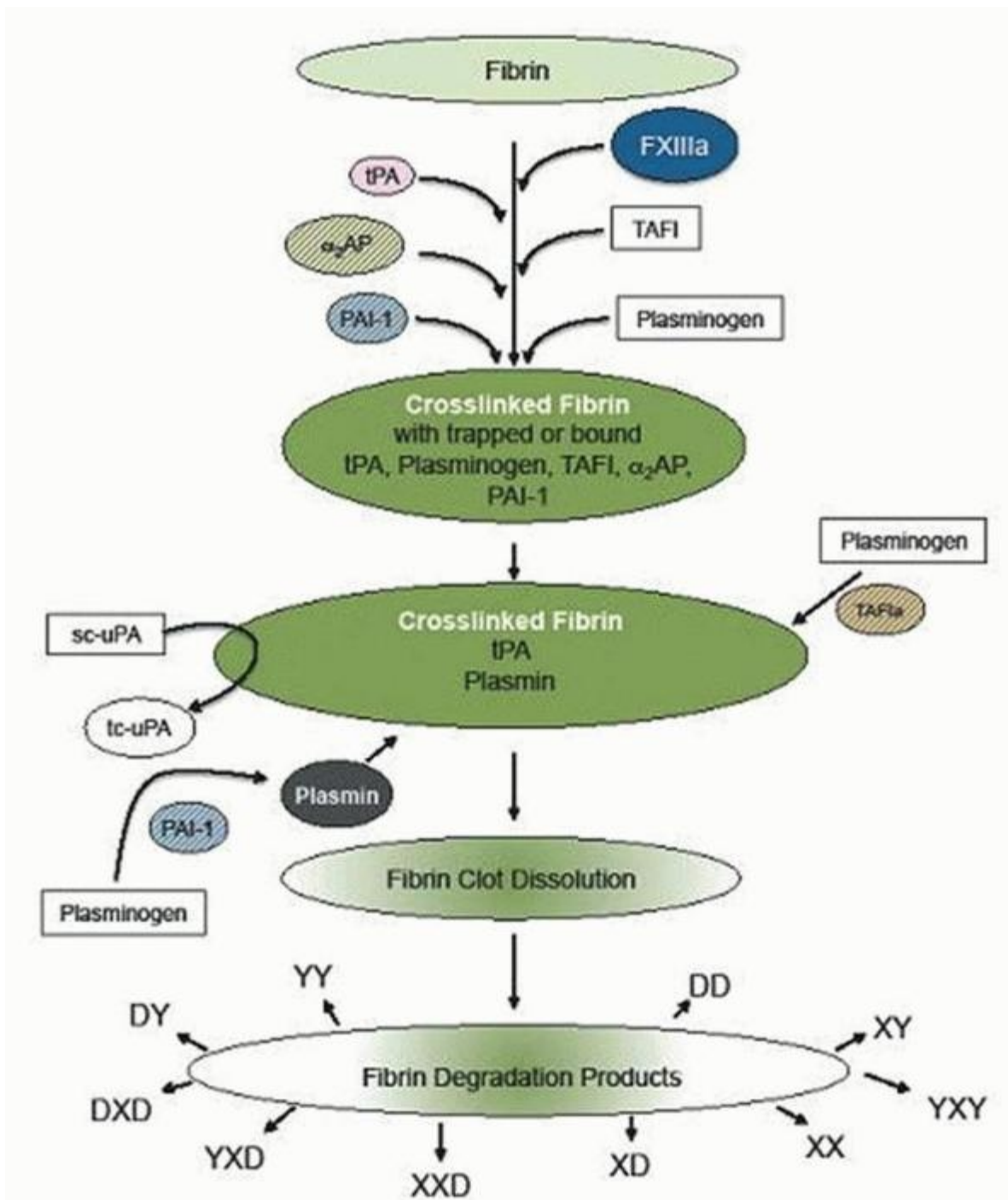

FIGURE 18.17. Schematic of the dynamic interaction between the proteins and inhibitors of fibrinolysis. Cross-linked fibrin formation is integrated with fibrin clot dissolution and degradation of its products. The enzymes (open circles), inhibitors (hatched circles), zymogens (open boxes), and complexes (large open ovals) are illustrated in a simplified form to show this multicomponent process. The key proteins involved are plasminogen, plasminogen activators (tissue-type plasminogen activator [t-PA], single-chain urokinase-type plasminogen activator [scu-PA], and two-chain urokinase-type plasminogen activator [tcu-PA]), plasminogen activator inhibitor-1 (PAI-1), α_2 -antiplasmin (α_2 -AP), and thrombin-activatable fibrinolysis inhibitor (TAFI). t-PA and plasminogen both bind to the fibrin surface, where t-PA is an effective catalyst of plasminogen activation. Initially, plasmin proteolysis of fibrin generates new, higher affinity binding sites for plasminogen, setting up an amplifying loop of plasminogen activation. Reinforcing this process, generated plasmin can convert the single-chain form of urokinase, an ineffective catalyst, to its active form, thus increasing the concentration of available plasminogen activation. Opposing these events are antifibrinolytic mechanisms. α_2 -AP, both soluble and cross-linked to fibrin, forms complexes with plasmin, rendering it inactive. PAI-1 rapidly reacts with both t-PA and two-chain urokinase, reducing the concentration of plasminogen activators. Formation of activated TAFI (TAFIa) results in removal plasmin-generated COOH-terminal lysine residues, thus suppressing the rate of fibrin lysis. Fibrin degradation occurs by cleavage at the D-E-D domains of fibrin polymers by plasmin to yield a variety of polymers as illustrated (see Fig. 18.16).

Gene Structure and Expression

The plasminogen gene is located on the long arm of chromosome 6 at band q26-q27^{1791,1792} (Table 18.9). It spans 52.5 kb of DNA with 19 exons. It is in close proximity to two genes for apolipoprotein A and for the plasminogen-related genes A and B.^{1793,1794} and ¹⁷⁹⁵ The first exon codes for the signal sequence; each of the five kringle domains is encoded by two exons, as is the activation peptide. Plasminogen expression is normally stable, with the regulation of the activity of the fibrinolytic system occurring mainly via the regulation of the plasminogen activators and their inhibitors. However, plasminogen is an acute-phase reactant protein.^{1701,1792} Two sequence elements common to acute-phase reactant genes have been located at positions 76 to 81 and -553 to -558.¹⁷⁹² Other potential regulatory transcriptional elements have been identified, including HNF-1, AP-1, CREB, and GATA.¹⁷⁹⁵

Biochemistry

Plasminogen is synthesized in the liver and is present in a wide variety of tissues and body fluids, including saliva, lacrimal gland secretions, seminal vesicle fluid, and prostate secretions.¹⁷⁹⁶ Plasminogen circulates in plasma at an approximate concentration of 200 mg/L (2 μ mol/L; Table 18.10). It has a circulating $t_{1/2}$ of 2.2 days.¹⁷⁹⁷ The $t_{1/2}$ in disease states, in which the fibrinolytic system is activated, can be shortened dramatically.

Human plasminogen is a single-chain glycoprotein of a relative molecular weight of 88,000 containing 2% carbohydrate (Table 10 and Fig. 18.18). Two major carbohydrate variants of plasminogen are found in roughly equal amounts in human plasma: plasminogen variant 1 is glycosylated at two sites, Asn²⁸⁹ and Thr³⁴⁶, whereas plasminogen variant 2 is glycosylated only at Thr³⁴⁶. Isoelectric focusing of either of these major carbohydrate variants, even when the proteins are isolated from a single plasma donor, reveals additional heterogeneity derived from variable sialic acid content.^{1798,1799,1800} and ¹⁸⁰¹ Heterogeneity in the primary sequence of plasminogen has also been observed, reflecting the presence of two high-incidence polymorphisms and a number of low-incidence polymorphisms in the human population. Functional differences between the two major carbohydrate forms have been reported.^{1802,1803,1804,1805} and ¹⁸⁰⁶ An additional glycosylation site at Ser²⁴⁹ containing a trisaccharide has been identified.¹⁸⁰⁷

The primary structure of plasminogen contains 791 amino acids segregated into an NH₂-terminal activation peptide domain (residues Glu¹-Lys⁷⁷), a region containing five kringles (K1-K5; residues Lys⁷⁸-Arg⁵⁴¹), and a catalytic domain (residues Val⁵⁶²-Asn⁷⁹¹)^{1791,1808,1809} (Fig. 18.18). As secreted into the blood, plasminogen has a glutamic acid at its NH₂-terminus, referred to as Glu-plasminogen. Proteolysis by plasmin at one of several potential sites in the NH₂-terminal region results in a degraded form of plasminogen; the most common product is Lys⁷⁸-plasminogen. Removal of the NH₂-terminal peptide region results in a major structural change in the plasminogen molecule, yielding a species of plasminogen that has a higher affinity than Glu-plasminogen for fibrin and is a better substrate for plasminogen activators.¹⁸¹⁰ The primary site for Lys-plasminogen formation is at the fibrin clot; the $t_{1/2}$ of Lys-plasminogen is shorter than the full-length molecule ($t_{1/2}$ = 0.8 days). Each kringle domain contains 78 to 80 amino acids. The K1 and K4 kringle domains have been identified as containing sites that are responsible for regulating the binding of plasminogen to fibrin,^{1811,1812} α_2 -antiplasmin,¹⁸¹³ histidine-rich glycoprotein,¹⁸¹⁴ the kininogens,¹⁸¹⁵ thrombospondin,¹⁸¹⁶ and cell surface receptors. These sites on the plasminogen kringles (called lysine-binding sites) bind lysyl residues in the target molecules; COOH-terminal lysyl residues are bound more avidly. Lysine analogs (i.e., ϵ -aminocaproic acid and tranexamic acid) can compete with lysyl residues in proteins for binding to plasminogen and, hence, are useful inhibitors of fibrinolysis.^{1817,1818} The conformational change associated with the removal of the NH₂-terminal activation peptide also occurs on binding of

lysine or its analogs to the appropriate kringles in Glu-plasminogen.^{1818,1819} and ¹⁸²⁰ The shape of the Glu-plasminogen molecule changes from a prolate ellipsoid of axial ratio 2.6 to a more random coil-type structure of axial ratio > 5, similar in dimension to Lys-plasminogen.^{1821,1822} A fragment of plasminogen comprising K1-K4, also known as angiostatin, has been shown to inhibit angiogenesis.¹⁸²³ The catalytic domain of plasminogen (Val⁵⁶²-Asn⁷⁹¹) shows considerable homology to trypsin and other serine proteases and includes the catalytic triad (His⁶⁰³, Asp⁶⁴⁶, and Ser⁷⁴¹) typical of these proteases.¹⁸²⁴

Function

Plasminogen is a zymogen devoid of enzymatic activity until converted to the serine protease plasmin by cleavage of the Arg⁵⁶¹-Val⁵⁶² peptide bond by plasminogen activators such as u-PA and t-PA (Fig. 18.19). In plasma or bound to fibrin in a blood clot, cleavage of this peptide bond by either t-PA or u-PA converts Glu-plasminogen into Glu-plasmin, a two-chain enzyme that can degrade fibrin, fibrinogen, and a number of other molecules.

P.483

Plasmin is composed of a heavy chain (kringle domains) and a light chain (catalytic domain) that are attached by two disulfide bonds. Glu-plasmin can autodigest by cleaving itself—most commonly at Lys⁷⁷ to generate Lys-plasmin.^{1825,1826} Inhibition of plasmin by α₂-antiplasmin is the primary route for regulation of plasmin's hemostatic function; suppression of plasmin activity beyond the locale of fibrin deposition is imperative if systemic fibrinogenolysis is to be prevented. Plasmin bound through its lysine-binding sites to fibrin reacts more slowly with α₂-antiplasmin than when free in solution. This differential reactivity effectively localizes plasmin activity to the fibrin surface.

TABLE 18.9 MOLECULAR GENETICS OF PROTEINS AND INHIBITORS OF THE FIBRINOLYTIC SYSTEM

Protein	Molecular Weight (Da)	Gene Location: Chromosome	Gene Size (kb)	Gene Organization: No. of Exons	Messenger RNA Size (kb)	UNIPROT Accession Number^a
Plasminogen	88,000	6p26-q27	52.5	19	2.9	P00747
Tissue-type plasminogen activator	70,000	8p12-q11.2	32.7	14	2.7	P00750
Urokinase-type plasminogen activator	54,000	10q24	6.4	11	2.4	P00749
Thrombin-activatable fibrinolysis inhibitor	58,000	13q14.11	48	11	1.8	Q961Y4
PAI-1	50,000	7q21.3-q22	12.2	9	3.2	P05121
PAI-2	60,000	18q22.1	16.5	8	1.9	P05120
α ₂ -Antiplasmin	70,000	17p13	16	10	2.2	P08697
Factor VII-activating protease	64,000	10q25-q26	35	13	3.0	Q14520

PAI, plasminogen activator inhibitor.

^a <http://www.uniprot.org>.

Plasminogen Activators

The process of plasminogen activation can occur through three distinct pathways: (a) the intrinsic activator system (analogous to the contact system of blood coagulation), (b) the extrinsic activators (t-PA and u-PA), and (c) an exogenous

activator system involving pharmacologic agents (thrombolytic drugs). The pathway used in vivo appears to be the extrinsic pathway. However, both the intrinsic and exogenous activator systems could play an important role in human disease.

TABLE 18.10 BIOCHEMICAL PROPERTIES OF PROTEINS AND INHIBITORS OF THE FIBRINOLYTIC SYSTEM

Protein	Molecular Weight (Da) ^a	Amino Acid Number	Plasma Concentration		t _{1/2}	Carbohydrate (%)
			nmol/L	µg/ml		
Plasminogen	88,000	791	200	2,000	2.2 days	2
Tissue-type plasminogen activator	70,000	527	0.005	0.07	2.4 min	7/13
Urokinase-type plasminogen activator	54,000	411	0.002	0.04	5 min	7
Thrombin-activatable fibrinolysis inhibitor	58,000	401	4.5	75	10 min ^a	23 ^b
PAI-1	50,000	379	0.01	0.20	<10 min	13
PAI-2	60,000	415	<0.005	<0.07	—	22 ^b
α ₂ -Antiplasmin	70,000	464	70	1,000	2.6 days	13
Factor VII-activating protease	64,000	537	12	190	—	5

PAI, plasminogen activator inhibitor.

^a Activated form.

^b Estimated value calculated from difference of molecular weight determined by sodium dodecyl sulfate-polyacrylamide gel electrophoresis and weight of sum of amino acids derived from complementary DNA.

Intrinsic Activators

The body has evolved a mechanism to recognize invasion by foreign substances. Many of these foreign substances contain negatively charged surfaces that allow for the activation of the intrinsic (contact) pathway (factor XII, prekallikrein, HMWK, and factor XI). Plasminogen can interact with this intrinsic pathway of blood coagulation to generate plasmin. There is continued debate as to the extent to which the intrinsic pathway functions in regulating normal fibrinolysis. It has been estimated that this pathway contributes only approximately 15% of the total fibrinolytic activity in human plasma.¹⁸²⁷ Several studies have established that kallikrein and factors IXa and XIIa can directly activate plasminogen to plasmin.^{1828,1829,1830} and¹⁸³¹ At this time, it is best to conclude that the physiologic significance and relevance of the contact system

P.484

in fibrinolysis are not entirely clear. It has been suggested that individuals with factor XII deficiency as well as deficiencies in some of the other intrinsic coagulation factors may have a subtle, but potentially significant, defect in fibrinolysis under certain clinical conditions. Additional studies are needed to address this controversial subject.

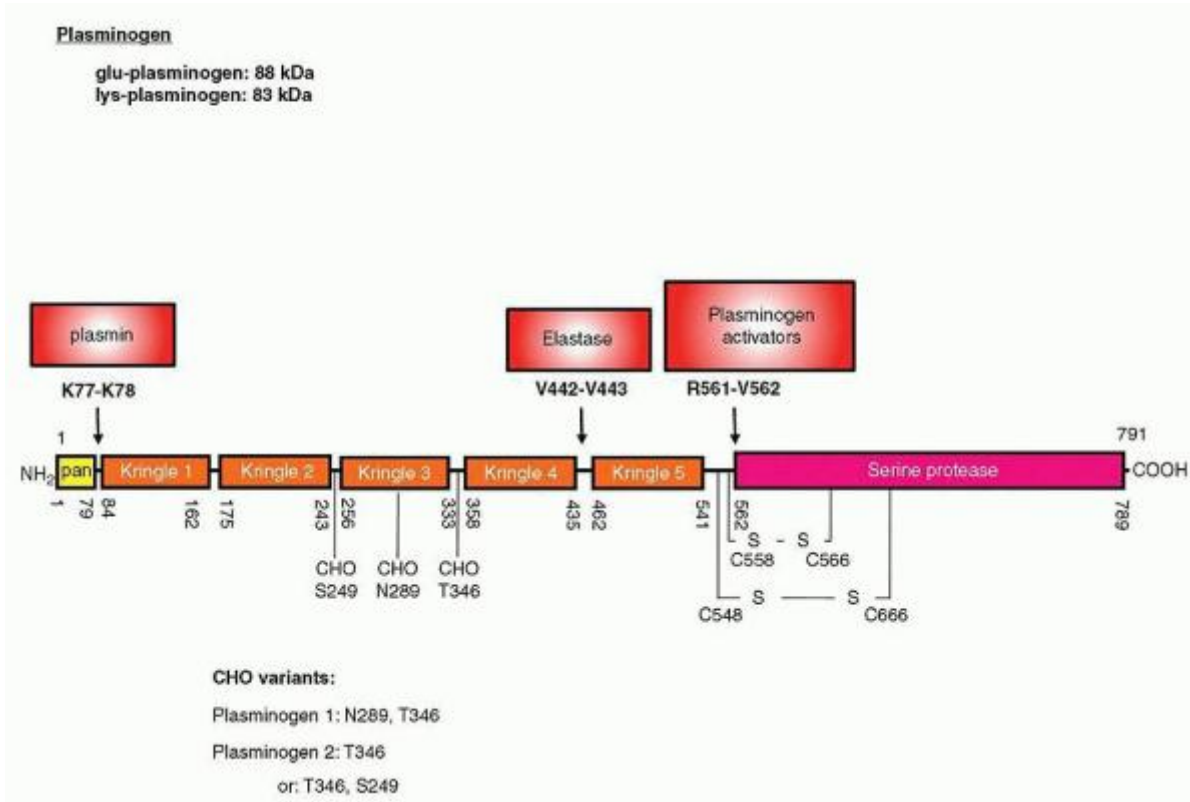

FIGURE 18.18. Schematic of plasminogen. Plasminogen is the inactive precursor of the enzyme plasmin, which is the primary catalyst of fibrin degradation. Human plasminogen is a single-chain glycoprotein containing 2% carbohydrate (CHO). CHO variants are shown for plasminogens 1 and 2. The primary structure of plasminogen contains 791 amino acids segregated into an NH₂-terminal activation peptide domain (pan), a region containing five kringles, and a catalytic domain. Proteolysis by plasmin at one of several potential sites in this NH₂-terminal region results in a degraded form of plasminogen; the most common product is K⁷⁸-plasminogen. Cleavage by plasminogen activators at R⁵⁶¹-V⁵⁶² results in plasmin.

Extrinsic Activator: Tissue Plasminogen Activator

There are two dominant extrinsic activator systems in the body: t-PA and u-PA. These activators have unique structures and properties that affect the specificity and rate of plasmin generation.

The t-PA molecule is predominantly a product of endothelial cells^{1832,1833,1834,1835,1836}; it is also produced by vascular smooth muscle cells,¹⁸³⁷ neuronal cells,¹⁸³⁸ megakaryocytes,^{1839,1840} mast cells,^{1841,1842} monocytes,¹⁸⁴³ and fibroblasts.¹⁸⁴⁴ Factors that regulate its secretion and release from the endothelium are important mediators of blood clotting or inflammation. These include thrombin, histamine, acetylcholine, bradykinin, epinephrine, ILs, shear stress, and vaso-occlusion.^{1845,1846} t-PA antigen is present in normal plasma at approximately 5 µg/L (70 pmol/L; Table 18.10).^{1847,1848,1849,1850} and ¹⁸⁵¹ Functional concentrations have been reported to be < 20 pmol/L with the remainder of the t-PA antigen found in complex with PAI-1.^{1848,1852,1853} The t_{1/2} in plasma is quite short, with pharmacokinetic modeling indicating a t_{1/2} of 2.4 minutes for active t-PA and 5 minutes for the t-PA/PAI-1 complex.^{1854,1855} The t-PA molecule and the t-PA/PAI-1 complex are cleared from the plasma by two specific cell receptor systems in the liver as well as receptor-mediated clearance by endothelial cells¹⁸⁵⁶ (for review see^{1778,1857,1858}).

Gene Structure and Expression

The human gene for t-PA is found on chromosome 8, bands p12-q11.2, and spans 32.7 kb¹⁸⁵⁹ (Table 18.9). There are 14 exons with distinct structural motifs encoded by individual exons.^{1860,1861} and ¹⁸⁶² The processed transcript codes for a protein product of 562 amino acids: residues 1 to 23 comprise the signal peptide, whereas residues 24 to 32 function as a propeptide region. Further processing removes residues 32 to 35 to yield the circulating protein product. The 5'-flanking region of the t-PA gene extends more than 9,500 bp with a functional retinoic acid response element identified at -7,300 bp¹⁸⁶³ and a multihormone responsive enhancer localized to the region -7,145 to -9,758 bp.^{1864,1865} and ¹⁸⁶⁶ A number of cisacting elements have been identified in the proximal promoter region. A transcription initiation site 209 bp upstream of

the translation start site was initially identified. A consensus TATA sequence was identified 22 bp upstream from this transcription start site.^{1861,1862} Subsequently, a TATA-independent transcript initiation site 99 bp upstream from the translation start site was identified as the primary site of transcription initiation in fibroblasts¹⁸⁶⁷ and endothelial cells.¹⁸⁶⁸ The significance of t-PA transcripts with different-length 5'-untranslated regions is not established; deletion of the entire 5'-untranslated region of t-PA was observed to increase the stability of the t-PA transcript.¹⁸⁶⁹

P.485

Translational control of t-PA gene expression has been observed in some cell types, implicating a regulatory role for the 3'-untranslated region of the t-PA transcript.^{1870,1871}

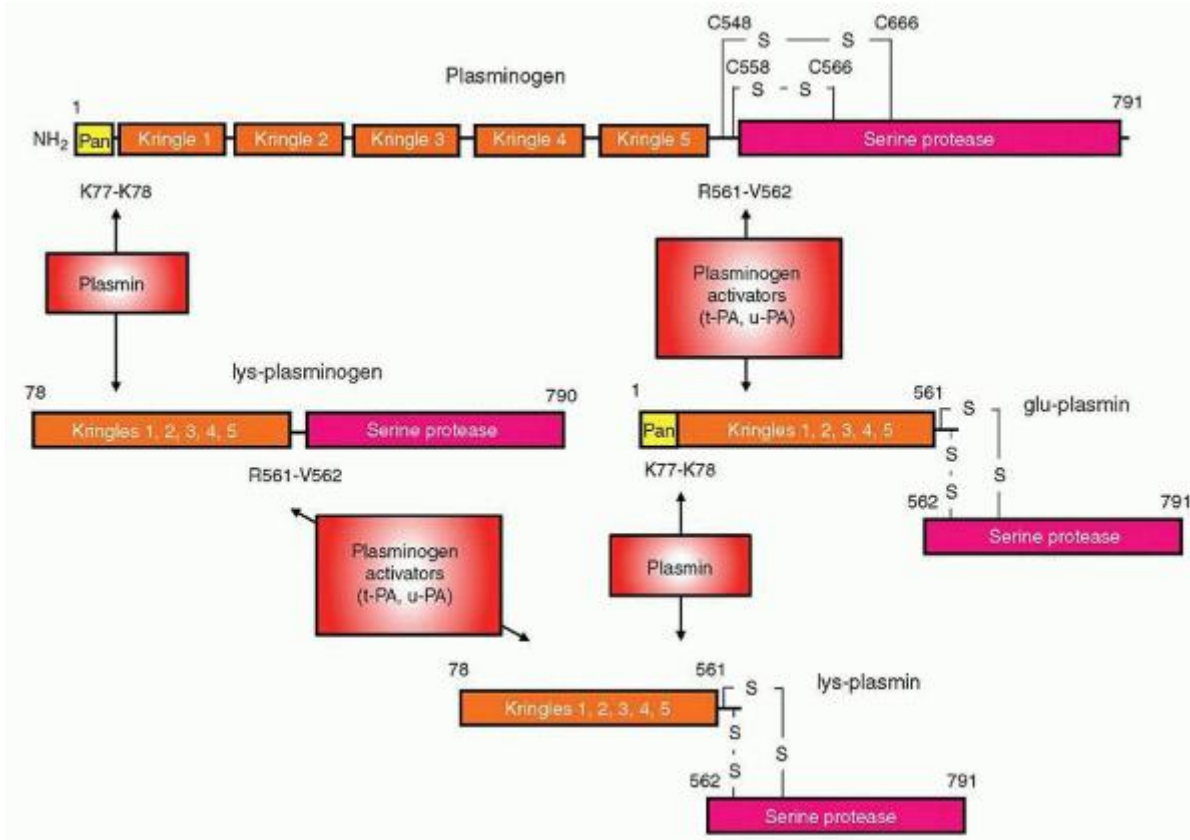

FIGURE 18.19. Molecular forms of plasmin(ogen). Plasminogen in its native form has a glutamic acid at residue 1 and is referred to as glu-plasminogen. Glu-plasminogen has a molecular weight of 88,000 Da and contains 791 amino acids. Cleavage at R⁵⁶¹-V⁵⁶² in glu-plasminogen by plasminogen activators (tissue-type plasminogen activator [t-PA] and urokinase-type plasminogen activator [u-PA]) yields glu-plasmin. Glu-plasmin consists of an NH₂-terminal heavy chain linked by two disulfide bonds to a catalytic domain. At the localized clot level, plasmin that is formed can cleave glu-plasminogen at the NH₂-terminal bond K⁷⁷-K⁷⁸ to yield lys-plasminogen. Lys-plasminogen can be activated by plasminogen activators that hydrolyze the R⁵⁶¹-V⁵⁶² bond to yield lys-plasmin.

A number of polymorphisms of the t-PA gene have been identified. A 311-bp Alu insertion/deletion polymorphism within the eighth intron of the t-PA gene has been extensively studied.^{1872,1873,1874,1875,1876} and ¹⁸⁷⁷ A similar polymorphism in the angiotensin-converting enzyme gene has been linked to plasma levels of this enzyme.¹⁸⁷⁸ In contrast, no correlation of plasma t-PA levels with its Alu polymorphism has been observed.^{1874,1875} and ¹⁸⁷⁶ With one exception,¹⁸⁷² clinical studies have indicated no correlation between this polymorphism and the incidence of stroke or myocardial infarction.^{1874,1875} and ¹⁸⁷⁶ A single nucleotide polymorphism (-7351 C/T) in an Sp1-binding site in the far upstream enhancer element of the t-PA gene has been linked to the vascular release rate of t-PA in vivo¹⁸⁷⁹ and to the frequency of occurrence of first myocardial infarction.¹⁸⁸⁰

No cases of congenital deficiency of t-PA have been reported. Transgenic mice lacking a functional t-PA gene developed normally and displayed a normal basal hemostatic phenotype.¹⁸⁸¹ Mice in which both the t-PA and u-PA genes were disabled had shortened lifespans and experienced severe, spontaneous thrombotic episodes.^{1881,1882}

Biochemistry

The t-PA molecule is a serine proteinase with a molecular weight of 70 kDa¹⁸⁸³ (Table 18.10 and Fig. 18.20). It was originally isolated as a single polypeptide chain of 527 amino acids¹⁸⁸⁴ with an NH₂-terminal serine residue; full-length t-PA has an NH₂-terminal extension of three amino acids (Gly-Ala-Arg).^{1885,1886} and ¹⁸⁸⁷ Numbering in this chapter is based on Ser¹-t-PA, the most extensively studied form because of its availability as a recombinant product.

The single-chain t-PA molecule is an efficient plasminogen activator in the presence of fibrin^{1888,1889,1890} and ¹⁸⁹¹ and is converted into a somewhat more active two-chain molecule by cleavage of the peptide bond between Arg²⁷⁵ and Ile²⁷⁶.^{1799,1889,1890,1891} and ¹⁸⁹² This cleavage is performed primarily by the action of plasmin during fibrinolysis; factor Xa and kallikrein can also catalyze this conversion. The t-PA molecule divides structurally and functionally into two major regions with the Arg²⁷⁵-Ile²⁷⁶ bond as the boundary: the 38-kDa NH₂-terminal portion (Ser¹-Arg²⁷⁵), called the heavy or A-chain in the two-chain molecule, contains structures involved in fibrin binding, fibrin-specific plasminogen activation, and plasma clearance mechanisms; and the 28-kDa catalytic region (Ile²⁷⁶-Pro⁵²⁷), called the light or B-chain, is homologous to the proteolytic domain of other serine proteases. Specifically, the A-chain contains a fibronectin fingerlike domain,¹⁸⁹³ an EGF-like domain,¹⁸⁹⁴ and two kringle domains.^{369,1895} The finger domain extends from residues 4 to 50 and is involved in the binding of t-PA to fibrin.^{1896,1897} The binding of the finger region to fibrin is not blocked by ε-aminocaproic acid.¹⁸⁹⁸ The finger domain of t-PA has sequence homology and structural homology¹⁸⁹⁹ to similar structures found in fibronectin. Selected mutations in the finger or

P.486

the EGF domain have been shown to result in prolonged half-lives in vivo for the modified t-PA molecules, indicating a role for these regions in uptake mechanisms.^{1900,1901} The kringle domains of t-PA span residues 87 to 176 (kringle 1) and residues 176 to 262 (kringle 2). The biologic role of kringle 1 remains undiscovered.^{1896,1897} and ¹⁸⁹⁸ The kringle 2 domain is involved in the binding of t-PA to fibrin.^{1896,1897} This binding interaction is blocked by lysine and its analogs such as ε-aminocaproic acid,¹⁸⁹⁶ indicating the presence of a plasminogen-like lysine-binding pocket. The overall crystal structure of t-PA kringle 2¹⁹⁰² resembles that of kringle 4 of plasminogen, although differences are observed in the arrangement of residues forming the lysine-binding sites.^{1902,1903,1904} and ¹⁹⁰⁵ The light or B-chain of t-PA contains the active site catalytic triad of this serine protease (His³²², Asp³⁷¹, and Ser⁴⁷⁸).^{663,1884,1906} Both the single- and two-chain forms of t-PA cleave plasminogen at Arg⁵⁶¹-Val⁵⁶² to yield the enzyme plasmin. The catalytic efficiency of single-chain t-PA toward plasminogen in solution and toward tripeptide paranitroanilide substrates is lower than the two-chain form.^{1889,1891,1907} Both forms have been crystallized^{1908,1909} and exhibit enhanced and roughly equivalent rates of proteolysis of plasminogen when fibrin is present.¹⁸⁸⁹

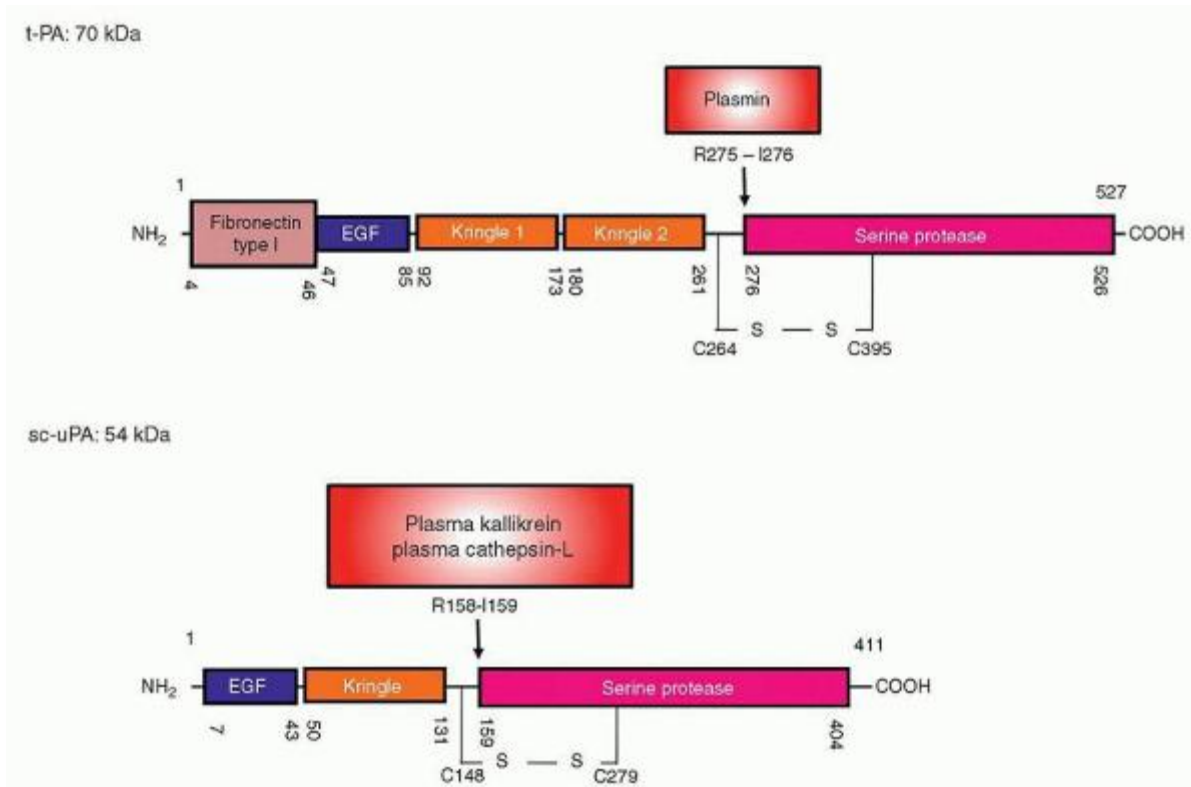

FIGURE 18.20. Fibrinolytic proteins tissue-type plasminogen activator (t-PA) and single-chain urokinase-type plasminogen activator (sc-uPA). The single-chain t-PA molecule is an efficient plasminogen activator in the presence of fibrin and is converted into a somewhat more active two-chain molecule by cleavage of the peptide bond between R²⁷⁵ and I²⁷⁶. This cleavage is performed primarily by the action of plasmin during fibrinolysis. Structurally t-PA contains a fibronectin type I domain, an epidermal growth factor (EGF)-like domain, and two kringle domains, as well as a serine protease-type catalytic domain. The kringle 2 domain and the fibronectin domain of t-PA are involved in the binding of t-PA to fibrin. sc-uPA is an ineffective catalyst. Plasmin or plasma kallikrein can hydrolyze the K¹⁵⁸-I¹⁵⁹ peptide bond, converting sc-uPA into the fully active two-chain form (two-chain urokinase-type plasminogen activator). u-PA is composed of an EGF domain (EGF), a single kringle domain, and the serine protease-type catalytic domain. One glycosylation site (CHO) is present in the serine protease domain.

The t-PA molecule has three potential N-linked glycosylation sites and one O-linked site. The O-linked site is found at Thr⁶¹ in the EGF domain.¹⁹¹⁰ The presence of a fucose at this site appears to facilitate the uptake of t-PA by hepatocytes.¹⁹¹¹ Two major carbohydrate variants of t-PA have been identified. Type I is glycosylated at Asn¹¹⁷ (kringle 1), Asn¹⁸⁴ (kringle 2), and Asn⁴⁴⁸ (catalytic domain), whereas type II is glycosylated only at Asn¹¹⁷ and Asn⁴⁴⁸.^{1912,1913} The presence of carbohydrate at Asn¹⁸⁴ appears to downregulate the fibrinolytic activity of type I t-PA by interfering with the association between the lysine-binding site of its kringle 2 domain and fibrin.

Regulation

Regulation of t-PA activity in blood is accomplished by three primary mechanisms: Control of its catalytic potential via the fibrin dependence of plasminogen activation; control of systemic levels of functional t-PA by the concerted processes of rapid t-PA removal by hepatic clearance and of inhibition by the circulating serpin PAI-1; and control of t-PA activity levels at the site of injury by the competing processes of increased t-PA secretion by traumatized and recruited cells versus PAI-1 release by activated platelets. t-PA manifests its full fibrinolytic potential only when bound to fibrin.^{1914,1915} and ¹⁹¹⁶ This binding interaction aligns t-PA and plasminogen on the fibrin surface so that the catalytic efficiency of t-PA is enhanced several hundredfold. This is vital to the localization of plasmin generation at the site of fibrin deposition. Systemic t-PA levels in blood are under highly dynamic control characterized by maintenance of relatively low levels of the protein (70 pmol/L) with a high clearance rate ($t_{1/2} = 2.4$ minutes) and by maintenance of an extremely effective inhibitor, PAI-1 (second-order rate constant for complex formation = 10^7 to 10^8 M⁻¹second⁻¹), at a

circulating concentration severalfold higher than t-PA. The release of t-PA from the vessel wall is another important regulator of fibrinolysis.^{1917,1918} The rate at which clots lyse is dependent on how rapidly t-PA is secreted by the relevant cells in the vicinity of an injury.^{1919,1920} For example, activated platelets secrete serotonin that can induce endothelial cells to release t-PA; they also release PAI-1 from their α -granules. Although only a fraction of this PAI-1 is in the active form, it functions to downregulate plasminogen activation.^{1921,1922} and ¹⁹²³

Extrinsic Activator: Urokinase Plasminogen Activator

The other major extrinsic activator in the blood is u-PA. This activator was first identified in the urine,^{1924,1925} and ¹⁹²⁶ where it is present at relatively high concentrations (40 to 80 $\mu\text{g/L}$).^{1926,1927} It was subsequently detected in the media of cultured human kidney cells, endothelial cells, malignant cell lines, and tumors; and in plasma.^{1928,1929,1930} and ¹⁹³¹ u-PA is a serine protease and is synthesized as a single-chain molecule called prourokinase or single-chain u-PA (scu-PA). The plasma concentration of scu-PA ranges from 2 to 4 ng/ml (37 to 74 pmol/L; Table 18.10)¹⁹³²; the $t_{1/2}$ of scu-PA is quite short, approximately 5 minutes, and metabolism occurs in both the liver and the kidney. scu-PA has a very low level of proteolytic activity.¹⁹³³ Plasmin can hydrolyze the Lys¹⁵⁸-Ile¹⁵⁹ peptide bond, converting scu-PA into the two-chain form (tcu-PA).^{1924,1934,1935} and ¹⁹³⁶ The mechanism in blood by which scu-PA is converted into tcu-PA still remains poorly defined. It has been postulated that, within a thrombus, t-PA initially activates plasminogen bound to fibrin to form plasmin, and that it is this fibrin-localized plasmin that then converts scu-PA into tcu-PA.^{1937,1938} and ¹⁹³⁹ This process results in an amplification of the rate of plasmin formation. The main site of urokinase-driven plasminogen activation appears to be extravascular, where it has an important role in promoting degradation of extracellular matrix by triggering the activation of plasminogen and, possibly, matrix metalloproteinases.¹⁹⁴⁰ Regulation of urokinase is important to normal and pathologic processes including embryogenesis, wound healing, tumor cell invasion, and metastasis.^{1941,1942} and ¹⁹⁴³ Inhibitors of urokinase have been shown to suppress the growth of primary tumors and to interfere with metastasis of tumor cells.^{1944,1945,1946,1947,1948,1949,1950} and ¹⁹⁵¹

Gene Structure and Expression

The human u-PA gene spans 6.4 kb with 11 exons¹⁹⁵² and is located on chromosome 10, band q24¹⁹⁵³ (Table 18.9). The overall intron-exon arrangement is similar to that of the t-PA gene. The primary amino acid sequence of the purified, intact two-chain molecule has been determined,^{1924,1925,1954} and the cDNA has been isolated and sequenced¹⁹⁵⁵: The gene specifies a protein of 431 amino acids, with the first 20 residues constituting a signal peptide.

The disruption of the urokinase gene (u-PA^{-/-}) in mice is not lethal.¹⁸⁸¹ These mice did not display spontaneous thrombi in their vasculature. The phenotype of u-PA^{-/-} mice included occasional minor fibrin deposits in the liver and intestine, excessive fibrin deposits in chronic nonhealing skin lesions, and increased susceptibility to bacterial infections.^{1881,1956,1957} and ¹⁹⁵⁸

Biochemistry

u-PA is a single-chain glycoprotein containing 411 amino acids ($M_r = 54,000$; Table 18.10; Fig. 18.20). It has 12 disulfide bonds with one (Cys¹⁴⁸-Cys²⁷⁹) serving to link the catalytic domain (B-chain) to the NH₂-terminal domain (A-chain). Posttranslational modifications include glycosylation at Asn³⁰², addition of a single fucose residue at Thr¹⁸,¹⁹⁵⁹ and regulatory phosphorylation at Ser¹³⁸/Ser³⁰³.¹⁹⁶⁰ u-PA is composed of an EGF domain (residues 7 to 43), a single kringle domain (residues 50 to 131), a connecting peptide region (residues 132 to 157), and the serine protease-type catalytic domain (residues 159 to 411). The EGF domain contains the residues essential for urokinase binding to the urokinase receptor¹⁹⁶¹ and appears to be the domain responsible for the ability of urokinase to induce cellular proliferation and differentiation.^{1962,1963} and ¹⁹⁶⁴ The function of the kringle domain of urokinase remains to be established. It displays no binding affinity for fibrin. Recent evidence indicates that the kringle domain may have a role in mediating the process by which urokinase stimulates smooth muscle migration.^{1965,1966} and ¹⁹⁶⁷ Residues His²⁰⁴, Asp²⁵⁵, and Ser³⁵⁶ form the catalytic triad of urokinase; unlike the single-chain form of t-PA, they are not properly positioned for efficient catalysis. scu-PA does not form complexes with PAI-1 or react with peptidyl chloromethylketones that inhibit the two-chain form; scu-PA-catalyzed hydrolysis of tripeptide paranitroanilide substrates proceeds with 0.1% to 0.4% the efficiency of tcu-PA,^{1968,1969} and plasminogen activation by scu-PA appears to be equally inefficient when compared to tcu-PA.^{1939,1970}

The urokinase molecule is asymmetric in shape with the growth factor, kringle, and catalytic domains arranged like differently configured beads on a string.^{1959,1971,1972} and ¹⁹⁷³ A crystal structure for the entire urokinase molecule has not been accomplished. However, a crystal structure at a resolution of 2.5 Å has been reported for the catalytic domain. The molecule used was a recombinant, nonglycosylated human u-PA (residues 159 to 411) with its active site histidine residue derivatized with a peptidyl chloromethylketone.¹⁹⁷⁴ The catalytic domain of u-PA has the expected overall topography and

S1 specificity pocket of a tryp-sinlike protease, an S2 pocket of hydrophobic character, and a solvent-accessible S3 pocket suitable for binding a wide range of amino acid side chains. The crystal structure of a mutant urokinase catalytic domain (residues 159 to 404: C122A and N302Q) at a resolution of 1.5 Å has also been reported.¹⁹⁷⁵

Activation

Conversion of single-chain urokinase to an active two-chain form occurs principally through hydrolysis of the Lys¹⁵⁸-Ile¹⁵⁹ bond. This molecular form, referred to as high-molecular-weight tcu-PA, is composed of NH₂-terminal heavy chain (residues 1 to 158) linked by one disulfide bond to the catalytic domain. In the blood, during fibrinolysis, plasmin is the primary catalyst of this conversion; in addition, both kallikrein and factor XIIa,¹⁹³⁴ products of the intrinsic pathway of coagulation, hydrolyze this bond. A number of other proteases that cleave the Lys¹⁵⁸-Ile¹⁵⁹ bond have also been identified, including several cathepsins,^{1976,1977,1978} and¹⁹⁷⁹ mast cell tryptase,¹⁹⁸⁰ nerve growth factor-γ,¹⁹⁸¹ human T-cell serine proteinase-1,¹⁹⁸² and FSAP.¹⁹⁸³ A second, catalytically active form of two-chain urokinase, known as low-molecular-weight tcu-PA, is found in plasma when fibrinolysis is stimulated. It is formed by an additional plasmin cleavage at Lys¹³⁵-Lys¹³⁶. This yields a truncated heavy chain containing most of the connecting peptide region (residues 136 to 158) linked to the catalytic domain by the Cys¹⁴⁸-Cys²⁷⁹ disulfide bond. This cleavage produces a more efficient enzyme, and this low-molecular-weight form is used clinically for thrombolytic therapy. Another low-molecular-weight form of scu-PA arises from cleavage of the Glu¹⁴³-Leu¹⁴⁴ bond by the matrix metalloproteinases Pump 1 and metalloproteinase 3.^{1984,1985} and¹⁹⁸⁶ This form appears to be a better clot-lysing agent than low-molecular-weight tcu-PA.¹⁹⁸⁷

Neutrophil cathepsin G and elastase from granulocytes cleave scu-PA at the Ile¹⁵⁹-Ile¹⁶⁰ bond, yielding a two-chain molecule that is inactive.^{1988,1989} Thrombin^{1934,1990,1991} and, more efficiently, the thrombin-thrombomodulin complex¹⁹⁹² cleave scu-PA at Arg¹⁵⁶-Phe¹⁵⁷, yielding an inactive two-chain urokinase species. The release of the dipeptide Phe¹⁵⁷-Lys¹⁵⁸ from the catalytic domain is catalyzed by cathepsin C¹⁹⁷⁷ or plasmin.¹⁹⁹³

Function

t-PA appears to be the primary plasminogen activator in the vasculature, with fibrin-localized scu-PA conversion to tcu-PA acting

P.488

as an amplifying rather than initiating mechanism for plasmin formation.^{1939,1994} Direct scu-PA activation of Glu-plasminogen bound to COOH-terminal lysine residues found in partially proteolyzed fibrin has been proposed as contributing to clot lysis.^{1995,1996} and¹⁹⁹⁷ This catalytic role of scu-PA, although direct, still depends temporally on t-PA-derived plasmin to create the circumstance (plasmin proteolyzed fibrin) under which it can contribute to overall fibrinolysis.

Extrinsic Activator: Factor VII-Activating Protease

Recently, a novel serine protease in human plasma has been described that can support coagulation by activating factor VII.^{477,1983,1998} It was originally described as plasma hyaluronan-binding protein and was isolated by adsorption to immobilized hyaluronic acid as a disulfide-linked heterodimer.¹⁹⁹⁸ Independently, a thrombin-like amidolytic activity was purified from commercial prothrombin complex concentrates.^{1999,2000} Sequencing data indicated that this protease and plasma hyaluronan-binding protein were the same proteins. Subsequently, the protease from prothrombin complex concentrates was shown to be a potent activator of factor VII and termed FSAP.⁴⁷⁷ The capacity of FSAP to activate factor VII has been challenged.²⁰⁰¹ This protease has also been shown to be an efficient activator of single-chain urokinase and appears to catalyze the inactivating proteolysis of TFPI.²⁰⁰² Its single-chain precursor has been purified from plasma.²⁰⁰³

Gene Structure and Expression

FSAP has been mapped to chromosome 10, bands q25-q26.²⁰⁰⁴ It spans 35 kb and is composed of 13 exons (Table 18.10). Its transcript specifies a protein of 560 amino acids; the first 23 amino acids comprise the signal peptide sequence. Two single nucleotide polymorphisms have been identified. One, called FSAP Marburg I (SNP-1), yields a Gly511Glu substitution near the COOH-terminus of the protease resulting in impairment of its scu-PA-activating properties.^{2005,2006} and²⁰⁰⁷ The second polymorphism, Marburg II, contains a Glu370Gln mutation that does not appear to have an effect on the catalytic properties of FSAP.

Biochemistry and Activation

FSAP is a single-chain glycoprotein containing 537 amino acids with an M_r of 64 kDa.¹⁹⁹⁸ It circulates at a concentration of approximately 12 μg/ml (190 nmol/L; Table 18.10). It is composed of 5% carbohydrate and is glycosylated at Asn³¹ (NH₂-

terminal strand) and Asn¹⁸⁴ (kringle domain).²⁰⁰³ The structure consists of an amino terminal strand (residues 1 to 52) that is followed by three EGF-like domains (residues 53 to 166), a kringle domain (residues 170 to 254) and a COOH-terminus serine protease domain (residues 290 to 537). FSAP has structural regions that are homologous to those found in hepatocyte growth factor activator.²⁰⁰⁸ It binds to GAGs such as heparin.

The conversion to the active two-chain form requires cleavage of the Arg²⁹⁰-Ile²⁹¹ bond. This generates a heavy chain (residues 1 to 290) and a light chain or catalytic domain (residues 291 to 537). The two chains are linked by a single disulfide bond (Cys²⁷⁸-Cys⁴¹²). The active site residues of this serine protease are Asp³⁸², His³³⁹, and Ser⁴⁸⁶. Preparations of single-chain FSAP rapidly convert to the two-chain form. Whether this is due to an intrinsic activity of the single-chain molecule or to trace amounts of the two-chain form in single-chain preparations has not been resolved.²⁰⁰⁹ Heparin promotes conversion of single-chain FSAP preparations to the two-chain form,²⁰¹⁰ as do natural RNA²⁰¹¹ and histones.²⁰¹² The high-molecular-weight form of two-chain urokinase has been shown to convert single-chain FSAP to the two-chain form and may represent a physiologic activator.²⁰⁰³ The rate of this reaction is affected by heparin. In addition to factor VII and single-chain urokinase, other substrates for FSAP, determined from in vitro assays, include factor V/factor Va, factor VIII/factor VIIIa, fibrinogen, single-chain t-PA, fibronectin, and vitronectin.²⁰¹³ Similar to plasmin, two-chain FSAP binds to aprotinin. In vitro assays indicate that it also complexes with serpins such as C1-inhibitor,²⁰¹⁴ α_2 -antiplasmin, and antithrombin-heparin.^{1983,2015} Stoichiometric inhibitors of FSAP include C1-esterase inhibitor, α_2 -antiplasmin, and TFPI.²⁰¹⁶

Function

The physiologic function of FSAP still is unclear. The ability of two-chain FSAP to convert factor VII to factor VIIa in the absence of tissue factor suggests that it could contribute to the maintenance of normal factor VIIa levels in blood or contribute to the localized production of factor VIIa at the site of vascular injury. In a system of synthetic hemophilia (factor VIII deficiency), two-chain FSAP has been shown to correct the hemostatic defect.⁴⁷⁸ Similar results have been found with the addition of exogenous factor VIIa to hemophilia blood.⁴⁴⁶ The two-chain form of FSAP appears to be an efficient activator of single-chain urokinase, comparing favorably with plasmin when heparin is present.¹⁹⁸³ It has been suggested²⁰¹³ that GAG-binding properties of FSAP may localize it to cell surfaces and extracellular matrix proteins, where it may play a role as an initiator of urokinase-dependent proteolytic cascades. The role of FSAP in inflammatory processes is under investigation.²⁰¹⁷

INHIBITORS OF THE FIBRINOLYTIC SYSTEM

A wide variety of natural inhibitors of fibrinolysis exist in plasma, blood cells, tissues, and extracellular matrices. These natural inhibitors can act either to inhibit plasmin directly or to block the conversion of plasminogen to plasmin (Fig. 18.17). In this section, TAFI, PAI-1, PAI-2, and α_2 -antiplasmin inhibitor are reviewed in terms of their gene structure and expression, biochemistry, and function.

Thrombin-activatable Fibrinolysis Inhibitor

TAFI (E.C.3.4.17.20) (for reviews, see^{2018,2019,2020,2021} and²⁰²²) is a plasma zymogen with homology to procarboxypeptidases A and B. Its plasma concentration is 75 nmol/L (4.5 μ g/ml; Table 18.10). TAFI is synthesized in the liver and is thought to circulate in blood in complex with plasminogen. A small pool of TAFI (< 1% of plasma concentration) is found in platelets and has been found to enhance the attenuation of fibrinolysis in vitro.^{2023,2024} Activation of TAFI yields an exopeptidase (TAFIa) with carboxypeptidase B-like substrate specificity. It catalyzes the removal of basic amino acids (arginines, lysines) from the COOH-termini of polypeptides. Its primary physiologic activator appears to be the thrombin-thrombomodulin complex, thus defining TAFIa as a coagulation-dependent activity.⁹⁶⁹ COOH-terminal lysines that appear in fibrin as it degrades have been identified as the primary substrates for TAFIa (Fig. 18.21). The initial phase of plasmin proteolysis yields products that amplify plasminogen activation by t-PA. These fibrin degradation products thus constitute a positive feedback process, thereby accelerating clot lysis. COOH-terminal lysines that appear in fibrin as it is degraded by plasmin function as additional binding sites where efficient plasminogen activation can occur. Removal of these terminal lysine residues by TAFIa reduces the number of plasminogen-binding sites, thus serving to downregulate the rate of plasmin generation and thereby the rate of clot lysis. Thus, TAFI/TAFIa functions as an antifibrinolytic factor by suppressing the positive feedback pathway of fibrinolysis. The importance in vivo of the TAFI/TAFIa-mediated regulation of fibrinolysis remains to be established. Several studies involving animal models of thrombosis^{1964,1965,1966} and^{1967,2025,2026} and²⁰²⁷ have provided in

P.489

vivo evidence consistent with the proposed role of the TAFI/TAFIa system in regulating fibrinolysis. However, TAFI knockout mice develop normally and prove no more sensitive to a wide range of hemostatic challenges than their wild-

type littermates.²⁰²⁸ In humans, TAFI antigen concentration has been correlated with an increase in risk for deep vein thrombosis.^{2029,2030}

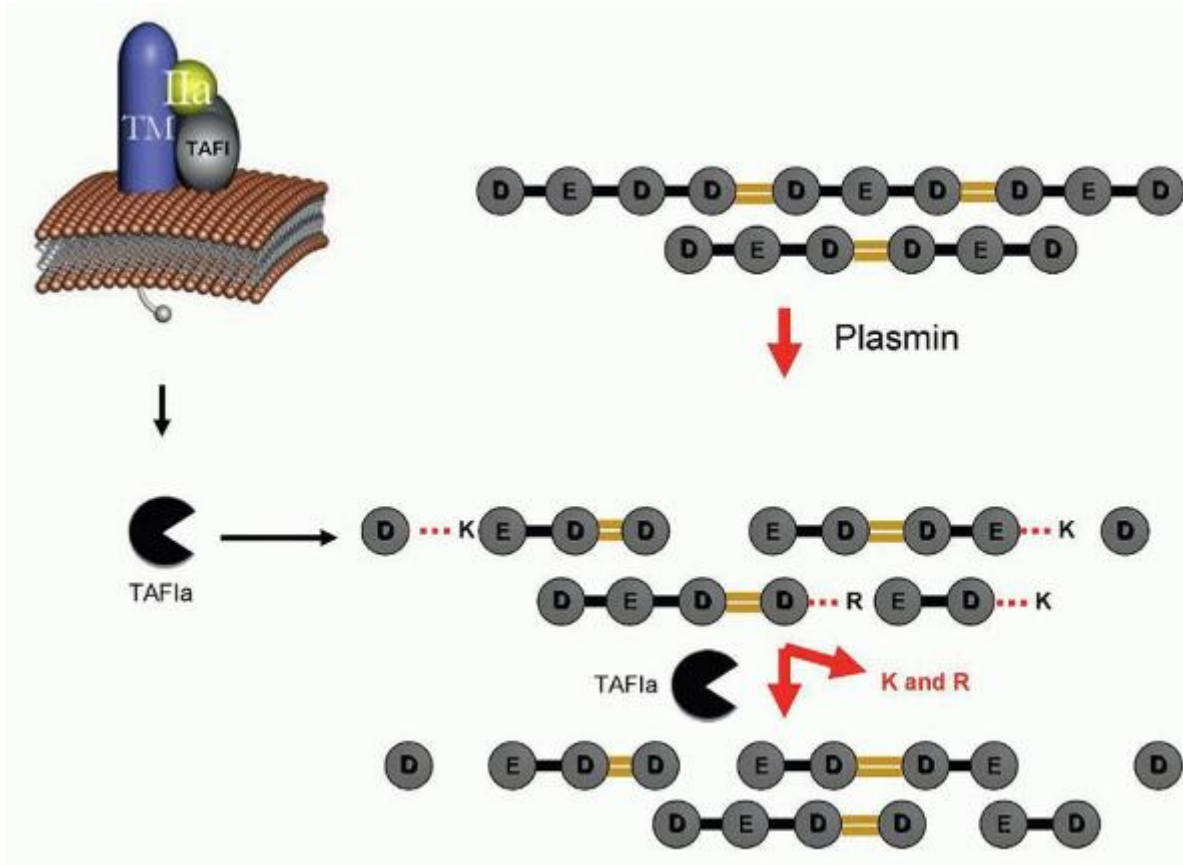

FIGURE 18.21. Mechanism of thrombin-activatable fibrinolysis inhibitor (TAFI) regulation of fibrinolysis. Thrombin-thrombomodulin (IIa-TM) cleaves TAFI to its active carboxypeptidase form TAFIa. TAFIa interferes with fibrinolysis by cleaving COOH-terminal Arg (R) or Lys (K) residues made available as a consequence of partial plasmin digestion of the fibrin clot. Removing these residues attenuates the self-amplifying mechanism of fibrin-based plasmin formation wherein partial plasmin proteolysis of fibrin increases the number of binding sites (COOH-terminal lysines) available for efficient plasminogen activation. (From Mann KG. Coagulation explosion. Vermont Bus Graph 1997, with permission.)

The nomenclature associated with carboxypeptidase B-type activity in serum reflects the history of its isolation and characterization. The presence of a carboxypeptidase B-type activity in serum that differed from that of carboxypeptidase N, a previously characterized enzyme found in plasma, was first reported by two groups: Hendriks et al.^{18,2031,2032} named the enzyme carboxypeptidase unstable because of its short $t_{1/2}$ compared to carboxypeptidase N; Campbell and Okada²⁰³³ named their activity carboxypeptidase R because of its apparent preference for substrates with COOH-terminal arginine residues, again in contrast to carboxypeptidase N, which showed a selectivity for COOH-terminal lysines. Subsequently, Eaton et al.^{19,2034} purified a novel plasminogen-binding protein from human plasma, which, based on sequence homology and enzymatic properties, proved to be a procarboxypeptidase. They named this protein plasma procarboxypeptidase B. Independently, Bajzar et al.,³⁶ using an assay designed to detect the factor responsible for thrombin-dependent inhibition of fibrinolysis, purified a protein from human plasma. Initial characterization of this protein indicated that it was a procarboxypeptidase B-type protein, which converted to an active carboxypeptidase on treatment with thrombin. This group named the protein TAFI. Further characterization established that TAFI is identical to protein plasma procarboxypeptidase B.^{19,1010} Whether carboxypeptidase R and carboxypeptidase unstable are identical to TAFI has not been resolved because of differences in the reported molecular mass and subunit structure of these proteins.

Gene Structure and Expression

TAFI is a member of a multigene family that includes the pancreatic and mast cell carboxypeptidases but not other carboxypeptidases with a specificity for basic amino acids, such as carboxypeptidases N, M, H, and D.^{2035,2036} TAFI shares a

34% to 40% amino acid identity with its family members, including exact conservation of cysteine residues and residues critical for catalysis, zinc binding, and substrate binding.

The human gene for TAFI maps to chromosome 13²⁰³⁷ and is composed of 11 exons within 48 kb of DNA²⁰³⁵ (Table 18.9). When the TAFI gene is compared with the genes from rat pancreatic carboxypeptidases A1, A2, and B and human mast cell carboxypeptidase A, the positions of intron/exon boundaries are conserved, whereas the intron lengths diverge significantly. The TAFI promoter lacks a consensus TATA sequence but does have a 70-bp sequence in the 5'-flanking region of the gene that is required for liver-specific transcription.²⁰³⁵ Transcription is initiated at multiple sites. Primer extension analysis of human liver Poly (A)⁺ RNA identified nine major transcription start sites with similar frequencies of usage.²⁰³⁵ The TAFI transcript is polyadenylated at three different sites.

The TAFI transcript encodes a gene product of 423 amino acids. The first 22 amino acids comprise a signal peptide that is absent in the circulating form of the protein. Three single nucleotide polymorphisms in the coding region of the human TAFI gene have been identified, resulting in two distinct isoforms of TAFI: a base change of C to T at base 678, resulting in a silent mutation; a base change of A to G at base 505, yielding a Thr to Ala substitution at amino acid position 147; and a base change of C to T at base 1,057, resulting in an Ile to Thr substitution at TAFI residue 325. No functional difference was observed between purified TAFIa (Ala¹⁴⁷) and TAFIa (Thr¹⁴⁷).²⁰³⁸ However, purified TAFIa (Ile³²⁵) showed greater activity and stability than TAFIa (Thr³²⁵).

The plasma concentration of TAFI antigen has been observed to vary approximately 10-fold in the human population. The origin of this variability appears to be primarily genetic.²⁰³⁹ Polymorphisms in the TAFI gene that have been shown to be strongly associated with plasma TAFI levels include a number in the 5'-flanking region,^{2029,2040} the 3'-untranslated region,²⁰⁴⁰ and the coding region.²⁰⁴¹

Biochemistry

The TAFI transcript specifies a preprotein of 423 amino acids composed of a signal peptide, an activation peptide domain, and a catalytic domain. Removal of the signal peptide yields the circulating zymogen of 401 amino acids (45 kDa); when analyzed by

P.490

SDS-PAGE, the apparent molecular weight of TAFI is 58 kDa (Fig. 18.22). The difference in mass derives from a high level of glycosylation involving all four of the potential sites (Asn²², Asn⁵¹, Asn⁶³, and Asn⁸⁶) present in the activation peptide domain (residues 1 to 92). In addition to its structural role in suppressing the catalytic potential of TAFI, the activation peptide domain mediates the association in blood of TAFI with plasminogen.¹⁹ The sequence of the catalytic domain (residues 93 to 401; 35 kDa) displays exact conservation when compared to pancreatic and mast cell carboxypeptidases of cysteine residues and residues critical for catalysis, Zn²⁺ binding, and substrate binding.^{19,2035} The activated form of TAFI is a carboxypeptidase that catalyzes the removal of arginine or lysine residues from the COOH-termini of polypeptides. TAFIa is inhibited by agents that can chelate Zn²⁺, such as o-phenanthroline, and by 2-guanidinoethylmercaptosuccinic acid, a specific inhibitor of pancreatic and mast cell carboxypeptidases.^{19,36} TAFIa is an unstable enzyme at physiologic pH and temperature.^{18,19,36} At 37°C, TAFIa has a functional $t_{1/2}$ of approximately 10 minutes; its loss of activity is coincident with a significant change in conformation.²⁰⁴²

Activation

The activation of TAFI requires the cleavage of the zymogen at Arg⁹², yielding an activation peptide of approximately 15 kDa and an active carboxypeptidase of 35 kDa (Fig. 18.22). Trypsin,¹⁹ plasmin,^{19,2043} plasmin-anionic GAG complex,²⁰⁴³ thrombin,^{19,36} thrombin-thrombomodulin complex,⁹⁶⁹ and meizothrombin-thrombomodulin complex¹⁰⁹⁷ all catalyze this reaction in vitro. A ranking of these catalysts in terms of relative catalytic efficiency shows the following order: thrombin-thrombomodulin (1.0) > meizothrombin-thrombin (0.1) = plasmin-anionic GAG (0.1) > plasmin (0.006) > thrombin (0.0008). The complement protease MASP-1 also has been shown to activate TAFI.²⁰⁴⁴ The relative contributions of thrombin and plasmin to TAFI generation in vivo may be regulated by the availability of their respective cofactors at the site of vascular injury: cell-associated thrombomodulin versus the extent of exposure of subendothelial extracellular matrix. Platelet factor 4 has been reported to inhibit activation of TAFI by the thrombin-thrombomodulin complex.²⁰⁴⁵

TAFI: 58 kDa

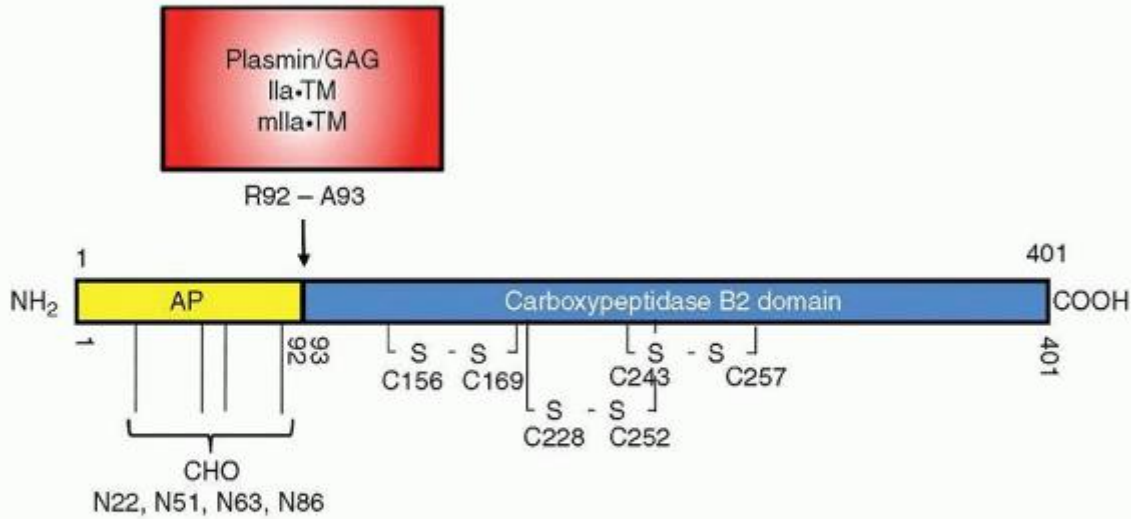

Plasmin/GAG: Plasmin + Glycosaminoglycan

Ila•TM: Thrombin•Thrombomodulin Complex

mlla•TM: Meizothrombin•Thrombomodulin Complex

FIGURE 18.22. Schematic of thrombin-activatable fibrinolysis inhibitor (TAFI). Activation of TAFI yields an exopeptidase (TAFIa) with carboxypeptidase B-like substrate specificity. It catalyzes the removal of basic amino acids (arginines, lysines) from the COOH-termini of polypeptides. TAFI contains four glycosylation sites in its activation peptide region. TAFIa is an unstable enzyme undergoing spontaneous conformational change resulting in a loss of catalytic activity ($t_{1/2} = 8-10$ min).

Function

Thrombin cleavage of fibrinogen yields insoluble fibrin polymers and soluble fibrinopeptides, all bearing COOH-terminal arginine residues. These COOH-terminal arginines are substrates for TAFIa, and the kinetics of their release in an *in vitro* clot lysis system¹⁰¹¹ and whole blood system where des-Arg FPB was detected¹⁰¹³ have been reported. The significance of this removal of arginine residues from these sites is not known. The activation of many of the cofactors and zymogens of the coagulation and fibrinolytic cascades results in the generation of functional proteins with COOH-terminal arginines or lysines. Their status as TAFIa substrates is unknown. Bradykinin and several enkephalins have been shown *in vitro* to be good TAFIa substrates²⁰³⁴; to date, only circumstantial evidence connects TAFIa and bradykinin *in vivo*.²⁰⁴⁶

Extensive *in vitro* data^{1011,1104,1775,1776,2042,2047,2048} attest to the ability of TAFIa to slow the rate of fibrin degradation by plasmin generated *in situ*. Proteolysis of insoluble fibrin by plasmin proceeds through repetitive cleavages at lysine residues terminating in the formation of soluble fibrin degradation products. Before solubilization, each cleavage shortens the fibrin molecule and generates a new COOH-terminal lysine residue. COOH-terminal lysines in partially degraded fibrin have been shown to function as potent cofactors for t-PA-catalyzed activation of Glu-plasminogen.^{2049,2050,2051,2052} and²⁰⁵³ Removal of the COOH-terminal lysines by TAFIa thus reduces the number of sites available for plasminogen binding, thereby reducing the rate of plasmin generation with consequent prolongation of fibrin dissolution^{1011,1775,2054} (Fig. 18.21). TAFIa functions as an attenuator of fibrinolysis,²⁰⁵⁵ and thus an adequate rate of TAFIa generation may be critical in the stabilization of the blood clot. For example, plasmas with specific deficiencies in the coagulation pathway showed reduced rates of thrombin production, decreased levels of TAFIa, and premature clot lysis.^{1776,2026,2056}

Regulation

TAFI circulates in plasma bound to plasminogen¹⁹ and is a substrate for factor XIIIa, which catalyzes its covalent attachment to

P.491

fibrin.¹⁰¹² Whether these two mechanisms for concentrating TAFI at the site of fibrin formation contribute to the function of TAFI in vivo is not established. It has been proposed,²⁰⁵⁷ because the thrombin-thrombomodulin complex has a K_m 10 to 20 times the plasma concentration of TAFI, that rates of TAFI activation would vary directly with changes in TAFI concentration.

A plasma inhibitor of TAFIa has not been described. Carboxypeptidase inhibitors from potato²⁰⁵⁸ and the leech²⁰⁵⁹ active against TAFIa have been identified. TAFIa is an unstable enzyme under physiologic conditions.^{18,19,36} It undergoes a spontaneous conformational change with a $t_{1/2}$ of 10 minutes at 37°C.²⁰⁴² This appears to be the primary route of inactivation because proteolytic cleavage at Arg³⁰² by thrombin or plasmin has now been identified as secondary to and dependent on the inactivating conformation change.^{2060,2061}

TAFI plasma concentrations vary significantly in the human population. Although genetic factors appear to be the largest contributor to this variation,²⁰⁴⁰ a growing number of stimuli have been shown to affect TAFI plasma concentration.^{2030,2039,2062,2063,2064} and²⁰⁶⁵ It has been proposed, in light of the intrinsic instability of TAFIa and the absence of a specific inhibitor, that control of the concentration of TAFIa through control of the level of TAFI gene expression is the primary regulator of the TAFI/TAFIa system in vivo.²⁰⁶⁶

Plasminogen Activator Inhibitor-1

PAI-1 is the primary physiologic inhibitor of plasminogen activation in blood, targeting u-PA and t-PA.²⁰⁶⁷ It also appears to have a role, independent of its antiproteolytic function, in tissue remodeling by interfering with vitronectin-dependent processes of cell adhesion and migration. Congenital deficiency of PAI-1 is rare, with homozygous individuals displaying abnormal bleeding in response to trauma.^{2068,2069,2070,2071} and²⁰⁷² In a normal population, plasma PAI-1 concentration varies over a 15-fold range (6 to 80 ng/ml; Table 18.10)^{2073,2074} and exhibits a circadian variation.²⁰⁷⁵ Some of this variability stems from polymorphisms in the PAI-1 gene; however, a larger fraction of the variability appears to derive from the responsiveness of PAI-1 gene expression to a wide variety of physiologic effectors and conditions as well as pharmacologic agents.²⁰⁷⁶ Higher levels of plasma PAI-1 prolong fibrin removal by shortening the functional lifetime of plasminogen activators, thereby shifting hemostasis to a more thrombotic state.²⁰⁷⁷ The $t_{1/2}$ of PAI-1 in blood is < 10 minutes. Potential sites of constitutive PAI-1 synthesis in humans include the liver, spleen, adipose tissue, and cells of the vasculature, including endothelial cells, smooth muscle cells, macrophages, and megakaryocytes. The relative contributions from these sources to plasma PAI-1 levels in normal or specific pathologic conditions remain unresolved. The major fraction of PAI-1 in blood is present in platelets, apparently synthesized and stored in the α -granules during the maturation of megakaryocytes.²⁰⁷⁸ Although 75% to 80% of platelet PAI-1 is present in the latent form, there appears to be enough active PAI-1 released from platelets at sites of thrombus formation to contribute to the suppression of fibrinolysis.^{1922,1923}

PAI-1 is a single-chain protein with an M_r of 50,000 (13% carbohydrate; Table 18.10). It is a typical serpin with its reactive site bond, Arg³⁴⁶-Met³⁴⁷, positioned in an exposed loop region²⁰⁷⁹ where it is available for complexation with its target proteases. However, this conformation, with the reactive site accessible to proteases, is unstable ($t_{1/2} \leq 90$ minutes), reverting spontaneously to a latent form of the inhibitor in which the reactive loop is buried in β sheet A of the protein core. This positioning of the reactive loop is observed in PAI-1 and other serpins after cleavage of the reactive site bond.²⁰⁸⁰ Plasma PAI-1 circulates in noncovalent association with vitronectin^{2073,2081} ($K_d \leq 0.05$ nmol/L); in vitro, this association results in a twofold increase in its functional $t_{1/2}$ and, in the presence of heparin, increases PAI-1 reactivity with thrombin.¹⁶⁰³

Gene Structure and Expression

PAI-1 is an inhibitory serpin with significant sequence homology to α_1 -antitrypsin, antithrombin, and α_1 -antichymotrypsin.^{1382,2082,2083,2084,2085,2086,2087} and²⁰⁸⁸ It shares the fundamental structural plan of these serpins: three β sheets, nine α -helices, and a reactive site loop. PAI-1 is distinguished from the other inhibitory serpins in that it lacks cysteine residues.

The human gene for PAI-1 is located on chromosome 7 bands q21.3-q22 in close proximity to the loci for erythropoietin, paraoxonase, and cystic fibrosis.^{2089,2090} (Table 18.9). It covers 12.2 kb of DNA with nine exons specifying the 23 amino acids of the signal peptide and 379 amino acids of the mature protein.^{2091,2092,2093} and²⁰⁹⁴ Introns, totaling approximately 9,000 bp, define boundaries of individual structural subdomains or are found in random coil regions of the protein.^{2091,2092} The transcription start site is located 25 bp downstream of a consensus TATA sequence.^{2092,2094} The 5'-flanking region of the PAI-1 gene shows an extensive region of nucleotide sequence identity with the 5'-flanking region of the gene encoding t-

PA.^{2093,2094} The 3' region of the human PAI-1 gene contains alternative polyadenylation sites resulting in two mRNA species of different lengths (2.4 and 3.2 kb).²⁰⁹¹

Normal plasma levels of PAI-1 antigen range between 6 and 80 ng/ml. Polymorphisms in the PAI-1 gene appear to correlate with different plasma levels of PAI-1; thus, genotype-specific regulation of PAI-1 accounts for some of the observed variation in the normal population. Nine polymorphisms have been described, with three of these the subject of human population studies.²⁰⁹⁵ A polymorphism located 675 bp upstream of the transcription start site consists of a single guanine insertion/deletion variation (4G/5G) leading to a sequence of four or five guanine nucleotides in the promoter.²⁰⁹⁶ Individuals homozygous for the 4G polymorphism have the highest levels of PAI-1; heterozygotes show intermediate levels; those homozygous for the 5G allele have the lowest levels.^{2097,2098,2099,2100} and ²¹⁰¹ The basis of this differential expression of the PAI-1 gene appears to be the specificity of a transcriptional repressor protein that binds the 5G allele and not the 4G allele.²¹⁰¹ The predictive relationship between the 4G/5G genotype, plasma PAI-1 level, and the risk of thrombosis is controversial.^{2102,2103} and ²¹⁰⁴ The two other polymorphisms investigated both in vitro and in human population studies include an eight-allele (CA)_n repeat in intron 3²¹⁰⁵ and a two-allele Hind III restriction fragment length polymorphism of the 3'-flanking region. Individuals with one of the homozygous genotypes associated with the Hind III site exhibit higher plasma PAI-1 activity than the complementary homozygous individuals.²¹⁰⁵ In vitro studies of the Hind III polymorphism have shown genotype-specific regulation of PAI-1 synthesis by a number of effector molecules.^{2106,2107,2108} and ²¹⁰⁹

Congenital PAI-1 deficiency is a rare disorder, with homozygous PAI-1-deficient individuals showing abnormal bleeding after trauma or surgery.^{2068,2069} A study of an extended family with 19 heterozygotes and 7 individuals homozygous for a null mutation in the PAI-1 gene found no significant developmental or other abnormalities in the homozygotes beyond abnormal bleeding episodes.²⁰⁷¹ Homozygous PAI-1-deficient mice display normal fertility, viability, and development, with no identified histologic abnormalities.^{2110,2111} A mild hyperfibrinolytic state and greater resistance to venous thrombosis were reported. Mice with combined homozygous deficiency of PAI-1 and α_2 -antiplasmin show normal fertility and development while displaying a higher fibrinolytic capacity.²¹¹² However, this increase appears to depend on the α_2 -antiplasmin deficiency alone, suggesting a less critical role for PAI-1 in the regulation of fibrinolysis.

Biochemistry

PAI-1 is a single-chain glycoprotein of 379 amino acids that has no cysteine residues. It is an inhibitory serpin with a reactive

P.492

site bond, Arg³⁴⁶-Met³⁴⁷, positioned in a surface-exposed, disordered loop of 20 amino acids.²⁰⁷⁹ Reaction with t-PA or u-PA involves rapid formation (second-order rate constant = 10^7 to 10^8 M⁻¹second⁻¹) of a reversible complex; specific interactions between a negatively charged region (amino acids 350 to 355) of the PAI-1 molecule and positively charged regions in t-PA^{2113,2114} or in u-PA²¹¹⁵ are important to this initial association. Cleavage of the reactive site Arg³⁴⁶-Met³⁴⁷ bond in PAI-1 by the protease triggers a large conformational change in both the inhibitor and the protease that renders the protease unable to efficiently hydrolyze the normally transient ester linkage between its active site serine residue and the carboxyl moiety of the targeted peptide bond. PAI-1 converts to an inactive (latent) form spontaneously; it can be returned to its active conformation by treatment with denaturants.²¹¹⁶ The crystal structure of latent PAI-1 indicates that the reactive site loop is inserted into the β sheet A of the molecule, making it unavailable to proteases.²¹¹⁷ The crystal structure of a mutant PAI-1 stabilized in the active conformation by substitutions at four sites (N150→H; K154→T; Q319→L; M354→I) shows the reactive site bond to be located at the apex of a flexible, exterior loop.²⁰⁷⁹ The vitronectin binding site of PAI-1 involves five residues located on the exterior of the molecule.²¹¹⁸ Extensive structural differences have been noted when this region is compared in active and latent conformations of PAI-1.²⁰⁷⁹ Stabilization of the conformation of this region of PAI-1 by the PAI-1 vitronectin binding interaction presumably impedes the insertion of the reactive site loop into β sheet A of the molecule.

Function

PAI-1 is the central physiologic inhibitor of the plasminogen activator t-PA in blood. It reacts with both the secreted, singlechain form of t-PA and the two-chain form generated by plasmin during the process of fibrin dissolution. Both PAI-1 and t-PA are characterized by high turnover rates (t-PA, $t_{1/2}$ = 3 to 4 minutes; PAI-1, $t_{1/2}$ = 10 minutes) with functional PAI-1 circulating concentrations maintained at least at severalfold molar excess over the concentration of functional t-PA (14 pmol/L). From the circulating concentration of PAI-1 and the second-order rate constant for the association of PAI-1 with either form of t-PA (10^7 to 10^8 M⁻¹second⁻¹), the predicted $t_{1/2}$ of t-PA is < 1 minute. This is consistent with the observation

that approximately 80% of the t-PA antigen in plasma (70 pmol/L) is found complexed with PAI-1. PAI-1-t-PA complexes have a clearance $t_{1/2}$ of approximately 5 minutes.¹⁸⁵⁴ Although other plasma proteins have been identified in vitro with inhibitory activity toward plasminogen activators (PAI-2, PAI-3, protease nexin), only PAI-1-plasminogen activator complexes have been detected in vivo.^{1127,2119}

PAI-1 is an important inhibitor of u-PA. Unlike t-PA, PAI-1 forms complexes only with the two-chain form of urokinase; it does not complex with the single-chain form of urokinase. The second-order rate constant for the association of PAI-1 and t-PA is in the range of $10^8 \text{ M}^{-1} \text{ second}^{-1}$. Conversion of circulating scu-PA (37 to 74 pmol/L) to t-PA occurs at sites of fibrin lysis. Urokinase is also involved in physiologic and pathologic processes such as embryo development, wound healing, cell migration, inflammation, and metastasis of tumor cells. A large body of in vitro work supports a regulatory role for PAI-1 as a protease inhibitor in u-PA-mediated events outside the vasculature, and as a consequence, its dysregulation has been implicated in the pathogenesis of fibrosis in different organs.²¹²⁰

PAI-1 also appears to be involved in regulating cell adhesion and migration by a mechanism independent of its function as a protease inhibitor. Its high-affinity association with the somatomedin B domain of vitronectin makes it an effective competitor with other ligands such as urokinase-type plasminogen activator receptor (uPAR)^{2121,2122,2123} and ²¹²⁴ and integrins including $\alpha_v\beta_3$ ²¹²⁵ that also bind to vitronectin at this site. The ability to interfere with the binding of such cell-associated ligands to matrix-associated vitronectin suggests a role for PAI-1 as a regulator of the interaction of cells with the extracellular matrix.

Plasminogen Activator Inhibitor-2

PAI-2 is a member of the serpin subfamily designated the ovalbumin-related serpins.²¹²⁶ It was initially identified in human placenta as an inhibitor of urokinase.²¹²⁷ It has also been referred to as the placental-type PAI.^{2127,2128,2129,2130,2131} and ²¹³² It is not normally detected in plasma, although it has been detected in human thrombi.²¹³³ During pregnancy, PAI-2 is found in plasma at levels that may exceed those of PAI-1.²¹¹⁹ PAI-2 appears to have significant functions within the cytoplasm of certain cell types and in the extracellular region outside of the vasculature, where it may regulate urokinase-dependent events. However, its role in hemostasis remains problematic and a definitive intracellular role for PAI-2 is not established.²¹³⁴ PAI-2 (-/-) null mice developed normally and did not display any phenotypic abnormalities.²¹³⁵

Gene Structure and Expression

The gene for PAI-2 is located on chromosome 18, band q22.1, and spans 16.5 kb^{2136,2137,2138,2139,2140} and ²¹⁴¹ (Table 18.9). Its transcript specifies a protein of 415 amino acids that lacks a cleavable NH_2 -terminal signal sequence. PAI-2 is synthesized and secreted by human white blood cells such as monocytes and macrophages, and cells of epithelial lineage such as keratinocytes and certain tumor cells.^{2142,2143,2144} and ²¹⁴⁵ A large number of agonists have been shown to affect transcription rates of the PAI-2 gene (reviewed in ^{2126,2146,2147}). For example, the PAI-2 gene has been shown to respond dramatically to TNF ²¹⁴⁸ and to lipopolysaccharide.²¹⁴⁹ In human monocytes, exposure to lipopolysaccharide induced approximately a 100-fold increase in PAI-2 mRNA levels.²¹⁵⁰ Posttranscriptional regulation of PAI-2 mRNA levels has also been documented.^{2151,2152} Regulation of the stability of PAI-2 mRNA has been shown to derive in part from an AU rich-mRNA destabilizing determinant in the 3'-untranslated region²¹⁵² and from an mRNA instability element identified within exon 4 of the coding region.²¹⁵³

Biochemistry and Function

There are two forms of PAI-2: an intracellular nonglycosylated form ($M_r = 47 \text{ kDa}$) and a secreted glycosylated form ($M_r = 60 \text{ kDa}$) (Table 18.10). However, the nonglycosylated form has been observed in the blood of pregnant women.²¹¹⁹ Glycosylation occurs at Asn^{75} , Asn^{115} , and Asn^{339} . PAI-2 is structurally distinguished from other serpins by the presence of a unique 33-residue-long loop (CD loop: residues 66 to 98) positioned between helices C and D. This solvent-exposed loop region has two glutamine residues (Gln^{83} and Gln^{86}) that have been shown to be sites for factor XIIIa-catalyzed cross-linking of PAI-2 to fibrinogen.^{2133,2154} PAI-2 cross-linked to fibrinogen remains functional after its fibrinogen carrier is converted to insoluble fibrin.²¹⁵⁴ The CD loop has also been implicated in the association of intracellular PAI-2 with other cytoplasmic proteins.²¹⁵⁵ The crystal structure of PAI-2 at 2-Å resolution has recently been reported using a PAI-2 mutant lacking the CD loop.²¹⁵⁶ The reactive site bond ($\text{Arg}^{380}\text{-Thr}^{381}$) is located in a highly disordered reactive center loop extending from Thr^{367} to Pro^{386} . PAI-2 is a serpin inhibitor that can inhibit plasminogen activators. The second-order rate constants defining its interactions with two-chain urokinase ($1 \times 10^6 \text{ M}^{-1} \text{ second}^{-1}$) and two-chain t-PA ($2 \times 10^5 \text{ M}^{-1} \text{ second}^{-1}$) are approximately 100-fold lower than those characterizing the reaction of PAI-1 with these proteases. Unlike PAI-1, PAI-2 reacts very slowly with the single-chain form of t-PA. Also unlike PAI-1, PAI-2-t-PA or PAI-2-u-PA complexes have not been detected in

plasma. Thus, it has been suggested that PAI-2 may not play an important role in regulating intravascular clot lysis. However, fibrin deposition at sites of chronic inflammation within blood vessels may represent an instance in which monocyte-derived PAI-2 could end up cross-linked to fibrin, thereby exerting some effect in the vasculature.^{2133,2154} An extravascular role for PAI-2 in aspects of tissue remodeling and wound healing that depend on urokinase catalysis is consistent with the observed induction of PAI-2 production by inflammatory mediators in cell types such as keratinocytes and macrophages.

The nonglycosylated form of PAI-2 is found in the cytosol of a number of cell types. Data supporting a diverse set of roles for intracellular pools of PAI-2 include effects on cellular differentiation,²¹⁵⁵ cell proliferation,²¹⁵⁷ TNF- α -induced apoptosis,^{2158,2159} signal transduction,²¹⁶⁰ and, in monocytes, multiple roles in modulating adhesion, proliferation, and differentiation.²¹⁶¹

α_2 -Antiplasmin (α_2 -Plasmin Inhibitor)

α_2 -Antiplasmin (or α_2 -plasmin inhibitor) is the primary plasmin inhibitor in human plasma^{2162,2163,2164} and²¹⁶⁵ and thus is an important regulator of fibrinolysis.²¹⁶⁶ Congenital deficiency of α_2 -antiplasmin is rare, with homozygous individuals displaying a severe to moderate bleeding disorder.²¹⁶⁷ α_2 -Antiplasmin is a single-chain glycoprotein with a calculated mass of 58 kDa²¹⁶⁸ and a relative molecular weight of 70 kDa. It is present in plasma at a concentration of 70 mg/L (Table 18.10). The primary site of synthesis is the liver, although the kidney may be another contributing source²¹⁶⁹; its in vivo $t_{1/2}$ is 2.6 days.^{2170,2171} Two NH₂-terminal variants of α_2 -antiplasmin are isolated from human plasma in roughly equivalent amounts: α_2 -antiplasmin Met¹, the full-length protein secreted into the blood; and α_2 -antiplasmin Asn¹, lacking the first 12 amino acids (Asn¹³ in α_2 -antiplasmin Met¹).^{2172,2173} α_2 -Antiplasmin is a member of the serine protease inhibitor superfamily. It forms a stable 1:1 stoichiometric complex with plasmin that has no proteolytic or esterase activity.^{2163,2164,2174} It is structurally distinct from related serpins in having a 55-amino acid extension at its COOH-terminus.^{1466,1467} This region mediates α_2 -antiplasmin binding to specific regions (lysine-binding sites) on the kringle domains of plasminogen and plasmin.^{2175,2176} and²¹⁷⁷ Approximately 30% of α_2 -antiplasmin in human plasma lacks part of this COOH-terminal region (residues 449 to 464). This truncated form appears to be functionally inert in plasma,^{2177,2178} although it has been shown, when purified, to slowly form complexes with plasmin.^{2179,2180}

The α_2 -antiplasmin molecule has three domains defining its role in fibrinolysis: the reactive site (Arg³⁷⁶-Met³⁷⁷), the plasminogen-binding site (both of which are critical to its reactivity with plasmin^{2175,2176,2181}), and a cross-linking site mediating the attachment of α_2 -antiplasmin to the α -chain of fibrin during clotting.¹⁵³¹ The binding of the plasminogen-binding domain of α_2 -antiplasmin to a lysine-binding site of plasmin has been shown to occur more rapidly than the association between the active site of plasmin and the reactive site of α_2 -antiplasmin.²¹⁸² Thus, the rate of binding of α_2 -antiplasmin depends primarily on the availability of the lysine-binding site(s) of plasmin. This dependence of the rate of inhibition on an exosite interaction between the two molecules results in the differential reactivity of α_2 -antiplasmin with its primary targets in clotting blood: plasmin released into the circulating blood ($t_{1/2}$ = 0.1 second) versus plasmin bound through its lysine-binding sites to fibrin or cellular sites at the site of vascular injury ($t_{1/2}$ = 10 seconds).

Gene Structure and Expression

α_2 -Antiplasmin is a member of a multigene family of serine protease inhibitors that includes α_1 -antitrypsin, antithrombin, PAI-1, and α_1 -antichymotrypsin.^{1382,1467,2082} These serpins interact with their target proteases at a reactive Arg-X peptide bond positioned in a loop structure located 30 to 40 amino acids from the inhibitor COOH-terminus. α_2 -Antiplasmin differs from other members of its family in having a 55-amino acid extension at its COOH-terminus.

The human gene for α_2 -antiplasmin is located on chromosome 17, band p13²¹⁸³ and is composed of 10 exons distributed over 16 kb of DNA²¹⁸⁴ (Table 18.9). The 5'-untranslated region and leader sequence are interrupted by three introns; a TATA box sequence is found 17 nucleotides upstream from the transcription initiation site. Exons 4 through 10 code for the protein, with exon 10 specifying both the reactive site and the unique COOH-terminal plasminogen-binding site. One common polymorphism, RGW, has been mechanically linked to differences in the levels of α_2 -antiplasmin Met¹ and α_2 -antiplasmin Asn¹.^{2185,2186}

Congenital α_2 -antiplasmin deficiency has been described²¹⁶⁷; the transmission is autosomal recessive. Bleeding problems vary from severe to moderate in homozygotes. The majority of heterozygotes have no bleeding problems, although exceptions have been described.^{2187,2188} One instance of congenital deficiency, α_2 -antiplasmin Enschede,²¹⁸⁹ is characterized by dysfunctional full-length α_2 -antiplasmin at normal plasma concentrations. All other cases involve quantitative defects with the four characterized instances showing mutations in the coding exons^{2190,2191} and²¹⁹² or an intron splicing donor site²¹⁹³ with consequent truncated, nonsecreted peptide products. Homozygous α_2 -antiplasmin-

deficient mice have been generated.²¹⁹⁴ They display normal fertility, viability, and development, and show no overt bleeding disorder.

Biochemistry

α_2 -Antiplasmin is a single-chain glycoprotein of 464 amino acids with an M_r of 70 kDa (13% carbohydrate; Table 18.10). Glycosylation occurs at Asn⁹⁹, Asn²⁶⁸, Asn²⁸², and Asn²⁸⁹. α_2 -Antiplasmin contains four cysteine residues but only one S-S bridge.²¹⁹⁵ It is a member of the α_1 -proteinase inhibitor class of the serine proteinase inhibitor superfamily.^{1382,1467}

α_2 -Antiplasmin functions as the primary inhibitor of plasmin in blood.²¹⁷⁰ It is synthesized primarily in the liver with a signal peptide of 27 amino acids and circulates at a concentration of 1 $\mu\text{mol/L}$ ²¹⁶⁸ with a $t_{1/2}$ of 2.6 days.^{2170,2171} Isolation from plasma yields both Met¹- α_2 -antiplasmin (464 amino acids) and a truncated form with an NH₂-terminal Asn (Asn¹³- α_2 -antiplasmin)²¹⁷²; the truncated form appears to be generated within circulating blood by a plasma protease.^{2194,2196} Plasma α_2 -antiplasmin is also found to have two COOH-terminal forms: a slow-reacting, non-plasminogen-binding form (30%) that lacks the terminal 26 amino acids and the fully active molecule with an intact COOH-terminal extension.^{2177,2179} Conversion to the non-plasminogen-binding form occurs in the blood.²¹⁷⁸ α_2 -Antiplasmin has three functionally important domains: a reactive site, a plasmin/plasminogen-binding site, and a cross-linking site. The reactive site of the inhibitor is the Arg³⁷⁶-Met³⁷⁷ peptide bond.¹⁴⁶⁶ α_2 -Antiplasmin reacts with plasmin in a two-step process. First, a rapid (second-order rate constant = 2 to 4 $\times 10^7 \text{ M}^{-1} \text{ second}^{-1}$) reversible interaction yields a 1:1 complex ($K_d = 10^{-10} \text{ M}$). Second, a slower first-order ($t_{1/2} = 166$ seconds) covalent bond forms between the active site seryl residue of plasmin and Arg³⁷⁶ of α_2 -antiplasmin with subsequent release of a COOH-terminal fragment (residues 377 to 464) of α_2 -antiplasmin. The plasmin/plasminogen-binding domain is located within residues 410 to 464, with Lys⁴⁶⁴ acting as the key residue.^{2197,2198} and ²¹⁹⁹ It complexes with lysine-binding site(s) located in the kringle structures of plasminogen and plasmin, exhibiting at least a 10-fold stronger binding to plasmin.¹⁸¹³ Lysine-binding sites on kringles 1^{1813,2200} and 4²¹⁹⁵ have been identified as the points of interaction with α_2 -antiplasmin, although their relative importance individually is not resolved.²¹⁹⁵ Maximum rates of α_2 -antiplasmin inhibition of plasmin require the unimpeded interaction of both the plasminogen-binding domain and the reactive

P.494

site of α_2 -antiplasmin with their respective target domains in the plasmin molecule.²¹⁸² Cross-linking of α_2 -antiplasmin at Gln¹⁴ to the α -chain of fibrin is catalyzed by activated factor XIII.²²⁰¹ In vitro, Asn¹³ α_2 -antiplasmin is more efficiently cross-linked to fibrin.^{2196,2202}

Function

α_2 -Antiplasmin is the primary plasmin inhibitor in human plasma. Its effective concentration in plasma is in the range of 0.5 $\mu\text{mol/L}$. Approximately one-third of the circulating pool (1 $\mu\text{mol/L}$) is poorly reactive,^{2177,2179} and another fraction is bound to circulating plasminogen ($K_d = 4 \mu\text{mol/L}$).²¹⁸² α_2 -Antiplasmin stabilizes the fibrin scaffolding of the developing blood clot by attenuating the rate of plasmin-driven fibrinolysis and protects against systemic degradation of fibrinogen and other proteins by plasmin. Fibrin, as the key cofactor for efficient t-PA activation of plasminogen, localizes plasmin generation to the site of fibrin formation. Generated plasmin is partitioned: one fraction is surface associated through binding interactions between its lysine-binding sites and active site and insoluble fibrin; the other fraction mixes with the circulating blood. α_2 -Antiplasmin rapidly inhibits solution phase plasmin ($t_{1/2} \sim 0.1$ second), preventing systemic fibrinogen degradation until more than 50% of its neutralizing capacity has been exhausted.²¹⁷⁰ The in vitro rate of inhibition of fibrin-bound plasmin by α_2 -antiplasmin decreases by at least a factor of 100 ($t_{1/2} \geq 10$ seconds).²²⁰³ This decrease in reactivity reflects the dependence of the rate of inhibition on the availability of both the lysine-binding and active sites of plasmin. Offsetting this, α_2 -antiplasmin is accumulated on fibrin through a factor XIIIa-catalyzed tethering of the NH₂-terminal of α_2 -antiplasmin to the α -chain of fibrin. Approximately 20% of the available α_2 -antiplasmin is rapidly bound to fibrin. This process has been shown to play a significant role in stabilizing the fibrin clot against lysis.^{1774,2204}

PHYSIOLOGIC REGULATION OF FIBRINOLYSIS

The physiologic regulation of fibrinolysis centers on controlling the rate and location of plasmin formation. Under quiescent conditions, there is little systemic plasmin formation. t-PA is a poor catalyst of the conversion of plasminogen to plasmin in the absence of fibrin. In addition, circulating levels of active t-PA are continually suppressed by reactions with PAI-1, thus further reducing the potential for solution phase plasminogen activation by t-PA. scu-PA has negligible activity toward plasminogen in solution. Further, there is no gradual accumulation of plasmin in the blood because the circulating concentration and efficacy of α_2 -antiplasmin limit the $t_{1/2}$ of plasmin formed away from a fibrin surface to 0.1 second. Thus, significant plasmin formation occurs only after the formation of fibrin. t-PA and plasminogen bind to fibrin as the

clot forms, localizing plasmin generation to the clot. Initial plasmin degradation of fibrin actually increases the number of plasminogen-binding sites in the fibrin, thus amplifying plasmin formation rates. Plasmin also cleaves scu-PA to generate the active two-chain form of the catalyst, further enhancing rates of plasmin activation. In addition, fibrin-bound plasmin is protected from inactivation by circulating α_2 -antiplasmin. These mechanisms ensure that plasmin formation is not premature, that plasmin formation is localized to the clot; the extent of plasmin formation is tied to the amount of fibrin present, thus allowing the process to efficiently dissolve thrombi of different sizes.

Regulation of fibrinolysis is achieved through a dynamic balance α_2 between profibrinolytic and antifibrinolytic processes maintained by complex interactions between circulating proteins, clot-based factors, and endothelial cells. Recruitment of the proteins key to fibrinolysis to the site of injury occurs simultaneously with the initiation of fibrin formation. The fibrin clot not only serves as a substrate, but also acts in a role similar to the phospholipid surface in coagulation, functioning as a surface for the activation and localization of fibrinolytic proteins. The association of plasminogen and t-PA with fibrin enhances the rate of plasminogen activation by t-PA. Plasmin bound to fibrin is protected from inhibition by α_2 -antiplasmin.^{2142,2182,2205} These mechanisms both enhance fibrinolysis and serve to limit proteolytic activity to the clot. However, profibrinolytic processes are balanced by antifibrinolytic responses. PAI-1 associates with fibrin and inactivates t-PA and u-PA within the meshwork of the clot.²²⁰⁶ Factor XIIIa crosslinks and stabilizes the fibrin clot and renders it less susceptible to plasmin proteolysis. Factor XIIIa also cross-links α_2 -antiplasmin to fibrin; this incorporation has been shown to play an important role in fibrin clot stabilization.^{1773,1774,2204} TAFIa removes COOH-terminal lysines from partially proteolyzed fibrin, reducing the number of plasminogen-binding sites and attenuating the rate of plasmin formation. In addition, activated platelets release PAI-1 and α_2 -antiplasmin at the fibrin surface, thus supplementing the ongoing downregulation of plasmin levels by the plasma pools of these serpins.^{2207,2208,2209,2210} and ²²¹¹

Cellular Regulation of Fibrinolysis

The fibrin clot and, thus, fibrinolysis are localized to the surface of the blood vessel at sites where the normally nonthrombogenic façade presented by the endothelium is either mechanically removed or altered in its molecular composition. The unperturbed endothelium secretes PAI-1²²¹² and is actively antifibrinolytic. Once the endothelial layer is disturbed, α -thrombin is generated, and fibrin formation proceeds at that site.²²¹³ Intact endothelial surfaces in the vicinity of the injury become “activated” via interaction with products of the coagulation cascade, shifting from an antifibrinolytic to a profibrinolytic state. “Activated” endothelial cells express t-PA and u-PA as well as specific receptors for the plasminogen activators.^{2214,2215} and ²²¹⁶ t-PA is likely the primary activator of plasminogen at the fibrin surface.^{1914,1987,2217} u-PA has profibrinolytic activity but appears to be primarily associated with extracellular matrix degradation and initiation of tissue repair and remodeling.^{2218,2219} and ²²²⁰

In addition to receptors for plasminogen activators, receptors for plasminogen^{2221,2222} have been identified on a number of cell types including platelets, monocytes, fibroblasts, and endothelial cells, in which they appear to localize and accelerate plasmin formation. Plasmin generated at the cell surface is protected from serpin inhibitors by binding to specific cell receptors. Therefore, the cell surface can serve as a sanctuary for plasmin activity.

Urokinase-type Plasminogen Activator Receptor

uPAR is synthesized and expressed by normal and malignant cells including monocytes, neutrophils, fibroblasts, platelets, and endothelial cells.^{2218,2223,2224,2225,2226,2227,2228} and ²²²⁹ A primary function of uPAR is to localize u-PA-mediated plasmin generation to the cell surface; however, more generally, uPAR mediates cell migration and tissue remodeling during development and wound healing.^{2230,2231} Thus, uPAR function appears to be enmeshed with coagulation, fibrinolytic, and inflammatory processes.^{2230,2231} and ²²³² uPAR binds both singlechain u-PA and plasminogen via high-affinity interactions, forming a ternary complex that enhances plasminogen activation^{2225,2233} and initiates proteolysis of the extracellular matrix.²²³⁴ The receptor is a heterogeneously glycosylated single-chain polypeptide ($M_r = 50,000$ to $60,000$) of 313 amino acids.²²³⁵ Although uPAR is an integral membrane protein, there is no defined transmembrane sequence. uPAR is instead anchored to the cellular membrane by a glycosyl-phosphatidylinositol moiety.²²³⁶ The glycolipid is most likely attached to Gly²⁸³, indicating that

P.495

the mature protein consists of 283 amino acids.^{2236,2237} Because uPAR has no intracellular domain, uPAR mediated signaling presumably occurs through surface interactions with other components of the plasma membrane. At least 9 stable and 33 membrane-associated binding proteins have been identified.²²³⁸ The neutrophils of individuals experiencing the hematopoietic stem cell disorder paroxysmal nocturnal hemoglobinuria, a disease in which these glycosyl-phosphatidylinositol moieties are lacking, show impaired transendothelial migration.^{2227,2239} The absence of the receptor

may play a role in the hypercoagulable state associated with this disorder. The crystal structure of uPAR has been reported in its ligand free form²²⁴⁰ and complexed with sc-UPA.²²⁴¹

Tissue-type Plasminogen Activator Receptors

Many structurally unrelated components that bind t-PA have been described. These receptors can be separated into two distinct functional groups: activation receptors and clearance receptors. Activation receptors are described as localizing t-PA onto a cell surface and enhancing the activation of plasminogen by t-PA.²²⁴² Receptors in the activation category include annexin II (42 kDa),^{2243,2244} heparan sulfate and chondroitin sulfate-like proteoglycans,²²⁴⁵ cytokeratin 8 and 18,^{2246,2247} and tubulin.²²⁴⁸ In patients with promyelocytic leukemia, overexpression of the t-PA receptor annexin II has been associated with a hyperfibrinolytic state resulting in bleeding.²²⁴⁹ The t-PA receptor(s) on endothelial cells is poorly defined (for descriptions of these receptors, see Bachmann¹⁷⁸⁸).

Clearance receptors are responsible for clearing t-PA from the circulation and its subsequent degradation. These receptors control not only the plasma concentration of t-PA but also the levels of inactive t-PA/PAI-1 complexes. t-PA clearance occurs principally in the liver and involves two different receptors: the mannose receptor and the LRP/ α_2 -macroglobulin receptor. The mannose receptor is a major t-PA receptor and binds t-PA with a high-affinity K_d of 1 to 4 nmol/L.^{2250,2251} and²²⁵² Liver endothelial cells and Kupffer cells bind t-PA via the mannose receptor. The other major pathway for t-PA clearance is through the LRP/ α_2 -macroglobulin receptor. This receptor has a relative molecular weight of 600 kDa.¹⁷⁸⁸ This receptor mediates the clearance of t-PA, t-PA/PAI-1, and u-PA/PAI-1 complexes, toxins, cytokines, apolipoprotein E-enriched chylomicron remnants, and complexes of α_2 -macroglobulin.²²⁵³ Free and PAI-1-complexed t-PA have also been shown to be cleared from the circulation through a glycoprotein 330-kDa LRP receptor and a 130-kDa very-low-density lipoprotein receptor.^{2253,2254} and²²⁵⁵

Role of Platelets in the Regulation of Fibrinolysis

Platelets are vital to procoagulant events and contribute to the fibrinolytic process as well. Platelets bind both t-PA and plasminogen and support plasmin generation.^{2256,2257} and²²⁵⁸ Plasmin bound to the platelet surface is also protected from inhibition by α_2 -antiplasmin.²²⁵⁹ Platelets likewise contribute to the antifibrinolytic mechanism. Activated platelets release PAI-1, α_2 -antiplasmin, C1-esterase inhibitor, and α_2 -macroglobulin, which function to inhibit plasminogen activators and plasmin. Therefore, platelets, when present at high concentrations, can promote thrombosis and inhibit fibrinolysis.

Several studies have shown that plasmin can directly modify the function of platelets.^{2259,2260,2261,2262,2263} and²²⁶⁴ When plasmin is present at a low concentration, it can inhibit platelet aggregation by arachidonic acid metabolism or by proteolysis of membrane glycoproteins. At a high plasmin concentration, a proteolytic modification of the platelets occurs that affects fibrinogen binding and platelet aggregation. Plasmin is also able to increase the number of plasminogen binding sites on the surface of platelets, an alteration that may function as a positive feedback loop for t-PA-mediated plasmin production. Increasing the size of the pool of fibrin-localized, platelet-bound plasminogen would augment the other readily activatable pool (plasminogen bound to fibrin), thereby increasing the amount of plasminogen available for efficient t-PA activation. Plasmin has also been shown to degrade the platelet-binding site for factor XIIIa, decreasing the rate of clot stabilization.²²³³

CONCLUSION

This chapter describes the process of blood coagulation by dividing it into sections based on procoagulant, anticoagulant, and fibrinolytic enzymes, cofactors, and inhibitors in the overall process of fibrin formation and fibrin dissolution. The role of each protein is described as either essential or accessory to hemostasis. The overall process of blood coagulation and fibrinolysis is better described when all the players are considered as contributing to a threshold-limited, complex, intertwined process that together promotes hemostasis.

Our understanding of the coagulation process has ancient historical roots; the accomplishments of numerous clinical and basic investigators have provided a relatively complete description of the inventory, connectivity, and dynamics of the overall process that occurs after vascular injury. Significant progress has been made in achieving a complete set of x-ray crystal structures for all the proteins involved in these processes (Table 18.5). The challenge for the future is the use of this knowledge in the development of new technology for the advancement of diagnosis, prophylaxis, and treatment of vascular disease.

ACKNOWLEDGMENTS

We, the authors, would like to thank Matthew Gissel and Stacia Rymarchyk for their assistance in the preparation of this chapter. This work was supported by an NIH grant (HL46703).

REFERENCES

1. Mann KG. Normal hemostasis. In: Kelley WN, ed. Textbook of internal medicine. Philadelphia, PA: JB Lippincott, Co, 1992:1240-1245.
2. Lloyd-Jones D, Adams R, Brown T, et al. Subcommittee. AHA/ACC. Heart disease and stroke statistics—2010 update: a report from the American Heart Association. *Circulation* 2010;121:e46-e215.
3. MacFarlane RG. An enzyme cascade in the blood clotting mechanism and its function as a biochemical amplifier. *Nature* 1964;202:498-499.
4. Davie EW, Ratnoff OD. Waterfall sequence for intrinsic blood clotting. *Science* 1964;145:1310-1312.
5. Mann KG, Nesheim ME, Church WR, Haley P, Krishnaswamy S. Surface-dependent reactions of the vitamin K-dependent enzyme complexes. *Blood* 1990;76:1-16.
6. Orfeo T, Butenas S, Brummel-Ziedins KE, Mann KG. The tissue factor requirement in blood coagulation. *J Biol Chem* 2005;280:42887-42896.
7. Gailani D, Broze GJ Jr. Factor XI activation in a revised model of blood coagulation. *Science* 1991;253:909-912.
8. Radcliffe R, Nemerson Y. Activation and control of factor VII by activated factor X and thrombin. Isolation and characterization of a single chain form of factor VII. *J Biol Chem* 1975;250:388-395.
9. Toole JJ, Knopf JL, Wozney JM, Sultzman LA, Buecker JL, Pittman DD, Kaufman RJ, Brown E, Shoemaker C, Orr EC. Molecular cloning of a cDNA encoding human antihemophilic factor. *Nature* 1984;312:342-347.
10. Hill-Eubanks DC, Parker CG, Lollar P. Differential proteolytic activation of factor VIII-von Willebrand factor complex by thrombin. *Proc Natl Acad Sci U S A* 1989;86:6508-6512.
11. Eaton D, Rodriguez H, Vehar GA. Proteolytic processing of human factor VIII. Correlation of specific cleavages by thrombin, factor Xa, and activated protein C with activation and inactivation of factor VIII coagulant activity. *Biochemistry* 1986;25:505-512.
12. Lollar P, Hill-Eubanks DC, Parker CG. Association of the factor VIII light chain with von Willebrand factor. *J Biol Chem* 1988;263:10451-10455.
13. Nesheim ME, Mann KG. Thrombin-catalyzed activation of single chain bovine factor V. *J Biol Chem* 1979;254:1326-13234.
14. Nesheim ME, Foster WB, Hewick R, Mann KG. Characterization of factor V activation intermediates. *J Biol Chem* 1984;259:3187-3196.
15. Suzuki K, Dahlback B, Stenflo J. Thrombin-catalyzed activation of human coagulation factor V. *J Biol Chem* 1982;257:6556-6564.
16. Naito K, Fujikawa K. Activation of human blood coagulation factor XI independent of factor XII. Factor XI is activated by thrombin and factor XIa in the presence of negatively charged surfaces. *J Biol Chem* 1991;266:7353-7358.
17. Lorand L, Konishi K. Activation of the fibrin-stabilizing factor of plasma by thrombin. *Arch Biochem Biophys* 1964;105:58.
18. Hendriks D, Wang W, Scharpe S, Lommaert MP, van Sande M. Purification and characterization of a new arginine carboxypeptidase in human serum. *Biochim Biophys Acta* 1990;1034:86-92.
19. Eaton DL, Malloy BE, Tsai SP, Henzel W, Drayna D. Isolation, molecular cloning, and partial characterization of a novel carboxypeptidase B from human plasma. *J Biol Chem* 1991;266:21833-21838.
20. Kalafatis M, Swords NA, Rand MD, Mann KG. Membrane-dependent reactions in blood coagulation: role of the vitamin K-dependent enzyme complexes. *Biochim Biophys Acta* 1994;1227:113-129.
21. Collen D, Lijnen HR. Molecular basis of fibrinolysis, as relevant for thrombolytic therapy. *Thromb Haemost* 1995;74:167-171.
22. Henkin J, Marcotte P, Yang HC. The plasminogen-plasmin system. *Prog Cardiovasc Dis* 1991;34:135-164.
23. Mann K. Thrombin generation in hemorrhage control and vascular occlusion. *Circulation* 2011;124:225-235.
24. Mann KG, Brummel K, Butenas S. What is all that thrombin for? *J Thromb Haemost* 2003;1:1504-1514.

25. Mann KG, Butenas S, Brummel KE. The dynamics of thrombin formation. *Arterioscler Thromb Vasc Biol* 2003;23:17-25.
26. Warner ED, Brinkhous KM, Smith HP. A quantitative study of blood clotting. *Am J Physiol* 1936;114:667-675.
27. Quick AJ. On the constitution of prothrombin. *Am J Physiol* 1943;140:212-214.
28. Langdell RD, Wagner RH, Brinkhous KM. Effect of antihemophilic factor on one-stage clotting tests: a presumptive test of hemophilia and a single one-stage anti-hemophilic factor assay procedure. *J Lab Clin Med* 1953;41:7637-7647.
29. Hathaway WE, Belhasen LP, Hathaway HS. Evidence for a new plasma thromboplastin factor. I. Case report, coagulation studies and physicochemical properties. *Blood* 1965;26:521-532.
30. Colman RW, Bagdasarian A, Talamo RC, et al. Williams trait. Human kininogen deficiency with diminished levels of plasminogen proactivator and prekallikrein associated with abnormalities of the Hageman factor-dependent pathways. *J Clin Invest* 1975;56:1650-1662.
31. Hoak JC, Swanson LW, Warner ED, Connor WE. Myocardial infarction associated with severe factor-XII deficiency. *Lancet* 1966;2:884-886.
32. Tefler TP, Denson KW, Wright DR. A "new" coagulation defect. *Br J Haematol* 1956;2:308-312.
33. Owren PA, Cooper T. Parahemophilia. *Arch Intern Med* 1955;95:194-201.
34. Roberts HR, Foster PA. Inherited disorders of prothrombin conversion. Philadelphia, PA: JB Lippincott, 1987:162-181.
35. Biggs R, Douglas AS, MacFarlane RG. Christmas disease: a condition previously mistaken for hemophilia. *Br Med J* 1952;2:1384.
36. Bajzar L, Manuel R, Nesheim ME. Purification and characterization of TAFI, a thrombin-activable fibrinolysis inhibitor. *J Biol Chem* 1995;270:14477-14484.
37. Lawson JH, Kalafatis M, Stram S, Mann KG. A model for the tissue factor pathway to thrombin. I. An empirical study. *J Biol Chem* 1994;269:23357-23366.
38. Bone R. Sepsis and multiple organ failure: consensus and controversy. In: Lamy M, Thijs LG, eds. *Mediators of sepsis*. New York, NY: Springer-Verlag, 1992:3-12.
39. Colman RW. Contact activation pathway: inflammatory, fibrinolytic, anticoagulant, antiadhesive and antiangiogenic activities. In: Colman RW, Hirsh J, Marder VJ, Clowes AW, George JN, eds. *Hemostasis and thrombosis: basic principles & clinical practice*. Philadelphia, PA: Lippincott Williams & Wilkins, 2001:103-121.
40. Renne T, Pozgajova M, Gruner S, et al. Defective thrombus formation in mice lacking coagulation factor XII. *J Exp Med* 2005;202:271-281.
41. Kleinschnitz C, Stoll G, Bendszus M, et al. Targeting coagulation factor XII provides protection from pathological thrombosis in cerebral ischemia without interfering with hemostasis. *J Exp Med* 2006;203:513-518.
42. Nesheim ME, Taswell JB, Mann KG. The contribution of bovine factor V and factor Va to the activity of prothrombinase. *J Biol Chem* 1979;254:10952-10962.
43. Krishnaswamy S. Prothrombinase complex assembly. Contributions of protein-protein and protein-membrane interactions toward complex formation. *J Biol Chem* 1990;265:3708-3718.
44. Tracy PB, Nesheim ME, Mann KG. Coordinate binding of factor Va and factor Xa to the unstimulated platelet. *J Biol Chem* 1981;256:743-751.
45. Krishnaswamy S, Field KA, Edgington TS, Morrissey JH, Mann KG. Role of the membrane surface in the activation of human coagulation factor X. *J Biol Chem* 1992;267:26110-26120.
46. Mann KG. Prothrombin. *Methods Enzymol* 1976;45:123-156.
47. Kalafatis M, Xue J, Lawler CM, Mann KG. Contribution of the heavy and light chains of factor Va to the interaction with factor Xa. *Biochemistry* 1994;33:6538-6545.
48. Walker RK, Krishnaswamy S. The influence of factor Va on the active site of factor Xa. *J Biol Chem* 1993;268:13920-13929.
49. Nemerson Y. Tissue factor and hemostasis [published erratum appears in *Blood* 1988 Apr;71(4):1178]. *Blood* 1988;71:1-8.

50. Edgington TS, Mackman N, Brand K, Ruf W. The structural biology of expression and function of tissue factor. *Thromb Haemost* 1991;66:67-79.
51. Nakagaki T, Foster DC, Berkner KL, Kiesel W. Initiation of the extrinsic pathway of blood coagulation: evidence for the tissue factor dependent autoactivation of human coagulation factor VII. *Biochemistry* 1991;30:10819-10824.
52. Morrissey JH, Macik BG, Neuenschwander PF, Comp PC. Quantitation of activated factor VII levels in plasma using a tissue factor mutant selectively deficient in promoting factor VII activation. *Blood* 1993;81:734-744.
53. Drake TA, Morrissey JH, Edgington TS. Selective cellular expression of tissue factor in human tissues. Implications for disorders of hemostasis and thrombosis. *Am J Pathol* 1989;134:1087-1097.
54. Rodgers GM, Greenberg CS, Shuman MA. Characterization of the effects of cultured vascular cells on the activation of blood coagulation. *Blood* 1983;61:1155-1162.
55. Maynard JR, Dreyer BE, Stemerman MB, Pitlick FA. Tissue-factor coagulant activity of cultured human endothelial and smooth muscle cells and fibroblasts. *Blood* 1977;50:387-396.

P.496

56. Wilcox JN, Smith KM, Schwartz SM, Gordon D. Localization of tissue factor in the normal vessel wall and in the atherosclerotic plaque. *Proc Natl Acad Sci U S A* 1989;86:2839-2843.
57. Callander NS, Varki N, Rao LV. Immunohistochemical identification of tissue factor in solid tumors. *Cancer* 1992;70:1194-1201.
58. Fleck RA, Rao LV, Rapaport SI, Varki N. Localization of human tissue factor antigen by immunostaining with monospecific, polyclonal anti-human tissue factor antibody [corrected and republished article originally printed in *Thromb Res* 1990 Mar 1;57(5):765-781]. *Thromb Res* 1990;59:421-437.
59. Rodgers GM. Hemostatic properties of normal and perturbed vascular cells. *FASEB J* 1988;2:116-123.
60. Conkling PR, Greenberg CS, Weinberg JB. Tumor necrosis factor induces tissue factor-like activity in human leukemia cell line U937 and peripheral blood monocytes. *Blood* 1988;72:128-133.
61. Lawson JH, Mann KG. Cooperative activation of human factor IX by the human extrinsic pathway of blood coagulation. *J Biol Chem* 1991;266:11317-11327.
62. Mann KG, Krishnaswamy S, Lawson JH. Surface-dependent hemostasis. *Semin Hematol* 1992;29:213-226.
63. Ahmad SS, Rawala-Sheikh R, Walsh PN. Components and assembly of the factor X activating complex. *Semin Thromb Hemost* 1992;18:311-323.
64. Revak SD, Cochrane CG, Johnston AR, Hugli TE. Structural changes accompanying enzymatic activation of human Hageman factor. *J Clin Invest* 1974;54:619-627.
65. Saito H, Ratnoff OD, Pensky J. Radioimmunoassay of human Hageman factor (factor XII). *J Lab Clin Med* 1976;88:506-514.
66. Gordon EM, Williams SR, Frenck B, Mazur CA, Speroff L. Dose-dependent effects of postmenopausal estrogen and progestin on antithrombin III and factor XII. *J Lab Clin Med* 1988;111:52-56.
67. Mitropoulos KA, Martin JC, Burgess AI, et al. The increased rate of activation of factor XII in late pregnancy can contribute to the increased reactivity of factor VII. *Thromb Haemost* 1990;63:349-355.
68. Gordon EM, Johnson TR, Ramos LP, Schmeidler-Sapiro KT. Enhanced expression of factor XII (Hageman factor) in isolated livers of estrogen- and prolactin-treated rats. *J Lab Clin Med* 1991;117:353-358.
69. Stavrou E, Schmaier A. Factor XII: what does it contribute to our understanding of the physiology and pathophysiology of hemostasis & thrombosis. *Thromb Res* 2010;125:210-215.
70. Woodruff R, Sullenger B, Becker R. The many faces of the contact pathway and their role in thrombosis. *J Thromb Thrombol* 2011;32:9-20.

71. Ghebrehiwet B, CebadaMora C, Tantral L, Jesty J, Peerschke EI. gC1qR/p33 serves as a molecular bridge between the complement and contact activation systems and is an important catalyst in inflammation. *Adv Exp Med Biol* 2006;586:95-105.
72. Peerschke EI, Minta JO, Zhou SZ, et al. Expression of gC1q-R/p33 and its major ligands in human atherosclerotic lesions. *Mol Immunol* 2004;41:759-766.
73. Maas C, Govers-Riemslog J, Bouma B, et al. Misfolded proteins activate factor XII in humans, leading to kallikrein formation without initiating coagulation. *J Clin Invest* 2008;118:3208-3218.
74. Citarella F, Tripodi M, Fantoni A, Bernardi F, Romeo G, Rocchi M. Assignment of human coagulation factor XII (fXII) to chromosome 5 by cDNA hybridization to DNA from somatic cell hybrids. *Hum Genet* 1988;80:397-398.
75. Royle NJ, Nigli M, Cool D, MacGillivray RT, Hamerton JL. Structural gene encoding human factor XII is located at 5q33-qter. *Somat Cell Mol Genet* 1988;14:217-221.
76. Cool DE, MacGillivray RT. Characterization of the human blood coagulation factor XII gene. Intron/exon gene organization and analysis of the 5'-flanking region. *J Biol Chem* 1987;262:13662-13673.
77. Citarella F, Misiti S, Felici A, Aiuti A, La Porta C, Fantoni A. The 5' sequence of human factor XII gene contains transcription regulatory elements typical of liver specific, estrogen-modulated genes. *Biochim Biophys Acta* 1993;1172:197-199.
78. Griffin JH, Cochrane CG. Human factor XII (Hageman factor). *Methods Enzymol* 1976;45:56-65.
79. McMullen BA, Fujikawa K, Kisiel W. The occurrence of beta-hydroxyaspartic acid in the vitamin K-dependent blood coagulation zymogens. *Biochem Biophys Res Commun* 1983;115:8-14.
80. Fujikawa K, McMullen BA. Amino acid sequence of human beta-factor XIIa. *J Biol Chem* 1983;258:10924-10933.
81. McMullen BA, Fujikawa K. Amino acid sequence of the heavy chain of human alpha-factor XIIa (activated Hageman factor). *J Biol Chem* 1985;260:5328-5341.
82. Cool DE, Edgell CJ, Louie GV, Zoller MJ, Brayer GD, MacGillivray RT. Characterization of human blood coagulation factor XII cDNA. Prediction of the primary structure of factor XII and the tertiary structure of beta-factor XIIa. *J Biol Chem* 1985;260:13666-13676.
83. Harris RJ, Ling VT, Spellman MW. O-linked fucose is present in the first epidermal growth factor domain of factor XII but not protein C. *J Biol Chem* 1992;267:5102-5107.
84. Pixley RA, Colman RW. Factor XII: Hageman factor. *Methods Enzymol* 1993;222:51-65.
85. Rojkaer R, Schousboe I. Partial identification of the Zn₂⁺-binding sites in factor XII and its activation derivatives. *Eur J Biochem* 1997;247:491-496.
86. Schousboe I. Contact activation in human plasma is triggered by zinc ion modulation of factor XII (Hageman factor). *Blood Coagul Fibrinolysis* 1993;4:671-678.
87. Bernardo M, Day D, Olson S, Shore J. Surface-independent acceleration of factor XII activation by zinc ions. I. Kinetic characterization of the metal ion rate enhancement. *J Biol Chem* 1993;268:12468.
88. Bernardo MM, Day DE, Halvorson HR, Olson ST, Shore JD. Surface-independent acceleration of factor XII activation by zinc ions. II. Direct binding and fluorescence studies. *J Biol Chem* 1993;268:12477-12483.
89. Cochrane CG, Revak SD, Wuepper KD. Activation of Hageman factor in solid and fluid phases. A critical role of kallikrein. *J Exp Med* 1973;138:1564-1583.
90. Revak SD, Cochrane CG, Griffin JH. The binding and cleavage characteristics of human Hageman factor during contact activation. A comparison of normal plasma with plasmas deficient in factor XI, prekallikrein, or high molecular weight kininogen. *J Clin Invest* 1977;59:1167-1175.
91. Griffin JH. Role of surface in surface-dependent activation of Hageman factor (blood coagulation factor XII). *Proc Natl Acad Sci U S A* 1978;75:1998-2002.
92. Kirby EP, McDevitt PJ. The binding of bovine factor XII to kaolin. *Blood* 1983;61:652-659.
93. Wiggins RC, Cochrane CC. The autoactivation of rabbit Hageman factor. *J Exp Med* 1979;150:1122-1133.

94. Miller G, Silverberg M, Kaplan AP. Autoactivatability of human Hageman factor (factor XII). *Biochem Biophys Res Commun* 1980;92:803-810.
95. Silverberg M, Dunn JT, Garen L, Kaplan AP. Autoactivation of human Hageman factor. Demonstration utilizing a synthetic substrate. *J Biol Chem* 1980;255:7281-7286.
96. Dunn JT, Silverberg M, Kaplan AP. The cleavage and formation of activated human Hageman factor by autodigestion and by kallikrein. *J Biol Chem* 1982;257:1779-1784.
97. Espana F, Ratnoff OD. Activation of Hageman factor (factor XII) by sulfatides and other agents in the absence of plasma proteases. *J Lab Clin Med* 1983;102:31-45.
98. Tankersley DL, Finlayson JS. Kinetics of activation and autoactivation of human factor XII. *Biochemistry* 1984;23:273-279.
99. Thorisdottir H, Ratnoff OD, Maniglia AJ. Activation of Hageman factor (factor XII) by bismuth subgallate, a hemostatic agent. *J Lab Clin Med* 1988;112:481-486.
100. Zhuo R, Siedlecki CA, Vogler EA. Autoactivation of blood factor XII at hydrophilic and hydrophobic surfaces. *Biomaterials* 2006;27:4325-4332.
101. Ziats NP, Pankowsky DA, Tierney BP, Ratnoff OD, Anderson JM. Adsorption of Hageman factor (factor XII) and other human plasma proteins to biomedical polymers. *J Lab Clin Med* 1990;116:687-696.
102. Ratnoff OD. Activation of Hageman factor by L-homocystine. *Science* 1968;162:1007-1009.
103. Becker CG, Wagner M, Kaplan AP, et al. Activation of factor XII-dependent pathways in human plasma by hematin and protoporphyrin. *J Clin Invest* 1985;76:413-419.
104. Kurachi K, Fujikawa K, Davie EW. Mechanism of activation of bovine factor XI by factor XII and factor XIIa. *Biochemistry* 1980;19:1330-1338.
105. Fujikawa K, Heimark RL, Kurachi K, Davie EW. Activation of bovine factor XII (Hageman factor) by plasma kallikrein. *Biochemistry* 1980;19:1322-1330.
106. Tans G, Rosing J, Griffin JH. Sulfatide-dependent autoactivation of human blood coagulation Factor XII (Hageman Factor). *J Biol Chem* 1983;258:8215-8222.
107. Hojima Y, Cochrane CG, Wiggins RC, Austen KF, Stevens RL. In vitro activation of the contact (Hageman factor) system of plasma by heparin and chondroitin sulfate E. *Blood* 1984;63:1453-1459.
108. Koenig JM, Chahine A, Ratnoff OD. Inhibition of the activation of Hageman factor (factor XII) by soluble human placental collagens types III, IV, and V. *J Lab Clin Med* 1991;117:523-527.
109. Silverberg M, Diehl SV. The autoactivation of factor XII (Hageman factor) induced by low-Mr heparin and dextran sulphate. The effect of the Mr of the activating polyanion. *Biochem J* 1987;248:715-720.
110. Tans G, Verkley AJ, Yu J, Griffin JH. Sulfatide bilayers as a surface for contact activation in human plasma. *Biochem Biophys Res Commun* 1987;149:1002-1007.
111. Griep MA, Fujikawa K, Nelsestuen GL. Possible basis for the apparent surface selectivity of the contact activation of human blood coagulation factor XII. *Biochemistry* 1986;25:6688-6694.
112. Johne J, Blume C, Benz PM, et al. Platelets promote coagulation factor XII mediated proteolytic cascade systems in plasma. *Biol Chem* 2006;387:173-178.
113. Klein S, Spannagl M, Engelmann B. Phosphatidylethanolamine participates in the stimulation of the contact system of coagulation by very-low-density lipoproteins. *Arterioscler Thromb Vasc Biol* 2001;21:1695-1700.
114. Schmaier A. Contact activation. In: Loscalzo J, Schafer AI, eds. *Thrombosis and hemorrhage*. Baltimore, MA: Williams and Wilkins, 1998:105-127.
115. Motta G, Rojkaer R, Hasan AA, Cines DB, Schmaier AH. High molecular weight kininogen regulates prekallikrein assembly and activation on endothelial cells: a novel mechanism for contact activation. *Blood* 1998;91:516-528.
116. Rojkaer R, Hasan AA, Motta G, Schousboe I, Schmaier AH. Factor XII does not initiate prekallikrein activation on endothelial cells. *Thromb Haemost* 1998;80:74-81.

117. Hovinga JK, Schaller J, Stricker H, Wuillemin WA, Furlan M, Lammle B. Coagulation factor XII Locarno: the functional defect is caused by the amino acid substitution Arg 353→Pro leading to loss of a kallikrein cleavage site. *Blood* 1994;84:1173-1181.
118. Clarke BJ, Cote HC, Cool DE, et al. Mapping of a putative surface-binding site of human coagulation factor XII. *J Biol Chem* 1989;264:11497-11502.
119. Citarella F, Ravon DM, Pascucci B, Felici A, Fantoni A, Hack CE. Structure/function analysis of human factor XII using recombinant deletion mutants. Evidence for an additional region involved in the binding to negatively charged surfaces. *Eur J Biochem* 1996;238:240-249.
120. Kaplan AP, Austen KF. A pre-albumin activator of prekallikrein. *J Immunol* 1970;105:802-811.
121. Wuepper KD, Tucker ES III, Cochrane CG. Plasma kinin system: proenzyme components. *J Immunol* 1970;105:1307-1311.
122. Cochrane CG, Griffin JH. Molecular assembly in the contact phase of the Hageman factor system. *Am J Med* 1979;67:657-664.
123. Kaplan AP, Austen KF. A prealbumin activator of prekallikrein. II. Derivation of activators of prekallikrein from active Hageman factor by digestion with plasmin. *J Exp Med* 1971;133:696-712.
124. Revak SD, Cochrane CG, Bouma BN, Griffin JH. Surface and fluid phase activities of two forms of activated Hageman factor produced during contact activation of plasma. *J Exp Med* 1978;147:719-729.
125. Revak SD, Cochrane CG. The relationship of structure and function in human Hageman factor. The association of enzymatic and binding activities with separate regions of the molecule. *J Clin Invest* 1976;57:852-860.
126. Gordon EM, Gallagher CA, Johnson TR, Blossey BK, Ilan J. Hepatocytes express blood coagulation factor XII (Hageman factor). *J Lab Clin Med* 1990;115:463-469.
127. Kaplan AP, Silverberg M, Ghebrehiwet B. The intrinsic coagulation/kinin pathway—the classical complement pathway and their interactions. *Adv Exp Med Biol* 1986;198(Pt B):11-25.
128. Chien P, Pixley RA, Stumpo LG, Colman RW, Schreiber AD. Modulation of the human monocyte binding site for monomeric immunoglobulin G by activated Hageman factor. *J Clin Invest* 1988;82:1554-1559.
129. Toossi Z, Sedor JR, Mettler MA, Everson B, Young T, Ratnoff OD. Induction of expression of monocyte interleukin 1 by Hageman factor (factor XII). *Proc Natl Acad Sci U S A* 1992;89:11969-11972.
130. Wachtfogel YT, Pixley RA, Kucich U, et al. Purified plasma factor XIIa aggregates human neutrophils and causes degranulation. *Blood* 1986;67:1731-1737.
131. Schmaier AH. The elusive physiologic role of factor XII. *J Clin Invest* 2008;118:3006-3009.
132. Mandle R Jr, Kaplan AP. Hageman factor substrates. Human plasma prekallikrein: mechanism of activation by Hageman factor and participation in hageman factor-dependent fibrinolysis. *J Biol Chem* 1977;252:6097-6104.
133. Forbes CD, Pensky J, Ratnoff OD. Inhibition of activated Hageman factor and activated plasma thromboplastin antecedent by purified serum C1 inactivator. *J Lab Clin Med* 1970;76:809-815.
134. Schreiber AD, Kaplan AP, Austen KF. Inhibition by C1INH of Hagemann factor fragment activation of coagulation, fibrinolysis, and kinin generation. *J Clin Invest* 1973;52:1402-1409.
135. de Agostini A, Lijnen HR, Pixley RA, Colman RW, Schapira M. Inactivation of factor XII active fragment in normal plasma. Predominant role of C-1-inhibitor. *J Clin Invest* 1984;73:1542-1549.
136. Pixley RA, Schapira M, Colman RW. The regulation of human factor XIIa by plasma proteinase inhibitors. *J Biol Chem* 1985;260:1723-1729.
137. Stead N, Kaplan AP, Rosenberg RD. Inhibition of activated factor XII by antithrombin-heparin cofactor. *J Biol Chem* 1976;251:6481-6488.
138. Pixley RA, Schapira M, Colman RW. Effect of heparin on the inactivation rate of human activated factor XII by antithrombin III. *Blood* 1985;66:198-203.
139. Berrettini M, Schleef RR, Espana F, Loskutoff DJ, Griffin JH. Interaction of type 1 plasminogen activator inhibitor with the enzymes of the contact activation system. *J Biol Chem* 1989;264:11738-11743.

140. Kleniewski J, Donaldson VH. Endothelial cells produce a substance that inhibits contact activation of coagulation by blocking the activation of Hageman factor. *Proc Natl Acad Sci U S A* 1993;90:198-202.
141. Ratnoff OD, Everson B, Embury P, et al. Inhibition of the activation of Hageman factor (factor XII) by human vascular endothelial cell culture supernates. *Proc Natl Acad Sci U S A* 1991;88:10740-10743.
142. Ratnoff OD, Gleich GJ, Shurin SB, Kazura J, Everson B, Embury P. Inhibition of the activation of hageman factor (factor XII) by eosinophils and eosinophilic constituents. *Am J Hematol* 1993;42:138-145.
143. Niwano H, Embury PB, Greenberg BD, Ratnoff OD. Inhibitory action of amyloid precursor protein against human Hageman factor (factor XII). *J Lab Clin Med* 1995;125:251-256.
144. Fisher CA, Schmaier AH, Addonizio VP, Colman RW. Assay of prekallikrein in human plasma: comparison of amidolytic, esterolytic, coagulation, and immunochemical assays. *Blood* 1982;59:963-970.
145. McConnell DJ, Mason B. The isolation of human plasma prekallikrein. *Br J Pharmacol* 1970;38:490-502.
146. Mandle RJ, Colman RW, Kaplan AP. Identification of prekallikrein and high-molecular-weight kininogen as a complex in human plasma. *Proc Natl Acad Sci U S A* 1976;73:4179-4183.
147. Scott CF, Colman RW. Function and immunochemistry of prekallikrein-high molecular weight kininogen complex in plasma. *J Clin Invest* 1980;65:413-421.
148. Girolami A, Scarparo P, Candeo N, Lombardi A. Congenital prekallikrein deficiency. *Expert Rev Hematol* 2010;3:685-695.
149. Bojanini EU, Loaiza-Bonilla A, Pimentel A. Prekallikrein deficiency presenting as recurrent cerebrovascular accident: case report and review of the literature. *Case Report Hematol* 2012;2012:723204. doi:10.1155/2012/723204.
150. Beaubien G, Rosinski-Chupin I, Mattei MG, Mbikay M, Chretien M, Seidah NG. Gene structure and chromosomal localization of plasma kallikrein. *Biochemistry* 1991;30:1628-1635.
151. Yu H, Anderson PJ, Freedman BI, Rich SS, Bowden DW. Genomic structure of the human plasma prekallikrein gene, identification of allelic variants, and analysis in end-stage renal disease. *Genomics* 2000;69:225-234.
152. Veloso D, Shilling J, Shine J, Fitch WM, Colman RW. Recent evolutionary divergence of plasma prekallikrein and factor XI. *Thromb Res* 1986;43:153-160.
153. Chung DW, Fujikawa K, McMullen BA, Davie EW. Human plasma prekallikrein, a zymogen to a serine protease that contains four tandem repeats. *Biochemistry* 1986;25:2410-2417.
154. Ciechanowicz A, Bader M, Wagner J, Ganten D. Extra-hepatic transcription of plasma prekallikrein gene in human and rat tissues. *Biochem Biophys Res Commun* 1993;197:1370-1376.
155. Cerf ME, Raidoo DM. Immunolocalization of plasma kallikrein in human brain. *Metab Brain Dis* 2000;15:315-323.
156. Asakai R, Davie EW, Chung DW. Organization of the gene for human factor XI. *Biochemistry* 1987;26:7221-7228.
157. Scott CF, Liu CY, Colman RW. Human plasma prekallikrein: a rapid high-yield method for purification. *Eur J Biochem* 1979;100:77-83.
158. McMullen BA, Fujikawa K, Davie EW. Location of the disulfide bonds in human coagulation factor XI: the presence of tandem apple domains. *Biochemistry* 1991;30:2056-2060.
159. Page JD, You JL, Harris RB, Colman RW. Localization of the binding site on plasma kallikrein for high-molecular-weight kininogen to both apple 1 and apple 4 domains of the heavy chain. *Arch Biochem Biophys* 1994;314:159-164.
160. Herwald H, Jahnen-Dechent W, Alla SA, Hock J, Bouma BN, Muller-Esterl W. Mapping of the high molecular weight kininogen binding site of prekallikrein. Evidence for a discontinuous epitope formed by distinct segments of the prekallikrein heavy chain. *J Biol Chem* 1993;268:14527-14535.
161. Wuepper KD, Cochrane CG. Plasma prekallikrein: isolation, characterization, and mechanism of activation. *J Exp Med* 1972;135:1-20.
162. Shariat-Madar Z, Mahdi F, Schmaier AH. Identification and characterization of prolylcarboxypeptidase as an endothelial cell prekallikrein activator. *J Biol Chem* 2002;277:17962-17969.
163. Bouma BN, Miles LA, Beretta G, Griffin JH. Human plasma prekallikrein. Studies of its activation by activated factor XII and of its inactivation by diisopropyl phosphorfluoridate. *Biochemistry* 1980;19:1151-1160.

164. van der Graaf F, Tans G, Bouma BN, Griffin JH. Isolation and functional properties of the heavy and light chains of human plasma kallikrein. *J Biol Chem* 1982;257:14300-14305.
165. Burger D, Schleuning WD, Schapira M. Human plasma prekallikrein. Immunoaffinity purification and activation to alpha- and beta-kallikrein. *J Biol Chem* 1986;261:324-327.
166. Colman RW, Wachtfogel YT, Kucich U, et al. Effect of cleavage of the heavy chain of human plasma kallikrein on its functional properties. *Blood* 1985;65:311-318.
167. Nagasawa S, Nakayasu T. Human plasma prekallikrein as a protein complex. *J Biochem (Tokyo)* 1973;74:401-403.
168. Habal FM, Movat HZ, Burrowes CE. Isolation of two functionally different kininogens from human plasma— separation from proteinase inhibitors and interaction with plasma kallikrein. *Biochem Pharmacol* 1974;23:2291-2303.
169. Toda N, Okamura T. Endothelium-dependent and -independent responses to vasoactive substances of isolated human coronary arteries. *Am J Physiol* 1989;257:H988-H995.
170. Hong SL. Effect of bradykinin and thrombin on prostacyclin synthesis in endothelial cells from calf and pig aorta and human umbilical cord vein. *Thromb Res* 1980;18:787-795.
171. Gurewich V, Johnstone M, Loza JP, Pannell R. Pro-urokinase and prekallikrein are both associated with platelets. Implications for the intrinsic pathway of fibrinolysis and for therapeutic thrombolysis. *FEBS Lett* 1993;318:317-321.
172. Loza JP, Gurewich V, Johnstone M, Pannell R. Platelet-bound prekallikrein promotes pro-urokinase-induced clot lysis: a mechanism for targeting the factor XII dependent intrinsic pathway of fibrinolysis. *Thromb Haemost* 1994;71:347-352.
173. Wachtfogel YT, Kucich U, James HL, et al. Human plasma kallikrein releases neutrophil elastase during blood coagulation. *J Clin Invest* 1983;72:1672-1677.
174. Schapira M, Scott CF, Colman RW. Protection of human plasma kallikrein from inactivation by C1 inhibitor and other protease inhibitors. The role of high molecular weight kininogen. *Biochemistry* 1981;20:2738-2743.
175. van der Graaf F, Koedam JA, Bouma BN. Inactivation of kallikrein in human plasma. *J Clin Invest* 1983;71:149-158.
176. Schapira M, Scott CF, Colman RW. Contribution of plasma protease inhibitors to the inactivation of kallikrein in plasma. *J Clin Invest* 1982;69:462-468.
177. van der Graaf F, Koedam JA, Griffin JH, Bouma BN. Interaction of human plasma kallikrein and its light chain with C1 inhibitor. *Biochemistry* 1983;22:4860-4866.
178. Schapira M, Scott CF, James A, et al. High molecular weight kininogen or its light chain protects human plasma kallikrein from inactivation by plasma protease inhibitors. *Biochemistry* 1982;21:567-572.
179. Schmaier AH, Gustafson E, Idell S, Colman RW. Plasma prekallikrein assay: reversible inhibition of C-1 inhibitor by chloroform and its use in measuring prekallikrein in different mammalian species. *J Lab Clin Med* 1984;104:882-892.
180. DeLa Cadena RA, Colman RW. The sequence HGLGHGHEQQHGLGHGH in the light chain of high molecular weight kininogen serves as a primary structural feature for zinc-dependent binding to an anionic surface. *Protein Sci* 1992;1:151-160.
181. Bjork I, Olson ST, Sheffer RG, Shore JD. Binding of heparin to human high molecular weight kininogen. *Biochemistry* 1989;28:1213-1221.
182. Olson ST, Sheffer R, Francis AM. High molecular weight kininogen potentiates the heparin-accelerated inhibition of plasma kallikrein by antithrombin: role for antithrombin in the regulation of kallikrein. *Biochemistry* 1993;32:12136-12147.
183. Meijers JC, Kanters DH, Vlooswijk RA, van Erp HE, Hessing M, Bouma BN. Inactivation of human plasma kallikrein and factor XIa by protein C inhibitor. *Biochemistry* 1988;27:4231-4237.
184. Espana F, Estelles A, Griffin JH, Aznar J. Interaction of plasma kallikrein with protein C inhibitor in purified mixtures and in plasma. *Thromb Haemost* 1991;65:46-51.
185. Koedam JA, Meijers JC, Sixma JJ, Bouma BN. Inactivation of human factor VIII by activated protein C. Cofactor activity of protein S and protective effect of von Willebrand factor. *J Clin Invest* 1988;82:1236-1243.
186. Schmaier A, Bradford H, Silver L, et al. High molecular weight kininogen is an inhibitor of platelet calpain. *J Clin Invest* 1986;77:1565-1573.

187. Schmaier AH, Zuckerberg A, Silverman C, Kuchibhotla J, Tuszyński GP, Colman RW. High-molecular weight kininogen. A secreted platelet protein. *J Clin Invest* 1983;71:1477-1489.
188. Scott CF, Shull B, Muller-Esterl W, Colman RW. Rapid direct determination of low and high molecular weight kininogen in human plasma by Particle Concentration Fluorescence Immunoassay (PCFIA). *Thromb Haemost* 1997;77:109-118.
189. Cheung PP, Kunapuli SP, Scott CF, Wachtfogel YT, Colman RW. Genetic basis of total kininogen deficiency in Williams' trait. *J Biol Chem* 1993;268:23361-23365.
190. Kaplan A, Ghebrehiwet B. The plasma bradykinin-forming pathways and its interrelationships with complement. *Mol Immunol* 2010;47:2161-2169.
191. Takagaki Y, Kitamura N, Nakanishi S. Cloning and sequence analysis of cDNAs for human high molecular weight and low molecular weight prekininogens. Primary structures of two human prekininogens. *J Biol Chem* 1985;260:8601-8609.
192. Kitamura N, Kitagawa H, Fukushima D, Takagaki Y, Miyata T, Nakanishi S. Structural organization of the human kininogen gene and a model for its evolution. *J Biol Chem* 1985;260:8610-8617.
193. Cheung PP, Cannizzaro LA, Colman RW. Chromosomal mapping of human kininogen gene (KNG) to 3q26—qter. *Cytogenet Cell Genet* 1992;59:24-26.
194. Schmaier AH, Kuo A, Lundberg D, Murray S, Cines DB. The expression of high molecular weight kininogen on human umbilical vein endothelial cells. *J Biol Chem* 1988;263:16327-16333.
195. Chen LM, Chung P, Chao S, Chao L, Chao J. Differential regulation of kininogen gene expression by estrogen and progesterone in vivo. *Biochim Biophys Acta* 1992;1131:145-151.
196. Chhibber G, Cohen A, Lane S, Farber A, Meloni FJ, Schmaier AH. Immunoblotting of plasma in a pregnant patient with hereditary angioedema. *J Lab Clin Med* 1990;115:112-121.
197. Takano M, Kondo J, Yayama K, Okamoto H. Expression of low-molecular-weight kininogen mRNA in human fibroblast WI38 cells. *Jpn J Pharmacol* 1996;71:341-343.
198. Higashiyama S, Ohkubo I, Ishiguro H, Sasaki M, Matsuda T, Nakamura R. Heavy chain of human high molecular weight and low molecular weight kininogens binds calcium ion. *Biochemistry* 1987;26:7450-7458.
199. Salvesen G, Parkes C, Abrahamson M, Grubb A, Barrett AJ. Human low-Mr kininogen contains three copies of a cystatin sequence that are divergent in structure and in inhibitory activity for cysteine proteinases. *Biochem J* 1986;234:429-434.
200. Schmaier AH, Bradford H, Silver LD, et al. High molecular weight kininogen is an inhibitor of platelet calpain. *J Clin Invest* 1986;77:1565-1573.
201. Bradford HN, Schmaier AH, Colman RW. Kinetics of inhibition of platelet calpain II by human kininogens. *Biochem J* 1990;270:83-90.
202. Zini JM, Schmaier AH, Cines DB. Bradykinin regulates the expression of kininogen binding sites on endothelial cells. *Blood* 1993;81:2936-2946.
203. Meloni FJ, Schmaier AH. Low molecular weight kininogen binds to platelets to modulate thrombin-induced platelet activation. *J Biol Chem* 1991;266:6786-6794.
204. Meloni FJ, Gustafson EJ, Schmaier AH. High molecular weight kininogen binds to platelets by its heavy and light chains and when bound has altered susceptibility to kallikrein cleavage. *Blood* 1992;79:1233-1244.
205. Jiang YP, Muller-Esterl W, Schmaier AH. Domain 3 of kininogens contains a cell-binding site and a site that modifies thrombin activation of platelets. *J Biol Chem* 1992;267:3712-3717.
206. Wachtfogel YT, DeLa Cadena RA, Kunapuli SP, et al. High molecular weight kininogen binds to Mac-1 on neutrophils by its heavy chain (domain 3) and its light chain (domain 5). *J Biol Chem* 1994;269:19307-19312.
207. Puri RN, Zhou F, Hu CJ, Colman RF, Colman RW. High molecular weight kininogen inhibits thrombin-induced platelet aggregation and cleavage of aggrecan by inhibiting binding of thrombin to platelets. *Blood* 1991;77:500-507.
208. Kunapuli SP, Bradford HN, Jameson BA, et al. Thrombin-induced platelet aggregation is inhibited by the heptapeptide Leu271-Ala277 of domain 3 in the heavy chain of high molecular weight kininogen. *J Biol Chem* 1996;271:11228-11235.

209. Hasan AA, Cines DB, Zhang J, Schmaier AH. The carboxyl terminus of bradykinin and amino terminus of the light chain of kininogens comprise an endothelial cell binding domain. *J Biol Chem* 1994;269:31822-31830.
210. Hasan AA, Amenta S, Schmaier AH. Bradykinin and its metabolite, Arg-Pro-Pro-Gly-Phe, are selective inhibitors of alpha-thrombin-induced platelet activation [published erratum appears in *Circulation* 1996 Oct 1;94(7):1794]. *Circulation* 1996;94:517-528.
211. Reddigari SR, Kuna P, Miragliotta G, Shibayama Y, Nishikawa K, Kaplan AP. Human high molecular weight kininogen binds to human umbilical vein endothelial cells via its heavy and light chains. *Blood* 1993;81:1306-1311.
212. Hasan AA, Cines DB, Herwald H, Schmaier AH, Muller-Esterl W. Mapping the cell binding site on high molecular weight kininogen domain 5. *J Biol Chem* 1995;270:19256-61.
213. Retzios AD, Rosenfeld R, Schiffman S. Effects of chemical modifications on the surface- and protein-binding properties of the light chain of human high molecular weight kininogen. *J Biol Chem* 1987;262:3074-3081.
214. Pixley RA, Lin Y, Isordia-Salas I, Colman RW. Fine mapping of the sequences in domain 5 of high molecular weight kininogen (HK) interacting with heparin and zinc. *J Thromb Haemost* 2003;1:1791-1798.
215. Tait JF, Fujikawa K. Identification of the binding site for plasma prekallikrein in human high molecular weight kininogen. A region from residues 185 to 224 of the kininogen light chain retains full binding activity. *J Biol Chem* 1986;261:15396-15401.
216. Tait JF, Fujikawa K. Primary structure requirements for the binding of human high molecular weight kininogen to plasma prekallikrein and factor XI. *J Biol Chem* 1987;262:11651-11656.
217. Vogel R, Kaufmann J, Chung DW, Kellermann J, Muller-Esterl W. Mapping of the prekallikrein-binding site of human H-kininogen by ligand screening of lambda gt11 expression libraries. Mimicking of the predicted binding site by anti-idiotypic antibodies. *J Biol Chem* 1990;265:12494-12502.
218. Kerbiriou DM, Griffin JH. Human high molecular weight kininogen. Studies of structure-function relationships and of proteolysis of the molecule occurring during contact activation of plasma. *J Biol Chem* 1979;254:12020-12027.
219. Bock PE, Shore JD. Protein-protein interactions in contact activation of blood coagulation. Characterization of fluorescein-labeled human high molecular weight kininogen-light chain as a probe. *J Biol Chem* 1983;258:15079-15086.
220. Sun D, McCrae KR. Endothelial-cell apoptosis induced by cleaved high-molecular-weight kininogen (HKa) is matrix dependent and requires the generation of reactive oxygen species. *Blood* 2006;107:4714-4720.
221. Gustafson EJ, Schmaier AH, Wachtfogel YT, Kaufman N, Kucich U, Colman RW. Human neutrophils contain and bind high molecular weight kininogen. *J Clin Invest* 1989;84:28-35.
222. Gustafson EJ, Schutsky D, Knight LC, Schmaier AH. High molecular weight kininogen binds to unstimulated platelets. *J Clin Invest* 1986;78:310-318.
223. Greengard JS, Heeb MJ, Ersdal E, Walsh PN, Griffin JH. Binding of coagulation factor XI to washed human platelets. *Biochemistry* 1986;25:3884-3890.
224. van Iwaarden F, de Groot PG, Sixma JJ, Berrettini M, Bouma BN. High-molecular weight kininogen is present in cultured human endothelial cells: localization, isolation, and characterization. *Blood* 1988;71:1268-1276.
225. Schmaier AH, Smith PM, Purdon AD, White JG, Colman RW. High molecular weight kininogen: localization in the unstimulated and activated platelet and activation by a platelet calpain(s). *Blood* 1986;67:119-130.
226. Greengard JS, Griffin JH. Receptors for high molecular weight kininogen on stimulated washed human platelets. *Biochemistry* 1984;23:6863-6869.
227. Walsh PN, Sinha D, Koshy A, Seaman FS, Bradford H. Functional characterization of platelet-bound factor XIa: retention of factor XIa activity on the platelet surface. *Blood* 1986;68:225-230.
228. Chavakis T, Boeckel N, Santoso S, Voss R, Isordia-Salas I, Pixley RA, Morgenstern E, Colman RW, Preissner KT. Inhibition of platelet adhesion and aggregation by a defined region (Gly-486-Lys-502) of high molecular weight kininogen. *J Biol Chem* 2002;277:23157-23164.
229. Chavakis T, Preissner KT. Potential pharmacological applications of the anti-thrombotic molecule high molecular weight kininogen. *Curr Vasc Pharmacol* 2003;1:59-64.

230. Saito H, Goldsmith GH Jr. Plasma thromboplastin antecedent (PTA, factor XI): a specific and sensitive radioimmunoassay. *Blood* 1977;50:377-385.
231. Thompson RE, Mandle R Jr, Kaplan AP. Association of factor XI and high molecular weight kininogen in human plasma. *J Clin Invest* 1977;60:1376-1380.
232. Lipscomb MS, Walsh PN. Human platelets and factor XI. Localization in platelet membranes of factor XI-like activity and its functional distinction from plasma factor XI. *J Clin Invest* 1979;63:1006-1014.
233. Tuszynski GP, Bevacqua SJ, Schmaier AH, Colman RW, Walsh PN. Factor XI antigen and activity in human platelets. *Blood* 1982;59:1148-1156.
234. Schiffman S, Yeh CH. Purification and characterization of platelet factor XI. *Thromb Res* 1990;60:87-97.
235. Walsh PN. The effects of collagen and kaolin on the intrinsic coagulant activity of platelets. Evidence for an alternative pathway in intrinsic coagulation not requiring factor XII. *Br J Haematol* 1972;22:393-405.
236. Schiffman S, Rapaport SI, Chong MM. Platelets and initiation of intrinsic clotting. *Br J Haematol* 1973;24:633-642.
237. Todd T, Perry D. A review of long-term prophylaxis in the rare inherited coagulation factor deficiencies. *Haemophilia* 2010;16:569-583.
238. Rapaport SI, Proctor RR, Patch MJ. The mode of inheritance of PTA deficiency: evidence for the existence of major PTA deficiency and minor PTA deficiency. *Blood* 1961;18:149-155.
239. Asakai R, Chung DW, Ratnoff OD, Davie EW. Factor XI (plasma thromboplastin antecedent) deficiency in Ashkenazi Jews is a bleeding disorder that can result from three types of point mutations. *Proc Natl Acad Sci U S A* 1989;86:7667-7671.
240. Asakai R, Chung DW, Davie EW, Seligsohn U. Factor XI deficiency in Ashkenazi Jews in Israel. *N Engl J Med* 1991;325:153-158.
241. Seligsohn U, Peretz H. Molecular genetics aspects of factor XI deficiency and Glanzmann thrombasthenia. *Haemostasis* 1994;24:81-85.
242. Leiba H, Ramot B, Many A. Heredity and coagulation studies in ten families with factor XI (plasma thromboplastin antecedent) deficiency. *Br J Haematol* 1965;11:654-665.
243. Seligsohn U. Factor XI deficiency. *Thromb Haemost* 1993;70:68-71.
244. Santoro R, Prejanò S, Iannaccaro P. Factor XI deficiency: a description of 34 cases and literature review. *Blood Coagul Fibrinolysis* 2011;22:431-435.
245. Sidi A, Seligsohn U, Jonas P. Factor XI deficiency: detection and management during urological surgery. *J Urol* 1978;119:528-530.
246. Hu CJ, Baglia FA, Mills DC, Konkle BA, Walsh PN. Tissue-specific expression of functional platelet factor XI is independent of plasma factor XI expression. *Blood* 1998;91:3800-3807.
247. Ragni MV, Sinha D, Seaman F, Lewis JH, Spero JA, Walsh PN. Comparison of bleeding tendency, factor XI coagulant activity, and factor XI antigen in 25 factor XI-deficient kindreds. *Blood* 1985;65:719-724.
248. Bolton-Maggs PH, Young Wan-Yin B, McCraw AH, Slack J, Kernoff PB. Inheritance and bleeding in factor XI deficiency. *Br J Haematol* 1988;69:521-528.
249. Baglia FA, Walsh PN. Prothrombin is a cofactor for the binding of factor XI to the platelet surface and for platelet-mediated factor XI activation by thrombin. *Biochemistry* 1998;37:2271-2281.
250. Kato A, Asakai R, Davie EW, Aoki N. Factor XI gene (F11) is located on the distal end of the long arm of human chromosome 4. *Cytogenet Cell Genet* 1989;52:77-78.
251. Gailani D, Sun MF, Sun Y. A comparison of murine and human factor XI. *Blood* 1997;90:1055-1064.
252. Clarkson K, Rosenfeld B, Fair J, Klein A, Bell W. Factor XI deficiency acquired by liver transplantation. *Ann Intern Med* 1991;115:877-879.
253. Hsu TC, Shore SK, Seshsamma T, Bagasra O, Walsh PN. Molecular cloning of platelet factor XI, an alternative splicing product of the plasma factor XI gene. *J Biol Chem* 1998;273:13787-13793.

254. Pugh RE, McVey JH, Tuddenham EG, Hancock JF. Six point mutations that cause factor XI deficiency. *Blood* 1995;85:1509-1516.
255. Meijers JC, Davie EW, Chung DW. Expression of human blood coagulation factor XI: characterization of the defect in factor XI type III deficiency. *Blood* 1992;79:1435-1440.
256. Wistinghausen B, Reischer A, Oddoux C, Ostrer H, Nardi M, Karparkin M. Severe factor XI deficiency in an Arab family associated with a novel mutation in exon 11. *Br J Haematol* 1997;99:575-577.
257. Martincic D, Zimmerman SA, Ware RE, Sun MF, Whitlock JA, Gailani D. Identification of mutations and polymorphisms in the factor XI genes of an African American family by dideoxyfingerprinting [published erratum appears in *Blood* 1999 Mar 1;93(5):1786]. *Blood* 1998;92:3309-3317.
258. Hancock JF, Wieland K, Pugh RE, et al. A molecular genetic study of factor XI deficiency. *Blood* 1991;77:1942-1948.
259. Peretz H, Zivelin A, Usher S, Seligsohn U. A 14-bp deletion (codon 554 del AAGgtaacagatg) at exon 14/intron N junction of the coagulation factor XI gene disrupts splicing and causes severe factor XI deficiency. *Hum Mutat* 1996;8:77-78.
260. Walsh PN. Factor XI. In: Colman RW, Hirsh J, Marder VJ, Clowes AW, George JN, eds. *Hemostasis and thrombosis: basic principles & clinical practice*. Philadelphia, PA: Lippincott Williams & Wilkins, 2001:191-202.
261. Seligsohn U. Factor XI deficiency in humans. *J Thromb Haemost* 2009;7 (Suppl 1):84-87.
262. Fujikawa K, Chung DW, Hendrickson LE, Davie EW. Amino acid sequence of human factor XI, a blood coagulation factor with four tandem repeats that are highly homologous with plasma prekallikrein. *Biochemistry* 1986;25:2417-2424.
263. Wiggins RC, Bouma BN, Cochrane CG, Griffin JH. Role of high-molecularweight kininogen in surface-binding and activation of coagulation Factor XI and prekallikrein. *Proc Natl Acad Sci U S A* 1977;74:4636-4640.
264. Baglia FA, Walsh PN. A binding site for thrombin in the apple 1 domain of factor XI. *J Biol Chem* 1996;271:3652-3658.
265. Baglia FA, Jameson BA, Walsh PN. Identification and chemical synthesis of a substrate-binding site for factor IX on coagulation factor XIa. *J Biol Chem* 1991;266:24190-24197.
266. Sun Y, Gailani D. Identification of a factor IX binding site on the third apple domain of activated factor XI. *J Biol Chem* 1996;271:29023-29028.
267. Sun MF, Zhao M, Gailani D. Identification of amino acids in the factor XI apple 3 domain required for activation of factor IX. *J Biol Chem* 1999;274: 36373-36378.
268. Walsh PN, Griffin JH. Contributions of human platelets to the proteolytic activation of blood coagulation factors XII and XI. *Blood* 1981;57:106-118.
269. Baglia FA, Jameson BA, Walsh PN. Identification and characterization of a binding site for platelets in the Apple 3 domain of coagulation factor XI. *J Biol Chem* 1995;270:6734-6740.
270. Baglia FA, Seaman FS, Walsh PN. The Apple 1 and Apple 4 domains of factor XI act synergistically to promote the surface-mediated activation of factor XI by factor XIIa. *Blood* 1995;85:2078-2083.
271. Ho DH, Baglia FA, Walsh PN. Factor XI binding to activated platelets is mediated by residues R(250), K(255), F(260), and Q(263) within the apple 3 domain. *Biochemistry* 2000;39:316-323.
272. Baglia FA, Jameson BA, Walsh PN. Identification and characterization of a binding site for factor XIIa in the Apple 4 domain of coagulation factor XI. *J Biol Chem* 1993;268:3838-3844.
273. Choi S, Smith S, Morrissey J. Polyphosphate is a cofactor for the activation of factor XI by thrombin. *Blood* 2011;118:6963-6970.
274. Morrissey J, Choi S, Smith S. Polyphosphate: an ancient molecule that links platelets, coagulation, and inflammation. *Blood* 2012;119:5972-5979.
275. Bouma BN, Griffin JH. Human blood coagulation factor XI. Purification, properties, and mechanism of activation by activated factor XII. *J Biol Chem* 1977;252:6432-6437.
276. Kurachi K, Davie EW. Activation of human factor XI (plasma thromboplastin antecedent) by factor XIIa (activated Hageman factor). *Biochemistry* 1977;16:5831-5839.
277. Emsley J, McEwan P, Gailani D. Structure and function of factor XI. *Blood* 2010;115:2569-2577.

278. Broze GJ Jr, Gailani D. The role of factor XI in coagulation. *Thromb Haemost* 1993;70:72-74.
279. Baglia FA, Walsh PN. Thrombin-mediated feedback activation of factor XI on the activated platelet surface is preferred over contact activation by factor XIIa or factor XIa. *J Biol Chem* 2000;275:20514-20519.
280. Walsh PN. Platelets and factor XI bypass the contact system of blood coagulation. *Thromb Haemost* 1999;82:234-242.
281. Fujikawa K, Legaz ME, Kato H, Davie EW. The mechanism of activation of bovine factor IX (Christmas factor) by bovine factor XIa (activated plasma thromboplastin antecedent). *Biochemistry* 1974;13:4508-4516.
282. DiScipio RG, Kurachi K, Davie EW. Activation of human factor IX (Christmas factor). *J Clin Invest* 1978;61:1528-1538.
283. Osterud B, Bouma BN, Griffin JH. Human blood coagulation factor IX. Purification, properties, and mechanism of activation by activated factor XI. *J Biol Chem* 1978;253:5946-5951.
284. Smith SB, Gailani D. Update on the physiology and pathology of factor IX activation by factor XIa. *Expert Rev Hematol* 2008;1:87-98.
285. Müller F, Gailani D, Renné T. Factor XI and XII as antithrombotic targets. *Curr Opin Hemato* 2011;18:349-355.
286. Heck LW, Kaplan AP. Substrates of Hageman factor. I. Isolation and characterization of human factor XI (PTA) and inhibition of the activated enzyme by alpha 1- antitrypsin. *J Exp Med* 1974;140:1615-1630.
287. Beeler DL, Marcum JA, Schiffman S, Rosenberg RD. Interaction of factor XIa and antithrombin in the presence and absence of heparin. *Blood* 1986;67:1488-1492.
288. Scott CF, Schapira M, Colman RW. Effect of heparin on the inactivation rate of human factor XIa by antithrombin-III. *Blood* 1982;60:940-947.
289. Scott CF, Schapira M, James HL, Cohen AB, Colman RW. Inactivation of factor XIa by plasma protease inhibitors: predominant role of alpha 1-protease inhibitor and protective effect of high molecular weight kininogen. *J Clin Invest* 1982;69:844-852.
290. Walsh PN, Sinha D, Kueppers F, Seaman FS, Blankstein KB. Regulation of factor XIa activity by platelets and alpha 1-protease inhibitor. *J Clin Invest* 1987;80:1578-1586.
291. Damus PS, Hicks M, Rosenberg RD. Anticoagulant action of heparin. *Nature* 1973;246:355-357.
292. Soons H, Janssen-Claessen T, Tans G, Hemker HC. Inhibition of factor XIa by antithrombin III. *Biochemistry* 1987;26:4624-4629.
293. Meijers JC, Vlooswijk RA, Bouma BN. Inhibition of human blood coagulation factor XIa by C-1 inhibitor. *Biochemistry* 1988;27:959-963.
294. Saito H, Goldsmith GH, Moroi M, Aoki N. Inhibitory spectrum of alpha 2-plasmin inhibitor. *Proc Natl Acad Sci U S A* 1979;76:2013-2017.
295. Scott CF, Colman RW. Factors influencing the acceleration of human factor XIa inactivation by antithrombin III. *Blood* 1989;73:1873-1879.
296. Rosenberg RD, Damus PS. The purification and mechanism of action of human antithrombin-heparin cofactor. *J Biol Chem* 1973;248:6490-6505.
297. Espana F, Berrettini M, Griffin JH. Purification and characterization of plasma protein C inhibitor. *Thromb Res* 1989;55:369-384.
298. Soons H, Janssen-Claessen T, Hemker HC, Tans G. The effect of platelets in the activation of human blood coagulation factor IX by factor XIa. *Blood* 1986;68:140-148.
299. Cronlund AL, Walsh PN. A low molecular weight platelet inhibitor of factor XIa: purification, characterization, and possible role in blood coagulation. *Biochemistry* 1992;31:1685-1694.
300. Bush AI, Martins RN, Rumble B, et al. The amyloid precursor protein of Alzheimer's disease is released by human platelets. *J Biol Chem* 1990;265:15977-15983.
301. Smith RP, Higuchi DA, Broze GJ Jr. Platelet coagulation factor XIa-inhibitor, a form of Alzheimer amyloid precursor protein. *Science* 1990;248:1126-1128.
302. Van Nostrand WE, Schmaier AH, Farrow JS, Cunningham DD. Protease nexin-II (amyloid beta-protein precursor): a platelet alpha-granule protein. *Science* 1990;248:745-748.

303. Zhang Y, Scandura JM, Van Nostrand WE, Walsh PN. The mechanism by which heparin promotes the inhibition of coagulation factor XIa by protease nexin-2. *J Biol Chem* 1997;272:26139-26144.
304. Dam H. Cholesterinstoffwechsel in hühnereiern und hühnchen. *Biochem Z* 1929;215:475-492.
305. Dam H. Cholesterol synthesis in the animal body. *Biochem Z* 1930;220: 158-163.
306. Dam H. Hemorrhages in chicks reared on artificial diets. A new deficiency disease. *Nature (London)* 1934;133:909-910.
307. Doisy EA, Binkley SB, Thayer SA. Vitamin K. *Chem Rev* 1941;28:477-517.
308. Owen CA, Bowie EWJ. The history of the development of oral anticoagulant drugs. In: Poller L, Hirsch J, eds. *Oral anticoagulants*. London: Arnold, 1996:1-8.
309. Magnusson S, Sottrup-Jensen L, Petersen TE, Morris HR, Dell A. Primary structure of the vitamin K-dependent part of prothrombin. *FEBS Lett* 1974;44:189-193.
310. Stenflo J, Ferlund P, Egan W, Roepstorff P. Vitamin K dependent modifications of glutamic acid residues in prothrombin. *Proc Natl Acad Sci U S A* 1974;71:2730-2733.
311. Stenflo J. Vitamin K and the biosynthesis of prothrombin. IV. Isolation of peptides containing prosthetic groups from normal prothrombin and the corresponding peptides from dicoumarol-induced prothrombin. *J Biol Chem* 1974;249:5527-5535.
312. Nelsestuen GL, Zytovicz TH, Howard JB. The mode of action of vitamin K. Identification of gamma-carboxyglutamic acid as a component of prothrombin. *J Biol Chem* 1974;249:6347-6350.
313. Kulman JD, Harris JE, Haldeman BA, Davie EW. Primary structure and tissue distribution of two novel proline-rich gamma-carboxyglutamic acid proteins. *Proc Natl Acad Sci U SA* 1997;94:9058-9062.
314. Hauschka PV, Lian JB, Cole DE, Gundberg CM. Osteocalcin and matrix Gla protein: vitamin K-dependent proteins in bone. *Physiol Rev* 1989;69:990-1047.
315. Olivera BM. Conus venom peptides, receptor and ion channel targets, and drug design: 50 million years of neuropharmacology. *Mol Biol Cell* 1997;8:2101-2109.
316. Olivera BM, Rivier J, Clark C, et al. Diversity of Conus neuropeptides. *Science* 1990;249:257-263.
317. Olivera BM, Rivier J, Scott JK, Hillyard DR, Cruz LJ. Conotoxins. *J Biol Chem* 1991;266:22067-22070.
318. Hasanbasic I, Rajotte I, Blostein M. The role of gamma-carboxylation in the anti-apoptotic function of gas6. *J Thromb Haemost* 2005;3:2790-2797.
319. Leytus SP, Foster DC, Kurachi K, Davie EW. Gene for human factor X: a blood coagulation factor whose gene organization is essentially identical with that of factor IX and protein C. *Biochemistry* 1986;25:5098-5102.
320. Patthy L. Evolutionary assembly of blood coagulation proteins. *Semin Thromb Hemostas* 1990;16:245-259.
321. Stenberg LM, Brown MA, Nilsson E, Ljungberg O, Stenflo J. A functional prothrombin gene product is synthesized by human kidney cells. *Biochem Biophys Res Commun* 2001;280:1036-1041.
322. Sacchi E, Tagliabue L, Scoglio R, et al. Plasma factor VII levels are influenced by a polymorphism in the promoter region of the FVII gene. *Blood Coagul Fibrinolysis* 1996;7:114-117.
323. Spek CA, Koster T, Rosendaal FR, Bertina RM, Reitsma PH. Genotypic variation in the promoter region of the protein C gene is associated with plasma protein C levels and thrombotic risk. *Arterioscler Thromb Vasc Biol* 1995;15:214-218.
324. Green F, Kelleher C, Wilkes H, Temple A, Meade T, Humphries S. A common genetic polymorphism associated with lower coagulation factor VII levels in healthy individuals. *Arterioscler Thromb* 1991;11:540-546.
325. Burns P, Hoffman CJ, Katz JP, Miller RH, Lawson WE, Hultin MB. Vitamin K-dependent clotting factors are elevated in young adults who have close relatives with ischemic heart disease. *J Lab Clin Med* 1993;122:720-727.
326. Hofmann R, Lehmer A, Buresch M, Hartung R, Ulm K. Clinical relevance of urokinase plasminogen activator, its receptor, and its inhibitor in patients with renal cell carcinoma. *Cancer* 1996;78:487-492.
327. Bladbjerg EM, Tholstrup T, Marckmann P, Sandstrom B, Jespersen J. Dietary changes in fasting levels of factor VII coagulant activity (FVII:C) are accompanied by changes in factor VII protein and other vitamin K-dependent proteins. *Thromb Haemost* 1995;73:239-242.

328. Mukherjee M, Dawson G, Sembhi K, Kakkar VV. Triglyceride dependence of factor VII coagulant activity in deep venous thrombosis. *Thromb Haemost* 1996;76:500-501.
329. Talstad I, Gamst ON. Warfarin resistance due to malabsorption. *J Intern Med* 1994;236:465-467.
330. O'Reilly RA. Warfarin metabolism and drug-drug interactions. *Adv Exp Med Biol* 1987;214:205-212.
331. Lee CJ, Chandrasekaran V, Wu S, Duke RE, Pedersen LG. Recent estimates of the structure of the factor VIIa (FVIIa)/tissue factor (TF) and factor Xa (FXa) ternary complex. *Thromb Res* 2010;125(Suppl 1):S7-S10. S0049-3848(10)00075-7 [pii]. doi:10.1016/j.thromres.2010.01.022.
332. Lee CJ, Lin P, Chandrasekaran V, et al. Proposed structural models of human factor Va and prothrombinase. *J Thromb Haemost* 2008;6:83-89. JTH2821 [pii]. doi:10.1111/j.1538-7836.2007.02821.x.
333. Bilik R, Superina RA, Poon AO. Coagulation plasma factor levels are early indicators of graft nonfunction following liver transplantation in children. *J Pediatr Surg* 1992;27:302-306.
334. Bilik R, Yellen M, Superina RA. Surgical complications in children after liver transplantation. *J Pediatr Surg* 1992;27:1371-1375.
335. Casella JF, Lewis JH, Bontempo FA, Zitelli BJ, Markel H, Starzl TE. Successful treatment of homozygous protein C deficiency by hepatic transplantation [published erratum appears in *Lancet* 1988 May 28;1(8596):1238]. *Lancet* 1988;1:435-438.
336. Cransac M, Carles J, Bernard PH, et al. Heterozygous protein C deficiency and dysfibrinogenemia acquired by liver transplantation. *Transpl Int* 1995;8:307-311.
337. Stenflo J, Fernlund P. Beta-hydroxyaspartic acid in vitamin K-dependent plasma proteins from scorbutic and warfarin-treated guinea pigs. *FEBS Lett* 1984;168:287-292.
338. Gronke RS, VanDusen WJ, Garsky VM, et al. Aspartyl beta-hydroxylase: in vitro hydroxylation of a synthetic peptide based on the structure of the first growth factor-like domain of human factor IX. *Proc Natl Acad Sci U S A* 1989;86:3609-3613.
339. Bristol JA, Ratcliffe JV, Roth DA, Jacobs MA, Furie BC, Furie B. Biosynthesis of prothrombin: intracellular localization of the vitamin K-dependent carboxylase and the sites of gamma-carboxylation. *Blood* 1996;88:2585-2593.
340. Wallin R, Stanton C, Hutson SM. Intracellular maturation of the gammacarboxyglutamic acid (Gla) region in prothrombin coincides with release of the propeptide. *Biochem J* 1993;291 (Pt 3):723-727.
341. Wasley LC, Rehemtulla A, Bristol JA, Kaufman RJ. PACE/furin can process the vitamin K-dependent pro-factor IX precursor within the secretory pathway. *J Biol Chem* 1993;268:8458-8465.
342. Drews R, Paleyanda RK, Lee TK, et al. Proteolytic maturation of protein C upon engineering the mouse mammary gland to express furin. *Proc Natl Acad Sci U S A* 1995;92:10462-10466.
343. Foster DC, Holly RD, Sprecher CA, Walker KM, Kumar AA. Endoproteolytic processing of the human protein C precursor by the yeast Kex2 endopeptidase coexpressed in mammalian cells. *Biochemistry* 1991;30:367-372.
344. Wu SM, Cheung WF, Frazier D, Stafford DW. Cloning and expression of the cDNA for human gamma-glutamyl carboxylase. *Science* 1991;254:1634-1636.
345. Suttie JW. Vitamin K-dependent carboxylase. *Annu Rev Biochem* 1985;54:459-477.
346. Li T, Chang CY, Jin DY, Lin PJ, Khvorova A, Stafford DW. Identification of the gene for vitamin K epoxide reductase. *Nature* 2004;427:541-544.
347. Gardill SL, Suttie JW. Vitamin K epoxide and quinone reductase activities. Evidence for reduction by a common enzyme. *Biochem Pharmacol* 1990;40:1055-1061.
348. Furie B, Furie BC. Molecular basis of vitamin K-dependent gamma-carboxylation. *Blood* 1990;75:1753-1762.
349. Cosgriff SW. The effectiveness of an oral vitamin K in controlling excessive hypothermia during anticoagulant therapy. *Ann Intern Med* 1956;45:14-22.
350. Hirsh J. Optimal intensity and monitoring warfarin. *Am J Cardiol* 1995;75:39B-42B.
351. Hirsh J, Dalen JE, Deykin D, Poller L, Bussey H. Oral anticoagulants. Mechanism of action, clinical effectiveness, and optimal therapeutic range. *Chest* 1995;108:231S-246S.

352. Danziger J. Vitamin K-dependent proteins, warfarin, and vascular calcification. *Clin J Am Soc Nephrol* 2008;3:1504-1510.
353. Chatrou M, Winckers K, Hackeng T, Reutelingsperger C, Schurgers L. Vascular calcification: the price to pay for anticoagulation therapy with vitamin K-antagonists. *Blood Rev* 2012;26:155-166.
354. Drakenberg T, Fernlund P, Roepstorff P, Stenflo J. beta-Hydroxyaspartic acid in vitamin K-dependent protein C. *Proc Natl Acad Sci U S A* 1983;80:1802-1806.
355. McMullen BA, Fujikawa K, Kisiel W, et al. Complete amino acid sequence of the light chain of human blood coagulation factor X: evidence for identification of residue 63 as beta- hydroxyaspartic acid. *Biochemistry* 1983;22:2875-2884.
356. Stenflo J, Lundwall A, Dahlback B. beta-Hydroxyasparagine in domains homologous to the epidermal growth factor precursor in vitamin K-dependent protein S. *Proc Natl Acad Sci U S A* 1987;84:368-372.
357. Stenflo J, Ohlin AK, Owen WG, Schneider WJ. beta-Hydroxyaspartic acid or beta-hydroxyasparagine in bovine low density lipoprotein receptor and in bovine thrombomodulin. *J Biol Chem* 1988;263:21-24.
358. Sunnerhagen MS, Persson E, Dahlqvist I, et al. The effect of aspartate hydroxylation on calcium binding to epidermal growth factor-like modules in coagulation factors IX and X. *J Biol Chem* 1993;268:23339-23344.
359. Derian CK, VanDusen W, Przysiecki CT, et al. Inhibitors of 2-ketoglutaratedependent dioxygenases block aspartyl beta-hydroxylation of recombinant human factor IX in several mammalian expression systems. *J Biol Chem* 1989;264:6615-6618.
360. Nelson RM, VanDusen WJ, Friedman PA, Long GL. beta-Hydroxyaspartic acid and beta-hydroxyasparagine residues in recombinant human protein S are not required for anticoagulant cofactor activity or for binding to C4b-binding protein. *J Biol Chem* 1991;266:20586-20589.
361. Miletich JP, Broze GJ Jr. Beta protein C is not glycosylated at asparagine 329. The rate of translation may influence the frequency of usage at asparagine-X-cysteine sites. *J Biol Chem* 1990;265:11397-11404.
362. Grinnell BW, Hermann R, Yan SB. Human protein C inhibits selectin-mediated cell adhesion: role of unique fucosylated oligosaccharide. *Glycobiology* 1994;4:221-225.
363. Baker ME, French FS, Joseph DR. Vitamin K-dependent protein S is similar to rat androgen-binding protein. *Biochem J* 1987;243:293-296.
364. Fujimaki K, Yamazaki T, Taniwaki M, Ichinose A. The gene for human protein Z is localized to chromosome 13 at band q34 and is coded by eight regular exons and one alternative exon. *Biochemistry* 1998;37:6838-6846.
365. Brenner B, Tavori S, Zivelin A, et al. Hereditary deficiency of all vitamin K-dependent procoagulants and anticoagulants. *Br J Haematol* 1990;75:537-542.
366. Boneh A, Bar-Ziv J. Hereditary deficiency of vitamin K-dependent coagulation factors with skeletal abnormalities. *Am J Med Genet* 1996;65:241-243.
367. Spronk HM, Farah RA, Buchanan GR, Vermeer C, Soute BA. Novel mutation in the gamma-glutamyl carboxylase gene resulting in congenital combined deficiency of all vitamin K-dependent blood coagulation factors. *Blood* 2000;96:3650-3652.
368. Brenner B, Sanchez-Vega B, Wu SM, Lanir N, Stafford DW, Solera J. A missense mutation in gamma-glutamyl carboxylase gene causes combined deficiency of all vitamin K-dependent blood coagulation factors. *Blood* 1998;92:4554-4559.
369. Soriano-Garcia M, Park CH, Tulinsky A, Ravichandran KG, Skrzypczak-Jankun E. Structure of Ca²⁺ prothrombin fragment 1 including the conformation of the Gla domain. *Biochemistry* 1989;28:6805-6810.
370. Tulinsky A, Park CH, Skrzypczak-Jankun E. Structure of prothrombin fragment 1 refined at 2.8 Å resolution. *J Mol Biol* 1988;202:885-901.
371. Park CH, Tulinsky A. Three-dimensional structure of the kringle sequence: structure of prothrombin fragment 1. *Biochemistry* 1986;25:3977-3982.
372. Soriano-Garcia M, Padmanabhan K, de Vos AM, Tulinsky A. The Ca₂⁺ ion and membrane binding structure of the Gla domain of Ca- prothrombin fragment 1. *Biochemistry* 1992;31:2554-2566.

373. Bode W, Mayr I, Baumann U, Huber R, Stone SR, Hofsteenge J. The refined 1.9 Å crystal structure of human alpha-thrombin: interaction with D-Phe-Pro-Arg chloromethylketone and significance of the Tyr-Pro-Pro-Trp insertion segment. *EMBO J* 1989;8:3467-3475.
374. Rydel TJ, Ravichandran KG, Tulinsky A, et al. The structure of a complex of recombinant hirudin and human alpha-thrombin. *Science* 1990;249:277-280.
375. Banner DW, Hadvary P. Crystallographic analysis at 3.0-Å resolution of the binding to human thrombin of four active site-directed inhibitors. *J Biol Chem* 1991;266:20085-20093.
376. Martin PD, Robertson W, Turk D, Huber R, Bode W, Edwards BF. The structure of residues 7-16 of the A alpha-chain of human fibrinogen bound to bovine thrombin at 2.3-Å resolution. *J Biol Chem* 1992;267:7911-7920.
377. Vitali J, Martin PD, Malkowski MG, et al. The structure of a complex of bovine alpha-thrombin and recombinant hirudin at 2.8-Å resolution. *J Biol Chem* 1992;267:17670-17678.
378. Padmanabhan K, Padmanabhan KP, Tulinsky A, et al. Structure of human des(1-45) factor Xa at 2.2 Å resolution. *J Mol Biol* 1993;232:947-966.
379. Brandstetter H, Bauer M, Huber R, Lollar P, Bode W. X-ray structure of clotting factor IXa: active site and module structure related to Xase activity and hemophilia B. *Proc Natl Acad Sci USA* 1995;92:9796-9800.
380. Kembal-Cook G, Johnson DJ, Tuddenham EG, Harlos K. Crystal structure of active site-inhibited human coagulation factor VIIa (des-Gla). *J Struct Biol* 1999;127:213-223.
381. Sichler K, Banner DW, D'Arcy A, et al. Crystal structures of uninhibited factor VIIa link its cofactor and substrate-assisted activation to specific interactions. *J Mol Biol* 2002;322:591-603.
382. Mather T, Oganessyan V, Hof P, et al. The 2.8 Å crystal structure of Glu domainless activated protein C. *EMBO J* 1996;15:6822-6831.
383. Stafford DW. The vitamin K cycle. *J Thromb Haemost* 2005;3:1873-1878.
384. Nelsestuen GL, Shah AM, Harvey SB. Vitamin K-dependent proteins. *Vitam Horm* 2000;58:355-389.
385. Stenflo J. Contributions of Gla and EGF-like domains to the function of vitamin K-dependent coagulation factors. *Crit Rev Eukaryot Gene Expr* 1999;9:59-88.
386. Sunnerhagen M, Olah GA, Stenflo J, Forsen S, Drakenberg T, Trehwella J. The relative orientation of Gla and EGF domains in coagulation factor X is altered by Ca_2^+ binding to the first EGF domain. A combined NMR- small angle X-ray scattering study. *Biochemistry* 1996;35:11547-11559.
387. Prendergast FG, Mann KG. Differentiation of metal ion-induced transitions of prothrombin fragment 1. *J Biol Chem* 1977;252:840-850.
388. Gerads I, Govers-Riemslog JW, Tans G, Zwaal RF, Rosing J. Prothrombin activation on membranes with anionic lipids containing phosphate, sulfate, and/or carboxyl groups. *Biochemistry* 1990;29:7967-7974.
389. Pei G, Powers DD, Lentz BR. Specific contribution of different phospholipid surfaces to the activation of prothrombin by the fully assembled prothrombinase. *J Biol Chem* 1993;268:3226-3233.
390. McDonald JF, Shah AM, Schwalbe RA, Kisiel W, Dahlback B, Nelsestuen GL. Comparison of naturally occurring vitamin K-dependent proteins: correlation of amino acid sequences and membrane binding properties suggests a membrane contact site. *Biochemistry* 1997;36:5120-5127.
391. Kung C, Hayes E, Mann KG. A membrane-mediated catalytic event in prothrombin activation. *J Biol Chem* 1994;269:25838-25848.
392. Nelsestuen GL, Kisiel W, Di Scipio RG. Interaction of vitamin K dependent proteins with membranes. *Biochemistry* 1978;17:2134-2138.
393. Schwalbe RA, Ryan J, Stern DM, Kisiel W, Dahlback B, Nelsestuen GL. Protein structural requirements and properties of membrane binding by gammacarboxyglutamic acid-containing plasma proteins and peptides. *J Biol Chem* 1989;264:20288-20296.
394. Arni RK, Padmanabhan K, Padmanabhan KP, Wu TP, Tulinsky A. Structure of the non-covalent complex of prothrombin kringle 2 with PPACK-thrombin. *Chem Phys Lipids* 1994;67-68:59-66.

395. Shikamoto Y, Morita T, Fujimoto Z, Mizuno H. Crystal structure of Mg_2^+ - and Ca_2^+ -bound Gla domain of factor IX complexed with binding protein. *J Biol Chem* 2003;278:24090-24094.
396. Huang M, Rigby AC, Morelli X, et al. Structural basis of membrane binding by Gla domains of vitamin K-dependent proteins. *Nat Struct Biol* 2003;10:751-756.
397. Sunnerhagen M, Forsen S, Hoffren AM, Drakenberg T, Teleman O, Stenflo J. Structure of the Ca_2^+ -free Gla domain sheds light on membrane binding of blood coagulation proteins. *Nat Struct Biol* 1995;2:504-509.
398. Christiansen WT, Jalbert LR, Robertson RM, Jhingan A, Prorok M, Castellino FJ. Hydrophobic amino acid residues of human anticoagulation protein C that contribute to its functional binding to phospholipid Vesicles. *Biochemistry* 1995;34:10376-10382.
399. Jalbert LR, Chan JC, Christiansen WT, Castellino FJ. The hydrophobic nature of residue-5 of human protein C is a major determinant of its functional interactions with acidic phospholipid vesicles. *Biochemistry* 1996;35:7093-7099.
400. Zhang L, Castellino FJ. The binding energy of human coagulation protein C to acidic phospholipid vesicles contains a major contribution from leucine 5 in the gamma-carboxyglutamic acid domain. *J Biol Chem* 1994;269:3590-3595.
401. Doolittle RF, Feng DF, Johnson MS. Computer-based characterization of epidermal growth factor precursor. *Nature* 1984;307:558-560.
402. Ohlin AK, Landes G, Bourdon P, Oppenheimer C, Wydro R, Stenflo J. Betahydroxyaspartic acid in the first epidermal growth factor-like domain of protein C. Its role in Ca_2^+ binding and biological activity. *J Biol Chem* 1988;263:19240-19248.
403. Sugo T, Bjork I, Holmgren A, Stenflo J. Calcium-binding properties of bovine factor X lacking the gamma-carboxyglutamic acid-containing region. *J Biol Chem* 1984;259:5705-5710.
404. Sugo T, Fernlund P, Stenflo J. erythro-beta-Hydroxyaspartic acid in bovine factor IX and factor X. *FEBS Lett* 1984;165:102-106.
405. Baron M, Norman DG, Harvey TS, et al. The three-dimensional structure of the first EGF-like module of human factor IX: comparison with EGF and TGFalpha. *Protein Sci* 1992;1:81-90.
406. Ullner M, Selander M, Persson E, Stenflo J, Drakenberg T, Teleman O. Three-dimensional structure of the apo form of the N-terminal EGF-like module of blood coagulation factor X as determined by NMR spectroscopy and simulated folding. *Biochemistry* 1992;31:5974-5983.
407. Montelione GT, Wuthrich K, Burgess AW, et al. Solution structure of murine epidermal growth factor determined by NMR spectroscopy and refined by energy minimization with restraints. *Biochemistry* 1992;31:236-249.
408. Selander-Sunnerhagen M, Ullner M, Persson E, Teleman O, Stenflo J, Drakenberg T. How an epidermal growth factor (EGF)-like domain binds calcium. High resolution NMR structure of the calcium form of the NH₂-terminal EGF-like domain in coagulation factor X. *J Biol Chem* 1992;267:19642-19649.
409. Muranyi A, Finn BE, Gippert GP, Forsen S, Stenflo J, Drakenberg T. Solution structure of the N-terminal EGF-like domain from human factor VII. *Biochemistry* 1998;37:10605-10615.
410. Hopfner KP, Lang A, Karcher A, et al. Coagulation factor IXa: the relaxed conformation of Tyr99 blocks substrate binding. *Structure* 1999;7:989-996.
411. Campbell ID, Downing AK. Building protein structure and function from modular units. *Trends Biotechnol* 1994;12:168-172.
412. Stenflo J, Stenberg Y, Muranyi A. Calcium-binding EGF-like modules in coagulation proteinases: function of the calcium ion in module interactions. *Biochim Biophys Acta* 2000;1477:51-63.
413. Giannelli F, Green PM, Sommer SS, et al. Haemophilia B: database of point mutations and short additions and deletions—eighth edition. *Nucleic Acids Res* 1998;26:265-268.
414. Husten EJ, Esmon CT, Johnson AE. The active site of blood coagulation factor Xa. Its distance from the phospholipid surface and its conformational sensitivity to components of the prothrombinase complex. *J Biol Chem* 1987;262:12953-12961.
415. Kelly CR, Dickinson CD, Ruf W. Ca_2^+ binding to the first epidermal growth factor module of coagulation factor VIIa is important for cofactor interaction and proteolytic function. *J Biol Chem* 1997;272:17467-17472.

416. Rand MD, Lindblom A, Carlson J, Villoutreix BO, Stenflo J. Calcium binding to tandem repeats of EGF-like modules. Expression and characterization of the EGF-like modules of human Notch-1 implicated in receptor-ligand interactions. *Protein Sci* 1997;6:2059-2071.
417. Handford P, Downing AK, Rao Z, Hewett DR, Sykes BC, Kieley CM. The calcium binding properties and molecular organization of epidermal growth factor-like domains in human fibrillin-1. *J Biol Chem* 1995;270: 6751-6756.
418. Bajaj SP, Rapaport SI, Brown SF. Isolation and characterization of human factor VII. Activation of factor VII by factor Xa. *J Biol Chem* 1981;256:253-259.
419. Fair DS. Quantitation of factor VII in the plasma of normal and warfarin-treated individuals by radioimmunoassay. *Blood* 1983;62:784-791.
420. Rivard GE, Kovac I, Kunschak M, Thone P. Clinical study of recovery and half-life of vapor-heated factor VII concentrate. *Transfusion* 1994;34:975-979.
421. Seligsohn U, Kasper CK, Osterud B, Rapaport SI. Activated factor VII: presence in factor IX concentrates and persistence in the circulation after infusion. *Blood* 1979;53:828-837.
422. Connelly JB, Roderick PJ, Cooper JA, Meade TW, Miller GJ. Positive association between self-reported fatty food consumption and factor VII coagulant activity, a risk factor for coronary heart disease, in 4246 middle-aged men. *Thromb Haemost* 1993;70:250-252.
423. Giansily-Blaizot M, Aguilar-Martinez P, Schved JF. Genotypic heterogeneity may explain phenotypic variations in inherited factor VII deficiency. *Haematologica* 2002;87:328-329.
424. Iannello S, Prestipino M, Belfiore F. Genetic deficiency of factor VII and hemorrhagic diathesis. A case report and literature review. *Panminerva Med* 1998;40:226-238.
425. Ragni MV, Lewis JH, Spero JA, Hasiba U. Factor VII deficiency. *Am J Hematol* 1981;10:79-88.
426. Triplett DA, Brandt JT, Batard MA, Dixon JL, Fair DS. Hereditary factor VII deficiency: heterogeneity defined by combined functional and immunochemical analysis. *Blood* 1985;66:1284-1287.
427. Baribeau G. [Congenital hypoproconvertinemia]. *Union Med Can* 1971;100: 240-247.
428. Carew JA, Pollak ES, High KA, Bauer KA. Severe factor VII deficiency due to a mutation disrupting an Sp1 binding site in the factor VII promoter. *Blood* 1998;92:1639-1645.
429. Boyer C, Wolf M, Rothschild C, et al. An enzyme immunoassay (ELISA) for the quantitation of human factor VII. *Thromb Haemost* 1986;56:250-255.
430. Lechler E. Use of prothrombin complex concentrates for prophylaxis and treatment of bleeding episodes in patients with hereditary deficiency of prothrombin, factor VII, factor X, protein C protein S, or protein Z. *Thromb Res* 1999;95:S39-S50.
431. Cohen LJ, McWilliams NB, Neuberg R, et al. Prophylaxis and therapy with factor VII concentrate (human) immuno, vapor heated in patients with congenital factor VII deficiency: a summary of case reports. *Am J Hematol* 1995;50:269-276.
432. Levi D, Pefkarou A, Fort JA, DeFaria W, Tzakis AG. Liver transplantation for factor VII deficiency. *Transplantation* 2001;72:1836-1837.
433. Berrettini M, Mariani G, Schiavoni M, et al. Pharmacokinetic evaluation of recombinant, activated factor VII in patients with inherited factor VII deficiency. *Haematologica* 2001;86:640-645.
434. Eskandari N, Feldman N, Greenspoon JS. Factor VII deficiency in pregnancy treated with recombinant factor VIIa. *Obstet Gynecol* 2002;99:935-937.
435. Hunault M, Bauer KA. Recombinant factor VIIa for the treatment of congenital factor VII deficiency. *Semin Thromb Hemost* 2000;26:401-405.
436. Lusher JM, Roberts HR, Davignon G, et al. A randomized, double-blind comparison of two dosage levels of recombinant factor VIIa in the treatment of joint, muscle and mucocutaneous haemorrhages in persons with haemophilia A and B, with and without inhibitors. rFVIIa Study Group. *Haemophilia* 1998;4:790-798.
437. Shapiro AD, Gilchrist GS, Hoots WK, Cooper HA, Gastineau DA. Prospective, randomised trial of two doses of rFVIIa (NovoSeven) in haemophilia patients with inhibitors undergoing surgery. *Thromb Haemost* 1998;80:773-778.

438. Shapiro AD. Recombinant factor VIIa in the treatment of bleeding in hemophilic children with inhibitors. *Semin Thromb Hemost* 2000;26:413-419.
439. Negrier C, Hay CR. The treatment of bleeding in hemophilic patients with inhibitors with recombinant factor VIIa. *Semin Thromb Hemost* 2000;26:407-412.
440. Ingerslev J. Efficacy and safety of recombinant factor VIIa in the prophylaxis of bleeding in various surgical procedures in hemophilic patients with factor VIII and factor IX inhibitors. *Semin Thromb Hemost* 2000;26:425-432.
441. Science JMECFCDaC. Utilization and clinical data on in-hospital, off-label uses of recombinant factor VIIa. Comparative effectiveness review summary guides for clinicians 2010.
442. Hedner U. Recombinant activated factor VII as a universal haemostatic agent. *Blood Coagul Fibrinolysis* 1998;9(Suppl 1):S147-S152.
443. van 't Veer C, Mann KG. The regulation of the factor VII-dependent coagulation pathway: rationale for the effectiveness of recombinant factor VIIa in refractory bleeding disorders. *Semin Thromb Hemost* 2000;26:367-372.
444. Monroe DM, Hoffman M, Oliver JA, Roberts HR. Platelet activity of high-dose factor VIIa is independent of tissue factor. *Br J Haematol* 1997;99:542-547.
445. Hoffman M, Monroe DM III, Roberts HR. Activated factor VII activates factors IX and X on the surface of activated platelets: thoughts on the mechanism of action of high-dose activated factor VII. *Blood Coagul Fibrinolysis* 1998;9(Suppl 1):S61-S65.
446. Butenas S, Brummel KE, Branda RF, Paradis SG, Mann KG. Mechanism of factor VIIa-dependent coagulation in hemophilia blood. *Blood* 2002;99:923-930.
447. Borensztajn K, Chafa O, Alhenc-Gelas M, et al. Characterization of two novel splice site mutations in human factor VII gene causing severe plasma factor VII deficiency and bleeding diathesis. *Br J Haematol* 2002;117:168-171.
448. Carew JA, Pollak ES, Lopaciuk S, Bauer KA. A new mutation in the HNF4 binding region of the factor VII promoter in a patient with severe factor VII deficiency. *Blood* 2000;96:4370-4372.
449. Hunault M, Arbini AA, Carew JA, Peyvandi F, Bauer KA. Characterization of two naturally occurring mutations in the second epidermal growth factor-like domain of factor VII. *Blood* 1999;93:1237-1244.
450. Hunault M, Arbini AA, Carew JA, Bauer KA. Mechanism underlying factor VII deficiency in Jewish populations with the Ala244Val mutation. *Br J Haematol* 1999;105:1101-1108.
451. Takamiya O, Seta M, Tanaka K, Ishida F. Human factor VII deficiency caused by S339C mutation located adjacent to the specificity pocket of the catalytic domain. *Clin Lab Haematol* 2002;24:233-238.
452. McVey JH, Boswell E, Mumford AD, Kemball-Cook G, Tuddenham EG. Factor VII deficiency and the FVII mutation database. *Hum Mutat* 2001;17:3-17.
453. Aasrum M, Prydz H. Gene targeting of tissue factor, factor X, and factor VII in mice: their involvement in embryonic development. *Biochemistry (Mosc)* 2002;67:25-32.
454. Rosen ED, Chan JC, Idusogie E, et al. Mice lacking factor VII develop normally but suffer fatal perinatal bleeding. *Nature* 1997;390:290-294.
455. de Grouchy J, Dautzenberg MD, Turleau C, Beguin S, Chavin-Colin F. Regional mapping of clotting factors VII and X to 13q34. Expression of factor VII through chromosome 8. *Hum Genet* 1984;66:230-233.
456. O'Hara PJ, Grant FJ, Haldeman BA, et al. Nucleotide sequence of the gene coding for human factor VII, a vitamin K-dependent protein participating in blood coagulation. *Proc Natl Acad Sci U S A* 1987;84:5158-5162.
457. Gilgenkrantz S, Briquel ME, Andre E, et al. Structural genes of coagulation factors VII and X located on 13q34. *Ann Genet* 1986;29:32-35.
458. Marder VJ, Shulman NR. Clinical aspects of the congenital factor VII deficiency. *Am J Med* 1964;37:182.
459. Greenberg D, Miao CH, Ho WT, Chung DW, Davie EW. Liver-specific expression of the human factor VII gene. *Proc Natl Acad Sci U S A* 1995;92: 12347-12351.
460. Pollak ES, Hung HL, Godin W, Overton GC, High KA. Functional characterization of the human factor VII 5'-flanking region. *J Biol Chem* 1996;271: 1738-47.

461. Wilcox JN, Noguchi S, Casanova J. Extrahepatic synthesis of factor VII in human atherosclerotic vessels. *Arterioscler Thromb Vasc Biol* 2003;23: 136-41.
462. Erdmann D, Heim J. Orphan nuclear receptor HNF-4 binds to the human coagulation factor VII promoter. *J Biol Chem* 1995;270:22988-96.
463. Friso S, Lotto V, Choi S, et al. Promoter methylation in coagulation F7 gene influences plasma FVII concentrations and relates to coronary artery disease. *J Med Genet* 2012;49:192-199.
464. Berkner K, Busby S, Davie E, et al. Isolation and expression of cDNAs encoding human factor VII. *Cold Spring Harb Symp Quant Biol* 1986;51 Pt 1:531-541.
465. Hagen FS, Gray CL, O'Hara P, et al. Characterization of a cDNA coding for human factor VII. *Proc Natl Acad Sci U S A* 1986;83:2412-2416.
466. Sabharwal AK, Birktoft JJ, Gorka J, Wildgoose P, Petersen LC, Bajaj SP. High affinity Ca_2^+ -binding site in the serine protease domain of human factor VIIa and its role in tissue factor binding and development of catalytic activity. *J Biol Chem* 1995;270:15523-15530.
467. Higashi S, Nishimura H, Fujii S, Takada K, Iwanaga S. Tissue factor potentiates the factor VIIa-catalyzed hydrolysis of an ester substrate. *J Biol Chem* 1992;267:17990-17996.
468. Toomey JR, Smith KJ, Stafford DW. Localization of the human tissue factor recognition determinant of human factor VIIa. *J Biol Chem* 1991;266:19198-19202.
469. Kumar A, Fair DS. Specific molecular interaction sites on factor VII involved in factor X activation. *Eur J Biochem* 1993;217:509-518.
470. Eigenbrot C, Kirchofer D, Dennis MS, et al. The factor VII zymogen structure reveals reregistration of beta strands during activation. *Structure* 2001;9:627-636.
471. Banner DW, D'Arcy A, Chene C, et al. The crystal structure of the complex of blood coagulation factor VIIa with soluble tissue factor. *Nature* 1996;380: 41-46.
472. Wildgoose P, Nemerson Y, Hansen LL, Nielsen FE, Glazer S, Hedner U. Measurement of basal levels of factor VIIa in hemophilia A and B patients. *Blood* 1992;80:25-28.
473. Neuenschwander PF, Fiore MM, Morrissey JH. Factor VII autoactivation proceeds via interaction of distinct protease-cofactor and zymogen-cofactor complexes. Implications of a two-dimensional enzyme kinetic mechanism. *J Biol Chem* 1993;268:21489-21492.
474. Lawson JH, Krishnaswamy S, Butenas S, Mann KG. Extrinsic pathway proteolytic activity. *Methods Enzymol* 1993;222:177-195.
475. Seligsohn U, Osterud B, Brown SF, Griffin JH, Rapaport SI. Activation of human factor VII in plasma and in purified systems: roles of activated factor IX, kallikrein, and activated factor XII. *J Clin Invest* 1979;64:1056-1065.
476. Lawson JH, Butenas S, Mann KG. The evaluation of complex-dependent alterations in human factor VIIa. *J Biol Chem* 1992;267:4834-4843.
477. Kisiel W, Fujikawa K, Davie EW. Activation of bovine factor VII (proconvertin) by factor XIIa (activated Hageman factor). *Biochemistry* 1977;16:4189-4194.
478. Romisch J, Feussner A, Vermohlen S, Stohr HA. A protease isolated from human plasma activating factor VII independent of tissue factor. *Blood Coagul Fibrinolysis* 1999;10:471-479.
479. Puy C, López-Sagaseta J, Hermida J, Montes R. The endothelial cells down-regulate the generation of factor VIIa through EPCR binding. *Br J Haematol* 2010;149:111-117.
480. Persson E, Olsen O. Allosteric activation of coagulation factor VIIa. *Front Biosci* 2011;16:3156-163.
481. Vadivel K, Bajaj S. Structural biology of factor VIIa/tissue factor initiated coagulation. *Front Biosci* 2012;17:2476-2494.
482. Osterud B, Rapaport SI. Activation of factor IX by the reaction product of tissue factor and factor VII: additional pathway for initiating blood coagulation. *Proc Natl Acad Sci U S A* 1977;74:5260-5264.
483. Jesty J, Silverberg SA. Kinetics of the tissue factor-dependent activation of coagulation factors IX and X in a bovine plasma system. *J Biol Chem* 1979;254:12337-12345.

484. Morrison SA, Jesty J. Tissue factor-dependent activation of tritium-labeled factor IX and factor X in human plasma. *Blood* 1984;63:1338-1347.
485. Krishnaswamy S. The interaction of human factor VIIa with tissue factor. *J Biol Chem* 1992;267:23696-23706.
486. Silverberg SA, Nemerson Y, Zur M. Kinetics of the activation of bovine coagulation factor X by components of the extrinsic pathway. Kinetic behavior of two-chain factor VII in the presence and absence of tissue factor. *J Biol Chem* 1977;252:8481-8488.
487. Butenas S, Mann KG. Kinetics of human factor VII activation. *Biochemistry* 1996;35:1904-1910.
488. Osterud B, Miller-Andersson M, Abildgaard U, Prydz H. The effect of anti-thrombin III on the activity of the coagulation factors VII, IX and X. *Thromb Haemost* 1976;35:295-304.
489. Jesty J. The inhibition of activated bovine coagulation factors X and VII by antithrombin III. *Arch Biochem Biophys* 1978;185:165-173.
490. Rao LV, Nordfang O, Hoang AD, Pendurthi UR. Mechanism of antithrombin III inhibition of factor VIIa/tissue factor activity on cell surfaces. Comparison with tissue factor pathway inhibitor/factor Xa-induced inhibition of factor VIIa/tissue factor activity. *Blood* 1995;85:121-129.
491. Lawson JH, Butenas S, Ribarik N, Mann KG. Complex-dependent inhibition of factor VIIa by antithrombin III and heparin. *J Biol Chem* 1993;268:767-770.
492. Rao LV, Rapaport SI, Hoang AD. Binding of factor VIIa to tissue factor permits rapid antithrombin III/heparin inhibition of factor VIIa. *Blood* 1993;81:2600-2607.
493. Rapaport SI, Rao LV. Initiation and regulation of tissue factor-dependent blood coagulation. *Arterioscler Thromb* 1992;12:1111-1121.
494. Biggs R, Denson KW. The fate of prothrombin and factors VIII, IX, and X transfused to patients deficient in these factors. *Br J Haematol* 1963;9:687-688.
495. Thompson AR. Structure, function, and molecular defects of factor IX. *Blood* 1986;67:565-572.
496. Stern DM, Knitter G, Kiesel W, Nawroth PP. In vivo evidence of intravascular binding sites for coagulation factor IX. *Br J Haematol* 1987;66:227-232.
497. Wolberg AS, Stafford DW, Erie DA. Human factor IX binds to specific sites on the collagenous domain of collagen IV. *J Biol Chem* 1997;272:16717-16720.
498. Gui T, Lin HF, Jin DY, et al. Circulating and binding characteristics of wild-type factor IX and certain Gla domain mutants in vivo. *Blood* 2002;100:153-158.
499. Cheung WF, van den BJ, Kuhn K, Kjellen L, Hudson BG, Stafford DW. Identification of the endothelial cell binding site for factor IX. *Proc Natl Acad Sci USA* 1996;93:11068-11073.
500. van Hylckama V, van der Linden I, Bertina RM, Rosendaal FR. High levels of factor IX increase the risk of venous thrombosis. *Blood* 2000;95:3678-3682.
501. Thompson AR, Chen SH. Characterization of factor IX defects in hemophilia B patients. *Methods Enzymol* 1993;222:143-169.
502. Shetty S, Ghosh K, Mohanty D. Hemophilia B in a female. *Acta Haematol* 2001;106:115-117.
503. Espinos C, Lorenzo JI, Casana P, Martinez F, Aznar JA. Haemophilia B in a female caused by skewed inactivation of the normal X-chromosome. *Haematologica* 2000;85:1092-1095.
504. Boggio LN, Green D. Acquired hemophilia. *Rev Clin Exp Hematol* 2001;5: 389-404.
505. Giannelli F, Green PM, Sommer SS, et al. Haemophilia B: database of point mutations and short additions and deletions, 7th edition. *Nucleic Acids Res* 1997;25:133-135.
506. Knobe KE, Persson KE, Sjorin E, Villoutreix BO, Stenflo J, Ljung RC. Functional analysis of the EGF-like domain mutations Pro55Ser and Pro55Leu, which cause mild hemophilia B. *J Thromb Haemost* 2003;1:782-790.
507. Krepischi-Santos AC, Carneiro JD, Svartman M, Bendit I, Odone-Filho V, Vianna-Morgante AM. Deletion of the factor IX gene as a result of translocation t(X;1) in a girl affected by haemophilia B. *Br J Haematol* 2001;113: 616-620.

508. Vianello F, Belvini D, Dal Bello F, et al. Mild bleeding diathesis in a boy with combined severe haemophilia B (C(10400)→T) and heterozygous factor V Leiden. *Haemophilia* 2001;7:511-514.
509. Ljung R, Petrini P, Tengborn L, Sjorin E. Haemophilia B mutations in Sweden: a population-based study of mutational heterogeneity. *Br J Haematol* 2001;113:81-86.
510. Ivaskевичius V, Jurgutis R, Rost S, et al. Lithuanian haemophilia A and B registry comprising phenotypic and genotypic data. *Br J Haematol* 2001;112:1062-1070.
511. Chowdhury MR, Kabra M, Menon PS. Factor IX gene polymorphisms in Indian population. *Am J Hematol* 2001;68:246-248.
512. Chan V, Yam I, Yip B, et al. Single nucleotide polymorphisms of the factor IX gene for linkage analysis in the southern Chinese population. *Br J Haematol* 2000;111:540-543.
513. Lefkowitz JB, Nuss R, Haver T, Jacobson L, Thompson AR, Manco-Johnson M. Factor IX Denver, ASN 346→ASP mutation resulting in a dysfunctional protein with defective factor VIIIa interaction. *Thromb Haemost* 2001;86:862-870.
514. Wu PC, Hamaguchi N, Yu YS, Shen MC, Lin SW. Hemophilia B with mutations at glycine-48 of factor IX exhibited delayed activation by the factor VIIa-tissue factor complex. *Thromb Haemost* 2000;84:626-634.
515. Bowen DJ. Haemophilia A and haemophilia B: molecular insights. *Mol Pathol* 2002;55:127-144.
516. Goodeve A, Perry D, Cumming T, et al. Genetics of haemostasis. *Haemophilia* 2012;18(Suppl 4):73-80.
517. Roth DA, Kessler CM, Pasi KJ, Rup B, Courter SG, Tubridy KL. Human recombinant factor IX: safety and efficacy studies in hemophilia B patients previously treated with plasma-derived factor IX concentrates. *Blood* 2001;98:3600-3606.
518. Franchini M, Frattini F, Crestani S, Bonfanti C. Haemophilia B: current pharmacotherapy and future directions. *Expert Opin Pharmacother* 2012;13:2053-2063.
519. DiMichele DM, Kroner BL. The North American immune tolerance registry: practices, outcomes, outcome predictors. *Thromb Haemost* 2002;87:52-57.
520. High K. Gene-based approaches to the treatment of hemophilia. *Ann N Y Acad Sci* 2002;961:63-64.
521. Herzog RW, Hagstrom JN. Gene therapy for hereditary hematological disorders. *Am J Pharmacogenomics* 2001;1:137-144.
522. Grieger JC, Samulski RJ. Adeno-associated virus as a gene therapy vector: vector development, production and clinical applications. *Adv Biochem Eng Biotechnol* 2005;99:119-145.
523. VandenDriessche T, Thorrez L, Acosta-Sanchez A, et al. Efficacy and safety of adeno-associated viral vectors based on serotype 8 and 9 vs. lentiviral vectors for hemophilia B gene therapy. *J Thromb Haemost* 2007;5:16-24.
524. Nathwani AC, Davidoff AM, Hanawa H, et al. Sustained high-level expression of human factor IX (hFIX) after liver-targeted delivery of recombinant adeno-associated virus encoding the hFIX gene in rhesus macaques. *Blood* 2002;100:1662-1669.
525. White SJ, Page SM, Margaritis P, Brownlee GG. Long-term expression of human clotting factor IX from retrovirally transduced primary human keratinocytes in vivo. *Hum Gene Ther* 1998;9:1187-1195.
526. Cherington V, Chiang GG, McGrath CA, et al. Retroviral vector-modified bone marrow stromal cells secrete biologically active factor IX in vitro and transiently deliver therapeutic levels of human factor IX to the plasma of dogs after reinfusion. *Hum Gene Ther* 1998;9:1397-1407.
527. Ponder KP. Gene therapy for hemophilia. *Curr Opin Hematol* 2006;13: 301-307.
528. High K. Gene transfer for hemophilia: can therapeutic efficacy in large animals be safely translated to patients? *J Thromb Haemost* 2005;3:1682-1691.
529. Nathwani AC, Gray JT, McIntosh J, et al. Safe and efficient transduction of the liver after peripheral vein infusion of self-complementary AAV vector results in stable therapeutic expression of human FIX in nonhuman primates. *Blood* 2007;109:1414-1421.
530. Jiang H, Pierce GF, Ozelo MC, et al. Evidence of multiyear factor IX expression by AAV-mediated gene transfer to skeletal muscle in an individual with severe hemophilia B. *Mol Ther* 2006;14:452-455.

531. Manno CS, Pierce GF, Arruda VR, et al. Successful transduction of liver in hemophilia by AAV-factor IX and limitations imposed by the host immune response. *Nat Med* 2006;12:342-347.
532. High K. The gene therapy journey for hemophilia: are we there yet? *Blood* 2012.
533. Buckle V, Craig IW, Hunter D, Edwards JH. Fine assignment of the coagulation factor IX gene. *Cytogenet Cell Genet* 1985;40:593-594.
534. Camerino G, Grzeschik KH, Jaye M, et al. Regional localization on the human X chromosome and polymorphism of the coagulation factor IX gene (hemophilia B locus). *Proc Natl Acad Sci U S A* 1984;81:498-502.
535. Chance PF, Dyer KA, Kurachi K, et al. Regional localization of the human factor IX gene by molecular hybridization. *Hum Genet* 1983;65:207-208.
536. Anson DS, Choo KH, Rees DJ, et al. The gene structure of human anti-haemophilic factor IX. *EMBO J* 1984;3:1053-1060.
537. Choo KH, Gould KG, Rees DJ, Brownlee GG. Molecular cloning of the gene for human anti-haemophilic factor IX. *Nature* 1982;299:178-180.
538. Picketts DJ, Mueller CR, Lillicrap D. Transcriptional control of the factor IX gene: analysis of five cis-acting elements and the deleterious effects of naturally occurring hemophilia B Leyden mutations. *Blood* 1994;84:2992-3000.
539. Naka H, Brownlee GG. Transcriptional regulation of the human factor IX promoter by the orphan receptor superfamily factor, HNF4, ARP1 and COUP/Ear3. *Br J Haematol* 1996;92:231-240.
540. Graves BJ, Johnson PF, McKnight SL. Homologous recognition of a promoter domain common to the MSV LTR and the HSV tk gene. *Cell* 1986;44:565-576.
541. Paonessa G, Gounari F, Frank R, Cortese R. Purification of a NF1-like DNA-binding protein from rat liver and cloning of the corresponding cDNA. *EMBO J* 1988;7:3115-123.
542. Sladek FM, Zhong WM, Lai E, Darnell JE Jr. Liver-enriched transcription factor HNF-4 is a novel member of the steroid hormone receptor superfamily. *Genes Dev* 1990;4:2353-2365.
543. Mueller CR, Maire P, Schibler U. DBP, a liver-enriched transcriptional activator, is expressed late in ontogeny and its tissue specificity is determined posttranscriptionally. *Cell* 1990;61:279-291.
544. Kurachi S, Deyashiki Y, Takeshita J, Kurachi K. Genetic mechanisms of age regulation of human blood coagulation factor IX. *Science* 1999;285:739-743.
545. Nguyen P, Cornillet P, Potron G. A new case of severe hemophilia B Leyden, associated with a G to C mutation at position -6 of the factor IX promoter. *Am J Hematol* 1995;49:259-260.
546. Reijnen MJ, Peerlinck K, Maasdam D, Bertina RM, Reitsma PH. Hemophilia B Leyden: substitution of thymine for guanine at position -21 results in a disruption of a hepatocyte nuclear factor 4 binding site in the factor IX promoter. *Blood* 1993;82:151-158.
547. Briet E, Bertina RM, van Tilburg NH, Veltkamp JJ. Hemophilia B Leyden: a sex-linked hereditary disorder that improves after puberty. *N Engl J Med* 1982;306:788-790.
548. Briet E, Wijnands MC, Veltkamp JJ. The prophylactic treatment of hemophilia B Leyden with anabolic steroids. *Ann Intern Med* 1985;103:225-226.
549. Brady JN, Notley C, Cameron C, Lillicrap D. Androgen effects on factor IX expression: in-vitro and in-vivo studies in mice. *Br J Haematol* 1998;101:273-279.
550. Kurachi K, Davie EW. Isolation and characterization of a cDNA coding for human factor IX. *Proc Natl Acad Sci U S A* 1982;79:6461-6464.
551. Harris RJ, van Halbeek H, Glushka J, et al. Identification and structural analysis of the tetrasaccharide NeuAc alpha(2→6)Gal beta(1→4)GlcNAc beta(1→3) Fuc alpha 1→O-linked to serine 61 of human factor IX. *Biochemistry* 1993;32:6539-6547.
552. Agarwala KL, Kawabata S, Takao T, et al. Activation peptide of human factor IX has oligosaccharides O-glycosidically linked to threonine residues at 159 and 169. *Biochemistry* 1994;33:5167-5171.

553. Nishimura H, Takao T, Hase S, Shimonishi Y, Iwanaga S. Human factor IX has a tetrasaccharide O-glycosidically linked to serine 61 through the fucose residue. *J Biol Chem* 1992;267:17520-17525.
554. Kuraya N, Omichi K, Nishimura H, Iwanaga S, Hase S. Structural analysis of O-linked sugar chains in human blood clotting factor IX. *J Biochem (Tokyo)* 1993;114:763-765.
555. Rao Z, Handford P, Mayhew M, Knott V, Brownlee GG, Stuart D. The structure of a Ca_2^+ -binding epidermal growth factor-like domain: its role in protein-protein interactions. *Cell* 1995;82:131-141.
556. Celie PH, Lenting PJ, Mertens K. Hydrophobic contact between the two epidermal growth factor-like domains of blood coagulation factor IX contributes to enzymatic activity. *J Biol Chem* 2000;275:229-234.
557. Christophe OD, Lenting PJ, Kolkman JA, Brownlee GG, Mertens K. Blood coagulation factor IX residues Glu78 and Arg94 provide a link between both epidermal growth factor-like domains that is crucial in the interaction with factor VIII light chain. *J Biol Chem* 1998;273:222-227.
558. Braunstein KM, Noyes CM, Griffith MJ, Lundblad RL, Roberts HR. Characterization of the defect in activation of factor IX Chapel Hill by human factor XIa. *J Clin Invest* 1981;68:1420-1426.
559. Griffith MJ, Breitzkreutz L, Trapp H, et al. Characterization of the clotting activities of structurally different forms of activated factor IX. Enzymatic properties of normal human factor IXa alpha, factor IXa beta, and activated factor IX Chapel Hill. *J Clin Invest* 1985;75:4-10.
560. Jackson CM, Nemerson Y. Blood coagulation. *Annu Rev Biochem* 1980;49: 765-811.
561. Baglia FA, Sinha D, Walsh PN. Functional domains in the heavy-chain region of factor XI: a high molecular weight kininogen-binding site and a substrate-binding site for factor IX. *Blood* 1989;74:244-251.
562. Kurachi K, Fujikawa K, Schmer G, Davie EW. Inhibition of bovine factor IXa and factor Xbeta by antithrombin III. *Biochemistry* 1976;15:373-377.
563. Geng Y, Verhamme I, Messer A, et al. A sequential mechanism for exosite-mediated factor IX activation by factor XIa. *J Biol Chem* 2012.
564. Lenting PJ, ter Maat H, Clijsters PP, Donath MJ, van Mourik JA, Mertens K. Cleavage at arginine 145 in human blood coagulation factor IX converts the zymogen into a factor VIII binding enzyme. *J Biol Chem* 1995;270: 14884-14890.
565. Noyes CM, Griffith MJ, Roberts HR, Lundblad RL. Identification of the molecular defect in factor IX Chapel Hill: substitution of histidine for arginine at position 145. *Proc Natl Acad Sci U S A* 1983;80:4200-4202.
566. Giannelli F, Green PM, High KA, et al. Haemophilia B: database of point mutations and short additions and deletions—fourth edition, 1993. *Nucleic Acids Res* 1993;21:3075-3087.
567. Hockin MF, Jones KC, Everse SJ, Mann KG. A model for the stoichiometric regulation of blood coagulation. *J Biol Chem* 2002;277:18322-18333.
568. Cawthorn KM, van 't Veer C, Lock JB, DiLorenzo ME, Branda RF, Mann KG. Blood coagulation in hemophilia A and hemophilia C. *Blood* 1998;91:4581-4592.
569. Brummel KE, Paradis SG, Butenas S, Mann KG. Thrombin functions during tissue factor-induced blood coagulation. *Blood* 2002;100:148-152.
570. Rsoenberg J, McKenna PW, Rosenberg RD. Inhibition of human factor IXa by human antithrombin. *J Biol Chem* 1975;250:8883-8888.
571. Schmaier AH, Dahl LD, Hasan AA, Cines DB, Bauer KA, Van Nostrand WE. Factor IXa inhibition by protease nexin-2/amyloid beta-protein precursor on phospholipid vesicles and cell membranes. *Biochemistry* 1995;34:1171-1178.
572. Isawa H, Yuda M, Yoneda K, Chinzei Y. The insect salivary protein, prolixin-S, inhibits factor IXa generation and Xase complex formation in the blood coagulation pathway. *J Biol Chem* 2000;275:6636-6641.
573. Bauer KA. Selective inhibition of coagulation factors: advances in antithrombotic therapy. *Semin Thromb Hemost* 2002;28(Suppl 2):15-24.
574. Nishimura S, Ishida T, Imai K. [Monoclonal antibody therapy for disorders of hemostasis and coagulation]. *Nippon Rinsho* 2002;60:525-530.

575. Refino CJ, Jeet S, DeGuzman L, Bunting S, Kirchhofer D. A human antibody that inhibits factor IX/IXa function potently inhibits arterial thrombosis without increasing bleeding. *Arterioscler Thromb Vasc Biol* 2002;22:517-522.
576. Sullenger B, Woodruff R, Monroe D. Potent anticoagulant aptamer directed against factor IXa blocks macromolecular substrate interaction. *J Biol Chem* 2012;287:12779-12786.
577. Roser-Jones C, Chan M, Howard E, Becker K, Rusconi C, Becker R. Factor IXa as a target for pharmacologic inhibition in acute coronary syndrome. *Cardiovasc Ther* 2011;28:e22-e35.
578. Antman EM. Hirudin in acute myocardial infarction. Safety report from the Thrombolysis and Thrombin Inhibition in Myocardial Infarction (TIMI) 9A Trial. *Circulation* 1994;90:1624-1630.
579. Adams TE, Everse SJ, Mann KG. Predicting the pharmacology of thrombin inhibitors. *JThromb Haemost* 2003;1:1024-1027.
580. Randomized trial of intravenous heparin versus recombinant hirudin for acute coronary syndromes. The Global Use of Strategies to Open Occluded Coronary Arteries (GUSTO) IIa Investigators. *Circulation* 1994;90:1631-1637.
581. Howard EL, Becker KC, Rusconi CP, Becker RC. Factor IXa inhibitors as novel anticoagulants. *Arterioscler Thromb Vasc Biol* 2007;27:722-727.
582. Becker RC, Rusconi C, Sullenger B. Nucleic acid aptamers in therapeutic anticoagulation. Technology, development and clinical application. *Thromb Haemost* 2005;93:1014-1020.
583. Davie EW, Fujikawa K, Kurachi K, Kisiel W. The role of serine proteases in the blood coagulation cascade. *Adv Enzymol Relat Areas Mol Biol* 1979;48:277-318.
584. Di Scipio RG, Hermodson MA, Yates SG, Davie EW. A comparison of human prothrombin, factor IX (Christmas factor), factor X (Stuart factor), and protein S. *Biochemistry* 1977;16:698-706.
585. Roberts HR, Lechler E, Webster WP, Penick G. Survival of transfused factor X in patients with Stuart Disease. *Thromb Diath Haemorrh* 1965;13:305-313.
586. de Visser MC, Poort SR, Vos HL, Rosendaal FR, Bertina RM. Factor X levels, polymorphisms in the promoter region of factor X, and the risk of venous thrombosis. *Thromb Haemost* 2001;85:1011-1017.
587. Uprichard J, Perry DJ. Factor X deficiency. *Blood Rev* 2002;16:97-110.
588. Menegatti M, Peyvandi F. Factor X deficiency. *Semin Thromb Hemost* 2009;35:407-415.
589. Peyvandi F, Menegatti M, Santagostino E, et al. Gene mutations and three-dimensional structural analysis in 13 families with severe factor X deficiency. *Br J Haematol* 2002;117:685-692.
590. Morishita E, Yamaguchi K, Asakura H, et al. One missense mutation in the factor X gene causing factor X deficiency—factor X Kanazawa. *Int J Hematol* 2001;73:390-392.
591. Simioni P, Vianello F, Kalafatis M, et al. A dysfunctional factor X (factor X San Giovanni Rotondo) present at homozygous and double heterozygous level: identification of a novel microdeletion (delC556) and missense mutation (Lys(408)→Asn) in the factor X gene. A study of an Italian family.
592. Deam S, Srinivasan N, Westby J, Horn EH, Dolan G. F X Nottingham and F X Taunton. Two novel mutations in factor X resulting in loss of functional activity and an interpretation using molecular modelling. *Thromb Haemost* 2001;85:265-269.
593. Millar DS, Elliston L, Deex P, et al. Molecular analysis of the genotype-phenotype relationship in factor X deficiency. *Hum Genet* 2000;106:249-257.
594. Cooper DN, Millar DS, Wacey A, Pemberton S, Tuddenham EG. Inherited factor X deficiency: molecular genetics and pathophysiology. *Thromb Haemost* 1997;78:161-172.
595. Denson KW, Lurie A, de Cataldo F, Mannucci PM. The factor-X defect: recognition of abnormal forms of factor X. *Br J Haematol* 1970;18:317-327.
596. Vianello F, Lombardi AM, Boldrin C, Luni S, Girolami A. A new factor X defect (factor X Padua 3): a compound heterozygous between true deficiency (Gly(380)→Arg) and an abnormality (Ser(334)->Pro). *Thromb Res* 2001;104:257-264.

597. Girolami A, Scarparo P, Vettore S, Candeo N, Scandellari R, Lombardi A. Unexplained discrepancies in the activity—antigen ratio in congenital FX deficiencies with defects in the catalytic domain. *Clin Appl Thromb Hemost* 2009;15:621-627.
598. Choufani EB, Sanchorawala V, Ernst T, et al. Acquired factor X deficiency in patients with amyloid light-chain amyloidosis: incidence, bleeding manifestations, and response to high- dose chemotherapy. *Blood* 2001;97:1885-1887.
599. Beardell FV, Varma M, Martinez J. Normalization of plasma factor X levels in amyloidosis after plasma exchange. *Am J Hematol* 1997;54:68-71.
600. Girmann G, Wilker D, Stadie H, Scheurlen PG. Acquired isolated factor X deficiency associated with systemic amyloidosis. Case report and review of literature. *Klin Wochenschr* 1980;58:859-862.
601. Girolami A, Candeo N, Vettore S, Lombardi A, Girolami B. The clinical significance of the lack of arterial or venous thrombosis in patients with congenital prothrombin or FX deficiency. *J Thromb Thrombolysis* 2010;29:299-302.
602. Dewerchin M, Liang Z, Moons L, et al. Blood coagulation factor X deficiency causes partial embryonic lethality and fatal neonatal bleeding in mice. *Thromb Haemost* 2000;83:185-190.
603. Miao CH, Leytus SP, Chung DW, Davie EW. Liver-specific expression of the gene coding for human factor X, a blood coagulation factor. *J Biol Chem* 1992;267:7395-7401.
604. Scambler PJ, Williamson R. The structural gene for human coagulation factor X is located on chromosome 13q34. *Cytogenet Cell Genet* 1985;39:231-233.
605. Rocchi M, Roncuzzi L, Santamaria R, Archidiacono N, Dente L, Romeo G. Mapping through somatic cell hybrids and cDNA probes of protein C to chromosome 2, factor X to chromosome 13, and alpha 1-acid glycoprotein to chromosome 9. *Hum Genet* 1986;74:30-33.
606. Huang MN, Hung HL, Stanfieldoakley SA, High KA. Characterization of the Human Blood-Coagulation Factor-X Promoter. *J Biol Chem* 1992;267:15440-15446.
607. Wilberding JA, Castellino FJ. Characterization of the murine coagulation factor X promoter. *Thromb Haemost* 2000;84:1031-1038.
608. Hung HL, High KA. Liver-enriched transcription factor HNF-4 and ubiquitous factor NF-Y are critical for expression of blood coagulation factor X. *J Biol Chem* 1996;271:2323-2331.
609. Hung HL, Pollak ES, Kudaravalli RD, Arruda V, Chu K, High KA. Regulation of human coagulation factor X gene expression by GATA-4 and the Sp family of transcription factors. *Blood* 2001;97:946-951.
610. Di Scipio RG, Hermodson MA, Davie EW. Activation of human factor X (Stuart factor) by a protease from Russell's viper venom. *Biochemistry* 1977;16:5253-5260.
611. Fujikawa K, Davie EW. Bovine factor X (Stuart factor). *Methods Enzymol* 1976;45:89-95.
612. Nakagawa H, Takahashi N, Fujikawa K, et al. Identification of the oligosaccharide structures of human coagulation factor X activation peptide at each glycosylation site. *Glycoconj J* 1995;12:173-181.
613. Young RJ, Campbell M, Borthwick AD, et al. Structure- and property-based design of factor Xa inhibitors: pyrrolidin-2-ones with acyclic alanyl amides as P4 motifs. *Bioorg Med Chem Lett* 2006;16:5953-5957.
614. Osterud B, Rapaport SI. Synthesis of intrinsic factor X activator. Inhibition of the function of formed activator by antibodies to factor VIII and to factor IX. *Biochemistry* 1970;9:1854-1861.
615. McGee MP, Li LC, Xiong H. Diffusion control in blood coagulation. Activation of factor X by factors IXa/VIIIa assembled on human monocyte membranes. *J Biol Chem* 1992;267:24333-24339.
616. Rand MD, Lock JB, van 't Veer C, Gaffney DP, Mann KG. Blood clotting in minimally altered whole blood. *Blood* 1996;88:3432-3445.
617. Butenas S, van 't Veer C, Mann KG. Evaluation of the initiation phase of blood coagulation using ultrasensitive assays for serine proteases. *J Biol Chem* 1997;272:21527-21533.
618. Neuenschwander PF, Morrissey JH. Deletion of the membrane anchoring region of tissue factor abolishes autoactivation of factor VII but not cofactor function. Analysis of a mutant with a selective deficiency in activity. *J Biol Chem* 1992;267:14477-14482.

619. Monkovic DD, Tracy PB. Activation of human factor V by factor Xa and thrombin. *Biochemistry* 1990;29:1118-1128.
620. Gajdusek C, Carbon S, Ross R, Nawroth P, Stern D. Activation of coagulation releases endothelial cell mitogens. *J Cell Biol* 1986;103:419-428.
621. Gasic GP, Arenas CP, Gasic TB, Gasic GJ. Coagulation factors X, Xa, and protein S as potent mitogens of cultured aortic smooth muscle cells. *Proc Natl Acad Sci U S A* 1992;89:2317-2320.
622. Altieri DC, Stamnes SJ. Protease-dependent T cell activation: ligation of effector cell protease receptor-1 (EPR-1) stimulates lymphocyte proliferation. *Cell Immunol* 1994;155:372-383.
623. Bae J, Yang L, Rezaie A. Factor X/Xa elicits protective signaling responses in endothelial cells directly via PAR-2 and indirectly via endothelial protein C receptor-dependent recruitment of PAR-1. *J Biol Chem* 2010;285:32803-34812.
624. Altieri DC, Morrissey JH, Edgington TS. Adhesive receptor Mac-1 coordinates the activation of factor X on stimulated cells of monocytic and myeloid differentiation: an alternative initiation of the coagulation protease cascade. *Proc Natl Acad Sci U S A* 1988;85:7462-7466.
625. Altieri DC, Edgington TS. Identification of effector cell protease receptor-1. A leukocyte- distributed receptor for the serine protease factor Xa. *J Immunol* 1990;145:246-253.
626. Tracy PB, Nesheim ME, Mann KG. Platelet factor Xa receptor. *Methods Enzymol* 1992;215:329-360.
627. Lindhout T, Willems G, Blezer R, Hemker HC. Kinetics of the inhibition of human factor Xa by full-length and truncated recombinant tissue factor pathway inhibitor. *Biochem J* 1994;297(Pt 1):131-136.
628. Huang ZF, Wun TC, Broze GJ Jr. Kinetics of factor Xa inhibition by tissue factor pathway inhibitor. *J Biol Chem* 1993;268:26950-26955.
629. Iversen N, Lindahl AK, Abildgaard U. Elevated plasma levels of the factor Xa-TFPI complex in cancer patients. *Thromb Res* 2002;105:33-36.
630. Gitel SN, Medina VM, Wessler S. Inhibition of human activated Factor X by antithrombin III and alpha 1- proteinase inhibitor in human plasma. *J Biol Chem* 1984;259:6890-6895.
631. Miletich JP, Jackson CM, Majerus PW. Properties of the factor Xa binding site on human platelets. *J Biol Chem* 1978;253:6908-6916.
632. Marciniak E. Factor-Xa inactivation by antithrombin. 3. Evidence for biological stabilization of factor Xa by factor V-phospholipid complex. *Br J Haematol* 1973;24:391-400.
633. Pinto DJ, Galembo RA Jr, Quan ML, et al. Discovery of potent, efficacious, and orally bioavailable inhibitors of blood coagulation factor Xa with neutral P1 moieties. *Bioorg Med Chem Lett* 2006;16:5584-5589.
634. Kakar P, Watson T, Lip GY. Drug evaluation: rivaroxaban, an oral, direct inhibitor of activated factor X. *Curr Opin Investig Drugs* 2007;8:256-265.
635. Kochanny MJ, Adler M, Ewing J, et al. Substituted thiophene-anthranilamides as potent inhibitors of human factor Xa. *Bioorg Med Chem* 2007;15:2127-2146.
636. Eriksson B, Quinlan D, Weitz J. Comparative pharmacodynamics and pharmacokinetics of oral direct thrombin and factor xa inhibitors in development. *Clin Pharmacokinet* 2009;48:1-22.
637. De Caterina R, Husted S, Wallentin L, et al. New oral anticoagulants in atrial fibrillation and acute coronary syndromes: ESC Working Group on Thrombosis-Task Force on Anticoagulants in Heart Disease position paper. *J Am Coll Cardiol* 2012;59:1413-1425.
638. Weitz J. New oral anticoagulants: a view from the laboratory. *Am J Hematol* 2012;87(Suppl 1):S133-S136.
639. Augoustides JG. Breakthroughs in anticoagulation: advent of the oral direct factor Xa inhibitors. *J Cardiothorac Vasc Anesth* 2012;26:740-745. S1053-0770(12)00203-0 [pii]. doi:10.1053/j.jvca.2012.03.029.
640. Lundblad RL, Kingdon HS, Mann KG. Thrombin. *Methods Enzymol* 1976;45:156-176.
641. McDuffie FC, Giffin C, Niedringhaus R, et al. Prothrombin, thrombin and prothrombin fragments in plasma of normal individuals and of patients with laboratory evidence of disseminated intravascular coagulation. *Thromb Res* 1979;16:759-773.
642. Kisiel W, Hanahan DJ. Purification and characterization of human Factor II. *Biochim Biophys Acta* 1973;304:103-113.

643. Chow BK, Ting V, Tufaro F, MacGillivray RT. Characterization of a novel liver-specific enhancer in the human prothrombin gene. *J Biol Chem* 1991;266:18927-18933.
644. Bancroft JD, McDowell SA, Degen SJ. The human prothrombin gene: transcriptional regulation in HepG2 cells. *Biochemistry* 1992;31:12469-12476.
645. Roberts HR, Lefkowitz JB. Inherited disorders of prothrombin conversion. In: Colman RW, Hirsh J, Marder VJ, Salzman EW, eds. *Hemostasis and thrombosis basic principals and clinical practice*. Philadelphia: Lippincott, 1994:200-218.
646. Rouvier J, Braude R, Altman R. Proceedings: fibrinogenolysis: studies on its degradation products. *Thromb Diath Haemorrh* 1975;34:340.
647. Girolami A, Scandellari R, Scapin M, Vettore S. Congenital bleeding disorders of the vitamin K-dependent clotting factors. *Vitam Horm* 2008;78:281-374.
648. Sun WY, Degen SJ. Gene targeting in hemostasis. Prothrombin. *Front Biosci* 2001;6:D222-D238.
649. Xue J, Wu Q, Westfield LA, et al. Incomplete embryonic lethality and fatal neonatal hemorrhage caused by prothrombin deficiency in mice. *Proc Natl Acad Sci U S A* 1998;95:7603-7607.
650. Sun WY, Witte DP, Degen JL, et al. Prothrombin deficiency results in embryonic and neonatal lethality in mice. *Proc Natl Acad Sci U S A* 1998;95:7597-7602.
651. Bancroft JD, Schaefer LA, Degen SJ. Characterization of the Alu-rich 5'-flanking region of the human prothrombin-encoding gene: identification of a positive cis-acting element that regulates liver-specific expression. *Gene* 1990;95:253-260.
652. Degen SJ. The prothrombin gene and its liver-specific expression. *Semin Thromb Hemost* 1992;18:230-242.
653. Degen SJ, Davie EW. Nucleotide sequence of the gene for human prothrombin. *Biochemistry* 1987;26:6165-6177.
654. Degen SJ, MacGillivray RT, Davie EW. Characterization of the complementary deoxyribonucleic acid and gene coding for human prothrombin. *Biochemistry* 1983;22:2087-2097.
655. Poort SR, Rosendaal FR, Reitsma PH, Bertina RM. A common genetic variation in the 3'-untranslated region of the prothrombin gene is associated with elevated plasma prothrombin levels and an increase in venous thrombosis. *Blood* 1996;88:3698-703.
656. Perez-Ceballos E, Corral J, Alberca I, et al. Prothrombin A19911G and G20210A polymorphisms' role in thrombosis. *Br J Haematol* 2002;118:610-614.
657. Nguyen A. Prothrombin G20210A polymorphism and thrombophilia. *Mayo Clin Proc* 2000;75:595-604.
658. Favaloro E, McDonald D, Lippi G. Laboratory investigation of thrombophilia: the good, the bad, and the ugly. *Semin Thromb Hemost* 2009;35:695-710.
659. Coppola A, Tufano A, Cerbone A, Di Minno G. Inherited thrombophilia: implications for prevention and treatment of venous thromboembolism. *Semin Thromb Hemost* 2009;35:683-694.
660. Butkowski RJ, Elion J, Downing MR, Mann KG. Primary structure of human prethrombin 2 and alpha-thrombin. *J Biol Chem* 1977;252:4942-4957.
661. MacGillivray RT, Davie EW. Characterization of bovine prothrombin mRNA and its translation product. *Biochemistry* 1984;23:1626-1634.
662. Mizuochi T, Fujii J, Kisiel W, Kobata A. Studies on the structures of the carbohydrate moiety of human prothrombin. *J Biochem(Tokyo)* 1981;90:1023-1031.
663. Patthy L. Evolution of the proteases of blood coagulation and fibrinolysis by assembly from modules. *Cell* 1985;41:657-663.
664. Castellino FJ, Beals JM. The genetic relationships between the kringle domains of human plasminogen, prothrombin, tissue plasminogen activator, urokinase, and coagulation factor XII. *J Mol Evol* 1987;26:358-369.
665. Deguchi H, Takeya H, Gabazza EC, Nishioka J, Suzuki K. Prothrombin kringle 1 domain interacts with factor Va during the assembly of prothrombinase complex. *Biochem J* 1997;321:729-735.

666. Sugo T, Nakamikawa C, Tanabe S, Matsuda M. Activation of prothrombin by factor Xa bound to the membrane surface of human umbilical vein endothelial cells: its catalytic efficiency is similar to that of prothrombinase complex on platelets. *J Biochem(Tokyo)* 1995;117:244-250.
667. Bajaj SP, Butkowski RJ, Mann KG. Prothrombin fragments. Ca_2^+ binding and activation kinetics. *J Biol Chem* 1975;250:2150-2156.
668. Kotkow KJ, Deitcher SR, Furie B, Furie BC. The second kringle domain of prothrombin promotes factor Va-mediated prothrombin activation by prothrombinase. *J Biol Chem* 1995;270:4551-4557.
669. Krishnaswamy S, Walker RK. Contribution of the prothrombin fragmentw 2 domain to the function of factor Va in the prothrombinase complex. *Biochemistry* 1997;36:3319-3330.
670. Wood J, Silveira J, Maille N, Haynes L, Tracy P. Prothrombin activation on the activated platelet surface optimizes expression of procoagulant activity. *Blood* 2011;117:1710-1718.
671. Whelihan M, Zachary V, Orfeo T, Mann K. Prothrombin activation in blood coagulation: the erythrocyte contribution to thrombin generation. *Blood* 2012;120(18):3837-3845.
672. Krishnaswamy S, Church WR, Nesheim ME, Mann KG. Activation of human prothrombin by human prothrombinase. Influence of factor Va on the reaction mechanism. *J Biol Chem* 1987;262:3291-3299.
673. Kim P, Nesheim M. Further evidence for two functional forms of prothrombinase each specific for either of the two prothrombin activation cleavages. *J Biol Chem* 2007;282:32568-32581.
674. Doyle MF, Mann KG. Multiple active forms of thrombin. IV. Relative activities of meizothrombins. *J Biol Chem* 1990;265:10693-10701.
675. Haynes L, Bouchard B, Tracy P, Mann K. Prothrombin activation by platelet-associated prothrombinase proceeds through the prethrombin-2 pathway via a concerted mechanism. *J Biol Chem* 2012.
676. Myrnel KH, Lundblad RL, Mann KG. Characteristics of the association between prothrombin fragment 2 and alpha-thrombin. *Biochemistry* 1976;15:1767-1773.
677. Nesheim ME, Abbott T, Jenny R, Mann KG. Evidence that the thrombin-catalyzed feedback cleavage of fragment 1.2 at Arg154-Ser155 promotes the release of thrombin from the catalytic surface during the activation of bovine prothrombin. *J Biol Chem* 1988;263:1037-1044.
678. Tracy PB, Eide LL, Mann KG. Human prothrombinase complex assembly and function on isolated peripheral blood cell populations. *J Biol Chem* 1985;260:2119-2124.
679. Bovill EG, Tracy RP, Hayes TE, Jenny RJ, Bhushan FH, Mann KG. Evidence that meizothrombin is an intermediate product in the clotting of whole blood. *Arterioscler Thromb Vasc Biol* 1995;15:754-758.
680. Mosesson MW. The roles of fibrinogen and fibrin in hemostasis and thrombosis. *Semin Hematol* 1992;29:177-188.
681. Davey MG, Luscher EF. Actions of thrombin and other coagulant and proteolytic enzymes on blood platelets. *Nature* 1967;216:857-858.
682. Mann KG, Jenny RJ, Krishnaswamy S. Cofactor proteins in the assembly and expression of blood clotting enzyme complexes. *Annu Rev Biochem* 1988;57:915-956.
683. Fay PJ. Subunit structure of thrombin-activated human factor VIIIa. *Biochim Biophys Acta* 1988;952:181-190.
684. Kisiel W, Canfield WM, Ericsson LH, Davie EW. Anticoagulant properties of bovine plasma protein C following activation by thrombin. *Biochemistry* 1977;16:5824-5831.
685. Fenton JW. Regulation of thrombin generation and functions. *Semin Thromb Hemost* 1988;14:234-240.
686. Bar-Shavit R, Benezra M, Eldor A, et al. Thrombin immobilized to extracellular matrix is a potent mitogen for vascular smooth muscle cells: non-enzymatic mode of action [published erratum appears in *Cell Regul* 1990 Oct;1(11):873]. *Cell Regul* 1990;1:453-463.
687. Bar-Shavit R, Kahn AJ, Mann KG, Wilner GD. Identification of a thrombin sequence with growth factor activity on macrophages. *Proc Natl Acad Sci U S A* 1986;83:976-980.

688. McNamara CA, Sarembock IJ, Gimple LW, Fenton JW, Coughlin SR, Owens GK. Thrombin stimulates proliferation of cultured rat aortic smooth muscle cells by a proteolytically activated receptor [see comments]. *J Clin Invest* 1993;91:94-98.
689. Sago H, Iinuma K. Cell shape change and cytosolic Ca_2^+ in human umbilical-vein endothelial cells stimulated with thrombin. *Thromb Haemost* 1992;67: 331-334.
690. Tsopanoglou NE, Pipili-Synetos E, Maragoudakis ME. Thrombin promotes angiogenesis by a mechanism independent of fibrin formation. *Am J Physiol* 1993;264:C1302-C1307.
691. Folkman J. Tumor angiogenesis. *Adv Cancer Res* 1985;43:175-203.
692. Tsopanoglou NE, Maragoudakis ME. On the mechanism of thrombin-induced angiogenesis. Potentiation of vascular endothelial growth factor activity on endothelial cells by up-regulation of its receptors. *J Biol Chem* 1999;274:23969-23976.
693. Jenny NS, Lundblad RL, Mann KG. Thrombin. In: Colman RW, Marder VJ, Clowes AW, George JN, Goldhaber SZ, eds. *Hemostasis and thrombosis: basic principles and clinical practice*. Philadelphia, PA: Lippincott Williams & Wilkins, 2006:193-213.
694. Bjork I, Lindahl U. Mechanism of the anticoagulant action of heparin. *Mol Cell Biochem* 1982;48:161-182.
695. Rosenberg RD. Chemistry of the hemostatic mechanism and its relationship to the action of heparin. *Fed Proc* 1977;36:10-18.
696. Butenas S, van't Veer C, Mann KG. "Normal" thrombin generation. *Blood* 1999;94:2169-2178.
697. Toomey JR, Kratzer KE, Lasky NM, Stanton JJ, Broze GJ Jr. Targeted disruption of the murine tissue factor gene results in embryonic lethality. *Blood* 1996;88:1583-1587.
698. Bugge TH, Xiao Q, Kombrinck KW, et al. Fatal embryonic bleeding events in mice lacking tissue factor, the cell-associated initiator of blood coagulation. *Proc Natl Acad Sci U S A* 1996;93:6258-6263.
699. Carmeliet P, Mackman N, Moons L, et al. Role of tissue factor in embryonic blood vessel development. *Nature* 1996;383:73-75.
700. Carmeliet P, Moons L, Dewerchin M, et al. Insights in vessel development and vascular disorders using targeted inactivation and transfer of vascular endothelial growth factor, the tissue factor receptor, and the plasminogen system. *Ann NY Acad Sci* 1997;811:191-206.
701. Scarpati EM, Wen D, Broze GJ Jr, et al. Human tissue factor: cDNA sequence and chromosome localization of the gene. *Biochemistry* 1987;26:5234-5238.
702. Kao FT, Hartz J, Horton R, Nemerson Y, Carson SD. Regional assignment of human tissue factor gene (F3) to chromosome 1p21- p22. *Somat Cell Mol Genet* 1988;14:407-410.
703. Mackman N, Morrissey JH, Fowler B, Edgington TS. Complete sequence of the human tissue factor gene, a highly regulated cellular receptor that initiates the coagulation protease cascade. *Biochemistry* 1989;28:1755-1762.
704. Mackman N, Fowler BJ, Edgington TS, Morrissey JH. Functional analysis of the human tissue factor promoter and induction by serum. *Proc Natl Acad Sci U S A* 1990;87:2254-2258.
705. Ranganathan G, Blatti SP, Subramaniam M, Fass DN, Maihle NJ, Getz MJ. Cloning of murine tissue factor and regulation of gene expression by transforming growth factor type beta 1. *J Biol Chem* 1991;266:496-501.
706. Geczy CL. Cellular mechanisms for the activation of blood coagulation. *Int Rev Cytol* 1994;152:49-108.
707. Camerer E, Kolsto AB, Prydz H. Cell biology of tissue factor, the principal initiator of blood coagulation. *Thromb Res* 1996;81:1-41.
708. Morrissey JH. Tissue factor and factor VII initiation of coagulation. In: Colman RW, Hirsh J, Marder VJ, Clowes AW, George JN, eds. *Hemostasis and thrombosis*. Philadelphia, PA: Lippincott Williams & Wilkins, 2001:89-101.
709. Andoh K, Kubota T, Takada M, Tanaka H, Kobayashi N, Maekawa T. Tissue factor activity in leukemia cells. Special reference to disseminated intravascular coagulation. *Cancer* 1987;59:748-754.
710. Tanaka M, Yamanishi H. The expression of tissue factor antigen and activity on the surface of leukemic cells. *Leuk Res* 1993;17:103-111.

711. Tallman MS, Hakimian D, Kwaan HC, Rickles FR. New insights into the pathogenesis of coagulation dysfunction in acute promyelocytic leukemia. *Leuk Lymphoma* 1993;11:27-36.
712. Osterud B, Flaegstad T. Increased tissue thromboplastin activity in monocytes of patients with meningococcal infection: related to an unfavourable prognosis. *Thromb Haemost* 1983;49:5-7.
713. Kadish JL, Wenc KM, Dvorak HF. Tissue factor activity of normal and neoplastic cells: quantitation and species specificity. *J Natl Cancer Inst* 1983;70:551-557.
714. Silberberg JM, Gordon S, Zucker S. Identification of tissue factor in two human pancreatic cancer cell lines. *Cancer Res* 1989;49:5443-5447.
715. Bauer KA, Conway EM, Bach R, Konigsberg WH, Griffin JD, Demetri G. Tissue factor gene expression in acute myeloblastic leukemia. *Thromb Res* 1989;56:425-430.
716. Mueller BM, Reisfeld RA, Edgington TS, Ruf W. Expression of tissue factor by melanoma cells promotes efficient hematogenous metastasis. *Proc Natl Acad Sci U S A* 1992;89:11832-11836.
717. Faulk WP, Labarrere CA, Carson SD. Tissue factor: identification and characterization of cell types in human placenta. *Blood* 1990;76:86-96.
718. Blakely ML, Van der Werf WJ, Berndt MC, Dalmaso AP, Bach FH, Hancock WW. Activation of intragraft endothelial and mononuclear cells during discordant xenograft rejection. *Transplantation* 1994;58:1059-1066.
719. Salom RN, Maguire JA, Hancock WW. Endothelial activation and cytokine expression in human acute cardiac allograft rejection. *Pathology* 1998;30:24-29.
720. Gertler JP, Weibe DA, Ocasio VH, Abbott WM. Hypoxia induces procoagulant activity in cultured human venous endothelium. *J Vasc Surg* 1991;13:428-433.
721. O'Rourke JF, Pugh CW, Bartlett SM, Ratcliffe PJ. Identification of hypoxically inducible mRNAs in HeLa cells using differential-display PCR. Role of hypoxia-inducible factor-1. *Eur J Biochem* 1996;241:403-410.
722. Herbert JM, Corseaux D, Lale A, Bernat A. Hypoxia primes endotoxin-induced tissue factor expression in human monocytes and endothelial cells by a PAF-dependent mechanism. *J Cell Physiol* 1996;169:290-299.
723. Mackman N. Regulation of the tissue factor gene. *Thromb Haemost* 1997;78:747-754.
724. Yan SF, Zou YS, Gao Y, et al. Tissue factor transcription driven by Egr-1 is a critical mechanism of murine pulmonary fibrin deposition in hypoxia. *Proc Natl Acad Sci U S A* 1998;95:8298-8303.
725. Broze GJ Jr, Leykam JE, Schwartz BD, Miletich JP. Purification of human brain tissue factor. *J Biol Chem* 1985;260:10917-10920.
726. Morrissey JH, Fakhrai H, Edgington TS. Molecular cloning of the cDNA for tissue factor, the cellular receptor for the initiation of the coagulation protease cascade. *Cell* 1987;50:129-135.
727. Spicer EK, Horton R, Bloem L, et al. Isolation of cDNA clones coding for human tissue factor: primary structure of the protein and cDNA. *Proc Natl Acad Sci U S A* 1987;84:5148-5152.
728. Bazan JF. Structural design and molecular evolution of a cytokine receptor superfamily. *Proc Natl Acad Sci U S A* 1990;87:6934-6938.
729. Paborsky LR, Caras IW, Fisher KL, Gorman CM. Lipid association, but not the transmembrane domain, is required for tissue factor activity. Substitution of the transmembrane domain with a phosphatidylinositol anchor. *J Biol Chem* 1991;266:21911-21916.
730. Paborsky LR, Harris RJ. Post-translational modifications of recombinant human tissue factor. *Thromb Res* 1990;60:367-376.
731. Harlos K, Martin DM, O'Brien DP, et al. Crystal structure of the extracellular region of human tissue factor [published erratum appears in *Nature* 1994 Oct 20;371(6499):720]. *Nature* 1994;370:662-666.
732. Muller YA, Ultsch MH, Kelley RF, de Vos AM. Structure of the extracellular domain of human tissue factor: location of the factor VIIa binding site. *Biochemistry* 1994;33:10864-10870.
733. Muller YA, Ultsch MH, de Vos AM. The crystal structure of the extracellular domain of human tissue factor refined to 1.7 Å resolution. *J Mol Biol* 1996;256:144-159.

734. Muller YA, Kelley RF, de Vos AM. Hinge bending within the cytokine receptor superfamily revealed by the 2.4 Å crystal structure of the extracellular domain of rabbit tissue factor. *Protein Sci* 1998;7:1106-1115.
735. Huang M, Syed R, Stura EA, et al. The mechanism of an inhibitory antibody on TF-initiated blood coagulation revealed by the crystal structures of human tissue factor, Fab 5G9 and TF.G9 complex. *J Mol Biol* 1998;275:873-894.
736. Kahn ML, Zheng YW, Huang W, et al. A dual thrombin receptor system for platelet activation. *Nature* 1998;394:690-694.
737. Bach R, Konigsberg WH, Nemerson Y. Human tissue factor contains thioesterlinked palmitate and stearate on the cytoplasmic half-cystine. *Biochemistry* 1988;27:4227-4231.
738. Rehemtulla A, Ruf W, Edgington TS. The integrity of the cysteine 186-cysteine 209 bond of the second disulfide loop of tissue factor is required for binding of factor VII. *J Biol Chem* 1991;266:10294-10299.
739. Paborsky LR, Tate KM, Harris RJ, et al. Purification of recombinant human tissue factor. *Biochemistry* 1989;28:8072-8077.
740. Krudysz-Amblo J, Jennings M, Mann K, Butenas S. Carbohydrates and activity of natural and recombinant tissue factor. *J Biol Chem* 2010;285:3371-3382.
741. Butenas S, Amblo-Krudysz J, Mann K. Posttranslational modifications of tissue factor. *Front Biosci (Elite Ed)* 2012;4:381-391.
742. Egorina E, Sovershaev M, Osterud B. Regulation of tissue factor procoagulant activity by post-translational modifications. *Thromb Res* 2008;122:831-837.
743. Zioncheck TF, Roy S, Vehar GA. The cytoplasmic domain of tissue factor is phosphorylated by a protein kinase C-dependent mechanism. *J Biol Chem* 1992;267:3561-3564.
744. Nemerson Y, Repke D. Tissue factor accelerates the activation of coagulation factor VII: the role of a bifunctional coagulation cofactor. *Thromb Res* 1985;40:351-358.
745. Ruf W, Rehemtulla A, Morrissey JH, Edgington TS. Phospholipid-independent and -dependent interactions required for tissue factor receptor and cofactor function. *J Biol Chem* 1991;266:2158-2166.
746. Pedersen AH, Nordfang O, Norris F, et al. Recombinant human extrinsic pathway inhibitor. Production, isolation, and characterization of its inhibitory activity on tissue factor-initiated coagulation reactions. *J Biol Chem* 1990;265:16786-16793.
747. Neuenschwander PF, Branam DE, Morrissey JH. Importance of substrate composition, pH and other variables on tissue factor enhancement of factor VIIa activity. *Thromb Haemost* 1993;70:970-977.
748. Komiyama Y, Pedersen AH, Kisiel W. Proteolytic activation of human factors IX and X by recombinant human factor VIIa: effects of calcium, phospholipids, and tissue factor. *Biochemistry* 1990;29:9418-9425.
749. Camerer E, Trejo J. Cryptic messages: is noncoagulant tissue factor reserved for cell signaling? *Proc Natl Acad Sci U S A* 2006;103:14259-14260.
750. Ahamed J, Versteeg HH, Kerver M, et al. Disulfide isomerization switches tissue factor from coagulation to cell signaling. *Proc Natl Acad Sci U S A* 2006;103:13932-13937.
751. Morel O, Toti F, Hugel B, et al. Procoagulant microparticles: disrupting the vascular homeostasis equation? *Arterioscler Thromb Vasc Biol* 2006;26:2594-2604.
752. Butenas S, Bouchard BA, Brummel-Ziedins KE, Parhami-Seren B, Mann KG. Tissue factor activity in whole blood. *Blood* 2005;105:2764-2770.
753. Giesen PL, Rauch U, Bohrmann B, et al. Blood-borne tissue factor: another view of thrombosis. *Proc Natl Acad Sci USA* 1999;96:2311-2315.
754. Butenas S, Orfeo T, Mann K. Tissue factor in coagulation: Which? Where? When? *Arterioscler Thromb Vasc Biol* 2009;29:1989-1996.
755. Chen VM, Hogg PJ. Allosteric disulfide bonds in thrombosis and thrombolysis. *J Thromb Haemost* 2006;4:2533-2541.
756. Ruf W. Role of thiol pathways in TF procoagulant regulation. *Thromb Res* 2012;129:S11-S12.

757. Marder VJ, Mannucci PM, Firkin BG, Hoyer LW, Meyer D. Standard nomenclature for factor VIII and von Willebrand factor: a recommendation by the International Committee on Thrombosis and Haemostasis. *Thromb Haemost* 1985;54:871-872.
758. Leyte A, Verbeet MP, Brodniewicz-Proba T, van Mourik JA, Mertens K. The interaction between human blood-coagulation factor VIII and von Willebrand factor. Characterization of a high-affinity binding site on factor VIII. *Biochem J* 1989;257:679-683.
759. Bendetowicz AV, Morris JA, Wise RJ, Gilbert GE, Kaufman RJ. Binding of factor VIII to von willebrand factor is enabled by cleavage of the von Willebrand factor propeptide and enhanced by formation of disulfide-linked multimers. *Blood* 1998;92:529-538.
760. Mannucci PM. Desmopressin (DDAVP) in the treatment of bleeding disorders: the first 20 years. *Blood* 1997;90:2515-2521.
761. Tuddenham EG, Lane RS, Rotblat F, et al. Response to infusions of polyelectrolyte fractionated human factor VIII concentrate in human haemophilia A and von Willebrand's disease. *Br J Haematol* 1982;52:259-267.
762. Over J, Sixma JJ, Bruine MH, et al. Survival of 125iodine-labeled Factor VIII in normals and patients with classic hemophilia. Observations on the heterogeneity of human Factor VIII. *J Clin Invest* 1978;62:223-234.
763. Weiss HJ, Sussman II, Hoyer LW. Stabilization of factor VIII in plasma by the von Willebrand factor. Studies on posttransfusion and dissociated factor VIII and in patients with von Willebrand's disease. *J Clin Invest* 1977;60:390-404.
764. Brinkhous KM, Sandberg H, Garris JB, et al. Purified human factor VIII procoagulant protein: comparative hemostatic response after infusions into hemophilic and von Willebrand disease dogs. *Proc Natl Acad Sci U S A* 1985;82:8752-8756.
765. Hoyer LW. Molecular pathology and immunology of factor VIII (hemophilia A and factor VIII inhibitors). *Hum Pathol* 1987;18:153-161.
766. Rizza CR, Spooner RJ. Treatment of haemophilia and related disorders in Britain and Northern Ireland during 1976-80:report on behalf of the directors of haemophilia centres in the United Kingdom. *Br Med J (Clin Res Ed)* 1983;286:929-933.
767. Kaufman RJ, Antonarakis SE, Fay PJ. Factor VIII and hemophilia A. In: Colman RW, Hirsh J, Marder VJ, Clowes AW, George JN, eds. *Hemostasis and thrombosis: basic principles & clinical practice*. Philadelphia, PA: Lippincott Williams & Wilkins, 2001:135-156.
768. Freije D, Schlessinger D. A 1.6-Mb contig of yeast artificial chromosomes around the human factor VIII gene reveals three regions homologous to probes for the DXS115 locus and two for the DXYS64 locus. *Am J Hum Genet* 1992;51:66-80.
769. Migeon BR, McGinniss MJ, Antonarakis SE, et al. Severe hemophilia A in a female by cryptic translocation: order and orientation of factor VIII within Xq28 [published erratum appears in *Genomics* 1993 Jun;16(3):792]. *Genomics* 1993;16:20-25.
770. Gitschier J, Wood WI, Goralka TM, et al. Characterization of the human factor VIII gene. *Nature* 1984;312:326-330.
771. Purrello M, Alhadeff B, Esposito D, et al. The human genes for hemophilia A and hemophilia B flank the X chromosome fragile site at Xq27.3. *EMBO J* 1985;4:725-729.
772. Tantravahi U, Murty VV, Jhanwar SC, et al. Physical mapping of the factor VIII gene proximal to two polymorphic DNA probes in human chromosome band Xq28:implications for factor VIII gene segregation analysis. *Cytogenet Cell Genet* 1986;42:75-79.
773. Wood WI, Capon DJ, Simonsen CC, et al. Expression of active human factor VIII from recombinant DNA clones. *Nature* 1984;312:330-337.
774. Webster WP, Zukoski CF, Hutchin P, Reddick RL, Mandel SR, Penick GD. Plasma factor VIII synthesis and control as revealed by canine organ transplantation. *Am J Physiol* 1971;220:1147-1154.
775. Groth CG, Hathaway WE, Gustafsson A, et al. Correction of coagulation in the hemophilic dog by transplantation of lymphatic tissue. *Surgery* 1974;75:725-733.
776. Lewis JH, Bontempo FA, Spero JA, Ragni MV, Starzl TE. Liver transplantation in a hemophiliac [letter]. *N Engl J Med* 1985;312:1189-1190.
777. Bontempo FA, Lewis JH, Gorenc TJ, et al. Liver transplantation in hemophilia A. *Blood* 1987;69:1721-1724.

778. Liu L, Xia S, Seifert J. Transplantation of spleen cells in patients with hemophilia A. A report of 20 cases. *Transpl Int* 1994;7:201-206.
779. Kelly DA, Summerfield JA, Tuddenham EG. Localization of factor VIII: antigen in guinea-pig tissues and isolated liver cell fractions. *Br J Haematol* 1984;56:535-543.
780. Wion KL, Kelly D, Summerfield JA, Tuddenham EG, Lawn RM. Distribution of factor VIII mRNA and antigen in human liver and other tissues. *Nature* 1985;317:726-729.
781. Vehar GA, Keyt B, Eaton D, et al. Structure of human factor VIII. *Nature* 1984;312:337-342.
782. Jenny RJ, Pittman DD, Toole JJ, et al. Complete cDNA and derived amino acid sequence of human factor V. *Proc Natl Acad Sci U S A* 1987;84:4846-4850.
- 782a. Koschinsky ML, Funk WD, van Oost BA, MacGillivray RT. Complete cDNA sequence of human preceruloplasmin. *Proc Natl Acad Sci U S A* 1986;83:5086-5090.
783. Shen BW, Spiegel PC, Chang CH, et al. The tertiary structure and domain organization of coagulation factor VIII. *Blood* 2008;111:1240-1247. blood-2007-08-109918 [pii]. doi:10.1182/blood-2007-08-109918.
784. Poole S, Firtel RA, Lamar E, Rowekamp W. Sequence and expression of the discoidin I gene family in *Dictyostelium discoideum*. *J Mol Biol* 1981;153:273-289.
785. Stubbs JD, Lekutis C, Singer KL, et al. cDNA cloning of a mouse mammary epithelial cell surface protein reveals the existence of epidermal growth factor-like domains linked to factor VIII-like sequences. *Proc Natl Acad Sci U S A* 1990;87:8417-8421.
786. Fass DN, Knutson GJ, Katzmann JA. Monoclonal antibodies to porcine factor VIII coagulant and their use in the isolation of active coagulant protein. *Blood* 1982;59:594-600.
787. Andersson LO, Forsman N, Huang K, et al. Isolation and characterization of human factor VIII: molecular forms in commercial factor VIII concentrate, cryoprecipitate, and plasma. *Proc Natl Acad Sci U S A* 1986;83:2979-2983.
788. Fay PJ, Anderson MT, Chavin SI, Marder VJ. The size of human factor VIII heterodimers and the effects produced by thrombin. *Biochim Biophys Acta* 1986;871:268-278.
789. Elder B, Lakich D, Gitschier J. Sequence of the murine factor VIII cDNA. *Genomics* 1993;16:374-379.
790. Bihoreau N, Pin S, de Kersabiec AM, Vidot F, Fontaine-Aupart MP. Copperatom identification in the active and inactive forms of plasma-derived FVIII and recombinant FVIII-delta II. *Eur J Biochem* 1994;222:41-48.
791. Tagliavacca L, Moon N, Dunham WR, Kaufman RJ. Identification and functional requirement of Cu(I) and its ligands within coagulation factor VIII. *J Biol Chem* 1997;272:27428-27434.
792. Saenko EL, Shima M, Rajalakshmi KJ, Scandella D. A role for the C2 domain of factor VIII in binding to von Willebrand factor. *J Biol Chem* 1994;269:11601-11605.
793. Saenko EL, Scandella D. The acidic region of the factor VIII light chain and the C2 domain together form the high affinity binding site for von Willebrand factor. *J Biol Chem* 1997;272:18007-18014.
794. Foster PA, Fulcher CA, Houghten RA, Zimmerman TS. An immunogenic region within residues Val1670-Glu1684 of the factor VIII light chain induces antibodies which inhibit binding of factor VIII to von Willebrand factor. *J Biol Chem* 1988;263:5230-5234.
795. Shima M, Scandella D, Yoshioka A, et al. A factor VIII neutralizing monoclonal antibody and a human inhibitor alloantibody recognizing epitopes in the C2 domain inhibit factor VIII binding to von Willebrand factor and to phosphatidylserine. *Thromb Haemost* 1993;69:240-246.
796. Lenting PJ, Donath MJ, van Mourik JA, Mertens K. Identification of a binding site for blood coagulation factor IXa on the light chain of human factor VIII. *J Biol Chem* 1994;269:7150-7155.
797. Lenting PJ, van de Loo JW, Donath MJ, van Mourik JA, Mertens K. The sequence Glu1811-Lys1818 of human blood coagulation factor VIII comprises a binding site for activated factor IX. *J Biol Chem* 1996;271:1935-1940.
798. Fay PJ, Beattie T, Huggins CF, Regan LM. Factor VIIIa A2 subunit residues 558-565 represent a factor IXa interactive site. *J Biol Chem* 1994;269:20522-20527.

799. O'Brien LM, Medved LV, Fay PJ. Localization of factor IXa and factor VIIIa interactive sites. *J Biol Chem* 1995;270:27087-27092.
800. Fay PJ, Koshibu K. The A2 subunit of factor VIIIa modulates the active site of factor IXa. *J Biol Chem* 1998;273:19049-19054.
801. Kembball-Cook G, Tuddenham EG. The factor VIII mutation database on the World Wide Web: the haemophilia A mutation, search, test and resource site. *HAMSTeRS update (version 3.0)*. *Nucleic Acids Res* 1997;25:128-132.
802. Jenkins PV, Freas J, Schmidt KM, Zhou Q, Fay PJ. Mutations associated with hemophilia A in the 558-565 loop of the factor VIIIa A2 subunit alter the catalytic activity of the factor Xase complex. *Blood* 2002;100:501-508.
803. Pemberton S, Lindley P, Zaitsev V, Card G, Tuddenham EG, Kembball-Cook G. A molecular model for the triplicated A domains of human factor VIII based on the crystal structure of human ceruloplasmin. *Blood* 1997;89:2413-2421.
804. Pratt KP, Shen BW, Takeshima K, Davie EW, Fujikawa K, Stoddard BL. Structure of the C2 domain of human factor VIII at 1.5 Å resolution. *Nature* 1999;402:439-442.
805. Autin L, Miteva MA, Lee WH, Mertens K, Radtke KP, Villoutreix BO. Molecular models of the procoagulant factor VIIIa-factor IXa complex. *J Thromb Haemost* 2005;3:2044-2056.
806. Lapan KA, Fay PJ. Localization of a factor X interactive site in the A1 subunit of factor VIIIa. *J Biol Chem* 1997;272:2082-2088.
807. Regan LM, O'Brien LM, Beattie TL, Sudhakar K, Walker FJ, Fay PJ. Activated protein C-catalyzed proteolysis of factor VIIIa alters its interactions within factor Xase. *J Biol Chem* 1996;271:3982-3987.
808. Pittman DD, Wang JH, Kaufman RJ. Identification and functional importance of tyrosine sulfate residues within recombinant factor VIII. *Biochemistry* 1992;31:3315-3325.
809. Michnick DA, Pittman DD, Wise RJ, Kaufman RJ. Identification of individual tyrosine sulfation sites within factor VIII required for optimal activity and efficient thrombin cleavage. *J Biol Chem* 1994;269:20095-20102.
810. Hironaka T, Furukawa K, Esmon PC, et al. Comparative study of the sugar chains of factor VIII purified from human plasma and from the culture media of recombinant baby hamster kidney cells. *J Biol Chem* 1992;267:8012-8020.
811. van Dieijen G, Tans G, Rosing J, Hemker HC. The role of phospholipid and factor VIIIa in the activation of bovine factor X. *J Biol Chem* 1981;256:3433-3442.
812. van Dieijen G, van Rijn JL, Govers-Riemslog JW, Hemker HC, Rosing J. Assembly of the intrinsic factor X activating complex—interactions between factor IXa, factor VIIIa and phospholipid. *Thromb Haemost* 1985;53: 396-400.
813. Duffy EJ, Parker ET, Mutucumarana VP, Johnson AE, Lollar P. Binding of factor VIIIa and factor VIII to factor IXa on phospholipid vesicles. *J Biol Chem* 1992;267:17006-17011.
814. Lollar P, Knutson GJ, Fass DN. Stabilization of thrombin-activated porcine factor VIII:C by factor IXa phospholipid. *Blood* 1984;63:1303-1308.
815. Lamphear BJ, Fay PJ. Factor IXa enhances reconstitution of factor VIIIa from isolated A2 subunit and A1/A3-C1-C2 dimer. *J Biol Chem* 1992;267: 3725-3730.
816. Lamphear BJ, Fay PJ. Proteolytic interactions of factor IXa with human factor VIII and factor VIIIa. *Blood* 1992;80:3120-3126.
817. Fay PJ, Beattie TL, Regan LM, O'Brien LM, Kaufman RJ. Model for the factor VIIIa-dependent decay of the intrinsic factor Xase. Role of subunit dissociation and factor IXa-catalyzed proteolysis. *J Biol Chem* 1996;271:6027-6032.
818. O'Brien DP, Johnson D, Byfield P, Tuddenham EG. Inactivation of factor VIII by factor IXa. *Biochemistry* 1992;31:2805-2812.
819. Fay PJ, Smudzin TM, Walker FJ. Activated protein C-catalyzed inactivation of human factor VIII and factor VIIIa. Identification of cleavage sites and correlation of proteolysis with cofactor activity. *J Biol Chem* 1991;266: 20139-20145.
820. Lu D, Kalafatis M, Mann KG, Long GL. Comparison of activated protein C/protein S-mediated inactivation of human factor VIII and factor V. *Blood* 1996;87:4708-4717.
821. Regan LM, Lamphear BJ, Huggins CF, Walker FJ, Fay PJ. Factor IXa protects factor VIIIa from activated protein C. Factor IXa inhibits activated protein C-catalyzed cleavage of factor VIIIa at Arg562. *J Biol Chem* 1994;269: 9445-9452.

822. Tracy PB, Giles AR, Mann KG, Eide LL, Hoogendoorn H, Rivard GE. Factor V (Quebec): a bleeding diathesis associated with a qualitative platelet Factor V deficiency. *J Clin Invest* 1984;74:1221-1228.
823. Mann KG, Kalafatis M. Factor V: a combination of Dr Jekyll and Mr Hyde. *Blood* 2003;101:20-30.
824. Kalafatis M. Coagulation factor V: a plethora of anticoagulant molecules. *Curr Opin Hematol* 2005;12:141-148.
825. Camire R. A new look at blood coagulation factor V. *Curr Opin Hematol* 2011;18:338-342.
826. Cui J, O'Shea KS, Purkayastha A, Saunders TL, Ginsburg D. Fatal haemorrhage and incomplete block to embryogenesis in mice lacking coagulation factor V. *Nature* 1996;384:66-68.
827. Seligsohn U, Zivelin A, Zwang E. Combined factor V and factor VIII deficiency among non-Ashkenazi Jews. *N Engl J Med* 1982;307:1191-1195.
828. Lippi G, Favaloro E, Montagnana M, Manzato F, Guidi G, Franchini M. Inherited and acquired factor V deficiency. *Blood Coagul Fibrinolysis* 2011;22:160-166.
829. Dansako H, Ishimaru F, Takai Y, et al. Molecular characterization of the ERGIC-53 gene in two Japanese patients with combined factor V-factor VIII deficiency. *Ann Hematol* 2001;80:292-294.
830. Khoriaty R, Vasievich M, Ginsburg D. The COPII pathway and hematologic disease. *Blood* 2012;120:31-38.
831. Baruch D, Lindhout T, Dupuy E, Caen JP. Thrombin-induced platelet factor Va formation in patients with a gray platelet syndrome. *Thromb Haemost* 1987;58:768-771.
832. Weiss HJ, Lages B. Platelet prothrombinase activity and intracellular calcium responses in patients with storage pool deficiency, glycoprotein IIb-IIIa deficiency, or impaired platelet coagulant activity—a comparison with Scott syndrome. *Blood* 1997;89:1599-1611.
833. Janeway CM, Rivard GE, Tracy PB, Mann KG. Factor V Quebec revisited. *Blood* 1996;87:3571-3578.
834. Vos HL. An online database of mutations and polymorphisms in and around the coagulation factor V gene. *J Thromb Haemost* 2007;5:185-188.
835. Wang H, Riddell DC, Guinto ER, MacGillivray RT, Hamerton JL. Localization of the gene encoding human factor V to chromosome 1q21-25. *Genomics* 1988;2:324-328.
836. Kane WH, Ichinose A, Hagen FS, Davie EW. Cloning of cDNAs coding for the heavy chain region and connecting region of human factor V, a blood coagulation factor with four types of internal repeats. *Biochemistry* 1987;26:6508-6514.
837. Mazzorana M, Baffet G, Kneip B, Launois B, Guguen-Guillouzo C. Expression of coagulation factor V gene by normal adult human hepatocytes in primary culture. *Br J Haematol* 1991;78:229-235.
838. Gewirtz AM, Shen YM. Effect of phorbol myristate acetate on c-myc, beta-actin, and FV gene expression in morphologically recognizable human megakaryocytes: a kinetic analysis employing in situ hybridization. *Exp Hematol* 1990;18:945-952.
839. Gewirtz AM, Shapiro C, Shen YM, Boyd R, Colman RW. Cellular and molecular regulation of factor V expression in human megakaryocytes. *J Cell Physiol* 1992;153:277-287.
840. Gewirtz AM, Keefer M, Doshi K, Annamalai AE, Chiu HC, Colman RW. Biology of human megakaryocyte factor V. *Blood* 1986;67:1639-1648.
841. Christella M, Thomassen LG, Castoldi E, et al. Endogenous factor V synthesis in megakaryocytes contributes negligibly to the platelet factor V pool. *Haematologica* 2003;88:1150-1156.
842. Gould WR, Simioni P, Silveira JR, Tormene D, Kalafatis M, Tracy PB. Megakaryocytes endocytose and subsequently modify human factor V in vivo to form the entire pool of a unique platelet-derived cofactor. *J Thromb Haemost* 2005;3:450-456.
843. Camire RM, Pollak ES, Kaushansky K, Tracy PB. Secretable human platelet-derived factor V originates from the plasma pool. *Blood* 1998;92:3035-3041.
844. Handagama P, Rappolee DA, Werb Z, Levin J, Bainton DF. Platelet alpha-granule fibrinogen, albumin, and immunoglobulin G are not synthesized by rat and mouse megakaryocytes. *J Clin Invest* 1990;86:1364-1368.
845. Colman RW. Where does platelet factor V originate? *Blood* 1999;93:3152-3153.

846. Cerveny TJ, Fass DN, Mann KG. Synthesis of coagulation factor V by cultured aortic endothelium. *Blood* 1984;63:1467-1474.
847. Rodgers GM. Vascular smooth muscle cells synthesize, secrete and express coagulation factor V. *Biochim Biophys Acta* 1988;968:17-23.
848. Kane WH, Majerus PW. Purification and characterization of human coagulation factor V. *J Biol Chem* 1981;256:1002-1007.
849. Nesheim ME, Myrmet KH, Hibbard L, Mann KG. Isolation and characterization of single chain bovine factor V. *J Biol Chem* 1979;254:508-517.
850. Dahlback B. Human coagulation factor V purification and thrombin-catalyzed activation. *J Clin Invest* 1980;66:583-591.
851. Katzmann JA, Nesheim ME, Hibbard LS, Mann KG. Isolation of functional human coagulation factor V by using a hybridoma antibody. *Proc Natl Acad Sci U S A* 1981;78:162-166.
852. Mann KG, Lawler CM, Vehar GA, Church WR. Coagulation Factor V contains copper ion. *J Biol Chem* 1984;259:12949-12951.
853. Undas A, Williams EB, Butenas S, Orfeo T, Mann KG. Homocysteine inhibits inactivation of factor Va by activated protein C. *J Biol Chem* 2001;276:4389-4397.
854. Kalafatis M. Identification and partial characterization of factor Va heavy chain kinase from human platelets. *J Biol Chem* 1998;273:8459-8466.
855. Pittman DD, Tomkinson KN, Michnick D, Selighsohn U, Kaufman RJ. Posttranslational sulfation of factor V is required for efficient thrombin cleavage and activation and for full procoagulant activity. *Biochemistry* 1994;33:6952-6959.
856. Pittman DD, Tomkinson KN, Kaufman RJ. Post-translational requirements for functional factor V and factor VIII secretion in mammalian cells. *J Biol Chem* 1994;269:17329-17337.
857. Fernandez JA, Hackeng TM, Kojima K, Griffin JH. The carbohydrate moiety of factor V modulates inactivation by activated protein C. *Blood* 1997;89:4348-4354.
858. Nicolaes GA, Villoutreix BO, Dahlback B. Partial glycosylation of Asn2181 in human factor V as a cause of molecular and functional heterogeneity. Modulation of glycosylation efficiency by mutagenesis of the consensus sequence for N-linked glycosylation. *Biochemistry* 1999;38:13584-13591.
859. Hoekema L, Nicolaes GA, Hemker HC, Tans G, Rosing J. Human factor Va1 and factor Va2: properties in the procoagulant and anticoagulant pathways. *Biochemistry* 1997;36:3331-3335.
860. Rosing J, Bakker HM, Thomassen MC, Hemker HC, Tans G. Characterization of two forms of human factor Va with different cofactor activities. *J Biol Chem* 1993;268:21130-21136.
861. Kim SW, Ortel TL, Quinn-Allen MA, et al. Partial glycosylation at asparagine-2181 of the second C-type domain of human factor V modulates assembly of the prothrombinase complex. *Biochemistry* 1999;38:11448-11454.
862. Kalafatis M, Rand MD, Mann KG. Factor Va-membrane interaction is mediated by two regions located on the light chain of the cofactor. *Biochemistry* 1994;33:486-493.
863. Villoutreix BO, Dahlback B. Structural investigation of the A domains of human blood coagulation factor V by molecular modeling. *Protein Sci* 1998;7:1317-1325.
864. Pellequer JL, Gale AJ, Getzoff ED, Griffin JH. Three-dimensional model of coagulation factor Va bound to activated protein C. *Thromb Haemost* 2000;84:849-857.
865. Adams TE, Hockin MF, Mann KG, Everse SJ. The crystal structure of activated protein C-inactivated bovine factor Va: Implications for cofactor function. *Proc Natl Acad Sci U S A* 2004;101:8918-8923. 10.1073/pnas.04030721010403072101 [pii].
866. Saleh M, Peng W, Quinn-Allen MA, et al. The factor V C1 domain is involved in membrane binding: identification of functionally important amino acid residues within the C1 domain of factor V using alanine scanning mutagenesis. *Thromb Haemost* 2004;91:16-27.
867. Autin L, Steen M, Dahlback B, Villoutreix BO. Proposed structural models of the prothrombinase (FXa-FVa) complex. *Proteins* 2006;63:440-450.

868. Esmon CT. The subunit structure of thrombin-activated factor V. Isolation of activated factor V, separation of subunits, and reconstitution of biological activity. *J Biol Chem* 1979;254:964-973.
869. Guinto ER, Esmon CT. Formation of a calcium-binding site on bovine activated factor V following recombination of the isolated subunits. *J Biol Chem* 1982;257:10038-10043.
870. Kane WH, Majerus PW. The interaction of human coagulation factor Va with platelets. *J Biol Chem* 1982;257:3963-3969.
871. Laue TM, Johnson AE, Esmon CT, Yphantis DA. Structure of bovine blood coagulation factor Va. Determination of the subunit associations, molecular weights, and asymmetries by analytical ultracentrifugation. *Biochemistry* 1984;23:1339-1348.
872. Thorelli E, Kaufman RJ, Dahlback B. Cleavage requirements for activation of factor V by factor Xa. *Eur J Biochem* 1997;247:12-20.
873. Vicic WJ, Lages B, Weiss HJ. Release of human platelet factor V activity is induced by both collagen and ADP and is inhibited by aspirin. *Blood* 1980;56:448-455.
874. Bradford HN, Annamalai A, Doshi K, Colman RW. Factor V is activated and cleaved by platelet calpain: comparison with thrombin proteolysis. *Blood* 1988;71:388-394.
875. Allen DH, Tracy PB. Human coagulation factor V is activated to the functional cofactor by elastase and cathepsin G expressed at the monocyte surface. *J Biol Chem* 1995;270:1408-1415.
876. Camire RM, Kalafatis M, Tracy PB. Proteolysis of factor V by cathepsin G and elastase indicates that cleavage at Arg1545 optimizes cofactor function by facilitating factor Xa binding. *Biochemistry* 1998;37:11896-11906.
877. Kalafatis M, Mann KG. The role of the membrane in the inactivation of factor va by plasmin. Amino acid region 307-348 of factor V plays a critical role in factor Va cofactor function. *J Biol Chem* 2001;276:18614-18623.
878. Zeibdawi AR, Pryzdial EL. Mechanism of factor Va inactivation by plasmin. Loss of A2 and A3 domains from a Ca_2^+ -dependent complex of fragments bound to phospholipid. *J Biol Chem* 2001;276:19929-19936.
879. Lee CD, Mann KG. Activation/inactivation of human factor V by plasmin. *Blood* 1989;73:185-190.
880. Tracy RP, Rubin DZ, Mann KG, et al. Thrombolytic therapy and proteolysis of factor V. *J Am Coll Cardiol* 1997;30:716-724.
881. Mann KG, Hockin MF, Begin KJ, Kalafatis M. Activated protein C cleavage of factor Va leads to dissociation of the A2 domain. *J Biol Chem* 1997;272:20678-20683.
882. Hockin MF, Cawthern KM, Kalafatis M, Mann KG. A model describing the inactivation of factor Va by APC: bond cleavage, fragment dissociation, and product inhibition. *Biochemistry* 1999;38:6918-6934.
883. Dahlback B, Carlsson M, Svensson PJ. Familial thrombophilia due to a previously unrecognized mechanism characterized by poor anticoagulant response to activated protein C: prediction of a cofactor to activated protein C. *Proc Natl Acad Sci U S A* 1993;90:1004-1008.
884. Bertina RM, Koeleman BP, Koster T, et al. Mutation in blood coagulation factor V associated with resistance to activated protein C. *Nature* 1994;369:64-67.
885. Kalafatis M, Bernardi F, Simioni P, Lunghi B, Girolami A, Mann KG. Phenotype and genotype expression in pseudohomozygous factor VLEIDEN: the need for phenotype analysis. *Arterioscler Thromb Vasc Biol* 1999;19:336-342.
886. Ridker PM, Miletich JP, Hennekens CH, Buring JE. Ethnic distribution of factor V Leiden in 4047 men and women. Implications for venous thromboembolism screening. *JAMA* 1997;277:1305-1307.
887. Kalafatis M, Mann KG. Factor V Leiden and thrombophilia. *Arterioscler Thromb Vasc Biol* 1997;17:620-627.
888. Kujovich J. Factor V Leiden thrombophilia. *Genet Med* 2011;13:1-16.
889. Beauchamp NJ, Daly ME, Hampton KK, Cooper PC, Preston FE, Peake IR. High prevalence of a mutation in the factor V gene within the U.K. population: relationship to activated protein C resistance and familial thrombosis. *Br J Haematol* 1994;88:219-222.

890. Ridker PM, Hennekens CH, Lindpaintner K, Stampfer MJ, Eisenberg PR, Miletich JP. Mutation in the gene coding for coagulation factor V and the risk of myocardial infarction, stroke, and venous thrombosis in apparently healthy men [see comments]. *N Engl J Med* 1995;332:912-917.
891. Dahlback B. Factor V gene mutation causing inherited resistance to activated protein C as a basis for venous thromboembolism. *J Intern Med* 1995;237:221-227.
892. Abildgaard CF, Suzuki Z, Harrison J, Jefcoat K, Zimmerman TS. Serial studies in von Willebrand's disease: variability versus "variants". *Blood* 1980;56:712-716.
893. Koutts J, Walsh PN, Plow EF, Fenton JW, Bouma BN, Zimmerman TS. Active release of human platelet factor VIII-related antigen by adenosine diphosphate, collagen, and thrombin. *J Clin Invest* 1978;62:1255-1263.
894. Gill JC, Endres-Brooks J, Bauer PJ, Marks WJ Jr, Montgomery RR. The effect of ABO blood group on the diagnosis of von Willebrand disease. *Blood* 1987;69:1691-1695.
895. van Schie M, van Loon J, de Maat M, Leebeek F. Genetic determinants of von Willebrand factor levels and activity in relation to the risk of cardiovascular disease: a review. *J Thromb Haemost* 2011;9:899-908.
896. Moake JL, Olson JD, Troll JH Jr, Weinger RS, Peterson DM, Cimo PL. Interaction of platelets, von Willebrand factor, and ristocetin during platelet agglutination. *J Lab Clin Med* 1980;96:168-184.
897. Weiss HJ, Rogers J, Brand H. Defective ristocetin-induced platelet aggregation in von Willebrand's disease and its correction by factor VIII. *J Clin Invest* 1973;52:2697-2707.
898. Von Willebrand EA. Hereditary pseudohaemophilia. *Haemophilia* 1999;5:223-231.
899. Jorpes EJ. von Willebrand och von Willebrans sjukdom. *Nord Med* 1962;67:729.
900. Nilsson IM, Blomback M, Jorpes EJ, et al. von Willebrand's disease and its correction with human plasma fraction I-O. *Acta Med Scand* 1957;159:179.
901. Biggs R, Matthews JM. The treatment of haemorrhage in von Willebrand's disease and the blood level of Factor VIII (AHG). *Br J Haematol* 1963;9:203.
902. Rodeghiero F, Castaman G, Dini E. Epidemiological investigation of the prevalence of von Willebrand's disease. *Blood* 1987;69:454-459.
903. Werner EJ, Broxson EH, Tucker EL, Giroux DS, Shults J, Abshire TC. Prevalence of von Willebrand disease in children: a multiethnic study. *J Pediatr* 1993;123:893-898.
904. Berliner SA, Seligsohn U, Zivelin A, Zwang E, Soffer G. A relatively high frequency of severe (type III) von Willebrand's disease in Israel. *Br J Haematol* 1986;62:535-543.
905. Lenk H, Nilsson IM, Holmberg L, Weissbach G. Frequency of different types of von Willebrand's disease in the GDR. *Acta Med Scand* 1988;224:275-280.
906. Ates E, Bakkaloglu A, Saatci U, Soylemezoglu O. von Willebrand factor antigen compared with other factors in vasculitic syndromes. *Arch Dis Child* 1994;70:40-43.
907. Stevens TR, James JP, Simmonds NJ, et al. Circulating von Willebrand factor in inflammatory bowel disease. *Gut* 1992;33:502-506.
908. Blann AD. von Willebrand factor antigen as an acute phase reactant and marker of endothelial cell injury in connective tissue diseases: a comparison with CRP, rheumatoid factor, and erythrocyte sedimentation rate. *Z Rheumatol* 1991;50:320-322.
909. Pottinger BE, Read RC, Paleolog EM, Higgins PG, Pearson JD. von Willebrand factor is an acute phase reactant in man. *Thromb Res* 1989;53:387-394.
910. Denis C, Lenting P. von Willebrand factor: at the crossroads of bleeding and thrombosis. *Int J Hematol* 2012;95:353-361.
911. Mancuso DJ, Tuley EA, Westfield LA, et al. Structure of the gene for human von Willebrand factor. *J Biol Chem* 1989;264:19514-19527.
912. Mancuso DJ, Tuley EA, Westfield LA, et al. Human von Willebrand factor gene and pseudogene: structural analysis and differentiation by polymerase chain reaction. *Biochemistry* 1991;30:253-269.

913. Shelton-Inloes BB, Chehab FF, Mannucci PM, Federici AB, Sadler JE. Gene deletions correlate with the development of alloantibodies in von Willebrand disease. *J Clin Invest* 1987;79:1459-1465.
914. Jaffe EA, Hoyer LW, Nachman RL. Synthesis of von Willebrand factor by cultured human endothelial cells. *Proc Natl Acad Sci U S A* 1974;71:1906-1909.
915. Sporn LA, Chavin SI, Marder VJ, Wagner DD. Biosynthesis of von Willebrand protein by human megakaryocytes. *J Clin Invest* 1985;76:1102-1106.
916. Wagner DD, Olmsted JB, Marder VJ. Immunolocalization of von Willebrand protein in Weibel-Palade bodies of human endothelial cells. *J Cell Biol* 1982;95:355-360.
917. Schwachtgen JL, Janel N, Berek L, et al. Ets transcription factors bind and transactivate the core promoter of the von Willebrand factor gene. *Oncogene* 1997;15:3091-3102.
918. Slot JW, Bouma BN, Montgomery R, Zimmerman TS. Platelet factor VIII-related antigen: immunofluorescent localization. *Thromb Res* 1978;13: 871-881.
919. Coller BS, Hirschman RJ, Gralnick HR. Studies on the Factor VIII/von Willebrand factor antigen on human platelets. *Thromb Res* 1975;6:469-480.
920. Guan J, Guillot PV, Aird WC. Characterization of the mouse von Willebrand factor promoter. *Blood* 1999;94:3405-3412.
921. Jahroudi N, Lynch DC. Endothelial-cell-specific regulation of von Willebrand factor gene expression. *Mol Cell Biol* 1994;14:999-1008.
922. Schwachtgen JL, Remacle JE, Janel N, et al. Oct-1 is involved in the transcriptional repression of the von willebrand factor gene promoter. *Blood* 1998;92:1247-1258.
923. Ardekani AM, Greenberger JS, Jahroudi N. Two repressor elements inhibit expression of the von Willebrand factor gene promoter in vitro. *Thromb Haemost* 1998;80:488-494.
924. Aird WC, Edelberg JM, Weiler-Guettler H, Simmons WW, Smith TW, Rosenberg RD. Vascular bed-specific expression of an endothelial cell gene is programmed by the tissue microenvironment. *J Cell Biol* 1997;138: 1117-1124.
925. Edelberg JM, Aird WC, Wu W, et al. PDGF mediates cardiac microvascular communication. *J Clin Invest* 1998;102:837-843.
926. Collins CJ, Underdahl JP, Levene RB, et al. Molecular cloning of the human gene for von Willebrand factor and identification of the transcription initiation site. *Proc Natl Acad Sci U S A* 1987;84:4393-4397.
927. Hamilton KK, Sims PJ. Changes in cytosolic Ca_2^+ associated with von Willebrand factor release in human endothelial cells exposed to histamine. Study of microcarrier cell monolayers using the fluorescent probe indo-1. *J Clin Invest* 1987;79:600-608.
928. Menon C, Berry EW, Ockelford P. Beneficial effect of D.D.A.V.P. on bleeding-time in von Willebrand's disease. *Lancet* 1978;2:743-744.
929. Takeuchi M, Nagura H, Kaneda T. DDAVP and epinephrine-induced changes in the localization of von Willebrand factor antigen in endothelial cells of human oral mucosa. *Blood* 1988;72:850-854.
930. Denis C, Christophe O, Oortwijn B, Lenting P. Clearance of von Willebrand factor. *Thrombosis and Haemostasis* 2008;99:271-278.
931. Sadler JE, Shelton-Inloes BB, Sorace JM, Harlan JM, Titani K, Davie EW. Cloning and characterization of two cDNAs coding for human von Willebrand factor. *Proc Natl Acad Sci U S A* 1985;82:6394-6398.
932. Lynch DC, Zimmerman TS, Collins CJ, et al. Molecular cloning of cDNA for human von Willebrand factor: authentication by a new method. *Cell* 1985;41:49-56.
933. Shelton-Inloes BB, Titani K, Sadler JE. cDNA sequences for human von Willebrand factor reveal five types of repeated domains and five possible protein sequence polymorphisms. *Biochemistry* 1986;25:3164-171.
934. Verweij CL, Diergaarde PJ, Hart M, Pannekoek H. Full-length von Willebrand factor (vWF) cDNA encodes a highly repetitive protein considerably larger than the mature vWF subunit [published erratum appears in *EMBO J* 1986 Nov;5(11):3074]. *EMBO J* 1986;5:1839-1847.

935. Titani K, Kumar S, Takio K, et al. Amino acid sequence of human von Willebrand factor. *Biochemistry* 1986;25:3171-3184.
936. Ginsburg D, Handin RI, Bonthron DT, et al. Human von Willebrand factor (vWF): isolation of complementary DNA (cDNA) clones and chromosomal localization. *Science* 1985;228:1401-1406.
937. Koller E, Winterhalter KH, Trueb B. The globular domains of type VI collagen are related to the collagen-binding domains of cartilage matrix protein and von Willebrand factor. *EMBO J* 1989;8:1073-1077.
938. Sadler JE, Mancuso DJ, Randi AM, Tuley EA, Westfield LA. Molecular biology of von Willebrand factor. *Ann NY Acad Sci* 1991;614:114-124.
939. Hunt LT, Barker WC. von Willebrand factor shares a distinctive cysteine-rich domain with thrombospondin and procollagen. *Biochem Biophys Res Commun* 1987;144:876-882.
940. Verweij CL, Hofker M, Quadt R, Briet E, Pannekoek H. RFLP for a human von Willebrand factor (vWF) cDNA clone, pvWF1100. *Nucleic Acids Res* 1985;13:8289.
941. Santoro SA. Adsorption of von Willebrand factor/factor VIII by the genetically distinct interstitial collagens. *Thromb Res* 1981;21:689-691.
942. Cruz MA, Yuan H, Lee JR, Wise RJ, Handin RI. Interaction of the von Willebrand factor (vWF) with collagen. Localization of the primary collagen-binding site by analysis of recombinant vWF a domain polypeptides [published erratum appears in *J Biol Chem* 1995 Aug 18;270(33):19668]. *J Biol Chem* 1995;270:10822-10827.
943. Weiss HJ, Turitto VT, Baumgartner HR. Effect of shear rate on platelet interaction with subendothelium in citrated and native blood. I. Shear rate—dependent decrease of adhesion in von Willebrand's disease and the Bernard-Soulier syndrome. *J Lab Clin Med* 1978;92:750-764.
944. Sakariassen KS, Nievelstein PF, Collier BS, Sixma JJ. The role of platelet membrane glycoproteins Ib and IIb-IIIa in platelet adherence to human artery subendothelium. *Br J Haematol* 1986;63:681-691.
945. Matsushita T, Sadler JE. Identification of amino acid residues essential for von Willebrand factor binding to platelet glycoprotein Ib. Charged-to-alanine scanning mutagenesis of the A1 domain of human von Willebrand factor. *J Biol Chem* 1995;270:13406-13414.
946. Bockenstedt P, Greenberg JM, Handin RI. Structural basis of von Willebrand factor binding to platelet glycoprotein Ib and collagen. Effects of disulfide reduction and limited proteolysis of polymeric von Willebrand factor. *J Clin Invest* 1986;77:743-749.
947. Girma JP, Kalafatis M, Pietu G, et al. Mapping of distinct von Willebrand factor domains interacting with platelet GPIb and GPIIb/IIIa and with collagen using monoclonal antibodies. *Blood* 1986;67:1356-1366.
948. Pareti FI, Fujimura Y, Dent JA, Holland LZ, Zimmerman TS, Ruggeri ZM. Isolation and characterization of a collagen binding domain in human von Willebrand factor. *J Biol Chem* 1986;261:15310-15315.
949. Ruggeri ZM, De Marco L, Gatti L, Bader R, Montgomery RR. Platelets have more than one binding site for von Willebrand factor. *J Clin Invest* 1983;72:1-12.
950. Schullek J, Jordan J, Montgomery RR. Interaction of von Willebrand factor with human platelets in the plasma milieu. *J Clin Invest* 1984;73:421-428.
951. Goto S, Salomon DR, Ikeda Y, Ruggeri ZM. Characterization of the unique mechanism mediating the shear-dependent binding of soluble von Willebrand factor to platelets. *J Biol Chem* 1995;270:23352-23361.
952. Ruggeri ZM, Bader R, De Marco L. Glanzmann thrombasthenia: deficient binding of von Willebrand factor to thrombin-stimulated platelets. *Proc Natl Acad Sci U S A* 1982;79:6038-6041.
953. Fujimoto T, Hawiger J. Adenosine diphosphate induces binding of von Willebrand factor to human platelets. *Nature* 1982;297:154-156.
954. Fujimoto T, Ohara S, Hawiger J. Thrombin-induced exposure and prostacyclin inhibition of the receptor for factor VIII/von Willebrand factor on human platelets. *J Clin Invest* 1982;69:1212-1222.
955. Fay PJ, Coumans JV, Walker FJ. von Willebrand factor mediates protection of factor VIII from activated protein C-catalyzed inactivation. *J Biol Chem* 1991;266:2172-2177.

956. Swords NA, Mann KG. The assembly of the prothrombinase complex on adherent platelets. *Arterioscler Thromb* 1993;13:1602-1612.
957. Furlan M, Lammle B. Assays of von Willebrand factor-cleaving protease: a test for diagnosis of familial and acquired thrombotic thrombocytopenic purpura. *Semin Thromb Hemost* 2002;28:167-172.
958. Chung DW, Fujikawa K. Processing of von Willebrand factor by ADAMTS-13. *Biochemistry* 2002;41:11065-11070.
959. Fujikawa K, Suzuki H, McMullen B, Chung D. Purification of human von Willebrand factor-cleaving protease and its identification as a new member of the metalloproteinase family. *Blood* 2001;98:1662-1666.
960. Gerritsen HE, Robles R, Lammle B, Furlan M. Partial amino acid sequence of purified von Willebrand factor-cleaving protease. *Blood* 2001;98:1654-1661.
961. Tsai HM. ADAMTS13 and microvascular thrombosis. *Expert Rev Cardiovasc Ther* 2006;4:813-825.
962. Morawitz P. Die chemie der blutgerinnung. *Ergebn Physiol* 1905;4:307.
963. Fuld E, Spiro K. Der einfluss einiger gerrinnungshemmender agentien auf das Vogel plasma. *Beitr z Chem Phys u Path (Hofmeister's)* 1904;5:171.
964. Bar-Shavit R, Kahn A, Mudd MS, Wilner GD, Mann KG, Fenton JW. Localization of a chemotactic domain in human thrombin. *Biochemistry* 1984;23:397-400.
965. Spraggon G, Everse SJ, Doolittle RF. Crystal structures of fragment D from human fibrinogen and its crosslinked counterpart from fibrin. *Nature* 1997;389:455-462.
966. Hantgan R, McDonagh J, Hermans J. Fibrin assembly. *Ann NY Acad Sci* 1983;408:344-366.
967. Lorand L, Jeong JM, Radek JT, Wilson J. Human plasma factor XIII: subunit interactions and activation of zymogen. *Methods Enzymol* 1993;222:22-35.
968. Yee VC, Pedersen LC, Le TI, Bishop PD, Stenkamp RE, Teller DC. Three-dimensional structure of a transglutaminase: human blood coagulation factor XIII. *Proc Natl Acad Sci U S A* 1994;91:7296-7300.
969. Bajzar L, Morser J, Nesheim M. TAFI, or plasma procarboxypeptidase B, couples the coagulation and fibrinolytic cascades through the thrombinthrombomodulin complex. *J Biol Chem* 1996;271:16603-16608.
970. Lollar P, Parker CG. Subunit structure of thrombin-activated porcine factor VIII. *Biochemistry* 1989;28:666-674.
971. Berk BC, Taubman MB, Cragoe EJ Jr, Fenton JW, Griendling KK. Thrombin signal transduction mechanisms in rat vascular smooth muscle cells. Calcium and protein kinase C-dependent and -independent pathways. *J Biol Chem* 1990;265:17334-17340.
972. Michel MC, Brass LF, Williams A, Bokoch GM, LaMorte VJ, Motulsky HJ. Alpha 2-adrenergic receptor stimulation mobilizes intracellular Ca_2^+ in human erythroleukemia cells [published erratum appears in *J Biol Chem* 1989 Oct 5;264(28):16963]. *J Biol Chem* 1989;264:4986-4991.
973. He CJ, Rondeau E, Medcalf RL, Lacave R, Schleuning WD, Sraer JD. Thrombin increases proliferation and decreases fibrinolytic activity of kidney glomerular epithelial cells. *J Cell Physiol* 1991;146:131-140.
974. Glenn KC, Carney DH, Fenton JW, Cunningham DD. Thrombin active site regions required for fibroblast receptor binding and initiation of cell division. *J Biol Chem* 1980;255:6609-6616.
975. Herbert JM, Lamarche I, Dol F. Induction of vascular smooth muscle cell growth by selective activation of the thrombin receptor. Effect of heparin. *FEBS Lett* 1992;301:155-158.
976. Harlan JM, Thompson PJ, Ross RR, Bowen-Pope DF. Alpha-thrombin induces release of platelet-derived growth factor-like molecule(s) by cultured human endothelial cells. *J Cell Biol* 1986;103:1129-1133.
977. Vlodavsky I, Folkman J, Sullivan R, Fridman R, Ishai-Michaeli R, Sasse J, Klagsbrun M. Endothelial cell-derived basic fibroblast growth factor: synthesis and deposition into subendothelial extracellular matrix. *Proc Natl Acad Sci U S A* 1987;84:2292-2296.
978. Ross R, Glomset J, Kariya B, Harker L. A platelet-dependent serum factor that stimulates the proliferation of arterial smooth muscle cells in vitro. *Proc Natl Acad Sci U S A* 1974;71:1207-1210.
979. Majesky MW, Lindner V, Twardzik DR, Schwartz SM, Reidy MA. Production of transforming growth factor beta 1 during repair of arterial injury. *J Clin Invest* 1991;88:904-910.

980. Clinton SK, Fleet JC, Loppnow H, et al. Interleukin-1 gene expression in rabbit vascular tissue in vivo. *Am J Pathol* 1991;138:1005-1014.
981. Douglas SA, Loudon C, Vickery-Clark LM, et al. A role for endogenous endothelin-1 in neointimal formation after rat carotid artery balloon angioplasty. Protective effects of the novel nonpeptide endothelin receptor antagonist SB 209670. *Circ Res* 1994;75:190-197.
982. Sigal SL, Gellman J, Sarembock IJ, et al. Effects of serotonin-receptor blockade on angioplasty-induced vasospasm in an atherosclerotic rabbit model. *Arterioscler Thromb* 1991;11:770-783.
983. Mugge A, Heistad DD, Densen P, et al. Activation of leukocytes with complement C5a is associated with prostanoid-dependent constriction of large arteries in atherosclerotic monkeys in vivo. *Atherosclerosis* 1992;95:211-222.
984. Seino Y, Ikeda U, Ikeda M, et al. Interleukin 6 gene transcripts are expressed in human atherosclerotic lesions. *Cytokine* 1994;6:87-91.
985. Malik AB, Fenton JW. Thrombin-mediated increase in vascular endothelial permeability. *Semin Thromb Hemost* 1992;18:193-199.
986. Sugama Y, Malik AB. Thrombin receptor 14-amino acid peptide mediates endothelial hyperadhesivity and neutrophil adhesion by P-selectin-dependent mechanism. *Circ Res* 1992;71:1015-1019.
987. Hollenberg MD, Yang SG, Laniyonu AA, Moore GJ, Saifeddine M. Action of thrombin receptor polypeptide in gastric smooth muscle: identification of a core pentapeptide retaining full thrombin-mimetic intrinsic activity. *Mol Pharmacol* 1992;42:186-191.
988. Vouret-Craviari V, Obberghen-Schilling E, Rasmussen UB, Pavirani A, Lecocq JP, Pouyssegur J. Synthetic alpha-thrombin receptor peptides activate G protein-coupled signaling pathways but are unable to induce mitogenesis. *Mol Biol Cell* 1992;3:95-102.
989. Vu TK, Hung DT, Wheaton VI, Coughlin SR. Molecular cloning of a functional thrombin receptor reveals a novel proteolytic mechanism of receptor activation. *Cell* 1991;64:1057-1068.
990. Walker FJ. Regulation of activated protein C by protein S. The role of phospholipid in factor Va inactivation. *J Biol Chem* 1981;256:11128-11131.
991. Esmon CT. The roles of protein C and thrombomodulin in the regulation of blood coagulation. *J Biol Chem* 1989;264:4743-476.
992. Walker FJ, Fay PJ. Regulation of blood coagulation by the protein C system. *FASEB J* 1992;6:2561-2567.
993. Jenny NS, Mann KG. Thrombin. In: Colman RW, Hirsh J, Marder VJ, Clowes AW, George JN, eds. *Hemostasis and thrombosis; basic principles & clinical practice*. Philadelphia, PA: Lippincott Williams & Wilkins, 2001:171-189.
994. Poort SR, Michiels JJ, Reitsma PH, Bertina RM. Homozygosity for a novel missense mutation in the prothrombin gene causing a severe bleeding disorder. *Thromb Haemost* 1994;72:819-824.
995. Reuner KH, Ruf A, Grau A, et al. Prothrombin gene G20210→A transition is a risk factor for cerebral venous thrombosis. *Stroke* 1998;29:1765-1769.
996. Hillarp A, Zoller B, Svensson PJ, Dahlback B. The 20210 A allele of the prothrombin gene is a common risk factor among Swedish outpatients with verified deep venous thrombosis [see comments]. *Thromb Haemost* 1997;78:990-992.
997. Ferraresi P, Marchetti G, Legnani C, et al. The heterozygous 20210 G/A prothrombin genotype is associated with early venous thrombosis in inherited thrombophilias and is not increased in frequency in artery disease. *Arterioscler Thromb Vasc Biol* 1997;17:2418-2422.
998. Margaglione M, Brancaccio V, Giuliani N, et al. Increased risk for venous thrombosis in carriers of the prothrombin G->A20210 gene variant. *Ann Intern Med* 1998;129:89-93.
999. Lundblad RL, Noyes CM, Mann KG, Kingdon HS. The covalent differences between bovine α- and α'-thrombin: a structural explanation for the changes in catalytic activity. *J Biol Chem* 1979;254:8524-8528.
1000. Witting JI, Miller TM, Fenton JW. Human alpha- and gamma-thrombin specificity with tripeptide p- nitroanalide substrates under physiologically relevant conditions. *Thromb Res* 1987;46:567-574.
1001. Stevens WK, Cote HF, MacGillivray RT, Nesheim ME. Calcium ion modulation of meizothrombin autolysis at Arg55-Asp56 and catalytic activity. *J Biol Chem* 1996;271:8062-8067.

1002. Tracy PB, Eide LL, Bowie EJ, Mann KG. Radioimmunoassay of factor V in human plasma and platelets. *Blood* 1982;60:59-63.
1003. Keenan JP, Solum NO. Quantitative studies on the release of platelet fibrinogen by thrombin. *Br J Haematol* 1972;23:461-466.
1004. Niewiarowski S, Thomas DP. Platelet factor 4 and adenosine diphosphate release during human platelet aggregation. *Nature* 1969;222:1269-1270.
1005. Levine SP, Wohl H. Human platelet factor IV: Purification and characterization by affinity chromatography. Purification of human platelet factor IV. *J Biol Chem* 1976;251:324-328.
1006. Lawler JW, Slayter HS, Coligan JE. Isolation and characterization of a high molecular weight glycoprotein from human blood platelets. *J Biol Chem* 1978;253:8609-8616.
1007. Zucker MB, Mosesson MW, Broekman MJ, Kaplan KL. Release of platelet fibronectin (cold-insoluble globulin) from alpha granules induced by thrombin or collagen; lack of requirement for plasma fibronectin in ADP-induced platelet aggregation. *Blood* 1979;54:8-12.
1008. Viskup RW, Tracy PB, Mann KG. The isolation of human platelet factor V [published erratum appears in *Blood* 1987 Jul;70(1):339]. *Blood* 1987;69: 1188-1195.
1009. Larsen E, Celi A, Gilbert GE, et al. PADGEM protein: a receptor that mediates the interaction of activated platelets with neutrophils and monocytes. *Cell* 1989;59:305-312.
1010. Hamburger SA, McEver RP. GMP-140 mediates adhesion of stimulated platelets to neutrophils. *Blood* 1990;75:550-554.
1011. Wang W, Boffa MB, Bajzar L, Walker JB, Nesheim ME. A study of the mechanism of inhibition of fibrinolysis by activated thrombin-activable fibrinolysis inhibitor. *J Biol Chem* 1998;273:27176-27181.
1012. Valnickova Z, Enghild JJ. Human procarboxypeptidase U, or thrombin-activable fibrinolysis inhibitor, is a substrate for transglutaminases. Evidence for transglutaminase-catalyzed cross-linking to fibrin. *J Biol Chem* 1998;273:27220-27224.
1013. Brummel KE, Butenas S, Mann KG. An integrated study of fibrinogen during blood coagulation. *J Biol Chem* 1999;274:22862-22870.
1014. dem Borne PA, Mosnier LO, Tans G, Meijers JC, Bouma BN. Factor XI activation by meizothrombin: stimulation by phospholipid vesicles containing both phosphatidylserine and phosphatidylethanolamine. *Thromb Haemost* 1997;78:834-839.
1015. Tans G, Nicolaes GA, Thomassen MC, et al. Activation of human factor V by meizothrombin. *J Biol Chem* 1994;269:15969-15972.
1016. Di Cera E. Thrombin as an anticoagulant. *Prog Mol Biol Transl Sci* 2011;99:145-184.
1017. Esmon CT, Owen WG. Identification of an endothelial cell cofactor for thrombin-catalyzed activation of protein C. *Proc Natl Acad Sci U S A* 1981;78: 2249-2252.
1018. Bagdasarian A, Colman RW. Subcellular localization and purification of platelet alpha1- antitrypsin. *Blood* 1978;51:139-156.
1019. Schwarz HP, Heeb MJ, Wencel-Drake JD, Griffin JH. Identification and quantitation of protein S in human platelets. *Blood* 1985;66:1452-1455.
1020. Novotny WF, Girard TJ, Miletich JP, Broze GJ Jr. Platelets secrete a coagulation inhibitor functionally and antigenically similar to the lipoprotein associated coagulation inhibitor. *Blood* 1988;72:2020-2025.
1021. Antoniades HN. Human platelet-derived growth factor (PDGF): purification of PDGF-I and PDGF-II and separation of their reduced subunits. *Proc Natl Acad Sci U S A* 1981;78:7314-7317.
1022. Heldin CH, Westermark B, Wasteson A. Platelet-derived growth factor. Isolation by a large-scale procedure and analysis of subunit composition. *Biochem J* 1981;193:907-913.
1023. Deuel TF, Huang JS, Proffitt RT, Baenziger JU, Chang D, Kennedy BB. Human platelet-derived growth factor. Purification and resolution into two active protein fractions. *J Biol Chem* 1981;256:8896-8899.

1024. Raines EW, Ross R. Platelet-derived growth factor. I. High yield purification and evidence for multiple forms. *J Biol Chem* 1982;257:5154-5160.
1025. Childs CB, Proper JA, Tucker RF, Moses HL. Serum contains a platelet-derived transforming growth factor. *Proc Natl Acad Sci U S A* 1982;79:5312-5316.
1026. Clemmons DR, Isley WL, Brown MT. Dialyzable factor in human serum of platelet origin stimulates endothelial cell replication and growth. *Proc Natl Acad Sci U S A* 1983;80:1641-1645.
1027. King GL, Buchwald S. Characterization and partial purification of an endothelial cell growth factor from human platelets. *J Clin Invest* 1984;73:392-396.
1028. Harrison P, Cramer EM. Platelet alpha-granules. *Blood Rev* 1993;7:52-62.
1029. Hou L, Howells GL, Kapas S, Macey MG. The protease-activated receptors and their cellular expression and function in blood-related cells. *Br J Haematol* 1998;101:1-9.
1030. Vu TK, Wheaton VI, Hung DT, Charo I, Coughlin SR. Domains specifying thrombin-receptor interaction. *Nature* 1991;353:674-677.
1031. Schmidt VA, Nierman WC, Maglott DR, et al. The human proteinaseactivated receptor-3 (PAR-3) gene. Identification within a Par gene cluster and characterization in vascular endothelial cells and platelets. *J Biol Chem* 1998;273:15061-15068.
1032. Seegers WH, McCoy L, Kipfer RK, Murano G. Preparation and properties of thrombin. *Arch Biochem Biophys* 1968;128:194-201.
1033. Mann KG, Batt CW. The molecular weights of bovine thrombin and its primary autolysis products. *J Biol Chem* 1969;244:6555-6557.
1034. Rosenberg RD, Waugh DF. Multiple bovine thrombin components. *J Biol Chem* 1970;245:5049-5056.
1035. Boissel JP, Le Bonniec B, Rabiet MJ, Labie D, Elion J. Covalent structures of beta and gamma autolytic derivatives of human alpha-thrombin. *J Biol Chem* 1984;259:5691-5697.
1036. Fenton JW, Landis BH, Walz DA, Finlayson JS. Human Thrombins. In: Lundblad RL, Fenton JW, Mann KG, eds. *The chemistry and biology of thrombin*. Ann Arbor, MI: Ann Arbor Press, 1977:43-70.
1037. Lottenberg R, Hall JA, Fenton JW, Jackson CM. The action of thrombin on peptide p-nitroanilide substrates: hydrolysis of Tos-Gly-Pro-Arg-pNA and D-Phe-Pip-Arg-pNA by human alpha and gamma and bovine alpha and betathrombins. *Thromb Res* 1982;28:313-332.
1038. Lorand L, Credo RB. Thrombin and fibrin stabilization. In: Lundblad RL, Fenton JW, Mann KG, eds. *The chemistry and biology of thrombin*. Ann Arbor, MI: Ann Arbor Press, 1977:311-323.
1039. Bezeaud A, Denninger MH, Guillin MC. Interaction of human alpha-thrombin and gamma-thrombin with antithrombin III, protein C and thrombomodulin. *Eur J Biochem* 1985;153:491-496.
1040. Seegers WH, McCoy LE, Walz DA, Reuterby J, Andary TJ. Isolation of thrombin-E and the evolution of enzyme activity from prothrombin. *Experientia* 1974;30:1130-1132.
1041. Matafonov A, Sarilla S, Sun M, et al. Activation of factor XI by products of prothrombin activation. *Blood* 2011;118:437-445.
1042. Lundblad RL, Nesheim ME, Straight DL, et al. Bovine alpha- and beta-thrombin. Reduced fibrinogen-clotting activity of beta-thrombin is not a consequence of reduced affinity for fibrinogen. *J Biol Chem* 1984;259:6991-6995.
1043. Berliner LJ, Shen YY. Physical evidence for an apolar binding site near the catalytic center of human alpha-thrombin. *Biochemistry* 1977;16:4622-4626.
1044. Di Cera E, Guinto ER, Vindigni A, et al. The Na⁺ binding site of thrombin. *J Biol Chem* 1995;270:22089-22092.
1045. Tulinsky A. Molecular interactions of thrombin. *Semin Thromb Hemost* 1996;22:117-124.
1046. Folkers PJ, Clore GM, Driscoll PC, Dodt J, Kohler S, Gronenborn AM. Solution structure of recombinant hirudin and the Lys-47—Glu mutant: a nuclear magnetic resonance and hybrid distance geometry-dynamical simulated annealing study. *Biochemistry* 1989;28:2601-2617.

1047. Haruyama H, Wuthrich K. Conformation of recombinant desulfatohirudin in aqueous solution determined by nuclear magnetic resonance. *Biochemistry* 1989;28:4301-4312.
1048. Stone SR, Braun PJ, Hofsteenge J. Identification of regions of alpha-thrombin involved in its interaction with hirudin. *Biochemistry* 1987;26:4617-4624.
1049. Braun PJ, Dennis S, Hofsteenge J, Stone SR. Use of site-directed mutagenesis to investigate the basis for the specificity of hirudin. *Biochemistry* 1988;27:6517-6522.
1050. Chang JY, Ngai PK, Rink H, Dennis S, Schlaeppli JM. The structural elements of hirudin which bind to the fibrinogen recognition site of thrombin are exclusively located within its acidic C-terminal tail. *FEBS Lett* 1990;261:287-290.
1051. Stone SR, Hofsteenge J. Kinetics of the inhibition of thrombin by hirudin. *Biochemistry* 1986;25:4622-4628.
1052. Gorman JJ. Inhibition of human thrombin assessed with different substrates and inhibitors. Characterization of fibrinopeptide binding interaction. *Biochim Biophys Acta* 1975;412:273-282.
1053. Olson ST, Bock PE, Kvassman J, Shore JD, Lawrence DA, Ginsburg D, Bjork I. Role of the catalytic serine in the interactions of serine proteinases with protein inhibitors of the serpin family. Contribution of a covalent interaction to the binding energy of serpin-proteinase complexes. *J Biol Chem* 1995;270:30007-30017.
1054. Fuchs HE, Shifman MA, Pizzo SV. In vivo catabolism of alpha 1-proteinase inhibitor-trypsin, antithrombin III-thrombin and alpha 2-macroglobulinmethylamine. *Biochim Biophys Acta* 1982;716:151-157.
1055. Ganrot PO. Inhibition of plasmin activity by alpha-2-macroglobulin. *Clin Chim Acta* 1967;16:328-329.
1056. Barrett AJ. Alpha 2-macroglobulin. *Methods Enzymol* 1981;80(Pt C):737-754.
1057. Barrett AJ, Starkey PM. The interaction of alpha 2-macroglobulin with proteinases. Characteristics and specificity of the reaction, and a hypothesis concerning its molecular mechanism. *Biochem J* 1973;133:709-724.
1058. Pizzo SV, Gonias SL. Receptor-mediated protease regulation. In: Conn PM, ed. *The receptors*. Orlando, FL: Academic Press, 1984:177-206.
1059. Gonias SL, Pizzo SV. Chemical and structural modifications of alpha 2-macroglobulin: effects on receptor binding and endocytosis studied in an in vivo model. *Ann NY Acad Sci* 1983;421:457-471.
1060. Dahlback B, Villoutreix BO. Regulation of blood coagulation by the protein C anticoagulant pathway: novel insights into structure-function relationships and molecular recognition. *Arterioscler Thromb Vasc Biol* 2005;25:1311-1320.
1061. Wildhagen K, Lutgens E, Loubale S, ten Cate H, Nicolaes G. The structure-function relationship of activated protein C. Lessons from natural and engineered mutations. *Thrombosis and Haemostasis* 2011;106:1034-1045.
1062. Griffin J, Zlokovic B, Mosnier L. Protein C anticoagulant and cytoprotective pathways. *Int J Hematol* 2012;95:333-345.
1063. Mammen EF, Thomas WR, Seegers WH. Activation of purified prothrombin to autoprothrombin I or autoprothrombin II (platelet cofactor II) or autoprothrombin II-A. *Thromb Diath Haemorrh* 2002;5:218-250.
1064. Miletich J, Sherman L, Broze G Jr. Absence of thrombosis in subjects with heterozygous protein C deficiency. *N Engl J Med* 1987;317:991-996.
1065. Okajima K, Koga S, Kaji M, et al. Effect of protein C and activated protein C on coagulation and fibrinolysis in normal human subjects. *Thromb Haemost* 1990;63:48-53.
1066. Marlar RA, Sills RH, Groncy PK, Montgomery RR, Madden RM. Protein C survival during replacement therapy in homozygous protein C deficiency. *Am J Hematol* 1992;41:24-31.
1067. Bauer KA. Coumarin-induced skin necrosis [editorial; comment]. *Arch Dermatol* 1993;129:766-768.
1068. Epstein DJ, Bergum PW, Bajaj SP, Rapaport SI. Radioimmunoassays for protein C and factor X. Plasma antigen levels in abnormal hemostatic states. *Am J Clin Pathol* 1984;82:573-581.
1069. McGehee WG, Klotz TA, Epstein DJ, Rapaport SI. Coumarin necrosis associated with hereditary protein C deficiency. *Ann Intern Med* 1984;101:59-60.
1070. Broekmans AW, Bertina RM, Loeliger EA, Hofmann V, Klingemann HG. Protein C and the development of skin necrosis during anticoagulant therapy [letter]. *Thromb Haemost* 1983;49:251.

1071. Goldberg SL, Orthner CL, Yalisove BL, Elgart ML, Kessler CM. Skin necrosis following prolonged administration of coumarin in a patient with inherited protein S deficiency. *Am J Hematol* 1991;38:64-66.
1072. Thompson AR. Molecular genetics of hemostatic proteins. In: Colman RW, Hirsh J, Marder VJ, and Salzman EW, eds. *Hemostasis and thrombosis: basic principles and clinical practice*. Philadelphia, PA: Lippincott, 1994:55-80.
1073. Bovill EG, Hasstedt SJ, Leppert MF, Long GL. Hereditary thrombophilia as a model for multigenic disease. *Thromb Haemost* 1999;82:662-666.
1074. Lu D, Bovill EG, Long GL. Molecular mechanism for familial protein C deficiency and thrombosis in protein C Vermont (Glu20→Ala and Val34→Met). *J Biol Chem* 1994;269:29032-29038.
1075. Hasstedt SJ, Bovill EG, Callas PW, Long GL. An unknown genetic defect increases venous thrombosis risk, through interaction with protein C deficiency. *Am J Hum Genet* 1998;63:569-576.
1076. Plutzky J, Hoskins JA, Long GL, Crabtree GR. Evolution and organization of the human protein C gene. *Proc Natl Acad Sci U S A* 1986;83:546-550.
1077. Kato A, Miura O, Sumi Y, Aoki N. Assignment of the human protein C gene (PROC) to chromosome region 2q14—q21 by in situ hybridization. *Cytogenet Cell Genet* 1988;47:46-47.
1078. Spek CA, Greengard JS, Griffin JH, Bertina RM, Reitsma PH. Two mutations in the promoter region of the human protein C gene both cause type I protein C deficiency by disruption of two HNF-3 binding sites. *J Biol Chem* 1995;270:24216-24221.
1079. Miao CH, Ho WT, Greenberg DL, Davie EW. Transcriptional regulation of the gene coding for human protein C. *J Biol Chem* 1996;271:9587-9594.
1080. Furie B, Furie BC. The molecular basis of blood coagulation. *Cell* 1988;53: 505-518.
1081. Taylor FB Jr, Chang A, Hinshaw LB, Esmon CT, Archer LT, Beller BK. A model for thrombin protection against endotoxin. *Thromb Res* 1984;36:177-185.
1082. Comp PC. Hereditary disorders predisposing to thrombosis. *Prog Hemost Thromb* 1986;8:71-102.
1083. Grinnell BW, Walls JD, Gerlitz B, et al. Native and modified recombinant human protein C: function, secretion, and posttranslational modifications. In: Bruley DF, Drohan WN, eds. *Protein C and related anticoagulants*. Houston, MA: Gulf Publishing Company, 1991:29-63.
1084. Esmon CT. Protein C. *Prog Hemost Thromb* 1984;7:25-54.
1085. Stenflo J. Structure and function of protein C. *Semin Thromb Hemost* 1984;10:109-121.
1086. Preissner KT. Biological relevance of the protein C system and laboratory diagnosis of protein C and protein S deficiencies. *Clin Sci(Lond)* 1990;78:351-64.
1087. Ohlin AK, Stenflo J. Calcium-dependent interaction between the epidermal growth factor precursor-like region of human protein C and a monoclonal antibody. *J Biol Chem* 1987;262:13798-13804.
1088. Ohlin AK, Linse S, Stenflo J. Calcium binding to the epidermal growth factor homology region of bovine protein C. *J Biol Chem* 1988;263:7411-7417.
1089. Rezaie AR, Mather T, Sussman F, Esmon CT. Mutation of Glu-80→Lys results in a protein C mutant that no longer requires Ca₂⁺ for rapid activation by the thrombin-thrombomodulin complex. *J Biol Chem* 1994;269:3151-3154.
1090. Cheng CH, Geng JP, Castellino FJ. The functions of the first epidermal growth factor homology region of human protein C as revealed by a charge-to-alanine scanning mutagenesis investigation. *Biol Chem* 1997;378:1491-1500.
1091. Castellino FJ. Human protein C and activated protein C. *Trends Cardiovasc Med* 1995;5:55-62.
1092. Grinnell BW, Hermann RB, Yan SB. Human protein C inhibits selectin-mediated cell adhesion: role of unique fucosylated oligosaccharide. *Glycobiology* 1994;4:221-225.
1093. Kisiel W. Human plasma protein C: isolation, characterization, and mechanism of activation by alpha-thrombin. *J Clin Invest* 1979;64:761-769.
1094. Kisiel W, Canfield WM. Snake venom proteases that activate blood-coagulation factor V. *Methods Enzymol* 1981;80:275-285.

1095. Weiler-Guettler H, Christie PD, Beeler DL, et al. A targeted point mutation in thrombomodulin generates viable mice with a prethrombotic state. *J Clin Invest* 1998;101:1983-1989.
1096. Varadi K, Philapitsch A, Santa T, Schwarz HP. Activation and inactivation of human protein C by plasmin. *Thromb Haemost* 1994;71:615-621.
1097. Cote HC, Bajzar L, Stevens WK, et al. Functional characterization of recombinant human meizothrombin and Meizothrombin(desF1). Thrombomodulin-independent activation of protein C and thrombin-activatable fibrinolysis inhibitor (TAFI), platelet aggregation, antithrombin-III inhibition. *J Biol Chem* 1997;272:6194-6200.
1098. Haley PE, Doyle MF, Mann KG. The activation of bovine protein C by factor Xa. *J Biol Chem* 1989;264:16303-16310.
1099. Thompson EA, Salem HH. Factors IXa, Xa, XIa and activated protein C do not have protein C activating ability in the presence of thrombomodulin. *Thromb Haemost* 1988;59:339.
1100. Wu Q, Tsiang M, Lentz SR, Sadler JE. Ligand specificity of human thrombomodulin. Equilibrium binding of human thrombin, meizothrombin, and factor Xa to recombinant thrombomodulin. *J Biol Chem* 1992;267:7083-7088.
1101. McRae SJ, Stafford AR, Fredenburgh JC, Weitz JI. In the presence of phospholipids, glycosaminoglycans potentiate factor Xa-mediated protein C activation by modulating factor Xa activity. *Biochemistry* 2007;46:4195-4203.
1102. Klein JD, Walker FJ. Purification of a protein C activator from the venom of the southern copperhead snake (*Agkistrodon contortrix contortrix*). *Biochemistry* 1986;25:4175-4179.
1103. Norstrom EA, Tran S, Steen M, Dahlback B. Effects of factor Xa and protein S on the individual activated protein C-mediated cleavages of coagulation factor Va. *J Biol Chem* 2006;281:31486-31494.
1104. Bajzar L, Nesheim ME, Tracy PB. The profibrinolytic effect of activated protein C in clots formed from plasma is TAFI-dependent. *Blood* 1996;88: 2093-2100.
1105. Bajzar L, Kalafatis M, Simioni P, Tracy PB. An antifibrinolytic mechanism describing the prothrombotic effect associated with factor VLeiden. *J Biol Chem* 1996;271:22949-22952.
1106. Esmon CT. Structure and functions of the endothelial cell protein C receptor. *Crit Care Med* 2004;32:S298-S301.
1107. Fukudome K, Esmon CT. Identification, cloning, and regulation of a novel endothelial cell protein C/activated protein C receptor. *J Biol Chem* 1994;269:26486-26491.
1108. Montes R, Puy C, Molina E, Hermida J. Is EPCR a multi-ligand receptor? Pros and cons. *Thrombosis and Haemostasis* 2012;107:815-826.
1109. Hancock WW, Grey ST, Hau L, et al. Binding of activated protein C to a specific receptor on human mononuclear phagocytes inhibits intracellular calcium signaling and monocyte-dependent proliferative responses. *Transplantation* 1995;60:1525-1532.
1110. Ahmad MF, Bach FH, Esmon CT, Hancock WW. Cloning and in vitro analysis of the endothelial protein C receptor (EPCR) on human monocytes show that monocyte EPCR does not mediate the anti-inflammatory effects of activated protein C. *Blood* 1997;90:32a.
1111. Esmon CT. Inflammation and the activated protein C anticoagulant pathway. *Semin Thromb Hemost* 2006;32(Suppl 1):49-60.
1112. Taylor FB Jr, Chang A, Esmon CT, D'Angelo A, Vigano-D'Angelo S, Blick KE. Protein C prevents the coagulopathic and lethal effects of *Escherichia coli* infusion in the baboon. *J Clin Invest* 1987;79:918-925.
1113. Hancock WW, Tsuchida A, Hau H, Thomson NM, Salem HH. The anticoagulants protein C and protein S display potent antiinflammatory and immunosuppressive effects relevant to transplant biology and therapy. *Transplant Proc* 1992;24:2302-2303.
1114. Mosnier LO, Zlokovic BV, Griffin JH. The cytoprotective protein C pathway. *Blood* 2007;109:3161-3172.
1115. Della Valle P, Pavani G, D'Angelo A. The protein C pathway and sepsis. *Thromb Res* 2012;129:296-300.
1116. Taoka Y, Okajima K, Uchiba M, et al. Activated protein C reduces the severity of compression-induced spinal cord injury in rats by inhibiting activation of leukocytes. *J Neurosci* 1998;18:1393-1398.
1117. Moore KL, Andreoli SP, Esmon NL, Esmon CT, Bang NU. Endotoxin enhances tissue factor and suppresses thrombomodulin expression of human vascular endothelium in vitro. *J Clin Invest* 1987;79:124-130.

1118. Nawroth PP, Handley DA, Esmon CT, Stern DM. Interleukin 1 induces endothelial cell procoagulant while suppressing cell-surface anticoagulant activity. *Proc Natl Acad Sci U S A* 1986;83:3460-3464.
1119. Hirokawa K, Aoki N. Regulatory mechanisms for thrombomodulin expression in human umbilical vein endothelial cells in vitro. *J Cell Physiol* 1991;147:157-165.
1120. Maruyama I, Soejima Y, Osame M, et al. Increased expression of thrombomodulin on the cultured human umbilical vein endothelial cells and mouse hemangioma cells by cyclic AMP. *Thromb Res* 1991;61:301-310.
1121. Ohji T, Urano H, Shirahata A, et al. Transforming growth factor beta 1 and beta 2 induce downmodulation of thrombomodulin in human umbilical vein endothelial cells. *Thromb Haemost* 1995;73:812-818.
1122. Moore KL, Esmon CT, Esmon NL. Tumor necrosis factor leads to the internalization and degradation of thrombomodulin from the surface of bovine aortic endothelial cells in culture. *Blood* 1989;73:159-165.
1123. Conway EM, Rosenberg RD. Tumor necrosis factor suppresses transcription of the thrombomodulin gene in endothelial cells. *Mol Cell Biol* 1988;8:5588-5592.
1124. Lentz SR, Tsiang M, Sadler JE. Regulation of thrombomodulin by tumor necrosis factor-alpha: comparison of transcriptional and posttranscriptional mechanisms. *Blood* 1991;77:542-550.
1125. Ohdama S, Takano S, Ohashi K, Miyake S, Aoki N. Pentoxifylline prevents tumor necrosis factor-induced suppression of endothelial cell surface thrombomodulin. *Thromb Res* 1991;62:745-755.
1126. Yu K, Morioka H, Fritze LM, Beeler DL, Jackman RW, Rosenberg RD. Transcriptional regulation of the thrombomodulin gene. *J Biol Chem* 1992;267:23237-23247.
1127. Heeb MJ, Espana F, Geiger M, Collen D, Stump DC, Griffin JH. Immunological identity of heparin-dependent plasma and urinary protein C inhibitor and plasminogen activator inhibitor-3. *J Biol Chem* 1987;262:15813-15816.
1128. Stief TW, Radtke KP, Heimbürger N. Inhibition of urokinase by protein C-inhibitor (PCI). Evidence for identity of PCI and plasminogen activator inhibitor 3. *Biol Chem Hoppe Seyler* 1987;368:1427-1433.
1129. Espana F, Griffin JH. Plasma protein C inhibitor (PCI) inhibits procoagulant and profibrinolytic enzymes. *Blood* 1987;70:401a.
1130. Dahlback B. Purification of human C4b-binding protein and formation of its complex with vitamin K-dependent protein S. *Biochem J* 1983;209:847-856.
1131. Fair DS, Revak DJ. Quantitation of human protein S in the plasma of normal and warfarin-treated individuals by radioimmunoassay. *Thromb Res* 1984;36:527-535.
1132. Walker FJ. Regulation of activated protein C by a new protein. A possible function for bovine protein S. *J Biol Chem* 1980;255:5521-5524.
1133. Suzuki K, Nishioka J, Matsuda M, Murayama H, Hashimoto S. Protein S is essential for the activated protein C-catalyzed inactivation of platelet-associated factor Va. *J Biochem(Tokyo)* 1984;96:455-460.
1134. Walker FJ, Chavin SI, Fay PJ. Inactivation of factor VIII by activated protein C and protein S. *Arch Biochem Biophys* 1987;252:322-328.
1135. Walker FJ. Protein S and the regulation of activated protein C. *Semin Thromb Hemost* 1984;10:131-138.
1136. Walker FJ. Regulation of vitamin K-dependent protein S. Inactivation by thrombin. *J Biol Chem* 1984;259:10335-10339.
1137. Solymoss S, Tucker MM, Tracy PB. Kinetics of inactivation of membrane-bound factor Va by activated protein C. Protein S modulates factor Xa protection. *J Biol Chem* 1988;263:14884-14890.
1138. Marlar R, Gausman J. Protein S abnormalities: a diagnostic nightmare. *Protein S abnormalities: a diagnostic nightmare* 2011;86:418-421.
1139. Comp PC, Nixon RR, Cooper MR, Esmon CT. Familial protein S deficiency is associated with recurrent thrombosis. *J Clin Invest* 1984;74:2082-2088.
1140. Schwarz HP, Fischer M, Hopmeier P, Batard MA, Griffin JH. Plasma protein S deficiency in familial thrombotic disease. *Blood* 1984;64:1297-1300.

1141. Comp PC, Esmon CT. Recurrent venous thromboembolism in patients with a partial deficiency of protein S. *N Engl J Med* 1984;311:1525-1528.
1142. Broekmans AW, Bertina RM, Reinalda-Poot J, et al. Hereditary protein S deficiency and venous thrombo-embolism. A study in three Dutch families. *Thromb Haemost* 1985;53:273-277.
1143. Kamiya T, Sugihara T, Ogata K, et al. Inherited deficiency of protein S in a Japanese family with recurrent venous thrombosis: a study of three generations. *Blood* 1986;67:406-410.
1144. Mahasandana C, Suvatte V, Chuansumrit A, et al. Homozygous protein S deficiency in an infant with purpura fulminans. *J Pediatr* 1990;117:750-753.
1145. Pegelow CH, Ledford M, Young JN, Zilleruelo G. Severe protein S deficiency in a newborn. *Pediatrics* 1992;89:674-676.
1146. Heeb MJ, Mesters RM, Tans G, Rosing J, Griffin JH. Binding of protein S to factor Va associated with inhibition of prothrombinase that is independent of activated protein C. *J Biol Chem* 1993;268:2872-2877.
1147. Heeb MJ, Rosing J, Bakker HM, Fernandez JA, Tans G, Griffin JH. Protein S binds to and inhibits factor Xa. *Proc Natl Acad Sci U S A* 1994;91:2728-2732.
1148. Mitchell CA, Kelemen SM, Salem HH. The anticoagulant properties of a modified form of protein S. *Thromb Haemost* 1988;60:298-304.
1149. Ploos van Amstel HK, Reitsma PH, van der Logt CP, Bertina RM. Intron-exon organization of the active human protein S gene PS alpha and its pseudogene PS beta: duplication and silencing during primate evolution. *Biochemistry* 1990;29:7853-7861.
1150. Watkins PC, Eddy R, Fukushima Y, et al. The gene for protein S maps near the centromere of human chromosome 3. *Blood* 1988;71:238-241.
1151. Schmidel DK, Tatro AV, Phelps LG, Tomczak JA, Long GL. Organization of the human protein S genes. *Biochemistry* 1990;29:7845-7852.
1152. Edenbrandt CM, Lundwall A, Wydro R, Stenflo J. Molecular analysis of the gene for vitamin K dependent protein S and its pseudogene. Cloning and partial gene organization. *Biochemistry* 1990;29:7861-7868.
1153. Ploos van Amstel HK, Reitsma PH, Bertina RM. The human protein S locus: identification of the PS alpha gene as a site of liver protein S messenger RNA synthesis. *Biochem Biophys Res Commun* 1988;157:1033-1038.
1154. Ploos van Amstel HK, Huisman MV, Reitsma PH, Wouter tC, Bertina RM. Partial protein S gene deletion in a family with hereditary thrombophilia. *Blood* 1989;73:479-483.
1155. Fair DS, Marlar RA. Biosynthesis and secretion of factor VII, protein C, protein S, and the Protein C inhibitor from a human hepatoma cell line. *Blood* 1986;67:64-70.
1156. Hoskins J, Norman DK, Beckmann RJ, Long GL. Cloning and characterization of human liver cDNA encoding a protein S precursor. *Proc Natl Acad Sci U S A* 1987;84:349-353.
1157. Fair DS, Marlar RA, Levin EG. Human endothelial cells synthesize protein S. *Blood* 1986;67:1168-1171.
1158. Stern D, Brett J, Harris K, Nawroth P. Participation of endothelial cells in the protein C-protein S anticoagulant pathway: the synthesis and release of protein S. *J Cell Biol* 1986;102:1971-1978.
1159. Hooper WC, Phillips DJ, Ribeiro MJ, et al. Tumor necrosis factor-alpha downregulates protein S secretion in human microvascular and umbilical vein endothelial cells but not in the HepG-2 hepatoma cell line. *Blood* 1994;84:483-489.
1160. Maillard C, Berruyer M, Serre CM, Dechavanne M, Delmas PD. Protein-S, a vitamin K-dependent protein, is a bone matrix component synthesized and secreted by osteoblasts. *Endocrinology* 1992;130:1599-1604.
1161. Smiley ST, Boyer SN, Heeb MJ, Griffin JH, Grusby MJ. Protein S is inducible by interleukin 4 in T cells and inhibits lymphoid cell procoagulant activity. *Proc Natl Acad Sci U S A* 1997;94:11484-11489.
1162. DiScipio RG, Davie EW. Characterization of protein S, a gamma-carboxyglutamic acid containing protein from bovine and human plasma. *Biochemistry* 1979;18:899-904.
1163. Lundwall A, Dackowski W, Cohen E, et al. Isolation and sequence of the cDNA for human protein S, a regulator of blood coagulation. *Proc Natl Acad Sci U S A* 1986;83:6716-6720.

1164. Joseph DR, Baker ME. Sex hormone-binding globulin, androgen-binding protein, and vitamin K-dependent protein S are homologous to laminin A, merosin, and *Drosophila* crumbs protein. *FASEB J* 1992;6:2477-2481.
1165. Gershagen S, Fernlund P, Edenbrandt CM. The genes for SHBG/ABP and the SHBG-like region of vitamin K-dependent protein S have evolved from a common ancestral gene. *J Steroid Biochem Mol Biol* 1991;40:763-769.
1166. Stenberg Y, Linse S, Drakenberg T, Stenflo J. The high affinity calcium-binding sites in the epidermal growth factor module region of vitamin K-dependent protein S. *J Biol Chem* 1997;272:23255-23260.
1167. Walker FJ. Properties of chemically modified protein S: effect of the conversion of gamma-carboxyglutamic acid to gamma-methyleneglutamic acid on functional properties. *Biochemistry* 1986;25:6305-6311.
1168. Van Wijnen M, Stam JG, Chang GT, et al. Characterization of mini-protein S, a recombinant variant of protein S that lacks the sex hormone binding globulin-like domain. *Biochem J* 1998;330(Pt 1):389-396.
1169. He X, Shen L, Malmberg AC, Smith KJ, Dahlback B, Linse S. Binding site for C4b-binding protein in vitamin K-dependent protein S fully contained in carboxy-terminal laminin-G-type repeats. A study using recombinant factor IX-protein S chimeras and surface plasmon resonance. *Biochemistry* 1997;36:3745-3754.
1170. Pauls JE, Hockin MF, Long GL, Mann KG. Self-association of human protein S. *Biochemistry* 2000;39:5468-5473.
1171. Yegneswaran S, Wood GM, Esmon CT, Johnson AE. Protein S alters the active site location of activated protein C above the membrane surface. A fluorescence resonance energy transfer study of topography. *J Biol Chem* 1997;272:25013-25021.
1172. Koppelman SJ, Hackeng TM, Sixma JJ, Bouma BN. Inhibition of the intrinsic factor X activating complex by protein S: evidence for a specific binding of protein S to factor VIII. *Blood* 1995;86:1062-1071.
1173. Hackeng TM, Sere KM, Tans G, Rosing J. Protein S stimulates inhibition of the tissue factor pathway by tissue factor pathway inhibitor. *Proc Natl Acad Sci U S A* 2006;103:3106-3111.
1174. Peraramelli S, Rosing J, Hackeng T. TFPI-dependent activities of protein S. *Thromb Res* 2012;129(Suppl 2):S23-S26.
1175. Hackeng TM, Hessing M, van tV, et al. Protein S binding to human endothelial cells is required for expression of cofactor activity for activated protein C. *J Biol Chem* 1993;268:3993-4000.
1176. Koppelman SJ, van't Veer C, Sixma JJ, Bouma BN. Synergistic inhibition of the intrinsic factor X activation by protein S and C4b-binding protein. *Blood* 1995;86:2653-2660.
1177. Smiley ST, Stitt TN, Grusby MJ. Cross-linking of protein S bound to lymphocytes promotes aggregation and inhibits proliferation. *Cell Immunol* 1997;181:120-126.
1178. Chang GT, Aaldering L, Hackeng TM, Reitsma PH, Bertina RM, Bouma BN. Construction and characterization of thrombin-resistant variants of recombinant human protein S. *Thromb Haemost* 1994;72:693-697.
1179. Dahlback B. Purification of human vitamin K-dependent protein S and its limited proteolysis by thrombin. *Biochem J* 1983;209:837-846.
1180. Suzuki K, Nishioka J, Hashimoto S. Regulation of activated protein C by thrombin-modified protein S. *J Biochem(Tokyo)* 1983;94:699-705.
1181. Prowse CV, Esnouf MP. The isolation of a new warfarin-sensitive protein from bovine plasma. *Biochem Soc Trans* 1977;5:255-256.
1182. Broze GJ Jr, Miletich JP. Human Protein Z. *J Clin Invest* 1984;73:933-938.
1183. Broze GJ Jr. Protein Z-dependent regulation of coagulation. *Thromb Haemost* 2001;86:8-13.
1184. Han X, Fiehler R, Broze GJ Jr. Isolation of a protein Z-dependent plasma protease inhibitor. *Proc Natl Acad Sci U S A* 1998;95:9250-9255.
1185. Undar L, Karadogan I, Ozturk F. Plasma protein Z levels inversely correlate with plasma interleukin-6 levels in patients with acute leukemia and non-Hodgkin's lymphoma. *Thromb Res* 1999;94:131-134.
1186. Raczkowski CA, Reichlin M, Esmon CT, Comp PC. Protein Z is a negatively responding acute phase protein. *Blood* 1987;70(Suppl 1):393a.
1187. Yurdakok M, Gurakan B, Ozbag E, Vigit S, Dundar S, Kirazli S. Plasma protein Z levels in healthy newborn infants. *Am J Hematol* 1995;48:206-207.

1188. Kemkes-Matthes B, Matthes KJ. Protein Z. *Semin Thromb Hemost* 2001;27:551-556.
1189. Bertolino G, Montani N, Lorezutti F, Balduini CL, Gamba G. Behavior of plasma protein Z levels in patients with abnormal haemostasis: Correlation with coagulation screening times. *Thromb Haemost* 1997;78(Suppl 1):235a.
1190. Kemkes-Matthes B, Matthes KJ. Protein Z, a new haemostatic factor, in liver diseases. *Haemostasis* 1995;25:312-316.
1191. Bertolino G, Montani N, Anesi E, Palladini G, Capezzer M, Gamba G. Plasma protein Z levels in patients with systemic AL amyloidosis. *Thromb Haemost* 1999;(Suppl):136a.
1192. Usalan C, Erdem Y, Altun B, et al. Protein Z levels in haemodialysis patients. *Int Urol Nephrol* 1999;31:541-545.
1193. Cobankara V, Ozatly D, Haznedaroglu IC, et al. Circulating protein Z in reactive and clonal thrombocytosis and in ITP. *Thromb Haemost* 1999;Suppl:563a.
1194. Miletich JP, Broze GJ Jr. Human plasma protein Z antigen: range in normal subjects and effect of warfarin therapy. *Blood* 1987;69:1580-1586.
1195. Yin ZF, Huang ZF, Cui J, et al. Prothrombotic phenotype of protein Z deficiency. *Proc Natl Acad Sci U S A* 2000;97:6734-6738.
1196. Corral J, Gonzalez-Conejero R, Hernandez-Espinosa D, Vicente V. Protein Z/Z-dependent protease inhibitor (PZ/ZPI) anticoagulant system and thrombosis. *Br J Haematol* 2007;137:99-108.
1197. Bafunno V, Santacroce R, Margaglione M. The risk of occurrence of venous thrombosis: focus on protein Z. *Thromb Res* 2011;128:508-515.
1198. Vasse M. Protein Z, a protein seeking a pathology. *Thrombosis and Haemostasis* 2008;100:548-556.
1199. Kemkes-Matthes B, Matthes KJ, Sutor AH. Protein Z bei Kindern mit Blutungsereignissen unklarer Genese. Erste klinische Daten. In: Scharrer I, Schramm W, eds. *Hamophilie- Symposium Hamburg*. Berlin: Springer, 1995:325.
1200. Kemkes-Matthes B, Matthes KJ. Protein Z deficiency: a new cause of bleeding tendency. *Thromb Res* 1995;79:49-55.
1201. Greten J, Kreis I, Liliensiek B, et al. Localisation of protein Z in vascular lesions of patients with atherosclerosis. *Vasa* 1998;27:144-148.
1202. Ichinose A, Takeya H, Espling E, Iwanaga S, Kisiel W, Davie EW. Amino acid sequence of human protein Z, a vitamin K-dependent plasma glycoprotein. *Biochem Biophys Res Commun* 1990;172:1139-1144.
1203. Sejima H, Hayashi T, Deyashiki Y, Nishioka J, Suzuki K. Primary structure of vitamin K-dependent human protein Z. *Biochem Biophys Res Commun* 1990;171:661-668.
1204. Vasse M. The protein Z/protein Z-dependent protease inhibitor complex. Systemic or local control of coagulation? *Hamostaseologie* 2011;31:155-158.
1205. Heeb MJ, Cabral KM, Ruan L. Down-regulation of factor IXa in the factor Xase complex by protein Z-dependent protease inhibitor. *J Biol Chem* 2005;280:33819-33825.
1206. Hogg PJ, Stenflo J. Interaction of human protein Z with thrombin: evaluation of the species difference in the interaction between bovine and human protein Z and thrombin. *Biochem Biophys Res Commun* 1991;178:801-807.
1207. Conway EM. Thrombomodulin and its role in inflammation. *Semin Immunopathol* 2012;34:107-125. doi:10.1007/s00281-011-0282-8.
1208. Imada S, Yamaguchi H, Nagumo M, Katayanagi S, Iwasaki H, Imada M. Identification of fetomodulin, a surface marker protein of fetal development, as thrombomodulin by gene cloning and functional assays. *Dev Biol* 1990;140:113-122.
1209. Healy AM, Rayburn HB, Rosenberg RD, Weiler H. Absence of the blood-clotting regulator thrombomodulin causes embryonic lethality in mice before development of a functional cardiovascular system. *Proc Natl Acad Sci U S A* 1995;92:850-854.
1210. Wen DZ, Dittman WA, Ye RD, Deaven LL, Majerus PW, Sadler JE. Human thrombomodulin: complete cDNA sequence and chromosome localization of the gene. *Biochemistry* 1987;26:4350-4357.
1211. Espinosa R III, Sadler JE, Le Beau MM. Regional localization of the human thrombomodulin gene to 20p12-cen. *Genomics* 1989;5:649-650.

1212. Jackman RW, Beeler DL, Fritze L, Soff G, Rosenberg RD. Human thrombomodulin gene is intron depleted: nucleic acid sequences of the cDNA and gene predict protein structure and suggest sites of regulatory control. *Proc Natl Acad Sci U S A* 1987;84:6425-6429.
1213. Shirai T, Shiojiri S, Ito H, et al. Gene structure of human thrombomodulin, a cofactor for thrombin-catalyzed activation of protein C. *J Biochem(Tokyo)* 1988;103:281-285.
1214. Maruyama I, Bell CE, Majerus PW. Thrombomodulin is found on endothelium of arteries, veins, capillaries, and lymphatics, and on syncytiotrophoblast of human placenta. *J Cell Biol* 1985;101:363-371.
1215. DeBault LE, Esmon NL, Olson JR, Esmon CT. Distribution of the thrombomodulin antigen in the rabbit vasculature. *Lab Invest* 1986;54:172-178.
1216. Conway EM, Nowakowski B, Steiner-Mosonyi M. Human neutrophils synthesize thrombomodulin that does not promote thrombin-dependent protein C activation. *Blood* 1992;80:1254-1263.
1217. Satta N, Freyssinet JM, Toti F. The significance of human monocyte thrombomodulin during membrane vesiculation and after stimulation by lipopolysaccharide. *Br J Haematol* 1997;96:534-542.
1218. McCachren SS, Diggs J, Weinberg JB, Dittman WA. Thrombomodulin expression by human blood monocytes and by human synovial tissue lining macrophages. *Blood* 1991;78:3128-3132.
1219. Suzuki K, Nishioka J, Hayashi T, Kosaka Y. Functionally active thrombomodulin is present in human platelets. *J Biochem(Tokyo)* 1988;104:628-632.
1220. Conway EM, Nowakowski B. Biologically active thrombomodulin is synthesized by adherent synovial fluid cells and is elevated in synovial fluid of patients with rheumatoid arthritis. *Blood* 1993;81:726-733.
1221. Raife TJ, Lager DJ, Madison KC, et al. Thrombomodulin expression by human keratinocytes. Induction of cofactor activity during epidermal differentiation. *J Clin Invest* 1994;93:1846-1851.
1222. Jackson DE, Mitchell CA, Bird P, Salem HH, Hayman JA. Immunohistochemical localization of thrombomodulin in normal human skin and skin tumours. *J Pathol* 1995;175:421-432.
1223. Lager DJ, Callaghan EJ, Worth SF, Raife TJ, Lentz SR. Cellular localization of thrombomodulin in human epithelium and squamous malignancies. *Am J Pathol* 1995;146:933-943.
1224. Scarpati EM, Sadler JE. Regulation of endothelial cell coagulant properties. Modulation of tissue factor, plasminogen activator inhibitors, and thrombomodulin by phorbol 12-myristate 13-acetate and tumor necrosis factor [published erratum appears in *J Biol Chem* 1990 Aug 25;265(24):14696]. *J Biol Chem* 1989;264:20705-20713.
1225. Ishii H, Horie S, Kizaki K, Kazama M. Retinoic acid counteracts both the downregulation of thrombomodulin and the induction of tissue factor in cultured human endothelial cells exposed to tumor necrosis factor. *Blood* 1992;80:2556-2562.
1226. Hayashi T, Honda G, Suzuki K. An atherogenic stimulus homocysteine inhibits cofactor activity of thrombomodulin and enhances thrombomodulin expression in human umbilical vein endothelial cells. *Blood* 1992;79:2930-2936.
1227. Ogawa S, Gerlach H, Esposito C, Pasagian-Macaulay A, Brett J, Stern D. Hypoxia modulates the barrier and coagulant function of cultured bovine endothelium. Increased monolayer permeability and induction of procoagulant properties. *J Clin Invest* 1990;85:1090-1098.
1228. Esposito C, Gerlach H, Brett J, Stern D, Vlassara H. Endothelial receptor-mediated binding of glucose-modified albumin is associated with increased monolayer permeability and modulation of cell surface coagulant properties. *J Exp Med* 1989;170:1387-1407.
1229. Archipoff G, Beretz A, Bartha K, et al. Role of cyclic AMP in promoting the thromboresistance of human endothelial cells by enhancing thrombomodulin and decreasing tissue factor activities. *Br J Pharmacol* 1993;109:18-28.
1230. Dittman WA, Nelson SC, Greer PK, Horton ET, Palomba ML, McCachren SS. Characterization of thrombomodulin expression in response to retinoic acid and identification of a retinoic acid response element in the human thrombomodulin gene. *J Biol Chem* 1994;269:16925-16932.
1231. Takada Y, Shinkai F, Kondo S, et al. Fluid shear stress increases the expression of thrombomodulin by cultured human endothelial cells. *Biochem Biophys Res Commun* 1994;205:1345-1352.
1232. Malek AM, Jackman R, Rosenberg RD, Izumo S. Endothelial expression of thrombomodulin is reversibly regulated by fluid shear stress. *Circ Res* 1994;74:852-860.

1233. Conway EM, Liu L, Nowakowski B, Steiner-Mosonyi M, Jackman RW. Heat shock of vascular endothelial cells induces an up-regulatory transcriptional response of the thrombomodulin gene that is delayed in onset and does not attenuate. *J Biol Chem* 1994;269:22804-22810.
1234. Tazawa R, Yamamoto K, Suzuki K, Hirokawa K, Hirosawa S, Aoki N. Presence of functional cyclic AMP responsive element in the 3'-untranslated region of the human thrombomodulin gene. *Biochem Biophys Res Commun* 1994;200:1391-1397.
1235. Suzuki K, Kusumoto H, Deyashiki Y, et al. Structure and expression of human thrombomodulin, a thrombin receptor on endothelium acting as a cofactor for protein C activation. *EMBO J* 1987;6:1891-1897.
1236. Petersen TE. The amino-terminal domain of thrombomodulin and pancreatic stone protein are homologous with lectins. *FEBS Lett* 1988;231:51-53.
1237. Kurosawa S, Stearns DJ, Jackson KW, Esmon CT. A 10-kDa cyanogen bromide fragment from the epidermal growth factor homology domain of rabbit thrombomodulin contains the primary thrombin binding site. *J Biol Chem* 1988;263:5993-5996.
1238. Stearns DJ, Kurosawa S, Esmon CT. Microthrombomodulin. Residues 310-486 from the epidermal growth factor precursor homology domain of thrombomodulin will accelerate protein C activation. *J Biol Chem* 1989;264:3352-3356.
1239. Suzuki K, Hayashi T, Nishioka J, et al. A domain composed of epidermal growth factor-like structures of human thrombomodulin is essential for thrombin binding and for protein C activation. *J Biol Chem* 1989;264:4872-4876.
1240. Zushi M, Gomi K, Honda G, et al. Aspartic acid 349 in the fourth epidermal growth factor-like structure of human thrombomodulin plays a role in its Ca_2^+ -mediated binding to protein C. *J Biol Chem* 1991;266:19886-19889.
1241. Zushi M, Gomi K, Yamamoto S, Maruyama I, Hayashi T, Suzuki K. The last three consecutive epidermal growth factor-like structures of human thrombomodulin comprise the minimum functional domain for protein C-activating cofactor activity and anticoagulant activity. *J Biol Chem* 1989;264:10351-10353.
1242. Lin JH, McLean K, Morser J, et al. Modulation of glycosaminoglycan addition in naturally expressed and recombinant human thrombomodulin. *J Biol Chem* 1994;269:25021-25030.
1243. Ye J, Rezaie AR, Esmon CT. Glycosaminoglycan contributions to both protein C activation and thrombin inhibition involve a common arginine-rich site in thrombin that includes residues arginine 93, 97, and 101. *J Biol Chem* 1994;269:17965-17970.
1244. Bourin MC, Lindahl U. Glycosaminoglycans and the regulation of blood coagulation. *Biochem J* 1993;289(Pt 2):313-330.
1245. Bourin MC, Ohlin AK, Lane DA, Stenflo J, Lindahl U. Relationship between anticoagulant activities and polyanionic properties of rabbit thrombomodulin. *J Biol Chem* 1988;263:8044-8052.
1246. He X, Ye J, Esmon CT, Rezaie AR. Influence of Arginines 93, 97, and 101 of thrombin to its functional specificity. *Biochemistry* 1997;36:8969-8976.
1247. Tsiang M, Lentz SR, Sadler JE. Functional domains of membrane-bound human thrombomodulin. EGF-like domains four to six and the serine/threonine-rich domain are required for cofactor activity. *J Biol Chem* 1992;267:6164-6170.
1248. Lu RL, Esmon NL, Esmon CT, Johnson AE. The active site of the thrombin-thrombomodulin complex. A fluorescence energy transfer measurement of its distance above the membrane surface. *J Biol Chem* 1989;264:12956-12962.
1249. Conway EM, Boffa MC, Nowakowski B, Steiner-Mosonyi M. An ultrastructural study of thrombomodulin endocytosis: internalization occurs via clathrin-coated and non-coated pits. *J Cell Physiol* 1992;151:604-612.
1250. Conway EM, Pollefeyst S, Collen D, Steiner-Mosonyi M. The amino terminal lectin-like domain of thrombomodulin is required for constitutive endocytosis. *Blood* 1997;89:652-661.
1251. Ye J, Liu LW, Esmon CT, Johnson AE. The fifth and sixth growth factor-like domains of thrombomodulin bind to the anion-binding exosite of thrombin and alter its specificity. *J Biol Chem* 1992;267:11023-11028.
1252. Vindigni A, White CE, Komives EA, Di Cera E. Energetics of thrombin-thrombomodulin interaction. *Biochemistry* 1997;36:6674-6681.

1253. Ye J, Esmon NL, Esmon CT, Johnson AE. The active site of thrombin is altered upon binding to thrombomodulin. Two distinct structural changes are detected by fluorescence, but only one correlates with protein C activation. *J Biol Chem* 1991;266:23016-23021.
1254. Ye J, Esmon CT, Johnson AE. The chondroitin sulfate moiety of thrombomodulin binds a second molecule of thrombin. *J Biol Chem* 1993;268:2373-2379.
1255. Musci G, Berliner LJ, Esmon CT. Evidence for multiple conformational changes in the active center of thrombin induced by complex formation with thrombomodulin: an analysis employing nitroxide spin-labels. *Biochemistry* 1988;27:769-773.
1256. Liu LW, Rezaie AR, Carson CW, Esmon NL, Esmon CT. Occupancy of anion binding exosite 2 on thrombin determines Ca_2+ dependence of protein C activation. *J Biol Chem* 1994;269:11807-11812.
1257. Esmon CT, Esmon NL, Harris KW. Complex formation between thrombin and thrombomodulin inhibits both thrombin-catalyzed fibrin formation and factor V activation. *J Biol Chem* 1982;257:7944-7947.
1258. Esmon NL, Carroll RC, Esmon CT. Thrombomodulin blocks the ability of thrombin to activate platelets. *J Biol Chem* 1983;258:12238-12242.
1259. Hofsteenge J, Taguchi H, Stone SR. Effect of thrombomodulin on the kinetics of the interaction of thrombin with substrates and inhibitors. *Biochem J* 1986;237:243-251.
1260. Bourin MC, Boffa MC, Bjork I, Lindahl U. Functional domains of rabbit thrombomodulin. *Proc Natl Acad Sci U S A* 1986;83:5924-5928.
1261. Preissner KT, Delvos U, Muller-Berghaus G. Binding of thrombin to thrombomodulin accelerates inhibition of the enzyme by antithrombin III. Evidence for a heparin-independent mechanism. *Biochemistry* 1987;26:2521-2528.
1262. Lentz SR, Sadler JE. Inhibition of thrombomodulin surface expression and protein C activation by the thrombogenic agent homocysteine. *J Clin Invest* 1991;88:1906-1914.
1263. Maruyama I, Majerus PW. Protein C inhibits endocytosis of thrombin-thrombomodulin complexes in A549 lung cancer cells and human umbilical vein endothelial cells. *Blood* 1987;69:1481-1484.
1264. Maruyama I, Majerus PW. The turnover of thrombin-thrombomodulin complex in cultured human umbilical vein endothelial cells and A549 lung cancer cells. Endocytosis and degradation of thrombin. *J Biol Chem* 1985;260:15432-15438.
1265. Horvat R, Palade GE. Thrombomodulin and thrombin localization on the vascular endothelium; their internalization and transcytosis by plasmalemmal vesicles. *Eur J Cell Biol* 1993;61:299-313.
1266. Beretz A, Freyssinet JM, Gauchy J, et al. Stability of the thrombin-thrombomodulin complex on the surface of endothelial cells from human saphenous vein or from the cell line EA.hy 926. *Biochem J* 1989;259:35-40.
1267. Boehme MW, Deng Y, Raeth U, et al. Release of thrombomodulin from endothelial cells by concerted action of TNF- α and neutrophils: in vivo and in vitro studies. *Immunology* 1996;87:134-140.
1268. Takano S, Kimura S, Ohdama S, Aoki N. Plasma thrombomodulin in health and diseases. *Blood* 1990;76:2024-2029.
1269. Glaser CB, Morser J, Clarke JH, et al. Oxidation of a specific methionine in thrombomodulin by activated neutrophil products blocks cofactor activity. A potential rapid mechanism for modulation of coagulation. *J Clin Invest* 1992;90:2565-2573.
1270. Pizzo SV, Wu SM. α -Macroglobulins and Kunins. In: Colman RW, Hirsh J, Marder VJ, Clowes AW, George JN, eds. *Hemostasis and thrombosis: basic principles & clinical practice*. Philadelphia, PA: Lippincott Williams & Wilkins, 2001:367-379.
1271. Sottrup-Jensen L. α 2-Macroglobulin and related thiol ester plasma proteins. In: Putnam FW, ed. *The plasma proteins*. Orlando, FL: Academic Press, 1987:191-287.
1272. Travis J, Salvesen GS. Human plasma proteinase inhibitors. *Annu Rev Biochem* 1983;52:655-709.
1273. Starkey PM, Barrett AJ. Evolution of α 2-macroglobulin. The demonstration in a variety of vertebrate species of a protein resembling human α 2-macroglobulin. *Biochem J* 1982;205:91-95.
1274. Kruger U. [Chronic obstructive lung disease and α -2-macroglobulin deficiency in serum—case report]. *Pneumologie* 1993;47:531-534.

1275. Kanoh Y, Ohtani H, Koshiba K. [Studies on alpha 2 macroglobulin deficiency in association with cancer metastasis]. *Nihon Rinsho Meneki Gakkai Kaishi* 1997;20:30-43.
1276. Umans L, Serneels L, Overbergh L, Lorent K, Van Leuven F, van den BH. Targeted inactivation of the mouse alpha 2-macroglobulin gene. *J Biol Chem* 1995;270:19778-19785.
1277. Webb DJ, Wen J, Lysiak JJ, Umans L, Van Leuven F, Gonias SL. Murine alphamacroglobulins demonstrate divergent activities as neutralizers of transforming growth factor-beta and as inducers of nitric oxide synthesis. A possible mechanism for the endotoxin insensitivity of the alpha2-macroglobulin gene knock-out mouse. *J Biol Chem* 1996;271:24982-24988.
1278. Matthijs G, Devriendt K, Cassiman JJ, van den BH, Marynen P. Structure of the human alpha-2 macroglobulin gene and its promotor. *Biochem Biophys Res Commun* 1992;184:596-603.
1279. Kan CC, Solomon E, Belt KT, Chain AC, Hiorns LR, Fey G. Nucleotide sequence of cDNA encoding human alpha 2-macroglobulin and assignment of the chromosomal locus. *Proc Natl Acad Sci U S A* 1985;82:2282-2286.
1280. Fukushima Y, Bell GI, Shows TB. The polymorphic human alpha 2-macroglobulin gene (A2M) is located in chromosome region 12p12.3—p13.3. *Cytogenet Cell Genet* 1988;48:58-59.
1281. Devriendt K, Zhang J, Van Leuven F, van den BH, Cassiman JJ, Marynen P. A cluster of alpha 2-macroglobulin-related genes (alpha 2 M) on human chromosome 12p: cloning of the pregnancy-zone protein gene and an alpha 2M pseudogene. *Gene* 1989;81:325-334.
1282. Swenson RP, Howard JB. Structural characterization of human alpha2-macroglobulin subunits. *J Biol Chem* 1979;254:4452-4456.
1283. Sottrup-Jensen L, Stepanik TM, Wierzbicki DM, Jones CM, Lonblad PB, Kristensen T, Mortensen SB, Petersen TE, Magnusson S. The primary structure of alpha 2-macroglobulin and localization of a Factor XIIIa cross-linking site. *Ann NY Acad Sci* 1983;421:41-60.
1284. Carlsson-Bosted L, Moestrup SK, Gliemann J, Sottrup-Jensen L, Stigbrand T. Three different conformational states of pregnancy zone protein identified by monoclonal antibodies. *J Biol Chem* 1988;263:6738-6741.
1285. Christensen U, Simonsen M, Harrit N, Sottrup-Jensen L. Pregnancy zone protein, a proteinase-binding macroglobulin. Interactions with proteinases and methylamine. *Biochemistry* 1989;28:9324-9331.
1286. Meyer C, Hinrichs W, Hahn U. Human α 2-macroglobulin—another variation on the Venus flytrap. *Angew Chem Int Ed Engl* 2012;51:5045-5047.
1287. Mortensen SB, Sottrup-Jensen L, Hansen HF, Petersen TE, Magnusson S. Primary and secondary cleavage sites in the bait region of alpha 2- macro-globulin. *FEBS Lett* 1981;135:295-300.
1288. Marrero A, Duquerroy S, Trapani S, et al. The crystal structure of human α (2)-macroglobulin reveals a unique molecular cage. *Angew Chem Int Ed Engl* 2012;51:3340-3344.
1289. Sottrup-Jensen L, Petersen TE, Magnusson S. A thiol-ester in alpha 2-macroglobulin cleaved during proteinase complex formation. *FEBS Lett* 1980;121:275-279.
1290. Howard JB. Reactive site in human alpha 2-macroglobulin: circumstantial evidence for a thiolester. *Proc Natl Acad Sci USA* 1981;78:2235-2239.
1291. Gonias SL, Reynolds JA, Pizzo SV. Physical properties of human alpha 2-macroglobulin following reaction with methylamine and trypsin. *Biochim Biophys Acta* 1982;705:306-314.
1292. Harpel PC. Human Plasma alpha 2-macroglobulin. An inhibitor of plasma kallikrein. *J Exp Med* 1970;132:329-352.
1293. Harpel PC. Alpha2-plasmin inhibitor and alpha2-macroglobulin-plasmin complexes in plasma. Quantitation by an enzyme-linked differential antibody immunosorbent assay. *J Clin Invest* 1981;68:46-55.
1294. Mitchell L, Piovella F, Ofosu F, Andrew M. Alpha-2-macroglobulin may provide protection from thromboembolic events in antithrombin III-deficient children. *Blood* 1991;78:2299-2304.
1295. Abbink JJ, Nuijens JH, Eerenberg AJ, et al. Quantification of functional and inactivated alpha 2-macroglobulin in sepsis. *Thromb Haemost* 1991;65:32-39.
1296. Huang SS, O'Grady P, Huang JS. Human transforming growth factor beta. alpha 2-macroglobulin complex is a latent form of transforming growth factor beta. *J Biol Chem* 1988;263:1535-1541.

1297. Borth W, Luger TA. Identification of alpha 2-macroglobulin as a cytokine binding plasma protein. Binding of interleukin-1 beta to "F" alpha 2-macroglobulin. *J Biol Chem* 1989;264:5818-5825.
1298. Matsuda T, Hirano T, Nagasawa S, Kishimoto T. Identification of alpha 2-macroglobulin as a carrier protein for IL-6. *J Immunol* 1989;142:148-152.
1299. Dennis PA, Saksela O, Harpel P, Rifkin DB. Alpha 2-macroglobulin is a binding protein for basic fibroblast growth factor. *J Biol Chem* 1989;264:7210-7216.
1300. Wollenberg GK, LaMarre J, Rosendal S, Gonias SL, Hayes MA. Binding of tumor necrosis factor alpha to activated forms of human plasma alpha 2 macroglobulin. *Am J Pathol* 1991;138:265-272.
1301. Legres LG, Pochon F, Barray M, Gay F, Chouaib S, Delain E. Evidence for the binding of a biologically active interleukin-2 to human alpha 2-macroglobulin. *J Biol Chem* 1995;270:8381-8384.
1302. Kovacs DM. alpha2-macroglobulin in late-onset Alzheimer's disease. *Exp Gerontol* 2000;35:473-479.
1303. McGeer PL, McGeer EG. Polymorphisms in inflammatory genes and the risk of Alzheimer disease. *Arch Neurol* 2001;58:1790-1792.
1304. Zappia M, Cittadella R, Manna I, et al. Genetic association of alpha2-macroglobulin polymorphisms with AD in southern Italy. *Neurology* 2002;59: 756-758.
1305. Broze GJ Jr. The role of tissue factor pathway inhibitor in a revised coagulation cascade. *Semin Hematol* 1992;29:159-169.
1306. Broze GJ Jr, Girard TJ, Novotny WF. Regulation of coagulation by a multivalent Kunitz-type inhibitor. *Biochemistry* 1990;29:7539-7546.
1307. Rapaport SI. The extrinsic pathway inhibitor: a regulator of tissue factor-dependent blood coagulation. *Thromb Haemost* 1991;66:6-15.
1308. Broze GJ Jr. Tissue factor pathway inhibitor and the revised theory of coagulation. *Annu Rev Med* 1995;46:103-112.
1309. Broze GJ Jr, Lange GW, Duffin KL, MacPhail L. Heterogeneity of plasma tissue factor pathway inhibitor. *Blood Coagul Fibrinolysis* 1994;5:551-559.
1310. Novotny WF, Girard TJ, Miletich JP, Broze GJ Jr. Purification and characterization of the lipoprotein-associated coagulation inhibitor from human plasma. *J Biol Chem* 1989;264:18832-18837.
1311. Bajaj MS, Kuppaswamy MN, Saito H, Spitzer SG, Bajaj SP. Cultured normal human hepatocytes do not synthesize lipoprotein-associated coagulation inhibitor: evidence that endothelium is the principal site of its synthesis. *Proc Natl Acad Sci U S A* 1990;87:8869-8873.
1312. Sanders NL, Bajaj SP, Zivelin A, Rapaport SI. Inhibition of tissue factor/factor VIIa activity in plasma requires factor X and an additional plasma component. *Blood* 1985;66:204-212.
1313. Lesnik P, Vonica A, Guerin M, et al. Anticoagulant activity of tissue factor pathway inhibitor in human plasma in preferentially associated with dense subspecies of LDL and HDL and with Lp(a). *Arterioscler Thromb* 1993;13:1066-1075.
1314. Broze GJ Jr. Tissue factor pathway inhibitor. *Thromb Haemost* 1995;74:90-93.
1315. Broze GJ, Girard T. Tissue factor pathway inhibitor: structure-function. *Front Biosci* 2012;17:262-280.
1316. Maroney S, Ellery P, Mast A. Alternatively spliced isoforms of tissue factor pathway inhibitor. *Thromb Res* 2010;125:S52-S56.
1317. Maroney S, Mast A. Platelet tissue factor pathway inhibitor modulates intravascular coagulation. *Thromb Res* 2012;129:S21-S22.
1318. Holroyd E, White T, Pan S, Simari R. Tissue factor pathway inhibitor as a multifunctional mediator of vascular structure. *Front Biosci (Elite Ed)* 2012;4:392-400.
1319. Huang ZF, Higuchi D, Lasky N, Broze GJ Jr. Tissue factor pathway inhibitor gene disruption produces intrauterine lethality in mice. *Blood* 1997;90: 944-951.
1320. Chan JC, Carmeliet P, Moons L, et al. Factor VII deficiency rescues the intrauterine lethality in mice associated with a tissue factor pathway inhibitor deficit. *J Clin Invest* 1999;103:475-482.

1321. Westrick RJ, Bodary PF, Xu Z, Shen YC, Broze GJ, Eitzman DT. Deficiency of tissue factor pathway inhibitor promotes atherosclerosis and thrombosis in mice. *Circulation* 2001;103:3044-3046.
1322. Kato H. Regulation of functions of vascular wall cells by tissue factor pathway inhibitor: basic and clinical aspects. *Arterioscler Thromb Vasc Biol* 2002;22:539-548.
1323. LaRosa SP, Opal SM. Tissue factor pathway inhibitor and antithrombin trial results. *Crit Care Clin* 2005;21:433-448.
1324. Abraham E, Reinhart K, Svoboda P, et al. Assessment of the safety of recombinant tissue factor pathway inhibitor in patients with severe sepsis: a multicenter, randomized, placebo-controlled, single-blind, dose escalation study. *Crit Care Med* 2001;29:2081-2089.
1325. van der Logt CP, Kluck PM, Wiegant J, Landegent JE, Reitsma PH. Refined regional assignment of the human tissue factor pathway inhibitor (TFPI) gene to chromosome band 2q32 by non-isotopic in situ hybridization. *Hum Genet* 1992;89:577-578.
1326. van der Logt CP, Reitsma PH, Bertina RM. Intron-exon organization of the human gene coding for the lipoprotein-associated coagulation inhibitor: the factor Xa dependent inhibitor of the extrinsic pathway of coagulation. *Biochemistry* 1991;30:1571-1577.
1327. Girard TJ, Eddy R, Wesselschmidt RL, et al. Structure of the human lipoprotein-associated coagulation inhibitor gene. Intro/exon gene organization and localization of the gene to chromosome 2. *J Biol Chem* 1991;266:5036-5041.
1328. Enyoji K, Emi M, Mukai T, et al. Human tissue factor pathway inhibitor (TFPI) gene: complete genomic structure and localization on the genetic map of chromosome 2q. *Genomics* 1993;17:423-428.
1329. Ameri A, Kuppuswamy MN, Basu S, Bajaj SP. Expression of tissue factor pathway inhibitor by cultured endothelial cells in response to inflammatory mediators. *Blood* 1992;79:3219-3226.
1330. Broze GJ Jr, Miletich JP. Isolation of the tissue factor inhibitor produced by HepG2 hepatoma cells. *Proc Natl Acad Sci USA* 1987;84:1886-1890.
1331. Wun TC, Kretzmer KK, Girard TJ, Miletich JP, Broze GJ Jr. Cloning and characterization of a cDNA coding for the lipoprotein-associated coagulation inhibitor shows that it consists of three tandem Kunitz-type inhibitory domains. *J Biol Chem* 1988;263:6001-6004.
1332. Novotny WF, Palmier M, Wun TC, Broze GJ Jr, Miletich JP. Purification and properties of heparin-releasable lipoprotein-associated coagulation inhibitor. *Blood* 1991;78:394-400.
1333. Ndonwi M, Tuley E, Broze GJ. The Kunitz-3 domain of TFPI-alpha is required for protein S-dependent enhancement of factor Xa inhibition. *Blood* 2010;116:1344-1351.
1334. Enyoji K, Miyata T, Kamikubo Y, Kato H. Effect of heparin on the inhibition of factor Xa by tissue factor pathway inhibitor: a segment, Gly212-Phe243, of the third Kunitz domain is a heparin-binding site. *Biochemistry* 1995;34:5725-5735.
1335. Smith PL, Skelton TP, Fiete D, et al. The asparagine-linked oligosaccharides on tissue factor pathway inhibitor terminate with SO4-4GalNAc beta 1, 4GlcNAc beta 1,2 Mana alpha. *J Biol Chem* 1992;267:19140-19146.
1336. Broze GJ Jr, Warren LA, Novotny WF, Higuchi DA, Girard JJ, Miletich JP. The lipoprotein-associated coagulation inhibitor that inhibits the factor VII-tissue factor complex also inhibits factor Xa: insight into its possible mechanism of action. *Blood* 1988;71:335-343.
1337. Broze GJ Jr. Tissue factor pathway inhibitor and the current concept of blood coagulation. *Blood Coagul Fibrinolysis* 1995;6(Suppl 1):S7-S13.
1338. Sandset PM, Abildgaard U, Larsen ML. Heparin induces release of extrinsic coagulation pathway inhibitor (EPI). *Thromb Res* 1988;50:803-813.
1339. Lindahl AK, Abildgaard U, Stokke G. Release of extrinsic pathway inhibitor after heparin injection: increased response in cancer patients. *Thromb Res* 1990;59:651-656.
1340. van't Veer C, Kalafatis M, Bertina RM, Simioni P, Mann KG. Increased tissue factor-initiated prothrombin activation as a result of the Arg506 → Gln mutation in factor VLEIDEN. *J Biol Chem* 1997;272:20721-20729.

1341. Eitzman DT, Westrick RJ, Bi X, Manning SL, Wilkinson JE, Broze GJ, Ginsburg D. Lethal perinatal thrombosis in mice resulting from the interaction of tissue factor pathway inhibitor deficiency and factor V Leiden. *Circulation* 2002;105:2139-2142.
1342. Hamamoto T, Yamamoto M, Nordfang O, Petersen JG, Foster DC, Kiesel W. Inhibitory properties of full-length and truncated recombinant tissue factor pathway inhibitor (TFPI). Evidence that the third Kunitz-type domain of TFPI is not essential for the inhibition of factor VIIa-tissue factor complexes on cell surfaces. *J Biol Chem* 1993;268:8704-8710.
1343. Wesselschmidt RL, Girard TJ, Likert KM. Tissue factor pathway inhibitor: The carboxyterminus is required for optimal inhibition of factor Xa. *Blood* 1992;779:2004-2010.
1344. Ndonwi M, Broze GJ. Protein S enhances the tissue factor pathway inhibitor inhibition of factor Xa but not its inhibition of factor VIIa-tissue factor. *J Thromb Haemost* 2008;6:1044-1046.
1345. van't Veer C, Mann KG. Regulation of tissue factor initiated thrombin generation by the stoichiometric inhibitors tissue factor pathway inhibitor, antithrombin-III, and heparin cofactor-II. *J Biol Chem* 1997;272:4367-4377.
1346. van't Veer C, Golden NJ, Kalafatis M, Mann KG. Inhibitory mechanism of the protein C pathway on tissue factor-induced thrombin generation. Synergistic effect in combination with tissue factor pathway inhibitor. *J Biol Chem* 1997;272:7983-7994.
1347. Warshawsky I, Bu G, Mast A, Saffitz JE, Broze GJ Jr, Schwartz AL. The carboxy terminus of tissue factor pathway inhibitor is required for interacting with hepatoma cells in vitro and in vivo. *J Clin Invest* 1995;95:1773-1781.
1348. Warshawsky I, Broze GJ Jr, Schwartz AL. The low density lipoprotein receptor-related protein mediates the cellular degradation of tissue factor pathway inhibitor. *Proc Natl Acad Sci U S A* 1994;91:6664-6668.
1349. Narita M, Bu G, Olins GM, et al. Two receptor systems are involved in the plasma clearance of tissue factor pathway inhibitor in vivo. *J Biol Chem* 1995;270:24800-24804.
1350. Janciauskiene S. Conformational properties of serine proteinase inhibitors (serpins) confer multiple pathophysiological roles. *Biochim Biophys Acta* 2001;1535:221-235.
1351. Rau J, Beaulieu L, Huntington J, Church F. Serpins in thrombosis, hemostasis and fibrinolysis. *J Thromb Haemost* 2007;5:102-115.
1352. Huntington J. Serpin structure, function and dysfunction. *J Thromb Haemost* 2011;9:26-34.
1353. Kuhle S, Lane DA, Jochmanns K, et al. Homozygous antithrombin deficiency type II (99 Leu to Phe mutation) and childhood thromboembolism. *Thromb Haemost* 2001;86:1007-1011.
1354. Yamamoto K, Takeshita K, Shimokawa T, et al. Plasminogen activator inhibitor-1 is a major stress-regulated gene: implications for stress-induced thrombosis in aged individuals. *Proc Natl Acad Sci USA* 2002;99:890-895.
1355. Khan H, Salman KA, Ahmed S. Alpha-1 antitrypsin deficiency in emphysema. *J Assoc Physicians India* 2002;50:579-582.
1356. Koide M, Shirahama S, Tokura Y, Takigawa M, Hayakawa M, Furukawa F. Lupus erythematosus associated with C1 inhibitor deficiency. *J Dermatol* 2002;29:503-507.
1357. Propst T, Propst A, Dietze O, Judmaier G, Braunsteiner H, Vogel W. Alpha-1-antitrypsin deficiency and liver disease. *Dig Dis* 1994;12:139-149.
1358. Davis RL, Shrimpton AE, Carrell RW, et al. Association between conformational mutations in neuroserpin and onset and severity of dementia. *Lancet* 2002;359:2242-2247.
1359. Stratikos E, Gettins PG. Formation of the covalent serpin-proteinase complex involves translocation of the proteinase by more than 70 Å and full insertion of the reactive center loop into beta-sheet A. *Proc Natl Acad Sci U S A* 1999;96:4808-4813.
1360. Kaslik G, Patthy A, Balint M, Graf L. Trypsin complexed with alpha 1-proteinase inhibitor has an increased structural flexibility. *FEBS Lett* 1995;370:179-183.
1361. Stavridi ES, O'Malley K, Lukacs CM, et al. Structural change in alpha-chymotrypsin induced by complexation with alpha 1-antichymotrypsin as seen by enhanced sensitivity to proteolysis. *Biochemistry* 1996;35:10608-10615.

1362. Fa M, Bergstrom F, Karolin J, Johansson LB, Ny T. Conformational studies of plasminogen activator inhibitor type 1 by fluorescence spectroscopy. Analysis of the reactive centre of inhibitory and substrate forms, and of their respective reactive-centre cleaved forms. *Eur J Biochem* 2000;267:3729-3734.
1363. Fa M, Bergstrom F, Hagglof P, Wilczynska M, Johansson LB, Ny T. The structure of a serpin-protease complex revealed by intramolecular distance measurements using donor-donor energy migration and mapping of interaction sites. *Structure Fold Des* 2000;8:397-405.
1364. Herve M, Ghelis C. Conformational stability of the covalent complex between elastase and alpha 1-proteinase inhibitor. *Arch Biochem Biophys* 1991;285:142-146.
1365. Streusand VJ, Bjork I, Gettins PG, Petitou M, Olson ST. Mechanism of acceleration of antithrombin-proteinase reactions by low affinity heparin. Role of the antithrombin binding pentasaccharide in heparin rate enhancement. *J Biol Chem* 1995;270:9043-9051.
1366. Plotnick MI, Mayne L, Schechter NM, Rubin H. Distortion of the active site of chymotrypsin complexed with a serpin. *Biochemistry* 1996;35:7586-7590.
1367. Baglin TP, Carrell RW, Church FC, Esmon CT, Huntington JA. Crystal structures of native and thrombin-complexed heparin cofactor II reveal a multistep allosteric mechanism. *Proc Natl Acad Sci USA* 2002;99:11079-11084.
1368. Li W, Johnson D, Esmon C, Huntington J. Structure of the antithrombin-thrombin-heparin ternary complex reveals the antithrombotic mechanism of heparin. *Nat Struct Mol Biol* 2004;11:857-862.
1369. Li W, Adams T, Nangalia J, Esmon C, Huntington J. Molecular basis of thrombin recognition by protein C inhibitor revealed by the 1.6-A structure of the heparin-bridged complex. *Proc Natl Acad Sci U S A* 2008;105:4661-4666.
1370. Li W, Huntington J. Crystal structures of protease nexin-1 in complex with heparin and thrombin suggest a 2-step recognition mechanism. *Blood* 2012;120:459-467.
1371. Im H, Woo MS, Hwang KY, Yu MH. Interactions causing the kinetic trap in serpin protein folding. *J Biol Chem* 2002;277:46347-46354.
1372. Whisstock J, Skinner R, Lesk AM. An atlas of serpin conformations. *Trends Biochem Sci* 1998;23:63-67.
1373. Huntington JA, Read RJ, Carrell RW. Structure of a serpin-protease complex shows inhibition by deformation. *Nature* 2000;407:923-926.
1374. Djie MZ, Stone SR, Le Bonniec BF. Intrinsic specificity of the reactive site loop of alpha1-antitrypsin, alpha1-antichymotrypsin, antithrombin III, and protease nexin I. *J Biol Chem* 1997;272:16268-16273.
1375. Zhou A, Carrell RW, Huntington JA. The serpin inhibitory mechanism is critically dependent on the length of the reactive center loop. *J Biol Chem* 2001;276:27541-27547.
1376. Lawrence DA, Olson ST, Muhammad S, et al. Partitioning of serpin-proteinase reactions between stable inhibition and substrate cleavage is regulated by the rate of serpin reactive center loop insertion into beta-sheet A. *J Biol Chem* 2000;275:5839-5844.
1377. Potempa J, Korzus E, Travis J. The serpin superfamily of proteinase inhibitors: structure, function, and regulation. *J Biol Chem* 1994;269:15957-15960.
1378. Laskowski M, Qasim MA. What can the structures of enzyme-inhibitor complexes tell us about the structures of enzyme substrate complexes? *Biochim Biophys Acta* 2000;1477:324-337.
1379. Silverman GA, Bird PI, Carrell RW, et al. The serpins are an expanding super-family of structurally similar but functionally diverse proteins. Evolution, mechanism of inhibition, novel functions, and a revised nomenclature. *J Biol Chem* 2001;276:33293-33296.
1380. Gils A, Declerck PJ. Structure-function relationships in serpins: current concepts and controversies. *Thromb Haemost* 1998;80:531-541.
1381. Wright HT. The structural puzzle of how serpin serine proteinase inhibitors work. *Bioessays* 1996;18:453-464.
1382. Huber R, Carrell RW. Implications of the three-dimensional structure of alpha 1-antitrypsin for structure and function of serpins. *Biochemistry* 1989;28:8951-8966.
1383. Ye S, Goldsmith EJ. Serpins and other covalent protease inhibitors. *Curr Opin Struct Biol* 2001;11:740-745.

1384. Bode W, Huber R. Structural basis of the endoproteinase-protein inhibitor interaction. *Biochim Biophys Acta* 2000;1477:241-252.
1385. Collen D, Schetz J, De Cock F, Holmer E, Verstraete M. Metabolism of anti-thrombin III (heparin cofactor) in man: effects of venous thrombosis and of heparin administration. *Eur J Clin Invest* 1977;7:27-35.
1386. Menache D, O'Malley JP, Schorr JB, et al. Evaluation of the safety, recovery, half-life, and clinical efficacy of antithrombin III (human) in patients with hereditary antithrombin III deficiency. Cooperative Study Group [see comments]. *Blood* 1990;75:33-39.
1387. Muszbek L, Bereczky Z, Kovács B, Komáromi I. Antithrombin deficiency and its laboratory diagnosis. *Clin Chem Lab Med* 2010;48:S67-S78.
1388. Harper PL, Luddington RJ, Daly M, et al. The incidence of dysfunctional anti-thrombin variants: four cases in 210 patients with thromboembolic disease. *Br J Haematol* 1991;77:360-364.
1389. Lane DA, Kunz G, Olds RJ, Thein SL. Molecular genetics of antithrombin deficiency. *Blood Rev* 1996;10:59-74.
- P.497
1390. Perry DJ, Carrell RW. Molecular genetics of human antithrombin deficiency. *Hum Mutat* 1996;7:7-22.
1391. Picard V, Nowak-Gottl U, Biron-Andreani C, et al. Molecular bases of anti-thrombin deficiency: twenty-two novel mutations in the antithrombin gene. *Hum Mutat* 2006;27:600.
1392. van Boven HH, Lane DA. Antithrombin and its inherited deficiency states. *Semin Hematol* 1997;34:188-204.
1393. Vinazzer H. Hereditary and acquired antithrombin deficiency. *Semin Thromb Hemost* 1999;25:257-263.
1394. White B, Perry D. Acquired antithrombin deficiency in sepsis. *Br J Haematol* 2001;112:26-31.
1395. Wiedermann C, Romisch J. The anti-inflammatory actions of antithrombin—a review. *Acta Med Austriaca* 2002;29:89-92.
1396. Baudo F, Redaelli R, Caimi TM, Mostarda G, Somaini G, de Cataldo F. The continuous infusion of recombinant activated factor VIIa (rFVIIa) in patients with factor VIII inhibitors activates the coagulation and fibrinolytic systems without clinical complications. *Thromb Res* 2000;99:21-24.
1397. Bock SC, Harris JF, Balazs I, Trent JM. Assignment of the human anti-thrombin III structural gene to chromosome 1q23-25. *Cytogenet Cell Genet* 1985;39:67-69.
1398. Olds RJ, Lane DA, Chowdhury V, De SV, Leone G, Thein SL. Complete nucleotide sequence of the antithrombin gene: evidence for homologous recombination causing thrombophilia. *Biochemistry* 1993;32:4216-4224.
1399. Fernandez-Rachubinski FA, Weiner JH, Blajchman MA. Regions flanking exon 1 regulate constitutive expression of the human antithrombin gene. *J Biol Chem* 1996;271:29502-29512.
1400. Murano G, Williams L, Miller-Andersson M, Aronson DL, King C. Some properties of antithrombin-III and its concentration in human plasma. *Thromb Res* 1980;18:259-262.
1401. Peterson CB, Blackburn MN. Isolation and characterization of an antithrombin III variant with reduced carbohydrate content and enhanced heparin binding. *J Biol Chem* 1985;260:610-615.
1402. Prochownik EV, Markham AF, Orkin SH. Isolation of a cDNA clone for human antithrombin III. *J Biol Chem* 1983;258:8389-8394.
1403. Bock SC, Wion KL, Vehar GA, Lawn RM. Cloning and expression of the cDNA for human antithrombin III. *Nucleic Acids Res* 1982;10:8113-8125.
1404. Franzen LE, Svensson S, Larm O. Structural studies on the carbohydrate portion of human antithrombin III. *J Biol Chem* 1980;255:5090-5093.
1405. Mizuochi T, Fujii J, Kurachi K, Kobata A. Structural studies of the carbohydrate moiety of human antithrombin III. *Arch Biochem Biophys* 1980;203:458-465.

1406. Turk B, Brieditis I, Bock SC, Olson ST, Bjork I. The oligosaccharide side chain on Asn-135 of alpha-antithrombin, absent in beta-antithrombin, decreases the heparin affinity of the inhibitor by affecting the heparin-induced conformational change. *Biochemistry* 1997;36:6682-6691.
1407. Mourey L, Samama JP, Delarue M, Petitou M, Choay J, Moras D. Crystal structure of cleaved bovine antithrombin III at 3.2 Å resolution. *J Mol Biol* 1993;232:223-241.
1408. Johnson DJ, Langdown J, Li W, Luis SA, Baglin TP, Huntington JA. Crystal structure of monomeric native antithrombin reveals a novel reactive center loop conformation. *J Biol Chem* 2006;281:35478-35486.
1409. Wardell MR, Abrahams JP, Bruce D, Skinner R, Leslie AG. Crystallization and preliminary X-ray diffraction analysis of two conformations of intact human antithrombin. *J Mol Biol* 1993;234:1253-1258.
1410. Skinner R, Abrahams JP, Whisstock JC, Lesk AM, Carrell RW, Wardell MR. The 2.6 Å structure of antithrombin indicates a conformational change at the heparin binding site. *J Mol Biol* 1997;266:601-609.
1411. Olson ST, Bjork I, Shore JD. Kinetic characterization of heparin-catalyzed and uncatalyzed inhibition of blood coagulation proteinases by antithrombin. *Methods Enzymol* 1993;222:525-559.
1412. Olson ST, Shore JD. Demonstration of a two-step reaction mechanism for inhibition of alpha-thrombin by antithrombin III and identification of the step affected by heparin. *J Biol Chem* 1982;257:14891-14895.
1413. Casu B, Oreste P, Torri G, et al. The structure of heparin oligosaccharide fragments with high anti- (factor Xa) activity containing the minimal antithrombin III-binding sequence. Chemical and ¹³C nuclear-magnetic-resonance studies. *Biochem J* 1981;197:599-609.
1414. O'Reilly MS, Pirie-Shepherd S, Lane WS, Folkman J. Antiangiogenic activity of the cleaved conformation of the serpin antithrombin. *Science* 1999;285: 1926-1928.
1415. Gray E, Hogwood J, Mulloy B. The anticoagulant and antithrombotic mechanisms of heparin. *Handb Exp Pharmacol* 2012;207:43-61.
1416. Johnson DJ, Li W, Adams TE, Huntington JA. Antithrombin-S195A factor Xa-heparin structure reveals the allosteric mechanism of antithrombin activation. *EMBO J* 2006;25:2029-2037.
1417. Rau J, Mitchell J, Fortenberry Y, Church F. Heparin cofactor II: discovery, properties, and role in controlling vascular homeostasis. *Semin Thromb Hemost* 2011;37:339-348.
1418. Tollefsen DM, Pestka CA, Monafó WJ. Activation of heparin cofactor II by dermatan sulfate. *J Biol Chem* 1983;258:6713-6716.
1419. Tollefsen DM, Majerus DW, Blank MK. Heparin cofactor II. Purification and properties of a heparin-dependent inhibitor of thrombin in human plasma. *J Biol Chem* 1982;257:2162-2169.
1420. Griffith MJ, Carraway T, White GC, Dombrose FA. Heparin cofactor activities in a family with hereditary antithrombin III deficiency: evidence for a second heparin cofactor in human plasma. *Blood* 1983;61:111-118.
1421. Andersson TR, Sie P, Pelzer H, Aamodt LM, Nustad K, Abildgaard U. Elevated levels of thrombin-heparin cofactor II complex in plasma from patients with disseminated intravascular coagulation. *Thromb Res* 1992;66:591-598.
1422. Corral J, Aznar J, Gonzalez-Conejero R, et al. Homozygous deficiency of heparin cofactor II: relevance of P17 glutamate residue in serpins, relationship with conformational diseases, and role in thrombosis. *Circulation* 2004;110:1303-1307.
1423. Simioni P, Lazzaro AR, Coser E, Salmistraro G, Girolami A. Hereditary heparin cofactor II deficiency and thrombosis: report of six patients belonging to two separate kindreds. *Blood Coagul Fibrinolysis* 1990;1:351-356.
1424. Weisdorf DJ, Edson JR. Recurrent venous thrombosis associated with inherited deficiency of heparin cofactor II [published erratum appears in *Br J Haematol* 1991 Mar;77(3):446]. *Br J Haematol* 1991;77:125-126.
1425. Andersson TR, Larsen ML, Handeland GF, Abildgaard U. Heparin cofactor II activity in plasma: application of an automated assay method to the study of a normal adult population. *Scand J Haematol* 1986;36:96-102.
1426. Blinder MA, Marasa JC, Reynolds CH, Deaven LL, Tollefsen DM. Heparin cofactor II: cDNA sequence, chromosome localization, restriction fragment length polymorphism, and expression in *Escherichia coli*. *Biochemistry* 1988;27:752-759.
1427. Herzog R, Lutz S, Blin N, Marasa JC, Blinder MA, Tollefsen DM. Complete nucleotide sequence of the gene for human heparin cofactor II and mapping to chromosomal band 22q11. *Biochemistry* 1991;30:1350-1357.

1428. Ragg H. A new member of the plasma protease inhibitor gene family. *Nucleic Acids Res* 1986;14:1073-1088.
1429. Zhang GS, Mehringer JH, Van Deerlin VM, Kozak CA, Tollefsen DM. Murine heparin cofactor II: purification, cDNA sequence, expression, and gene structure [published erratum appears in *Biochemistry* 1994 Jun 21;33(24):7744]. *Biochemistry* 1994;33:3632-3642.
1430. Whinna HC, Blinder MA, Szewczyk M, Tollefsen DM, Church FC. Role of lysine 173 in heparin binding to heparin cofactor II. *J Biol Chem* 1991;266: 8129-8135.
1431. Blinder MA, Tollefsen DM. Site-directed mutagenesis of arginine 103 and lysine 185 in the proposed glycosaminoglycan-binding site of heparin cofactor II. *J Biol Chem* 1990;265:286-291.
1432. Tollefsen DM. Heparin cofactor II. *Adv Exp Med Biol* 1997;425:35-44.
1433. Ragg H, Ulshofer T, Gerewitz J. On the activation of human leuserpin-2, a thrombin inhibitor, by glycosaminoglycans. *J Biol Chem* 1990;265:5211-5218.
1434. Van Deerlin VM, Tollefsen DM. The N-terminal acidic domain of heparin cofactor II mediates the inhibition of alpha-thrombin in the presence of glycosaminoglycans. *J Biol Chem* 1991;266:20223-20231.
1435. Sheehan JP, Wu Q, Tollefsen DM, Sadler JE. Mutagenesis of thrombin selectively modulates inhibition by serpins heparin cofactor II and anti-thrombin III. Interaction with the anion-binding exosite determines heparin cofactor II specificity. *J Biol Chem* 1993;268:3639-3645.
1436. Church FC, Pratt CW, Hoffman M. Leukocyte chemoattractant peptides from the serpin heparin cofactor II. *J Biol Chem* 1991;266:704-709.
1437. Joslin G, Wittwer A, Adams S, Tollefsen DM, August A, Perlmutter DH. Cross-competition for binding of alpha 1-antitrypsin (alpha 1 AT)-elastase complexes to the serpin-enzyme complex receptor by other serpin-enzyme complexes and by proteolytically modified alpha 1 AT. *J Biol Chem* 1993;268:1886-1893.
1438. Griffith MJ, Noyes CM, Church FC. Reactive site peptide structural similarity between heparin cofactor II and antithrombin III. *J Biol Chem* 1985;260:2218-2225.
1439. Fortenberry YM, Whinna HC, Gentry HR, Myles T, Leung LL, Church FC. Molecular mapping of the thrombin-heparin cofactor II complex. *J Biol Chem* 2004;279:43237-43244.
1440. Parker KA, Tollefsen DM. The protease specificity of heparin cofactor II. Inhibition of thrombin generated during coagulation. *J Biol Chem* 1985;260:3501-3505.
1441. Giri TK, Ahn CW, Wu KK, Tollefsen DM. Heparin cofactor II levels do not predict the development of coronary heart disease: the Atherosclerosis Risk in Communities (ARIC) study. *Arterioscler Thromb Vasc Biol* 2005;25:2689-2690.
1442. McGuire EA, Tollefsen DM. Activation of heparin cofactor II by fibroblasts and vascular smooth muscle cells. *J Biol Chem* 1987;262:169-175.
1443. Tollefsen D. Vascular dermatan sulfate and heparin cofactor II. *Prog Mol Biol Transl Sci* 2010;93:351-372.
1444. Andrew M, Mitchell L, Berry L, et al. An anticoagulant dermatan sulfate proteoglycan circulates in the pregnant woman and her fetus. *J Clin Invest* 1992;89:321-326.
1445. Massouh M, Jatoi A, Gordon EM, Ratnoff OD. Heparin cofactor II activity in plasma during pregnancy and oral contraceptive use. *J Lab Clin Med* 1989;114:697-699.
1446. Liu L, Dewar L, Song Y, et al. Inhibition of thrombin by antithrombin III and heparin cofactor II in vivo. *Thromb Haemost* 1995;73:405-412.
1447. Ikeda Y, Aihara K, Yoshida S, et al. Heparin cofactor II, a serine protease inhibitor, promotes angiogenesis via activation of the AMP-activated protein kinase-endothelial nitric-oxide synthase signaling pathway. *J Biol Chem* 2012;287:34256-34263.
1448. Jeppsson JO, Laurell CB, Fagerhol M. Properties of isolated human alpha1-antitrypsins of Pi types M, S and Z. *Eur J Biochem* 1978;83:143-153.
1449. Jeppsson JO, Laurell CB, Nosslin B, Cox DW. Catabolic rate of alpha1-antitrypsin of Pi types S, and MMalton and of asialylated M-protein in man. *Clin Sci Mol Med* 1978;55:103-107.

1450. Shalygin VA, Eroshenko LB, Solnyshko AL, Bocharov RV, Shalygin AV. [Diagnostic and prognostic significance of study of acute phase proteins in children with appendicular peritonitis]. *Klin Lab Diagn* 2002;7-9.
1451. Primhak RA, Tanner MS. Alpha-1 antitrypsin deficiency. *Arch Dis Child* 2001;85:2-5.
1452. Ekeowa U, Marciniak S, Lomas D. $\alpha(1)$ -antitrypsin deficiency and inflammation. *Expert Rev Clin Immunol* 2011;7:243-252.
1453. Lewis E. Expanding the clinical indications for $\alpha(1)$ - antitrypsin therapy. *Mol Med* 2012;18:957-970.
1454. Metz R, DiCola M, Kurihara T, et al. Mode of action of RNA/DNA oligonucleotides: progress in the development of gene repair as a therapy for alpha(1)-antitrypsin deficiency. *Chest* 2002;121:91S-97S.
1455. Davies JC, Geddes DM, Alton EW. Prospects for gene therapy in lung disease. *Curr Opin Pharmacol* 2001;1:272-277.
1456. Vadolas J, Williamson R, Ioannou PA. Gene therapy for inherited lung disorders: an insight into pulmonary defence. *Pulm Pharmacol Ther* 2002;15:61-72.
1457. Gooptu B, Lomas D. Conformational pathology of the serpins: themes, variations, and therapeutic strategies. *Annu Rev Biochem* 2009;78:147-176.
1458. Leicht M, Long GL, Chandra T, et al. Sequence homology and structural comparison between the chromosomal human alpha 1-antitrypsin and chicken ovalbumin genes. *Nature* 1982;297:655-659.
1459. Rabin M, Watson M, Kidd V, Woo SL, Breg WR, Ruddle FH. Regional location of alpha 1-antichymotrypsin and alpha 1-antitrypsin genes on human chromosome 14. *Somat Cell Mol Genet* 1986;12:209-214.
1460. Purrello M, Alhadeff B, Whittington E, et al. Comparison of cytologic and genetic distances between long arm subtelomeric markers of human auto-some 14 suggests uneven distribution of crossing-over. *Cytogenet Cell Genet* 1987;44:32-40.
1461. Darlington GJ, Astrin KH, Muirhead SP, Desnick RJ, Smith M. Assignment of human alpha 1-antitrypsin to chromosome 14 by somatic cell hybrid analysis. *Proc Natl Acad Sci U S A* 1982;79:870-873.
1462. Bao JJ, Reed-Fourquet L, Sifers RN, Kidd VJ, Woo SL. Molecular structure and sequence homology of a gene related to alpha 1- antitrypsin in the human genome. *Genomics* 1988;2:165-173.
1463. Hofker MH, Nelen M, Klasen EC, et al. Cloning and characterization of an alpha 1-antitrypsin like gene 12 KB downstream of the genuine alpha 1-antitrypsin gene. *Biochem Biophys Res Commun* 1988;155:634-642.
1464. Rollini P, Fournier RE. Differential regulation of gene activity and chromatin structure within the human serpin gene cluster at 14q32.1 in macrophage microcell hybrids. *Nucleic Acids Res* 2000;28:1767-1777.
1465. Hu C, Perlmutter DH. Cell-specific involvement of HNF-1beta in alpha(1)-antitrypsin gene expression in human respiratory epithelial cells. *Am J Physiol Lung Cell Mol Physiol* 2002;282:L757-L765.
1466. Holmes WE, Nelles L, Lijnen HR, Collen D. Primary structure of human alpha 2-antiplasmin, a serine protease inhibitor (serpin). *J Biol Chem* 1987;262:1659-1664.
1467. Lijnen HR, Holmes WE, Van Hoef B, Wiman B, Rodriguez H, Collen D. Amino-acid sequence of human alpha 2-antiplasmin. *Eur J Biochem* 1987;166:565-574.
1468. Johnson D, Travis J. Structural evidence for methionine at the reactive site of human alpha- 1-proteinase inhibitor. *J Biol Chem* 1978;253:7142-7144.
1469. Matheson NR, van Halbeek H, Travis J. Evidence for a tetrahedral intermediate complex during serpin- proteinase interactions. *J Biol Chem* 1991;266:13489-13491.
1470. Loebermann H, Tokuoka R, Deisenhofer J, Huber R. Human alpha 1-proteinase inhibitor. Crystal structure analysis of two crystal modifications, molecular model and preliminary analysis of the implications for function. *J Mol Biol* 1984;177:531-557.
1471. Schulze AJ, Frohnert PW, Engh RA, Huber R. Evidence for the extent of insertion of the active site loop of intact alpha 1 proteinase inhibitor in beta-sheet A. *Biochemistry* 1992;31:7560-7565.
1472. Smith KF, Harrison RA, Perkins SJ. Structural comparisons of the native and reactive-centre-cleaved forms of alpha 1-antitrypsin by neutron and x-ray-scattering in solution. *Biochem J* 1990;267:203-212.

1473. Murakami T, Komiyama Y, Masuda M, Karakawa M, Iwasaka T, Takahashi H. Evaluation of factor XIa-alpha 1-antitrypsin in plasma, a contact phase-activated coagulation factor-inhibitor complex, in patients with coronary artery disease. *Arterioscler Thromb Vasc Biol* 1995;15:1107-1113.
1474. Wuillemin WA, Hack CE, Bleeker WK, Biemond BJ, Levi M, ten Cate H. Inactivation of factor XIa in vivo: studies in chimpanzees and in humans. *Thromb Haemost* 1996;76:549-555.
1475. Scully MF, Toh CH, Hoogendoorn H, et al. Activation of protein C and its distribution between its inhibitors, protein C inhibitor, alpha 1-antitrypsin and alpha 2-macroglobulin, in patients with disseminated intravascular coagulation. *Thromb Haemost* 1993;69:448-453.
1476. Carter PE, Dunbar B, Fothergill JE. Genomic and cDNA cloning of the human C1 inhibitor. Intron-exon junctions and comparison with other serpins. *Eur J Biochem* 1988;173:163-169.
1477. Orfan NA, Kolski GB. Angioedema and C1 inhibitor deficiency. *Ann Allergy* 1992;69:167-172.
1478. Phanish MK, Owen A, Parry DH. Spontaneous regression of acquired C1 esterase inhibitor deficiency associated with splenic marginal zone lymphoma presenting with recurrent angio-oedema. *J Clin Pathol* 2002;55:789-790.
1479. Shiozawa S, Shiozawa K. Angioedema and acquired C1 esterase inhibitor deficiency. *Intern Med* 2002;41:333-334.
1480. Han ED, MacFarlane RC, Mulligan AN, Scafidi J, Davis AE, III. Increased vascular permeability in C1 inhibitor-deficient mice mediated by the bradykinin type 2 receptor. *J Clin Invest* 2002;109:1057-1063.
1481. Frank M. Hereditary angioedema: a current state-of-the-art review, VI: novel therapies for hereditary angioedema. *Ann Allergy Asthma Immunol* 2011.
1482. Antoniu M. Therapeutic approaches in hereditary angioedema. *Ann Allergy Asthma Immunol* 2011;100:S23-S29.
1483. Singer M, Jones, Jones. Hereditary angioedema: a current state-of-the-art review, VI: novel therapies for hereditary angioedema. *Ann Allergy Asthma Immunol* 2011;100:S23-S29.
1484. Banz Y, Rieben R. Role of complement and perspectives for intervention in ischemia-reperfusion damage. *Ann Med* 2012;44:205-217.
1485. Bock SC, Skriver K, Nielsen E, et al. Human C1 inhibitor: primary structure, cDNA cloning, and chromosomal localization. *Biochemistry* 1986;25:4292-4301.
1486. Zahedi K, Prada AE, Davis AE, III. Structure and regulation of the C1 inhibitor gene. *Behring Inst Mitt* 1993:115-119.
1487. Kang HR, Yim EY, Oh SY, et al. Normal C1 inhibitor mRNA expression level in type I hereditary angioedema patients: newly found C1 inhibitor gene mutations. *Allergy* 2006;61:260-264.
1488. Tosi M. Molecular genetics of C1 inhibitor. *Immunobiology* 1998;199:358-365.
1489. Perkins SJ, Smith KF, Amatayakul S, et al. Two-domain structure of the native and reactive centre cleaved forms of C1 inhibitor of human complement by neutron scattering. *J Mol Biol* 1990;214:751-763.
1490. Perkins SJ, Smith KF, Nealis AS, et al. Secondary structure changes stabilize the reactive-centre cleaved form of SERPINS. A study by 1H nuclear magnetic resonance and Fourier transform infrared spectroscopy. *J Mol Biol* 1992;228:1235-1254.
1491. Perkins SJ. Three-dimensional structure and molecular modelling of C1-inhibitor. *Behring Inst Mitt* 1993:63-80.
1492. Laurell AB, Johnson U, Martensson U, Sjöholm AG. Formation of complexes composed of C1r, C1s, and C1 inactivator in human serum on activation of C1. *Acta Pathol Microbiol Scand Sect C Immunol* 1978;86:299.
1493. Forbes CD, Pinsky J, Ratnoff OD. Inhibition of activated Hageman factor and activated plasma thromboplastin antecedent by purified serum C1 inactivator. *J Lab Clin Med* 1979;76:809.
1494. Wuillemin WA, Minnema M, Meijers JC, et al. Inactivation of factor XIa in human plasma assessed by measuring factor XIa-protease inhibitor complexes: major role for C1-inhibitor. *Blood* 1995;85:1517-1526.
1495. Nilsson T. On the interaction between human plasma kallikrein and C1-esterase inhibitor. *Thromb Haemost* 1983;49:193-195.
1496. Geiger M, Zechmeister-Machhart M, Uhrin P, et al. Protein C inhibitor (PCI). *Immunopharmacology* 1996;32:53-56.
1497. Seregni E, Botti C, Ballabio G, Bombardieri E. Biochemical characteristics and recent biological knowledge on prostate-specific antigen. *Tumori* 1996;82:72-77.

1498. Suzuki K, Nishioka J, Hashimoto S. Protein C inhibitor. Purification from human plasma and characterization. *J Biol Chem* 1983;258:163-168.
1499. Laurell M, Christensson A, Abrahamsson PA, Stenflo J, Lilja H. Protein C inhibitor in human body fluids. Seminal plasma is rich in inhibitor antigen deriving from cells throughout the male reproductive system. *J Clin Invest* 1992;89:1094-1101.
1500. Laurell M, Stenflo J, Carlson TH. Turnover of I-protein C inhibitor and I-alpha 1-antitrypsin and their complexes with activated protein C. *Blood* 1990;76:2290-2295.
1501. Meijers JC, Marquart JA, Bertina RM, Bouma BN, Rosendaal FR. Protein C inhibitor (plasminogen activator inhibitor-3) and the risk of venous thrombosis. *Br J Haematol* 2002;118:604-609.
1502. Uhrin P, Dewerchin M, Hilpert M, et al. Disruption of the protein C inhibitor gene results in impaired spermatogenesis and male infertility. *J Clin Invest* 2000;106:1531-1539.
1503. Meijers JC, Chung DW. Organization of the gene coding for human protein C inhibitor (plasminogen activator inhibitor-3). Assignment of the gene to chromosome 14. *J Biol Chem* 1991;266:15028-15034.
1504. Billingsley GD, Walter MA, Hammond GL, Cox DW. Physical mapping of four serpin genes: alpha 1-antitrypsin, alpha 1-antichymotrypsin, corticosteroidbinding globulin, and protein C inhibitor, within a 280-kb region on chromosome 14q32.1. *Am J Hum Genet* 1993;52:343-353.
1505. Suzuki K, Deyashiki Y, Nishioka J, et al. Characterization of a cDNA for human protein C inhibitor. A new member of the plasma serine protease inhibitor superfamily. *J Biol Chem* 1987;262:611-616.
1506. Seixas S, Garcia O, Trovoada MJ, Santos MT, Amorim A, Rocha J. Patterns of haplotype diversity within the serpin gene cluster at 14q32.1: insights into the natural history of the alpha1-antitrypsin polymorphism. *Hum Genet* 2001;108:20-30.
1507. Nishioka J, Ning M, Hayashi T, Suzuki K. Protein C inhibitor secreted from activated platelets efficiently inhibits activated protein C on phosphatidylethanolamine of platelet membrane and microvesicles. *J Biol Chem* 1998;273:11281-11287.
1508. Krebs M, Uhrin P, Vales A, et al. Protein C inhibitor is expressed in keratinocytes of human skin. *J Invest Dermatol* 1999;113:32-37.
1509. Radtke KP, Fernandez JA, Greengard JS, et al. Protein C inhibitor is expressed in tubular cells of human kidney. *J Clin Invest* 1994;94:2117-2124.
1510. Fujita M, Izutani W, Takahashi K, Nishizawa K, Shirono H, Koga J. Role of each Asn-linked glycan in the anticoagulant activity of human protein C inhibitor. *Thromb Res* 2002;105:95-102.
1511. Pratt CW, Church FC. General features of the heparin-binding serpins antithrombin, heparin cofactor II and protein C inhibitor. *Blood Coagul Fibrinolysis* 1993;4:479-490.
1512. Neese LL, Wolfe CA, Church FC. Contribution of basic residues of the D and H helices in heparin binding to protein C inhibitor. *Arch Biochem Biophys* 1998;355:101-108.
1513. Li W, Adams TE, Kjellberg M, Stenflo J, Huntington JA. Structure of native protein C inhibitor provides insight into its multiple functions. *J Biol Chem* 2007;282:13759-13768.
1514. Espana F, Vicente V, Tabernero D, Scharer I, Griffin JH. Determination of plasma protein C inhibitor and of two activated protein C-inhibitor complexes in normals and in patients with intravascular coagulation and thrombotic disease. *Thromb Res* 1990;59:593-608.
1515. Meijers J, Herwald H. Protein C inhibitor. *Semin Thromb Hemost* 2011;37:349-354.
1516. Suzuki K. The multi-functional serpin, protein C inhibitor: beyond thrombosis and hemostasis. *J Thromb Haemost* 2008;6:2017-2026.
1517. Fortenberry Y, Hlavacek A, Church F. Protein C inhibitor inhibits factor VIIa when bound to tissue factor. *J Thromb Haemost* 2011;9:861-863.
1518. Rezaie A, Cooper S, Church F, Esmon C. Protein C inhibitor is a potent inhibitor of the thrombin-thrombomodulin complex. *J Biol Chem* 1995;270:25336-25339.

1519. Heeb MJ, Espana F, Griffin JH. Inhibition and complexation of activated protein C by two major inhibitors in plasma. *Blood* 1989;73:446-454.
1520. Hoogendoorn H, Nesheim ME, Giles AR. A qualitative and quantitative analysis of the activation and inactivation of protein C in vivo in a primate model. *Blood* 1990;75:2164-2171.
1521. Mosnier LO, Elisen MG, Bouma BN, Meijers JC. Protein C inhibitor regulates the thrombin-thrombomodulin complex in the up- and down regulation of TAFI activation. *Thromb Haemost* 2001;86:1057-1064.
1522. Strandberg K, Astermark J, Bjorgell O, Becker C, Nilsson PE, Stenflo J. Complexes between activated protein C and protein C inhibitor measured with a new method: comparison of performance with other markers of hypercoagulability in the diagnosis of deep vein thrombosis. *Thromb Haemost* 2001;86:1400-1408.
1523. Barkan G, Gaspar A. Zur Frage der Reversibilitat der Fibringerinnung II. *Biochem Ztschr* 1923;139:291-301.
1524. Muszbek L, Ariens RA, Ichinose A. Factor XIII: recommended terms and abbreviations. *JThromb Haemost* 2007;5:181-183.
1525. Robbins KC. A study on the conversion of fibrinogen to fibrin. *Am J Physiol* 1944;142:581-588.
1526. Laki K, Lorand L. On the solubility of fibrin clots. *Science* 1948;108:280.
1527. Lorand L. A study on the solubility of fibrin clots in urea. *Acta Physiol Acad Sci Hung* 1948;1:192-196.
1528. Muszbek L, Yee VC, Hevessy Z. Blood coagulation factor XIII: structure and function. *Thromb Res* 1999;94:271-305.
1529. Procyk R, Adamson L, Block M, Blomback B. Factor XIII catalyzed formation of fibrinogen-fibronectin oligomers—a thiol enhanced process. *Thromb Res* 1985;40:833-852.
1530. Procyk R, Blomback B. Factor XIII-induced crosslinking in solutions of fibrinogen and fibronectin. *Biochim Biophys Acta* 1988;967:304-313.
1531. Tamaki T, Aoki N. Cross-linking of alpha 2-plasmin inhibitor to fibrin catalyzed by activated fibrin-stabilizing factor. *J Biol Chem* 1982;257: 14767-14772.
1532. Chen R, Doolittle RF. Cross-linking sites in human and bovine fibrin. *Biochemistry* 1971;10:4487-4491.
1533. Kanaide H, Shainoff JR. Cross-linking of fibrinogen and fibrin by fibrinstablizing factor (factor XIIIa). *J Lab Clin Med* 1975;85:574-597.
1534. Mosher DF, Schad PE. Cross-linking of fibronectin to collagen by blood coagulation Factor XIIIa. *J Clin Invest* 1979;64:781-787.
1535. Mosher DF. Cross-linking of fibronectin to collagenous proteins. *Mol Cell Biochem* 1984;58:63-68.
1536. Mui PT, Ganguly P. Cross-linking of actin and fibrin by fibrin-stabilizing factor. *Am J Physiol* 1977;233:H346-H349.
1537. Lynch GW, Slayter HS, Miller BE, McDonagh J. Characterization of thrombospondin as a substrate for factor XIII transglutaminase. *J Biol Chem* 1987;262:1772-1778.
1538. Lorand L. Factor XIII and the clotting of fibrinogen: from basic research to medicine. *JThromb Haemost* 2005.
1539. Dardik R, Loscalzo J, Inbal A. Factor XIII (FXIII) and angiogenesis. *JThromb Haemost* 2006;4:19-25.
1540. Muszbek L, Bereczky Z, Bagoly Z, Komáromi I, Katona É. Factor XIII: a coagulation factor with multiple plasmatic and cellular functions. *Physiol Rev* 2011;91:931-972.
1541. Ichinose A. Factor XIII is a key molecule at the intersection of coagulation and fibrinolysis as well as inflammation and infection control. *Int J Hematol* 2012;95:362-370.
1542. Sane DC, Kontos JL, Greenberg CS. Roles of transglutaminases in cardiac and vascular diseases. *Front Biosci* 2007;12:2530-2545.
1543. Weisberg LJ, Shiu DT, Greenberg CS, Kan YW, Shuman MA. Localization of the gene for coagulation factor XIII a-chain to chromosome 6 and identification of sites of synthesis. *J Clin Invest* 1987;79:649-652.
1544. Board PG, Webb GC, McKee J, Ichinose A. Localization of the coagulation factor XIII A subunit gene (F13A) to chromosome bands 6p24—p25. *Cytogenet Cell Genet* 1988;48:25-27.
1545. Ichinose A, Davie EW. Characterization of the gene for the a subunit of human factor XIII (plasma transglutaminase), a blood coagulation factor. *Proc Natl Acad Sci USA* 1988;85:5829-5833.

1546. Webb GC, Coggan M, Ichinose A, Board PG. Localization of the coagulation factor XIII B subunit gene (F13B) to chromosome bands 1q31-32.1 and restriction fragment length polymorphism at the locus. *Hum Genet* 1989;81:157-160.
1547. Grundmann U, Nerlich C, Rein T, Zettlmeissl G. Complete cDNA sequence encoding the B subunit of human factor XIII. *Nucleic Acids Res* 1990;18: 2817-2818.
1548. Ichinose A, McMullen BA, Fujikawa K, Davie EW. Amino acid sequence of the b subunit of human factor XIII, a protein composed of ten repetitive segments. *Biochemistry* 1986;25:4633-4638.
1549. Bottenus RE, Ichinose A, Davie EW. Nucleotide sequence of the gene for the b subunit of human factor XIII. *Biochemistry* 1990;29:11195-11209.
1550. Morley BJ, Campbell RD. Internal homologies of the Ba fragment from human complement component Factor B, a class III MHC antigen. *EMBO J* 1984;3:153-157.
1551. Chung LP, Gagnon J, Reid KB. Amino acid sequence studies of human C4b binding protein: N-terminal sequence analysis and alignment of the fragments produced by limited proteolysis with chymotrypsin and the peptides produced by cyanogen bromide treatment. *Mol Immunol* 1985;22:427-435.
1552. Miloszewski KJA, Losowsky MS. Fibrin stabilization and factor XIII deficiency. In: Horwood e, ed. *Fibrinogen, fibrin stabilization and fibrinolysis*. Chichester, UK: L Francis, 1988:175-202.
1553. Kohler H, Ichinose A, Seitz R, Ariens R, Muszbek L. Diagnosis and classification of factor XIII deficiencies. *J Thromb Haemost* 2011;9:1404-1406.
1554. Lowey AG, McDonagh J, Mikkola H, Teller DC, Yee VC. Structure and function of factor XIII. In: Colman RW, Hirsh J, Marder VJ, Clowes AW, George JN, eds. *Hemostasis and thrombosis*. Philadelphia, PA: Lippincott Williams & Wilkins, 2001:233-247.
1555. Biswas A, Ivaskevicius V, Seitz R, Thomas A, Oldenburg J. An update of the mutation profile of Factor 13 A and B genes. *Blood Review* 2011;25:193-204.
1556. Ariens RA, Lai TS, Weisel JW, Greenberg CS, Grant PJ. Role of factor XIII in fibrin clot formation and effects of genetic polymorphisms. *Blood* 2002;100:743-754.
1557. Reiner AP, Schwartz SM, Frank MB, et al. Polymorphisms of coagulation factor XIII subunit A and risk of nonfatal hemorrhagic stroke in young white women. *Stroke* 2001;32:2580-2587.
1558. Mikkola H, Syrjala M, Rasi V, et al. Deficiency in the A-subunit of coagulation factor XIII: two novel point mutations demonstrate different effects on transcript levels. *Blood* 1994;84:517-525.
1559. Kohler HP, Stickland MH, Ossei-Gerning N, Carter A, Mikkola H, Grant PJ. Association of a common polymorphism in the factor XIII gene with myocardial infarction. *Thromb Haemost* 1998;79:8-13.
1560. Wartiovaara U, Perola M, Mikkola H, et al. Association of FXIII Val34Leu with decreased risk of myocardial infarction in Finnish males. *Atherosclerosis* 1999;142:295-300.
1561. Catto AJ, Kohler HP, Coore J, Mansfield MW, Stickland MH, Grant PJ. Association of a common polymorphism in the factor XIII gene with venous thrombosis. *Blood* 1999;93:906-908.
1562. Franco RF, Reitsma PH, Lourenco D, et al. Factor XIII Val34Leu is a genetic factor involved in the etiology of venous thrombosis. *Thromb Haemost* 1999;81:676-679.
1563. Elbaz A, Poirier O, Canaple S, Chedru F, Cambien F, Amarenco P. The association between the Val34Leu polymorphism in the factor XIII gene and brain infarction. *Blood* 2000;95:586-591.
1564. Renner W, Koppel H, Hoffmann C, et al. Prothrombin G20210A, Factor V Leiden, and Factor XIII Val34Leu. Common mutations of blood coagulation factors and deep vein thrombosis in Austria. *Thromb Res* 2000;99:35-39.
1565. Lorand L. Factor XIII: structure, activation, and interactions with fibrinogen and fibrin. *Ann NY Acad Sci* 2001;936:291-311.
1566. Kohler HP, Ariens RA, Whitaker P, Grant PJ. A common coding polymorphism in the FXIII A-subunit gene (FXIIIVal34Leu) affects cross-linking activity [letter]. *Thromb Haemost* 1998;80:704.
1567. Kangsadalampai S, Board PG. The Val34Leu polymorphism in the A subunit of coagulation factor XIII contributes to the large normal range in activity and demonstrates that the activation peptide plays a role in catalytic activity. *Blood* 1998;92:2766-2770.

1568. Anwar R, Gallivan L, Edmonds SD, Markham AF. Genotype/phenotype correlations for coagulation factor XIII: specific normal polymorphisms are associated with high or low factor XIII specific activity. *Blood* 1999;93:897-905.
1569. Ariens RA, Philippou H, Nagaswami C, Weisel JW, Lane DA, Grant PJ. The factor XIII V34L polymorphism accelerates thrombin activation of factor XIII and affects cross-linked fibrin structure. *Blood* 2000;96:988-995.
1570. Undas A, Sydor WJ, Brummel K, Musial J, Mann KG, Szczeklik A. Aspirin alters the cardioprotective effects of the factor XIII Val34Leu polymorphism. *Circulation* 2003;107:17-20.
1571. Schwartz ML, Pizzo SV, Hill RL, McKee PA. Human Factor XIII from plasma and platelets. Molecular weights, subunit structures, proteolytic activation, and cross-linking of fibrinogen and fibrin. *J Biol Chem* 1973;248:1395-1407.
1572. Radek JT, Jeong JM, Wilson J, Lorand L. Association of the A subunits of recombinant placental factor XIII with the native carrier B subunits from human plasma. *Biochemistry* 1993;32:3527-3534.
1573. Yorifuji H, Anderson K, Lynch GW, Van de WL, McDonagh J. B protein of factor XIII: differentiation between free B and complexed B. *Blood* 1988;72:1645-1650.
1574. Katona E, Haramura G, Karpati L, Fachel J, Muszbek L. A simple, quick one-step ELISA assay for the determination of complex plasma factor XIII (A2B2). *Thromb Haemost* 2000;83:268-273.
1575. Takahashi N, Takahashi Y, Putnam FW. Primary structure of blood coagulation factor XIIIa (fibrinolygase, transglutaminase) from human placenta. *Proc Natl Acad Sci USA* 1986;83:8019-8023.
1576. Ichinose A, Hendrickson LE, Fujikawa K, Davie EW. Amino acid sequence of the a subunit of human factor XIII. *Biochemistry* 1986;25:6900-6906.
1577. Carrell NA, Erickson HP, McDonagh J. Electron microscopy and hydrodynamic properties of factor XIII subunits. *J Biol Chem* 1989;264:551-556.
1578. McDonagh J. Structure and function of factor XIII. In: Colman RW, Hirsh J, Marder VJ, Sandberg H, eds. *Hemostasis and thrombosis: basic principles and clinical practice*. Philadelphia, PA: Lippincott, 1994:301-313.
1579. Ichinose A, Kaetsu H. Molecular approach to structure-function relationship of human coagulation factor XIII. *Methods Enzymol* 1993;222:36-51.
1580. Pedersen LC, Yee VC, Bishop PD, Le TI, Teller DC, Stenkamp RE. Transglutaminase factor XIII uses proteinase-like catalytic triad to crosslink macromolecules. *Protein Sci* 1994;3:1131-1135.
1581. Yee VC, Pedersen LC, Bishop PD, Stenkamp RE, Teller DC. Structural evidence that the activation peptide is not released upon thrombin cleavage of factor XIII. *Thromb Res* 1995;78:389-397.
1582. Fox BA, Yee VC, Pedersen LC, et al. Identification of the calcium binding site and a novel ytterbium site in blood coagulation factor XIII by x-ray crystallography. *J Biol Chem* 1999;274:4917-4923.
1583. Yee VC, Le TI, Bishop PD, Pedersen LC, Stenkamp RE, Teller DC. Structure and function studies of factor XIIIa by x-ray crystallography. *Semin Thromb Hemost* 1996;22:377-384.
1584. Pedersen LC. X-ray structure determination of factor XIII. University of Washington, 1994.
1585. Weisberg LJ, Shiu DT, Conkling PR, Shuman MA. Identification of normal human peripheral blood monocytes and liver as sites of synthesis of coagulation factor XIII a-chain. *Blood* 1987;70:579-582.
1586. Wolpl A, Lattke H, Board PG, et al. Coagulation factor XIII A and B subunits in bone marrow and liver transplantation. *Transplantation* 1987;43:151-153.
1587. Poon MC, Russell JA, Low S, et al. Hemopoietic origin of factor XIII A subunits in platelets, monocytes, and plasma. Evidence from bone marrow transplantation studies. *J Clin Invest* 1989;84:787-792.
1588. McDonagh J, McDonagh RP Jr, Delage JM, Wagner RH. Factor XIII in human plasma and platelets. *J Clin Invest* 1969;48:940-946.
1589. Henriksson P, Becker S, Lynch G, McDonagh J. Identification of intracellular factor XIII in human monocytes and macrophages. *J Clin Invest* 1985;76:528-534.
1590. Muszbek L, Adany R, Szegedi G, Polgar J, Kawai M. Factor XIII of blood coagulation in human monocytes. *Thromb Res* 1985;37:401-410.

1591. Takagi T, Doolittle RF. Amino acid sequence studies on factor XIII and the peptide released during its activation by thrombin. *Biochemistry* 1974;13:750-756.
1592. Kaetsu H, Hashiguchi T, Foster D, Ichinose A. Expression and release of the a and b subunits for human coagulation factor XIII in baby hamster kidney (BHK) cells. *J Biochem(Tokyo)* 1996;119:961-969.
1593. Mignatti P, Morimoto T, Rifkin DB. Basic fibroblast growth factor, a protein devoid of secretory signal sequence, is released by cells via a pathway independent of the endoplasmic reticulum-Golgi complex. *J Cell Physiol* 1992;151:81-93.
1594. Rubartelli A, Cozzolino F, Talio M, Sitia R. A novel secretory pathway for interleukin-1 beta, a protein lacking a signal sequence. *EMBO J* 1990;9:1503-1510.
1595. Kreager JA, Devine DV, Greenberg CS. Cytofluorometric identification of plasmin-sensitive factor XIIIa binding to platelets. *Thromb Haemost* 1988;60:88-93.
1596. Greenberg CS, Shuman MA. Specific binding of blood coagulation factor XIIIa to thrombin- stimulated platelets. *J Biol Chem* 1984;259:14721-14727.
1597. Nagy JA, Kradin RL, McDonagh J. Biosynthesis of factor XIII A and B subunits. *Adv Exp Med Biol* 1988;231:29-49.
1598. Mikuni Y, Iwanaga S, Konishi K. A peptide released from plasma fibrin stabilizing factor in the conversion to the active enzyme by thrombin. *Biochem Biophys Res Commun* 1973;54:1393-1403.
1599. Credo RB, Curtis CG, Lorand L. Ca₂₊-related regulatory function of fibrinogen. *Proc Natl Acad Sci U S A* 1978;75:4234-4237.
1600. Curtis CG, Brown KL, Credo RB, et al. Calcium-dependent unmasking of active center cysteine during activation of fibrin stabilizing factor. *Biochemistry* 1974;13:3774-3780.
1601. Hornyak TJ, Shafer JA. Role of calcium ion in the generation of factor XIII activity. *Biochemistry* 1991;30:6175-6182.
1602. Brummel-Ziedins KE, Branda RF, Butenas S, Mann KG. Discordant fibrin formation in hemophilia. *J Thromb Haemost* 2009;7:825-832.
1603. Naski MC, Lorand L, Shafer JA. Characterization of the kinetic pathway for fibrin promotion of alpha- thrombin-catalyzed activation of plasma factor XIII. *Biochemistry* 1991;30:934-941.
1604. Janus TJ, Lewis SD, Lorand L, Shafer JA. Promotion of thrombin-catalyzed activation of factor XIII by fibrinogen. *Biochemistry* 1983;22:6269-6272.
1605. Gorman JJ, Folk JE. Structural features of glutamine substrates for human plasma factor XIIIa (activated blood coagulation factor XIII). *J Biol Chem* 1980;255:419-427.
1606. Chung SI, Folk JE. Kinetic studies with transglutaminases. The human blood enzymes (activated coagulation factor 13 and the guinea pig hair follicle enzyme. *J Biol Chem* 1972;247:2798-2807.
1607. Lord ST. Fibrinogen and fibrin: scaffold proteins in hemostasis. *Curr Opin Hematol* 2007;14:236-241.
1608. Mosesson MW. Fibrinogen and fibrin structure and functions. *JThromb Haemost* 2005;3:1894-1904.
1609. Everse SJ. New insights into fibrin(ogen) structure and function 2002.
1610. Hantgan RR, Simpson PJ, Francis CW, Marder VJ. Fibrinogen structure and physiology. In: Colman RW, Hirsh J, Marder VJ, Clowes AW, George JN, eds. *Hemostasis and thrombosis: basic principles and clinical practice*. Philadelphia, PA: Lippincott Williams & Wilkins, 2001:203-232.
1611. Doolittle RF, Yang Z, Mochalkin I. Crystal structure studies on fibrinogen and fibrin. *Ann NY Acad Sci* 2001;936:31-43.
1612. Blomback B. Fibrinogen: evolution of the structure-function concept. Keynote address at fibrinogen 2000 congress. *Ann NY Acad Sci* 2001;936:1-10.
1613. Straub PW. A study of fibrinogen production by human liver slices in vitro by immunoprecipitin method. *J Clin Invest* 1963;42:130.
1614. Takeda Y. Studies of the metabolism and distribution of fibrinogen in healthy men with autologous 125-I-labeled fibrinogen. *J Clin Invest* 1966;45:103-111. 10.1172/JCI105314.
1615. Collen D, Tytgat G, Claeys H, Piessens R. Metabolism and distribution of fibrinogen. I. Fibrinogen turnover in physiological conditions in humans. *Br J Haematol* 1972;22:681-700.

1616. Rausen AA, Cruchoad A, McMillan CW. A study of fibrinogen turnover in classical hemophilia and congenital afibrinogenemia. *Blood* 1961;18:710.
1617. de Maat M. Effects of diet, drugs, and genes on plasma fibrinogen levels. *Ann N Y Acad Sci* 2001;936:509-521.
1618. Blomback B, Blomback M, Henschen A, Hessel B, Iwanaga S, Woods KR. N-terminal disulphide knot of human fibrinogen. *Nature* 1968;218:130-134.
1619. Doolittle RF. Evolution of fibrinogen molecules. *Thromb Diath Haemorrh Suppl* 1970;39:25-42.
1620. Doolittle RF. Difference in the clotting of lamprey fibrinogen by lamprey and bovine thrombins. *Biochem J* 1965;94:735-741.
1621. Doolittle RF. The structure and evolution of vertebrate fibrinogen. *Ann NY Acad Sci* 1983;408:13-27.
1622. Takagi T, Doolittle RF. Amino acid sequence studies on the alpha chain of human fibrinogen. Location of four plasmin attack points and a covalent cross-linking site. *Biochemistry* 1975;14:5149-5156.
1623. Henschen A, Lottspeich F. Sequence homology between gamma-chain and beta-chain in human fibrin. *Thromb Res* 1977;11:869-880.
1624. Watt KW, Takagi T, Doolittle RF. Amino acid sequence of the beta chain of human fibrinogen: homology with the gamma chain. *Proc Natl Acad Sci U S A* 1978;75:1731-1735.
1625. Doolittle RF. A detailed consideration of a principal domain of vertebrate fibrinogen and its relatives. *Protein Sci* 1992;1:1563-1577.
1626. Kant JA, Fornace AJ Jr, Saxe D, Simon MI, McBride OW, Crabtree GR. Evolution and organization of the fibrinogen locus on chromosome 4: gene duplication accompanied by transposition and inversion. *Proc Natl Acad Sci USA* 1985;82:2344-2348.
1627. Doolittle RF, Cottrell BA, Riley M. Amino acid compositions of the subunit chains of lamprey fibrinogen. Evolutionary significance of some structural anomalies. *Biochim Biophys Acta* 1976;453:439-452.
1628. Strong DD, Laudano AP, Hawiger J, Doolittle RF. Isolation, characterization, and synthesis of peptides from human fibrinogen that block the staphylococcal clumping reaction and construction of a synthetic clumping particle. *Biochemistry* 1982;21:1414-1420.
1629. Crabtree GR, Kant JA. Coordinate accumulation of the mRNAs for the alpha, beta, and gamma chains of rat fibrinogen following defibrination. *J Biol Chem* 1982;257:7277-7279.
1630. Morgan JG, Holbrook NJ, Crabtree GR. Nucleotide sequence of the gamma chain gene of rat fibrinogen: conserved intronic sequences. *Nucleic Acids Res* 1987;15:2774-2776.
1631. Francis CW, Muller E, Henschen A, Simpson PJ, Marder VJ. Carboxyl-terminal amino acid sequences of two variant forms of the gamma chain of human plasma fibrinogen. *Proc Natl Acad Sci USA* 1988;85:3358-3362.
1632. Pan Y, Doolittle RF. cDNA sequence of a second fibrinogen alpha chain in lamprey: an archetypal version alignable with full-length beta and gamma chains. *Proc Natl Acad Sci U S A* 1992;89:2066-2070.
1633. Weissbach L, Grieninger G. Bipartite mRNA for chicken alpha-fibrinogen potentially encodes an amino acid sequence homologous to beta- and gamma-fibrinogens. *Proc Natl Acad Sci U S A* 1990;87:5198-5202.
1634. Jones FS, Hoffman S, Cunningham BA, Edelman GM. A detailed structural model of cytotactin: protein homologies, alternative RNA splicing, and binding regions. *Proc Natl Acad Sci U S A* 1989;86:1905-1909.
1635. Xu X, Doolittle RF. Presence of a vertebrate fibrinogen-like sequence in an echinoderm. *Proc Natl Acad Sci U S A* 1990;87:2097-2101.
1636. Baker NE, Mlodzik M, Rubin GM. Spacing differentiation in the developing *Drosophila* eye: a fibrinogen-related lateral inhibitor encoded by scabrous. *Science* 1990;250:1370-1377.
1637. Olaisen B, Teisberg P, Gedde-Dahl T Jr. Fibrinogen gamma chain locus is on chromosome 4 in man. *Hum Genet* 1982;61:24-26.
1638. Henry I, Uzan G, Weil D, et al. The genes coding for A alpha-, B beta-, and gamma-chains of fibrinogen map to 4q2. *Am J Hum Genet* 1984;36: 760-768.

1639. Rixon MW, Chan WY, Davie EW, Chung DW. Characterization of a complementary deoxyribonucleic acid coding for the alpha chain of human fibrinogen. *Biochemistry* 1983;22:3237-3244.
1640. Chung DW, Que BG, Rixon MW, Mace M Jr, Davie EW. Characterization of complementary deoxyribonucleic acid and genomic deoxyribonucleic acid for the beta chain of human fibrinogen. *Biochemistry* 1983;22:3244-3250.
1641. Crabtree GR. The molecular biology of fibrinogen. In: Stamatoyanopolous G, Nienhuis AW, Leder P, Majerus PW, eds. *The molecular basis of blood diseases*. Philadelphia, PA: Saunders, 1987:631-661.
1642. Fish R, Neerman-Arbez M. Fibrinogen gene regulation. *Thromb Haemost* 2012;108:419-426.
1643. Chung DW, Harris JE, Davie EW. Nucleotide sequences of the three genes coding for human fibrinogen. *Adv Exp Med Biol* 1990;281:39-48.
1644. Crabtree GR, Kant JA. Molecular cloning of cDNA for the alpha, beta, and gamma chains of rat fibrinogen. A family of coordinately regulated genes. *J Biol Chem* 1981;256:9718-9723.
1645. Crabtree G, Kant J, Fornace AJ, Rauch C, Fowlkes D. Regulation and characterization of the mRNAs for the A alpha, B beta and gamma chains of fibrinogen. *Ann N Y Acad Sci* 1983;408:457-468.
1646. Hu CH, Harris JE, Davie EW, Chung DW. Characterization of the 5'-flanking region of the gene for the alpha chain of human fibrinogen. *J Biol Chem* 1995;270:28342-28349.
1647. Mizuguchi J, Hu CH, Cao Z, Loeb KR, Chung DW, Davie EW. Characterization of the 5'-flanking region of the gene for the gamma chain of human fibrinogen. *J Biol Chem* 1995;270:28350-28356.
1648. Fowlkes DM, Mullis NT, Comeau CM, Crabtree GR. Potential basis for regulation of the coordinately expressed fibrinogen genes: homology in the 5' flanking regions. *Proc Natl Acad Sci U S A* 1984;81:2313-2316.
1649. Otto JM, Grenett HE, Fuller GM. The coordinated regulation of fibrinogen gene transcription by hepatocyte-stimulating factor and dexamethasone. *J Cell Biol* 1987;105:1067-1072.
1650. Chung DW, Davie EW. gamma and gamma' chains of human fibrinogen are produced by alternative mRNA processing. *Biochemistry* 1984;23:4232-4236.
1651. Fornace AJ Jr, Cummings DE, Comeau CM, Kant JA, Crabtree GR. Structure of the human gamma-fibrinogen gene. Alternate mRNA splicing near the 3' end of the gene produces gamma A and gamma B forms of gamma- fibrinogen. *J Biol Chem* 1984;259:12826-12830.
1652. Fu Y, Grienering G. Fib420: a normal human variant of fibrinogen with two extended alpha chains. *Proc Natl Acad Sci U S A* 1994;91:2625-2628.
1653. Francis CW, Mosesson MW. Terminology for fibrinogen gamma-chains differing in carboxyl terminal amino acid sequence. *Thromb Haemost* 1989;62:813-814.
1654. Fu Y, Weissbach L, Plant PW, et al. Carboxy-terminal-extended variant of the human fibrinogen alpha subunit: a novel exon conferring marked homology to beta and gamma subunits. *Biochemistry* 1992;31:11968-11972.
1655. Grienering G. Contribution of the alpha EC domain to the structure and function of fibrinogen-420. *Ann NY Acad Sci* 2001;936:44-64.
1656. Green FR. Fibrinogen polymorphisms and atherothrombotic disease. *Ann NY Acad Sci* 2001;936:549-559.
1657. Vischetti M, Zito F, Donati MB, Iacoviello L. Analysis of gene-environment interaction in coronary heart disease: fibrinogen polymorphisms as an example. *Ital Heart J* 2002;3:18-23.
1658. Iacoviello L, Vischetti M, Zito F, Benedetta DM. Genes encoding fibrinogen and cardiovascular risk. *Hypertension* 2001;38:1199-1203.
1659. Martinez J. Congenital dysfibrinogenemia. *Curr Opin Hematol* 1997;4:357-365.
1660. Degen JL. Genetic interactions between the coagulation and fibrinolytic systems. *Thromb Haemost* 2001;86:130-137.
1661. Menart C, Sprunck N, Duhaut P, Pinede L, Demolombe-Rague S, Negrier C. Recurrent spontaneous intracerebral hematoma in a patient with afibrinogenemia. *Thromb Haemost* 1998;79:241-242.
1662. Ehmann WC, al Mondhiry H. Splenic rupture in afibrinogenemia: conservative versus surgical management. *Am J Med* 1995;99:444.

1663. De Marco L, Girolami A, Zimmerman TS, Ruggeri ZM. von Willebrand factor interaction with the glycoprotein IIb/IIIa complex. Its role in platelet function as demonstrated in patients with congenital afibrinogenemia. *J Clin Invest* 1986;77:1272-1277.
1664. Ni H, Denis CV, Subbarao S, et al. Persistence of platelet thrombus formation in arterioles of mice lacking both von Willebrand factor and fibrinogen. *J Clin Invest* 2000;106:385-392.
1665. Parameswaran R, Dickinson JP, de Lord S, Keeling DM, Colvin BT. Spontaneous intracranial bleeding in two patients with congenital afibrinogenemia and the role of replacement therapy. *Haemophilia* 2000;6:705-708.
1666. Suh TT, Holmback K, Jensen NJ, et al. Resolution of spontaneous bleeding events but failure of pregnancy in fibrinogen-deficient mice. *Genes Dev* 1995;9:2020-2033.
1667. Holmback K, Danton MJ, Suh TT, Daugherty CC, Degen JL. Impaired platelet aggregation and sustained bleeding in mice lacking the fibrinogen motif bound by integrin alpha IIb beta 3. *EMBO J* 1996;15:5760-5771.
1668. Phillips DR, Charo IF, Parise LV, Fitzgerald LA. The platelet membrane glycoprotein IIb-IIIa complex. *Blood* 1988;71:831-843.
1669. Bugge TH, Kombrinck KW, Flick MJ, Daugherty CC, Danton MJ, Degen JL. Loss of fibrinogen rescues mice from the pleiotropic effects of plasminogen deficiency. *Cell* 1996;87:709-719.
1670. Drew AF, Kaufman AH, Kombrinck KW, et al. Ligneous conjunctivitis in plasminogen-deficient mice. *Blood* 1998;91:1616-1624.
1671. Drew AF, Tucker HL, Kombrinck KW, Simon DI, Bugge TH, Degen JL. Plasminogen is a critical determinant of vascular remodeling in mice. *Circ Res* 2000;87:133-139.
1672. Kao WW, Kao CW, Kaufman AH, et al. Healing of corneal epithelial defects in plasmin. *Invest Ophthalmol Vis Sci* 1998;39:502-508.
1673. Drew AF, Schiman HL, Kombrinck KW, Bugge TH, Degen JL, Kaufman AH. Persistent corneal haze after excimer laser photokeratectomy in plasminogen-deficient mice. *Invest Ophthalmol Vis Sci* 2000;41:67-72.
1674. Degen JL, Drew AF, Palumbo JS, et al. Genetic manipulation of fibrinogen and fibrinolysis in mice. *Ann NY Acad Sci* 2001;936:276-290.
1675. Brennan SO, Fellowes AP, George PM. Molecular mechanisms of hypo- and afibrinogenemia. *Ann NY Acad Sci* 2001;936:91-100.
1676. Higgins DL, Shafer JA. Fibrinogen Petoskey, a dysfibrinogenemia characterized by replacement of Arg-A alpha 16 by a histidyl residue. Evidence for thrombin-catalyzed hydrolysis at a histidyl residue. *J Biol Chem* 1981;256:12013-12017.
1677. Henschen A, Kehl M, Southan C. Genetically abnormal fibrinogens—strategies for structure elucidation, including fibrinopeptide analysis. *Curr Probl Clin Biochem* 1984;14:273-320.
1678. Matsuda M. Molecular abnormalities of fibrinogen - the present status of structure elucidation. In: Iwanaga S, Takada A, Henschen A, eds. *Fibrinogen 4 current basis and clinical aspects*. Amsterdam: Excerpta Medica, 1990: 139-152.
1679. Kaudewitz H, Henschen A, Soria C, et al. The molecular defect of the genetically abnormal fibrinogen Christchurch II. In: Muller-Berghaus G, Scheefers-Borchel V, Selmayr E, Henschen A, eds. *Fibrinogen and its derivatives*. Amsterdam: Elsevier, 1986:31-36.
1680. Ebert RF. *Index of variant human fibrinogen*. Boca Raton, FL: CRC Press, 1994.
1681. Hanss M, Biot F. A database for human fibrinogen variants. *Ann NY Acad Sci* 2001;936:89-90.
1682. Yu S, Sher B, Kudryk B, Redman CM. Intracellular assembly of human fibrinogen. *J Biol Chem* 1983;258:13407-13410.
1683. Yu S, Sher B, Kudryk B, Redman CM. Fibrinogen precursors. Order of assembly of fibrinogen chains. *J Biol Chem* 1984;259:10574-10581.
1684. Hirose S, Oda K, Ikehara Y. Biosynthesis, assembly and secretion of fibrinogen in cultured rat hepatocytes. *Biochem J* 1988;251:373-377.
1685. Lee SY, Lee KP, Lim JW. Identification and biosynthesis of fibrinogen in human uterine cervix carcinoma cells. *Thromb Haemost* 1996;75:466-470.

1686. Haidaris PJ. Induction of fibrinogen biosynthesis and secretion from cultured pulmonary epithelial cells. *Blood* 1997;89:873-882.
1687. Haidaris PJ, Courtney MA. Tissue-specific and ubiquitous expression of fibrinogen gamma-chain mRNA. *Blood Coagul Fibrinolysis* 1990;1:433-437.
1688. Haidaris PJ, Courtney MA. Liver-specific RNA processing of the ubiquitously transcribed rat fibrinogen gamma-chain gene. *Blood* 1992;79:1218-1224.
1689. Nickerson JM, Fuller GM. Modification of fibrinogen chains during synthesis: glycosylation of B beta and gamma chains. *Biochemistry* 1981;20:2818-2821.
1690. Nickerson JM, Fuller GM. In vitro synthesis of rat fibrinogen: identification of preA alpha, preB beta, and pre gamma polypeptides. *Proc Natl Acad Sci U S A* 1981;78:303-307.
1691. Townsend RR, Hilliker E, Li YT, Laine RA, Bell WR, Lee YC. Carbohydrate structure of human fibrinogen. Use of 300-MHz ¹H-NMR to characterize glycosidase-treated glycopeptides. *J Biol Chem* 1982;257:9704-9710.
1692. Kottgen E, Hell B, Muller C, Tauber R. Demonstration of glycosylation variants of human fibrinogen, using the new technique of glycoprotein lectin immunosorbent assay (GLIA). *Biol Chem Hoppe Seyler* 1988;369:1157-1166.
1693. Langer BG, Hong SK, Schmelzer CH, Bell WR. Deglycosylation of a native, protease-sensitive glycoprotein by peptide N-glycosidase F without protease inhibitors. *Anal Biochem* 1987;166:212-217.
1694. Seydewitz HH, Kaiser C, Rothweiler H, Witt I. The location of a second in vivo phosphorylation site in the A alpha-chain of human fibrinogen. *Thromb Res* 1984;33:487-498.
1695. Blomback B, Hessel B, Hogg D. Disulfide bridges in NH₂-terminal part of human fibrinogen. *Thromb Res* 1976;8:639-658.
1696. Zhang JZ, Kudryk B, Redman CM. Symmetrical disulfide bonds are not necessary for assembly and secretion of human fibrinogen. *J Biol Chem* 1993;268:11278-11282.
1697. Zhang JZ, Redman C. Fibrinogen assembly and secretion. Role of intrachain disulfide loops. *J Biol Chem* 1996;271:30083-30088.
1698. Zhang JZ, Redman CM. Identification of B beta chain domains involved in human fibrinogen assembly. *J Biol Chem* 1992;267:21727-21732.
1699. Zhang JZ, Redman CM. Role of interchain disulfide bonds on the assembly and secretion of human fibrinogen. *J Biol Chem* 1994;269:652-658.
1700. Zhang JZ, Redman CM. Assembly and secretion of fibrinogen. Involvement of amino-terminal domains in dimer formation. *J Biol Chem* 1996;271:12674-12680.
1701. Jenkins GR, Seiffert D, Parmer RJ, Miles LA. Regulation of plasminogen gene expression by interleukin-6. *Blood* 1997;89:2394-2403.
1702. Nieuwenhuizen W. Sites in fibrin involved in the acceleration of plasminogen activation by t-PA. Possible role of fibrin polymerisation. *Thromb Res* 1994;75:343-347.
1703. Bailey K, Astbury WT, Rudall KM. Fibrinogen and fibrin as members of the keratin-myosin group. *Nature* 1943;151:716-717.
1704. Crick FHC, Kendrew JC. X-ray analysis and protein structure. *Adv Prot Chem* 1957;12:133-214.
1705. Scheraga HA, Laskowski M. The fibrinogen-fibrin conversion. *Adv Prot Chem* 1957;12:1-131.
1706. Shulman S. The size and shape of bovine fibrinogen. Studies of sedimentation, diffusion and viscosity. *J Am Chem Soc* 1953;75:5846-5852.
1707. Caspary EA, Kekwick RA. Some physicochemical properties of human fibrinogen. *Biochem J* 1957;67:41-48.
1708. Hall CE, Slayter HS. The fibrinogen molecule: its size, shape and mode of polymerization. *J Biophys Biochem Cy* 1959;5:11-15.
1709. Cohen C. Invited discussion at 1960 Symposium on Protein Structure. *J Polym Sci* 1961;49:144-145.
1710. Nussenzweig V, Seligmann M, Pelimont J, Grabar P. Les produits de degradation du fibrinogene humain par la plasmine. I. Separation et proprietes physico-chimiques. *Ann Inst Pasteur* 1961;100:377-389.

1711. Marder VJ, Shulman NR, Carroll WR. High molecular weight derivatives of human fibrinogen produced by plasmin. I. Physicochemical and immunological characterization. *J Biol Chem* 1969;244:2111-2119.
1712. Rao SP, Poojary MD, Elliott BW Jr, Melanson LA, Oriel B, Cohen C. Fibrinogen structure in projection at 18 Å resolution. Electron density by co-ordinated cryo-electron microscopy and X-ray crystallography. *J Mol Biol* 1991;222: 89-98.
1713. Brown JH, Volkmann N, Jun G, Henschen-Edman AH, Cohen C. The crystal structure of modified bovine fibrinogen. *Proc Natl Acad Sci U S A* 2000;97:85-90.
1714. Yang Z, Mochalkin I, Veerapandian L, Riley M, Doolittle RF. Crystal structure of native chicken fibrinogen at 5.5-Å resolution. *Proc Natl Acad Sci U S A* 2000;97:3907-3912.
1715. Yang Z, Kollman JM, Pandi L, Doolittle RF. Crystal structure of native chicken fibrinogen at 2.7 Å resolution. *Biochemistry* 2001;40:12515-12523.
1716. Doolittle RF, Watt KW, Cottrell BA, Strong DD, Riley M. The amino acid sequence of the alpha-chain of human fibrinogen. *Nature* 1979;280:464-468.
1717. Murakawa M, Okamura T, Kamura T, Shibuya T, Harada M, Niho Y. Diversity of primary structures of the carboxy-terminal regions of mammalian fibrinogen A alpha-chains. Characterization of the partial nucleotide and deduced amino acid sequences in five mammalian species; rhesus monkey, pig, dog, mouse and Syrian hamster. *Thromb Haemost* 1993;69:351-360.
1718. Kollman JM, Pandi L, Sawaya MR, Riley M, Doolittle RF. Crystal structure of human fibrinogen. *Biochemistry* 2009;48:3877-3886. doi:10.1021/bi802205g.
1719. Madrazo J, Brown JH, Litvinovich S, et al. Crystal structure of the central region of bovine fibrinogen (E5 fragment) at 1.4-Å resolution. *Proc Natl Acad Sci U S A* 2001;98:11967-11972.
1720. Yee VC, Pratt KP, Cote HC, et al. Crystal structure of a 30 kDa C-terminal fragment from the gamma chain of human fibrinogen.
1721. Doolittle RF, Spraggon G, Everse SJ. Crystal structures of fragments D and double-D from fibrinogen and fibrin. *Thromb Haemost* 1999;82:271-276.
1722. Pratt KP, Cote HC, Chung DW, Stenkamp RE, Davie EW. The primary fibrin polymerization pocket: three-dimensional structure of a 30-kDa C-terminal gamma chain fragment complexed with the peptide Gly-Pro-Arg-Pro. *Proc Natl Acad Sci U S A* 1997;94:7176-7181.
1723. Yang Z, Spraggon G, Pandi L, Everse SJ, Riley M, Doolittle RF. Crystal structure of fragment D from lamprey fibrinogen complexed with the peptide Gly-His-Arg-Pro-amide. *Biochemistry* 2002;41:10218-10224.
1724. Kostelansky MS, Betts L, Gorkun OV, Lord ST. 2.8 Å crystal structures of recombinant fibrinogen fragment D with and without two peptide ligands: GHRP binding to the "b" site disrupts its nearby calcium-binding site. *Biochemistry* 2002;41:12124-12132.
1725. Kostelansky MS, Lounes KC, Ping LF, Dickerson SK, Gorkun OV, Lord ST. Probing the gamma2 calcium-binding site: studies with gammaD298,301A fibrinogen reveal changes in the gamma294-301 loop that alter the integrity of the "a" polymerization site. *Biochemistry* 2007;46:5114-5123.
1726. Carr ME Jr, Hermans J. Size and density of fibrin fibers from turbidity. *Macromolecules* 1978;11:46-50.
1727. Ferry JD. The mechanism of polymerization of fibrinogen. *Proc Natl Acad Sci U S A* 1952;38:5980-5984.
1728. Laudano AP, Doolittle RF. Synthetic peptide derivatives that bind to fibrinogen and prevent the polymerization of fibrin monomers. *Proc Natl Acad Sci U S A* 1978;75:3085-3089.
1729. Litvinov RI, Gorkun OV, Owen SF, Shuman H, Weisel JW. Polymerization of fibrin: specificity, strength, and stability of knob-hole interactions studied at the single-molecule level. *Blood* 2005;106:2944-2951.
1730. Everse SJ, Spraggon G, Veerapandian L, Riley M, Doolittle RF. Crystal structure of fragment double-D from human fibrin with two different bound ligands. *Biochemistry* 1998;37:8637-8642.
1731. Everse SJ, Spraggon G, Veerapandian L, Doolittle RF. Conformational changes in fragments D and double-D from human fibrin(ogen) upon binding the peptide ligand Gly-His-Arg-Pro-amide. *Biochemistry* 1999;38:2941-2946.

1732. Doolittle RF, Chen A, Pandi L. Differences in binding specificity for the homologous gamma- and beta-chain "holes" on fibrinogen: exclusive binding of Ala-His-Arg-Pro-amide by the beta-chain hole. *Biochemistry* 2006;45: 13962-13969.
1733. Betts L, Merenbloom BK, Lord ST. The structure of fibrinogen fragment D with the 'A' knob peptide GPRVVE. *JThromb Haemost* 2006;4:1139-1141.
1734. Mihalyi E. Electrophoretic investigation of fibrin and fibrinogen dissolved in urea solutions. *Acta Chem Scand* 1950;4:351-358.
1735. Bailey K, Bettelheim FR, Lorand L, Middlebrook WR. Action of thrombin in the clotting of fibrinogen. *Nature* 1951;167:233-234.
1736. Blomback B. Studies on the action of thrombotic enzymes on bovine fibrinogen as measured by N-terminal analysis. *Arkiv Kemi* 2003;12:321.
1737. Doolittle RF. Structural aspects of the fibrinogen to fibrin conversion. *Adv Protein Chem* 1973;27:1-109.
1738. Blomback B, Hessel B, Hogg D, Therkildsen L. A two-step fibrinogen—fibrin transition in blood coagulation. *Nature* 1978;275:501-505.
1739. Blomback B, Vestermark A. Isolation of fibrinopeptides by chromatography. *Arkiv Kemi* 1958;12:173.
1740. Shainoff JR, Page IH. Cofibrins and fibrin intermediates as indicators of thrombin activity in vivo. *Circ Res* 1960;8:1013-1022.
1741. Hanna LS, Scheraga HA, Francis CW, Marder VJ. Comparison of structures of various human fibrinogens and a derivative thereof by a study of the kinetics of release of fibrinopeptides. *Biochemistry* 1984;23:4681-4687.
1742. Lewis SD, Shields PP, Shafer JA. Characterization of the kinetic pathway for liberation of fibrinopeptides during assembly of fibrin. *J Biol Chem* 1985;260:10192-10199.
1743. Mihalyi E. Clotting of bovine fibrinogen. Kinetic analysis of the release of fibrinopeptides by thrombin and of the calcium uptake upon clotting at high fibrinogen concentrations. *Biochemistry* 1988;27:976-982.
1744. Vindigni A, Di Cera E. Release of fibrinopeptides by the slow and fast forms of thrombin. *Biochemistry* 1996;35:4417-4426.
1745. Pechik I, Yakovlev S, Mosesson MW, Gilliland GL, Medved L. Structural basis for sequential cleavage of fibrinopeptides upon fibrin assembly. *Biochemistry* 2006;45:3588-3597.
1746. Bettelheim FR, Bailey K. The products of the action of thrombin on fibrinogen. *Biochim Biophys Acta* 1952;9:578-579.
1747. Barlow GH, Holleman WH, Lorand L. The action of Arvin on fibrin stabilizing factor (factor XIII). *Res Comm Chem Path Pharm* 1970;83:39-42.
1748. Edgar W, Prentice CRM. The proteolytic actions of anacrod on human fibrinogen and polypeptide chains. *Thromb Res* 1973;2:85-96.
1749. Dyr JE, Blomback B, Hessel B, Kornalik F. Conversion of fibrinogen to fibrin induced by preferential release of fibrinopeptide B. *Biochim Biophys Acta* 1989;990:18-24.
1750. Mosesson MW, DiOrio JP, Muller MF, et al. Studies on the ultrastructure of fibrin lacking fibrinopeptide B (beta-fibrin). *Blood* 1987;69:1073-1081.
1751. Shainoff JR, Dardik BN. Fibrinopeptide B and aggregation of fibrinogen. *Science* 1979;204:200-202.
1752. Doolittle RF. Fibrinogen and fibrin. In: Bloom AL, Thomas DP, eds. *Haemostasis and thrombosis*. Edinburgh: Churchill Livingstone, 1981:163-191.
1753. Hantgan RR, Hermans J. Assembly of fibrin. A light scattering study. *J Biol Chem* 1979;254:11272-11281.
1754. Hantgan R, Fowler W, Erickson H, Hermans J. Fibrin assembly: a comparison of electron microscopic and light scattering results. *Thromb Haemost* 1980;44:119-124.
1755. Weisel JW, Phillips GN Jr, Cohen C. The structure of fibrinogen and fibrin: II. Architecture of the fibrin clot. *Ann NY Acad Sci* 1983;408:367-379.
1756. Fowler WE, Hantgan RR, Hermans J, Erickson HP. Structure of the fibrin protofibril. *Proc Natl Acad Sci U S A* 1981;78:4872-4876.

1757. Mosesson MW, Siebenlist KR, Amrani DL, DiOrio JP. Identification of covalently linked trimeric and tetrameric D domains in crosslinked fibrin. *Proc Natl Acad Sci U S A* 1989;86:1113-1117.
1758. Kudryk B, Okada M, Redman CM, Blomback B. Biosynthesis of dog fibrinogen. Characterization of nascent fibrinogen in the rough endoplasmic reticulum. *Eur J Biochem* 1982;125:673-682.
1759. Gorkun OV, Veklich YI, Medved LV, Henschen AH, Weisel JW. Role of the alpha C domains of fibrin in clot formation. *Biochemistry* 1994;33:6986-6997.
1760. Weisel JW, Papsun DM. Involvement of the COOH-terminal portion of the alpha-chain of fibrin in the branching of fibers to form a clot. *Thromb Res* 1987;47:155-163.
1761. Doolittle RF, Pandi L. Binding of synthetic B knobs to fibrinogen changes the character of fibrin and inhibits its ability to activate tissue plasminogen activator and its destruction by plasmin. *Biochemistry* 2006;45:2657-2667.
1762. Folk JE, Finlayson JS. The epsilon-(gamma-glutamyl)lysine crosslink and the catalytic role of transglutaminases. *Adv Protein Chem* 1977;31:1-133.
1763. Pisano JJ, Finlayson JS, Peyton MP. Cross-link in fibrin polymerized by factor 13:epsilon-(gamma- glutamyl)lysine. *Science* 1968;160:892-893.
1764. Shen LL, Hermans J, McDonagh J, McDonagh RP, Carr M. Effects of calcium ion and covalent crosslinking on formation and elasticity of fibrin cells. *Thromb Res* 1975;6:255-265.
1765. Gerth C, Roberts WW, Ferry JD. Rheology of fibrin clots. II. Linear viscoelastic behavior in shear creep. *Biophys Chem* 1974;2:208-217.
1766. McDonagh RP Jr, McDonagh J, Duckert F. The influence of fibrin crosslinking on the kinetics of urokinase- induced clot lysis. *Br J Haematol* 1971;21: 323-332.
1767. Shen LL, McDonagh RP, McDonagh J, Hermans J. Early events in the plasmin digestion of fibrinogen and fibrin. Effects of plasmin on fibrin polymerization. *J Biol Chem* 1977;252:6184-6189.
1768. Francis CW, Marder VJ. Increased resistance to plasmic degradation of fibrin with highly crosslinked alpha-polymer chains formed at high factor XIII concentrations. *Blood* 1988;71:1361-1365.
1769. Chen R, Doolittle RF. Identification of the polypeptide chains involved in the cross-linking of fibrin. *Proc Natl Acad Sci U S A* 1969;63:420.
1770. McKee PA, Mattock P, Hill RL. Subunit structure of human fibrinogen, soluble fibrin, and cross-linked insoluble fibrin. *Proc Natl Acad Sci U S A* 1970;66:738-744.
1771. Cottrell BA, Strong DD, Watt KW, Doolittle RF. Amino acid sequence studies on the alpha chain of human fibrinogen. Exact location of cross-linking acceptor sites. *Biochemistry* 1979;18:5405-5410.
1772. Gaffney PJ, Whitaker AN. Fibrin crosslinks and lysis rates. *Thromb Res* 1979;14:85-94.
1773. Sakata Y, Aoki N. Cross-linking of alpha 2-plasmin inhibitor to fibrin by fibrin- stabilizing factor. *J Clin Invest* 1980;65:290-297.
1774. Sakata Y, Aoki N. Significance of cross-linking of alpha 2-plasmin inhibitor to fibrin in inhibition of fibrinolysis and in hemostasis. *J Clin Invest* 1982;69:536-542.
1775. Sakharov DV, Plow EF, Rijken DC. On the mechanism of the antifibrinolytic activity of plasma carboxypeptidase B. *J Biol Chem* 1997;272:14477-14482.
1776. Broze GJ Jr, Higuchi DA. Coagulation-dependent inhibition of fibrinolysis: role of carboxypeptidase-U and the premature lysis of clots from hemophilic plasma. *Blood* 1996;88:3815-3823.
1777. Marder VJ. Immunologic structure of fibrinogen and its plasmin degradation products. Theoretical and clinical considerations. In: Laki K, ed. *Fibrinogen*. New York: Marcel Dekker Inc. Edward Arnold (Publishers Ltd.), 1968:339-358.
1778. Marder VJ. Physicochemical studies of intermediate and final products of plasmin digestion of human fibrinogen. *Thromb Diath Haemorrh* 1970;80: 187-195.
1779. Larrieu MJ, Marder VJ, Inceman S. Effects of fibrinogen degradation products on platelets and coagulation. *Thromb Diath Haemorrh Suppl* 1966;20:215-226.

1780. Marder VJ, Shulman NR, Carroll WR. The importance of intermediate degradation products of fibrinogen in fibrinolytic hemorrhage. *Trans Assoc Am Physicians* 1967;80:156-167.
1781. Francis CW, Marder VJ, Barlow GH. Plasmic degradation of crosslinked fibrin. Characterization of new macromolecular soluble complexes and a model of their structure. *J Clin Invest* 1980;66:1033-1043.
1782. Pizzo SV, Taylor LM Jr, Schwartz ML, Hill RL, McKee PA. Subunit structure of fragment D from fibrinogen and cross-linked fibrin. *J Biol Chem* 1973;248:4584-4590.
1783. Marder VJ, Francis CW. Plasmin degradation of cross-linked fibrin. *Ann NY Acad Sci* 1983;408:397-406.
1784. Francis CW, Marder VJ. A molecular model of plasmic degradation of cross-linked fibrin. *Semin Thromb Hemost* 1982;8:25-35.
1785. Gaffney PJ, Brasher M. Subunit structure of the plasmin-induced degradation products of crosslinked fibrin. *Biochim Biophys Acta* 1973;295:308-313.
1786. Hudry-Clergeon G, Patural L, Sussillon M. Identification d'un complexe (D-D) E dans les produits de degradation de la fibrine bovine stabilisee par I^S Factor XIII. *Pathol Biol* 1974;22(Suppl):47-52.
1787. Gaffney PJ, Lane DA, Kakkar VV, Brasher M. Characterisation of a soluble D dimer-E complex in crosslinked fibrin digests. *Thromb Res* 1975;7:89-99.
1788. Bachmann F. Plasminogen-plasmin enzyme system. In: Colman RW, Hirsh J, Marder VJ, Clowes AW, George JN, eds. *Hemostasis and thrombosis: basic principles and clinical practice*. Philadelphia, PA: Lippencott Williams & Wilkins, 2001:275-320.
1789. Bugge TH, Flick MJ, Daugherty CC, Degen JL. Plasminogen deficiency causes severe thrombosis but is compatible with development and reproduction. *Genes Dev* 1995;9:794-807.
1790. Ploplis VA, Carmeliet P, Vazirzadeh S, Van VI, Moons L, Plow EF, Collen D. Effects of disruption of the plasminogen gene on thrombosis, growth, and health in mice. *Circulation* 1995;92:2585-2593.
1791. Murray JC, Buetow KH, Donovan M, et al. Linkage disequilibrium of plasminogen polymorphisms and assignment of the gene to human chromosome 6q26-6q27. *Am J Hum Genet* 1987;40:338-350.
1792. Petersen TE, Martzen MR, Ichinose A, Davie EW. Characterization of the gene for human plasminogen, a key proenzyme in the fibrinolytic system. *J Biol Chem* 1990;265:6104-6111.
1793. Ichinose A. Multiple members of the plasminogen-apolipoprotein(a) gene family associated with thrombosis. *Biochemistry* 1992;31:3113-3118.
1794. Magnaghi P, Citterio E, Magaretti N, Acquati F, Ottolenghi S, Taramelli R. Molecular characterisation of the human apo(a)-plasminogen gene family clustered on the telomeric region of chromosome 6 (6q26-27). *Hum Mol Genet* 1994;3:437-442.
1795. Kida M, Wakabayashi S, Ichinose A. Characterization of the 5'-flanking regions of plasminogen-related genes A and B. *FEBS Lett* 1997;404:95-99.
1796. Raum D, Marcus D, Alper CA, Levey R, Taylor PD, Starzl TE. Synthesis of human plasminogen by the liver. *Science* 1980;208:1036-1037.
1797. Collen D, Tytgat G, Claeys H, Verstraete M, Wallen P. Metabolism of plasminogen in healthy subjects: effect of tranexamic acid. *J Clin Invest* 1972;51: 1310-1318.
1798. Wallen P, Wiman B. Characterization of human plasminogen. I. On the relationship between different molecular forms of plasminogen demonstrated in plasma and found in purified preparations. *Biochim Biophys Acta* 1970;221:20-30.
1799. Wallen P, Wiman B. Characterization of human plasminogen. II. Separation and partial characterization of different molecular forms of human plasminogen. *Biochim Biophys Acta* 1972;257:122-134.
1800. Summari L, Arzadon L, Bernabe P, Robbins KC. Studies on the isolation of the multiple molecular forms of human plasminogen and plasmin by isoelectric focusing methods. *J Biol Chem* 1972;247:4691-4702.
1801. Pirie-Shepherd SR, Jett EA, Andon NL, Pizzo SV. Sialic acid content of plasminogen 2 glycoforms as a regulator of fibrinolytic activity. Isolation, carbohydrate analysis, and kinetic characterization of six glycoforms of plasminogen. *J Biol Chem* 1995;270:5877-5881.

1802. Takada A, Takada Y. Physiology of plasminogen: with special reference to activation and degradation. *Haemostasis* 1988;18(Suppl 1):25-35.
1803. Gonzalez-Gronow M, Grenett HE, Fuller GM, Pizzo SV. The role of carbohydrate in the function of human plasminogen: comparison of the protein obtained from molecular cloning and expression in *Escherichia coli* and COS cells. *Biochim Biophys Acta* 1990;1039:269-276.
1804. Hatton MW, Southward S, Ross-Ouellet B. Catabolism of plasminogen glycoforms I and II in rabbits: relationship to plasminogen synthesis by the rabbit liver in vitro. *Metabolism* 1994;43:1430-1437.
1805. Molgaard L, Ponting CP, Christensen U. Glycosylation at Asn-289 facilitates the ligand-induced conformational changes of human Glu-plasminogen. *FEBS Lett* 1997;405:363-368.
1806. Hatton MW, Day S, Ross B, Southward SM, DeReske M, Richardson M. Plasminogen II accumulates five times faster than plasminogen I at the site of a balloon de-endothelializing injury in vivo to the rabbit aorta: comparison with other hemostatic proteins. *J Lab Clin Med* 1999;134:260-266.
1807. Pirie-Shepherd SR, Stevens RD, Andon NL, Enghild JJ, Pizzo SV. Evidence for a novel O-linked sialylated trisaccharide on Ser-248 of human plasminogen 2. *J Biol Chem* 1997;272:7408-7411.
1808. Forsgren M, Raden B, Israelsson M, Larsson K, Heden LO. Molecular cloning and characterization of a full-length cDNA clone for human plasminogen. *FEBS Lett* 1987;213:254-260.
1809. Malinowski DP, Sadler JE, Davie EW. Characterization of a complementary deoxyribonucleic acid coding for human and bovine plasminogen. *Biochemistry* 1984;23:4243-4250.
1810. Rakoczi I, Wiman B, Collen D. On the biological significance of the specific interaction between fibrin, plasminogen and antiplasmin. *Biochim Biophys Acta* 1978;540:295-300.
1811. Wiman B, Wallen P. The specific interaction between plasminogen and fibrin. A physiological role of the lysine binding site in plasminogen. *Thromb Res* 1977;10:213-222.
1812. Thorsen S, Clemmensen I, Sottrup-Jensen L, Magnusson S. Adsorption to fibrin of native fragments of known primary structure from human plasminogen. *Biochim Biophys Acta* 1981;668:377-387.
1813. Wiman B, Lijnen HR, Collen D. On the specific interaction between the lysine-binding sites in plasmin and complementary sites in alpha2-antiplasmin and in fibrinogen. *Biochim Biophys Acta* 1979;579:142-154.
1814. Lijnen HR, Hoylaerts M, Collen D. Isolation and characterization of a human plasma protein with affinity for the lysine binding sites in plasminogen. Role in the regulation of fibrinolysis and identification as histidine-rich glycoprotein. *J Biol Chem* 1980;255:10214-10222.
1815. Selim TE, Ghoneim HR, Uknis AB, Colman RW, DeLa Cadena RA. Highmolecular-mass and low-molecular-mass kininogens block plasmin-induced platelet aggregation by forming a complex with kringle 5 of plasminogen/plasmin. *Eur J Biochem* 1997;250:532-538.
1816. Silverstein RL, Leung LL, Harpel PC, Nachman RL. Complex formation of platelet thrombospondin with plasminogen. Modulation of activation by tissue activator. *J Clin Invest* 1984;74:1625-1633.
1817. Thorsen S, Astrup T. Substrate composition and the effect of epsilonaminocaproic acid on tissue plasminogen activator and urokinase-induced fibrinolysis. *Thromb Diath Haemorrh* 1974;32:306-324.
1818. Violand BN, Byrne R, Castellino FJ. The effect of alpha-,omega-amino acids on human plasminogen structure and activation. *J Biol Chem* 1978;253:5395-5401.
1819. Sjolholm I. Studies on the conformational changes of plasminogen induced during activation to plasmin and by 6-aminohexanoic acid. *Eur J Biochem* 1973;39:471-479.
1820. Castellino FJ. Biochemistry of human plasminogen. *Semin Thromb Hemost* 1984;10:18-23.
1821. Mangel WF, Lin BH, Ramakrishnan V. Characterization of an extremely large, ligand-induced conformational change in plasminogen. *Science* 1990;248:69-73.
1822. Ramakrishnan V, Patthy L, Mangel WF. Conformation of Lys-plasminogen and the kringle 1-3 fragment of plasminogen analyzed by small-angle neutron scattering. *Biochemistry* 1991;30:3963-3969.
1823. O'Reilly MS, Holmgren L, Shing Y, et al. Angiostatin: a novel angiogenesis inhibitor that mediates the suppression of metastases by a Lewis lung carcinoma. *Cell* 1994;79:315-328.

1824. Peisach E, Wang J, de los ST, Reich E, Ringe D. Crystal structure of the proenzyme domain of plasminogen. *Biochemistry* 1999;38:11180-11188.
1825. Violand BN, Castellino FJ. Mechanism of the urokinase-catalyzed activation of human plasminogen. *J Biol Chem* 1976;251:3906-3912.
1826. Claeys H, Vermynen J. Physico-chemical and proenzyme properties of NH₂-terminal glutamic acid and NH₂-terminal lysine human plasminogen. Influence of 6-aminohexanoic acid. *Biochim Biophys Acta* 1974;342:351-359.
1827. Kluft C, Dooijewaard G, Emeis JJ. Role of the contact system in fibrinolysis. *Semin Thromb Hemost* 1987;13:50-68.
1828. Colman RW. Activation of plasminogen by human plasma kallikrein. *Biochem Biophys Res Commun* 1969;35:273-279.
1829. Mandle RJ Jr, Kaplan AP. Hageman-factor-dependent fibrinolysis: generation of fibrinolytic activity by the interaction of human activated factor XI and plasminogen. *Blood* 1979;54:850-862.
1830. Goldsmith GH Jr, Saito H, Ratnoff OS. The activation of plasminogen by Hageman factor (Factor XII) and Hageman factor fragments. *J Clin Invest* 1978;62:54-60.
1831. Schousboe I, Feddersen K, Rojkaer R. Factor XIIa is a kinetically favorable plasminogen activator. *Thromb Haemost* 1999;82:1041-1046.
1832. Booyse FM, Scheinbuks J, Radek J, Osikowicz G, Feder S, Quarfoot AJ. Immunological identification and comparison of plasminogen activator forms in cultured normal human endothelial cells and smooth muscle cells. *Thromb Res* 1981;24:495-504.
1833. Goldsmith GH Jr, Ziats NP, Robertson AL Jr. Studies on plasminogen activator and other proteases in subcultured human vascular cells. *Exp Mol Pathol* 1981;35:257-264.
1834. Levin EG, Loskutoff DJ. Cultured bovine endothelial cells produce both urokinase and tissue- type plasminogen activators. *J Cell Biol* 1982;94:631-636.
1835. Levin EG. Latent tissue plasminogen activator produced by human endothelial cells in culture: evidence for an enzyme-inhibitor complex. *Proc Natl Acad Sci U S A* 1983;80:6804-6808.
1836. Allen RA, Pepper DS. Isolation and properties of human vascular plasminogen activator. *Thromb Haemost* 1981;45:43-50.
1837. Papadaki M, Ruef J, Nguyen KT, et al. Differential regulation of protease activated receptor-1 and tissue plasminogen activator expression by shear stress in vascular smooth muscle cells. *Circ Res* 1998;83:1027-1034.
1838. Wang Y, Hand AR, Wang YH, et al. Functional and morphologic evidence of the presence of tissue- plasminogen activator in vascular nerves: implications for a neurologic control of vessel wall fibrinolysis and rigidity. *J Neurosci Res* 1998;53:443-453.
1839. Brisson-Jeanneau C, Solberg LA Jr, Sultan Y. Presence of functionally active tissue plasminogen activator in human CFU-M derived megakaryocytes in vitro. *Fibrinolysis* 1990;4:107-115.
1840. Brisson-Jeanneau C, Nelles L, Rouer E, Sultan Y, Benarous R. Tissue-plasminogen activator RNA detected in megakaryocytes by in situ hybridization and biotinylated probe. *Histochemistry* 1990;95:23-26.
1841. Bankl HC, Grossschmidt K, Pikula B, Bankl H, Lechner K, Valent P. Mast cells are augmented in deep vein thrombosis and express a profibrinolytic phenotype. *Hum Pathol* 1999;30:188-194.
1842. Sillaber C, Baghestanian M, Bevec D, et al. The mast cell as site of tissue-type plasminogen activator expression and fibrinolysis. *J Immunol* 1999;162:1032-1041.
1843. Hart PH, Vitti GF, Burgess DR, Singleton DK, Hamilton JA. Human monocytes can produce tissue-type plasminogen activator. *J Exp Med* 1989;169:1509-1514.
1844. Tyagi SC, Lewis K, Pikes D, et al. Stretch-induced membrane type matrix metalloproteinase and tissue plasminogen activator in cardiac fibroblast cells. *J Cell Physiol* 1998;176:374-382.
1845. Collen D, Lijnen HR, Todd PA, Goa KL. Tissue-type plasminogen activator. A review of its pharmacology and therapeutic use as a thrombolytic agent. *Drugs* 1989;38:346-388.
1846. Lucas RV, Miller ML. The fibrinolytic system. Recent advances. *Cleve Clin J Med* 1988;55:531-541.

1847. Rijken DC, Juhan-Vague I, De Cock F, Collen D. Measurement of human tissue-type plasminogen activator by a two-site immunoradiometric assay. *J Lab Clin Med* 1983;101:274-284.
1848. Stalder M, Hauert J, Kruithof EK, Bachmann F. Release of vascular plasminogen activator (v-PA) after venous stasis: electrophoretic-zymographic analysis of free and complexed v-PA. *Br J Haematol* 1985;61:169-176.
1849. Holvoet P, Cleemput H, Collen D. Assay of human tissue-type plasminogen activator (t-PA) with an enzyme-linked immunosorbent assay (ELISA) based on three murine monoclonal antibodies to t-PA. *Thromb Haemost* 1985;54:684-687.
1850. Nicoloso G, Hauert J, Kruithof EK, Van Melle G, Bachmann F. Fibrinolysis in normal subjects—comparison between plasminogen activator inhibitor and other components of the fibrinolytic system. *Thromb Haemost* 1988;59: 299-303.
1851. Takada Y, Takada A. Plasma levels of t-PA free PAI-1 and a complex of t-PA with PAI-1 in human males and females at various ages. *Thromb Res* 1989;55:601-609.
1852. Booth NA, Walker E, Maughan R, Bennett B. Plasminogen activator in normal subjects after exercise and venous occlusion: t-PA circulates as complexes with C1-inhibitor and PAI-1. *Blood* 1987;69:1600-1604.
1853. Eitzman DT, Fay WP, Ginsburg D. Plasminogen activator inhibitor-1. In: Becker RC, ed. *Textbook of coronary thrombosis and thrombolysis*. Boston, MA: Kluwer Academic Publishers, 1997:65-78.
1854. Chandler WL, Alessi MC, Aillaud MF, Henderson P, Vague P, Juhan-Vague I. Clearance of tissue plasminogen activator (TPA) and TPA/plasminogen activator inhibitor type 1 (PAI-1) complex: relationship to elevated TPA antigen in patients with high PAI-1 activity levels. *Circulation* 1997;96:761-768.
1855. Garabedian HD, Gold HK, Leinbach RC, Yasuda T, Johns JA, Collen D. Dose-dependent thrombolysis, pharmacokinetics and hemostatic effects of recombinant human tissue-type plasminogen activator for coronary thrombosis. *Am J Cardiol* 1986;58:673-679.
1856. Camani C, Kruithof EK. Clearance receptors for tissue-type plasminogen activator. *Int J Hematol* 1994;60:97-109.
1857. Emeis JJ, van den Hoogen CM, Jense D. Hepatic clearance of tissue-type plasminogen activator in rats. *Thromb Haemost* 1985;54:661-664.
1858. Bakhit C, Lewis D, Billings R, Malfroy B. Cellular catabolism of recombinant tissue-type plasminogen activator. Identification and characterization of a novel high affinity uptake system on rat hepatocytes. *J Biol Chem* 1987;262:8716-8720.
1859. Benham FJ, Spurr N, Povey S, et al. Assignment of tissue-type plasminogen activator to chromosome 8 in man and identification of a common restriction length polymorphism within the gene. *Mol Biol Med* 1984;2:251-259.
1860. Browne MJ, Tyrrell AW, Chapman CG, et al. Isolation of a human tissue-type plasminogen-activator genomic DNA clone and its expression in mouse L cells. *Gene* 1985;33:279-284.
1861. Fisher R, Waller EK, Grossi G, Thompson D, Tizard R, Schleuning WD. Isolation and characterization of the human tissue-type plasminogen activator structural gene including its 5' flanking region. *J Biol Chem* 1985;260:11223-11230.
1862. Degen SJ, Rajput B, Reich E. The human tissue plasminogen activator gene. *J Biol Chem* 1986;261:6972-6985.
1863. Bulens F, Ibanez-Tallon I, Van Acker P, et al. Retinoic acid induction of human tissue-type plasminogen activator gene expression via a direct repeat element (DR5) located at -7 kilobases. *J Biol Chem* 1995;270:7167-7175.
1864. Bulens F, Merchiers P, Ibanez-Tallon I, De Vriese A, Nelles L, Claessens F, Belayew A, Collen D. Identification of a multihormone responsive enhancer far upstream from the human tissue-type plasminogen activator gene. *J Biol Chem* 1997;272:663-671.
1865. Merchiers P, Bulens F, Stockmans I, et al. 1,25-Dihydroxyvitamin D(3) induction of the tissue-type plasminogen activator gene is mediated through its multihormone-responsive enhancer. *FEBS Lett* 1999;460:289-296.
1866. Merchiers P, Bulens F, De Vriese A, Collen D, Belayew A. Involvement of Sp1 in basal and retinoic acid induced transcription of the human tissue-type plasminogen activator gene. *FEBS Lett* 1999;456:149-154.
1867. Henderson BR, Sleigh MJ. TATA box-independent transcription of the human tissue plasminogen activator gene initiates within a sequence conserved in related genes. *FEBS Lett* 1992;309:130-134.
1868. Costa M, Shen Y, Maurer F, Medcalf RL. Transcriptional regulation of the tissue-type plasminogen-activator gene in human endothelial cells: identification of nuclear factors that recognise functional elements in the tissue-type plasminogen-activator gene promoter. *Eur J Biochem* 1998;258:123-131.

1869. Ouyang Y, Huang P, Huang C. Influence of 5'-untranslated region (UTR) sequence on the regulation of tissue plasminogen activator (t-PA) mRNA expression. *Sci China B* 1995;40:1378-1383.
1870. Huarte J, Belin D, Vassalli A, Strickland S, Vassalli JD. Meiotic maturation of mouse oocytes triggers the translation and polyadenylation of dormant tissue-type plasminogen activator mRNA. *Genes Dev* 1987;1:1201-1211.
1871. Ouyang Y, Huang P, Huang C. Inhibitory effect of 3'-untranslated region (3'-UTR) of human tissue- plasminogen activator (ht-PA) mRNA on its expression. *Sci China B* 1995;38:1253-1260.
1872. van der Bom JG, de Knijff P, Haverkate F, et al. Tissue plasminogen activator and risk of myocardial infarction. The Rotterdam Study. *Circulation* 1997;95:2623-2627.
1873. Tishkoff SA, Ruano G, Kidd JR, Kidd KK. Distribution and frequency of a polymorphic Alu insertion at the plasminogen activator locus in humans. *Hum Genet* 1996;97:759-764.
1874. Iacoviello L, Di Castelnuovo A, de Knijff P, et al. Alu-repeat polymorphism in the tissue-type plasminogen activator (t-PA) gene, t-PA levels and risk of familial myocardial infarction (AMI). *Fibrinolysis* 1996;10(Suppl 2):13-16.
1875. Ridker PM, Baker MT, Hennekens CH, Stampfer MJ, Vaughan DE. Alu-repeat polymorphism in the gene coding for tissue-type plasminogen activator (t-PA) and risks of myocardial infarction among middle-aged men. *Arterioscler Thromb Vasc Biol* 1997;17:1687-1690.
1876. Steeds R, Adams M, Smith P, Channer K, Samani NJ. Distribution of tissue plasminogen activator insertion/deletion polymorphism in myocardial infarction and control subjects. *Thromb Haemost* 1998;79:980-984.
1877. Ludwig M, Wohn KD, Schleuning WD, Olek K. Allelic dimorphism in the human tissue-type plasminogen activator (TPA) gene as a result of an Alu insertion/deletion event. *Hum Genet* 1992;88:388-392.
1878. Rigat B, Hubert C, Alhenc-Gelas F, Cambien F, Corvol P, Soubrier F. An insertion/deletion polymorphism in the angiotensin I-converting enzyme gene accounting for half the variance of serum enzyme levels. *J Clin Invest* 1990;86:1343-1346.
1879. Ladenvall P, Wall U, Jern S, Jern C. Identification of eight novel single-nucleotide polymorphisms at human tissue-type plasminogen activator (t-PA) locus: association with vascular t-PA release in vivo. *Thromb Haemost* 2000;84:150-155.
1880. Ladenvall P, Johansson L, Jansson JH, et al. Tissue-type plasminogen activator -7,351C/T enhancer polymorphism is associated with a first myocardial infarction. *Thromb Haemost* 2002;87:105-109.
1881. Carmeliet P, Schoonjans L, Kieckens L, et al. Physiological consequences of loss of plasminogen activator gene function in mice. *Nature* 1994;368:419-424.
1882. Carmeliet P, Collen D. Targeted gene manipulation and transfer of the plasminogen and coagulation systems in mice. *Fibrinolysis* 1996;10:195-213.
1883. Pohl G, Kallstrom M, Bergsdorf N, Wallen P, Jornvall H. Tissue plasminogen activator: peptide analyses confirm an indirectly derived amino acid sequence, identify the active site serine residue, establish glycosylation sites, and localize variant differences. *Biochemistry* 1984;23:3701-3707.
1884. Pennica D, Holmes WE, Kohr WJ, et al. Cloning and expression of human tissue-type plasminogen activator cDNA in *E. coli*. *Nature* 1983;301:214-221.
1885. Wallen P, Pohl G, Bergsdorf N, et al. Structural characterization of tissue plasminogen activator purified by immunosorbent chromatography. In: Davidson JF, Bachmann F, Bouvier CA, et al, eds. *Progress in fibrinolysis*. Edinburgh: Churchill-Livingstone, 1983:338-343.
1886. Berg DT, Grinnell BW. Signal and propeptide processing of human tissue plasminogen activator: activity of a pro-tPA derivative. *Biochem Biophys Res Commun* 1991;179:1289-1296.
1887. Jornvall H, Pohl G, Bergsdorf N, Wallen P. Differential proteolysis and evidence for a residue exchange in tissue plasminogen activator suggest possible association between two types of protein microheterogeneity. *FEBS Lett* 1983;156:47-50.
1888. Boose JA, Kuismanen E, Gerard R, Sambrook J, Gething MJ. The single-chain form of tissue-type plasminogen activator has catalytic activity: studies with a mutant enzyme that lacks the cleavage site. *Biochemistry* 1989;28:635-643.
1889. Rijken DC, Hoylaerts M, Collen D. Fibrinolytic properties of one-chain and two-chain human extrinsic (tissue-type) plasminogen activator. *J Biol Chem* 1982;257:2920-2925.

1890. Rijken DC, Groeneveld E. Isolation and functional characterization of the heavy and light chains of human tissue-type plasminogen activator. *J Biol Chem* 1986;261:3098-3102.
1891. Ranby M, Bergsdorf N, Nilsson T. Enzymatic properties of the one- and two-chain form of tissue plasminogen activator. *Thromb Res* 1982;27:175-183.
1892. Ny T, Elgh F, Lund B. The structure of the human tissue-type plasminogen activator gene: correlation of intron and exon structures to functional and structural domains. *Proc Natl Acad Sci U S A* 1984;81:5355-5359.
1893. Banyai L, Varadi A, Patthy L. Common evolutionary origin of the fibrin-binding structures of fibronectin and tissue-type plasminogen activator. *FEBS Lett* 1983;163:37-41.
1894. Verde P, Stoppelli MP, Galeffi P, Di Nocera P, Blasi F. Identification and primary sequence of an unspliced human urokinase poly(A)+ RNA. *Proc Natl Acad Sci U S A* 1984;81:4727-4731.
1895. Holland SK, Harlos K, Blake CC. Deriving the generic structure of the fibronectin type II domain from the prothrombin Kringle 1 crystal structure. *EMBO J* 1987;6:1875-1880.
1896. van Zonneveld AJ, Veerman H, Pannekoek H. On the interaction of the finger and the kringle-2 domain of tissue-type plasminogen activator with fibrin. Inhibition of kringle-2 binding to fibrin by epsilon-amino caproic acid. *J Biol Chem* 1986;261:14214-14218.
1897. Verheijen JH, Caspers MP, Chang GT, de Munk GA, Pouwels PH, Enger-Valk BE. Involvement of finger domain and kringle 2 domain of tissue-type plasminogen activator in fibrin binding and stimulation of activity by fibrin. *EMBO J* 1986;5:3525-3530.
1898. de Munk GA, Caspers MP, Chang GT, Pouwels PH, Enger-Valk BE, Verheijen JH. Binding of tissue-type plasminogen activator to lysine, lysine analogues, and fibrin fragments. *Biochemistry* 1989;28:7318-7325.
1899. Downing AK, Driscoll PC, Harvey TS, et al. Solution structure of the fibrin binding finger domain of tissue-type plasminogen activator determined by ¹H nuclear magnetic resonance. *J Mol Biol* 1992;225:821-833.
1900. Lijnen HR, Collen D. Strategies for the improvement of thrombolytic agents. *Thromb Haemost* 1991;66:88-110.
1901. Madison EL. Probing structure-function relationships of tissue-type plasminogen activator by site-specific mutagenesis. *Fibrinolysis* 2002;8(Suppl 1):221.
1902. de Vos AM, Ultsch MH, Kelley RF, et al. Crystal structure of the kringle 2 domain of tissue plasminogen activator at 2.4-Å resolution. *Biochemistry* 1992;31:270-279.
1903. De Serrano VS, Sehl LC, Castellino FJ. Direct identification of lysine-33 as the principal cationic center of the omega-amino acid binding site of the recombinant kringle 2 domain of tissue-type plasminogen activator. *Arch Biochem Biophys* 1992;292:206-212.
1904. Chang Y, Zajicek J, Castellino FJ. Role of tryptophan-63 of the kringle 2 domain of tissue-type plasminogen activator in its thermal stability, folding, and ligand binding properties. *Biochemistry* 1997;36:7652-7663.
1905. Chang Y, Nilsen SL, Castellino FJ. Functional and structural consequences of aromatic residue substitutions within the kringle-2 domain of tissue-type plasminogen activator. *J Pept Res* 1999;53:656-664.
1906. Davie EW, Ichinose A, Leytus SP. Structural features of the proteins participating in blood coagulation and fibrinolysis. *Cold Spring Harbor Symp Quant Biol* 1986;51:509-514.
1907. Andreasen PA, Petersen LC, Dano K. Diversity in catalytic properties of single chain and two chain tissue-type plasminogen activator. *Fibrinolysis* 1991;5:207-215.
1908. Lamba D, Bauer M, Huber R, et al. The 2.3 Å crystal structure of the catalytic domain of recombinant two-chain human tissue-type plasminogen activator. *J Mol Biol* 1996;258:117-135.
1909. Renatus M, Engh RA, Stubbs MT, et al. Lysine 156 promotes the anomalous proenzyme activity of tPA: X-ray crystal structure of single-chain human tPA. *EMBO J* 1997;16:4797-4805.
1910. Harris RJ, Leonard CK, Guzzetta AW, Spellman MW. Tissue plasminogen activator has an O-linked fucose attached to threonine-61 in the epidermal growth factor domain. *Biochemistry* 1991;30:2311-2314.
1911. Hajjar KA, Reynolds CM. alpha-Fucose-mediated binding and degradation of tissue-type plasminogen activator by HepG2 cells. *J Clin Invest* 1994;93:703-710.

1912. Parekh RB, Dwek RA, Thomas JR, et al. Cell-type-specific and site-specific N-glycosylation of type I and type II human tissue plasminogen activator. *Biochemistry* 1989;28:7644-7662.
1913. Spellman MW, Basa LJ, Leonard CK, et al. Carbohydrate structures of human tissue plasminogen activator expressed in Chinese hamster ovary cells. *J Biol Chem* 1989;264:14100-14111.
1914. Hoylaerts M, Rijken DC, Lijnen HR, Collen D. Kinetics of the activation of plasminogen by human tissue plasminogen activator. Role of fibrin. *J Biol Chem* 1982;257:2912-2919.
1915. Zamarron C, Lijnen HR, Collen D. Kinetics of the activation of plasminogen by natural and recombinant tissue-type plasminogen activator. *J Biol Chem* 1984;259:2080-2083.
1916. Loscalzo J. Structural and kinetic comparison of recombinant human single- and two-chain tissue plasminogen activator. *J Clin Invest* 1988;82:1391-1397.
1917. Dichek D, Quertermous T. Thrombin regulation of mRNA levels of tissue plasminogen activator and plasminogen activator inhibitor-1 in cultured human umbilical vein endothelial cells. *Blood* 1989;74:222-228.
1918. Diamond SL, Eskin SG, McIntire LV. Fluid flow stimulates tissue plasminogen activator secretion by cultured human endothelial cells. *Science* 1989;243:1483-1485.
1919. Emeis JJ. Regulation of the acute release of tissue-type plasminogen activator from the endothelium by coagulation activation products. *Ann NY Acad Sci* 1992;667:249-258.
1920. Eijnden-Schrauwen Y, Kooistra T, de Vries RE, Emeis JJ. Studies on the acute release of tissue-type plasminogen activator from human endothelial cells in vitro and in rats in vivo: evidence for a dynamic storage pool. *Blood* 1995;85:3510-3517.
1921. Fay WP, Eitzman DT, Shapiro AD, Madison EL, Ginsburg D. Platelets inhibit fibrinolysis in vitro by both plasminogen activator inhibitor-1-dependent and -independent mechanisms. *Blood* 1994;83:351-356.
1922. Levi M, Biemond BJ, van Zonneveld AJ, ten Cate JW, Pannekoek H. Inhibition of plasminogen activator inhibitor-1 activity results in promotion of endogenous thrombolysis and inhibition of thrombus extension in models of experimental thrombosis. *Circulation* 1992;85:305-312.
1923. Braaten JV, Handt S, Jerome WG, Kirkpatrick J, Lewis JC, Hantgan RR. Regulation of fibrinolysis by platelet-released plasminogen activator inhibitor 1: light scattering and ultrastructural examination of lysis of a model platelet-fibrin thrombus. *Blood* 1993;81:1290-1299.
1924. Steffens GJ, Gunzler WA, Otting F, Frankus E, Flohe L. The complete amino acid sequence of low molecular mass urokinase from human urine. *Hoppe Seylers Z Physiol Chem* 1982;363:1043-1058.
1925. Gunzler WA, Steffens GJ, Otting F, Kim SM, Frankus E, Flohe L. The primary structure of high molecular mass urokinase from human urine. The complete amino acid sequence of the A chain. *Hoppe Seylers Z Physiol Chem* 1982;363:1155-1165.
1926. Husain SS, Gurewich V, Lipinski B. Purification and partial characterization of a single-chain high- molecular-weight form of urokinase from human urine. *Arch Biochem Biophys* 1983;220:31-38.
1927. Stump DC, Thienpont M, Collen D. Urokinase-related proteins in human urine. Isolation and characterization of single-chain urokinase (pro-urokinase) and urokinase-inhibitor complex. *J Biol Chem* 1986;261:1267-1273.
1928. Shatos MA, Orfeo T, Doherty JM, Penar PL, Collen D, Mann KG. Alpha-thrombin stimulates urokinase production and DNA synthesis in cultured human cerebral microvascular endothelial cells. *Arterioscler Thromb Vasc Biol* 1995;15:903-911.
1929. van Hinsbergh VW. Regulation of the synthesis and secretion of plasminogen activators by endothelial cells. *Haemostasis* 1988;18:307-327.
1930. Wun TC, Schleuning WD, Reich E. Isolation and characterization of urokinase from human plasma. *J Biol Chem* 1982;257:3276-3283.
1931. Stump DC, Lijnen HR, Collen D. Purification and characterization of single-chain urokinase-type plasminogen activator from human cell cultures. *J Biol Chem* 1986;261:1274-1278.
1932. Darras V, Thienpont M, Stump DC, Collen D. Measurement of urokinase-type plasminogen activator (u-PA) with an enzyme-linked immunosorbent assay (ELISA) based on three murine monoclonal antibodies. *Thromb Haemost* 1986;56:411-414.

1933. Collen D, Zamarron C, Lijnen HR, Hoylaerts M. Activation of plasminogen by pro-urokinase. II. Kinetics. *J Biol Chem* 1986;261:1259-1266.
1934. Ichinose A, Fujikawa K, Suyama T. The activation of pro-urokinase by plasma kallikrein and its inactivation by thrombin. *J Biol Chem* 1986;261:3486-3489.
1935. Kasai S, Arimura H, Nishida M, Suyama T. Primary structure of single-chain pro-urokinase. *J Biol Chem* 1985;260:12382-12389.
1936. Stump DC, Lijnen HR, Collen D. Purification and characterization of a novel low molecular weight form of single-chain urokinase-type plasminogen activator. *J Biol Chem* 1986;261:17120-17126.
1937. Gurewich V, Pannell R, Broeze RJ, Mao J. Characterization of the intrinsic fibrinolytic properties of pro-urokinase through a study of plasmin-resistant mutant forms produced by site-specific mutagenesis of lysine(158). *J Clin Invest* 1988;82:1956-1962.
1938. Gurewich V, Pannell R. Fibrin binding and zymogenic properties of single-chain urokinase (pro-urokinase). *Semin Thromb Hemost* 1987;13:146-151.
1939. Pannell R, Gurewich V. Activation of plasminogen by single-chain urokinase or by two-chain urokinase—a demonstration that single-chain urokinase has a low catalytic activity (pro-urokinase). *Blood* 1987;69:22-26.
1940. Lijnen HR. Elements of the fibrinolytic system. *Ann NY Acad Sci* 2001;936:226-236.
1941. Han B, Nakamura M, Mori I, Nakamura Y, Kakudo K. Urokinase-type plasminogen activator system and breast cancer (Review). *Oncol Rep* 2005;14:105-112.
1942. Blasi F. Proteolysis, cell adhesion, chemotaxis, and invasiveness are regulated by the u-PA-u-PAR-PAI-1 system. *Thromb Haemost* 1999;82:298-304.
1943. Quax PH, van Leeuwen RT, Verspaget HW, Verheijen JH. Protein and messenger RNA levels of plasminogen activators and inhibitors analyzed in 22 human tumor cell lines. *Cancer Res* 1990;50:1488-1494.
1944. Evans DM, Sloan-Stakleff K, Arvan M, Guyton DP. Time and dose dependency of the suppression of pulmonary metastases of rat mammary cancer by amiloride. *Clin Exp Metastasis* 1998;16:353-357.
1945. Banerji A, Fernandes A, Bane S, Ahire S. The field bean protease inhibitor has the potential to suppress B16F10 melanoma cell lung metastasis in mice. *Cancer Lett* 1998;129:15-20.
1946. Kobayashi H, Gotoh J, Shinohara H, Moniwa N, Terao T. Inhibition of the metastasis of Lewis lung carcinoma by antibody against urokinase-type plasminogen activator in the experimental and spontaneous metastasis model. *Thromb Haemost* 1994;71:474-480.
1947. Xiao G, Liu YE, Gentz R, et al. Suppression of breast cancer growth and metastasis by a serpin myoepithelium-derived serine proteinase inhibitor expressed in the mammary myoepithelial cells. *Proc Natl Acad Sci U S A* 1999;96:3700-3705.
1948. Rabbani SA, Harakidas P, Davidson DJ, Henkin J, Mazar AP. Prevention of prostate-cancer metastasis in vivo by a novel synthetic inhibitor of urokinasetype plasminogen activator (uPA). *Int J Cancer* 1995;63:840-845.
1949. Alonso DF, Tejera AM, Farias EF, Bal de Kier JE, Gomez DE. Inhibition of mammary tumor cell adhesion, migration, and invasion by the selective synthetic urokinase inhibitor B428. *Anticancer Res* 1998;18:4499-4504.
1950. Alonso DF, Farias EF, Ladedo V, Davel L, Puricelli L, Bal de Kier JE. Effects of synthetic urokinase inhibitors on local invasion and metastasis in a murine mammary tumor model. *Breast Cancer Res Treat* 1996;40:209-223.
1951. Jankun J, Keck RW, Skrzypczak-Jankun E, Swiercz R. Inhibitors of urokinase reduce size of prostate cancer xenografts in severe combined immunodeficient mice. *Cancer Res* 1997;57:559-563.
1952. Riccio A, Grimaldi G, Verde P, Sebastio G, Boast S, Blasi F. The human urokinase-plasminogen activator gene and its promoter. *Nucleic Acids Res* 1985;13:2759-2771.
1953. Tripputi P, Blasi F, Verde P, Cannizzaro LA, Emanuel BS, Croce CM. Human urokinase gene is located on the long arm of chromosome 10. *Proc Natl Acad Sci U S A* 1985;82:4448-4452.
1954. Gunzler WA, Steffens GJ, Otting F, Buse G, Flohe L. Structural relationship between human high and low molecular mass urokinase. *Hoppe Seylers Z Physiol Chem* 1982;363:133-141.

1955. Holmes WE, Pennica D, Blaber M. Cloning and expression of the gene for pro-urokinase in *Escherichia coli* Biotechnology 1985;3:923-929.
1956. Gyetko MR, Chen GH, McDonald RA, et al. Urokinase is required for the pulmonary inflammatory response to *Cryptococcus neoformans*. A murine transgenic model. J Clin Invest 1996;97:1818-1826.
1957. Shapiro RL, Duquette JG, Nunes I, et al. Urokinase-type plasminogen activator-deficient mice are predisposed to staphylococcal botryomycosis, pleuritis, and effacement of lymphoid follicles. Am J Pathol 1997;150:359-369.
1958. Beck JM, Preston AM, Gyetko MR. Urokinase-type plasminogen activator in inflammatory cell recruitment and host defense against *Pneumocystis carinii* in mice. Infect Immun 1999;67:879-884.
1959. Li X, Bokman AM, Llinas M, Smith RA, Dobson CM. Solution structure of the kringle domain from urokinase-type plasminogen activator. J Mol Biol 1994;235:1548-1559.
1960. Franco P, Iaccarino C, Chiaradonna F, et al. Phosphorylation of human prourokinase on Ser138/303 impairs its receptor-dependent ability to promote myelomonocytic adherence and motility. J Cell Biol 1997;137:779-791.
1961. Mazar AP, Buko A, Petros AM, et al. Domain analysis of urokinase plasminogen activator (u-PA): preparation and characterization of intact A-chain molecules. Fibrinolysis 2003;6(Suppl 1):49-55.
1962. He CJ, Rebibou JM, Peraldi MN, Meulders Q, Rondeau E. Growth factor-like effect of urokinase type plasminogen activator in human renal cells. Biochem Biophys Res Commun 1991;176:1408-1416.
1963. Koopman JL, Slomp J, de Bart AC, Quax PH, Verheijen JH. Mitogenic effects of urokinase on melanoma cells are independent of high affinity binding to the urokinase receptor. J Biol Chem 1998;273:33267-33272.
1964. Rabbani SA, Gladu J, Mazar AP, Henkin J, Goltzman D. Induction in human osteoblastic cells (SaOS2) of the early response genes *fos*, *jun*, and *myc* by the amino terminal fragment (ATF) of urokinase. J Cell Physiol 1997;172:137-145.
1965. Goncharova EA, Vorotnikov AV, Gracheva EO, et al. Activation of p38 MAPkinase and caldesmon phosphorylation are essential for urokinase-induced human smooth muscle cell migration. Biol Chem 2002;383:115-126.
1966. Lee KN, Jackson KW, McKee PA. Effect of a synthetic carboxy-terminal peptide of alpha(2)-antiplasmin on urokinase-induced fibrinolysis. Thromb Res 2002;105:263-270.
1967. Mukhina S, Stepanova V, Traktouev D, et al. The chemotactic action of urokinase on smooth muscle cells is dependent on its kringle domain. Characterization of interactions and contribution to chemotaxis. J Biol Chem 2000;275:16450-16458.
1968. Gurewich V, Pannell R, Louie S, Kelley P, Suddith RL, Greenlee R. Effective and fibrin-specific clot lysis by a zymogen precursor form of urokinase (pro-urokinase). A study in vitro and in two animal species. J Clin Invest 1984;73:1731-1739.
1969. Pannell R, Gurewich V. Pro-urokinase: a study of its stability in plasma and of a mechanism for its selective fibrinolytic effect. Blood 1986;67:1215-1223.
1970. Ellis V, Scully MF, Kakkar VV. Plasminogen activation by single-chain urokinase in functional isolation. A kinetic study. J Biol Chem 1987;262:14998-15003.
1971. Nowak UK, Li X, Teuten AJ, Smith RA, Dobson CM. NMR studies of the dynamics of the multidomain protein urokinase-type plasminogen activator. Biochemistry 1993;32:298-309.
1972. Hansen AP, Petros AM, Meadows RP, Fesik SW. Backbone dynamics of a two-domain protein: 15N relaxation studies of the amino-terminal fragment of urokinase-type plasminogen activator. Biochemistry 1994;33:15418-15424.
1973. Hansen AP, Petros AM, Meadows RP, et al. Solution structure of the aminoterminal fragment of urokinase-type plasminogen activator. Biochemistry 1994;33:4847-4864.
1974. Spraggon G, Phillips C, Nowak UK, et al. The crystal structure of the catalytic domain of human urokinase-type plasminogen activator. Structure 1995;3:681-691.
1975. Nienaber V, Wang J, Davidson D, Henkin J. Re-engineering of human urokinase provides a system for structure-based drug design at high resolution and reveals a novel structural subsite. J Biol Chem 2000;275:7239-7248.
1976. Kobayashi H, Schmitt M, Goretzki L, et al. Cathepsin B efficiently activates the soluble and the tumor cell receptor-bound form of the proenzyme urokinasetype plasminogen activator (Pro-uPA). J Biol Chem 1991;266:5147-5152.

1977. Nauland U, Rijken DC. Activation of thrombin-inactivated single-chain urokinase-type plasminogen activator by dipeptidyl peptidase I (cathepsin C). *Eur J Biochem* 1994;223:497-501.
1978. Schmitt M, Goretzki L, Chucholowski N, et al. Effective activation of the pro-enzyme form of the urokinase-type plasminogen activator (pro-uPA) by the cysteine protease cathepsin L. *Fibrinolysis* 1992;6(Suppl 2):122.
1979. Drag B, Petersen LC. Activation of pro-urokinase by cathepsin G in the presence of glucosaminoglycans. *Fibrinolysis* 1994;8:192-199.
1980. Stack MS, Johnson DA. Human mast cell tryptase activates single-chain urinary-type plasminogen activator (pro-urokinase). *J Biol Chem* 1994;269:9416-9419.
1981. Wolf BB, Vasudevan J, Henkin J, Gonias SL. Nerve growth factor-gamma activates soluble and receptor-bound single chain urokinase-type plasminogen activator. *J Biol Chem* 1993;268:16327-16331.
1982. Brunner G, Simon MM, Kramer MD. Activation of pro-urokinase by the human T cell-associated serine proteinase HuTSP-1. *FEBS Lett* 1990;260:141-144.
1983. Romisch J, Vermohlen S, Feussner A, Stohr H. The FVII activating protease cleaves single-chain plasminogen activators. *Haemostasis* 1999;29:292-299.
1984. Marcotte PA, Kozan IM, Dorwin SA, Ryan JM. The matrix metalloproteinase pump-1 catalyzes formation of low molecular weight (pro)urokinase in cultures of normal human kidney cells. *J Biol Chem* 1992;267:13803-13806.
1985. Ugwu F, Van Hoef B, Bini A, Collen D, Lijnen HR. Proteolytic cleavage of urokinase-type plasminogen activator by stromelysin-1 (MMP-3). *Biochemistry* 1998;37:7231-7236.
1986. Orgel D, Schroder W, Hecker-Kia A, Weithmann KU, Kolkenbrock H, Ulbrich N. The cleavage of pro-urokinase type plasminogen activator by stromelysin- 1. *Clin Chem Lab Med* 1998;36:697-702.
1987. Collen D, Lijnen HR. Basic and clinical aspects of fibrinolysis and thrombolysis. *Blood* 1991;78:3114-3124.
1988. Schmitt M, Kanayama N, Henschen A, et al. Elastase released from human granulocytes stimulated with N-formyl-chemotactic peptide prevents activation of tumor cell prourokinase (pro- uPA). *FEBS Lett* 1989;255:83-88.
1989. Learmonth MP, Li W, Namiranian S. Modulation of the cell binding property of single chain urokinase-type plasminogen activator by neutrophil cathepsin G. *Fibrinolysis* 1992;6(Suppl 4):113-116.
1990. Braat EA, Levi M, Bos R, et al. Inactivation of single-chain urokinase-type plasminogen activator by thrombin in human subjects. *J Lab Clin Med* 1999;134:161-167.
1991. Braat EA, Rijken DC. The inactivation of single-chain urokinase-type plasminogen activator by thrombin may provide an additional explanation for the antifibrinolytic effect of factor XI. *Thromb Haemost* 1999;81:657.
1992. de Munk GA, Parkinson JF, Groeneveld E, Bang NU, Rijken DC. Role of the glycosaminoglycan component of thrombomodulin in its acceleration of the inactivation of single-chain urokinase-type plasminogen activator by thrombin. *Biochem J* 1993;290(Pt 3):655-659.
1993. Lijnen HR, Van Hoef B, Collen D. Activation with plasmin of tow-chain urokinase-type plasminogen activator derived from single-chain urokinasetype plasminogen activator by treatment with thrombin. *Eur J Biochem* 1987;169:359-364.
1994. Robbins KC, Summaria L, Hsieh B, Shah RJ. The peptide chains of human plasmin. Mechanism of activation of human plasminogen to plasmin. *J Biol Chem* 1967;242:2333-2342.
1995. Fleury V, Lijnen HR, Angles-Cano E. Mechanism of the enhanced intrinsic activity of single-chain urokinase- type plasminogen activator during ongoing fibrinolysis. *J Biol Chem* 1993;268:18554-18559.
1996. Longstaff C, Clough AM, Gaffney PJ. Kinetics of plasmin activation of single chain urinary-type plasminogen activator (scu-PA) and demonstration of a high affinity interaction between scu-PA and plasminogen. *J Biol Chem* 1992;267:173-179.
1997. Lenich C, Pannell R, Gurewich V. The effect of the carboxy-terminal lysine of urokinase on the catalysis of plasminogen activation. *Thromb Res* 1991;64:69-80.
1998. Choi-Miura NH, Tobe T, Sumiya J, et al. Purification and characterization of a novel hyaluronan-binding protein (PHBP) from human plasma: it has three EGF, a kringle and a serine protease domain, similar to hepatocyte growth factor activator. *J Biochem(Tokyo)* 1996;119:1157-1165.

1999. Hunfeld A, Etscheid M, König H, Seitz R, Dodt J. Identification of the thrombin-like activity of PCC's. *Ann Haematol* 1998;76:A101.
2000. Hunfeld A, Etscheid M, König H, Seitz R, Dodt J. Detection of a novel plasma serine protease during purification of vitamin K-dependent coagulation factors. *FEBS Lett* 1999;456:290-294.
2001. Stavenuiter F, Dienava-Verdoold I, Boon-Spijker M, Brinkman H, Meijer A, Mertens K. Factor seven activating protease (FSAP): does it activate factor VII? *J Thromb Haemost* 2012;10:859-866.
2002. Kanse S, Declerck P, Ruf W, Broze G, Etscheid M. Factor VII-activating protease promotes the proteolysis and inhibition of tissue factor pathway inhibitor. *Arterioscler Thromb Vasc Biol* 2012;32:427-433.
2003. Kannemeier C, Feussner A, Stohr HA, Weisse J, Preissner KT, Romisch J. Factor VII and single-chain plasminogen activator-activating protease: activation and autoactivation of the proenzyme. *Eur J Biochem* 2001;268:3789-3796.
2004. Sumiya J, Asakawa S, Tobe T, et al. Isolation and characterization of the plasma hyaluronan-binding protein (PHBP) gene (HABP2). *J Biochem(Tokyo)* 1997;122:983-990.
2005. Romisch J, Feussner A, Nerlich C, Stohr HA, Weimer T. The frequent Marburg I polymorphism impairs the pro-urokinase activating potency of the factor VII activating protease (FSAP). *Blood Coagul Fibrinolysis* 2002;13:433-441.
2006. Gulesserian T, Hron G, Endler G, Eichinger S, Wagner O, Kyrle PA. Marburg I polymorphism of factor VII-activating protease and risk of recurrent venous thromboembolism. *Thromb Haemost* 2006;95:65-67.
2007. Sedding D, Daniel JM, Muhl L, et al. The G534E polymorphism of the gene encoding the factor VII-activating protease is associated with cardiovascular risk due to increased neointima formation. *J Exp Med* 2006;203:2801-2807.
2008. Miyazawa K, Shimomura T, Kitamura A, Kondo J, Morimoto Y, Kitamura N. Molecular cloning and sequence analysis of the cDNA for a human serine protease responsible for activation of hepatocyte growth factor. Structural similarity of the protease precursor to blood coagulation factor XII. *J Biol Chem* 1993;268:10024-10028.
2009. Etscheid M, Hunfeld A, König H, Seitz R, Dodt J. Activation of proPHBSP, the zymogen of a plasma hyaluronan binding serine protease, by an intermolecular autocatalytic mechanism. *Biol Chem* 2000;381:1223-1231.
2010. Choi-Miura NH, Takahashi K, Yoda M, Saito K, Mazda T, Tomita M. Proteolytic activation and inactivation of the serine protease activity of plasma hyaluronan binding protein. *Biol Pharm Bull* 2001;24:448-452.
2011. Nakazawa F, Kannemeier C, Shibamiya A, et al. Extracellular RNA is a natural cofactor for the (auto-)activation of Factor VII-activating protease (FSAP). *Biochem J* 2005;385:831-838.
2012. Yamamichi S, Fujiwara Y, Kikuchi T, Nishitani M, Matsushita Y, Hasumi K. Extracellular histone induces plasma hyaluronan-binding protein (factor VII activating protease) activation in vivo. *Biochem Biophys Res Commun* 2011;409:483-488.
2013. Romisch J. Factor VII activating protease (FSAP): a novel protease in hemostasis. *Biol Chem* 2002;383:1119-1124.
2014. Choi-Miura NH, Saito K, Takahashi K, Yoda M, Tomita M. Regulation mechanism of the serine protease activity of plasma hyaluronan binding protein. *Biol Pharm Bull* 2001;24:221-5.
2015. Etscheid M, Beer N, Seitz R, Dodt J. Regulation of the plasma hyaluronanbinding serine protease. *Ann Haematol* 2002;81:A16.
2016. Stephan F, Dienava-Verdoold I, Bulder I, et al. Tissue factor pathway inhibitor is an inhibitor of factor VII-activating protease. *J Thromb Haemost* 2012;10:1165-1171.
2017. Stephan F, Aarden L, Zeerleder S. FSAP, a new player in inflammation? *Hamostaseologie* 2012;32:51-55.
2018. Nesheim M, Bajzar L. The discovery of TAFI. *J Thromb Haemost* 2005;3: 2139-2146.
2019. Mosnier LO, Bouma BN. Regulation of fibrinolysis by thrombin activatable fibrinolysis inhibitor, an unstable carboxypeptidase B that unites the pathways of coagulation and fibrinolysis. *Arterioscler Thromb Vasc Biol* 2006;26:2445-2453. 01.ATV.0000244680.14653.9a [pii]. doi:10.1161/01.ATV.0000244680.14653.9a.
2020. Boffa MB, Koschinsky ML. Curiouser and curiouser: recent advances in measurement of thrombin-activatable fibrinolysis inhibitor (TAFI) and in understanding its molecular genetics, gene regulation, and biological roles. *Clin Biochem* 2007;40:431-442.

2021. Heylen E, Willemse J, Hendriks D. An update on the role of carboxypeptidase U (TAFI) in fibrinolysis. *Front Biosci* 2011;16:2427-2450.
2022. Declerck P. Thrombin activatable fibrinolysis inhibitor. *Hamostaseologie* 2011;31:165-166.
2023. Mosnier L, Buijtenhuijs P, Marx P, Meijers J, Bouma B. Identification of thrombin activatable fibrinolysis inhibitor (TAFI) in human platelets. *Blood* 2003;101:4844-4846.
2024. Schadinger S, Lin J, Garand M, Boffa M. Secretion and antifibrinolytic function of thrombin-activatable fibrinolysis inhibitor from human platelets. *J Thromb Haemost* 2010;8:2523-9.
2025. Redlitz A, Nicolini FA, Malucky JL, Topol EJ, Plow EF. Inducible carboxypeptidase activity. A role in clot lysis in vivo. *Circulation* 1996;93:1328-1330.
2026. Minnema MC, Friederich PW, Levi M, et al. Enhancement of rabbit jugular vein thrombolysis by neutralization of factor XI. In vivo evidence for a role of factor XI as an anti-fibrinolytic factor. *J Clin Invest* 1998;101:10-14.
2027. Gresele P, Momi S, Berrettini M, et al. Activated human protein C prevents thrombin-induced thromboembolism in mice. Evidence that activated protein C reduces intravascular fibrin accumulation through the inhibition of additional thrombin generation. *J Clin Invest* 1998;101:667-676.
2028. Nagashima M, Yin ZF, Broze GJ Jr, Morser J. Thrombin-activatable fibrinolysis inhibitor (TAFI) deficient mice. *Front Biosci* 2002;7:d556-d568.
2029. Franco RF, Fagundes MG, Meijers JC, et al. Identification of polymorphisms in the 5'-untranslated region of the TAFI gene: relationship with plasma TAFI levels and risk of venous thrombosis. *Haematologica* 2001;86:510-517.
2030. van Tilburg NH, Rosendaal FR, Bertina RM. Thrombin activatable fibrinolysis inhibitor and the risk for deep vein thrombosis. *Blood* 2000;95:2855-2859.
2031. Wang W, Hendriks DF, Scharpe SS. Carboxypeptidase U, a plasma carboxypeptidase with high affinity for plasminogen. *J Biol Chem* 1994;269:15937-15944.
2032. Hendriks D, Scharpe S, van Sande M, Lommaert MP. Characterisation of a carboxypeptidase in human serum distinct from carboxypeptidase N. *J Clin Chem Clin Biochem* 1989;27:277-285.
2033. Campbell W, Okada H. An arginine specific carboxypeptidase generated in blood during coagulation or inflammation which is unrelated to carboxypeptidase N or its subunits. *Biochem Biophys Res Commun* 1989;162:933-939.
2034. Tan AK, Eaton DL. Activation and characterization of procarboxypeptidase B from human plasma. *Biochemistry* 1995;34:5811-5816.
2035. Boffa MB, Reid TS, Joo E, Nesheim ME, Koschinsky ML. Characterization of the gene encoding human TAFI (thrombin-activable fibrinolysis inhibitor; plasma procarboxypeptidase B). *Biochemistry* 1999;38:6547-6558.
2036. Skidgel RA. Basic carboxypeptidases: regulators of peptide hormone activity. *Trends Pharmacol Sci* 1988;9:299-304.
2037. Vanhoof G, Wauters J, Schatteman K, et al. The gene for human carboxypeptidase U (CPU)—a proposed novel regulator of plasminogen activation—maps to 13q14.11. *Genomics* 1996;38:454-455.
2038. Zhao L, Morser J, Bajzar L, Nesheim M, Nagashima M. Identification and characterization of two thrombin-activatable fibrinolysis inhibitor isoforms. *Thromb Haemost* 1998;80:949-955.
2039. Juhan-Vague I, Renucci JF, Grimaux M, et al. Thrombin-activatable fibrinolysis inhibitor antigen levels and cardiovascular risk factors. *Arterioscler Thromb Vasc Biol* 2000;20:2156-2161.
2040. Henry M, Aubert H, Morange PE, et al. Identification of polymorphisms in the promoter and the 3' region of the TAFI gene: evidence that plasma TAFI antigen levels are strongly genetically controlled. *Blood* 2001;2053-2058.
2041. Brouwers GJ, Vos HL, Leebeek FW, et al. A novel, possibly functional, single nucleotide polymorphism in the coding region of the thrombin-activatable fibrinolysis inhibitor (TAFI) gene is also associated with TAFI levels. *Blood* 2001;98:1992-1993.
2042. Boffa MB, Wang W, Bajzar L, Nesheim ME. Plasma and recombinant thrombinactivable fibrinolysis inhibitor (TAFI) and activated TAFI compared with respect to glycosylation, thrombin/thrombomodulin-dependent activation, thermal stability, and enzymatic properties. *J Biol Chem* 1998;273:2127-2135.

2043. Mao SS, Cooper CM, Wood T, Shafer JA, Gardell SJ. Characterization of plasmin-mediated activation of plasma procarboxypeptidase B. Modulation by glycosaminoglycans. *J Biol Chem* 1999;274:35046-35052.
2044. Hess K, Ajjan R, Phoenix F, Dobó J, Gál P, Schroeder V. Effects of MASP-1 of the complement system on activation of coagulation factors and plasma clot formation. *PLoS One* 2012;7.
2045. Mosnier LO. Platelet factor 4 inhibits thrombomodulin-dependent activation of thrombin-activatable fibrinolysis inhibitor (TAFI) by thrombin. *J Biol Chem* 2011;286:502-510.
2046. Koschinsky ML, Boffa MB, Nesheim ME, et al. Association of a single nucleotide polymorphism in CPB2 encoding the thrombin-activable fibrinolysis inhibitor (TAF1) with blood pressure. *Clin Genet* 2001;60:345-349.
2047. dem Borne PA, Bajzar L, Meijers JC, Nesheim ME, Bouma BN. Thrombin-mediated activation of factor XI results in a thrombin-activatable fibrinolysis inhibitor-dependent inhibition of fibrinolysis. *J Clin Invest* 1997;99:2323-2327.
2048. Plow EF, Herren T, Redlitz A, Miles LA, Hoover-Plow JL. The cell biology of the plasminogen system. *FASEB J* 1995;9:939-945.
2049. Suenson E, Lutzen O, Thorsen S. Initial plasmin-degradation of fibrin as the basis of a positive feed-back mechanism in fibrinolysis. *Eur J Biochem* 1984;140:513-522.
2050. Pannell R, Black J, Gurewich V. Complementary modes of action of tissue-type plasminogen activator and pro-urokinase by which their synergistic effect on clot lysis may be explained. *J Clin Invest* 1988;81:853-859.
2051. Norrman B, Wallen P, Ranby M. Fibrinolysis mediated by tissue plasminogen activator. Disclosure of a kinetic transition. *Eur J Biochem* 1985;149:193-200.
2052. Fleury V, Angles-Cano E. Characterization of the binding of plasminogen to fibrin surfaces: the role of carboxy-terminal lysines. *Biochemistry* 1991;30:7630-7638.
2053. Sakharov DV, Rijken DC. Superficial accumulation of plasminogen during plasma clot lysis. *Circulation* 1995;92:1883-1890.
2054. Foley J, Cook P, Nesheim M. Kinetics of activated thrombin-activatable fibrinolysis inhibitor (TAFI)-catalyzed cleavage of C-terminal lysine residues of fibrin degradation products and removal of plasminogen-binding sites. *J Biol Chem* 2011;286:19280-19286.
2055. Nesheim M. Fibrinolysis and the plasma carboxypeptidase. *Curr Opin Hematol* 1998;5:309-313.
2056. Bouma BN, Mosnier LO, Meijers JC, Griffin JH. Factor XI dependent and independent activation of thrombin activatable fibrinolysis inhibitor (TAFI) in plasma associated with clot formation. *Thromb Haemost* 1999;82:1703-1708.
2057. Bajzar L. Thrombin activatable fibrinolysis inhibitor and an antifibrinolytic pathway. *Arterioscler Thromb Vasc Biol* 2000;20:2511-2518.
2058. Ryan CA, Hass GM, Kuhn RW. Purification and properties of a carboxypeptidase inhibitor from potatoes. *J Biol Chem* 1974;249:5495-5499.
2059. Reverter D, Vendrell J, Canals F, et al. A carboxypeptidase inhibitor from the medical leech *Hirudo medicinalis*. Isolation, sequence analysis, cDNA cloning, recombinant expression, and characterization. *J Biol Chem* 1998;273:32927-32933.
2060. Boffa MB, Bell R, Stevens WK, Nesheim ME. Roles of thermal instability and proteolytic cleavage in regulation of activated thrombin-activable fibrinolysis inhibitor. *J Biol Chem* 2000;275:12868-12878.
2061. Marx PF, Hackeng TM, Dawson PE, Griffin JH, Meijers JC, Bouma BN. Inactivation of active thrombin-activable fibrinolysis inhibitor takes place by a process that involves conformational instability rather than proteolytic cleavage. *J Biol Chem* 2000;275:12410-12415.
2062. Sato T, Miwa T, Akatsu H, et al. Pro-carboxypeptidase R is an acute phase protein in the mouse, whereas carboxypeptidase N is not. *J Immunol* 2000;165:1053-1058.
2063. Silveira A, Schatteman K, Goossens F, et al. Plasma procarboxypeptidase U in men with symptomatic coronary artery disease. *Thromb Haemost* 2000;84:364-368.
2064. Schatteman KA, Goossens FJ, Scharpe SS, Neels HM, Hendriks DF. Assay of procarboxypeptidase U, a novel determinant of the fibrinolytic cascade, in human plasma. *Clin Chem* 1999;45:807-813.

2065. Chetaille P, Alessi MC, Kouassi D, Morange PE, Juhan-Vague I. Plasma TAFI antigen variations in healthy subjects. *Thromb Haemost* 2000;83:902-905.
2066. Boffa MB, Hamill JD, Bastajian N, Dillon R, Nesheim ME, Koschinsky ML. A role for CCAAT/enhancer-binding protein in hepatic expression of thrombin-activable fibrinolysis inhibitor. *J Biol Chem* 2002;277:25329-25336.
2067. Van De Craen B, Declerck P, Gils A. The Biochemistry, Physiology and Pathological roles of PAI-1 and the requirements for PAI-1 inhibition in vivo. *Thromb Res* 2012;130:576-585.
2068. Dieval J, Nguyen G, Gross S, Delobel J, Kruithof EK. A lifelong bleeding disorder associated with a deficiency of plasminogen activator inhibitor type 1. *Blood* 1991;77:528-532.
2069. Fay WP, Shapiro AD, Shih JL, Schleef RR, Ginsburg D. Brief report: complete deficiency of plasminogen-activator inhibitor type 1 due to a frame-shift mutation. *N Engl J Med* 1992;327:1729-1733.
2070. Lee MH, Vosburgh E, Anderson K, McDonagh J. Deficiency of plasma plasminogen activator inhibitor 1 results in hyperfibrinolytic bleeding. *Blood* 1993;81:2357-2362.
2071. Fay WP, Parker AC, Condrey LR, Shapiro AD. Human plasminogen activator inhibitor-1 (PAI-1) deficiency: characterization of a large kindred with a null mutation in the PAI-1 gene. *Blood* 1997;90:204-208.
2072. Minowa H, Takahashi Y, Tanaka T, et al. Four cases of bleeding diathesis in children due to congenital plasminogen activator inhibitor-1 deficiency. *Haemostasis* 1999;29:286-291.
2073. Declerck PJ, De Mol M, Alessi MC, et al. Purification and characterization of a plasminogen activator inhibitor 1 binding protein from human plasma. Identification as a multimeric form of S protein (vitronectin). *J Biol Chem* 1988;263:15454-15461.
2074. Declerck PJ, Alessi MC, Verstreken M, Kruithof EK, Juhan-Vague I, Collen D. Measurement of plasminogen activator inhibitor 1 in biologic fluids with a murine monoclonal antibody-based enzyme-linked immunosorbent assay. *Blood* 1988;71:220-225.
2075. Wiman B, Hamsten A. The fibrinolytic enzyme system and its role in the etiology of thromboembolic disease. *Semin Thromb Hemost* 1990;16:207-216.
2076. Stiko A, Hervio L, Loskutoff DJ. Plasminogen activator inhibitors. In: Colman RF, Hirsh J, Marder VJ, Clowes AW, George JN, eds. *Hemostasis and thrombosis: basic principles and clinical practice*. Philadelphia, PA: Lippincott Williams & Wilkins, 2002:355-365.
2077. Huber K. Plasminogen activator inhibitor type-1 (part two): role for failure of thrombolytic therapy. PAI-1 resistance as a potential benefit for new fibrinolytic agents. *J Thromb Thrombolysis* 2001;11:195-202.
2078. Alessi MC, Chomiki N, Berthier R, Schweitzer A, Fossat C, Juhan-Vague I. Detection of plasminogen activator inhibitor-1 (PAI-1) mRNA in human megakaryocytes by in situ hybridization. *Thromb Haemost* 1994;72:931-936.
2079. Sharp AM, Stein PE, Pannu NS, et al. The active conformation of plasminogen activator inhibitor 1, a target for drugs to control fibrinolysis and cell adhesion. *Structure Fold Des* 1999;7:111-118.
2080. Aertgeerts K, De Bondt HL, De Ranter CJ, Declerck PJ. Mechanisms contributing to the conformational and functional flexibility of plasminogen activator inhibitor-1. *Nat Struct Biol* 1995;2:891-897.
2081. Wiman B, Almquist A, Sigurdardottir O, Lindahl T. Plasminogen activator inhibitor 1 (PAI) is bound to vitronectin in plasma. *FEBS Lett* 1988;242: 125-128.
2082. Schulze AJ, Huber R, Bode W, Engh RA. Structural aspects of serpin inhibition. *FEBS Lett* 1994;344:117-124.
2083. Ginsburg D, Zeheb R, Yang AY, et al. cDNA cloning of human plasminogen activator-inhibitor from endothelial cells. *J Clin Invest* 1986;78:1673-1680.
2084. Ny T, Sawdey M, Lawrence D, Millan JL, Loskutoff DJ. Cloning and sequence of a cDNA coding for the human beta-migrating endothelial-cell-type plasminogen activator inhibitor. *Proc Natl Acad Sci U S A* 1986;83:6776-6780.
2085. Sawdey M, Ny T, Loskutoff DJ. Messenger RNA for plasminogen activator inhibitor. *Thromb Res* 1986;41:151-160.
2086. Pannekoek H, Veerman H, Lambers H, et al. Endothelial plasminogen activator inhibitor (PAI): a new member of the Serpin gene family. *EMBO J* 1986;5:2539-2544.

2087. Andreasen PA, Riccio A, Welinder KG, et al. Plasminogen activator inhibitor type-1: reactive center and amino-terminal heterogeneity determined by protein and cDNA sequencing. *FEBS Lett* 1986;209:213-218.
2088. Wun TC, Kretzmer KK. cDNA cloning and expression in *E. coli* of a plasminogen activator inhibitor (PAI) related to a PAI produced by Hep G2 hepatoma cell. *FEBS Lett* 1987;210:11-16.
2089. Klinger KW, Winqvist R, Riccio A, et al. Plasminogen activator inhibitor type 1 gene is located at region q21.3- q22 of chromosome 7 and genetically linked with cystic fibrosis. *Proc Natl Acad Sci U S A* 1987;84:8548-8552.
2090. Schwartz CE, Stanislovitis P, Phelan MC, Klinger K, Taylor HA, Stevenson RE. Deletion mapping of plasminogen activator inhibitor, type I (PLANH1) and beta-glucuronidase (GUSB) in 7q21—q22. *Cytogenet Cell Genet* 1991;56: 152-153.
2091. Loskutoff DJ, Linders M, Keijer J, Veerman H, van Heerikhuizen H, Pannekoek H. Structure of the human plasminogen activator inhibitor 1 gene: nonrandom distribution of introns. *Biochemistry* 1987;26:3763-3768.
2092. Strandberg L, Lawrence D, Ny T. The organization of the human-plasminogen-activator-inhibitor-1 gene. Implications on the evolution of the serineprotease inhibitor family. *Eur J Biochem* 1988;176:609-616.
2093. Bosma PJ, Kooistra T, Siemieniak DR, Slightom JL. Further characterization of the 5'-flanking DNA of the gene encoding human plasminogen activator inhibitor-1. *Gene* 1991;100:261-266.
2094. Bosma PJ, van den Berg EA, Kooistra T, Siemieniak DR, Slightom JL. Human plasminogen activator inhibitor-1 gene. Promoter and structural gene nucleotide sequences. *J Biol Chem* 1988;263:9129-9141.
2095. Nordt TK, Lohrmann J, Bode C. Regulation of PAI-1 expression by genetic polymorphisms. Impact on atherogenesis. *Thromb Res* 2001;103(Suppl 1):S1-S5.
2096. Dawson SJ, Wiman B, Hamsten A, Green F, Humphries S, Henney AM. The two allele sequences of a common polymorphism in the promoter of the plasminogen activator inhibitor-1 (PAI-1) gene respond differently to interleukin-1 in HepG2 cells. *J Biol Chem* 1993;268:10739-10745.
2097. Nordenhem A, Wiman B. Plasminogen activator inhibitor-1 (PAI-1) content in platelets from healthy individuals genotyped for the 4G/5G polymorphism in the PAI-1 gene. *Scand J Clin Lab Invest* 1997;57:453-461.
2098. Ye S, Green FR, Scarabin PY, et al. The 4G/5G genetic polymorphism in the promoter of the plasminogen activator inhibitor-1 (PAI-1) gene is associated with differences in plasma PAI-1 activity but not with risk of myocardial infarction in the ECTIM study. *Etude CasTemoins de l'infarctus du Myocarde. Thromb Haemost* 1995;74:837-841.
2099. Margaglione M, Cappucci G, Colaizzo D, et al. The PAI-1 gene locus 4G/5G polymorphism is associated with a family history of coronary artery disease. *Arterioscler Thromb Vasc Biol* 1998;18:152-156.
2100. Margaglione M, Cappucci G, d'Addetta M, et al. PAI-1 plasma levels in a general population without clinical evidence of atherosclerosis: relation to environmental and genetic determinants. *Arterioscler Thromb Vasc Biol* 1998;18:562-567.
2101. Eriksson P, Kallin B, t Hooft FM, Bavenholm P, Hamsten A. Allele-specific increase in basal transcription of the plasminogen- activator inhibitor 1 gene is associated with myocardial infarction. *Proc Natl Acad Sci U S A* 1995;92:1851-1855.
2102. Ridker PM, Hennekens CH, Lindpaintner K, Stampfer MJ, Miletich JP. Arterial and venous thrombosis is not associated with the 4G/5G polymorphism in the promoter of the plasminogen activator inhibitor gene in a large cohort of US men. *Circulation* 1997;95:59-62.
2103. Huber K, Christ G, Wojta J, Gulba D. Plasminogen activator inhibitor type-1 in cardiovascular disease. Status report 2001. *Thromb Res* 2001;103(Suppl 1):S7-S19.
2104. Tsantes A, Nikolopoulos G, Bagos P, Bonovas S, Kopterides P, Vaiopoulos G. The effect of the plasminogen activator inhibitor-1 4G/5G polymorphism on the thrombotic risk. *Thromb Res* 2008;122:736-742.
2105. Dawson S, Hamsten A, Wiman B, Henney A, Humphries S. Genetic variation at the plasminogen activator inhibitor-1 locus is associated with altered levels of plasma plasminogen activator inhibitor-1 activity. *Arterioscler Thromb* 1991;11:183-190.
2106. Grenett HE, Benza RL, Li XN, et al. Expression of plasminogen activator inhibitor type I in genotyped human endothelial cell cultures: genotype-specific regulation by insulin. *Thromb Haemost* 1999;82:1504-1509.

2107. Booyse FM, Aikens ML, Grenett HE. Endothelial cell fibrinolysis: transcriptional regulation of fibrinolytic protein gene expression (t-PA, u-PA, and PAI-1) by low alcohol. *Alcohol Clin Exp Res* 1999;23:1119-1124.
2108. Li XN, Grenett HE, Benza RL, et al. Genotype-specific transcriptional regulation of PAI-1 expression by hypertriglyceridemic VLDL and Lp(a) in cultured human endothelial cells. *Arterioscler Thromb Vasc Biol* 1997;17:3215-3223.
2109. Grenett HE, Benza RL, Fless GM, Li XN, Davis GC, Booyse FM. Genotype-specific transcriptional regulation of PAI-1 gene by insulin, hypertriglyceridemic VLDL, and Lp(a) in transfected, cultured human endothelial cells. *Arterioscler Thromb Vasc Biol* 1998;18:1803-1809.
2110. Carmeliet P, Kieckens L, Schoonjans L, et al. Plasminogen activator inhibitor-1 gene-deficient mice. I. Generation by homologous recombination and characterization. *J Clin Invest* 1993;92:2746-2755.
2111. Carmeliet P, Stassen JM, Schoonjans L, et al. Plasminogen activator inhibitor-1 gene-deficient mice. II. Effects on hemostasis, thrombosis, and thrombolysis. *J Clin Invest* 1993;92:2756-2760.
2112. Dewerchin M, Collen D, Lijnen HR. Enhanced fibrinolytic potential in mice with combined homozygous deficiency of alpha2-antiplasmin and PAI-1. *Thromb Haemost* 2001;86:640-646.
2113. Madison EL, Goldsmith EJ, Gething MJ, Sambrook JF, Gerard RD. Restoration of serine protease-inhibitor interaction by protein engineering. *J Biol Chem* 1990;265:21423-21426.
2114. Madison EL, Goldsmith EJ, Gerard RD, Gething MJ, Sambrook JF. Serpin-resistant mutants of human tissue-type plasminogen activator. *Nature* 1989;339:721-724.
2115. Adams DS, Griffin LA, Nachajko WR, Reddy VB, Wei CM. A synthetic DNA encoding a modified human urokinase resistant to inhibition by serum plasminogen activator inhibitor. *J Biol Chem* 1991;266:8476-8482.
2116. Hekman CM, Loskutoff DJ. Endothelial cells produce a latent inhibitor of plasminogen activators that can be activated by denaturants. *J Biol Chem* 1985;260:11581-11587.
2117. Mottonen J, Strand A, Symersky J, et al. Structural basis of latency in plasminogen activator inhibitor-1. *Nature* 1992;355:270-273.
2118. Lawrence DA, Berkenpas MB, Palaniappan S, Ginsburg D. Localization of vitronectin binding domain in plasminogen activator inhibitor-1. *J Biol Chem* 1994;269:15223-15228.
2119. Kruithof EK, Tran-Thang C, Gudinchet A, et al. Fibrinolysis in pregnancy: a study of plasminogen activator inhibitors. *Blood* 1987;69:460-466.
2120. Ghosh A, Vaughan D. PAI-1 in tissue fibrosis. *J Cell Physiol* 2012;227:493-507.
2121. Kjoller L, Kanse SM, Kirkegaard T, et al. Plasminogen activator inhibitor-1 represses integrin- and vitronectin-mediated cell migration independently of its function as an inhibitor of plasminogen activation. *Exp Cell Res* 1997;232:420-429.
2122. Waltz DA, Natkin LR, Fujita RM, Wei Y, Chapman HA. Plasmin and plasminogen activator inhibitor type 1 promote cellular motility by regulating the interaction between the urokinase receptor and vitronectin. *J Clin Invest* 1997;100:58-67.
2123. Kanse SM, Kost C, Wilhelm OG, Andreasen PA, Preissner KT. The urokinase receptor is a major vitronectin-binding protein on endothelial cells. *Exp Cell Res* 1996;224:344-353.
2124. Deng G, Curriden SA, Wang S, Rosenberg S, Loskutoff DJ. Is plasminogen activator inhibitor-1 the molecular switch that governs urokinase receptor-mediated cell adhesion and release? *J Cell Biol* 1996;134:1563-1571.
2125. Stefansson S, Lawrence DA. The serpin PAI-1 inhibits cell migration by blocking integrin alpha V beta 3 binding to vitronectin. *Nature* 1996;383:441-443.
2126. Kruithof EK, Baker MS, Bunn CL. Biological and clinical aspects of plasminogen activator inhibitor type 2. *Blood* 1995;86:4007-4024.
2127. Kawano T, Morimoto K, Uemura Y. Partial purification and properties of urokinase inhibitor from human placenta. *J Biochem(Tokyo)* 1970;67:333-342.
2128. Kawano T, Uemura Y. Inhibition of tissue activator by urokinase inhibitor. *Thromb Diath Haemorrh* 1971;25:129-133.

2129. Kawano T, Morimoto K, Uemura Y. Urokinase inhibitor in human placenta. *Nature* 1968;217:253-254.
2130. Astedt B, Hagerstrand I, Lecander I. Cellular localisation in placenta of placental type plasminogen activator inhibitor. *Thromb Haemost* 1986;56:63-65.
2131. Holmberg L, Lecander I, Persson B, Astedt B. An inhibitor from placenta specifically binds urokinase and inhibits plasminogen activator released from ovarian carcinoma in tissue culture. *Biochim Biophys Acta* 1978;544:128-137.
2132. Astedt B, Lecander I, Brodin T, Lundblad A, Low K. Purification of a specific placental plasminogen activator inhibitor by monoclonal antibody and its complex formation with plasminogen activator. *Thromb Haemost* 1985;53:122-125.
2133. Ritchie H, Robbie LA, Kinghorn S, Exley R, Booth NA. Monocyte plasminogen activator inhibitor 2 (PAI-2) inhibits u-PA-mediated fibrin clot lysis and is cross-linked to fibrin. *Thromb Haemost* 1999;81:96-103.
2134. Lee J, Cochran B, Lobov S, Ranson M. Forty years later and the role of plasminogen activator inhibitor type 2/SERPIN2 is still an enigma. *Semin Thromb Hemost* 2011;37:395-407.
2135. Dougherty KM, Pearson JM, Yang AY, Westrick RJ, Baker MS, Ginsburg D. The plasminogen activator inhibitor-2 gene is not required for normal murine development or survival. *Proc Natl Acad Sci U S A* 1999;96:686-691.
2136. Webb AC, Collins KL, Snyder SE, et al. Human monocyte Arg-Serpin cDNA. Sequence, chromosomal assignment, and homology to plasminogen activator-inhibitor. *J Exp Med* 1987;166:77-94.
2137. Samia JA, Alexander SJ, Horton KW, et al. Chromosomal organization and localization of the human urokinase inhibitor gene: perfect structural conservation with ovalbumin. *Genomics* 1990;6:159-167.
2138. Schleuning WD, Medcalf RL, Hession C, Rothenbuhler R, Shaw A, Kruihof EK. Plasminogen activator inhibitor 2: regulation of gene transcription during phorbol ester-mediated differentiation of U-937 human histiocytic lymphoma cells. *Mol Cell Biol* 1987;7:4564-4567.
2139. Wun TC, Reich E. An inhibitor of plasminogen activation from human placenta. Purification and characterization. *J Biol Chem* 1987;262:3646-3653.
2140. Ye RD, Wun TC, Sadler JE. cDNA cloning and expression in *Escherichia coli* of a plasminogen activator inhibitor from human placenta. *J Biol Chem* 1987;262:3718-3725.
2141. Ye RD, Ahern SM, Le Beau MM, Lebo RV, Sadler JE. Structure of the gene for human plasminogen activator inhibitor-2. The nearest mammalian homologue of chicken ovalbumin. *J Biol Chem* 1989;264:5495-5502.
2142. Kruihof EK. Plasminogen activator inhibitors—a review. *Enzyme* 1988;40:113-121.
2143. Chapman HA Jr, Stone OL. A fibrinolytic inhibitor of human alveolar macrophages. Induction with endotoxin. *Am Rev Respir Dis* 1985;132:569-575.
2144. Saksela O, Hovi T, Vaheri A. Urokinase-type plasminogen activator and its inhibitor secreted by cultured human monocyte-macrophages. *J Cell Physiol* 1985;122:125-132.
2145. Wohlwend A, Belin D, Vassalli JD. Plasminogen activator-specific inhibitors produced by human monocytes/macrophages. *J Exp Med* 1987;165:320-339.
2146. Bachmann F. The enigma PAI-2. Gene expression, evolutionary and functional aspects. *Thromb Haemost* 1995;74:172-179.
2147. Dear AE, Medcalf RL. The cellular and molecular biology of plasminogen activator inhibitor type-2. *Fibrinolysis* 1995;9:321-330.
2148. Medcalf RL, Kruihof EK, Schleuning WD. Plasminogen activator inhibitor 1 and 2 are tumor necrosis factor/cachectin-responsive genes. *J Exp Med* 1988;168:751-759.
2149. Schwartz BS, Monroe MC, Levin EG. Increased release of plasminogen activator inhibitor type 2 accompanies the human mononuclear cell tissue factor response to lipopolysaccharide. *Blood* 1988;71:734-741.
2150. Suzuki T, Hashimoto S, Toyoda N, et al. Comprehensive gene expression profile of LPS-stimulated human monocytes by SAGE. *Blood* 2000;96:2584-2591.
2151. Maurer F, Tierney M, Medcalf RL. An AU-rich sequence in the 3'-UTR of plasminogen activator inhibitor type 2 (PAI-2) mRNA promotes PAI-2 mRNA decay and provides a binding site for nuclear HuR. *Nucleic Acids Res* 1999;27:1664-1673.

2152. Maurer F, Medcalf RL. Plasminogen activator inhibitor type 2 gene induction by tumor necrosis factor and phorbol ester involves transcriptional and post-transcriptional events. Identification of a functional nonameric AU-rich motif in the 3'-untranslated region. *J Biol Chem* 1996;271:26074-26080.
2153. Tierney MJ, Medcalf RL. Plasminogen activator inhibitor type 2 contains mRNA instability elements within exon 4 of the coding region. Sequence homology to coding region instability determinants in other mRNAs. *J Biol Chem* 2001;276:13675-13684.
2154. Ritchie H, Lawrie LC, Crombie PW, Mosesson MW, Booth NA. Cross-linking of plasminogen activator inhibitor 2 and alpha 2- antiplasmin to fibrin(ogen). *J Biol Chem* 2000;275:24915-24920.
2155. Jensen PJ, Wu Q, Janowitz P, Ando Y, Schechter NM. Plasminogen activator inhibitor type 2: an intracellular keratinocyte differentiation product that is incorporated into the cornified envelope. *Exp Cell Res* 1995;217:65-71.
2156. Harrop SJ, Jankova L, Coles M, et al. The crystal structure of plasminogen activator inhibitor 2 at 2.0 Å resolution: implications for serpin function. *Structure Fold Des* 1999;7:43-54.
2157. Hibino T, Matsuda Y, Takahashi T, Goetinck PF. Suppression of keratinocyte proliferation by plasminogen activator inhibitor-2. *J Invest Dermatol* 1999;112:85-90.
2158. Dickinson JL, Bates EJ, Ferrante A, Antalis TM. Plasminogen activator inhibitor type 2 inhibits tumor necrosis factor alpha-induced apoptosis. Evidence for an alternate biological function. *J Biol Chem* 1995;270:27894-27904.
2159. Dickinson JL, Norris BJ, Jensen PH, Antalis TM. The C-D interhelical domain of the serpin plasminogen activator inhibitor-type 2 is required for protection from TNF-alpha induced apoptosis. *Cell Death Differ* 1998;5:163-171.
2160. Shafren DR, Gardner J, Mann VH, Antalis TM, Suhrbier A. Picornavirus receptor down-regulation by plasminogen activator inhibitor type 2. *J Virol* 1999;73:7193-7198.
2161. Yu H, Maurer F, Medcalf RL. Plasminogen activator inhibitor type 2: a regulator of monocyte proliferation and differentiation. *Blood* 2002;99:2810-2818.
2162. Collen D. Identification and some properties of a new fast-reacting plasmin inhibitor in human plasma. *Eur J Biochem* 1976;69:209-216.
2163. Mullertz S, Clemmensen I. The primary inhibitor of plasmin in human plasma. *Biochem J* 1976;159:545-553.
2164. Moroi M, Aoki N. Isolation and characterization of alpha2-plasmin inhibitor from human plasma. A novel proteinase inhibitor which inhibits activator-induced clot lysis. *J Biol Chem* 1976;251:5956-5965.
2165. Collen D, De C, Verstraete M. Immunochemical distinction between antiplasmin and alpha-antitrypsin. *Thromb Res* 1975;7:245-249.
2166. Schaller J, Gerber S. The plasmin-antiplasmin system: structural and functional aspects. *Cell Mol Life Sci* 2011;68:785-801.
2167. Favier R, Aoki N, de Moerloose P. Congenital alpha(2)-plasmin inhibitor deficiencies: a review. *Br J Haematol* 2001;114:4-10.
2168. Aoki N, Sumi Y, Miura O, Hirosawa S. Human alpha 2-plasmin inhibitor. *Methods Enzymol* 1993;223:185-197.
2169. Menoud PA, Sappino N, Boudal-Khoshbeen M, Vassalli JD, Sappino AP. The kidney is a major site of alpha(2)-antiplasmin production. *J Clin Invest* 1996;97:2478-2484.
2170. Collen D, Wiman B. Turnover of antiplasmin, the fast-acting plasmin inhibitor of plasma. *Blood* 1979;53:313-324.
2171. Mast AE, Enghild JJ, Pizzo SV, Salvesen G. Analysis of the plasma elimination kinetics and conformational stabilities of native, proteinase-complexed, and reactive site cleaved serpins: comparison of alpha 1-proteinase inhibitor, alpha 1-antichymotrypsin, antithrombin III, alpha 2-antiplasmin, angiotensinogen, and ovalbumin. *Biochemistry* 1991;30:1723-1730.
2172. Bangert K, Johnsen AH, Christensen U, Thorsen S. Different N-terminal forms of alpha 2-plasmin inhibitor in human plasma. *Biochem J* 1993;291 (Pt 2):623-625.
2173. Koyama T, Koike Y, Toyota S, Miyagi F, Suzuki N, Aoki N. Different NH2-terminal form with 12 additional residues of alpha 2- plasmin inhibitor from human plasma and culture media of Hep G2 cells. *Biochem Biophys Res Commun* 1994;200:417-422.

2174. Wiman B, Collen D. Purification and characterization of human antiplasmin, the fast-acting plasmin inhibitor in plasma. *Eur J Biochem* 1977;78:19-26.
2175. Hortin GL, Gibson BL, Fok KF. Alpha 2-antiplasmin's carboxy-terminal lysine residue is a major site of interaction with plasmin. *Biochem Biophys Res Commun* 1988;155:591-596.
2176. Wiman B, Almquist A, Ranby M. The non-covalent interaction between plasmin and alpha 2-antiplasmin. *Fibrinolysis* 1989;3:231-235.
2177. Sugiyama N, Sasaki T, Iwamoto M, Abiko Y. Binding site of alpha 2-plasmin inhibitor to plasminogen. *Biochim Biophys Acta* 1988;952:1-7.
2178. Wiman B, Nilsson T, Cedergren B. Studies on a form of alpha 2-antiplasmin in plasma which does not interact with the lysine-binding sites in plasminogen. *Thromb Res* 1982;28:193-199.
2179. Christensen U, Clemmensen I. Purification and reaction mechanisms of the primary inhibitor of plasmin from human plasma. *Biochem J* 1978;175:635-641.
2180. Clemmensen I, Thorsen S, Mullertz S, Petersen LC. Properties of three different molecular forms of the alpha 2 plasmin inhibitor. *Eur J Biochem* 1981;120:105-112.
2181. Hortin GL, Trimpe BL, Fok KF. Plasmin's peptide-binding specificity: characterization of ligand sites in alpha 2-antiplasmin. *Thromb Res* 1989;54:621-632.
2182. Wiman B, Collen D. On the kinetics of the reaction between human antiplasmin and plasmin. *Eur J Biochem* 1978;84:573-578.
2183. Kato A, Hirosawa S, Toyota S, et al. Localization of the human alpha 2-plasmin inhibitor gene (PLI) to 17p13. *Cytogenet Cell Genet* 1993;62:190-191.
2184. Hirosawa S, Nakamura Y, Miura O, Sumi Y, Aoki N. Organization of the human alpha 2-plasmin inhibitor gene. *Proc Natl Acad Sci U S A* 1988;85:6836-6840.
2185. Christiansen V, Jackson K, Lee K, McKee P. The effect of a single nucleotide polymorphism on human alpha 2-antiplasmin activity. *Blood* 2007;109: 5286-5292.
2186. Lee K, Jackson K, Christiansen V, Lee C, Chun J, McKee P. Why alpha2antiplasmin must be converted to a derivative form for optimal function. *J Thromb Haemost* 2007;5:2095-2104.
2187. Kordich L, Feldman L, Porterie P, Lago O. Severe hemorrhagic tendency in heterozygous alpha 2-antiplasmin deficiency. *Thromb Res* 1985;40:645-651.
2188. Griffin GC, Mammen EF, Sokol RJ, Perrotta AL, Stoyanovich A, Abildgaard CF. Alpha 2-antiplasmin deficiency. An overlooked cause of hemorrhage. *Am J Pediatr Hematol Oncol* 1993;15:328-330.
2189. Holmes WE, Lijnen HR, Nelles L, et al. Alpha 2-antiplasmin Enschede: alanine insertion and abolition of plasmin inhibitory activity. *Science* 1987;238:209-211.
2190. Miura O, Sugahara Y, Aoki N. Hereditary alpha 2-plasmin inhibitor deficiency caused by a transport-deficient mutation (alpha 2-PI-Okinawa). Deletion of Glu137 by a trinucleotide deletion blocks intracellular transport. *J Biol Chem* 1989;264:18213-18219.
2191. Miura O, Hirosawa S, Kato A, Aoki N. Molecular basis for congenital deficiency of alpha 2-plasmin inhibitor. A frameshift mutation leading to elongation of the deduced amino acid sequence. *J Clin Invest* 1989;83:1598-1604.
2192. Yoshinaga H, Nakahara M, Koyama T, et al. A single thymine nucleotide deletion responsible for congenital deficiency of plasmin inhibitor. *Thromb Haemost* 2002;88:144-148.
2193. Yoshinaga H, Hirosawa S, Chung DH, Miyasaka N, Aoki N, Favier R. A novel point mutation of the splicing donor site in the intron 2 of the plasmin inhibitor gene. *Thromb Haemost* 2000;84:307-311.
2194. Lijnen HR. Gene targeting in hemostasis. Alpha2-antiplasmin. *Front Biosci* 2001;6:D239-D247.
2195. Christensen U, Bangert K, Thorsen S. Reaction of human alpha2-antiplasmin and plasmin stopped-flow fluorescence kinetics. *FEBS Lett* 1996;387:58-62.
2196. Lee K, Jackson K, Christiansen V, Chung K, McKee P. A novel plasma proteinase potentiates alpha2-antiplasmin inhibition of fibrin digestion. *Blood* 2004;103:3783-3788.

2197. Frank P, Douglas J, Locher M, Llinás M, Schaller J. Structural/functional characterization of the alpha 2-plasmin inhibitor C-terminal peptide. *Biochemistry* 2003;42:1078-1085.
2198. Gerber S, Lejon S, Locher M, Schaller J. The human alpha(2)-plasmin inhibitor: functional characterization of the unique plasmin(ogen)-binding region. *Cell Mol Life Sci* 2010;67:1505-1518.
2199. Lu B, Sofian T, Law R, Coughlin P, Horvath A. Contribution of conserved lysine residues in the alpha2-antiplasmin C terminus to plasmin binding and inhibition. *J Biol Chem* 2011;286:24544-24552.
2200. Mimuro J, Koike Y, Sumi Y, Aoki N. Monoclonal antibodies to discrete regions in alpha 2-plasmin inhibitor. *Blood* 1987;69:446-453.
2201. Reed GL, Matsueda GR, Haber E. Platelet factor XIII increases the fibrinolytic resistance of platelet- rich clots by accelerating the crosslinking of alpha 2-antiplasmin to fibrin [see comments]. *Thromb Haemost* 1992;68:315-320.
2202. Sumi Y, Ichikawa Y, Nakamura Y, Miura O, Aoki N. Expression and characterization of pro alpha 2-plasmin inhibitor. *J Biochem(Tokyo)* 1989;106:703-707.
2203. Wiman B, Collen D. On the role of alpha2-antiplasmin in the regulation of fibrinolysis. In: Collen D, Wiman B, Verstraete M, eds. *The physiological inhibitors of coagulation and fibrinolysis*. North Holland: Elsevier, 1979:177-185.
2204. Fraser S, Booth N, Mutch N. The antifibrinolytic function of factor XIII is exclusively expressed through α 2-antiplasmin cross-linking. *Blood* 2011;117:6371-6374.
2205. Sprengers ED, Kluft C. Plasminogen activator inhibitors. *Blood* 1987;69:381-387.
2206. Reilly CF, Hutzelmann JE. Plasminogen activator inhibitor-1 binds to fibrin and inhibits tissue- type plasminogen activator-mediated fibrin dissolution. *J Biol Chem* 1992;267:17128-17135.
2207. Plow EF, Miles LA, Collen D. Platelet alpha 2-antiplasmin. *Methods Enzymol* 1989;169:296-300.
2208. Plow EF, Collen D. The presence and release of alpha 2-antiplasmin from human platelets. *Blood* 1981;58:1069-1074.
2209. Gogstad GO, Stormorken H, Solum NO. Platelet alpha 2-antiplasmin is located in the platelet alpha-granules. *Thromb Res* 1983;31:387-390.
2210. Erickson LA, Hekman CM, Loskutoff DJ. The primary plasminogen-activator inhibitors in endothelial cells, platelets, serum, and plasma are immunologically related. *Proc Natl Acad Sci U S A* 1985;82:8710-8714.
2211. Kruithof EK, Tran-Thang C, Bachmann F. Studies on the release of a plasminogen activator inhibitor by human platelets. *Thromb Haemost* 1986;55:201-205.
2212. Philips M, Juul AG, Thorsen S. Human endothelial cells produce a plasminogen activator inhibitor and a tissue-type plasminogen activator-inhibitor complex. *Biochim Biophys Acta* 1984;802:99-110.
2213. Stern D, Nawroth P, Handley D, Kiesel W. An endothelial cell-dependent pathway of coagulation. *Proc Natl Acad Sci U S A* 1985;82:2523-2527.
2214. Levin EG, Santell L, Osborn KG. The expression of endothelial tissue plasminogen activator in vivo: a function defined by vessel size and anatomic location. *J Cell Sci* 1997;110 (Pt 2):139-148.
2215. Grant PJ, Medcalf RL. Hormonal regulation of haemostasis and the molecular biology of the fibrinolytic system. *Clin Sci(Colch)* 1990;78:3-11.
2216. Hajjar KA, Hamel NM, Harpel PC, Nachman RL. Binding of tissue plasminogen activator to cultured human endothelial cells. *J Clin Invest* 1987;80:1712-1719.
2217. Bachmann F, Kruithof IE. Tissue plasminogen activator: chemical and physiological aspects. *Semin Thromb Hemost* 1984;10:6-17.
2218. Blasi F, Vassalli JD, Dano K. Urokinase-type plasminogen activator: proenzyme, receptor, and inhibitors. *J Cell Biol* 1987;104:801-804.
2219. Dano K, Andreasen PA, Grondahl-Hansen J, Kristensen P, Nielsen LS, Skriver L. Plasminogen activators, tissue degradation, and cancer. *Adv Cancer Res* 1985;44:139-266.
2220. Blasi F. Surface receptors for urokinase plasminogen activation. *Fibrinolysis* 1988;2:73.

2221. Kwon M, MacLeod T, Zhang Y, Waisman D. S100A10, annexin A2, and annexin a2 heterotetramer as candidate plasminogen receptors. *Front Biosci* 2005;10:300-325.
2222. Das R, Pluskota E, Plow E. Plasminogen and its receptors as regulators of cardiovascular inflammatory responses. *Trends Cardiovasc Med* 2010;20:120-124.
2223. Miles LA, Levin EG, Plescia J, Collen D, Plow EF. Plasminogen receptors, urokinase receptors, and their modulation on human endothelial cells. *Blood* 1988;72:628-635.
2224. Miles LA, Plow EF. Receptor mediated binding of the fibrinolytic components, plasminogen and urokinase, to peripheral blood cells. *Thromb Haemost* 1987;58:936-942.
2225. Cubellis MV, Nolli ML, Cassani G, Blasi F. Binding of single-chain prourokinase to the urokinase receptor of human U937 cells. *J Biol Chem* 1986;261:15819-15822.
2226. Vassalli JD, Baccino D, Belin D. A cellular binding site for the Mr 55,000 form of the human plasminogen activator, urokinase. *J Cell Biol* 1985;100:86-92.
2227. Ploug M, Plesner T, Ronne E, et al. The receptor for urokinase-type plasminogen activator is deficient on peripheral blood leukocytes in patients with paroxysmal nocturnal hemoglobinuria. *Blood* 1992;79:1447-1455.
2228. Romer J, Lund LR, Eriksen J, Pyke C, Kristensen P, Dano K. The receptor for urokinase-type plasminogen activator is expressed by keratinocytes at the leading edge during re-epithelialization of mouse skin wounds. *J Invest Dermatol* 1994;102:519-522.
2229. Pyke C, Kristensen P, Ralfkiaer E, Grondahl-Hansen J, Eriksen J, Blasi F, Dano K. Urokinase-type plasminogen activator is expressed in stromal cells and its receptor in cancer cells at invasive foci in human colon adenocarcinomas. *Am J Pathol* 1991;138:1059-1067.
2230. Del Rosso M, Margheri F, Serrati S, Chillà A, Laurenzana A, Fibbi G. The urokinase receptor system, a key regulator at the intersection between inflammation, immunity, and coagulation. *Curr Pharm Des* 2011;17:1924-1943.
2231. Mazar A, Ahn R, TV OH. Development of novel therapeutics targeting the urokinase plasminogen activator receptor (uPAR) and their translation toward the clinic. *Curr Pharm Des* 2011;17:1970-1978.
2232. Fuhrman B. The urokinase system in the pathogenesis of atherosclerosis. *Atherosclerosis* 2012;222:8-14.
2233. Ellis V, Dano K. Potentiation of plasminogen activation by an anti-urokinase monoclonal antibody due to ternary complex formation. A mechanistic model for receptor-mediated plasminogen activation. *J Biol Chem* 1993;268:4806-4813.
2234. Ellis V, Ploug M, Plesner T, Dano K. Gene expression and function of the cellular receptor for uPA (uPAR). In: Glas-Greenwalt P, ed. *Fibrinolysis in disease*. Boca Raton, FL: CRC Prss, 1995:30-42.
2235. Roldan AL, Cubellis MV, Masucci MT, et al. Cloning and expression of the receptor for human urokinase plasminogen activator, a central molecule in cell surface, plasmin dependent proteolysis [published erratum appears in *EMBO J* 1990 May;9(5):1674]. *EMBO J* 1990;9:467-474.
2236. Ploug M, Ronne E, Behrendt N, Jensen AL, Blasi F, Dano K. Cellular receptor for urokinase plasminogen activator. Carboxyl-terminal processing and membrane anchoring by glycosyl-phosphatidylinositol. *J Biol Chem* 1991;266:1926-1933.
2237. Moller LB, Ploug M, Blasi F. Structural requirements for glycosyl-phosphatidylinositol-anchor attachment in the cellular receptor for urokinase plasminogen activator. *Eur J Biochem* 1992;208:493-500.
2238. Eden G, Archinti M, Furlan F, Murphy R, Degryse B. The urokinase receptor interactome. *Curr Pharm Des* 2011;17:1874-1889.
2239. Ploug M, Eriksen J, Plesner T, Hansen NE, Dano K. A soluble form of the glycolipid-anchored receptor for urokinase-type plasminogen activator is secreted from peripheral blood leukocytes from patients with paroxysmal nocturnal hemoglobinuria. *Eur J Biochem* 1992;208:397-404.
2240. Xu X, Gårdsvoll H, Yuan C, Lin L, Ploug M, Huang M. Crystal structure of the urokinase receptor in a ligand-free form. *J Mol Biol* 2012;416:629-641.
2241. Barinka C, Parry G, Callahan J, et al. Structural basis of interaction between urokinase-type plasminogen activator and its receptor. *J Mol Biol* 2006;363:482-495.
2242. Hajjar KA. Cellular receptors in the regulation of plasmin generation. *Thromb Haemost* 1995;74:294-301.

2243. Dudani AK, Ganz PR. Endothelial cell surface actin serves as a binding site for plasminogen, tissue plasminogen activator and lipoprotein(a). *Br J Haematol* 1996;95:168-178.
2244. Flood E, Hajjar K. The annexin A2 system and vascular homeostasis. *Vascul Pharmacol* 2011;54:59-67.
2245. Bohm T, Geiger M, Binder BR. Isolation and characterization of tissue-type plasminogen activator-binding proteoglycans from human umbilical vein endothelial cells. *Arterioscler Thromb Vasc Biol* 1996;16:665-672.
2246. Kralovich KR, Li L, Hembrough TA, Webb DJ, Karns LR, Gonias SL. Characterization of the binding sites for plasminogen and tissue-type plasminogen activator in cytokeratin 8 and cytokeratin 18. *J Protein Chem* 1998;17:845-854.
2247. Hembrough TA, Kralovich KR, Li L, Gonias SL. Cytokeratin 8 released by breast carcinoma cells in vitro binds plasminogen and tissue-type plasminogen activator and promotes plasminogen activation. *Biochem J* 1996;317 (Pt 3):763-769.
2248. Beebe DP, Wood LL, Moos M. Characterization of tissue plasminogen activator binding proteins isolated from endothelial cells and other cell types. *Thromb Res* 1990;59:339-350.
2249. Menell JS, Cesarman GM, Jacovina AT, McLaughlin MA, Lev EA, Hajjar KA. Annexin II and bleeding in acute promyelocytic leukemia. *N Engl J Med* 1999;340:994-1004.
2250. Taylor ME, Conary JT, Lennartz MR, Stahl PD, Drickamer K. Primary structure of the mannose receptor contains multiple motifs resembling carbohydrate-recognition domains. *J Biol Chem* 1990;265:12156-12162.
2251. Otter M, Barrett-Bergshoeff MM, Rijken DC. Binding of tissue-type plasminogen activator by the mannose receptor. *J Biol Chem* 1991;266:13931-13935.
2252. Noorman F, Barrett-Bergshoeff MM, Rijken DC. Role of carbohydrate and protein in the binding of tissue-type plasminogen activator to the human mannose receptor. *Eur J Biochem* 1998;251:107-113.
2253. Andreasen PA, Sottrup-Jensen L, Kjoller L, et al. Receptor-mediated endocytosis of plasminogen activators and activator/inhibitor complexes. *FEBS Lett* 1994;338:239-245.
2254. Moestrup SK. The alpha 2-macroglobulin receptor and epithelial glycoprotein-330: two giant receptors mediating endocytosis of multiple ligands. *Biochim Biophys Acta* 1994;1197:197-213.
2255. Kasza A, Petersen HH, Heegaard CW, et al. Specificity of serine proteinase/serpin complex binding to very-low-density lipoprotein receptor and alpha2-macroglobulin receptor/low-density-lipoprotein-receptor-related protein. *Eur J Biochem* 1997;248:270-281.
2256. Miles LA, Plow EF. Binding and activation of plasminogen on the platelet surface. *J Biol Chem* 1985;260:4303-4311.
2257. Miles LA, Ginsberg MH, White JG, Plow EF. Plasminogen interacts with human platelets through two distinct mechanisms. *J Clin Invest* 1986;77: 2001-2009.
2258. Adelman B, Rizk A, Hanners E. Plasminogen interactions with platelets in plasma. *Blood* 1988;72:1530-1535.
2259. Redlitz A, Fowler BJ, Plow EF, Miles LA. The role of an enolase-related molecule in plasminogen binding to cells. *Eur J Biochem* 1995;227:407-415.
2260. Schafer AI, Adelman B. Plasmin inhibition of platelet function and of arachidonic acid metabolism. *J Clin Invest* 1985;75:456-461.
2261. Schafer AI, Zavoico GB, Loscalzo J, Maas AK. Synergistic inhibition of platelet activation by plasmin and prostaglandin I₂. *Blood* 1987;69:1504-1507.
2262. Niewiarowski S, Senyi AF, Gillies P. Plasmin-induced platelet aggregation and platelet release reaction. Effects on hemostasis. *J Clin Invest* 1973;52:1647-1659.
2263. Miller JL, Katz AJ, Feinstein MB. Plasmin inhibition of thrombin-induced platelet aggregation. *Thromb Diath Haemorrh* 1975;33:286-309.
2264. Guccione MA, Kinlough-Rathbone RL, Packham MA, Harfenist EJ, Rand ML, Greenberg JP, Perry DW, Mustard JF. Effects of plasmin on rabbit platelets. *Thromb Haemost* 1985;53:8-14.

Chapter 19 Endothelium: Angiogenesis and the Regulation of Hemostasis

> Table of Contents > Part II - The Normal Hematologic System > Section 5 - Hemostasis > Chapter 19 - Endothelium: Angiogenesis and the Regulation of Hemostasis

Chapter 19

Endothelium: Angiogenesis and the Regulation of Hemostasis

Paul J. Shami

George M. Rodgers

NORMAL ANGIOGENESIS

Blood circulation requires the production and maintenance of a vast network of vessels that have specialized functions depending on their organ location. The vascular network involves a complex interaction between endothelial cells (ECs), specialized cells such as smooth muscle cells and pericytes, and the extracellular matrix. Vasculogenesis is the de novo development of vessels.¹ It is seen mainly at the embryonic stage of development with the differentiation of a common pluripotent precursor, the hemangioblast, into endothelial and hematopoietic cells. Angiogenesis is the development of new vessels from pre-existing vessels.¹ It is an essential process for wound healing and the maintenance of the integrity of the vascular network. Pathologic angiogenesis is seen in disease states including cancer, retinal, and autoimmune diseases.²

As outlined by Conway, Collen, and Carmeliet,¹ physiologic angiogenesis is a well-organized stepwise process that involves dilation and increased permeability of the parent vessel, dissolution of the extracellular matrix, division and migration of EC, cord formation, and the development of lumina, and, finally, the maintenance of new vessel integrity. The entire process involves the complex and choreographed effects of multiple inducers and inhibitors (Table 19.1).

The first step in angiogenesis is vasodilation. This is mediated through the activation of the soluble guanylate cyclase by nitric oxide (NO).³ NO also up-regulates vascular endothelial growth factor (VEGF) production.⁴ By causing intercellular adhesion molecules to redistribute (platelet-EC adhesion molecule-1 and VE-cadherin, among others), VEGF induces an increase in vascular permeability.^{5,6} The VEGF-induced increase in vascular permeability is negatively controlled by angiopoietin-1 (Ang1) through its receptor, Tie2.⁷ The next key step to vascular development is the dissolution of the extracellular matrix, which is accomplished by proteases belonging to the matrix metalloproteinase family.^{8,9} These proteases also induce the liberation of EC growth factors from the extracellular matrix, including VEGF and basic fibroblast growth factor. The action of matrix metalloproteinases is negatively controlled by a family of protease inhibitors, including the tissue inhibitors of metalloproteinases.¹⁰

Degradation of the extravascular matrix allows the development of the key element of the angiogenesis process, namely, EC division and migration. The list of factors that stimulate this process is extensive (Table 19.1), but a key role is played by VEGF in concert with Ang1.^{6,11,12,13,14,15} and¹⁶ Angiopoietin-2 (Ang2) could have angiogenic effects in the presence of VEGF, whereas it is antiangiogenic in the absence of VEGF.^{14,15,16} and¹⁷ The role played by the endothelial NO synthase and NO has been the subject of controversy, with reports showing that NO has both pro- and antiangiogenic effects.^{18,19,20,21} Other factors that stimulate angiogenesis include basic fibroblast growth factor and platelet-derived growth factor.^{22,23,24} EC growth is negatively controlled by endogenous angiogenesis inhibitors that include angiostatin, endostatin, interferons, and antithrombin.^{25,26,28} ECs then migrate in large part through the action of integrins ($\alpha_v\beta_3$ and $\alpha_v\beta_1$).²⁹ The end result of EC division and migration is sprouting and the formation of cords.¹ This is followed by lumen formation, which is controlled by different VEGF isoforms, Ang1, and integrins.^{1,15} Thrombospondin-1 acts as an endogenous inhibitor of lumen development.¹

Once formed, new vessels survive for years.¹ This prolonged survival is maintained by the interaction of VEGF with its receptor VEGFR-2, phosphoinositide 3-kinase, β -catenin, and VE-cadherin.^{1,30} The angiopoietins also play a role in maintaining vessel survival through their receptors Tie1 and Tie2. Ang1 stabilizes the vessel, whereas Ang2 has an opposite effect^{14,15,31} (see later). An essential element in the maintenance of the integrity of vessels is their "coating" with smooth muscle cells and pericytes.³² Evidence suggests that vascular smooth muscle cells and ECs have a common precursor.³³ On stimulation with platelet-derived growth factor-BB, these precursor cells differentiate into smooth muscle cells, whereas VEGF stimulation drives them to differentiate into EC.³³ Besides providing physical support for endothelial vessels, smooth muscle cells and pericytes are a source of factors that are important for the maintenance and control of

vascular integrity and function.^{1,32} The extracellular matrix plays a key role in that respect by being a dynamic storage site for growth factors and proenzymes that are important in vessel function and angiogenesis.¹

Vascular Endothelial Growth Factor and Its Receptors

VEGF is the pivotal factor controlling angiogenesis. As such, it is the best-studied angiogenic factor. Several proteins belong to the VEGF family and include VEGF (also known as VEGF-A), VEGF-B, VEGF-C, VEGF-D, and placental growth factor.¹⁴ Although VEGF-A is the main angiogenic factor discussed here, VEGF-B seems to play an important role in coronary vascular development.³⁴ VEGF-C is essential for lymphangiogenesis by interacting with the VEGFR-3 receptor.³⁵ The function of VEGF-D has yet to be determined.¹⁴

Being the major regulator of angiogenesis, VEGF is a mitogen and survival factor for EC.^{11,14} As mentioned earlier, it is also a potent inducer of vascular permeability, an essential step in the angiogenic process.^{1,11,14} It has two well-characterized receptors, VEGFR-1 and VEGFR-2 (also known as Flt-1 and Flk-1/kinase domain receptor, respectively).¹⁴ They are both tyrosine kinases. VEGFR-2 is the main effector of a VEGF-induced chemotactic and mitogenic response in EC. VEGFR-2 also mediates the ECs' permeability effects.¹⁴ The role of VEGFR-1 in EC response to VEGF has not been totally elucidated. However, it seems to negatively control the VEGF effects by acting as a decoy.^{14,36,37} Indeed, mice that have been engineered not to express VEGFR-1 have evidence of excess and disorganized angiogenesis.³⁶ In addition to its role in angiogenesis, VEGF has been shown to be trophic for nerve cells, lung epithelial cells, and cardiac muscle fibers.³⁸

Angiopoietins and Their Receptors

Angiopoietins and Tie receptors play an important role in angiogenesis. To date, four angiopoietins have been identified.¹⁴ However, only Ang1 and Ang2 have been fully characterized. They interact with the Tie tyrosine kinase receptors, mainly Tie2. Ang1 plays an important role in stabilizing the vasculature.¹⁴ Supportive cells express Ang1 and interact with EC through the Tie2 receptor. Genetically engineered mouse embryos that lack Ang1 develop a normal primary vasculature. However, they do not undergo further vascular remodeling.¹⁶ Transgenic mice that

P.499

overexpress Ang1 have evidence of vascularization characterized by larger vessels rather than a greater number of vessels.¹⁵ Additionally, those vessels are resistant to leak, further supporting the role of Ang1 as a stabilizing factor.

TABLE 19.1 ACTIVATORS AND INHIBITORS OF ANGIOGENESIS

Activators	Function	Inhibitors	Function
VEGF, VEGF-C, PIGF, and homologs	Stimulate angiogenesis, permeability; stimulate lymphangiogenesis, pathologic angiogenesis	VEGFR-1, soluble VEGFR-1, and NP-1	Sink for VEGF, VEGF-B, PIGF (VEGFR-1), and VEGFR ₁₆₅ (NP-1)
VEGFR	VEGFR-2: angiogenic signaling; VEGFR-3: (lymph) angiogenic signaling	Ang2	Ang1 antagonist; induces vessel regression in absence of angiogenic signals
Ang1 and Tie2 receptor	Ang1: stabilizes vessels, inhibits permeability	TSP-1	ECM proteins; inhibits EC migration, growth, and adhesion
	Ang2: destabilizes vessels before sprouting	TSP-2	Inhibits angiogenesis
Platelet-derived growth factor-BB and receptors	Recruit smooth muscle cells	Meth-1, Meth-2	Contains metalloprotease, thrombospondin, and disintegrin domains
TGF-β ₁ , endoglin,	Stabilize vessels by stimulating Angiostatin and related		Inhibits EC survival

TGF- β receptors	ECM production	plasminogen kringle	and migration
Fibroblast growth factor, hepatocyte growth factor, monocyte chemotactic protein-1	Stimulate angiogenesis, stimulate arteriogenesis	Endostatin	Inhibits EC survival and migration
Integrins $\alpha_V\beta_3$, $\alpha_V\beta_5$	MMP receptors	Vasostatin, calreticulin	Inhibits EC growth
VE-cadherin, platelet-EC adhesion molecule	EC junctional molecules, promote EC survival	Platelet factor-4	Heparin-binding molecule; inhibits binding of bFGF and VEGF
Ephrins	Regulate arterial/venous specifications	Tissue inhibitors of metalloproteinases, MMP inhibitors	Suppresses pathologic angiogenesis
		Proteolytic fragment of MMP	Inhibits binding of MMP2 to $\alpha_V\beta_3$
Plasminogen activators, MMPs	Cell migration and matrix remodeling; liberate bFGF/VEFG from ECM; activate TGF- β_1 ; generate angiostatin		
Plasminogen-activator inhibitor-1	Stabilizes nascent vessels (prevents ECM dissolution)	IFN- α , - β , - γ ; IL-4, -12, -18	Inhibits EC migration, IFN- α down-regulates bFGF
Nitric oxide synthase, cyclo-oxygenase-2	Nitric oxide/prostaglandins stimulate angiogenesis and vasodilation	Prothrombin kringle 2 antithrombin fragment	Suppresses EC growth
AC133	Angioblast differentiation	Prolactin fragment; secreted protein (acidic and rich in cysteine) fragment	Inhibits bFGF and VEGF; inhibits EC binding and activity of VEGF

Ang, angiopoietin; bFGF, b-fibroblast growth factor; EC, endothelial cells; ECM, extracellular matrix; IFN, interferon; IL, interleukin; Meth, metalloproteinase and thrombospondin; MMP, matrix metalloproteinase; NP, neuropilin; PlGF, placental growth factor; TGF, transforming growth factor; TSP, thrombospondin; VEGF, vascular endothelial growth factor; VEGFR, vascular endothelial growth factor receptor.

Adapted from Conway EM, Collen D, Carmeliet P. Molecular mechanisms of blood vessel growth. *Cardiovasc Res* 2001;49:507-521.

The function of Ang2 has been more difficult to characterize.^{14,17} It too binds with high affinity to the Tie2 receptor. Transgenic overexpression of Ang2 in mice is embryonically lethal and induces a phenotype that is similar to Ang1 or Tie2 knockout experiments. Thus, it has been suggested that Ang2, by acting as an antagonist of Tie2, negates the stabilizing effects of Ang1 on the vasculature. As such, Ang2 may be a destabilizing factor that helps initiate angiogenesis and vascular remodeling.¹⁴

NOTCH Signaling

Carmeliet and Jain have proposed a model for vessel development whereby in the angiogenesis process, ECs can be divided into two categories, namely tip cells and stalk cells.³⁹ Tip cells migrate and lead vessel development whereas stalk cells divide. The process is controlled by the NOTCH signaling pathway. VEGF activation of VEGFR-2 leads to up-regulation of DLL4 in tip cells. DLL4 then activates NOTCH in stalk cells. NOTCH down-regulates VEGFR-2 and up-regulates VEGFR-1 in stalk cells, making them less sensitive to VEGF-stimulated sprouting. The end result is to maintain the lead of tip cells in vessel development.⁴⁰ However, NOTCH stimulates stalk cell proliferation in vivo through activation of WNT signaling.⁴¹ NOTCH up-regulates its own inhibitor Nrarp in stalk cells.⁴² It has been observed that the tip cell position is dynamic with stalk cells moving into the tip position depending on modulation of VEGFR-1 and VEGFR-2 expression.^{39,42}

Origin of Endothelium

Asahara et al. have shown that human buffy coat cells can differentiate into cells expressing endothelial markers, including VEGFR-1, VEGFR-2, and CD31.⁴³ This raises the possibility that circulating endothelial stem cells can be recruited to sites of angiogenesis. This may be particularly relevant for tumor angiogenesis,

P.500

whereby tumors can develop their vasculature both from recruitment of local endothelium and circulating endothelial stem cells.⁴⁴ Factors involved in the recruitment of endothelial stem cells may include stromal cell-derived factor-1, thrombopoietin, and soluble kit ligand.⁴⁴

Angiogenesis in Normal and Malignant Hematopoiesis

There is mounting evidence suggesting the presence of a common precursor for ECs and hematopoietic cells.⁴⁵ This hemangioblast gives rise to both ECs and hematopoietic cells in embryonic development. Embryonic stem cells express VEGFR-2 and can give rise, depending on culture conditions, to hematopoietic progenitor cells and angioblasts.⁴⁵ Stimulation of hematopoietic stem cells with growth factors, including kit ligand, interleukin-3, granulocytemacrophage colony-stimulating factor, and granulocyte colony-stimulating factor, induces the release by those cells of VEGF, which then induces the release of hematopoietic growth factors by bone marrow ECs.⁴⁵ Thus, there is a dynamic interaction between hematopoietic and endothelial elements in the bone marrow. This interaction seems to modulate, at least in part, hematopoiesis.

Several studies have shown evidence of increased angiogenesis in hematopoietic malignancies.⁴⁶ Such evidence has been demonstrated in multiple myeloma and lymphomas, as well as in acute and chronic leukemias.^{46,47,48,49,50,51,52} and ^{53,55,56} Malignant hematopoietic cells have been shown to produce angiogenic factors, including VEGF.⁴⁶ Expression of angiogenic factors has been suggested to have prognostic significance in hematopoietic malignancies, although results have been variable.⁴⁶ Similar to the effect observed in normal hematopoiesis, VEGF stimulates the production of hematopoietic growth factors by ECs.⁴⁶ Consequently, malignant cells exploit their environment to their advantage by developing a synergistic relationship with ECs (Fig. 19.1). This has led to the active investigation of antiangiogenic agents as a novel therapeutic strategy for hematologic malignancies.

In addition to the effects of vascular endothelium in modulating and responding to angiogenic stimuli, vascular endothelium also influences other functions,^{56,57} including vasoconstriction, selective permeability, hemostasis, antigen presentation, and the inflammatory response. The EC surface is a dynamic interface between soluble and cellular constituents of the blood and the remainder of the body.⁵⁸ A brief discussion of ECs structure and regulation of hemostasis follows.

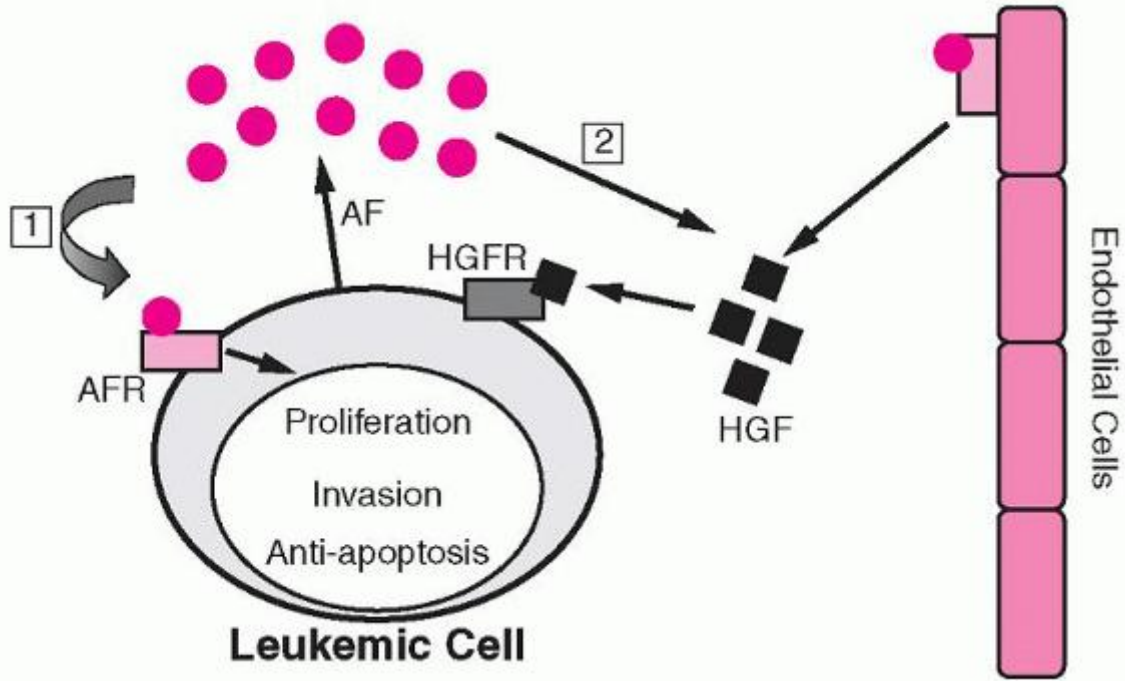

FIGURE 19.2. Relationship of vascular surface area to volume in the vascular system. Diameters are plotted from published data. (From Rushmer RF. Properties of the vascular system. In: Cardiovascular dynamics. Philadelphia, PA: WB Saunders, 1976. Modified from reference 59, with permission.)

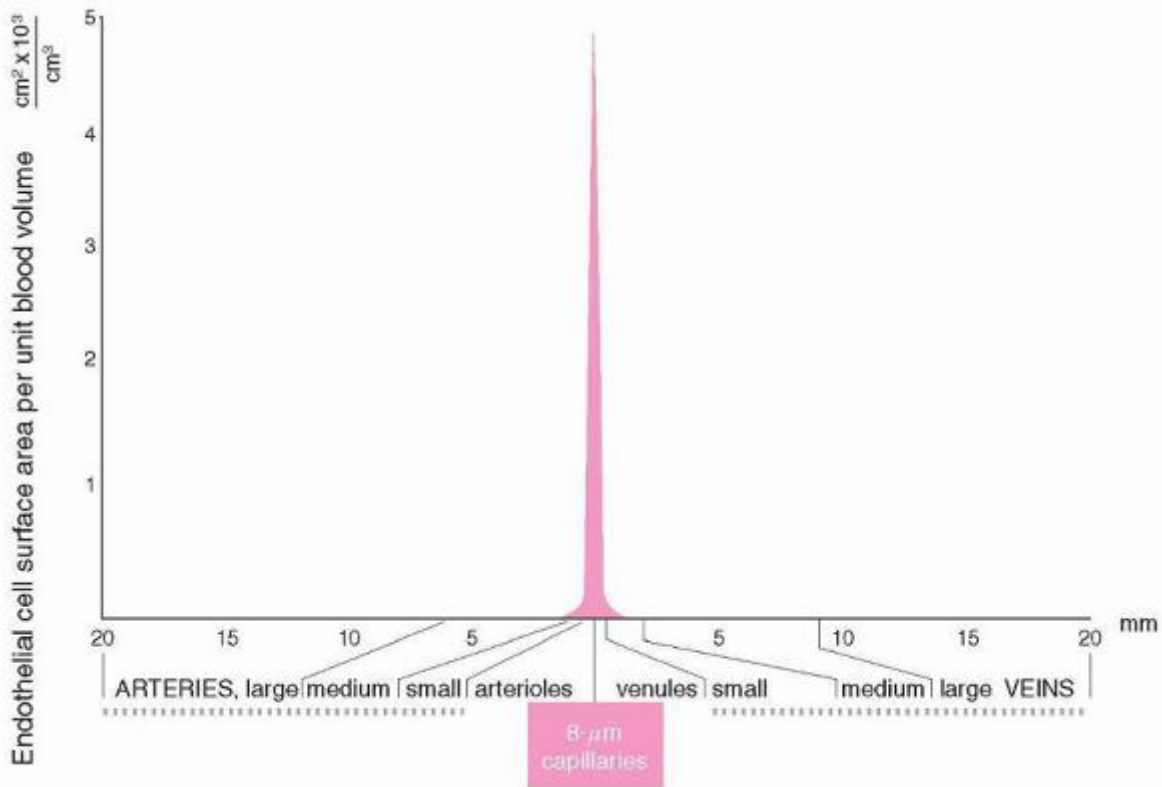

FIGURE 19.1. Hypothesis for the role of angiogenesis in leukemia. (1) Angiogenic factors (AFs) produced by leukemic cells can stimulate cell growth and invasion, or inhibit apoptosis (autocrine mechanism). (2) AFs produced by leukemic cells can also stimulate endothelial cell proliferation and the production of endothelial cell hematopoietic growth factors (HGFs)

(paracrine mechanism). AFR, angiogenic factor receptor; HGFR, hematopoietic growth factor receptor. (From Dickson DJ, Shami PJ. Angiogenesis in acute and chronic leukemias. *Leuk Lymphoma* 2001;42:847-853, with permission.)

ENDOTHELIAL CELL STRUCTURE

Individual ECs measure approximately 20 to 50 μm^2 in surface area. The total vascular surface area in a normal adult is estimated to be at least 4,000 m^2 .⁵⁸ However, the geometry of the vascular system is not static. As indicated in Figure 19.2, the surface area facing a unit volume of blood differs, depending on the vascular bed being considered. For example, the surface areato-volume ratio is approximately 1,000 times greater in capillaries than in large blood vessels.⁵⁹ This vascular geometry has implications for regulation of hemostasis and is discussed later.

P.501

ECs are anchored to the vessel wall by basement membrane secreted by ECs and smooth muscle cells. Basement membrane contains a large number of connective tissue components, including collagen, microfibrils, glycosaminoglycans (GAGs), fibronectin, and thrombospondin. These components may serve as ligands for a number of cell adhesion processes that are important in angiogenesis, hemostasis, vascular repair, and inflammation.^{57,60}

ECs typically exist as a cell monolayer, exhibiting contact inhibition and a cobblestone appearance (Fig. 19.3). Two types of cell-cell junctional structures have been reported: adherens junctions and tight junctions. These structures regulate permeability and maintain polarity.⁶¹ Two cell receptors thought to be important in EC monolayer organization are platelet-EC adhesion molecule-1⁶² and vascular cadherin.⁶³ CD146 (MelCAM) is associated with the EC cytoskeleton and likely serves as an EC junction component.⁶⁴ Members of the junctional adhesion molecule family appear to be components of tight junctions.⁶⁵

ECs contain unique intracellular structures called Weibel-Palade bodies⁶⁶; these organelles contain the adhesion protein von Willebrand factor, which is secreted constitutively and also in response to cell stimulation.⁶⁷ The Weibel-Palade body membrane contains P-selectin, which is expressed on the EC surface after EC activation. When expressed on the vascular surface, P-selectin mediates neutrophil and monocyte adhesion to the vessel wall.⁶⁸ Selectin-independent platelet adhesion to endothelium has also been reported.⁶⁹ The role of P-selectin in inflammation and thrombosis is being increasingly recognized.⁷⁰ Integrins mediating platelet-EC and leukocyte-EC interactions are discussed in Chapters 17 and 7, respectively. Additional EC proteins have been reported to undergo regulated release or cell-surface expression, including tissue plasminogen activator (TPA), interleukin-8, endothelin-1, and multimerin.⁷¹ These and other proteins may be contained in Weibel-Palade bodies or other distinct organelles. The regulated secretion of these EC proteins has been reviewed.⁷¹

Endothelial Cell Phenotypes: Resting versus Activated

The concept of differing EC phenotypes (e.g., resting [constitutive] vs. activated) has been applied to numerous EC functions,⁷² including the inflammatory response, regulation of coagulation, and angiogenesis. This chapter focuses on EC phenotypes as related to the functions of angiogenesis, and hemostasis and thrombosis. Other EC functions have been reviewed elsewhere.^{57,72}

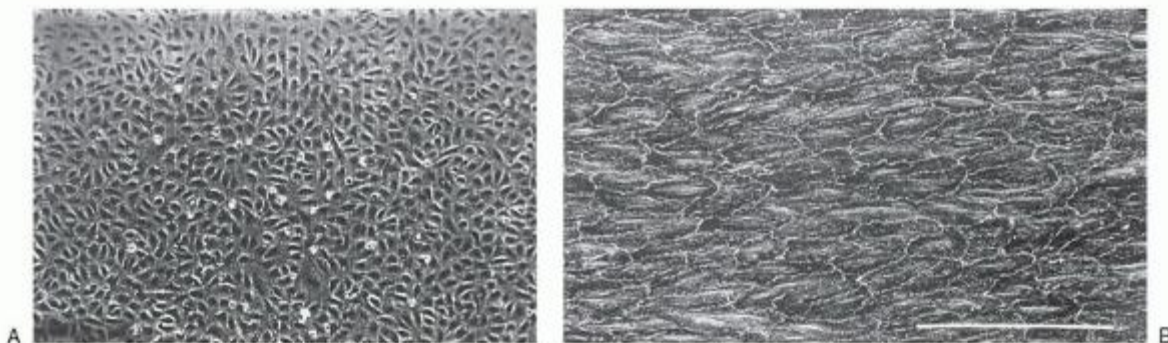

FIGURE 19.3. Endothelial cell morphology. A: Cultured human umbilical arterial endothelial cells with the typical cobblestone appearance (phase-contrast, $\times 100$). B: Scanning electron photomicrograph of a primate aorta. The bar indicates a distance of 100 μm . (From Faggiotto A, Ross R, Harker L. Studies of hypercholesterolemia in the nonhuman

primate. I. Changes that lead to fatty streak formation. *Arteriosclerosis* 1984;4:323-340, with permission of the American Heart Association.)

THE VESSEL WALL AND HEMOSTASIS: GENERAL CONCEPTS

The three major cell types of the normal vessel wall are ECs (intima), smooth muscle cells (media), and connective tissue elements, such as fibroblasts (adventitia). The circulating coagulation proteins contained in the blood are in immediate contact with quiescent vascular endothelium that normally presents a thromboresistant surface in that ECs are unable to initiate coagulation^{73,74} or promote platelet adhesion and activation.^{75,76,77} and⁷⁸ Thus, in the absence of vascular trauma or perturbation (activation), blood remains fluid as a result of antithrombotic activities expressed by ECs. However, after traumatic vascular injury, exposure of blood to cells within the vessel wall, especially fibroblasts, or to extracellular matrix (subendothelium) results in rapid initiation of coagulation because fibroblasts⁷³ and subendothelium containing EC remnants⁷⁹ constitutively express tissue factor (TF) procoagulant activity. Alternatively, perturbation (activation) of EC by stimuli, such as cytokines,⁸⁰ may induce altered EC hemostatic function (in the absence of vascular injury), resulting in net EC expression of thrombotic activity. These hemostatic properties of unperturbed and perturbed EC are critical in determining the coagulant balance of the vessel wall and the extent of activation of coagulation.

A cell-based model of hemostasis has been presented in which fibroblasts or perturbed EC express TF to initiate coagulation; amplification and propagation of coagulation then occur on the platelet surface. Modulation of coagulation occurs via EC antithrombotic activities and plasma protease inhibitors.⁸¹

ANTITHROMBOTIC PROPERTIES OF UNPERTURBED ENDOTHELIUM

Antithrombotic mechanisms responsible for unperturbed (native) EC thromboresistance are illustrated in Figure 19.4. Major antithrombotic properties can be classified as antiplatelet activities, anticoagulant activities, and fibrinolytic activities.

Antiplatelet Activities

Vascular endothelium inhibits platelet function by several mechanisms. The EC plasma membrane does not permit adherence of resting platelets.⁸² Additionally, ECs synthesize and secrete three potent antiplatelet agents: prostacyclin (PGI₂), NO, and certain

P.502

adenine nucleotides. PGI₂ is constitutively synthesized by EC cyclo-oxygenase (prostaglandin H synthase) and phospholipase A₂ in response to thrombin⁸³ and other vasoactive agonists.⁸⁴ In addition to PGI₂'s ability to prevent adhesion of activated platelets to EC, this agent also possesses potent vasodilating properties.⁷⁶ PGI₂ inhibits platelet function by increasing levels of platelet cyclic adenosine monophosphate. Aspirin inhibits the synthesis of PGI₂ by irreversibly acetylating and inactivating EC cyclo-oxygenase.⁸⁵ Recovery of PGI₂ production by EC occurs with subsequent EC synthesis of cyclo-oxygenase.

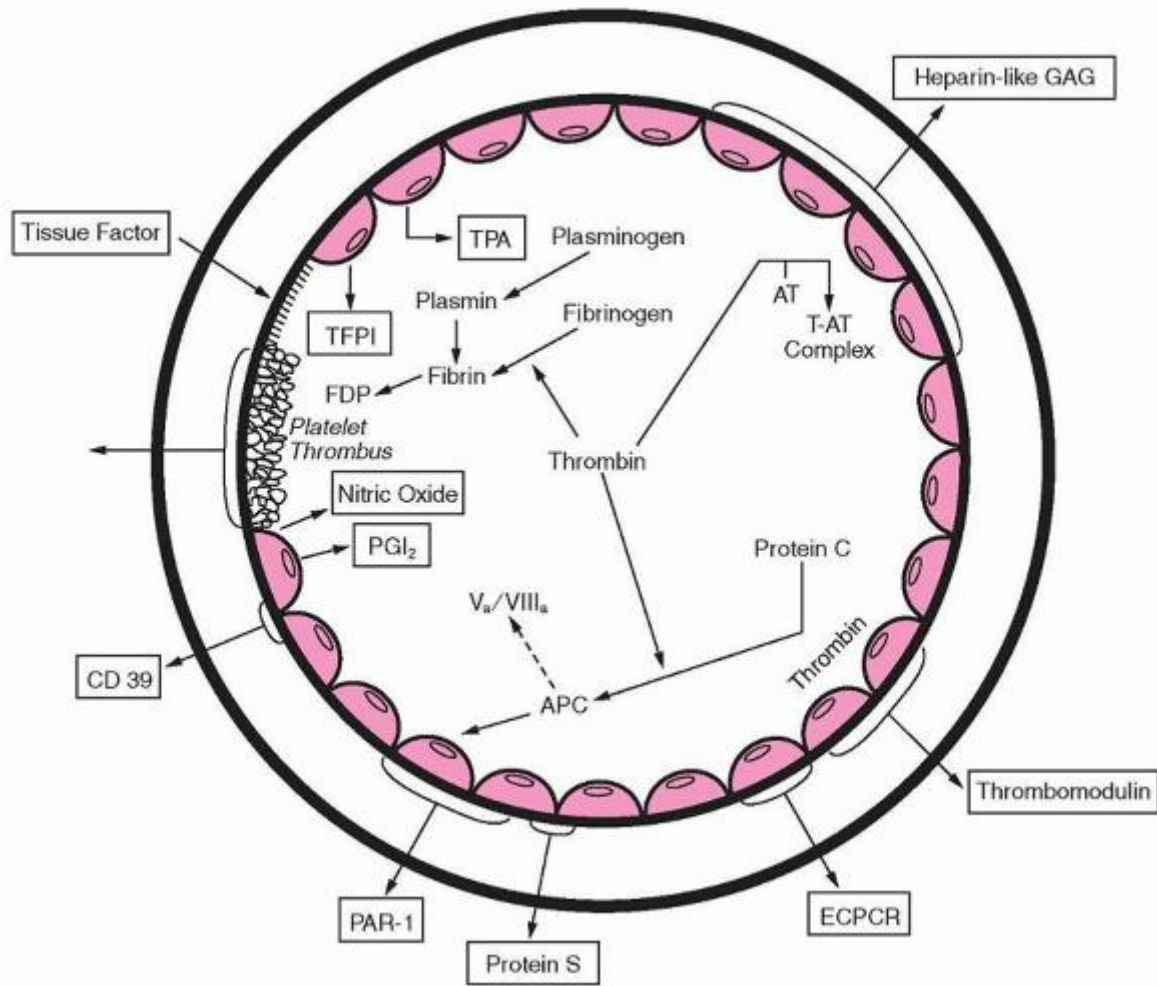

FIGURE 19.4. Vessel wall antithrombotic properties. The major antithrombotic properties are depicted in boxes. Heparinlike glycosaminoglycans (GAG), such as heparan sulfate, catalyze inactivation of serine proteases, such as thrombin (T) and factor Xa, by antithrombin (AT). Formation of the T-thrombomodulin complex activates protein C to activated protein C (APC). The endothelial cell (EC) protein C receptor (ECPCR) promotes protein C activation. Binding of APC to EC-bound protein S (and factor V) promotes proteolysis of factors Va and VIIIa (dashed line), inhibiting coagulation. APC also possesses anti-inflammatory properties that are mediated by EC protease-activated receptor (PAR)-1. This APC activity requires ECPCR (not shown). Secretion of vessel wall prostacyclin (PGI₂) and nitric oxide and expression of CD39 limit platelet thrombus formation at sites of vascular injury. Tissue plasminogen activator (TPA) is secreted and bound to EC to initiate fibrinolysis. Secretion of tissue factor pathway inhibitor (TFPI) by EC suppresses tissue factor-mediated initiation of coagulation. Dermatan sulfate-catalyzed activation of heparin cofactor II and an inhibitor to contact activation are not illustrated in the figure. FDP, fibrin degradation products. (Modified from Rodgers GM. Hemostatic properties of normal and perturbed vascular cells. *FASEB J* 1988;2:116-123.)

A second inducible form of cyclo-oxygenase, called cyclooxygenase-2, has been identified in a variety of cells, including ECs.^{86,87} Both cyclo-oxygenase proteins are homologous, with similar molecular weights and structural features. Investigators believe that cyclo-oxygenase-2 mediates the vascular response to injury and inflammation.

NO is thought to be important primarily in regulating vascular tone,^{88,89} although this agent is also a potent inhibitor of platelet adhesion to vascular endothelium.⁷⁷ Constitutive and inducible pathways generate NO from the terminal guanidino nitrogen of arginine in a reaction catalyzed by NO synthetase.^{88,90} The constitutive mechanism generates small amounts of NO and mediates physiologic responses. Increased synthesis of NO occurs in response to cytokines (inducible pathway), such as tumor necrosis factor, to mediate inflammatory events.⁸⁹ Both the constitutive and inducible forms of NO synthetase are present in ECs. Other stimuli to NO generation include adenosine diphosphate (ADP), thrombin, shear stress, and bradykinin.⁵⁷ EC-derived NO also inhibits leukocyte adhesion, as well as vascular smooth muscle cell

proliferation. Elevated levels of cyclic guanosine monophosphate result from NO stimulation and mediate the biologic activities of this antiplatelet agent. Synthesis of NO is insensitive to the effects of aspirin.

A third EC antiplatelet property is ectoenzymes that rapidly metabolize ADP and adenosine triphosphate to adenosine monophosphate and adenosine.⁹¹ ADP is a potent platelet agonist, and adenosine is a potent inhibitor of platelet function. Thus, ECs can convert a platelet agonist to an antiplatelet agent by this mechanism. EC ectoenzymes are insensitive to the effects of aspirin. This ectoenzyme antiplatelet property of EC may explain earlier reports of EC thromboresistance to platelet adhesion. The EC ecto-ADPase responsible for inhibition of platelet function is CD39.⁹² Deletion of this EC receptor in mice results in a prothrombotic state and platelet dysfunction.⁹³

Anticoagulant Activities

Vascular ECs synthesize and express heparinlike GAG, such as heparan sulfate and dermatan sulfate, on their luminal surface.⁹⁴ These GAGs catalyze the inactivation of serine proteases, such

P.503

as thrombin and factor Xa, by protease inhibitors, such as antithrombin and heparin cofactor II, respectively, via formation of a covalent protease-antiprotease complex. Of these two protease inhibitors, antithrombin is considered to be more important.⁹⁵ The molecular basis for the effect of heparin in promoting antithrombin neutralization of serine proteases involves interaction of a specific pentasaccharide sequence of the EC heparinlike molecule with an allosteric site on the antithrombin molecule.^{94,95} This interaction results in conformational changes in antithrombin that permit more efficient binding to and inhibition of protease molecules. In vivo, antithrombin molecules are associated with EC GAG,⁹⁴ providing a mechanism for instantaneous control over activation of coagulation. Surprisingly, mice deficient in the enzyme responsible for generating the pentasaccharide activity do not show a procoagulant phenotype.⁹⁶ Nevertheless, this heparan sulfate-antithrombin mechanism is considered to be an important natural anticoagulant process because deficiency of antithrombin in humans is associated with a thrombotic tendency.⁹⁷ In contrast, the clinical relevance of the heparin cofactor II mechanism is uncertain.⁹⁸

Another key vascular anticoagulant activity is the protein C pathway that consists of two plasma proteins—protein C and protein S—and an EC receptor, thrombomodulin (Fig. 19.4). ECs synthesize and express protein S⁹⁹ and thrombomodulin,¹⁰⁰ whereas protein C is synthesized by the liver. Thrombin generation leads to thrombin's binding to thrombomodulin; the thrombin-thrombomodulin complex then activates protein C to generate activated protein C (APC).¹⁰¹ APC binds to protein S, resulting in inhibition of coagulation by proteolysis of two coagulation cofactor proteins, factors Va and VIIIa. Inactivation of factors Va and VIIIa prevents further thrombin formation. The involvement of factor V in mediating the anticoagulant effect of APC has been described.¹⁰² It appears that APC down-regulation of coagulation (proteolysis of factors Va and VIIIa) occurs more efficiently on vascular endothelium rather than on platelets.¹⁰³

An additional component of the protein C pathway exists: the EC protein C receptor (ECPCR). This protein binds protein C to enhance protein C activation by the thrombin-thrombomodulin complex.^{104,105} ECPCR is found primarily on large-vessel endothelium¹⁰⁶ and is induced by thrombin stimulation. Blocking ECPCR with a monoclonal antibody in a primate model indicates that ECPCR plays a major role in in vivo protein C activation.¹⁰⁷

Certain components of the protein C pathway possess additional anticoagulant activities. For example, APC also possesses profibrinolytic activity that results from the ability of APC to neutralize plasminogen-activator inhibitor-3 (PAI-3) activity.¹⁰⁰ Thrombomodulin may also inhibit factor Xa.¹⁰⁸ An additional antithrombotic activity of protein S has been described as inhibition of TF activity by enhancing the interaction between TF pathway inhibitor (TFPI) and factor Xa.¹⁰⁹ Recurrent thrombosis has been associated with deficiency or abnormality of the protein C pathway components, indicating that this anticoagulant mechanism is relevant for in vivo hemostasis.

APC possesses activities other than those associated with anticoagulant activity. In gene-expression studies using microarray techniques, APC was found to modulate anti-inflammatory and cell-survival pathways. APC suppressed adhesion molecule expression, decreased activity of the nuclear factor- κ B transcription pathway, and inhibited apoptosis.¹¹⁰ Recent information suggests that APC uses the ECPCR to signal EC via the protease-activated receptor (PAR)-1 pathway (discussed later).¹¹¹

Regulation of TF procoagulant activity by a plasma protein called TFPI has been described.^{112,113,114} This protein is synthesized primarily by EC¹¹⁵ and is an important regulator of TF-factor VIIa activation of factor X (discussed in Chapter 18). Additionally, TFPI can inhibit vascular cell proliferation.¹¹⁶ TFPI may be important for in vivo hemostasis because administration of this inhibitor in the setting of TF-induced disseminated intravascular coagulation reduces thrombosis.¹¹⁷

and low levels of TFPI are a risk factor for thrombosis.¹¹⁸ Heparin or low-molecular-weight heparin releases TFPI from EC storage sites.¹¹⁹

Fibrinolytic Activities

ECs synthesize and secrete plasminogen activators, primarily TPA, in response to stimulation by thrombin or vasoactive stimuli, such as histamine and vasopressin.¹²⁰ TPA has been localized to the Weibel-Palade organelles in EC.¹²¹ Specific EC receptors for TPA exist.¹²² In response to inflammatory mediators, ECs synthesize another plasminogen activator, urokinase,¹²³ which activates plasminogen in the fluid phase or bound to fibrin. Activation of plasminogen by TPA generates plasmin; localization of TPA and plasminogen to the fibrin clot leads to physiologic fibrinolysis and release of soluble fibrin degradation products (Fig. 19.4). Fibrin degradation products possess potent antiplatelet and antithrombin activities and contribute to the anticoagulant effect of fibrinolysis. Activation of plasminogen is regulated by PAIs. The major inhibitor of TPA is PAI-1; PAI-1 is secreted by vascular EC¹²⁴ but is also present in platelet α -granules.¹²⁵ This inhibitor also regulates urokinase activity.¹²⁶ PAI-2 is a less significant inhibitor of TPA that is found primarily in placenta.¹²⁶ Details of the fibrinolytic mechanism and its regulation are discussed in Chapter 18.

PROTHROMBOTIC PROPERTIES OF UNPERTURBED ENDOTHELIUM

Unperturbed ECs possess procoagulant activities that promote coagulation after vascular injury or perturbation.⁸⁰ However, in the absence of initiating stimuli, these activities remain latent and do not contribute to thrombosis. Major prothrombotic activities of resting EC include binding sites (receptors) for coagulation zymogens or proteases (factor XII,¹²⁷ factor XI,¹²⁸ factors X and Xa,^{129,130,131,132} factors IX and IXa,^{129,133,134} and thrombin¹³⁵) and cofactor proteins [high-molecular-weight kininogen,¹³⁶ factor VIIIa,¹³⁴ and factor Va¹³⁷] and synthesis and expression of factor V^{138,139} and von Willebrand factor.¹⁴⁰ Resting ECs can also activate bound factor XII and promote functional cleavage of prekallikrein.¹²⁷ Investigators have also reported a factor XII-independent pathway for prekallikrein activation on EC; this activation is mediated by an EC-associated thiol protease.¹³⁶ In addition, when high-molecular-weight kininogen is bound to EC, factor XI (XIa) can associate with EC to promote factor IX activation.¹⁴¹ On the other hand, ECs also secrete an inhibitor to contact activation.¹⁴² The role of EC in activation of intrinsic coagulation has been reviewed.¹⁴³ These prothrombotic activities are illustrated in Figure 19.5.

EC receptors for coagulation proteases permit assembly of complexes consisting of cofactor proteins, proteases, and zymogen substrates that result in optimal activation and localization of coagulation.¹⁴⁴ Whereas factor V is secreted primarily into the fluid phase,¹³⁸ von Willebrand factor is secreted both into plasma and the subendothelium, providing a source of adhesive protein for the platelet response to vascular injury.¹⁴⁵

HEMOSTATIC PROPERTIES OF PERTURBED ENDOTHELIUM

In this discussion, the term EC perturbation means exposure of EC to diverse stimuli, such as traumatic vascular injury, certain cytokines, atherogenic stimuli (homocysteine, modified low-density lipoprotein [LDL]), lipopolysaccharide (endotoxin), immune complexes, and certain infectious organisms. From this list, it is obvious that a variety of inflammatory, infectious, or malignant

P.504

disorders, as well as metabolic defects, may be associated with hemostatic dysfunction resulting from altered EC hemostatic properties. With the exception of traumatic vascular injury, alteration of these key EC coagulant properties is not associated with cytotoxicity or EC desquamation. The major hemostatic properties reviewed in this section include TF activity, thrombomodulin activity (protein C pathway), factor V activation, and fibrinolytic activities (TPA, PAI-1). In general, these activities are concordantly regulated, with stimuli that induce TF expression also suppressing protein C activation and fibrinolysis. The net result of these events is that the perturbed EC surface is converted from an antithrombotic surface to a prothrombotic surface.

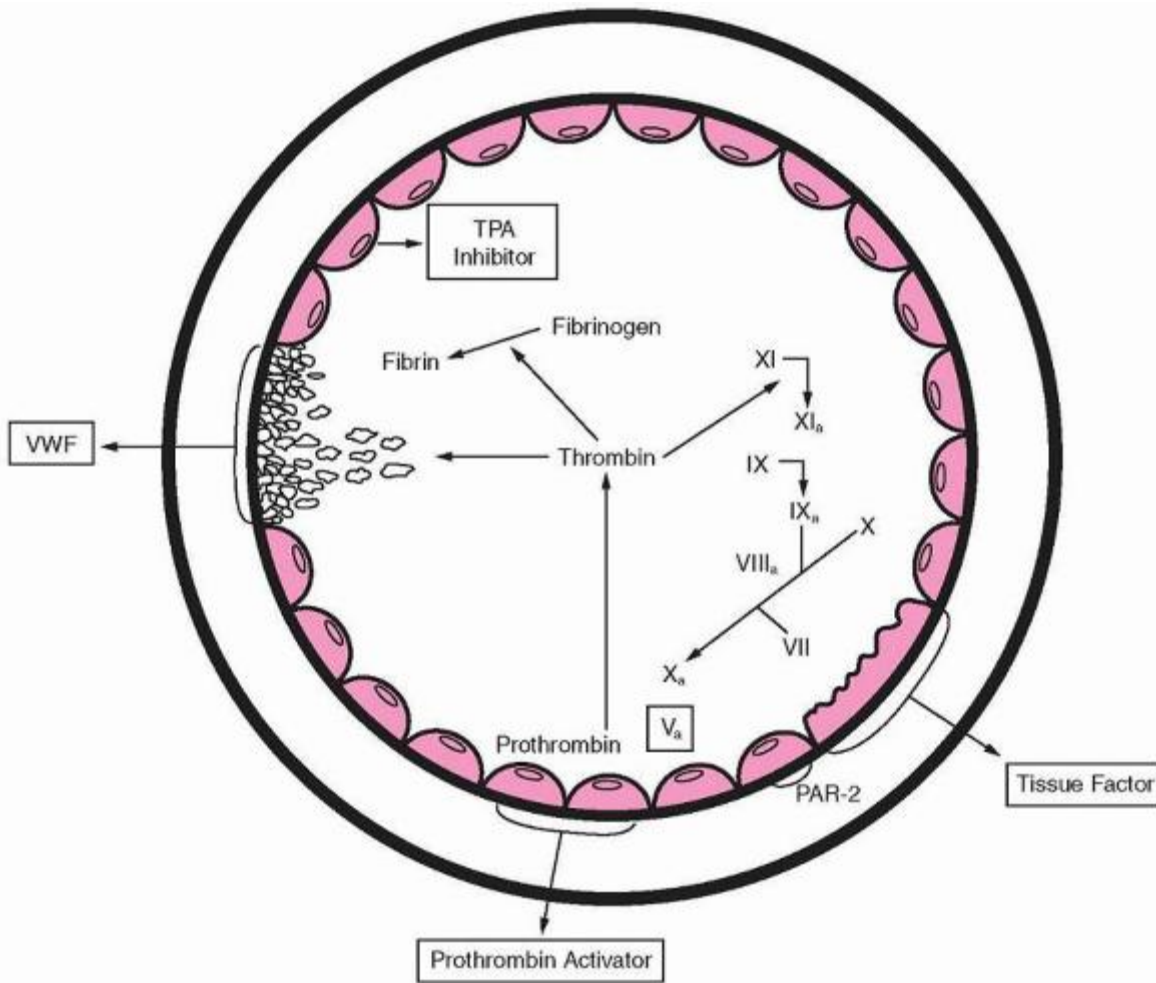

FIGURE 19.5. Vessel wall prothrombotic properties. The major prothrombotic properties are depicted in boxes. Expression of tissue factor activity initiates coagulation, and endothelial cell (EC) synthesis of factor V promotes thrombin formation. Thrombin formation is enhanced by feedback activation of factor XI. Vessel wall injury also promotes platelet adhesion and thrombus formation by exposure of subendothelial von Willebrand factor (VWF). An inducible EC prothrombin activator may directly generate thrombin. EC can be induced to express an activator of factor V (Va). Thrombin exerts multiple procoagulant activities, including platelet activation and cleavage of fibrinogen, resulting in the fibrin clot. Thrombin binding to thrombomodulin activates thrombin-activatable fibrinolysis inhibitor to down-regulate fibrinolysis (not shown). EC secretion of tissue plasminogen activator (TPA) inhibitor further stabilizes the fibrin clot by preventing fibrinolysis. Also not shown are EC-binding sites for coagulation zymogens or proteases. Protease-activated receptor (PAR)-2 is activated by the tissue factor-factor VIIa complex and factor Xa to contribute to EC activation by pathologic stimuli. (Modified from Rodgers GM. Hemostatic properties of normal and perturbed vascular cells. *FASEB J* 1988;2:116-123.)

The key hemostatic activity induced by EC perturbants is TF expression, because TF is considered to be the major initiator of coagulation.¹⁴⁶ Details of the regulation of cellular TF activity are given in Chapter 18. Stimuli reported to induce EC TF activity include cytokines, lipopolysaccharide, oxidized LDL, homocysteine, and certain infectious organisms. Expression of EC TF antigen in pathologic human and primate tissues using immunohistochemical methods has been reported,^{147,148} and¹⁴⁹ including vascular tissue from patients with sickle-cell anemia¹⁵⁰ and skin biopsies from patients treated with intradermal cytokines.¹⁵¹ The importance of vessel wall TF activity in arterial and venous thrombosis has been recently confirmed.¹⁵²

EC TF procoagulant activity may be modulated by a novel EC protease, PAR-2. PARs represent a group of G-protein-coupled receptors present in ECs and other tissues.¹⁵³ Thrombin or other proteases cleave the amino terminus of the receptor exodomain; the amino-terminus fragment then binds to the cell-associated domain of the receptor to activate

the protease.¹⁵⁴ In ECs and fibroblasts, activated PAR-1 is internalized and sorted to lysosomes; this process terminates thrombin signaling.¹⁵³

There are at least four members of the PAR family.¹⁵³ Human PAR-1, PAR-3, and PAR-4 can be activated by thrombin, and it is proposed that their *in vivo* role is sensing thrombin generation.¹⁵³ ECs contain both PAR-1 and PAR-2,^{153,155} but thrombin does not activate PAR-2. Rather, data indicate that PAR-2 may be activated directly by TF-factor VIIa and indirectly by TF-factor VIIa-generated factor Xa.¹⁵⁶ It has been proposed that PAR-2 may function as a coagulation protease "sensor" and thereby contribute to EC activation by pathologic stimuli.¹⁵⁶ Stimulation of EC PAR-2 also increases TF expression.¹⁵⁵ EC PAR-2 may mediate additional thrombin-induced vascular functions, including leukocyte adhesion¹⁵⁷ and mitogenesis.^{158,159} Studies investigating embryonic development indicate that PAR-1 messenger RNA is abundant in EC, suggesting that PAR-1 signaling in EC is important in vascular development.¹⁶⁰ PAR-1 also mediates the EC response to APC; APC and ECPCR cleave PAR-1 to initiate signaling events.¹¹¹ Figure 19.6 illustrates the interactions between the TF-factor VIIa complex and EC PAR-2, with resulting alteration of EC function. The role of PARs in vascular biology and disease has been recently reviewed.¹⁶¹

An additional mechanism for EC generation of thrombin has been reported. Perturbed ECs express a prothrombin activator that can generate thrombin independent of the intrinsic and extrinsic coagulation pathways.¹⁶² The description of trypsin expression by

P.505

cultured EC and by vascular EC *in situ* suggests that a variety of EC-derived proteases may also regulate blood coagulation.¹⁶³

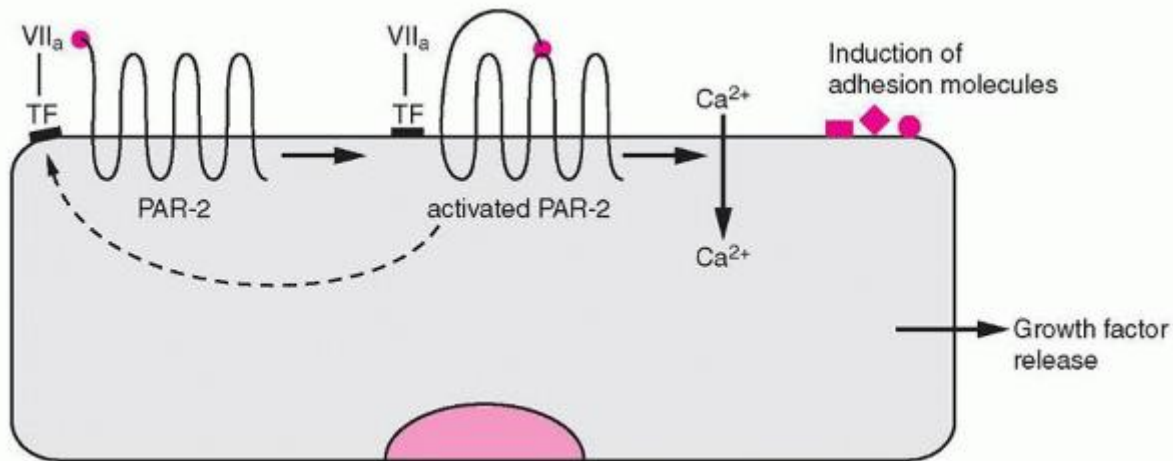

FIGURE 19.6. Interactions of the tissue factor (TF)-factor VIIa complex with the endothelial cell protease-activated receptor (PAR)-2 and their consequences. Expression of endothelial cell TF results in TF-dependent factor VIIa activation of PAR-2. Cleavage of the amino terminus of PAR-2 reveals a tethered ligand sequence that binds to PAR-2 to initiate signaling, triggering responses that include calcium influx, expression of surface adhesion molecules for leukocytes, and release of growth factors.^{153,156} Activation of PAR-2 may also enhance endothelial cell expression of TF activity¹⁵⁵ (dashed line).

Because both ECs¹³⁹ and platelets¹⁶⁴ can activate prothrombin, the question arises as to the importance of EC in thrombin generation. One study observed synergism of thrombin generation when a reconstituted model containing ECs, platelets, and purified coagulation proteins was tested.¹⁶⁵ Synergy was maximal at platelet concentrations $<1 \times 10^8$ /ml.¹⁶⁵ Thus, in thrombocytopenic states, the large surface area of vascular endothelium, especially in the microcirculation,⁵⁹ may play a role in amplifying platelet prothrombin activation. Studies with human arterial vascular tissue indicate that vascular tissue alone (in the absence of platelets) is sufficient to generate large amounts of thrombin.¹⁶⁶

Regulation of the anticoagulant protein C pathway by EC perturbants has also been a subject of interest because of the recurrent thrombotic disorders associated with deficiency of protein C pathway components (proteins C and S).^{100,101} Down-regulation of the protein C pathway has focused on thrombomodulin, the EC membrane protein that activates protein C after complexing with thrombin. Several mechanisms have been identified to explain the role of thrombomodulin in down-regulating protein C activation. Thrombomodulin has structural homology to the native LDL

receptor,¹⁶⁷ a prototypical membrane receptor involved in endocytosis. The effects of tumor necrosis factor on the protein C pathway appear to result from enhanced endocytosis and subsequent degradation of thrombomodulin.¹⁶⁸ Additionally, tumor necrosis factor, a cytokine that reduces protein C activation, has been reported to inhibit transcription of thrombomodulin RNA.¹⁶⁹

Another important EC hemostatic property regulated by relevant perturbing stimuli is secretion of PAI-1 and TPA. Treatment of cultured EC with interleukin-1 results in both diminished TPA secretion and increased PAI-1 secretion.¹⁷⁰ Increased amounts of PAI-1 relative to TPA diminish vascular fibrinolytic activity, resulting in enhanced thrombotic potential because of failure to lyse fibrin thrombi.

In addition to the humoral and biochemical stimuli discussed earlier, biomechanical forces (shear stress) can regulate EC gene expression and phenotype.¹⁷¹ For example, either laminar or turbulent shear stress has been reported to regulate a large number of EC genes differentially, including adhesion molecules and growth factors, as well as hemostasis proteins.¹⁷² Shear stress also attenuates cytokine-induced EC TF expression.¹⁷³ These data indicate that vascular endothelium is responsive to biomechanical stimuli. A uniquely flow-induced EC gene is the transcription factor, lung Kruppel-like factor, which may be an important regulator of EC function.¹⁷⁴

Diversity of Endothelial Cell Hemostatic Properties

There is significant heterogeneity in arterial, venous, and capillary EC with regard to expression of hemostatic and other functional activities.^{58,175} For example, aortic EC express more factor V activity than do venous EC,¹³⁰ and PGI₂, a major metabolite secreted by human venous EC, is not substantially produced by human capillary cells.¹⁷⁶ Different fibrinolytic and anticoagulant properties have been reported between cultured venous and capillary EC.¹⁷⁷ Increases in blood flow lead to up-regulation of NO synthase messenger RNA in aortic, but not pulmonary, arterial EC.¹⁷⁸ Vascular anticoagulant activity in the microcirculation is reinforced by geometric aspects of the vessel wall.⁵⁹ For example, the thrombomodulin concentration in the microcirculation would increase more than a thousandfold⁵⁹ compared with a large vessel. Consequently, in large vessels, thrombin circulates freely to catalyze coagulation, whereas in the microcirculation, thrombin exists mostly bound to thrombomodulin, promoting anticoagulation.¹⁰¹

The differential concentration of thrombomodulin in large versus small vessels may also affect vascular fibrinolysis in specific vascular beds. Thrombin-activatable fibrinolysis inhibitor is stimulated by low thrombomodulin concentrations but decreased at high concentrations of thrombomodulin.¹⁷⁹ This implies that enhanced fibrinolysis would be seen in the microcirculation that contains high levels of thrombomodulin activity.

These data suggest a vascular model in which procoagulant activities are dominant in the arterial circulation and anticoagulant activities are dominant in the microcirculation. This distribution of vascular hemostatic properties is consistent with the necessity for rapid thrombin generation and fibrin clot formation after arterial injury, while providing the venous and microcirculation with anticoagulant mechanisms to protect against thrombosis.⁸⁰ Unique EC environments may also explain localization of certain pathologic processes. For example, verotoxin-induced EC platelet thrombi localized to arterioles and capillaries may be explained by distinct responses of EC to verotoxin,¹⁸⁰ and endogenously generated NO is more effective in inhibiting thrombosis in venules than in arterioles.¹⁸¹

The concept of EC diversity is also supported by gene-expression profile studies that have identified characteristic expression patterns of arterial versus venous EC as well as large versus microvascular EC.¹⁸²

REFERENCES

1. Conway EM, Collen D, Carmeliet P. Molecular mechanisms of blood vessel growth. *Cardiovasc Res* 2001;49:507-521.
2. Carmeliet P, Jain RK. Angiogenesis in cancer and other diseases. *Nature* 2000;407:249-257.
3. Nathan C. Nitric oxide as a secretory product of mammalian cells. *FASEB J* 1992;6:3051-3064.
4. Kimura H, Weisz A, Kurashima Y, et al. Hypoxia response element of the human vascular endothelial growth factor gene mediates transcriptional regulation by nitric oxide: control of hypoxia-inducible factor-1 activity by nitric oxide. *Blood* 2000;95:189-197.
5. Eliceiri BP, Paul R, Schwartzberg PL, et al. Selective requirement for Src kinases during VEGF-induced angiogenesis and vascular permeability. *Mol Cell* 1999;4:915-924.
6. Gale NW, Yancopoulos GD. Growth factors acting via endothelial cell-specific receptor tyrosine kinases: VEGFs, angiopoietins, and ephrins in vascular development. *Genes Dev* 1999;13:1055-1066.

7. Thurston G, Rudge JS, Ioffe E, et al. Angiopoietin-1 protects the adult vasculature against plasma leakage. *Nat Med* 2000;6:460-463.
8. Nelson AR, Fingleton B, Rothenberg ML, Matrisian LM. Matrix metalloproteinases: biologic activity and clinical implications. *J Clin Oncol* 2000;18:1135-1149.
9. Stetler-Stevenson WG. Matrix metalloproteinases in angiogenesis: a moving target for therapeutic intervention. *J Clin Invest* 1999;103:1237-1241.
10. Brew K, Dinakarpandian D, Nagase H. Tissue inhibitors of metalloproteinases: evolution, structure and function. *Biochim Biophys Acta* 2000;1477:267-283.
11. Ferrara N, Gerber HP. The role of vascular endothelial growth factor in angiogenesis. *Acta Haematol* 2001;106:148-156.
12. Veikkola T, Karkkainen M, Claesson-Welsh L, Alitalo K. Regulation of angiogenesis via vascular endothelial growth factor receptors. *Cancer Res* 2000;60:203-212.
13. Singh H, Tahir TA, Alawo DO, et al. Molecular control of angiopoietin signaling. *Biochem Soc Trans.* 2011;39:1592-1596.
14. Yancopoulos GD, Davis S, Gale NW, et al. Vascular-specific growth factors and blood vessel formation. *Nature* 2000;407:242-248.
15. Suri C, McClain J, Thurston G, et al. Increased vascularization in mice over-expressing angiopoietin-1. *Science* 1998;282:468-471.
16. Suri C, Jones PF, Patan S, et al. Requisite role of angiopoietin-1, a ligand for the TIE2 receptor, during embryonic angiogenesis. *Cell* 1996;87:1171-1180.
17. Maisonpierre PC, Suri C, Jones PF, et al. Angiopoietin-2, a natural antagonist for Tie2 that disrupts in vivo angiogenesis. *Science* 1997;277:55-60.
18. Pipili-Synetos E, Sakkoula E, Haralabopoulos G, et al. Evidence that nitric oxide is an endogenous antiangiogenic mediator. *Br J Pharmacol* 1994;111:894-902.
19. Ziche M, Morbidelli L, Masini E, et al. Nitric oxide mediates angiogenesis in vivo and endothelial cell growth and migration in vitro promoted by substance P. *J Clin Invest* 1994;94:2036-2044.
20. Papapetropoulos A, Garcia-Cardena G, Madri JA, Sessa WC. Nitric oxide production contributes to the angiogenic properties of vascular endothelial growth factor in human endothelial cells. *J Clin Invest* 1997;100:3131-3139.
21. Pipili-Synetos E, Kritikou S, Papadimitriou E, et al. Nitric oxide synthase expression, enzyme activity and NO production during angiogenesis in the chick chorioallantoic membrane. *Br J Pharmacol* 2000;129:207-213.
22. Fernandez B, Buehler A, Wolfram S, et al. Transgenic myocardial overexpression of fibroblast growth factor-1 increases coronary artery density and branching. *Circ Res* 2000;87:207-213.
23. Carmeliet P. Fibroblast growth factor-1 stimulates branching and survival of myocardial arteries: a goal for therapeutic angiogenesis? *Circ Res* 2000;87:176-178.
24. Lindahl P, Bostrom H, Karlsson L, et al. Role of platelet-derived growth factors in angiogenesis and alveogenesis. *Curr Top Pathol* 1999;93:27-33.
25. O'Reilly MS, Holmgren L, Shing Y, et al. Angiostatin: a novel angiogenesis inhibitor that mediates the suppression of metastases by a Lewis lung carcinoma. *Cell* 1994;79:315-328.
26. O'Reilly MS, Boehm T, Shing Y, et al. Endostatin: an endogenous inhibitor of angiogenesis and tumor growth. *Cell* 1997;88(2):277-285.
27. O'Reilly MS. Angiostatin: an endogenous inhibitor of angiogenesis and of tumor growth. *EXS* 1997;79:273-294.
28. Carmeliet P. Mechanisms of angiogenesis and arteriogenesis. *Nat Med* 2000;6:389-395.
29. Eliceiri BP, Cheresh DA. The role of α integrins during angiogenesis: insights into potential mechanisms of action and clinical development. *J Clin Invest* 1999;103:1227-1230.

30. Carmeliet P, Lampugnani MG, Moons L, et al. Targeted deficiency or cytosolic truncation of the VE-cadherin gene in mice impairs VEGF-mediated endothelial survival and angiogenesis. *Cell* 1999;98:147-157.
31. Holash J, Maisonpierre PC, Compton D, et al. Vessel cooption, regression, and growth in tumors mediated by angiopoietins and VEGF. *Science* 1999;284:1994-1998.
32. Hirschi KK, D'Amore PA. Pericytes in the microvasculature. *Cardiovasc Res* 1996;32:687-698.
33. Yamashita J, Itoh H, Hirashima M, et al. Flk1-positive cells derived from embryonic stem cells serve as vascular progenitors. *Nature* 2000;408(6808):92-96.
34. Bellomo D, Headrick JP, Silins GU, et al. Mice lacking the vascular endothelial growth factor-B gene (*Vegfb*) have smaller hearts, dysfunctional coronary vasculature, and impaired recovery from cardiac ischemia. *Circ Res* 2000;86: E29-E35.
35. Olofsson B, Jeltsch M, Eriksson U, Alitalo K. Current biology of VEGF-B and VEGF-C. *Curr Opin Biotechnol* 1999;10:528-535.
36. Fong GH, Rossant J, Gertsenstein M, Breitman ML. Role of the Flt-1 receptor tyrosine kinase in regulating the assembly of vascular endothelium. *Nature* 1995;376:66-70.
37. Hiratsuka S, Minowa O, Kuno J, et al. Flt-1 lacking the tyrosine kinase domain is sufficient for normal development and angiogenesis in mice. *Proc Natl Acad Sci U S A* 1998;95:9349-9354.
38. Carmeliet P. Angiogenesis in life, disease and medicine. *Nature* 2005;438: 932-936.
39. Carmeliet P, Jain RK. Molecular mechanisms and clinical applications of angiogenesis. *Nature* 2011;473:298-307.
40. Phng LK, Potente M, Leslie JD, et al. Nrarp coordinates endothelial Notch and Wnt signaling to control vessel density in angiogenesis. *Dev Cell* 2009;16: 70-82.
41. Phng LK, Gerhardt H. Angiogenesis: a team effort coordinated by Notch. *Dev Cell* 2009;16:196-208.
42. Jakobsson L, Franco CA, Bentley K, et al. Endothelial cells dynamically compete for the tip cell position during angiogenic sprouting. *Nat Cell Biol* 2010;12:943-953.
43. Asahara T, Murohara T, Sullivan A, et al. Isolation of putative progenitor endothelial cells for angiogenesis. *Science* 1997;275:964-967.
44. Perry BN, Arbiser JL. The duality of angiogenesis: implications for therapy of human disease. *J Invest Dermatol* 2006;126:2160-2166.
45. Ribatti D, Vacca A, De Falco G, et al. Role of hematopoietic growth factors in angiogenesis. *Acta Haematol* 2001;106:157-161.
46. Dickson DJ, Shami PJ. Angiogenesis in acute and chronic leukemias. *Leuk Lymphoma* 2001;42:847-853.
47. Tosi P, Tura S. Antiangiogenic therapy in multiple myeloma. *Acta Haematol* 2001;106:208-213.
48. Salven P. Angiogenesis in lymphoproliferative disorders. *Acta Haematol* 2001;106:184-189.
49. Hussong JW, Rodgers GM, Shami PJ. Evidence of increased angiogenesis in patients with acute myeloid leukemia. *Blood* 2000;95:309-313.
50. Padro T, Ruiz S, Bieker R, et al. Increased angiogenesis in the bone marrow of patients with acute myeloid leukemia. *Blood* 2000;95:2637-2645.
51. Aguayo A, Kantarjian H, Manshouri T, et al. Angiogenesis in acute and chronic leukemias and myelodysplastic syndromes. *Blood* 2000;96: 2240-2245.
52. Moehler TM, Neben K, Ho AD, Goldschmidt H. Angiogenesis in hematologic malignancies. *Ann Hematol* 2001;80:695-705.
53. Kini AR, Kay NE, Peterson LC. Increased bone marrow angiogenesis in B cell chronic lymphocytic leukemia. *Leukemia* 2000;14:1414-1418.
54. Albitar M. Angiogenesis in acute myeloid leukemia and myelodysplastic syndrome. *Acta Haematol* 2001;106:170-176.
55. Di Raimondo F, Palumbo GA, Molica S, Giustolisi R. Angiogenesis in chronic myeloproliferative disorders. *Acta Haematol* 2001;106:177-183.

56. Petty RG, Pearson JD. Endothelium—the axis of vascular health and disease. *J R Coll Physicians Lond* 1989;23:92-102.
57. Cines DB, Pollak ES, Buck CA, et al. Endothelial cells in physiology and in the pathophysiology of vascular disorders. *Blood* 1998;91:3527-3561.
58. Aird WC. Spatial and temporal dynamics of the endothelium. *J Thromb Haemost* 2005;3:1392-1406.
59. Busch C, Cancilla PA, DeBault LE, et al. Use of endothelium cultured on microcarriers as a model for the microcirculation. *Lab Invest* 1982;47: 498-504.
60. Carlos TM, Harlan JM. Leukocyte-endothelial adhesion molecules. *Blood* 1994;84:2068-2101.
61. Dejana E, Corada M, Lampugnani MG. Endothelial cell to cell junctions. *FASEB J* 1995;9:910-918.
62. Albelda SM, Oliver PD, Romer LH, Buck CA. Endo-CAM, a novel endothelial cell-cell adhesion molecule. *J Cell Biol* 1990;110:1227-1237.
63. Heimark RL, Degner M, Schwartz SM. Identification of a Ca²⁺-dependent cell-cell adhesion molecule. *J Cell Biol* 1990;110:1745-1756.
64. Bardin N, Anfosso F, Masse JM, et al. Identification of CD146 as a component of the endothelial junction involved in the control of cell-cell cohesion. *Blood* 2001;98:3677-3684.
65. Aurrand-Lions M, Johnson-Leger C, Wong C, et al. Heterogeneity of endothelial junctions is reflected by differential expression and specific subcellular localization of the three JAM family members. *Blood* 2001;98:3699-3707.
66. Weibel ER, Palade GE. New cytoplasmic components in arterial endothelia. *J Cell Biol* 1964;23:101-113.
67. Wagner DD, Olmstead JB, Marder VJ. Immunolocalization of von Willebrand protein in Weibel-Palade bodies of human endothelial cells. *J Cell Biol* 1982;95:355-360.
68. McEver RP, Beckstead JH, Moore KL, et al. GMP-140, a platelet membrane alpha-granule protein, is also synthesized by vascular endothelial cells and is localized in Weibel-Palade bodies. *J Clin Invest* 1989;84:92-99.
69. André P, Denis CV, Ware J, et al. Platelets adhere to and translocate on von Willebrand factor presented by endothelium in stimulated veins. *Blood* 2000;96:3322-3328.
70. Wagner DD. New links between inflammation and thrombosis. *Arterioscl Thromb Vasc Biol* 2005;25:1321-1324.
71. Rondaij MG, Bierings R, Kragt A, van Mourik JA, Voorberg J. Dynamics and plasticity of Weibel-Palade bodies in endothelial cells. *Arterioscler Thromb Vasc Biol* 2006;26:1002-1007.
72. Augustin HG, Kozian DH, Johnson RC. Differentiation of endothelial cells: analysis of the constitutive and activated endothelial cell phenotypes. *Bioessays* 1994;16:901-906.
73. Rodgers GM, Greenberg CS, Shuman MA. Characterization of the effects of cultured vascular cells on the activation of blood coagulation. *Blood* 1983;61:1155-1162.
74. Rosenberg RD, Rosenberg JS. Natural anticoagulant mechanisms. *J Clin Invest* 1984;74:1-6.
75. Jaffe EA. Physiologic functions of normal endothelial cells. *Ann N Y Acad Sci* 1985;454:279-291.
76. Moncada S. Prostacyclin and arterial wall biology. *Arteriosclerosis* 1982;2:193-207.
77. Radomski MW, Palmer RMJ, Moncada S. Endogenous nitric oxide inhibits human platelet adhesion to vascular endothelium. *Lancet* 1987;2:1057-1058.
78. Zimmermann H. Nucleotides and CD39: principal modulatory players in hemostasis and thrombosis. *Nat Med* 1999;5:987-988.
79. Mulder AB, Hegge-Paping KSM, Magielse CPE, et al. Tumor necrosis factor α -induced endothelial tissue factor is located on the cell surface rather than in the subendothelial matrix. *Blood* 1994;84:1559-1566.
80. Rodgers GM. Hemostatic properties of normal and perturbed vascular cells. *FASEB J* 1988;2:116-123.
81. Monroe DM, Hoffman M. What does it take to make the perfect clot? *Arterioscl Thromb Vasc Biol* 2006;26:41-48.
82. Czervionke RL, Hoak JC, Fry GL. Effect of aspirin on thrombin-induced adherence of platelets to cultured cells from the blood vessel wall. *J Clin Invest* 1978;62:847-856.

83. Weksler BB, Marcus AJ, Jaffe EA. Synthesis of prostaglandin I₂ (prostacyclin) by cultured human and bovine endothelial cells. *Proc Natl Acad Sci U S A* 1977;74:3922-3926.
84. Jaffe EA. Endothelial cell structure and function. In: Hoffman R, Benz EJ, Shattil SJ, et al., eds. *Hematology: basic principles and practice*, New York, NY: Churchill Livingstone, 1991:1198-1213.
85. Roth GJ, Siok CJ. Acetylation of the NH₂-terminal serine of prostaglandin synthetase by aspirin. *J Biol Chem* 1978;253:3782-3784.
86. Hla T, Neilson K. Human cyclooxygenase-2 cDNA. *Proc Natl Acad Sci U S A* 1992;89:7384-7388.
87. Jones DA, Carlton DP, McIntyre TM, et al. Molecular cloning of human prostaglandin endoperoxidase synthase type II and demonstration of expression in response to cytokines. *J Biol Chem* 1993;268:9049-9054.
88. Moncada S, Palmer RM, Higgs EA. Nitric oxide: physiology, pathophysiology, and pharmacology. *Pharmacol Rev* 1991;43:109-142.
89. Lowenstein CJ, Dinerman JL, Snyder SH. Nitric oxide: a physiologic messenger. *Ann Intern Med* 1994;120:227-237.
90. Palmer RMJ, Ashton DS, Moncada S. Vascular endothelial cells synthesize nitric oxide from L-arginine. *Nature* 1988;333:664-666.
91. Pearson JD, Gordon JL. Nucleotide metabolism by endothelium. *Annu Rev Physiol* 1985;47:617-627.
92. Marcus AJ, Broekman MJ, Drosopoulos JHF, et al. The endothelial cell ecto-ADPase responsible for inhibition of platelet function is CD39. *J Clin Invest* 1997;99:1351-1360.
93. Enjyoji K, Sevigny J, Lin Y, et al. Targeted disruption of CD39/ATP diphosphohydrolase results in disordered hemostasis and thromboregulation. *Nat Med* 1999;5:1010-1017.
94. Bourin M-C, Lindahl U. Glycosaminoglycans and the regulation of blood coagulation. *Biochem J* 1993;289:313-330.
95. Bock SC. Antithrombin III and heparin cofactor II. In: Colman RW, Hirsh J, Marder VJ, et al., eds. *Hemostasis and thrombosis: basic principles and clinical practice*, 4th ed. Philadelphia, PA: Lippincott Williams & Wilkins, 2001:321-333.
96. HajMohammadi S, Enjyoji K, Princivalle M, et al. Normal levels of anticoagulant heparan sulfate are not essential for normal hemostasis. *J Clin Invest* 2003;111:989-999.
97. Hirsh J. Congenital antithrombin III deficiency. Incidence and clinical features. *Am J Med* 1989;87(Suppl 3B):34s-38s.
98. Bertina RM, van der Linden IK, Engesser L, et al. Hereditary heparin cofactor II deficiency and the risk of development of thrombosis. *Thromb Haemost* 1987;57:196-200.
99. Stern D, Brett J, Harris K, Nawroth P. Participation of endothelial cells in the protein C-protein S anticoagulant pathway: the synthesis and release of protein S. *J Cell Biol* 1986;102:1971-1978.
100. Esmon CT. The regulation of natural anticoagulant pathways. *Science* 1987;235:1348-1352.
101. Esmon CT. The roles of protein C and thrombomodulin in the regulation of blood coagulation. *J Biol Chem* 1989;264:4743-4746.
102. Shen L, Dahlback B. Factor V and protein S as synergistic cofactors to activated protein C in degradation of factor VIII_a. *J Biol Chem* 1994;269: 18735-18738.
103. Oliver JA, Monroe DM, Church FC, et al. Activated protein C cleaves factor V_a more efficiently on endothelium than on platelet surfaces. *Blood* 2002;100:539-546.
104. Fukudome K, Esmon CT. Identification, cloning and regulation of a novel endothelial cell protein C/activated protein C receptor. *J Biol Chem* 1994;269:26486-26491.
105. Esmon CT. The endothelial cell protein C receptor. *Thromb Haemost* 2000;83:639-643.
106. Laszik Z, Mitro A, Taylor FB, et al. Human protein C receptor is present primarily on endothelium of large blood vessels: implications for control of the protein C pathway. *Circulation* 1997;96:3633-3640.
107. Taylor FB, Peer GT, Lockhart MS, et al. Endothelial cell protein C receptor plays an important role in protein C activation in vivo. *Blood* 2001;97: 1685-1688.
108. Thompson EA, Salem HH. Inhibition by thrombomodulin of factor X_a-mediated cleavage of prothrombin. *J Clin Invest* 1986;78:13-17.

109. Hackeng TM, Sere KM, Tans G, Rosing J. Protein S stimulates inhibition of the tissue factor pathway by tissue factor pathway inhibitor. *Proc Natl Acad Sci U S A* 2006;103:3106-3111.
P.507
110. Joyce DE, Gelbert L, Ciaccia A, et al. Gene expression profile of antithrombotic protein C defines new mechanisms modulating inflammation and apoptosis. *J Biol Chem* 2001;276:11199-11203.
111. Reiwald M, Petrovan RJ, Donner A, et al. Activation of endothelial cell protease activated receptor 1 by the protein C pathway. *Science* 2002;296: 1880-1882.
112. Wun T-C, Kretzmer KK, Girard TJ, et al. Cloning and characterization of a cDNA coding for the lipoprotein-associated coagulation inhibitor shows that it consists of three tandem Kunitz-type inhibitory domains. *J Biol Chem* 1988;263:6001-6004.
113. Rapaport SI. Inhibition of factor VII_a/tissue factor-induced blood coagulation: with particular emphasis upon a factor X_a-dependent inhibitory mechanism. *Blood* 1989;73:359-365.
114. Novotny WF. Tissue factor pathway inhibitor. *Semin Thromb Hemost* 1994;20:101-108.
115. Bajaj MS, Kuppuswamy MN, Saito H, et al. Cultured normal human hepatocytes do not synthesize lipoprotein-associated coagulation inhibitor: evidence that endothelium is the principal site of its synthesis. *Proc Natl Acad Sci U S A* 1990;87:8869-8873.
116. Kato H. Regulation of functions of vascular wall cells by tissue factor pathway inhibitor: basic and clinical aspects. *Arterioscler Thromb Vasc Biol* 2002;22:535-548.
117. Day KC, Hoffman LC, Palmier MO, et al. Recombinant lipoprotein-associated coagulation inhibitor inhibits tissue thromboplastin induced intravascular coagulation in the rabbit. *Blood* 1990;76:1538-1545.
118. Dahm A, Van Hylckama Vlieg A, Bendz B, et al. Low levels of tissue factor pathway inhibitor (TFPI) increase the risk of venous thrombosis. *Blood* 2003;101:4387-4392.
119. Sandset PM, Abildgaard U, Larsen ML. Heparin induces release of extrinsic coagulation pathway inhibitor (EPI). *Thromb Res* 1988;50:803-813.
120. Grant PJ, Medcalf RL. Hormonal regulation of haemostasis and the molecular biology of the fibrinolytic system. *Clin Sci* 1990;78:3-11.
121. Huber D, Cramer EM, Kaufmann JE, et al. Tissue-type plasminogen activator (t-PA) is stored in Weibel-Palade bodies in human endothelial cells both in vitro and in vivo. *Blood* 2002;15:3637-3645.
122. Hajjar KA, Hamel NM, Harpel PC, Nachman RL. Binding of tissue plasminogen activator to cultured human endothelial cells. *J Clin Invest* 1987;80:1712-1719.
123. Levin EG, Loskutoff DJ. Cultured bovine endothelial cells produce both urokinase and tissue-type plasminogen activators. *J Cell Biol* 1982;94:631-636.
124. Philips M, Juul AG, Thorsen S. Human endothelial cells produce a plasminogen activator inhibitor and a tissue-type plasminogen activator-inhibitor complex. *Biochim Biophys Acta* 1984;802:99-110.
125. Erickson LA, Ginsberg MH, Loskutoff DJ. Detection and partial characterization of an inhibitor of plasminogen activator in human platelets. *J Clin Invest* 1984;74:1465-1472.
126. Sprengers ED, Kluft C. Plasminogen activator inhibitors. *Blood* 1987;69: 381-387.
127. Reddigari SR, Shibayama Y, Brunnee T, Kaplan AP. Human Hageman factor (Factor XII) and high molecular weight kininogen compete for the same binding site on human umbilical vein endothelial cells. *J Biol Chem* 1993;268:11982-11987.
128. Shariat-Mader Z, Mahdi F, Schmaier AH. Factor XI assembly and activation on human umbilical vein endothelial cells in culture. *Thromb Haemost* 2001;85:544-551.
129. Heimark RL, Schwartz SM. Binding of coagulation factors IX and X to the endothelial cell surface. *Biochem Biophys Res Commun* 1983;111:723-731.

130. Rodgers GM, Shuman MA. Characterization of the interaction between factor X_a and bovine aortic endothelial cells. *Biochim Biophys Acta* 1985;844: 320-329.
131. Stern DM, Nawroth PP, Kiesel W, et al. A coagulation pathway on bovine aortic segments leading to generation of factor X_a and thrombin. *J Clin Invest* 1984;74:1910-1921.
132. Bono F, Herault J-P, Avril C, et al. Human umbilical vein endothelial cells express high affinity receptors for factor X_a. *J Cell Physiol* 1997;172:36-43.
133. Stern DM, Drillings M, Nossel HL, et al. Binding of factors IX and IX_a to cultured vascular endothelial cells. *Proc Natl Acad Sci U S A* 1983;80:4119-4123.
134. Stern DM, Nawroth PP, Kiesel W, et al. The binding of factor IX_a to cultured bovine aortic endothelial cells: induction of a specific site in the presence of factors VIII and X. *J Biol Chem* 1985;260:6717-6722.
135. Shuman MA. Thrombin-cellular interactions. *Ann N Y Acad Sci* 1986;485: 228-239.
136. Motta G, Rojksjaer R, Hasan AAK, et al. High molecular weight kininogen regulates prekallikrein assembly and activation on endothelial cells: a novel mechanism for contact activation. *Blood* 1998;91:516-528.
137. Maruyama I, Salem HH, Majerus PW. Coagulation factor V_a binds to human umbilical vein endothelial cells and accelerates protein C activation. *J Clin Invest* 1984;74:224-230.
138. Cerveny TJ, Fass DN, Mann KG. Synthesis of coagulation factor V by cultured aortic endothelium. *Blood* 1984;63:1467-1474.
139. Rodgers GM, Shuman MA. Prothrombin is activated on vascular endothelial cells by factor X_a and calcium. *Proc Natl Acad Sci U S A* 1983;80:7001-7005.
140. Jaffe EA, Hoyer LW, Nachman RL. Synthesis of antihemophilic factor antigen by cultured human endothelial cells. *J Clin Invest* 1973;52:2757-2764.
141. Berrettini M, Schleaf RR, Heeb MJ, et al. Assembly and expression of an intrinsic factor IX activator complex on the surface of cultured human endothelial cells. *J Biol Chem* 1992;267:19833-19839.
142. Ratnoff OD, Everson B, Embury P, et al. Inhibition of the activation of Hageman factor (factor XII) by human vascular endothelial cell supernates. *Proc Natl Acad Sci U S A* 1991;88:10740-10743.
143. Brinkman H-JM, van Mourik JA. Vessel wall-mediated activation of the blood coagulation system. In: van Hinsberg VWM, ed. *Vascular control of hemostasis*. Amsterdam: Harwood Academic Publishers, 1996:85-106.
144. Mann KG, Lawson JH. The role of the membrane in the expression of the vitamin K-dependent enzymes. *Arch Pathol Lab Med* 1992;116:1330-1336.
145. Houdijk WPM, deGroot PF, Nievelstein PFEM, et al. Subendothelial proteins and platelet adhesion: von Willebrand factor and fibronectin, not thrombospondin, are involved in platelet adhesion to extracellular matrix of human vascular endothelial cells. *Arteriosclerosis* 1986;6:24-33.
146. Nemerson Y. Tissue factor and hemostasis. *Blood* 1988;71:1-8.
147. Courtney M-A, Haidaris PJ, Marder VJ, Sporn LA. Tissue factor mRNA expression in the endothelium of an intact umbilical vein. *Blood* 1996;87:174-179.
148. Drake TA, Cheng J, Chang A, Taylor FB. Expression of tissue factor, thrombomodulin, and E-selectin in baboons with lethal *Escherichia coli* sepsis. *Am J Pathol* 1993;142:1458-1470.
149. More L, Sim R, Hudson M, et al. Immunohistochemical study of tissue factor expression in normal intestine and idiopathic inflammatory bowel disease. *J Clin Pathol* 1993;46:703-708.
150. Hammerschmidt DE. Tissue factor expression in sickle cell anemia. *J Lab Clin Med* 2001;137:440.
151. Speiser W, Kapiotis S, Kopp CW, et al. Effect of intradermal tumor necrosis factor- α -induced inflammation on coagulation factors in dermal vessel endothelium: an in vivo study of human skin biopsies. *Thromb Haemost* 2001;85:362-367.
152. Day SM, Reeve JL, Pedersen B, et al. Macrovascular thrombosis is driven by tissue factor derived primarily from the blood vessel wall. *Blood* 2005;105:192-198.
153. Coughlin SR. How the protease thrombin talks to cells. *Proc Natl Acad Sci U S A* 1999;96:11023-11027.

154. Vu TK, Hung DT, Wheaton VI, Coughlin SR. Molecular cloning of a functional thrombin receptor reveals a novel proteolytic mechanism of receptor activation. *Cell* 1991;64:1057-1068.
155. Alm A-K, Norstrom E, Sundelin J, Nystedt S. Stimulation of proteinase activated receptor-2 causes endothelial cells to promote blood coagulation in vitro. *Thromb Haemost* 1999;81:984-988.
156. Camerer E, Huang W, Coughlin SR. Tissue factor- and factor X-dependent activation of protease-activated receptor-2 by factor VII_a. *Proc Natl Acad Sci U S A* 2000;97:5255-5260.
157. Hattori R, Hamilton KK, Fugate RD, et al. Stimulated secretion of von Willebrand factor is accompanied by rapid redistribution to the cell surface of the intracellular granule membrane protein GMP-140. *J Biol Chem* 1989;264:7768-7771.
158. McNamara CA, Sarembock IJ, Gimple LW, et al. Thrombin stimulates proliferation of cultured rat aortic smooth muscle cells by a proteolytically activated receptor. *J Clin Invest* 1993;91:94-98.
159. Mirza H, Yatsula V, Bahou WF. The proteinase activated receptor-2 (PAR-2) mediates mitogenic responses in human vascular endothelial cells. *J Clin Invest* 1996;97:1705-1714.
160. Griffin CT, Srinivasan Y, Zheng Y-W, et al. A role for thrombin receptor signaling in endothelial cells during embryonic development. *Science* 2001;293:1666-1670.
161. Hirano K. The roles of proteinase-activated receptors in the vascular physiology and pathophysiology. *Arterioscl Thromb Vasc Biol* 2007;27:27-36.
162. Liu L, Rodgers GM. Characterization of an inducible endothelial cell pro-thrombin activator. *Blood* 1996;88:2989-2994.
163. Koshikawa N, Nagashima Y, Miyagi Y, et al. Expression of trypsin in vascular endothelial cells. *FEBS Lett* 1997;409:442-448.
164. Miletich JP, Jackson CM, Majerus PW. Properties of the factor X_a binding site on human platelets. *J Biol Chem* 1978;253:6908-6916.
165. Rodgers GM, Shuman MA. Enhancement of prothrombin activation on platelets by endothelial cells and mechanism of activation of factor V. *Thromb Res* 1987;45:145-152.
166. Pathak A, Zhao R, Monroe DM, et al. Thrombin generation in vascular tissue. *J Thromb Haemost* 2006;4:60-67.
167. Jackman RW, Beeler DL, VandeWater L, Rosenberg RD. Characterization of a thrombomodulin cDNA reveals structural similarity to the low density lipoprotein receptor. *Proc Natl Acad Sci U S A* 1986;83:8834-8838.
168. Moore KL, Esmon CT, Esmon NL. Tumor necrosis factor leads to the internalization and degradation of thrombomodulin from the surface of bovine aortic endothelial cells in culture. *Blood* 1989;73:159-165.
169. Dittman WA, Majerus PW. Structure and function of thrombomodulin: a natural anticoagulant. *Blood* 1990;75:329-336.
170. Bevilacqua MP, Schleef RR, Gimbrone MA, Loskutoff DJ. Regulation of the fibrinolytic system of cultured human vascular endothelium by interleukin 1. *J Clin Invest* 1986;78:587-591.
171. Hathcock JJ. Flow effects on coagulation and thrombosis. *Arterioscl Thromb Vasc Biol* 2006;26:1729-1737.
172. Garcia-Cardena G, Comander J, Anderson KR, et al. Biomechanical activation of vascular endothelium as a determinant of its functional phenotype. *Proc Natl Acad Sci U S A* 2001;98:4478-4485.
173. Matsumoto Y, Kawai Y, Watanabe K, et al. Fluid shear stress attenuates tumor necrosis factor- α -induced tissue factor expression in cultured human endothelial cells. *Blood* 1998;91:4164-4172.
174. Dekker RJ, van Soest S, Fontijn RD, et al. Prolonged fluid shear stress induces a distinct set of endothelial cell genes, most specifically lung Kruppel-like factor (KLF2). *Blood* 2002;100:1689-1698.
175. Aird WC, Edelberg JM, Weiler-Guettler H, et al. Vascular bed-specific expression of an endothelial cell gene is programmed by the tissue microenvironment. *J Cell Biol* 1997;138:1117-1124.
176. Charo IF, Shak S, Karasek MA, et al. Prostaglandin I₂ is not a major metabolite of arachidonic acid in cultured endothelial cells from human foreskin microvessels. *J Clin Invest* 1984;74:914-919.

177. Speiser W, Anders E, Preissner KT, et al. Differences in coagulant and fibrinolytic activities of cultured human endothelial cells derived from omental tissue microvessels and umbilical veins. *Blood* 1987;69:964-967.
178. Everett AD, Le Cras TD, Xue C, Johns RA. eNOS expression is not altered in pulmonary vascular remodeling due to increased pulmonary blood flow. *Am J Physiol* 1998;274:L1058-L1065.
179. Mosnier LO, Meijers JCM, Bouma BN. Regulation of fibrinolysis in plasma by TAFI and protein C is dependent on the concentration of thrombomodulin. *Thromb Haemost* 2001;85:5-11.
180. Morigi M, Galbusera M, Binda E, et al. Verotoxin-1-induced up-regulation of adhesive molecules renders microvascular endothelial cells thrombogenic at high shear stress. *Blood* 2001;98:1828-1835.
181. Broeders MAW, Tangelder G-J, Slaaf DW, et al. Endogenous nitric oxide protects against thromboembolism in venules but not in arterioles. *Arterioscler Thromb Vasc Biol* 1998;18:139-145.
182. Chi JT, Chang HY, Haraldsen G, et al. Endothelial cell diversity revealed by global expression profiling. *Proc Natl Acad Sci U S A* 2003;100: 10623-10628

Part III - Transfusion Medicine

Chapter 20 Red Cell, Platelet, and White Cell Antigen

> Table of Contents > Part III - Transfusion Medicine > Chapter 20 - Red Cell, Platelet, and White Cell Antigen

Chapter 20

Red Cell, Platelet, and White Cell Antigen

Kathryn E. Webert

James W. Smith

Donald M. Arnold

Howard H. W. Chan

Nancy M. Heddle

John G. Kelton

INTRODUCTION

This chapter reviews the biochemistry and importance of various blood group antigens with a focus on red cells, platelets, and white blood cells. Because the circulating blood cells originate from a common progenitor cell, it is not surprising that there are a number of common blood group antigens. But what is surprising is the fact that the various cell lineages have so many unique and different antigens.

Studies characterizing the red cell antigens were first performed approximately 100 years ago, whereas studies investigating the platelet and white cell antigens were performed much more recently. There are a number of explanations for this, including the earlier recognition of red cells and the early attempts to transfuse these cells. Additionally, red cells have proved to be not only more plentiful, but also easier for investigators to work with. Indeed, the early techniques used to study red cell antigens, such as primary and secondary agglutination reactions using direct and indirect antiglobulin tests, proved so robust that they are still used today.

The nomenclature used for red cells is complex, yet historically interesting. Until recently, there was no attempt to be systematic. In the past, some blood groups were named after the individual (Kell is derived from Mrs. Kellner) or animal (Rh is derived from the rhesus monkey) lacking the antigen. Others were named after the discoverers (e.g., LW was named for Landsteiner and Weiner). Finally, some names are best described as quaint (e.g., the Lutheran blood group system was named according to a mislabeled blood sample). As is discussed, a more systematic approach for naming antigenic systems of red cells, platelets, and white cells is now used. However, the traditional names are still frequently used and, to add to the confusion, a number of laboratories continue to use other traditional nomenclatures (e.g., the Fisher-Race terminology continues to be used for the Rh system).

For biologists, a compelling question presents itself: What are the purposes of blood group antigens? For the majority of antigens, the answer is unknown, but there is increasing evidence that suggests certain antigens participate in host defense. Blood group antigens of red cells, platelets, and white cells can be made of proteins, carbohydrates attached to proteins, or lipids. Within each category, the antigen can be intrinsically produced during the formation of that cell, or it can be adsorbed from the plasma. Similarly, the antigens can be attached to the surface of the cell, can be partially embedded within the membrane (phosphatidylinositol glycan), or can be transmembrane. Recognizing this, investigators have grouped red cell antigens according to the functional activities of their associated carbohydrate, lipid, or protein.^{1,2} These include functions such as membrane stabilization, transport across the membrane, receptor function, enzymatic activity, and others. However, it is important to emphasize that although these blood group antigens are one component of this particular function, there is little evidence that they exist solely for this function. Consequently, although it is interesting to understand how a protein or carbohydrate associated with a blood group antigen contributes to a cell's integrity, it may not be the sole explanation for the presence of the antigen.

Any discussion of blood group antigens must touch on disease associations. In this review, we also comment on generally agreed on associations. Readers should be cautious about the reported associations between certain blood groups and diseases, as these associations could be collateral to other factors. However, there is general agreement that infectious agents, especially parasites and some bacteria, have led to blood group antigenic selection. Perhaps this is best exemplified by the geographic distribution of the Duffy blood group system, which is encoded by two alleles. The Fy(a-b-) phenotype is rare in most populations, with the exception being blacks originating from West Africa. Studies have demonstrated that the Duffy glycoprotein can serve as a receptor for *Plasmodium vivax*, an etiologic agent of malaria; hence, there is a strong selection advantage for those individuals not expressing this glycoprotein (i.e., Fy [a-b-]).

These dramatic observations and other studies provide indirect evidence that perhaps the major biologic advantage of antigens on cells is to enhance the ability of the species to distinguish self from non-self. Hence, one can anticipate in the ongoing "evolutionary warfare" between species and their invaders that when a microorganism uses a component of a blood group to invade that cell, spontaneous mutations producing another blood group would have a selective advantage. Additionally, nonhazardous mutations, which do not provide advantage or disadvantage, might not necessarily be deleted. It is likely that this helps to explain the enormous number of blood groups found on red cells, platelets, and white cells. Some of these blood groups are common (typically termed public systems within the platelet nomenclature), whereas others are rare (termed private systems).

This chapter summarizes red cell and platelet blood groups by first summarizing the approach to nomenclature and then reviewing the common blood groups.

P.510

RED BLOOD CELL ANTIGENS

In humans, 33 blood group systems with 298 antigens have been identified.^{3,4,5} Additional antigens have been identified but have not been assigned to established systems. Red blood cell antigens may be proteins, glycoproteins, or glycolipids. Most red cell antigens are synthesized by the red cells; however, some antigens, such as those of the Lewis and Chido/Rodgers systems, are adsorbed onto the red cell membrane from the plasma. Some red cell antigens are specific to red cells; however, others are found on other cells throughout the body.

The importance of red cell antigens is multifold. Since the work of Landsteiner in the early 1900s, it has been recognized that knowledge and understanding of blood groups are essential for transfusion therapy. In routine practice, it is necessary to determine the compatibility of certain red blood cell antigens between the blood donor and the blood recipient. This is because individuals who lack antigens on their red blood cells can form alloantibodies, or be alloimmunized, if they are exposed to blood expressing the antigen. This might occur with transfusion of blood products or during pregnancy. Antibodies that react with red blood cell antigens can cause problems such as delayed and immediate hemolytic transfusion reactions (HTRs) and hemolytic disease of the newborn (HDN). Furthermore, the study of red cell antigens and the associated membrane structures allows for a greater understanding of the physiology of red blood cells. For example, abnormalities of some blood group systems, such as Rh and Kell, may be associated with both functional and morphologic changes in the red cells. Finally, study of the inheritance of blood group antigens provides a greater understanding of the mechanisms of gene expression.

In this chapter, the red cell antigen groups are presented in order of relative clinical importance. The summary tables, given in each antigen section, list important clinical information and the most important antigens of each blood group

system. As noted, many red cell antigens (as well as the platelet antigens) have an interesting but inconsistent approach to nomenclature. However, because these names are commonly used, they are used along with the nomenclature proposed by the International Society of Blood Transfusion (ISBT).

International Society of Blood Transfusion Terminology

The ISBT Working Party on Terminology for Red Cell Surface Antigens was established in 1980 with the goal of creating a uniform nomenclature. Blood antigens were categorized into systems, collections, and series. The most recent monograph produced by the Working Party was produced in 2004 and included blood group antigens categorized into 29 systems, six collections, and two series.⁶ Updates to this monograph have been published online (<http://ibgri.blood.co.uk/ibgri/ISBT%20Pages/ISBT%20terminology%20pages/terminology%20Home%20page.htm#system>) and there are now 30 systems recognized.

Systems

A blood group system is genetically discrete from other blood group systems and consists of one or more antigens governed by either a single gene locus or a complex of two or more closely linked genes with virtually no recombination events occurring among them. Furthermore, it must be defined by a human alloantibody, and the gene encoding it must have been identified and sequenced. There are currently 30 recognized systems (Table 20.1).

Collections

The concept of collections was introduced into the ISBT terminology in 1988 to bring together related sets of antigens (genetically, biochemically, or serologically), which could not correctly be classified as systems because they have not been shown to be genetically distinct from all existing systems. Seven collections are currently recognized (Table 20.2).

Series

An antigen may be assigned a number if it is a low-frequency antigen (the 700 series) or if it is a high-frequency antigen (the 901 series). A low-frequency antigen is an antigen that has an incidence of <1% in most populations tested, similar to the platelet designation of "private." The 700 series currently consists of 18 antigens (Table 20.3). High-frequency antigens are antigens with an incidence of >90% in most populations, similar to the platelet "public" system. Originally, high-frequency antigens were assigned to the 900 series. However, because so many of the original antigens assigned to the 900 series have been reassigned to collections, the 901 series was created. There are currently six antigens in the 901 series (Table 20.4).

Each blood group antigen is given an identification number consisting of six digits. The first three numbers represent the system to which the antigen has been assigned. The second three digits identify the antigen. Each system also has an alphabetic symbol. For example, the ABO system is number 001, and the A antigen is the first antigen of that system; thus, it has the ISBT number 001001 or ABO001. By convention, the zeros may be omitted, and numbers are separated by a dot (i.e., the A antigen would be 1.1 or ABO1). This terminology is useful for databases and as a classification system; however, most clinical laboratories still use traditional terminology.

Red Cell Blood Group Systems

ABO (ISBT 001) and Hh (ISBT 018) Blood Group Systems

SUMMARY OF IMPORTANT CHARACTERISTICS OF ABO ANTIBODIES

Antibody Specificity	Clinically Significant	Antibody Class	Frequency of Antigen-Negative Blood HDNHTR(White Population)		
Anti-A	Yes	IgM; some IgG	Yes	Yes	Common (53%)
Anti-B	Yes	IgM; some IgG	Yes	Yes	Common (87%)

HDN, hemolytic disease of the newborn; HTR, hemolytic transfusion reaction; Ig, immunoglobulin.

The ABO blood group system was discovered by Landsteiner in 1900 when he noticed that the red cells of some individuals could be agglutinated by the serum of others. It remains the most important of all blood group systems for several reasons: (a) when the ABO antigen is not expressed on the red cell, individuals always have ABO antibodies in their plasma, with the stimulus for antibody production being a variety of environmental agents; and (b) the ABO antibodies

formed are frequently mixtures of both immunoglobulin M (IgM) and IgG antibodies, both having thermal reactivity at 37°C and both capable of activating complement.

These unique characteristics of the antigens and antibodies of the ABO blood group system provide optimal conditions for rapid

P.511

P.512

red cell destruction if ABO-incompatible blood is transfused: A clinical scenario termed an acute HTR.

TABLE 20.1 BLOOD GROUP SYSTEMS

IS System BT Name No.(symbol)	No. of Antigens	Antigen(s)	Gene Name(s)		Gene Product(s)	Chromosomal Location
			ISB T	HGN C		
001 ABO (ABO)	4	A, B, AB, A1	<i>ABO</i>	<i>ABO</i>	A = α -3-N-acetyl-D-galactosaminyltransferase B = α -3-D-galactosyltransferase	9q34.2
002 MNS (MNS)	46	M, N, S, s, U, He, Mi ^a , M ^c , Vw, Mur, M ^g , Vr, M ^e , Mt ^a , St ^a , Ri ^a , Cl ^a , Ny ^a , Hut, Hil, M ^v , Far, s ^D , Mit, Dantu, Hop, Nob, En ^a , En ^a KT, N', Or, DANE, TSEN, MINY, MUT, SAT, ERIK, Os ^a , ENEP, ENEH, HAG, ENAV, MARS, ENDA, ENEV, MNTD	<i>MNS</i>	<i>GYP A</i> <i>GYP B</i> <i>GYP E</i>	Glycophorin A (GYPA) Glycophorin B (GYPB) Glycophorin E (GYPE)	4q31.21
003 P (P1)	3		P1, P ^K , NOR	<i>PI</i>		22q11.2- qter
004 Rh (RH)	54	D, C, E, c, e, f, Ce, C ^w , C ^x , V, E ^w , G, Hr _o , Hr, hr ^s , VS, C ^G , CE, D ^w , c-like, cE, hr ^H , Rh29, Go ^a , hr ^B , Rh32, Rh33, Hr ^B , Rh35, Be ^a , Evans, Rh39, Tar, Rh41, Rh42, Crawford, Nou, Riv, Sec, Dav, JAL, STEM, FPTT, MAR, BARC, JAHK, DAK, LOCR, CENR, CEST, CELO, CEAG, PARG, CEVF	<i>RH</i>	<i>RHD</i> <i>RHCE</i>	Acetylated RhD protein Acetylated RhCE protein	1p36.11
005 Lutheran (LU)	20	Lu ^a , Lu ^b , Lu3, Lu4, Lu5, Lu6, Lu7, Lu8, Lu9, Lu11, Lu12, Lu13, Lu14, Lu16, Lu17, Au ^a ,	<i>LU</i>	<i>B-CAM</i>	B-cell adhesion molecule	19q12- q13

		Au ^b , Lu20, Lu21, LURC					
006Kell (KEL)	35	K, k, Kp ^a , Kp ^b , Ku, Js ^a , Js ^b , U1 ^a , K11, K12, K13, K14, K16, K17, K18, K19, Km, Kp ^c , K22, K23, K24, VLAN, TOU, RAZ, VONG, KALT, KTIM, KYO, KUCI, KANT, KASH, KELP, KETI, KHUL, KYOR	<i>KEL KEL</i>	Zinc endopeptidase	7q33		
007Lewis (LE)	6	Le ^a , Le ^b , Le ^{ab} , Le ^{bH} , ALe ^b , BLe ^b	<i>LE</i>	<i>FUT3</i>	α -1,3/1,4-L- Fucosyltransferase	19p13.3	
008Duffy (FY)	6	Fy ^a , Fy ^b , Fy3, Fy4, Fy5, Fy6	<i>FY</i>	<i>DARC</i>	Duffy antigen receptor for chemokines	1q21-q22	
009Kidd (JK)	3	Jk ^a , Jk ^b , JK3	<i>JK</i>	<i>SLC14A1</i>	Urea transporter	18q11- q12	
010Diego (DI)	22	Di ^a , Di ^b , Wr ^a , Wr ^b , Wd ^a , Rb ^a , WARR, ELO, Wu, Bp ^a , Mo ^a , Hg ^a , Vg ^a , Sw ^a , BOW, NFLD, Jn ^a , KREP, Tr ^a , Fr ^a , SW1, DISK	<i>DI</i>	<i>SLC4A1</i>	Anion exchanger 1, solute carrier family 4/band 3	17q12- q21	
011Yt (YT)	2	Yt ^a , Yt ^b	<i>YT</i>	<i>ACHE</i>	Acetylcholinesterase	7q22	
012Xg (XG)	2	Xg ^a , CD99	<i>XG</i>	<i>XG</i>	Xg ^a glycoprotein	Xp22.32	
013Scianna (SC)	7	Sc1, Sc2, Sc3, Rd, STAR, SCER, SCAN	<i>SC</i>	<i>ERMAP</i>	Erythrocyte membrane- associated protein (ERMAP)	1p34	
014Dombrock (DO)	8	Do ^a , Do ^b , Gy ^a , Hy, Jo ^a , DOYA, DOMR, DOLG	<i>DO</i>	<i>ART4</i>	ADP-ribosyltransferase	412p13.2- q13.3	
015Colton (CO)	4	Co ^a , Co ^b , Co3, Co4	<i>CO</i>	<i>AQP1</i>	Aquaporin-1 (AQP1)	7p14	
016Landsteine r-Wiener (LW)	3	LW ^a , LW ^{ab} , LW ^b	<i>LW</i>	<i>ICAM4</i>	Intracellular adhesion molecule 4 (ICAM4)	19p13.2- cen	
017Chido/Rod gers (CH/RG)	9	Ch1, Ch2, Ch3, Ch4, Ch5, Ch6, WH, Rg1, Rg2	<i>CH/ RG</i>	<i>C4B/C 4A</i>	Complement component protein[en]Complement component 4B protein	6p21.3	
018H (H)	1	H	<i>H</i>	<i>FUT1</i>	Galactoside 2- α -L- fucosyltransferase 1	19q13.1- qter	
019Kx (XK)	1	Kx	<i>KX</i>	<i>XK</i>	Membrane transport protein XK	Xp21.1	
020Gerbich (GE)	11	Ge2, Ge3, Ge4, Wb, Ls ^a , An ^a , Dh ^a , GEIS, GEPL, GEAT, GET1	<i>GE</i>	<i>GYP</i>	Glycophorin C (GPC) and GPD (glycophorin C precursor)	2q14-q21	
021Cromer (CROM)	18	Cr ^a , Tc ^a , Tc ^b , Tc ^c , Dr ^a , Es ^a , IFC, WES ^a , WES ^b , UMC, GUTI,	<i>CRO M</i>	<i>CD55</i>	CD55/decay accelerating factor (DAF)	1q32	

		SERF, ZENA, CROV, CRAM, CROZ, CRUE, CRAG			
022Knops (KN)	9	Kn ^a , Kn ^b , McC ^a , S11, Yk ^a , McC ^b , S12, S13, KCAM	<i>KN</i>	<i>CR1</i>	CD35/CR1 1q32
023Indian (IN)	4	In ^a , In ^b , INFI, INJA	<i>IN</i>	<i>CD44</i>	CD44 11p13
024Ok (OK)	3	Ok ^a , OKGV, OKVM	<i>OK</i>	<i>BSG</i>	Basigin 19p13.3
025Raph (RAPH)	1	MER2	<i>RAP</i>	<i>CD151</i>	CD151 11p15.5
026John Milton Hagen (JM)	6	JMH, JMHK, JMHL, JMHG, JMHM, JMHQ	<i>JMH</i>	<i>SEMA</i> 7A	Semaphorin 7A 15q22.3- q23
027I (I)	1	I	<i>I</i>	<i>GCNT</i> 2	I-β-1, 6-N- acetylglucosaminyltrans- ferase A 6p24.2
028Globoside (GLOB)	1	P	<i>GLOB</i> <i>B</i>	<i>3GA</i> <i>LNT1</i>	UDP-N-acetyl- galactosamine globo- triaosylceramide 3-β-N acetylgalactosaminyl- transferase 3q25
029Gill (GIL)	1	GIL	<i>GIL</i>	<i>AQP3</i>	Aquaporin-3 (AQP3) 9p13
030Rh- associated glycoprotei n (RHAG)	4	Duclos, Ol ^a , DSLK ^a , RHAG 4	<i>RHA</i>	<i>RHAG</i> <i>G</i>	6p12.3
031Forssman (FOR)	1	FORS1	<i>GBG</i> <i>GBGT</i>	<i>T1</i>	globoside alpha-1,3-N- acetylgalactosaminyltran- sferase 1 9q34.13- q34.3
032JR	1	Jr ^a	<i>ABC</i> <i>G2</i>	<i>ABCG</i> 2	ATP-binding cassette, sub-family G (WHITE), member 2 4q22.1
033LAN	1	LAN	<i>ABC</i> <i>B6</i>	<i>ABCB</i> 6	ATP-binding cassette, sub-family B (MDR/TAP), member 6 2q36

HCNC, HUGO gene nomenclature committee (www.genenames.org); ISBT, International Society of Blood Transfusion; No, number.

Data from Daniels GL, Fletcher A, Garratty G, et al. International Society of Blood Transfusion Working Party on terminology for red cell surface antigens. *Vox Sang* 2004;87:304-316; Denomme GA, Rios M, Reid ME. Molecular protocols in transfusion medicine. San Diego, CA: Academic Press, 2000; Logdberg L, Reid MA, Lamont RE, et al. Human Blood Group Genes 2004: chromosomal locations and cloning strategies. *Transfus Med Rev* 2005;19:45-57; Costa FP, Hue-Roye K, Sausais L, et al. Absence of DOMR, a new antigen in the Dombrock blood group system that weakens expression of Do(b), Gy(a), Hy, Jo(a), and DOYA antigens, *Transfusion* 2010; 50:2026-2031; Smart EA and Storry JR. The OK blood group system: a review. *Immunohematology* 2010; 26:124-126; Walker PS,

Reid ME. The Gerbich blood group system: a review. *Immunohematology* 2010; 26:124-126; and International Society of Blood Transfusion Working Party on terminology for red cell antigens web site:

http://www.isbtweb.org/fileadmin/user_upload/WP_on_Red_Cell_Immunogenetics_and/Updates/Table_of_blood_group_antigens_within_systems_v3_2_130331.pdf Accessed April 3, 2013

There are three alleles of the ABO gene in the ABO blood group system (A, B, and O) that are inherited in Mendelian fashion (Table 20.1). Both A and B are codominant alleles, whereas O is a recessive allele. Hence, these three result in four different phenotypes: A, B, AB, and O. An individual with the A phenotype can be homozygous for the A gene (AA) or heterozygous (AO). Similarly, the B phenotype can be the result of homozygous (BB) or heterozygous (BO) gene inheritance. The genotype of the AB phenotype is AB, and the group O phenotype is always genetically OO. Thus, there are four ABO group phenotypes (A, B, AB, and O) that arise from six possible genotypes (AA, AO, BB, BO, AB, and OO). The alleles normally occupy the same position of a paired chromosome. Rarely, individuals may express a cisAB phenotype in which the A and B alleles appear to be carried on the same chromosome. This phenomenon is caused by a collection of mutant ABO alleles that encode a glycosyltransferase capable of synthesizing both A and B antigens.⁷

The frequencies of ABO phenotypes are variable among different ethnic populations. In whites, the O and A phenotypes are the most common, occurring in >40% of the population. The B phenotype is found in approximately 10% of whites, and the AB phenotype is encountered in only 3% of individuals. In contrast, around the world, the O phenotype is the most common ABO phenotype, particularly in South and Central America. The A phenotype is found in 10 to 35% of individuals throughout the world with the highest frequency among the aborigines of northern Scandinavia and northern America.

ABO Gene

The ABO gene is located at 9q34.2. The gene consists of at least seven exons spanning over 18 kb in the DNA genome. The A and B alleles result from differences in seven nucleotides, resulting in different substrate specificity of the encoded enzyme. The difference in substrate specificity is mainly determined by the amino acids 266 and 268 in exon 7.⁸ The O phenotype is due to either a frameshift mutation leading to a stop codon or, rarely, a mutation producing a nonfunctional enzyme. Numerous mutations are found in ABO, but the most common mutation results in the A₂ phenotype. In A₂, the A allele of the ABO gene has two nucleotides different from the A₁ phenotype, which results in diminished enzymatic activity and, consequently, weakened antigen expression. For example, a red cell with A₁ phenotype carries more than 800,000 A antigens, but only 250,000 A antigens are present in a red cell with the phenotype A₂.⁹ Similarly, weak subgroups of group B have been described due to mutations of the B allele of the ABO gene.

ABO Antigens

The antigens of the ABO system are located on carbohydrate oligosaccharide chains, which are parts of glycosphingolipids or gp molecules. There are four different types of oligosaccharide chains: Type 2 and type 4 oligosaccharide chains are predominantly on the red cell membrane; type 1 chains are found in plasma, saliva, and body fluids; and type 3 chains are found in the mucins secreted by gastric mucosa or ovarian cysts.

The ABO gene does not encode directly for the antigens but encodes for enzymes that add specific sugars to the red cell membrane. These sugars are the ABO red cell antigens that are detectable with serologic testing. The A allele encodes for the $\alpha(1,3)$ N-acetyl-galactosaminyl-transferase which adds an N-acetylgalactosamine to the red cell membrane. The B allele encodes for the $\alpha(1,3)$ galactosyltransferase which adds a galactose to the red cell membrane. In an individual with the AB phenotype, the A and B transferases coexist and compete for the same substrate. The O

P.513

allele encodes for a nonfunctional transferase; hence, a specific sugar is not attached to the red cell membrane. Mutations of the A and B alleles result in amino acid substitutions within the transferases, and this translates into weakened expression of the A and B antigens (frequently classified as subgroups). The most common subgroups associated with the A allele are A₁ and A₂. The A₁ subgroup occurs in approximately 80% of group A individuals, and the A₂ subgroup is present in approximately 20%. The other subgroups of A are less frequently encountered, with the A₃ subgroup being the next most frequent, occurring in 1 in 1,000 individuals. The clinical relevance of A and B subgroups is of greater significance in blood donors than recipients. Because of the weakened antigen expression on the red cells of an individual who has inherited a subgroup allele, it is possible that serologic phenotyping of red cells results in misclassification of the red cell phenotype as group O. For a blood recipient, this would not be a problem, as group O blood is compatible with all other

groups (universal donor); however, if a donor unit of blood from an individual with an A or B subgroup is misclassified as group O and transfused to an O individual, intravascular hemolysis could result.

TABLE 20.2 COLLECTIONS OF ANTIGENS

ISBT Number	Name	Symbol	Antigen Number	Antigen Symbol	Antigen Incidence (%)	
205	Cost	COST	205001	Cs ^a	95	
			205002	Cs ^b	34	
207	Ii	I	207002	I	^a	
208	Er	ER	208001	Er ^a	>99	
			208002	Er ^b	<1	
			208003	Er3	>99	
209		GLOB	209002	P ^k	>99 ^a	
			209003	LKE	98	
210			210001	Le ^c	1	
			210002	Le ^d	6	
212	Vel	VEL	212001	Vel	>99	
			212002	ABTI	>99	
213		MN	213001	Hu		
			CHO	213002	M ¹	
				213003	Tm	
				213004	Can	
				213005	Sext	
213006	Sj					

ISBT, International Society of Blood Transfusion.

^aBy standard serologic tests, may appear to be low incidence. Reference: International Society of Blood Transfusion Working Party on Terminology for Red Cell Antigens web site: http://www.isbtweb.org/fileadmin/user_upload/WP_on_Red_Cell_Immunogenetics_and/Table_of_collections_v3.0_121028.pdf. Accessed April 3, 2013.

On the red cell membrane, both the A and B transferases add sugar moieties to a substrate that is encoded by the H (FUT1) gene. FUT1 is located at chromosome 19q13.1-qter, and the genes inherited at this locus are inherited in a Mendelian manner. Two alleles have been identified at this locus: H and h. The allele H, most frequently inherited, encodes for an enzyme termed H transferase type II [$\alpha(1,2)$ fucosyl-transferases; FUT1], which adds an L-fucose to the terminal galactose molecule of oligosaccharide chains in an $\alpha(1-2)$ linkage. This structure is called H substance, and it is to this structure that the A and B transferases add specific sugars resulting in A and B antigens. The rare allele sometimes inherited at the H locus is h. This h allele encodes for a nonfunctional transferase. If the h allele is inherited in the homozygous state (hh), L-fucose molecules (H substance) are not present on the red cell membrane. Without the presence of H substance on the red cell membrane, the A and B transferases, even when present, are not able to add the specific sugars that give A and B antigen specificity. This hh genotype is known as the Bombay phenotype: Serologically, the red cells group as O; however, unlike the true O phenotype, which has large amounts of H antigen on the red cells, red cells from the Bombay phenotype lack H antigen (Fig. 20.1). Children of a parent with the Bombay phenotype (hh) may have normal A or B antigen expression, or both, if they inherit

the dominant H allele from the other parent. The clinical relevance of the Bombay phenotype relates to the ability of these individuals to form not only anti-A and anti-B but also anti-H. The presence of all three of these antibodies makes it difficult to find compatible blood if transfusion is required. The only compatible blood for an individual with the Bombay (hh) phenotype is blood from another Bombay individual, and this phenotype is extremely rare.

TABLE 20.3 THE 700 SERIES (LOW-INCIDENCE ANTIGENS)

ISBT Number	Name	Symbol
700002	Batty	By
700003	Christiansen	Chr ^a
700005	Biles	Bi
700006	Box	Bx ^a
700017	Torkildsen	To ^a
700018	Peters	Pt ^a
700019	Reid	Re ^a
700021	Jensen	Je ^a
700028	Livesay	Li ^a
700039	Milne	
700040	Rasmussen	RASM
700044		JFV
700045	Katagiri	Kg
700047	Jones	JONES
700049		HJK
700050		HOFM
700052		SARA
700054		REIT

ISBT, International Society of Blood Transfusion.

Reference: International Society of Blood Transfusion Working Party on Terminology for Red Cell Antigens web site:

http://www.isbtweb.org/fileadmin/user_upload/WP_on_Red_Cell_Immunogenetics_and/Table_of_low_incident_antigens_700_series_v2.0_110914.pdf. Accessed April 3, 2013.

TABLE 20.4 THE 901 SERIES (HIGH-INCIDENCE ANTIGENS)

ISBT Number	Name	Symbol	Incidence (%)	Implicated in Hemolytic Disease of the Newborn and/or Hemolytic Transfusion Reaction
901003	August	At ^a	>99	Yes
901008		Emm	>99	No
901009	Anton	AnWj	>99	Yes
901011	Sid	Sd ^a	91	No
901014		PEL	>99	Yes
901016		MAM	>99	Yes

ISBT, International Society of Blood Transfusion.

Adapted from International Society of Blood Transfusion Working Party on Terminology for Red Cell Antigens web site:

http://www.isbtweb.org/fileadmin/user_upload/WP_on_Red_Cell_Immunogenetics_and/Table_of_high_incidence_antigens_901_series_v3.0_121028.pdf. Accessed April 3, 2013.

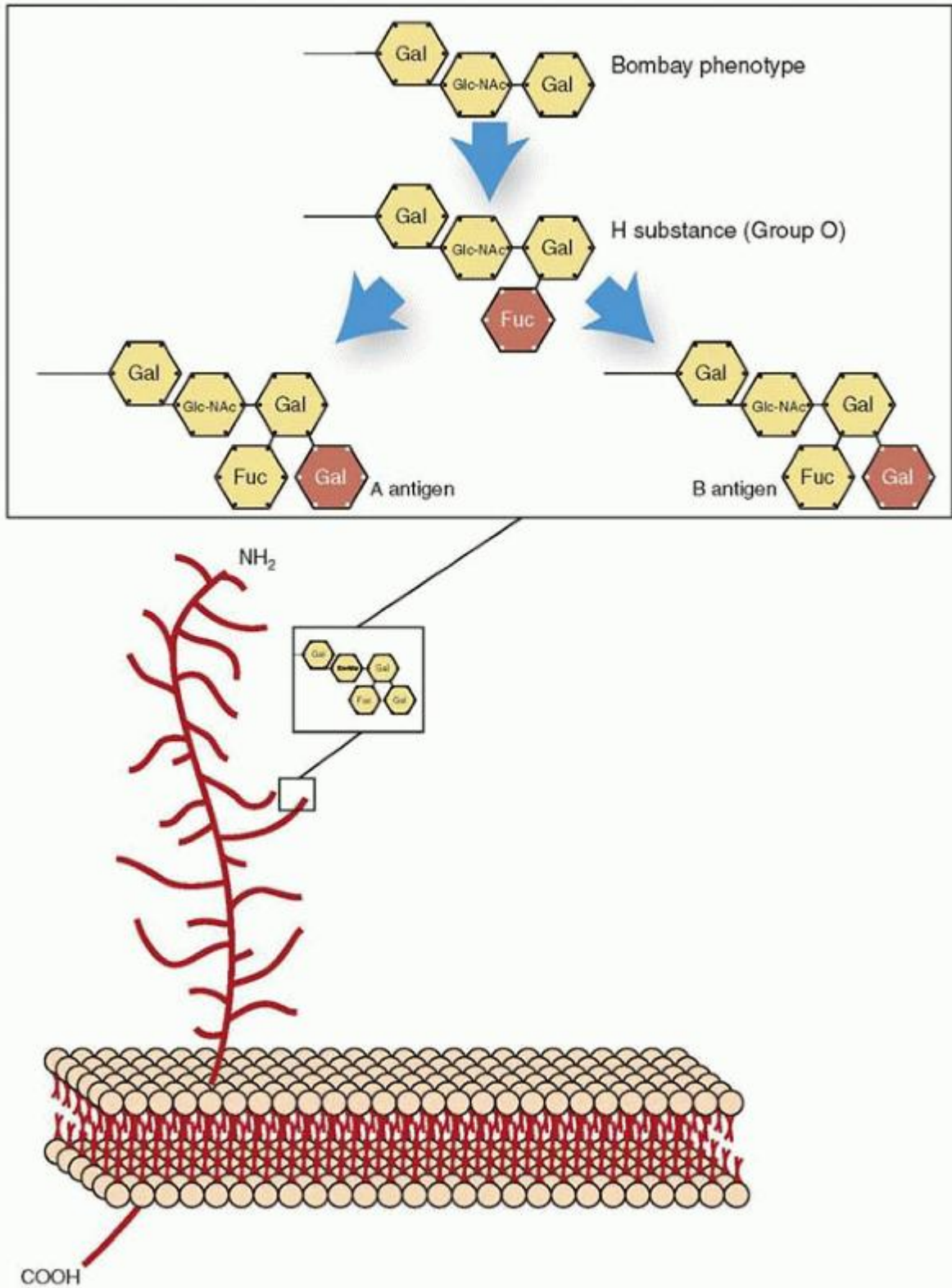

FIGURE 20.1 Biosynthesis of ABO blood group antigens. The antigens of the ABO system are located on the carbohydrate of type II oligosaccharides. H transferase is required to add fucose to the oligosaccharide chain and form H substance. Without the presence of H substance, A transferase and B transferase are not able to add terminal sugar moieties to the oligosaccharide chain. Fuc, l-fucose; Gal, d-galactose; Glc-NAc, d-N-acetyl-glucosamine.

The ABO(H) antigens are found not only on red cells, but also on other blood cells; in most body fluids (except cerebrospinal fluid); and on the cell membranes of tissues such as intestine, urothelium, and vascular endothelium. The expression of ABO(H) antigens on the red cell membrane and tissue membranes is controlled by the FUT1 (H) gene. The expression of ABO(H) antigens into body fluids is controlled by the FUT2 (Se) gene. The FUT2 gene, similar to the FUT1 (H) gene, is located at chromosome 19 (19cen-qter); however, they are not part of the ABO system. The dominant Se allele codes for H transferase type 1 [$\alpha(1,2)$ fucosyltransferase; FUT2]. Without the prior addition of a fucose to the oligosaccharide chains, A and B antigens would not be expressed in the body secretions, irrespective of the presence of A and B transferases (Fig. 20.1).

Despite the wide distribution of ABO(H) antigens in various cell membranes and body fluids, the normal physiologic function of these glycoproteins and glycolipids is largely unclear. The carbohydrate moieties of the ABO(H) antigens might contribute to the formation of glycocalyx. However, based on the observation that individuals who lack all ABH antigens (Bombay phenotype) have normal red cell survival and function, the role of ABO antigens in maintaining a state of health is unknown.¹⁰ There is some evidence that ABO blood groups may be associated with certain diseases.¹¹ For example, the normal range of von Willebrand factor (vWF) antigen level varies among individuals with different ABO blood groups. Individuals with blood group O have the lowest vWF antigen level, followed by group A, then group B, and the highest levels in those with group AB.¹² However,

P.515

the normal range of vWF is generally defined as the level in the normal general population irrespective of the ABO blood group. It has been postulated that ABO antigen expression can affect the glycosylation, thus altering the proteolysis and clearance of vWF.^{13,14} Studies have shown that individuals with blood group O are less susceptible to arterial and venous thromboembolism possibly associated with a lower level of vWF.^{14,15} and ¹⁶ In addition, blood group ABO may be associated with resistance to certain infections and, therefore, may offer a survival advantage. For example, individuals with blood group O may be less susceptible to severe Plasmodium falciparum malaria,^{17,18} but may be more likely to have severe infection with Vibria cholerae O139^{19,20} or Escherichia coli O139.²¹ Gastric cancer and peptic ulcer disease have been reported to be more prevalent in individuals with blood group O^{22,23} because of the association between blood group O and a gastric pathogen, Helicobacter pylori. It has been shown that H. pylori binds more readily to gastric epithelium in group O individuals because of lack of expression of ABO and Lewis antigens in non-hematopoietic tissue (see also section on Lewis antigens).²⁴ In contrast, secretors of ABO and Lewis antigens in the gastrointestinal tract are more susceptible to norovirus,²⁵ rhinoviruses, echoviruses, influenza viruses, and respiratory syncytial virus.²⁶

Antibodies and Clinical Significance

All immunocompetent individuals produce antibodies against the missing ABO(H) blood group antigens (Table 20.5). Anti-A and anti-B production does not require red cell stimulation through transfusion or pregnancy but occurs predominately through environmental exposure, such as bacteria.²⁷ Anti-A and anti-B are usually detectable within 3 to 6 months after birth.²⁸ By the age of 5 years, the titers of anti-A and anti-B antibodies reach maximum and persist throughout adulthood. The titers of IgM anti-A and anti-B antibodies may gradually decline with advanced age.²⁹ Newborn infants do not usually have a significant amount of anti-A or anti-B in their plasma; therefore, pretransfusion testing is not usually required for transfusions within the first 4 months of life. Infants born to alloimmunized mothers are an exception to this rule, as other specific blood group antibodies may have crossed the placenta and may be present in the infant's circulation.

The “naturally occurring” anti-A and anti-B antibodies are predominantly IgM, although variable amounts of IgG may be present. Like most IgM immunoglobulins, ABO antibodies are especially effective at complement activation for two reasons: the antibodies have thermal activity most reactive at body temperature, and the high density of antigen sites on the red cell membrane allows for large numbers of antibodies to bind to the cell membrane. Therefore, the transfusion of ABO-incompatible blood typically presents as acute intravascular hemolysis. Anti-ABO antibodies, anti-human leukocyte antigen (HLA) antibodies, and anti-human platelet antigen (HPA) antibodies can cause alloimmunization resulting in platelet transfusion refractoriness.³⁰ The ABH expression on the platelet is linked to the red cell phenotype; yet the expression on the platelet may be determined mainly by the enzyme H transferase type II (FUT1).³¹

TABLE 20.5 SUMMARY OF ABO GENES AND ANTIGENS

Phenotype	Antibody	Antigen	Gene Product	Gene
A	Anti-B	N-acetylgalactosamine	A transferase	9q34.1-q34.2

B	Anti-A	D-galactose	B transferase	9q34.1-q34.2
AB	None	<i>N</i> -acetylgalactosamine and D-galactose	A transferase and B transferase	9q34.1-q34.2
O	Anti-A and anti-B	L-fucose	Absent or nonfunctional A or B transferase	Absent or nonfunctional gene
A ₂	Anti-B and variable amount of anti-A ₁	<i>N</i> -acetylgalactosamine	A transferase	9q34.1-q34.2

In allogeneic stem cell transplant, ABO incompatibility may cause hemolysis, pure red cell aplasia, and delayed engraftment of donor cells.³² However, ABO incompatibility may not affect the long-term survival.^{32,33} After ABO unmatched hematopoietic stem cell transplantation, the patient's red cells will switch to the donor's blood group. Due to the fact that ABO antigens are not limited to the red cells, peripheral tissue may continue to express the recipient's original antigens for life.³⁴ These isohemagglutinin will be adsorbed onto the red cells and cause ABO discrepancy during crossmatch.^{35,36} Similarly, in kidney transplantation, ABO-incompatible recipients have higher graft loss in the immediate posttransplant period, but the long-term survival is similar to those with ABO-mismatched recipients.³⁷ Moreover, delay in the production of ABO antibodies in infants may provide an "immunologic gap" for ABO-incompatible organ transplantation.³⁸

The antibodies against ABO antigens are not a major cause of HDN for several reasons. First, soluble A or B substance in the fetal plasma can neutralize the alloantibodies. Second, antigens A or B expressed on other body tissues may also bind alloantibodies. Third, alloantibodies against ABO antigens are specific for sugar molecules; these antibodies generally have a weaker binding affinity than anti-bodies reacting with protein antigens such as the D antigen.

In routine blood group typing, the transfusion recipient's red cells are typed using commercial sources of anti-A and anti-B antibodies (forward or cell typing). The presence of anti-A and anti-B in the serum/plasma of the recipient is detected by testing the serum/plasma against group A and group B red cells (reverse or serum typing). The interpretation of these two tests must agree for the patient's blood group to be assigned. Sometimes, the serum and cell grouping do not agree; this is termed ABO discrepancy. In these circumstances, the laboratory should proceed with additional testing to correctly identify the patient's ABO blood group. New technologies in blood group genotyping may identify and resolve these discrepancies.

Discrepancies in ABO grouping can be found in various conditions. For example, the ABO(H) antigens may be weakened in the donors with mutations of the ABO alleles. In patients with some types of leukemia or cancer, or having diseases associated with chromosome 9 translocations, the ABO(H) antigens may also be weakened and serologically typed as negative for that particular antigen. Alternatively, an individual may acquire an ABO antigen on the red cells; for example, one can acquire a B antigen after bacterial infections, or acquire an A antigen associated with Tn activation of the red cells.³⁹

P.516

Rh Blood Group System (ISBT 004)

SUMMARY OF IMPORTANT CHARACTERISTICS OF RH ANTIBODIES

Antibody Specificity	Clinically Significant	Antibody Class	Frequency of Antigen-Negative Blood HDNHTR(White Population)		
Anti-D	Yes	IgG; some IgM	Yes	Yes	Common (15%)

HDN, hemolytic disease of the newborn; HTR, hemolytic transfusion reaction; Ig, immunoglobulin.

The Rh blood group system was discovered by Landsteiner and Weiner in 1940.⁴⁰ They injected rabbits with red cells from the rhesus monkey, and the antibody produced was initially termed Rh and is now known as anti-D. Unlike the ABO blood group system, Rh antibodies are not environmentally stimulated; however, the D antigen is highly immunogenic, causing anti-D formation in up to 70% of D-negative individuals who are exposed to D-positive blood. Anti-D is IgG and is known to cause HTRs and HDN.

Rh Terminology

Three different systems of nomenclature have been developed to describe the genes and antigens of the Rh blood group system antigens: The Wiener system, the Fisher-Race system, and the Rosenfield numeric terminology. Wiener proposed that the Rh antigens were the products of a single gene.⁴¹ The Fisher-Race nomenclature was based on the theory that reactions observed with various Rh antisera could be explained by three pairs of allelic genes: Cc, Dd, and Ee.⁴² Genetic analysis does not support either of these models. However, both the Wiener notation and the Fisher-Race nomenclature remain widely used today because of familiarity. In 1962, Rosenfield et al. proposed a system of nomenclature that was based on serologic findings.⁴³ The symbols were used to convey phenotypic information rather than genetic information.⁴⁴ In this system, the antigens are numerically named in order of their discovery or assignment to the Rh blood group system. The various nomenclatures for common Rh system antigens are listed in Table 20.6.

TABLE 20.6 RH BLOOD GROUP SYSTEM: ANTIGENS

Rosenfield Numeric Terminology Fisher-Race Terminology Wiener Terminology

Rh1	D	Rh _o
Rh2	C	rh'
Rh3	E	rh''
Rh4	c	hr'
Rh5	e	hr''
Rh6	ce (f)	hr
Rh7	Ce	rh _i
Rh8	C ^w	rh ^{w1}
Rh9	C ^x	rh ^x
Rh10	V (Ce ^s)	hr ^v
Rh11	E ^w	rh ^{w2}
Rh12	G	rh ^G

Genes

The Rh antigens are encoded by two genes: RHD and RHCE. The genes are located at chromosome 1p36.11 (Table 20.1). RHD encodes for the D antigen, whereas RHCE encodes for the Cc and Ee antigens. The d antigen does not exist; however, by convention, d is used to connote the absence of the D antigen. RHD and RHCE each contain ten exons and are distributed over 69 kilobase pairs (kbp).⁴⁵ Both the RHD and the RHCE genes encode for similar polypeptides of 417 amino acids with 12 membrane-spanning domains.⁴⁵ In the red cell membrane, these two polypeptides form a complex with a glycoprotein termed the Rh-associated glycoprotein (RhAG), which is encoded by the RHAG gene (RH50) on chromosome 6. The RhAg and associated antigens have recently been designated the thirtieth blood group system. The structure of the Rh antigens suggests that they are transport proteins and the RhAG protein may play a role in the transport of ammonium. The Rh-associated proteins are transport proteins involved in ammonia/ammonium transport.^{46,47} The physiologic role of the Rh protein is poorly defined, but it has been suggested that these proteins may act to keep total blood ammonia low by trapping ammonium within the red blood cell.^{46,48}

Antigens

There are 54 antigens that have been assigned to the Rh blood group system: D, C, E, c, e, f, Ce, C^w, C^x, V, E^w, G, Hr_o, Hr, hr^s, VS, C^G, CE, D^w, c-like, cE, hr^H, Rh29, Go^a, hr^B, Rh32, Rh33, Hr^B, Rh35, Be^a, Evans, Rh39, Tar, Rh41, Rh42, Crawford, Nou, Riv, Sec, Dav, JAL, STEM, FPTT, MAR, BARC, JAHK, DAK, LOCR, CENR, CEST, CELO, CEAG, PARG, and CEVF (Table 20.1). Of the 54 antigens in the Rh blood group system, the most common and important are D, C, E, c, and e. Although individuals can become alloimmunized to the C, c, E, and e antigens after red cell exposure through transfusion or pregnancy, these antigens are much less immunogenic than D. Less than 3% of individuals exposed to the C, c, E, and e antigens become alloimmunized; hence, pretransfusion testing is not routinely performed to match for these antigens. The principal phenotypes of the Rh blood group system and their frequencies are outlined in Table 20.7.

An individual is considered to be Rh positive if his or her red cells express the D antigen. The term Rh negative refers to the absence of the D antigen. The absence of the D antigen occurs in approximately 15% to 17% of individuals in white populations and is less frequent in other populations.⁴⁹ In white populations, the absence of the D antigen is usually due to the deletion of the RHD gene.⁴⁹ In Asian and black populations, the absence of the D antigen is usually due to an inactive RHD rather than a gene deletion.^{50,51}

TABLE 20.7 RH BLOOD GROUP SYSTEM: PRINCIPAL PHENOTYPES

Fisher-Race	Wiener	Frequency (%)		
		Whites	Blacks	Asians
DCe	R ¹	42	17	70
DcE	R ²	14	11	21
Dce	R ⁰	4	44	3
DCE	R ^z	<0.01	<0.01	1
ce	r	37	26	3
Ce	r'	2	2	2
cE	r''	1	<0.01	<0.01
CE	r ^y	<0.01	<0.01	<0.01

P.517

Cis Product Antigens. Ce(rh₁) is an antigen that almost always accompanies C and e when they are encoded by the same haplotype.⁴⁴

Cc and Ee Variant Antigens. Various Rh antigens appear to be determined by alleles of the Cc and Ee antigens. Variants of C include C^w(Rh8), C^x(Rh9), and MAR. Variants of the E antigen include E^w(Rh11) and E^T(Rh24). Variants of the e antigen include hr^B (Rh31), hr^s (Rh19), and e^s(Rh20).

G Antigen (Rh12). The G antigen is found on any red cell that also has the C or D antigen.

Weak D Phenotype

Some red cells that express the D antigen require prolonged incubation with the anti-D reagent or application of the antiglobulin test for agglutination to occur. These red cells are considered to be D antigen-positive and are described as weak D, formerly termed D^u. The weak D phenotype is thought to occur by one of three mechanisms: (a) inheritance of an RHD gene encoding for a weakened expression of D, (b) interaction of the D allele with other genes, and (c) inheritance of an RHD gene missing some epitopes. In the first mechanism, the weak D phenotype is due to an RHD gene encoding for a D protein with reduced D antigen expression.⁴⁴ This is more common in the black population and generally occurs in association with the Dce haplotype. In the white population, weak D is less common but may occur in association with the haplotype DCe or DcE.⁴⁴ In the second mechanism, the weak D phenotype occurs as a result of the position of the D allele. This is most easily conceptualized using the Fisher-Race terminology. Red cells from individuals with a C allele in a trans position to the D allele (i.e., Dce/Ce) have weakened expression of D due to C being on the opposite chromosome. Individuals with the weak D phenotype by either of these two mechanisms do not form alloantibodies after exposure to D-positive red cells. Finally, the third mechanism, sometimes termed partial D, occurs when individuals lack part of the D antigen complex. The D antigen is thought to be a mosaic consisting of several individual parts or epitopes. Most D-positive individuals inherit the gene encoding the entire D antigen. However, the partial D phenotype describes red cells that are deficient in components of D, resulting in a decreased expression of the D antigen (weak D). Individuals with partial D may produce anti-D if transfused with D-positive red cells.

The weak D and partial D phenotypes have implications for the practice of transfusion medicine. Donors with weak D red cells should be considered Rh(D) positive. It is important that donor blood with weak D not be mislabeled as Rh(D) negative because the weak D antigen could induce an immune response if this blood were transfused to an Rh(D)-negative individual.³³ It is generally recommended that patients who phenotype as weak D can be transfused with Rh(D)-positive

blood. The most common types of weak D do not appear to be at risk of alloimmunization to the D antigen, therefore, these individuals can safely receive D-positive blood and would not require Rh immune globulin prophylaxis during pregnancy. However, it should be noted that some weak D types, identified by molecular analysis or the RHD gene are susceptible to alloimmunization.⁵²

Rh_{null} Phenotype

The Rh_{null} phenotype occurs when red cells do not express Rh antigens. This phenotype occurs because of at least two mechanisms. First, the inheritance of an abnormal RHAG gene appears to result in the absence of the Rh antigen expression despite the presence of normal RHD and RHCE genes.³⁰ This is termed regulator type Rh_{null}. The second mechanism is termed amorph type of Rh_{null} and involves the inheritance of a mutation in the RHCE genes in association with a D-negative background.⁵³ The Rh_{null} phenotype is associated with abnormalities in the red cell membrane causing stomatocytosis and hemolysis. The presence of the Rh proteins in the red cell membrane appears to be necessary for the expression of other membrane proteins such as the LW, Duffy, and U antigens. Rh_{null} cells have been demonstrated to lack the LW and Fy5 antigens and have weakened expression of the S, s, and U antigens.⁵⁴ Fortunately, the Rh_{null} phenotype is rare, as these individuals form an alloantibody (anti-Rh29) that reacts with all other red cells except Rh_{null} when they are transfused. Thus, obtaining compatible blood can be challenging.

Antibodies and Clinical Significance

Most Rh antibodies are IgG, although some may be IgM. They are usually not capable of activating complement. Anti-D is one of the most common Rh antibodies because of the high immunogenicity of the D antigen. Anti-D can cause severe HDN and HTR. The frequency of anti-D has greatly decreased with the use of prophylactic Rh immune globulin administration to Rh(D)-negative mothers during pregnancy and at delivery if the infant is Rh(D) positive. Antibodies against antigens of the Rh system including C, c, E, and e can be associated with mild HTR or HDN.⁴⁹

Kell Blood Group System (ISBT 006)

SUMMARY OF IMPORTANT CHARACTERISTICS OF KELL ANTIBODIES

Antibody Specificity	Clinically Significant	Antibody Class	Frequency of Antigen-Negative Blood HDNHTR(White Population)		
Anti-K	Yes	IgG; rarely IgM	Yes	Yes	Very common (98%)
Anti-k	Yes	IgG; rarely IgM	Yes	Yes	Rare (<2%)

HDN, hemolytic disease of the newborn; HTR, hemolytic transfusion reaction; Ig, immunoglobulin.

The Kell blood group system was discovered in 1946 and was named after Mrs. Kellner, the mother of the first child discovered to be affected with HDN because of Kell antibodies.^{55,56}

Genes and Antigens

The Kell blood group system consists of 35 antigens: K, k, Kp^a, Kp^b, Ku, Js^a, Js^b, Ul^a, K11, K12, K13, K14, K16, K17, K18, K19, Km, Kp^c, K22, K23, K24, VLAN, TOU, RAZ, VONG, KALT, KTIM, KYO, KUCI, KANT, KASH, KELP, KETI, KHUL, and KYOR. The antigens are coded by a complex of genetic loci, known as the Kell locus, which is located at 7q33 (Table 20.1). The KEL gene contains 19 exons distributed over 21.5 kbp.⁴⁵ There are at least four subloci in the complex, each of which has an allele for a high-frequency antigen (k, Kp^b, Js^b, and KEL11) and for one or more alleles for a lower-frequency antigen (K, Kp^a and Kp^c, Js^a, and KEL17).⁵⁷ The most common haplotype is k/Kp^b/Js^b/Kel11. The phenotype frequency of the common Kell antigens is shown in Table 20.8. The k antigen is a high-frequency antigen that is present in more than 98% of whites and blacks. The K antigen is much less common.

The KEL gene encodes a type 2 integral membrane protein, called zinc endopeptidase, containing 732 amino acids, which is present at 3,500 to 17,000 copies per red blood cell.^{45,56} The protein has enzymatic activity, and it has been demonstrated in vitro to cleave big endothelin-3, which is a peptide with vasoconstrictor activity.⁵⁸ The Kell protein is associated with the Kx protein in the red cell membrane (see section Kx Blood Group System [ISBT 019]).⁵⁹ Individuals have been identified who do not express the Kell protein (Kell_{null} phenotype) and who are healthy with no structural or functional abnormalities of their red cells identified.

TABLE 20.8 PRINCIPAL PHENOTYPES OF BLOOD SYSTEMS

System	Phenotype	Frequency (%)		System	Phenotype	Frequency (%)		
		Whites	Other			Whites	Other	
ABO	O	45	49 ^a	Xg	Xg(a+)	Males, 65.6;		
	A	40	27				females, 88.7	
	B	11	20			Xg(a-)	Males, 34.4;	
	AB	4	4				females, 11.3	
MNS	M+N-	28	26 ^a	Scianna	Sc:1,-2	99.7 ^c		
	M+N+	50	44			Sc:1,2	0.3	
	M-N+	22	30			Sc:-1,2	Very rare	
	S+s-U+	11	3			Sc:-1,-2	Very rare	
	S+s+U+	44	28	Dombrock	Do(a+b-+)	17.2	11 ^a	
	S-s+U+	45	69			Do(a+b+)	49.5	44
S-s-U-	0	<1		Do(a-b+)	33.3	45		
	S-s-U+w	0	Rare	Colton	Co(a+b-)	89.3		
P	P ₁	79	94 ^a		Co(a+b+)	10.4		
Lutheran	Lu(a+b-)	0.15			Co(a-b+)	0.3		
	Lu(a+b+)	7.5			Co(a-b-)	Very rare		
	Lu(a-b+)	92.35	Landsteiner-Wiener	LW(a+b-)	>99	93.9 ^d		
	Lu(a-b-)	Very rare		LW(a+b+)	<1	6.0		
Kell	K+k-	0.2	Rare ^a		LW(a-b+)	Very rare 0.1		
	K+k+	8.8	2		LW(a-b-)	Very rare Very rare		
	K-k+	91.0	98	Chido/Rodgers	Ch+, Rg+	95.0		
	Kp(a+b-)	Rare	0			Ch-, Rg+	2.0	
	Kp(a+b+)	2.3	Rare			Ch+, Rg-	3.0	
	Kp(a-b+)	97.7	100			Ch-, Rg-	Very rare	
	Js(a+b-)	0	1	Hh	H+	>99.9		
	Js(a+b+)	Rare	19	Kx	Kx+	~100		
Js(a-b+)	100	80		Kx-	Rare			

	K _o	Very rare	Very rare	Gerbich	Ge2, Ge3, Ge4	100	
Lewis	Le(a+b-)	22	23 ^a		Wb, Ls ^a , An ^a , Dh ^a	Rare	
	Le(a+b+)	72	55	Cromer	Cr ^a , Tc ^a , Dr ^a , Es ^a , IFC, WES ^b , UMC	100	
	Le(a-b+)	6	22		Tc ^b , Tc ^c , WES ^a	Rare	
	Le(a-b-)	Rare	Rare				
Duffy	Fy (a+b-)	17	9 ^a	Knops	Kn(a+b-)	94.5	99.9 ^a
	Fy(a+b+)	49	1		Kn(a-b+)	1	0
	Fy(a-b+)	34	22		Kn(a+b+)	4.5	0.1
	Fy(a-b-)	Rare	68	McC(a+)	98	94	
Kidd	Jk(a+b-)	28	57 ^a		Sl _a (a+)	98	60
	Jk(a+b+)	49	34		Yk _a (a+)	92	98
	Jk(a-b+)	23	9	Indian	In(a+b-)	Very rare	Very rare ^c
	Jk(a-b-)	Very rare	Very rare		In(a+b+)	<1	7
Diego	Di(a+b-)	Rare	Rare ^a		In(a-b+)	>99	93
	Di(a+b+)	Rare	Rare	Ok	Ok(a+)	100	
	Di(a-b+)	>99.9	>99.9	Raph	MER2+	92	
Yt	Yt(a+b-)	91.9	97 ^b		MER2-	8	
	Yt(a+b+)	7.9	23				
	Yt(a-b+)	0.2	0				

^aBlacks;

^bIsraelis;

^cMost populations;

^dFinns;

^eIranians/Arabs.

Data from AABB technical manual, 14th ed. Bethesda, MD: American Association of Blood Banks, 2002; and Denomme GA, Rios M, Reid ME. Molecular protocols in transfusion medicine. San Diego, CA: Academic Press, 2000.

P.519

Antibodies and Clinical Significance

The K antigen is very immunogenic. Only the D antigen has greater potential to induce alloimmunization. Because of this, anti-K is often encountered. Anti-K typically is induced by blood transfusion. The antibody tends to be IgG. Anti-K is

clinically significant and has been implicated in both HTR and HDN. There is poor correlation with maternal anti-K titer and disease severity.⁶⁰ Furthermore, HDN associated with anti-K tends to be more severe than HDN caused by anti-D. This is thought to occur because the Kell antigens are well expressed on fetal cells and appear on erythroid progenitor cells. It is postulated that anti-K, in addition to causing hemolysis, also causes a suppression of erythropoiesis.^{61,62}

The k antigen is also highly immunogenic. However, because only individuals not expressing the k antigen (i.e., KK phenotype) produce anti-k, and because the k antigen is present in most individuals, anti-k is much less common. Anti-k has been associated with both HDN and HTR. The other Kell blood group system antibodies are much less common but are also clinically significant.

Duffy Blood Group System (ISBT 008)

SUMMARY OF IMPORTANT CHARACTERISTICS OF DUFFY ANTIBODIES

Antibody Specificity	Clinically Significant	Antibody Class	Frequency of Antigen-Negative Blood HDNHTR(White Population)		
Fy ^a	Yes	IgG	Yes	Yes	Common (34%)
Fy ^b	Yes	IgG	Yes	Yes	Common (17%)

HDN, hemolytic disease of the newborn; HTR, hemolytic transfusion reaction; Ig, immunoglobulin.

The Duffy blood group system was discovered in 1950 in the serum of a multiply transfused male patient with hemophilia, Mr. Duffy.⁶³

Gene and Antigens

The Duffy system consists of six antigens, Fy^a, Fy^b, Fy³, Fy⁴, Fy⁵, and Fy⁶, which are encoded at the Duffy locus on chromosome 1q21-q22 (Table 20.1). The gene, DARC (or FY), contains two exons distributed over 1.521 kbp.⁴⁵ The antigens, Fy^a and Fy^b, are encoded by a pair of codominant alleles. The phenotypes of the Duffy system and their frequencies are presented in Table 20.8. The most common phenotype in the white population is Fy(a+b+), and the most common phenotype in the black population is Fy(a-b-). The Fy^x antigen represents a form of weak Fy^b. The Fy⁵ antigen is defined by an interaction of the Duffy and Rh gene products.⁴⁴ The antigens Fy^a, Fy^b, and Fy⁶ are sensitive to denaturation by enzymes such as papain, ficin, or α-chymotrypsin. Fy³ and Fy⁵ are not sensitive to enzyme denaturation.

The Duffy DARC gene encodes for a glycoprotein (DARC) that is found on red cells as well as other tissues including brain, heart, lung, kidney, and spleen. On red cells, the glycoprotein has been identified as a receptor for various chemokines and may contribute to chemokine-induced leukocyte migration to sites of inflammation.^{64,65} DARC may also play a role in renal disease as increased DARC expression has been noted in different causes of renal injury.⁶⁶ It is thought that DARC expression is increased in an attempt to control inflammation.⁶⁶ The glycoprotein is also the receptor for *P. vivax* and *P. knowlesi*. Therefore, individuals who do not express Fy^a or Fy^b on their red cells are not susceptible to these forms of malaria. In parts of Africa where malarial infection is common, most individuals are Fy(a-b-), likely because of natural selection.⁴⁴

Antibodies and Clinical Significance

The Duffy antibodies are usually IgG. Anti-Fy^a is a common alloantigen. Fy^a is considered clinically significant, as it has been associated with HDN and HTR. Anti-Fy^b is uncommon. It has been associated with mild HTR and only rarely with HDN.^{44,67} The other Duffy antibodies are much less common.

Kidd Blood Group System (ISBT 009)

SUMMARY OF IMPORTANT CHARACTERISTICS OF KIDD ANTIBODIES

Antibody Specificity	Clinically Significant	Antibody Class	Frequency of Antigen-Negative Blood HDNHTR(White Population)		
Jk ^a	Yes	IgG; rarely IgM	Yes	Yes	Common (23%)
Jk ^b	Yes	IgG; rarely IgM	Yes	Yes	Common (28%)

HDN, hemolytic disease of the newborn; HTR, hemolytic transfusion reaction; Ig, immunoglobulin.

The Kidd blood group system consists of three antigens: Jk^a, Jk^b, and JK3 (Table 20.1). The system was named for the woman (Mrs. Kidd) whose serum was found to contain the antibody, and the antigen was named Jk for the initials of the woman's child (John Kidd) affected by HDN.⁶⁸

Gene and Antigens

The Kidd blood group system gene is located at chromosome 18q11-q12. The gene, SLC14A1, also known as JK or HUT11, is distributed over 30 kbp and contains 11 exons.⁴⁵ It encodes for the urea transporter hUT-B1.⁶⁹ The principal phenotypes of the Kidd blood group system and their frequencies are outlined in Table 20.8. The antigens Jk^a and Jk^b are found at relatively the same frequencies in the white populations but differ in other ethnic groups such as blacks and Asians.⁴⁵ The Jk(a-b-) phenotype is rare and is found primarily in the Polynesian population.⁷⁰ These null red cells have been demonstrated to be resistant to lysis by 2M urea; however, this phenotype is not associated with shortened red cell survival or clinical symptoms.⁷¹

Antibodies and Clinical Significance

The Kidd antibodies are usually IgG but occasionally are IgM. These antibodies tend to be short-lived; therefore, they are frequently not detected before transfusion. However, they are capable of a rapid amnestic response and have been associated with severe delayed HTRs. The antibodies have rarely been associated with HDN, usually of mild severity.⁵⁶

P.520

MNS Blood Group System (ISBT 002)

SUMMARY OF IMPORTANT CHARACTERISTICS OF MNS ANTIBODIES

Antibody Specificity	Clinically Significant	Antibody Class	Frequency of Antigen-Negative Blood HDNHTR(White Population)		
Anti-M	Seldom	IgG; some IgM	Few	Few	Common (22%)
Anti-N	Rarely	IgM; rarely IgG	Rare	Rare	Very rare (<1%)
Anti-S	Occasionally	IgG; some IgM	Yes	Yes	Common (45%)
Anti-s	Yes	IgG; rarely IgM	Yes	Yes	Very rare (<1%)

HDN, hemolytic disease of the newborn; HTR, hemolytic transfusion reaction; Ig, immunoglobulin.

The MNS blood group system was discovered in 1927. The M and N antigens get their names from the letters in the word immune, because anti-M and anti-N antibodies were discovered in the sera of rabbits immunized with human red cells. The letter I was not used because it was felt this would be confused with the number 1.^{72,73} The S antigen was named after the city in which it was discovered—Sydney, Australia.⁷³

Genes and Antigens

The MNS blood group system consists of 46 antigens: M, N, S, s, U, He, Mi^a, M^c, Vw, Mur, M^e, Vr, M^e, Mt^a, St^a, Ri^a, Cl^a, Ny^a, Hut, Hil, M^v, Far, s^d, Mit, Dantu, Hop, Nob, En^a, ENKT, N', Or, DANE, TSEN, MINY, MUT, SAT, ERIK, Os^a, ENEP, ENEH, HAG, ENAV, MARS, ENDA, ENEV, and MNTD (Table 20.1). The M and N antigens are carried on glycoprotein A, whereas the antithetical antigens, S and s, are carried on glycoprotein B. They are encoded by the GYPA, GYPB, and GYPE genes located at chromosome 4q31.21. GYPA has seven exons distributed over 60 kbp.⁴⁵ GYPB has five exons and is distributed over 58 kbp.⁴⁵ GYPA and GYPB contribute to most of the carbohydrate on the red cell membrane. The sialic acid of the O-glycans on these sialoglycoproteins results in the red cell membrane being negatively charged. This negative charge prevents red cells from sticking together, prevents red cell adherence to endothelial cells of the blood vessel walls, and protects from invasion by pathogens.^{74,74,75,76} The presence of glycoprotein A has been demonstrated to be necessary for the adhesion of

certain malarial parasites (*P. falciparum*) as well as for bacteria and viruses (e.g., influenza virus and encephalomyocarditis virus).^{76,77,78,79} and ⁸⁰ Other proposed functions of glycophorin A include regulation of transport of band 3 to the red cell membrane and complement regulation.^{70,78,81,82} and ⁸³ The main phenotypes and frequencies of the MNS blood group system are listed in Table 20.8.

Antibodies and Clinical Significance

Anti-M and anti-N antibodies are typically IgM and are reactive at cold temperatures. Antibodies against M and N are naturally occurring (environmentally stimulated). They are not generally considered to be clinically significant. Rarely, anti-M has been implicated in cases of HDN and HTR.^{61,62,63} and ⁶⁴ Anti-N has only rarely been associated with HDN or HTR. In contrast, antibodies against S, s, and U are capable of causing HTR and HDN.⁷⁰ Anti-S and anti-s tend to be IgG and occasionally are IgM. Antibodies to many low-prevalence antigens in the MNS system have also been associated with HDN.⁷⁶

P Blood Group System and Related Antigens (ISBT 003)

SUMMARY OF IMPORTANT CHARACTERISTICS OF P ANTIBODIES

Antibody Specificity	Clinically Significant	Antibody Class	Frequency of Antigen-Negative Blood HDNHTR(White Population)	
P1	Rare	IgM; rarely IgG	No	Rare Common (21%)

HDN, hemolytic disease of the newborn; HTR, hemolytic transfusion reaction; Ig, immunoglobulin.

The first P system antigen was discovered by Landsteiner and Levine in 1927.⁴⁴ Initially, the system was thought to include the P, P^k, and LKE antigens, but these antigens have subsequently been assigned to the globoside antigens (see section GLOB Collection [ISBT 209]).⁴⁴

Genes and Antigens

The P blood group system consists of a single antigen: P1 (Table 20.1). P1 is the product of a galactosyltransferase encoded by the gene P1, which is located at chromosome 22q11.2-qter.⁴⁵ It has been suggested that this transferase is encoded by the gene A4GALT, but this has been contradicted by recent studies.⁵² The P1 antigen is similar to the ABO antigens because it is composed of a chain of sugars linked to glycolipids on red cells (Fig. 20.2). P1 is formed when β-D-galactose (Gal) is added in an α(1-4) linkage to paragloboside.⁴⁴ In the white population, 79% of individuals express the P1 antigen.⁴⁴

Antibodies and Clinical Significance

Anti-P1 is naturally occurring and is commonly found in individuals lacking the P1 antigen. Anti-P1 is usually IgM. It has not been reported to cause HDN and has been associated with HTR only in rare instances.⁸⁴ Identification of anti-P1 is aided by the fact that the activity of the antibodies is inhibited by hydatid cyst fluid or pigeon egg white.⁴⁴

Individuals who lack the P1 antigen who also do not express the P and P^k antigens may produce anti-P,P1,P^k, also known as anti-Tj^a. This antibody can be either IgM or IgG and has been associated with severe hemolytic reactions.^{85,86}

Lutheran Blood Group System (ISBT 005)

SUMMARY OF IMPORTANT CHARACTERISTICS OF LUTHERAN ANTIBODIES

Antibody Specificity	Clinically Significant	Antibody Class	Frequency of Antigen-Negative Blood HDNHTR(White Population)	
Lu ^a	Seldom	IgM; some IgG	Mild No	Very common (92%)
Lu ^b	Seldom	IgG; some IgM	Mild No	Very rare (0.1%)

HDN, hemolytic disease of the newborn; HTR, hemolytic transfusion reaction; Ig, immunoglobulin.

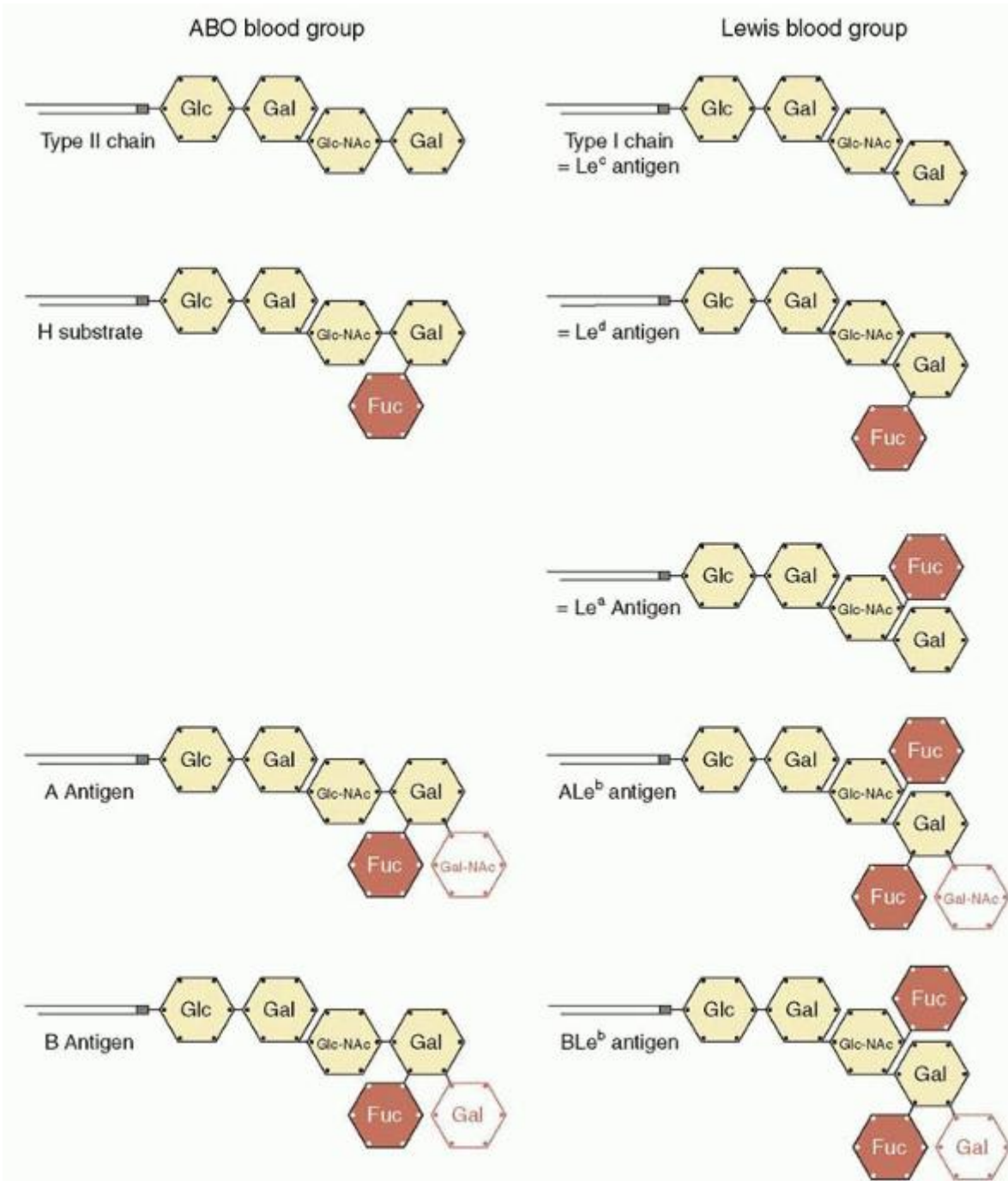

FIGURE 20.2 Differences between ABO (A) and Lewis (B) blood groups. ABO blood group antigens are synthesized in the red cells on type II oligosaccharides, but Lewis blood group antigens are produced in the plasma on type I oligosaccharides and then adsorbed onto the red cell surface. Type II oligosaccharide chains differ from type I chains in the linking position of the terminal galactose moiety. The Le (FUT3) gene encodes type III H transferase, which adds a fucose group (redcolored fucose group) to the second-last sugar moiety of the type I oligosaccharide chain. Synthesis of the Le^c and Le^d antigens does not depend on the activity of the Le gene. Fuc, l-fucose; Gal, d-galactose; Gal-NAc, d-N-acetyl-galactosamine; Glc, d-glucosamine; Glc-NAc, d-N-acetyl-glucosamine.

The first Lutheran blood group antibody (anti-Lu^a) was found in 1946 in the serum of a previously transfused patient named Lutteran. The label on the sample was misread, and the blood group system was named Lutheran.⁷⁰

Genes and Antigens

The Lutheran blood group system consists of 20 antigens: Four pairs of antigens (Lu^a/Lu^b, Lu6/Lu9, Lu8/Lu14, and Au^a/Au^b) and 11 independent antigens (Lu3, Lu4, Lu5, Lu7, Lu11, Lu12, Lu13, Lu16, Lu17, Lu20, Lu21, and LURC) (Table 20.1).⁶ The antigens are encoded by the B-CAM (LU) gene located at chromosome 19q12-q13. The gene contains 15 exons and is distributed over approximately 12 kbp.³⁹ The gene products include the Lutheran glycoprotein, which is 597 amino acids long, and a spliced version of the B-cell adhesion molecule (B-CAM), which is 557 amino acids in length.^{45,70} The Lutheran glycoproteins are members of the Ig superfamily and have been demonstrated to act as a receptor for laminin.^{87,88} The Lutheran blood group may play a role in the pathophysiology of sickle cell disease and polycythemia vera. In sickle cell disease, B-CAM and Lu are overexpressed on red cells, which may mediate increased red cell adhesion to laminin.⁸⁹ In polycythemia, there is increased phosphorylation of the Lu glycoprotein, which increases red cell adhesion.⁹⁰ The principal phenotypes of the Lutheran blood group system and their frequencies are outlined in Table 20.8.

Antibodies and Clinical Significance

The Lutheran antigens are not very immunogenic; therefore, antibodies in this system are rare.⁷⁰ Anti-Lu^a and anti-Lu^b are usually IgG and are reactive on the indirect antiglobulin test. Anti-Lu^a has not been implicated in HTR but has been implicated in mild HDN.⁷⁰ Anti-Lu^b has been associated with mild, subclinical HDN.^{91,92}

P.522

Lewis Blood Group System (ISBT 007)

SUMMARY OF IMPORTANT CHARACTERISTICS OF LEWIS ANTIBODIES

Antibody Specificity	Clinically Significant	Antibody Class	Frequency of Antigen-Negative Blood HDN/HTR (White Population)	
Le ^a	Seldom	IgM	No	Rare Rare (6%)
Le ^b	Seldom	IgM	No	Rare Common (22%)

HDN, hemolytic disease of the newborn; HTR, hemolytic transfusion reaction; Ig, immunoglobulin.

The Lewis blood group system is different from other blood group systems, as the antigens (Le^a and Le^b) are formed in the plasma and adsorbed onto the red cell membrane. This unique feature has implications for transfusion practices for several reasons: (a) transfused red cells always adsorb Lewis antigens from the plasma of the transfusion recipient; hence, within several days of the transfusion, the phenotype of the circulating transfused red cells is the same as the patient's red cell phenotype; and (b) soluble antigen in transfused plasma has the potential to inhibit Lewis system antibodies that may be in the plasma of some individuals.

Genes and Antigens

The two alleles (Le and le) are inherited in Mendelian fashion. Le is the dominant allele, and le is the recessive allele. The FUT3 (Le) gene is located on chromosome 19 (19p13.3)^{93,94} and is closely linked to the FUT1 (Hh) and FUT2 (Sese) genes. There are 11 different mutations of the FUT3 gene.^{95,96} The silent le allele is due to mutations that result in defective gene products. The FUT3 gene encodes for an enzyme, $\alpha(1,3/1,4)$ fucosyltransferase (FUT3, H transferase type 3), which adds fucose molecules to carbohydrate precursor chains (Fig. 20.3). The enzyme itself is a type II membrane-bound protein of 361 amino acids.⁹⁷

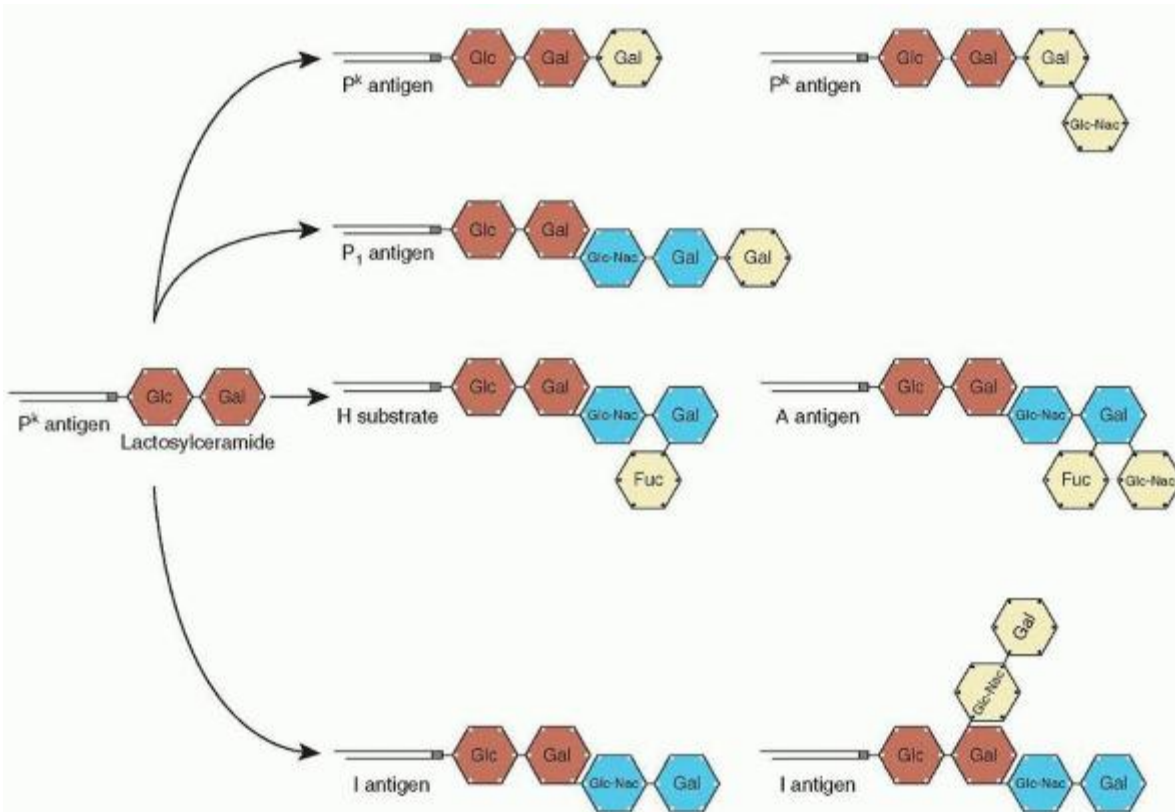

FIGURE 20.3 The relationship among ABO, P, and Ii blood group systems. These antigens are located on terminal oligosaccharides. Among these blood groups, the structure in common is lactosylceramide (red sugar moieties). Lewis blood group antigens also share similar structures, but they are not synthesized in red cells. Fuc, l-fucose; Gal, d-galactose; Gal-NAc, d-N-acetyl-galactosamine; Glc, d-glucosamine; Glc-NAc, d-N-acetyl-glucosamine.

Antigens

As mentioned previously, Lewis antigens (Le^a and Le^b) on the red cells are not intrinsic to the red cell membrane but are absorbed from the plasma onto the cells.⁹⁸ The antigenic epitopes are located at the fucose moieties of glycosphingolipids. The biosynthesis of the antigens Le^a and Le^b involves two different pathways. The formation of antigen Le^a is catalyzed by the enzyme FUT3 that adds a fucose group to the type 1 oligosaccharide precursor chain (Fig. 20.3). In individuals with FUT2 (SeSe or Sese genotypes), most type 1 oligosaccharide precursor chains are converted to an intermediate product similar to the H antigen. The intermediate product is subsequently catalyzed by the enzyme FUT3 and forms the Le^b antigen. Therefore, the phenotypes $Le(a-b+)$ and $Le(a+b-)$ are not due entirely to the FUT3 gene but depend on the presence or absence of the FUT2 (Se) gene. This relationship between the FUT2 and FUT1 genes has practical implications for the laboratory. For example, the easiest way to determine an individual's secretor status is to type his or her red cells to determine their Lewis phenotype. The $Le(a+b-)$ phenotype indicates that the individual is a nonsecretor; the $Le(a-b+)$ phenotype indicates that the individual is a secretor; and the $Le(a-b-)$ phenotype does not allow secretor status to be assigned. If the FUT2

P.523

product (FUT2) is partially active, such as in individuals with Se^w , some type 1 precursor chain is converted to Le^a antigen, and the remaining is converted to Le^b . The resultant phenotype, $Le(a+b+)$, is rare in whites but common in Asians. The fucose residual may also be added to the type 2 oligosaccharide precursor chain and forms the Le^x and Le^y antigens that are similar to ABO(H) antigens in biochemical structure.

In the Lewis blood group system, the phenotype distribution varies among different ethnic groups. The $Le(a-b+)$ phenotype is found in 70% of the white population and approximately 50% of the black population. The $Le(a-b-)$ phenotype is less common in the white population but is found in approximately 30% of the black population. The $Le(a+b+)$ phenotype is rare in both the white and black populations (Table 20.8).

In addition to red blood cells, Lewis antigens are found on other cell surfaces, such as gastric mucosa. They are also found in the lipopolysaccharide envelope of *Helicobacter pylori*.⁹⁹ Although the gastric mucosa predominately expresses Le^a and Le^b, the cell envelope of *H. pylori* mainly expresses Le^x and Le^y.⁹⁹ The relationship between the Lewis antigens and the pathogenesis of *H. pylori* infection is uncertain. The similarity of the antigens may deceive the host immune system and facilitate the colonization of *H. pylori*.¹⁰⁰ In a murine model, *H. pylori* infection has been shown to induce antibodies cross-reactive to gastric mucosa and to contribute to the development of chronic gastritis and peptic ulcers.¹⁰¹ However, this has not been firmly established in humans because no concordance in the expression of the Lewis antigen has been found between the bacteria and the host.^{102,103} Some studies showed that Le^b and H antigens on the gastric mucosa mediated the binding of *H. pylori* via a binding protein (blood group antigen-binding adhesin).^{104,105} However, other studies demonstrated that *H. pylori* adherence is not dependent on the Lewis antigen.¹⁰⁶ Similarly, it has been disputed whether blood group O is a risk factor for peptic ulcer disease.^{107,108} and ¹⁰⁹ Also, the isoform antigens Le^x and Le^y may be found as neoantigens on malignant tissue.¹¹⁰

Antibodies and Clinical Significance

Like the ABO system, antibodies specific for Lewis antigens are naturally occurring, being formed through exposure to environmental antigens. The antibodies are usually IgM, complement activating, and reactive at or below room temperature. Although Lewis antibodies have been reported to cause HTRs, this does not usually occur for several reasons. First, although Lewis antibodies can activate complement, the process is relatively slow, thus allowing the inhibitors within the complement cascade to stop the process before the membrane attack complex is activated. Second, soluble antigen present in the plasma of the transfused blood product can neutralize the antibody, preventing subsequent binding of antibody to transfused red cells. Finally, within 24 to 48 hours of transfusion, the transfused red cells absorb Lewis antigens from the patient's plasma, taking on the Lewis phenotype of the patient's own red cells. This latter mechanism also prevents delayed transfusion reactions from occurring. Lewis antibodies may be clinically relevant if the antibody causes in vitro hemolysis during serologic laboratory testing. When these "in vitro hemolytic antibodies" are detected, they should be considered clinically relevant, and antigen-negative blood should be selected for transfusion. Lewis antibodies do not cause HDN because they are IgM and do not cross the placenta. Furthermore, Lewis antigens are poorly developed on fetal red cells.

Anti-Le^a antibody is more common than anti-Le^b antibody. Both anti-Le^a and anti-Le^b antibody are found in individuals with the Le(a-b-) phenotype. In contrast, individuals with the Le(a-b-) phenotype do not develop anti-Le^a because of the presence of residual Le^a antigen in the secretions.

Diego Blood Group System (ISBT 010)

SUMMARY OF IMPORTANT CHARACTERISTICS OF DIEGO ANTIBODIES

Antibody Specificity	Clinically Significant	Antibody Class	Frequency of Antigen-Negative Blood HDNHTR(White Population)
Di ^a	Yes	IgG; some IgM	Yes Rare Very common (>99.9%)
Di ^b	Yes	IgG; some IgM	Yes Rare Very rare (<0.1%)

HDN, hemolytic disease of the newborn; HTR, hemolytic transfusion reaction; Ig, immunoglobulin.

The Diego blood group system consists of 22 antigens: Di^a, Di^b, Wr^a, Wr^b, Wd^a, Rb^a, WARR, ELO, Wu, Bp^a, Mo^a, Hg^a, Vg^a, Sw^a, BOW, NFLD, Jn^a, KREP, Tr^a, Fr^a, SW1, and DISK (Table 20.1).⁶

Gene and Antigens

The Diego system antigens are carried on the band 3 protein. The antigens are encoded by the gene SLC4A1, which is found at chromosome 17q12-q21 (Table 20.1). SLC4A1 contains 20 exons and is distributed over 228 kbp.⁴⁵ Band 3 is a multipass transmembrane protein that serves as an anion transporter. The Di^a antibody was initially found in the serum of a Venezuelan woman and was implicated in HDN.¹¹¹ The principal phenotypes of the Diego blood group system and their frequencies are outlined in Table 20.8. The expression of the antigen Di^a is almost exclusively restricted to populations of Mongolian descent, such as American Indians, Chinese, and Japanese.¹⁰⁰ An altered version of the band 3 protein is found in a condition known as Southeast Asian ovalocytosis. This condition may confer a degree of resistance to *Plasmodium falciparum*.¹¹²

Antibodies and Clinical Significance

Anti-Di^a and anti-Di^b are usually IgG and are detected by the indirect antiglobulin test. HDN has been reported with both anti-Di^a and anti-Di^b.^{113,114,115,116} and ¹¹⁷ HTR is rare but has been reported.¹¹⁸

Yt Blood Group System (Cartwright) (ISBT 011)

SUMMARY OF IMPORTANT CHARACTERISTICS OF YT ANTIBODIES

Antibody Specificity	Clinically Significant	Antibody Class	Frequency of Antigen-Negative Blood HDNHTR(White Population)		
Yt ^a	Rare	IgG	No	Yes	Very rare (0.2%)
Yt ^b	Rare	IgG	No	Yes	Very common (91.9%)

HDN, hemolytic disease of the newborn; HTR, hemolytic transfusion reaction; Ig, immunoglobulin.

The Yt system consists of two antigens: Yt^a and Yt^b (Table 20.1). The system was named after Cartwright, the individual discovered producing the antibody. Because all of the other letters in the individual's name were already being used, the last letter, T, was selected. The letter Y was placed first to denote "why not T?".⁷⁰

P.524

Gene and Antigens

The ACHSE gene is located at chromosome 7q22. It encodes for an acetylcholinesterase, which is a dimerized glycosyl phosphatidylinositol (GPI)-linked glycoprotein in the red blood cell membrane. Its function is unknown; however, the molecule is enzymatically active. Yt^a and Yt^b antigens result from a single amino acid substitution, which does not appear to affect the enzymatic activity of acetylcholinesterase.¹¹⁹ The antigens are antithetical. Yt^a occurs with a frequency of approximately 99%, and Yt^b has a frequency of approximately 8% (Table 20.8).¹²⁰ Because they are carried on a GPI-linked protein, Yt antigens may be absent or reduced in individuals with paroxysmal nocturnal hemoglobinuria (see Chapter 31).

Antibodies and Clinical Significance

Antibodies against the Yt antigens are usually IgG. They do not activate complement. Yt antibodies have been implicated in delayed HTR but not in HDN.¹¹²

Xg Blood Group System (ISBT 012)

SUMMARY OF IMPORTANT CHARACTERISTICS OF XG ANTIBODIES

Antibody Specificity	Clinically Significant	Antibody Class	Frequency of Antigen-Negative Blood HDNHTR(White Population)		
Xg ^a	No	IgG	No	No	Common (males, 34.4%; females, 11.3%)

HDN, hemolytic disease of the newborn; HTR, hemolytic transfusion reaction; Ig, immunoglobulin.

The Xg blood group system consists of two antigens: Xg^a and CD99 (Table 20.1). The Xg^a antigen was discovered in 1962 by Mann in the serum of a multiply transfused male. Because the antigen frequency appeared to differ between males and females, the antigen was named Xg^a, as it appeared to be controlled by the X chromosome. The γ in the name stands for Grand Rapids, the hometown of the patient.¹²¹

Gene and Antigens

The gene encoding Xg^a, XG, is found at Xp22.32. The gene is not subject to lyonization or X inactivation. The gene that encodes CD99, now also named CD99 (previously MIC2), is closely linked to XG. The Xg^a antigen is located on a sialoglycoprotein. The antigen is only weakly expressed on the red cells of infants. The Xg^a antigen is resistant to treatment by sialidase and dithiothreitol (DTT); however, it is sensitive to treatment with proteolytic enzymes. The principal phenotypes of the Xg blood group system and their frequencies are outlined in Table 20.8.

Antibodies and Clinical Significance

Anti-Xg^a antibodies are usually IgG and may be able to activate complement. Anti-Xga can be naturally occurring.¹²² Alloantibodies to CD99 have been detected in only two healthy individuals and are not thought to be clinically significant.¹²² There have been no documented cases of HTR or HDN with these antibodies.

Scianna Blood Group System (ISBT 013)

SUMMARY OF IMPORTANT CHARACTERISTICS OF SCIANNA ANTIBODIES

Antibody Specificity	Clinically Significant	Antibody Class	HDNHTR	Frequency of Antigen-Negative Blood (White Population)
Sc1	No	IgG	Rare No	Very rare (<1%)
Sc2	No	IgG	Rare No Very common (>99%)	

HDN, hemolytic disease of the newborn; HTR, hemolytic transfusion reaction; Ig, immunoglobulin.

The Scianna blood group system consists of seven antigens: Sc1, Sc2, Sc3, Rd, STAR, SCER, and SCAN (Table 20.1).

Gene and Antigens

The gene for this system, ERMAP, is located on chromosome 1p34 and is linked to Rh. ERMAP encodes a glycoprotein (erythroid membrane-associated protein), the function of which is not known. However, based on its structure, ERMAP is known to be a member of the butyrophilin-like family of the immunoglobulin superfamily.¹²³ The Sc1 antigen is a high-frequency antigen, with the incidence in most populations being close to 99.9% (Table 20.8).⁴⁵ Sc2 is antithetical to Sc1 and is present in approximately 1% of the population.⁴⁵ The antigens are resistant to treatment of red cells with proteolytic enzymes such as papain, ficin, trypsin, α-chymotrypsin, and sialidase.⁷⁰

Antibodies and Clinical Significance

The Scianna antibodies are usually IgG. Scianna antibodies can activate complement and have been reported to cause mild HDN.^{124,125,126} The antibodies have not been associated with severe HTR.^{125,126}

SUMMARY OF IMPORTANT CHARACTERISTICS OF DOMBROCK ANTIBODIES

Antibody Specificity	Clinically Significant	Antibody Class	Frequency of Antigen-Negative Blood (White Population)	
			HDN	HTR
Do ^a	Rare	IgG	No	Yes Common (33.3%)
Do ^b	Rare	IgG	No	Yes Common (17.2%)

HDN, hemolytic disease of the newborn; HTR, hemolytic transfusion reaction; Ig, immunoglobulin.

Dombrock Blood Group System (ISBT 014)

The Dombrock blood group system consists of eight antigens: Do^a, Do^b, Gy^a, Hy, Jo^a, DOYA, DOMR, and DOLG (Table 20.1).^{4,127}

Gene and Antigens

The gene for the Dombrock blood group system, ART4 (or DO), is found at chromosome 12q13.2-q13.3.¹²⁸ The antigens P.525

in the Dombrock system have been demonstrated to be carried on a GPI-linked glycoprotein.^{129,130,131} and ¹³² Homology studies suggest that the Dombrock glycoprotein is a member of the adenosine 5'-diphosphate ribosyl-transferase ectoenzyme gene family and has been identified as ADP-ribosyltransferase 4 (ART4).^{131,132} and ^{133,134,135} However, the function of this molecule is uncertain, as no enzymatic activity has been demonstrated on the red cells and no pathology has been associated with absence of this glycoprotein.¹³⁵

The antigens Do^a and Do^b are antithetical. The frequencies of the three main phenotypes defined by these antigens are listed in Table 20.8. The antigens Gy^a, Hy, and Jo^a are high-incidence antigens, with gene frequencies of >99% in all

populations studied.¹³⁶ The antigens are resistant to papain or ficin treatment but sensitive to trypsin, pronase, or DTT (200 mmol/L) treatment.¹³³

Antibodies and Clinical Significance

The Dombrock antibodies are usually IgG and do not activate complement. They have not been associated with clinical HDN, but the antibodies have been associated with severe HTR.^{135,137,138} and¹³⁹ A baby born to a mother with an anti-DOMR antibody required phototherapy for hyperbilirubinemia.⁴

Colton Blood Group System (ISBT 015)

SUMMARY OF IMPORTANT CHARACTERISTICS OF COLTON ANTIBODIES

Antibody Specificity	Clinically Significant	Antibody Class	Frequency of Antigen-Negative Blood HDNHTR(White Population)		
Co ^a	Yes	IgG	Yes	Yes	Very rare (0.3%)
Co ^b	Yes	IgG	No	Yes	Very common (90.3%)

HDN, hemolytic disease of the newborn; HTR, hemolytic transfusion reaction; Ig, immunoglobulin.

The Colton blood group system was discovered in 1967. It consists of three antigens: Co^a, Co^b, and Co3 (Table 20.1).

Gene and Antigens

The Colton blood group antigens are encoded by a gene located at 7p14. The gene, AQP1 (CO), contains four exons distributed over 2.2 kbp.⁴⁵ The gene encodes a glycoprotein called the channelforming integral protein-1 (CHIP-1) or aquaporin 1 (AQP1).¹⁴⁰ AQP1 functions as a water transport channel. The antigen is strongly expressed in the proximal tubules and cortical collecting ducts of the kidney and is responsible for 80% of water reabsorption in the kidney. In red cells, AQP1 is responsible for osmotic water permeability.¹ Most individuals with the null phenotype, Co(a-b-), have red cells with markedly reduced osmotic water permeability but no obvious phenotype abnormality and are apparently healthy¹; however, a Colton-deficient individual with congenital dyserythropoietic anemia has been described.¹⁴¹ Also, Colton-deficient individuals have been demonstrated to develop an inability to concentrate urine after water deprivation.¹⁴² The principal phenotypes of the Colton blood group system and their frequencies are outlined in Table 20.8.

Antibodies and Clinical Significance

Antibodies against the Colton blood group antigens are usually IgG and may activate complement. These antibodies are clinically significant and have been implicated in acute and delayed transfusion reactions.^{143,144,145,146,147} and¹⁴⁸

Landsteiner-Wiener Blood Group System (ISBT 016)

SUMMARY OF IMPORTANT CHARACTERISTICS OF LANDSTEINER-WIENER ANTIBODIES

Antibody Specificity	Clinically Significant	Antibody Class	Frequency of Antigen-Negative Blood HDNHTR(White Population)		
LW ^a	Yes	IgG; some IgM	Yes	Yes	Very rare (<1%)
LW ^b	Yes	IgG; some IgM	Yes	Yes	Very common (>99%)

HDN, hemolytic disease of the newborn; HTR, hemolytic transfusion reaction; Ig, immunoglobulin.

The Landsteiner-Wiener blood group system consists of three antigens: LW^a, LW^{ab}, and LW^b (Table 20.1).

Genes and Antigens

The gene encoding the Landsteiner-Wiener blood group system antigens, ICAM-4, is found at chromosome 19p13.2-cen. The ICAM-4 gene contains three exons distributed over 2.6 kbp.⁴⁵ It encodes the LW glycoprotein, also known as intracellular adhesion molecule 4 (ICAM4). The LW glycoprotein is associated with the Rh proteins in the red blood cell membrane as part of a multiprotein macromolecular complex.¹⁴⁹ The LW glycoprotein is an intercellular adhesion molecule and has been demonstrated to bind to CD11/CD18 integrins located on leukocytes.¹⁵⁰ It is hypothesized that its

function may involve being a marker for lymphocyte maturation and differentiation.⁷⁰ LW_{null} red cells appear to have normal morphology and survival.¹⁴⁹

The frequencies of the Landsteiner-Wiener blood group system phenotypes are outlined in Table 20.5. LW^a is the most commonly expressed antigen, found in more than 99% of whites. The expression of LW antigens is influenced by the expression of the Rh blood group system D antigen. Individuals who are D antigen-positive have increased expression of LW antigens compared to those individuals who are D antigen-negative.¹⁵¹

Antibodies and Clinical Significance

Antibodies to the LW antigens are usually IgG but are occasionally IgM. The antibodies have been associated with mild HDN and HTR. Production of LW autoantibodies may occur in conditions associated with transient loss of LW antigens. Conditions associated with loss of LW antigens include pregnancy, Hodgkin disease, lymphoma, leukemia, sarcoidosis, and solid malignancies.^{70,112}

P.526

Chido/Rodgers Blood Group System (ISBT 017)

SUMMARY OF IMPORTANT CHARACTERISTICS OF CHIDO/RODGERS ANTIBODIES

Antibody Specificity	Clinically Significant	Antibody Class	Frequency of Antigen-Negative Blood HDNHTR(White Population)		
Ch	No	IgG	No	No	Rare (2%)
Rg	No	IgG	No	No	Rare (2%)

HDN, hemolytic disease of the newborn; HTR, hemolytic transfusion reaction; Ig, immunoglobulin.

The Chido and Rodgers system consists of nine antigens: Ch1 to 6, Rg1, Rg2, and WH (Table 20.1). The Chido antigen was initially described by Harris et al.¹⁵² The antigen was described as “nebulous” because the antigen strength was variable. The Chido and Rodgers system is not composed of true red cell antigens, as they are not actually located on intrinsic structures of the red cell. Instead, they are on the fourth component of the complement system (C4), which becomes bound to red cells. However, the antigens are detected on the surface of red cells by conventional methods and were therefore initially considered to be red cell antigens and were included in the ISBT terminology as the 17th system (ISBT 017).

Genes and Antigens

The genetic loci of the Rodgers and Chido antigens are closely linked and are located on chromosome 6p21.3 in genes closely linked to major histocompatibility complex (MHC) II. Both genes encode complement components. The C4B (CH) gene contains 41 exons and encodes for C4b.⁴⁵ The C4A (RG) gene contains 41 exons distributed over 21 kbp and encodes for C4a.⁴⁵ The Chido antigen is located on the C4d fragment of C4b.^{153,154} and ¹⁵⁵ The expression of the antigen is variable, as it is determined by the concentration of plasma complement, which is genetically determined.¹⁵⁶ The Rodgers antigen is located on the C4a component of complement.^{153,155} The principal phenotypes of the Chido/Rodgers blood group system and their frequencies are outlined in Table 20.8. Ch1 to 6 and Rg1 and Rg2 have frequencies >90%, whereas WH has a frequency of approximately 15%. The antigens are sensitive to treatment with proteases and resistant to treatment with sialidase, DTT, and acid.

Inherited low levels of C4 have been demonstrated to be associated with various autoimmune disorders, including autoimmune chronic active hepatitis.^{157,158} Individuals who are Ch-(lack C4b) have an increased risk of bacterial meningitis. Individuals who are Rg- (lack C4a) have an increased risk of systemic lupus erythematosus.^{158,159}

Antibodies and Clinical Significance

Antibodies in the Chido/Rodgers system are usually IgG and do not activate complement. They are not clinically significant. Antibodies to these antigens are typically found in individuals who have been transfused. They generally do not cause HTR but may result in anaphylactic reactions if large volumes of plasma are transfused.^{160,161} These antibodies have not been implicated in HDN.

Kx Blood Group System (ISBT 019)

SUMMARY OF IMPORTANT CHARACTERISTICS OF KX ANTIBODIES

Antibody Specificity	Clinically Significant	Antibody Class	Frequency of Antigen-Negative Blood HDNHTR(White Population)		
Kx	No	IgG	No	No	Very rare (<0.1%)

HDN, hemolytic disease of the newborn; HTR, hemolytic transfusion reaction; Ig, immunoglobulin.

The Kx blood group system consists of one antigen: Kx (Table 20.1).

Genes and Antigens

The Kx antigen is carried on the XK protein, which is encoded by the XK gene. The XK gene is located on the short arm of the X chromosome (Xp21.1). The structure of XK resembles a glutamate transporter; however, its actual cellular function has not yet been determined.⁶⁰ In the red blood cell membrane, the XK protein is found in a complex with the Kell glycoprotein. The two proteins are covalently linked by a disulfide bond.⁵⁹ It is thought that the expression of the XK protein is required for the normal expression of the Kell antigens on red cells.

The XK protein has the structure of a membrane transporter protein; however, its function is not known.¹⁶² Patients with absent XK, due to gene deletions or mutations, are said to have the McLeod syndrome. The McLeod phenotype is inherited in an X-linked pattern, unlike the KEL gene, which has an autosomal mode of inheritance.⁶⁰ The McLeod syndrome is a condition occurring in males characterized by decreased expression of the Kell blood group system antigens, acanthocytes, hemolytic anemia, and elevated serum creatinine kinase.¹ Associated symptoms include muscle wasting, decreased deep tendon reflexes, choreiform movements, and cardiomyopathy.⁵⁶ The McLeod phenotype may also occur in patients with X-linked chronic granulomatous disease. X-linked chronic granulomatous disease has been demonstrated to occur because of deletion of or mutations in the CYBB gene, which is also located on the X chromosome at a location discrete from that of the KEL locus. The association between the two disorders is due to deletions of parts of the X chromosome that include both genes.⁵⁶ Other X-linked conditions that have been associated with the McLeod phenotype include retinitis pigmentosa and Duchenne muscular dystrophy.^{163,164}

Antibodies and Clinical Significance

Patients who lack the Kx antigen form alloantibodies if they are transfused with antigen-positive blood. Patients with the McLeod phenotype who have been transfused have been reported to form anti-Kx.^{143,165} It is suggested that these patients receive Kx-negative blood, but there are no reports of the antibody causing HDN or HTR. Furthermore, some patients without clinical or hematologic features of the McLeod syndrome have been demonstrated to form an IgG autoantibody with Kx specificity.^{165,166} The autoantibody does not appear to cause hemolysis.

P.527

Gerbich Blood Group System (ISBT 020)

SUMMARY OF IMPORTANT CHARACTERISTICS OF GERBICH ANTIBODIES

Antibody Specificity	Clinically Significant	Antibody Class	Frequency of Antigen-Negative Blood HDNHTR(White Population)		
Ge2, Ge3, Ge4	Rare	IgG	Rare	Rare	Very rare (<0.1%)
Wb, Ls ^a , An ^a , Dh ^a	Rare	IgG	Rare	Rare	Very common (>99%)

HDN, hemolytic disease of the newborn; HTR, hemolytic transfusion reaction; Ig, immunoglobulin.

The Gerbich blood group system was discovered in 1960 and is named for a patient who lacked the antigen, Mrs. Gerbich.⁷⁰

Gene and Antigens

The Gerbich blood group system contains 11 antigens: Ge2, Ge3, Ge4, GEPL, GEAT, and GET1 which occur at high frequencies, and Wb, Ls^a, An^a, Dh^a, and GEIS, which occur at low frequencies (Table 20.1). The principal phenotypes of the Gerbich blood group system and their frequencies are outlined in Table 20.8. The antigens are encoded by the GYPC gene

on chromosome 2 (2q14-q21).¹³² The gene contains four exons distributed over 13.5 kbp.⁴⁵ The antigens are carried on glycoprotein C or glycoprotein D, or both. The functions of glycoprotein C and glycoprotein D are thought to involve the structural integrity of the red cell membrane, as the glycoproteins are involved in linking the red cell membrane and the membrane skeleton.¹⁶⁷ This is supported by the fact that red cells deficient in the Gerbich antigens, called the Leach phenotype, are elliptocytes.¹⁶⁸ Glycoprotein C can serve as a binding site for *P. falciparum*.¹⁶⁹

Antibodies and Clinical Significance

The antibodies against the Gerbich blood group system tend to be IgG. These antibodies have only rarely been reported to cause HDN or HTR.^{70,170,171}

Cromer Blood Group System (ISBT 021)

SUMMARY OF IMPORTANT CHARACTERISTICS OF CROMER ANTIBODIES

Antibody Specificity	Clinically Significant	Antibody Class	Frequency of Antigen-Negative Blood		
			HDN	HTR	(White Population)
Cr ^a	Seldom	IgG	No	Yes	Very rare (<1%)

HDN, hemolytic disease of the newborn; HTR, hemolytic transfusion reaction; Ig, immunoglobulin.

The Cromer blood group system was discovered in 1965 and named after Mrs. Cromer, the first patient found to produce the antibodies.⁷⁰

Genes and Antigens

The Cromer blood group system consists of 18 antigens: Cr^a, Tc^a, Tc^b, Tc^c, Dr^a, Es^a, IFC, WES^a, WES^b, UMC, GUTI, SERF, ZENA, CROV, CRAM, CROZ, CRUE, and CRAG. (Table 20.1). The antigens in the Cromer blood group system are encoded by the CD55 (DAF or CROM) gene located at chromosome 1q32. The gene contains 11 exons and is distributed over 40 kbp.⁴⁵ The antigens are located on a glycoprotein called decay accelerating factor (DAF). DAF accelerates the decay of C3 and C5 convertases, thus inhibiting the amplification of complement activation by both the classic and alternate pathways. DAF is also a receptor for *Escherichia coli* and enterovirus.¹⁷² Individuals with the null phenotype of the Cromer system, known as the Inab phenotype, have been described but do not have significant complement-induced lysis in vivo.¹⁷³

Tc^a, Tc^b, and Tc^c are antithetical antigens, as are WES^a and WES^b. Tc^b, Tc^c, and WES^a are low-incidence antigens, whereas the rest are high-incidence antigens^{138,174} (Table 20.8).

Antibodies and Clinical Significance

Antibodies to Cromer antigens do not cause HDN, perhaps because DAF is strongly expressed on the apical surface of trophoblasts and, therefore, absorbs antibodies from the maternal serum.^{1,175} Antibodies to Cromer antigens have not been implicated in HTR, likely because the placenta is a rich source of fetal-derived DAF which is thought to adsorb the antibodies.^{176,177}

Knops Blood Group System (ISBT 022)

SUMMARY OF IMPORTANT CHARACTERISTICS OF KNOPS ANTIBODIES

Antibody Specificity	Clinically Significant	Antibody Class	Frequency of Antigen-Negative Blood		
			HDN	HTR	(White Population)
Kn ^a	No	IgG	No	No	Very rare (<1%)
Kn ^b	No	IgG	No	No	Very common (>99.9%)

HDN, hemolytic disease of the newborn; HTR, hemolytic transfusion reaction; Ig, immunoglobulin.

The Knops blood group system was established in 1991. It is named after Mrs. Knops, the first antibody producer.⁷⁰

Genes and Antigens

The Knops system consists of eight antigens and one provisional antigen: Kn^a, Kn^b, McC^a, S11, Yk^a, McC^b, S12, and KCAM. S13 is a provisional antigen (Table 20.1). Most of the antigens are common, occurring with a prevalence of >90% in most populations (Table 20.8). The S11 antigen occurs with a much greater prevalence in white populations (98%) than in black populations (60%).¹ Kn^b occurs at a low incidence.

The antigens in the Knops blood group system are encoded by the CR1 (KN) gene found at chromosome 1q32.⁴⁵ The antigens are found on a glycoprotein called complement receptor 1 (CR1) that is also known as CD35. The gene is located within the regulation of the complement activation cluster. CR1 is a member of the complement control family. It inhibits both the classic and alternate pathways of complement activation by cleavage of C4b and C3b, thus protecting the red cells from hemolysis. It is hypothesized that low levels of CR1 on red cells may increase deposition of immune complexes on blood vessel walls, resulting in damage to the blood vessels.¹⁷⁸ Some antigens in the Knops blood group system may act as a binding site for *P. falciparum*.

Antibodies and Clinical Significance

Antibodies in the Knops blood group system are usually IgG and do not bind complement.⁷⁰ They have not been implicated in HDN or HTR.

P.528

Indian Blood Group System (ISBT 023)

SUMMARY OF IMPORTANT CHARACTERISTICS OF INDIAN ANTIBODIES

Antibody Specificity	Clinically Significant	Antibody Class	Frequency of Antigen-Negative Blood HDNHTR(White Population)		
In ^a	No	IgG	No	No	Very common (>99%)
In ^b	Seldom	IgG	No	Rare	Very rare (<1%)

HDN, hemolytic disease of the newborn; HTR, hemolytic transfusion reaction; Ig, immunoglobulin.

The Indian blood group was so named because 4% of Indians from Bombay express the antigen.⁷⁰

Genes and Antigens

The Indian blood group system consists of four antigens: In^a, In^b, INFI, and INJA (Table 20.1). The antigens of the Indian blood group system are encoded by the CD44 gene located at chromosome 11p13. The gene contains at least 19 exons and is distributed over 50 kbp.⁴⁵ CD44 is thought to be the major human hyaluron receptor and also may bind fibrinogen, laminin, collagen, and osteopontin.¹ The interaction between CD44 and hyaluron is likely required for the adhesion of lymphoid and erythroid cells to the bone marrow stroma during lymphopoiesis and erythropoiesis. A patient with a novel form of congenital dyserythropoietic anemia and CD44 deficiency was noted to have the In(a-b-) phenotype.¹⁷⁹ The principal phenotypes of the Indian blood group system and their frequencies are outlined in Table 20.8.

Antibodies and Clinical Significance

Antibodies in the Indian system are usually IgG and do not activate complement.⁷⁰ These antibodies have not been associated with HDN, but anti-In^b has been implicated in one immediate HTR.¹⁸⁰

Ok Blood Group System (ISBT 024)

SUMMARY OF IMPORTANT CHARACTERISTICS OF OK ANTIBODIES

Antibody Specificity	Clinically Significant	Antibody Class	Frequency of Antigen-Negative Blood HDNHTR(White Population)		
Ok ^a	No	IgG	No	No	Very rare (<0.1%)

HDN, hemolytic disease of the newborn; HTR, hemolytic transfusion reaction; Ig, immunoglobulin.

The Ok blood group system consists of one antigen: Ok^a, OKGV, and OKVM (Table 20.1).³ Antibodies against the Ok^a antigen were initially identified in 1979 in the serum of a Japanese woman, Mrs. Okbutso.⁷⁰

Genes and Antigens

The Ok^a antigen is encoded by the BSG (OK) gene, which is located at 19p13.3. The BSG gene contains seven exons distributed over 1.8 kbp.⁴⁵ The gene encodes for basigin or CD147, an extracellular matrix metalloproteinase inducer. Basigin has been shown to induce the production of matrix metalloproteinase in fibroblasts and in tumor cells. It plays a role in tumor angiogenesis as it induces expression of vascular endothelial growth factor and hyaluronase.^{3,181} In addition,

it regulates lymphocyte responsiveness, monocarboxylate transporter expression and spermatogenesis. It also functions as a signaling receptor for the cyclophilin family of proteins^{3,182}. The Ok^a antigen is resistant to treatment with proteases, sialidase, DTT, and acid.

Antibodies and Clinical Significance

Antibodies in the initial patient with anti-Ok^a were IgG and did not activate complement. Anti-Ok^a has not been associated with HTR or HDN, but it has been demonstrated to cause decreased red cell survival.

RAPH Blood Group System (ISBT 025)

SUMMARY OF IMPORTANT CHARACTERISTICS OF RAPH ANTIBODIES

Antibody Specificity	Clinically Significant	Antibody Class	Frequency of Antigen-Negative Blood HDNHTR(White Population)		
MER2	No	IgG	No	No	Rare (8%)

HDN, hemolytic disease of the newborn; HTR, hemolytic transfusion reaction; Ig, immunoglobulin.

The RAPH blood group system consists of one antigen: MER2 (Table 20.1). The system is named after the first patient known to have antibodies against the antigen. The MER2 antigen was given system status in 1999.

Genes and Antigens

The gene, CD151 (RAPH), is found on chromosome 11p15.5 and it encodes for the CD151 protein. Although the exact function of CD151 is unknown, anti-MER2 was found in three individuals. All individuals had renal failure and two had sensorineural deafness and pretibial epidermolysis bullosa.^{183,184} This suggests that CD151 is likely essential for the assembly of the kidney basement membrane, is a component of the inner ear, and has some functional significance in the skin.^{183,185} Ninety-two percent of English blood donors are positive for MER2 (Table 20.8).⁷⁰

Antibodies and Clinical Significance

Antibodies against MER2 are IgG. They have not been documented to cause HDN but there is a case report of an anti-MER2 possibly associated with HTR.¹⁸⁴

John Milton Hagen Blood Group System (ISBT 026)

SUMMARY OF IMPORTANT CHARACTERISTICS OF JOHN MILTON HAGEN ANTIBODIES

Antibody Specificity	Clinically Significant	Antibody Class	Frequency of Antigen-Negative Blood HDNHTR(White Population)		
JMH1	No	IgG	No	No	Very rare (<0.1%)

HDN, hemolytic disease of the newborn; HTR, hemolytic transfusion reaction; Ig, immunoglobulin.

P.529

The John Milton Hagen blood group system consists of six antigens: JMH, JMhk, JMhL, JMhG, JMhM, and JMhQ (Table 20.1). It was recognized as a system by the ISBT Working Party in July 2000.¹⁸⁶

Genes and Antigens

The JMH antigen is encoded by SEMA7A, which is located on chromosome 15q22.3-q23. The gene product is semaphoring 7A. The function of semaphoring 7A is unknown.

Antibodies and Clinical Significance

Antibodies against JMH are usually autoimmune and do not tend to be clinically significant. Individuals producing alloanti-JMH have been reported.^{187,188} The antibodies tend to be IgG. They have not been documented to cause HDN or HTR.

I Blood Group System (ISBT 027)

SUMMARY OF IMPORTANT CHARACTERISTICS OF I ANTIBODIES (INCLUDING I COLLECTION)

Antibody	Clinically	Antibody	HDNHTR	Frequency of Antigen-Negative Blood	
-----------------	-------------------	-----------------	---------------	--	--

Specificity	Significant	Class	(White Population)		
I	Seldom	IgM	No	No	Very uncommon (adults)
i	Seldom	IgM	No	No	Very common (adults)

HDN, hemolytic disease of the newborn; HTR, hemolytic transfusion reaction; Ig, immunoglobulin.

The I blood group system consists of one antigen: I (Table 20.1). This antigen was previously classified in the Ii Collection but was recognized as a blood group system in 2004.^{6,186} The i antigen, the precursor of the I antigen, provisionally remains within the Ii Collection of antigens (ISBT 207).

Genes and Antigens

The I antigen is located on the same carbohydrate chains on which the ABH antigens are located (Fig. 20.3). The enzyme responsible for the conversion of i-active straight chains to I-active branched chains is N-acetylglucosaminyltransferase A and is encoded by GCNT2 on chromosome 6p24.2.

Antibodies and Clinical Significance

The anti-I antibody is found as an IgM autoantibody in most normal individuals. The antibody is generally reactive at low temperatures and is not clinically significant. Anti-I cold agglutinins increase in titer after infection with *Mycoplasma pneumoniae* and tend to be polyclonal in nature.¹⁸⁹ Monoclonal anti-I autoantibodies are found in high titers in cold hemolytic agglutinin disease. These antibodies are clinically significant and cause hemolysis. Anti-I alloantibodies are rare because the i phenotype is very uncommon. When they occur in adults with the i phenotype, they are clinically significant and can cause hemolysis.

Globoside Blood Group System (ISBT 028)

SUMMARY OF IMPORTANT CHARACTERISTICS OF GLOBOSIDE ANTIBODIES

Antibody Specificity	Clinically Significant	Antibody Class	Frequency of Antigen-Negative Blood (White Population)		
			HDN	HTR	Blood (White Population)
P	Yes	IgG (biphasic activity)	Very rare		

HDN, hemolytic disease of the newborn; HTR, hemolytic transfusion reaction; Ig, immunoglobulin.

The Globoside blood group system consists of one antigen: P (Table 20.1). This antigen was previously classified in the Globose Collection of antigens along with Pk and LKE. These antigens were initially considered to be part of the P blood group system and are related to the P1 antigen.

Genes and Antigens

The P antigen has been demonstrated to be on almost all human red blood cells.⁴⁴ It is synthesized from globotriaosylceramide by the action of UDP-N-acetylgalactosaminyltransferase (P synthase) encoded by B3GALNT1 (B3GALT3) found at chromosome 3q25. The function of the P antigen is not known. It has been demonstrated to be a receptor for parvovirus B19 and individuals who lack this antigen have been demonstrated to be naturally resistant to parvovirus B19 infection.^{190,191}

Antibodies and Clinical Significance

Autoantibodies against the P antigen are uncommon and may be idiopathic or secondary to other disorders such as syphilis and infections with various agents (e.g., measles, mumps, Epstein-Barr virus, cytomegalovirus, varicella-zoster virus, adenovirus, influenza A, *M. pneumoniae*, *Haemophilus influenzae*, and *E. coli*).¹⁹² Anti-P has been implicated in paroxysmal cold hemoglobinuria and is known as the Donath-Landsteiner antibody. This antibody is IgG and has biphasic activity in that it binds to red blood cells and fixes complement component C1 at low temperatures (0° to 4°C) and causes hemolysis at higher temperatures. Please see Chapter 31 for a more complete discussion of paroxysmal cold hemoglobinuria.

Gill Blood Group System (ISBT 029)

The Gill Blood group system consists of one antigen: Gil (Table 20.2).

SUMMARY OF IMPORTANT CHARACTERISTICS OF GILL ANTIBODIES

Antibody Specificity	Clinically Significant	Antibody Class	HDN/HTR	Frequency of Antigen-Negative Blood (White Population)	
GIL	No	IgG	No	Possibly (rare)	Very rare

HDN, hemolytic disease of the newborn; HTR, hemolytic transfusion reaction; Ig, immunoglobulin.
P.530

Genes and Antigens

The Gil antigen is located on the glycerol transporter aquaporin 3 encoded by the AQP3 gene found on chromosome 9p13.¹⁹³ Aquaporin 3 functions as a water and glycerol channel.¹⁹⁴

Antibodies and Clinical Significance

The Gil antigen is a high-frequency antigen. It has not been implicated in HDN but may have possibly been associated with one HTR.¹⁹⁵

RhAG Blood Group System (ISBT 030)

The RhAG Blood group system is the newest blood group system. The RhAG blood group system consists of 4 antigens: two high-frequency antigens, Duclos and DSLK (Duclos-like), and 2 low-frequency antigens, OI^a and RHAG4 (Table 20.2). The antigens are encoded by the RHAG gene located at chromosome 6p12.3.

Genes and Antigens

RHAG is the ancestral gene from which RHCE and RHD arose.¹⁹⁶ The RhAG protein consists of 409 amino acids. It associates with the Rh proteins and forms the Rh-core complex in the red cell membrane.¹⁹⁷ As described earlier, the RhAG protein is important in that it must be present for the expression of the Rh antigens. This may occur because of mutations or deletions in RHAG or the Rh antigens. If the RhAG protein is not present, the red cells lack Rh antigens and are said to be Rh_{null}.¹⁹⁶ The RhAG protein is also believed to contribute to the red cell membrane structure through its interactions with various proteins including band 3, glycophorin A and B, LW, and CD47.¹⁹⁶ Further, it has been demonstrated to be an ammonia transporter.^{47,198}

Antibodies and Clinical Significance

There are no reports of alloantibodies against the RhAg antigens.

Low-incidence Antigens (700 Series)

An antigen is considered to be a low-incidence antigen if (a) it occurs in <1% of a population tested; (b) it is not part of an existing blood group system or related closely enough to another antigen to merit collection status; and (c) it is serologically distinct from other low-incidence antigens. Furthermore, to allow identification of further examples, red cells containing the antigen and antibody must be available. Table 20.3 lists the 18 low-incidence antigens that comprise the 700 series of the ISBT terminology.

Typically, these antibodies arise as a result of no known stimulus. Occasionally, antibodies to these antigens may be discovered in mothers of neonates with HDN. Because of the low frequency of these antigens, initial screening against a standard red cell panel is negative; however, the serum is positive when tested against paternal cells. Family studies often detect other individuals with the antigen.

High-incidence Antigens (901 Series)

An antigen is considered to be a high-incidence antigen if it is found on >90% of individuals in populations tested. Antigens that are found in >99% of the population are termed public antigens. As noted previously, high-incidence antigens were initially included in the 900 series but are now contained in the 901 series. The 901 series currently contains six antigens (Table 20.4).

The significance of high-incidence antigens is that the rare individual lacking a high-incidence antigen may experience severe HTRs when transfused with antigen-positive blood. Because by definition the majority of the population expresses the antigen, it is very difficult to find compatible blood for such a patient.

Collections of Antigens

In the ISBT terminology, related sets of antigens (genetically, biochemically, or serologically) that cannot correctly be classified as systems, as they have not been shown to be genetically distinct from all existing systems, are designated as collections. Six collections are currently recognized: Cost, li, Er, GLOB, Le^c/Le^d, and Vel and MN/CHO (Table 20.2).

li Collection (ISBT 027)

The I antigen was described in 1956 by Weiner et al.¹⁹⁹ The antigen was named I for individuality. In 2004, the I Blood Group System (ISBT 027) was created and now contains the I antigen. The i antigen provisionally remains within the li Collection of antigens.^{6,200}

Genes and Antigens

The li antigens are synthesized on red blood cells and are located on the same carbohydrate chains on which the ABH antigens are located (Fig. 20.2). The I antigens are located below the ABH antigens. The antigens are synthesized by a regulated, stepwise addition of sugars by a series of glycosyltransferases.²⁰⁰ The i antigen consists of the disaccharides, galactose-N-acetyl-glucosamine, linked in a straight, nonbranched chain. The I antigen consists of the linear chains modified into branched chains.²⁰¹ Adult red blood cells express predominantly the I antigen. Conversely, fetal cells predominantly express the i antigen with little or no I expression. However, during the first 18 months of life, the infant's red cells gradually express more I and less i. Very rarely, adult red blood cells express predominantly the i antigen. The gene involved is most likely GCNT2 (IGnt), which is found on chromosome 6p24.2.²⁰⁰

Antibodies and Clinical Significance

The anti-i autoantibody may commonly be found in individuals with lymphoproliferative disorders such as chronic lymphocytic leukemia, lymphoma, and Hodgkin disease. Patients with mononucleosis secondary to Epstein-Barr virus infection may have transient anti-i, which causes hemolysis.

GLOB Collection (ISBT 209)

The GLOB or globoside collection of antigens includes Pk and LKE antigens (Table 20.2). The antigens of the GLOB collection were initially considered to be part of the P blood group system, and they are related to the P1 antigen. Prior to 2004, this collection also included the P antigen.

PLATELET ANTIGENS

Alloantibodies directed against platelet surface antigens can cause isolated thrombocytopenia. The antibodies most commonly play a role in neonatal alloimmune thrombocytopenia (NAT) and posttransfusion purpura (PTP), but they also mediate the destruction of platelets in passive alloimmune thrombocytopenia (PAT), posttransfusion refractoriness (PTR), and transplantation-associated thrombocytopenia (TAT).³⁰ Although the mechanisms of platelet clearance are understood in some disorders (e.g., NAT), the platelet-antibody interaction and resulting thrombocytopenia are less well understood in others (e.g., PTP). Limiting factors include the lack of appropriate investigational technology and the rarity of some of the disorders. Until recently, the identification of

P.531

incompatible antigens relied on serologic methods that require well-characterized antisera. After the identification of the genetic basis for the major platelet alloantigens, a number of different genotyping techniques were developed. This advance has made it possible for more laboratories to perform platelet alloantigen investigations based on DNA methodology rather than relying on the requirements for sufficient platelets and appropriate typing antisera for serology-based phenotyping.

Immunization to platelet alloantigens can occur in normal individuals when exposed during pregnancy, transfusion, or transplantation to alloantigens they lack. Unlike red cell alloantibodies, it is uncommon for alloantibodies against platelets to form spontaneously.

Platelet Glycoprotein Polymorphisms

Alloantigens are expressed on platelet proteins, glycoproteins, and carbohydrates. Many of these proteins are found exclusively on platelets as complexes containing two or more different polypeptide chains and are termed platelet-specific proteins. Most of these platelet glycoproteins also function as cell receptors. These receptors play a major role in the interaction of platelets with the damaged vessel wall (adhesion) and with other platelets (aggregation).

On platelets, most alloantigens are caused by a structural change in a protein due to an alternate amino acid that is encoded by a polymorphism in the gene. Many of these polymorphisms arise from single base pair mutations within the gene. To date, all the polymorphisms on platelets have been diallelic, with only a single mutation recorded at each respective locus (Fig. 20.4).

Because of the tremendous variability in the human genome among individuals, a typical person can be heterozygous for 24,000 to 40,000 substitutions, each encoding a different amino acid.^{202,203} and ²⁰⁴ Thus, it is likely that there are many polymorphisms that encode variant forms of platelet proteins that have yet to be identified.

Nomenclature

Like red cells, the initial platelet alloantigens were described and characterized based on the binding of alloantibodies from immunized individuals to platelet proteins. Before the advent of glycoprotein-specific assays, the rate of identifying novel alloantigens was low, and the practice of identifying the antigen by the first few letters of the proband surname was sufficient. Alleles were noted with a superscript a or b and were assigned in the temporal order in which they were identified with serum from alloimmunized patients (e.g., Ko^a Ko^b; Bak^a Bak^b). However, a rapid increase in the detection rate of new antigens also coincided with confusing reports when the same alloantigen was discovered more than once by different investigators and given more than one designation.

This prompted a reconsideration and standardization of the nomenclature in the form of the human platelet antigen (HPA) system.²⁰⁵ The system was based on organizing the antigens based on their recognition by specific alloantisera. HPA designations were assigned to antigens at a certain locus as they were reported chronologically in the literature. However, to establish consistency in the terminology, the high- and low-frequency alleles were assigned a and b, respectively. Thus, the PL^{A1}/PL^{A2} antigens became HPA-1a/-1b, and the Bak^a/Bak^b antigens became HPA-3a/-3b. For a few loci, alloantibodies to the low-frequency antigen had been reported first, which resulted in the reversal of a/b allele assignments (e.g., HPA-2a/-2b = Ko^b/Ko^a; HPA-5a/-5b = Br^b/Br^a). It was proposed that the Platelet Nomenclature Committee, a joint panel of the ISBT and the International Society of Thrombosis and Haemostasis, be charged with ensuring the orderly assignment of new HPA designations after confirmation of the alloantibody reactivity and specificity. A list of HPA assignments based on the 2002 platelet workshop describes 16 HPA systems and antigens (Table 20.9). Some alloantibodies have been reported that recognize only the low-frequency antigens at certain loci, mainly on gpIIIa. Thus, their HPA designations are not considered at present to be true antigen systems, because there is, as yet, no evidence that the antithetical high-frequency polymorphism induces structural changes that would be immunogenic in an individual homozygous for the low-frequency allele. Only HPA-1 through HPA-5 and HPA-15 alloantigens constitute complete systems in which alloantibodies to both alleles have been reported.

The HPA system is useful when considering the alloimmune thrombocytopenias, especially for the simple identification of the relevant pathologic alloantibody and the zygosity of the patient for that allele. However, it should be noted that the HPA system is misleading from a genetic point of view.²⁰⁶ Many polymorphisms evolved at different loci on the PL^{A1} variant of the gpIIIa gene. Thus, there are two HPA designations (i.e., HPA-1a and HPA-4a) for the single gpIIIa gene encoding Leu33 and Arg143. Furthermore, Newman noted that if alloantibodies were found to all the high-frequency alleles on gpIIIa, then the designations PL^{A1}, Pen^a, Mo^b, Ca^b, and Sr^b all would refer to the same molecular entity. However, although a description of the gene by its haplotype would be of benefit when considering the concept that combinations of polymorphisms could have different effects on protein function, at present, there is no nomenclature that can efficiently describe haplotypes.

Platelet-specific Alloantigens: Biochemistry and Genetics

Glycoprotein IIb/IIIa (αIIbβ3)

Glycoproteins IIb and IIIa form a heterodimer complex that is a member of the integrin family of integral membrane proteins, a superfamily of noncovalently associated α and β subunits involved in cell-cell and cell-vessel contact. Of these, gpIIb/IIIa, with 50,000 to 80,000 surface copies, is expressed most abundantly by far on platelets.²⁰⁷ Activated gpIIb/IIIa mediates platelet aggregation through binding to fibrinogen and VWF. A complex of the α and β subunits is required for expression of the gpIIb and gpIIIa subunits on the surface. A deficiency of gpIIb/IIIa results in Glanzmann thrombasthenia, an inherited bleeding disorder.^{208,209} The gene for gpIIIa, located on chromosome 17, may be the most polymorphic of the human integrin subunits.^{210,211,212,213} and ²¹⁴ Hence, a large number of platelet alloantigens, including HPA-1 (PL^A), HPA-4 (Pen), HPA-6 (Ca/Tu), HPA-7 (Mo), HPA-8 (Sr), HPA-10 (La), HPA-11 (Gro), HPA-14 (Oe), and HPA-16 (Duv) determinants, are located on gpIIIa. Polymorphisms of the gene on chromosome 17 encoding the α subunit, gpIIb, are responsible for the HPA-3 (Bak) and HPA-9 (Max) alloantigens. Glycoprotein IIb is synthesized exclusively by megakaryocytes; thus,

gpIIb/IIIa is unique to platelets. However, the gpIIIa subunit also is expressed on endothelial cells in association with the subunit αv to form the vitronectin receptor, also expressed in low numbers on the platelet surface.

Glycoprotein Ia/IIa ($\alpha 2\beta 1$)

The collagen receptor, gplIa/IIa, is a member of the integrin family of cell surface receptors. These membrane glycoprotein heterodimers consist of noncovalently associated α and β subunits.^{68,215,216,217} and ²¹⁸ Patients in whom deficiencies of gplIa/IIa are reported demonstrate chronic mucocutaneous bleeding associated with prolonged bleeding times.^{219,220} Three or more alleles of the $\alpha 2$ gene regulate the level of expression of gplIa/IIa on platelets.^{221,222} and ²²³ Quantitative binding of platelets to type I or III collagens correlates with the number of gplIa/IIa molecules expressed on the platelet surface.²²² Alloantibodies to the HPA-5 (Br/Zav) and HPA-13 (Sit) determinants are expressed on gplIa.

P.532

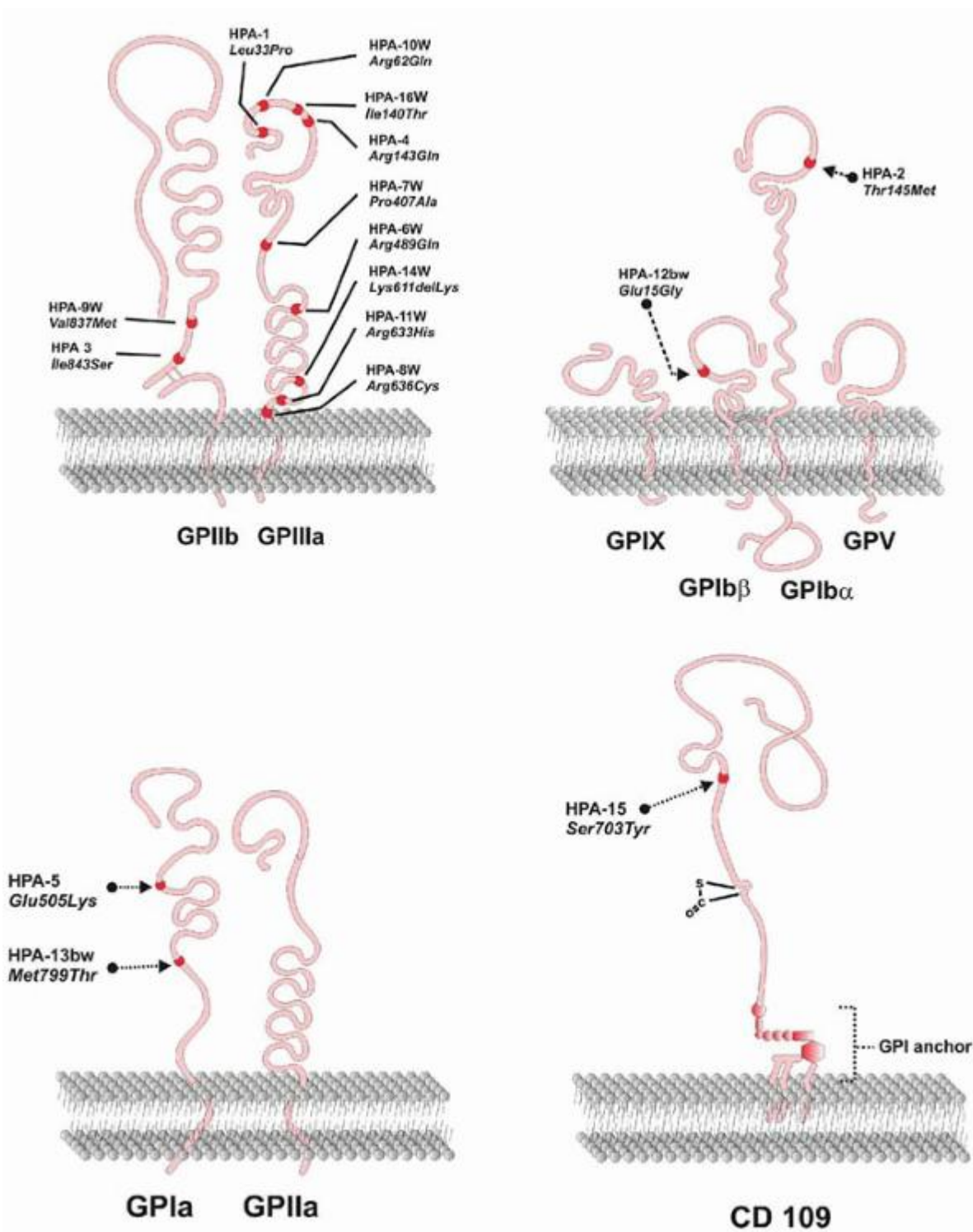

FIGURE 20.4 Schematic representation of amino acid substitutions that determine human platelet antigens (HPAs). The relative locations of the various amino acid substitutions encoded by single nucleotide polymorphisms are indicated on the respective platelet glycoprotein (GP). One antigen (HPA-14bw) results from an in-frame deletion of three nucleotides on the HPA-1b allele of the β -IIIa (ITGB3) gene. Immunization to the alloantigens determined by the highly polymorphic gene for GPIIIa accounts for the majority of clinically significant alloimmune thrombocytopenias.

Glycoprotein CD109

CD109 is a monomeric 175-kD glycoprotein that is anchored to the platelet membrane by glycosylphosphatidyl-inositol (GPI).²²⁴ The precise function for the GPI-anchored protein is not known. However, the recent determination of the cDNA

sequence for CD109 indicates that it is a novel member of the $\alpha 2M/C3, C4, C5$ family of thioester-containing proteins and thus may mediate covalent cell-substrate and cell-cell interactions.²²⁵ Although CD109 expression has been reported to be activation dependent on platelets, this has not been established. It is possible that the protein is constitutively expressed on the resting platelet and undergoes structural changes after activation that expose epitopes for certain monoclonal antibodies.^{224,226,227} The HPA-15 (Gov) alloantigens are expressed on CD109.^{224,226}

P.533

TABLE 20.9 HUMAN PLATELET ALLOANTIGENS

HPA System	Antigen	Original Designation	Amino Acid Substitution	Glycoprotein	Reference
1	HPA-1a	Zw ^a , PL ^{A1}	Leu33	β IIIa	211
	HPA-1b	Zw ^b , PL ^{A2}	Pro33		
2	HPA-2a	Ko ^b	Thr145	Ib α	425
	HPA-2b	Ko ^a , Sib ^a	Met145		
3	HPA-3a	Bak ^a , Lek ^a	Ile843	α IIb	225
	HPA-3b	Bak ^b	Ser843		
4	HPA-4a	Yuk ^b , Pen ^a	Arg143	β IIIa	238
	HPA-4b	Yuk ^a , Pen ^b	Gln143		
5	HPA-5a	Br ^b , Zav ^b	Glu505	Ia	221
	HPA-5b	Br ^a , Zav ^a , Hc ^a	Lys505		
	HPA-6bw	Ca ^a , Tu ^a	Gln489 Arg489	β IIIa	241
HPA-7bw	Mo ^a	Ala407	β IIIa	243	
		Pro407			
HPA-8bw	Sr ^a	Cys636	β IIIa	221	
HPA-9bw	Max ^a	Arg636			
		Met837 Val837	α IIb	245	
HPA-10bw	La ^a	Gln62	β IIIa	246	
		Arg62			
HPA-11bw	Gro ^a	His633 Arg633	β IIIa	248	
HPA-12bw	Iy ^a	Glu15 Gly15	Ib β	250	
HPA-13bw	Sit ^a	Met799 Thr799	Ia	252	
HPA-14bw	Oe ^a	Deleted-Lys611 Lys611	β IIIa	253	

15	HPA-15a Gov ^b	Ser703	CD109	224
	HPA-15b Gov ^a	Tyr703		
	HPA-16bwDuv ^a	Ile140	βIIIa	254
	Thr140			

HPA, human platelet antigen.

Glycoprotein Ib/IX/V

Glycoprotein Ib consists of two disulfide-linked proteins (gplbα and gplbβ) and is found on the platelet surface in association with gplX and gpV.²²⁸ The four polypeptides share similar structural features, including a region of leucine-rich repeats, and are encoded by four separate genes. The short arm of chromosome 22 contains the gene for gplbα; the long arm contains the gene for gplbβ.^{229,230} The genes for gplX and gpV are located on chromosome 3.²³¹ The gplb-IX-V complex resides on the platelet surface as a heptamer, with one molecule of gpV flanked by two molecules each of gplX, gplbα, and gplbβ.^{228,232} A region within the amino-terminal domain of gplbα functions as the major receptor for VWF, which mediates platelet contact and adhesion to damaged endothelium.^{233,234} and ²³⁵ A deficiency or lack of gplb-IX-V is associated with the Bernard-Soulier syndrome, an inherited bleeding disorder.^{236,237} and ²³⁸ Platelets express approximately 25,000 copies of the gplb-IX-V complex.²³⁹ Alloantibodies have been reported that recognize the HPA-2 (Ko) and HPA-12 (Iy) determinants on gplbα and gplbβ, respectively.

Clinically Significant Platelet Alloantigens

HPA-1: PI^A Polymorphism

SUMMARY: HPA-1 ANTIGENS

Antibody Specificity	Clinically Significant	NAT	PTP	PAT	PTR	TAT	Comments
HPA-1a	Yes	Yes	Yes	Yes	Yes	Yes	Associated with severe thrombocytopenia
HPA-1b	Seldom	Yes	Yes	No	Yes	No	

HPA, human platelet antigen; NAT, neonatal alloimmune thrombocytopenia; PAT, passive alloimmune thrombocytopenia; PTP, posttransfusion purpura; PTR, posttransfusion refractoriness; TAT, transplantation-associated thrombocytopenia.

The HPA-1a/1b alloantigen system has been associated with all of the alloimmune thrombocytopenic syndromes P.534

and is the primary cause of NAT and PTP in whites.²⁴⁰ Alloimmunization to the HPA-1 antigens is important both for the frequency (>75%) and for the severity of thrombocytopenia, which often is greater for syndromes involving the gplIb/IIIa complex.³⁰ A Leu (HPA-1a) to Pro (HPA-1b) change at residue 33 is encoded by a T to C substitution at position 196 of gpIIIa (ITGB3) cDNA.²⁴¹ The gene frequencies in the white population are 0.85 and 0.15 for HPA-1a and HPA-1b, respectively. A third allele for the HPA-1 system has recently been reported.²⁴² A naturally occurring Leu33Val change resulting from a C to G change at position 175 on the ITGB3 gene was shown to affect the binding of some anti-PL^{A1} antisera. The mutation occurs 5' to the polymorphism at position 176 encoding the HPA-1 antigens and therefore it is likely that current genotyping methods will incorrectly identify the Val33 β3 gene as encoding the Leu33 form of the protein. It is possible that the frequency of this polymorphism is higher than the 2 per 2,951 individuals reported.²⁴² A second substitution, Leu to Arg at residue 40, of <3% of HPA-1b alleles, has no known clinical significance.^{243,244}

Alloimmunization to HPA-1a is associated with the immune response genes HLA-DRB3*0101 or -DQB1*0201. Heterogeneity in the binding of anti-HPA-1a antibodies to platelets may be a consequence of a complex and disulfide-bonded structure in the amino-terminal portion of gpIIIa that imposes a threedimensional structural constraint on the HPA-1a antigen.^{245,246,247} and ²⁴⁸ Further evidence for structural factors distant to the Leu33Pro substitution in the control over the expression of the HPA-1a epitope was recently reported in 1 of 6,000 individuals tested for antigen status using phenotyping and genotyping. An Arg93Gln substitution on the Leu33 allele disrupted the formation of the HPA-1a antigen

phenotype in an individual who had been typed positive for PL^{A1} using genotyping.²⁴⁹ Alloantibodies to PL^{A1} inhibit clot retraction and platelet aggregation, possibly by blocking fibrinogen binding.^{250,251}

HPA-5: Br/Zav Polymorphism

SUMMARY: HPA-5 ANTIGENS

Antibody Specificity	Clinically Significant	NAT	PTP	PAT	PTR	TAT	Comments
HPA-5a	Yes	Yes	Yes	No	Yes	No	Usually causes moderate thrombocytopenia
HPA-5b	Yes	Yes	Yes	Yes	Yes	Yes	

HPA, human platelet antigen; NAT, neonatal alloimmune thrombocytopenia; PAT, passive alloimmune thrombocytopenia; PTP, posttransfusion purpura; PTR, posttransfusion refractoriness; TAT, transplantation-associated thrombocytopenia.

The HPA-5a/5b alloantigens have been associated with all of the alloimmune thrombocytopenic syndromes and are the second most common cause of NAT in whites.²⁴⁰ A Glu (HPA-5a) to Lys (HPA-5b) change at residue 505 is encoded by a G to A substitution at position 1648 of gplα (MMRN1) cDNA.²⁵² The frequencies in the white population are 0.89 and 0.11 for HPA-5a and HPA-5b, respectively. The HPA-5b allele is in linkage disequilibrium with the -52T polymorphism associated with lower levels of surface gplαIIa.^{221,222} However, platelets from HPA-5aa and HPA-5bb homozygous donors do not demonstrate differences in their static adhesion to collagen.²⁵²

HPA-15: Gov Polymorphism

SUMMARY: HPA-15 ANTIGENS

Antibody Specificity	Clinically Significant	NAT	PTP	PAT	PTR	TAT	Comments
HPA-15a	Yes	Yes	No	No	Yes	No	Usually causes moderate thrombocytopenia
HPA-15b	Yes	Yes	?	No	Yes	No	

HPA, human platelet antigen; NAT, neonatal alloimmune thrombocytopenia; PAT, passive alloimmune thrombocytopenia; PTP, posttransfusion purpura; PTR, posttransfusion refractoriness; TAT, transplantation-associated thrombocytopenia.

The HPA-15a/15b (Gov^{a/b}) alloantigens have been associated with NAT, PTP, and PTR.^{224,226,253} Large studies on the frequency of the HPA-15 alloantibodies have recently been made possible by the adaptation of the monoclonal antibody immobilization of platelet antigens (MAIPA) technology to include monoclonal capture antibodies for CD109. These studies indicate that immunization to the HPA-15a/15b alloantigens is second only to the HPA-1a antigen, occurring as often as HPA-5a/5b antibodies.²⁵⁴ The HPA-15a/15b antigens are the result of a Ser (HPA-15a) to Tyr (HPA-15b) change at residue 703 encoded by a C to A substitution at position 2108 of CD109 cDNA.²⁵⁵ Large European studies indicate that the frequencies for the HPA-15a and -15b antigens are 0.59 and 0.41, respectively. The HPA-15a/15b alloantigens are unique because they can be removed from the platelet surface by the action of phospholipase on the membrane anchor.²²⁴

HPA-3: Bak Polymorphism

SUMMARY: HPA-3 ANTIGENS

Antibody Specificity	Clinically Significant	NAT	PTP	PAT	PTR	TAT	Comments
HPA-3a	Yes	Yes	Yes	No	No	No	Can cause severe thrombocytopenia
HPA-3b	Seldom	?	Yes	No	Yes	No	

HPA, human platelet antigen; NAT, neonatal alloimmune thrombocytopenia; PAT, passive

alloimmune thrombocytopenia; PTP, posttransfusion purpura; PTR, posttransfusion refractoriness; TAT, transplantation-associated thrombocytopenia. The HPA-3a/3b (Bak^{a/b}, Lek^a) alloantigens have been associated with NAT and PTP. Although less common, HPA-3a antibodies can occasionally cause thrombocytopenia as severe as the HPA-1a mediated disease. An Ile (HPA-3a) to Ser (HPA-3b) change at residue 843 is encoded by a T to G substitution at position 2622 of gpIIb (*ITGA2B*) cDNA,²⁵⁶ creating the HPA-3 epitopes on the heavy chain of the integrin subunit. The frequencies in the white population are 0.61 and 0.39 for HPA-3a and HPA-3b, respectively. Unlike other platelet-specific alloantigens, posttranslational glycosylation modifications may contribute to the expression of the HPA-3a/3b epitopes.^{256,257 and 258}

P.535

HPA-2: Ko Polymorphism

SUMMARY: HPA-2 ANTIGENS

Antibody Specificity	Clinically Significant	NAT	PTP	PAT	PTR	TAT	Comments
HPA-2a	Yes	?	No	No	?	No	Usually causes moderate thrombocytopenia
HPA-2b	Yes	Yes	No	No	Yes	No	

HPA, human platelet antigen; NAT, neonatal alloimmune thrombocytopenia; PAT, passive alloimmune thrombocytopenia; PTP, posttransfusion purpura; PTR, posttransfusion refractoriness; TAT, transplantation-associated thrombocytopenia.

The HPA-2a/2b (Ko^{a/b}) antigens have been associated with NAT and PTR and are expressed on gplb α .^{259,260,261,262} and ²⁶³ A Thr HPA-2a to Met HPA-2b change at residue 145 is encoded by a G to A substitution at position 524 of gplb α (GP1BA) cDNA. The frequencies in the white population are 0.911 and 0.089 for HPA-2a and HPA-2b, respectively.²⁶¹ Some evidence has been reported that shows anti-HPA-2 alloantibodies prevent ristocetin-induced agglutination²⁶¹; however, this has not been confirmed in other studies.^{264,265} The HPA-2 antigens may be in linkage disequilibrium with a variable number of tandem repeat (VNTR) polymorphism that is responsible for four different molecular weights for the gplb α molecule. A tandem of 13 amino acids in the mucin-rich domain can be expressed with one to four repeats, thus encoding polypeptides of different lengths (VNTR-A, -B, -C, and -D alleles have 4, 3, 2, and 1 repeats, respectively).²⁶⁶ The HPA-2b allele may have originated on the VNTR-B allele, from which the VNTR-A allele was derived. Because <1,000 base pairs separate the HPA-2 and VNTR loci, the rate of cross-over during meiosis would be low, and, in most populations, the HPA-2b antigen is expressed on the VNTR-A and -B alleles.^{260,267} However, there is evidence that crossover may have occurred.²⁶⁸

HPA-4: Pen Polymorphism

SUMMARY: HPA-4 ANTIGENS

Antibody Specificity	Clinically Significant	NAT	PTP	PAT	PTR	TAT	Comments
HPA-4a	Yes ^a	Yes	Yes	No	No	No	Usually causes moderate thrombocytopenia
HPA-4b	Yes ^a	Yes	No	No	No	No	

HPA, human platelet antigen; NAT, neonatal alloimmune thrombocytopenia; PAT, passive alloimmune thrombocytopenia; PTP, posttransfusion purpura; PTR, posttransfusion refractoriness; TAT, transplantation-associated thrombocytopenia.

^a Anti+HPA-4 alloantibodies are important in the Asian population due to the higher frequency of the

HPA-4b allele.

The HPA-4a/4b (Pen^{a/b} /Yuk^{b/a}) alloantigens have been associated with NAT and PTP. An Arg (HPA-4a) to Gln (HPA-4b) change at residue 143 is encoded by a G to A substitution at position 525 of gpIIIa (ITGB3) cDNA.²⁶⁹ Because the frequencies in the white population are >0.99 and <0.01 for HPA-4a and HPA-4b, respectively, this alloantigen system is of little consequence clinically in North America and Europe. However, HPA-4b is expressed in approximately 1% of Asians and contributes significantly to platelet alloimmunization. Anti-HPA-4a antibodies can inhibit platelet aggregation, consistent with the proximity of the epitope to the RGD-binding domain.²⁵⁰

Low-frequency Antigens

It is now clear that immunization to low-frequency polymorphisms is more common than previously thought. These antigens have been identified following detection of antibody in the maternal serum that reacts only to determinants on the paternal platelets. In some cases the antigen has been found in a few other individuals in the general population. However, the vast majority of cases referred for NAT testing that test negative for antibodies to the common antigens cannot be explained by incompatibility for low-frequency alleles.²⁷⁰ Genetic variations of the ITGA2B (gpIIb) and ITGB3 (gpIIIa) genes that entered the human genome after the HPA-1a/1b and HPA-3a/3b polymorphisms have been reported in association with alloimmunization causing NAT. For example, HPA-9bw (Max^a) antigen is found only in individuals carrying the HPA-3b (Bak^b) form of the ITGA2B gene.²⁷¹ The majority of the low-frequency antigens on gpIIIa have occurred as mutations on the Leu33 form of the ITGB3 gene. Of interest, a second immunogenic polymorphism (Hit^a) has been identified that results in a third allele of HPA-7w.²⁷² Until alloimmunization to the antithetical antigen is demonstrated in an individual homozygous for the low-frequency antigen, these polymorphisms are not considered true alloantigen systems within the HPA nomenclature. Table 20.10 summarizes the low-frequency polymorphisms identified to date.

Other Platelet Antigens

The Nak^a antibody originally was reported in a multitransfused Japanese patient.^{272a} The antibody bound to gpIV on approximately 90% of donor platelets. However, further studies demonstrated that individuals who formed the anti-Nak^a antibodies actually lacked gpIV on their platelets.^{273,274} The antibody bound to epitopes on gpIV that were not encoded

P.536

by polymorphisms; thus, anti-Nak^a is more correctly called an isoantibody, similar to the anti-gpIIb/IIIa antibodies induced in transfused individuals who lack gpIIb/IIIa on their platelets (Glanzmann thrombasthenia).

TABLE 20.10 LOW-FREQUENCY PLATELET ALLOANTIGENS

HPA	Synonym	Protein	Nucleotide	Amino Acid	Reference
6bw	Ca ^a , Tu ^a	IIIa	G1544A	Arg489Gln	457,458 and 459
7bw	Mo ^a	IIIa	C1297G	Pro407Ala	460
7cw	Hit ^a	IIIa	C1297T	Pro409Ser	272
8bw	Sr ^a	IIIa	C1984T	Arg636Cys	461
9bw	Max ^a	Iib	G2603A	Val837Met	271
10bw	La ^a	IIIa	G281A	Arg62Gln	462
11bw	Gro ^a	IIIa	G1996A	Arg633His	463,464
12bw	Iy ^a	Ib	G141A	Gly15Glu	465,466
13bw	Sit ^a	Ia	T2531C	Met799Thr	467
14bw	Oe ^a	IIIa	1909-1911 del AAG	Lys611 del	468
16bw	Duv ^a	IIIa	C497T	Thr140Ile	299
17bw	Va ^a	IIIa	C622T	Thr195Met	469
18bw	Cab ^a	Ia	G2235T	Gln716His	470

19bwSta ^a	IIIa	A487C	Lys137Gln	471
20bwKno ^a	Iib	C1949T	Thr619Met	471
21bwNos ^a	IIIa	G1960A	Glu628Lys	471
22bwSey ^a	Iib	A584C	Lys164Thr	471a
23bwHug ^a	IIIa	C1942T	Arg622Trp	471a
24bwCab2	Iib	G1508A	Ser472Asn	472
25bwSwi ^a	Ia	C3347T	Thr1087Met	473
26bwSec ^a	IIIa	G1818T	Lys580Asn	474

Alloantigens Not Specific to Platelets

Alloantigens that are not restricted to the megakaryocyte lineage can also be expressed on platelets. These include the ABH blood determinants and MHC class I molecules.

ABH Blood Group Antigens

It is now known that most of the membrane proteins on the surface of platelets can express determinants of the ABH blood groups. These include the gplb/IX/V, gpIib/IIIa, gpIV, gpV, CD31, and CD109 molecules.^{275,276} and ²⁷⁷ Approximately 25% of platelets mismatched for the A or B blood groups are immediately cleared when transfused to an incompatible recipient. The remaining ABO-incompatible platelets have a normal survival, possibly explained by the platelet-to-platelet variability in the number of A and B antigens.^{278,279} and ²⁸⁰

Human Leukocyte Antigens

The class I HLAs are expressed on the surface of platelets. These highly polymorphic antigens are the major cause of refractoriness to platelet transfusion. In contrast to the relatively constant numbers of molecules on lymphocytes, the level of expression of the HLA molecule on platelets can vary markedly (up to 35-fold) among different individuals.^{281,282} Because the HLA-C antigen levels are very low on platelets, only the HLA-A and -B antigens are a consideration when cross-matching for transfusion.²⁸³ Although a number of reports suggest that HLA antigens can play a role in causing NAT, other studies indicate that HLA antibodies may be innocent bystanders and would not play a role in fetal/neonatal thrombocytopenia.^{284,285,286} and ²⁸⁷

Alloimmune Thrombocytopenic Disorders

Platelet-specific alloantibodies play a major role in the immunopathology and thrombocytopenia observed in NAT and PTP. Alloantibodies also mediate platelet clearance in two less common syndromes: PAT and TAT. In addition, antiplatelet antibodies may play a role in refractoriness to platelet transfusions. However, more commonly in these patients, the thrombocytopenia is complicated by septicemia or by HLA antibodies.

Neonatal Alloimmune Thrombocytopenia

NAT is caused by maternal IgG alloantibodies that cross the placenta and cause the destruction of fetal platelets. Maternal alloimmunization to paternally derived alloantigens on the fetal platelets can occur early, often within the first trimester of the first pregnancy. Although analogous to HDN, alloimmunization to inherited paternal platelet antigens and the destruction of fetal platelets can occur during the first pregnancy with an antigenincompatible fetus. Thus, NAT often presents as unexpected isolated severe thrombocytopenia in an otherwise healthy neonate. Thrombocytopenia can be severe, with the platelet count falling to $<10 \times 10^9/L$ within the first few days after birth, and may take several weeks to return to normal. Clinical findings include petechiae in 90%; gastrointestinal tract hemorrhage in 30%; and hemoptysis, hematuria, and retinal bleeding in $<10\%$ of patients. Intracranial hemorrhage is found in 10% to 20% of neonates and can occur early during pregnancy. Hydrocephalus, porencephalic cysts, and epilepsy can complicate recovery from fetal and neonatal intracranial bleeding. Anemia and hyperbilirubinemia can occur from extravasation and resorption of blood.

Although more than 23 different platelet alloantigen systems have been described, most cases of NAT are caused by alloantibodies to HPA-1a (PL^{A1}, Zw^a) (78%), HPA-5b (Br^a, Zav^a), and HPA-15b (Gov^a). Recent evidence suggests that alloimmunization to HPA-15 antigens in NAT can occur more often than thought previously and can be as frequent as immunization to HPA-5 antigens. Other alloantigens implicated in NAT include HPA-1b, HPA-2b, HPA-3a, HPA-3b, HPA-4a, HPA-4b, HPA-5a, and HPA-15a. However, it is now clear that immunization to "private" alloantigens also can cause NAT. The majority of these have been found as rare polymorphisms on paternal $\beta 3$ (ITGB3). The mother carries the common

form of the gene and becomes immunized to alloantigens expressed only on the fetal platelets and on those from the father and his immediate family (e.g., HPA-8bw). In some cases, a polymorphism has also been detected in a few unrelated individuals in the general population and is termed a low-frequency antigen (e.g., HPA-6bw). These rare alloantigens have been, to date, reported only in NAT, which requires only one exposure to paternal alloantigens during pregnancy. This is in contrast to the other classic alloimmune syndrome, PTP, which is associated with two temporally distinct exposures to the immunizing antigen. The PTP patient is usually immunized initially via pregnancy and is later re-exposed via transfusion. This requirement for two exposure events would exclude the rare platelet alloantigens from a role in PTP. However, it is possible that a selection bias could eventually increase the relative frequency of the rare antigens in the general population and allow for their participation in PTP and other transfusion and transplantation-mediated alloimmune disorders. In theory, directed donations of blood, organs, or bone marrow to family members could cause alloimmunization involving a rare alloantigen. It is now apparent that the low-frequency alloantigen HPA-9bw (Max³) may be implicated more frequently in some cases of severe thrombocytopenia and intracranial hemorrhage than was previously suggested. Two recent reports indicate that immunization to HPA-9bw is not uncommon and can account for up to 2% of confirmed cases of NAT.^{288,289}

In large studies, antibodies to HPA-1a are found in the majority (78%) of serologically confirmed cases of NAT, with antibodies to HPA-5a and -5b and HPA-15a and -15b antigens identified in approximately 20%. All other specificities account for the remaining small percentage of alloantibodies found. However, up to 60% of clinically identified cases of NAT lack serologic evidence of antiplatelet alloantibodies.²⁴⁰ In some cases, a portion of clinically identified NAT may be reported "antibody-negative," possibly due to a lack of assay sensitivity or specificity. The first report of platelet alloantibodies in 1969 was followed by almost 20 years in which only three additional alloantibody specificities were detected using then-current methodology, including the platelet suspension immunofluorescence test and direct binding enzyme immunoassays. When the use of glycoprotein-specific assays for antiplatelet antibody studies became established, the rate of detection of new alloantibodies and antigens increased significantly.³⁰ By measuring the binding of maternal IgG to specific platelet glycoproteins, the MAIPA and radioimmunoprecipitation assays are able to detect specific antiplatelet alloantibodies binding to proteins expressed in low numbers on the platelet surface (e.g., I₁a) and discriminate this from background binding of IgG to non-platelet-specific epitopes (e.g., anti-HLA). Although the sensitive and specific MAIPA assay is used widely in reference laboratories to screen for alloantibodies, it too is limited by the requirement for specific monoclonal antibodies to various platelet glycoproteins to detect antiplatelet antibodies. Thus, some clinical NAT cases may not be corroborated with a positive laboratory test for alloantibodies because the maternal immunization is directed against epitopes on platelet proteins to which monoclonal antibodies are unavailable. This was demonstrated by the report of alloimmunization to epitopes on a novel platelet

P.537

protein, CD109. Although no alloantibodies were detected using the routine MAIPA assay with capture monoclonal antibodies to glycoproteins Ia/IIa, Ib/IX, and IIb/IIIa, anti-Gov^{a/b} (HPA-15a/15b) reactivity was readily identified using radioimmunoprecipitation. Until monoclonal antibodies to CD109 are used routinely in the MAIPA, the radioimmunoprecipitation assay may be used to detect HPA-15 alloantibodies. The enhanced sensitivity imparted by radiolabeling the majority of platelet proteins, including those expressed in low numbers on the platelet surface, has established the radioimmunoprecipitation assay as a universal screening method for platelet alloantibodies in NAT.

NAT is estimated to occur in 1 in 1,000 to 2,500 births. The alloantibodies most often involved are directed against HPA-1a. Because the HPA-1b/1b (PL^{A1}-negative) phenotype is found in approximately 2% of the North American population, the theoretical risk for NAT in newborns is approximately 1 in 50 births, which is much higher than observed cases. Although it is possible that limitations in recognition and technical issues in testing for alloantibodies might play a role in the underdiagnosis of some cases of NAT, the lower-than-expected responsiveness to the HPA-1a antigen in susceptible women demonstrates that additional factors play a role in alloimmunization.²⁹⁰ Maternal immunization to HPA-1a shows an HLA restriction, wherein HPA-1b/1b women who produce alloantibodies are almost exclusively HLA-DRB3*0101 or -DQB1*0201. The risk factor in the case of -DQB1*0201 is 141, similar to that for the HLA-B27 restriction in the autoimmune disease ankylosing spondylitis.²⁹¹ In one case of NAT, T cells were shown to play a role in the HLA restriction. Peptides that contain the same Leu33 polymorphism that is recognized by anti-HPA-1a antibodies were able to stimulate T cells sharing CDR3 motifs.²⁹² However, alloimmunization to the HPA-1b (PL^{A2}) antigen is not associated with a specific HLA type and has a much lower incidence in NAT.^{293,294} This may explain the observation that although phenotype frequencies for HPA-1a and HPA-1b predict that anti-HPA-1b should be observed six times more frequently than anti-HPA-1a, alloimmunization to HPA-1a accounts for far more cases of NAT than anti-HPA-1b.³⁰ In a large study of clinically suspected

NAT, alloantibodies to HPA-1a were found more frequently by a ratio >100:1 when compared with anti-HPA-1b.²⁴⁰ Another risk factor may involve blood group antigens. In one report, severe NAT due to HPA-1a immunization was associated with maternal ABO genotypes, with group A mothers having a higher risk of giving birth to children with severe thrombocytopenia, possibly due to genetic linkage.²⁹⁵ Immunization to the HPA-5a/5b alloantigens also has been associated with specific class II genes.^{296,297} However, unlike the reversed relative risk versus the expected rates of immunization reported for the HPA-1a/1b system, the theoretical ratio of alloimmunization against HPA-5a versus HPA-5b is similar to the observed ratio.^{30,298}

The differences in the rate of immunization to platelet alloantigens also vary between different racial or ethnic populations. The distribution and frequency of platelet alloantigen genes in the worldwide population is a major factor in determining which alloantigens are most important in the investigation of NAT in different countries (Table 20.11). Although studies have shown that the HPA-1a antigen accounts for the majority of NAT cases in the white population, it has rarely been shown to play a role in the Japanese. This may be explained by the lower frequency for HPA-1b in the Japanese population compared with whites (0.02 vs. 0.15). Without accounting for differences in the frequency of immune response genes, alloimmunization to HPA-1a should be at least 50 times less in the Japanese population. Antibodies to HPA-4a/4b are most frequently reported in Japanese cases of alloimmunization. This may be related directly to the higher frequency for HPA-4b in the Japanese population compared with whites (0.0083 vs. <0.001), which would increase the number of individuals homozygous for the rare allele who would then be at risk for alloimmunization to HPA-4a.

TABLE 20.11 HUMAN PLATELET ANTIGEN (HPA) FREQUENCY BY ETHNIC GROUP

Antigen	Gene Frequency			References
	White	Black	Asian	
HPA-1a	0.85-0.89	0.92	0.99-1.00	242,425,426,427,428 and 429
HPA-1b	0.11-0.15	0.08	0.00-0.01	
HPA-2a	0.91-0.93	0.82-0.88	0.87-0.92	237,426,427,429,430
HPA-2b	0.07-0.09	0.11-0.18	0.08-0.13	
HPA-4a	1.00	1.00	0.99-1.00	242,427,428,429 and 430
HPA-4b	0.00	0.00	0.00-0.01	
HPA-5a	0.87-0.95	0.79	0.95-0.97	426,427,428,429 and 430
HPA-5b	0.05-0.13	0.21	0.03-0.05	

Immunization to platelet nonspecific alloantigens such as ABO and HLA is more likely to play a role in transfusion- and transplantation-associated thrombocytopenia rather than NAT. As these antibodies pass from the mother into the fetal circulation, they are likely to be targeted to the larger population of HLA- and ABO-bearing cells rather than to platelets. In cases in which only ABO or HLA antibodies are observed in NAT, it is possible that platelet-specific alloantibodies are present but go undetected due to the technical limitations of current assays.

Diagnostic tests for NAT should be designed to determine the maternal and paternal platelet alloantigen haplotypes to assess the presence of antigen incompatibilities. Genotyping should be used to determine the alloantigen status because few laboratories have adequate typing sera available to perform immunophenotyping for all the relevant alloantigens. Because genotyping uses very little sample, it also allows for the determination of fetal platelet antigens directly, rather than inferring them from the paternal platelet typing. To detect platelet-specific alloantibodies in maternal serum, a specific and sensitive assay should be used that can discriminate the presence of coexisting platelet nonspecific antibodies (e.g., anti-HLA). Due to the possibility of maternal alloimmunization to relatively low-frequency alloantigens, including HPA-5b, it is preferable to test for antiplatelet antibodies using the father's platelets as a target. Although it is important to assess the risk for NAT in future pregnancies, this can be complicated by the presence of both alleles in a heterozygous father. In such cases, the fetal platelet alloantigens can be determined by genotyping fetal amniocytes obtained between 16 and 20 weeks' gestation. Although the presence of high-titer anti-HPA-1a is associated with severe neonatal thrombocytopenia when tested before 28 weeks' gestation, fetal/neonatal morbidity and severe thrombocytopenia have been observed when no antiplatelet antibody can be detected. Therapy with intravenous γ -globulin also can reduce

antibody levels in women who still deliver severely affected children, making it difficult to predict severity of thrombocytopenia based on antibody titer.²⁹⁹

Posttransfusion Purpura

PTP typically presents as severe thrombocytopenia resulting within 7 to 10 days after an immunogenic blood transfusion. It usually affects elderly women who have been sensitized to the platelet alloantigen during a previous pregnancy.^{30,300}

Because prior transfusion also has been reported as the initial immunizing event, occasionally males can develop PTP. As in NAT, the most common alloantibody implicated in PTP is directed against

P.538

HPA-1a and follows transfusion of antigen-positive blood to HPA-1b/1b/HLA-DR3-positive individuals. The frequency of PTP has decreased significantly in recent years, likely as a result of routine pre-storage leukoreduction in certain countries.³⁰¹

Thrombocytopenia can result from the transfusion of any blood product—not only platelets—and is most commonly seen after the infusion of packed red cells. Fever and chills are often observed during the transfusion; this is followed by petechiae and ecchymoses once thrombocytopenia develops. It is important to recognize this rare disorder because the severe thrombocytopenia can cause mucosal surface bleeding and subsequent anemia, with fatal intracranial hemorrhage observed in approximately 10% of patients. Therapy using high-dose intravenous γ -globulin has been shown to be effective and may be augmented with transfusion of antigen-negative platelets. Because PTP often presents in postoperative patients, the differential diagnosis of PTP includes other common thrombocytopenic syndromes such as heparin-induced thrombocytopenia and bacteremia. However, unlike PTP, these other disorders do not commonly present with severe thrombocytopenia ($<10 \times 10^9/L$). In addition, heparin-induced thrombocytopenia is often associated with thrombotic complications rather than the overt bleeding that characterizes PTP.

The major challenge of PTP is to understand the mechanism underlying the destruction of autologous platelets that follows the exposure and sensitization to immunizing blood product. A number of theories have been proposed to explain the clearance of the antigen-negative (HPA-1b/1b) platelets in the presence of anti-HPA-1a antibodies. The mechanisms proposed include the adsorption of alloantigen-alloantibody immune complexes to receptors on recipient platelets with subsequent clearance mediated by complement or by the reticuloendothelial system (innocent bystander syndrome); the binding to autologous platelets of soluble or microparticle-associated alloantigen derived from the destruction of transfused blood product, thus making the recipient platelets a target for the alloantibodies; or, finally, the presence of pseudospecific alloantibodies that are produced in the early phase of the anamnestic response and can bind to determinants on autologous platelets, leading to their destruction.^{30,300} This is supported by evidence that anti-HPA-1a antibodies from patients with PTP not only have a higher titer than NAT, but also react to a broader, more complex epitope.²⁴²

As in NAT, platelet typing and antiplatelet antibody testing are necessary to identify the pathogenic alloantibodies. However, because of the severe thrombocytopenia in the acute stages of PTP, genotyping is required to assess the risk for alloimmunization. Although anti-HPA-1a is most often implicated, PTP also is reported in association with alloimmunization to other platelet-specific antigens, including HPA-1b, HPA-3a/3b, HPA-4a, HPA-5a/5b, HPA-2b, and HPA-15b. Some of these antigens are distributed with relatively low frequencies in the population, and screening for antiplatelet antibodies should therefore use sensitive and specific assays and an informative panel of target platelets.

Passive Alloimmune Thrombocytopenia

The abrupt onset of thrombocytopenia within a few hours after transfusion of a blood product is a hallmark of PAT. Platelet-specific alloantibodies in the blood product (usually plasma) rapidly clear the recipient's antigen-positive platelets. This syndrome manifests within hours of transfusion and has a shorter duration of thrombocytopenia than PTP, mediated by the amount and specificity of the transfused alloantibody. Testing for PAT has shown that it is difficult to measure alloantibody in the recipient's plasma, suggesting that the transfused antibodies are limited and bind to the incompatible platelets soon after transfusion. However, the alloantibody can be detected in the donor plasma, and in one case, sensitization of recipient platelets by the transfused alloantibody *in vivo* was demonstrated using direct radioimmunoprecipitation to measure IgG bound to platelet gpIIb/IIIa directly on the patient's platelets.³⁰² Alloantibodies against the HPA-1a and HPA-5b antigens have been implicated in passive alloimmune thrombocytopenia.^{30,300} Severe thrombocytopenia is found in association with the transfusion of blood products containing alloantibodies to the HPA-1a antigen. The finding that even red blood cell concentrates can cause PAT due to anti-HPA-1a antibodies correlates with reports that as little as 10 ml of plasma containing alloantibodies can cause thrombocytopenia in transfused volunteers.³⁰³

Because thrombocytopenia can occur in multiple transfusion recipients, it is important to investigate cases of suspect PAT to ensure that the alloimmunized blood donor does not donate blood in the future.³⁰⁴

Transplantation-associated Alloimmune Thrombocytopenia

Alloimmune mechanisms can explain the rare syndrome of transplantation-associated alloimmune thrombocytopenia that can complicate transplantation either with a solid organ or with allogeneic bone marrow.³⁰ Both anti-HPA-1a and anti-HPA-5b alloantibodies can cause thrombocytopenia that may develop very soon or sometimes longer after transplantation. In one case, a man with Ph1 chromosome-positive chronic myelogenous leukemia developed severe thrombocytopenia ($17 \times 10^9/L$) 18 months after receiving an allogeneic bone marrow transplant from his HLA-matched sister.³⁰⁵ An immune mechanism was suggested by the repeated platelet count increase after treatment with high-dose intravenous γ -globulin and remission after splenectomy. Anti-HPA-1a antibodies were detected in Ig eluted from the patient's platelets. Although chromosome analysis of the patient's marrow demonstrated a normal Ph1-negative female karyotype, sensitive Southern blot analysis of splenic cell DNA identified a small amount (3%) of residual male cells. The patient's sister was HPA-1a positive, and another brother was HPA-1a negative. Although pretransplant platelet alloantigen studies were not done, it was deduced that the patient was likely HPA-1a negative (HPA-1b/1b) and that the thrombocytopenia was mediated by a host versus donor alloimmune thrombocytopenia in which the patient's residual lymphoid cells developed an anti-HPA-1a alloimmune response to HPA-1a-positive platelets derived from the engrafted bone marrow.

Alloimmune-mediated platelet destruction due to a bone marrow transplant recipient's pre-existing anti-HPA-5b antibodies was suggested by a rapid transient increase in platelet count from 43 to $108 \times 10^9/L$ after administration of intravenous γ -globulins.³⁰⁶ The patient received the allogeneic marrow from her HLA-matched brother who typed positive for HPA-5b. The detection of a small amount (<5%) of group A blood cells in the recipient after transplantation with her brother's group O marrow indicated that a chimeric state existed in this patient. The thrombocytopenia eventually improved as the level of circulating antibody decreased.

Thrombocytopenia that may also have an alloimmune mechanism was reported in patients after autologous peripheral blood stem cell transplantation for metastatic breast carcinoma.³⁰⁷ Both patients had pre-existing anti-HPA-1a antibodies that rose in titer after transplantation. Because moderate to severe thrombocytopenia is expected soon after transplantation due to marrow ablative treatment, variable rate of engraftment of donor marrow-derived megakaryocyte precursors, and fever and other comorbid clinical factors, it is difficult to determine the pathogenic mechanism in these patients. Although the thrombocytopenia may have resulted from a refractory state caused by the rapid clearance of transfused platelets by alloantibodies, it is also possible that platelets derived from engrafted autologous marrow were destroyed in a PTP-like syndrome.

P.539

Solid organ transplants rarely can lead to alloimmune thrombocytopenia. Donor-derived immunocompetent lymphoid cells contained within the organs transplanted from a single donor to three recipients (two kidneys, one liver) are suspected to be the cause of severe thrombocytopenia (platelet count nadirs: 2, 2, and $12 \times 10^9/L$) that developed within 5 to 8 days.³⁰⁸ The severe thrombocytopenia in the renal transplant patients was refractory to intravenous γ -globulins and platelet transfusions. One patient recovered after splenectomy 50 days after transplantation, and the other died due to multiorgan failure associated with bacteremia and severe thrombocytopenia. The thrombocytopenia resolved in the liver transplant recipient after receiving a new liver following rejection of the first transplant. Serum from the multiparous female organ donor was shown to contain anti-HPA-1a alloantibodies. Platelet typing and antibody studies of the transplant recipients showed that although they typed HPA-1a positive, anti-HPA-1a antibodies were detected in their posttransplant, but not pretransplant, sera. These observations suggest that anti-HPA-1a antibodies derived from transplanted immunocompetent lymphoid cells were responsible for the severe thrombocytopenia in these patients. A similar case of donor lymphocyte-induced thrombocytopenia was caused by a liver transplant obtained from a donor who died of bleeding related to severe autoimmune thrombocytopenia. Anti-gpIIb/IIIa antibodies without allospecificity were detected in both the organ donor and the posttransplant recipient serum.³⁰⁹

Platelet Transfusion Refractoriness

Nonimmune patient-dependent factors usually are involved when unexpectedly poor platelet count increments are observed after transfusion. Although ABO or HLA incompatibility and platelet storage can contribute to reduced platelet

count recovery,^{276,310,311} and ³¹² more often septicemia, drugs, and increased platelet consumption in severely thrombocytopenic patients are responsible for platelet transfusion refractoriness.

Although there is only anecdotal evidence that platelet-specific alloantibodies can cause platelet transfusion refractoriness,^{263,313} some refractory patients do benefit from transfusion with platelets that are HLA and platelet alloantigen compatible.³¹⁴ However, in a prospective study, platelet-specific alloantibodies accounted for, at most, 5% of the patients with platelet transfusion refractoriness.³¹⁵ Depletion of leukocytes prior to storage of platelets for transfusion has reduced the incidence of platelet transfusion refractoriness.³¹⁶

Platelet Polymorphisms as Risk Factors for Cardiovascular Disease

There is increasing evidence that ischemic vascular disease may result from interactions between environmental factors (e.g., smoking), genetic susceptibility, and concurrent diseases (e.g., diabetes). There is good evidence to show that platelets can play a major role in the formation of an occlusive thrombus at the site of a ruptured atherosclerotic plaque.³¹⁷ The rate of formation or the susceptibility for platelets to participate in thrombus formation may depend partly on factors that include certain polymorphisms on the platelet glycoproteins.

Measures of platelet reactivity using in vitro assays demonstrate heterogeneous results, indicating that there is a range of platelet reactivity among individuals. For example, some individuals' platelets may be considered hyperreactive based on the lower epinephrine dose threshold that induces platelet aggregation. The major platelet glycoproteins that function as receptors and mediate aggregation and adhesion can also differ antigenically and structurally between individuals. Recent evidence suggests that certain polymorphisms on glycoproteins IIb/IIIa, Ib/IX/V, and IaIIa may be associated with enhanced platelet function in vivo.

Platelet aggregation is mediated by gpIIb/IIIa, the major receptor for fibrinogen and VWF. GpIIb/IIIa is highly polymorphic, having four known alleles of the α IIb subunit and eight alleles of the β 3 subunit.³¹⁸ The Leu33Pro alleles on β 3 are the most clinically important. The Leu33 allele encodes the HPA-1a alloantigen, which is highly immunogenic to some Pro33 (HPA-1b/1b) individuals. Although these alleles are distributed within the general white population with frequencies of 0.85 (HPA-1a) and 0.15 (HPA-1b), the frequency for HPA-1b was found to be almost four times higher among younger patients with myocardial infarction or unstable angina.³¹⁹ Since that first report, other studies have not been able either to establish or to exclude HPA-1b as a risk factor for ischemic vascular disease.³²⁰

However, in vitro studies indicate that gpIIb/IIIa-mediated functions such as aggregation, adhesion, spreading, and clot retraction demonstrate heterogeneity and that the HPA-1b phenotype was associated with a lower activity threshold.^{321,322} Interactions between platelet integrins and the extracellular matrix are important for cell migration, which is directly involved in restenosis after angioplasty. Recent studies using the HPA-1a or HPA-1b forms of gpIIIa transfected into Chinese hamster ovary cells demonstrated enhanced migration activity when the HPA-1b form of the protein was a constituent of the integrin complex, as either α IIb β 3 or α v β 3.³²³ Further, a reduced affinity of the platelet function inhibitor abciximab for platelets with the HPA-1b phenotype suggested that patients with this allele may have a less favorable outcome to treatment after percutaneous coronary intervention.²⁸¹ Recent reports suggest that postoperative patients on long-term mechanical circulatory support may be at higher risk for bleeding depending on their HPA-1 polymorphism.^{324,325} Other studies involving the Ile843Ser polymorphism responsible for the HPA-3 alloantigens on α IIb have not established an association with cardiovascular disease. Although small studies have reported a link with both the HPA-3a and HPA-3b antigens with either stroke or myocardial infarction, larger studies have not reported a similar association.^{326,327,328} and ³²⁹ However, a recent report in a Chinese population demonstrated an increased incidence of the HPA-3bb genotype in younger patients (<60 years) with acute ischemic stroke.³³⁰

Three dimorphisms of gpIb α have potential relevance in thrombotic risk. The Thr145Met alleles encode the HPA-2 alloantigens, which are in linkage disequilibrium with a VNTR polymorphism in the macroglycopeptide region of gpIb α . This results in a duplication of the 13-amino acid sequence one to four times (VNTR D to VNTR-A) and would result in an increasingly longer polypeptide. However, the few studies that report an association between any of the variable polymorphisms and the risk for coronary artery disease have not been supported in others.^{331,332} and ³³³ An additional polymorphism in the Kozak region of the molecule may be important for regulating the efficiency of translation of gpIb α , thus affecting the number of receptors expressed.^{334,335} However, an association between this dimorphism and a risk for arterial thrombosis could not be demonstrated in subsequent studies.^{336,337} and ³³⁸ One study from Australia did report an association between the Kozak polymorphism and ischemic stroke, suggesting that further studies may be warranted.³³⁹

The level of expression of a major collagen receptor, gpIaIIa, can vary up to threefold depending on the inheritance of linked, allelic polymorphisms in the MMRN1 (α 2 or gpl α) gene. The 807-T/C/G polymorphism segregates independently of the alleles encoding the HPA-5a/5b and HPA-13bw alloantigens. Although some studies suggested an association of the

807T allele (high receptor density) with myocardial infarction or stroke, other studies were unable to confirm this observation.^{340,341,342} and ³⁴³ However, in a large study of 2,237 male patients, an association between younger patients with the 807T allele and myocardial infarction

P.540

was reported.³⁴⁴ Evidence of a functional effect of the HPA-5 alleles was described by Kunicki et al. The binding of platelets to decorin, but not collagen, was attenuated when the platelet donor expressed at least one of the low-frequency HPA-5b alleles. In addition, antibodies to HPA-5a were able to inhibit adhesion to decorin.³⁴⁵

WHITE BLOOD CELL ANTIGENS

Antigens expressed on granulocytes, lymphocytes, and monocytes are traditionally known as self antigens. These include the human neutrophil antigens (HNAs) and HLA class I and II. Class I HLA antigens are present on every cell and tissue in the body, except for red cells, sperm, and some placental cells. Class II HLA antigens are expressed mainly on select cells of the immune system (e.g., T and B cells, macrophages, and monocytes). White cells also express some antigens that are shared with other cells, including red cells and platelets.

White cell antigens play a pivotal role in host defense, selfrecognition, and autoimmunity. White blood cell alloantigen sensitization is implicated in fetal neutropenia, febrile nonhemolytic transfusion reactions (FNHTRs), transfusion-associated acute lung injury (TRALI), graft rejection, and graft versus host disease (GVHD). Because of their high degree of polymorphism, these antigens are used as molecular “fingerprints” in forensic medicine, paternity testing, and anthropologic studies. Many white cell antigens are recognized by monoclonal antibodies, which identify proteins that are markers of differentiation, cell adhesion molecules, and various phagocytic, complement, and chemotactic receptors. These antibodies and antigens (discussed elsewhere; see Chapter 10) have been well characterized and are assigned to cluster designation (CD) antigens based on their patterns of reactivity.

In this section the major white blood cell antigens on granulocytes and lymphocytes are discussed and disease states associated with pathologic antibodies directed at these antigens are emphasized. Monocytes share some antigens with lymphocytes (including class I and II HLAs) and neutrophils (HNA-4a), but these cells are not discussed in detail.

Granulocyte Antigens

The HNA antigen system is specific to granulocytes. Granulocytes also express antigens that are shared with other tissues and cells including HLA class I and certain blood group antigens. The antigens on granulocytes were initially defined using human alloantisera, most often through the diagnosis and investigation of infants with alloimmune neonatal neutropenia. HNA-1a and HNA-1b antigens are most often implicated in alloimmune neutropenia and the availability of monoclonal antibodies has facilitated the detailed characterization of these alloantigens. In addition to alloimmune neonatal neutropenia, alloimmunization to these granulocyte antigens has been implicated in the development of FNHTRs and TRALI. Sensitization occurs when an individual lacking these antigens is exposed through transfusion or pregnancy.

Nomenclature

In 1998, the Granulocyte Working Party of the ISBT introduced the HNA nomenclature for granulocyte antigens, which replaced the old N terminology.³⁴⁶ Unlike the HPA nomenclature system for platelet alloantigens, the neutrophil alloantigen nomenclature assigns different antigens on the same glycoprotein to the same HNA antigen system, with alleles distinguished by lowercase letters. For example, NA1, NA2, and SH antigens of the old terminology are polymorphisms of the same protein, the FcγRIIIb receptor (CD16b), encoded by FCGR3B gene, and thus are designated as HNA-1a, HNA-1b, and HNA-1c in the new terminology (HNA-1 = FcγRIIIb). Seven alloantigens have been assigned HNA designations on five glycoproteins (HNA-1 to HNA-5) (Table 20.12). The HNA nomenclature does not account for the different haplotypes possible for certain genes (e.g., FcγRIIIb). It works best for antigen systems with two alleles at a single locus, but like the HPA system for platelet alloantigens, the HNA system does not define the haplotypes that may result from crossover between alleles. Thus, although the majority of base substitutions at position 266 of FCGR3B (FcγRIIIb) encoding the HNA-1c antigen have been found on the HNA-1b form of the gene, HNA-1c can also occur with variants of HNA-1b. Modifications to the nomenclature may be required in the future to clarify these issues and to address the antigen system by its molecular characterization.

TABLE 20.12 HUMAN NEUTROPHIL ALLOANTIGENS

HNA System Antigen Original Designation Glycoprotein

1	HNA-1aNA1 HNA-1bNA2 HNA-1cSH	FcγRIIIb (CD16b)
2	HNA-2aNB1	CD177
3	HNA-3a5b	CTL2
4	HNA-4aMart ^a	CR3 (CD11b)
5	HNA-5aOnd ^a	Leukocyte function antigen-1 (CD11a)

HNA, human neutrophil antigen.

Modified from Stronek D. Neutrophil alloantigens. *Trans Med Rev* 2002;16:67-75.

HNA-1a, -1b, and -1c

One of the most immunogenic neutrophil membrane proteins is the Fcγ receptor IIIb (FcγRIIIb), a neutrophil-specific receptor that binds the Fc portion of IgG antibodies. 30% of granulocyte autoantibodies in infants with autoimmune neutropenia are specific for epitopes on this receptor, most commonly HNA-1a and HNA-1b,³⁴⁷ and most cases of alloimmune neonatal neutropenia are due to sensitization by these antigens.³⁴⁸

Together, FcγRIIIb and the highly homologous FcRIIIa form the Fc receptor class III, which binds to polymeric IgG antibodies with low affinity. FcγRIIIb is a 233-amino acid glycoprotein secured to the membrane via a GPI anchor, thus giving it lateral mobility within the phospholipid bilayer.^{308,309,311,349} cDNA analysis has revealed that five nucleotide base substitutions at positions 141, 147, 227, 277, and 349 on chromosome 1 are associated with HNA-1a/1b polymorphism of FCGR3B.^{350,351} Four of these changes encode a different amino acid, two of which result in a different glycosylation pattern because of the changes at bases 227 and 277. Thus, HNA-1b FcγRIIIb has two additional glycosylation sites, which accounts for the larger molecular mass of this form of the gene product (65 to 80 kD) compared with the HNA-1a FcγRIIIb product (50 to 65 kD). The soluble FcγRIIIb found in plasma has the same HNA antigens as those found on neutrophils, which have been shown to be the source of the soluble glycoprotein.³⁵² The frequencies for HNA-1a and HNA-1b demonstrate marked differences among different racial groups. The HNA-1a frequency in whites ranges from 0.30 to 0.37, and

P.541

that of HNA-1b ranges from 0.63 to 0.70. However, in the Asian population, the frequency of HNA-1a is higher (0.60 to 0.66) and HNA-1b is lower (0.30 to 0.33).^{353,354,355} and ³⁵⁶

The FCGR3B gene (which encodes for FcγRIIIb protein) shares homology with the FCGR3A gene. A C733T change in FCGR3A creates an early stop codon, resulting in FcγRIIIb, a GPI-anchored protein that is 21 amino acids shorter than FcγRIIIa, a transmembrane protein. At positions 227 and 349, FcγRIIIa is the same as the HNA-1a form of FcγRIIIb, but at positions 141, 147, and 277, FcγRIIIa is homologous to HNA-1b FcγRIIIb. Neither anti-HNA-1a nor anti-HNA-1b antibodies recognize FcγRIIIa, suggesting that these alloantigens depend on tertiary conformations that are modified due to changes in the membrane anchor. Genotyping procedures with genomic DNA require multisite analysis to ensure differentiation of the HNA-1a and HNA-1b partial polymorphisms on FcγRIIIa from those on FcγRIIIb.^{354,357,358}

The HNA-1c polymorphism results from an Ala78Asp change due to a C266A substitution in FCGR3B.³⁵⁸ HNA-1c is expressed on neutrophils in 4% to 5% of whites, but is expressed much more frequently (25% to 38%) in blacks.^{358,359} and ³⁶⁰ In many individuals with the HNA-1c polymorphism, the FCGR3B gene is duplicated on the same chromosome^{361,362} and in most cases, HNA-1c results from a mutation in the HNA-1b form of FcγRIIIb.

HNA-2a

The neutrophil HNA-2a alloantigen has been implicated in alloimmune neonatal neutropenia, FNHTRs, autoimmune neutropenia, and TRALI.^{363,364} It is expressed on CD177, a 58- to 64-kD GPI-anchored glycoprotein on neutrophils in 97% of whites.³⁶⁵ The function of HNA-2a glycoprotein is unclear but it is assumed to have a receptor role.³⁶⁶ It belongs to the Ly-6 gene family,³⁶⁷ which encodes proteins characterized by repeating cysteine-rich domains including the urokinase-type plasminogen activator, the reactive inhibitor of lysis receptor (CD59), and polycythemia rubra vera-1.³⁶⁸ The HNA-2a negative phenotype seems to be the result of intron fragments in the mature mRNA, which prevents expression of HNA-

2a on the cell surface and not due to a gene deficiency or deletion.³⁶⁹ This is supported by the observation that the sensitization of HNA-2a-negative individuals does not produce alloantibodies that react with HNA-2a itself, but rather with a different unrelated antigen.³⁷⁰ Unlike other neutrophil polymorphisms, the HNA-2a antigen is expressed only on a subpopulation of neutrophils and the proportion of neutrophils expressing HNA-2a has been reported to remain remarkably stable in an individual over time. HNA-2a has a higher level of expression in women compared with men.^{357,365,371}

HNA-3a (5b)

HNA-3a has been characterized as a 70- to 95-kD glycoprotein on neutrophils, but its presence on lymphocytes, platelets, endothelial, kidney, spleen, and placental cells has been indirectly assumed as a result of adsorption studies.^{366,372} Alloantibodies to HNA-3a are well-known granulocyte agglutinins and have been implicated in neonatal alloimmune neutropenia³⁷³ and TRALI.^{374,375} Indeed, alloantibodies directed against HNA-3a antigen have been frequently implicated in severe and fatal TRALI reactions.

The molecular nature and cellular distribution of HNA-3a has been recently elucidated.^{376,377} The polymorphism is encoded by an Arg154Gln substitution on choline transporter-like protein-2 (CTL2). Approximately half of HNA-3a-specific antibodies from patients with TRALI bind a cyclic peptide of arg154 CTL2, suggesting that tertiary structures distal to the antigen site may be important in the formation of the epitope.³⁷⁸ Approximately 5% of the population is homozygous for HNA-3b and would be at risk for alloimmunization to HNA-3a. The immunogenicity of the HNA-3b antigen is much lower than HNA-3a.³⁷⁹

HNA-4a (Mart) and HNA-5a (Ond)

HNA-4a and HNA-5a are high-frequency antigens localized on leukocyte adhesion molecules on granulocytes and nongranulocytic leukocytes. HNA-4a is located on the α M chain (CR3, CD11b) and HNA-5a is expressed on the α L chain (leukocyte function antigen-1, CD11a) of the leukocyte β 2 integrin family. HNA-4a results from a single-nucleotide substitution of G302A, which encodes an Arg61His exchange, and HNA-5a results from a G2446C substitution, which encodes an Arg766Thr exchange.³⁸⁰ Although sensitization by these antigens has led to alloantibody formation, only one case of neonatal alloimmune neutropenia has been linked to anti-HNA-4a antibodies.³⁸¹

Shared Antigens

Granulocytes also express antigens that are associated with other peripheral blood cells and tissues. The class I HLA antigens (HLA-A, -B, and -C) are found on granulocytes, but not in sufficient quantities to allow their detection by cytotoxicity tests used for lymphocytes. No class II HLA antigens can be detected on mature granulocytes; however, they are present on immature cells.

Detecting Antibodies to Granulocyte Antigens

The two most commonly used tests to detect granulocyte-specific antibodies.³⁸² are the granulocyte agglutination test (GAT)³⁸³ and the granulocyte immunofluorescence test (GIFT)³⁸⁴ GAT uses a microtechnique with purified granulocyte suspensions in microtest plates. GIFT is performed in microtiter plates where cell-bound antibodies are detected with fluorescein-conjugated anti-human Ig. Coexisting antibodies to HLA and other granulocyte-specific antigens may interfere with these assays. Even with the use of well-characterized test sera and procedures to eliminate HLA reactivity (e.g., absorption or chloroquine stripping), the GAT and GIFT assays have limited sensitivity and specificity. Biochemical characterization of granulocyte antigens has facilitated the development of more specific methods for the investigation of granulocyte-specific antibodies. These include antigen capture (e.g., the monoclonal antibody-specific immobilization of granulocyte antigens assay), immunoblot, and immunoprecipitation assays, similar to the assays used to study platelets.

Clinical Significance of Granulocyte Antigens

Alloantibodies

Alloantibodies specific for the HNA-1a, -1b, and -1c antigens on Fc γ RIIIb are most commonly implicated in alloimmune neonatal neutropenia.^{348,384} Affected neonates are born to mothers who lack the antigen. IgG alloantibodies in the mother may form any time after the first trimester of pregnancy (when the hematopoietic cells are developed and cross the placenta) causing the destruction of fetal neutrophils. Symptomatic infants may present with delayed separation of the umbilical cord, skin infections, otitis media, or pneumonia within the first 2 weeks of life.³⁸⁵ Although most infections are mild, overwhelming sepsis can occur, with a mortality rate of approximately 5%. The neutropenia is generally self-limiting, reflecting the transient nature of maternal antibodies in the infant, and most infants recover within 2 weeks to 6 months as the titer of the alloantibody diminishes.

HNA-1a, -1b, and -1c antibodies and to a lesser extent HNA-2a and HNA-3a antibodies have also been implicated in FNHTRs.³⁸⁶ While most of these febrile reactions to red cell concentrates appear to be caused by granulocyte-specific antibodies in the recipient that mediate destruction of the transfused cells, most reactions to platelet transfusions are the result of cytokines that accumulate in the platelet product during storage.³⁸⁷ Pre-storage leukoreduction

P.542

reduces the risk of FNHTRs. FNHTRs may also occur with the transfusion of plasma containing HLA or neutrophil-specific antibodies.

TRALI is a rare but serious complication of blood transfusion characterized by hypoxemia, respiratory distress, and pulmonary infiltrations on chest radiograph within 6 hours of a completed transfusion.³⁸⁸ Although the pathophysiology of TRALI remains uncertain, investigators have postulated that antibody-mediated leukocyte activation in the lungs results in inflammation and complement activation causing increased vascular permeability, capillary leakage, and pulmonary tissue damage.³⁸⁹ HNA-1a, HNA-1b, HNA-2a, and HNA-3a antibodies have been implicated in TRALI reactions³⁹⁰; and antibodies against HNA-3a, which are strong granulocyte agglutinins, have been associated with severe TRALI reactions. Risk factors for TRALI include the volume of the blood product transfused,³⁹¹ the type of blood product (plasma transfusions are most commonly implicated) and the underlying condition of the patient (critically ill, surgical, etc.). Pooled plasma from multiple donors (including solvent detergent-treated plasma) may reduce the risk of TRALI since the pathogenic antibody is diluted.³⁹²

Kopko et al. performed a look-back investigation on a TRALI fatality associated with transfused plasma containing anti-HNA3a.³⁷⁵ Among 36 recipients who were available for review, 15 transfusion reactions were observed in 13 patients including eight severe reactions highly suggestive of TRALI. The association between anti-HNA-3a and severe or fatal TRALI reactions remains unconfirmed in the absence of well-designed prospective surveillance studies.

Granulocyte antibodies have also been implicated in immunemediated neutropenia following bone marrow transplantation, refractoriness to granulocyte transfusions, and drug-induced neutropenia.

Autoantibodies

Primary autoimmune neutropenia is caused by granulocyte-specific autoantibodies. The syndrome occurs most often in infancy and usually resolves spontaneously by 1 to 2 years. In a serologic investigation of 240 cases of antibody-positive autoimmune neutropenia in infancy, 31% of autoantibodies showed preferential binding to granulocytes that were homozygous HNA-1a and 3% to granulocytes that were homozygous HNA-2a.³⁴⁷ Other autoantibody specificities demonstrated were FcγRIIIb (27%), CD11b/CD18 (21%), CR1 (14%), and FcγRII (2%). Secondary autoimmune neutropenia is most often associated with another autoimmune disease such as Felty syndrome, systemic lupus erythematosus, or malignancy (e.g., lymphoma). In those cases, granulocyte-specific antibodies are not as readily detectable.

Lymphocyte Antigens

Numerous monoclonal antibodies, assigned a CD designation, recognize a number of molecules associated with various aspects of lymphocyte function and differentiation. The most clinically important lymphocyte antigens are the HLAs, and they will be the focus of this section. Lymphocytes also express a number of shared antigens, including HNA-3a, HNA-4a, and HNA-5a, and blood group antigens ABH, Lewis, Ii, P1, and P.

HLA Antigens

HLA antigens are encoded by the MHC, a cluster of genes encompassing approximately one thousandth of the human genome. The MHC is located on the short arm of chromosome 6 (band 6p 21.3) and was defined initially by investigation of antibodies in individuals sensitized through pregnancy or transfusion.³⁹³ These antigens are distributed on many types of cells and tissues and are important in the regulation of the immune response. They play a primary role in graft rejection and GVHD in transplantation and transfusion. The immune response to specific antigens is controlled by immune response genes, which are also located in the MHC (for discussion elsewhere, see Chapter 18).

The HLA complex on chromosome 6 has over 200 genes, more than 40 of which encode leukocyte antigens (Fig. 20.5). Of the three coding regions in the MHC, only the class I and II antigens are involved in the immune response. The class I genes encode HLA-A, -B, -C, -E, -F, and -G, and the class II genes encode HLA-DP, -DQ, -DR, -DN, and -DO. These class I and II gene products are structurally and functionally distinct. The class III genes encode complement components C2, C4A, C4B, Bf, 21-hydroxylase, and tumor necrosis factor-α and -β.³⁹⁴

Molecular Structure

The class I HLA molecule consists of two polypeptide chains, α and β , each encoded by different genes^{395,396,397} and ³⁹⁸ (Fig. 20.6). The HLA-A, -B, and -C genes encode the larger α -chain, a 45-kD transmembrane protein with three amino acid domains. Two of these, $\alpha 1$ and $\alpha 2$, account for most of the variation in the molecule due to polymorphisms of the HLA genes. A constant region, similar to the constant region of Ig molecules, is in the $\alpha 3$ domain close to the cell membrane. The class I α -chain is noncovalently associated with a smaller molecule, β_2 -microglobulin. No polymorphisms have been reported on this 12-kD extracellular protein encoded by a gene on chromosome 15. X-ray crystallography demonstrates further similarities to Ig molecules. The membrane-proximal $\alpha 3$ domain and the β_2 -microglobulin portions of the HLA molecule have Ig-like folds, in contrast with the $\alpha 1$ and 2 portions, which form a platform topped by α helices. A groove between these helices is the binding site for a peptide fragment from a processed antigen.

Class II HLA molecules also share similarities with Igs. Like the class I molecules, they consist of a heavy (α) and a light chain (β) (Fig. 20.6). The heavy α -chain has a molecular weight of 34 kD, and the smaller β -chain has a molecular weight of 29 kD. Both chains are transmembrane molecules, each with two structural domains. Similar to the class I molecule, HLA class II has a functional antigen-binding groove formed by the distal $\alpha 1$ and $\beta 1$ domains.³⁹⁹ The $\alpha 2$ and $\beta 2$ constant regions share homology with Ig constant regions, β_2 -microglobulin, T-cell receptors, and class I heavy chains. This homology may account for similarity in the crystallographic structure of the class I and class II antigens.⁴⁰⁰

Nomenclature

The nomenclature of the HLA antigens has been standardized by the World Health Organization (WHO) nomenclature committee, which regularly reviews newly reported specificities and genetic loci from results of International Histocompatibility Testing Workshops^{401,402} and ⁴⁰³ (Table 20.13). The nomenclature specifies the region of the gene (e.g., HLA-A) and a number. Because the antigens were originally defined by the reactivity of antisera, some early specificities have been further subclassified. These specificities are called splits and usually are written to incorporate the parent antigen in parentheses (e.g., HLA-A9 is split to HLA-23[9] and HLA-24[9]). It is also common among the HLA-A and -B alleles for specific antisera to cross-react with more than one antigen. Antisera that react with one specificity in these cross-reactive groups (CREGs) may demonstrate reactions with other antigens in the same group (e.g., HLA-A2 and -A28 or -A19 [consisting of A29 to A33]).^{404,405} and ⁴⁰⁶ Those HLA regions and genes that have been defined using molecular techniques are identified using a unique nomenclature. The nomenclature for the class I antigens includes the locus name, an asterisk (*), and a four-digit number (e.g., HLA-A*0101). The first two digits of the number refer to the serologic specificity. Because both the α and β (A and B) genes are polymorphic for the class II antigens, the chain also must be specified (e.g., HLA-DRB1*0101 or HLA-DQA1*0101). The immunogenetics/HLA (IMGT/HLA) database found at <http://www.ebi.ac.uk/imgt/hla> provides a current database for sequences of the human major histocompatibility complex (HLA) and includes the official sequences for the WHO HLA Nomenclature Committee.⁴⁰⁷

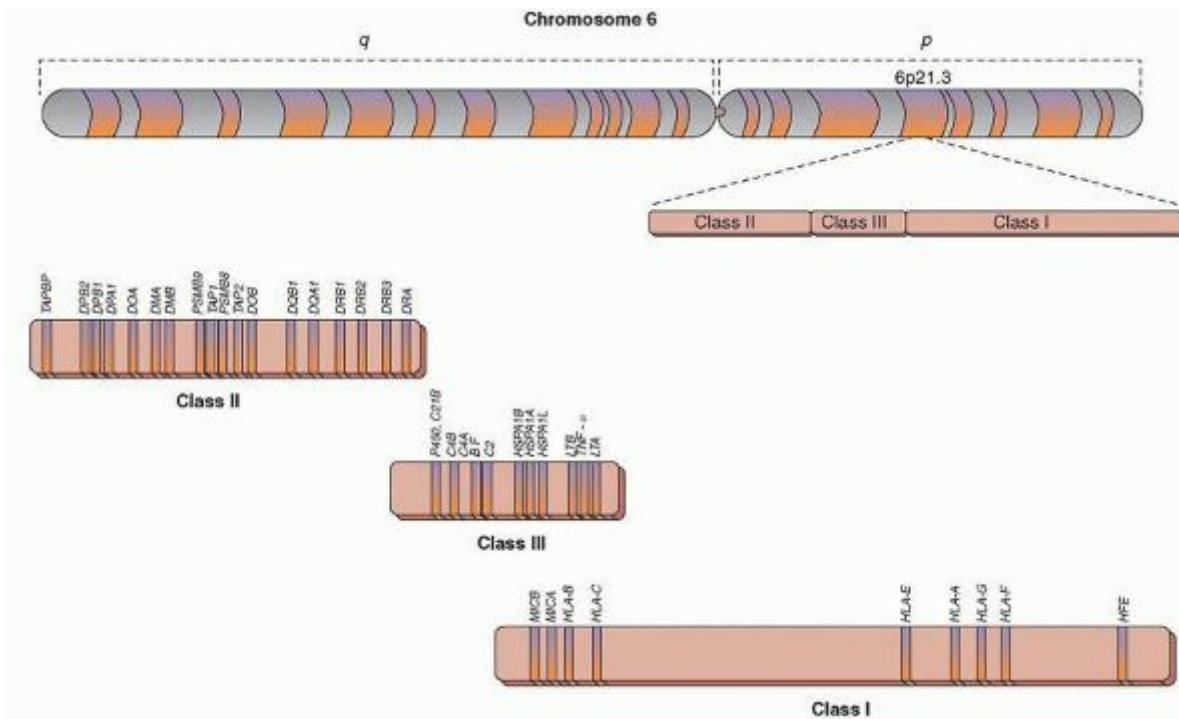

FIGURE 20.5 Organization of the major histocompatibility complex (MHC) on chromosome 6. A partial gene map of the human leukocyte antigen (HLA) complex is shown. The major loci of the genes expressed in the HLA class I and class II regions are depicted, as well as the unrelated class III genes. The following genes are shown in order, but not to scale: BF (complement factor B or CBF), C2 (complement component 2), C21B (cytochrome P450, subfamily 21 or TTC21B), C4A/C4B (complement components C4A/C4B), HSP (heat shock protein), LMP (large multifunctional protease), LTA/LTB (lymphotoxins A and B), MICA/MICB (MHC class I chains A and B), P450 (cytochrome P450), PSMB8 and 9 (proteasome β 8 and 9), TAP1/TAP2 (transporter proteins associated with antigen processing), TAPBP (TAP-binding protein, tapasin), TNF (tumor necrosis factor- α), and HSPA1A/HSPA1B/HSPA1L (heat shock proteins 1A A-type/1A B-type/1A-like).

Class I Human Leukocyte Antigen

HLA-A, HLA-B, and HLA-C antigens (class Ia) are expressed on all nucleated cells and on (anucleate) platelets. In addition, soluble HLA-A and -B antigens can be found in plasma where they circulate in association with high-density lipoproteins.^{408,409,410} and⁴¹¹ Adsorption of these vesicles into other cell membranes may explain why red cells also carry these antigens. The class I antigens are products of the highly polymorphic HLA-A, -B, and -C genes.^{396,412,413} Molecular techniques have vastly increased the number of HLA-A specificities; however, it may not be appropriate to designate these as antigens, because the resulting proteins may not initiate alloantibody formation. These alleles are more correctly referred to as genetic polymorphisms. HLA-E, -F, and -G molecules (class Ib) are similar in structure to the class Ia molecule but have a different tissue distribution.^{414,415} and⁴¹⁶

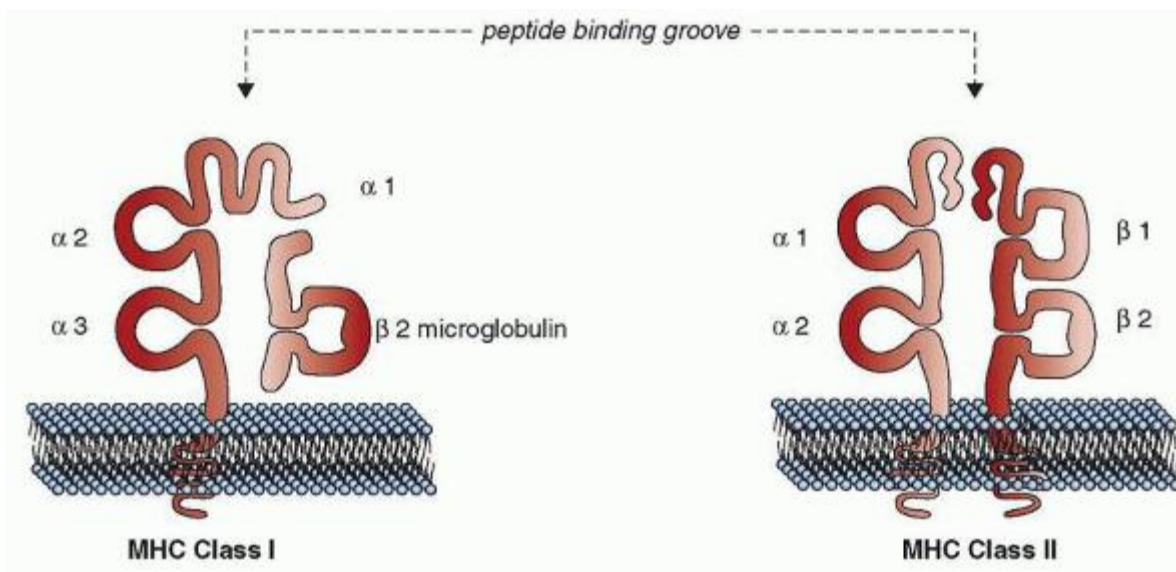

FIGURE 20.6 Schematic representation of the human leukocyte antigen (HLA) class I and class II molecules. The class I and class II molecules are each composed of two polypeptide chains that are manufactured separately in the endoplasmic reticulum. A peptide-binding groove is created by the $\alpha 1$ and $\alpha 2$ peptide-binding domains of the class I molecule. A similar peptide-binding structure is created in the class II molecule by the association of the $\alpha 1$ and $\beta 1$ peptide-binding domains. The HLA class I and II molecules also have immunoglobulinlike domains ($\alpha 3$: Class I; $\alpha 1$ and $\beta 1$: Class II) proximal to a transmembrane domain and cytoplasmic tail. MHC, major histocompatibility complex.

P.544

TABLE 20.13 SEROLOGIC ANTIGENS AND DNA POLYMORPHISMS OF THE HLA SYSTEM

Locus	Serologic Antigens	Alleles
HLA-A	A1 to A80	A*0101 to A*8001
HLA-B	B7 to B81	B*0702 to B*8301
HLA-C	Cw1 to Cw10	Cw*0102 to Cw*1803
DRA	none	DRA*0101 to DRA*0102
DRB1	none	DRB1*0101 to DRB1*1612
DQA1	DQ1 to DQ9	DQA1*0101 to DQA1*0602
DQB1	none	DQB1*0501 to DQB1*0634
DPA1	DPw1 to DPw6	DPA1*0103 to DPA1*0401
DPB1	none	DPB1*0101 to DPB1*9901

tHLA, human leukocyte antigen.

Modified from Williams TM. HLA antigens and alleles. In: Simon TL, Snyder EL, Solheim BG, et al., eds. Rossi's principles of transfusion medicine, 4th ed. Hoboken, NJ: John Wiley and Sons Ltd, 2009:890.

Class II Human Leukocyte Antigen

The class II HLAs are found on lymphocytes, monocytes, macrophages, endothelial cells, activated T cells, and Langerhans cells.^{394,399} Many of these cells play an important role in initiating the immune response. The class II genes are proximal to the centromere on the short arm of chromosome 6 and consist of one α -chain (DRA) gene and one or two β -chain (DRB) genes. Therefore, one DRA- and one DRB1-encoded polypeptide are expressed by all individuals. The other DRB genes

(HLA-DRB2 to HLA-DRB9) do not always encode a polypeptide that is coexpressed with the DRB1 product. Only the DRB3, 4, and 5 gene products are associated with a DRB1-encoded polypeptide. Although two α -chain genes and two β -chain genes are found for the DQ and DP regions, only one product ($\alpha + \beta$) is expressed.⁴¹⁷

Class III Human Leukocyte Antigen

The class III region of the MHC contains a cluster of genes responsible for complement, hormones, intracellular peptide processing, and other developmental characteristics. Thus, the class III region is not actually a part of the HLA complex, but is located within the HLA region, because its components are either related to the functions of HLA antigens or are under similar control mechanisms to the HLA genes. Complement components encoded by this region include C4A, C4B, C2, and properdin factor B (Bf). The C4A and C4B loci encode C4 variants. These polymorphic genes also are responsible for the Rodgers (C4A) and the Chido (C4B) red cell phenotypes.^{418,419} and ⁴²⁰ Other proteins, including 21-hydroxylase and tumor necrosis factor- α and - β , are also encoded in this MHC region.

Methods of Detecting Class I and II Human Leukocyte Antigens and Antibodies

Both serologic and molecular techniques have been used to identify polymorphisms of the class I genes. Serologic methods use lymphocytotoxic (functional) assays, in which sera with known anti-HLA-A, -B, and -C specificities are incubated with test cells. Cell viability is monitored after the addition of complement, which damages the cell membrane of antibody-sensitized lymphocytes, allowing the uptake of dye such as eosin.^{421,422} Because of the requirement for a relatively large and informative number of specific typing sera, commercial kits are generally used for serotyping. Molecular methods can detect polymorphisms, and sequencing can identify changes at each locus. Lymphocytotoxic techniques can also identify anti-HLA antibodies. In these assays, patient serum is screened against a panel of typed cells. Generally, 30 to 60 different target cell phenotypes are required to identify the antibody specificities. These methods are used to select potentially compatible platelets for patients who are refractory to platelet transfusions.

The class II antigens have also been detected using both serologic and cellular assays. Serologic typing for the class II antigens is performed using a method similar to that used for the class I antigens; however, instead of using unfractionated lymphocytes, the typing of class II antigens is done using only B lymphocytes. These are first isolated from peripheral blood and incubated with specific anti-DR/-DQ sera to determine the class II phenotype. It is now known that a single gene does not exist for HLA-D; however, the term continues to be applied to functional assays such as the mixed lymphocyte culture, the primed lymphocyte typing test, and T-cell clones.⁴²³ Because of the limitations of the functional assays, molecular methods have largely replaced the cellular assays for HLA class II typing. This typing is used for the identification of compatible bone marrow donors and recipients.

Inheritance of Human Leukocyte Antigens

Closely linked genes on one chromosome, such as those of the MHC, are often inherited as a unit cluster or haplotype. A child inherits one haplotype from each parent, resulting in four possible phenotypes. In some cases, an individual exhibits only two or three of the four HLA-A and -B antigens as a result of homozygosity or chromosome deletions. Heterozygosity at some gene loci is only detectable by molecular-based assays and not the less sensitive serologic assays; for example, an individual may type serologically as homozygous HLA-A2 yet by molecular studies is heterozygous HLA-A*0201/HLA-A*0202.

The chance that any two of the children are completely identical is 25%. However, crossover can occur during meiosis, thus creating a new haplotype. For the MHC, there is a crossover rate of 0.8% between the A and B loci and approximately 0.5% between the B and DR loci. Because of linkage disequilibrium, alleles at linked loci are associated more frequently than would be expected. Thus, HLA-A1 (13.8%) and HLA-B8 (9%) are in linkage disequilibrium because their actual haplotype frequency (6%) is much higher than would be expected (1.3%) if they were independently inherited. Linkage disequilibrium contributes to racial differences in haplotype frequency (e.g., HLA-A1, -B8 is rare in Asians; HLA-A34 is almost exclusive to blacks). Inheritance of the class III gene cluster as a closely linked unit, referred to as a complotype, is associated with certain disease states.^{419,424}

Clinical Significance of the Major Histocompatibility Complex and Human Leukocyte Antigen

The highly polymorphic antigens of the MHC provide useful markers in forensic medicine, in paternity testing, for anthropologic studies and for disease associations.^{425,426} and ⁴²⁷ Matching across HLAs determines the suitability of donors for solid organ and bone marrow transplantation and HLA antibodies have been implicated in transfusion reactions and in platelet refractoriness.

Association with Disease

Many diseases have been associated with specific HLA-A, -B, -C, and -DR antigens and with complement allotypes and HLA haplotypes (Table 20.14),^{428,429,430,431,432} and ⁴³³ for example Hodgkin's lymphoma and the A1, B5, B8, and B18 haplotypes. However, the A1, B8 haplotype is prevalent in long-term survivors, suggesting that it may have a protective effect.⁴³⁴ Other HLA-associated

P.545

malignancies include cutaneous T-cell lymphoma, Burkitt lymphoma, cervical squamous cell carcinoma, Kaposi sarcoma, and colorectal carcinoma. Other disease associations were with the HLA-B antigens (e.g., ankylosing spondylitis and HLA-B27)^{435,436}; however, the use of molecular techniques has now demonstrated strong associations of some class II molecules with certain diseases, including autoimmune conditions. Three loci, DQB1, DQA1, and DRB1, may be associated with susceptibility or resistance to insulin-dependent diabetes mellitus.^{437,438} The α - and β -chains from each haplotype might form pairs of molecules with modified peptide-binding properties, which, together with a dosage effect, may play a role in accelerating the disease. The importance of specific peptide-binding grooves, possibly controlled by amino acids at key positions, is also demonstrated in the HLA associations with celiac disease and rheumatoid arthritis.⁴³⁹

TABLE 20.14 ASSOCIATIONS BETWEEN CERTAIN HLA MARKERS AND DISEASE

Disease	Associated HLA Antigens and Alleles	Relative Risk
Birdshot retinochoroidopathy	A29	109.0
Ankylosing spondylitis	B27	87.4
Reactive arthropathy, including Reiter syndrome	B27	37.0
Dermatitis herpetiformis	DR3	15.9
Idiopathic membranous glomerulonephritis	DR3	12.0
Celiac disease	DR3	10.8
	DR7, DR11	6.0-10.0
	DR7, DQB1*0201	Not assessed
DR11, DQA1*0501		
Sicca syndrome	DR3	9.7
Idiopathic Addison disease	DR3	6.3
Systemic lupus erythematosus	DR3	5.8
Grave disease	DR3	3.7
Myasthenia gravis	DR3	2.5
	B8	3.4
Type 1 diabetes mellitus	DR3	3.3
(insulin-dependent)	DR4	6.4
	DR2	0.19
	DQB1*0302	9.5
	DQB1*0201	2.4
	DQB1*0602	0.15
	DRB*0101	Not assessed
Goodpasture syndrome	DR2	15.9
Multiple sclerosis	DR2	4.1

	DRB1*1501	Not assessed
	DRB5*0101	
	DQB1*0602	
Pemphigus vulgaris (Ashkenazi Jews)	DR4	14.1
Postpartum thyroiditis	DR4	5.3
Rheumatoid arthritis	DR4	4.2
Behçet syndrome	B51	3.8
Psoriasis vulgaris	Cw6	13.3
Hashimoto disease	DR11	3.2

HLA, human leukocyte antigen.

Modified from Klein J, Sato A. The HLA system. *N Engl J Med* 2000;343:782-786.

Certain immune response genes are linked to HLA haplotypes, conferring an increased susceptibility to antibody formation. For example, HLA-B8-DR3-positive individuals are more prone to forming alloantibodies to HPA-1a, the major platelet antigen most commonly implicated in NAT and posttransfusion purpura.^{440,441} Although a number of mechanisms have been proposed to explain the association between certain diseases and specific HLAs, including cross-reactive antibody responses, linkage of an HLA locus with a non-HLA disease-associated gene, regulation of T-cell development, thymic selection of T-cell receptor repertoire on HLA molecules with self-peptides, and interaction of class II HLA molecules with superantigens (cross-reactive), the exact mechanisms are unknown.

Transplantation

For solid organ transplants, HLA matching has reduced graft rejection and improved graft survival, with closer matches (6/6 for HLA-A, -B, and -DR) associated with better outcomes. The importance of HLA-A, -B, and -DR matching on graft survival has been consistently observed, especially for second kidney transplants.^{310,406,442,443} and ⁴⁴⁴ Similarly, the success of bone marrow transplantation depends on the degree of HLA matching. Related HLA-identical transplantations are associated with lower rates of delayed engraftment, rejection, or GVHD than transplants with marrow from non-HLA-identical relatives.^{445,446} and ⁴⁴⁷ Nevertheless, matching for HLA-A, -B, and -DR does not eliminate the risk of acute GVHD and graft rejection^{448,449} and ⁴⁵⁰; more precise matching for DRB1, DQB, and HLA-C using molecular techniques may further reduce the risk.^{451,452} and ⁴⁵³

Transfusion-associated Acute Lung Injury

HLA antibodies have been implicated in TRALI reactions. In early studies by Popovky and Moore, class I HLA antibodies were detected in the plasma of 59% of donors implicated in 36 cases of TRALI.⁴⁵⁴ Since then, reports of the frequency of anti-HLA class I antibodies in implicated donor plasma have varied widely but support an etiologic role of these antibodies in at least some patients. In a review of 26 patients with TRALI in which antibody-antigen concordance had been demonstrated, 12 showed class I HLA specificity, 15 showed class II specificity, and three were specific for neutrophil antigens.⁴⁵⁵ The role of class II HLA antibodies in TRALI is uncertain, as neutrophils, the effector cells in TRALI, do not express HLA class II antigens. One hypothesis is monocyte activation, which is supported by the observation of monocyte activation and proinflammatory cytokine generation following the incubation of recipient monocytes with class II HLA antibodies in plasma from donors implicated in TRALI reactions.⁴⁵⁶

Platelet Transfusion Refractoriness

Immune platelet refractoriness is another transfusion complication thought to be mediated by HLA antibodies. Alloantibodies against HLA-A and HLA-B formed after exposure to prior transfusions or pregnancies cause early destruction of transfused platelets. The use of HLA-A and HLA-B-matched platelet transfusions is often beneficial in these difficult cases. When HLA-identical donors are not available, the selection of CREG-compatible HLA antigen matches or matching of highly immunogenic epitopes using molecular techniques can be used.⁴⁰⁴

Acknowledgments

Donald M. Arnold is supported by a New Investigator Award funded by the Canadian Institutes for Health Research and Hoffman-LaRoche. Nancy M. Heddle is an adjunct scientist with Canadian Blood Services. John G. Kelton is the recipient of a Canada Research Chair.

The authors thank Aurelio Santos for providing invaluable help with graphic design and preparation of figures, and Heather Patterson for secretarial support.

REFERENCES

1. Reid ME, Yahalom V. Blood groups and their function. *Baillieres Best Pract Res Clin Haematol* 2000;13(4):485-509.
2. Daniels G. Functions of red cell surface proteins. *Vox Sang* 2007;93(4): 331-340.
3. Smart EA, Storry JR. The OK blood group system: a review. *Immunohematology* 2010;26(3):124-126.
4. Costa FP, Hue-Roye K, Sausais L, et al. Absence of DOMR, a new antigen in the Dombrock blood group system that weakens expression of Do(b), Gy(a), Hy, Jo(a), and DOYA antigens. *Transfusion* 2010;50(9):2026-20231.
5. Walker PS, Reid ME. The Gerbich blood group system: a review. *Immunohematology* 2010;26(2):60-65.
6. Daniels GL, Fletcher A, Garratty G, et al. Blood group terminology 2004: from the International Society of Blood Transfusion Committee on Terminology for Red Cell Surface Antigens. *Vox Sang* 2004;87(4):304-316.
7. Yazer MH, Olsson ML, Palcic MM. The cis-AB blood group phenotype: fundamental lessons in glycobiology. *Transfus Med Rev* 2006;20(3):207-217.
8. Yamamoto F, Hakomori S. Sugar-nucleotide donor specificity of histo-blood group A and B transferases is based on amino acid substitutions. *J Biol Chem* 1990;265(31):19257-19262.
9. Cartron JP. Quantitative and thermodynamic study of weak A erythrocyte phenotypes. *Rev Fr Transfus Immunohematol* 1976;19(1):35-54.
10. Reid ME, Bird GW. Associations between human red cell blood group antigens and disease. *Transfus Med Rev* 1990;4(1):47-55.
11. Anstee DJ. The relationship between blood groups and disease. *Blood* 2010;115(23):4635-4643.
12. Gill JC, Endres-Brooks J, Bauer PJ, Marks WJ, Jr, Montgomery RR. The effect of ABO blood group on the diagnosis of von Willebrand disease. *Blood* 1987;69(6):1691-1695.
13. James PD, Paterson AD, Notley C, et al. Genetic linkage and association analysis in type 1 von Willebrand disease: results from the Canadian type 1 VWD study. *J Thromb Haemost* 2006;4(4):783-792.
14. Jenkins PV, O'Donnell JS. ABO blood group determines plasma von Willebrand factor levels: a biologic function after all? *Transfusion* 2006;46(10): 1836-1844.
15. Tregouet DA, Heath S, Saut N, et al. Common susceptibility alleles are unlikely to contribute as strongly as the FV and ABO loci to VTE risk: results from a GWAS approach. *Blood* 2009;113(21):5298-5303.
16. Kamphuisen PW, Eikenboom JC, Bertina RM. Elevated factor VIII levels and the risk of thrombosis. *Arterioscler Thromb Vasc Biol* 2001;21(5):731-738.
17. Rowe JA, Handel IG, Thera MA, et al. Blood group O protects against severe *Plasmodium falciparum* malaria through the mechanism of reduced rosetting. *Proc Natl Acad Sci U S A* 2007;104(44):17471-17476.
18. Fry AE, Griffiths MJ, Auburn S, et al. Common variation in the ABO glycosyltransferase is associated with susceptibility to severe *Plasmodium falciparum* malaria. *Hum Mol Genet* 2008;17(4):567-576.
19. Harris JB, Khan AI, LaRocque RC, et al. Blood group, immunity, and risk of infection with *Vibrio cholerae* in an area of endemicity. *Infect Immun* 2005;73(11):7422-7427.
20. Glass RI, Holmgren J, Haley CE, et al. Predisposition for cholera of individuals with O blood group. Possible evolutionary significance. *Am J Epidemiol* 1985;121(6):791-796.
21. Blackwell CC, Dundas S, James VS, et al. Blood group and susceptibility to disease caused by *Escherichia coli* O157. *J Infect Dis* 2002;185(3):393-396.

22. Aird I, Bentall HH, Mehigan JA, Roberts JA. The blood groups in relation to peptic ulceration and carcinoma of colon, rectum, breast, and bronchus; an association between the ABO groups and peptic ulceration. *Br Med J* 1954;2(4883):315-321.
23. Clarke CA, Cowan WK, Edwards JW, et al. The relationship of the ABO blood groups to duodenal and gastric ulceration. *Br Med J* 1955;2(4940):643-646.
24. Aspholm-Hurtig M, Dailide G, Lahmann M, et al. Functional adaptation of BabA, the *H. pylori* ABO blood group antigen binding adhesin. *Science* 2004;305(5683):519-522.
25. Thorven M, Grahn A, Hedlund KO, et al. A homozygous nonsense mutation (428G→A) in the human secretor (FUT2) gene provides resistance to symptomatic norovirus (GGII) infections. *J Virol* 2005;79(24):15351-15355.
26. Raza MW, Blackwell CC, Molyneaux P, et al. Association between secretor status and respiratory viral illness. *BMJ* 1991;303(6806):815-818.
27. Springer GF, Horton RE. Blood group isoantibody stimulation in man by feeding blood group-active bacteria. *J Clin Invest* 1969;48(7):1280-1291.
28. Fong SW, Qaqundah BY, Taylor WF. Developmental patterns of ABO isoagglutinins in normal children correlated with the effects of age, sex, and maternal isoagglutinins. *Transfusion* 1974;14(6):551-559.
29. Somers H, Kuhns WJ. Blood group antibodies in old age. *Proc Soc Exp Biol Med* 1972;141(3):1104-1107.
30. Warkentin TE, Smith JW. The alloimmune thrombocytopenic syndromes. *Transfus Med Rev* 1997;11(4):296-307.
31. Cooling LL, Kelly K, Barton J, Hwang D, Koerner TA, Olson JD. Determinants of ABH expression on human blood platelets. *Blood* 2005;105(8):3356-3364.
32. Stussi G, Halter J, Schanz U, Seebach JD. ABO-histo blood group incompatibility in hematopoietic stem cell and solid organ transplantation. *Transfus Apher Sci* 2006;35(1):59-69.
33. Seebach JD, Stussi G, Passweg JR, et al. ABO blood group barrier in allogeneic bone marrow transplantation revisited. *Biol Blood Marrow Transplant* 2005;11(12):1006-1013.
34. Matsui T, Shimoyama T, Matsumoto M, et al. ABO blood group antigens on human plasma von Willebrand factor after ABO-mismatched bone marrow transplantation. *Blood* 1999;94(8):2895-2900.
35. Daniel-Johnson J, Schwartz J. How do I approach ABO-incompatible hematopoietic progenitor cell transplantation? *Transfusion* 2011;51(6):1143-1149.
36. O'Donghaile D, Kelley W, Klein HG, Flegel WA. Recommendations for transfusion in ABO-incompatible hematopoietic stem cell transplantation. *Transfusion* 2012;52(2):456-458.
37. Montgomery JR, Berger JC, Warren DS, James NT, Montgomery RA, Segev DL. Outcomes of ABO-incompatible kidney transplantation in the United States. *Transplantation* 2012;93(6):603-609.
38. Subramanian V, Ramachandran S, Klein C, et al. ABO-incompatible organ transplantation. *Int J Immunogenet* 2012;39(4):282-290.
39. Roath S, Todd CE, Shaw D. Transient acquired blood group B antigen associated with diverticular bowel disease. *Acta Haematol* 1987;77(3):188-190.
40. Anstee DJ, Tanner MJ. Biochemical aspects of the blood group Rh (rhesus) antigens. *Baillieres Clin Haematol* 1993;6(2):401-422.
41. Weiner AS. Genetic theory of the Rh blood types. *Proc Soc Exp Biol Med* 1943;54:316-319.
42. Race RR. An "incomplete" antibody in human serum. *Nature* 1944;153: 771-772.
43. Rosenfield RE, Allen FH Jr, Swisher SN, Kochwa S. A review of Rh serology and presentation of a new terminology. *Transfusion* 1962;2:287-312.
44. AABB technical manual, 14th ed. Bethesda, MD: American Association of Blood Banks, 2002.
45. Denome GA, Rios M, Reid ME. Molecular protocols in transfusion medicine. San Diego, CA: Academic Press, 2000.
46. Westhoff CM. Deciphering the function of the Rh family of proteins. *Transfusion* 2005;45(Suppl 2):117S-121S.

47. Marini AM, Matassi G, Raynal V, Andre B, Cartron JP, Cherif-Zahar B. The human rhesus-associated RhAG protein and a kidney homologue promote ammonium transport in yeast. *Nat Genet* 2000;26(3):341-344.
48. Van Kim CL, Colin Y, Cartron JP. Rh proteins: key structural and functional components of the red cell membrane. *Blood Rev* 2006;20(2):93-110.
49. Westhoff CM, Reid ME. Rh, Kell, Duffy, and Kidd blood group systems. In: Hillyer CD, Silberstein LE, Ness PM, eds. *Blood banking and transfusion medicine: basic principles and practice*. Philadelphia, PA: Churchill Livingstone, 2003:31-46.
50. Okuda H, Kawano M, Iwamoto S, et al. The RHD gene is highly detectable in RhD-negative Japanese donors. *J Clin Invest* 1997;100(2):373-379.
51. Singleton BK, Green CA, Avent ND, et al. The presence of an RHD pseudogene containing a 37 base pair duplication and a nonsense mutation in Africans with the rh D-negative blood group phenotype. *Blood* 2000;95(1):12-18.
52. Flegel WA, Denomme GA, Yazer MH. On the complexity of D antigen typing: a handy decision tree in the age of molecular blood group diagnostics. *J Obstet Gynaecol Can* 2007;29(9):746-752.
53. Huang CH, Chen Y, Reid ME, Seidl C. Rhnull disease: the amorph type results from a novel double mutation in RhCe gene on D-negative background. *Blood* 1998;92(2):664-671.
54. Tippett P. Regulator genes affecting red cell antigens. *Transfus Med Rev* 1990;4(1):56-8.
55. Coombs RR, Mourant AE, Race RR. In-vivo isosensitisation of red cells in babies with haemolytic disease. *Lancet* 1946;1(6391):264-266.
56. Westhoff CM, Reid ME. Review: the Kell, Duffy, and Kidd blood group systems. *Immunohematology* 2004;20(1):37-49.
57. Quinley ED. *Immunohematology: principles and practice*. Philadelphia, PA: J.B. Lippincott Company; 1993.
58. Lee S, Lin M, Mele A, et al. Proteolytic processing of big endothelin-3 by the Kell blood group protein. *Blood* 1999;94(4):1440-1450.
59. Russo D, Redman C, Lee S. Association of XK and Kell blood group proteins. *J Biol Chem* 1998;273(22):13950-13956.
60. Redman CM, Russo D, Lee S. Kell, kx and the McLeod syndrome. *Baillieres Best Pract Res Clin Haematol* 1999;12(4):621-635.
61. Weiner CP, Widness JA. Decreased fetal erythropoiesis and hemolysis in Kell hemolytic anemia. *Am J Obstet Gynecol* 1996;174(2):547-551.
62. Vaughan JI, Warwick R, Letsky E, Nicolini U, Rodeck CH, Fisk NM. Erythropoietic suppression in fetal anemia because of Kell alloimmunization. *Am J Obstet Gynecol* 1994;171(1):247-252.
63. Cutbrush M, Mollison PI, Parkin PM. A new human blood group. *Nature* 1950;165:188.
64. Horuk R, Chitnis CE, Darbonne WC, et al. A receptor for the malarial parasite *Plasmodium vivax*: the erythrocyte chemokine receptor. *Science* 1993;261(5125):1182-1184.
65. Rot A. Contribution of Duffy antigen to chemokine function. *Cytokine Growth Factor Rev* 2005;16(6):687-694.
66. Liu XH, Hadley TJ, Xu L, Peiper SC, Ray PE. Up-regulation of Duffy antigen receptor expression in children with renal disease. *Kidney Int* 1999;55(4):1491-1500.
67. Vescio LA, Farina D, Rogido M, Sola A. Hemolytic disease of the newborn caused by anti-fyb. *Transfusion* 1987;27(4):366.
68. Diamond MS, Springer TA. The dynamic regulation of integrin adhesiveness. *Curr Biol* 1994;4(6):506-517.
69. Lucien N, Sidoux-Walter F, Roudier N, et al. Antigenic and functional properties of the human red blood cell urea transporter hUT-B1. *J Biol Chem* 2002;277(37):34101-34108.
70. Reid ME, Westhoff CM. Other blood group systems and antigens. In: Hillyer CD, Silberstein LE, Ness PM, editors. *Blood banking and transfusion medicine: basic principles and practice*. Philadelphia, PA: Churchill Livingstone, 2003:47-61.
71. Heaton DC, McLoughlin K. Jk(a-b-) red blood cells resist urea lysis. *Transfusion* 1982;22(1):70-71.
72. Levine P. A review of Landsteiner's contributions to human blood groups. *Transfusion* 1961;1:45-52.
73. Garratty G, Dzik W, Issitt PD, Lublin DM, Reid ME, Zelinski T. Terminology for blood group antigens and genes-historical origins and guidelines in the new millennium. *Transfusion* 2000;40(4):477-489.

74. Blanchard D. Human red cell glycoporphins: biochemical and antigenic properties. *Transfus Med Rev* 1990;4(3):170-186.
75. Anstee DJ. Blood group-active surface molecules of the human red blood cell. *Vox Sang* 1990;58(1):1-20.
76. Reid ME. MNS blood group system: a review. *Immunohematology* 2009;25(3):95-101.
77. Cartron JP, Prou O, Luilier M, Soulier JP. Susceptibility to invasion by *Plasmodium falciparum* of some human erythrocytes carrying rare blood group antigens. *Br J Haematol* 1983;55(4):639-647.
78. Hadley TJ, Miller LH, Haynes JD. Recognition of red cells by malaria parasites: the role of erythrocyte-binding proteins. *Transfus Med Rev* 1991;5(2):108-122.
79. Allaway GP, Burness AT. Site of attachment of encephalomyocarditis virus on human erythrocytes. *J Virol* 1986;59(3):768-770.
80. Orlandi PA, Klotz FW, Haynes JD. A malaria invasion receptor, the 175-kilodalton erythrocyte binding antigen of *plasmodium falciparum* recognizes the terminal Neu5Ac(alpha 2-3)gal- sequences of glycoporphin A. *J Cell Biol* 1992;116(4):901-909.
81. Tomita A, Radike EL, Parker CJ. Isolation of erythrocyte membrane inhibitor of reactive lysis type II. Identification as glycoporphin A. *J Immunol* 1993;151(6):3308-3323.
82. Groves JD, Tanner MJ. Glycophorin A facilitates the expression of human band 3-mediated anion transport in xenopus oocytes. *J Biol Chem* 1992;267(31):22163-22170.
83. Groves JD, Tanner MJ. The effects of glycoporphin A on the expression of the human red cell anion transporter (band 3) in xenopus oocytes. *J Membr Biol* 1994;140(1):81-88.
84. Chandeysson PL, Flye MW, Simpkins SM, Holland PV. Delayed hemolytic transfusion reaction caused by anti-P1 antibody. *Transfusion* 1981;21(1): 77-82.
85. Westhoff CM, Reid ME. ABO and related antigens. In: Hillyer CD, Silberstein LE, Ness PM, eds. *Blood banking and transfusion medicine: basic principles and practice*. Philadelphia, PA: Churchill-Livingstone, 2003:21-30.
86. Levene C, Sela R, Rudolphson Y, Nathan I, Karplus M, Dvilansky A. Hemolytic disease of the newborn due to anti-PP1 P k (anti-tj a). *Transfusion* 1977;17(6):568-572.
87. Telen MJ. Red cell antigens. In: Anderson KC, Ness PM, eds. *Scientific basis of transfusion medicine: implications for clinical practice*, 2nd ed. Philadelphia, PA: W.B. Saunders Company, 2000:145-162.
88. Udani M, Zen Q, Cottman M, et al. Basal cell adhesion molecule/Lutheran protein. The receptor critical for sickle cell adhesion to laminin. *J Clin Invest* 1998;101(11):2550-2558.
89. Wautier MP, El Nemer W, Gane P, et al. Increased adhesion to endothelial cells of erythrocytes from patients with polycythemia vera is mediated by laminin alpha5 chain and Lu/BCAM. *Blood* 2007;110(3):894-901.
90. Eyler CE, Telen MJ. The lutheran glycoprotein: a multifunctional adhesion receptor. *Transfusion* 2006;46(4):668-677.
91. Dube VE, Zoes CS. Subclinical hemolytic disease of the newborn associated with IgG anti-lub. *Transfusion* 1982;22(3):251-253.
92. Inderbitzen PE, Windle B. An example of HDN probably due to anti-lua. *Transfusion* 1982;22(6):542.
93. Molthan L. Lewis phenotypes of American Caucasians, American Negroes and their children. *Vox Sang* 1980;39(6):327-330.
94. Reguigne-Arnould I, Couillin P, Mollicone R, et al. Relative positions of two clusters of human alpha-L-fucosyltransferases in 19q (FUT1-FUT2) and 19p (FUT6-FUT3-FUT5) within the microsatellite genetic map of chromosome 19. *Cytogenet Cell Genet* 1995;71(2):158-162.
95. Orntoft TF, Vestergaard EM, Holmes E, et al. Influence of Lewis alpha1-3/4-Lfucosyltransferase (FUT3) gene mutations on enzyme activity, erythrocyte phenotyping, and circulating tumor marker sialyl-lewis a levels. *J Biol Chem* 1996;271(50):32260-32268.
96. Pang H, Koda Y, Soejima M, Kimura H. Significance of each of three missense mutations, G484A, G667A, and G808A, present in an inactive allele of the human Lewis gene (FUT3) for alpha(1,3/1,4)fucosyltransferase inactivation. *Glycoconj J* 1998;15(10):961-967.

97. Kukowska-Latallo JF, Larsen RD, Nair RP, Lowe JB. A cloned human cDNA determines expression of a mouse stage-specific embryonic antigen and the Lewis blood group alpha(1,3/1,4)fucosyltransferase. *Genes Dev* 1990;4(8):1288-1303.
98. Marcus DM, Cass LE. Glycosphingolipids with Lewis blood group activity: uptake by human erythrocytes. *Science* 1969;164(3879):553-555.
99. Simoons-Smit IM, Appelmelk BJ, Verboom T, et al. Typing of *Helicobacter pylori* with monoclonal antibodies against Lewis antigens in lipopolysaccharide. *J Clin Microbiol* 1996;34(9):2196-2200.
100. Appelmelk BJ, Simoons-Smit I, Negrini R, et al. Potential role of molecular mimicry between *Helicobacter pylori* lipopolysaccharide and host Lewis blood group antigens in autoimmunity. *Infect Immun* 1996;64(6): 2031-2040.
101. Guruge JL, Falk PG, Lorenz RG, Dans M, et al. Epithelial attachment alters the outcome of *Helicobacter pylori* infection. *Proc Natl Acad Sci U S A* 1998;95(7):3925-3930.
102. Heneghan MA, McCarthy CF, Moran AP. Relationship of blood group determinants on *Helicobacter pylori* lipopolysaccharide with host Lewis phenotype and inflammatory response. *Infect Immun* 2000;68(2):937-941.
103. Heneghan MA, McCarthy CF, Janulaityte D, Moran AP. Relationship of anti-Lewis x and anti-Lewis y antibodies in serum samples from gastric cancer and chronic gastritis patients to *Helicobacter pylori*-mediated autoimmunity. *Infect Immun* 2001;69(8):4774-4781.
104. Boren T, Falk P, Roth KA, Larson G, Normark S. Attachment of *Helicobacter pylori* to human gastric epithelium mediated by blood group antigens. *Science* 1993;262(5141):1892-1895.
105. Ilver D, Arnqvist A, Ogren J, et al. *Helicobacter pylori* adhesin binding fucosylated histo-blood group antigens revealed by retagging. *Science* 1998;279(5349):373-377.
106. Clyne M, Drumm B. Absence of effect of Lewis A and Lewis B expression on adherence of *Helicobacter pylori* to human gastric cells. *Gastroenterology* 1997;113(1):72-80.
107. Hein HO, Suadicani P, Gyntelberg F. Genetic markers for peptic ulcer. A study of 3387 men aged 54 to 74 years: the Copenhagen Male Study. *Scand J Gastroenterol* 1997;32(1):16-21.
108. Niv Y, Fraser G, Delpre G, et al. *Helicobacter pylori* infection and blood groups. *Am J Gastroenterol* 1996;91(1):101-104.
109. Umlauf F, Keeffe EB, Offner F, et al. *Helicobacter pylori* infection and blood group antigens: lack of clinical association. *Am J Gastroenterol* 1996;91(10):2135-2138.
110. Garratty G. Blood group antigens as tumor markers, parasitic/bacterial/viral receptors, and their association with immunologically important proteins. *Immunol Invest* 1995;24(1-2):213-232.
111. Zelinski T. Erythrocyte band 3 antigens and the Diego blood group system. *Transfus Med Rev* 1998;12(1):36-45.
112. Byrne KM, Byrne PC. Review: other blood group systems—Diego, Yt, Xg, Scianna, Dombrock, Colton, Landsteiner-Wiener, and Indian. *Immunohematology* 2004;20(1):50-58.
113. Alves de Lima LM, Berthier ME, Sad WE, DiNapoli J, Johnson CL, Marsh WL. Characterization of an anti-Dia antibody causing hemolytic disease in a newborn infant. *Transfusion* 1982;22(3):246-247.
114. Monestier M, Rigal D, Meyer F, Juron-Dupraz F, Baboin-Jaubert M, Marseglia GL. Hemolytic disease of newborn infants caused by anti-Diego antibodies. *Arch Fr Pediatr* 1984;41(9):641-643.
115. Kusnierz-Alejska G, Bochenek S. Haemolytic disease of the newborn due to anti-Dia and incidence of the Dia antigen in Poland. *Vox Sang* 1992;62(2):124-126.
116. Chen CC, Broadberry RE, Chang FC, Ding F, Lin M. Hemolytic disease of the newborn caused by maternal anti-Dib: a case report in Taiwan. *Zhonghua Yi Xue Za Zhi (Taipei)* 1993;52(4):262-264.
117. Mochizuki K, Ohto H, Hirai S, et al. Hemolytic disease of the newborn due to anti-Di: a case study and review of the literature. *Transfusion* 2006;46(3):454-460.
118. Hinckley ME, Huestis DW. Case report. An immediate hemolytic transfusion reaction apparently caused by anti-Dia. *Rev Fr Transfus Immunohematol* 1979;22(5):581-585.
119. Spring FA, Gardner B, Anstee DJ. Evidence that the antigens of the Yt blood group system are located on human erythrocyte acetylcholinesterase. *Blood* 1992;80(8):2136-2141.

120. Levene C, Bar-Shany S, Manny N, Moulds JJ, Cohen T. The Yt blood groups in Israeli Jews, Arabs, and Druse. *Transfusion* 1987;27(6):471-474.
121. Mann JD, Cahan A, Gelb AG, et al. A sex-linked blood group. *Lancet* 1962;1(7219):8-10.
122. Johnson NC. XG: the forgotten blood group system. *Immunohematology* 2011;27(2):68-71.
123. Williams AF, Barclay AN. The immunoglobulin superfamily—domains for cell surface recognition. *Annu Rev Immunol* 1988;6:381-405.
124. DeMarco M, Uhl L, Fields L, Pacini D, Gorlin JB, Kruskall MS. Hemolytic disease of the newborn due to the Scianna antibody, anti-Sc2. *Transfusion* 1995;35(1):58-60.
125. Velliquette RW. Review: the Scianna blood group system. *Immunohematology* 2005;21(2):70-76.
126. Bruncker PA, Flegel WA. Scianna: the lucky 13th blood group system. *Immunohematology* 2011;27(2):41-57.
127. Lomas-Francis C, Reid ME. The Dombrock blood group system: a review. *Immunohematology* 2010;26(2):71-78.
128. Eiberg H, Mohr J. Dombrock blood group (DO): assignment to chromosome 12p. *Hum Genet* 1996;98(5):518-521.
129. Telen MJ, Rosse WF, Parker CJ, Moulds MK, Moulds JJ. Evidence that several high-frequency human blood group antigens reside on phosphatidylinositollinked erythrocyte membrane proteins. *Blood* 1990;75(7):1404-1407.
130. Spring FA, Reid ME. Evidence that the human blood group antigens Gya and Hy are carried on a novel glycosylphosphatidylinositol-linked erythrocyte membrane glycoprotein. *Vox Sang* 1991;60(1):53-59.
131. Gubin AN, Njoroge JM, Wojda U, et al. Identification of the Dombrock blood group glycoprotein as a polymorphic member of the ADP-ribosyltransferase gene family. *Blood* 2000;96(7):2621-2627.
132. Spring FA, Reid ME, Nicholson G. Evidence for expression of the Joa blood group antigen on the Gya/Hy-active glycoprotein. *Vox Sang* 1994;66(1):72-77.
133. Reid ME. The Dombrock blood group system: a review. *Transfusion* 2003;43(1):107-114.
134. Logdberg L, Reid ME, Lamont RE, Zelinski T. Human blood group genes 2004: chromosomal locations and cloning strategies. *Transfus Med Rev* 2005;19(1):45-57.
135. Reid ME. Complexities of the Dombrock blood group system revealed. *Transfusion* 2005;45(Suppl 2):92S-99S.
136. Banks JA, Hemming N, Poole J. Evidence that the Gya, Hy and Joa antigens belong to the Dombrock blood group system. *Vox Sang* 1995;68(3):177-182.
137. Judd WJ, Steiner EA. Multiple hemolytic transfusion reactions caused by anti-Doa. *Transfusion* 1991;31(5):477-478.
138. Halverson G, Shanahan E, Santiago I, et al. The first reported case of anti-Dob causing an acute hemolytic transfusion reaction. *Vox Sang* 1994;66(3): 206-209.
139. Baumgarten R, van Gelder W, van Wintershoven J, Maaskant-Van Wijk PA, Beckers EA. Recurrent acute hemolytic transfusion reactions by antibodies against Doa antigens, not detected by cross-matching. *Transfusion* 2006;46(2):244-249.
140. Smith BL, Preston GM, Spring FA, Anstee DJ, Agre P. Human red cell aquaporin CHIP. I. molecular characterization of ABH and Colton blood group antigens. *J Clin Invest* 1994;94(3):1043-1049.
141. Agre P, Smith BL, Baumgarten R, et al. Human red cell aquaporin CHIP. II. Expression during normal fetal development and in a novel form of congenital dyserythropoietic anemia. *J Clin Invest* 1994;94(3):1050-1058.
142. King LS, Choi M, Fernandez PC, Cartron JP, Agre P. Defective urinary-concentrating ability due to a complete deficiency of aquaporin-1. *N Engl J Med* 2001;345(3):175-179.
143. Reid ME, Oyen R, Marsh WL. Summary of the clinical significance of blood group alloantibodies. *Semin Hematol* 2000;37(2):197-216.
144. Covin RB, Evans KS, Olshock R, Thompson HW. Acute hemolytic transfusion reaction caused by anti-Coa. *Immunohematology* 2001;17(2):45-49.
145. Savona-Ventura C, Grech ES, Zieba A. Anti-Co3 and severe hemolytic disease of the newborn. *Obstet Gynecol* 1989;73(5 Pt 2):870-872.

146. Lacey PA, Robinson J, Collins ML, et al. Studies on the blood of a Co (a-b-) proposita and her family. *Transfusion* 1987;27(3):268-271.
147. Fuhrmann U, Kloppenburg W, Kruger HW. Delivery of a pregnant woman with a rare phenotype in the Colton-blood group system (author's transl.). *Geburtshilfe Frauenheilkd* 1979;39(1):66-67.
148. Michalewska B, Wielgos M, Zupanska B, Bartkowiak R. Anti-Co(a) implicated in severe haemolytic disease of the foetus and newborn. *Transfus Med* 2008;18(1):71-73.
149. Delahunty M, Zennadi R, Telen MJ. LW protein: a promiscuous integrin receptor activated by adrenergic signaling. *Transfus Clin Biol* 2006;13(1-2):44-49.
150. Bailly P, Tontti E, Hermand P, Cartron JP, Gahmberg CG. The red cell LW blood group protein is an intercellular adhesion molecule which binds to CD11/CD18 leukocyte integrins. *Eur J Immunol* 1995;25(12):3316-3320.
151. Mallinson G, Martin PG, Anstee DJ, et al. Identification and partial characterization of the human erythrocyte membrane component(s) that express the antigens of the LW blood-group system. *Biochem J* 1986;234(3):649-652.
152. Harris JP, Tegoli J, Swanson J, Fisher N, Gavin J, Noades J. A nebulous antibody responsible for cross-matching difficulties (Chido). *Vox Sang* 1967;12(2):140-142.
153. O'Neill GJ, Yang SY, Tegoli J, Berger R, Dupont B. Chido and Rodgers blood groups are distinct antigenic components of human complement C4. *Nature* 1978;273(5664):668-670.
154. O'Neill GJ. The genetic control of Chido and Rodgers blood group substances. *Semin Hematol* 1981;18(1):32-38.
155. Tilley CA, Romans DG, Crookston MC. Localisation of Chido and Rodgers determinants to the C4d fragment of human C4. *Nature* 1978;276(5689): 713-715.
156. Giles CM. A new genetic variant for Chido. *Vox Sang* 1984;46(3):149-156.
157. Constans J, Bernard P, Bioulac-Sage P, Barcat D, Conri C. Familial autoimmune hepatitis and C4 deficiency. *Rev Med Interne* 1998;19(10):731-733.
158. Sullivan KE. Complement deficiency and autoimmunity. *Curr Opin Pediatr* 1998;10(6):600-606.
159. Moulds JM, Warner NB, Arnett FC. Complement component C4A and C4B levels in systemic lupus erythematosus: quantitation in relation to C4 null status and disease activity. *J Rheumatol* 1993;20(3):443-447.
160. Lambin P, Le Pennec PY, Hauptmann G, Desaint O, Habibi B, Salmon C. Adverse transfusion reactions associated with a precipitating anti-C4 antibody of anti-Rodgers specificity. *Vox Sang* 1984;47(3):242-249.
161. Westhoff CM, Sipherd BD, Wylie DE, Toalson LD. Severe anaphylactic reactions following transfusions of platelets to a patient with anti-Ch. *Transfusion* 1992;32(6):576-579.
162. Lee S. The value of DNA analysis for antigens of the Kell and Kx blood group systems. *Transfusion* 2007;47(Suppl 1):325-395.
163. Issitt PD. Race-related red cell alloantibody problems. *Br J Biomed Sci* 1994;51(2):158-167.
164. Redman CM, Lee S. The Kell blood group system. *Transfus Clin Biol* 1995;2(4):243-249.
165. Russo DC, Oyen R, Powell VI, et al. First example of anti-Kx in a person with the McLeod phenotype and without chronic granulomatous disease. *Transfusion* 2000;40(11):1371-1375.
166. Sullivan CM, Kline WE, Rabin BI, Johnson CL, Marsh WL. The first example of autoanti-Kx. *Transfusion* 1987;27(4):322-324.
167. Daniels G. Functional aspects of red cell antigens. *Blood Rev* 1999;13(1): 14-35.
168. Anstee DJ, Tanner MJ. Blood group antigen deficiencies associated with abnormal red cell shape. *Blood Rev* 1988;2(2):115-120.
169. Maier AG, Duraisingh MT, Reeder JC, et al. Plasmodium falciparum erythrocyte invasion through glycoporphin C and selection for Gerbich negativity in human populations. *Nat Med* 2003;9(1):87-92.
170. Sacks DA, Johnson CS, Platt LD. Isoimmunization in pregnancy to Gerbich antigen. *Am J Perinatol* 1985;2(3):208-210.
171. Arndt PA, Garratty G, Daniels G, et al. Late onset neonatal anaemia due to maternal anti-ge: possible association with destruction of erythroid progenitors. *Transfus Med* 2005;15(2):125-132.

172. Daniels GL, Anstee DJ, Cartron JP, et al. Terminology for red cell surface antigens. ISBT Working Party Oslo Report. International Society of Blood Transfusion. *Vox Sang* 1999;77(1):52-57.
173. Telen MJ, Green AM. The Inab phenotype: characterization of the membrane protein and complement regulatory defect. *Blood* 1989;74(1):437-441.
174. Storry JR, Reid ME. The Cromer blood group system: a review. *Immunohematology* 2002;18(4):95-103.
175. Holmes CH, Simpson KL, Wainwright SD, et al. Preferential expression of the complement regulatory protein decay accelerating factor at the fetomaternal interface during human pregnancy. *J Immunol* 1990;144(8): 3099-3105.
176. Kowalski MA, Pierce SR, Edwards RL, Ethirajan S, Ryan K, Livergood MP. Hemolytic transfusion reaction due to anti-Tc(a). *Transfusion* 1999;39(9): 948-950.
177. Storry JR, Reid ME, Yazer MH. The Cromer blood group system: a review. *Immunohematology* 2010;26(3):109-118.
178. Ng YC, Schifferli JA, Walport MJ. Immune complexes and erythrocyte CR1 (complement receptor type 1): effect of CR1 numbers on binding and release reactions. *Clin Exp Immunol* 1988;71(3):481-485.
179. Parsons SF, Jones J, Anstee DJ, et al. A novel form of congenital dyserythropoietic anemia associated with deficiency of erythroid CD44 and a unique blood group phenotype [In(a-b-), Co(a-b-)]. *Blood* 1994;83(3):860-868.
180. Joshi SR. Immediate haemolytic transfusion reaction due to anti-Inb. *Vox Sang* 1992;63(3):232-233.
181. Nabeshima K, Iwasaki H, Koga K, Hojo H, Suzumiya J, Kikuchi M. Emmprin (Basigin/CD147): matrix metalloproteinase modulator and multifunctional cell recognition molecule that plays a critical role in cancer progression. *Pathol Int* 2006;56(7):359-367.
182. Yurchenko V, Constant S, Bukrinsky M. Dealing with the family: CD147 interactions with cyclophilins. *Immunology* 2006;117(3):301-309.
183. Karamatic Crew V, Poole J, Long S, et al. Two MER2-negative individuals with the same novel CD151 mutation and evidence for clinical significance of anti-MER2. *Transfusion* 2008;48(9):1912-1916.
184. Kagan A, Feld S, Chemke J, Bar-Khayim Y. Occurrence of hereditary nephritis, pretibial epidermolysis bullosa and beta-thalassemia minor in two siblings with end-stage renal disease. *Nephron* 1988;49(4):331-332.
185. Karamatic Crew V, Burton N, Kagan A, et al. CD151, the first member of the tetraspanin (TM4) superfamily detected on erythrocytes, is essential for the correct assembly of human basement membranes in kidney and skin. *Blood* 2004;104(8):2217-2223.
186. Daniels GL, Anstee DJ, Cartron JP, et al. International Society of Blood Transfusion Working Party on Terminology for Red Cell Surface Antigens. *Vox Sang* 2001;80(3):193-197.
187. Mudad R, Rao N, Issitt PD, Roy RB, Combs MR, Telen MJ. JMH variants: serologic, clinical, and biochemical analyses in two cases. *Transfusion* 1995;35(11):925-930.
188. Richard M, St-Laurent J, Perreault J, Long A, St-Louis M. A new SEMA7A variant found in native Americans with alloantibody. *Vox Sang* 2011;100(3): 322-326.
189. Gerbal A, Maslet C, Salmon C. Immunological aspects of the acquired B antigen. *Vox Sang* 1975;28(5):398-403.
190. Brown KE, Hibbs JR, Gallinella G, et al. Resistance to parvovirus B19 infection due to lack of virus receptor (erythrocyte P antigen). *N Engl J Med* 1994;330(17):1192-1196.
191. Brown KE, Anderson SM, Young NS. Erythrocyte P antigen: cellular receptor for B19 parvovirus. *Science* 1993;262(5130):114-117.
192. Gehrs BC, Friedberg RC. Autoimmune hemolytic anemia. *Am J Hematol* 2002;69(4):258-271.
193. Roudier N, Ripoche P, Gane P, et al. AQP3 deficiency in humans and the molecular basis of a novel blood group system, GIL. *J Biol Chem* 2002;277(48):45854-45859.
194. Ishibashi K, Sasaki S, Fushimi K, et al. Molecular cloning and expression of a member of the aquaporin family with permeability to glycerol and urea in addition to water expressed at the basolateral membrane of kidney collecting duct cells. *Proc Natl Acad Sci U S A* 1994;91(14):6269-6273.
195. Daniels GL, Delong EN, Hare V, et al. GIL: a red cell antigen of very high frequency. *Immunohematology* 1998;14(2):49-52.

196. Chou ST, Westhoff CM. The Rh and RhAG blood group systems. *Immunohematology* 2010;26(4):178-186.
197. Matassi G, Cherif-Zahar B, Raynal V, Rouger P, Cartron JP. Organization of the human RH50A gene (RHAG) and evolution of base composition of the RH gene family. *Genomics* 1998;47(2):286-293.
198. Gruswitz F, Chaudhary S, Ho JD, et al. Function of human Rh based on structure of RhCG at 2.1 A. *Proc Natl Acad Sci U S A* 2010;107(21):9638-9643.
199. Wiener AS, Unger LJ, Cohen L, Feldman J. Type-specific cold auto-antibodies as a cause of acquired hemolytic anemia and hemolytic transfusion reactions: biologic test with bovine red cells. *Ann Intern Med* 1956;44(2):221-240.
200. Cooling L. Polylactosamines, there's more than meets the "li": a review of the I system. *Immunohematology* 2010;26(4):133-155.
201. Hakomori S. Blood group ABH and li antigens of human erythrocytes: chemistry, polymorphism, and their developmental change. *Semin Hematol* 1981;18(1):39-62.
202. Venter JC, Adams MD, Myers EW, et al. The sequence of the human genome. *Science* 2001;291(5507):1304-1351.
203. Cargill M, Altshuler D, Ireland J, et al. Characterization of single-nucleotide polymorphisms in coding regions of human genes. *Nat Genet* 1999;22(3):231-238.
204. Halushka MK, Mathews DJ, Bailey JA, Chakravarti A. GIST: a web tool for collecting gene information. *Physiol Genomics* 1999;1(2):75-81.
205. von dem Borne AE, Decary F. Nomenclature of platelet-specific antigens. *Transfusion* 1990;30(5):477.
206. Newman PJ. Nomenclature of human platelet alloantigens: a problem with the HPA system? *Blood* 1994;83(6):1447-1451.
207. Phillips DR, Charo IF, Parise LV, Fitzgerald LA. The platelet membrane glycoprotein IIb-IIIa complex. *Blood* 1988;71(4):831-843.
208. Bray PF, Shuman MA. Identification of an abnormal gene for the GPIIIa subunit of the platelet fibrinogen receptor resulting in Glanzmann's thrombasthenia. *Blood* 1990;75(4):881-888.
209. Nurden AT, Nurden P. Inherited defects of platelet function. *Rev Clin Exp Hematol* 2001;5(4):314,34; quiz following 431.
210. Bray PF, Rosa JP, Johnston GI, et al. Platelet glycoprotein IIb. chromosomal localization and tissue expression. *J Clin Invest* 1987;80(6):1812-1817.
211. Wilhide CC, Jin Y, Guo Q, et al. The human integrin beta3 gene is 63 kb and contains a 5'-UTR sequence regulating expression. *Blood* 1997;90(10):3951-3961.
212. Zimrin AB, Eisman R, Vilaire G, Schwartz E, Bennett JS, Poncz M. Structure of platelet glycoprotein IIIa. A common subunit for two different membrane receptors. *J Clin Invest* 1988;81(5):1470-1475.
213. Zimrin AB, Gidwitz S, Lord S, et al. The genomic organization of platelet glycoprotein IIIa. *J Biol Chem* 1990;265(15):8590-8595.
214. Jin Y, Wilhide CC, Dang C, et al. Human integrin beta3 gene expression: evidence for a megakaryocytic cell-specific cis-acting element. *Blood* 1998;92(8):2777-2790.
215. Albelda SM, Buck CA. Integrins and other cell adhesion molecules. *FASEB J* 1990;4(11):2868-2880.
216. Hemler ME. VLA proteins in the integrin family: structures, functions, and their role on leukocytes. *Annu Rev Immunol* 1990;8:365-400.
217. Lawler J, Hynes RO. An integrin receptor on normal and thrombasthenic platelets that binds thrombospondin. *Blood* 1989;74(6):2022-2027.
218. Ruoslahti E, Engvall E. Integrins and vascular extracellular matrix assembly. *J Clin Invest* 1997;100(Suppl 11):S53-S56.
219. Kehrel B. Platelet-collagen interactions. *Semin Thromb Hemost* 1995;21(2):123-129.
220. Saelman EU, Nieuwenhuis HK, Hese KM, et al. Platelet adhesion to collagen types I through VIII under conditions of stasis and flow is mediated by GPIa/IIa (alpha 2 beta 1-integrin). *Blood* 1994;83(5):1244-1250.

221. Kritzik M, Savage B, Nugent DJ, Santoso S, Ruggeri ZM, Kunicki TJ. Nucleotide polymorphisms in the alpha2 gene define multiple alleles that are associated with differences in platelet alpha2 beta1 density. *Blood* 1998;92(7):2382-2388.
222. Kunicki TJ, Orckowski R, Annis D, Honda Y. Variability of integrin alpha 2 beta 1 activity on human platelets. *Blood* 1993;82(9):2693-2703.
223. Kunicki TJ, Kritzik M, Annis DS, Nugent DJ. Hereditary variation in platelet integrin alpha 2 beta 1 density is associated with two silent polymorphisms in the alpha 2 gene coding sequence. *Blood* 1997;89(6):1939-1943.
224. Smith JW, Hayward CP, Horsewood P, Warkentin TE, Denomme GA, Kelton JG. Characterization and localization of the Gova/b alloantigens to the glycosylphosphatidylinositol-anchored protein CDw109 on human platelets. *Blood* 1995;86(7):2807-2814.
225. Lin M, Sutherland DR, Horsfall W, et al. Cell surface antigen CD109 is a novel member of the alpha(2) macroglobulin/C3, C4, C5 family of thioestercontaining proteins. *Blood* 2002;99(5):1683-1691.
226. Kelton JG, Smith JW, Horsewood P, Humbert JR, Hayward CP, Warkentin TE. Gova/b alloantigen system on human platelets. *Blood* 1990;75(11): 2172-2176.
227. Sutherland DR, Yeo E, Ryan A, Mills GB, Bailey D, Baker MA. Identification of a cell surface antigen associated with activated T lymphoblasts and activated platelets. *Blood* 1991;77(1):84-93.
228. Modderman PW, Admiraal LG, Sonnenberg A, von dem Borne AE. Glycoproteins V and Ib-IX form a noncovalent complex in the platelet membrane. *J Biol Chem* 1992;267(1):364-369.
229. Clemetson KJ, Wenger RH, Wicki AN, Clemetson JM, Kieffer N, Drouin J. Molecular biology of human platelet membrane glycoprotein Ib. *Prog Clin Biol Res* 1990;356:77-88.
230. Kelly MD, Essex DW, Shapiro SS, et al. Complementary DNA cloning of the alternatively expressed endothelial cell glycoprotein Ib beta (GPIb beta) and localization of the GPIb beta gene to chromosome 22. *J Clin Invest* 1994;93(6):2417-2424.
231. Yagi M, Edelhoff S, Distechi CM, Roth GJ. Human platelet glycoproteins V and IX: mapping of two leucine-rich glycoprotein genes to chromosome 3 and analysis of structures. *Biochemistry* 1995;34(49):16132-16137.
232. Andrews RK, Shen Y, Gardiner EE, Dong JF, Lopez JA, Berndt MC. The glycoprotein Ib-IX-V complex in platelet adhesion and signaling. *Thromb Haemost* 1999;82(2):357-364.
233. Rivera J, Lozano ML, Corral J, Gonzalez-Conejero R, Martinez C, Vicente V. Platelet GP Ib/IX/V complex: physiological role. *J Physiol Biochem* 2000;56(4):355-365.
234. Titani K, Takio K, Handa M, Ruggeri ZM. Amino acid sequence of the von Willebrand factor-binding domain of platelet membrane glycoprotein Ib. *Proc Natl Acad Sci U S A* 1987;84(16):5610-5614.
235. Vicente V, Houghten RA, Ruggeri ZM. Identification of a site in the alpha chain of platelet glycoprotein Ib that participates in von Willebrand factor binding. *J Biol Chem* 1990;265(1):274-280.
236. Drouin J, McGregor JL, Parmentier S, Izaguirre CA, Clemetson KJ. Residual amounts of glycoprotein Ib concomitant with near-absence of glycoprotein IX in platelets of Bernard-Soulier patients. *Blood* 1988;72(3):1086-1088.
237. Lopez JA, Andrews RK, Afshar-Kharghan V, Berndt MC. Bernard-Soulier syndrome. *Blood* 1998;91(12):4397-4418.
238. Ware J, Russell SR, Vicente V, et al. Nonsense mutation in the glycoprotein Ib alpha coding sequence associated with Bernard-Soulier syndrome. *Proc Natl Acad Sci U S A* 1990;87(5):2026-2030.
239. Lopez JA, Dong JF. Structure and function of the glycoprotein Ib-IX-V complex. *Curr Opin Hematol* 1997;4(5):323-329.
240. Mueller-Eckhardt C, Kiefel V, Grubert A, et al. 348 cases of suspected neonatal alloimmune thrombocytopenia. *Lancet* 1989;1(8634):363-366.
241. Newman PJ, Derbes RS, Aster RH. The human platelet alloantigens, PIA1 and PIA2, are associated with a leucine33/proline33 amino acid polymorphism in membrane glycoprotein IIIa, and are distinguishable by DNA typing. *J Clin Invest* 1989;83(5):1778-1781.
242. Santoso S, Kroll H, Andrei-Selmer CL, et al. A naturally occurring LeuVal mutation in beta3-integrin impairs the HPA-1a epitope: the third allele of HPA-1. *Transfusion* 2006;46(5):790-799.

243. Unkelbach K, Kalb R, Breitfeld C, Santoso S, Kiefel V, Mueller-Eckhardt C. New polymorphism on platelet glycoprotein IIIa gene recognized by endonuclease msp I: implications for PIA typing by allele-specific restriction analysis. *Transfusion* 1994;34(7):592-595.
244. Walchshofer S, Ghali D, Fink M, Panzer-Grumayer ER, Panzer S. A rare leucine 40/arginine40 polymorphism on platelet glycoprotein IIIa is linked to the human platelet antigen 1b. *Vox Sang* 1994;67(2):231-234.
245. Beer J, Collier BS. Evidence that platelet glycoprotein IIIa has a large disulfide-bonded loop that is susceptible to proteolytic cleavage. *J Biol Chem* 1989;264(29):17564-17573.
246. Honda S, Honda Y, Bauer B, Ruan C, Kunicki TJ. The impact of three-dimensional structure on the expression of PIA alloantigens on human integrin beta 3. *Blood* 1995;86(1):234-242.
247. Valentin N, Visentin GP, Newman PJ. Involvement of the cysteine-rich domain of glycoprotein IIIa in the expression of the human platelet alloantigen, PIA1: evidence for heterogeneity in the humoral response. *Blood* 1995;85(11):3028-3033.
248. Calvete JJ, Arias J, Alvarez MV, Lopez MM, Henschen A, Gonzalez-Rodriguez J. Further studies on the topography of human platelet glycoprotein IIb. Localization of monoclonal antibody epitopes and the putative glycoprotein IIa- and fibrinogen-binding regions. *Biochem J* 1991;273(Pt 3):767-775.
249. Watkins NA, Schaffner-Reckinger E, Allen DL, et al. HPA-1a phenotype-genotype discrepancy reveals a naturally occurring Arg93Gln substitution in the platelet beta 3 integrin that disrupts the HPA-1a epitope. *Blood* 2002;99(5):1833-1839.
250. Furihata K, Nugent DJ, Bissonette A, Aster RH, Kunicki TJ. On the association of the platelet-specific alloantigen, pena, with glycoprotein IIIa. Evidence for heterogeneity of glycoprotein IIIa. *J Clin Invest* 1987;80(6):1624-1630.
251. van Leeuwen EF, Leeksa OC, van Mourik JA, Engelfriet CP, von dem Borne AE. Effect of the binding of anti-Zwa antibodies on platelet function. *Vox Sang* 1984;47(4):280-289.
252. Santoso S, Kalb R, Walka M, Kiefel V, Mueller-Eckhardt C, Newman PJ. The human platelet alloantigens Br(a) and Brb are associated with a single amino acid polymorphism on glycoprotein Ia (integrin subunit alpha 2). *J Clin Invest* 1993;92(5):2427-2432.
253. Bordin JO, Kelton JG, Warner MN, et al. Maternal immunization to Gov system alloantigens on human platelets. *Transfusion* 1997;37(8):823-828.
254. Berry JE, Murphy CM, Smith GA, et al. Detection of Gov system antibodies by MAIPA reveals an immunogenicity similar to the HPA-5 alloantigens. *Br J Haematol* 2000;110(3):735-742.
255. Schuh AC, Watkins NA, Nguyen Q, et al. A tyrosine703serine polymorphism of CD109 defines the Gov platelet alloantigens. *Blood* 2002;99(5):1692-1698.
256. Lyman S, Aster RH, Visentin GP, Newman PJ. Polymorphism of human platelet membrane glycoprotein IIb associated with the Baka/Bakb alloantigen system. *Blood* 1990;75(12):2343-2348.
257. Djaffar I, Vilette D, Pidard D, Wautier JL, Rosa JP. Human platelet antigen 3 (HPA-3): localization of the determinant of the alloantibody lek(a) (HPA-3a) to the C-terminus of platelet glycoprotein IIb heavy chain and contribution of O-linked carbohydrates. *Thromb Haemost* 1993;69(5):485-489.
258. Take H, Tomiyama Y, Shibata Y, et al. Demonstration of the heterogeneity of epitopes of the platelet-specific alloantigen, Baka. *Br J Haematol* 1990;76(3):395-400.
259. Bizzaro N, Dianese G. Neonatal alloimmune amegakaryocytosis. Case report. *Vox Sang* 1988;54(2):112-114.
260. Ishida F, Saji H, Maruya E, Furihata K. Human platelet-specific antigen, Siba, is associated with the molecular weight polymorphism of glycoprotein Ib alpha. *Blood* 1991;78(7):1722-1729.
261. Kuijpers RW, Ouwehand WH, Bleeker PM, Christie D, von dem Borne AE. Localization of the platelet-specific HPA-2 (ko) alloantigens on the N-terminal globular fragment of platelet glycoprotein Ib alpha. *Blood* 1992;79(1): 283-288.
262. Murata M, Furihata K, Ishida F, Russell SR, Ware J, Ruggeri ZM. Genetic and structural characterization of an amino acid dimorphism in glycoprotein Ib alpha involved in platelet transfusion refractoriness. *Blood* 1992;79(11):3086-3090.
263. Saji H, Maruya E, Fujii H, et al. New platelet antigen, Siba, involved in platelet transfusion refractoriness in a Japanese man. *Vox Sang* 1989;56(4):283-287.

264. Li CQ, Dong JF, Lopez JA. The mucin-like macroglycopeptide region of glycoprotein Ibalpha is required for cell adhesion to immobilized von Willebrand factor (VWF) under flow but not for static VWF binding. *Thromb Haemost* 2002;88(4):673-677.
265. Mazzucato M, Pradella P, de Angelis V, Steffan A, de Marco L. Frequency and functional relevance of genetic threonine145/methionine145 dimorphism in platelet glycoprotein Ib alpha in an Italian population. *Transfusion* 1996;36(10):891-894.
266. Lopez JA, Ludwig EH, McCarthy BJ. Polymorphism of human glycoprotein Ib alpha results from a variable number of tandem repeats of a 13-amino acid sequence in the mucin-like macroglycopeptide region. Structure/function implications. *J Biol Chem* 1992;267(14):10055-10061.
267. Ishida F, Furihata K, Ishida K, et al. The largest variant of platelet glycoprotein Ib alpha has four tandem repeats of 13 amino acids in the macroglycopeptide region and a genetic linkage with methionine145. *Blood* 1995;86(4):1357-1360.
268. Aramaki KM, Reiner AP. A novel isoform of platelet glycoprotein Ib alpha is prevalent in African Americans. *Am J Hematol* 1999;60(1):77-79.
269. Wang R, Furihata K, McFarland JG, Friedman K, Aster RH, Newman PJ. An amino acid polymorphism within the RGD binding domain of platelet membrane glycoprotein IIIa is responsible for the formation of the Pena/Penb alloantigen system. *J Clin Invest* 1992;90(5):2038-2043.
270. Ghevaert C, Rankin A, Huiskes E, et al. Alloantibodies against low-frequency human platelet antigens do not account for a significant proportion of cases of fetomaternal alloimmune thrombocytopenia: evidence from 1054 cases. *Transfusion* 2009;49(10):2084-2089.
271. Noris P, Simsek S, de Bruijne-Admiraal LG, et al. Max(a), a new low-frequency platelet-specific antigen localized on glycoprotein IIb, is associated with neonatal alloimmune thrombocytopenia. *Blood* 1995;86(3):1019-1026.
272. Koh Y, Taniue A, Ishii H, et al. Neonatal alloimmune thrombocytopenia caused by an antibody specific for a newly identified allele of human platelet antigen-7. *Transfusion* 2010;50(6):1276-1284.
- 272a. Tomiyama Y, Take H, Ikeda H, et al. Identification of the platelet-specific alloantigen, Naka, on platelet membrane glycoprotein IV. *Blood* 1990;75(3): 684-687.
273. Yanai H, Chiba H, Fujiwara H, et al. Phenotype-genotype correlation in CD36 deficiency types I and II. *Thromb Haemost* 2000;84(3):436-441.
274. Yamamoto N, Ikeda H, Tandon NN, et al. A platelet membrane glycoprotein (GP) deficiency in healthy blood donors: Naka- platelets lack detectable GPIV (CD36). *Blood* 1990;76(9):1698-1703.
275. Kelton JG, Smith JW, Horsewood P, et al. ABH antigens on human platelets: expression on the glycosyl phosphatidylinositol-anchored protein CD109. *J Lab Clin Med* 1998;132(2):142-148.
276. Ogasawara K, Ueki J, Takenaka M, Furihata K. Study on the expression of ABH antigens on platelets. *Blood* 1993;82(3):993-999.
277. Stockelberg D, Hou M, Rydberg L, Kutti J, Wadenvik H. Evidence for an expression of blood group A antigen on platelet glycoproteins IV and V. *Transfus Med* 1996;6(3):243-248.
278. Aster RH. Effect of anticoagulant and ABO incompatibility on recovery of transfused human platelets. *Blood* 1965;26(6):732-743.
279. Carr R, Hutton JL, Jenkins JA, Lucas GF, Amphlett NW. Transfusion of ABO mismatched platelets leads to early platelet refractoriness. *Br J Haematol* 1990;75(3):408-413.
280. Dunstan RA, Mansbach CM, 2nd. Biochemical characterisation of A blood group activity on human platelets. *Vox Sang* 1985;49(2):149-153.
281. Kao KJ. Plasma and platelet HLA in normal individuals: quantitation by competitive enzyme-linked immunoassay. *Blood* 1987;70(1):282-286.
282. Kao KJ, Scornik JC, Riley WJ, McQueen CF. Association between HLA phenotype and HLA concentration in plasma or platelets. *Hum Immunol* 1988;21(2):115-124.
283. Snary D, Barnstable CJ, Bodmer WF, Crumpton MJ. Molecular structure of human histocompatibility antigens: the HLA-C series. *Eur J Immunol* 1977;7(8):580-585.

284. Panzer S, Auerbach L, Cechova E, et al. Maternal alloimmunization against fetal platelet antigens: a prospective study. *Br J Haematol* 1995;90(3): 655-660.
285. King KE, Kao KJ, Bray PF, et al. The role of HLA antibodies in neonatal thrombocytopenia: a prospective study. *Tissue Antigens* 1996;47(3):206-211.
286. Moncharmont P, Dubois V, Obegi C, et al. HLA antibodies and neonatal alloimmune thrombocytopenia. *Acta Haematol* 2004;111(4):215-220.
287. Thude H, Schorner U, Helfricht C, Loth M, Maak B, Barz D. Neonatal alloimmune thrombocytopenia caused by human leucocyte antigen-B27 antibody. *Transfus Med* 2006;16(2):143-149.
288. Peterson JA, Balthazor SM, Curtis BR, McFarland JG, Aster RH. Maternal alloimmunization against the rare platelet-specific antigen HPA-9b (max a) is an important cause of neonatal alloimmune thrombocytopenia. *Transfusion* 2005;45(9):1487-1495.
289. Kaplan C, Porcelijn L, Vanlieferinghen P, et al. Anti-HPA-9bw (maxa) fetomaternal alloimmunization, a clinically severe neonatal thrombocytopenia: difficulties in diagnosis and therapy and report on eight families. *Transfusion* 2005;45(11):1799-1803.
290. Davoren A, McParland P, Crowley J, Barnes A, Kelly G, Murphy WG. Antenatal screening for human platelet antigen-1a: results of a prospective study at a large maternity hospital in Ireland. *BJOG* 2003;110(5):492-496.
291. Bussel JB, Kunicki TJ, Michelson AD. Platelets: new understanding of platelet glycoproteins and their role in disease. *Hematology Am Soc Hematol Educ Program* 2000:222-240.
292. Maslanka K, Yassai M, Gorski J. Molecular identification of T cells that respond in a primary bulk culture to a peptide derived from a platelet glycoprotein implicated in neonatal alloimmune thrombocytopenia. *J Clin Invest* 1996;98(8):1802-1808.
293. Kuijpers RW, von dem Borne AE, Kiefel V, et al. Leucine33-proline33 substitution in human platelet glycoprotein IIIa determines HLA-DRw52a (Dw24) association of the immune response against HPA-1a (Zwa/PIA1) and HPA-1b (Zwb/PIA2). *Hum Immunol* 1992;34(4):253-256.
294. Uhrynowska M, Maslanka K, Zupanska B. Neonatal thrombocytopenia: incidence, serological and clinical observations. *Am J Perinatol* 1997;14(7): 415-418.
295. Ahlen MT, Husebekk A, Killie MK, Kjeldsen-Kragh J, Olsson ML, Skogen B. The development of severe neonatal alloimmune thrombocytopenia due to anti-HPA-1a antibodies is correlated to maternal ABO genotypes. *Clin Dev Immunol* 2012;2012:156867.
296. Mueller-Eckhardt C, Santoso S, Kiefel V. Platelet alloantigens—molecular, genetic, and clinical aspects. *Vox Sang* 1994;67(Suppl 3):89-93.
297. Semana G, Zazoun T, Alizadeh M, Morel-Kopp MC, Genetet B, Kaplan C. Genetic susceptibility and anti-human platelet antigen 5b alloimmunization role of HLA class II and TAP genes. *Hum Immunol* 1996;46(2):114-119.
298. Santoso S, Kiefel V, Mueller-Eckhardt C. Immunochemical characterization of the new platelet alloantigen system Bra/Brb. *Br J Haematol* 1989;72(2): 191-198.
299. Jallu V, Meunier M, Brement M, Kaplan C. A new platelet polymorphism duv(a+), localized within the RGD binding domain of glycoprotein IIIa, is associated with neonatal thrombocytopenia. *Blood* 2002;99(12):4449-4456.
300. Santoso S, Kiefel V. Human platelet alloantigens. *Wien Klin Wochenschr* 2001;113(20-21):806-813.
301. Williamson LM, Stainsby D, Jones H, et al. The impact of universal leukodepletion of the blood supply on hemovigilance reports of posttransfusion purpura and transfusion-associated graft-versus-host disease. *Transfusion* 2007;47(8):1455-1467.
302. Warkentin TE, Smith JW, Hayward CP, Ali AM, Kelton JG. Thrombocytopenia caused by passive transfusion of anti-glycoprotein Ia/IIa alloantibody (anti-HPA-5b). *Blood* 1992;79(9):2480-2484.
303. Shulman NR, Aster RH, Leitner A, Hiller MC. Immunoreactions involving platelets. V. post-transfusion purpura due to a complement-fixing antibody against a genetically controlled platelet antigen. A proposed mechanism for thrombocytopenia and its relevance in "autoimmunity". *J Clin Invest* 1961;40(9):1597-1620.

304. Scott EP, Moilan-Bergeland J, Dalmasso AP. Posttransfusion thrombocytopenia associated with passive transfusion of a platelet-specific antibody. *Transfusion* 1988;28(1):73-76.
305. Panzer S, Kiefel V, Bartram CR, et al. Immune thrombocytopenia more than a year after allogeneic marrow transplantation due to antibodies against donor platelets with anti-PIA1 specificity: evidence for a host-derived immune reaction. *Br J Haematol* 1989;71(2):259-264.
306. Bierling P, Pignon JM, Kuentz M, et al. Thrombocytopenia after bone marrow transplantation caused by a recipient origin Br(a) allo-antibody: presence of mixed chimerism 3 years after the graft without hematologic relapse. *Blood* 1994;83(1):274-279.
307. Roy V, Verfaillie CM. Refractory thrombocytopenia due to anti-PLA1 antibodies following autologous peripheral blood stem cell transplantation: case report and review of literature. *Bone Marrow Transplant* 1996;17(1):115-117.
308. West KA, Anderson DR, McAlister VC, et al. Alloimmune thrombocytopenia after organ transplantation. *N Engl J Med* 1999;341(20):1504-1507.
309. Friend PJ, McCarthy LJ, Filo RS, et al. Transmission of idiopathic (autoimmune) thrombocytopenic purpura by liver transplantation. *N Engl J Med* 1990;323(12):807-811.
310. Claas FH, de Waal LP, Beelen J, et al. Transplantation of highly sensitized patients on the basis of acceptable HLA-A and B mismatches. *Clin Transpl* 1989:185-190.
311. Heal JM, Blumberg N, Masel D. An evaluation of crossmatching, HLA, and ABO matching for platelet transfusions to refractory patients. *Blood* 1987;70(1):23-30.
312. Norol F, Nadjahi J, Bachir D, et al. Transfusion and alloimmunization in sickle cell anemia patients. *Transfus Clin Biol* 1994;1(1):27-34.
313. Langenscheidt F, Kiefel V, Santoso S, Mueller-Eckhardt C. Platelet transfusion refractoriness associated with two rare platelet-specific alloantibodies (anti-Baka and anti-PIA2) and multiple HLA antibodies. *Transfusion* 1988;28(6):597-600.
314. Kekomaki R. Use of HLA- and HPA—matched platelets in alloimmunized patients. *Vox Sang* 1998;74(Suppl 2):359-363.
315. Novotny VM. Platelet transfusion refractoriness—prevention and therapeutical approaches. *Transfus Clin Biol* 1995;2(1):47-49.
316. Pavenski K, Freedman J, Semple JW. HLA alloimmunization against platelet transfusions: pathophysiology, significance, prevention and management. *Tissue Antigens* 2012;79(4):237-245.
317. Rauch U, Osende JI, Fuster V, Badimon JJ, Fayad Z, Chesebro JH. Thrombus formation on atherosclerotic plaques: pathogenesis and clinical consequences. *Ann Intern Med* 2001;134(3):224-238.
318. Santoso S, Kiefel V. Human platelet-specific alloantigens: update. *Vox Sang* 1998;74(Suppl 2):249-253.
319. Weiss EJ, Bray PF, Tayback M, et al. A polymorphism of a platelet glycoprotein receptor as an inherited risk factor for coronary thrombosis. *N Engl J Med* 1996;334(17):1090-1094.
320. Santoso S. Platelet polymorphisms in thrombotic disorders. *Transfus Clin Biol* 2001;8(3):261-266.
321. Michelson AD, Furman MI, Goldschmidt-Clermont P, et al. Platelet GP IIIa pl(A) polymorphisms display different sensitivities to agonists. *Circulation* 2000;101(9):1013-1018.
322. Vijayan KV, Goldschmidt-Clermont PJ, Roos C, Bray PF. The pl(A2) polymorphism of integrin beta(3) enhances outside-in signaling and adhesive functions. *J Clin Invest* 2000;105(6):793-802.
323. Sajid M, Vijayan KV, Souza S, Bray PF. PIA polymorphism of integrin beta 3 differentially modulates cellular migration on extracellular matrix proteins. *Arterioscler Thromb Vasc Biol* 2002;22(12):1984-1989.
324. Potapov EV, Ignatenko S, Nasser BA, et al. Clinical significance of PIA polymorphism of platelet GP IIb/IIIa receptors during long-term VAD support. *Ann Thorac Surg* 2004;77(3):869; discussion 874.
325. Potapov EV, Hetzer R. Impact of PIA polymorphism of platelet GP IIb/IIIa receptors on clinical course during long-term LVAD support is independent of type of LVAD. *Ann Thorac Surg* 2006;82(3):1167.
326. Bottiger C, Kastrati A, Koch W, et al. Polymorphism of platelet glycoprotein IIb and risk of thrombosis and restenosis after coronary stent placement. *Am J Cardiol* 1999;84(9):987-991.

327. Carter AM, Catto AJ, Bamford JM, Grant PJ. Association of the platelet glycoprotein IIb HPA-3 polymorphism with survival after acute ischemic stroke. *Stroke* 1999;30(12):2606-2611.
328. Kroll H, Fechter A, Gardemann A. The role of the glycoprotein IIb fibrinogen receptor subunit T2622G gene polymorphism (HPA-3) on coronary artery disease and acute myocardial infarction. *Thromb Haemost* 2001;85(1):182-183.
329. Reiner AP, Schwartz SM, Kumar PN, et al. Platelet glycoprotein IIb polymorphism, traditional risk factors and non-fatal myocardial infarction in young women. *Br J Haematol* 2001;112(3):632-636.
330. Duan H, Cai Y, Sun X. Platelet glycoprotein IIb/IIIa polymorphism HPA-3 b/b is associated with increased risk of ischemic stroke in patients under 60 years of age. *Med Sci Monit* 2012;18(1):CR19-CR24.
331. Gonzalez-Conejero R, Lozano ML, Rivera J, et al. Polymorphisms of platelet membrane glycoprotein Ib associated with arterial thrombotic disease. *Blood* 1998;92(8):2771-2776.
332. Ito T, Ishida F, Shimodaira S, Kitano K. Polymorphisms of platelet membrane glycoprotein Ib alpha and plasma von Willebrand factor antigen in coronary artery disease. *Int J Hematol* 1999;70(1):47-51.
333. Murata M, Matsubara Y, Kawano K, et al. Coronary artery disease and polymorphisms in a receptor mediating shear stress-dependent platelet activation. *Circulation* 1997;96(10):3281-3286.
334. Afshar-Kharghan V, Li CQ, Khoshnevis-Asl M, Lopez JA. Kozak sequence polymorphism of the glycoprotein (GP) Ibalpha gene is a major determinant of the plasma membrane levels of the platelet GP Ib-IX-V complex. *Blood* 1999;94(1):186-191.
335. Meisel C, Afshar-Kharghan V, Cascorbi I, et al. Role of Kozak sequence polymorphism of platelet glycoprotein Ibalpha as a risk factor for coronary artery disease and catheter interventions. *J Am Coll Cardiol* 2001;38(4):1023-1027.
336. Corral J, Lozano ML, Gonzalez-Conejero R, et al. A common polymorphism flanking the ATG initiator codon of GPIb alpha does not affect expression and is not a major risk factor for arterial thrombosis. *Thromb Haemost* 2000;83(1):23-28.
337. Croft SA, Hampton KK, Daly ME, Steeds RP, Channer KS, Samani NJ. Kozak sequence polymorphism in the platelet GPIbalpha gene is not associated with risk of myocardial infarction. *Blood* 2000;95(6):2183-2184.
338. Frank MB, Reiner AP, Schwartz SM, et al. The Kozak sequence polymorphism of platelet glycoprotein Ibalpha and risk of nonfatal myocardial infarction and nonfatal stroke in young women. *Blood* 2001;97(4):875-879.
339. Baker RI, Eikelboom J, Lofthouse E, et al. Platelet glycoprotein Ibalpha Kozak polymorphism is associated with an increased risk of ischemic stroke. *Blood* 2001;98(1):36-40.
340. Carlsson LE, Santoso S, Spitzer C, Kessler C, Greinacher A. The alpha2 gene coding sequence T807/A873 of the platelet collagen receptor integrin alpha2beta1 might be a genetic risk factor for the development of stroke in younger patients. *Blood* 1999;93(11):3583-3586.
341. Corral J, Gonzalez-Conejero R, Rivera J, Ortuno F, Aparicio P, Vicente V. Role of the 807 C/T polymorphism of the alpha2 gene in platelet GP Ia collagen receptor expression and function—effect in thromboembolic diseases. *Thromb Haemost* 1999;81(6):951-956.
342. Croft SA, Hampton KK, Sorrell JA, et al. The GPIa C807T dimorphism associated with platelet collagen receptor density is not a risk factor for myocardial infarction. *Br J Haematol* 1999;106(3):771-776.
343. Moshfegh K, Wuillemin WA, Redondo M, et al. Association of two silent polymorphisms of platelet glycoprotein Ia/IIa receptor with risk of myocardial infarction: a case-control study. *Lancet* 1999;353(9150):351-354.
344. Santoso S, Kunicki TJ, Kroll H, Haberbosch W, Gardemann A. Association of the platelet glycoprotein Ia C807T gene polymorphism with nonfatal myocardial infarction in younger patients. *Blood* 1999;93(8):2449-2453.
345. Kunicki TJ, Williams SA, Diaz D, Farndale RW, Nugent DJ. Platelet adhesion to decorin but not collagen I correlates with the integrin alpha2 dimorphism E534K, the basis of the human platelet alloantigen (HPA)-5 system. *Haematologica* 2012;97(5):692-695.
346. Bux J. Molecular genetics of granulocyte polymorphisms. *Vox Sang* 2000;78(Suppl 2):125-130.
347. Bux J, Behrens G, Jaeger G, Welte K. Diagnosis and clinical course of auto-immune neutropenia in infancy: analysis of 240 cases. *Blood* 1998;91(1): 181-186.
348. Bux J, Jung KD, Kauth T, Mueller-Eckhardt C. Serological and clinical aspects of granulocyte antibodies leading to alloimmune neonatal neutropenia. *Transfus Med* 1992;2(2):143-149.

349. Brand A, Sintnicolaas K, Claas FH, Eernisse JG. ABH antibodies causing platelet transfusion refractoriness. *Transfusion* 1986;26(5):463-466.
350. Ory PA, Clark MR, Kwoh EE, Clarkson SB, Goldstein IM. Sequences of complementary DNAs that encode the NA1 and NA2 forms of fc receptor III on human neutrophils. *J Clin Invest* 1989;84(5):1688-1691.
351. Ravetch JV, Perussia B. Alternative membrane forms of fc gamma RIII(CD16) on human natural killer cells and neutrophils. Cell type-specific expression of two genes that differ in single nucleotide substitutions. *J Exp Med* 1989;170(2):481-497.
352. Huizinga TW, de Haas M, Kleijer M, Nuijens JH, Roos D, von dem Borne AE. Soluble fc gamma receptor III in human plasma originates from release by neutrophils. *J Clin Invest* 1990;86(2):416-423.
353. Bierling P, Poulet E, Fromont P, Seror T, Bracq C, Duedari N. Neutrophilspecific antigen and gene frequencies in the French population. *Transfusion* 1990;30(9):848-849.
354. Hessner MJ, Curtis BR, Endean DJ, Aster RH. Determination of neutrophil antigen gene frequencies in five ethnic groups by polymerase chain reaction with sequence-specific primers. *Transfusion* 1996;36(10):895-899.
355. Lin M, Chen CC, Wang CL, Lee HL. Frequencies of neutrophil-specific antigens among Chinese in Taiwan. *Vox Sang* 1994;66(3):247.
356. Ohto H, Matsuo Y. Neutrophil-specific antigens and gene frequencies in Japanese. *Transfusion* 1989;29(7):654.
357. Matsuo K, Procter J, Stroncek D. Variations in genes encoding neutrophil antigens NA1 and NA2. *Transfusion* 2000;40(6):645-653.
358. Bux J, Stein EL, Bierling P, et al. Characterization of a new alloantigen (SH) on the human neutrophil fc gamma receptor IIIb. *Blood* 1997;89(3):1027-1034.
359. Kissel K, Hofmann C, Gittinger FS, Daniels G, Bux J. HNA-1a, HNA-1b, and HNA-1c (NA1, NA2, SH) frequencies in African and American blacks and in Chinese. *Tissue Antigens* 2000;56(2):143-148.
360. Lehrnbecher T, Foster CB, Zhu S, et al. Variant genotypes of the low-affinity fcgamma receptors in two control populations and a review of low-affinity fcgamma receptor polymorphisms in control and disease populations. *Blood* 1999;94(12):4220-4232.
361. Koene HR, Kleijer M, Roos D, de Haas M, Von dem Borne AE. Fc gamma RIIIB gene duplication: evidence for presence and expression of three distinct Fc gamma RIIIB genes in NA(1+,2+)SH(+) individuals. *Blood* 1998;91(2): 673-679.
362. Steffensen R, Gulen T, Varming K, Jersild C. FcgammaRIIIB polymorphism: evidence that NA1/NA2 and SH are located in two closely linked loci and that the SH allele is linked to the NA1 allele in the Danish population. *Transfusion* 1999;39(6):593-598.
363. Lalezari P. Alloimmune neonatal neutropenia and neutrophil-specific antigens. *Vox Sang* 1984;46(6):415-417.
364. Verheugt FW, von dem Borne AE, Decary F, Engelfriet CP. The detection of granulocyte alloantibodies with an indirect immunofluorescence test. *Br J Haematol* 1977;36(4):533-544.
365. Goldschmeding R, van Dalen CM, Faber N, et al. Further characterization of the NB 1 antigen as a variably expressed 56-62 kD GPI-linked glycoprotein of plasma membranes and specific granules of neutrophils. *Br J Haematol* 1992;81(3):336-345.
366. Bux J. Molecular nature of granulocyte antigens. *Transfus Clin Biol* 2001;8(3):242-247.
367. Kissel K, Santoso S, Hofmann C, Stroncek D, Bux J. Molecular basis of the neutrophil glycoprotein NB1 (CD177) involved in the pathogenesis of immune neutropenias and transfusion reactions. *Eur J Immunol* 2001;31(5): 1301-1309.
368. Temerinac S, Klippel S, Strunck E, et al. Cloning of PRV-1, a novel member of the uPAR receptor superfamily, which is overexpressed in polycythemia rubra vera. *Blood* 2000;95(8):2569-2576.
369. Kissel K, Scheffler S, Kerowgan M, Bux J. Molecular basis of NB1 (HNA-2a, CD177) deficiency. *Blood* 2002;99(11):4231-4233.
370. Stroncek DF, Shankar RA, Plachta LB, Clay ME, Dalmaso AP. Polyclonal antibodies against the NB1-bearing 58- to 64-kDa glycoprotein of human neutrophils do not identify an NB2-bearing molecule. *Transfusion* 1993;33(5): 399-404.

371. Stroncek DF, Shankar RA, Noren PA, Herr GP, Clement LT. Analysis of the expression of NB1 antigen using two monoclonal antibodies. *Transfusion* 1996;36(2):168-174.
372. Lawler SD, Shatwell HS. A study of anti-5b leuco-agglutinins. *Vox Sang* 1967;13(2):187-193.
373. de Haas M, Muniz-Diaz E, Alonso LG, et al. Neutrophil antigen 5b is carried by a protein, migrating from 70 to 95 kDa, and may be involved in neonatal alloimmune neutropenia. *Transfusion* 2000;40(2):222-227.
374. Nordhagen R, Conradi M, Dromtorp SM. Pulmonary reaction associated with transfusion of plasma containing anti-5b. *Vox Sang* 1986;51(2):102-107.
375. Kopko PM, Marshall CS, MacKenzie MR, Holland PV, Popovsky MA. Transfusion-related acute lung injury: report of a clinical look-back investigation. *JAMA* 2002;287(15):1968-1971.
376. Curtis BR, Cox NJ, Sullivan MJ, et al. The neutrophil alloantigen HNA-3a (5b) is located on choline transporter-like protein 2 and appears to be encoded by an R>Q154 amino acid substitution. *Blood* 2010;115(10):2073-2076.
377. Greinacher A, Wesche J, Hammer E, et al. Characterization of the human neutrophil alloantigen-3a. *Nat Med* 2010;16(1):45-48.
378. Curtis BR, Sullivan MJ, Holyst MT, Szabo A, Bougie DW, Aster RH. HNA-3a-specific antibodies recognize choline transporter-like protein-2 peptides containing arginine, but not glutamine at position 154. *Transfusion* 2011;51(10):2168-2174.
379. Reil A, Wesche J, Greinacher A, Bux J. Geno- and phenotyping and immunogenicity of HNA-3. *Transfusion* 2011;51(1):18-24.
380. Simsek S, van der Schoot CE, Daams M, et al. Molecular characterization of antigenic polymorphisms (ond(a) and mart(a)) of the beta 2 family recognized by human leukocyte alloantisera. *Blood* 1996;88(4):1350-1358.
381. Fung YL, Pitcher LA, Willett JE, et al. Alloimmune neonatal neutropenia linked to anti-HNA-4a. *Transfus Med* 2003;13(1):49-52.
382. Bux J, Chapman J. Report on the Second International Granulocyte Serology Workshop. *Transfusion* 1997;37(9):977-983.
383. Jiang AF, Lalezari P. A micro-technique for detection of leukocyte agglutinins. *J Immunol Methods* 1975;7(1):103-108.
384. Puig N, de Haas M, Kleijer M, et al. Isoimmune neonatal neutropenia caused by Fc gamma RIIIb antibodies in a Spanish child. *Transfusion* 1995;35(8):683-687.
385. Maheshwari A, Christensen RD, Calhoun DA. Immune-mediated neutropenia in the neonate. *Acta Paediatr Suppl* 2002;91(438):98-103.
386. de Rie MA, van der Plas-van Dalen CM, Engelfriet CP, von dem Borne AE. The serology of febrile transfusion reactions. *Vox Sang* 1985;49(2):126-134.
387. Heddle NM, Klama L, Singer J, et al. The role of the plasma from platelet concentrates in transfusion reactions. *N Engl J Med* 1994;331(10): 625-628.
388. Kleinman S, Caulfield T, Chan P, et al. Toward an understanding of transfusion-related acute lung injury: statement of a consensus panel. *Transfusion* 2004;44(12):1774-1789.
389. Webert KE, Blajchman MA. Transfusion-related acute lung injury. *Curr Opin Hematol* 2005;12(6):480-487.
390. Curtis BR, McFarland JG. Mechanisms of transfusion-related acute lung injury (TRALI): anti-leukocyte antibodies. *Crit Care Med* 2006;34(Suppl 5):S118-S123.
391. Win N, Chapman CE, Bowles KM, et al. How much residual plasma may cause TRALI? *Transfus Med* 2008;18(5):276-280.
392. Flesch BK, Petershofen EK, Bux J. TRALI—new challenges for histocompatibility and immunogenetics in transfusion medicine. *Tissue Antigens* 2011;78(1):1-7.
393. Kedzierska A, Turowski G. Histocompatibility HLA system of man. Consideration in the light of current concepts. I. Organization and polymorphism. *Przegl Lek* 2001;58(5):459-462.
394. Klein J, Sato A. The HLA system. First of two parts. *N Engl J Med* 2000;343(10):702-709.

395. Borrego F, Kabat J, Kim DK, et al. Structure and function of major histocompatibility complex (MHC) class I specific receptors expressed on human natural killer (NK) cells. *Mol Immunol* 2002;38(9):637-660.
396. Boyington JC, Sun PD. A structural perspective on MHC class I recognition by killer cell immunoglobulin-like receptors. *Mol Immunol* 2002;38(14): 1007-1021.
397. Maenaka K, Jones EY. MHC superfamily structure and the immune system. *Curr Opin Struct Biol* 1999;9(6):745-753.
398. Natarajan K, Li H, Mariuzza RA, Margulies DH. MHC class I molecules, structure and function. *Rev Immunogenet* 1999;1(1):32-46.
399. Brown JH, Jardetzky TS, Gorga JC, et al. Three-dimensional structure of the human class II histocompatibility antigen HLA-DR1. *Nature* 1993;364(6432):33-39.
400. Forbes SA, Trowsdale J. The MHC Quarterly Report. *Immunogenetics* 1999;50(3-4):152-159.
401. Terminology: nomenclature for factors of the HLA system, 1980. World Health Organization. *Immunology* 1982;46(1):231-234.
402. Bodmer JG, Parham P, Albert ED, Marsh SG. Putting a hold on "HLA-H". the WHO Nomenclature Committee for Factors of the HLA System. *Nat Genet* 1997;15(3):234-235.
403. Klein J, Sato A. Birth of the major histocompatibility complex. *Scand J Immunol* 1998;47(3):199-209.
404. Duquesnoy RJ. HLA Matchmaker: a molecularly based algorithm for histocompatibility determination. I. Description of the algorithm. *Hum Immunol* 2002;63(5):339-352.
405. McKenna RM, Takemoto SK. Improving HLA matching for kidney transplantation by use of CREGs. *Lancet* 2000;355(9218):1842-1843.
406. Opelz G. Impact of HLA compatibility on survival of kidney transplants from unrelated live donors. *Transplantation* 1997;64(10):1473-1475.
407. Robinson J, Waller MJ, Parham P, et al. IMGT/HLA and IMGT/MHC: sequence databases for the study of the major histocompatibility complex. *Nucleic Acids Res* 2003;31(1):311-314.
408. Koelman CA, Ensink W, Mulder A, Tanke J, Doxiadis II, Claas FH. Anti-HLA antibodies interfere in the detection of soluble HLA class I molecules. *Hum Immunol* 1999;60(5):414-423.
409. Steinborn A, Rebmann V, Scharf A, Sohn C, Grosse-Wilde H. Soluble HLA-DR levels in the maternal circulation of normal and pathologic pregnancy. *Am J Obstet Gynecol* 2003;188(2):473-479.
410. van Rood JJ, van Leeuwen A, van Santen MC. Anti HL-A2 inhibitor in normal human serum. *Nature* 1970;226(5243):366-367.
411. Zavazava N, Wobst B, Ferstl R, Muller-Ruchholtz W. Soluble MHC class I molecules in human body fluids. *J Clin Lab Anal* 1994;8(6):432-436.
412. Stevanovic S. Structural basis of immunogenicity. *Transpl Immunol* 2002;10(2-3):133-136.
413. Bodmer J. World distribution of HLA alleles and implications for disease. *Ciba Found Symp* 1996;197:233,53; discussion 253-258.
414. Allan DS, Lepin EJ, Braud VM, O'Callaghan CA, McMichael AJ. Tetrameric complexes of HLA-E, HLA-F, and HLA-G. *J Immunol Methods* 2002;268(1): 43-50.
415. Gobin SJ, van den Elsen PJ. Transcriptional regulation of the MHC class Ib genes HLA-E, HLA-F, and HLA-G. *Hum Immunol* 2000;61(11):1102-1107.
416. O'Callaghan CA, Bell JI. Structure and function of the human MHC class Ib molecules HLA-E, HLA-F and HLA-G. *Immunol Rev* 1998;163:129-138.
417. Schreuder GM, Hurley CK, Marsh SG, et al. The HLA Dictionary 1999: a summary of HLA-A, -B, -C, -DRB1/3/4/5, -DQB1 alleles and their association with serologically defined HLA-A, -B, -C, -DR and -DQ antigens. *Tissue Antigens* 1999;54(4):409-437.
418. Porter RR. The polymorphism of the complement genes in HLA. *Ann Inst Pasteur Immunol* 1985;136C(1):91-101.
419. Porter RR. The complement components coded in the major histocompatibility complexes and their biological activities. *Immunol Rev* 1985;87:7-17.

420. Yu CY, Campbell RD, Porter RR. A structural model for the location of the Rodgers and the Chido antigenic determinants and their correlation with the human complement component C4A/C4B isotypes. *Immunogenetics* 1988;27(6):399-405.
421. Drew SI, Carter BM, Terasaki PI, et al. Cell surface antigens detected on mature and leukemic granulocytic populations by cytotoxicity testing. *Tissue Antigens* 1978;12(2):75-86.
422. Terasaki PI, Bernoco D, Park MS, Ozturk G, Iwaki Y. Microdroplet testing for HLA-A, -B, -C, and -D antigens. The Phillip Levine Award Lecture. *Am J Clin Pathol* 1978;69(2):103-120.
423. Festenstein H. The biological consequences of altered MHC expression on tumours. *Br Med Bull* 1987;43(1):217-227.
424. Hobart MJ. Phenotypic genetics of complement components. *Philos Trans R Soc Lond B Biol Sci* 1984;306(1129):325-331.
425. Parham P, Ohta T. Population biology of antigen presentation by MHC class I molecules. *Science* 1996;272(5258):67-74.
426. Salmon D, Salmon C. Blood groups and genetic markers polymorphism and probability of paternity. *Transfusion* 1980;20(6):684-694.
427. Walker RH, Meyers MA, Phillips LM. The probability of exclusion of the HLA-A,B system in North American whites and blacks in parentage tests. *Transfusion* 1987;27(1):75-79.
428. Gebe JA, Swanson E, Kwok WW. HLA class II peptide-binding and autoimmunity. *Tissue Antigens* 2002;59(2):78-87.
429. Grumet FC. HLA and disease. *Clin Immunol Rev* 1983;2(1):123-155.
430. Haines JL, Bradford Y, Garcia ME, et al. Multiple susceptibility loci for multiple sclerosis. *Hum Mol Genet* 2002;11(19):2251-2256.
431. Moller P, Berg K. Family studies in Bechterew's syndrome (ankylosing spondylitis) III. genetics. *Clin Genet* 1983;24(2):73-89.
432. Pascual M, Mataran L, Jones G, et al. HLA haplotypes and susceptibility to rheumatoid arthritis. More than class II genes. *Scand J Rheumatol* 2002;31(5):275-278.
433. Tsuchiya N, Ohashi J, Tokunaga K. Variations in immune response genes and their associations with multifactorial immune disorders. *Immunol Rev* 2002;190:169-181.
434. Hors J, Dausset J. HLA and susceptibility to Hodgkin's disease. *Immunol Rev* 1983;70:167-192.
435. Caffrey MF, James DC. Human lymphocyte antigen association in ankylosing spondylitis. *Nature* 1973;242(5393):121.
436. Schlossman SF, Reinherz EL. Human T-cell subsets in health and disease. *Springer Semin Immunopathol* 1984;7(1):9-18.
437. Pociot F, McDermott MF. Genetics of type 1 diabetes mellitus. *Genes Immun* 2002;3(5):235-249.
438. Wong FS, Wen L. The study of HLA class II and autoimmune diabetes. *Curr Mol Med* 2003;3(1):1-15.
439. Jawaheer D, Li W, Graham RR, et al. Dissecting the genetic complexity of the association between human leukocyte antigens and rheumatoid arthritis. *Am J Hum Genet* 2002;71(3):585-594.
440. Mueller-Eckhardt C, Mueller-Eckhardt G, Willen-Ohff H, et al. Immunogenicity of and immune response to the human platelet antigen Zwa is strongly associated with HLA-B8 and DR3. *Tissue Antigens* 1985;26(1):71-76.
441. van Eden W, Gonzalez NM, de Vries RR, Convit J, van Rood JJ. HLA-linked control of predisposition to lepromatous leprosy. *J Infect Dis* 1985;151(1):9-14.
442. Hosenpud JD, Edwards EB, Lin HM, Daily OP. Influence of HLA matching on thoracic transplant outcomes. An analysis from the UNOS/ISHLT thoracic registry. *Circulation* 1996;94(2):170-174.
443. Terasaki PI, McClelland JD, Yuge J, et al. Advances in kidney transplantation: 1985-1995. *Clin Transpl* 1995:487-501.
444. Terasaki PI, Cecka JM, Gjertson DW, Takemoto S. High survival rates of kidney transplants from spousal and living unrelated donors. *N Engl J Med* 1995;333(6):333-336.
445. Anasetti C, Amos D, Beatty PG, et al. Effect of HLA compatibility on engraftment of bone marrow transplants in patients with leukemia or lymphoma. *N Engl J Med* 1989;320(4):197-204.

446. Beatty PG, Clift RA, Mickelson EM, et al. Marrow transplantation from related donors other than HLA-identical siblings. *N Engl J Med* 1985;313(13):765-771.
447. Storb R, Thomas ED. Allogeneic bone-marrow transplantation. *Immunol Rev* 1983;71:77-102.
448. Hansen JA, Clift RA, Thomas ED, Buckner CD, Storb R, Giblett ER. Transplantation of marrow from an unrelated donor to a patient with acute leukemia. *N Engl J Med* 1980;303(10):565-567.
449. Hows JM, Yin JL, Marsh J, et al. Histocompatible unrelated volunteer donors compared with HLA nonidentical family donors in marrow transplantation for aplastic anemia and leukemia. *Blood* 1986;68(6):1322-1328.
450. McGlave PB, Beatty P, Ash R, Hows JM. Therapy for chronic myelogenous leukemia with unrelated donor bone marrow transplantation: results in 102 cases. *Blood* 1990;75(8):1728-1732.
451. Nagler A, Brautbar C, Slavin S, Bishara A. Bone marrow transplantation using unrelated and family related donors: the impact of HLA-C disparity. *Bone Marrow Transplant* 1996;18(5):891-897.
452. Petersdorf EW, Longton GM, Anasetti C, et al. The significance of HLA-DRB1 matching on clinical outcome after HLA-A, B, DR identical unrelated donor marrow transplantation. *Blood* 1995;86(4):1606-1613.
453. Petersdorf EW, Longton GM, Anasetti C, et al. Definition of HLA-DQ as a transplantation antigen. *Proc Natl Acad Sci U S A* 1996;93(26):15358-15363.
454. Popovsky MA, Moore SB. Diagnostic and pathogenetic considerations in transfusion-related acute lung injury. *Transfusion* 1985;25(6):573-577.
455. Goldman M, Webert KE, Arnold DM, et al. Proceedings of a Consensus Conference: towards an understanding of TRALI. *Transfus Med Rev* 2005;19(1):2-31.
456. Kopko PM, Paglieroni TG, Popovsky MA, Muto KN, MacKenzie MR, Holland PV. TRALI: correlation of antigen-antibody and monocyte activation in donor-recipient pairs. *Transfusion* 2003;43(2):177-184.
457. Kekomaki R, Jouhikainen T, Ollikainen J, Westman P, Laes M. A new platelet alloantigen, Tua, on glycoprotein IIIa associated with neonatal alloimmune thrombocytopenia in two families. *Br J Haematol* 1993;83(2):306-310.
458. McFarland JG, Blanchette V, Collins J, Newman PJ, Wang R, Aster RH. Neonatal alloimmune thrombocytopenia due to a new platelet-specific alloantibody. *Blood* 1993;81(12):3318-3323.
459. Wang R, McFarland JG, Kekomaki R, Newman PJ. Amino acid 489 is encoded by a mutational "hot spot" on the beta 3 integrin chain: the CA/TU human platelet alloantigen system. *Blood* 1993;82(11):3386-3391.
460. Kuijpers RW, Simsek S, Faber NM, Goldschmeding R, van Wermerkerken RK, von dem Borne AE. Single point mutation in human glycoprotein IIIa is associated with a new platelet-specific alloantigen (Mo) involved in neonatal alloimmune thrombocytopenia. *Blood* 1993;81(1):70-76.
461. Kroll H, Kiefel V, Santoso S, Mueller-Eckhardt C. Sra, a private platelet antigen on glycoprotein IIIa associated with neonatal alloimmune thrombocytopenia. *Blood* 1990;76(11):2296-2302.
462. Peyruchaud O, Bourre F, Morel-Kopp MC, et al. HPA-10w(b) (Ia(a)): genetic determination of a new platelet-specific alloantigen on glycoprotein IIIa and its expression in COS-7 cells. *Blood* 1997;89(7):2422-2428.
463. Simsek S, Vlekke AB, Kuijpers RW, Goldschmeding R, von dem Borne AE. A new private platelet antigen, Groa, localized on glycoprotein IIIa, involved in neonatal alloimmune thrombocytopenia. *Vox Sang* 1994;67(3):302-306.
464. Simsek S, Folman C, van der Schoot CE, von dem Borne AE. The Arg633His substitution responsible for the private platelet antigen Gro(a) unravelled by SSCP analysis and direct sequencing. *Br J Haematol* 1997;97(2): 330-335.
465. Kiefel V, Vicariot M, Giovangrandi Y, et al. Alloimmunization against Iy, a low-frequency antigen on platelet glycoprotein Ib/IX as a cause of severe neonatal alloimmune thrombocytopenic purpura. *Vox Sang* 1995;69(3):250-24.
466. Ishida F, Ito T, Santoso S, Kodaira H, Kitano K, Kiyosawa K. Low prevalence of a polymorphism of platelet membrane glycoprotein Ib beta associated with neonatal alloimmune thrombocytopenic purpura in Asian populations. *Int J Hematol* 1999;69(1):54-56.
467. Santoso S, Amrhein J, Hofmann HA, et al. A point mutation Thr(799) Met on the alpha(2) integrin leads to the formation of new human platelet alloantigen Sit(a) and affects collagen-induced aggregation. *Blood* 1999;94(12):4103-4111.

468. Santoso S, Kiefel V, Richter IG, et al. A functional platelet fibrinogen receptor with a deletion in the cysteine-rich repeat region of the beta(3) integrin: the Oe(a) alloantigen in neonatal alloimmune thrombocytopenia. *Blood* 2002;99(4):1205-1214.
469. Stafford P, Garner SF, Rankin A, Kekomaki R, Watkins NA, Ouwehand WH. A single-nucleotide polymorphism in the human ITGB3 gene is associated with the platelet-specific alloantigen Va (HPA-17bw) involved in fetal maternal alloimmune thrombocytopenia. *Transfusion* 2008;48(7):1432-1438.
470. Bertrand G, Jallu V, Saillant D, Kervran D, Martageix C, Kaplan C. The new platelet alloantigen Cab a: a single point mutation Gln 716 His on the alpha 2 integrin. *Transfusion* 2009;49(10):2076-2083.
471. Peterson JA, Gitter ML, Kanack A, et al. New low-frequency platelet glycoprotein polymorphisms associated with neonatal alloimmune thrombocytopenia. *Transfusion* 2010;50(2):324-333.
- 471a. Peterson JA, Pechauer SM, Gitter ML, Szabo A, Curtis BR, Aster RH. The human platelet antigen-21bw is relatively common among Asians and is a potential trigger for neonatal alloimmune thrombocytopenia. *Transfusion* 2012;52(4):915-916.
472. Jallu V, Bianchi F, Bertrand G, Kaplan C. New K103 beta3 allele identified in a context of severe neonatal thrombocytopenia. *Transfusion* 2011;51(9): 1980-1984.
473. Kroll H, Feldmann K, Zwingel C, et al. A new platelet alloantigen, Swi(a), located on glycoprotein Ia identified in a family with fetal and neonatal alloimmune thrombocytopenia. *Transfusion* 2011;51(8):1745-1754.
474. Sachs UJ, Bakchoul T, Eva O, et al. A point mutation in the EGF-4 domain of beta(3) integrin is responsible for the formation of the Sec(a) platelet alloantigen and affects receptor function. *Thromb Haemost* 2012;107(1):80-87.

Chapter 21 Transfusion Medicine

The first documented transfusion of blood in humans occurred in 1667, but it was not until almost 300 years later that transfusion became a therapeutic practicality.¹ Landsteiner's landmark discovery in the early 1900s of blood groups and agglutinating antibodies was the key that unlocked this therapeutic pathway. The development of anticoagulants, blood preservatives, and sterile collection sets in the middle of the 20th century made blood banking possible by enabling the collection and preservation of donor blood for later use.

In the past few decades, the complexity of blood banking and blood component therapy has virtually exploded. The recognition of both infectious and noninfectious complications of transfusion led to numerous practice changes involving blood donor screening, component production and modification, compatibility testing, and blood utilization. The menu of blood component options and therapeutic services has progressively expanded, along with efforts to establish evidence-based guidelines for their optimal use. Specialized recommendations have been developed for supporting specific patient populations such as immunosuppressed patients, chronic transfusion recipients, hematopoietic cell transplant recipients, and neonates.^{2,3} In the United States, all blood establishments (blood banks and transfusion services) are regulated by the US Food and Drug Administration (FDA).⁴ FDA regulations govern all aspects of blood collection, component processing, storage, compatibility testing, and administration. The FDA requires blood establishments to comply with highly stringent quality assurance standards that ensure control of processes and restrict variability. The AABB (formerly known as the American Association of Blood Banks) issues accreditation standards and recommendations that further establish the standard of practice in the US.⁵

Today, Transfusion Medicine is itself a Board-recognized clinical specialty. In addition to overseeing the complex donor center and transfusion service operations, Transfusion Medicine physicians are increasingly important participants in the clinical care team. Transfusion Medicine specialists can guide the selection of therapeutic options to best support a patient's medical needs, and can coordinate the supply and delivery of these blood components and therapeutic services.⁶ This chapter serves as an introduction to blood components and transfusion services available in the United States.

BLOOD DONATION AND COLLECTION

Donor Selection

In the United States (US), donor eligibility criteria are established and enforced by the FDA and to a lesser degree by the American Association of Blood Banks (AABB). Donor selection is undertaken with two goals in mind: to protect the health of the donor by ensuring that a donation does not place the donor at risk, and to protect the recipient by ensuring that the donor meets all health and screening criteria so that the risk of transmitting infectious agents or causing other adverse

events is minimized.² In the US, most fresh blood products are from unpaid volunteers. These donors have decreased risk of transmitting infectious agents, especially in the “window period,” when screening tests fail to detect infection.^{7,8} Paying donors for fresh transfusion products was stopped after studies in the 1970s showed that paid donors had a much higher prevalence of hepatitis.^{8,9,10,11} and¹² Commercial plasma-derivative manufacturers still use paid donors, but comply with FDA-approved donor eligibility criteria and employ pathogen reduction processes during manufacturing that reduce infectious risks, as discussed later in this chapter.

Donor Identification and Registration

Donor registration must accurately identify the potential donor, including name, birthdate, address, and phone number, so the donor can be traced if needed. Records must link donors to all prior donations and test results and be kept for at least 10 years.

Donor Information

The donor must be given educational material describing signs and symptoms of AIDS and activities associated with increased risk of acquiring human immunodeficiency virus (HIV). The donor must be informed that testing may not detect all infections, and that individuals who have engaged in risk behavior should not donate.²

Donor Health History

Information to be elicited is defined by the FDA and the AABB. The medical history is obtained by a trained interviewer, or donors may complete an FDA-approved self-administered questionnaire on paper or a computer. Responses are then reviewed with the donor by qualified staff.² The history includes a review of current health, ensuring that the donor feels well, is free of signs of infection, and that his or her cardiovascular status can tolerate an acute blood volume loss of 10% to 15%. The donor is questioned about recent exposures to blood, potential exposure to HIV or hepatitis, sexual contact with individuals at risk for HIV, needle sharing by the donor or sexual partners, travel to or residence in areas endemic for malaria or variant Creutzfeldt-Jakob disease, medications, and immunizations.

The donor must meet certain requirements of age and vital signs. The hemoglobin must be at least 12.5 g/dl. Donor weight must be sufficient so that the donation constitutes no more than a 15% loss of blood volume. There must be no arm stigmata of parenteral drug abuse.⁵

Informed Consent

The donor must sign the health history form verifying that all questions were answered truthfully, that the donation process is understood, and that he consents to testing for infectious agents transmitted by transfusion, including HIV and hepatitis.²

Additional Donor Criteria for Specific Components

Donors may be eligible to donate some blood components but not others.

Medications That Impact Therapeutic Effectiveness of Particular Blood Components

Acetylsalicylic acid (ASA) irreversibly acetylates platelet cyclooxygenase and inhibits platelet aggregation.¹³ Platelet-mediated

P.548

hemostasis is restored, however, if ASA-inhibited platelets are mixed with untreated platelets.¹⁴ After a single dose of aspirin, ASA-exposed platelets are inhibited for the rest of their lifespan, but platelets produced after clearance of the drug restore hemostatic function. Therefore, platelets from donors who have taken ASA are acceptable as long as 48 hours have elapsed from the last dose. Platelets donated within 2 days of ASA ingestion are acceptable for use if mixed with platelets from unexposed donors.⁵

Nonsteroidal anti-inflammatory drugs (NSAIDs) may impair platelet function, but the effects of many are reversible¹³—that is, platelet function is restored once the platelets are removed from the offending drug.¹⁵ Therefore, individuals taking reversible NSAIDs can donate platelets for transfusion. Individuals who are taking irreversible NSAIDs, however, or other irreversible antiplatelet agents (e.g., ticlopidine) are not eligible to donate platelets for transfusion.⁵

Warfarin reduces levels of functional blood clotting factors (see Chapter 55). Transfusable plasma units or cryoprecipitate cannot be made from donors taking this medication.⁵

TRALI Mitigation Strategies for “High Plasma Volume” Components

Studies in the early 2000s indicated that blood products containing a large volume of plasma (e.g., plasma and apheresis platelet units) were associated with a higher per unit risk of transfusion-related acute lung injury (TRALI) compared to components containing small amounts of plasma (e.g., red cell units and cryoprecipitate). Furthermore, plasma or platelet units containing donor antibodies to white blood cell (HLA and neutrophil) antigens were implicated in a substantial proportion of TRALI cases.^{16,17} In an attempt to reduce the frequency of TRALI, the AABB recommended in 2006 that blood collection agencies take steps to reduce production of high plasma volume products from donors with an increased likelihood of having WBC antibodies.¹⁸ Women with a history of pregnancy are at highest risk of being immunized to WBC antigens. Therefore, in response to AABB recommendations, many blood collection facilities have stopped making transfusable plasma components from women with a history of pregnancy or from all women. Whole blood collections are still accepted from these women, but the plasma portion of their collections is used only for cryoprecipitate production and/or manufacturing into plasma derivatives. It has been more challenging to exclude women with a history of pregnancy from plateletpheresis donations, as the platelet supply is difficult to sustain. Some blood collection facilities exclude multiparous women as platelet donors or screen them for the presence of HLA antibodies.

Directed Donations

A directed donation (DD) is a donation in which the donor directs his/her donated blood product to a specific designated patient.² The donation must usually be ordered by the recipient's doctor. DD programs exist primarily for emotional reasons, although these programs are required to be offered in certain states. In these programs, patients anticipating the need for blood can select who their donors will be. The donor is often a family member or acquaintance of the recipient. DDs are not of medical benefit where an established blood supply exists but can be useful in rare circumstances when specific characteristics of the donor's blood are medically needed (e.g., for rare HLA or blood types obtained from family members). Directed donors must meet all regular donation criteria; however, exceptions can be made if rare types are needed. Data show DDs are no more safe than regular community donations from an infectious disease perspective. Directed donors are more likely to be first-time donors, who have a higher incidence of HIV and HCV than repeat blood donors.¹⁹ DDs theoretically may have higher risk of causing transfusion complications such as (1) hemolytic disease of the newborn in future pregnancies after a woman has received blood from her husband or his relatives,²⁰ (2) TRALI in a mother to child transfusion, or (3) transfusion-associated graft-versus-host disease (TA-GVHD) from a related family donation.²¹ Directed donations from blood relatives are irradiated to prevent TA-GVHD.

BLOOD COLLECTION PROCESS

Phlebotomy and collection of blood proceed only if the donor is deemed suitable after pre-donation screening. Blood is collected in accordance with established standards⁵ and is collected either manually or with an automated collection device.

Whole Blood (Manual) Collection

The phlebotomy site is swabbed with a disinfectant.²² Blood is collected in a primary plastic collection bag with a large bore needle allowing rapid flow and mixture with anticoagulant. The volume drawn is standardized for the collection bag used (either 450 or 500 ml). The blood draw is controlled by scales that discontinue flow when the desired weight is collected. Blood and anticoagulant are mixed gently during the collection. Specimen tubes for testing are also procured. Because most whole blood units will be separated into components, the primary bag has one to three attached satellite bags allowing separation of components in a sterile closed system. The collection tubing is heat-sealed into segments that are left attached to provide samples for crossmatching. The whole blood is transported to a laboratory where it can be separated into its components (red cells, plasma, platelets).

Blood Component Separation

Whole blood is centrifuged to sediment the red blood cells (RBCs) (Fig. 21.1). Most of the supernatant "platelet-rich plasma" is pushed off into an attached sterile satellite bag. The bag containing platelet-rich plasma may then be centrifuged at a higher rate to sediment platelets. Most of the plasma is then removed into a third satellite bag. This leaves behind a platelet pellet which is then resuspended in 40 to 70 ml of residual plasma resulting in a platelet concentrate. If platelet concentrates are not going to be produced from the donation, the initial centrifugation of the whole blood is done at high speed, and the plasma is removed directly from the red blood cells and frozen. Further processing of plasma and red cell components is discussed later in this chapter.

Terminology

The whole blood in the original collection bag (450 or 500 ml) is referred to as one whole blood unit, and each component made from that unit is defined as one "unit" of that component. Because a whole blood unit constitutes approximately

10% of a donor's blood volume, each component can be considered roughly 10% replacement therapy for an adult patient.

“Closed” versus “Open” Systems

If blood component manipulation is done without opening the system to air (closed system), all components may be stored to the limit of their viability. If the bag or tubing is entered, however, the system is considered potentially open to air/bacteria, and the product outdates in 4 hours if stored at room temperature or 24 hours if refrigerated. Devices using high-temperature welds can sterilely attach additional containers or tubing to the original unit in a way that prevents entry of bacteria. With these “sterile connection devices,” blood components may be split into aliquots, filtered, or otherwise manipulated without loss of shelf life.²

P.549

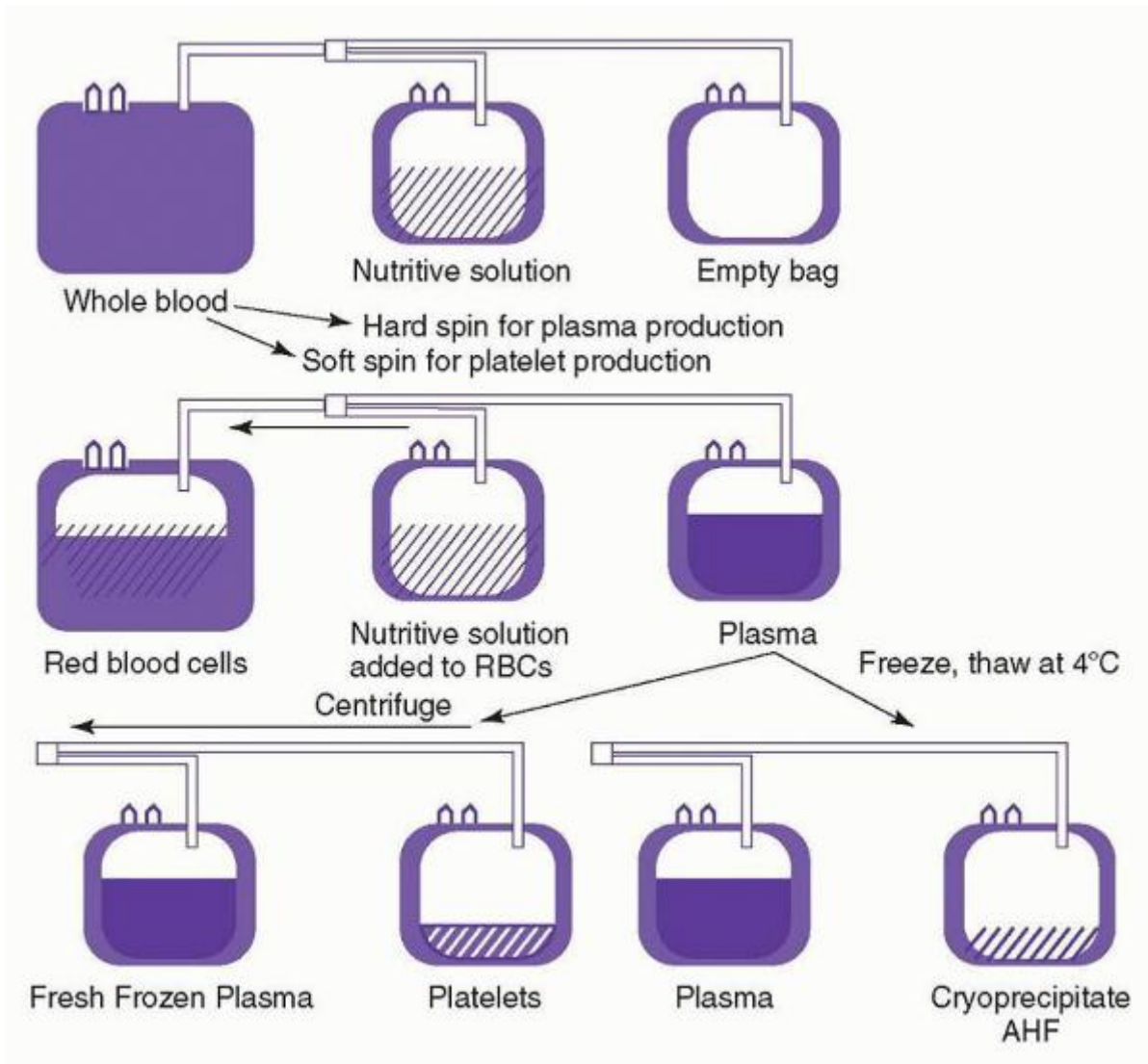

FIGURE 21.1. Preparation of components from a whole blood donation. AHF, antihemophilic factor; RBC, red blood cell. (Reprinted from Jeter EK, Spivey MA. Blood components and their use. In: Jeter EK, ed. Introduction to transfusion medicine: a case study approach. Bethesda, MD: American Association of Blood Banks Press, 1996:5, with permission.)

Automated Blood Collection and Separation Devices: Apheresis

The word apheresis is derived from a Greek word that means to separate or to take away. Initially, it referred to a manual process in which whole blood was withdrawn from the donor and centrifuged, the plasma retained, and the red cells

returned to the donor. In 1914, Abel experimentally removed plasma from anephric dogs, and replaced it with crystalloid.²³ It was not until the advent of plastic bags that manual apheresis could be used routinely in humans. Between 1950 and 1980, manual apheresis was the primary source of plasma for fractionation.

In the 1970s and 1980s automated cell separator devices changed the approach to apheresis. This technology has become the routine collection method for many blood components and is used in the treatment of many diseases.^{2,24}

In discontinuous centrifugal devices, anticoagulated blood is collected into a spinning disposable bowl. Centrifugal force causes red cells to move to the outside of the bowl, and platelet-rich plasma moves to the inside. White blood cells (WBCs) (buffy coat) settle in between. With optical detectors, the desired component is pumped into an attached plastic blood bag. The remaining components are returned to the donor.

Continuous flow devices continuously subject incoming blood to a centrifugal force, establishing a standing cell gradient. The fraction(s) to be removed is pumped into a bag, and the rest is reinfused continuously. The extracorporeal blood volume is lower than with the discontinuous technique, and the procedure is faster. An increasing proportion of blood components are being collected using automated cell separation. These devices can collect multiple unit-equivalents of platelets, plasma, or red blood cells from one donation. Apheresis is the main source of plasma for fractionation because multiple units of plasma may be obtained without red cells and possible resultant iron deficiency. Apheresis technology is now used to collect the majority of platelets in the US and in many regions apheresis platelets have entirely replaced platelets derived from whole blood units. Apheresis platelets have several advantages. Up to three therapeutic platelets doses (equivalent to 18 whole blood-derived platelet units) can be obtained from one apheresis donation. This minimizes possible recipient exposure to infectious agents. If a donor is large enough, it is possible to obtain two RBC unit-equivalents from one apheresis donation, returning plasma, platelets, and saline to the donor to minimize volume loss. Some apheresis devices can be programmed to collect any desired combination of red cells, plasma, or platelet products from the same donation. Apheresis technology is also used for therapeutic plasma exchange (TPE) and for collection of peripheral blood hematopoietic progenitor cells (HPCs) or donor lymphocytes, as discussed later in this chapter and in Chapter 102.²

Membrane filtration can be combined with apheresis to collect plasma. Blood is pumped over a membrane with a specific pore size that permits passage of plasma but not cells. Such devices have been used to collect plasma for fractionation or to perform TPE.

Complications of Donation

Most people easily tolerate blood donation but occasional problems arise, the most common of which are from venipuncture, consisting of bruises, soreness, and hematoma. These complications may be striking but usually resolve spontaneously. Nerve irritation and/or injury (0.02% to 0.9%) and arterial puncture (0.003% to 0.01%) are less common. Donors normally compensate for volume loss by increasing heart rate and vascular resistance, but 2% to 7% of donors experience vasovagal reactions, with syncope occurring in 0.1% to 0.3%. Fatigue (8%), nausea, and vomiting (1.1%) are also seen.^{25,26,27,28} and ²⁹ Apheresis donors can develop transient symptomatic hypocalcemia (tingling or muscle cramps) from the citrate infused when anticoagulated blood components are returned to them. These symptoms are treated by slowing the flow of the device and or giving the donor oral calcium supplements.³⁰ Intravenous calcium infusions are needed only during prolonged apheresis procedures such as those for HPC collection.²⁴

P.550

Donor Testing

Every blood donation undergoes a series of tests to determine its suitability for transfusion. In the United States, the following tests must be performed on every unit collected: ABO group and Rh type, red cell antibody screen, serologic tests for infectious markers including hepatitis B surface antigen (HBsAg), antibodies to hepatitis B core (HBc) antigen, hepatitis C, HIV-1 and -2, human T-cell lymphotropic virus (HTLV)-I and -II, and syphilis, and nucleic acid tests for HIV-1 RNA, HCV RNA, and West Nile virus RNA.⁵ In 2010 the FDA recommended one-time testing of allogeneic donors for antibodies to *T. cruzi* (the causative agent of Chagas disease).³¹ Donor testing is discussed more fully later in this chapter.

Blood components are not released for transfusion unless all donor tests for infectious markers are negative.⁵ This extensive testing results in a delay of 24 to 48 hours from the time of collection until an RBC component can be released for transfusion. Platelet products are typically not available until 36 to 48 hours after collection because of additional bacterial testing (see Bacterial Contamination).

RED BLOOD CELL PRESERVATION AND STORAGE

RBCs are collected and stored in solutions that maintain their viability.

Anticoagulant/Preservative Solutions

Blood banking was not practical until anticoagulant and preservative solutions capable of preserving red cells in viable form were developed.

Citrate anticoagulant is used for essentially all transfusable blood components today. It chelates ionized calcium in blood, blocking calcium-dependent coagulation steps. After transfusion, citrate is readily metabolized by the liver.³²

During World War I, a sodium citrate and glucose solution was developed that permitted blood storage for several days. This citrated blood was used to treat shock in British and American soldiers.³² During World War II, it was found that the addition of citric acid (acid citrate dextrose [ACD]) preserved RBCs for 21 days. Continued efforts resulted in citrate phosphate dextrose (CPD) solution,³³ a modified ACD, with added NaH_2PO_4 and a higher pH. Stored in CPD, red cell phosphate and 2,3-diphosphoglycerate (2,3-DPG) are maintained at higher levels than in ACD; however, RBC viability was still only 21 days.

In the 1950s, it was noted that red cells that had lost their adenosine triphosphate (ATP) did not survive well during storage.³⁴ Nakao³⁵ showed that ATP content and posttransfusion viability of aged red cells could be improved by the addition of adenine, which allows the RBCs to maintain the adenine nucleotide pool. Simon et al.³⁶ described the maintenance of red cell ATP levels using preservatives containing glucose and low concentrations of adenine, leading to the adenine-supplemented anticoagulants now in use.^{32,37}

CPDA-1, which is CPD fortified with adenine, became available in the United States in 1978. It had been used extensively in Europe for several years before then. Initial concerns about potential toxicity of adenine proved to be unfounded. CPDA-1 is now a common anticoagulant-preservative and allows storage of RBC concentrates for 35 days.⁵

Packed Red Cells versus Red Cells in Additive Solutions

After whole blood is collected into CPD or CPDA-1, the red cells may be centrifuged, allowing removal of most of the plasma ("packed RBCs"). Approximately 20% of the anticoagulant-containing plasma must be left to provide metabolic substrate for RBCs during storage. Another approach to red cell preservation involves more complete removal of the anticoagulated plasma from the red cells ("dry pack"), followed by resuspension of the red cells in 100 ml of an additive solution. Such additive solutions contain saline, adenine, and glucose, with or without mannitol to decrease hemolysis. The storage of RBCs in additive solutions is extended to 42 days.^{2,32} RBCs in additive solution are now the most common preparations for transfusion. RBCs collected in any of the anticoagulants and preservatives must be stored at 1° to 6°C to maintain optimum function.⁵

Changes in Red Cells during Storage

Stored liquid RBCs undergo biochemical and structural changes that have major influences on their viability and function after transfusion.^{32,38,39,40} and ⁴¹

Structural Changes

A number of red cell changes contribute to decreased cell viability after storage.^{38,40,41} RBCs are normally disc shaped. Soon after storage they become spherical with surface projections (spherocytosis). Later defects include loss of membrane lipids and protein, as well as alterations in structural proteins. Loss of membrane deformability correlates with viability.³⁹ The more severe membrane changes are irreversible and probably contribute to decreased posttransfusion RBC survival.^{38,40}

Blood bag plasticizers appear to influence membrane stability. Red cells are stored in polyvinyl chloride (PVC) bags that contain the plasticizer di-2-ethylhexylphthalate (DEHP). Morphologic deterioration is greater in RBCs stored in containers that do not have DEHP, with increased hemolysis and loss of deformability, suggesting that DEHP has a direct membrane stabilizing effect.^{42,43} Adding DEHP can both prevent and repair deterioration of stored red cells, with many of the spherical cells reverting to normal discoid morphology.⁴⁴ However, concerns have been raised about potential toxic effects of DEHP. Efforts are being made to find alternatives to DEHP.⁴⁵

Biochemical Changes

During storage, red cells metabolize glucose, producing lactic and pyruvic acid, resulting in lower pH and decreased glycolysis. As glycolysis slows, RBC ATP content falls. Because human RBCs contain no enzymes to synthesize adenine or other purines de novo, the nucleotide pool gradually becomes exhausted. In the presence of adenine, ATP may be

regenerated. Understanding this has led to prolonged RBC storage by the addition of exogenous adenine and inorganic phosphate, both of which improve the cells' ability to regenerate ATP.³²

Red cells lose potassium and gain sodium during storage. This is because the $\text{Na}^+ - \text{K}^+$ gradient is normally maintained by a $\text{Na}^+ - \text{K}^+$ ATPase that does not function well at 4°C. Gamma irradiation of red cells to prevent graft-versus-host disease (GVHD) (see section GVHD) doubles the rate of potassium leakage.^{46,47} Red cells reabsorb potassium after transfusion.⁴⁸

Red Cell 2,3-Diphosphoglycerate

Another significant change in stored RBCs is 2,3-DPG depletion, which decreases RBC oxygen delivery.^{32,49,50} In blood preserved in ACD, 2,3-DPG drops to below 50% within 48 hours. In CPD, CPDA-1, and additive solution-stored red cells, 2,3-DPG is better maintained but is still depleted after about 2 weeks. Studies show that if RBCs are cooled down rapidly to 17 to 18 degrees C within 1 hour after collection, the fall of 2,3-DPG can be delayed

P.551

significantly.⁵¹ 2,3-DPG levels improve rapidly within the first 6 hours after transfusion, and return to near-normal levels within 24 hours.^{48,52}

The clinical implications of transfusion of blood with decreased 2,3-DPG content is controversial^{32,53} The oxygen dissociation curve of cells that are 2,3-DPG-depleted is shifted to the left, resulting in increased hemoglobin oxygen affinity and decreased tissue oxygenation. These changes are thought to be of limited clinical significance because the stored red cells rapidly regain their 2,3-DPG in the circulation. In select patients, such as those in shock, lower RBC 2,3-DPG levels may have a negative effect. However, the acidosis that may be present in such patients shifts the oxygen dissociation curve to the right. Because of such compensatory mechanisms, the need for blood specifically altered to preserve or reconstitute red cell 2,3-DPG has not been demonstrated.

Rejuvenating Solutions

A number of chemical agents—dihydroxyacetone,⁵⁴ pyruvate,⁵⁵ phosphoenolpyruvate,⁵⁶ and inosine⁵⁷—are capable of maintaining near-normal red cell 2,3-DPG content during storage, or of replenishing 2,3-DPG after storage. Although none of these chemicals are likely to be used in transfusion because of their side effects, studies with these agents have resulted in the development of rejuvenating solutions.

Rejuvenating solutions contain pyruvate, inosine, glucose, phosphate, and adenine, and may be added to red cells up to 3 days after the expiration date. Treatment with rejuvenating solutions corrects the metabolic defects of the red cell, with a return to normal levels of ATP and 2,3-DPG. These rejuvenated red cells may either be washed and transfused within 24 hours or frozen for later use.² Such rejuvenated red cells have a normal survival and oxygen affinity.^{58,59} and⁶⁰ In practice, rejuvenation is rarely performed.

In Vivo Recovery of Stored Red Cells

After transfusion of stored blood, red cells that have developed lethal degrees of damage are removed promptly from the circulation of the recipient. Red cells that survive the first 24 hours after transfusion have normal survival thereafter.^{61,62} Therefore, the criterion by which the adequacy for transfusion of banked blood is assessed is the proportion of transfused red cells that remain in circulation at 24 hours after transfusion. Generally, 75% survival at 24 hours is considered evidence of adequate viability; the anticoagulant systems in current use readily achieve this goal. Work to develop optimal additive solutions capable of maintaining red cell ATP and 2,3-DPG levels and to prolong red cell storage time continues.

Clinical Implications of Stored Blood

Whether the age of transfused blood affects clinical outcomes is highly controversial, with many studies coming to different conclusions^{63,64} For a variety of complex methodologic reasons, the ability of even well-designed randomized controlled trials to demonstrate significant clinical differences based on the age of transfused blood has been questioned.⁶⁵

Frozen Red Cells

Red cell freezing is a labor-intensive process that is used primarily for storing rare blood types or prolonged storage of autologous red cells in the event of planned or postponed surgery. Glycerol is gradually added to the red cells as a cryoprotectant to a final concentration of 40% (weight/volume). The cells are then frozen at -65°C or colder for up to 10 years. Immediately after thawing, an automated cell processor must be used to wash the glycerol from the cells. The washed cells are resuspended in isotonic saline and glucose. In most cases, postthaw storage is limited to 24 hours

because an open system is used to process the cells.² However a closed system maintaining sterility has been developed and RBCs processed in this manner can be stored in a refrigerator for up to 2 weeks after thawing.^{66,67}

Potential new technologies for RBC biopreservation are now under investigation, such as hypothermic storage and lyophilization. Hypothermic red cell storage potentially maintains higher levels of 2,3-DPG but still requires improvements. Lyophilization of red cells potentially would allow stable, indefinite, room temperature storage and would be ideal for remote storage and military applications. These methods have still not been sufficiently developed.⁶⁸

PLATELET PREPARATION AND STORAGE

Preparation of Platelet Concentrates

Platelets, like erythrocytes, are actively metabolizing cells and require specific conditions for their preparation and storage to optimally maintain viability and function.^{69,70} They are prepared for transfusion either as platelet concentrates from whole blood or by apheresis. Although the preparation differs, both products are stored under the same conditions.

Platelet concentrates may be prepared from whole blood collected into bags with satellites (Fig. 21.1). The anticoagulants in current use, CPD and CPDA-1, are satisfactory for preparation of platelet concentrates. The whole blood is kept at room temperature and must be processed within 8 hours of collection. The unit of whole blood is centrifuged at low speed at room temperature, and the supernatant, platelet-rich plasma is expressed into a satellite bag. The supernatant is centrifuged again to further concentrate the platelets. Most of the supernatant platelet-poor plasma is expressed, and after 1 hour, the platelets are gently resuspended in the remaining plasma (50 to 60 ml). Approximately 60% to 75% of the donor platelets, or a minimum of 5.5×10^{10} platelets/unit, are recovered.⁷¹

In Europe and Canada, whole blood platelet concentrates are prepared from the buffy coat.² Briefly, the whole blood unit is spun inverted at high speed, and the platelet-poor plasma and the buffy coat are withdrawn, each into its own satellite bag. The buffy coat is then centrifuged at low speed to separate the platelets from the red and white cells. The functional quality of these platelets is comparable to those prepared by the American method.⁷¹ Platelet concentrates prepared from buffy coat contain fewer white cells than those prepared from platelet-rich plasma, although filtration is necessary to meet the European standards for leukoreduced products. In some European countries, platelet concentrates are pooled, resuspended in an additive solution, and filtered before storage.⁷² In the United States and Canada, the pooling of platelets before storage has been evaluated^{73,74,75}; currently, only one system has been FDA-approved for this use in the US.⁷⁶

Apheresis (Pheresis) Platelets

In the US the majority of platelets are collected from single donors by apheresis using the automated collection devices described earlier.² Platelets collected in this way must contain at least 3×10^{11} platelets in approximately 300 ml of plasma by AABB standards. This is equal to about six whole blood platelet concentrates. With improved apheresis technology many platelets collections are so abundant that they can be split into multiple products that still meet the 3×10^{11} requirement. Apheresis platelets are leukocyte-reduced by the collection technology. Because the procedure

P.552

is carried out in a closed system, the platelets can be stored for 5 days in the appropriate plastic bag.^{2,5,77} Apheresis platelets are usually collected from random donors but can also be collected from HLA-compatible donors to support alloimmunized patients. There is no significant functional difference between apheresis platelets and those from whole blood donations.⁷⁵ However, pheresis platelets typically contain fewer WBCs and, therefore, are less likely to cause febrile transfusion reactions than whole blood-derived platelet concentrates,^{78,79} unless these concentrates have been leukoreduced prior to storage.^{80,81} The use of apheresis platelets also results in fewer donor exposures for recipients.

Platelet Storage and Functional Integrity

Platelet products must be kept under specific conditions to ensure optimal recovery and function. Unlike red cells, platelets stored at 4°C undergo shape changes and lose their viability. Platelet survival and function are optimized by storage at room temperature (20° to 24°C).^{82,83} During storage, platelets metabolize glucose to lactate and hydrogen, which are buffered by bicarbonate present in the plasma, resulting in a release of CO₂. The nature of the bag in which platelet concentrates are stored is important. The plastics used in the early era of platelet transfusion were made of PVC and plasticizers and were not permeable to O₂ and CO₂. In these bags, stored platelets become depleted of oxygen, resulting in a shift from oxidative to glycolytic metabolism, with increased lactate generation, decreased pH, and decreased platelet viability. As the pH decreases below 6.2, platelets undergo shape change, are damaged, and show

reduced in vivo recovery. The platelets could not be stored for longer than 72 hours in the PVC bags. The plastic blood bags currently in use are more gas permeable. This permits continued oxidative metabolism and prolongation of storage time.^{84,85} and ⁸⁶ Although platelet viability is maintained for up to 7 days in the new plastic containers,^{87,88} storage of platelet concentrates at room temperature is currently approved for only 5 days in the US because of the risk of bacterial growth.^{89,90} Viability is best preserved if the platelets are gently agitated during storage. Platelets must be stored in sufficient plasma to maintain a pH greater than or equal to 6.2.⁵

Even under optimum storage conditions, platelets, like red cells, develop a storage lesion.⁹¹ After storage at room temperature, the changes that occur in the platelets include decreased aggregation in response to single platelet agonists such as adenosine diphosphate, and reduction in adenosine diphosphate and ATP content both in granules and in the metabolic pool. Beta-thromboglobulin and platelet factor-4 are released, and both dense and alpha-granules are depleted. There is increased surface expression of P-selectin (CD62), a molecule derived from the alpha-granule membrane of the resting platelet. Platelets may develop morphologic changes and impaired responses to hypotonic shock. It has been difficult, however, to correlate the clinical response to platelet transfusions with specific in vitro findings.

The in vivo effectiveness of stored platelets is dependent on the recovery of transfused platelets in the circulation of recipients. This has been assessed through platelet recovery and survival studies in normal volunteers using autologous radiolabeled platelets.⁹² Platelet recovery is the percentage of transfused platelets that are found in circulation immediately after transfusion. Even when fresh platelets are transfused, only about two thirds of the transfused platelets are recovered in the circulation⁹³; the remaining 30% to 40% are pooled in the spleen.⁹⁴ At the end of storage, mean platelet recovery is approximately 40% to 50%.^{86,95} After the initial recovery, there is little difference in survival of fresh versus stored platelets; both show a half-life of 3 to 5 days in healthy adults.⁸³ In patients, however, the observed recovery and survival of transfused platelets are often substantially lower than these figures (as discussed in the section Dosage and Expected Response).

The in vivo hemostatic efficacy of transfused platelets is difficult to assess. The use of bleeding times in thrombocytopenic patients as an indicator of function is not of value because of great variability in technique and lack of reproducibility of results.⁹⁶ Function is best assessed through clinical assessment of hemostasis.⁹⁷ The clinical response generally correlates with the posttransfusion platelet increment.

Platelet Additive Solutions

Platelet additive solution (PAS) use is less developed than additive solutions for RBCs, especially in the US. Removal of variable amounts of plasma and storage of platelet in PAS has many potential advantages, including optimized survival, decreased adverse reactions (e.g., allergic, febrile, TRALI), and pathogen inactivation.⁹⁸

PAS generally contain acetate, which functions both as a metabolic substrate and as a buffer. Platelets stored in one of these solutions (platelet additive solution-2) showed increased P-selectin expression and decreased in vivo recovery compared to platelets stored in plasma^{72,99}; moreover, platelets stored in the additive solution resulted in lower transfusion responses.^{99,100} Another solution, platelet additive solution-3, however, appears to show suitable preservation of platelet function for 7 days and is now in use in both Europe and the US. Platelet additive solutions are included in the pathogen reduction systems for platelets that are approved in Europe. These systems include exposure of the platelets to pathogen reduction agents and UV light, as discussed later in this chapter. This processing appears to be associated with some loss of platelet product potency, but the clinical importance of these changes is unclear.^{101,102}

Frozen Platelets

Frozen storage of platelets has been investigated and a potential role of such preparations has been established only for patients with alloantibodies for whom satisfactory donors cannot be found. Autologous platelets may be frozen using dimethyl sulfoxide as the cryoprotective agent. In vitro recovery of frozen and thawed platelets and posttransfusion increments may be satisfactory for clinical use, although only approximately half of the platelets survive the freeze-thaw process.^{103,104} This recovery may be improved by combining a platelet additive solution with a reduced concentration of dimethyl sulfoxide.¹⁰⁵ Theoretically, autologous frozen platelet transfusions may permit support of highly alloimmunized patients through periods of chemotherapy-induced myelosuppression.^{104,106} Currently, frozen platelets are not available for clinical use; however, studies are beginning to evaluate preserving platelets by freeze-drying with trehalose.^{107,108}

PREPARATION OF PLASMA COMPONENTS

Plasma is obtained from whole blood donations and apheresis collections. The plasma may be used for transfusion, further processed by the blood center into cryoprecipitate, or sent to commercial facilities for manufacturing into plasma derivatives.

Plasma Components for Transfusion

Plasma components such as FFP and cryoprecipitate are produced from individual volunteer blood donations and are briefly described here. As noted earlier, transfusable plasma units are not typically made from donors with an increased likelihood of having antibodies to WBC (e.g., women or women with a history of pregnancy); this strategy reduces the TRALI risk associated with plasma transfusion.

P.553

Fresh Frozen Plasma, Plasma Frozen within 24 Hours (FP24)

Fresh frozen plasma (FFP) is prepared by separating citrated plasma from whole blood and freezing it within 8 hours of collection or by freezing citrated apheresis plasma within 6 hours of collection. Each unit of FFP prepared from whole blood contains approximately 200 ml of plasma. Apheresis plasma may be packaged into 200- or 400-ml bags. FFP may be stored at -18°C or below for up to 1 year. Under these conditions, there is minimal loss of activity of the labile coagulation factors V and VIII. One milliliter of FFP contains approximately one unit of coagulation factor activity. After thawing, FFP may be stored in the refrigerator for up to 24 hours before use.

A product called "Plasma frozen within 24 hours after phlebotomy" (FP24) has largely replaced FFP production in the United States. As discussed earlier, TRALI mitigation strategies have restricted the donations from which transfusable plasma units can be made. In order to maintain a sufficient supply of plasma components for transfusion, most blood collection facilities in the US are labeling their plasma units as "Plasma frozen within 24 hours after phlebotomy" rather than "FFP." This labeling permits blood centers to make transfusable plasma units from donations that reach the component processing facility more than 8 hours after collection. The content of FP24 is identical to that of FFP except that the Factor VIII content may be reduced to 80% that of FFP.^{109,110,111} This Factor VIII content is more than sufficient for the therapeutic applications in which plasma is utilized, e.g., trauma, liver disease, warfarin reversal, etc. Therefore, FFP and FP24 are typically used interchangeably.¹¹²

Liquid Plasma, Thawed Plasma

Liquid plasma is a term for plasma that is separated from whole blood and stored at 1°C to 6°C without freezing. Thawed plasma is a term for FFP or FP24 that is thawed and stored in the refrigerator for up to 5 days after thawing. The only significant difference between these products and FFP/FP24 is the content of the labile coagulation factors (V and VIII).

After 5 days of refrigerated storage, Factor VIII and V levels are at about 65% to 75% of their original levels. After 28 days' storage, Factor VIII activity is approximately 40% of normal and Factor V levels approximately 50% to 60% of normal. Other coagulation factors, including fibrinogen, ADAMTS 13, and factors II, VII, IX, X, and XIII, are generally stable under refrigerated storage conditions.^{112,113,114,115} and ^{116,117}

Liquid plasma or thawed plasma should not be used for clotting factor replacement in patients who have specific deficiencies of factor V or VIII. However, these products can be used for plasma replacement in massively bleeding patients, as these products will still maintain clinically hemostatic factor levels in the patient (i.e., 30% of normal). Because Vitamin K-related factors are not depleted during refrigerated storage, these prolonged storage products would be equivalent to FFP or FP24 for warfarin reversal.

Plasma, Cryoprecipitate Reduced

This is the supernatant remaining after removal of cryoprecipitate from FFP (see "Cryoprecipitated Antihemophilic Factor"). Storage conditions are the same as for FFP. This product is deficient in fibrinogen, Factor VIII, von Willebrand factor (vWF), and factor XIII. Cryoprecipitate-reduced plasma was initially thought to be superior to FFP for treatment of TTP because of its lower vWF content. Randomized studies have verified that this fluid is therapeutically effective for TTP; however, it is not superior to FFP.¹¹⁸

Cryoprecipitated Antihemophilic Factor

Cryoprecipitated AHF, or cryoprecipitate, is an extract of FFP that is enriched in high-molecular-weight plasma proteins. It is prepared by thawing one unit of FFP at 1°C to 6°C . Under these conditions, the high-molecular-weight proteins remain

as a precipitate. The precipitated protein is concentrated by centrifugation, and all except approximately 15 ml of supernatant is removed. The remaining 15 ml and the precipitate are refrozen. Each unit of this cryoprecipitate contains approximately 80 to 120 units of Factor VIII and at least 150 mg of fibrinogen. It also contains factor XIII, fibronectin, and the high-molecular-weight multimers of vWF.

Cryoprecipitate was originally developed for the treatment of hemophilia A. It is no longer the treatment of choice for that disorder, because less infectious alternatives are available. At the present time, cryoprecipitate is most often used for correction of hypofibrinogenemia (<100 mg/dl) in bleeding patients. Cryoprecipitate has also been used topically, along with thrombin and calcium, as a "fibrin glue." However, commercial products that are much more effective as topical hemostatic or sealant agents are now available. A commercial fibrinogen concentrate for intravenous infusion is available, but as of April 2012 this product was approved in the US only for treatment of congenital fibrinogen deficiency.

The typical dose of cryoprecipitate of one unit per 5 to 10 kg can be expected to raise the recipient's fibrinogen level by approximately 70 mg/dl.^{2,3} Multiple units of cryoprecipitate are often pooled before administration.

Commercial Plasma Derivatives

Commercial plasma derivatives are made from pooled plasma collected from hundreds or thousands of donors. In the United States, paid plasmapheresis donors provide most of the plasma derivatives, but excess ("recovered") plasma from volunteer whole blood donations is used also. Plasma units are pooled and fractionated into a number of purified proteins. The most commonly used fractionation procedure is based on Cohn's cold ethanol fractionation process, developed in the 1940s.¹¹⁹ As the temperature, ionic strength, pH, and ethanol concentration are varied, plasma can be separated into several fractions. Fraction I contains Factor VIII and fibrinogen, fraction II contains the immunoglobulins, and fraction V contains albumin. Fractions III and IV contain a number of other coagulation factors and proteins. Although other approaches such as ion-exchange chromatography have been applied to the preparation of certain plasma products, Cohn's method remains the standard.

Because the plasma pools used for the production of plasma derivatives are derived from many donors, contamination with infectious agents is common. All plasma derivatives are treated by methods demonstrated to inactivate HIV, HCV, and hepatitis B virus (HBV), such as prolonged heat and treatment with organic solvents and detergents, which inactivates lipid-coated viruses. Pooled plasma products, however, could still transmit infectious agents that lack a lipid coat and that are resistant to heat. Human parvovirus B19 is one such agent. The FDA requires screening for, and exclusion of, donations that contain high titers of the B19 virus,¹²⁰ but low levels of B19 virus can still be present in the pools. Many plasma derivatives undergo additional purification steps such as affinity chromatography, precipitation, or nanofiltration that would further reduce their contamination by infectious agents.^{119,121}

There are many commercial plasma derivatives available. Some examples are described in the following.

Solvent/Detergent-treated Plasma

Solvent/detergent-treated plasma is made from hundreds or thousands of units of FFP that have been thawed, pooled, subjected to treatment with organic solvents and detergents, filtered, and refrozen.¹²² The product was developed to reduce the risk

P.554

of transmitting enveloped viruses, such as HIV, HCV, and HBV. It appears to be therapeutically equivalent to FFP.¹²² A version of this product introduced in the US in the late 1990s was withdrawn after reports of thromboembolic complications. European versions of this product, however, are in current use and have a good safety record. In contrast to individual plasma units, this pooled plasma product has not been associated with transfusion-related acute lung injury (TRALI), presumably because of dilution of antibodies from individual donors during plasma pooling.

Coagulation Factor Concentrates

The coagulation factor concentrates, both the recombinant products and those made from plasma, are discussed in detail elsewhere as part of the management of inherited or acquired coagulation disorders (see Chapters 53 and 54). Recombinant coagulation products are used when available; these include Factors VIII, IX, and VIIa. Some factors are available only as plasma-derived concentrates, including fibrinogen and protein C.

Immunoglobulins

Intramuscular immune globulin preparations are prepared from pooled plasma by cold ethanol fractionation. They contain dimeric and polymeric IgG, artifacts of the fractionation procedure, which are capable of nonspecifically activating

complement by both the classic and alternative pathways. This mechanism probably explains the major adverse effects that occur if these products are administered intravenously.¹¹⁹ Products labeled for intramuscular use must therefore not be given intravenously.

Intravenous immune globulin preparations (IVIgs) are produced by various chemical modifications designed to decrease the aggregation of IgG. Nonspecific complement activation is reduced, whereas the ability of the Ig molecules to interact with pathogenic organisms and complement is retained. Many of these products may also be administered subcutaneously.

Nonspecific immune globulin preparations contain a broad spectrum of antibodies naturally present in the donor population. They are most often used for treatment of primary immunodeficiency or as immune modulators.¹²³ Immune globulins against a particular target are derived from the plasma of donors selected for high concentrations of antibodies to that target. Such preparations include Rh immune globulin, hepatitis B immune globulin, and Varicella zoster immune globulin.

IVIgs have been associated with some adverse reactions, including renal failure, hemolysis, and thrombotic events. Both IM and IV immune globulin products should be used with caution in patients with IgA deficiency, because they may contain small quantities of IgA.

BLOOD COMPONENT MODIFICATION

Leukocyte Reduction

When whole blood is separated by centrifugation, WBCs sediment at the interface between red cells and platelet-rich plasma. Therefore, WBCs typically contaminate both red cell and platelet components, with concentrations of WBCs approximately 10^9 /product. WBCs in blood components can mediate febrile transfusion reactions, stimulate HLA alloimmunization in transfusion recipients, and transmit some cell-associated pathogens such as cytomegalovirus (CMV).¹²⁴ Therefore, it is desirable to remove WBCs from transfusable blood components.

Historically, several methods have been used to reduce the number of WBCs in transfusable blood components. Relatively nonspecific methods were used initially, including saline washing of red cells or physical separation of the WBC layer (buffy coat) from the RBCs.¹²⁴ Later, microaggregate filters were used to remove WBCs after centrifugation.¹²⁵ These methods resulted in white cell reduction of 70% to 90% and were effective in preventing most febrile reactions to red cells. Freezing and deglycerolization of red cells have also been used to remove WBCs and result in approximately 2-log WBC removal. Ultimately selective leukoreduction filters were developed that can reduce WBCs from blood components by 3 or more logs. These synthetic fiber filters remove WBCs by a combination of mesh density, chemical attraction, and active adhesion.¹²⁴ All leukocyte-reduced red cells are now produced using these special filters and, by FDA criteria, have less than 5×10^6 WBCs/unit and at least 85% of the original RBC component.

Leukofiltration of RBC components may be performed at the blood collection center, in the hospital transfusion service, or at the bedside. Filtration prior to storage reduces WBC breakdown products in the blood component and there is some evidence that RBC viability is better preserved. The clinical importance of these benefits has not been demonstrated.¹²⁴ In practice, most RBC leukofiltration is performed by blood collection centers within the first few days after collection.

Apheresis platelets usually contain very few WBCs and usually qualify as leukoreduced ($<5 \times 10^6$ WBCs) without the need for filtration. In contrast, whole blood-derived platelet concentrates contain large numbers of WBCs, and many of the febrile transfusion reactions to these products appear to be due to cytokines produced by the WBCs in these products during storage.^{126,127,128} and ¹²⁹ Therefore, removal of WBCs from whole blood-derived platelet concentrates before storage is beneficial. One system is approved in the US that allows prestorage leukocyte reduction and pooling of whole blood platelets.

The use of leukoreduced products has evolved over the last decade or two. Initially these products were indicated for patients with a history of febrile, nonhemolytic transfusion reactions, to reduce the risk of HLA alloimmunization, and as an alternative to cytomegalovirus (CMV) antibody screening of donors to reduce the risk of transfusion-transmitted CMV. Now the use of leukoreduced products has become nearly universal, although the medical necessity of universal leukoreduction remains somewhat controversial.¹³⁰

Washed Products

Saline washing with automated cell washers can be used to reduce the amount of plasma in cellular blood products. These washers are capable of removing approximately 99% of plasma proteins from red cell products.² Although cell washing was previously also used for leukocyte reduction, it is no longer used for this purpose. Today, washing is primarily used to

reduce incompatible plasma and also prevent severe allergic reactions (which are thought to be triggered by donor plasma proteins). Washing is also used to reduce RBC supernatant potassium, which may be required prior to massive or rapid infusion of stored RBC to neonates. Washing on an automated cell processor takes 30 to 45 minutes/unit. Because the washing procedure is usually performed in an "open" system, the red cells have only a 24-hour shelf life after washing. A closed processing system has been developed that may permit longer storage of washed cells.⁶⁶ Although many facilities perform red cell washing, few offer washed platelets. Use of automated cell washers to wash platelets has been described.² However, in practice, it may be difficult to ensure adequate platelet recovery and viability after washing.

Irradiation of Blood Products

Gamma irradiation of cellular blood components is used to prevent transfusion-related GVHD by impairing the proliferative capacity of lymphocytes in the blood component. The recommended dose

P.555

for the irradiation of blood and blood products is 2500 cGy at the center of the irradiation field, with a minimum dose of 1500 cGy at any point in the field.^{5,131} This dose of radiation has no significant adverse effect on red cell, platelet, or granulocyte function. However, there are changes in the red cell membrane that result in an increased loss of potassium from the cell, limiting the storage time of red cell concentrates to 28 days.^{46,47} The amount of accumulated free potassium in the supernatant of irradiated red cells may be clinically important in massive transfusion, especially in the neonate.¹³² It may be desirable to irradiate proximate to transfusion, or wash stored irradiated RBCs if massive transfusion of irradiated products is required for a patient at risk for hyperkalemia. The dose of irradiation used for cellular blood components is not sufficient to inactivate pathogens.¹³³ The irradiation doses required for pathogen inactivation would irreparably damage blood components.

ALTERNATIVES TO ALLOGENEIC DONOR BLOOD

Autologous Blood

Autologous blood donation is blood donated by a patient, intended for transfusion back into the same patient. Blood collected for autologous use is not released to other patients.

Use of a patient's own (autologous) blood may reduce or eliminate the need for allogeneic blood. There are three types of autologous blood collection procedures. In preoperative autologous donation (PAD), patients donate one or more units of blood to a blood bank during the weeks preceding an elective procedure. In acute normovolemic hemodilution (ANH), blood units are collected in the operating room immediately prior to surgery. In autologous blood cell salvage, blood lost during or after a surgical procedure is salvaged for reinfusion.

Preoperative Autologous Donation

Preoperative blood donation (PAD) is most often used for patients who are expected to require transfusion during elective surgery. It is also used in patients for whom crossmatch-compatible blood cannot otherwise be made available, as in patients with rare blood groups or with multiple alloantibodies. For autologous collections, the donor eligibility criteria are not as stringent as for allogeneic donors. The key consideration is whether the patient can tolerate the acute withdrawal of a unit of whole blood representing 10% to 15% of their blood volume. Patients with significant cerebral or cardiac disease should be evaluated before they are enrolled in a PAD program. Children are also eligible for autologous blood donation, but the volume of blood collected and anticoagulant used must be adjusted to body weight.

An autologous donor may donate blood every 3 days as long as the donor's hemoglobin remains at or above 11 g/dl. An "aggressive" donation schedule stimulates a more substantial endogenous erythropoietin response, with the potential for more autologous units collected or a higher patient hemoglobin at surgery.¹³⁴ In most instances, the units of blood are stored in the liquid state for up to 35 to 42 days. They may be frozen if a longer interval between donation and surgery is required, but this significantly increases the cost and is not routinely recommended.^{135,136}

All autologous collections must be tested for ABO group and Rh type. The units must be labeled For Autologous Use Only. If autologous blood is to be transfused at an institution that is not the collecting facility, the blood unit must be tested for transfusion-transmitted infectious diseases.⁵ Units with reactive infectious disease tests must be labeled with biohazard labels. Regulators permit the use of autologous units with positive infectious disease tests. However, some hospitals do not accept such units because of concerns related to the risk of accidental transfusion of the unit into the wrong patient.

PAD is not necessarily beneficial to the patient. There is a reported 12-fold increase in the number of autologous donors hospitalized after a donation compared to allogeneic donors, with an increased risk in the elderly.¹³⁷ Iron supplementation

is recommended, but may not be sufficient to prevent anemia, especially if the last unit of autologous blood is collected <7 days preoperatively. This anemia may increase the patient's likelihood of requiring transfusion.¹³⁸ PAD is expensive and the logistics of collecting and shipping the blood in the desired timeframe are complex. Autologous blood may be wasted or transfused unnecessarily, particularly if collected for procedures in which transfusion is rarely needed.^{139,140}

Transfusion complications such as bacterial contamination, febrile nonhemolytic transfusion reactions (FNHTRs), allergic reactions, and volume overload can occur with autologous transfusion.¹⁴¹ The possibility of an accident or error such as the transfusion of the wrong unit or an allogeneic unit into the autologous donor/patient has been reported to be as high as 1.2%.¹⁴² The cost-effectiveness of PAD is has been questioned, given its high cost, risks, and limited benefit.¹⁴³

Acute Normovolemic Hemodilution

The second approach to autologous blood procurement involves the withdrawal of blood immediately before the surgical procedure and replacing the blood with crystalloid, colloid, or both, thereby acutely lowering the patient's hematocrit.^{139,144} The blood lost during surgery is therefore relatively dilute, reducing total red cell loss. The higher hematocrit blood withdrawn immediately prior to surgery is used for transfusion. Patients most likely to benefit from this maneuver are those with anticipated large surgical blood losses who can tolerate low intraoperative hematocrits.^{145,146}

Units collected by ANH can be stored at room temperature for up to 8 hours or at 1°C to 6°C for up to 24 hours.¹⁴⁷ The blood so collected does not undergo any storage-related changes. The relative efficacy of ANH in comparison to other blood conservation techniques has been debated.^{146,148,149} The cost of ANH is significantly less than that of PAD because there is little incremental cost associated with collecting the blood and no required testing.¹⁴⁹

Intraoperative and Postoperative Salvage and Reinfusion

A third approach to autologous transfusion is the collection and retransfusion of blood lost during or after surgery.^{2,150} Perioperative salvage has been shown to be effective in reducing the need for allogeneic blood in a variety of surgical procedures. The AABB publishes Standards for Perioperative Autologous Blood Collection and Administration, which provide guidance for use of these blood conservation options.¹⁴⁷

There are two basic techniques available. Intraoperatively, an anticoagulated vacuum suction device can be used to collect blood from the surgical field and deliver it to a centrifuge-like device that washes the shed blood with saline before it is reinfused. Only red cells are salvaged by this method (platelets and plasma are lost). There has been concern about the safety of reinfusing materials suctioned from obstetric, cancerous, or contaminated surgical fields. Published experience to date, however, suggests that reinfusion of salvaged cells after processing with leukoreduction filters may be safe in these settings.¹⁵¹ Postoperatively, blood shed into joints or body cavities can be collected into sterile containers. The salvaged material must be filtered to remove fat and particles, and may then be reinfused either directly or after washing. The shed fluid contains red cell stroma, free hemoglobin, activated clotting factors, and fibrin degradation products.

P.556

It appears that there is not an increased risk associated with infusion of unwashed shed blood if the volume reinfused is limited to approximately 1 L. There is little value to salvaging shed blood in settings where the volume of fluid drained from the surgical site is small or has a low hematocrit. Because these devices are expensive, patient selection is important.¹⁵²

Erythropoiesis Stimulating Agents

Erythropoiesis stimulating agents (ESA) have been used to stimulate red cell production in patients, either to increase the number of units that can be collected preoperatively^{134,153,154} or to increase preoperative red cell mass.¹⁵⁵ The use of epoietin alfa has been approved to facilitate autologous blood donation in the European Union, Canada, and Japan, but not in the United States.¹⁵⁶ Epoietin alfa has also been approved for perisurgical use in anemic patients (Hgb ≤13 g/dl) in the US and Canada.

Artificial Oxygen Carriers

Some aspects that make the artificial oxygen carriers particularly appealing include: the prospect of being free of most or all of the infectious risks of allogeneic blood; no need to perform blood grouping and cross match; extended shelf life and possibility of storage at room temperature; the potential for a virtually unlimited supply; and the possibility of development of homogeneous and standardized products with controlled characteristics optimized to achieve the goal of oxygen delivery without raising all other complexities of allogeneic blood.^{157,158,159} and ¹⁶⁰ No artificial oxygen carrier is currently approved by the FDA for clinical human use in the US.

Perfluorocarbon (PFC) emulsions boost oxygen delivery by increasing the amount of dissolved oxygen. Use of these oxygen carriers must be coupled with oxygen and increased FiO_2 to further increase the amount of dissolved oxygen. The PFCs that reached clinical trials include Fluosol-DA (Alpha Therapeutics, Los Angeles, CA) and Oxygent (Alliance Pharmaceutical Corporation, San Diego, CA). Fluosol-DA was initially used to improve oxygen delivery to the heart muscle during percutaneous transluminal coronary angiography, but it was subsequently withdrawn because of difficulties in storage and preparation, and lack of utilization in angioplasty.

Hemoglobin-based oxygen carriers (HBOCs) increase the oxygen delivery by increasing total hemoglobin. Despite being an effective oxygen carrier, vasoconstriction (initially attributed to extravasation of the HBOC to interstitial space and scavenging nitric oxide)¹⁶¹, hypertension, and renal, pancreatic, and liver injury have been described as complications. Approaches such as purification, polymerization, cross-linking, conjugating with other macromolecules, and encapsulating in vesicles or other nanoparticles have been pursued to minimize toxicity and associated complications in subsequent generations of HBOCs.¹⁶²

A 2008 meta-analysis of 16 trials on 5 different HBOCs indicated that regardless of the individual product or indication studied, HBOCs are associated with significantly higher risk of death (relative risk of 1.30) and myocardial infarction (relative risk of 2.71) compared to the controls.^{163,164,165} A new generation of products is in development as “oxygen bridges” until anemia management via compensatory erythropoiesis with production of cellular hemoglobin can be achieved with the use of ESA and intravenous iron therapy.

USE OF BLOOD COMPONENTS

Table 21.1 lists the blood components available for clinical use and briefly summarizes the indications for the use of each. The use of each component is discussed in detail in the following sections.

Patient Informed Consent

Although approximately 14 million units of RBCs are transfused in the United States each year, their efficacy has never been demonstrated in well-designed trials. For purposes of obtaining the patient's informed consent, the treating physicians and patient must understand that not all is known about the relative risks and benefits of blood transfusion.

The elements of transfusion consent comprise: a discussion of blood transfusion risks^{166,167} and benefits; alternatives to blood; an opportunity to ask questions; and patient consent.¹⁶⁸ Consent should occur as far in advance of transfusion as possible, so that alternatives to allogeneic blood such as autologous blood can be made available. Some states have legislated that alternatives to allogeneic blood be offered to patients whenever there is a reasonable possibility that a blood transfusion may be necessary. It should also be noted that blood transfusion has been legislated to be a medical service not subject to commerce and trade laws, thus excluding the principle of implied warranty and granting blood banks immunity from strict product liability.¹⁶⁹

Patient Blood Management

Of the estimated 39 million discharges in the US in 2004, 5.8% (2.3 million) were associated with blood transfusion.¹⁷⁰ The rate of blood transfusion more than doubled from 1997 to 2009. Increased provider awareness of the costs associated with blood transfusion¹⁷¹ and recognition of the potential negative outcomes have stimulated initiatives in Patient Blood Management.¹⁷² Blood Management has been defined as the appropriate use of blood and blood components, with a goal of minimizing their use. This goal has been motivated historically by: 1) known blood risks; 2) unknown blood risks; 3) preservation of the national blood inventory; and 4) constraints from escalating costs.¹⁷²

Patient-focused blood management¹⁷³ is an evidence-based approach that is multidisciplinary (transfusion medicine specialists, surgeons, anesthesiologists, and critical care specialists) and multiprofessional (physicians, nurses, pump technologists, and pharmacists). Preventative strategies are emphasized to identify, evaluate, and manage anemia^{174,175} (e.g., pharmacologic therapy¹³⁹ and reduced iatrogenic blood losses from diagnostic testing)¹⁷⁶; to optimize hemostasis (e.g., pharmacologic therapy¹⁷⁷ and point of care testing)¹⁷⁸; and to establish decision thresholds (e.g., guidelines) for the appropriate administration of blood therapy (the impact of these activities on blood transfusion outcomes is illustrated in Figure 21.2.^{172,179,180}

In the US, The Joint Commission (TJC) developed Patient Blood Management Performance Measures which have been placed in their Topic Library. These are available to be used as additional patient safety activities and/or quality improvement projects by provider institutions.¹⁸¹

Patient Blood Management strategies for patients undergoing cardiac surgery have been shown to be safe and effective in reducing transfusion, while at the same time delivering high-quality outcomes. One institution reported that only 11% of

patients undergoing cardiac surgeries received blood transfusions; this program ranked first in their state for lowest risk-adjusted mortality.¹⁸²

RED CELL TRANSFUSION

The main indication for RBC transfusion is inadequate oxygen delivery as a result of anemia and, in some cases, hypovolemia. Wound healing is not impaired in the presence of anemia, and transfusion does not improve wound healing. Patients with chronic diseases should never be transfused simply because of mild asymptomatic anemia or as part of supportive care.

P.557

TABLE 21.1 BLOOD COMPONENTS AND INDICATIONS FOR USE

Component	Composition	Volume	Indications and Expected Benefit
Whole blood	RBC and plasma (approx. Hct, 40%); WBCs; platelets ^a	500 ml	To increase red cell mass and plasma volume (plasma deficient in labile clotting factors V and VIII); for hypovolemic anemia, massive transfusion, or exchange transfusion in neonates
Packed RBCs	RBC and reduced plasma (approx. Hct, 75%); WBCs; platelets ^a	250 ml	To increase red cell mass in symptomatic anemia; 10 ml/kg raises Hct by 10%
RBCs, adenine-saline added	RBC and 100 ml of additive solution (approx. Hct, 60%); WBCs; platelets ^a ; little plasma	330 ml	To increase red cell mass in symptomatic anemia; 10 ml/kg raises Hct by 8%
RBCs, leukocytes reduced (prepared by filtration)	>85% original volume of RBCs; <5 × 10 ⁶ WBCs	>85% of original volume	To increase red cell mass; <5 × 10 ⁶ WBCs to decrease the likelihood of febrile reactions, immunization to leukocytes (HLA antigens), or CMV transmission
RBCs, washed	RBCs (approx. Hct, 75%); reduced WBCs; no plasma	225 ml	To increase red cell mass; reduce risk of allergic reactions to plasma proteins; or reduce free potassium dose
RBCs, frozen	RBCs (approx. Hct, 75%);	225 ml	To increase red cell mass; minimize febrile or allergic transfusion reactions; use for prolonged RBC blood storage
RBCs, deglycerolized	<5 × 10 ⁶ WBCs; no platelets; no plasma		
Granulocytes, pheresis	Granulocytes (>1.0 × 10 ¹⁰ polymorphonuclear cells/unit); lymphocytes; platelets (>2.0 × 10 ¹¹ /unit); some RBCs	220 ml	To provide granulocytes for selected patients with sepsis and severe neutropenia (<0.5 × 10 ⁹ /L)
Platelet concentrates	Platelets (>5.5 × 10 ¹⁰ /unit); RBCs; WBCs; plasma	50 ml	Bleeding due to thrombocytopenia or thrombocytopathy; 1 unit/10 kg raises platelet count by 17-50 × 10 ⁹ /L

Platelets, pheresis	Platelets ($>3 \times 10^{11}$ /unit); RBCs; WBCs; plasma	300 ml	Same as platelets; sometimes HLA-matched; benefit is equivalent to 6 platelet concentrates
Platelets, leukocytes reduced	Platelets (as above); $<5 \times 10^6$ WBCs/final dose of pooled or pheresis platelets	300 ml	Same as platelets; $<5 \times 10^6$ WBCs to decrease the likelihood of febrile reactions, alloimmunization to leukocytes (HLA antigens), or CMV transmission
FFP; thawed plasma	FFP: all coagulation factors; thawed plasma: reduced factors V and VIII	200 ml	Treatment of some coagulation disorders; 10 ml/kg of FFP raises factor levels by approximately 10%
Cryoprecipitated antihemophilic factor	Fibrinogen; factors VIII and XIII; von Willebrand factor	15 ml	Deficiency of fibrinogen, 1 unit/5 kg raises fibrinogen 70 mg/dl; also used for factor XIII replacement; not first-choice therapy for hemophilia A, von Willebrand disease, topical fibrin sealant

approx., approximate; CMV, cytomegalovirus; FFP, fresh frozen plasma; Hct, hematocrit; RBC, red blood cell; WBC, white blood cell.

^aWBCs and platelets are nonfunctional.

Modified from Triulzi DJ, ed. Blood transfusion therapy: a physician's handbook, 7th ed. Bethesda, MD: American Association of Blood Banks, 2002.

Indications for Red Blood Cell Therapy

The therapeutic goal of a blood transfusion is to improve oxygen delivery according to the physiologic need of the recipient. The usual response to an acute reduction in hemoglobin in the normovolemic state is to increase cardiac output to maintain adequate oxygen delivery.¹⁸³ The heart is the principal organ at risk in acute anemia. In a normal heart, increased lactate production and an oxygen extraction ratio of 50% occur at a hemoglobin of approximately 3.5 to 4 g/dl.¹⁸⁴ In a model of coronary stenosis, the anaerobic state occurs at a hemoglobin of approximately 6 to 7 g/dl.¹⁸⁵ No single number, either extraction ratio or hemoglobin, can serve as an absolute indicator of transfusion need. However, the use of a physiologic value in conjunction with clinical assessment of the patient status would permit a rational decision regarding the appropriateness of transfusion before the onset of hypoxia or ischemia.¹⁸⁶

Literature on mortality in surgical patients refusing transfusion provides insight into the circumstances in which transfusion may be of benefit. In a review of 16 reports of the surgical outcomes in Jehovah's Witness patients who underwent major surgery without blood transfusion, mortality associated with anemia occurred in only 1.4% of the 1,404 operations.¹⁸⁷ A more detailed analysis of 61 studies of Jehovah's Witness patients found that, with the exception of three patients who died after cardiac surgery, all deaths attributed to anemia occurred in patients with hemoglobin ≤ 5 g/dl.¹⁸⁸ In one large study of surgical patients refusing transfusion, the risk of death was found to be higher in patients with cardiovascular disease than in those without.¹⁸⁹ A subsequent analysis¹⁹⁰ found that although the risk of death was low in patients with postoperative hemoglobin levels of 7.1 to 8.0 g/dl, morbidity occurred in 9.4%; the odds of death in patients with a postoperative hemoglobin level ≤ 8 g/dl increased 2.5 times for each gram decrease in hemoglobin level.¹⁹⁰

A large retrospective study of elderly patients who underwent surgical repair of hip fracture found that transfusion of patients with hemoglobin levels ≥ 8 g/dl did not influence 30-day or

P.558

90-day mortality.¹⁹¹ This was confirmed by a subsequent¹⁹² randomized, prospective study. Prospective, randomized trials in patients undergoing cardiac surgery¹⁹³ and receiving critical care¹⁹⁴ have each demonstrated that such patients can tolerate anemia without transfusion to hemoglobin levels between 7 and 8 g/dl, with equivalent clinical outcomes comparable to patients maintained at hemoglobin levels of greater than 10 g/dl. A Cochrane meta-analysis of prospective

randomized trials comparing “high” versus “low” hemoglobin thresholds on more than 3700 patients¹⁹⁵ found that a hemoglobin of 7 g/dl was sufficient for the majority of patients.

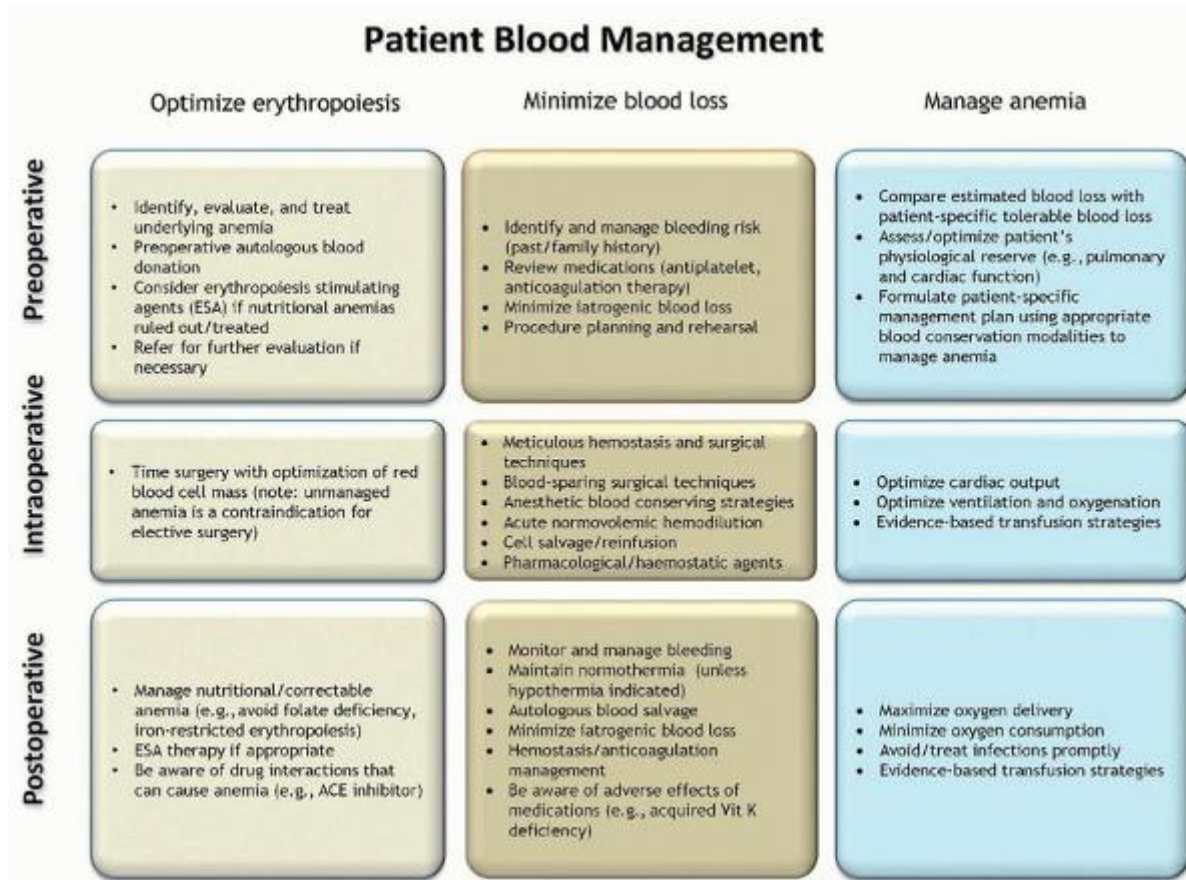

FIGURE 21.2. Patient blood management. These principles applied in the perisurgical period enable treating physicians to have the time and tools to provide patient-centered evidenced-based patient blood management in order to minimize allogeneic blood transfusions. (From Goodnough LT, Shander A. Patient blood management. *Anesthesiology* 2012;116:1367-1376, with permission.)

AABB clinical practice guidelines suggest that patients should not be transfused with red blood cells, in the absence of symptoms/signs of anemia, unless the Hgb concentration is less than 7 to 8 g/dl, or less than 8 g/dl for patients with symptoms or known to have cardiovascular disease.¹⁹⁶ Comprehensive blood management guidelines from the Societies of Thoracic Surgeons and Cardiovascular Anesthesiologists contain similar recommendations, suggesting that RBC transfusion may be life-saving when hemoglobin is less than 6 and is reasonable in most patients when hemoglobin is less than 7.¹⁹⁷ However, it is unlikely that a hemoglobin value alone should serve as a “transfusion trigger;” patients should be managed, rather than laboratory values.¹⁹⁸

Red Cell Transfusion in Specific Settings

Massive Hemorrhage

One of the major indications for blood transfusion is the restoration of circulating blood elements after the loss of large amounts of blood (Table 21.2).¹⁹⁹ In general, adults who lose <20% of their blood volume (or approximately 1 L) do well without red cell transfusion, providing that fluid resuscitation is adequate to maintain the circulating blood volume and that further blood loss is avoided. Young healthy patients can sustain losses of up to 30% to 40% of blood volume as long as intravascular blood volume is adequately maintained with intravenous (IV) fluids.

Massive hemorrhage is generally defined as transfusion of more than 10 U of RBC (one complete blood volume replacement) within 24 hours. Massive hemorrhage is a common complication in a number of clinical settings. In traumatic injury, hemorrhage is a major cause of morbidity and is responsible for almost 50% of deaths occurring within 24 hours of injury and up to 80% of intraoperative trauma mortalities.^{200,201} and ²⁰² In addition, cardiovascular and hepatobiliary procedures can frequently result in massive bleeding^{203,204}; postpartum hemorrhage events can complicate

labor and delivery; and diverticulosis or varices can lead to significant gastrointestinal bleeding.^{204,205,206} and ²⁰⁷ Blood component support before and after control of massive hemorrhage is critical in these

P.559

scenarios.²⁰⁶ Despite the need for consensus on the management of patients with massive bleeding, currently no such consensus exists.

TABLE 21.2 CLINICAL SIGNS OF BLOOD LOSS

Volume Lost		Clinical Signs
ml	% of Blood Volume	
500	10	None; occasionally vasovagal syncope
1,000	20	At rest, there may be no clinical evidence of volume loss; a slight postural drop in blood pressure may be seen; tachycardia with exercise
1,500	30	Resting supine blood pressure and pulse may be normal; neck veins flat when supine; postural hypotension
2,000	40	Central venous pressure, cardiac output, systolic blood pressure below normal even when supine and at rest; air hunger, cold clammy skin; tachycardia
2,500	50	Signs of shock; tachycardia, hypotension, oliguria, drowsiness, or coma

An estimated 10% of military trauma patients and 3% to 5% of civilian trauma patients receive massive transfusions (MTs).^{205,208,209} Within the standard definition of massive hemorrhage there appears to be an important subset of patients who may benefit from blood components in addition to RBCs, specifically, those with rapid massive bleeding.²¹⁰ Both Moore et al.²¹⁰ and Holcomb et al.²⁰⁵ demonstrated that patients receiving 10 U of RBCs in the first 6 hours after injury had a higher rate of mortality than those receiving the same quantity of RBCs over a 24-hour period. Early identification of this patient population and specific massive transfusion (MT) support strategies involving multiple blood components have been associated with improved survival.²¹¹

In response, transfusion services have implemented protocols to quickly and efficiently provide packages of blood products to patients with massive hemorrhage. There are a number of criteria available to help evaluate the effectiveness of different strategies used by transfusion services. Evaluation of the effectiveness of these protocols should include several parameters: clinical outcomes (survival, length of hospital stay, multisystem organ failure, infection rate, etc); post-resuscitation laboratory parameters (hemoglobin, prothrombin time [PT], partial thromboplastin time [PTT], fibrinogen, and PLT count); and 24-hour blood component and crystalloid use. A recent review summarizes the literature to date, highlights some of the limitations of the available evidence, and identifies areas in need of additional study.²¹²

Recent data from the US Army's Institute of Surgical Research have shown improvement in outcomes when soldiers requiring MTs received resuscitations with ratios of component types that were similar to whole blood transfusions.^{213,214} Subsequent reports, primarily in the military literature, further support a component therapy transfusion in ratios of 1 U RBC/1 U plasma/1 random donor unit of PLTs.^{205,215,216} and ²¹⁷ However, these are retrospective studies, with a survivorship bias.^{205,215,216} and ²¹⁷ The military data also lack adjustment for confounding variables such as injury severity.^{205,215,216} and ²¹⁷ Nevertheless, these data have led to widespread support of this ratio, particularly the 1:1 ratio of RBC/plasma, although considerable debate remains on this topic.^{218,219} and ²²⁰

Civilian trauma studies have also evaluated the impact of more aggressive ratios and noted an association with improved survival with use of MT protocols.^{221,222,223} and ²²⁴ Similar to the military data, such studies also support using a more aggressive RBC/plasma ratio, reporting a significant reduction (41% vs 62%) in 30-day mortality as compared with those that received less plasma.²²⁵ This was independent of age and Trauma Related Injury Severity Score, which by themselves were independent predictors of mortality.²²⁵

Several studies have called into question the benefit of higher plasma ratios.^{223,226} Nevertheless, the cumulative data appear to support early, proactive support with high ratios of plasma to RBC along with additional support with platelets.^{218,219} Not all studies showed a mortality benefit, and in the absence of randomized trials, data to convincingly support a particular ratio or formula are needed. However, the existing data suggest that a well-organized MT protocol

that is activated in a timely fashion is likely to demonstrate improved patient outcomes and result in less overall blood product usage in large trauma centers.^{218,219}

Elective Surgery

In preparation for surgery, preoperative requests for typed and crossmatched blood should be based on the predetermined likelihood of a procedure requiring a blood transfusion. "Maximum surgical blood order schedules" or "standard blood orders" specify the number of units that should be crossmatched for a variety of procedures and include guidelines for pretransfusion assessment.^{227,228} A pretransfusion request for type and crossmatch should be sent to the blood bank if it is likely ($\geq 10\%$ probability) that blood will be required for a specific surgical procedure. The request should be for a type and screen if it is unlikely ($< 10\%$) that the patient will require blood. As discussed previously under patient blood management, preoperative evaluation and management of anemia to correct deficits in red cell mass is the single most important determinant of the likelihood of perioperative blood transfusions.¹⁷²

Nutritional Deficiencies and Other Anemic States

RBCs are often transfused in the management of various types of anemia. Published guidelines (see above) advise transfusing on the basis of clinical indications. Physiologic adaptations to anemia, including elevated red cell 2,3-DPG content and increased cardiac output, compensate to preserve oxygen transport and delivery to a significant extent in chronic anemias. Transfusion is rarely indicated in these patients if there is time to correct anemia with alternative therapies.

Patients who are anemic solely because of deficiency of iron, folate, or B₁₂ rarely require transfusion. Patients with "lifethreatening" anemia (Hgb < 6.5 g/dl) by WHO (World Health Organization) and NCI (National Cancer Institute) criteria may require transfusion.²²⁹ Elderly patients who present with pernicious or severe iron deficiency anemia may require red cell transfusion, particularly when angina or congestive heart failure has been the cause of the patient seeking medical attention. Iron-deficient patients who are also bleeding actively (e.g., from the gastrointestinal tract) may also require red cell transfusion. In such situations, the goal of transfusion is not to correct the patient's hemoglobin concentration, but to raise it sufficiently to stabilize the patient until specific therapy can be administered.

Hemolytic Anemias

Patients with acute or chronic hemolytic anemias may require red cell transfusion; often, this need arises at the time of a hemolytic or aplastic crisis. Such patients are often critically ill, and safe transfusion requires careful clinical attention. In autoimmune hemolytic anemia,^{230,231} the clinician may be faced with a severely anemic patient for whom crossmatch-compatible blood cannot be obtained. These patients produce an antibody that

P.560

reacts with all RBCs including their own, and the transfusion of serologically incompatible red cells may be necessary. At a hemoglobin < 6 g/dl, most patients require transfusion. In these cases, withholding transfusion in the absence of "compatible" RBCs places the patient in needless danger. Although "incompatible" cells will have a shorter than normal lifespan, transfusion reactions are infrequent. The risk of complications is increased if the patient has brisk hemolysis and a large volume of blood is infused, or if the patient has an undetected alloantibody in addition to the autoantibody. If time allows, special techniques should be used to evaluate these patients for alloantibodies prior to transfusion (see "Autoagglutination"). Consultation with a transfusion medicine specialist is recommended in these cases.

Hypoproliferative Anemias

In aplastic and sideroblastic anemias, myelodysplastic states, and myelofibrosis, patients often depend on regular transfusion of red cells and may die of transfusion-induced iron overload after several years of such support unless precautions are taken to remove iron. The development and use of erythropoiesis stimulating agents have reduced the need for transfusion in many patients with hypoproliferative anemia, such as those with end-stage kidney disease (see Chapter 41) and in patients with chemotherapy-induced anemia.²³²

Hereditary Red Cell Disorders

In children with thalassemia (see Chapter 34), bone marrow hyperplasia with its undesirable effects on the skeleton may be ameliorated, and iron absorption decreased, by regular transfusions to maintain a near-normal hemoglobin concentration.²³³ Such a program is possible only in conjunction with an aggressive iron chelation program, as the iron load otherwise leads to fatal hemosiderosis. In patients with sickle cell disease and vaso-occlusive crises (see Chapter 33), the adverse microvascular effects of sickle cells can be relieved temporarily by hydration with crystalloid therapy to

restore intravascular volume, rather than with RBC transfusions (to avoid chronically unnecessary risks of alloimmunization and iron overload). Red cell exchange may be indicated when impaired oxygenation leads to <90% O₂ saturation, in order to address the generation of sickle cells in acute chest syndromes. A multicenter trial (STOP trial) showed a significant decrease in the incidence of stroke in patients with abnormal transcranial Doppler studies who were treated with simple or exchange transfusions to maintain their hemoglobin S concentrations <30%, compared to patients who remained on standard supportive care with transfusion only when clinically indicated.²³⁴

Pretransfusion Testing of Red Cells

Compatibility Testing Process

The process of selecting red cells for transfusion involves three stages. Blood grouping involves determination of the ABO group and Rh type of both recipient and donor specimens. The recipient's serum or plasma is screened for the presence of unexpected red cell antibodies. Crossmatching, either serologically or electronically, after selection of a donor unit of the appropriate group and type determines whether the donor cells are compatible with the recipient's plasma.

Properly selected blood products will be compatible with the recipient, indicating that transfusion should not result in hemolysis of donor red cells. Because only the ABO and Rh(D) red cell antigens are prophylactically matched in routine transfusion practice, there are always significant antigenic differences between donor and recipient, both for red cells and for the accompanying leukocytes, platelets, and plasma. Repeated exposure to foreign antigens with chronic transfusion or pregnancy may result in antibody formation in the recipient.

There is no room for error in the provision of blood for transfusion. If clerical or laboratory error results in donor and recipient being mismatched for the ABO group, transfusion of even a few milliliters of red cells may lead to a life-threatening transfusion reaction with shock, intravascular coagulation, and acute renal failure. Such reactions are uncommon because of rigid adherence to a routine designed to maximize safety at all levels of the transfusion process; however, with the decrease in the risk of transfusion-transmitted infections, such reactions are becoming one of the leading risks of transfusion.^{166,235} Careful identification of the patient for whom the blood is ordered, including complete labeling of the specimen at the bedside of that patient, is essential. Careful ABO blood grouping along with comparing results of ABO testing with historical records for each patient adds to the level of safety. Ensuring positive identification of crossmatched units of blood and verifying that the information identifying the unit with the intended recipient is reviewed in the presence of that recipient before the administration of the blood are crucial.^{2,5}

Blood Grouping

The presence of ABO antigens is determined by testing the unknown RBCs with anti-A and anti-B sera by one of a variety of methods including slide, tube, gel, or microplate tests.² Identifying which ABO antigens are on the surface of an individual's RBCs is called the forward grouping or forward typing. Cells agglutinated only with anti-A serum are group A; those reacting only with anti-B are group B. Those reacting with both antisera are group AB, and red cells that fail to agglutinate with either anti-A or anti-B are group O.

“Reverse grouping” or “reverse typing” should be performed to confirm the reaction obtained by the forward grouping test. This involves testing the reactions of the serum or plasma from the person of unknown type with reagent red cells of known A and B type. Agglutination of the red cells indicates the presence of anti-A or anti-B in the individual's serum. The conclusions of forward and reverse tests should agree as shown in Table 21.3.

The antisera used in blood group antigen detection can be obtained from donors with naturally occurring high levels of antibodies, from people or animals specifically stimulated to produce antibodies against blood groups, or from monoclonal antibodies of mouse or human origin. The advantages of monoclonal antibodies include their high quality and stability and their ease of production in large quantities. Antisera must be of known specificity and potency, and control testing must be done on a routine basis.²

The Rh type of red cells is determined by examining the cells' reaction with anti-D serum from commercial sources. Commercial

P.561

antisera may be modified by the manufacturer with the addition of high concentrations of protein or by chemically altering the immunoglobulin (Ig) G molecules in such a way that they perform as direct agglutinins in the laboratory. This permits rapid, reliable testing to determine the D antigen status of the cells. However, these high-protein reagents may cause false positive reactions because of spontaneous aggregation of some red cells in their presence. If this happens, an

Rh-negative patient could be typed as Rh-positive if the recommended Rh control is not tested simultaneously. This problem has led to the development of low-protein, saline-reactive monoclonal reagents. Monoclonal anti-D reagents contain both human IgM and polyclonal IgG antibodies and are currently most widely used. They can also be used in the antiglobulin test for weak D. As with all reagents, the manufacturers' instructions must be followed.²

TABLE 21.3 ABO GROUPING

Patient Blood Group	Expected Reactions of			
	Anti-A	Anti-B	A Cells	B Cells
O	None	None	+	+
A	+	None	None	+
B	None	+	+	None
AB	+	+	None	None

Red cells reacting weakly with anti-D reagents are called weak D. If donor blood is being tested, the absence of D must be confirmed. If the initial test for D is negative, a second, more sensitive test must be performed using a method that detects weak D. If D is detected by either method, the unit is labeled Rh-positive.^{2,5} In patients, testing for weak D is not required. Patients who are typed as Rh-negative, but who are really weak D-positive, will not be adversely affected by the transfusion of Rh-negative products. Patients known to be weak D-positive, however, may be given Rh-positive donor blood. Before concluding that a patient is weak D-positive, care must be taken to ensure that the patient has not recently been transfused with Rh-positive red cells or experienced a large fetal-maternal hemorrhage.

Testing for Red Cell Antibodies

Antibodies in potential blood transfusion recipients fall into several categories. The most common blood group antibodies that are clinically significant and may be implicated in hemolytic transfusion reactions or hemolytic disease of the newborn are shown in Table 21.4.

TABLE 21.4 SIGNIFICANCE OF CERTAIN BLOOD GROUP ANTIBODIES

Blood Group System	Antibody	Relative Frequency in Antibody Screening	Clinical Significance	
			Hemolytic Transfusion Reaction	Hemolytic Disease of the Newborn
ABO	Anti-A	All group B and O	Yes	Yes
	Anti-B	All group A and O	Yes	Yes
Rhesus	Anti-D	Common	Yes	Yes
	Anti-c	Common	Yes	Yes
	Anti-E	Common	Yes	Yes
	Anti-C	Common	Yes	Yes
	Anti-e	Uncommon	Yes	Yes
Kell	Anti-K	Common	Yes	Yes
	Anti-k	Rare	Yes	Yes
Kidd	Anti-Jka	Common	Yes	Yes
	Anti-Jkb	Rare	Yes	Yes
Duffy	Anti-Fya	Common	Yes	Yes
	Anti-Fyb	Uncommon	Yes	Yes

MNS	Anti-M	Common	Rare	Rare
	Anti-N	Rare	Rare	Rare
	Anti-S	Uncommon	Yes	Yes
	Anti-s	Rare	Yes	Yes
Lewis	Anti-Lea	Common	Yes	No
	Anti-Leb	Uncommon	No	No
P	Anti-P1	Common	Rare	No
Ii	Anti-I	Uncommon	No	No

All human plasmas contain naturally occurring antibodies that react with the complementary antigens of the ABH system. These are of great importance in transfusion, as they are complementfixing IgM antibodies; transfusion of incompatible red cells leads to immediate hemolytic reactions. Many people also have naturally occurring antibodies (usually low-titer IgM antibodies reacting at or below room temperature) that react with some antigens of the Lewis, P, Ii, MN, or other systems; these are rarely active above room temperature and are only occasionally important in transfusion. Finally, people exposed to foreign red cells by prior transfusion or pregnancy may produce IgG antibodies to antigens of certain other systems, primarily Rh (C, c, D, E, e), Kell, Duffy, Kidd, and Ss, but many less common possibilities exist. These red cell antibodies are clinically significant. They do not often lead to intravascular hemolytic reactions, but transfused incompatible red cells may exhibit decreased survival caused by increased clearance in the reticuloendothelial system. Many of these IgG antibodies can also cause hemolytic disease of the fetus and newborn.^{2,236}

There are two major classes of antibodies that react with red cells. Complete or saline antibodies agglutinate red cells suspended in saline solution; these are usually IgM. Antibodies that do not react visibly in saline and are capable of producing agglutination reactions only with special techniques to make their interaction with red cells detectable are called incomplete agglutinins; these are generally IgG antibodies.

The best example of a room temperature saline agglutination test is that used in ABO grouping. Other red cell antibodies that are readily detected in saline suspension are those belonging to

P.562

the Lewis, MN, P, and Ii blood group systems. With the important exception of ABO system antibodies, many of the others detected with this test are of no clinical significance, as they are not reactive at 37°C.

The best examples of incomplete agglutinins, or IgG antibodies, are those that react with antigens of the Rh system. If such antibodies are not detected in the recipient, immediate hemolysis of transfused, incompatible red cells is extremely rare. However, their presence may lead to a significantly decreased survival of transfused cells and the development of an extravascular hemolytic syndrome (delayed hemolytic transfusion reaction [DHTR]).

Antiglobulin Test

The antiglobulin (Coombs) test (Figs. 21.3 and 21.4) is based on the reaction between an antihuman globulin (AHG) reagent and antibody- or complement-coated red cells. AHG reagents are commercially available and are prepared either by the injection of an animal with human globulin or through hybridoma technology. AHG reagents may be polyspecific or monospecific. The polyspecific reagents contain antibodies with both antihuman IgG and anticomplement activity. Monospecific AHG reagents, anti-IgG, anti-C3b, and anti-C3d, are used to determine which protein is responsible for a positive direct antiglobulin test.²

The direct antiglobulin test is performed by washing the patient's cells with saline, adding polyspecific AHG, and observing for agglutination (Fig. 21.3). Positive reactions (agglutination) suggest the presence of IgG antibodies or complement bound to the red cell.² The indirect antiglobulin test is used to determine the presence of red cell antibodies in serum or plasma (Fig. 21.4). Reagent red cells are incubated with the patient's serum or plasma, washed to remove unbound immunoglobulins, mixed with AHG (usually monospecific anti-IgG), and then centrifuged briefly. The cell button is gently resuspended and examined for agglutination. A positive reaction suggests that IgG antibodies in the patient's plasma have bound to the reagent cells. A positive indirect antiglobulin test therefore indicates the presence of antibodies capable of reacting with red cells and possibly capable of hemolyzing such cells if they were transfused.

Direct and indirect antiglobulin tests are the simplest approaches to the detection of IgG anti-red cell antibodies. Because many of these serologic reactions are rather weak, the addition of various media has been used to enhance the agglutination reaction. These tests involve procedures that diminish the mutually repulsive electrostatic forces between red cells, permitting visible agglutination by IgG antibodies.² Antigens that often require such enhancing tests include those of the Kidd (Jk^a and Jk^b), Rh (D, C, E, c, e), Kell, and Duffy (Fy^a and Fy^b) systems.

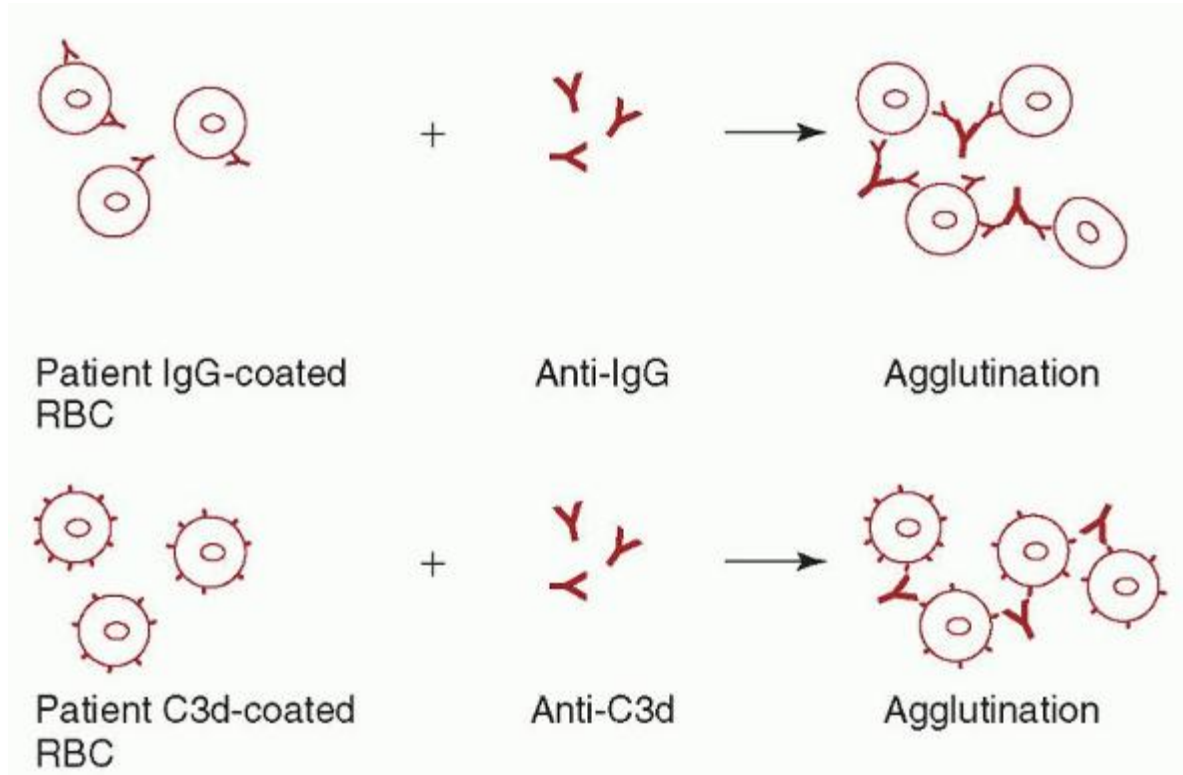

FIGURE 21.3. Direct antiglobulin test with anti-immunoglobulin G (IgG) and anti-C3d. RBC, red blood cell. (Reprinted from Jeter EK, Spivey MA. Pretransfusion testing. In: Jeter EK, ed. Introduction to transfusion medicine: a case study approach. Bethesda, MD: American Association of Blood Banks Press, 1996;56, with permission.)

Media That Enhance Agglutination

Adding albumin, low-ionic-strength saline (LISS) or polyethylene glycol (PEG) solutions to antibody identification tests can enhance the sensitivity of the test system.²³⁷ These solutions augment the antibody-antigen interaction in a variety of ways, enhancing the detection of weak or otherwise undetectable antibodies. Treating reagent red cells with proteolytic enzymes such as papain or ficin also increases the sensitivity for some antibodies such as those reacting with Rh and Kidd system antigens. These enzyme reagents weaken or destroy other red cell antigens (M, N, Fy^a, Fy^b, and, in some cases, S, s)—a trait that can be helpful in the identification of multiple red cell antibodies in a single serum sample.²

Other Antibody Identification Tests

Sera containing several antibodies may be analyzed by absorbing with one or more selected red cells.^{2,236} Antibodies so adsorbed may be eluted from the cells, and their specificity may be determined. Alternatively, the specificity of antibodies not absorbed and remaining in the supernatant can be identified. When necessary, the identity of certain antibodies may be confirmed by their inhibition by soluble antigens, such as A, B, and Lewis substances present in the saliva of secretors. Neonatal (cord) red cells exhibit a number of antigens very weakly and may be used to investigate antibody specificity.

Selection of Red Cells for Transfusion

A series of serologic tests is used to select donor blood for patients. Although individual transfusion services prefer different specific methods, the general principles of compatibility testing are the same.

A properly labeled, fresh sample of patient blood must be provided. If the patient has been transfused or has been pregnant within the preceding 3 months, the specimen must be obtained within 3 days of the anticipated transfusion.⁵

Donor

The ABO group of the donor unit must be confirmed. The donor unit Rh typing must also be repeated if the unit is labeled as Rh-negative. These tests are performed to confirm the blood group and to ensure that the unit has not been mislabeled.

Recipient

The recipient's ABO group and Rh type must be determined. The recipient's serum is screened for the presence of antibodies that may have been induced by prior pregnancy or transfusion. A set of commercially prepared group O red cells, expressing 18 clinically relevant antigens (D, C, E, c, e, M, N, S, s, P₁, Le^a, Le^b, K, k, Fy^a, Fy^b, Jk^a, and Jk^b), is used in this test in accordance with FDA rules. The use of group O reagent red cells avoids agglutination by anti-A or anti-B. These reagent cells are incubated with the patient's serum and tested with the indirect antiglobulin test for reactions indicating the presence of antibody in the serum.²

If such screening reactions are positive, the antibody specificity can be determined by reaction of the serum with a commercially prepared panel of reagent red cells of known antigenic composition. If an antibody has been found on the screen and the patient's clinical status allows, it is best to withhold transfusion until identification is complete. The incidence of unexpected RBC antibodies in patients requiring transfusion is low.^{238,239}

P.563

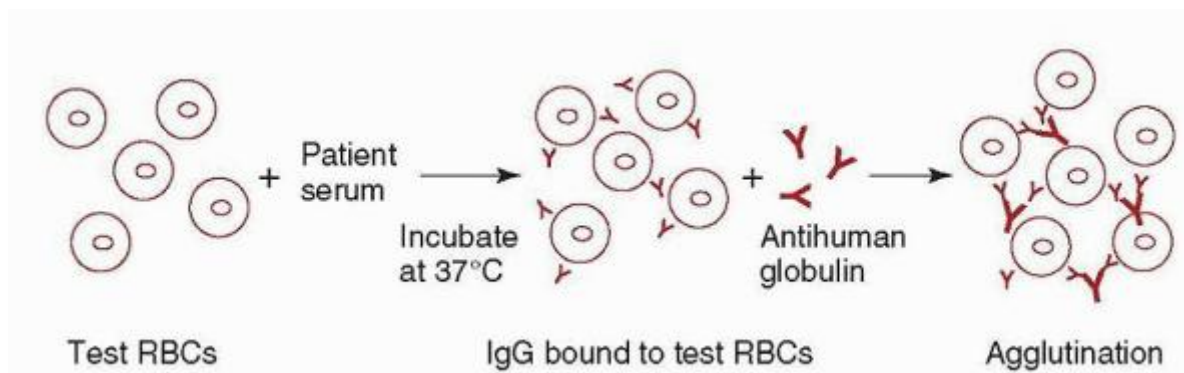

FIGURE 21.4. Indirect antiglobulin test. IgG, immunoglobulin G; RBC, red blood cell. (Reprinted from Jeter EK, Spivey MA. Pretransfusion testing. In: Jeter EK, ed. Introduction to transfusion medicine: a case study approach. Bethesda, MD: American Association of Blood Banks Press, 1996;56, with permission.)

Type and Screen

If it is unlikely that blood will be required, for example, for a surgical procedure with <10% likelihood of transfusion, a "type and screen" rather than a crossmatch should be requested. In this instance, the blood bank types the patient's blood and screens for unexpected antibodies; if antibodies are not found, the blood bank ensures that blood of the appropriate group is available for transfusion if necessary. In such an event, a telephone call can trigger a rapid crossmatch test and blood will be available with minimal delay. The appropriate use of type and screen improves the efficiency of the blood bank. It assists in inventory control by not segregating blood for patients who are unlikely to require it and is therefore more cost-effective.

Crossmatch

If no antibody has been detected on the screen and there is no record of the previous presence of a clinically significant antibody, only verification of ABO compatibility between the donor unit and recipient is required before transfusion. This can be done either by an immediate spin crossmatch or a computer crossmatch.

The immediate spin crossmatch consists of mixing the patient's serum with donor saline-suspended red cells at room temperature, spinning the tube, and reading the results immediately. The purpose of this test is to detect ABO incompatibility due to the presence of anti-A, anti-B, or both, in the patient's serum.²

The conditions for computer or "electronic" crossmatch are outlined in the AABB standards.⁵ Briefly, the computer system must be validated to prevent release of ABO-incompatible blood. This computer crossmatch can be used only for patients who do not have a record of clinically significant antibodies. The recipient's ABO blood group must have been determined

on at least two separate tests. The system must contain complete information on the donor unit and the recipient, including ABO group and Rh type. Data entered must be verified as correct before the release of blood. The system must contain logic to alert the user to discrepancies for either the donor unit or the recipient, including unit labeling, blood grouping, and ABO incompatibilities.

If a clinically significant red cell antibody has been found when a patient's plasma or serum is screened for unexpected antibodies, antibody identification should be performed. Once the antibody specificity has been identified, donor units that lack the corresponding antigen should be selected, and a crossmatch using an indirect antiglobulin test should be performed on each unit to ensure compatibility. The physician should also be advised about the nature of the problem, as well as the potential for delays if further units are required.

Once a unit of blood is crossmatched for a patient, there must be positive identification of the patient and the blood product both in the laboratory before release of a blood product to the nursing ward as well as at the patient's bedside by the transfusionist. Before every transfusion, the requisition, the label on the blood product, and the patient's identification must be checked. These aspects of patient and blood product identification are critical safety steps and must be documented.⁵

Uncrossmatched Blood for Emergency Transfusion

For patients in hemorrhagic shock, it is necessary to transfuse blood immediately, and no blood bank testing should be attempted before emergency transfusion. The risk of transfusing group O "uncrossmatched" red cells is extremely low and is certainly much lower than the risk of the patient's death if blood transfusion is delayed. If a patient is to be given uncrossmatched blood, a specimen of the patient's blood should be obtained prior to transfusion so that typing and screening can be performed while the transfusion is proceeding.

Once the patient's blood group has been determined, ABO group-compatible uncrossmatched blood may be used.⁵ Until the patient's Rh type is determined, uncrossmatched blood should be Rh(D)-negative when used in women of childbearing age, in whom sensitization to D would be undesirable. As Rh-negative blood is often in limited supply, Rh-positive blood is often used for emergency transfusion of older females and of males of unknown blood group. In such cases, sensitization may occur, but the risk of an immediate hemolytic reaction is low.²³⁶

Despite the lack of a crossmatch, transfusion of group-specific blood under emergency situations is safe. The incidence of red cell alloantibodies in healthy people is low, and most such antibodies do not cause dangerous acute intravascular hemolytic transfusion reactions. However, the decision to use uncrossmatched blood is the responsibility of the attending physician, who must weigh the risks against the expected benefits and document in the patient's record the need for the uncrossmatched blood.

Table 21.5 outlines the selection of blood and plasma by ABO type. If the blood group is known, group-compatible red cells and plasma can be selected. If the blood group is not known, group O

P.564

red cells should be used; if plasma is required, group AB plasma should be used because it contains no anti-A or anti-B.

TABLE 21.5 SELECTION OF BLOOD AND PLASMA BY ABO TYPE

Component	Recipient ABO Type	Selection of Blood Component	
		Preferred	Alternate
Red blood cells	O	O	None
	A	A	O
	B	B	O
	AB	AB	A, B, O
Fresh frozen plasma	O	O	A, B, AB
	A	A	AB
	B	B	AB

AB

AB

None

Modified from Jeter EK, Spivey MA. Introduction to transfusion medicine: a case study approach. Bethesda, MD: American Association of Blood Banks Press, 1996.

Crossmatching Problems

Standard serologic techniques often depend on agglutination as an end point. There are several agglutinating phenomena that can interfere with the correct interpretation of these serologic tests and may delay antibody identification and crossmatching. Pseudoagglutination refers to red cell clumping (rouleaux formation) that typically occurs in the presence of dysproteinemias, or after the administration of dextran or hydroxyethyl starch. Dilution in saline abolishes the reaction.^{2,236} Autoagglutination refers to red cell agglutination by the patient's own serum or plasma and often indicates the presence of a cold agglutinin. Washing patient red cells with warm saline can often remove enough of the antibodies so testing can be completed.² Polyagglutination is the phenomenon in which a patient's red cells are agglutinated by most or all group-compatible sera. During bacterial or viral infections, enzymes of the infecting organism can cause alteration of antigenic structures on the red cell membrane, exposing previously hidden antigens such as T, or more rarely, Tn.²³⁶ Most adult sera contain naturally acquired antibodies capable of reacting with these determinants. The situation may be elucidated by testing the patient's red cells with cord serum, which lacks the antibodies necessary for this reaction, and by examining for reactions with plant lectins that have specific activity with the antigens involved in polyagglutination.^{240,241}

Red Cell Autoantibodies

A positive indirect antiglobulin test against all screening and donor red cells often indicates the presence of an IgG, warm-reacting autoantibody. The patient's direct antiglobulin test is also positive. Such autoantibodies may preclude the identification of any serologically compatible donor units. If red cells are transfused, it is essential that ABO compatibility be ensured. The patient's serum should be screened for alloantibodies that might be masked by the autoantibody.^{2,230,231,242,243} Such screening requires the removal of the autoantibody from the patient's serum, so that any alloantibodies present can be identified. If the patient has not been transfused within the last 3 to 4 months, this can be done by absorbing autoantibody from the serum with autologous red cells, from which already attached antibody has been removed by enzyme or chemical treatment.² Alternatively, autoantibody may be removed by absorption with a panel of cells selected to lack the antigens to which the patient may become alloimmunized. The autoantibody-depleted serum can then be examined for the presence of residual alloantibodies, and a serologic crossmatch can be done. If only the autoreactive antibody is present, transfusion of red cells is generally well tolerated.

Alloantibody to High-incidence Antigens

Occasionally, a patient may have a red cell antibody that does not react with the patient's own cells but reacts with all donor red cells. Identification of these antibodies is particularly challenging, requiring rare cells that lack common red cell antigens. Assistance of specialized laboratories may be needed both to identify the antibody to a high-incidence antigen as well as to locate compatible blood. In some of these cases, it is not clear whether the antibody is likely to cause significant hemolysis. The utilization of DNA-based methodologies to identify donors with rare blood types is a useful tool in these challenging situations.²⁴⁴

Drugs

Some drugs may stimulate an autoantibody in the patient that reacts with all reagent cells tested as well as with donor red cell units crossmatched. Drugs implicated include α -methyl dopa, levodopa, fludarabine, and procainamide.² In some cases, the *in vitro* findings may be identical to those found in autoimmune hemolytic anemias. The presence of these antibodies may or may not be clinically significant but may result in a delay if a transfusion is required. In most cases, however, drug-induced antibodies are associated with a positive direct antiglobulin test that is not part of the standard pretransfusion or crossmatch testing, and the indirect antiglobulin test is negative. The mechanisms of drug-induced hemolytic anemias are discussed in Chapter 29.

Red Cell Genotyping

The use of DNA-based methods for red cell antigen identification can assist in securing the optimal blood products for transfusion. The molecular bases for many of the major blood group antigens have been identified and DNA-based methods for their detection developed. Because these methods do not directly detect the presence of red cell antigens, challenges with widespread application still exist.²⁴⁴ When used with standard serologic testing, however, such methods are useful in identifying donors for patients with multiple red cell antibodies or blood donors with rare antigen types.

Additionally, these methods are helpful in determining a patient's red cell antigen makeup when chronically or recently transfused or when access to a blood specimen increases patient risk (e.g., fetus).

Special Considerations in Neonatal Transfusion

Pretransfusion Testing

The so-called naturally occurring IgM ABO antibodies do not begin to appear until approximately 3 to 6 months of age. However, IgG antibodies of maternal origin, including maternal anti-A or anti-B, may be passively transferred to the fetus. Thus, pretransfusion testing in the newborn consists of ABO and Rh typing of the infant's cells and an antibody screen for passively transferred maternal IgG antibodies, including anti-A or anti-B. If the initial antibody screen is negative, the infant may be transfused with products compatible with the patient's ABO/Rh type, and no further compatibility testing is required for the first 4 months of life. If a clinically significant antibody of maternal origin is detected, units that are antigen-negative or crossmatch-compatible must be issued until the antibody is no longer detectable in the infant's serum.⁵

Selection of Products for Neonatal Transfusion

Preterm infants may require multiple transfusions to replace blood drawn for laboratory tests. It has become common practice to limit donor exposure by reserving one unit or one half unit for a single preterm infant. Serial aliquots may be obtained using a sterile connection device up to the outdate of the unit.^{245,246,247} Blood products for low-birth-weight infants should be irradiated to prevent transfusion-related GVHD and should be CMV reduced risk (i.e., CMV antibody negative and/or leukoreduced). Either CPDA-1 or additive red cells may be used for aliquot transfusions. However, the safety of additive solutions has not been demonstrated in the setting of massive transfusion of infants (i.e., one unit or more in a neonate). The amount of free potassium in the supernatant of the irradiated blood may also become clinically important in the setting of massive transfusion.¹³² For massively transfused infants at increased risk of hyperkalemia, the dose of free potassium in the red cell product may be decreased by delaying irradiation until just before issue or by washing the RBCs.

Exchange Transfusion

The most common indication for exchange transfusion in the neonate is hyperbilirubinemia that has not responded adequately to

P.565

phototherapy, particularly that associated with hemolytic disease of the newborn. Usually, one to two blood volumes are exchanged.

Red cells collected in CPD or CPDA-1 that are less than 1 week old are preferred. Because several clotting factors in newborns are at the low end of hemostatic levels, many centers perform exchanges using whole blood, or red cells reconstituted with plasma, to prevent further lowering of factor levels by the exchange. Red cells used for the exchange transfusion should be irradiated to prevent transfusion-related GVHD.²

Administration of Blood

The first step before the administration of blood or of a blood product is to obtain consent for the transfusion from the patient. Every hospital should set its own policy. A note in the chart indicating that the risks of transfusion as well as the indications and alternatives have been discussed with the patient and that the patient has accepted this form of therapy may be adequate, depending on applicable laws and regulations. There must be a written order for the administration of the product.⁵

All blood products should be given through an appropriate blood administration set containing a filter; careful aseptic technique should be practiced at all times. There must be confirmation and documentation that the information identifying the blood product with the patient has been verified in the presence of the patient.⁵

Vital signs should be documented before and after transfusion and as clinically required. For the first 15 minutes after the infusion has begun, the patient should be kept under close observation to detect any signs of a serious transfusion reaction. If none is observed, the infusion rate may be increased. One unit of red cells is often given in 1 to 4 hours, depending on the amount to be transfused and on the patient's cardiovascular status. Infusion of a unit for longer than 4 hours is not recommended, as there is a risk of bacterial proliferation because the opened unit is at room temperature. Normal (0.9%) saline, 5% albumin, or ABO-compatible plasma may be added. No other solution and no medication should be added to or infused through the same tubing as a blood product unless there is documentation of compatibility or FDA

approval.⁵ Dextrose causes red cells to agglutinate or hemolyze; hypotonic saline causes hemolysis. Ringer's lactate or other solutions containing calcium must never be added to a blood product because the calcium present leads to coagulation. After the transfusion has been completed, the transfusion tag or record should become part of the patient's chart.

When the patient being transfused is in severe congestive heart failure, additional measures should be taken. Administration of diuretics before or during the transfusion may not be adequate to prevent aggravation of heart failure by volume overload. In the presence of heart failure, transfusion should proceed slowly (e.g., 1 ml/kg/h) with careful observation and additional diuretics given if clinically indicated. If slower rates than this are needed, the blood component may be divided by the blood bank into two or more parts and each part transfused over 4 hours. The unused portions should be kept in the blood bank until needed for transfusion.

PLATELET TRANSFUSION

Platelet transfusion may be life-saving when hemorrhage is caused by thrombocytopenia. Modern treatment for hematologic malignancies would not be possible without the ability to prevent or treat thrombocytopenic bleeding. Similarly, many surgical procedures would not be feasible without platelet transfusions. Whether this therapeutic modality is effective depends on recipient factors, such as the presence of sepsis, azotemia, drugs, and platelet antibodies, and on the ability of the blood bank to provide functional platelets in sufficient numbers.^{93,248,249}

Administration of Platelets

Platelet concentrates may be provided by the blood bank in their individual plastic bags or pooled before transfusion. Apheresis platelets do not require any preparation. Once the blood bag is opened by puncturing one of the sealed ports, the platelets must be administered within 4 hours.⁵ Platelets must be administered through a filter approved for platelet use, either a standard 170- μ m filter or a leukoreduction platelet filter.

Dosage and Expected Response

The usual dose of platelets is one unit for each 10 kg body weight, or approximately six units (or one apheresis platelet) for a typical adult dose.²⁵⁰ The *in vivo* recovery of transfused platelets should be assessed by a platelet count obtained 10 minutes to 1 hour posttransfusion.^{251,252}

As noted earlier, even under ideal circumstances, only two thirds of transfused platelets are expected to be found in the circulation of the recipient. One can estimate the maximum expected increase in circulating platelet count after transfusion of one apheresis platelet product containing the minimum of 3×10^{11} platelets into a 70-kg adult with a blood volume of 5 L as follows: Maximum increase in count = $2/3 \times 3 \times 10^{11}$ platelets distributed in 5 L blood volume = $40 \times 10^9/L$.

In practice, the observed posttransfusion platelet recovery in patients is often much lower than ideal. Hematology patients typically achieve an increment of approximately $20 \times 10^9/L$, about 50% of ideal, after infusion of 3×10^{11} platelets.²⁵³ A recovery as low as 30% of the ideal is generally considered "acceptable."²⁵⁴ This would correspond to an increase in platelet count of approximately $13 \times 10^9/L$ after transfusion of one apheresis platelet product to a 70-kg adult. The expected and "acceptable" increases in platelet count would be proportionately lower in a larger adult and higher with transfusion of a larger dose of platelets.

Many investigators have assessed the acceptability of a posttransfusion platelet increment by calculating a corrected count increment (CCI). With the CCI, the measured increment in circulating platelet count is corrected for the patient's size and for the dose of platelets given as follows: $CCI = (\text{posttransfusion count} - \text{pretransfusion count}) \times \text{body surface area (m}^2\text{)}/\text{number of platelets administered (}10^{11}\text{)}$.

The maximum achievable CCI is approximately $25 \times 10^9/L$. The typical CCI in patients is approximately one half of this, and the lowest "acceptable" CCI is considered to be approximately $7.5 \times 10^9/L$.^{251,254} Patients with *in vivo* recoveries or CCIs lower than acceptable values should be evaluated for causes of platelet refractoriness such as an enlarged spleen or alloimmunization (as discussed in the section, "Platelet Refractoriness and Alloimmunization").

In healthy adults, the half-life of transfused platelets is 3 to 5 days.⁸³ In thrombocytopenic patients, however, platelet survival is reduced. A fixed rate of platelet consumption of $7.1 \times 10^9/L/\text{day}$ has been measured in otherwise stable patients with severe thrombocytopenia.²⁵⁵ It is assumed that this platelet consumption is associated with maintenance of vascular integrity. The rate of consumption may be higher in critically ill patients.

Given the limited absolute increase in platelet count achieved with the standard dose of platelets and the presence of ongoing platelet consumption, many patients return to their baseline platelet count within 1 to 2 days of platelet

transfusion.²⁴⁹ In stable patients, the transfusion-free interval may be increased by administering larger doses of platelets with each transfusion.^{256,257} However, this strategy can result in an increase in the total number of platelets transfused.²⁵³

Indications for Platelet Transfusion

The risks of posttraumatic and spontaneous bleeding increase as the platelet count falls. In general, assuming that platelet function

P.566

is normal, there is minimal risk of spontaneous bleeding due to thrombocytopenia at platelet counts $>50 \times 10^9/L$, and this level is usually sufficient to permit surgical procedures.²⁵⁸ As the count falls below this level, there is an increasing risk of microvascular bleeding, characterized by petechiae, ecchymoses, oozing at venipuncture and incision sites, epistaxis, menorrhagia, gastrointestinal bleeding, or intracranial hemorrhage.

The precise degree of bleeding risk at any given platelet count is difficult to determine, as many other clinical variables have important effects. These include the cause of thrombocytopenia; the duration of thrombocytopenia; the nature of concurrent disease processes including sepsis, uremia, vasculitis, or malignant processes invading blood vessels or other organs; the coexistence of coagulopathies, such as liver disease, vitamin K deficiency, intravascular coagulation, or heparin treatment; and the presence of drugs such as ASA or semisynthetic penicillins that interfere with platelet function.²⁵⁹

In general, the risk of significant spontaneous hemorrhage increases gradually as the platelet count drops to $<50 \times 10^9/L$ ²⁶⁰ and is high at counts $<5 \times 10^9/L$ ^{248,249} (Figs. 21.5 and 21.6).

Clinical practice guidelines,^{258,261,262} and a Cochrane metaanalysis²⁶³ for platelet transfusion therapy have been published. Additionally, a Performance Indicator for prophylactic platelet transfusions has been developed by The Joint Commission¹⁸¹ for patients with malignant hematologic diseases or those who undergo stem cell transplantation, in which a platelet count threshold of 10,000/mm is appropriate for prophylactic platelet transfusions.²⁶⁴

Current guidelines from the European Union and United States recommend a transfusion trigger of $10 \times 10^9/L$ for platelets transfused prophylactically.^{261,265} These guidelines are based on outcomes from four randomized clinical trials that compared prophylactic triggers of $10 \times 10^9/L$ versus $20 \times 10^9/L$ in patients with acute leukemia and in autologous and allogeneic hematopoietic stem cell transplant recipients.^{264,266,267} and²⁶⁸ Two additional prospective studies also demonstrated safety with the lower threshold of $10 \times 10^9/L$ for prophylactic platelet transfusions.^{269,270} The impact of these thresholds on numbers of platelet and blood transfusions is variable, however²⁷⁰; one study demonstrated a 36% and 16% reduction in platelet and blood transfusions, respectively,²⁷⁰ while another showed no differences.²⁶⁹

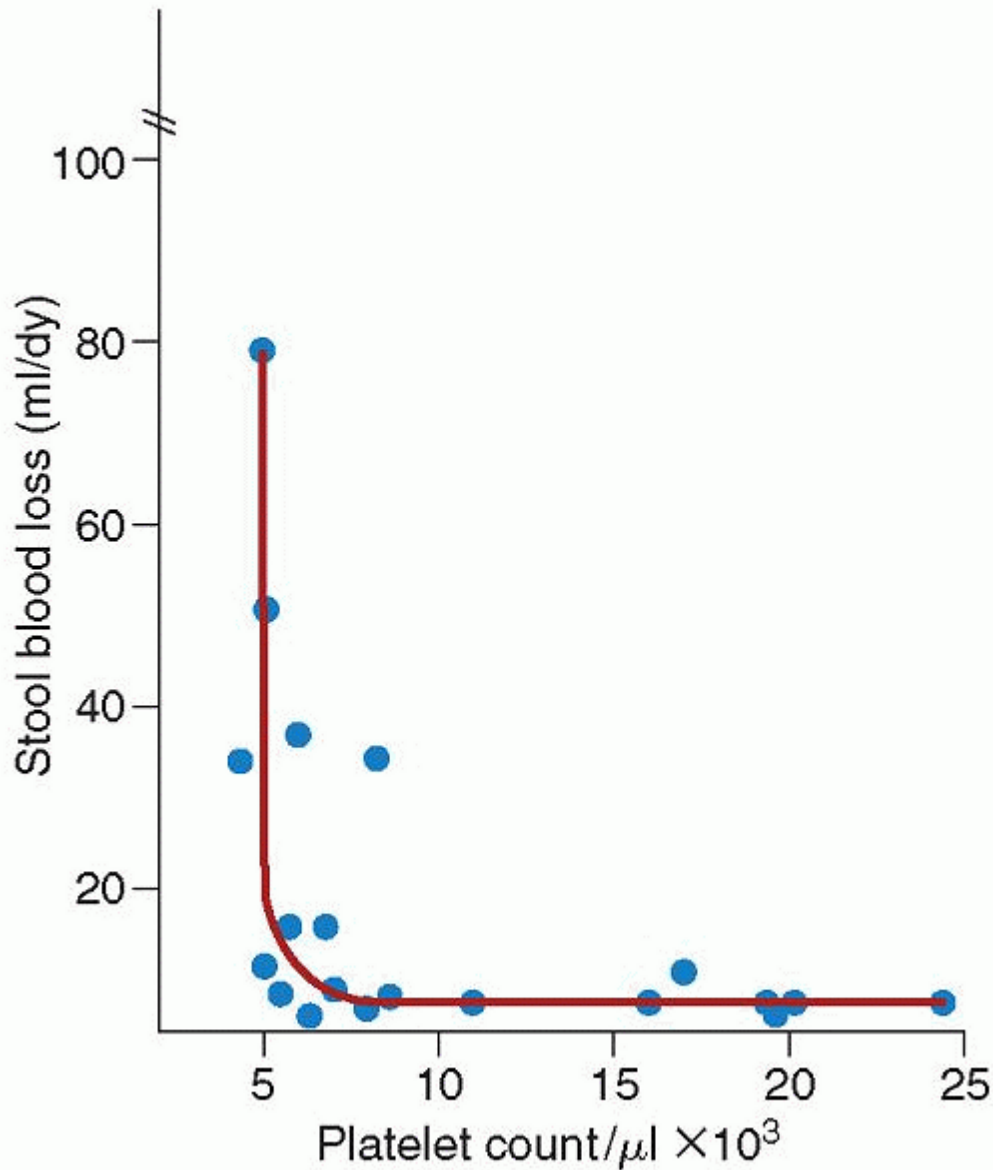

FIGURE 21.5. Stool blood loss as a measure of thrombocytopenic bleeding. When stool blood loss was determined in 20 aplastic thrombocytopenic patients, blood loss was less than 5 ml/d at platelet counts $>10 \times 10^9/\text{L}$. At platelet counts between 5 and $10 \times 10^9/\text{L}$, blood loss averaged 9 ± 7 ml/d. At levels $<5 \times 10^9/\text{L}$, blood loss was markedly elevated at 50 ± 20 ml/d. (From Slichter SJ. Controversies in platelet transfusion therapy. *Annu Rev Med* 1980;31:523, with permission; and modified from Slichter SJ, Harker LA. Thrombocytopenia: mechanisms and management of defects in platelet production. *Clin Haematol* 1978;7:523. Reprinted with permission from *Annu Rev Med* 1980;31 by Annual Reviews, www.annualreviews.org.)

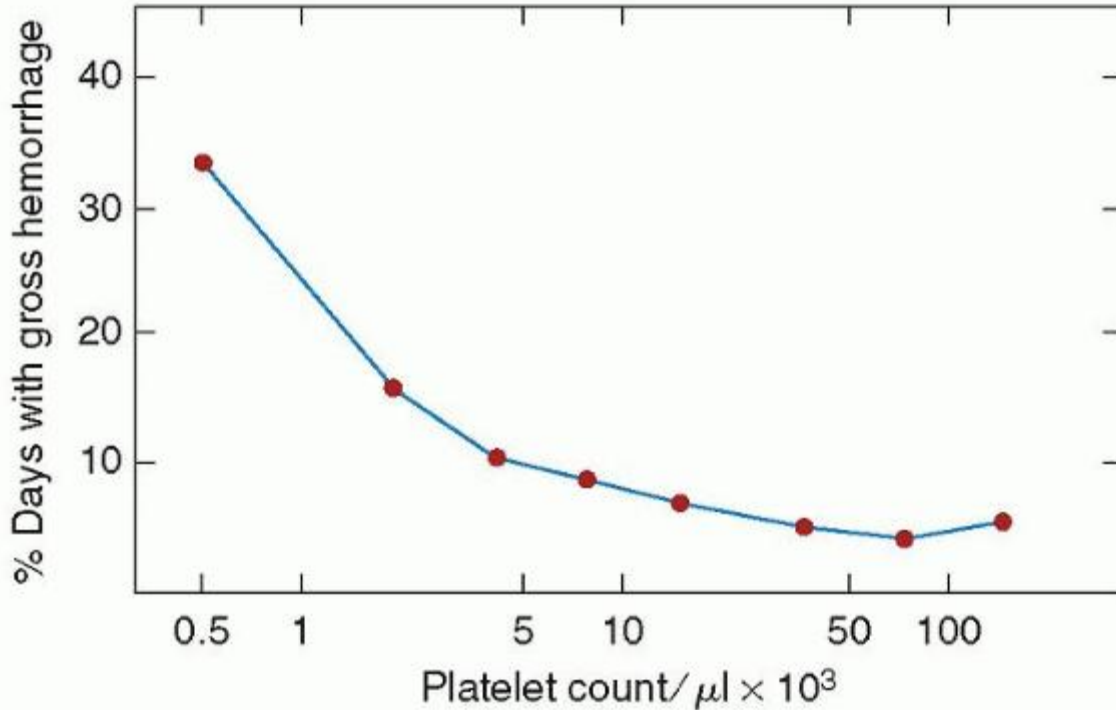

FIGURE 21.6. Clinical bleeding as a manifestation of platelet count. Fraction of total bleeding days with grossly visible hemorrhage according to platelet count, in 92 thrombocytopenic leukemic patients. (From Slichter SJ. Controversies in platelet transfusion therapy. *Annu Rev Med* 1980;31:522; and modified from Gaydos LA, Freireich EJ, Mantel N. The quantitative relation between platelet count and hemorrhage in patients with acute leukemia. *N Engl J Med* 1962;266:907. Reprinted with permission from the *Annu Rev Med* 1980;31 by Annual Reviews, www.annualreviews.org.)

A recent trial²⁷¹ demonstrated that “low dose” prophylactic platelet transfusions are equally effective as those with “standard” or “high” dose. For therapeutic platelet transfusions, algorithms for platelet transfusions based on point of care testing have demonstrated promise in patients who have platelet-derived bleeding such as in cardiothoracic surgery^{178,272} and in trauma.²¹² Additional evidence-based studies in platelet transfusion are needed.²⁷³

Prophylactic Platelet Transfusion

Prophylactic platelet transfusion in the management of acute leukemia prevents major bleeding episodes, except perhaps during the terminal phase of the patient's illness.^{274,275} However, no difference in mortality has been demonstrated between patients transfused prophylactically and those transfused only when bleeding occurred.²⁷⁵ Despite lack of such proof, it is common practice to attempt to prevent bleeding problems by administering prophylactic transfusions to thrombocytopenic patients.

The indications for prophylactic transfusion remain controversial. Until recently, it was common practice to transfuse platelets when the count was $<20 \times 10^9/\text{L}$. A number of studies have demonstrated that reducing the trigger for prophylactic platelet transfusion from 20×10^9 to $10 \times 10^9/\text{L}$ resulted in decreased platelet transfusion without an increased frequency of significant hemorrhage. In these studies, however, the trigger for transfusion was liberalized in the presence of clinical factors suspected to increase the risk of hemorrhage, such as fever, an increased WBC count, coagulopathy, bleeding, or invasive procedures. When significant hemorrhagic events occurred, they were often in patients with morning platelet counts $>20 \times 10^9/\text{L}$.^{264,266,276} Infection, vascular lesions, or prolonged duration of thrombocytopenia may contribute to the risk of significant hemorrhage.^{266,276} Thus, it appears that a prophylactic transfusion trigger of $10 \times 10^9/\text{L}$ is as safe as one of 20×10^9 in most patients with acute leukemia or after myeloablative hematopoietic cell transplant.²⁶⁸ However, an assessment of individual clinical risk factors is appropriate.

A strategy of therapeutic-only platelet transfusions in patients after autologous peripheral blood stem cell transplantation was found to reduce platelet transfusions by one half, despite 27% of transfusions given in breach of protocol guidelines, with no difference in number of red blood cell transfusions required.²⁷⁷ Important questions remain regarding whether prophylactic

platelet transfusions are effective in reducing the risk of bleeding in clinically stable patients. A trial of prophylactic platelets study (TOPPS) versus therapeutic platelet transfusions in thrombocytopenic patients with malignancy, is currently underway in the UK.²⁷⁸

Prophylactic platelet transfusion is usually recommended before major surgical procedures in patients with platelet count $<50 \times 10^9/L$.^{250,261,279} The safety of performing surgical procedures at counts below this level has not been formally evaluated. It has been demonstrated that bone marrow aspirations and biopsies, bronchoscopies, and lumbar punctures may be safely performed in patients with platelet counts of <20 to $25 \times 10^9/L$.²⁶¹ However, the minimum safe platelet level for specific invasive procedures remains to be defined.

Prophylactic transfusion of platelets is generally not recommended in patients with platelet consumption disorders, such as idiopathic thrombocytopenic purpura (ITP) and thrombotic thrombocytopenic purpura (TTP). In ITP, there is reduced recovery and survival of transfused platelets; transfusion usually does not result in a measurable increase in platelet count. There is some evidence that platelet transfusion may be harmful in patients with TTP.^{280,281} However, platelet transfusion may be used to treat lifethreatening bleeding in patients with these disorders.²⁶²

Therapeutic Platelet Transfusion

Rapid massive bleeding is unlikely to be due solely to thrombocytopenia and suggests the presence of a vascular injury. Rapid massive bleeding in the postoperative setting is usually surgical in nature and, therefore, not correctable by platelet transfusion. However, bypass-induced platelet dysfunction may contribute to bleeding after cardiac surgery²⁸²; platelet transfusion may improve hemostasis in such situations.

Platelet transfusion is most useful in thrombocytopenic patients with microvascular bleeding (e.g., oozing or mucous membrane or gastrointestinal bleeding). Transfusion to achieve a platelet count of $50 \times 10^9/L$ is generally recommended^{250,258,262,279} for bleeding patients. However, hemostasis may be achieved through repeated platelet transfusion even in the absence of a demonstrable rise in platelet count. Transfusion is indicated in bleeding patients with platelet dysfunction, regardless of the platelet count.

Dilutional thrombocytopenia may occur after massive transfusion of red cells and plasma volume expanders. In the absence of platelet consumption, a platelet count of $<50 \times 10^9/L$ is not generally seen unless more than two blood volumes (20 red cell units in an adult) have been replaced.^{217,283,284} However, in settings such as trauma where there is activation of coagulation and consumption of platelets in addition to blood loss, there is some evidence that pre-emptive use of platelets in the resuscitation support may be of benefit.^{212,219,220}

In all situations, the clinical decision regarding platelet transfusions requires consideration of several variables, including an estimation of platelet count and function, cause of thrombocytopenia, and state of the coagulation system; the presence or likelihood of bleeding (the development of petechiae, spontaneous mucous membrane oozing, and retinal hemorrhages are often danger signals indicating hemostatic incompetence); and the hazards of transfusion, which include all those encountered with the transfusion of any blood product.

Platelet Refractoriness and Alloimmunization

Refractoriness to platelet transfusions is a clinical state that can be defined as an unacceptable recovery of transfused platelets on two or more occasions. As noted previously, a CCI of <5 to $7.5 \times 10^9/L$ measured at 10 minutes to 1 hour after the transfusion is a commonly used definition of an unacceptable response or, as a general rule of thumb, an absolute increment of $<13 \times 10^9/L$ after transfusion of six units of platelets to a 70-kg adult. Clinical factors reported to be associated with refractoriness to platelet transfusion are listed in Table 21.6.^{93,254,263,285,286} and ²⁸⁷

TABLE 21.6 FACTORS REPORTED TO BE ASSOCIATED WITH PLATELET REFRACTORINESS

Immune Factors

Alloantibodies

Anti-HLA

Antiplatelet glycoprotein

ABO

Autoantibodies

Idiopathic thrombocytopenic purpura

Drug-related

Nonimmune Factors

Splenomegaly

Fever, infection

Disseminated intravascular coagulation

Immune complexes

Bone marrow transplantation

Amphotericin

Immune Causes of Refractoriness

The major immune cause of refractoriness is the presence of anti-HLA antibodies. These antibodies are stimulated by pregnancy or by transfusion of WBC-containing blood products. Platelets bear HLA class I antigens on their surface. Anti-HLA antibodies are produced by 30% to 50% of recipients of WBC-containing blood products (Table 21.7).¹²⁴ They are found in up to 30% of untransfused

P.568

women with a history of pregnancy.^{288,289} After exposure to blood products, up to two thirds of women with a history of pregnancy produce HLA antibodies.²⁹⁰ Transfusion of platelets that are serologically incompatible with a pre-existing HLA antibody typically results in no increase in platelet counts.^{291,292}

TABLE 21.7 EFFICACY OF LEUKOCYTE-REDUCED PRODUCTS IN PREVENTING TRANSFUSION-INDUCED HLA ALLOIMMUNIZATION

Author	Type of Blood Products Received	
	Control	Leukoreduced
Elghouzzi	26/93 (0.28)	10/67 (0.15)
Schiffer	13/31 (0.42)	5/25 (0.20)
Andreu	11/35 (0.31)	4/34 (0.12)
Sniecinski	10/20 (0.50)	3/20 (0.15)
Rebulla	5/15 (0.33)	4/16 (0.25)
Van Marwijk	11/26 (0.42)	2/27 (0.07)
Oksanen	3/15 (0.20)	2/16 (0.12)
Handa	9/23 (0.39)	4/49 (0.08)
Lane	7/20 (0.35)	3/26 (0.11)
Williamson	21/56 (0.37)	15/67 (0.22)
TRAP	59/131 (0.45)	25/137 (0.18)

Note: This is a summary of prospective controlled trials in hematology and oncology patients. Each numerator indicates the number of patients developing HLA antibodies; the denominator indicates the number of patients transfused with that type of blood product. The number in parentheses represents the calculated proportion of patients making antibodies. Modified from Dzik WH. Leukoreduced blood components: laboratory and clinical aspects. In: Simon TL, Dzik WH, Snyder EL, et al., eds. Rossi's

principles of transfusion medicine, 3rd ed. Philadelphia, PA: Lippincott Williams & Wilkins, 2002:270-287.

The incidence of clinically significant alloantibodies to platelet-specific glycoproteins in transfusion recipients is unclear. Antibodies to platelet glycoproteins have been detected almost exclusively in patients who also have broadly reactive anti-HLA antibodies. Using the sensitive MAIPA (monoclonal antibody immobilization of platelet antigen) assays, investigators have reported detection of antibodies to platelet glycoproteins in as many as 25% of HLA-alloimmunized transfusion recipients.^{293,294,295} and ²⁹⁶ A significant proportion of the antibodies detected have ill-defined specificity, and the contribution of such antibodies to platelet refractoriness is unclear. The presence of platelet-specific antibodies in patients who are broadly sensitized to HLA presents an enormous transfusion support challenge. Although many blood centers maintain HLA-typed donor registries, at present, very few of these donors are typed for platelet antigens. The solid-phase red cell adherence or recently developed MAIPA-based platelet crossmatching assays could theoretically be used to test HLA-selected products for compatibility with a patient's antiplatelet antibodies, although it has not yet been established whether these assays have adequate sensitivity and specificity for this application.

As discussed earlier, high-titered ABO antibodies have been implicated in platelet refractoriness. Many investigators recommend a trial of ABO-compatible products in refractory patients, although studies have not demonstrated a high likelihood of improvement.

Antiplatelet autoantibodies are usually associated with absolute refractoriness to platelet transfusion. However, in the event of life-threatening bleeding, patients with ITP may benefit clinically from repeated infusions of platelets even in the absence of a demonstrable rise in platelet count. Antifibrinolytics or recombinant factor VIIa may also be helpful in this setting, as discussed later (see "Role of Pharmacologic Agents in Managing Thrombocytopenic Patients").

Nonimmune Causes of Refractoriness

Of the nonimmune factors implicated in refractoriness, splenomegaly is the most potent. Transfused platelets pool in the enlarged spleen; increasing the dose of platelets does not necessarily improve the posttransfusion increment. Each of the other nonimmune factors listed in Table 21.6 has been reported to be associated with refractoriness, although the importance of each factor has not been demonstrated consistently.^{93,254,285,286,297}

Prevention of HLA Alloimmunization

Although platelets express HLA class I molecules on their surface, purified platelets do not appear to induce primary immunization to HLA antigens. It appears that the presence of WBCs is necessary, presumably because of their dual expression of both HLA class I and class II antigens.²⁹⁸ Multiple studies have demonstrated that the prophylactic use of leukoreduced blood products significantly decreases the incidence of HLA immunization in transfusion recipients (Table 21.7).^{124,299,300} Use of leukoreduced blood products is recommended for patients who are likely to require intensive platelet transfusion support, because the development of anti-HLA antibodies would complicate such support.

Purified platelets can stimulate a secondary immune response to HLA.²⁹⁸ Patients with prior pregnancy are highly likely to produce HLA antibodies after transfusion. HLA alloimmunization has been observed in up to two thirds of such patients. The use of leukoreduced products appears to be of limited benefit in such patients: HLA antibodies are produced by 33% to 44% of patients with a history of pregnancy despite the use of leukoreduced products.^{290,299,301}

As an alternative to removing WBCs from blood products, *in vitro* studies indicate that ultraviolet (UV) irradiation of WBCs abrogates their ability to present HLA antigens in mixed lymphocyte culture.^{302,303} *In vivo* studies demonstrate that UV irradiation of blood products is as effective as leukocyte reduction in preventing primary HLA alloimmunization.²⁹⁰ UV irradiation of platelet products requires special blood containers and equipment and is not currently available in the United States.

Early studies suggested that HLA alloimmunization in platelet transfusion recipients could be reduced by minimizing donor exposure through the use of pheresis platelets rather than pooled platelet concentrates.^{304,305} However, it has been shown that if all products are leukoreduced, there is no incremental benefit to the use of pheresis products.²⁹⁰

Diagnosis and Management of Alloimmunization

Historically, anti-HLA antibodies have been detected by lymphocytotoxicity assays. Newer methods of testing for HLA antibodies include enzyme or flow-based immunoassays in which HLA glycoproteins are immobilized on a plastic plate or beads.³⁰⁶ A commercially available solid-phase red cell adherence assay permits screening for serologic reactivity against platelets selected from inventory.³⁰⁷

Early studies demonstrated that thrombocytopenic patients with lymphocytotoxic antibodies could be successfully supported with platelets obtained from donors who were HLA-identical to the patient, or donors who were partially HLA-matched and whose lymphocytes were serologically compatible with the patient's antibody.^{291,308} These observations led to the practice of providing apheresis platelets from "HLA-matched" donors for patients with lymphocytotoxic antibodies. Depending on the availability of family members, the rarity of the patient's HLA type, and the size of the HLA-typed donor registry, it may be difficult or impossible to locate platelet donors who are HLA-identical to the patient.

Therefore, many platelets provided as HLA-matched bear one or more antigens that are foreign to the recipient. Serologic crossmatching of partially mismatched products can be used to identify those that are more likely to result in a good posttransfusion increment.^{291,292,309}

In most HLA-alloimmunized patients, the specificity of the antibody can be defined.^{297,310,311} Patients can be successfully supported with products that lack the HLA antigen(s) to which the antibodies are directed.^{297,310} If the platelet inventory is HLA-typed, products lacking the offending antigen(s) can usually be found in inventory; thus, many patients can be supported with products on the shelf, without the need for special donor recruitment or serologic crossmatching.

Alternatively, serologic crossmatching of HLA-untyped products may be used to support patients whose antibodies are not broadly reactive. For many alloimmunized patients, it is possible to identify serologically compatible platelets among HLA-untyped products in the blood center inventory using the solid-phase red cell adherence crossmatching assay.³⁰⁷ However, compatible products are unlikely to be found in inventory for patients who have broadly reactive antibodies; such patients require specific recruitment of HLA-selected donors.

In summary, HLA-alloimmunized patients may be supported (a) by using products from donors who are HLA-identical to the patient or who lack HLA antigens foreign to the recipient; (b) by using products that are partially HLA-matched and serologically compatible; (c) by identifying the specificity of the patient's HLA antibody and avoiding products that bear the offending antigen(s); or (d) by serologic crossmatching of products in inventory. These methods are equally effective clinically.²⁹⁷ The first method is often limited by the inadequate availability of donors. The last method is not applicable to patients with broadly reactive

P.569

antibodies, who comprise approximately 10% to 15% of alloimmunized patients.^{307,311}

It should be noted that HLA antibodies may appear or disappear over the course of a patient's treatment.^{93,297} It is important to monitor patients' responses to platelet transfusion and to reevaluate them serologically if they do not respond to products that were previously acceptable.

Platelet Transfusions for Refractory Patients

Strategies for the optimal use of platelets are undergoing evolution.²⁷⁸ A published guideline suggests withholding prophylactic transfusion for nonbleeding patients who do not achieve acceptable posttransfusion increments in platelet counts.²⁶¹ However, many clinicians arbitrarily transfuse one dose of platelets daily, based on the assumption that some platelets are necessary to maintain vascular integrity.²⁵⁵ For bleeding patients, many practitioners recommend infusion of larger or more frequent doses of platelets.^{254,312}

Role of Pharmacologic Agents in Managing Thrombocytopenic Patients

Attempts to improve responses with intravenous immunoglobulin (IgG) therapy in patients refractory to platelets have not convincingly demonstrated benefit; some found improved 1 hour but not 24 hour posttransfusion increments.³¹³ Fibrinolytic inhibitors were shown to be of value in avoiding platelet transfusions in aplastic patients,³¹⁴ by helping stabilize any clots that are being formed.³¹⁵ Anecdotal reports³¹⁶ have suggested that recombinant factor VIIa (rFVIIa) may stop bleeding, particularly in patients with refractory, severe thrombocytopenia.^{317,318} However, a randomized trial failed to demonstrate any difference between the placebo group and the three rFVIIa cohorts combined, in the primary endpoint of bleeding score at 38 hours³¹⁹. Raising red cell mass by blood transfusion or treatment with erythropoiesis stimulating agents (ESA) has been shown to improve coagulopathy related to anemia³²⁰ or uremia,³²¹ but evidence for clinical efficacy is needed. Thrombopoiesis-stimulating agents have been shown to be efficacious in improving platelet counts in patients with immune thrombocytopenias.^{322,323} Platelets contain significant amounts of micro RNAs that may provide proteins that affect hemostasis and inflammation.^{324,325} Finally, development of fibrinogen-coated, ADP-encapsulated liposomes may offer a promising platelet substitute.³²⁶

Selection of Platelet Products

ABO Group

The clinical importance of ABO compatibility in platelet transfusion is controversial. Platelets bear both intrinsic³²⁷ and adsorbed³²⁸ antigens of the ABH system. Transfusion of ABO-incompatible platelets may be associated with decreased posttransfusion platelet recovery and normal survival.^{329,330,331} and³³² The reduction in recovery is variable and may be related to the isohemagglutinin titer of the recipient. Rarely, a high titer of anti-A or anti-B may cause frank refractoriness to ABO-incompatible platelets.^{333,334} and³³⁵

Platelet products contain a significant amount of donor plasma. Rarely, high-titered donor isoagglutinins in platelet products may cause intravascular hemolysis of recipient red cells,³³⁶ especially platelets from group O donors.^{337,338} Some investigators have suggested that patients who receive platelets mismatched for ABO develop refractoriness at a higher rate than patients who receive ABO-compatible products.^{335,339,340} However, these studies were small, did not control for the presence of HLA antibodies, and differed in their observations as to whether it was cell or plasma compatibility that was important. Most important, patients who developed refractoriness to ABO-incompatible products did not show better responses when given ABO-identical products, suggesting that ABO may not have been the cause of refractoriness.^{338,340} In practice, it is difficult to ensure availability of ABO-identical platelet products, and many centers simply limit the volume of incompatible plasma transfused.

Rh Type

Platelets do not carry Rh antigens, and the donor's Rh type is important only because the red cells present in the platelet concentrate may immunize Rh-negative recipients. Although early studies found that as many as 19% of D-negative recipients of platelets from D-positive donors developed anti-D, several recent studies in hematology/oncology patients found that immunization did not occur.^{341,342} It is possible that the difference in observations is related both to an increase in intensity of chemotherapy as well as to a substantial improvement in the purity of platelet products. The red cell content of most apheresis platelets currently is below the dose thought to be immunizing. For most platelet recipients, anti-D prophylaxis would be of little benefit.³⁴³ For pediatric patients and females with future childbearing potential, however, it may be reasonable to consider administration of intravenous anti-D Ig to prevent D immunization.^{343,344} and³⁴⁵

PLASMA TRANSFUSION

Use of Plasma Components

FFP or FP24 are utilized in patients who are bleeding or who are having an invasive procedure and who are deficient in multiple coagulation factors or in a single factor for which there is no specific factor concentrate available. They are also used for replacement of clotting factors during massive transfusion, for reversal of warfarin (if immediate reversal is necessary), and as the replacement fluid for plasma exchange procedures in patients with TTP.^{3,346} They should not be used as volume expanders or for therapeutic plasma exchange for other disorders, because alternative fluids with lower risks of infectious diseases, allergic reactions, and TRALI are available for these purposes (e.g., crystalloid, albumin, starch). The typical dose of plasma is 10 to 20 ml/kg.³ Patients may not tolerate infusion of larger volumes. The expected rise in coagulation factor activity is approximately 10% for each 10 cc/kg of plasma infused.³⁴⁷

Efficacy of Plasma Transfusions

In a recent evidence-based review, the Transfusion Practices Committee of the AABB recommended plasma therapy for only a few clinical indications, based on the available evidence in the literature (which was assessed to be of "weak quality"): trauma patients with substantial hemorrhage, patients undergoing complex cardiovascular surgery, and patients with intracranial hemorrhage requiring emergency reversal of warfarin-associated coagulopathy.³⁴⁸ Patients with mild prolongations of the INR (less than 1.7) are not at risk of bleeding and do not need plasma therapy for minor procedures,³⁴⁹ so that for the majority of clinical settings there is ample evidence that plasma transfusions are inappropriate. However, logistical/technical barriers that prevent effective and timely plasma therapy (possibly resulting in plasma therapies that are "too little, too late") have probably contributed to the paucity of evidence demonstrating any benefit for plasma therapy.¹⁷⁷

One of the largest prospective studies of plasma transfusions and their effect on INR and bleeding included both medical and surgical patients with pretransfusion INR of between 1.1 and 1.85.³⁵⁰ The authors reported that less than 1% of patients

P.570

had normalization of their INR and only 15% had at least 50% correction. The median dose of plasma was 2 units (only 5 to 7 ml/kg), and there was no correlation between plasma dose and change in INR. This study had many of the limitations common to other reports³⁵¹ in this clinical arena: lack of control groups, only modest prolongation in coagulation tests, poorly-defined clinical endpoints (e.g., change in hemoglobin or need for transfusion), and/or an inadequate dose of plasma therapy.

The paucity of evidence for the benefit of plasma transfusion therapy has been accompanied by growing evidence that risks of plasma have been underrecognized; in a prospective study, 6% of transfused patients developed transfusion-associated cardiac overload,³⁵² which is much higher than previously-reported rates in retrospective studies.^{353,354} Transfusion-related acute lung injury³⁵⁵ is a significant cause of morbidity/mortality from blood transfusions, whose incidence has declined subsequently with use of plasma from male donors or female donors who have no history of pregnancy.³⁵⁶

GRANULOCYTE TRANSFUSIONS

Severe bacterial and fungal infections in the setting of prolonged chemotherapy-associated neutropenia are common causes of morbidity and mortality in the treatment of malignancy. Risk of serious bacterial infection appears as the neutrophil count falls below $1.0 \times 10^9/L$ and increases rapidly below $0.5 \times 10^9/L$. Fungal infections occur with much higher frequency as the neutrophil count falls below $0.2 \times 10^9/L$.³⁵⁷ Other risk factors include the duration of neutropenia and the rate of fall of the neutrophil count.³⁵⁸ The use of growth factors (e.g., granulocyte colony-stimulating factor [G-CSF]) has reduced the severity and duration of neutropenia, but many patients still have long periods of poor granulocyte production, lasting 2 to 3 weeks or longer.^{359,360} and ³⁶¹ Although the idea of enhancing host defenses with granulocyte infusions dates back 60 years, difficulty obtaining adequate granulocyte yields as well as safety concerns stifled the initial interest generated after early clinical successes in the 1970s.^{362,363} Modern apheresis techniques, growth factors which increased yields, and positive results from clinical trials led to renewed interest in applying granulocyte therapy to a wider range of patients.^{364,365}

Clinical Indications and Efficacy

Currently, there is no definitive evidence from controlled trials to support or refute the use of granulocyte transfusion therapy in neutropenic patients.^{366,367,368} Currently a large randomized control trial is being undertaken in an attempt to clarify this situation; nonetheless, prior clinical granulocyte transfusion trials in the setting of neutropenia give insight into populations that may benefit from this therapy. A review of 32 papers³⁶⁹ revealed that most studies have been uncontrolled, involved small heterogeneous populations of patients, and had different treatment approaches. Approximately 62% of the 206 patients with bacterial sepsis were reported to have benefited from granulocyte transfusion; conversely, 71% of 63 patients with invasive fungal infection did not respond to the infusions. Seven controlled trials were completed between 1972 and 1982: Three showed a positive effect, two showed benefit in specific patient populations, and two demonstrated no benefit. Some studies were likely limited by the cytoapheresis techniques used and the low cell yields obtained, as most donors were pretreated with corticosteroids only. Further analysis confirmed the importance of higher neutrophil doses as well as leukocyte compatibility in the three positive trials. More recent trials^{370,371} provide additional evidence supporting the use of granulocyte transfusions in critically ill neutropenic patients with bacterial as well as candida sepsis. Based on this information, granulocyte therapy may warrant consideration in severely neutropenic patients with bacterial infections unresponsive to typical antimicrobial therapy.

The applicability of granulocyte infusions in the setting of invasive fungal infections remains unclear. No study has shown clear efficacy in patients with active aspergillosis, although often the neutrophil dose was not known or was suboptimal. Limited clinical and animal model data give some indication of usefulness in the setting of candidal and noninvasive fungal infections.^{370,372,373} As the overall data are limited, a brief trial of granulocyte infusions may be warranted in patients with self-limited neutropenia and documented fungal infection who are refractory to standard antifungal therapy.

The effect of the prophylactic use of granulocyte transfusions to diminish the risk of serious infections in severely neutropenic patients during therapy of hematologic malignancies and after bone marrow transplantation has been investigated in a number of controlled trials.^{365,374} Although prophylactic granulocyte transfusion may decrease the risk of septicemia, the increased incidence of adverse effects observed with this therapy may outweigh the beneficial effects.^{375,376,377,378,379,380} and ³⁸¹ Until there are more published randomized, controlled clinical trials, the use of prophylactic granulocyte transfusions should be carefully considered and viewed as experimental.

Granulocyte transfusions may also be indicated in infected patients with severe neutrophil dysfunction (e.g., chronic granulomatous disease and leukocyte adhesion deficiency) who are not responding to appropriate antimicrobial therapy.

Although controlled trials have not been performed, transfused granulocytes do migrate within recipients and appear to be of therapeutic benefit.^{382,383} and ³⁸⁴ Because of the adverse effects associated with the transfusion of granulocytes, they should be used judiciously in the patient with severe documented infections, as the infusions may result in alloimmunization of the recipient and render him or her unresponsive to granulocyte transfusion therapy at a later date.

Neonatal bacterial sepsis continues to be a major cause of morbidity and mortality. The neutrophil function in neonates is impaired, with diminished chemotaxis and abnormal adhesion properties. Infection may result in neutropenia and depletion of the neutrophil storage pool. Granulocytes have been used to treat neonatal sepsis with varying results.³⁶⁷ The efficacy of this approach has been evaluated in six controlled trials with four studies demonstrating a survival benefit. Overall, data analysis does not show clear benefit when other available therapies are considered.^{362,367} When compared with standard therapy of intravenous Ig, neonates with group B Streptococcus may experience increased survival after receiving granulocyte support.³⁸⁵ Although conflicting data exist, centers that experience a high mortality rate in septic infants with neutropenia and ongoing neutrophil storage pool depletion may consider a trial of granulocyte therapy. The recommended dose is 1×10^9 granulocytes/kg of body weight.³⁶⁵

Donor Preparation/Selection

High granulocyte yields were initially obtained using preparations from donors with chronic myelogenous leukemia.³⁸⁶ Subsequently, methods were developed to collect sufficient granulocytes from normal donors. Apheresis became the standard method for collecting granulocyte concentrates.^{358,387,388} The quantity and quality of granulocytes obtained depend on the apheresis collection technique as well as the level of donor neutrophils. Infusion of hydroxyethyl starch or dextran to improve the sedimentation of donor red cells during centrifugation improves the efficiency of apheresis, but the granulocyte yield remains low³⁵⁸. Data suggested a daily granulocyte dose of about 10×10^{10} cells would be needed to achieve benefit.³⁸⁹ Oral corticosteroids produce a transient donor neutrophilia, but the collection yield remains in

P.571

the range of 2 to 3×10^{10} .³⁹⁰ Studies have shown the ability of G-CSF to increase the dose/collection. Donors treated with G-CSF with or without corticosteroids produce yields ranging from 2.4 to 9.9×10^{10} granulocytes. Although adverse effects occur in 30% to 69% of donors, most consist of mild to moderate degrees of bone pain, headache, myalgias, and fatigue. Data from the bone marrow transplant literature support the short-term safety of G-CSF use in healthy donors, although rare serious adverse events have been reported. Long-term follow-up data are limited and deserve further attention.³⁹¹ G-CSF administration to healthy donors is generally performed under institutional review board-reviewed protocols. Based on available evidence, donor pretreatment with a single dose of G-CSF (300 to 600 μ g subcutaneously) with dexamethasone (8 mg orally) 12 hours before collection gives reliable yields in a well-tolerated and cost-effective manner. Although repeated daily G-CSF stimulation and granulocyte collection have been reported,^{392,393} standard practice is to perform a second collection no sooner than 7 days after the initial cytappheresis procedure.³⁹⁴

Prospective granulocyte donors should meet all FDA and AABB standards for donation. Because granulocyte products must usually be transfused before completion of donor infectious disease testing, donors who have been tested recently are strongly preferred. Donors should also be free of disorders that might be exacerbated by dexamethasone (e.g., diabetes) or G-CSF (e.g., arthritis, vasculitis, splenomegaly, gout, thrombocytopenia). Donor/recipient pairs should be ABO-compatible because of the large RBC content in the product. RBC compatibility must be verified for each granulocyte product. CMV infections are a significant risk when seropositive donors are used for immunocompromised seronegative patients; therefore, CMV-negative patients should receive CMV-negative products.³⁸⁶

Patients requiring granulocyte transfusions may have become alloimmunized to HLA, and or RBC antigens during the course of prior transfusion support or pregnancy. Studies suggest decreased recovery and survival as well as failure of granulocytes to localize at the site of inflammation in patients who have lymphocytotoxic or granulocyte-specific antibodies.^{386,395} Recipients can be screened for the presence of HLA antibodies particularly if clinical suspicion for alloimmunization is high. In alloimmunized patients, HLA-compatible random donors or family members can be used; random donors may be preferred over family members if related allogeneic transplantation is anticipated as part of the treatment for the underlying disease. If laboratory tests for alloimmunization are not readily available, the likelihood of sensitization may be estimated by reviewing the patient's record for a history of platelet refractoriness or febrile transfusion reactions.

Granulocyte Collection/Storage

Once an appropriate donor has been selected and prepared, granulocytes are typically collected by leukapheresis during which 7 to 10 L of blood is processed over 3 to 4 hours. Hydroxyethyl starch is often used to reduce RBC contamination by

sedimentation. According to AABB standards, at least 1×10^{10} granulocytes/apheresis are collected.⁵ Current techniques achieve mean yields of 2 to 3×10^{10} /leukapheresis in 200 to 400 ml of plasma, with 10 to 30 ml of RBCs, and 1 to 6×10^{11} platelets. For pediatric recipients, whole blood buffy coats from donors stimulated with G-CSF may present an alternative to apheresis.³⁹⁶ Although granulocytes can be stored for up to 24 hours at room temperature, transfusion within 8 hours of collection is recommended. Biochemical assessments of the effects of storage on subsequent function (e.g., nicotinamide adenine dinucleotide phosphate oxidase activity, adhesion protein expression, respiratory burst activity, and bactericidal activity) reveal that effective storage may be possible for up to 48 hours at 10°C.³⁹⁷

Administration of Granulocytes

Granulocytes should be administered on a daily basis until the patient's endogenous neutrophil count rises to 0.5×10^9 /L or until the infection clears. Granulocyte concentrates should be given through a standard filter set to ensure that aggregates are not administered. The concentrate should be given slowly (over 1 to 2 hours) with the patient under constant observation, including the use of pulse oximetry. Transfusion reactions occur in 10% to 50% of patients but are usually mild, consisting of fever and chills. Premedication with antihistamines, acetaminophen, or steroids is common practice before infusion. More severe reactions occur in 1% to 5% of patients and tend to be pulmonary in nature. A serious potential interaction between granulocyte transfusions and amphotericin B has been reported,³⁹⁸ but this association has not been substantiated by others.^{399,400} Nevertheless, many physicians administer granulocytes and amphotericin at least 8 hours apart to limit the potential for increased pulmonary toxicity. If there are any signs or symptoms of respiratory distress, the transfusion should be discontinued immediately, the recipient should be examined for hypoxemia or pulmonary edema, and a chest radiograph should be done to assess for pulmonary infiltrates. If major adverse effects do occur, the recipient should be studied for the presence of antibodies that react with neutrophils. Granulocyte products contain lymphocytes and are capable of causing transfusion-associated GVHD (TA-GVHD). Thus all granulocyte products should be irradiated with 1500 to 3000 cGy to prevent transfusion-related GVHD without significantly impairing granulocyte function.³⁹⁷ Pre- and posttransfusion neutrophil counts should be determined to guide therapy. With large doses ($>8 \times 10^{10}$), neutrophil increments may exceed 2×10^9 /L immediately after infusion and may last for 24 to 48 hours.⁴⁰¹

ADVERSE EFFECTS OF BLOOD TRANSFUSION

The potential complications of blood transfusion therapy are many, but most present problems only in patients requiring repeated or large numbers of transfusions. The risks associated with the transfusion of any specific unit of blood are low. However, the risks must be weighed against the benefits at the time each transfusion is ordered.

Transfusion complications can be classified as immunologic and nonimmunologic (Table 21.8). Many of the immune reactions are caused by the stimulation of antibody production by foreign alloantigens present on transfused red cells, leukocytes, platelets, or plasma proteins. Such alloimmunization may lead to immunologically mediated reactions when transfusions carrying these antigens are administered in the future. These include hemolytic reactions caused by red cell incompatibility; febrile or pulmonary reactions caused by leukocytes and platelet antigens; allergic or anaphylactic reactions caused by antibodies reacting with soluble antigens, usually plasma proteins, in the transfused material; and GVHD caused by engraftment of transfused lymphocytes in immunosuppressed recipients.

The nonimmune reactions are caused by the physical or chemical properties of the transfused blood products, as well as contaminating infectious agents. Nonimmune reactions include circulatory overload and certain adverse effects encountered specifically when large numbers of transfusions are given.

Immunologic Transfusion Reactions

Alloimmunization to Transfused Antigens

Alloantibodies Reacting with Red Cell Antigens

Although the antigenic composition of transfused red cells always differs from that of the recipient, only a minority of P.572

multitransfused recipients develop red cell alloantibodies. The risk of red cell alloimmunization has been estimated at 1.0% to 1.4% per unit transfused^{402,403}; in multitransfused patients, the incidence of such antibodies ranges from 5% to 30%.^{404,405} Multiple red cell antibodies may be encountered. Antibodies to Rh system antigens and to Kell (K) are most often detected. Antibodies to antigens of the Duffy (Fy) and Kidd (Jk) systems also occur, but transfusion-induced antibodies to other red cell antigens are less commonly found.

TABLE 21.8 ADVERSE EFFECTS OF TRANSFUSION**Immunologic**

Alloimmunization to:

Red cell antigens

HLA antigens

Platelet-specific antigens

Neutrophil-specific antigens

Hemolytic transfusion reactions

Acute

Delayed

Febrile nonhemolytic transfusion reactions

Transfusion-related acute lung injury (TRALI)

Allergic transfusion reactions

Posttransfusion purpura (PTP)

Transfusion-related immunomodulatory effects (TRIM)

Transfusion-associated graft-versus-host disease (TA-GVHD)

Nonimmunologic

Transfusion-associated circulatory overload (TACO)

Massive transfusion

Metabolic

Hypothermia

Dilutional

Miscellaneous

Plasticizers

Transfusion hemosiderosis

Infectious

Hepatitis: A, B, C, delta, other

Human immunodeficiency virus-1/-2

Human T-lymphotropic virus-I/-II

Syphilis

Cytomegalovirus

West Nile virus

Parasites: malaria, *Babesia*, trypanosomes

Variant Creutzfeldt-Jakob disease

Bacterial contamination

Other organisms

The production of such antibodies is a property of both the recipient's immune response and the immunogenicity of the different red cell antigens. The incidence of antibodies does not appear to be related to the patient's diagnosis. For example, patients with hemoglobinopathies, thalassemia, and leukemia and those undergoing surgery requiring multiple transfusions produce antibodies with approximately the same frequency.^{404,406} The reported incidence of RBC alloimmunization for patients with thalassemias is 5% to 10%, versus 20% to 30% for those with sickle cell anemia. The increased incidence of alloimmunization in sickle cell patients has been attributed to the difference in race between the blood donor pool and the patient population.⁴⁰⁷ As a result, there is a greater likelihood of minor-antigen incompatibility between donor and recipient. The differing immunogenicity of various red cell antigens also plays a role. For patients with sickle cell anemia, red cells phenotypically matched for Rh and Kell antigens are recommended. This measure was shown to reduce the alloimmunization rate in this population from 3% to 0.3% per unit transfused.⁴⁰⁸

Alloantibodies Reacting with Leukocyte Antigens

Alloimmunization to HLA and other leukocyte-associated antigens has been discussed earlier with respect to problems encountered in granulocyte and platelet transfusion. These antibodies occur mainly in multiparous women^{289,409} and multitransfused patients. In patients receiving nonleukoreduced transfusion support for aplastic anemia or acute leukemia, 20% to 70% become immunized to HLA antigens.⁴¹⁰ Interestingly, HLA alloimmunization is significantly increased in male patients with pre-existing RBC antibodies compared to multiply transfused male patients without such antibodies.⁴¹¹ As discussed in the section "Platelet Transfusion" and shown in Table 21.7, the prophylactic use of leukocyte-reduced blood products significantly reduces the incidence of HLA alloimmunization in patients with no prior exposure to these antigens.

Alloantibodies Reacting with Plasma Proteins

Although antibodies to soluble plasma proteins such as lipoproteins and to Gm and Inv determinants on IgG are often detectable in multitransfused patients, transfusion reactions have rarely been attributed to such antibodies.^{412,413} and ⁴¹⁴ Some anaphylactic reactions are attributed to anti-IgA antibodies,^{415,416,417} especially in patients who are IgA-deficient, although the presence of antibodies that react with IgA is not always clearly correlated with the occurrence of this type of transfusion reaction.⁴¹⁸

Hemolytic Transfusion Reactions

The development of antibodies capable of reacting with red cell antigens may lead to red cell destruction, usually involving transfused rather than recipient cells. The clinical significance of such reactions ranges from life-threatening to trivial. Whether hemolysis occurs immediately within the circulation, more slowly within the reticuloendothelial system, or not at all depends on the antigen and antibody involved.^{419,420} and ^{421,422}

The incidence of such reactions is variably reported. Several studies from the Mayo Clinic document a hemolytic reaction rate, both immediate and delayed, of between 1 in 6,200 and 1 in 1,400 red cell transfusions. In these reports, reactions caused by clerical error and ABO mismatching were virtually nonexistent, but some reactions were attributed to weak atypical antibodies missed in pretransfusion testing.^{419,423} The high reaction rate was related in part to a high index of suspicion and in part to the use of sensitive tests for serologic evidence of minor delayed hemolytic transfusion reactions (DHTRs). In contrast, in a review of fatal hemolytic reactions reported to the US Bureau of Biologics (now the FDA's Center for Biologics Evaluation and Research or CBER), 86% were caused by ABO incompatibility, and of these, 89% were caused by simple clerical error.^{424,425} More recent FDA data has shown a decrease in deaths due to ABO incompatibility although overall, hemolytic transfusion reactions still represent a leading cause of transfusion-related mortality.⁴²⁶

Immediate (Intravascular) Hemolytic Transfusion Reactions

Immediate hemolytic transfusion reactions (IHTRs) are most typically associated with ABO incompatibility, because anti-A and anti-B antibodies are predominantly IgM and are capable of binding complement and causing immediate destruction of red cells.

P.573

An IHTR caused by ABO incompatibility is rare and is usually related to human error. Other red cell antigens such as Jk^a, K, and Fy^a (which may bind complement) may also lead to such reactions.

Infrequently, hemolytic transfusion reactions may be caused by destruction of recipient red cells after the transfusion of plasmacontaining antibodies.^{427,428} For example, anti-A₁ occurring naturally in group A donors of subgroup A₂ has been reported to cause hemolytic transfusion reactions.⁴²⁹ More recently, hemolytic transfusion reactions have been reported

in association with apheresis platelets containing abnormally high titer ($>1:250$) anti-A or anti-B antibodies in the plasma. Plasma volume reduction is recommended for such products if the plasma is incompatible with the recipient.⁴³⁰ Hemolytic reactions caused by the transfusion of plasma containing other antibodies are extremely rare, as blood donors are screened for red cell antibodies other than ABO.

Signs and Symptoms. IHTRs occur soon after the incompatible transfusion has begun. Occasionally, they are mild; more typically, there is a sudden change clinically. Fever with or without chills is one of the most common manifestations of such reactions. Other signs and symptoms include anxiety, chest or back pain, flushing, dyspnea, tachycardia, and hypotension. If the patient is under general anesthesia, these symptoms may not be recognized; only severe hypotension and evidence of oozing or hemoglobinuria serve as clues to the presence of a hemolytic reaction.

IHTRs may be life-threatening, and complications may include acute renal failure, shock, and intravascular coagulation. It has been estimated that a fatal immediate hemolytic reaction occurs in approximately 1/600,000 red cell transfusions⁴²². The mortality of a severe IHTR increases with the amount of blood transfused, with a 44% mortality rate in patients receiving more than 1 L of incompatible blood.

Pathophysiology. The primary event in IHTRs is the interaction between the antibody and the red cell membrane, resulting in the development of immune complexes, activation of complement leading to the release of C3a and C5a with anaphylatoxic activity, and the coagulation mechanism via cytokines and factor XII (leading to both consumptive coagulopathy and generation of bradykinin). Vasomotor mediators implicated in the transfusion reaction include histamine, serotonin, and cytokines. Shock results from release of such vasoactive substances.^{421,422}

The renal failure that may occur in this setting is of complex and poorly understood etiology but appears to be primarily ischemic, caused by a combination of hypotension, vasoconstriction (via nitric oxide inactivation by hemoglobin), and intravascular coagulation. The free hemoglobin circulating in such patients was once thought to be the major cause of renal failure by precipitating in and obstructing the renal tubules, but there is adequate evidence to discount this hypothesis. Infusion of incompatible red cell stroma, free of hemoglobin, is sufficient to produce acute renal failure.⁴²⁰

Management. On any suspicion of a hemolytic transfusion reaction, the transfusion must be discontinued immediately, as the severity of the reaction is related to the volume of red cells infused. A recheck of the patient's identity with the information on the discontinued blood unit is necessary to rule out bedside identification errors. The reaction must be reported to the blood bank without delay; a posttransfusion blood sample and the discontinued bag of blood should be sent to the blood bank for investigation of the cause of the reaction. Hydration must be begun immediately to prevent renal failure. An infusion of normal saline is given to maintain the blood pressure and increase the urine flow rate to 100 ml/h. Diuretics may be needed to maintain urine output. If oliguric renal failure develops, fluid challenges must be restricted. Once renal failure is established, the usual supportive measures, including fluid restriction, management of electrolyte balance, and dialysis, are required.

Additional interventions may be needed depending on the severity of the reaction. Some recommend early heparinization at moderate dose as management of coagulopathy if no specific contraindication exists; its use remains controversial. The patient may require support of the defective hemostatic mechanisms with platelets and cryoprecipitate or plasma. In massive intravascular hemolytic transfusion reactions, exchange transfusion has been performed.⁴³¹

Investigation of Immediate Transfusion Reactions. The following steps must be carried out in the investigation of patients with immediate transfusion reactions. The patient's identity must be confirmed, and all the records on the patient and the donor blood label must be checked for clerical errors. A new, properly labeled sample of blood must be drawn from the patient and sent to the blood bank with the discontinued unit of blood. The posttransfusion sample must be visually checked for hemolysis. In intravascular reactions, free plasma hemoglobin can be detected most quickly by centrifuging a tube of blood anticoagulated with ethylenediaminetetraacetic acid (EDTA) or heparin; pink to red plasma indicates intravascular hemolysis—that is, evidence of red cell destruction. There must be an investigation for possible alloantibodies. A direct antiglobulin test must be performed on the specimen submitted at the time of the reaction. If the test is positive, the pretransfusion sample should also be tested, because the patient may have had a positive direct antiglobulin test before transfusion.

Red cell typing should be repeated on all specimens. If the posttransfusion ABO and Rh types do not agree with pretransfusion results, there has been an error in patient identification or typing. Antibody detection tests should be repeated on the pre- and post-reaction samples. The direct antiglobulin test on the post-reaction specimen may reveal sensitization of red cells in the patient only if the antibody or complement-coated transfused incompatible cells have not been immediately destroyed. A serologic crossmatch should be positive, although the antibody may not be readily demonstrable in serum at the time the reaction is suspected clinically. In a minority of patients in whom there is a high

clinical suspicion of a hemolytic transfusion reaction, no immunologic abnormality may be identified. In some, repeated examination for antibodies over a prolonged period of time may eventually reveal the cause; in others, results may be persistently negative. In such patients, ⁵¹Cr red cell survival testing may be of value in documenting hemolysis caused by incompatibility.^{432,433,434} and ⁴³⁵

Patients with major hemolytic transfusion reactions should be assessed for the possible presence of intravascular coagulation, and their renal function should be monitored closely. Urinary hemosiderin or free hemoglobin in the urine may also be detected; wine-colored urine is typical of intravascular hemolysis. The laboratory can confirm the identity of the pigment. Demonstration of methemalbuminemia, reduced serum haptoglobin, or hyperbilirubinemia may provide supportive evidence.

Prevention. Most IHTRs are preventable. The most likely cause is human error, such as mislabeling of the patient sample, drawing the sample from the wrong patient, transcription errors, and improper identification of the unit with the recipient. Mechanisms to ensure positive identification of the patient (recipient), the blood sample, and the transfusion component must be in place to prevent IHTRs.⁵

Delayed Hemolytic Transfusion Reactions

DHTRs generally are much milder than those occurring immediately, and red cell destruction is predominantly extravascular.^{419,423,436,437} The transfused red cells are destroyed beginning 2 to 10 days after a transfusion. Investigation may reveal the presence of a red cell antibody not detected in the pretransfusion blood sample. The direct antiglobulin test is often positive, but the reaction is transient and may be missed if it is performed too late. The test reverts to negative as the incompatible red cells are removed from the circulation.

P.574

DHTRs almost always represent secondary, or anamnestic, antibody responses. On first exposure to an immunogenic red cell antigen, a primary antibody response generally is delayed in onset and slow to reach its peak. For example, anti-D appears a minimum of 4 to 8 weeks after transfusion and may not develop for up to 5 months, after most or all the donor red cells have been removed by the aging process.⁴¹⁹ The antibody level gradually declines, and antibody screening and crossmatch tests may be negative. After a subsequent transfusion, the previously sensitized recipient manifests a much more brisk immune response, with high concentrations of IgG antibody developing within days. Donor cells remaining in the circulation may become coated with antibody and removed by the reticuloendothelial system. Rarely, primary immunization after transfusion may lead to a DHTR.⁴³⁸

In delayed hemolytic reactions, destruction of the sensitized red cells is predominantly extravascular; that is, the IgG-coated red cells are removed by the reticuloendothelial system. Often, there are no symptoms, with a new red cell antibody and positive direct antiglobulin test detected incidentally.⁴³⁹ If present, symptoms and signs may include fever, falling hematocrit, jaundice, and, infrequently, hemoglobinemia and hemoglobinuria. Rarely, the reactions may be dramatic; renal failure is uncommon, but fatalities have been reported. The antibodies responsible for DHTRs are well defined. Antibodies to Kidd (Jk) antigens and to antigens of the Rh system are the major offenders, with anti-Kell and anti-Duffy (Fy) implicated in most other delayed reactions. Anti-Kidd antibodies are particularly troublesome because the plasma concentration of these antibodies declines more rapidly than others, so pretransfusion tests are more commonly negative in patients who are in fact sensitized.²³⁶

Investigation of Delayed Hemolytic Transfusion Reaction. If a DHTR is suspected, a fresh blood sample should be obtained from the patient. This sample should be screened for the presence of previously undetectable red cell antibodies. A direct antiglobulin test should be done. If it is positive, the antibodies should be eluted from the red cells and identified. If the transfused cells have already been destroyed, the direct antiglobulin test will not be positive, but an antibody should be detectable in the patient's serum. The physician must be advised and the patient given a card indicating the presence of the antibody. The blood bank must retain a permanent record of clinically significant antibodies because the antibody may again become undetectable.

Management. In most instances, no specific therapy is necessary. The few patients who experience severe reactions should be treated with adequate hydration. If further transfusions are indicated, crossmatch-compatible blood negative for the offending antigen(s) should be administered. The physician and patient should be informed about the antibody so that transfusions may be administered safely in the future.

Pseudo-hemolytic Transfusion Reactions

In patients manifesting a clinical syndrome consistent with intravascular hemolysis, but in whom no blood group incompatibility can be identified, other explanations should be considered. Conditions that mimic hemolytic transfusion reactions are called pseudo-hemolytic transfusion reactions.⁴²¹ These include bacterial contamination with organisms such as *Yersinia*, resorption of large hematomas, and hemolysis caused by drug reactions or vascular prostheses. Pretransfusion hemolysis of donor blood caused by mechanical trauma, freezing, heat, or hypotonic solutions, should always be considered a potential cause of such a reaction.⁴²¹

Febrile Nonhemolytic Transfusion Reactions

FNHTRs^{440,441,442} have been reported in a variable proportion of patients receiving transfusions, ranging between 0.5% and 3.0%; they are more common in multiply transfused patients. The typical reaction consists of a chill followed by fever of 1°C or greater, usually during or within a few hours of the transfusion. Headache, nausea, and vomiting may occur. Occasionally, the reaction may be severe but usually these reactions are mild. Whatever their degree, febrile transfusion reactions usually run their course within a few hours. Some causes of FNHTRs are as follows.

Alloimmunization to antigens on leukocytes and platelets is one of the most common causes of nonhemolytic febrile reactions. Early studies detected the presence of leukoagglutinins in such patients.^{443,444} HLA antibodies are most commonly found, followed by platelet-specific antibodies; granulocyte-specific antibodies are detected in only a minority of patients.^{445,446} and ⁴⁴⁷

Another cause of FNHTRs is the transfusion of cytokines that have developed during product storage, especially in nonleukoreduced whole blood-derived platelet concentrates stored at room temperature.⁴⁴⁸ During storage, leukocytes in platelet concentrates release cytokines that appear to be responsible for the febrile reaction.¹²⁶ The causative role of accumulated cytokines is supported by the observation that leukoreduction filtration after storage does not eliminate many of the FNHTRs to platelet concentrates.¹²⁷ The incidence of FNHTRs to nonleukoreduced platelet concentrates increases with the age of the platelet concentrate and the leukocyte concentration in the product. The reactions appear to be mediated by the supernatant of the platelet products.^{126,129,449} The concentration of cytokines in platelet concentrates and incidence of FNHTRs can be decreased by leukoreducing the products soon after collection. Apheresis platelets are leukoreduced by the collection technology and have reduced cytokine levels.⁴⁵⁰

The possibility of bacterial contamination of the product must be considered as a possible cause of FNHTR. Symptoms caused by transfusion of bacteria or their toxins can be mild or may be fatal. Platelet components are involved more often because they are stored at room temperature. However, certain organisms such as *Yersinia enterocolitica* proliferate in red cells at storage temperatures of 1°C to 6°C. Bacterial contamination is often not considered as a cause of a febrile reaction; it may be more prevalent than reported because of underinvestigation.^{451,452} and ⁴⁵³

Management of Febrile Reactions

The approach to management of febrile transfusion reactions must be based on an understanding of all the possible causes. Although many such reactions are caused by WBC alloimmunization or cytokines, fever may also be an indication of an unsuspected hemolytic transfusion reaction or contamination of the donor blood by bacteria or endotoxin. For these reasons, every transfusion complicated by a febrile transfusion reaction should be discontinued until the patient has been carefully assessed by a physician and the blood bank alerted. Although controversial, the physician, depending on the clinical condition of the patient and the institution's policies regarding such steps, may elect to restart the transfusion if a hemolytic or bacterially contaminated transfusion has been ruled out.

The possibility of a hemolytic reaction should be considered when fever occurs. If suspected, the donor unit, along with a patient blood specimen, should be returned to the blood bank for investigation. Other tests for hemolysis should be done as discussed previously, if clinically indicated. The donor unit and patient blood should be cultured if there is any suspicion of bacterial contamination.

The symptoms of a febrile transfusion reaction may often be ameliorated with an antipyretic such as acetaminophen or hydrocortisone in patients who develop severe reactions. Meperidine may be used to decrease or stop severe shaking chills. Antihistamines are indicated only if the patient also has allergic symptoms such as hives.

Prevention of Febrile Transfusion Reactions

Febrile transfusion reactions to red cells occur most commonly in patients who have been sensitized to WBC antigens by previous

transfusions or pregnancies. In such patients, the risk of a febrile transfusion reaction varies with the leukocyte content of the donor unit. Use of leukoreduced red cells may decrease the incidence of FNHTRs.^{454,455} and ⁴⁵⁶ Every patient who experiences a reaction does not routinely need specific preventive measures, because only a minority will have a second reaction.

When whole blood-derived platelets are given, febrile reactions are common. Removal of leukocytes from these components at the time of transfusion often fails to prevent FNHTR because of the high level of cytokines in these products.^{126,129} Reduction of the level of cytokines by using platelet concentrates stored for a shorter time, prestorage leukoreduction of the platelet concentrates, plasma reduction, or use of apheresis platelets reduces the incidence of FNHTR to platelet products.^{79,457} If reactions persist, premedication with antipyretics or corticosteroids may be required. Because granulocyte concentrates cannot be modified by leukoreduction, premedication should be considered in patients who receive these products.

Transfusion-related Acute Lung Injury

Transfusion-related acute lung injury (TRALI) most commonly presents as severe respiratory distress of sudden onset, caused by a syndrome of noncardiogenic pulmonary edema resembling the adult respiratory distress syndrome.^{458,459} Chills, fever, chest pain, hypotension, and cyanosis, as well as the usual manifestations of pulmonary edema, may be seen. TRALI is reported by the FDA as the number-one cause of transfusion-associated fatality.^{426,460} The incidence of TRALI varies greatly, from 1 in 5,000 to 1 in 557,000 depending on the blood component involved.^{355,426}

It is hypothesized that TRALI reactions may be the result of two cumulative events⁴⁶¹: the first event is linked to the patient (i.e., underlying sepsis, hematologic disease, and/or postsurgical status), and the second event is related to the transfusion of potential granulocyte primers such as inflammatory cytokines, active lipids, and/or alloantibodies.^{355,462} The diagnosis of a TRALI reaction is based on the onset of acute lung injury (ALI) within 6 hours of transfusion.^{463,464} ALI is characterized by an acute onset of hypoxemia (oxygen saturation <90% by pulse oximetry for a patient breathing room air or a $\text{PaO}_2/\text{FiO}_2 \leq 300$ mmHg), bilateral infiltrates on frontal chest radiograph, and no evidence of circulatory overload. Based on studies of adult respiratory distress syndrome, which has similar pulmonary manifestations, it has been suggested that agglutination of granulocytes and complement activation occur in the pulmonary vascular bed, leading to capillary endothelial damage with consequent fluid leak into the alveoli.⁴⁶⁵

Management involves supportive measures for the pulmonary edema and hypoxia, including ventilatory support if required. Hemodynamic monitoring may be required to determine whether fluid overload is a factor; if not, diuretics are of no proven value.⁴⁶⁶ The AABB requires evaluation of donors implicated in TRALI.⁵ Donors whose plasma is implicated in such reactions should be examined for the presence of granulocyte-specific and HLA antibodies that react with recipient leukocytes. It is recommended to avoid further transfusion of plasma-containing products from implicated donors found to have anti-HLA or antigranulocyte antibodies. In 2006, the AABB recommended that blood banks minimize the production of high-plasma-content components (such as plasma products and pheresis platelets) from donors at risk for alloimmunization (e.g., women with a history of pregnancy).¹⁸ This change has resulted in a decrease of reported TRALI cases^{355,356,426}.

Allergic Reactions

Allergic reactions are common in transfusion recipients, with an estimated incidence of 1% to 3%,⁴⁴¹ but their actual incidence may be higher because they are often not reported. They range from urticarial lesions (hives), other skin rashes, bronchospasm, and angioedema to anaphylactic shock. Minor reactions are doserelated, with an incidence related to the volume of plasma transfused. Whole blood and plasma are more likely than concentrated red cells to cause such reactions; washed red cells or albumin are rarely implicated. Minor urticarial reactions are the only transfusion reactions that do not necessitate immediate discontinuation of the transfusion. Fortunately, the incidence of severe anaphylactic transfusion reactions is very low, as such reactions can be life-threatening.

Most allergic reactions are thought to be mediated by recipient IgE to proteins or other soluble substances in donor plasma. The interaction between the antigen and IgE stimulates the release of histamine from mast cells and basophils. Most patients do not have repeated allergic reactions, but those with a history of atopy are at higher risk for additional reactions. For patients with repeated allergic reactions, premedication with an H₁-blocking antihistamine is usually sufficient for prevention. If maximal premedication fails to control the allergic response, reducing the plasma content of the transfused blood product is another option. This can be accomplished by centrifuging the product and removing almost all the plasma or by red cell washing.

In patients with severe anaphylactoid or anaphylactic reactions, antibodies reacting with IgA in donor plasma should be considered. The incidence of genetically determined IgA deficiency in the otherwise normal population is high, ranging from 1 in 400 to 1 in 500.⁴⁶⁷ Without necessarily having prior transfusion exposure, approximately 20% to 25% of such patients produce antibodies to IgA, generally class-specific (i.e., reacting with all IgA molecules). Such patients should be transfused, when necessary, with washed red cells⁴⁶⁸ or with IgA-deficient blood products. In addition, many patients with normal IgA levels have antibodies that react with some, but not all, IgA molecules; the incidence of such limited-specificity antibodies has been reported at 2% of normal adults,⁴⁶⁹ but the incidence may be as high as 21% in multiply transfused patients.⁴⁴⁰ The concentration of such limited-specificity antibodies generally is low, and the resulting reactions are usually milder, but the possibility of a major reaction exists.⁴¹⁷

Posttransfusion Purpura

Posttransfusion purpura^{470,471} and ^{472,473} is the development of life-threatening thrombocytopenia 5 to 10 days after transfusion. This rare complication is caused by the development of alloantibodies directed against platelet-specific antigens; anti-HPA-1a is often implicated, although antibodies with other specificities have also been reported (see Chapter 47). Posttransfusion purpura is thought to occur as a result of a secondary immunologic response to the platelet-specific antigen, most patients having been sensitized by prior pregnancy or transfusion. The mechanism of destruction of the patient's own platelets is uncertain. Management includes high-dose IVIG,⁴⁷⁴ corticosteroids,⁴⁷⁵ or plasma exchange.⁴⁷³

Posttransfusion thrombocytopenia may also be associated with the passive administration of a platelet-specific antibody.^{476,477} and ⁴⁷⁸ Both anti-HPA-1a and anti-HPA-5a have been implicated; these cases can be defined as passive posttransfusion purpura, and the resulting thrombocytopenia occurs within hours of the transfusion. It is important to identify the donors of these blood products to prevent further infusion of plasma-containing products from such donors.

Transfusion-related Immunomodulation

Allogeneic blood transfusion results in the transfer of not only RBCs, but also significant amounts of potential immune effector cells, their products (e.g., cytokines), and various substances that may be seen by the host immune system as foreign antigens.

P.576

A large body of literature exists that substantiates the modulation of host immune systems by transfused allogeneic cells and substances, raising the possibility of the development of clinical syndromes generally referred to as transfusion-related immunomodulation (TRIM).⁴⁷⁹ Beneficial transfusion-related immunomodulatory effects have been reported in renal transplant patients, women with recurrent spontaneous abortions, and patients with Crohn's disease.⁴⁸⁰

A large number of clinical studies have been performed specifically addressing two potential harmful TRIM-associated effects: cancer recurrence and postoperative bacterial infections. The aim of the studies has been to document TRIM and to ascertain the potential benefit of leukoreduction or use of autologous blood.^{481,482,483,484,485,486,487,488} and ⁴⁸⁹ Despite some reported observations of a transfusion-associated increased risk of cancer recurrence or postoperative infections, many studies include potential confounders or sources of bias. Meta-analyses have concluded that a deleterious clinical effect of transfusion immunomodulation remains controversial.^{490,491,492}

Transfusion-associated Graft-versus-Host Disease

Most cellular blood products, including red cell, platelet, and granulocyte products, contain viable, immunocompetent T lymphocytes.⁴⁹³ When transfused into immunoincompetent recipients, these donor lymphocytes may proliferate in the patient and lead to the clinical syndrome of transfusion-associated graft-versus-host disease.^{494,495} TA-GVHD has also been reported in immunocompetent patients, especially those who receive transfusions from family members or from random donors who share HLA antigens, as is the case when the donor is homozygous for a shared HLA haplotype.^{496,497} In these cases, the recipient does not recognize the donor cells as foreign, allowing the transfused lymphocytes to proliferate and cause TA-GVHD. A higher incidence has been reported in countries such as Japan, whose populations are genetically similar.

Transfusion of leukocyte or platelet concentrates or fresh blood has been responsible for most cases of posttransfusion GVHD. Frozen-thawed plasma products (FFP, cryoprecipitate) have not been definitively associated with TA-GVHD. TA-GVHD occurs earlier than that seen after bone marrow transplantation, usually within 1 to 2 weeks, but is otherwise similar.⁴⁹⁸ Fever is the most common symptom, followed by a typical erythematous, maculopapular skin rash that begins centrally and spreads peripherally to the hands and feet. Abnormalities of hepatic function, nausea, and bloody diarrhea

often occur as the process progresses. Leukopenia followed by pancytopenia due to marrow failure is quite common in TA-GVHD and is seen most often 2 to 3 weeks after the onset of symptoms. The diagnosis is based on the clinical picture and can be confirmed histologically with a skin biopsy. Laboratory confirmation that the GVHD is transfusion-induced can be obtained by demonstrating the presence of donor lymphocytes in the patient. This can be done by HLA typing of patient and donor cells by DNA methods for class I and II antigens, by cytogenetic analysis, or by analysis of DNA microsatellite polymorphisms or variable-number tandem repeats.⁴⁹³ Severe systemic infections are the most common cause of death, which often occurs within 3 to 4 weeks from the time of the implicated transfusion. Despite aggressive treatment, the fatality rate in TA-GVHD is significantly higher than that associated with bone marrow transplantation and has been reported to be >90%.⁴⁹⁸

Corticosteroids, antithymocyte globulin, cyclosporine, and growth factors have all been used with minimal success in the treatment of TA-GVHD. Although a few reports of spontaneous resolution have been reported, current treatment approaches have used combinations of immunosuppressant medications with lymphocyte-directed antibody therapy (anti-CD3, anti-interleukin-2 receptor, antithymocyte globulin). Because of the lack of effective treatment regimens, TA-GVHD should be prevented by pretransfusion irradiation of all blood products administered to patients at risk. Irradiation inhibits proliferation of donor lymphocytes with little significant adverse effect on red cell, platelet, or granulocyte function. Changes in the red cell membrane do occur that result in an increased loss of potassium from the cell, limiting the storage time of irradiated red cells to 28 days. This may be important in neonates, as the dose of free potassium may be high in a relatively large-volume transfusion, necessitating the use of freshly irradiated or washed RBCs. The recommended dose for the irradiation of blood and blood products is 2,500 cGy at the center of the irradiation field, with a minimum dose of 1,500 cGy at any point in the field.^{5,131}

Based primarily on case reports and reviews, a number of immunosuppressed and immunocompetent patient groups can be stratified according to risk for developing TA-GVHD⁴⁹⁸ (Table 21.9).

Nonimmunologic Adverse Effects of Blood Transfusion

Transfusion-associated Circulatory Overload

Transfusion of red cell preparations or plasma products may result in transfusion-associated circulatory overload (TACO). In chronically anemic patients, the plasma volume expands so that the blood volume is normal. Virtually the entire volume of the blood product infused remains in the circulation; in elderly patients with limited cardiac reserve or in severely anemic patients in congestive heart failure, transfusion may lead to fatal pulmonary edema. Diuretic therapy and other measures to manage heart failure may be of some benefit; partial exchange transfusion may be indicated. Prevention of these reactions is most important. Transfusions should be administered slowly, at a rate of 1 to 2 ml of blood/kg of body weight per hour, with the

P.577

patient under close observation. Splitting red cell components or volume-reducing apheresis platelets can be helpful in managing the most difficult cases.

TABLE 21.9 PATIENTS AT INCREASED RISK FOR TRANSFUSION-ASSOCIATED GRAFT-VERSUS-HOST DISEASE

High Risk

Bone marrow transplant (allogeneic and autologous)

Intrauterine transfusions

Granulocyte or HLA-matched platelet transfusions

Transfusions from blood relatives

Congenital immunodeficiencies

Hodgkin disease

Moderate Risk

Hematologic malignancy (acute myelogenous leukemia/acute lymphocytic leukemia/non-Hodgkin lymphoma)

Patients treated with purine-analog drugs (e.g., chronic lymphocytic leukemia)

Malignancies treated with intensive chemo-/radiotherapy (i.e., neuroblastoma, sarcoma)

Solid organ transplant recipients

Preterm infants

Newborns receiving exchange transfusion

Low/Theoretical Risk

Human immunodeficiency virus/acquired immunodeficiency syndrome

Healthy term newborns

Modified from Schroeder ML. Transfusion-associated graft-versus-host disease. *Br J Haematol* 2002;117:275-287.

Massive Transfusion

Metabolic Effects

Stored blood differs in its composition from that circulating in the body. If large amounts of stored blood are infused rapidly, one may observe adverse effects related to such differences. The elevated K^+ content of stored red cells rarely leads to hyperkalemia, but it is a risk in the presence of renal failure, shock with acidosis, or hemolysis. Plasma contains a significant amount of citrate as anticoagulant; recipients with normal circulatory status promptly metabolize this in the liver, but during plasma exchange or in patients in shock or severe liver failure, citrate excess may lead to hypocalcemia. Hypocalcemic reactions caused by citrate may be treated by intravenous calcium infusion.⁴⁹⁹

Hypothermia

Hypothermia may occur if a large volume of cold blood is infused rapidly. Hypothermia is one of the most common complications of massive transfusion and contributes to the associated coagulopathy. Neonates and the elderly are particularly sensitive to this reaction. Hypothermia affects the way the liver metabolizes citrate, resulting in an increased risk of hypocalcemia. Rapid infusions of citrated blood products in such patients, especially through central venous lines, may lead to arrhythmias. Hypothermia interferes with platelet function and clotting, both of which are improved when the patient is warmed.⁴⁹⁹ One way of approaching this problem is with the use of warmed intravenous fluids or blood. Blood-warming devices are available that can adequately warm the blood administered, even during a rapid and massive transfusion. All patients who are receiving large amounts of red cells and plasma should have those products administered through blood-warming devices. Blood warmers must be checked regularly to ensure that they maintain their temperature. If the blood is overheated, hemolysis and the associated complications of transfusing hemolyzed blood may result.

Any one of these potential problems alone is rarely significant. However, in the critically ill patient who requires massive transfusion, acidosis, hypoxemia, hypothermia, hypocalcemia, and hypo- or hyperkalemia often coexist, with a consequent risk of cardiac arrhythmias. Neonates receiving exchange transfusions are particularly susceptible to such physical and metabolic effects.^{132,500}

Dilutional Coagulopathy

Massive transfusion of one to two blood volumes in patients results, first, in abnormalities of the prothrombin time (PT) and of the activated partial thromboplastin time (APTT); and second, in thrombocytopenia.⁵⁰¹ Massively transfused patients are often affected by sepsis, shock, and intravascular coagulation, which may aggravate the dilutional hemostatic defects.

In practice, most patients tolerate otherwise uncomplicated dilutional coagulopathy well. Factor VIII activity may rise as a response to stress; factor V falls, but rarely to dangerous levels. Moderately severe thrombocytopenia, accompanied in some cases by a significant degree of platelet dysfunction, may be a more significant problem. Transfusion therapy of such patients is best guided by laboratory measurements, but clinical assessment is most important because conventional coagulation tests take time to obtain. As discussed earlier in this chapter, for patients undergoing rapid massive transfusion, the first line of treatment (with regard to hemostatic blood products) should include plasma to correct the levels of coagulation factors, followed by platelet products.^{205,206,208,222,224}

Age of Transfused Blood

In 2008, a study suggested a relationship between the length of blood product storage and the in-hospital mortality of transfused cardiac surgery patients.⁶³ The study was retrospective in nature and elicited much discussion and further investigation. Metaanalyses of studies looking at the effect of age of transfused blood on patient outcomes failed to clarify an association.^{502,503,504} Prospective studies are now ongoing.^{505,506} and ⁵⁰⁷

The changes that stored red blood cells undergo while awaiting transfusion are referred to as the “storage lesion.” In short, these changes are a decrease in both 2,3-diphosphoglycerate, ATP, and an increase in extracellular potassium. Red cell membrane changes result in decreased flexibility of the cell, hemolysis, and formation of microparticles. Whether the red cell storage lesion is responsible for deleterious clinical effects awaits further investigation.

Miscellaneous

Air embolism is a potential hazard when perioperative infusion devices are used.⁵⁰⁸ Fat embolism may occur in the rare situation in which blood products are transfused via the bone marrow. The plastic materials used to ensure the flexibility of some blood storage bags can leach into the product and, although no adverse effects have been demonstrated to date,⁵⁰⁹ attempts are being made to identify alternatives.

Iron Overload: Transfusion Hemosiderosis

Iron overload is a major problem in patients who require longterm red cell transfusion support for chronic anemias due to bone marrow failure.^{510,511} Each unit of red cells contains approximately 0.25 g of iron. After a large number of red cell transfusions, in the absence of blood loss, the recipient develops the stigmata of transfusion siderosis: impaired growth, failure of sexual maturation, myocardial and hepatic dysfunction, hyperpigmentation, and, often, diabetes. Patients such as those with thalassemia who are at risk of this complication should receive prophylactic aggressive iron chelation therapy.

INFECTIOUS COMPLICATIONS OF BLOOD TRANSFUSION

Overview of Blood Donor Screening for Infectious Diseases

In the 1960s, transfusion-associated hepatitis (TAH) occurred in more than 30% of multiply transfused patients. The development and implementation of a screening test for HBsAg and the switch to an all-volunteer blood supply resulted in a dramatic reduction in the incidence of both B and non-A, non-B (NANB) TAH (Fig. 21.7).⁵¹² However, a significant risk of NANB hepatitis persisted.

In the early 1980s, the blood banking industry was further challenged with the appearance of AIDS. In the early and mid-1980s, before the identification of the causative agents of AIDS or NANB hepatitis, the idea of using surrogate tests to identify donations at increased risk of transmitting one of these infections was introduced. Candidate tests included those that would detect the consequences of an infection (e.g., elevated alanine aminotransferase [ALT] in the case of NANB hepatitis or inverted helper-tosuppressor T-cell ratio in the case of AIDS) or those likely to be positive in individuals who engaged in high-risk sexual activity or needle sharing (e.g., antibody to the hepatitis B core antigen [anti-HBc]).^{513,514,515} and ⁵¹⁶ Before the availability of a specific test for HIV, some blood suppliers implemented HBc antibody testing or donor

P.578

T-cell testing in an attempt to reduce the risk of transmitting AIDS through blood transfusion.

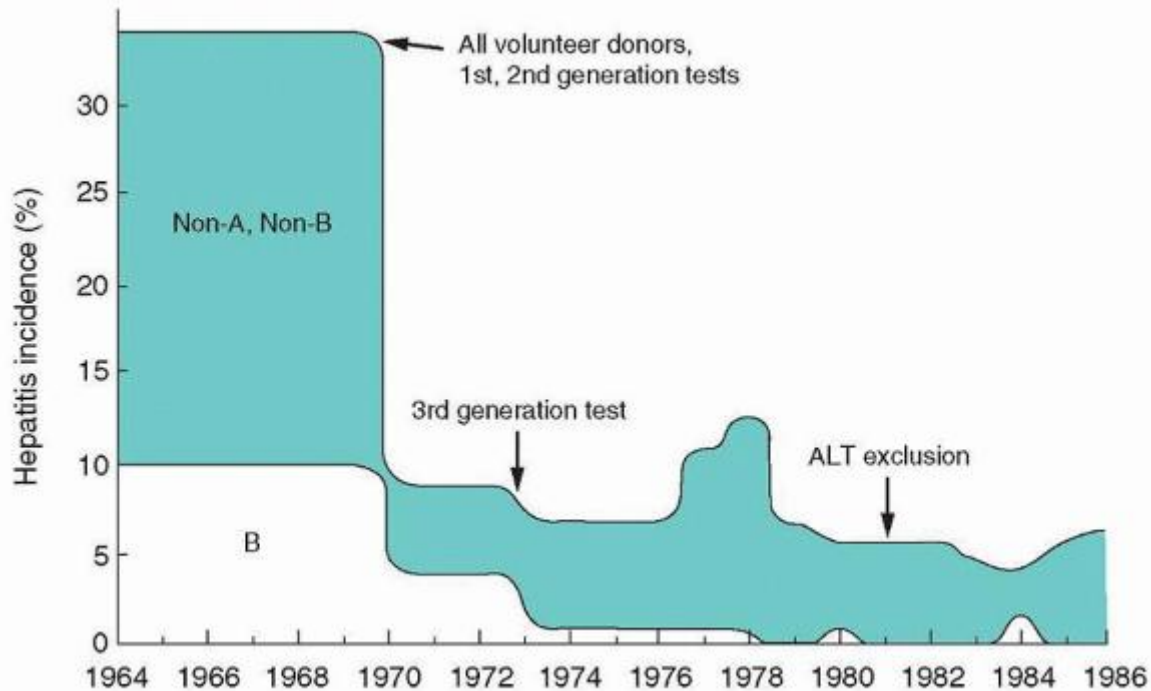

FIGURE 21.7. Annualized incidence of posttransfusion hepatitis B and non-A, non-B at the National Institutes of Health, 1964 to 1986. First-, second-, and third-generation tests refer to tests for hepatitis B surface antigen. ALT, alanine aminotransferase. (Reprinted from Alter HJ. You'll wonder where the yellow went: a 15-year retrospective of posttransfusion hepatitis. In: Moore SB, ed. Transfusion-transmitted viral diseases. Arlington, VA: American Association of Blood Banks, 1987, with permission.)

After the development and implementation of a test for HIV antibody in 1985, it became clear that there is a delay between the onset of infection and the development of detectable antibody. A blood donation made during this “window period” could pass infectious disease screening tests but transmit infection. The FDA required blood centers to inform prospective donors about the window period and to question them directly about specific risk behaviors. Gradually, improvements in the sensitivity of the HIV antibody test led to shortening the HIV window period from 45 days to about 22 days.^{517,518}

During the mid-1980s, surrogate tests for NANB hepatitis and risk activity (ALT and HbC antibody) became required in the United States. A donor screening test for the retrovirus HTLV-I was implemented in 1988. The first donor screening test for antibody to hepatitis C became available in 1990, and an improved test became available in 1992. In 1996, a donor screening test for HIV-1 p24 antigen was implemented because available information suggested that this test could shorten the HIV window period by an additional 6 days.⁵¹⁸ By this time, the risks of transfusion-transmitted HIV and hepatitis were too low to measure prospectively and could only be estimated with the aid of mathematic modeling (Fig. 21.8).^{519,520} and ⁵²¹

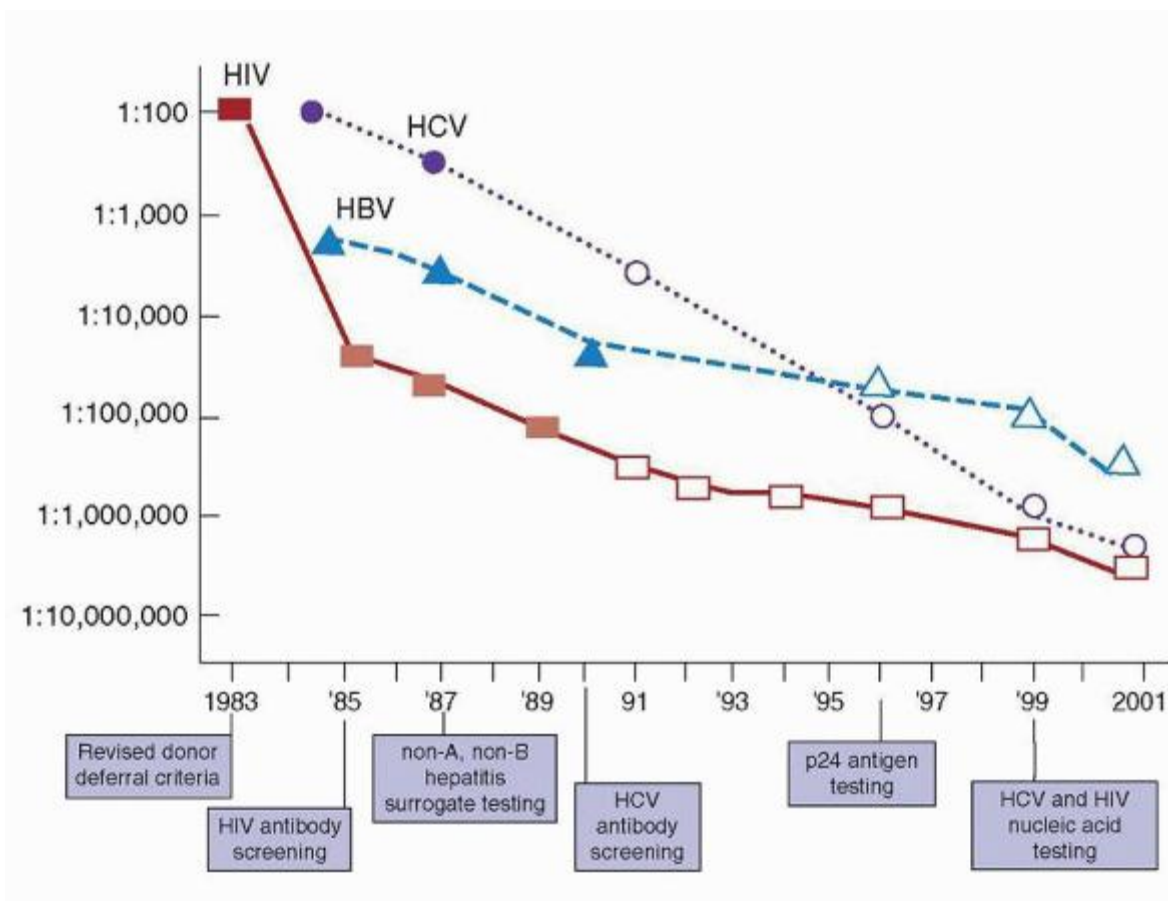

FIGURE 21.8. Decline in risk of human immunodeficiency virus (HIV), hepatitis B virus (HBV), and hepatitis C virus (HCV) transmission by transfusion, 1983 to 2001. Estimates indicated by solid symbols are based on donor prevalence measurements; estimates indicated by shaded symbols are based on recipient follow-up studies; estimates indicated by open symbols represent projections based on mathematical modeling. Estimated risk of infection per unit transfused in 2000-2001 was 1:220,000 for HBV, 1:1.6 million for HCV, and 1:1.8 million for HIV. (From Fiebig E, Busch MP, with permission; modified from Busch MP, Kleinman SH, Nemo GJ. Current and emerging infectious risks of blood transfusions. *JAMA* 2003;289:959-962.)

Despite the extremely low risk of transfusion-transmitted HIV and hepatitis, there continued to be immense public pressure to further improve transfusion safety. In 1999, nucleic acid testing (NAT) for HIV and HCV RNA was added to blood donor screening via clinical trials. Initially available NAT methods were labor-intensive and could not be applied to rapid screening of large numbers of blood donations. NAT screening was rendered feasible by performing the assays on “minipools” of donor specimens (initially pooling 16 to 24 samples together for testing, more recently 6 to 16 samples). Clinical trials of minipool NAT for HIV and HCV RNA confirmed that this testing detects infection earlier than antigen or antibody assays.^{522,523} NAT testing for HIV and HCV RNA is now required by the FDA. With implementation of licensed NAT for HIV, the FDA permitted discontinuation of the HIV p24 antigen test.

NAT assays continue to be improved and new assays developed. Donor NAT assays for HIV and HCV RNA are now fully
P.579

automated and have been multiplexed to include HBV DNA detection. Testing for West Nile virus RNA was initiated in 2003 using investigational assays; this testing is now required by FDA.

Additional donor serologic screening tests have also been developed or are in development. A donor screening assay for antibodies to *T. cruzi* became available in 2007; FDA now requires every donor to be tested once for this infection (see below). Tests for *Babesia* infection are in development.

Residual Risks of Infection

Table 21.10 lists the tests currently performed on volunteer blood donations in the United States. It is thought that the residual risk of transmitting HIV and hepatitis by transfusion is related mainly to window period donations. The probability that a donation was made during the window period can be calculated from the observed incidence of new infections in blood donors and the length of the window period.^{19,521,524} The implementation of nucleic acid testing for HIV and HCV has permitted direct detection of donors with newly-acquired infections (i.e., donors who are NAT-positive, antibody negative). New HIV and HCV infections in repeat blood donors are very rare. However, studies indicate that first-time donors are two to three times more likely than repeat donors to have newly-acquired infection.¹⁹ Thus, current estimates of transfusion risk include an adjustment for a 2- to 3-fold higher probability that a first-time donor is in the window period compared to a repeat donor.^{523,524,525} and ⁵²⁶ Table 21.11 shows the current risk estimates for transfusion-transmitted HIV, HCV, and HBV based on the length of the window period and the estimated frequency of window period donations.

Because the current risks of transmitting HIV and HCV are low, the absolute benefit gained from further incremental improvements in blood donor testing for these infections would be very small. The implementation of individual-unit NAT for HIV and HCV, for example, would be associated with extremely high cost with very little incremental improvement in blood safety in the US.^{527,528} Similarly, the value of processes to chemically inactivate residual pathogens in blood products has been questioned in view of the low residual risks of HIV and HCV. These treatments, however, might represent a reasonable approach toward reducing the risk of transmitting infectious agents for which there are currently no donor screening tests.^{529,530} Some pathogen reduction treatments for platelets and fresh plasma are in use outside the US, but as of April 2012 these were not approved for use in the US. Commercial plasma derivatives are, however, subjected to a solvent/detergent treatment that inactivates lipid-enveloped viruses such as HIV, HCV, and HBV. Solvent/detergent treatment cannot be applied to cellular blood components.

TABLE 21.10 INFECTIOUS DISEASE TESTING PERFORMED ON U.S. BLOOD DONATIONS

Infection	Tests Designed to Detect
Hepatitis B	Hepatitis B surface antigen IgM and IgG antibody to hepatitis B core antigen HBV DNA ^a
Hepatitis C	IgG antibody to hepatitis C peptides Hepatitis C virus RNA ^a
HIV-1/-2	IgM and IgG antibody to HIV-1/-2 HIV-1 RNA ^a
HTLV-I/-II	IgG antibody to HTLV-I/-II
Syphilis	IgM and IgG antibody to treponemal antigens <i>Or</i> nontreponemal serologic reactivity (e.g., rapid plasma reagin)
WNV	WNV RNA ^a
<i>T. cruzi</i>	IgG antibody to <i>T. cruzi</i> ^b

HIV, human immunodeficiency virus; HTLV, human T-cell lymphotropic virus; Ig, immunoglobulin; WNV, West Nile virus.

^a Nucleic acid testing is usually performed on minipools of 6 to 16 donor samples.

^b *T. cruzi* antibody testing may be limited to one-time testing of each donor.

TABLE 21.11 CURRENT ESTIMATED RISKS OF TRANSFUSION-TRANSMITTED INFECTION BASED ON WINDOW PERIOD/INCIDENCE ESTIMATES^a

Agent	Window Period (Days)^b	Incidence of New Infections in Repeat Donors (per 100,000)	Estimated Risk/Unit Transfused^c
--------------	---	---	---

		Person-Years)	
Hepatitis B	38	2.49	1:280,000
Hepatitis C	7.4	2.98	1:1,149,000
Human immunodeficiency virus	9.0	2.16	1:1,467,000

^aEstimates are based on figures from Zou S, Dorsey KA, Notari EP, et al. Prevalence, incidence, and residual risk of human immunodeficiency virus and hepatitis C virus infections among United States blood donors since the introduction of nucleic acid testing. *Transfusion* 2010;50:1495-1504⁵²⁵; and Zou S, Stramer SL, Notari EP, et al. Current incidence and residual risk of hepatitis B infection among blood donors in the United States. *Transfusion* 2009;49:1609-1620.⁵²⁶

^b Window-period estimates assume minipool nucleic acid testing for HIV and HCV and no HBV DNA testing.

^c Estimated risk/unit transfused is calculated using an adjustment for the proportion of units from first-time donors, whose incidence of infection is two to four times higher than that of repeat donors.

Modified from Galel S. Infectious disease screening. In: Roback JD, Grossman BJ, Harris T, Hillyer CD, eds. *AABB technical manual*, 17th ed. Bethesda, MD: AABB, 2011:239-270.⁵⁴⁴

Transfusion-associated Hepatitis

Before the development of serologic tests capable of determining the cause of TAH, all TAH was thought to be due to hepatitis B (the “serum hepatitis” agent). After the HBsAg test became available, however, it was discovered that hepatitis B accounted for only about 25% to 30% of TAH cases.^{531,532} Subsequent studies excluded hepatitis A virus (HAV), CMV, and the Epstein-Barr virus (EBV) as common causes of TAH. The designation NANB hepatitis was created to describe the majority of TAH cases.⁵³³ In 1988, the major causative agent of NANB hepatitis was identified as HCV.^{534,535} Widespread testing of all blood donations for this virus was implemented in 1990. An improved test for hepatitis C became available in 1992. Since then, TAH has become rare.

Hepatitis B

The discovery of HBsAg and application of this test to blood donor screening led to a dramatic reduction in transmission of HBV by transfusion (Fig. 21.7).⁵³⁶ Screening of all blood products for HBsAg began in 1970 in the United States with low-sensitivity tests and was made mandatory in 1972. The high-sensitivity HBsAg test in current use becomes positive an average of 38 days after the onset of infectivity.⁵³⁷ This test detects most but not all donors who are infectious for hepatitis B. Three types of individuals with hepatitis B infection may be missed by the current HBsAg test: (1) individuals with early infection whose HBsAg has not yet become detectable; (2) individuals who were previously vaccinated against HBV and have anti-HBs but who acquire HBV infection after subsequent exposure (so-called “vaccine breakthrough” infections);

P.580

and (3) individuals with chronic infection whose HBsAg has fallen below the limits of detection (“occult HBV infection”).

Units from individuals with chronic occult HBV (category 3 above) are currently excluded from the US blood supply by donor testing for anti-HBc. In the US, anti-HBc-positive donations are permitted into pooled plasma derivatives, however, because HBV infectivity is eradicated from these products by the pathogen inactivation processes to which the products are subjected. Based on currently mandated donor screening tests (i.e., HBsAg and anti-HBc), the current estimated risk of HBV transmission by individual blood components in the United States is 1 in 280,000 units⁵²⁶ (Table 21.11).

As of April 2012, HBV DNA testing of blood donors was not required in the US. However, most US blood donors were, in fact, being tested for HBV DNA because probes for this target were included in the donor screening NAT assays used for HIV and HCV RNA detection. In November 2011 the US FDA issued a draft guidance document indicating its intention to make HBV DNA screening a requirement.⁵³⁸ HBV DNA tests detect some, but not all, of the HBV-infected donors missed by

HBsAg testing.⁵³⁹ HBV DNA screening of blood donors has more value in HBV endemic countries where donors are not screened for anti-HBc.⁵⁴⁰

Hepatitis C

Donor screening for HCV includes NAT for HCV RNA as well as HCV antibody testing. It is estimated that the donor RNA test detects infection an average of 7.4 days after exposure. Based on window period/incidence modeling, the risk of HCV transmission by transfusion of fresh blood products is now estimated to be approximately 1 in 1,149,000 (Table 21.11).⁵²⁵

Hepatitis A Virus

Transfusion-related transmission of HAV by fresh blood products is rare.^{541,542} However, transmission of HAV has been associated with pooled plasma products.⁵⁴³ Because HAV is not lipid-enveloped, infectivity is not eliminated by solvent/detergent treatment. Therefore, immunization to HAV is recommended for patients who are expected to receive pooled plasma products, such as those with clotting disorders.⁵⁴³ The FDA does not require donor screening for this agent. Some plasma-derivative manufacturers, however, test plasma pools for HAV nucleic acid in an effort to reduce the risk of transmitting this agent.

Human Immunodeficiency Virus Type 1 and Type 2

Current donor screening for HIV includes nucleic acid testing for HIV-1 RNA and testing for antibodies to HIV-1 and HIV-2. The window period for HIV, based on time to detection of RNA via minipool nucleic acid screening, is currently estimated at 9 days.⁵²⁵ The current estimated risk of HIV transmission by transfusion is approximately 1:1,467,000 units (Table 21.11). Donor questioning regarding HIV risk behavior and the temporary exclusion of individuals at increased risk of being in the HIV window period are critical and essential elements of this safety level.⁵⁴⁴ Whether certain deferral periods could be shortened without compromising blood transfusion safety has been the topic of intense public discussion.⁵⁴⁵

Other Infections

Essentially any infection that can circulate in the blood of an apparently healthy blood donor can be transmitted by transfusion. Recently, the AABB's Transfusion-Transmitted Diseases (TTD) Committee evaluated a number of potentially transmissible infections, their risks of causing severe disease, and the need for intervention strategies.⁵⁴⁶ This analysis is available online and is updated periodically. Some of the agents that have been the focus of recent interventions or public debate are discussed below.

Infections Transmitted by Arthropods

Over the past decade, much attention has been focused on infectious agents that can be transmitted to donors by insects and further transmitted to patients via transfusion.⁵⁴⁶ This category of pathogens includes West Nile virus, *Trypanosoma cruzi*, babesia, malaria, and dengue fever.

West Nile Virus

West Nile virus was first detected in the United States in 1999, and has since spread through the North American continent in annual epidemics. Birds are the natural reservoir of the virus, which is spread to humans by mosquitos.⁵⁴⁷ Eighty percent of infected individuals are asymptomatic, 20% have a relatively nonspecific febrile illness, and <1% develop neuroinvasive disease (meningitis, encephalitis, or flaccid paralysis), which can lead to chronic disability or death.

WNV was first demonstrated to be transmissible by transfusion in 2002, when infection in 23 recipients was linked to blood components later found to contain WNV RNA but no WNV antibody.⁵⁴⁸ In 2003, minipool NAT screening of blood donations for West Nile virus RNA was implemented throughout the United States using investigational assays. WNV NAT assays are now FDA-approved and required. Transmissions despite minipool donor testing led to the discovery that 20% to 30% of donors with WNV infection may be missed by minipool testing because of low levels of circulating virus.^{549,550} Therefore, at times of high WNV activity, donor WNV RNA screening must be performed on individual donations.⁵⁵¹

Malaria

Malaria is a common infection globally. However, transfusion-transmitted malaria is rare in the United States, with only zero to three cases per year occurring during the last decade.⁵⁵² This degree of safety is remarkable considering that there is no donor screening test for malaria in the United States. Screening is accomplished entirely by donor questioning. According to current FDA guidelines, individuals are deferred from donation for 1 year after travel to a malarious area and for 3 years after living in a malarious area. Almost 3% of otherwise eligible donors are excluded on the basis of this questioning. Of the donors implicated in the recent cases of transfusion-transmitted malaria in the United States, approximately 60% (including the majority of *Plasmodium falciparum* infections) should have been excluded by donor

deferral criteria. The remaining cases are largely related to chronic asymptomatic infections in donors who are beyond the deferral period.⁵⁵²

Babesiosis

Babesiosis is caused by a protozoan parasite that infects human RBCs. It is transmitted by the Ixodes tick, the same vector that transmits the causative agents of Lyme disease and human granulocytic anaplasmosis. US cases of babesiosis were first identified in the northeast United States but have now also been identified in Minnesota, Wisconsin, and California.⁵⁵³

Incubation ranges from 1 to 6 weeks or longer. Symptoms range from none to mild flulike symptoms to a malaria-type illness with hemolytic anemia. Asymptomatic individuals may remain infective for months or years.⁵⁴⁶ More than 150 cases of transfusion-transmitted babesiosis have been identified, including fatalities. Asplenic, immunocompromised, and elderly patients appear to be at increased risk for severe infection. It is suspected

P.581

that transfusion-transmitted babesiosis is vastly underrecognized. The need for an intervention to reduce transfusion-transmitted babesia in the US has been acknowledged at the national level.^{553,554} Antibody screening of donors or pathogen reduction could theoretically reduce transmission, but there is currently no intervention approved for use.

Lyme disease is caused by the spirochete *Borrelia burgdorferi* and is transmitted by the same tick vector that transmits babesiosis. The organism has been found to survive the storage conditions of RBC and platelet components. Nevertheless, there have been no documented cases of transfusion-transmitted Lyme disease.⁵⁴⁶

Trypanosoma cruzi

Trypanosoma cruzi, the protozoan parasite that causes Chagas disease, is endemic in portions of Mexico, Central America, and South America. It is transmitted to humans by the reduviid bug. Acute infection is usually self-limited, although rarely it may involve myocarditis or meningoencephalitis and may be fatal, particularly in immunocompromised patients. In most cases, however, the acute infection goes undiagnosed, and the infection becomes chronic. After decades, 20% to 30% of chronically infected individuals develop cardiac or intestinal dysfunction that can be fatal. The transmission of *T. cruzi* by transfusion is well documented in endemic areas.⁵⁴⁶ A blood donor screening assay for *T. cruzi* antibody became available in the US in 2007. The vast majority of the infected donors detected have been immigrants from endemic areas; US-acquired *T. cruzi* appears to be rare. Therefore, the FDA has endorsed a strategy of testing each US donor only once for this infection.³¹

Dengue Virus

Studies in dengue-endemic regions outside the continental US have documented a high prevalence of blood donors with asymptomatic viremia during dengue outbreaks.⁵⁵⁵ Concern about this virus in the US has increased recently with recognition of infections in the southern part of the country.⁵⁵⁶ Although there does not currently appear to be a need for blood donor screening for this virus within the continental US, activity of this virus will need to be monitored.

Transmissible Spongiform Encephalopathies: Creutzfeldt-Jakob Disease and Variant Creutzfeldt-Jakob Disease

Both classical Creutzfeldt-Jakob disease (CJD) and variant Creutzfeldt-Jakob disease (vCJD) are rapidly progressive fatal infections of the nervous system caused by prions.⁵⁴⁶ Individuals at increased risk for classical CJD are currently excluded from blood donation in the United States, despite evidence that this disease is not transmissible by transfusion.⁵⁴⁶

In contrast, variant CJD (vCJD) does appear to be transmissible by transfusion. Human vCJD is caused by the same prion that causes bovine spongiform encephalopathy (BSE), or "mad cow disease." As of April 2012, four cases of apparent transfusion-transmitted vCJD had been identified in the UK, where a BSE epidemic occurred between 1980 and 1996. In addition, one case of vCJD had been identified postmortem in a hemophilia patient in the UK who died of other causes. Worldwide, steps have been taken in an effort to minimize the risk of vCJD transmission by blood products in the absence of a donor screening test for the infection. In the United States, individuals are currently excluded from donating blood if they lived in the UK for 3 months or more between 1980 and 1996, if they lived in Europe for 5 years or more since 1980, or if they received a transfusion in the UK or France since 1980.⁵⁵⁷ Filters that may absorb prions are in development, and attempts to develop blood donor screening tests are also underway.⁵⁴⁶ Because prions lack lipid coats and nucleic acid, the causative agent of vCJD would not be inactivated by any of the pathogen inactivation processes currently in use or under development.

Bacterial Contamination

Bacteria are present in approximately 1/3,000 cellular blood components.⁵⁵⁸ Potential sources of bacteria include asymptomatic bacteremia in the donor and bacteria from the donor's skin. Bacterial contaminants multiply fairly readily in platelet components, which are stored at room temperature, but less readily in red cell products, which are refrigerated.

Recognition of morbidity and mortality from transfusion of bacterially contaminated platelets prompted the AABB to implement, in 2004, a requirement for bacterial testing of platelet components. AABB now also requires diversion of the first several milliliters of donor blood into a sample pouch to reduce contamination of platelet units by skin contaminants.⁵

The quantity of bacteria in blood components just after collection is too low to detect by any diagnostic assay. The platelet bacterial screening process used by most US blood centers involves a 36 to 48 hour quarantine of the platelet components. First, there is a 24-hour hold after collection to allow potentially contaminating bacteria to multiply to detectable levels. Then, a sample is taken from each product and inoculated into a blood culture bottle. If the culture is negative after 12 to 24 hours, the product is made available for use, but the culture is continued for the shelf life of the unit. About 1 in 5,000 apheresis platelets are found by this screening to be bacterially contaminated.⁵⁵⁹ This screening process is imperfect, however, and still fails to detect some bacterially contaminated platelets. Recently, a strip immunoassay which could be used by hospitals to retest platelets was reported to find bacteria in approximately 1 in 3000 pheresis platelets that had been negative on their culture screen.⁵⁶⁰ This immunoassay or alternative tests are associated with false positives and logistical challenges, however, and still fail to detect some contaminated products.⁵⁶¹ Given the imperfections of current platelet screens, and the lack of any bacterial screen for red cell products, bacterial contamination must remain in the differential diagnosis when transfusion recipients become febrile or hypotensive following transfusions. The pathogen inactivation systems in development for cellular blood components all appear likely to inhibit the growth of bacteria.⁵⁶²

Cytomegalovirus

CMV is a DNA virus in the herpesvirus family.⁵⁶³ Like other herpesviruses, it remains latent after acute infection, with the potential for reactivation.

In immunologically normal adults, CMV disease manifestations range from none to a mononucleosis-like syndrome. In immunosuppressed or immunodeficient patients, however, both primary and reactivation disease may be associated with overwhelming manifestations including thrombocytopenia, hemolytic anemia, pneumonitis, colitis, hepatitis, meningoencephalitis, and death. Effective antiviral treatment is available. The incidence of severe disease can be reduced by prophylactic treatment of high-risk patients with antiviral drugs or by careful monitoring of such patients and initiation of therapy with the first evidence of infection.⁵⁶³

CMV is transmitted only through cellular blood components. The incidence of transmission of CMV by transfusion appears to be low (<1%) in immunologically normal recipients.⁵⁶⁴ Immunodeficient patients, however, are at increased risk of acquiring CMV from transfusion. CMV transmission to these patients can be greatly reduced by restricting their cellular

P.582

components to products obtained from CMV-seronegative donors or by use of leukoreduced blood components.⁵⁶³ Most studies have detected no transmission of CMV by leukoreduced blood components. Some transmissions were detected, however, in a large randomized study that evaluated the incidence of CMV infection and CMV disease in 502 bone marrow transplant recipients randomized to receive either leukoreduced (i.e., leukofiltered) or CMV antibody negative blood components.⁵⁶⁵ CMV infection was observed in 1.3% of recipients of seronegative components and in 2.4% of recipients of leukoreduced components, a difference that was not statistically significant. However, in the leukoreduced arm, all CMV-infected patients developed disease, and five out of six died; in the serologically screened arm, there were no cases of CMV-related disease or death. A meta-analysis estimated that the risk of transfusion-transmitted CMV is approximately 1.5% with use of CMV antibody-screened components, compared to 2.5% with leukoreduced, antibody-unscreened components.⁵⁶⁶ Most of the cellular components in the US are leukoreduced. Whether it is clinically beneficial to perform CMV antibody screening in addition to leukoreduction remains controversial.⁵⁶³

It is generally recommended that cellular products with a reduced risk of transmitting CMV (leukoreduced or CMV antibody negative) be used for patients at increased risk of severe primary CMV disease, including unborn babies (i.e., intrauterine transfusion), low-birth-weight infants of seronegative mothers, seronegative recipients of seronegative solid organ or HPC transplants, and seronegative patients with severe cellular immunodeficiency (e.g., HIV-infected patients). Products with reduced CMV risk are often provided also for seronegative patients who are likely to require transplantation in the future, in order to reduce their future risk of CMV-reactivation disease.⁵⁶³

There is no clinical benefit of providing products of reduced CMV risk to patients who are already seropositive. Although second-strain infections may occur, these have not been shown to be clinically important given the high risk of reactivation disease these patients face. In CMV-positive recipients of allogeneic hematopoietic progenitor cell transplants, the use of CMV-positive stem cell donors has no detectable adverse effect on patient outcomes.⁵⁶⁷ Therefore, it seems that CMV-seropositive blood components would also be acceptable in this setting.

Seronegative recipients of seropositive organ and stem cell transplants are at high risk of CMV disease⁵⁶⁸ and are likely to be monitored closely, treated prophylactically, or both. It is unclear whether providing blood products with reduced CMV risk to such patients is of clinical benefit.

Pathogen Reduction Technologies

Donor screening and testing cannot completely eliminate the possibility of transfusion-transmitted infection or blood product contamination. The ideal pathogen reduction technology (PRT) would effectively inactivate residual pathogens without adversely affecting the function, toxicity, or immunogenicity of the blood component. Most commercial plasma derivatives are treated with heat and/or organic solvents and detergents (SD). SD treatment inactivates lipid-coated agents. Cellular blood components, however, cannot withstand this treatment. Most of the PRTs in development for cellular products consist of blood product additives that bind to and damage DNA and thereby prevent residual pathogens from proliferating in the blood component or in the recipient. These treatments would theoretically also prevent transfusion-related GVHD because the DNA of WBCs in the blood product would also be affected. The efficacy of PRT agents is dependent on their ability to penetrate cellular membranes or viral envelopes and reach the target nucleic acid. Because of concern that DNA-altering agents could cause long-term toxicity in transfusion recipients, many of the PRT systems include processes that remove the DNA-binding agent or inactivate it. PRTs in distribution outside the US and in development have been recently reviewed.^{530,562} Examples are listed in Table 21.12.

PRTs can reduce the residual risk related to window period transmissions of HIV, HCV, and HBV, but these risks are small. The primary benefit of PRTs is to reduce transmission of agents for which there are currently no tests.⁵²⁹ These treatments are costly. The incremental costs of PRT can be offset if they are approved by regulators as eliminating the need for irradiation, CMV antibody screening, and bacterial testing.⁵²⁹ Elimination of platelet bacterial testing would also expedite release of these products.

Several PRT systems for plasma are in use outside the US. One (S/D plasma) is a commercial product manufactured from pools of donor plasma. A pooled product has both theoretical advantages and disadvantages. For example, pooling dilutes antibodies from individual donors and thereby theoretically reduces the risk of antibody-mediated transfusion complications such as TRALI. However, pooling could increase a recipient's risk of exposure to an emerging pathogen that is not removed or inactivated by the manufacturing process. PRTs that involve treatment of individual plasma units are more logistically challenging. All of the plasma PRTs listed in Table 21.12 have been determined to satisfy the Council of Europe plasma quality standards.

As of April 2012, the amotosalen/UV and riboflavin/UV PRTs for platelet products were in distribution in some countries outside of the US. Both of these treatments appear to be associated with some loss of platelet product potency.^{101,102} The clinical importance of the potency changes relative to the theoretical benefit of PRT is unclear.

THERAPEUTIC APHERESIS

Therapeutic apheresis is an important modality of therapy in the management of several diseases.^{30,569,570,571,572,573,574} and ⁵⁷⁵ The term plasmapheresis refers to the selective removal of plasma. This includes the collection of plasma from normal donors. A therapeutic plasma exchange, on the other hand, refers to the removal of a large proportion of a patient's plasma and replacement with crystalloid or colloid fluids and/or plasma product. These terms are often used interchangeably. Therapeutic cytapheeresis, the removal of red cells, leukocytes, or platelets, is used infrequently in the

management of patients with hemoglobinopathies, leukostasis, or thrombocytosis, respectively.

TABLE 21.12 PATHOGEN REDUCTION TECHNOLOGIES FOR TRANSFUSABLE BLOOD COMPONENTS

Component	Technology	Manufacturer
Plasma: commercially prepared pools	• Solvent/detergent treatment	Octapharma
Plasma: individual units	• Amotosalen (psoralen) + UV light	Cerus

	• Riboflavin (vitamin B2) + UV light	Terumo BCT
	• Methylene blue + light	MacoPharma
Platelets	• Amotosalen (psoralen) + UV light	Cerus
	• Riboflavin (vitamin B2) + UV light	Terumo BCT
	• UV light	MacoPharma
Red Blood Cells	• Frangible nucleic acid crosslinker	Cerus
Whole Blood	• Riboflavin (vitamin B2) + UV light	Terumo BCT

UV, ultraviolet.

Modified from Galel S. Infectious disease screening. In: Roback JD, Grossman BJ, Harris T, Hillyer CD, eds. AABB technical manual, 17th ed. Bethesda, MD: AABB, 2011:239-270.⁵⁴⁴

Guidelines for clinical practice have been developed by the American Society for Apheresis (ASFA) and are regularly updated every 3 to 7 years with a systematic review of the medical literature. The current guidelines published in 2010⁵⁷⁶ review the therapeutic apheresis procedures most commonly performed (i.e., therapeutic plasma exchange (TPE), red blood cell exchange, erythrocytapheresis, thrombocytapheresis, leukocytapheresis, extracorporeal photopheresis (ECP), immunoadsorption (IA), selective removal methods, adsorptive cytapheresis, and membrane differential filtration. Additionally, the guidelines contain 59 specific disease fact sheets listing the type of apheresis procedure to be performed and the rationale for it, the recommended blood volume to be exchanged, and the duration of the treatment.

The disorders for which therapeutic apheresis has been used are divided into four categories: category I, for which apheresis is the accepted first line of therapy; Category II, for which apheresis is considered a second-line therapy, after a patient has failed or is unable to undergo the first-line therapy; category III, for which the optimum role of apheresis therapy is not established and decision making should be individualized; and category IV disorders, in which published evidence demonstrates or suggests apheresis to be ineffective or harmful.^{570,576,577} Some of the indications for TPE (categories I and II) are listed in Table 21.13.

Therapeutic Plasma Exchange

Indications

The therapeutic goal of therapeutic plasma exchange (TPE) is to remove plasma components such as monoclonal proteins and cryoglobulins,⁵⁷³ immune complexes,⁵⁷¹ lipoproteins, or toxins⁵⁷³ responsible for physical or metabolic problems. These may include removal of autoantibodies, as in myasthenia gravis⁵⁷⁴ and Goodpasture syndrome⁵⁷³; or alloantibodies, as in posttransfusion purpura or patients with Factor VIII inhibitors.⁵⁷² The existence and pathogenic role of antibodies or immune complexes are presumed in several situations often treated with TPE, including neurologic disorders such as Guillain-Barré syndrome,^{569,574,578,579} and⁵⁸⁰ polyneuropathy,⁵⁷⁴ and various nephritides.^{573,581} In thrombotic thrombocytopenic purpura (TTP), TPE using cryoprecipitate-reduced plasma⁵⁸² or frozen plasma as the replacement fluid serves to either replace the missing vWF-cleaving metalloprotease or to remove autoantibodies to this protein.^{118,583} TPE or plasma transfusion^{584,585} and⁵⁸⁶ may be life-saving in this disease, as it controls the microangiopathy.

TABLE 21.13 SOME INDICATIONS FOR THERAPEUTIC PLASMA EXCHANGE

Accepted as Therapy (Category I)

- Thrombotic thrombocytopenic purpura
- Posttransfusion purpura
- Guillain-Barré syndrome
- Myasthenia gravis
- Chronic inflammatory demyelinating polyneuropathy
- Goodpasture syndrome
- Refsum disease

Accepted as Supportive Therapy (Category II)

Cold agglutinin hemolytic anemia

ABO-incompatible marrow transplant

Cryoglobulinemia

Lambert-Eaton myasthenic syndrome

Rapidly progressive glomerulonephritis

Autoimmune thrombocytopenia

Myeloma and Waldenström macroglobulinemia, and other paraproteinemias with renal failure or hyperviscosity

Coagulation factor inhibitors

Familial hypercholesterolemia

Technical Considerations

The amount of plasma to be removed from the patient is determined by the physician, depending on the clinical situation. A patient's plasma volume may be estimated at 40 ml/kg, determined from a nomogram based on the patient's sex, height, weight, and hematocrit⁵⁸⁷; or estimated according to the weight and hematocrit by the following formula:

Circulating blood volume = patient weight (kg) × 70 ml/kg.

Circulating plasma volume = circulating blood volume × (1.0 - hematocrit [expressed as a decimal]).

TPE is typically performed with 1.0 to 1.5 plasma volume exchanges or approximately 3,000 to 4,500 ml. If <1,000 ml is removed from an adult, it may be possible to replace the loss with crystalloid alone; if a more extensive plasma exchange is performed, use of a colloid is necessary. Albumin (5%) is the replacement fluid most commonly used in the United States. FFP or FP24 is indicated in certain instances, such as TTP or as a component of the replacement fluid in the setting of a coagulopathy.

After exchange of one plasma volume, approximately 62% of the original plasma has been removed. The efficiency of plasma exchange decreases with further exchange (Table 21.14).

In practice, measurement of plasma protein concentrations after exchange has confirmed the approximate validity of these estimates. However, efficacy varies with the plasma factor to be removed. IgM and fibrinogen, which are largely confined to the intravascular space, are removed most efficiently.^{588,589} and ⁵⁹⁰ IgG is removed less efficiently by plasma exchange because only 45% to 50% of the body's IgG is located in the intravascular space, although IgG levels can be reduced by repeated TPE. Patients receiving plasma exchange for immunologic diseases generally have 1.0 to 1.5 plasma volumes exchanged at each procedure; this is often repeated, for a total of 5 to 7 exchanges over a period of 7 to 10 days. Such plasma exchange schedules have been determined empirically; the optimal exchange regimens for different diseases are unknown.

Therapeutic Cytapheresis

Therapeutic leukapheresis is used in the treatment of patients with leukostasis as a result of extremely high circulating concentrations of immature cells.^{572,591,592} At blast counts $>100 \times 10^9/L$, there is an increasing risk of cerebral and pulmonary leukostasis, resulting

P.584

in impaired capillary blood flow resulting from obstruction of small vessels. This situation may be encountered in the acute leukemias but rarely in chronic lymphocytic leukemia or chronic myelogenous leukemia. Therapeutic leukapheresis decreases the circulating blast count more rapidly than chemotherapy alone; chemotherapy must be instituted promptly once the patient is stabilized, to prevent rebound leukocytosis. The only exception is in pregnancy, in which leukapheresis may be indicated until after the delivery of the fetus, thereby protecting the fetus from the teratogenic effects of chemotherapy.

TABLE 21.14 PLASMA EXCHANGE: THEORETICAL EFFICIENCY

Number of Plasma Volumes Exchanged Percent (%) of Original Plasma Remaining

0.5	60
1.0	38
1.5	22
2.0	15

Therapeutic leukapheresis has also been used in the treatment of patients with other leukemic diseases, such as chronic lymphocytic leukemia that is resistant to drugs, Sézary syndrome, and hairy cell leukemia, and as maintenance therapy in chronic myelogenous leukemia. However, it has not found a distinct role in such conditions.^{572,592,593} Collection of leukocytes by apheresis, followed by ex vivo exposure of the leukocytes to UV light in the presence of a psoralen, and reinfusion of the treated leukocytes ("photopheresis") has become standard therapy for cutaneous T-cell lymphoma. This procedure may be useful in the treatment of other disorders such as GVHD.⁵⁹²

Therapeutic plateletpheresis^{572,594,595} is performed very rarely and is not considered to be first-line therapy. It is indicated in patients with very high platelet counts, usually >1.0 to $1.5 \times 10^{12}/L$, in whom the high count is directly responsible for serious thrombotic or hemorrhagic problems, or in whom other urgent clinical situations necessitate immediate lowering of the platelet count. Therapeutic plateletpheresis must be followed by cytotoxic therapy to prevent rebound after the procedure, or its effect is very short-lived.

Erythrocytapheresis (red cell exchange) is used in sickle cell disease to replace sickled cells with normal erythrocytes and thereby prevent thromboses and improve capillary circulation.⁵⁷² Stroke prevention by maintaining hemoglobin S level below 30% and acute chest syndrome are the two major indications for red cell exchange in patients with sickle disease.⁵⁷⁶

Therapeutic Absorption of Plasma Constituents

Apheresis technology may be used to selectively remove constituents of plasma implicated in disease processes. In these procedures, a patient's plasma is withdrawn and separated by apheresis technology, passed over a selective absorption column, and reinfused into the patient. This technique has been used to selectively remove IgG (staphylococcal protein A columns) or low-density-lipoprotein (LDL) cholesterol.⁵⁹² Selective apheresis may specifically treat diseases such as LDL-hypercholesterolemia. Patients with LDL-hypercholesterolemia are at risk of developing severe coronary artery disease despite a low-fat diet and cholesterol-lowering agents. Selective LDL apheresis involves separation of the patient's plasma, followed by selective removal of apoB-containing atherogenic lipoproteins, preserving the cardioprotective HDL cholesterol, after which the cleansed plasma is recombined with the cellular portion of the blood and returned to the patient. This procedure was shown to be safe and efficacious in controlling patients with familial hypercholesterolemia.⁵⁹⁶

Adverse Effects

Adverse reactions to therapeutic apheresis are common but usually mild.^{597,598} and ⁵⁹⁹ In a 1-year period in Canada, there were side effects in 12% of more than 5,235 procedures in 627 patients.⁵⁹⁸ They included vasovagal reactions, fluid imbalance with hypovolemia or overload, fever, chills, and hypocalcemic citrate reactions ranging from paresthesias to arrhythmias. If plasma is used as the replacement fluid, urticarial reactions may be encountered. Mild dilutional coagulopathy and thrombocytopenia occur but are rarely significant.^{600,601} Problems related to venous access are common. The possibility of immunologic rebound after plasma exchange has been suggested but has not been observed clinically,^{602,603} perhaps because many patients so treated are also receiving immunosuppressive agents for the underlying diseases. Infections related to indwelling venous lines are not uncommon. Deaths have been reported with therapeutic apheresis.^{597,599,604} It is important that patients be carefully assessed and the indications reviewed before implementing this form of therapy.

SUMMARY

Blood transfusion is an essential component of therapy for a wide variety of disorders. The menu of blood components and the technologies for collecting, processing, and screening blood are constantly changing. Collaboration between transfusion medicine professionals and patient care teams ensures the most appropriate application of blood transfusion therapies.

Acknowledgments

The authors wish to thank Judy Kawamoto for providing the technical and organizational expertise that was essential to the preparation of this manuscript.

REFERENCES

1. Rossi EC, Simon TL. Transfusion in the new millennium. In: Simon TL, Dzik WH, Snyder EL, et al., eds. Rossi's principles of transfusion medicine, 3rd ed. Philadelphia, PA: Lippincott Williams & Wilkins, 2002:1-12.
2. Roback JD, Grossman BJ, Harris T and Hillyer CD, eds. Technical manual 17th edition AABB. Bethesda, MD: American Association of Blood Banks (AABB), 2011.
3. King KE, ed. Blood transfusion therapy a physician's handbook, 9th ed. Bethesda, MD: American Association of Blood Banks, 2008.
4. Code of Federal Regulations. Title 21, CFR Parts 211 and 610. In. Washington, DC: US Government Printing Office, 2011 (revised annually).
5. Standards for blood banks and transfusion services, 28th ed. Bethesda, MD: American Association of Blood Banks, 2012.
6. Goodnough LT. What is a transfusion medicine specialist? *Transfusion* 1999;39(9):1031-1033.
7. Contreras M. Is the unpaid/paid donation debate for better or for worse?—advantages of unpaid donations. *Blood Coagul Fibrinol* 1994;5(Suppl 4):S27-S28.
8. van der Poel CL, Seifried E, Schaasberg WP. Paying for blood donations: still a risk? *Vox Sang* 2002;83(4):285-293.
9. Cherubin CE, Prince AM. Serum hepatitis specific antigen (SH) in commercial and volunteer sources of blood. *Transfusion* 1971;11(1):25-27.
10. Szmuness W, Prince AM, Brotman B, et al. Hepatitis B antigen and antibody in blood donors: an epidemiologic study. *J Infect Dis* 1973;127(1):17-25.
11. Alter HJ, Holland PV, Purcell RH, et al. Posttransfusion hepatitis after exclusion of commercial and hepatitis-B antigen-positive donors. *Ann Intern Med* 1972;77(5):691-699.
12. Domen RE. Paid-versus-volunteer blood donation in the United States: a historical review. *Transfus Med Rev* 1995;9(1):53-59.
13. Catella-Lawson F, Reilly MP, Kapoor SC, et al. Cyclooxygenase inhibitors and the antiplatelet effects of aspirin. *N Engl J Med* 2001;345(25):1809-1817.
14. Cerskus AL, Ali M, Davies BJ, et al. Possible significance of small numbers of functional platelets in a population of aspirin-treated platelets in vitro and in vivo. *Thromb Res* 1980;18(3-4):389-397.
15. Schafer AI. Effects of nonsteroidal antiinflammatory drugs on platelet function and systemic hemostasis. *J Clin Pharmacol* 1995;35(3):209-219.
16. Chapman CE, Stainsby D, Jones H, et al. Ten years of hemovigilance reports of transfusion-related acute lung injury in the United Kingdom and the impact of preferential use of male donor plasma. *Transfusion* 2009;49(3):440-452.
17. Eder AF, Benjamin RJ. TRALI risk reduction: donor and component management strategies. *J Clin Apher* 2009;24(3):122-129.
18. Transfusion-related acute lung injury. Association Bulletin #06-07 (November 3, 2006). Bethesda, MD: AABB, 2006.
19. Dodd RY, Notari EP, Stramer SL. Current prevalence and incidence of infectious disease markers and estimated window-period risk in the American Red Cross blood donor population. *Transfusion* 2002;42:975-979.
20. Kanter MH, Hodge SE. Risk of hemolytic disease of the newborn as a result of directed donations from relatives. *Transfusion* 1989;29:620-625.
21. Wales PW, Lau W, Kim PC. Directed blood donation in pediatric general surgery: Is it worth it? *J Pediatr Surg* 2001;36(5):722-725.
22. McDonald CP, Lowe P, Roy A, et al. Evaluation of donor arm disinfection techniques. *Vox Sang* 2001;80:135-141.
23. Abel JJ, Rowntree LG, Turner BB. Plasma removal with return of corpuscles (plasmapheresis). *J Pharmacol Exp Ther* 1914; V(6). *Transfus Sci* 1990;11(2):166-177.
24. Winters JL, Gottschall JL, eds. Therapeutic apheresis: a physician's handbook AABB/AFSA. Bethesda, MD: Amer Assn of Blood Banks, 2011.
25. Newman BH. Donor reactions and injuries from whole blood donation. *Transfus Med Rev* 1997;11(1):64-75.

26. Newman BH. Whole-blood donation: blood donor suitability and adverse events. *Curr Hematol Rep* 2004;3(6):437-443.
27. Newman BH, Pichette S, Pichette D, et al. Adverse effects in blood donors after whole-blood donation: a study of 1000 blood donors interviewed 3 weeks after whole-blood donation. *Transfusion* 2003;43(5):598-603.
28. Newman BH. Arterial puncture phlebotomy in whole-blood donors. *Transfusion* 2001;41(11):1390-1392.
29. Ranasinghe E, Harrison JF. Bruising following blood donation, its management and the response and subsequent return rates of affected donors. *Transfus Med* 2000;10(2):113-116.
30. Gilcher RO. Apheresis: principles and technology of hemapheresis. In: Simon TL, Dzik WH, Snyder EL, et al., eds. *Rossi's principles of transfusion medicine*, 3rd ed. Philadelphia, PA: Lippincott Williams & Wilkins, 2002:648-658.
31. Food and Drug Administration: guidance for industry: use of serological tests to reduce the risk of transmission of *trypanosoma cruzi* infection in whole blood and blood components intended for transfusion. FDA Guidance, December 2010.
<http://www.fda.gov/BiologicsBloodVaccines/GuidanceComplianceRegulatoryInformation/Guidances/Blood/ucm235855.htm>. Accessed August 6, 2012.
32. Beutler E. Liquid preservation of red blood cells. In: Simon TL, Dzik WH, Snyder EL, Stowell CP, Strauss RG, eds. *Rossi's principles of transfusion medicine*, 3rd ed. Philadelphia, PA: Lippincott Williams & Wilkins, 2002: 50-61.
33. Gibson JG 2nd, Rees SB, McManus TJ, Scheitlin WA. A citrate-phosphatedextrose solution for the preservation of human blood. *Am J Clin Pathol* 1957;28:569-578.
34. Gabrio BW, Finch CA, Huennekens FM. Erythrocyte preservation: a topic in molecular biochemistry. *Blood* 1956;11:103-113.
35. Nakao K, Wada T, Kamiyama T, Nakao M, Nagano K. A direct relationship between adenosine triphosphate-level and in vivo viability of erythrocytes. *Nature* 1962;194:877-878.
36. Simon ER. Red cell preservation: further studies with adenine. *Blood* 1962;20:485-491.
37. Peck CC, Moore GL, Bolin RB. Adenine in blood preservation. *Crit Rev Clin Lab Sci* 1981;13:173-212.
38. Spinella PC, Sparrow RL, Hess JR, Norris PJ. Properties of stored red blood cells: understanding immune and vascular reactivity. *Transfusion* 2011;51(4):894-900.
39. Card RT. Red cell membrane changes during storage. *Transfus Med Rev* 1988;2:40-47.
40. Wolfe LC. The membrane and the lesions of storage in preserved red cells. *Transfusion* 1985;25:185-203.
41. Wolfe L. The red cell membrane and the storage lesion. *Clin Haematol* 1985;14:259-276.
42. Estep TN, Pedersen RA, Miller TJ, Stupar KR. Characterization of erythrocyte quality during the refrigerated storage of whole blood containing di-(2-ethylhexyl) phthalate. *Blood* 1984;64:1270-1276.
43. Labow RS, Card RT, Rock G. The effect of the plasticizer di(2-ethylhexyl) phthalate on red cell deformability. *Blood* 1987;70:319-323.
44. Rock G, Tocchi M, Ganz PR, Tackaberry ES. Incorporation of plasticizer into red cells during storage. *Transfusion* 1984;24:493-498.
45. Holme S. Current issues related to the quality of stored RBCs. *Transfus Apher Sci* 2005;33:55-61.
46. Jeter EK, Gadsden RH, Cate J. Effects of irradiation on red cells stored in CPDA-1 and CPD-ADSOL (AS-1). *Ann Clin Lab Sci* 1991;21:177-186.
47. Davey RJ, McCoy NC, Yu M, Sullivan JA, Spiegel DM, Leitman SF. The effect of prestorage irradiation on posttransfusion red cell survival. *Transfusion* 1992;32:525-528.
48. Valeri CR, Hirsch NM. Restoration in vivo of erythrocyte adenosine triphosphate, 2,3-diphosphoglycerate, potassium ion, and sodium ion concentrations following the transfusion of acid-citrate-dextrose-stored human red blood cells. *J Lab Clin Med* 1969;73:722-733.
49. Juel R. 2,3-Diphosphoglycerate: its role in health and disease. *CRC Crit Rev Clin Lab Sci* 1979;10:113-146.
50. Sohmer PR, Dawson RB. The significance of 2,3-DPG in red blood cell transfusions. *CRC Crit Rev Clin Lab Sci* 1979;11:107-174.

51. Llohn AH, Vetlesen A, Fagerhol MK, Kjeldsen-Kragh J. The effect of pre-storage cooling on 2,3-DPG levels in red cells stored in SAG-M. *Transfus Apher Sci* 2005;33:113-118.
52. Beutler E, Wood L. The in vivo regeneration of red cell 2,3 diphosphoglyceric acid (DPG) after transfusion of stored blood. *J Lab Clin Med* 1969;74: 300-304.
53. What is the clinical importance of alterations of the hemoglobin oxygen affinity in preserved blood—especially as produced by variations of red cell 2,3 DPG content? *Vox Sang* 1978;34:111-127.
54. Moore GL, Ledford ME, Brummell MR, Brooks DF. The potential use of dihydroxyacetone for improved 2,3-DPG maintenance in red blood cell storage: solution stability and use in packed cell storage. *Transfusion* 1980;20:24-31.
55. Dawson RB, Hershey RT, Myers CS. Blood preservation. XXIX. Pyruvate maintains normal red cell 2,3-DPG for six weeks of storage in CPD-adenine. *Transfusion* 1980;20:218-223.
56. Hamasaki N, Hirota-Chigita C. Acid-citrate-dextrose-phosphoenolpyruvate medium as a rejuvenant for blood storage. *Transfusion* 1983;23:1-7.
57. Chanutin A. Effect of storage of blood in ACD-adenine-inorganic phosphate plus nucleosides on metabolic intermediates of human red cells. *Transfusion* 1967;7:409-419.
58. Valeri CR, Zaroulis CG. Rejuvenation and freezing of outdated stored human red cells. *N Engl J Med* 1972;287:1307-1313.
59. Brecher ME, Zylstra-Halling VW, Pineda AA. Rejuvenation of erythrocytes preserved with AS-1 and AS-3. *Am J Clin Pathol* 1991;96:767-769.
60. Lockwood WB, Hudgens RW, Szymanski IO, Teno RA, Gray AD. Effects of rejuvenation and frozen storage on 42-day-old AS-3 RBCs. *Transfusion* 2003;43:1527-1532.
61. Mollison PL. Methods of determining the posttransfusion survival of stored red cells. *Transfusion* 1984;24:93-96.
62. Moroff G, Sohmer PR, Button LN. Proposed standardization of methods for determining the 24-hour survival of stored red cells. *Transfusion* 1984;24:109-114.
63. Koch CG, Li L, Sessler DI, et al. Duration of red-cell storage and complications after cardiac surgery. *N Engl J Med* 2008;358(12):1229-1239.
64. Hess JR. Red cell changes during storage. *Transfus Apher Sci. Official Journal of the World Apheresis Association: Official Journal of the European Society for Haemapheresis* 2010;43(1):51-59.
65. Pereira A. Will clinical studies elucidate the connection between the length of storage of transfused red blood cells and clinical outcomes? An analysis based on the simulation of randomized controlled trials. *Transfusion* 2013;53:34-40.
66. Valeri CR, Ragno G, Pivacek LE, et al. A multicenter study of in vitro and in vivo values in human RBCs frozen with 40-percent (wt/vol) glycerol and stored after deglycerolization for 15 days at 4 degrees C in AS-3: assessment of RBC processing in the ACP 215. *Transfusion* 2001;41:933-939.
67. Valeri CR. Status report on the quality of liquid and frozen red blood cells. *Vox Sang* 2002;83(Suppl 1):193-196.
68. Scott KL, Lecak J, Acker JP. Biopreservation of red blood cells: past, present, and future. *Transfus Med Rev* 2005;19:127-142.
69. Slichter SJ, Harker LA. Preparation and storage of platelet concentrates. I. Factors influencing the harvest of viable platelets from whole blood. *Br J Haematol* 1976;34:395-402.
70. Slichter SJ, Harker LA. Preparation and storage of platelet concentrates. II. Storage variables influencing platelet viability and function. *Br J Haematol* 1976;34:403-419.
71. Murphy S, Heaton WA, Rebullia P. Platelet production in the old world—and the new. *Transfusion* 1996;36:751-74.
72. Bunescu A, Hild M, Lundahl J, Egberg N. Platelet storage in PAS-2 or autologous plasma: impact on functional parameters. *Transfus Med* 2001;11: 105-110.
73. Heddle NM, Cook RJ, Blajchman MA, et al. Assessing the effectiveness of whole blood-derived platelets stored as a pool: a randomized block noninferiority trial. *Transfusion* 2005;45:896-903.
74. Sweeney J, Kouttab N, Holme S, Kurtis J, Cheves T, Nelson E. Storage of platelet-rich plasma-derived platelet concentrate pools in plasma and additive solution. *Transfusion* 2006;46:835-840.

75. Vassallo RR, Murphy S. A critical comparison of platelet preparation methods. *Curr Opin Hematol* 2006;13:323-330.
76. Medsep Corp. 510(k) Traditional pre-market notification BK050034: response to FDA request for additional information: pall platelet pool and store set with pall eBDS. 2005. <http://www.fda.gov/cber/510k/k050034.htm>. Accessed.
77. Dumont LJ, VandenBroeke T. Seven-day storage of apheresis platelets: report of an in vitro study. *Transfusion* 2003;43:143-150.
78. Sarkodee-Adoo CB, Kendall JM, Sridhara R, Lee EJ, Schiffer CA. The relationship between the duration of platelet storage and the development of transfusion reactions. *Transfusion* 1998;38:229-235.
79. Kelley DL, Mangini J, Lopez-Plaza I, Triulzi DJ. The utility of < or =3-day-old whole-blood platelets in reducing the incidence of febrile nonhemolytic transfusion reactions. *Transfusion* 2000;40:439-442.
80. Yazer MH, Podlosky L, Clarke G, Nahirniak SM. The effect of prestorage WBC reduction on the rates of febrile nonhemolytic transfusion reactions to platelet concentrates and RBC. *Transfusion* 2004;44:10-15.
81. Paglino JC, Pomper GJ, Fisch GS, Champion MH, Snyder EL. Reduction of febrile but not allergic reactions to RBCs and platelets after conversion to universal prestorage leukoreduction. *Transfusion* 2004;44:16-24.
82. Murphy S, Gardner FH. Effect of storage temperature on maintenance of platelet viability—deleterious effect of refrigerated storage. *N Engl J Med* 1969;280:1094-1098.
83. Murphy S. Platelet storage for transfusion. *Semin Hematol* 1985;22:165-177.
84. Murphy S, Gardner FH. Platelet storage at 22 degrees C: role of gas transport across plastic containers in maintenance of viability. *Blood* 1975;46:209-218.
85. Murphy S, Gardner FH. Platelet storage at 22 degrees C; metabolic, morphologic, and functional studies. *J Clin Invest* 1971;50:370-377.
86. Murphy S, Kahn RA, Holme S, et al. Improved storage of platelets for transfusion in a new container. *Blood* 1982;60:194-200.
87. Hogge DE, Thompson BW, Schiffer CA. Platelet storage for 7 days in second-generation blood bags. *Transfusion* 1986;26:131-135.
88. Simon TL, Nelson EJ, Murphy S. Extension of platelet concentrate storage to 7 days in second-generation bags. *Transfusion* 1987;27:6-9.
89. Braine HG, Kickler TS, Charache P, et al. Bacterial sepsis secondary to platelet transfusion: an adverse effect of extended storage at room temperature. *Transfusion* 1986;26:391-393.
90. Heal JM, Singal S, Sardisco E, Mayer T. Bacterial proliferation in platelet concentrates. *Transfusion* 1986;26:388-390.
91. Murphy S. Similarities among the events occurring during the storage of red cells and platelets for transfusion. *Transfus Med Rev* 1987;1:138-143.
92. Slichter SJ. Poststorage platelet viability in thrombocytopenic recipients is reliably measured by radiochromium-labeled platelet recovery and survival measurements in normal volunteers. *Transfusion* 1986;26:8-13.
93. Slichter SJ. Mechanisms and management of platelet refractoriness. In: Nance ST, ed. *Transfusion medicine in the 1990's*. Arlington, VA: American Association of Blood Banks, 1990:95-179.
94. Harker LA. The role of the spleen in thrombokinetics. *J Lab Clin Med* 1971;77:247-53.
95. Snyder EL, Ezekowitz M, Aster R, et al. Extended storage of platelets in a new plastic container. II. In vivo response to infusion of platelets stored for 5 days. *Transfusion* 1985;25:209-214.
96. Rodgers RP, Levin J. A critical reappraisal of the bleeding time. *Semin Thromb Hemost* 1990;16:1-20.
97. Vostal JG, Reid TJ, Mondoro TH. Summary of a workshop on in vivo efficacy of transfused platelet components and platelet substitutes. *Transfusion* 2000;40:742-750.
98. Alhumaidan H, Sweeney J. Current status of additive solutions for platelets. *J Clin Apher* 2012;27:93-98.
99. de Wildt-Eggen J, Nauta S, Schrijver JG, van Marwijk Kooy M, Bins M, van Prooijen HC. Reactions and platelet increments after transfusion of platelet concentrates in plasma or an additive solution: a prospective, randomized study. *Transfusion* 2000;40:398-403.

100. Kerkhoffs JL, Eikenboom JC, Schipperus MS, et al. A multicenter randomized study of the efficacy of transfusions with platelets stored in platelet additive solution II versus plasma. *Blood* 2006;108:3210-3215.
101. Irsch J, Lin L. Pathogen inactivation of platelet and plasma blood components for transfusion using the INTERCEPT blood system. *Transfus Med Hemother* 2011;38:19-31.
102. Marschner S, Goodrich R. Pathogen reduction technology treatment of platelets, plasma and whole blood using riboflavin and UV light. *Transfus Med Hemother* 2011;38:8-18.
103. Vecchione JJ, Melaragno AJ, Hollander A, et al. Circulation and function of human platelets isolated from units of CPDA-1, CPDA-2, and CPDA-3 anticoagulated blood and frozen with DMSO. *Transfusion* 1982;22:206-209.
104. Lazarus HM, Kaniecki-Green EA, Warm SE, et al. Therapeutic effectiveness of frozen platelet concentrates for transfusion. *Blood* 1981;57:243-249.
105. Vadhan-Raj S, Kavanagh JJ, Freedman RS, et al. Safety and efficacy of transfusions of autologous cryopreserved platelets derived from recombinant human thrombopoietin to support chemotherapy-associated severe thrombocytopenia: a randomised cross-over study. *Lancet* 2002;359:2145-2152.
106. Schiffer CA, Aisner J, Wiernik PH. Frozen autologous platelet transfusion for patients with leukemia. *N Engl J Med* 1978;299:7-12.
107. Wolkers WF, Walker NJ, Tablin F, Crowe JH. Human platelets loaded with trehalose survive freeze-drying. *Cryobiology* 2001;42:79-87.
108. Tang M, Wolkers WF, Crowe JH, Tablin F. Freeze-dried rehydrated human blood platelets regulate intracellular pH. *Transfusion* 2006;46:1029-1037.
109. Smith JF, Ness PM, Moroff G, Luban NL. Retention of coagulation factors in plasma frozen after extended holding at 1-6 degrees C. *Vox Sang* 2000;78:28-30.
110. O'Neill EM, Rowley J, Hansson-Wicher M, et al. Effect of 24-hour whole-blood storage on plasma clotting factors. *Transfusion* 1999;39(5):488-491.
111. Cardigan R, Lawrie AS, Mackie IJ, Williamson LM. The quality of fresh-frozen plasma produced from whole blood stored at 4 degrees C overnight. *Transfusion* 2005;45(8):1342-1348.
112. Davenport, RD. Resource guide on labeling, storage, comparability of plasma components. <http://www.aabb.org/development/education/material/Documents/resourceguide.pdf>. Accessed.
113. Downes KA, Wilson E, Yomtovian R, Sarode R. Serial measurement of clotting factors in thawed plasma stored for 5 days. *Transfusion* 2001;41:570.
114. Smak Gregoor PJ, Harvey MS, Briet E, Brand A. Coagulation parameters of CPD fresh-frozen plasma and CPD cryoprecipitate-poor plasma after storage at 4 degrees C for 28 days. *Transfusion* 1993;33(9):735-738.
115. Bostrom F, Sjodahl M, Wehlin L, Egberg N, Lundahl J. Coagulation parameters in apheresis and leukodepleted whole-blood plasma during storage. *Transfusion* 2007;47(3):460-463.
116. Scott EA, Puca KE, Pietz BC, Duchateau BK, Friedman KD. Comparison and stability of ADAMTS13 activity in therapeutic plasma products. *Transfusion* 2007;47(1):120-125.
117. Lamboo M, Poland DC, Eikenboom JC, et al. Coagulation parameters of thawed fresh-frozen plasma during storage at different temperatures. *Transfus Med* 2007;17(3):182-186.
118. Raife TJ, Friedman KD, Dwyre DM. The pathogenicity of von Willebrand factor in thrombotic thrombocytopenic purpura: reconsideration of treatment with cryopoor plasma. *Transfusion* 2006;46(1):74-79.
119. Ofosu FA, Freedman J, Semple JW. Plasma-derived biological medicines used to promote haemostasis. *Thromb Haemost* 2008;99:851-862.
120. Food and Drug Administration: guidance for industry: nucleic acid testing (NAT) to reduce the possible risk of parvovirus B19 transmission by plasma-derived products. July 2009. <http://www.fda.gov/BiologicsBloodVaccines/GuidanceComplianceRegulatoryInformation/Guidances/Blood/ucm071592.htm>. Accessed.
121. Groner A. Pathogen safety of plasma-derived products—Haemate P/Humate-P. *Haemophilia: the official journal of the World Federation of Hemophilia* 2008;14(Suppl 5):54-71.

122. Hellstern P, Solheim BG. The use of solvent/detergent treatment in pathogen reduction of plasma. *Transfus Med Hemother* 2011;38:65-70.
123. Darabi K, Abdel-Wahab O, Dzik WH. Current usage of intravenous immune globulin and the rationale behind it: the Massachusetts General Hospital data and a review of the literature. *Transfusion* 2006;46:741-753.
- P.585
124. Dzik WH. Leukoreduced blood components: laboratory and clinical aspects. In: Simon TL, Dzik WH, Snyder EL, Stowell CP, Strauss RG, eds. *Rossi's principles of transfusion medicine*, 3rd ed. Philadelphia, PA: Lippincott Williams & Wilkins, 2002:270-287.
125. Parravicini A, Rebulli P, Apuzzo J, Wenz B, Sirchia G. The preparation of leukocyte-poor red cells for transfusion by a simple cost-effective technique. *Transfusion* 1984;24:508-509.
126. Heddle NM, Klama L, Singer J, et al. The role of the plasma from platelet concentrates in transfusion reactions. *N Engl J Med* 1994;331:625-628.
127. Mangano MM, Chambers LA, Kruskall MS. Limited efficacy of leukopoor platelets for prevention of febrile transfusion reactions. *Am J Clin Pathol* 1991;95:733-738.
128. Muylle L, Wouters E, De Bock R, Peetermans ME. Reactions to platelet transfusion: the effect of the storage time of the concentrate. *Transfus Med* 1992;2:289-293.
129. Heddle NM, Klama LN, Griffith L, Roberts R, Shukla G, Kelton JG. A prospective study to identify the risk factors associated with acute reactions to platelet and red cell transfusions. *Transfusion* 1993;33:794-797.
130. Vamvakas EC, Blajchman MA. Universal WBC reduction: the case for and against. *Transfusion* 2001;41:691-712.
131. Moroff G, Luban NL. The irradiation of blood and blood components to prevent graft-versus-host disease: technical issues and guidelines. *Transfus Med Rev* 1997;11:15-26.
132. Holman P, Blajchman MA, Heddle N. Noninfectious adverse effects of blood transfusion in the neonate. *Transfus Med Rev* 1995;9:277-287.
133. Hiemstra H, Tersmette M, Vos AH, Over J, van Berkel MP, de Bree H. Inactivation of human immunodeficiency virus by gamma radiation and its effect on plasma and coagulation factors. *Transfusion* 1991;31:32-39.
134. Goodnough LT, Skikne B, Brugnara C. Erythropoietin, iron, and erythropoiesis. *Blood* 2000;96:823-833.
135. The National Blood Resource Education Program Expert Panel. The use of autologous blood. *JAMA* 1990;263:414-417.
136. Birkmeyer JD, Goodnough LT, AuBuchon JP, Noordsij PG, Littenberg B. The cost-effectiveness of preoperative autologous blood donation for total hip and knee replacement. *Transfusion* 1993;33:544-551.
137. Popovsky MA, Whitaker B, Arnold NL. Severe outcomes of allogeneic and autologous blood donation: frequency and characterization. *Transfusion* 1995;35:734-737.
138. Brecher ME, Goodnough LT. The rise and fall of preoperative autologous blood donation (editorial). *Transfusion* 2002;42:1618-1622.
139. Goodnough LT, Brecher ME, Kanter MH, AuBuchon JP. Transfusion medicine. Second of two parts—blood conservation. *N Engl J Med* 1999;340:525-533.
140. Goodnough LT, Monk TG, Brecher ME. Autologous blood procurement in the surgical setting: lessons learned in the last 10 years. *Vox Sang* 1996;71: 133-141.
141. Domen RE. Adverse reactions associated with autologous blood transfusion: evaluation and incidence at a large academic hospital. *Transfusion* 1998;38:296-300.
142. Mackey J, Lipton KS. AABB position on testing of autologous units. *Association Bulletin* 95-4 ed. Bethesda, MD: American Association of Blood Banks, 1995.
143. Goodnough LT. Autologous blood donation. *Anesthesiol Clin North America* 2005;23:263-270, vi.

144. Monk TG, Goodnough LT, Brecher ME, et al. Acute normovolemic hemodilution can replace preoperative autologous blood donation as a standard of care for autologous blood procurement in radical prostatectomy. *Anesth Analg* 1997;85:953-958.
145. Goodnough LT, Monk TG, Brecher ME. Acute normovolemic hemodilution should replace the preoperative donation of autologous blood as a method of autologous-blood procurement. *Transfusion* 1998;38:473-476.
146. Weiskopf RB. Efficacy of acute normovolemic hemodilution assessed as a function of fraction of blood volume lost. *Anesthesiology* 2001;94:439-446.
147. AABB. Standards for perioperative autologous blood collection and administration, 4th ed. Bethesda, MD: AABB, 2009.
148. Segal JB, Blasco-Colmenares E, Norris EJ, Guallar E. Preoperative acute normovolemic hemodilution: a meta-analysis. *Transfusion* 2004;44:632-644.
149. Monk TG, Goodnough LT, Brecher ME, Colberg JW, Andriole GL, Catalona WJ. A prospective randomized comparison of three blood conservation strategies for radical prostatectomy. *Anesthesiology* 1999;91:24-33.
150. Williamson KR, Taswell HF. Intraoperative blood salvage: a review. *Transfusion* 1991;31:662-675.
151. Ashworth A, Klein AA. Cell salvage as part of a blood conservation strategy in anaesthesia. *Br J Anaesth* 2010;105(4):401-416.
152. Ritter MA, Keating EM, Faris PM. Closed wound drainage in total hip or total knee replacement. A prospective, randomized study. *J Bone Joint Surg Am* 1994;76:35-38.
153. Goodnough LT, Rudnick S, Price TH, et al. Increased preoperative collection of autologous blood with recombinant human erythropoietin therapy. *N Engl J Med* 1989;321:1163-1168.
154. Goodnough LT, Price TH, Friedman KD, et al. A phase III trial of recombinant human erythropoietin therapy in nonanemic orthopedic patients subjected to aggressive removal of blood for autologous use: dose, response, toxicity, and efficacy. *Transfusion* 1994;34:66-71.
155. Effectiveness of perioperative recombinant human erythropoietin in elective hip replacement. Canadian Orthopedic Perioperative Erythropoietin Study Group. *Lancet* 1993;341:1227-1232.
156. Goodnough LT, Monk TG, Andriole GL. Erythropoietin therapy. *N Engl J Med* 1997;336:933-938.
157. Kocian R, Spahn DR. Haemoglobin, oxygen carriers and perioperative organ perfusion. *Best Pract Res Clin Anaesthesiol* 2008;22:63-80.
158. Shander A, Goodnough LT. Why an alternative to blood transfusion? *Crit Care Clin* 2009;25:261-277, Table of Contents.
159. Goodnough LT, Shander A. Blood management. *Arch Pathol Lab Med* 2007;131:695-701.
160. Goodnough LT, Shander A. Evolution in alternatives to blood transfusion. *Hematol J* 2003;4:87-91.
161. Hai CM. Systems biology of HBOC-induced vasoconstriction. *Curr Drug Discov Technol* 2012;9(3):204-211.
162. Inayat MS, Bernard AC, Gallicchio VS, et al. Oxygen carriers: a selected review. *Transfus Apher Sci* 2006;34:25-32.
163. Natanson C, Kern SJ, Lurie P, Banks SM, Wolfe SM. Cell-free hemoglobin-based blood substitutes and risk of myocardial infarction and death: a meta-analysis. *JAMA* 2008;299:2304-2312.
164. Greenburg AG, Light WR, Dube GP. Reconstructing hemoglobin-based oxygen carriers. *Transfusion* 2010;50:2764-2767; author reply 7.
165. Shander A, Javidroozi M, Thompson G. Hemoglobin-based blood substitutes and risk of myocardial infarction and death. *JAMA* 2008;300:1296-1297; author reply 8-9.
166. Vamvakas EC, Blajchman MA. Transfusion-related mortality: the ongoing risks of allogeneic blood transfusion and the available strategies for their prevention. *Blood* 2009;113:3406-3417.
167. Perkins HA, Busch MP. Transfusion-associated infections: 50 years of relentless challenges and remarkable progress. *Transfusion* 2010;50:2080-2899.
168. Goodnough LT, Brecher ME, Kanter MH, AuBuchon JP. Transfusion medicine. First of two parts—blood transfusion. *N Engl J Med* 1999;340:438-447.

169. Starr D. Blood: an epic history of medicine and commerce. New York: AA Knopf, 1998.
170. Morton J, Anastassopoulos KP, Patel ST, et al. Frequency and outcomes of blood products transfusion across procedures and clinical conditions warranting inpatient care: an analysis of the 2004 healthcare cost and utilization project nationwide inpatient sample database. *Am J Med Qual* 2010;25: 289-296.
171. Shander A, Hofmann A, Ozawa S, Theusinger OM, Gombotz H, Spahn DR. Activity-based costs of blood transfusions in surgical patients at four hospitals. *Transfusion* 2010;50:753-765.
172. Goodnough LT, Shander AS. Patient blood management. *Anesthesiology* 2012;116:1367-1376.
173. Waters JH, Ness PM. Patient blood management: a growing challenge and opportunity. *Transfusion* 2011;51:902-903.
174. Goodnough LT, Maniatis A, Earnshaw P, et al. Detection, evaluation, and management of preoperative anaemia in the elective orthopaedic surgical patient: NATA guidelines. *Br J Anaesth* 2011;106:13-22.
175. Spahn DR, Moch H, Hofmann A, Isbister JP. Patient blood management: the pragmatic solution for the problems with blood transfusions. *Anesthesiology* 2008;109:951-953.
176. Salisbury AC, Reid KJ, Alexander KP, et al. Diagnostic blood loss from phlebotomy and hospital-acquired anemia during acute myocardial infarction. *Arch Intern Med*. Epub 8/8/11.
177. Goodnough LT, Shander A. How I treat warfarin-associated coagulopathy in patients with intracerebral hemorrhage. *Blood* 2011;117:6091-6099.
178. Despotis GJ, Joist JH, Goodnough LT. Monitoring of hemostasis in cardiac surgical patients: impact of point-of-care testing on blood loss and transfusion outcomes. *Clin Chem* 1997;43:1684-1696.
179. Shander A, Fink A, Javidroozi M, et al. Appropriateness of allogeneic red blood cell transfusion: the international Consensus Conference on transfusion outcomes. *Transfus Med Rev* 2011;25:232-246.
180. Kim DU. The quest for quality blood banking program in the new millennium: the American way. *Int J Hematol* 2002;76(Suppl 2):258-262.
181. The Joint Commission. Patient Blood Management Performance Measures Project 2011. http://www.jointcommission.org/patient_blood_management_performance_measures_project/. Accessed.
182. Moskowitz DM, McCullough JN, Shander A, et al. The impact of blood conservation on outcomes in cardiac surgery: is it safe and effective? *Ann Thorac Surg* 2010;90:451-458.
183. Finch CA, Lenfant C. Oxygen transport in man. *N Engl J Med* 1972;286: 407-415.
184. Levy PS, Chavez RP, Crystal GJ, et al. Oxygen extraction ratio: a valid indicator of transfusion need in limited coronary vascular reserve? *J Trauma* 1992;32:769-773; discussion 73-74.
185. Levy PS, Kim SJ, Eckel PK, et al. Limit to cardiac compensation during acute isovolemic hemodilution: influence of coronary stenosis. *Am J Physiol* 1993;265:H340-H349.
186. Goodnough LT, Despotis GJ, Hogue CW Jr, Ferguson TB Jr. On the need for improved transfusion indicators in cardiac surgery. *Ann Thorac Surg* 1995;60:473-480.
187. Kitchens CS. Are transfusions overrated? Surgical outcome of Jehovah's Witnesses. *Am J Med* 1993;94:117-119.
188. Viele MK, Weiskopf RB. What can we learn about the need for transfusion from patients who refuse blood? The experience with Jehovah's Witnesses. *Transfusion* 1994;34:396-401.
189. Carson JL, Duff A, Poses RM, et al. Effect of anaemia and cardiovascular disease on surgical mortality and morbidity. *Lancet* 1996;348:1055-1060.
190. Carson JL, Noveck H, Berlin JA, Gould SA. Mortality and morbidity in patients with very low postoperative Hb levels who decline blood transfusion. *Transfusion* 2002;42:812-818.
191. Carson JL, Duff A, Berlin JA, et al. Perioperative blood transfusion and postoperative mortality. *JAMA* 1998;279:199-205.
192. Carson JL, Terrin ML, Noveck H, et al. Liberal or restrictive transfusion in high-risk patients after hip surgery. *N Engl J Med* 2011;365:2453-2462.
193. Hajjar LA, Vincent JL, Galas FR, et al. Transfusion requirements after cardiac surgery: the TRACS randomized controlled trial. *JAMA* 2010;304:1559-1567.

194. Hebert PC, Wells G, Blajchman MA, et al. A multicenter, randomized, controlled clinical trial of transfusion requirements in critical care. *Transfusion Requirements in Critical Care Investigators, Canadian Critical Care Trials Group. N Engl J Med* 1999;340:409-417.
195. Carless PA, Henry DA, Carson JL, Hebert PP, McClelland B, Ker K. Transfusion thresholds and other strategies for guiding allogeneic red blood cell transfusion. *Cochrane Database Syst Rev* 2010;10:CD002042.
196. Carson JL, Grossman BJ, Kleinman S, et al. Red blood cell transfusion: a clinical practice guideline from the AABB. *Ann Intern Med* 2012;157(1):49-58.
197. Ferraris VA, Brown JR, Despotis GJ, et al. 2011 update to the Society of Thoracic Surgeons and the Society of Cardiovascular Anesthesiologists blood conservation clinical practice guidelines. *Ann Thorac Surg* 2011;91: 944-982.
198. Welch HG, Meehan KR, Goodnough LT. Prudent strategies for elective red blood cell transfusion. *Ann Intern Med* 1992;116:393-402.
199. Ross S, Jeter E. Emergency surgery: trauma and massive transfusion. In: Petz LD, Kleinman S, Swisher SN, Spence RK, Strauss RG, eds. *Clinical practice of transfusion medicine*, 3rd ed. New York: Churchill Livingstone, 1996: 563-579.
200. Kauvar DS, Lefering R, Wade CE. Impact of hemorrhage on trauma outcome: an overview of epidemiology, clinical presentations, and therapeutic considerations. *J Trauma* 2006;60:S3-S11.
201. Acosta JA, Yang JC, Winchell RJ, et al. Lethal injuries and time to death in a level I trauma center. *J Am Coll Surg* 1998;186:528-533.
202. Sauaia A, Moore FA, Moore EE, et al. Epidemiology of trauma deaths: a reassessment. *J Trauma* 1995;38:185-193.
203. Trowbridge C, Stammers A, Klayman M, Brindisi N, Woods E. Characteristics of uncontrolled hemorrhage in cardiac surgery. *J Extra Corpor Technol* 2008;40:89-93.
204. Rose AH, Kotze A, Doolan D, Norfolk DR, Bellamy MC. Massive transfusion—evaluation of current clinical practice and outcome in two large teaching hospital trusts in Northern England. *Vox Sang* 2009;97:247-253.
205. Holcomb JB, Jenkins D, Rhee P, et al. Damage control resuscitation: directly addressing the early coagulopathy of trauma. *J Trauma* 2007;62(2):307-310.
206. Burtelow M, Riley E, Druzin M, Fontaine M, Viele M, Goodnough LT. How we treat: management of life-threatening primary postpartum hemorrhage with a standardized massive transfusion protocol. *Transfusion* 2007;47: 1564-1572.
207. Barnert J, Messmann H. Diagnosis and management of lower gastrointestinal bleeding. *Nat Rev Gastroenterol Hepatol* 2009;6:637-646.
208. Borgman MA, Spinella PC, Perkins JG, et al. The ratio of blood products transfused affects mortality in patients receiving massive transfusions at a combat support hospital. *J Trauma* 2007;63:805-813.
209. Como JJ, Dutton RP, Scalea TM, Edelman BB, Hess JR. Blood transfusion rates in the care of acute trauma. *Transfusion* 2004;44:809-813.
210. Moore FA, Nelson T, McKinley BA, et al. Massive transfusion in trauma patients: tissue hemoglobin oxygen saturation predicts poor outcome. *J Trauma* 2008;64:1010-1023.
211. Cotton BA, Dossett LA, Au BK, Nunez TC, Robertson AM, Young PP. Room for (performance) improvement: provider-related factors associated with poor outcomes in massive transfusion. *J Trauma* 2009;67:1004-1012.
212. Young PP, Cotton BA, Goodnough LT. Massive transfusion protocols for patients with substantial hemorrhage. *Trans Med Rev* 2011; 25: 293-303.
213. Hess JR, Zimrin AB. Massive blood transfusion for trauma. *Curr Opin Hematol* 2005;12:488-492.
214. Hess JR, Holcomb JB, Hoyt DB. Damage control resuscitation: the need for specific blood products to treat the coagulopathy of trauma. *Transfusion* 2006;46:685-686.
215. Schreiber MA, Perkins J, Kiraly L, Underwood S, Wade C, Holcomb JB. Early predictors of massive transfusion in combat casualties. *J Am Coll Surg* 2007;205:541-545.
216. Dutton RP, Carson JL. Indications for early red blood cell transfusion. *J Trauma* 2006;60:S35-S40.
217. Ketchum L, Hess JR, Hiippala S. Indications for early fresh frozen plasma, cryoprecipitate, and platelet transfusion in trauma. *J Trauma* 2006;60: S51-S58.

218. Zielinski MD, Park MS, Jenkins D. Appropriate evidence-based practice guidelines for plasma transfusion would include a high ratio of plasma to red blood cells based on the available data. *Transfusion* 2010;50:2762; author reply 3-4.
219. Stansbury LG, Dutton RP, Stein DM, Bochicchio GV, Scalea TM, Hess JR. Controversy in trauma resuscitation: do ratios of plasma to red blood cells matter? *Transfus Med Rev* 2009;23:255-265.
220. Callum JL, Nascimento B, Tien H, Rizoli S. Editorial: "formula-driven" versus "lab-driven" massive transfusion protocols: at a state of clinical equipoise. *Transfus Med Rev* 2009;23:247-254.
221. Sihler KC, Napolitano LM. Complications of massive transfusion. *Chest* 2010;137:209-220.
222. Cotton BA, Gunter OL, Isbell J, et al. Damage control hematology: the impact of a trauma exsanguination protocol on survival and blood product utilization. *J Trauma* 2008;64(5):1177-1182; discussion 82-83.
223. Kashuk JL, Moore EE, Johnson JL, et al. Postinjury life threatening coagulopathy: is 1:1 fresh frozen plasma:packed red blood cells the answer? *J Trauma* 2008;65:261-270; discussion 70-71.
224. Shaz BH, Dente CJ, Nicholas J, et al. Increased number of coagulation products in relationship to red blood cell products transfused improves mortality in trauma patients. *Transfusion* 2010;50(2):493-500.
225. Gunter OL, Jr., Au BK, Isbell JM, Mowery NT, Young PP, Cotton BA. Optimizing outcomes in damage control resuscitation: identifying blood product ratios associated with improved survival. *J Trauma* 2008;65:527-534.
226. Snyder CW, Weinberg JA, McGwin G Jr, et al. The relationship of blood product ratio to mortality: survival benefit or survival bias? *J Trauma* 2009;66:358-362; discussion 62-64.
227. Friedman BA. An analysis of surgical blood use in United States hospitals with application to the maximum surgical blood order schedule. *Transfusion* 1979;19:268-278.
228. Axelrod FB, Pepkowitz SH, Goldfinger D. Establishment of a schedule of optimal preoperative collection of autologous blood. *Transfusion* 1989;29: 677-680.
229. Groopman JE, Itri LM. Chemotherapy-induced anemia in adults: incidence and treatment. *J Natl Cancer Inst* 1999;91:1616-1634.
230. Petz LD. Blood transfusion in acquired hemolytic anemias. In: Petz LD, Kleinman S, Swisher SN, Spence RK, Strauss RG, eds. *Clinical practice of transfusion medicine*, 3rd ed. New York: Churchill Livingstone, 1996:469-499.
231. Petz LD, Garratty G. Blood transfusion in autoimmune hemolytic anemia. In: *immune hemolytic anemias*, 2nd ed. Philadelphia, PA: Churchill Livingstone, 2004:375-400.
232. Weiss G, Goodnough LT. Anemia of chronic disease. *N Engl J Med* 2005;352:1011-1023.
233. Greenwalt TJ, Zelenski KR. Transfusion support for haemoglobinopathies. *Clin Haematol* 1984;13:151-165.
234. Lee MT, Piomelli S, Granger S, et al. Stroke Prevention Trial in Sickle Cell Anemia (STOP): extended follow-up and final results. *Blood* 2006;108: 847-852.
235. Stainsby D, Russell J, Cohen H, Lilleyman J. Reducing adverse events in blood transfusion. *Br J Haematol* 2005;131:8-12.
236. Klein HG, Anstee DJ. *Mollison's blood transfusion in clinical medicine*, 11th ed. Malden, MA: Blackwell Publishing, 2005.
237. Shirey RS, Boyd JS, Ness PM. Polyethylene glycol versus low-ionic-strength solution in pretransfusion testing: a blinded comparison study. *Transfusion* 1994;34:368-370.
238. Winters JL, Pineda AA, Gorden LD, et al. RBC alloantibody specificity and antigen potency in Olmsted County, Minnesota. *Transfusion* 2001;41: 1413-1420.
239. Hoeltge GA, Domen RE, Rybicki LA, Schaffer PA. Multiple red cell transfusions and alloimmunization. Experience with 6996 antibodies detected in a total of 159,262 patients from 1985 to 1993. *Arch Pathol Lab Med* 1995;119:42-45.
240. Judd WJ. The role of lectins in blood group serology. *Crit Rev Clin Lab Sci* 1980;12(3):171-214.
241. Levene C, Levene NA, Buskila D, Manny N. Red cell polyagglutination. *Transfusion medicine reviews* 1988;2(3):176-185.
242. Laine ML, Beattie KM. Frequency of alloantibodies accompanying autoantibodies. *Transfusion* 1985;25:545-546.

243. Wallhermfechtel MA, Pohl BA, Chaplin H. Alloimmunization in patients with warm autoantibodies. A retrospective study employing three donor alloabsorptions to aid in antibody detection. *Transfusion* 1984;24:482-485.
244. Anstee DJ. Red cell genotyping and the future of pretransfusion testing. *Blood* 2009;114:248-256.
245. Hume H, Bard H. Small volume red blood cell transfusions for neonatal patients. *Transfusion medicine reviews* 1995;9(3):187-199.
246. Luban NL, Strauss RG, Hume HA. Commentary on the safety of red cells preserved in extended-storage media for neonatal transfusions. *Transfusion* 1991;31:229-235.
247. Wang-Rodriguez J, Mannino FL, Liu E, et al. A novel strategy to limit blood donor exposure and blood waste in multiply transfused premature infants. *Transfusion* 1996;36(1):64-70.
248. Slichter SJ. Controversies in platelet transfusion therapy. *Annu Rev Med* 1980;31:509-540.
249. Slichter SJ, Harker LA. Thrombocytopenia: mechanisms and management of defects in platelet production. *Clin Haematol* 1978;7:523-539.
250. Practice parameter for the use of fresh-frozen plasma, cryoprecipitate, and platelets. Fresh-Frozen Plasma, Cryoprecipitate, and Platelets Administration Practice Guidelines Development Task Force of the College of American Pathologists. *JAMA* 1994;271:777-781.
251. Daly PA, Schiffer CA, Aisner J, Wiernik PH. Platelet transfusion therapy. One-hour posttransfusion increments are valuable in predicting the need for HLA-matched preparations. *JAMA* 1980;243:435-438.
252. O'Connell B, Lee EJ, Schiffer CA. The value of 10-minute posttransfusion platelet counts. *Transfusion* 1988;28:66-67.
253. Tinmouth AT, Freedman J. Prophylactic platelet transfusions: which dose is the best dose? A review of the literature. *Transfus Med Rev* 2003;17:181-193.
254. Petz LD. Platelet transfusions. In: Petz LD, Kleinman S, Swisher SN, Spence RK, Strauss RG, eds. *Clinical practice of transfusion medicine*, 3rd ed. New York: Churchill Livingstone, 1996:359-412.
255. Hanson SR, Slichter SJ. Platelet kinetics in patients with bone marrow hypoplasia: evidence for a fixed platelet requirement. *Blood* 1985;66:1105-1109.
256. Norol F, Bierling P, Roudot-Thoraval F, et al. Platelet transfusion: a dose-response study. *Blood* 1998;92:1448-1453.
257. Klumpp TR, Herman JH, Gaughan JP, et al. Clinical consequences of alterations in platelet transfusion dose: a prospective, randomized, double-blind trial. *Transfusion* 1999;39:674-681.
258. Consensus conference. Platelet transfusion therapy. *JAMA* 1987;257: 1777-1780.
259. Beutler E. Platelet transfusions: the 20,000/microL trigger. *Blood* 1993;81:1411-1413.
260. Gaydos LA, Freireich EJ, Mantel N. The quantitative relation between platelet count and hemorrhage in patients with acute leukemia. *N Engl J Med* 1962;266:905-909.
261. Schiffer CA, Anderson KC, Bennett CL, et al. Platelet transfusion for patients with cancer: clinical practice guidelines of the American Society of Clinical Oncology. *J Clin Oncol* 2001;19:1519-1538.
262. Contreras M. Consensus conference on platelet transfusion: 27 and 28 November 1997: final statement. *Leukemia* 1998;12:1330-1331.
263. Stanworth SJ, Hyde C, Heddle N, Rebulla P, Brunskill S, Murphy MF. Prophylactic platelet transfusion for haemorrhage after chemotherapy and stem cell transplantation. *Cochrane Database Syst Rev* 2004;4:CD004269.
264. Rebulla P, Finazzi G, Marangoni F, et al. The threshold for prophylactic platelet transfusions in adults with acute myeloid leukemia. Gruppo Italiano Malattie Ematologiche Maligne dell'Adulto. *N Engl J Med* 1997;337: 1870-1875.
265. British Committee for Standards in Haematology, Blood Transfusion Task Force. Guidelines for the use of platelet transfusions. *Br J Haematol* 2003;122:10-23.
266. Wandt H, Frank M, Ehninger G, et al. Safety and cost effectiveness of a $10 \times 10^9/L$ trigger for prophylactic platelet transfusions compared with the traditional $20 \times 10^9/L$ trigger: a prospective comparative trial in 105 patients with acute myeloid leukemia. *Blood* 1998;91:3601-3606.

267. Heckman KD, Weiner GJ, Davis CS, Strauss RG, Jones MP, Burns CP. Randomized study of prophylactic platelet transfusion threshold during induction therapy for adult acute leukemia: 10,000/microL versus 20,000/microL. *J Clin Oncol* 1997;15:1143-1149.
268. Zumberg MS, del Rosario ML, Nejame CF, et al. A prospective randomized trial of prophylactic platelet transfusion and bleeding incidence in hematopoietic stem cell transplant recipients: 10,000/L versus 20,000/microL trigger. *Biol Blood Marrow Transplant* 2002;8:569-576.
269. Nevo S, Fuller AK, Hartley E, Borinsky ME, Vogelsang GB. Acute bleeding complications in patients after hematopoietic stem cell transplantation with prophylactic platelet transfusion triggers of 10×10^9 and 20×10^9 per L. *Transfusion* 2007;47:801-812.
270. Bührkuhl DC. An update on platelet transfusion in hematocology supportive care. *Transfusion* 2010;50:2266-2276.
271. Slichter SJ, Kaufman RM, Assmann SF, et al. Dose of prophylactic platelet transfusions and prevention of hemorrhage. *N Engl J Med* 2010;362: 600-613.
272. Nuttall GA, Oliver WC, Santrach PJ, et al. Efficacy of a simple intraoperative transfusion algorithm for nonerythrocyte component utilization after cardiopulmonary bypass. *Anesthesiology* 2001;94:773-781; discussion 5A-6A.
273. Delaney M, Meyer E, Cserti-Gazdewich C, et al. A systematic assessment of the quality of reporting for platelet transfusion studies. *Transfusion* 2010;50:2135-2144.
274. Higby DJ, Cohen E, Holland JF, Sinks L. The prophylactic treatment of thrombocytopenic leukemic patients with platelets: a double blind study. *Transfusion* 1974;14:440-446.
275. Murphy S, Litwin S, Herring LM, et al. Indications for platelet transfusion in children with acute leukemia. *Am J Hematol* 1982;12:347-356.
276. Bernstein SH, Nademanee AP, Vose JM, et al. A multicenter study of platelet recovery and utilization in patients after myeloablative therapy and hematopoietic stem cell transplantation. *Blood* 1998;91:3509-3517.
277. Wandt H, Schaefer-Eckart K, Frank M, Birkmann J, Wilhelm M. A therapeutic platelet transfusion strategy is safe and feasible in patients after autologous peripheral blood stem cell transplantation. *Bone Marrow Transplant* 2006;37:387-392.
278. Blajchman MA, Slichter SJ, Heddle NM, Murphy MF. New strategies for the optimal use of platelet transfusions. *Hematology Am Soc Hematol Educ Program* 2008:198-204.
279. Practice Guidelines for blood component therapy: a report by the American Society of Anesthesiologists Task Force on Blood Component Therapy. *Anesthesiology* 1996;84:732-747.
280. Harkness DR, Byrnes JJ, Lian EC, Williams WD, Hensley GT. Hazard of platelet transfusion in thrombotic thrombocytopenic purpura. *JAMA* 1981;246:1931-1933.
281. Gordon LI, Kwaan HC, Rossi EC. Deleterious effects of platelet transfusions and recovery thrombocytosis in patients with thrombotic microangiopathy. *Semin Hematol* 1987;24:194-201.
282. Harker LA, Malpass TW, Branson HE, Hessel EA 2nd, Slichter SJ. Mechanism of abnormal bleeding in patients undergoing cardiopulmonary bypass: acquired transient platelet dysfunction associated with selective alpha-granule release. *Blood* 1980;56:824-834.
283. Counts RB, Haisch C, Simon TL, Maxwell NG, Heimbach DM, Carrico CJ. Hemostasis in massively transfused trauma patients. *Ann Surg* 1979;190: 91-99.
284. Miller RD, Robbins TO, Tong MJ, Barton SL. Coagulation defects associated with massive blood transfusions. *Ann Surg* 1971;174:794-801.
285. Bishop JF, McGrath K, Wolf MM, et al. Clinical factors influencing the efficacy of pooled platelet transfusions. *Blood* 1988;71:383-387.
286. Novotny VM. Prevention and management of platelet transfusion refractoriness. *Vox Sang* 1999;76:1-13.
287. Alcorta I, Pereira A, Ordinas A. Clinical and laboratory factors associated with platelet transfusion refractoriness: a case-control study. *Br J Haematol* 1996;93:220-224.
288. Densmore TL, Goodnough LT, Ali S, Dynis M, Chaplin H. Prevalence of HLA sensitization in female apheresis donors. *Transfusion* 1999;39:103-106.

289. Payne R. The development and persistence of leukoagglutinins in parous women. *Blood* 1962;19:411-424.
290. Leukocyte reduction and ultraviolet B irradiation of platelets to prevent alloimmunization and refractoriness to platelet transfusions. The Trial to Reduce Alloimmunization to Platelets Study Group. *N Engl J Med* 1997;337: 1861-1869.
291. Yankee RA, Graff KS, Dowling R, Henderson ES. Selection of unrelated compatible platelet donors by lymphocyte HL-A matching. *N Engl J Med* 1973;288:760-764.
292. Friedberg RC, Donnelly SF, Mintz PD. Independent roles for platelet cross-matching and HLA in the selection of platelets for alloimmunized patients. *Transfusion* 1994;34:215-220.
293. Schnaidt M, Northoff H, Wernet D. Frequency and specificity of platelet-specific alloantibodies in HLA-immunized haematologic-oncologic patients. *Transfus Med* 1996;6:111-114.
294. Kurz M, Greinix H, Hocker P, et al. Specificities of anti-platelet antibodies in multitransfused patients with haemato-oncological disorders. *Br J Haematol* 1996;95:564-569.
295. Kickler T, Kennedy SD, Braine HG. Alloimmunization to platelet-specific antigens on glycoproteins IIb-IIIa and Ib/IX in multiply transfused thrombocytopenic patients. *Transfusion* 1990;30:622-625.
296. Brand A. Alloimmune platelet refractoriness: incidence declines, unsolved problems persist. *Transfusion* 2001;41:724-726.
297. Petz LD, Garratty G, Calhoun L, et al. Selecting donors of platelets for refractory patients on the basis of HLA antibody specificity. *Transfusion* 2000;40:1446-1456.
298. Claas FH, Smeenk RJ, Schmidt R, van Steenbrugge GJ, Eernisse JG. Alloimmunization against the MHC antigens after platelet transfusions is due to contaminating leukocytes in the platelet suspension. *Exp Hematol* 1981;9:84-89.
299. Vamvakas EC. Meta-analysis of randomized controlled trials of the efficacy of white cell reduction in preventing HLA-alloimmunization and refractoriness to random-donor platelet transfusions. *Transfus Med Rev* 1998;12:258-270.
300. Heddle NM. The efficacy of leukodepletion to improve platelet transfusion response: a critical appraisal of clinical studies. *Transfus Med Rev* 1994;8: 15-28.
301. Sintnicolaas K, van Marwijk Kooij M, van Prooijen HC, et al. Leukocyte depletion of random single-donor platelet transfusions does not prevent secondary human leukocyte antigen-alloimmunization and refractoriness: a randomized prospective study. *Blood* 1995;85:824-828.
302. Lindahl-Kiessling K, Safwenberg J. Inability of UV-irradiated lymphocytes to stimulate allogeneic cells in mixed lymphocyte culture. *Int Arch Allergy Appl Immunol* 1971;41:670-678.
303. Kahn RA, Duffy BF, Rodey GG. Ultraviolet irradiation of platelet concentrate abrogates lymphocyte activation without affecting platelet function in vitro. *Transfusion* 1985;25:547-550.
304. Sintnicolaas K, Vriesendorp HM, Sizoo W, et al. Delayed alloimmunisation by random single donor platelet transfusions. A randomised study to compare single donor and multiple donor platelet transfusions in cancer patients with severe thrombocytopenia. *Lancet* 1981;1:750-754.
305. Gmur J, von Felten A, Osterwalder B, et al. Delayed alloimmunization using random single donor platelet transfusions: a prospective study in thrombocytopenic patients with acute leukemia. *Blood* 1983;62:473-479.
306. Girnita AL, Webber SA, Zeevi A. Anti-HLA alloantibodies in pediatric solidorgan transplantation. *Pediatr Transplant* 2006;10:146-153.
307. Gelb AB, Leavitt AD. Crossmatch-compatible platelets improve corrected count increments in patients who are refractory to randomly selected platelets. *Transfusion* 1997;37:624-630.
308. Yankee RA, Grumet FC, Rogentine GN. Platelet transfusion. The selection of compatible platelet donors for refractory patients by lymphocyte HL-A typing. *N Engl J Med* 1969;281:1208-1212.
309. Moroff G, Garratty G, Heal JM, et al. Selection of platelets for refractory patients by HLA matching and prospective crossmatching. *Transfusion* 1992;32:633-640.
310. Bryant PC, Vayntrub TA, Schrandt HA, Kalil JE, Grumet FC. HLA antibody enhancement by double addition of serum: use in platelet donor selection. *Transfusion* 1992;32:839-844.

311. Zimmermann R, Wittmann G, Zingsem J, Blasczyk R, Weisbach V, Eckstein R. Antibodies to private and public HLA class I epitopes in platelet recipients. *Transfusion* 1999;39:772-780.
312. Murphy WG, Palmer JP, Green RH. The management of haemorrhage in the refractory non-alloimmunized thrombocytopenic patient. *Vox Sang* 1994;67(Suppl 3):99-103.
313. Kickler T, Braine HG, Piantadosi S, Ness PM, Herman JH, Rothko K. A randomized, placebo-controlled trial of intravenous gammaglobulin in alloimmunized thrombocytopenic patients. *Blood* 1990;75:313-316.
314. Gardner FH, Helmer RE 3rd. Aminocaproic acid. Use in control of hemorrhage in patients with amegakaryocytic thrombocytopenia. *JAMA* 1980;243:35-37.
315. Kalmadi S, Tiu R, Lowe C, Jin T, Kalaycio M. Epsilon aminocaproic acid reduces transfusion requirements in patients with thrombocytopenic hemorrhage. *Cancer* 2006;107:136-140.
316. Goodnough LT, DiPersio JF. Issues in the management of cancer-related thrombocytopenia. *Oncology (Williston Park)* 2002;16:1558-1567; discussion 70, 72-74.
317. Goodnough LT. Experiences with recombinant human factor VIIa in patients with thrombocytopenia. *Semin Hematol* 2004;41:25-29.
318. Logan AC, Goodnough LT. Recombinant factor VIIa: an assessment of evidence regarding its efficacy and safety in the off-label setting. *Hematology Am Soc Hematol Educ Program* 2010;2010:153-159.
319. Pihusch M, Bacigalupo A, Szer J, et al. Recombinant activated factor VII in treatment of bleeding complications following hematopoietic stem cell transplantation. *J Thromb Haemost* 2005;3:1935-1944.
320. Valeri CR, Cassidy G, Pivacek LE, et al. Anemia-induced increase in the bleeding time: implications for treatment of nonsurgical blood loss. *Transfusion* 2001;41:977-983.
321. Moia M, Mannucci PM, Vizzotto L, Casati S, Cattaneo M, Ponticelli C. Improvement in the haemostatic defect of uraemia after treatment with recombinant human erythropoietin. *Lancet* 1987;2:1227-1229.
322. Kuter DJ, Bussel JB, Lyons RM, et al. Efficacy of romiplostim in patients with chronic immune thrombocytopenic purpura: a double-blind randomised controlled trial. *Lancet* 2008;371:395-403.
323. Bussel JB, Kuter DJ, Pullarkat V, Lyons RM, Guo M, Nichol JL. Safety and efficacy of long-term treatment with romiplostim in thrombocytopenic patients with chronic ITP. *Blood* 2009;113:2161-2171.
324. Edelstein LC, Bray PF. MicroRNAs in platelet production and activation. *Blood* 2011;117:5289-5296.
325. Ryan P, Atreya C. Blood cell microRNAs: what are they and what future do they hold? *Transfus Med Rev* 2011;25:247-251.
326. Okamura Y, Takeoka S, Eto K, et al. Development of fibrinogen gamma-chain peptide-coated, adenosine diphosphate-encapsulated liposomes as a synthetic platelet substitute. *J Thromb Haemost* 2009;7:470-477.
327. Dunstan RA, Simpson MB, Knowles RW, Rosse WF. The origin of ABH antigens on human platelets. *Blood* 1985;65:615-619.
328. Kelton JG, Hamid C, Aker S, Blajchman MA. The amount of blood group A substance on platelets is proportional to the amount in the plasma. *Blood* 1982;59:980-985.
329. Aster RH. Effect of anticoagulant and ABO incompatibility on recovery of transfused human platelets. *Blood* 1965;26:732-743.
330. Duguesnoy RJ, Anderson AJ, Tomasulo PA, Aster RH. ABO compatibility and platelet transfusions of alloimmunized thrombocytopenic patients. *Blood* 1979;54:595-599.
331. Heal JM, Blumberg N, Masel D. An evaluation of crossmatching, HLA, and ABO matching for platelet transfusions to refractory patients. *Blood* 1987;70:23-30.
332. Aster RH. New approaches to an old problem. Refractoriness to platelet transfusions. *Transfusion* 1988;28:95-96.
333. Brand A, Sintnicolaas K, Claas FH, Eernisse JG. ABH antibodies causing platelet transfusion refractoriness. *Transfusion* 1986;26:463-466.
334. Murphy S. ABO blood groups and platelet transfusion. *Transfusion* 1988;28:401-402.

335. Lee EJ, Schiffer CA. ABO compatibility can influence the results of platelet transfusion. Results of a randomized trial. *Transfusion* 1989;29:384-389.
336. McManigal S, Sims KL. Intravascular hemolysis secondary to ABOincompatible platelet products. An underrecognized transfusion reaction. *Am J Clin Pathol* 1999;111:202-206.
337. Josephson CD, Mullis NC, Van Demark C, Hillyer CD. Significant numbers of apheresis-derived group O platelet units have "high-titer" anti-A/A,B: implications for transfusion policy. *Transfusion* 2004;44:805-808.
338. Heal JM, Blumberg N. Optimizing platelet transfusion therapy. *Blood Rev* 2004;18:149-165.
339. Carr R, Hutton JL, Jenkins JA, Lucas GF, Amphlett NW. Transfusion of ABOmismatched platelets leads to early platelet refractoriness. *Br J Haematol* 1990;75:408-413.
340. Heal JM, Rowe JM, McMican A, Masel D, Finke C, Blumberg N. The role of ABO matching in platelet transfusion. *Eur J Haematol* 1993;50:110-117.
341. Cid J, Lozano M, Fernandez-Aviles F, et al. Anti-D alloimmunization after D-mismatched allogeneic hematopoietic stem cell transplantation in patients with hematologic diseases. *Transfusion* 2006;46(2):169-173.
342. Menitove JE. Immunoprophylaxis for D- patients receiving platelet transfusions from D+ [correction of D-] donors? *Transfusion* 2002;42:136-138.
343. Cid J, Lozano M. Risk of Rh(D) alloimmunization after transfusion of platelets from D+ donors to D- recipients. *Transfusion* 2005;45(3):453; author reply 453-454.
344. Haspel RL, Walsh L, Sloan SR. Platelet transfusion in an infant leading to formation of anti-D: implications for immunoprophylaxis. *Transfusion* 2004;44:747-749.
345. Sandler SG. Treating immune thrombocytopenic purpura and preventing Rh alloimmunization using intravenous rho (D) immune globulin. *Transfus Med Rev* 2001;15:67-76.
346. AABB, American Red Cross, America's Blood Centers and the Armed Services Blood Program. Circular of information for the use of human blood and blood components. <http://www.aabb.org/resources/bct/Documents/coi0809r.pdf>. Accessed.
347. Chowdary P, Saayman AG, Paulus U, et al. Efficacy of standard dose and 30 ml/kg fresh frozen plasma in correcting laboratory parameters of haemostasis in critically ill patients. *Br J Haematol* 2004;125(1):69-73.
348. Roback JD, Caldwell S, Carson J, et al. Evidence-based practice guidelines for plasma transfusion. *Transfusion* 2010;50:1227-1239.
349. Holland LL, Brooks JP. Toward rational fresh frozen plasma transfusion: the effect of plasma transfusion on coagulation test results. *Am J Clin Pathol* 2006;126:133-139.
350. Abdel-Wahab OI, Healy B, Dzik WH. Effect of fresh-frozen plasma transfusion on prothrombin time and bleeding in patients with mild coagulation abnormalities. *Transfusion* 2006;46:1279-1285.
351. Segal JB, Dzik WH. Paucity of studies to support that abnormal coagulation test results predict bleeding in the setting of invasive procedures: an evidence-based review. *Transfusion* 2005;45:1413-1425.
352. Li G, Rachmale S, Kojicic M, et al. Incidence and transfusion risk factors for transfusion-associated circulatory overload among medical intensive care unit patients. *Transfusion* 2011;51:338-343.
353. Rana R, Fernandez-Perez ER, Khan SA, et al. Transfusion-related acute lung injury and pulmonary edema in critically ill patients: a retrospective study. *Transfusion* 2006;46:1478-1483.
354. Yazer M. The Pittsburgh centralized transfusion model: less is more. *Transfusion* 2007;47:164S-168S; discussion 82S-83S.
355. Shaz BH, Stowell SR, Hillyer CD. Transfusion-related acute lung injury: from bedside to bench and back. *Blood* 2011;117:1463-1471.
356. Lin Y, Saw CL, Hannach B, Goldman M. Transfusion-related acute lung injury prevention measures and their impact at Canadian Blood Services Transfusion. *Epub* 9/2/2011.
357. Bodey GP, Buckley M, Sathe YS, Freireich EJ. Quantitative relationships between circulating leukocytes and infection in patients with acute leukemia. *Ann Intern Med* 1966;64:328-340.

358. McCullough J. Granulocyte transfusion. In: Petz LD, Kleinman S, Swisher SN, Spence RK, Strauss RG, eds. *Clinical practice of transfusion medicine*, 3rd ed. New York: Churchill Livingstone, 1996:413-432.
359. Crawford J, Ozer H, Stoller R, et al. Reduction by granulocyte colony-stimulating factor of fever and neutropenia induced by chemotherapy in patients with small-cell lung cancer. *N Engl J Med* 1991;325:164-170.
360. Bishop MR, Tarantolo SR, Geller RB, et al. A randomized, double-blind trial of filgrastim (granulocyte colony-stimulating factor) versus placebo following allogeneic blood stem cell transplantation. *Blood* 2000;96:80-85.
361. Ojeda E, Garcia-Bustos J, Aguado M, et al. A prospective randomized trial of granulocyte colony-stimulating factor therapy after autologous blood stem cell transplantation in adults. *Bone Marrow Transplant* 1999;24:601-607.
362. Klein HG, Strauss RG, Schiffer CA. Granulocyte transfusion therapy. *Semin Hematol* 1996;33:359-368.
363. Dale DC, Liles WC, Price TH. Renewed interest in granulocyte transfusion therapy. *Br J Haematol* 1997;98:497-501.
364. Strauss RG. Therapeutic granulocyte transfusions in 1993. *Blood* 1993;81:1675-1678.
365. Strauss RG. Neutrophil collections and transfusion. In: Simon TL, Snyder EL, Solheim BG, et al, eds. *Rossi's principles of transfusion medicine*, 4th ed. Philadelphia, PA: Lippincott Williams & Wilkins, 2009:219-227.
366. Massey E, Paulus U, Doree C, Stanworth S. Granulocyte transfusions for preventing infections in patients with neutropenia or neutrophil dysfunction. *Cochrane Database Syst Rev* 2009;1:CD005341.
367. Pammi M, Brocklehurst P. Granulocyte transfusions for neonates with confirmed or suspected sepsis and neutropenia. *Cochrane Database Syst Rev* 2011;10:CD003956.
368. Stanworth SJ, Massey E, Hyde C, et al. Granulocyte transfusions for treating infections in patients with neutropenia or neutrophil dysfunction. *Cochrane Database Syst Rev* 2005;3:CD005339.
369. Strauss RG. Clinical perspectives of granulocyte transfusions: efficacy to date. *J Clin Apher* 1995;10:114-118.
370. Price TH, Bowden RA, Boeckh M, et al. Phase I/II trial of neutrophil transfusions from donors stimulated with G-CSF and dexamethasone for treatment of patients with infections in hematopoietic stem cell transplantation. *Blood* 2000;95:3302-3309.
371. Peters C, Minkov M, Matthes-Martin S, et al. Leucocyte transfusions from rhG-CSF or prednisolone stimulated donors for treatment of severe infections in immunocompromised neutropenic patients. *Br J Haematol* 1999;106: 689-696.
372. Lee JJ, Chung IJ, Park MR, et al. Clinical efficacy of granulocyte transfusion therapy in patients with neutropenia-related infections. *Leukemia* 2001;15:203-207.
373. Safdar A, Hanna HA, Boktour M, et al. Impact of high-dose granulocyte transfusions in patients with cancer with candidemia: retrospective case-control analysis of 491 episodes of *Candida* species bloodstream infections. *Cancer* 2004;101:2859-2865.
374. Mousset S, Hermann S, Klein SA, et al. Prophylactic and interventional granulocyte transfusions in patients with haematological malignancies and life-threatening infections during neutropenia. *Ann Hematol* 2005;84:734-741.
375. Winston DJ, Ho WG, Howell CL, et al. Cytomegalovirus infections associated with leukocyte transfusions. *Ann Intern Med* 1980;93:671-675.
376. Clift RA, Sanders JE, Thomas ED, Williams B, Buckner CD. Granulocyte transfusions for the prevention of infection in patients receiving bone-marrow transplants. *N Engl J Med* 1978;298:1052-1057.
377. Ford JM, Cullen MH, Roberts MM, Brown LM, Oliver RT, Lister TA. Prophylactic granulocyte transfusions: results of a randomized controlled trial in patients with acute myelogenous leukemia. *Transfusion* 1982;22: 311-316.
378. Schiffer CA, Aisner J, Daly PA, Schimpff SC, Wiernik PH. Alloimmunization following prophylactic granulocyte transfusion. *Blood* 1979;54:766-774.
379. Strauss RG, Connett JE, Gale RP, et al. A controlled trial of prophylactic granulocyte transfusions during initial induction chemotherapy for acute myelogenous leukemia. *N Engl J Med* 1981;305:597-603.
380. Winston DJ, Ho WG, Young LS, Gale RP. Prophylactic granulocyte transfusions during human bone marrow transplantation. *Am J Med* 1980;68:893-897.
381. Winston DJ, Ho WG, Gale RP. Prophylactic granulocyte transfusions during chemotherapy of acute nonlymphocytic leukemia. *Ann Intern Med* 1981;94:616-622.

382. Buescher ES, Gallin JI. Leukocyte transfusions in chronic granulomatous disease: persistence of transfused leukocytes in sputum. *N Engl J Med* 1982;307:800-803.
383. Chusid MJ, Shea ML, Sarff LD. Determination of posttransfusion granulocyte kinetics by chemiluminescence in chronic granulomatous disease. *J Lab Clin Med* 1980;95:168-174.
384. Yomtovian R, Abramson J, Quie P, McCullough J. Granulocyte transfusion therapy in chronic granulomatous disease. Report of a patient and review of the literature. *Transfusion* 1981;21:739-743.
385. Cairo MS, Worcester CC, Rucker RW, et al. Randomized trial of granulocyte transfusions versus intravenous immune globulin therapy for neonatal neutropenia and sepsis. *J Pediatr* 1992;120:281-285.
386. Atallah E, Schiffer CA. Granulocyte transfusion. *Curr Opin Hematol* 2006;13:45-49.
387. McCullough J. Leukapheresis and granulocyte transfusion. *CRC Crit Rev Clin Lab Sci* 1979;10:275-327.
388. Menitove JE, Abrams RA. Granulocyte transfusions in neutropenic patients. *Crit Rev Oncol Hematol* 1987;7:89-113.
389. Bodey GP. Infection in cancer patients. A continuing association. *Am J Med* 1986;81:11-26.
390. Dale DC, Fauci AS, Guerry DI, Wolff SM. Comparison of agents producing a neutrophilic leukocytosis in man. Hydrocortisone, prednisone, endotoxin, and etiocholanolone. *J Clin Invest* 1975;56:808-813.
391. Gutierrez-Delgado F, Bensinger W. Safety of granulocyte colony-stimulating factor in normal donors. *Curr Opin Hematol* 2001;8:155-160.
392. Ikemoto J, Yoshihara S, Fujioka T, et al. Impact of the mobilization regimen and the harvesting technique on the granulocyte yield in healthy donors for granulocyte transfusion therapy. *Transfusion* 2012. doi:10.1111/j.1537-2995.2012.03661.x.
393. Worel N, Kurz M, Peters C, Hocker P. Serial granulocytapheresis under daily administration of rHuG-CSF: effects on peripheral blood counts, collection efficiency, and yield. *Transfusion* 2001;41:390-395.
394. Stroncek DF, Yau YY, Oblitas J, Leitman SF. Administration of G-CSF plus dexamethasone produces greater granulocyte concentrate yields while causing no more donor toxicity than G-CSF alone. *Transfusion* 2001;41: 1037-1044.
395. McCullough J, Clay M, Hurd D, Richards K, Ludvigsen C, Forstrom L. Effect of leukocyte antibodies and HLA matching on the intravascular recovery, survival, and tissue localization of 111-indium granulocytes. *Blood* 1986;67:522-528.
396. Kikuta A, Ohto H, Nemoto K, et al. Therapeutic transfusions of granulocytes collected by simple bag method for children with cancer and neutropenic infections: results of a single-centre pilot study. *Vox Sang* 2006;91:70-76.
397. Hubel K, Dale DC, Liles WC. Granulocyte transfusion therapy: update on potential clinical applications. *Curr Opin Hematol* 2001;8:161-164.
398. Wright DG, Robichaud KJ, Pizzo PA, Deisseroth AB. Lethal pulmonary reactions associated with the combined use of amphotericin B and leukocyte transfusions. *N Engl J Med* 1981;304:1185-1189.
399. Karp DD, Ervin TJ, Tuttle S, Gorgone BC, Lavin P, Yunis EJ. Pulmonary complications during granulocyte transfusions: incidence and clinical features. *Vox Sang* 1982;42:57-61.
400. Dana BW, Durie BG, White RF, Huestis DW. Concomitant administration of granulocyte transfusions and amphotericin B in neutropenic patients: absence of significant pulmonary toxicity. *Blood* 1981;57:90-94.
401. Price TH. Granulocyte colony-stimulating factor-mobilized granulocyte concentrate transfusions. *Curr Opin Hematol* 1998;5:391-395.
402. Lostumbo MM, Holland PV, Schmidt PJ. Isoimmunization after multiple transfusions. *N Engl J Med* 1966;275:141-144.
403. Giblett ER. A critique of the theoretical hazard of inter vs. intra-racial transfusion. *Transfusion* 1961;1:233-238.
404. Blumberg N, Peck K, Ross K, Avila E. Immune response to chronic red blood cell transfusion. *Vox Sang* 1983;44:212-217.
405. Davies SC, McWilliam AC, Hewitt PE, Devenish A, Brozovic M. Red cell alloimmunization in sickle cell disease. *Br J Haematol* 1986;63:241-245.
406. Coles SM, Klein HG, Holland PV. Alloimmunization in two multitransfused patient populations. *Transfusion* 1981;21:462-466.

407. Vichinsky EP, Earles A, Johnson RA, Hoag MS, Williams A, Lubin B. Alloimmunization in sickle cell anemia and transfusion of racially unmatched blood. *N Engl J Med* 1990;322:1617-1621.
408. Vichinsky EP, Luban NL, Wright E, et al. Prospective RBC phenotype matching in a stroke-prevention trial in sickle cell anemia: a multicenter transfusion trial. *Transfusion* 2001;41:1086-1092.
409. Overweg J, Engelfriet CP. Cytotoxic leucocyte iso-antibodies formed during the first pregnancy. *Vox Sang* 1969;16:97-104.
410. Dutcher JP, Schiffer CA, Aisner J, Wiernik PH. Alloimmunization following platelet transfusion: the absence of a dose-response relationship. *Blood* 1981;57:395-398.
411. Buetens O, Shirey RS, Goble-Lee M, et al. Prevalence of HLA antibodies in transfused patients with and without red cell antibodies. *Transfusion* 2006;46:754-756.
412. Allen JC, Kunkel HG. Antibodies against gamma-globulin after repeated blood transfusions in man. *J Clin Invest* 1966;45:29-39.
413. Kernoff PB, Bowell PJ. Gm types and antibodies in multitransfused haemophiliacs. *Br J Haematol* 1973;24:443-450.
414. McVerry BA, Machin SJ. Incidence of allo-immunization and allergic reactions to cryoprecipitate in haemophilia. *Vox Sang* 1979;36:77-80.
415. Schmidt AP, Taswell HF, Gleich GJ. Anaphylactic transfusion reactions associated with anti-IgA antibody. *N Engl J Med* 1969;280:188-193.
416. Pineda AA, Taswell HF. Transfusion reactions associated with anti-IgA antibodies: report of four cases and review of the literature. *Transfusion* 1975;15:10-15.
417. Sandler SG, Mallory D, Malamut D, Eckrich R. IgA anaphylactic transfusion reactions. *Transfus Med Rev* 1995;9:1-8.
418. Rivat L, Rivat C, Daveau M, Ropartz C. Comparative frequencies of anti-IgA antibodies among patients with anaphylactic transfusion reactions and among normal blood donors. *Clin Immunol Immunopathol* 1977;7:340-348.
419. Taswell HF, Pineda AA, Moore SB. Hemolytic transfusion reactions: frequency and clinical and laboratory aspects. In: Bell CA, ed. *A Seminar on immune-related cell destruction* Washington, DC: American Association of Blood Banks, 1981:71-92.
420. Greenwalt TJ. Pathogenesis and management of hemolytic transfusion reactions. *Semin Hematol* 1981;18:84-94.
421. Beauregard P, Blajchman MA. Hemolytic and pseudo-hemolytic transfusion reactions: an overview of the hemolytic transfusion reactions and the clinical conditions that mimic them. *Transfus Med Rev* 1994;8:184-199.
422. Davenport RD. Hemolytic transfusion reactions. In: Simon TL, Dzik WH, Snyder EL, Stowell CP, Strauss RG, eds. *Rossi's principles of transfusion medicine*, 3rd ed. Philadelphia, PA: Lippincott Williams & Wilkins, 2002:815-828.
423. Pineda AA, Taswell HF, Brzica SM Jr. Transfusion reaction. An immunologic hazard of blood transfusion. *Transfusion* 1978;18:1-7.
424. Honig CL, Bove JR. Transfusion-associated fatalities: review of Bureau of Biologics reports 1976-1978. *Transfusion* 1980;20:653-661.
425. Sazama K. Reports of 355 transfusion-associated deaths: 1976 through 1985. *Transfusion* 1990;30:583-590.
426. Vamvakas EC, Blajchman MA. Blood still kills: six strategies to further reduce allogeneic blood transfusion-related mortality. *Transfus Med Rev* 2010;24:77-124.
427. Pierce RN, Reich LM, Mayer K. Hemolysis following platelet transfusions from ABO-incompatible donors. *Transfusion* 1985;25:60-62.
428. Zoes C, Dube VE, Miller HJ, Vye MV. Anti-A1 in the plasma of platelet concentrates causing a hemolytic reaction. *Transfusion* 1977;17:29-32.
429. Lundberg WB, McGinniss MH. Hemolytic transfusion reaction due to anti-A. *Transfusion* 1975;15:1-9.
430. Fontaine MJ, Mills AM, Weiss S, Hong WJ, Viele M, Goodnough LT. How we treat: risk mitigation for ABO-incompatible plasma in plateletpheresis products. *Transfusion* 2012;52(10):2081-2085.
431. Seager OA, Nesmith MA, Begelman KA, et al. Massive acute hemodilution for incompatible blood reaction. *JAMA* 1974;229:790-792.

432. Davey RJ. The uses of radiolabeled red cells in transfusion medicine. *Transfus Med Rev* 1988;2:151-160.
433. Recommended method for radioisotope red-cell survival studies. International Committee for Standardization in Haematology. *Br J Haematol* 1980;45: 659-666.
434. Baldwin ML, Barrasso C, Ness PM, Garratty G. A clinically significant erythrocyte antibody detectable only by 51Cr survival studies. *Transfusion* 1983;23:40-44.
435. Davey RJ, Gustafson M, Holland PV. Accelerated immune red cell destruction in the absence of serologically detectable alloantibodies. *Transfusion* 1980;20:348-353.
436. Chaplin H, Jr. The implication of red cell-bound complement in delayed hemolytic transfusion reaction. *Transfusion* 1984;24:185-187.
437. Moore SB, Taswell HF, Pineda AA, Sonnenberg CL. Delayed hemolytic transfusion reactions. Evidence of the need for an improved pretransfusion compatibility test. *Am J Clin Pathol* 1980;74:94-97.
438. Patten E, Reddi CR, Riglin H, Edwards J. Delayed hemolytic transfusion reaction caused by a primary immune response. *Transfusion* 1982;22:248-250.
439. Ness PM, Shirey RS, Thoman SK, Buck SA. The differentiation of delayed serologic and delayed hemolytic transfusion reactions: incidence, long-term serologic findings, and clinical significance. *Transfusion* 1990;30:688-693.
440. Barton JC. Nonhemolytic, noninfectious transfusion reactions. *Semin Hematol* 1981;18:95-121.
441. Stack G, Pomper GJ. Febrile, allergic, and nonimmune transfusion reactions. In: Simon TL, Dzik WH, Snyder EL, Stowell CP, Strauss RG, eds. *Rossi's principles of transfusion medicine*, 3rd ed. Philadelphia, PA: Lippincott Williams & Wilkins, 2002:831-851.
442. Judd WJ, Barnes A. Clinical and serological aspects of transfusion reactions: a technical workshop. Arlington, VA: American Association of Blood Banks, 1982.
443. Payne R, Rolfs MR. Further observations on leukoagglutinin transfusion reactions in women: with special reference to leukoagglutinin transfusion reactions in women. *Am J Med* 1960;29:449-458.
444. Perkins HA, Payne R, Ferguson J, Wood M. Nonhemolytic febrile transfusion reactions. Quantitative effects of blood components with emphasis on isoantigenic incompatibility of leukocytes. *Vox Sang* 1966;11:578-600.
445. Decary F, Ferner P, Giavedoni L, et al. An investigation of nonhemolytic transfusion reactions. *Vox Sang* 1984;46:277-285.
446. de Rie MA, van der Plas-van Dalen CM, Engelfriet CP, von dem Borne AE. The serology of febrile transfusion reactions. *Vox Sang* 1985;49:126-134.
447. Brubaker DB. Clinical significance of white cell antibodies in febrile nonhemolytic transfusion reactions. *Transfusion* 1990;30:733-737.
448. Davenport RD, Kunkel SL. Cytokine roles in hemolytic and nonhemolytic transfusion reactions. *Transfus Med Rev* 1994;8:157-168.
449. Muylle L, Peetermans ME. Effect of prestorage leukocyte removal on the cytokine levels in stored platelet concentrates. *Vox Sang* 1994;66:14-17.
450. Wadhwa M, Seghatchian MJ, Dilger P, et al. Cytokines in WBC-reduced apheresis PCs during storage: a comparison of two WBC-reduction methods. *Transfusion* 2000;40:1118-1126.
451. Goldman M, Blajchman MA. Blood product-associated bacterial sepsis. *Transfus Med Rev* 1991;5:73-83.
452. Wagner SJ, Friedman LI, Dodd RY. Transfusion-associated bacterial sepsis. *Clin Microbiol Rev* 1994;7:290-302.
453. Sazama K. Bacteria in blood for transfusion. A review. *Arch Pathol Lab Med* 1994;118:350-365.
454. Meryman HT, Hornblower M. The preparation of red cells depleted of leukocytes. Review and evaluation. *Transfusion* 1986;26:101-106.
455. Bruil A, Beugeling T, Feijen J, van Aken WG. The mechanisms of leukocyte removal by filtration. *Transfus Med Rev* 1995;9:145-166.
456. Lieden G, Hilden JO. Febrile transfusion reactions reduced by use of buffy-coat-poor erythrocyte concentrates. *Vox Sang* 1982;43:263-265.

457. Heddle NM, Blajchman MA, Meyer RM, et al. A randomized controlled trial comparing the frequency of acute reactions to plasma-removed platelets and prestorage WBC-reduced platelets. *Transfusion* 2002;42:556-566.
458. Popovsky MA, Moore SB. Diagnostic and pathogenetic considerations in transfusion-related acute lung injury. *Transfusion* 1985;25:573-577.
459. Popovsky MA, Chaplin HC Jr, Moore SB. Transfusion-related acute lung injury: a neglected, serious complication of hemotherapy. *Transfusion* 1992;32:589-592.
460. Holness L, Knippen MA, Simmons L, Lachenbruch PA. Fatalities caused by TRALI. *Transfus Med Rev* 2004;18:184-188.
461. Silliman CC, Ambruso DR, Boshkov LK. Transfusion-related acute lung injury. *Blood* 2005;105:2266-2273.
462. Silliman CC, Boshkov LK, Mehdizadehkashi Z, et al. Transfusion-related acute lung injury: epidemiology and a prospective analysis of etiologic factors. *Blood* 2003;101:454-462.
463. Kleinman S, Caulfield T, Chan P, et al. Toward an understanding of transfusion-related acute lung injury: statement of a consensus panel. *Transfusion* 2004;44:1774-1789.
464. Toy P, Popovsky MA, Abraham E, et al. Transfusion-related acute lung injury: definition and review. *Crit Care Med* 2005;33:721-726.
465. Jacob HS. Complement-mediated leucoembolization: a mechanism of tissue damage during extracorporeal perfusions, myocardial infarction and in shock—a review. *Q J Med* 1983;52:289-296.
466. Levy GJ, Shabot MM, Hart ME, Mya WW, Goldfinger D. Transfusion-associated noncardiogenic pulmonary edema. Report of a case and a warning regarding treatment. *Transfusion* 1986;26:278-281.
467. Oen K, Petty RE, Schroeder ML. Immunoglobulin A deficiency: genetic studies. *Tissue Antigens* 1982;19:174-182.
468. Yap PL, Pryde EA, McClelland DB. IgA content of frozen-thawed-washed red blood cells and blood products measured by radioimmunoassay. *Transfusion* 1982;22:36-38.
469. Vyas GN, Perkins HA. Letter: anti-IgA in blood donors. *Transfusion* 1976;16:289-290.
470. Abramson N, Eisenberg PD, Aster RH. Post-transfusion purpura: immunologic aspects and therapy. *N Engl J Med* 1974;291:1163-1166.
471. Pegels JG, Bruynes EC, Engelfriet CP, von dem Borne AE. Post-transfusion purpura: a serological and immunochemical study. *Br J Haematol* 1981;49: 521-530.
472. Shulman NR, Aster RH, Leitner A, Hiller MC. Immunoreactions involving platelets. V. Post-transfusion purpura due to a complement-fixing antibody against a genetically controlled platelet antigen. A proposed mechanism for thrombocytopenia and its relevance in "autoimmunity". *J Clin Invest* 1961;40:1597-1620.
473. Gonzalez CE, Pengetze YM. Post-transfusion purpura. *Curr Hematol Rep* 2005;4:154-159.
474. Hamblin TJ, Naorose Abidi SM, Nee PA, Copplestone A, Mufti GJ, Oscier DG. Successful treatment of post-transfusion purpura with high dose immunoglobulins after lack of response to plasma exchange. *Vox Sang* 1985;49: 164-167.
475. Slichter SJ. Post-transfusion purpura: response to steroids and association with red blood cell and lymphocytotoxic antibodies. *Br J Haematol* 1982;50:599-605.
476. Ballem PJ, Buskard NA, Decary F, Doubroff P. Post-transfusion purpura secondary to passive transfer of anti-P1A1 by blood transfusion. *Br J Haematol* 1987;66:113-114.
477. Nijjar TS, Bonacosa IA, Israels LG. Severe acute thrombocytopenia following infusion of plasma containing anti P1A1. *Am J Hematol* 1987;25:219-221.
478. Scott EP, Moilan-Bergeland J, Dalmasso AP. Posttransfusion thrombocytopenia associated with passive transfusion of a platelet-specific antibody. *Transfusion* 1988;28:73-76.
479. Vamvakas EC, Blajchman MA. Deleterious clinical effects of transfusion-associated immunomodulation: fact or fiction? *Blood* 2001;97:1180-1195.
480. Vamvakas EC, Blajchman MA. Transfusion-related immunomodulation (TRIM): an update. *Blood Rev* 2007;21:327-348.
481. Heiss MM, Mempel W, Jauch KW, et al. Beneficial effect of autologous blood transfusion on infectious complications after colorectal cancer surgery. *Lancet* 1993;342:1328-1333.

482. Jensen LS, Kissmeyer-Nielsen P, Wolff B, Qvist N. Randomised comparison of leucocyte-depleted versus buffy-coat-poor blood transfusion and complications after colorectal surgery. *Lancet* 1996;348:841-845.
483. van de Watering LM, Hermans J, Houbiers JG, et al. Beneficial effects of leukocyte depletion of transfused blood on postoperative complications in patients undergoing cardiac surgery: a randomized clinical trial. *Circulation* 1998;97:562-568.
484. Tartter PI, Mohandas K, Azar P, Endres J, Kaplan J, Spivack M. Randomized trial comparing packed red cell blood transfusion with and without leukocyte depletion for gastrointestinal surgery. *Am J Surg* 1998;176:462-466.
485. Busch OR, Hop WC, Hoyneck van Papendrecht MA, Marquet RL, Jeekel J. Blood transfusions and prognosis in colorectal cancer. *N Engl J Med* 1993;328:1372-1376.
486. Houbiers JG, Brand A, van de Watering LM, et al. Randomised controlled trial comparing transfusion of leucocyte-depleted or buffy-coat-depleted blood in surgery for colorectal cancer. *Lancet* 1994;344:573-578.
487. Busch OR, Hop WC, Marquet RL, Jeekel J. Autologous blood and infections after colorectal surgery. *Lancet* 1994;343:668; author reply 668-669.
488. Hanazaki K, Matsushita A, Nakagawa K, Misawa R, Amano J. Risk factors of intrahepatic recurrence after curative resection of hepatocellular carcinoma. *Hepatogastroenterology* 2005;52:580-586.
489. Motoyama S, Okuyama M, Kitamura M, et al. Use of autologous instead of allogeneic blood transfusion during esophagectomy prolongs disease-free survival among patients with recurrent esophageal cancer. *J Surg Oncol* 2004;87:26-31.
490. Vamvakas EC. Transfusion-associated cancer recurrence and postoperative infection: meta-analysis of randomized, controlled clinical trials. *Transfusion* 1996;36:175-186.
491. Vamvakas EC. Meta-analysis of randomized controlled trials investigating the risk of postoperative infection in association with white blood cell-containing allogeneic blood transfusion: the effects of the type of transfused red blood cell product and surgical setting. *Transfus Med Rev* 2002;16:304-314.
492. Vamvakas EC. Deleterious clinical effects of transfusion immunomodulation: proven beyond a reasonable doubt. *Transfusion* 2006;46:492-494; author reply 4-5.
493. Carey PM, Sacher RA. Transfusion-associated graft versus host disease. In: Simon TL, Dzik WH, Snyder EL, Stowell CP, Strauss RG, eds. *Rossi's principles of transfusion medicine*, 3rd ed. Philadelphia, PA: Lippincott Williams & Wilkins, 2002:852-864.
494. Brubaker DB. Human posttransfusion graft-versus-host disease. *Vox Sang* 1983;45:401-420.
495. Anderson KC, Weinstein HJ. Transfusion-associated graft-versus-host disease. *N Engl J Med* 1990;323:315-321.
496. Petz LD, Calhoun L, Yam P, et al. Transfusion-associated graft-versus-host disease in immunocompetent patients: report of a fatal case associated with transfusion of blood from a second-degree relative, and a survey of predisposing factors. *Transfusion* 1993;33:742-750.
497. Triulzi D, Duquesnoy R, Nichols L, et al. Fatal transfusion-associated graft-versus-host disease in an immunocompetent recipient of a volunteer unit of red cells. *Transfusion* 2006;46(6):885-888.
498. Schroeder ML. Transfusion-associated graft-versus-host disease. *Br J Haematol* 2002;117:275-287.
- P.586
499. Jenner PW, Holland PV. Diagnosis and management of transfusion reactions. In: Petz LD, Kleinman S, Swisher SN, Spence RK, Strauss RG, eds. *Clinical practice of transfusion medicine*, 3rd ed. New York: Churchill Livingstone, 1996:905-929.
500. Luban NL. Massive transfusion in the neonate. *Transfus Med Rev* 1995;9: 200-214.
501. Hardy JF, de Moerloose P, Samama CM. The coagulopathy of massive transfusion. *Vox Sang* 2005;89:123-127.
502. Zimrin AB, Hess JR. Current issues relating to the transfusion of stored red blood cells. *Vox Sang* 2009;96(2):93-103.

503. Triulzi DJ, Yazer MH. Clinical studies of the effect of blood storage on patient outcomes. *Transfus Apher Sci: Official Journal of the World Apheresis Association: Official Journal of the European Society for Haemapheresis* 2010;43(1):95-106.
504. Vamvakas EC. Meta-analysis of clinical studies of the purported deleterious effects of "old" (versus "fresh") red blood cells: are we at equipoise? *Transfusion* 2010;50(3):600-610.
505. Koch, CG. The red cell storage duration and outcomes in cardiac surgery study. 2009. <http://clinicaltrials.gov/>. Accessed.
506. Lacroix J, Hebert P, Fergusson D, et al. The Age of Blood Evaluation (ABLE) randomized controlled trial: study design. *Transfus Med Rev* 2011;25(3): 197-205.
507. Steiner ME, Assmann SF, Levy JH, et al. Addressing the question of the effect of RBC storage on clinical outcomes: the Red Cell Storage Duration Study (RECESS) (Section 7). *Transfus Apher Sci: Official Journal of the World Apheresis Association: Official Journal of the European Society for Haemapheresis* 2010;43(1):107-116.
508. Linden JV, Kaplan HS, Murphy MT. Fatal air embolism due to perioperative blood recovery. *Anesth Analg* 1997;84(2):422-426.
509. FDA public health notification: PVC devices containing the plasticizer DEHP. In: U.S. Food and Drug Administration, Center for Devices and Radiological Health, 2002.
510. Jacobs A. Iron overload—clinical and pathologic aspects. *Semin Hematol* 1977;14:89-113.
511. Ley TJ, Griffith P, Nienhuis AW. Transfusion haemosiderosis and chelation therapy. *Clin Haematol* 1982;11:437-464.
512. Alter HJ. You'll wonder where the yellow went: a 15-year retrospective of posttransfusion hepatitis. In: Moore SB, ed. *Transfusion-transmitted viral diseases*. Arlington, VA: American Association of Blood Banks, 1987:53-86.
513. Galel SA, Lifson JD, Engleman EG. Prevention of AIDS transmission through screening of the blood supply. *Annu Rev Immunol* 1995;13:201-227.
514. Aach RD, Szmunes W, Mosley JW, et al. Serum alanine aminotransferase of donors in relation to the risk of non-A, non-B hepatitis in recipients: the transfusion-transmitted viruses study. *N Engl J Med* 1981;304:989-994.
515. Alter HJ, Holland PV. Indirect tests to detect the non-A, non-B hepatitis carrier state. *Ann Intern Med* 1984;101:859-861.
516. Stevens CE, Aach RD, Hollinger FB, et al. Hepatitis B virus antibody in blood donors and the occurrence of non-A, non-B hepatitis in transfusion recipients. An analysis of the Transfusion-Transmitted Viruses Study. *Ann Intern Med* 1984;101:733-738.
517. Petersen LR, Satten GA, Dodd R, et al. Duration of time from onset of human immunodeficiency virus type 1 infectiousness to development of detectable antibody. The HIV Seroconversion Study Group. *Transfusion* 1994;34: 283-289.
518. Busch MP, Lee LL, Satten GA, et al. Time course of detection of viral and serologic markers preceding human immunodeficiency virus type 1 seroconversion: implications for screening of blood and tissue donors. *Transfusion* 1995;35:91-97.
519. Busch MP. Closing the windows on viral transmission by blood transfusion. In: Stramer SL, ed. *Blood safety in the new millennium*. Bethesda, MD: American Association of Blood Banks, 2001:33-54.
520. Schreiber GB, Busch MP, Kleinman SH, Korelitz JJ. The risk of transfusion-transmitted viral infections. The Retrovirus Epidemiology Donor Study. *N Engl J Med* 1996;334:1685-1690.
521. Busch MP, Kleinman SH, Nemo GJ. Current and emerging infectious risks of blood transfusions. *JAMA* 2003;289:959-962.
522. Galel SA, Strong DM, Tegtmeier GE, et al. Comparative yield of HCV RNA testing in blood donors screened by 2.0 versus 3.0 antibody assays. *Transfusion* 2002;42:1507-1513.
523. Stramer SL, Glynn SA, Kleinman SH, et al. Detection of HIV-1 and HCV infections among antibody-negative blood donors by nucleic acid-amplification testing. *N Engl J Med* 2004;351:760-768.
524. Glynn SA, Kleinman SH, Wright DJ, Busch MP. International application of the incidence rate/window period model. *Transfusion* 2002;42:966-972.

525. Zou S, Dorsey KA, Notari EP, et al. Prevalence, incidence, and residual risk of human immunodeficiency virus and hepatitis C virus infections among United States blood donors since the introduction of nucleic acid testing. *Transfusion* 2010;50:1495-1504.
526. Zou S, Stramer SL, Notari EP, et al. Current incidence and residual risk of hepatitis B infection among blood donors in the United States. *Transfusion* 2009;49:1609-1620.
527. Busch MP, Dodd RY. NAT and blood safety: what is the paradigm? *Transfusion* 2000;40:1157-1160.
528. Busch MP, Glynn SA, Stramer SL, et al. A new strategy for estimating risks of transfusion-transmitted viral infections based on rates of detection of recently infected donors. *Transfusion* 2005;45:254-264.
529. McCullough J. Pathogen inactivation: a new paradigm for preventing transfusion-transmitted infections. *Am J Clin Pathol* 2007;128:945-955.
530. Weibert KE, Cserti CM, Hannon J, et al. Proceedings of a Consensus Conference: pathogen inactivation-making decisions about new technologies. *Transfus Med Rev* 2008;22(1):1-34.
531. Aach RD, Kahn RA. Post-transfusion hepatitis: current perspectives. *Ann Intern Med* 1980;92:539-546.
532. Alter HJ, Holland PV, Purcell RH. The emerging pattern of post-transfusion hepatitis. *Am J Med Sci* 1975;270:329-334.
533. Prince AM, Brotman B, Grady GF, et al. Long-incubation post-transfusion hepatitis without serological evidence of exposure to hepatitis-B virus. *Lancet* 1974;2:241-246.
534. Choo QL, Kuo G, Weiner AJ, Overby LR, Bradley DW, Houghton M. Isolation of a cDNA clone derived from a blood-borne non-A, non-B viral hepatitis genome. *Science* 1989;244:359-362.
535. Kuo G, Choo QL, Alter HJ, et al. An assay for circulating antibodies to a major etiologic virus of human non-A, non-B hepatitis. *Science* 1989;244:362-364.
536. Blumberg BS. Australia antigen and the prevention of posttransfusion hepatitis. *Vox Sang* 1985;48:55-59.
537. Kleinman SH, Busch MP. Assessing the impact of HBV NAT on window period reduction and residual risk. *J Clin Virol* 2006;36(Suppl 1):S23-S29.
538. Food and Drug Administration: guidance for industry: use of nucleic acid tests on pooled and individual samples from donors of whole blood and blood components, including source plasma, to reduce the risk of transmission of hepatitis B virus. November 2011.
<http://www.fda.gov/downloads/BiologicsBloodVaccines/GuidanceComplianceRegulatoryInformation/Guidances/Blood/UCM281536.pdf>. Accessed.
539. Stramer SL, Zou S, Notari EP, et al. Blood donation screening for hepatitis B virus markers in the era of nucleic acid testing: are all tests of value? *Transfusion* 2012;52:440-446.
540. Louisirirochanakul S, Oota S, Khuponsarb K, et al. Occult hepatitis B virus infection in Thai blood donors. *Transfusion* 2011;51:1532-1540.
541. Giacoia GP, Kasprisin DO. Transfusion-acquired hepatitis A. *South Med J* 1989;82:1357-1360.
542. Diwan AH, Stubbs JR, Carnahan GE. Transmission of hepatitis A via WBC-reduced RBCs and FFP from a single donation. *Transfusion* 2003;43: 536-540.
543. Fiore AE, Wasley A, Bell BP. Prevention of hepatitis A through active or passive immunization: recommendations of the Advisory Committee on Immunization Practices (ACIP). *MMWR Recomm Rep* 2006;55:1-23.
544. Galel S. Infectious disease screening. In: Roback JD, Grossman BJ, Harris T, Hillyer CD, eds. *AABB technical manual*, 17th ed. Bethesda, MD: AABB, 2011:239-270.
545. US Department of Health and Human Services. HHS Advisory Committee on Blood Safety and Availability (report). Committee recommendations., (June 2010) Washington, DC: HHS, 2010.
http://www.hhs.gov/ash/bloodsafety/advisorycommittee/recommendations/06112010_recommendations.pdf. Accessed.
546. Emerging infectious disease agents and their potential threat to transfusion safety. AABB.
<http://www.aabb.org/resources/bct/eid/Pages/default.aspx>. Accessed.
547. Hayes EB, Gubler DJ. West Nile virus: epidemiology and clinical features of an emerging epidemic in the United States. *Annu Rev Med* 2006;57:181-194.

548. Pealer LN, Marfin AA, Petersen LR, et al. Transmission of West Nile virus through blood transfusion in the United States in 2002. *N Engl J Med* 2003;349:1236-1245.
549. Stramer SL, Foster GA, Townsend RL, et al. Evaluation of the yield of triggering and detragging criteria for West Nile Virus (WNV) NAT. *Transfusion* 2009;49(Suppl 3):30A.
550. Busch MP, Caglioti S, Robertson EF, et al. Screening the blood supply for West Nile virus RNA by nucleic acid amplification testing. *N Engl J Med* 2005;353:460-467.
551. Food and Drug Administration. Guidance for industry: use of nucleic acid tests to reduce the risk of transmission of West Nile Virus from donors of whole blood and blood components intended for transfusion. November 2009. <http://www.fda.gov/downloads/BiologicsBloodVaccines/GuidanceComplianceRegulatoryInformation/Guidances/Blood/UCM189464.pdf>. Accessed.
552. Mungai M, Tegtmeier G, Chamberland M, Parise M. Transfusion-transmitted malaria in the United States from 1963 through 1999. *N Engl J Med* 2001;344:1973-1978.
553. Herwaldt BL, Linden JV, Bosserman E, Young C, Olkowska D, Wilson M. Transfusion-associated babesiosis in the United States: a description of cases. *Ann Intern Med* 2011;155:509-519.
554. Leiby DA. Transfusion-transmitted Babesia spp.: bull's-eye on Babesia microti. *Clin Microbiol Rev* 2011;24:14-28.
555. Stramer SL, Linnen JM, Carrick JM, et al. Dengue viremia in blood donors identified by RNA and detection of dengue transfusion transmission during the 2007 dengue outbreak in Puerto Rico. *Transfusion* 2012;52(8):1657-1666.
556. Centers for Disease Control and Prevention. Locally acquired Dengue—Key West, Florida, 2009-2010. *MMWR Morb Mortal Wkly Rep* 2010;59:577-581.
557. Food and Drug Administration. Guidance for industry: revised preventive measures to reduce the possible risk of transmission of Creutzfeldt-Jakob disease (CJD) and variant Creutzfeldt-Jakob disease (vCJD) by blood and blood products. May 2010. <http://www.fda.gov/downloads/biologicsbloodvaccines/guidancecomplianceregulatoryinformation/guidances/UCM213415.pdf>. Accessed.
558. Hillyer CD, Josephson CD, Blajchman MA, et al. Bacterial contamination of blood components: risks, strategies, and regulation: joint ASH and AABB educational session in transfusion medicine. *Hematology Am Soc Hematol Educ Program* 2003:575-589.
559. Eder AF, Kennedy JM, Dy BA, et al. Limiting and detecting bacterial contamination of apheresis platelets: inlet-line diversion and increased culture volume improve component safety. *Transfusion* 2009;49:1554-1563.
560. Jacobs MR, Smith D, Heaton WA, Zantek ND, Good CE. Detection of bacterial contamination in prestorage culture-negative apheresis platelets on day of issue with the Pan Genera Detection test. *Transfusion* 2011;51:2573-2582.
561. Tomasulo P, Su L. Is it time for new initiatives in the blood center and/or the hospital to reduce bacterial risk of platelets? *Transfusion* 2011;51: 2527-2533.
562. Stramer SL, Hollinger FB, Katz LM, et al. Emerging infectious disease agents and their potential threat to transfusion safety. *Transfusion* 2009;49(Suppl 2):1S-235S.
563. Blajchman MA, Goldman M, Freedman JJ, Sher GD. Proceedings of a Consensus Conference: prevention of post-transfusion CMV in the era of universal leukoreduction. *Transfus Med Rev* 2001;15:1-20.
564. Preiksaitis JK, Brown L, McKenzie M. The risk of cytomegalovirus infection in seronegative transfusion recipients not receiving exogenous immunosuppression. *J Infect Dis* 1988;157:523-529.
565. Bowden RA, Slichter SJ, Sayers M, et al. A comparison of filtered leukocyte-reduced and cytomegalovirus (CMV) seronegative blood products for the prevention of transfusion-associated CMV infection after marrow transplant. *Blood* 1995;86:3598-3603.
566. Vamvakas EC. Is white blood cell reduction equivalent to antibody screening in preventing transmission of cytomegalovirus by transfusion? A review of the literature and meta-analysis. *Transfus Med Rev* 2005;19:181-199.
567. Boeckh M, Nichols WG. The impact of cytomegalovirus serostatus of donor and recipient before hematopoietic stem cell transplantation in the era of antiviral prophylaxis and preemptive therapy. *Blood* 2004;103:2003-2008.

568. Preiksaitis JK, Sandhu J, Strautman M. The risk of transfusion-acquired CMV infection in seronegative solid-organ transplant recipients receiving non-WBC-reduced blood components not screened for CMV antibody (1984 to 1996): experience at a single Canadian center. *Transfusion* 2002;42:396-402.
569. McLeod BC. An approach to evidence-based therapeutic apheresis. *J Clin Apher* 2002;17:124-132.
570. McLeod BC. Introduction to the third special issue: clinical applications of therapeutic apheresis. *J Clin Apher* 2000;15:1-5.
571. Koo AP. Therapeutic apheresis in autoimmune and rheumatic diseases. *J Clin Apher* 2000;15:18-27.
572. Grima KM. Therapeutic apheresis in hematological and oncological diseases. *J Clin Apher* 2000;15:28-52.
573. Winters JL, Pineda AA, McLeod BC, Grima KM. Therapeutic apheresis in renal and metabolic diseases. *J Clin Apher* 2000;15:53-73.
574. Weinstein R. Therapeutic apheresis in neurological disorders. *J Clin Apher* 2000;15:74-128.
575. Kim HC. Therapeutic pediatric apheresis. *J Clin Apher* 2000;15:129-157.
576. Szczepiorkowski ZM, Winters JL, Bandarenko N, et al. Guidelines on the use of therapeutic apheresis in clinical practice—evidence-based approach from the Apheresis Applications Committee of the American Society for Apheresis. *J Clin Apher* 2010;25:83-177.
577. Winters JL. Apheresis medicine state of the art in 2010: American Society for Apheresis fifth special edition of the *Journal of Clinical Apheresis*. *J Clin Apher* 2011;26:239-242.
578. Kincaid JC. Apheresis in treatment of the inflammatory demyelinating peripheral neuropathies. *Ther Apher* 2002;6:53-56.
579. Randomized trial of plasma exchange, intravenous immunoglobulin, and combined treatments in Guillain-Barre syndrome. Plasma Exchange/Sandoglobulin Guillain-Barre Syndrome Trial Group. *Lancet* 1997;349: 225-230.
580. Cheng BC, Chang WN, Chen JB, et al. Long-term prognosis for Guillain-Barre syndrome: evaluation of prognostic factors and clinical experience of automated double filtration plasmapheresis. *J Clin Apher* 2003;18:175-180.
581. Levy JB, Pusey CD. Still a role for plasma exchange in rapidly progressive glomerulonephritis? *J Nephrol* 1997;10:7-13.
582. Rock G, Shumak KH, Sutton DM, Buskard NA, Nair RC. Cryosupernatant as replacement fluid for plasma exchange in thrombotic thrombocytopenic purpura. Members of the Canadian Apheresis Group. *Br J Haematol* 1996;94:383-386.
583. Moake JL. Thrombotic thrombocytopenic purpura and the hemolytic uremic syndrome. *Arch Pathol Lab Med* 2002;126:1430-1433.
584. Rock GA, Shumak KH, Buskard NA, et al. Comparison of plasma exchange with plasma infusion in the treatment of thrombotic thrombocytopenic purpura. Canadian Apheresis Study Group. *N Engl J Med* 1991;325:393-397.
585. Bukowski RM, King JW, Hewlett JS. Plasmapheresis in the treatment of thrombotic thrombocytopenic purpura. *Blood* 1977;50:413-417.
586. Matzdorff AC. Thrombotic thrombocytopenic purpura. *N Engl J Med* 2006;355:630; author reply
587. Buffaloe GW, Heineken FG. Plasma volume nomograms for use in therapeutic plasma exchange. *Transfusion* 1983;23:355-357.
588. Derksen RH, Schuurman HJ, Meyling FH, Struyvenberg A, Kater L. The efficacy of plasma exchange in the removal of plasma components. *J Lab Clin Med* 1984;104:346-354.
589. Keller AJ, Urbaniak SJ. Intensive plasma exchange on the cell separator: effects on serum immunoglobulins and complement components. *Br J Haematol* 1978;38:531-540.
590. Volkin RL, Starz TW, Winkelstein A, et al. Changes in coagulation factors, complement, immunoglobulins, and immune complex concentrations with plasma exchange. *Transfusion* 1982;22:54-58.
591. Lichtman MA, Rowe JM. Hyperleukocytic leukemias: rheological, clinical, and therapeutic considerations. *Blood* 1982;60:279-283.
592. Vamvakas EC, Pineda AA. Specialized therapeutic hemapheresis procedures. In: Simon TL, Dzik WH, Snyder EL, Stowell CP, Strauss RG, eds. *Rossi's principles of transfusion medicine*, 3rd ed. Philadelphia, PA: Lippincott Williams & Wilkins, 2002:685-698.

593. Porcu P, Danielson CF, Orazi A, Heerema NA, Gabig TG, McCarthy LJ. Therapeutic leukapheresis in hyperleucocytic leukaemias: lack of correlation between degree of cytoreduction and early mortality rate. *Br J Haematol* 1997;98:433-436.
594. Goldfinger D, Thompson R, Lowe C, Kurz L, Belkin G. Long-term plateletpheresis in the management of primary thrombocytosis. *Transfusion* 1979;19:336-338.
595. Taft EG, Babcock RB, Scharfman WB, Tartaglia AP. Plateletpheresis in the management of thrombocytosis. *Blood* 1977;50:927-933.
596. Sachais BS, Katz J, Ross J, Rader DJ. Long-term effects of LDL apheresis in patients with severe hypercholesterolemia. *J Clin Apher* 2005;20:252-255.
597. Strauss RG, McLeod BC. Complications of therapeutic apheresis. In: Popovsky MA, ed. *Transfusion reactions*. Bethesda, MD: AABB Press, 2001:315-338.
598. Sutton DM, Nair RC, Rock G. Complications of plasma exchange. *Transfusion* 1989;29:124-127.
599. McLeod BC, Sniecinski I, Ciavarella D, et al. Frequency of immediate adverse effects associated with therapeutic apheresis. *Transfusion* 1999;39:282-288.
600. Chirnside A, Urbaniak SJ, Prowse CV, Keller AJ. Coagulation abnormalities following intensive plasma exchange on the cell separator. II. Effects on factors I, II, V, VII, VIII, IX, X and antithrombin III. *Br J Haematol* 1981;48:627-634.
601. Keller AJ, Chirnside A, Urbaniak SJ. Coagulation abnormalities produced by plasma exchange on the cell separator with special reference to fibrinogen and platelet levels. *Br J Haematol* 1979;42:593-603.
602. Bystryk JC, Graf MW, Uhr JW. Regulation of antibody formation by serum antibody. II. Removal of specific antibody by means of exchange transfusion. *J Exp Med* 1970;132:1279-1287.
603. Derksen RH, Schuurman HJ, Gmelig Meyling FH, Struyvenberg A, Kater L. Rebound and overshoot after plasma exchange in humans. *J Lab Clin Med* 1984;104:35-43.
604. Huestis DW. Mortality in therapeutic haemapheresis. *Lancet* 1983;1:1043.

Part IV - Disorders of Red Cells

Section 1 - Introduction

Chapter 22 Anemia: General Considerations

> Table of Contents > Part IV - Disorders of Red Cells > Section 1 - Introduction > Chapter 22 - Anemia: General Considerations

Chapter 22

Anemia: General Considerations

Robert T. Means, Jr.

Bertil Glader

This introductory chapter focuses on the general concepts of anemia, the classification of the most common types of anemia, the approach to patients with hemolysis, and the assessment of posthemorrhagic anemia. Anemia rarely is a disease by itself; almost always it is a sign of an acquired or genetic abnormality. The various medical conditions that lead to anemia encompass nearly the full spectrum of human disease.

DEFINITION OF ANEMIA

Red blood cells (RBCs) circulate in the peripheral blood for 100 to 120 days, and approximately 1% of the body's red cells are lost and replaced each day. Red cells recognized as being old are removed from the circulation by macrophages in the spleen, liver, and bone marrow (Chapter 6). An erythropoietic feedback loop ensures that the total red cell mass remains constant. A reduced RBC mass results from loss of RBCs from the circulation at a rate greater than their production: this may reflect increased RBC clearance, decreased RBC production, or both.

Anemia is functionally defined as an insufficient RBC mass to adequately deliver oxygen to peripheral tissues. For practical purposes, any of the three concentration measurements performed on whole blood can be used to establish the presence of anemia: the hemoglobin (Hb) concentration, typically expressed as grams Hb per deciliter (g/dl) in the United States and as grams per liter in Europe; the hematocrit (Hct; also called the packed cell volume [PCV] or volume of packed red blood cells [vPRC]), which represents the proportion of blood volume represented by RBCs, expressed as a percent or as a decimal; and the RBC concentration in cells per microliter ($10^6/\mu\text{l}$) in the United States or per liter ($10^{12}/\text{L}$) by international terminology.

In the past, these parameters were measured using manual physical and chemical techniques. The term “hematocrit” originally referred to the graduated tube in which the vPRC was measured following centrifugation. Now these parameters are determined by electronic cell counters and Hb analyzers (Chapter 1). In most of the current analyzers, RBC concentration, Hb concentration, and mean corpuscular volume (MCV in fl) are directly measured. These measured values are used to calculate the hematocrit (Hct), mean corpuscular Hb (MCH), and mean corpuscular Hb concentration (MCHC):

$$\text{Hct (\%)} = \text{MCV (fl)} \times \text{RBC (}10^6/\mu\text{l)} / 10$$

$$\text{MCH (pg)} = \text{Hb (g/dl)} \times 10 / (\text{RBC (}10^6/\mu\text{l)})$$

$$\begin{aligned} \text{MCHC (\%)} &= \text{Hb (g/dl)} \times 100 / \text{Hct (\%)} \text{ concentration} \\ &= \text{MCH (pg)} \times 100 / \text{MCV (fl)}^1 \end{aligned}$$

Most physicians prefer to define anemia using the Hb concentration, although for practical purposes the Hct is comparably reliable. The electronic counters also generate an index of red cell size, the red cell distribution width (RDW). The RDW is a quantitative measure of the variation in red cell size, and the higher the value, the more heterogeneous the RBC population size. The mean normal Hb and Hct values and the lower limits of the normal ranges of these parameters depend on the age and gender of the subjects, as well as their altitude of residence.

Anemia in Adults

Many references consider Hb concentrations of 14 g/dl and 12 g/dl as the lower limits of normal, at sea level, in adult men and women, respectively, particularly in the industrialized world.² These values have received wide acceptance and often are used in population surveys.³ However, data from a large, diverse, and carefully selected sample suggest that these values are somewhat high. The sample studied during the second National Health and Nutrition Examination Survey (NHANES II), 1976-1980, was selected statistically as representative of the entire population of the United States.⁴ Age, gender, and race, as well as geographic and socioeconomic factors, were figured into the selection process. For the purpose of determining normal values, subjects were excluded if they were pregnant, if a hereditary hemoglobinopathy was detected, or if the transferrin saturation, MCV, or erythrocyte protoporphyrin value was abnormal. By these means, iron deficient subjects were effectively excluded. The values of the remaining 11,547 subjects were used to calculate a 95% reference range. In adult subjects (age 10 to 44 years), the lower limit of normal was 13.2 g/dl in men and 11.7 g/dl in women (Fig. 22.1). Values for African-American subjects were approximately 0.5 to 0.6 g/dl lower than those of Caucasian subjects. Consistent with these observations, the World Health Organization (WHO) defines the lower limit of normal for Hb concentration at sea level to be 12.0 g/dl in women and 13.0 g/dl in men.⁵

P.588

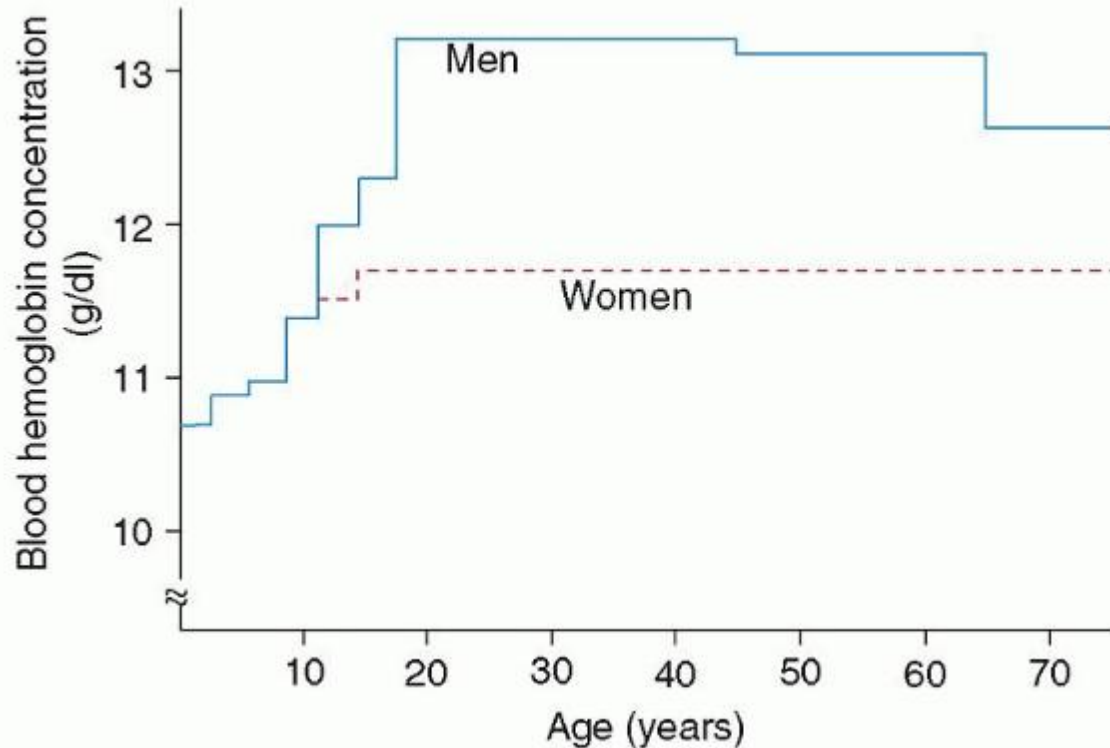

FIGURE 22.1. The lower limit of normal blood hemoglobin concentration in men and women of various ages. Values were calculated from a sample of 11,547 subjects selected to represent the population of the United States. Subjects with iron deficiency, pregnancy, or an abnormal hemoglobin value were excluded from the sample. (Data from Dallman PR, Yip R, Johnson C. Prevalence and causes of anemia in the United States, 1976 to 1980. *Am J Clin Nutr* 1984;39(3):437-445.)

Hemoglobin Values in the Elderly

Anemia is a common condition in the older population. In a community dwelling American population of individuals over 65 years, 8.5% have a Hb concentration meeting the WHO definition of anemia.⁶ Other investigators have confirmed that the prevalence of anemia rises steadily with age, increasing from approximately 10% in individuals 65 years and older to 20% in individuals over 85 years.⁷ It is a significant predictor of morbidity, mortality, and performance status in the elderly, whether considered as a general risk factor or in the setting of a specific clinical circumstance, such as heart failure.^{8,9,10} and¹¹ While clinical conditions such as iron deficiency, B12 or folate deficiency, the decline in testosterone production in male aging,¹² and the impact on EPO production of the routine decline in creatinine clearance with advancing age,⁸ are likely responsible for a majority of cases, the etiology of a significant proportion of these anemias cannot be readily explained.⁷ Studies of the development of otherwise unexplained anemia in the aging population have suggested the involvement of a number of possible mechanisms, from an increased incidence of underlying diseases which may be associated with cytokine activation and the anemia of chronic disease,^{13,14} to changes in the hematopoietic reserve^{15,16} or even in the characteristics of hematopoietic progenitors themselves.¹⁷ Taken together, slightly lower limits of normal Hb concentration may be applicable in evaluating the elderly. However, the too-easy acceptance of mild anemia as a physiologic phenomenon in the elderly runs the risk of ignoring a potentially valuable early clue to an important underlying disorder.

Hemoglobin Values in Infants and Children

At the other extreme of life, the definition of anemia in infancy and childhood is different from that in adults. The lower limit of normal Hb concentration at birth is 14 g/dl, and this decreases to 11 g/dl by 1 year of age. This Hb decrement, referred to as the physiologic anemia of infancy, occurs as part of the normal physiologic adaptation from the relatively hypoxic intrauterine existence to the well-oxygenated extrauterine environment (Chapter 43). Also, as fetal erythropoiesis is replaced, the MCV decreases from birth (100 to 130 fl) to 1 year of age (70 to 85 fl).

Even after the first year of life, normal childhood Hb and MCV values remain considerably lower than those occurring in adolescents and adults (Table 22.1). From the NHANES II study, the lower limit of normal Hb concentration in both male and female children aged 1 to 2 years was 10.7 g/dl, and the value rose with advancing age until adult levels were reached at age 15 to 18 years.

There has been no completely satisfactory explanation for these differences in normal Hb values of children and adults, but it is not due to nutritional deficiencies. Interestingly, it has been demonstrated that serum inorganic phosphate is 50% higher in children compared to adults, and this hyperphosphatemia is associated with elevated erythrocyte adenosine triphosphate and 2,3-diphosphoglycerate content, and thus the erythrocyte oxygen affinity is decreased in children compared to adults. On this basis, it has been postulated that lower Hb values in children may be due to altered Hb-oxygen affinity and may thereby represent a physiologic anemia of childhood.¹⁸

At puberty, the Hb concentration in children reaches the same levels seen in adults. The higher Hb levels in males presumably are a reflection of the effects of androgens on erythropoiesis.

Limitations in the Use of Hemoglobin Concentration, Hematocrit, and Red Blood Cell Measurements in Defining Anemia

For practical purposes, the blood Hb and Hct determinations are equally useful in assessing for anemia in most patients, but there are limitations that must be recognized:

- Hb and Hct changes may reflect altered plasma volume, not a change in RBC mass (Table 22.2). In pregnancy, for example, the plasma volume increases, thereby decreasing the Hb concentrations, although in fact, total RBC mass actually is increased, but to a lesser degree than the plasma volume.^{19,20,21,22} Similarly, individuals with massive splenomegaly may have some anemia because of hypersplenism, but the degree of anemia may appear more severe because of an increased plasma volume. Conversely, burn patients lose plasma, not RBC, through the injured skin, leaving Hb and Hct concentrated at a higher level. Other causes of dehydration with depletion of intravascular space also produce a spuriously high Hb concentration. In chronically ill patients with a reduced red cell mass, the magnitude of anemia may be masked by an associated contraction of the plasma volume.^{23,24,25,26,27}
- Another consideration is that Hb and Hct changes may reflect underlying physiologic conditions with different oxygen

P.589

needs. For example, chronically hypoxemic subjects, such as individuals who live at high altitudes or patients with a right-to-left cardiac shunt, are typically polycythemic with elevated Hb/Hct levels. A normal Hb/Hct level in such a patient actually may represent anemia by the functional criterion of adequately meeting tissue oxygen requirements.

TABLE 22.1 RED BLOOD CELL CHARACTERISTICS IN CHILDHOOD

Age	Lowest Normal Hb (g/dl)	Normal Red Blood Cell Size Mean Corpuscular Volume (fl)	Fetal Hb (%)
Birth	14.0	100-130	55-90
1 mo	12.0	90-110	50-80
2 mo	10.5	80-100	30-55
3-6 mo	10.5	75-90	5-25
6 mo-1 y	11.0	70-85	<5
1-4 y	11.0	70-85	<2
4 y-puberty	11.5	75-90	<2
Adult female	12.0	80-95	<2
Adult male	14.0	80-95	<2

Hb, hemoglobin.

TABLE 22.2 CONDITIONS ASSOCIATED WITH DISCORDANCE BETWEEN HEMOGLOBIN CONCENTRATION AND RED CELL MASS

Increase in plasma volume relative to RBC mass (Hb disproportionately low)

Hydremia of pregnancy

Congestive splenomegaly

Recumbency (vs. upright)

Decrease in plasma volume relative to RBC mass (Hb high, normal, or low; but high relative to RBC mass)

Dehydration

Protracted diarrhea (especially in infants)

Peritoneal dialysis with hypertonic solutions

Diabetic acidosis

Diabetes insipidus with restricted fluid intake

Burn patients

Stress erythrocytosis, spurious polycythemia

Decrease in plasma volume and RBC mass (Hb normal, RBC mass low)

Acute blood loss

Chronic disease

Hb, hemoglobin; RBC, red blood cell.

- Some abnormal Hb variants have an altered ability to bind and release oxygen, and this can be associated with changes in Hb concentration. For example, Hb Yakima has increased oxygen affinity with a low P50, and higher than normal Hgb levels are characteristic. Conversely, Hb Kansas has decreased oxygen affinity, high P50, and lower than normal Hgb levels. Despite the disparate Hb levels in these cases, both satisfy the criteria of appropriate oxygen delivery for tissue oxygen needs.
- Acute blood loss is another example of the problem of denoting anemia by the Hb concentration or Hct. Immediately after loss of a liter of blood, the Hb concentration/Hct is normal, because the initial response to acute hemorrhage is vasoconstriction. The shift of fluid from extravascular to intravascular space, and thus the decrease in Hb concentration, does not begin for 6 hours, and can continue for 48 to 72 hours. Reticulocytosis occurs after 24 to 48 hours.
- Impaired partial synthesis of one globin chain, as in thalassemia trait, may be reflected in a low Hb (10 g/dl) and a high RBC count (6.5 million/ μ l), thus giving anemia by one measure (Hb) and erythrocytosis by another (RBC). This is largely why the RBC count is the least reliable and least commonly used indicator of anemia.

In addition to the issues listed above, changes in posture also have effects on red cell concentration that can influence Hb and Hct measurements. When normal individuals assume a recumbent position, the Hct falls an average 7% (range, 4% to 10%) within 1 hour.²⁸ When the upright position is resumed, the Hct increases by a similar amount within 15 minutes. These changes have been attributed to alterations in plasma volume as fluid moves between the circulation and the extravascular spaces in the lower limbs as a result of hydrostatic forces.

CLINICAL EFFECTS OF ANEMIA

Patients with anemia usually seek medical attention because of decreased work or exercise tolerance, shortness of breath, palpitations, or other signs of cardiorespiratory adjustments to anemia. At times, they feel fine, but their friends or family may note pallor. It is not uncommon that anemia in a child is first recognized by a visiting relative, the process sometimes occurring so slowly as to not be noted by parents or other immediate family members.

Cardiovascular and Pulmonary Features of Anemia

The clinical manifestations of anemia depend on the magnitude and rate of reduction in the oxygen carrying capacity of the blood, the capacity of the cardiovascular and pulmonary systems to compensate for the anemia, and the associated features of the underlying disorder that resulted in the development of anemia. The Hb concentration is not the only determinant of the observed symptoms. Coexistent cardiovascular or pulmonary disease, particularly in older individuals, may exaggerate the symptoms associated with a degree of anemia that would be well tolerated under other circumstances.

If the anemia has been insidious in onset and there is no cardiopulmonary disease, the patient's adjustment may be so effective that the blood Hb concentration may fall to 8 g/dl or even lower before the patient experiences enough symptoms to appreciate the situation.²⁹ In cases of iron deficiency anemia, pernicious anemia, or other types of slowly developing anemia, Hb concentrations may reach levels of 6 g/dl or lower before patients are motivated to seek medical attention.³⁰ This is particularly true in children where no limitations of physical activity may be apparent despite the existence of very severe anemia.³¹ The physiologic adjustments that take place with a slowly falling red cell mass chiefly involve the cardiovascular system and changes in the Hb-oxygen dissociation curve.

In many patients, respiratory and circulatory symptoms are noticeable only after exertion; however, when anemia is sufficiently severe, dyspnea and awareness of vigorous or rapid heart action may be noted even at rest. When anemia develops rapidly, shortness of breath, tachycardia, dizziness or faintness (particularly upon arising from a sitting or recumbent posture), and extreme fatigue are prominent. In chronic anemia, only moderate dyspnea or palpitation may occur, but in some patients, congestive heart failure,³² angina pectoris, or intermittent claudication³³ can be the presenting manifestation. In patients with severe chronic anemia, tachycardia and postural hypotension may not be present because the total blood volume actually may be increased because of an expanded plasma volume. In the elderly particularly, cardiovascular adaptation to anemia is predominantly by increasing stroke volume, rather than by heart rate.³⁴ It is in these cases that rapid administration of a blood transfusion may precipitate congestive heart failure by aggravating an already expanded blood volume. Concern about this possibility should not preclude expansion of the blood's oxygen carrying capacity by transfusion if necessary; rather the judicious use of diuretics in the peritransfusion period should be considered in patients with clinical signs of volume overload.

Heart murmurs are a common cardiac sign associated with anemia. They usually are systolic in time and best heard in the pulmonic area.^{35,36,37} Often, they are moderate in intensity, and at times may be rough in quality and raise suspicion of organic valvular heart disease. In a study from Bosnia, 25% of the heart murmurs investigated in a pediatric cardiology clinic were attributable to anemia and resolved with its correction.³⁸

P.590

Pallor

Pallor is a sign of anemia, but many factors other than Hb concentration affect skin color. These include the degree of dilation of peripheral vessels, the degree of pigmentation, and the fluid content of the subcutaneous tissues. Certain people routinely have pale-appearing skin without being anemic. Patients with myxedema may manifest pallor without anemia. In simple vasovagal syncope, pallor results from cutaneous vasoconstriction and is not a sign of anemia. Jaundice, cyanosis, racial skin pigmentation, and dilation of the peripheral vessels all can mask the pallor of anemia.

The pallor associated with anemia is best detected in the mucous membranes of the mouth and pharynx, the conjunctivae, the lips, and the nail beds. In the hands, the skin of the palms first becomes pale, but the creases may retain their usual pink color until the Hb concentration is less than 7 g/dl.

A distinctly sallow color implies chronic anemia. A lemonyellow pallor suggests pernicious anemia, but it is observed only when the condition is well advanced. Definite pallor associated with mild scleral and cutaneous icterus suggests hemolytic anemia. Marked pallor associated with petechiae or ecchymoses suggests more generalized bone marrow failure due to acute leukemia, aplasia, or myelodysplastic syndromes.

Skin and Mucosal Changes

Other changes in the integument occur with anemia. Thinning, loss of luster, and early graying of the hair may occur, the last especially in patients with pernicious anemia, in whom it may precede the development of anemia. The nails may lose their luster, become brittle, and break easily. This finding is especially noticeable in chronic iron deficiency anemia,³⁹ in which the nails may actually become concave instead of convex. Chronic leg ulcers may occur, especially in patients with sickle cell anemia and rarely in those with other hemolytic anemias. Glossitis occurs in association with pernicious anemia.

When nutritional deficiency is associated with anemia, symmetric dermatitis may develop, fissures may be present at the angles of the mouth, glossitis may occur, and erythematous lesions on the face, neck, hands, or elbows may be found.

Neuromuscular Features

Headache, vertigo, tinnitus, faintness, scotomata, lack of mental concentration, drowsiness, restlessness, and muscular weakness are common symptoms of severe anemia. Paresthesias are common in pernicious anemia and may be associated with other symptoms and signs of peripheral neuropathy, and more especially with combined system disease.

Ophthalmologic Findings

A variety of ophthalmologic findings have been observed in anemic patients.^{40,41,42} Approximately 20% of such patients have flame-shaped hemorrhages, hard exudates, cottonwood spots, or venous tortuosity affecting the retina. The hemorrhages occur even in the absence of coexisting thrombocytopenia. Papilledema related solely to anemia has been described,^{43,44} and it clears when the anemia disappears.

Gastrointestinal Changes

Gastrointestinal symptoms are common in anemic patients. Some are manifestations of the underlying disorder (e.g., hiatal hernia, duodenal ulcer, or gastric carcinoma); others may be a consequence of the anemic condition, whatever its cause. Glossitis and atrophy of the papillae of the tongue commonly occur in pernicious anemia and less often in iron deficiency anemia. Painful, ulcerative, and necrotic lesions in the mouth and pharynx occur in aplastic anemia and in acute leukemia, usually reflecting the neutropenia accompanying these conditions. Dysphagia may occur in chronic iron deficiency anemia.

EVALUATION AND CLASSIFICATION OF ANEMIA

History and Physical Examination

All aspects of the history and clinical examination are important. The duration of the symptoms and their onset, whether insidious or acute, should be established. It is very helpful to know the most recent date at which a routine hematologic examination was normal.

The family history is most useful for increasing suspicion of hereditary hemolytic diseases (including hemoglobinopathies) and hereditary bleeding disorders (including hereditary vascular abnormalities like hereditary hemorrhagic telangiectasias). Key clues are histories of bleeding, jaundice, gallstones, and splenectomy (see Approach to Hemolysis).

The patient's occupation, household customs, and hobbies must be ascertained because certain drugs, solvents, and other chemicals may produce hemolytic anemia or aplastic anemia, as well as granulocytopenia and thrombocytopenia. Also, social habits (alcohol use), travel history (to malarious or other infectious areas), and drug history are all important in ascertaining the underlying etiology.

The dietary history is critical to the analysis, and questions regarding the diet must be specific in the hope of obtaining quantitative information. In very young children, those who obtain the bulk of their nutrition from cow's milk (good for calories, very low in iron) are at great risk for iron deficiency anemia. Changes in weight are most important in both adults and children. Formerly obese individuals who have undergone bariatric surgery and other individuals who have undergone gastric resection are at risk for anemia from iron, copper, and other nutrient deficiencies.⁴⁵

The patient should be questioned about early graying of the hair, burning sensations of the tongue, skin changes, sores about the angles of the mouth, and discomfort and brittleness of the fingernails, which are symptoms of anemias caused by deficiency of specific nutrients.

Change in stool habits may be an important clue to neoplasms of the colon and rectum underlying the anemia. The significance of tarry stools often is not appreciated by patients, and specific inquiry is necessary. The amount of blood lost from hemorrhoids may be overlooked or overestimated. In men, occult blood loss most often is from the gastrointestinal tract.

In women, additional important information includes an appraisal of the amount of blood lost during menstruation. Data about number of pads or tampons used and the presence or absence of clots should be obtained. The average amount of blood lost per period is approximately 50 ml, representing roughly 25 mg of elemental iron. Menstrual flow should be deemed excessive if more than 12 pads are used each period, if clots are passed after the first day, or if the period duration exceeds 7 days. The number of pregnancies and abortions and the interval since the most recent of these are also important, for each represents significant iron loss.

The presence or absence of fever must be known; its presence suggests infection, lymphoma, other neoplasm, or collagen vascular disease. Pains in the limbs, paresthesias, and difficulty in walking suggest pernicious anemia. Abnormal color of the urine, suggesting blood or Hb, may signify urinary tract disease or hematologic problems. Bilirubin is not detected in the urine of people with uncomplicated hemolytic anemia (“acholuric

P.591

jaundice”), but a darker than normal color may result from the increased excretion of urobilinogen and its conversion to urobilin.

Bruises, ecchymoses, and petechiae are other important points in the history. Their presence indicates that the disorder producing anemia may also involve platelets or the liver. Alternatively, the anemia itself may be the consequence of blood loss resulting from a disorder of hemostasis.

In all instances, the presence or absence of symptoms suggestive of an underlying disease such as chronic renal disease, liver disease, chronic infection, endocrinopathy, or malignancy must be explored. Anemia can be the presenting feature of many of these disorders.

The physical examination can provide further clues to the cause of anemia. Scleral icterus suggests the presence of hemolytic anemia or ineffective erythropoiesis. Sternal tenderness near the middle or lower third of the sternum, of which the patient may have been unaware, may represent acute expansion of hematopoietic marrow and can be a useful sign in some patients with acute leukemia. Palpation of the liver and spleen and a systemic check for lymphadenopathy can provide clues to infection, lymphoma, leukemia, or metastatic carcinoma.

The initial patient evaluation should include a urinalysis. Even when the color of the urine does not suggest blood, the routine urinalysis should be tested for occult blood. A positive reaction may be due to hematuria, hemoglobinuria, or even myoglobinuria. Hematuria may be differentiated from the other conditions by finding RBCs on microscopic examination of the urine, or by centrifuging a fresh urine specimen, thereby clearing the bloody color from the supernatant and depositing the RBCs in the bottom of the tube. Hematuria reflects disease of the kidneys or urinary tract. Sickle cell trait may be accompanied by innocuous hematuria. Hemoglobinuria implies intravascular hemolysis. The significance of urobilinogen has been noted above.

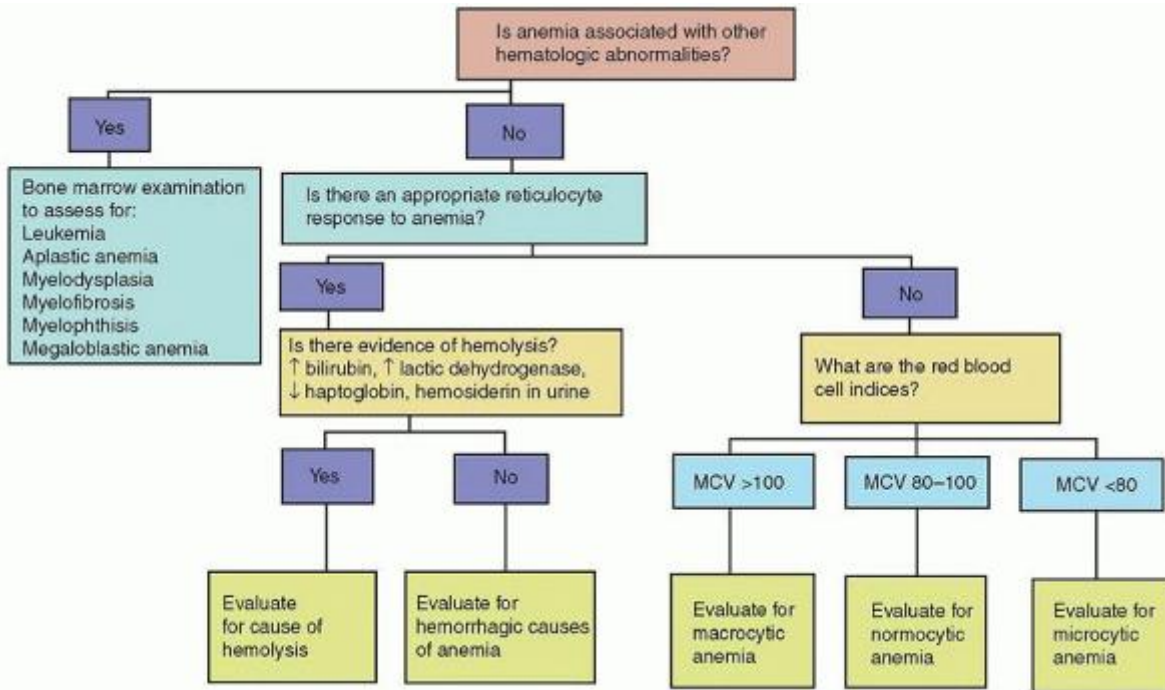

FIGURE 22.2. Questions to ask in the initial evaluation of anemia. MCV, mean corpuscular volume (fl); ↑, increased; ↓, decreased.

Evaluation of Basic Hematology Laboratory Data

To identify the cause of anemia, information from the medical history and physical examination must be integrated with some key laboratory tests. There is no one simple classification of anemia. A useful approach entails asking several questions, outlined in the following sections (Fig. 22.2).

Is Anemia Associated with Other Hematologic Abnormalities?

Specifically, is the anemia associated with thrombocytopenia or abnormalities in white blood cell numbers or the presence of abnormal leukocytes? If the answer to this question is yes, consideration must be given to the possibility of bone marrow failure due to aplastic anemia, leukemia, or other malignant marrow disease. Alternatively, pancytopenia can be secondary to peripheral destruction or sequestration of cells as in hypersplenism. In most cases, these disorders can be differentiated by careful review of screening hematologic studies and close attention to the medical history and physical examination.

Is There an Appropriate Reticulocyte Response to Anemia?

The number of erythrocytes in the circulation at a given time is the result of a dynamic equilibrium between the delivery of red cells into the circulation on the one hand and their destruction or loss from the circulation on the other. Each day, approximately 1% of the RBC pool is replaced by young erythrocytes released from the marrow. The homeostatic mechanisms of the body bring about recovery from anemia by accelerating erythropoiesis, and this response of the normal marrow is brought about through

P.592

the release of erythropoietin. At maximum stimulation, the bone marrow is capable of producing erythrocytes at six to eight times the normal rate.

The reticulocyte count provides an initial assessment of whether the cause of anemia is due to impaired RBC production or to increased loss in the peripheral circulation (e.g., blood loss, hemolysis) (Fig. 22.2). The reticulocyte count is traditionally measured by microscopic examination of a smear prepared from fresh blood stained with a supravital stain, such as new methylene blue. The normal reticulocyte count by light microscopy is 0.5% to 1.5% of the total red cells. More recently, automated methods based on flow cytometry have become widely utilized. The automated methods count a larger number of cells, and exhibit a greater degree of reproducibility.⁴⁶

In the presence of anemia, the reticulocyte count must be corrected because it is spuriously elevated when it is related to the reduced number of RBC in an anemic patient. An additional correction of this index needs to be made because reticulocytes released under intense erythropoietin stimulation remain in the peripheral blood for more than the usual 1-day survival time of nonstress reticulocytes. There are a number of ways to adjust the reticulocyte count for the degree of anemia (Table 22.3). While all of these methods have value, the absolute reticulocyte count is traditionally the easiest to estimate.

Automated reticulocyte counting also allows the evaluation of other parameters, such as reticulocyte hemoglobin content (CHR) and the proportion of immature reticulocytes (immature reticulocyte fraction, IRF). Availability of these methods depends on the particular cell counting equipment. A CHR < 28 pg suggests iron deficiency,⁴⁷ while a reduced IRF (<0.23) suggests underproduction.⁴⁸ The degree to which the IRF adds to information provided by any of the adjusted reticulocyte parameters is unclear.

If Anemia Is Associated with Reticulocytosis, Is There Any Evidence for Hemolysis?

The most characteristic presentation of hemolysis is reticulocytosis with some degree of hyperbilirubinemia as a marker of increased heme catabolism. Other markers reflect direct red cell injury (e.g., increased serum lactic dehydrogenase) or increased excretion of Hb (e.g., low serum haptoglobin, hemoglobinemia, hemoglobinuria, and increased urinary hemosiderin). The evaluation and diagnostic considerations related to hemolytic anemia are complex and are considered separately elsewhere in this chapter (see Approach to Hemolysis).

TABLE 22.3 METHODS OF CORRECTING THE RETICULOCYTE COUNT FOR THE DEGREE OF ANEMIA

Reticulocyte count = % reticulocytes in red blood cell (RBC) population

Corrected reticulocyte count = % reticulocytes \times (patient Hct/45)

Reticulocyte production index

= Corrected reticulocyte count \div maturation time in peripheral blood in days^a (Normal values of all of

above 0.5-1.5%)

Absolute reticulocyte count = % reticulocytes \times RBC count/L³

(Normal values for the absolute reticulocyte count are from 25 to 75 $\times 10^9$ /L; values $< 100 \times 10^9$ /L indicate an inappropriately low erythropoietic response to anemia.)

^a Reticulocyte maturation time = 1 day for Hct $\geq 40\%$; 1.5 days for Hct 30-40%; 2.0 days for Hct 20-30%; 2.5 days for Hct $< 20\%$.

Data from Hillman RS, Finch CA. Red cell manual, 5th ed. Philadelphia, PA: FA Davis, 1985.

If Anemia Is Associated with a Less Than Appropriate Reticulocyte Response, What Are the Red Cell Indices?

Anemia with low reticulocytes usually reflects some impairment of normal erythropoiesis, and this can be due to two kinds of defects. Erythropoiesis may be impaired because of a reduction in red cell precursors (hypogenerative). Alternatively, red cell production may be ineffective, a condition characterized by erythroid hyperplasia in the bone marrow, but with the production of essentially nonviable red cells, most of which do not reach circulation.

There are numerous causes of anemia with low reticulocyte counts, and it is in this group that analysis of RBC indices is most helpful. Of these, the MCV tends to be the single most useful measurement,^{49,50,51} although some clinicians prefer to use the MCH.⁵² The MCV and MCH almost always correlate closely.^{53,54}

An initial step in classification of anemias with low reticulocyte counts separates them into three groups on the basis of average cell size: the macrocytic, microcytic, and normocytic anemias (Fig. 22.2). Anemia is classified as macrocytic if MCV exceeds 100 fl. Usually, the MCH is also increased, whereas the MCHC remains within normal limits (Fig. 22.3). Microcytic anemia is identified when the MCV is less than 80 fl in adults. The anemia is normocytic when the indices are within normal limits, with an MCV between 80 and 100 fl. In children, MCV values vary as a function of age, and, correspondingly, the definition of microcytic, normocytic, and macrocytic differ accordingly (Table 22.1). As a practical matter for those who take care of children, it is important to know the age-related differences in RBC size, because many laboratory reports contain only adult normal values, often signaling the child's age appropriate hematologic values as abnormal.

The MCHC is useful in detecting severe hypochromia, but it is rarely abnormal when the MCV is normal.^{51,52,53,54,55,56} A reduced value for MCHC is observed most often in association with iron deficiency, and this index tends to be the last to fall as iron deficiency worsens.^{57,58,59} The changes in MCHC with iron deficiency were seen more frequently in the past when centrifugal methods were used to determine the Hct before the availability of electronic cell counting. Because of plasma trapping, centrifugal Hct methods overestimate the volume of packed red cells and, therefore,

P.593

underestimate MCHC. Plasma trapping increases from 1% to 3% with normal blood to as much as 6% in iron deficiency, a consequence of anisocytosis and reduced cell deformability.⁶⁰

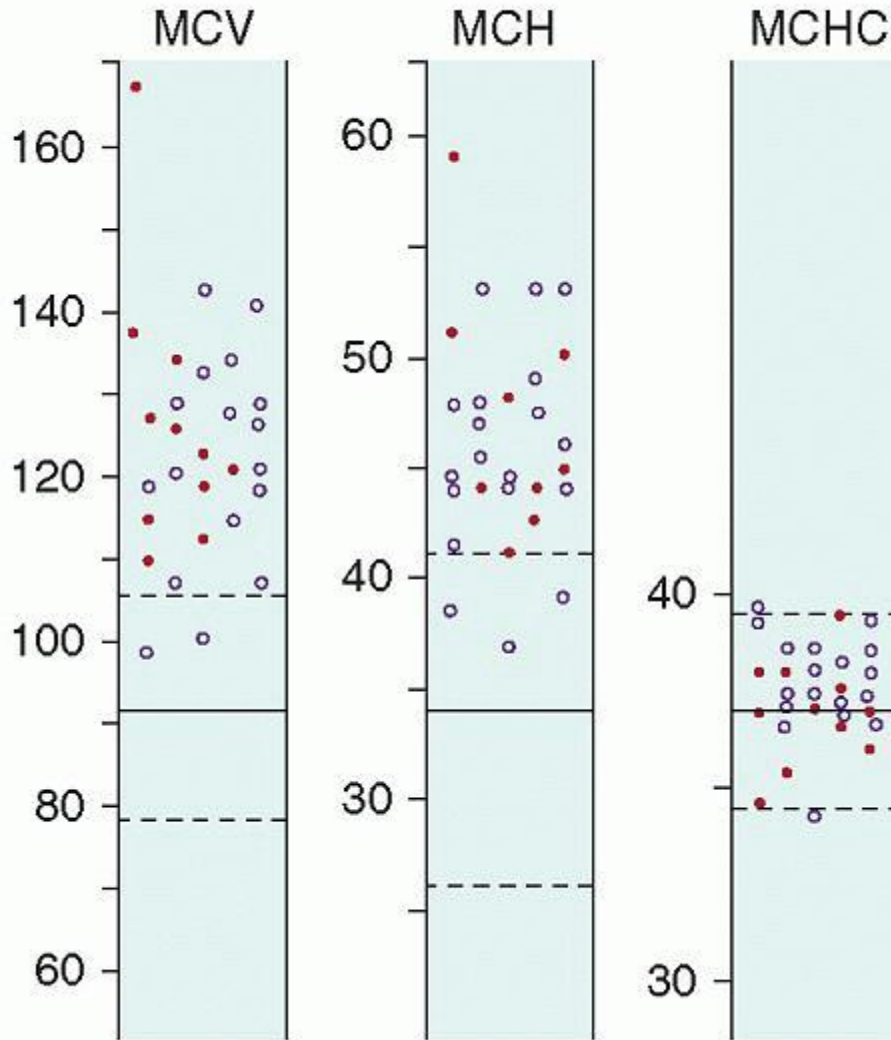

FIGURE 22.3. Erythrocyte indices in 28 patients with untreated or relapsed pernicious anemia. Dashed lines enclose the 95% confidence limits in normal subjects. Solid dots indicate males; open circles indicate females. MCH, mean corpuscular hemoglobin; MCHC, mean corpuscular hemoglobin concentration; MCV, mean corpuscular volume. (From Hallberg L. Blood volume, hemolysis and regeneration of blood in pernicious anemia. *Scand J Clin Lab Invest* 1955;7(Suppl 16):1-127, with permission.)

Is the Anemia Associated with a Low Reticulocyte Response and Microcytic Red Blood Cells?

The large majority of patients in this category have defects in cellular Hb synthesis due to either iron deficiency, thalassemia trait, or Hb E syndromes (see Approach to Microcytic Anemia).

Is the Anemia Associated with a Low Reticulocyte Response and Macrocytic Red Blood Cells?

In these patients, the anemia is characterized by reticulocytopenia with red cells having an increased MCV. Many of these disorders are due to megaloblastic anemia resulting in impaired nuclear development, and the formation of other blood cells is also affected (see Approach to Macrocytic Anemia).

Is the Anemia Associated with a Low Reticulocyte Response and Normocytic Red Blood Cells?

Normocytic anemia, low reticulocyte count, and normal bilirubin levels characterize a large number of anemias. The anemia of chronic disease usually is normocytic, although rarely may be slightly microcytic. In these cases, there usually is clinical evidence of a syndrome associated with cytokine activation. The anemia of renal failure is normocytic and largely is due to reduced erythropoietin production. Acquired pure red cell aplasia (PRCA) is a normocytic anemia, which occurs in adults and children (see Approach to Normocytic Anemia).

Is the Anemia Associated with Populations of Red Cells of Different Size?

The red cell indices represent mean values and do not reveal any variation that may exist within a population of cells. The MCV can be normal if there are combined abnormalities, such as when iron deficiency (decreased MCV) is accompanied by a megaloblastic anemia (increased MCV). For these purposes, it is important to examine the peripheral blood smear. Also, the electronically derived RDW allows for recognition of these phenomena because it quantifies the degree of heterogeneity of RBC size (i.e., anisocytosis) in a population of cells, and this has proven to be of value.^{49,61} The upper limit of normal values for RDW is 14.6%.⁴³ An increased RDW value is an early and pronounced finding in iron deficiency and most megaloblastic anemias; no differences from normal are seen in heterozygous thalassemia. In iron deficiency, the RDW value may become abnormal even before the MCV falls below the lower limits of normal.

Is the Anemia Associated with Abnormalities Seen on the Blood Smear?

Despite the technical advances provided by current electronic complete blood cell count (CBC) measurements, review of the peripheral blood smear remains a critical aspect of the diagnostic evaluation for anemia. It confirms the electronically determined classification of RBC size. Most important, it also allows for recognition of the many variations in RBC size and shape that frequently are seen in patients with hemolysis.

Microcytes and macrocytes can be detected on the blood smear on the basis of a change in red cell diameter. Normal red cells approximate the size of the nucleus of a small lymphocyte, and the area of central pallor is one-third to one-half of the diameter of the red cell (Fig. 22.4A). An increase in the area of central pallor of erythrocytes on the blood smear is indicative of hypochromia, and when the change is pronounced, little more than a faint ring of color in the periphery may be apparent (Fig. 22.4B). Hypochromia and microcytosis almost always occur together.

The automated analysis of the blood has made the erythrocyte indices more accurate and reproducible.⁶² However, the evaluation of the blood smear still remains important because it may reveal abnormal cell populations too small to affect the erythrocyte indices. For example, as iron deficiency develops, some microcytic cells are produced while the RBC indices are still normal. Furthermore, as B12 deficiency progresses, some characteristic oval macrocytes and hypersegmented neutrophils may appear long before there are MCV or Hb changes (Fig. 22.5B,C). Moreover, examination of the smear is important for detecting conditions characterized by two populations of cells, only one of which is of abnormal size. This dimorphic anemia is particularly characteristic of sideroblastic anemias (Fig. 22.4E). It also is seen in iron deficiency after iron therapy is started (Fig. 22.4C), and in iron deficient individuals who have been transfused.

Review of the blood smear may reveal underlying causes of the anemia. A leukoerythroblastic picture (teardrop RBC, nucleated RBC, early white blood cell precursors, or abnormalities in platelet shape) suggests marrow infiltration by hematologic or other malignant cells (Fig. 22.6). The marked elevation in serum proteins in multiple myeloma may result in a stacking of RBCs in rouleaux formation. The appearance of RBC in agglutinates (as opposed to their stacking into rouleaux) is seen with cold agglutinin disease. Also, probably one of the most valuable outcomes of reviewing the blood smear is that it often reveals abnormal red cell shapes characteristic of certain hemolytic anemias in particular.

Is a Bone Marrow Examination Needed to Clarify the Cause of Anemia?

Examination of the bone marrow is most useful in reticulocytopenic anemias, particularly when there is more than one hematopoietic cell line affected. Both hypoplasia and marrow infiltrative disease due to leukemia, tumor, or granulomas (myelophthitic anemia) may readily be demonstrated in the bone marrow aspirate and biopsy. Myelofibrosis can be recognized as a component of myeloid metaplasia. If the marrow is normocellular except for reduced erythropoiesis, the underlying cause may be red cell aplasia, renal disease, or endocrinopathy.

Examination of iron in bone marrow macrophages was traditionally considered the definitive way to demonstrate decreased iron stores. In most cases, however, the diagnosis of iron deficiency can be made by simple blood tests, thus obviating the need for an iron stain of the bone marrow. On the other hand, to make the diagnosis of sideroblastic anemia, a bone marrow examination is necessary to identify ringed sideroblasts. Megaloblastic anemias usually can be recognized by peripheral blood findings, but a marrow examination will confirm the diagnosis.

In some anemias with low reticulocyte counts, marrow erythropoiesis surprisingly is quite active. This is referred to as ineffective erythropoiesis, and it occurs when developing red cells are defective and are destroyed before they leave the marrow or shortly thereafter. A very small fraction of erythropoiesis is ineffective, even in normal subjects; however, in certain conditions, especially megaloblastic anemias, thalassemias, sideroblastic anemias, and congenital dyserythropoietic anemias, ineffective erythropoiesis becomes greatly exaggerated. The increased intramedullary destruction of erythroblasts in these conditions is associated with accelerated heme catabolism, resulting in an elevated unconjugated bilirubin level in the plasma. Also, the serum lactic dehydrogenase level, a marker of cell destruction, is

markedly elevated. Ineffective erythropoiesis can be confused with hemolytic anemia because signs of excessive red cell destruction and

P.594

erythroid hyperplasia of the bone marrow are found in both conditions. However, the two conditions are distinguished from one another by the degree of reticulocytosis, which is increased in hemolytic anemia and usually low in ineffective erythropoiesis.

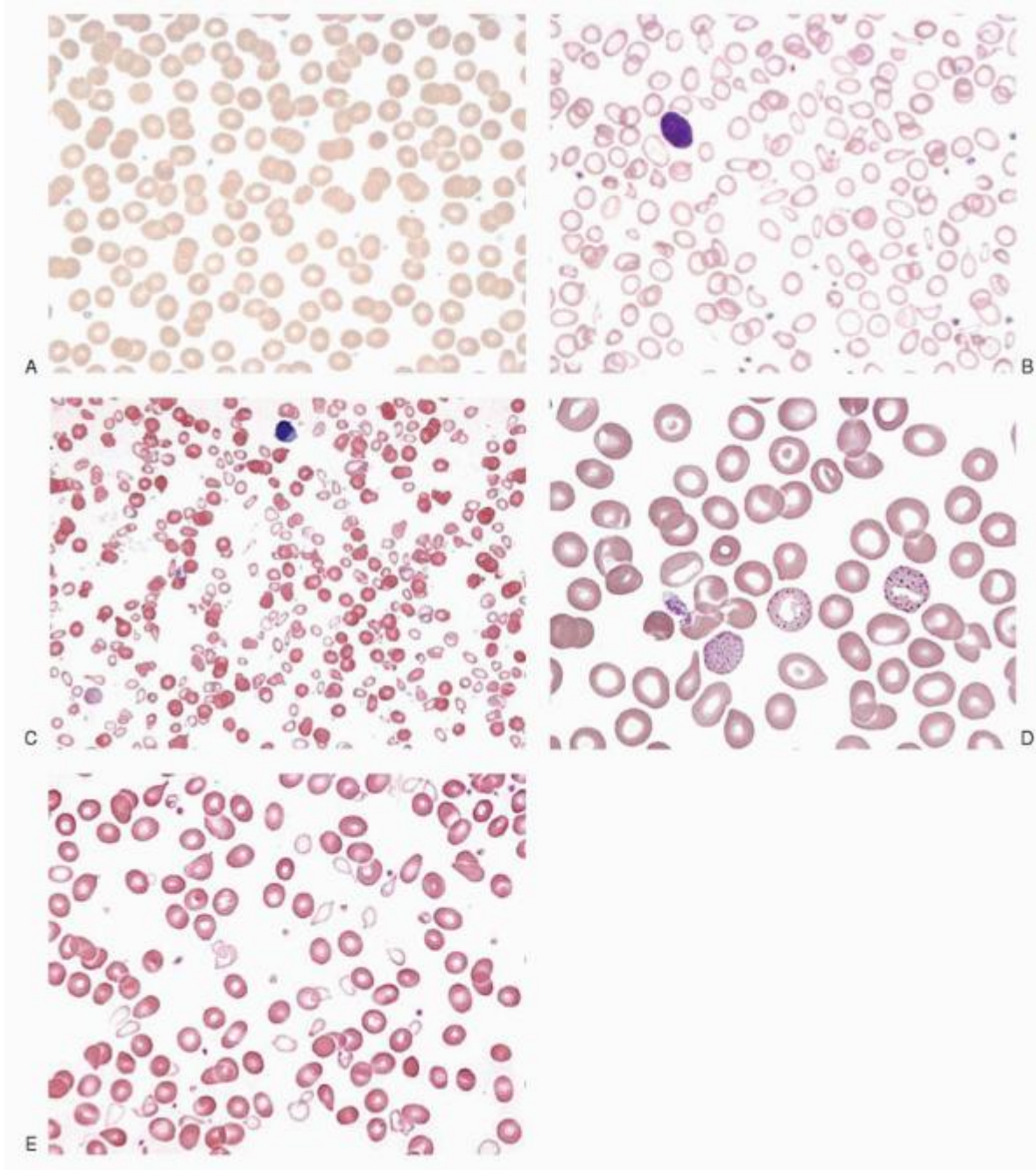

FIGURE 22.4. Peripheral blood smear of erythrocytes in a variety of hypochromic, microcytic anemia. A: Normal red cells. B: Iron deficiency anemia. Note the large area of central pallor. C: Dimorphic population of cells in iron deficiency anemia responding to treatment. D: Thalassemia minor. The cells are thin and appear pale but nearly normal in diameter. Note the basophilic stippling in several RBC: Sideroblastic anemia. A hypochromic, microcytic population of cells is mixed with relatively normocytic red blood cell. Part C from Tkachuk DC, Hirschmann JV] in Wintrobe's atlas of clinical hematology.

Philadelphia, PA: Lippincott Williams & Wilkins, 2007. Part D from Pierira I, George TI, Arber DA in Atlas of peripheral blood. Philadelphia, PA: Lippincott Williams & Wilkins, 2012 and Tkachuk DC, Hirschmann JV in Wintrobe's atlas of clinical hematology. Philadelphia, PA: Lippincott Williams & Wilkins, 2007.

APPROACH TO MACROCYTIC ANEMIA

Macrocytosis is a common finding in clinical settings. In 1.7% to 3.6% of cases involving patients seeking medical care, MCV is increased, often in the absence of anemia.^{63,64,65,66,67,68} Mild macrocytosis (MCV of 100 to 110 fl) is particularly common and often remains unexplained, even after careful study.⁶³ Even so, this finding should not be ignored, because it can be an important early clue to reversible disease. For example, it may appear 1 year or more before anemia develops in patients with pernicious anemia, and neurologic disease can progress during that interval.⁶⁹

Morphologic and biochemical criteria allow macrocytic anemias to be divided into two groups: the megaloblastic anemias and the nonmegaloblastic macrocytic anemias. The types of macrocytic anemias clinicians encounter vary considerably depending on the population served. If alcoholism is common in the

P.595

population, it is likely to be the most common cause. In cancer patients, high MCVs are most likely due to chemotherapy. In hospitals largely serving the elderly, pernicious anemia and other nutritional anemias may predominate.⁶⁸

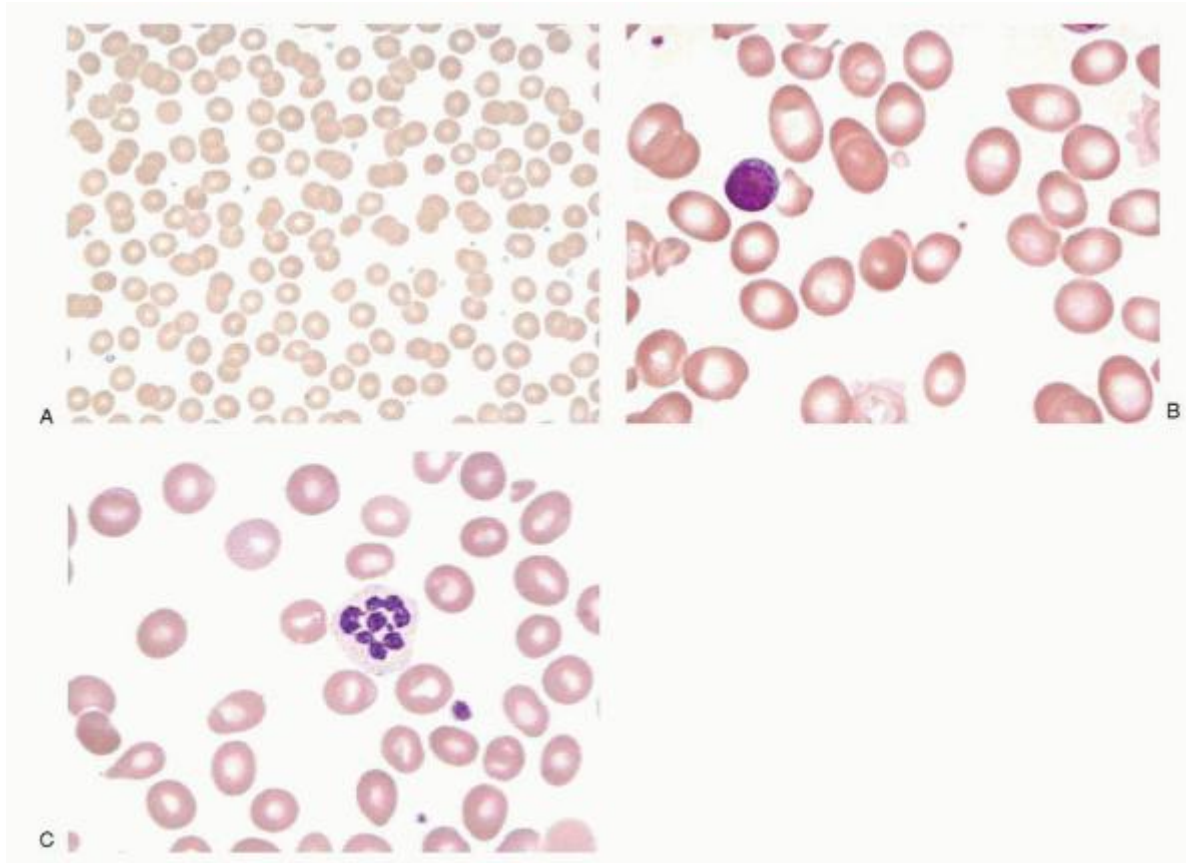

FIGURE 22.5. Megaloblastic anemia. A: Normal red cells. B: Macroovalocytes in pernicious anemia. From Pierira I, George TI, Arber DA in Atlas of peripheral blood. Philadelphia, PA: Lippincott Williams & Wilkins, 2012. C: Hypersegmented neutrophils seen in patient with megaloblastic anemia.

When confronted with a diagnostic problem involving macrocytic anemia, the physician should first distinguish between megaloblastic and nonmegaloblastic anemia (Fig. 22.7). The most useful steps for this purpose are morphologic examinations.

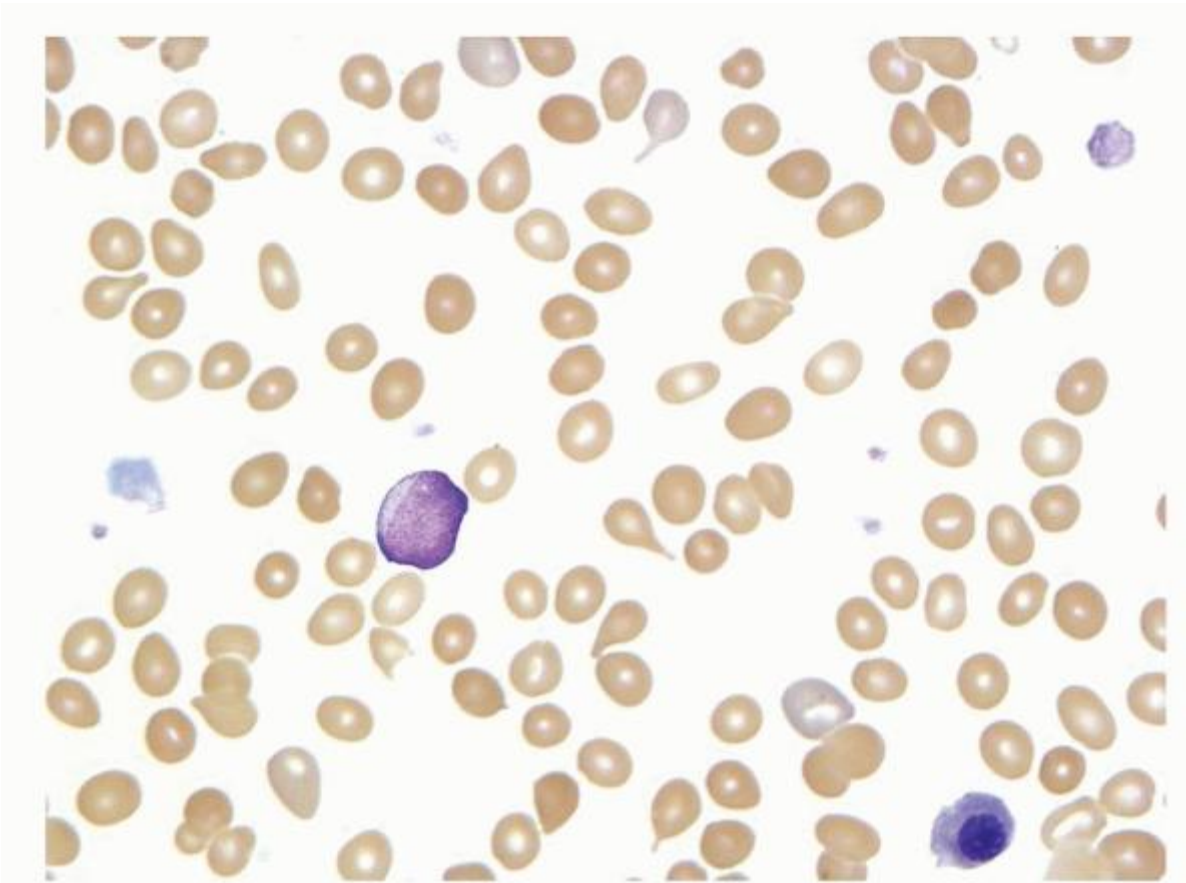

FIGURE 22.6. Peripheral blood smear. A leukoerythroblastic response seen in patient with metastatic breast cancer. From Pierira I, George TI, Arber DA in Atlas of peripheral blood. Philadelphia, PA: Lippincott Williams & Wilkins, 2012.

Megaloblastic Anemias

The term megaloblast is a designation that was first applied by Ehrlich to the abnormal erythrocyte precursors found in the bone marrow of patients with pernicious anemia. Megaloblasts are characterized by their large size and by specific alterations in the appearance of their nuclear chromatin (Fig. 22.8). These distinctive cells are now known to be the morphologic expression of a biochemical abnormality: retarded DNA synthesis.⁷⁰ RNA synthesis remains unimpaired while cell division is restricted.^{71,72} As a result, cytoplasmic components, especially Hb, are synthesized in excessive amounts during the delay between cell divisions. An enlarged cell is the product of such a process. Megaloblastic anemias are defined by the presence of these cells or by other evidence of defective DNA synthesis.

A pathogenetic classification of the causes of megaloblastic anemias is presented in Table 22.4. Most often, megaloblastic anemia is the consequence of deficiency of vitamin B₁₂ or folate, or both. Less commonly, megaloblastic anemia results from inherited or drug-induced disorders of DNA synthesis.

Hematologic Features of Megaloblastic Anemia

Examination of the blood smear often reveals the two most valuable findings for differentiating megaloblastic from nonmegaloblastic anemia: neutrophil hypersegmentation and oval macrocytes.

Neutrophil hypersegmentation is one of the most sensitive and specific signs of megaloblastic anemia (Fig. 22.5C). Normally, the nuclei of circulating, segmented neutrophils have fewer than five

P.596

lobes. In megaloblastic anemia, neutrophils with six or more lobes may be detected. In a large study, more than 98% of patients with megaloblastic anemia had at least one six-lobed neutrophil of the 100 cells examined, as compared with only 2% of normal control subjects.⁷³ Hypersegmentation is among the first hematologic abnormalities to appear as the megaloblastic state develops.⁷⁴ It persists for an average of 14 days after institution of specific therapy.⁷⁵

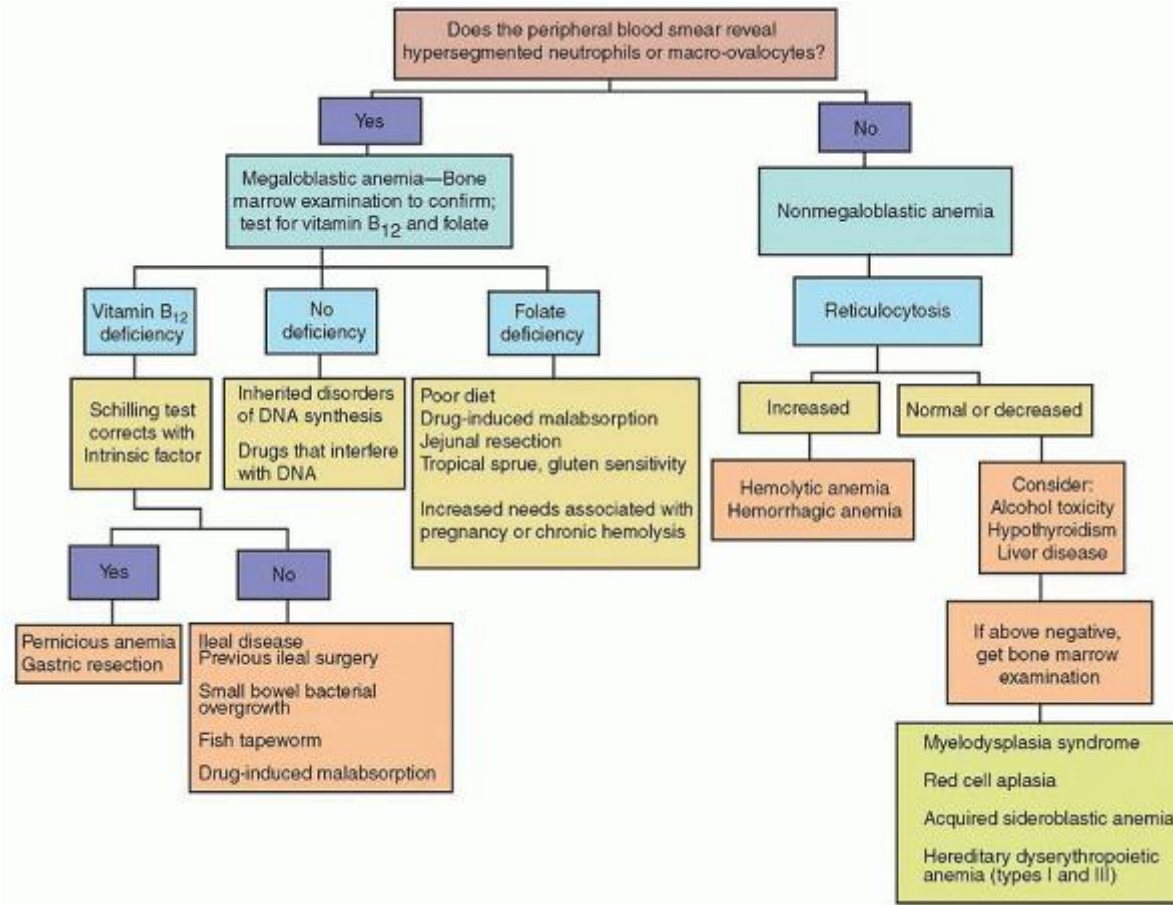

FIGURE 22.7. Diagnostic approach to a patient with macrocytic anemia.

The main products of megaloblastic erythropoiesis are macrocytic erythrocytes with a distinctly oval shape. Such cells are well filled with Hb, and often central pallor is reduced or absent (Fig. 22.5B). The oval shape may be useful in distinguishing megaloblastic anemias from other causes of macrocytosis; the macroreticulocytes that characterize accelerated erythropoiesis tend to be round and distinctly blue or gray in Romanowsky dyes.

Although oval macrocytes are prominent in megaloblastic anemia, the size and shape of the erythrocytes may vary considerably. Quantitative measures of anisocytosis, such as the RDW, are substantially increased, and the increase may precede the development of anemia.⁷⁶ Morphologic changes on the blood smear, however, are most conspicuous when anemia is pronounced.

Megaloblastic anemias usually develop gradually, and the degree of anemia is often severe when first detected. Hb values less than 7 or 8 g/dl are not unusual. Macrocytosis characteristically precedes the development of anemia^{69,77,78} and may even do so by several years. The MCV usually is between 110 and 130 fl.

Bone Marrow

A megaloblastic marrow is cellular and usually hyperplastic, with erythrocyte precursors predominating. The characteristic megaloblasts are distinguished by their large size and especially by their delicate nuclear chromatin. The chromatin has been described as particulate or sieve-like, as distinguished from the normal denser chromatin of normoblasts (Fig. 22.8). This morphologic change may be detected at all stages of erythrocyte development; however, the identification of orthochromatic megaloblasts is particularly useful in the recognition of megaloblastic anemia because they differ so markedly from any cell found in normal marrow. In the orthochromatic megaloblast, the abundant cytoplasm appears mature (pink), whereas the nucleus appears immature as a result of the megaloblastic change.

Leukopoiesis is also abnormal; extraordinarily large (up to 20 or 30 μm) leukocytes are found. These abnormalities of cellular development may occur at any stage in the myeloid series, but they are particularly common among the metamyelocytes. The nucleus of these giant metamyelocytes is enlarged, both absolutely and in relation to the total cell size; it may be bizarre in shape and in chromatin structure or staining properties.

In general, megakaryopoiesis is less disturbed than that of either of the other two cell lines; however, when megaloblastic change is severe, megakaryocytes may be reduced in number and abnormalities of nuclear chromatin may be evident.

P.597

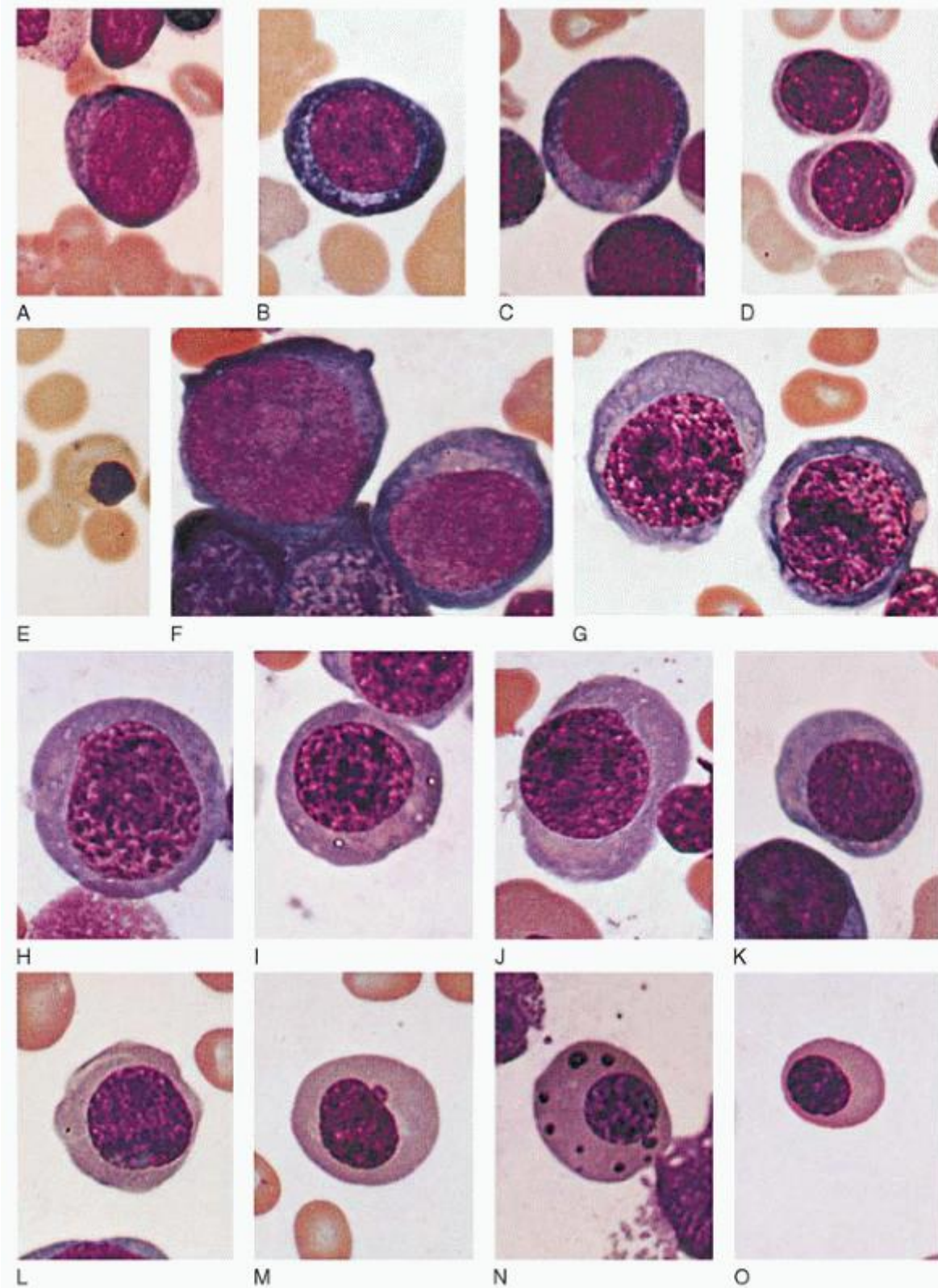

FIGURE 22.8. Normoblasts and megaloblasts contrasted (Wright stain X 1000). A-E: Normoblast. A: Pronormoblast. B: Basophilic normoblast. C: Early polychromatophilic normoblast. D: Late polychromatophilic normoblast. E: Orthochromatonic normoblast with stippling. F-O: Megaloblasts. F: Promegaloblast (left) and basophilic megaloblast (right). G-K: Polychromatophilic megaloblasts. L-O: Orthochromatonic megaloblasts.

Vitamin B₁₂ and Folate Levels in Serum and Erythrocytes

Once it is established that a patient has CBC and morphologic evidence of megaloblastic anemia, it should next be determined if this is due to vitamin B₁₂ or folate deficiency (Chapter 36). Useful studies include measurement of serum and RBC folate levels and serum Vitamin B₁₂ levels. Unlike serum vitamin B₁₂, serum folate is labile, being sensitive to short-term changes in folate balance. Thus, serum folate concentration may increase within a few hours after consumption of folate-containing food. Furthermore, a low intake of folate may result in reduced serum levels before true deficiency develops.⁷⁴ The erythrocyte folate level is a much better index of tissue folate stores. Erythrocyte folate levels are established during formation of the red cell and persist throughout its lifespan. Thus, it may take 3 to 4 months of folate deprivation

P.598

before low values are obtained. Other studies such as serum homocysteine and serum methylmalonic acid can confirm a diagnosis of B12 deficiency, particularly when initial assays are at odds with the clinical and hematologic picture. Vitamin B₁₂ absorption studies (Schilling test) or antibodies to intrinsic factor or parietal cells, can further define the specific causes of these disorders.

TABLE 22.4 PATHOGENETIC CLASSIFICATION OF MEGALOBLASTIC ANEMIA

Vitamin B₁₂ deficiency

Dietary deficiency (rare)

Lack of intrinsic factor

Pernicious anemia

Gastric surgery

Ingestion of caustic materials

Biologic competition for vitamin B₁₂:

Small-bowel bacterial overgrowth

Fish tapeworm disease

Familial selective vitamin B₁₂ malabsorption (Imerslund-Gräsbeck syndrome)

Drug-induced vitamin B₁₂ malabsorption

Chronic pancreatic disease

Zollinger-Ellison syndrome

Diseases of the ileum

Previous ileal resection

Regional enteritis

Folate deficiency

Dietary deficiency

Increased requirements:

Pregnancy

Chronic hemolytic anemia

Alcoholism

Congenital folate malabsorption

Drug-induced folate deficiency

Extensive intestinal (jejuna) resection

Combined folate and vitamin B₁₂ deficiency
 Tropical sprue
 Gluten-sensitive enteropathy
 Inherited disorders of DNA synthesis
 Orotic aciduria
 Lesch-Nyhan syndrome
 Thiamine responsive megaloblastic anemia
 Transcobalamin II deficiency
 Homocystinuria and methylmalonic aciduria
 Drug- and toxin-induced disorders of DNA synthesis
 Folate antagonists (e.g., methotrexate)
 Purine antagonists (e.g., 6-mercaptopurine)
 Pyrimidine antagonists (e.g., cytosine arabinoside)
 Alkylating agents (e.g., cyclophosphamide)
 Zidovudine (AZT, Retrovir)
 Trimethoprim
 Oral contraceptives
 Nitrous oxide
 Arsenic
 Nonmegaloblastic Macrocytic Anemias

Nonmegaloblastic anemias are not united by any common pathogenetic mechanism. They simply represent macrocytic anemias in which the RBC precursors appear normal without the characteristic nuclear and cytoplasmic findings of megaloblastosis. When macrocytosis is found, it tends to be mild; the MCV usually ranges from 100 to 110 fl and rarely exceeds 120 fl.⁶⁴ Several causes of nonmegaloblastic macrocytosis are recognized (Table 22.5).

Accelerated Erythropoiesis

Mild to moderate macrocytosis often follows erythropoietin-mediated acceleration of red cell production, as may be induced by blood loss or hemolysis. In part, this increased cell size occurs because reticulocytes are approximately 20% larger than mature red cells.⁷⁹ Also, under conditions of accelerated red cell production, a premature release of bone marrow reticulocytes (shift reticulocytes) occurs, and these cells are even larger and contain more RNA than normal circulating reticulocytes.⁸⁰ Last, an erythroblast cell division may be skipped under this erythropoietic stress, a phenomenon that results in a macroreticulocyte that is approximately twice the normal size.⁸¹

TABLE 22.5 NONMEGALOBLASTIC MACROCYTIC ANEMIAS

Hemolytic anemia/reticulocytosis
 Posthemorrhagic anemia
 Alcoholism
 Liver disease
 Myelodysplastic syndrome
 Myelophthisic anemias
 Aplastic anemia

Acquired sideroblastic anemia

Congenital dyserythropoietic anemia (CDA) types I and III

Diamond-Blackfan anemia

Hypothyroidism

Spurious macrocytosis (paraproteinemia, inflammation)

Alcoholism

Macrocytosis, usually mild, is evident in 40% to 96% of alcoholics, many of whom have no anemia.^{82,83,84} The finding is so characteristic of the condition that testing for macrocytosis has been used as part of the screening procedure for the detection of chronic alcohol use. It may be present in both heavy and moderate drinkers.⁸⁵ Macrocytosis and anemia in alcoholic individuals have several causes. Folate deficiency can lead to megaloblastic anemia, and alcoholic cirrhosis may be associated with spur cell hemolytic anemia. Most often, however, alcoholic macrocytosis is associated with none of these factors and instead results from poorly defined direct effects of alcohol on the bone marrow. Antibodies against acetaldehyde-modified RBC protein are detected in up to 94% of alcoholics with high MCVs, but less frequently in those with normal MCVs.⁸⁵ There are no morphologic stigmata of megaloblastic anemia. Serum and erythrocyte folate levels are usually normal, and the macrocytosis does not respond to folate treatment. If the patient abstains from alcohol use, the MCV returns to normal levels after 2 to 4 months.

Liver Disease

The causes of anemia in liver disease are multifactorial, resulting from intravascular dilution due to hypervolemia, impaired ability of the marrow to respond optimally to the anemia, and in some patients, a severe hemolytic anemia associated with morphologically abnormal erythrocytes (spur cells). The anemia is usually mild to moderate. In cirrhotic patients, the Hb level averages approximately 12 g/dl, and remains above 10 g/dl in the absence of bleeding or severe hemolysis. The anemia of liver disease is mildly macrocytic: the MCV rarely exceeds 115 fl in the absence of megaloblastic changes in the bone marrow. In addition, liver disease is associated with thin macrocytes, defined as cells with increased surface area⁸⁶ but without a corresponding increase in volume.⁸⁷ The increased surface area of thin macrocytes is the consequence of excessive membrane lipids, especially

P.599

cholesterol,⁸⁷ but also phospholipids. On the blood smear, thin macrocytes are characterized by an increased diameter and a visibly enlarged area of central pallor. The characteristic target cell of liver disease is a thin macrocyte. Because the volume of such cells is normal, their presence has no effect on the erythrocyte indices.

Miscellaneous Anemias

Macrocytosis may accompany various anemias with low reticulocyte counts, including myelodysplastic and myelophthistic conditions. The reason for macrocytosis in these disorders is not well understood.

Congenital red cell hypoplasia or Diamond-Blackfan anemia (DBA) is a pure RBC aplasia in children that is due to impaired differentiation of developing erythroblasts (Chapter 39). This disorder is characterized by a life-long anemia that presents in the first few months of life. Many children with DBA have congenital abnormalities, including short stature and skeletal defects (usually affecting the thumb). The diagnosis of DBA is suggested by a macrocytic (although sometimes normocytic) anemia with reticulocytopenia presenting in the first 6 months of life. Bone marrow examination reveals decreased erythroid precursors.

Congenital dyserythropoietic anemias (CDAs) are a group of anemias characterized by ineffective erythropoiesis and dyserythropoiesis (Chapter 40). The term dyserythropoiesis refers to the presence of morphologically abnormal erythroblasts in the bone marrow with multinuclearity, karyorrhexis, or megaloblastic changes. Three major types of CDA have been distinguished on the basis of morphologic and serologic classification, and these have been designated CDA types I, II, and III. The degree of anemia encountered in the CDAs varies considerably. It may range from a mild to moderate anemia that is only discovered or diagnosed later in life to a severe anemia apparent in infancy. Morphologically, the anemia is generally mildly macrocytic in CDA types I and III and is normocytic in CDA type II. In all of the disorders, the bone marrow findings are consistent with ineffective erythropoiesis: there is erythroid hyperplasia along with morphologically abnormal precursors. An elevation in serum lactate dehydrogenase and indirect bilirubin levels may be observed. Decreased serum haptoglobin often is seen.

Spurious macrocytosis can result from laboratory artifacts. Cold agglutinins, marked leukocytosis, or other acute phase reactants can lead to an incorrect high MCV value.⁶⁵ Care is needed so that these situations do not lead to a fruitless search for a disorder known to cause macrocytic anemia. Since reticulocytes are larger than mature RBCs, significant reticulocytosis can increase the MCV. This is not a spurious macrocytosis, but it is misleading.

APPROACH TO MICROCYTIC ANEMIA

Most microcytic anemias are due to deficient Hb synthesis, often associated with iron deficiency or impaired iron use (Table 22.6). The differentiation of iron deficiency from the anemia of chronic disease and the differentiation of iron deficiency from thalassemia trait syndromes are both common clinical issues. Significant microcytosis is detected in nearly 3% of all patients who require admission to the hospital.^{56,88}

The typical Hb level seen in adults with a variety of microcytic anemias is depicted in Table 22.7. The laboratory evaluation of microcytic anemias focuses on screening hematologic studies, followed by more definitive tests to distinguish iron deficiency anemia, the anemia of chronic disease, hemoglobinopathies, or sideroblastic anemias (Fig. 22.9). A few commonly used studies are described below; others are described elsewhere in this text.

Iron Pathway Disorders

The principal source of iron for Hb production is that carried by transferrin, the iron-transport protein in plasma. Under normal circumstances, plasma iron levels are not rate limiting in erythropoiesis, and transferrin is able to supply all the iron required for normal or accelerated production rates. However, in iron deficiency anemia, the storage sites in macrophages are depleted of iron and the plasma iron concentration falls. When transferrin saturation with iron is less than 16%, the red cell production rate decreases, and hypochromic, microcytic cells are manufactured. This state is known as iron deficient erythropoiesis.

TABLE 22.6 PATHOGENIC CLASSIFICATION OF MICROCYTIC ANEMIAS

Disorders of iron metabolism

Iron deficiency anemia

Anemia of chronic disorders

Disorders of globin synthesis

α - and β -thalassemias

Hemoglobin E syndromes (AE, EE, E- β -thalassemia)

Hemoglobin C syndromes (AC, CC)

Sideroblastic anemias

Hereditary sideroblastic anemia

Acquired sideroblastic anemia

Refractory anemia with ringed sideroblasts

Malignancies

Myeloproliferative disorders

Lead intoxication (usually normocytic)

In the anemia associated with chronic disorders (Chapter 41), the macrophage iron level is normal or increased, but export of iron from macrophages is downregulated.⁸⁹ Thus, iron accumulates in the macrophage, whereas the plasma level falls, and the marrow is deprived of adequate supplies.

Together, iron deficiency anemia and the anemia of chronic disease are among the most common causes of anemia. Iron deficiency predominates in children and young women; but it also occurs in older individuals, in whom it may reflect occult bleeding due to underlying pathology. The anemia of chronic disorders is most common among elderly people,⁹⁰ but it also can occur in younger individuals affected by certain chronic inflammatory states.

TABLE 22.7 TYPICAL HEMOGLOBIN AND MEAN ORPUSCULAR VOLUME VALUES IN ADULTS WITH CERTAIN ANEMIAS

Condition	Hb Concentration (g/dl)	MCV (fl)
Normal men	16 (14-18)	89 (80-100)
Normal women	14 (12-16)	89 (80-100)
Iron deficiency anemia	8 (4-12)	74 (55-85)
Anemia of chronic diseases	10 (8-13)	85 (75-95)
β -Thalassemias minor	12 (9-14)	68 (55-75)
β -Thalassemias major	(2-7)	(48-72)
Hemoglobin H disease	9 (7-11)	70 (53-88)
Hemoglobin E trait (AE)	14 (12-17)	73 (71-78)
Homozygous hemoglobin E (EE)	12 (11-15)	64 (58-76)
Hemoglobin C disease (CC)	10 (7-14)	77 (55-93)
Congenital sideroblastic anemia	6 (4-10)	77 (49-104)
Acquired sideroblastic anemia	10 (7-12)	104 (83-118)

Note: Values are means, with approximate range in parentheses. Hb, hemoglobin; MCV, mean corpuscular volume.

P.600

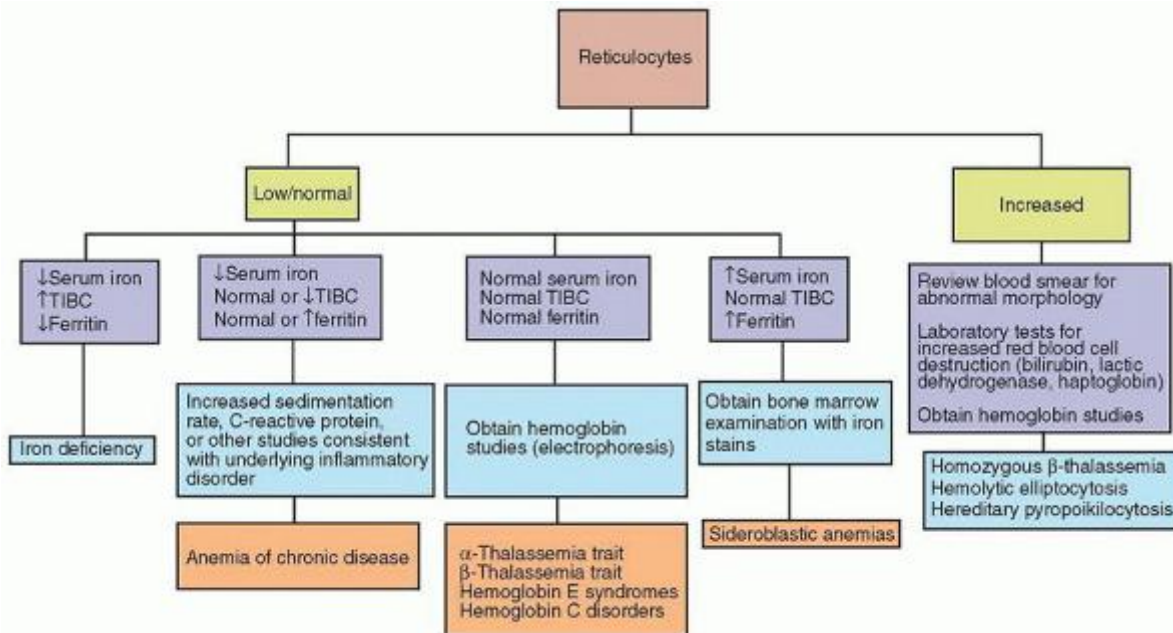

FIGURE 22.9. Diagnostic approach to a patient with microcytic anemia. ↑, increased; ↓, decreased.

Distinguishing typical iron deficiency anemia from the anemia of chronic disorders is usually not difficult. Anemia, hypochromia, and microcytosis are typically more pronounced in iron deficiency, as are the degrees of anisocytosis and poikilocytosis. The anemia of chronic disease is usually normocytic. However, when iron deficiency is early and mild, the morphologic findings in the two conditions may be similar.

Measurement of Serum Iron and Iron-binding Capacity

Serum iron levels are a measure of the amount of iron bound to transferrin. Total iron-binding capacity (TIBC) is an indirect measurement of transferrin in terms of the amount of iron it will bind. Transferrin also can be measured directly by immunologic techniques and is available in many laboratories.

A limitation in the use of serum iron determinations is the considerable variability in values.^{51,62,91,92} A technical problem relates to contamination of glassware and reagents with iron, although the use of disposable, plastic equipment has significantly reduced such contamination as a clinical issue. Even if technical problems are eliminated, serum iron values in an individual can vary from 10% to 40% within a single day or from day to day,^{93,94} and many normal subjects demonstrate a predictable diurnal variation, with highest values in the morning and lowest values in the evening.⁵² In contrast to serum iron, TIBC (or transferrin) values show only slight day-to-day fluctuation or diurnal variation.⁹¹ It also must be recognized that serum iron levels are influenced by the recent ingestion and absorption of iron medication.

The normal mean serum iron value for men is approximately 120 µg/dl (21.8 µmol/L). The composite normal range is approximately 70 to 200 µg/dl (13 to 36 µmol/L); however, values vary substantially from one laboratory to another. The TIBC averages 340 µg/L (61 µmol/L) in both men and women, with a composite normal range of 250 to 435 µg/dl (45 to 78 µmol/L). TIBC saturation is calculated with the following formula: $TIBC\ saturation\ (\%) = (serum\ iron \times 100) / TIBC$. The normal value is 20% to 45%. Values below 16% are noted in association with both iron deficiency and the anemia of chronic disorders (Fig. 22.10). The degree of reduction tends to be greater in iron deficiency than in chronic disorders, but considerable overlap exists between these two conditions. In both children and adults, however, a value of less than 5% is almost certainly due to iron deficiency anemia. In sideroblastic anemias, and in transfused thalassemic patients, the TIBC saturation invariably is increased and often approaches 100%. In laboratories that measure transferrin directly, an iron transferrin saturation index is calculated that provides the same information as the TIBC saturation.

The absolute value for TIBC may be helpful in distinguishing between iron deficiency and the anemia of chronic disorders. The TIBC often is increased in iron deficiency and decreased in chronic disease (Fig. 22.11), and some consider it to be the best test to distinguish these two disorders,⁹⁵ although in hospitalized patients elevated TIBC is an insensitive marker of iron deficiency.⁹⁶

Serum Ferritin

Determination of serum ferritin concentration also is used for evaluating iron stores in patients with iron deficiency.⁹⁷

Ferritin

P.601

is chiefly an intracellular iron storage protein, but trace amounts are also secreted into plasma. In most clinical circumstances, the serum ferritin concentration is proportional to total body iron stores. In contrast to serum iron measurements, ferritin values are not influenced by recent iron therapy.⁹⁸

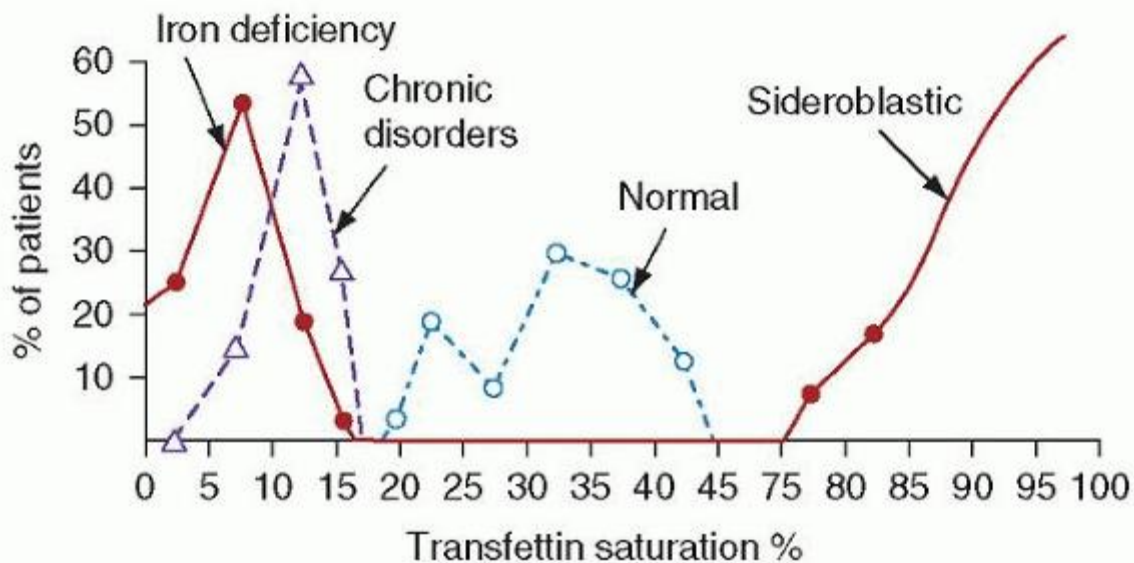

FIGURE 22.10. Transferrin iron saturation in patients with several types of anemia. The values are low (>16%) in iron deficiency anemia and the anemia of chronic disorders, with considerable overlap. Values of less than 5% are found only in iron deficiency. Transferrin saturation is increased in sideroblastic anemia.

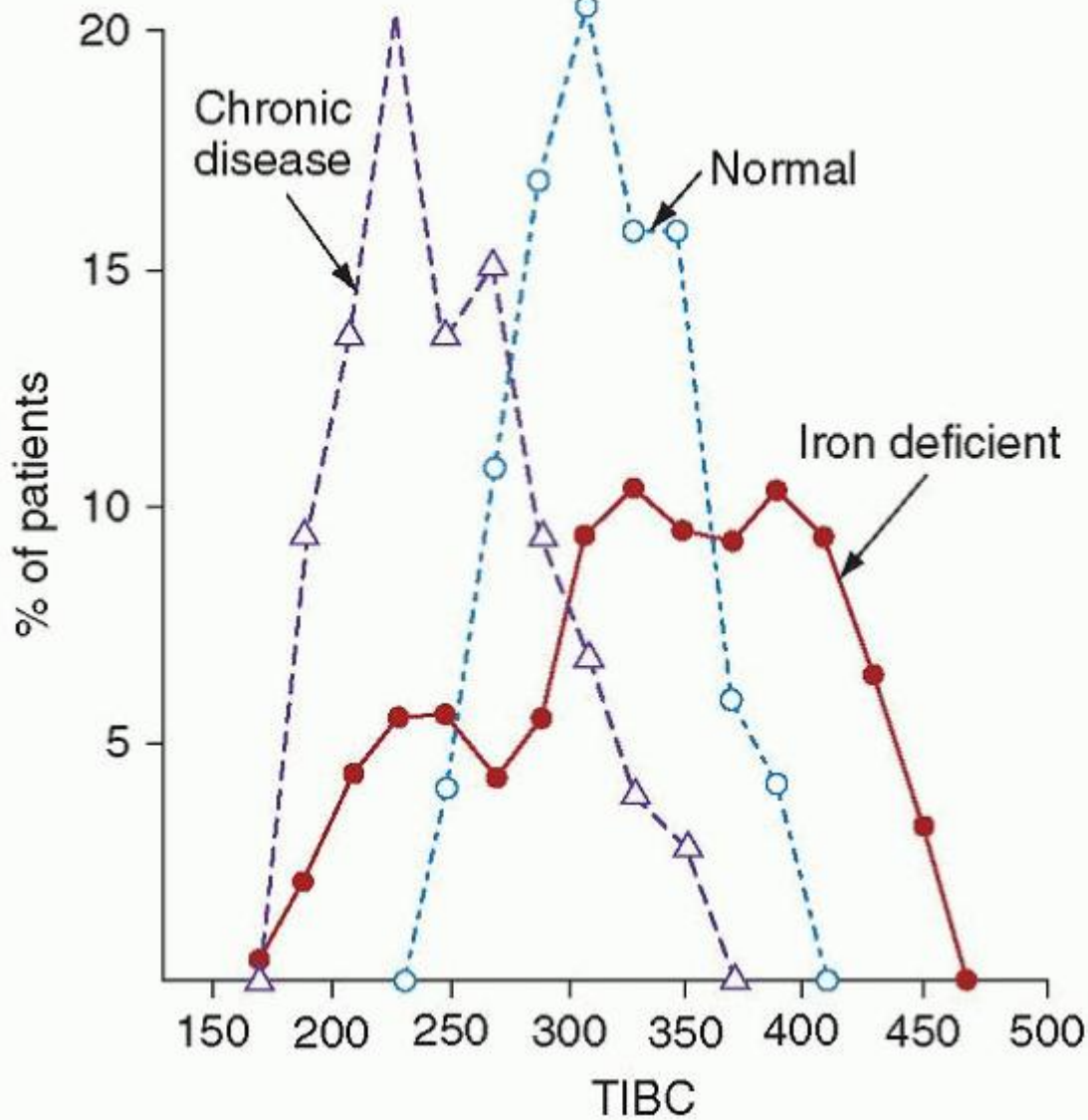

FIGURE 22.11. Total iron-binding capacity (TIBC) in patients with iron deficiency and in those with chronic disease. A high value indicates iron deficiency. Low to normal values are found in chronic disease but may also occur in iron deficiency.

The mean ferritin value for normal adult men is 90 to 95 $\mu\text{g/L}$, with a range of approximately 20 to 500 $\mu\text{g/L}$. For women, mean values of approximately 35 $\mu\text{g/L}$ are noted, with a usual range of 10 to 200 $\mu\text{g/L}$, when iron deficiency anemia is excluded.⁹⁹ In infants, values are high at birth but rapidly fall to approximately 30 $\mu\text{g/L}$, where they remain until puberty. Serum ferritin values in men tend to rise steadily with age. These levels show little or no diurnal variation. Day-to-day variation averages approximately 15%, mostly because of methodologic factors.⁹⁹

In patients with uncomplicated iron deficiency, mean ferritin values of 3 to 6 $\mu\text{g/L}$ have been reported. In patients with excessive iron stores, values are usually greater than 1,000 $\mu\text{g/L}$ and may reach 10,000 $\mu\text{g/L}$ (Fig. 22.12).¹⁰⁰ Also, the serum ferritin level in patients with anemia of chronic diseases may increase disproportionately relative to the increase in iron stores, probably because ferritin is an acute phase reactant. This phenomenon complicates the diagnosis of iron deficiency when it coexists with inflammatory disease. In some other illnesses, the serum ferritin level increases because of factors other than augmented iron stores. One such condition is liver disease, in which damage to the hepatic cell can cause the

release of intracellular ferritin (nonglycosylated and iron-rich).¹⁰⁰ Serum ferritin values also may be inappropriately increased in association with various malignancies, especially hematologic malignancies.^{99,101,102}

Evaluation of Bone Marrow Iron Stores

In bone marrow aspirates, hemosiderin appears as goldenyellow refractile granules. More often, the specimen is stained by the Prussian blue method, which renders hemosiderin blue.¹⁰³ Experienced observers can grade the marrow hemosiderin stores from 0 to 6+ (Table 22.8).¹⁰⁴ Normal marrow is graded 1+ to 3+. In iron deficiency, marrow hemosiderin is absent; in the anemia of chronic disorders, iron is always present, most often of grade 2 or 3+, but sometimes 4 or 5+. Iron stores are greatly increased (5 to 6+) in thalassemia major and in sideroblastic anemias. Nowadays the marrow assessment of iron is used much less, because serum ferritin provides a simple measurement that correlates with clinical iron states in the anemia of chronic disease and in iron deficiency states.

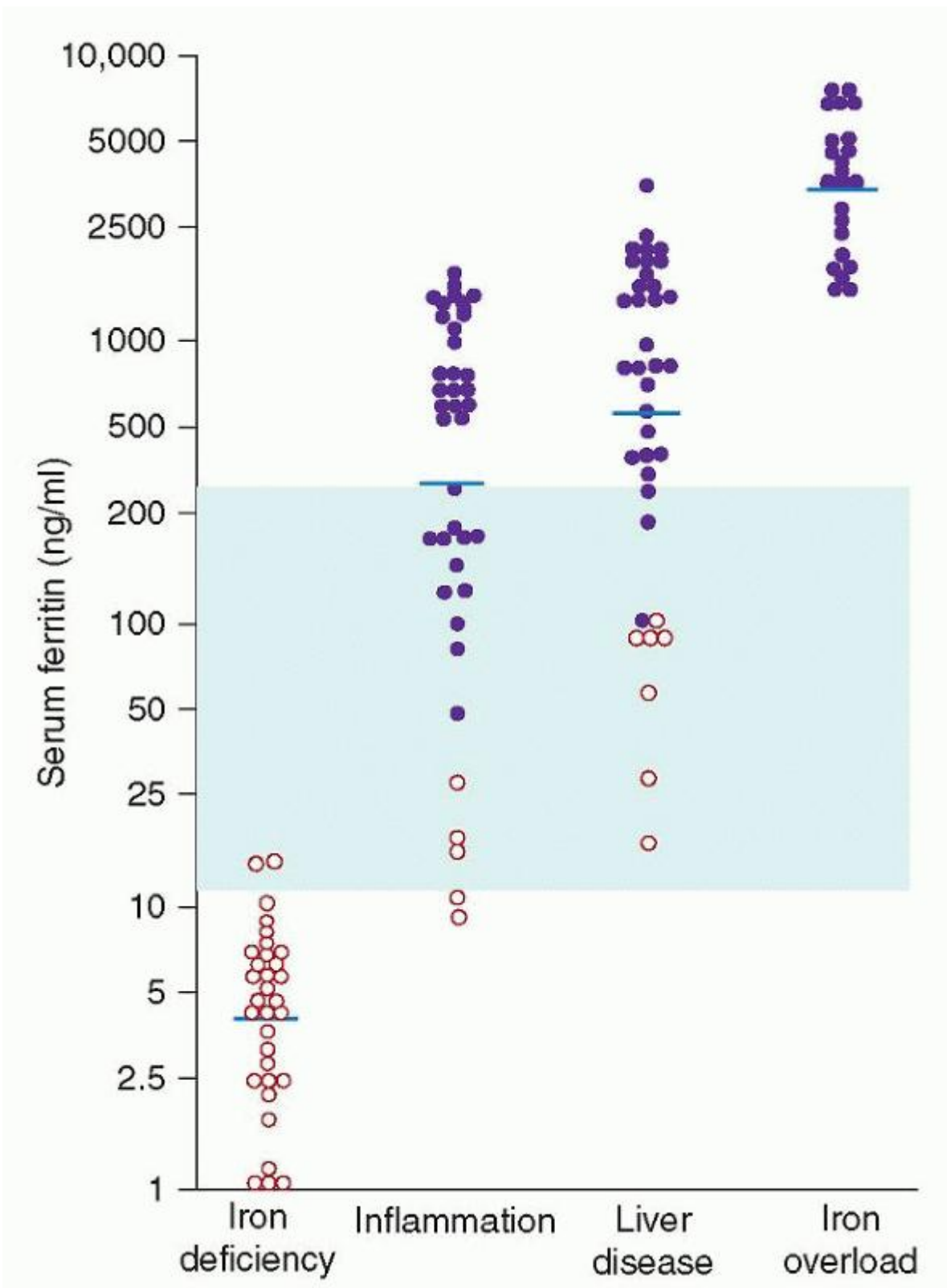

FIGURE 22.12. Measurements of serum ferritin in uncomplicated iron deficiency, inflammation, liver disease, and iron overload. Geometric mean values for each group (horizontal line). Patients with iron deficiency (total iron-binding capacity >400 $\mu\text{g}/100\text{ ml}$ and transferrin saturation below 16% or absent marrow iron or both) (open circles). Normal range (shaded area). From Lipshitz D, Cook JD, Finch CA. A clinical evaluation of serum ferritin as an index of iron stores. *N Engl J Med* 1974;290:1213-1216, with permission.

Transferrin Receptors

Transferrin receptors (TfRs) are disulfide-linked transmembrane proteins that facilitate the entry of transferrin-bound iron into

P.602

cells (Chapter 23). A soluble, truncated form of the protein can be detected in plasma, and its immunologic quantification can be useful in detecting iron deficiency and distinguishing it from the anemia of chronic disease. Values in iron deficient subjects are clearly increased, and are typically not increased in uncomplicated anemia of chronic disease.^{105,106,107} Therefore, TfR determination may be useful in distinguishing iron deficiency from the anemia of chronic disease, but must be interpreted in association with the ferritin concentration.⁹⁶ It has been proposed that the ratio of serum TfR concentration to the logarithm of the serum ferritin concentration has a better capacity to distinguish iron deficiency from the anemia of chronic disease than does the unadjusted serum TfR concentration¹⁰⁸ (Fig. 22.13). Serum TfR levels also vary with the total mass of red cell precursors. Therefore, the value increases in hemolytic anemia, thalassemia, and polycythemia, and decreases in hypoplastic anemia and renal failure.⁷⁶

TABLE 22.8 CRITERIA FOR GRADING IRON STAINS IN BONE MARROW ASPIRATES

Grade	Criteria	Iron Content (µg/g)
0	No iron granules observed	42 ± 23
1+	Small granules in reticulum cells, seen only with oil-immersion lens	130 ± 50
2+	Few small granules visible with low-power lens	223 ± 75
3+	Numerous small granules in all narrow particles	406 ± 131
4+	Large granules in small clumps	762 ± 247
5+	Dense, large clumps of granules	1,618 ± 464
6+	Very large deposits, obscuring marrow detail	3,681 ± 1,400

Gale E, Torrance J, Bothwell T. The quantitative estimation of total iron stores in human bone marrow. *J Clin Invest* 1963;42:1076.

Other Tests to Assess Iron Metabolism

Erythrocyte Zinc Protoporphyrin

Red cell precursors normally synthesize slightly more protoporphyrin than is needed for heme synthesis. The excess remains with the cell throughout its lifespan and has been called free erythrocyte protoporphyrin (FEP). When iron is not available for heme synthesis, protoporphyrin accumulates in excess as zinc protoporphyrin. Measurement of FEP is available as a screening test for iron deficiency, and the test requires only a drop of blood and 1 minute of processing.^{51,109} The level of FEP increases dramatically in iron deficiency and is a sensitive laboratory abnormality in this condition.^{51,109,110,111,112} The erythrocyte zinc protoporphyrin content also is greatly increased in lead poisoning but is normal in thalassemia.^{109,110}

Liver Iron Stores

Iron stores can also be estimated by liver biopsy using both histochemical and chemical methods of analysis.^{113,114} Even gross inspection of a Prussian blue-stained biopsy specimen can provide a reasonably reliable estimate of iron stores.¹¹⁵ Criteria for grading the preparations from 1 to 4+ have been established,^{113,114,116} and these correlate well with chemical analysis. Chemical analysis has been important in evaluating hemochromatosis and transfusion iron overload, because a disproportionate amount of iron is in parenchymal cells in the form of ferritin, which does not stain with Prussian blue.¹¹⁷ Measurement of hepatic iron stores has been used mainly to assess iron overload states, because the correlation between serum ferritin and true tissue iron content is not as good when there is elevated tissue iron content. Currently, however, magnetic resonance imaging using T2* technology is replacing liver biopsy as a noninvasive way to measure liver iron content.^{118,119}

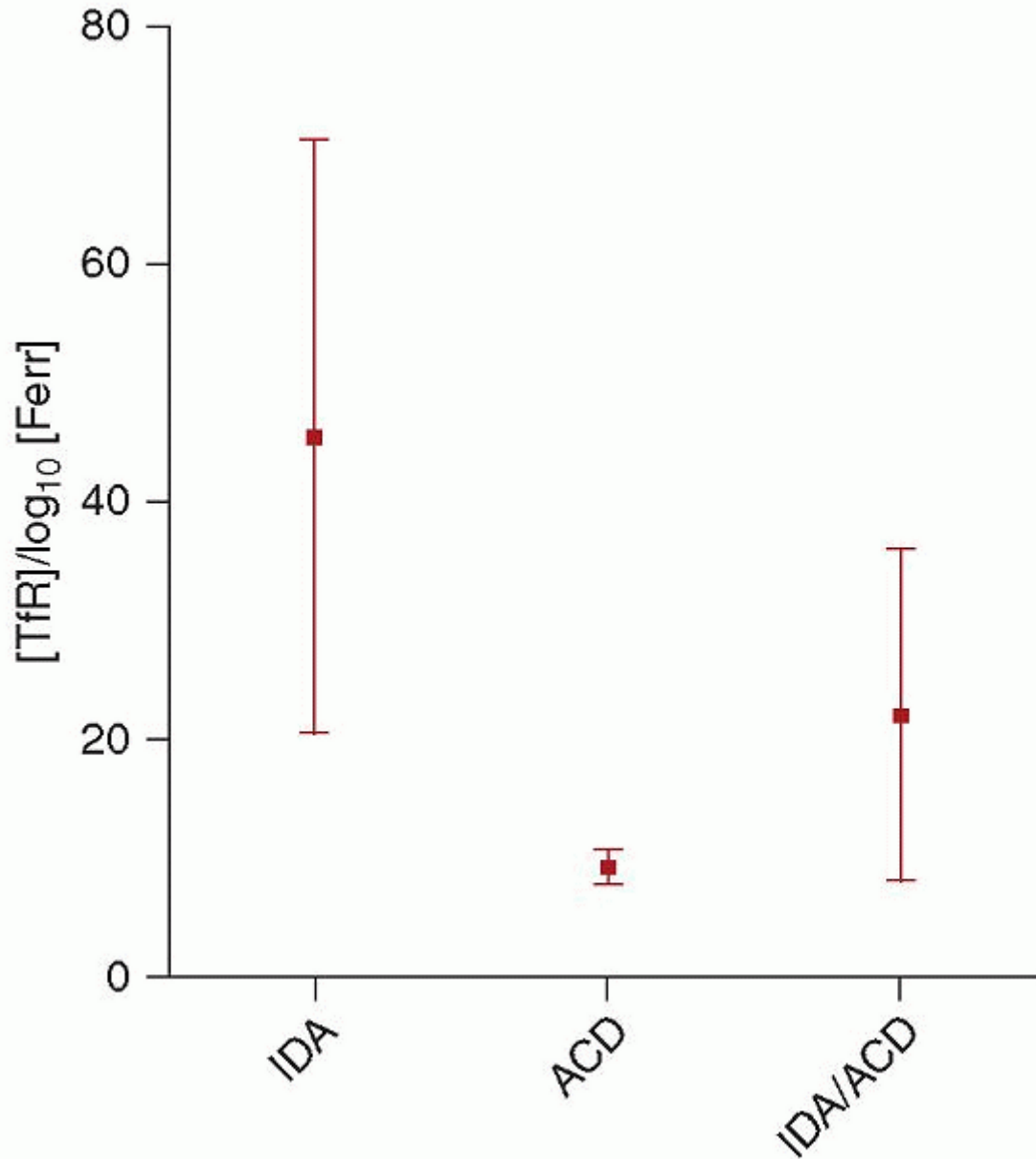

FIGURE 22.13. Ratio of serum transferrin receptor concentration [TfR] to \log_{10} serum ferritin concentration [Ferr] in anemic patients with iron deficiency (IDA; $n = 19$), anemia of chronic disease (ACD; $n = 65$), and features of both syndromes (IDA/ACD; $n = 7$). Bars indicate the mean (dot) and 95% confidence intervals of values in the three groups.

Urinary Iron Excretion

Storage iron has been evaluated by urinary excretion of iron after the administration of a chelating agent.^{120,121,122,123} The chelator most commonly used for this purpose is deferoxamine. A rough correlation exists between iron stores and urinary iron excretion after deferoxamine administration.

Disorders of Hemoglobin Synthesis

The Hb disorders associated with microcytosis include the thalassemias and certain structural Hb variants.

The thalassemias are a group of inherited disorders in which synthesis of one of the normal polypeptide chains of globin is severely deficient (Chapter 34). In mild forms of the disease (thalassemia minor), hypochromia and microcytosis are prominent, whereas anemia is absent or mild. In other thalassemic disorders, including homozygous β -thalassemia (β -thalassemia major) and Hb E β -thalassemia, hypochromic, microcytic anemia is usually quite severe.

Some structurally abnormal Hb also may be associated with moderate microcytosis. This is particularly characteristic of patients carrying an Hb E gene. Heterozygotes for this hemoglobinopathy typically have microcytosis without anemia.^{124,125,126} Homozygotes have a greater degree of microcytosis and either mild or no anemia.^{53,124,125} Like thalassemia, Hb E diseases are characterized by reduced β -chain synthesis.¹²⁷ Microcytosis also occurs in homozygous Hb C disease.^{128,129}

The possibility of thalassemia minor is often raised by finding that the microcytosis is more severe than might be expected for the mild degree of anemia. In addition, basophilic stippling and target cells tend to be more prominent in thalassemia than in iron deficiency. An important feature of thalassemia trait-like conditions (which include the Hb E syndromes) is that the RBC count often is very high normal to elevated despite having anemia and small RBC. This characteristic has allowed several different measures for differentiating iron deficiency from thalassemia trait and Hb E disorders. One of the most useful is a modification of the Mentzer index,¹³⁰ which is based on the MCV and RBC count:

MCV/RBC (10^6) > 14 (suggestive of iron deficiency)

MCV/RBC (10^6) 12 to 14 (indeterminate)

MCV/RBC (10^6) < 12 (suggestive of thalassemia trait disorders)

RDW, a measure of anisocytosis derived from erythrocyte volume distribution, has been advocated for distinguishing iron deficiency from thalassemia minor in patients with microcytosis.^{49,58,61,131} Anisocytosis is an early and prominent finding in iron deficiency, often detectable before significant microcytosis, hypochromia, or even anemia is apparent. In contrast, anisocytosis tends to be absent or mild in thalassemia minor. The normal value for RDW is $13.4 \pm 1.2\%$ (mean, 2 SD), and the upper limit of normal is 14.6% (40). In iron deficiency, the value is $16.3 \pm 1.8\%$, whereas in β - or α -thalassemia minor, the value is normal ($13.6 \pm 1.6\%$). An increased RDW appears to be 90% to 100% sensitive for iron deficiency but only 50% to 70% specific.¹³² An increased value for RDW in an otherwise normal complete blood count most often represents early iron deficiency, but other nutritional deficiencies are also possible causes.

P.603

Homozygous hemoglobinopathies, especially Hb C¹²⁵ and Hb E,^{53,126} tend to be microcytic and normochromic, and many target cells are apparent in the blood smear (Chapter 34).

Distinguishing homozygous β -thalassemia (β -thalassemia major) from β -thalassemia minor is rarely a problem, because the former is accompanied by signs of hemolysis and ineffective erythropoiesis; there also are characteristic findings on the blood smear, including nucleated red cells, extreme anisocytosis and poikilocytosis, and target cells (Chapter 34). However, it is a common diagnostic problem to distinguish patients with β -thalassemia trait from those with iron deficiency. In almost all cases of β -thalassemia trait, the fraction of Hb A₂ is increased, whereas the value for Hb A₂ is normal or decreased in iron deficiency.¹³³ An exception is that if a patient with β -thalassemia trait happens to be iron deficient at the time of evaluation, the Hb A₂ be normal. When iron replete, the same patient's Hb A₂ will be elevated as expected.

α -Thalassemia syndromes result from decreased α -globin chain synthesis that is directed by four structural genes. Four different α -thalassemia syndromes have been recognized on chromosome 16. Silent carrier state (α -thalassemia II) individuals lack one α globin gene; the α , β -globin chain synthetic ratio is decreased from unity, but these individuals are hematologically normal and have no clinical problems. α -Thalassemia trait (α -thalassemia I) individuals lack two α -globin genes, α -globin synthesis is impaired, and there is a mild hypochromic microcytic anemia. Hb H disease is caused by the deletion of three α -globin genes, and the consequence of this is a mild to moderate hemolytic anemia. Beyond the neonatal period, the unbalanced chain synthesis leads to an excess in β -globin chains which form Hb H (β_4 tetramers). Hb H is mildly unstable, particularly in the presence of oxidant stress, thereby causing intermittent hemolysis. Homozygous α -thalassemia (hydrops) is due to a deletion of all four α -globin genes, resulting in severe anemia because of the complete absence of α -globin chains. This disorder is incompatible with life, and fetuses are aborted early, are stillborn, or die within the first few hours of life.

A common clinical problem is to identify α -thalassemia trait, which has a similar presentation to β -thalassemia trait and to iron deficiency. The diagnosis often is a presumptive one, made after excluding iron deficiency, β -thalassemia trait, and any other abnormal Hb. The α -thalassemia syndromes occur primarily in those of Asian and African descent, and it is of interest that in Africans with α -thalassemia trait, the globin gene deletions occur on different chromosomes (i.e., trans deletions), whereas in Asians with α -thalassemia trait, the gene deletions occur on the same chromosome (i.e., cis

deletion). As a consequence of these racial differences, Hb H disease and homozygous α -thalassemia occur only in Asians. Moreover, virtually all Africans with α -thalassemia have α -thalassemia trait (Chapter 34).

GENERAL DIAGNOSTIC APPROACH TO HEMOGLOBINOPATHIES AND THALASSEMIAS

The clinical and laboratory features of specific thalassemia and hemoglobinopathy syndromes are discussed in the chapters addressing those syndromes. Thalassemia and hemoglobinopathy syndromes are suspected in patients with microcytosis, in patients with unexplained hemolytic anemia, and in patients with the red cell abnormalities suggestive of hemoglobinopathies, such as sickle cells or the characteristic inclusions of Hb C disease. The principal tool in the identification of hemoglobinopathies and thalassemia is the hemoglobin electrophoresis. Hb C, Hb E, Hb S, and Hb H can be detected by electrophoresis. The presence of increased amounts of Hb A₂ and/or Hb F indicates β -thalassemia variants. The most common approach to Hb electrophoresis uses cellulose acetate at alkaline pH (usually 8.2-8.6); however, Hb A₂ and Hb C migrate to the same position, and must be distinguished by electrophoresis at an acidic pH on citrate agar. Specific quantitative tests using alkali denaturation for Hb F or ion-exchange microcolumns for Hb A₂ are widely available. Isoelectric focusing can separate a number of Hb types not clearly distinguished in cellulose acetate or citrate agar, and high pressure liquid chromatography (HPLC) techniques have replaced electrophoretic methods in many reference laboratories. DNA sequencing is often employed in the analysis of rare or novel Hb variants.

α -Thalassemia syndromes are not associated with increases in Hb A₂ and Hb F, and thus are not detectable on electrophoresis unless three α genes are deleted, resulting in Hb H disease. For this reason, the diagnosis of α -thalassemia trait is usually made presumptively, having excluded iron deficiency and β -thalassemia. Specific DNA-based testing is available, but it is seldom used for routine diagnostic purposes. Its major value is in prenatal diagnosis, and the counseling of potential parents at risk for having children with homozygous α -thalassemia. Unstable Hbs are detected by the heat denaturation test.

Sideroblastic Anemias

The sideroblastic anemias are due to acquired and hereditary disorders of heme synthesis (Chapter 24). A classic morphologic feature of this type of anemia, as seen in the peripheral blood smear, is the presence of erythrocyte dimorphism (Fig. 22.4E), with a microcytic population of cells mixed with a normal red cell population and the presence of occasional, heavily stippled, hypochromic cells. In hereditary (X-linked) sideroblastic anemia, the anemia and microcytosis are pronounced (Table 22.7), and these changes are accompanied by considerable anisocytosis and poikilocytosis. The serum iron concentration usually is elevated, and the TIBC is increased. In all cases of sideroblastic anemia, regardless of the specific etiology, impaired heme synthesis leads to retention of iron within the mitochondria. Morphologically, this is seen in marrow aspirates which reveal many nucleated red cells with iron granules (i.e., aggregates of iron in mitochondria) that have a perinuclear distribution.^{134,135} These unusual cells, known as ringed sideroblasts, are found only in pathologic states and are distinct from the sideroblasts (erythroblasts with diffuse cytoplasmic ferritin granules) seen in 30% to 50% of normal RBC precursors in marrow. Most common sideroblastic anemias occur in middle age and later life, and these acquired disorders can be idiopathic, secondary to drugs, alcohol, or myeloproliferative disorders (Table 22.6). In addition, there are rare congenital sideroblastic anemias that conform to an X-linked pattern of inheritance, usually occurring in males, although skewed lyonization has resulted in affected females. Autosomal-dominant and sporadic cases also occur. Several different genetic mutations have been identified in these congenital sideroblastic anemias.¹³⁶ Severe anemias are recognized in infancy or early childhood, whereas milder cases may not become apparent until early adulthood or later. Patients may present with pallor, icterus, moderate splenomegaly, or hepatomegaly. Iron overload is a major complication of this disorder. In some cases in which there is little or no anemia, there still may be clinical evidence of iron overload (i.e., diabetes mellitus and liver dysfunction).

APPROACH TO NORMOCYTIC ANEMIA

Normocytic anemias are those in which the values for MCV are within normal limits, between 80 and 100 fl in adults. At times, however, the anemias that fall into this category also may be macrocytic or microcytic. For example, the anemia associated with hypothyroidism and liver disease may be either normocytic or slightly macrocytic. Also, because of reticulocytosis, the anemia

P.604

associated with acute hemorrhage or chronic hemolysis may be normocytic or slightly macrocytic. The anemia of chronic disorders, although most often normocytic, is sometimes microcytic, and its pathogenesis is best understood in the context of microcytic anemias, as described above. Lastly, iron deficiency early in the course of anemia may be normocytic before becoming microcytic.

The normocytic anemias are not related to one another by common pathogenetic mechanisms. In many instances, anemia is only of incidental importance, a minor manifestation of a systemic disease with other, more serious consequences. Importantly, however, sometimes anemia is the first evidence of disease and the sign leading to discovery of the underlying disorder.

Despite the varied etiologic background and the often incidental nature of the normocytic anemias, they can be classified in a way that forms a basis for diagnostic investigation (Fig. 22.14). As a first step, it should be determined whether the erythropoietic response is appropriate to the degree of anemia. When bone marrow function is unimpaired and the iron supply is ample, erythropoiesis can increase manyfold. In most cases, marrow examination is not necessary to determine that the erythropoietic response is adequate, because reticulocytosis may be prominent, and polychromatophilic macrocytes may be detected on routinely stained smears. These manifestations of appropriate marrow response are typical of hemolytic anemia and posthemorrhagic anemia. The history, physical examination, and signs of excessive erythrocyte destruction (e.g., hyperbilirubinemia) provide the information necessary to differentiate these two conditions. The diagnostic approach to anemias due to hemolysis and after acute hemorrhage are discussed separately below.

When anemia is apparent but the erythropoietic response is less than appropriate, most likely the underlying disorder directly or indirectly affects the bone marrow. Indirect effects should be investigated first, because often a diagnosis can be made without resorting to marrow aspiration and biopsy. For example, several disorders are associated with reduced secretion of erythropoietin (Table 22.9). In these conditions, screening tests usually uncover an underlying systemic disease, and for this purpose, renal function, liver function, and thyroid status should be assessed by use of appropriate biochemical tests. Although severe protein-calorie malnutrition is accompanied by reduced erythropoietin secretion and a mild normocytic anemia, such undernutrition is rare in developed countries and thus is not likely to be confused with other systemic disorders. The anemia of chronic disease typically presents as a normocytic anemia with low reticulocytes. This can be recognized by the underlying inflammatory state and the previously described iron studies. One of the causes of this is thought to be a blunted erythropoietic response due to the presence of inflammatory cytokines (Chapter 41).

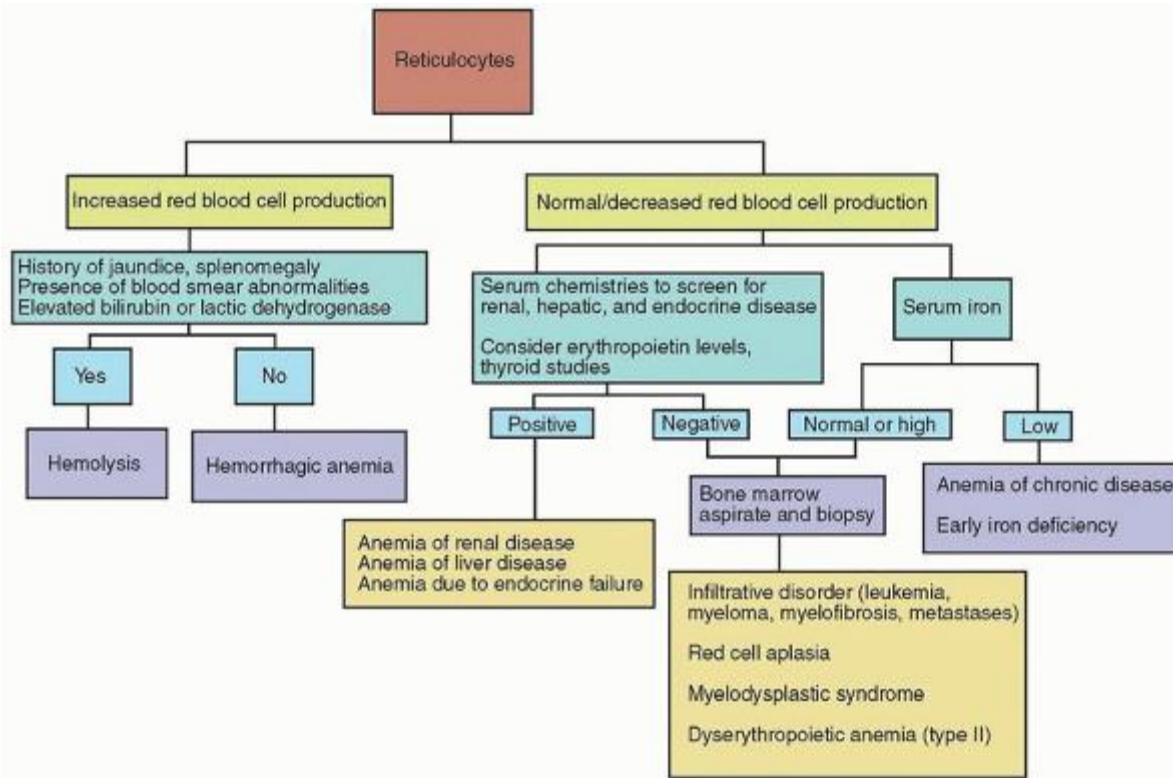

FIGURE 22.14. Diagnostic approach to a patient with normocytic anemia.

Normocytic anemia with marked reticulocytopenia also is a characteristic of pure red cell aplasia (PRCA). Acquired PRCA in adults represents a relatively rare group of disorders usually occurring in the fifth to seventh decades of life (Chapter 39). The anemia can occur as a primary disorder or secondary to some other disease. Early studies suggested an association with thymoma, but more recent data indicate this is much less common. Most cases of PRCA are seen with a variety of hematologic malignancies (in particular chronic lymphocytic leukemia) and also with nonhematologic malignancies,

rheumatoid arthritis, systemic lupus erythematosus, and in association with a variety of drugs and chemicals. Laboratory data reveals isolated anemia, reticulocytopenia, and a bone marrow almost completely void of erythroblasts. The remainder of the CBC is normal.

Transient erythroblastopenia of childhood (TEC) is a form of RBC aplasia occurring in young children, caused by transient antibody-mediated suppression of normal erythropoiesis that frequently follows a viral infection (Chapter 39). In contrast to Diamond-Blackfan syndrome, there are no congenital abnormalities and no abnormal RBC features. The natural history of transient erythroblastopenia of childhood is one of spontaneous recovery over a few weeks.

P.605

TABLE 22.9 CLASSIFICATION OF THE NORMOCYTIC ANEMIAS

Anemia associated with appropriately increased erythrocyte production

Posthemorrhagic anemia

Hemolytic anemia

Decreased erythropoietin secretion

Impaired source:

Renal: anemia of renal insufficiency

Hepatic: anemia of liver disease

Reduced stimulus (decreased tissue oxygen needs)

Anemia of endocrine deficiency

Protein-calorie malnutrition

Anemia of chronic disorders

Anemia with impaired marrow response

Red blood cell aplasia

Acquired pure red cell aplasia in adults

Transient erythroblastopenia of childhood

Transient aplastic crises associated with hemolysis

Aplastic anemia (pancytopenia)

Bone marrow infiltrative disorders

Leukemia

Myeloma

Other myelophthisic anemias

Myelodysplastic anemias

Congenital dyserythropoietic anemia ([CDA] type II)

Aplastic crises with hemolytic anemia is a self-limiting form of red cell aplasia seen in patients with chronic hemolytic anemia. It is characterized by a rapid decrease in the steady-state Hb concentration and a very low reticulocyte count (see Approach to Hemolysis).

When the normocytic anemia with reticulocytopenia is associated with leukopenia and thrombocytopenia, there should be suspicion for intrinsic marrow disease due to aplastic anemia, leukemia, myelofibrosis, or myelophthisis. Morphologic abnormalities suggestive of marrow infiltration found on the blood smear include nucleated red cells, teardrop poikilocytes, immature leukocytes, and large, bizarre platelets or megakaryocyte fragments (Fig. 22.6). When such

changes are detected, as well as in any patient with anemia along with other cytopenias, marrow aspiration and biopsy should be performed.

Of the different congenital dyserythropoietic anemias, type II CDA is the most common, and it is the one that almost always presents as a normocytic anemia. This disorder is recognized by distinct multinuclearity of the marrow normoblasts (Chapter 40).

APPROACH TO HEMOLYSIS

Hemolytic disorders are characterized by signs of accelerated erythrocyte destruction together with those of vigorous blood regeneration. Under maximal stimulation, the normal marrow is capable of undergoing hyperplasia until its production rate increases approximately six to eight times.¹³⁷ With optimal marrow compensation, the survival of red cells in the circulation can decrease from the normal 120 days to as few as 15 to 20 days without anemia developing. Such an increase in destruction and production of erythrocytes can result in a compensated hemolytic state without anemia being present. In this regard, it is of interest that a significant fraction of patients with hereditary spherocytosis patients are not anemic. However, when red cell survival is so short that anemia develops despite a vigorous erythropoietic response, the term hemolytic anemia is appropriate.

Pathogenesis and Classification

Disorders associated with hemolytic anemia have been classified in various ways, none of which is entirely satisfactory. On clinical grounds, hemolytic anemias have been divided into acute and chronic forms, but such a division is of limited usefulness because acute episodes may develop during the course of chronic hemolytic disorders. Of somewhat greater use is a classification based on the site of hemolysis: whether it is predominantly within the circulation (intravascular) or within tissue macrophages (extravascular). Most hemolytic diseases are characterized by extravascular red cell destruction. The intravascular hemolytic disorders are accompanied by unique manifestations, such as hemoglobinemia, hemoglobinuria, and hemosiderinuria, and this type of hemolysis is easily recognized (Table 22.10).¹³⁸

Hemolytic disorders also may be considered to be caused by an intrinsic defect in the cell itself or by extrinsic agents acting on otherwise normal red cells. It is this classification which generally is most useful to the clinician (Table 22.11). Most intrinsic defects are inherited, whereas the extrinsic ones are acquired. Exceptions to this generalization are few; these include paroxysmal nocturnal hemoglobinuria (Chapter 31), an acquired disorder characterized by an intrinsic red cell defect. Also, certain inherited intrinsic defects (e.g., the most common form of glucose-6-phosphate dehydrogenase [G6PD] deficiency) are associated with no ill effects in the absence of an extrinsic agent, usually an infection or exposure to a drug (see Chapter 28).

Intrinsic and extrinsic abnormalities originally were defined by performing cross-transfusion erythrocyte survival studies. When normal erythrocytes are transfused to patients with an extrinsic cause for hemolysis, the donated cells are destroyed as rapidly as the patient's own cells. On the other hand, when the patient's RBCs are removed from their unfavorable environment and transfused to a normal recipient, their survival time is normal. In contrast, when the disorder is due to an intrinsic red cell defect, the RBCs of the patient, when given to a normal recipient, are removed from the circulation more rapidly than those of the recipient; the normal erythrocytes, if transfused into the patient, maintain a normal lifespan. While such cross-transfusion experiments played an important role in clarifying the pathogenesis of various hemolytic disorders, obviously they cannot be used in the evaluation of patients.

The intrinsic disorders of the erythrocyte are due to defects affecting the red cell membrane (Chapter 27), disorders of cell metabolism (Chapter 28), or various Hb abnormalities (Chapters 33, 34 and 35) (Table 22.11).

The acquired hemolytic anemias are further subclassified on the basis of the extrinsic factors causing hemolysis. These include antibodies (Chapters 29 and 30) and other nonimmune causes

P.606

(Chapter 32), including physical trauma, infectious agents, physical agents, chemical agents, hypophosphatemia, and liver disease (spur cell anemia). A separate category is needed for paroxysmal nocturnal hemoglobinuria, which is unique among the acquired hemolytic anemias in that it is related to an intrinsic abnormality of the red cell (Chapter 31).

TABLE 22.10 HEMOLYTIC ANEMIAS CHARACTERIZED BY SIGNIFICANT INTRAVASCULAR RED CELL DESTRUCTION

Paroxysmal nocturnal hemoglobinuria

Erythrocyte fragmentation disorders

Transfusion reactions resulting from ABO isoantibodies
Paroxysmal cold hemoglobinuria
Acquired autoimmune hemolytic anemia (occasionally)
Associated with certain infections
Blackwater fever in falciparum malaria
Clostridial sepsis
Caused by certain chemical agents
Arsine poisoning
Snake and spider venoms
Drug reactions with glucose-6-phosphate dehydrogenase (G6PD) deficiency
Intravenous administration of distilled water
Thermal injury

TABLE 22.11 CLASSIFICATION OF MOST COMMON CAUSES OF HEMOLYSIS

Acquired Hemolytic Disorders

Immuno-hemolytic anemias

Autoimmune hemolytic anemia
Hemolytic disease of the newborn
Transfusion of incompatible blood

Traumatic and traumatic hemolytic anemia

Prosthetic valves and other cardiac abnormalities
Hemolytic uremic syndrome (HUS)
Thrombotic thrombocytopenic purpura (TTP)
March hemoglobinuria
Disseminated intravascular coagulation (DIC)

Infection

Protozoa (Malaria, Toxoplasmosis, Leishmaniasis, Babesiosis)
Bacteria (Clostridial infection, cholera, bartonellosis, typhoid, etc.)

Other causes

Paroxysmal nocturnal hemoglobinuria (PNH)
Spur cell anemia in liver disease
Associated with hemodialysis and uremia
Thermal red blood cell (RBC) injury
Hypophosphatemia
Snake venoms

Inherited Hemolytic Disorders

RBC Membrane abnormalities

Hereditary spherocytosis

Hereditary elliptocytosis syndromes

Hereditary stomatocytosis

Hereditary xerocytosis

RBC Enzyme disorders

Glucose-6-phosphate dehydrogenase (G6PD) deficiency

Pyruvate kinase (PK) deficiency

Glucose-phosphate isomerase (GPI) deficiency

Pyrimidine 5' nucleotidase deficiency

RBC Hemoglobin disorders

Sickle cell anemia syndromes

Thalassemia syndromes

Unstable hemoglobin disorders

Each of these different hemolytic anemias is discussed in detail elsewhere in this book. The remainder of this section focuses on the general clinical and laboratory features that are common to most congenital and acquired hemolytic anemias.

Clinical Features of Congenital Hemolytic Anemia

Degree of Anemia

The severity of anemia varies greatly, even among patients with the same congenital disorder. Most commonly, the anemia with congenital hemolytic disorders is mild to moderate because the shortened erythrocyte survival is partially offset by increased activity of the bone marrow. Often, patients accommodate remarkably well to the anemia and may exhibit few signs or symptoms. Consequently, detection can be delayed until later in childhood and discovered incidentally. Moreover, some patients have no anemia at all. The disease may then remain unsuspected until late in adult life unless jaundice, a crisis, or complications of gallbladder disease draw attention to the condition. Sometimes, such cases are discovered only in the course of a family study.

In some congenital hemolytic disorders, such as homozygous β -thalassemia, the rate of red cell destruction far exceeds the erythropoietic capacity of the marrow, and these individuals usually have a very severe anemia requiring life-long red cell transfusions.

Jaundice

Jaundice often is first noted in the neonatal period,¹³⁹ and phototherapy frequently is used to reduce the hyperbilirubinemia and, sometimes, exchange transfusions are required. In some older children and adults with congenital hemolytic anemia, icterus is absent or mild enough to pass unnoticed. Careful inquiry often elicits a history of episodes of jaundice or the passing of dark urine associated with trivial infections. In other cases, jaundice is persistent but never becomes intense. Often, slight scleral icterus is the only sign of hemolytic disease. As noted earlier, the jaundice of hemolytic disease is acholuric; the bilirubin, being unconjugated, is not excreted in the urine. Furthermore, pruritus is absent. These features help to distinguish the icterus of hemolytic disease from that found with disorders of the hepatobiliary system.

Aplastic Crises

Aplastic crises result from transient failure of red cell production (Fig. 22.15) caused by infection with the type B19 human parvovirus.^{140,141,142} and¹⁴³ The same virus also causes erythema infectiosum (fifth disease, a common childhood exanthem)^{144,145} and may cause an acute polyarthropathy syndrome in adults as well as aseptic meningitis¹⁴⁶ and fetal death with hydrops fetalis.^{147,148} Parvovirus infection may occur sporadically but most often is an epidemic disease that can affect several family members simultaneously or multiple people in a large geographic area. Schoolage children (age 5 to 10 years) are most at risk for parvovirus infection,¹⁴³ but cases have been reported of parvovirus infection in young adults.^{143,149} Any patient with moderately severe chronic hemolytic disease who becomes infected with parvovirus is at

risk for an aplastic crisis. Blood Hb concentrations fall several grams, sometimes to life-threatening levels,¹⁴⁹ and the reticulocyte count falls abruptly, usually to less than 1%. The magnitude of the crisis depends on the severity of the underlying hemolytic process. In most cases, leukocyte and platelet counts are unaffected, but neutropenia and thrombocytopenia can occur and, rarely, may be severe.¹⁴² The bone marrow is cellular, but erythroid hypoplasia is the characteristic finding; in particular, the more mature erythrocyte precursors tend to disappear. Giant pronormoblasts may be observed. Recovery is heralded by reticulocytosis. The entire episode, from onset of symptoms to reappearance of reticulocytes, lasts approximately 10 to 12 days

P.607

in subjects with normal immunologic responses, but may persist much longer in patients with defective or suppressed immune systems.¹⁵⁰ Parvovirus infection also produces erythroid aplasia in normal subjects, but the decrease in Hb concentration is minimal when erythrocyte survival is normal,¹⁵¹ and such small changes go undetected. During the acute phase of aplastic crisis, parvovirus DNA often can be detected in the serum by polymerase chain reaction assays.¹⁴⁴ The appearance of a specific immunoglobulin (Ig) M (IgM) antibody in serum is a marker of recent infection.¹⁴² It is replaced by an IgG antibody that persists for years and is found in 60% of normal subjects. A single infection apparently confers life-long immunity. However, parvovirus antibody titers are only helpful in the immunocompetent.

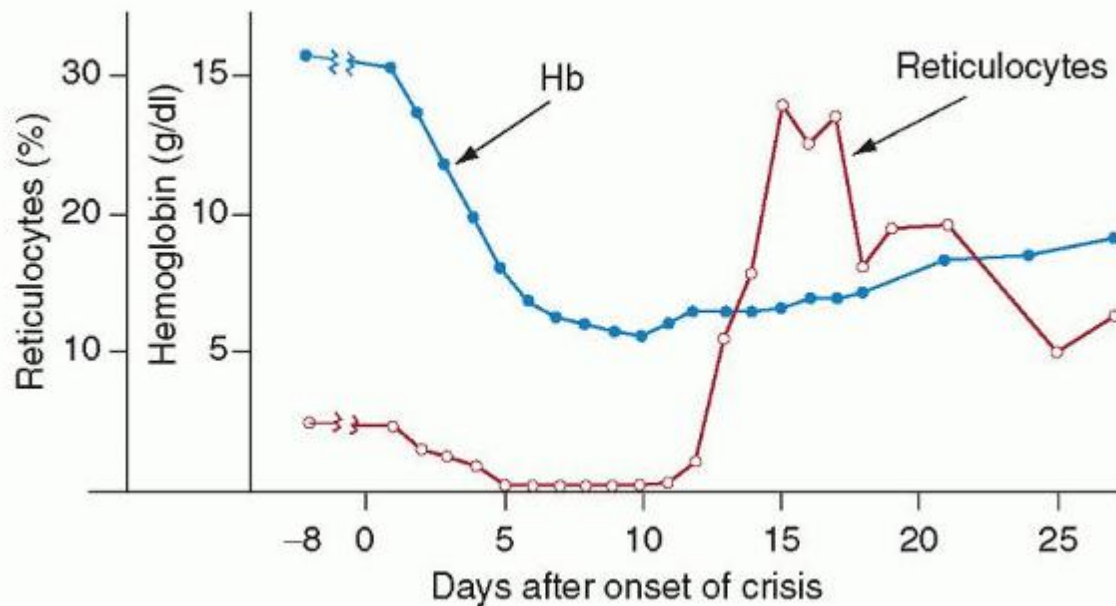

FIGURE 22.15. Severe aplastic crisis in a patient with hereditary spherocytosis who previously had well-compensated hemolysis. Note the profound reticulocytopenia during the early phases of the reaction, followed by reticulocytosis. Hb, hemoglobin. (Data plotted from Owren P. Congenital hemolytic jaundice. The pathogenesis of the “hemolytic crisis.” *Blood* 1948;3:231-248.)

Splenomegaly

The spleen typically is enlarged in patients with congenital hemolytic anemias, except for individuals with sickle cell anemia older than 5 years of age. Most often, the degree of enlargement is mild to moderate. At times, splenomegaly leads to discovery of the disease because the spleen is detected on a routine physical examination. It is not uncommon for children with hereditary spherocytosis to first be recognized by the finding of splenomegaly during a routine physical examination in an otherwise healthy child.

Cholelithiasis

Gallstones and their complications play a significant role in the clinical manifestations of congenital hemolytic anemias. Symptoms of gallbladder disease rarely may be the initial manifestations of a hemolytic process and the ones that bring the illness to the attention of a physician. Gallstones typical of hemolytic anemia are so-called black pigment stones.^{152,153} They differ from brown pigment stones and cholesterol stones, neither of which is associated with hemolysis. The hepatic

bile of patients with hemolytic anemia contains greatly increased amounts and concentrations of unconjugated bilirubin, decreased concentrations of bile acids,^{153,154} and increased concentrations of ionized calcium.¹⁵⁵

The prevalence of cholelithiasis in patients with hemolytic anemia increases with age and with the intensity of the hemolytic process. In a large study series involving Jamaican patients with sickle cell anemia, the prevalence ranged from 8% among patients 16 to 25 years old to 55% in patients older than age 35 years with reticulocyte counts greater than 15%.¹⁵⁶

Leg Ulcers

Chronic ulcerations of the legs are peculiar and uncommon complications of chronic hemolytic disease. They are particularly characteristic of sickle cell anemia (Chapter 33),¹⁵⁷ but also occur in association with other hemolytic disorders,^{158,159,160} and ¹⁶¹ such as hereditary spherocytosis¹⁶² (Chapter 31). The ulcers often are bilateral and tend to involve the areas overlying or proximal to the medial or lateral malleoli. They tend to be chronic or recurrent and, upon healing, leave the skin indurated and pigmented.

Skeletal Abnormalities

When hemolytic anemia is severe during active phases of growth and development, the pronounced expansion of erythroid bone marrow may lead to a tower-shaped skull, thickening and striation of frontal and parietal bones ("frontal bossing"), maxillary and dental abnormalities, and other distortions of bony structures. Such abnormalities are particularly characteristic of severe thalassemia major, the so-called thalassemic facies (Chapter 34). Nowadays it is much less common to see these skeletal malformations, because patients with homozygous β -thalassemia are transfused aggressively with red cells to maintain a higher Hb level, and this suppresses expansion of the erythroid marrow and its subsequent effects on bone structure. However, in patients with thalassemia intermedia, a slightly milder clinical variant not necessitating RBC transfusions, the characteristic bone changes may occur because of the expanded size of the erythroid marrow. The skeletal changes also may occur in patients with sickle cell anemia and in exceptional patients with other forms of congenital hemolytic anemia.¹⁶⁰

Clinical Features of Acquired Hemolytic Anemia

Hemolytic anemia sometimes develops acutely, such as after the transfusion of incompatible blood or the ingestion of an oxidant drug by patients with G6PD deficiency or in association with an acute febrile illness. Some instances of autoimmune hemolytic anemia, thrombotic thrombocytopenic purpura, and other hemolytic disorders may also begin abruptly.¹⁶² Aching pains in the back, abdomen, or limbs are common, as are headaches, malaise, vomiting, shaking chills, and fever.¹⁶² Abdominal pain may be severe, and the accompanying muscular spasm and rigidity may simulate the signs of an acute abdominal condition requiring surgical treatment. Pallor, jaundice, tachycardia, and other symptoms of severe anemia may be prominent.

Acquired hemolytic anemia also can begin insidiously, developing gradually over a period of weeks or months. Cardiovascular adjustments to the anemia may be adequate, and patients may have few symptoms. Pallor, scleral icterus, or a jaundiced complexion may be the first evidence of illness, and often, these signs are noticed by friends or associates before they are appreciated by the patient or the family. As in congenital hemolytic anemia, the course may be interrupted by aplastic crises.¹⁴¹

In other instances, the clinical setting may be dominated by the manifestations of an underlying disease of which the hemolytic anemia is one manifestation. For example, signs and symptoms of lymphoma, lupus erythematosus, or mycoplasma pneumonia may overshadow those of the associated hemolytic process.

Laboratory Features of Hemolysis

The laboratory studies used to identify a hemolytic process include those related to the increase in erythrocyte destruction and those related to the compensatory increase in the rate of erythropoiesis.

Signs of Increased Red Blood Cell Destruction

Serum Bilirubin

The amount of bilirubin in the circulation depends in part on the rate at which the bilirubin is formed and in part on the efficiency with which it is excreted by the liver. Hyperbilirubinemia is a hallmark of hemolytic anemia (Fig. 22.16), although occasionally the serum bilirubin is within the normal range despite brisk hemolytic disease.¹⁶³ The increased serum bilirubin level in hemolysis almost always consists of the unconjugated (indirectreacting) pigment. The conjugated fraction remains within normal limits, and no bilirubin is evident in the urine. Except for during the neonatal period, values greater than 5 mg/dl are unusual in patients with hemolytic anemia and suggest coexisting hepatic dysfunction.

Serum Lactic Dehydrogenase

Serum lactic dehydrogenase (LDH) often is increased in patients with hemolytic anemia, although not to as great an extent as in megaloblastic anemia. The increase in LDH probably results from liberation of the erythrocyte enzyme into the plasma during

P.608

hemolysis.¹⁶³ Increased serum LDH is a nonspecific finding, because it also is elevated in other medical conditions associated with tissue injury.

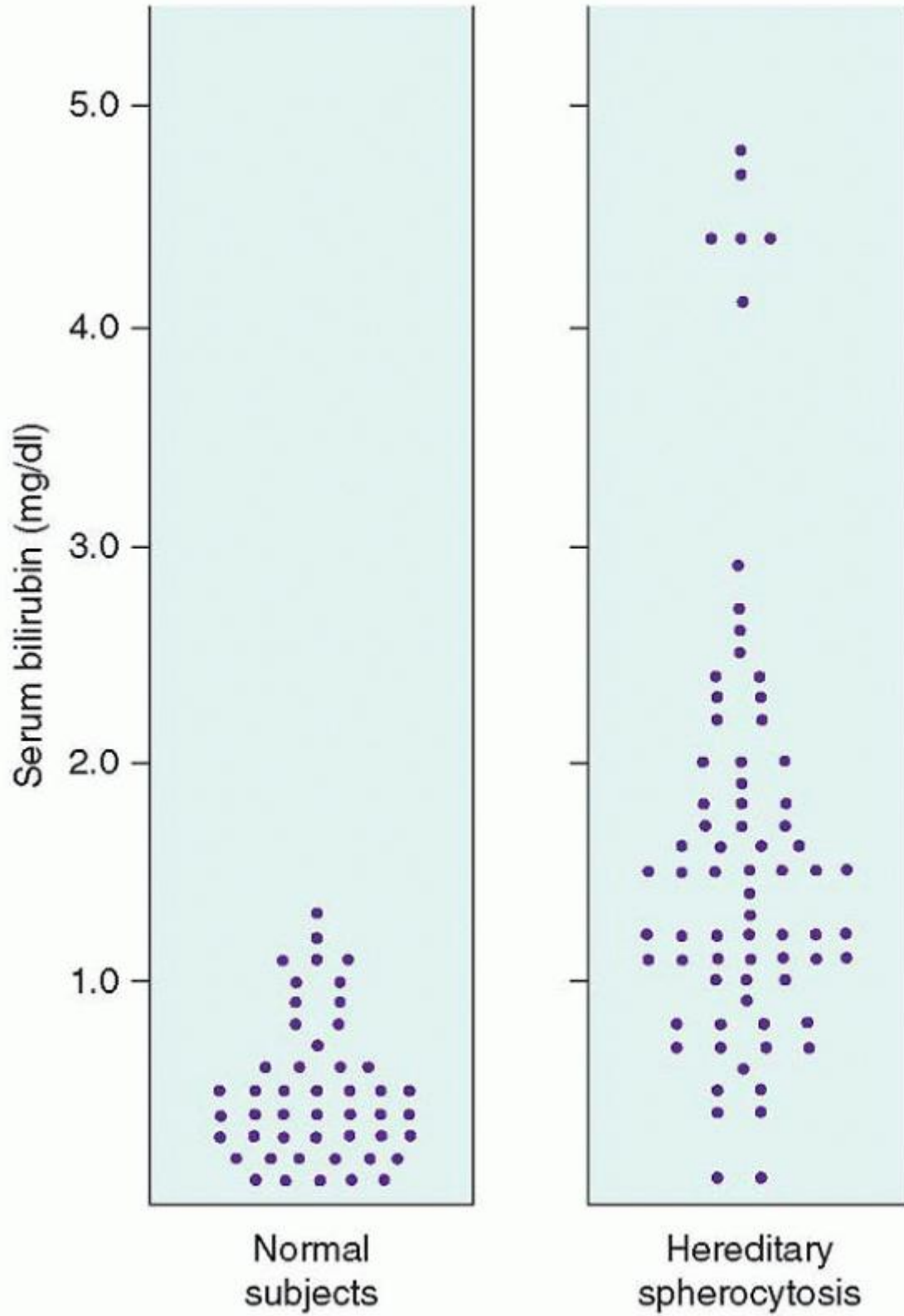

FIGURE 22.16. Total serum bilirubin values in 48 normal subjects and 72 patients with hereditary spherocytosis. (Data from Mackinney A, Norton NE, Kosower NS. Ascertaining genetic carriers of hereditary spherocytosis by statistical analysis of multiple laboratory tests. *J Clin Invest* 1962;41:554-567, with permission.)

Serum Haptoglobin

When Hb enters the plasma, it binds to haptoglobin, and the complex is removed by hepatocytes. As a result, serum haptoglobin decreases in individuals with hemolytic disease. Moreover, despite the intravascular site of haptoglobin function, this protein becomes depleted in association with both intravascular and extravascular hemolysis, such as sickle cell anemia,¹⁶⁴ hereditary spherocytosis,^{164,165} hereditary elliptocytosis,¹⁶⁶ and pyruvate kinase deficiency.¹⁶⁰ Haptoglobin also disappears in megaloblastic anemia and other conditions with intramedullary hemolysis (ineffective erythropoiesis) (Fig. 22.17).¹⁶⁷ In microangiopathic hemolytic anemias with intravascular hemolysis, low haptoglobin levels are the most sensitive marker of red cell destruction, and may be seen in the absence of anemia or hemoglobinemia).

The interpretation of haptoglobin levels sometimes is complicated by the fact that haptoglobin is an acute phase reactant, the synthesis of which increases in response to inflammatory, infectious, or malignant disease. Haptoglobin values also may fall in association with liver disease because of impaired synthesis and in hereditary deficiency of the protein.

Erythrocyte Survival

The strictest definition of hemolysis requires demonstration that the red cell lifespan is reduced. From a practical perspective, however, erythrocyte lifespan determinations are rarely necessary, because they provide little additional information beyond what can be assessed by more easily obtained data, such as serial observations of the degree of anemia, reticulocytosis, and jaundice. For these reasons, determination of red cell survival is reserved for use in evaluating patients with especially difficult diagnostic problems.

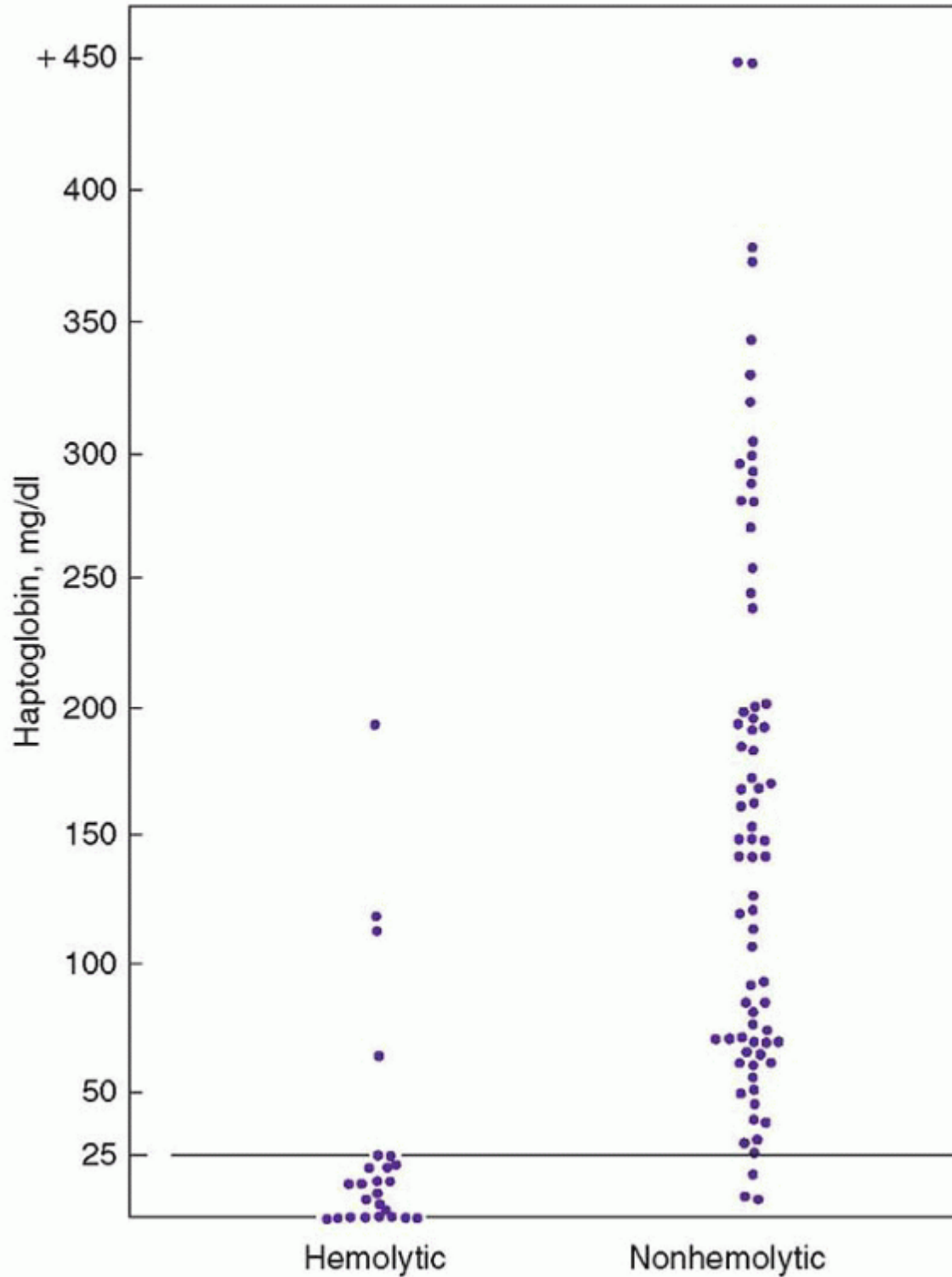

FIGURE 22.17. Serum haptoglobin in hemolytic and nonhemolytic disease. (From Marchand A, Galen RS, Van Lente F. The predictive value of serum haptoglobin in hemolytic disease. *JAMA* 1980;243:1909, with permission.)

Rate of Carbon Monoxide Production

Determinations of the rate of endogenous carbon monoxide production provide accurate assessments of the rate of heme catabolism. With these methods, values of approximately two to ten times the normal rate have been detected in small

groups of patients with hemolytic disease. At the present stage of development, however, these methods are not available for routine clinical use.^{168,169}

Signs of Intravascular Hemolysis

When erythrocytes are destroyed within the circulation, and also when extravascular destruction is so rapid that it exceeds the capacity of the macrophage system, Hb is released into the plasma. The disposal of Hb and its heme group occurs by several mechanisms (Chapter 6), and characteristic laboratory abnormalities are found (Table 22.12).

Hemoglobinemia

At low concentrations, plasma Hb may be measured by means of the benzidine reaction, which allows detection not only of Hb but also of any other heme pigments that may be present. If special precautions are observed to avoid artifactual hemolysis during collection of blood, normal values of less than 1 mg/dl of plasma are found. Plasma usually appears visibly red when Hb exceeds

P.609

50 mg/dl. At levels greater than 100 mg/dl, Hb can be measured directly by the cyanomethemoglobin method.

TABLE 22.12 LABORATORY SIGNS OF HEMOLYSIS

Accelerated red cell destruction
 Decreased erythrocyte lifespan
 Increased heme catabolism
 Increased serum unconjugated bilirubin level
 Increased carbon monoxide production
 Increased rate of urobilinogen excretion
 Increased serum lactate dehydrogenase
 Decreased serum haptoglobin
 Hemoglobinemia
 Hemoglobinuria
 Hemosiderinuria
 Methemalbuminemia
 Decreased serum hemopexin
 Fall in blood hemoglobin level at a rate >1.0 g/dl/wk
 Accelerated erythropoiesis
 Complete blood count
 Reticulocytosis
 Macrocytosis
 Blood smear findings
 Polychromatophilia
 Basophilic, stippling
 Erythroblastosis
 Abnormal red blood cell forms
 Bone marrow (erythroid hyperplasia)

Ferrokinetic (increased plasma iron turnover)**Biochemical (increased erythrocyte creatine)**

Plasma Hb levels are normal in most patients with hereditary hemolytic anemias, including hereditary spherocytosis, but can be increased in severe, acquired, immunohemolytic anemia, at times reaching 100 mg/dl.¹⁷⁰ Particularly high values, up to 1,000 mg/dl, are found only in patients with disorders associated with intravascular hemolysis.¹³⁸

Hemoglobinuria

When plasma Hb exceeds the haptoglobin binding capacity, Hb dimers are excreted into the urine, resulting in hemoglobinuria. Urine that contains Hb ranges from faint pink to deeper red, or even to almost black, similar to a cola beverage.

Hemoglobinuria can be distinguished from hematuria (whole RBCs in the urine) by microscopic examination of a freshly voided urine specimen. Urine also may appear red because of ingestion of certain drugs (Pyridium) or food (beets), or because of porphyrinuria (Chapter 26) or myoglobinuria. Of these various red urinary pigments, only Hb and myoglobin produce a positive reaction in the commonly available tests for occult blood, which are based on the benzidine or orthotolidine reactions.¹⁷¹

Hemoglobinuria must be distinguished from myoglobinuria, which occurs as the result of massive muscle injury.^{172,173} and ¹⁷⁴ Myoglobin is a heme pigment of low molecular weight (17,000 Da); it is not bound by haptoglobin and therefore does not accumulate to an appreciable extent in plasma. Thus, inspection of the plasma can help to distinguish myoglobinuria from hemoglobinuria, the presence of a red color in the plasma favoring the latter. More precise identification is accomplished by spectroscopic analysis.

Urine Hemosiderin and Urinary Iron Excretion

Hb in the glomerular filtrate is partially reabsorbed by the proximal tubular cells, and the Hb iron is incorporated into ferritin and hemosiderin. Subsequently, the iron-containing tubular cells are sloughed into the urine. Hemosiderinuria, therefore, constitutes reliable evidence that hemoglobinemia has occurred in the recent past.^{138,170} After an acute episode of intravascular hemolysis, however, several days may pass before increased iron excretion can be detected. Moreover, the abnormality may persist for some time after the episode has terminated. In most conditions associated with chronic intravascular hemolysis, such as in some of the fragmentation hemolysis syndromes, increased iron excretion is a constant finding, whereas hemoglobinuria occurs only intermittently. Hemosiderinuria may be detected by means of a qualitative test based on the Prussian blue reaction.¹⁷⁰

Methemalbumin and Hemopexin

Hb in plasma is readily oxidized to methemoglobin, from which the heme group easily detaches. The liberated heme binds to hemopexin and also to albumin, forming methemalbumin. Hemopexin-heme and methemalbumin impart a coffee-brown color to plasma. With either combination, a spectral absorption band is observed at 620 to 630 nm, which, unlike a similar band in methemoglobin, does not disappear if hydrogen peroxide is added. With the addition of ammonium sulfide, the 620- to 630-nm band disappears and a band at 558 nm forms (Schumm test).¹⁷⁵ Low hemopexin values are seen in thalassemia major, sickle cell anemia, and the fragmentation hemolytic anemia that follows cardiac surgical procedures. The measurement of hemopexin is seldom used to assess hemolytic anemia.

Signs of Accelerated Erythropoiesis

Laboratory signs of increased erythropoiesis are almost always present in patients with chronic hemolytic disease. In patients who have had an acute hemolytic episode, signs of increased red cell production appear after 3 to 6 days (Table 22.12). These same signs of increased RBC production also occur after hemorrhage and after specific therapy for anemia caused by iron, folate, or vitamin B₁₂ deficiency.

Reticulocytosis

An increased number of reticulocytes continues to be the most readily available and most often used index of accelerated erythropoiesis. In cases of hemolytic anemia, the erythrocyte production rate and the absolute reticulocyte count is usually greatly increased when hemolysis is severe enough to produce anemia. In most types of hemolytic anemia, the reticulocyte count consistently increases to levels that correlate fairly well with the severity of the process. Exceptions occur during aplastic crises. Also, some patients with acquired immunohemolytic anemia may have normal reticulocyte counts, and in one report, values of less than 2% were found in 26% of 35 such patients.¹⁶² In these cases, it is thought that the autoantibodies are directed against marrow erythroid precursors as well as circulating erythrocytes.

Morphologic Findings in the Blood

When reticulocytes are increased, polychromatophilia and fine basophilic stippling are apparent on routinely stained smears of blood. Macrocytosis is found in association with most hemolytic disorders because of erythropoietin-mediated stimulation of Hb synthesis and because prematurely released (shift) reticulocytes are larger than normal erythrocytes. Exceptions occur in hereditary spherocytosis and sickle cell anemia, diseases in which the intrinsic defect of the cell tends to decrease its size.

When hemolysis is brisk, nucleated erythrocytes may be found in the blood (erythroblastosis), usually in numbers below 1% of all the nucleated cells. In infants, however, erythroblastosis may be more striking, especially in hemolytic disease of the newborn.

P.610

Neutrophilic leukocytosis and thrombocytosis may accompany hemolytic anemia. These findings tend to be most common and most pronounced in patients with acute hemolytic anemias. Platelets are not only numerous but also large. The changes are less pronounced in chronic hemolytic processes.

Bone Marrow

The major alteration in the bone marrow in hemolytic anemia is erythroid hyperplasia, as manifested by a reduction in the myeloid to erythroid ratio.

Laboratory Tests Useful in the Differential Diagnosis of Hemolysis

Specific Morphologic Abnormalities

Detection of certain distortions of red cell shape is of particular diagnostic use because their presence suggests only one or a few entities. Descriptive features of certain such abnormal red cells are presented in Table 22.13 and illustrated in Figures 22.18 and 22.19.

Spherocytes, erythrocytes that lack an area of central pallor (Fig. 22.18B), are the hallmark of hereditary spherocytosis. They are also found in most patients with acquired immunohemolytic anemias (Fig. 22.18C), thermal injury, hypophosphatemia, or certain kinds of chemical poisoning.

Oval cells or elliptocytes (Fig. 22.18D) are the sine qua non of common hereditary elliptocytosis, which usually is a morphologic curiosity, but not associated with significant hemolysis. However, some hereditary elliptocytosis variants are also associated with marked poikilocytosis (Fig. 22.18E and F), and these individuals have significant hemolytic anemia.

Stomatocytes (Fig. 22.18G), which suggest a disturbance in red cell cation content, are found in association with a rare inherited hemolytic disease and also in liver disease.

TABLE 22.13 MORPHOLOGIC ABNORMALITIES IN HEMOLYTIC ANEMIA

Cell	Description	Clinical Disorders
Spherocyte	Spheroid RBC with no central pallor	Hereditary spherocytosis Immunohemolytic anemia Burns
Elliptocytes	Oval RBC	Hereditary elliptocytosis Megaloblastic anemia
Stomatocytes	Uniconcave red cell; slitlike rather than circular area of central pallor	Hereditary stomatocytosis Alcoholism
Acanthocytes	5-10 spicules of various lengths, irregular in spacing and thickness	Spur cell anemia with liver disease Abetalipoproteinemia
Echinocytes	10-30 spicules evenly distributed over cell surface	Uremia
Sickle cells	RBC with sickle shape	Sickle cell anemia

Target cells	Solid area in center of central pallor	Thalassemia Hemoglobin C disorders Liver disease Lecithin-cholesterol acyltransferase deficiency Postsplenectomy
Schistocytes	Triangular, helmet-shaped, fragmented, or greatly distorted cell; small	Microangiopathic anemia Turbulent blood flow Hemolytic uremic syndrome

RBC, red blood cell.

Acanthocytes indicate disturbed erythrocyte lipid composition; they occur in association with abetalipoproteinemia and the spur cell anemia that occasionally accompanies hepatic cirrhosis.

Echinocytes (sea urchin cells) are a nonspecific abnormality and are also found in uremia.

Sickle cell anemia was named after the unmistakable sickle-shaped red cells that characterize that disorder (Figs. 22.19A,B).

Target cells (Fig. 22.19C) are characteristic of thalassemia, Hb E syndromes, and Hb C disorders. Target cells also occur in nonhemolytic states, such as obstructive jaundice and after splenectomy.

Schistocytes, helmet cells, or other fragmented red cells (Fig. 22.19D) suggest hemolysis associated with physical trauma to the erythrocyte or with diseases affecting small blood vessels.

Bite cells are erythrocytes that look as if a semicircular bite has been taken from one edge. Hemighosts are red cells that look as if the Hb has shifted to one side of the cell, leaving the other side clear. These hemighosts also are referred to as blister cells and may appear to contain a coagulum of Hb that has separated from the membrane (Fig. 22.19E). These cells are seen in patients with oxidant-induced injury, such as in G6PD deficiency.

Autoagglutination may be apparent in blood smears (Fig. 22.19F) or may even be visible to the naked eye when the blood is allowed to flow along the side of a glass container. The phenomenon is particularly characteristic of immunohemolytic disease caused by cold agglutinins. Autoagglutination must be distinguished from rouleau formation, a manifestation of multiple myeloma and related diseases and the phenomenon responsible for accelerated rates of erythrocyte sedimentation.

Direct Antiglobulin Test

The test used for detection of immunohemolytic anemia is the direct antiglobulin or Coombs test (see discussion in Chapter 29). Positive test results indicate that the red cells are coated with IgG or complement components, especially C3. However, 2% to 5% of patients with immunohemolytic disease have negative test results because the amount of globulin on the cell surface is below the detection limits.¹⁷⁶ Occasionally, patients have weakly positive test results and no clinical evidence of hemolysis. Positive tests are found in as many as 34% of patients with AIDS without other evidence of immunohemolytic disease.¹⁷⁷

Osmotic Fragility Test

The osmotic fragility test is a measure of the resistance of erythrocytes to hemolysis by osmotic stress. The test consists of exposing red cells to decreasing strengths of hypotonic saline solutions and measuring the degree of hemolysis. A symmetric, sigmoidal curve is obtained in most subjects (Fig. 22.20). Increased fragility is indicated by a shift of the curve to the left, whereas osmotic resistance (reduced fragility) is signified by a rightward shift of the curve. Increased osmotic fragility is observed in conditions associated with spherocytosis. With prior incubation of sterile blood for 24 hours,¹⁷⁸ the increased osmotic fragility of spherocytes is greatly accentuated, whereas normal cells become only slightly more fragile. The osmotic fragility of unincubated blood may be normal in some patients with hereditary spherocytosis, and for this reason, the test should be performed on incubated samples. Determination of osmotic fragility is of value chiefly in confirming important morphologic findings, especially the presence of spherocytes. In most cases, however, the osmotic fragility test does not provide information that was not already available from an expert examination of a well-prepared,

stained blood smear. Osmotic gradient ektacytometry is more sensitive and specific than the osmotic fragility test for the diagnosis of hereditary spherocytosis, but is not widely available.¹⁵⁹

P.611

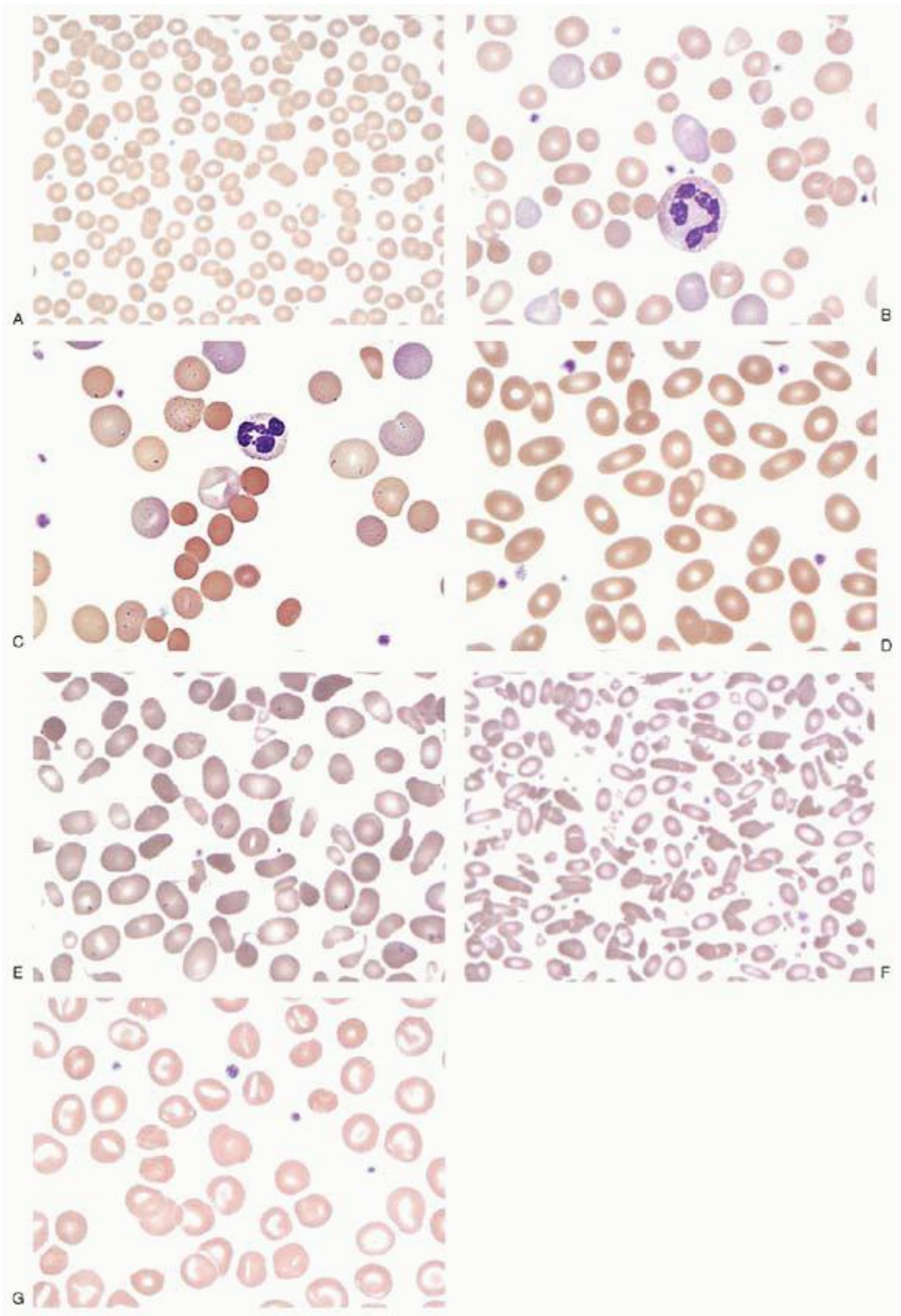

FIGURE 22.18. Red blood cell abnormalities associated with hemolysis. A: Normal red blood cells for comparison. B: Microspherocytes from patient with hereditary spherocytosis. C: Spherocytes from patient with autoimmune hemolytic

anemia. D: Hereditary elliptocytosis—common variant with minimal or no hemolysis. E: Hereditary elliptocytosis—hemolytic variant. F: Hereditary elliptocytosis—pyropoikilocytosis variant. G: Hereditary stomatocytosis. Parts C, E, and G from Pierira I, George TI, Arber DA in Atlas of peripheral blood. Philadelphia, PA: Lippincott Williams & Wilkins, 2012.

P.612

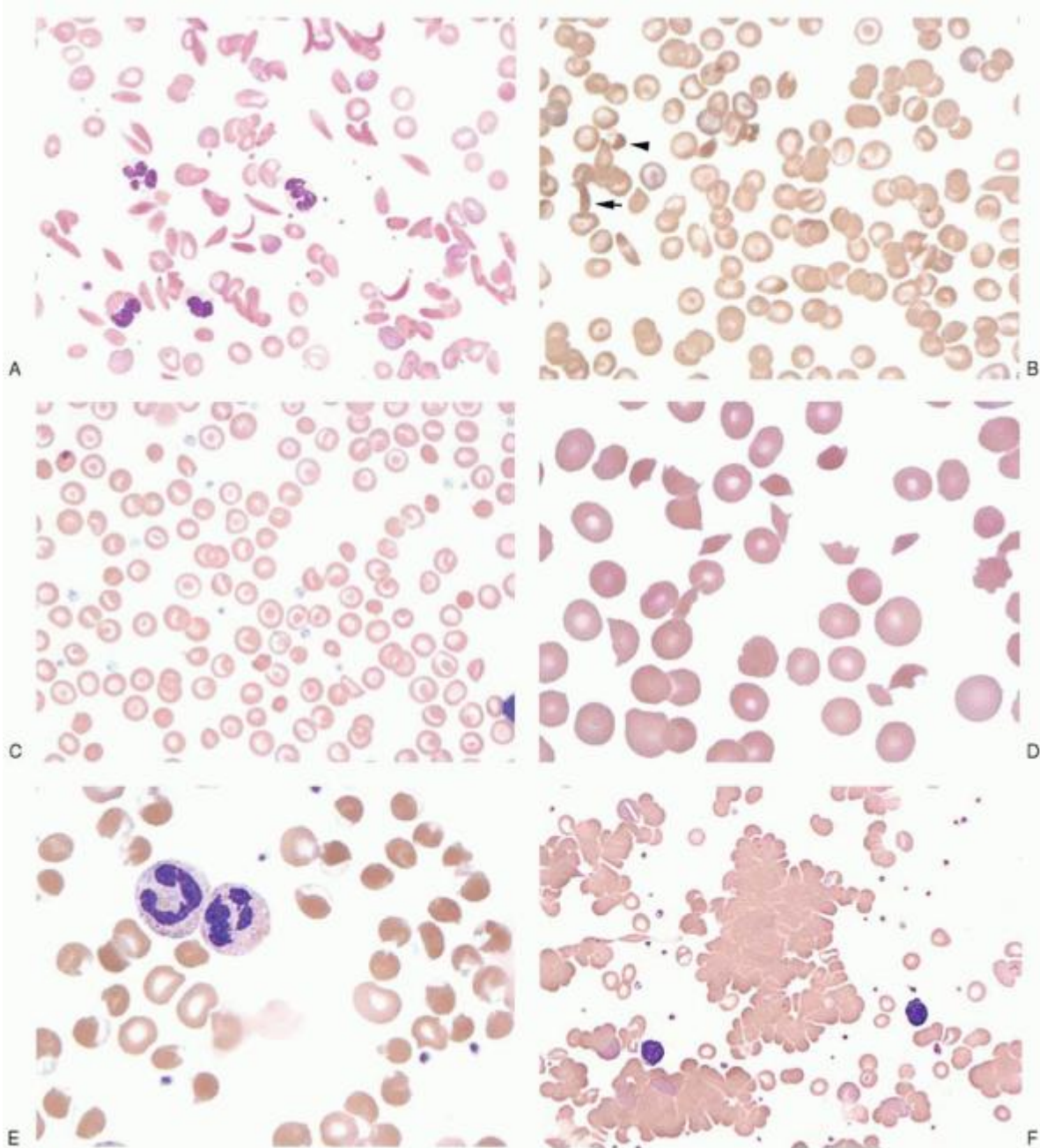

FIGURE 22.19. A: Sickle cell anemia. B: Sickle hemoglobin SC disease. C: Target cells in hemoglobin EE. D: Schistocytes in patient with thrombotic thrombocytopenic purpura. E: Blister cell from oxidative assault in patient with glucose-6-phosphate dehydrogenase deficiency. F: Autoagglutination in cold agglutinin disease. Parts A, B, D, E, and F from Pierira I, George TI, Arber DA in Atlas of peripheral blood. Philadelphia, PA: Lippincott Williams & Wilkins, 2012.

Tests for Hemolytic Disorders Associated with Heinz Body Formation

In certain disorders, the hemolytic process involves precipitation of Hb, with the formation of inclusions known as Heinz bodies. These inclusions are rapidly removed by the spleen. Heinz body formation is the principal mechanism of hemolysis in G6PD deficiency and related disorders (Chapter 28), in unstable Hb disease (Chapter 35), in the thalassemias (Chapter 34), and in certain kinds of chemical injury (Chapter 32). Heinz bodies are not observed when ordinary staining procedures are used, but require the use of special supravital stains (Fig. 22.21). Cells containing these inclusions may be found in the blood during an acute hemolytic episode in subjects with G6PD deficiency and also in splenectomized individuals with unstable Hb disease. When the spleen is intact, however, the inclusions are

P.613

removed with such efficiency that the inclusion-containing cells often are not seen.

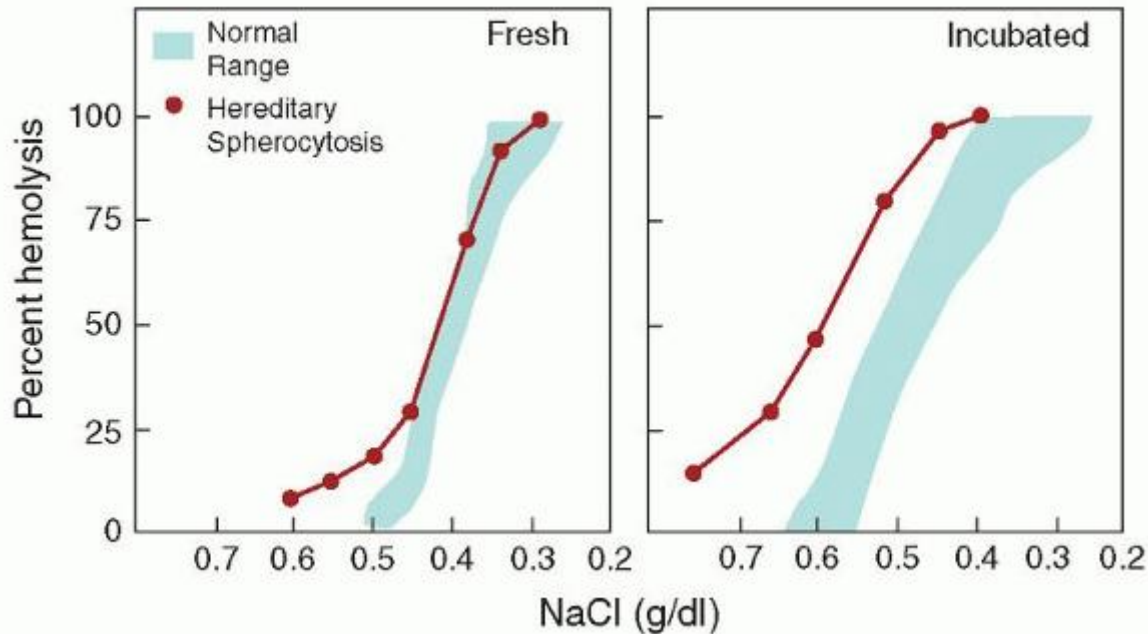

FIGURE 22.20. Osmotic fragility (as manifested by percent hemolysis) of normal and hereditary spherocytosis (HS) erythrocytes after incubation in salt solutions of varying tonicity. In fresh HS erythrocytes, note the “tail” of cells with increased sensitivity as a result of splenic conditioning (left). In the incubated red blood cell (RBC), note that the entire HS population of RBCs is more osmotically sensitive (right). From Glader BE, Naumovski L. Hereditary red blood cell disorders. In: Rimoin DL, Connor JM, Pyeritz RE, Emery AE, eds. Principles and practice of medical genetics. New York: Churchill Livingstone, 1996, with permission.

Diagnostic Strategy for the Patient with Hemolytic Anemia

Establishing the Presence of Hemolytic Anemia

The most common manifestations of chronic hemolytic anemia include anemia and reticulocytosis, often associated with various signs of excessive blood destruction. In contrast, an acute hemolytic anemia initially may not be accompanied by signs of accelerated red cell production. Such a diagnosis may be suspected because of the abrupt onset of hemoglobinuria or other signs of intravascular hemolysis or because of a rapid fall in blood Hb concentration from previously stable levels.

Conditions Sometimes Mistaken for Hemolytic Anemia

Anemias associated with acute hemorrhage and those with partially treated deficiency states are characterized by transient anemia and reticulocytosis (Table 22.14). They usually can be distinguished from hemolytic disease by the absence of icterus and by a rising Hct on subsequent determinations.

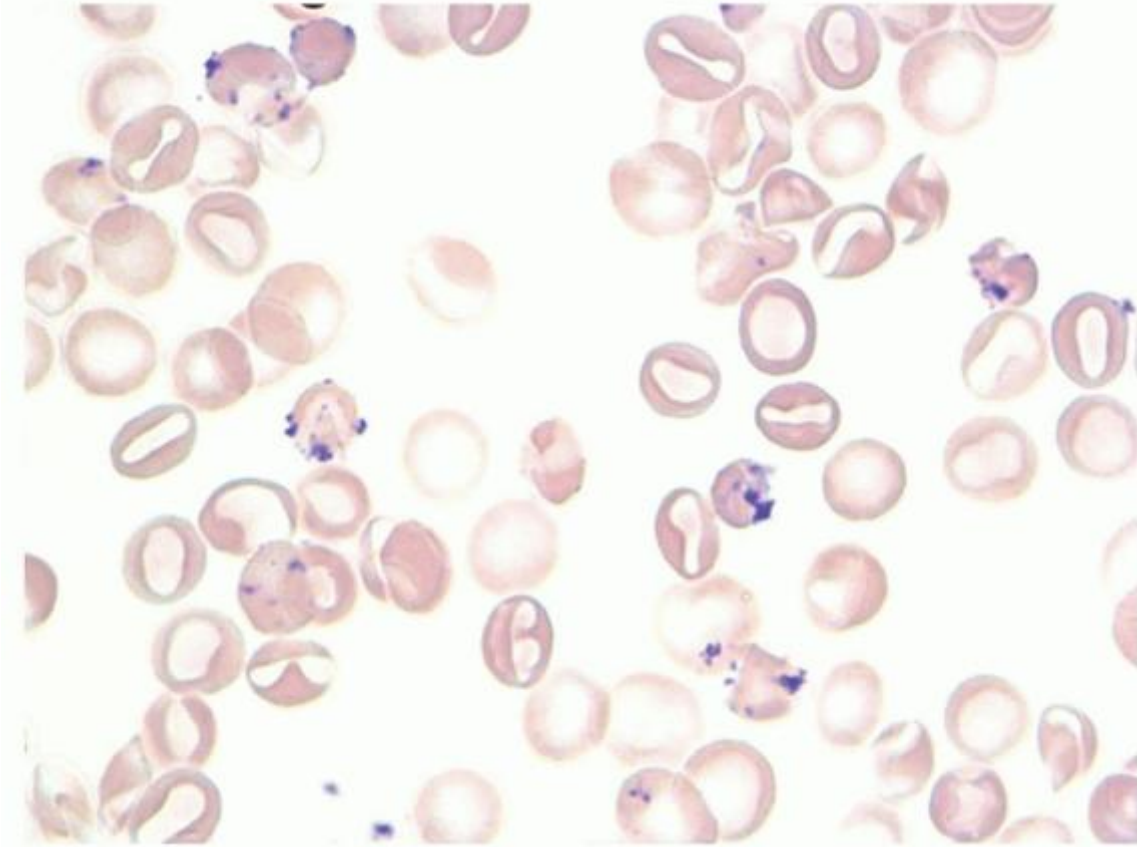

FIGURE 22.21. Heinz bodies (seen with brilliant cresyl blue supravital stains of blood) during hemolytic episodes in patient with glucose-6-phosphate dehydrogenase (G6PD) deficiency. From Pierira I, George TI, Arber DA in Atlas of peripheral blood. Philadelphia, PA: Lippincott Williams & Wilkins, 2012.

Anemias caused by ineffective erythropoiesis often are accompanied by jaundice and erythroid marrow hyperplasia; however, the reticulocyte count usually is not increased.

A particularly confusing situation may arise after occult hemorrhage into the retroperitoneal space or other tissue compartments; anemia develops rapidly, and reticulocytosis follows. Furthermore, indirect hyperbilirubinemia may occur as the result of reabsorption of the products of Hb breakdown at the site of hemorrhage. Thus, the picture of hemolytic anemia may be simulated in several ways. Diagnosis depends on detecting signs of the hemorrhage itself or the disease process leading to it. If occult hemorrhage is suspected, serial observations usually clarify the situation; once the hemorrhage ceases, the Hct, reticulocyte count, and bilirubin values return to normal.

In individuals with acholuric jaundice but without anemia, the differential diagnosis lies between a compensated hemolytic state and Gilbert syndrome or other disorders of bilirubin catabolism. Reticulocytosis or morphologic abnormalities of erythrocytes are typical findings in the former. In mild compensated hemolytic disease, however, one cannot always be certain that the hematologic values will be abnormal. Fasting induces an exaggerated increase in bilirubin levels in patients with Gilbert syndrome,¹⁷⁹ and this phenomenon may be useful in distinguishing Gilbert syndrome from hemolytic anemia.

Anemia associated with marrow invasion may be accompanied by erythroblastosis and bizarre abnormalities of erythrocyte shape. Mild reticulocytosis may develop because of premature release of cells from the marrow. Usually, however, patients do not have jaundice, and evidence of the invasive disease may be detected by examination of the bone marrow.

Determining the Specific Cause of Hemolysis

Information from the medical history and physical examination, careful review of the CBC and peripheral blood smear, and results from the direct antiglobulin test, taken together, form the basis of the initial diagnosis assessment of hemolysis. From these data, five groups of patients can be distinguished.

- Those patients in whom the diagnosis is clear because of medical history such as obvious exposure to infectious, chemical, or physical agents. Some infections, such as malaria, can cause hemolysis directly, whereas in other cases it is more indirect, associated with an underlying G6PD deficiency or an unstable Hb, such as Hb H.

TABLE 22.14 CONDITIONS SOMETIMES MISTAKEN FOR HEMOLYTIC ANEMIA

Associated with anemia and reticulocytosis

Hemorrhage

Recovery from iron, folate, or vitamin B₁₂ deficiency

Recovery from marrow failure

Associated with jaundice and anemia

Ineffective erythropoiesis (intramedullary hemolysis)

Bleeding into a body cavity or tissue

Associated with jaundice without anemia

Defective bilirubin conjugation

Crigler-Najjar syndrome

Gilbert syndrome

Marrow invasion (myelofibrosis, metastatic disease)

Myoglobinuria

P.614

- Those patients with a positive direct antiglobulin test. Such individuals may be presumed to have immunohemolytic anemia. The subsequent investigation requires a search for an underlying disease as well as a serologic study of the nature of the antibody.
- Those patients with antiglobulin-negative, spherocytic hemolytic anemia. Such patients probably have hereditary spherocytosis. It is appropriate to confirm the presence of spherocytes by the osmotic fragility test and also to attempt to establish the familial nature of the illness by studying family members. Immunohemolytic anemia may be associated with spherocytosis and is occasionally associated with a negative antiglobulin reaction. Exposure to chemical or infectious agents producing spherocytosis may not always be easy to establish.
- Those patients with other specific morphologic abnormalities of erythrocytes. The significance of various types of abnormally shaped red cells was discussed previously. Some poikilocytes, such as elliptocytes and sickle cells, are virtually pathognomonic findings.
- Those with no specific morphologic abnormalities and a negative reaction to the antiglobulin test. These patients warrant a battery of screening tests, including Hb electrophoresis, the heat denaturation test for unstable Hb disease, tests for common red cell enzymes such as G6PD and pyruvate kinase, and a screening test for paroxysmal nocturnal hemoglobinuria.

If all of these procedures yield normal results, making the diagnosis is likely to be difficult. Possibilities include one of the rarer erythrocyte enzyme deficiencies or an unusual variant of congenital dyserythropoietic anemia. These entities can be established only by using specific assays and, soon to be available, genomic sequencing for enzyme and cytoskeletal protein gene mutations.

APPROACH TO ACUTE POSTHEMORRHAGIC ANEMIA

When blood loss occurs in small amounts over a prolonged period, no anemia develops until iron stores are depleted. In such circumstances, the hematologic findings are those of iron deficiency anemia. On the other hand, when larger amounts of blood are lost over shorter periods of time, anemia may develop, although iron stores remain adequate. This latter condition is called acute posthemorrhagic anemia.

The patient may be asymptomatic and appear to be in shock, or the entire situation might be confused with an acute hemolytic process.

The physiologic changes that occur with acute blood loss in otherwise healthy individuals are summarized in Table 22.15. The immediate effects of acute hemorrhage are primarily cardiovascular. The plasma volume and red cell mass are reduced in proportional amounts; consequently, no decrease is observed in the Hct.^{180,181} Because of the time required for extracellular fluid to restore the blood volume, the amount of blood loss tends to be underestimated by the degree of anemia, especially early in the disease course. The platelet count increases, often reaching levels above normal within 1 hour, and values greater than 1 million platelets/ul can be observed. There also is a neutrophilic leukocytosis over 2 to 5 hours. Typically, the leukocyte count is 10 to 20 × 10⁴/μL. The leukocytosis is explained in part by the effect of epinephrine on granulocyte demargination and release from the marrow granulocyte reserve.

When first detected, the anemia following acute hemorrhage is normocytic with few signs of erythrocyte regeneration. The Hct or Hb may not reach the minimum value until 3 days or more after the hemorrhage ceases.

Some increase in the number of reticulocytes is usually perceptible within 3 to 5 days, and maximal values are reached at 6 to 11 days.¹⁸² The degree of reticulocytosis is related to the magnitude of hemorrhage, but rarely exceeds 15%. Other signs of erythrocyte regeneration include polychromatophilia and macrocytosis, and the MCV may transiently increase. If the patient is seen for the first time during this stage, the findings may be mistaken for those of hemolytic anemia; however, signs of increased bilirubin production are conspicuously absent, unless there has been bleeding into a body cavity or tissue space.

TABLE 22.15 CLINICAL FEATURES OF ACUTE HEMORRHAGE IN HEALTHY YOUNG ADULTS

Volume of Blood Loss (ml)	Blood Volume (%)	Symptoms
500-1,000	10-20	Few if any symptoms
1,000-1,500	20-30	Asymptomatic while at rest in a recumbent position; light-headedness and hypotension when upright; tachycardia
1,500-2,000	30-40	Symptoms present when subject is recumbent; thirst, shortness of breath, clouding or loss of consciousness; blood pressure, cardiac output, venous pressure decrease; pulse usually becomes rapid; extremities become cold, clammy, and pale
2,000-2,500	40-50	Lactic acidosis, shock; irreversible shock, death

An external hemorrhage of a magnitude sufficient to cause significant anemia is usually evident. Similarly, substantial bleeding from the gastrointestinal or female reproductive tract is likely to be a dramatic event with readily detected signs and symptoms. Internal bleeding, as from a ruptured aneurysm, may be less apparent but should be suspected when there is the abrupt onset of shock or unexplained hypotension and tachycardia. Often, these manifestations are accompanied by symptoms referable to the site of bleeding. Hemorrhage into the retroperitoneal space, a body cavity, or a cyst sometimes presents a diagnostic problem. There may be a rapid onset of anemia accompanied by hyperbilirubinemia arising from the breakdown and absorption of RBCs. Under such circumstances, the picture may be transiently confused with acute hemolytic anemia. In all cases, the onset of a sudden, unexplained anemia should lead to the suspicion of covert bleeding. The suspicion is strengthened if signs of regeneration, such as reticulocytosis, appear and no evidence of excessive blood destruction is found.

Elective surgery is a special circumstance in which hemorrhage is predictable. Surgical mortality is clearly increased when patients are severely anemic. In Jehovah's Witness patients who refuse transfusion, surgical mortality is approximately 60% at Hb values less than 6 g/dl and more than 30% at values between 6 and 8 g/dl.¹⁸³ At values greater than 8 g/dl, no increased mortality is observed. An older guideline requiring preoperative transfusion if the Hb is less than 10 g/dl has been replaced by a lower trigger point, 7 g/dl, in otherwise healthy, younger patients.^{184,185} Surgeons and anesthesiologists use several techniques to avoid the need for allogeneic transfusions.¹⁸⁶ These techniques include the use of autotransfusion of cells harvested during surgery¹⁸⁷ and preoperative harvesting of autologous blood.^{188,189} The preoperative or postoperative use of erythropoietin injection or iron medication has proved disappointing^{190,191} but may have a role with severely anemic Jehovah's Witness patients.¹⁹²

REFERENCES

1. Koepke JA. Practical laboratory hematology. New York: Churchill Livingstone, 1991:587.
2. Wintrobe M. Blood of normal men and women. Bull Johns Hopkins Hosp 1933;53:118-130.
3. AMA Council on Food and Nutrition, C.o.I.D. Iron deficiency in the United States. JAMA 1968;203(6):407-412.
4. Dallman PR, Yip R, Johnson C. Prevalence and causes of anemia in the United States, 1976 to 1980. Am J Clin Nutr 1984;39(3):437-445.
5. Khusun H, Yip R, Schultink W, Dillon DH. World Health Organization hemoglobin cut-off points for the detection of anemia are valid for an Indonesian population. J Nutr 1999;129(9):1669-1674.
6. Zakai NA, Katz R, Hirsch C, et al. A prospective study of anemia status, hemoglobin concentration, and mortality in an elderly cohort: the Cardiovascular Health Study. Arch Intern Med 2005;165(19):2214-2220.
7. Guralnik JM, Eisenstaedt RS, Ferrucci C, et al. Prevalence of anemia in persons 65 years and older in the United States: evidence for a high rate of unexplained anemia. Blood 2004;104(8):2263-2268.
8. Ble A, Fink JC, Woodman RC, et al. Renal function, erythropoietin, and anemia of older persons: the InCHIANTI study. Arch Intern Med 2005;165(19): 2222-2227.
9. Penninx BW, Pahor M, Cesari M, et al. Anemia is associated with disability and decreased physical performance and muscle strength in the elderly. J Am Geriatr Soc 2004;52(5):719-724.
10. Kosiborod M, Curtis JP, Wang Y, et al. Anemia and outcomes in patients with heart failure: a study from the National Heart Care Project. Arch Intern Med 2005;165(19):2237-2244.
11. Lipschitz D. Medical and functional consequences of anemia in the elderly. J Am Geriatr Soc 2003;51(Suppl 3):S10-S13.
12. Spivak JL. Anemia in the elderly: time for new blood in old vessels? Arch Intern Med 2005;165(19):2187-2189.
13. Daly MP, Sobal J. Anemia in the elderly. A survey of physicians' approaches to diagnosis and workup. J Fam Pract 1989;28(5):524-528.
14. Stander PE. Anemia in the elderly. Symptoms, causes, and therapies. Postgrad Med 1989;85(2):85-90, 92, 96.
15. Morra L, Moccia F, Mazarello, GP, et al. Defective in vitro growth of BFU-E of elderly subjects revealed by hydrocortisone. Biomed Pharmacother 1993;47(4):167-171.
16. Morra L, Moccia F, Mazarello, GP, et al. Defective burst-promoting activity of T lymphocytes from anemic and nonanemic elderly people. Ann Hematol 1994;68:67-71.
17. Lipschitz DA, Udupa KB, Milton KP, Thompson CO. Effect of age on hematopoiesis in man. Blood 1984;63(3):502-509.
18. Card RT, Brain MC. The "anemia" of childhood: evidence for a physiologic response to hyperphosphatemia. N Engl J Med 1973;288(8):388-392.
19. Caton W, Roby CC. Plasma volume and extravascular fluid volume during pregnancy and the puerperium. Am J Obstet Gynecol 1949;57:471-481.
20. Blekta M, Hlvaty V, Trnkova M, et al. Volume of whole blood and absolute amount of serum proteins in the early stage of late toxemia of pregnancy. Am J Obstet Gynecol 1970;106(1):10-13.
21. Sturgeon P. Studies of iron requirements in infants. III. Influence of supplemental iron during normal pregnancy on mother and infant. A. The mother. Br J Haematol 1959;5(1):31-44.
22. Low JA, Johnston EE, McBride RL. Blood volume adjustments in the normal obstetric patient with particular reference to the third trimester of pregnancy. Am J Obstet Gynecol 1965;91:356-363.
23. Bateman JC. A study of blood volume and anemia in cancer patients. Blood 1951;6(7):639-651.
24. Berlin N, Hyde G, Parsons RJ, et al, The blood volume in various medical and surgical conditions. N Engl J Med 1952;125:638-646.

25. Clark JH, Nelson W, Lyons C, et al. Chronic shock: the problem of reduced blood volume in the chronically ill patient in three parts. *Ann Surg* 1947;125(5):618-646.
26. Ellison EH, Zollinger RM, Cedars N, Britt CL. Value of blood volume determinations in gastrointestinal disease. *AMA Arch Surg* 1953;66(6):869-877.
27. Peden JC Jr, Maxwell M, Ohin A, Moyer CA. et al. A consideration of indications for preoperative transfusions based on analysis of blood volumes and circulating proteins in normal and malnourished patients with and without cancer. *Ann Surg* 1960;151:303-318.
28. Fawcett J, Wynn V. Effects of posture on plasma volume and some blood constituents. *J Clin Pathol* 1960;13:304-310.
29. Dawson AA, Ogston D, Fullerton HW. Evaluation of diagnostic significance of certain symptoms and physical signs in anaemic patients. *Br Med J* 1969;3(668):436-439.
30. Desforges JF. Anemia in uremia. *Arch Intern Med* 1970;126(5):808-811.
31. Cropp GJ. Cardiovascular function in children with severe anemia. *Circulation* 1969;39(6):775-784.
32. Bartels E. Anemia as the cause of severe congestive heart failure: report of a case. *Ann Intern Med* 1937;11:400-404.
33. Pickering G, Wayne E. Observations on angina pectoris and intermittent claudication in anemia. *Clin Sci* 1933;1:305-325.
34. Aessopos A, Defteros S, Famakis D, et al. Cardiovascular adaptation to chronic anemia in the elderly: an echocardiographic study. *Clin Invest Med* 2004;27(5):265-273.
35. Varat MA, Adolph RJ, Fowler NO. Cardiovascular effects of anemia. *Am Heart J* 1972;83(3):415-426.
36. Dawson AA, Palmer KN. The significance of cardiac murmurs in anemia. *Am J Med Sci* 1966;252(5):554-557.
37. Argano BJ. Phonocardiographic findings in anemia. *Chest* 1971;60(6): 599-601.
38. Mesihovic-Dinarevic S, Ibrahimovic J, Hasanbegovic J, et al. Heart murmur and anaemia in the pediatric population. *Bosn J Basic Med Sci* 2005;5(3):39-45.
39. Hogan GR, Jones B. The relationship of koilonychia and iron deficiency in infants. *J Pediatr* 1970;77(6):1054-1057.
40. Marshall RA. A review of lesions in the optic fundus in various diseases of the blood. *Blood* 1959;14(7):882-891.
41. Aisen ML, Bacon BR, Goodman AM, Chester EM. Retinal abnormalities associated with anemia. *Arch Ophthalmol* 1983;101(7):1049-1052.
42. Merin S, Freund M. Retinopathy in severe anemia. *Am J Ophthalmol* 1968;66(6):1102-1106.
43. Oski FA, Gottlieb AJ, Delvorio-Papadopoulos M, Miller WW. Red-cell 2,3-diphosphoglycerate levels in subjects with chronic hypoxemia. *N Engl J Med* 1969;280(21):1165-1166.
44. Schwaber JR, Blumberg AG. Papilledema associated with blood loss anemia. *Ann Intern Med* 1961;55:1004-1007.
45. Wu J, Ricker M, Muench J. Copper deficiency as a cause of unexplained hematologic and neurologic deficits in patient with prior gastrointestinal surgery. *J Am Board Fam Med* 2006;19:191-194.
46. Preloznik-Zupan I, Cernelc P, Zontar D. Reticulocyte analysis using light microscopy and two different flow cytometric procedures. *Pflugers Arch* 2000;440(Suppl 5):R185-R187.
47. Thomas C, Kirshbaum A, Boehm D, Thomas L. The diagnostic plot: a concept for identifying different states of iron deficiency and monitoring the response to epoetin therapy. *Med Oncol* 2006;23(1):23-36.
48. Chang CC, Kass L. Clinical significance of immature reticulocyte fraction determined by automated reticulocyte counting. *Am J Clin Pathol* 1997;108(1):69-73.
49. Bessman JD, Gilmer PR Jr, Gardner FH. Improved classification of anemias by MCV and RDW. *Am J Clin Pathol* 1983;80(3):322-326.
50. Fischer SL, Fischer SP. Mean corpuscular volume. *Arch Intern Med* 1983;143:282-283.
51. Marsh WL Jr, Koenig HM. The laboratory evaluation of microcytic red blood cells. *Crit Rev Clin Lab Sci* 1982;16(3):195-254.

52. Hershko C, Bar-Or D, Geabiel Y, et al. Diagnosis of iron deficiency anemia in a rural population of children. Relative usefulness of serum ferritin, red cell protoporphyrin, red cell indices, and transferrin saturation determinations. *Am J Clin Nutr* 1981;34(8):1600-1610.
53. Fairbanks VF, Oliveros R, Brandahar JH, et al. Homozygous hemoglobin E mimics beta-thalassemia minor without anemia or hemolysis: hematologic, functional, and biosynthetic studies of first North American cases. *Am J Hematol* 1980;8(1):109-121.
54. Hamilton PJ, Davidson RL. The interrelationships and stability of Coulter S-determined blood indices. *J Clin Pathol* 1973;26(9):700-705.
55. Gottfried EL. Erythrocyte indexes with the electronic counter. *N Engl J Med* 1979;300(22):1277.
56. Okuno T, Chou A. The significance of small erythrocytes. *Am J Clin Pathol* 1975;64(1):48-52.
57. Conrad M, Crosby WH. The natural history of iron deficiency induced by phlebotomy. *Blood* 1962;20:173-185.
58. England JM, Ward SM, Down MC. Microcytosis, anisocytosis and the red cell indices in iron deficiency. *Br J Haematol* 1976;34(4):589-597.
59. Klee GG, Fairbanks VF, Pierre RV, et al. Routine erythrocyte measurements in diagnosis of iron-deficiency anemia and thalassemia minor. *Am J Clin Pathol* 1976;66(5):870-877.
60. England JM, Walford DM, Waters DA. Re-assessment of the reliability of the haematocrit. *Br J Haematol* 1972;23(2):247-256.
61. Bessman JD, Feinstein DI. Quantitative anisocytosis as a discriminant between iron deficiency and thalassemia minor. *Blood* 1979;53(2):288-293.
62. Dallman PR. Diagnosis of anemia and iron deficiency: analytic and biological variations of laboratory tests. *Am J Clin Nutr* 1984;39(6):937-941.
63. Breedveld FC, Bieger R, van Wermeskerken RK. The clinical significance of macrocytosis. *Acta Med Scand* 1981;209(4):319-322.
64. Davidson RJ, Hamilton PJ. High mean red cell volume: its incidence and significance in routine haematology. *J Clin Pathol* 1978;31(5):493-498.
65. Lindenbaum J. Status of laboratory testing in the diagnosis of megaloblastic anemia. *Blood* 1983;61(4):624-627.
66. McPhedran P, Barnes MG, Weinstein JS, Robertson TG. Interpretation of electronically determined macrocytosis. *Ann Intern Med* 1973;78(5):677-683.
67. O'Neill BJ, Marlin GE, Streeter AM. Red-cell macrocytosis in chronic obstructive airway disease. *Med J Aust* 1972;1(6):283.
68. Colon-Otero G, Menke D, Hook CC. A practical approach to the differential diagnosis and evaluation of the adult patient with macrocytic anemia. *Med Clin North Am* 1992;76(3):581-597.
69. Carmel R. Macrocytosis, mild anemia, and delay in the diagnosis of pernicious anemia. *Arch Intern Med* 1979;139(1):47-50.
70. Wickramasinghe SN. Kinetics and morphology of haemopoiesis in pernicious anaemia. *Br J Haematol* 1972;22(2):111-115.
71. Beck WS. The metabolic basis of megaloblastic erythropoiesis. *Medicine* 1964;43:715-726.
72. Ganzoni A, Hillman RS, Finch CA. Maturation of the macroreticulocyte. *Br J Haematol* 1969;16(1):119-135.
73. Lindenbaum J, Nath BJ. Megaloblastic anaemia and neutrophil hypersegmentation. *Br J Haematol* 1980;44(3):511-513.
74. Herbert V. Experimental nutritional folate deficiency in man. *Trans Assoc Am Physicians* 1962;75:307-320.
75. Nath BJ, Lindenbaum J. Persistence of neutrophil hypersegmentation during recovery from megaloblastic granulopoiesis. *Ann Intern Med* 1979;90(5): 757-760.
76. Beguin Y, Loo M, R'Zik S, et al. Quantitative assessment of erythropoiesis and functional classification of anemia based on measurements of serum transferrin receptor and erythropoietin. *Blood* 1993;81(4):1067-1076.
77. Hall CA. Vitamin B12 deficiency and early rise in mean corpuscular volume. *JAMA* 1981;245(11):1144-1146.

78. Wilkinson J. Megalocytic anemias. *Lancet* 1949;1:249-255.
79. Killman SA. On the size of normal human reticulocytes. *Acta Med Scand* 1964;176:529-533.
80. Hillman RS, Finch CA. Erythropoiesis: normal and abnormal. *Semin Hematol* 1967;4(4):327-336.
81. Brecher G, Stohlman F. Reticulocyte size and erythropoietic stimulation. *Proc Soc Exp Biol Med* 1961;107:887-891.
82. Lindenbaum J. Folate and vitamin B₁₂ deficiencies in alcoholism. *Semin Hematol* 1980;17:119-129.
83. Stimmel B, Korts D, Jackson G, Gilbert HS. Failure of mean red cell volume to serve as a biologic marker for alcoholism in narcotic dependence. A randomized control trial. *Am J Med* 1983;74(3):369-374.
84. Unger KW, Johnson D Jr. Red blood cell mean corpuscular volume: a potential indicator of alcohol usage in a working population. *Am J Med Sci* 1974;267(5):281-289.
85. Koivisto H, Hietala J, Antila P, et al. Long-term ethanol consumption and macrocytosis: diagnostic and pathogenic implications. *J Lab Clin Med* 2006;147(4):191-196.
86. Werre JM, Helleman PW, Verkop MC, De Gier J. Causes of macroplania of erythrocytes in diseases of the liver and biliary tract with special reference to leptocytosis. *Br J Haematol* 1970;19(2):223-235.
87. Bingham J. The macrocytosis of hepatic disease. *Blood* 1959;14:694-707.
88. Cunningham LO, Rising JA. Erythrocytic microcytosis: clinical implications in 100 patients. *Am J Med Sci* 1977;273(2):149-155.
89. Delaby C, Pilard N, Goncalves AS, et al. Presence of the iron exporter ferroportin at the plasma membrane of macrophages is enhanced by iron loading and down-regulated by hepcidin. *Blood* 2005;106(12):3979-3984.
90. Yip R, Dallman PR. The roles of inflammation and iron deficiency as causes of anemia. *Am J Clin Nutr* 1988;48(5):1295-1300.
91. Statland BE, Winkel P. Relationship of day-to-day variation of serum iron concentrations to iron-binding capacity in healthy young women. *Am J Clin Pathol* 1977;67(1):84-90.
92. Itano M. CAP Comprehensive chemistry. Serum iron survey. *Am J Clin Pathol* 1978;70(Suppl 3):516-522.
93. Statland B, Winkel P, Bokelund H. Variation of serum iron concentration in young healthy men: within-day and day-to-day changes. *Clin Biochem* 1976;9:26-29.
94. Werkman HP, Trijbels JM, Schretlen ED. The "short-term" iron rhythm. *Clin Chim Acta* 1974;53(1):65-68.
95. Wians FH Jr, Urban JE, Keffer JH, Kraft SH. Discriminating between iron deficiency anemia and anemia of chronic disease using traditional indices of iron status vs transferrin receptor concentration. *Am J Clin Pathol* 2001;115(1):112-118.
96. Means RT Jr, Allen J, Sears DA, Schuster SJ, et al. Serum soluble transferrin receptor and the prediction of marrow aspirate iron results in a heterogeneous group of patients. *Clin Lab Haematol* 1999;21(3):161-167.
97. Finch CA, Belotti V, Stray S, et al. Plasma ferritin determination as a diagnostic tool. *West J Med* 1986;145(5):657-663.
98. Lipshitz D, Cook JD, Finch CA. A clinical evaluation of serum ferritin as an index of iron stores. *N Engl J Med* 1974;290:1213-1216.
99. Worwood M. Serum ferritin. *CRC Crit Rev Clin Lab Sci* 1979;10(2):171-204.
100. Jacobs A, Worwood M. Ferritin in serum. Clinical and biochemical implications. *N Engl J Med* 1975;292(18):951-956.
101. Esumi N, Ikushima S, Todo S, Imashuku S. Hyperferritinemia in malignant histiocytosis and virus-associated hemophagocytic syndrome. *N Engl J Med* 1987;316(6):346-347.
102. Matzner Y, Konijn AM, Hershko C. Serum ferritin in hematologic malignancies. *Am J Hematol* 1980;9(1):13-22.
103. Rath C, Finch CA. Sternal marrow hemosiderin. *J Lab Clin Med* 1948;33:81-86.
104. Gale E, Torrance J, Bothwell T. The quantitative estimation of total iron stores in human bone marrow. *J Clin Invest* 1963;42:1076-1082.
105. Ferguson BJ, Skikne BS, Stray S, et al. Serum transferrin receptor distinguishes the anemia of chronic disease from iron deficiency anemia. *J Lab Clin Med* 1992;119(4):385-390.

106. Punnonen K, Irjala K, Rajamaki A. Iron-deficiency anemia is associated with high concentrations of transferrin receptor in serum. *Clin Chem* 1994;40(5):774-776.
107. Kuvibidila S, Warriar RP, Ode D, Yu LL. Serum transferrin receptor concentrations in women with mild malnutrition. *Am J Clin Nutr* 1996;63(4):596-601.
108. Punnonen K, Irjala K, Rajamaki A. Serum transferrin receptor and its ratio to serum ferritin in the diagnosis of iron deficiency. *Blood* 1997;89(3):1052-1057.
109. Marsh WL Jr, Nelson DP, Koenig HM. Free erythrocyte protoporphyrin (FEP) II. The FEP test is clinically useful in classifying microcytic RBC disorders in adults. *Am J Clin Pathol* 1983;79(6):661-666.
110. Stockman JA 3rd, et al. The measurement of free erythrocyte porphyrin (FEP) as a simple means of distinguishing iron deficiency from beta-thalassemia trait in subjects with microcytosis. *J Lab Clin Med* 1975;85(1):113-119.
111. Zanella A, Gridelli L, Berzuini A, et al. Sensitivity and predictive value of serum ferritin and free erythrocyte protoporphyrin for iron deficiency. *J Lab Clin Med* 1989;113(1):73-78.
112. Garrett S, Worwood M. Zinc protoporphyrin and iron-deficient erythropoiesis. *Acta Haematol* 1994;91(1):21-25.
113. Frey WG 3rd, Gardner MH, Pillsbury JA. Quantitative measurement of liver iron by needle biopsy. *J Lab Clin Med* 1968;72(1):52-57.
114. MacDonald R, Pechet GS. Tissue iron and hemochromatosis. *Arch Intern Med* 1965;116:381-391.
115. Conn HO, Strauss RH, Conn MB. Estimation of hepatic hemosiderin by gross inspection of iron-stained histologic sections. *Yale J Biol Med* 1972;45(2):133-138.
116. Lundin P, Lundquist A, Lundvall O. Evaluation of fine-needle aspiration biopsy smears in the diagnosis of liver iron overload. *Acta Med Scand* 1969;186(5):369-373.
117. Edwards CQ, Carroll M, Bray P, Cartwright GE. Hereditary hemochromatosis. Diagnosis in siblings and children. *N Engl J Med* 1977;297(1):7-13.
118. Wood JC. Magnetic resonance imaging measurement of iron overload. *Curr Opin Hematol* 2007;14(3):183-190.
119. Wood JC, Enrique C, Ghugre N, et al. MRI R2 and R2* mapping accurately estimates hepatic iron concentration in transfusion-dependent thalassemia and sickle cell disease patients. *Blood* 2005;106(4):1460-1465.
120. Cumming RL, Millar JA, Smith JA, Goldberg A. Clinical and laboratory studies on the action of desferrioxamine. *Br J Haematol* 1969;17(3):257-263.
121. Desenne JJ, Layrisse M. Mobilisation of iron by desferrioxamine in cases with low serum iron. *Acta Haematol* 1969;41(3):129-134.
122. Fielding J. Differential ferrioxamine test for measuring chelatable body iron. *J Clin Pathol* 1965;18:88-97.
123. Harker LA, Funk DD, Finch CA. Evaluation of storage iron by chelates. *Am J Med* 1968;45(1):105-115.
124. Craft J, Coleman D, Coulter HO, et al. Hematologic abnormalities in Southeast Asian refugees. *JAMA* 1983;249(23):3204-3206.
125. Cunningham TM. Hemoglobin E in Indochinese refugees. *West J Med* 1982;137(3):186-190.
126. Fairbanks VF, Gilchrist GS, Brimhall B, et al. Hemoglobin E trait reexamined: a cause of microcytosis and erythrocytosis. *Blood* 1979;53(1):109-115.
127. Benz EJ Jr, Berman BW, Tonkonow BL, et al. Molecular analysis of the betathalassemia phenotype associated with inheritance of hemoglobin E (alpha 2 beta2(26)Glu leads to Lys). *J Clin Invest* 1981;68(1):118-126.
128. Charache S, Conley CL, Waugh DF, et al. Pathogenesis of hemolytic anemia in homozygous hemoglobin C disease. *J Clin Invest* 1967;46(11):1795-1811.
129. Fabry ME, Kaul DK, Raventos C, et al. Some aspects of the pathophysiology of homozygous Hb CC erythrocytes. *J Clin Invest* 1981;67(5):1284-1291.
130. Mentzer WC Jr. Differentiation of iron deficiency from thalassaemia trait. *Lancet* 1973;1(7808):882.
131. Johnson CS, Tegos C, Beutler E. Thalassemia minor: routine erythrocyte measurements and differentiation from iron deficiency. *Am J Clin Pathol* 1983;80(1):31-36.

132. McClure S, Custer E, Bessman JD. Improved detection of early iron deficiency in nonanemic subjects. *JAMA* 1985;253(7):1021-1023.
133. Wasi P, Disthasongchan P, Na-Nakorn S. The effect of iron deficiency on the levels of hemoglobins A2 and E. *J Lab Clin Med* 1968;71(1):85-91.
134. Mollin D. Sideroblasts and sideroblastic anaemia. *Br J Haematol* 1965;11:41-48.
135. Bessis M, Jensen WN. Sideroblastic anaemia, mitochondria and erythroblast iron. *Br J Haematol* 1965;11:49-51.
136. Fleming MD. The genetics of inherited sideroblastic anemias. *Semin Hematol* 2002;39(4):270-281.
137. Crosby W, Akeroyd JH. The limit of hemoglobin synthesis in hereditary anemia. *Am J Med* 1952;13:273-283.
138. Ham T. Hemoglobinuria. *Am J Med* 1955;18:990-1006.
139. Stamey C, Diamond L. Congenital hemolytic anemia in the newborn: relationship to kernicterus. *J Dis Child* 1957;94:616.
140. Owren PA. Congenital hemolytic jaundice; the pathogenesis of the hemolytic crisis. *Blood* 1948;3:231-248.
141. Lefrere JJ, Courouze AM, Bertrand Y, et al. Human parvovirus and aplastic crisis in chronic hemolytic anemias: a study of 24 observations. *Am J Hematol* 1986;23(3):271-275.
- P.616
142. Young N. Hematologic and hematopoietic consequences of B19 parvovirus infection. *Semin Hematol* 1988;25(2):159-172.
143. Young N, Mortimer P. Viruses and bone marrow failure. *Blood* 1984;63(4): 729-737.
144. Chorba T, Coccia P, Holman RC, et al. The role of parvovirus B19 in aplastic crisis and erythema infectiosum (fifth disease). *J Infect Dis* 1986;154(3): 383-393.
145. Plummer FA, Hammond GW, Forward K, et al. An erythema infectiosum-like illness caused by human parvovirus infection. *N Engl J Med* 1985;313(2):74-79.
146. Koduri PR, Naides SJ. Aseptic meningitis caused by parvovirus B19. *Clin Infect Dis* 1995;21(4):1053.
147. Anand A, Gray ES, Brown T, et al. Human parvovirus infection in pregnancy and hydrops fetalis. *N Engl J Med* 1987;316(4):183-186.
148. Yaegashi N, Okamura N, Tsunodo A, et al. A study by means of a new assay of the relationship between an outbreak of erythema infectiosum and non-immune hydrops fetalis caused by human parvovirus B19. *J Infect* 1995;31(3):195-200.
149. Rao KR, Patel AR, Anderson MJ, et al. Infection with parvovirus-like virus and aplastic crisis in chronic hemolytic anemia. *Ann Intern Med* 1983;98(6): 930-932.
150. Kurtzman GJ, Cohen BS, Field AM, et al. Immune response to B19 parvovirus and an antibody defect in persistent viral infection. *J Clin Invest* 1989;84(4): 1114-1123.
151. Potter CG, Potter AC, Hatton CS, et al. Variation of erythroid and myeloid precursors in the marrow and peripheral blood of volunteer subjects infected with human parvovirus (B19). *J Clin Invest* 1987;79(5):1486-1492.
152. Ostrow JD. The etiology of pigment gallstones. *Hepatology* 1984;4(Suppl 5): 215S-222S.
153. Trotman BW. Pigment gallstone disease. *Semin Liver Dis* 1983;3(2):112-119.
154. Trotman BW, Bernstein SE, Balistrieri WF, et al. Hemolysis-induced gallstones in mice: increased unconjugated bilirubin in hepatic bile predisposes to gallstone formation. *Gastroenterology* 1981;81(2):232-236.
155. Trotman BW, Lakshminarayanan N, Bernstein SE, et al. Interaction of hemolysis and genotype on ionized calcium in bile of mice with hemolysis-induced gallstones. *Gastroenterology* 1984;87(5):1127-1130.
156. McCall IW, Desai P, Serjeant BE, Serjeant GR. Cholelithiasis in Jamaican patients with homozygous sickle cell disease. *Am J Hematol* 1977;3:15-21.
157. Wolfort FG, Krizek TJ. Skin ulceration in sickle cell anemia. *Plast Reconstr Surg* 1969;43(1):71-77.

158. Gendel B. Chronic leg ulcer in diseases of the blood. *Blood* 1948;3: 1283-1289.
159. Motulsky A, Singer K, Crosby WH, et al, Hereditary elliptocytosis and its relationship to other familial hemolytic diseases. *Blood* 1954;9:57-72.
160. Tanaka KR, Paglia DE. Pyruvate kinase deficiency. *Semin Hematol* 1971;8(4):367-396.
161. Leger L, Orr TG. Chronic leg ulcerations in congenital hemolytic jaundice. *South Med* 1940;33:463-464.
162. Wallerstein R, Aggeler PM. Acute hemolytic anemia. *Am J Med* 1964;37: 92-104.
163. Mackinney A, Morton NE, Kosower NS. Ascertaining genetic carriers of hereditary spherocytosis by statistical analysis of multiple laboratory tests. *J Clin Invest* 1962;41:554-567.
164. Zinkham WH, Liljestrand JD, Dixon SM, Hutchison JL. Observations on the rate and mechanism of hemolysis in individuals with Hb Zurich [His E7(63) beta leads to Arg]: II. Thermal denaturation of hemoglobin as a cause of anemia during fever. *Johns Hopkins Med J* 1979;144(4):109-116.
165. Danon D. A rapid micro method for recording red cell osmotic fragility by continuous decrease of salt concentration. *J Clin Pathol* 1963;16:377-382.
166. Brus I, Lewis SM. The haptoglobin content of serum in haemolytic anaemia. *Br J Haematol* 1959;5:348-355.
167. Marchand A, Galen RS, Van Lente F. The predictive value of serum haptoglobin in hemolytic disease. *JAMA* 1980;243(19):1909-1911.
168. Strocchi A, Schwartz S, Elefson M. et al. A simple carbon monoxide breath test to estimate erythrocyte turnover. *J Lab Clin Med* 1992;120(3):392-399.
169. Franco RS. The measurement and importance of red cell survival. *Am J Hematol* 2009;84(2):109-114.
170. Crosby W, Dameshek W. The significance of hemoglobinemia and associated hemosiderinuria, with particular reference to various types of hemolytic anemia. *J Lab Clin Med* 1951;38:829-841.
171. Leonards J. Simple test for hematuria compared with established tests. *JAMA* 1962;179:807-808.
172. Rowland LP, Fahn S, Hirshberg E, Harter DH. Myoglobinuria. *Arch Neurol* 1964;10:537-562.
173. Benoit FL, Theil GB, Watten RH. Myoglobinuria and persistence of fetal myoglobin. *Ann Intern Med* 1964;61:1133-1139.
174. Schmid R, Mahler R. Chronic progressive myopathy with myoglobinuria: demonstration of a glycogenolytic defect in the muscle. *J Clin Invest* 1959;38:2044-2058.
175. Rosen H, Sears DA, Meisenzahl D. Spectral properties of hemospexin-heme. The Schumm test. *J Lab Clin Med* 1969;74(6):941-945.
176. Gilliland BC, Baxter E, Evans RS. Red-cell antibodies in acquired hemolytic anemia with negative antiglobulin serum tests. *N Engl J Med* 1971;285(5):252-256.
177. De Angelis V, Biasinutto C, Prudella P, et al. Clinical significance of positive direct antiglobulin test in patients with HIV infection. *Infection* 1994;22(2): 92-95.
178. Selwyn J, Dacie JV. Autohemolysis and other changes resulting from incubation in vitro of red cells from patients with congenital hemolytic anemia. *Blood* 1954;9:414-438.
179. Powell LW. Clinical aspects of unconjugated hyperbilirubinemia. *Semin Hematol* 1972;9(1):91-105.
180. Adamson J, Hillman RS. Blood volume and plasma protein replacement following acute blood loss in normal man. *JAMA* 1968;205(9):609-612.
181. Ebert R, Stead EA Jr, Gibson JG II. Response of normal subjects to acute blood loss. *Arch Intern Med* 1941;68:578-590.
182. Schidt E. Observations on blood regeneration in man. *Am J Med Sci* 1937;193:313-336.
183. Carson JL. Morbidity risk assessment in the surgically anemic patient. *Am J Surg* 1995;170(Suppl 6A):32S-36S.
184. Greenburg AG. A physiologic basis for red blood cell transfusion decisions. *Am J Surg* 1995;170(Suppl 6A):44S-48S.
185. Spence RK. Surgical red blood cell transfusion practice policies. *Blood Management Practice Guidelines Conference. Am J Surg* 1995;170(Suppl 6A): 3S-15S.

186. Goldberg MA. Erythropoiesis, erythropoietin, and iron metabolism in elective surgery: preoperative strategies for avoiding allogeneic blood exposure. *Am J Surg* 1995;170(Suppl 6A):37S-43S.
187. Rickenbacker W, Myers JL, Waldhausen JA. Current status of cardiac surgery: a 40 year review. *J Am Coll Cardiol* 1989;14:535-544.
188. Goodnough LT, Shafron D, Marcus RE. The impact of preoperative autologous blood donation on orthopaedic surgical practice. *Vox Sang* 1990;59(2):65-69.
189. Goodnough LT, Price TH, Friedman KD, et al. A phase III trial of recombinant human erythropoietin therapy in nonanemic orthopedic patients subjected to aggressive removal of blood for autologous use: dose, response, toxicity, and efficacy. *Transfusion* 1994;34(1):66-71.
190. Crosby L, Parski VA, Cottingham E, Cmolik C. Iron supplementation for acute blood loss anemia after coronary artery bypass surgery: a randomized, placebo-controlled study. *Heart Lung* 1994;23(6):493-499.
191. Klueber RM, Wolff BG. Evaluation of anemia caused by hemorrhoidal bleeding. *Dis Colon Rectum* 1994;37(10):1006-1007.
192. Madura JA. Use of erythropoietin and parenteral iron dextran in a severely anemic Jehovah's Witness with colon cancer. *Arch Surg* 1993;128(10):1168-1170.

Section 2 - Disorders of Iron Metabolism and Heme Synthesis

Chapter 23 Iron Deficiency and Related Disorders

> Table of Contents > Part IV - Disorders of Red Cells > Section 2 - Disorders of Iron Metabolism and Heme Synthesis > Chapter 23 - Iron Deficiency and Related Disorders

Chapter 23

Iron Deficiency and Related Disorders

Lawrence T. Goodnough

Elizabeta Nemeth

Iron deficiency has been recognized since medieval times. Chlorosis, a term derived from the Greek word meaning green, was applied by Varandaeus to a disorder that was later described in 1554 as “De morbo virgineo.”¹ The disease became well known as the “green-sickness,” due to a greenish pallor occurring almost exclusively in teenaged girls.² It was depicted in paintings by the Dutch masters and was alluded to by Shakespeare. Other clinical features were breathlessness, palpitations, slight ankle edema, and gastrointestinal complaints. Emotional disturbances, depression, irritability, and moodiness were common.

Chlorosis became especially common in the last decade of the 19th century and then declined in incidence. Today, most believe that chlorosis resulted from a combination of factors affecting adolescent girls: the demands of growth and the onset of menses, an inadequate diet, and a legacy of poor iron stores from early childhood. In the 1830s, anemia, hypochromia, and lack of iron in the blood were linked to this disorder.³ In 1832, Pierre Blaud described the response of chlorosis to his deservedly famous pills (ferrous sulfate plus potassium carbonate). Many observers, including Niemeyer and Osler, confirmed his findings.⁴ Ferrous sulfate remains a cornerstone of modern treatment of iron deficiency.

In the late 1920s and early 1930s, a distinct hypochromic anemia was described. Like chlorosis, chronic hypochromic anemia chiefly affected women. It differed from chlorosis in that it was detected later in life, especially in the fourth and fifth decades.⁵ Other distinguishing clinical features were epithelial changes involving the tongue and nails and achlorhydria. The anemia most often affected women with poor diets, multiple pregnancies, or menstrual irregularities. Today, menstruating women continue to be among the most likely individuals to develop iron deficiency, along with young children whose growth outstrips their iron supply. An understanding of normal iron physiology is essential to best appreciate the pathophysiology of iron deficiency anemia.

TABLE 23.1 IMPORTANT FE-CONTAINING COMPOUNDS IN THE HUMAN

Protein	Function	Fe Oxidation State	Amount (g)	Percent of Total
Hemoglobin	Erythrocyte O ₂ transport	2 (heme)	2.600	65.0
Myoglobin	Muscle O ₂ storage	2 (heme)	0.130	6.0
Transferrin	Plasma Fe transport	3	0.003	0.1
Ferritin	Intracellular Fe storage	3	0.520	13.0
Hemosiderin	Intracellular Fe storage	3	0.480	12.0
Others (enzymes)			0.150	3.9
Catalase, peroxidase	H ₂ O ₂ degradation	2		
Cytochromes	Electron transport	2/3 (heme)		
Aconitase	Tricarboxylic acid cycle	4Fe•4S cluster		
Ferrochelatase	Heme biosynthesis	2Fe•2S cluster		
Duodenal cytochrome b-like protein (Dcytb)	Intestinal Fe reduction	2 (heme)		

Adapted from Theil E, Raymond K. Transition-metal storage, transport, and biomineralization. In: Bertini I, Gray HB, Lippard SJ, Valentine JS, eds.

Bioinorganic chemistry. Mill Valley, CA: University Science Books, 1994:611.

NORMAL IRON PHYSIOLOGY

Total Body Iron

Iron endowment varies with age and sex. Full-term infants begin life with approximately 75 mg/kg body weight of iron, primarily acquired from their mothers during the third trimester of gestation. These abundant stores are rapidly depleted over the first few months of life, and most young children have tenuous iron balance, as their intake must keep pace with rapid growth. Requirements decrease after adolescence, and men have a small gradual increase in iron stores throughout life. The body iron content of normal adult men is 50 mg/kg body weight or greater. In contrast, postpubertal women have increased losses of iron due to menstruation, pregnancy, and childbirth, resulting in a body iron endowment averaging 35 mg/kg. After menopause, women accumulate iron linearly in parallel with adult men.

Most of the body iron is found in heme-containing oxygen transport and storage proteins, including hemoglobin and myoglobin (Table 23.1). Smaller amounts are incorporated into enzymes with active sites containing heme or iron-sulfur clusters, including enzymes of electron transport chain, peroxidases, catalases, and ribonucleotide reductase. Most nonheme iron (approximately 1 g in adult men) is stored as ferritin or hemosiderin in macrophages

P.618

and hepatocytes. Only a tiny fraction of iron (~0.1%) is in transit in the plasma, bound to the carrier protein, transferrin.

Iron Balance

Iron is not actively excreted from the body; it is eliminated only through the loss of epithelial cells from the gastrointestinal tract, epidermal cells of the skin, and, in menstruating women, red blood cells. On the basis of long-term studies of body iron turnover, the total average daily loss of iron has been estimated at ~1 to 2 mg in normal adult men and nonmenstruating women.⁶ Although iron is a physiologic component of sweat, only a tiny amount of iron (22.5 µg/L) is lost by this route.⁷ Urinary iron excretion amounts to <0.05 mg/day and is largely accounted for by sloughed cells.

Menstruating women lose an additional, highly variable amount over each menstrual cycle, from 0.006 (average) to more than 0.025 mg/kg/day.⁸

These iron losses are normally balanced by an equivalent amount of iron absorbed from the diet (1 to 2 mg/day). The bioavailability of iron in the U.S. diet has been estimated to be ~16.6%, but only a fraction of dietary iron is absorbed and the amount of bioavailable iron is lower in many parts of the world. Fractional absorption of dietary iron can increase up to three- to fivefold (3 to 5 mg/day) if iron stores are depleted. Thus, iron balance is primarily, if not exclusively, achieved by control of absorption rather than by control of excretion.

Intestinal Absorption

Iron is absorbed in the duodenum, and humans and other omnivorous mammals have at least two distinct pathways for iron absorption: one for uptake of heme iron and another for ferrous (Fe^{2+}) iron. Heme iron is derived from hemoglobin, myoglobin, and other heme proteins in foods of animal origin, representing approximately 10% to 15% of iron content in the typical Western diet,⁹ although heme-derived iron accounts for 2/3 of absorbed iron in meat-eating humans. Exposure to acid and proteases present in gastric juices frees the heme from its apoprotein. Heme is taken up by mucosal cells, but the specific receptor is still unknown.¹⁰ Once heme iron has entered the cell, the porphyrin ring is enzymatically cleaved by heme oxygenase.¹¹ The liberated iron then probably follows the same pathways as those used by nonheme iron. A small proportion of the heme iron may pass into the plasma intact via heme exporter protein FLVCR (feline leukemia virus, subgroup C receptor),¹² which transfers heme onto a heme-binding protein, hemopexin.¹³ Absorption of heme iron is relatively unaffected by the overall composition of the diet.⁹

Dietary nonheme iron is largely in the form of ferric hydroxide or loosely bound to organic molecules such as phytates, oxalate, sugars, citrate, lactate, and amino acids. Low gastric pH is thought to be important for the solubility of inorganic iron. Dietary constituents may also have profound effects on the absorption of nonheme iron, making the bioavailability of food iron highly variable.⁹ Ascorbate, animal tissues, keto sugars, organic acids, and amino acids enhance inorganic iron absorption, whereas phytates, polyphenols, and calcium inhibit it.¹⁴ Depending on various combinations of enhancing and inhibitory factors, dietary iron assimilation can vary as much as tenfold.

Molecular Mechanisms of Iron Absorption

Absorption of nonheme iron occurs in the duodenum, where ferrous iron is imported into enterocytes by divalent metal ion transporter 1 (DMT1, also known as Nramp2, DCT1, SLC11A2).^{15,16} DMT1 is a protein with 12 predicted transmembrane segments, which is expressed on the apical surface of absorptive enterocytes. Levels of DMT1 are markedly increased in iron-deficient animals¹⁷ and in some animals with increased intestinal iron absorption resulting from other causes.¹⁸ In addition to iron, DMT1 may also contribute to the absorption of other nutritionally important metals (e.g., Mn^{2+}).¹⁹ Evidence in vitro demonstrates that DMT1 is a proton-coupled symporter.^{15,20} The Na^+/H^+ exchanger in the duodenum is thought to create the "acid microclimate" that provides the proton electrochemical gradient as the driving force for iron uptake.¹⁶

DMT1 does not transport the Fe^{3+} form of iron, but as discussed previously, most dietary nonheme iron arrives at the brush border as Fe^{3+} ion. A duodenal cytochrome b-like ferrireductase enzyme, Dcytb (also called CYBRD1), likely reduces dietary Fe^{3+} to make it a substrate for transport by DMT1.²¹ Dcytb is induced in response to stimuli that increase iron absorption; however, since knockout mice appear to have normal metabolism, Dcytb may not be the only ferrireductase enzyme involved in absorption of nonheme iron.²²

A variable fraction of iron taken into the mucosal cell is delivered to the plasma. The remainder is used by the cell or incorporated into ferritin,²³ an intracellular iron storage protein discussed in a later section. Iron retained in mucosal ferritin is not absorbed, rather, it is lost from the body when the senescent mucosal cells are sloughed into the intestine at the end of their 3- to 4-day lifespan (10^{11} cells/day).²⁴

Iron not stored in the absorptive enterocytes is transferred across the basolateral membrane of the cell to the lamina propria and ultimately to the plasma. This is accomplished, at least in part, by the iron exporter ferroportin (also known as FPN1, IREG1, MTP1, SLC40A1), a multi-transmembrane segment protein expressed on the basolateral surface of enterocytes.^{25,26,27,28} Ferroportin is also expressed in other tissues involved in handling large iron fluxes including macrophages recycling iron from old red blood cells, hepatocytes storing iron, and placental trophoblast delivering iron from mother to fetus. Complete ablation of ferroportin in mice, including extraembryonic tissues, resulted in embryonic death,²⁸ whereas selective inactivation that preserved placental ferroportin expression resulted in live births, demonstrating the essential function of ferroportin in materno-fetal iron transfer. Ferroportin is also essential for systemic iron homeostasis as inactivation of ferroportin in all tissues in mice other than placenta led to the development of severe

anemia resembling iron deficiency, and stemmed from the inability to mobilize iron from enterocytes, macrophages, and hepatocytes.²⁸

Similar to apical iron uptake, basolateral iron efflux is aided by an enzyme that changes the oxidation state of iron. Ferroportin exports Fe^{2+} and this iron must be oxidized to its Fe^{3+} form to bind to transferrin. A membrane-bound multicopper oxidase, hephaestin, has been implicated in this process.²⁹ Hephaestin closely resembles ceruloplasmin,³⁰ which has been shown to be involved in efflux of iron from hepatocytes and macrophages. Mice carrying a large deletion in the X-chromosomal hephaestin gene²⁹ have impaired placental iron transfer and decreased intestinal iron absorption.^{31,32} Their iron deficiency results in anemia during the neonatal period, but affected animals generally recover and show only subtle evidence of iron deficiency as adults. The simplest interpretation is that hephaestin is important in placental iron transport but dispensable for intestinal iron uptake. The functional relationship between hephaestin and ferroportin has not yet been defined in detail. A model incorporating current knowledge of nonheme iron transport is shown in Figure 23.1.

Regulation of Iron Absorption

Because the total body iron content is largely determined by the efficiency of absorption of iron, the regulation of absorption has been of great interest for many years. Both systemic mechanisms and local mechanisms within enterocytes (discussed later in the chapter) regulate dietary iron uptake. The systemic signals that are of prime importance in determining absorptive rate are the

P.619

amount of storage iron in the body and the erythropoietic activity. When storage iron is depleted, iron absorption is increased; when it is excessive, iron absorption is decreased. This has been termed the stores regulator.³³ The erythroid regulator³³ modulates iron absorption in response to erythropoietic need and mediates an increase in intestinal iron absorption when the red cell production rate is increased. This is observed in effective as well as in ineffective erythropoiesis when erythroid precursors are destroyed relatively close to their site of origin in the bone marrow (as seen in thalassemia syndromes, congenital dyserythropoietic anemias, and sideroblastic anemias). It is now known that the hormone hepcidin functions as both the stores and erythroid regulator.

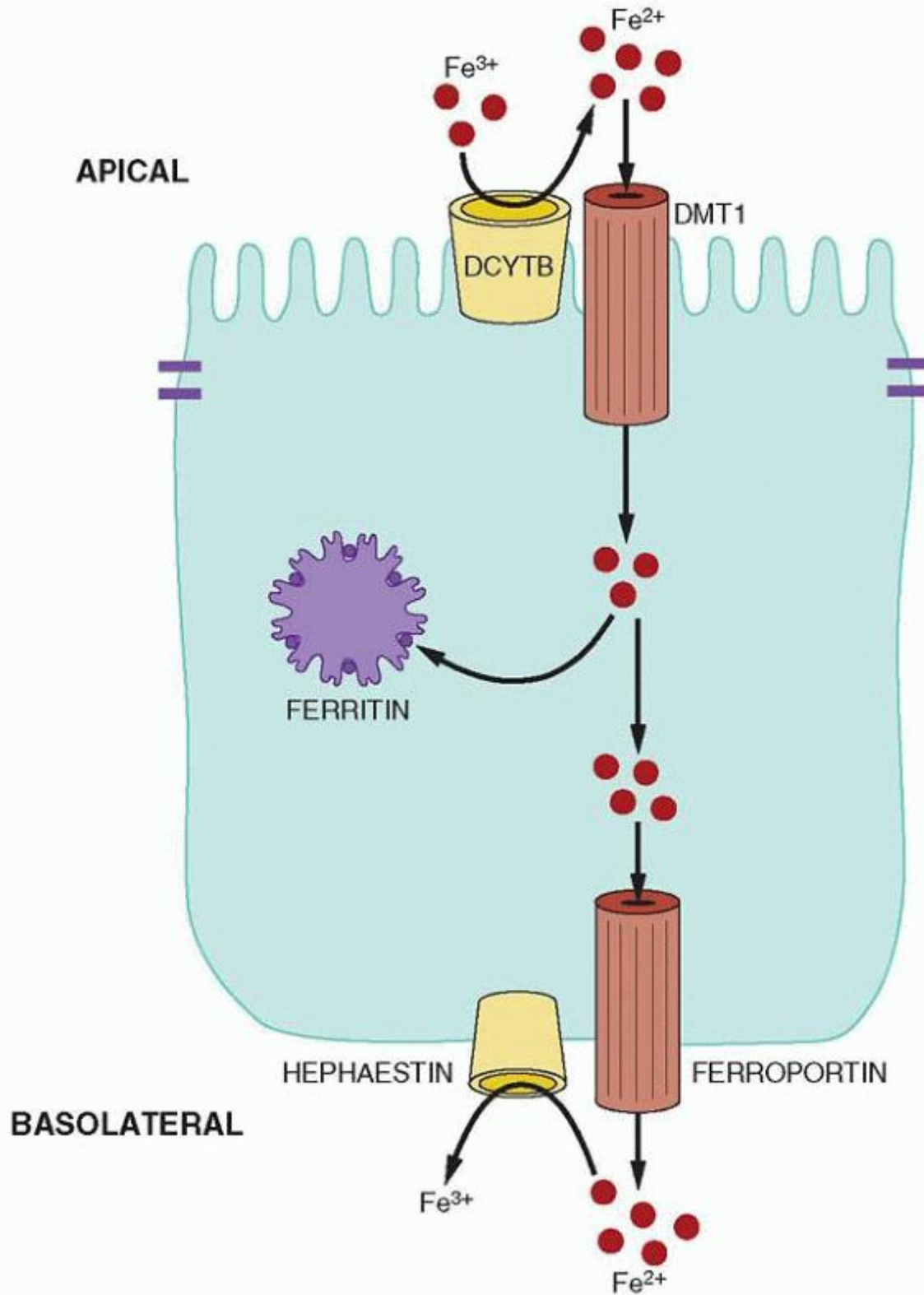

FIGURE 23.1. Nonheme iron absorption in the intestine. The figure shows a drawing of an absorptive enterocyte from the proximal duodenum. The apical brush border is at the top. Dietary nonheme iron enters the gut as the ferric (Fe^{3+}) ion and is converted to the ferrous (Fe^{2+}) ion by a surface reductase activity, probably mediated by the duodenal cytochrome b-like (DCYTB) protein. The Fe^{2+} iron enters the cell through the action of divalent metal ion transporter 1 (DMT1). Within

the cell, some iron is stored, and some is transported across the basolateral membrane. Ferroportin is believed to function as a basolateral Fe^{2+} iron transporter. Hephaestin, a ferroxidase, facilitates basolateral iron export, possibly by oxidizing the iron as it exits the cell to the Fe^{3+} form to bind to plasma apotransferrin.

Hepcidin and Systemic Regulation of Iron Metabolism

Hormone hepcidin has emerged as the key systemic regulator of iron homeostasis. Hepcidin is a small peptide of 25 amino acids, produced in the liver, secreted into the plasma, and excreted through the kidneys.^{34,35} Hepcidin is structurally similar to antimicrobial peptides involved in innate immunity, but its main role is to inhibit iron fluxes into plasma.³⁶ Mutations in the human hepcidin gene cause severe, early-onset iron overload.³⁷ Mice lacking hepcidin also develop severe iron overload,³⁸ whereas transgenic mice constitutively expressing hepcidin have severe iron deficiency anemia.³⁹ A single injection of synthetic hepcidin into mice exerts a prolonged hypoferremic effect.⁴⁰ All of these effects can be explained by the biologic activity of hepcidin. Hepcidin binds to the iron exporter ferroportin, causing ferroportin endocytosis and lysosomal degradation,⁴¹ and resulting in cessation of cellular iron export. Thus, hepcidin directly and coordinately controls the entry of iron into the plasma from ferroportin-expressing cells, including absorptive cells of the intestine and tissue macrophages (Fig. 23.2).

Alterations in hepcidin production lead to changes in iron absorption and recycling. Multiple signals are known to regulate hepcidin expression, including iron, erythropoiesis, inflammation, and growth factors.

As with other hormones that are feedback regulated by the substances whose concentration they control, hepcidin expression is controlled by iron. When iron is deficient, hepatocytes produce less hepcidin, allowing more iron to enter plasma. When iron is abundant, hepcidin production increases, limiting further iron absorption and release from stores. In human volunteers ingesting a single dose of oral iron, hepcidin concentrations in urine increased within several hours and were proportional to the increase in transferrin saturation.⁴² Serum hepcidin concentrations in healthy subjects also correlate with body iron stores as reflected by serum ferritin.⁴³ The specific forms of iron that increase hepcidin synthesis may include diferric plasma transferrin and intracellular iron in hepatocytes, and the transduction pathways that regulate hepcidin synthesis in response to these iron forms are just now being elucidated.

The two transferrin receptors TfR1 and TfR2, and HFE, an MHC class I-like membrane protein, may serve as holotransferrin sensors.³⁶ HFE can interact with both transferrin receptors, but this interaction is modulated by holotransferrin concentrations. Because HFE and holotransferrin binding sites on TfR1 overlap, increasing concentrations of holotransferrin result in displacement of HFE from TfR1, and free HFE then interacts with

P.620

TfR2.^{44,45} TfR2 protein is further stabilized by binding of holotransferrin.⁴⁶ The holotransferrin/HFE/TfR2 complex then stimulates hepcidin expression through an incompletely understood pathway, possibly by potentiating BMP pathway signaling. HFE, however, may also regulate hepcidin expression without complexing with TfR2.⁴⁷ The role of HFE or TfR2 in hepcidin regulation by iron is supported by genetic evidence: HFE and TfR2 mutations in humans or mice cause hepcidin deficiency and an adult form of hemochromatosis.³⁶

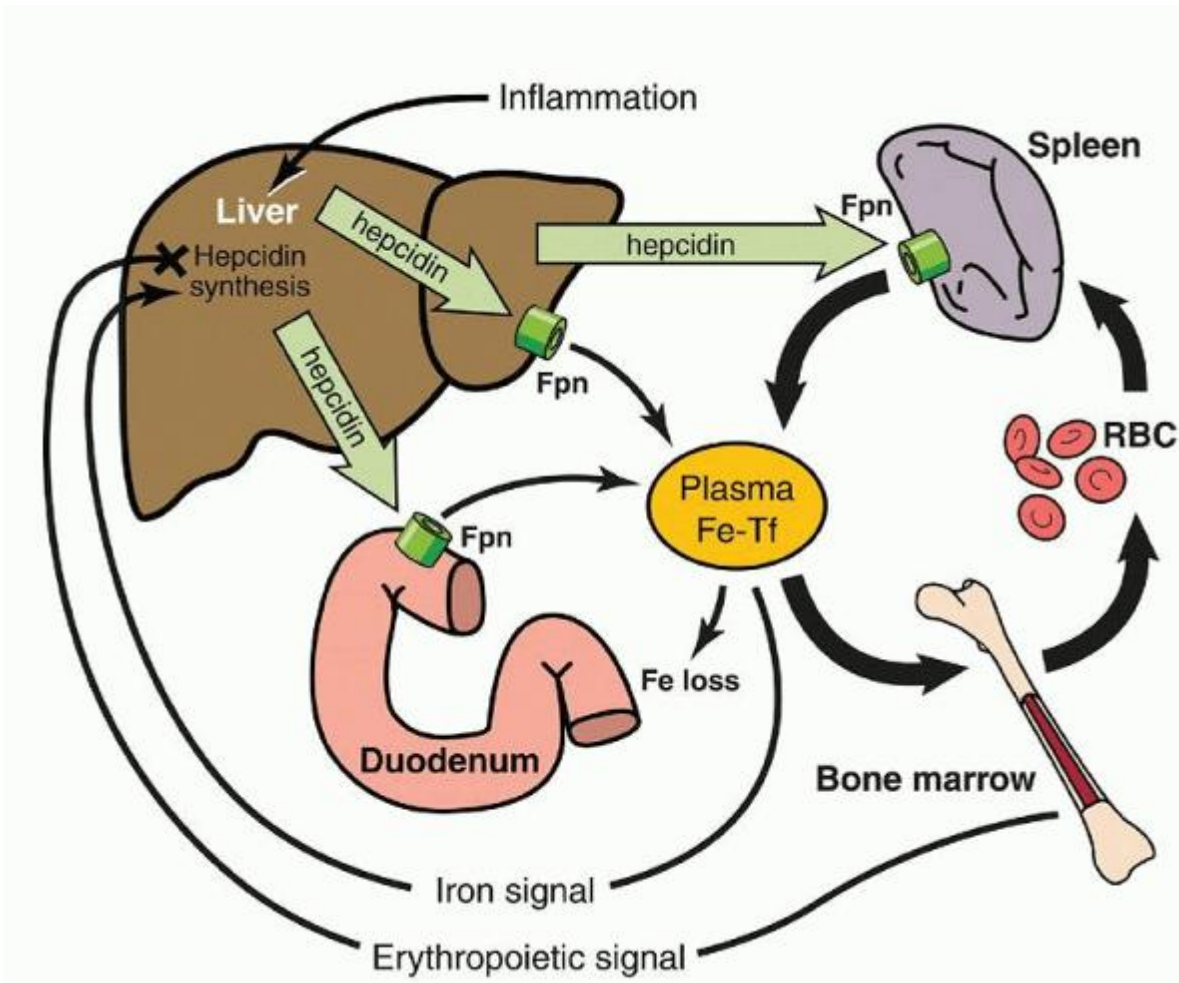

FIGURE 23.2. Regulation of systemic iron homeostasis by hepcidin. Hepcidin controls the entry of iron into plasma by causing degradation of its receptor, the iron exporter ferroportin. The major iron flows that are regulated by hepcidin-ferroportin interactions include the release of iron from macrophages that recycle iron in the spleen and the liver, dietary iron absorption in the duodenum, and, at least in part, the release of iron from storage in hepatocytes. The feedback stimulation of hepcidin by plasma holotransferrin and iron stores ensures that extracellular iron concentration and iron stores stay within normal limits. Hepcidin synthesis is suppressed by erythropoietic activity, ensuring a sufficient supply of iron to the bone marrow when demand for hemoglobin synthesis is high. During inflammation, hepcidin production is stimulated and iron entry into plasma is inhibited, causing the hypoferrremia and anemia of inflammation. From Ganz T. Molecular control of iron transport. *J Am Soc Nephrol* 2007;18(2):394-400.

The BMP pathway with its canonical signaling via Smad proteins has a central role in the regulation of hepcidin transcription. BMP receptors are tetramers of serine/threonine kinase receptors, with two type I and two type II subunits. Recent data indicate that type I subunits Alk2 and Alk3 and type II subunit ActRIIA and BMPRII are specific BMP receptors involved in iron regulation.^{48,49} In the liver, BMP pathway signaling to hepcidin is modulated by a coreceptor hemojuvelin and, at least in mice, by the ligand BMP6.^{50,51,52} Loss of hemojuvelin or BMP6 in mice decreases hepcidin expression and impairs hepcidin response to acute or chronic iron loading.⁵³ In humans, hemojuvelin mutations result in severe hepcidin deficiency and cause juvenile hemochromatosis.⁵⁴ No pathogenic human mutations in BMP6 have yet been identified. It remains to be clarified how BMP receptors and hemojuvelin interact with iron-sensing molecules that regulate hepcidin expression.

Two other membrane proteins, a serine protease matriptase-2 (MT-2, also called transmembrane protease serine 6, Tmprss6) and the receptor neogenin also influence hepcidin synthesis, likely by modulating hemojuvelin concentration on the cell membrane.^{55,56} Whether these molecules are involved in iron sensing is unclear, but the concentration of hepatic MT-2 is acutely increased by iron deficiency.⁵⁷ Mutations in MT-2 in humans and in mice lead to increased hepcidin expression and development of iron-restricted anemia, discussed later in this chapter.

As already mentioned, hepcidin synthesis also increases in response to stored intracellular iron in hepatocytes but the underlying mechanism is yet unclear. Hepatic BMP6 mRNA increases in response to iron loading, suggesting that BMP6 may be a mediator of intracellular iron signal.⁵⁸ However, hepcidin increase after chronic iron loading is still observed in BMP6-deficient mice,⁵³ indicating that additional pathways must play a role in hepcidin regulation by intracellular iron. Figure 23.3 summarizes our current understanding of the molecular mechanisms involved in hepcidin regulation by iron.

Hepcidin synthesis, and consequently absorption of iron and its availability for erythropoiesis, is also regulated by erythropoiesis itself. Increased erythropoietic activity due to bleeding, hemolysis, or administration of erythropoietin in humans or mice causes hepcidin suppression.^{59,60,61} Very low hepcidin concentrations are observed in patients with absolute iron deficiency anemia, or anemias with high erythropoietic activity.⁴³ In turn, low hepcidin allows increased absorption of dietary iron and release of iron from stores, thus increasing iron supply to the bone marrow for hemoglobin synthesis. The mechanisms by which erythropoiesis regulates hepcidin production are not well understood, but it is thought that erythroid precursors in the bone marrow secrete a factor which exerts its effect on hepatocytes and causes hepcidin suppression.⁶⁰

The suppressive effect of erythropoiesis on hepcidin is particularly prominent in diseases with ineffective erythropoiesis such as β -thalassemia,^{62,63} where erythrocyte precursors massively expand but undergo apoptosis rather than mature into erythrocytes. The severe suppression of hepcidin, particularly in untransfused β -thalassemia, leads to increased iron absorption and the development of lethal iron overload. Growth differentiation factor GDF-15, a BMP-related protein released by erythroid precursors during cellular stress or apoptosis, may contribute to hepcidin suppression in anemias with expanded but ineffective erythropoiesis.⁶⁴ However, GDF-15 does not seem to be involved in homeostatic hepcidin suppression by effective erythropoiesis.⁶⁵

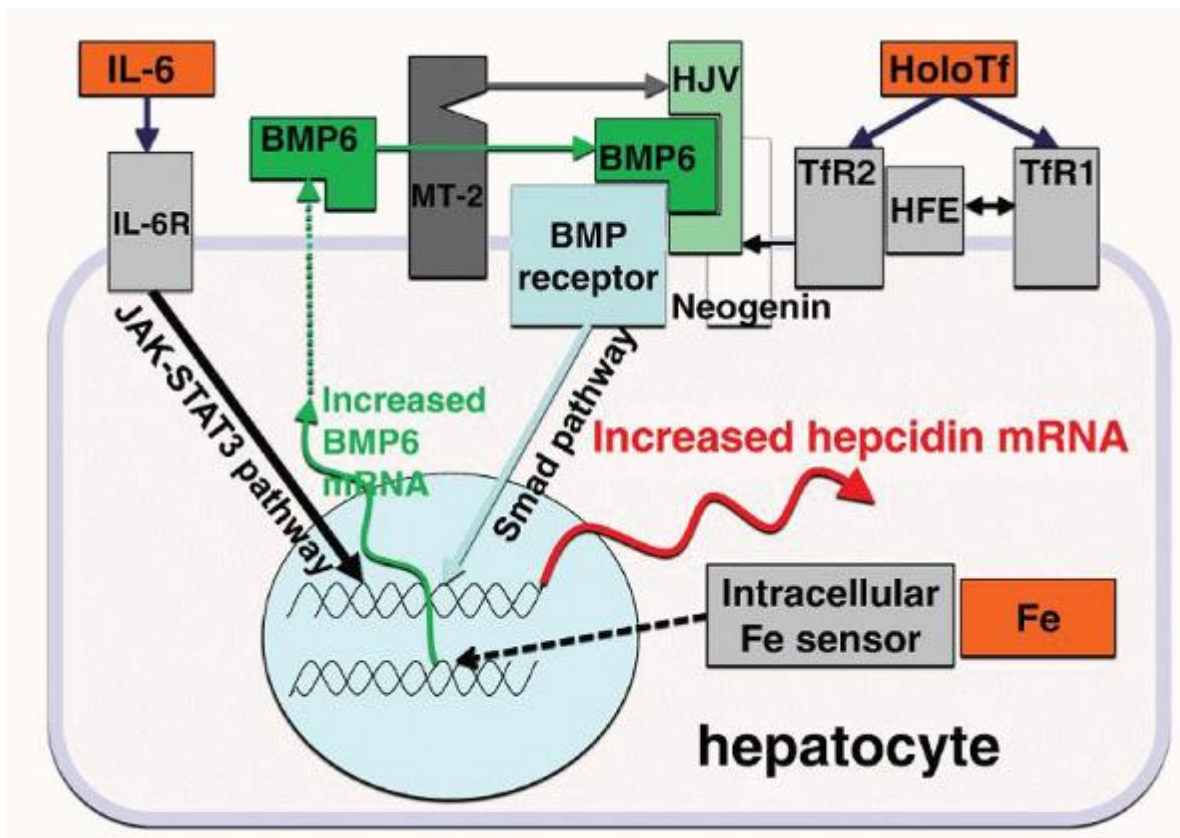

FIGURE 23.3. Molecular mechanisms of hepcidin regulation. Hepcidin is regulated by iron, inflammation, and erythropoiesis, but molecular details for the latter are not understood. In the iron-regulated pathway, extracellular iron in the form of holotransferrin (HoloTf) is sensed by the two transferrin receptors (Tfr1 and Tfr2). Binding of HoloTf to its receptors promotes HFE interaction with Tfr2 instead of Tfr1, and HFE/Tfr2 complex then sensitizes the BMP receptor to its ligands such as BMP6. Hemojuvelin (HJV), a membrane-linked BMP pathway coreceptor, also potentiates the BMP receptor activation. Once activated, BMP receptors initiate SMAD signaling which increases hepcidin transcription. This pathway is also modulated by matriptase-2 (MT-2) protease which cleaves hemojuvelin, and by neogenin which may augment or stabilize membrane hemojuvelin. Intracellular iron in hepatocytes also increases hepcidin expression, possibly

through a mechanism that enhances BMP6 production, eventually leading to activation of the BMP receptor. Alternative ligands with BMP6-like activity must exist because mice that lack BMP6 still increase hepcidin mRNA in response to iron stores. Hepcidin transcription is prominently increased by inflammation, predominantly through the activity of IL-6, its receptor, and its canonical JAK-STAT3 pathway. From Ganz T, Nemeth E. Hepcidin and iron homeostasis. *Biochim Biophys Acta*. 2012 Jan 26 [Epub].

Hepcidin gene expression is induced in response to inflammatory cytokines,⁶⁶ accounting for iron sequestration in the anemia of inflammation (see Chapter 45).^{59,67} IL-6 signaling through the STAT-3 pathway seems to be a key regulator of hepcidin expression in inflammation.^{68,69} Apart from increased transcription, elevated hepcidin concentrations in circulation could result from impaired renal clearance of hepcidin. Because of its small size (2.7 kDa), hepcidin is filtered through the glomerular membrane and is then taken up and degraded in the proximal tubule. A fraction of the filtered hepcidin is excreted into urine, and urinary hepcidin concentrations are proportionate to plasma hepcidin levels in healthy subjects.⁴³ In chronic kidney diseases, however, hepcidin clearance is impaired,⁷⁰ contributing to the hormone accumulation in plasma.

Regulation of Iron Absorption by Intracellular Mechanisms

In addition to the regulation by systemic signals, iron absorption is subject to local regulation by intracellular mechanisms in duodenal enterocytes. At least two mechanisms have been described: one related to the enterocyte iron levels and the other to the hypoxia pathway.

Intracellular iron levels in enterocytes (and most other cells) are sensed by two iron-regulatory proteins (IRP1 and IRP2).⁷¹ When cytoplasmic iron is low, IRPs bind to iron-regulatory elements (IREs),⁷² stem-loop structures located in the 5' or 3' untranslated regions of different mRNAs. Binding of IRPs to 3' IREs stabilizes mRNAs by protecting them from endonucleolytic cleavage, resulting in increased protein synthesis. mRNAs which contain 3' IREs encode iron uptake proteins such as transferrin

P.621

receptor and a DMT1 isoform. In contrast, IRP binding to 5' IREs blocks translation of mRNA, by preventing the interaction with the cap-binding complex eIF4F and the small ribosomal subunit,⁷³ resulting in decreased protein synthesis. 5' IREs are present in ferritin mRNA and one of ferroportin transcripts. In iron-replete cells, neither IRP binds to IREs, resulting in greater degradation of 3' IRE-containing transcripts (e.g., Tfr1), and increased translation of 5' IRE-containing transcripts (e.g., ferritin), thus shifting the cellular phenotype from an iron-importing to an iron-storing one.

How does intracellular iron concentration modulate IRP binding to IREs? IRP1 contains a 4Fe•4S iron-sulfur cluster that, when saturated with iron, converts IRP1 to a cytosolic aconitase that catalyzes the conversion of citrate to isocitrate.^{74,75,76} In this enzyme form, IRP1 has low affinity for IREs in mRNAs. When iron-poor, IRP1 loses its aconitase activity and greatly increases its affinity for IREs. IRP2 is less abundant than IRP1 and does not have an identified enzyme function. Instead, intracellular iron levels control its degradation.^{77,78} In iron-replete cells, IRP2 is ubiquitinated by an iron-sensitive E3 ubiquitin ligase complex containing FBXL5 protein,^{79,80} and ubiquitinated IRP2 is degraded by proteasomes.

Targeted inactivation of the genes encoding murine IRPs has shed light on the roles of IRP1 and IRP2 in vivo. It is still not entirely clear why it is necessary to have two IRPs, but they may respond differently over the physiologically relevant range of oxygen tensions.⁸¹ There are no obvious consequences from the loss of IRP1 alone, and loss of IRP2 results in mildly abnormal iron homeostasis and iron-deficient erythropoiesis.^{82,83} Loss of both IRP proteins is incompatible with life.⁸⁴ Tissue-specific knockout of both IRPs in the intestine of mice confirmed their role in the regulation of iron transport in enterocytes. These animals had higher protein levels of ferroportin and ferritin and lower protein levels of DMT1. The knockout mice also had impaired intestinal function and died within 4 weeks of birth.⁸⁵

Even though IRPs regulate translation of ferroportin mRNA through its 5' IRE, duodenal ferroportin protein expression is paradoxically increased in iron deficiency. Recently, an alternative ferroportin transcript (FPN1B) was identified that could explain this phenomenon. FPN1B, which is highly expressed in the duodenum, lacks IRE and thus is not subject to translational repression by IRPs when intracellular levels are low.⁸⁶ This ensures that the transfer of iron from absorptive enterocytes into plasma continues even when those cells are iron deficient.

Dcytb mRNA also does not contain an IRE but is strongly upregulated in iron-deficient duodenum,⁸⁷ indicating additional regulation of transcription of iron-related genes. Hypoxia-inducible factor (HIF) transcription factors may serve as important local regulators of intestinal iron absorption. Iron deficiency induced HIF signaling in duodenum of mice, and caused increased DcytB and DMT1 expression, and an increase in iron uptake.⁸⁸ Accordingly, targeted deletion of Hif-2α in

the intestine resulted in dramatic decrease in the expressions of DMT1-IRE and Dcytb mRNA.⁸⁹ In vitro studies further demonstrated that HIF-2 α directly binds to the promoters of DMT1 and Dcytb, activating their transcription. Thus, HIF-2 α appears to be one of the critical local regulators of iron absorption.

Iron Cycle

Most functional iron in the body is not derived from daily intestinal absorption (1 to 2 mg/day) but rather from recycling of iron (20 to 25 mg/day) from senescent erythrocytes and other cells (Fig. 23.4). The most important source and destination of recycled iron is the erythron. At the end of a 4-month lifespan, effete erythrocytes are engulfed by reticuloendothelial macrophages, which lyse the cells and degrade hemoglobin to liberate their iron. This process is poorly understood, but it appears to involve the action of heme oxygenase for enzymatic degradation of heme. Some of this iron may remain stored in macrophages as ferritin or hemosiderin, but most is delivered to the plasma, and the rate of iron export is determined by the hepcidin-ferroportin interaction. In plasma, iron becomes bound to transferrin, completing the cycle. A small amount of iron, probably <2 mg, leaves the plasma each day to enter hepatic parenchymal cells and other tissues. Here, the iron is stored or used for synthesis of cellular heme proteins, such as myoglobin and the cytochromes.

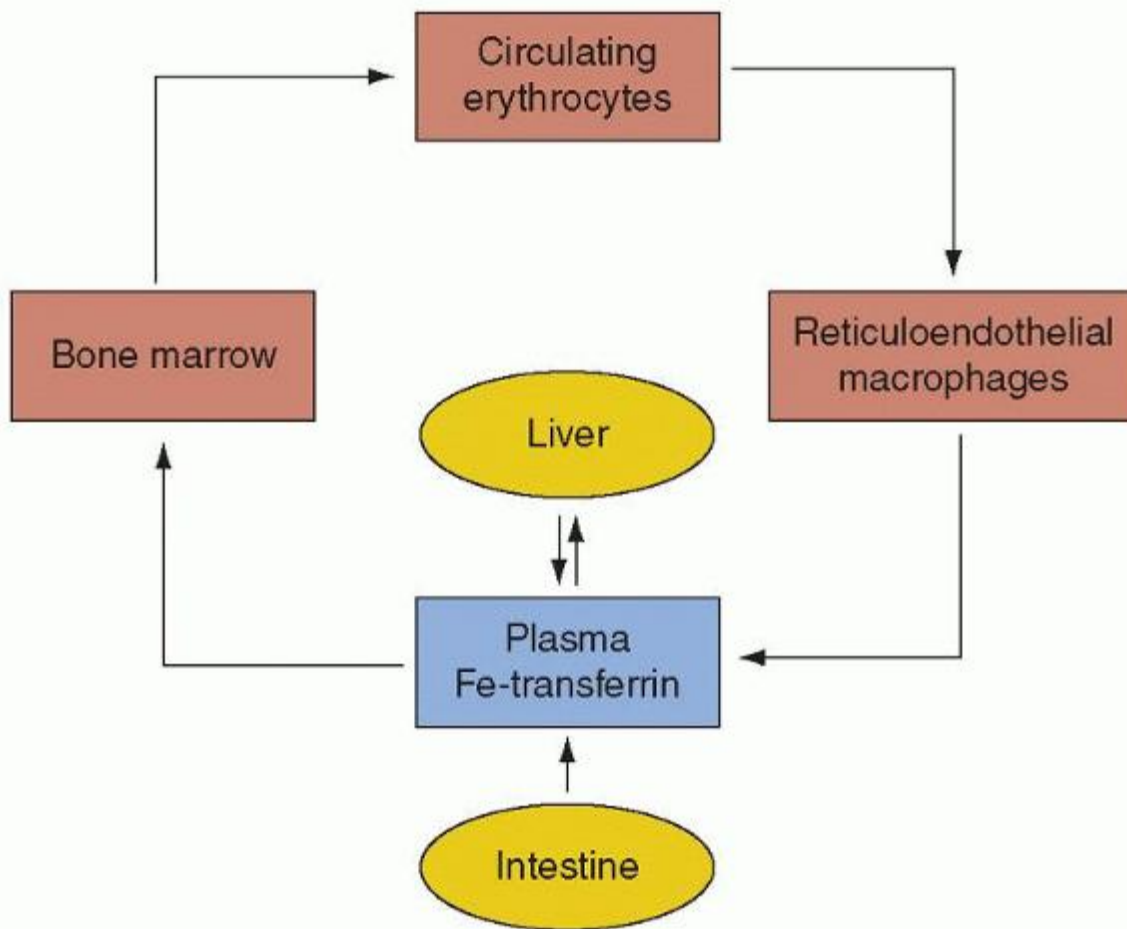

FIGURE 23.4. Iron cycle in humans. Iron (Fe) enters the body through the small intestine and travels in the plasma bound to transferrin. It is delivered to the erythroid bone marrow, where it is incorporated into hemoglobin and released into the circulation in mature erythrocytes. After a lifespan of approximately 120 days, erythrocytes are engulfed by macrophages in the reticuloendothelial system. There the Fe is extracted from hemoglobin and returned to plasma, where it becomes bound to transferrin, completing the cycle. Fe in excess of tissue needs is stored in the liver.

Plasma Transport

The plasma iron-binding protein, transferrin, is a glycoprotein with a molecular weight of approximately 80 kDa.⁹⁰ Transferrin is synthesized chiefly in the liver and actively secreted by hepatocytes, but lesser amounts are made in other tissues, including the central nervous system, the ovary, the testis, and helper T lymphocytes (T4⁺ subset). The rate of

synthesis shows an inverse relationship to iron in stores; when iron stores are depleted, more transferrin is synthesized, and when iron stores are overfilled, the level of transferrin decreases. Transferrin keeps iron nonreactive in the circulation and extravascular fluid, delivering it to cells bearing transferrin receptors.

Transferrin can be measured directly using immunologic techniques; and normal concentration in the plasma is approximately 2 to 3 g/L. Alternatively, transferrin is quantified in terms of the amount of iron it will bind, a measure called the total iron-binding capacity (TIBC; normal values for plasma iron and TIBC are given in Appendix A). In the average subject, the plasma iron concentration is $\sim 18 \mu\text{mol/L}$ ($100 \mu\text{g/dl}$), and the TIBC is $\sim 56 \mu\text{mol/L}$ ($300 \mu\text{g/dl}$). Thus, only about one third of the available transferrin binding sites are occupied, leaving a large capacity to deal with excess iron. Plasma iron concentration varies over the course of the day, with the highest values in the morning and the lowest in the evening. Levels of serum transferrin are more constant, and there is no apparent diurnal variation in TIBC. General practice has been to evaluate transferrin saturation using a first morning, fasting sample to standardize the results, but this may not be helpful.⁹¹

Transferrin has two homologous iron-binding domains, each of which binds an atom of trivalent (ferric) iron.⁹² The iron atoms

P.622

are incorporated one at a time and appear to bind randomly at either or both of the two sites. When binding is complete, the iron lies in a pocket formed by two polypeptide loops. One mole of anion, usually carbonate or bicarbonate, is taken up, and 3 moles of hydrogen ion are released for each mole of iron bound. There are functional differences between the two iron-binding sites,⁹³ but it is not clear that these have physiologic importance.

Under physiologic circumstances, ferric iron binds to transferrin with very high affinity, with an affinity constant of $\sim 1\text{-}6 \times 10^{22} \text{ M}^{-1}$. The affinity of iron-transferrin interaction is pH-dependent, decreasing as pH is lowered. Other transition metals, such as copper, chromium, manganese, gallium, aluminum, indium, and cobalt, can be bound by transferrin but with less affinity than iron.

Iron Delivery to Erythroid Precursors

The biologic importance of transferrin in erythropoiesis is illustrated by abnormalities observed in patients and mice with congenital atransferrinemia.^{94,95} and ^{96,97,98} When transferrin is severely deficient, red cells display the morphologic stigmata of iron deficiency. This occurs despite the fact that intestinal iron absorption is markedly increased in response to a perceived need for iron for erythropoiesis. Nonhematopoietic tissues avidly assimilate the non-transferrin-bound metal. Similarly, mutant mice lacking tissue receptors for transferrin die during embryonic development from severe anemia, apparently resulting from ineffective iron delivery to erythroid precursor cells.⁹⁸

Transferrin delivers its iron to developing normoblasts and other cells by binding to specific cell-surface receptors. The transferrin receptor (TfRC, TfR1) is a disulfide-linked homodimer of a glycoprotein with a single membrane-spanning segment and a short cytoplasmic segment. It is a type II membrane protein, with its N terminus located within the cell. The native molecular weight of TfR1 is $\sim 180 \text{ kDa}$. Each TfR1 homodimer can bind two transferrin molecules. Diferric transferrin is bound with higher affinity (association constant $2\text{-}7 \times 10^9 \text{ M}$) than monoferric transferrin. As a result, diferric transferrin has a competitive advantage in delivering iron to the erythroid precursors.⁹⁹ Apotransferrin has little affinity for the receptor at physiologic pH but considerable affinity at lower pH, an important factor in intracellular iron release.

Transferrin receptor 2 (TfR2), which shares $\sim 45\%$ homology with TfR1 in its large extracellular domain,¹⁰⁰ binds transferrin with lower affinity, and its role in cellular iron uptake is unclear. TfR2 is highly expressed in the liver and, as discussed earlier in this chapter, acts as an iron sensor that regulates hepcidin expression.³⁶ TfR2 is also expressed in erythroid precursor cells, where it interacts with the erythropoietin receptor and enhances the delivery of EpoR to cell surface.¹⁰¹

The role of TfR1 is relatively well understood. TfR1 numbers are modulated during erythroid cell maturation, reaching their peak in intermediate normoblasts. Very few TfR1 molecules are found on burst-forming-unit erythroid cells, and only slightly greater numbers are found on colony-forming-unit erythroid cells. However, by the early normoblast stage, approximately 300,000 receptors are found on each cell, increasing to 800,000 at the intermediate stages. The rate of iron uptake is directly related to the number of receptors. The number decreases as reticulocytes mature, and late in maturation, erythroid cells shed all remaining receptors by exocytosis and by proteolytic cleavage.¹⁰² The shed receptors (referred to as soluble transferrin receptors, sTfR) can be found in plasma in a concentration that correlates with the rate of erythropoiesis.¹⁰³ An increase in plasma sTfR is a sensitive indicator of erythroid mass and tissue iron deficiency.^{104,105}

After ligand and receptor interact, iron-loaded transferrin undergoes receptor-mediated endocytosis (Fig. 23.5).¹⁰⁶ Specialized endocytic vesicles form, which are acidified to a pH of 5 to 6 by the influx of protons. The low pH facilitates release of iron from transferrin and strengthens the apotransferrin-receptor interaction. Released iron is reduced by an endosomal ferrireductase, STEAP3,¹⁰⁷ and transferred to the cytosol by DMT1.¹⁰⁸ Because DMT1 must cotransport protons with iron atoms, vesicle acidification is also important for the function of this transporter. After the iron enters the cytosol, the protein components of the endosome return to the membrane surface, where neutral pH promotes the release of apotransferrin to the plasma. Both transferrin and TfR1 participate in multiple rounds of iron delivery.

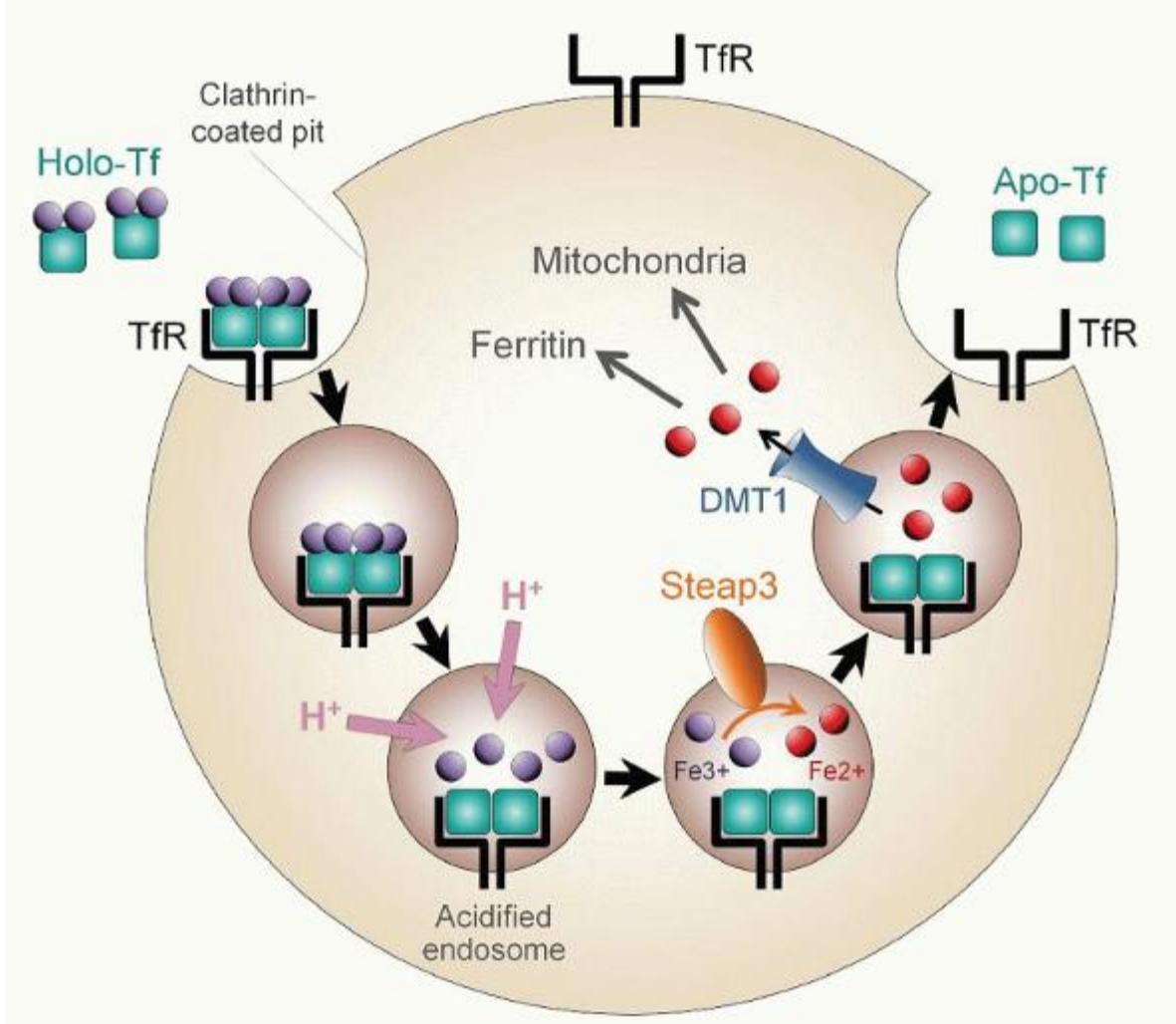

FIGURE 23.5. Cellular uptake of iron-transferrin. Iron bound to plasma Tf (HoloTf) is delivered to the cell by binding to cell-surface transferrin receptor 1 (TfR). The ligand-receptor complex enters the cell through invagination of clathrin-coated pits to form specialized endosomes. The endosomes become acidified through the entry of protons, releasing Fe^{3+} iron from Tf and strengthening the apo-Tf/TfR complex at low pH. The released iron is reduced to Fe^{2+} by STEAP3 ferrireductase and exits the endosome through the divalent metal ion transporter 1 (DMT1) to go to sites of storage and use within the cell (ferritin, mitochondria). The apo-Tf/TfR complex then returns to the cell surface, where apo-Tf is released. Both Tf and TfR participate in multiple rounds of iron delivery.

Mutations in DMT1 can have profound effect on erythroid development. Although rare, DMT1 mutations have been described in several patients with congenital iron deficiency anemia.^{109,110,111} The patients suffer from severe microcytic, hypochromic anemia, due to the inability to transport iron out of Tf/TfR1 endocytic vesicles, thus preventing iron delivery for heme synthesis. Although DMT1 is also involved in duodenal iron absorption, most of these patients develop hepatic overload at a young age, suggesting that iron absorption is at least partially intact, probably due to dietary heme absorption. Blood transfusions to correct the anemia also contribute to patients' iron overload.

Once inside the cell, erythroid iron must be shuttled to the mitochondrion, where it will be incorporated into protoporphyrin IX by ferrochelatase, the final enzyme of heme biosynthesis. How iron that is exported from endosome

reaches the mitochondrion and is transported across the outer mitochondrial membrane is not well understood. Iron transport across the inner mitochondrial membrane seems to be mediated by mitoferrin-1, a transmembrane iron transporter.¹¹² Inactivation of the mitoferrin-1 gene in mice prevents red blood cell production, underscoring the importance of this protein in erythroid biology. An alternative mechanism for iron delivery from Tf/TfR endosome to the mitochondrion has also been proposed. The “kiss and run” hypothesis suggests that the Tf-containing endosome directly contacts the mitochondrion,¹¹³ thereby bypassing the cytosol. The details of the mechanism remain to be determined.

P.623

The rate of iron entry into normoblasts is intimately related to heme biosynthesis.¹¹⁴ In less mature erythrocyte precursors, an optimal amount of heme may be necessary to sustain TfR1 synthesis.¹¹⁵ Furthermore, a decrease in intracellular free heme concentration induced by inhibitors of heme synthesis (e.g., isoniazid) leads to increased iron uptake, and an increase in intracellular free heme induced by inhibitors of globin synthesis (e.g., cycloheximide) has the opposite effect. These phenomena appear to reflect a feedback inhibition system that regulates the supply of iron according to the needs of the cell for hemoglobin synthesis. This is part of a highly coordinated erythroid regulatory system that acts to balance the amounts of α - and β -globin proteins and heme, avoiding toxic buildup of any intermediates of hemoglobin production.¹¹⁶

Iron Metabolism within Normoblasts

In the normal subject, ~80% to 90% of the iron that enters erythroid precursor cells is ultimately taken up by mitochondria and incorporated into heme. Most of the remainder is stored in ferritin.¹¹⁷ Granules of ferritin may sometimes be detected using the Prussian blue reaction.¹¹⁸ Normoblasts with Prussian blue-positive (siderotic) granules are called sideroblasts, and, if the granules persist after enucleation, the mature cells are called siderocytes. In normal individuals, approximately half of the normoblasts are sideroblasts, each containing less than five small granules. By electron microscopy, these normal siderotic granules are seen to be aggregations of ferritin, often surrounded by a membrane (siderosomes).¹¹⁹ Isolated molecules of ferritin not surrounded by a membrane may also be seen by electron microscopy but not with light microscopy. Another kind of sideroblast, the ringed sideroblast, is found only under pathologic circumstances (sideroblastic anemias; see Chapter 24). In the ringed sideroblast, siderotic granules form a full or partial ring around the nucleus, and electron microscopy reveals that the iron is deposited in mitochondria. The spleen plays an active role in the removal of the iron-laden mitochondria when cells enter the circulation.

It is intriguing that even though erythroid precursors require large amounts of iron and heme for hemoglobin synthesis, they have been found to express the heme exporter FLVCR and the iron exporter ferroportin. FLVCR, initially identified as the receptor for feline leukemia virus subgroup C which causes erythroid aplasia in cats, is highly expressed in early erythroid precursors. The loss of FLVCR in mice caused embryonic lethality due to the lack of definitive erythropoiesis.¹²⁰ When FLVCR was ablated postnatally, the mice developed a hyperchromic macrocytic anemia with proerythroblast maturation arrest. These studies suggest that FLVCR is necessary for survival of erythroid precursors. Because heme is toxic to cells at high concentrations, it is thought that FLVCR functions as a safety valve to prevent accumulation of excess heme early during erythroid differentiation.

Erythroid precursors also express ferroportin^{86,121} but its role in erythroid maturation is yet unclear. It is interesting that erythroid cells preferentially express non-IRE ferroportin transcript during the stages of rapid iron uptake, thus avoiding any iron-induced increase in ferroportin translation dependent on the IRE/IRP system.

Macrophage Iron Recycling

Although there are many types of tissue macrophages, those that participate in the catabolism of red blood cells can be subdivided into two categories. One type, exemplified by pulmonary alveolar macrophages, is able to phagocytose erythrocytes or other cells and convert the iron they contain into storage forms, but lacks the ability to return the iron to the circulation. This type of macrophage appears to retain the iron throughout its life span. The second type of macrophage, comprising the reticuloendothelial system, acquires iron in a similar fashion but is able to return it to the plasma. The latter macrophages, found especially in the sinuses of the spleen and the liver, play a primary role in the normal reutilization of iron from destroyed red cells, allowing completion of the iron cycle shown in Figure 23.4.

After erythrophagocytosis by reticuloendothelial macrophages, the red cell membrane is destroyed, heme is released from hemoglobin, and iron is liberated by heme oxygenase. The subcellular location of these events is not well defined. Subsequently, two phases of macrophage iron release are observed: an early phase, complete within a few hours after

erythrophagocytosis, and a later phase, taking place over a period of days.¹²² Iron is exported from macrophages through ferroportin, the iron exporter that is also found on the basolateral surface of absorptive enterocytes.²⁸ The early phase probably reflects immediate export of iron resulting from the sequential induction of ferroportin mRNA expression by heme released from hemoglobin, and ferroportin protein translation by heme-derived iron acting via the IRE/IRP system.¹²³ The later phase of iron release probably represents mobilization of stored iron in response to iron demand. This is likely achieved by modulating expression of hepcidin, the iron-regulatory hormone that causes degradation of macrophage ferroportin. Expression of hepcidin decreases when erythroid iron needs increase, allowing more ferroportin molecules to remain on the membrane of recycling macrophages.¹²⁴ Iron exported through ferroportin must be oxidized to be bound to transferrin. The ferroxidase reaction is catalyzed by the plasma copper protein, ceruloplasmin.¹²⁵ When the gene encoding ceruloplasmin was disrupted in mice, macrophages failed to release their iron at a normal rate, resulting in hypoferremia despite the presence of normal iron stores.¹²⁵ The abnormality was corrected by administering ceruloplasmin intravenously. A similar phenomenon was noted in aceruloplasminemic human subjects.¹²⁶ Ceruloplasmin probably acts by catalyzing the oxidation of ferrous iron to the ferric form, which is a prerequisite for iron binding by apotransferrin.

Because of the large daily iron flux through erythrophagocytosing macrophages (20 to 25 mg), iron release from macrophages is a critical determinant of the availability of iron for plasma transferrin and, consequently, for erythropoiesis. The anemia of inflammation, also called the anemia of chronic disease,¹²⁷ characterized by macrophage iron retention, illustrates the deleterious effects of perturbing the delicate balance between macrophage iron storage and release (see Chapter 45).

Intracellular iron in macrophages is stored in two compounds: ferritin and hemosiderin. Iron-free ferritin (apoferritin) exists as a sphere with a diameter of 13 nm.¹²⁸ It has a hollow central cavity, 6 nm in diameter, which communicates with the surface by six channels through which iron and other small molecules can enter and leave. The protein shell is constructed of 24 molecules of two distinct ferritin subunits, designated H (for heavy or heart) and L (for light or liver), and these proteins are ubiquitously expressed. H and L ferritins are highly homologous, suggesting that they were derived from a common ancestral protein. However, there are functional differences between the two subunits. Loss of ferritin H in mice causes early embryonic lethality indicating that there is no functional redundancy between the two ferritin subunits.¹²⁹ H chains contain a ferroxidase center not found in L chains and are able to oxidize iron.^{130,131} Ferritin shells rich in H chains reflect this property and acquire iron more rapidly,¹³² whereas those rich in L chains appear to be more stable and resistant to denaturation. The primary role of ferritin is cellular protection against oxidative damage that would be caused by highly reactive free iron.¹³³

At least 20 distinct ferritin heteropolymers, with varying proportions of L and H chains, have been isolated from human tissue.¹³⁴ Fully assembled, iron-free apoferritin has a molecular weight of approximately 400 to 500 kDa. When iron is

P.624

incorporated into the molecule, it is deposited in the central core. Theoretically, a single ferritin molecule could hold up to ~4,500 iron atoms. More often, molecules with 2,000 or fewer iron atoms are found. The iron is stored as a trivalent polymer of ferric hydroxide and phosphate.

Although H and L chains make up the abundant cytoplasmic ferritin molecules, a unique ferritin protein is present in mitochondria, and is encoded by a distinct intronless gene.¹³⁵ Mitochondrial ferritin appears to have a ferroxidase activity, making it most analogous to H-ferritin.¹³⁶ Although incompletely understood, the role of mitochondrial ferritin is important enough that it has been conserved among species and can even be found in fruit flies.¹³⁷

In a wide variety of cell types, the synthesis of apoferritin is stimulated by exposure to iron.¹³⁸ This effect of iron takes place at the translational level of protein synthesis, via the IRE/IRP system described earlier in the chapter. An iron-responsive element (IRE) found at the 5' end of ferritin mRNAs is both necessary and sufficient for the iron effect.¹³⁹ In red cell precursors, hemin rather than iron itself may exert a similar function.^{115,140}

Apoferritin is formed first, and iron is added later. A cytosolic iron chaperone, poly(rC)-binding protein 1 (PCBP1), delivers iron in the form of Fe²⁺ to ferritin.¹⁴¹ Iron then enters ferritin through one of the six penetrating channels. As it passes into the core, it is oxidized to the Fe³⁺ form by molecular oxygen, with apoferritin catalyzing the oxidative process.¹⁴² Iron is deposited irregularly and in varying amounts, forming microcrystals. Mobilization of iron from ferritin depends on iron reduction or chelation.

Ferritin is also found in plasma in small amounts (12 to 300 µg/L), and in the absence of inflammation,¹⁴³ the circulating ferritin concentration correlates roughly with the amount of iron in stores. Plasma ferritin appears to be actively secreted into plasma, primarily by macrophages^{144,145} and is iron-poor compared to tissue ferritin.

Hemosiderin was formerly distinguished from ferritin on the basis of solubility and the Perls Prussian blue reaction. However, these distinctions are not reliable; as with hemosiderin, ferritin can also be stained with Prussian blue and can exist in insoluble forms. Hemosiderin is not a precisely definable chemical entity.¹⁴⁶ It appears to be formed by incomplete degradation of ferritin and conglomeration of iron, ferritin proteins, and other subcellular constituents. It differs from ferritin in having a higher iron-to-protein ratio as well as being less soluble in aqueous solutions. Standard hemosiderin preparations may contain a variety of organic constituents, including proteins, lipids, sialic acid, and porphyrins. In most instances, hemosiderin appears to be derived from ferritin. Hemosiderin appears to represent a more stable and less available form of storage iron than ferritin. Newly deposited or newly mobilized iron enters or leaves the ferritin compartment. Only after prolonged storage or continued mobilization does the hemosiderin compartment change in size.

Iron Metabolism in Other Tissues

Iron is required in small amounts by all tissues for the synthesis of iron-containing enzymes and proteins, including cytochromes, catalase, ribonucleotide reductase, ferrochelatase, and globins. Cells are generally thought to acquire their iron from transferrin through binding to cell-surface transferrin receptor 1, although there is little experimental evidence that this is the major iron acquisition mechanism in most cases. Aside from erythroid precursors and tumor cells, iron uptake by hepatic parenchymal cells has been most extensively studied. Normally, approximately 5% of iron leaving plasma is accounted for by this pathway.¹⁴⁷ This fraction increases markedly when transferrin saturation increases or when erythropoiesis is depressed. Transferrin is not essential for iron assimilation by hepatocytes or most other nonhematopoietic cells, as demonstrated by atransferrinemic human patients and hypotransferrinemic (hpx) mice, both of which develop marked iron overload in nonhematopoietic tissues.

The placenta also accepts iron from transferrin and may do so even at relatively low plasma iron levels, thus effectively competing with the maternal erythroid bone marrow. The export of iron from placental trophoblast into fetal circulation occurs through ferroportin, and this step is controlled by fetal hepcidin.¹²⁴ Some iron in placenta is stored within ferritin and hemosiderin.

Skeletal muscle uses iron for myoglobin synthesis and also maintains an iron storage pool that, although large, is not easily mobilized for use by other tissues.¹⁴⁸ Proliferating cells in many tissues have increased numbers of transferrin receptors compared to their quiescent counterparts, reflecting their need for iron.

IRON DEFICIENCY ANEMIA

Pathogenesis of Iron Deficiency Anemia

Although its handling is frequently termed "iron metabolism", iron itself is not metabolized; iron disorders are of iron balance or distribution. Iron deficiency anemia, hemochromatosis, and the anemia of chronic disease/inflammation are each examples of this principle.

Three pathogenic factors are implicated in the anemia of iron deficiency. First, hemoglobin synthesis is impaired as a consequence of reduced iron supply. Second, there is a generalized defect in cellular proliferation. Third, survival of erythroid precursors and erythrocytes is reduced, particularly when the anemia is severe.

When transferrin saturation falls below ~15%, the supply of iron to the marrow is inadequate to meet basal requirements for hemoglobin production (generally ~25 mg of iron daily in average adults). As a result, the amount of free erythrocyte protoporphyrin increases, reflecting the excess of protoporphyrin over iron in heme synthesis. Globin protein synthesis is reduced and each cell that is produced contains less hemoglobin, resulting in microcytosis and hypochromia. This is the normal adaptive response to iron deficiency in humans and mice. If globin synthesis was not decreased in heme deficiency, misfolding and precipitation of excess globin chains would lead to apoptosis. Globin synthesis is controlled by heme availability at both the transcriptional and translational levels. Heme regulates globin gene expression by its ability to bind a transcription suppressor Bach1. When heme is deficient, Bach1 associates with small Maf proteins (sMafs) and causes transcriptional repression of globin genes.^{149,150} When heme is abundant, heme binding to Bach1 causes its dissociation from sMafs and Bach1 degradation,^{151,152} permitting sMaf interaction with transcriptional activators to increase expression of globin genes.

On the translational level, heme regulates globin synthesis by binding to and controlling the activity of heme-regulated eIF2α kinase (HRI).¹⁵³ HRI functions by phosphorylating the α subunit of a key regulatory translation initiation factor eIF2 and preventing its participation in the initiation of translation. With high intracellular heme concentrations, heme binds to

HRI and renders it inactive, but in heme deficiency, heme dissociates from HRI, and the kinase is activated by autophosphorylation. HRI then phosphorylates eIF2 α , preventing the recycling of eIF2 for another round of protein synthesis initiation, resulting in reduced globin protein synthesis and preventing formation of toxic globin precipitates in the absence of heme. In Hri^{-/-} mice, the adaptive hypochromic and microcytic response to iron deficiency was absent.¹¹⁶ Iron deficiency and consequently decreased heme levels instead resulted in aggregation of globins within the erythrocytes and their precursors, causing increased apoptosis of

P.625

erythroid precursors in the bone marrow and spleen, and accelerated destruction of mature RBCs that were hyperchromic and normocytic.

Cellular proliferation is also restricted in iron deficiency, and red blood cell numbers fall. Although there is relative erythroid hyperplasia in the bone marrow, both the degree of erythroid hyperplasia and the reticulocyte count are low for the degree of anemia. There is a significant component of "ineffective erythropoiesis" in iron deficiency, and a proportion of immature erythroid cells in iron-deficient subjects are so defective that they are rapidly destroyed. Their iron is reused within the bone marrow, making the interpretation of ferrokinetic studies more complicated.^{154,155}

In iron deficiency, survival of circulating erythrocytes is normal or somewhat shortened.^{156,157,158,159} Cross-transfusion studies indicate that the shortened survival results from an intracorporeal defect. There is a strong correlation between the degree to which red cell survival is shortened and the proportion of morphologically abnormal cells on blood smear.¹⁵⁶ The principal site of destruction is the spleen.¹⁵⁸ The reduced erythrocyte viability is associated with decreased membrane deformability.¹⁶⁰ This abnormality appears to result from oxidative damage to the membrane.^{160,161}

Other iron-containing proteins are also reduced in iron deficiency, and some of these may be responsible for clinical and pathologic manifestations. It is suggested that many of the enzymes are depleted in proportion to the degree of anemia.¹⁶² Among the iron proteins reduced in iron deficiency are cytochrome c,^{162,163} cytochrome oxidase,^{164,165} α -glycerophosphate oxidase,^{166,167} muscle myoglobin,^{162,163} succinic dehydrogenase, and aconitase.

In iron-deficient rats, impaired exercise performance correlated with reduced levels of α -glycerophosphate oxidase in muscle.^{166,167} As a result, glycolysis was impaired, which led to lactic acidosis and, in turn, adversely affected work performance. Lactic acidosis was also noted in a patient with severe iron deficiency anemia.¹⁶⁸ Levels of catecholamines are increased in the blood and urine of iron-deficient patients and animals.^{169,170} The increase is explained in part by decreased tissue levels of monoamine oxidase.^{171,172} Conceivably, a disturbance in catecholamine metabolism may contribute to the behavioral disturbances seen in iron-deficient children.^{173,174} As described later, there are several characteristic epithelial changes in iron deficiency. The pathogenesis of these abnormalities is not understood, but it is reasonable to assume that deficiencies in tissue iron enzymes are at fault.

TABLE 23.2 GENES INVOLVED IN HEREDITARY IRON DEFICIENCY ANEMIA

Protein (Gene Symbol)	Chromosome	Protein Function	Disease Caused by Mutations
DMT1 (SLC11A2)	12	Transmembrane iron transporter	Hypochromic, microcytic anemia, usually with hepatic iron overload ^{109,110,111}
Glutaredoxin 5 (GLRX5)	14	Participates in iron-sulfur cluster biogenesis	Anemia with iron overload and sideroblasts ¹⁷⁵
Transferrin (TF)	3	Plasma iron-binding protein; ligand for TfR1 and TfR2	Atransferrinemia, iron deficiency anemia with tissue iron overload ^{94,95,97}
Ceruloplasmin (CP)	3	Plasma ferroxidase	Aceruloplasminemia, mild iron deficiency anemia associated with iron accumulation in the liver and brain ¹⁷⁶
Matriptase-2 (TMPRSS6)	22	Hepcidin suppressor, acts by cleaving membrane hemojuvelin	Iron-refractory iron deficiency anemia (IRIDA) ^{177,178,189,190}

Modified from Andrews NC. Forging a field: the golden age of iron biology. *Blood* 2008;112:219-230.

Genetic Forms of Iron Deficiency Anemia

Genes involved in hereditary iron deficiency anemia are listed in Table 23.2.^{81,97,175,176,177,178} The main biologic and clinical difference in genetic forms of iron deficiency anemia are outlined in Table 23.3.

Several forms of genetic iron deficiency anemia are associated with hypochromic microcytic anemia and iron overload outside of the erythron. These are caused by autosomal recessive mutations in several genes and are exceedingly rare. DMT1 (SLC11A2) encodes an iron transporter involved in dietary iron absorption and iron transfer from Tf/TfR endosomes into the cytosol of erythroid precursors. Glutaredoxin 5 (GLRX5) is an enzyme involved in mitochondrial iron-sulfur cluster biogenesis. The human patients carrying these mutations have similar blood films and erythrocyte abnormalities, but also have hepatic iron overload that is not fully explained by their transfusion histories.^{109,110,111,175,179,180} Deficiency of serum transferrin, called hypotransferrinemia or atransferrinemia, is due to mutations in the transferrin gene itself.^{97,181} This interrupts iron delivery to erythroid precursors, triggering an increase in intestinal iron absorption and consequent tissue iron deposition. Deficiency of another major plasma protein, ceruloplasmin, also causes mild iron deficiency anemia associated with iron accumulation in the liver and brain.¹⁷⁶ Iron deficiency results from lack of ferroxidase activity needed to mobilize iron from storage.^{176,182,183}

Some patients have congenital, iron-refractory iron deficiency anemia (IRIDA) without iron overload.^{178,184,185,186,187,188,189} and¹⁹⁰ The disease is caused by recessive mutations in the *Tmprss6* gene, which encodes serine protease matriptase-2. This gene is mutated in a novel mouse mutant, Mask.¹⁹¹ In addition to a hair pattern that led to the strain name, Mask mice have severe iron deficiency anemia attributable to elevated hepcidin expression. Matriptase-2 is highly expressed in the liver, and acts by cleaving hemojuvelin, a BMP pathway coreceptor and a key regulator of hepcidin expression.^{56,178} Measurement of serum hepcidin concentrations in IRIDA patients confirmed that hepcidin levels were much higher than would be expected for the degree of iron deficiency and anemia, where hepcidin is usually undetectable.^{178,189,190} How *TMPRSS6* expression or activity is regulated is still unknown. Further studies will be needed to evaluate the possibility that less severe or heterozygous mutations increase susceptibility to common, acquired iron deficiency anemia. In genome-wide association studies (GWAS), common variants of *TMPRSS6* were associated with alterations in hemoglobin levels, serum iron,

P.626

or erythrocyte volume,^{192,193,194} and¹⁹⁵ suggesting that *TMPRSS6* has a critical role in maintenance of iron homeostasis and normal erythropoiesis.

TABLE 23.3 MAIN BIOLOGIC AND CLINICAL DIFFERENCES IN GENETIC FORMS OF IRON DEFICIENCY ANEMIA

	DMT1	Glutaredoxin 5	Atransferrinemia	Aceruloplasminemia	TMPRSS6 (Matriptase-2)
Age at diagnosis	At birth	Usually midlife	Late onset provided some Tf is present	Late onset with moderate anemia	18-24 mo
Liver iron overload	Yes	Yes	Yes	Yes	No
Brain damage	No	No	No	Yes	No
Serum iron	High	High	Low	Low	Low
Transferrin saturation	High	High	High or nonmeasurable	Low	Low
Ringed sideroblasts	No	Yes	No	No	No
Hepcidin levels	Low to normal	Not yet measured	Low	Low	High for anemia

Ferritin	Low to mildly elevated	High	High	High	Low to normal
-----------------	------------------------	------	------	------	---------------

Provided courtesy of Photis Beris.

CLINICAL FEATURES OF IRON DEFICIENCY

Stages in the Development of Iron Deficiency

When it is not a result of major blood loss, iron deficiency is the end result of a long period of negative iron balance. As the total body iron level begins to fall, a characteristic sequence of events ensues. First, the iron stores in the hepatocytes and the macrophages of the liver, spleen, and bone marrow are depleted. Once stores are gone, plasma iron content decreases, and the supply of iron to marrow becomes inadequate for normal hemoglobin production. Consequently, the amount of free erythrocyte protoporphyrin increases, production of microcytic erythrocytes begins, and the blood hemoglobin level decreases, eventually reaching abnormal levels.

This progression corresponds to three recognized stages. The first stage, also called prelatent iron deficiency or iron depletion, represents a reduction in iron stores without reduced serum iron levels.¹⁹⁶ This stage is usually detected by a low serum ferritin measurement, unless inflammation is present in which case serum ferritin does not reflect storage iron.¹⁴³ Latent iron deficiency is said to exist when iron stores are exhausted but the blood hemoglobin level remains higher than the lower limit of normal.¹⁹⁷ In this second stage, certain biochemical abnormalities of iron-limited erythropoiesis may be detected, including reduced transferrin saturation, increased TIBC,¹⁹⁸ increased free erythrocyte protoporphyrin,¹⁹⁹ increased zinc protoporphyrin,²⁰⁰ and increased serum transferrin receptor (sTfR).²⁰¹ The mean corpuscular volume usually remains within normal limits, but a few microcytes may be detected on a blood smear. Patients report generalized fatigue or malaise, even though they are not yet anemic.

Finally, in the third stage, the blood hemoglobin concentration falls below the lower limit of normal, and iron deficiency anemia is apparent. Iron-containing enzymes, such as the cytochromes, also reach abnormally low levels during this period. Clinical manifestations include a constellation of constitutional symptoms: fatigue, decreased exercise tolerance with tachycardia, dermatologic manifestations, decreased intellectual performance, dysphagia, depression, and restless legs syndrome.²⁰² This progression forms the basis for the stages of iron deficiency outlined in Table 23.4. It has been confirmed by experiments in which normal volunteers were gradually depleted of iron by phlebotomy.^{203,204}

TABLE 23.4 STAGES IN THE DEVELOPMENT OF IRON DEFICIENCY

	Stage 1 (Prelatent)	Stage 2 (Latent)	Stage 3 (Anemia)
Bone marrow iron	Reduced	Absent	Absent
Serum ferritin	Reduced	<30 µg/L	<30 µg/L
Transferrin saturation	Normal	<16%	<16%
Free erythrocyte protoporphyrin, zinc protoporphyrin	Normal	↑	↑
Serum transferrin receptor	Normal	↑	↑
Reticulocyte hemoglobin content	Normal	↓	↓
Hemoglobin	Normal	Normal	Reduced
Mean corpuscular volume	Normal	Normal	Reduced
Symptoms	Rare	Fatigue, malaise in some patients	Pallor, pica, epithelial changes

↑, increased; ↓, decreased.

Prevalence

Iron deficiency is the most common nutritional deficiency in both developing and developed countries. Iron deficiency anemia may be defined by cutoff hemoglobin values of 12.1 g/dl in women and 13.8 g/dl in men at or near sea level, with

higher cutoff values at high altitude.²⁰⁵ In the United States, the most comprehensive surveys for iron deficiency anemia have been the National Health and Nutrition Examination Surveys (NHANES). According to data from NHANES III, covering the years 1988 to 1994, the

P.627

prevalence of hypoferrremia in the United States was <1% in adult men <50 years of age, 2% to 4% in adult men >50 years of age, 9% to 11% in menstruating teenagers and women, and 5% to 7% in postmenopausal women. Inasmuch as serum ferritin is an acute phase reactant regulated by inflammation, these data may underestimate the prevalence of anemia in some populations, particularly the elderly. Recent analyses have estimated prevalence of iron deficiency anemia in the elderly (>65 years of age) and extreme elderly (>75 years of age) ranging from 10% to up to 36%.^{206,207,208}

Iron deficiency is particularly common in young children and pregnant women. Iron deficiency was detected in 9% of infants and toddlers, with anemia in approximately one third of those children.²⁰⁹ In infancy, the occurrence of iron deficiency was equal in both sexes. It is usually detected between the ages of 6 and 20 months. The peak incidence was at a younger age in infants born prematurely than in those born at term, because premature infants do not have full opportunity to acquire maternal iron during the third trimester. The prevalence of iron deficiency was also higher among people living in chronic poverty.²¹⁰ Iron deficiency tends to run in families, possibly as a result of economic factors. If an iron-deficient child is identified, the mother and siblings of that child are frequently also deficient. Despite the prevalence of iron deficiency anemia in these populations, the US preventative services task force recommends screening only for pregnant women.²¹¹

Etiology

Iron deficiency occurs as a late manifestation of prolonged negative iron balance, as a result of major blood loss, or because of failure to meet an increased physiologic need for iron. The normal mechanisms for maintaining iron balance were discussed earlier in this chapter. Factors leading to negative iron balance, increased requirements, or inadequate iron for erythropoiesis are listed in Table 23.5. In many instances, multiple etiologic factors are involved. The association of a marginal diet with some source of blood loss, such as that associated with menstruation, is a common combination. Another example is hookworm infestation, which produces anemia primarily in those people whose diets are marginally adequate.

Diet

The total amount of iron in the diet roughly correlates with caloric content; in the United States, the average diet contains ~6 mg of iron per 1,000 kcal. The bioavailability of dietary iron in specific foods was described earlier in this chapter.

The early stages of human evolution were characterized by hunter-gatherer food patterns and by diets rich in meat. In evolutionary terms, agriculture is a recent development to which humans have not fully adapted. Thus, individuals whose diets are rich in meat, a source of heme iron, usually absorb more iron from their diets than those who subsist on grains and vegetables. The increased prevalence of iron deficiency among the economically deprived and people in developing countries is explained in part by the fact that heme iron is less abundant in their diets.

Because many factors influence the bioavailability of iron, it is difficult to make recommendations about the optimal amount of iron in the diet. In the usual mixed diets of Western countries, adult men should consume 5 to 10 mg/day, and adult women should consume 7 to 20 mg/day.¹⁹⁶ Because women are usually smaller and consume less food than men, and because their requirements are greater, their daily iron intake may be marginal. Iron deficiency is rarely seen in American men as a result of diet alone. Exceptions to this rule are sufficiently unusual to justify case reports.²¹²

In many countries, foods are fortified to compensate for the insufficient amounts of iron in the diet.^{213,214} Selection of the food to fortify and the iron compound to use in fortification requires consideration of a number of factors. The iron salt should be absorbable but should not affect appearance, taste, or shelf life. The salt must be chosen with consideration of the food to be fortified, and that choice must be individualized to the target population. In Western countries, wheat flour is a typical choice; its use is widespread, and highly available ferrous salts can be used in such products as bread because their shelf life is inherently short. Target foods in other countries include salt, sugar, rice, and condiments. For infants, fortified milk- or soy-based formulas and dry cereals are important sources of iron in the diet.

TABLE 23.5 ETIOLOGIC FACTORS IN IRON DEFICIENCY ANEMIA

NEGATIVE IRON BALANCE

Decreased Iron Intake

Inadequate diet
Impaired absorption
Achlorhydria
Gastric surgery
Celiac disease
H. pylori infection
Duodenal bypass
Drugs that increase gastric pH
Tannins, phytates, bran
Competing metals
Inflammation, ↑ Hepsidin

Increased Iron Loss

Blood donation
Iatrogenic: diagnostic phlebotomy for testing
Gastrointestinal bleeding
Intestinal parasites
Anatomic lesions: hemorrhoids, gastritis, diverticulosis, varices, hiatal hernia, Meckel's diverticulum, arteriovenous malformation, peptic ulcer
Neoplasm
Inflammatory bowel disease
Milk-induced enteropathy (infants)
Use of salicylate or nonsteroidal anti-inflammatory agents (NSAIDS)
Excessive menstrual flow
Gynecologic neoplasm
Bladder neoplasm
Epistaxis
Hemoglobinuria
Self-induced bleeding (autophlebotomy)
Pulmonary hemosiderosis
Tuberculosis
Bronchiectasis
Hereditary hemorrhagic telangiectasia
Anticoagulant, antiplatelet therapies
Chronic hemodialysis
Runner's anemia

Increased Requirements

Infancy

Pregnancy

Lactation

Genetic Forms of Iron Deficiency Anemia

P.628

Impaired Absorption

Achlorhydria is common in iron-deficient subjects, both as a result of the deficiency and as a factor in its development.²¹⁵ Gastric acid facilitates absorption of nonheme iron,²¹⁶ probably by increasing its solubility rather than affecting the activity of the proton-symporter DMT1, and absorption of inorganic iron is profoundly impaired in patients with atrophic gastritis. Therapeutic measures used to reduce gastric acidity, such as the administration of antacids and drugs that block acid production, also impair iron absorption but usually not to a clinically significant degree. Gastric infection with *Helicobacter pylori* is now recognized as an important cause of otherwise unexplained iron deficiency anemia, which responds to eradication of the bacterial infection.²¹⁷

Iron deficiency anemia is a common complication of gastric surgeries, including total gastrectomy,²¹⁸ partial gastrectomy,²¹⁹ and vagotomy with gastroenterostomy.²²⁰ Reduction in gastric acidity is only one factor in the impaired iron absorption that follows such operations. Other gastric secretions that aid in iron absorption may also be lost.²²¹ Also, because most iron absorption takes place in the duodenum, the rapid intestinal transit that follows loss of the reservoir function of the stomach may lead to decreased absorption. For the same reason, iron deficiency is more common when the duodenum is surgically bypassed.²²⁰ Finally, recurrent bleeding, as well as increased sloughing of iron-containing epithelial cells, may contribute to the development of postgastrectomy anemia.²²¹

In addition to gastrectomy, other defects in the gastrointestinal tract may lead to malabsorption of iron, contributing to the development of iron deficiency. The anemia associated with celiac disease (gluten sensitivity, sprue, idiopathic steatorrhea) is often hypochromic rather than megaloblastic^{222,223}; in fact, iron deficiency anemia may be the initial and dominant manifestation of celiac disease, with steatorrhea detectable only by laboratory test analysis.^{222,224} Both malabsorption and intestinal blood loss are factors in the development of iron deficiency.²²³ Most patients with tropical sprue are deficient in iron.²²⁵

Copper Deficiency

It has long been known that copper deficiency is associated with abnormalities in iron metabolism and iron deficiency anemia. In recent years, it has become clear that this is due, at least in part, to the importance of the copper-containing ferroxidases ceruloplasmin and hephaestin. As mentioned earlier in this chapter, these enzymes are required for the optimal mobilization of iron from cells to plasma. They oxidize Fe^{2+} exported by ferroportin into Fe^{3+} form which can then bind to apotransferrin.

Blood Loss

Blood loss is a significant cause of iron deficiency anemia. It is important not only because of its prevalence, but also because the accurate detection, precise diagnosis, and proper management of the bleeding lesion may be of far greater importance to the ultimate well-being of the patient than repletion of iron stores. Each 1 ml of red blood cells contains ~1 mg of iron. Thus, assuming the consumption of an average diet, chronic RBC loss of as little as 1 to 2 ml/day can result in a negative iron balance.

Gastrointestinal Bleeding

Gastrointestinal bleeding is the most common cause of iron deficiency in adult men and is second only to menstrual blood loss as a cause in women. Any hemorrhagic lesion of the alimentary tract may cause iron deficiency. Most commonly, the lesions cause occult bleeding or the steady loss of small amounts of blood. They may go unnoticed or may be tolerated until the symptoms of anemia supervene. The list of etiologies presented here is not meant to be comprehensive; many other, less common, lesions have been reported to occur in association with isolated cases of iron deficiency anemia.

Two thirds of patients with hemorrhoids experience rectal bleeding, which is usually obvious to the patient. Nevertheless, a large majority of patients allow at least 1 year to elapse before seeking medical attention, and perhaps one third wait for more than 10 years. Nevertheless, although hemorrhoids are frequently associated with iron deficiency anemia, the clinician should be reluctant to accept them as the only bleeding lesions; a careful investigation is warranted because hemorrhoids may divert attention from another, less obvious, lesion elsewhere in the alimentary tract.

Upper gastrointestinal bleeding is typically due to duodenal or gastric ulcers or gastritis, all of which can cause sufficient blood loss to result in iron deficiency. Certain drugs are associated with gastrointestinal bleeding. Of these, nonsteroidal anti-inflammatory drugs (NSAIDs), including aspirin, are the most important. NSAID administration causes mucosal damage manifested by petechial hemorrhage, erosions, and ulcers. The problem is more likely to occur in elderly patients and women and with higher ("anti-inflammatory") doses than with lower ("analgesic") ones.²²⁶

Studies with aspirin demonstrate that at doses of 2 to 6 g daily, 70% of patients have gastrointestinal bleeding at an average rate of 5 ml/day.²²⁷ Regular use of aspirin more often than four times weekly is associated with bleeding.²²⁸ The incidence of aspirin-induced bleeding has probably decreased as the pattern of analgesic use has changed.

Acetaminophen, which is not associated with gastrointestinal bleeding, has become more popular than aspirin as an over-the-counter analgesic. Newer NSAID preparations are also less likely to cause significant gastrointestinal blood loss. The popularity of aspirin is on the rise again for prophylaxis of coronary artery disease, but in low doses. Other drugs associated with gastrointestinal bleeding include stanozolol, anticoagulants, antiplatelet agent therapy for coronary artery disease corticosteroids, and ethacrynic acid.

Iron deficiency anemia occurs in ~15% of patients with esophageal hiatal hernia.²²⁹ Anemia is particularly common (30%) with the paraesophageal variety of lesions and in large hernias.²³⁰ Reasons for the bleeding include reflux esophagitis and trauma to the gastric mucosa at the neck of the hernial sac.²²⁹ Anemia may be the presenting manifestation even in the absence of dyspeptic symptoms.

Colonic diverticuli can also bleed in patients with diverticulosis and diverticulitis. Usually, the blood loss is small and intermittent and may resemble the pattern of hemorrhoidal bleeding. Intestinal bleeding can also result from the presence of adenomatous polyps. A careful investigation for other sources of intestinal blood loss is warranted to exclude the possibility of a neoplasm.

Iron deficiency anemia may be the first sign of a malignant neoplasm of the gastrointestinal tract, and management of the bleeding lesion is important.^{143,231,232,233} Carcinoma of the cecum is often clinically silent until anemia occurs. Less often, in carcinomas of other parts of the colon, as well as of the stomach and the ampulla of Vater, iron deficiency anemia may be the only initial symptom.

In a survey of 32 patients with ulcerative colitis, 26 (81%) had iron deficiency anemia.²³⁴ Average fecal blood loss of 6 to 25 ml/day was noted in five patients who were moderately anemic with relatively mild symptoms of colitis.

An important cause of gastrointestinal blood loss in tropical areas is infection with intestinal and genitourinary parasites,²³⁵ including whipworm, *Trichuris trichiura*²³⁶; hookworm, *Necator americanus* or *Ancylostoma duodenale*^{237,238}; and schistosomes.²³⁹ Hookworm is particularly important, affecting some 20% of the world's population.²²⁵ It is endemic in a zone extending from the southern United States to northern Argentina in

P.629

the Western hemisphere, as well as in Mediterranean countries, South Asia, and Africa. The worms attach to the upper small intestine and suck blood from the host. The amount of blood lost is proportional to the number of worms harbored, which can be estimated by the fecal excretion of hookworm eggs. Female subjects harboring >100 worms (5 ml/day of blood loss) and male subjects harboring >250 worms (12.5 ml/day of blood loss) tend to become anemic.²³⁷ Other factors affecting iron balance including an iron-deficient diet, repeated pregnancies, and achlorhydria are contributory factors in development of hookworm anemia. At one time, many people believed that hookworm anemia resulted from elaboration of a toxin, but this is not the case. The anemia has all of the characteristics of iron deficiency and may be improved with iron therapy, whether or not the worms are removed. Conversely, removal of worms with an effective antihelminthic agent does not correct the anemia unless iron stores are replenished.

Schistosomiasis and trichuriasis are other parasitic infections associated with iron deficiency.²³⁵ With *Schistosoma mansoni*, blood loss is from the intestine, whereas with *Schistosoma haematobium* the loss is from the urinary tract.²³⁹ *Trichuris* (whipworm) has caused iron deficiency in inhabitants of Central America.²³⁶

Menstruation

Menstrual blood loss is the most common cause of iron deficiency in women.^{8,240,241,242} In healthy normal women, menstrual blood flow averages ~35 ml per menstrual period, and the upper limit of normal is ~80 ml per period. Although flow varies considerably among different women, it is remarkably constant from one period to the next in the same person. In Swedish women with a dietary intake of ~10 mg of iron per day, 67% of women with menstrual blood loss >80 ml per period were anemic.^{240,241} In another study, British women with iron deficiency anemia lost an average of 85 ml per period.²⁴² In contrast, a Canadian population with flows >80 ml per period had no overt anemia or hypoferrremia.²⁴³

Menstrual blood flow is increased by the use of certain intrauterine contraceptive devices²⁴⁴ and is reduced by the use of oral contraceptives. Estimating menstrual blood loss from information obtained in interviews is difficult because few women have a basis for determining the normality of their flow. It is important to elicit a history including a detailed description of the events during each menstrual period. Any of the following findings are indications of excessive menstrual flow: (a) inability to control flow with tampons alone; (b) use of more than 12 pads per period or 4 per day, unless the patient is unusually fastidious; (c) passage of clots, especially if they are larger than ~2 cm in diameter or if they persist after the first day; and (d) period duration exceeding 7 days.

Blood Donation

There are 5 million regular blood donors in the United States,²⁴⁵ and regular blood donation is an important source of iron loss. Each unit of blood donated contains 200 ml RBC²⁴⁶ equaling ~200 mg of iron. In most blood centers, a hemoglobin concentration, which is an insensitive determination for iron status, is the only indicator for iron deficiency anemia. As assessed by serum ferritin concentration, iron stores were reduced in 8% of male and 23% of female blood donors.²⁴⁵ The authors concluded that the use of iron supplements decreased the incidence of deficiency, and should be recommended to people who choose to donate more than once or twice a year. In a recent analysis of the RISE (Retrovirus Epidemiology Donor Iron Status Evaluation) study,²⁴⁷ for frequent blood donors, two thirds of women and almost half the men were iron deficient: the true prevalence among regular donors is even higher, inasmuch as the RISE study enrolled only frequent donors who had been accepted for donation, and excluded those deferred because of anemia. The unavoidable conclusion is that presently, blood collection practices fail to protect committed blood donors from iron deficiency.²⁴⁸ Re-examination of measures to prevent iron deficiency in women of child-bearing age by iron replacement after donation²⁴⁹ may now be in order to protect donors better, including changes in evaluation of iron status, in the hemoglobin standard, and internally between donations.²⁵⁰

Alveolar Hemorrhage

Acute hemorrhage into the pulmonary alveoli may be severe enough to cause the blood hemoglobin level to fall 1.5 to 3.0 g/dl in 24 hours.²⁵¹ Reticulocytosis and hyperbilirubinemia often accompany such episodes, leading to an incorrect diagnosis of hemolytic anemia. Iron in the shed blood is converted to hemosiderin by pulmonary macrophages, but it cannot be used for hemoglobin synthesis. Thus, repeated hemorrhages can lead to iron deficiency despite a normal total amount of body iron. Hemoptysis and alveolar infiltrates are the other prominent manifestations. However, if the hemorrhages are small, the hemoptysis may be unnoticed, making the diagnosis difficult without a chest x-ray examination. Patients may swallow the blood-containing sputum, rendering the stools positive for occult blood and resulting in further diagnostic confusion.

Idiopathic pulmonary hemosiderosis, an illness of children and young adults, is characterized by alveolar hemorrhage that is not due to another form of lung disease.^{252,253} Iron deficiency anemia almost invariably accompanies the disease and may be the initial and only symptom. Hemoptysis and alveolar infiltrates, however, are common manifestations. Interstitial fibrosis may develop after repeated episodes, with dyspnea, clubbing, and even cor pulmonale.

Anemia is also a common finding in antiglomerular basement membrane antibody disease (Goodpasture syndrome).^{253,254} The presence of renal disease distinguishes this illness from other forms of pulmonary hemosiderosis, but kidney involvement may not be evident early in the course of the disease or the degree of proteinuria or microscopic hematuria may be modest. Eventually, however, most patients develop azotemia. Focal or diffuse glomerulonephritis is evident from renal biopsy, and linear deposits of immunoglobulins are characteristic of, although not completely specific for, the disease. Detection of antibasement membrane antibodies in serum is ~80% to 85% sensitive and 98% specific for the diagnosis.²⁵¹

Other illnesses associated with pulmonary alveolar hemorrhage include rapidly progressive glomerulonephritis, systemic lupus erythematosus, and certain other collagen vascular diseases and systemic vasculitides. The presence of antineutrophil cytoplasm antibodies or other autoantibodies is considered a particularly poor prognostic sign in patients with pulmonary hemosiderosis.²⁵² Alveolar hemorrhage is also observed as a toxic reaction to trimellitic anhydride, d-penicillamine, or lymphangiography.

Hemoglobinuria

Paroxysmal nocturnal hemoglobinuria can result in urinary iron losses averaging 1.8 to 7.8 mg/day.²⁵⁵ Consequently, this rare disorder often is complicated by hypoferremia and hypochromic anemia.²⁵⁶ Hemoglobinuria in other disorders, such as the erythrocyte fragmentation syndromes associated with prosthetic cardiac valves, also may be complicated by iron deficiency.^{257,258}

Factitious Anemia

Self-induced blood-letting (autophlebotomy) is an unusual cause of iron deficiency.^{259,260} In almost all reported instances, such anemia occurred in unmarried women in paramedical occupations. Blood was removed by venipuncture or injuring preexisting

P.630

hemorrhoids, by laceration of the gastrointestinal tract with such instruments as knitting needles, or by means that remained obscure. A single case was reported in which an infant apparently developed severe iron deficiency as a result of deliberate parental action in which all iron from the child's diet was removed.²⁶¹

Hereditary Hemorrhagic Telangiectasia

Hereditary hemorrhagic telangiectasia is an uncommon disorder characterized by recurrent hemorrhages from the nose, gastrointestinal tract, and other sites. Iron deficiency anemia, sometimes very difficult to control, is an important complication of the illness.²⁶²

Iatrogenic Blood Loss

Diagnostic phlebotomy can result in substantial iron losses in patients with chronic disorders, particularly in hospitalized patients.^{263,264} In a study of 100 adult hospital inpatients in the 1980s, the average blood loss from diagnostic phlebotomy was 12.4 ml/day or 175.0 ml over the course of hospitalization on general wards.²⁶³ Patients in intensive care units lost an average of 41.5 ml/day or 762.0 ml during their stay. Of the 100 patients, 36 required blood transfusions, in part because of the losses from phlebotomy. Phlebotomy can contribute to a negative iron balance, and in patients with marginal iron stores, may precipitate or aggravate iron deficiency anemia and prevent compensatory erythropoiesis.

Chronic Renal Failure Treated with Hemodialysis

Iron deficiency affects a significant fraction of patients treated with hemodialysis now that the anemia related to chronic kidney disease is treated with pharmacologic agents and blood transfusions are restricted.^{265,266} Absolute iron deficiency results from the loss of blood associated with the dialysis process and diagnostic tests. Gastrointestinal blood losses may also be substantial, averaging 6.27 ml/day in one study.²⁶⁷ Telangiectasias are among the most common bleeding gastrointestinal lesions in patients with renal failure. Other factors contributing to negative iron balance include reduced dietary iron intake and malabsorption of iron caused by the aluminum hydroxide used to control hypophosphatemia.

Administration of erythropoiesis stimulating agents (ESA) results in a "functional iron deficiency" even when body iron stores are replete.²⁶⁸ The intense, periodic erythropoietic stimulus due to ESA therapy exceeds the mobilization of iron from macrophages, so that adequate transferrin-bound iron is not available to red blood cell precursors.^{268,269} and ²⁷⁰ For this reason, parenteral iron supplementation is often provided as an adjunct to ESA therapy in patients with ESKD.^{143,268}

Runner's Anemia

Iron deficiency anemia can occur in long-distance runners.²⁷¹ Over 50% of regular joggers and competitive runners become iron deficient.²⁷² Mild mechanical hemolysis accompanies strenuous exercise, resulting in hemoglobinemia and hemoglobinuria (also called march hemoglobinuria). Gastrointestinal bleeding contributes to blood loss and iron deficiency.^{272,273} and ²⁷⁴ Fecal blood excretion increases substantially after a race or an intense training exercise and may reach 5 to 7 ml/day. Stress, intestinal ischemia, and the jarring effect of running have been advanced as possible explanations for the gastrointestinal blood loss.

Decreased Total Body Iron at Birth

Body iron concentration in normal neonates averages ~75 to 100 mg/kg weight. Similar concentrations are found throughout fetal development, resulting in a linear relationship between body iron and body weight. Newborn babies in the upper range of normal birth weights have more iron than those in the lower range. Premature infants are at higher risk of iron deficiency during the first year of life, because they have not had the full opportunity to accumulate iron stores during the third trimester of gestation.

Newborn iron levels can be influenced by the technique that the obstetrician uses to clamp the umbilical cord at delivery.²⁷⁵ As much as 100 ml of fetal blood may remain in the placenta with early clamping of the cord. Cord clamping delayed for only 3 minutes can result in a 58% increase in red cell volume. If delayed clamping is impractical, as in cesarean section procedures, a similar effect can be achieved by clamping the cord at the placental end, raising the clamp, and allowing gravity to drain the cord.²⁷⁶ Although the newborn has no immediate need for these erythrocytes, the iron they contain can be used later to meet the demands of growth.

The fetus is an effective scavenger of maternal iron, in which fetal hepcidin controls the placental transfer of iron from maternal plasma to the fetal circulation,¹²⁴ therefore, maternal iron stores have little or no effect on the body iron stores of the newborn.²⁷⁷ No difference was found between the hemoglobin values in infants of anemic mothers and those in infants of nonanemic mothers either at birth or later.²⁷⁸ Furthermore, iron supplementation during pregnancy has no effect on the subsequent development of iron deficiency in the infant, although it may be protective for the mother. Finally, as measured by serum ferritin levels, maternal iron stores bear no relation to fetal stores.²⁷⁶ These observations are consistent with results of studies in animals that demonstrate iron transported across the placenta against a gradient, even at the expense of maternal iron stores.²⁷⁹

Growth

In the absence of disease, iron requirements of an adult man are relatively low and vary little. In contrast, in infancy, childhood, and adolescence, the requirements for iron are relatively great because of the increased needs of rapidly growing tissues. The most rapid relative growth rates in human development occur in the first year of life. Body weight and blood volume approximately triple, and the circulating hemoglobin mass nearly doubles. Still greater relative growth occurs in premature and low birth-weight infants. Premature infants weighing 1.5 kg may increase their weight and blood volume sixfold and may triple the circulating hemoglobin mass in 1 year. To meet the demands imposed by growth, the normal-term infant must acquire 135 to 200 mg of iron during the first year of life. A premature infant may require as much as 350 mg in the same period.²⁸⁰

The relatively slower rates of growth in children through the remainder of the first decade require a positive iron balance of ~0.2 to 0.3 mg/day. The growth spurt that occurs in the early teens requires a positive balance of ~0.5 mg/day in girls and 0.6 mg/day in boys.¹⁹⁶ Toward the end of this period, the onset of menstruation occurs in girls, and their requirements then equal those of adult women.

Diet in Infancy and Childhood

Iron stores in the infant are typically depleted by 4 to 6 months of age as a result of the demands of growth. During this critical period, a normal full-term infant must absorb ~0.4 to 0.6 mg of iron daily from the diet. To achieve this level of absorption, an iron intake of 1 mg/kg/day is recommended for full-term infants, 2 to 4 mg/kg/day for preterm infants, and at least 6 mg (to a maximum of 15 mg) for preterm infants receiving erythropoietin therapy.²⁸¹ These amounts may be difficult to achieve without supplementation.

Both human milk and cow's milk contain relatively small amounts of iron, but the infant more readily absorbs the iron in P.631

human milk. In one study, 49% of the iron in human breast milk was absorbed, compared with 10% of the iron in cow's milk.²⁸² As a result, iron deficiency is relatively uncommon in the first 6 months of life in infants exclusively fed breast milk.

Formula-fed infants are likely to become iron deficient unless iron-supplemented formulas are used. In the United States, such formulas are often supplemented with iron (10 to 12 mg/L) as ferrous sulfate, of which a variable proportion is absorbed.²⁸¹ Approximately 7% to 12% of the iron in cow's milk-based formulas is absorbed, with the lower percentage seen when formulas with higher iron content are given.²⁸³ Less iron is absorbed from soy-based formulas, but soy formulas containing 12 mg/L of iron appear to be adequate.²⁸⁴ Fortified dry cereals for infants are another important source of iron in the diet of both breast-fed and formula-fed infants. Currently, infant cereals are fortified with small-particle elemental iron at a concentration of 0.45 mg/g, from which ~4% is absorbed.²⁸⁵ Two servings per day will supply the needs of most infants.

Excessive intake of cow's milk is an important cause of iron deficiency in the first 2 years of life.^{280,286} Not only is cow's milk a poor source of iron, it may cause gastrointestinal blood loss (see next section). In general, cow's milk should not be given to infants <1 year of age, although it may be tolerated if the remainder of the diet is iron-rich.²⁸⁷ Some parents allow their toddler children to use the bottle as a pacifier and constant companion, and the children become addicted ("milkaholics"). In one study, inadequate diet was considered the only factor in the development of iron deficiency in 20 of 55 infants²⁸⁸;

few patients in this series had iron deficiency resulting from defective stores at birth, unless the diet was also inadequate. A unique disorder termed Bahima disease, described in Uganda, was attributed to the practice of feeding children a diet of cow's milk almost exclusively.²⁸⁹

Blood Loss in Infancy

Occult hemorrhage, often without obvious anatomic lesions, may be observed in some iron-deficient infants.^{285,290,291} The process is often accompanied by diffuse disease of the bowel with protein-losing enteropathy and impaired absorption of other nutrients.^{292,293} It probably results from hypersensitivity to a heat-labile protein in cow's milk.^{294,295} The daily loss of 1 to 4 ml of blood, along with increased serum albumin turnover, was observed while fresh cow's milk was consumed, and these abnormalities ceased abruptly with the substitution of heat-treated or soybean-protein feeding formulas.

Pregnancy and Lactation

Pregnancy is a major drain on the limited iron reserves of young women. Each pregnancy results in an average loss to the mother of 680 mg of iron, the equivalent of 1,300 ml of blood. An additional 450 mg of iron must be available to support the expanded blood volume during pregnancy. The latter amount of iron does not represent a net loss after delivery because the iron is returned to stores; it must be available. However, during the pregnancy or iron deficiency will supervene.

Prorated over the full term of pregnancy, the iron requirement amounts to ~2.5 mg/day (Table 23.6). Because most of the loss occurs during the third trimester, the requirement is small early in pregnancy and rises to as much as 3.0 to 7.5 mg/day in the third trimester. These amounts are greater than those that can be absorbed from even the best of diets, and stores may be insufficient to meet them. For this reason, iron supplementation is frequently recommended as a component of prenatal care. In the absence of supplements, maternal iron deficiency may occur, usually manifesting in the third trimester.

Lactation results in a daily iron loss of ~0.5 to 1.0 mg. The iron content of human breast milk is probably not affected by the maternal iron stores.²⁹⁶ Because normal menstruation is usually inhibited while breastfeeding continues, iron requirements in the lactating mother approximate those of the menstruating woman.

TABLE 23.6 IRON BALANCE IN PREGNANCY

Iron Fate	Mean Amount (mg)	Range (mg)
Lost to fetus	270	200-370
Lost in placenta, cord	90	30-170
Lost with bleeding at delivery	150	90-310
Normal body iron loss	170	150-200
Added to expanded red blood cell mass	450	200-600
Total	1,130	670-1,650
Returned to stores when red blood cell mass contracts after delivery	450	200-600
Net loss (over 9 months)	680	470-1,050

Signs and Symptoms of Iron Deficiency

The onset of iron deficiency anemia is usually insidious, and the progression of symptoms is gradual. As a result, patients accommodate remarkably well to advancing anemia and may delay a visit to their physicians for prolonged periods.

Fatigue and Other Nonspecific Symptoms

Iron deficiency anemia can be associated with irritability, palpitations, dizziness, breathlessness, headache, and fatigue. Fatigue is a particularly common complaint among patients. Even latent iron deficiency (i.e., iron deficiency without any anemia at all) has been described to result in fatigue,²⁹⁷ but others were unable to confirm this observation.²⁹⁸ Nevertheless, iron therapy has been shown to ameliorate fatigue: a group of 44 nonanemic women reporting fatigue were treated both with iron and with placebo in random order. Symptomatic improvement in women receiving iron was significantly better than that of women given the placebo, but only in women whose iron stores were depleted. In a recent randomized clinical trial of intravenous iron therapy in 90 premenopausal nonanemic women presenting with

fatigue, serum ferritin ≤ 50 ng/ml and Hgb ≥ 12 g/dl, fatigue scores decreased significantly within 6 weeks of therapy compared to placebo, particularly in women with baseline serum ferritin ≤ 15 ng/ml.²⁹⁹

Neuromuscular System

Despite the lack of symptoms at rest, investigators have demonstrated that even mild degrees of iron deficiency anemia impair muscular performance, as measured by standardized exercise tests.^{173, 300} Total exercise time, maximal workload, heart rate, and serum lactate levels after exercise are all affected adversely in proportion to the degree of anemia. Furthermore, work performance and productivity at tasks requiring sustained or prolonged activity are impaired in iron-deficient subjects and improve when iron is administered.^{301,302} As a result, measures directed toward iron nutrition of a workforce can produce important economic dividends, more than offsetting the costs of the treatment program.

Abnormalities in muscle metabolism are noted even when deficiency is mild.³⁰³ Blood lactate levels were measured in mildly

P.632

iron-deficient female athletes after standardized exercise tests. Peak lactate levels fell significantly after 2 weeks of iron treatment. This observation led to the suggestion that iron deficiency forces the muscles to depend to a greater extent on anaerobic metabolism than occurs in normal subjects.

Animal studies demonstrate that muscle function is disturbed in iron deficiency. The spontaneous activity level of iron-deficient rats decreased,³⁰⁴ and short-term exercise tolerance in treadmill running tests was reduced,^{166,167,303,305} even at mild degrees of deficiency.³⁰⁶ These abnormalities could not be explained by anemia alone, because they persisted after anemia was corrected by exchange transfusion.^{166,167} All were corrected promptly when iron was administered. In contrast, in a patient study no abnormalities of muscle function were noted in six nonanemic patients with long-standing iron deficiency, induced for the treatment of polycythemia vera.³⁰⁷

A variety of behavioral disturbances have been observed in iron-deficient children.^{174,308,309,310,311,312} These children have been reported to be irritable and disruptive, with short attention spans and a lack of interest in their surroundings. Neurologic development in infants³¹³ and scholastic performance in older children³¹⁴ may be impaired. Cognitive performance is defective in iron-deficient rats.³¹⁵ All of these behavioral abnormalities are ameliorated with the initiation of iron therapy.

The ability to maintain body temperature on exposure to cold is impaired in iron-deficient patients³¹⁶ and animals.³¹⁷ Occasional patients experience neuralgia pains, vasomotor disturbances, or numbness and tingling. In children, iron deficiency has been associated with neurologic sequelae, including developmental delay, ischemic stroke, increased intracranial pressure, papilledema, and the clinical picture of pseudotumor cerebri.³¹⁸ The pathogenesis is probably complex, involving severe anemia, thrombocytosis, and reduced levels of tissue iron enzymes.

Epithelial Tissues

Patients with long-standing iron deficiency may develop a constellation of symptoms characterized by defective structure or function of epithelial tissues. Especially affected are the nails, the tongue and mouth, the hypopharynx, and the stomach. These epithelial lesions tend to occur together in the same patients at the same time^{319,320} but also may occur as isolated findings.

In iron-deficient subjects, the fingernails may become brittle, fragile, or longitudinally ridged, but these findings are quite nonspecific. Alterations more typical of iron deficiency are nail thinning, flattening, and ultimately the development of koilonychia, concave or "spoon-shaped" nails (Fig. 23.6). Koilonychia is now rarely seen in clinical practice, but of 400 babies attending a wellbaby clinic in West Virginia before 1970, 5.5% had koilonychia, and nearly all of these infants appeared to be iron deficient.³²¹ Koilonychia is a relatively nonspecific finding, which can also result from prolonged repeated exposure to hot soapsuds and other caustic agents.



FIGURE 23.6. Koilonychia in a 1.5-year-old child with iron deficiency anemia.

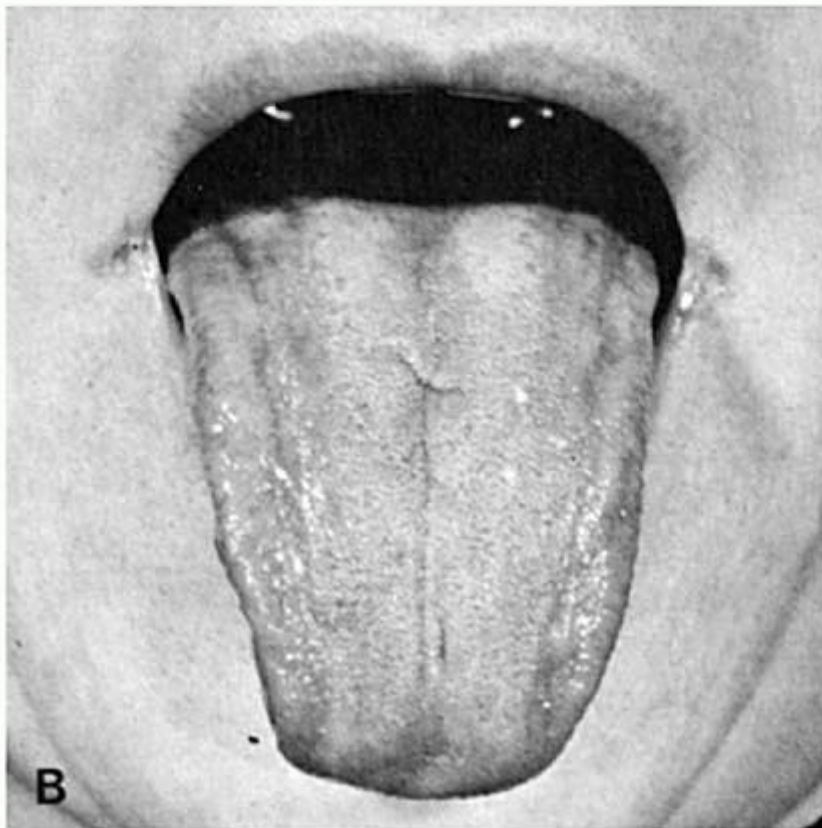
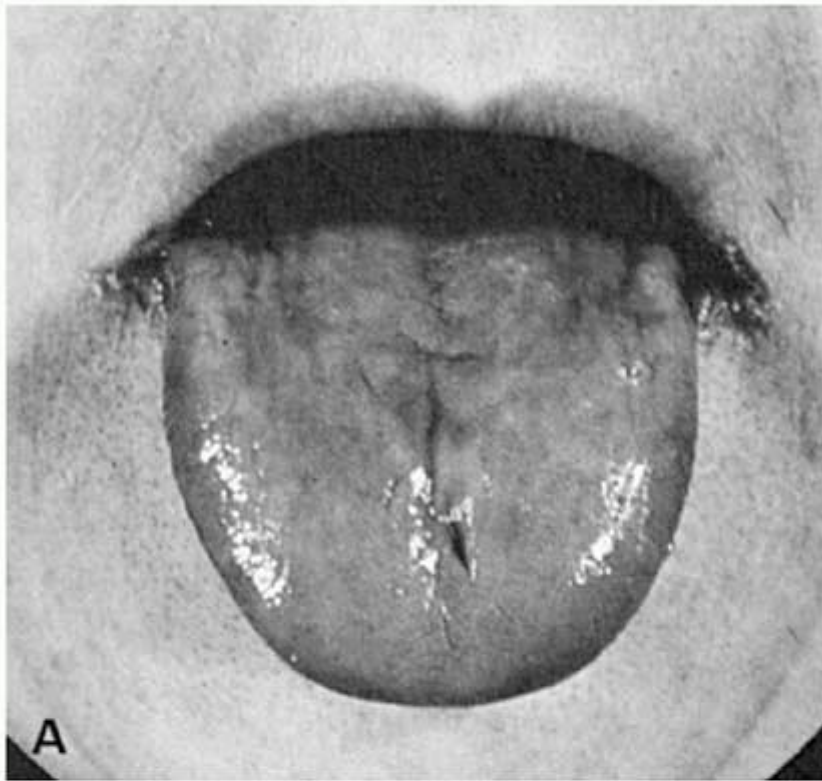

FIGURE 23.7. Tongue of a patient with iron deficiency anemia. Moderately severe papillary atrophy evident before therapy (A) and restoration after iron repletion (B). (Courtesy of R. W. Monto, Detroit, MI.)

Oral abnormalities, including atrophy of the lingual papillae, are the most common of iron deficiency-induced epithelial changes (Fig. 23.7, Table 23.7). These may present as soreness or burning of the tongue, either spontaneously or stimulated by food or drink, and by varying degrees of redness.³¹⁹ The filiform papillae over the anterior two thirds of the tongue are the first to atrophy and may disappear completely. In severe cases, fungiform papillae also may be affected, leaving the tongue completely smooth and waxy or glistening.³²² These changes are generally reversed after 1 to 2 weeks of iron therapy. Angular stomatitis, characterized by ulcerations or fissures at the corners of the mouth, is a less specific sign of iron deficiency, and it also occurs in riboflavin and pyridoxine deficiencies.

P.633

TABLE 23.7 EPITHELIAL LESIONS ASSOCIATED WITH IRON DEFICIENCY

Site	Finding
Nails	Flattening
	Koilonychia
Tongue	Soreness
	Mild papillary atrophy
	Absence of filiform papillae
Mouth	Angular stomatitis
Hypopharynx	Dysphagia
	Esophageal webs
Stomach	Achlorhydria
	Gastritis

The association of dysphagia, angular stomatitis, and lingual abnormalities with hypochromic anemia was reported as early as the beginning of the 20th century. Dysphagia affects women more often than men and is relatively uncommon in patients younger than age 30 years. However, it has been observed in adolescents^{174,319} and even toddlers. Patients with sideropenic dysphagia (also known as Paterson-Kelly syndrome and Plummer-Vinson syndrome) note a gradual onset of difficulty swallowing and describe discomfort localized to the area of the neck near the cricoid cartilage. They experience dysphagia with solid foods but have little problem with liquids. If not treated, the dysphagia worsens, and ultimately the diet is so restricted that it interferes with the maintenance of balanced nutrition.

The most common anatomic lesion is a “web” of mucosa at the juncture between the hypopharynx and the esophagus.³²³ These webs, which may be multiple, usually extend from the anterior wall into the lumen of the esophagus, but they may encircle the lumen completely, forming a cufflike structure. In some patients, a benign stricture is noted, and the opening into the esophagus at the cricoid area may be reduced to the size of a pinhole or slit. Postcricoid webs may occur in the absence of documented iron deficiency, but nearly all affected patients were iron deficient in one investigative series.³²⁰ Both webs and strictures may be demonstrated by radiographic examination (lateral view) of the neck after barium swallow (Fig. 23.8). Multiple exposures or cineradiography are required for optimal demonstration of these abnormalities.

At biopsy, the webs appear to be constructed of normal epithelium with underlying loose connective tissue, sometimes showing a chronic inflammatory reaction. In a small percentage, hyperchromatic nuclei and increased mitotic activity are observed in the basal cell layer. Biopsy of the strictures demonstrates chronic nonspecific inflammation and degeneration of striated muscle. Carcinoma in the postcricoid area has been noted as a late complication of the syndrome in 4% to 16% of patients.³¹⁹ For relief of the dysphagia, clinicians often must rupture the webs, dilate the stenosis, or both, although treatment with iron supplements relieves dysphagia in mild cases if the associated webs are small.^{324,325}

The variation in the prevalence of sideropenic dysphagia suggests that factors other than iron deficiency may contribute to oroesophageal abnormalities. Genetic factors may be important, as may some unrecognized coexisting nutritional abnormalities.

Immunity and Infection

The relationship between iron deficiency and infection is complex.^{326,327,328} Iron deficiency clearly results in at least two abnormalities in the immune response: defective lymphocytemediated immunity and impaired bacterial killing by phagocytes. Evidence of defective cellular immunity includes as much as a 35% reduction in the number of circulating T cells. Both helper and suppressor T cells are affected.³²⁹ In addition, iron-deficient subjects do not respond as well as normal subjects to certain skin test antigens, such as to *Candida*, diphtheria, and *Trichophyton*. These abnormalities can be corrected by the administration of iron. No abnormalities have been noted in testing with tuberculin or dinitrochlorobenzene. Ribonucleotide reductase is an iron-containing enzyme required for the synthesis of DNA for cell division. Some authors have suggested that reduced levels of this enzyme might lead to impaired ability of the T cells to proliferate, thereby accounting for the defects in cell-mediated immunity, but others have reported changes in cytokine production in iron-deficient patients.

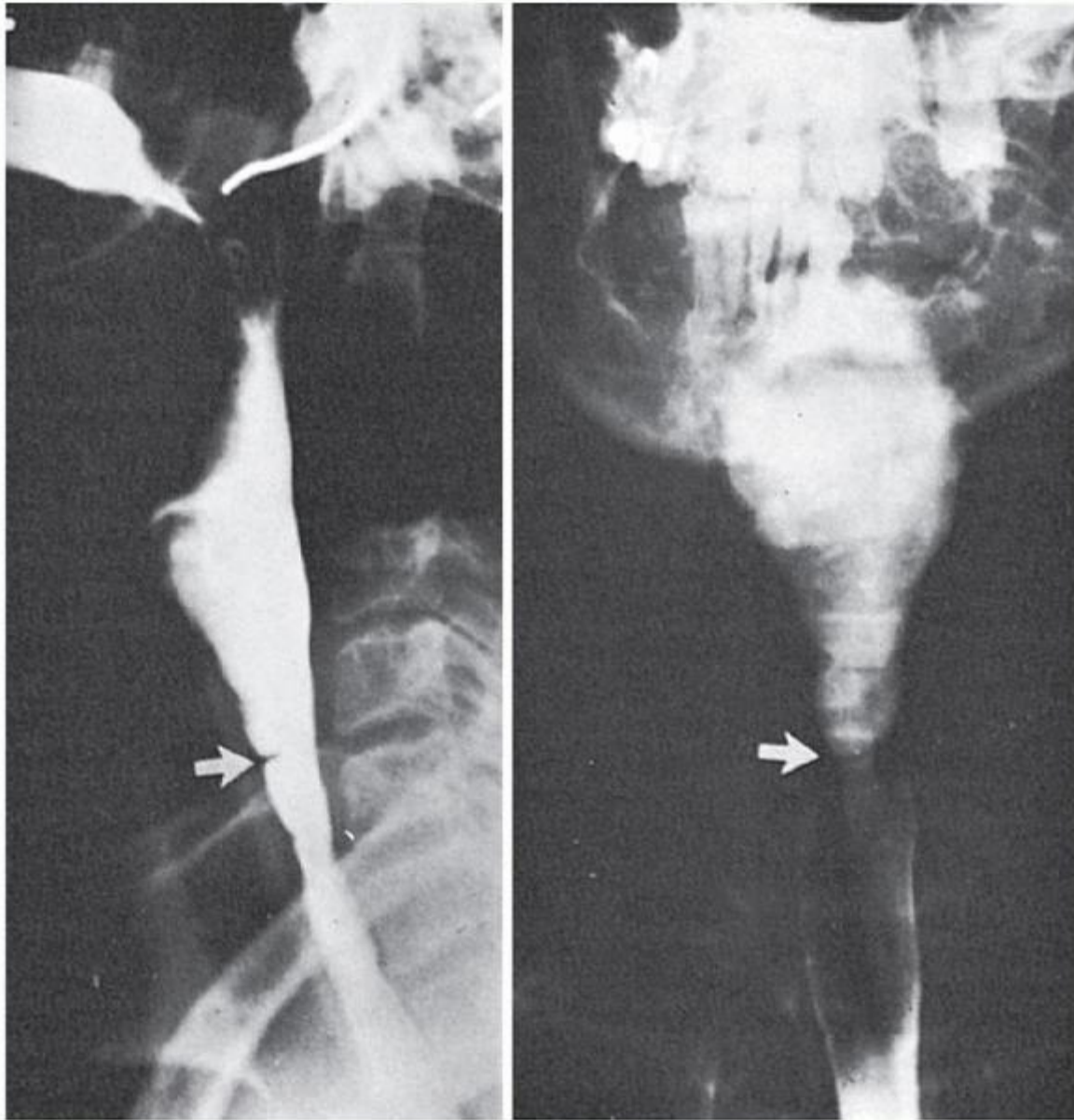

FIGURE 23.8. Esophageal web (arrows) in Plummer-Vinson syndrome.

The nitroblue tetrazolium dye test of phagocyte function yielded abnormal results in iron-deficient children, and the abnormality could be corrected by iron administration.^{330,331} Furthermore, a decrease in the magnitude of the “oxidative burst” accompanying phagocytosis was observed.³³² Finally, killing of several types of pathogenic bacteria by neutrophils was defective.^{330,333}

The sequence of changes in neutrophil function was studied as iron deficiency developed in rats. Myeloperoxidase activity was reduced to a greater extent and responded more slowly to iron therapy than did defects in the oxidative burst.³³⁴

Because the oxidative burst is considerably more important in bacterial killing than is myeloperoxidase, the observations suggest that the neutrophil conserves its most important function as the deficiency develops. The defect in the oxidative burst could be demonstrated only with the use of agents that induced phagocytosis; no defect was noted when the burst was stimulated by soluble agents. Thus, phagocytosis, rather than the oxidative burst itself, may be at fault.

In experiments in an iron-deficient mouse model, lack of hepcidin was responsible for the high inflammatory response to lipopolysaccharide treatment.³³⁵ Taken together, these abnormalities provide a basis for an expectation that resistance to infection may be impaired in iron deficiency. However, a clinically relevant relationship between states of iron deficiency and susceptibility

P.634

to infections remains controversial.³³⁶ Conversely, considerable data suggest that iron deficiency and iron sequestration by binding proteins protect against infection by depriving the invading organisms of the metal.^{337,338} Thus, optimal immune function is highly dependent on iron balance; both iron-deficient and iron overloaded hosts are at higher risk for infection.

Pica

Pica is a striking symptom of iron deficiency. Hippocrates wrote that a "craving to eat earth" was associated with "corruption of the blood." Abnormal eating patterns were also a prominent manifestation of chlorosis. Pagophagia, defined as the purposeful eating of at least one tray of ice daily for 2 months, is a common form of pica. In one study, the ingestion of ice averaged nearly 2 kg/day, and some patients ate an astounding 4 to 9 kg/day.³³⁹ This dramatic symptom was relieved within 1 to 14 days after iron was administered. Another study found that pagophagia was a symptom of iron deficiency in 23 of 38 consecutive adult patients, and iron therapy was curative.³⁴⁰ Pica is especially striking when the patient consumes bizarre, nonfood substances.³⁴¹

Crosby estimated the incidence of pica in his iron-deficient patients to be 50%.³⁴² Approximately one half of them ate ice; the rest experienced "food pica." The latter consists of compulsively eating one food, often something that is brittle and makes a crunching sound when chewed.³⁴³ Because patients may be ashamed of this compulsive habit, they often do not volunteer the information during the medical interview. Direct tactful inquiry is necessary to elicit the history of pica.

Genitourinary System

Disturbances in menstruation are common in iron deficiency, and not infrequently, iron deficiency results from, or is exacerbated by, excessive menstrual blood loss. Beeturia, the excretion of a pink to red pigment in the urine after the ingestion of beets, has been reported to be more common in iron-deficient patients than in normal subjects.³⁴⁴ However, it is likely that a significant fraction of the normal population also has this symptom.³⁴⁵

Skeletal System

Changes in the skull similar to those found in association with thalassemia or chronic hemolytic anemia have been reported in children with iron deficiency anemia of long duration.^{346,347} The diploic spaces may be widened, and the outer tables thinned, at times with vertical striations producing a hair-on-end appearance. In addition, abnormalities of the long bones are noted, especially the metacarpals and phalanges, with expansion of the medulla and thinning of the cortices.³⁴⁸ These changes likely result from expansion of the erythroid marrow during bone growth and development.

LABORATORY EVALUATION

Complete Blood Count and Peripheral Smear

The severity of anemia depends on the presenting circumstances of iron deficiency. If discovered when the patient is being evaluated for preadmission testing for elective surgery (Fig. 23.9),³⁴⁸ or for an underlying or unrelated disease, the anemia can be mild to moderate (Hgb 8 g/dl to 12 g/dl). If symptoms of anemia are the presenting complaint, the blood hemoglobin level may be 8 g/dl or lower.

Anisocytosis is an important early sign in iron deficiency and one that has differential diagnostic value when quantified.^{349,350} The red cell distribution width (RDW) is increased in iron deficiency, and this often is useful in distinguishing iron deficiency from thalassemia trait conditions in which the RDW is normal. Both the percentage and the absolute number of reticulocytes may be normal or slightly increased. In experimentally induced iron deficiency in certain animal species, including rats, mice, and pigs, reticulocytosis is pronounced. The chief finding on blood smear is

hypochromia, observed as an increase in the size of the region of central pallor (Fig. 23.10). The more severe the anemia, the more severe the hypochromia and the greater the percentage of erythrocytes affected. When hypochromia is extreme, most of the red blood cells appear as mere rings. Tiny microcytes and a moderate number of poikilocytes, particularly tailed and elongated elliptical forms (pencil cells), are also found. In almost all instances, however, a variable number of well-filled red corpuscles are present, and some macrocytes, often polychromatophilic, can be distinguished. The mean corpuscular volume and mean corpuscular hemoglobin values are reduced in most patients, and the mean corpuscular hemoglobin concentration is reduced in long-standing or severe disease. The degree of change in the red cell indices is related in part to the duration and in part to the severity of the anemia. In mild iron deficiency of short duration, the indices may be within normal ranges.

Iron-related Indices

The laboratory diagnosis of absolute iron deficiency has traditionally been based on low serum iron, low percent transferrin saturation, and low ferritin.¹⁴³ However, it has long been known that inflammation can mimic some aspects of iron deficiency by impairing the utilization of existing iron stores for red cell production, and inducing an iron-sequestration syndrome and hypoferrremia.³⁵¹ The molecular mechanisms that underlie the redistribution of iron during inflammation are discussed in Chapter 45, but may center on cytokine-stimulated overproduction of hepcidin, particularly IL-6.³⁶

Serum ferritin has the potential to differentiate true iron deficiency from inflammatory iron sequestration. However, both inflammation and intracellular iron accumulation stimulate the production of the iron storage protein ferritin whose soluble form is detectable in plasma and serum. Therefore, interpretation of serum ferritin in patients with inflammation due to comorbidities is more challenging. The generally accepted cut-off level for serum ferritin to indicate absolute iron deficiency has been ≤ 12 ng/ml.³⁵² However, studies correlating the presence or absence of stainable iron with serum ferritin in patients and in normal individuals, and also patients with anemia responsive to iron therapy, indicate that this threshold level of ferritin had only a sensitivity of 25% for detecting iron deficiency.³⁵³ The sensitivity could be improved to 92%, with a positive predictive value of 83%, by using a diagnostic cutoff value of ≤ 30 ng/ml.

The differentiation among absolute iron deficiency, functional iron deficiency, and iron-sequestration syndromes (Fig. 23.11) is important for patient management.²⁶⁸ Functional iron deficiency is manifest by a fall in iron saturation either during endogenous erythropoietin-stimulated erythropoiesis,^{268,354,355} or with initiation of ESA therapy even in normal volunteers with adequate iron stores.^{268,356} The manifestation of functional iron deficiency is reduced transferrin saturation, as illustrated in Figure 23.12. Absolute iron deficiency may be the presenting sign of occult blood loss from gastrointestinal lesions including malignancy,^{233,357} whereas an iron sequestration phenotype is indicative of an underlying inflammatory disorder. Commonly used laboratory tests such as serum iron, total iron-binding capacity, mean corpuscular volume, transferrin saturation, and ferritin provide limited diagnostic value.^{127,358}

Increased soluble transferrin receptor (sTfR) has been reported to be an indicator of iron deficiency,³⁵⁹ because sTfR is released

P.635

P.636

by erythropoietic precursors in proportion to their expansion, and is not increased by inflammation. However, this assay was found to have a specificity of 84% and a positive predictive value of only 58% in a population of patients likely to be typical of the most difficult diagnostic environments for assessing iron status.³⁵³ Interpretation of increased sTfR therefore may be challenging, even in the absence of known causes of increased erythropoiesis other than iron deficiency. Similarly, attempts to combine ferritin and sTfR results (sTfR/log ferritin)³⁶⁰ still fall short when analyzed for diagnostic sensitivity and specificity, and must be corrected for acute phase reactant changes in the setting of inflammation.³⁵⁸

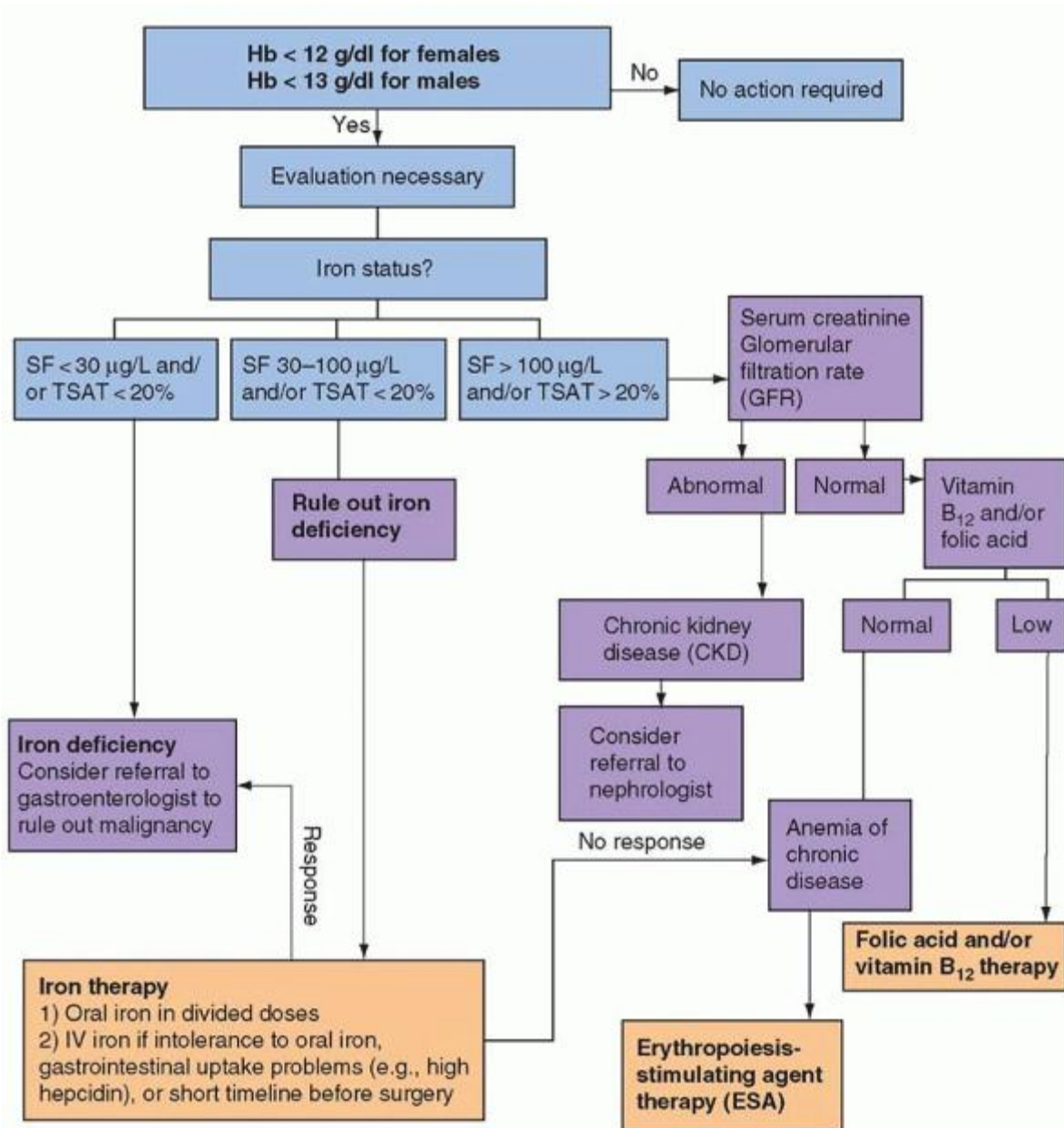

FIGURE 23.9. Screening, evaluation, and management of preoperative anemia in elective orthopedic surgical patients. Algorithm for the detection, evaluation, and management of preoperative anemia. SF, serum ferritin; TSAT, transferrin saturation. From Goodnough LT, et al. Detection, evaluation, and management of preoperative anaemia in the elective orthopaedic surgical patient: NATA guidelines. Br J Anaesth 2011;106:13-22.

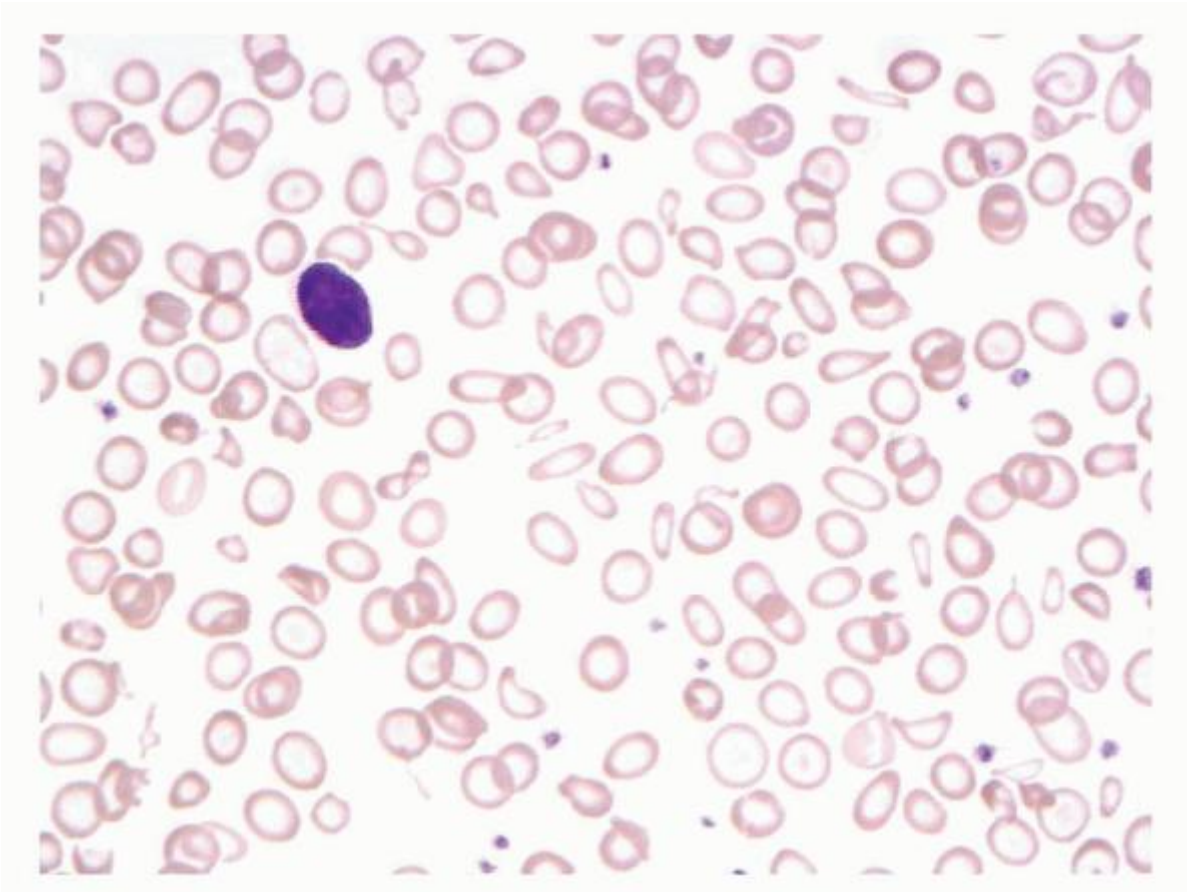

FIGURE 23.10. Blood smear from a patient with microcytic anemia due to iron deficiency. (Courtesy of Irma Pereira MT [ASCP]SH.)

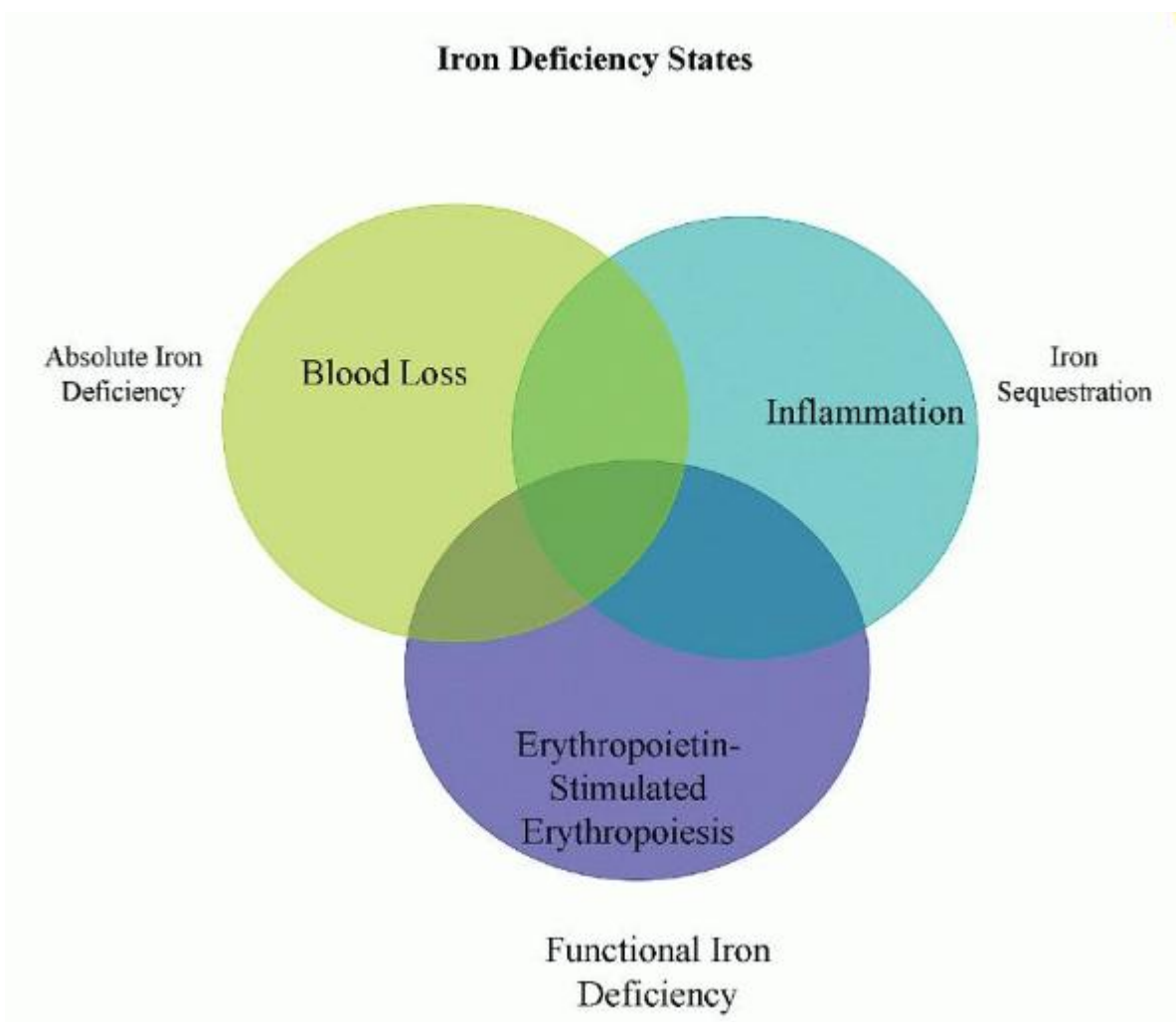

FIGURE 23.11. Iron deficiency states. The relationships between absolute iron deficiency, iron sequestration, and functional iron deficiency are illustrated. Patients can have one or more combinations that all result in iron-restricted erythropoiesis. (From Goodnough LT. Transfusion. 2011 Dec 12 [Epub].)

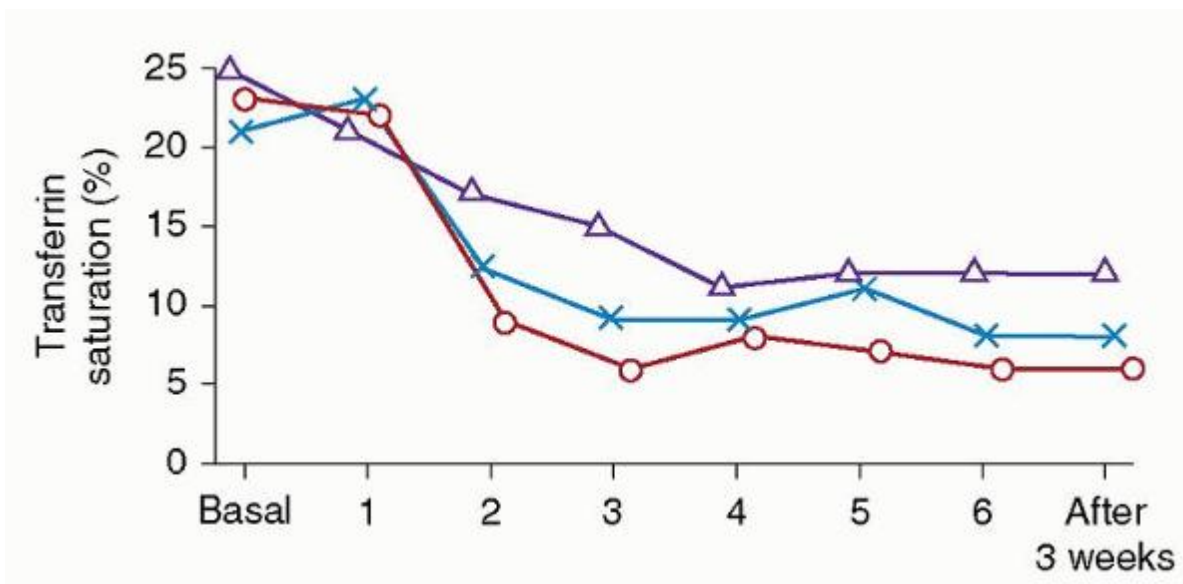

FIGURE 23.12. The impact of endogenous erythropoietin-mediated erythropoiesis or ESA (erythropoiesis stimulating agent) mediated erythropoiesis, on iron saturation. Patients undergoing autologous blood donation prior to elective

orthopedic surgery are shown at baseline and after treatment with placebo or one of two doses of recombinant human erythropoietin (rHuEPO) at each visit during the donation period. All patients received supplemental oral iron. Mean transferrin saturation in 24 patients receiving placebo (Δ), 300 U per kg rHuEPO (Z), or 600 U per kg rHuEPO (θ). (From Mercuriali F, Zanella A, Barosi G, et al. Use of erythropoietin to increase the volume of autologous blood donated by orthopedic patients. *Transfusion* 1993;33:55-60.)

The development of sensitive, accurate, and reproducible immunoassays^{43,361} and mass-spectrometric assays³⁶² for human hepcidin has allowed detailed definition of physiologic and pathologic changes of hepcidin in healthy volunteers and in patients. In contrast to ferritin, changes in hepcidin concentrations are frequently the cause of, rather than the result of, iron disorders. Measurements of hepcidin may be useful for diagnosing absolute iron deficiency or differentiating it from iron-sequestration syndromes. In absolute iron deficiency, serum hepcidin concentrations are very low.⁴³ Low hepcidin would also identify patients most likely to respond to iron therapy. In iron sequestration syndromes, on the other hand, hepcidin would be expected to be high as the pathogenic mediator of iron restriction in inflammation. In patients with mixed presentations, hepcidin may be regulated by opposing stimuli and its levels tend to be variable.³⁶³ For example, in conditions with mixed iron deficiency and inflammation, hepcidin may be low, normal, or elevated depending on the degree of iron deficiency or inflammation. In resistance to ESA therapy due to chronic kidney disease, hepcidin levels may be high because of decreased hepcidin renal clearance and possibly inflammation. In the absence of inflammation, in conditions of accelerated erythropoiesis due to endogenous erythropoietin or ESA stimulation, hepcidin levels will be low. Thus in patients with mixed conditions, hepcidin levels may not help treating physicians arrive at a definitive diagnosis but may give guidance in identifying patients who are likely to respond to iron (oral vs. IV) therapy (i.e., hepcidin levels are low with marginal storage iron or accelerated erythropoiesis). More complex algorithms will need to be developed and tested to provide optimal guidance in the evaluation and management of anemia.^{86,364} Expected changes in hepcidin levels and iron parameters in various clinical conditions, in iron therapy strategies, and in the potential use of hepcidin-targeted therapies in patients with various forms of anemia, are summarized in Table 23.8.

TABLE 23.8 POTENTIAL ROLE OF HEPCIDIN IN DIAGNOSIS AND MANAGEMENT OF PATIENTS WITH IRON-RESTRICTED ERYTHROPOIESIS

Condition	Expected Hepcidin Levels	Iron Parameters	Iron Therapy Strategies	Potential Hepcidin Therapy
Absolute iron deficiency anemia (IDA)	Low	Low TSAT and ferritin	PO or IV if poorly tolerated or malabsorbed	No
Functional iron deficiency (ESA therapy, CKD)	Variable, depending on \pm CKD	Low TSAT, variable ferritin	IV	Antagonist (if hepcidin levels not low)
Iron sequestration (anemia of inflammation [AI])	High Low TSAT, normal-to-elevated ferritin	IV	Antagonist	
Mixed anemia (AI/IDA) or (AI/functional iron deficiency)	Variable	Low TSAT, low-to-normal ferritin	IV ^a	Antagonist (if hepcidin levels not low)

^aMixed anemia is a diagnosis of exclusion without a therapeutic trial of iron.

CKD, chronic kidney disease; ESA, erythropoiesis-stimulating agent; IV, intravenous; PO, oral; TSAT, transferrin saturation.

From Goodnough LT. Iron deficiency syndromes and iron-restricted erythropoiesis. *Transfusion*. 2011 Dec 29 [Epub].

Clinically, it would be helpful to detect the earliest changes in red cell indices that reflect iron-restricted erythropoiesis. One approach would be to identify newly formed iron-deficient cells when they are released from the bone marrow as reticulocytes. Flow cytometric analysis of reticulocytes allows determination of reticulocyte hemoglobin content

(CHr)^{365,366} or percentage of hypochromic reticulocytes (% HYPO).³⁶⁷ As illustrated in Figure 23.13, this approach can also identify functional iron deficiency in iron-replete volunteers receiving ESA therapy.³⁶⁸ The % HYPO measure is regarded as a time-averaged marker of iron-restricted erythropoiesis (20 to 120 day), whereas the CHr measure is a real-time parameter (48 hours).³⁶⁹ Many existing laboratory analyzers are capable of measuring CHr but may require modification with software patches.

Leukocytes and Platelets

The leukocytes are usually normal in number, but mild granulocytopenia may occur in long-standing cases of iron deficiency. Recent large-volume hemorrhage may cause a slight neutrophilic leukocytosis, and occasional myelocytes may be found in peripheral blood. In iron deficiency due to parasitic infestation, eosinophilia may be present.

Thrombocytosis commonly accompanies iron deficiency.³⁷⁰ The platelet count often increases to approximately twice the normal level, and values return to normal after iron therapy. The cause of the thrombocytosis of iron deficiency is unknown.

P.637

Percent Hypochromic Red Cells (%HYPO)

- **Flow cytometry with 2 detectors**
 - High angle for Hb content
 - Low angle for cell size
 - Allows construction of a histogram for Hb content

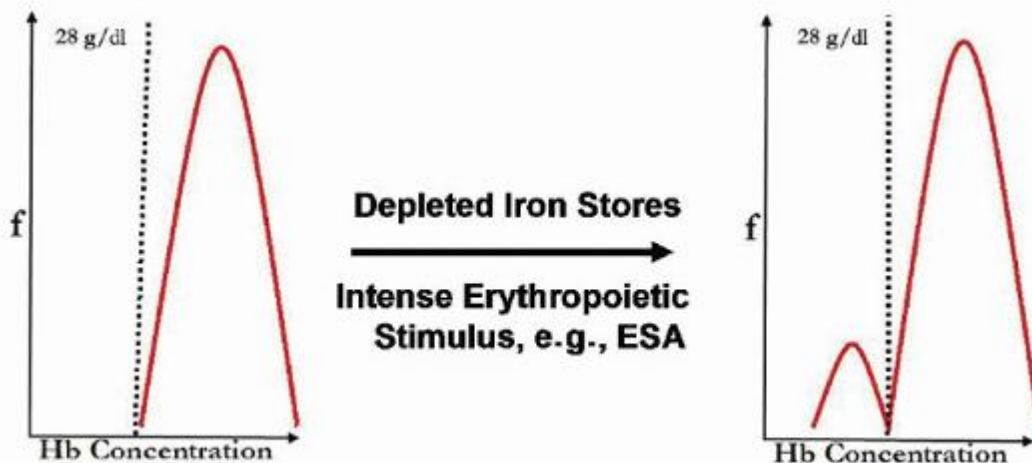

FIGURE 23.13. The effect of depleted iron stores or erythropoiesis-stimulating agent (ESA) therapy on flow-cytometry detection of percentage hypochromic reticulocytes (% HYPO). (From Goodnough LT, Nemeth E, Ganz T. Detection, evaluation, and management of iron-restricted erythropoiesis. *Blood* 2010;116:4754-4761.)

Bone Marrow

Macrophage iron is absent or severely reduced in the marrow, spleen, and liver of iron-deficient subjects. Fewer than 10% of the marrow normoblasts are sideroblasts. In addition, the iron-deficient bone marrow is characterized by mild to moderate erythroid hyperplasia. There may be striking nuclear distortions, resembling those found in dyserythropoietic anemias.³⁷¹ Karyorrhexis and nuclear budding are particularly common, but multinuclearity, nuclear fragmentation, and even intranuclear bridging may be observed. The individual normoblasts appear small and may have scanty cytoplasm,

often with irregular ragged borders. When therapy is given, erythroid hyperplasia initially increases, but as erythropoiesis is restored to normal, the cellularity of the marrow likewise becomes normal.

MANAGEMENT OF IRON DEFICIENCY

Management is primarily focused on repletion of iron stores. Most of the time, this therapy is straightforward, simple, and inexpensive. The response to treatment is predictable and gratifying. There is, however, an important caveat: correction of the iron deficiency is only part of the task confronting the clinician. Particularly in older adults, iron deficiency may be an early sign of a serious illness, such as an occult gastrointestinal malignancy. Clearly, correction of the anemia without recognition and treatment of a possible underlying disease is poorly practiced medicine. The cause of iron deficiency anemia can be identified in the great majority of cases. Once an etiologic diagnosis is made, appropriate therapy can begin.

Iron can be administered orally or intravenously. The oral route is the safest and least expensive. It is important to note that therapeutic doses are quite different for oral and intravenous preparations. Most iron-deficient patients respond well to oral therapy, but intravenous administration of iron may sometimes be required.

Oral Iron Therapy

The most common preparation used orally is ferrous sulfate, which has been a mainstay of treatment for iron deficiency since it was first introduced by the French physician Pierre Bland in the 19th century. It is effective, reasonably well tolerated, and inexpensive. If equivalent amounts of elemental iron are given, ferrous gluconate and ferrous fumarate are equally satisfactory and have approximately the same incidence of side effects. Although iron deficiency clearly promotes increased absorption, individual variations are great, and absorption may be vastly different at varying degrees of anemia and in the presence of complicating illnesses.

The dose is best calculated in terms of elemental iron. For adults, the optimal response occurs when ~200 mg of elemental iron is given orally each day. The usual ferrous sulfate tablet (325 mg) contains ~65 mg of elemental iron. Iron is absorbed more completely when the stomach is empty; when iron ingestion occurs after or with a meal, absorption decreases substantially.³⁷² However, gastrointestinal irritation is common when the stomach is empty. Consequently, patients are frequently advised to take oral iron immediately after or even with a meal. The gain in patient acceptance may be more important than the reduced absorption of iron. However, it is important to remember that, whereas absorption is enhanced by the presence of orange juice, meat, poultry, and fish, other substances such as cereals, tea, and milk inhibit it. This is particularly important in toddlers, because administration of oral iron with milk often compromises therapy.

For iron-deficient children, the optimal dosage is 1.5 to 2.0 mg elemental iron per kilogram of body weight given orally three times per day. Palatable elixirs and syrups are the most satisfactory pediatric preparations, although they can stain the teeth if not given carefully. Children usually tolerate this form of therapy on an empty stomach.

In adults, a 200-mg daily oral dose produces a maximal rate of hemoglobin regeneration. However, the maximal rate is not necessarily the only legitimate therapeutic goal. If the underlying disease has been corrected and the anemia is mild to moderate, a slower rate of response may be acceptable. Thus, if such patients cannot tolerate 200 mg/day of elemental iron, it is reasonable to reduce the dose to 100 mg/day.³⁷³ Because less iron is given, tolerance improves. In this circumstance, speed of response is exchanged for increased patient compliance, although it may be necessary to treat for longer. Regardless of the form of oral therapy used, treatment should be continued for at least 3 to 6 months after the anemia is relieved. If treatment does not continue, relapse is common. The continued therapy allows for repletion of iron stores.

Side Effects of Oral Iron Therapy

Some patients given oral iron report gastrointestinal symptoms, including heartburn, nausea, abdominal cramps, and diarrhea. However, functional gastrointestinal symptoms are common in the general population, and patients may incorrectly ascribe them to iron treatment. In one double-blind study, ferrous sulfate, ferrous gluconate, ferrous fumarate, and placebo were administered in identically appearing tablets.³⁷⁴ No significant differences were found among the three iron salts. Approximately 12% of subjects had symptoms that could reasonably be ascribed to iron ingestion. Often, tolerance of iron salts improves when a small dose is given at first and increased over the course of several days to the full dose. A polysaccharide-iron complex is marketed that is alleged to be as effective as ferrous sulfate while causing fewer side effects. The question of whether it is as well absorbed as ferrous sulfate has not been definitively resolved.

Enteric-coated preparations are designed to reduce side effects by retarding dissolution of the iron. However, this effect may markedly decrease absorption, especially in achlorhydric individuals, whose gastric juice cannot dissolve the coating.

Sustained-release preparations also reduce side effects by retarding dissolution, but in so doing, the most actively absorbing regions of the intestine are bypassed. According to most studies,³⁷⁵ absorption is therefore reduced.

P.638

Failure of Oral Iron Therapy

Clinicians often encounter patients said to have iron deficiency anemia unresponsive to oral therapy. The most common explanations for failure to respond to oral iron include (a) incorrect diagnosis, (b) complicating illness, (c) failure of the patient to take prescribed medication, (d) inadequate prescription (dose or form), (e) continuing iron loss in excess of intake, and (f) malabsorption of iron.

In managing a problem of alleged failure to respond to iron, it is important to review the data on which the diagnosis of iron deficiency anemia was based and to take note of any laboratory procedures that might have yielded erroneous information. At times, even though iron deficiency is present, a coexisting cause for anemia may impair response. Examples are iron deficiency as a complication of the anemia of inflammation in rheumatoid arthritis, *H. pylori* infection, as well as so-called dimorphic anemia, in which iron deficiency and pernicious anemia coexist.

In some patients, blood loss is so great that oral iron therapy cannot keep up with it. If this situation is not correctable (e.g., in the case of hereditary hemorrhagic telangiectasia), parenteral therapy must be given. Finally, rare patients may be unable to absorb iron. This is unusual; even patients with sprue or total gastrectomy are usually able to absorb adequate amounts of ferrous sulfate. Patients with iron-refractory iron deficiency syndrome (IRIDA) have a mutation in the protease TMPRSS6 causing increased hepcidin production^{177,178,189,190} and are refractory to oral iron therapy but partially responsive to intravenous iron therapy.

In individuals who are compliant with oral therapy and not actively bleeding, but still poorly responsive to treatment, addition of ascorbic acid (usually 500 mg twice a day) may improve iron absorption and the hemoglobin response.^{376,377} and³⁷⁸ Subclinical ascorbic acid deficiency has been suggested as an etiology of refractory iron deficiency anemia.³⁷⁹

Even under the best of circumstances, oral iron supplementation is poorly tolerated and patients may be noncompliant, not only from side effects of oral iron but because of their diagnosis or the therapy they are undergoing for their disease. Nevertheless, in stable patients with mild to moderate anemia in which there is some time for management strategies, and particularly in those patients in whom diagnostic laboratory testing has not definitively ruled out iron-restricted erythropoiesis, a therapeutic trial of oral iron therapy can be recommended.³⁸⁰ In general, absorption of oral iron inversely correlates with hepcidin levels.^{381,382} Thus, hepcidin measurements may help to determine a priori which patients are good candidates for oral iron therapy. Exceptions may be patients who malabsorb iron because of damage to the intestinal lining such as in celiac disease, and in patients undergoing treatment with proton-pump inhibitors.

In a study of patients with anemia,³⁵³ 5 of 54 who had bone marrow examinations had absent iron stores indicating absolute iron deficiency. There were an additional eight patients who were categorized as iron deficient because of their response to oral iron therapy; half of these had serum ferritins ≥ 12 ng/ml and one of the patients had a serum ferritin >100 ng/ml. This analysis suggests that in the absence of a diagnostic bone marrow examination, it is difficult to rule out iron deficiency confidently, and an empiric trial of iron therapy may be desirable to identify patients who have absolute iron deficiency for successful patient management, because it may be a sign of serious underlying illness,^{231,383} including malignancy.^{233,357}

Failure to respond to a trial of oral iron therapy does not rule out iron-restricted erythropoiesis or even true iron deficiency in the setting of inflammation, as inflammatory hepcidin elevation would cause impaired iron absorption.³⁶ Furthermore, ongoing blood (and iron) losses may exceed even maximal gastrointestinal absorption of iron.³⁸⁴ Clinical situations are often complex, and blood loss, iron-restricted erythropoiesis and high hepcidin levels can coexist in patients in whom absorption of dietary or oral iron supplements is impaired.³⁶⁴ In these instances, and in circumstances of ongoing blood loss,³⁸⁴ intravenous iron therapy may be needed either as a diagnostic trial or as definitive therapy.³⁸⁵

Intravenous Iron Therapy

Therapy with ESAs in management of the anemia of chronic renal failure has led to substantial clinical experience in supplemental intravenous iron therapy in this setting.^{386,387} Hyporesponsiveness to ESA therapy is a common phenomenon^{388,389} due to a variety of comorbid conditions, but particularly related to functional iron deficiency.^{354,356} Patients with anemia undergoing dialysis may show suboptimal or no response to oral iron therapy for several reasons.

During ESA therapy, although absorption of iron can increase up to fivefold³⁹⁰ presumably due to hepcidin suppression by increased erythropoiesis, ongoing external iron losses due to hemodialysis and blood testing can exceed the intake.^{391,392} Furthermore, some patients have poor compliance with iron therapy or significantly reduced gastrointestinal iron absorption. Absorption of oral iron can be enhanced with ascorbate by at least 30%, because it prevents formation of insoluble and unabsorbable compound and reduces ferric iron to ferrous iron.³⁹² Iron absorption and release from stores may be impaired due to high hepcidin levels from diminished clearance by the kidneys, not completely corrected by routine hemodialysis, as well as from inflammation.

IV iron administration is recommended in renal dialysis patients undergoing ESA therapy.³⁹³ Patients treated with IV iron (100 mg twice weekly) achieved a 46% reduction in ESA dosage required to maintain hematocrit (Hct) levels between 30% and 34%, compared to patients supplemented with oral iron.³⁹⁴ To further address the management of iron-restricted erythropoiesis in CKD patients undergoing dialysis, a randomized controlled trial evaluated the efficacy of IV iron supplementation in patients with ferritin between 500 and 1,200 ng/ml.³⁹⁵ The administration of IV iron (and increasing the dose of ESA by 25%) resulted in a greater correction of anemia compared with increasing the dose of ESA alone. After the end of the trial, there was greater success in reducing the dose of ESA in the patients receiving IV iron, compared to the non-iron-treated arm.

IV iron therapy also improves responses to ESA therapy in patients with inflammatory bowel disease³⁹⁶ compared to responses in a similar patient group who received oral iron supplementation.³⁹⁷ Decreased reticulocyte hemoglobin (CHr) is an indicator of the inadequacy of iron supply in the face of increased iron demand stimulated by ESA therapy.³⁵⁹ The requirement for a kinetic balance between iron delivery and level of erythropoietin stimulation may explain the need for intravenous iron supplemental therapy in ESA-treated patients, even those with replete iron stores.³⁹³ The clinical response to the combination of IV iron and ESA therapy may be attributed to the ability of the parenteral route to circumvent the inflammation-induced block to intestinal iron absorption and deliver a large dose of iron to the reticuloendothelial system, which could increase iron efflux from macrophages, perhaps by increasing the translation of ferroportin mRNA.

Currently approved intravenous iron preparations are listed in Table 23.9.³⁹⁸ The risk-benefit profile of IV iron continues to undergo evaluation in renal dialysis patients,^{393,399} as well as in patients with anemia of chronic diseases.¹²⁷ IV iron can allow up to a fivefold greater erythropoietic response to significant blood loss anemia in normal individuals.^{400,401} A greater rate of red cell production is probably not possible unless red marrow expands into yellow marrow space, as is seen in patients with hereditary anemias.^{402,403} One potential limitation to IV iron therapy may be that much of the administered iron ends up in

P.639

the reticuloendothelial system as storage iron, from where it is not readily available for erythropoiesis,⁴⁰³ particularly if hepcidin concentrations are elevated. However, for patients with iron deficiency, 50% of IV iron is incorporated into hemoglobin within 3 to 4 weeks.⁴⁰⁴ For patients with anemia of chronic disease or renal failure, IV iron is mobilized less rapidly from the reticuloendothelial system.⁴⁰⁵ Nevertheless, when iron dextran was given intravenously to patients with the anemia of rheumatoid arthritis, cellular hemoglobin concentrations increased significantly.⁴⁰⁶

TABLE 23.9 CURRENTLY AVAILABLE INTRAVENOUS IRON PREPARATIONS

	DexFerru		Venofe					
Trade Name	m	INFeD	Ferrlecit r	Feraheme	Ferinject^a	Monofer^a		
Manufacturer	American Regent, Inc	s	Pharmacosmo	Sanofi Aventis	Vifor	AMAG	Vifor	Pharmacosmo s
Carbohydrate	High-molecular-weight dextran	Low-molecular-weight dextran	Gluconate	Sucrose	Carboxymethyl dextran	Carboxymaltose	Isomaltoside	1,000
Molecular weight measured by	265,000	165,000	289,000-440,000	34,000-60,000	750,000	150,000	150,000	

manufacturer (Da)							
Total-dose or >500 mg infusion	Yes	Yes	No	No	Yes	Yes	Yes
Premedication	TDI only	TDI only	No	No	No	No	No
Test dose required	Yes	Yes	No	No	No	No	No
Iron concentration (mg/ml)	50	50	12.5	20	30	50	100
Vial volume (ml)	1-2	2	5	5	17	2 or 10	1, 2, 5, or 10
Black box warning	Yes	Yes	No	No	No	No	No
Preservative	None	None	Benzyl alcohol	None	None	None	None

^aNot approved in the United States.

Note: Ferric gluconate and iron sucrose are also referred to as iron salts.

TDI, total-dose infusion.

From Goodnough LT, Shander AS. Current status of pharmacologic therapies in patient blood management. *Anesth Analg* 2012; in press.

In patients with malignancy and chemotherapy-induced anemia, five trials have studied IV iron in the setting of therapy with ESAs. In one study⁴⁰⁷ of patients undergoing chemotherapy, 155 patients were treated with ESA and randomized to receive either no iron; oral iron as 325 mg of ferrous sulfate twice daily; 100-mg boluses of IV iron dextran weekly until the total calculated iron deficit was administered; or a single of IV iron dextran to the same calculated dose. There were significant improvements in hemoglobin levels and hematopoietic responses in both patient groups treated with IV iron arms, compared to those receiving oral iron or no iron therapy.

Another study⁴⁰⁸ assigned 189 patients to receive ESA weekly plus no iron, oral iron as 325 mg of ferrous sulfate thrice daily, or IV ferrous gluconate as 125 mg weekly boluses. The cohort treated with IV iron had improved hemoglobin and hematopoietic responses compared to the other cohorts. A third study⁴⁰⁹ randomly assigned 67 patients with lymphoproliferative malignancies not receiving chemotherapy with IV or no iron. Again, IV iron resulted in improved hemoglobin and hematopoietic responses. A fourth study of 398 patients with chemotherapy-induced anemia who were treated with ESA therapy, found significant improvement in hemoglobin levels and hematopoietic responses in the patient cohort treated with IV iron,⁴¹⁰ further confirmed by a fifth study.⁴¹¹

Iron-restricted erythropoiesis has been shown to be a consideration at time of cancer diagnosis even before ESA therapy: 17% of carefully screened patients were found to have serum ferritins <100 ng/ml and 59% had transferrin saturations (TSAT) less than 20% at diagnosis.⁴¹² Additionally, renewed attention has been placed on the dose-response relationship between ESA dosage and red cell production responses in ESA-treated patients. Once ESA therapy is administered, even subjects with normal baseline levels develop TSAT and ferritin decreases to levels indicating iron-restricted erythropoiesis.^{354,356} Accordingly, guidelines by the National Comprehensive Cancer Network (NCCN) have recommended that iron studies be obtained at baseline in order to identify patients who are candidates for supplemental iron therapy, and that if subsequent hemoglobin levels after 4 weeks of ESA therapy indicate no response (<1 g/dl increase in hemoglobin), then IV iron supplemental therapy should be considered, along with an increase in ESA dose.⁴¹³

Despite these beneficial effects in treatment of iron deficiency, intravenous iron administration may generate oxidative stress and other inflammatory changes.³⁹³ A mouse model showed that red cell transfusion of aged blood resulted in oxidative stress and inflammatory cytokine secretion in response to macrophage-ingested iron from membrane-encapsulated hemoglobin, but not from stroma-free lysate derived from stored red cells.⁴¹⁴ Long-term effects of the intravenous iron preparations will require careful study in relevant clinical settings.^{327,415}

The hypoferrremia and anemia of inflammation can be viewed as a mechanism of defense against providing iron to unwanted pathogens,⁴¹⁶ and therefore adaptive. On the other hand, others are not convinced that iron deficiency or iron-restrictive anemia should be regarded as a desirable condition that benefits patients with infection or inflammation. Although more evidence is clearly needed, in patients who show symptoms attributable to moderate or severe anemia of inflammation, and who do not suffer from overwhelming or difficult to control infection, iron-restricted erythropoiesis can and should be treated, an argument that is not new.³⁷³ In iron-restricted anemias other than absolute iron deficiency, the optimal treatment is still evolving and may be improved by the ongoing development of hepcidin-targeted therapies.

Important clinical subjects for further study in this area should include improving the diagnosis of various forms of iron-restricted anemia in complex clinical settings, testing optimal combinations of ESA and IV iron treatments, analysis of the relative risk-benefits of ESA and IV iron therapy, and the appropriate

P.640

use of adjuncts such as anti-inflammatory therapy or frequent dialysis. Basic scientific insights that could facilitate the progress in this area include understanding the molecular nature of the erythropoietic iron regulator and suppressor of hepcidin, details of the mechanisms by which circulating and stored iron regulates hepcidin, the contribution of hepcidin-independent mechanisms to anemia of inflammation, and the role of genetics in sporadic iron deficiency.

Side Effects of Parenteral Iron Therapy

Side effects may be local or systemic. With intravenous injection, rates of administration greater than 100 mg/minute are associated with pain in the vein injected, flushing, and a metallic taste.⁴¹⁷ Such reactions are brief in duration and relieved immediately by slowing the injection. Systemic reactions may be either immediate or delayed. Immediate side effects include hypotension, headache, malaise, urticaria, nausea, and rare anaphylactoid reactions, particularly to iron dextran. Delayed reactions include lymphadenopathy, myalgia, arthralgia, and fever. Most of the reactions are mild and transient, but the anaphylactoid reactions may be life-threatening.^{417,418} For iron dextran therapy, the clinician should be prepared for the possibility of anaphylaxis by having epinephrine, oxygen, and facilities for resuscitation available. Sodium ferric gluconate, iron sucrose, and iron saccharates are generally better tolerated than the iron-dextran complex, as long as the recommended dosages are not exceeded.^{143,385}

Response to Therapy

When specific iron therapy is given, patients often show rapid subjective improvement, with disappearance or marked diminution of fatigue, lassitude, and other nonspecific symptoms. This response may occur before any improvement in anemia is observed. Similarly, pica has been reported to be relieved within 1 week of therapy.³³⁹

The earliest hematologic evidence of response to treatment is an increase in the percentage of reticulocytes and their hemoglobin content. The reticulocytes attain a maximal value on the fifth to tenth day after institution of therapy and thereafter gradually return to normal. The maximal value usually ranges from 5% to 10% and is inversely related to the level of hemoglobin. The reticulocyte response may not be detectable in mild iron deficiency anemia.

The blood hemoglobin level is the most accurate measure of the degree of anemia in iron deficiency. During the response to therapy, the red cell count may increase temporarily to values above normal, but the hemoglobin value lags behind. The red cell indices may remain abnormal for some time after the normal hemoglobin level is restored. As recovery occurs, a normocytic cell population gradually replaces the microcytic cell population, and one of the early signs of response to therapy is an increase in the RDW from pretreatment levels. When treatment is fully effective, hemoglobin reaches normal levels by 2 months after therapy is initiated, regardless of starting values.

Of the epithelial lesions in iron deficiency, those affecting the tongue and nails are the most responsive to treatment. After 1 to 2 weeks, small regenerating filiform papillae are observed. After 3 months, the tongue has usually returned to normal; however, in patients with severe anemia, some atrophy may persist. Koilonychia usually disappears in 3 to 6 months, with the concavity moving toward the end of the nail as the nail grows. Gastritis and the associated defects in gastric secretion often do not respond to therapy, especially in older adults. In patients younger than 30 years of age, gastric acid secretion and normal epithelial architecture may be restored.²¹⁵

Dysphagia may be relieved by iron therapy if the associated postcricoid webs are small or medium sized.³²⁴ The webs themselves are not altered, however, and relapse of the anemia is associated with recurring dysphagia. With more severe lesions, dilatation of the esophagus is required for relief.

Relapse occurs in a significant fraction of patients who respond to iron treatment, in part because of failure to complete the full course of therapy and in part because of recurrence (or continuation) of the predisposing condition or illness.

Preventive Treatment

Certain people are at such high risk for developing iron deficiency that prophylactic measures may be considered. These include infants, pregnant women, adolescents, regular blood donors, women with menorrhagia, and patients receiving continuous, high-dose aspirin therapy. Iron supplementation has been recommended for pregnant women for almost half a century. Although the advantages of this practice have not been definitively established,^{419,420} the large iron cost of pregnancy and delivery to the mother (Table 23.6) indicate that it is warranted, evidenced by recommendations by the US preventative services task force that pregnant women be screened for iron deficiency.²¹¹

In 1999, the Committee on Nutrition of the American Academy of Pediatrics made recommendations for iron supplementation in infants.²⁸¹ They suggest that breastfeeding is preferable for the first 5 to 6 months of life if it is feasible, and beyond 6 months of age, breast-fed infants should receive supplemental iron at 1 mg/kg/day. Infants who are not breast-fed should be given formula supplemented with 12 mg/L of iron through the first year of life. The Committee recommends using iron-fortified cereal at the time that a solid diet is begun. Finally, fresh cow's milk should be avoided until after the first birthday.

Recovery from Anemia after Acute Hemorrhage

Morphologic evidence of active red cell regeneration should disappear after 10 to 14 days, if hemorrhage does not recur. The leukocyte count should be normal after 3 to 4 days. Sustained reticulocytosis is suggestive of continued bleeding. Persistent leukocytosis may result from the same cause, from hemorrhage into body cavities, or from complications. The latter, particularly infections, tend to delay the hematopoietic response.

Acute Iron Intoxication

The accidental ingestion of iron compounds by children who have mistaken the tablets for candy is a common problem, particularly with toddlers whose mothers are taking iron-containing prenatal vitamin supplements.^{421,422} and ⁴²³ A few cases have also been reported in adults.⁴²⁴ At one time, the associated mortality rate was as high as 50%. Those persons who died had swallowed 3 to 10 g or more.

Symptoms of iron intoxication have been classified in four stages. In the first stage, gastrointestinal symptoms predominate (vomiting, diarrhea, and melena). Shock may ensue, followed by dyspnea, lethargy, and coma. These events occur in the first 6 hours after ingestion. In the second stage, lasting from 6 to 24 hours after ingestion, transient improvement occurs and may continue to recovery. In stage three, metabolic acidosis is present. Death may take place 12 to 48 hours after ingestion. Stage four consists of intestinal obstruction as a late complication caused by scarring of the intestine.

These ill effects are the consequence of the local irritative action of the iron, resulting in mucosal ulceration and bleeding. Capillary dilatation and diapedesis of red cells may occur. Many factors cause the shock, including the absorption of iron in amounts far above the binding capacity of the plasma. Serum iron values as high as 3,000 µg/dl have been observed. Late coma is the result of hypoxia, metabolic disturbances, and hepatic damage.

P.641

The introduction of deferoxamine as a therapeutic agent has greatly modified the outlook.⁴²⁵ In the setting of acute iron poisoning this hexadentate chelator, which has a high specific affinity for iron, can be given orally and intravenously. The molecular complex is small and is excreted quickly by the kidneys. Nonetheless, it is prudent to manage iron poisoning in consultation with an experienced toxicologist.

ACKNOWLEDGMENTS

Substantial portions of this chapter were adapted from previous chapters written by G. Richard Lee and Nancy Andrews.

REFERENCES

1. Lange J. Medicinalium epistolarum miscelanea varia et rara, 1554. *Am J Dis Child* 1932;48:393.
2. Cabot RC. Diseases of blood. In: Osler Sir W, ed. *Modern medicine*. Philadelphia, PA: Lea & Febiger, 1913:650.
3. Fowler W. Chlorosis—an obituary. *Ann Med Hist* 1936;8:168.
4. Haden RL. Historical aspects of iron therapy in anemia. *JAMA* 1938;111:1059.
5. Wintrobe MM, Beebe RT. Idiopathic hypochromic anemia. *Medicine* 1933;12:187-243.
6. Green R, Charlton R, Seftel H, et al. Body iron excretion in man: a collaborative study. *Am J Med* 1968;45:336-353.
7. Brune M, Magnusson B, Persson H, Hallberg L. Iron losses in sweat. *Am J Clin Nutr* 1986;43:438-443.
8. Hallberg L, Rossander-Hulten L. Iron requirements in menstruating women. *Am J Clin Nutr* 1991;54:1047-1058.
9. Morris ER. An overview of current information on bioavailability of dietary iron to humans. *Fed Proc* 1983;42:1716-1720.
10. Khan AA, Quigley JG. Control of intracellular heme levels: heme transporters and heme oxygenases. *Biochim Biophys Acta* 2011;1813:668-682.
11. Raffin SB, Woo CH, Roost KT, Price DC, Schmid R. Intestinal absorption of hemoglobin iron-heme cleavage by mucosal heme oxygenase. *J Clin Invest* 1974;54:1344-1352.
12. Quigley JG, Yang Z, Worthington MT, et al. Identification of a human heme exporter that is essential for erythropoiesis. *Cell* 2004;118:757-766.
13. Yang Z, Philips JD, Doty RT, et al. Kinetics and specificity of feline leukemia virus subgroup C receptor (FLVCR) export function and its dependence on hemopexin. *J Biol Chem* 2010;285:28874-28882.
14. Lopez MA, Martos FC. Iron availability: an updated review. *Int J Food Sci Nutr* 2004;55:597-606.
15. Gunshin H, Fujiwara Y, Custodio AO, Drenzo C, Robine S, Andrews NC. Slc11a2 is required for intestinal iron absorption and erythropoiesis but dispensable in placenta and liver. *J Clin Invest* 2005;115:1258-1266.
16. Mackenzie B, Garrick MD. Iron Imports. II. Iron uptake at the apical membrane in the intestine. *Am J Physiol Gastrointest Liver Physiol* 2005;289:G981-G986.
17. Gunshin H, Mackenzie B, Berger UV, et al. Cloning and characterization of a mammalian proton-coupled metal-ion transporter. *Nature* 1997;388: 482-488.
18. Canonne-Hergaux F, Levy JE, Fleming MD, Montross LK, Andrews NC, Gros P. Expression of the DMT1 (NRAMP2/DCT1) iron transporter in mice with genetic iron overload disorders. *Blood* 2001;97:1138-1140.
19. Illing AC, Shawki A, Cunningham CL, Mackenzie B. Substrate profile and metal-ion selectivity of human divalent metal-ion transporter-1. *J Biol Chem* 2012;31;287:30485-30496.
20. Mackenzie B, Ujwal ML, Chang MH, Romero MF, Hediger MA. Divalent metal-ion transporter DMT1 mediates both H⁺-coupled Fe²⁺ transport and uncoupled fluxes. *Pflugers Arch* 2006;451:544-558.
21. McKie AT, Barrow D, Latunde-Dada GO, et al. An iron-regulated ferric reductase associated with the absorption of dietary iron. *Science* 2001;291: 1755-1759.
22. McKie AT. The role of Dcytb in iron metabolism: an update. *Biochem Soc Trans* 2008;36:1239-1241.
23. Sheehan RG, Frenkel EP. The control of iron absorption by the gastrointestinal mucosal cell. *J Clin Invest* 1972;51:224-231.
24. Potten CS, Loeffler M. Stem cells: attributes, cycles, spirals, pitfalls and uncertainties. Lessons for and from the crypt. *Development* 1990;110:1001-1020.
25. Abboud S, Haile DJ. A novel mammalian iron-regulated protein involved in intracellular iron metabolism. *J Biol Chem* 2000;275:19906-19912.
26. McKie AT, Marciani P, Rolfs A, et al. A novel duodenal iron-regulated transporter, IREG1, implicated in the basolateral transfer of iron to the circulation. *Mol Cell* 2000;5:299-309.
27. Donovan A, Brownlie A, Zhou Y, et al. Positional cloning of zebrafish ferroportin1 identifies a conserved vertebrate iron exporter. *Nature* 2000;403: 776-781.

28. Donovan A, Lima CA, Pinkus JL, et al. The iron exporter ferroportin/Slc40a1 is essential for iron homeostasis. *Cell Metab* 2005;1:191-200.
29. Vulpe CD, Kuo YM, Murphy TL, et al. Hephaestin, a ceruloplasmin homologue implicated in intestinal iron transport, is defective in the sla mouse. *Nat Genet* 1999;21:195-199.
30. Hellman NE, Gitlin JD. Ceruloplasmin metabolism and function. *Annu Rev Nutr* 2002;22:439-458.
31. Bannerman RM, Bannerman CE, Kingston PJ. Hereditary iron deficiency: X-linked anaemia (sla) in newborn and suckling mice. *Br J Haematol* 1973;25:280.
32. Edwards JA, Bannerman RM. Hereditary defect of intestinal iron transport in mice with sex-linked anemia. *J Clin Invest* 1970;49:1869-1871.
33. Finch C. Regulators of iron balance in humans. *Blood* 1994;84:1697-1702.
34. Krause A, Neitz S, Magert HJ, et al. LEAP-1, a novel highly disulfide-bonded human peptide, exhibits antimicrobial activity. *FEBS Lett* 2000;480:147-150.
35. Park CH, Valore EV, Waring AJ, Ganz T. Hepcidin, a urinary antimicrobial peptide synthesized in the liver. *J Biol Chem* 2001;276:7806-7810.
36. Ganz T, Nemeth E. Hepcidin and disorders of iron metabolism. *Annu Rev Med* 2011;62:347-360.
37. Roetto A, Papanikolaou G, Politou M, et al. Mutant antimicrobial peptide hepcidin is associated with severe juvenile hemochromatosis. *Nat Genet* 2003;33:21-22.
38. Viatte L, Lesbordes-Brion JC, Lou DQ, et al. Dereglulation of proteins involved in iron metabolism in hepcidin-deficient mice. *Blood* 2005;105:4861-4864.
39. Nicolas G, Bennoun M, Porteu A, et al. Severe iron deficiency anemia in transgenic mice expressing liver hepcidin. *Proc Natl Acad Sci U S A* 2002;99:4596-4601.
40. Rivera S, Nemeth E, Gabayan V, Lopez MA, Farshidi D, Ganz T. Synthetic hepcidin causes rapid dose-dependent hypoferremia and is concentrated in ferroportin-containing organs. *Blood* 2005;106:2196-2199.
41. Nemeth E, Tuttle MS, Powelson J, et al. Hepcidin regulates cellular iron efflux by binding to ferroportin and inducing its internalization. *Science* 2004;306:2090-2093.
42. Lin L, Valore EV, Nemeth E, Goodnough JB, Gabayan V, Ganz T. Iron transferrin regulates hepcidin synthesis in primary hepatocyte culture through hemojuvelin and BMP2/4. *Blood* 2007;110:2182-2189.
43. Ganz T, Olbina G, Girelli D, Nemeth E, Westerman M. Immunoassay for human serum hepcidin. *Blood* 2008;112:4292-4297.
44. Schmidt PJ, Toran PT, Giannetti AM, Bjorkman PJ, Andrews NC. The transferrin receptor modulates Hfe-dependent regulation of hepcidin expression. *Cell Metab* 2008;7:205-214.
45. Gao J, Chen J, Kramer M, Tsukamoto H, Zhang AS, Enns CA. Interaction of the hereditary hemochromatosis protein HFE with transferrin receptor 2 is required for transferrin-induced hepcidin expression. *Cell Metab* 2009;9:217-227.
46. Johnson MB, Enns CA. Diferric transferrin regulates transferrin receptor 2 protein stability. *Blood* 2004;104:4287-4293.
47. Schmidt PJ, Fleming MD. Transgenic HFE-dependent induction of hepcidin in mice does not require transferrin receptor-2. *Am J Hematol* 2012;87:588-595.
48. Steinbicker AU, Bartnikas TB, Lohmeyer LK, et al. Perturbation of hepcidin expression by BMP type I receptor deletion induces iron overload in mice. *Blood* 2011;118:4224-4230.
49. Xia Y, Babitt JL, Sidis Y, Chung RT, Lin HY. Hemojuvelin regulates hepcidin expression via a selective subset of BMP ligands and receptors independently of neogenin. *Blood* 2008;111:5195-5204.
50. Babitt JL, Huang FW, Wrighting DM, et al. Bone morphogenetic protein signaling by hemojuvelin regulates hepcidin expression. *Nat Genet* 2006;38:531-539.
51. Andriopoulos B Jr, Corradini E, Xia Y, et al. BMP6 is a key endogenous regulator of hepcidin expression and iron metabolism. *Nat Genet* 2009;41:482-487.
52. Meynard D, Kautz L, Darnaud V, Canonne-Hergaux F, Coppin H, Roth MP. Lack of the bone morphogenetic protein BMP6 induces massive iron overload. *Nat Genet* 2009;41:478-481.

53. Ramos E, Kautz L, Rodriguez R, et al. Evidence for distinct pathways of hepcidin regulation by acute and chronic iron loading in mice. *Hepatology* 2011;53:1333-1341.
54. Papanikolaou G, Samuels ME, Ludwig EH, et al. Mutations in HFE2 cause iron overload in chromosome 1q-linked juvenile hemochromatosis. *Nat Genet* 2004;36:77-82.
55. Lee DH, Zhou LJ, Zhou Z, et al. Neogenin inhibits HJV secretion and regulates BMP-induced hepcidin expression and iron homeostasis. *Blood* 2010;115:3136-3145.
56. Silvestri L, Pagani A, Nai A, De Domenico I, Kaplan J, Camaschella C. The serine protease matriptase-2 (TMPRSS6) inhibits hepcidin activation by cleaving membrane hemojuvelin. *Cell Metab* 2008;8:502-511.
57. Zhang AS, Anderson SA, Wang J, et al. Suppression of hepatic hepcidin expression in response to acute iron deprivation is associated with an increase of matriptase-2 protein. *Blood* 2011;117:1687-1699.
58. Kautz L, Meynard D, Monnier A, et al. Iron regulates phosphorylation of Smad1/5/8 and gene expression of Bmp6, Smad7, Id1, and Atoh8 in the mouse liver. *Blood* 2008;112:1503-1509.
59. Nicolas G, Chauvet C, Viatte L, et al. The gene encoding the iron regulatory peptide hepcidin is regulated by anemia, hypoxia, and inflammation. *J Clin Invest* 2002;110:1037-1044.
60. Pak M, Lopez MA, Gabayan V, Ganz T, Rivera S. Suppression of hepcidin during anemia requires erythropoietic activity. *Blood* 2006;108:3730-3735.
61. Ashby DR, Gale DP, Busbridge M, et al. Erythropoietin administration in humans causes a marked and prolonged reduction in circulating hepcidin. *Haematologica* 2010;95:505-508.
62. Origa R, Galanello R, Ganz T, et al. Liver iron concentrations and urinary hepcidin in beta-thalassemia. *Haematologica* 2007;92:583-588.
63. Kearney SL, Nemeth E, Neufeld EJ, et al. Urinary hepcidin in congenital chronic anemias. *Pediatr Blood Cancer* 2007;48:57-63.
64. Tanno T, Bhanu NV, Oneal PA, et al. High levels of GDF15 in thalassemia suppress expression of the iron regulatory protein hepcidin. *Nat Med* 2007;13:1096-1101.
65. Tanno T, Rabel A, Lee YT, Yau YY, Leitman SF, Miller JL. Expression of growth differentiation factor 15 is not elevated in individuals with iron deficiency secondary to volunteer blood donation. *Transfusion* 2010;50:1532-1535.
66. Nemeth E, Valore EV, Territo M, Schiller G, Lichtenstein A, Ganz T. Hepcidin, a putative mediator of anemia of inflammation, is a type II acute-phase protein. *Blood* 2003;101:2461-2463.
67. Weinstein DA, Roy CN, Fleming MD, Loda MF, Wolfsdorf JJ, Andrews NC. Inappropriate expression of hepcidin is associated with iron refractory anemia: implications for the anemia of chronic disease. *Blood* 2002;100: 3776-3781.
68. Nemeth E, Rivera S, Gabayan V, et al. IL-6 mediates hypoferrremia of inflammation by inducing the synthesis of the iron regulatory hormone hepcidin. *J Clin Invest* 2004;113:1271-1276.
69. Wrighting DM, Andrews NC. Interleukin-6 induces hepcidin expression through STAT3. *Blood* 2006;108:3204-3209.
70. Zaritsky J, Young B, Wang HJ, et al. Hepcidin—a potential novel biomarker for iron status in chronic kidney disease. *Clin J Am Soc Nephrol* 2009;4: 1051-1056.
71. Hentze MW, Muckenthaler MU, Andrews NC. Balancing acts: molecular control of mammalian iron metabolism. *Cell* 2004;117:285-297.
72. Eisenstein RS. Iron regulatory proteins and the molecular control of mammalian iron metabolism. *Annu Rev Nutr* 2000;20:627-662.
73. Muckenthaler M, Gray NK, Hentze MW. IRP-1 binding to ferritin mRNA prevents the recruitment of the small ribosomal subunit by the cap-binding complex eIF4F. *Mol Cell* 1998;2:383-388.
74. Kaptain S, Downey WE, Tang C, et al. A regulated RNA binding protein also possesses aconitase activity. *Proc Natl Acad Sci U S A* 1991;88:10109-10113.
75. Constable A, Quick S, Gray NK, Hentze MW. Modulation of the RNA-binding activity of a regulatory protein by iron in vitro: switching between enzymatic and genetic function? *Proc Natl Acad Sci U S A* 1992;89:4554-4558.

76. Haile DJ, Rouault TA, Tang CK, Chin J, Harford JB, Klausner RD. Reciprocal control of RNA-binding and aconitase activity in the regulation of the iron-responsive element binding protein: role of the iron-sulfur cluster. *Proc Natl Acad Sci U S A* 1992;89:7536-7540.
77. Guo B, Phillips JD, Yu Y, Leibold EA. Iron regulates the intracellular degradation of iron regulatory protein 2 by the proteasome. *J Biol Chem* 1995;270:21645-21651.
78. Samaniego F, Chin J, Iwai K, Rouault TA, Klausner RD. Molecular characterization of a second iron-responsive element binding protein, iron regulatory protein 2. Structure, function, and post-translational regulation. *J Biol Chem* 1994;269:30904-30910.
79. Vashisht AA, Zumbrennen KB, Huang X, et al. Control of iron homeostasis by an iron-regulated ubiquitin ligase. *Science* 2009;326:718-721.
80. Salahudeen AA, Thompson JW, Ruiz JC, et al. An E3 ligase possessing an iron-responsive hemerythrin domain is a regulator of iron homeostasis. *Science* 2009;326:722-726.
81. Meyron-Holtz EG, Ghosh MC, Rouault TA. Mammalian tissue oxygen levels modulate iron-regulatory protein activities in vivo. *Science* 2004;306: 2087-2090.
82. Cooperman SS, Meyron-Holtz EG, Olivierre-Wilson H, Ghosh MC, McConnell JP, Rouault TA. Microcytic anemia, erythropoietic protoporphyria, and neurodegeneration in mice with targeted deletion of iron-regulatory protein 2. *Blood* 2005;106:1084-1091.
83. LaVaute T, Smith S, Cooperman S, et al. Targeted deletion of the gene encoding iron regulatory protein-2 causes misregulation of iron metabolism and neurodegenerative disease in mice. *Nat Genet* 2001;27:209-214.
84. Smith SR, Ghosh MC, Ollivierre-Wilson H, Hang Tong W, Rouault TA. Complete loss of iron regulatory proteins 1 and 2 prevents viability of murine zygotes beyond the blastocyst stage of embryonic development. *Blood Cells Mol Dis* 2006;36:283-287.
85. Galy B, Ferring-Appel D, Kaden S, Grone HJ, Hentze MW. Iron regulatory proteins are essential for intestinal function and control key iron absorption molecules in the duodenum. *Cell Metab* 2008;7:79-85.
86. Zhang DL, Hughes RM, Ollivierre-Wilson H, Ghosh MC, Rouault TA. A ferroportin transcript that lacks an iron-responsive element enables duodenal and erythroid precursor cells to evade translational repression. *Cell Metab* 2009;9:461-473.
87. Dupic F, Fruchon S, Bensaid M, et al. Duodenal mRNA expression of iron related genes in response to iron loading and iron deficiency in four strains of mice. *Gut* 2002;51:648-653.
88. Shah YM, Matsubara T, Ito S, Yim SH, Gonzalez FJ. Intestinal hypoxia-inducible transcription factors are essential for iron absorption following iron deficiency. *Cell Metab* 2009;9:152-164.
89. Mastrogiannaki M, Matak P, Keith B, Simon MC, Vaulont S, Peyssonnaud C. HIF-2alpha, but not HIF-1alpha, promotes iron absorption in mice. *J Clin Invest* 2009;119:1159-1166.
90. Huebers HA, Finch CA. The physiology of transferrin and transferrin receptors. *Physiol Rev* 1987;67:520-582.
91. Dale JC, Burritt MF, Zinsmeister AR. Diurnal variation of serum iron, iron-binding capacity, transferrin saturation, and ferritin levels. *Am J Clin Pathol* 2002;117:802-808.
92. Aisen P, Listowsky I. Iron transport and storage proteins. *Annu Rev Biochem* 1980;49:357-393.
93. Zak O, Aisen P. Evidence for functional differences between the two sites of rabbit transferrin: effects of serum and carbon dioxide. *Biochim Biophys Acta* 1990;1052:24-28.
94. Goya N, Miyazaki S, Kodate S, Ushio B. A family of congenital atransferrinemia. *Blood* 1972;40:239-245.
95. Heilmeyer L, Keller W, Vivell O, et al. Congenital atransferrinemia in a 7-year-old girl. *Dtsch Med Wochenschr* 1961;86:1745-1751.
96. Kaplan J, Craven C, Alexander J, Kushner J, Lamb J, Bernstein S. Regulation of the distribution of tissue iron. Lessons learned from the hypotransferrinemic mouse. *Ann N Y Acad Sci* 1988;526:124-135.
97. Beutler E, Gelbart T, Lee P, Trevino R, Fernandez MA, Fairbanks VF. Molecular characterization of a case of atransferrinemia. *Blood* 2000;96:4071-4074.

98. Levy JE, Jin O, Fujiwara Y, Kuo F, Andrews NC. Transferrin receptor is necessary for development of erythrocytes and the nervous system. *Nat Genet* 1999;21:396-399.
99. Huebers H, Csiba E, Huebers E, Finch CA. Molecular advantage of diferric transferrin in delivering iron to reticulocytes: a comparative study. *Proc Soc Exp Biol Med* 1985;179:222-226.
100. Kawabata H, Nakamaki T, Ikonomi P, Smith RD, Germain RS, Koeffler HP. Expression of transferrin receptor 2 in normal and neoplastic hematopoietic cells. *Blood* 2001;98:2714-2719.
101. Forejtnikova H, Vieillevoye M, Zermati Y, et al. Transferrin receptor 2 is a component of the erythropoietin receptor complex and is required for efficient erythropoiesis. *Blood* 2010;116:5357-5367.
102. Ahn J, Johnstone RM. Origin of a soluble truncated transferrin receptor. *Blood* 1993;81:2442-2451.
103. Beguin Y. Soluble transferrin receptor for the evaluation of erythropoiesis and iron status. *Clin Chim Acta* 2003;329:9-22.
104. Huebers HA, Beguin Y, Pootrakul P, Einspahr D, Finch CA. Intact transferrin receptors in human plasma and their relation to erythropoiesis. *Blood* 1990;75:102-107.
105. R'Zik S, Beguin Y. Serum soluble transferrin receptor concentration is an accurate estimate of the mass of tissue receptors. *Exp Hematol* 2001;29: 677-685.
106. Aisen P. Transferrin receptor 1. *Int J Biochem Cell Biol* 2004;36:2137-2143.
107. Ohgami RS, Campagna DR, Greer EL, et al. Identification of a ferrireductase required for efficient transferrin-dependent iron uptake in erythroid cells. *Nat Genet* 2005;37:1264-1269.
108. Fleming MD, Romano MA, Su MA, Garrick LM, Garrick MD, Andrews NC. Nramp2 is mutated in the anemic Belgrade (b) rat: evidence of a role for Nramp2 in endosomal iron transport. *Proc Natl Acad Sci U S A* 1998;95:1148-1153.
109. Mims MP, Guan Y, Pospisilova D, et al. Identification of a human mutation of DMT1 in a patient with microcytic anemia and iron overload. *Blood* 2005;105:1337-1342.
110. Iolascon A, d'Apolito M, Servedio V, Cimmino F, Piga A, Camaschella C. Microcytic anemia and hepatic iron overload in a child with compound heterozygous mutations in DMT1 (SCL11A2). *Blood* 2006;107:349-354.
111. Beaumont C, Delaunay J, Hetet G, Grandchamp B, de Montalembert M, Tchernia G. Two new human DMT1 gene mutations in a patient with microcytic anemia, low ferritinemia, and liver iron overload. *Blood* 2006;107: 4168-4170.
112. Shaw GC, Cope JJ, Li L, et al. Mitoferrin is essential for erythroid iron assimilation. *Nature* 2006;440:96-100.
113. Sheftel AD, Zhang AS, Brown C, Shirihai OS, Ponka P. Direct interorganellar transfer of iron from endosome to mitochondrion. *Blood* 2007;110:125-132.
114. Richardson DR, Lane DJ, Becker EM, et al. Mitochondrial iron trafficking and the integration of iron metabolism between the mitochondrion and cytosol. *Proc Natl Acad Sci U S A* 2010;107:10775-10782.
115. Battistini A, Coccia EM, Marziali G, et al. Intracellular heme coordinately modulates globin chain synthesis, transferrin receptor number, and ferritin content in differentiating Friend erythroleukemia cells. *Blood* 1991;78: 2098-2103.
116. Han AP, Yu C, Lu L, et al. Heme-regulated eIF2alpha kinase (HRI) is required for translational regulation and survival of erythroid precursors in iron deficiency. *EMBO J* 2001;20:6909-6918.
117. Primosigh JV, Thomas ED. Studies on the partition of iron in bone marrow cells. *J Clin Invest* 1968;47:1473-1482.
118. Douglas AS, Dacie JV. The incidence and significance of iron-containing granules in human erythrocytes and their precursors. *J Clin Pathol* 1953;6: 307-313.
119. Bessis MC, Breton-Gorius J. Ferritin and ferruginous micelles in normal erythroblasts and hypochromic hypersideremic anemias. *Blood* 1959;14:423-432.
120. Keel SB, Doty RT, Yang Z, et al. A heme export protein is required for red blood cell differentiation and iron homeostasis. *Science* 2008;319:825-828.
121. Cianetti L, Segnalini P, Calzolari A, et al. Expression of alternative transcripts of ferroportin-1 during human erythroid differentiation. *Haematologica* 2005;90:1595-1606.
122. Fillet G, Beguin Y, Baldelli L. Model of reticuloendothelial iron metabolism in humans: abnormal behavior in idiopathic hemochromatosis and in inflammation. *Blood* 1989;74:844-851.

123. Delaby C, Pilard N, Puy H, Canonne-Hergaux F. Sequential regulation of ferroportin expression after erythrophagocytosis in murine macrophages: early mRNA induction by haem, followed by iron-dependent protein expression. *Biochem J* 2008;411:123-131.
124. Ganz T. Hpcidin and iron regulation, 10 years later. *Blood* 2011;117:4425-4433.
125. Harris ZL, Durley AP, Man TK, Gitlin JD. Targeted gene disruption reveals an essential role for ceruloplasmin in cellular iron efflux. *Proc Natl Acad Sci U S A* 1999;96:10812-10817.
126. Harris ED. The iron-copper connection: the link to ceruloplasmin grows stronger. *Nutr Rev* 1995;53:170-173.
127. Weiss G, Goodnough LT. Anemia of chronic disease. *N Engl J Med* 2005;352:1011-1023.
128. Harrison PM, Arosio P. The ferritins: molecular properties, iron storage function and cellular regulation. *Biochim Biophys Acta* 1996;1275:161-203.
129. Ferreira C, Santambrogio P, Martin ME, et al. H ferritin knockout mice: a model of hyperferritinemia in the absence of iron overload. *Blood* 2001;98:525-532.
130. Lawson DM, Treffry A, Artymiuk PJ, et al. Identification of the ferroxidase centre in ferritin. *FEBS Lett* 1989;254:207-210.
131. Levi S, Luzzago A, Cesareni G, et al. Mechanism of ferritin iron uptake: activity of the H-chain and deletion mapping of the ferro-oxidase site. A study of iron uptake and ferro-oxidase activity of human liver, recombinant H-chain ferritins, and of two H-chain deletion mutants. *J Biol Chem* 1988;263:18086-18092.
132. Santambrogio P, Levi S, Cozzi A, Rovida E, Albertini A, Arosio P. Production and characterization of recombinant heteropolymers of human ferritin H and L chains. *J Biol Chem* 1993;268:12744-12748.
133. Arosio P, Levi S. Cytosolic and mitochondrial ferritins in the regulation of cellular iron homeostasis and oxidative damage. *Biochim Biophys Acta* 2010;1800:783-792.
134. Drysdale JW, Adelman TG, Arosio P, et al. Human isoferritins in normal and disease states. *Semin Hematol* 1977;14:71-88.
135. Levi S, Corsi B, Bosisio M, et al. A human mitochondrial ferritin encoded by an intronless gene. *J Biol Chem* 2001;276:24437-24440.
136. Langlois d'Estaintot B, Santambrogio P, Granier T, et al. Crystal structure and biochemical properties of the human mitochondrial ferritin and its mutant Ser144Ala. *J Mol Biol* 2004;340:277-293.
137. Missirlis F, Holmberg S, Georgieva T, Dunkov BC, Rouault TA, Law JH. Characterization of mitochondrial ferritin in *Drosophila*. *Proc Natl Acad Sci U S A* 2006;103:5893-5898.
138. Munro H. The ferritin genes: their response to iron status. *Nutr Rev* 1993;51:65-73.
139. Hentze MW, Caughman SW, Rouault TA, et al. Identification of the iron-responsive element for the translational regulation of human ferritin mRNA. *Science* 1987;238:1570-1573.
140. Lin JJ, Daniels-McQueen S, Patino MM, Gaffield L, Walden WE, Thach RE. Derepression of ferritin messenger RNA translation by hemin in vitro. *Science* 1990;247:74-77.
141. Shi H, Bencze KZ, Stemmler TL, Philpott CC. A cytosolic iron chaperone that delivers iron to ferritin. *Science* 2008;320:1207-1210.
142. Theil EC, Takagi H, Small GW, et al. The ferritin iron entry and exit problem. *Inorg Clin Acta* 1999;297:242-251.
143. Goodnough LT, Nemeth E, Ganz T. Detection, evaluation, and management of iron-restricted erythropoiesis. *Blood* 2010;116:4754-4761.
144. Cragg SJ, Wagstaff M, Worwood M. Detection of a glycosylated subunit in human serum ferritin. *Biochem J* 1981;199:565-571.
145. Cohen LA, Gutierrez L, Weiss A, et al. Serum ferritin is derived primarily from macrophages through a nonclassical secretory pathway. *Blood* 2010;116:1574-1584.
146. Weir MP, Sharp GA, Peters TJ. Electron microscopic studies of human haemosiderin and ferritin. *J Clin Pathol* 1985;38:915-918.
147. Finch CA, Deubelbeiss K, Cook JD, et al. Ferrokinetics in man. *Medicine (Baltimore)* 1970;49:17-53.

148. Torrance JD, Charlton RW, Schman A, Lynch SR, Bothwell TH. Storage iron in "muscle". *J Clin Pathol* 1968;21:495-500.
149. Tahara T, Sun J, Igarashi K, Taketani S. Heme-dependent up-regulation of the alpha-globin gene expression by transcriptional repressor Bach1 in erythroid cells. *Biochem Biophys Res Commun* 2004;324:77-85.
150. Tahara T, Sun J, Nakanishi K, et al. Heme positively regulates the expression of beta-globin at the locus control region via the transcriptional factor Bach1 in erythroid cells. *J Biol Chem* 2004;279:5480-5487.
151. Ogawa K, Sun J, Taketani S, et al. Heme mediates derepression of Maf recognition element through direct binding to transcription repressor Bach1. *EMBO J* 2001;20:2835-2843.
152. Zenke-Kawasaki Y, Dohi Y, Katoh Y, et al. Heme induces ubiquitination and degradation of the transcription factor Bach1. *Mol Cell Biol* 2007;27:6962-6971.
153. Chen JJ. Regulation of protein synthesis by the heme-regulated eIF2alpha kinase: relevance to anemias. *Blood* 2007;109:2693-2699.
154. Cavill I, Ricketts C, Napier JA, Jacobs A. Ferrokinetics and erythropoiesis in man: red-cell production and destruction in normal and anaemic subjects. *Br J Haematol* 1977;35:33-40.
155. Robinson SH. Increased formation of early-labeled bilirubin in rats with iron deficiency anemia: evidence for ineffective erythropoiesis. *Blood* 1969;33:909-917.
156. Diez-Ewald M, Layrisse M. Mechanisms of hemolysis in iron deficiency anemia. Further studies. *Blood* 1968;32:884-894.
157. Loria A, Sanchez-Medal L, Lisker R, De Rodriguez E, Labardini J. Red cell life span in iron deficiency anaemia. *Br J Haematol* 1967;13:294-302.
158. Macdougall LG, Judisch JM, Mistry SB. Red cell metabolism in iron deficiency anemia. II. The relationship between red cell survival and alterations in red cell metabolism. *J Pediatr* 1970;76:660-675.
159. Rasch CA, Cotton EK, Griggs RC, Harris JW. Shortened survival of auto-transfused ⁵¹Cr-labeled erythrocytes in infants with severe iron-deficiency anemia. *Semin Hematol* 1976;13:181-186.
160. Yip R, Mohandas N, Clark MR, Jain S, Shohet SB, Dallman PR. Red cell membrane stiffness in iron deficiency. *Blood* 1983;62:99-106.
161. Jain SK, Yip R, Hoesch RM, Pramanik AK, Dallman PR, Shohet SB. Evidence of peroxidative damage to the erythrocyte membrane in iron deficiency. *Am J Clin Nutr* 1983;37:26-30.
162. Siimes MA, Refino C, Dallman PR. Manifestation of iron deficiency at various levels of dietary iron intake. *Am J Clin Nutr* 1980;33:570-574.
163. Hagler L, Askew EW, Neville JR, Mellick PW, Coppes RI Jr, Lowder JF Jr. Influence of dietary iron deficiency on hemoglobin, myoglobin, their respective reductases, and skeletal muscle mitochondrial respiration. *Am J Clin Nutr* 1981;34:2169-2177.
164. Dallman PR, Goodman JR. Enlargement of mitochondrial compartment in iron and copper deficiency. *Blood* 1970;35:496-505.
165. Dallman PR, Schwartz HC. Distribution of cytochrome c and myoglobin in rats with dietary iron deficiency. *Pediatrics* 1965;35:677-686.
166. Finch CA, Gollnick PD, Hlastala MP, Miller LR, Dillmann E, Mackler B. Lactic acidosis as a result of iron deficiency. *J Clin Invest* 1979;64:129-137.
167. Finch CA, Miller LR, Inamdar AR, Person R, Seiler K, Mackler B. Iron deficiency in the rat. Physiological and biochemical studies of muscle dysfunction. *J Clin Invest* 1976;58:447-453.
168. Geerken RG, Gibbons RB. Lactic acidosis associated with iron deficiency anemia. *JAMA* 1972;221:292-293.
169. Voorhess ML, Stuart MJ, Stockman JA, Oski FA. Iron deficiency anemia and increased urinary norepinephrine excretion. *J Pediatr* 1975;86:542-547.
170. Wagner A, Fortier N, Giroux A, Lukes J, Snyder LM. Catecholamines in adult iron deficiency patients. *Experientia* 1979;35:681-682.

171. Symes AL, Sourkes TL, Youdim MB, Gregoriadis G, Birnbaum H. Decreased monoamine oxidase activity in liver of iron-deficient rats. *Can J Biochem* 1969;47:999-1002.
172. Youdim MB, Grahame-Smith DG, Woods HF. Some properties of human platelet monoamine oxidase in iron-deficiency anaemia. *Clin Sci Mol Med* 1976;50:479-485.
173. Dallman PR. Manifestations of iron deficiency. *Semin Hematol* 1982;19:19-30.
174. Oski FA. The nonhematologic manifestations of iron deficiency. *Am J Dis Child* 1979;133:315-322.
175. Camaschella C, Campanella A, De Falco L, et al. The human counterpart of zebrafish shiraz shows sideroblastic-like microcytic anemia and iron overload. *Blood* 2007;110:1353-1358.
176. Harris ZL, Takahashi Y, Miyajima H, Serizawa M, MacGillivray RT, Gitlin JD. Aceruloplasminemia: molecular characterization of this disorder of iron metabolism. *Proc Natl Acad Sci U S A* 1995;92:2539-2543.
177. Folgueras AR, de Lara FM, Pendas AM, et al. Membrane-bound serine protease matriptase-2 (Tmprss6) is an essential regulator of iron homeostasis. *Blood* 2008;112:2539-2545.
178. Finberg KE, Heeney MM, Campagna DR, et al. Mutations in *TMPRSS6* cause iron-refractory iron deficiency anemia (IRIDA). *Nat Genet* 2008;40:569-571.
179. Priwitzerova M, Nie G, Sheftel AD, Pospisilova D, Divoky V, Ponka P. Functional consequences of the human DMT1 (SLC11A2) mutation on protein expression and iron uptake. *Blood* 2005;106:3985-3987.
180. Lam-Yuk-Tseung S, Camaschella C, Iolascon A, Gros P. A novel R416C mutation in human DMT1 (SLC11A2) displays pleiotropic effects on function and causes microcytic anemia and hepatic iron overload. *Blood Cells Mol Dis* 2006;36:347-354.
181. Trenor CC 3rd, Campagna DR, Sellers VM, Andrews NC, Fleming MD. The molecular defect in hypotransferrinemic mice. *Blood* 2000;96:1113-1118.
182. Di Raimondo D, Pinto A, Tuttolomondo A, Fernandez P, Camaschella C, Licata G. Aceruloplasminemia: a case report. *Intern Emerg Med* 2008;3: 395-399.
183. Miyajima H. Aceruloplasminemia, an iron metabolic disorder. *Neuropathology* 2003;23:345-350.
184. Buchanan DD, Silburn PA, Chalk JB, Le Couteur DG, Mellick GD. The Cys282Tyr polymorphism in the HFE gene in Australian Parkinson's disease patients. *Neurosci Lett* 2002;327:91-94.
185. Hartman KR, Barker JA. Microcytic anemia with iron malabsorption: an inherited disorder of iron metabolism. *Am J Hematol* 1996;51:269-275.
186. Parsons SK, Fleming MD, Nathan DG, Andrews NC. Iron deficiency anemia associated with an error of iron metabolism in two siblings: a thirty year follow up. *Hematology*. 1996;1:65-73.
187. Pearson HA, Lukens JN. Ferrokinetics in the syndrome of familial hypoferremic microcytic anemia with iron malabsorption. *J Pediatr Hematol Oncol* 1999;21:412-417.
188. Mayo MM, Samuel SM. Iron deficiency anemia due to a defect in iron metabolism: a case report. *Clin Lab Sci* 2001;14:135-138.
189. Melis MA, Cau M, Congiu R, et al. A mutation in the *TMPRSS6* gene, encoding a transmembrane serine protease that suppresses hepcidin production, in familial iron deficiency anemia refractory to oral iron. *Haematologica* 2008;93:1473-1479.
190. Guillem F, Lawson S, Kannengiesser C, Westerman M, Beaumont C, Grandchamp B. Two nonsense mutations in the *TMPRSS6* gene in a patient with microcytic anemia and iron deficiency. *Blood* 2008;112:2089-2091.
191. Du X, She E, Gelbart T, et al. The serine protease *TMPRSS6* is required to sense iron deficiency. *Science* 2008;320:1088-1092.
192. Benyamin B, Ferreira MA, Willemsen G, et al. Common variants in *TMPRSS6* are associated with iron status and erythrocyte volume. *Nat Genet* 2009;41:1173-1175.
193. Chambers JC, Zhang W, Li Y, et al. Genome-wide association study identifies variants in *TMPRSS6* associated with hemoglobin levels. *Nat Genet* 2009;41:1170-1172.

194. Tanaka T, Roy CN, Yao W, et al. A genome-wide association analysis of serum iron concentrations. *Blood* 2010;115:94-96.
195. Ganesh SK, Zakai NA, van Rooij FJ, et al. Multiple loci influence erythrocyte phenotypes in the CHARGE Consortium. *Nat Genet* 2009;41:1191-1198.
196. Heinrich HC. Iron deficiency without anemia. *Lancet* 1968;2:460.
197. Verloop MC. Iron depletion without anemia: a controversial subject. *Blood* 1970;36:657-671.
198. Ballas SK. Normal serum iron and elevated total iron-binding capacity in iron-deficiency states. *Am J Clin Pathol* 1979;71:401-403.
199. Koller ME, Romslo I, Finne PH, Brockmeier F, Tyssebotn I. The diagnosis of iron deficiency by erythrocyte protoporphyrin and serum ferritin analyses. *Acta Paediatr Scand* 1978;67:361-366.
200. Labbe RF, Vreman HJ, Stevenson DK. Zinc protoporphyrin: a metabolite with a mission. *Clin Chem* 1999;45:2060-2072.
201. Cook JD. The measurement of serum transferrin receptor. *Am J Med Sci* 1999;318:269-276.
202. Trost LB, Bergfeld WF, Calogeras E. The diagnosis and treatment of iron deficiency and its potential relationship to hair loss. *J Am Acad Dermatol* 2006;54:824-844.
203. Conrad ME, Crosby WH. The natural history of iron deficiency induced by phlebotomy. *Blood* 1962;20:173-185.
- P.642
204. Jacob RA, Sandstead HH, Klevay LM, Johnson LK. Utility of serum ferritin as a measure of iron deficiency in normal males undergoing repetitive phlebotomy. *Blood* 1980;56:786-791.
205. Beutler E, Waalen J. The definition of anemia: what is the lower limit of normal of the blood hemoglobin concentration? *Blood* 2006;107:1747-1750.
206. Guyatt GH, Patterson C, Ali M, et al. Diagnosis of iron-deficiency anemia in the elderly. *Am J Med* 1990;88:205-209.
207. Guralnik JM, Eisenstaedt RS, Ferrucci L, Klein HG, Woodman RC. Prevalence of anemia in persons 65 years and older in the United States: evidence for a high rate of unexplained anemia. *Blood* 2004;104:2263-2268.
208. Ferrucci L, Semba RD, Guralnik JM, et al. Proinflammatory state, hepcidin, and anemia in older persons. *Blood* 2010;115:3810-3816.
209. Looker AC, Dallman PR, Carroll MD, Gunter EW, Johnson CL. Prevalence of iron deficiency in the United States. *JAMA* 1997;277:973-976.
210. Karp RJ, Haaz WS, Starko K, Gorman JM. Iron deficiency in families of iron-deficient inner-city school children. *Am J Dis Child* 1974;128:18-20.
211. Killip S, Bennett JM, Chambers MD. Iron deficiency anemia. *Am Fam Physician* 2007;75:671-678.
212. Rosenbaum E, Leonard JW. Nutritional iron deficiency anemia in an adult male. Report of a case. *Ann Intern Med* 1964;60:683-688.
213. Hurrell RF. Fortification: overcoming technical and practical barriers. *J Nutr* 2002;132:806S-812S.
214. Salgueiro MJ, Zubillaga M, Lysionek A, Caro R, Weill R, Boccio J. Fortification strategies to combat zinc and iron deficiency. *Nutr Rev* 2002;60:52-58.
215. Jacobs A, Lawrie JH, Entwistle CC, Campbell H. Gastric acid secretion in chronic iron-deficiency anaemia. *Lancet* 1966;2:190-192.
216. Skikne BS, Lynch SR, Cook JD. Role of gastric acid in food iron absorption. *Gastroenterology* 1981;81:1068-1071.
217. Hershko C, Lahad A, Kereth D. Gastropathic sideropenia. *Best Pract Res Clin Haematol* 2005;18:363-380.
218. Adams JF. The clinical and metabolic consequences of total gastrectomy. II. Anaemia. Metabolism of iron, vitamin B12 and folic acid. *Scand J Gastroenterol* 1968;3:145-151.

219. Hines JD, Hoffbrand AV, Mollin DL. The hematologic complications following partial gastrectomy. A study of 292 patients. *Am J Med* 1967;43:555-569.
220. Magnusson BE. Iron absorption after antrectomy with gastroduodenostomy. Studies on the absorption from food and from iron salt using a double radio-iron isotope technique and whole-body counting. *Scand J Haematol Suppl* 1976;26:1-111.
221. Sutton DR, Stewart JS, Baird IM, Coghill NF. "Free" iron loss in atrophic gastritis, post-gastrectomy states, and adult coeliac disease. *Lancet* 1970;2:387-389.
222. Kilpatrick ZM, Katz J. Occult celiac disease as a cause of iron deficiency anemia. *JAMA* 1969;208:999-1001.
223. Kosnai I, Kuitunen P, Siimes MA. Iron deficiency in children with coeliac disease on treatment with gluten-free diet. Role of intestinal blood loss. *Arch Dis Child* 1979;54:375-378.
224. Egan-Mitchell B, Fottrell PF, McNicholl B. Early or pre-coeliac mucosa: development of gluten enteropathy. *Gut* 1981;22:65-69.
225. Fleming AF. Iron deficiency in the tropics. *Clin Haematol* 1982;11:365-388.
226. Graham DY, Smith JL. Gastroduodenal complications of chronic NSAID therapy. *Am J Gastroenterol* 1988;83:1081-1084.
227. Scott JT, Porter IH, Lewis SM, Dixon AS. Studies of gastrointestinal bleeding caused by corticosteroids, salicylates, and other analgesics. *Q J Med* 1961;30:167-188.
228. Jick H. Effects of aspirin and acetaminophen in gastrointestinal hemorrhage. Results from the Boston Collaborative Drug Surveillance Program. *Arch Intern Med* 1981;141:316-321.
229. Windsor CW, Collis JL. Anaemia and hiatus hernia: experience in 450 patients. *Thorax* 1967;22:73-78.
230. Cameron AJ. Incidence of iron deficiency anemia in patients with large diaphragmatic hernia. A controlled study. *Mayo Clin Proc* 1976;51:767-769.
231. Annibale B, Capurso G, Chistolini A, et al. Gastrointestinal causes of refractory iron deficiency anemia in patients without gastrointestinal symptoms. *Am J Med* 2001;111:439-445.
232. Acher PL, Al-Mishlab T, Rahman M, Bates T. Iron-deficiency anaemia and delay in the diagnosis of colorectal cancer. *Colorectal Dis* 2003;5:145-148.
233. Raje D, Mukhtar H, Oshowo A, Ingham Clark C. What proportion of patients referred to secondary care with iron deficiency anemia have colon cancer? *Dis Colon Rectum* 2007;50:1211-1214.
234. Beal RW, Skyring AP, McRae J, Firkin BG. The anemia of ulcerative colitis. *Gastroenterology* 1963;45:589-603.
235. Stephenson LS, Latham MC, Ottesen EA. Malnutrition and parasitic helminth infections. *Parasitology* 2000;121(Suppl):S23-S38.
236. Stephenson LS, Holland CV, Cooper ES. The public health significance of *Trichuris trichiura*. *Parasitology* 2000;121(Suppl):S73-S95.
237. Roche M, Layrresse M. The nature and causes of "hookworm anemia". *Am J Trop Med Hyg* 1966;15:1029-1102.
238. Stoltzfus RJ, Albonico M, Chwaya HM, et al. Hemoquant determination of hookworm-related blood loss and its role in iron deficiency in African children. *Am J Trop Med Hyg* 1996;55:399-404.
239. Stephenson L. The impact of schistosomiasis on human nutrition. *Parasitology* 1993;107(Suppl):S107-S123.
240. Hallberg L, Hogdahl AM, Nilsson L, Rybo G. Menstrual blood loss—a population study. Variation at different ages and attempts to define normality. *Acta Obstet Gynecol Scand* 1966;45:320-351.
241. Hallberg L, Hogdahl AM, Nilsson L, Rybo G. Menstrual blood loss and iron deficiency. *Acta Med Scand* 1966;180:639-650.
242. Jacobs A, Butler EB. Menstrual blood-loss in iron-deficiency anaemia. *Lancet* 1965;2:407-409.
243. Beaton GH, Thein M, Milne H, Veen MJ. Iron requirements of menstruating women. *Am J Clin Nutr* 1970;23:275-283.
244. Hefnawi F, Askalani H, Zaki K. Menstrual blood loss with copper intrauterine devices. *Contraception* 1974;9:133-139.
245. Simon TL, Garry PJ, Hooper EM. Iron stores in blood donors. *JAMA* 1981;245:2038-2043.

246. Goodnough LT, Bravo JR, Hsueh YS, Keating LJ, Brittenham GM. Red blood cell mass in autologous and homologous blood units. Implications for risk/benefit assessment of autologous blood crossover and directed blood transfusion. *Transfusion* 1989;29:821-822.
247. Cable RG, Glynn SA, Kiss JE, et al. Iron deficiency in blood donors: analysis of enrollment data from the REDS-II Donor Iron Status Evaluation (RISE) study. *Transfusion* 2011;51:511-522.
248. Brittenham GM. Iron deficiency in whole blood donors. *Transfusion* 2011;51:458-461.
249. Simon TL, Hunt WC, Garry PJ. Iron supplementation for menstruating female blood donors. *Transfusion* 1984;24:469-472.
250. Public Workshop Summary: hemoglobin standards and maintaining adequate iron stores in blood donors. <https://www.aabb.org/resources/governmentregulatory/donoreligibility>. Accessed January 25 2012.
251. Leatherman JW, Davies SF, Hoidal JR. Alveolar hemorrhage syndromes: diffuse microvascular lung hemorrhage in immune and idiopathic disorders. *Medicine (Baltimore)* 1984;63:343-361.
252. Le Clainche L, Le Bourgeois M, Fauroux B, et al. Long-term outcome of idiopathic pulmonary hemosiderosis in children. *Medicine (Baltimore)* 2000;79:318-326.
253. Specks U. Diffuse alveolar hemorrhage syndromes. *Curr Opin Rheumatol* 2001;13:12-17.
254. van der Ent CK, Walenkamp MJ, Donckerwolcke RA, van der Laag J, van Diemen-Steenvoorde R. Pulmonary hemosiderosis and immune complex glomerulonephritis. *Clin Nephrol* 1995;43:339-341.
255. Hartmann RC, Jenkins DE Jr, McKee LC, Heyssel RM. Paroxysmal nocturnal hemoglobinuria: clinical and laboratory studies relating to iron metabolism and therapy with androgen and iron. *Medicine (Baltimore)* 1966;45: 331-363.
256. Kann HE, Jr., Mengel CE, Wall RL. Paroxysmal nocturnal hemoglobinuria "obscured" by the presence of iron deficiency. *Ann Intern Med* 1967;67: 593-596.
257. Reynolds RD, Coltman CA Jr, Beller BM. Iron treatment in sideropenic intravascular hemolysis due to insufficiency of Starr-Edwards valve prostheses. *Ann Intern Med* 1967;66:659-666.
258. Roeser HP, Powell LW. Urinary iron excretion in valvular heart disease and after heart valve replacement. *Blood* 1970;36:785-792.
259. Quinn JP, O'Keefe JP. Factitious anemia due to surreptitious phlebotomy through a Hickman catheter. *Ann Intern Med* 1985;102:720-721.
260. Stone DR, Duran A, Fine KC. Lab-fraud anemia. *N Engl J Med* 1988;319: 727-728.
261. Ernst TN, Philp M. Severe iron deficiency anemia. An example of covert child abuse (Munchausen by proxy). *West J Med* 1986;144:358-359.
262. Peery WH. Clinical spectrum of hereditary hemorrhagic telangiectasia (Osler-Weber-Rendu disease). *Am J Med* 1987;82:989-997.
263. Smoller BR, Kruskall MS. Phlebotomy for diagnostic laboratory tests in adults. Pattern of use and effect on transfusion requirements. *N Engl J Med* 1986;314:1233-1235.
264. Salisbury AC, Reid KJ, Alexander KP, et al. Diagnostic blood loss from phlebotomy and hospital-acquired anemia during acute myocardial infarction. *Arch Intern Med*. 2011Aug 8 [Epub].
265. Goodnough LT, Strasburg D, Riddell Jt, Verbrugge D, Wish J. Has recombinant human erythropoietin therapy minimized red-cell transfusions in hemodialysis patients? *Clin Nephrol* 1994;41:303-307.
266. Eckardt KU. Pathophysiology of renal anemia. *Clin Nephrol* 2000;53:S2-S8.
267. Rosenblatt SG, Drake S, Fadem S, Welch R, Lifschitz MD. Gastrointestinal blood loss in patients with chronic renal failure. *Am J Kidney Dis* 1982;1:232-236.
268. Goodnough LT. Iron deficiency syndromes and iron-restricted erythropoiesis. *Transfusion* 2011 Dec 29 [Epub].
269. Finch CA, Huebers H. Perspectives in iron metabolism. *N Engl J Med* 1982;306:1520-1528.
270. Goodnough LT, Skikne B, Brugnara C. Erythropoietin, iron, and erythropoiesis. *Blood* 2000;96:823-833.
271. Dang CV. Runner's anemia. *JAMA* 2001;286:714-716.

272. Nachtigall D, Nielsen P, Fischer R, Engelhardt R, Gabbe EE. Iron deficiency in distance runners. A reinvestigation using Fe-labelling and non-invasive liver iron quantification. *Int J Sports Med* 1996;17:473-479.
273. McMahon LF Jr, Ryan MJ, Larson D, Fisher RL. Occult gastrointestinal blood loss in marathon runners. *Ann Intern Med* 1984;100:846-847.
274. Stewart JG, Ahlquist DA, McGill DB, Ilstrup DM, Schwartz S, Owen RA. Gastrointestinal blood loss and anemia in runners. *Ann Intern Med* 1984;100:843-845.
275. Pisacane A. Neonatal prevention of iron deficiency. *BMJ* 1996;312:136-137.
276. Daniel DG, Weerakkody AN. Neonatal prevention of iron deficiency. Blood can be transfused from cord clamped at placental end. *BMJ* 1996;312: 1102-1103.
277. Rios E, Lipschitz DA, Cook JD, Smith NJ. Relationship of maternal and infant iron stores as assessed by determination of plasma ferritin. *Pediatrics* 1975;55:694-699.
278. Lanzkowsky P. The influence of maternal iron-deficiency anaemia on the haemoglobin of the infant. *Arch Dis Child* 1961;36:205-209.
279. Fletcher J, Suter PE. The transport of iron by the human placenta. *Clin Sci* 1969;36:209-220.
280. Oski FA, Stockman JA 3rd. Anemia due to inadequate iron sources or poor iron utilization. *Pediatr Clin North Am* 1980;27:237-253.
281. American Academy of Pediatrics. Committee on Nutrition. Iron fortification of infant formulas. *Pediatrics* 1999;104:119-123.
282. Saarinen UM, Siimes MA, Dallman PR. Iron absorption in infants: high bioavailability of breast milk iron as indicated by the extrinsic tag method of iron absorption and by the concentration of serum ferritin. *J Pediatr* 1977;91:36-39.
283. Saarinen UM, Siimes MA. Iron absorption from infant milk formula and the optimal level of iron supplementation. *Acta Paediatr Scand* 1977;66:719-722.
284. Hertrampf E, Cayazzo M, Pizarro F, Stekel A. Bioavailability of iron in soy-based formula and its effect on iron nutriture in infancy. *Pediatrics* 1986;78:640-645.
285. Rios E, Hunter RE, Cook JD, Smith NJ, Finch CA. The absorption of iron as supplements in infant cereal and infant formulas. *Pediatrics* 1975;55: 686-693.
286. Sandoval C, Berger E, Ozkaynak MF, Tugal O, Jayabose S. Severe iron deficiency anemia in 42 pediatric patients. *Pediatr Hematol Oncol* 2002;19: 157-161.
287. Yeung GS, Zlotkin SH. Efficacy of meat and iron-fortified commercial cereal to prevent iron depletion in cow milk-fed infants 6 to 12 months of age: a randomized controlled trial. *Can J Public Health* 2000;91:263-267.
288. Dawson JP, Desforges JF. Dietary and storage factors in iron-deficiency anemia of infancy. *AMA J Dis Child* 1958;96:169-178.
289. Jelliffe DB, Blackman V. Bahima disease. Possible "milk anemia" in late childhood. *J Pediatr* 1962;61:774-779.
290. Wilson JF, Heiner DC, Lahey ME. Milk-induced gastrointestinal bleeding in infants with hypochromic microcytic anemia. *JAMA* 1964;189:568-572.
291. Wilson JF, Lahey ME, Heiner DC. Studies on iron metabolism. V. Further observations on cow's milk-induced gastrointestinal bleeding in infants with iron-deficiency anemia. *J Pediatr* 1974;84:335-344.
292. Guha DK, Walia BN, Tandon BN, Deo MG, Ghai OP. Small bowel changes in iron-deficiency anaemia of childhood. *Arch Dis Child* 1968;43:239-244.
293. Hoag MS, Wallerstein RO, Pollycove M. Occult blood loss in iron deficiency anemia of infancy. *Pediatrics* 1961;27:199-203.
294. Woodruff CW, Clark JL. The role of fresh cow's milk in iron deficiency. I. Albumin turnover in infants with iron deficiency anemia. *Am J Dis Child* 1972;124:18-23.
295. Woodruff CW, Wright SW, Wright RP. The role of fresh cow's milk in iron deficiency. II. Comparison of fresh cow's milk with a prepared formula. *Am J Dis Child* 1972;124:26-30.

296. Celada A, Busset R, Gutierrez J, Herreros V. No correlation between iron concentration in breast milk and maternal iron stores. *Helv Paediatr Acta* 1982;37:11-16.
297. Beutler E, Larsh SE, Gurney CW. Iron therapy in chronically fatigued, non-anemic women: a double-blind study. *Ann Intern Med* 1960;52:378-394.
298. Elwood PC, Waters WE, Greene WJ, Sweetnam P, Wood MM. Symptoms and circulating haemoglobin level. *J Chronic Dis* 1969;21:615-628.
299. Krayenbuehl PA, Battegay E, Breyman C, Furrer J, Schulthess G. Intravenous iron for the treatment of fatigue in nonanemic, premenopausal women with low serum ferritin concentration. *Blood* 2011;118:3222-3227.
300. Gardner GW, Edgerton VR, Senewiratne B, Barnard RJ, Ohira Y. Physical work capacity and metabolic stress in subjects with iron deficiency anemia. *Am J Clin Nutr* 1977;30:910-917.
301. Basta SS, Soekirman, Karyadi D, Scrimshaw NS. Iron deficiency anemia and the productivity of adult males in Indonesia. *Am J Clin Nutr* 1979;32:916-925.
302. Edgerton VR, Gardner GW, Ohira Y, Gunawardena KA, Senewiratne B. Iron-deficiency anaemia and its effect on worker productivity and activity patterns. *Br Med J* 1979;2:1546-1549.
303. Edgerton VR, Bryant SL, Gillespie CA, Gardner GW. Iron deficiency anemia and physical performance and activity of rats. *J Nutr* 1972;102:381-399.
304. Glover J, Jacobs A. Activity pattern of iron-deficient rats. *Br Med J* 1972;2:627-628.
305. Ohira Y, Koziol BJ, Edgerton VR, Brooks GA. Oxygen consumption and work capacity in iron-deficient anemic rats. *J Nutr* 1981;111:17-25.
306. Koziol BJ, Ohira Y, Edgerton VR, Simpson DR. Changes in work tolerance associated with metabolic and physiological adjustment to moderate and severe iron deficiency anemia. *Am J Clin Nutr* 1982;36:830-839.
307. Rector WG Jr, Fortuin NJ, Conley CL. Non-hematologic effects of chronic iron deficiency. A study of patients with polycythemia vera treated solely with venesections. *Medicine (Baltimore)* 1982;61:382-389.
308. Lozoff B. Behavioral alterations in iron deficiency. *Adv Pediatr* 1988;35: 331-359.
309. Lozoff B. Iron deficiency and infant development. *J Pediatr* 1994;125:577-578.
310. Lozoff B, Brittenham GM. Behavioral alterations in iron deficiency. *Hematol Oncol Clin North Am* 1987;1:449-464.
311. Lozoff B, Klein NK, Nelson EC, McClish DK, Manuel M, Chacon ME. Behavior of infants with iron-deficiency anemia. *Child Dev* 1998;69:24-36.
312. Oski FA, Honig AS, Helu B, Howanitz P. Effect of iron therapy on behavior performance in nonanemic, iron-deficient infants. *Pediatrics* 1983;71:877-880.
313. Lozoff B. Perinatal iron deficiency and the developing brain. *Pediatr Res* 2000;48:137-139.
314. Grantham-McGregor S, Ani C. A review of studies on the effect of iron deficiency on cognitive development in children. *J Nutr* 2001;131:649S-666S; discussion 66S-68S.
315. Massaro TF, Widmayer P. The effect of iron deficiency on cognitive performance in the rat. *Am J Clin Nutr* 1981;34:864-870.
316. Martinez-Torres C, Cubeddu L, Dillmann E, et al. Effect of exposure to low temperature on normal and iron-deficient subjects. *Am J Physiol* 1984;246:R380-R383.
317. Dillman E, Gale C, Green W, Johnson DG, Mackler B, Finch C. Hypothermia in iron deficiency due to altered triiodothyronine metabolism. *Am J Physiol* 1980;239:R377-R381.
318. Yager JY, Hartfield DS. Neurologic manifestations of iron deficiency in childhood. *Pediatr Neurol* 2002;27:85-92.
319. Chisholm M. Tissue changes associated with iron deficiency. *Clin Haematol* 1973;2:303-321.
320. Chisholm M, Ardran GM, Callender ST, Wright R. Iron deficiency and autoimmunity in post-cricoid webs. *Q J Med* 1971;40:421-433.
321. Hogan GR, Jones B. The relationship of koilonychia and iron deficiency in infants. *J Pediatr* 1970;77:1054-1057.

322. Jacobs A, Cavill I. The oral lesions of iron deficiency anaemia: pyridoxine and riboflavin status. *Br J Haematol* 1968;14:291-295.
323. Ekberg O, Malmquist J, Lindgren S. Pharyngo-oesophageal webs in dysphageal patients. A radiologic and clinical investigation in 1,134 patients. *Rofo* 1986;145:75-80.
324. Chisholm M, Ardran GM, Callender ST, Wright R. A follow-up study of patients with post-cricoid webs. *Q J Med* 1971;40:409-420.
325. Khosla SN. Cricoid webs—incidence and follow-up study in Indian patients. *Postgrad Med J* 1984;60:346-348.
326. Brock JH, Mulero V. Cellular and molecular aspects of iron and immune function. *Proc Nutr Soc* 2000;59:537-540.
327. Jurado RL. Iron, infections, and anemia of inflammation. *Clin Infect Dis* 1997;25:888-895.
328. Theurl I, Fritsche G, Ludwiczek S, Garimorth K, Bellmann-Weiler R, Weiss G. The macrophage: a cellular factory at the interphase between iron and immunity for the control of infections. *Biometals* 2005;18:359-367.
329. Kuvibidila S, Dardenne M, Savino W, Lepault F. Influence of iron-deficiency anemia on selected thymus functions in mice: thymulin biological activity, T-cell subsets, and thymocyte proliferation. *Am J Clin Nutr* 1990;51:228-232.
330. Chandra RK. Reduced bactericidal capacity of polymorphs in iron deficiency. *Arch Dis Child* 1973;48:864-866.
331. Chandra RK, Saraya AK. Impaired immunocompetence associated with iron deficiency. *J Pediatr* 1975;86:899-902.
332. Yetgin S, Altay C, Ciliv G, Laleli Y. Myeloperoxidase activity and bactericidal function of PMN in iron deficiency. *Acta Haematol* 1979;61:10-14.
333. Dallman PR. Iron deficiency and the immune response. *Am J Clin Nutr* 1987;46:329-334.
334. Murakawa H, Bland CE, Willis WT, Dallman PR. Iron deficiency and neutrophil function: different rates of correction of the depressions in oxidative burst and myeloperoxidase activity after iron treatment. *Blood* 1987;69:1464-1468.
335. Pagani A, Nai A, Corna G, et al. Low hepcidin accounts for the proinflammatory status associated with iron deficiency. *Blood* 2011;118:736-746.
336. Oppenheimer SJ. Iron and its relation to immunity and infectious disease. *J Nutr* 2001;131:616S-635S; discussion 335-35S.
337. Murray MJ, Murray AB, Murray MB, Murray CJ. The adverse effect of iron repletion on the course of certain infections. *Br Med J* 1978;2:1113-1135.
338. Ganz T. Iron in innate immunity: starve the invaders. *Curr Opin Immunol* 2009;21:63-67.
339. Coltman CA Jr. Pagophagia and iron lack. *JAMA* 1969;207:513-516.
340. Reynolds RD, Binder HJ, Miller MB, Chang WW, Horan S. Pagophagia and iron deficiency anemia. *Ann Intern Med* 1968;69:435-440.
341. Moore DF Jr, Sears DA. Pica, iron deficiency, and the medical history. *Am J Med* 1994;97:390-393.
342. Crosby WH. Pica. *JAMA* 1976;235:2765.
343. Crosby WH. Food pica and iron deficiency. *Arch Intern Med* 1971;127: 960-961.
344. Tunnessen WW, Smith C, Oski FA. Beeturia. A sign of iron deficiency. *Am J Dis Child* 1969;117:424-426.
345. Watts AR, Lennard MS, Mason SL, Tucker GT, Woods HF. Beeturia and the biological fate of beetroot pigments. *Pharmacogenetics* 1993;3:302-311.
346. Aksoy M, Camli N, Erdem S. Roentgenographic bone changes in chronic iron deficiency anemia. A study in twelve patients. *Blood* 1966;27:677-686.
347. Lanzkowsky P. Radiological features of iron-deficiency anemia. *Am J Dis Child* 1968;116:16-29.
348. Goodnough LT, Maniatis A, Earnshaw P, et al. Detection, evaluation, and management of preoperative anaemia in the elective orthopaedic surgical patient: NATA guidelines. *Br J Anaesth* 2011;106:13-22.
349. Bessman JD, Feinstein DI. Quantitative anisocytosis as a discriminant between iron deficiency and thalassemia minor. *Blood* 1979;53:288-293.

350. Bessman JD, Gilmer PR Jr, Gardner FH. Improved classification of anemias by MCV and RDW. *Am J Clin Pathol* 1983;80:322-326.
351. Freireich EJ, Miller A, Emerson CP, Ross JF. The effect of inflammation on the utilization of erythrocyte and transferrin bound radioiron for red cell production. *Blood* 1957;12:972-983.
352. Ali MA, Luxton AW, Walker WH. Serum ferritin concentration and bone marrow iron stores: a prospective study. *Can Med Assoc J* 1978;118:945-946.
353. Mast AE, Blinder MA, Gronowski AM, Chumley C, Scott MG. Clinical utility of the soluble transferrin receptor and comparison with serum ferritin in several populations. *Clin Chem* 1998;44:45-51.
354. Mercuriali F, Zanella A, Barosi G, et al. Use of erythropoietin to increase the volume of autologous blood donated by orthopedic patients. *Transfusion* 1993;33:55-60.
355. Goodnough LT, Price TH, Rudnick S. Iron-restricted erythropoiesis as a limitation to autologous blood donation in the erythropoietin-stimulated bone marrow. *J Lab Clin Med* 1991;118:289-296.
356. Eschbach JW, Haley NR, Egrie JC, Adamson JW. A comparison of the responses to recombinant human erythropoietin in normal and uremic subjects. *Kidney Int* 1992;42:407-416.
357. Rockey DC, Cello JP. Evaluation of the gastrointestinal tract in patients with iron-deficiency anemia. *N Engl J Med* 1993;329:1691-1695.
358. Thomas C, Thomas L. Anemia of chronic disease: pathophysiology and laboratory diagnosis. *Lab Hematol* 2005;11:14-23.
359. Ferguson BJ, Skikne BS, Simpson KM, Baynes RD, Cook JD. Serum transferrin receptor distinguishes the anemia of chronic disease from iron deficiency anemia. *J Lab Clin Med* 1992;119:385-390.
360. Punnonen K, Irjala K, Rajamaki A. Serum transferrin receptor and its ratio to serum ferritin in the diagnosis of iron deficiency. *Blood* 1997;89:1052-1057.
361. Kroot JJ, Laarakkers CM, Geurts-Moespot AJ, et al. Immunochemical and mass-spectrometry-based serum hepcidin assays for iron metabolism disorders. *Clin Chem* 2010;56:1570-1579.
362. Castagna A, Camprostrini N, Zaninotto F, Girelli D. Hepcidin assay in serum by SELDI-TOF-MS and other approaches. *J Proteomics* 2010;73:527-536.
363. Pasricha SR. Is it time for hepcidin to join the diagnostic toolkit for iron deficiency? *Expert Rev Hematol* 2012;5:153-155.
364. Keel SB, Abkowitz JL. The microcytic red cell and the anemia of inflammation. *N Engl J Med* 2009;361:1904-1906.
365. Brugnara C, Laufer MR, Friedman AJ, Bridges K, Platt O. Reticulocyte hemoglobin content (CHr): early indicator of iron deficiency and response to therapy. *Blood* 1994;83:3100-3101.
366. Brugnara C, Zurakowski D, DiCanzio J, Boyd T, Platt O. Reticulocyte hemoglobin content to diagnose iron deficiency in children. *JAMA* 1999;281: 2225-2230.
367. Brugnara C. Use of reticulocyte cellular indices in the diagnosis and treatment of hematological disorders. *Int J Clin Lab Res* 1998;28:1-11.
368. Brugnara C, Colella GM, Cremins J, et al. Effects of subcutaneous recombinant human erythropoietin in normal subjects: development of decreased reticulocyte hemoglobin content and iron-deficient erythropoiesis. *J Lab Clin Med* 1994;123:660-667.
369. Macdougall IC. What is the most appropriate strategy to monitor functional iron deficiency in the dialysed patient on rhEPO therapy? Merits of percentage hypochromic red cells as a marker of functional iron deficiency. *Nephrol Dial Transplant* 1998;13:847-849.
370. Hicsonmez G, Suzer K, Suloglu G, Donmez S. Platelet counts in children with iron deficiency anemia. *Acta Haematol* 1978;60:85-89.
371. Hill RS, Pettit JE, Tattersall MH, Kiley N, Lewis SM. Iron deficiency and dyserythropoiesis. *Br J Haematol* 1972;23:507-512.

372. Grebe G, Martinez-Torres C, Layrissa M. Effect of meals and ascorbic acid on the absorption of a therapeutic dose of iron as ferrous and ferric salts. *Curr Ther Res Clin Exp* 1975;17:382-397.
373. Crosby WH. The rationale for treating iron deficiency anemia. *Arch Intern Med* 1984;144:471-472.
374. Hallberg L, Ryttinger L, Solvell L. Side-effects of oral iron therapy. A double-blind study of different iron compounds in tablet form. *Acta Med Scand Suppl* 1966;459:3-10.
375. Callender ST. Quick- and slow-release iron: a double-blind trial with a single daily dose regimen. *Br Med J* 1969;4:531-532.
376. Baird IM, Walters RL, Sutton DR. Absorption of slow-release iron and effects of ascorbic acid in normal subjects and after partial gastrectomy. *Br Med J* 1974;4:505-508.
377. Israels MC, Simmons AV. Ferrous sulphate with ascorbic acid in iron-deficiency anaemia. *Lancet* 1967;1:1297-1299.
378. Sharma DC, Mathur R. Correction of anemia and iron deficiency in vegetarians by administration of ascorbic acid. *Indian J Physiol Pharmacol* 1995;39:403-406.
379. Cacciola E, Consoli U, Giustolisi R. Ascorbic acid deficiency may be a cause of refractoriness to iron-therapy in the treatment of iron-deficiency anemia. *Haematologica* 1994;79:96-97.
380. Goodnough LT. The new age of iron: evaluation and management of iron-restricted erythropoiesis. *Semin Hematol* 2009;46:325-327.
381. Young MF, Glahn RP, Ariza-Nieto M, et al. Serum hepcidin is significantly associated with iron absorption from food and supplemental sources in healthy young women. *Am J Clin Nutr* 2009;89:533-538.
382. Ruivard M, Laine F, Ganz T, et al. Iron absorption in dysmetabolic iron overload syndrome is decreased and correlates with increased plasma hepcidin. *J Hepatol* 2009;50:1219-1225.
383. Hershko C, Skikne B. Pathogenesis and management of iron deficiency anemia: emerging role of celiac disease, helicobacter pylori, and autoimmune gastritis. *Semin Hematol* 2009;46:339-350.
384. Van Wyck DB, Mangione A, Morrison J, Hadley PE, Jehle JA, Goodnough LT. Large-dose intravenous ferric carboxymaltose injection for iron deficiency anemia in heavy uterine bleeding: a randomized, controlled trial. *Transfusion* 2009;49:2719-2728.
385. Auerbach M, Goodnough LT, Picard D, Maniatis A. The role of intravenous iron in anemia management and transfusion avoidance. *Transfusion* 2008;48:988-1000.
386. Eschbach JW, Egrie JC, Downing MR, Browne JK, Adamson JW. Correction of the anemia of end-stage renal disease with recombinant human erythropoietin. Results of a combined phase I and II clinical trial. *N Engl J Med* 1987;316:73-78.
387. Sadjadi SA. Reduction in recombinant human erythropoietin doses by the use of chronic intravenous iron supplementation. *Am J Kidney Dis* 1995;26:1000-1001.
388. Means RT Jr. Commentary: an anemia of chronic disease, after all? *J Investig Med* 1999;47:203.
389. Adamson JW. Hyporesponsiveness to erythropoiesis stimulating agents in chronic kidney disease: the many faces of inflammation. *Adv Chronic Kidney Dis* 2009;16:76-82.
390. Skikne BS, Cook JD. Effect of enhanced erythropoiesis on iron absorption. *J Lab Clin Med* 1992;120:746-751.
391. Fishbane S, Frei GL, Maesaka J. Reduction in recombinant human erythropoietin doses by the use of chronic intravenous iron supplementation. *Am J Kidney Dis* 1995;26:41-46.
392. Wingard RL, Parker RA, Ismail N, Hakim RM. Efficacy of oral iron therapy in patients receiving recombinant human erythropoietin. *Am J Kidney Dis* 1995;25:433-439.
393. KDOQI. Clinical practice guidelines and clinical practice recommendations for anemia in chronic kidney disease. *Am J Kidney Dis* 2006;47:S11-S145.
394. Silverberg DS, Iaina A, Peer G, et al. Intravenous iron supplementation for the treatment of the anemia of moderate to severe chronic renal failure patients not receiving dialysis. *Am J Kidney Dis* 1996;27:234-238.
395. Coyne DW, Kapoian T, Suki W, et al. Ferric gluconate is highly efficacious in anemic hemodialysis patients with high serum ferritin and low transferrin saturation: results of the Dialysis Patients' Response to IV Iron with Elevated Ferritin (DRIVE) Study. *J Am Soc Nephrol* 2007;18:975-984.

396. Gasche C, Dejaco C, Waldhoer T, et al. Intravenous iron and erythropoietin for anemia associated with Crohn disease. A randomized, controlled trial. *Ann Intern Med* 1997;126:782-787.
397. Schreiber S, Howaldt S, Schnoor M, et al. Recombinant erythropoietin for the treatment of anemia in inflammatory bowel disease. *N Engl J Med* 1996;334:619-623.
398. Auerbach M. Ferumoxytol as a new, safer, easier-to-administer intravenous iron: yes or no? *Am J Kidney Dis* 2008;52:826-829.
399. Goodnough LT, Shander AS. Current status of pharmacologic therapies in patient blood management. *Anesth Analg* 2012;in press.
400. Hillman RS, Henderson PA. Control of marrow production by the level of iron supply. *J Clin Invest* 1969;48:454-460.
401. Hamstra RD, Block MH. Erythropoiesis in response to blood loss in man. *J Appl Physiol* 1969;27:503-507.
402. Crosby WH. The metabolism of hemoglobin and bile pigment in hemolytic disease. *Am J Med* 1955;18:112-122.
403. Beutler E. The utilization of saccharated Fe⁵⁹ oxide in red cell formation. *J Lab Clin Med* 1958;51:415-419.
404. Wood JK, Milner PF, Pathak UN. The metabolism of iron-dextran given as a total-dose infusion to iron deficient Jamaican subjects. *Br J Haematol* 1968;14:119-129.
405. Beamish MR, Davies AG, Eakins JD, Jacobs A, Trevett D. The measurement of reticuloendothelial iron release using iron-dextran. *Br J Haematol* 1971;21:617-622.
406. Bentley DP, Williams P. Parenteral iron therapy in the anaemia of rheumatoid arthritis. *Rheumatol Rehabil* 1982;21:88-92.
407. Auerbach M, Ballard H, Trout JR, et al. Intravenous iron optimizes the response to recombinant human erythropoietin in cancer patients with chemotherapy-related anemia: a multicenter, open-label, randomized trial. *J Clin Oncol* 2004;22:1301-1307.
408. Henry DH, Dahl NV, Auerbach M, Tchekmedyian S, Laufman LR. Intravenous ferric gluconate significantly improves response to epoetin alfa versus oral iron or no iron in anemic patients with cancer receiving chemotherapy. *Oncologist* 2007;12:231-242.
409. Hedenus M, Birgegard G, Nasman P, et al. Addition of intravenous iron to epoetin beta increases hemoglobin response and decreases epoetin dose requirement in anemic patients with lymphoproliferative malignancies: a randomized multicenter study. *Leukemia* 2007;21:627-632.
410. Bastit L, Vandebroek A, Altintas S, et al. Randomized, multicenter, controlled trial comparing the efficacy and safety of darbepoetin alpha administered every 3 weeks with or without intravenous iron in patients with chemotherapy-induced anemia. *J Clin Oncol* 2008;26:1611-1618.
411. Auerbach M, Silberstein PT, Webb RT, et al. Darbepoetin alfa 300 or 500 mg once every 3 weeks with or without intravenous iron in patients with chemotherapy-induced anemia. *Am J Hematol* 2010;85:655-663.
412. Henry DH. Iron or vitamin B12 deficiency in anemic cancer patients prior to erythropoiesis stimulating agent therapy. *Commun Oncologist* 2007;4: 95-101.
413. National Comprehensive Cancer Network. Practice guidelines I oncology: cancer and chemotherapy induced anemia. V.3.2009. http://www.nccn.org/professionals/physician_gls/f_guidelines.asp. Accessed January 26, 2012.
414. Gilson CR, Kraus TS, Hod EA, et al. A novel mouse model of red blood cell storage and posttransfusion in vivo survival. *Transfusion* 2009;49: 1546-1553.
415. Bishu K, Agarwal R. Acute injury with intravenous iron and concerns regarding long-term safety. *Clin J Am Soc Nephrol* 2006;1(Suppl 1):S19-S23.
416. Weiss G. Iron and immunity: a double-edged sword. *Eur J Clin Invest* 2002;32(Suppl 1):70-78.
417. Hamstra RD, Block MH, Schocket AL. Intravenous iron dextran in clinical medicine. *JAMA* 1980;243:1726-1731.
418. Becker CE, MacGregor RR, Walker KS, Jandl JH. Fatal anaphylaxis after intramuscular iron-dextran. *Ann Intern Med* 1966;65:745-748.
419. Beaton GH. Iron needs during pregnancy: do we need to rethink our targets? *Am J Clin Nutr* 2000;72:265S-271S.

420. Haram K, Nilsen ST, Ulvik RJ. Iron supplementation in pregnancy—evidence and controversies. *Acta Obstet Gynecol Scand* 2001;80:683-688.
421. Aisen P, Cohen G, Kang JO. Iron toxicosis. *Int Rev Exp Pathol* 1990;31:1-46.
422. McGuigan MA. Acute iron poisoning. *Pediatr Ann* 1996;25:33-38.
423. Morris CC. Recent trends in pediatric iron poisonings. *South Med J* 2000;93:1229.
424. Wallack MK, Winkelstein A. Acute iron intoxication in an adult. *JAMA* 1974;229:1333-1334.
425. Mills KC, Curry SC. Acute iron poisoning. *Emerg Med Clin North Am* 1994;12:397-413.

Chapter 24 Sideroblastic Anemias

> Table of Contents > Part IV - Disorders of Red Cells > Section 2 - Disorders of Iron Metabolism and Heme Synthesis > Chapter 24 - Sideroblastic Anemias

Chapter 24

Sideroblastic Anemias

Sylvia S. Bottomley

The sideroblastic anemias are a heterogeneous group of disorders^{1,2} and ³ uniquely characterized by pathologic iron deposits in erythroblast mitochondria^{4,5} (Fig. 24.1A) that are housed within a distinct, mitochondrial ferritin.^{6,7} The iron-glutted mitochondria account for the so-called ring sideroblast, an erythroblast in which numerous Prussian blue-positive granules often appear in a perinuclear distribution, particularly in the later stages of its maturation (Fig. 24.1B).

The basis for the mitochondrial iron accumulation in the various sideroblastic anemias can be regarded as either insufficient generation of heme as a result of primary defects in the heme biosynthetic pathway or from faults in mitochondrial functions that involve iron pathways, creating an imbalance between mitochondrial iron import and its utilization. Iron delivery to the erythroid cell does not appear to be downregulated in the face of these alterations, and iron continues to be transported normally to mitochondria, where it accumulates.^{8,9} Globin synthesis is also reduced, but this effect is secondary, as it can be corrected *in vitro* by the addition of heme.^{10,11}

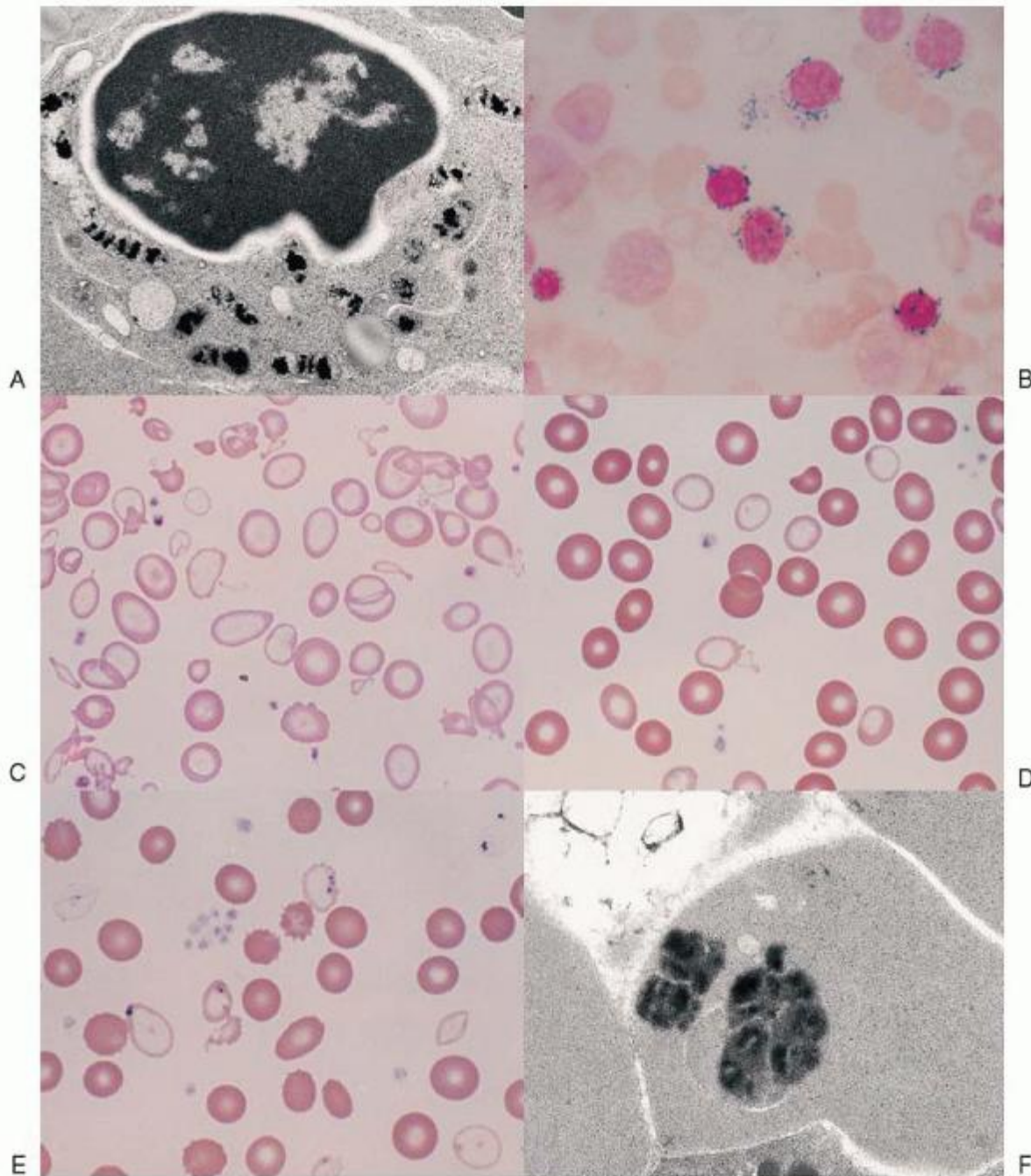

FIGURE 24.1. Morphologic features of sideroblastic anemia. A: Electron micrograph of an erythroblast with iron-laden mitochondria. B: Bone marrow smear (Prussian blue stain) with ring sideroblasts. C, D: Blood smears (Wright stain) of severe and mild sideroblastic anemia. E: Siderocytes (Wright stain). F: Electron micrograph of a Pappenheimer body in a peripheral red blood cell.

Kinetically, the sideroblastic anemias are characterized by ineffective erythropoiesis, like other erythroid disorders with defective cytoplasmic or nuclear maturation.^{12,13} Erythroid hyperplasia of the bone marrow is accompanied by a normal or only slightly increased reticulocyte count. The plasma iron turnover rate is increased, but

P.644

iron incorporation into circulating red cells is reduced. Red cell survival tends to be normal or slightly reduced. Slight hyperbilirubinemia may be noted, as well as an increase in urobilinogen excretion, as a result of a raised erythropoietic

component of the “early-label” bilirubin peak.¹⁴ Thus, it can be inferred that a substantial proportion of the developing ring sideroblasts are nonviable, and their expiration through enhanced apoptotic mechanisms within the marrow^{15,16,17} accounts for the kinetic abnormalities.

The progeny of surviving ring sideroblasts are often but not always hypochromic and microcytic erythrocytes, a finding that provides morphologic evidence of impaired hemoglobin production as well as an initial clue to the diagnosis. The degree of hypochromia and microcytosis varies considerably from one form of sideroblastic anemia to another (Fig. 24.1C,D). Often, dimorphism is pronounced, with a hypochromic/microcytic population of cells existing side by side with a normal or even a macrocytic one. The siderotic mitochondria of the developing cell may be retained in some circulating erythrocytes (Pappenheimer bodies) and are regularly found with concurrent hypofunction or absence of the spleen; these cells are the nearly pathognomonic siderocytes in the Wright-stained blood smear¹⁸ (Fig. 24.1E,F).

A common feature of many sideroblastic anemias that are not reversible is an excess of total body iron. The serum iron concentration is increased, often to the point of complete saturation of transferrin, and the level of serum ferritin roughly reflects the degree of iron overload. The ineffective erythropoiesis mediates increased intestinal absorption of iron by suppressing hepcidin production.^{19,20} The consequent iron overload state is called erythropoietic hemochromatosis, and its clinical and pathologic features and course can rival those of hereditary hemochromatosis^{21,22} (see Chapter 25). The occasional concomitant presence of alleles for genetic hemochromatosis accentuates the iron overload,^{23,24} and²⁵ but their prevalence in patients with sideroblastic anemia does not appear to be greater than in the general population.^{22,26,27} and²⁸

Diverse defects affecting the utilization of iron by the developing red cell are reflected in the various forms of sideroblastic anemia (Table 24.1). Within the congenital group, the majority appear as isolated anemia, the X-linked and a recently identified autosomal recessive type being the most frequent; however, in a large proportion of cases the cause remains unexplained. Very uncommon are several genetically defined syndromic forms involving multiple systems. Acquired sideroblastic anemia is considerably more common than the congenital forms and occurs as a clonal disorder manifesting only anemia or multilineage dysplasia or even myeloproliferative features. Several diverse factors, such as ethanol, certain drugs, copper deficiency, and hypothermia, produce the ring sideroblast abnormality that is fully reversible.

TABLE 24.1 CLASSIFICATION OF THE SIDEROBLASTIC ANEMIAS (SAs)

Congenital SA

X-linked (XLSA)

Mitochondrial carrier protein SLC25A38 deficiency

Glutaredoxin 5 deficiency

Associated with erythropoietic protoporphyria

Cause unknown

Associated with genetic syndromes

X-linked with ataxia (XLSA/A)

Myopathy, lactic acidosis, and sideroblastic anemia (MLASA)

Congenital sideroblastic anemia and B cell immunodeficiency (SIFD)

Pearson marrow-pancreas syndrome

Thiamine-responsive megaloblastic anemia (TRMA)

Acquired Clonal SA

Refractory anemia with ring sideroblasts (RARS)

Refractory anemia with ring sideroblasts and thrombocytosis (RARS-T)

Refractory cytopenia with multilineage dysplasia and ring sideroblasts (RCMD-RS)

Reversible SA: Associated with

Alcoholism

Certain drugs (isoniazid, chloramphenicol, linezolid)

Copper deficiency (nutritional, malabsorption, zinc ingestion, copper chelation)

Hypothermia

HISTORICAL ASPECTS

The history of sideroblastic anemias can be said to have begun in 1945 with Cooley's report of a family with X-linked microcytic hypochromic anemia²⁹ (Table 24.2). Near that time iron-containing granules in erythroblasts, including their perinuclear distribution, were described separately,^{31,32} and 10 years later were demonstrated to represent iron-laden mitochondria.⁴ Over the next two decades these ring sideroblasts were recognized in pyridoxine-responsive anemia and in numerous patients with "refractory" anemia of unknown cause, hereditary or acquired, forming the basis for a 1965 symposium and adoption of the term sideroblastic anemia.¹ By then, the iron overload of these disorders had also become fully appreciated.^{35,36}

The spectrum of the sideroblastic anemias was widened further by finding various reversible causes of the phenotype as well as by descriptions of certain congenital syndromic forms (Table 24.2). With the advent of molecular biology tools, the genetic causes of several clinically distinct types of congenital sideroblastic anemia and in part their pathogenesis have been elucidated during the last two decades.

HEME SYNTHESIS IN ERYTHROID CELLS

Developing erythroid cells have the greatest requirement of any cell type for heme for hemoglobin, and they produce more than 80% of the heme in the body. The expression and regulation of erythroid heme synthesis are unique in that they are linked (a) to the differentiation events after the signaling action of erythropoietin on erythroid precursors when they acquire the machinery for hemoglobin synthesis, (b) to the availability of iron, and (c) to the production of globin during development of the red cell. As in hepatocytes, 5-aminolevulinic acid (ALA) synthase and porphobilinogen (PBG) deaminase have considerably lower relative activities than the remaining enzymes in the heme biosynthetic pathway (see Chapter 6) and are sites of pathway regulation.⁶² In contrast to the liver, the relative activity of ferrochelatase, the terminal enzyme in the pathway, appears also to be low in erythroid cells.⁶² Furthermore, developing red cells express erythroid-specific isozymes or messenger RNA (mRNA) transcripts of the first four enzymes of heme synthesis, namely ALA synthase, ALA dehydratase, PBG deaminase, and uroporphyrinogen III synthase.

ALA synthase, the first and rate-controlling enzyme of heme synthesis, is generated in the cytosol as a precursor protein with an N-terminal signal sequence that is proteolytically cleaved and processed on transport of the protein into the mitochondrial matrix.^{63,64} The mature mitochondrial protein catalyzes the formation of ALA from glycine and succinyl coenzyme A (CoA) and requires pyridoxal 5'-phosphate (PLP) as an obligate cofactor. Recently it was discovered that the erythroid-specific mitochondrial carrier family protein SLC25A38 importing glycine across the mitochondrial inner membrane to likely meet the high molar requirement of this substrate by the ALAS enzyme is

P.645

necessary for normal erythroid heme synthesis.⁶⁰ Two separate genes encode the ALA synthase isoenzymes.^{65,66} The housekeeping gene (ALAS1), located on chromosome 3,^{66,67} is expressed ubiquitously,⁶⁸ whereas the erythroid-specific gene (ALAS2) is on the X chromosome.^{65,66,69,70} Expression of the housekeeping gene, at least in hepatocytes, is controlled by glucose levels and is increased by certain steroids, various drugs, and chemicals (see Chapter 26). This gene is repressed by administration of heme, the end product of the pathway, so that heme levels tightly regulate transcription of its mRNA in a feedback manner.⁶⁸ Expression of the erythroid gene is essential for hemoglobin production, and ALAS1 cannot compensate if ALAS2 is lacking.⁷¹ ALAS2 is activated and transcribed in concert with other erythroid genes through the action of erythropoietin^{63,68} (Fig. 24.2); it is not repressed by heme but is upregulated by hypoxia.⁷² Cellular iron supply may also control ALAS2 mRNA levels,⁷³ whereas exogenous heme inhibits translation of ALAS2 mRNA,⁷⁴ although the mechanisms by which these occur are not known. Translational regulation of erythroid ALA synthase mRNA is mediated through interaction of its cis-acting iron-responsive element (IRE)^{75,76} with iron regulatory proteins (IRP1 and IRP2; also called IRE binding proteins 1 and 2)^{77,78,79} that are modulated through iron-sulfur (Fe-S) clusters generated in mitochondria and by cellular iron status^{80,81} (Fig. 24.2) (see Chapter 23). In this manner, regulation of protoporphyrin production is linked to iron availability and to mitochondrial function for the formation of heme. The low ALA synthase activity observed in erythroid cells in iron deficiency is consistent with such a control mechanism.⁸² While the signal sequences of the ALAS1 and ALAS2 precursor proteins contain two heme-binding motifs implicated in regulating translocation of the enzyme into mitochondria by interaction of heme with these motifs^{83,84} (Fig. 24.2), mitochondrial import of ALAS2 does not appear to

be affected by heme.⁸⁵ Within the mitochondrion, the ALAS2 isoform uniquely associates with the succinyl-CoA synthetase β A subunit, seemingly to stabilize the ALAS2, to control the generation of its substrate succinyl-CoA, or both.⁸⁶ The role of a major splice isoform of ALAS2 that is functional in vivo⁸⁷ in the regulation of the enzyme or erythroid heme synthesis remains to be determined.

TABLE 24.2 MILESTONES IN THE HISTORY OF SIDEROBLASTIC ANEMIAS

First Description or Discovery	Year	Reference(s)
X-linked microcytic hypochromic anemia by T. Cooley	1945	29
Three brothers with pyridoxine-responsive anemia mentioned	1940s	30
Perinuclear iron-positive granules in erythroblasts	1947	31, 32
Case report of pyridoxine-responsive anemia	1956	33
Acquired refractory anemia with sideroblastic bone marrow	1956	34
Iron deposits in erythroblast mitochondria	1957	4
<i>Sideroblastic anemia</i> term adopted at international symposium	1965	1
Associated iron overload	1965	35, 36
Reversible sideroblastic anemia from antituberculosis agents	1965	37
Experimental sideroblastic anemia with antituberculosis drugs	1965, 1974	38, 39
Reversible sideroblastic anemia from chloramphenicol	1967	40
Reversible sideroblastic anemia from alcohol	1969	41
Thiamine-responsive megaloblastic anemia (Rogers syndrome)	1969	42
Sideroblastic anemia in erythropoietic protoporphyria	1973, 1993	43, 44
Sideroblastic anemia from copper deficiency	1974	45, 46
Pearson marrow-pancreas syndrome	1979	47
Sideroblastic anemia associated with hypothermia	1982	48
X-linked sideroblastic anemia with ataxia (XLSA/A)	1985	49
RARS inclusion in classification of myelodysplastic syndromes	1986	50
Mitochondrial DNA deletion as cause of Pearson syndrome	1989	51
Mutation in <i>ALAS2</i> as cause of XLSA	1992	52
Mutation in <i>ABCB7</i> as cause of XLSA/A	1999	53
Mutations in <i>SLC19A2</i> as cause of TRMA	1999	54,55 and 56
MLASA and causative mutation in <i>PUS1</i>	2004	57,58
Mutation in <i>GLRX5</i> as a cause of AR sideroblastic anemia	2007	59
Mutations in <i>SLC25A38</i> as cause of AR sideroblastic anemia	2009	60
Mutation in <i>YARS2</i> as another cause of MLASA	2010	61

AR, autosomal recessive; MLASA, myopathy, lactic acidosis, and sideroblastic anemia; RARS, refractory anemia with ring sideroblasts; TRMA, thiamine-responsive megaloblastic anemia; XLSA, X-linked sideroblastic anemia; XLSA/A,

X-linked sideroblastic anemia with ataxia.

ALA dehydratase, a cytosolic enzyme, catalyzes the formation of the pyrrole PBG from two molecules of ALA. For this enzyme, two tissue-specific isozymes are produced by a single gene, which contains two promoter regions, generating housekeeping and erythroid-specific transcripts with alternative first noncoding exons (exons 1A and 1B).^{88,89} Although both transcripts encode identical polypeptides, the erythroid-regulated form would provide for the production of the large amounts of heme for hemoglobin. Not being a rate-limiting enzyme for heme biosynthesis, its expression in erythroid cells in manyfold excess amounts⁶² may also serve as the proteasome inhibitor CF-2 to inhibit protein degradations.⁹⁰

P.646

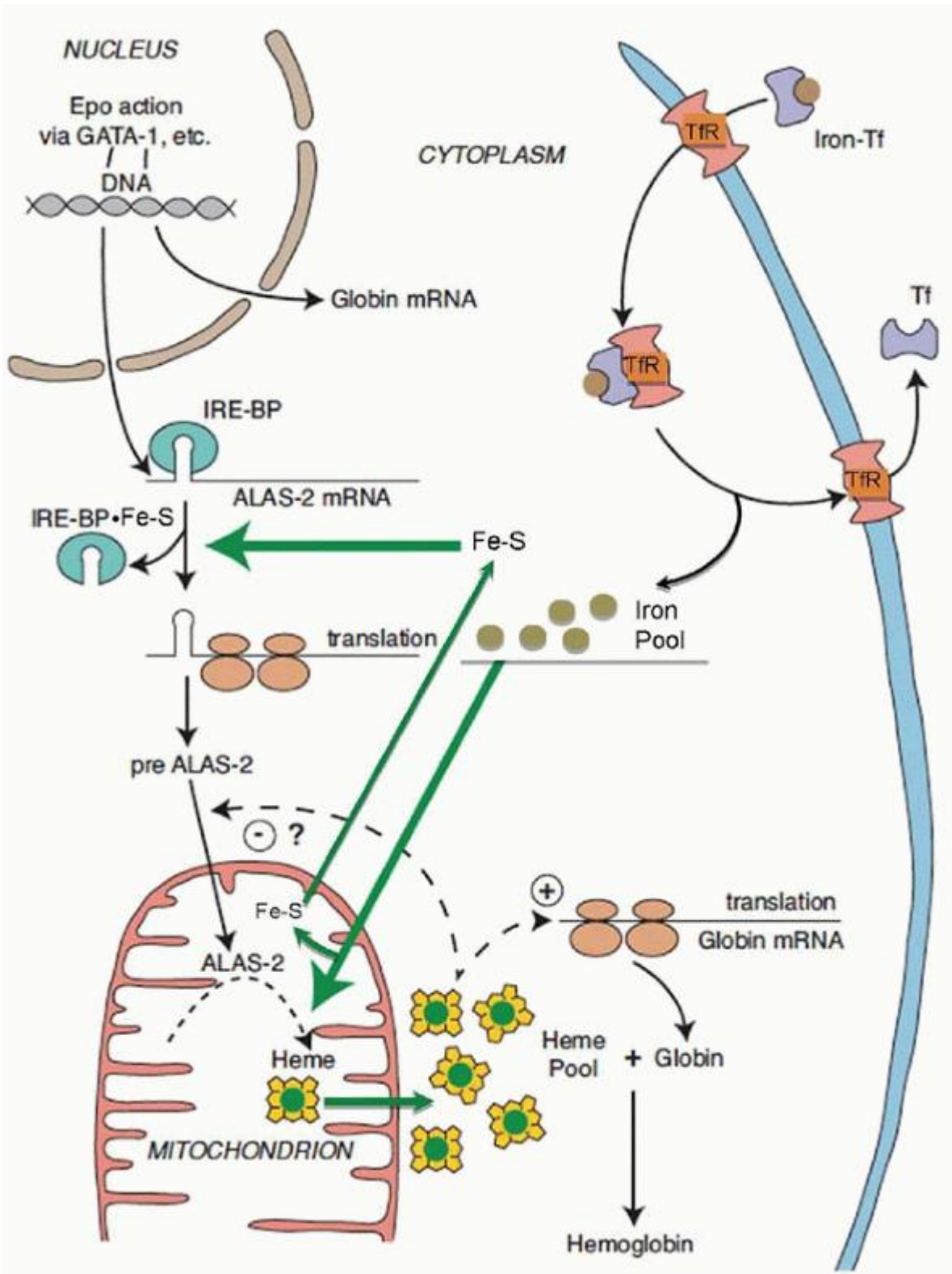

FIGURE 24.2. Pathways of regulation of erythroid 5-aminolevulinate synthase (ALAS2). Epo, erythropoietin; Fe-S, iron-sulfur cluster; Tf, transferrin; TfR, transferrin receptor; IRE-BP, iron-responsive element binding protein; - denotes inhibition, + denotes stimulation. (Modified from May BK, Dogra SC, Sadlon TJ, et al. Molecular regulation of heme biosynthesis in higher vertebrates. *Progr Nucleic Acid Res Mol Biol* 1995;51:1-51.)

In the case of PBG deaminase, which acts in the cytosol to form the linear tetrapyrrole hydroxymethylbilane from four molecules of PBG (see Chapter 6), two tissue-specific isoenzymes also are produced by a single gene.⁹¹ The gene has two

overlapping transcription units, each with its own promoter: an upstream ubiquitous promoter and another downstream promoter active only in erythroid cells. Two mRNAs are generated by alternative splicing, one encoding the ubiquitous PBG deaminase isoenzyme and the other encoding the erythroid isoenzyme. To what extent the erythroid-specific enzyme has a regulatory role in the overall production of heme in erythroid cells is not known. In response to erythropoietin or hypoxia, bone marrow PBG deaminase activity increased 3.5-fold, apparently by de novo synthesis.⁹²

The gene for uroporphyrinogen III synthase likewise has two promoters generating housekeeping and erythroid-specific transcripts with unique 5'-untranslated sequences (exons 1 and 2A).⁹³ As for ALA dehydratase and PBG deaminase, the erythroid promoter activity is increased during erythroid differentiation. Uroporphyrinogen decarboxylase, the fifth enzyme of the pathway with its site of action in the cytosol, is not known to have erythroid-regulatory features; however, its mRNA is markedly increased in erythroid tissue⁹⁴ and the enzyme activity is higher in erythroid cells than in the liver.⁶²

After translation, all three terminal enzymes of heme biosynthesis (coproporphyrinogen oxidase, protoporphyrinogen oxidase, ferrochelatase), like ALA synthase, are transported to their mitochondrial sites of action. Single genes encode these enzymes, and erythroid-specific transcription products are not known for them. However, erythroid-specific regulation of their expression is accommodated by the presence of promoter sequences in their genes for binding of erythroid transcription factors (e.g., GATA-1, NFE-2)^{95,96} and⁹⁷ to enhance production of these enzymes during erythropoiesis.⁹⁸ Ferrochelatase, the last enzyme of the heme synthetic pathway, catalyzes the insertion of iron into protoporphyrin to form heme. A repressor sequence in the promoter region of its gene is believed to be involved in the regulation of the binding of the erythroid transcription factors GATA-1 and NFE-2 to their recognition sites.⁹⁷ The activity of ferrochelatase relative to the activity of ALA synthase is in considerable excess,^{62,99} but the enzyme becomes rate-limiting as a defective protein in erythropoietic protoporphyria (see Chapter 26). As it contains an Fe-S cluster, its expression and stability are also dependent on cellular iron levels and intact Fe-S cluster assembly machinery,^{100,101} and its activity is regulated by the essential mitochondrial ATPase inhibitory factor 1 (Atpif1) through modulation of mitochondrial pH and redox potential.¹⁰²

P.647

The large amounts of iron required for erythroid heme synthesis are delivered through transferrin receptor-mediated endocytosis of iron transferrin (see Chapter 23), and iron availability ultimately limits the normal rate of heme synthesis in erythroid cells.¹⁰³ High expression of transferrin receptors is also linked to erythropoietin-induced differentiation^{68,103}; an erythroid-specific isoform of human transferrin receptor has been described¹⁰⁴; and erythroid-active elements have been identified in the promoter of the murine gene.^{105,106} During the height of hemoglobinization, the erythroid cell may not depend upon the "standard" mode for regulation of intracellular iron homeostasis via the IRE/IRP system to ensure a maximal supply of iron to mitochondria.¹⁰⁷ With erythroid maturation and the accumulation of cellular hemoglobin, the transferrin receptor number progressively decreases.¹⁰³ While surface transferrin receptors and iron uptake are increased in iron-deficient erythroblasts,^{108,109} they are not altered in states of impaired heme synthesis, such as in the presence of succinylacetone¹¹⁰ or in erythroid cells from patients with sideroblastic anemia.⁸ Transport of iron out of the endosome by the divalent metal transporter DMT1 requires an endosomal ferrireductase (Steap3) in erythroid cells.¹¹¹ How the further transfer of iron to mitochondria and to apoferritin is accomplished is not understood. It may be facilitated by a cytoplasmic chaperone,¹¹² or through direct interaction of endosomes with mitochondria.¹¹³ Iron is imported across the mitochondrial inner membrane by mitoferrin 1 that is highly expressed in erythroid cells and stabilized by interacting with the ATP-binding cassette protein ABCB10.^{114,115} An oligomeric complex of mitoferrin 1, ABCB10 and ferrochelatase appears to facilitate the incorporation of iron into protoporphyrin to form heme.¹¹⁶ Iron imported into the mitochondrion is also used for the generation of Fe-S clusters, which in part are exported to the cytosol for their addition to IRP1 in the regulation of cellular iron uptake⁸¹ and translation of ALAS2,¹¹⁷ and for expression of ferrochelatase.^{100,101}

TABLE 24.3 GENETIC AND HEMATOLOGIC FEATURES OF THE CONGENITAL SIDEROBLASTIC ANEMIAS (CSAs)

Mode of Inheritance	Defective Enzyme/Protein	Gene/Chromosomal Location of Gene	Erythrocyte		Severity of Anemia
			Mean Corpuscular Volume	Protoporphyrin	

X-linked sideroblastic anemia	X-linked ALAS2	ALAS2/Xp11.21	Decreased ^a	Decreased	Mild to severe	
Mitochondrial carrier protein deficiency	Autosomal	SLC25A38	SLC25A38/3p22.1	Decreased	Decreased	Severe
Glutaredoxin 5 deficiency	Autosomal	Glutaredoxin 5	GLRX5/14q32.13	Decreased	Not reported	Mild to severe
Protoporphyrinemia	Autosomal	Ferrochelatase	FECH/18q21.3	Decreased	Markedly increased	Mild
Unknown cause	?	?	Variable	Variable	Mild to severe	
X-linked sideroblastic anemia with ataxia	X-linked	ABCB7 mitochondrial transporter	ABCB7/Xq13.1-q13.3	Decreased	Increased	Mild
Myopathy, lactic acidosis, and sideroblastic anemia	Autosomal	Pseudouridine synthase 1	PUS1/12q24.33	Normal/increased	Not reported	Severe in time
		Mitochondrial tyrosyl tRNA synthetase	YARS2/12p11.21	Not reported	Not reported	Severe
CSA and B cell immunodeficiency	Autosomal	?	?	Decreased	Not reported	Severe
Pearson syndrome	Sporadic/maternal	Respiratory chain components	Multiple/mitochondrial DNA	Increased	Increased	Severe
Thiamine-responsive megaloblastic anemia	Autosomal	Thiamine transporter	SLC19A2/1q23.3	Increased	Normal/increased	Mild to severe

^a Often normal or increased in females expressing the disorder.

The export of heme out of the mitochondrion into the cytosol for its pairing with globins of hemoglobin and other heme proteins is mediated at least in the mouse by an isoform of the feline leukemia virus C receptor (FLVCR1), named FLVCR1b¹¹⁸. This heme exporter is essential for erythropoiesis as its loss leads to heme accumulation in the mitochondrion and termination of erythroid differentiation.

The events coordinating the production of globin chains with the rate of heme synthesis are well understood, and appear to occur at more than one level. Heme is required for initiation of globin mRNA translation and it acts by inhibiting a protein kinase called heme-regulated inhibitor (HRI), which inactivates the translational initiation factor 2 (eIF-2 α) in the absence of heme¹¹⁹ (Fig. 24.2). Moreover, absence of this kinase adversely modifies the phenotype of disorders of heme synthesis (iron deficiency, protoporphyria) and of globin production (β -thalassemia).¹¹⁹ In addition, heme controls globin gene expression at the transcriptional level.^{120,121}

CONGENITAL SIDEROBLASTIC ANEMIAS

Congenital sideroblastic anemias have emerged as not uncommon disorders. They are clinically and genetically heterogeneous, with diverse underlying causes, inheritance patterns, phenotypes, and associated features. Genetic analysis and molecular approaches have revealed a spectrum of specific defects, some appearing as isolated anemia and others involving multiple systems^{3,122,123} (Table 24.3). Defined underlying defects affect heme biosynthesis directly or indirectly by disrupting Fe-S cluster biogenesis, or they involve pathways related to mitochondrial protein synthesis. However, in at least one third of cases the root cause remains undiscovered. Severity of anemia is highly variable within some types, and morphologic features overlap among them.

P.648

Genetic Defects Expressed Only in the Erythron

Inheritance Patterns and Pathogenesis

X-Linked Sideroblastic Anemia

The inheritance follows an X-linked pattern, the anemia occurring most commonly in males and their maternal uncles and cousins.^{29,124,125,126,127} and ^{128,129,130} Minimal expression of the erythroid abnormality may be seen in carrier females that is consistent with variable X inactivation affecting the mutant locus of the disorder. However, in many kindreds, the anemia has occurred only in females and may have been lethal in hemizygous male conceptions.^{131,132,133,134,135,136}

Early observations already implicated defects in ALA synthase as underlying the impaired heme biosynthesis in this form of sideroblastic anemia. In patients who responded to pyridoxine supplementation, the incorporation of glycine, but not of ALA, into heme was reduced in reticulocytes.³⁰ ALA synthase activity in bone marrow was low before pyridoxine administration and returned to normal or supranormal levels after an erythropoietic response.^{129,137,138} and ¹³⁹ It was presumed that the residual activity or stability of a defective erythroid ALA synthase was enhanced by additional supply of its coenzyme PLP through a mass action effect (e.g., if the enzyme had a reduced affinity for the coenzyme¹³⁸ or was abnormally sensitive to proteolysis¹³⁷). Usually, pharmacologic amounts of pyridoxine are required when an erythropoietic response occurs, but the response is variable and rarely complete. Individuals may present with profound anemia only in adulthood or even late in life,^{129,140,141,142} suggesting that the disorder can progress with time. In some cases, prior additional dietary or medicinal intake of pyridoxine,¹⁴³ possible changes in pyridoxine metabolism with advancing age,¹⁴⁴ or initiation of hemodialysis^{145,146} can be factors in unmasking mild phenotypes that were not symptomatic at a younger age. In female patients expressing the disease, skewed X inactivation in hematopoietic tissue that occurs with advancing age¹⁴⁷ and involves progressive inactivation of the X chromosome bearing the normal allele has been the explanation as the anemia usually evolved in adulthood^{135,136} or late in life.¹⁴⁸ Constitutive skewed X inactivation to account for disease expression in females in childhood is very uncommon.¹³⁶

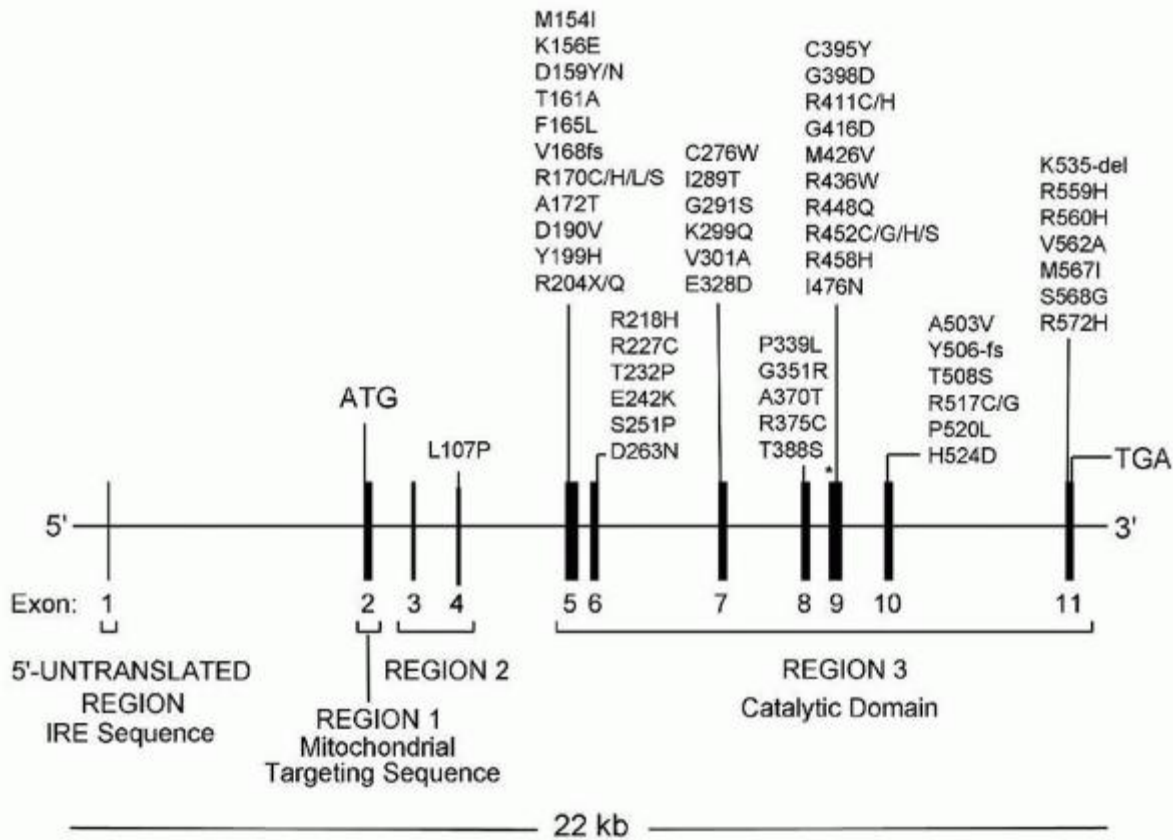

FIGURE 24.3. Diagram of the structure of the human erythroid 5-aminolevulinic acid synthase gene (ALAS2) and the location of mutations identified to date in X-linked sideroblastic anemia. Two mutations in the promoter region (c.-206C>G; c.-91_44del) and two mutations disrupting the intron 1 enhancer of ALAS2 are not indicated. IRE, iron-responsive element; kb, kilobases. *Codon K391, the pyridoxal 5'-phosphate binding lysine. (Data from HGMD® Professional 2012.2 and unpublished material.)

After the cloning and characterization of the erythroid ALA synthase gene^{75,149} and its localization to the X chromosome, linkage of the disorder to the ALAS2 locus was established,^{129,150} and many heterogeneous missense mutations involving invariant or highly conserved amino acid residues in the catalytic domain of the enzyme have been found to cause the disorder¹⁵¹ (Fig. 24.3). A nonsense mutation in one case,¹³⁵ nucleotide deletions, and regulatory mutations in the promoter region and in the intron 1 enhancer sequence^{151a} of the ALAS2 gene have been the exceptions. Hence, in at least four families described up to 68 years ago,^{29,125,128,152} the underlying molecular defect in ALAS2 could also be defined.^{25,153,154} and ¹⁵⁵ A majority of the mutations identified to date reside in exons 5 and 9 (Fig. 24.3); the latter contains the PLP-binding lysine (K391) of the enzyme.¹⁵⁶ Among the 66 distinct mutations so far encountered, only 22% occurred in more than one unrelated family or proband, and nearly one third of the probands are female. An apparent somatic mutation in the ALAS2 gene was found in an older male patient with acquired sideroblastic anemia.¹⁵⁷

Sites of ALAS2 mutations and severity of anemia or extent of its responsiveness to pyridoxine supplements can be correlated to a considerable extent. The activity of the recombinant enzyme is reduced for many, but not all, ALAS2 mutants so far examined and is variably enhanced by PLP.^{52,129,130,142,153,158,159} Some mutants have altered substrate kinetics^{159,160} or fail to bind to the β -subunit of succinyl-CoA synthetase.^{86,160} A three-dimensional structure model of the human enzyme¹⁶¹ and the resolved crystal structure of the significantly homologous ALAS of *Rhodobacter capsulatus*¹⁶² made it possible to explain how altered structure by many of the naturally occurring mutations that give rise to X-linked sideroblastic anemia (XLSA) affects the function of the enzyme. For example, mutations changing an amino acid located in the vicinity of the PLP-binding site exhibit a response to pyridoxine, whereas mutations involving sites of substrate binding, enzyme stability, or folding are refractory to pyridoxine.¹⁶² However, while clinical severity can thus be related at least in part to the effect of a specific mutation on enzyme function, marked variation in severity of anemia has been observed between some kindreds bearing the same mutation as well as within a few

kinships,^{129,130,163,164} implicating undefined genetic differences or environmental factors for the apparent variable penetrance.

Mitochondrial Carrier Protein SLC25A38 Deficiency

A significant segment of congenital sideroblastic anemias (~15%) is associated with biallelic mutations in the gene encoding the erythroid-specific mitochondrial inner membrane carrier protein SLC25A38.^{60,165} The SLC25A38 gene has an amino terminal targeting signal and three mitochondrial carrier family protein domains that encode six transmembrane helices. From its structural features, the protein is predicated to function as an amino acid transporter. Data so far obtained in the yeast *Saccharomyces cerevisiae* deficient in the protein indicate a heme biosynthetic defect and suggest that it serves as a glycine importer across the mitochondrial inner membrane.⁶⁰

Heterogeneous mutations spread throughout the SLC25A38 protein domains have been reported in 26 families, including three sibling pairs.^{60,166} The mutations are missense type occurring in conserved amino acids at substrate contact points as well as nonsense and splicing errors. Two thirds of patients are homozygous and one third are compound heterozygotes for defects.

Glutaredoxin 5 Deficiency

The human counterpart of a zebrafish mutant (shiraz) deficient in glutaredoxin 5,⁸⁰ which is essential for the synthesis of Fe-S clusters such as for IRP1 and thus ALAS2 translation, was identified in a single patient.⁵⁹ A homozygous mutation in the GLRX5 gene that affects intron 1 splicing and markedly reduces GLRX5 RNA production was associated with microcytic sideroblastic anemia. The anemia was detected in the fifth decade, became severe by age 60, and improved with iron chelation therapy for the associated iron overload. Studies in cell lines derived from the patient indicated severe impairment of Fe-S cluster biogenesis and also revealed markedly reduced levels of ferrochelatase.¹⁶⁷

Sideroblastic Anemia in Protoporphyrin

Marked deficiency of ferrochelatase underlies erythropoietic protoporphyria as a result of a large variety of mutations in the gene encoding the enzyme (see Chapter 26). The defect is manifested mainly, if not exclusively, in erythroid cells and leads to marked accumulation of free protoporphyrin, the substrate of the enzyme, during the final stages of erythroid maturation when the defective ferrochelatase becomes rate-limiting for heme production.¹⁶⁸ Erythroid heme synthesis appears to be compromised in most patients as reflected in a mild microcytic hypochromic anemia.¹⁶⁹ In ten patients marrow ring sideroblasts with typical mitochondrial iron deposits were observed^{43,44} but not in one sibling pair with mild microcytosis without anemia.¹⁶⁸ Bone marrow examination has generally not been performed in this disorder so that the incidence of the ring sideroblast feature is not known. The genetic heterogeneity in protoporphyria may account for the phenotypic variation of hematologic features.

Undefined Congenital Sideroblastic Anemia(s)

It is estimated that at least one third of nonsyndromic cases of congenital sideroblastic anemia are currently molecularly unexplained.¹⁶⁵ These may have autosomal or X-linked defects not yet detectable in the known causative genes, or defects in novel genes to be discovered. Novel genetic defects are also likely in some previously described kindreds. For example, in two families sideroblastic anemia occurred in a vertical distribution including father-to-son transmission and consistent with a dominant trait.^{170,171} In another family manifesting the anemia in both genders, a defect in mitochondrial DNA was postulated¹⁷²; the mild anemia was characterized by erythrocyte dimorphism and macrocytosis.

Clinical and Laboratory Features of XLSA and SLC25A38 Deficiency

If severe, XLSA is recognized in infancy or early childhood. However, not infrequently the disorder is milder or asymptomatic and may be discovered only in young adulthood or even in later life. Because severity of anemia can also vary within kindreds,^{129,130,164} diagnosis in family members may be delayed or overlooked unless complete pedigree studies or DNA analyses for an ALAS2 mutation identified in the proband are performed. In contrast, patients with SLC25A38 genetic defects typically present at birth or in early childhood with severe anemia.

All patients develop manifestations of iron overload. Linkage to human leukocyte antigen (HLA) is not evident²² as HFE mutations were underrepresented in a series of XLSA patients examined.²⁶ Mild to moderate enlargement of the liver and spleen is common, but liver function usually is normal or only mildly disturbed at presentation. Liver biopsy reveals iron deposition that is indistinguishable from hereditary hemochromatosis³⁶ (Fig. 24.4). In the X-linked form the iron burden does not correlate with the severity of anemia, and, not infrequently, well-established but asymptomatic micronodular cirrhosis is discovered in the third or fourth decade.^{22,36,134,141,173} Hepatocellular carcinoma developed in two reported

cases.^{163,174} Clinical diabetes or abnormal glucose tolerance may or may not be related to the iron overload process. Skin hyperpigmentation is uncommon. The most dangerous manifestations of the iron overload are cardiac arrhythmias and congestive heart failure, which usually occur late in the disease course. In severely affected infants or young children, growth and development tend to be impaired.¹²⁷

The hallmark is a microcytic anemia. In severe cases, microcytosis and hypochromia are pronounced (mean corpuscular volume [MCV], 50 to 60 fl), and striking anisocytosis, poikilocytosis, target cells, and occasional siderocytes are prominent findings on blood smear (Fig. 24.1C). The red cell volume distribution is usually abnormally wide and, notably, dimorphism is seen in males with the X-linked form¹²⁴ as well as in autosomal forms of the disease.^{60,166,170} Some female carriers of the X-linked trait have a biphasic Coulter counter red cell histogram^{25,128} (Fig. 24.5), or only a very small microcytic erythrocyte population. However, most women who express XLSA exhibit macrocytosis, although dimorphism may be evident (Fig. 24.1D). Presumably few viable erythrocytes with a markedly defective or nonfunctional mutant ALAS2 enzyme as often encountered in women reach the circulation, so that most of the erythrocytes are progeny of the residual normal clone that are released from the marrow at an accelerated rate in response to the anemic hypoxia. Leukocyte and platelet values usually are normal; they may be reduced in the presence of splenomegaly (hypersplenism). Erythroid hyperplasia is found on marrow examination, and maturation is usually normoblastic with poorly developed cytoplasm. Megaloblastic changes may be observed if complicating folate deficiency is present. Marrow reticuloendothelial iron is increased, and the telltale ring sideroblast emblem is prominent in late, nondividing erythroblasts.^{175,176} Transferrin saturation is increased, as is the serum ferritin level, and transferrin levels tend to be decreased. Ferrokinetic studies reflect ineffective erythropoiesis. A reduced serum haptoglobin level is consistent with the ineffective erythropoiesis.

The erythrocyte protoporphyrin level usually is low or normal.^{12,131} In one female patient, the low protoporphyrin level was shown to be restricted to the microcytic red cells.¹³² Kindreds in which the erythrocyte protoporphyrin is increased^{131,170} can be considered to represent disorders other than XLSA or SLC25A38 deficiency.

Treatment and Prognosis

Approximately two thirds of patients with sideroblastic anemia due to identified ALAS2 defects can be expected to respond to

P.650

pyridoxine administration. Doses of 50 to 100 mg/day are large compared with the estimated adult daily requirement for vitamin B₆ of 1.5 to 2.0 mg and are sufficient for a maximal response, although in some cases a supplement of only 2 to 4 mg/day was found to be effective.¹²⁹ Higher doses may be toxic. No convincing evidence is available that the parenteral route or PLP, the active coenzyme form, is more effective than oral administration. However, the response to pyridoxine is quite variable. With an optimal response, reticulocytosis is observed, blood hemoglobin concentration returns to normal or near-normal levels in 1 to 2 months, and low erythrocyte protoporphyrin levels increase to normal.^{12,177} The morphologic red cell abnormalities then

P.651

diminish but very rarely completely resolve, even when ALA synthase activity and the hemoglobin level are restored with pyridoxine supplementation. Approximately two thirds of responding patients experience a distinct but suboptimal improvement with pyridoxine administration, and the hemoglobin concentration stabilizes at less than normal levels. When an effect of pyridoxine is achieved, continued maintenance treatment is necessary because relapses follow within several months after discontinuance of the vitamin. In a few instances, subsequent remissions with resumed treatment were less complete.¹² In the occasional case with accompanying megaloblastic changes, folic acid should be given, which usually leads to normoblastic maturation, suboptimal reticulocytosis, and some increase in the hemoglobin level. In severely anemic individuals who do not respond to pyridoxine, periodic red cell transfusions are necessary to relieve symptoms and to allow normal growth and development of children. Transfusion of red cells should be kept to a minimum to lessen or delay the development of iron overload.

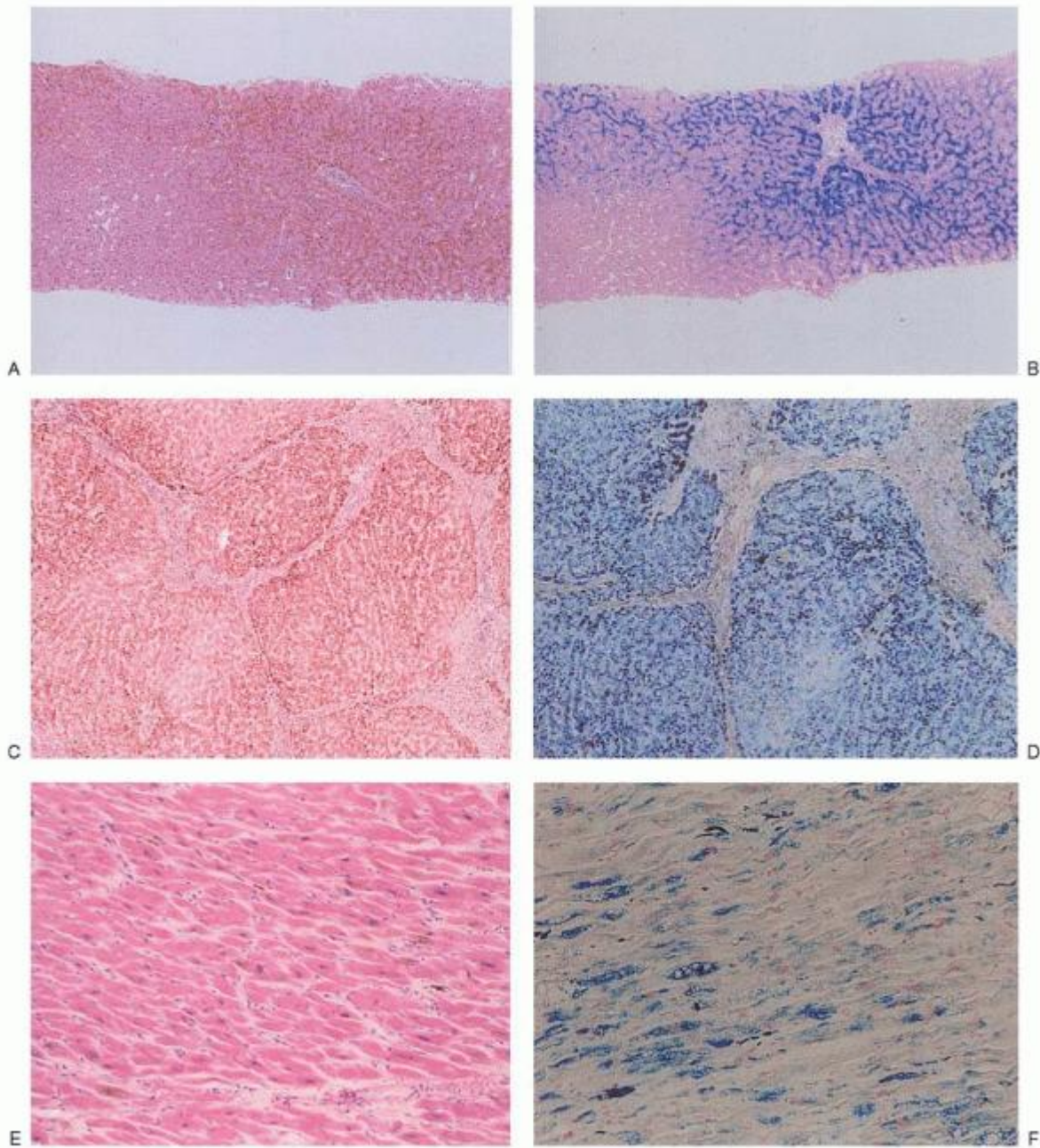

FIGURE 24.4. Histopathology of the iron overload in congenital sideroblastic anemia. A, B: Liver section of a 26-year-old man with SLC25A38 deficiency and moderate hemochromatosis. C, D: Autopsy liver section of a 45-year-old man with X-linked sideroblastic anemia, micronodular cirrhosis, and hemochromatosis. E, F: Section from the heart of the latter patient with marked hemosiderosis. (A, C, and E: Hematoxylin stain; B, D, and F: Prussian blue stain.)

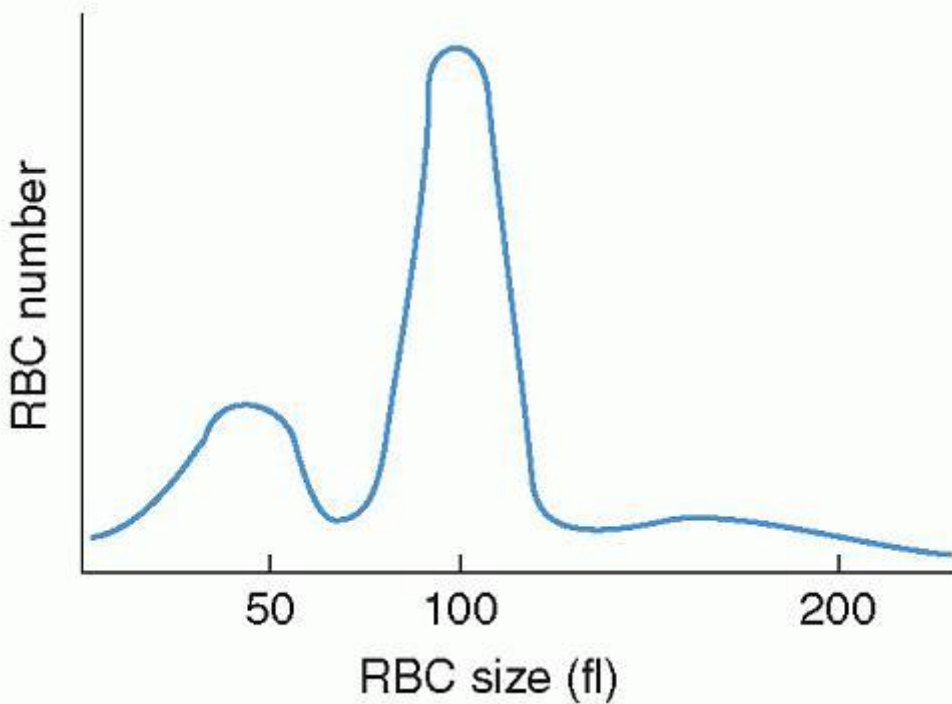

FIGURE 24.5. Dimorphic red cell distribution in a female patient with mild X-linked sideroblastic anemia. Redrawn from the output of a Coulter analyzer. RBC, red blood cell.

Based on the assessed extent of iron overload, including liver biopsy, an iron depletion program should be instituted to prevent or stabilize already established organ damage.^{134,178,179,180} Therapeutic phlebotomies are well tolerated and preferred in patients with mild or moderate anemia in the absence of contraindications such as heart disease.^{134,173,181,182} and¹⁸³ After the initial removal of all storage iron, maintenance phlebotomies should be continued indefinitely. For patients with severe anemia, or for those who depend on regular transfusions and thus become massively iron loaded,^{184,185} an iron-chelating agent is administered. As recommended for thalassemia,¹⁸⁵ deferoxamine is infused over 12 hours subcutaneously or intravenously, at 40 mg/kg/day, and for at least 5 days each week. Although iron removal with deferoxamine is enhanced by ascorbate, large supplements can cause acute cardiac toxicity by facilitating excessive mobilization of ferritin iron, and any intake of the vitamin should be limited to 200 mg daily.¹⁸⁶ The risks of deferoxamine treatment are minimal.^{179,187} Occasional local reactions can be controlled with inclusion of small amounts of hydrocortisone in the infusate. Rare hypersensitivity is amenable to desensitization.¹⁸⁸ Reported visual and auditory neurotoxicity is unlikely without excessive doses of the drug. The new, orally active tridentate iron chelator deferasirox (Exjade) has an efficacy similar to deferoxamine or better^{180,189}; the recommended initial daily dose is 20 mg/kg and can be increased to 30 mg/kg. Although the long-term safety profile of this agent is not known, it has emerged as a preferred iron chelator. The goal of iron chelation therapy is to maintain the serum ferritin concentration below 500 µg/L. The increased risk of infection with *Yersinia* (and perhaps other organisms) in iron overload, although uncommon, increases further with deferoxamine treatment.^{179,190} Removal of the iron excess has occasionally reduced severity of the anemia^{8,25,182,183} by improving erythroblast mitochondrial function, such as restoration of secondary ferrochelatase deficiency¹⁸³; by enhancing pyridoxine responsiveness²⁵; and by diminishing the ineffective erythropoiesis.¹⁸²

Splenectomy in congenital sideroblastic anemia appears to be invariably complicated by thromboembolic complications and, often, a fatal outcome.^{140,141,153,191,192} Factors other than persistent thrombocytosis seem to play a role. Control of the platelet count and anticoagulant therapy usually are not effective, so splenectomy is contraindicated.

These supportive measures provide for a favorable prognosis and often for normal survival. Curative bone marrow transplantation was achieved in seven reported patients without known molecular defects,^{193,194,195,196} and¹⁹⁷ including recovery from chronic graft-versus-host disease after subsequent orthotopic liver transplantation in one of these cases¹⁹⁸; one patient succumbed to graft-versus-host disease and prior iron overload.¹⁹⁶ Hematopoietic stem cell transplantation has also been successful in several unreported cases with SLC25A38 deficiency.

In contrast to acquired clonal sideroblastic anemia, predisposition to leukemic evolution has not been observed.

Sideroblastic Anemia as a Component of Genetic Syndromes

X-Linked Sideroblastic Anemia with Ataxia

In a large kindred with XLSA associated with nonprogressive ataxia (XLSA/A),⁴⁹ linkage to the phosphoglycerate kinase locus at Xq13 was demonstrated¹⁹⁹ and linkage to ALAS2 was excluded using a highly polymorphic repeat sequence within intron 7 of the ALAS2 gene.⁷⁰ Cloning and chromosomal mapping to Xq13.1-q13.3 of the human ABCB7 gene,^{200,201} an ortholog of the ATM1 gene in yeast that encodes a transporter protein required for mitochondrial iron homeostasis,²⁰² led to identification of a mutation in this gene as the underlying defect in the kindred.⁵³ Distinct mutations in the ABCB7 gene have been identified in three additional families.^{203,204,205} All the mutations result in substitutions of conserved amino acids (Ile400Met, Glu433Lys, Val411Leu, Glu209Asp) and affect a region of the protein involved in binding and transport of a substrate. It is postulated that ABCB7 participates in the export of Fe-S clusters generated in mitochondria for assembly of cytosolic Fe-S cluster-containing proteins.²⁰⁶ Expression of wild-type ABCB7, but not mutant ABCB7, in Atm1p-deficient yeast restores phenotypic defects as well as the production of cytosolic Fe-S proteins.²⁰³ As in yeast,²⁰⁶ a defective ABCB7 protein leads to mitochondrial siderosis in the human disorder. How heme synthesis becomes impaired in erythroid cells has not been elucidated and may be a consequence of reduced Fe-S cluster biogenesis impacting on the translation of ALAS2.^{80,167} Because free protoporphyrin, as well as zinc protoporphyrin, accumulates in erythrocytes,^{49,203,204,205} the generation of ferrochelatase,^{101,207} an Fe-S-containing protein, is probably affected. Neither ALA synthase nor ferrochelatase has been examined in erythroid cells with the XLSA/A defects. The mechanism for the neural dysfunction in this disorder remains elusive. As in Friedreich ataxia,²⁰⁸ disrupted mitochondrial iron homeostasis in neural cells is likely involved in the pathogenesis.

Among five kindreds so far encountered, the neurologic features are overriding and include delayed motor and cognitive development, incoordination, and nonprogressive cerebellar atrophy with or without atrophy of pons and medulla.^{49,203,204,205,209} The anemia is mild to moderate, and morphologic features are indistinguishable from the isolated heritable forms of sideroblastic anemia, including variable abnormalities in female carriers as observed in XLSA. Both free and zinc-chelated erythrocyte protoporphyrin are increased. Iron overload has not been evident.

P.652

Mitochondrial Myopathy, Lactic Acidosis, and Sideroblastic Anemia

This autosomal recessive disorder results from mutations in the genes encoding either pseudouridine synthase (PUS1)^{58,165,210,211} or mitochondrial tyrosyl transferase (YARS2).^{61,212} In the former, missense or nonsense mutations so far described predict an inactive protein. Mitochondrial and cytoplasmic transfer RNAs lack pseudouridine at the expected sites,²¹³ likely causing faulty translation of mitochondrial genes of respiratory complexes I and IV. The YARS2 mutations reduce levels of the enzyme and lead to decreased mitochondrial protein synthesis and respiratory chain dysfunction.⁶¹ How these protein deficiencies lead to mitochondrial iron accumulation and anemia is unclear.

The PUS1 defects have occurred in four families of Jewish Iranian descent, in one family from the Shetland Islands, and in one Italian family^{57,58,165,210,211}; in the Iranian families consanguinity was present, and parents of the Italian brothers were distantly related. The disorder is characterized by muscle weakness, basal lactic acidemia and normocytic sideroblastic anemia with clinical onset in childhood or around adolescence.⁵⁷ Some cases have exhibited intellectual impairment and/or craniofacial abnormalities. Diminished oxidative phosphorylation is reflected in decreased activity of mitochondrial enzymes of the respiratory chain as well as in the raised blood lactic acid level. The myopathy and the anemia are variably progressive, and transfusions are usually required by the third decade of life if not earlier.

Based on reports of one family and two further unrelated cases with YARS2 mutations,^{61,212} the myopathy and anemia appear of variable severity. While some cases developed a cardiomyopathy, intellectual impairment or developmental abnormalities were not observed.

Congenital Sideroblastic Anemia and B-Cell Immunodeficiency

A novel syndrome of severe microcytic sideroblastic anemia that is associated with B-cell immunodeficiency, periodic fevers and developmental delay and presents in infancy has been described in 12 children.^{213a} In addition, neurologic defects and other multisystem derangements are variably present. Commonly early death was attributed to cardiac or multi-organ failure. The molecular etiology remains to be determined.

Pearson Marrow-Pancreas Syndrome

This progressive, congenital multisystem mitochondrial disorder is associated with sporadic major deletions, rearrangements, or duplications of mitochondrial DNA, leading to the loss of multiple proteins encoded by the mitochondrial genome.^{214,215} About one half of cases are heteroplasmic for a 4,977 bp deletion that involves mitochondrially encoded subunits of respiratory complex I (NADH dehydrogenase), complex IV (cytochrome c oxidase), and complex V (ATP synthase) as well as several mitochondrial tRNA genes.²¹⁵ Thus, translation of mitochondrial DNA-encoded proteins may be affected. The spectrum of mitochondrial genomic deletions has also extended to other non-overlapping deletions. The heteroplasmic nature of mitochondrial DNA at the cellular and organ levels is considered to account for the high variability of tissues involved over time.

The disorder generally presents within the first 6 months after birth with anemia, metabolic acidosis, and exocrine pancreatic insufficiency. Also common is development of hepatic and renal failure. Some infants lack the metabolic derangements initially and present only with anemia, resulting in oversight of this syndrome. Usually 25% are anemic in the neonatal period; by 6 months of age, anemia is evident in 75% of cases. Any associated neutropenia and thrombocytopenia are mild. The anemia tends to be severe and is normocytic or macrocytic.²¹⁶ In the bone marrow, erythroid precursors are often reduced in number but ring sideroblasts are prominent, in which abnormalities in mitochondrial ultrastructure are pronounced.²¹⁷ A distinctive feature is the presence of striking vacuoles in myeloid and erythroid precursors.⁴⁷ Erythrocyte protoporphyrin values were increased when measured.

Approximately one half of patients succumb to the metabolic derangements. The anemia may improve or remit in up to one third of cases by 10 years of age. Survivors often develop the Kearns-Sayre syndrome.^{214,218}

Thiamine-responsive Megaloblastic Anemia

This autosomal recessive syndrome, also known as Rogers syndrome,⁴² is caused by mutations in the SLC19A2 gene, which encodes a 497 amino acid high-affinity thiamine transporter.^{54,55,56} The protein is predicted to have 12 transmembrane spanning regions. Twenty-eight distinct mutations have been reported to date.²¹⁹ Most of these are nonsense or frameshift type; missense mutations result in proteins that are not properly targeted to the cell membrane for their site of function.^{220,221} The dominating megaloblastic feature of the anemia is considered to be due to defective nucleic acid synthesis because limited intracellular thiamine impairs the pentose phosphate pathway and de novo synthesis of ribose-5-P.²²² The unique additional feature of marrow ring sideroblasts may relate to the role of thiamine in the generation of succinyl-CoA, a substrate of ALAS2.²²³

The cardinal clinical characteristic of the syndrome is the triad of megaloblastic anemia, non-type I diabetes mellitus, and sensorineural deafness. Other clinical features have been described in some cases.²¹⁹ The disorder has typically manifested between infancy and adolescence.^{219,224} Some patients have a milder phenotype, and a few have presented as adults.

Hematologic findings are macrocytic anemia, variable degrees of neutropenia and thrombocytopenia with megaloblastic changes and fewer marrow ring sideroblasts than in other congenital sideroblastic anemias.²²⁴ Thiamine (vitamin B1) in pharmacologic doses (25 mg/day) usually improves the anemia and the diabetes initially, but it has become ineffective in adulthood.²²⁵

Animal Models of Sideroblastic Anemia

The first genetically designed animal model of sideroblastic anemia was developed in zebrafish (the sau mutant, sauternes), in which hematopoiesis resembles that of higher vertebrates also at the molecular level, as hematopoietic gene expression and function are conserved.²²⁶ The chemically induced mutant gene encodes the zebrafish ortholog of human ALAS2 and expresses embryonic hypochromic anemia with severe heme deficiency. The two mutation sites, predicting Val249Asp and Leu305Gln substitutions, are in exon 6 and exon 7, respectively, and represent conserved amino acids across large phylogenetic boundaries, including the human. However, the mutants' blood cells did not reveal ring sideroblasts, perhaps because of species differences in cellular iron metabolism.

A second model in zebrafish (the sir mutant, shiraz) has a deficiency of glutaredoxin 5, an essential component of Fe-S cluster assembly, and expresses hypochromic anemia.⁸⁰ In the absence of the Fe-S cluster, the iron regulatory protein IRP1 blocks ALAS2 translation by binding to the IRE of the ALAS2 mRNA. As in the ALAS2 zebrafish mutant, ring sideroblasts were not observed and may reflect species differences.

In a transgenic mouse model with homozygous deficiency of ALAS2, erythroid differentiation is arrested, and embryos die by day 11.5.⁷¹ Mice chimeric for ALAS2-null mutant cells or transgenic mice generated with partial ALAS2 expression²²⁷ exhibit the phenotype of human XLSA, with severe anemia and typical ring sideroblasts in the marrow.

In another mouse model, deletion of the *Abcb7* gene led to fatal neonatal bone marrow failure, demonstrating that *Abcb7* is

P.653

essential for hematopoiesis.²²⁸ While marrow ring sideroblasts were not observed in these animals or in animals chimeric for the human *Abcb7* mutation Glu433Lys, siderocytes were detected in the peripheral blood.

The combination of isoniazid (INH) and cycloserine administered to guinea pigs produces sideroblastic anemia in a few weeks.^{38,39} Blood PLP concentrations become reduced, and bone marrow ALA synthase as well as ferrochelatase activity is diminished.³⁹ The latter may be secondary to mitochondrial damage by the iron deposits.

The flexed-tail (f/f) mouse has a transient embryonic and neonatal anemia associated with siderotic granules (iron-laden mitochondria) in erythrocytes and reduced heme synthesis, which coincides with the physiologic cessation of hepatic erythropoiesis.^{229,230} The defect is a frameshift mutation in the *f* gene (sideroflexin, *sfxn1*) that encodes a protein proposed to facilitate transport of a component required for iron utilization into or out of mitochondria.²³¹

ACQUIRED CLONAL SIDEROBLASTIC ANEMIA

Since the initial description of acquired idiopathic sideroblastic anemia by Bjorkman,³⁴ a considerable spectrum of its manifestations has been recognized. The anemia is a component of certain stem cell disorders, namely the myelodysplastic syndromes^{50,232,233} and the myeloproliferative diseases.^{234,235,236,237} Uncommonly, the ring sideroblast abnormality has been observed in acute leukemia and in erythroleukemia at the time of diagnosis.^{238,239} The disorder arises in conjunction with the clonal overgrowth of an altered hematopoietic progenitor cell having a proliferative advantage over the normal cell population and, thus, was included among the myelodysplastic syndromes.⁵⁰ Currently three variants are distinguished: refractory anemia with ring sideroblasts (RARS), RARS with thrombocytosis (RARS-T), and refractory cytopenia with multilineage dysplasia and ring sideroblasts (RCMD-RS) (Table 24.1).

Etiology and Pathogenesis

Clonality

The clonal nature of the disorder was first suggested by the morphologic and kinetic findings of two populations of red cells, the hypochromic, short-lived cell population being the product of the abnormal clone that bears the characteristic ring sideroblasts.^{240,241,242} The clonal derivation of the disorder was specifically indicated by the finding of a single glucose-6-phosphate dehydrogenase isoenzyme in hematopoietic cells, but not in fibroblasts, of an individual who was also heterozygous for a glucose-6-phosphate dehydrogenase polymorphism.²⁴³ Further evidence was provided with simultaneous clonality and cytochemical analysis of erythroid progenitors,²⁴⁴ and cytogenetic studies corroborated the clonality of the abnormal hematopoiesis.^{245,246} Chromosomal abnormalities are detectable in bone marrow cells of up to 50% of patients, and deletions in chromosomes 5, 11, and 20 as well as trisomy 8 and loss of Y occur most frequently.^{247,248} Although structurally abnormal X chromosomes are uncommon, Xq13 breakpoints were particularly associated with myelodysplasia and ring sideroblasts in one study.²⁴⁹ Another recurring cytogenetic abnormality is an isodicentric chromosome Xq13.1 (*idicXq13.1*) occurring only in females.²⁵⁰ In a few patients, abnormalities of the long arm of chromosome 3 were associated with thrombocytosis.^{251,252}

More recently it was found that the RARS-T subtype is associated with the V617F mutation in Janus-associated kinase 2 (JAK2), which is common in myeloproliferative disorders,²⁵³ in up to 65% of cases.^{254,255,256} How the more active mutant JAK2, by dysregulating the JAK-STAT (signal transducer and activator of transcription) signaling pathway, may play a role in the pathogenesis of the ring sideroblast, if it does at all, is not known. A strong correlation has also been found between somatic mutations in splicing factor SF3B1, a core component of the RNA splicing machinery located at the U2snRNP spliceosome catalytic site, and the presence of ring sideroblasts in patients with MDS, ranging from an incidence of 57% to 82%.^{257,258,259,260} While mutant SF3B1 thus appears to initiate production of the sideroblastic phenotype, the downstream mechanism(s) leading to the dysregulated iron metabolism in the mitochondrion remains to be identified.^{260a} It has been suggested that the presence of a SF3B1 mutation imparts a "benign" clinical phenotype and favorable prognosis.^{258,260b}

The natural history of this acquired sideroblastic anemia syndrome is commonly characterized by a chronic, stable anemia and, uncommonly, by a progressive marrow failure state or leukemic evolution.^{247,261} An initial genetic change causing expansion of an abnormal hematopoietic clone manifested by defective erythroid cell development is thus insufficient to result in a malignancy, even when persisting for many years. A "second hit" or mutation appears to be necessary for any leukemic evolution²⁶² that can be reversible, whereas the initial manifested defect expressed in the sideroblastic state persists.^{263,264}

Abnormalities in Heme Synthesis

The defective erythropoiesis is characterized at least in part by impaired hemoglobin synthesis, as reflected in the presence of a hypochromic erythrocyte population. Various studies had indicated that the biosynthesis of heme is impaired at the levels of ALA synthase and ferrochelatase. Reduced activity of ALA synthase in marrow cells was the most consistent abnormality in earlier series of patients^{138,265,266} and²⁶⁷ and was particularly demonstrable in the youngest erythroblast fraction.²⁶⁸ In occasional patients, the addition of PLP enhanced the low enzyme activity in vitro, but reported erythropoietic responses to pyridoxine or to PLP administration,²⁶⁹ as well as restoration of low ALA synthase activity to normal,^{265,270} were unusual and may have reflected an inherited defect of ALAS2.^{135,142} In a later study, the activity of detergent-solubilized ALA synthase in bone marrow cells was actually somewhat increased,¹³⁹ suggesting enhanced translation of the enzyme in response to raised cellular iron levels.

A constant feature is mild to moderate elevation of the erythrocyte protoporphyrin,²⁴⁰ rarely reaching values encountered in hereditary protoporphyria^{62,240,242,271} (see Chapter 26). The latter cases may now be explained by a likely acquired deletion of a ferrochelatase allele due to a cytogenetic abnormality of the clonal disorder.²⁷² The erythrocyte protoporphyrin increases further after pyridoxine administration but without improvement of the anemia,^{240,265,273,274} suggesting a block at the ferrochelatase step. Impaired activity of this enzyme was found in approximately one half of patients studied,^{138,267} likely representing a secondary effect of the mitochondrial iron deposition. Studies of iron metabolism in erythroid cells revealed increased accumulation of nonheme iron into membrane or mitochondrial fractions and reduced incorporation of iron into heme.^{8,9} Thus, impaired iron utilization for heme biosynthesis remained the common denominator in the pathogenesis.

Subsequently, a defect(s) intrinsic to mitochondria, causing diminished heme production in the abnormal clone as well as accounting for the decreased activity of several other mitochondrial enzymes (i.e., cytochrome oxidase, oligomycin-sensitive adenosine triphosphatase, and mitochondrial serine protease) in granulocytes and erythroblasts²⁷⁵ was sought. Various heteroplasmic point mutations of conserved nucleotides in mitochondrial DNA, as well as in transfer RNAs and mitochondrial ribosomal RNAs, were found in hematopoietic cells of patients with clonal sideroblastic anemia.^{276,277} Many of these affect cytochrome c oxidase and may be implicated in impaired reduction of iron for its incorporation into protoporphyrin by ferrochelatase. Such mitochondrial defects are consistent with the heterogeneity of hemoglobin content found

P.654

between individual erythroblasts by scanning microspectrophotometry,²⁷⁸ as well as with the variable size of hypochromic microcytic erythrocyte and ring sideroblast cell populations in the disorder. A gradual accumulation of affected erythroid precursors and the known higher mutation rate in mitochondrial DNA than in nuclear DNA would provide a basis for the slowly progressive nature of the anemia and its expression in later life, respectively.

A uniformly reduced transcript of the ABCB7 transporter was observed in 33 patients with RARS²⁷⁹ and may indicate one mechanism leading to this ring sideroblast phenotype. In vitro studies also suggested a link between this ABCB7 down-regulation and SF3B1 mutations²⁸⁰ in association with reduced erythroid development and the aberrant expression of mitochondrial ferritin in CD34⁺ cells that had previously been observed in low-risk myelodysplastic syndromes.²⁸¹

Nuclear Abnormalities

The principal, often macrocytic, red cell population in the blood may represent the progeny of the normal residual erythroid precursors with a shortened marrow maturation time in response to raised erythropoietin levels. The commonly observed morphologic nuclear abnormalities of erythroid precursors and their defective DNA synthesis and mitosis,^{282,283} however, suggest that more viable precursors of the dysplastic clone produce the macrocytic erythrocytes, whereas a greater proportion of developing cells expressing impaired heme synthesis is destroyed in the bone marrow. By analogy, various other aberrations of erythroid cell metabolism can occur in dysplastic hematopoietic clones,²⁸⁴ including altered genetic control of globin chain production. Thus, hemoglobin H disease was acquired in association with erythroleukemia, acute leukemia, and myelofibrosis,²⁸⁵ as well as in sideroblastic anemia with myeloproliferative features²⁸⁶ and in patients with sideroblastic anemia before leukemia developed.²⁸⁷

Iron Overload

Excessive absorption of dietary iron occurs over time in many, if not all, patients with stable disease and can be attributed to the ineffective erythropoiesis, as in congenital sideroblastic anemias and other long-standing disorders with erythroid maturation defects.²⁰ The consequent iron accumulation closely resembles that of hereditary hemochromatosis. Although

the presence of at least one allele for this disorder would likely contribute to the iron overload,²² the incidence of HFE mutations was no greater than in the normal population in most studies.^{22,27,28,288} Inadvertent administration of iron for the anemia and red cell transfusions add predictably to the parenchymal iron deposition.^{184,261,289}

Clinical Features

The disorder usually occurs in middle-aged and older individuals, but younger persons, including children, are not spared. The anemia develops insidiously and may be discovered during a routine examination or in association with an unrelated complaint. The older individual more often experiences symptoms of fatigue and angina if there is coexisting coronary artery disease. Physical examination may reveal no abnormality except for pallor. Hepatosplenomegaly is found in one third to one half of patients. With advanced iron overload, usually after repeated red cell transfusions, symptoms and signs of liver decompensation as well as heart failure and arrhythmia occur.

Laboratory Findings

The anemia is usually moderate and may be normocytic but more often is macrocytic (Fig. 24.6). The mean corpuscular hemoglobin concentration is normal or slightly reduced, and a variable population of hypochromic cells is found on blood smear. A particularly characteristic finding is the presence of occasional basophilic stippling in hypochromic cells that stains positive for iron.^{23,240} Typical Pappenheimer bodies are uncommon unless there is associated hyposplenism or the spleen is absent. Leukocyte and platelet values are usually within the normal range. The presence of the erythroid abnormalities alone constitutes the RARS subtype of the disorder in the World Health Organization (WHO) classification of myelodysplastic syndromes²³³ (see Chapter 73). Associated moderate leukopenia, thrombocytopenia, or both tend to be accompanied by other myelodysplastic features, such as morphologically abnormal leukocytes (e.g., the pseudo-Pelger anomaly) or immature forms in the peripheral blood,²⁴⁷ and define the WHO category RCMD-RS.²³³ The presence of leukocytosis, thrombocytosis, or both is indicative of a mixed myelodysplastic/myeloproliferative disease.^{234,235,236,237}

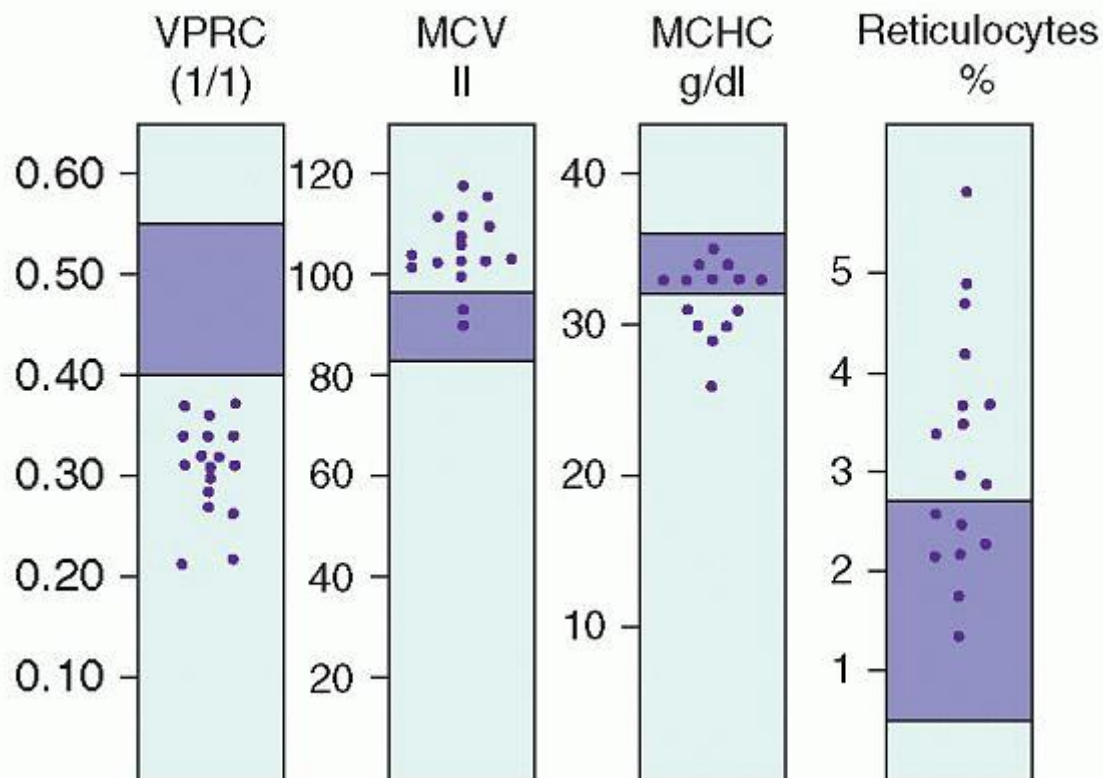

FIGURE 24.6. Characteristics of the anemia in 17 patients with acquired clonal sideroblastic anemia. Shaded areas, normal range (mean \pm 2 standard deviations). VPRC, volume of packed red cells; MCV, mean corpuscular volume; MCHC, mean corpuscular hemoglobin concentration. (From Kushner JP, Lee GR, Wintrobe MM, et al. Idiopathic refractory sideroblastic anemia. Clinical and laboratory investigation of 17 patients and review of the literature. *Medicine* 1971;50:139-159.)

Erythroid hyperplasia is found on bone marrow examination. A feature claimed to be helpful in distinguishing idiopathic sideroblastic anemia from erythroleukemia is the lack of periodic acid-Schiff (PAS)-positive material in the erythroblasts. Mild megaloblastic changes are common and may or may not be related to accompanying folate deficiency. Marrow hemosiderin content is increased, and ring sideroblasts constitute up to 100% of the erythroblasts unless masked by concomitant iron deficiency.^{2,240,290,291} In contrast to hereditary sideroblastic anemia, ring sideroblasts are evident at all stages of erythroid maturation.¹⁷⁵ Their distinctive expression of mitochondrial ferritin also permits their detection by flow cytometry methods.^{7,292} Because the hematologic phenotype often may be indistinguishable from XLSA in female patients,^{135,136} the analysis of X inactivation status and DNA for ALAS2 defects should be considered.

Serum transferrin saturation is increased in most patients and exceeds 90% in approximately one third of them.²⁴⁰ Substantially increased deposition of iron is found in the liver, but hepatic dysfunction is rare at presentation. Serum ferritin levels are elevated.

Characteristically, the erythrocyte protoporphyrin is moderately increased, up to 300 µg/dl (normal is 20 to 65 µg/dl). Values ranged from 1,055 to 10,514 µg/dl in the patients with probable acquired deletion of one ferrochelatase allele in the hematopoietic clone, and some had associated dermal photosensitivity.^{62,242,271,272}

Treatment and Prognosis

Treatment consists of supportive measures. Pyridoxine administration cannot be expected to be beneficial because ALAS2 defects are not involved in the pathogenesis. Administration of large doses of androgen (e.g., 50 to 300 mg of oxymetholone per day)²⁴⁰ is rarely useful and tends to produce or worsen fluid retention

P.655

and hepatic dysfunction. The effectiveness of erythropoietin has been examined in patients with the myelodysplastic syndromes, including RARS. Most, if not all, patients with uncomplicated sideroblastic anemia have high levels of endogenous erythropoietin, and it would appear unlikely that additional administration of the hormone would be beneficial. However, prolonged administration of recombinant erythropoietin, with or without granulocyte colony-stimulating factor, can lead to gratifying improvement or even correction of the anemia in around 40% of patients,^{293,294} in particular in individuals who have a low or intermediate-1 International Prognostic Scoring System (IPSS) score.²⁹⁵ A response is also more likely to occur if the endogenous serum erythropoietin level is not commensurate with the degree of the anemia,²⁹⁶ and large doses may be required.

Many studies evaluating various drug regimens for the myelodysplasias included the RARS subtypes. The drugs used have included the hypomethylating agents 5-azacytidine and decitabine, anti-tumor necrosis factor (TNF) fusion protein (etanercept), antithymocyte globulin (ATG), thalidomide and its derivative lenalidomide, and valproic acid.^{297,298} and ²⁹⁹ On average, major responses with improved erythropoiesis or hematopoiesis have been less than 50% (see Chapter 73).

Many patients are not significantly incapacitated by the anemia. Without abnormalities of the other hematopoietic cell lines and with minimal iron overload, often no progression occurs for many years.²⁴⁷ Such individuals frequently succumb to other concurrent diseases, but continued medical follow-up is indicated. Iron status should also be assessed with laboratory studies once per year. Transfusion of packed red cells is necessary for patients with symptomatic anemia, but it should be kept to a minimum because it accelerates the iron overload.

Iron overload, particularly when accentuated by repeated transfusions, can be a significant cause of morbidity and mortality (liver failure or heart failure)^{261,300} and is improved with chelation.^{301,302} When the serum ferritin level is approximately 500 µg/L or higher, along with the increased transferrin saturation, it should be countered. Histologic and chemical determination of iron in the liver biopsy provides the optimal assessment of the degree of iron overload. In mildly or moderately anemic individuals, iron removal can be accomplished with graded phlebotomies. Patients with more severe anemia or who are transfusion-dependent require iron chelation as described for congenital sideroblastic anemias. Because each unit of blood deposits 200 mg of iron, iron overload develops fairly rapidly with regular transfusions, and it is controlled more easily if treatment with an iron chelator is begun after approximately 20 units of blood have been given. In some cases, anemia was improved after iron removal^{8,303,304,305}; an independent effect of deferoxamine on erythropoiesis was also implicated.^{304,305}

The survival of patients with isolated anemia who are stable and not transfusion-dependent may not differ from that of healthy individuals. A prospective study of 232 patients, which validated the proposal of the two types of the disorder, provided prognostic information.²⁴⁷ In pure sideroblastic anemia, with the marrow failure restricted to the erythroid cell lineage and now called RARS, overall survival was the same as in age-matched controls, and leukemic transformation was

not observed. In RARS with features of impaired granulopoiesis, megakaryopoiesis, or both, survival was reduced to 56% at 3 years, and, in approximately 5% of cases, evolution to acute leukemia occurred. Other factors associated with the development of leukemia are the presence of few ring sideroblasts, more severe ineffective erythropoiesis, and impaired bone marrow colony formation.^{247,261} The probability of leukemic transformation is also increased in the presence of certain bone marrow karyotype abnormalities (e.g., monosomy 7, deletion 20q, or complex defects).^{247,248,306} When sideroblastic anemia followed therapy for various malignant disorders, leukemic evolution tended to be the rule.^{307,308}

REVERSIBLE SIDEROBLASTIC ANEMIAS

Alcoholism

Anemia associated with alcoholism usually has numerous causes.³⁰⁹ A ring sideroblast abnormality is never the sole cause but occurs in 25% to 30% of anemic alcoholic patients^{310,311} and probably only in the presence of malnutrition and folate deficiency.^{41,311}

The production of heme is impaired by ethanol, as indicated by the ability of heme to restore the concomitantly inhibited globin synthesis in reticulocytes³¹² and by the observation that the heme-regulated inhibitor activity of globin translation increases.³¹³ Inhibitory effects of alcohol have been observed at several steps of the heme biosynthetic pathway. Reduced activity of erythrocyte ALA dehydratase³¹⁴ was believed to be related to zinc depletion.³¹⁵ Activity levels of erythrocyte uroporphyrinogen decarboxylase, leukocyte coproporphyrinogen oxidase, and ferrochelatase are also decreased in alcoholic patients; those of ALA synthase and PBG deaminase are increased.^{314,316} Certain abnormalities of vitamin B₆ metabolism have been observed. Serum levels of PLP are low in chronically ill alcoholic persons³¹⁷ but do not correlate with the presence or absence of ring sideroblasts.³¹¹ Acetaldehyde enhanced the degradation of PLP,^{317,318} and, in one study, alcohol-induced sideroblastic anemia responded to PLP but not to the combination of folic acid and pyridoxine.³¹⁹ The colony formation of early (burst-forming unit-erythroid) and late (colony-forming unit-erythroid) human erythroid progenitor cells is preferentially suppressed by ethanol and acetaldehyde over that of myeloid cell progenitors at concentrations found in vivo and is partially reversed by folic acid and pyridoxine.³²⁰ Thus, a direct role of vitamin B₆ deficiency in the sideroblastic change is uncertain. Important in the pathogenesis may be the direct effects of ethanol, acetaldehyde, or both on the heme biosynthetic steps or on mitochondrial metabolism, because these agents also inhibit hepatic mitochondrial protein synthesis.³²¹

Blood hemoglobin values range from 6 to 10 g/dl, and the MCV is normal or increased. The transient sideroblastic change is commonly evident in dimorphic circulating erythrocytes. Siderocytes, present in approximately one third of patients, are a specific finding³⁰⁹ and provide the most persistent clue for the ethanol-associated ring sideroblast defect. Megaloblastic hematopoiesis resulting from folate deficiency is frequent but is not always present.³⁰⁹ A striking finding is vacuolization of pronormoblasts. The percentage of marrow ring sideroblasts ranges up to 70%, and they typically represent later stage normoblasts.⁴¹ Marrow iron stores usually are increased, as are the serum transferrin saturation and the serum ferritin level.

Withdrawal of alcohol is followed by disappearance of ring sideroblasts within a few days to 2 weeks³¹⁰ (Fig. 24.7). Recovery from the anemia may occur over several weeks and also depends on the presence of other erythroid defects induced by alcohol³¹⁰ as well as any associated medical illness that affects erythropoiesis (see Chapter 41). A prompt recovery phase may exhibit reticulocytosis and erythroid hyperplasia in the bone marrow resembling hemolytic anemia.³¹⁰

Drugs

Antituberculosis Agents

Reversible sideroblastic anemia occurs in association with the treatment of tuberculosis with INH; in a few patients, pyrazinamide and cycloserine also were implicated.³²² These drugs interfere with vitamin B₆ metabolism, and deprivation of PLP reduces ALA synthesis and, thus, heme production.³²² INH reacts with pyridoxal to form a hydrazone and inhibits pyridoxal phosphokinase. Bone marrow ALA synthase activity is also inhibited

P.656

by INH in a dose-dependent manner in vitro and is restored by PLP.¹³⁸ Cycloserine inhibits PLP-requiring enzyme reactions and directly inactivates pyridoxal.³²² Pyrazinamide appears to have anti-vitamin B₆ properties, but a specific mechanism has not been determined.

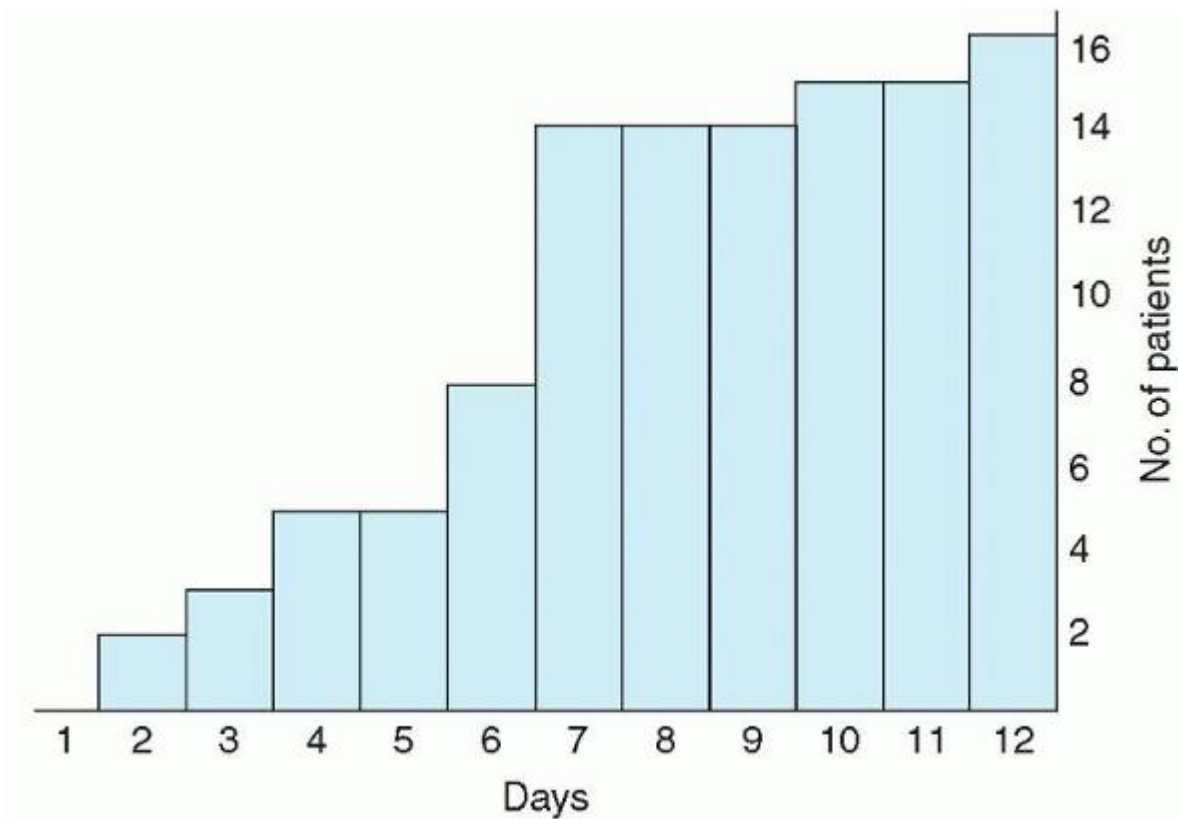

FIGURE 24.7. The rate of clearance in days of ring sideroblasts in 16 alcoholic patients after alcohol intake ceased. (From Eichner ER, Hillman RS. The evolution of anemia in alcoholic patients. *Am J Med* 1971;50:218-232.)

The relative incidence of anemia in relation to the extensive use of these drugs appears to be low, perhaps because of the regular concomitant administration of pyridoxine. Unknown contributory factors or another hematologic disorder may render certain individuals more susceptible to the antipyridoxine effects of the drugs.³²² In one study, ring sideroblasts or increased erythroblast iron was found in 58% of all patients treated for tuberculosis.³²³ Anemia has occurred from 1 to 10 months after institution of INH treatment. It is moderately severe (volume of packed red cells, 0.20 to 0.26 L/L), the red cell indices are usually reduced, and the erythrocytes show dimorphic morphologic features with prominent hypochromia and microcytosis.³²⁴ Ring sideroblasts are invariably present in the bone marrow. Serum pyridoxal concentrations were subnormal in most patients studied.³²⁵ Transferrin saturation tends to be increased. The anemia usually is promptly and fully reversed on withdrawal of the drug or by administering large doses of pyridoxine while continuing use of the drug.

Chloramphenicol and Linezolid

In contrast to the sporadic or idiosyncratic and usually fatal aplastic anemia occurring within weeks or months of chloramphenicol use, the dose-dependent and reversible hematologic toxicity of the drug is predictable and is characterized by suppression of erythropoiesis³²⁶ and by the ring sideroblast abnormality.^{40,327} A primary mitochondrial injury by the agent impairs heme synthesis as well as erythroid differentiation and proliferation. Therapeutic concentrations of chloramphenicol (10 µg/ml) inhibit the synthesis of mitochondrial membrane proteins, such as cytochrome $a + a_3$ and b , and, thus, mitochondrial respiration.^{328,329} Impaired heme synthesis is evident in reduced activities of ferrochelatase³³⁰ and ALA synthase,³³¹ which appear to be secondary effects as these enzymes are synthesized in the cytosol. The greater sensitivity of erythroid cells to chloramphenicol has been demonstrated *in vitro*, in that therapeutic concentrations of the drug inhibit erythroid colony growth but not granulocyte colony growth.³³²

The anemia may reach moderately severe levels. Bone marrow study reveals variable degrees of hypocellularity and ring sideroblasts as well as prominent vacuolization of early erythroid precursors. Erythrokinetic parameters reflect a hypoproliferative state. Reticulocytopenia, increased serum iron values, and prolonged plasma iron clearance are characteristic.³²⁶ These abnormalities, as well as the ring sideroblasts and anemia, disappear upon withdrawal of the drug.

Linezolid causes reversible myelosuppression and the ring sideroblast abnormality has also been observed.³³³ Its toxicity resembles that of chloramphenicol in that it inhibits mitochondrial protein synthesis (mRNA translation), although it

blocks assembly of the initiation complex, while chloramphenicol inhibits peptidyl transferases and thus peptide elongation.³³⁴ Vacuolization of erythroid precursors is common, and the hematologic abnormalities disappear upon discontinuation of the drug.

Other Drugs

Several miscellaneous drugs have been implicated in producing sideroblastic anemia in a few patients. These include fusidic acid, busulfan, melphalan, penicillamine and triethylene tetramine dihydrochloride.

Copper Deficiency

Deficiency of copper generally does not occur in humans because requirements are low relative to its wide distribution in food.³³⁵ However, copper deficiency anemia is encountered in various clinical settings and typically leads to sideroblastic anemia and neutropenia. It has developed after prolonged parenteral nutrition^{45,46,336,337} and forced enteral feeding^{338,339} if copper was not included in the formulations, and in association with intestinal malabsorption³⁴⁰; some patients have had prior gastrointestinal operations, e.g., gastrectomy, bariatric surgery.^{341,342} Copper deficiency also occurs with the use of copper-chelating agents³⁴³ and after prolonged ingestion of zinc, such as in the form of zinc supplements³⁴⁴ and with the chronic use of denture cream containing zinc.^{345,346} In six instances, the deficiency developed from ingestion of coins and was attributed to their zinc content.^{347,348,349,350} and³⁵¹

A novel syndrome of severe sideroblastic anemia with the neurologic manifestations of central nervous system demyelination, or peripheral neuropathy with optic neuritis, or myelopathy and profound copper deficiency was recognized only 10 years ago^{352,353,354} and was proposed to represent another combined system disorder resembling vitamin B₁₂ deficiency.³⁵⁵ Subsequently numerous cases with this syndrome were reported.³⁴¹ In some, excess zinc ingestion was present and not infrequently remote prior gastric resection was noted.³⁴¹ Myeloneuropathy has been the most frequent neurologic abnormality.

The pathogenesis is understood in part from extensive studies of the severe anemia that develops late in the course of dietary copper deficiency in swine.³⁵⁶ In these animals the anemia is microcytic and hypochromic and is associated with several defects of iron metabolism. Intestinal absorption and mobilization of iron from reticuloendothelial cells and hepatocytes to transferrin are impaired because of the associated lack of ceruloplasmin (ferroxidase). In reticulocytes of deficient animals, protoporphyrin production from glycine and ALA and ferrochelatase activity are not reduced,³⁵⁷ but iron metabolism in erythroid mitochondria is impaired in that heme synthesis from ferric iron and protoporphyrin is decreased.³⁵⁸ It was postulated that the reduction of ferric iron to ferrous iron is defective, being somehow linked to the diminished levels of cytochrome oxidase also observed. Low levels of intracellular copper enzymes, such as cytochrome oxidase, may interfere with hematopoiesis in other ways and also account for the neutropenia as well as the neuropathology in humans. The cause of copper deficiency after ingestion of excess zinc has been attributed to induction of the intestinal protein metallothionein by zinc,³⁵⁹ which preferentially binds copper,³⁶⁰ prevents its absorption, and enhances its excretion.³⁶¹

The anemia is progressive and may be profound if untreated. The MCV usually is normal or slightly increased at presentation;

P.657

hypochromic microcytic erythrocytes may be detectable on the blood smear. The granulocytes are commonly $<1,000/\text{mm}^3$; the platelet count is usually normal. The bone marrow tends to be hypoplastic, with impaired myeloid maturation.^{45,46} Vacuolization of early erythroid and granulocytic precursors is a prominent finding, as are large iron-positive cytoplasmic inclusions in plasma cells.^{45,354} In most instances, moderate numbers of ring sideroblasts are observed, in particular if the anemia is sufficiently severe. The hematologic features have occasionally led to the erroneous diagnosis of a myelodysplastic syndrome before the copper deficiency was recognized.^{354,362,363}

Serum iron levels and transferrin saturation are normal. The serum copper and ceruloplasmin levels are uniformly low. In cases of zinc-induced copper deficiency, serum zinc levels are increased from two- to threefold above the mean normal value.

With correction of the copper deficit, recovery of the hematologic abnormalities is uniformly prompt and complete. In some cases, recovery followed discontinuation of the excess zinc intake alone. Zinc as a therapeutic agent should thus be prescribed with caution,^{364,365} and its use as a stimulus for general well-being should be discouraged. Moreover, the zinc content has been removed from denture cream products. The neurologic abnormalities may improve or only stabilize with

continued copper supplementation.^{341,353,354,362} The usual dose of copper may not be sufficient for all patients as relapse has occurred,³⁶⁶ and longterm follow-up is advised for all patients.

Hypothermia

In 1982, O'Brien et al. described three patients who, during episodic hypothermia, exhibited erythroid hypoplasia and ring sideroblasts as well as thrombocytopenia in the presence of a normal number of megakaryocytes.⁴⁸ As the body temperature returned to normal, these changes slowly reversed. The ring sideroblast abnormality might be explained by the well-known inhibition of the translocation of proteins into mitochondria by reduced temperature.^{48,367} Heme synthesis³⁶⁸ and iron incorporation into hemoglobin by reticulocytes³⁶⁹ have also been shown to be diminished at lowered temperatures.

ANEMIA FROM DEFECTS IN ERYTHROID HEME SYNTHESIS WITHOUT RING SIDEROBLASTS

Anemia of Lead Poisoning

Lead poisoning has occurred from a wide array of sources, including lodged bullets, inhaled fumes in various industries or lead particles in a firing range, ingested contaminated herbs and food supplements, and beverages containing lead solubilized from glazes of utensils and linings of stills.^{370,371} In children, the primary source was ingestion of lead-based paint chips. Organic lead is acquired by absorption through the skin or by gasoline sniffing. Heterozygotes of hereditary ALA dehydratase deficiency are said to be more susceptible to lower levels of lead exposure,³⁷² as are persons with one or both genes for the less common allele (ALAD2) of the enzyme.³⁷³ Although lead has been eliminated from various consumer products and occupational exposure is monitored, it may still remain the most common cause of occupational poisoning worldwide.³⁷⁴

The anemia that accompanies lead poisoning (plumbism) is in part the result of various inhibitory effects of lead on heme biosynthesis.^{375,376} Most enzymes in the heme biosynthetic pathway are inhibited by lead to varying degrees. Presumably, lead displaces an essential metal or reacts with active-site thiol groups of the enzymes, but the precise mechanism is not worked out in most cases. ALA dehydratase is most sensitive to lead *in vitro* and *in vivo*, followed by ferrochelatase, coproporphyrinogen oxidase, and PBG deaminase, respectively. The effects of lead on the production of heme are also interrelated with iron metabolism. In erythroid cells, lead impedes the intracellular delivery of iron to waiting ferrochelatase, and the surrogate metal zinc is inserted into protoporphyrin by ferrochelatase as in iron deficiency³⁷⁷ so that zinc protoporphyrin accumulates. These events probably account for the usual absence of the ring sideroblast abnormality in persons with lead intoxication. Ferrochelatase may be directly inhibited in acute and more severe lead intoxication, and, only then, nonchelated protoporphyrin accumulates in erythrocytes.^{378,379} Lead also impairs globin synthesis.³⁸⁰ With prolonged lead exposure, erythroid hypoplasia may occur.³⁸¹

Other effects of lead increase the rate of red cell destruction. Changes in the spatial arrangement of red cell membrane proteins caused by lead are believed to inhibit adenosine triphosphatase, leading to cellular loss of K^+ .³⁸² If the lead burden is sufficiently severe (i.e., with blood lead concentrations of 200 $\mu\text{g}/\text{dl}$ or greater), impaired erythrocyte pyrimidine 5'-nucleotidase activity causes accumulation of nucleotides that inhibit the pentose phosphate shunt³⁸³ and promote hemolysis as in the genetically determined deficiency of the enzyme (see Chapter 28).

The typical clinical manifestations are autonomic neuropathy causing abdominal pain and ileus (lead colic) and motor neuropathy (lead palsy).³⁸⁴ A lead line may be seen on the gums and tonsils. Occasionally, renal dysfunction (lead nephropathy) may prompt the diagnosis. These classic features denote advanced lead toxicity, and more common are insidious, nonspecific musculoskeletal and neuropsychiatric complaints.³⁷⁰

The hematologic changes in lead poisoning are variable and can be attributed to the multiplicity of toxic actions on the erythron. More recently, anemia was present in only 25% of adult patients.³⁷⁰ Anemia in children is also a late sign of lead poisoning by current standards³⁸⁵ and frequently is superimposed on pre-existing iron deficiency.³⁸⁶ The severity of the anemia ranges from mild to moderate, and the red cells tend to be mildly hypochromic and microcytic (Table 24.4). The reticulocyte count may be raised in patients with overt hemolysis.³⁸⁴ Coarse basophilic stippling may be prominent (Fig. 24.8), representing polysomal aggregates that presumably are retained because RNA degradation is impaired as a result of the pyrimidine 5'-nucleotidase deficiency, but it is not always present and does not correlate with the lead burden.^{385,387} Osmotic fragility of the erythrocytes is decreased; mechanical fragility is increased consequent to the membrane injury.³⁸⁷ An electrophoretically "fast" hemoglobin similar to hemoglobin A₃ may be found.³⁸⁸ The bone marrow usually reveals erythroid hyperplasia, but it may be hypoplastic. Authentic ring sideroblasts are uncommon, if they occur at all.

The mean red cell life span is reduced with a random pattern of destruction despite problems with the accelerated ⁵¹Cr elution from red cells due to lead effects on the red cell membrane.³⁸⁹ Serum iron levels tend to be normal or slightly

increased unless the patient has associated iron deficiency. The findings of ferrokinetic studies are consistent with ineffective erythropoiesis accompanied by mild hemolysis.³⁸⁹

Parameters of heme biosynthesis reflect the inhibition of the various enzymatic steps and correlate with the lead burden.³⁷⁵ ALA dehydratase activity in erythrocytes is reduced in proportion to blood lead levels, and, in contrast to the hereditary deficiency of the enzyme, its in vitro activity is restored to normal by reducing agents such as glutathione or dithiothreitol.³⁷⁵ As a consequence of the reduced activity, urinary ALA is greatly increased, whereas levels of PBG are rarely increased, a combination that distinguishes plumbism from acute porphyrias, in which PBG is excreted in greater excess than ALA. Urinary coproporphyrin, and to a lesser degree uroporphyrin, levels are also increased in

P.658

lead poisoning. The zinc protoporphyrin level in erythrocytes is increased more than in iron deficiency.

TABLE 24.4 HEMATOLOGIC CHANGES IN THE ANEMIA OF LEAD POISONING IN ADULTS

		Normal (Range)	Lead Poisoning (Range)
Hemoglobin (g/dl)	Male	14.0-18.0	10.7
	Female	12-16	8-13
Volume packed red cells (L/L)	Male	0.40-0.54	0.35
	Female	0.37-0.47	0.29-0.43
Mean corpuscular volume (fl)		89 (83-96)	79 (70-92)
Mean corpuscular hemoglobin concentration (g/dl)		34 (32-36)	31 (27-36)
Reticulocytes (%)		1.6 (0.6-2.7)	4.4 (1.5-11.6)
Stippled cells (%)		Rare	1.8 (0.1-7.5)
Leukocytes ($\times 10^9/L$)		4-11	4-15

Adapted from Dagg JH, Goldberg A, Lochhead A, et al. The relationship of lead poisoning to acute intermittent porphyria.

QJM 1965;34:163-175 and Griggs RC. Lead poisoning: hematologic aspects. Prog Hematol 1964;4:117-137.

The upper limit of the “normal” level of blood lead, which is mostly contained in erythrocytes, is 30 $\mu\text{g}/\text{dl}$ of whole blood. Adults with concentrations of 30 to 75 $\mu\text{g}/\text{dl}$ show decreased ALA dehydratase activity, increased urinary excretion of ALA, and an increase in erythrocyte protoporphyrin,³⁹⁰ and may have nonspecific symptoms of lead poisoning. Clear symptoms usually are associated with concentrations that exceed 75 $\mu\text{g}/\text{dl}$. Concentrations in urine >0.1 mg/24 hours also establish the diagnosis of lead intoxication. When urinary lead excretion is borderline, response to slow intravenous infusion of 25 mg/kg (not to exceed 2 g) of the chelator calcium disodium ethylenediaminetetraacetic acid can confirm the diagnosis; excretion of more than 0.2 mg of lead in 24 hours indicates an increased lead burden.

Treatment consists of removal of the lead source and administration of ethylenediaminetetraacetic acid, 50 mg/kg/day in two divided doses, by slow intravenous infusion with ample fluids for 5 days.^{371,390} This regimen may be repeated in 3 to 4 weeks, depending on the response of blood lead levels. Renal function should be monitored. Recovery usually is prompt. An oral chelating agent, 2,3-dimercaptosuccinic acid, is also available.³⁹¹

Certain Porphyrias

Heme biosynthesis is strikingly perturbed in the various porphyrias that result from heterogeneous molecular defects in each of the enzymes in the pathway (see Chapter 26). Tissue-specific differences of expression and of regulation of these enzymes likely account for the absence of anemia in most porphyrias, as the defective enzymes do not become rate-limiting in the erythroid cell. In a few of them, erythroid heme production may be minimally compromised, as noted for protoporphyria previously; or accumulation of biosynthetic intermediates perturbs erythroid cell development, survival, or both.

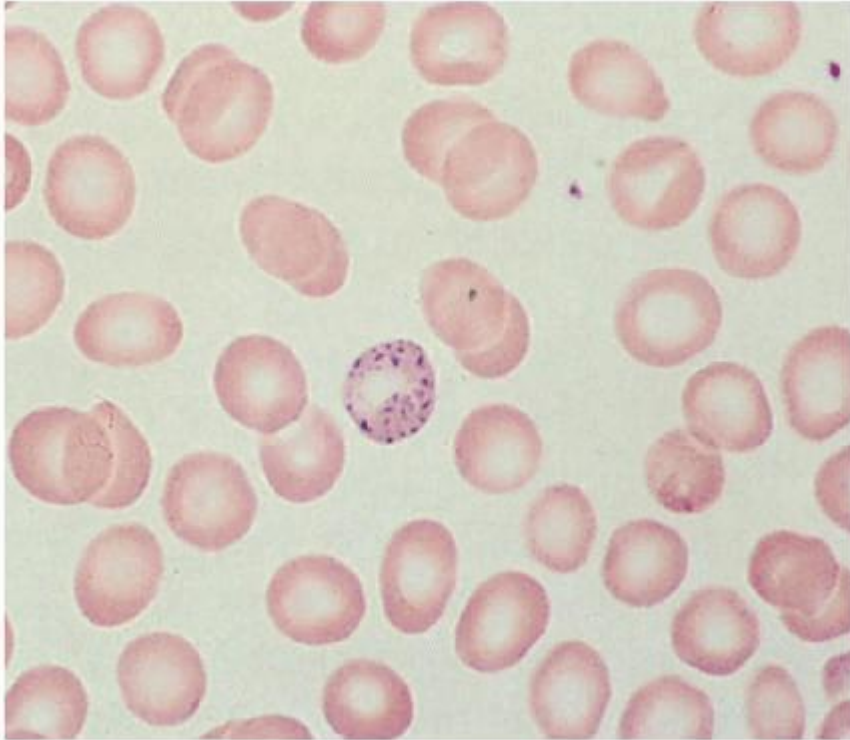

FIGURE 24.8. Hypochromia and red cell stippling in lead poisoning.

Congenital Erythropoietic Porphyria

In this rare disorder, expressed as an autosomal recessive trait, erythroid heme biosynthesis is not diminished.^{392,393} Because of the low residual uroporphyrinogen III synthase activity, uroporphyrin I accumulates, mainly in erythroid cells. Variable anemia is associated with dyserythropoiesis and varying degrees of peripheral hemolysis. The porphyrin accumulates in the nuclei of developing erythroblasts and is believed to affect their maturation. Anemia often is not the principal clinical problem. In some patients, the hemolytic process was improved by splenectomy.

Hepatoerythropoietic Porphyria

Hepatoerythropoietic porphyria represents the homozygous deficiency of uroporphyrinogen decarboxylase and is expressed as a variably severe form of porphyria cutanea tarda typically manifesting during infancy or early childhood.³⁹⁴ About 40 cases have been reported, and anemia was noted in more than 50% of patients.³⁹⁵ Severe anemia or a hemolytic process is the exception. The level of erythrocyte protoporphyrin, primarily as zinc protoporphyrin, is increased and is attributed to a relatively increased conversion of uroporphyrinogen III to protoporphyrin late in erythroid maturation when iron supply may become rate limiting. The anemia has not been characterized.

Harderoporphyria

Anemia has been encountered in this erythropoietic variant of hereditary coproporphyria, in which large amounts of the tricarboxylic harderoporphyria accumulate.^{396,397,398} Affected individuals carry distinctive homozygous or compound heterozygous mutations in the coproporphyrinogen III oxidase gene, and the mutant enzyme has 18% to 24% residual activity.³⁹⁷ Clinically, neonatal hemolytic anemia with hyperbilirubinemia and hepatosplenomegaly is followed by mild microcytic anemia and variable photosensitivity in adulthood. Neurovisceral symptoms of acute porphyria may occur.³⁹⁸ Expression of the defect is usually limited to erythroid tissue and is characterized by impaired heme synthesis and dyserythropoiesis with associated iron overload.³⁹⁷

P.659

KEY CLINICAL SUMMARY POINTS

• General Definition of Sideroblastic Anemia (SA)

Sideroblastic anemia comprises a wide spectrum of heritable or acquired erythropoietic disorders. Regardless of clinical and peripheral blood abnormalities, the unifying feature of all forms of SA is the presence of bone marrow ring sideroblasts.

• Prompt Diagnosis of a Sideroblastic Anemia

Consider in all adults and children/infants with unexplained anemia of any severity from history, clinical examination, and basic laboratory data. Certain features are suggestive: history of chronic anemia; exposure to factors causing reversible SA (Table 24.1); family history of anemia; presence of neurologic abnormalities, myopathy, lactic acidosis, immunodeficiency in children or young adults.

Suspect a congenital SA in the presence of microcytosis without evidence of iron deficiency or thalassemia; the MCV and erythrocyte morphology are most accurate before any red cell transfusion (Fig. 24.9).

Establish the diagnosis of SA by performing a Prussian blue stain on the bone marrow aspirate smear.

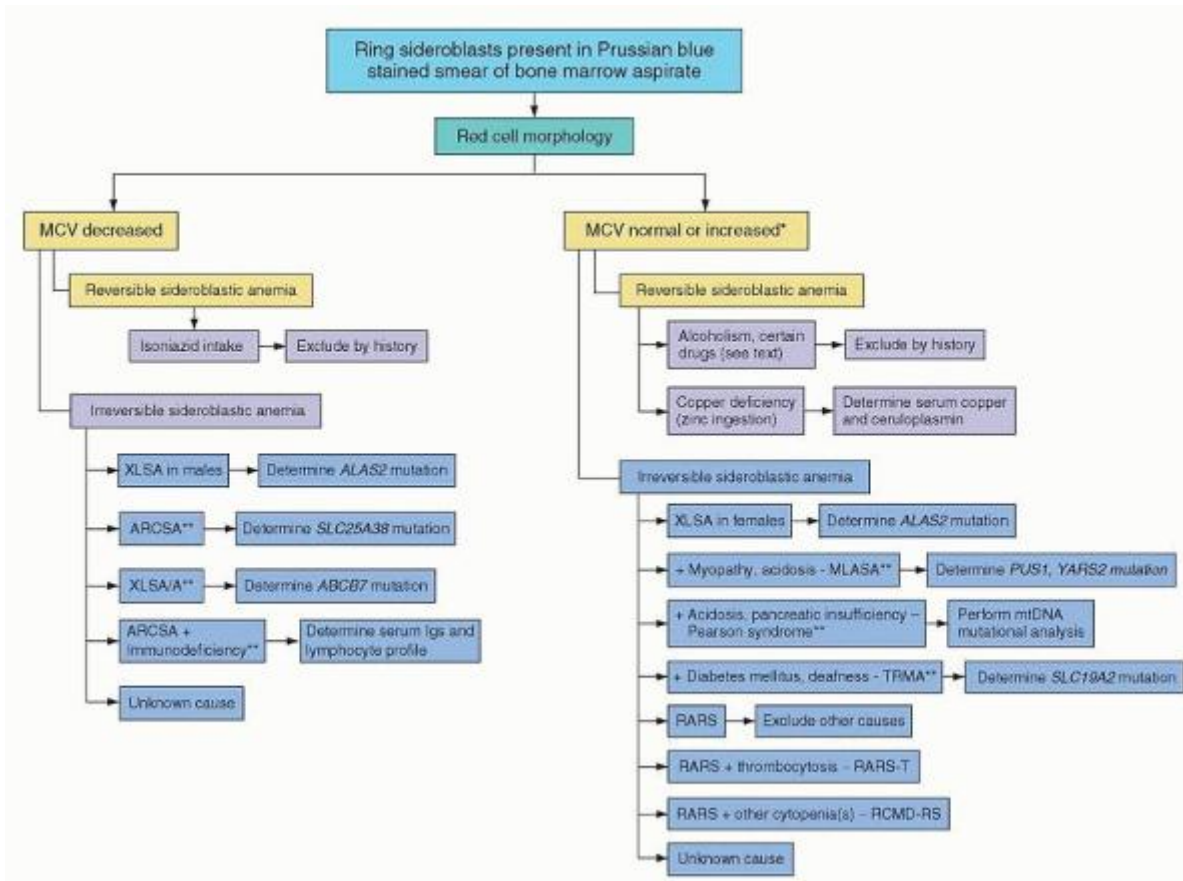

FIGURE 24.9. Schema for diagnostic evaluation of patients with a sideroblastic anemia. MCV, mean corpuscular volume; XLSA, X-linked sideroblastic anemia; ARCSA, autosomal recessive sideroblastic anemia; XLSA/A, X-linked sideroblastic anemia with ataxia; Igs, immunoglobulins; MLASA, myopathy, lactic acidosis, and sideroblastic anemia; mtDNA, mitochondrial DNA; TRMA, thiamine-responsive megaloblastic anemia. *Microcytic hypochromic red cells may be present in the blood smear in many, but not all, of these disorders. **Typically present in infancy or childhood.

• Differential Diagnosis

If ring sideroblasts are evident in the marrow, review the patient's constellation of clinical findings to narrow the differential diagnosis (Table 24.1, Fig. 24.9).

Where the causative gene is known, mutation analysis provides definitive diagnosis of a congenital SA; some molecular genetic tests are available in several clinical laboratories listed on the www.genetests.org website, others may be available in certain research laboratories.

Evaluate for iron overload with serum iron profile and ferritin; assess parenchymal organ involvement as indicated.

- Treatment

Withdraw an identified reversible cause.

Recommend a therapeutic trial of pyridoxine (adult dose 50 to 100 mg/day) in patients with microcytic SA until the genetic cause can be determined; the vitamin is only effective in some cases with XLSA.

For symptomatic anemia, provide supportive treatment with red cell transfusion.

Remove excess body iron by phlebotomy if anemia is mild; by use of iron chelation in patients with severe/transfusion-dependent anemia.

P.660

Prescribe thiamine (25 mg/day) in the TRMA syndrome.

Manage the clinical aberrations associated with the syndromic forms of congenital SA with available supportive measures.

- Follow-up

Educate the patient and family about the disease and relevant inheritance.

Encourage patients to keep records of diagnostic studies and recommended therapy.

In cases with congenital SA, provide for examination of family members and for their genetic testing as indicated.

WEBSITE RESOURCE

www.UpToDate.com—contains three sections on sideroblastic anemias: causes; pathophysiology; diagnosis and treatment.

REFERENCES

1. Mollin DL. Sideroblasts and sideroblastic anaemia. *Br J Haematol* 1965;11:41-48.
2. Bottomley SS. Sideroblastic anaemia. *Clin Haematol* 1982;11:389-409.
3. Fleming MD. Congenital sideroblastic anemias: iron and heme lost in mitochondrial translation. *Hematology Am Soc Hematol Educ Program*, 2011: 525-531.
4. Caroli J, Bernard J, Bessis M, et al. Hemochromatose avec anemie hypochrome et absence d'hémoglobine anormale. *Presse Med* 1957;65: 1991-1992.
5. Sorenson GD. Electron microscopic observations of bone marrow from patients with sideroblastic anemia. *Am J Pathol* 1962;40:297-314.
6. Levi S, Corsi B, Bosisio M, et al. A human mitochondrial ferritin gene. *J Biol Chem* 2001;276:24437-24440.
7. Cazzola M, Invernizzi R, Bergamaschi G, et al. Mitochondrial ferritin expression in erythroid cells from patients with sideroblastic anemia. *Blood* 2003;101:1996-2000.
8. Bottomley SS. The spectrum and role of iron overload in sideroblastic anemia. *Ann NY Acad Sci* 1988;526:331-332.
9. May A, deSouza P, Barnes K, et al. Erythroblast iron metabolism in sideroblastic marrows. *Br J Haematol* 1982;52:611-621.
10. White JM, Brain MC, Ali MAM. Globin synthesis in sideroblastic anaemia. I. α and β peptide chain synthesis. *Br J Haematol* 1971;20:263-275.
11. White JM, Ali MAM. Globin synthesis in sideroblastic anaemia. II. The effect of pyridoxine, δ -aminolevulinic acid and haem, in vitro. *Br J Haematol* 1973;24:481-489.
12. Harris JW, Horrigan DL. Pyridoxine-responsive anemia—prototype and variations on the theme. *Vitam Horm* 1964;22:721-753.
13. Singh AK, Shinton NK, Williams JDF. Ferrokinetic abnormalities and their significance in patients with sideroblastic anaemia. *Br J Haematol* 1970;18:67-77.
14. Barrett PVD, Cline MJ, Berlin NI. The association of the urobilin “early peak” and erythropoiesis in man. *J Clin Invest* 1966;45:1657-1667.

15. Muta K, Krantz SB. Inhibition of heme synthesis induces apoptosis in human erythroid progenitor cells. *J Cell Physiol* 1995;163:38-50.
16. Matthes TW, Meyer G, Samii K, et al. Increased apoptosis in acquired sideroblastic anaemia. *Br J Haematol* 2000;111:843-852.
17. Hellstrom-Lindberg E, Schmidt-Mende J, Forsblom AM, et al. Apoptosis in refractory anaemia with ringed sideroblasts is initiated at the stem cell level and associated with increased activation of caspases. *Br J Haematol* 2001; 112:714-726.
18. Cartwright GE, Deiss A. Sideroblasts, siderocytes and sideroblastic anemia. *N Engl J Med* 1975;292:185-193.
19. Pippard MJ, Weatherall DJ. Iron absorption in non-transfused iron loading anaemias: prediction of risk for iron loading and response to iron chelation treatment, in β thalassemia intermedia and congenital sideroblastic anaemias. *Haematologia (Budap)* 1984;17:2-24.
20. Tanno T, Miller JL. Iron loading and overloading due to ineffective erythropoiesis. *Adv Hematol* 2010; 2010:358283 (Epub 2010 May 11).
21. Bottomley SS. Secondary iron overload disorders. *Semin Hematol* 1998;35:77-86.
22. Bottomley SS. Iron overload in sideroblastic and other non-thalassemic anemias. In: Barton JC, Edwards CQ, eds. *Hemochromatosis: genetics, pathophysiology, diagnosis and treatment*. Cambridge: Cambridge University Press, 2000:442-452.
23. Cartwright GE, Edwards CQ, Skolnick MH, et al. Association of HLA-linked hemochromatosis with idiopathic refractory sideroblastic anemia. *J Clin Invest* 1980;65:989-992.
24. Yaouanq J, Grosbois B, Jouanolle AM, et al. Haemochromatosis Cys282Tyr mutation in pyridoxine-responsive sideroblastic anaemia. *Lancet* 1997;349:1475-1476.
25. Cotter PD, May A, Li L, et al. Four new mutations in the erythroid-specific 5-aminolevulinic acid synthase (ALAS2) gene causing X-linked sideroblastic anemia: increased pyridoxine responsiveness after removal of iron overload by phlebotomy and coinheritance of hereditary hemochromatosis. *Blood* 1999;93:1757-1769.
26. Bottomley SS, Wasson EG, Wise PD. Role of the hemochromatosis HFE gene mutation(s) in the iron overload of hereditary sideroblastic anemia (Abstract). *Blood* 1997;90(Suppl 1):11b.
27. Beris P, Samii K, Darbellay R, et al. Iron overload in patients with sideroblastic anaemia is not related to the presence of the haemochromatosis Cys282Tyr and His63Asp mutations. *Br J Haematol* 1999;104:97-99.
28. Grosbois B, Bibes B, Jouanolle AM, et al. Haemochromatosis mutations and idiopathic acquired sideroblastic anemia (IASA) (Abstract). *Blood* 1999;94 (Suppl 1):15b.
29. Cooley TB. A severe type of hereditary anemia with elliptocytosis. Interesting sequence of splenectomy. *Am J Med Sci* 1945;209:561-568.
30. Vogler WR, Mingioli ES. Heme synthesis in pyridoxine-responsive anemia. *N Engl J Med* 1965;273:347-353.
31. McFadzean AJS, Davis LJ. Iron-staining erythrocytic inclusions with special reference to acquired haemolytic anaemia. *Glasgow Med J* 1947;28:237-279.
32. Dacie JV, Doniach I. The basophilic property of the iron-containing granules in siderocytes. *J Pathol Bacteriol* 1947;59:684-686.
33. Harris JW, Whittington RM, Weisman R Jr, et al. Pyridoxine-responsive anemia in the human adult. *Proc Soc Exp Biol Med* 1956;91:427-432.
34. Bjorkman SE. Chronic refractory anemia with sideroblastic bone marrow. A study of four cases. *Blood* 1956;11:250-259.
35. Brain MC, Herdan A. Tissue iron stores in sideroblastic anaemia. *Br J Haematol* 1965;11:107-113.
36. Hathway D, Harris JW, Stenger RJ. Histopathology of the liver in pyridoxine-responsive anemia. *Arch Pathol Lab Med* 1967;83:175-179.
37. Verwilghen R, Reybroeck G, Callens L, et al. Antituberculous drugs and sideroblastic anaemia. *Br J Haematol* 1965;11:92-98.
38. Harriss EB, MacGibbon BH, Mollin DL. Experimental sideroblastic anaemia. *Br J Haematol* 1965;11:99-106.

39. Tanaka M, Bottomley SS. Bone marrow Δ -aminolevulinic acid synthetase in experimental sideroblastic anemia. *J Lab Clin Med* 1974;84:92-98.
40. Beck EA, Ziegler G, Schmid R, et al. Reversible sideroblastic anemia caused by chloramphenicol. *Acta Haematol (Basel)* 1967;38:1-10.
41. Hines JD. Reversible megaloblastic and sideroblastic marrow abnormalities in alcoholic patients. *Br J Haematol* 1969;16:87-101.
42. Porter FS, Rogers LE, Sidbury JB Jr. Thiamine-responsive megaloblastic anemia. *J Pediatr* 1969;74:494-504.
43. Scott AJ, Ansford AJ, Webster BH, et al. Erythropoietic protoporphyria with features of a sideroblastic anemia terminating in liver failure. *Am J Med* 1973; 54:251-259.
44. Rademakers LHPM, Koningsberger JC, Sorber CWJ, et al. Accumulation of iron in erythroblasts of patients with erythropoietic protoporphyria. *Eur J Clin Invest* 1993;23:130-138.
45. Dunlap WM, James GW, Hume DM. Anemia and neutropenia caused by copper deficiency. *Ann Intern Med* 1974;80:470-476.
46. Vilter RW, Bozian RC, Hess EV, et al. Manifestations of copper deficiency in a patient with systemic sclerosis on intravenous hyperalimentation. *N Engl J Med* 1974;291:188-191.
47. Pearson HA, Lobel JS, Kocoshis SA, et al. A new syndrome of refractory sideroblastic anemia with vacuolization of marrow precursors and exocrine pancreatic dysfunction. *J Pediatr* 1979;95:976-984.
48. O'Brien H, Amess JAL, Mollin DL. Recurrent thrombocytopenia, erythroid hypoplasia and sideroblastic anaemia associated with hypothermia. *Br J Haematol* 1982;51:451-456.
49. Pagon RA, Bird TD, Detter JC, et al. Hereditary sideroblastic anaemia and ataxia: an X-linked recessive disorder. *J Med Genet* 1985;22:267-273.
50. Bennett JM. Classification of the myelodysplastic syndromes. *Clin Haematol* 1986;15:909-923.
51. Rotig A, Colonna M, Bonnefont JP, et al. Mitochondrial DNA deletion in Person's marrow/pancreas syndrome. *Lancet* 1989;1(8643):902-903.
52. Cotter PD, Baumann M, Bishop DF. Enzymatic defect in "X-linked" sideroblastic anemia: molecular evidence for erythroid δ -aminolevulinic synthase deficiency. *Proc Natl Acad Sci U S A* 1992;89:4028-4032.
53. Allikmets R, Raskind WH, Hutchinson A, et al. Mutation of a putative mitochondrial iron transporter gene (ABC7) in X-linked sideroblastic anemia and ataxia (XLSA/A). *Hum Mol Genet* 1999;8:743-749.
54. Labay V, Raz T, Baron D, et al. Mutations in SLC19A2 cause thiamine-responsive megaloblastic anaemia associated with diabetes mellitus and deafness. *Nat Genet* 1999;22:300-304.
55. Fleming JC, Tartaglioni E, Steinkamp MP, et al. The gene mutated in thiamine-responsive anaemia with diabetes and deafness (TRMA) encodes a functional thiamine transporter. *Nat Genet* 1999;22:305-308.
56. Diaz GA, Banikazemi M, Oishi K, et al. Mutations in a new gene encoding a thiamine transporter cause thiamine-responsive megaloblastic anaemia syndrome. *Nat Genet* 1999;22:309-312.
57. Casas KA, Fischel-Ghodsian N. Mitochondrial myopathy and sideroblastic anemia. *Am J Med Genet* 2004;125A:201-204.
58. Bykhovskaya Y, Casas K, Mengesha E, et al. Missense mutation in pseudouridine synthase 1 (PUS1) causes mitochondrial myopathy and sideroblastic anemia (MLASA). *Am J Hum Genet* 2004;74:1303-1308.
59. Camaschella C, Campanella A, De Falco L, et al. The human counterpart of zebrafish shiraz shows sideroblastic-like microcytic anemia and iron overload. *Blood* 2007;110:1353-1358.
60. Guernsey DL, Jiang H, Campagna DR, et al. Mutations in mitochondrial carrier family gene SLC25A38 cause nonsyndromic autosomal recessive congenital sideroblastic anemia. *Nat Genet* 2009;41:651-653.
61. Riley LG, Cooper S, Hickey P, et al. Mutation of the mitochondrial tyrosyl-tRNA synthetase gene, YARS2, causes myopathy, lactic acidosis, and sideroblastic anemia-MLASA syndrome. *Am J Hum Genet* 2010;89:52-59.
62. Bottomley SS, Muller-Eberhard U. Pathophysiology of heme synthesis. *Semin Hematol* 1988;25:282-302.

63. Sadlon TJ, Dell'Oso T, Surinya KH, et al. Regulation of erythroid 5-aminolevulinate synthase expression during erythropoiesis. *Int J Biochem Cell Biol* 1999;31:1153-1167.
64. Dzikaite V, Konopka A, Brock JH, et al. A novel endoproteolytic processing activity in mitochondria of erythroid cells and the role in heme synthesis. *Blood* 2000;96:740-746.
65. Cox TC, Bawden MJ, Abraham NG, et al. Erythroid 5-aminolevulinate synthase is located on the X chromosome. *Am J Hum Genet* 1990;46:107-111.
66. Bishop DF, Henderson AS, Astrin KH. Human δ -aminolevulinate synthase: assignment of the housekeeping gene to 3p21 and the erythroid-specific gene to the X chromosome. *Genomics* 1990;7:207-214.
67. Cotter PD, Drabkin HA, Varkony T, et al. Assignment of the human housekeeping δ -aminolevulinate synthase gene (ALAS1) to chromosome band 3p21.1 by PCR analysis of somatic cell hybrids. *Cytogenet Cell Genet* 1995;69:207-208.
68. May BK, Dogra SC, Sadlon TJ, et al. Molecular regulation of heme biosynthesis in higher vertebrates. *Progr Nucleic Acid Res Mol Biol* 1995;51:1-51.
69. Cotter PD, Willard HF, Gorski JL, et al. Assignment of human erythroid δ -aminolevulinate synthase (ALAS2) to a distal subregion of band Xp11.21 by PCR analysis of somatic cell hybrids containing X-autosome translocations. *Genomics* 1992;13:211-212.
70. Cox TC, Kozman HM, Raskind WH, et al. Identification of a highly polymorphic marker within intron 7 of the ALAS2 gene and suggestion of at least two loci for X-linked sideroblastic anemia. *Hum Mol Genet* 1992;1:639-641.
71. Nakajima O, Takahashi S, Harigae H, et al. Heme deficiency in erythroid lineage causes differentiation arrest and cytoplasmic iron overload. *EMBO J* 1999;18:6282-6289.
72. Hofer T, Wenger H, Kramer MF, et al. Hypoxic up-regulation of erythroid 5-aminolevulinate synthase. *Blood* 2003;101:348-350.
73. Fuchs O, Ponka P. The role of iron supply in the regulation of 5-aminolevulinate synthase mRNA levels in murine erythroleukemia cells. *Neoplasma* 1996;43:31-36.
74. Smith SJ, Cox TM. Translation control of erythroid 5-aminolevulinate synthase in immature human erythroid cells by heme. *Cell Mol Biol* 1997;43:103-114.
75. Cox TC, Bawden MJ, Martin A, et al. Human erythroid 5-aminolevulinate synthase: promoter analysis and identification of an iron-responsive element in the mRNA. *EMBO J* 1991;10:1891-1902.
76. Dandekar T, Stripecke R, Gray NK, et al. Identification of a novel iron-responsive element in murine and human erythroid δ -aminolevulinic acid synthase mRNA. *EMBO J* 1991;10:1903-1909.
77. Melefors O, Goossen B, Johansson HE, et al. Translational control of 5-aminolevulinate synthase mRNA by iron-responsive elements in erythroid cells. *J Biol Chem* 1993;268:5974-5978.
78. Bhasker CR, Burgiel G, Neupert B, et al. The putative iron-responsive element in the human erythroid 5-aminolevulinate synthase mRNA mediates translational control. *J Biol Chem* 1993;268:12699-12705.
79. Gray NK, Hentze MW. Iron regulatory protein prevents binding of the 43s translation pre-initiation complex to ferritin and eALAS mRNAs. *EMBO J* 1994;13:3882-3891.
80. Wingert RA, Galloway JL, Barut B, et al. Deficiency of glutaredoxin 5 reveals Fe-S clusters are required for vertebrate haem synthesis. *Nature* 2005;436:1035-1039.
81. Rouault TA. The role of iron regulatory proteins in mammalian iron homeostasis and disease. *Nature Chem Biol* 2006;2:406-414.
82. Houston T, Moore MR, McColl KEL, et al. Erythroid 5-aminolaevulinate synthase activity during normal and iron deficient erythropoiesis. *Br J Haematol* 1991;78:561-564.
83. Lathrop JT, Timko MP. Regulation by heme of mitochondrial protein transport through a conserved amino acid motif. *Science* 1993;259:522-525.
84. Goodfellow BJ, Dias JS, Ferreira GC, et al. The solution structure and heme binding of the presequence of murine 5-aminolevulinate synthase. *FEBS Lett* 2001;505:325-331.

85. Munakata H, Sun J-Y, Yoshida K, et al. Role of the heme regulatory motif in the heme-mediated inhibition of mitochondrial import of 5-aminolevulinic acid synthase. *J Biochem* 2004;136:233-238.
86. Furuyama K, Sassa S. Interaction between succinyl Co-A synthetase and the heme-biosynthetic enzyme ALAS-E is disrupted in sideroblastic anemia. *J Clin Invest* 2000;105:757-764.
87. Cox TC, Sadlon TJ, Schwarz QP, et al. The major splice variant of human 5-aminolevulinic acid synthase-2 contributes significantly to erythroid heme biosynthesis. *Int J Biochem Cell Biol* 2004;36:281-295.
88. Kaya AH, Plewinska M, Wong DM, et al. Human δ -aminolevulinic acid dehydratase (ALAD) gene: structure and alternative splicing of the erythroid and housekeeping mRNAs. *Genomics* 1994;19:242-248.
89. Bishop TR, Miller MW, Beall J, et al. Genetic regulation of δ -aminolevulinic acid dehydratase during erythropoiesis. *Nucleic Acids Res* 1996;24:2511-2518.
90. Guo GG, Gu M, Etlinger JD. 240-kDa proteasome inhibitor (CF-2) is identical to δ -aminolevulinic acid dehydratase. *J Biol Chem* 1994;269:12399-12402.
91. Chretien S, Dubart A, Beaupain D, et al. Alternative transcription and splicing of the human porphobilinogen deaminase gene results either in tissue-specific or in housekeeping expression. *Proc Natl Acad Sci U S A* 1988;85:6-10.
92. Beru N, Goldwasser E. Studies of the effect of erythropoietin on heme synthesis. *Adv Exp Med Biol* 1989;271:87-94.
93. Aizencang G, Solis C, Bishop D, et al. Human uroporphyrinogen-III synthase: genomic organization, alternative promoters, and erythroid-specific expression. *Genomics* 2000;90:223-231.
94. Romeo PH, Raich N, Dubart A, et al. Molecular cloning and nucleotide sequence of a complete human uroporphyrinogen decarboxylase cDNA. *J Biol Chem* 1986;261:9825-9831.
95. Takahashi S, Taketani S, Akasaka J, et al. Differential regulation of coproporphyrinogen oxidase gene between erythroid and nonerythroid cells. *Blood* 1998;92:3436-3444.
96. Taketani S, Inazawa J, Abe T, et al. The human protoporphyrinogen oxidase gene (PPOX): organization and location to chromosome 1. *Genomics* 1995;29:698-703.
97. Magness ST, Tugores A, Diala ES, et al. Analysis of the human ferrochelatase promoter in transgenic mice. *Blood* 1998;92:320-328.
98. Busfield SJ, Riches KJ, Sainsbury AJ, et al. Retrovirally-produced erythropoietin effectively induces differentiation and proliferation of J2E erythroid cells. *Growth Factors* 1993;9:87-97.
99. Houston T, Moore MR, McColl KEL, et al. Regulation of haem biosynthesis in normoblastic erythropoiesis: role of 5-aminolaevulinic acid synthase and ferrochelatase. *Biochim Biophys Acta* 1994;1201:85-93.
100. Taketani S, Adachi Y, Nakahashi Y. Regulation of the expression of human ferrochelatase by intracellular iron levels. *Eur J Biochem* 2000;267:4685-4692.
101. Crooks DR, Ghosh MC, Haller RG, et al. Posttranslational stability of the heme biosynthetic enzyme ferrochelatase is dependent on iron availability and intact iron-sulfur cluster assembly machinery. *Blood* 2010;115:860-869.
102. Shah DI, Takahashi-Makise N, Cooney JD, et al. Mitochondrial Atpif1 regulates haem synthesis in developing erythroblasts. *Nature* 2012;491:608-612.
103. Ponka P. Tissue-specific regulation of iron metabolism and heme synthesis: distinct control mechanisms in erythroid cells. *Blood* 1997;89:1-25.
104. Cotner T, DasGupta A, Papayannopoulou TH, et al. Characterization of a novel form of transferrin receptor preferentially expressed on normal erythroid progenitors and precursors. *Blood* 1989;73:214-221.
105. Lok CN, Ponka P. Identification of an erythroid active element in the transferrin receptor gene. *J Biol Chem* 2000;275:24185-24190.
106. Marziali G, Perrotti E, Ilari R, et al. Role of Ets-1 in transcription and regulation of transferrin receptor and erythroid differentiation. *Oncogene* 2002;21:7933-7944.
107. Schranzhofer M, Schifrer M, Cabrera JA, et al. Remodeling the regulation of iron metabolism during erythroid differentiation to ensure efficient heme biosynthesis. *Blood* 2006;107:4159-4167.
108. Bottomley SS, Moore MZ. Regulation of iron metabolism in erythroblasts (Abstract). *Blood* 1985;66:43a.

109. Muta K, Nishimura J, Ideguchi H, et al. Erythroblast transferrin receptors and transferrin kinetics in iron deficiency and various anemias. *Am J Hematol* 1987;25:155-163.
110. Bottomley SS, Wolfe LC, Bridges KR. Iron metabolism in K562 erythroleukemia cells. *J Biol Chem* 1985;260:6811-6815.
111. Ohgami RS, Campagna DR, Greer EL, et al. Identification of a ferrireductase required for efficient transferrin-dependent iron uptake in erythroid cells. *Nature Genet* 2005; 37:1264-1269.
112. Shi H, Bencze TL, Stemmler CC, Philpott CC. A cytosolic iron chaperone that delivers iron to ferritin. *Science* 2008;320:1207-1210.
113. Sheftel AD, Zhang AS, Brown C, et al. Direct interorganellar transfer of iron from endosome to mitochondrion. *Blood* 2007;110:125-132.
114. Shaw GC, Cope JJ, Li L, et al. Mitoferrin is essential for erythroid iron assimilation. *Nature* 2006;440:96-100.
115. Chen W, Paradkar PN, Li L, et al. Abcb10 physically interacts with mitoferrin 1 (Slc25a37) to enhance its stability and function in erythroid mitochondria. *Proc Nat Acad Sci USA* 2009;106:16263-16268.
116. Chen W, Dailey HA, Paw BH. Ferrocyclase forms an oligomeric complex with mitoferrin-1 and Abcb10 for erythroid heme synthesis. *Blood* 2010;116:628-630.
117. Rouault TA. Linking physiological functions of iron. *Nature Chem Biol* 2005;1:193-194.
118. Chiabrando D, Marro S, Mercurio S, et al. The mitochondrial heme exporter FLVCR1b mediates erythroid differentiation. *J Clin Invest* 2012;122:4569-4579.
119. Chen J-J. Regulation of protein synthesis by the heme-regulated eIF2 α kinase: relevance to anemias. *Blood* 2007;109:2693-2699.
120. Charnay P, Maniatis T. Transcriptional regulation of globin gene expression in the human erythroid cell line K562. *Science* 1983;220:1281-1283.
121. Tahara T, Sun J, Nakanishi K, et al. Heme positively regulates the expression of beta-globin at the locus control region via transcriptional factor Bach1 in erythroid cells. *J Biol Chem* 2004;279:5480-5487.
122. Bottomley SS. Congenital sideroblastic anemias. *Curr Hematol Rep* 2006;5:41-49.
123. Camaschella C. Hereditary sideroblastic anemias: pathophysiology, diagnosis, and treatment. *Semin Hematol* 2009;46:371-377.
124. Rundles RW, Falls HF. Hereditary (? sex-linked) anemia. *Am J Med Sci* 1946; 211:641-658.
125. Losowsky MS, Hall R. Hereditary sideroblastic anaemia. *Br J Haematol* 1965; 11:70-85.
126. Elves MW, Bourne MS, Israels MCG. Pyridoxine-responsive anaemia determined by an X-linked gene. *J Med Genet* 1966;3:1-4.
127. Prasad AS, Tranchida L, Konno ET, et al. Hereditary sideroblastic anemia and glucose-6-phosphate dehydrogenase deficiency in a Negro family. *J Clin Invest* 1968;47:1415-1424.
128. Holmes J, May A, Geddes D, et al. A family study of congenital X-linked sideroblastic anaemia. *J Med Genet* 1990;27:26-28.
129. Cox TC, Bottomley SS, Wiley JS, et al. X-linked pyridoxine-responsive sidero-blastic anemia due to a Thr³⁸⁸-to-Ser substitution in erythroid 5-aminolevulinic synthase. *N Engl J Med* 1994;330:675-679.
130. Prades E, Chambon C, Dailey TA, et al. A new mutation of the ALAS2 gene in a large family with X-linked sideroblastic anemia. *Hum Gene* 1995;95: 424-428.
131. Pasanen AVO, Salmi M, Vuopio P, et al. Heme biosynthesis in sideroblastic anemia. *Int J Biochem* 1980;12:969-974.
132. Lee GR, McDiarmid WD, Cartwright GE, et al. Hereditary, X-linked, sideroachrestic anemia. The isolation of two erythrocyte populations differing in Xga blood type and porphyrin content. *Blood* 1968;32:59-70.
133. Weatherall DJ, Pembrey ME, Hall EG, et al. Familial sideroblastic anaemia: problem of Xg and X chromosome inactivation. *Lancet* 1970;2:744-748.
134. Peto TEA, Pippard MJ, Weatherall DJ. Iron overload in mild sideroblastic anaemias. *Lancet* 1983;1:375-378.

135. Bottomley SS, Wise PD, Wasson EG, et al. X-linked sideroblastic anemia in ten female probands due to ALAS2 mutations and skewed X chromosome inactivation (Abstract). *Am J Hum Genet* 1998;63(Suppl):A352.
136. Aivado M, Gattermann N, Rong A, et al. X-linked sideroblastic anemia associated with a novel ALAS2 mutation and unfortunate skewed X-chromosome inactivation patterns. *Blood Cells Mol Dis* 2006;37:40-45.
137. Aoki Y, Maranaka S, Nakabayashi K, et al. δ -aminolevulinic acid synthetase in erythroblasts of patients with pyridoxine-responsive anemia. *J Clin Invest* 1979;64:1196-1203.
138. Konopka L, Hoffbrand AV. Haem synthesis in sideroblastic anaemia. *Br J Haematol* 1979;42:73-83.
139. Bottomley SS, Healy HM, Brandenburg MA, et al. 5-Aminolevulinic acid synthase in sideroblastic anemias: mRNA and enzyme activity levels in bone marrow cells. *Am J Hematol* 1992;41:76-83.
140. Byrd RB, Cooper T. Hereditary iron-loading anemia with secondary hemochromatosis. *Ann Intern Med* 1961;55:103-123.
141. Bottomley SS. Sideroblastic anemia: death from iron overload. *Hosp Pract* 1991;26(Suppl 3):55-56.
142. Cotter PD, May A, Fitzsimons EJ, et al. Late-onset X-linked sideroblastic anemia. *J Clin Invest* 1995;96:2090-2096.
143. Rosenberg SJ, Bennett JM. Pyridoxine-responsive anemia. *N Y State J Med* 1969;69:1430-1433.
144. Joosten E, van den Berg A, Riezler R, et al. Metabolic evidence that deficiencies of vitamin B-12 (cobalamin), folate and vitamin B-6 occur commonly in elderly people. *Am J Clin Nutr* 1993;58:468-476.
145. Nankivell BJ. Vitamin B6 deficiency on hemodialysis causing sideroblastic anemia. *Nephron* 1991;59:674-675.
146. Furuyama K, Harigae H, Kinoshita C, et al. Late-onset X-linked sideroblastic anemia following hemodialysis. *Blood* 2003;101:4623-4624.
147. Busque L, Mio R, Mattioli J, et al. Nonrandom X-inactivation patterns in normal females: lyonization ratios vary with age. *Blood* 1996;88:59-65.
148. Cazzola M, May A, Bergamischi G, et al. Familial-skewed X-chromosome inactivation as a predisposing factor for late-onset X-linked sideroblastic anemia in carrier females. *Blood* 2000;96:4363-4365.
149. Conboy JG, Cox TC, Bottomley SS, et al. Human erythroid 5-aminolevulinate synthase: gene structure and species-specific differences in alternative RNA splicing. *J Biol Chem* 1992;267:18753-18758.
150. Noble JS, Taylor GR, Losowsky MS, et al. Linkage analysis of a large pedigree with hereditary sideroblastic anaemia. *J Med Genet* 1995;32:389-392.
151. HGMD Professional. <http://www.hgmd.org> (Accessed August 1, 2012).
- 151a. Furuyama K, Kaneko K, Fujiwara T, et al. Identification of the novel erythroid-specific enhancer in the first intron of human ALAS2 gene; the mutation disrupting GATA transcription factor-binding site in the enhancer causes X-linked sideroblastic anemia. *Am Soc Hematol Ann Meeting* 2012; Abstract 3185. <https://ash.confex.com/ash/2012/webprogram/Paper47838.html>.
152. Cotton HB, Harris JW. Familial pyridoxine-responsive anemia (Abstract). *J Clin Invest* 1962;31:1352.
153. Cotter PD, Rucknagel DL, Bishop DF. X-linked sideroblastic anemia: identification of the mutation in the erythroid-specific δ -aminolevulinate synthase gene (ALAS2) in the original family described by Cooley. *Blood* 1994;84: 3915-3924.
154. Edgar AJ, Losowsky MS, Noble JS, et al. Identification of an arginine⁴⁵² to histidine substitution in the erythroid 5-aminolaevulinate synthase gene in a large pedigree with X-linked sideroblastic anaemia. *Eur J Haematol* 1997;58:1-4.
155. Koc S, Bishop DF, Li L, et al. Iron overload in pyridoxine-responsive X-linked sideroblastic anemia: greater severity in a heterozygote than in her hemizygous brother (Abstract). *Blood* 1997;90(Suppl):16b.
156. Ferreira GC, Neame PJ, Dailey HA. Heme biosynthesis in mammalian systems: evidence of a Schiff base linkage between pyridoxal 5' phosphate cofactor and a lysine residue in 5-aminolevulinate synthase. *Protein Sci* 1993;2:1959-1965.
157. May A, Al-Sabah AI, Lawless SL. Acquired sideroblastic anemia unresponsive to pyridoxine caused by a somatic mutation in ALA synthase 2 (Abstract). *Blood* 2005;106:988a-989a.
158. Furuyama K, Harigae H, Heller T, et al. Arg452 substitution of the erythroid-specific 5-aminolaevulinate synthase, a hot spot mutation in X-linked sidero-blastic anaemia, does not itself affect enzyme activity. *Eur J Haematol* 2006;76:33-41.

159. Bottomley SS, Wise PD, Wasson EG, et al. The spectrum of molecular defects in the erythroid 5-aminolevulinic synthase gene in hereditary sideroblastic anemia (Abstract). *Blood* 1998;92(Suppl 1):669a.
160. Bishop DF, Tschaikovskii V, Hoffbrand AV, et al. X-linked sideroblastic anemia due to carboxy-terminal ALAS2 mutations that cause loss of binding to the β -subunit of succinyl-CoA synthetase (SUCLA2). *J Biol Chem* 2012;287:28943-28955.
161. Shoolingin-Jordan PM, Al-Daihan S, Alexeev D. 5-Aminolevulinic acid synthase: mechanisms, mutations and medicine. *Biochim Biophys Acta* 2003; 1647:361-366.
162. Astner I, Schulze JO, van den Heuvel J, et al. Crystal structure of 5-aminolevulinic acid synthase, the first enzyme of heme biosynthesis, and its link to XLSA in humans. *EMBO J* 2005;24:3166-3177.
163. Barton JC, Lee PL. Disparate phenotypic expression of ALAS2 R452H (nt 1407 G→A) in two brothers, one with severe sideroblastic anemia and iron overload, hepatic cirrhosis, and hepatocellular carcinoma. *Blood Cells Mol Dis* 2006;36:342-346.
164. Cazzola M, May A, Bergamischi G, et al. Absent phenotypic expression of X-linked sideroblastic anemia in one of 2 brothers with a novel ALAS2 mutation. *Blood* 2002;100:4236-4238.
165. Bergmann AK, Campagna DR, McLoughlin EM, et al. Systematic molecular genetic analysis of congenital sideroblastic anemia: evidence for genetic heterogeneity and identification of novel mutations. *Pediatr Blood Cancer* 2010;54:273-278.
166. Kannengiesser C, Sanchez M, Sweeney M, et al. Missense SLC25A38 variations play an important role in autosomal recessive inherited sideroblastic anemia. *Haematologica* 2011;96:808-813.
167. Yeh H, Jeong SY, Ghosh MC, et al. Glutaredoxin 5 deficiency causes sideroblastic anemia by specifically impairing heme biosynthesis and depleting cytosolic iron in human erythroblasts. *J Clin Invest* 2010;120:1749-1761.
168. Bottomley SS, Tanaka M, Everett MA. Diminished erythroid ferrochelatase activity in protoporphyria. *J Lab Clin Med* 1975;86:126-131.
169. Holme SA, Worwood M, Anstey AV, et al. Erythropoiesis and iron metabolism in dominant erythropoietic protoporphyria. *Blood* 2007;110:4108-4110.
170. van Waveren Hogervorst GD, van Roermund HPC, Snijders PJ. Hereditary sideroblastic anaemia and autosomal inheritance of erythrocyte dimorphism in a Dutch family. *Eur J Haematol* 1987;38:405-409.
171. Amos RJ, Miller ALC, Amess JAL. Autosomal inheritance of sideroblastic anaemia. *Clin Lab Haematol* 1988;10:347-353.
172. Tuckfield A, Ratnaike S, Hussein S, et al. A novel form of hereditary sideroblastic anaemia with macrocytosis. *Br J Haematol* 1997;97:279-285.
173. Fairbanks VF, Dickson ER, Thompson ME. Hereditary sideroblastic anemia. *Hosp Pract* 1991;26(Suppl 3):53-55.
174. Cuijpers MLH, van Spronsen DJ, Muus P, et al. Need for early recognition and therapeutic guidelines of congenital sideroblastic anaemia. *Int J Hematol* 2011;94:97-100.
175. Hall R, Losowsky MS. The distribution of erythroblast iron in sideroblastic anaemias. *Br J Haematol* 1966;12:334-340.
176. Wickramasinghe SN, Fulker MJ, Losowsky MS, et al. Microspectrophotometric and electron microscopic studies of bone marrow in hereditary sideroblastic anaemia. *Acta Haematol (Basel)* 1971;45:236-244.
177. Raab SO, Haut A, Cartwright GE, Wintrobe MM. Pyridoxine-responsive anemia. *Blood* 1961;18:285-302.
178. Schafer AI, Rabinow S, LeBoff MS, et al. Long-term efficacy of desferrioxamine iron chelation therapy in adults with acquired transfusional iron overload. *Arch Intern Med* 1985;145:1217-1221.
179. Porter JB. Practical management of iron overload. *Br J Haematol* 2001;115:239-252.
180. Porter JB. Concepts and goals in the management of transfusional iron overload. *Am J Hematol* 2007;82(Suppl):1136-1139.
181. Harris JW, Danish EH, Brittenham GM, et al. Pyridoxine responsive hereditary sideroblastic erythropoiesis and iron overload: two microcytic subpopulations in the affected male, one normocytic and one microcytic subpopulation in the obligate female carrier. *Am J Hematol* 1993;42:400-401.
182. Hines JD. Effect of pyridoxine plus chronic phlebotomy on the function and morphology of bone marrow and liver in pyridoxine-responsive anaemia. *Semin Hematol* 1976;13:133-140.

183. Vogler WR, Mingioli ES. Porphyrin synthesis and heme synthetase activity in pyridoxine-responsive anemia. *Blood* 1968;32:979-988.
184. Marcus RE, Huehns ER. Transfusional iron overload. *Clin Lab Hematol* 1985;7:195-212.
185. Olivieri NF, Brittenham GM. Iron-chelating therapy and the treatment of thalassemia. *Blood* 1997;89:739-761.
186. Nienhuis AW, Benz EJ, Propper R, et al. Thalassemia major: molecular and clinical aspects. *Ann Int Med* 1979;91:883-897.
187. Kushner JP, Porter JB, Olivieri NF. Secondary iron overload. *Hematology (Am Soc Hematol Educ Program)* 2001;47-61.
188. Miller KB, Rosenwasser LJ, Bessette JM, et al. Rapid desensitisation for desferrioxamine anaphylactic reaction. *Lancet* 1981;1:1059.
189. Cappellini MD, Cohen A, Piga A, et al. A phase 3 study of deferasirox (ICL670), a once-daily oral iron chelator, in patients with β -thalassemia. *Blood* 2006;107:3455-3462.
190. Robins-Browne R, Prpic J. Effects of iron and desferrioxamine on infections with *Yersinia enterocolitica*. *Infect Immunity* 1985;47:774-779.
191. Aleali SH, Castro O, Spencer RP, Finch SC. Sideroblastic anemia with splenic abscess and fatal thromboemboli after splenectomy. *Ann Intern Med* 1975; 83:661-663.
192. Byrne MT, Bergmann AK, Ruiz I, et al. Postsplenectomy thromboembolic disease. *BMJ Case Rep* 2010 Sep 17;2010. pii: bcr1220092514. doi: 10.1136/bcr.12.2009.2514.
193. Gonzalez MI, Caballero D, Vazquez L, et al. Allogeneic peripheral stem cell transplantation in a case of hereditary sideroblastic anaemia. *Br J Haematol* 2000;109:658-660.
194. Urban C, Binder B, Hauer C, et al. Congenital sideroblastic anemia successfully treated by allogeneic bone marrow transplantation. *Bone Marrow Transplant* 1992;10:373-375.
195. Ayas M, Al-Jefri A, Mustafa MM, et al. Congenital sideroblastic anaemia successfully treated using allogeneic stem cell transplantation. *Br J Haematol* 2001;113:938-939.
196. Medeiros BC, Kolhouse JF, Cagnoni PI, et al. Non-myeloablative allogeneic hematopoietic stem cell transplantation for congenital sideroblastic anemia. *Bone Marrow Transplant* 2003;31:1053-1055.
197. Meo A, Ruggeri A, LaRosa MA, et al. Iron burden and liver fibrosis decrease during a long-term phlebotomy program and iron chelating treatment after bone marrow transplantation. *Hemoglobin* 2006;30:131-137.
198. Urban CH, Deutschmann A, Kerbl R, et al. Organ tolerance following cadaveric liver transplantation for chronic graft-versus-host disease after allogeneic bone marrow transplantation. *Bone Marrow Transplant* 2002;30:535-537.
199. Raskind WH, Wijsman E, Pagon RA, et al. X-linked sideroblastic anemia and ataxia: linkage to phosphoglycerate kinase at Xq13. *Am J Hum Genet* 1991;48:335-341.
200. Savary S, Allikmets R, Denizot F, et al. Isolation and chromosomal mapping of a novel ATP-binding cassette transporter conserved in mouse and human. *Genomics* 1997;41:275-278.
201. Shimada Y, Okuno S, Kawai A, et al. Cloning and chromosomal mapping of a novel ABC transporter gene (hABC7), a candidate for X-linked sideroblastic anemia with cerebellar ataxia. *J Hum Genet* 1998;43:115-122.
202. Kispal G, Csere P, Prohl C, et al. The mitochondrial proteins Atmp and Nfs1p are required for biogenesis of cytosolic Fe/S proteins. *EMBO J* 1999;18: 3981-3989.
203. Bekri S, Kispal G, Lange H, et al. Human ABC7 transporter: gene structure and mutation causing X-linked sideroblastic anemia with ataxia with disruption of cytosolic iron-sulfur protein maturation. *Blood* 2000;96: 3256-3264.
204. Maguire A, Hellier K, Hammans S, et al. X-linked cerebellar ataxia and sideroblastic anaemia associated with a missense mutation in the ABC7 gene predicting V411L. *Br J Haematol* 2001;115:910-917.
205. D'Hooghe M, Selleslag D, Mortier G, et al. X-linked sideroblastic anemia and ataxia: a new family with identification of a fourth kABC7 gene mutation. *J Eur Paediatr Neurol* 2012;16:730-735.
206. Lill R. Function and biogenesis of iron-sulphur proteins. *Nature* 2009;460: 831-838.
207. Taketani S, Kakimoto K, Ueta H, et al. Involvement of ABC7 in the biosynthesis of heme in erythroid cells: interaction of ABC7 with ferrochelatase. *Blood* 2003;101:3274-3280.

208. Richardson DR, Huang ML, Whitnall M, et al. The ins and outs of mitochondrial iron-loading: the metabolic defect in Friedreich's ataxia. *J Mol Med (Berl)* 2010;88:323-329.
209. Hellier KD, Hatchwell E, Duncombe AS, et al. X-linked sideroblastic anaemia with ataxia: another mitochondrial disease? *J Neurol Neurosurg Psychiatry* 2001;70:65-69.
210. Zeharia A, Fischel-Ghodsian N, Casas K, et al. Mitochondrial myopathy, sideroblastic anemia and lactic acidosis: an autosomal recessive syndrome in Persian Jews caused by a mutation in the PUS1 gene. *J Child Neurol* 2005;20:449-452.
211. Fernandez-Vizarra E, Berardinelli A, Valente L, et al. Nonsense mutation in pseudouridylate synthase 1 (PUS1) in two brothers affected by myopathy, lactic acidosis and sideroblastic anemia (MLASA). *J Med Genet* 2007;44: 173-180.
212. Sasarman F, Nishimura T, Thiffault I, Shoubridge EA. A novel mutation in YARS2 causes myopathy with lactic acidosis and sideroblastic anemia. *Hum Mutat* 2012;33:1201-1206.
213. Patton JR, Bykhovskaya Y, Mengesha E, et al. Mitochondrial myopathy and sideroblastic anemia (MLASA). Missense mutation in the pseudouridine synthase 1 (PUS1) gene is associated with loss of tRNA pseudouridylation. *J Biol Chem* 2005;280:19823-19828.
- 213a. Wiseman DH, May A, Jolles S, et al. A novel syndrome of congenital sideroblastic anemia, B-cell immunodeficiency, periodic fevers, and developmental delay (SIFD). *Blood* 2013;122:112-123.
- P.661
214. Rotig A, Cormier V, Blanche S, et al. Pearson's marrow-pancreas syndrome. A multisystem mitochondrial disorder of infancy. *J Clin Invest* 1990;86:1601-1608.
215. Rotig A, Bourgeron T, Chretien D, et al. Spectrum of mitochondrial DNA rearrangements in the Pearson marrow pancreas syndrome. *Hum Mol Genet* 1995;4:1327-1330.
216. Smith OP, Hann IM, Woodward CE, et al. Pearson's marrow/pancreas syndrome: haematological features associated with deletion and duplication of mitochondrial DNA. *Br J Haematol* 1995;90:469-472.
217. Bader-Neunier B, Mielot F, Breton-Gorius J, et al. Hematologic involvement in mitochondrial cytopathies in childhood. A retrospective study of bone marrow smears. *Pediatr Res* 1999;46:158-162.
218. Simonz HJ, Barlocher K, Rotig A. Kearns-Sayre's syndrome developing in a boy who survived Pearson's syndrome caused by mitochondrial DNA deletion. *Doc Ophthalmol* 1992;82:73-79.
219. Bergmann AK, Sahai I, Falcone JF, et al. Thiamine-responsive megaloblastic anemia: identification of novel compound heterozygotes and mutation update. *J Pediatr* 2009;155:888-892.
220. Baron D, Asaraf YG, Cohen N, et al. Lack of plasma membrane targeting of a G172D mutant thiamine transporter derived from Rogers syndrome family. *Mol Med* 2002;8:462-494.
221. Subramanian VS, Marchant JS, Parker I, et al. Cell biology of the human thiamine transporter-1 (hTHTRD). *J Biol Chem* 2003;278:3976-3984.
222. Boros LG, Steinkamp MP, Fleming JC, et al. Defective RNA ribose synthesis in fibroblasts from patients with thiamine-responsive megaloblastic anemia. *Blood* 2003;102:3556-3561.
223. Abboud MR, Alexander D, Najjar SS. Diabetes mellitus, thiamine-dependent megaloblastic anemia, and sensorineural deafness associated with deficient alpha-ketoglutarate dehydrogenase deficiency. *J Pediatr* 1985; 107:537-541.
224. Neufeld EJ, Fleming JC, Tartaglioni E, et al. Thiamine-responsive megaloblastic anemia syndrome: a disorder of high-affinity thiamine transport. *Blood Cell Mol Dis* 2001;27:135-138.
225. Ricketts CJ, Minton JA, Samuel J, et al. Thiamine-responsive megaloblastic anemia syndrome: long-term follow-up and mutation analysis of seven families. *Acta Paediatr* 2006;95:99-104.
226. Brownlie A, Donovan A, Pratt SJ, et al. Positional cloning of the zebrafish sauternes gene: a model for congenital sideroblastic anaemia. *Nat Genet* 1998;20:244-250.
227. Nakajima O, Okano S, Harada H, et al. Transgenic rescue of erythroid 5-aminolevulinic acid synthase-deficient mice results in the formation of ring sideroblasts and siderocytes. *Genes Cells* 2006;11:685-700.

228. Pondarre C, Campagna DR, Antiochos B, et al. Abcb7, the gene responsible for X-linked sideroblastic anemia with ataxia, is essential for hematopoiesis. *Blood* 2007;109:3567-3569.
229. Gruneberg H. The anaemia of flexed-tail mice (*Mus musculus*). II. Siderocytes. *J Genet* 1942;44:246-271.
230. Chui DH, Sweeney GD, Patterson M, et al. Hemoglobin synthesis in siderocytes of flexed-tail mutant (f/f) fetal mice. *Blood* 1977;50:165-177.
231. Fleming MD, Campagna DR, Haslett JN, et al. A mutation in a mitochondrial transmembrane protein is responsible for the pleiotropic hematological and skeletal phenotype of flexed-tail (f/f) mice. *Genes Dev* 2001;15: 652-657.
232. Juneja SK, Imbert M, Sigaux F, et al. Prevalence and distribution of ringed sideroblasts in primary myelodysplastic syndromes. *J Clin Pathol* 1983;36:566-569.
233. Swerdlow SH, Campo E, Harris NL, et al. World Health Organization Classification of Tumours of Haematopoietic and Lymphoid Tissues, 4th ed.; IARC Press: Lyon, 2008.
234. Streeter RR, Pfsant CA, Reinhard E. Prognostic significance of thrombocytosis in idiopathic sideroblastic anemia. *Blood* 1977;50:427-432.
235. Gupta R, Abdalla SH, Bain BJ. Thrombocytosis with sideroblastic erythropoiesis: a mixed myeloproliferative myelodysplastic syndrome. *Leukemia Lymphoma* 1999;34:615-619.
236. Shaw GR. Ringed sideroblasts with thrombocytosis: an uncommon mixed myelodysplastic/myeloproliferative disease of older adults. *Br J Haematol* 2005;131:180-184.
237. Broseus J, Florensa L, Zipperer E, et al. Clinical features and course of refractory anemia with ring sideroblasts associated with marked thrombocytosis. *Haematologica* 2012;97:1036-1041.
238. Catovsky D, Shaw MT, Hoffbrand AV, et al. Sideroblastic anaemia and its association with leukaemia and myelomatosis: a report of five cases. *Br J Haematol* 1971;20:385-393.
239. Eastman PM, Schwartz R, Schrier SL. Distinctions between idiopathic ineffective erythropoiesis and diGuglielmo's disease: clinical and biochemical differences. *Blood* 1972;40:487-499.
240. Kushner JP, Lee GR, Wintrobe MM, et al. Idiopathic refractory sideroblastic anemia. Clinical and laboratory investigation of 17 patients and review of the literature. *Medicine* 1971;50:139-159.
241. Dacie JV, Smith MD, White JC, et al. Refractory normoblastic anaemia: a clinical and haematological study of seven cases. *Br J Haematol* 1959; 5:56-82.
242. Riedler GF, Straub PW. Abnormal iron incorporation, survival, protoporphyrin content and fluorescence of one red cell population in preleukemic sideroblastic anemia. *Blood* 1972;40:345-352.
243. Prchal JT, Throckmorton DW, Carroll AJ, et al. A common progenitor for human myeloid and lymphoid cells. *Nature* 1978;274:590-591.
244. Suzuki H, Asano H, Ohashi H, et al. Clonality analysis of refractory anemia with ring sideroblasts: simultaneous study of clonality and cytochemistry of bone marrow progenitors. *Leukemia* 1999;13:130-134.
245. Amenomori T, Tomonaga M, Jinnai I, et al. Cytogenetic and cytochemical studies on progenitor cells of primary acquired sideroblastic anemia (PASA): involvement of multipotent myeloid stem cells in PASA clone and mosaicism with normal clone. *Blood* 1987;70:1367-1372.
246. Lawrence HJ, Broudy VC, Magenis RE. Cytogenetic evidence for involvement of B lymphocytes in acquired idiopathic sideroblastic anemia. *Blood* 1987;70:1003-1005.
247. Germing U, Gattermann N, Aivado M, et al. Two types of acquired idiopathic sideroblastic anaemia (AISA): a time-tested distinction. *Br J Haematol* 2000;108:724-728.
248. Heim S, Mitelman F. Chromosome abnormalities in the myelodysplastic syndromes. *Clin Haematol* 1986;15:1003-1021.
249. Dewald GW, Brecher M, Travis LB, et al. Twenty-six patients with hematologic disorders and X chromosome abnormalities. Frequent idic(x) (q13) chromosomes and Xq13 anomalies associated with pathologic ringed sideroblasts. *Cancer Genet Cytogenet* 1989;42:173-185.

250. Dierlamm J, Michaux L, Criel A, et al. Isodicentric (X)(q13) in haematological malignancies: presentation of five new cases, application of fluorescence in situ hybridization (FISH) and review of the literature. *Br J Haematol* 1995;91:885-891.
251. Carroll AJ, Poon M-C, Robinson NC, et al. Sideroblastic anemia associated with thrombocytosis and a chromosome 3 abnormality. *Cancer Genet Cytogenet* 1986;22:183-187.
252. Fukuoka T, Kameoka H, Yasukawa M, et al. Translocation t(1;3) (p36;q21) in sideroblastic anaemia. *Acta Haematol (Basel)* 1989;82:146-149.
253. Kralovics R, Passamonti F, Buser AS, et al. A gain-in-function mutation of JAK2 in myeloproliferative disorders. *N Engl J Med* 2005;352:1779-1790.
254. Szpurka H, Tiu R, Murugesan G, et al. Refractory anemia with ringed sidero-blasts with marked thrombocytosis (RARS-T), another myeloproliferative condition characterized by JAK2 V617F mutation. *Blood* 2006;108: 2173-2181.
255. Gattermann N, Billiet J, Kronenwett R, et al. High frequency of the Jack2 V617F mutation in patients with thrombocytosis (platelet count $>600 \times 10^9/L$) and ringed sideroblasts more than 15% considered as MDS/MPD, unclassifiable. *Blood* 2007;109:1334-1335.
256. Schmitt-Graeff AH, Teo S-S, Olschweski M, et al. JAK2^{V617F} mutation status identifies subtypes of refractory anemia with ringed sideroblasts associated with marked thrombocytosis. *Haematologica* 2008;93:34-40.
257. Yoshida K, Sanada M, Shiraishi Y, et al. Frequent pathway mutations of splicing machinery in myelodysplasia. *Nature* 2011;478:64-69.
258. Papaemmanuil E, Cazzola M, Boultonwood J, et al. Somatic SF3B1 mutation in myelodysplasia with ring sideroblasts. *N Engl J Med* 2011;365:1384-1395.
259. Visconte V, Makishima H, Jankowska A, et al. SF3B1, a splicing factor is frequently mutated in refractory anemia with ring sideroblasts. *Leukemia* 2012;26:542-545.
260. Patnaik MM, Lasho TM, Hodnefield JM, et al. SF3B1 mutations are prevalent in myelodysplastic syndromes with ring sideroblasts but do not hold independent prognostic value. *Blood* 2012;119:569-572.
- 260a. Gattermann N. SF3B1 and the riddle of the ring sideroblast. *Blood* 2012;120:3167-3168.
- 260b. Malcovati L, Papaemmanuil E, Bowen DT, et al. Clinical significance of SF3B1 mutations in myelodysplastic syndromes and myelodysplastic/myeloproliferative neoplasms. *Blood* 2011;118:6239-6246.
261. Cazzola M, Barosi G, Gobbi PG, et al. Natural history of idiopathic refractory sideroblastic anemia. *Blood* 1988;71:305-312.
262. Raskind WH, Tirumali N, Jacobson R, et al. Evidence for a multistep pathogenesis of a myelodysplastic syndrome. *Blood* 1984;63:1318-1323.
263. Barton JC, Conrad ME, Parmley RT. Acute lymphoblastic leukemia in idiopathic refractory sideroblastic anemia. Evidence for a common lymphoid and myeloid progenitor cell. *Am J Hematol* 1980;9:109-115.
264. Hussein KK, Salem Z, Bottomley SS, et al. Acute leukemia in idiopathic sideroblastic anemia: response to combination chemotherapy. *Blood* 1982;59: 652-656.
265. Bottomley SS, Tanaka M, Self J. Δ -aminolevulinic acid synthetase activity in normal bone marrow and in patients with idiopathic sideroblastic anemia. *Enzyme* 1973;16:138-145.
266. Aoki Y, Urata G, Wada O, et al. Measurement of δ -aminolevulinic acid synthetase activity in human erythroblasts. *J Clin Invest* 1974;53:1326-1334.
267. Bottomley SS. Porphyrin and iron metabolism in sideroblastic anemia. *Semin Hematol* 1977;14:169-185.
268. Fitzsimons EJ, May A, Elder GH, et al. 5-Aminolaevulinic acid synthase activity in developing human erythroblasts. *Br J Haematol* 1988;69:281-285.
269. Mason DY, Emerson PM. Primary acquired sideroblastic anaemia: response to treatment with pyridoxal-5-phosphate. *BMJ* 1973;1:389-390.
270. Meier PJ, Fehr J, Meyer UA. Pyridoxine-responsive primary acquired sideroblastic anaemia. In vitro and in vivo effect of vitamin B6 on decreased 5-aminolaevulinic acid synthase activity. *Scand J Haematol* 1982;29:421-424.

271. Lim HW, Cooper D, Sassa S, et al. Photosensitivity, abnormal porphyrin profile, and sideroblastic anemia. *J Am Acad Dermatol* 1992;27:287-292.
272. Sarkany RPE, Ross G, Willis F. Acquired erythropoietic protoporphyria as a result of myelodysplasia causing loss of chromosome 18. *Br J Dermatol* 2006; 155:464-466.
273. Bottomley SS. Observations on free erythrocyte protoporphyrin in sideroachrestic anemia. *Clin Chim Acta* 1965;12:542-545.
274. Lee GR, Cartwright GE, Wintrobe MM. Response of free erythrocyte protoporphyrin to pyridoxine therapy in a patient with sideroachrestic (sideroblastic) anemia. *Blood* 1966;27:557-567.
275. Aoki Y. Multiple enzymatic defects in mitochondria in hematological cells of patients with primary sideroblastic anemia. *J Clin Invest* 1980;66:43-49.
276. Gattermann N. From sideroblastic anemia to the role of mitochondrial DNA mutations in myelodysplastic syndrome. *Leuk Res* 2000;24:141-151.
277. Wulfert M, Kupper AC, Tapprich C, et al. Analysis of mitochondrial DNA in 104 patients with myelodysplastic syndromes. *Exp. Hematol* 2008;36: 577-586.
278. Coulombel L, Tchernia G, Mielot F, et al. Hemoglobin content of individual erythroblasts in hematopoietic dysplasia. Marked heterogeneity at late stages of maturation. *Exp Hematol* 1984;12:587-593.
279. Boultonwood J, Pellagatti A, Nikpour M, et al. The role of the iron transporter ABCB7 in refractory anemia with ring sideroblasts. *PLoS ONE* 2008;3:e1970.
280. Nikpour M, Scharenberg C, Liu A, et al. The transporter ABCB7 is a mediator of the phenotype of acquired refractory anemia with ring sideroblasts. *Leukemia* 2013;27:889-896.
281. Tehranchi R, Invernizzi R, Grandien A, et al. Aberrant mitochondrial iron distribution and maturation arrest characterize early erythroid precursors in low-risk myelodysplastic syndromes. *Blood* 2005;106:247-253.
282. Huber C, Huber H, Stacher A, et al. Autoradiographic and cytophotometric studies on hematopoiesis in primary refractory and sideroachrestic anemia. *Blut* 1972;24:142-152.
283. Wickramasinghe SN, Hughes M. Capacity of ringed sideroblasts to synthesize nucleic acids and protein in patients with primary acquired sideroblastic anaemia. *Br J Haematol* 1978;38:345-352.
284. Jacobs A, Clark RE. Pathogenesis and clinical variations in the myelodysplastic syndromes. *Clin Haematol* 1986;15:925-951.
285. Higgs DR, Wood WG, Barton C, et al. Clinical features and molecular analysis of acquired hemoglobin H disease. *Am J Med* 1983;75:181-191.
286. Yoo D, Schechter GP, Amigable AN, et al. Myeloproliferative syndrome with sideroblastic anemia and acquired hemoglobin H disease. *Cancer* 1980;45:78-83.
287. Boehme WM, Piira TA, Kurnick JE, et al. Acquired hemoglobin H in refractory sideroblastic anemia. A preleukemic marker. *Arch Intern Med* 1978;138: 603-606.
288. Nearman ZP, Szpurka H, Serio B, et al. Hemochromatosis-associated gene mutations in patients with myelodysplastic syndromes with refractory anemia with ringed sideroblasts. *Am J Hematol* 2007;82:1076-1079.
289. Schafer AI, Cheron RG, Dluhy R, et al. Clinical consequences of acquired transfusional iron overload in adults. *N Engl J Med* 1981;304:319-324.
290. Stavem P, Rorvik TO, Rootwelt K, et al. Severe iron deficiency causing loss of ring sideroblasts. *Scand J Haematol* 1983;31:389-391.
291. Minuk LA, Hsia CC. Refractory anemia with ring sideroblasts masked by iron deficiency anemia. *Blood* 2011;117:5793.
292. Della Porta MG, Malcovati L, Invernizzi R, et al. Flow cytometry evaluation of erythroid dysplasia in patients with myelodysplastic syndrome. *Leukemia* 2006;20:549-555.
293. Mantovani L, Lentini G, Hentschel B, et al. Treatment of anaemia in myelodysplastic syndromes with prolonged administration of recombinant human granulocyte colony-stimulating factor and erythropoietin. *Br J Haematol* 2000;109:367-375.

294. Terpos E, Mougiou A, Kouraklis A, et al. Prolonged administration of erythropoietin increases erythroid response rate in myelodysplastic syndromes: a phase II trial in 281 patients. *Br J Haematol* 2002;118:174-180.
295. Jadersten M, Montgomery SM, Dybedal I, et al. Long-term outcome of treatment of anemia in MDS with erythropoietin and G-CSF. *Blood* 2005;106:803-811.
296. Wallvik J, Stenke L, Bernell P, et al. Serum erythropoietin (EPO) levels correlate with survival and independently predict response to EPO treatment in patients with myelodysplastic syndrome. *Eur J Haematol* 2002;68:180-186.
297. Raza A, Reeves JA, Feldman EJ, et al. Phase 2 study of lenalidomide in transfusion-dependent, low-risk, and intermediate-1-risk myelodysplastic syndromes with karyotypes other than deletion 5q. *Blood* 2008;111:86-93.
298. Kuendgen A, Knipp S, Fox F, et al. Results of a phase 2 study of valproic acid alone or in combination with all-trans retinoic acid in 75 patients with myelodysplastic syndrome and relapsed or refractory acute myeloid leukemia. *Ann Hematol* 2005;84:61-66.
299. Greenberg PL, Young NS, Gattermann N. Myelodysplastic syndromes. *Hematology Am Soc Hematol Educ Program*. 2002;2002:136-161.
300. Malcovati L. Impact of transfusion dependency and secondary iron overload on the survival of patients with myelodysplastic syndromes. *Leuk Res* 2007;31S3:S2-S6.
301. Leitch HA, Leger CS, Goodman TA, et al. Improved survival in patients with myelodysplastic syndrome receiving iron chelation therapy. *Clin Leuk* 2008;2:205-211.
302. Neukirchen J, Fox F, Kundgen A, et al. Improved survival in MDS patients receiving iron chelation therapy—A matched pair analysis of 188 patients from the Dusseldorf MDS registry. *Leuk Res* 2012;36:1067-1070.
303. French TJ, Jacobs P. Sideroblastic anaemia associated with iron overload treated by repeated phlebotomy. *S Afr Med J* 1976;50:594-596.
304. Jensen PD, Heickendorf L, Pedersen B, et al. The effect of iron chelation on haemopoiesis in MDS patients with transfusional iron overload. *Br J Haematol* 1996;94:288-299.
305. Del Rio Garma J, Fernandez Lago C, Batlle Fonrodona FJ. Desferrioxamine in the treatment of myelodysplastic syndromes. *Haematologica* 1997;82: 639-640.
306. Yunis JJ, Lobell M, Arnesen MA. Refined chromosome study helps define prognostic subgroups in most patients with primary myelodysplastic syndrome and acute myelogenous leukaemia. *Br J Haematol* 1988;68:189-194.
307. Kitahara M, Cosgriff TM, Eyre HJ. Sideroblastic anemia as a preleukemic event in patients treated for Hodgkin's disease. *Ann Intern Med* 1980;92: 625-627.
308. Khaleeli M, Keane WM, Lee GR. Sideroblastic anemia in multiple myeloma: a preleukemic change. *Blood* 1973;41:17-25.
309. Savage D, Lindenbaum J. Anemia in alcoholics. *Medicine* 1986;65:322-338.
310. Eichner ER, Hillman RS. The evolution of anemia in alcoholic patients. *Am J Med* 1971;50:218-232.
311. Pierce HI, McGuffin RG, Hillman RS. Clinical studies in alcoholic sideroblastosis. *Arch Intern Med* 1976;136:283-289.
312. Freedman ML, Cohen HS, Rosman J, et al. Ethanol inhibition of reticulocyte protein synthesis: the role of haem. *Br J Haematol* 1975;30:351-363.
313. Freedman MC, Rosman J. A rabbit reticulocyte model for the role of hemin-controlled repressor in hypochromic anemias. *J Clin Invest* 1976:594-603.
314. McColl KL, Thompson GG, Moore MR, et al. Acute ethanol ingestion and haem biosynthesis in healthy subjects. *Eur J Clin Invest* 1980;10:107-112.
315. Abdulla M, Svensson S. Effect of oral zinc intake on δ -aminolevulinic acid dehydratase in red blood cells. *Scand J Clin Lab Invest* 1979;39:31-36.
316. Frazer MB, Schachter BA. Increased bone marrow delta-aminolevulinic acid synthetase activity in acute reversible sideroblastic anemia of alcoholics. *Am J Hematol* 1980;8:149-156.
317. Lumeng L, Li T. Vitamin B₆ metabolism in chronic alcohol abuse. Pyridoxal phosphate levels in plasma and the effects of acetaldehyde on pyridoxal phosphate synthesis and degradation in human erythrocytes. *J Clin Invest* 1974;53:693-704.

318. Lumeng L. The role of acetaldehyde in mediating the deleterious effect of ethanol on pyridoxal-5-phosphate metabolism. *J Clin Invest* 1978;62:286-293.
319. Hines JD, Cowan DH. Studies on the pathogenesis of alcohol-induced sideroblastic bone marrow abnormalities. *N Engl J Med* 1970;283:441-446.
320. Meagher RC, Sieber F, Spivak JL. Suppression of hematopoietic-progenitorcell proliferation by ethanol and acetaldehyde. *N Engl J Med* 1982;307: 845-849.
321. Burke JP, Rubin E. The effects of ethanol and acetaldehyde on the products of protein synthesis by liver mitochondria. *Lab Invest* 1979;41:393-400.
322. Bottomley SS. Sideroblastic anaemia. In: Jacobs A, Worwood M, eds. *Iron in biochemistry and medicine II*. London: Academic Press, 1980:363-392.
323. Roberts PD, Hoffbrand AV, Mollin DL. Iron and folate metabolism in tuberculosis. *BMJ* 1966;2:198-202.
324. Haden HT. Pyridoxine-responsive sideroblastic anemia due to antituberculous drugs. *Arch Intern Med* 1967;120:602-606.
325. Standal BR, Kao-Chen SM, Yang G, et al. Early changes in pyridoxine status in patients receiving isoniazid therapy. *Am J Clin Nutr* 1974;27:479-484.
326. Scott JL, Finegold SM, Belkin GA, et al. A controlled double-blind study of the hematologic toxicity of chloramphenicol. *N Engl J Med* 1965;272:1137-1142.
327. Skinnider LF, Ghadially FN. Chloramphenicol-induced mitochondrial and ultrastructural changes in hemopoietic cells. *Arch Pathol Lab Med* 1976;100:601-605.
328. Martelo OJ, Manyan DR, Smith US, et al. Chloramphenicol and bone marrow mitochondria. *J Lab Clin Med* 1969;74:927-942.
329. Firkin FC. Mitochondrial lesions in reversible erythropoietic depression due to chloramphenicol. *J Clin Invest* 1972;51:2085-2092.
330. Manyan DR, Arimura GK, Yunis AA. Chloramphenicol-induced erythroid suppression and bone marrow ferrochelatase activity in dogs. *J Lab Clin Med* 1972;79:137-144.
331. Rosenberg A, Marcus O. Effect of chloramphenicol on reticulocyte δ -aminolaevulinic acid synthetase in rabbits. *Br J Haematol* 1974;26:79-83.
332. Yunis AA, Adamson JW. Differential in vitro sensitivity of marrow erythroid and granulocytic colony forming cells to chloramphenicol. *Am J Hematol* 1977;2:355-363.
333. Saini N, Jacobson JO, Iha S, et al. The perils of not digging deep enough—Uncovering a rare cause of acquired anemia. *Am J Hematol* 2012;87:413-416.
334. Kloss P, Xiong L, Shinabanger DL, et al. Resistance mutations in 23S tRNA identify the site of action of the protein synthesis inhibitor LZD in the ribosomal peptidyl transferase center. *J Mol Biol* 1999;294:93-101.
335. Williams DM. Copper deficiency in humans. *Semin Hematol* 1983;20: 118-128.
336. Hirase N, Abe Y, Sadamura S, et al. Anemia and neutropenia in a case of copper deficiency: role of copper in normal hematopoiesis. *Acta Haematol (Basel)* 1992;87:195-197.
337. Saitoh T, Matsushima T, Toyama K, et al. Copper deficiency pancytopenia with infectious complications after hemolytic anemia. *Ann Hematol* 2006;85:881-882.
338. Banno S, Niita K, Kikuchi M, et al. Anemia and neutropenia in elderly patients caused by copper deficiency for long-term enteral nutrition. *Jpn J Clin Hematol* 1994;35:1276-1281.
339. Nagano T, Toyoda T, Tanabe H, et al. Clin features of hematological disorders caused by copper deficiency during long term enteral nutrition. *Int Med* 2005;44:554-559.
340. Halfdanarson TR, Kumar N, Hogan WJ, Murray AJ. Copper deficiency in celiac disease. *J Clin Gastroenterol* 2009;43:162-164.
341. Kumar N. Copper deficiency myelopathy (Human swayback). *Mayo Clin Proc* 2006;81:1371-1384.

342. Choi EH, Strum W. Hypocupremia-related myeloneuropathy following gastrojejunal bypass surgery. *Ann Nutr Metab* 2010;57:190-192.
343. Perry AR, Pagliuca A, Fitzsimons EJ, et al. Acquired sideroblastic anaemia induced by a copper-chelating agent. *Int J Hematol* 1996;64:69-72.
344. Fiske DN, McCoy HE III, Kitchens CS. Zinc-induced sideroblastic anemia: report of a case, review of the literature, and description of the hematologic syndrome. *Am J Hematol* 1994;46:147-150.
345. Nations SP, Boyer PJ, Love LA. Denture cream: an unusual source of excess zinc, leading to hypocupremia and neurologic disease. *Neurology* 2008;71:639-643.
346. Hedera P, Peltier A, Fink JK, et al. Myeloneuropathy and pancytopenia due to copper deficiency and high zinc levels of unknown origin. II. The denture cream is a primary source of excessive zinc. *Neurotoxicol* 2009;30: 996-999.
347. Broun ER, Greist A, Tricot G, et al. Excessive zinc ingestion. A reversible cause of sideroblastic anemia and bone marrow depression. *JAMA* 1990;264: 1441-1443.
348. Bennett DR, Baird CJ, Chan K-M, et al. Zinc toxicity following massive coin ingestion. *Am J Forensic Med Pathol* 1997;18:148-153.
349. Hassan HA, Netchvolodoff C, Raufman JP. Zinc-induced copper deficiency in a coin swallower. *Am J Gastroenterol* 2000;95:2975-2977.
350. Kumar A, Jazieh AR. Case report of sideroblastic anemia caused by ingestion of coins. *Am J Hematol* 2001;66:126-129.
351. Pawa S, Khalifa AJ, Ehrinpreis MN, et al. Zinc toxicity from massive and prolonged coin ingestion in an adult. *Am J Med Sci* 2008;336:430-433.
352. Schleper B, Stuerenburg HJ. Copper deficiency-associated myelopathy in a 46-year old woman. *J Neurol* 2001;248:705-706.
353. Prodan CI, Holland NR, Wisdom PJ, et al. CNS demyelination associated with copper deficiency and hyperzincemia. *Neurology* 2002;59:1453-1456.
354. Gregg XT, Reddy V, Prchal JT. Copper deficiency masquerading as myelodysplastic syndrome. *Blood* 2002;100:1493-1495.
355. Prodan CI, Holand NR, Wisdom PJ, et al. Myelopathy due to copper deficiency. *Neurology* 2004;62:1655-1656.
356. Lee GR, Nacht S, Lukens JN, et al. Iron metabolism in copper-deficient swine. *J Clin Invest* 1968;47:2058-2069.
357. Lee GR, Cartwright GE, Wintrobe MM. Heme biosynthesis in copper deficient swine. *Proc Soc Exp Biol Med* 1968;127:977-981.
358. Williams DM, Loukopoulos D, Lee GR, et al. Role of copper in mitochondrial iron metabolism. *Blood* 1976;48:77-85.
359. Cousins RJ. Absorption, transport, and hepatic metabolism of copper and zinc: special reference to metallothionein and ceruloplasmin. *Physiol Rev* 1985;65:238-309.
360. Day FA, Panemangalore M, Brady FO. In vivo and ex vivo effects of copper on rat liver metallothionein. *Proc Soc Exp Med* 1981;168:306-310.
361. Brewer GJ, Gretchen MH, Prasad AS, et al. Oral zinc therapy for Wilson's disease. *Ann Intern Med* 1983;99:314-320.
362. Kumar N, Elliott MA, Hoyer JD, et al. "Myelodysplasia," myeloneuropathy, and copper deficiency. *Mayo Clin Proc* 2005;80:943-946.
363. Weihl CC, Lopate G. Motor neuron disease associated with copper deficiency. *Muscle Nerve* 2006;34:789-793.
364. Porter KG, McMaster D, Elmes ME, et al. Anemia and low serum-copper during zinc therapy. *Lancet* 1977;2:774.
365. Frambach DA, Bendel RE. Zinc supplementation and anemia. *JAMA* 1991;265:869.
366. Prodan CI, Bottomley SS, Holland NR, Lind SE. Relapsing hypocupraemic myelopathy requiring high-dose oral copper replacement. *J Neurol Neurosurg Psychiatry* 2006;77:1092-1093.
367. Pfanner N, Hartl F-U, Neupert W. Import of proteins into mitochondria: a multi-step process. *Eur J Biochem* 1988;175:205-212.

368. Morrell H, Savoie JC, London IM. The biosynthesis of heme and incorporation of glycine into globin in rabbit bone marrow in vitro. *J Biol Chem* 1958;233:923-929.
369. Jandl JH, Inman JK, Simmons RL, et al. Transfer of iron from serum iron binding protein to human reticulocytes. *J Clin Invest* 1959;38:161-185.
370. Cullen MR, Robins JM, Eskenazi B. Adult inorganic lead intoxication: presentation of 31 new cases and a review of recent advances in the literature. *Medicine* 1983;62:221-247.
371. Rempel D. The lead-exposed worker. *JAMA* 1989;262:532-534.
372. Doss M, Baumann H, Lorrek M, et al. Lead poisoning as a toxogenetic disease. *Klin Wochenschr* 1984;62:430-431.
373. Wetmur JG, Kaya AH, Plewinska M, et al. Molecular characterization of the human δ -aminolevulinatase 2 (ALAD²) allele: implications for molecular screening of individuals for genetic susceptibility to lead poisoning. *Am J Hum Genet* 1991;49:757-763.
374. Pagliuca A, Mufti GJ. Lead poisoning: an age old problem. *BMJ* 1990;300:830.
375. Sassa S. Toxic effects of lead, with particular reference to porphyrin and heme metabolism. In: DeMatteis F, Aldridge WN, eds. *Heme and hemoproteins*. New York: Springer, 1978:333-371.
376. Moore MR, Meredith PA, Goldberg A. Lead and heme biosynthesis. In: Singhal RL, Thomas JA, eds. *Lead toxicity*. Baltimore, MD: Urban & Schwarzenberg, 1980:80-117.
377. Labbe RF, Vreman HJ, Stevenson DK. Zinc protoporphyrin: a metabolite with a mission. *Clin Chem* 1999;45:2060-2072.
378. Schwartz S, Stephenson B, Sarkar D, et al. Quantitative assay of erythrocyte "free" and zinc protoporphyrin: clinical and genetic studies. *Int J Biochem* 1980;12:1053-1057.
379. Rossi E, Costin KA, Garcia-Webb P. Effect of occupational lead exposure on lymphocyte enzymes involved in heme biosynthesis. *Clin Chem* 1990;36:1980-1983.
380. Piddington SK, White JM. The effect of lead on total globin and α - and β -chain synthesis; in vitro and in vivo. *Br J Haematol* 1974;27:415-427.
381. Leikin S, Eng G. Erythrokinetic studies of the anemia of lead poisoning. *Pediatrics* 1963;31:996-1002.
382. White JM, Selhi HS. Lead and the red cell. *Br J Haematol* 1975;30:133-138.
383. Lachant NA, Tomoda A, Tanaka KR. Inhibition of the pentose phosphate shunt by lead: a potential mechanism for hemolysis in lead poisoning. *Blood* 1984;63:518-524.
384. Dagg JH, Goldberg A, Lochhead A, et al. The relationship of lead poisoning to acute intermittent porphyria. *Q J Med* 1965;34:163-175.
385. Schwartz J, Landrigan PJ, Baker EL, et al. Lead-induced anemia: dose-response relationships and evidence for a threshold. *Am J Public Health* 1990; 80:165-168.
386. Clark M, Royal J, Seeler R. Interaction of iron deficiency and lead and the hematologic findings in children with severe lead poisoning. *Pediatrics* 1988; 81:247-254.
387. Griggs RC. Lead poisoning: hematologic aspects. *Progr Hematol* 1964;4: 117-137.
388. Charache S, Weatherall DJ. Fast hemoglobin in lead poisoning. *Blood* 1966; 28:377-386.
389. Berk PD, Tschudy DP, Shepley LA, et al. Hematologic and biochemical studies in a case of lead poisoning. *Am J Med* 1970;48:137-144.
390. Klaassen CD. Heavy metals and heavy-metal antagonists. In: Hardman JG, Limbird LE, eds. *Goodman & Gilman's the pharmacological basis of therapeutics*, 10th ed. New York: McGraw-Hill, 2001:1851-1875.
391. Lolocono NJ, Moulton T, Mitchell ME, et al. Controlled study of meso-2,3-dimercaptosuccinic acid for the management of childhood lead intoxication. *J Pediatr* 1992;120:133-139.
392. Fritsch C, Bolsen K, Ruzicka T, et al. Congenital erythropoietic porphyria. *J Am Acad Dermatol* 1997;36:594-610.
393. de Verneuil H, Ged C, Moreau-Gaudry F. Congenital erythropoietic porphyria. In: Kadish KM, Smith KM, Guillard R, eds. *The porphyrin handbook*, vol. 14—medical aspects of porphyrins. Amsterdam: Academic Press, 2003:43-65.

394. Elder GH. Porphyria cutanea tarda and related disorders. In: Kadish KM, Smith KM, Guillard R, eds. The porphyrin handbook, vol 14—medical aspects of porphyrins. Amsterdam: Academic Press, 2003:67-92.
395. Cantatore-Francis JL, Cohen-Pfeffer J, Balwani M, et al. Hepatoerythropoietic porphyria misdiagnosed as child abuse. *Arch Dermatol* 2010;146:529-533.
396. Nordmann Y, Grandchamp B, de Verneuil H, et al. Harderoporphyria: a variant hereditary coproporphyria. *J Clin Invest* 1983;72:1139-1149.
397. Schmitt C, Gouya L, Malonova E, et al. Mutations in human CPO gene predict clinical expression of either hepatic hereditary coproporphyria or erythropoietic harderoporphyria. *Hum Mol Genet* 2005;14:3089-3098.
398. Hasanoglu A, Balwani M, Kasapakra CS, et al. Harderoporphyria due to homozygosity for coproporphyrinogen oxidase missense mutation H327R. *J Inher Metab Dis* 2011;34:255-231.

Chapter 25 Hemochromatosis

> Table of Contents > Part IV - Disorders of Red Cells > Section 2 - Disorders of Iron Metabolism and Heme Synthesis > Chapter 25 - Hemochromatosis

Chapter 25

Hemochromatosis

Corwin Q. Edwards

James C. Barton

IRON OVERLOAD

Iron overload can result from any process that causes iron accumulation in excess of iron loss. Examples of such processes include (a) erythrocyte transfusions in individuals who do not experience blood loss (e.g., patients with hemolytic anemia, aplastic anemia, and sideroblastic anemia); (b) absorption of excessive amounts of normal dietary iron (hemochromatosis types 1 through 4, disorders of ineffective erythropoiesis); and (c) absorption of increased amounts of excessive dietary iron (e.g., high-dose medicinal iron and African iron overload).

Definition

The definition of iron overload typically includes a description of an individual's iron phenotype, such as (a) an elevated serum ferritin concentration; (b) excessive iron in the liver or myocardium (estimated histologically or by chemical methods); and (c) the requirement of a greater than normal number of phlebotomies to induce iron-limited erythropoiesis.

HEMOCHROMATOSIS

Hemochromatosis Type 1, HFE Hemochromatosis

The definition of “classical,” autosomal recessive hemochromatosis (type 1) typical of Western European whites once required demonstration of the rare triad of cutaneous hyperpigmentation (“bronzing”), diabetes mellitus, and cirrhosis that was presumed to represent complications of severe iron overload. The eventual ability to measure iron in liver and other tissues, serum, and by phlebotomy to achieve iron depletion revealed that hemochromatosis was more common than previously believed and that the diagnosis could be defined by severity of iron overload. In 1996, it was discovered that most patients with this type of hemochromatosis were homozygous for a common missense mutation (C282Y) of the HFE gene on chromosome 6p21.3. Thus, most current definitions of hemochromatosis in Western European whites include specification of the iron phenotype and HFE genotype. Three important relationships of phenotype and genotype definitions are: (a) HFE C282Y homozygosity is a genetic configuration that markedly increases the risk that iron overload will eventually develop without other readily demonstrable cause; (b) iron phenotypes and organ-specific complications of HFE C282Y homozygotes vary greatly due to genetic and environmental factors; and (c) iron overload, not HFE C282Y homozygosity or abnormal HFE protein, causes tissue injury in target organs.

Hemochromatosis Type 2, Juvenile Hemochromatosis

Hemochromatosis type 2 is characterized by nontransfusion iron overload, often severe, that typically occurs in children or young adults.

Type 2a, Mutations of Hemojuvelin Gene (HJV)

Hemochromatosis type 2a is an autosomal recessive disorder due to pathogenic mutations in the hemojuvelin gene (HJV; chromosome 1q21).^{1, 2} The iron overload phenotype of patients with HJV hemochromatosis is much more severe at the same age than the phenotype of typical patients with hemochromatosis due to HFE C282Y homozygosity and the penetrance of hemochromatosis type 2a genotypes (risk to cause iron overload) is also greater. Hemochromatosis type 2a often causes abdominal pain and hepatomegaly in children, hypogonadotrophic hypogonadism in teenagers, arthropathy, and severe heart failure, cardiac arrhythmias, and cirrhosis before the age of 30 years.³ Based on the volume of blood removed to achieve iron depletion in some patients, it can be deduced that they absorbed 3.2 to 3.9 mg of dietary iron per day.⁴ In severe HFE hemochromatosis, 2 mg of iron or less is absorbed daily.^{5, 6}

Two pathogenic HJV mutations (either homozygous or compound heterozygous configuration) occur in each patient. The most common HJV mutation causes a change in nucleotide 959G→T, which codes for substitution of the normal glycine by valine in position 320 of the polypeptide sequence of the HJV protein (HJV G320V). This mutation has been detected in patients with juvenile-onset hemochromatosis of diverse European ethnicities.^{7, 8} About 30 pathogenic HJV mutations have been reported. Many are novel (not detected in unrelated patients with hemochromatosis type 2a.)^{7, 8, 9, 10, 11} Some HJV hemochromatosis patients also have an abnormal HFE genotype but the latter does not account for iron overload in most cases.¹²

Hemojuvelin is involved in the up-regulation of hepcidin synthesis, not in the regulation of HFE function. Decreased hemojuvelin activity decreases hepcidin synthesis, thus decreasing hepcidin binding and inactivation of ferroportin. Consequently, regulation of iron transport out of absorptive enterocytes into the plasma via ferroportin is decreased, even in the presence of increased storage iron.

Type 2b, Mutations of Hepcidin Gene (HAMP)

Hemochromatosis type 2b is associated with iron overload of variable severity and age of onset and is also transmitted as an autosomal recessive trait.^{12, 13} This disorder is rare. Hemochromatosis type 2b is due to mutations in the hepcidin gene (HAMP, chromosome 19q13). HAMP is an acronym for hepcidin antimicrobial peptide. The word hepcidin is derived from hepatic bactericidal protein.

The first reported HAMP mutation (nucleotide 208T→C) causes substitution of the normal cysteine by arginine at amino acid 70 (C70R).¹⁴ Approximately 12 other HAMP mutations have been reported.^{15, 16, 17, 18} Mutant hepcidin has decreased ability to bind to ferroportin, its only receptor. Consequently, ferroportin is not degraded and thus continues to transport iron across the basolateral membrane of absorptive enterocytes in the presence of excess iron stores.¹⁹ Some hemochromatosis type 2b patients, usually those heterozygous for pathogenic HAMP promoter or coding region mutations, also have HFE mutations that contribute to the pathogenesis of iron overload ("digenic" hemochromatosis).

Hemochromatosis Type 3, Mutations of Transferrin Receptor-2 Gene (TFR2)

Hemochromatosis type 3 is a rare autosomal recessive disorder reported in persons of European or Asian ancestry caused by mutations of the transferrin receptor-2 gene (TFR2) located on chromosome 7q22.²⁰ The clinical phenotype is moderately variable and resembles either that of HFE hemochromatosis or that of juvenile hemochromatosis types 2a and 2b. Fewer than 20 pathogenic TFR2

P.663

mutations have been reported.^{20, 21, 22, 23, 24} The penetrance of hemochromatosis type 3 genotypes is relatively great. Consanguinity has been identified in some affected families. TFR2 Y250X and R455Q have been detected in individuals or kindreds who were not closely related.²⁰ Pathogenic TFR2 mutations either result in gain-of-function or in decreased quantities of functional transferrin receptor-2. TFR2 protein is thought to modulate the signaling pathway that controls hepcidin expression²⁵ with consequent low hepcidin²⁶ and increased iron absorption and deposition in hepatocytes.

Hemochromatosis Type 4, Mutations of Ferroportin Gene (SLC40A1)

Hemochromatosis type 4 is an uncommon heterogeneous disorder transmitted as an autosomal dominant trait. It is caused by mutations of a gene of the solute carrier family 40 (member #1) (SLC40A1, chromosome 2q32), which encodes the synthesis of ferroportin, the sole receptor of hepcidin.^{27, 28, 29, 30} There are two distinct ferroportin hemochromatosis phenotypes. Loss-of-function SLC40A1 mutations encode ferroportin that either is not presented normally to the cell surface or has defective iron transport activity. Such mutations decrease iron absorption from the intestine and inhibit iron egress from macrophages. Phenotypes of affected patients include normal or low transferrin saturation, mild anemia, and predominance of iron retention in macrophages. Gain-of-function mutations encode ferroportin that cannot bind hepcidin normally or be internalized after hepcidin binding (hepcidin resistance). This increases iron absorption and

stimulates iron export by macrophages. Affected patients have elevated transferrin saturation and iron deposition in hepatocytes.

Ferroportin mutations are cosmopolitan. Most reported mutations are restricted to single families. SLC40A1 V162del has been reported in persons with iron overload from Australia, Europe, and Asia. SLC40A1 A77D has been reported in persons with iron overload in Italy, Australia, and India. SLC40A1 Q248H occurs as a polymorphism in natives who reside in diverse areas of sub-Saharan Africa and in African Americans, but probably does not cause iron overload.³¹

HISTORY

Hemochromatosis Type 1, Classical, Hereditary

The first report of a person with hemochromatosis was included in a discussion of diabetes mellitus in 1865.³² The patient was a 28-year-old Parisian man who sold newspapers and who died of a febrile illness that complicated his diabetes. His autopsy revealed hepatomegaly and hypertrophic cirrhosis. The second case of hemochromatosis was reported in 1871 and described a 51-year-old man who lived in Paris.³³ He had skin bronzing of his face and hands. His autopsy revealed a chocolate-colored, enlarged liver. Microscopic examination of his liver showed pigment granules inside and outside of hepatocytes. In 1886, the term pigmentation cirrhosis was used to describe the triad of skin bronzing, diabetes mellitus, and hepatic cirrhosis.³⁴ The name hämochromatose was first used by von Recklinghausen in his 1889 description of 12 individuals who had pigmentation of multiple organs.³⁵ He believed that the iron that accumulated in organs came from red blood cells.

ETIOLOGY

Cloning of the HFE Gene

In 1996, the hemochromatosis gene was isolated by positional cloning and two common mutations that account for most cases of hemochromatosis in persons of Western European descent were discovered.³⁶ The gene was named HFE (H = hemochromatosis; Fe = iron).^{37, 38} The cloning of HFE was reported more than 130 years after the first case description of hemochromatosis at autopsy and confirmed reports during an interval of more than two decades that hemochromatosis was transmitted as an autosomal recessive condition linked to the HLA locus on the short arm of chromosome 6.^{39, 40, 41, 42, 43, 44, 45, 46, 47}

Function of the HFE Gene

The normal HFE gene encodes normal HFE protein which is expressed in duodenal crypt cells and reticuloendothelial cells.⁴⁸ In a normal individual, HFE protein binds to β_2 -microglobulin, which decreases the affinity of cell membrane transferrin receptors for transferrin.^{49, 50, 51, 52} This decreases iron absorption. In iron deficiency, HFE protein synthesis is decreased, binding of HFE protein to β_2 -microglobulin is decreased, the affinity of the transferrin receptor for transferrin is increased, and thus duodenal crypt cells absorb more iron.

Effects of HFE Gene Mutations

The HFE protein binding site for the β_2 -microglobulin binding site has two cysteine molecules that form a disulfide bridge. In HFE C282Y homozygotes, tyrosine replaces a cysteine molecule at amino acid position 282 in the product of both HFE gene copies (maternal and paternal) and thus the disulfide bridge is absent. This prevents binding of the abnormal HFE protein to β_2 -microglobulin on the cell surface. Excessive iron is then absorbed through the crypt cells and passed into the circulation.^{53, 54, 55, 56, 57, 58} Despite these observations, the full function and participation of the HFE protein in iron absorption has not been elucidated. Studies of penetrance of hemochromatosis demonstrate that HFE C282Y homozygosity is necessary but probably not sufficient for iron overload to develop.

PATHOPHYSIOLOGY

Normal adults absorb an amount of iron each day that precisely balances daily losses (men ~1 mg, women 1 to 3 mg). In healthy children and infants, daily iron absorption corresponds to the iron requirements of growth and development. In acute blood loss or iron deficiency, daily iron absorption increases until the total body deficit has been replaced. In persons with hemochromatosis, the absorption of dietary iron is inappropriately great in comparison with quantities of total body iron. In some persons with HFE hemochromatosis and iron overload, daily iron absorption may exceed 2 mg at a time when iron absorption should have decreased to nearly zero.^{59, 60} In some children with juvenile hemochromatosis, average daily iron absorption may exceed 3 mg/day. Phlebotomy therapy to achieve iron depletion in hemochromatosis may increase iron absorption to 10 mg/day and iron absorption may remain inappropriately elevated long after iron deficiency resolves.^{61, 62, 63} Iron loading in hemochromatosis types 1 to 4 is caused either by an abnormality in hepcidin

synthesis or a decrease of its activity via decreased function of ferroportin. HFE, HJV, and TFR2 probably all have a contributory role in regulating hepcidin synthesis.

Effects of Hepcidin

Hepcidin, the central regulator of iron absorption, is a low-molecular-weight thionin-like, defensin-like peptide with many cysteine pairs encoded by the HAMP gene. Hepcidin has antimicrobial activity against bacteria and fungi, is present in plasma, and is excreted in urine. Hepcidin is synthesized in hepatocytes in response to anemia, hypoxia, and inflammatory stimuli mediated by interleukin 6,^{64, 65, 66, 67, 68, 69, 70, 71} and in the presence of adequate or increased amounts of iron.^{72, 73, 74, 75} It is also involved in the abnormalities of iron metabolism that occur in the anemia of chronic disease.^{76, 77, 78, 79} Hepcidin levels are inversely related to iron absorption.

P.664

Ferroportin, the sole receptor for hepcidin, occurs as a multimer on the surfaces of cells responsible for gathering and recycling iron: enterocytes (basolateral surfaces), macrophages, hepatocytes, and placental syncytiotrophoblasts. The binding of cell surface ferroportin by hepcidin results in ferroportin tyrosine phosphorylation at the plasma membrane, dephosphorylation, and degradation by ubiquitination.^{19, 69, 80} Thus, hepcidin participates in regulation of plasma iron levels and tissue distribution of iron by post-translational regulation of ferroportin.

Hepcidin Effect in Iron Deficiency

In iron deficiency, hepcidin production is down-regulated so the amount of hepcidin available to bind ferroportin is reduced. More iron is exported from absorptive enterocytes by ferroportin than usual, resulting in increased absorption of iron through duodenal enterocytes into the plasma.⁸¹

Hepcidin Effect in Iron Repletion

In normally iron-replete humans, the production of hepcidin is up-regulated. The hepcidin binds with ferroportin inducing ferroportin internalization and degradation.^{19, 69, 80} Consequently, the amount of ferroportin is reduced and iron absorption from duodenal enterocytes into plasma decreases.

Hepcidin Effect in Hemochromatosis

Dysregulation of hepcidin production underlies the pathophysiology of most types of hemochromatosis (types 1, 2a, 2b, and 3). In iron-loaded individuals with HFE hemochromatosis, for example, hepcidin expression by the liver is inappropriately low^{82, 83} and thus iron absorption continues despite increased iron stores. Hepcidin levels are decreased in all types of hemochromatosis except in patients with "classical" ferroportin hemochromatosis (type 4). In those patients, iron overload is caused by a mutation in the ferroportin gene (SLC40A1) that results in diminished or absent functional quantities of ferroportin.⁸¹ In such cases, hepcidin production and regulation are normal.

Molecular Basis of Increased Iron Absorption in Hemochromatosis

Several factors in the duodenum contribute to inappropriately high iron absorption in HFE hemochromatosis. In enterocytes, DMT1 (divalent metal transporter-1) transports iron across the apical microvillous membrane into the cell in the presence of hydrogen ions derived from gastric acid and ferroportin transports iron across the basolateral membrane into the plasma. Untreated C282Y homozygotes have inappropriate up-regulation of DMT1 and ferroportin mRNA expression in proportion to their serum ferritin level.⁸⁴ Absorption of heme iron is also increased in proportion to serum ferritin levels.^{5, 60} The interaction of transferrin, transferrin receptor, and HFE protein at the basolateral membranes of duodenal absorption cells may play a minor role in regulating iron absorption in persons with HFE hemochromatosis.⁸⁵ SLC40A1 mutations that encode ferroportin that either is not presented normally to the cell surface or has defective iron export activity are associated with loss-of-function, normal or low transferrin saturation, and predominance of iron retention in macrophages. Such mutations decrease iron absorption from the intestine and inhibit iron export from macrophages.

The complicated interactions of HFE, DMT1, transferrin, transferrin receptors, hemojuvelin, hepcidin, and ferroportin in regulating iron absorption in normal individuals and in persons with hemochromatosis are a topic of intense and productive research.^{75, 80, 86, 87, 88, 89, 90}

ORGAN AND CELLULAR INJURY DUE TO IRON OVERLOAD

After many years of increased iron absorption, hepatocyte and Kupffer cell iron storage sites become overloaded and iron accumulates progressively in the myocardium, pancreas, anterior pituitary, spleen, and other organs. Cardiac myocytes, beta-cells of the pancreatic islets, and gonadotroph cells of the anterior pituitary have especially great affinity for otherwise unbound iron. Some individuals with severe iron overload due to hemochromatosis have body iron burdens that are more than 10 times normal. Usually, such individuals do not develop symptoms or signs of illness until after they have had iron overload for three to five decades. Exceptions include the organ damage and death that can occur before the age of 30 years in persons with severe iron overload due to juvenile hemochromatosis.

Iron that is bound to transferrin or stored in modest amounts in ferritin is not toxic. In the presence of excessive iron stores, non-transferrin-bound or non-ferritin iron occurs and generates reactive oxygen species (oxyradicals), especially the hydroxyl radical.^{91, 92, 93, 94, 95, 96, 97} It is likely that hydroxyl, alkoxyl, and peroxy radicals are involved in lipid peroxidation which damages microsomes, mitochondria, and lysosomes. Hydroxyl radicals are also thought to be involved in iron-related damage of enzymes, proteins, nucleic acids, and polysaccharides. Lipid peroxidation then results in disruption of membrane-dependent functions of lysosomes, mitochondria, endoplasmic reticulum, cell membranes, and DNA.^{91, 94} Excess iron and iron-induced oxyradicals may also activate stellate cell transformation to fibroblasts in the liver and act as carcinogens in hepatocytes or extrahepatic parenchymal cells.

DIFFERENTIAL DIAGNOSIS OF IRON OVERLOAD

Many heritable or acquired disorders are associated with increased body iron stores. Some of these disorders appear in Table 25.1,^{1, 12, 13, 20, 21, 22, 23, 24, 26, 27, 36, 72, 73, 74, 98, 99, 100, 101, 102, 103, 104, 105, 106, 107, 108, 109, 110, 111, 112, 113, 114, 115, 116, 117, 118, 119, 120, 121, 122, 123, 124, 125, 126, 127, 128, 129, 130, 131, 132, 133, 134, 135, 136, 137, 138, 139, 140, 141, 142, 143, 144, 145, 146, 147, 148, 149, 150, 151, 152, 153, 154, 155, 156, 157, 158, 159, 160, 161, 162, 163, 164, 165, 166, 167, 168, 169, 170, 171, 172, 173, 174, 175, 176, 177, 178, 179, 180, 181, 182, 183, 184, 185, 186, 187, 188, 189, 190, 191, 192, 193, 194, 195, 196, 197, 198, 199, 200,} including gene location, mode of heritability, and gene mutation responsible for the disorder. Table 25.1 provides guidance for physicians who are evaluating and managing patients with iron overload.

HFE HEMOCHROMATOSIS GENE

HFE Location

The HFE gene is located approximately 4 megabases telomeric to the HLA region on the short arm of chromosome 6(6p). HFE is structurally similar to other HLA class I-like genes. HFE is composed of seven exons, of which the first six encode for the six domains of the HFE protein. The seven exons of HFE result in formation of a messenger RNA transcript of 4.2 kilobases. This in turn results in the synthesis of the HFE product, a protein of 343 amino acids. The most common mutation of HFE (C282Y) associated with iron overload is caused by a mutation of one nucleotide base 845G→A in exon 4 of the HFE gene.³⁶

HFE Mutations

More than 60 mutations of the HFE gene have been reported.^{15, 36, 201, 202, 203, 204, 205, 206, 207, 208, 209, 210, 211, 212, 213, 214, 215, 216, 217, 218, 219, 220, 221, 222, 223, 224, 225, 226, 227, 228, 229, 230, 231, 232, 233, 234, 235, 236, 237, 238, 239} The most common mutation that occurs in people who have hemochromatosis is a change in nucleotide 845 from the normal guanidine to adenine in exon 4 of the HFE gene (referred to as 845G→A). This nucleotide change results in the substitution of tyrosine in place of the normal cysteine in amino acid position 282, referred to as Cysteine282Tyrosine, Cys282Tyr, or C282Y. This mutation causes the majority of iron accumulation in subjects who have hemochromatosis.³⁶

P.665

TABLE 25.1 HERITABLE AND ACQUIRED DISORDERS ASSOCIATED WITH IRON OVERLOAD: DIFFERENTIAL DIAGNOSIS

Heritable Disorder	Chromosomal Assignment	Heritability	Cause of Iron Loading	References
<i>HFE</i> Hemochromatosis	6p21.3	Autosomal recessive	Mutations of <i>HFE</i>	36

Juvenile Hemochromatosis

<i>HJV</i> Hemochromatosis	1q21	Autosomal recessive	Mutations of hemojuvelin	1, 12, 98, 99, 100, 101
<i>HAMP</i> Hemochromatosis	19q13	Autosomal recessive	Hepcidin antimicrobial peptide gene mutations	13, 72, 73, 74
<i>TFR2</i> Hemochromatosis	7q22	Autosomal recessive	Inactivation of transferrin receptor 2	20, 21, 22, 23, 24, 26, 102
<i>SLC40A1</i> Hemochromatosis	2q32	Autosomal dominant	Ferroportin gene mutations	27, 101, 103, 104, 105, 106, 107
H-Ferritin Hemochromatosis	11q 12-q13	Autosomal dominant	H-ferritin gene mutations	108
Porphyria cutanea tarda	1p34	Autosomal dominant or sporadic	Heterogeneous	109, 111, 112, 113, 114, 115, 116, 117, 118, 119, 120, 121, 122, 123, 124, 125, 126, 128, 129
African iron overload	Unknown	Autosomal dominant	Unknown	130, 131, 132, 133, 134, 135, 136, 137
Neonatal iron overload	Unknown	Heterogeneous	<i>In utero</i> iron transfer	138, 139, 140, 141, 142, 143, 144
Atransferrinemia	3q21	Autosomal recessive	Transferrin gene mutations and red cell transfusions	145, 146
Aceruloplasminemia	3q23-q24	Autosomal recessive	Ceruloplasmin gene mutations	147, 148, 149, 150, 151, 152, 153, 154
Hereditary hyperferritinemia and cataract syndrome	19q13.1-q13.3.3	Autosomal dominant	L-Ferritin gene mutations	155, 156, 157, 158, 159, 160, 161, 162, 163, 164, 165
Friedreich ataxia	9p23-p11,9q13	Autosomal recessive	Frataxin gene mutations	166, 167, 168, 169, 170, 171, 172, 173
Panθοthenase kinase-associated neurodegeneration	20p13-p12.3	Autosomal recessive	Panθοthenase kinase gene mutations	174, 175
β -Thalassemia major	11p15.5	Autosomal recessive	β -Globin gene mutations, chronic hemolysis, red cell transfusions	—
Other chronic hemolytic anemias				
Hereditary X-linked sideroblastic anemia	Xp11.21	X-Linked	δ -Aminolevulinic acid synthase gene mutations	176, 177, 178
X-Linked sideroblastic	Xq13.1-q13.3	X-Linked	ABCB7 mutations ^a	179, 180, 181, 182

anemia with ataxia				
MLASA syndrome ^b	12q24.33	Autosomal recessive	Pseudouridine synthase-1 mutations	183, 184
<i>GLRX5</i> sideroblastic anemia	14q32.13	Autosomal recessive	Glutaredoxin 5 mutations	185, 186
<i>DMT1</i> iron overload ^c	12q13	Autosomal recessive	<i>SLC11A2</i> mutations ^d	187, 188
Pyruvate kinase deficiency	1q21	Autosomal recessive	Pyruvate kinase gene mutations	189, 190, 191
G6PD deficiency ^e	Xq28	X-Linked	G6PD gene mutations	192, 193
Congenital dyserythropoietic anemias				
Type I	15q15.1-q15.3	Autosomal recessive	Ineffective erythropoiesis	194, 195
Type II	20q11.2	Autosomal recessive	Ineffective erythropoiesis	196, 197, 198
Type III	15q21	Autosomal dominant	Ineffective erythropoiesis	199, 200

Acquired Disorder Cause of Iron Loading

Transfusions	Red cell iron infusion
Medicinal iron	Excessive iron ingestion
Iron injections	Parenteral injection
Myelodysplasia with ring sideroblasts	Excessive iron absorption; transfusion
Portacaval shunt	Excessive iron absorption
Hemodialysis	Iron infusion
Nonalcoholic fatty liver disease	Excessive iron absorption

^a ABCB7, ATP-binding cassette, subfamily B, member 7.

^b MLASA, myopathy with lactic acidosis and sideroblastic anemia.

^c *DMT1*, divalent metal transporter-1.

^d *SLC11A2*, solute carrier family 11, member 2.

^e G6PD, glucose-6-phosphate dehydrogenase.

P.666

The second most common HFE gene mutation in hemochromatosis patients is a change in nucleotide 187 from the normal cytidine to guanidine 187C→G in exon 2. This results in substitution of aspartate for the normal histidine at amino acid position 63. Both the C282Y and H63D mutations were identified in the initial report of the isolation and cloning of HFE.³⁶

Of the reported mutations of the HFE gene, 31 are missense mutations that result in substitution of the normal amino acid by another. There are 27 reported nonsense mutations of HFE, 12 of which are splice errors that are associated with intron sequence variants. Eight mutations involve a nucleotide change that does not result in an amino acid substitution (synonymous mutations). Some important HFE gene mutations are given in Table 25.2. Other mutations occur in noncoding regions of HFE.²⁴⁰ It is expected that other rare mutations of the HFE gene will be identified in adults with hemochromatosis phenotypes.

HFE Mutations in Hemochromatosis Patients and in Different Populations

In the first report of the HFE gene and its mutations, 83% of subjects with hemochromatosis were C282Y homozygotes.³⁶ The prevalence of homozygosity for C282Y varies from 33% to 100% among groups of hemochromatosis patients. In the United States, 59% to 89% of hemochromatosis patients are C282Y homozygotes. The percentage of hemochromatosis patients from 14 countries who have the C282Y and H63D genotypes is presented in Table 25.3.^{36 98 228 241 242 243 244 245}

TABLE 25.2 SIXTY-SEVEN MUTATIONS OF THE HEMOCHROMATOSIS GENE (HFE) IN HEMOCHROMATOSIS TYPE 1: NUCLEOTIDE AND AMINO-ACID CHANGES, TYPE OF MUTATION, EXON OR INTRON INVOLVED, AND EFFECT OF THE MUTATION ON IRON LOADING

Nucleotide Complementary DNA Position	Change AminoAcid	Symbols	Type of Mutation		Exon or Intron Affected	Effect on Iron Loading Probands or Homozygotes	Reference
			Missense	Nonsense			
c.-20G→A		fs	—	Yes	5'UTR	↑	201
88C→T	Leu30Leu	L30L	No	No	Exon 2	None	202
128G→A; ^a	Gly43Asp;	G43D;	Yes	—	Exon 2	↑	203
187C→G	His63Asp	H63D					
138T→G	Leu46Trp	L46W	Yes	—	Exon 2	↑	204
c.del149-170 ^b	Leu50fs	L50fs	—	Yes	Exon 2	None	205, 206
128G→A	Gly43Asp	G43D	Yes	—	Exon 2	↑	15
157G→A	Val53Met	V53M	Yes	—	Exon 2	None	207
175G→A	Val59Met	V59M	Yes	—	Exon 2	None	207
187C→G	His63Asp	H63D	Yes	—	Exon 2	↑	36
187C→G ^a	His63Asp;	H63D;	Yes	—	Exon 2,4	↑	208
845G→C	Cys282Tyr	C282Y					
189T→C	His63His	H63H	No	No	Exon 2	None	207
193A→T	Ser65Cys	S65C	Yes	—	Exon 2	↑	209
196C→T	Arg66Cys	R66C	Yes	—	Exon 2	↑	202
199C→T	Arg67Cys	R67C	Yes	—	Exon 2	↑	206

c.del	203	Val68fs	V68fs	—	Yes	Exon 2	↑↑	210
211C→T	Arg74Stop	R71X ^c	—	Yes	Exon 2	↑↑	15, 206, 239	
277G→C	Gly93Arg	G93R	Yes	—	Exon 2	↑↑	211	
c.del	277	Gly93fs	G93fs ^d	—	Yes	Exon 2	↑↑	212
314T→C	Ile105Thr	I105T	Yes	—	Exon 2	↑	211	
340G→A	Glu114Lys	E114K	Yes	—	Exon 2	↑	206	
IVS2 (+4)T→C	Splice error	—	—	—	Intron 2	None	213	
381A→C	Gln127His	Q127H	Yes	—	Exon 3	↑	207	
385G→A	Asp129Asn	D129N	Yes	—	Exon 3	None	204	
414C→G	Try138Stop	Y138X	—	Yes	Exon 3	↑↑	204	
471del	Ala158fs	A158fs	—	Yes	Exon 3	↑↑214		
c.del478	Pro160fs	P160fs	—	Yes	Exon 3	↑↑	215	
502G→C	Glu168Gln	E168Q	Yes	—	—	↑	216	
502G→C; ^a	Glu168Gln; E168Q;	Yes	—	—	Exon3	↑	217	
187C→G	His63Asp	H63D						
502G→T	Glu168Stop	E168X	—	Yes	Exon 3	↑↑	218	
506G→A	Trp169Stop	W169X	—	Yes	Exon 3	↑↑	218	
527	C→T	Ala176ValA176V	Yes	—	—	Exon 3	↑	219
548T→C	Leu183Pro	L183P	Yes	—	Exon 3	↑↑	220	
IVS3 (+1)G→T	Splice error	Null allele	—	Yes	Exon 3	↑↑	221	
IVS3 (+21)T→C	Gly43Asp	G43D	Yes	—	Intron 3	↑	202	
IVS3(+21)T→C	Splice error	—	—	Yes	Intron 3	None	202	
IVS3(-48)C→G	Splice error	—	—	—	Yes	Intron 3	None	222
c.del616-48C→T	fs	X	—	Yes	Exon 4	None	223	
636G→C	Val212Val	V212V	No	No	Exon 4	None	224	
671G→A	Arg224Gly	R224G	Yes	—	Exon 4	↑	202	
689A→T	Tyr230Phe	Y230F	Yes	—	Exon 4	↑↑	204	
c.del691-693	Tyr231fs	Y231X	—	Yes	Exon 4	↑↑	225	
696C→T	Pro232Pro	P232P	No	No	Exon 4	None	202	
697C→T	Gln233Stop	Q233X	—	Yes	Exon 4	↑↑	226	
c.dup794	Trp267fs	W267fs	—	Yes	Exon 4	↑↑	227	
724G→A	Asp242Asp	D242D	No	No	Exon 4	None	223	
747G→A	Lys249Lys	K249K	No	No	Exon 4	None	223	
814G→T	Val272Leu	V272L	Yes	—	Exon 4	?	228	
829G→A	Glu277Lys	E277K	Yes	—	Exon 4	None	229	

845G→A	Cys282Tyr	C282Y	Yes	—	Exon 4	↑↑	36
845G→C	Cys282Ser	C282S	Yes	—	Exon 4	↑↑	230
845G→A ^a	Cys282Tyr;	C282Y;	Yes	—	Exon 4	↑	231
842C→A	Thr281Lys	T281K					
848A→C	Gln283Pro	Q283P	Yes	—	Exon 4	↑↑	232
884T→A	Val295Glu	V295E	Yes	—	Exon 4	None	223
884T→C	Val295Ala	V295A	Yes	—	Exon 4	?	210
867G→C	Leu289Leu	L289L	No	No	Exon 4	None	202
IVS4 (+37)A→G	Splice error	—	—	Yes	Intron 4	None	207
IVS4 (+48) G→A	Splice error	—	—	Yes	Intron 4	None	233
IVS4 (+109)A→G	Splice error	—	—	Yes	Intron 4	None	207
IVS4 (-44)T→C	Splice error	—	—	Yes	Intron 4	?	234
IVS4(-50) A→G	Splice error	—	—	Yes	Intron 4	?	235
IVS4 (+115)T→C	Splice error	—	—	Yes	Intron 4	None	207
942T→C	Synonymous	—	No	No	—	None	219
989G→T	Arg330Met	R330M	Yes	—	Exon 5	↑↑	207
IVS5 (+1)G→A	Splice error	—	—	Yes	Intron 5	↑	236
IVS5 (-47)G→A	Splice error	—	—	Yes	Intron 5	?	234
c.1022-1034del13	His341fs	H341X	—	Yes	Exon 6	↑↑	234
HFE _{del}	HFE _{del}	—	—	Yes		↑ or ↑↑	237, 238

↑, increased; ↑↑, markedly increased; ?, effect unknown; A, adenine; C, cytosine; G, guanine; T, thymine; fs, frameshift; IVS, intron sequence variant; 5'UTR, untranslated region.

^a Double missense complex allele in *cis* (on same allele).

^b Originally published as 370del22.^{205, 206}

^c Originally described as R74X.^{15, 206}

^d W94fs may be correct designation.²⁰⁶

The prevalence of HFE mutations is high in some populations, such as those of Central, Western, and Northern Europe, and in countries that were populated predominantly by people who originated in these areas of Europe, including the United States, Canada, and Australia.^{241, 277} It is predicted that the prevalence of HFE mutations is very low in parts of the world with little or no ancestry from Central and Western Europe, including sub-Saharan Africa (Native Africans), the Middle East, the Orient, and Native Americans in North, Central, and South America. The frequency of homozygosity for the HFE C282Y mutation in the United States varies from 0% to 1.00% in whites, 0% to 0.22% in Mexican Americans, and 0% to 0.06% in blacks (Table 25.4). The prevalence of C282Y, H63D, and wild-type HFE genotypes from nine studies in the United States is presented in Table 25.4.^{211, 242, 244, 278, 279, 280, 281, 282, 283} Extensive data about genotype frequencies in many countries, and from different regions within countries, have been published.^{241, 277, 284}

TABLE 25.3 PREVALENCE (%) OF HFE GENOTYPES IN HEMOCHROMATOSIS PATIENTS IN 14 COUNTRIES

Country	Studied (N)	C282Y/C282Y	C282Y/wt	C282Y/H63D	H63D/H63D	H63D/wt	wt/wt	References
United States	81859.4-88.6	0.6-26.7	4.5-20.3	0-7.0	0-8.1	0.6-12.0	36, 242, 246	
Canada	12895.3	0	0	0	1.6	3.1	247	
France	1,09767.2-92.4	0.9-4.4	2.3-7.1	1.1-8.2	1.5-4.9	0-9.8	241, 248, 249, 250, 251, 252	
Germany	28872.0-94.6	1.1-2.0	0-8.3	2.8	0-6.0	0-5.3	253, 254, 255, 256	
United Kingdom	27790.0-100.0	0-1.7	0-5.5	0-0.9	0	0-4.3	228, 257, 258, 259, 260	
Spain	25957.0-92.8	0-6.0	0-11.0	0-4.5	0-11.0	3.2-13.6	261, 263, 264, 265, 266, 267	
Portugal	2588.0	6.2	1.5	0	0	4.6	—	
Italy	26333.3-69.0	2.7-6.3	4.4-10.0	1.3-3.3	4.0-13.3	11.3-36.7	268, 270	
Sweden	12589.0-92.0	1.1	3.4	1.1	1.1	1.1	270, 271	
Australia	18488.8-100.0	0-5.6	0-1.4	0	0	0-4.0	272, 273	
Greece	1050.0	—	—	—	—	50.0	274	
Brazil	1553.3	6.6	0	0	6.6	33.5	275	
Austria	4077.5	0	7.5	2.5	2.5	10.0	98	
Belgium	4993.9	0	4.1	0	2.0	0	276	
Total	3,57833.0-100.0	0-6.6	0-11.0	0-8.2	0-13.0	0-50.0	—	

wt, wild type.

Hemochromatosis and Iron Overload Screening Study

The largest study of the prevalence of HFE mutations and of serum iron tests was recently completed and published. It is called the HEIRS Study (Hemochromatosis and Iron Overload Screening Study).^{136, 285, 286, 287, 288, 289} Tests for the C282Y and H63D mutations of HFE, serum iron concentration, transferrin saturation, and serum ferritin concentration were measured in about 102,000 outpatients in the United States and Canada. Participants were recalled for additional evaluation if they were C282Y homozygotes or if they had elevated results of transferrin saturation (percent

saturation >50% in men, >45% in women) or elevated serum ferritin (>300 µg/L in men, >200 µg/L in women).

TABLE 25.4 PREVALENCE (%) OF HFE GENOTYPES IN THE UNITED STATES

Population	Studied (N)	C282Y/C282Y	C282Y/wt	C282Y/H63D	H63D/H63D	wt/wt	Reference
------------	-------------	-------------	----------	------------	-----------	-------	-----------

Whites

Kaiser	30,4180.44	9.80	1.80	2.40	23.3	62.4	278
NHANES III	2,0160.30	9.50	2.40	2.20	23.6	62.1	279
Connecticut	1001.00	8.00	0	4.00	24.0	63.0	280
Alabama	1760	13.10	6.80	3.40	15.4	60.3	211
Maine	1,0010.70	9.70	2.20	1.70	24.6	61.1	281
New Mexico	2870	9.80	2.40	2.40	19.9	65.5	282
Alabama	1420.70	10.60	3.50	2.80	19.7	62.7	244
California	1930	15.00	1.00	3.60	24.3	58.0	242
Missouri	1,4500.40	8.90	2.40	3.50	23.9	61.0	283
Total	35,7830-1.00	8.00-13.10	0-6.80	1.70-4.00	15.4-24.6	58.0-65.0	—
Blacks							
Kaiser	1,4620	3.50	0.30	0.20	8.4	87.5	278
NHANES III	1,6000.06	2.30	0.06	0.32	5.6	91.7	279
Connecticut	560	2.00	0	0	3.5	94.5	280
Michigan	1720	3.00	0	0	3.0	94.0	569
Total	3,2900-0.06	2.00-3.50	0-0.30	0-0.32	3.0-8.4	87.5-95.0	—
Mexican Americans							
Kaiser	4,0490.22	3.50	0.84	1.40	20.6	73.4	278
NHANES III	1,5550.03	2.75	0.19	1.10	19.7	76.3	279
Connecticut	1000	3.00	1.00	1.00	15.0	82.0	280
Total	5,7040-0.22	2.80-3.50	0.19-1.00	1.00-1.40	15.0-21.0	73.0-82.0	—

TABLE 25.5 PREVALENCE OF HFE C282Y AND H63D GENOTYPE ACCORDING TO RACE OR ETHNIC GROUP IN THE HEIRS STUDY^a

Race or Ethnic Group	Total No. of Participants	C282Y/C282Y		C282Y/H63D		H63D/H63D		C282Y Heterozygotes		H63D Heterozygotes		No HFE Mutation	
		No.	Prevalence (%)	No.	Prevalence (%)	No.	Prevalence (%)	No.	Prevalence (%)	No.	Prevalence (%)	No.	Prevalence (%)
White	44,082	280.44	90.82	2.0	1,02.4	4,510	10,524	26,761					
		1			29	48	37	79					
Native American	648	10.11	70.77	71.3	355.7	12820	47072						
Hispanic	12,459	70.027	480.33	1541.1	3512.9	2,1918	9,7078						

						9	0
Black	27,124	40.014	350.071	300.089	6052.3	1,525.7	24,992
						0	30
Pacific Islander	698	00.012	00.096	00.20	152.0	628.4	62189
Asian	12,772	00.00003	00.0055	290.20	160.12	1,078.4	11,691
		9				0	57
Multiple/Unknown	1,928	6—	19—	21—	111—	313—	1,45—
							8
All	99,711	29—	1,0 —	1,2—	5,6—	15,8—	76,6—
		9	17	70	81	29	15

Prevalence rates were derived with Hardy-Weinberg proportions within the five ethnic groups who were not C282Y homozygotes.

“Data from participants with complete information on *HFE* C282Y and H63D mutations, transferrin saturation, and serum ferritin levels, except 1,457 who heard about the study from a participating family member, were included.

Modified from Adams PC, Reboussin DM, Barton JC, et al. Hemochromatosis and iron-overload screening in a racially diverse population. *N Engl J Med* 2005;352:1769-1778.²⁸⁷

Used with permission.

The Study centers were Washington DC; Birmingham, Alabama; Irvine, California; Portland, Oregon; Honolulu, Hawaii; and London, Ontario, Canada. Of 99,711 study subjects, 44,082 were Caucasians, 27,124 were blacks, 12,772 were Asians, 12,459 were Hispanics, 698 were Pacific Islanders, and 648 were Native Americans. The prevalence of C282Y homozygosity was highest in Caucasians (0.44%, 4.4 per 1,000) and lowest in Asians (0.39 per 1,000,000), followed by Pacific Islanders (0.012%), blacks (0.014%), Hispanics (0.027%), and Native Americans (0.11%). The prevalence of the C282Y/C282Y, C282Y/H63D, and H63D/H63D genotypes in the study participants is presented in Table 25.5.²⁸⁷ Among Caucasians, the H63D/H63D and the C282Y/H63D genotypes were about 4 times and 3.5 times as common, respectively, as the C282Y/C282Y genotype.²⁸⁷

Prevalence of HFE Mutations in Other Large Population Studies

In a study of 65,238 Norwegians, 0.68% were C282Y homozygotes.²⁹⁰ In a study of 41,038 participants in a Southern California health appraisal clinic, the prevalence of C282Y homozygosity among 30,418 whites was 0.46% (139 homozygotes).²⁷⁸

Association of Iron Loading and HFE Mutations

Some mutations are associated with severe iron loading, such as C282Y, R330M, IVS3 (+1) G→T, E168X, C282S, R74X, and G93fs (Table 25.2). Some mutations are believed to have a modest or moderate effect on iron accumulation, for example, H63D, S65C, G93R, I105T, and E168Q. Other HFE mutations have been identified in individuals without iron overload or in whom the effect of the mutation on iron accumulation could not be determined, such as V53M, V59M, Q127H, E277K, and in several intron sequence variants. Some mutations code for the normal amino acid (synonymous mutations) and do not affect iron absorption. The HFE mutations with severe, mild, or unknown effects on iron accumulation are shown in Table 25.2.

Interaction of Mutations of Hfe and of Other Genes

Interaction of Mutations of HFE and Hcpidin

Mutations of HFE and other genes involved in maintaining iron homeostasis can have a synergistic effect on iron accumulation in hemochromatosis. A striking example of this is the heavy iron loading that occurred in an individual who had C282Y homozygosity and a mutation of the hepcidin gene (a HAMP mutation resulting in deletion of four nucleotides and methionine50deletion, an intron sequence variant in exon 2 and intron 1, referred to as M50del IVS2+1(-G), a

frameshift deletion). This represents a “digenic” configuration of a mutation in each of two autosomal recessive genes, neither of which alone would likely cause heavy iron accumulation. This digenic genotype caused massive iron overload by age 27 years.²⁹¹ The affected man underwent removal of 27 g of iron for 4 years before his serum ferritin concentration became normal (at diagnosis 1,645 µg/L, after treatment 40 µg/L). Mutations of other genes, such as the transferrin receptor-2 or ferroportin, can also result in heavy iron accumulation in individuals who also have HFE mutations.

Some investigators reported that a variant in the D-loop of mitochondrial DNA (mtDNA) where a T→C substitution occurred at nucleotide 16189 (mtDNA 16189T→C) was associated with more severe iron phenotypes in patients with hemochromatosis.²⁹² Other investigators did not confirm this report.²⁹³ It seems likely that additional mutations in diverse genes will be found to explain increased or decreased rates of iron absorption in C282Y homozygotes.

P.670

FREQUENCY OF HEMOCHROMATOSIS IN MEN AND WOMEN

Hemochromatosis is transmitted as an autosomal recessive condition and therefore there should be equal numbers of male and female homozygotes. Overt iron overload, organ injury, and illness occur more frequently in men than in women with this disorder. Men with hemochromatosis have approximately two and a half times as much mobilizable body storage iron as women. Most women are protected from severe iron overload by the menstrual loss of 15 to 25 mg of iron each month and by the transfer of approximately 750 mg of iron to the fetus during pregnancy. Regardless, menstrual blood losses and pregnancy do not explain all of the differences in body iron stores between male and female homozygotes. Testosterone suppresses hepcidin production²⁹⁴ and this could account in part for the tendency of men with hemochromatosis to develop more severe iron overload than women.

TABLE 25.6 CLINICAL OBSERVATIONS (%) IN SUBJECTS WITH HEMOCHROMATOSIS^a FROM NINE STUDIES

Author	Sheldon	Finch	Milder	Milman	Fargion	Niederau	Adams	Moirand	Bulaj
Year Published	1935	1955	1980	1991	1992	1996	1996	1997	2000
Reference #	295	296	297	298	299	300	302	301	245
Number of patients	311	787	34	179	212	251	194	352	505
Men	295	711	34	140	181	224	141	176	315
Women	16	76	—	39	31	27	53	176	190
Symptoms (% of patients)									
Weakness	13	70	73	79	—	82	64	54	—
Weight loss	—	44	53	69	—	—	—	—	—
Arthralgias	—	—	47	44	—	44	—	40	—
Abdominal pain	26	29	50	34	—	56	—	—	—
Loss of libido and/or impotence	6	14	56	41	—	36	—	—	—
Amenorrhea	—	—	—	10	—	15	—	—	—
Cardiac complaints	—	33	35	—	—	—	—	—	—
Asymptomatic	—	—	15	—	—	—	—	—	—
Physical and laboratory findings (% of patients)									
Skin pigmentation	84	85	82	70	35	72	38	52	—

Hepatomegaly	92	93	76	84	75	81	41	—	—
Abnormal hepatic function tests	—	—	54	92	—	—	30	—	10
Cirrhosis	92	—	94	84	69	57	—	20	17
Hepatoma	6	14	18	—	12	—	4	—	3
Splenomegaly	55	50	38	12	—	10	—	—	8
Diabetes	79	82	53	47	30	—	24	12	10
Testicular atrophy	—	16	50	—	—	—	18	—	—
Hypogonadism, documented	—	—	40 ^b	—	20 ^b	—	—	—	—
Hypogonadotrophic hypogonadism	—	—	100 ^b	—	—	—	—	—	5
Arthropathy	—	—	44	—	13	—	37	—	—
Cardiac arrhythmia	—	35	26	—	20	35	14	14	8
Congestive heart failure	—	33	35	15	—	—	14	—	—

^aThese symptoms of illness, abnormal physical examination findings, and laboratory abnormalities were observed in patients in nine studies from seven countries.

^b Findings in men only; not all men were studied.

Modified from Barton JC, Edwards CQ, eds. Hemochromatosis: genetics, pathophysiology, diagnosis and treatment. Cambridge, UK. Cambridge University Press. 2000:315.

Used with permission of publisher.

CLINICAL FEATURES OF HEMOCHROMATOSIS

Symptoms

The presence or absence of symptoms in persons with hemochromatosis is related to the stage at which the diagnosis is established. Individuals diagnosed to have hemochromatosis during a routine office visit are expected to have no organ injury and many of them are not heavily iron loaded, if at all. This is common among women, young men, children, and the healthy siblings who undergo family screening after a proband is diagnosed. Subjects in whom the diagnosis is established after they seek medical attention due to symptoms are typically ill (Table 25.6).^{245, 295, 296, 297, 298, 299, 300, 301, 302} These persons usually have iron overload and evidence of organ injury. The frequency of symptoms, physical signs, and laboratory abnormalities in subjects with hemochromatosis (sick probands)

P.671

compared with probands who were identified during screening and compared with their homozygous relatives who were identified during family evaluation (clinically unselected homozygotes) are given in Table 25.7.³⁰³ Approximately 90% to 98% of people who are found to have hemochromatosis during screening are asymptomatic.

TABLE 25.7 CLINICAL OBSERVATIONS IN HEMOCHROMATOSIS PROBANDS IDENTIFIED DUE TO ILLNESS OR ONLY DUE TO UTAH SCREENING STUDIES^a

Abnormality	59 Sick Probands (%)	38 Screening Probands (%)	p Value ^b
Symptoms			
Asymptomatic		0	90<0.0001
Abdominal pain		48	5<0.0001

Weakness, lethargy	54	5<0.0001
Palpitations	37	5<0.0010
Impotence (men)	25	3<0.0080
Weight loss	17	5<0.0160
Clinical findings		
Skin pigmentation	71	19<0.0001
Arthropathy	48	10<0.0001
Hepatomegaly	56	3<0.0001
Liver enzyme elevation	68	8<0.0001
Liver iron stain grade 3-4 ^c	98	21<0.0001
Hepatic cirrhosis	42	0<0.0001
Diabetes mellitus	27	0<0.0010
Cardiomegaly	14	0<0.0370
Documented hypogonadism	16	0<0.0260

^aData summarized from Witte DL, Crosby WH, Edwards CQ, et al. Practice guideline development task force of the College of American Pathologists. Hereditary hemochromatosis. Clin Chim Acta 1996;245:139-200.³⁰³

^b p values calculated by chi-square test.

^c Scale of 0-4; normal grade 0-1.

Modified from Edwards CQ, Griffen LM, Bulaj ZJ, et al. Hemochromatosis: genetics, pathophysiology, diagnosis and treatment. Cambridge, UK: Cambridge University Press, 2000;314.

Used with permission of publisher.

The most common symptom in nonscreening hemochromatosis patients at diagnosis is arthralgias, (approximately 40% of homozygotes).²⁴⁵ The joints most commonly involved with typical hemochromatosis arthropathy are metacarpal-phalangeal (MCP) joints, especially the second and third.³⁰⁴ Pain or other manifestations can also occur in knees, hips, shoulders, and other diarthrodial joints. Weakness, fatigue, and lethargy are common but nonspecific symptoms. Weight loss, abdominal pain, loss of libido in men, and palpitations also occur in some iron-loaded homozygotes. The prevalences of arthralgias, abdominal pain, loss of libido or impotence, and palpitations in different study populations are displayed in Tables 25.6 and 25.7.

Physical Examination Abnormalities

Gray or bronze pigmentation is the most common physical examination abnormality in hemochromatosis homozygotes diagnosed in nonscreening settings (35% to 84%). Other common findings include arthropathy (13% to 68%), hepatomegaly (54% to 93%), splenomegaly (10% to 55%), irregular heartbeat, congestive heart failure, telangiectases, and loss of midline body hair or testicular atrophy. The frequency of physical abnormalities in hemochromatosis from nine studies is shown in Table 25.6. The prevalence of self-reported illness according to HFE genotype in two very large US and US-Canadian population screening studies is given in Tables 25.8³⁰¹ and 25.9.²⁷⁸

Laboratory Abnormalities

The most common laboratory abnormalities in subjects with hemochromatosis are elevations of serum iron concentration, percent transferrin saturation, and serum ferritin concentration.^{136, 305} Transferrin saturation may be elevated in children or teenage homozygotes before serum ferritin elevation occurs, long before symptoms or physical examination abnormalities develop. This is attributed to the increased release of iron by macrophages via ferroportin in the presence of low hepcidin levels. The typical values of transferrin saturation according to the method of ascertainment

in 291 Utah homozygous probands are presented in Table 25.10.²⁴⁵ The results of transferrin saturation and serum ferritin concentration in normal individuals, C282Y heterozygotes, C282Y/H63D compound heterozygotes, and H63D homozygotes according to HFE genotype from a large US population screening study are shown in Table 25.11.²⁷⁸

In untreated C282Y homozygotes, the average hemoglobin concentration is greater than that of control subjects without common HFE mutations.^{306, 307} Likewise, the value of mean corpuscular volume of untreated C282Y homozygotes is elevated, sometimes above the upper reference limit, even in patients without liver disease.³⁰⁶ The mean red blood cell count and mean coefficient of variation of mean corpuscular volume (RDW) are lower in C282Y homozygotes.³⁰⁸ These erythrocyte-associated characteristics, usually more pronounced in men than women, are due to the ample amounts of iron constantly available to marrow erythroblasts via transferrin, the saturation of which is increased in most C282Y homozygotes. Genome-wide linkage analyses confirm that a locus (loci) on chromosome 6p21 is significantly associated with hemoglobin concentration.³⁰⁹ This locus is presumed to be HFE.

Radiographs of hands are often abnormal in homozygotes who have arthralgias. Approximately 50% of homozygotes have radiographic changes. The plain films reveal narrowing of the MCP joint spaces, subperiosteal bone resorption, and periarticular demineralization. Plain films of knees may reveal chondrocalcinosis, linear calcium deposition in the cartilage that is visible across the joint space.

The next most common laboratory abnormality in untreated hemochromatosis patients diagnosed in nonscreening venues is elevation of serum levels of alanine aminotransferase and aspartate aminotransferase (8% to 92%). The prevalence of this abnormality varies markedly according to the method of ascertainment (Tables 25.6 and 25.7). Usually, these enzyme levels are elevated two to five times the upper limit of normal in nonscreening subjects. The significance of elevated serum levels of hepatic transaminases is often different in C282Y homozygotes detected in screening programs than in nonscreening patients. In HEIRS Study participants with hyperferritinemia, mean serum levels of transaminase activities were significantly lower in C282Y homozygotes than nonhomozygotes. The probability of being a C282Y homozygote increased as the transaminase activities decreased. Thus, study participants with hyperferritinemia detected in screening are more likely to be C282Y homozygotes if they have normal liver transaminase activities.³¹⁰ If hepatic failure is present, serum transaminase

P.672

and bilirubin levels may be very elevated. Other common laboratory abnormalities include elevation of serum glucose concentration (0% to 82%); arrhythmia on electrocardiography; cardiomegaly on chest radiography; decreased ejection fraction on echocardiography; elevated or very low thyroid-stimulating hormone in hypothyroidism or hyperthyroidism, respectively; and blood test evidence of hypogonadism, usually the hypogonadotropic type with decreased serum concentrations of testosterone, dihydrotestosterone, luteinizing hormone, and follicle-stimulating hormone.³¹¹ Tables 25.6 and 25.7 show the frequency of lab abnormalities in individuals who have hemochromatosis.

TABLE 25.8 ASSOCIATION BETWEEN HFE GENOTYPE AND MEDICAL CONDITIONS RELATED TO IRON OVERLOAD IN 98,529 PRIMARY CARE PATIENTS IN THE HEIRS STUDY

Self-Diagnosis and Genotype	Men (N = 36,474)		Women (N = 62,055)	
	Odds Ratio	p Value ^a	Odds Ratio	p Value ^a
Arthritis		<0.001	<0.001	
C282Y/C282Y	0.99		1.10	
C282Y/H63D	0.83		0.86	
H63D/H63D	1.28 ^b		1.02	
C282Y/+	1.07		1.01	
H63D/+	1.02		1.01	
No C282Y or H63D mutation	1.00		1.00	
Diabetes		0.003		<0.001
C282Y/C282Y	1.06		0.80	

C282Y/H63D	0.91	0.79	
H63D/H63D	0.89	1.13	
C282Y/+	0.81 ^b	1.05	
H63D/+	0.98	0.97	
No C282Y or H63D mutation	1.00	1.00	
Liver Disease^c			0.14
C282Y/C282Y	3.28 ^a	0.60	
C282Y/H63D	1.65 ^a	0.82	
H63D/H63D	0.71	1.13	
C282Y/+	1.12	1.23	
H63D/+	1.06	0.92	
No C282Y or H63D mutation	1.00	1.00	
Heart disease			0.74
C282Y/C282Y	0.62	0.26	
C282Y/H63D	1.08	0.90	
H63D/H63D	1.00	1.47 ^a	
C282Y/+	0.88	1.10	
H63D/+	0.89	0.96	
No C282Y or H63D mutation	1.00	1.00	
Impotence or infertility			0.005
C282Y/C282Y	1.42	1.09	
C282Y/H63D	1.00	0.85	
H63D/H63D	1.13	0.99	
C282Y/+	0.85	0.93	
H63D/+	0.96	0.95	
No C282Y or H63D mutation	1.00	1.00	

^a *p* values for the genotype effect are from logistic-regression models and indicate the probability of observing these differences in prevalence if there is no effect of the C282Y or H63D allele. Participants who joined the study only because they heard about it from a participating family member were excluded.

^b Odds ratio is significant at *p* < 0.05; CI, confidence interval.

^c Includes all types of liver disease.

Modified from Adams PC, Reboussin DM, Barton JC, et al. Hemochromatosis and iron-overload screening in a racially diverse population. *N Engl J Med* 2005;352:1769-1778.²⁸⁷

Used with permission.

TABLE 25.9 PREVALENCE OF HEALTH PROBLEMS ACCORDING TO HFE GENOTYPE IN 41,038 PATIENTS IN KAISER PERMANENTE HEALTH APPRAISAL CLINIC

	Men		Women	
	N	%	N	%
Arthropathy				
C282Y/C282Y	16/56	29	29/68	43
C282Y/H63D	112/292	38	143/301	48
wt/wt	3,975/10,889	37	5,324/11,458	47
Diabetes				
C282Y/C282Y	1/56	2	6/68	9
C282Y/H63D	29/292	10	15/301	5
wt/wt	1,045/10,889	10	843/11,458	7
Liver Problems				
C282Y/C282Y	4/56	7	6/68	9
C282Y/H63D	11/292	4	11/301	4
wt/wt	534/11,889	5	392/11,458	3
Arrhythmias				
C282Y/C282Y	8/56	14	23/68	34
C282Y/H63D	53/292	18	103/301	34
wt/wt	1,868/10,889	17	3,730/11,458	33
Impotence				
C282Y/C282Y	15/56	27	—	—
C282Y/H63D	118/292	40	—	—
wt/wt	3,904/10,889	36	—	—

Modified from Beutler E, Felitti VJ, Koziol JA, et al. Penetrance of 845G→A (C282Y) *HFE* hereditary haemochromatosis mutation in the USA. *Lancet* 2002;359:211-218.²⁷⁸

Used with permission.

TABLE 25.10 TRANSFERRIN SATURATION AND SERUM FERRITIN CONCENTRATION VALUES OF HEMOCHROMATOSIS HOMOZYGOTES ACCORDING TO THE METHOD OF ASCERTAINMENT: UTAH STUDIES OF 505 HOMOZYGOTES

Variable	Probands Identified					
	Probands Identified Due to Illness (Sick) (N = 184)		by Elevated Transferrin Saturation (Screening) (N = 107)		Clinically Unselected Homozygous Relatives of Probands ^a (N = 214)	
	Men	Women	Men	Women	Men	Women
Number	136	48	66	41	113	101

Age (yr) ^b	51	51	37	45	41	44
Transferrin saturation (%) ^b	87	81	82	79	82	69
Ferritin concentration (ng/ml) ^c Median	1300	657	421	319	552	170
Tenth, ninetieth percentiles	518, 3,164	242, 2,682	99, 1,274	69, 1,023	147, 1,495	28, 580

^a The homozygous relatives were 164 siblings, 10 parents, 19 offspring, 7 nieces, 6 nephews, 1 aunt, 2 uncles, 1 grandmother, and 4 persons who married into an affected family and had transferrin saturation values similar to those of homozygotes.

^b Mean values.

^c The *p* values calculated by the Kruskal-Wallis nonparametric test for the comparison of ferritin concentrations were as follows: clinically affected probands as compared with probands identified because they had elevated transferrin saturation values: <0.001 for men, 0.002 for women; clinically affected probands as compared with clinically unselected homozygous relatives: <0.001 for men, <0.001 for women; probands identified because of elevated transferrin saturation values compared with clinically unselected homozygous relatives: 0.37 for men, 0.004 for women.

Modified from Bulaj ZJ, Ajioka RS, Phillips JD, et al. Disease-related conditions in relatives of patients with hemochromatosis. *N Engl J Med* 2000;343:1530.²⁴⁵ Used with permission of publisher.

Liver Biopsy Findings

Liver morphology by microscopy is usually normal in homozygotes whose serum ferritin is not elevated. When serum ferritin concentration is elevated, the hepatic parenchymal cell stainable iron is usually increased. The same comments apply to the measured hepatic iron concentration. Many 40- to 50-year-old male homozygotes have hepatic fibrosis when hemochromatosis is diagnosed (2% to 32%) (Table 25.12).²⁴⁵ A range of 0% to 92% of male homozygotes have cirrhosis at the time of diagnosis, usually the sick individuals (Tables 25.6 and 25.7). Most women with hemochromatosis do not have fibrosis or cirrhosis at diagnosis. Cirrhosis is not expected to occur until the hepatic iron concentration is elevated to approximately 22,000 µg (22 mg) of iron per gram of liver dry weight (normal, approximately 1,000 µg iron per gram dry weight).³¹² Hemochromatosis homozygotes who are only identified because they participated in screening studies rarely have heavy liver iron overload or hepatic fibrosis (Tables 25.7 and 25.12).^{245, 285, 303}

In hemochromatosis patients, an elevated serum concentration of collagen type IV correlates strongly ($p < 0.0001$) with hepatic fibrosis or cirrhosis.³¹³ Serum collagen type IV levels in a group of 42 hemochromatosis patients were compared to those of 19 control subjects. A serum concentration of collagen type IV >115 ng/ml had a sensitivity of 100% and a specificity of 69% for far-advanced hepatic fibrosis (grade 3) and cirrhosis (grade 4).³¹³ Among homozygotes who are diagnosed very late, 10% to 29% of those with cirrhosis develop hepatocellular carcinoma.^{314, 315, 316, 317} Hepatocellular carcinoma in hemochromatosis may be multifocal rather than focal and may not cause marked elevation of α -fetoprotein that is common in individuals who have a large nodular hepatoma. Multifocal hepatocellular carcinoma may not be visible by ultrasonography until the diameter of the nodules reaches 1 cm. The frequency of hepatic fibrosis, cirrhosis, and hepatocellular carcinoma in hemochromatosis patients is presented in Tables 25.6, 25.7, and 25.12.

P.674

TABLE 25.11 MEAN VALUES OF TRANSFERRIN SATURATION AND SERUM FERRITIN CONCENTRATION BY HEMOCHROMATOSIS GENOTYPE FROM A U.S. POPULATION STUDY

	wt/wt ^a	C282Y/wt	C282Y/H63D	C282Y/C282Y
--	--------------------	----------	------------	-------------

Men (N)	12,601	1,603	300	73
Transferrin saturation (%)	27	31	40	64
^b Serum ferritin (μg/L)	118	122	191	395
Women (N)	13,674	1,690	305	79
Transferrin saturation (%)	23	27	32	46
^b Serum ferritin (μg/L)	52	56	70	159

^a wt, wild type.

^b Geometric mean.

Modified from Beutler E, Felitti VJ, Koziol JA, et al. Penetrance of 845G→A (C282Y) *HFE* hereditary haemochromatosis mutation in the USA. *Lancet* 2002;359:211-218.²⁷⁸

Used with permission.

HFE MUTATIONS AND OTHER CONDITIONS

Arthropathy

Arthropathy is common in patients diagnosed to have hemochromatosis in nonscreening settings and is a major cause of morbidity in some individuals.^{18, 21, 22, 23, 24} The proportion of nonscreening patients who have severe iron overload is relatively high and the prevalence of hemochromatosis arthropathy is significantly greater in patients whose serum ferritin levels are greater than 1,000 μg/L at diagnosis than in those with lower serum ferritin levels.^{20, 26} Hemochromatosis homozygotes with arthropathy usually experience symmetrical arthralgias in the second and third MCP and proximal interphalangeal (PIP) joints.³¹⁸ MCP joint swelling, decreased range of motion, and decreased ability to make a fist are typical physical findings. Radiographic findings include hypertrophy and related abnormalities of MCP and PIP joints, subchondral cysts with sclerotic margins at the metacarpal heads, and joint space narrowing, usually with asymmetric cartilage loss. Other degenerative changes that occur in some cases include chondrocalcinosis, involvement of radiocarpal joints, osteophytes at severely affected MCP joints, and generalized osteoporosis of affected hands.^{2, 319, 320} Approximately two-thirds of patients with hand arthropathy have or will develop hip or knee arthropathy. Knee radiographs often reveal chondrocalcinosis.³²⁰ Many patients with hip or knee arthropathy eventually require joint replacement. Other diarthrodial joints are affected less frequently (e.g., shoulders, elbows, ankles, and toes).

TABLE 25.12 LIVER BIOPSY FINDINGS IN SICK, SCREENING, AND CLINICALLY UNSELECTED HOMOZYGOUS RELATIVES: UTAH STUDY OF 505 HOMOZYGOTES

Variable	Sick Probands Identified Due to Illness (N = 184)	Screening Probands Identified by Elevated Transferrin Saturation (N = 107)	Clinically Unselected Homozygous Relatives of Probands (N = 214)				
	Men	Women	Men	Women	Men	Women	
Number	136	48	66	41	113	101	
Liver biopsies (N)	123	44	54	33	78	40	
Cirrhosis	55	10	3	2	14	2	
Fibrosis	32	9	6	2	13	4	
Hepatocellular carcinoma	14	0	0	0	2	0	

Modified from Bulaj ZJ, Ajioka RS, Phillips JD, et al. Disease-related conditions in relatives of patients with hemochromatosis. *N Engl J Med* 2000;343:1531.²⁴⁵

In persons diagnosed to have hemochromatosis in screening programs, the proportion who have severe iron overload is relatively low and thus typical hemochromatosis arthropathy is not common. Among the 98,529 participants in the HEIRS screening study (36,474 men and 62,055 women), there was no significant difference in the incidence of self-reported arthritis between groups of C282Y homozygotes and participants without HFE mutations.²⁸⁷ In another large questionnaire study, there was no significant difference in the prevalence of arthropathy between 45 C282Y homozygotes who were identified by screening and 9,299 control subjects.²⁷⁸ The results of another screening study were similar.³²¹

P.675

The prevalence of common HFE mutations did not differ significantly in 1,000 patients who had inflammatory arthritis and in 1,000 normal control subjects.³²² In another study of patients without a diagnosis of hemochromatosis, the prevalence of HFE C282Y was greater in those with radiographic evidence of hand osteoarthritis than in control subjects. Serum ferritin levels were similar in patients with and without hand osteoarthritis.⁴¹ Some HFE C282Y homozygotes develop rheumatoid-factor-positive rheumatoid arthritis,³²³ psoriatic arthritis, gouty arthritis, or other types of arthropathy not attributable to iron overload. Osteoporosis defined by decreased bone mineral density was present in 34% of 38 C282Y homozygotes and C282Y/H63D compound heterozygotes who had not undergone iron depletion therapy. Osteopenia was present in 79%. Vitamin D and parathyroid hormone values were normal. Hypogonadism was present in 13%.³²⁴

Diabetes Mellitus

Diabetes was reported in early accounts of hemochromatosis^{32, 33, 34} and for years was considered to be essential for establishing a diagnosis of hemochromatosis. Diabetes remains common in patients with hemochromatosis who have severe iron overload and cirrhosis (Tables 25.6 and 25.7).^{299, 300, 315, 325} Siderosis of pancreatic islets, pancreatic fibrosis, and cirrhosis contribute significantly to diabetes pathogenesis in such cases but other factors also influence diabetes risk and expression. Some hemochromatosis homozygotes who have diabetes have elevated body mass index and decreased insulin secretory capacity.^{326, 327} Similar abnormalities occur in mouse models of hemochromatosis.³²⁸ Cirrhosis contributes to insulin resistance and hyperglucagonemia. A family history of diabetes in first-degree relatives is a significant predictor of diabetes risk among persons with hemochromatosis,^{329, 330} consistent with observations that diabetes and hemochromatosis segregate independently as genetic traits.³⁹ Diabetes is associated with decreased survival after diagnosis in nonscreening patients with hemochromatosis and C282Y homozygosity.³³¹

As hemochromatosis case definition has changed from that of a rare, severe iron overload phenotype to a relatively common disorder defined primarily by HFE C282Y homozygosity, the prevalence of diabetes in hemochromatosis case series has decreased to a level that approaches that of the general age- and sex-matched population.³³² Among the 98,529 participants in the HEIRS Study (36,474 men and 62,055 women), there was no significant difference in the prevalence of self-reported diabetes between groups of C282Y homozygotes and the participants with normal HFE genotypes.²⁸⁷ In a study of 22,347 control subjects without HFE mutations, 8.4% reported having diabetes, whereas 5.6% of 124 C282Y homozygotes reported having diabetes. Similarly, 7.0% of C282Y/H63D compound heterozygotes had diabetes.²⁷⁸ The prevalence of HFE C282Y in groups of patients with diabetes is similar to that in corresponding control subjects.^{278, 333, 334, 335, 336, 337, 338}

Other Endocrinopathy

Hypogonadism, thyroid disease, and adrenal insufficiency occur in some hemochromatosis patients, usually those who have been heavily iron loaded for decades. Of nondiabetes endocrinopathy in hemochromatosis, the second most common type is hypogonadism (Tables 25.6 and 25.7). This is usually of the hypogonadotrophic type.^{311, 339} Iron is deposited selectively in the gonadotroph cells of the anterior pituitary.^{295, 311, 339, 340, 341, 342, 343, 344, 345, 346, 347} In a group of 141 ironloaded hemochromatosis patients, 9 patients (6%) had abnormally low testosterone levels. Of these nine patients, eight (89%) also had low values of luteinizing hormone and follicle-stimulating hormone. These findings are characteristic of hypogonadotrophic hypogonadism.³¹¹ Hypothalamic dysfunction occurs in some patients.^{119, 311, 339, 344, 348, 349, 350, 351, 352, 353} Other patients with hemochromatosis have primary gonadal failure typically unrelated to iron overload. In a different study of 181 unrelated men who were HFE C282Y homozygotes, none had hypogonadism.³⁵⁴ It seems reasonable to evaluate for hemochromatosis in individuals who have hypopituitarism of unknown cause.³⁵⁵

In the HEIRS Study, hypothyroidism was detected in 1.7% of 176 HFE C282Y homozygotes and 1.3% of 312 control subjects who did not have C282Y. None of the C282Y homozygotes and 1% of the controls had hyperthyroidism. These minor differences in prevalence were not statistically significant.³⁵⁶

Polycystic ovary syndrome (PCOS) affects approximately 5% of white women and is often associated with decreased serum hepcidin concentration. Homozygosity for the HFE C282Y mutation also is associated with decreased serum hepcidin. In a study of 107 unrelated women who were C282Y homozygotes, a 13-year-old and a 16-year-old had PCOS. Each had elevated serum ferritin concentration and grade 3 to 4 hepatic parenchymal stainable iron.³⁵⁴ It seems likely that low serum hepcidin concentration due to both PCOS with loss of menses at a very young age and HFE hemochromatosis contributed to early-onset iron overload.

Hepatocellular Carcinoma

The relative risk of hepatocellular carcinoma in patients with hemochromatosis who have cirrhosis is 219-fold higher than in patients with hemochromatosis who do not have cirrhosis.^{315, 357} Among patients who have both end-stage hemochromatosis and cirrhosis, 10% to 29% develop hepatoma.^{314, 315, 316, 317, 358, 359} About 3% to 4% of patients with hemochromatosis complicated by cirrhosis develop hepatocellular carcinoma per year.^{357, 360} There are also reports of hepatoma in hemochromatosis patients who did not have cirrhosis.^{361, 362, 363, 364, 365, 366} The histology of primary liver cancer in hemochromatosis is heterogeneous. Although the majority of primary liver cancers in hemochromatosis are of the hepatocellular type, biliary cancers also occur, including cholangiocarcinoma and combined hepatocellular cholangiocarcinoma.^{317, 366}

In some reports, the proportion of patients with hepatocellular carcinoma who also have C282Y homozygosity^{367, 368} or C282Y heterozygosity is significantly increased.^{368, 369, 370} In another report, the prevalence of HFE mutations in patients with hepatocellular carcinoma was similar to that in control subjects.³⁷¹ Positive associations of HFE mutations, chronic viral hepatitis, and hepatocellular carcinoma have been reported.^{367, 370} Recent guidelines have been published about the evaluation and management of patients who have hepatocellular carcinoma.^{372, 373, 374}

Colorectal Polyps and Colorectal Cancer

In the Prostate, Lung, Colorectal and Ovarian Cancer Screening Trial, a study of 679 persons with advanced distal adenoma and 697 control persons revealed no significant relationship of C282Y and H63D or dietary iron intake on the risk of advanced distal adenomatous colorectal polyps.³⁷⁵ In a study of 475 case patients and 833 control subjects, C282Y and H63D mutations were associated with an increased risk of colon cancer.³⁷⁶ In a cohort study of 28,509 participants, C282Y homozygotes had twofold increased risk for colorectal cancer and female C282Y homozygotes were at twofold increased risk for breast cancer.³⁷⁷

Other Types of Cancer

Iron can be carcinogenic. Possible mechanisms of carcinogenesis include redox cycling of iron, that produces reactive oxygen species and free radicals, which in turn cause lipid peroxidation and damage to proteins and DNA.³⁷⁸ Iron may facilitate tumor cell growth and modify immune system responses.³⁷⁹ The results of some studies suggested that HFE mutations were associated with

P.676

colorectal or breast or other carcinomas,^{377, 380, 381, 382} whereas results of some studies did not identify HFE mutations as a risk factor for cancer.^{383, 384, 385, 386} In the cohort study of 28,509 participants cited above, male C282Y homozygotes did not have increased risk for prostate cancer.³⁷⁷ C282Y/H63D compound heterozygotes and C282Y heterozygotes did not have increased risk for colorectal, breast, prostate, or other cancers.³⁷⁷ In a meta-analysis of the risk of 66,263 people with HFE mutations to develop 31 different disorders, compared with 226,515 control subjects without HFE mutations, there was no identifiable risk for the development of cancers other than hepatocellular carcinoma.³⁸⁴

Porphyria Cutanea Tarda

The most common type of porphyria is sporadic porphyria cutanea tarda. An elevated amount of storage iron is characteristic of this disorder. The interaction of iron and porphyria cutanea tarda has been reviewed.^{112, 387, 388, 389} In addition, the presence of one or two HFE C282Y or H63D mutations is common in subjects with sporadic porphyria cutanea tarda and increased storage iron. Some patients with porphyria cutanea tarda (either sporadic or familial) and heavy iron loading are homozygous for HFE mutations.^{109, 111, 390, 391, 392, 393}

Porphyria cutanea tarda occurs in individuals who have decreased activity of uroporphyrinogen decarboxylase which results in the accumulation of uroporphyrinogen I. In the presence of excess iron, accumulated uroporphyrinogen undergoes iron-mediated oxidation, resulting in production of uroporphomethene. Uroporphomethene then further inhibits the already decreased activity of uroporphyrinogen decarboxylase.^{394, 395} An association of the uroporphyrinogen

decarboxylase gene on chromosome 1q and hemochromatosis alleles on chromosome 6p was first reported in 1989.¹⁰⁹ This was substantiated after HFE was cloned and sequenced and HFE mutations were identified.^{111, 112, 396} In a study of 108 subjects in Utah who had porphyria cutanea tarda, 19% were C282Y homozygotes and 7% were C282Y/H63D compound heterozygotes.¹¹¹ The HFE mutation(s) causes increased iron absorption which further depresses the already decreased activity of the enzyme uroporphyrinogen decarboxylase. This results in the accumulation of uroporphyrin I in organs. Deposition of porphyrin in skin causes photosensitivity, blistering, and scarring.

Risk factors for the expression of porphyria cutanea tarda include common HFE mutations,^{396, 397, 398, 399, 400, 401, 402, 403} hepatitis C, alcoholism, oral estrogen therapy (but possibly not transdermal estrogen),^{110, 387, 398} and tamoxifen.³⁹⁷ Hepatitis C infection, a potent risk factor, occurs in 28% to 74% of individuals with porphyria cutanea tarda. A 2002 study from Galveston was performed to assess the factors involved in the expression of porphyria cutanea tarda.³⁹⁹ In 39 consecutive patients with porphyria cutanea tarda, 9% had HFE genotype C282Y/C282Y, 9% had C282Y/wt, 12% had C282Y/H63D, 9% had H63D/H63D, and 26% had H63D/wt. None had the S65C mutation. Among these patients, 79% drank alcohol, 73% of 11 women took estrogens, 86% were smokers, and 74% were positive for the hepatitis C antibody. The authors concluded that HFE mutations were common and that the expression of porphyria cutanea tarda was multifactorial. Three or more risk factors for expression of porphyria cutanea tarda were detected in 92% of the 39 patients.³⁹⁹

The prevalence of the C282Y, H63D, and S65C mutations of HFE and antibody to the hepatitis C virus was compared in 65 patients with sporadic porphyria cutanea tarda and in 108 control subjects.⁴⁰⁰ Of the porphyria patients, 17% had the C282Y mutation (4% of controls). There was no significant difference in the prevalence of the H63D and S65C mutations or compound C282Y/H63D heterozygosity between groups. Hepatitis C antibodies were detected in 28% of the patients with porphyria cutanea tarda. In another study of porphyria cutanea tarda patients in France, hepatitis C was identified as the major risk factor for porphyria.⁴⁰¹

In a study of 190 German patients with sporadic porphyria cutanea tarda and 115 age-matched healthy blood donors, 39% of patients with porphyria had HFE C282Y (3% of control subjects) and 12% were C282Y homozygotes (0% of controls).⁴⁰² The H63D mutation was present in 45% of patients with porphyria (10% of controls) and 9% of patients with porphyria were C282Y/H63D compound heterozygotes. In studies among the Basque population in Spain, patients with porphyria cutanea tarda did not have increased frequency of HFE C282Y, H63D, or S65C mutations. Hepatitis C was present in 35% of the porphyria patients.⁴⁰³

Tamoxifen therapy in patients with breast cancer has been associated with the occurrence of porphyria cutanea tarda.^{397, 404, 405} A woman with porphyria cutanea tarda that was caused by oral contraceptives only experienced full remission of porphyria while undergoing anastrozole therapy for metastatic adenocarcinoma of the breast.⁴⁰⁴

Steatohepatitis

Many reports of the prevalence of HFE gene mutations and/or hyperferritinemia in subjects with nonalcoholic steatohepatitis were reviewed recently.^{406, 407, 408, 409, 410, 411, 412, 413, 414, 415, 416, 417, 418, 419, 420, 421} In 36 men in Massachusetts who had nonalcoholic steatohepatitis, 2.8% were C282Y homozygotes, 17.0% were C282Y heterozygotes, 5.6% were H63D homozygotes, and 44.0% were H63D heterozygotes.⁴¹⁹ In 348 control subjects, none was a C282Y homozygote, 11.0% were C282Y heterozygotes, 2.9% were H63D homozygotes, and 26.0% were heterozygous for the H63D mutation. Individuals with nonalcoholic steatohepatitis who had a HFE mutation had higher levels of transferrin saturation and serum ferritin, and those with C282Y had significantly higher levels of alanine aminotransferase and a greater level of hepatic fibrosis than those without C282Y.⁴¹⁹ Insulin resistance syndrome is common in people who have nonalcoholic steatohepatitis, with or without mutations of HFE.^{415, 417, 420, 421, 422}

Hereditary Spherocytosis

Individuals who have hereditary spherocytosis may develop severe iron overload and hepatic cirrhosis if they are HFE C282Y homozygotes or heterozygotes.^{393, 423, 424, 425, 426, 427, 428, 429, 430, 431, 432, 433} Iron overload can also occur in patients with hereditary spherocytosis who do not have common HFE mutations.^{434, 435} In a Utah family, for example, two brothers with C282Y homozygosity had iron overload.⁴²⁴ Iron overload in the propositus with both hemochromatosis and hereditary spherocytosis was much more severe than that of his brother who had hemochromatosis without hereditary spherocytosis. The son of the propositus was a C282Y heterozygote who also had hereditary spherocytosis. His serum ferritin concentration and liver iron stores were modestly elevated.

β-Thalassemia Minor

β -Thalassemia minor and hemochromatosis sometimes occur in the same person. In one family, an index patient with β -thalassemia minor and hemochromatosis had a brother with β -thalassemia minor who was a C282Y homozygote. The proband's wife was also a C282Y homozygote. One of their children had β -thalassemia minor and hemochromatosis, whereas the other had hemochromatosis alone. The proband's brother married a woman who was a C282Y/wt heterozygote. Both of their children were C282Y homozygotes.⁴³⁶ Some persons with β -thalassemia minor who have common HFE mutations develop iron load.^{437, 438, 439, 440, 441, 442} In a study of 22 iron-loaded Italian patients with β -thalassemia minor and 62 relatives, β -thalassemia trait appears to worsen the iron-related complications of C282Y homozygosity. It is believed that the mild ineffective erythropoiesis of

P.677

β -thalassemia trait exaggerates the amount of iron absorbed by the duodenum. C282Y heterozygotes and H63D heterozygotes with β -thalassemia trait did not develop iron overload.⁴³⁷ In some other populations, heterozygosity for common HFE mutations appeared to be unassociated with development of iron overload in persons who also had thalassemia minor.^{443, 444, 445, 446}

On the island of Sardinia, an area not reached by Celtic migrations, HFE C282Y is very rare. The H63D mutation prevalence is similar to that of other populations,²⁷⁷ and the prevalence of β -thalassemia minor is 13%.⁴³⁸ Among 152 Sardinian men who had β -thalassemia minor, approximately 2.6% were H63D homozygotes, 29.5% were H63D/wt heterozygotes, and 68% were wt/wt (normal HFE genotype). Concurrent control subjects were not studied.⁴³⁸

In a study from Turin, 71 subjects with transfusion-dependent β -thalassemia major and 200 control subjects were tested for C282Y and H63D.⁴³⁹ None of the patients (or controls) was a C282Y homozygote. One patient (1.4%) was a C282Y/H63D compound heterozygote (similar to 0% among controls); 21.0% of patients (20.0% of controls) were H63D heterozygotes; and one patient (1.4%) was a H63D homozygote (1.0% in controls). The latter patient had greater iron overload than expected. The authors concluded that H63D homozygosity caused the heavy hepatic iron accumulation and advanced hepatic fibrosis. Individuals with either HFE H63D or C282Y were more heavily iron loaded than could be explained by transfusion-dependent homozygous β -thalassemia alone.

Refractory Anemia with Ringed Sideroblasts

Iron accumulation varies in this myelodysplastic disorder.¹⁵⁸ In 40 patients from Switzerland, Greece, and France who had refractory anemia with ringed sideroblasts and nontransfusion iron overload, 1.25% had C282Y. This prevalence was similar to that in 200 normal control subjects (2.50%). The prevalence of the H63D mutation was also similar in patients and controls (19% and 13%, respectively).⁴⁴⁷ Ineffective erythropoiesis alone may account for the increased intestinal absorption of iron in most nontransfused patients with refractory anemia with ringed sideroblasts.

X-Linked Sideroblastic Anemia

Some men with X-linked sideroblastic anemia (mutations of the aminolevulinic synthase gene, (ALAS2) with ringed sideroblasts and heavy iron overload also have HFE mutations. Coinheritance of X-linked sideroblastic anemia and HFE gene mutations was first described in a 59 year-old French man who had hepatic iron overload and C282Y/H63D compound heterozygosity. His iron overload was much more severe than that of his 61 year-old brother who had X-linked sideroblastic anemia but no HFE mutation.⁴⁴⁸

Among 18 unrelated patients with X-linked sideroblastic anemia, 17.0% had HFE C282Y (5.5% in white controls) and 23.0% had H63D (15.0% in controls).⁴⁴⁹ Prevalence of the C282Y mutation was significantly greater in the patients with sideroblastic anemia than in controls, but prevalence of H63D was similar in both groups. After iron depletion, the responsiveness of anemia to pyridoxine supplementation increased in some patients. Coinheritance of one or more HFE mutations and a mild mutation of ALAS2 can result in heavy iron overload.⁴⁵⁰ The iron status of patients with mutations of ALAS2, with or without HFE mutations, has been reviewed.^{451, 452, 453, 454}

Infections in Hemochromatosis Patients

Individuals who have hemochromatosis, especially those with cirrhosis, are susceptible to infection by organisms that rarely cause illness in people with normal body iron stores, including *Vibrio vulnificus* and *Yersinia enterocolitica*.^{455, 456} ^{457, 458, 459, 460, 461, 462, 463, 464, 465, 466, 467, 468} *Listeria*,^{469, 470} *Escherichia coli*,⁴⁷¹ and zygomycosis^{472, 473, 474} may also cause severe and sometimes unusual infections in hemochromatosis patients.

Vibrio vulnificus

V. vulnificus is a motile free-living, Gram-negative bacillus that grows as normal flora in warm coastal saline waters worldwide. It usually does not cause infection in humans except in persons who have iron overload, cirrhosis, compromised immunity, or renal insufficiency. When ingested with raw shellfish (especially oysters), it can cause gastroenteritis, septic arthritis, or fatal septicemia.^{466, 467, 468, 475, 476} Serious wound infections have also occurred in patients with hemochromatosis.⁴⁶⁸ Invasive organisms are encapsulated. The organism thrives in blood that has elevated iron content⁴⁶⁰ but can also derive iron for its own metabolism from erythrocytes or hemoglobin. Most infections in patients with hemochromatosis have been reported from states adjacent to the Gulf of Mexico and from Northern Australia. In both areas, HFE hemochromatosis is common in whites and *V. vulnificus* is abundant in coastal waters.

Yersinia enterocolitica

Y. enterocolitica belongs to the family Enterobacteriaceae. It can cause transfusion-associated sepsis, gastroenteritis, septic arthritis, hepatic abscesses, osteomyelitis, or bloody diarrhea. It is usually ingested in contaminated water, pork, milk, bean sprouts, or chocolate.^{477, 478} Unlike *V. vulnificus*, *Yersinia* is often present in colder climates or occurs as a contaminant in any climate. In patients with hemochromatosis, *Yersinia* can cause severe infections,⁴⁰⁴ including bacteremia⁴⁷⁷ and multiple hepatic abscesses.^{470, 478, 479, 480, 481, 482, 483}

IgG Deficiency

Some patients with hemochromatosis and HFE C282Y homozygosity have frequent, severe, or unusual infections and common variable immunodeficiency or immunoglobulin (Ig) G subclass deficiency.⁴⁸⁴ Approximately 30% of probands have selective IgG isotype deficiency, especially that of subclasses IgG₁ or IgG₃. Deficiency of IgA or IgM is uncommon. Mean values of age, transferrin saturation, and serum ferritin at diagnosis and phlebotomy units required to induce iron depletion were similar in probands with or without CVID or IgGSD; phlebotomy had no effect on IgG levels.⁴⁸⁴ There was concordance of Ig and hemochromatosis phenotypes in probands and respective human leukocyte antigen (HLA)-identical siblings and a significant positive association of selective IgG deficiency to C282Y-bearing chromosome 6p HLA haplotypes that included HLA-A*03, B*07. This suggests that a gene that modulates IgG subclass levels occurs on these hemochromatosis-associated chromosomes.⁴⁸⁴

Coronary Artery Disease

Hemochromatosis can cause cardiac arrhythmias or congestive heart failure due to siderosis of conducting fibers and cardiac myocytes.^{297, 300, 302, 485, 486, 487, 488, 489, 490, 491, 492} This complication is much more prevalent in juvenile hemochromatosis than in HFE hemochromatosis. It was estimated that German adults with hemochromatosis had a 300-fold increased risk of developing cardiomyopathy.³¹⁵ In a more recent Swedish study of nationwide, population-based health and census registers, the risk of cardiomyopathy in persons with hemochromatosis was significantly elevated (hazard ratio 3.2 [95% CI 2.15 to 4.81]), but the risk of ischemic heart disease was barely elevated.⁴⁹³ Neither cardiomyopathy nor ischemic heart disease risk was increased in first-degree relatives of persons with hemochromatosis.⁴⁹³ Most studies have revealed no association between coronary

P.678

artery disease and HFE mutations.^{494, 495, 496, 497, 498, 499, 500, 501, 502, 503, 504, 505} Other studies suggest that an association exists.^{506, 507} Total mean serum cholesterol and low-density lipoprotein levels were lower in C282Y homozygotes than in HFE wild-type participants in the HEIRS Study.⁵⁰⁸ Whether these differences influence manifestations of coronary or peripheral atherosclerosis in C282Y homozygotes is unknown.

DIAGNOSIS

History and Physical Examination Findings

Recent guidelines and reviews have been published about screening and about the evaluation and management of individuals in whom hemochromatosis is suspected, and for relatives of a person who has HFE hemochromatosis.^{360, 509, 510, 511, 512, 513} A large percentage of HFE C282Y homozygotes who are identified during screening studies do not have symptoms of illness and do not have persistently elevated serum ferritin concentration.^{136, 278, 287, 514, 515} Currently, screening of the general population for hemochromatosis is not recommended.⁵¹⁶

Hemochromatosis with iron overload may be suspected in an individual who has some combination of the following: arthralgias, right upper quadrant abdominal pain, impotence, palpitations, unexplained fatigue or weight loss, gray-bronze skin, hepatomegaly, stigmata of portal hypertension, diabetes, or hypogonadism. Most hemochromatosis homozygotes do not have these findings. Individuals in whom the diagnosis is established during routine screening are nearly always

asymptomatic and have no physical examination abnormalities. People in whom the diagnosis is established after seeking evaluation due to illness usually have several of the symptoms and physical examination abnormalities stated above. Only heavily iron-loaded patients with far-advanced organ injury have all of the above symptoms and physical examination abnormalities. The wide variation in the frequency of symptoms and signs of hemochromatosis from 12 reports appears in Tables 25.6, Tables 25.7, Tables 25.8 and 25.9.

Laboratory Findings

Transferrin saturation is the first blood test to become elevated in hemochromatosis homozygotes and usually is greater than 60% in symptomatic men and greater than 50% in symptomatic women.^{245, 302, 303, 517} Unbound iron-binding capacity is usually decreased in untreated homozygotes.^{518, 519, 520, 521} In iron-loaded patients, serum ferritin concentration is elevated. Liver stainable iron and the hepatic iron index are also elevated in iron-loaded homozygotes. The sensitivity of elevated transferrin saturation to identify a patient with hemochromatosis is 94% to 98%, and its specificity is 70% to 98%.^{303, 517} Typical results of transferrin saturation and serum ferritin concentration in different groups of hemochromatosis homozygotes are displayed in Tables 25.10 and 25.11. HFE C282Y homozygosity was present in 89% of hemochromatosis patients in the Utah studies, whether or not iron overload was present.²⁴⁵

Evaluation of Relatives

After the diagnosis of hemochromatosis is established in an index patient (proband), it is important to study his or her siblings. Test selection is the same as for the index patient: transferrin saturation; serum ferritin concentration; and HFE mutation analysis to identify C282Y, H63D, and S65C alleles. Young homozygous siblings of a hemochromatosis proband may have a normal serum ferritin concentration.²⁴⁵ Serum ferritin levels should be measured at 2- or 3-year intervals. When serum ferritin becomes elevated, it is reasonable to begin intermittent phlebotomy therapy to prevent accumulation of excess iron in the liver and other organs.

HFE homozygous relatives who have marked elevation of serum ferritin concentration greater than 700 $\mu\text{g/L}$ ⁵²² or greater than 1,000 $\mu\text{g/L}$ ^{523, 524} and elevated serum concentrations of hepatic transaminases may have hepatic cirrhosis. Liver biopsy in such individuals is usually necessary to determine the presence or absence of hepatic fibrosis or cirrhosis and allows measurement of hepatic iron stores. Typical liver biopsy findings in iron-loaded homozygotes appear in Figure 25.1 and Table 25.12. The great majority of homozygous relatives identified during family screening are less iron loaded and have fewer complications than their corresponding probands. Authors of a recent article made recommendations about when and for whom to advise liver biopsy in these settings.⁵²⁵

Heterozygous Relatives

HFE heterozygotes do not become iron loaded unless they have an additional disorder that increases iron accumulation.⁵²⁶ There was no difference in the amount of heme iron or non-heme-iron absorption in C282Y heterozygotes and normal control subjects. Similarly, differences in non-transferrin-bound iron, transferrin saturation, or serum ferritin levels did not differ significantly between C282Y heterozygotes and normal controls.⁵²⁷ Transferrin saturation and serum ferritin concentration measurements in large numbers of C282Y heterozygotes and normal individuals are displayed in Table 25.11.²⁷⁸

Because approximately 10% of whites of Central, Western, and Northern European ancestry are C282Y heterozygotes, the occurrence of hemochromatosis in whites in consecutive generations is common. It seems reasonable to measure transferrin saturation or unbound iron-binding capacity in the interested parents and adult children of homozygotes, in addition to all siblings of the proband.

Homozygous Relatives

In a study of the relatives of 291 hemochromatosis probands, 214 homozygous relatives were identified.²⁴⁵ When these 214 clinically unselected individuals were stratified by age and sex, it became apparent that 90% of the homozygous male relatives were iron loaded by age 40 years, and 52% had iron-related organ injury. Clinically unselected female homozygous relatives became iron loaded on average approximately one decade later

P.679

than men. After age 50, 88% of clinically unselected female homozygous relatives became iron loaded and 16% of them had iron-related organ injury.²⁴⁵ The results of transferrin saturation and serum ferritin concentration tests in 291 probands and their 214 clinically unselected homozygous relatives in the Utah studies are displayed in Table 25.10.

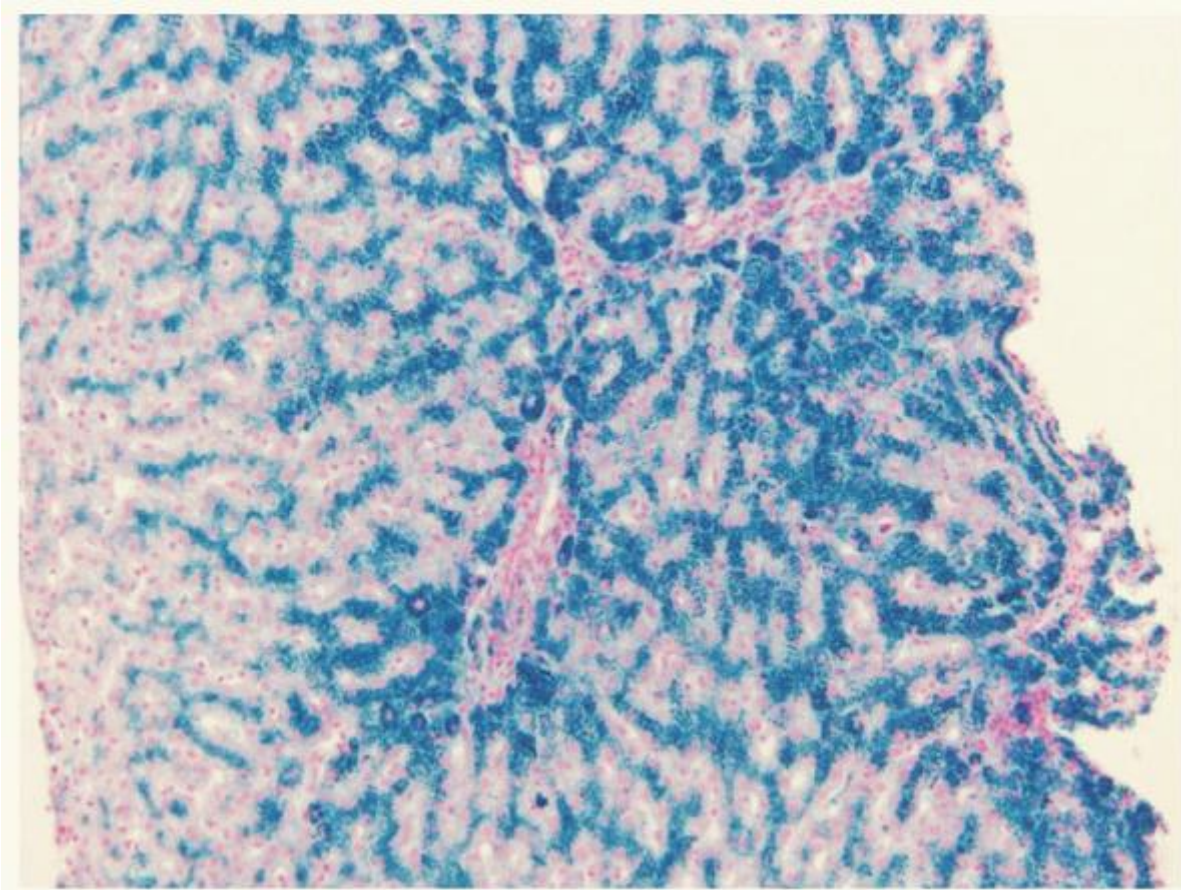

FIGURE 25.1. Grade 4 hepatic parenchymal cell stainable iron in a 30-year-old asymptomatic HFE C282Y homozygous woman who was evaluated after her sick brother was found to have hemochromatosis.

MANAGEMENT

Phlebotomy Therapy

Detailed discussions of phlebotomy therapy for hemochromatosis patients have been published.^{303, 528} Overall, men require approximately twice as many units of phlebotomy to induce iron depletion as women.^{301, 303, 529} Complications of hemochromatosis that respond to and complications that do not improve after phlebotomy therapy are displayed in Table 25.13. Treatment for specific problems usually should be managed as in patients who do not have hemochromatosis.

Initial Weekly Phlebotomy Schedule

The main treatment of iron-loaded hemochromatosis patients is phlebotomy therapy.^{303, 528, 529} In a phlebotomy of 500 ml of whole blood with a hematocrit of 40%, 200 ml of packed red blood cells are removed. Because each 1 ml of packed red cells contains about 1 mg of iron, each 500-ml phlebotomy removes about 200 mg of iron. When the diagnosis of iron overload due to hemochromatosis is established, it is important to start the first phase of phlebotomy therapy. Serum ferritin level, not serum iron or transferrin saturation levels, should be used to monitor levels of storage iron during phlebotomy.⁵³⁰

TABLE 25.13 CLINICAL CHANGES EXPECTED FOLLOWING PHLEBOTOMY THERAPY

Observed Complications of Iron Overload	Expected Treatment Outcome
No complications	Prevention of complications of iron overload; normal life expectancy.
Weakness, fatigue, lethargy	May resolve if only due to iron overload.
Elevated hepatic transaminases in serum	Resolution or marked improvement.

Hepatomegaly	Resolution often occurs.
Hepatic cirrhosis ^a	Usually no change.
Increased risk for primary liver cancer ^b	May persist in presence of cirrhosis.
Right upper quadrant pain ^c	Resolution if only due to iron overload.
Arthropathy	Arthralgias may improve; joint deformity not expected to resolve; worsening sometimes occurs.
Hypogonadotropic hypogonadism	May resolve if pituitary injury is not extensive.
Diabetes mellitus	Occasional improvement, often temporary.
Hyperthyroidism, hypothyroidism	Resolution is rare.
Cardiomyopathy	Resolution sometimes occurs.
Hyperpigmentation	Resolution usually occurs.
Hyperferritinemia ^d	Resolution.
Hyperferremia	Usually decreases, then rises again after cessation of phlebotomies.
Excess absorption and storage of nonferrous metals ^e	Little or no change.
Infection with <i>Vibrio vulnificus</i> or other bacteria	Little or no change.

^a Regression was reported in some patients. Falize L, Guillygomarch A, Perrin M, Laine F, Guyader D, Brissot P, Turlin B, Deugnier Y. *Hepatology* 2006;44:472-477.⁴⁴⁶

^b Increased risk is usually only in those who have hepatic cirrhosis.

^c Right upper quadrant pain that is only due to iron overload usually improves, but not if the pain is due to hepatocellular carcinoma, portal vein thrombosis, gallbladder disease, or other non-iron causes.

^d Serum iron levels may be normal or subnormal in persons with hemochromatosis due to severe iron deficiency, chronic inflammatory or infectious disease, vitamin C deficiency, or prolonged fasting.

^e Cobalt, manganese, zinc, and lead.

Modified from Barton JC, McDonnell SM, Adams PC, et al. Management of hemochromatosis. *Ann Intern Med* 1998;129:935.⁵²⁸ Used with permission of publisher.

Most iron-loaded homozygotes tolerate removal of 500 ml of whole blood each week. Some women, small individuals, or elderly patients may only tolerate removal of 250 ml of whole blood each week. Twice-weekly phlebotomy may be performed for very heavily iron-loaded patients who have cardiac arrhythmias or hepatic failure in an effort to improve cardiac and hepatic function quickly. Phlebotomy therapy should be continued until the hemoglobin drops by approximately 1 to 2 g/dl below baseline, the mean corpuscular volume drops by approximately 3 to 5 fl below baseline, and serum ferritin concentration drops to 20 to 50 µg/L. These findings provide evidence of iron-limited erythropoiesis, which concludes the initial rapid sequence phase of phlebotomy therapy. The patient then enters the second, life-long maintenance phase of phlebotomy therapy.^{303, 528, 529, 530, 531, 532}

Life-long Maintenance Phlebotomy Schedule

After the initial iron depletion is accomplished, the patient enters the life-long maintenance phase of phlebotomy therapy. Removal of 500 ml of whole blood every 2 to 4 months (every 3 to 6 months in women) prevents re-accumulation of

excessive organ storage iron. The goals of life-long maintenance phlebotomy therapy include maintenance of a normal hemoglobin level and maintenance

P.680

of the serum ferritin concentration less than 300 µg/L in men and less than 200 µg/L in women.⁵³³ A very low serum ferritin and the presence of anemia indicate that the frequency of phlebotomy therapy can be decreased to 4- or 6-month intervals.

Patients and physicians often want to estimate the duration of weekly phlebotomy therapy to achieve iron depletion. Based on a study of the correlation of serum ferritin to the number of grams of iron removed by phlebotomy therapy, 1 µg/L of pretreatment serum ferritin corresponded to ~8 mg of mobilizable iron.⁵²² A person whose pretreatment serum ferritin concentration is 600 µg/L is likely to have ~4,800 mg (8×600 mg) of mobilizable storage iron. Each ml of centrifuged red blood contains about 1 mg of iron and each 500-ml unit of blood with a hematocrit of 40% contains approximately 200 mg of iron. Therefore, a patient whose serum ferritin is 600 µg/L is predicted to undergo ~24 units of phlebotomy to achieve iron depletion ($[8 \times 600 \text{ mg}] = 4,800 \text{ mg}/200 \text{ mg/unit} = 24 \text{ units}$). This simple estimate holds reasonably well except in patients whose serum ferritin is elevated out of proportion to storage iron due to hepatic necrosis or another source of inflammation that causes hyperferritinemia. After patients achieve iron depletion by phlebotomy, the number of units of whole blood removed, multiplied by 200 mg iron per phlebotomy, provides a reliable calculation of the number of grams of iron that were removed.

Hemochromatosis Homozygotes as Blood Donors

Experts in the Department of Transfusion Medicine at the National Institutes of Health in Bethesda studied hemochromatosis patients as blood donors for patients treated at the National Institutes of Health.⁵³⁴ They evaluated 1,402 units of blood from hemochromatosis donors and concluded that if such individuals do not have serologic results necessitating deferral, they do not pose a health risk for recipients. The authors also noted that these donors could significantly augment the blood supply at the Institutes. After 27 months of study, blood from hemochromatosis donors represented 14% of all blood donations. In another report, an ethicist at the Centre for Environmental Philosophy and Bioethics of the University of Ghent, Belgium concluded that hemochromatosis patients can be free, voluntary, altruistic blood donors if they do not request any benefit other than blood removal.⁵³⁵ When phlebotomy therapy is performed in a setting other than a blood bank, the blood cannot be collected and processed properly for future transfusion.

Clinical Changes after Iron Depletion

If hepatic cirrhosis and arthropathy were not present before iron depletion therapy, these complications of hemochromatosis may be preventable by initial iron depletion followed by life-long maintenance phlebotomy therapy. An important question is whether hepatic fibrosis or cirrhosis can diminish following iron depletion. Regression of hepatic fibrosis was studied in 36 hemochromatosis patients who underwent two liver biopsies, the first one before and the second after iron depletion, with an interval of at least 2 years between biopsies.⁵³⁶ Regression of fibrosis occurred in 9 of 13 patients whose initial fibrosis was far advanced (grade 3), and in 8 of 23 whose initial biopsy showed cirrhosis (grade 4). The clinical changes that may occur following iron depletion appear in Table 25.13.⁵²⁸

Dietary Recommendations

Persons with hemochromatosis have increased risk to develop a life-threatening infection with *V. vulnificus* from raw shellfish (see the section, "Infections"). It is prudent to advise these individuals not to consume raw shellfish, although consumption of cooked shellfish is safe. Much more iron can be removed in each 500-ml whole blood phlebotomy each week than can be absorbed during that week. For this reason, it is not necessary to impose severe dietary restrictions in an attempt to avoid all foods that contain iron. Regardless, heme iron of meat, especially red meat, is readily absorbed. It is reasonable to advise patients to eat red meat in moderation, to decrease dietary intake of saturated fat and animal protein, and to increase consumption of fresh vegetables and fruit, as for anyone else who follows a prudent cardiovascular diet.⁵²⁸

Alcohol Intake

Alcohol can be hepatotoxic. Individuals with hepatic damage from iron overload may benefit from avoiding drinks containing alcohol. It is estimated that 30 g^{317, 537} or greater than 60 g^{538, 539} of alcohol per day can worsen iron-related liver damage. Consumption of these amounts of alcohol by a person with cirrhosis may also increase the risk of hepatocellular carcinoma.^{317, 538, 539}

Vitamins

It is reasonable to advise hemochromatosis patients to avoid medicinal intake of vitamin C (ascorbic acid) because it can increase the absorption of dietary iron, mobilization of storage iron, or production of free radicals.^{540, 541, 542, 543, 544} Vitamin C also may cause oxidative damage of the myocardium and cardiac conduction system, resulting in rare fatal arrhythmias in ironloaded patients who have hemochromatosis or thalassemia major.^{541, 544, 545, 546, 547} It seems reasonable for hemochromatosis patients to not take multiple vitamins that contain iron.

PROGNOSIS

The outlook for an iron-loaded hemochromatosis patient is related to whether the patient undergoes iron depletion therapy before the development of cirrhosis or diabetes mellitus. In a study of 111 hemochromatosis patients in England, the average survival of 85 people who underwent phlebotomy therapy was 63 months, compared with 18 months in the 26 subjects who did not become iron depleted.³¹⁴ In a study of survival among 251 hemochromatosis patients in Germany, survival of those who became iron depleted was similar to that of the background population.³⁰⁰ Hemochromatosis patients with diabetes had a 10-year survival of 65%; in patients without diabetes, the survival was 90%. The 10-year survival of hemochromatosis patients with cirrhosis was 72%, whereas survival of patients without cirrhosis was 82%. Iron overload that could not be depleted within 18 months from the onset of phlebotomy therapy was also associated with decreased survival. In 422 hemochromatosis probands homozygous for HFE C282Y, serum levels of ferritin greater than 1,000 µg/L at diagnosis were positively associated with male sex and cirrhosis. Even with treatment, the relative risk of death from iron overload was fivefold greater in probands with serum levels of ferritin greater than 1,000 µg/L.⁵⁴⁸ Additional reports of survival and prognosis of hemochromatosis patients have been published.^{299, 325, 549, 550}

IMAGING OF THE LIVER

Computed Tomographic Scanning of the Liver

Single-energy computed tomographic (CT) scanning is not adequately sensitive to distinguish hepatic iron overload from a fatty liver. CT scanning also has very limited value in the assessment of sources of hepatic inhomogeneity, including edema, regenerative nodules, perfusion abnormalities, iron, fibrosis, or cirrhosis.⁵⁵¹ Similarly, density histogram analysis of unenhanced hepatic CT does not distinguish among most diffuse liver diseases.⁵⁵²

P.681

Dual-energy CT scanning is able to distinguish hepatic iron from fat.⁵⁵³ In a dual-energy CT scan, an iron-loaded liver appears brighter than paraspinous muscles.

Magnetic Resonance Imaging of the Liver

Magnetic resonance (MR) imaging has largely replaced CT scanning in the evaluation of livers that are presumed to be cirrhotic. Some of the advantages of MR scanning include superior contrast resolution, multiplanar capability, greater sensitivity and specificity in the detection and characterization of abnormalities, and no use of ionizing radiation.⁵⁵¹ MR imaging can be used to identify hepatic cirrhosis, regenerating nodules, increased iron, and hepatocellular carcinoma in subjects who have hemochromatosis.^{554, 555, 556, 557, 558, 559, 560, 561, 562, 563, 564}

Iron is a paramagnetic element that becomes magnetized in a magnetic field. The result is that the transverse (T2) relaxation time of iron becomes shortened compared with the longitudinal (T1) relaxation time. In an iron-loaded liver, the shortened T2 relaxation time causes a decrease in signal intensity. The result is that an iron-loaded liver appears darker than paraspinous muscles on T2-weighted MR images. The proton transverse relaxation rate (R2) is related to the presence of iron. For this reason, the R2 value is expected to allow measurement of a wide range of liver iron concentrations on MRI machines that have a magnetic field strength of 1.5 Tesla.⁵⁵⁵ Comparison of both MR imaging and biomagnetic liver susceptometry in 23 patients yielded a high correlation over a wide range of hepatic iron concentration.⁵⁵⁶

Gradient-echo MR scanning after gadolinium is considered to provide the most useful information about iron stores, using both T1- and T2-weighted images. An MR magnet strength of 1.5 tesla provides better predictive ability than a 0.5-tesla magnet. The intensity of the signal in liver is often compared to signal intensity in paraspinous muscles. Iron causes increased attenuation of the gradient-echo signal in hepatocytes,^{551, 554, 557, 559, 560} which means that iron-loaded liver tissue appears darker than paraspinous muscle. Whereas CT cannot quantify iron stores less than five times normal, gradient-echo MR allows quantification of iron stores that are minimally increased.^{555, 557, 561, 562, 563, 564}

Gradient-echo sequences allow quantification of storage iron that correlates well with chemical measurement of iron in a liver biopsy sample. Thus, MR scanning can provide credible estimation of the hepatic iron concentration in patients who, for any reason, do not undergo liver biopsy. After iron depletion, there is a decreased amount of attenuation of the gradient-echo signal, so the liver appears lighter than before.^{561, 562, 563, 564} Conventional T1-weighted and T2-weighted spin-echo MR⁵⁶⁵ or MR T2-star (T2*) imaging^{565, 566, 567, 568} can identify increased amounts of iron in myocardium and liver. Organs that are iron loaded have low signal intensity, so they appear dark on T2* MR images.

REFERENCES

1. Roetto, A., A. Totaro, M. Cazzola, et al. Juvenile hemochromatosis locus maps to chromosome 1q. *Am J Hum Genet* 1999;64(5):1388-1393.
2. Rivard, S.R., C. Lanzara, D. Grimard, et al. Juvenile hemochromatosis locus maps to chromosome 1q in a French Canadian population. *Eur J Hum Genet* 2003;11(8):585-589.
3. Janosi, A., H. Andrikovics, K. Vas, et al. Homozygosity for a novel nonsense mutation (G66X) of the HJV gene causes severe juvenile hemochromatosis with fatal cardiomyopathy. *Blood* 2005;105(1):432.
4. Cazzola, M., P. Cerani, A. Rovati, et al. Juvenile genetic hemochromatosis is clinically and genetically distinct from the classical HLA-related disorder. *Blood* 1998;92(8):2979-2981.
5. Bezwoda, W.R., P.B. Disler, S.R. Lynch, et al. Patterns of food iron absorption in iron-deficient white and indian subjects and in venesected haemochromatotic patients. *Br J Haematol* 1976;33(3):425-436.
6. Milder MS, Cook JD, Finch CA. Influence of food iron absorption on the plasma iron level in idiopathic hemochromatosis. *Acta Haematol* 1978;60(2): 65-75.
7. Papanikolaou, G., M.E. Samuels, E.H. Ludwig, et al. Mutations in HFE2 cause iron overload in chromosome 1q-linked juvenile hemochromatosis. *Nat Genet* 2004;36(1):77-82.
8. Lanzara, C., A. Roetto, F. Daraio, et al. Spectrum of hemojuvelin gene mutations in 1q-linked juvenile hemochromatosis. *Blood* 2004;103(11):4317-4321.
9. Lee, P.L., E. Beutler, S.V. Rao, J.C. Barton. Genetic abnormalities and juvenile hemochromatosis: mutations of the HJV gene encoding hemojuvelin. *Blood* 2004;103(12):4669-4671.
10. Robson, K.J., A.T. Merryweather-Clarke, E. Cadet, et al. Recent advances in understanding haemochromatosis: a transition state. *J Med Genet* 2004;41(10):721-730.
11. Gehrke, S.G., A. Pietrangelo, M. Kascak, et al. HJV gene mutations in European patients with juvenile hemochromatosis. *Clin Genet* 2005;67(5):425-428.
12. Rivard, S.R., C. Mura, H. Simard, et al. Clinical and molecular aspects of juvenile hemochromatosis in Saguenay-Lac-Saint-Jean (Quebec, Canada). *Blood Cells Mol Dis* 2000;26(1):10-14.
13. Roetto, A., G. Papanikolaou, M. Politou, et al. Mutant antimicrobial peptide hepcidin is associated with severe juvenile hemochromatosis. *Nat Genet* 2003;33(1):21-22.
14. Roetto, A., F. Daraio, P. Porporato, et al. Screening hepcidin for mutations in juvenile hemochromatosis: identification of a new mutation (C70R). *Blood* 2004;103(6):2407-2409.
15. Beutler L, Beutler E. Hematologically important mutations: iron storage diseases. *Blood Cells Mol Dis* 2004;33(1):40-44.
16. Delatycki, M.B., K.J. Allen, P. Gow, et al. A homozygous HAMP mutation in a multiply consanguineous family with pseudo-dominant juvenile hemochromatosis. *Clin Genet* 2004;65(5):378-383.
17. Majore, S., F. Binni, A. Pennese, et al. HAMP gene mutation c.208T>C (p.C70R) identified in an Italian patient with severe hereditary hemochromatosis. *Hum Mutat* 2004;23(4):400.
18. Matthes, T., P. Aguilar-Martinez, L. Pizzi-Bosman, et al. Severe hemochromatosis in a Portuguese family associated with a new mutation in the 5'-UTR of the HAMP gene. *Blood* 2004;104(7):2181-2183.
19. Nemeth, E., M.S. Tuttle, J. Powelson, et al. Hepcidin regulates cellular iron efflux by binding to ferroportin and inducing its internalization. *Science* 2004;306(5704):2090-2093.
20. Camaschella, C., A. Roetto, A. Cali, et al. The gene TFR2 is mutated in a new type of haemochromatosis mapping to 7q22. *Nat Genet* 2000;25(1):14-15.

21. Roetto, A., A. Totaro, A. Piperno, et al. New mutations inactivating transferrin receptor 2 in hemochromatosis type 3. *Blood* 2001;97(9):2555-2560.
22. Cazzola M. Novel genes, proteins, and inherited disorders of iron overload: iron metabolism is less boring than thought. *Haematologica* 2002;87(2): 115-116.
23. Mattman, A., D. Huntsman, G. Lockitch, et al. Transferrin receptor 2 (TfR2) and HFE mutational analysis in non-C282Y iron overload: identification of a novel TfR2 mutation. *Blood* 2002;100(3):1075-1077.
24. Roetto A, Camaschella C. New insights into iron homeostasis through the study of non-HFE hereditary haemochromatosis. *Best Pract Res Clin Haematol* 2005;18(2):235-250.
25. Chua, A.C., R.D. Delima, E.H. Morgan, et al. Iron uptake from plasma transferrin by a transferrin receptor 2 mutant mouse model of haemochromatosis. *J Hepatol* 2010;52(3):425-431.
26. Nemeth, E., A. Roetto, G. Garozzo, T. Ganz, C. Camaschella Hpcidin is decreased in TFR2 hemochromatosis. *Blood* 2005;105(4):1803-1806.
27. Montosi, G., A. Donovan, A. Totaro, et al. Autosomal-dominant hemochromatosis is associated with a mutation in the ferroportin (SLC11A3) gene. *J Clin Invest* 2001;108(4):619-623.
28. Njajou, O.T., N. Vaessen, M. Joosse, et al. A mutation in SLC11A3 is associated with autosomal dominant hemochromatosis. *Nat Genet* 2001;28(3):213-214.
29. Cremonesi, L., G.L. Forni, N. Soriani, et al. Genetic and clinical heterogeneity of ferroportin disease. *Br J Haematol* 2005;131(5):663-670.
30. De, D.I., D.M. Ward, E. Nemeth, et al. The molecular basis of ferroportinlinked hemochromatosis. *Proc Natl Acad Sci U S A* 2005;102(25):8955-8960.
31. Barton, J.C., R.T. Acton, P.L. Lee, C. West SLC40A1 Q248H allele frequencies and Q248H-associated risk of non-HFE iron overload in persons of sub-Saharan African descent. *Blood Cells Mol Dis* 2007;39(2):206-11.
32. Trousseau A. Glycosurie, diabete sucre. *Cliniq Med hotel Paris* 1865;2:663.
33. Troisier M. Diabete sucre. *Bull Soc Anat Paris* 1871;44:231.
34. Hanot V, Schachmann M. Sur la cirrhose pigmentaire dans de diabete sucre. *Arch Physiol Norm Pathol* 1886;7:50.
35. von Recklinghausen FD. Uber hamochromatose, in Tagelb der Versamml Deutsch Natur und Arzte in Heidelberg1889.324.
36. Feder, J.N., A. Gnirke, W. Thomas, et al. A novel MHC class I-like gene is mutated in patients with hereditary haemochromatosis. *Nat Genet* 1996;13(4):399-408.
37. Mercier B, Mura C, Ferec C. Putting a hold on 'HLA-H'. *Nat Genet* 1997;15(3):234.
38. Bodmer, J.G., P. Parham, E.D. Albert, S.G. Marsh. Putting a hold on 'HLA-H'. The WHO Nomenclature Committee for Factors of the HLA System. *Nat Genet* 1997;15(3):234-235.
39. Saggi R, Feingold J. Idiopathic haemochromatosis: an autosomal recessive disease. *Clin Genet* 1974;5(3):234-241.
40. Simon, M., Y. Pawlotsky, M. Bourel, R. Fauchet, B. Genetet. Letter: idiopathic hemochromatosis associated with HL-A 3 tissular antigen. *Nouv Presse Med* 1975;4(19):1432.
41. Cartwright, G.E., M. Skolnick, D.B. Amos, et al. Inheritance of hemochromatosis: linkage to HLA. *Trans Assoc Am Physicians* 1978;91:273-281.
42. Edwards, C.Q., G.E. Cartwright, M.H. Skolnick, D.B. Amos. Genetic mapping of the hemochromatosis locus on chromosome six. *Hum Immunol* 1980;1(1):19-22.
43. Edwards CQ, Skolnick MH, Kushner JP. Hereditary hemochromatosis: contributions of genetic analyses. *Prog Hematol* 1981;12:43-71.
44. Lipinski, M., J. Hors, J.P. Saleun, et al. Idiopathic hemochromatosis: linkage with HLA. *Tissue Antigens* 1978;11(5):471-474.
45. Simon, M., M. Bourel, B. Genetet, R. Fauchet. Idiopathic hemochromatosis. Demonstration of recessive transmission and early detection by family HLA typing. *N Engl J Med* 1977;297(19):1017-1021.

46. Kravitz, K., M. Skolnick, C. Cannings, et al. Genetic linkage between hereditary hemochromatosis and HLA. *Am J Hum Genet* 1979;31(5):601-619.
47. Cartwright, G.E., C.Q. Edwards, K. Kravitz, et al. Hereditary hemochromatosis. Phenotypic expression of the disease. *N Engl J Med* 1979;301(4): 175-179.
48. Parkkila, S., A. Waheed, R.S. Britton, et al. Immunohistochemistry of HLA-H, the protein defective in patients with hereditary hemochromatosis, reveals unique pattern of expression in gastrointestinal tract. *Proc Natl Acad Sci U S A* 1997;94(6):2534-2539.
49. Feder, J.N., D.M. Penny, A. Irrinki, et al. The hemochromatosis gene product complexes with the transferrin receptor and lowers its affinity for ligand binding. *Proc Natl Acad Sci U S A* 1998;95(4):1472-1477.
50. Lebron, J.A., M.J. Bennett, D.E. Vaughn, et al. Crystal structure of the hemochromatosis protein HFE and characterization of its interaction with transferrin receptor. *Cell* 1998;93(1):111-123.
51. Bacon BR, Schilsky ML. New knowledge of genetic pathogenesis of hemochromatosis and Wilson's disease. *Adv Intern Med* 1999;44:91-116.
52. Lebron JA, West AP Jr, Bjorkman PJ. The hemochromatosis protein HFE competes with transferrin for binding to the transferrin receptor. *J Mol Biol* 1999;294(1):239-245.
53. Philpott CC. Molecular aspects of iron absorption: insights into the role of HFE in hemochromatosis. *Hepatology* 2002;35(5):993-1001.
54. Townsend A, Drakesmith H. Role of HFE in iron metabolism, hereditary haemochromatosis, anaemia of chronic disease, and secondary iron overload. *Lancet* 2002;359(9308):786-790.
55. Fletcher LM, Halliday JW. Haemochromatosis: understanding the mechanism of disease and implications for diagnosis and patient management following the recent cloning of novel genes involved in iron metabolism. *J Intern Med* 2002;251(3):181-192.
56. Fleming RE, Sly WS. Mechanisms of iron accumulation in hereditary hemochromatosis. *Annu Rev Physiol* 2002;64:663-680.
57. Waheed, A., J.H. Grubb, X.Y. Zhou, et al. Regulation of transferrin-mediated iron uptake by HFE, the protein defective in hereditary hemochromatosis. *Proc Natl Acad Sci U S A* 2002;99(5):3117-3122.
58. Parkkila, S., O. Niemela, R.S. Britton, et al. Molecular aspects of iron absorption and HFE expression. *Gastroenterology* 2001;121(6):1489-1496.
59. Smith PM, Godfrey BE, Williams R. Iron absorption in idiopathic haemochromatosis and its measurement using a whole-body counter. *Clin Sci* 1969;37(2):519-531.
60. Lynch SR, Skikne BS, Cook JD. Food iron absorption in idiopathic hemochromatosis. *Blood* 1989;74(6):2187-2193.
61. Crosby WH, Conrad ME Jr, Wheby MS. The Rate of Iron Accumulation in Iron Storage Disease. *Blood* 1963;22:429-440.
62. Adams PC, Kertesz AE, Valberg LS. Rate of iron reaccumulation following iron depletion in hereditary hemochromatosis. Implications for venesection therapy. *J Clin Gastroenterol* 1993;16(3):207-210.
63. Sargent T, Saito H, Winchell HS. Iron absorption in hemochromatosis before and after phlebotomy therapy. *J Nucl Med* 1971;12(10):660-667.
64. Nemeth, E., E.V. Valore, M. Territo, et al. Hpcidin, a putative mediator of anemia of inflammation, is a type II acute-phase protein. *Blood* 2003;101(7):2461-2463.
65. Beaumont C. Molecular mechanisms of iron homeostasis. *Med Sci (Paris)* 2004;20(1):68-72.
66. Nemeth, E., S. Rivera, V. Gabayan, et al. IL-6 mediates hypoferrremia of inflammation by inducing the synthesis of the iron regulatory hormone hepcidin. *J Clin Invest* 2004;113(9):1271-1276.
67. Lee, P., H. Peng, T. Gelbart, E. Beutler. The IL-6- and lipopolysaccharide-induced transcription of hepcidin in HFE-, transferrin receptor 2-, and beta 2-microglobulin-deficient hepatocytes. *Proc Natl Acad Sci U S A* 2004;101(25):9263-9265.
68. Ganz, T, Nemeth E. Iron imports. IV. Hpcidin and regulation of body iron metabolism. *Am J Physiol Gastrointest Liver Physiol* 2006;290(2): G199-G203.
69. Nemeth E, Ganz T. Regulation of iron metabolism by hepcidin. *Annu Rev Nutr* 2006;26:323-342.

70. Ganz T. Hepcidin—a peptide hormone at the interface of innate immunity and iron metabolism. *Curr Top Microbiol Immunol* 2006;306:183-198.
71. Ganz, T, Nemeth E. Regulation of iron acquisition and iron distribution in mammals. *Biochim Biophys Acta* 2006;1763(7):690-699.
72. Krause, A., S. Neitz, H.J. Magert, et al. LEAP-1, a novel highly disulfide-bonded human peptide, exhibits antimicrobial activity. *FEBS Lett* 2000;480(2-3):147-150.
73. Park, C.H., E.V. Valore, A.J. Waring, T. Ganz. Hepcidin, a urinary antimicrobial peptide synthesized in the liver. *J Biol Chem* 2001;276(11):7806-7810.
74. Pigeon, C., G. Ilyin, B. Courselaud, et al. A new mouse liver-specific gene, encoding a protein homologous to human antimicrobial peptide hepcidin, is overexpressed during iron overload. *J Biol Chem* 2001;276(11):7811-7819.
75. Pietrangelo A. Molecular insights into the pathogenesis of hereditary haemochromatosis. *Gut* 2006;55(4):564-568.
76. Weinstein, D.A., C.N. Roy, M.D. Fleming, et al. Inappropriate expression of hepcidin is associated with iron refractory anemia: implications for the anemia of chronic disease. *Blood* 2002;100(10):3776-3781.
77. Dallalio G, Fleury T, Means RT. Serum hepcidin in clinical specimens. *Br J Haematol* 2003;122(6):996-1000.
78. Means RT. Hepcidin and cytokines in anaemia. *Hematology* 2004;9(5-6): 357-362.
79. Andrews NC. Anemia of inflammation: the cytokine-hepcidin link. *J Clin Invest* 2004;113(9):1251-1253.
80. Ganz T. Hepcidin—a regulator of intestinal iron absorption and iron recycling by macrophages. *Best Pract Res Clin Haematol* 2005;18(2):171-182.
81. Papanikolaou G, et al. Hepcidin in iron overload disorders. *Blood* 2005;105(10):4103-4105.
82. Hunter, H.N., D.B. Fulton, T. Ganz, H.J. Vogel. The solution structure of human hepcidin, a peptide hormone with antimicrobial activity that is involved in iron uptake and hereditary hemochromatosis. *J Biol Chem* 2002;277(40):37597-37603.
83. Bridle, K.R., D.M. Frazer, S.J. Wilkins, et al. Disrupted hepcidin regulation in HFE-associated haemochromatosis and the liver as a regulator of body iron homeostasis. *Lancet* 2003;361(9358):669-673.
84. Stuart, K.A., G.J. Anderson, D.M. Frazer, et al. Duodenal expression of iron transport molecules in untreated haemochromatosis subjects. *Gut* 2003;52(7):953-959.
85. Kelleher, T., E. Ryan, S. Barrett, et al. Increased DMT1 but not IREG1 or HFE mRNA following iron depletion therapy in hereditary haemochromatosis. *Gut* 2004;53(8):1174-1179.
86. Pietrangelo A. Hereditary hemochromatosis. *Annu Rev Nutr* 2006;26: 251-270.
87. Beutler E. Cell biology. "Pumping" iron: the proteins. *Science* 2004;306(5704):2051-2053.
88. Andrews NC. Molecular control of iron metabolism. *Best Pract Res Clin Haematol* 2005;18(2):159-169.
89. Siah, C.W., J. Ombiga, L.A. Adams, D. Trinder, J.K. Olynyk. Normal iron metabolism and the pathophysiology of iron overload disorders. *Clin Biochem Rev* 2006;27(1):5-16.
90. Swinkels, D.W., M.C. Janssen, J. Bergmans, J.J. Marx. Hereditary hemochromatosis: genetic complexity and new diagnostic approaches. *Clin Chem* 2006;52(6):950-968.
91. Eaton JW, Qian M. Molecular bases of cellular iron toxicity. *Free Radic Biol Med* 2002;32(9):833-840.
92. Gordeuk VR, McLaren GD, Samowitz W. Etiologies, consequences, and treatment of iron overload. *Crit Rev Clin Lab Sci* 1994;31(2):89-133.
93. Britton RS. Metal-induced hepatotoxicity. *Semin Liver Dis* 1996;16(1):3-12.
94. Britton RS, Bacon BR. Role of free radicals in liver diseases and hepatic fibrosis. *Hepatogastroenterol* 1994;41(4):343-348.
95. Britton RS, Leicester KL, Bacon BR. Iron toxicity and chelation therapy. *Int J Hematol* 2002;76(3):219-228.
96. Fleming, R.E., M.C. Migas, C.C. Holden, et al. Transferrin receptor 2: continued expression in mouse liver in the face of iron overload and in hereditary hemochromatosis. *Proc Natl Acad Sci U S A* 2000;97(5):2214-2219.

97. Le Lan, C., O. Loreal, T. Cohen, et al. Redox active plasma iron in C282Y/C282Y hemochromatosis. *Blood* 2005;105(11):4527-4531.
98. Datz, C., M.R. Lalloz, W. Vogel, et al. Predominance of the HLA-H Cys282Tyr mutation in Austrian patients with genetic haemochromatosis. *J Hepatol* 1997;27(5):773-779.
99. Camaschella, C., A. Roetto, M. Cicilano, et al. Juvenile and adult hemochromatosis are distinct genetic disorders. *Eur J Hum Genet* 1997;5(6):371-375.
100. Roetto, A., F. Alberti, F. Daraio, et al. Exclusion of ZIRT1 as candidate gene of juvenile hemochromatosis and refinement of the critical interval on 1q21. *Blood Cells Mol Dis* 2000;26(3):205-210.
101. Camaschella, C., S. Fargion, M. Sampietro, et al. Inherited HFE-unrelated hemochromatosis in Italian families. *Hepatology* 1999;29(5):1563-1564.
102. Girelli, D., C. Bozzini, A. Roetto, et al. Clinical and pathologic findings in hemochromatosis type 3 due to a novel mutation in transferrin receptor 2 gene. *Gastroenterology* 2002;122(5):1295-1302.
103. Papadopoulos, P., D. Bhavsar, E. Zappone, et al. A second human ferritin H locus on chromosome 11. *Cytogenet Cell Genet* 1992;61(2):107-108.
104. Richard, C.W., 3rd, D.A. Withers, T.C. Meeker, et al. A radiation hybrid map of the proximal long arm of human chromosome 11 containing the multiple endocrine neoplasia type 1 (MEN-1) and bcl-1 disease loci. *Am J Hum Genet* 1991;49(6):1189-1196.
105. Gatti, R.A., R. Shaked, T.K. Mohandas, W. Salser. Human ferritin genes: chromosomal assignments and polymorphisms. *Am J Hum Genet* 1987;41(4): 654-667.
106. Cragg SJ, Drysdale J, Worwood M. Genes for the 'H' subunit of human ferritin are present on a number of human chromosomes. *Hum Genet* 1985;71(2):108-112.
107. Worwood, M., J.D. Brook, S.J. Cragg, et al. Assignment of human ferritin genes to chromosomes 11 and 19q13.3—19qter. *Hum Genet* 1985;69(4):371-374.
108. Kato, J., K. Fujikawa, M. Kanda, et al. A mutation, in the iron-responsive element of H ferritin mRNA, causing autosomal dominant iron overload. *Am J Hum Genet* 2001;69(1):191-197.
109. Edwards, C.Q., L.M. Griffen, D.E. Goldgar, M.H. Skolnick, J.P. Kushner. HLA-linked hemochromatosis alleles in sporadic porphyria cutanea tarda. *Gastroenterology* 1989;97(4):972-981.
110. Bulaj, Z.J., M.R. Franklin, J.D. Phillips, et al. Transdermal estrogen replacement therapy in postmenopausal women previously treated for porphyria cutanea tarda. *J Lab Clin Med* 2000;136(6):482-488.
111. Bulaj, Z.J., J.D. Phillips, R.S. Ajioka, et al. Hemochromatosis genes and other factors contributing to the pathogenesis of porphyria cutanea tarda. *Blood* 2000;95(5):1565-1571.
112. Bonkovsky, H.L., M. Poh-Fitzpatrick, N. Pimstone, et al. Porphyria cutanea tarda, hepatitis C, and HFE gene mutations in North America. *Hepatology* 1998;27(6):1661-1669.
113. Skowron, F., F. Berard, P. Grezard, et al. Role of the hemochromatosis gene in porphyria cutanea tarda. Prospective study of 56 cases. *Ann Dermatol Venereol* 2001;128(5):600-604.
114. Dereure, O., P. Aguilar-Martinez, D. Bessis, et al. HFE mutations and transferrin receptor polymorphism analysis in porphyria cutanea tarda: a prospective study of 36 cases from southern France. *Br J Dermatol* 2001;144(3):533-539.
115. Trombini, P., V. Mauri, A. Salvioni, et al. S65c frequency in Italian patients with hemochromatosis, porphyria cutanea tarda and chronic viral hepatitis with iron overload. *Haematologica* 2001;86(3):316-317.
116. Bonkovsky HL, Lambrecht RW. Iron-induced liver injury. *Clin Liver Dis* 2000;4(2):409-429, vi-vii.
117. Malina, L., E. Zd'arsky, S. Dandova, et al. Significance and prevalence of the C282Y gene mutation of primary hemochromatosis in the pathogenesis of porphyria cutanea tarda. *Cas Lek Cesk* 2000;139(23):728-730.
118. Martinelli, A.L., M.A. Zago, A.M. Roselino, et al. Porphyria cutanea tarda in Brazilian patients: association with hemochromatosis C282Y mutation and hepatitis C virus infection. *Am J Gastroenterol* 2000;95(12):3516-3521.
119. Brady, J.J., H.A. Jackson, A.G. Roberts, et al. Co-inheritance of mutations in the uroporphyrinogen decarboxylase and hemochromatosis genes accelerates the onset of porphyria cutanea tarda. *J Invest Dermatol* 2000;115(5):868-874.

120. Bonkovsky, H.L., D. Naishadham, R.W. Lambrecht, et al. Roles of iron and HFE mutations on severity and response to therapy during retreatment of advanced chronic hepatitis C. *Gastroenterology* 2006;131(5):1440-1451.
121. Christiansen, L., A. Bygum, K. Thomsen, et al. Denaturing gradient gel electrophoresis analysis of the hemochromatosis (HFE) gene: impact of HFE gene mutations on the manifestation of porphyria cutanea tarda. *Clin Chem* 1999;45(11):2025-2026.
122. Sampietro M, Fiorelli G, Fargion S. Iron overload in porphyria cutanea tarda. *Haematologica* 1999;84(3):248-253.
123. Mendez, M., L. Sorkin, M.V. Rossetti, et al. Familial porphyria cutanea tarda: characterization of seven novel uroporphyrinogen decarboxylase mutations and frequency of common hemochromatosis alleles. *Am J Hum Genet* 1998;63(5):1363-1375.
124. Elder GH. Porphyria cutanea tarda. *Semin Liver Dis* 1998;18(1):67-75.
125. Stuart, K.A., F. Busfield, E.C. Jazwinska, et al. The C282Y mutation in the haemochromatosis gene (HFE) and hepatitis C virus infection are independent cofactors for porphyria cutanea tarda in Australian patients. *J Hepatol* 1998;28(3):404-409.
126. Elder GH, Worwood M. Mutations in the hemochromatosis gene, porphyria cutanea tarda, and iron overload. *Hepatol* 1998;27(1):289-291.
127. Sampietro, M., A. Piperno, L. Lupica, et al. High prevalence of the His63Asp HFE mutation in Italian patients with porphyria cutanea tarda. *Hepatol* 1998;27(1):181-184.
128. O'Reilly, F.M., C. Darby, J. Fogarty, et al. Screening of patients with iron overload to identify hemochromatosis and porphyria cutanea tarda. *Arch Dermatol* 1997;133(9): 1098-1101.
129. Roberts, A.G., S.D. Whatley, S. Nicklin, et al. The frequency of hemochromatosis-associated alleles is increased in British patients with sporadic porphyria cutanea tarda. *Hepatology* 1997;25(1):159-161.
130. Gangaidzo, I.T., V.M. Moyo, T. Saungweme, et al. Iron overload in urban Africans in the 1990s. *Gut* 1999;45(2):278-283.
131. Moyo, V.M., E. Mandishona, S.J. Hasstedt, et al. Evidence of genetic transmission in African iron overload. *Blood* 1998;91(3):1076-1082.
132. Wurapa, R.K., V.R. Gordeuk, G.M. Brittenham, et al. Primary iron overload in African Americans. *Am J Med* 1996;101(1):9-18.
133. Baer D. Hereditary iron overload and African Americans. *Am J Med* 1996;101(1):5-8.
134. Barton, J.C., C.Q. Edwards, L.F. Bertoli, T.W. Shroyer, S.L. Hudson. Iron overload in African Americans. *Am J Med* 1995;99(6):616-623.
135. Gordeuk, V., J. Mukiibi, S.J. Hasstedt, et al. Iron overload in Africa. Interaction between a gene and dietary iron content. *N Engl J Med* 1992;326(2):95-100.
136. Barton, J.C., R.T. Acton, F.W. Dawkins, et al. Initial screening transferrin saturation values, serum ferritin concentrations, and HFE genotypes in whites and blacks in the Hemochromatosis and Iron Overload Screening Study. *Genet Test* 2005;9(3):231-241.
137. Barton JC, Acton RT. Inheritance of two HFE mutations in African Americans: cases with hemochromatosis phenotypes and estimates of hemochromatosis phenotype frequency. *Genet Med* 2001;3(4):294-300.
138. Elleder, M., A. Chlumska, S. Hadravska, D. Pilat. Neonatal (perinatal) hemochromatosis. *Cesk Patol* 2001;37(4):146-153.
139. Murray KF, Kowdley KV. Neonatal hemochromatosis. *Pediatrics* 2001;108(4):960-964.
140. Vohra, P., C. Haller, S. Emre, et al. Neonatal hemochromatosis: the importance of early recognition of liver failure. *J Pediatr* 2000;136(4):537-541.
141. Liet, J.M., C. Urtin-Hostein, M. Joubert, et al. [Neonatal hemochromatosis]. *Arch Pediatr* 2000;7(1):40-44.
142. Oddone, M., C. Bellini, W. Bonacci, et al. Diagnosis of neonatal hemochromatosis with MR imaging and duplex Doppler sonography. *Eur Radiol* 1999;9(9):1882-1885.

143. Rodriguez Velasco, A., G.R. Garcia, S. Tejada Vega, et al. Neonatal hemochromatosis. Report of 3 autopsy cases. *Rev Invest Clin* 1999;51(2):81-87.
144. Sigurdsson, L., J. Reyes, S.A. Kocoshis, et al. Neonatal hemochromatosis: outcomes of pharmacologic and surgical therapies. *J Pediatr Gastroenterol Nutr* 1998;26(1):85-89.
145. Beutler, E., T. Gelbart, P. Lee, et al. Molecular characterization of a case of atransferrinemia. *Blood* 2000;96(13):4071-4074.
146. Hromec, A., J. Payer, Jr., Z. Killinger, I. Rybar, J. Rovensky. Congenital atransferrinemia. *Deutsche medizinische Wochenschrift* 1994;119(18):663-666.
147. Yoshida, K., K. Kaneko, H. Miyajima, et al. Increased lipid peroxidation in the brains of aceruloplasminemia patients. *J Neurol Sci* 2000;175(2):91-95.
148. Harris, Z.L., A.P. Durley, T.K. Man, J.D. Gitlin. Targeted gene disruption reveals an essential role for ceruloplasmin in cellular iron efflux. *Proc Natl Acad Sci U S A* 1999;96(19):10812-10817.
149. Yazaki, M., K. Yoshida, A. Nakamura, et al. A novel splicing mutation in the ceruloplasmin gene responsible for hereditary ceruloplasmin deficiency with hemosiderosis. *J Neurol Sci* 1998;156(1):30-34.
150. Harris ZL, Klomp LW, Gitlin JD. Aceruloplasminemia: an inherited neurodegenerative disease with impairment of iron homeostasis. *Am J Clin Nutr* 1998;67(5 Suppl):972S-977S.
151. Klomp LW, Gitlin JD. Expression of the ceruloplasmin gene in the human retina and brain: implications for a pathogenic model in aceruloplasminemia. *Hum Mol Genet* 1996;5(12):1989-1996.
152. Okamoto, N., S. Wada, T. Oga, et al. Hereditary ceruloplasmin deficiency with hemosiderosis. *Hum Genet* 1996;97(6):755-758.
153. Takahashi, Y., H. Miyajima, S. Shirabe, et al. Characterization of a nonsense mutation in the ceruloplasmin gene resulting in diabetes and neurodegenerative disease. *Hum Mol Genet* 1996;5(1):81-84.
154. Yoshida, K., K. Furihata, S. Takeda, et al. A mutation in the ceruloplasmin gene is associated with systemic hemosiderosis in humans. *Nat Genet* 1995;9(3):267-272.
155. Brooks, D.G., K. Manova-Todorova, J. Farmer, et al. Ferritin crystal cataracts in hereditary hyperferritinemia cataract syndrome. *Invest Ophthalmol Vis Sci* 2002;43(4):1121-1126.
156. Perez de Nanclares, G., L. Castano, P. Martul, et al. Molecular analysis of hereditary hyperferritinemia-cataract syndrome in a large Basque family. *J Pediatr Endocrinol Metabol* 2001;14(3):295-300.
157. Cremonesi, L., A. Fumagalli, N. Soriani, et al. Double-gradient denaturing gradient gel electrophoresis assay for identification of L-ferritin iron-responsive element mutations responsible for hereditary hyperferritinemia-cataract syndrome: identification of the new mutation C14G. *Clin Chem* 2001;47(3): 491-497.
158. Cazzola, M, Skoda RC. Translational pathophysiology: a novel molecular mechanism of human disease. *Blood* 2000;95(11):3280-3288.
159. Allerson CR, Cazzola M, Rouault TA. Clinical severity and thermodynamic effects of iron-responsive element mutations in hereditary hyperferritinemia-cataract syndrome. *J Biol Chem* 1999;274(37):26439-26447.
160. Balas, A., M.J. Aviles, F. Garcia-Sanchez, J.L. Vicario. Description of a new mutation in the L-ferritin iron-responsive element associated with hereditary hyperferritinemia-cataract syndrome in a Spanish family. *Blood* 1999;93(11):4020-4021.
161. Barton JC, Beutler E, Gelbart T. Coinheritance of alleles associated with hemochromatosis and hereditary hyperferritinemia-cataract syndrome. *Blood* 1998;92(11):4480.
162. Martin, M.E., S. Fargion, P. Brissot, B. Pellat, C. Beaumont. A point mutation in the bulge of the iron-responsive element of the L ferritin gene in two families with the hereditary hyperferritinemia-cataract syndrome. *Blood* 1998;91(1):319-323.
163. Piperno A. Classification and diagnosis of iron overload. *Haematologica* 1998;83(5):447-455.
164. Gasparini, P., S. Calvano, E. Memeo, L. Bisceglia, L. Zelante. Assignment of ferritin L gene (FTL) to human chromosome band 19q13.3 by in situ hybridization. *Ann Genet* 1997;40(4):227-228.

165. Girelli, D., R. Corrocher, L. Bisceglia, et al. Hereditary hyperferritinemicataract syndrome caused by a 29-base pair deletion in the iron responsive element of ferritin L-subunit gene. *Blood* 1997;90(5):2084-2088.
166. Pianese, L., A. Tamaro, M. Turano, et al. Identification of a novel transcript of X25, the human gene involved in Friedreich ataxia. *Neurosci Lett* 2002;320(3):137-140.
167. Miranda, C.J., M.M. Santos, K. Ohshima, et al. Frataxin knockin mouse. *FEBS Lett* 2002;512(1-3):291-297.
168. Kaplan J. Spinocerebellar ataxias due to mitochondrial defects. *Neurochem Int* 2002;40(6):553-557.
169. McCabe, D.J., N.W. Wood, F. Ryan, et al. Intrafamilial phenotypic variability in Friedreich ataxia associated with a G130V mutation in the FRDA gene. *Arch Neurol* 2002;59(2):296-300.
170. Juvonen, V., S.M. Kulmala, J. Ignatius, M. Penttinen, M.L. Savontaus Dissecting the epidemiology of a trinucleotide repeat disease—example of FRDA in Finland. *Hum Genet* 2002;110(1):36-40.
171. Berciano, J., I. Mateo, C. De Pablos, J.M. Polo, O. Combarros Friedreich ataxia with minimal GAA expansion presenting as adult-onset spastic ataxia. *J Neurol Sci* 2002;194(1):75-82.
172. Albano, L.M., M. Zatz, C.A. Kim, et al. Friedreich's ataxia: clinical and molecular study of 25 Brazilian cases. *Rev Hosp Clin Fac Med Sao Paulo* 2001;56(5):143-148.
173. McDaniel, D.O., B. Keats, V.V. Vedanarayanan, S.H. Subramony. Sequence variation in GAA repeat expansions may cause differential phenotype display in Friedreich's ataxia. *Mov Disord* 2001;16(6):1153-1158.
174. Zhou, B., S.K. Westaway, B. Levinson, et al. A novel pantothenate kinase gene (PANK2) is defective in Hallervorden-Spatz syndrome. *Nat Genet* 2001;28(4):345-349.
175. Taylor, T.D., M. Litt, P. Kramer, et al. Homozygosity mapping of Hallervorden-Spatz syndrome to chromosome 20p12.3-p13. *Nat Genet* 1996;14(4): 479-481.
176. Cotter, P.D., A. May, E.J. Fitzsimons, et al. Late-onset X-linked sideroblastic anemia. Missense mutations in the erythroid delta-aminolevulinate synthase (ALAS2) gene in two pyridoxine-responsive patients initially diagnosed with acquired refractory anemia and ringed sideroblasts. *J Clin Invest* 1995;96(4):2090-2096.
177. Cox, T.C., S.S. Bottomley, J.S. Wiley, et al. X-linked pyridoxine-responsive sideroblastic anemia due to a Thr388-to-Ser substitution in erythroid 5-aminolevulinate synthase. *N Engl J Med* 1994;330(10):675-679.
178. Cotter, P.D., H.F. Willard, J.L. Gorski, D.F. Bishop. Assignment of human erythroid delta-aminolevulinate synthase (ALAS2) to a distal subregion of band Xp11.21 by PCR analysis of somatic cell hybrids containing X; autosome translocations. *Genomics* 1992;13(1):211-212.
179. Shimada, Y., S. Okuno, A. Kawai, et al. Cloning and chromosomal mapping of a novel ABC transporter gene (hABC7), a candidate for X-linked sideroblastic anemia with spinocerebellar ataxia. *J Hum Genet* 1998;43(2):115-122.
180. Allikmets, R., W.H. Raskind, A. Hutchinson, et al. Mutation of a putative mitochondrial iron transporter gene (ABC7) in X-linked sideroblastic anemia and ataxia (XLSA/A). *Hum Mol Genet* 1999;8(5):743-749.
181. Bekri, S., G. Kispal, H. Lange, et al. Human ABC7 transporter: gene structure and mutation causing X-linked sideroblastic anemia with ataxia with disruption of cytosolic iron-sulfur protein maturation. *Blood* 2000;96(9): 3256-3264.
182. Maguire, A., K. Hellier, S. Hammans, A. May. X-linked cerebellar ataxia and sideroblastic anaemia associated with a missense mutation in the ABC7 gene predicting V411L. *Br J Haematol* 2001;115(4):910-917.
183. Casas, K., Y. Bykhovskaya, E. Mengesha, et al. Gene responsible for mitochondrial myopathy and sideroblastic anemia (MSA) maps to chromosome 12q24.33. *Am J Med Genet Part A* 2004;127A(1):44-49.
184. Bykhovskaya, Y., K. Casas, E. Mengesha, A. Inbal, N. Fischel-Ghodsian. Missense mutation in pseudouridine synthase 1 (PUS1) causes mitochondrial myopathy and sideroblastic anemia (MLASA). *Am J Hum Genet* 2004;74(6):1303-1308.
185. Wingert, R.A., J.L. Galloway, B. Barut, et al. Deficiency of glutaredoxin 5 reveals Fe-S clusters are required for vertebrate haem synthesis. *Nature* 2005;436(7053):1035-1039.
186. Camaschella, C., A. Campanella, L. De Falco, et al. The human counterpart of zebrafish shiraz shows sideroblastic-like microcytic anemia and iron overload. *Blood* 2007;110(4):1353-1358.
187. Vidal, S., A.M. Belouchi, M. Cellier, B. Beatty, P. Gros. Cloning and characterization of a second human NRAMP gene on chromosome 12q13. *Mamm Genome* 1995;6(4):224-230.

188. Mims, M.P., Y. Guan, D. Pospisilova, et al. Identification of a human mutation of DMT1 in a patient with microcytic anemia and iron overload. *Blood* 2005;105(3):1337-1342.
189. Manco, L, Abade A. Pyruvate kinase deficiency: prevalence of the 1456C—>T mutation in the Portuguese population. *Clin Genet* 2001;60(6):472-473.
190. Zanella, A., P. Bianchi, A. Iurlo, et al. Iron status and HFE genotype in erythrocyte pyruvate kinase deficiency: study of Italian cases. *Blood Cells Mol Dis* 2001;27(3):653-661.
191. Wang, C., L.R. Chiarelli, P. Bianchi, et al. Human erythrocyte pyruvate kinase: characterization of the recombinant enzyme and a mutant form (R510Q) causing nonspherocytic hemolytic anemia. *Blood* 2001;98(10):3113-3120.
192. Vulliamy T, Beutler E, Luzzatto L. Variants of glucose-6-phosphate dehydrogenase are due to missense mutations spread throughout the coding region of the gene. *Hum Mutat* 1993;2(3):159-167.
193. Pai, G.S., J.A. Sprenkle, T.T. Do, C.E. Mareni, B.R. Migeon. Localization of loci for hypoxanthine phosphoribosyltransferase and glucose-6-phosphate dehydrogenase and biochemical evidence of nonrandom X chromosome expression from studies of a human X-autosome translocation. *Proc Natl Acad Sci U S A* 1980;77(5):2810-3813.
194. Tamary, H., L. Shalmon, H. Shalev, et al. Localization of the gene for congenital dyserythropoietic anemia type I to a <1-cM interval on chromosome 15q15.1-15.3. *Am J Hum Genet* 1998;62(5):1062-1069.
195. Facon, T., L. Mannessier, P. Lepelley, et al. Congenital diserythropoietic anemia type I. Report on monozygotic twins with associated hemochromatosis and short stature. *Blut* 1990;61(4):248-250.
196. Iolascon, A., J. Delaunay, S.N. Wickramasinghe, et al. Natural history of congenital dyserythropoietic anemia type II. *Blood* 2001;98(4):1258-1260.
197. Perrotta, S., E.M. del Giudice, R. Carbone, et al. Gilbert's syndrome accounts for the phenotypic variability of congenital dyserythropoietic anemia type II (CDA-II). *J Pediatr* 2000;136(4):556-559.
198. Gasparini, P., E. Miraglia del Giudice, J. Delaunay, et al. Localization of the congenital dyserythropoietic anemia II locus to chromosome 20q11.2 by genomewide search. *Am J Hum Genet* 1997;61(5):1112-1116.
199. Lind, L., H. Sandstrom, A. Wahlin, et al. Localization of the gene for congenital dyserythropoietic anemia type III, CDAN3, to chromosome 15q21-q25. *Hum Mol Genet* 1995;4(1):109-112.
200. Wickramasinghe, S.N., A. Wahlin, D. Anstee, et al. Observations on two members of the Swedish family with congenital dyserythropoietic anaemia, type III. *Eur J Haematol* 1993;50(4):213-221.
201. Del-Castillo-Rueda, A., M.I. Moreno-Carralero, L.A. Alvarez-Sala-Walther, et al. Two novel mutations in the SLC40A1 and HFE genes implicated in iron overload in a Spanish man. *Eur J Haematol* 2011;86(3):260-264.
202. Biasiotto, G., S. Belloli, G. Ruggeri, et al. Identification of new mutations of the HFE, hepcidin, and transferrin receptor 2 genes by denaturing HPLC analysis of individuals with biochemical indications of iron overload. *Clin Chem* 2003;49(12):1981-1988.
203. Dupradeau, F.Y., S. Pissard, M.P. Coulhon, et al. An unusual case of hemochromatosis due to a new compound heterozygosity in HFE (p.[Gly43Asp;H is63Asp]+[Cys282Tyr]): structural implications with respect to binding with transferrin receptor 1. *Hum Mutat* 2008;29(1):206.
204. Mendes, A.I., A. Ferro, R. Martins, et al. Non-classical hereditary hemochromatosis in Portugal: novel mutations identified in iron metabolism-related genes. *Ann Hematol* 2008;88(3):229-234.
205. Kinkely, S.M., B.D. Brown, A.T. Lyng, et al. Absence of overt iron overload in two individuals compound heterozygotes for a 22 base pair deletion of exon 2 and the C282Y missense mutation of the HFE gene. *Clin Genet* 2003;63(2):163-165.
206. Aguilar-Martinez, P., B. Grandchamp, S. Cunat, et al. Iron overload in HFE C282Y heterozygotes at first genetic testing: a strategy for identifying rare HFE variants. *Haematologica* 2011;96(4):507-514.
207. de Villiers, J.N., R. Hillermann, L. Loubser, M.J. Kotze. Spectrum of mutations in the HFE gene implicated in haemochromatosis and porphyria. *Hum Mol Genet* 1999;8(8):1517-1522.
208. Thorstensen, K., A. Asberg, M. Kvitland, et al. Detection of an unusual combination of mutations in the HFE gene for hemochromatosis. *Genet Test* 2000;4(4):371-376.

209. Henz S, Reichen J, Liechti-Gallati S. HLA-H gene mutations and haemochromatosis: the likely association of H63D with mild phenotype and the detection of S65C, a novel variant in exon 2. *J Hepatol* 1997;26:57A.
210. Jones, D.C., N.T. Young, C. Pigott, et al. Comprehensive hereditary hemochromatosis genotyping. *Tissue Antigens* 2002;60(6):481-488.
211. Barton, J.C., R. Sawada-Hirai, B.E. Rothenberg, R.T. Acton. Two novel missense mutations of the HFE gene (I105T and G93R) and identification of the S65C mutation in Alabama hemochromatosis probands. *Blood Cells Mol Dis* 1999;25(3-4):147-155.
212. Barton, J.C., C. West, P.L. Lee, E. Beutler, A previously undescribed frameshift deletion mutation of HFE (c.del277; G93fs) associated with hemochromatosis and iron overload in a C282Y heterozygote. *Clin Genet* 2004;66(3):214-216.
213. Beutler, E, West C, New diallelic markers in the HLA region of chromosome 6. *Blood Cells Mol Dis* 1997;23(2):219-229.
214. Cukjati, M., S. Koren, V. Curin Serbec, B. Vidan-Jeras, R. Ruprecht. A novel homozygous frameshift deletion c.471del of HFE associated with hemochromatosis. *Clin Genet* 2007;71(4):350-353.
215. Pointon, J.J., C.Y. Lok, J.D. Shearman, et al. A novel HFE mutation (c.del478) results in nonsense-mediated decay of the mutant transcript in a hemochromatosis patient. *Blood Cells Mol Dis* 2009;43(2):194-198.
216. Oberkanins, C., A. Moritz, J.N. de Villiers, M.J. Kotze, F. Kury. A reverse-hybridization assay for the rapid and simultaneous detection of nine HFE gene mutations. *Genet Test* 2000;4(2):121-124.
217. Menardi, G., L. Perotti, M. Prucca, et al. A very rare association of three mutations of the HFE gene for hemochromatosis. *Genet Test* 2002;6(4):331-334.
218. Piperno, A., C. Arosio, L. Fossati, et al. Two novel nonsense mutations of HFE gene in five unrelated Italian patients with hemochromatosis. *Gastroenterology* 2000;119(2):441-445.
219. Imanishi, H., W. Liu, J. Cheng, et al. Idiopathic hemochromatosis with the mutation of Ala176Val heterozygous for HFE gene. *Intern Med* 2001;40(6):479-483.
220. Swinkels, D.W., H. Venselaar, E.T. Wiegerinck, et al. A novel (Leu183Pro-) mutation in the HFE-gene co-inherited with the Cys282Tyr mutation in two unrelated Dutch hemochromatosis patients. *Blood Cells Mol Dis* 2008;40(3):334-338.
221. Wallace DF, Dooley JS, Walker AP. A novel mutation of HFE explains the classical phenotype of genetic hemochromatosis in a C282Y heterozygote. *Gastroenterol* 1999;116(6):1409-1412.
222. Beutler E, Gelbart T., A common intron 3 mutation (IVS3 -48c→g) leads to misdiagnosis of the c.845G→A (C282Y) HFE gene mutation. *Blood Cells Mol Dis* 2000;26(3):229-233.
223. Barton, J.C., S.A. Lafreniere, C. Leiendecker-Foster, et al. HFE, SLC40A1, HAMP, HJV, TFR2, and FTL mutations detected by denaturing high-performance liquid chromatography after iron phenotyping and HFE C282Y and H63D genotyping in 785 HEIRS Study participants. *Am J Hematol* 2009;84(11):710-714.
224. Bradbury, R., E. Fagan, Goodson, E. al. New mutations in the HFE gene for haemochromatosis. *J Med Genet* 1999;36(Suppl 1):S96.
225. Takano, A., H. Niimi, Y. Atarashi, et al. A novel Y231del mutation of HFE in hereditary haemochromatosis provides in vivo evidence that the Huh-7 is a human haemochromatotic cell line. *Liver Int* 2011;31(10):1593-1597.
226. Mariani, R., S. Pelucchi, C. Arosio, et al. Genetic and metabolic factors are associated with increased hepatic iron stores in a selected population of p.Cys282Tyr heterozygotes. *Blood Cells Mol Dis* 2010;44(3):159-163.
227. Cunat, S., M. Giansily-Blaizot, M. Bismuth, et al. Global sequencing approach for characterizing the molecular background of hereditary iron disorders. *Clin Chem* 2007;53(12):2060-2069.
228. A simple genetic test identifies 90% of UK patients with haemochromatosis. The UK Haemochromatosis Consortium. *Gut* 1997;41(6):841-844.
229. Bradbury R, Fagan E, Payne SJ. Two novel polymorphisms (E277K and V212V) in the haemochromatosis gene HFE. *Hum Mutat* 2000;15(1):120.
230. Rosmorduc, O., R. Poupon, I. Nion, et al. Differential HFE allele expression in hemochromatosis heterozygotes. *Gastroenterol* 2000;119(4):1075-1086.

231. Phillips, M., C.A. Meadows, M.Y. Huang, A. Millson, E. Lyon. Simultaneous detection of C282Y and H63D hemochromatosis mutations by dual-color probes. *Mol Diagn* 2000;5(2):107-116.
232. Le Gac, G., F.Y. Dupradeau, C. Mura, et al. Phenotypic expression of the C282Y/Q283P compound heterozygosity in HFE and molecular modeling of the Q283P mutation effect. *Blood Cells Mol Dis* 2003;30(3):231-237.
233. Jeffrey, G.P., S. Chakrabarti, R.A. Hegele, P.C. Adams. Polymorphism in intron 4 of HFE may cause overestimation of C282Y homozygote prevalence in haemochromatosis. *Nat Genet* 1999;22(4):325-326.
234. Mikhailova, S.V., V.N. Babenko, M.I. Voevoda, A.G. Romashchenko. The ethnospecific distribution of the HFE haplotypes for IVS2(+4)t/c, IVS4(-44) t/c, and IVS5(-47)g/a in populations of Russia and possible effects of these single-nucleotide polymorphisms in splicing. *Genet Test Mol Biomarkers* 2010;14(4):461-469.
235. Zaahl, M.G., A.T. Merryweather-Clarke, M.J. Kotze, et al. Analysis of genes implicated in iron regulation in individuals presenting with primary iron overload. *Hum Genet* 2004;115(5):409-417.
236. Steiner, M., K. Ocran, J. Genschel, et al. A homozygous HFE gene splice site mutation (IVS5+1 G/A) in a hereditary hemochromatosis patient of Vietnamese origin. *Gastroenterology* 2002;122(3):789-795.
237. Le Gac, G., I. Gourlaouen, C. Ronsin, et al. Homozygous deletion of HFE produces a phenotype similar to the HFE p.C282Y/p.C282Y genotype. *Blood* 2008;112(13):5238-5240.
238. Pelucchi, S., R. Mariani, F. Bertola, C. Arosio, A. Piperno. Homozygous deletion of HFE: the Sardinian hemochromatosis? *Blood* 2009;113(16):3886.
239. Beutler, E., M.J. Griffin, T. Gelbart, C. West. A previously undescribed nonsense mutation of the HFE gene. *Clin Genet* 2002;61(1):40-42.
240. Pointon, J.J., D. Wallace, A.T. Merryweather-Clarke, K.J. Robson. Uncommon mutations and polymorphisms in the hemochromatosis gene. *Genet Test* 2000;4(2):151-161.
241. Rochette, J., J.J. Pointon, C.A. Fisher, et al. Multicentric origin of hemochromatosis gene (HFE) mutations. *Am J Hum Genet* 1999;64(4):1056-1062.
242. Beutler, E., T. Gelbart, C. West. Mutation analysis in hereditary hemochromatosis. *Blood Cells Mol Dis* 1996;22(2):187-194; discussion 194a-194b.
243. Sham, R.L., C.Y. Ou, J. Cappuccio, et al. Correlation between genotype and phenotype in hereditary hemochromatosis: analysis of 61 cases. *Blood Cells Mol Dis* 1997;23(2):314-320.
244. Barton, J.C., W.W. Shih, R. Sawada-Hirai, et al. Genetic and clinical description of hemochromatosis probands and heterozygotes: evidence that multiple genes linked to the major histocompatibility complex are responsible for hemochromatosis. *Blood Cells Mol Dis* 1997;23(1):135-145; discussion 145a-b.
245. Bulaj, Z.J., R.S. Ajioka, J.D. Phillips, et al. Disease-related conditions in relatives of patients with hemochromatosis. *N Engl J Med* 2000;343(21):1529-1535.
246. Brandhagen, D.J., V.F. Fairbanks, W.P. Baldus, et al. Prevalence and clinical significance of HFE gene mutations in patients with iron overload. *Am J Gastroenterol* 2000;95(10):2910-2914.
247. Adams PC, Chakrabarti S. Genotypic/phenotypic correlations in genetic hemochromatosis: evolution of diagnostic criteria. *Gastroenterology* 1998;114(2):319-323.
248. Jouanolle, A.M., P. Fergelot, G. Gandon, et al. A candidate gene for hemochromatosis: frequency of the C282Y and H63D mutations. *Hum Genet* 1997;100(5-6):544-547.
249. Mura C, Ragueneas O, Ferec C. HFE mutations analysis in 711 hemochromatosis probands: evidence for S65C implication in mild form of hemochromatosis. *Blood* 1999;93(8):2502-2505.
250. Aguilar, M.P., C. Biron, F. Blanc, et al. Compound heterozygotes for hemochromatosis gene mutations: may they help to understand the pathophysiology of the disease? *Blood Cells Mol Dis* 1997;23(2):269-276.
251. Borot, N., M. Roth, L. Malfroy, et al. Mutations in the MHC class I-like candidate gene for hemochromatosis in French patients. *Immunogenetics* 1997;45(5):320-324.
252. Mercier, G., A. Burckel, C. Bathelier, E. Boillat, G. Lucotte. Mutation analysis of the HLA-H gene in French hemochromatosis patients, and genetic counseling in families. *Genet Couns* 1998;9(3):181-186.

253. Erhardt, A., C. Niederau, Y. Osman, M. Hassan, D. Haussinger. Demonstration of HFE polymorphism in German patients with hereditary hemochromatosis. *Deutsche medizinische Wochenschrift* 1999;124(48):1448-1452.
254. Gottschalk, R., C. Seidl, S. Schilling, et al. Iron-overload and genotypic expression of HFE mutations H63D/C282Y and transferrin receptor HinfI and BclI polymorphism in German patients with hereditary haemochromatosis. *Eur J Immunogenet* 2000;27(3):129-134.
255. Hellerbrand, C., A.K. Bosserhoff, S. Seegers, et al. Mutation analysis of the HFE gene in German hemochromatosis patients and controls using automated SSCP-based capillary electrophoresis and a new PCR-ELISA technique. *Scand J Gastroenterol* 2001;36(11):1211-1216.
256. Nielsen, P., S. Carpinteiro, R. Fischer, et al. Prevalence of the C282Y and H63D mutations in the HFE gene in patients with hereditary haemochromatosis and in control subjects from Northern Germany. *Br J Haematol* 1998;103(3):842-845.
257. Willis, G., B.A. Jennings, E. Goodman, I.W. Fellows, J.Z. Wimperis. A high prevalence of HLA-H 845A mutations in hemochromatosis patients and the normal population in eastern England. *Blood Cells Mol Dis* 1997;23(2):288-291.
258. Murphy, S., M.D. Curran, N. McDougall, et al. High incidence of the Cys 282 Tyr mutation in the HFE gene in the Irish population—implications for haemochromatosis. *Tissue Antigens* 1998;52(5):484-488.
259. Ryan E, C. O'Keane, Crowe J. Hemochromatosis in Ireland and HFE. *Blood Cells Mol Dis* 1998;24(4):428-432.
260. Miedzybrodzka, Z., S. Loughlin, D. Baty, et al. Haemochromatosis mutations in North-East Scotland. *Br J Haematol* 1999;106(2):385-387.
261. de Juan, D., A. Reta, A. Castiella, et al. HFE gene mutations analysis in Basque hereditary haemochromatosis patients and controls. *Eur J Hum Genet* 2001;9(12):961-964.
262. Guix, P., A. Picornell, M. Parera, et al. Prevalence of the C282Y mutation for haemochromatosis on the Island of Majorca. *Clin Genet* 2000;58(2):123-128.
263. Sanchez, M., M. Bruguera, E. Quintero, et al. Hereditary hemochromatosis in Spain. *Genet Test* 2000;4(2):171-176.
264. Fabrega, E., B. Castro, L. Sanchez-Castro, et al. The prevalence of the Cys282Tyr mutation in the hemochromatosis gene in Cantabria in patients diagnosed with hereditary hemochromatosis. *Med Clin (Barc)* 1999;112(12): 451-453.
265. Sanchez, M., M. Bruguera, J. Bosch, et al. Prevalence of the Cys282Tyr and His63Asp HFE gene mutations in Spanish patients with hereditary hemochromatosis and in controls. *J. Hepatol.* 1998;29(5):725-728.
266. Moreno, L., P. Vallcorba, D. Boixeda, et al. The usefulness of the detection of Cys282Tyr and His63Asp mutations in the diagnosis of hereditary hemochromatosis. *Rev Clin Esp* 1999;199(10):632-636.
267. Jorquera, F., A. Dominguez, V. Diaz-Golpe, et al. C282Y and H63D mutations of the haemochromatosis gene in patients with iron overload. *Rev Esp Enferm Dig* 2001;93(5):293-302.
268. Carella, M., L. D'Ambrosio, A. Totaro, et al. Mutation analysis of the HLA-H gene in Italian hemochromatosis patients. *Am J Hum Genet* 1997;60(4):828-832.
269. Piperno, A., M. Sampietro, A. Pietrangelo, et al. Heterogeneity of hemochromatosis in Italy. *Gastroenterology* 1998;114(5):996-1002.
270. Cardoso, E.M., P. Stal, K. Hagen, et al. HFE mutations in patients with hereditary haemochromatosis in Sweden. *J Intern Med* 1998;243(3):203-208.
271. Olsson, K.S., B. Ritter, L. Sandberg, E. The ancestral haplotype in patients with genetic haemochromatosis from central and western Sweden, in International Symposium, Iron in Biology and Medicine. Saint-Malo, France; 1999:253.
272. Jazwinska, E.C., L.M. Cullen, F. Busfield, et al. Haemochromatosis and HLAH. *Nat Genet* 1996;14(3):249-251.
273. Rossi, E., S. Henderson, C.Y. Chin, et al. Genotyping as a diagnostic aid in genetic haemochromatosis. *J Gastroenterol Hepatol* 1999;14(5):427-430.
274. Papanikolaou, G., M. Politou, A. Roetto, et al. Linkage to chromosome 1q in Greek families with juvenile hemochromatosis. *Blood Cells Mol Dis* 2001;27(4):744-749.
275. Bittencourt, P.L., S.A. Palacios, C.A. Couto, et al. Analysis of HLA-A antigens and C282Y and H63D mutations of the HFE gene in Brazilian patients with hemochromatosis. *Braz J Med Biol Res* 2002;35(3):329-335.

276. Van Vlierberghe, H., L. Messiaen, M. Hautekeete, A. De Paepe, A. Elewaut. Prevalence of the Cys282Tyr and His63Asp mutation in Flemish patients with hereditary hemochromatosis. *Acta Gastroenterol Belg* 2000;63(3):250-253.
277. Merryweather-Clarke, A.T., J.J. Pointon, A.M. Jouanolle, J. Rochette, K.J. Robson. Geography of HFE C282Y and H63D mutations. *Genet Test* 2000;4(2):183-198.
278. Beutler, E., V.J. Felitti, J.A. Koziol, N.J. Ho, T. Gelbart. Penetrance of 845G—> A (C282Y) HFE hereditary haemochromatosis mutation in the USA. *Lancet* 2002;359(9302):211-218.
279. Steinberg, K.K., M.E. Cogswell, J.C. Chang, et al. Prevalence of C282Y and H63D mutations in the hemochromatosis (HFE) gene in the United States. *JAMA* 2001;285(17):2216-2222.
280. Marshall DS, Linfert DR, Tsongalis GJ. Prevalence of the C282Y and H63D polymorphisms in a multi-ethnic control population. *Int J Mol Med* 1999;4(4):389-393.
281. Bradley, L.A., D.D. Johnson, G.E. Palomaki, et al. Hereditary haemochromatosis mutation frequencies in the general population. *J Med Screen* 1998;5(1):34-36.
282. Garry, P.J., G.D. Montoya, R.N. Baumgartner, et al. Impact of HLA-H mutations on iron stores in healthy elderly men and women. *Blood Cells Mol Dis* 1997;23(2):277-287.
283. McDonnell, S.M., A. Hover, D. Gloe, et al. Population-based screening for hemochromatosis using phenotypic and DNA testing among employees of health maintenance organizations in Springfield, Missouri. *Am J Med* 1999;107(1):30-37.
284. Hanson EH, Imperatore G, Burke W. HFE gene and hereditary hemochromatosis: a HuGE review. *Human Genome Epidemiology. Am J Epidemiol* 2001;154(3):193-206.
285. Adams, P.C., L. Passmore, S. Chakrabarti, et al. Liver diseases in the hemochromatosis and iron overload screening study. *Clin Gastroenterol Hepatol* 2006;4(7):918-923.
286. Tucker, D.C., R.T. Acton, N. Press, et al. Predictors of belief that genetic test information about hemochromatosis should be shared with family members. *Genet Test* 2006;10(1):50-59.
287. Adams, P.C., D.M. Reboussin, J.C. Barton, et al. Hemochromatosis and iron-overload screening in a racially diverse population. *N Engl J Med* 2005;352(17):1769-1778.
288. Adams, P.C., D.M. Reboussin, C. Leiendecker-Foster, et al. Comparison of the unsaturated iron-binding capacity with transferrin saturation as a screening test to detect C282Y homozygotes for hemochromatosis in 101,168 participants in the hemochromatosis and iron overload screening (HEIRS) study. *Clin Chem* 2005;51(6):1048-1052.
289. McLaren, C.E., J.C. Barton, P.C. Adams, et al. Hemochromatosis and Iron Overload Screening (HEIRS) study design for an evaluation of 100,000 primary care-based adults. *Am J Med Sci* 2003;325(2):53-62.
290. Asberg, A., K. Hveem, K. Thorstensen, et al. Screening for hemochromatosis: high prevalence and low morbidity in an unselected population of 65,238 persons. *Scand J Gastroenterol* 2001;36(10):1108-1115.
291. Merryweather-Clarke, A.T., E. Cadet, A. Bomford, et al. Digenic inheritance of mutations in HAMP and HFE results in different types of haemochromatosis. *Hum Mol Genet* 2003;12(17):2241-2247.
292. Livesey, K.J., V.L. Wimhurst, K. Carter, et al. The 16189 variant of mitochondrial DNA occurs more frequently in C282Y homozygotes with haemochromatosis than those without iron loading. *J Med Genet* 2004;41(1):6-10.
293. Beutler, E., L. Beutler, P.L. Lee, J.C. Barton. The mitochondrial nt 16189 polymorphism and hereditary hemochromatosis. *Blood Cells Mol Dis* 2004;33(3):344-345.
294. Bachman, E., R. Feng, T. Trivison, et al. Testosterone suppresses hepcidin in men: a potential mechanism for testosterone-induced erythrocytosis. *J Clin Endocrinol Metab* 2010;95(10):4743-4747.
295. Sheldon JH. *Haemochromatosis*. London: Oxford University Press 1935: 1-382.
296. Finch SC, Finch CA. Idiopathic hemochromatosis, an iron storage disease. A. Iron metabolism in hemochromatosis. *Medicine (Baltimore)* 1955;34(4): 381-430.
297. Milder, M.S., J.D. Cook, S. Stray, C.A. Finch. Idiopathic hemochromatosis, an interim report. *Medicine (Baltimore)* 1980;59(1):34-49.
298. Milman N., Hereditary haemochromatosis in Denmark 1950-1985; Clinical, biochemical and histological features in 179 patients and 13 preclinical cases. *Dan Med Bull* 1991;38(4):385-393.

299. Fargion, S., C. Mandelli, A. Piperno, et al. Survival and prognostic factors in 212 Italian patients with genetic hemochromatosis. *Hepatology* 1992;15(4): 655-659.
300. Niederau, C., R. Fischer, A. Purschel, et al. Long-term survival in patients with hereditary hemochromatosis. *Gastroenterology* 1996;110(4):1107-1119.
301. Moirand, R., P.C. Adams, V. Bicheler, P. Brissot, Y. Deugnier. Clinical features of genetic hemochromatosis in women compared with men. *Ann Intern Med* 1997;127(2):105-110.
302. Adams PC, Valberg LS, Evolving expression of hereditary hemochromatosis. *Semin Liver Dis* 1996;16(1):47-54.
303. Witte, D.L., W.H. Crosby, C.Q. Edwards, V.F. Fairbanks, F.A. Mitros. Practice guideline development task force of the College of American Pathologists. Hereditary hemochromatosis. *Clin Chim Acta* 1996;245(2):139-200.
304. Schumacher, H.R., P.C. Straka, M.A. Krikker, A.T. Dudley. The arthropathy of hemochromatosis. Recent studies. *Ann N Y Acad Sci* 1988;526:224-233.
305. Barton, J.C., R.T. Acton, L. Lovato, et al. Initial screening transferrin saturation values, serum ferritin concentrations, and HFE genotypes in Native Americans and whites in the Hemochromatosis and Iron Overload Screening Study. *Clin Genet* 2006;69(1):48-57.
306. Barton JC, Bertoli LF, Rothenberg BE. Peripheral blood erythrocyte parameters in hemochromatosis: evidence for increased erythrocyte hemoglobin content. *J Lab Clin Med* 2000;135(1):96-104.
307. McLaren, C.E., J.C. Barton, V.R. Gordeuk et al. Determinants and characteristics of mean corpuscular volume and hemoglobin concentration in white HFE C282Y homozygotes in the hemochromatosis and iron overload screening study. *Am J Hematol* 2007;82(10):898-905.
308. Barton, J.C., C. Leiendoeker-Foster, D.M. Reboussin, et al. Relationships of serum free thyroxine and erythrocyte measures in euthyroid HFE C282Y homozygotes and control subjects: the HEIRS Study. *Int J Lab Hematol* 2009;32(3):282-287.
309. Iliadou, A., D.M. Evans, G. Zhu, et al. Genomewide scans of red cell indices suggest linkage on chromosome 6q23. *J Med Genet* 2007;44(1):24-30.
310. Adams, P.C., M. Speechley, J.C. Barton, et al. Probability of C282Y homozygosity decreases as liver transaminase activities increase in participants with hyperferritinemia in the HEIRS Study. *Hepatology* 2011;55(6):1722-1726.
311. McDermott JH, Walsh CH. Hypogonadism in hereditary hemochromatosis. *J Clin Endocrinol Metab* 2005;90(4):2451-2455.
312. Bassett ML, Halliday JW, Powell LW. Value of hepatic iron measurements in early hemochromatosis and determination of the critical iron level associated with fibrosis. *Hepatology* 1986;6(1):24-29.
313. George, D.K., G.A. Ramm, N.I. Walker, L.W. Powell, D.H. Crawford. Elevated serum type IV collagen: a sensitive indicator of the presence of cirrhosis in haemochromatosis. *J Hepatol* 1999;31(1):47-52.
314. Bomford, A, Williams R. Long term results of venesection therapy in idiopathic haemochromatosis. *Q J Med* 1976;45(180):611-623.
315. Niederau, C., R. Fischer, A. Sonnenberg, et al. Survival and causes of death in cirrhotic and in noncirrhotic patients with primary hemochromatosis. *N Engl J Med* 1985;313(20):1256-1262.
316. Tiniakos, G, Williams R. Cirrhotic process, liver cell carcinoma and extrahepatic malignant tumors in idiopathic haemochromatosis. Study of 71 patients treated with venesection therapy. *Appl Pathol* 1988;6(2):128-138.
317. Deugnier, Y.M., D. Guyader, L. Crantock, et al. Primary liver cancer in genetic hemochromatosis: a clinical, pathological, and pathogenetic study of 54 cases. *Gastroenterology* 1993;104(1):228-234.
318. Schumacher HR, Jr. Hemochromatosis and arthritis. *Arthritis Rheum* 1964;7:41-50.
319. Zoller, H., I. McFarlane, I. Theurl, et al. Primary iron overload with inappropriate hepcidin expression in V162del ferroportin disease. *Hepatology* 2005;42(2):466-472.
320. Stevens SM, Edwards CQ. Recognizing and managing hemochromatosis and hemochromatosis arthropathy. *J Musculoskel Med* 2004;21:212-225.

321. Sherrington, C.A., M.W. Knudman, M.L. Divitini, et al. Population-based study of the relationship between mutations in the hemochromatosis (HFE) gene and arthritis. *J Gastroenterol Hepatol* 2006;21(3):595-598.
322. Willis, G., D.G. Scott, B.A. Jennings, et al. HFE mutations in an inflammatory arthritis population. *Rheumatology (Oxford)* 2002;41(2):176-179.
323. Lonardo, A., P. Neri, M.T. Mascia, A. Pietrangelo. Hereditary hemochromatosis masquerading as rheumatoid arthritis. *Ann Ital Med Int* 2001;16(1):46-49.
324. Guggenbuhl, P., Y. Deugnier, J.F. Boisdet, et al. Bone mineral density in men with genetic hemochromatosis and HFE gene mutation. *Osteoporos Int* 2005;16(12):1809-1814.
325. Adams PC, Speechley M, Kertesz AE. Long-term survival analysis in hereditary hemochromatosis. *Gastroenterology* 1991;101(2):368-372.
326. McClain, D.A., D. Abraham, J. Rogers, et al. High prevalence of abnormal glucose homeostasis secondary to decreased insulin secretion in individuals with hereditary haemochromatosis. *Diabetologia* 2006;49(7):1661-1669.
327. Wilson JG, Iron and glucose homeostasis: new lessons from hereditary haemochromatosis. *Diabetologia* 2006;49(7):1459-1461.
328. Cooksey, R.C., H.A. Jouihan, R.S. Ajioka, et al. Oxidative stress, beta-cell apoptosis, and decreased insulin secretory capacity in mouse models of hemochromatosis. *Endocrinology* 2004;145(11):5305-5312.
329. Balcerzak SP, Mintz DH, Westerman MP. Diabetes mellitus and idiopathic hemochromatosis. *Am J Med Sci* 1968;255:53-62.
330. Dymock, I.W., J. Cassar, D.A. Pyke, W.G. Oakley, R. Williams. Observations on the pathogenesis, complications and treatment of diabetes in 115 cases of haemochromatosis. *Am J Med* 1972;52(2):203-210.
331. Barton JC, Acton RT. Longer survival associated with HLA-A*03, B*14 among 212 hemochromatosis probands with HFE C282Y homozygosity and HLA-A and -B typing and haplotyping. *Eur J Haematol* 2010;85(5):439-447.
332. O'Sullivan, E.P., J.H. McDermott, M.S. Murphy, S. Sen, C.H. Walsh. Declining prevalence of diabetes mellitus in hereditary haemochromatosis—the result of earlier diagnosis. *Diabetes Res Clin Pract* 2008;81(3):316-320.
333. Singh, B.M., R.A. Grunewald, M. Press, B.R. Muller, P.H. Wise. Prevalence of haemochromatosis amongst patients with diabetes mellitus. *Diabet Med* 1992;9(8):730-731.
334. O'Brien, T., B. Barrett, D.M. Murray, S. Dinneen, D.J. O'Sullivan. Usefulness of biochemical screening of diabetic patients for hemochromatosis. *Diabetes Care* 1990;13(5):532-534.
335. Conte, D., D. Manachino, A. Colli, et al. Prevalence of genetic hemochromatosis in a cohort of Italian patients with diabetes mellitus. *Ann Intern Med* 1998;128(5):370-373.
336. Sampson, M.J., T. Williams, P.J. Heyburn, et al. Prevalence of HFE (hemochromatosis gene) mutations in unselected male patients with type 2 diabetes. *J Lab Clin Med* 2000;135(2):170-173.
337. Ellervik, C., T. Mandrup-Poulsen, B.G. Nordestgaard, et al. Prevalence of hereditary haemochromatosis in late-onset type 1 diabetes mellitus: a retrospective study. *Lancet* 2001;358(9291):1405-1409.
338. Hahn, J.U., M. Steiner, S. Bochnig, et al. Evaluation of a diagnostic algorithm for hereditary hemochromatosis in 3,500 patients with diabetes. *Diabetes Care* 2006;29(2):464-466.
339. Paris I, Hermans M, Buyschaert M. Endocrine complications of genetic hemochromatosis. *Acta Clin Belg* 1999;54(6):334-345.
340. Macdonald RA, Mallory GK. Hemochromatosis and hemosiderosis. Study of 211 autopsied cases. *Arch Intern Med* 1960;105:686-700.
341. Peillon F, Racadot J. Histopathological in the hypophysis in 6 cases of hemochromatosis. *Ann Endocrinol (Paris)* 1969;30(6):800-807.
342. Bergeron C, Kovacs K. Pituitary siderosis. A histologic, immunocytologic, and ultrastructural study. *Am J Pathol* 1978;93(2):295-309.
343. Charbonnel, B., M. Chupin, A. Le Grand, J. Guillon. Pituitary function in idiopathic haemochromatosis: hormonal study in 36 male patients. *Acta Endocrinol (Copenh)* 1981;98(2):178-183.

344. Kelly, T.M., C.Q. Edwards, A.W. Meikle, J.P. Kushner. Hypogonadism in hemochromatosis: reversal with iron depletion. *Ann Intern Med* 1984;101(5):629-632.
345. Tweed MJ, Roland JM. Haemochromatosis as an endocrine cause of subfertility. *BMJ* 1998;316(7135):915-916.
346. McNeil, L.W., L.C. McKee, Jr., D. Lorber, D. Rabin. The endocrine manifestations of hemochromatosis. *Am J Med Sci* 1983;285(3):7-13.
347. Wilkinson H. Haemochromatosis associated with arthritis and hypopituitarism. *Ann Clin Biochem* 1996;33(pt 2):171-173.
348. Altman, J.J., M. Zygelman, M. Roger, J. Fiet, P. Passa. The GnRH test in idiopathic hemochromatosis. *J Endocrinol Invest* 1980;3(3):223-227.
349. Duranteau, L., P. Chanson, J. Blumberg-Tick, et al. Non-responsiveness of serum gonadotropins and testosterone to pulsatile GnRH in hemochromatosis suggesting a pituitary defect. *Acta Endocrinol (Copenh)* 1993;128(4): 351-354.
350. Siminoski K, M. D'Costa, Walfish PG. Hypogonadotropic hypogonadism in idiopathic hemochromatosis: evidence for combined hypothalamic and pituitary involvement. *J Endocrinol Invest* 1990;13(10):849-853.
351. Piperno, A., M.R. Rivolta, R. D'Alba, et al. Preclinical hypogonadism in genetic hemochromatosis in the early stage of the disease: evidence of hypothalamic dysfunction. *J Endocrinol Invest* 1992;15(6):423-428.
352. Williams TC, Frohman LA. Hypothalamic dysfunction associated with hemochromatosis. *Ann Intern Med* 1985;103(4):550-551.
353. Lufkin, E.G., W.P. Baldus, E.J. Bergstralh, P.C. Kao. Influence of phlebotomy treatment on abnormal hypothalamic-pituitary function in genetic hemochromatosis. *Mayo Clin Proc* 1987;62(6):473-479.
354. Barton JC. Hemochromatosis, HFE C282Y homozygosity, and polycystic Ovary Syndrome: report of two cases and possible effects of androgens and hepcidin. *Acta haematologica* 2011;126(3):138-140.
355. Lewis AS, Courtney CH, Atkinson AB. All patients with 'idiopathic' hypopituitarism should be screened for hemochromatosis. *Pituitary* 2009;12(3): 273-275.
356. Barton, J.C., C. Leiendecker-Foster, D.M. Reboussin, et al. Thyroid-stimulating hormone and free thyroxine levels in persons with HFE C282Y homozygosity, a common hemochromatosis genotype: the HEIRS study. *Thyroid* 2008;18(8):831-838.
357. Bruix, J, Sherman M. Management of hepatocellular carcinoma. *Hepatology* 2005;42(5):1208-1236.
358. Beaton MD, Adams PC. Prognostic factors and survival in patients with hereditary hemochromatosis and cirrhosis. *Can J Gastroenterol* 2006;20(4): 257-260.
359. Willis, G., V. Bardsley, I.W. Fellows, et al. Hepatocellular carcinoma and the penetrance of HFE C282Y mutations: a cross sectional study. *BMC Gastroenterol* 2005;5:17.
360. Bacon, B.R., P.C. Adams, K.V. Kowdley, L.W. Powell, A.S. Tavill. Diagnosis and management of hemochromatosis: 2011 practice guideline by the American Association for the Study of Liver Diseases. *Hepatology* 2011;54(1): 328-343.
361. von Delius, S., C. Lersch, E. Schulte-Frohlinde, et al. Hepatocellular carcinoma associated with hereditary hemochromatosis occurring in non-cirrhotic liver. *Z Gastroenterol* 2006;44(1):39-42.
362. Goh, J., G. Callagy, G. McEntee, et al. Hepatocellular carcinoma arising in the absence of cirrhosis in genetic haemochromatosis: three case reports and review of literature. *Eur J Gastroenterol Hepatol* 1999;11(8):915-919.
363. Pellise, M., J. Gonzalez-Abraldes, M. Navasa, R. Miquel, M. Bruguera. Hepatocellular carcinoma in a patient with hereditary hemochromatosis without cirrhosis. *Gastroenterol Hepatol* 2001;24(3):132-134.
364. McPhail, D., L. Tetley, C. Dufes, I.F. Uchegbu. Liposomes encapsulating polymeric chitosan based vesicles-a vesicle in vesicle system for drug delivery. *Int J Pharm* 2000;200(1):73-86.
365. Bralet, M.P., C. Degott, J. Belghiti, B. Terris. Prevalence of the haemochromatosis gene mutation in non-cirrhotic liver with hepatocellular carcinoma. *J Hepatol* 1998;28(4):740.
366. Morcos, M., S. Dubois, M.P. Bralet, et al. Primary liver carcinoma in genetic hemochromatosis reveals a broad histologic spectrum. *Am J Clin Pathol* 2001;116(5):738-743.

367. Fargion, S., M.A. Stazi, A.L. Fracanzani, et al. Mutations in the HFE gene and their interaction with exogenous risk factors in hepatocellular carcinoma. *Blood Cells Mol Dis* 2001;27(2):505-511.
368. Pirisi, M., P. Toniutto, A. Uzzau, et al. Carriage of HFE mutations and outcome of surgical resection for hepatocellular carcinoma in cirrhotic patients. *Cancer* 2000;89(2):297-302.
369. Hellerbrand, C., A. Poppl, A. Hartmann, J. Scholmerich, G. Lock. HFE C282Y heterozygosity in hepatocellular carcinoma: evidence for an increased prevalence. *Clin Gastroenterol Hepatol* 2003;1(4):279-284.
370. Fracanzani, A.L., S. Fargion, M.A. Stazi, et al. Association between heterozygosity for HFE gene mutations and hepatitis viruses in hepatocellular carcinoma. *Blood Cells Mol Dis* 2005;35(1):27-32.
371. Racchi, O., R. Mangerini, D. Rapezzi, et al. Mutations of the HFE gene and the risk of hepatocellular carcinoma. *Blood Cells Mol Dis* 1999;25(5-6):350-353.
372. Bruix, J, Sherman M. Management of hepatocellular carcinoma: an update. *Hepatology* 2011;53(3):1020-1022.
373. EASL-EORTC clinical practice guidelines: management of hepatocellular carcinoma. *J Hepatol* 2012;56(4):908-943.
374. Kudo, M., N. Izumi, N. Kokudo, et al. Management of hepatocellular carcinoma in Japan: consensus-based Clinical Practice Guidelines proposed by the Japan Society of Hepatology (JSH) 2010 updated version. *Dig Dis* 2011;29(3):339-364.
375. McGlynn, K.A., L.C. Sakoda, Y. Hu, et al. Hemochromatosis gene mutations and distal adenomatous colorectal polyps. *Cancer Epidemiol Biomarkers Prev* 2005;14(1):158-163.
376. Shaheen, N.J., L.M. Silverman, T. Keku, et al. Association between hemochromatosis (HFE) gene mutation carrier status and the risk of colon cancer. *J Natl Cancer Inst* 2003;95(2):154-159.
377. Osborne, N.J., L.C. Gurrin, K.J. Allen, et al. HFE C282Y homozygotes are at increased risk of breast and colorectal cancer. *Hepatology* 2010;51(4): 1311-1318.
378. Meneghini R. Iron homeostasis, oxidative stress, and DNA damage. *Free Radic Biol Med* 1997;23(5):783-792.
379. Deugnier Y, Turlin B, Loreal O. Iron and neoplasia. *J Hepatol* 1998;28 Suppl 1:21-25.
380. Gannon, P.O., S. Medelci, C. Le Page, et al. Impact of hemochromatosis gene (HFE) mutations on epithelial ovarian cancer risk and prognosis. *Int J Cancer* 2011;128(10): 2326-2334.
381. Robertson DM. Hemochromatosis and ovarian cancer. *Womens Health (Lond Engl)* 2011;7(5):525-527.
382. Onitilo AA, Engel JM, Sajjad SM. The possible role of hemochromatosis in testicular cancer. *Med Hypotheses* 2011;77(2):179-181.
383. Ekblom, K., S.L. Marklund, R. Palmqvist, et al. Iron biomarkers in plasma, HFE genotypes, and the risk for colorectal cancer in a prospective setting. *Dis Colon Rectum* 2012;55(3): 337-344.
384. Ellervik, C., H. Birgens, A. Hemochromatosis genotypes and risk of 31 disease endpoints: meta-analyses including 66,000 cases and 226,000 controls. *Hepatology* 2007;46(4):1071-1080.
385. Hucl, T., M.L. Kylanpaa-Back, H. Witt, et al. HFE genotypes in patients with chronic pancreatitis and pancreatic adenocarcinoma. *Genet Med* 2007;9(7):479-483.
386. Robinson, J.P., V.L. Johnson, P.A. Rogers, et al. Evidence for an association between compound heterozygosity for germ line mutations in the hemochromatosis (HFE) gene and increased risk of colorectal cancer. *Cancer Epidemiol Biomarkers Prev* 2005;14(6):1460-1463.
387. Ryan Caballes F, Sendi H, Bonkovsky HL. Hepatitis C, porphyria cutanea tarda and liver iron: an update. *Liver Int* 2012;32(6):880-893.
388. Aarsand AK, Boman H, Sandberg S. Familial and sporadic porphyria cutanea tarda: characterization and diagnostic strategies. *Clin Chem* 2009;55(4):795-803.
389. Wallace DF, Subramaniam VN. Co-factors in liver disease: the role of HFE-related hereditary hemochromatosis and iron. *Biochim Biophys Acta* 2009;1790(7):663-670.
390. Mehrany, K., L.A. Drage, D.J. Brandhagen, M.R. Pittelkow. Association of porphyria cutanea tarda with hereditary hemochromatosis. *J Am Acad Dermatol* 2004;51(2):205-211.
391. de Geus HR, Dees A. Sporadic porphyria cutanea tarda due to haemochromatosis. *Neth J Med* 2006;64(8):307-309.

392. Bygum, A., L. Christiansen, N.E. Petersen, et al. Familial and sporadic porphyria cutanea tarda: clinical, biochemical and genetic features with emphasis on iron status. *Acta Derm Venereol* 2003;83(2):115-120.
393. Olsson KS, Ritter B, Hansson N. The HLA-A1-B8 haplotype hitchhiking with the hemochromatosis mutation: does it affect the phenotype? *Eur J Haematol* 2007;79(5):429-434.
394. Phillips, J.D., H.A. Bergonia, C.A. Reilly, M.R. Franklin, J.P. Kushner. A porphomethene inhibitor of uroporphyrinogen decarboxylase causes porphyria cutanea tarda. *Proc Natl Acad Sci U S A* 2007;104(12):5079-5084.
395. Danton, M, Lim CK. Porphomethene inhibitor of uroporphyrinogen decarboxylase: analysis by high-performance liquid chromatography/electrospray ionization tandem mass spectrometry. *Biomed Chromatogr* 2007;21(7):661-663.
396. Roberts, A.G., S.D. Whatley, R.R. Morgan, M. Worwood, G.H. Elder. Increased frequency of the haemochromatosis Cys282Tyr mutation in sporadic porphyria cutanea tarda. *Lancet* 1997;349(9048): 321-323.
397. Cruz, M.J., S. Alves, T. Baudrier, F. Azevedo. Porphyria cutanea tarda induced by tamoxifen. *Dermatol Online J* 2010;16(9):2.
398. Munoz-Santos, C., A. Guilabert, N. Moreno, et al. Familial and sporadic porphyria cutanea tarda: clinical and biochemical features and risk factors in 152 patients. *Medicine (Baltimore)* 2010;89(2):69-74.
399. Egger, N.G., D.E. Goeger, D.A. Payne, et al. Porphyria cutanea tarda: multiplicity of risk factors including HFE mutations, hepatitis C, and inherited uroporphyrinogen decarboxylase deficiency. *Dig Dis Sci* 2002;47(2):419-426.
400. Lamoril, J., C. Andant, L. Gouya, et al. Hemochromatosis (HFE) and transferrin receptor-1 (TFRC1) genes in sporadic porphyria cutanea tarda (sPCT). *Cell Mol Biol (Noisy-le-grand)* 2002;48(1):33-41.
401. Cribier, B., C. Chiaverini, N. Dali-Youcef, et al. Porphyria cutanea tarda, hepatitis C, uroporphyrinogen decarboxylase and mutations of HFE gene. A case-control study. *Dermatology* 2009;218(1):15-21.
402. Tannapfel, A., U. Stolzel, E. Kostler, et al. C282Y and H63D mutation of the hemochromatosis gene in German porphyria cutanea tarda patients. *Virchows Arch.* 2001;439(1):1-5.
403. Castiella, A., E. Zapata, M.D. de Juan, et al. Porphyria cutanea tarda. An analysis of HFE gene mutations, hepatitis viruses, alcohol intake, and other risk factors in 54 patients from Guipuzcoa, Basque Country, Spain. *Rev Esp Enferm Dig* 2008;100(12):774-778.
404. Bertoli LF, Barton JC. Remission of porphyria cutanea tarda after anastrozole treatment of breast cancer. *Clin Breast Cancer* 2007;7(9):716-718.
405. Agarwal, R., T.J. Peters, R.C. Coombes, D.M. Vigushin. Tamoxifen-related porphyria cutanea tarda. *Med Oncol* 2002;19(2):121-123.
406. Corradini, E, Pietrangelo A. Iron and steatohepatitis. *J Gastroenterol Hepatol* 2012;27 Suppl 2:42-46.
407. Dongiovanni, P., A.L. Fracanzani, S. Fargion, L. Valenti. Iron in fatty liver and in the metabolic syndrome: a promising therapeutic target. *J Hepatol* 2011;55(4):920-932.
408. Hernaez, R., E. Yeung, J.M. Clark, et al. Hemochromatosis gene and nonalcoholic fatty liver disease: a systematic review and meta-analysis. *J Hepatol* 2011;55(5):1079-1085.
409. Clouston AD, Jonsson JR, Powell EE. Steatosis as a cofactor in other liver diseases: hepatitis C virus, alcohol, hemochromatosis, and others. *Clin Liver Dis* 2007;11(1):173-189, x.
410. Valenti, L., A.L. Fracanzani, E. Bugianesi, et al. HFE genotype, parenchymal iron accumulation, and liver fibrosis in patients with nonalcoholic fatty liver disease. *Gastroenterology* 2010;138(3):905-912.
411. Thakur, V., R.C. Guptan, A.Z. Hashmi, et al. Absence of hemochromatosis associated Cys282Tyr HFE gene mutation and low frequency of hemochromatosis phenotype in nonalcoholic chronic liver disease patients in India. *J Gastroenterol Hepatol* 2004;19(1):86-90.
412. Duseja, A., R. Das, M. Nanda, et al. Nonalcoholic steatohepatitis in Asian Indians is neither associated with iron overload nor with HFE gene mutations. *World J Gastroenterol* 2005;11(3):393-395.
413. Gaya, D.R., A.L. McLay, K.A. Oien, R.J. Spooner, T.G. Reilly. A tale of two sisters. *J Clin Pathol* 2004;57(4):439-441.
414. Yamauchi, N., Y. Itoh, Y. Tanaka, et al. Clinical characteristics and prevalence of GB virus C, SEN virus, and HFE gene mutation in Japanese patients with nonalcoholic steatohepatitis. *J Gastroenterol* 2004;39(7):654-660.

415. Deguti, M.M., A.M. Sipahi, L.C. Gayotto, et al. Lack of evidence for the pathogenic role of iron and HFE gene mutations in Brazilian patients with nonalcoholic steatohepatitis. *Braz J Med Biol Res* 2003;36(6):739-745.
416. Bugianesi, E., N. Leone, E. Vanni, et al. Expanding the natural history of nonalcoholic steatohepatitis: from cryptogenic cirrhosis to hepatocellular carcinoma. *Gastroenterology* 2002;123(1):134-140.
417. Bacon BR. Hemochromatosis: diagnosis and management. *Gastroenterol* 2001;120(3):718-725.
418. Fargion, S., M. Mattioli, A.L. Fracanzani, et al. Hyperferritinemia, iron overload, and multiple metabolic alterations identify patients at risk for nonalcoholic steatohepatitis. *Am J Gastroenterol* 2001;96(8):2448-2455.
419. Bonkovsky, H.L., Q. Jawaid, K. Tortorelli, et al. Non-alcoholic steatohepatitis and iron: increased prevalence of mutations of the HFE gene in non-alcoholic steatohepatitis. *J Hepatol* 1999;31(3):421-429.
420. Mendler, M.H., B. Turlin, R. Moirand, et al. Insulin resistance-associated hepatic iron overload. *Gastroenterology* 1999;117(5):1155-1163.
421. George, D.K., S. Goldwurm, G.A. MacDonald, et al. Increased hepatic iron concentration in nonalcoholic steatohepatitis is associated with increased fibrosis. *Gastroenterol* 1998;114(2):311-318.
422. Bacon, B.R., M.J. Farahvash, C.G. Janney, B.A. Neuschwander-Tetri. Nonalcoholic steatohepatitis: an expanded clinical entity. *Gastroenterol* 1994;107(4):1103-1109.
423. Montes-Cano, M.A., F. Rodriguez-Munoz, R. Franco-Osorio, A. Nunez-Roldan, M.F. Gonzalez-Escribano. Hereditary spherocytosis associated with mutations in HFE gene. *Ann Hematol* 2003;82(12):769-772.
424. Edwards, C.Q., M.H. Skolnick, M.M. Dadone, J.P. Kushner. Iron overload in hereditary spherocytosis: association with HLA-linked hemochromatosis. *Am J Hematol* 1982;13(2):101-109.
425. Mohler DN, Wheby MS. Hemochromatosis heterozygotes may have significant iron overload when they also have hereditary spherocytosis. *Am J Med Sci* 1986;292(5):320-324.
426. O'Mahony S, O'Brien PA, Whelton MJ. Genetic haemochromatosis and congenital spherocytosis. *Lancet* 1987;1(8527):282.
427. Blacklock HA, Meerkin M. Serum ferritin in patients with hereditary spherocytosis. *Br J Haematol* 1981;49(1):117-122.
428. Zimelman AP, Miller A. Primary hemochromatosis with hereditary spherocytosis. *Arch Intern Med* 1980;140(7):983-984.
429. Takegoshi, T., T. Nishino, M. Tanino, A. Nonokura, G. Ohta. An autopsy case of hemochromatosis and hepatoma combined with hereditary spherocytosis. *Jpn J Med* 1984;23(1):48-52.
430. Fargion, S., M.D. Cappellini, A. Piperno, et al. Association of hereditary spherocytosis and idiopathic hemochromatosis. A synergistic effect in determining iron overload. *Am J Clin Pathol* 1986;86(5):645-649.
431. Brandenburg, J.B., F. Demarmels Biasiutti, H.U. Lutz, W.A. Wuillemin. Hereditary spherocytosis and hemochromatosis. *Ann Hematol* 2002;81(4):202-209.
432. Barry, M., P.J. Scheuer, S. Sherlock, C.F. Ross, R. Williams. Hereditary spherocytosis with secondary haemochromatosis. *Lancet* 1968;2(7566):481-485.
433. Hoblinger, A., C. Erdmann, C.P. Strassburg, T. Sauerbruch, F. Lammert. Coinheritance of hereditary spherocytosis and reversibility of cirrhosis in a young female patient with hereditary hemochromatosis. *Eur J Med Res* 2009;14(4):182-184.
434. Ichiche, M., P. Lacor, A. Hoorens, et al. Congenital spherocytosis with hereditary hemochromatosis without pathogenic mutations in the HFE gene. *Eur J Intern Med* 2004;15(7):460-462.
435. Barton, J.C., P.L. Lee, C. West, S.S. Bottomley. Iron overload and prolonged ingestion of iron supplements: clinical features and mutation analysis of hemochromatosis-associated genes in four cases. *Am J Hematol* 2006;81(10):760-767.
436. Edwards CQ, Skolnick MH, Kushner JP. Coincidental nontransfusional iron overload and thalassemia minor: association with HLA-linked hemochromatosis. *Blood* 1981;58(4):844-848.
437. Piperno, A., R. Mariani, C. Arosio, et al. Haemochromatosis in patients with beta-thalassaemia trait. *Br J Haematol* 2000;111(3):908-914.
438. Melis, M.A., M. Cau, F. Deidda, et al. H63D mutation in the HFE gene increases iron overload in beta-thalassemia carriers. *Haematologica* 2002;87(3): 242-245.

439. Longo, F., G. Zecchina, L. Sbaiz, et al. The influence of hemochromatosis mutations on iron overload of thalassemia major. *Haematologica* 1999;84(9):799-803.
440. Martins, R., I. Picanco, A. Fonseca, et al. The role of HFE mutations on iron metabolism in beta-thalassemia carriers. *J Hum Genet* 2004;49(12):651-655.
441. Ruiz-Arguelles, G.J., J. Garces-Eisele, V. Reyes-Nunez, et al. Heterozygosity for the H63D mutation in the hereditary hemochromatosis (HFE) gene may lead into severe iron overload in beta-thalassemia minor: observations in a thalassaemic kindred. *Rev Invest Clin* 2001;53(2):117-120.
442. Miniero, R., I. Tardivo, A. Roetto, M. De Gobbi. Heterozygous beta-thalassemia and homozygous H63D hemochromatosis in a child: an 18-year follow-up. *Pediatr Hematol Oncol* 2005;22(2):163-166.
443. Garewal, G., R. Das, J. Ahluwalia, R.K. Marwaha. Prevalence of the H63D mutation of the HFE in north India: its presence does not cause iron overload in beta thalassemia trait. *European J Hematol* 2005;74(4):333-336.
444. Kaur, G., C.C. Rappap, M. Xavier, et al. Distribution of C282Y and H63D mutations in the HFE gene in healthy Asian Indians and patients with thalassaemia major. *Natl Med J India* 2003;16(6):309-310.
445. Politou, M., V. Kalotychou, M. Pissia, et al. The impact of the mutations of the HFE gene and of the SLC11A3 gene on iron overload in Greek thalassemia intermedia and beta(s)/beta(thal) anemia patients. *Haematologica* 2004;89(4):490-492.
446. Jazayeri, M., V. Bakayev, P. Adibi, et al. Frequency of HFE gene mutations in Iranian beta-thalassaemia minor patients. *Eur J Haematol* 2003;71(6):408-411.
447. Beris, P., K. Samii, R. Darbellay, et al. Iron overload in patients with sideroblastic anaemia is not related to the presence of the haemochromatosis Cys282Tyr and His63Asp mutations. *Br J Haematol* 1999;104(1):97-99.
448. Yaouanq, J., B. Grosbois, A.M. Jouanolle, J. Goasguen, R. Leblay. Haemochromatosis Cys282Tyr mutation in pyridoxine-responsive sideroblastic anaemia. *Lancet* 1997;349(9063):1475-1476.
449. Cotter, P.D., A. May, L. Li, et al. Four new mutations in the erythroid-specific 5-aminolevulinic synthase (ALAS2) gene causing X-linked sideroblastic anemia: increased pyridoxine responsiveness after removal of iron overload by phlebotomy and coinheritance of hereditary hemochromatosis. *Blood* 1999;93(5):1757-1769.
450. Lee, P.L., J.C. Barton, S.V. Rao, et al. Three kinships with ALAS2 P520L (c. 1559 C → T) mutation, two in association with severe iron overload, and one with sideroblastic anemia and severe iron overload. *Blood Cells Mol Dis* 2006;36(2):292-297.
451. Barton JC, Lee PL. Disparate phenotypic expression of ALAS2 R452H (nt 1407 G → A) in two brothers, one with severe sideroblastic anemia and iron overload, hepatic cirrhosis, and hepatocellular carcinoma. *Blood Cells Mol Dis* 2006;36(3):342-346.
452. Barton, J.C., P.L. Lee, L.F. Bertoli, E. Beutler. Iron overload in an African American woman with SS hemoglobinopathy and a promoter mutation in the X-linked erythroid-specific 5-aminolevulinic synthase (ALAS2) gene. *Blood Cells Mol Dis* 2005;34(3):226-228.
453. Park JY, Park SH, Weiss RH. Disparate effects of roscovitine on renal tubular epithelial cell apoptosis and senescence: implications for autosomal dominant polycystic kidney disease. *Am J Nephrol* 2009;29(6):509-515.
454. Camaschella C. Hereditary sideroblastic anemias: pathophysiology, diagnosis, and treatment. *Semin Hematol* 2009;46(4):371-377.
455. Ralph A, Currie BJ. *Vibrio vulnificus* and *V. parahaemolyticus* necrotising fasciitis in fishermen visiting an estuarine tropical northern Australian location. *J Infect* 2007;54(3):e111-e114.
456. Blake, P.A., M.H. Merson, R.E. Weaver, D.G. Hollis, P.C. Heublein. Disease caused by a marine *Vibrio*. Clinical characteristics and epidemiology. *N Engl J Med* 1979;300(1):1-5.
457. Highly invasive new bacterium isolated from US east coast waters. *JAMA* 1984;251(3):323-325.
458. Abbott M, Galloway A, Cunningham JL. Haemochromatosis presenting with a double *Yersinia* infection. *J Infect* 1986;13(2):143-145.
459. Muench KH. Hemochromatosis and infection: alcohol and iron, oysters and sepsis. *Am J Med* 1989;87(3N):40N-43N.

460. Bullen, J.J., P.B. Spalding, C.G. Ward, J.M. Gutteridge. Hemochromatosis, iron and septicemia caused by *Vibrio vulnificus*. *Arch Intern Med* 1991;151(8):1606-1609.
461. Robins-Browne RM, Rabson AR, Koornhof HJ. Generalized infection with *Yersinia enterocolitica* and the role of iron. *Contrib Microbiol Immunol* 1979;5:277-282.
462. Olesen, L.L., T. Ejlersen, S.M. Paulsen, P.R. Knudsen. Liver abscesses due to *Yersinia enterocolitica* in patients with haemochromatosis. *J Intern Med* 1989;225(5):351-354.
463. Conway, S.P., N. Dudley, P. Sheridan, H. Ross. Haemochromatosis and aldosterone deficiency presenting with *Yersinia pseudotuberculosis* septicaemia. *Postgrad Med J* 1989;65(761):174-176.
464. Munoz Martinez, T., J. Garcia Perez, J. Collazos Gonzalez, J. de Miguel Prieto. *Yersinia enterocolitica* bacteremia and hemochromatosis. *Rev Clin Esp* 1991;189(2):92.
465. Vadillo, M., X. Corbella, V. Pac, P. Fernandez-Viladrich, R. Pujol. Multiple liver abscesses due to *Yersinia enterocolitica* discloses primary hemochromatosis: three cases reports and review. *Clin Infect Dis* 1994;18(6):938-941.
466. Kumamoto KS, Vukich DJ. Clinical infections of *Vibrio vulnificus*: a case report and review of the literature. *J Emerg Med* 1998;16(1):61-66.
467. Johnson RW, Arnett FC. A fatal case of *Vibrio vulnificus* presenting as septic arthritis. *Arch Intern Med* 2001;161(21):2616-2618.
468. Barton JC, Acton RT. Hemochromatosis and *Vibrio vulnificus* Wound Infections. *J Clin Gastroenterol* 2009;43(9):890-893.
469. Manso, C., I. Rivas, J. Peraire, F. Vidal, C. Richart. Fatal *Listeria meningitis*, endocarditis and pericarditis in a patient with haemochromatosis. *Scand J Infect Dis* 1997;29(3):308-309.
470. Crosbie J, Varma J, Mansfield J. *Yersinia enterocolitica* infection in a patient with hemochromatosis masquerading as proximal colon cancer with liver metastases: report of a case. *Dis Colon Rectum* 2005;48(2):390-392.
471. MacSween RNM. Acute abdominal crises, circulatory collapse and sudden death in haemochromatosis. *Q J Med* 1966;35:589.
472. McNab AA, McKelvie, P. Iron overload is a risk factor for zygomycosis. *Arch Ophthalmol* 1997;115(7):919-921.
473. Singh, N, Sun HY. Iron overload and unique susceptibility of liver transplant recipients to disseminated disease due to opportunistic pathogens. *Liver Transpl* 2008;14(9):1249-1255.
474. Kefala-Agoropoulou, K., E. Roilides, A. Lazaridou. Pearson syndrome in an infant heterozygous for C282Y allele of HFE gene. *Hematology* 2007;12(6): 549-553.
475. Gerhard, G.S., K.A. Levin, J. Price Goldstein, et al. *Vibrio vulnificus* septicemia in a patient with the hemochromatosis HFE C282Y mutation. *Arch Pathol Lab Med* 2001;125(8):1107-1109.
476. Kim, D.M., H.S. Cho, J.I. Kang, H.S. Kim, C.Y. Park. Deferasirox plus ciprofloxacin combination therapy after rapid diagnosis of *Vibrio vulnificus* sepsis using real-time polymerase chain reaction. *J Infect* 2008;57(6):489-492.
477. Piroth, L., P. Meyer, P. Bielefeld, J.F. Besancenot. *Yersinia* bacteremia and iron overload. *Rev Med Interne* 1997;18(12):932-938.
478. Menecier, D., M. Lapprand, E. Hernandez, et al. Liver abscesses due to *Yersinia pseudotuberculosis* discloses a genetic hemochromatosis. *Gastroenterol Clin Biol* 2001;25(12):1113-1115.
479. Bergmann TK, Vinding K, Hey H. Multiple hepatic abscesses due to *Yersinia enterocolitica* infection secondary to primary haemochromatosis. *Scand J Gastroenterol* 2001;36(8):891-895.
480. Hopfner, M., R. Nitsche, A. Rohr, et al. *Yersinia enterocolitica* infection with multiple liver abscesses uncovering a primary hemochromatosis. *Scand J Gastroenterol* 2001;36(2):220-224.
481. Abdelli, N., G. Thieffin, P. Chevalier, P. Zeitoun. Spontaneously regressive liver abscess caused by *Yersinia enterocolitica* revealing genetic hemochromatosis: a second case. *Gastroenterol Clin Biol* 1996;20(2):212-213.
482. Collazos, J., E. Guerra, A. Fernandez, J. Mayo, E. Martinez. Miliary liver abscesses and skin infection due to *Yersinia enterocolitica* in a patient with unsuspected hemochromatosis. *Clin Infect Dis* 1995;21(1):223-224.

483. Benbrika, S., L. Boukari, J. Stirnemann, et al. A case of yersiniosis with multiple liver abscesses. *Rev Med Interne* 2005;26(2):151-152.
484. Barton JC, Bertoli LF, Acton RT. Common variable immunodeficiency and IgG subclass deficiency in central Alabama hemochromatosis probands homozygous for HFE C282Y. *Blood Cells Mol Dis* 2003;31(1):102-111.
485. Shizukuda, Y., D.J. Tripodi, G. Zalos, et al. Incidence of Cardiac Arrhythmias in Asymptomatic Hereditary Hemochromatosis Subjects With C282Y Homozygosity. *Am J Cardiol* 2012;109(6):856-860.
486. Moller, D.V., R. Pecini, F. Gustafsson, et al. Hereditary hemochromatosis (HFE) genotypes in heart failure: relation to etiology and prognosis. *BMC Med Genet* 2010;11:117.
487. Cutler, D.J., J.M. Isner, A.W. Bracey, et al. Hemochromatosis heart disease: an unemphasized cause of potentially reversible restrictive cardiomyopathy. *Am J Med* 1980;69(6):923-928.
488. Cecchetti, G., A. Binda, A. Piperno, et al. Cardiac alterations in 36 consecutive patients with idiopathic haemochromatosis: polygraphic and echocardiographic evaluation. *Eur Heart J* 1991;12(2):224-230.
489. Olson LJ, Baldus WP, Tajik AJ. Echocardiographic features of idiopathic hemochromatosis. *Am J Cardiol* 1987;60(10):885-889.
490. Dabestani, A., J.S. Child, J.K. Perloff, et al. Cardiac abnormalities in primary hemochromatosis. *Ann N Y Acad Sci* 1988;526:234-244.
491. Buja LM, Roberts WC. Iron in the heart. Etiology and clinical significance. *Am J Med* 1971;51(2):209-221.
492. Olson, L.J., W.D. Edwards, D.R. Holmes, Jr., et al. Endomyocardial biopsy in hemochromatosis: clinicopathologic correlates in six cases. *J Am Coll Cardiol* 1989;13(1):116-120.
493. Elmberg, M., R. Hultcrantz, J.F. Simard, et al. Risk of ischaemic heart disease and cardiomyopathy in patients with haemochromatosis and in their first-degree relatives: a nationwide, population-based study. *J Intern Med* 2011;272(1):45-54.
494. van der A.D., M.M. Rovers, D.E. Grobbee, et al. Mutations in the HFE gene and cardiovascular disease risk: an individual patient data meta-analysis of 53 880 subjects. *Circul Cardiovas Genet* 2008;1(1):43-50.
495. Dunn, T., D. Blankenship, N. Beal, et al. HFE mutations in heart disease. *Heart Vessels* 2008;23(5):348-355.
496. Gunn, I.R., F.K. Maxwell, D. Gaffney, A.D. McMahon, C.J. Packard. Haemochromatosis gene mutations and risk of coronary heart disease: a west of Scotland coronary prevention study (WOSCOPS) substudy. *Heart* 2004;90(3):304-306.
497. Bozzini, C., D. Girelli, E. Tinazzi, et al. Biochemical and genetic markers of iron status and the risk of coronary artery disease: an angiography-based study. *Clin Chem* 2002;48(4):622-628.
498. Calado, R.T., R.F. Franco, A. Pazin-Filho, et al. HFE gene mutations in coronary atherothrombotic disease. *Braz J Med Biol Res* 2000;33(3):301-306.
499. Battiloro, E., D. Ombres, E. Pascale, et al. Haemochromatosis gene mutations and risk of coronary artery disease. *Eur J Hum Genet* 2000;8(5):389-392.
500. Nassar, B.A., E.M. Zayed, L.M. Title, et al. Relation of HFE gene mutations, high iron stores and early onset coronary artery disease. *Can J Cardiol* 1998;14(2):215-220.
501. Miller, M, Hutchins GM. Hemochromatosis, multiorgan hemosiderosis, and coronary artery disease. *JAMA* 1994;272(3):231-233.
502. Waalen, J, Beutler E. Beware of multiple comparisons: a study of symptoms associated with mutations of the HFE hemochromatosis gene. *Clin Chim Acta* 2005;361(1-2):128-134.
503. Zorc, M., H. Hruskovicova, M.G. Petrovic, et al. Haemochromatosis-causing mutations C282Y and H63D are not risk factors for coronary artery disease in Caucasians with type 2 diabetes. *Folia Biol (Praha)* 2004;50(2):69-70.
504. Surber, R., H.H. Sigusch, H. Kuehnert, H.R. Figulla. Haemochromatosis (HFE) gene C282Y mutation and the risk of coronary artery disease and myocardial infarction: a study in 1279 patients undergoing coronary angiography. *J Med Genet* 2003;40(5):e58.
505. Ferrari, M., G.S. Werner, J. Rieber, et al. No influence of hemochromatosis-related gene mutations on restenosis rate in a retrospective study of 137 patients after coronary stent implantation. *Int J Cardiovasc Intervent* 2001;4(4):181-186.

506. Pardo Silva, M.C., O.T. Njajou, B.Z. Alizadeh, et al. HFE gene mutations increase the risk of coronary heart disease in women. *Eur J Epidemiol* 2010;25(9):643-649.
507. Dijck-Brouwer, D.A., B.G. Hepkema, F.P. van der Dijs, et al. Curacao patients with coronary artery disease have a higher prevalence of the HFE C282Y mutation. *West Indian Med J* 2004;53(3):143-146.
508. Adams, P.C., J.S. Pankow, J.C. Barton, et al. HFE C282Y homozygosity is associated with lower total and low-density lipoprotein cholesterol: the hemochromatosis and iron overload screening study. *Circul Cardiovasc Genet* 2009;2(1):34-37.
509. Barton JC, Adams PC. Clinical guidelines: HFE hemochromatosis-screening, diagnosis and management. *Nat Rev Gastroenterol Hepatol* 2010;7(9): 482-484.
510. Pietrangelo A. Hereditary hemochromatosis: pathogenesis, diagnosis, and treatment. *Gastroenterology* 2010;139(2):393-408, 408 e1-e2.
511. Gan EK, Powell LW, Olynyk JK. Natural history and management of HFE hemochromatosis. *Semin Liver Dis* 2011;31(3):293-301.
512. van Bokhoven MA, van Deursen CT, Swinkels DW. Diagnosis and management of hereditary haemochromatosis. *BMJ* 2011;342:c7251.
513. Cooper, K., J. Bryant, J. Picot, et al. A decision analysis model for diagnostic strategies using DNA testing for hereditary haemochromatosis in at risk populations. *Q J Med* 2008;101(8):631-641.
514. Adams, P.C., D.M. Reboussin, J.C. Barton, et al. Serial serum ferritin measurements in untreated HFE C282Y homozygotes in the Hemochromatosis and Iron Overload Screening Study. *Int J Lab Hematol* 2008;30(4):300-305.
515. McLaren, G.D., C.E. McLaren, P.C. Adams, et al. Clinical manifestations of hemochromatosis in HFE C282Y homozygotes identified by screening. *Can J Gastroenterol* 2008;22(11): 923-930.
516. Nadakkavukaran IM, Gan EK, Olynyk JK. Screening for hereditary haemochromatosis. *Pathology* 2012;44(2):148-152.
517. Powell, L.W., D.K. George, S.M. McDonnell, K.V. Kowdley. Diagnosis of hemochromatosis. *Ann. Intern. Med* 1998;129(11):925-931.
518. Murtagh, L.J., M. Whiley, S. Wilson, H. Tran, M.L. Bassett. Unsaturated iron binding capacity and transferrin saturation are equally reliable in detection of HFE hemochromatosis. *Am J Gastroenterol* 2002;97(8):2093-2099.
519. Jackson, H.A., K. Carter, C. Darke, et al. HFE mutations, iron deficiency and overload in 10,500 blood donors. *Br J Haematol* 2001;114(2):474-484.
520. Adams, P.C., A.E. Kertesz, C.E. McLaren, et al. Population screening for hemochromatosis: a comparison of unbound iron-binding capacity, transferrin saturation, and C282Y genotyping in 5,211 voluntary blood donors. *Hepatology* 2000;31(5):1160-1164.
521. Lee, P.L., N.J. Ho, R. Olson, E. Beutler. The effect of transferrin polymorphisms on iron metabolism. *Blood Cells Mol Dis* 1999;25(5-6):374-379.
522. Bassett, M.L., J.W. Halliday, R.A. Ferris, L.W. Powell. Diagnosis of hemochromatosis in young subjects: predictive accuracy of biochemical screening tests. *Gastroenterol* 1984;87(3):628-633.
523. Allen, K.J., N.A. Bertalli, N.J. Osborne, et al. HFE Cys282Tyr homozygotes with serum ferritin concentrations below 1000 microg/L are at low risk of hemochromatosis. *Hepatology* 2010;52(3):925-933.
524. Morrison, E.D., D.J. Brandhagen, P.D. Phatak, et al. Serum ferritin level predicts advanced hepatic fibrosis among U.S. patients with phenotypic hemochromatosis. *Ann Intern Med* 2003;138(8):627-633.
525. Bassett ML, Hickman PE, Dahlstrom JE. The changing role of liver biopsy in diagnosis and management of haemochromatosis. *Pathology* 2011;43(5):433-439.
526. Bulaj, Z.J., L.M. Griffen, L.B. Jorde, C.Q. Edwards, J.P. Kushner. Clinical and biochemical abnormalities in people heterozygous for hemochromatosis. *N Engl J Med* 1996;335(24):1799-1805.
527. Hunt JR, Zeng H. Iron absorption by heterozygous carriers of the HFE C282Y mutation associated with hemochromatosis. *Am J Clin Nutr* 2004;80(4): 924-931.
528. Barton, J.C., S.M. McDonnell, P.C. Adams, et al. Management of hemochromatosis. Hemochromatosis Management Working Group. *Ann Intern Med* 1998;129(11):932-939.

529. Edwards, C.Q., M.M. Dadone, M.H. Skolnick, J.P. Kushner. Hereditary haemochromatosis. *Clin Haematol* 1982;11(2):411-435.
530. Barton JC, Bottomley SS. Iron deficiency due to excessive therapeutic phlebotomy in hemochromatosis. *Am J Hematol* 2000;65(3):223-226.
531. Barton JC, Bertoli LF, Rothenberg BE. Screening for hemochromatosis in routine medical care: an evaluation of mean corpuscular volume and mean corpuscular hemoglobin. *Genet Test* 2000;4(2):103-110.
532. Bolan, C.D., C. Conry-Cantilena, G. Mason, T.A. Rouault, S.F. Leitman. MCV as a guide to phlebotomy therapy for hemochromatosis. *Transfusion* 2001;41(6):819-827.
533. Adams PC, Barton JC. How I treat hemochromatosis. *Blood* 2010;116(3): 317-325.
534. Leitman, S.F., J.N. Browning, Y.Y. Yau, et al. Hemochromatosis subjects as allogeneic blood donors: a prospective study. *Transfusion* 2003;43(11): 1538-1544.
535. Pennings G. Demanding pure motives for donation: the moral acceptability of blood donations by haemochromatosis patients. *J Med Ethics* 2005;31(2): 69-72.
536. Falize, L., A. Guillygomarc'h, M. Perrin, et al. Reversibility of hepatic fibrosis in treated genetic hemochromatosis: a study of 36 cases. *Hepatology* 2006;44(2):472-477.
537. LeSage, G.D., W.P. Baldus, V.F. Fairbanks, et al. Hemochromatosis: genetic or alcohol-induced? *Gastroenterology* 1983;84(6):1471-1477.
538. Fletcher LM, Powell LW. Hemochromatosis and alcoholic liver disease. *Alcohol* 2003;30(2):131-136.
539. Fletcher, L.M., J.L. Dixon, D.M. Purdie, L.W. Powell, D.H. Crawford. Excess alcohol greatly increases the prevalence of cirrhosis in hereditary hemochromatosis. *Gastroenterology* 2002;122(2):281-289.
540. Herbert V, Hemochromatosis and vitamin C. *Ann Intern Med* 1999;131(6): 475-476.
541. Nienhuis AW. Vitamin C and iron. *N Engl J Med* 1981;304(3):170-171.
542. Roeckel IE, Dickson LG. Understanding iron absorption and metabolism, aided by studies of hemochromatosis. *Ann Clin Lab Sci* 1998;28(1):30-33.
543. Conte, D., L. Brunelli, L. Ferrario, et al. Effect of ascorbic acid on desferrioxamine-induced urinary iron excretion in idiopathic hemochromatosis. *Acta Haematol* 1984;72(2):117-120.
544. Herbert V, Shaw S, Jayatilleke E. Vitamin C-driven free radical generation from iron. *J Nutr* 1996;126(4 Suppl):1213S-20S.
545. McLaran, C.J., J.H. Bett, J.A. Nye, J.W. Halliday. Congestive cardiomyopathy and haemochromatosis—rapid progression possibly accelerated by excessive ingestion of ascorbic acid. *Aust N Z J Med* 1982;12(2):187-188.
546. O'Brien RT. Ascorbic acid enhancement of desferrioxamine-induced urinary iron excretion in thalassemia major. *Ann N Y Acad Sci* 1974;232(0):221-225.
547. Henry W. Echocardiographic evaluation of the heart in thalassemia major. *Ann Intern Med* 1979;91:892.
548. Barton, J.C., R.T. Acton, J. So, S. Chan, P.C. Adams. Increased risk of death from iron overload among 422 treated probands with HFE hemochromatosis and serum levels of ferritin greater than 1000 µg/L at diagnosis. *Clin Gastroenterol Hepatol* 2012;10(4):412-416.
549. Wojcik, J.P., M.R. Speechley, A.E. Kertesz, S. Chakrabarti, P.C. Adams. Natural history of C282Y homozygotes for hemochromatosis. *Can J Gastroenterol* 2002;16(5):297-302.
550. Milman N, et al. Clinically overt hereditary hemochromatosis in Denmark 1948-1985: epidemiology, factors of significance for long-term survival, and causes of death in 179 patients. *Ann Hematol* 2001;80(12):737-744.
551. Vitellas, K.M., M.T. Tzalonikou, W.F. Bennett, K.K. Vaswani, J.G. Bova. Cirrhosis: spectrum of findings on unenhanced and dynamic gadolinium-enhanced MR imaging. *Abdom Imaging* 2001;26(6):601-615.
552. Fritz, G.A., H. Schoellnast, H.A. Deutschmann, et al. Density histogram analysis of unenhanced hepatic computed tomography in patients with diffuse liver diseases. *J Comput Assist Tomogr* 2006;30(2):201-205.
553. Duvauferrier, R., P. Bellanger, M. Campillo, E. al. Dual energy CT in hereditary hemochromatosis. *Diagn Interv Radiol* 1990;2:39-47.

554. Merkle EM, Nelson RC, Dual gradient-echo in-phase and opposed-phase hepatic MR imaging: a useful tool for evaluating more than fatty infiltration or fatty sparing. *Radiographics* 2006;26(5):1409-1418.
555. St Pierre, T.G., P.R. Clark, W. Chua-anusorn, et al. Noninvasive measurement and imaging of liver iron concentrations using proton magnetic resonance. *Blood* 2005;105(2):855-861.
556. Carneiro, A.A., J.P. Fernandes, D.B. de Araujo, et al. Liver iron concentration evaluated by two magnetic methods: magnetic resonance imaging and magnetic susceptometry. *Magn Reson Med* 2005;54(1):122-128.
557. Alustiza, J.M., J. Artetxe, A. Castiella, et al. MR quantification of hepatic iron concentration. *Radiology* 2004;230(2):479-484.
558. Lwakatare F, Hayashida Y, Yamashita Y. MR imaging of hepatocellular carcinoma arising in genetic hemochromatosis. *Magn Reson Med Sci* 2003;2(1):57-59.
559. Siegelman, E.S., D.G. Mitchell, R. Rubin, et al. Parenchymal versus reticuloendothelial iron overload in the liver: distinction with MR imaging. *Radiology* 1991;179(2):361-366.
560. Pomerantz S, Siegelman ES. MR imaging of iron depositional disease. *Magn Reson Imaging Clin N Am* 2002;10(1):105-120, vi.
561. Guyader D, Gandon Y. Quantification of iron overload. *Bull Acad Natl Med* 2000;184(2):337-347; discussion 347-348.
562. Ernst, O., G. Sergent, P. Bonvarlet, et al. Hepatic iron overload: diagnosis and quantification with MR imaging. *AJR Am J Roentgenol* 1997;168(5): 1205-1208.
563. Kreeftenberg, H.G., Jr., E.L. Mooyaart, J.R. Huizenga, W.J. Sluiter. Quantification of liver iron concentration with magnetic resonance imaging by combining T1-, T2-weighted spin echo sequences and a gradient echo sequence. *Neth J Med* 2000;56(4):133-137.
564. Larrubia, J.R., J.L. Mendoza, J.A. Perez de la Serna, et al. Diagnosis of hemochromatosis with magnetic resonance. *An Med Interna* 2000;17(8):419-421.
565. Ptaszek, L.M., E.T. Price, M.Y. Hu, P.C. Yang. Early diagnosis of hemochromatosis-related cardiomyopathy with magnetic resonance imaging. *J Cardiovasc Magn Reson* 2005;7(4):689-692.
566. Cheong, B., S. Huber, R. Muthupillai, S.D. Flamm. Evaluation of myocardial iron overload by T2* cardiovascular magnetic resonance imaging. *Tex Heart Inst J* 2005;32(3):448-449.
567. Anderson, L.J., S. Holden, B. Davis, et al. Cardiovascular T2-star (T2*) magnetic resonance for the early diagnosis of myocardial iron overload. *Eur Heart J* 2001;22(23):2171-2179.
568. Pepe, A., V. Positano, M.F. Santarelli, et al. Multislice multiecho T2* cardiovascular magnetic resonance for detection of the heterogeneous distribution of myocardial iron overload. *J Magn Reson Imaging* 2006;23(5):662-668.
569. Monaghan, K.G., B.A. Rybicki, M. Shurafa, G.L. Feldman. Mutation analysis of the HFE gene associated with hereditary hemochromatosis in African Americans. *Am J Hematol* 1998;58(3):213-217.

Chapter 26 Porphyrrias

> Table of Contents > Part IV - Disorders of Red Cells > Section 2 - Disorders of Iron Metabolism and Heme Synthesis > Chapter 26 - Porphyrrias

Chapter 26

Porphyrias

Sylvia S. Bottomley

The porphyrias are diverse disorders that arise from various inherited enzyme defects in the heme biosynthesis pathway (Fig. 26.1). The first authentic cases of porphyria were described in 1874.^{2, 3} Since that time, eight genetically distinct forms of porphyria have been characterized (Fig. 26.1; Table 26.1), each caused by a partial deficiency, and in one type by activation, of a different enzyme within the pathway (Table 26.2). The genes encoding these enzymes have been cloned, their chromosomal location is defined, and DNA analyses have revealed many heterogeneous molecular defects in all the porphyrias. The biosynthetic blocks resulting from the defective enzymes are expressed either in the liver or in the bone marrow, the sites where most of body heme is produced. The clinical and pathologic phenotype of each porphyria is dictated by effects of the associated enzyme defect and the mode of inheritance (Table 26.2) and is often influenced by

certain metabolic and environmental factors that affect the tightly regulated heme pathway. In some “late-onset porphyrias,” acquired clonal hematopoietic disorders may harbor a somatic mutation involving a heme synthesis enzyme that contributes to the expression of the porphyria.

Although the pathophysiologic mechanisms of the clinical manifestations of the porphyrias are only partly understood, two cardinal features prevail: cutaneous photosensitivity and neurologic symptoms of intermittent autonomic neuropathy, motor nerve palsies, and central nervous system disturbances. The cutaneous photosensitivity is a manifestation of the unique fluorescent properties of the porphyrins (the oxidized forms of the natural porphyrinogens in the heme synthesis pathway) that accumulate in those porphyrias in which the enzyme defects cause porphyrin accumulation (Fig. 26.1). The neurologic manifestations are associated with increased production of the porphyrin precursors 5-aminolevulinic acid (ALA) and porphobilinogen (PBG), which characterize the acute or inducible porphyrias. Among some of these, however, photosensitivity occurs as well if the enzyme defect also leads to accumulation of porphyrins. The distinguishing clinical manifestations of the porphyrias form the basis for the classification in Table 26.1. The diagnosis of a specific porphyria is ascertained by its characteristic profile of accumulated and excreted metabolic intermediates of the heme synthesis pathway (Table 26.2). It can be further confirmed by the activity of the affected enzyme but best by identification of the molecular defect causing the porphyria.

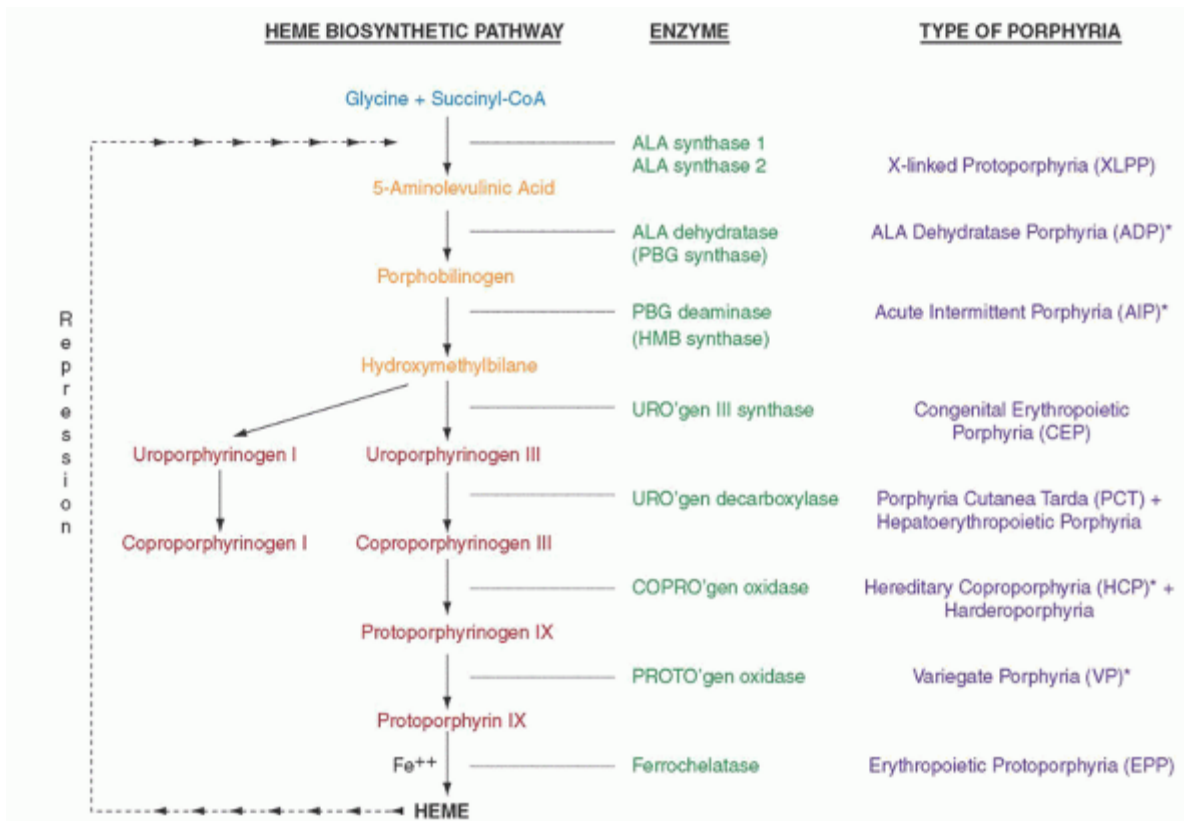

FIGURE 26.1. The heme biosynthetic pathway, its enzymes, and the eight forms of human porphyria associated with genetic defects of these enzymes. The major compound accumulated and excreted in excess in the seven porphyrias beyond the ALA synthase step is the substrate of the respective deficient enzyme; genetic defects in the erythroid ALA synthase (ALAS2) causing increased enzyme activity lead to increased flux of intermediates through the pathway and accumulated protoporphyrins. In the acute or inducible porphyrias (*), increased hepatic ALA production results from release of the normal negative feedback on ALA synthase exerted by heme,¹ indicated by the trail of arrows. ALA, 5-aminolevulinic acid; Fe⁺⁺, ferrous iron.

P.683

TABLE 26.1 CLASSIFICATION OF THE PORPHYRIAS

I. Porphyrias with only cutaneous photosensitivity

Congenital erythropoietic porphyria (CEP)

Porphyria cutanea tarda (PCT); hepatoerythropoietic porphyria (HEP)

Erythropoietic protoporphyria (EPP)

X-linked protoporphyria (XLPP)

II. Acute porphyrias with only neurologic manifestations

Acute intermittent porphyria (AIP)

ALA dehydratase porphyria (ADP)

III. Acute porphyrias with both neurologic manifestations and cutaneous photosensitivity

Variegate porphyria (VP)

Hereditary coproporphyria (HCP)

IV. Dual porphyrias

PORPHYRIAS WITH CUTANEOUS PHOTOSENSITIVITY

Congenital Erythropoietic Porphyria

Congenital erythropoietic porphyria (CEP; Gunther porphyria), the second least common of the porphyrias, is characterized by a marked accumulation in erythroid precursors of uroporphyrin and coproporphyrin, which are predominantly of the isomer I type because defects reside in the gene for the enzyme uroporphyrinogen III synthase (UROS; Fig. 26.1). Many marrow erythroblasts and immature circulating erythrocytes exhibit intense red fluorescence in ultraviolet light. The large amounts of porphyrins released from these cells cause the most intense photosensitivity of all the porphyrias.

TABLE 26.2 GENETIC AND METABOLIC FEATURES OF THE PORPHYRIAS

Type of Porphyria	Inheritance	Defective Enzyme	Gene (Symbol/Location) ^a	Enzyme Activity (%) ^b Heterozygote	Porphyrin/Precursor Accumulated/Excreted ^d	Route of Excretion	Tissue Source	Homozygote ^c
X-linked protoporphyria	X-linked	5-Aminolevulinic acid synthase 2	<i>ALAS2</i> /Xp11.21	2 to 3 times normal		Free and zinc protoporphyrin	Feces	Bone marrow
ALA dehydratase	Autosomal recessive	ALA dehydratase (PBG synthase)	<i>ALAD</i> /9q33.1	33.50	<10	ALA, coproporphyrin	Urine	Liver
Acute intermittent	Autosomal dominant	PBG deaminase (HMB synthase)	<i>HMBS</i> /11q23.3	50	1-16	PBG, ALA	Urine	Liver
Congenital erythropoietic	Autosomal recessive	Uroporphyrinogen III synthase	<i>UROS</i> /10q25.2-q26.3	50	1-20	Uroporphyrin I, coproporphyrin I	Urine	Bone marrow
Cutanea tarda	Autosomal	Uroporphyrinogen III cosynthase	<i>UROD</i> /1p34.3	50	3-27	Uroporphyrin I	Urine	Liver

	dominant, or acquired	nogen decarboxylase				yrin I + III, 7- COOH porphyrin	ne	
Hereditary coproporphyrin ia	Autosomal dominant	Coproporphyrinogen oxidase	<i>CPOX</i> /3q12 50	2-10 ^e		Coproporphyrin III^f, PBG^f, ALA^f	Feces, urine	Liver
Variegata	Autosomal dominant	Protoporphyrinogen oxidase	<i>PPOX</i> /1q22 50	0-20		Protoporphyrin Coproporphyrin^f, PBG^f, ALA^f	Feces, Urine	Liver
Protoporphyrin a	Autosomal recessive	Ferrochelatase	<i>FECH</i> /18q2 50 1.3	<10		Free protoporphyrin	Feces	Bone marrow
Protoporphyrin a	"Pseudodominant" ^g	Ferrochelatase	<i>FECH</i> /18q2 50-70 1.3	20-30		Free protoporphyrin	Feces	Bone marrow

ALA, 5-aminolevulinic acid; PBG, porphobilinogen; HMB, hydroxymethylbilane.

^a Gene symbol and chromosomal location as listed in the Human Gene Mutation Database, located at <http://www.hgmd.org>.

^b Percentage of normal.

^c Often a compound heterozygote.

^d The major metabolite and route are shown in boldface. The route of porphyrin

excretion is determined by the number of carboxyl groups on the porphyrin and hence by its water solubility.

^e In harderoporphyrin the activity is 18% to 24% of normal (see text).

^f Increased in urine during acute attack; in VP urine coproporphyrin is increased when symptoms are only cutaneous.

^g One allele is mutant and the other allele is usually underexpressed (see text).

Probably first recognized by Schultz² and Baumstark³ in 1874, CEP was described comprehensively and distinguished from other porphyrias by Gunther in 1911.⁴ It is a very rare disease, with less than 200 cases reported. It occurs with equal frequency in males and females and in a wide variety of racial groups. Usually, the illness is first detected in infancy⁵ but, in a number of instances, was not apparent until later in life.⁶ All evidence is consistent with transmission of the disorder as an autosomal recessive trait.^{5, 7}

Molecular Basis and Pathogenesis

The pattern of porphyrin accumulation in CEP reflects a defect in the conversion of PBG to uroporphyrinogen III. This conversion requires two enzymes: PBG-deaminase (PBGD) and UROS (Fig. 26.1). Affected individuals are homozygotes or compound heterozygotes for mutations in the UROS gene that result in markedly reduced activity of UROS (1% to 20% of normal), leading to the overproduction of uroporphyrinogen I through nonenzymatic cyclization of the substrate hydroxymethylbilane in erythroid precursors.^{5, 7} In heterozygotes (parents and some siblings of

patients with the disease), the activity of the synthase is intermediate (approximately 50%) between that found in affected individuals and that in normal subjects.⁸ The UROS gene resides on chromosome 10 (10q25.2-q26.3)⁹ and has alternative promoters that generate identical housekeeping and erythroid-specific transcripts.⁷ Forty-six distinct mutant alleles have been identified and molecular defects include point mutations, deletions, insertions, splicing defects, intron branch chain mutations, and erythroid-specific promoter mutations.^{5, 7, 10} Approximately one third are homoallelic and about 20% of alleles remain undefined. The most common mutation (Cys73Arg) has occurred in one third of alleles (and in nearly one half of homoallelic cases) and correlates with the most severe phenotype of nonimmune hydrops fetalis, transfusion-dependent anemia from birth, or both, particularly in homoallelic cases.⁵ In most instances, mild forms of the disease have been heteroallelic or only one mutant allele could be identified. Residual enzyme activity of the mutant proteins expressed in prokaryotic systems, or gene promoter-reporter activities in cases of promoter mutations, have provided more precise genotype/phenotype correlations.^{5, 7, 11} However, in two instances marked divergence of phenotypic expression among siblings suggested undefined modifying factors.^{12, 13} In another family it was demonstrated that the clinical phenotype is markedly affected by co-inheritance of an activating (gain-of-function) mutation in the erythroid-specific 5-aminolevulinic synthase (ALAS2) gene.¹⁴

In addition, variant genetic forms of the CEP phenotype are described. (1) In two patients porphyrin patterns and enzyme assays were consistent with a uroporphyrinogen decarboxylase (UROD) rather than a UROS defect, and the presence of a second dyserythropoietic defect was suggested to account for the clinical severity.^{15, 16} (2) A variant caused by a mutation in the X-linked erythroid transcription factor GATA binding protein 1 (GATA1) demonstrated that CEP can result from a genetic defect in a transacting factor.¹⁷ (3) CEP has occurred as a milder form in later life.^{6, 18} Of 16 such cases, 8 were associated with a myelodysplastic syndrome; the pattern of excess porphyrins was characteristic of childhood-onset CEP but at lower concentrations and erythrocyte UROS activity was normal.¹⁸ Presumably UROS mutations could not be identified if only a minor clone of uroporphyrin cells harbors a somatic mutation; alternatively another gene that determines UROS activity remains a possibility. This late-onset form of CEP has been termed "erythropoietic uroporphyrin secondary to myeloid malignancy."¹⁸

Although defective UROS operating in the erythron characterizes the primary inherited abnormality, no overall deficiency of heme production is evident, perhaps because normal UROS activity appears to be the highest relative to all other heme biosynthetic enzymes in erythroid cells. It is more than 1,000 times greater than the activity of ALA synthase,¹⁹ the rate limiting enzyme, so that even very low residual enzyme activity seems to be sufficient to support normal or even increased rates of heme synthesis. Uroporphyrin I is the predominant urinary porphyrin, but increased excretion of uroporphyrin III also invariably occurs, implying up-regulation of the UROS or of enzymes higher up in the pathway. These findings are consistent with the idea that the pathophysiology of CEP is a result of the accumulation of uroporphyrin I rather than of subnormal production of uroporphyrinogen III and heme.²⁰ However, it is unclear why uroporphyrin I, not coproporphyrin I, is the main porphyrin excreted, which may relate to the relative UROD activity in normal erythroid cells being on the order of one tenth of that of UROS.¹⁹

The large amounts of porphyrins released from erythroid cells and deposited in multiple tissues²¹ exert the principal damage in the skin and subcutaneous regions through oxygen-dependent phototoxic reactions on excitation by light (see section "Porphyria Cutanea Tarda").^{22, 23} This relentless process leads in varying degrees to the formation of subepidermal bullae, secondary infection, scarring, epidermal atrophy, and resorption of acral structures. Laboratory parameters of hemolysis correlate with severity of anemia. Associated splenic sequestration leads to splenomegaly and variable leukopenia and thrombocytopenia. Whether photolysis of the porphyrin-laden erythrocytes occurs *in vivo* is not known.

Clinical Description

The first sign of this affliction is often discoloration of the infant's diapers by the urine, which ranges in color from pink to deep burgundy and fluoresces under Wood's light.²⁴ The most prominent manifestation is pronounced cutaneous photosensitivity. Exposure to visible light is followed by the development of vesicular or bullous lesions containing a porphyrin-rich, fluorescent fluid. The lesions tend to heal slowly, leaving pigmented scars (Fig. 26.2A). Often, they become infected, ulcerated, and necrotic. Over a period of years, patients develop progressive mutilation and disfigurement with loss of portions of the fingers, nose, eyelids, or ears (Fig. 26.2B). Corneal scarring can lead to blindness.⁵ Skin not exposed to light is unaffected. Hypertrichosis is prominent and fine hair growth may cover much of the face and extremities. The patients often adopt extreme precautions to avoid the sun. Deposition of porphyrin in the dentin of the teeth causes them to appear red (erythrodontia), brown, or yellowish. Even if discoloration is not apparent in ordinary light, the teeth exhibit

red fluorescence in ultraviolet light. At necropsy, the entire skeleton has this red fluorescence.²¹ Osteopenia and osteolytic lesions can occur.²⁵

Anemia, the result of both hemolysis and ineffective erythropoiesis, is detected in most patients, and usually the spleen is enlarged. The most severe phenotypes are transfusion-dependent.

Laboratory Findings

The anemia is normocytic, normochromic, and of variable severity. Detailed morphologic descriptions of the blood and bone marrow have been reported in a few patients. Anisocytosis, poikilocytosis, polychromasia, basophilic stippling, and nucleated erythrocytes are fairly common features of the peripheral blood.²⁶ Following splenectomy, needlelike fluorescent red cell inclusions that may represent precipitated porphyrin have been observed.²⁷ Morphologic abnormalities of the bone marrow range from erythroid hyperplasia to striking dyserythropoiesis.^{5, 17, 26, 28} Nuclear inclusions containing hemoglobin may be present.^{15, 28} Results of studies of the marrow with light and fluorescence microscopy suggest the coexistence of normal and abnormal erythropoietic cells.^{15, 28} Fluorescence is restricted to the morphologically abnormal cells and is most marked in cell nuclei.^{15, 28, 29} Evidence of a dual nature of the erythroid precursors has been supported by ultrastructural studies in two cases.^{15, 30} Kinetically, the anemia is characterized by both a shortened red cell survival and ineffective erythropoiesis.³¹ Its morphologic and kinetic features closely resemble those of congenital dyserythropoietic anemia type I (Chapter 40).

The most characteristic metabolic abnormality is greatly increased urinary excretion of uroporphyrin I, a biologically useless isomer that cannot be converted to heme. Urinary excretion of uroporphyrin III and coproporphyrins I and III is also increased but to a lesser extent than uroporphyrin I.^{5, 20} Total urinary porphyrin excretion may exceed 100,000 µg daily (normal is <300 µg), and the urine usually fluoresces on exposure to ultraviolet light. Fecal excretion of porphyrins, especially coproporphyrin I, is greatly increased.²⁰ The concentration of uroporphyrin I is increased in erythrocytes and plasma, but the marrow porphyrin content exceeds that of the peripheral blood or other tissues.²⁰

Treatment

Splenectomy may partially or completely relieve the hemolytic anemia and may also lead to reduced porphyrinuria and

P.685

photosensitivity.^{26, 27, 28} However, this operation is not always beneficial³² and is not always warranted by the degree of anemia. Suppression of erythropoiesis by transfusion decreases porphyrin excretion.^{5, 33} A young boy with CEP was successfully treated with chronic hypertransfusion;³⁴ transfusion-induced iron overload was avoided by means of concomitant iron chelation therapy. After puberty, his relapse on this regimen was controlled with the addition of hydroxyurea.³⁵



FIGURE 26.2. Congenital erythropoietic porphyria. A: In an Indian boy. Note facial hypertrichosis, scarring, and discoloration of the teeth. B: In a 50-year-old Caucasian man. Note the severe photomutilation. (Courtesy of Dr. Neville Pimstone, University of California, Davis, CA.)

Another patient was treated successfully with long-term orally administered charcoal at a dose of 60 g three times daily.³⁶ Oral charcoal appeared to act by binding porphyrins excreted in bile and serving as a sump that diverted circulating and skin porphyrins to a fecal route of elimination in two cases^{37, 38} but had no effect in others.⁵ In two patients, severe anemia improved with administration of the antioxidants α -tocopherol and ascorbic acid.²⁵ Hematopoietic stem cell transplantation (HSCT) remains the only known curative treatment and to date was successful in 17 of 21 patients.^{5, 7, 39}

In theory, the most definitive method to control the disease would be transfer of the normal gene into hematopoietic stem cells of the affected patient. After *in vitro* correction of the enzyme defect by viral transfer of the normal gene into deficient cells, long-term correction of the disease in CEP mice had provided support for hematopoietic stem cell gene therapy clinical trials, and gene correction of CEP-derived iPSCs (induced pluripotent stem cells) was recently achieved to circumvent potential proviral insertional leukemogenesis.⁴⁰ In another approach, the function of the common mutant protein Cys73Arg could be rescued with a proteasome inhibitor in cultured cells.⁴¹ Prenatal diagnosis or exclusion of the disorder is possible with enzyme assay or DNA analysis of amniotic fluid cells.^{42, 43}

Most patients must rely on avoidance of exposure to sunlight. They should be instructed to wear photoprotective clothing, including gloves and broad-brimmed hats. Conventional sunscreen agents are ineffective because they do not screen out the wavelengths in the Soret band of the nearly visible spectrum (around 400 nm) that are responsible for inducing porphyrin-mediated photosensitivity.⁴⁴ To be effective, a local agent must be visible on the skin. Reflective materials, such as zinc oxide and titanium oxide, are useful, as is ordinary pigmented theatrical makeup.⁴⁵ Preparations containing substituted quinones (such as 2-hydroxyl-1,4 naphthoquinone, also known as hemotannic acid or Lawsone) and dihydroxyacetone turn the skin a cosmetically acceptable brownish-tan and may be effective. Therapy with β -carotene beadlets may also offer some protection from the deleterious effects of light (see section "Erythropoietic Protoporphyrin"). A single-observer clinical study of 29 CEP cases together with a proposal for a management algorithm derived from the patient cohort has recently been presented.^{39, 46}

Congenital Erythropoietic Porphyria in Animals

CEP (pink tooth) in cattle appears to be milder than the human disorder. The disease is inherited as an autosomal recessive trait, and heterozygous animals are clinically and biochemically normal,^{47, 48} although an increased ratio of

coproporphyrin I to coproporphyrin III in the urine was reported.⁴⁹ Photosensitivity of the skin areas not covered by pigmented hair and hemolytic anemia are observed. The teeth and bones are stained red. UROS activity is severely impaired in erythrocyte lysates.⁵⁰

A similar disorder has been observed in pigs and cats.^{51, 52} A naturally occurring feline CEP was recently characterized by clinical phenotype, biochemical analysis, and molecular studies.⁵³ In the fox squirrel (*Sciurus niger*), as part of the apparently normal physiology of the species, large amounts of uroporphyrin I are deposited in the tissues and excreted in the urine.⁵⁴ As in human CEP, the normoblasts and young erythrocytes show a red fluorescence; however, hemolytic anemia is lacking, and the fox squirrel seems to suffer no ill effects. Erythroid UROS activity is lower than that found in the closely related but nonporphyric gray squirrel (*Sciurus carolinensis*).⁵⁴

In knockin mouse models of patient mutations, the phenotypes closely resemble the human disorder.^{55, 56} These mice would appear suitable for studies of pathogenesis and therapies in CEP.

P.686

Porphyria Cutanea Tarda

Porphyria cutanea tarda (PCT) is the most commonly encountered porphyric disorder. It results from reduced activity of UROD (Fig. 26.1) in the liver, leading to accumulation of uroporphyrins (oxidized uroporphyrinogens), their release into plasma, and excretion in the urine.²⁰ Clinical manifestations are limited to the skin in the form of a photosensitive bullous dermatosis as a consequence of the circulating uroporphyrins. Neurovisceral symptoms never occur. Symptoms usually arise in mid- or later life (hence the name tarda) and are nearly always brought on by genetic and environmental factors, most often hepatic siderosis, alcohol abuse, hepatitis C virus, and estrogen therapy. Since the first comprehensive description of the disease in 1937,⁵⁷ three variant forms of the illness have been recognized: familial, sporadic, and toxic.

Molecular Basis and Pathogenesis

Among the variants of the disorder, a genetic basis has been established for one, designated familial PCT (type II), but it accounts on average for only 20% to 30% of cases.^{58, 59, 60, 61} Studies of patients with subnormal UROD activity in both hepatic and extrahepatic tissues, and their relatives, revealed that the enzyme defect is inherited as an autosomal dominant trait.^{62, 63, 64, 65} Enzyme activity is one-half normal in all tissues, as is the amount of UROD protein detected with antibodies.^{66, 67, 68} In the rare homozygous form, designated hepatoerythropoietic porphyria (HEP), residual enzyme activity ranges from 3% to 27% of normal,^{20, 68, 69, 70, 71} but immunoreactive enzyme is variable.^{67, 68, 72} Since the cloning of the human UROD gene,⁷³ located on chromosome 1 (1p34),⁷⁴ at least 113 different mutations in the gene have been identified.^{10, 75} Usually, a given mutation is found in one or in a few kindreds only. The majority are various point mutations in the coding region of the gene or splice site mutations, resulting in changes of amino acids, frameshifts, or deletions; in some instances, large nucleotide deletions were detected. The defects usually result in the production of an unstable or inactive enzyme from the mutant allele. Functional consequences of many of the mutations have been defined or predicted on the crystal structure of the enzyme.^{76, 77} In the homozygous version among about 40 cases reported, 15 different mutations have been identified.^{10, 75, 78} The mutations are homoallelic or heteroallelic, causing instability or impaired catalytic activity of the enzyme, and survival hinges on residual enzyme activity encoded by the alleles.

When reduced UROD activity is restricted to the liver and a genetic basis for the disorder is not evident, it is called sporadic PCT (type I).^{64, 66, 79} Both the catalytic activity and the immunoreactivity of erythrocyte UROD are normal in this variant.^{67, 79} In the liver, catalytic activity of UROD is subnormal, but immunoreactive enzyme is present in normal or increased amounts.⁷⁹ After prolonged remission is induced by phlebotomy therapy, both catalytic activity and immunoreactivity become normal.⁸⁰ These findings, coupled with lack of a family history in most cases of sporadic PCT, have implied that this form of the disease is acquired and not inherited. At the molecular level, no mutations could be found in the UROD gene or its promoter region.⁸¹ However, in a few families, clinically manifest PCT was associated with decreased UROD activity in liver and normal activity in erythrocytes and other tissues.⁷⁵ These cases were called type III PCT; molecular studies have not identified UROD mutations in them.⁸²

The cutaneous damage produced by the accumulated uroporphyrins in plasma and skin of patients with PCT is the consequence of the fundamental properties of the porphyrins. As they absorb light at 400 to 410 nm (Soret band), not only does their photoexcitation yield energy as fluorescence, but in the aerobic environment of tissues, reactive oxygen species (superoxide anion and other reactive metabolites) are produced⁴⁴ that are damaging to cells. In vivo, superoxide

anions are generated by activation of xanthine oxidase.⁸³ The complement system is light activated in vitro in sera containing porphyrins and in vivo in the skin of porphyric patients, promoting release of proteases from dermal mast cells.²³ Chemotactic activity is also generated under these conditions, and the peroxides produced by photoexcitation of the porphyrin and those arising from polymorphonuclear leukocytes with activation of the complement system may act synergistically to contribute to the development of the cutaneous lesions. As a consequence of these events, the dermal-epidermal junction becomes disrupted and leads to skin fragility and the formation of vesicles and bullae that easily rupture. Sclerodermoid changes of the skin result from a light-independent effect (the “dark effect”) of the uroporphyrin on collagen synthesis by skin fibroblasts.⁸⁴ The pathogenesis of the hyperpigmentation, hypopigmentation, and hypertrichosis is not understood.

Most family members carrying a defective gene of familial PCT do not have clinically apparent disease but a significant number have increased excretion of porphyrins;⁷⁷ in occasional pedigrees, overt manifestations of the disease were noted in several generations.⁶³ Clinical expression of both familial and sporadic PCT is nearly always associated with prevalent confounding factors that cause hepatic injury, so the disorder remains silent without these. In large series of PCT, most patients had more than one of four cardinal hepatotoxic risk factors, namely hepatic iron excess, excessive alcohol use, viral infection (hepatitis C), and medicinal estrogens,^{60, 61, 85} although these are far more common than the estimated frequency of PCT (approximately 1 per 25,000).²⁰

Hepatic Iron

The central role of iron in the clinical expression of PCT has been recognized for 52 years.^{86, 87} Numerous studies documented hepatocellular siderosis in most patients with significant uroporphyrinuria.^{88, 89, 90} The iron deposits generally are moderate in amount, 1.5 to 4 times normal, but are usually greater with co-inheritance of hemochromatosis susceptibility alleles (Chapter 25).^{88, 91, 92, 93} Except for the geographic variation in the frequency of the hemochromatosis HFE alleles,^{75, 94} on average, 35% of patients with PCT are heterozygous for the Cys282Tyr mutation, and 15% are homozygous or double heterozygotes with the His63Asp mutation.^{60, 61, 85, 94} The cause of excess hepatic iron in the remaining cases appears to result from down-regulation of hepcidin expression regardless of iron status and consequent to the oxidative stress associated with the other risk factors for PCT.⁹⁵ However, in another study serum hepcidin levels were found increased.⁹⁶ Transfusional iron overload also promotes clinical expression of PCT.⁹⁷

Depletion of iron by repetitive phlebotomy⁹⁸ or by administration of deferoxamine⁹⁹ uniformly induces both clinical and biochemical remissions. Replenishment of iron stores promptly reignites symptoms in patients in whom a remission has been induced by phlebotomy.^{88, 100} The explanation for the provoking influence of iron is based on studies in mouse models, which indicate that the hepatic UROD activity of 50% in UROD-deficient animals must be reduced to 20% or less of normal in order for PCT to be manifest and is achieved by concomitant iron overload.^{101, 102} An inhibitor of the enzyme was found in liver cytosol of these animals, as well as of PCT patients, and is a porphomethene that is generated by iron-dependent partial oxidation of uroporphyrinogen via catalysis by cytochrome P4501A2 (CYP1A2) or another enzyme.^{103, 104} This is consistent with the diminished hepatic UROD activity without reduction in enzyme protein in symptomatic PCT patients and the restoration of hepatic UROD activity to its genetically determined level after iron depletion.^{60, 79, 80} The mechanism for the generation of sufficient inhibitor in patients with sporadic PCT that does not occur in iron overload states in general remains to be defined. The oxidative environment in the

P.687

hepatocyte generated by the common environmental risk factors accompanying clinical expression of the disorder, as well as other traits such as the allele variants of CYP1A2 and G51M1A,¹⁰⁵ probably play an important role.⁹⁴

Alcohol

Ethanol exacerbates PCT. Heavy alcohol intake was found in 25% to 100% of patients in many studies,^{60, 61, 85, 89, 94, 106} and hepatic cirrhosis is not uncommon.^{89, 90} Yet the porphyria is an uncommon complication of alcoholic liver disease, occurring in only approximately 2% of cases.¹⁰⁷ The association of clinically expressed PCT with alcoholism would relate to its hepatotoxicity and its effect of stimulating iron absorption.¹⁰⁸ In this regard, PCT is particularly common among the Bantu population of South Africa, where it is associated with excessive consumption of alcoholic beverages brewed in iron containers,¹⁰⁹ thus providing a double threat to susceptible people. Studies have suggested that an undefined hemochromatosis gene plays a role in the iron overload of this population when iron intake is excessive (Chapter 25).¹¹⁰

Hepatitis C

A striking association between symptomatic PCT, familial and sporadic, and hepatitis C is well recognized but is variable around the world. Although most patients with hepatitis C infection do not have the porphyria, as many as 80% of PCT patients are chronically infected with the virus in some locations.^{60, 61, 75, 94, 111} This infection elicits oxidative stress in hepatocytes as well as down-regulation of hepcidin expression⁹⁴ and would explain, at least in part, the liver damage often found in PCT. Association of PCT with human immunodeficiency virus (HIV) infection also occurs,¹¹² and such patients may be infected with both HIV and the hepatitis C virus.^{94, 112, 113} Dual infection causes more severe hepatic disease; whether the HIV virus per se plays a role in the expression of PCT is not known. Thus, patients should be evaluated for the presence of hepatitis C and HIV at the time of diagnosis.

Estrogens

The association of estrogen ingestion and expression of PCT has been reported numerous times but occurs only in a very small percentage of patients who ingest estrogens, consistent with an underlying predisposition to the disease. The cutaneous symptoms have occurred with the use of estrogen as a post-menopausal supplement,⁶⁰ for contraception,¹¹⁴ and for prostatic carcinoma.¹¹⁵ Uncommonly, patients present with the disorder during pregnancy,¹¹⁶ but pregnancy has also not exacerbated PCT.¹¹⁷ The mechanism of the estrogen effect is thought to relate to its adverse effects on the liver such as steatosis and steatohepatitis. It is generally a lesser factor, as venesection alone has brought about full recovery. Most women needing estrogen supplements at the usual dose can probably use them, provided that storage iron is removed and maintained at a low level.

Other Susceptibility Factors

Additional susceptibility factors that are positively associated with PCT are smoking, allele variants of CYP1A2 and GSTM, and ascorbic acid deficiency.^{61, 105, 118, 119} Several diverse drugs and radiation have also been implicated in precipitating PCT in a few cases.

Renal Failure

PCT occurs in patients with renal failure undergoing hemodialysis.¹²⁰ Symptoms may first arise in this setting for several reasons. Iron overload is not uncommon in such patients, and intravenous iron used in conjunction with erythropoietin for the anemia may precipitate clinical PCT.¹²¹ Hemodialysis or peritoneal dialysis does not effectively clear circulating plasma uroporphyrins,^{122, 123} presumably because porphyrins are bound to proteins.¹²⁴ The uremic state may also contribute to an inhibited UROD and uroporphyrin accumulation independent of an underlying enzyme defect or inhibition.¹²⁵ In most reported cases, the lack of family or molecular studies makes it difficult to classify the porphyria.

Clinical Description

Cutaneous changes represent the clinical manifestations of PCT.^{20, 89} Skin lesions are found predominantly on light-exposed areas such as the face and hands and, in women, on the legs and feet as well. There is little discomfort with sun exposure per se, and blue (visible) light triggers only an insidious cutaneous damage. The most common complaint is marked skin fragility in areas subjected to repeated minor trauma, such as the hands and forearms (Fig. 26.3). Vesicles and bullae form primarily on the dorsa of the hands and may erode, leaving atrophic scars that often display zones of both hyperpigmentation and hypopigmentation. Small, 1- to 2-mm, firm, whitish papules (milia) are commonly noted on the hands and, at times, on the face.

Facial hypertrichosis occurs in most patients, is generally more noticeable in women, and may be an isolated presenting feature.¹²⁶ Hypertrichosis, sometimes striking, is occasionally observed on areas of the skin that are rarely exposed to the sun, such as the trunk and legs. Other findings include hyperpigmentation of facial skin, alopecia, and scleroderma-like changes on the skin of the face, neck, and hands. The histologic appearance of the scleroderma-like lesions is identical to that seen in patients with systemic scleroderma.⁸⁹ Occasionally, patients have overt signs and symptoms of underlying liver disease, but no good correlation exists between the degree of liver disease and the occurrence or severity of the porphyria.

In the homozygous form of familial PCT, or HEP, the skin changes just described usually occur before the age of 5 years and photosensitivity may be severe, resembling CEP and including disfigurement.^{75, 78} Developmental delay and seizures have also been reported. Other features are pink urine, dental fluorescence, and occasionally hepatosplenomegaly. Severity of clinical manifestations can vary in affected children within a family; in some instances the clinical phenotype is unusually mild.^{78, 127}

Laboratory Findings

Patients with symptomatic PCT excrete greatly increased amounts of porphyrins in the urine. Uroporphyrin and heptacarboxylic porphyrin predominate, with lesser amounts of coproporphyrin and small amounts of 5- and 6-carboxylate porphyrins.^{89, 128} Usually, the daily urinary excretion of uroporphyrin is approximately 3,000 µg (normal, <50 µg), but considerably higher values may be found. Uroporphyrin in the urine is predominantly isomer I, whereas the heptacarboxylic porphyrin is predominantly isomer

P.688

III.^{20, 89} Photosensitive cutaneous symptoms rarely occur when the daily urinary excretion of uroporphyrin is <1,000 µg. Urinary coproporphyrin rarely exceeds 600 µg daily.⁸⁹ An unusual and distinctive tetracarboxylic porphyrin, isocoproporphyrin, is excreted in feces,¹²⁹ and a slight increase may be noted in total fecal porphyrin excretion.²⁰ Plasma porphyrin level is typically increased, with a fluorescence peak at neutral pH near 619 nm. Homozygotes for the defect have mild anemia; it was severe in three cases.⁷⁵ The erythrocyte protoporphyrin was found to be moderately increased when measured and is primarily zinc protoporphyrin.^{75, 78}



FIGURE 26.3. Porphyria cutanea tarda in a 60-year-old man. Note denuded skin areas over the fingers, an erosion, blisters, and milia.

The serum iron concentration and, hence, transferrin saturation are commonly increased as is the serum ferritin level.^{60, 89} Values for liver function tests vary considerably from one case to another. Some patients have mild degrees of jaundice and slight to moderate elevations in serum transaminase levels. Liver biopsy specimens display characteristic reddish-pink fluorescence.^{89, 90, 130} On microscopic examination, siderosis, periportal inflammation, focal necrosis, fatty infiltration, and some evidence of fibrosis are common findings.^{89, 90, 130, 131} Often, fluorescent and birefringent needle inclusions are noted.¹³¹ Electron microscopic studies reveal needlelike lucent areas, which appear to be in lysosomes.¹³² Microscopic examinations of skin biopsy specimens show bullae formed by the separation of the epidermis from the dermis; periodic acid-Schiff-positive, diastase-resistant material around vessel walls in the upper dermis; and a sparse inflammatory cell infiltrate.^{89, 133} Immunofluorescence studies display deposition of immunoglobulin G (and less often immunoglobulin M) or complement around upper dermal vessels and at the dermal-epidermal junction.¹³³

Treatment

Exposure to alcohol and excessive estrogen supplements in women, as well as smoking, should be avoided. Abstinence from alcohol can lead to remissions in some patients with the porphyria associated with alcoholic liver disease, but removal of iron by phlebotomy can induce remissions even if alcohol intake continues.^{98, 134} It is of interest that occasionally remission has been achieved in patients with PCT and hepatitis C after antiviral treatment alone.¹³⁵ Conversely, poor response to interferon- α is common in patients with hepatitis C and PCT.¹³⁶ Transdermal administration of estrogen was found to be safe in a small number of patients¹³⁷ and avoids any possible first-pass effects of the hormone on the liver.

The definitive treatment of both sporadic and familial PCT is the removal of iron stores by phlebotomy, which leads to clinical and biochemical remission in virtually every case and may improve concomitant hepatitis C virus infection. It is recommended that any antiviral therapy be deferred until a de-ironed state is reached.⁹⁴ If there are no contraindications, 500 ml of blood is removed every 1 to 2 weeks. Initial serum transferrin saturation and ferritin values are obtained to estimate the iron burden. Liver biopsy must also be considered to assess the disease status of associated viral hepatitis and hemochromatosis. Clinical remissions often occur after the removal of approximately 3 L of blood;^{89, 98} patients who also have hemochromatosis usually require considerably more therapy and indefinite regular maintenance phlebotomies. The optimal approach is to achieve mild iron deficiency, defined by onset of iron-limited erythropoiesis in which the mean corpuscular volume is decreased to low normal, the serum transferrin saturation is low normal, and the serum ferritin is near 20 $\mu\text{g/L}$ or lower. Although further overproduction of uroporphyrins is halted thereafter, the chronically accumulated, relatively hydrophobic porphyrins are released slowly from the liver. Patients should be advised that formation of new skin lesions ceases gradually, and full recovery often extends over several months to a year or more.⁸⁹ Remissions for years are the rule^{89, 98} and are permanent when the known precipitating factors are avoided or removed; any clinical and biochemical relapse responds to another course of phlebotomies.^{89, 98}

Hydroxychloroquine and chloroquine have also been used in the treatment of PCT. After the administration of chloroquine (0.5 to 1.0 g/day) for several days, a large amount of the porphyrins stored in the liver was mobilized and excreted in the urine.¹³⁸ This purging effect results from the formation of an easily excreted water-soluble complex between uroporphyrin and the drug.¹³⁹ The chloroquine effect was often accompanied by malaise, anorexia, fever, and signs of hepatocellular damage. Subsequent use of lower doses made it possible to avoid the toxic response without impairing efficacy,¹⁴⁰ but this maneuver does not always preclude toxicity.⁸⁹ Because of the potential danger of the hepatic reaction to antimalarials and because phlebotomy is usually safe and effective, administration of low doses of hydroxychloroquine or chloroquine should be reserved for patients for whom phlebotomy is unsuitable. Moreover, patients with HFE hemochromatosis appear not to respond to this therapy.¹⁴¹

The use of sunscreen agents effective in the Soret band of the spectrum and avoidance of sunlight through protective clothing can be useful until the beneficial effects of phlebotomy are achieved. These measures are the principal means to help patients with the homozygous form of PCT in whom phlebotomy is not effective. The antimalarials may be beneficial in these individuals.⁷⁵ Severe anemia and cutaneous symptoms responded to erythropoietin in one case.¹⁴² Efforts toward somatic gene therapy were initiated by demonstrating correction of the enzyme defect with retroviral gene transfer in vitro in transformed B-cell lines¹⁴³ and may become a prospect in vivo as noted for CEP. Prenatal exclusion of HEP has been possible.¹⁴⁴

Treatment of patients with PCT and renal failure presents special challenges. The disorder may be particularly severe because such patients lack the renal excretory pathway for porphyrins, leading to higher porphyrin levels in plasma and tissues. Chloroquine-porphyrin complexes are not filtered out by standard hemodialysis. High-flux hemodialysis appears to remove porphyrins from plasma better and may be of some benefit.¹⁴⁵ The treatment of choice is administration of recombinant erythropoietin to mobilize stored iron and relieve the anemia so that phlebotomies can be performed as necessary to induce remission.^{146, 147} This method is preferable to the alternative of depleting iron stores with iron chelation.¹⁴⁷ In patients refractory to these treatment methods, the porphyria fully resolved after renal transplantation.¹⁴⁸

Toxic Porphyria Cutanea Tarda

In Turkey between 1956 and 1961, an epidemic of acquired porphyria affecting more than 3,000 people occurred as the result of exposure to flour contaminated with a seed-wheat fungicide, hexachlorobenzene.^{149, 150, 151} Members of both sexes were affected, and many of the subjects were children. Affected people developed hepatomegaly, hypertrichosis, hyperpigmentation, uroporphyrinuria, and a photosensitive dermatosis. Uroporphyrinuria and a variety of other signs and symptoms persisted in some individuals for more than 25 years,^{152, 153} and no effective therapy has been devised for this toxic porphyria. Studies in animals demonstrated that hexachlorobenzene, or one of its metabolites, is a potent inhibitor of hepatic UROD.^{154, 155} Iron magnifies this inhibitory effect,¹⁵⁴ and clear genetic susceptibility to this type of acquired porphyria has been shown in mice.¹⁵⁶

Other polyhalogenated aromatic hydrocarbons also have produced a toxic porphyria in humans. 2,3,7,8-Tetrachlorodibenzo-p-dioxin, a by-product in the manufacture of the herbicides 2,4-dichlorophenoxyacetic acid, 2,4,5-trichlorophenoxyacetic acid, and some polychlorinated biphenyls have proved porphyrinogenic for humans.¹⁵⁷ Animal studies indicate that compounds

P.689

of this class inhibit hepatic UROD activity.¹⁵⁸ As in the case of hexachlorobenzene-induced porphyria, iron magnifies the inhibition of UROD, and iron depletion minimizes the inhibitory effect of these agents.¹⁵⁹ The parallel between the permissive effects of iron in these toxic porphyria models and the role of iron in the pathogenesis of both familial and sporadic PCT is striking.

Hepatocellular Carcinoma

An increased frequency of hepatocellular carcinomas is recognized in patients with PCT,^{160, 161, 162} and such tumors are associated with a long symptomatic period before the start of treatment as well as with the presence of cirrhosis or chronic active hepatitis.¹⁶¹ The body iron status is not known in these cases, but iron overload could also play a role. Thus, in the presence of hepatitis or cirrhosis, surveillance for hepatocellular carcinoma with regular hepatic imaging is indicated.

In contrast, documented evidence supports a PCT-like illness as a manifestation of porphyrin-producing hepatoma in an otherwise normal liver (paraneoplastic PCT) in several cases.^{163, 164, 165, 166} When the tumor could be surgically removed, the cutaneous symptoms and biochemical abnormalities remitted.^{163, 166}

Animal Models of Porphyria Cutanea Tarda

The first genetically designed animal model of PCT and HEP was developed in zebrafish, designated yquem.¹⁶⁷ Heterozygous and homozygous mutants have 67% and 36% of wild-type UROD activity, respectively. The enzyme deficiency was linked to a missense mutation in the UROD gene, predicting a Met38Arg substitution that involves a conserved amino acid across all species examined, including humans. The mutant phenotype could be rescued by transient and germline expression of the wild-type allele.

Transgenic mice with one disrupted UROD allele (UROD^{+/-}) have half the wild-type hepatic UROD protein and enzyme activity but no accumulation of porphyrins.¹⁰¹ However, in response to iron loading, hepatic porphyrins accumulate, and UROD activity declines to 20%. When bred to HFE^{-/-} mice, UROD^{+/-}/HFE^{-/-} animals developed a porphyric phenotype with further reduction of UROD activity to 14%, resembling the human condition.

HFE^{-/-} mice that are fed ethanol also develop uroporphyrin and reduced hepatic UROD activity, seemingly mediated by effects of ethanol on hepatic iron metabolism.¹⁶⁸ Additional mouse models have been informative for understanding the susceptibility factors in PCT. CYP1A2 knockout mice are highly resistant to developing uroporphyrin induced by chemicals.¹⁶⁹ In mice that are genetically unable to synthesize ascorbic acid, a threshold of body iron was demonstrated at which a biphenyl-induced uroporphyrin accumulation occurs despite ascorbate repletion.¹⁷⁰ Extensive study of such animal models of hepatic uroporphyrin has provided a paradigm of the complex interactions among genetic factors, chemicals, drugs, and endogenous factors including iron homeostasis.¹⁷¹

PCT was identified in a flock of German Blackface sheep with clinical features similar to human PCT.¹⁷² It is associated with a point mutation in the UROD gene, predicting the amino acid substitution Leu131Pro, which is located in the active site cleft of the UROD protein.

Erythropoietic Protoporphyrin

Erythropoietic protoporphyria (EPP), the third porphyric disorder with only cutaneous manifestations, is not uncommon, with an estimated prevalence of 1 per 75,000 to 200,000. Since the first clear description of the disease by Magnus et al. in 1961,¹⁷³ hundreds of cases have been reported throughout the world.^{20, 174, 175, 176} Defects in the gene encoding ferrochelatase (FECH), the last enzyme in the heme biosynthetic pathway (Fig. 26.1), underlie most cases and result in accumulation of free protoporphyrin, mainly in erythroid tissue. The cutaneous manifestations are distinctive, but considerable individual variation is noted in clinical severity as well as in biochemical abnormalities. Three patterns of inheritance are recognized for the disorder (Table 26.2), and two variants occur.

Molecular Basis and Pathogenesis

Subnormal FECH activity is found in all tissues examined from patients with EPP, namely bone marrow,¹⁷⁷ reticulocytes,¹⁷⁸ liver,¹⁷⁹ cultured skin fibroblasts,¹⁷⁹ and lymphocytes.¹⁸⁰ However, the protoporphyrin accumulates principally, if not

entirely, in erythroid cells,¹⁸¹ whose contribution to heme production far exceeds that of all other tissues. Although the normal relative activity of FECH in erythroid tissue, in contrast to liver, is the second lowest among the enzymes of the heme biosynthetic pathway and is only three times higher than 5-aminolevulinate synthase,¹⁹ defective FECH in EPP does not appear to be rate limiting until late in erythroid development.¹⁷⁷ Patients often exhibit a mild hypochromic-microcytic anemia as a consequence of the FECH deficiency that in turn appears to limit iron assimilation.^{177, 182, 183, 184} Protoporphyrin begins to accumulate in bone marrow erythroblasts just before the nucleus is lost,¹⁸⁵ and reticulocytes and young erythrocytes probably are the major source of protoporphyrin in plasma on its rapid release from these cells.^{186, 187} Because of its low water solubility, the protoporphyrin is not excreted in urine but is taken up by the liver and excreted exclusively through the biliary tract.

Based on clinical features and FECH activity in many pedigrees, inheritance of this porphyria was first believed to most often follow an autosomal dominant pattern with incomplete penetrance.^{183, 188} In a few families, autosomal recessive inheritance was evident.^{174, 189} However, FECH activity in tissue lysates from patients with clinical EPP is always only 20% to 30% of normal,^{20, 181} not the 50% value expected for an autosomal-dominant enzyme deficiency. Neither levels of FECH activity nor levels of erythrocyte and fecal protoporphyrin consistently correlate with severity of symptoms. Moreover, most obligate carriers of the disorder have no symptoms. Their erythrocyte and fecal protoporphyrin levels are usually normal, and tissue FECH activity is approximately 50% of normal.^{20, 179, 181} To explain these findings, it was proposed that more than one allele is involved in the full expression of the disease.^{174, 190}

Upon the cloning and characterization of the human FECH gene,¹⁹¹ which is located on chromosome 18 (18q21.3),¹⁹² at least 187 different molecular defects have been identified and are highly heterogeneous, commonly as missense/nonsense mutations, nucleotide deletions and insertions, and intronic point mutations near intron/exon splice sites in one FECH allele.^{10, 192a} Most often, the defects lead to frameshifts or deletions, resulting in a truncated protein ("null allele"). The entire FECH gene was absent in one patient as a result of a chromosome 18q deletion.¹⁹³ Two types of regulatory defects in the gene have also been reported, impairing transcription due to hypermethylation of the promoter region¹⁹⁴ or a point mutation affecting transcription factor binding in the promoter.¹⁹⁵ In about 4% of cases a mutation is present on each allele, defining recessive inheritance,^{10, 196} where the majority are missense mutations. Although these few double heterozygotes clarify the phenotypic differences between symptomatic and asymptomatic family members, all other manifesting cases usually coinherit a "low-expression" normal FECH allele trans to a deleterious mutant allele.^{197, 198} The low-expression allele is highly associated with a specific ancestral haplotype involving a single nucleotide polymorphism site in the FECH gene (IVS3-48T/C) that influences the use of a constitutive aberrant acceptor splice site in the gene.¹⁹⁹ The aberrantly spliced RNA fraction is degraded, decreasing the steady-state level of FECH mRNA expressed by the allele by $\geq 20\%$. Hence the term

P.690

"pseudodominant EPP" came into use for patients with a FECH mutation trans to a hypomorphic IVS3-48C allele, to distinguish them from those with autosomal recessive EPP who are hetero- or homoallelic for FECH mutations. The frequency of the hypomorphic IVS3-48C allele differs widely between ethnic groups, ranging from 67.8% in Japanese to <1% in West Africans, and in general correlates with prevalence of clinical EPP among individuals with a mutant FECH allele in the different populations.¹⁷⁶ When a low-expression allele is not found, a dominant-negative effect of FECH mutants may be operative.²⁰⁰ Because the enzyme activity is restricted to its homodimers,²⁰¹ a mutant monomer may generate nonfunctional homodimers and impaired or unstable heterodimers, resulting in residual enzyme activity of <50% of normal.^{202, 203} Thus, the ultimate effect of a specific mutation in the FECH gene depends on how it affects the integrity of the protein and whether the nonmutated allele is expressed at a lower level to reduce FECH activity to below a threshold of around 30% of normal as found in clinically overt EPP.

More recently a third pattern of inheritance of EPP that is X-linked was described and is referred to as X-linked protoporphyria (XLPP).²⁰⁴ In the United Kingdom and in the US, the disorder accounts for 2% and 10% of unrelated EPP patients, respectively.^{192a, 205} FECH enzyme activity is normal but erythrocyte protoporphyrin concentrations are higher than in EPP due to FECH deficiency. Around 40% is zinc protoporphyrin, indicating that the supply of the iron substrate as well as ferrochelatase activity becomes rate limiting. To date, five distinct mutations have been identified in exon 11 of the erythroid-specific 5-aminolevulinate synthase gene (ALAS2) (Fig. 26.1), which resides on the X chromosome, and lead to predicted amino acid sequence disruption or deletion of up to 40 C-terminal amino acids of the enzyme.^{192a, 204, 205a} The recombinant mutants have two- to three-fold increased activity,^{205b} explaining the protoporphyrin overproduction. This gain-of-function in the enzyme contrasts with all other previously described ALAS2 mutations that decrease enzyme

activity and cause X-linked sideroblastic anemia (Chapter 24). It also reflects a critical role of the C-terminal structure of ALAS2 for its activity and thus erythroid heme synthesis.

About 5% of EPP families in a large cohort were mutation-negative for FECH and ALAS2.²⁰⁵ However, in these the disease was strongly associated with inheritance of the IVS3-48C allele and decreased FECH activity, suggesting that most may have mutations in regions of the FECH gene that are not included in current strategies for mutation detection. In one case mild photosensitivity was ascribed to the IVS3-48CC genotype alone.²⁰⁵

The pathophysiology of EPP is mediated by the accumulated protoporphyrin. As it leaks out of erythroid cells into plasma, it gains entry into tissues. It is extracted solely by the liver and secreted unchanged into the bile. The liver is capable of clearing large amounts of protoporphyrin, but its secretion across the canalicular membrane and into the bile appears to be rate limiting.²⁰⁶ Yet despite microscopic evidence of hepatobiliary changes in many EPP patients, cholestasis leads to cirrhosis and hepatic failure in only a few (<5%).²⁰⁷ This complication tends to be an abrupt event, is unrelenting, and is not predictable from prior biochemical features or the clinical course of the patient. However, it occurs more commonly in compound heterozygotes for two mutations¹⁹⁶ and in XLPP²⁰⁴ than in heterozygotes. Profoundly reduced ferrochelatase activity predisposes to liver failure.²⁰⁸ In an analysis of 112 EPP patients, all 18 who developed liver disease carried a null allele mutation, whereas none of 20 patients having missense mutations had liver disease as yet.²⁰⁹ Undetected molecular derangements¹⁹⁴ or undefined hepatic factors,²¹⁰ including a greater hepatic source of the excess protoporphyrin related to the defect, can be postulated. Excess alcohol intake²¹¹ and viral hepatitis,²¹² as well as hyperthyroidism,^{212a} also accentuate the genetic disorder.

In the skin, the hydrophobic protoporphyrin transfers to endothelial cells of capillaries to produce the light-induced skin damage in patients with EPP.^{213, 214} Porphyrin-sensitized, oxygen-dependent histochemical reactions and the activation of complement eliciting an inflammatory response are involved in the pathogenesis.^{22, 23} The extensive double-bond structure of the protoporphyrin renders it particularly photoactive, resulting in the unique acute epidermal phototoxicity,¹⁷³ in contrast to the porphyrins that accumulate in the other porphyrias with cutaneous photosensitivity. The activated porphyrin also stimulates fibroblast proliferation, accounting for a characteristic waxy thickening of the sun-exposed skin.²³

Variant Erythropoietic Protoporphyrinemia

The presence of an abnormal transcript of mitoferrin 1 (MFRN1) associated with reduced FECH activity was identified in a series of 7 patients with the EPP phenotype but without genetic defects in FECH in 6 of them, although no cause for the aberrant splicing of MFRN1 mRNA was found in the MFRN1 sequence.²¹⁵ Four patients also had a previously reported C-terminal deletional ALAS2 mutation, and 4 cases had advanced liver disease. MFRN1, which transports iron into mitochondria, is highly expressed and regulated in erythroid cells.²¹⁶ A molecular complex of FECH protein, MFRN1 and ABCB10 (a MFRN1 stabilizer) integrates mitochondrial iron import with heme synthesis.²¹⁷ Thus, aberrant MFRN1 can contribute to the EPP phenotype in some patients, apparently by reducing FECH activity.

Late-onset Erythropoietic Protoporphyrinemia Variant

EPP that is clinically indistinguishable from the inherited forms has developed in later years in the setting of a myelodysplastic syndrome²¹⁸ including the sideroblastic anemia subtype (Chapter 24),¹⁹ or a myeloproliferative disorder.²¹⁹ Two cases were associated with severe cholestatic liver disease.^{219, 260} In several instances acquired deletion of one FECH gene was demonstrated.^{218, 219, 220} An associated low-expression allele or a mutation in the other FECH allele, or altered erythroid heme biosynthesis in the dysplastic clone, likely contributes to the clinical expression in such cases. One case with late-onset XLPP has also been reported.^{220a}

Clinical Description

EPP typically first manifests in childhood or early adolescence.^{20, 183, 221} The cutaneous features of photosensitivity are unlike those seen in patients with other porphyrias; bullae, scarring, sensitivity to trauma, hypertrichosis, and hyperpigmentation are extremely unusual.²¹³ In some cases, the symptoms are only subjective.^{222, 223} Exposure to the sun (or to UV light) for periods of a few minutes up to several hours induces diffuse, intensely unpleasant sensations of prickling, itching, or burning (photoparesthesias) followed by the development of erythema, urticaria, and edema.^{183, 213} Less commonly, solar urticaria, a confluent, hivelike rash, occurs within minutes of exposure and lasts approximately 30 minutes.^{173, 213} In general, the signs and symptoms involve only the uncovered areas of the body and subside in the course of hours or days without significant sequelae.

Occasionally, these early reactions are followed within a day or two by vesicular eczematous lesions (solar eczema) that become crusted, last for several weeks, and heal with scar formation.²²⁴ Chronic skin changes may include shallow pitted

scars or pseudovesicles over the cheeks and nose and thickened leathery skin (pachydermia) over the dorsa of the hands (Fig. 26.4A and B).^{183, 213, 224} Many cutaneous manifestations of EPP do not differ greatly from those found in patients with photosensitivity of unknown cause (so-called polymorphic light eruptions), which is common and is not associated with abnormal porphyrin metabolism. In one study of over 600 light-sensitive patients, only 8% were found to have laboratory evidence of EPP.²²⁵

A number of EPP patients have been identified with palmar keratoderma.²²⁶ They represent a subtype of EPP, which is characterized by seasonal palmar keratoderma, relatively low erythrocyte protoporphyrin concentrations, and recessive inheritance

P.691

with different hetero- or homoallelic FECH mutations. These individuals appear to carry a lower risk of liver disease than other patients with recessive EPP.²²⁶



FIGURE 26.4. Erythropoietic Protoporphyrin. A, B: In a 29-year-old man. Note cobblestonelike, flesh-colored, lichenoid papules over the nose and dorsum of the hand joints. C: Dilute suspension of erythrocytes under the fluorescence microscope. Note a fraction of fluorescing cells. (Courtesy of Dr. Maureen Poh-Fitzpatrick, Columbia University, New York.) D, E: Needle biopsy section of liver. Note deposits of protoporphyrin pigment in the parenchyma and a portal triad (D), and birefringence of the deposits, including a dark Maltese cross figure near the left center (E).

Cholelithiasis tends to develop early in life¹⁸³ and ultimately occurs in approximately 10% of patients. The gallstones fluoresce and consist, in part, of precipitated protoporphyrin.^{20, 227}

Although EPP is generally a benign disorder with clinical manifestations limited to the skin, as noted above a small subset of patients (<5%) develops progressive liver disease, leading to a fatal cirrhosis in the second to fourth decades of life.^{207, 209} At autopsy, massive hepatic deposits of protoporphyrin are found.^{207, 228} Associated with the fulminant liver failure are rising

P.692

blood protoporphyrin levels with progressive cholestasis, hemolysis, increasing photosensitivity, and neurologic crises resembling those of the acute porphyrias.^{207, 229, 230} The neurologic dysfunction was best correlated with a markedly increased level of plasma protoporphyrin and was believed to cause neurotoxicity, leading to axonal degeneration.²³⁰

Laboratory Findings

The free erythrocyte protoporphyrin (FEP) concentration is greatly increased in symptomatic patients. Reported values range from 600 to 4,500 µg/dl (normal, <50 µg/dl).^{20, 183} However, in the XLPP form of EPP about 40% of the protoporphyrin is in the form of zinc-protoporphyrin and total erythrocyte protoporphyrin values ranged from 1,130 to 11,000 µg/dl.²⁰⁴ Increased levels of erythrocyte protoporphyrin are observed in certain other conditions, especially iron deficiency anemia and in lead poisoning, but only rarely do they exceed 300 µg/dl; the excess protoporphyrin is present as the zinc chelate²³¹ and is distinguished spectrally from the nonchelated FEP that is found in EPP and XLPP.²³² Plasma protoporphyrin is usually increased as well, and a normal plasma porphyrin in a patient with increased erythrocyte protoporphyrin may exclude EPP. In asymptomatic carriers, the FEP ranges from normal values to 200 µg/dl.²⁰ The life-threatening liver disease may be predicted by increasing FEP and plasma protoporphyrin levels along with altered liver function tests. In patients with severe protoporphyrin liver disease, the FEP concentration generally exceeds 2,000 µg/dl, and values >8,000 µg/dl have been reported.²⁰⁷

Fluorescence microscopy of a dilute suspension of freshly obtained blood reveals fluorescence in a variable proportion of erythrocytes (Fig. 26.4C).¹⁷³ Protoporphyrin is increased chiefly in young erythrocytes¹⁸⁶ but is heterogeneous, and a population of reticulocytes without protoporphyrin is also present, reflecting a nonuniform expression of the genetic defect at the cellular level.¹⁸⁷ In asymptomatic carriers, a small population of such fluorocytes may be detected even when the FEP concentration is normal.¹⁷⁴

Most patients with EPP have mild, slightly hypochromic anemia and reduced iron stores.^{182, 183, 184, 225} Studies of red cell survival and iron kinetics have failed to detect a characteristic abnormality,^{20, 225} but hemolysis was occasionally reported.²³³ Severe hemolytic anemia may occur with advanced hepatic disease that is exacerbated by photo-oxidative stress occurring during the prolonged operative procedure of liver transplantation.²³⁴ Why some cases exhibit the ring sideroblast abnormality in erythroblasts (Chapter 24)^{235, 236} but others do not¹⁷⁷ is not clear and may relate to the nature of the defect. This feature has not been systematically studied.

Fecal protoporphyrin excretion usually is increased in symptomatic patients.¹⁸³ Values may be as high as 1,400 µg/g (dry weight; normal, <100 µg/g) and vary widely from patient to patient, although variations in a given patient are not great.²³⁷ In some carriers, fecal protoporphyrin is increased even when the FEP is normal. An increasing ratio of FEP to fecal protoporphyrin and an increasing ratio of biliary protoporphyrin to biliary bile acids may also suggest impending hepatic decompensation.^{207, 237, 238} Urinary porphyrin and porphyrin precursor concentrations are normal.

The majority of patients with EPP have no clinical evidence of liver disease, although 20% to 30% have slight elevations of liver enzymes; in the eight families with XLPP a higher percentage of liver dysfunction was noted.²⁰⁴ However, in most if not all cases, the liver contains dark brown pigment deposits (Fig. 26.4D) in hepatocytes, Kupffer cells, and portal macrophages as well as within the lumens of ductules and interlobular ducts that exhibit the characteristic red fluorescence of protoporphyrin when transilluminated with light of wavelength 380 to 500 nm.²³⁹ These deposits are crystalline in nature on electron microscopy. They also exhibit a distinctive type of birefringence, not shared by any other pigment known to occur in the liver, that is demonstrable in routinely fixed and stained paraffin-embedded sections and is

as sensitive as the red fluorescence (Fig. 26.4E).²³⁹ Not infrequently, the pigmentation is accompanied by bile stasis and varying degrees of portal inflammation, fibrosis, and ductular proliferation. In patients who have developed the protoporphyric liver disease, liver histology shows micronodular or macronodular cirrhosis and massive deposits of the pigment throughout.²⁰⁷

DNA analysis with amplification of exons and flanking intronic sequences has detected FECH or ALAS2 mutations in about 95% of patients with EPP.^{176, 205} As large intragenic deletions in FECH are not uncommon their identification requires the use of a gene dosage analysis method.²⁴⁰ EPP patients are at risk of vitamin D deficiency and monitoring 25-hydroxyvitamin D is advised.^{241, 242}

Treatment

Therapy is directed at reducing the consequences of sun exposure and minimizing the hepatotoxic effects of protoporphyrin. Topical sunscreens must be effective in the 400-nm portion of the spectrum to be useful. The only readily available effective topical preparations are opaque formulations containing oxidates of zinc or titanium. Most proprietary sunscreens contain compounds that reduce transmission only of the sun-burning portion of the spectrum between 290 and 320 nm. The induction of carotenemia (serum carotene levels above 400 µg/dl) can be effective in reducing photosensitivity,²¹³ although some studies suggested lack of efficacy.²⁴³ Carotenemia is best induced by the administration of synthetic β-carotene beadlets (Lumitene™, Tishcon Corporation, Westbury, NY) in adults at a dose of 120 to 180 mg/day, but doses up to 300 mg/day may be needed.²⁴⁴ The ability of carotene to quench photoexcited oxygen and to scavenge highly reactive free radicals probably explains its action.²⁴⁵ Increased tolerance to sunlight occurs after 3 to 4 weeks of treatment, and the protective effect may last 4 to 8 weeks after cessation of the drug.²¹³ In northern climates, this therapy may be required only in spring and summer, but winter sports enthusiasts may benefit from more prolonged therapy. To date, no significant side effects have been reported in patients using β-carotene.

In patients unresponsive to β-carotene, narrow-band ultraviolet B (TL-01) phototherapy and psoralen and ultraviolet A light treatment have been effective.^{246, 247} Two patients experienced marked reduction in photosensitivity with administration of pyridoxine.²⁴⁸ Oral cysteine also appears to be effective as a free radical quencher,²⁴⁹ and, in a preliminary report, a flavonoid mixture (hydroxyethylrutinosides) was effective as an antioxidant.²⁵⁰

An α-melanocyte-stimulating-hormone analog, afamelanotide (Scenesse™, Clinuvel, Melbourne, Australia), is probably the most effective agent for alleviating the photosensitivity of EPP by promoting melanin synthesis and increasing skin pigmentation.^{251, 252} It has become available in some European countries and is currently in a Phase 3 clinical trial in the United States. The preparation is a 16-mg sustained-release resorbable implant (grain of rice size) formulation of afamelanotide that is inserted subcutaneously. Studies to date showed that this prophylactic treatment significantly increased sunlight tolerance and improved quality of life.

Multiple attempts to minimize the hepatotoxic effects of protoporphyrin have been directed at both reducing the amount of protoporphyrin presented to the liver for excretion and depleting hepatic protoporphyrin stores. Suppression of erythropoiesis and the erythrocyte protoporphyrin accumulation can be achieved with transfusion therapy,²⁵³ but the hazards of transfusion-induced iron overload and the risk of transfusion-related infectious disorders make this form of therapy undesirable. Administration of iron with the rationale of enhancing porphyrin conversion to heme was followed by decreases in stool

P.693

and erythrocyte porphyrins and improved liver function,²⁵⁴ but the disease was aggravated by oral iron therapy in others.²⁵⁵ The use of nonabsorbable porphyrin binders, namely cholestyramine and activated charcoal, aimed at reducing enterohepatic recirculation of porphyrin, and/or bile acids, to promote fecal porphyrin excretion have benefited selected patients.^{256, 257, 258} None of these approaches is well established, owing to inconsistent or uncertain efficacy and experience in relatively few cases.

In some patients with liver failure, the circulating protoporphyrin burden could be reduced by hemin infusion, plasma exchange, red cell exchange, or by extracorporeal albumin dialysis^{259, 260}; parenteral and oral n-acetyl cysteine was beneficial in one case.²⁶¹ Once severe liver damage has occurred, usually no form of medical therapy is effective. Thus, liver transplantation was undertaken as a life-saving measure.^{262, 263} The results have been favorable in part, with patient and graft survival rates up to 66% at 5 years.^{263, 264, 265} However, the protoporphyrin burden from erythroid tissue remains and recurrence of protoporphyrin hepatopathy is common, supporting most evidence that the primary if not the only contribution of the excess protoporphyrin is from bone marrow. Moreover, in a case with EPP due to heteroallelic FECH mutations and coincidental acute leukemia, a successful marrow transplant from a sibling carrying one FECH mutation

cured the patient's manifestations of the porphyria.²⁶⁶ HSCT has also been performed in four EPP patients with a prior liver transplant to treat or prevent disease recurrence in the graft.^{267, 268} Although in three of the four cases successful engraftment led to clinical and biochemical resolution, two succumbed to infectious complications. In a fifth patient bone marrow transplantation following medical control of severe progressive protoporphyria cholestasis was curative.²⁶⁹ Apart from its inherent risks, HSCT would appear to be the ideal treatment in EPP patients prone to severe liver disease before liver transplantation becomes necessary. Identification of patients at risk of severe liver disease remains the principal challenge.

The most definitive treatment for the disease would be replacement of the defective gene in affected tissues. Targeting the hematopoietic stem cells with gene therapy will probably suffice once it is technically feasible. In vitro studies have demonstrated effective transfer of normal FECH complementary DNA into cultured fibroblasts from patients with EPP with correction of the biochemical defect.^{270, 271} Genetic analysis of EPP patients' spouses for carrier status of a FECH mutation and a low-output FECH allele allows assessment for the probability of clinical disease in offspring as well as prenatal testing or pre-implantation genetic diagnosis.

Erythropoietic Protoporphyrin in Animals

Bovine EPP was described in 1977²⁷² and is transmitted as an autosomal recessive trait.²⁷³ Affected calves have acute photosensitization during the first few weeks of life, the erythrocyte and fecal protoporphyrin is greatly increased, and FECH is reduced to 10% in all tissues examined.¹⁸¹ The animals do not develop anemia or hepatobiliary disease. Carrier dams have approximately half the normal FECH activity. DNA analysis revealed a novel stop codon mutation (X417L).²⁷⁴

A protoporphyric disorder occurs in mice that are fed a diet containing 2.5% by weight of griseofulvin and exhibits a pronounced hepatic component.²⁷⁵ It is similar in many respects to the human disease, and the hepatic histopathologic abnormalities are indistinguishable by light or electron microscopy.^{276, 277, 278} Another murine EPP (fch) is produced by chemical mutagenesis with ethylnitrosourea.²⁷⁹ It is characterized by photosensitivity, severe hepatobiliary dysfunction in early life, and microcytic hypochromic anemia as well as a redistribution of storage iron to the spleen.²⁸⁰ FECH activity in various tissues is 2.7% to 6.3% of normal in homozygotes and approximately 50% in heterozygotes. A point mutation has been identified in the FECH gene (Fechm1Pas), and prokaryotic expression studies have substantiated it as the basis for the porphyria.²⁸¹ Bone marrow transplantation is effective in this mouse model.²⁸² Moreover, reversal of the phenotype and restoration of normal hematopoiesis have been achieved with pre-selective gene therapy^{283, 284} as well as with the use of a dual gene therapy technology.²⁸⁵ A third mouse model exhibiting a protoporphyria is produced by targeted deletion of iron-regulatory protein 2 (IRP2).²⁸⁶ The phenotype is manifested by iron-limited erythropoiesis, marked overexpression of ALAS2 from loss of IRP-dependent translational repression, and markedly increased levels of free and zinc protoporphyrin. These features closely resemble those of XLDPP.

A genetically designed model of EPP was developed in zebrafish named dracula.²⁸⁷ Protoporphyrin IX accumulates in the mutant embryos, and the phenotype shows light-dependent hemolysis and liver disease. The mutation is a G to T transversion at a splice donor site in the FECH gene and creates a stop codon.

ACUTE OR INDUCIBLE PORPHYRIAS WITH NEUROLOGIC MANIFESTATIONS

Porphyrias manifesting neurologic and psychiatric illness are called acute porphyrias to reflect the often abrupt onset of symptoms. They are also referred to as inducible porphyrias because symptoms are usually brought on by endogenous or exogenous factors that stimulate heme biosynthesis through certain biochemical mechanisms. These disorders are deficiencies of the remaining four enzymes of the heme synthetic pathway that restrict the capacity for the production of heme in the liver and lead to derepression of ALA synthase: PBGD, ALA dehydratase (ALAD), coproporphyrinogen oxidase (CPOX), and protoporphyrinogen oxidase (PPOX) (Fig. 26.1). During acute attacks, hepatic ALA synthase is markedly induced, and the porphyrin precursors ALA and PBG accumulate because PBGD becomes rate limiting, normally having the second lowest relative activity among the enzymes of the hepatic heme synthetic pathway.¹⁹ These events are best understood in the liver, and they may occur in neural tissue. Deficiencies of CPOX and PPOX also result in accumulation of their respective porphyrin substrates and therefore can be accompanied by photosensitivity, whereas only the precursors accumulate with deficient PBGD and ALAD, and photosensitivity does not occur.

Acute Intermittent Porphyria

Patients with acute intermittent porphyria (AIP; pyrroloporphyria, Swedish porphyria) were probably reported by Gunther.⁴ The extensive family studies in Sweden by Waldenström provided the first comprehensive description of the disorder.⁵⁷ It is transmitted in an autosomal dominant manner with low penetrance and results from mutations in the gene encoding PBGD (hydroxymethylbilane synthase, uroporphyrinogen I synthase) (Fig. 26.1).²⁸⁸ The prevalence of the trait in most countries had been estimated at 1 to 2 per 100,000.²⁰ More recent population screening studies in northern

Europe with enzyme assays and DNA analysis indicate a much higher prevalence of carriers, ranging from 1 to 2 per 10,000, and an even higher prevalence in Sweden and France.²⁰ A study of psychiatric patients in the United States showed a higher prevalence of AIP than in the general population (approximately 0.21%).²⁸⁹

Molecular Basis and Pathogenesis

A decreased conversion of PBG to porphyrins observed in liver tissue from patients with AIP provided the first evidence that the enzyme PBGD is defective.²⁹⁰ Decreased catalytic activity of PBGD to approximately half of normal was subsequently demonstrated

P.694

in all tissues examined, including liver,²⁹¹ erythrocytes,²⁹² cultured skin fibroblasts,²⁹³,²⁹⁴ cultured amniotic cells,²⁹⁴ and mitogen-stimulated lymphocytes.²⁹⁵ Considerable heterogeneity of the defect became evident from biochemical and immunologic studies of the enzyme in erythrocytes from patients with AIP. Up to 10% of unrelated and clinically affected individuals had either normal or indeterminate levels of erythrocyte PBG-D activity.²⁹⁶,²⁹⁷,²⁹⁸ Overlapping enzyme activity levels could be resolved with internal family reference values,²⁹⁹ consistent with apparent genetic regulation of the enzyme activity.³⁰⁰ Patients with normal erythrocyte PBGD activity responded to an ALA loading test with increased excretion of PBG and reduced excretion of fecal protoporphyrin, just like patients with low PBGD activity in erythrocytes, suggesting that the defect is expressed in the liver but not in erythrocytes.³⁰¹ Approximately 80% of patients with half-normal PBGD catalytic activity were found to have half-normal PBGD protein concentration, referred to as cross-reacting immunologic material negative, and approximately 20% of pedigrees were cross-reacting immunologic material positive (i.e., the PBGD catalytic activity was half-normal, but the PBGD protein was normal or even increased).²⁸⁸,³⁰² In addition, molecular heterogeneity was indicated by detection of differing restriction haplotypes for the PBGD gene locus.²⁸⁸,³⁰³

After the cloning and sequencing of the PBGD gene,³⁰⁴ the molecular basis for two isoforms of the enzyme was established,³⁰⁵,³⁰⁶,³⁰⁷ and genetic defects responsible for AIP could be identified. A single PBGD gene, located in the chromosomal region 11q23.3,³⁰⁸ under the control of two independently regulated promoters, produces two transcripts through alternative splicing. In the mRNA of the enzyme produced in all cells (ubiquitous mRNA), exon 1 is spliced to exon 3, whereas exon 1 is excluded in the transcript in erythroid cells, and translation begins in exon 3 (Fig. 26.5). Thus, the erythroid-specific protein lacks the 17 amino acids that are encoded by exon 1 for the ubiquitous enzyme.

Close to 400 different mutations have been identified in the PBGD gene, most of which were found in single pedigrees.¹⁰,²⁸⁸,³⁰⁹ High frequencies of a few mutations in restricted geographic areas (e.g., Sweden, The Netherlands, Switzerland, Canada, Argentina) are believed to represent founder effects.²⁸⁸ On the other hand, approximately 3% of all index cases with AIP may have de novo mutations.³¹⁰ Approximately two thirds of mutations are singlebase substitutions, and the remaining mutations consist of insertions or deletions, resulting in a spectrum of splice defects of transcripts, frameshifts, stop codons, unstable proteins, or reduced catalytic activities of the enzyme; a few are in the promoter region of the gene.¹⁰,²⁸⁸,³⁰⁹,³¹¹ The least common mutations (i.e., involving the exon 1-intron 1 junction or exon 1) restrict the PBGD defect to nonerythroid tissues and account for the normal activity of the enzyme in erythrocytes observed in such cases. In four families, double heterozygotes or homozygotes for point mutations had severe PBGD deficiency.³¹²,³¹³,³¹⁴,³¹⁵ Although, in general, no correlation between the genotypes and phenotypes has been found, some prevalent mutations exhibit higher penetrance.³¹⁶,³¹⁷ Using the knowledge of the three-dimensional structure of PBGD, structural and functional outcomes of the mutations can be predicted.³¹⁸,³¹⁹ For instance, many mutations change amino acids in the vicinity of the active site of the enzyme, and a number of these are involved in binding the primer or substrate of the enzyme; others perturb conformation of the protein.

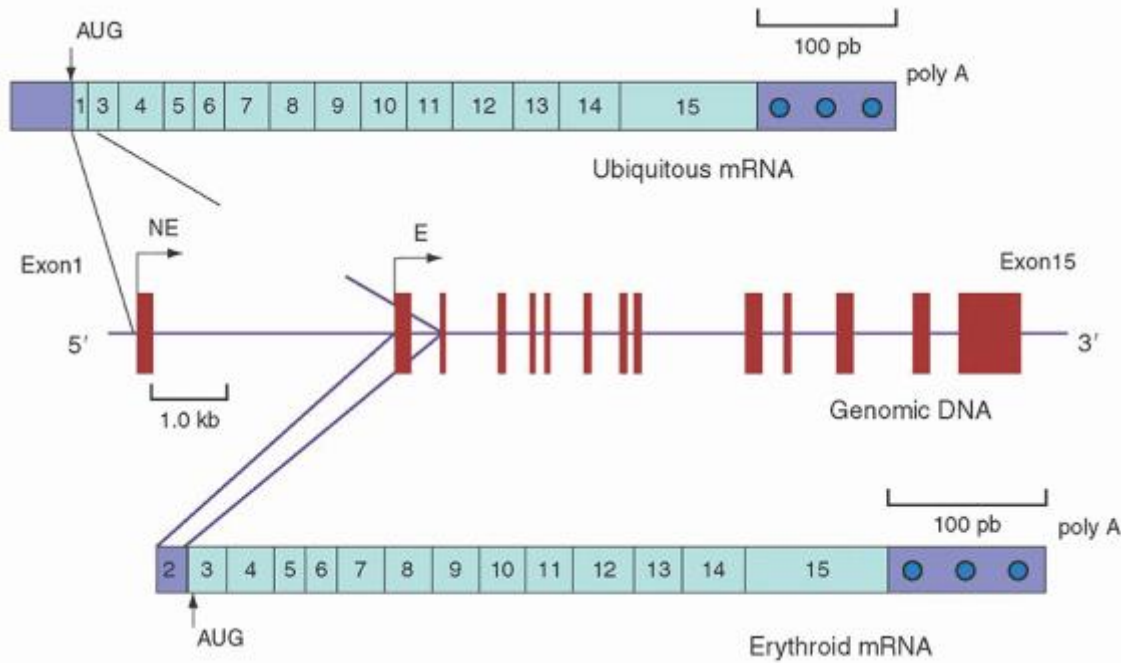

FIGURE 26.5. Structure of the human PBG deaminase gene and its two transcripts produced by alternative splicing. E, erythroid promoter; NE, nonerythroid promoter. (From Deybach J-C, Puy H. Acute intermittent porphyria: from clinical to molecular aspects. In: Kadish KM, Smith KM, Guillard R, eds. The porphyrin handbook-medical aspects of porphyrins, vol. 14. Amsterdam: Academic Press, 2003;14:23-41, with permission.)

The genetic lesion and its wide spectrum underlying AIP are well defined; however, the pathogenesis of the clinical manifestations remains poorly understood. Several mechanisms have been postulated for the neurovisceral symptoms and signs that characterize the disorder.²⁰ The prevailing one is that the porphyrin precursor ALA, which accumulates after the induction of hepatic ALA synthase (ALAS1)^{320, 321} in response to diminished cellular heme because of the PBGD deficiency, is toxic to the nervous system. Studies in animals indicate that ALA can alter neural structure and function as an agonist for γ -aminobutyric acid receptors,^{322, 323} it inhibits release of neurotransmitters at neuromuscular junctions^{324, 325} and spinal cord synapses,³²⁶ and it exerts lethal effects on neuronal and glial cells in culture.³²⁷ Additional support for ALA as the responsible neurotoxin are the observations that patients with severe ALAD deficiency (see below) and patients with hereditary tyrosinemia,³²⁸ both of whom excrete excess ALA but not PBG, display neurologic features similar to those of patients with AIP. Furthermore, the finding that liver transplantation in patients with AIP promptly normalizes the

P.695

overproduction of ALA and PBG and eliminates chronic debilitating neurovisceral attacks has established the hepatic overproduction of the porphyrin precursors as the cause of the neurologic symptoms.^{329, 330, 331} On the other hand, urine and serum levels of ALA, along with PBG, correlate only roughly with symptoms and signs.³²¹ It has not been possible to produce an acute porphyric attack by administering ALA to animals,³³² a normal human subject,³³³ or even patients with latent porphyria,³³⁴ although convulsion can be induced by intraventricular injection of ALA and PBG in rats.^{334, 335}

A second postulated mechanism has been that episodic depletion of cellular heme from marginal to critical levels deprives enzymatic oxidations and energy-producing reactions involving hemoproteins in neural tissues.^{320, 336} Experimental inhibition of the heme biosynthetic pathway in dorsal root ganglia cultures causes severe segmental degeneration.³³⁷ The administration of heme to patients suffering an acute porphyric attack usually reverses the neuropathic manifestations, but this effect more likely results from inhibition of the hepatic ALA overproduction by the heme (Fig. 26.1); it is not known whether intravenously administered heme enters the brain.

Another mechanism was suggested by studies in animals that implicated accumulation of neurotoxic levels of tryptophan and serotonin. Heme depletion impairs catabolism of tryptophan by the heme-dependent enzyme hepatic tryptophan pyrrolase.^{338, 339} In one study, patients with attacks of AIP had serum levels of tryptophan, serotonin, and urinary 5-hydroxyindoleacetic acid that were above normal and that declined after heme administration.³⁴⁰ Levels of melatonin,

implicated in the regulation of the circadian rhythm, were found to be decreased. Results of studies in animals and in cultured pineal glands suggested that melatonin may also be involved in the regulation of heme synthesis in some manner.³⁴¹

Most people (approximately 90%) heterozygous for the PBGD defect never have symptoms, but certain precipitating factors cause both biochemical and clinical evidence of the porphyric diathesis. Steroid compounds, both endogenous and synthetic, and medications are the most commonly identified precipitating factors of symptoms.²⁰ Gonadal hormones, especially the 5- β steroids and ovarian hormones or their metabolites, are most significant and are potent inducers of hepatic ALA synthase.²⁰ They probably account for the typical onset of symptoms in early adulthood, as well as for the susceptibility of women to porphyric attacks during the luteal phase of the menstrual cycle, when progesterone is high. Hence, the benefit of agonistic analogs of luteinizing hormone-releasing hormone (LHRH) can be attributed to induction of pituitary refractoriness to LHRH to suppress production of progesterone and its 5- β metabolites.³⁴² The barbiturates and sulfonamides head the list of countless drugs that can provoke porphyric attacks and usually do so by inducing hepatic cytochrome P450 enzymes for their metabolism via microsomal hydroxylation, thereby increasing the need for hepatocellular heme and leading to induction of ALA synthase,²⁰ or by direct transcriptional activation of ALA synthase.³⁴³ However, the response of patients is highly variable.^{20, 344} Dieting or decreased caloric intake with intercurrent illness may precede acute attacks. With carbohydrate administration, through high doses of glucose, the urinary excretion of ALA and PBG often strikingly decreases, and symptoms tend to improve.^{321, 345} The missing link of this fasting-feeding response by the liver was found to be in the regulation of hepatic ALA synthase by PGC-1 α .³⁴⁶ Although this transcriptional co-activator mediates hepatic gluconeogenesis and fatty acid oxidation in response to fasting, it also induces ALA synthase.

Clinical Description

The clinical features of the defect are typically acute symptoms and signs reflecting neurovisceral and psychiatric deficits (Table 26.3). They are more common in women and are highly variable, even among affected siblings. Attacks usually last for several days to even several months and are separated by symptomless intervals varying from months to decades. Patients may have as few as three attacks in a lifetime or several per year (Fig. 26.6).³²¹ Most often, the acute attack is an autonomic neuropathy manifested by moderate to severe abdominal pain that is unrelenting, at times cramping, variable in location, and characteristically accompanied by constipation, which may be severe, and often vomiting (Table 26.3). In some cases, pain is predominant in the back and limbs. The abdomen is usually soft, with no rebound tenderness or other signs of peritoneal irritation, and dilated bowel loops may be palpable. The abdominal radiograph may show evidence of segmental intestinal dilation and spasm. Other common findings are tachycardia, labile hypertension or hypotension, and urinary retention.³²¹ The pulse

P.696

rate is often considered a good index for judging the activity of the disease and even the diagnosis.³⁴⁷

TABLE 26.3 SIGNS AND SYMPTOMS OF ACUTE INTERMITTENT PORPHYRIA

Signs and Symptoms	Incidence (%)
Abdominal pain	85-95
Vomiting	43-88
Constipation	48-84
Tachycardia	28-80
Muscle weakness	42-68
Mental changes	40-58
Hypertension	36-54
Extra-abdominal pains	50-52
Sensory deficit	9-38
Fever	9-37
Convulsions	10-20

Respiratory paralysis

Data from three reports, 417 patients: Stein JA, Tschudy DP. Acute intermittent porphyria. A clinical and biochemical study of 46 patients. *Medicine* 1970;49:1-16; Waldenström J. The porphyrias as inborn errors of metabolism. *Am J Med* 1957;22:758-773; and Goldberg A. Acute intermittent porphyria: a study of 50 cases. *QJM* 1959;28:183-209.

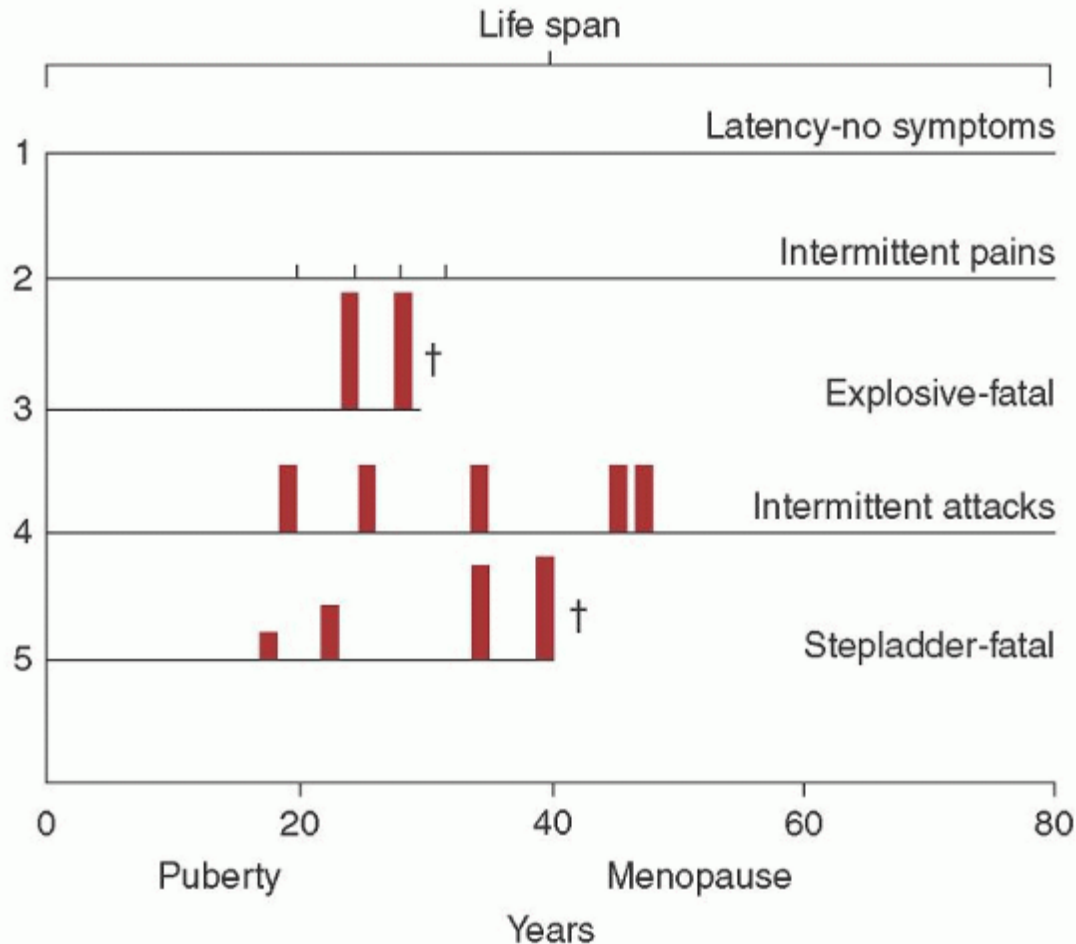

FIGURE 26.6. Typical courses of acute intermittent porphyria. (From Moore MR, McColl KEL, Rimington C. Disorders of porphyrin metabolism. New York: Plenum, 1987:79, with permission.)

Less often, and with prolonged or more severe attacks, peripheral motor neuropathy occurs. Symptoms include weakness in one or more extremities, especially the upper extremities and proximal musculature, that may progress to flaccid quadriparesis.^{348, 349} Bulbar and respiratory muscle paralysis can be life-threatening. Blindness has resulted from both occipital lobe and optic nerve involvement.^{321, 350, 351} Sensory abnormalities occur less often. The extreme variability of neurologic abnormalities is further indicated by manifestations of central nervous system disturbances. Acute anxiety and emotional lability with progression to confusion, frank psychosis, and coma occasionally dominate the clinical presentation.^{349, 352, 353, 354} Tonic-clonic seizures occurred in 17% to 32% in two series of patients,^{321, 355} whereas lifetime prevalence of seizures among patients in Sweden was only 5%.³⁵⁶ Seizures may result from profound hyponatremia caused by inappropriate antidiuretic hormone secretion, reflecting hypothalamic dysfunction, or may be a cerebral manifestation of the metabolic defect.^{20, 321} Death may occur when psychomotor manifestations intensify, or from cardiac arrhythmia.³²¹

In older reports, the mortality rate from neurologic involvement was approximately 30%.³⁵⁷ Improvement in supportive care in the 1970s reduced the mortality rate to approximately 10%,^{344, 345} and the introduction of therapy with intravenous heme reduced the mortality rate further.^{355, 358} Nevertheless, delayed diagnosis of severe attacks in particular continues to occur up to the present, leading to marked disability or a fatal outcome.^{359, 360} If peripheral nerve deficits

develop, they may clear slowly, over months or years, or never completely. Depression, including suicidal tendencies, may occur with frequent attacks or with chronic symptoms.³⁵⁵

Chronic hypertension and renal impairment develop in up to 50% of patients with AIP as late complications.^{344, 356, 361, 362} The hypertension may predispose and nephrotoxic effects of porphyrin precursors may contribute to renal insufficiency.³⁶³ Moreover, end-stage renal disease is associated with higher plasma ALA/PBG levels and accumulation of plasma porphyrins, leading to progression of peripheral neuropathy and even cutaneous lesions resembling PCT. In such cases combined liver and kidney transplantation should be considered.^{331, 364}

Several studies indicate a significant association between primary liver cancer and AIP in European countries.³⁶² In Sweden, where the incidence of AIP is high, in the latest analyses the annual occurrence of hepatocellular carcinoma in AIP gene carriers was 0.8%,^{365, 365a} and in France and Switzerland 0.3% and 0.16%, respectively.³⁶⁶ Liver cirrhosis and other risk factors, such as alcohol and viral hepatitis, were uncommon in these series.^{362, 366} Impaired detoxification capacity of mutagenic substances by the liver with impaired heme synthesis or toxicity of ALA are thought to enhance a genetic change over time. In Sweden it is recommended that all patients carrying an acute porphyria gene be screened yearly for hepatocellular carcinoma after age 50 using liver imaging.³⁶⁵ In one patient with hepatoma but not porphyria, the tumor produced large amounts of PBG as an apparent paraneoplastic feature.³⁶⁷

The few reported children homozygous for the genetic defect^{313, 314, 315, 368} manifested central nervous system defects, including hypoplasia of brain structures and altered postnatal cerebral myelination, with variable developmental delay and neurologic deficits. Neurovisceral features were not observed.

Laboratory Findings

Results of routine hematologic measurements usually are within normal limits; however, leukocytosis occasionally is observed during acute attacks,³²¹ a finding that may support an erroneous impression of an abdominal condition requiring an emergency operation. Anemia is an uncommon finding and, when present, may not be related to the porphyria.³²¹ Some patients have an unexplained reduction in both the plasma volume and the red cell mass even though the volume of packed red cells is normal.³⁶⁹ Red cell survival is normal, suggesting that the decreased red cell mass results from reduced erythropoiesis.

The telltale urinary overexcretion of the porphyrin precursors, PBG and, to a lesser extent ALA, is diagnostic. The ratio of PBG to ALA in urine is usually 3:1, whereas in lead poisoning, ALA dehydratase porphyria (see below) and hereditary tyrosinemia urinary ALA is markedly increased but PBG is normal or only slightly raised. Normally, <7 mg of ALA and <4 mg of PBG are excreted in 24 hours regardless of the analytic method used. During acute attacks, the urinary excretion of PBG generally ranges from 20 to 200 mg daily.^{321, 370} In one study, 21 symptomatic patients excreted an average of 83 mg of PBG in 24 hours (range, 8 to 150 mg).³²¹ A rough correlation exists between the amount of PBG excreted and the severity of clinical symptoms. ALA and PBG excretion diminishes during remission and may return to normal. In 12 asymptomatic patients, the average urinary PBG excretion was 32 mg in 24 hours (range, 12 to 60 mg), and ALA excretion was 10 mg in 24 hours (range, 6 to 18 mg).³²¹ Serum normally contains only trace amounts of ALA and PBG, but patients with AIP may have serum PBG concentrations as high as 300 µg/dl during acute attacks.²⁰ Increases in the liver content of ALA and PBG have been noted at autopsy in patients who died during acute attacks.

A rapid qualitative method of detecting excess PBG in urine is the Watson-Schwartz test.³⁷⁰ This test yields negative results in normal subjects and positive results when PBG excretion exceeds approximately 6 mg/L.³⁷¹ Other urinary chromogens, particularly urobilinogen, as well as certain drugs and drug metabolites may also form a similar color when they react with Ehrlich reagent, but only the PBG-Ehrlich complex is water soluble and cannot be extracted with chloroform and butanol. When properly performed and interpreted, the Watson-Schwartz test is reliable. In inexperienced hands, false-positive results are common; in one referral center, 75% of patients with supposedly positive findings had normal values when quantified by chromatography.³²¹ The commercial PBG Test Kit (Thermo Fisher Scientific Inc., Middleton, VA) is recommended for rapid detection of PBG in urine.³⁷² The urine should also be saved for subsequent quantitation of ALA and PBG by ion exchange chromatography³⁷³ and of porphyrins for specific diagnosis of the type of acute porphyria.

Because PBG is a colorless compound, freshly excreted urine from patients with AIP appears normal in color. On exposure to light and air, two reactions are accelerated that cause PBG-containing urine to darken on storage. First, PBG is oxidized to porphobilin, a dark brown, amorphous product.³⁷⁴ Second, PBG may be nonenzymatically converted to a mixture of porphyrins, especially uroporphyrin, a reaction favored at acidic pH, and quantitation of uroporphyrin and coproporphyrin in urine then detects mild to moderate elevations.³⁷¹ Therefore, the so-called urine porphyrin screen commonly carried out is also positive. However, it merely detects an increased concentration of coproporphyrin, which is associated with a variety of illnesses, and thus of no diagnostic value. Fecal porphyrin excretion is normal or only slightly increased.^{20, 375}

Another useful measurement for diagnosis and detection of relatives with the latent defect, in whom urinary PBG excretion is often normal,^{292, 298} is the erythrocyte PBGD activity, provided it is recognized that the erythrocyte value may be indeterminate or normal in up to 10% of cases because of heterogeneity of PBGD mutations and, rarely, because the enzyme is not affected in red cells.^{296, 297, 298, 299} If biochemical studies indicate the presence of AIP, DNA analysis is encouraged to identify the

P.697

disease-causing mutation.³⁷⁶ The marked genetic heterogeneity encountered precludes the feasibility of a routine genetic test for diagnosis, although molecular techniques have been refined to localize the region of a mutation and simplify sequencing of the relevant DNA segment of new probands. Then, carriers within the family are easy to detect for preventive measures.

Hyponatremia, reduced blood volume, and mild elevation of blood urea nitrogen often are observed during acute attacks.³²¹ The findings may be attributed to vomiting. The syndrome of inappropriate antidiuretic hormone secretion has been documented^{20, 321} and is presumably the result of a hypothalamic abnormality. When carefully sought, other evidence for hypothalamic involvement is found, such as disturbed regulation of growth hormone and adrenocorticotrophic hormone secretion. However, the increased antidiuretic hormone secretion may be an appropriate response in patients with unexplained reduction in total blood volume,³⁷⁷ and fluid restriction would not be proper therapy for such patients. In one study of 45 patients hospitalized for acute porphyric attacks, hyponatremia was more often related to vomiting, poor intake, and excess renal sodium loss than to inappropriate secretion of antidiuretic hormone.³⁷⁸ Hypomagnesemia associated with tetany has also been reported.³⁴⁵

Abnormal electroencephalographic patterns are a common laboratory sign of the neurologic dysfunction. Diffuse nonspecific slowing of the wave pattern was found in 14 of 24 patients during an acute attack.³²¹ In the presence of encephalopathy, magnetic resonance (MR) imaging studies have usually shown reversible contrast-enhancing subcortical white matter lesions of variable size with normal diffusion-weighted MR images, interpreted to represent vasogenic edema.^{379, 380} In some cases with cortical blindness, similar lesions were limited to the occipital lobes.³⁸¹ The cerebrospinal fluid usually is normal. The peripheral neuropathy is a "dying back" process in which neuron damage follows axonal demyelination.^{20, 348} Electrophysiologic studies and microscopic examination of nervous tissue^{382, 383, 384} indicate that the acute attack affects primarily neuronal bodies, leading to an acute axonal degeneration of peripheral and autonomic nerves and to neuronal loss and gliosis in the central nervous system. In patients with latent porphyria, slower motor and sensory conduction velocities are detectable,³⁸⁵ as is parasympathetic dysfunction of peripheral nerves when assessed with bedside tests of cardiovascular reflexes.³⁸⁶ Parasympathetic dysfunction has also been demonstrated by spectral analysis of heart rate variability,³⁸⁷ which may predispose to arrhythmias in symptomatic and latent disease.

Treatment

When an acute attack occurs, patients usually require hospitalization because the clinical course is difficult to predict, and causes for the symptoms other than porphyria must be excluded. Precipitating factors should be removed, but often the specific factor in a particular attack cannot be identified. Pain should be treated with safe analgesics and narcotics such as morphine. Fluid, electrolyte, and caloric deficits should be restored. Carbohydrate is administered intravenously (as 10% dextrose) so that the equivalent of 300 to 500 g of glucose is given daily.^{321, 345, 376} Propranolol has been effective in reducing tachycardia and hypertension in some patients³⁸⁸ but must be used very cautiously if at all in patients with hypovolemia.³⁸⁹ Maintenance of the patient's morale and alleviation of fear are also important and facilitate recovery.

Although carbohydrate loading may suffice for mild attacks, for most acute attacks the very effective therapy with intravenous hemin (a soluble hydroxyl derivative of heme) should be started.³⁷⁶ This compound has been used in therapeutic trials since the early 1970s,^{390, 391} with the rationale being to correct the apparent heme deficiency and repress hepatic ALA synthase and thus the overproduction of porphyrin precursors. Hemin became commercially available in 1983 (Panhematin™, currently supplied by Lundbeck, Inc., Deerfield, IL, 313 mg of hemin/vial), and its use in the treatment of the acute attack was a major advance. Early initiation of this therapy leads to a more rapid response and fewer residual neural deficits.^{376, 392} The lyophilized hemin is best reconstituted with albumin to enhance stability³⁹³ and is administered at a dose of 3 to 5 mg/kg body weight once daily for 4 to 5 days. Phlebitis at the site of injection may occur.

After infusion of hemin, dramatic reductions in ALA and PBG concentrations in serum and urine are observed, and clinical symptoms often improve within 24 to 48 hours. Because of instability of the hemin in solution, thrombocytopenia and a mild transient coagulopathy manifested by prolongation of both the partial thromboplastin time and the prothrombin time occurred with some regularity during hemin infusion therapy and are attributed to degradation products of

hemin.^{394, 395} Reconstitution of the compound with albumin decreases the incidence of phlebitis and prevents the anticoagulant effect.^{376, 393} A Finnish preparation, heme arginate, is more stable and does not produce coagulopathy.³⁹⁶ This product is not available in the United States but has been introduced in Canada (Normosang™, distributed by Medunik Canada). The patient's therapeutic and clinical course is best monitored with plasma PBG determination.³⁹⁷ Tin protoporphyrin, an inhibitor of heme oxygenase, in combination with heme arginate restored efficacy when tolerance to the heme developed, but it is not widely available.

The management of seizures is a considerable challenge. If they are related to metabolic disturbances of hyponatremia and hypomagnesemia, correction of these derangements may control them. However, if seizures are related to the porphyric diathesis or are a chronic associated problem, their management may be difficult because most anticonvulsants are contraindicated.³⁹⁸ An agent such as clonazepam appears to be safe, but its efficacy in the control of grand mal seizures is not documented. Magnesium sulfate was used effectively in one reported case.³⁹⁹ Several antiepileptic drugs (gabapentin, vigabatrin, and levetiracetam) are not metabolized by the liver and are the treatment of choice for epilepsy in acute hepatic porphyrias.^{400, 401}

Prompt diagnosis of the symptomatic patient is of essence to guide specific therapy and reduce morbidity or mortality. The disorder is often not recognized and diagnosis is delayed because the clinical features mimic many other conditions, or may be atypical as when dominated by encephalopathy or new onset seizures.^{359, 360, 380, 402, 403} Prevention of acute attacks is the cornerstone of treating the patient in whom the diagnosis has been established and includes identification of carriers among relatives. Avoidance of most drugs is important, as thoroughly discussed by Hift et al.⁴⁰⁴ Patients should receive a list of safe and unsafe drugs (Table 26.4) or be provided with access information to updated drug lists. Extensive lists of drugs and their status are found at the web sites www.porphyrifoundation.com (in the United States) and www.porphyrria-europe.com (in European Union countries, South Africa, and Canada), and a guide for drug prescription at www.drugs-porphyrria.org. For anesthesia purposes, an adequate number of agents that are considered safe have been evaluated.⁴⁰⁶ Patients should be warned that fasting may induce attacks; they should regularly take in sufficient calories to maintain a normal body weight and promptly consult a physician whenever adequate oral intake is interrupted by intercurrent illness. Two nutritional hepatic markers, insulinlike growth factor 1 and transthyretin, have been found useful for assessment of disease morbidity and severity in the clinical follow-up of AIP patients.⁴⁰⁷ Rarely prevention of frequent recurrent attacks may require weekly or biweekly infusions of hemin.³⁷⁶ Treatment with recombinant erythropoietin reduced PBG excretion, increased well-being, and decreased severity of attacks in anemic patients in one study.⁴⁰⁸

P.698

TABLE 26.4 SOME MAJOR DRUGS CONSIDERED UNSAFE OR SAFE IN THE ACUTE PORPHYRIAS

Unsafe

Alcohol	Fentanyl	Novobiocin
Barbiturates ^a	Glutethimide	Phenylbutazone
Carbamazepine	Griseofulvin ^a	Primidone
Carisoprodol	Ketoconazole	Progesterone, synthetic progestins
Clonazepam (high doses)	Lamotrigine	Pyrazinamide
Danazol	Mephénytoin ^a	Pyrazolones (aminopyrine, antipyrine)
Diclofenac, other NSAIDs	Meprobamate ^a	Rifampin
Diphenylhydantoin ^a	Mebutamate	Succinimides
Enalapril	Tybutamate	Sulfonamide antibiotics ^a
Ergot preparations	Methyprylon	Tramadol
Estrogens	Metoclopramide	Trimethadione
Ethchlorvynol	Nifedipine	Valproic acid

Safe

Acetaminophen	Digoxin	Penicillin and derivatives
Aspirin	Erythropoietin	Propranolol
Atropine	Estrogens (natural/endogenous)	Phenothiazines
Chloral hydrate	Gabapentin	Ranitidine
Cimetidine	Gentamycin	Streptomycin
Colchicine	Glucocorticoids	Tetracyclines
Coumarins	Insulin	Thiouracil
Cytarabine	Levetiracetam	Thyroxine
Daunorubicin	Narcotic analgesics	Vigabatrin

Note: Statements about drugs in acute porphyria are based on experience with patients, on tests in animals with experimental porphyria, and on studies in cell cultures; a system for prediction of drug porphyrogenicity from structural and functional information is proposed.⁴⁰⁵ As most drugs have not been tested, the extensive list of unsafe and safe drugs at www.drugs-porphyria.com should be consulted.

^a Drugs that have most often been cited as agents precipitating acute attacks. Adapted from References 20 and 376.

In women whose attacks are related to the menstrual cycle, prevention may be achieved by suppression of ovulation with oral contraceptives.^{20, 321} Paradoxically, oral contraceptive steroids can also worsen symptoms in some women.^{20, 376} Long-acting LHRH agonists that permit suppression of ovulation without the administration of exogenous steroids can be highly effective in women who have frequent cyclical attacks.^{342, 376, 409} Pregnancy is generally uncomplicated,⁴¹⁰ although one study reported an excess risk of perinatal death.⁴¹¹ Meticulous prenatal and perinatal care can ensure a good outcome.^{344, 412} Hemin can be administered safely during pregnancy.⁴¹³ Low-dose estrogen replacement is probably safe in women with an acute porphyria who are naturally menopausal.⁴¹⁴

Liver transplantation has become established as a treatment option for severe refractory AIP in carefully selected patients as it leads to phenotypic cure.^{329, 330, 331} Recently an increased incidence of hepatic artery thrombosis associated with the procedure was reported, with the recommendation to use antiplatelet therapy after transplantation.⁴¹⁵ Domino liver transplantation has also been performed, from donors with AIP.⁴¹⁶ As expected, recipients developed AIP, confirming that the liver is the source of the neurotoxin in the disorder.

Administration of recombinant human PBGD was found to be safe and effective in removing PBG from plasma and urine in asymptomatic AIP carriers.⁴¹⁷ It has not been investigated for efficacy in patients during overt disease. Studies toward gene therapy with nonviral gene delivery in human and murine PBGD-deficient fibroblasts have demonstrated restoration of PBGD activity.⁴¹⁸

Acute Intermittent Porphyria in Animals

Several lines of cats with naturally occurring porphyria clinically resemble CEP, but the biochemical and molecular findings were found to be typical of AIP.⁴¹⁹ Both autosomal dominant and recessive inheritance is associated with distinct mutations in the PBGD gene.

The neurologic syndrome of AIP related to the PBGD defect was verified in transgenic mouse experiments.⁴²⁰ The PBGD-deficient mice exhibit the typical biochemical characteristics as well as the neuropathologic features of the human disease when treated with phenobarbital.⁴²¹ The data suggested that heme deficiency and consequent dysfunction of heme proteins can cause porphyric neuropathy. Moreover, the limited heme synthesis in the PBGD-deficient mice impairs activation of cytochrome P450 genes by phenobarbital,⁴²² whereas zinc mesoporphyrin represses the induced hepatic ALA synthase and reduces heme oxygenase activity,⁴²³ making this compound a potential candidate for treatment of acute porphyrias. Administration of recombinant PBGD enzyme can reduce PBG excretion by 75%,⁴²⁴ and adenoviral-mediated expression of PBGD in liver restores enzyme activity and protects against the phenobarbital-induced neuropathy in this

animal model.^{425, 426, 427} These results suggest that gene therapy for AIP targeting only the liver could be sufficient to control the human disease.

5-Aminolevulinic Acid Dehydratase Deficiency Porphyrria

ALA dehydratase deficiency porphyria (ADP; plumboporphyria) is the least common porphyria and has been described in seven unrelated cases. It is inherited as an autosomal recessive trait, and mutations in both ALAD alleles result in the disorder. The clinical phenotype is strikingly similar to that of AIP.

Molecular Basis and Pathogenesis

ALAD (PBG synthase) is the second enzyme in the heme biosynthetic pathway (Fig. 26.1) and is encoded by a single gene, located on chromosome 9 (9q34).⁴²⁸ The ALAD gene contains two promoter regions that generate housekeeping (ubiquitous) and erythroid-specific transcripts by alternative splicing of a separate exon 1 in each case to exon 2, and both transcripts encode identical ALAD polypeptides.⁴²⁹ In eight reported patients (including two siblings), the erythrocyte enzyme activity was <10% of normal, and, in the asymptomatic parents and relatives carrying the trait, it was approximately 50%,^{430, 431, 432, 433, 434, 435, 436} in keeping with an earlier study of a family with heterozygous ALAD deficiency and absence of clinical manifestations.⁴³⁷ Immunologic studies demonstrated considerably more enzyme protein (20% to 33%) than catalytic activity, implying that a structural defect affects the active site of the enzyme.^{436, 438, 439, 440} In five of the cases, mutations have been identified in both alleles of the ALAD gene,^{10, 435, 436, 441, 442, 443} and they were compound heterozygotes. The mutations often occurred near the catalytic site of the enzyme and were thought likely to affect binding of the structural zincs of the enzyme. However, subsequent research indicated that all the mutations so far associated with the porphyria favor a variable shift of the wild-type octameric structure of the enzyme to a much less active hexamer as the mechanism for the impaired enzyme activities, representing the first example of a conformational disease.⁴⁴⁴

P.699

In an asymptomatic child heterozygous for a novel ALAD mutation, enzyme activity was only 12%, whereas it was 30% in family members carrying the mutation.⁴⁴⁵ In the case with late onset,⁴³³ likewise, only a single mutation was identified, ALAD activity was 1% of normal, and the late clinical expression of the disease was considered to be related to the patient's coincidental acquisition of the clonal disorder polycythemia vera.⁴⁴⁶

Heterogeneity of the genetic defects probably accounts for the phenotypic variation among the patients. The mechanism for the dominating neurologic features present in all the cases appears to be similar to those discussed for AIP, and the large accumulation of ALA caused by the biosynthetic block supports its implicated importance as a neurotoxin in the pathogenesis. The neuropathies of hereditary tyrosinemia³²⁸ and lead intoxication are likewise associated with ALA accumulation, and ALAD is the enzyme in the heme synthetic pathway that is most susceptible to lead. The role of the two common alleles of human ALAD (ALAD1 and ALAD2), resulting in three polymorphic isozyme phenotypes^{447, 448} in these conditions, is not defined.

Clinical Description

The clinical findings have differed among the small number of cases with ADP. Two unrelated male patients who were reported as the first described cases of the disease had onset of major symptoms of abdominal pain and motor neuropathies, with some respiratory muscle involvement, in adolescence;⁴³⁰ they were reported as surviving more than 20 years later.⁴⁴⁹ Four other young males also manifested acute episodes of symptoms and courses resembling the variable neural manifestations of acute porphyrias.^{434, 435, 436} In contrast, a child was afflicted with recurrent severe neurovisceral manifestations as well as severe respiratory muscle compromise since birth.⁴³¹ Motor neuropathy but no abdominal symptoms first developed in a man at age 63, persisted, and progressed in association with development of a clonal hematopoietic disorder.^{433, 446} Heterozygotes for ALAD deficiency are asymptomatic.

Laboratory Findings

The distinguishing laboratory finding in ADP is a markedly increased urinary excretion of ALA that has ranged from 8 to 80 times the normal value and correlates with clinical severity; the PBG values are slightly increased, up to six times normal.^{430, 431, 434, 435, 436, 443} Plasma ALA concentration is increased approximately 10-fold.⁴³³ Urinary coproporphyrin (isomer III) is also typically raised 10- to 70-fold but remains unexplained. Fecal porphyrins are normal in most cases. The erythrocyte zinc protoporphyrin is increased, from 3 to 30 times normal.

This spectrum of biochemical abnormalities closely resembles those found in lead poisoning, although in the latter the abnormal values are usually considerably lower; blood lead determinations would exclude this diagnosis. Despite the defects in both alleles, erythropoiesis does not appear to be compromised but hemoglobin values were often not reported. Heterozygotes for an ALAD defect have no biochemical abnormalities except for the reduced levels of ALAD activity.⁴³⁷

Treatment

Supportive measures as outlined for AIP are generally helpful for acute episodes of ADP as well. Heme infusions have been of benefit in alleviating the neuropathic symptoms.^{432, 435, 436} In the small child, the disease was reported to impair nutrition and normal development markedly. At age 6, liver transplantation was performed to attempt to reduce the metabolic abnormalities.⁴⁵⁰ The high basal urinary excretion of ALA and porphyrin was not influenced by this procedure, indicating that these products originated mainly in extrahepatic tissues. However, clinical challenges with drugs and intercurrent illnesses no longer increased the urinary ALA and PBG, so heme synthesis does not appear to be induced in nonhepatic tissues.⁴⁵⁰ It was hypothesized that a bone marrow transplant might more effectively remove the major source of the abnormal metabolites.

ACUTE OR INDUCIBLE PORPHYRIAS WITH BOTH NEUROLOGIC AND CUTANEOUS MANIFESTATIONS

Variegate Porphyria

Variegate porphyria (VP; South African porphyria) is inherited as an autosomal dominant trait with low penetrance and is caused by mutations in the gene encoding PPOX, the enzyme that catalyzes the penultimate step of heme biosynthesis (Fig. 26.1). Consequent proximal backup in porphyrins leads to skin fragility and photosensitivity. Because the production of heme also becomes reduced and ALA synthesis is induced, acute neurovisceral attacks occur that closely mimic the picture of AIP. The disorder is called variegate because it can present with neurologic attacks, photocutaneous lesions, or both.

Although Gunther⁴ and Waldenström⁵⁷ recognized cases of porphyria in which neurologic and cutaneous manifestations occurred together, the extensive investigations of Dean and Barnes in South Africa first provided the most complete information about this disease and clearly distinguished it from AIP. They identified 300 patients whose lineage was traced to a single couple having migrated from Holland in 1688.¹⁰⁹ This common ancestor of almost all South African patients explained the prevalence of the disease of approximately 3 per 1,000 among the white (Afrikaner) population;⁴⁵¹ the sobriquet South African porphyria stems from this prevalence. VP is less common outside South Africa, but hundreds of cases have been reported from other countries.⁴⁵² The prevalence of VP in Finland has been estimated at 1.3 per 100,000.⁴⁵³ In the United States and Europe, it has probably been underestimated or overlooked^{454, 455} because the cutaneous manifestations tend to be more mild in temperate and cold latitudes than in South Africa. Indirect evidence suggested that George III of England and other members of the royal houses of Stuart, Hanover, and Prussia suffered from this form of porphyria (often called the royal malady).⁴⁵⁶ Attempts at retrospective diagnosis with DNA material from deceased relatives of George III were undertaken but have not proved conclusively that he had VP.⁴⁵⁷ An analysis of hair from the king had revealed high concentrations of arsenic, and its source was considered consistent with the king's medications as was its likely contribution to his illness by interfering with heme metabolism.⁴⁵⁸ Measured against the nature of VP as currently understood, the case for porphyria in George III is now largely discredited.⁴⁵⁹

Molecular Basis and Pathogenesis

PPOX activity is half-normal in cultured skin fibroblasts⁴⁶⁰ and blood lymphocytes⁴⁶¹ and accounts for the observed pattern of porphyrin excretion (Table 26.2). The gene for the enzyme was the last of the heme synthesis enzymes cloned and characterized,^{462, 463, 464, 465} and it has been mapped to chromosome 1 (1q22).^{462, 464} To date, 179 distinct mutations in the PPOX gene have been identified in patients with VP throughout the world^{10, 452} and include missense and nonsense mutations, insertions, deletions, and splice site mutations. Most of the mutations occur in single pedigrees, and only approximately 8% occur in four or more families. One mutation (C452T) in exon 3 of the gene, causing replacement of arginine by tryptophan in codon 59 (Arg59Trp), is found in 95% of VP patients in South Africa.⁴⁶⁶ It is also found in Holland, and extended haplotype studies in South African and Dutch VP families carrying the mutation

P.700

have confirmed their common ancestry.⁴⁶⁷ When expressed in *Escherichia coli*, the mutant protein had an almost undetectable catalytic activity, presumably related to its location in the binding motif of flavin adenine dinucleotide, an essential co-factor for the enzyme.⁴⁶⁸ On average, mutations in heterozygotes are associated with a PPOX activity of 50%,

with loss of all enzyme activity from the mutant allele, and thus are referred to as severe mutations. In double heterozygotes and homozygotes, enzyme activities are <20% of normal, which would be contributed by residual activity of the mutant protein encoded by at least one of the alleles in heteroallelic cases or by residual activity from both alleles in homoallelic cases. Such mutations are referred to as mild. The functional consequences of many of the mutations have been predicted on the structure of the crystallized protein.^{469, 470}

The photosensitivity symptoms result from the accumulating porphyrins, which are released into plasma and exert the photochemical reactions in the skin.²³ Protoporphyrinogen is a competitive inhibitor of CPOX⁴⁷¹ and, as such, is believed to account also for the accumulation and increased excretion of coproporphyrin.

The neurovisceral symptoms in VP are attributed to an associated relative deficiency of hepatic PBGD.⁴⁷² This enzyme is inhibited by coproporphyrinogen and protoporphyrinogen in an allosteric manner, and their accumulation can account for the relative PBGD deficiency.⁴⁷³ The inhibition is insufficient to produce biochemical changes of increased ALA and PBG excretion during quiescent periods. Together with increased demands for heme and induction of ALA synthase by endogenous or exogenous porphyrinogenic agents, the PBGD step is considered to become rate limiting so that the porphyrin precursors accumulate, accounting for the neurovisceral manifestations as in AIP. That the liver is the principal site for the accumulation of heme synthesis intermediates appeared to be confirmed in a patient with VP who was considered recovered from the porphyria following liver transplantation for alcohol-associated cirrhosis.⁴⁷⁴

Clinical Description

VP is rarely expressed before puberty, and it is not uncommon for the disease to remain clinically and biochemically latent throughout life.⁴⁵² Previously, in South Africa, 90% of patients were symptomatic, and cutaneous involvement was the initial feature in one half of patients.⁴⁵¹ More recent experience reflects a changing pattern with <10% of VP patients experiencing a neurovisceral attack,^{475, 476} and, with the advent of genetic testing, up to 60% are asymptomatic.⁴⁵² The changes are attributed to more sensitive diagnostic testing, physician and patient education, and less use of drugs that precipitate symptoms. In the United States and Europe, skin manifestations are uncommon and, when present, tend to be mild and rarely are the initial manifestation of the disease.^{452, 453}

The characteristic cutaneous feature is severe mechanical fragility of the skin that is limited to sun-exposed areas, especially the face and hands (Fig. 26.7), and is often indistinguishable from PCT. Trivial mechanical trauma to these areas results in detachment of the epidermis from the dermis, with formations of bullae or erosions. The light microscopic and ultrastructural changes in the skin of patients with VP are also similar to those found in PCT. Vascular walls are particularly affected, and the pathologic changes are observed in asymptomatic patients with increased porphyrin excretion.⁴⁷⁷ In addition, facial hypertrichosis and hyperpigmentation are common.

The neurovisceral attacks of VP do not differ in any important respect from those of AIP, although hyponatremia was quite common;⁴⁵¹ psychiatric features are uncommon.⁴⁵² Acute attacks are less common in VP than in AIP and usually occurred after exposure to a porphyrinogenic drug (Table 26.4).^{358, 451, 478} In early studies, the mortality rate during an acute attack approached 25% but was subsequently reduced dramatically.^{358, 479}



A



B

FIGURE 26.7. Cutaneous manifestations of variegate porphyria. A: Bulla on index finger, pigmented scars, and collapsed blisters at fingertips of a 27-year-old woman. B: Hands of a 36-year-old man. Note erosions on back of hands, depigmented scars of past lesions, and subungual involvement. (Courtesy of Dr. Lennox Eales, University of Cape Town, South Africa.)

Hepatocellular carcinoma developed in six reported cases;⁴⁸⁰ four of them were elderly individuals (age ≥ 70). Because VP presenting in old age is uncommon, it is possible that the porphyria manifested a paraneoplastic feature in some of them, as observed in PCT. Regular screening for the tumor in patients with VP is suggested.⁴⁸⁰

To date, 13 unrelated compound heterozygotes and two homozygotes for PPOX defects have been encountered.^{10, 452} The major clinical features are severe photosensitivity and, commonly, mental retardation, seizures, sensory neuropathy, retarded growth, and skeletal abnormalities. With onset in adolescence, the permanent neurologic features are absent, but neurovisceral attacks may occur.

Laboratory Findings

Patients with symptomatic VP with skin disease or with neurovisceral features uniformly have abnormal biochemical findings. The most characteristic laboratory abnormality is the excretion of large amounts of protoporphyrin and coproporphyrin in the feces.^{20, 451, 479} In South African patients, fecal protoporphyrin excretion reached 1,500 $\mu\text{g/g}$ dry weight, and fecal coproporphyrin excretion reached 1,300 $\mu\text{g/g}$ dry weight (normal total fecal porphyrin excretion is <200 $\mu\text{g/g}$).⁴⁵¹ A significant feature is the presence of 5-COOH porphyrins.⁴⁸¹ The diagnosis of VP can be established by fecal analysis during an acute attack, during periods when only cutaneous manifestations are present, or during a

P.701

clinically latent stage of the disease with high-performance liquid chromatography techniques. However, up to 30% of asymptomatic patients have normal fecal porphyrin profiles.⁴⁵² Measurement of porphyrins in bile sampled by duodenal aspiration was shown in a series of patients to provide a clearer differentiation between patients or carriers and normal subjects, particularly in people in whom fecal porphyrin values are indeterminate.⁴⁸² The mean biliary porphyrin value in patients with VP was 68.0 $\mu\text{mol/l}$, as compared with 0.7 $\mu\text{mol/l}$ in normal controls, and the lowest patient value was more than nine times the highest control value.

Because the plasma porphyrins are commonly increased in VP, examination of plasma for the characteristic fluorescence emission spectrum (emission maximum, 626 nm, at neutral pH)²⁰ is probably the fastest way to establish the diagnosis in symptomatic patients. For the detection of asymptomatic carriers, this method was found to be 100% specific and 86% sensitive in one study.⁴⁸³ It was not considered sufficiently sensitive in another study⁴⁸⁴ or when it was compared to DNA analysis.⁴⁸⁵

During acute attacks, ALA and PBG are excreted in large amounts in the urine, as in AIP. However, the demonstration of excessive urinary ALA or PBG justifies only the diagnosis of acute porphyric attack, and a more specific diagnosis is not possible without analysis of the feces or plasma. In contrast to AIP, urinary excretion of ALA and PBG generally returns to normal after an acute attack^{20, 451, 452} and usually is normal or only slightly increased in patients in whom the only clinical manifestations are cutaneous. During latent periods, urinary porphyrin excretion is usually normal; during acute attacks, or in the presence of superimposed liver dysfunction, it may be greatly increased.^{20, 451, 479} When cutaneous symptoms alone are present, coproporphyrin is the major urinary porphyrin, but uroporphyrin excretion may also be increased.⁴⁵¹ During acute attacks, nonenzymatic conversion of PBG to uroporphyrin may occur, giving rise to an artifactually dramatic elevation of urinary uroporphyrin excretion.⁴⁵¹

Measurement of PPOX activity can establish the diagnosis. Because it is a mitochondrial enzyme, the assay requires nucleated cells, such as Epstein-Barr-transformed lymphocytes.^{472, 473} Time and costs involved make it impractical as a routine diagnostic test. The erythrocyte protoporphyrin is somewhat increased in heterozygotes. In homozygotes or double heterozygotes, it ranges from five to ten times above normal; anemia is usually absent.

Treatment

Acute attacks should be prevented and treated as outlined for AIP. Hemin or heme arginate is used for severe attacks and is most effective if administered early in the course of the attack.³⁹² Glucose may be of benefit.⁴⁵¹ Protection against sun exposure is the only practical way to deal with the photosensitivity.

Identifying abnormal gene carriers in families is important because, as in AIP, most acute attacks can be prevented by avoiding precipitating drugs or other factors. Because biochemical studies apart from assay of the PPOX enzyme are often inconclusive in asymptomatic individuals, mutational analysis is the definitive approach for detection of carriers.

Animal Models of Variegate Porphyria

A mouse model for South African VP with the Arg59Trp mutation has been established by targeted gene replacement.⁴⁸⁶ The biochemical features closely resemble the human disease.

A zebrafish mutant (montalcino) with a defect in the *ppox* gene has been isolated and displays a recessive inheritance pattern.⁴⁸⁷ The mutant also has hypochromic anemia, which could be partially rescued by the human gene.

Hereditary Coproporphyrin

Hereditary coproporphyrin (HCP) is transmitted as an autosomal dominant trait with a low penetrance. Mutations in the gene encoding CPOX (Fig. 26.1) result in impaired activity of the enzyme and lead to accumulation and excessive excretion of coproporphyrin. Analogous to VP, the porphyrin produces photosensitivity, and neurovisceral attacks occur with induction of heme biosynthesis.

Excessive fecal excretion of coproporphyrin by a patient with porphyria was first noted in 1936,⁴⁸⁸ clinical features were recorded in 1949,⁴⁸⁹ and the first comprehensive description of the disorder was that of Berger and Goldberg.⁴⁹⁰ A review describing clinical and laboratory findings in 111 patients with HCP appeared in 1977.⁴⁹¹ The disorder is less common than AIP and VP.

Molecular Basis and Pathogenesis

CPOX activity is reduced to half-normal in all tissues examined, including cultured skin fibroblasts,⁴⁹² mixed leukocytes,⁴⁹¹ lymphocytes,⁴⁹³ liver,^{494, 495} and kidney.⁴⁹⁵ In homozygotes, enzyme activity was 10% of normal.^{496, 497} The cloning and characterization of the CPOX gene,^{498, 499, 500} which is located on chromosome 3 (3q12),⁵⁰¹ led to the identification of numerous mutations in the gene. To date, 64 different mutations have been reported, and almost all have been restricted to single families.^{10, 502} The mutations are predominantly missense mutations affecting enzyme function or stability or leading to production of incomplete proteins. Despite the marked allelic heterogeneity at the molecular level and a wide range of residual enzyme activities of mutant proteins, clinical features are similar.

The pathogenesis of the clinical features can be viewed as the same as in VP, with induction of ALA synthase during attacks.⁵⁰³ The photosensitivity occurs mainly during periods of a neurovisceral attack, probably because plasma levels of the photosensitizing coproporphyrin become sufficiently elevated. Coproporphyrin is transported efficiently from the hepatocyte into bile or plasma and does not accumulate in the liver.⁵⁰⁴

Clinical Description

The disease is generally latent before puberty, and two thirds of patients have no symptoms.^{491, 505} In one patient, the first attack occurred at age 84.⁵⁰⁵ Acute attacks are usually precipitated by drugs,⁵⁰⁶ and acute peripheral neuropathy may be the only manifestation.^{507, 508} The neuropathic findings are similar to those of AIP^{509, 510} but are generally less severe; occasionally, only psychiatric features are evident.⁵⁰⁶ Photosensitivity is less common than in VP, and unlike in the latter, it tends to occur mainly in the presence of neurovisceral episodes. Rarely, intermittent episodes of cutaneous symptoms may be the only clinical manifestation of the disease.⁴⁹¹ They are similar to those of VP and PCT. The few homozygotes reported had early manifestations.^{490, 496, 497}

One case of hepatocellular carcinoma associated with HCP has been reported.⁵¹¹ After surgical resection, no recurrence was observed at 5 years of follow-up.

Laboratory Findings

The fecal coproporphyrin level is usually increased after puberty and may approach or exceed 10,000 µg/g dry weight during an attack. An increase in the fecal coproporphyrin isomer III-to-isomer I ratio is uniformly a distinguishing feature, including latent cases in whom fecal coproporphyrin may be normal.^{502, 512} During acute attacks, urinary coproporphyrin excretion may be profoundly increased but usually is normal during remissions. As in VP, urinary ALA and PBG are typically increased only during attacks.

Treatment

HCP should be managed as described under AIP and VP. Heme arginate is effective for acute attacks^{513, 514} as well as for needed

P.702

maintenance therapy with regular infusions.⁵¹⁵ Detection of affected relatives of patients is important because avoiding specific drugs will probably prevent overt symptoms. CPOX assay is not available as a clinical test, leaving stool porphyrin determinations as the only practical method for screening carriers short of molecular analysis when the mutation in the family can be identified.

Erythropoietic Harderoporphyria

In this clinically distinct variant of HCP, unique kinetic characteristics of the CPOX enzyme are associated with accumulation of a tricarboxylic coproporphyrin, harderoporphyrin.^{516, 517} In five affected patients the enzyme activity ranged from 18% to 24%.⁵¹⁷ The two missense mutations reported, predicting the codon changes Lys404Glu and His327Arg, affect the second decarboxylation of coproporphyrinogen III to protoporphyrinogen IX with the inappropriate release of harderoporphyrin, the intermediate substrate of the reaction, from the enzyme.^{517, 518, 519}

Homozygotes for the Lys404Glu mutation, or double heterozygotes paired with a CPOX null allele, had transient neonatal hemolytic anemia and mild microcytic anemia with variable photosensitivity in adulthood; neurologic symptoms were absent. Associated iron overload is attributed to presumed ineffective dyserythropoiesis.⁵¹⁷ Erythrocyte porphyrins are increased two-to threefold. Urine coproporphyrin plus harderoporphyrin is increased about twentyfold. Fecal porphyrins are increased severalfold and the predominant porphyrin is harderoporphyrin. The infant homoallelic for the His327Arg mutation with a harderoporphyrin phenotype and massively increased urine porphyrins succumbed early to an apparent acute porphyric attack.⁵¹⁹ Heterozygotes have a normal phenotype.

DUAL PORPHYRIA

During the last three decades, a number of families were discovered to have defects of two distinct porphyrias. In two families, individuals had one or the other trait. Two cases of PCT were described in a family in which five other members had VP.⁵²⁰ In a second instance, the father had PCT and the daughter had typical EPP.⁵²¹

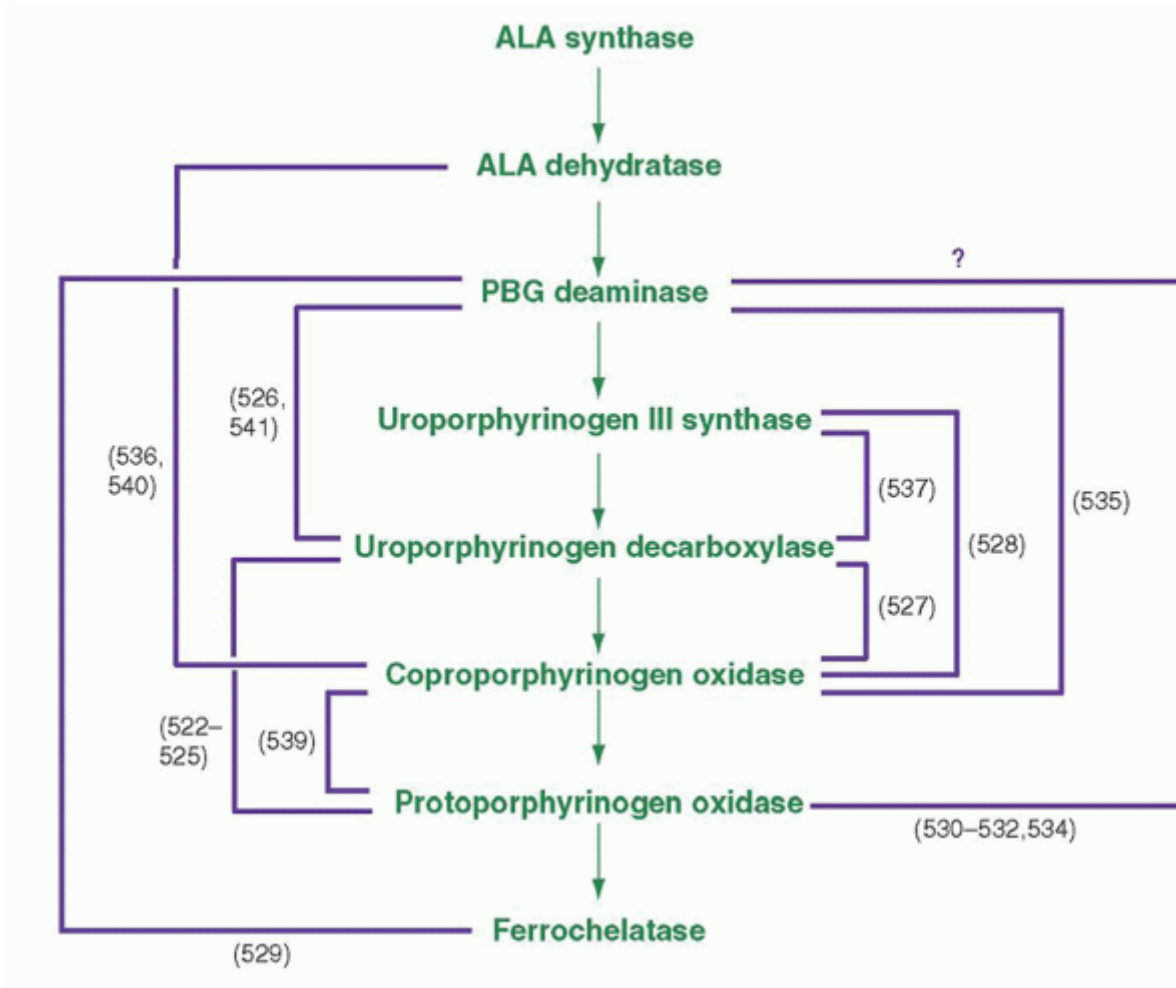

FIGURE 26.8. Enzyme defects in dual porphyrias. Pairs of the respective enzymes involved in the 10 reported forms of dual porphyria are joined by brackets. ALA, 5-aminolevulinic acid; PBG, porphobilinogen. (Reference numbers in parentheses.)

Based on clinical and biochemical studies and a few mutational analyses, 10 different combinations have been described in which patients possessed two porphyria defects (Fig. 26.8). The first such type reported involved the occurrence of VP and PCT.⁵²² In South Africa, 25 of 106 patients with VP excreted porphyrins typical of PCT as well. The clinical features and subsequent enzyme assays⁵²³ were consistent with those of both porphyrias. Biochemical data in further cases were also

consistent with concomitant defects of VP and PCT, but family studies were not reported.^{524, 525} Additional dual porphyrias consisting of an acute form plus a cutaneous form that have been encountered include AIP with PCT, with clinical manifestations of both defects;⁵²⁶ HCP with PCT;⁵²⁷ HCP with CEP in a child manifesting hepatosplenomegaly, hemolytic anemia, severe photodermatitis, and impaired growth and mental development;⁵²⁸ and AIP with possible EPP and severe neurovisceral manifestations that were fatal.⁵²⁹ In the latter case, biochemical studies reflected a PBGD defect as well as FECH deficiency. Analysis of the sciatic nerve revealed reduced PBGD activity coupled with increased activity of ALA synthase, representing the first such data in human neural tissue.

In 1985, a large kindred of 200 descendants stemming from a marriage in 1886 was encountered in Chester, Scotland, in which clinical presentations had been typical of AIP and, in some cases, were severe and fatal.^{530, 531, 532} Biochemical studies reflected values ranging from those observed in AIP to those found in VP. Clinically affected patients had both deficient PBGD and PPOX activities in peripheral blood leukocytes, although there appeared to be some overlap with control values in some cases.⁵³⁰ A linkage analysis with polymorphic markers suggested that the locus for the disease is on chromosome 11 and separate from the PBGD gene.⁵³³ Later DNA analyses of this family revealed a nonsense mutation in the PBGD gene but a defect was not detected in the PPOX gene.⁵³⁴ A second form of two co-existing acute porphyria defects involved PBGD and CPOX.⁵³⁵ Among 17 family members examined, the dual enzyme deficiency was found in five, PBGD deficiency alone in four, and CPOX deficiency alone in two.⁵³⁵ Only the proband with both defects suffered mild acute attacks of porphyria and had the most marked changes in porphyrin and porphyrin precursor

P.703

excretions, probably involving a precipitating factor. In a third example, HCP with partial ALAD deficiency was characterized by a severe neurologic attack.⁵³⁶ A boy had a deficiency of enzymes representing two nonacute porphyrias, UROS and UROD, which caused severe photosensitivity and hemolytic anemia,⁵³⁷ with subsequent development of severe osteoporosis, renal and liver siderosis, and nephrotic syndrome.⁵³⁸ A last reported family with digenic inheritance of HCP and VP was confirmed at the molecular genetic level.⁵³⁹ Identification of specific molecular defects had substantiated two other forms of dual porphyria mentioned above.^{540, 541}

The occurrence of these combinations of porphyrias, for the most part, probably represents coincidental inheritance of two defects. In some instances, consanguinity of parents was noted. Atypical findings of porphyrins and their precursors encountered in the diagnostic evaluation may indicate the presence of a complex porphyric state.

KEY CLINICAL SUMMARY POINTS

Broad Definitions of the Eight Porphyrias

The porphyrias comprise a group of distinct genetic disorders, each resulting from the partial deficiency (with one exception) of a specific enzyme in the eight-step heme biosynthetic pathway (Fig. 26.1) with its root cause known at the molecular level. The pathophysiology of clinical manifestations rests on the toxicity profile of the accumulated pathway intermediate(s) (Table 26.2) caused by the enzyme deficiency, much like roadwork causing a traffic jam in front of the roadwork. Additionally, although heme synthesis is essential in all cells, the metabolic block of a defective enzyme in porphyrias is expressed either in the liver or in the erythroid tissue, the principal sites of body heme production. Thus,

Acute hepatic porphyrias (AIP, VP, HCP, ADP) are clinically expressed when the impaired heme pathway in the liver is taxed further through its marked induction by factors such as drugs (P450 inducers), progesterone, and dietary restrictions so that PBG and neurotoxic ALA accumulate, leading exclusively to neurovisceral manifestations. The sites of the primary biosynthetic block in VP and HCP account for porphyrin accumulations also causing cutaneous photosensitivity.

Porphyria cutanea tarda (PCT), or chronic hepatic porphyria, is expressed in the liver and is linked to deficient UROD in combination with various hepatotoxins (iron, alcohol, viral hepatitis, estrogen), causing insidious, protracted skin fragility and a bullous photodermatitis due to uroporphyrin accumulation. Although familial PCT (Type II), associated with inherited UROD deficiency, is less common than the sporadic (Type I) form, a genetic basis for the latter has not been identified.

Erythropoietic protoporphyria (EPP) is expressed in erythroid cells where the deficient FECH enzyme becomes rate limiting for heme synthesis. The nature of the accumulated protoporphyrin uniquely elicits acute cutaneous photosensitivity without blistering or skin fragility. Fulminant protoporphyric liver disease occurs unpredictably in $\leq 5\%$ of patients.

X-linked protoporphyria (XLPP), as EPP, is expressed in erythroid tissue but is much less common. It is unique among the porphyrias in that it is caused by genetic gain-of-function defects in the erythroid ALAS (ALAS2) enzyme. The overactive, rate controlling enzyme of the erythroid heme pathway drives the pathway excessively so that FECH and iron become rate

limiting. Both free and zinc protoporphyrin accumulate in greater amounts and protoporphyric liver disease is more frequent than in EPP.

Congenital erythropoietic porphyria (CEP) is expressed in erythroid cells where the roadblock due to marked UROS deficiency coupled to the site of 85% of body heme production results in massive uroporphyrin and coproporphyrin accumulation, causing the most severe photodermatosis of the cutaneous porphyrias with usual onset in early life.

In the presence of clinical manifestations, accurate diagnosis of each porphyria can be established with characteristic laboratory test abnormalities.

Diagnosis and Treatment of Acute Hepatic Porphyrias (AIP, VP, HCP)

Diagnosis

Consider an acute porphyria attack in all adults with unexplained symptoms seen in acute porphyria (Table 26.3). Suggestive features are as follows: abdominal pain, muscle weakness, CNS disturbance, seizures, hyponatremia, dark or orange-red urine.

Test for increased urine PBG in single-voided sample with Rapid PBG Test Kit (Thermo Fisher Scientific Inc., Middleton, VA), which is singularly specific for diagnosis of an acute attack in AIP, VP, and HCP. Then save same urine sample to establish the porphyria type by quantitation of ALA, PBG, and porphyrin levels together with measurements of plasma porphyrin, fecal porphyrins, and erythrocyte PBGD (Table 26.2).

During remission, these quantitative tests can usually but not always establish the diagnosis. Suggestive but inconclusive results can be confirmed by mutational analysis.

Treatment

For a documented acute attack: (1) Usually hospitalize patient for control of acute symptoms: withdraw unsafe medications (Table 26.4), correct dehydration/electrolyte imbalance; provide nutritional support and narcotic analgesics for pain, phenothiazine for nausea/vomiting, β -adrenergic blockers for hypertension; consider seizure precautions. (2) Begin hemin (3 to 4 mg/kg/day for at least 4 days) as soon as possible; give intravenous glucose (10%, 300 g/day) for mild attacks or while awaiting hemin delivery. (3) Monitor patient closely for respiratory and neurologic status; serum electrolytes, magnesium, and renal function; bladder distention.

Follow-up

(1) Educate patient and family about the disease, its inheritance, precipitating factors, and important preventive measures. (2) Encourage patient to wear medical alert bracelet and to keep records of diagnostic studies and recommended therapy. (3) Treat chronic manifestations such as pain and depression, and disability. (4) Provide access to genetic testing for patient and family members. (5) Consider monitoring for hepatocellular carcinoma with hepatic imaging. (6) For severe recurrent attacks unresponsive to supportive therapy, consider curative liver transplantation as last resort.

Diagnosis and Treatment of Porphyria Cutanea Tarda (PCT)

Diagnosis

Consider in all patients with symptoms of cutaneous fragility, blister formation, poorly healing ulcerations.

Plasma porphyrin is increased. Urine uroporphyrin with 7-carboxylate porphyrin is usually $\geq 1,000 \mu\text{g}/24 \text{ hrs}$. In Type II PCT erythrocyte UROD activity is $\sim 50\%$ of normal and is normal in Type I PCT.

Assess for factors precipitating clinical disease: iron overload with serum transferrin saturation, serum ferritin, DNA analysis for genetic hemochromatosis; hepatitis C, HIV; alcohol excess; estrogen use; chronic renal disease.

P.704

Treatment

(1) Discontinue any risk agents. (2) Perform one unit (500 ml) phlebotomy every 2 weeks to serum ferritin level of ~ 20 ; if phlebotomy is contraindicated or not tolerated, use oral hydroxychloroquine (100 mg twice a week) or chloroquine (125 mg twice a week). (3) In presence of chronic renal disease, facilitate phlebotomy with erythropoietin. (4) Provide

sunscreens against the 400 to 420 nm light spectrum until primary therapy is effective. (5) Treat any concomitant hepatitis after patient is de-ironed.

Follow-up

(1) Educate patient about the disease and preventive measures. (2) Monitor plasma porphyrin yearly for potential symptom recurrence. (3) In the presence of hepatitis or cirrhosis, monitor yearly for hepatocellular carcinoma with hepatic imaging. (4) Consider mutation analysis if Type II PCT likely, then genetic testing of family members.

Diagnosis and Treatment of Erythropoietic Protoporphyrinemia and X-linked Protoporphyrinemia

Diagnosis

Consider in infants/children with cutaneous symptoms of intense burning pain often within minutes of sun/light exposure, with or without redness or swelling. Chronic changes of sun-exposed skin include shallow facial scars and/or leathery skin over dorsal hands. Very rarely advanced liver disease may be the predominant presenting feature. In adults the clinical phenotype suggests late onset disease associated with a clonal hematopoietic disorder.

In EPP, free erythrocyte protoporphyrin is ≥ 600 $\mu\text{g}/\text{dl}$; plasma porphyrin is usually increased. In XLPP, erythrocyte protoporphyrin is $\geq 1,000$ $\mu\text{g}/\text{dl}$, $\sim 60\%$ as free and $\sim 40\%$ as zinc-protoporphyrin. Fecal porphyrins may be increased or normal.

Assess hepatic function.

Treatment

(1) Avoid sunlight (including long-wave UV light that passes through windows) with protective clothing. (2) Suggest a tanning product that increases pigmentation. (3) Advise a trial of synthetic β -carotene (Lumitine™, Tishcon Corp., Westbury, NY) to improve sunlight tolerance. (4) Prescribe the α -melanocyte-stimulating hormone analog afamelanotide (Scenesse™, Clinuvel, Melbourne, Australia) upon its approval; it is available in Europe and in clinical trial in the United States. (5) Prevent vitamin D insufficiency with supplementation if blood levels are low. (6) Avoid cholestatic agents (e.g., estrogens) if hepatic dysfunction present.

For severe liver disease: cholestyramine and other porphyrin absorbents, plasmapheresis and intravenous hemin may be helpful; liver transplantation and/or HSCT may be required.

Follow-up

(1) Educate patient and family about the disease. (2) Provide patient and family members access to genetic testing. (3) Monitor erythrocyte protoporphyrin(s) and hepatic function yearly; if cholelithiasis is suspected, monitor with imaging.

Diagnosis and Treatment of Congenital Erythropoietic Porphyria

Diagnosis

Consider in infants/children with symptoms of marked skin fragility, bullous photodermatosis prone to infection, disfigurement of face and hands in time; red, fluorescent diaper discoloration may be an initial clue for the disorder. Beginning in adults, the cutaneous symptoms most likely reflect late onset disease associated with a clonal hematopoietic disorder.

Measurement of erythrocyte, plasma, urine, and fecal porphyrins reveals massively increased levels of uroporphyrin I and coproporphyrin I.

Evaluate for hemolytic anemia and test for dental fluorescence.

Treatment

(1) Rigorously protect from sunlight and treat infected skin lesions. (2) Give red cell transfusions for symptomatic anemia; splenectomy may be necessary for marked hypersplenism. (3) Erythrocyte hypertransfusion reduces porphyrin accumulation and requires management of attendant iron overload. (4) Porphyrin binders (e.g., oral charcoal) may decrease the porphyrin burden. (5) Consider HSCT for severe progressive disease; it has been successful and curative in 17 of 21 patients so treated.

Follow-up

See Reference 39.

Mutation Analysis

After biochemical studies have defined the type of porphyria, DNA analysis to identify the disease causing mutation(s) is recommended, permitting rapid and accurate detection of asymptomatic at-risk family members. Mutation analysis is available for each porphyria at The Mount Sinai Porphyria Diagnostic Laboratory, toll-free at 866-322-7963.

WEBSITE RESOURCES

<http://rarediseasesnetwork.epi.usf.edu/porphyrias/index.htm>

www.UpToDate.com

www.porphyrifoundation.com

www.porphyrina-europe.org

www.aiporphyria.com

www.drugs-porphyrina.com

REFERENCES

1. May BK, Dogra SC, Sadlon TJ, et al. Molecular regulation of heme biosynthesis in higher vertebrates. *Prog Nucleic Acid Res Mol Biol* 1995;51:1-51.
2. Schultz JH. Ein Fall von Pemphigus leprosus, kompliziert durch Lepra visceralis. Inaugural dissertation. University of Griefswald, 1874.
3. Baumstark F. Zwei Pathologische Harnfarbstoffe. *Pfluger's Arch Gesamte Physiol* 1874;9:568-584.
4. Gunther H. Die Haematoporphyria. *Dtsch Arch Klin Med* 1911;105:89-146.
5. de Verneuil H, Ged C, Moreau-Gaudry F. Congenital erythropoietic porphyria In: Kadish KM, Smith KM, Guillard R, eds. *The porphyrin handbook—medical aspects of porphyrins*. Amsterdam: Academic Press, 2003;14:43-65.
6. Kontos AP, Ozog D, Bichakjian C, et al. Congenital erythropoietic porphyria associated with myelodysplasia presenting in a 72-year-old man: report of a case and review of the literature. *Br J Haematol* 2003;148:160-164.
7. Desnick RJ, Astrin KH. Congenital erythropoietic porphyria: advances in pathogenesis and treatment. *Br J Haematol* 2002;117:779-795.
8. Romeo G, Glenn BL, Levin EY. Uroporphyrinogen III cosynthetase in asymptomatic carriers of congenital erythropoietic porphyria. *Biochem Genet* 1970;4:719-726.
9. Astrin KH, Warner CA, Yoo HW, et al. Regional assignment of the human uroporphyrinogen III synthase (URO III S) gene to chromosome 10q25.3-q26.3. *Hum Genet* 1991;87:18-22.
10. Human Gene Mutation Database—HGMD® Professional 2013.1. www.hgmd.org. Accessed July 1, 2013.
11. Berry AA, Desnick RJ, Astrin KH, et al. Two brothers with mild congenital erythropoietic porphyria due to a novel genotype. *Arch Dermatol* 2005;141: 1575-1579.
12. Ged C, Megarbane H, Chouery E, et al. Congenital erythropoietic porphyria: report of a novel mutation with absence of clinical manifestations in a homozygous mutant sibling. *J Invest Dermatol* 2004;123:589-591.
13. To-Figueras J, Badenas C, Mascaro JM, et al. Study of the genotype-phenotype relationship in four cases of congenital erythropoietic porphyria. *Blood Cells Mol Dis* 2007;38:242-246.
14. To-Figueras J, Ducamp S, Clayton J, et al. ALAS2 acts as a modifier gene in patients with congenital erythropoietic porphyria. *Blood* 2011;118:1443-1451.
15. Kushner JP, Pimstone NR, Kjeldsberg CR, et al. Congenital erythropoietic porphyria, diminished activity of uroporphyrinogen decarboxylase and dyserythropoiesis. *Blood* 1982;59:725-737.
16. Rimington C, With TK. Porphyrin studies in congenital erythropoietic porphyria. *Dan Med Bull* 1973;20:5-12.
17. Phillips JD, Steensma DP, Pulsipher MA, et al. Congenital erythropoietic porphyria due to a mutation in GATA1: the first trans-acting mutation causative for a human porphyria. *Blood* 2007;109:2618-2621.
18. Sarkany RPE, Ibboston SH, Whatley SD, et al. Erythropoietic uroporphyrina associated with myeloid malignancy is likely distinct from autosomal recessive congenital erythropoietic porphyria. *J Invest Dermatol* 2011;131:1172-1175.
19. Bottomley SS, Muller-Eberhard U. Pathophysiology of heme synthesis. *Semin Hematol* 1988;25:282-302.

20. Anderson KE, Sassa S, Bishop DF, et al. Disorders of heme biosynthesis: X-linked sideroblastic anemia and the porphyrias. In: Scriver CS, Beaudet AI, Sly WS, et al., eds. *The molecular and metabolic bases of inherited disease*, 8th ed. New York, NY: McGraw-Hill, 2001:2961-3062.
21. Bhutani LK, Sood SK, Das PK, et al. Congenital erythropoietic porphyria: an autopsy report. *Arch Dermatol* 1974;110:427-431.
22. Poh-Fitzpatrick MB. Molecular and cellular mechanisms of porphyrin photosensitization. *Photodermatology* 1986;3:148-157.
23. Lim HW. Pathophysiology of cutaneous lesions in porphyrias. *Semin Hematol* 1989;26:114-119.
24. Pollack SS, Rosenthal MS. Images in clinical medicine. Diaper diagnosis of porphyria. *N Engl J Med* 1994;330:114.
25. Fritsch C, Bolsen K, Ruzicka T, et al. Congenital erythropoietic porphyria. *J Am Acad Dermatol* 1997;36:594-610.
26. Haining RG, Cowger L, Shurtleff DB, et al. Congenital erythropoietic porphyria. I. Case report, special studies and therapy. *Am J Med* 1968;45: 624-637.
27. Merino A, To-Figueras J, Herrero C. Atypical red cell inclusions in congenital erythropoietic porphyria. *Br J Haematol* 2005;132:124.
28. Varadi S. Haematological aspects in a case of erythropoietic porphyria. *Br J Haematol* 1958;4:270-280.
29. Schmid R, Schwartz S, Watson CJ. Porphyrin content of bone marrow and liver in the various forms of porphyria. *Arch Intern Med* 1954;93:167-190.
30. Gross S, Schoenberg MD, Mumaw VR. Electron microscopy of the red cells in erythropoietic porphyria. *Blood* 1965;25:49-55.
31. London IM, West R, Shemin D, et al. Porphyrin formation and hemoglobin metabolism in congenital porphyria. *J Biol Chem* 1950;184:365-378.
32. Kaufman BM, Vickers HR, Rayne J, et al. Congenital erythropoietic porphyria: report of a case. *Br J Dermatol* 1967;79:210-220.
33. Haining RG, Cowger ML, Labbe RF, et al. Congenital erythropoietic porphyria. The effects of induced polycythemia. *Blood* 1970;36:297-309.
34. Piomelli S, Poh-Fitzpatrick MB, Seaman C, et al. Complete suppression of the symptoms of congenital erythropoietic porphyria by long-term treatment with high-level transfusions. *N Engl J Med* 1986;314:1029-1031.
35. Guarini L, Piomelli S, Poh-Fitzpatrick MB. Hydroxyurea in congenital erythropoietic porphyria. *N Engl J Med* 1994;330:1091-1092.
36. Pimstone NR, Gandhi SN, Mukerji SK. Therapeutic efficacy of chronic charcoal therapy in congenital erythropoietic porphyria. *N Engl J Med* 1987;316:390-393.
37. Mukerji SK, Pimstone NR, Gandhi SN, et al. Biochemical diagnosis and monitoring therapeutic modulation of disease activity in an unusual case of congenital erythropoietic porphyria. *Clin Chem* 1985;31:1946-1951.
38. Tishler PV, Winston SH. Rapid improvement in the chemical pathology of congenital erythropoietic porphyria with treatment with superactivated charcoal. *Methods Find Exp Clin Pharmacol* 1990;12:645-648.
39. Katugampola RP, Anstey AV, Finlay AY, et al. A management algorithm for congenital erythropoietic porphyria derived from a study of 29 cases. *Brit J Dermatol* 2012;167:888-900.
40. Bedel A, Taillepierre M, Guyonnet-Duperat V, et al. Metabolic correction of congenital erythropoietic porphyria with iPSCs free of reprogramming factors. *Am J Hum Genet* 2012;91:109-121.
41. Fortian A, Gonzalez E, Castano D, et al. Intracellular rescue of the uroporphyrinogen III synthase activity in enzymes carrying the hotspot mutation C73R. *J Biol Chem* 2011;286:13127-13133.
42. Ged C, Moreau-Gaudry F, Taine L, et al. Prenatal diagnosis in congenital erythropoietic porphyria by metabolic measurement and DNA mutation analysis. *Prenat Diag* 1996;16:83-86.
43. Deybach JC, Grandchamp B, Grelier M, et al. Prenatal exclusion of congenital erythropoietic porphyria (Gunther's disease) in a fetus at risk. *Hum Genet* 1980;53:217-221.
44. Spikes JD. Photobiology of porphyrins. *Prog Clin Biol Res* 1984;170:19-39.

45. Magnus IA. The cutaneous porphyrias. *Semin Hematol* 1968;5:380-407.
 46. Katugampola RP, Badminton MN, Finlay AY, et al. Congenital erythropoietic porphyria: a single-observer clinical study of 29 cases. *Brit J Dermatol* 2012;167:901-913.
 47. Joergensen SK, With TK. Congenital porphyria in swine and cattle in Denmark. *Nature* 1955;176:156-158.
 48. Watson CJ, Perman V, Spurrell FA, et al. Some studies of the comparative biology of human and bovine porphyria erythropoietica. *Trans Assoc Am Phys* 1958;71:196-206.
 49. Moore WE, Stephenson BD, Anderson AS, et al. Detection of the heterozygous state of bovine porphyria: analysis of urinary coproporphyrin isomers. *Proc Soc Exp Biol Med* 1970;134:926-928.
 50. Levin EY. Uroporphyrinogen III cosynthetase in bovine erythropoietic porphyria. *Science* 1968;161:907-908.
 51. Joergensen SK, With TK. Porphyria in domestic animals: Danish observations in pigs and cattle and comparison with human porphyria. *Ann N Y Acad Sci* 1963;104:701-709.
 52. Glenn BL, Glenn HG, Omtvedt I. Congenital porphyria in the domestic cat (*Felis catus*): preliminary investigations on inheritance pattern. *Am J Vet Res* 1968;29:1653-1657.
 53. Clavero S, Bishop DF, Giger U, et al. Feline congenital erythropoietic porphyria: two homozygous UROS missense mutations cause the enzyme deficiency and porphyrin accumulation. *Mol Med* 2010;16:381-388.
 54. Flyger V, Levin EY. Animal model: normal porphyria of fox squirrels (*Sciurus niger*). *Am J Pathol* 1977;87:269-272.
 55. Ged C, Mendez M, Robaert E, et al. A knock-in mouse model of congenital erythropoietic porphyria. *Genomics* 2006;87:84-92.
 56. Bishop DF, Clavero S, Mohandas N, Desnick RJ. Congenital erythropoietic porphyria: characterization of murine models of the severe common (C73R/C73R) and later-onset genotypes. *Mol Med* 2011;17:748-756.
 57. Waldenström J. Studien ueber Porphyrie. *Acta Med Scand* 1937;82(Suppl): 1-254.
 58. Elder GH, Roberts AG, de Salamanca RE. Genetics and pathogenesis of human uroporphyrinogen decarboxylase defects. *Clin Biochem* 1989;22: 163-168.
 59. Koszo F, Morvay M, Dobozy A, et al. Erythrocyte uroporphyrinogen decarboxylase activity in 80 unrelated patients with porphyria cutanea tarda. *Br J Dermatol* 1992;126:446-449.
 60. Bulaj ZJ, Phillips JD, Ajioka RS, et al. Hemochromatosis genes and other factors contributing to the pathogenesis of porphyria cutanea tarda. *Blood* 2000;95:1565-1571.
- P.705
61. Egger NG, Goeger DE, Payne DA, et al. Porphyria cutanea tarda: multiplicity of risk factors including HFE mutations, hepatitis C, and inherited uroporphyrinogen decarboxylase deficiency. *Dig Dis Sci* 2002;47:419-426.
 62. Kushner JP, Barbuto AJ, Lee GR. An inherited enzymatic defect in porphyria cutanea tarda: decreased uroporphyrinogen decarboxylase activity. *J Clin Invest* 1976;58:1089-1097.
 63. Benedetto AV, Kushner JP, Taylor JS. Porphyria cutanea tarda in three generations of a single family. *N Engl J Med* 1978;298:358-362.
 64. de Verneuil H, Aitken G, Nordmann Y. Familial and sporadic porphyria cutanea tarda: two different diseases. *Hum Genet* 1978;44:145-151.
 65. Alleman MA, Wilson JHP, van den Berg JWO, et al. Familial porphyria cutanea tarda: the pattern of porphyrins formed from porphobilinogen by hemolysates. *Clin Chem* 1982;28:1144-1147.
 66. Felsher BF, Carpio N, Engleking DW, et al. Decreased hepatic uroporphyrinogen decarboxylase activity in porphyria cutanea tarda. *N Engl J Med* 1982;306:766-769.
 67. Elder GH, Sheppard DM, Tovey JA, et al. Immunoreactive uroporphyrinogen decarboxylase in porphyria cutanea tarda. *Lancet* 1983;1:1301-1304.

68. de Verneuil H, Beaumont C, Deybach J-C, et al. Enzymatic and immunological studies of uroporphyrinogen decarboxylase in familial porphyria cutanea tarda and hepatoerythropoietic porphyria. *Am J Hum Genet* 1984;36:613-622.
69. Elder GH, Smith SG, Herrero C, et al. Hepatoerythropoietic porphyria: a new uroporphyrinogen decarboxylase defect or homozygous porphyria cutanea tarda? *Lancet* 1981;1:916-919.
70. Lazaro P, de Salamanca RE, Elder GH, et al. Is hepatoerythropoietic porphyria a homozygous form of porphyria cutanea tarda? Inheritance of uroporphyrinogen decarboxylase deficiency in a Spanish family. *Br J Dermatol* 1984;110:613-617.
71. Toback AC, Sassa S, Poh-Fitzpatrick MB. Hepatoerythropoietic porphyria: clinical, biochemical and enzymatic studies in a three-generation family lineage. *N Engl J Med* 1987;316:645-650.
72. Fujita H, Sassa S, Toback AC, et al. Immunochemical study of uroporphyrinogen decarboxylase in a patient with mild hepatoerythropoietic porphyria. *J Clin Invest* 1987;79:1533-1537.
73. Romeo PH, Raich N, Dubart A, et al. Molecular cloning and nucleotide sequence of a complete human uroporphyrinogen decarboxylase cDNA. *J Biol Chem* 1986;261:9825-9831.
74. Dubart A, Mattei MG, Raich N, et al. Assignment of human uroporphyrinogen decarboxylase (URO-D) to the p34 band on chromosome 1. *Hum Genet* 1986;73:277-279.
75. Elder GH. Porphyria cutanea tarda and related disorders. In: Kadish KM, Smith KM, Guillard R, eds. *The porphyrin handbook—medical aspects of porphyrins*. Amsterdam: Academic Press, 2003;14:67-92.
76. Phillips JD, Parker TL, Schubert HL, et al. Functional consequences of naturally occurring mutations in human uroporphyrinogen decarboxylase. *Blood* 2001;98:3179-3185.
77. Badenas C, To-Figueras J, Phillips JD, et al. Identification and characterization of novel uroporphyrinogen decarboxylase gene mutations in a large series of porphyria cutanea tarda patients and relatives. *Clin Genet* 2009;75: 346-353.
78. Cantatore-Francis JL, Cohen-Pfeffer J, Balwani M, et al. Hepatoerythropoietic porphyria misdiagnosed as child abuse. *Arch Dermatol* 2010;146:529-533.
79. Elder GH, Lee GB, Tovey JA. Decreased activity of hepatic uroporphyrinogen decarboxylase in sporadic porphyria cutanea tarda. *N Engl J Med* 1978;299:274-278.
80. Elder GH, Urquhart AJ, deSalamanca RE, et al. Immunoreactive uroporphyrinogen decarboxylase in the liver in porphyria cutanea tarda. *Lancet* 1985;2:229-232.
81. Garey JR, Franklin KF, Brown DA, et al. Analysis of uroporphyrinogen decarboxylase complementary DNAs in sporadic porphyria cutanea tarda. *Gastroenterology* 1993;105:165-169.
82. Mendez M, Poblete-Gutierrez P, Garcia-Bravo M, et al. Molecular heterogeneity of familial porphyria cutanea tarda in Spain: characterization of 10 novel mutations in the UROD gene. *Brit J Dermatol* 2007;157:501-507.
83. Athar M, Elmets CA, Bickers DR, et al. A novel mechanism for the generation of superoxide anions in hematoporphyrin derivative mediated cutaneous photosensitization. Activation of the xanthine oxidase pathway. *J Clin Invest* 1989;83:1137-1143.
84. Varigos G, Schiltz JR, Bickers DR. Uroporphyrin I stimulation of collagen biosynthesis in human skin fibroblasts. A unique dark effect of porphyrins. *J Clin Invest* 1982;69:129-135.
85. Munoz-Santos C, Guilabert A, Moreno N, et al. Familial and sporadic porphyria cutanea tarda. Clinical and biochemical features and risk factors in 152 patients. *Medicine* 2010;89:69-74.
86. Ippen H. Allgemeinsymptome der späten Hautporphyrie (Porphyria cutanea tarda) als Hinweise für deren Behandlung. *Dtsch Med Wochenschr* 1961;86:127-133.
87. Lamont NM, Hathorn M, Joubert SM. Porphyria in the African: a study of 100 cases. *Q J Med NS* 1961;30:373-392.
88. Felsher BF, Jones ML, Redeker AG. Iron and hepatic uroporphyrin synthesis: relation in porphyria cutanea tarda. *JAMA* 1973;226:663-665.
89. Grossman ME, Bickers DR, Poh-Fitzpatrick MB, et al. Porphyria cutanea tarda: clinical features and laboratory findings in 40 patients. *Am J Med* 1979;67:277-286.
90. Cortes JM, Oliva H, Paradinas FJ, et al. The pathology of the liver in porphyria cutanea tarda. *Histopathology* 1980;4:471-485.

91. Brugsch J. Hamochromatose und Melanodermieporphyrie als verschiedene Formen der Hamsynthesestörung bei Pigment Zirrhose und Bronzediabetes. *Z Gesamte Inn Med* 1958;13:411-415.
92. Sauer GF, Funk DD. Iron overload in cutaneous porphyria. *Arch Intern Med* 1969;124:190-196.
93. Bottomley SS. Porphyria cutanea tarda and hereditary hemochromatosis. *Boll Instituto Dermatol S Gallicano* 1986-87;8:237-240.
94. Ryan Caballes F, Sendi H, Bonkovsky HL. Hepatitis C, porphyria cutanea tarda and liver iron: an update. *Liver Int* 2012;32:880-893.
95. Ajioka RS, Phillips JD, Weiss RB, et al. Down-regulation of hepcidin in porphyria cutanea tarda. *Blood* 2008;112:4723-4728.
96. Darwich E, To-Figueras J, Molina-Lopez RA, et al. Increased serum hepcidin levels in patients with porphyria cutanea tarda. *J Eur Acad Dermatol Venerol* 2013;27:e68-74.
97. Goulding JM, Puarohit G, Borg A, et al. Porphyria cutanea tarda complicating transfusion-dependent myelodysplastic syndrome. *Br J Haematol* 2007;136:2.
98. Ippen H. Treatment of porphyria cutanea tarda by phlebotomy. *Semin Hematol* 1977;14:253-259.
99. Rocchi E, Gibertini P, Cassanelli M, et al. Iron removal therapy in porphyria cutanea tarda: phlebotomy versus slow subcutaneous desferrioxamine infusion. *Br J Dermatol* 1986;114:621-629.
100. Lundvall O. The effect of replenishment of iron stores after phlebotomy therapy in porphyria cutanea tarda. *Acta Med Scand* 1971;189:51-63.
101. Phillips JD, Jackson LK, Bunting M, et al. A mouse model of familial porphyria cutanea tarda. *Proc Natl Acad Sci U S A* 2001;98:259-564.
102. Franklin MR, Phillips JD, Kushner JP. Attenuation of polychlorinated biphenyl induced uroporphyrin by iron deprivation. *Environ Toxicol Pharmaol* 2005;20:417-423.
103. Phillips JD, Bergonia HA, Reilly CA, et al. A porphomethene inhibitor of uroporphyrinogen decarboxylase causes porphyria cutanea tarda. *Proc Natl Acad Sci U S A* 2007;104:5079-5084.
104. Phillips JD, Kushner JP, Bergonia HA, Franklin MR. Uroporphyrin in the Cyp1a2^{-/-} mouse. *Blood Cells Mol Dis* 2011;47:249-254.
105. Wickliffe JK, Abdel-Rahman SZ, Lee C, et al. CYP1A21F and GSTM1 alleles are associated with susceptibility to porphyria cutanea tarda. *Mol Med* 2011;17:241-247.
106. Elder GH. Alcohol intake and porphyria cutanea tarda. *Dermatol* 1999;17:431-436.
107. Hallen J, Krook H. Follow-up studies on an unselected ten-year material of 360 patients with liver cirrhosis in one community. *Acta Med Scand* 1963;173:479-493.
108. Felsher BF, Kushner JP. Hepatic siderosis and porphyria cutanea tarda: relation of iron excess to the metabolic defect. *Semin Hematol* 1977;14:243-251.
109. Dean G. The porphyrias: a study of inheritance and environment. Great Britain: Pitman Medical, 1971.
110. Gordeuk V, Mukiibi J, Med M. Iron overload in Africa. Interaction between a gene and dietary iron content. *N Engl J Med* 1992;326:95-100.
111. Gisbert JP, Garcia-Buey L, Paires JM, et al. Prevalence of hepatitis C infection in porphyria cutanea tarda: systematic review and meta-analysis. *J Hepatol* 2003;39:620-627.
112. Blauvelt A. Hepatitis C virus and human immunodeficiency virus infection can alter porphyrin metabolism and lead to porphyria cutanea tarda. *Arch Dermatol* 1996;132:1503-1504.
113. Gafa S, Zannini A, Gabrielli C. Porphyria cutanea tarda and HIV infection: effect of zidovudine treatment on a patient. *Infection* 1992;20:373-374.
114. Sixel-Dietrich F, Doss M. Hereditary uroporphyrinogen-decarboxylase deficiency predisposing porphyria cutanea tarda (chronic hepatic porphyria) in females after oral contraceptive medication. *Arch Dermatol Res* 1985;278:13-16.
115. Weimar VM, Weimar GW, Ceilley RI. Estrogen-induced porphyria cutanea tarda complicating treatment of prostatic carcinoma. *J Urol* 1978;120:643-644.

116. Baxi LV, Rubeo TJ Jr, Katz B, et al. Porphyria cutanea tarda and pregnancy. *Am J Obstet Gynecol* 1983;146:333-334.
117. Urbanek RW, Cohen DJ. Porphyria cutanea tarda: pregnancy versus estrogen effect. *J Am Acad Dermatol* 1994;31:390-392.
118. Jalil S, Grady JJ, Lee C, Anderson KE. Associations among behavior-related susceptibility factors in porphyria cutanea tarda. *Clin Gastroenterol Hepatol* 2010;8:297-302.
119. Sinclair PR, Gorman N, Shedlofsky SI, et al. Ascorbic acid deficiency in porphyria cutanea tarda. *J Lab Clin Med* 1997;130:197-201.
120. Goldsman CI, Taylor JS. Porphyria cutanea tarda and bullous dermatoses associated with chronic renal failure: a review. *Cleve Clin Q* 1983;50:151-161.
121. McKane W, Green CA, Farrington K. Porphyria cutanea tarda precipitated by intravenous iron in a hemodialysis patient. *Nephrol Dial Transplant* 2001;16:1936-1938.
122. Seubert S, Seubert A, Rumpf KW, et al. A porphyria cutanea tarda like distribution pattern of porphyrins in plasma, hemodialysate, hemofiltrate and urine in patients on chronic hemodialysis. *J Invest Dermatol* 1985;85:107-109.
123. Hebert AA, Farmer KL, Poh-Fitzpatrick MB. Peritoneal dialysis does not reduce serum porphyrin levels in porphyria cutanea tarda. *Nephron* 1992;60:240.
124. Koskelo P, Toivonen I, Rintola P. The binding of 14C-labeled porphyrins by plasma proteins. *Clin Chim Acta* 1970;29:559-565.
125. Mamet R, Gafter U, Korzets A, et al. Decreased uroporphyrinogen decarboxylase activity in patients with end-stage renal disease undergoing hemodialysis. *Nephron* 1995;70:202-206.
126. Boffa MJ, Reed P, Weinkove C, et al. Hypertrichosis as the presenting feature of porphyria cutanea tarda. *Clin Exp Dermatol* 1995;20:62-64.
127. Armstrong DKB, Sharpe PC, Chambers CR, et al. Hepatoerythropoietic porphyria: a missense mutation in the UROD gene is associated with mild disease and an unusual porphyrin excretion pattern. *Br J Dermatol* 2004;151:920-923.
128. Elder GH. Porphyrin metabolism in porphyria cutanea tarda. *Semin Hematol* 1977;14:227-242.
129. Elder GH. Differentiation of porphyria cutanea tarda symptomatica from other types of porphyria by measurement of isocoproporphyrin in feces. *J Clin Pathol* 1975;28:601-607.
130. Lundvall O, Enerback L. Hepatic fluorescence in porphyria cutanea tarda. Studies in fine needle aspiration biopsy smears. *J Clin Pathol* 1969;22:704-709.
131. James KR, Cortes JM, Paradinas FJ. Demonstration of intracytoplasmic needle-like inclusions in hepatocytes of patients with porphyria cutanea tarda. *J Clin Pathol* 1980;33:899-900.
132. Biempica L, Kosower N. Hepatic porphyrias: cytochemical and ultrastructural studies of liver in acute intermittent porphyria and porphyria cutanea tarda. *Arch Pathol Lab Med* 1974;98:336-343.
133. Epstein JH, Tuffanelli DL, Epstein WL. Cutaneous changes in the porphyrias (a microscopic study). *Arch Dermatol* 1973;107:689-698.
134. Topi GC, Amantea A, Griso D. Recovery from porphyria cutanea tarda with no specific therapy other than avoidance of hepatic toxins. *Br J Dermatol* 1984;111:75-82.
135. Rich JD, Mylonakis E, Nossa R, et al. Highly active antiretroviral therapy leading to resolution of porphyria cutanea tarda in a patient with AIDS and hepatitis C. *Dig Dis Sci* 1999;44:1034-1037.
136. Fernandez J, Castellano G, de Salamanca RE, et al. Porphyria cutanea tarda as a predictor of poor response to interferon alfa therapy in chronic hepatitis C. *Scand J Gastroenterol* 2003;38:314-319.
137. Bulaj Z, Franklin MR, Phillips JD, et al. Transdermal estrogen replacement therapy in postmenopausal women previously treated for porphyria cutanea tarda. *J Lab Clin Med* 2000;136:482-488.
138. Felsher BF, Redeker G. Effect of chloroquine on hepatic uroporphyrin metabolism in patients with porphyria cutanea tarda. *Medicine* 1966; 45:575-583.
139. Scholnick PL, Epstein JH, Marver HS. The molecular basis of the action of chloroquine in porphyria cutanea tarda. *J Invest Dermatol* 1973;61:226-232.

140. Ashton RE, Hawk JLM, Magnus IA. Low-dose oral chloroquine in the treatment of porphyria cutanea tarda. *Br J Dermatol* 1984;111:609-613.
141. Stolzel U, Kostler E, Schuppan D, et al. Hemochromatosis (HFE) gene mutations and response to chloroquine in porphyria cutanea tarda. *Arch Dermatol* 2003;139:309-313.
142. Horina JH, Wolf P. Epoetin for severe anemia in hepatoerythropoietic porphyria. *N Engl J Med* 2000;342:1294-1295.
143. Fontanellas A, Mazurier F, Moreau-Gaudry F, et al. Correction of uroporphyrinogen decarboxylase deficiency (hepatoerythropoietic porphyria) in Epstein-Barr virus-transformed B-cell lines by retrovirus-mediated selection of transduced cells. *Blood* 1999;94:465-474.
144. Ged C, Ozalla D, Herrero C, et al. Description of a new mutation in hepatoerythropoietic porphyria and prenatal exclusion of a homozygous fetus. *Arch Dermatol* 2002;138:957-960.
145. Carson RW, Dunnigan EJ, DuBose TD Jr, et al. Removal of plasma porphyrins with high-flux hemodialysis in porphyria cutanea tarda associated with end-stage renal disease. *J Am Soc Nephrol* 1992;2:1445-1450.
146. Anderson KE, Goeger DE, Carson RW, et al. Erythropoietin for the treatment of porphyria cutanea tarda in a patient on long-term hemodialysis. *N Engl J Med* 1990;322:315-317.
147. Shieh S, Cohen JL, Lim HW. Management of porphyria cutanea tarda in the setting of chronic renal failure: a case report and review. *J Am Acad Dermatol* 2000;42:645-652.
148. Ewing S, Crosby DL. Renal transplantation for porphyria cutanea tarda. *N Engl J Med* 1997;336:811.
149. Schmid R. Cutaneous porphyria in Turkey. *N Engl J Med* 1960;263:397-398.
150. Ockner RK, Schmid R. Acquired porphyria in man and rat due to hexachlorobenzene intoxication. *Nature* 1961;189:499-500.
151. Cam C, Nogogosyan G. Acquired toxic porphyria cutanea tarda due to hexachlorobenzene. *JAMA* 1963;183:88-91.
152. Peters HA, Gocmen A, Cripps DJ, et al. Epidemiology of hexachlorobenzene-induced porphyria in Turkey. Clinical and laboratory follow-up after 25 years. *Arch Neurol* 1982;39:744-749.
153. Cripps DJ, Peters HA, Gocmen A, et al. Porphyria turcica due to hexachlorobenzene: a 20 to 30 year follow-up study in 204 patients. *Br J Dermatol* 1984;111:413-422.
154. Smith AG, Francis JE. Synergism of iron and hexachlorobenzene inhibits hepatic uroporphyrinogen decarboxylase in inbred mice. *Biochem J* 1983;214:909-913.
155. Wainstock de Calmanovici R, Rios de Molina MDC, Tairade Yamasato MC, et al. Mechanism of hexachlorobenzene-induced porphyria in rats. *Biochem J* 1984;218:753-763.
156. Smith AG, Francis JE. Genetic variation of iron-induced uroporphyrin in mice. *Biochem J* 1993;291:29-35.
157. Poland A, Knutson JC. 2,3,7,8-Tetrachlorodibenzo-p-dioxin and related halogenated aromatic hydrocarbons: examination of the mechanism of toxicity. *Annu Rev Pharmacol Toxicol* 1982;22:517-554.
158. Smith AG, Francis JE, Kay SJE, et al. Hepatic toxicity and uroporphyrinogen decarboxylase activity following a single dose of 2,3,7,8-tetrachlorodibenzo-p-dioxin to mice. *Biochem Pharmacol* 1981;30:2825-2830.
159. Sweeney GD, Jones KG, Cole FM, et al. Iron deficiency prevents liver toxicity of 2,3,7,8-tetrachlorodibenzo-p-dioxin. *Science* 1979;204:332-335.
160. Kordac V. Frequency of occurrence of hepatocellular carcinoma in patients with porphyria cutanea tarda in long-term followup. *Neoplasma* 1972;19:135-139.
161. Siersma PD, ten Kate FJW, Mulder PGH, et al. Hepatocellular carcinoma in porphyria cutanea tarda: frequency and factors related to its occurrence. *Liver* 1992;12:56-61.
162. Fracanzani AL, Raioli E, Sampietro M, et al. Liver cancer risk is increased in patients with porphyria cutanea tarda in comparison to matched control patients with chronic liver disease. *J Hepatol* 2001;35:498-503.
163. Tio TH, Leijnse B, Jarrett A, et al. Acquired porphyria from a liver tumor. *Clin Sci* 1957;16:517-527.
164. Thompson PPH, Nicholson DC, Farnan T, et al. Cutaneous porphyria due to a malignant primary hepatoma. *Gastroenterology* 1970;59:779-783.

165. O'Reilly K, Snape J, Moore MR. Porphyria cutanea tarda resulting from primary hepatocellular carcinoma. *Clin Exp Dermatol* 1988;13:44-48.
166. Ochiai R, Morishima T, Kondo M. Symptomatic porphyria secondary to hepatocellular carcinoma. *Br J Dermatol* 1997;136:129-131.
167. Wang H, Long Q, Marty SD, et al. A zebrafish model for hepatoerythropoietic porphyria. *Nat Genet* 1998;20:239-243.
168. Sinclair PR, Gorman N, Trask HW, et al. Uroporphyrinuria caused by ethanol in Hfe(-/-) mice as a model for porphyria cutanea tarda. *Hepatology* 2003;37:351-358.
169. Sinclair PR, Gorman N, Dalton T, et al. Uroporphyrinuria produced in mice by iron and 5-aminolevulinic acid does not occur in Cyp1a2(-/-) null mice. *Biochem J* 1998;330:149-153.
170. Gorman N, Zaharia A, Trask HS, et al. Effect of iron and ascorbate on uroporphyrinuria in ascorbate-requiring mice as a model for porphyria cutanea tarda. *Hepatology* 2007;45:187-194.
171. Smith AG, Elder GH. Complex gene-chemical interactions: hepatic uroporphyrinuria as a paradigm. *Chem Res Toxicol* 2010;23:712-723.
172. Nezamzadeh R, Seubert A, Pohlenz J, et al. Identification of a mutation in the ovine uroporphyrinogen decarboxylase (UROD) gene associated with a type of porphyria. *Anim Genet* 2005;36:297-302.
173. Magnus IA, Jarrett A, Prankerd TAJ, et al. Erythropoietic protoporphyria: a new porphyria syndrome with solar urticaria due to protoporphyria. *Lancet* 1961;2:448-451.
174. Went LN, Klasen EC. Genetic aspects of erythropoietic protoporphyria. *Ann Hum Genet* 1984;48:105-117.
175. Norris PG, Nunn AV, Hawk JLM, et al. Genetic heterogeneity in erythropoietic protoporphyria: a study of the enzymatic defect in nine affected families. *J Invest Dermatol* 1990;95:260-263.
176. Gouya L, Martin-Schmitt C, Robreau A-M, et al. Contribution of a common single-nucleotide polymorphism to the genetic predisposition for erythropoietic protoporphyria. *Am J Hum Genet* 2006;78:2-14.
177. Bottomley SS, Tanaka M, Everett MA. Diminished ferrochelatase activity in protoporphyria. *J Lab Clin Med* 1975;86:126-131.
178. deGoeij A FPM, Christianse K, van Steveninck J. Decreased haem synthetase activity in blood cells of patients with erythropoietic protoporphyria. *Eur J Clin Invest* 1975;5:397-400.
179. Bonkowsky HL, Bloomer JR, Ebert PS, et al. Heme synthetase deficiency in human protoporphyria. Demonstration of the defect in liver and cultured skin fibroblasts. *J Clin Invest* 1975;56:1139-1148.
180. Sassa S, Zalai GL, Poh-Fitzpatrick MB, et al. Studies in porphyria: functional evidence of a partial deficiency of ferrochelatase activity in mitogen-stimulated lymphocytes from patients with erythropoietic protoporphyria. *J Clin Invest* 1982;69:809-815.
181. Bloomer JR, Hill HD, Kools AM, et al. Heme synthesis in protoporphyria. *Curr Probl Dermatol* 1990;20:135-147.
182. Mathews-Roth MM. Anemia in erythropoietic protoporphyria. *JAMA* 1974;230:824.
183. DeLeo VA, Poh-Fitzpatrick M, Mathews-Roth M, et al. Erythropoietic protoporphyria: ten years experience. *Am J Med* 1976;60:8-22.
184. Holme SA, Worwood M, Anstey AV, et al. Erythropoiesis and iron metabolism in dominanterthropoietic protoporphyria. *Blood* 2007;110:4108-4110.
185. Cripps DJ, MacEachern WN. Hepatic and erythropoietic protoporphyria. Aminolevulinic acid synthetase, fluorescence and microfluorometric study. *Arch Pathol* 1971;91:497-505.
186. Piomelli S, Lamola AA, Poh-Fitzpatrick MB, et al. Erythropoietic protoporphyria and lead intoxication: the molecular basis for difference in cutaneous photosensitivity. I. Different rates of disappearance of protoporphyrin from the erythrocytes, both in vivo and in vitro. *J Clin Invest* 1975;56: 1519-1527.
187. Brun A, Steen H, Sandberg S. Erythropoietic protoporphyria: two populations of reticulocytes, with and without protoporphyrin. *Eur J Clin Invest* 1996;26:270-278.
188. Bloomer JR, Bonkowsky HL, Ebert PS, et al. Inheritance in protoporphyria: comparison of heme synthetase activity in skin fibroblasts with clinical features. *Lancet* 1976;2:226-228.

189. Deybach JC, DaSilva V, Pasquier Y, et al. Ferrochelatase in human erythropoietic protoporphyria: the first case of a homozygous form of the enzyme deficiency. In: Nordmann Y, ed. *Porphyryns and porphyrias*. Paris: John Libbey, 1986:163-173.
190. Schmidt H, Snitker G, Thomsen K, et al. Erythropoietic protoporphyria. A clinical study based on 29 cases in 14 families. *Arch Dermatol* 1974;110:58-64.
191. Nakahashi Y, Taketani S, Okuda M, et al. Molecular cloning and sequence analysis of cDNA encoding human ferrochelatase. *Biochem Biophys Res Commun* 1990;173:748-755.
192. Taketani S, Inazawa J, Nakahashi Y, et al. Structure of the human ferrochelatase gene. Exon/intron gene organization and location of the gene to chromosome 18. *Eur J Biochem* 1992;205:217-222.
- 192a. Balwani M, Doheny D, Bishop DF, et al. Loss-of-function ferrochelatase and gain-of-function erythroid-specific 5-aminolevulinic synthase mutations causing erythropoietic protoporphyria and X-linked protoporphyria in North American patients reveal novel mutations and a high prevalence of X-linked protoporphyria. *Mol Med* 2013;19:26-35.
193. Magness ST, Tugores A, Christensen SR, et al. Deletion of the ferrochelatase gene in a patient with protoporphyria. *Hum Mol Genet* 1994;3:1695-1697.
194. Onaga Y, Ido A, Uto H, et al. Hypermethylation of the wild type ferrochelatase allele is closely associated with severe liver complication in a family with erythropoietic protoporphyria. *Biochem Biophys Res Commun* 2004;321:851-858.
195. DiPierro E, Cappellini MD, Mazzuacchelli R, et al. A point mutation affecting an SP1 binding site in the promoter of the ferrochelatase gene impairs gene transcription and causes erythropoietic protoporphyria. *Exp Hematol* 2005;33:584-591.
196. Whatley SD, Mason NG, Khan M, et al. Autosomal recessive erythropoietic protoporphyria in the United Kingdom: prevalence and relationship to liver disease. *J Med Genet* 2004;41:1-5.
197. Gouya L, Deybach JC, Lamoril J, et al. Modulation of the phenotype in dominant erythropoietic protoporphyria by a low expression of the normal ferrochelatase allele. *Am J Hum Genet* 1996;58:292-299.
198. Gouya L, Puy H, Lamoril J, et al. Inheritance of erythropoietic protoporphyria: a common wild-type ferrochelatase allelic variant with low expression accounts for clinical manifestations. *Blood* 1999;93:2105-2110.
199. Gouya L, Puy H, Robreau AM, et al. The penetrance of dominant erythropoietic protoporphyria is modulated by expression of wildtype FECH. *Nat Genet* 2002;30:27-28.
200. Magness ST, Maeda N, Brenner DA. An exon 10 deletion in the mouse ferrochelatase gene has a dominant-negative effect and causes mild protoporphyria. *Blood* 2002;100:1470-1477.
201. Burden AE, Wa C, Dailey TA, et al. Human ferrochelatase: crystallization, characterization of the [2Fe-2S] cluster and determination that the enzyme is a homodimer. *Biochim Biophys Acta* 1999;1435:191-197.
202. Najahi-Missaoui W, Dailey HA. Production and characterization of erythropoietic protoporphyric heterodimeric ferrochelatases. *Blood* 2005;106: 1098-1104.
203. Ohgari Y, Sawamoto M, Yamamoto M, et al. Ferrochelatase consisting of wild-type and mutated subunits from patients with a dominant-inherited disease, erythropoietic protoporphyria, is an active but unstable dimer. *Hum Mol Genet* 2005;14:327-334.
204. Whatley SD, Ducamp S, Gouya L, et al. C-terminal deletions in the ALAS2 gene lead to gain of function and cause X-linked dominant protoporphyria without anemia or iron overload. *Am J Hum Genet* 2008;83:408-414.
205. Whatley SD, Mason NG, Holme SA, et al. Molecular epidemiology of erythropoietic protoporphyria in the UK. *Br J Dermatol* 2010;162:642-646.
- 205a. Ducamp S, Schneider-Yin X, de Rooij F, et al. Molecular and functional analysis of the C-terminal region of human erythroid-specific 5-aminolevulinic synthase associated with X-linked dominant protoporphyria (XLDPP). *Hum Mol Genet* 2013;22:1280-1288.
- 205b. Bishop DF, Tchaikovskii V, Nazarenko I, et al. Molecular expression and characterization of erythroid-specific 5-aminolevulinic synthase gain-of-function mutations causing X-linked protoporphyria. *Mol Med* 2013;19:18-25.
206. Avner DL, Berenson MM. Hepatic clearance and biliary secretion of protoporphyria in the isolated, in situ perfused rat liver. *J Lab Clin Med* 1982;99:885-894.

207. Meerman L. Erythropoietic protoporphyria. An overview with emphasis on the liver. *Scand J Gastroenterol Suppl* 2000;232:79-85.
208. Bloomer JR, Wang Y, Singhal A, et al. Biochemical abnormality in erythropoietic protoporphyria: cause and consequences. *J Ped Gastroenterol* 2006;43:S36-S40.
209. Minder EI, Gouya L, Schneider-Yin X, et al. A genotype-phenotype correlation between null-allele mutations in the ferrochelatase gene and liver complications in patients with erythropoietic protoporphyria. *Cell Mol Biol* 2002;48:91-96.
210. Bloomer JR, Wang Y, Singhal A, et al. Molecular studies of liver disease in erythropoietic protoporphyria. *J Clin Gastroenterol* 2005;39(Suppl 2): S167-S175.
211. Bonkovsky HL, Schned AR. Fatal liver failure in protoporphyria. Synergism between ethanol excess and the genetic defect. *Gastroenterology* 1986;90:191-201.
212. Poh-Fitzpatrick MB, Whitlock RT, Leftkowitz JH. Changes in protoporphyrin distribution dynamics during liver failure and recovery in a patient with protoporphyria and Epstein-Barr viral hepatitis. *Am J Med* 1986; 80:943-950.
- 212a. Minder EI, Haldemann AR, Schneider-Yin X. Exacerbation of erythropoietic protoporphyria by hyperthyroidism. *J Inherit Metab Dis* 2010 Nov 11 [Epub ahead of print].
213. Baart de la Faille H, Bijlmer-lest JC, van Hattum J, et al. Erythropoietic protoporphyria: clinical aspects with emphasis on the skin. *Curr Prob Dermatol* 1990;20:123-134.
214. Brun A, Western A, Malik Z, et al. Erythropoietic protoporphyria: photodynamic transfer of protoporphyrin from intact erythrocytes to other cells. *Photochem Photobiol* 1990;51:573-577.
215. Wang Y, Langr NB, Shaw GC, et al. Abnormal mitoferrin-1 expression in patients with erythropoietic protoporphyria. *Exp Hematol* 2011;39: 784-794.
216. Chung J, Chen C, Paw BH. Heme metabolism and erythropoiesis. *Curr Opin Hematol* 2012;19:156-162.
217. Chen W, Dailey HA, Paw BH. Ferrochelatase forms an oligomeric complex with mitoferrin-1 and abcb10 for erythroid heme biosynthesis. *Blood*;116:628-630.
218. Sarkany RPE, Ross G, Willis F. Acquired erythropoietic protoporphyria as a result of myelodysplasia causing loss of chromosome 18. *Br J Dermatol* 2006;155:464-466.
219. Goodwin RG, Kell WJ, Laidler P, et al. Photosensitivity and acute liver injury in myeloproliferative disorder secondary to late-onset protoporphyria caused by deletion of a ferrochelatase gene in hematopoietic cells. *Blood* 2006;107:60-62.
220. Bharati A, Badminton MN, Whatley SD, et al. Late-onset erythropoietic protoporphyria in association with haematological malignancy. *Clin Exp Dermatol* 2006;31:668-670.
- 220a. Livideanu CB, Ducamp S, Lamant L, et al. Late-onset X-linked dominant protoporphyria: an etiology of photosensitivity in the elderly. *J Invest Dermatol* 2013;133:1688-1690.
221. Holme SA, Anstey AV, Finlay AY, et al. Erythropoietic protoporphyria in the U.K.: clinical features and effect on quality of life. *Br J Dermatol* 2006;155:574-581.
222. Berroeta L, Man I, Goudie DR, et al. Late presentation of erythropoietic protoporphyria: case report and genetic analysis of family members. *Brit J Dermatol* 2007;157:1030-1031.
223. Lecluse ALY, Kuck-Koot VCM, van Weelden H, et al. Erythropoietic protoporphyria without skin symptoms—you do not always see what they feel. *Eur J Pediatr* 2008;167:703-706.
224. Redeker AG, Berke M. Erythropoietic protoporphyria with eczema solare. *Arch Dermatol* 1962;86:569-574.
225. Poh-Fitzpatrick MB. Erythropoietic porphyrias: current mechanistic, diagnostic, and therapeutic considerations. *Semin Hematol* 1977;14:211-219.
226. Holme SA, Whatley SD, Roberts AG, et al. Seasonal palma keratoderma in erythropoietic protoporphyria indicates autosomal recessive inheritance. *J Invest Dermatol* 2009;129:599-605.
227. Goerz G, Krieg TH, Bolsen K, et al. Porphyrin-Untersuchungen eines Gallensteines bei der erythropoetischen Protoporphyrurie. *Arch Dermatol Res* 1976;256:283-289.
228. Bloomer JR, Enriquez R. Evidence that hepatic crystalline deposits in a patient with protoporphyria are composed of protoporphyrin. *Gastroenterology* 1982;82:569-572.

229. Muley SA, Midani HA, Rank JM, et al. Neuropathy in erythropoietic porphyrias. *Neurology* 1998;151:262-265.
230. Lock G, Holstege A, Mueller AR. Liver failure in erythropoietic protoporphyria associated with choledocholithiasis and severe post-transplantation polyneuropathy. *Liver* 1996;16:211-217.
231. Lamola AA, Yamane T. Zinc protoporphyrin in the erythrocytes of patients with lead intoxication and iron deficiency anemia. *Science* 1974;186: 936-938.
232. Lamola AA, Piomelli S, Poh-Fitzpatrick MB, et al. Erythropoietic protoporphyria and lead intoxication: the molecular basis for difference in cutaneous photosensitivity. II. Different binding of erythrocyte protoporphyrin to hemoglobin. *J Clin Invest* 1975;46:1528-1535.
233. Porter FS, Lowe BA. Congenital erythropoietic protoporphyria. Case reports, clinical studies and porphyrin analyses in two brothers. *Blood* 1963;22: 521-531.
234. Key NS, Rank JM, Freese D, et al. Hemolytic anemia in protoporphyria: possible precipitating role of liver failure and photic stress. *Am J Hematol* 1992;39:202-207.
235. Scott AJ, Ansford AJ, Webster BH, et al. Erythropoietic protoporphyria with features of a sideroblastic anemia terminating in liver failure. *Am J Med* 1973;54:251-259.
236. Rademakers LHPM, Koningsberger JC, Sorber CWJ, et al. Accumulation of iron in erythroblasts of patients with erythropoietic protoporphyria. *Eur J Clin Invest* 1993;23:130-138.
237. Poh-Fitzpatrick MB. Protoporphyrin metabolic balance in human protoporphyria. *Gastroenterology* 1985;88:1239-1242.
238. Morton KO, Schneider F, Weimer MK, et al. Hepatic and bile porphyrins in patients with protoporphyria and liver failure. *Gastroenterology* 1988;94:1488-1492.
239. Klatskin G, Bloomer JR. Birefringence of hepatic pigment deposits in erythropoietic protoporphyria. *Gastroenterology* 1974;67:294-302.
240. Whatley SD, Mason NG, Holme SA, et al. Gene dosage analysis identifies large deletions of the FECH gene in 10% of families with erythropoietic protoporphyria. *J Invest Dermatol* 2007;127:2790-2794.
241. Holme SA, Anstey AV, Badminton MN, et al. Serum 25-hydroxyvitamin D in erythropoietic protoporphyria. *Brit J Dermatol* 2008;159:211-213.
242. Spelt JM, de Rooij FW, Wilson JH, Zandbergen AA. Vitamin D deficiency in patients with erythropoietic protoporphyria. *J Inherit Metab Dis Short Report #146* (2009) Online.
243. Minder EI, Schneider-Yin X, Steurer J, Bachmann LM. A systematic review of treatment options for dermal photosensitivity in erythropoietic protoporphyria. *Cell Mol Biol (Noisy-le-grand)* 2009;55:84-97.
244. Thomsen K, Schmidt H, Fischer A. Beta-carotene in erythropoietic protoporphyria: 5 years experience. *Dermatologica* 1979;159:82-86.
245. Moshell AN, Bjornson L. Photoprotection in erythropoietic protoporphyria: mechanism of photoprotection by beta carotene. *J Invest Dermatol* 1977;68:157-160.
246. Collins P, Ferguson J. Narrow band UVB (TL-01) phototherapy: an effective preventative treatment for the photodermatoses. *Br J Dermatol* 1995;132:956-963.
247. Roelandts R. Photo(chemo)therapy and general management of erythropoietic protoporphyria. *Dermatologica* 1995;190:330-331.
248. Ross JB, Moss MA. Relief of photosensitivity of erythropoietic protoporphyria by pyridoxine. *J Am Acad Dermatol* 1990;22:340-342.
249. Mathews-Roth MM, Rosner B. Long-term treatment of erythropoietic protoporphyria with cysteine. *Photodermatol Photoimmunol Photomed* 2002;18:307-309.
250. Schoemaker JH, Bousema MT, Zijlstra H, et al. Treatment of erythropoietic protoporphyria with hydroxyethylrutosides. *Dermatologica* 1995;191:36-38.
251. Harms JH, Lautenschlager S, Minder CE, Minder EI. Mitigating photosensitivity of erythropoietic protoporphyria patients by an agonistic analog of α -melanocyte stimulating hormone. *Photochem Photobiol* 2009;85: 1434-1439.

252. Minder EI. Afamelanotide, an agonistic analog of α -melanocyte-stimulating hormone, in dermal phototoxicity of erythropoietic protoporphyria. *Expert Opin Investig Drugs* 2010;19:1591-1602.
253. Todd DJ, Callender ME, Mayne EE, et al. Erythropoietic protoporphyria, transfusion therapy, and liver disease. *Br J Dermatol* 1992;127:534-537.
254. Gordeuk VR, Brittenham GM, Hawkins CW, et al. Iron therapy for hepatic dysfunction in erythropoietic protoporphyria. *Ann Intern Med* 1986;105:27-31.
255. Milligan A, Graham-Brown RAC, Sarkany I, et al. Erythropoietic protoporphyria exacerbated by oral iron therapy. *Br J Dermatol* 1988;119:63-66.
256. McCullough AJ, Barron D, Mullen KD, et al. Fecal protoporphyrin excretion in erythropoietic protoporphyria: effect of cholestyramine and bile acid feeding. *Gastroenterology* 1988;94:177-181.
257. Yoo D-J, Lee HC, Yu E, et al. Cholestyramine resin for erythropoietic protoporphyria with severe hepatic disease: a case report. *Korean J Hepatol* 2010;16:83-88.
258. Gorschein A, Foster GR. Liver failure in protoporphyria: long-term treatment with oral charcoal. *Hepatology* 1999;29:995-996.
259. McGuire BM, Bloomer JR. Use of extracorporeal albumin dialysis for erythropoietic protoporphyria. *Liver Transpl* 2007;13:639-640.
260. Oshikawa Y, Fukushima S, Miyake T, et al. Photosensitivity and acute liver insufficiency in late-onset erythropoietic protoporphyria with a chromosome 18q abnormality. *Case Rep Dermatol* 2012;4:144-149.
261. Sperl J, Prochazkova J, Martasek P, et al. N-Acetyl cysteine averted liver transplantation in a patient with liver failure caused by erythropoietic protoporphyria. *Liver Transpl* 2009;15:352-354.
262. McGuire BM, Bonkovsky HL, Carithers RL, et al. Liver transplantation for erythropoietic protoporphyria liver disease. *Liver Transpl* 2005;11:1590-1596.
263. Anstey AV, Hift RJ. Liver disease in erythropoietic protoporphyria: emerging insights and their implications for management. *Gut* 2007;56:1009-1018.
264. Wahlin S, Stal P, Adam R, et al. Liver transplantation for erythropoietic protoporphyria in Europe. *Liver Transpl* 2011;17:1021-1026.
265. Dowman JK, Gunson BK, Mirza DF, et al. UK experience of liver transplantation for erythropoietic protoporphyria. *J Inherit Metab Dis* 2011;34: 539-545.
266. Poh-Fitzpatrick MB, Wang X, Anderson KE, et al. Erythropoietic protoporphyria: altered phenotype after bone marrow transplantation for myelogenous leukemia in a patient heteroallelic for ferrochelatase mutations. *J Am Acad Dermatol* 2002;46:861-866.
267. Rand EB, Bunin N, Cochran W, et al. Sequential liver and bone marrow transplantation for treatment of erythropoietic protoporphyria. *Pediatrics* 2006;118:1894-1897.
268. Wahlin S, Harper P. The role of BMT in erythropoietic protoporphyria. *Bone Marrow Transplant* 2010;45:393-394.
269. Wahlin S, Aschan J, Bjornstedt M, et al. Curative bone marrow transplantation in erythropoietic protoporphyria after reversal of severe cholestasis. *J Hepatol* 2007;46:174-179.
270. Mathews-Roth MM, Michel JL, Wise RJ. Amelioration of the metabolic defect in erythropoietic protoporphyria by expression of human ferrochelatase in cultured cells. *J Invest Dermatol* 1995;104:497-499.
271. Magness ST, Brenner DA. Ferrochelatase cDNA delivered by adenoviral vector corrects biochemical defect in protoporphyric cells. *Hum Gene Ther* 1995;6:1285-1290.
272. Ruth GR, Schwartz S, Stephenson B. Bovine protoporphyria: the first nonhuman model of this hereditary photosensitizing disease. *Science* 1977;198:199-201.
273. Bloomer JR, Morton KO, Reuter RJ, et al. Bovine protoporphyria: documentation of autosomal recessive inheritance and comparison with the human disease through measurement of heme synthase activity. *Am J Hum Genet* 1982;34:322-330.

274. Jenkins MM, LeBoeuf RD, Ruth GR, et al. A novel stop codon mutation (X417L) of the ferrochelatase gene in bovine protoporphyria, a natural animal model of the human disease. *Biochim Biophys Acta* 1998;1408:18-24.
275. DeMatteis F, Rimington C. Disturbance of porphyrin metabolism caused by griseofulvin in mice. *Br J Dermatol* 1963;75:91-104.
276. Matilla A, Molland EA. A light and electron microscopic study of the liver in case of erythrohepatic protoporphyria and in griseofulvin-induced porphyria in mice. *J Clin Pathol* 1974;27:698-709.
277. Gschnait F, Konrad K, Honigsmann H, et al. Mouse model for protoporphyria. I. The liver and hepatic protoporphyrin crystals. *J Invest Dermatol* 1975;65:290-299.
278. Konrad K, Honigsmann H, Gschnait F, et al. Mouse model for protoporphyria. II. Cellular and subcellular events in the photosensitivity flare of the skin. *J Invest Dermatol* 1975;65:300-310.
279. Tutois S, Montgutelli X, DaSilva V, et al. Erythropoietic protoporphyria in the house mouse. A recessive inherited ferrochelatase deficiency with anemia, photosensitivity and liver disease. *J Clin Invest* 1991;88:1730-1736.
280. Lyoumi S, Abitbol M, Andrieu V, et al. Increased plasma transferrin, altered body iron distribution and microcytic hypochromic anaemia in ferrochelatase-deficient mice. *Blood* 2007;109:811-818.
281. Boulechfar S, Lamoril J, Montagutelli X, et al. Ferrochelatase structural mutant (Fechm1Pas) in the house mouse. *Genomics* 1993;16:645-648.
282. Fontanellas A, Mazurier F, Landry M, et al. Reversion of hepatobiliary alterations by bone marrow transplantation in a murine model of erythropoietic protoporphyria. *Hepatology* 2000;32:73-81.
283. Pawliuk R, Bachelot T, Wise RJ, et al. Long-term cure of the photosensitivity of murine erythropoietic protoporphyria by preselective gene therapy. *Nat Med* 1999;5:768-773.
284. Fontanellas A, Mendez M, Mazurier F, et al. Successful therapeutic effect in a mouse model of erythropoietic protoporphyria by partial genetic correction and fluorescence-based selection of hematopoietic cells. *Gene Ther* 2001;8:618-626.
285. Richard E, Robert E, Cario-Andre M, et al. Hematopoietic stem cell gene therapy of murine protoporphyria by methylguanine-DNA-methyltransferase-mediated in vivo drug selection. *Gene Ther* 2004;11:1638-1647.
286. Cooperman SS, Meyron-Holtz EG, Olivierre-Wilson H, et al. Microcytic anemia, erythropoietic protoporphyria, and neurodegeneration in mice with targeted deletion of iron-regulatory protein 2. *Blood* 2005;106:1084-1091.
287. Childs S, Weinstein BM, Manzoor-Ali PK, et al. Zebrafish *Dracula* encodes ferrochelatase and its mutation provides a model for erythropoietic protoporphyria. *Current Biol* 2001;10:1001-1004.
288. Deybach J-C, Puy H. Acute intermittent porphyria: from clinical to molecular aspects. In: Kadish KM, Smith KM, Guillard R, eds. *The porphyrin handbook—medical aspects of porphyrins*. Amsterdam: Academic Press, 2003;14:23-41.
289. Tishler PV, Woodward B, O'Connor J, et al. High prevalence of intermittent acute porphyria in a psychiatric patient population. *Am J Psychiatry* 1985;142:1430-1436.
290. Strand LJ, Felsher BF, Redeker AG, et al. Heme biosynthesis in intermittent acute porphyria: decreased hepatic conversion of porphobilinogen to porphyrins and increased delta-aminolevulinic acid synthetase activity. *Proc Natl Acad Sci U S A* 1970;67:1315-1320.
291. Miyagi K, Cardinal R, Bossenmaier I, et al. The serum porphobilinogen and hepatic porphobilinogen deaminase in normal and porphyric individuals *J Lab Clin Med* 1971;78:683-695.
292. Meyer UA, Strand LJ, Doss M, et al. Intermittent acute porphyria: demonstration of a genetic defect in porphobilinogen metabolism. *N Engl J Med* 1972;286:1277-1282.
293. Bonkowsky HL, Tschudy DP, Weinbach EC, et al. Porphyrin synthesis and mitochondrial respiration in acute intermittent porphyria: studies using cultured human fibroblasts. *J Lab Clin Med* 1975;85:93-102.
294. Sassa S, Solish G, Levere RD, et al. Studies in porphyria. IV. Expression of the gene defect of acute intermittent porphyria in cultured human skin fibroblasts and amniotic cells: prenatal diagnosis of the porphyric trait. *J Exp Med* 1975;142:722-731.
295. Sassa S, Zalar GL, Kappas A. Studies in porphyria. VII. Induction of uroporphyrinogen-synthase and expression of the gene defect of acute intermittent porphyria in mitogen-stimulated human lymphocytes. *J Clin Invest* 1978;61:499-508.

296. Lamon JM, Frykholm BC, Tschudy DP. Family evaluations in acute intermittent porphyria using red cell uroporphyrinogen I synthase. *J Med Genet* 1979;16:134-139.
297. Wilson JHP, van den Berg JWO, Brouwers D, et al. Erythrocyte uroporphyrinogen-I-synthase activity in acute intermittent porphyria. *Neth J Med* 1979;22:13-16.
298. Bottomley SS, Bonkowsky HL, Kreimer-Birnbaum M. The diagnosis of acute intermittent porphyria. Usefulness and limitations of the erythrocyte uroporphyrinogen I synthase assay. *Am J Clin Pathol* 1981;76:133-139.
299. Astrup EG. Family studies on the activity of uroporphyrinogen I synthase in diagnosis of acute intermittent porphyria. *Clin Sci Mol Med* 1978;54:551-556.
300. Wetterberg L, Floderus Y, Thunell S, et al. Genetic regulation of the red cell uroporphyrinogen-I-synthetase level in families with acute intermittent porphyria. *Clin Genet* 1983;24:403-406.
301. Mustajoki P, Tenhunen R. Variant of acute intermittent porphyria with normal erythrocyte uroporphyrinogen-I-synthase activity. *Eur J Clin Invest* 1985;15:281-284.
302. Anderson PM, Reddy RM, Anderson KE, et al. Characterization of the porphobilinogen deaminase deficiency in acute intermittent porphyria. Immunologic evidence for heterogeneity of the genetic defect. *J Clin Invest* 1981;68:1-12.
303. Lee JS, Lundin G, Lannfelt L, et al. Genetic heterogeneity of the porphobilinogen deaminase gene in Swedish families with acute intermittent porphyria. *Hum Genet* 1991;87:484-488.
304. Raich N, Romeo PH, Dubart A, et al. Molecular cloning and complete primary sequence of human erythrocyte porphobilinogen deaminase. *Nucleic Acids Res* 1986;14:5955-5968.
305. Grandchamp B, de Verneuil H, Beaumont C, et al. Tissue-specific expression of porphobilinogen deaminase. Two isozymes from a single gene. *Eur J Biochem* 1987;162:105-110.
306. Chretien S, Dubart A, Beaupain D, et al. Alternative transcription and splicing of the human porphobilinogen deaminase gene result either in tissue-specific or in housekeeping expression. *Proc Natl Acad Sci U S A* 1988;85:6-10.
307. Yoo HW, Warner CA, Chen CH, et al. Hydroxymethylbilane synthase: complete genomic sequence and amplifiable polymorphisms in the human gene. *Genomics* 1993;15:21-29.
308. Namba M, Narahara K, Tsuji K, et al. Assignment of human PBGD to 11q24.1-11q24.2 by in situ hybridization and gene dosage studies. *Cytogenet Cell Genet* 1991;67:105-108.
309. Hrdinka M, Puy H, Martasek P. May 2006 update in porphobilinogen deaminase polymorphisms and mutations causing acute intermittent porphyria. Comparison with the situation in Slavic population. *Physiol Res* 2007;55(Suppl 2):S119-S136.
310. Whatley SD, Roberts AG, Elder GH. De-novo mutation and sporadic presentation of acute intermittent porphyria. *Lancet* 1995;346:1007-1008.
311. Brancaleoni V, Granata F, Colancecco A, et al. Seven novel genetic mutations within the 5'UTR and the housekeeping promoter of HMBS gene responsible for the non-erythroid form of acute intermittent porphyria. *Blood Cells Mol Dis* 2012;49:147-151.
312. Picat C, Delfau MH, deRoos FWM, et al. Identification of the mutations in the parents of a patient with a putative compound heterozygosity for acute intermittent porphyria. *J Inherited Metab Dis* 1990;13:684-686.
313. Llewellyn DH, Smyth SJ, Elder GH, et al. Homozygous acute intermittent porphyria: compound heterozygosity for adjacent base transitions in the same codon of the porphobilinogen deaminase gene. *Hum Genet* 1992;89:97-98.
314. Solis C, Martinez-Bermejo A, Naidich TP, et al. Acute intermittent porphyria. Studies of the severe homozygous dominant disease provides insights into the neurologic attacks of acute porphyrias. *Arch Neurol* 2004;61:1764-1770.
315. Hessels J, Vootman G, van der Wagen A, et al. Homozygous acute intermittent porphyria in a 7-year-old boy with massive excretions of porphyrins and porphyrin precursors. *J Inher Metab Dis* 2004;27:19-27.
316. Schreiber WE, Jamani A, Armstrong JG. Acute intermittent porphyria in a native North American family. Biochemical and molecular analysis. *Am J Clin Pathol* 1995;103:730-734.
317. Andersson C, Floderus Y, Wikberg A, et al. The W198X and R173W mutations in the porphobilinogen deaminase gene in acute intermittent porphyria have higher clinical penetrance than R167W. A population-based study. *Scand J Clin Lab Invest* 2000;60:643-648.

318. Brownlie PD, Lambert R, Louie GV, et al. The three-dimensional structures of mutants of porphobilinogen deaminase: toward an understanding of the structural basis of acute intermittent porphyria. *Protein Sci* 1994;3: 1644-1650.
319. Gill R, Kolstoe SE, Mohammed F, et al. Structure of human porphobilinogen deaminase at 2.8 Å: the molecular basis of acute intermittent porphyria. *Biochem J* 2009;420:17-25.
320. Meyer U, Schuurmans MM, Lindberg RL. Acute porphyrias: pathogenesis and manifestations. *Semin Liver Dis* 1998;18:43-52.
321. Stein JA, Tschudy DP. Acute intermittent porphyria. A clinical and biochemical study of 46 patients. *Medicine* 1970;49:1-16.
322. Brennan MJW, Cantrill RC. δ -Aminolaevulinic acid is a potent agonist for GABA autoreceptors. *Nature* 1979;280:514-515.
323. Brennan MJW, Cantrill RC, Kramer S. Effect of δ -aminolaevulinic acid on GABA receptor binding in synaptic plasma membranes. *Int J Biochem* 1980;12:833-835.
324. Feldman DS, Levere RD, Lieberman JS. Presynaptic neuromuscular inhibition by delta-aminolevulinic acid, a porphyrin precursor. *Trans Am Neurol Assoc* 1968;93:206-208.
325. Bornstein JC, Pickett JB, Diamond I. Inhibition of the evoked release of acetylcholine by the porphyrin precursor δ -aminolevulinic acid. *Ann Neurol* 1979;5:94-96.
326. Loots JM, Becker DM, Meyer BJ, et al. The effect of porphyrin precursors on monosynaptic reflex activity in the isolated hemisectioned frog spinal cord. *J Neural Transm* 1975;36:71-81.
327. Percy VA, Lamm MCL, Taljaard JF. Δ -Aminolaevulinic acid uptake, toxicity and effect on [14C] gamma aminobutyric acid uptake into neurons and glia in culture. *J Neurochem* 1981;36:69-76.
328. Mitchell G, Larochelle J, Lambert M, et al. Neurologic crises in hereditary tyrosinemia. *N Engl J Med* 1990;322:432-437.
329. Soonawalla ZF, Orug T, Badminton MN, et al. Liver transplantation as a cure for acute intermittent porphyria. *Lancet* 2004;363:705-706.
330. Dar FS, Asai K, Haque AR, et al. Liver transplantation for acute intermittent porphyria: a viable treatment? *Hepatobiliary Pancreat Dis Int* 2010;9: 93-96.
331. Wahlin S, Harper P, Sardh E, et al. Combined liver and kidney transplantation in acute intermittent porphyria. *Transpl Int* 2010;23:e18-21.
332. Marcus RJ, Wetterberg L, Yuwiler A, et al. Electroencephalographic and behavioral effects of experimental porphyria in the rat. *Electroencephalogr Clin Neurophysiol* 1970;29:602-607.
333. Mustajoki K, Timonen K, Gorchein A, et al. Sustained high plasma 5-aminolevulinic acid concentration in a volunteer: no porphyric symptoms. *Eur J Clin Invest* 1992;22:407-411.
334. Pierach CA, Edwards PS. Neurotoxicity of δ -aminolevulinic acid and porphobilinogen. *Exp Neurol* 1978;62:810-814.
335. Shanley BC, Percy VA, Neethling AC. Pathogenesis of neural manifestations in acute porphyria. *S Afr Med J* 1977;51:458-460.
336. Lin CS, Lee MJ, Park SB, Kiernan MC. Purple pigments: the pathophysiology of acute porphyric neuropathy. *Clin Neurophysiol* 2011;122:2336-2344.
337. Whetsell WO Jr, Sassa S, Kappas A. Porphyrin-heme biosynthesis in organotypic cultures of mouse dorsal root ganglia. Effects of heme and lead on porphyrin synthesis and peripheral myelin. *J Clin Invest* 1984;74:600-607.
338. Litman DA, Correia MA. L-Tryptophan: a common denominator of biochemical and neurological events of acute hepatic porphyria? *Science* 1983;222:1031-1033.
339. Litman DA, Correia MA. Elevated brain tryptophan and enhanced 5-hydroxytryptamine turnover in acute hepatic heme deficiency: clinical implications. *J Pharmacol Exp Ther* 1985;232:337-345.
340. Puy H, Deybach JC, Baudry P, et al. Decreased nocturnal plasma melatonin levels in patients with recurrent acute intermittent porphyria attacks. *Life Sci* 1993;53:621-627.

341. Puy H, Deybach JC, Bogdan A, et al. Increased δ -aminolevulinic acid and decreased pineal melatonin production. A common event in acute porphyria studies in the rat. *J Clin Invest* 1996;97:104-110.
342. Anderson KE, Spitz IM, Bardin W, et al. A gonadotropin releasing hormone analogue prevents cyclical attacks of porphyria. *Arch Int Med* 1990;150:1469-1474.
343. Podvinec M, Handschin C, Looser R, et al. Identification of the xenosensors regulating human 5-aminolevulinate synthase. *Proc Natl Acad Sci U S A* 2004;101:9127-9132.
344. Kaupinen R, Mustajoki P. Prognosis of acute porphyria: occurrence of acute attacks, precipitating factors, and associated diseases. *Medicine* 1992;71:1-13.
345. Tschudy DP, Valsamis M, Magnussen CR. Acute intermittent porphyria: clinical and selected research aspects. *Ann Intern Med* 1975;83:851-864.
346. Handschin C, Lin J, Rhee J, et al. Nutritional regulation of hepatic heme biosynthesis and porphyria through PGC-1 α . *Cell* 2005;122:505-515.
347. Ridley A, Hierons R, Cavanagh JB. Tachycardia and neuropathy of porphyria. *Lancet* 1968;2:708-710.
348. Pischik E, Kaupinen R. Neurological manifestations of acute intermittent porphyria. *Cell Mol Biol (Noisy-le-grand)* 2009;55:72-83.
349. Gurses C, Durukan A, Sencer S, et al. A severe neurological sequela in acute intermittent porphyria: presentation of a case from encephalopathy to quadriplegia. *Br J Radiol* 2008;81:e135-140.
350. Kang S-Y, Kang J-H, Choi JC, Lee JS. Posterior reversible encephalopathy syndrome in a patient with acute intermittent porphyria. *J Neurol* 2010;257:663-664.
351. DeFrancisco M, Savino PJ, Schatz NJ. Optic atrophy in acute intermittent porphyria. *Am J Ophthalmol* 1979;87:221-224.
352. Carney MWP. Hepatic porphyria with mental symptoms: four missed cases. *Lancet* 1972;2:100-101.
353. Guidotti TL, Charness ME, Lamon JM. Acute intermittent porphyria and the Kluver-Bucy syndrome. *Johns Hopkins Med J* 1979;145:233-235.
354. Crimlisk HL. The little imitator-porphyria: a neuropsychiatric disorder. *J Neurol Neurosurg Psychiatry* 1997;62:319-328.
355. Jeans JB, Savik K, Gross CR, et al. Mortality in patients with acute intermittent porphyria requiring hospitalization: a United States case series. *Am J Med Genet* 1996;65:269-273.
356. Bylesjo I, Forsgren L, Lithner F, et al. Epidemiology and clinical characteristics of seizures in patients with acute intermittent porphyria. *Epilepsia* 1996;37:230-235.
357. Beattie AD, Goldberg A. Acute intermittent porphyria. Natural history and prognosis. In: Doss M, ed. *Porphyryns in human diseases*. Basel: Karger, 1976:245-250.
358. Hift RJ, Meissner PN. An analysis of 112 acute porphyric attacks in Cape Town, South Africa. *Medicine* 2005;84:48-60.
359. Cuquemelle E, Ehrmann S, Razazi K, et al. An atypical case of Guillain-Barre syndrome: acute intermittent porphyria. *Intensive Care Med* 2012;38: 913-914.
360. Stein PE, Badminton MN, Barth JH, et al. Acute intermittent porphyria: fatal complications of treatment. *Clin Med* 2012;12:293-294.
361. Bylesjo I, Wikberg A, Andersson C. Clinical aspects of acute intermittent porphyria in northern Sweden: a population-based study. *Scand J Clin Lab Invest* 2009;69:612-618.
362. Stewart MF. Review of hepatocellular cancer, hypertension and renal impairment as late complications of acute porphyria and recommendations for patient follow-up. *J Clin Pathol* 2012 Jul 31 [Epub ahead of print].
363. Marsden JT, Chowdhury P, Wang J, et al. Acute intermittent porphyria and chronic renal failure. *Clin Nephrol* 2008;69:339-346.
364. Sardh E, Andersson DE, Henrichson A, Harper P. Porphyrin precursors and porphyrins in three patients with acute intermittent porphyria and end-stage renal disease under different therapy regimens. *Cell Mol Biol (Noisy-le-grand)* 2009;55:66-71.

365. Innala E, Andersson C. Screening for hepatocellular carcinoma in acute intermittent porphyria: a 15-year follow-up in northern Sweden. *J Intern Med* 2011;269:538-545.
- 365a. Sardh E, Wahlin S, Bjornstedt M, et al. High risk of primary liver cancer in a cohort of 179 patients with acute hepatic porphyria. *J Inher Metab Dis* 2013 Jan 23 [Epub ahead of print].
366. Deybach J-C, Puy H. Hepatocellular carcinoma without cirrhosis: think acute hepatic porphyrias and vice versa. *J Intern Med* 2011;269:521-524.
367. Pierach CA, Bossenmaier I, Cardinal RA, et al. Pseudo-porphyrin in a patient with hepatocellular carcinoma. *Am J Med* 1984;76:545-548.
368. Beukeveld GJJ, Wolthers BG, Nordmann Y, et al. A retrospective study of a patient with homozygous form of acute intermittent porphyria. *J Inherited Metab Dis* 1990;13:673-683.
369. Bloomer JR, Berk PD, Bonkowsky HL, et al. Blood volume and bilirubin production in acute intermittent porphyria. *N Engl J Med* 1971;284:17-20.
370. Watson CJ, Bossenmaier I, Cardinal R. Acute intermittent porphyria: urinary porphobilinogen and other Ehrlich reactors in the diagnosis. *JAMA* 1961;175:1987-1089.
371. Bissell DM. Laboratory evaluation in porphyria. *Semin Liver Dis* 1982;2:100-107.
372. Deacon AC, Peters TJ. Identification of acute porphyria: evaluation of a commercial screening test of urinary porphobilinogen. *Ann Clin Biochem* 1998;35(Pt 6):726-732.
373. Mauzerall D, Granick S. Occurrence and determination of δ -aminolevulinic acid and porphobilinogen in urine. *J Biol Chem* 1956;219:435-446.
374. Waldenström J, Vahlquist BC. Studien über die Entstehung der roten Harnpigmente (Uroporphyrin und Porphobilin) bei der akuten Porphyrie aus ihrer farblosen Vorstufe (Porphobilinogen). *Hoppe-Seyler's Z Physiol Chem* 1939;260:189-209.
375. Cripps DJ, Peters HA. Stool porphyrins in acute intermittent and hereditary coproporphyria. Adverse effect of tranquilizers. *Arch Neurol* 1970;23:80-84.
376. Anderson KE, Bloomer JR, Bonkovsky HL, et al. Recommendations for the diagnosis and treatment of the acute porphyrias. *Ann Int Med* 2005;142:439-450.
377. Stein JA, Curl FD, Valsamis M, et al. Abnormal ion and water metabolism in acute intermittent porphyria with new morphologic findings. *Am J Med* 1972;53:784-789.
378. Eales L, Dowdle EB, Sweeney GD. The electrolyte disorder of the acute porphyric attack and the possible role of delta-aminolaevulinic acid. *S Afr J Lab Clin Med* 1971;17:89-97.
379. Yen P-S, Chen C-J, Lui C-C. Diffusion-weighted magnetic resonance imaging of porphyric encephalopathy: a case report. *Eur Neurol* 2002;48:119-121.
380. Marmatton BV, Saldivar RA, Glynn SM, et al. Acute intermittent porphyria presenting as a diffuse encephalopathy. *Ann Neurol* 2005;57:581-584.
381. Kupferschmidt H, Bont A, Schnorf H, et al. Transient cortical blindness and occipital brain lesions in two patients with acute intermittent porphyria. *Ann Intern Med* 1995;123:598-600.
382. Ten Eyck FW, Martin WJ, Kernohan JW. Acute porphyria: necropsy studies in nine cases. *Proc Staff Meet Mayo Clinic* 1961;36:409-422.
383. Albers JW, Roberts WC, Daube JR. Electrodiagnostic findings in acute porphyric neuropathy. *Muscle Nerve* 1978;1:292-296.
384. Thorner PS, Bilbao JM, Sima AAF, et al. Porphyric neuropathy: an ultrastructural and quantitative case study. *Can J Neurol Sci* 1981;8:281-287.
385. Mustajoki P, Seppalainen AM. Neuropathy in latent hereditary hepatic porphyria. *BMJ* 1975;2:310-312.
386. Laiwah ACY, MacPhee GJA, Boyle P, et al. Autonomic neuropathy in acute intermittent porphyria. *J Neurol Neurosurg Psychiatry* 1985;48:1025-1030.
387. Blom H, Andersson C, Olofsson BO, et al. Assessment of autonomic nerve function in acute intermittent porphyria; a study based on spectral analysis of heart rate variability. *J Int Med* 1996;240:73-79.

388. Douer D, Weinberger A, Pinkhas J, et al. Treatment of acute intermittent porphyria with large doses of propranolol. *JAMA* 1978;240:766-768.
389. Bonkowsky HL, Tschudy DP. Hazard of propranolol in treatment of acute porphyria. *BMJ* 1974;4:47-48.
390. Bonkowsky HL, Tschudy DP, Collins A, et al. Repression of the overproduction of porphyrin precursors in acute intermittent porphyria by intravenous infusions of hematin. *Proc Natl Acad Sci U S A* 1971;68:2725-2729.
391. Watson CJ, Pierach CA, Bossenmaier I, et al. Use of hematin in the acute attack of "inducible" hepatic porphyrias. *Adv Intern Med* 1978;23:256-286.
392. Mustajoki P, Nordmann Y. Early administration of heme arginate for acute porphyric attacks. *Arch Intern Med* 1993;153:2004-2008.
393. Anderson KE, Bonkovsky HL, Bloomer JR, et al. Reconstitution of hematin for intravenous infusion. *Ann Int Med* 2006;144:537-538.
394. Goetsch CA, Bissell DM. Instability of hematin used in the treatment of acute hepatic porphyria. *N Engl J Med* 1986;315:235-238.
395. Green D, Ts'ao CH. Hematin: effects on hemostasis. *J Lab Clin Med* 1990;115:144-147.
396. Tenhunen R, Mustajoki P. Acute porphyria: treatment with heme. *Semin Liver Dis* 1998;18:53-55.
397. Sardh E, Harper P, Andersson DE, Floderus Y. Plasma porphobilinogen as a sensitive biomarker to monitor the clinical and therapeutic course of acute intermittent porphyria attacks. *Eur J Intern Med* 2009;20:201-207.
398. Winkler AS, Peters TJ, Elwes RDC. Neuropsychiatric porphyria in patients with refractory epilepsy: report of three cases. *J Neurol Neurosurg Psychiatry* 2005;76:380-383.
399. Sadeh M, Blatt I, Martonovits G, et al. Treatment of porphyric convulsions with magnesium sulfate. *Epilepsia* 1991;32:712-715.
400. Hahn M, Gildemeister OS, Krauss GL, et al. Effects of new anticonvulsant medications on porphyrin synthesis in cultured liver cells: potential implications for patients with acute porphyria. *Neurology* 1997;49:97-106.
401. Zaatreh MM. Levetiracetam in porphyric status epilepticus. A case report. *Clin Neuropharmacol* 2005;28:243-244.
402. Kochar DK, Pal M, Kochar SK, et al. Acute intermittent porphyria presenting with neurological emergency: review of six cases. *Neurol India* 2007;55:413-415.
403. Elder GH, Sandberg S. Identifying acute porphyria in patients with acute polyneuropathy or encephalopathy. *Nat Clin Pract Neurol* 2008;4:648-649.
404. Hift RJ, Meissner PN, Moore MR. Porphyria: a toxicogenic disease. In: Kadish KM, Smith KM, Guillard R, eds. *The porphyrin handbook—medical aspects*. Amsterdam: Academic Press, 2003;14:303-338.
405. Hift RJ, Thunell S, Brun A. Drugs in porphyria: from observation to a modern algorithm-based system for the prediction of porphyrogenicity. *Pharmacol Ther* 2011;132:158-169.
406. James MFM, Hift RJ. Porphyrias. *Br J Anaesth* 2000;85:143-153.
407. Delaby C, To-Figueras J, Deybach JC, et al. Role of two nutritional hepatic markers (insulin-like growth factor 1 and transthyretin) in the clinical assessment and follow-up of acute intermittent porphyria patients. *J Intern Med* 2009;266:277-285.
408. Winkler AS, Peters TJ, Marsden JT, et al. Erythropoietin treatment of the neuropsychiatric porphyrias. *Clin Chim Acta* 2003;338:61-66.
409. Bargetzi MJ, Meyer UA, Birkhaeuser MH. Premenstrual exacerbations in hepatic porphyria: prevention by intermittent administration of an LH-RH agonist in combination with a gestagen. *JAMA* 1989;261:864.
410. Marsden JT, Rees DC. A retrospective analysis of outcome of pregnancy in patients with acute porphyria. *J Inher Metab Dis* 2010;33:591-596.
411. Tollanes MC, Aarsand AK, Sandberg S. Excess risk of adverse pregnancy outcomes in women with porphyria; a population-based cohort study. *J Inher Metab Dis* 2011;34:217-223.
412. Aggarwal N, Bagga R, Sawhney H, et al. Pregnancy with acute intermittent porphyria: a case report and review of literature. *J Obstet Gynaecol Res* 2002;28:160-162.

413. Badminton MN, Deybach J-C. Treatment of an acute attack of porphyria during pregnancy. *Eur J Neurol* 2006;13:668-669.
414. Andersson C, Innala E, Backstrom T. Acute intermittent porphyria in women: clinical expression, use and experience of exogenous sex hormones. A population-based study in northern Sweden. *J Int Med* 2003;254:176-183.
415. Dowman JK, Gunson BK, Mirza DF, et al. LT-11-056 liver transplantation for acute intermittent porphyria is complicated by a high rate of hepatic artery thrombosis. *Liver Transpl* 2012;18:185-200.
416. Dowman JK, Gunson BK, Bramhall S, Newsome PN. Liver transplantation from donors with acute intermittent porphyria 2011;154:571-572.
417. Sardh E, Rejkjaer L, Andersson DEH, et al. Safety, pharmacokinetics and pharmacodynamics of recombinant human porphobilinogen deaminase in healthy subjects and symptomatic carriers of the acute intermittent porphyria gene who have increased porphyrin precursor excretion. *Clin Pharmacokinet* 2007;46:335-349.
418. Johansson A, Moller C, Harper P. Correction of the biochemical defect in porphobilinogen deaminase deficient cells by non-viral gene delivery. *Mol Cell Biochem* 2003;250:65071.
419. Clavero S, Bishop DF, Haskins ME, et al. Feline acute intermittent porphyria: a phenocopy masquerading as an erythropoietic porphyria due to dominant and recessive hydroxymethylbilane synthase mutations. *Hum Mol Genet* 2010;19:584-596.
420. Lindberg RLP, Porcher C, Grandchamp B, et al. Porphobilinogen deaminase deficiency in mice causes a neuropathy resembling that of human acute hepatic porphyria. *Nat Genet* 1996;12:195-199.
421. Lindberg RLP, Martini R, Baumgartner M, et al. Motor neuropathy in porphobilinogen deaminase-deficient mice imitates the peripheral neuropathy of human acute porphyria. *J Clin Invest* 1999;103:1127-1134.
422. Jover R, Hoffmann F, Scheffler-Koch V, et al. Limited heme synthesis in porphobilinogen deaminase-deficient mice impairs transcriptional activation of specific cytochrome P450 genes by phenobarbital. *Eur J Biochem* 2000;267:7128-7137.
423. Schuurmans MM, Hoffmann F, Lindberg RL, et al. Zinc mesoporphyrin represses induced hepatic 5-aminolevulinic acid synthase and reduces heme oxygenase activity in a mouse model of acute hepatic porphyria. *Hepatology* 2001;33:1217-1222.
424. Johanssen A, Moller C, Fogh J, et al. Biochemical characterization of porphobilinogen deaminase-deficient mice during phenobarbital induction of heme synthesis and the effect of enzyme replacement. *Mol Med* 2003; 193:193-199.
425. Johanssen A, Nowak G, Moller C, et al. Adenoviral-mediated expression of porphobilinogen deaminase in liver restores the metabolic defect in a mouse model of acute intermittent porphyria. *Mol Ther* 2004;10:337-343.
426. Yasuda M, Bishop DF, Fowkes M, et al. AAVB-mediated gene therapy prevents induced biochemical attacks of acute intermittent porphyria and improves neuromotor function. *Mol Ther* 2010;18:17-22.
427. Unzu C, Sampedro A, Mauleon I, et al. Sustained enzymatic correction by rAAV-mediated liver gene therapy protects against induced motor neuropathy in acute porphyria mice. *Mol Ther* 2011;19:243-250.
428. Potluri VR, Astrin KH, Wetmur JG, et al. Human δ -aminolevulinic acid dehydratase: chromosomal localization to 9q34 by in situ hybridization. *Hum Genet* 1987;76:236-239.
429. Kaya AH, Plewinska M, Wong DM, et al. Human δ -aminolevulinic acid dehydratase (ALAD) gene: structure and alternative splicing of the erythroid and housekeeping mRNAs. *Genomics* 1994;19:242-248.
430. Doss M, von Tiepermann R, Schneider J, et al. New type of hepatic porphyria with porphobilinogen synthase defect and intermittent acute clinical manifestation. *Klin Wochenschr* 1979;57:1123-1127.
431. Thunell S. Aminolaevulinic acid dehydratase porphyria in infancy. A clinical and biochemical study. *J Clin Chem Clin Biochem* 1987;25:5-14.
432. Hassoun A, Verstraeten L, Mercelis R, et al. Biochemical diagnosis in a 63-year-old man. *J Clin Chem Clin Biochem* 1989;27:781-786.
433. Mercelis R, Hassoun A, Verstraeten L, et al. Porphyric neuropathy and hereditary δ -aminolevulinic acid dehydratase deficiency in an adult. *J Neurol Sci* 1990;95:39-47.

434. Wolff C, Piderit F, Armas-Merino R. Deficiency of porphobilinogen synthase associated with acute crisis. Diagnosis of the first two cases in Chile by laboratory methods. *Eur J Clin Chem Clin Biochem* 1991;29:313-315.
435. Doss MO, Stauch R, Gross U, et al. The third case of Doss porphyria (δ -aminolevulinic acid dehydratase deficiency) in Germany. *J Inherit Metab Dis* 2004;27:529-536.
- P.706
436. Akagi R, Kato N, Inoue R, et al. δ -Aminolevulinic acid dehydratase (ALAD) porphyria: the first case in North America with two novel ALAD mutations. *Mol Genet Metab* 2006;87:329-336.
437. Bird TD, Hamernyik P, Nutter JY, et al. Inherited deficiency of delta-aminolevulinic acid dehydratase. *Am J Hum Genet* 1979;31:662-668.
438. de Verneuil H, Doss M, Brusco N, et al. Hereditary hepatic porphyria with delta aminolevulinic acid dehydratase deficiency: immunologic characterization of the non-catalytic enzyme. *Hum Genet* 1985;69:174-177.
439. Fujita H, Sassa S, Lundgren J, et al. Enzymatic defect in a child with hereditary hepatic porphyria due to homozygous δ -aminolevulinic acid dehydratase deficiency: immunochemical studies. *Pediatrics* 1987;80:880-885.
440. Sassa S, Fujita H, Doss M, et al. Hereditary hepatic porphyria due to homozygous δ -aminolevulinic acid dehydratase deficiency: studies in lymphocytes and erythrocytes. *Eur J Clin Invest* 1991;21:244-248.
441. Plewinska M, Thunell S, Holmberg L, et al. δ -Aminolevulinic acid dehydratase deficient porphyria: identification of the molecular lesions in a severely affected homozygote. *Am J Hum Genet* 1991;49:167-174.
442. Ishida N, Fujita H, Fukuda Y, et al. Cloning and expression of the defective genes from a patient with δ -aminolevulinic acid dehydratase porphyria. *J Clin Invest* 1992;89:1431-1437.
443. Maruno M, Furuyama K, Akagi R, et al. Highly heterogeneous nature of δ -aminolevulinic acid dehydratase (ALAD) deficiencies in ALAD porphyria. *Blood* 2001;97:2972-2978.
444. Jaffe EK, Stith L. ALAD porphyria is a conformational disease. *Am J Hum Genet* 2007;80:329-337.
445. Akagi R, Yasui Y, Harper P, et al. A novel mutation of δ -aminolevulinic acid dehydratase in a healthy child with 12% erythrocyte enzyme activity. *Br J Haematol* 1999;106:931-937.
446. Akagi R, Nishitani C, Harigae H, et al. Molecular analysis of δ -aminolevulinic acid dehydratase deficiency in a patient with an unusual late-onset porphyria. *Blood* 2000;96:3618-3623.
447. Astrin KH, Bishop DF, Wetmur JG, et al. δ -Aminolevulinic acid dehydratase isozymes and lead toxicity. *Ann N Y Acad Sci* 1987;514:23-29.
448. Wetmur JG, Kaya AH, Plewinska M, et al. Molecular characterization of the human δ -aminolevulinic acid dehydratase 2 (ALAD2) allele: implications for molecular screening of individuals for genetic susceptibility to lead poisoning. *Am J Hum Genet* 1991;49:757-763.
449. Gross U, Sassa S, Arndt T, et al. Survival of two patients with severe deltaaminolevulinic acid dehydratase deficiency porphyria. *J Inherit Metab Dis* 2001;24:60-64.
450. Thunell S, Henrichson A, Floderus Y, et al. Liver transplantation in a boy with acute porphyria due to aminolaevulinic acid dehydratase deficiency. *Eur J Clin Chem Clin Biochem* 1992;30:599-606.
451. Eales L, Day RS, Blekkenhorst GH. The clinical and biochemical features of variegate porphyria: an analysis of 300 cases studied at Groote Schuur Hospital, Capetown. *Int J Biochem* 1980;12:837-853.
452. Meissner P, Hift R, Corrigall A. Variegate porphyria. In: Kadish KM, Smith KM, Guillard R, eds. *The porphyrin handbook—medical aspects of porphyrins*. Amsterdam: Academic Press, 2003;14:89-120.
453. Mustajoki P. Variegate porphyria. Twelve years' experience in Finland. *QJM* 1980;44:191-203.
454. Fromke VL, Bossenmaier I, Cardinal R, et al. Porphyria variegata. Study of a large kindred in the United States. *Am J Med* 1978;65:80-88.
455. Muhlbauer JE, Pathak MA, Tishler PV, et al. Variegate porphyria in New England. *JAMA* 1982;247:3095-3102.

456. MacAlpine I, Hunter R, Rimington C. Porphyrinuria in the royal houses of Stuart, Hanover, and Prussia. A follow-up study of George 3d's illness. *Br Med J* 1968;1:7-18.
457. Rohl JCG, Warren M, Hunt D. Purple secret: genes, madness and the royal houses of Europe. London: Transworld Publishers, 1998.
458. Cox TM, Jack N, Lofthouse S, et al. King George III and porphyria: an elemental hypothesis and investigation. *Lancet* 2005;366:332-335.
459. Hift RJ, Peters TJ, Meissner PN. A review of the clinical presentation, natural history and inheritance of variegate porphyria: its implausibility as the source of the "Royal Malady". *J Clin Pathol* 2012;65:200-205.
460. Brenner DA, Bloomer JR. The enzymatic defect in variegate porphyria. *N Engl J Med* 1980;302:765-769.
461. Deybach JC, de Verneuil H, Nordmann Y. The inherited enzymatic defect in porphyria variegata. *Hum Genet* 1981;58:425-428.
462. Taketani S, Inazawa J, Abe T, et al. The human protoporphyrinogen oxidase gene (PPOX): organization and location to chromosome 1. *Genomics* 1995;29:698-703.
463. Dailey TA, Dailey HA. Human protoporphyrinogen oxidase: expression, purification, and characterization of the cloned enzyme. *Protein Sci* 1996;5:98-105.
464. Roberts AG, Whatley SD, Daniels J, et al. Partial characterization and assignment of the gene for protoporphyrinogen oxidase and variegate porphyria to human chromosome 1q23. *Hum Mol Genet* 1995;4:2387-2390.
465. Puy H, Robreau A-M, Rosipal R, et al. Protoporphyrinogen oxidase: complete genomic sequence and polymorphisms in the human gene. *Biochem Biophys Res Commun* 1996;226:226-230.
466. Meissner PN, Dailey TA, Hift RJ, et al. A R59W mutation in human protoporphyrinogen oxidase results in decreased enzyme activity and is prevalent in South Africans with variegate porphyria. *Nat Genet* 1996;13:95-97.
467. van Tuyl van Serooskerken AM, Drogemoller BI, Te Velde K, et al. Extended haplotype studies in South African and Dutch variegate porphyria families carrying the recurrent p.R59W mutation confirm a common ancestry. *Br J Dermatol* 2012;166:261-265.
468. Dailey HA, Dailey TA. Characteristics of human protoporphyrinogen oxidase in controls and variegate porphyrias. *Cell Mol Biol* 1997;43:67-73.
469. Corradi HR, Corrigan AV, Boix E, et al. Crystal structure of protoporphyrinogen oxidase from *Myxococcus xanthus* and its complex with the inhibitor acifluorfen. *J Biol Chem* 2006;282:38625-38633.
470. Qin X, Tan Y, Wang L, et al. Structural insight into human variegate porphyria disease. *FASEB J* 2011;25:653-664.
471. Elder GH, Evans JO. A radiochemical method for the measurement of coproporphyrinogen oxidase and the utilization of substrates other than coproporphyrinogen III by the enzyme from rat liver. *Biochem J* 1978; 169:205-214.
472. Meissner PN, Day RS, Moore MR, et al. Protoporphyrinogen oxidase and porphobilinogen deaminase in variegate porphyria. *Eur J Clin Invest* 1986;16:257-261.
473. Meissner P, Adams P, Kirsch R. Allosteric inhibition of human lymphoblast and purified porphobilinogen deaminase by protoporphyrinogen and coproporphyrinogen: a possible mechanism for the acute attack of variegate porphyria. *J Clin Invest* 1993;91:1436-1444.
474. Stojeba N, Meyer C, Jeanpierre C, et al. Recovery from a variegate porphyria by a liver transplantation. *Liver Transpl* 2004;10:935-938.
475. Hift RJ, Meissner PN, Corrigan AV, et al. Variegate porphyria in South Africa, 1688-1996—new developments in an old disease. *S Afr Med J* 1997;87: 722-731.
476. Hift RJ, Meissner D, Meissner PN. A systematic study of the clinical and biochemical expression of variegate porphyria in a large South African family. *Br J Dermatol* 2004;151:4165-4171.
477. Timonen K, Niemi KM, Mustajoki P, et al. Skin changes in variegate porphyria. Clinical, histopathological, and ultrastructural study. *Arch Dermatol Res* 1990;282:108-114.
478. Eales L. Acute porphyria: the precipitating and aggravating factors. *S Afr J Lab Clin Med* 1971;17:120-125.
479. Mustajoki P. Variegate porphyria. *Ann Intern Med* 1978;89:238-244.

480. Schneider-Yin X, van Tuyll van Serooskerken AM, Went P, et al. Hepatocellular carcinoma in variegate porphyria: a serious complication. *Acta Derm Venereol* 2010;90:512-515.
481. Kirsch RE, Meissner PN, Hift RJ. Variegate porphyria. *Semin Liver Dis* 1998;18:33-41.
482. Logan GM, Weimer MK, Ellefson M, et al. Bile porphyrin analysis in the evaluation of variegate porphyria. *N Engl J Med* 1991;324:1408-1411.
483. Long C, Smyth SJ, Woolf J, et al. Detection of latent variegate porphyria by fluorescence emission spectroscopy of plasma. *Br J Dermatol* 1993;129:9-13.
484. DaSilva V, Simonin S, Deybach JC, et al. Variegate porphyria: diagnostic value of fluorometric scanning of plasma porphyrins. *Clin Chim Acta* 1995;238:163-168.
485. Hift RJ, Davidson BP, van der Hooft C, et al. Plasma fluorescence scanning and fecal porphyrin analysis for the diagnosis of variegate porphyria: precise determination of sensitivity and specificity with detection of protoporphyrinogen oxidase mutations as a reference standard. *Clin Chem* 2004;50: 915-923.
486. Medlock AE, Meissner PN, Davidson BP, et al. A mouse model for South African (R59W) variegate porphyria: construction and initial characterization. *Cell Mol Biol* 2002;48:71-78.
487. Dooley KA, Fraenkel PG, Langer NB, et al. montalcino, A zebrafish model for variegate porphyria. *Exp Hematol* 2008;38:1132-1142.
488. Dobriner K. Simultaneous excretion of coproporphyrin I and III in a case of chronic porphyria. *Proc Soc Exp Biol Med* 1936;35:175-176.
489. Watson C, Schwartz S, Schulze W, et al. Studies in coproporphyrin III. Coproporphyrinuria; a hitherto unrecognized form characterized by lack of symptoms in spite of the excretion of large amount of coproporphyrin. *J Clin Invest* 1949;28:465-468.
490. Berger H, Goldberg A. Hereditary coproporphyrinuria. *BMJ* 1955;2:85-88.
491. Brodie MJ, Thompson GG, Moore MR, et al. Hereditary coproporphyrinuria. Demonstration of the abnormalities of haem biosynthesis in peripheral blood. *QJM* 1977;182:229-241.
492. Elder GH, Evans JO, Thomas N, et al. The primary enzyme defect in hereditary coproporphyrinuria. *Lancet* 1976;2:1217-1219.
493. Grandchamp B, Nordman Y. Decreased lymphocyte coproporphyrinogen III oxidase activity in hereditary coproporphyrinuria. *Biochem Biophys Res Commun* 1977;74:1089-1095.
494. Hawk JLM, Magnus I, Elder GH, et al. Deficiency of hepatic coproporphyrinogen oxidase in hereditary coproporphyrinuria. *J R Soc Med* 1978;71:775-777.
495. Doss M, von Tiepermann R, Pfluger KH. Coexistence of hereditary coproporphyrinuria and epilepsy: coproporphyrinogen oxidase deficiency in liver and kidney. *J Neurol* 1981;226:25-33.
496. Grandchamp B, Phung N, Nordmann Y. Homozygous case of hereditary coproporphyrinuria. *Lancet* 1977;2:1348-1349.
497. Doss MO, Goss U, Lamoril J et al. Compound heterozygous hereditary coproporphyrinuria with fluorescent teeth. *Ann Clin Biochem* 1999;36:680-682.
498. Martasek P, Camadro JM, Delfau-Larue MH, et al. Molecular cloning, sequencing and functional expression of a cDNA encoding human coproporphyrinogen oxidase. *Proc Natl Acad Sci U S A* 1994;91:3024-3028.
499. Taketani S, Kohno H, Furukawa T, et al. Molecular cloning, sequencing and expression of a cDNA encoding human coproporphyrinogen oxidase. *Biochim Biophys Acta* 1994;1183:547-549.
500. Delfau-Larue MH, Martasek P, Grandchamp B. Coproporphyrinogen oxidase: gene organization and description of a mutation leading to exon 6 skipping. *Hum Mol Genet* 1994;3:1325-1330.
501. Cacheux V, Martasek P, Fougerousse F, et al. Localization of the human coproporphyrinogen oxidase gene to chromosome band 3q12. *Hum Genet* 1994;94:557-559.
502. Allen KR, Whatley SD, Degg TJ, et al. Hereditary coproporphyrinuria: comparison of molecular and biochemical investigations in a large family. *J Inherit Metab Dis* 2005;28:779-785.

503. McIntyre N, Pearson AJG, Allan DJ, et al. Hepatic δ -aminolaevulinic acid synthetase in an attack of hereditary coproporphyrin and during remission. *Lancet* 1971;1:560-564.
504. Haeger-Aronsen B, Stathers G, Swahn G. Hereditary coproporphyrin. Study of a Swedish family. *Ann Intern Med* 1968;69:221-227.
505. Andrews J, Erdjument H, Nicholson DC. Hereditary coproporphyrin: incidence in a large English family. *J Med Genet* 1984;21:341-349.
506. Goldberg A, Rimington C, Lochhead AC. Hereditary coproporphyrin. *Lancet* 1967;1:632-636.
507. Barohn RJ, Sanchez JA, Anderson KE. Acute peripheral neuropathy due to hereditary coproporphyrin. *Muscle Nerve* 1994;17:793-799.
508. Lane PR, Massey KL, Worobetz LJ, et al. Acute hereditary coproporphyrin induced by the androgenic/anabolic steroid methandrostenolone (Dianabol). *J Am Acad Dermatol* 1994;30:308-312.
509. Casali C, LoMonaco M, D'Alessandro L, et al. Hereditary coproporphyrin: unusual nervous system involvement in two cases. *J Neurol* 1984;231: 99-101.
510. DiTrapani G, Casali C, Tonali P, et al. Peripheral nerve findings in hereditary coproporphyrin. Light and ultrastructural studies in two sural nerve biopsies. *Acta Neuropathol* 1984;63:96-107.
511. Andant C, Puy H, Deybach JC, et al. Occurrence of hepatocellular carcinoma in a case of hereditary coproporphyrin. *Am J Gastroenterol* 1997;92: 1389-1390.
512. Kuhnel A, Gross U, Doss MO. Hereditary coproporphyrin in Germany: clinical-biochemical studies in 53 patients. *Clin Biochem* 2000;33:465-473.
513. Manning DJ, Gray TA. Haem arginate in acute hereditary coproporphyrin. *Arch Dis Child* 1991;66:730-731.
514. Schoenfeld N, Mamet R, Dotan I, et al. Relation between uroporphyrin excretion, acute attacks of hereditary coproporphyrin and successful treatment with haem arginate. *Clin Sci* 1995;88:365-369.
515. Ma E, Mar V, Varigos G, et al. Haem arginate as effective maintenance therapy for hereditary coproporphyrin. *Australas J Dermatol* 2011;52:135-138.
516. Lamoril PJ, Puy H, Gouya L, et al. Neonatal hemolytic anemia due to inherited harderoporphyria; clinical characteristics and molecular basis. *Blood* 1998;91:1453-1457.
517. Schmitt C, Gouya L, Malonova E, et al. Mutations in human CPO gene predict clinical expression of either hepatic hereditary coproporphyrin or erythropoietic harderoporphyria. *Hum Mol Genet* 2005;14:3089-3098.
518. Lee D-S, Flachsova E, Bodnarova M, et al. Structural basis of hereditary coproporphyrin. *Proc Natl Acad Sci U S A* 2005;102:14232-14237.
519. Hasanoglu A, Balwani M, Kasapkara CS, et al. Harderoporphyria due to homozygosity for coproporphyrinogen oxidase missense mutation. *J Inherit Metab Dis* 2011;34:225-231.
520. Watson CJ, Cardinal RA, Bossenmaier I, et al. Porphyria variegata and porphyria cutanea tarda in sibs: chemical and genetic aspects. *Proc Natl Acad Sci U S A* 1975;72:5126-5129. Addendum. *Idem* 1976;73:1323.
521. Levine J, Johnson WT, Tschudy DP. The coexistence of two types of porphyria in one family. *Arch Dermatol* 1978;114:613-614.
522. Day RS, Eales L, Meissner D. Coexistent variegate porphyria and porphyria cutanea tarda. *N Engl J Med* 1982;307:36-41.
523. Sturrock ED, Meissner PN, Maeder DL, et al. Uroporphyrinogen decarboxylase and protoporphyrinogen oxidase in dual porphyria. *S Afr Med J* 1989;76:405-408.
524. Chan KM, Ladenson JH, Vaidya HO, et al. Dual porphyria: an underdiagnosed entity? *Clin Chem* 1987;33:1190-1193.
525. Sieg I, Bhutani LK, Doss MO. Dual porphyria of coexisting variegata and cutanea tarda. *Eur J Clin Chem Clin Biochem* 1995;33:405-410.
526. Doss MO. Dual porphyria in double heterozygotes with porphobilinogen deaminase and uroporphyrinogen decarboxylase deficiencies. *Clin Genet* 1989;35:146-151.

527. Doss MO, Gross U, Puy H, et al. Coexistence of hereditary coproporphyrinemia and porphyria cutanea tarda: a new form of dual porphyria. *Med Klin* 2002;97:1-5.
528. Nordmann Y, Amram D, Deybach J-C, et al. Coexistent hereditary coproporphyrinemia and congenital erythropoietic porphyria (Gunther disease). *J Inher Metab Dis* 1990;13:687-691.
529. Yamada M, Kondo M, Tanaka M, et al. An autopsy case of acute porphyria with a decrease of both uroporphyrinogen III synthetase and ferrochelatase activities. *Acta Neuropathol* 1984;64:6-11.
530. McColl KEL, Thompson GG, Moore MR, et al. Chester porphyria: biochemical studies of a new form of acute porphyria. *Lancet* 1985;2:796-799.
531. Qadiri MR, Church SE, McColl KEL, et al. Chester porphyria: a clinical study of a new form of acute porphyria. *BMJ* 1986;292:455-459.
532. Crimlisk H. Dobson's complaint: the story of the chester porphyria. *BMJ* 1999;318:336A.
533. Norton B, Lanyon WG, Moore MR, et al. Evidence for involvement of a second genetic locus on chromosome 11q in porphyrin metabolism. *Hum Genet* 1993;91:576-578.
534. Poblete-Gutierrez P, Wiederholt T, Martinez-Mir A, et al. Demystification of Chester porphyria: a nonsense mutation in the porphobilinogen deaminase gene. *Physiol Res* 2006;55(Suppl 2):S137-S144.
535. Gregor A, Kostrzewska E, Tarczyska-Nosal S, et al. Coexistence of hereditary coproporphyrinemia with acute intermittent porphyria. *Ann Med* 1994;26: 125-127.
536. Kaido M, Fukada K, Moriya M, et al. Porphyria with double errors in the heme biosynthetic pathway. *J Neurol* 2001;248:328-329.
537. Freesemann AG, Hofweber K, Doss MO. Coexistence of deficiencies of uroporphyrinogen III synthase and decarboxylase in a patient with congenital erythropoietic porphyria and in his family. *Eur J Clin Chem Clin Biochem* 1997;35:35-39.
538. Lange B, Hofweber K, Waldherr R, et al. Congenital erythropoietic porphyria associated with nephrotic syndrome and renal siderosis. *Acta Paediatr* 1995;84:1325-1328.
539. van Tuyll van Serooskerken AM, de Rooij FW, Edixhoven A, et al. Digenic inheritance of mutations in the coproporphyrinogen oxidase and protoporphyrinogen oxidase genes in a unique type of porphyria. *J Invest Dermatol* 2011;131:2249-2254.
540. Akagi R, Inoue R, Muranaka S, et al. Dual gene defects involving δ -aminolaevulinic acid dehydratase and coproporphyrinogen oxidase in a porphyria patient. *Br J Haematol* 2006;132:237-243.
541. Harraway JR, Florkowsky CM, Sies C, et al. Dual porphyria with mutations in both the UROD and HMBS genes. *Ann Clin Biochem* 2006;43:80-82.

Section 3 - Hemolytic Anemia

Chapter 27 Hereditary Spherocytosis, Hereditary Elliptocytosis, and Other Disorders Associated with Abnormalities of the Erythrocyte Membrane

> Table of Contents > Part IV - Disorders of Red Cells > Section 3 - Hemolytic Anemia > Chapter 27 - Hereditary Spherocytosis, Hereditary Elliptocytosis, and Other Disorders Associated with Abnormalities of the Erythrocyte Membrane
Chapter 27

Hereditary Spherocytosis, Hereditary Elliptocytosis, and Other Disorders Associated with Abnormalities of the Erythrocyte Membrane

Patrick G. Gallagher

Bertil Glader

This chapter focuses on hemolytic disorders and abnormalities of red blood cell (RBC) shape resulting from alterations of the erythrocyte membrane. The major emphasis is on the hereditary spherocytosis (HS) and hereditary elliptocytosis (HE) syndromes because these are most commonly encountered by clinicians.¹ The traditional classification of these disorders, retained in this chapter because of its clinical applicability (Fig. 27.1), has been based on RBC shape changes. There has been an explosion of knowledge regarding the biology of the erythrocyte membrane, providing a better understanding of membrane structure and function as well as revealing the heterogeneous and diverse pathobiology of these disorders. Readers should consult prior editions of this text for details of previously cited primary references.

THE ERYTHROCYTE MEMBRANE

The erythrocyte membrane, because of its easy accessibility, is the most studied biologic membrane. Composed of a lipid bilayer and an underlying cortical membrane skeleton (Fig. 27.2), the erythrocyte membrane provides the red cell with the deformability and stability required to withstand its travels through the circulation. The erythrocyte is subjected to high shear stress in the arterial system, dramatic changes in size in the microcirculation with capillary diameters as small as 7.5 μm , and marked fluctuations in tonicity, pH, and pO_2 as it travels through the body.²

The lipid bilayer is composed primarily of phospholipids intercalated with unesterified cholesterol and glycolipids. Phospholipids are asymmetrically organized, with the choline phospholipids, phosphatidylcholine (PC) and sphingomyelin (SM), primarily in the outer half of the bilayer; and the amino phospholipids, phosphatidylethanolamine (PE) and phosphatidylserine (PS), in the inner half of the bilayer.³ In pathologic states, such as thalassemia, sickle cell disease, and diabetes, loss of phospholipid asymmetry with externalization of PS leads to activation of blood clotting via conversion of prothrombin to thrombin and facilitates macrophage attachment to erythrocytes, marking them for destruction.⁴

Lipids are arranged in domains within the bilayers, as large, lipid-rich macroscopic domains, protein-bound microscopic domains, or domains associated with the detergent-resistant fraction of the membrane (called DRM or lipid rafts).^{5, 6} The role(s) of these domains has yet to be elucidated, but DRM domains may facilitate malarial invasion of the erythrocyte.^{7, 8}

The erythrocyte membrane contains about 15 major proteins and hundreds of minor ones.^{9, 10, 11} One erythrocyte proteomic study found 340 of 527 proteins were membrane-associated.¹² A human erythrocyte proteome database is maintained at the Max-Planck Unified (MAPU) proteome database: <http://www.mapuproteome.com/rbc>.¹³ Typically, membrane proteins are classified as integral, penetrating or crossing the lipid bilayer and interacting with the hydrophobic lipid core, or peripheral, interacting with integral proteins or lipids at the membrane surface but not penetrating into the bilayer core. The integral membrane proteins include the glycoporphins, the Rh proteins, Kell and Duffy antigens, and transport proteins such as band 3 (AE1, anion exchanger 1), Na^+, K^+ -ATPase, Ca^{2+} -ATPase, and Mg^{2+} -ATPase. An assortment of membrane receptors and antigens are present on various integral membrane proteins. Peripheral membrane proteins include the structural proteins of the spectrin-actin-based membrane skeleton.¹⁴

The membrane skeleton, composed of an intricately interwoven meshwork of proteins, interacts with both integral membrane proteins and the lipid bilayer.¹⁴ The major proteins of the membrane skeleton include spectrin, actin, ankyrin, protein 4.1R, and protein 4.2 (Fig. 27.2 and Table 27.1).

Spectrin is the principal structural component of the membrane skeleton, as well as its most abundant protein, comprising 25% to 30% of membrane protein. Spectrin functions include provision of structural support for the lipid bilayer, maintenance of cellular shape, and regulation of lateral movement of integral membrane proteins.⁹ Spectrin is composed of α and β chains, which, despite a number of similarities, including both containing 106 amino acid α -helical "spectrin repeats" composed of triple-helices linked by short connecting regions, are distinct proteins encoded by separate genes. $\alpha\beta$ -Spectrin chains intertwine in an antiparallel manner to form 100-nm long heterodimers. These $\alpha\beta$ -spectrin heterodimers self-associate with other $\alpha\beta$ -spectrin heterodimers to form $(\alpha\beta)_2$ heterotetramers, the functional spectrin subunit in the erythrocyte.¹⁵ Tetramers provide significant flexibility and structural support for the lipid bilayer, helping maintain cellular shape.^{9, 16} Spectrin heterodimer-tetramer interconversion is governed by a simple thermodynamic equilibrium that favors tetramer formation.¹⁷

The primary linkage of spectrin to the plasma membrane is via binding of spectrin tetramers to ankyrin, which in turn binds to the integral protein band 3.¹⁸ Protein 4.2 binds to band 3 and probably to ankyrin, presumably promoting their interactions.¹⁹

A second linkage of spectrin to the plasma membrane is mediated by its association with the "junctional complex," a multiprotein complex that includes spectrin, actin, adducin, and protein 4.1R.²⁰ Protein 4.1R directly interacts with both spectrin and actin, as well as other proteins of the junctional complex and the plasma membrane including band 3, glycoporphin C (GPC), p55, calmodulin, CD44, p1C1n, CASK, mature parasite-infected antigen, and phosphatidylserine.

Other important junctional complex proteins include the β subtype of actin, tropomyosin, tropomodulin, p55, and adducin.⁹ Adducin is a heterodimer of structurally

P.708

related proteins, α -, β -, or γ -adducin, which functions in the early assembly of the spectrin/actin complex by capping the ends of fast-growing actin filaments and by recruiting spectrin to the ends of actin filaments.^{20, 21}

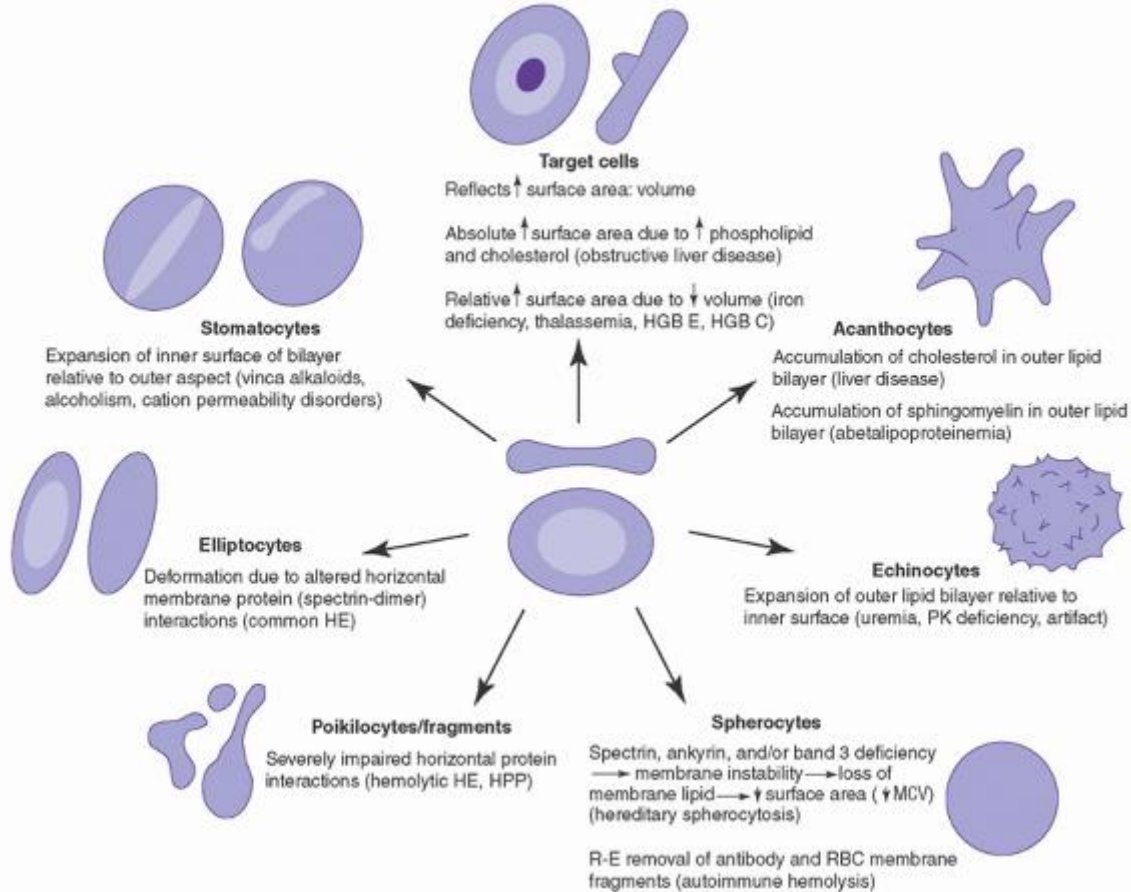

FIGURE 27.1. Diagrammatic representation of abnormal cells associated with alterations in the erythrocyte membrane. HE, hereditary elliptocytosis; HGB, hemoglobin; HPP, hereditary pyropoikilocytosis; MCV, mean corpuscular volume; PK, pyruvate kinase; RBC, red blood cell; R-E, reticuloendothelial.

Another membrane skeleton linkage to the plasma membrane is mediated via binding of a multiprotein complex containing the Rh proteins, the RH-associated glycoproteins, CD47, LW, glycophorin B, and protein 4.2 to ankyrin.

Erythrocyte membrane disorders result from alterations in the quantity or quality (or both) of individual proteins and their dynamic interactions with each other.^{2, 22} Disruption of the vertical protein-protein interactions of the membrane, i.e., the spectrin-ankyrin-band 3 linkage or the band 3-protein 4.2 interaction, leads to uncoupling of the membrane skeleton from the lipid bilayer. This leads to membrane instability with loss of lipids and some integral membrane proteins, resulting in loss of membrane surface area and the phenotype of spherocytosis (Fig. 27.2). Disruption of the horizontal interactions of membrane skeleton proteins, including perturbation of spectrin self-association or junctional complex protein-protein interactions, leads to membrane instability, altered membrane deformability and mechanical properties, and the phenotype of elliptocytosis (Fig. 27.2).²³

Development of biochemical techniques has allowed the separation and quantification of membrane proteins (Fig. 27.3) and the detection of membrane protein abnormalities in many hereditary red cell disorders. Advances in molecular biology have allowed determination of the precise genetic defects in many cases.

HEREDITARY SPHEROCYTOSIS

HS is a hemolytic disorder characterized by anemia, intermittent jaundice, splenomegaly, and responsiveness to splenectomy.^{24, 25} There is marked clinical heterogeneity, ranging from an asymptomatic condition to a fulminant hemolytic anemia. The morphologic hallmark of HS is the spherocyte, created by loss of membrane surface area and characterized by abnormal erythrocyte osmotic fragility (OF) in vitro. The interesting history of HS is recounted in detail by Dacie²⁶ and by Packman.²⁷ The earliest clinical account of the disorder is probably the 1871 report of Vanlair and Masius,²⁸ and the 1934 studies of Haden drew attention to a probable structural abnormality of the membrane as the basis for hemolysis.²⁹ Subsequent investigation of HS afforded important insights into the structure and function of cell membranes and the role of the spleen in maintaining erythrocyte integrity.

Prevalence and Genetics

HS is the most common of the hereditary hemolytic anemias among people of northern European descent. In the United States, the incidence of the disorder is approximately 1 in 3,000 to 5,000.^{24, 25} When mild and asymptomatic forms of the disease are considered, the incidence is closer to 1:2,000.^{30, 31} The disease is encountered worldwide, but its incidence and prevalence in other ethnic groups are not clearly established.

P.709

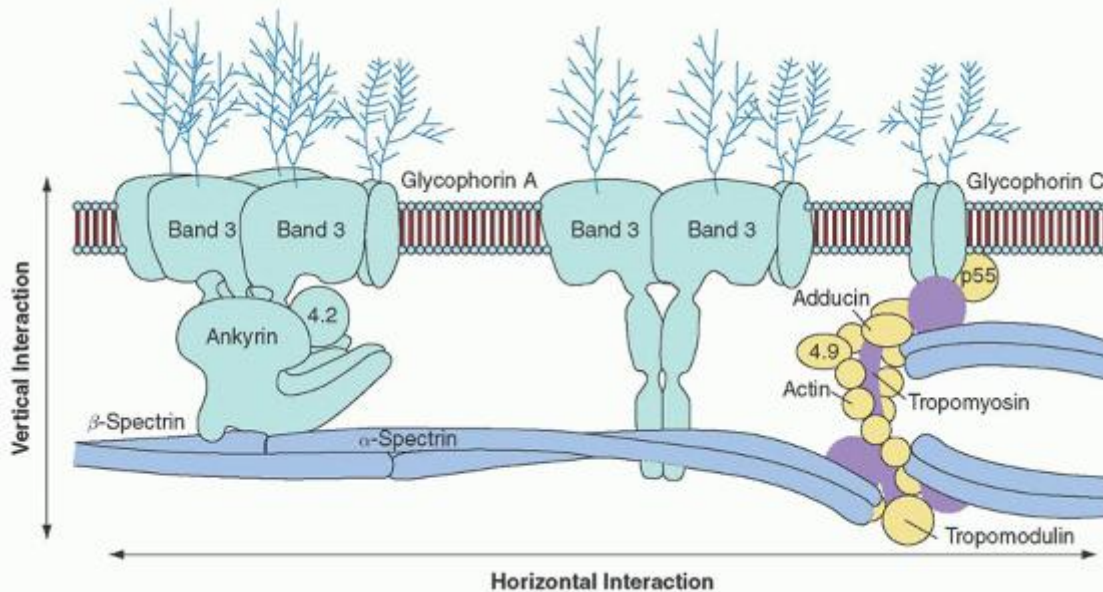

FIGURE 27.2. The erythrocyte membrane. A model of the major proteins of the erythrocyte membrane is shown: α - and β -spectrin, ankyrin, band 3 (the anion exchanger), 4.1R (protein 4.1R) and 4.2 (protein 4.2), Rh (Rhesus polypeptide), RhAG (Rh-associated glycoprotein), LW (Landsteiner-Weiner glycoprotein), actin, and glycophorin. Membrane protein-protein and protein-lipid interactions are often divided into two categories: (1) vertical interactions, which are perpendicular to the plane of the membrane and involve spectrin-ankyrin-band 3-protein 4.2 interactions and weak interactions between spectrin and the negatively charged lipids of the inner half of the membrane lipid bilayer; and (2) horizontal interactions, which are parallel to the plane of the membrane and include interactions between junctional complex proteins and spectrin or other membrane proteins. (Reprinted with permission from Perrotta S, Gallagher PG, Mohandas N. Hereditary spherocytosis. *Lancet* 2008;372:1411.)

In the majority of affected families, HS is transmitted in an autosomal dominant manner. Up to 25% of HS patients demonstrate nondominant inheritance, and the parents of these patients are clinically and hematologically normal.^{32, 33} In many of these patients, HS is due to a de novo mutation. In others, it is inherited in an autosomal recessive fashion, typically linked to abnormalities in the α -spectrin or protein 4.2 genes. A few cases of severe, homozygous HS have been reported, usually in cases where there is parental consanguinity.^{34, 35}

Pathogenesis

The pathogenesis of HS involves the interplay between an intrinsic erythrocyte membrane protein defect and an intact spleen that selectively retains, damages, and eventually destroys abnormal HS erythrocytes.

Membrane Protein Defects

The primary lesion in HS erythrocytes is caused by membrane protein defects that result in membrane instability. The first biochemical defect recognized in patients with HS was spectrin deficiency, and the degree of spectrin deficiency was found to correlate with the extent of spherocytosis, the degree of abnormality of the OF test, and the severity of hemolysis (Fig. 27.4).^{32, 33, 36, 37, 38} In some cases, spectrin deficiency is the result of impaired synthesis, whereas in other instances, it is caused by quantitative or qualitative deficiencies of other proteins that integrate spectrin into the cell membrane, especially ankyrin. In the latter case, free spectrin is degraded, thereby leading to spectrin deficiency. Analysis of red cell membrane proteins in patients with HS has identified several major abnormal patterns: spectrin deficiency alone, combined spectrin and ankyrin deficiency, band 3 deficiency, protein 4.2 deficiency, or no obvious biochemical abnormality. Each of the variant subsets is associated with mutations that result in different protein abnormalities and varied clinical expression (Table 27.2).³⁹ A tabulation of these mutations, searchable by gene or phenotype, maintained by investigators from Yale University and the National Human Genome Research Institute of the National Institutes of Health, is available at <http://research.nhgri.nih.gov/RBCmembrane/>.

Spectrin Deficiency

In the erythrocyte, α-spectrin is synthesized in three- to four fold excess with β-spectrin synthesis rate-limiting for membrane assembly of αβ-spectrin heterotetramers.^{40, 41} Excess α-chains normally are degraded. Clinical abnormalities caused by α-spectrin deficiency are found only in the homozygous or compound heterozygous state, as heterozygotes produce sufficient normal α-spectrin to balance β-spectrin production and maintain a normal phenotype. In contrast, defects of β-spectrin are clinically apparent in the heterozygous state because synthesis of β-spectrin is rate-limiting. Red cell membranes from patients with autosomal recessive HS due to α-spectrin deficiency have only 40% to 50% the normal amount of spectrin, whereas spectrin levels range from 60% to 80% in patients with autosomal dominant HS due to β-spectrin defects.^{24, 25}

Determination of the precise genetic defects in α-spectrin-linked HS has been slow. The large size of the α-spectrin gene (52 exons) and decreased mRNA associated with presumed null alleles has made mutation detection difficult. However, several variant alleles have been associated with α-spectrin-deficient, nondominant HS.^{42, 43} These include spectrin^{Bug Hill}, an alanine to aspartic acid substitution in the αII domain, and spectrin^{LEPRA}, low-expression Prague, a C to T substitution associated with increased utilization of an alternative acceptor splice site in intron 30. Whether these are disease-causing variants or are in linkage disequilibrium with other, as yet uncharacterized mutations, has not been determined.

Mutations of β-spectrin impair β-spectrin synthesis or produce truncated β-spectrin chains that are unstable or do not bind to ankyrin and, thus, are not assembled onto the membrane skeleton.^{44, 45} One HS-associated β-spectrin variant, β-Spectrin^{Kissimmee}, is a point mutation that leads to defective binding of spectrin to protein 4.1R.⁴⁶ Occasionally, cases of β-spectrin-linked HS arise de novo.⁴⁷

Ankyrin Defects

Combined spectrin and ankyrin deficiency is the most common biochemical abnormality found in the red cell membrane in cases

P.710

of typical, autosomal dominant HS.⁴⁸ Ankyrin is the principal binding site for spectrin on the red cell membrane, and studies of membrane skeleton assembly indicate that ankyrin deficiency leads to decreased incorporation of spectrin on the membrane despite normal spectrin synthesis. As expected, there is proportional deficiency of spectrin and ankyrin in these erythrocytes (Fig. 27.5).

TABLE 27.1 MAJOR HUMAN ERYTHROCYTE MEMBRANE PROTEINS, THEIR GENES, AND ASSOCIATED DISORDERS

SDS-PAGE Band	Protein	Amino Acids (#)	Molecular Weight × 10 ³ (kDa)	Oligomeric State	Gene Symbol	Chromosomal Location	Exons (#)	Associated Disorders
1	α-Spectrin	2,429	240/281	Heterodimer/tetramer	<i>SPTA1</i>	1q22-q23	52	HE, HPP, HS
2	β-Spectrin	2,137	220/246	Heterodimer/tetramer	<i>SPTB</i>	14q23-q24.1	32	HE, HPP,

				er				HS
2.1 ^a	Ankyrin-1	1,880	210/206	Monomer	<i>ANK1</i>	8p11.2	42	HS
2.9	α -Adducin	—	97/80	Heterodimer/tetramer	<i>ADD1</i>	4p16.3	16	—
				er				
2.9	β -Adducin	726	97/80	Heterodimer/tetramer	<i>ADD2</i>	2p13.3	17	—
				er				
3	Band 3 (AE1), anion exchanger1	911	90-100/102	Dimer or tetramer	<i>SLC4A1</i>	17q21	20	HS, HAc, SAO, HSt
4.1 ^b	Protein 4.1R	588	80 + 78/66	Monomer	<i>EPB41</i>	1p33-p34.2	>23	HE
4.2	Protein 4.2	691	2/77	Dimer or trimer	<i>EPB42</i>	15q15-q21	13	HS ¹⁴
4.9	Dematin	383	48-52/43-46	Trimer	<i>EPB49</i>	8p21.1	15	—
4.9	p55	466	55/53	Dimer	<i>MPP1</i>	Xq28	12	—
5	β -Actin	375	43/42	Oligomer	<i>ACTB</i>	7pter-q22	6	—
5	Tropomodulin	359	43/41	Monomer	<i>TMOD</i>	9q22	9	—
6	G3PD	335	35/36	Tetramer	<i>GAPD</i>	12p13	9	—
7	Stomatin	288	31/32	Oligomer	<i>STOM</i>	9q33.2	7	HSt
7	Tropomyosin	239	27 + 29/28	Heterodimer	<i>TPM3</i>	1q31	13	—
PAS-1 ^c	Glycophorin A	131	36/14	Dimer	<i>GYP A</i>	4q31.21	7	—
PAS-2 ^c	Glycophorin C	128	32/14	—	<i>GYP C</i>	2q14-q21	4	HE
PAS-3 ^c	Glycophorin B	72	20/8	Dimer	<i>GYP B</i>	4q31.21	5	—
PAS-3 ^c	Glycophorin D	107	23/11	—	<i>GYP D</i>	2q14 q21	4	HE

G3PD, glucose 3-phosphate dehydrogenase; HAc, hereditary acanthocytosis; HE, hereditary elliptocytosis; HPP, hereditary pyropoikilocytosis; HS, hereditary spherocytosis; HSt, hereditary stomatocytosis; PAS, periodic acid Schiff stain; SAO, Southeast Asian ovalocytosis; SDS-PAGE, sodium dodecyl sulfate-polyacrylamide gel electrophoresis.

^a Multiple ankyrin isoforms are seen on SDS-PAGE gels numbered 2.1, 2.1, 2.3, etc.

^b Protein 4.1R is a doublet (4.1a and 4.1b) on SDS-PAGE gels, with 4.1a derived from 4.1b by deamidation.

^c Glycophorins are visible only on PAS-stained gels.

Modified with permission from Gallagher PG, Lux SE, Disorders of the erythrocyte membrane. In: Nathan DG, Orkin SH, Ginsburg D, Look AT, eds. Hematology of infancy and childhood, 6th ed. Philadelphia, PA: WB Saunders, 2003:567-568.

Ankyrin gene mutations are the most common defect associated with dominant HS. The majority of ankyrin defects are private point mutations in the coding region of the ankyrin gene associated with reduced or absent expression of the

mutant allele.³⁴ Around 15% to 20% of these mutations arise de novo.⁴⁹ A few cases of spectrin/ankyrin-deficient HS are associated with mutations in the ankyrin gene erythroid promoter.^{50, 51, 52}

HS has been associated with karyotypic abnormalities involving deletions or translocations of the ankyrin-1 gene locus on chromosome 8p. Ankyrin deletions may be part of a contiguous gene syndrome associated with HS, mental retardation, typical facies, and hypogonadism.^{53, 54}

Band 3 Deficiency

Heterozygous band 3 mutations are found in 10% to 25% of patients with autosomal dominant HS.^{55, 56} Erythrocyte membranes demonstrate a 20% to 40% decrease of band 3 content and decreased or absent protein 4.2. Red cell anion transport is decreased proportional to the band 3 deficiency. Numerous band 3 gene mutations spread throughout the regions encoding both the cytoplasmic and membrane-spanning domains have been described. Many of these are null mutations associated with markedly reduced or absent band 3 mRNA. Others are missense mutations that disrupt band 3-membrane protein interactions or disrupt normal band 3 cellular trafficking from the endoplasmic reticulum to the plasma membrane.^{56, 57}

Affected patients typically exhibit mild to moderate HS.^{24, 25} Mushroom-shaped or "pincered" red cells on peripheral smear have been associated with band 3-deficient HS. Homozygotes or compound heterozygotes for band 3 mutations usually exhibit more severe HS. Band 3 alleles that influence band 3 expression have been reported that, when inherited in trans to a band 3 mutation, aggravate band 3 deficiency and worsen the clinical phenotype.^{58, 59, 60} Although band 3 is expressed in the distal tubules of the kidney, only a few patients with band 3-associated HS exhibit defects in urinary acidification.^{61, 62}

Protein 4.2 Deficiency

Autosomal recessive HS has been described in a subset of patients, primarily those of Japanese ancestry, whose erythrocyte membranes demonstrate marked deficiency of protein 4.2.⁶³ In some cases, there is co-existing deficiency of band 3 and ankyrin. Clinical severity and red cell morphology are variable,

P.711

with spherocytes, elliptocytes, or sphero-ovalocytes on peripheral smear. A few mutations of the protein 4.2 gene have been described in these patients, primarily null or missense mutations. One missense mutation, Protein 4.2^{Nippon}, associated with a spherocytic, ovalocytic, and elliptocytic hemolytic anemia, is relatively common in Japan.⁶⁴ Protein 4.2 deficiency also occurs in association with HS-associated mutations in the cytoplasmic domain of band 3, likely due to disruption of band 3-protein 4.2 interactions.

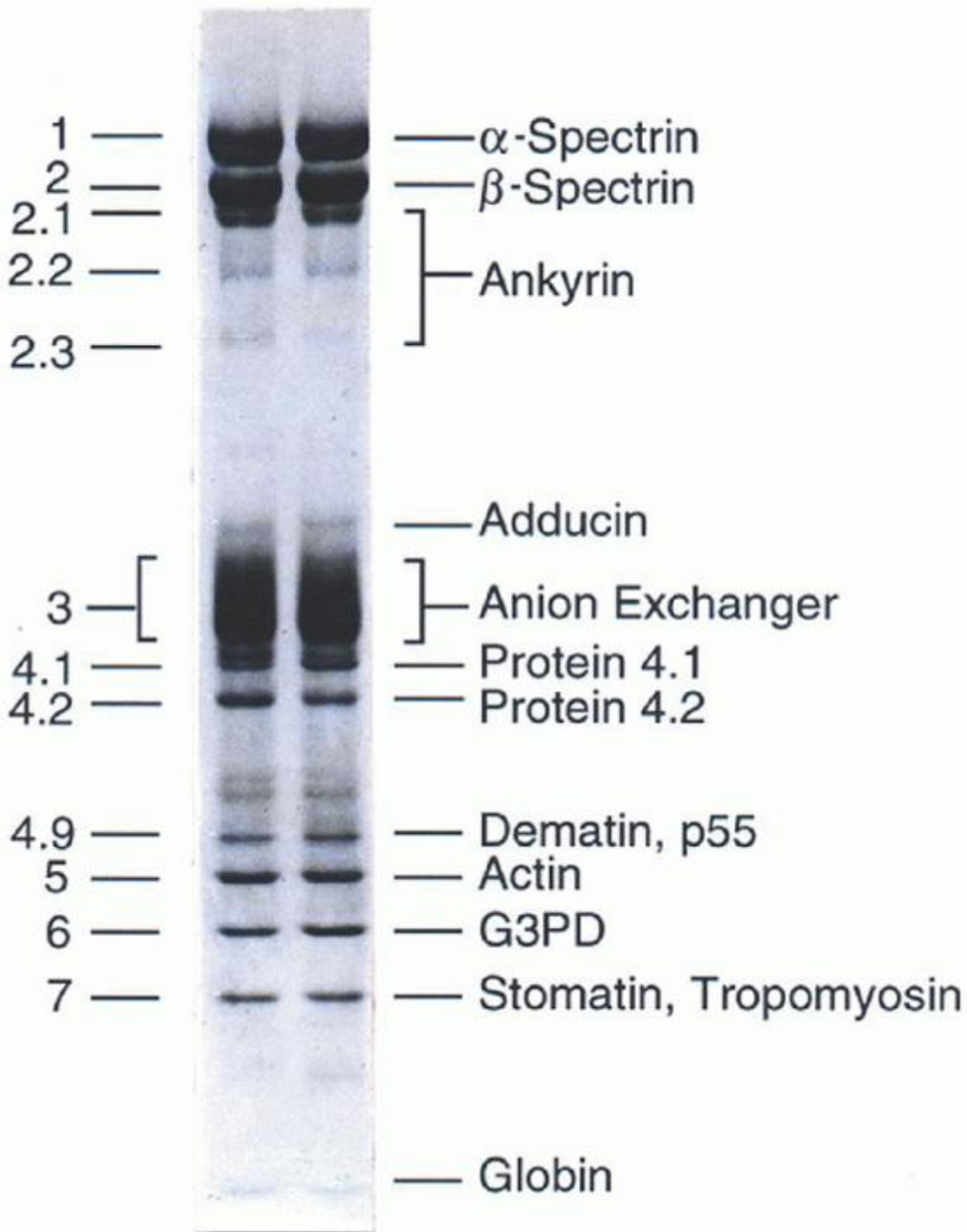

FIGURE 27.3. Protein composition of the red blood cell membrane skeleton. The major components of the erythrocyte membrane as separated by sodium dodecyl sulfate-polyacrylamide gel electrophoresis and revealed by Coomassie blue staining. G3PD, glucose 3-phosphate dehydrogenase. (Reprinted with permission from Gallagher PG, Tse WT, Forget BG. Clinical and molecular aspects of disorders of the erythrocyte membrane skeleton. *Semin Perinatol* 1990;14:352.)

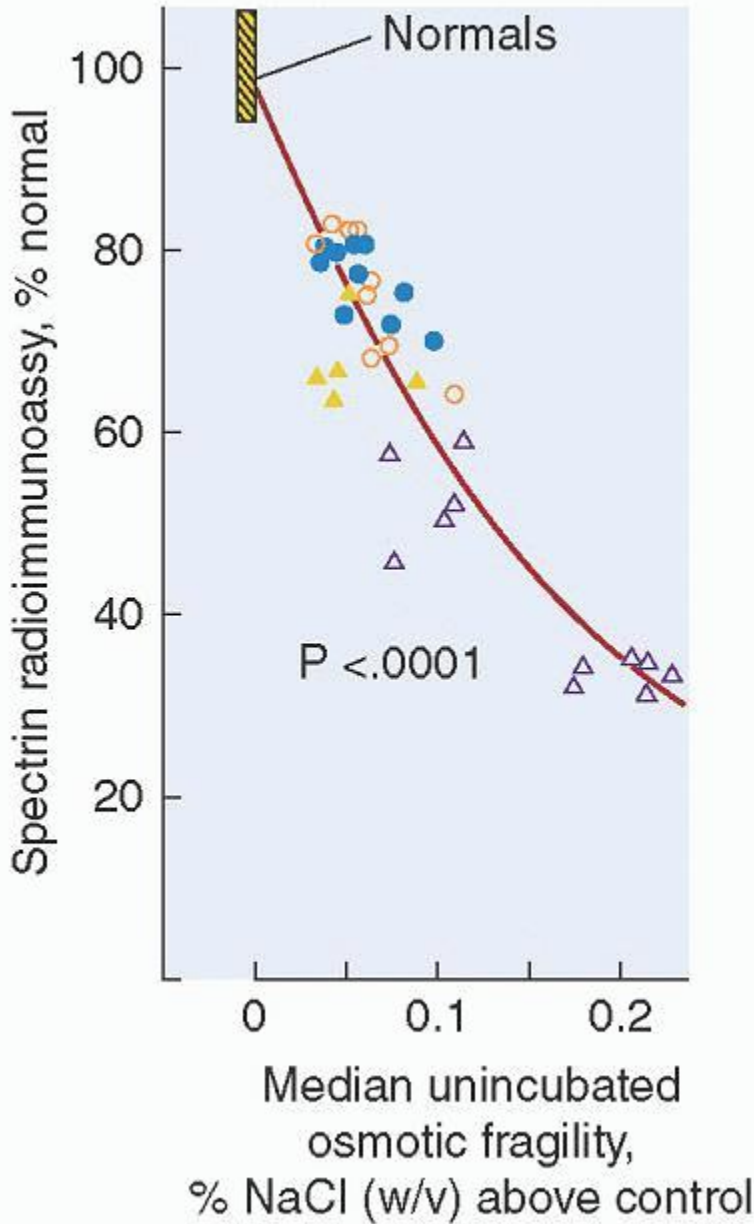

FIGURE 27.4. Relationship between spectrin deficiency and unincubated osmotic fragility in hereditary spherocytosis. Spectrin content, measured by radioimmunoassay, is shown on the vertical axis; and osmotic fragility, measured by the NaCl concentration that produces 50% hemolysis of red blood cells, is shown on the horizontal axis. Circles represent patients with typical, autosomal dominant HS and triangles represent patients with nondominant HS. Open symbols represent patients who have undergone splenectomy. (Reprinted with permission from Agre P, Asimos A, Casella JF, et al. Inheritance pattern and clinical response to splenectomy as a reflection of erythrocyte spectrin deficiency in hereditary spherocytosis. N Engl J Med 1986;315:1579.)

TABLE 27.2 CLASSIFICATION OF HEREDITARY SPHEROCYTOSIS

	Carrier	Mild Spherocytosis	Moderate Spherocytosis	Moderately Severe Spherocytosis ^a	Severe Spherocytosis ^b
Hemoglobin	Normal	11-15	8-12	6-8	<6

(g/dl)					
Reticulocytes (%)	1-3	3-8	8	10	10
Bilirubin (mg/dl)	0-1	1-2	2	2-3	3
Spectrin content (% of normal) ^c	100	80-100	50-80	40-80 ^d	20-50
Peripheral smear	Normal	Mild spherocytosis	Spherocytosis	Spherocytosis	Spherocytosis and poikilocytosis
Osmotic fragility: Fresh blood	Normal	Normal or slightly increased	Distinctly increased	Distinctly increased	Distinctly increased
Incubated blood	Slightly increased	Distinctly increased	Distinctly increased	Distinctly increased	Markedly increased

^a Values in untransfused patients.

^b By definition, patients with severe spherocytosis are transfusion-dependent.

^c Normal (\pm SD) = $245 \pm 27 \times 10^5$ spectrin dimers per erythrocyte. In most patients, ankyrin content is decreased to a comparable degree. A minority of hereditary spherocytosis patients lack band 3 or protein 4.2 and may have mild to moderate spherocytosis with normal amounts of spectrin and ankyrin.

^d The spectrin content is variable in this group of patients, presumably reflecting heterogeneity of the underlying pathophysiology.

Reprinted with permission from Walensky LD, Narla M, Lux SE. Disorders of the red blood cell membrane. In: Handin RI, Lux SE, Stossel TO, eds. Blood: principles and practice of hematology, 2nd ed. Philadelphia, PA: Lippincott Williams & Wilkins, 2003:1753.

Erythrocyte Abnormalities

The molecular basis of HS is heterogeneous, thus it is likely that the loss of membrane surface area is a consequence of several molecular mechanisms (Fig. 27.6). The common denominator

P.712

is a weakening of protein-protein interactions that link the membrane skeleton to the lipid bilayer, leading to microvesiculation, loss of membrane surface area, decreased surface/volume ratio, and spherocytosis. In cases associated with spectrin deficiency, the membrane skeleton is unable to provide adequate support for the lipid bilayer, causing destabilization of the lipid bilayer with the resultant loss of band 3-containing membrane microvesicles. In cases associated with band 3 deficiency, the lipid-stabilizing effect of band 3 is lost, releasing band 3-free microvesicles from the membrane. The loss of membrane surface area transforms red cells from biconcave discs to spherocytes with decreased cellular deformability, limiting their ability to pass through the sinusoids of the spleen and predisposing them to splenic entrapment, conditioning, and destruction.

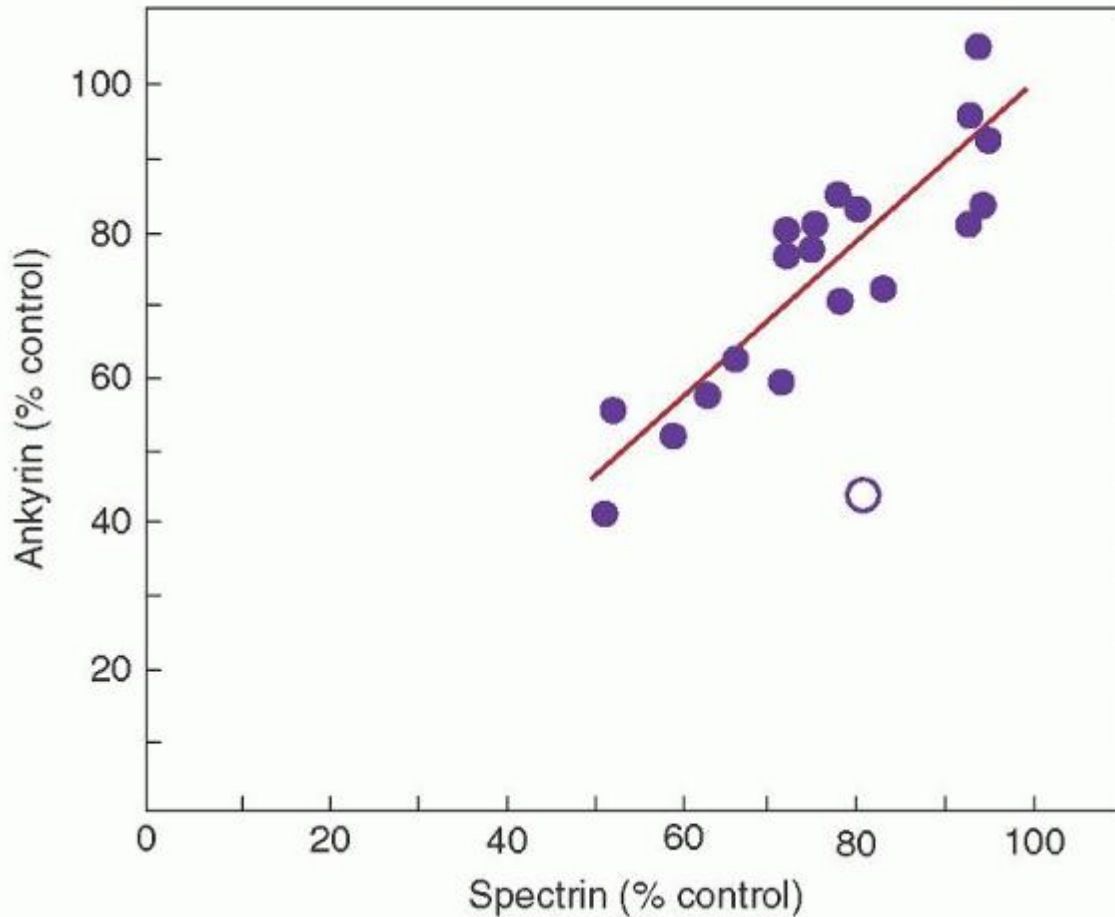

FIGURE 27.5. Role of spectrin and ankyrin in hereditary spherocytosis. The relationship between spectrin and ankyrin content in erythrocytes of patients with dominant hereditary spherocytosis. Each point, expressed as a percentage of control (100%), represents the mean value for a kindred for both spectrin and ankyrin levels. The line represents a computer-generated fitting of the data for 19 of the 20 kindreds. The degree of spectrin and ankyrin deficiencies is essentially identical in these kindreds with one exception (open circle), an otherwise typical family in which erythrocytes are primarily ankyrin-deficient. (Reprinted with permission from Savvides P, Shalev O, John KM, et al. Combined spectrin and ankyrin deficiency is common in autosomal dominant hereditary spherocytosis. *Blood* 1993;82:2953.)

The membrane defect in HS leads to a variety of secondary metabolic changes. These include increased sodium and potassium flux across the HS membrane, which leads to increased membrane sodium-potassium adenosine triphosphatase activation; accelerated adenosine triphosphate (ATP) breakdown; increased glycolytic rate; decreased 2,3-diphosphoglycerate (2,3-DPG) concentration, and lower intracellular pH. HS erythrocytes are slightly dehydrated, although the reason for decreased RBC water content is not known. Possibilities include activation of K-Cl cotransport, a pathway that leads to dehydration and is activated by acid pH, possibly in the acid environment of the splenic cords, or increased Na^+/K^+ pump activity stimulated in response to increased passive cation leaks, leading to decreased total cation content, water efflux from the red cell, and cellular dehydration. Dehydration of HS red cells is important because it can further impair their deformability.

Role of the Spleen

The spleen plays a critical role in the pathobiology of HS, as destruction of spherocytes in the spleen is the primary cause of hemolysis in HS patients.⁶⁵ The survival of infused HS red cells into normal recipients is reduced, whereas the survival of normal red cells in HS subjects is normal. Despite the persistence of spherocytosis after splenectomy, red cell survival is normal or only slightly reduced. Taken together, these observations demonstrate that an intrinsic red cell defect leads to RBC destruction, but only in the presence of an extrinsic factor—an intact spleen.

Splenic Entrapment

The unique anatomy of the splenic vasculature leads to sequestration of spherocytes selectively in the spleen. Arterial blood enters directly into the splenic cords, a network of channels formed by reticulum cells and lined by macrophages. Most of the blood that enters the splenic cords passes rapidly through direct channels, which reenter the venous system after traversing fenestrations between the lining endothelial cells. A small fraction of blood in the splenic cords percolates more slowly through this maze before reaching the venous sinuses. The hematocrit of blood from the splenic cords is high, the environment is acidic, and red cells are exposed to macrophages that line these channels. The size of fenestrations in the venous sinuses is small relative to the RBC size, and to pass through requires significant deformability of the red cell and its membrane.⁶⁶ This, however, is a major problem for spherocytes, which have lost surface area and are dehydrated. Splens removed from HS patients reveal congested cords, relatively empty venous sinuses, and few spherocytes traversing sinus walls. The most severely damaged spherocytes, cells unable to negotiate the fenestrations in the venous sinus, are removed from the circulation by macrophages. However, impaired deformability of HS red cells is only significant for the passage of these cells through the spleen. After splenectomy, red cell survival normalizes, even though spherocytes persist and sometimes are increased. Splenectomy has no effect on surface area loss by HS reticulocytes or mature red cells, because surface area loss is due to the intrinsic membrane lesion in these cells. The intrinsic membrane lesion is an independent event that continues even after splenectomy.

Splenic Conditioning

In addition to trapping HS red cells, the spleen also “conditions” these cells in a way that accelerates membrane loss and spherocyte formation. Some conditioned red cells reenter the systemic circulation, gradually shifting from osmotically normal to osmotically fragile cells during their circulation. Osmotically fragile microspherocytes are concentrated in and emanate from the splenic pulp. The more conditioned or spheroidal cells are responsible for the most fragile portion, or “the tail” of the fresh OF curve. The conditioning effect of the spleen is a cumulative injury, thought to result from several passages through the organ. The mechanism(s) of splenic conditioning is not clear. It may be the result of hemoconcentration and erythrocytosis with macrophage-induced membrane injury, possibly related to the lower pH in the spleen. The calculated transit time for spherocytes is short relative to the time required for severe metabolic compromise, thus it is unlikely that metabolic depletion is important, and the ATP content of HS cells in the spleen is normal.

Clinical Features

Anemia, jaundice, and splenomegaly are the clinical features of HS most commonly encountered. However, signs and symptoms are highly variable, both with respect to the age of onset and severity.^{24, 25} For example, anemia or hyperbilirubinemia may be of such magnitude as to require exchange transfusion in the neonatal period or cases may escape clinical recognition altogether, presenting very late in life.⁶⁷ Anemia usually is mild to moderate, but it may be absent, mild, moderate, or severe requiring transfusion. Beyond the neonatal period, jaundice is intermittent and is associated with fatigue, cold exposure, emotional distress, or pregnancy. An increase in scleral icterus and a darker urine color is commonly seen in children with nonspecific viral infections. Even when patients have no detectable jaundice, there is usually laboratory evidence of ongoing hemolysis. Splenomegaly is the rule, and in large family studies, palpable spleens

P.713

have been detected in more than 75% of affected members. No apparent correlation has been shown between spleen size and disease severity, but it may exist. The liver is normal in size and function.

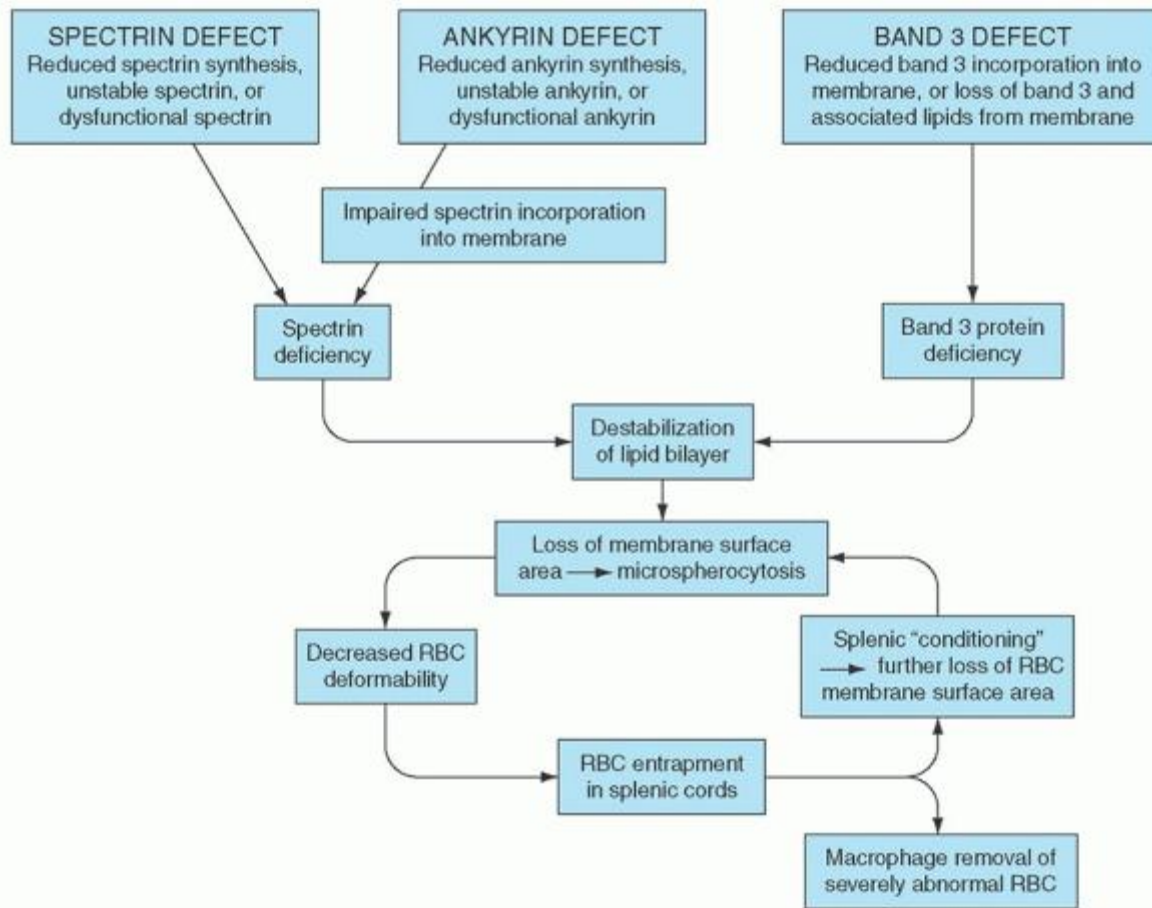

FIGURE 27.6. Pathophysiology of hereditary spherocytosis (HS). The primary defect in HS is a deficiency of membrane surface area, leading to the formation of spherocytes. Decreased surface area may be produced by different mechanisms: defects of spectrin and ankyrin lead to reduced density of the spectrin-actin membrane skeleton, destabilizing the overlying lipid bilayer and releasing band 3-containing microvesicles; or defects of band 3 and protein 4.2 lead to band 3 deficiency and loss of its lipid-stabilizing effect, resulting in the loss of band 3-free microvesicles. Both pathways result in loss of membrane surface area, spherocyte formation, and decreased deformability. These deformed erythrocytes become trapped in the hostile environment of the spleen cords, where splenic conditioning inflicts further membrane damage or they are removed by splenic macrophages. RBC, red blood cell.

From a clinical perspective, it has been useful to classify HS according to the severity of disease (Table 27.2).^{24, 25} Moderate HS is the most common presentation, recognized as a chronic hemolytic disorder with characteristic spherocytes on peripheral blood smear and an autosomal dominant pattern of inheritance.

Mild HS occurs in 20% to 30% of cases of HS. Anemia is absent, as the bone marrow is able to fully compensate for the persistent destruction of red cells, and there is little or no splenomegaly.^{68, 69} Because patients in this group usually are asymptomatic, they often are not diagnosed until later in life. Sometimes, they are identified as a result of hemolytic or aplastic episodes triggered by infection. Occasionally, the condition is identified through family surveys performed to document the hereditary nature of hemolytic disease in a relative.

Moderate HS accounts for 60% to 75% of all HS cases. It is associated with mild to moderate anemia, modest splenomegaly, and intermittent jaundice.^{68, 69} The reticulocyte count and serum bilirubin levels are elevated. Patients may require transfusion during intercurrent illness.

Severe HS occurs in ~5% of cases of HS. It is characterized by severe hemolytic anemia, the need for red cell transfusion particularly during infancy and early childhood, and usually an incomplete response to splenectomy. The pattern of inheritance is frequently nondominant.^{32, 33, 35}

The silent carrier of HS exists in families with autosomal recessive HS. In most cases, carriers have no signs of HS or minimal signs of HS, e.g., a slightly increased reticulocyte count, a few spherocytes on peripheral blood smear, a minimally

abnormal incubated OF, or abnormal erythrocyte spectrin content detected when using sensitive techniques.³² Using a conservative estimate of 1:5,000 HS incidence in the United States, combined with the observation that ~25% of cases are autosomal recessive, it has been calculated that the HS silent carrier state might exist in 1.4% of the U.S. population.

Hereditary Spherocytosis in Infancy

In the neonatal period, jaundice is likely to be the most prominent feature of HS. Thirty percent to 50% of adult HS patients report a history of neonatal jaundice and the diagnosis of HS is prominent in etiologic studies of severe neonatal hyperbilirubinemia.^{70, 71} The magnitude of hyperbilirubinemia may be severe, requiring phototherapy or exchange transfusion.⁷² Virtually all HS infants who are homozygous for the mutation responsible for Gilbert syndrome are jaundiced enough to require phototherapy.⁷² In contrast to jaundice, most newborns with HS are not anemic. Spherocytosis on the peripheral blood smear and reticulocytosis are frequently minimal or absent. However, anemia develops rapidly over the first few weeks of life in many infants and may require transfusion.⁷² Maturation of splenic filtering and development of the splenic circulation appear to increase the rate of hemolysis after birth; at the same time, the erythropoietic response to anemia is blunted. Within a few months, erythropoiesis increases, anemia improves, and the need for red cell transfusions disappears in all but the most severely affected infants.

Complications

The two major complications seen in HS are episodes of worsening anemia and the development of gall bladder disease.

P.714

Exacerbations of anemia occur in almost all HS patients, even in the large majority of HS patients who have mild or clinically silent disease, associated with various stresses such as infection, major surgery, trauma, pregnancy, etc. For example, previously mild anemia can become much more severe during pregnancy, usually because of the increased plasma volume, but occasionally as a consequence of accelerated hemolysis.⁷³ As with other chronic hemolytic states, some anemic crises are preceded by a febrile illness and may be observed concurrently in more than one affected member of a single family. In some cases, there may be increased hemolysis (decreased hemoglobin, increased reticulocytes, and increased bilirubin concentration) associated with nonspecific viral infections.⁷⁴

Aplastic/hypoplastic crises resulting from parvovirus B19 infection may occur, just as is seen in individuals with other chronic hemolytic disorders.⁷⁵ Parvovirus B19 selectively infects erythroid precursors and inhibits their growth. Erythropoietic arrest leads to a sudden decrease in hemoglobin concentration and reticulocytopenia. Recovery occurs within 7 to 10 days and is heralded by reticulocytosis and thrombocytosis. Parvovirus infection may be the first manifestation of HS, and multiple HS family members infected with parvovirus have developed aplastic crises at the same time, leading to descriptions of "epidemics" of HS.⁷⁶ Infection with parvovirus is a particular threat to susceptible pregnant women, because it can infect the fetus, leading to severe anemia, hydrops fetalis, and fetal death.

Less commonly, exaggeration of anemia is the result of exhaustion of folate reserves by the sustained increase in net DNA synthesis.⁷⁷ Megaloblastic arrest of erythropoiesis has been observed most commonly during pregnancy, in association with liver disease, or in patients recovering from an aplastic crisis.

Cholelithiasis is common in HS just as in other chronic hemolytic disorders. Bilirubin pigment gallstones may be found in infants and young children,⁷⁸ but the incidence of gallstones increases markedly with age, and they are present in 40% to 80% of adults. The history of family members with cholelithiasis in the second or third decade of life is a clue to the possibility of HS or another inherited hemolytic disorder. In patients with mild HS, cholelithiasis may be the initial presentation of the disease. The development of gallstones is increased approximately fivefold in HS patients who are homozygotes for the uridine diphosphateglucurono-syltransferase mutation responsible for Gilbert syndrome.^{79, 80} Because of their high incidence, HS patients should be periodically examined by ultrasound for the presence of gallstones, beginning early in childhood.

A few other unusual complications have been noted in HS patients. Heterotopia of the bone marrow has been noted rarely in the renal pelvis or along the vertebral column.⁸¹ These extramedullary masses of marrow may be mistaken for malignant tumors. After the spleen is removed, they undergo fatty metamorphosis. Hemosiderosis and multiple endocrine disorders resulting from transfusion-induced iron overload have been described. Interestingly, symptomatic iron overload also has been reported in some untransfused HS patients who are heterozygous for the hemochromatosis gene. Cases of HS and hematologic malignancy, including multiple myeloma, leukemia, and myeloproliferative disorders, have been reported, suggested to be linked to the persistent hematopoietic stress of HS; but the relationship with HS, if more than

coincidental, remains to be determined. Gout and chronic leg ulcers/dermatitis are unusual complications in adults with HS.^{82, 83} Other rare complications include thrombosis, spinocerebellar degenerative syndromes, movement disorder with myopathy, and hypertrophic cardiomyopathy.⁸⁴

Laboratory Features

The classic laboratory features of HS include anemia, reticulocytosis, increased mean corpuscular hemoglobin concentration (MCHC), spherocytes on the peripheral blood smear, hyperbilirubinemia, and an abnormal OF test.

Anemia is typically mild, accompanied by reticulocytosis with values of 5% to 20%. This compensation is associated with increased erythropoiesis and elevated levels of erythropoietin.^{68, 69} Erythrocyte indices demonstrate a normal or borderline low mean corpuscular volume (MCV) despite increased numbers of reticulocytes, reflecting the membrane loss and dehydration. The MCHC is usually increased ($\geq 35\%$) due to mild cellular dehydration.^{85, 86} Examination of indices obtained by automated cell counters can be used as a screening test for HS. In unsplenectomized children, an MCHC >35.4 /dl and a red cell distribution (RDW) width >14 had a sensitivity of 63% and a specificity of 100%⁸⁶ for the diagnosis of HS. Histograms of hyperdense erythrocytes (MCHC > 40 g/dl) obtained from laser-based cell counters have been used as a screening test for HS, and when combined with an elevated MCHC, have been claimed to identify nearly all cases of HS.

RBC morphology is distinctive but not diagnostic. Typical HS patients have obvious spherocytes on peripheral blood smear. Spherocytes lack central pallor, their mean cell diameter is decreased, and they appear more intensely hemoglobinized. Spherocytes are a feature of many hemolytic anemias, thus their identification alone does not establish a diagnosis of HS. The number of spherocytes and microspherocytes varies considerably from patient to patient; as few as 1 to 3/hpf in mild HS to as many as 20 to 30/hpf in moderate HS (Fig. 27.7). In severe HS, many poikilocytes also are present in addition to the spherocytosis. Unlike the spherocytes associated with immune hemolytic disease and thermal injury, most HS spherocytes are fairly uniform in size and density. Varying degrees of polychromatophilia and anisocytosis are noted. Because the degree of spherocytosis or "conditioning" is a function of cell age, reticulocytes and young red cells are morphologically normal. Specific morphologic findings, including pincer erythrocytes (band 3), spherocytic acanthocytes (β -spectrin), or spherostomatocytes (protein 4.2) have been correlated with specific membrane defects.^{24, 25}

Osmotic Fragility

Red cells behave as perfect osmometers when suspended in varying concentrations of hypotonic salt solutions, and OF of red cells is a measure of their spheroidicity. With a decreased membrane surface area relative to volume, spherocytes are unable to withstand

P.715

the introduction of small amounts of free water that occurs when they are placed in progressively more hypotonic solutions. As a consequence, spherocytes hemolyze more than discoid RBCs at any salt concentration (Fig. 27.8). Hemolysis is determined by measuring the fraction of total hemoglobin released from red cells into the extracellular fluid at progressively more dilute salt concentrations. The fresh OF test detects circulating spherocytes, cells that have been conditioned by the spleen. This appears as a "tail" produced by a small population of abnormal cells that undergo hemolysis at salt concentrations that do not affect normal red cells. The most sensitive test to detect spherocytes is the incubated OF test performed after incubating RBCs 18 to 24 hours under sterile conditions at 37°C. This procedure takes advantage of the observation that all erythrocytes lose membrane under these incubation conditions; however, the process is markedly accelerated in HS red cells. Hemolysis of HS cells may be complete at solute concentrations that cause little or no lysis of normal cells. HS individuals may have a normal fresh OF if reduced surface area is balanced by a reduction in volume (due to cell dehydration), but the OF after prolonged incubation at 37°C is usually abnormal. Although OF correlates well with the magnitude of spherocytosis, no correlation is observed between OF and hemoglobin concentration. The sensitivity of the incubated OF test may be outweighed by a loss of its specificity, i.e., spherocytes due to any cause exhibit abnormal incubated OF. A normal OF does not exclude the diagnosis of HS, as 10% to 20% of HS patients, i.e., those with mild HS, lack circulating spherocytes.

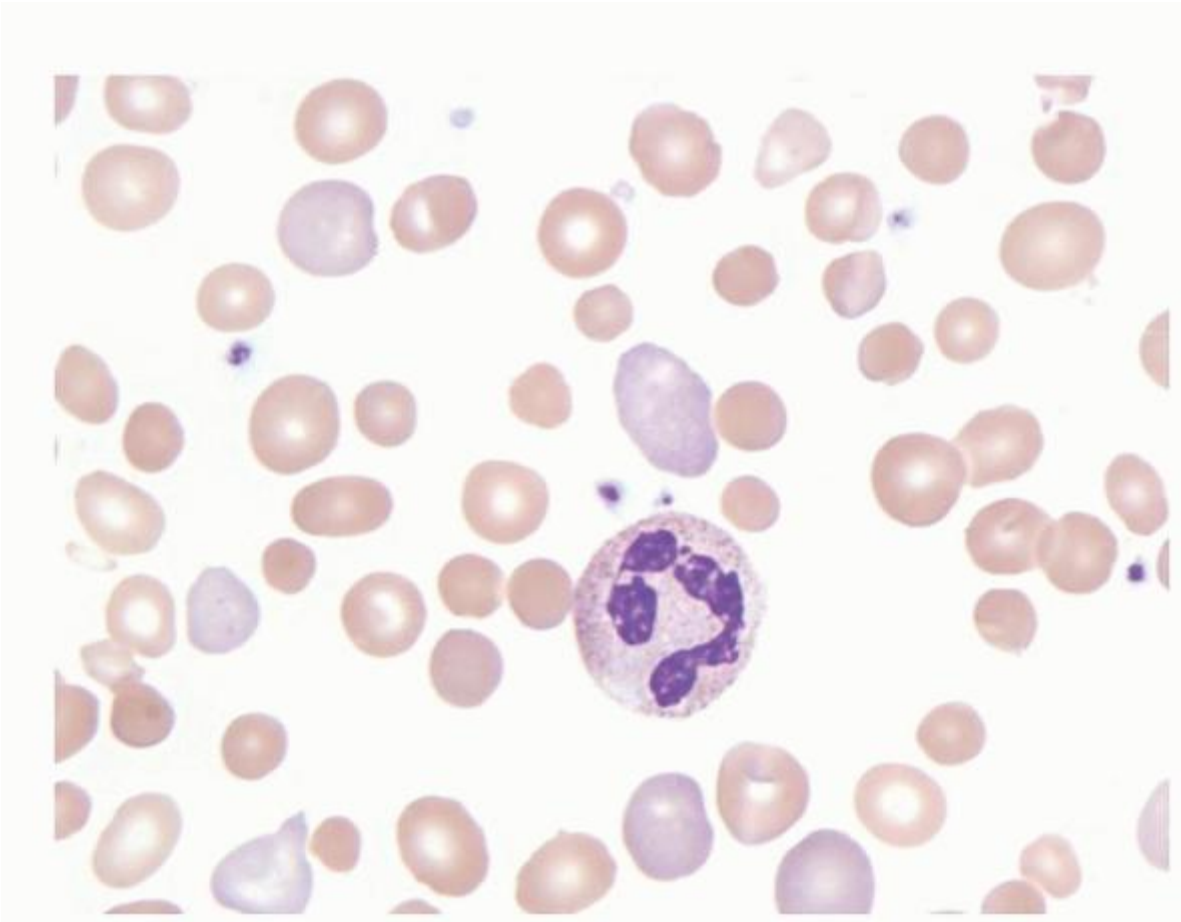

FIGURE 27.7. Hereditary spherocytosis. A typical Wright-stained peripheral blood smear from a patient with autosomal dominant hereditary spherocytosis is shown. Small, dense, round, conditioned spherocytes that lack central pallor are visible throughout.

Osmotic gradient ektacytometry is more sensitive and specific than the OF test for the diagnosis of HS but is not widely available.

Other laboratory tests used to diagnose HS include the autohemolysis test, the spontaneous hemolysis of red cells incubated under sterile conditions without glucose, the glycerol lysis test, and the pink test; but these rarely are used nowadays, and they offer no advantage over the OF test. The cryohemolysis test and eosin-5-maleimide (EMA) binding to erythrocytes, a flow cytometry-based method reflecting relative amounts of band 3 and Rh-related proteins, have been utilized for use as screening tests in HS.⁸⁷ These have been advocated over the incubated OF test as they are claimed to have a higher predictive value. These claims are based on the observation that there have been no reports of positive results in immune-mediated or non-membrane-associated hemolytic disease. However, these tests are not specific, detecting other erythrocyte abnormalities, especially those associated with abnormal band 3, including congenital dyserythropoietic anemia, and abnormalities of erythrocyte hydration and viscosity, including sickle cell disease and cryohydrocytosis.^{88, 89} The EMA binding test has gained wide popularity because of its ease in execution and relatively low cost of performance. Similar to OF testing, its predictive value is enhanced if family history, clinical information, and additional laboratory data are also available.⁸⁹

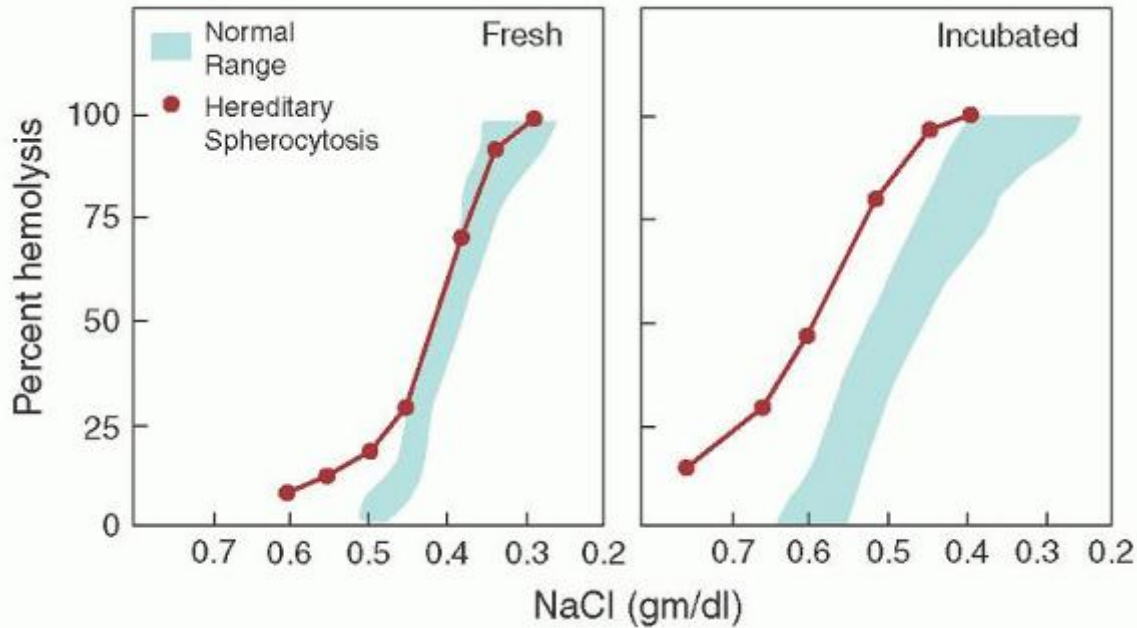

FIGURE 27.8. Osmotic fragility curves in hereditary spherocytosis. Diagrams of the osmotic fragility (OF) test, as manifested by percent hemolysis, of normal and hereditary spherocytosis (HS) erythrocytes after dilution in salt solutions of varying tonicity. (Left) In the fresh OF, a “tail” of osmotically sensitive HS erythrocytes produced by splenic conditioning is seen prior to splenectomy. (Right) In the incubated OF, the entire population of HS erythrocytes is more osmotically sensitive. (Reprinted with permission from Glader B, Other Hereditary Red Blood Cell Disorders. In: Emery and Rimoin's Principles and Practice of Medical Genetics. Rimoin DL, Connor JM, Pyeritz RE, Korf BR, Eds. Fifth Edition, Churchill Livingstone, New York 2007, pp1675-1698.)

In the past, doubt existed whether HS could be diagnosed in the newborn period because many HS infants have few circulating spherocytes. Moreover, fresh red cells from normal neonates are relatively resistant to OF, whereas incubated infant erythrocytes are osmotically more fragile. However, OF detects HS in many but not all infants if appropriate normal neonatal RBC controls are used. Osmotic gradient ektacytometry reliably detects HS in newborns.⁹⁰

The bone marrow is characterized by erythroid hyperplasia. Normoblasts may constitute 25% to 60% of all nucleated cells. When complicated by folate deficiency, megaloblastic features of both myeloid and erythroid precursors are prominent. Examination of the bone marrow is not needed to diagnose HS.

Molecular Studies

Once the diagnosis of HS is made, it is possible to further characterize the specific membrane lesion. Studies using polyacrylamide gel electrophoresis separation or specific radioimmunoassays allow quantification of major membrane proteins, looking for abnormalities in spectrin, ankyrin, band 3, protein 4.2, or other proteins. Detection of the specific genetic abnormality is accomplished via mutation screening or direct DNA sequence analyses. However, these studies are cumbersome, expensive, and available only in select research laboratories. Detailed molecular studies, which have proven to be highly informative for our understanding of both the pathogenesis of HS and normal membrane structure and function, are indicated for studying difficult or particularly interesting and informative cases.

Diagnosis

The diagnosis of HS generally is straightforward. Often, there is a family history of HS or a family history of anemia, splenectomy, or cholecystectomy. The signs and symptoms of HS are nonspecific and associated with many chronic hemolytic states (mild pallor, intermittent jaundice, and splenomegaly). Typical laboratory features include mild anemia, reticulocytosis, increased MCHC and RDW, normal MCV despite reticulocytosis, spherocytes on the peripheral blood smear, hyperbilirubinemia, and an abnormal incubated OF test. Other disorders, such as immune hemolytic disease, glucose-6-phosphate dehydrogenase deficiency, certain syndromes of red cell fragmentation, and thermal and chemical injury of red cells, also are associated with spherocytosis. In most of these conditions, spherocytes are but one of several types of abnormal RBCs present, whereas in HS, there are few abnormal forms other than spherocytes. Additional historical data, such as onset later in life, temporal relationship to prescription of various medications such as methyldopa,

or symptoms attributable to malignancy or connective tissue disease, as well as additional laboratory data, such as a positive direct antiglobulin reaction in immune hemolytic disease, may help differentiate other disorders from HS.

Treatment

For practical purposes, the treatment of HS revolves around supportive care, splenectomy, and management of postsplenectomy complications.^{91, 92}

Neonates with severe hyperbilirubinemia caused by HS are at risk for kernicterus,⁷¹ and such infants should be treated with phototherapy or exchange transfusion, or both, as clinically indicated.⁹³ Red cell transfusions are sometimes needed during

P.716

hemolytic or aplastic crises. Erythropoietin therapy for the first few months of life has been suggested to diminish the need for red cell transfusions until erythropoiesis reaches its full postnatal expression,^{94, 95} but this therapy is not well studied.

Folic acid is required to sustain erythropoiesis, and normal dietary folate may be inadequate for children and some adults with chronic hemolytic anemia. For this reason, HS patients are instructed to take supplementary folic acid to prevent the rare megaloblastic crises, although in mild cases, this is probably unnecessary.

HS is unique among the congenital hemolytic anemias in that splenectomy is permanently curative except in some severe, autosomal recessive cases^{96, 97}; and even these severe cases exhibit significant clinical improvement.^{65, 98} Within days of splenectomy, jaundice fades, the hemoglobin concentration rises, and red cell survival is dramatically improved. Transfusion requirements are decreased or eliminated, and the risk of cholelithiasis is reduced. Spherocytosis and increased OF persist, but the tail of the fresh OF curve, created by splenic conditioning, disappears. The MCV may fall but the MCHC does not change significantly.

For many years, splenectomy was recommended for all patients with HS without regard to clinical severity. The rationale was that splenectomy eliminated the need for transfusion therapy, ensured freedom from aplastic crises, and minimized the risk of gall bladder disease. This position has been tempered in recent years because it is now known that the spleen has a critical immunologic role in protecting against certain types of infections, and overwhelming postsplenectomy infection with encapsulated bacteria, especially *Streptococcus pneumoniae*, may occur. The emergence of penicillin-resistant pneumococci has heightened concerns, as has growing recognition of the increased risk of postsplenectomy cardiovascular disease, particularly thrombosis and pulmonary hypertension.^{99, 100, 101, 102, 103} Finally, the important role of the spleen in protection of individuals living in geographic regions where parasitic diseases such as malaria or babesiosis occur has re-emerged as international travel has become more common.

The risk of postsplenectomy sepsis is greatest in children younger than 5 years of age, but even older children and adults are at increased risk. Death from sepsis may occur decades after splenectomy.^{104, 105} In one comprehensive review, postsplenectomy infection was assessed in 850 HS patients, 786 of whom were children.¹⁰⁶ Most patients had undergone surgery during the first 5 years of life. Thirty cases of septicemia (3.52%) and 19 septic deaths (2.23%) were identified. The estimated rate of mortality from sepsis was approximately 200 times greater than that expected in the general population. Although most septic episodes were observed in children whose spleens were removed in the first years of life, older children and adults were also susceptible. Another report of 226 patients splenectomized for HS estimated the mortality from overwhelming sepsis to be 0.73/1,000 years. Mortality rates for 35 children who underwent splenectomy prior to 6 years of age and for 191 individuals who were older than 6 at the time of splenectomy were 1.12/1,000 and 0.66/1,000 years of life postsplenectomy, respectively, far beyond that of the general population. Rates for both these studies may overestimate the risk of postsplenectomy, as some of the participants underwent splenectomy prior to introduction of the pneumococcal vaccine.

The rationale that splenectomy prevents development of gallstones and symptomatic biliary tract disease, and also obviates the need for major gallbladder surgery, is not as valid today as it was in the past. Development of laparoscopic cholecystectomy has had a significant impact on the management of nonanemic patients with mild HS who have gallstones. In these patients, if they have no signs or symptoms related to their hemolytic anemia, it is reasonable to follow them without splenectomy. If surveillance ultrasound examinations reveal gallstones, laparoscopic cholecystectomy can be performed, preventing biliary tract disease.

The benefits of splenectomy must be balanced against the immediate and long-term risks of the procedure.^{107, 108} Recently published HS management guidelines recognize these concerns and recommend discussion between health care

providers, patient, and family when splenectomy is entertained.⁹¹ It seems reasonable to splenectomize HS patients with severe hemolytic anemia, and patients suffering from significant complications of anemia including growth failure, skeletal changes, extramedullary hematopoietic tumors, and leg ulcers/dermatitis. Splenectomy for patients with moderate HS and compensated, asymptomatic anemia is controversial, and should be undertaken on a case-by-case basis. Patients with mild HS and compensated hemolysis can be managed expectantly and referred for splenectomy if clinically indicated. The higher risk of overwhelming sepsis in young children who undergo splenectomy makes it important to defer the operation until at least age 6 in all but the most severe patients. Prior to splenectomy, patients should receive immunization with pneumococcal, Haemophilus influenzae, and meningococcal vaccines.

Laparoscopic splenectomy, associated with less postoperative discomfort, quicker recovery, shorter hospitalization, and decreased cost, is now the preferred method for splenectomy.^{109, 110} Operative complications of splenectomy, which include local infection, bleeding, and pancreatitis, are uncommon.¹¹¹ Partial splenectomy has been explored for infants and very young children with severe HS.^{112, 113, 114, 115, 116} The purpose of partial splenectomy is to preserve splenic immunologic function, reducing splenic destruction of spherocytes and thereby palliating hemolysis and anemia. Although long-term data for this procedure are lacking, intermediate follow-up demonstrates that there is sustained and clinically significant improvement in laboratory parameters and clinical signs and symptoms in most patients.¹¹⁷ In nonresponders, there was rapid regrowth of the spleen. A second (complete) splenectomy may eventually be required, but hopefully at a time when the patients are considerably older and the risk of sepsis is less. The role of radiologic imaging as part of the preoperative evaluation prior to partial splenectomy has been emphasized.¹¹⁸ Proponents of this procedure note that splenic function is preserved in young children when the risk of overwhelming sepsis is highest and that chronic transfusions and iron overload are decreased. Opponents note that patients who can be well managed with judicious transfusion therapy may be subjected to two operative procedures, possibly both with general anesthesia.

Postsplenectomy care includes counseling of patients or parents to seek prompt medical care during febrile illness. Use of early antibiotic therapy for splenectomized febrile children has led to a decrease in the incidence of severe postsplenectomy infection, leading some to propose having antibiotics available at home for immediate treatment of febrile illness. The emergence of penicillin-resistant pneumococci requires consideration when selecting antibiotic therapy in splenectomized patients.

The role of prophylactic antibiotics postsplenectomy is a matter of current controversy, and few data exist to provide recommendations. Some recommend that all splenectomized children (and adults) receive penicillin prophylactically for life. Others recommend prophylaxis up to 6 years of age, while others prescribe antibiotics for 10 years postsplenectomy. There are even fewer data regarding the prescription of prophylactic antibiotics in adults postsplenectomy.

There have been several reports of major thrombotic events postsplenectomy for HS.^{99, 100, 119} Some of these cases have actually been variants of stomatocytosis, where postsplenectomy risk of thrombosis is well known. Anticoagulants have not been evaluated in this setting.

P.717

HEREDITARY ELLIPTOCYTOSIS SYNDROMES

The HE syndromes are a family of genetically determined erythrocyte disorders characterized by elliptical red cells on the peripheral blood smear (Fig. 27.9).¹²⁰ Some HE syndromes are associated with symptomatic hemolytic disease, although most are clinically silent and are discovered incidentally when a blood smear is reviewed. The varied clinical and hematologic manifestations of HE are an expression of the numerous molecular defects that give rise to an elliptocytic-shaped erythrocyte.

The HE syndromes are classified into several groups (Table 27.3).¹²¹ Common HE is a dominantly inherited condition characterized by many elliptocytes in the peripheral blood smear. The clinical severity of common HE is extremely variable, ranging from an incidental asymptomatic condition, most commonly observed, to a mild to moderate hemolytic anemia. The clinical expression of hemolytic HE ranges from a moderate hemolytic anemia to severe, near-fatal, or fatal hemolytic anemia. Hereditary pyropoikilocytosis (HPP) is a severe hemolytic anemia, with red cell fragments, poikilocytes, and microspherocytes seen on a peripheral blood smear. From a clinical perspective, it is difficult to distinguish severe hemolytic HE from HPP. Once regarded as a separate condition, HPP is now recognized to be a variant of the HE disorders. Spherocytic HE is a rare condition in which both ovalocytes and spherocytes are present on the blood smear. Southeast Asian ovalocytosis (SAO), also known as stomatocytic elliptocytosis, is an HE variant prevalent in the malaria-infested belt

of Southeast Asia and the South Pacific, and it is characterized by rigid spoon-shaped cells that have either a longitudinal slit or a transverse ridge.

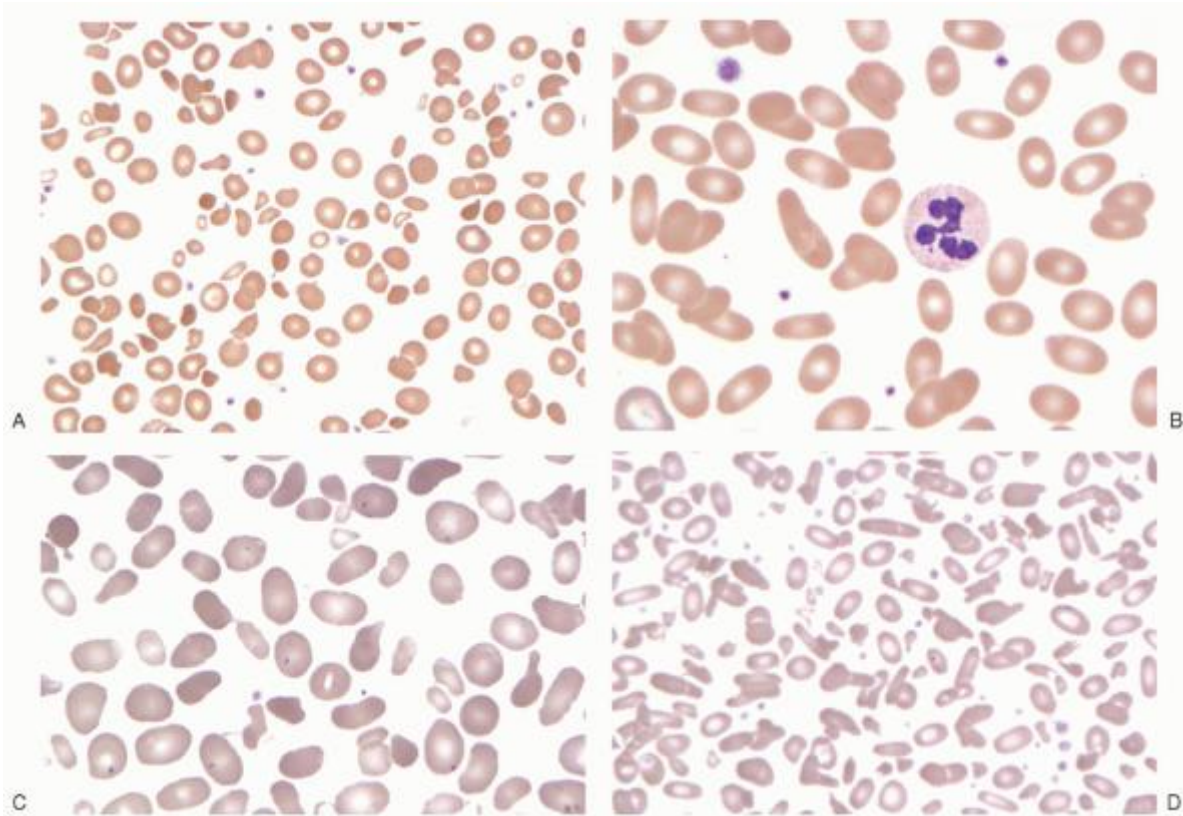

FIGURE 27.9. Hereditary elliptocytosis. Peripheral blood smears representative of different hereditary elliptocytosis syndromes are shown. A: Micropoikilocytes and elliptocytes in a neonate with transient poikilocytosis and an α -spectrin gene mutation. B: Same child at 7 months of age, now exhibiting morphology of common hereditary elliptocytosis. C: Compound heterozygous hereditary elliptocytosis due to two α -spectrin self-association-site structural mutations. Note distorted red cell shapes, elliptocytes, and fragments. D: Hereditary pyropoikilocytosis. Red cell abnormalities are similar to those in (A) and (C) with prominent budding and fragmentation. (Courtesy of Irma Pereira MT [ASCP]SH.)

Prevalence of Hereditary Elliptocytosis Variants

When considered together, the HE variants occur with an estimated frequency of 1:1,000 to 5,000. The distribution of HE is worldwide, and no racial or ethnic group appears to be spared.¹²¹ In the U.S. population, the prevalence of HE is approximately 3 to 5/10,000, and it appears to be much more common among patients of African ancestry. In areas where malaria is endemic, HE occurs considerably more frequently. In one study from equatorial Africa, common HE had a prevalence of 0.6%. Resistance of hereditary elliptocytes to invasion by malaria parasites may explain the high prevalence.¹²²

Pathogenesis of Hereditary Elliptocytosis Disorders

The HE disorders are caused by intrinsic membrane protein abnormalities, which lead to an alteration in RBC membrane function, changes in RBC shape, and, in some cases, hemolysis.

P.718

TABLE 27.3 CLASSIFICATION OF HEREDITARY ELLIPTOCYTOSIS SYNDROMES

Common HE	Hemolytic HE	Hereditary Pyropoikilocytosis	Spherocytic Elliptocytes	Southeast Asian Ovalocytosis
-----------	--------------	-------------------------------	--------------------------	------------------------------

Anemia	None	Moderate-severe	Severe	Mild to moderate	None
Hemolysis	None-mild	Moderate-severe	Severe	Mild to moderate	None
Splenomegaly	None	Present	Present	Present	None
Peripheral blood smear	15-90% elliptocytes	Elliptocytes; poikilocytes; fragments	Poikilocytosis; RBC budding with fragments; elliptocytes; microspherocytes	Rounded elliptocytes; spherocytes	Rounded elliptocytes, some having a transverse bar dividing cell
Osmotic fragility	Normal	Normal/increased	Increased	Increased	Normal to decreased
Inheritance	Dominant	Recessive	Recessive	Dominant	Dominant
Other	Poikilocytosis with severe hemolysis, seen transiently in some infants	Normal/low mean corpuscular volume	Low/very low mean corpuscular volume		Rigid erythrocytes

HE, hereditary elliptocytosis; RBC, red blood cell.

Membrane Protein Defects

A primary defect of the membrane skeleton leading to the HE phenotype was suggested by the retention of an elliptical shape by membrane ghosts and skeletons prepared from hereditary elliptocytes, uniform instability of HE membrane ghosts and skeletons to mechanical stress, and abnormal heat sensitivity of spectrin prepared from the red cells of some patients with HE. Subsequent studies have shown that the principal defect in HE is mechanical weakness or fragility of the erythrocyte membrane skeleton, due to qualitative and/or quantitative defects in several membrane skeleton proteins, α - and β -spectrin, protein 4.1R, or glycophorin C.¹²¹

The majority of HE-associated defects occur in spectrin, the principal structural protein of the membrane skeleton. Spectrin is composed of α - and β -spectrin, two structurally similar, nonidentical proteins encoded by separate genes. The majority of spectrin is triple helical repeats connected by nonhelical segments. The "spectrin repeat," originally defined in erythroid cells, is a conserved triple helical, coiled-coil bundle of amino acids found in a diverse array of proteins that participate in protein-protein interactions and complex formations, with functions as diverse as membrane assembly and signal transduction.^{9, 14} In the erythrocyte, α - and β -spectrin assemble side to side in an antiparallel position, forming a flexible rod in which the NH₂-terminus of α -spectrin and the COOH-terminus of β -spectrin form an α - β heterodimer. These heterodimers self-associate to form an atypical triple helical repeat in which one helix is contributed by the NH₂-terminus of α -spectrin and two helices are contributed by the COOH-terminus of β -spectrin to form tetramers, the form of spectrin critical for membrane stability as well as erythrocyte shape and function. Spectrin tetramers are connected into a highly ordered two-dimensional lattice through binding, at their tail ends, to actin oligomers at the junctional complex, facilitated by protein 4.1R, into a uniform hexagonal lattice.^{16, 20} Recent studies have shown that local dissociation of tetramers and reassociation of dimers provide the membrane the ability to accommodate the distortions required for passage through the microvasculature.¹⁷

Disruption of erythrocyte membrane skeleton protein interactions by mutations that alter protein structure, function, or amount leads to diminished membrane mechanical stability and in severe cases, to hemolysis. Most cases of HE are caused by spectrin mutations that perturb the interactions between $\alpha\beta$ -spectrin heterodimers, impairing spectrin tetramer formation, and, consequently, disrupting the integrity and mechanical stability of the membrane skeleton.¹⁵ Mutation of protein 4.1R likely perturbs formation of the spectrin-actin-protein 4.1R-glycophorin C junctional complex and attachment of this complex to the membrane. In 4.1R-deficient erythrocytes, abnormalities in membrane stability and cellular deformability are proportional to levels of protein 4.1R.

Spectrin Abnormalities

Most elliptogenic spectrin mutations are located in the region of spectrin self-association, impairing tetramer formation (Fig. 27.10). These mutations create abnormal proteolytic cleavage sites that typically reside in the third helix of a repetitive segment and give rise to abnormal tryptic peptides on two-dimensional tryptic peptide maps of spectrin. Abnormal tryptic digests of spectrin extracted from HE erythrocytes were first used to identify HE mutations, followed by identification of the precise genetic defects after cloning of the α - and β -spectrin genes. In α -spectrin, the majority of reported mutations are amino acid substitutions. In β -spectrin, mutations are amino acid substitutions and truncations of the COOH-terminus of the β -spectrin chain. When inherited in the heterozygous state, these mutations lead to typical HE. When inherited in trans to modifier alleles that worsen clinical severity, mild to moderate hemolytic HE is seen. Homozygosity and compound heterozygosity are associated with hemolytic HE and/or HPP. Several cases of homozygous β -spectrin self-association site mutations have been associated with fatal or near-fatal fetal and neonatal anemia.¹²³

Although most HE mutations are located in the region of spectrin self-association sites, a few spectrin mutations distant from this region have been described. In the heterozygous state, these mutations are asymptomatic, but may be associated with hemolytic HE or HPP in the homozygous state.

Functionally, HE-associated self-association contact site missense mutations likely disrupt predicted conformational rearrangements in the predicted protein structure (Fig. 27.11).¹²⁴ Mutations outside the self-association region likely disrupt long range protein-protein interactions, disrupting positively coupled, cooperative interactions of spectrin self-association, spectrin-ankyrin binding, and ankyrin-band 3 binding.²³ Thus, these mutations may act to block repeat-to-repeat transfer of conformational information, decrease the ability of spectrin to transregulate ankyrin binding, and disrupt the register of spectrin repeats and perturb binding of other proteins, e.g., ankyrin, to spectrin.^{23, 125}

P.719

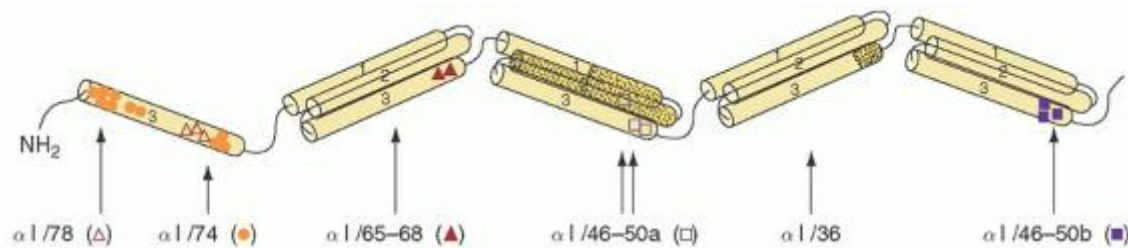

FIGURE 27.10. Defects of the $\alpha\beta$ -spectrin self-association site in hereditary elliptocytosis (HE) and hereditary pyropoikilocytosis (HPP). A model of the triple helical spectrin repeats that constitute the $\alpha\beta$ -spectrin self-association site is shown. Limited tryptic digestion of spectrin, followed by two-dimensional gel electrophoresis, identifies abnormal cleavage sites (arrows) in spectrin associated with various mutations. Symbols denote positions of various genetic defects identified in patients with HE or HPP. In most cases, the mutation found is adjacent to the abnormal cleavage site, either in the same helical coil or in helical coils juxtaposed next to each other in the triple helical model. The hashed lines denote the location of spectrin chain truncations. (Reprinted and modified with permission from Gallagher PG, Tse WT, Forget BG. Clinical and molecular aspects of disorders of the erythrocyte membrane skeleton. *Semin Perinatol* 14:351,1990.)

Clinically, the most severe clinical phenotypes are associated with mutation of the $\alpha\beta$ -spectrin self-association contact site, the atypical hybrid repeat created by 2 helices of β -spectrin and one of α -spectrin. Modifier alleles also influence clinical severity.¹²⁶ The most common of these is the low-expression allele, spectrin α^{LELY} (LELY: low-expression allele from Lyon).^{127, 128} In α^{LELY} , a mutation in intron 45 leads to variable splicing and loss of exon 46 in about half of the α -spectrin mRNA synthesized. Spectrin proteins lacking exon 46 have a reduced ability to participate in dimer and tetramer assembly and are degraded. When α^{LELY} is present as the only variant, it is clinically silent because normal α -spectrin is synthesized in large excess. However, when α^{LELY} is present in trans to an α -spectrin HE mutant, incorporation of the latter into heterodimers is favored, thereby leading to increased proportion of the elliptocytogenic spectrin in red cells and worsening clinical severity. Conversely, when co-inherited in cis to an HE α -spectrin mutation, it reduces the amount of the mutation incorporated into heterodimers and ameliorates clinical severity. α^{LELY} is a common allele, affecting ~30% of α -spectrin alleles of Europeans and 20% of Japanese and West Africans.¹²⁹

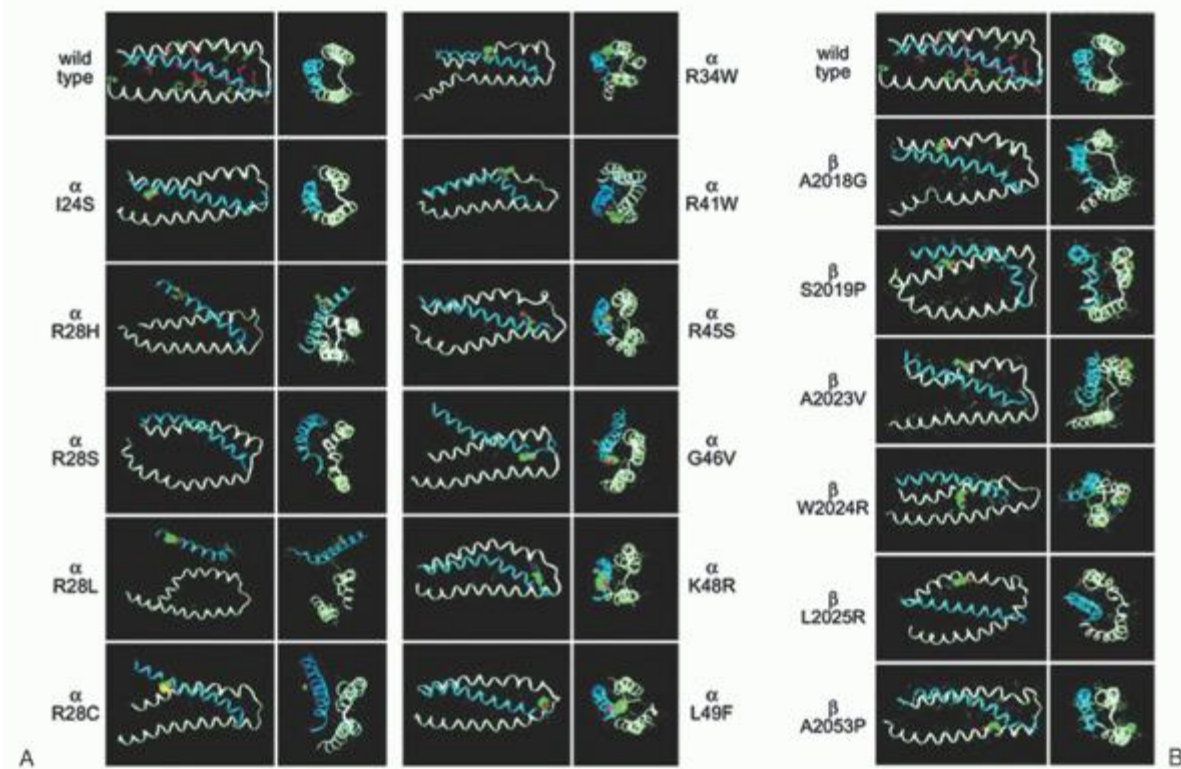

FIGURE 27.11. Molecular modeling of mutations of the $\alpha\beta$ -spectrin self-association site. Using dynamic modeling and energy minimization, the three-dimensional structure of the $\alpha\beta$ -self-association contact site was determined and the structural consequences of elliptocytosis-associated mutations determined. A: Mutations involving α -spectrin. B: Mutations involving β -spectrin. Longitudinal and end-on views are shown for each mutation. The mutated residue is depicted using a solid-filled representation. Every pathologic point mutation, including seemingly conservative substitutions such as G for A, A for V, or K for R (single-letter amino acid codes), led to conformational rearrangements in the predicted structure. The degree of structural disruption, as measured by root-mean-square deviation of the predicted backbone structure, correlated strongly with the severity of clinical disease associated with each mutation. (Reprinted with permission from Zhang Z, Weed SA, Gallagher PG, Morrow JS. Dynamic molecular modeling of pathogenic mutations in the spectrin self-association site. *Blood* 2001;98:1645.)

Protein 4.1R Defects

Protein 4.1R abnormalities associated with HE are much less common than spectrin mutations. One site on protein 4.1R binds to the distal end of the spectrin $\alpha\beta$ -heterodimer, increasing the

P.720

binding of spectrin to oligomeric actin. The NH_2 -terminal domain of 4.1R interacts with glycophorin C, phosphatidylinositol, and phosphatidylserine, facilitating the attachment of the distal end of the spectrin to the membrane. Complex patterns of alternate splicing lead to the production of various tissue and developmental-stage-specific isoforms of 4.1R, including an erythropoiesis stage-specific splicing event that generates the 80 kDa mature erythroid protein 4.1R isoform.¹³⁰

Deficiency of protein 4.1R has been described in several kindreds from southern France and northern Africa.¹²¹ Partial deficiency of protein 4.1R is associated with mild dominantly inherited HE. Heterozygotes have approximately 50% of the normal amount of protein 4.1R and have mild hemolytic anemia. Homozygotes have no detectable protein 4.1R and a severe transfusion-dependent hemolytic anemia with prominent elliptocytosis and spherocytosis. Homozygous 4.1R-deficient erythrocytes are deficient in p55 and glycophorin C, fragment more rapidly than normal at moderate shear stresses, and display a dramatically disrupted skeletal network.

Structural abnormalities of protein 4.1R associated with HE have also been found, including deletions and duplications of the exons encoding the spectrin-binding domain.^{131, 132}

Glycophorin C Deficiency

The Leach phenotype, typically associated with a 7 kb deletion of genomic DNA that removes exons 3 and 4 from the GPC/GPD locus, is characterized by GPC deficiency with elliptocytosis. GPC-deficient erythrocytes are also partially deficient in 4.1R, speculated to be the basis for the elliptocytosis, and lack p55. These abnormalities are presumed to be caused by disruption of a multiprotein complex that recruits, assembles, or stabilizes itself on the membrane. In contrast to other forms of HE, heterozygous carriers of glycophorin C deficiency are asymptomatic with normal RBC morphology. Homozygous-deficient individuals have mild elliptocytosis but no anemia.

Membrane Abnormalities Leading to Elliptocyte Formation

Disruption of erythrocyte membrane skeleton protein interactions by mutations that alter protein structure, function, or amount leads to diminished membrane mechanical stability and in severe cases, to hemolysis. The mechanism by which these protein defects result in elliptocyte formation is not clear. Elliptocytes acquire their shape after release from the marrow and as they age in vivo. Normal erythrocytes assume an elliptical shape in capillaries and in vitro when exposed to shear stress. They resume a normal biconcave shape after passage through the microcirculation and in vitro after removal of shear stress. If mechanical distortion is maintained for long periods, even normal red cells remain misshapen, suggesting that the membrane skeleton is altered as a consequence of sustained shape change. In HE, it is possible that altered membrane protein interactions lead to skeletal reorganization after less extensive deformation or shear stress. With repeated distortions imposed by passage through small capillaries, cells with unstable membrane skeletons gradually elongate to form irreversible elliptocytes. Erythrocytes with more severe skeletal defects presumably are unable to withstand normal circulatory shear stress and undergo fragmentation. This may explain the poikilocytosis seen in homozygous HE and HPP. In all hemolytic HE and HPP syndromes, more severely distorted cells are retained in splenic cords, thus splenectomy markedly ameliorates the associated anemia. Despite alterations in membrane mechanical fragility and stability, intravascular hemolysis has little role in the destruction of HE erythrocytes because hemoglobinuria, hemoglobinemia, and hemosiderinuria are not features of the hemolytic HE syndromes.

Clinical Features

The HE syndrome variants are clinically and hematologically heterogeneous, sharing the features of elliptocytes on a peripheral smear (Table 27.3). There is much overlap when these disorders are classified on a clinical, biochemical, or molecular basis.

Common Hereditary Elliptocytosis

Individuals with common HE are typically discovered accidentally when elliptocytes are identified during routine evaluation of the peripheral blood film.¹²¹ These individuals usually are not anemic, their red cell survival is normal, and there is no splenomegaly. In contrast to the clinical picture, the peripheral blood smear is striking, containing 15% to 100% elliptocytes (Fig. 27.8). Episodic hemolytic anemia may occur during acute or chronic illnesses. Other common HE cases involve mild compensated hemolysis without anemia.

Hemolytic anemia with prominent elliptocytosis and poikilocytosis, termed by some infantile poikilocytosis or infantile pyknocytosis, may be observed in the first few months of life. It is most common in patients of African ancestry. Affected infants have moderately severe hemolytic anemia and hyperbilirubinemia in the newborn period, the latter often necessitating exchange transfusion. The blood smear is characterized by elliptocytosis, marked red cell fragmentation, and poikilocytosis (Fig. 27.9B). These morphologic changes are indistinguishable from those noted in patients with HPP. In contrast to HPP, the hemolysis and anemia abate, evolving to asymptomatic typical common HE throughout childhood (Fig. 27.9C). The basis for this phenomenon is unknown, but increased concentrations of free 2,3-DPG observed in the neonatal period may contribute to membrane instability by perturbing protein 4.1R-actin interactions.¹³³

Hemolytic Hereditary Elliptocytosis

In some cases of HE, the hemolytic process is incompletely compensated and patients have a chronic hemolytic anemia of variable severity.¹²¹ Morphologic characteristics may include poikilocytosis, microelliptocytosis, and red cell fragmentation. The spleen may be enlarged, and gallstones occur with increased frequency. As in other hemolytic states, abrupt episodes of more severe anemia may occur in association with viral infection or other intercurrent illnesses, and hemolytic, aplastic, and megaloblastic crises may occur. There is overlap between the findings in patients with hemolytic HE and HPP (see below).

In some families, hemolytic HE has been transmitted through several generations. In other families, not all individuals with HE manifest chronic hemolysis, but instead exhibit asymptomatic common HE or, at the other end of the spectrum, severe HPP. This variation reflects the genetic heterogeneity of the HE syndromes. Some α -spectrin mutations, such as mutations

of codon 28, disrupt numerous critical protein-protein interactions, leading to severe membrane dysfunction, and are associated with greater clinical severity. Thus, homozygous or compound heterozygous patients with different spectrin mutations manifest variable clinical severity.¹³⁴ In some cases, inheritance of modifier alleles, such as the common α^{LELY} allele, that alter α -spectrin expression may worsen or ameliorate the clinical course. Even patients with mutations of different HE genes, such as patients with both α - and β -spectrin self-association site mutations, have been described. Given the vast combination of mutant alleles and modifier alleles, it is not surprising that there is great clinical, laboratory, and biochemical variability in the HE syndromes.

Hereditary Pyropoikilocytosis

This severe congenital hemolytic anemia, which overlaps with severe hemolytic HE, is characterized by a peripheral blood smear

P.721

that resembles those seen in patients with thermal burns.¹³⁵ Affected individuals, typically of African ancestry, present in infancy or early childhood with moderate-to-severe hemolytic anemia; and, unlike common HE, the hemolytic anemia is lifelong rather than transient. Complications of chronic hemolysis, including splenomegaly, cholelithiasis, and growth retardation, have been described. Intermittent transfusions may be required. Splenectomy improves or ameliorates the anemia. Most impressive are changes in red cell morphology, which include extreme poikilocytosis, microspherocytosis, microelliptocytosis, membrane budding, and cell fragments. The MCV may be extremely low, 30 to 50 fl, the MCHC is normal, and OF is increased. Thermal instability of HPP erythrocytes, susceptibility to budding and fragmentation upon heating to 46°C, once thought to be diagnostic of HPP, is not unique, as it is also found in some HE erythrocytes. Unlike HE red cells, HPP erythrocytes are also partially deficient in spectrin.

Studies of the genetics of HPP have revealed that many HPP probands have inherited structural mutations on both α -spectrin alleles from HE parents in a homozygous or compound heterozygous manner. In others, the HPP proband has inherited a structural mutation of spectrin from an HE parent on one allele and a null allele of α -spectrin from an asymptomatic parent whose red cells have no detectable biochemical abnormality.¹³⁶ This null or "thalassemia-like" allele synthesizes little or no normal spectrin, enhancing the relative expression of the structural spectrin mutant and contributing to a superimposed spectrin deficiency.

Spherocytic Elliptocytosis

This syndrome is characterized morphologically by two populations of cells: red cells that are more rounded than typical hereditary elliptocytes, and a variable number of microspherocytes.¹²¹ In contrast to other HE syndromes with hemolysis, no poikilocytes or fragments are seen. The disorder has been seen primarily in families of European descent and may account for as many as 15% to 25% of cases of HE in whites. Affected individuals have an incompletely compensated hemolytic process with mild anemia and a predisposition to aplastic crises. The relative numbers of spherocytes and elliptocytes vary considerably, even within families. As in HS, the osmotic fragility and mechanical fragility may be increased. Splenectomy is curative.

Southeast Asian Ovalocytosis

This interesting variant, also known as stomatocytic elliptocytosis, is characterized morphologically by plump, rounded elliptocytes (ovalocytes), many of which have one or two transverse ridges. These red cells are found in people from Malaysia, New Guinea, Indonesia, and the Philippines. Outside the neonatal period, their presence is not associated with shortened RBC life span, anemia, or hemolysis.^{137, 138} SAO RBCs demonstrate increased red cell rigidity, increased thermal stability, and decreased OF.¹³⁹

The molecular defect in SAO results from an abnormal band 3 protein lacking codons 400 to 408 at the cytoplasmic and membrane-spanning domains.¹⁴⁰ All individuals with the SAO phenotype are heterozygotes, with one normal band 3 allele and one mutant band 3 allele. The homozygous state has never been observed and is thought to be lethal in utero.¹⁴¹ There is tight binding of band 3 protein to ankyrin in SAO red cells, restricting the lateral mobility of band 3. Because band 3 protein is a receptor for malarial parasites, its reduced mobility may limit invagination and penetration by the parasite. In vitro, SAO erythrocytes are resistant to invasion by several strains of malaria. Studies of children in Papua New Guinea indicate that SAO does not actually reduce the incidence of infection with *Plasmodium falciparum*, but it does provide remarkable protection against cerebral malaria. This effect is likely due to reduced cytoadherence of SAO red cells to the cerebral vasculature, but the exact mechanism is not yet known.¹²¹ In populations in which SAO is prevalent, its frequency is increased in older individuals, suggesting a favorable effect on longevity.

Laboratory Evaluation

Initial laboratory studies in a patient with a suspected HE syndrome should assess whether the patient is anemic (hemoglobin concentration/hematocrit), whether the anemia is well compensated (reticulocyte count), and whether the anemia is caused by accelerated RBC destruction (increased serum lactate dehydrogenase and bilirubin concentration). The mean cell volume (MCV) is also important because some hemolytic HE and HPP variants with RBC fragmentation often demonstrate severe microcytosis as a result of RBC fragmentation.

Careful evaluation of the blood smear is essential both for the diagnosis of HE and the classification of the disorder into major subtypes. At least 15% and often as many as 50% to 90% of red cells are elliptical, whereas smears from normal subjects contain fewer than 15% elliptocytes. In patients in whom elliptocytosis is the only morphologic abnormality, hemolysis is usually minimal or absent, with the exception of spherocytic elliptocytosis, in which the presence of "fat" ovalocytes is associated with accelerated red cell destruction. In other patients with hemolytic forms of HE, poikilocytosis almost always is seen on the blood film, and in HPP, many red cells circulate as cell fragments and microspherocytes, producing a marked decrease in mean cell volume. OF is normal in nonhemolytic HE but is increased in hemolytic HE variants with poikilocytosis, HPP, and spherocytic elliptocytosis.

The finding of more than 30% oval red cells on the peripheral blood film, some containing a central slit or a transverse ridge, together with an absence of clinical and laboratory evidence of hemolysis in an individual from Southeast Asia or the South Pacific, is highly suggestive of SAO. A screening test for SAO is the failure of ovalocytes to undergo membrane changes (form spicules) after metabolic depletion or when suspended in hypertonic salt solutions. The mechanism of this resistance to change in shape presumably is because of the extreme rigidity of the red cell membrane. The OF is decreased (i.e., resistant to hemolysis) in SAO red cells.

Once the diagnosis of an HE syndrome is established, it is possible to further characterize the specific membrane lesion. Biochemical studies including studies of membrane protein quality and quantity; functional studies of spectrin, such as analyses of spectrin self-association; and tryptic mapping of spectrin digests to detect mutant spectrin peptides can be performed. Genetic studies to identify specific mutations and associated modifier alleles can also be performed. Like HS, these studies, available in specialized research laboratories, are indicated for studying difficult or particularly interesting and informative cases.

Treatment

In view of the benign nature of typical HE, therapeutic intervention is not indicated in most individuals. Patients with HE variants associated with severe hemolytic anemia should be provided supportive care comparable to that in HS, e.g., supplemental folic acid, periodic screening for cholelithiasis, and transfusion during hemolytic or aplastic crisis. Splenectomy is followed by dramatic improvement or normalization of the hemoglobin concentration and a decrease in the reticulocyte count, despite the persistence of elliptocytes on the peripheral smear.

No therapeutic interventions are required for individuals with SAO.

P.722

STOMATOCYTIC DISORDERS

Stomatocytes are erythrocytes with a central slit or mouth-shaped (stoma) area of central pallor when examined on dried smears. In wet preparations, they are uniconcave rather than biconcave, giving them a bowl-like appearance. In vitro, stomatocytes are produced by drugs that intercalate into the inner half of the lipid bilayer, thereby expanding the inner lipid surface area relative to that of the outer half of the bilayer. In contrast, echinocytes (RBCs with numerous fine spicules) are thought to be the result of preferential expansion of the outer lipid bilayer relative to the inner layer. A few stomatocytes may be observed in blood smears prepared from normal individuals.¹⁴² Acquired stomatocytosis has been associated with acute alcoholism and hepatobiliary disease, vinca alkaloid administration, neoplasms, and cardiovascular disease. Stomatocytosis is also sometimes observed as a processing artifact. Stomatocytes are associated with rare hereditary disorders of red cell cation permeability known as the hereditary stomatocytosis syndromes,¹⁴³ aberrant Rh blood group antigen expression, sitosterolemia, and familial deficiency of high-density lipoproteins. Each of these stomatocytic disorders is associated with mild to moderate hemolysis.

To appreciate the pathophysiology of the hereditary stomatocytosis syndromes (Table 27.4), an understanding of normal red cell cation and water transport is essential.¹⁴⁴ The RBC membrane, which is freely permeable to water, controls its

volume primarily through regulation of the monovalent cation content. Small passive cation leaks (Na⁺ in, K⁺ out) are normally balanced by the active outward transport of sodium (3 mEq/red cell/hour) and inward transport of potassium (2 mEq/red cell/hour). These cation pumps are linked, require ATP, and are dependent on the membrane enzyme Na⁺-K⁺-adenosine triphosphatase. If the membrane permeability leak to monovalent cations increases, cation pumps have limited compensatory ability, and, if this capacity is exceeded, red cell volume changes in parallel with the total cation change. Red cells swell when the inward sodium leak exceeds the potassium leak out; red cells shrink when the potassium leak out exceeds the inward sodium leak. These membrane permeability abnormalities are recognized by observing altered RBC hydration (decreased or increased MCHC) and altered red cell sodium, potassium, and total monovalent cation content.

TABLE 27.4 FEATURES OF HEREDITARY STOMATOCYTOSIS SYNDROMES

	Stomatocytosis (Hydrocytosis)			Intermediate Syndromes		
	Severe Hemolysis	Mild Hemolysis	Cryohydrocytosis	Stomatocytosis with Xerocytosis	Xerocytosis with High PC	Xerocytosis
Hemolysis	Severe	Mild to moderate	Moderate	Mild	Moderate	Moderate
Anemia	Severe	Mild to moderate	Mild to moderate	None	Mild	Moderate
Blood smear	Stomatocytes	Stomatocytes	Stomatocytes or nl	Stomatocytes	Targets	Targets, echinocytes
MCV (80-100 μ ³) ^a	110-150	95-130	90-105	91-98	84-92	100-110
MCHC (32-36%)	24-30	26-29	34-40	33-39	34-38	34-38
Unincubated osmotic fragility	Very increased	Increased	Normal	Decreased	Very decreased	Very decreased
RBC Na ⁺ (5-12 mEq/LRBC)	60-100	30-60	40-50	10-20	10-15	10-20
RBC K ⁺ (90-103 mEq/LRBC)	20-55	40-85	55-65	75-85	75-90	60-80
RBC Na ⁺ +K ⁺ (95-110 mEq/LRBC)	110-140	115-145	100-105	87-103	93-99	75-90
Phosphatidylcholine content	Normal	±Increased	Normal	Normal	Increased	Normal
Cold autohemolysis	No	No	Yes	No	No	?
Effect of splenectomy	Good	Good	Fair	?	?	?Poor
Genetics	AD, ?AR	AD	AD	AD	AD	AD

AD, autosomal dominant; AR, autosomal recessive; LRBC, liter of red blood cells; MCHC, mean corpuscular hemoglobin concentration; MCV, mean corpuscular volume; PC, phosphatidylcholine; RBC, red blood cell.

^a Values in parentheses are the normal range.

Modified with permission from Walensky LD, Narla M, Lux SE. Disorders of the red blood cell membrane. In: Handin RI, Lux SE, Stossel TO, eds. Blood: principles and practice of hematology, 2nd

ed. Philadelphia, PA: Lippincott Williams & Wilkins, 2003:1818.

Hereditary Stomatocytosis

Hereditary stomatocytosis (also known as hereditary hydrocytosis, or overhydrated stomatocytosis) refers to a heterogeneous group of autosomal dominant hemolytic anemias caused by altered sodium permeability of the red cell membrane (Table 27.4).^{145, 146} The major pathophysiologic abnormality is the result of a marked increase in sodium permeability (15 to 40 times normal), leading to increased RBC sodium, a lesser decrease in intracellular potassium, an increase in total monovalent cation content, and, thereby, an increase in cell water. Despite a marked compensatory increase of active sodium and potassium transport, increased pump activity is unable to compensate for the markedly increased inward sodium leak. Treatment of these cells with dimethyl adipimidate (a bifunctional imidoester that crosslinks proteins) normalizes membrane permeability, corrects cell

P.723

cation and water content, improves membrane deformability, and corrects the abnormal RBC morphology. Moreover, these treated RBCs have an improved survival in vivo. In most patients, excess cation permeability is associated with an absence of red cell membrane protein band 7 on sodium dodecyl sulfate gels. This protein is referred to as band 7.2b or stomatin,^{147, 148, 149} and its function is currently unknown. No abnormalities in the stomatin gene, which has been isolated and cloned, have been identified in stomatin-deficient individuals with hereditary stomatocytosis. Homozygous knock-out mice that completely lack the murine analog of erythrocyte stomatin exhibit no features of the hereditary stomatocytosis syndrome seen in humans, suggesting that stomatin deficiency is not the proximate cause of the disease in humans, although it may be a marker for another membrane defect that is responsible.¹⁵⁰

The severity of hemolytic disease is diverse, both between different families and among affected members of the same family. In most patients, symptoms related to intermittent anemia and jaundice are so mild that no therapy is required. Rarely, the anemia is of sufficient severity to require transfusion therapy. Exchange transfusion for severe neonatal hyperbilirubinemia was required in one case. Splenomegaly is an expected corollary of severe anemia. Approximately 10% to 50% of circulating red cells are stomatocytes (Fig. 27.12). The MCV is elevated, often strikingly, the MCHC is normal or low (as a result of increased cell water content), and OF is increased. Red cell sodium content is increased and potassium content is decreased. In most patients, hemolytic anemia is improved after splenectomy, but splenectomy is considered contraindicated in most cases because there is a high risk of postsplenectomy thromboembolic disease and chronic pulmonary hypertension. This has been attributed to increased erythrocyte endothelial cell adhesion due to increased phosphatidylserine exposure of overhydrated erythrocytes.¹⁵¹ Fortunately, most patients have compensated hemolysis and splenectomy is not required.

Hereditary Xerocytosis

Hereditary xerocytosis (also known as desiccycytosis or dehydrated stomatocytosis) is a rare autosomal dominant hemolytic anemia characterized by red cell dehydration due to net potassium loss from cells that is not accompanied by a proportional gain of sodium (Table 27.4).^{145, 152} Measurement of RBC cations reveals a slight increase in cell sodium content, a greater decrease in potassium concentration, and, thus, a decrease in the net intracellular cation content and cell dehydration. In some cases, reduced red cell 2,3-DPG has been noted. In several families, an increase in erythrocyte PC content has been observed. Although the total red cell membrane protein content may be elevated, specific abnormalities of stomatin or other membrane proteins have not been observed. The red cells in hereditary xerocytosis are sensitive to shear stress and readily undergo membrane fragmentation.

Xerocytosis patients characteristically have mild to moderate hemolysis. The MCHC is increased, reflecting cellular dehydration, whereas the MCV is slightly increased, reflecting both increased reticulocyte count and artifact from electronic cell counters which, because of alterations in cellular stiffness, estimate the MCV about 10% too high. Peripheral blood film reveals stomatocytes, target cells, spiculated cells, and some cells in which hemoglobin is concentrated ("puddled") in discrete areas on the cell periphery (Fig. 27.12). Peripheral blood smears from mildly affected patients is nearly normal. The OF is decreased. Splenectomy is to be avoided because it has minimal effect on the hemolytic anemia and increases the risk of thrombosis.^{153, 154} A subset of patients with hereditary xerocytosis also exhibits transient in utero ascites, nonimmune hydrops fetalis, and/or pseudohyperkalemia which are unrelated to the degree of anemia.^{155, 156, 157} The basis for the transient ascites and hydrops is unknown.

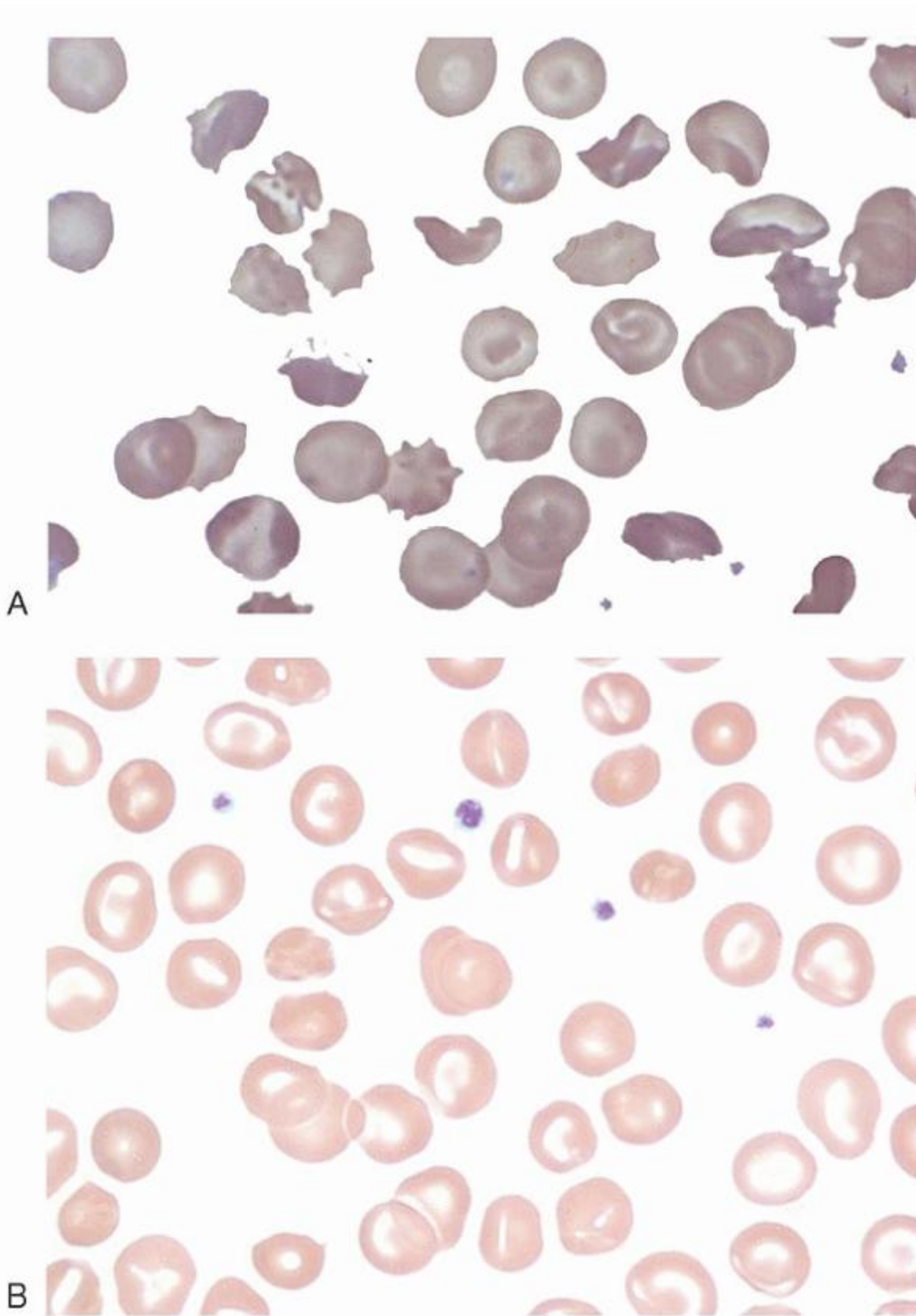

FIGURE 27.12. Hereditary stomatocytosis. A: Wright-stained peripheral blood smear from a patient with hereditary hydrocytosis. Instead of central pallor, characteristic erythrocytes have a central mouth-like or “stoma” appearance, hence the term stomatocytosis. B: Wright-stained peripheral blood smear from a patient with hereditary xerocytosis,

showing dense, abnormal erythrocyte forms where hemoglobin appears puddled at the periphery.

Recently, mutations in the mechanotransduction protein PIEZO1 were identified in patients with hereditary xerocytosis.¹⁵⁸ PIEZO1 is encoded by the FAM38A gene on chromosome 16, located in the region previously linked to both hereditary xerocytosis and pseudohyperkalemia (see section "Intermediate Stomatocytic Syndromes").^{159, 160, 161} This work suggests that PIEZO proteins play a previously unrecognized role in erythrocyte volume regulation, with PIEZO1-mutant erythrocytes gradually becoming dehydrated during their repeated cycles of travel through the microcirculation, associated with changes in oxygenation/deoxygenation. Thus, the PIEZO proteins may participate in the initial calcium-permeable cation conductance pathways involved in sickle cell dehydration.^{158, 162, 163}

Intermediate Stomatocytic Syndromes

Some cases of hereditary RBC cation permeability abnormalities share features of both hereditary stomatocytosis and xerocytosis (Table 27.4).^{145, 164} Affected individuals have stomatocytes and target cells on the peripheral blood smear. The OF of red cells is either normal or slightly increased. The sodium and potassium permeability is somewhat increased, but the intracellular cation concentration and the red cell volume usually are normal or slightly reduced.

P.724

Cryohydrocytosis is a variant of hydrocytosis with abnormal cation transport and overhydrated red cells (Table 27.4). Cryohydrocytosis cells exhibit a profound increase in cation permeability in vitro at low temperatures (5°C) compared with 37°C. A similar susceptibility to cold-induced cation permeability in which potassium and water loss predominates and xerocytes instead of hydrocytes are present has also been described. Blood samples left at room temperature for a few hours may manifest pseudohyperkalemia as a result of potassium efflux from red cells into the plasma. Despite the mildly dehydrated red cells, no anemia or hemolysis is associated with this defect. Careful analysis of potassium loss at low temperatures is an excellent way to distinguish between cryohydrocytosis, pseudohyperkalemia, and intermediate forms; at least five different phenotypes can be distinguished. In a group of cryohydrocytosis patients, two different mutations in the Rh-associated glycoprotein (RHAG), Ile61Arg or Phe65Ser, were found.¹⁶⁵ Additional studies support the role of Rh proteins as an ammonia channel in erythrocytes, with the cryohydrocytosis-associated mutations leading to increased cation conductance/permeability.^{166, 167}

A subgroup of stomatin-deficient cryohydrocytosis patients with hepatosplenomegaly, cataracts, seizures, and movement disorders has been described. In two affected kindreds, mutations in the glucose transporter 1 (GLUT1), encoded by the SLC2A1 gene, have been found.¹⁶⁸

Study of a group of stomatocytosis, spherocytosis, and spherostomatocytosis patients with large cation leaks at 0°C revealed varying patterns of cation loss over a range of temperatures. Erythrocyte membranes from some of these patients demonstrated band 3 deficiency. Several missense mutations in exon 17, encoding an intramembrane domain of band 3, were discovered in these patients.¹¹⁹ In vitro studies suggested that these mutations convert band 3 from an anion exchanger to a nonselective cation leak channel.¹⁶⁹

Rh-Null Disease

Most hematologists are familiar with the Rh antigen because of the immune sensitization that occurs in Rh-negative individuals exposed to Rh-positive red cells. The Rh locus (RH30) is composed of two closely linked genes, one encoding the D polypeptide and the other encoding the CE protein.¹⁷⁰ The importance of the Rh locus for membrane integrity was recognized through the discovery of rare individuals whose red cells have absent (Rh_{null}) or markedly decreased (Rh_{mod}) Rh antigen expression.¹⁷¹ Rh proteins are part of a multiprotein complex that includes 2 Rh proteins and 2 Rh-associated glycoproteins (RhAG).¹⁷² Other proteins that associate with this complex include CD47, LW, glycophorin B, and protein 4.2. The Rh-RhAG complex interacts with ankyrin to link the membrane skeleton to the lipid bilayer.¹⁷³

Rh_{null} and Rh_{mod} diseases are characterized by mild to moderate normocytic, normochromic hemolytic anemia with stomatocytes and occasional spherocytes on peripheral blood smear. Though the clinical syndromes are the same, the genetic basis of the Rh deficiency syndrome is heterogeneous, with at least two groups defined. The "amorph type" is due to defects involving the RH30 locus encoding the RhD and RhCE polypeptides. The "regulatory type" of Rh_{null} and Rh_{mod} phenotypes results from suppressor or "modifier" mutations at the RH50 locus encoding the Rh-associated glycoproteins. When one chain of the Rh-RhAG complex is absent, the entire Rh multiprotein complex is either not transported to or assembled at the membrane.

Sitosterolemia

Sitosterolemia, also known as phytosterolemia, is a recessively inherited disorder associated with elevated plasma levels of plant sterols. Affected patients exhibit early onset xanthomatosis and premature coronary artery disease.¹⁷⁴ Hematologic manifestations include macrothrombocytopenia and stomatocytic hemolytic anemia.^{175, 176} Mutations in the transporters ABCG5 or ABCG8 lead to gastrointestinal hyperabsorption and decreased biliary elimination of plant sterols as well as altered cholesterol metabolism.¹⁷⁷ Plant sterols are not synthesized endogenously in humans, but are passively absorbed in the intestine.¹⁷⁸ ABCG5 and ABCG8 actively pump plant sterols out of the intestinal cells back into the intestine and out of liver cells into bile ducts. It has been suggested that the stomatocytic phenotype is due to intercalation of plant sterols into the inner leaflet of the lipid bilayer.

Familial Deficiency of High-density Lipoproteins

Familial deficiency of high-density lipoproteins (Tangier disease) is a rare autosomal recessive disorder associated with accumulation of cholesterol esters in many tissues. Affected patients exhibit markedly reduced high-density lipoproteins and mild hypertriglyceridemia. Accretion of cholesterol leads to enlarged yellow- or orange-colored tonsils, hepatosplenomegaly, cloudy corneas, neuropathy, and premature atherosclerosis. Hematologic manifestations include a mild to moderate hemolytic anemia with stomatocytosis. Erythrocyte membranes have low free cholesterol content, leading to a decreased cholesterol/phospholipid ratio and a relative increase in PC. Patients with Tangier disease have mutations in ABCA1, a protein involved in the cellular export of cholesterol.

ACANTHOCYTIC DISORDERS

Acanthocytes are dense, contracted red cells with several irregularly spaced “thorny” projections on the surface. Acanthocytes differ from echinocytes in that there are fewer projections, and the width and length of these projections vary considerably. No central pallor is evident. By contrast, echinocytic spicules are similar in dimension and evenly distributed around the cell periphery. Acquired acanthocytosis is encountered in patients with severe liver disease, in malnourished states such as anorexia nervosa⁹, in hypothyroidism, and after splenectomy. Acanthocytosis also is seen in hereditary disorders such as abetalipoproteinemia, the McLeod phenotype, and the neuroacanthocytosis syndromes.

Spur Cell Anemia

Acanthocytosis in liver disease (hepatocellular injury) is attributable to a marked increase in the cholesterol content and the cholesterol to phospholipid ratio of red cell membranes (Fig. 27.13).¹⁷⁹ This red cell lipid profile is in contrast to the equal increase in both cholesterol and phospholipid seen in obstructive liver disease. In cirrhotic liver disease, abnormal lipoproteins produced by the liver are loaded with cholesterol; this excess cholesterol is readily transferred to RBCs, resulting in the formation of flat, scalloped cells.¹⁸⁰ These cells, however, are further conditioned by the spleen, resulting in membrane fragmentation, and the evolution of acanthocytes that look like “spurs.”

These spur RBCs are cholesterol loaded, with a decreased surface area to volume ratio, and their cellular deformability is decreased. Once formed, spur cells are destroyed over time by the spleen, accounting for the hemolytic anemia associated with severe liver disease. Such patients usually have moderate-to-severe hemolysis, hyperbilirubinemia, splenomegaly, as well as clinical and laboratory evidence of liver disease. This acanthocytic, spur cell anemia can occur in any condition associated with severe hepatocyte injury.

Abetalipoproteinemia

Abetalipoproteinemia is a rare, autosomal recessive disorder characterized by acanthocytosis, malabsorption of fat, hypolipidemia,

P.725

retinitis pigmentosa, and progressive ataxia.^{181, 182} Although affected infants ostensibly are normal at birth, steatorrhea, abdominal distention, and growth failure develop in the first months of life. Retinitis pigmentosa and progressive ataxia are first noted in children between 5 and 10 years of age. Without treatment, neurologic disability is progressive, with death usually occurring during the second or third decade. In some cases, cardiac arrhythmias and heart failure precede death. Many of the clinical abnormalities have been attributed to fat-soluble vitamin deficiency, especially vitamin E, but this has not been well studied. Retinal and neuromuscular abnormalities may be stabilized by the administration of vitamin E.

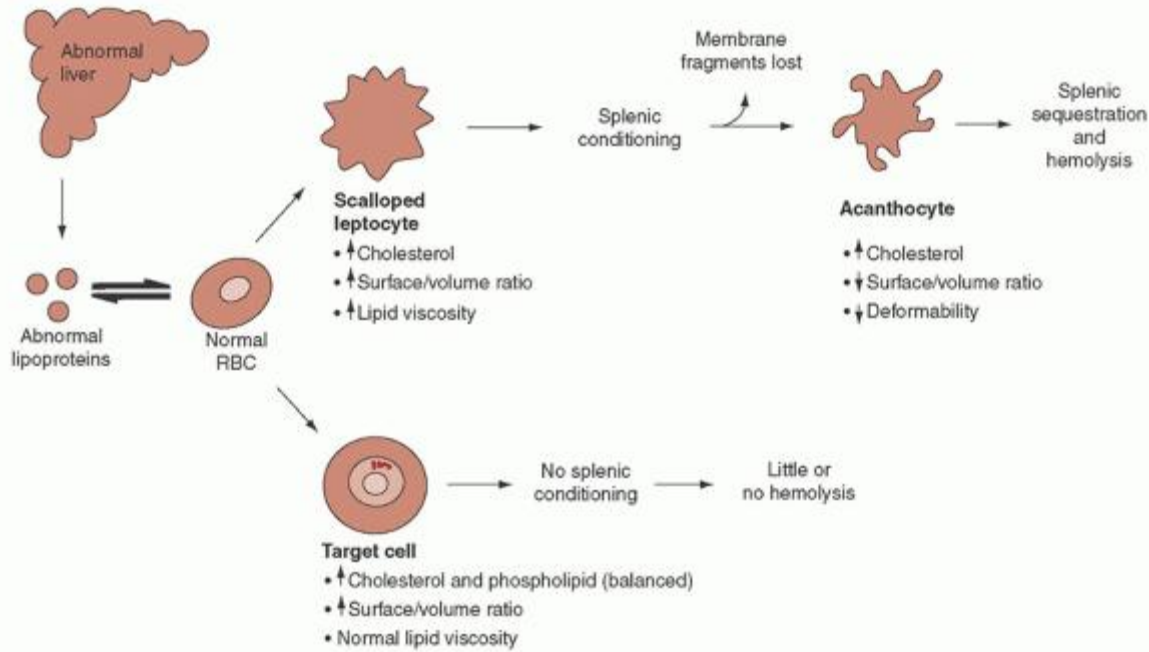

FIGURE 27.13. Alterations of erythrocyte shape in liver disease. N Schematic illustration of the pathophysiology of acanthocyte (“spur cell”) and target cell formation in liver disease. RBC, red blood cell. (Reprinted with permission from Gallagher PG, Lux SE, Disorders of the erythrocyte membrane. In: Nathan DG, Orkin SH, Ginsburg D, Look AT, eds. Hematology of infancy and childhood, 6th ed. Philadelphia, PA: WB Saunders, 2003:645.)

The primary biochemical defect is failure to synthesize or secrete lipoprotein-containing products of the apolipoprotein B gene, the B apoproteins B100 and B48, or defects in the multifunctional microsomal triglyceride transfer protein,¹⁸³ required for production of apoprotein B-containing β -lipoproteins.¹⁸⁴ Absorption of lipids through the intestine is defective, serum cholesterol levels are extremely low, and serum β -lipoprotein is absent. Secondary alterations in CD1 lead to immune defects.¹⁸⁵ The serum appears transparent. Clinical manifestations are variable depending upon the extent to which apolipoprotein B-mediated metabolic processes are affected.

Acanthocyte formation is thought to reflect an increase in the surface area of the outer lipid bilayer relative to the inner bilayer, attributed to increased SM in the outer bilayer mirroring the altered plasma lipid profile of these patients, presumably because of lipid exchange. Normal red cells become acanthocytic when infused into individuals with abetalipoproteinemia. In affected patients, red cell precursors and young erythrocytes are of normal shape, with acanthocyte formation increasing with erythrocyte aging, reaching up to 50% to 90% of erythrocytes on peripheral smear (Fig. 27.14). For unknown reasons, the anemia in abetalipoproteinemia (increased SM) is minimal to mild, whereas in spur cell anemia (increased cholesterol) there is moderate-to-severe hemolysis. Occasionally, severe anemia is observed in patients with abetalipoproteinemia. This is usually the result of broad nutritional deficiencies, including folate deficiency, related to malabsorption.

McLeod Phenotype

The McLeod phenotype, named after the first patient described, is an X-linked abnormality of the Kell blood group system.^{186, 187} Red cells, leukocytes, or both from affected patients react poorly with Kell antisera. Associated findings in affected males include acanthocytosis ranging from 8% to 85%, a mild, well-compensated hemolytic anemia, and susceptibility to alloimmunization by Kell antigens. Elevated serum creatine phosphokinase levels are seen, often accompanied by myopathy and peripheral neuropathy. Central nervous system abnormalities may appear, particularly after the fourth decade of life. Females have only occasional acanthocytes and minimal to no hemolysis. Because of the susceptibility to alloimmunization, it is important to diagnose affected patients, since if they are transfused, they may develop antibodies compatible only with McLeod red cells.

The McLeod phenotype is the result of mutation in the XK gene located on the X chromosome, which encodes a membrane protein necessary for Kell antigen expression. XK is linked to Kell, a zinc endopeptidase that carries the Kell antigens, by a disulfide bond. McLeod erythrocytes lack XK and Kell proteins. Contiguous X-chromosome gene deletions

including the XK gene have led to McLeod individuals with co-inherited chronic granulomatous disease, Duchenne's muscular dystrophy, and/or retinitis pigmentosa.¹⁸⁸

Neuroacanthocytosis Syndromes

The neuroacanthocytoses are a group of degenerative neurologic disorders marked by great phenotypic and genetic heterogeneity that share the features of acanthocytes on peripheral blood smear.^{189, 190} These disorders include the X-linked McLeod

P.726

syndrome described above; chorea-acanthocytosis (ChAc); and other neurodegenerative disorders such as Huntington's disease like 2 (HDL2), due to mutations in the junctophilin-3 gene; and pantothenate kinase-associated neurodegeneration (formerly known as Hallervorden-Spatz syndrome and its allelic variant HARP syndrome—hypobetalipoproteinemia, acanthocytosis, retinitis pigmentosa, and pallidal degeneration), due to mutations in the pantothenate kinase 2 (PANK2) gene.^{191, 192} The etiology of the acanthocytic erythroid phenotype in these disorders is unknown. Further investigation of the pathobiology in erythroid cells may provide important insights into the neurodegenerative processes affecting the brain.

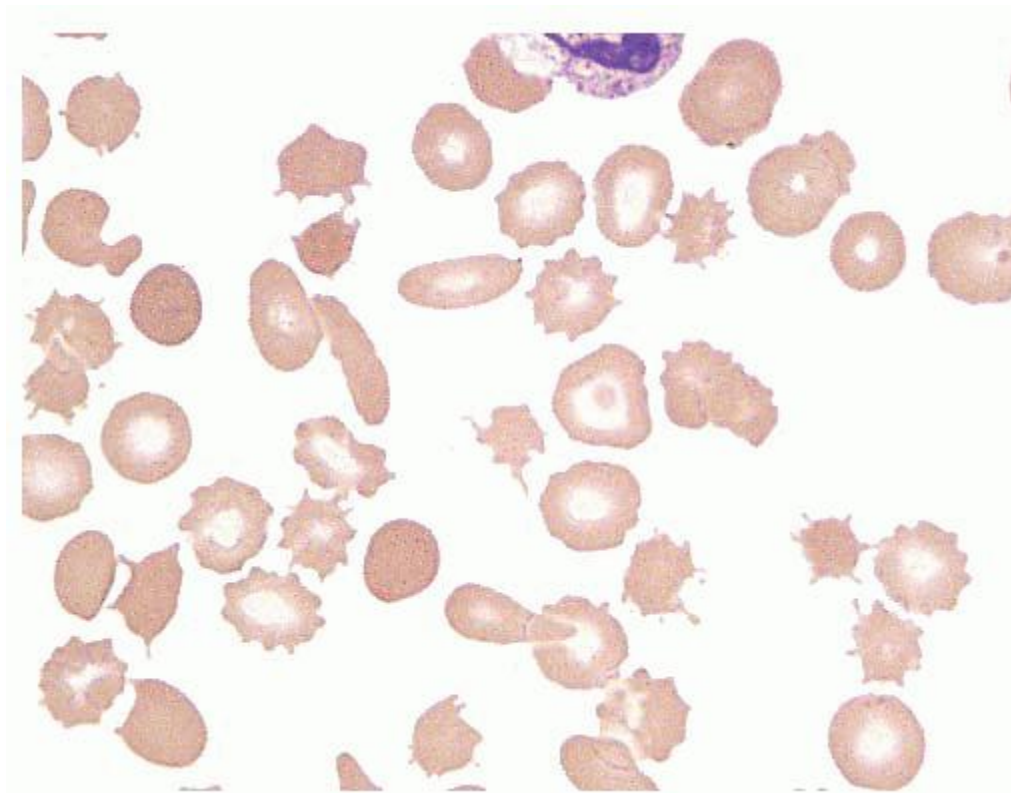

FIGURE 27.14. Acanthocytes. Blood smear from patient with liver disease. Note the numerous erythrocytes with thorny projections, or acanthocytes. (Courtesy of Irma Pereira MT [ASCP]SH.)

ChAc is an autosomal recessive disorder characterized by acanthocytes, normolipoproteinemia, and progressive neurologic disease, beginning in adolescence or adult life. Neurologic manifestations are variable and may include limb chorea, progressive orofacial dyskinesia, tongue biting, muscle wasting, and hypotonia. Mutations have been identified in the chorein gene (also known as CHAC or VPS13A—vacuolar protein sorting 13 homolog A) in ChAc patients.^{193, 194, 195, 196, 197} The role of chorein is unknown, either in erythrocytes or in the brain. In yeast, its homolog is involved in protein sorting and transport. Abnormalities in erythrocyte membrane phosphorylation have been identified, and perturbations in a network of interconnected kinases are suggested to play a role in acanthocyte formation.^{198, 199}

ECHINOCYTIC DISORDERS

Echinocytes are RBCs with numerous fine uniform spicules distributed equally throughout the cell surface. These cells differ morphologically from acanthocytes, which have fewer projections, and the spicules vary in size. It is thought that

echinocytes are the result of preferential expansion of the outer lipid bilayer relative to the inner layer. As mentioned previously, stomatocytes, in contrast, are produced by agents that expand the inner lipid surface area relative to the outer half of the bilayer. The presence of echinocytes on the peripheral blood film often is an artifact caused by interactions of red cells with glass. However, echinocytes also are seen in association with hemolytic anemias in patients with hypophosphatemia, pyruvate kinase deficiency, uremia; and are also seen in some long-distance runners. The mechanism of echinocytosis in these diverse disorders is not clear. In vitro, a variety of factors, such as exposure of red cells to certain drugs, calcium loading, or ATP depletion, can induce echinocyte formation. In echinocytes produced by ATP depletion or calcium loading, it has been suggested that altered phospholipid distribution is a consequence of decreased aminophospholipid translocase activity, an ATP-dependent enzyme that actively translocates aminophospholipids from the outer half of the bilayer to the inner half echinocytes.

TARGET CELL DISORDERS

Target cells are discoid RBCs with a centralized hemoglobinized area in the clear center, resembling a bull's eye or target. Target cells are the morphologic expression of an increase in the ratio of the cell surface area to cell volume. This ratio is influenced by increases in surface area as well as decreases in cell volume. An absolute increase in cell surface area due to net membrane accumulation of phospholipids and cholesterol is the basis of target cell formation in obstructive liver disease and disorders of intrahepatic cholestasis (Fig. 27.13). This accumulation is caused by abnormal low-density lipoproteins that occur in obstructive jaundice. These low-density lipoproteins are laden with cholesterol and lecithin, which is readily transferable to red cell membrane, thereby leading to an expansion of the cell membrane surface. This process explains why HS patients who develop sudden obstructive jaundice due to cholelithiasis have a decrease in hemolysis and normalization of OF; i.e., the increased membrane surface area temporarily normalizes the previously abnormal surface area to volume ratio of spherocytes. Decreased cell volume leading to target cell formation is associated with decreased hemoglobin synthesis (thalassemia or iron deficiency), several structural mutations of hemoglobin (S, C, D, and E), or some primary disorders of cell hydration.

Target cells have decreased OF, as the excess of membrane surface area leads to an increase of the critical hemolytic volume. Typically, an increase in cell surface area does not affect red cell survival, but decreased cell volume associated with cellular dehydration or reduced hemoglobin synthesis may.

Immediately postsplenectomy, target cells appear, reaching levels of 2% to 10%. Like other target cells, membrane lipids are increased, OF is decreased, and the cell surface area to volume ratio is increased.²⁰⁰ As discussed above, splenic conditioning normally removes excess membrane from erythrocytes. The exact mechanism responsible is not defined, although the reduction in red cell lipid content suggests that lipases may be involved. Postsplenectomy, red cells may eventually lose their excess lipid by conditioning in non-splenic sites, leading to a gradual decrease in target cells.

Familial Lecithin-Cholesterol Acyltransferase Deficiency

Target cells are also observed on peripheral smears of patients with lecithin-cholesterol acyltransferase (LCAT) deficiency. Familial LCAT deficiency is a rare, autosomal recessive disorder due to mutations in LCAT, an enzyme that catalyzes the transfer of fatty acids from PC to cholesterol.^{201, 202} Manifestations include mild anemia, corneal opacities, hyperlipidemia, renal disease, and premature atherosclerosis.^{202, 204} In the circulation, LCAT is complexed with high-density lipoproteins. Deficient plasma LCAT activity is responsible for a marked decrease in plasma levels of unesterified cholesterol and an increase in the amount of free cholesterol. The red cell membrane may contain twice the normal amounts of unesterified cholesterol, but PC also is increased, whereas SM and PE are reduced. These RBC lipid changes are reversible when the target cells are incubated with normal plasma. Typically the anemia of LCAT deficiency is mild, with both hemolysis and decreased erythropoiesis due to

P.727

renal disease implicated in its etiology. Foam cells and "sea-blue histiocytes" laden with unesterified cholesterol and PC are found in the bone marrow and the spleen of affected patients.

REFERENCES

1. Delaunay J. The molecular basis of hereditary red cell membrane disorders. *Blood Rev* 2007;21:1-20.
2. Mohandas N, Chasis JA, Shohet SB. The influence of membrane skeleton on red cell deformability, membrane material properties, and shape. *Semin Hematol* 1983;20:225-242.

3. Balasubramanian K, Schroit AJ. Aminophospholipid asymmetry: a matter of life and death. *Annu Rev Physiol* 2003;65:701-734.
4. Kuypers FA, de Jong K. The role of phosphatidylserine in recognition and removal of erythrocytes. *Cell Mol Biol (Noisy-le-grand)* 2004;50:147-158.
5. Holthuis JC, van Meer G, Huitema K. Lipid microdomains, lipid translocation and the organization of intracellular membrane transport (review). *Mol Membr Biol* 2003;20:231-241.
6. Salzer U, Prohaska R. Stomatin, flotillin-1, and flotillin-2 are major integral proteins of erythrocyte lipid rafts. *Blood* 2001;97:1141-1143.
7. Hiller NL, Akompong T, Morrow JS, Holder AA, Haldar K. Identification of a stomatin orthologue in vacuoles induced in human erythrocytes by malaria parasites. A role for microbial raft proteins in apicomplexan vacuole biogenesis. *J Biol Chem* 2003;278:48413-48421.
8. Murphy SC, Samuel BU, Harrison T, et al. Erythrocyte detergent-resistant membrane proteins: their characterization and selective uptake during malarial infection. *Blood* 2004;103:1920-1928.
9. Morrow JS, Rimm DL, Kennedy SP, Cianci CD, Sinard JH, Weed SA. Of membrane stability and mosaics: the spectrin cytoskeleton. In: Hoffman J, Jamieson J, eds. *Handbook of physiology*. London: Oxford University Press, 1997:485-540.
10. von Lohneysen K, Scott TM, Soldau K, Xu X, Friedman JS. Assessment of the red cell proteome of young patients with unexplained hemolytic anemia by two-dimensional differential in-gel electrophoresis (DIGE). *PLoS ONE* 2012;7:e34237.
11. van Gestel RA, van Solinge WW, van der Toorn HW, et al. Quantitative erythrocyte membrane proteome analysis with Blue-native/SDS PAGE. *J Proteomics* 2010;73:456-465.
12. Pasini EM, Kirkegaard M, Mortensen P, Lutz HU, Thomas AW, Mann M. In-depth analysis of the membrane and cytosolic proteome of red blood cells. *Blood* 2006;108:791-801.
13. Zhang Y, Zhang Y, Adachi J, et al. MAPU: Max-Planck unified database of organellar, cellular, tissue and body fluid proteomes. *Nucleic Acids Res* 2007;35:D771-779.
14. Bennett V, Baines AJ. Spectrin and ankyrin-based pathways: metazoan inventions for integrating cells into tissues. *Physiol Rev* 2001;81:1353-1392.
15. Ipsaro JJ, Harper SL, Messick TE, Marmorstein R, Mondragon A, Speicher DW. Crystal structure and functional interpretation of the erythrocyte spectrin tetramerization domain complex. *Blood* 2010;115:4843-4852.
16. Discher DE. New insights into erythrocyte membrane organization and microelasticity. *Curr Opin Hematol* 2000;7:117-122.
17. An X, Lecomte MC, Chasis JA, Mohandas N, Gratzer W. Shear-response of the spectrin dimer-tetramer equilibrium in the red blood cell membrane. *J Biol Chem* 2002;277:31796-31800.
18. Mohler PJ, Bennett V. Defects in ankyrin-based cellular pathways in metazoan physiology. *Front Biosci* 2005;10:2832-2840.
19. Cohen CM, Dotimas E, Korsgren C. Human erythrocyte membrane protein band 4.2 (pallidin). *Semin Hematol* 1993;30:119-137.
20. Gilligan DM, Bennett V. The junctional complex of the membrane skeleton. *Semin Hematol* 1993;30:74-83.
21. Franco T, Low PS. Erythrocyte adducin: a structural regulator of the red blood cell membrane. *Transfus Clin Biol* 2010;17:87-94.
22. Mohandas N, Chasis JA. Red blood cell deformability, membrane material properties and shape: regulation by transmembrane, skeletal and cytosolic proteins and lipids. *Semin Hematol* 1993;30:171-192.
23. Giorgi M, Cianci CD, Gallagher PG, Morrow JS. Spectrin oligomerization is cooperatively coupled to membrane assembly: a linkage targeted by many hereditary hemolytic anemias? *Exp Mol Pathol* 2001;70:215-230.
24. Eber S, Lux SE. Hereditary spherocytosis—defects in proteins that connect the membrane skeleton to the lipid bilayer. *Semin Hematol* 2004;41:118-141.
25. Perrotta S, Gallagher PG, Mohandas N. Hereditary spherocytosis. *Lancet* 2008;372:1411-1426.
26. Dacie J. *The haemolytic anaemias*. Edinburgh: Churchill Livingstone, 1985.

27. Packman CH. The spherocytic haemolytic anaemias. *Br J Haematol* 2001;112:888-899.
28. Vanlair CF, Masius JB. De la microcythemie. *Bull R Acad Med Belg* 1871;5:515.
29. Haclen RL. The mechanism of the increased fragility of the erythrocytes in congenital hemolytic jaundice. *Am J Med Sci* 1934;188:441-449.
30. Eber SW, Pekrun A, Neufeldt A, Schroter W. Prevalence of increased osmotic fragility of erythrocytes in German blood donors: screening using a modified glycerol lysis test. *Ann Hematol* 1992;64:88-92.
31. Godal HC, Heisto H. High prevalence of increased osmotic fragility of red blood cells among Norwegian blood donors. *Scand J Haematol* 1981;27:30-34.
32. Agre P, Asimos A, Casella JF, McMillan C. Inheritance pattern and clinical response to splenectomy as a reflection of erythrocyte spectrin deficiency in hereditary spherocytosis. *N Engl J Med* 1986;315:1579-1583.
33. Agre P, Orringer EP, Bennett V. Deficient red-cell spectrin in severe, recessively inherited spherocytosis. *N Engl J Med* 1982;306:1155-1161.
34. Edelman EJ, Maksimova Y, Duru F, Altay C, Gallagher PG. A complex splicing defect associated with homozygous ankyrin-deficient hereditary spherocytosis. *Blood* 2007;109:5491-5493.
35. Yetgin S, Aytac S, Gurakan F, Yurdakok M. Nonimmune hydrops fetalis in two cases of consanguineous parents and associated with hereditary spherocytosis and hemophagocytic hystiocytosis. *J Perinatol* 2007;27:252-254.
36. Coetzer TL, Lawler J, Liu SC, et al. Partial ankyrin and spectrin deficiency in severe, atypical hereditary spherocytosis. *N Engl J Med* 1988;318:230-234.
37. Eber SW, Armbrust R, Schroter W. Variable clinical severity of hereditary spherocytosis: relation to erythrocytic spectrin concentration, osmotic fragility, and autohemolysis. *J Pediatr* 1990;117:409-416.
38. Hanspal M, Yoon SH, Yu H, et al. Molecular basis of spectrin and ankyrin deficiencies in severe hereditary spherocytosis: evidence implicating a primary defect of ankyrin. *Blood* 1991;77:165-173.
39. Gallagher PG. Update on the clinical spectrum and genetics of red blood cell membrane disorders. *Curr Hematol Rep* 2004;3:85-91.
40. Hanspal M, Hanspal JS, Kalraiya R, et al. Asynchronous synthesis of membrane skeletal proteins during terminal maturation of murine erythroblasts. *Blood* 1992;80:530-539.
41. Moon RT, Lazarides E. beta-Spectrin limits alpha-spectrin assembly on membranes following synthesis in a chicken erythroid cell lysate. *Nature* 1983;305:62-65.
42. Tse WT, Gallagher PG, Jenkins PB, et al. Amino-acid substitution in alphaspectrin commonly coinherited with nondominant hereditary spherocytosis. *Am J Hematol* 1997;54:233-241.
43. Wichterle H, Hanspal M, Palek J, Jarolim P. Combination of two mutant alpha spectrin alleles underlies a severe spherocytic hemolytic anemia. *J Clin Invest* 1996;98:2300-2307.
44. Hassoun H, Vassiliadis JN, Murray J, et al. Characterization of the underlying molecular defect in hereditary spherocytosis associated with spectrin deficiency. *Blood* 1997;90:398-406.
45. Hassoun H, Vassiliadis JN, Murray J, et al. Hereditary spherocytosis with spectrin deficiency due to an unstable truncated beta spectrin. *Blood* 1996;87:2538-2545.
46. Becker PS, Tse WT, Lux SE, Forget BG. Beta spectrin Kissimmee: a spectrin variant associated with autosomal dominant hereditary spherocytosis and defective binding to protein 4.1. *J Clin Invest* 1993;92:612-616.
47. Miraglia del Giudice E, Lombardi C, Francese M, et al. Frequent de novo monoallelic expression of beta-spectrin gene (SPTB) in children with hereditary spherocytosis and isolated spectrin deficiency. *Br J Haematol* 1998;101:251-254.
48. Savvides P, Shalev O, John KM, Lux SE. Combined spectrin and ankyrin deficiency is common in autosomal dominant hereditary spherocytosis. *Blood* 1993;82:2953-2960.
49. Miraglia del Giudice E, Francese M, Nobili B, et al. High frequency of de novo mutations in ankyrin gene (ANK1) in children with hereditary spherocytosis. *J Pediatr* 1998;132:117-120.
50. Gallagher PG, Nilson DG, Wong C, et al. A dinucleotide deletion in the ankyrin promoter alters gene expression, transcription initiation and TFIID complex formation in hereditary spherocytosis. *Hum Mol Genet* 2005;14:2501-2509.

51. Gallagher PG, Sabatino DE, Basseres DS, et al. Erythrocyte ankyrin promoter mutations associated with recessive hereditary spherocytosis cause significant abnormalities in ankyrin expression. *J Biol Chem* 2001;276: 41683-41689.
52. Gallagher PG, Steiner LA, Liem RI, et al. Mutation of a barrier insulator in the human ankyrin-1 gene is associated with hereditary spherocytosis. *J Clin Invest* 2010;120:4453-4465.
53. Lux SE, Tse WT, Menninger JC, et al. Hereditary spherocytosis associated with deletion of human erythrocyte ankyrin gene on chromosome 8. *Nature* 1990;345:736-739.
54. Miya K, Shimojima K, Sugawara M, et al. A de novo interstitial deletion of 8p11.2 including ANK1 identified in a patient with spherocytosis, psychomotor developmental delay, and distinctive facial features. *Gene* 2012;506: 146-149.
55. Jarolim P, Murray JL, Rubin HL, et al. Characterization of 13 novel band 3 gene defects in hereditary spherocytosis with band 3 deficiency. *Blood* 1996;88:4366-4374.
56. Jarolim P, Rubin HL, Brabec V, et al. Mutations of conserved arginines in the membrane domain of erythroid band 3 lead to a decrease in membrane-associated band 3 and to the phenotype of hereditary spherocytosis. *Blood* 1995;85:634-640.
57. Quilty JA, Reithmeier RA. Trafficking and folding defects in hereditary spherocytosis mutants of the human red cell anion exchanger. *Traffic* 2000;1:987-998.
58. Alloisio N, Maillet P, Carre G, et al. Hereditary spherocytosis with band 3 deficiency. Association with a nonsense mutation of the band 3 gene (allele Lyon), and aggravation by a low-expression allele occurring in trans (allele Genas). *Blood* 1996;88:1062-1069.
59. Alloisio N, Texier P, Vallier A, et al. Modulation of clinical expression and band 3 deficiency in hereditary spherocytosis. *Blood* 1997;90:414-420.
60. Bracher NA, Lyons CA, Wessels G, Mansvelt E, Coetzer TL. Band 3 Cape Town (E90K) causes severe hereditary spherocytosis in combination with band 3 Prague III. *Br J Haematol* 2001;113:689-693.
61. Ribeiro ML, Alloisio N, Almeida H, et al. Severe hereditary spherocytosis and distal renal tubular acidosis associated with the total absence of band 3. *Blood* 2000;96:1602-1604.
62. Wrong O, Bruce LJ, Unwin RJ, Toye AM, Tanner MJ. Band 3 mutations, distal renal tubular acidosis, and Southeast Asian ovalocytosis. *Kidney Int* 2002;62:10-19.
63. Yawata Y, Kanzaki A, Yawata A, Doerfler W, Ozcan R, Eber SW. Characteristic features of the genotype and phenotype of hereditary spherocytosis in the Japanese population. *Int J Hematol* 2000;71:118-135.
64. Bouhassira EE, Schwartz RS, Yawata Y, et al. An alanine-to-threonine substitution in protein 4.2 cDNA is associated with a Japanese form of hereditary hemolytic anemia (protein 4.2NIPPON). *Blood* 1992;79:1846-1854.
65. Lusher JM, Barnhart MI. The role of the spleen in the pathophysiology of hereditary spherocytosis and hereditary elliptocytosis. *Am J Pediatr Hematol Oncol* 1980;2:31-39.
66. Park Y, Best CA, Badizadegan K, et al. Measurement of red blood cell mechanics during morphological changes. *Proc Natl Acad Sci U S A* 2010;107: 6731-6736.
67. Mendelbaum H. Congenital hemolytic jaundice: initial hemolytic crisis occurring at the age of 75. *Ann Intern Med* 1939;13:872-883.
68. Guarnone R, Centenara E, Zappa M, Zanella A, Barosi G. Erythropoietin production and erythropoiesis in compensated and anaemic states of hereditary spherocytosis. *Br J Haematol* 1996;92:150-154.
69. Rocha S, Costa E, Catarino C, et al. Erythropoietin levels in the different clinical forms of hereditary spherocytosis. *Br J Haematol* 2005;131:534-542.
70. Saada V, Cynober T, Brossard Y, et al. Incidence of hereditary spherocytosis in a population of jaundiced neonates. *Pediatr Hematol Oncol* 2006;23:387-397.
71. Sgro M, Campbell D, Shah V. Incidence and causes of severe neonatal hyperbilirubinemia in Canada. *CMAJ* 2006;175:587-590.
72. Berardi A, Lugli L, Ferrari F, et al. Kernicterus associated with hereditary spherocytosis and UGT1A1 promoter polymorphism. *Biol Neonate* 2006;90:243-246.

73. Pajor A, Lehoczy D, Szakacs Z. Pregnancy and hereditary spherocytosis. Report of 8 patients and a review. *Arch Gynecol Obstet* 1993;253:37-42.
74. Gehlbach SH, Cooper BA. Haemolytic anaemia in infectious mononucleosis due to inapparent congenital spherocytosis. *Scand J Haematol* 1970;7: 141-144.
75. Young NS. Hematologic manifestations and diagnosis of parvovirus B19 infections. *Clin Adv Hematol Oncol* 2006;4:908-910.
76. Lefrere JJ, Courouce AM, Girot R, Bertrand Y, Soulier JP. Six cases of hereditary spherocytosis revealed by human parvovirus infection. *Br J Haematol* 1986;62:653-658.
77. Delamore IW, Richmond J, Davies SH. Megaloblastic anaemia in congenital spherocytosis. *Br Med J* 1961;1:543-545.
78. Tamary H, Aviner S, Freud E, et al. High incidence of early cholelithiasis detected by ultrasonography in children and young adults with hereditary spherocytosis. *J Pediatr Hematol Oncol* 2003;25:952-954.
79. Economou M, Tsatra I, Athanassiou-Metaxa M. Simultaneous presence of Gilbert syndrome and hereditary spherocytosis: interaction in the pathogenesis of hyperbilirubinemia and gallstone formation. *Pediatr Hematol Oncol* 2003;20:493-495.
80. Iolascon A, Faienza MF, Moretti A, Perrotta S, Miraglia del Giudice E. UGT1 promoter polymorphism accounts for increased neonatal appearance of hereditary spherocytosis. *Blood* 1998;91:1093.
81. Kugler D, Jager D, Barth J. A patient with pancreatitis, anaemia and an intrathoracic tumour. Diagnosis: tumour-simulating asymptomatic intrathoracic extramedullary haematopoiesis (EMH) in a patient with hereditary spherocytosis. *Eur Respir J* 2006;27:856-859.
82. Giraldi S, Abbage KT, Marinoni LP, et al. Leg ulcer in hereditary spherocytosis. *Pediatr Dermatol* 2003;20:427-428.
83. Rabhi S, Benjelloune H, Meziane M, et al. Hereditary spherocytosis with leg ulcers healing after splenectomy. *South Med J* 2011;104:150-152.
84. Alter P, Maisch B. Non-compaction cardiomyopathy in an adult with hereditary spherocytosis. *Eur J Heart Fail* 2007;9:98-99.
85. Cynober T, Mohandas N, Tchernia G. Red cell abnormalities in hereditary spherocytosis: relevance to diagnosis and understanding of the variable expression of clinical severity. *J Lab Clin Med* 1996;128:259-269.
86. Michaels LA, Cohen AR, Zhao H, Raphael RI, Manno CS. Screening for hereditary spherocytosis by use of automated erythrocyte indexes. *J Pediatr* 1997;130:957-960.
87. King MJ, Smythe JS, Mushens R. Eosin-5-maleimide binding to band 3 and Rh-related proteins forms the basis of a screening test for hereditary spherocytosis. *Br J Haematol* 2004;124:106-113.
88. Bianchi P, Fermo E, Vercellati C, et al. Diagnostic power of laboratory tests for hereditary spherocytosis: a comparison study in 150 patients grouped according to molecular and clinical characteristics. *Haematologica* 2012;97:516-523.
89. D'Alcamo E, Agrigento V, Sclafani S, et al. Reliability of EMA binding test in the diagnosis of hereditary spherocytosis in Italian patients. *Acta Haematol* 2011;125:136-140.
90. Schroter W, Kahsnitz E. Diagnosis of hereditary spherocytosis in newborn infants. *J Pediatr* 1983;103:460-463.
91. Bolton-Maggs PH, Stevens RF, Dodd NJ, Lamont G, Tittensor P, King MJ. Guidelines for the diagnosis and management of hereditary spherocytosis. *Br J Haematol* 2004;126:455-474.
92. Bolton-Maggs PH, Langer JC, Iolascon A, Tittensor P, King MJ. Guidelines for the diagnosis and management of hereditary spherocytosis—2011 update. *Br J Haematol* 2012;156:37-49.
93. Christensen RD, Henry E. Hereditary spherocytosis in neonates with hyperbilirubinemia. *Pediatrics* 2010;125:120-125.
94. Hosono S, Hosono A, Mugishima H, et al. Successful recombinant erythropoietin therapy for a developing anemic newborn with hereditary spherocytosis. *Pediatr Int* 2006;48:178-180.
95. Tchernia G, Delhommeau F, Perrotta S, et al. Recombinant erythropoietin therapy as an alternative to blood transfusions in infants with hereditary spherocytosis. *Hematol J* 2000;1:146-152.
96. Baird RN, Macpherson AI, Richmond J. Red-blood-cell survival after splenectomy in congenital spherocytosis. *Lancet* 1971;2:1060-1061.

97. Chapman RG, McDonald LL. Red cell life span after splenectomy in hereditary spherocytosis. *J Clin Invest* 1968;47:2263-2267.
98. Reliene R, Mariani M, Zanella A, et al. Splenectomy prolongs in vivo survival of erythrocytes differently in spectrin/ankyrin- and band 3-deficient hereditary spherocytosis. *Blood* 2002;100:2208-2215.
99. Bonderman D, Jakowitsch J, Adlbrecht C, et al. Medical conditions increasing the risk of chronic thromboembolic pulmonary hypertension. *Thromb Haemost* 2005;93:512-516.
100. Hayag-Barin JE, Smith RE, Tucker FC Jr. Hereditary spherocytosis, thrombocytosis, and chronic pulmonary emboli: a case report and review of the literature. *Am J Hematol* 1998;57:82-84.
101. Jardine DL, Laing AD. Delayed pulmonary hypertension following splenectomy for congenital spherocytosis. *Intern Med J* 2004;34:214-216.
102. Smedema JP, Louw VJ. Pulmonary arterial hypertension after splenectomy for hereditary spherocytosis. *Cardiovasc J S Afr* 2007;18:84-89.
103. Wandersee NJ, Olson SC, Holzhauser SL, Hoffmann RG, Barker JE, Hillery CA. Increased erythrocyte adhesion in mice and humans with hereditary spherocytosis and hereditary elliptocytosis. *Blood* 2004;103:710-716.
104. Hansen K, Singer DB. Asplenic-hyposplenic overwhelming sepsis: postsplenectomy sepsis revisited. *Pediatr Dev Pathol* 2001;4:105-121.
105. Schilling RF. Estimating the risk for sepsis after splenectomy in hereditary spherocytosis. *Ann Intern Med* 1995;122:187-188.
106. Singer DB. Postsplenectomy sepsis. *Perspect Pediatr Pathol* 1973;1:285-311.
107. Casale M, Perrotta S. Splenectomy for hereditary spherocytosis: complete, partial or not at all? *Expert Rev Hematol* 2011;4:627-635.
108. Schilling RF. Risks and benefits of splenectomy versus no splenectomy for hereditary spherocytosis—a personal view. *Br J Haematol* 2009;145: 728-732.
109. Balague C, Targarona EM, Cerdan G, et al. Long-term outcome after laparoscopic splenectomy related to hematologic diagnosis. *Surg Endosc* 2004;18:1283-1287.
110. Rescorla FJ, Engum SA, West KW, Tres Scherer LR 3rd, Rouse TM, Grosfeld JL. Laparoscopic splenectomy has become the gold standard in children. *Am Surg* 2002;68:297-301; discussion 301-292.
111. Abdullah F, Zhang Y, Camp M, et al. Splenectomy in hereditary spherocytosis: review of 1,657 patients and application of the pediatric quality indicators. *Pediatr Blood Cancer* 2009;52:834-837.
112. Dutta S, Price VE, Blanchette V, Langer JC. A laparoscopic approach to partial splenectomy for children with hereditary spherocytosis. *Surg Endosc* 2006;20:1719-1724.
113. Rice HE, Oldham KT, Hillery CA, Skinner MA, O'Hara SM, Ware RE. Clinical and hematologic benefits of partial splenectomy for congenital hemolytic anemias in children. *Ann Surg* 2003;37:281-288.
114. Stoehr GA, Stauffer UG, Eber SW. Near-total splenectomy: a new technique for the management of hereditary spherocytosis. *Ann Surg* 2005;241:40-47.
115. Tchernia G, Gauthier F, Mielot F, et al. Initial assessment of the beneficial effect of partial splenectomy in hereditary spherocytosis. *Blood* 1993;81:2014-2020.
116. Yoshimoto A, Fujimura M, Nakao S. Pulmonary hypertension after splenectomy in hereditary stomatocytosis. *Am J Med Sci* 2005;330:195-197.
117. Buesing KL, Tracy ET, Kiernan C, et al. Partial splenectomy for hereditary spherocytosis: a multi-institutional review. *J Pediatr Surg* 2011;46: 178-183.
118. Hollingsworth CL, Rice HE. Hereditary spherocytosis and partial splenectomy in children: review of surgical technique and the role of imaging. *Pediatr Radiol* 2010;40:1177-1183.
119. Bruce LJ, Robinson HC, Guizouarn H, et al. Monovalent cation leaks in human red cells caused by single amino-acid substitutions in the transport domain of the band 3 chloride-bicarbonate exchanger, AE1. *Nat Genet* 2005;37: 1258-1263.

120. Dhermy D, Garbarz M, Lecomte MC, et al. Hereditary elliptocytosis: clinical, morphological and biochemical studies of 38 cases. *Nouv Rev Fr Hematol* 1986;28:129-140.
121. Gallagher PG. Hereditary elliptocytosis: spectrin and protein 4.1R. *Semin Hematol* 2004;41:142-164.
122. Dhermy D, Schrevel J, Lecomte MC. Spectrin-based skeleton in red blood cells and malaria. *Curr Opin Hematol* 2007;14:198-202.
123. Gallagher PG, Weed SA, Tse WT, et al. Recurrent fatal hydrops fetalis associated with a nucleotide substitution in the erythrocyte beta-spectrin gene. *J Clin Invest* 1995;95:1174-1182.
124. Zhang Z, Weed SA, Gallagher PG, Morrow JS. Dynamic molecular modeling of pathogenic mutations in the spectrin self-association domain. *Blood* 2001;98:1645-1653.
125. Johnson CP, Gaetani M, Ortiz V, et al. Pathogenic proline mutation in the linker between spectrin repeats: disease caused by spectrin unfolding. *Blood* 2007;109:3538-3543.
126. Delaunay J, Nouyrigat V, Proust A, et al. Different impacts of alleles alphaLEPRA and alphaLELY as assessed versus a novel, virtually null allele of the SPTA1 gene in trans. *Br J Haematol* 2004;127:118-122.
127. Alloisio N, Morle L, Marechal J, et al. Sp alpha V/41: a common spectrin polymorphism at the alpha IV-alpha V domain junction. Relevance to the expression level of hereditary elliptocytosis due to alpha-spectrin variants located in trans. *J Clin Invest* 1991;87:2169-2177.
128. Wilmotte R, Marechal J, Morle L, et al. Low expression allele alpha LELY of red cell spectrin is associated with mutations in exon 40 (alpha V/41 polymorphism) and intron 45 and with partial skipping of exon 46. *J Clin Invest* 1993;91:2091-2096.
129. Marechal J, Wilmotte R, Kanzaki A, et al. Ethnic distribution of allele alpha LELY, a low-expression allele of red-cell spectrin alpha-gene. *Br J Haematol* 1995;90:553-556.
130. Chasis JA, Coulombel L, McGee S, et al. Differential use of protein 4.1 translation initiation sites during erythropoiesis: implications for a mutation-induced stage-specific deficiency of protein 4.1 during erythroid development. *Blood* 1996;87:5324-5331.
131. Conboy J, Marchesi S, Kim R, Agre P, Kan YW, Mohandas N. Molecular analysis of insertion/deletion mutations in protein 4.1 in elliptocytosis. II. Determination of molecular genetic origins of rearrangements. *J Clin Invest* 1990;86:524-530.
132. Conboy J, Mohandas N, Tchernia G, Kan YW. Molecular basis of hereditary elliptocytosis due to protein 4.1 deficiency. *N Engl J Med* 1986;315:680-685.
133. Mentzer WC, Jr., Iarocci TA, Mohandas N, et al. Modulation of erythrocyte membrane mechanical stability by 2,3-diphosphoglycerate in the neonatal poikilocytosis/elliptocytosis syndrome. *J Clin Invest* 1987;79:943-949.
134. Iarocci TA, Wagner GM, Mohandas N, Lane PA, Mentzer WC. Hereditary poikilocytic anemia associated with the co-inheritance of two alpha spectrin abnormalities. *Blood* 1988;71:1390-1396.
135. Zarkowsky HS, Mohandas N, Speaker CB, Shohet SB. A congenital haemolytic anaemia with thermal sensitivity of the erythrocyte membrane. *Br J Haematol* 1975;29:537-543.
136. Costa DB, Lozovatsky L, Gallagher PG, Forget BG. A novel splicing mutation of the {alpha}-spectrin gene in the original hereditary pyropoikilocytosis kindred. *Blood* 2005;106:4367-4369.
137. Laosombat V, Dissaneevate S, Peerapittayamongkol C, Matsuo M. Neonatal hyperbilirubinemia associated with Southeast Asian ovalocytosis. *Am J Hematol* 1999;60:136-139.
138. Laosombat V, Viprakasit V, Dissaneevate S, et al. Natural history of Southeast Asian ovalocytosis during the first 3 years of life. *Blood Cells Mol Dis* 2010;45:29-32.
139. Mohandas N, Winardi R, Knowles D, et al. Molecular basis for membrane rigidity of hereditary ovalocytosis. A novel mechanism involving the cytoplasmic domain of band 3. *J Clin Invest* 1992;89:686-692.
140. Liu SC, Palek J, Yi SJ, et al. Molecular basis of altered red blood cell membrane properties in Southeast Asian ovalocytosis: role of the mutant band 3 protein in band 3 oligomerization and retention by the membrane skeleton. *Blood* 1995;86:349-358.

141. Liu SC, Jarolim P, Rubin HL, et al. The homozygous state for the band 3 protein mutation in Southeast Asian ovalocytosis may be lethal. *Blood* 1994;84:3590-3591.
142. Davidson RJ, How J, Lessels S. Acquired stomatocytosis: its prevalence of significance in routine haematology. *Scand J Haematol* 1977;19:47-53.
143. Mentzer WC Jr, Smith WB, Goldstone J, Shohet SB. Hereditary stomatocytosis: membrane and metabolism studies. *Blood* 1975;46:659-669.
144. Stewart GW, Turner EJ. The hereditary stomatocytoses and allied disorders: congenital disorders of erythrocyte membrane permeability to Na and K. *Baillieres Best Pract Res Clin Haematol* 1999;12:707-727.
145. Delaunay J. The hereditary stomatocytoses: genetic disorders of the red cell membrane permeability to monovalent cations. *Semin Hematol* 2004;41: 165-172.
146. Bruce LJ. Hereditary stomatocytosis and cation leaky red cells—recent developments. *Blood Cells Mol Dis* 2009;42:216-222.
147. Fricke B, Argent AC, Chetty MC, et al. The “stomatin” gene and protein in overhydrated hereditary stomatocytosis. *Blood* 2003;102:2268-2277.
148. Fricke B, Parsons SF, Knopfle G, von Düring M, Stewart GW. Stomatin is mistranslocated in the erythrocytes of overhydrated hereditary stomatocytosis, and is absent from normal primitive yolk sac-derived erythrocytes. *Br J Haematol* 2005;131:265-277.
149. Lande WM, Thiemann PV, Mentzer WC Jr. Missing band 7 membrane protein in two patients with high Na, low K erythrocytes. *J Clin Invest* 1982;70:1273-1280.
150. Zhu Y, Paszty C, Turetsky T, et al. Stomatocytosis is absent in “stomatin”-deficient murine red blood cells. *Blood* 1999;93:2404-2410.
151. Gallagher PG, Chang SH, Rettig MP, et al. Altered erythrocyte endothelial adherence and membrane phospholipid asymmetry in hereditary hydrocytosis. *Blood* 2003;101:4625-4627.
152. Glader BE, Fortier N, Albala MM, Nathan DG. Congenital hemolytic anemia associated with dehydrated erythrocytes and increased potassium loss. *N Engl J Med* 1974;291:491-496.
153. Schroter W, Ungefehr K, Tillmann W. Role of the spleen in congenital stomatocytosis associated with high sodium-low potassium erythrocytes. *Klin Wochenschr* 1981;59:173-179.
154. Smith BD, Segel GB. Abnormal erythrocyte endothelial adherence in hereditary stomatocytosis. *Blood* 1997;89:3451-3456.
155. Basu AP, Carey P, Cynober T, et al. Dehydrated hereditary stomatocytosis with transient perinatal ascites. *Arch Dis Child Fetal Neonatal Ed* 2003;88: F438-439.
156. Grootenboer S, Schischmanoff PO, Cynober T, et al. A genetic syndrome associating dehydrated hereditary stomatocytosis, pseudohyperkalemia and perinatal oedema. *Br J Haematol* 1998;103:383-386.
157. Grootenboer-Mignot S, Cretien A, Laurendeau I, et al. Sub-lethal hydrops as a manifestation of dehydrated hereditary stomatocytosis in two consecutive pregnancies. *Prenat Diagn* 2003;23:380-384.
158. Zarychanski R, Schulz VP, Houston BL, et al. Mutations in the mechanotransduction protein PIEZO1 are associated with hereditary xerocytosis. *Blood*. In press.
159. Carella M, Stewart G, Ajetunmobi JF, et al. Genomewide search for dehydrated hereditary stomatocytosis (hereditary xerocytosis): mapping of locus to chromosome 16 (16q23-qter). *Am J Hum Genet* 1998;63:810-816.
160. Iolascon A, Stewart GW, Ajetunmobi JF, et al. Familial pseudohyperkalemia maps to the same locus as dehydrated hereditary stomatocytosis (hereditary xerocytosis). *Blood* 1999;93:3120-3123.
161. Houston BL, Zelinski T, Israels SJ, et al. Refinement of the hereditary xerocytosis locus on chromosome 16q in a large Canadian kindred. *Blood Cells Mol Dis* 2011;47:226-231
162. Vanderpe DH, Xu C, Shmukler BE, et al. Hypoxia activates a Ca²⁺-permeable cation conductance sensitive to carbon monoxide and to GsMTx-4 in human and mouse sickle erythrocytes. *PLoS ONE* 2010;5:e8732.

163. Ma YL, Rees DC, Gibson JS, Ellory JC. The conductance of red blood cells from sickle cell patients: ion selectivity and inhibitors. *J Physiol* 2012;590: 2095-2105.
164. Clark MR, Shohet SB, Gottfried EL. Hereditary hemolytic disease with increased red blood cell phosphatidylcholine and dehydration: one, two, or many disorders? *Am J Hematol* 1993;42:25-30.
165. Bruce LJ, Guizouarn H, Burton NM, et al. The monovalent cation leak in over-hydrated stomatocytic red blood cells results from amino acid substitutions in the Rh-associated glycoprotein. *Blood* 2009;113:1350-1357.
166. Genetet S, Ripoche P, Picot J, et al. Human RhAG ammonia channel is impaired by the Phe65Ser mutation in overhydrated stomatocytic red cells. *Am J Physiol Cell Physiol* 2012;302:C419-428.
167. Stewart AK, Shmukler BE, Vandorpe DH, et al. Loss-of-function and gain-of-function phenotypes of stomatocytosis mutant RhAG F65S. *Am J Physiol Cell Physiol* 2011;301:C1325-1343.
168. Flatt JF, Guizouarn H, Burton NM, et al. Stomatin-deficient cryohydrocytosis results from mutations in SLC2A1: a novel form of GLUT1 deficiency syndrome. *Blood* 2011;118:5267-5277.
169. Guizouarn H, Martial S, Gabillat N, Borgese F. Point mutations involved in red cell stomatocytosis convert the electroneutral anion exchanger 1 to a non-selective cation conductance. *Blood* 2007;110:2158-2165.
170. Van Kim CL, Colin Y, Cartron JP. Rh proteins: key structural and functional components of the red cell membrane. *Blood Rev* 2005;20:93-110.
171. Sturgeon P. Hematological observations on the anemia associated with blood type Rhnull. *Blood* 1970;36:310-320.
172. Nicolas V, Le Van Kim C, Gane P, et al. Rh-RhAG/ankyrin-R, a new interaction site between the membrane bilayer and the red cell skeleton, is impaired by Rh(null)-associated mutation. *J Biol Chem* 2003;278:25526-25533.
173. Nicolas V, Mouro-Chanteloup I, Lopez C, et al. Functional interaction between Rh proteins and the spectrin-based skeleton in erythroid and epithelial cells. *Transfus Clin Biol* 2006;13:23-28.
174. Niu DM, Chong KW, Hsu JH, et al. Clinical observations, molecular genetic analysis, and treatment of sitosterolemia in infants and children. *J Inherit Metab Dis* 2010;33:437-443.
175. Rees DC, Iolascon A, Carella M, et al. Stomatocytic haemolysis and macrothrombocytopenia (Mediterranean stomatocytosis/macrothrombocytopenia) is the haematological presentation of phytosterolaemia. *Br J Haematol* 2005;130:297-309.
176. Wang G, Wang Z, Liang J, Cao L, Bai X, Ruan C. A phytosterolemia patient presenting exclusively with macrothrombocytopenia and stomatocytic hemolysis. *Acta Haematol* 2011;126:95-98.
177. Stefkova J, Poledne R, Hubacek JA. ATP-binding cassette (ABC) transporters in human metabolism and diseases. *Physiol Res* 2004;53:235-243.
178. Wang DQ. Regulation of intestinal cholesterol absorption. *Annu Rev Physiol* 2007;69:221-248.
179. Cooper RA. Anemia with spur cells: a red cell defect acquired in serum and modified in the circulation. *J Clin Invest* 1969;48:1820-1831.
180. Cooper RA. Hemolytic syndromes and red cell membrane abnormalities in liver disease. *Semin Hematol* 1980;17:103-112.
181. Hooper AJ, van Bockxmeer FM, Burnett JR. Monogenic hypocholesterolaemic lipid disorders and apolipoprotein B metabolism. *Crit Rev Clin Lab Sci* 2005;42:515-545.
182. Zamel R, Khan R, Pollex RL, Hegele RA. Abetalipoproteinemia: two case reports and literature review. *Orphanet J Rare Dis* 2008;3:19.
183. Hussain MM, Rava P, Walsh M, Rana M, Iqbal J. Multiple functions of microsomal triglyceride transfer protein. *Nutr Metab* 2012;9:14.
184. Tarugi P, Averna M, Di Leo E, et al. Molecular diagnosis of hypobetalipoproteinemia: an ENID review. *Atherosclerosis* 2007;195:e19-e27.
185. Zeissig S, Dougan SK, Barral DC, et al. Primary deficiency of microsomal triglyceride transfer protein in human abetalipoproteinemia is associated with loss of CD1 function. *J Clin Invest* 2010;120:2889-2899.

186. Danek A, Rubio JP, Rampoldi L, et al. McLeod neuroacanthocytosis: genotype and phenotype. *Ann Neurol* 2001;50:755-764.
187. Reid ME, Mohandas N. Red blood cell blood group antigens: structure and function. *Semin Hematol* 2004;41:93-117.
188. Peng J, Redman CM, Wu X, et al. Insights into extensive deletions around the XK locus associated with McLeod phenotype and characterization of two novel cases. *Gene* 2007;392:142-150.
189. Walker RH, Jung HH, Dobson-Stone C, et al. Neurologic phenotypes associated with acanthocytosis. *Neurology* 2007;68:92-98.
190. Jung HH, Danek A, Walker RH. Neuroacanthocytosis syndromes. *Orphanet J Rare Dis* 2011;6:68.
191. Hayflick SJ, Westaway SK, Levinson B, et al. Genetic, clinical, and radiographic delineation of Hallervorden-Spatz syndrome. *N Engl J Med* 2003;348: 33-40.
192. Pellicchia MT, Valente EM, Cif L, et al. The diverse phenotype and genotype of pantothenate kinase-associated neurodegeneration. *Neurology* 2005;64:1810-1812.
193. Dobson-Stone C, Velayos-Baeza A, Filippone LA, et al. Chorein detection for the diagnosis of chorea-acanthocytosis. *Ann Neurol* 2004;56:299-302.
194. Rampoldi L, Dobson-Stone C, Rubio JP, et al. A conserved sorting-associated protein is mutant in chorea-acanthocytosis. *Nat Genet* 2001;28:119-120.
195. Ueno S, Maruki Y, Nakamura M, et al. The gene encoding a newly discovered protein, chorein, is mutated in chorea-acanthocytosis. *Nat Genet* 2001;28:121-122.
196. Tomiyasu A, Nakamura M, Ichiba M, et al. Novel pathogenic mutations and copy number variations in the VPS13A gene in patients with chorea-acanthocytosis. *Am J Med Genet B Neuropsychiatr Genet* 2011;156B, 620-631.
197. Walker RH, Schulz VP, Tikhonova IR, et al. Genetic diagnosis of neuroacanthocytosis disorders using exome sequencing. *Mov Disord* 2012;27:539-543.
198. De Franceschi L, Scardoni G, Tomelleri C, et al. Computational identification of phospho-tyrosine sub-networks related to acanthocyte generation in neuroacanthocytosis. *PLoS ONE* 2012;7:e31015.
199. De Franceschi L, Tomelleri C, Matte A, et al. Erythrocyte membrane changes of chorea-acanthocytosis are the result of altered Lyn kinase activity. *Blood* 2011;118:5652-5663.
200. de Haan LD, Werre JM, Ruben AM, Huls HA, de Gier J, Staal GE. Alterations in size, shape and osmotic behaviour of red cells after splenectomy: a study of their age dependence. *Br J Haematol* 1988;69:71-80.
201. Hovingh GK, de Groot E, van der Steeg W, et al. Inherited disorders of HDL metabolism and atherosclerosis. *Curr Opin Lipidol* 2005;16:139-145.
202. Roshan B, Ganda OP, Desilva R, et al. Homozygous lecithin:cholesterol acyltransferase (LCAT) deficiency due to a new loss of function mutation and review of the literature. *J Clin Lipidol* 2011;5:493-499.
203. Argyropoulos G, Jenkins A, Klein RL, et al. Transmission of two novel mutations in a pedigree with familial lecithin:cholesterol acyltransferase deficiency: structure-function relationships and studies in a compound heterozygous proband. *J Lipid Res* 1998;39:1870-1876.
204. Asztalos BF, Schaefer EJ, Horvath KV, et al. Role of LCAT in HDL remodeling: investigation of LCAT deficiency states. *J Lipid Res* 2007;48:592-599.

WEBSITE RESOURCES

- <http://www.ncbi.nlm.nih.gov/pubmedhealth/PMH0001557/>
<http://ghr.nlm.nih.gov/condition/hereditary-spherocytosis>
<http://ghr.nlm.nih.gov/condition/hereditary-spherocytosis/show/OMIM>
<http://research.nhgri.nih.gov/RBCmembrane/>
<http://emedicine.medscape.com/article/206107-overview>

Chapter 28 Hereditary Hemolytic Anemias Due to Red Blood Cell Enzyme Disorders

> Table of Contents > Part IV - Disorders of Red Cells > Section 3 - Hemolytic Anemia > Chapter 28 - Hereditary Hemolytic Anemias Due to Red Blood Cell Enzyme Disorders

Chapter 28

Hereditary Hemolytic Anemias Due to Red Blood Cell Enzyme Disorders

Bertil Glader

OVERVIEW OF ERYTHROCYTE METABOLISM

Mature red blood cells (RBCs) are anucleate (thereby incapable of cell division), devoid of ribosomes (thereby incapable of protein synthesis) and lack mitochondria (thereby incapable of oxidative phosphorylation). Despite these limitations RBC survive 100 to 120 days in the circulation, and effectively deliver oxygen to peripheral tissues. Glucose is the main metabolic substrate of red blood cells and it is metabolized by two major pathways: the glycolytic or “energy producing” pathway and the hexose monophosphate (HMP) shunt or “protective” pathway. Under normal conditions approximately 90% of glucose flows through glycolysis, with a much smaller fraction being channeled through the HMP pathway. However, the fraction of glucose entering the pentose phosphate pathway can increase significantly under conditions of increased oxidative stress. The major products of glycolysis are ATP (a source of energy for numerous RBC membrane and metabolic reactions), NADH (a necessary cofactor for methemoglobin reduction by cytochrome b5 reductase), and 2,3-diphosphoglycerate ([2,3-DPG], an important intermediate that modulates hemoglobin-oxygen affinity) (Fig. 28.1). Mature RBC are incapable of de novo purine or pyrimidine synthesis, although many enzymes of nucleotide metabolism are present in erythrocytes. The latter are now known to be important for RBC preservation in vitro; and it also is recognized that abnormalities in purine and pyrimidine metabolism are associated with inherited hemolytic disease.

The consequences of red cell enzymopathies are diverse. Some enzyme variants cause hemolytic disease, with anemia being the sole expression of the enzymopathy. In other enzyme disorders hemolysis is one feature of a multisystem disease affecting many tissues. Also, in some cases erythrocyte enzyme abnormalities have no adverse effects on RBC function, and, if they occur in patients with hemolytic anemia, it is not always clear that the enzyme deficiency and hemolysis are causally related. This chapter focuses on the varied enzyme defects associated with hemolysis. These RBC enzyme disorders are due to abnormalities in the HMP shunt and glutathione metabolism, glycolytic enzyme deficiencies, and abnormalities in purine and pyrimidine metabolism.

DISORDERS OF HEXOSE MONOPHOSPHATE SHUNT AND GLUTATHIONE METABOLISM

The HMP shunt pathway metabolizes 5% to 10% of glucose utilized by red blood cells, and this is critical for protecting red cells against oxidant injury (Fig. 28.2). The HMP pathway is the only RBC source of reduced nicotinamide adenine dinucleotide phosphate (NADPH), a cofactor important in glutathione metabolism. Red blood cells contain relatively high concentrations of reduced glutathione (GSH), a sulfhydryl-containing tripeptide (glutamylcysteinylglycine) which functions as an intracellular reducing agent that protects cells against oxidant injury. Oxidants, such as superoxide anion (O_2^-) and hydrogen peroxide (H_2O_2), are produced by exogenous factors (i.e., drugs, infection) and also are formed within red cells as a consequence of reactions of hemoglobin with oxygen. However, when these oxidants accumulate within red cells, hemoglobin and other proteins are oxidized, leading to loss of function and RBC death. Under normal circumstances this does not occur, since GSH, in conjunction with the enzyme glutathione peroxidase (GSH-Px), rapidly inactivates these compounds. During the oxidant detoxification process, however, GSH itself is converted to oxidized glutathione (GSSG), and GSH levels fall. In order to sustain protection against persistent oxidant injury, GSH levels must be maintained, and this is accomplished by glutathione reductase (GSSG-R), which catalyzes reduction of GSSG to GSH. This reaction requires the NADPH generated by glucose-6-phosphate dehydrogenase (G6PD), the first enzymatic reaction of the HMP shunt. Thus, it is the tight coupling of the HMP shunt and glutathione metabolism that is responsible for protecting intracellular proteins from oxidative assault. Almost all hemolytic episodes related to altered HMP shunt and glutathione metabolism are due to G6PD deficiency, and this enzyme deficiency is known to affect millions of people throughout the world.^{1, 2, 3, 4} Rare cases of hemolysis associated with decreased GSSG-R activity, GSH-Px deficiency, and deficiencies of GSH synthetic enzymes also have been described.

Glucose-6-Phosphate Dehydrogenase Deficiency

The importance of this enzyme for red cell integrity was first recognized following the observation that some African-American soldiers taking the antimalarial drug primaquine would develop acute hemolytic anemia with hemoglobinuria. Initially it was observed that GSH was decreased in the RBC of susceptible individuals during acute hemolytic episodes. Subsequently, the activity of G6PD, one of the enzymes needed to keep adequate GSH levels, was found to be deficient in affected red cells.^{5, 6} Soon thereafter, the worldwide distribution of G6PD deficiency became apparent, and the variation of clinical expression of enzyme deficiency was discovered. In most individuals with G6PD deficiency, there is no anemia in the steady state, reticulocyte counts are normal, but RBC survival may be slightly decreased. However, episodic exacerbations of hemolysis accompanied by anemia occur in association with the administration of certain drugs, with some infections, and with the eating of fava beans. In a minority of cases G6PD deficiency is associated with a chronic hemolytic process. To date, over 400 G6PD biochemical variants have been recognized.^{2, 3, 7}

Genetics

The gene for G6PD is located on the X chromosome (band X q28),^{8, 9, 10} The fact that normal males and females have the same enzyme activity in their red cells is explained by the Lyon hypothesis.^{1, 11} This hypothesis maintains that one of two X chromosomes in each cell of the female embryo is inactivated and remains inactive throughout subsequent cell divisions for the duration of life. In fact, it was studies by Beutler on females with G6PD deficiency which were used in proof of the Lyon hypothesis.¹² Enzyme deficiency is expressed in males carrying a variant gene, whereas heterozygous females usually are clinically normal. However, dependent upon the degree of lyonization, and the degree to which the abnormal G6PD variant is expressed, the mean red blood cell enzyme activity in females may be normal, moderately

P.729

reduced, or grossly deficient. A female with 50% normal G6PD activity has 50% normal red cells and 50% G6PD-deficient red cells. The G6PD-deficient cells in females, however, are as vulnerable to hemolysis as are enzyme-deficient red blood cells in males.

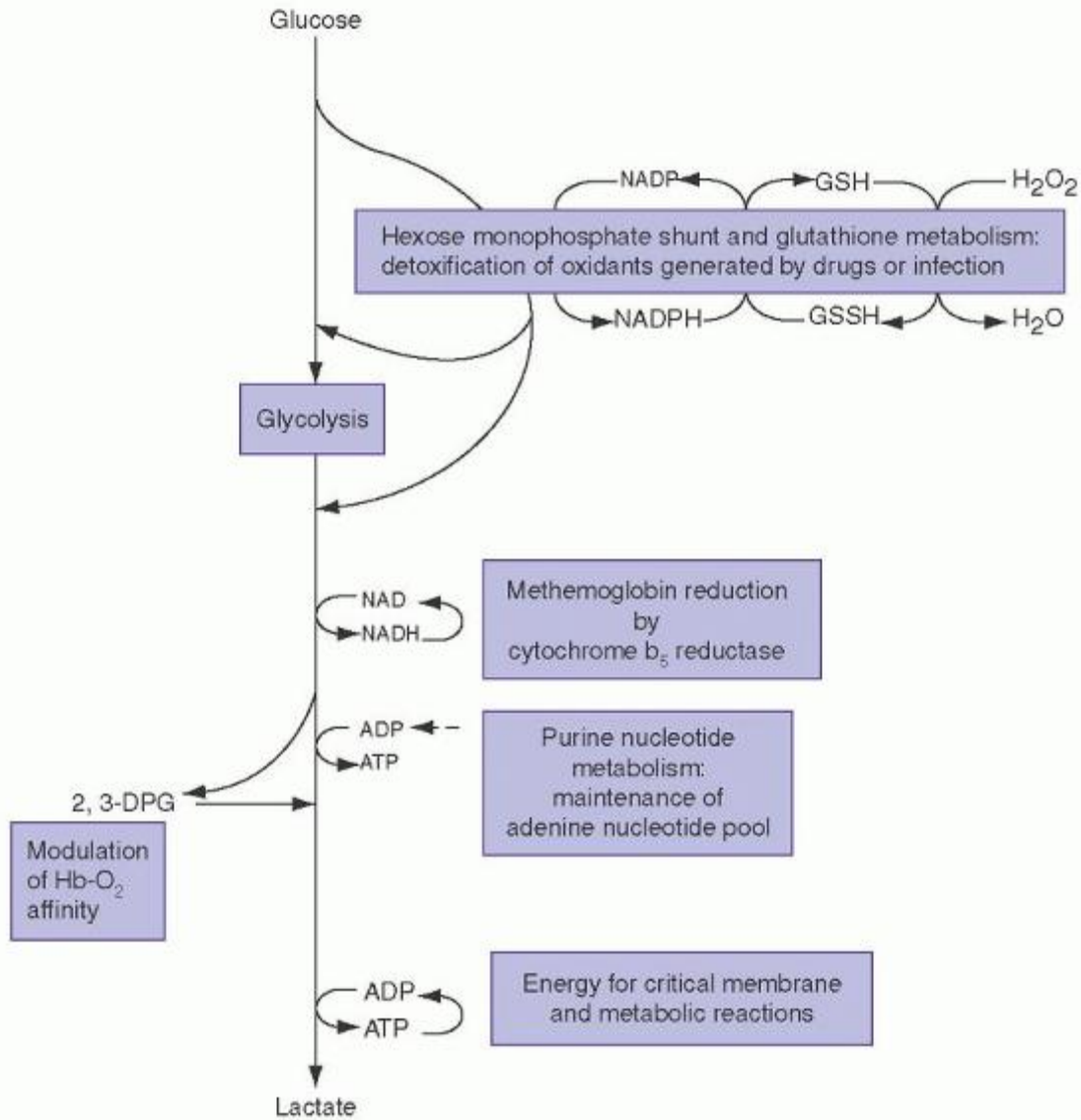

FIGURE 28.1. Summary of overall glycolysis, hexose monophosphate shunt, glutathione metabolism, and red blood cell (RBC) nucleotide metabolism. GSH, reduced glutathione; GSSG, oxidized glutathione; 2,3-DPG, 2,3-diphosphoglycerate; NADPH, nicotinamide adenine dinucleotide phosphate.

The concept of X chromosome inactivation and the study of G6PD has been informative in other areas. In particular, it has facilitated our understanding of monoclonal and multiclonal disorders of cell proliferation. Most tumors, both benign and malignant, can be demonstrated to have a clonal origin, being derived from one cell.^{13, 14, 15} For example, analysis of the G6PD enzyme in uterine myomata of women heterozygous for G6PD A and G6PD B revealed that any given tumor had either G6PD A or enzyme B, but not both.¹⁶ The same principle has been used to demonstrate the clonal origin of the malignant transformation of acute leukemia^{17, 18} and chronic myelocytic leukemia,¹⁹ and also the clonal nature of polycythemia vera,²⁰ primary thrombocythemia,²¹ and paroxysmal nocturnal hemoglobinuria.²²

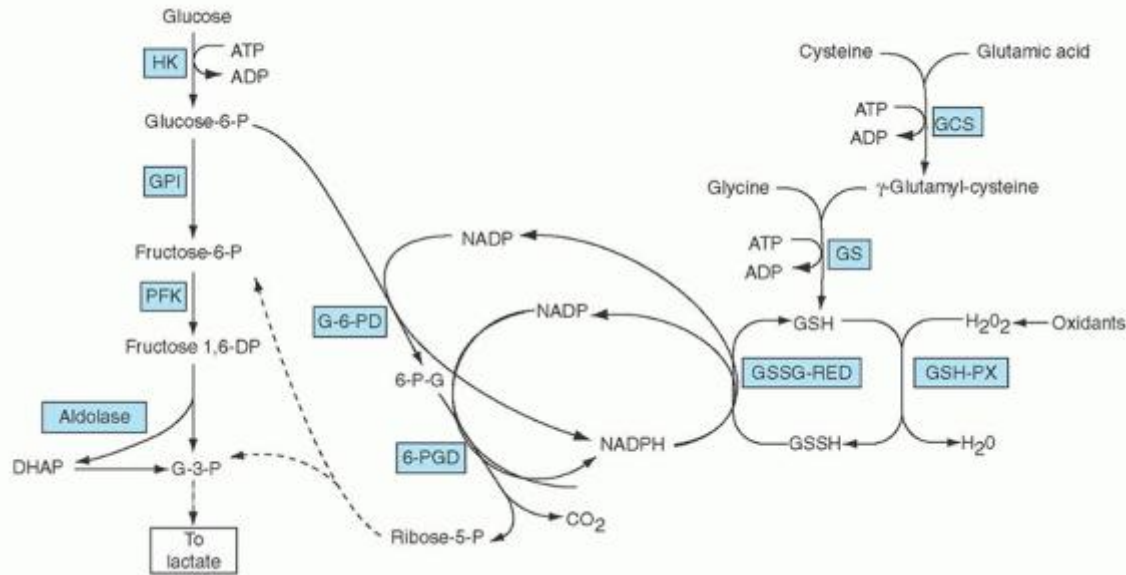

FIGURE 28.2. Hexose monophosphate (HMP) shunt, enzymes of glutathione (GSH) metabolism, protection from oxidant assault, and relationship to glycolytic metabolism. Enzyme abbreviations: GCS, γ -glutamyl-cystine-synthetase; G-6-PD, glucose-6-P dehydrogenase; GS, glutathione synthetase; GSH-Px, glutathione peroxidase; GSSG-Red, glutathione reductase; GPI, glucosephosphate isomerase; HK, hexokinase; PFK, phosphofructokinase; 6-PGD, 6-phosphogluconate dehydrogenase. Substrate abbreviations: DHAP, dihydroxyacetone phosphate; G-3-P, glyceraldehyde-3-phosphate; GSH, reduced glutathione; GSSG, oxidized glutathione; R-5-P, ribose-5-phosphate; 6-P-G, 6-phosphogluconate.

Prevalence and Geographic Distribution

Deficiency of G6PD is the most common metabolic disorder of red blood cells and has been estimated to affect over 400 million people worldwide.^{2, 3, 23} Although global in its distribution, G6PD deficiency is encountered with greatest frequency in the tropical and subtropical zones of the Eastern Hemisphere. The incidence of the deficiency state is approximately 20% among African Bantu males,^{24, 25} 12% in African-American men,²⁶ and 8% in Brazilian blacks. As many as 20% of female African-Americans may be heterozygous for G6PD mutants,²⁷ and as many as 1% are homozygous. In Sardinia, the incidence varies from 35% at low altitudes to 3% in areas above 600 meters.²⁸ The deficiency state has been reported from most areas of Greece, again with greatest frequency (20% to 32%) in the lowlands.²⁹ The condition is also prevalent among Sephardic Jews, and as many as 60% to 70% of Kurdish Jews may be affected.^{3, 30, 31} In the male Asian population, the incidence of G6PD deficiency is estimated to be 14% in Cambodia,³² 5.5% in South China,^{33, 34} 2.6% in India,³² and less than 0.1% in Japan.³⁵ In China the frequency of G6PD deficiency in males ranges from 0% to 17.4%, with the highest prevalence being seen in ethnic groups geographically related to historical malaria. It is rare among Native Americans.³⁶

Because of its high incidence among populations in which malaria was once endemic, G6PD deficiency is thought to have conferred a selective advantage against infection by falciparum malaria.^{37, 38, 39} Partial indirect support for this is that G6PD deficiency in Sardinia is more common at sea level compared to higher elevations, and this also parallels the endemicity of malaria. In addition, it has been observed that parasitized female heterozygotes for G6PD deficiency (who therefore have normal and G6PD-deficient RBC) have more malaria parasites in normal erythrocytes compared to their own G6PD-deficient cells.⁴⁰ Moreover, it has been demonstrated that the *in vitro* growth of malarial parasites is inhibited in G6PD-deficient red cells.⁴¹ The

P.730

precise reasons for the observed inhibition of parasite growth in G6PD-deficient red cells are not known. One possibility is that the oxidant stress which causes GSH instability, and destroys the host RBC, also kills the parasite.^{2, 42, 43, 44}

The Enzyme and Its Variants

The monomeric form of G6PD contains 515 amino acids and has a molecular weight of 59 kDa.^{45, 46} The active form of G6PD *in vivo* is a dimer which requires NADP for its stability.⁴⁷ The G6PD gene has been cloned and sequenced. It is known to contain 13 exons, and is over 18 kb in length.^{46, 48, 49}

The normal or wild-type enzyme is G6PD B, although hundreds of variant enzymes now have been identified. By international agreement, standardized methods have been used to characterize these enzyme variants, which differ on the basis of biochemical properties such as kinetic activity, electrophoretic mobility, the Michaelis constant for its substrate glucose-6-phosphate and cofactor NADP, the ability to utilize different substrate analogues, heat stability, and pH optima. Throughout the years the published list of recognized G6PD biochemical variants has been periodically updated,^{50, 51} and over 400 biochemical variant forms of G6PD are recognized.³ However, differences between some variants are subtle, and most likely reflect minor technical differences between laboratories rather than true enzyme differences. Moreover, advances in molecular biology have revealed that many biochemical G6PD variants, in fact, have the same DNA defect (see below).

The World Health Organization (WHO) has classified G6PD variants on the magnitude of the enzyme deficiency and also the severity of hemolysis.⁵² Class I variants have very severe enzyme deficiency (less than 10% to 20% of normal) and have chronic hemolytic anemia. Class II variants also have severe enzyme deficiency (less than 10% of normal), but there is usually only intermittent hemolysis. Class III variants have moderate enzyme deficiency (10% to 60% of normal) with intermittent hemolysis usually associated with infection or drugs. Class IV variants have no enzyme deficiency or hemolysis. Class V variants are those in which enzyme activity is increased. Variants in the last two groups, although of much interest to biologists, geneticists, and anthropologists, are of no major clinical significance.

The normal wild-type enzyme, G6PD B, is found in most Caucasians, Asians, and a majority of blacks. It has normal catalytic activity and is not associated with hemolysis (Class IV). A commonly encountered variant is G6PD A⁺ which is found in 20% to 30% of blacks from Africa.⁵³ It has normal catalytic properties and does not cause hemolysis (Class IV). It differs from G6PD B in that it has a much faster electrophoretic mobility (the letters A and B refer to relative electrophoretic mobilities). The structure of G6PD A⁺ differs from that of G6PD B by the substitution of a single amino acid, an asparagine for aspartate at the 126th position of the protein.⁵⁴ Another common variant, G6PD A⁻, is the enzyme responsible for primaquine sensitivity in blacks, and it is the most common variant associated with mild to moderate hemolysis (Class III). This G6PD variant is found in 10% to 15% of African-Americans, and with similar frequencies in western and central Africa.⁵⁵ It has an electrophoretic mobility identical to that of G6PD A⁺. However, this is an unstable enzyme and its catalytic activity, although nearly normal in bone marrow cells and reticulocytes,⁵⁶ decreases markedly in older RBC.⁵⁷ Hence, this variant is designated G6PD A⁻ compared with G6PD A⁺ (the + and - denote enzyme activity). G6PD Mediterranean is a common abnormal variant found in people whose origins are in the Mediterranean area. However, this same variant also is found in the Middle East and India.² The electrophoretic mobility of G6PD Mediterranean is identical to that of G6PD B, but its catalytic activity is markedly reduced, and hemolysis can be severe (Class II).⁵⁶ G6PD Canton is a common variant enzyme seen in Asians.⁵⁸ Its biochemical properties are very similar to those of G6PD Mediterranean.

Advances in molecular biology have further enhanced our understanding of G6PD deficiency, and now over 160 different gene mutations or mutation combinations have been identified.^{2, 59, 60, 61} These DNA changes almost all are missense mutations leading to single amino acid substitutions in the enzyme. Large deletions have not been identified, suggesting that complete absence of G6PD might be lethal.³ The mutations are located throughout the entire coding region of the gene.⁶² However, in Class I variants associated with chronic hemolysis, mutations are clustered around exon 10, an area that governs the formation of the active G6PD dimer.^{62, 63} The correlation between the different biochemical variants, the site of genetic mutation, and the extent of hemolysis is a matter of current investigation.²

An interesting example of how molecular biology has enhanced our understanding relates to G6PD A⁻, once thought to be a single unstable variant found in blacks throughout the world. However, molecular analysis now has demonstrated that G6PD A⁻ may have more than one genotype. In all cases there is a mutation at nucleotide 376 (A→G), which also is the nucleotide substitution characteristic of G6PD A⁺. In addition, the G6PD A⁻ variants have a second mutation, and in the majority of cases it is at nucleotide 202 (G→A).^{3, 64} A smaller fraction of G6PD A⁻ subjects have the second substitution at nucleotide 680 (G→T) or at nucleotide 968 (T→C).⁶⁵ Thus, the G6PD A⁻ variant, once thought to be a single homogeneous mutation in Africans, now turns out to represent at least three different genotypes.³ Also, a number of G6PD variants originally described in non-Africans are now found to have one of the known G6PD A⁻ mutations (Table 28.1). For example, G6PD Betica,⁶⁶ a Spanish variant and G6PD Matera,⁶⁷ an Italian variant, have demonstrated base substitutions at nucleotides 202 and 376, identical to the common G6PD A⁻ variant. They are examples, therefore, of G6PD A⁻. One subject with G6PD Betica had base substitutions at nucleotides 376 and 968, identical to the less common G6PD A⁻ variant.⁶⁶

There are several other variants that appear clinically and biochemically heterogeneous but have been found to be genetically more uniform. For example, G6PD Mediterranean involves many different ethnic groups, although most subjects have the same genetic defect, a single base substitution (C→T) at nucleotide 563.^{66, 67, 68} Moreover, just as in the case of G6PD A⁻, many of the different biochemical variants have turned out to have the same molecular defect as G6PD Mediterranean (Table 28.1).

In China there are at least 21 variants causing G6PD deficiency. The three most common are G6PD Canton (G→T at nucleotide 1,376), G6PD Kaiping (G→A at nucleotide 1,388), and G6PD Gaohe (A→G at nucleotide 95).⁶⁹

G6PD Canton and G6PD Gaohe are mainly regarded as WHO Class II variants, while G6PD Kaiping is considered a WHO Class III variant.

Because leukocyte and platelet G6PD is regulated by the same gene as that of red cells, documentation of decreased activity in the white blood cells^{70, 71, 72} and platelets⁷¹ of deficient individuals is not surprising. Because of the normally short survival of leukocytes and platelets, however, most individuals with G6PD deficiency do not manifest impairment of phagocytosis or bactericidal activity of granulocytes.^{71, 72} The exception to this occurs with Class I G6PD deficiency, where some affected individuals may have neutrophil dysfunction and increased susceptibility to infection.^{73, 74}

Pathophysiology

As red cells age, the activity of G6PD declines. The normal enzyme (G6PD B) has an in vivo half-life of 62 days.⁵⁶ Despite this loss of enzyme activity, normal old red blood cells contain sufficient G6PD activity to generate NADPH and thereby sustain GSH levels in the

P.731

face of oxidant stress. In contrast, the G6PD variants associated with hemolysis are unstable and have much shorter half-lives. The activity of G6PD A⁻ in reticulocytes is normal, but it declines rapidly thereafter with a half-life of only 13 days.^{56, 75} The instability of G6PD Mediterranean is even more pronounced, with a half-life measured in hours.⁵⁶ The clinical correlate of this age-related enzyme instability is that hemolysis in patients with G6PDA⁻ generally is mild and limited to older deficient erythrocytes. In contrast, the enzymatic defect in G6PD Mediterranean is due to much greater enzyme instability, and red blood cells of all ages are grossly deficient. Consequently, the entire red blood cell population of individuals with G6PD Mediterranean is susceptible to oxidant-induced injury, and this can lead to severe hemolytic anemia.

TABLE 28.1 BIOCHEMICAL, EPIDEMIOLOGIC, AND CLINICAL FEATURES OF SELECT G6PD VARIANTS

G6PD Variant Classification	Nucleotide Substitution	Amino Acid Substitution	Population	WHO Classification
A ⁻	202 G→A	68 Val→Met	Africa; Italy; Spain; 3	
Alabama	376 A→G	126 Asn→Asp	Canary Islands; Mexico	
Betica				
Ferrara				
Septic				
A ⁺	376 A→G	126 Asn→Asp	Africa	4
A ⁻	376 A→G	126 Asn→Asp	Africa; Spain;	3
	680 G→T	227 Asn→Asp	Canary Islands	
A ⁻	376 A→G	126 Asn→Asp		3
Betica	968 T→C	387 Arg→Cys		
Selma				
Mahidol	487 G→A	163 Gly→Asp	Southeast Asia;	3

Mediterranean	563 C→T	188 Ser→Phe	China; Taiwan Italy; Greece; Saudi Arabia;	2
Birmingham			Iran; Iraq; Israel; Egypt	
Cagili				
Dallas				
Panama				
Sassari				
Walter Reed	1,156 A→G	386 Lys→Glu		1
Iowa				
Iowa City				
Springfield				
Union	1,360 C→T	454 Arg→Cys	Philippines; Spain; Italy	2
Canton	1,376 G→T	459 Arg→Leu	China, Twain	3
Maewo				
Kaiping	1,388 G→A	463 Arg→His		2
Anant				
Dhon				
Petrich-like				
Sapporo-like				

Data modified from Beutler, E., G6PD deficiency. *Blood* 1994;84(11):3613-3636; Beutler, E., Glucose-6-phosphate dehydrogenase deficiency. *N Engl J Med* 1991;324(3):169-174; Miwa, S. and H. Fujii, Molecular basis of erythroenzymopathies associated with hereditary hemolytic anemia: tabulation of mutant enzymes. *Am J Hematol* 1996;51(2):122-132.

G6PD-deficient erythrocytes exposed to oxidants (infection, drugs, fava beans) become depleted of GSH. This reaction is central to the cell injury in this disorder since once GSH is depleted there is further oxidation of other RBC sulfhydryl-containing proteins. Oxidation of the sulfhydryl groups on hemoglobin leads to the formation of denatured globin or sulfhemoglobin. The latter form insoluble masses which attach to the red cell membrane by disulfide bridges, and these are known as Heinz bodies.⁷⁶ Also, with some Class I variants the oxidation of membrane sulfhydryl groups leads to the accumulation of membrane polypeptide aggregates, presumably due to disulfide bond formation between spectrin dimers and other membrane proteins.^{77, 78, 79, 80} The end result of these changes is the production of rigid, non-deformable erythrocytes that are susceptible to stagnation and destruction by reticuloendothelial macrophages in the spleen and liver.^{81, 82} Both extravascular and intravascular hemolysis occurs in G6PD-deficient individuals, the latter giving rise to hemoglobinemia and hemoglobinuria. Rare patients with unstable hemoglobinopathies also may manifest oxidant injury, since these abnormal hemoglobins are inordinately susceptible to mild oxidant stress (Chapter 35).

Clinical and Hematologic Features

The clinical expression of G6PD variants encompasses a continuous spectrum of hemolytic syndromes. In most affected individuals the deficiency state goes unrecognized, while in some it causes episodic or chronic anemia. The common clinical entities encountered are acute hemolytic anemia, favism, neonatal hyperbilirubinemia, and congenital nonspherocytic hemolytic anemia.

Acute Hemolytic Anemia

With most G6PD variants, hemolysis occurs only after exposure to oxidant stresses. In the steady state there is no anemia, no evidence of increased red cell destruction, nor alteration in blood morphology. Sudden destruction of enzyme-deficient erythrocytes is triggered by drugs having a high redox potential and by selected infectious or metabolic perturbations. The clinical and laboratory features of an acute hemolytic episode are best illustrated in a figure from a classic study with primaquine-induced hemolysis in subjects with G6PD A⁻ (Fig. 28.3)^{5, 6} After 2 to 4 days of primaquine ingestion, all the signs, symptoms, and

P.732

laboratory results characteristic of an acute hemolytic episode are observed. Jaundice, pallor, and dark urine, with or without abdominal and back pain, are sudden in onset. An abrupt decrement of 3 to 4 g/dl in hemoglobin concentration occurs. The peripheral blood smear contains spherocytes and eccentrocytes or “blister” cells. In response to anemia, red cell production increases; an increase in reticulocytes is apparent within 5 days and is maximal by 7 to 10 days after onset of hemolysis. Despite continued drug exposure, the acute hemolytic process ends spontaneously after about 1 week, and the hemoglobin concentration thereafter returns to normal levels. The anemia is self-limited because the old susceptible population of erythrocytes is replaced by younger RBC with sufficient G6PD activity to withstand an oxidative assault. Although red cell survival remains shortened as long as use of the drug continues, compensation by the erythroid marrow effectively abolishes the anemia in subjects with G6PD A⁻. In contrast, hemolysis occurring with the G6PD Mediterranean variant is more severe because a larger population of circulating erythrocytes is vulnerable to injury.⁸³ Hemolytic crises occur in heterozygous female subjects, as well as in hemizygous male patients. Of interest, the incidence of clinically significant G6PD deficiency in elderly women reportedly is increased, and this is thought to reflect skewed lyonization that occurs with aging. In a fascinating study from Hong Kong, the incidence of G6PD deficiency in elderly females (80 to 107 years) was increased (1.73%) compared to newborn girls (0.27%).⁸⁴ In virtually all cases acute hemolytic episodes are due to administration of drugs, or are associated with infection or fava bean exposure.

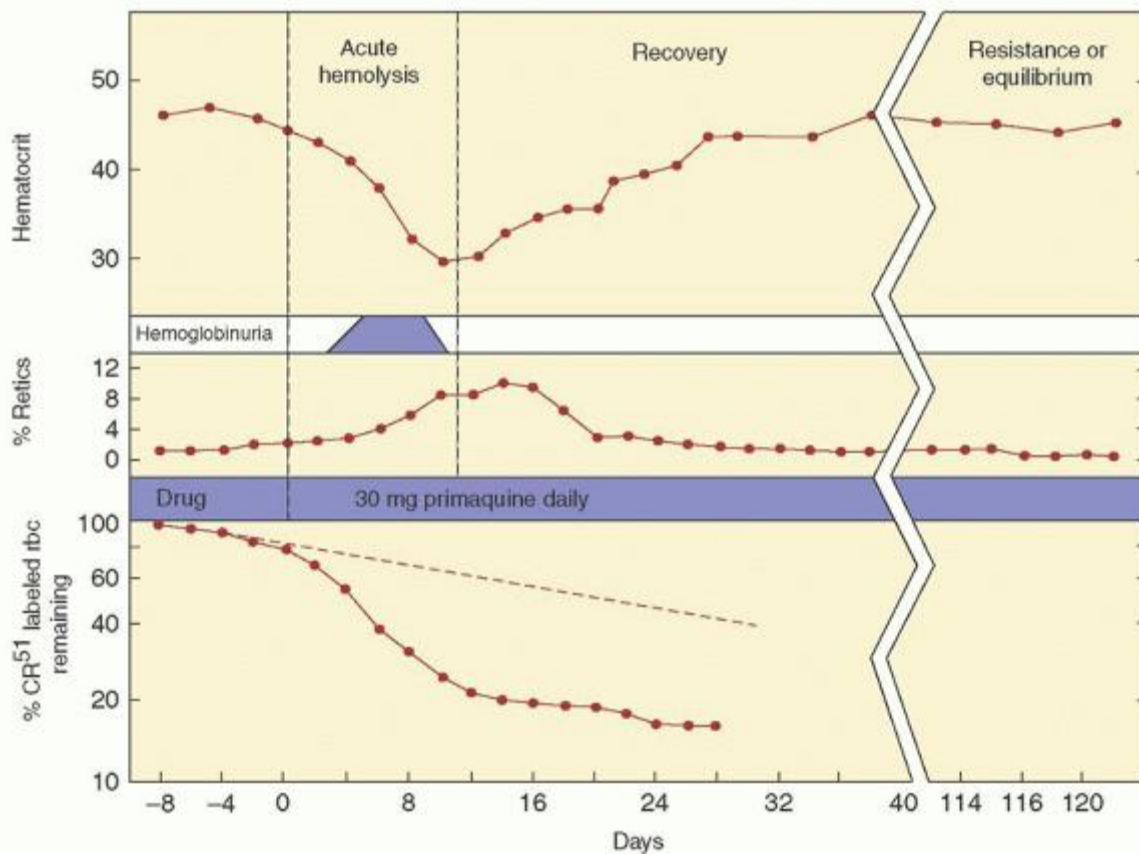

FIGURE 28.3. The course of primaquine-induced hemolysis in the glucose-6-phosphate dehydrogenase (G6PD) A⁻ variant. From Alving A, et al. Mitigation of the haemolytic effect of primaquine and enhancement of its action against exoerythrocytic forms of the Chesson strain of Plasmodium vivax by intermittent regimens of drug administration. Bull

WHO 1960;22:621-631.

Drug-induced Hemolysis. Primaquine is but one of several drugs that can precipitate hemolysis. The common denominator of these drugs is their interaction with hemoglobin and oxygen, thus accelerating the intracellular formation of H₂O₂ and other oxidizing radicals. The published lists of suspect drugs are lengthy; however, many of the putative hemolytic agents were incriminated before it was recognized that infections often mimic the adverse effects of drugs. Consequently, many hemolytic events previously ascribed to drugs may, in fact, have resulted from infections for which drugs were given. Aspirin is such a drug, and it now is recognized that it can safely be given to individuals with Class II and III G6PD variants. Some drugs and chemicals, however, are predictably injurious for all G6PD-deficient subjects,^{3, 30} and these agents are listed in Table 28.2. Other drugs, although producing a modest shortening of survival of G6PD-deficient red cells, can be given safely in usual therapeutic doses to individuals with Class II and III G6PD variants (Table 28.2). Ascorbic acid is safe in usual therapeutic doses, although large amounts may pose problems.⁸⁵ Similarly, acetaminophen (Tylenol), aminopyrine, sulfisoxazole (Gantrisin), sulfamethoxazole, and vitamin K can be given safely in usual therapeutic doses.³⁰ It also should be noted that other agents that are not drugs also can cause hemolysis in G6PD-deficient individuals. Examples of these include naphthalene (moth balls), henna compounds (used for hair dyes and tattoos), and some Chinese herbs.⁸⁶

Infection-induced Hemolysis. Infection is probably the most common factor inciting hemolysis,^{87, 88} About 20% of G6PD-deficient subjects with pneumonia experience an abrupt drop in hemoglobin concentration.⁸⁷ A variety of infectious agents has been implicated: salmonella,^{89, 90, 91} Escherichia coli,⁸⁷ β-hemolytic streptococci,⁹² and rickettsiae.⁹³ Hemolysis is particularly prominent in G6PD-deficient subjects with viral hepatitis.^{91, 94, 95} The accelerated destruction of red cells imposes a bilirubin load on an already damaged liver, resulting in an exaggerated increase in serum bilirubin level. Despite the magnitude of bilirubin retention, however, convalescence is generally complete and uneventful. Although hemolysis triggered by infection characteristically is mild, on rare occasions acute renal failure secondary to massive intravascular hemolysis can occur.^{93, 94} The mechanism for destruction of G6PD-deficient red cells during infection is not known. One possible explanation for this relationship is that oxidants generated by phagocytosing macrophages may diffuse into the extracellular medium, where they pose an oxidative threat to G6PD-deficient erythrocytes.⁹⁶

P.733

TABLE 28.2 DRUGS AND CHEMICALS ASSOCIATED WITH HEMOLYSIS IN G6PD DEFICIENCY

Unsafe (Class I, II, and III G6PD Variants)

Aceteanilide	Thiazolesulfone
Diaminodiphenyl sulfone (Dapsone)	Phenazopyridine (Pyridium)
Furazolidone (Furoxone)	Phenylhydrazine
Glibenclamide	Primaquine
Henna (Lawsone)	Sulfacetamide
Isobutyl nitrate	Sulfanilamide
Methylene blue	Sulfapyridine
Nalidixic acid (Neg—Gram)	Thiazolesulfone
Naphthalene (Mothballs)	Trinitrotoluene (TNT)
Niridazole (Ambilhar)	Urate oxidase (Rasburicase)
Nitrofurantoin (Furadantin)	

Safe in Usual Therapeutic Doses (Class II and III G6PD Variants^a)

Acetaminophen (Tylenol)	Trimethoprim
Acetophenetidin (Phenacetin)	Phenylbutazone
Acetylsalicylic acid (Aspirin)	Phenytoin

Aminopyrine (Pyramidon)	Probenecid (Benemid)
Antazoline (Antistine)	Procainamide hydrochloride (Pronestyl)
Antipyrine	Pyrimethamine (Daraprim)
Ascorbic Acid	Quinine
Benzhexol (Artane)	Streptomycin
Chloramphenicol	Sulfacytine
Chloroguanidine (Proguanil, Paludrine)	Sulfadiazine
Chloroquine	Sulfamethoxazole (Gantanol)
Colchicine	Sulfamethoxypyridazine (Kynex)
Diphenhydramine (Benadryl)	Sulfisoxazole (Gantrisin)
Isoniazid	Tiaprofenic acid
L-Dopa	Trimethoprim
Menadione sodium bisulfate (Hykinone)	Tripelennamine (Pyribenzamine)
<i>p</i> -Aminobenzoic acid	Vitamin K
<i>p</i> -Aminosalicylic acid	

^a Safety for Class I G6PD variants is not known.

Data modified from Beutler, E. Glucose-6-phosphate dehydrogenase deficiency: a historical perspective. *Blood* 2008;111(1):16-24.

Hemolysis Associated with Diabetic Acidosis. Diabetic ketoacidosis rarely is associated with triggering destruction of G6PD-deficient red cells.⁹⁷ Correction of acidosis and restoration of glucose homeostasis reverses the hemolytic process. Changes in blood pH, glucose,⁹⁸ and pyruvate⁹⁹ have been proposed as possible mechanisms for hemolysis. Also, occult infection may be a common trigger for inducing both acute hemolysis and diabetic acidosis.

Favism

Exposure to the fava bean (*Vicia fava*, broad bean) is toxic and potentially fatal for some individuals, and this has been known, allegedly, since the time of Pythagoras.¹ Studies several years ago revealed that individuals made ill by the fava bean invariably are deficient in G6PD.¹⁰⁰ Unlike other agents capable of inducing hemolysis, the fava bean is toxic for only some G6PD-deficient individuals. The variant most frequently implicated is G6PD Mediterranean and, as a result, favism is encountered commonly in Italy, Greece, and the Middle East, areas where fava beans are a dietary staple.^{3, 101} It also occurs in the Asian G6PD variants.³² Of particular interest, Africans and African-Americans with G6PD deficiency are much less susceptible, although hemolytic episodes have been reported.¹⁰²

Most cases of favism result from ingestion of fresh beans. Consequently, the peak seasonal incidence of this disorder in the Mediterranean is in the spring and coincides with harvesting of the bean.¹⁰³ Hemolysis of comparable severity can follow consumption of fried fava beans, a popular Chinese snack. Favism has been observed in nursing infants of mothers who have eaten the beans,¹⁰³ as well as in a newborn infant whose mother had eaten fava beans 5 days before delivery.¹⁰⁴ Enzyme deficiency was held responsible for fatal hydrops fetalis in the male infant of a hematologically normal Chinese woman who ingested fava beans during the final month of pregnancy.¹⁰⁵ Moreover, inhalation of pollen from the fava plant has been incriminated.¹⁰⁶

Favism occurs most commonly in children between the ages of 1 and 5 years. As with other clinical manifestations of G6PD deficiency syndromes, it is seen primarily in males, although it also can occur in females with severe enzyme deficiency. Symptoms of acute intravascular hemolysis occur within 5 to 24 hours of ingestion of the bean. Headache, nausea, back pain, chills, and fever are followed by hemoglobinuria, anemia, and jaundice. The drop in hemoglobin concentration is precipitous, often severe, and may require a red cell transfusion.

Favism does not occur in all susceptible G6PD individuals,¹⁰⁷ and it is thought that additional genetic factors are involved, presumably related to how fava bean oxidants are metabolized. Furthermore, the reaction to the fava bean by the same

individual at different times may not be consistent.¹⁰³ Clearly, a factor other than enzyme deficiency is operative. Two pyrimidine aglycones, divicine and isouramil, have been implicated as the toxic components of fava beans.^{108, 109} Both compounds rapidly overwhelm the GSH-generating capacity of G6PD-deficient cells and reproduce many of the metabolic derangements noted during hemolytic episodes.¹¹⁰ To date, however, there are no convincing data to explain the erratic hemolytic episodes seen in favism.

Neonatal Hyperbilirubinemia

Hyperbilirubinemia and hemolysis resulting from G6PD deficiency are well documented in the newborn period, rarely present at birth but with a peak incidence of clinical onset between days 2 and 3.^{111, 112, 113} In most cases there is more jaundice than anemia. Close monitoring of serum bilirubin levels in infants known to be G6PD-deficient is warranted.^{114, 115, 116} Neonatal hyperbilirubinemia is seen with G6PD Mediterranean (Class II) variants. An increase in the incidence of neonatal hyperbilirubinemia also is seen in Southeast Asia^{32, 117} and China¹¹⁸; and a significant fraction of the latter are associated with G6PD Canton.¹¹⁹ African-American infants with G6PD A⁻ (Class III) once were considered to be at minimal risk, but this is no longer held; and significant hyperbilirubinemia can occur in these neonates.^{111, 120, 121} In Africa, untreated hyperbilirubinemia often leads to kernicterus with severe neurologic injury or death.^{122, 123} It is of interest that data from the USA Kernicterus Registry from 1992 to 2004 indicate that over 30% of kernicterus cases are associated with G6PD deficiency.¹²⁴

The observation that the incidence of hyperbilirubinemia in G6PD-deficient infants born in Australia to Greek immigrants is lower than that noted in deficient infants in Greece suggests that local environmental variables are probably important.¹²⁵ Herbs used in traditional Chinese medicine and clothing impregnated with naphthalene also are examples of covert oxidants to which susceptible infants may be exposed. Lastly, drugs (e.g., sulfonamides) and fava bean ingestion by mothers in late gestation have been implicated as the inciting stimulus of hemolysis in newborns.^{105, 121, 126}

P.734

Although the cause of hyperbilirubinemia in G6PD-deficient infants sometimes reflects accelerated red cell breakdown,^{112, 123, 127} often there is no obvious RBC destruction or oxidant exposure. It has been suggested that hyperbilirubinemia may have another etiology, possibly related to impaired liver clearance of bilirubin. In support of this hypothesis are the observations that carboxyhemoglobin production, a marker of hemolysis or RBC breakdown, is the same in G6PD Mediterranean deficient neonates with and without hyperbilirubinemia.¹²⁸ It is now thought that the variable degree of hyperbilirubinemia in G6PD-deficient neonates reflects the presence or absence of the variant form of uridine-diphosphoglucuronosyl-transferase responsible for Gilbert's syndrome.¹¹⁶ The relative importance of the latter is underscored by the observation that most jaundiced G-6-PD neonates are not anemic and that evidence for increased bilirubin production secondary to hemolysis often is lacking.¹²⁹

Congenital Nonspherocytic Hemolytic Anemia

A very small fraction of G6PD-deficient individuals have chronic lifelong hemolysis in the absence of infection or drug exposure. These rare Class I G6PD variants are extremely heterogeneous with respect to biochemical kinetics, but have in common very low in vitro activity and/or marked enzyme instability.⁶³ Most of these variants have DNA mutations at exon 10, an area which affects monomer-dimer interactions and thereby enzyme activity.⁶³ The hemolytic anemia associated with Class I variants is indistinguishable from the congenital nonspherocytic hemolytic syndromes related to glycolytic enzyme deficiencies.

Anemia and jaundice often are noted first in the newborn period. Hyperbilirubinemia often necessitates exchange transfusion. Typically, hemolysis occurs in the absence of a recognized triggering factor, although exposure to drugs or chemicals with oxidant potential exaggerates an already established hemolytic process. Beyond infancy, signs and symptoms of the hemolytic disorder are subtle and inconstant. Exaggeration of anemia occurs after exposure to drugs with oxidant properties, even those that are safe for individuals with Class II and III G6PD variants. Hemolysis also can be accelerated with exposure to fava beans.¹³⁰

No hematologic alterations of the Class I variants are distinctive. The hemolytic process may be fully compensated, although mild to moderate anemia is the rule (hemoglobin 8 to 10 g/dl). Under basal conditions the usual reticulocyte count is 10% to 15%. Splenectomy is sometimes of benefit.¹³¹

In a few instances, leukocyte dysfunction associated with Class I variant G6PD deficiency has been described.^{73, 74, 132} The abnormality is characterized functionally by defective bactericidal activity (but normal chemotaxis and phagocytosis), and

clinically by recurrent infections with catalase-positive organisms. Overall, however, clinical infections are not a major problem in G6PD deficiency.

Diagnosis

Because of its prevalence and worldwide distribution, G6PD deficiency should be given serious consideration in the differential diagnosis of any nonimmune hemolytic anemia. Most commonly, anemia is first recognized during or after an infectious illness, after exposure to one of several suspect drugs or chemicals, or following exposure to fava beans. Also, G6PD deficiency should be considered in neonates with excessive and unexplained hyperbilirubinemia. Clinical and hematologic features reflect the severity of hemolysis but are not themselves specifically from G6PD deficiency. Irregularly contracted erythrocytes (eccentrocytes with hemoglobin puddled to one side of the RBC) and "bite" cells are seen in the Wright-stained peripheral blood smear. Previously, these bite cells were considered a consequence of splenic removal of Heinz bodies. Now, however, it is recognized that these RBC contain a coagulum of hemoglobin which has separated from the membrane, often leaving an unstained non-hemoglobin-containing cell membrane (i.e., having the appearance of a bite removed from the cell).⁸⁰ These morphologic alterations are a consequence of the oxidative assault on hemoglobin. Brilliant cresyl blue supravital stains of the peripheral blood may reveal Heinz bodies during hemolytic episodes.

The specific diagnosis of G6PD deficiency is made by adding a measured amount of hemolysate to an assay mixture containing substrate (glucose-6-phosphate) and cofactor (NADP) and then spectrophotometrically measuring the rate of NADPH generation.¹³³ Alternatively, a variety of screening tests which utilize hemolysate as a source of enzyme also can be used. The fluorescent spot test is the simplest, most reliable, and most sensitive of the screening methods.¹³⁴ This test is based on the fluorescence of NADPH, after glucose-6-phosphate and NADP are added to a hemolysate of test cells. Other screening methods detect NADPH generation indirectly by measuring the transfer of hydrogen ions from NADPH to an acceptor. In the methemoglobin reduction test,¹³⁵ methylene blue is the acceptor used for the transfer of hydrogen from NADPH to methemoglobin, thereby facilitating its reduction. It is important to mention this test because, when combined with a technique for the elution of methemoglobin from intact cells, it can be used to detect relative G6PD sufficiency of individual RBC,¹³⁶ thereby detecting the carrier state with approximately 75% reliability. Regardless of the screening test used to detect G6PD deficiency, it should be recognized that false negative reactions occur if the most severe enzyme-deficient red blood cells have been removed by hemolysis. This generally is not critical in testing male Caucasians, but it certainly is a problem in diagnosing some Caucasian females and blacks of both sexes, especially during the reticulocytosis following acute hemolysis. In these cases, family members can be studied. An alternative approach to diagnosis is to wait until the hemolytic crisis is over and reevaluate the patient after the red blood cell mass is repopulated with cells of all ages (approximately 2 to 3 months). False negative tests are less of a problem in diagnosing G6PD deficiency when quantitative spectrophotometric enzyme assays are utilized.

Treatment

Management of the patient with G6PD deficiency is determined by the clinical syndrome with which it is associated. Individuals having variants associated with acute hemolysis may have a significant fall in hemoglobin concentration requiring a RBC transfusion. This is the case more commonly in G6PD Mediterranean (Class II) than in G6PD A⁻ (Class III). All affected individuals should avoid exposure to drugs known to trigger hemolysis. Pregnant and nursing women known to be heterozygous for the deficiency also should avoid ingestion of drugs with oxidant potential, because some gain access to the fetal circulation and to breast milk. If the indication for its use is sound, however, an offending drug justifiably may be given despite modest shortening of red cell survival. For example, primaquine is safely given to individuals with the G6PD A⁻ variant, provided it is started cautiously (15 mg/day or 45 mg once or twice weekly) and the blood count is monitored closely.¹³⁷ The mild anemia caused by its administration is rapidly corrected by a compensatory erythropoietic effort and does not recur unless the dose of drug is escalated.

Chronic nonspherocytic hemolytic anemia due to Class I G6PD variants may require more active intervention. Exchange transfusion during the first week of life often is required to prevent bilirubin encephalopathy. Beyond the newborn period, anemia rarely is of such severity as to require regular blood transfusions. During aplastic crises, however, transfusions may be lifesaving. As with other syndromes resulting from G6PD deficiency, drugs capable of exaggerating hemolysis should be avoided. Splenectomy, although occasionally bringing about a modest improvement in hemoglobin concentration,¹³⁸ is generally without benefit.¹³¹ Because

of its antioxidant properties, vitamin E had been proposed as a therapeutic agent,^{139, 140, 141} but subsequent evaluation of large doses of the vitamin failed to demonstrate an ameliorative effect on anemia.¹⁴²

Therapy for hyperbilirubinemia and neonatal hemolysis resulting from G6PD deficiency includes the following: phototherapy or exchange transfusion to prevent kernicterus; RBC transfusion for symptomatic anemia; removal of potential oxidants that may be contributing to hemolysis, and treatment of associated infections. In infants known to be G6PD-deficient, prevention of severe hyperbilirubinemia by administration of a single IM dose of Sn-mesoporphyrin, an inhibitor of heme oxygenase, is highly effective and appears safe; but this therapy is not yet clinically available.^{143, 144} A study from Nigeria has reported a much poorer outcome for G6PD-deficient infants born at home, presumably a reflection of delayed identification and treatment of hyperbilirubinemia in these neonates.¹²³ In the United States, guidelines have been established for following hyperbilirubinemia in babies following discharge from the hospital.¹¹¹

Screening

Aside from the District of Columbia, there is no generalized neonatal screening program for G6PD deficiency in the United States. The approach here has been to recognize that neonatal hyperbilirubinemia may be caused by G6PD deficiency and these children should be tested and monitored closely. In some countries where the predominant G6PD variants are Class II mutations, screening programs have been instituted. Neonatal screening for G6PD deficiency has been very effective in reducing the incidence of favism later in life in Sardinia¹⁴⁵ and other regions where this potentially fatal complication is common.¹¹² Prenatal diagnosis utilizing molecular techniques is potentially available, but the benign course of most G6PD variants has precluded its development.¹⁴⁶

Routine blood bank screening has been considered unwarranted and G6PD deficiency is not considered a problem in transfusion medicine. Even in areas where G6PD deficiency is endemic, screening of blood donors is not required. One careful evaluation of the recipients of G6PD-deficient blood uncovered no deleterious consequences.¹⁴⁷ However, patients receiving G6PD Mediterranean blood may have an increased serum bilirubin and lactate dehydrogenase (LDH) concentration following transfusion, and this can be confused with a transfusion reaction.¹⁴⁸ In premature infants, simple transfusions with G6PD-deficient red cells have been associated with hemolysis and severe hyperbilirubinemia requiring exchange transfusion.¹⁴⁹ Also, massive intravascular hemolysis has occurred in an Indian neonate following an exchange transfusion with G6PD-deficient blood.¹⁵⁰ In view of these occurrences, it has been recommended that in areas where G6PD deficiency (presumably Class II variants) is common, donor blood should be screened for the enzyme before transfusing premature infants¹⁴⁹ or using the blood for a neonatal exchange transfusion.¹⁵⁰ This recommendation currently is not standard blood banking practice.

Related Disorders of Hexose Monophosphate Shunt and Glutathione Metabolism

In addition to G6PD, other enzymes of the HMP shunt pathway (6-phosphogluconate dehydrogenase [6PGD]), the closely linked reactions of glutathione metabolism (GSSG-R, GSH-Px), and the glutathione synthetic pathway are important in protecting RBC against oxidant injury. Rare abnormalities in these enzymes have been reported, and in some cases they are associated with hemolysis.

6-Phosphogluconate Dehydrogenase Deficiency

The enzyme 6PGD catalyzes the conversion of 6-phosphogluconate to pentose-5-phosphate (Fig. 28.2), and, in the process, NADPH is generated from NADP. Although deficiency of 6PGD is well documented, it appears to have little or no significance for red cell viability. Presumably this reflects the fact that NADPH is generated by the proximal enzyme, G6PD, suggesting that the second dehydrogenase may not be necessary for cell integrity.

Glutathione Reductase Deficiency

GSSG is reduced in the presence of NADPH by GSSG-R (Fig. 28.2). The enzyme contains flavin adenine dinucleotide (FAD) as a prosthetic component, and as a result, normal enzyme activity is dependent on the dietary availability of riboflavin. Not surprisingly, partial GSSG-R deficiency is a relatively common feature of disorders that are compounded by suboptimal nutrition.¹⁵¹ GSSG-R levels are restored within days by the administration of physiologic quantities of riboflavin.¹⁵² The association between riboflavin induced GSSG-R deficiency and various disease states is of no hematologic consequence.^{152, 153}

Genetically determined GSSG-R deficiency has been documented in three siblings who were offspring of a consanguineous marriage.¹⁵⁴ Enzyme activity was not enhanced by incubation of hemolysates with FAD. Despite near absence of erythrocyte GSSG-R activity, the siblings were hematologically normal, except for episodes of hemolysis after the ingestion

of fava beans. All three of the siblings acquired cataracts at an early age (24 to 32 years).¹⁵⁵ During the past 35 years, there have been no new reports of hereditary GSSG-R deficiency associated with hemolysis.

Glutathione Peroxidase Deficiency

GSH-Px catalyzes the oxidation of GSH by peroxides, including hydrogen peroxide and organic hydroperoxides (Fig. 28.2). Rare cases of hemolysis in association with moderate deficiency of erythrocyte GSH-Px activity have been described in adults and children.^{156, 157, 158} Of all the reported cases suggesting a relationship between hemolysis and GSH-Px deficiency, one of the most persuasive was that of a 9-month-old Japanese girl with chronic nonspherocytic hemolytic anemia.¹⁵⁹ This patient's erythrocyte GSH-Px activity was 17% of control activity, while her hematologically normal parents had 51% to 66% control enzyme activity. However, it is not known whether this specific enzyme defect was responsible for the patient's chronic hemolytic anemia. The general consensus today is that GSH-Px deficiency is probably not a cause of hemolysis or other hematologic problems. The reason for this opinion is that many healthy normal individuals, particularly those of Jewish or Mediterranean ancestry, have reduced GSH-Px activity without evidence of hemolysis.¹⁶⁰ Moreover, low GSH-Px activity, in the absence of hemolysis, also is observed in normal people from New Zealand with selenium (Se) deficiency (Se being an integral part of GSH-Px).^{161, 162} In view of these observations, the role of GSH-Px deficiency as a cause of hemolysis is questioned. Some argue that GSH-Px is only one of the cellular mechanisms available to detoxify peroxides. Under physiologic conditions, catalase and nonenzymatic reduction of oxidants by GSH also may be important factors regulating the rate of H₂O₂ detoxification. From a clinical perspective, because of the questionable role of GSH-Px, any patient with hemolytic anemia and reduced GSH-Px activity should be extensively evaluated for other causes of hemolysis.

Defects in Glutathione Synthesis

Glutathione is actively synthesized in RBC and has an intracellular half-life of only 4 days, in part due to cellular efflux of GSSG. RBC are capable of de novo GSH synthesis, and this is

P.736

accomplished by two critical enzymes (Fig. 28.3). γ -Glutamylcysteine synthetase (GCS) catalyzes the first step in GSH synthesis, the formation of γ -glutamyl-cysteine from glutamic acid and cysteine. Glutathione synthetase (GS) catalyzes the formation of GSH from glutamyl-cysteine and glycine. In many tissues, but not RBC, these two enzymes are part of the γ -glutamyl cycle, which is involved with the synthesis and degradation of GSH and is also thought to have a role in amino acid transport across cell membranes. Hereditary hemolytic anemia, characterized by reduced GSH content, has been reported in patients with deficiencies of both GCS and GS activity. The clinical effects of these disorders depends on the severity of enzyme deficiency and whether the γ -glutamyl cycle also is affected in non-erythroid tissues.

γ -Glutamyl-cysteine synthetase deficiency is a rare hemolytic anemia which was first described in two adults who were brother and sister.¹⁶³ Both of these patients had a lifelong history of mild hemolytic anemia, intermittent jaundice, cholelithiasis, and splenomegaly. They also manifested severe neurologic dysfunction and generalized aminoaciduria.¹⁶⁴ This disorder is an autosomal recessive condition and, in the family studied, presumed carriers had reduced GCS activity, although erythrocyte GSH levels were normal. Hemolytic anemia was seen only in the homozygous state where erythrocyte GSH levels were approximately 5% of normal, and there was markedly reduced GCS activity. A third patient with GCS deficiency, unrelated to the first cases, was a 22-year-old woman with markedly reduced RBC GCS activity, severely reduced erythrocyte GSH concentration, and chronic hemolytic anemia.¹⁶⁵ Family members of this patient had 50% reduced enzyme activity but no decrease in RBC-glutathione content or evidence of hemolysis. Of particular interest, in contrast to the first patients described with GCS deficiency, this patient had no neurologic disease. To date there have been a total of 8 probands reported with GCS deficiency and hemolysis; and 4 of these also have had severe neurologic disease.^{166, 167, 168} The molecular defect in these cases has been associated with different missense mutations. There is no specific therapy for GCS deficiency, although it would seem prudent to obtain periodic gallbladder ultrasound examinations since affected patients have had cholecystectomies.

Glutathione synthetase deficiency has been incriminated as the cause of chronic hemolytic anemia alone (due to isolated RBC enzyme deficiency) and as the cause of a generalized syndrome (due to enzyme deficiency in many tissues) characterized by mild hemolytic disease, severe metabolic acidosis, and mental deterioration. The first syndrome, mild hemolytic anemia and intermittent jaundice, has been described in several families.^{164, 169, 170, 171} Exposure to oxidant drugs and to fava beans has occasioned temporary acceleration of hemolysis. Splenomegaly has been noted in approximately one-half of the reported cases. A concurrent deficiency of glutathione-S-transferase is thought to be caused by the instability of this enzyme in the absence of adequate intracellular GSH.¹⁷² The second more generalized

syndrome is characterized by mild hemolytic anemia, persistent metabolic acidosis presenting in the newborn period, and progressive cerebral and cerebellar degeneration.^{173, 174, 175, 176} Acidosis is caused by the accumulation of 5-oxoproline, a metabolic product of γ -glutamylcysteine. Abnormally large quantities of the dipeptide are produced because of the loss of feedback inhibition of γ -GCS by GSH. This disorder is suspected in patients with hemolytic anemia and markedly reduced red blood cell GSH content. Virtually no GS activity is detected in homozygous-deficient individuals.^{163, 169, 177} Rarely, therapy is required for the hematologic consequences of GS deficiency. Exposure to drugs and chemicals with oxidant potential should be avoided by those individuals with chronic hemolytic anemia. In some cases, splenectomy has been efficacious in modifying the anemia, although hemolysis may continue as manifested by persistent reticulocytosis.^{170, 178} In those individuals with GS deficiency and oxoprolinemia, administration of oral sodium bicarbonate or citrate is necessary to control acidosis.¹⁷⁶

GLYCOLYTIC ENZYME ABNORMALITIES—GENERAL CONSIDERATIONS

Hemolytic anemias due to glycolytic enzymopathies are relatively rare, affecting a few thousand individuals,^{59, 179, 180} and this is in contrast to G6PD deficiency, which affects millions throughout the world. Abnormalities in virtually every glycolytic enzyme have been described, although over 90% of cases associated with hemolysis are due to pyruvate kinase (PK) deficiency (Fig. 28.4).

P.737

Most glycolytic enzymopathies manifest an autosomal recessive pattern of inheritance. Heterozygotes almost always are hematologically normal, although their red blood cells contain less than normal levels of enzyme activity. It once was thought that hemolysis occurred only in those individuals who were homozygous for the enzyme deficiency. However, true homozygosity for a given mutant enzyme now is known to be less common, and usually restricted to consanguineous kindred. The vast majority of cases of hemolytic anemia due to glycolytic enzyme deficiencies are a consequence of double heterozygosity for two different enzyme variants, and this accounts for the diverse biochemical and clinical heterogeneity of the red cell glycolytic enzymopathies. The one exception to this autosomal mode of inheritance for glycolytic enzymopathies is phosphoglycerate kinase (PGK) deficiency, which is an X-linked disorder.

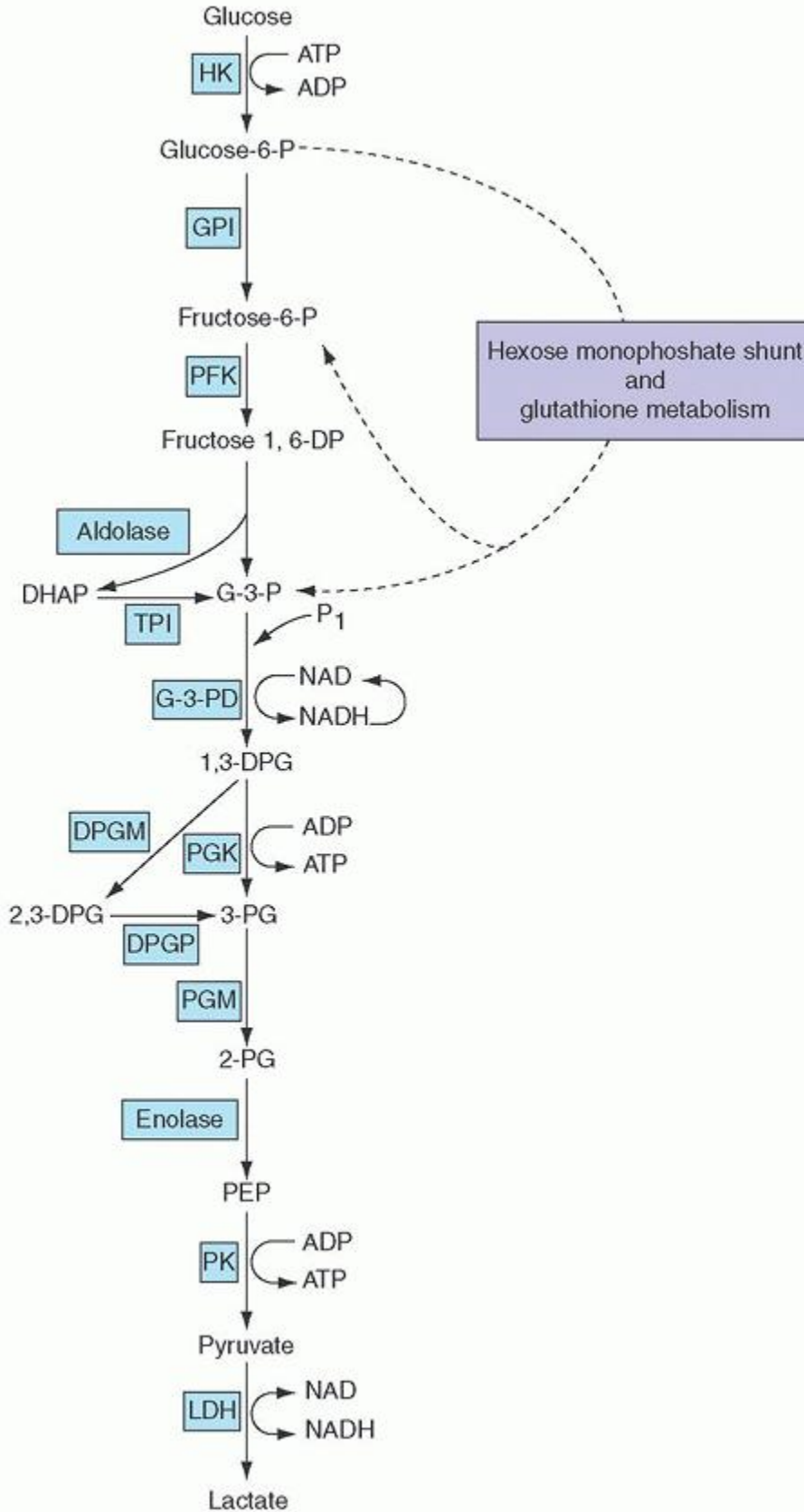

FIGURE 28.4. Overall metabolic pathway of glycolysis in the erythrocyte. Enzyme abbreviations: 2,3 DPGM, 2,3 diphosphoglycerate mutase; 2,3-DPGP, 2,3-diphosphoglycerate phosphatase; GPI, glucosephosphate isomerase; G-3-PD,

glyceraldehyde-3-phosphate dehydrogenase; HK, hexokinase; LDH, lactate dehydrogenase; PFK, phosphofructokinase; PGK, phosphoglycerate kinase; PGM, phosphoglycerate mutase; PK, pyruvate kinase; TPI, triosephosphate isomerase. Substrate abbreviations: 1,3-DPG, 1,3-diphosphoglycerate; DHAP, dihydroxyacetone phosphate; G-3-P, glyceraldehyde-3-phosphate; 2-PG, 2-phosphoglycerate; 3-PG, 3-phosphoglycerate; PEP, phosphoenolpyruvate.

Clinical manifestations of hemolysis due to glycolytic enzymopathies include chronic anemia, reticulocytosis, and some degree of hyperbilirubinemia. In the vast majority of cases the hemolytic process is recognized and diagnosed in childhood. Frequently there is a history of neonatal jaundice, often requiring an exchange transfusion, and rarely causing kernicterus. The magnitude of chronic anemia varies; there may be accelerated hemolysis with some nonspecific infections or transient aplastic crises associated with parvovirus infection. In some enzymopathies, such as PK deficiency, the adverse consequences are restricted to the erythrocyte. In other cases, such as in phosphofructokinase (PFK), aldolase, triosephosphate isomerase (TPI), and PGK deficiencies, hemolytic anemia is but one feature of multisystem disease (see Table 28.3).

The possibility of a glycolytic defect usually is considered when chronic hemolytic anemia cannot be explained by the more common causes (i.e., hereditary spherocytosis or hemoglobinopathies). There are no specific morphologic abnormalities, although anisocytosis and poikilocytosis are common. In virtually all cases a specific assay of RBC enzyme activity is necessary to make the diagnosis. Screening tests are readily available, but these have limited value when there is a partial deficiency or a mixed population of RBC. A particular problem in identifying glycolytic enzymopathies relates to the fact that the most severely deficient cells are removed (i.e., hemolyzed) and the remaining cells may be biochemically less abnormal. Consequently, "false negative" assays can obscure the correct diagnosis. For this reason, it sometimes is helpful to study parents and other family members for the presumed heterozygous state of the enzyme deficiency. In some cases DNA-based molecular diagnostic tests may be available.

TABLE 28.3 FEATURES OF GLYCOLYTIC AND NUCLEOTIDE ENZYMOPATHIES

Enzymopathy	Approximate Fraction of Enzymopathies^a (%)	Mode of Inheritance^b	Effects of Enzymopathy^c
Hexokinase (HK)	<1	AR	Mild/severe CNSHA
Glucosephosphate Isomerase (GPI)	3-5	AR	Moderate/severe CNSHA; ± neurologic deficits
Phosphofructokinase (PFK)	<1	AR	Mild CNSHA; ± myopathy
Aldolase	<1	AR	Mild/moderate CNSHA; ± myopathy
Triosephosphate Isomerase (TPI)	<1	AR	Moderate/severe CNSHA; neurologic deficits,
Phosphoglycerate Kinase (PGK)	<1	X-linked	Mild/severe CNSHA; ± neurologic deficits; ± myopathy
Pyruvate Kinase (PK)	80-90	AR	Moderate/severe CNSHA
Pyrimidine 5' Nucleotidase (P5'N)	2-3	AR	Moderate CNSHA
Adenosine Deaminase (ADA) excess	<1	AD	Mild CNSHA
Adenylate Kinase (AK)	<1	AR	CNSHA

^a Approximate estimates derived from Tanaka, KR, Zerez CR. Red cell enzymopathies of the glycolytic pathway. *Semin Hematol* 1990;27(2):165-85; Eber SW. Disorders of erythrocyte glycolysis and nucleotide metabolism. In: Handin R, Lux S, Stossel T, eds. *Blood: principles and practice of hematology*. Philadelphia, PA: Lippincott, Williams & Wilkins: 2003:1887-1920, 259; Beutler E. Red cell enzyme defects as nondiseases and as diseases. *Blood* 1979;54(1):1-7; Mentzer W. Pyruvate kinase

deficiency and disorders of glycolysis. In: Nathan DG, et al., eds. Hematology of infancy and childhood. Philadelphia, PA: WB Saunders, 2003.

^b AD, autosomal dominant; AR, autosomal recessive.

^c CNSHA, chronic nonspherocytic hemolytic anemia.

Therapy for red blood cell glycolytic defects is similar to that of other chronic hemolytic anemias. RBC transfusions often are needed. Splenectomy usually is beneficial in severely anemic patients since the spleen (along with the liver) participates in the destruction of enzymatically abnormal cells. In most cases, however, the response to splenectomy is only partial, although RBC transfusion requirements may decrease. Cholelithiasis is a common problem, and all patients with glycolytic enzymopathies should have periodic gallbladder ultrasound examinations, even following splenectomy. The biologic and clinical features of specific glycolytic disorders are summarized in the following paragraphs.

Pyruvate Kinase Deficiency

Of the enzymatic deficiencies involving glycolysis, PK deficiency is the most common and the most extensively studied. Over 400 cases have been reported.^{181, 182} Undoubtedly there are many more cases, since newly diagnosed patients currently are not reported unless there are unusual associated findings.

Geographic Distribution

Most cases of PK deficiency have been reported from Europe, the United States, and Japan; however, the disorder occurs worldwide.^{179, 183, 184} The frequency of the heterozygote state has been estimated on the basis of studies that screened various populations for low enzyme activity. In Germany and in the United States, the prevalence of apparent heterozygosity for PK deficiency has been estimated to be about 1%.¹⁸³ In one report from Hong Kong, 3% of newborn infants were noted to be heterozygous for a PK variant.¹⁸⁵ A particularly high frequency exists among the Pennsylvania Amish, in whom the disorder can be traced to a single immigrant couple.^{186, 187, 188} An increased incidence also has been observed in children from a polygamist community.¹⁸⁹ In studies looking at the most common PK mutations found in a Caucasian

P.738

population, a prevalence of PK deficiency has been estimated to be 51 per million population.¹⁹⁰

Biochemical Genetics

PK catalyzes the conversion of phosphoenolpyruvate (PEP) to pyruvate; and this is one of the two glycolytic reactions resulting in net ATP production (Fig. 28.4). PK is a tetrameric protein with a molecular weight of 230 kDa. There are two different PK genes (PKM2 and PKLR) which encode for 4 distinct PK isozymes.

The PKM2 is on chromosome 15 (15q22)¹⁹¹; and it encodes for two isozymes (PK-M2 and PK-M1). PK-M2 is the isozyme present in all tissues during fetal life. As fetal maturation proceeds, other tissue-specific PK isozymes begin to appear. PK-M2 persists as the predominant isoenzyme in mature leukocytes and certain other tissues (platelets, lung, kidney spleen, and adipose tissue). In addition, PK-M2 is the major isozyme in erythroid precursors.⁵⁹ PK-M1, which differs from PK-M2 as a result of alternative splicing, is the PK isozyme present in mature muscle and brain tissue.¹⁹²

The PKLR gene is on chromosome 1(1q21)¹⁹³; and it also encodes for two isozymes (PK-L and PK-R). PK-L is the predominant isozyme in hepatocytes.¹⁹⁴ PK-R is the isozyme present in mature erythrocytes.^{182, 195, 196} The hemolytic anemia associated with PK deficiency is due to mutations of the PKLR gene. In some patients with hemolytic anemia, a decrease in the liver PK-L isozyme has also been observed; but this is of no clinical significance since the liver also has residual PK-M2 activity.^{197, 198, 199} During normal erythroid differentiation, the PK isozyme switches from the M2 to the R-type.⁵⁹ Of interest, in one severe form of PK deficiency (PK Beppu), PK-M2-type persists in mature erythrocytes; and it has been proposed that this compensatory PK-M2 production allows affected red cells to survive, analogous to the beneficial effect of persistent fetal hemoglobin production in homozygous β -thalassemia.⁵⁹

Over 200 different mutations of the PKLR gene have been identified as causes of chronic hemolytic anemia. Most of these are missense mutations (approximately 70%), although a few are either nonsense or insertional mutations, deletions, or splicing abnormalities.^{59, 182, 200, 201} Most PK mutations are very rare, occurring only once; and the variable phenotypic expression of PK deficiency undoubtedly reflects the heterogeneity of these different PK mutants. A few mutations are seen with some frequency. A significant fraction of affected Caucasians (30% to 40%) have at least one 1529G→A

mutation resulting in an amino acid change (510Arg→Gln).^{202, 203} This particular mutation is common in the United States and in northern Europe. Homozygosity for this 1529G→A mutation was seen in children from a polygamist community in the western United States.²⁰⁴ A second common mutation, 1456C→T (484Arg→Trp), is observed in Spain, Portugal, and Italy, where it accounts for approximately 30% of all cases. A third common mutation, 1468C→T (Arg490→Trp), is found predominantly in the eastern hemisphere. The PK deficiency seen in the Amish population is associated with a 1436G→A (479Arg→His) mutation.¹⁸⁸ The PK deficiency in Gypsies is due to a deletion of 1,149 bp, resulting in the loss of exon 11.²⁰⁵

At one time, PK deficiency was thought to be a consequence of decreased production of a structurally normal enzyme; but it now is recognized that most PK variants are abnormal proteins which differ with respect to their biochemical kinetics and physical properties.^{206, 207, 208} The heterozygous state for a PK variant is clinically silent with no hemolysis or anemia.

There is little or no relationship between red cell PK activity in vitro and severity of hemolysis.^{59, 183} In part, this reflects the fact that in vitro assay conditions are very different from what exists in vivo. In addition, the presence of young RBC with elevated enzyme activity can mask the presence of a very unstable PK variant; or there can be persistence of PK-M2 in mature RBC.^{59, 209, 210} Moreover, since most individuals with PK deficiency are doubly heterozygous for two different PKLR mutants,⁵⁹ the study of RBC from affected subjects characterizes the mixture of PK variants without providing specific information about the individual enzymes. In the minority of individuals with homozygous disease, a relationship between defective PK enzymes and severity of hemolysis occasionally is apparent.^{206, 207, 211} Ongoing molecular biology studies are focused on determining the relationship of specific mutations (genotype) with hemolysis (phenotype).^{182, 200}

Pathophysiology

PK deficiency results in impaired glucose utilization and, thereby, decreased pyruvate and lactate production. In addition, glycolytic intermediates proximal to the block accumulate in red cells, and, of particular interest, the levels of 2,3-DPG may increase up to threefold.^{212, 213} The major impairment due to PK deficiency is a diminished capacity to generate ATP.²¹⁴ Paradoxically, however, PK-deficient patients with high reticulocyte counts may have normal or even elevated levels of ATP.²¹⁴ This occurs because PK-deficient reticulocytes generate ATP through mitochondrial oxidative phosphorylation, and this is associated with a 6 to 7 fold increase in oxygen consumption compared to normal reticulocytes.^{214, 215} The advantage of oxidative phosphorylation for PK-deficient reticulocytes is that ATP can be generated requiring minimal flow of pyruvate from glycolysis. When reticulocytes mature, however, mitochondria disappear, oxidative phosphorylation ceases and ATP levels fall. The effects of this will vary because there are marked cellular differences in the enzyme content of PK-deficient red cells. In severely PK-deficient RBC, the fall in ATP leads to cell injury, although the precise ATP-dependent reactions leading to irreversible membrane injury are not known. In some cases this injury is characterized by an increase in membrane calcium, accelerated potassium loss, decreased total monovalent cation content, and cellular dehydration.²¹⁵ The end result of these changes is a loss of membrane plasticity, and the formation of rigid RBC marked for premature destruction in the spleen.^{216, 217}

The reticulocytes most deficient in PK are doomed to almost immediate extinction once they lose their mitochondria. Less severely deficient cells survive to a nearly normal age, their ATP needs satisfied despite marginal metabolic resources.²¹⁵ This vulnerability of enzyme-deficient reticulocytes is seen in erythrokinetic studies which demonstrate that reticulocyte-rich fractions of blood from PK-deficient subjects have a shorter survival than do reticulocyte-poor fractions.^{215, 217} Given the unique metabolic abnormalities of the PK-deficient reticulocyte it is understandable why the spleen poses a problem for them. Because of their greater adhesive tendencies, reticulocytes endure a longer sojourn in the spleen,^{216, 217} where limited oxygen and glucose restrict effective oxidative phosphorylation.²¹⁵ Impaired ATP production then leads to RBC destruction in the spleen or in the liver after escape from the spleen.^{216, 217} Because severely deficient reticulocytes are metabolically more stable in the absence of the spleen, an exaggerated and sustained reticulocytosis usually follows splenectomy.¹⁸³

As noted previously, the concentration of 2,3-DPG may be up to three times normal.²¹² This increase is responsible for a rightward shift in the oxygen dissociation curve of hemoglobin. As a result, PK-deficient subjects have a greater exercise tolerance than would be expected from the degree of anemia.²¹³

Clinical Features

The clinical expression of PK deficiency is quite variable, ranging from hydrops fetalis^{218, 219} to pronounced neonatal jaundice requiring multiple exchange transfusions,^{185, 220, 221} and occasionally complicated by kernicterus^{186, 222} to a fully compensated hemolytic process detected as an incidental finding in adults.²²³

Unlike hemolysis associated with G6PD deficiency, the jaundice noted in PK-deficient infants invariably is associated with anemia and often with splenomegaly. The PK deficiency observed among the Pennsylvania Amish is particularly severe.¹⁸⁶

Beyond the neonatal period, anemia of varying degree, jaundice, and splenomegaly characterize erythrocyte PK deficiency. There are no specific or distinguishing clinical characteristics of this disorder; and no tissues are affected besides the red cells. Anemia may be surprisingly well tolerated because of the increased red cell 2,3-DPG content which is responsible for a rightward shift in the oxygen dissociation curve of hemoglobin.

The clinical course may be complicated by aplastic crises, characterized by an abrupt but temporary arrest of erythropoiesis and a precipitous drop in hemoglobin concentration and reticulocyte count. These crises usually are related to infection with parvovirus B19 which is cytotoxic for erythroid progenitors.^{224, 225} After the first decade of life, gallstones are detected with increased frequency.¹⁸³ Bone changes associated with hyperplastic bone marrow, such as those seen in thalassemia, occasionally may result in frontal bossing.²²⁶ Chronic leg ulcers occur rarely.^{227, 228} Pregnancy has been associated with good maternal and fetal outcomes.²²⁹ However, there also are reports of complications during pregnancy, including preeclampsia and worsening hemolytic anemia.²³⁰ Iron overload is a predictable complication of chronic transfusion therapy, but it may occur also in patients with a limited or no history of transfusions.²³¹ The rare cases of hemosiderosis occurring in minimally transfused PK-deficient individuals may be due to coexistent inheritance of the more common hereditary hemochromatosis gene.^{230, 232, 233}

Diagnosis

Anemia due to PK deficiency is moderate to severe in degree. The hemoglobin concentration characteristically is 6 to 12 g/dl.¹⁸³ The peripheral blood reveals all the morphologic hallmarks of accelerated erythropoiesis: polychromatophilia, anisocytosis, poikilocytosis, and variable numbers of nucleated red cells. Irregularly contracted erythrocytes with surface spicules,²³⁴ tailed poikilocytes,²¹⁴ and acanthocytes²²² have been observed in the smears of some affected individuals. Before splenectomy, the reticulocyte count may be increased (5% to 15%); but after splenectomy, reticulocyte counts as high as 70% occasionally are noted.^{183, 207} The latter is due to the longer survival of PK-deficient reticulocytes following splenectomy.

The hematologic features of PK deficiency are not distinctive. The specific diagnosis rests on laboratory documentation. The once-used autohemolysis test has no current role in the diagnosis of PK deficiency.²³⁵ Simple specific enzyme screening tests are available, but false negative results are common because of the many different variant enzyme kinetics. In cases where PK deficiency is suspected, a direct quantitative assay of the enzyme is essential. Leukocytes must be excluded from the system, because the leukocyte PKM2 gene is not affected in hemolytic variants to PK deficiency, and the PK activity of white blood cells is 300 times that of normal red cells.²³⁶ Most deficient individuals have 5% to 25% of the normal mean activity. Heterozygous carriers of a PK variant have approximately one-half normal activity, although there is considerable overlap with normal. The biochemical heterozygote sometimes is difficult to detect. Recommended methods for the characterization of PK variants have been established by the International Committee for Standardization in Hematology.²⁰⁶ In patients, usually infants, who are transfused before the enzyme disorder is recognized, the dilution of enzymedeficient RBC with transfused cells often makes it difficult to make the diagnosis based on chemical enzyme analysis.

In families with a child with PK deficiency, the issue of prenatal diagnosis in subsequent pregnancies is a matter of concern. Most assuredly molecular diagnostic techniques for the prenatal diagnosis of PK deficiency have proven to be useful.²³⁷ In particular, DNA analysis should be helpful in diagnosing those fetuses with the more common mutations described above, thought to account for 45% of cases of PK deficiency in non-Gypsy Caucasians. The large number of cases of PK deficiency in Gypsies are associated with a unique deletional mutation which also could be used for molecular diagnosis.²³⁷

Treatment

During the first years of life, severe anemia is managed with red cell transfusions. Maintenance of the hemoglobin concentration above 8 g/dl permits normal growth and development. The decision for transfusion therapy must relate to patient tolerance of anemia rather than an arbitrary level of hemoglobin. Because of increased red cell 2,3-DPG content, patients may tolerate moderately severe anemia with little problem.²¹³

Splenectomy is useful for long-term control of anemia. However, because of the well-known risk of post-splenectomy sepsis due to *Streptococcus pneumoniae* in young children, surgery should be delayed until 5 years of age whenever possible. Preoperative assessment of red cell survival and splenic sequestration is of no value in selecting patients for splenectomy, and this in part reflects the importance of the liver as a site of red cell destruction. Splenectomy most

commonly is followed by improvement but not a complete correction of the hemolytic disorder.^{183, 214, 217} Transfusion requirements, if present before splenectomy, decrease or are eliminated. In almost all patients, an incompletely compensated hemolytic process with reticulocytosis, some degree of hyperbilirubinemia, and an ongoing risk for gallstone formation usually persist.

A severe hemolytic anemia associated with PK deficiency in Basenji dogs has been corrected by bone marrow transplantation.²³⁸ Similarly, marrow transplantation has been shown to be effective in mutant mice with splenomegaly and chronic hemolytic anemia due to PK deficiency.²³⁹ These successes in animal studies clearly indicate a possible role for stem cell transplantation in this therapy in humans. There is one report of a 5-year-old boy with transfusion-dependent hemolytic anemia due to PK deficiency who received an HLA identical bone marrow transplant from his sister; and he is alive several years later without evidence of hemolysis.²⁴⁰ Despite the success in this one patient, in almost all cases of hemolytic anemia due to PK deficiency, the risk-benefit ratio currently remains weighted in favor of splenectomy over stem cell transplantation. In the future this may change. Moreover, PK deficiency (as a single gene defect, of recessive inheritance, affecting primarily one cell line, and being amenable to hematopoietic stem cell modification) is considered a candidate disease for gene therapy in the future.^{241, 242}

Other Enzymopathies Affecting Glycolysis

Hexokinase Deficiency

Hexokinase (HK) catalyzes the conversion of glucose to glucose-6 phosphate (Fig. 28.4). As the first enzyme in the glycolytic pathway, HK has a strategic role in the regulation of glucose consumption. The activity of HK declines rapidly as red cells age, and in older cells, HK activity is lower than that of any other glycolytic enzyme. The concentration of 2,3-DPG also may be low, and this has consequences on hemoglobin-oxygen affinity and work performance (see below).

There are four HK isozymes and each one is coded for by a different gene (HK1, HK2, HK3, HK4). The HK1 gene codes for the HK found in erythrocytes, and this gene maps to chromosome 10.^{243, 244, 245} Type I HK isozyme also is present in lymphocytes and platelets. However, deficiency of type I HK isozyme in lymphocytes is offset by an increase in the amount of type III isozyme.²⁴⁶ As with PK deficiency, deficient HK activity may result from

P.740

quantitative deficiency of an apparently normal enzyme^{247, 248} from abnormalities that affect substrate affinity,^{249, 250, 251} or heat stability.^{252, 253, 254} The molecular defect has been identified in a few cases of HK deficiency.^{255, 256}

Seventeen different kindred with HK deficiency have been described in families of European, Mediterranean, Scandinavian, and Asian background.^{245, 247, 248, 249, 251} The inheritance pattern is consistent with an autosomal recessive mode of transmission. In about 25% of reported cases, neonatal hyperbilirubinemia can occur and may require exchange transfusion.^{248, 250, 257} In many affected individuals, mild anemia or recurrent episodes of jaundice are not noted until after the first decade of life. Splenomegaly is common. Regular RBC transfusions may be required in severely affected patients.²⁴⁸ Splenectomy ameliorates but does not cure the hemolytic process.^{248, 249, 250} Symptoms may be out of proportion to the degree of anemia because low levels of erythrocyte 2,3-DPG reduce oxygen release to tissues at any given oxygen tension.^{213, 258}

There are no unique RBC features associated with HK deficiency. The diagnosis rests on the assay of red cell HK activity. Because HK is among the most age-dependent of red cell enzymes, its activity must be considered in relation to the reticulocyte count or the activity of other age-dependent enzymes.²⁴⁸

Glucosephosphate Isomerase Deficiency

Glucosephosphate isomerase (GPI) catalyzes the interconversion of fructose-6-phosphate and glucose-6-phosphate (Fig. 28.4). GPI deficiency is the second most common glycolytic enzymatic defect associated with hemolytic disease.²⁵⁹ Since the first description of the disorder in 1968,²⁶⁰ approximately 50 cases have been reported.^{59, 261, 262, 263, 264, 265} Just as for the case of PK deficiency, many more cases probably exist but are not published or listed in any rare disease registry. It is estimated that 0.2% of North Americans are heterozygous for a GPI mutant.²⁶⁶

The gene for GPI is located on chromosome 19. Several different gene mutations of GPI associated with hemolysis have been identified.^{59, 265, 267, 268, 269} A single form of GPI is synthesized by all cells of the body; consequently, structural mutations of the enzyme are expressed in all tissues.^{263, 270} Because most mutations result in enzyme instability,²⁷¹ the defect imposes functional compromise mainly in older mature erythrocytes. Both missense mutations and gene deletion have been described.^{265, 267, 272, 273} It is inherited in an autosomal recessive manner. Obligate heterozygotes for mutant

alleles are hematologically normal but have reduced red cell GPI activity. Symptomatic GPI deficiency results equally from homozygosity for a single mutant gene or compound heterozygosity for two different abnormal alleles.^{59, 267, 272, 274}

The severity of hemolytic disease varies considerably. Hydrops fetalis with death in neonates has been reported,^{274, 275, 276} and anemia and hyperbilirubinemia complicate the postnatal course in many patients.^{263, 270} Chronic transfusion therapy may be required. As with other chronic hemolytic anemias, the clinical course may be complicated by aplastic and hyperhemolytic crises. Mental retardation and excessive stores of hepatic glycogen were noted in a single patient.²⁷⁴ Neuromuscular impairment (hypotonia, ataxia, dysarthria, mental retardation) occasionally has been seen, but in only 5 of the known variants.²⁶⁵ Splenectomy has eliminated or dramatically reduced the transfusion requirement in most patients.^{260, 262, 263, 266} Post-splenectomy hemoglobin concentrations are 8 to 10 g/dl. Following splenectomy, reticulocyte counts may increase dramatically (50% to 75%).²⁶⁶

Red cell morphology is characterized by anisocytosis, poikilocytosis, polychromatophilia, and often the presence of nucleated red cells. Definitive diagnosis requires specific enzyme assay of a RBC hemolysate. Prenatal diagnosis of GPI by enzymatic assay of amniotic fluid cells has been demonstrated in a kindred with unusually severe hemolytic disease.²⁷⁵ Several abnormal GPI mutations have been identified and molecular diagnostic techniques for prenatal diagnosis are becoming available (P. Gallagher, Yale University, personal communication).

Phosphofructokinase Deficiency

PFK catalyzes the phosphorylation of fructose-6-phosphate to fructose-1,6-diphosphate, and this is one of the rate limiting reactions of glycolysis (Fig. 28.4). The PFK enzyme in RBC is a tetrameric protein made up of varying combinations of muscle or M type subunits, liver or L type subunits, and platelet or P type subunits.^{277, 278, 279} Three different structural loci encode for these M, L, or P subunits of PFK. The M type subunit is encoded for a gene on chromosome 1,²⁸⁰ and this gene has been characterized²⁸¹ and cloned.^{282, 283} The L type PFK subunit is encoded by a gene located on chromosome 21,²⁸⁴ and the structural organization of this gene also has been characterized²⁸⁵ and cloned.²⁸⁶ The gene encoding for the P subunit of PFK is located on chromosome 10.²⁸⁷ The subunits are variably expressed in different tissues. Muscle and liver PFK are composed exclusively of M4 and L4 tetramers, respectively. The red blood cell contains equal amounts of M and L subtypes and all possible tetrameric variations are present (L₄; L₃ M₁; L₂ M₂; L₁ M₃; M₄).²⁷⁹ Neutrophil PFK is composed primarily of L4 homotetramers, and platelet PFK consists of both P and L subunits. The variable structure of PFK in different tissues provides an explanation for the diversity of syndromes associated with deficiency states. These syndromes include chronic hemolytic disease with myopathy, hemolytic disease alone, and myopathy alone.²⁸⁸

The first PFK deficiency syndrome described was characterized by congenital nonspherocytic hemolytic disease and myopathy (Tarui's disease, glycogenosis type VII^{289, 290}). More than 39 unrelated families have been identified.²⁹¹ It is inherited as an autosomal recessive disorder. The myopathy is characterized by muscle fatigue and cramping with exercise and pathologically by increased muscle glycogen.²⁸⁹ There is a mild compensated hemolytic anemia. The hemoglobin concentration is normal, or even increased. Both myopathy and hemolytic disease result from the total lack of M subunit expression. Biopsies of muscle reveal that PFK activity is completely lacking, while erythrocyte PFK activity is about 50% of normal.^{289, 290, 292} The red cell PFK in these patients is composed exclusively of L4 subunits.^{279, 289} Glycolytic intermediates proximal to PFK are increased in concentration, and those distal to the block are decreased.^{292, 293} Of particular interest, 2,3-DPG is decreased,²⁹⁴ and this presumably leads to an unfavorable shift of the hemoglobin-oxygen affinity, thereby accounting for the mild erythrocytosis in some patients and absence of anemia despite shortened red cell survival in others.

PFK deficiency also has been implicated as the cause of hemolytic disease in the absence of myopathy.^{279, 293, 295, 296} Some individuals manifest mild myopathic symptoms during ischemic exercise tolerance tests.²⁹³ This syndrome is attributed to the synthesis of an unstable but catalytically active M subunit. Muscle cells are protected because of continued synthesis of the enzyme, whereas anucleate erythrocytes, incapable of protein synthesis, sustain early loss of enzyme activity.²⁹⁵ Although myopathy without hemolysis has also been attributed to PFK deficiency, hemolytic disease may have been dismissed because of the absence of anemia.²⁹³ Heterozygosity for L subunit deficiency is associated with about one-half normal red cell PFK activity, but with no myopathic or hemolytic features.^{293, 297, 298}

Aldolase Deficiency

Aldolase catalyzes the conversion of fructose-1,6-diphosphate to dihydroxyacetone and glyceraldehyde-3-phosphate (Fig. 28.4). Aldolase is a tetrameric protein, and three tissue isozymes

P.741

(A, B, C) have been identified.²⁹⁹ Type aldolase, the main isozyme in red blood cells and muscle, has been characterized and cloned.^{300, 301} The gene which encodes aldolase A is located on chromosome 16.³⁰²

Aldolase deficiency as a cause of hemolytic anemia is very rare, and has been identified in only four kindred. The first case was documented in a child whose parents were first cousins. In addition to mild hemolytic anemia, the child had hepatomegaly associated with increased glycogen deposition and psychomotor retardation.³⁰³ A second report of aldolase deficiency in a Japanese family described more severe hemolytic anemia (hemoglobin 6 g/dl; 7% to 8% reticulocytes) without attendant hepatomegaly or developmental delay.³⁰⁴ In a third case, a 4½-year-old boy in Germany was identified with aldolase deficiency.³⁰⁵ He had a history of neonatal jaundice, recurrent episodes of jaundice beyond the newborn period, and anemia requiring red cell transfusions in the first year of life. In addition, however, he had a myopathy characterized by severe muscle weakness, exercise intolerance, and laboratory evidence of rhabdomyolysis in association with fever and an upper respiratory infection. In a fourth reported case, a young girl of Sicilian extraction had a transfusion-dependent hemolytic anemia requiring splenectomy at 40 months of age.³⁰⁶ She also had a myopathy with recurrent and progressive episodes of rhabdomyolysis. She died due to hyperkalemia and rhabdomyolysis during a febrile illness associated with gastrointestinal hemorrhage at 54 months of age. Molecular analysis in each of the above cases has identified several different missense or nonsense mutations, each resulting in a thermolabile unstable enzyme.^{305, 306, 308} The mechanism of hemolysis in these cases is uncertain. Deficient red cells accumulate proximal glycolytic intermediates, especially fructose-1,6-diphosphate.

Triosephosphate Isomerase Deficiency

TPI catalyzes the reversible isomerization of glyceraldehyde -3-phosphate and dihydroxyacetone phosphate (Fig. 28.4). TPI is a dimeric enzyme composed of identical subunits. Several electrophoretically distinct bands result from posttranslational modification of a single protein³⁰⁹ that is encoded by a single structural gene located on the short arm of chromosome 12.³¹⁰ Only one isozyme of TPI is produced, and thus enzyme deficiency involves all body tissues. Enzyme activity is greatly reduced in red cells, as well as leukocytes, muscle, and skin fibroblasts.²⁶⁴ Thirty-five cases of TPI deficiency with hemolytic anemia have been identified. The enzyme abnormality in almost all cases is due to a single amino acid substitution which results in an unstable enzyme.³¹¹ Several different point mutations in the TPI gene have been identified and reviewed.^{312, 313, 314} Most are missense mutations resulting in a single amino acid substitution, and one is due to a deletion. The majority of the mutants result in heat-labile enzymes with residual catalytic activity. All clinically affected patients have been homozygotes or, less commonly, compound heterozygotes. Of the known mutations, one accounts for the molecular defect in most studied families with TPI deficiency; and this variant is due to a 315G→C mutation which results in an amino acid substitution (104 glu→asp).^{312, 314}

Hemolysis due to TPI deficiency is one aspect of a multiple system disease. A most unique feature of this enzymopathy is an associated severe neurologic disorder characterized by spasticity, motor retardation, and hypotonia.^{314, 315} It is inherited as an autosomal recessive disorder. Heterozygotes, with half normal erythrocyte TPI activity, are clinically normal. Of interest, the frequency of the heterozygous state for TPI deficiency is relatively high (0.1% to 0.5% in Caucasians, 5.5% in African-Americans).³¹⁶ Despite this estimate, less than 40 individuals with symptomatic disease have been identified.^{59, 288, 314} The rare incidence of clinically significant homozygous TPI deficiency suggests incompatibility with fetal life.

TPI deficiency is a progressive, ultimately fatal disease. In most cases, anemia and hyperbilirubinemia have been noted at birth or during the first weeks of life.^{314, 315, 317} The degree of anemia is variable, but most affected infants and children require periodic blood transfusions. Death from hemolytic anemia in the first week of life occurred in a sibling and a cousin of the patient described in the first reported case.³¹⁵ Splenectomy appears to have no discernible benefit.³¹⁵ Late in the first year of life, spasticity and a delay in the acquisition of motor skills are noted. Neurologic involvement generally is progressive, giving rise to paraparesis, weakness, and hypotonia. Recurrent systemic infections are a problem in most affected children, but it is not known whether these are related to impaired TPI activity in phagocytes. Death, probably from cardiac arrhythmias, usually occurs before the fifth birthday. In the only adult thus far identified as having TPI deficiency,³¹⁸ neurologic dysfunction, although profound, was stable. An interesting report of TPI deficiency with chronic hemolytic anemia has been described in a 13-year-old boy and his 23-year-old brother. Noteworthy was the observation that the 13-year-old boy had hyperkinetic torsion dyskinesia, but his 23-year-old brother had no neurologic abnormalities.^{319, 320}

The diagnosis of TPI deficiency is suspected in young children with chronic hemolytic disease not due to the more common causes of hemolysis. Associated motor neurologic symptoms raise the index of suspicion for TPI deficiency. There are no specific RBC abnormalities. In suspected cases it is necessary to assay for TPI activity in a RBC hemolysate. The large

number of cases associated with the codon 104 mutation has allowed the use of chorionic villous biopsy samples and molecular techniques for prenatal diagnosis.^{321, 322}

Phosphoglycerate Kinase Deficiency

PGK catalyzes the conversion of 1,3- diphosphoglycerate to 3-phosphoglycerate, and this is one of two glycolytic reactions resulting in net ATP generation from ADP (Fig. 28.1). An alternative fate of 1,3-DPG is the formation of 2,3-DPG, a reaction catalyzed by 2,3-diphosphoglyceromutase (DPGM). The product of the latter reaction is 2,3DPG, an important intermediate which is known to enhance oxygen release from hemoglobin. Hereditary deficiency of PGK activity has been recognized as a rare cause of chronic hemolytic anemia for 40 years.³²³ Red cells severely deficient in PGK predictably accumulate DHAP,³²⁴ have higher than normal concentrations of 2,3-DPG,³²⁴ and have decreased concentrations of ATP.³²³ The altered intermediate profile in PGK-deficient RBC thus reflects an increased flow of triose phosphates through the DPG pathway at the expense of ATP generation.

The genetics of this disorder are unique amongst glycolytic enzymopathies in that it is X-linked.³²³ PGK is known to be encoded by a single structural gene on the X chromosome q13.³²⁵ Biochemical variants of PGK with abnormal kinetics and/or enzyme instability have been observed in 26 separate families,³²⁶ and the single amino acid substitutions and genomic structure have been identified in almost all of these variants, most of which are due to missense mutations.^{59, 291, 326}

Similar to G6PD deficiency, male hemizyotes with little or no enzyme activity are symptomatic, with chronic hemolysis that can be severe, often requiring RBC transfusions.^{323, 327, 328} In contrast, females who are mosaics have normal and PGK-deficient red cells, and there may be variable degrees of hemolysis.^{323, 329} Clinical exacerbations of hemolysis, most of which appear to be triggered by intercurrent infections, are responsible for recurrent episodes of jaundice. Splenectomy obviates transfusion in most patients but does not fully correct the hemolytic process. In deficient male subjects, PGK activity is decreased in leukocytes,³²³ platelets, muscle, liver, and brain, as well as in red cells.³³⁰ Although leukocyte PGK activity may also be low, there is no evidence that affected individuals have leukocyte dysfunction or increased infections.

P.742

Of far greater consequence is progressive neurologic deterioration. Some deficient male infants experience apparently normal development until 3 to 4 years of age, when motor regression, expressive aphasia, and emotional lability become apparent. Seizures and progressive extrapyramidal disease follow late in the first decade.^{323, 324, 327, 331} Most PGK variants manifest both hemolysis and neurologic disease (PGK-Uppsala, PGK-Tokyo, PGK-Matsue, PGK-Michigan); however, there are exceptions. PGK-Shizuoka is characterized by hemolysis and muscle disease,³³² while PGK-San Francisco has only hemolysis without other symptoms.³³³ At the other extreme, recurrent exertional rhabdomyolysis producing renal failure but without associated neurologic or hematologic disease has been observed in PGK-Creteil.³³⁴ The absence of hemolysis in this variant is most intriguing, since red cell PGK activity was less than 3% of normal. Also, clinically silent variants producing PGK deficiency have been described, and these variants differ from the normal enzyme with respect to electrophoretic mobility and isoelectric focusing.³²⁵ The reasons for these major phenotypic differences in PGK deficiency remained to be defined.

Glycolytic Enzymopathies of Doubtful Clinical Significance

Hemolysis has been associated with deficiencies of other glycolytic enzymes, but the causal relationship between enzymopathy and reported hematologic disturbances is far from clear.²⁵⁹

Glyceraldehyde-3-Phosphate Dehydrogenase Deficiency

The enzyme glyceraldehyde-3-phosphate dehydrogenase (G3PD) catalyzes the reversible conversion of glyceraldehyde-3-phosphate to 1,3- diphosphoglycerate (see Fig. 28.4). This reaction is coupled to the reversible reduction of NAD to NADH. The latter is the major cofactor for methemoglobin reduction by cytochrome b5 reductase. Mild hemolytic anemia attributed to G3PD deficiency was described in two brief reports over 30 years ago.^{335, 336} The limited content of these reports precludes conclusions regarding the relationship between G3PD deficiency and hemolysis.

2,3-Diphosphoglyceromutase Deficiency

The enzyme 2,3-diphosphoglyceromutase (2,3-DPGM) has more than one metabolic role. Its main function relates to its catalytic role in the conversion of 1,3-DPG to 2,3-DPG (Fig. 28.4). This reaction is of special interest, because 2,3-DPG reduces the affinity of hemoglobin for oxygen, thereby shifting the oxygen hemoglobin dissociation curve to the right (see Chapter 6). A second function of the enzyme relates to its phosphatase activity which catalyzes the degradation of 2,3-

DPG to 3-PGA. These two different actions of 2,3-DPGM reflect two different active sites on the same molecule.³³⁷ Deficiency of red cell 2,3-DPGM is associated with deficiency of 2,3-DPG phosphatase of comparable magnitude.^{337, 338} The third metabolic role of this enzyme is to facilitate the conversion of 3-PGA to 2-PGA. The reports of 2,3-DPGM deficiency are too few and too disparate to permit a unified clinical description. Total deficiency of the mutase and phosphatase activity of DPGM and 2,3-DPG phosphatase activity was described in a 42-year-old man who was well except for ruddy cyanosis and a hemoglobin of 19 g/dl.³³⁸ Erythrocyte 2,3-DPG content was low, as was the p50 determination. Two of his children had approximately 55% normal 2,3-DPGM activity, suggesting they were heterozygous and their father was homozygous, with fully compensated hemolytic anemia.^{339, 340} Deficiency of 2,3-DPGM imparts no known metabolic lesion having implications for cell survival. Deficient cells consume glucose normally and contain normal or increased amounts of ATP, decreased glutathione concentration and reduced triose phosphates.^{338, 340} It seems doubtful that 2,3-DPGM deficiency is a cause of significant clinical disease.

Enolase Deficiency

Enolase catalyzes the conversion of 2-PGA to PEP (Fig. 28.4). Chronic hemolytic anemia associated with erythrocyte enolase deficiency was identified in two sisters.³⁴¹ Ingestion of nitrofurantoin exacerbated the condition, an occurrence not explained by the enzyme deficiency.

Lactate Dehydrogenase Deficiency

LDH catalyzes the terminal reaction in glycolysis, the conversion of pyruvate to lactate (Fig. 28.4). The enzyme is a tetrameric protein composed of H and M subunits. Severe deficiency of LDH in erythrocytes, leukocytes, platelets, and serum of a 65-year-old Japanese man has been reported.³⁴² This individual was homozygous for an autosomal recessively transmitted deficiency of the H subunit of LDH. Although no anemia or evidence of hemolysis was noted, red cells contained a marked increase of glyceraldehyde-3-phosphate, dihydroxyacetone phosphate, and fructose-1,6-diphosphate. This severe LDH deficiency was without effect on red cell integrity.

ABNORMALITIES OF PURINE AND PYRIMIDINE NUCLEOTIDE METABOLISM

Mature RBC are incapable of de novo purine or pyrimidine synthesis, although many enzymes of nucleotide metabolism are present in erythrocytes (Fig. 28.5). The latter are now known to be important for RBC preservation in vitro; and it also is recognized that abnormalities in purine and pyrimidine metabolism are associated with inherited hemolytic disease.

Initial interest in RBC nucleotide metabolism was stimulated by blood bank concerns related to ATP and 2,3-DPG loss during storage of red blood cells. Several studies demonstrated that

P.743

inosine, adenosine, and adenine each could minimize loss of organic phosphates and thereby improve viability of stored blood. These studies defined an important role for purine nucleoside metabolism in maintaining energy pools of stored RBC, and this has had a major impact on the science of transfusion medicine.³⁴³

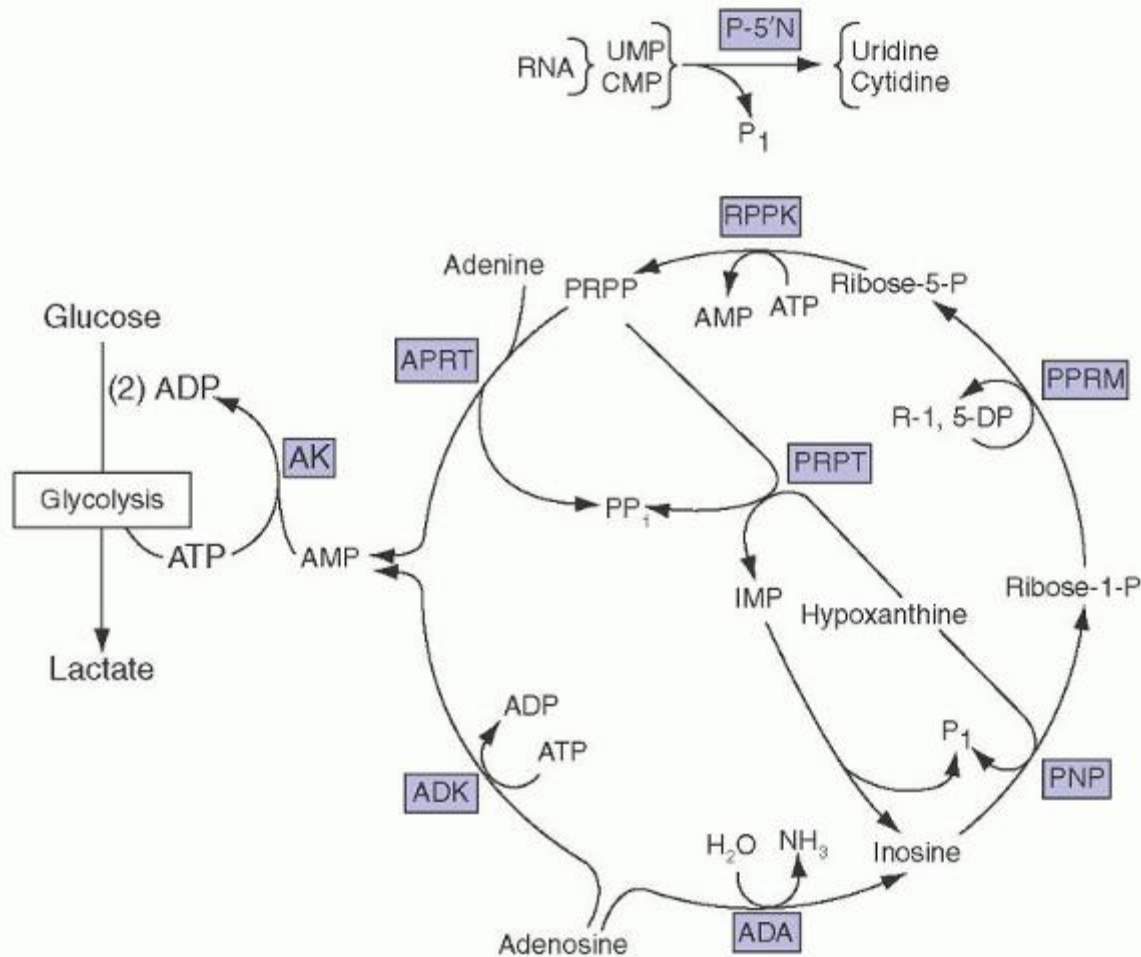

FIGURE 28.5. Schema of purine and pyrimidine metabolism in mature erythrocytes. Enzyme abbreviations: ADA, adenosine deaminase; ADK, adenosine kinase; AK, adenylate kinase; APRT, adenine phosphoribosyltransferase; RPPK, ribopyrophosphoryl kinase; PPRM, pyrophosphoribosyl mutase; PPRT, pyrophosphoribosyl transferase; PNP, purine nucleoside phosphorylase; P5'N pyrimidine 5' nucleotidase. Substrate abbreviations: AMP, adenosine monophosphate; IMP, inosine monophosphate.

In certain immune and metabolic disorders due to inborn errors of purine metabolism, erythrocytes share the same enzymatic deficiency, without any adverse effect on RBC function or viability. The RBC enzyme abnormalities in these cases can serve as a marker of disease in other tissues, and in some cases assay of red cell enzyme activity is used for diagnostic purposes.³⁴⁴ The two most common disorders for which the red cell is used as a biopsy tool are adenosine deaminase (ADA) deficiency associated with severe combined immune deficiency,³⁴⁵ and purine nucleoside phosphorylase deficiency associated with impaired T-cell immunity³⁴⁶ (see below).

Red cell purine and pyrimidine enzyme disorders also have been associated with inherited hemolytic syndromes, and these cases have further identified the important role of nucleotide metabolism in mature erythrocytes. The remainder of this section focuses on the pyrimidine and purine enzyme disorders associated with hemolysis pyrimidine 5' nucleotidase (P5'N) deficiency, ADA excess, and adenylate kinase (AK) deficiency.

Pyrimidine 5' Nucleotidase Deficiency

Ribosomal RNA in normal reticulocytes is degraded to 5' nucleotides. The enzyme P5'N further catalyzes the degradation of cytidine and uridine mononucleotides to inorganic phosphate and the corresponding nucleoside. Whereas the mononucleotides are impermeable to the RBC membrane, after P5'N exposure the nucleosides can passively diffuse from the cell. P5'N thus rids maturing reticulocytes of pyrimidine degradation products of RNA without compromising the purine (adenine) nucleotide pool necessary for energy-dependent reactions. Another enzyme, thymidylate nucleotidase, is thought to catalyze the degradation of thymidine monophosphate in a similar manner. This is supported by the

observation that P5'N-deficient cells exhibit brisk nucleotidase activity when thymidine and deoxyuridine monophosphates are used as substrates.^{347, 348, 349, 350}

Reticulocytes deficient in P5'N accumulate large quantities of cytidine and uridine compounds, increasing the total nucleotide pool to more than five times that present in normal red cells.^{348, 351, 352} Cases of P5'N deficiency formerly were classified as "high ATP syndromes" owing to the erroneous assumption that the large amount of nucleotide within deficient cells was adenine phosphate rather than pyrimidine phosphate.^{353, 354} In addition to the increased nucleotide pool content, elevated levels of GSH³⁵⁵ and decreased activity of ribosephosphate pyrophosphate (PRPP) synthetase are consistent but unexplained findings of P5'N deficiency.^{353, 354} As a consequence of impaired ribosomal degradation, intracellular aggregates form in P5'N-deficient cells, and these appear as basophilic stippling on Wright-stained peripheral blood smears.

The gene encoding P5'N is located on chromosome 7p15-p14.³⁵⁶ Over 20 different mutations in the gene for P5'N have been identified in 30 different families with this enzyme deficiency.^{357, 358}

P5'N deficiency is a rare RBC defect, yet it is the most common enzyme abnormality affecting nucleotide metabolism.^{259, 350, 357, 358} Over 60 patients representing a wide geographic distribution have been reported, with a predisposition for people of Mediterranean, Jewish, and African ancestry.^{350, 357, 358, 359} In all families studied, the disorder follows an autosomal recessive mode of transmission. Family members who are biochemical heterozygotes are hematologically normal, whereas homozygotes with less than 5% to 10% normal P5'N activity have lifelong hemolytic anemia associated with splenomegaly and intermittent jaundice. The disorder is characterized by mild to moderate anemia, reticulocytosis, and hyperbilirubinemia. Transfusions usually are not required. Splenectomy is followed by a modest increase in hemoglobin concentration but affords no significant benefit.^{354, 359, 360} There are no associated P5'N abnormalities in platelets or leukocytes. Developmental retardation has been noted.³⁶¹

The possibility of P5'N deficiency as the cause of hemolysis is suggested by the presence of marked basophilic stippling, a unique RBC morphologic feature characteristic of this hemolytic disorder. Definitive diagnosis requires demonstration of decreased RBC nucleotidase activity³⁵⁹ or increased pyrimidine nucleotides in erythrocytes. Normally, RBC nucleotides are almost entirely adenine nucleotides. However, in P5'N deficiency, up to 80% of nucleotide pool may be pyrimidine nucleotides. The latter is the basis for a simple screening test that utilizes ultraviolet spectroscopy to demonstrate a shift in the absorption spectrum of red cell lysates.³⁶⁰

The reason why P5'N deficiency leads to hemolytic anemia is not known, although there have been a variety of proposed mechanisms.^{362, 363} One curious explanation relates to a concomitant decrease in the G6PD activity of P5'N-deficient cells,³⁶⁴ which is associated with decreased pentose phosphate shunt activity and increased incubated Heinz body formation. The mechanism whereby P5'N deficiency affects pentose phosphate shunt activity involves both competitive inhibition of glucose-6-phosphate and noncompetitive inhibition of NADP for G6PD by pyrimidine nucleotides.³⁶⁴ Interestingly, both P5'N and G6PD deficiencies are characterized by hemolytic crises complicating intercurrent infections. Also of interest was the report of a Bangladeshi family which had the genes for both hemoglobin E and P5'N deficiency.³⁶⁵ One individual homozygous for both conditions had a severe hemolytic anemia, while family members homozygous for Hb E were asymptomatic and those homozygous for P5'N had a mild hemolytic anemia. Globin-chain synthetic studies indicated the interaction between these two genotypes was due to decreased Hgb E stability in P5'N-deficient erythrocytes. Since, as described above, the HMP shunt is impaired in P5'N deficiency, it was postulated that the marked hemoglobin instability in enzyme-deficient cells was due to oxidant stresses exerting their effects on Hb E, which normally is mildly unstable.³⁶⁵

P5'N enzyme is readily inactivated by heavy metals such as lead, and it has been proposed that the basophilic stippling in lead poisoning is secondary to acquired P5'N deficiency.^{366, 367} As blood lead levels approach 200 µg/dl packed red cells, P5'N activity decreases to levels comparable to those associated with the homozygous deficiency state, intracellular pyrimidine nucleotides accumulate, and basophilic stippling can be demonstrated.^{348, 367} As in congenital P5'N deficiency, pyrimidine nucleotide accumulation inhibits pentose phosphate shunt activity, further compounding a direct inhibitory action of lead on G6PD.³⁶⁸

Adenosine Deaminase Excess

Adenosine is a common substrate for two different enzymes, adenosine kinase (ADK) and ADA. The Km (adenosine) is much lower for ADK than for ADA, and thus normally metabolism proceeds through ADK with phosphorylation of adenosine to form AMP (Fig. 28.5). In the presence of plasma adenosine, ADK thereby helps maintain the red cell adenine nucleotide pool.^{369, 370} The enzyme ADA catalyzes the deamination of adenosine to form inosine.

Hereditary deficiency of ADA is associated with severe combined immunodeficiency,³⁴⁵ and since the enzyme deficiency also exists in erythrocytes, assay of red cell ADA can be used to diagnose this immune disorder. Red cell adenine nucleotide content is increased in severe ADA deficiency, but this has no adverse effects on RBC, and there is no anemia.^{371, 372}

P.744

Surprisingly, hereditary hemolytic anemia occurs in association with a 60- to 100-fold excess of normal ADA activity,³⁷³ and this has been described in a few families, including a large kindred of English-Irish ancestry and in a Japanese family.³⁷⁴ In these patients with hemolysis and increased RBC-ADA activity, erythrocyte ATP content is reduced.^{373, 374} The decrease in adenine nucleotides presumably occurs because elevated ADA activity, despite the higher K_m for adenosine, effectively competes with normal levels of ADK, thereby producing a "relative" deficiency of the latter enzyme.^{359, 370}

In patients with hemolytic anemia and marked ADA excess, the purified enzyme exhibits normal biochemical properties and the defect appears to be due to excess production of a structurally normal enzyme.^{375, 376, 377} The synthesis of this enzyme is directed by a gene on chromosome 20, and posttranslational modifications result in different tissue isozymes. No specific DNA mutation has been identified to account for increased ADA production in patients with hemolytic anemia.

This rare hemolytic enzymopathy is unique because it is associated with an enzyme excess, and also because it is inherited in an autosomal dominant pattern.^{373, 378} Clinical features include mild to moderate anemia, reticulocytosis, and hyperbilirubinemia. No other tissues share in enzyme excess, and there are no other systemic effects. There are no distinguishing clinical, hematologic, or morphologic features to aid in the diagnosis of this condition. The specific diagnosis can be suspected if red cell ATP levels are low and confirmed by demonstrating increased ADA activity in a hemolysate. Usually no specific therapy is indicated, since most patients have very mild anemia. In contrast to these rare patients with a marked excess of enzyme activity and hemolytic anemia, a much smaller increase in enzyme activity (2- to 4-fold) has been observed in most patients with congenital hypoplastic anemia (Diamond-Blackfan syndrome)^{379, 380} (see Chapter 43).

Adenylate Kinase Deficiency

AK catalyzes the interconversion of adenine nucleotides ($AMP + ATP \rightarrow 2 ADP$) (Fig. 28.5). This is thought to be the only enzyme reaction in mature RBC that can lead to ADP synthesis from AMP, and thus AK would appear to have a critical role in salvaging AMP, and protecting the erythrocyte adenine nucleotide pool.³⁸¹ In erythrocytes, AMP is formed in two reactions: the ADK-mediated phosphorylation of adenosine and the APRT-mediated phosphorylation of PRPP. There are three isozymes: AK1, AK2, and AK3.³⁸² AK 1 is the isozyme in red cells, muscle, and brain.

Hereditary nonspherocytic hemolytic anemia in association with AK deficiency has been described in nine different kindred distributed worldwide.^{381, 383, 384, 385, 386, 387, 388, 389, 390} This is an autosomal recessive disorder and heterozygote-deficient individuals are not affected. A moderate to severe chronic nonspherocytic hemolytic anemia has been reported in almost all homozygous or compound heterozygous enzyme-deficient individuals. Splenectomy sometimes is beneficial.³⁸⁷ Mental retardation has been reported in some cases with severe erythrocyte AK deficiency,^{384, 387, 388, 389} and this may reflect that AK1 is the isozyme in both RBC and brain.

The causal relationship of this enzyme abnormality to hemolysis is not entirely clear, because some individuals with profound AK deficiency have no evidence of hemolysis.³⁸¹ In one sibship, there was congenital hemolytic anemia and less than 1% normal erythrocyte AK activity in an 8-year-old girl, while her brother also had no detectable AK activity, but was hematologically normal.³⁸¹ In another family with AK deficiency, a 4-year-old girl had chronic hemolysis with occasional exacerbations during infections, and occasionally she required RBC transfusions.³⁸⁶ Her RBC had no detectable AK activity, while her parents had half normal activity. In this patient, decreased activity of other phosphotransferases was noted; in particular, PRPP-synthetase activity was reduced, just as in P5'N deficiency. The authors proposed that defects in multiple phosphotransferases may be responsible for the shortened lifespan of AK-deficient RBC.³⁸⁶ The significance of these observations is unknown.

Molecular analysis has revealed the gene defect in six of the known kindred with chronic hemolysis and AK deficiency. In the first case a single nucleotide substitution resulting in an amino acid change (Arg121→Trp) was detected.^{59, 382} Analysis of subsequent probands has revealed other missense mutations,^{388, 390} nonsense mutations,³⁸⁹ and deletion mutations.³⁹⁰

REFERENCES

1. Beutler E. Glucose-6-phosphate dehydrogenase deficiency: a historical perspective. *Blood* 2008;111(1):16-24.

2. Mason PJ, Bautista JM, Gilsanz F. G6PD deficiency: the genotype-phenotype association. *Blood Rev* 2007;21(5):267-283.
3. Beutler E. G6PD deficiency. *Blood* 1994;84(11):3613-3636.
4. Luzzatto L. Glucose 6-phosphate dehydrogenase deficiency: from genotype to phenotype. *Haematologica* 2006;91(10):1303-1306.
5. Carson PE, Flanagan C, Ickes CE, et al. Enzymatic deficiency in primaquine sensitive erythrocytes. *Science* 1956;124:484-485.
6. Alving AS, Johnson CF, Tarlov AR, Brewer GJ, Kellemeier RW and Carson PE. Mitigation of the haemolytic effect of primaquine and enhancement of its action against exoerythrocytic forms of the Chesson strain of *Plasmodium vivax* by intermittent regimens of drug administration. *Bull WHO* 1960;22:621-631.
7. Cappellini MD, Fiorelli G. Glucose-6-phosphate dehydrogenase deficiency. *Lancet* 2008;371(9606):64-74.
8. Kirkman H, Hendrikson E. Sex-linked electrophoretic differences in glucose-6-phosphate dehydrogenase. *Am J Hum Genet* 1963;15:241-258.
9. Pai GS, et al. Localization of loci for hypoxanthine phosphoribosyltransferase and glucose-6-phosphate dehydrogenase and biochemical evidence of nonrandom X chromosome expression from studies of a human X-autosome translocation. *Proc Natl Acad Sci U S A* 1980;77(5):2810-2813.
10. Szabo P, et al. Cytological mapping of the human glucose-6-phosphate dehydrogenase gene distal to the fragile-X site suggests a high rate of meiotic recombination across this site. *Proc Natl Acad Sci U S A* 1984;81(24): 7855-7859.
11. Lyon MF. Gene action in the X-chromosome of the mouse (*mus musculus* L). *Nature* 1961;190:372.
12. Beutler E. The normal human female as a mosaic of X-chromosome activity: studies using the gene for G6PD deficiency as a marker. *Proc Natl Acad Sci U S A* 1962;48:9.
13. Beutler E. Value of genetic variants of glucose-6-phosphate dehydrogenase. *N Engl J Med* 1967;276:389-391.
14. Fialkow PJ. Clonal origin of human tumors. *Biochim Biophys Acta* 1976;458(3):283-321.
15. Fialkow PJ, et al. Acute nonlymphocytic leukemia: expression in cells restricted to granulocytic and monocytic differentiation. *N Engl J Med* 1979;301(1):1-5.
16. Linder D, Gartler SM. Glucose-6-phosphate dehydrogenase mosaicism: utilization as a cell marker in the study of leiomyomas. *Science* 1965;150(692):67-69.
17. Beutler E, West C, Johnson C. Involvement of the erythroid series in acute myeloid leukemia. *Blood* 1979;53(6):1203-1205.
18. Wiggans RG, et al. Probable clonal origin of acute myeloblastic leukemia following radiation and chemotherapy of colon cancer. *Blood* 1978;52(4):659-663.
19. Fialkow PJ, Gartler SM, Yoshida A. Clonal origin of chronic myelocytic leukemia in man. *Proc Natl Acad Sci U S A* 1967;58(4):1468-1471.
20. Adamson JW, et al. Polycythemia vera: stem-cell and probable clonal origin of the disease. *N Engl J Med* 1976;295(17):913-916.
21. Gaetani GF, et al. Primary thrombocythemia: clonal origin of platelets, erythrocytes, and granulocytes in a GdB/GdMediterranean subject. *Blood* 1982;59(1):76-79.
22. Oni SB, Osunkoya BO, Luzzatto L. Paroxysmal nocturnal hemoglobinuria: evidence for monoclonal origin of abnormal red cells. *Blood* 1970;36(2):145-152.
23. Nkhoma ET, et al. The global prevalence of glucose-6-phosphate dehydrogenase deficiency: a systematic review and meta-analysis. *Blood Cells Mol Dis* 2009;42(3):267-278.
24. Bienzle U. Glucose-6-phosphate dehydrogenase deficiency. Part 1: Tropical Africa. *Clin Haematol* 1981;10(3):785-799.
25. Motulsky AG, Vandepitte J, Fraser GR. Population genetic studies in the Congo. I. Glucose-6-phosphate dehydrogenase deficiency, hemoglobin S, and malaria. *Am J Hum Genet* 1966;18(6):514-537.
26. Chinevere TD, et al. Prevalence of glucose-6-phosphate dehydrogenase deficiency in U.S. Army personnel. *Mil Med* 2006;171(9):905-907.

27. Tarlov AR, Brewer G, Carson PE, et al. Primaquine sensitivity. *Arch Intern Med* 1962;109:209-234.
28. Siniscalco M, Bernini L. Favism, thalassemia in Sardinia and their relationship to malaria. *Nature* 1961;190:1179-1180.
29. Stamatoyannopoulos G, Panayotopoulos A, Motulsky AG. The distribution of glucose-6-phosphate dehydrogenase deficiency in Greece. *Am J Hum Genet* 1966;18(3):296-308.
30. Beutler E. Glucose-6-phosphate dehydrogenase deficiency. *N Engl J Med* 1991;324(3):169-174.
31. Oppenheim A, Jury CL, Rund D, et al. G6PD Mediterranean accounts for the high prevalence of G6PD deficiency in Kurdish Jews. *Hum Genet* 1993;91:293-294.
32. Panich V. Glucose-6-phosphate dehydrogenase deficiency. Part 2. Tropical Asia. *Clin Haematol* 1981;10(3):800-814.
33. Chan TK, Todd D. Characteristics and distribution of glucose-6-phosphate dehydrogenase-deficient variants in South China. *Am J Hum Genet* 1972;24(4): 475-484.
34. McCurdy PR, et al. Further studies on glucose-6-phosphate dehydrogenase deficiency in Chinese subjects. *J Lab Clin Med* 1970;75(5):788-797.
35. Nakatsuji T, Miwa S. Incidence and characteristics of glucose-6-phosphate dehydrogenase variants in Japan. *Hum Genet* 1979;51(3):297-305.
36. Lisker R, Linares C, Motulsky AG. Glucose-6-phosphate dehydrogenase Mexico. A new variant with enzyme deficiency, abnormal mobility, and absence of hemolysis. *J Lab Clin Med* 1972;79(5):788-793.
37. Motulsky A. Metabolic polymorphisms and the role of infectious disease in human evolution. *Human Biology* 1961;32:28-62.
38. Luzzatto L. Genetics of red cells and susceptibility to malaria. *Blood* 1979;54(5):961-976.
39. Nagel RL, Roth EF Jr. Malaria and red cell genetic defects. *Blood* 1989;74(4):1213-1221.
40. Luzzatto L, Usanga FA, Reddy S. Glucose-6-phosphate dehydrogenase deficient red cells: resistance to infection by malarial parasites. *Science* 1969;164(881):839-842.
41. Luzzatto L, Sodeinde O, Martini G. Genetic variation in the host and adaptive phenomena in *Plasmodium falciparum* infection. *Ciba Found Symp* 1983;94:159-173.
42. Eckman JR. Glutathione metabolism in malaria infected erythrocytes. *Prog Clin Biol Res* 1984;155:1-12.
43. Roth EF Jr, et al. Pathways for the reduction of oxidized glutathione in the *Plasmodium falciparum*-infected erythrocyte: can parasite enzymes replace host red cell glucose-6-phosphate dehydrogenase? *Blood* 1986;67(3):827-830.
44. Yoshida A, Roth EF Jr, Glucose-6-phosphate dehydrogenase of malaria parasite *Plasmodium falciparum*. *Blood* 1987;69(5):1528-1530.
45. Cohen P, Rosemeyer MA. Human glucose-6-phosphate dehydrogenase: purification of the erythrocyte enzyme and the influence of ions on its activity. *Eur J Biochem* 1969;8(1):1-7.
46. Persico MG, et al. Isolation of human glucose-6-phosphate dehydrogenase (G6PD) cDNA clones: primary structure of the protein and unusual 5' non-coding region. *Nucleic Acids Res* 1986;14(6):2511-2522.
47. Mason P. New insights into G6PD deficiency. *Br J Haematol* 1996;94: 585-591.
48. Martini G, et al. Structural analysis of the X-linked gene encoding human glucose 6-phosphate dehydrogenase. *Embo J* 1986;5(8):1849-1855.
49. Takizawa T, et al. Human glucose-6-phosphate dehydrogenase: primary structure and cDNA cloning. *Proc Natl Acad Sci U S A* 1986;83(12):4157-4161.
50. Beutler E. The genetics of glucose-6-phosphate dehydrogenase deficiency. *Semin Hematol* 1990;27(2):137-164.
51. Yoshida A, Beutler E, Motulsky AG. Human glucose-6-phosphate dehydrogenase variants. *Bull World Health Organ* 1971;45(2):243-253.
52. Beutler E. The molecular biology of enzymes of erythrocyte metabolism. In: *The Molecular Basis of Blood Disease*, Stamatoyannopoulos G, Nienhus AW, Majerus PW, et al. Eds, WB Saunders, Philadelphia 1993.
53. Boyer S, Porter IH, Weilbacher RG. Electrophoretic heterogeneity of glucose-6-phosphate dehydrogenase and its relationship to enzyme deficiency in man. *Proc Natl Acad Sci U S A* 1962;48:1868-1876.

54. Yoshida A. A single amino acid substitution (asparagine to aspartic acid) between normal (B+) and the common Negro variant (A+) of human glucose-6-phosphate dehydrogenase. *Proc Natl Acad Sci U S A* 1967;57:835-840.
55. Reys L, Manso C, Stamatoyannopoulos G. Genetic studies on southeastern Bantu of Mozambique. I. Variants of glucose-6-phosphate dehydrogenase. *Am J Hum Genet* 1970;22(2):203-215.
56. Piomelli S, et al. In vivo lability of glucose-6-phosphate dehydrogenase in GdA- and GdMediterranean deficiency. *J Clin Invest* 1968;47(4):940-948.
57. Morelli A, et al. Biochemical mechanisms of glucose-6-phosphate dehydrogenase deficiency. *Proc Natl Acad Sci U S A* 1978;75(4):1979-1983.
58. McCurdy PR, et al. A Chinese variant of glucose-6-phosphate dehydrogenase. *J Lab Clin Med* 1966;67(3):374-385.
59. Miwa S, Fujii H. Molecular basis of erythroenzymopathies associated with hereditary hemolytic anemia: tabulation of mutant enzymes. *Am J Hematol* 1996;51(2):122-132.
60. Beutler E, Vulliamy TJ. Hematologically important mutations: glucose-6-phosphate dehydrogenase. *Blood Cells Mol Dis* 2002;28(2):93-103.
61. Luzzatto L, Mehta A, Vulliamy T. Glucose-6-phosphate dehydrogenase deficiency, In: Scriver C, et al., eds. *The metabolic and molecular bases of inherited disease*. New York, NY: McGraw Hill, 2001:4517-4553.
62. Mehta A, Mason PJ, Vulliamy TJ. Glucose-6-phosphate dehydrogenase deficiency. *Baillieres Best Pract Res Clin Haematol* 2000;13(1):21-38.
63. Fiorelli G, Martinez di Montemuros F, Cappellini MD. Chronic non-spherocytic haemolytic disorders associated with glucose-6-phosphate dehydrogenase variants. *Baillieres Best Pract Res Clin Haematol* 2000;13(1):39-55.
64. Hirono A, Beutler E. Molecular cloning and nucleotide sequence of cDNA for human glucose-6-phosphate dehydrogenase variant A(-). *Proc Natl Acad Sci U S A* 1988;85(11):3951-3954.
65. Beutler E, et al. Molecular heterogeneity of glucose-6-phosphate dehydrogenase A. *Blood* 1989;74(7):2550-2555.
66. Beutler E. Glucose-6-phosphate dehydrogenase: new perspectives. *Blood* 1989;73(6):1397-1401.
67. Vulliamy TJ, et al. Diverse point mutations in the human glucose-6-phosphate dehydrogenase gene cause enzyme deficiency and mild or severe hemolytic anemia. *Proc Natl Acad Sci U S A* 1988;85(14):5171-5175.
68. De Vita G, et al. Two point mutations are responsible for G6PD polymorphism in Sardinia. *Am J Hum Genet* 1989;44(2):233-240.
69. Jiang W, et al. Structure and function of glucose-6-phosphate dehydrogenase deficient variants in Chinese population. *Hum Genet* 2006;119(5):463-478.
70. Cooper MR, et al. Complete deficiency of leukocyte glucose-6-phosphate dehydrogenase with defective bactericidal activity. *J Clin Invest* 1972;51(4):769-778.
71. Miller DR, Wollman MR. A new variant of glucose-6-phosphate dehydrogenase deficiency hereditary hemolytic anemia, G6PD Cornell: erythrocyte, leukocyte, and platelet studies. *Blood* 1974;44(3):323-331.
72. Schiliro G, et al. Leukocyte function and characterization of leukocyte glucose-6-phosphate dehydrogenase in Sicilian mutants. *Pediatr Res* 1976;10(8): 739-742.
73. Costa E, et al. Neutrophil dysfunction in a case of glucose-6-phosphate dehydrogenase deficiency. *J Pediatr Hematol Oncol* 2002;24(2):164-165.
74. van Bruggen R, et al. Deletion of leucine 61 in glucose-6-phosphate dehydrogenase leads to chronic nonspherocytic anemia, granulocyte dysfunction, and increased susceptibility to infections. *Blood* 2002;100(3):1026-1030.
75. Yoshida A, Stamatoyannopoulos G, Motulsky AG. Negro variant of glucose-6-phosphate dehydrogenase deficiency (A-) in man. *Science* 1967;155(758):97-99.
76. Jacob HS. Mechanisms of Heinz body formation and attachment to red cell membrane. *Semin Hematol* 1970;7(3):341-354.
77. Coetzer T, Zail S. Membrane protein complexes in GSH-depleted red cells. *Blood* 1980;56(2):159-167.

78. Allen DW, Flynn TP, Johnson GJ. Erythrocyte membrane protein changes in glucose-6-phosphate dehydrogenase mutants with chronic hemolytic disease: an example of postsynthetic modification of membrane proteins. *Prog Clin Biol Res* 1982;97:33-43.
79. Allen DW, et al. Membrane polypeptide aggregates in glucose 6-phosphate dehydrogenase-deficient and in vitro aged red blood cells. *J Lab Clin Med* 1978;91(2):321-327.
80. Arese P, DeFlora A. Pathophysiology of hemolysis in glucose-6-phosphate dehydrogenase deficiency. *Semin Hematol* 1990;27(1):1-40.
81. Rifkind RA. Heinz body anemia: an ultrastructural study. II. Red cell sequestration and destruction. *Blood* 1965;26(4):433-448.
82. Tizianello A, et al. Sites of destruction of red cells in G-6-PD deficient Caucasians and in phenylhydrazine treated patients. *Scand J Haematol* 1968;5(2):116-128.
83. Pannacciulli I, et al. Hemolytic effects of standard single dosages of primaquine and chloroquine on G-6-PD-deficient caucasians. *J Lab Clin Med* 1969;74(4):653-661.
84. Au WY, et al. Glucose-6-phosphate dehydrogenase deficiency in female octogenarians, nanogenarians, and centenarians. *J Gerontol A Biol Sci Med Sci* 2006;61(10):1086-1089.
85. Udomratn T, et al. Effects of ascorbic acid on glucose-6-phosphate dehydrogenase-deficient erythrocytes: studies in an animal model. *Blood* 1977;49(3):471-475.

P.745

86. Raupp P, et al. Henna causes life threatening haemolysis in glucose-6-phosphate dehydrogenase deficiency. *Arch Dis Child* 2001;85(5):411-412.
87. Burka E, Weaver Z III, Marks P. Clinical spectrum of hemolytic anemia associated with glucose-6-phosphate dehydrogenase deficiency. *Ann Intern Med* 1966;64:817-825.
88. Shannon K, Buchanan GR. Severe hemolytic anemia in black children with glucose-6-phosphate dehydrogenase deficiency. *Pediatrics* 1982;70(3):364-369.
89. Chan TK, et al. The survival of glucose-6-phosphate dehydrogenase-deficient erythrocytes in patients with typhoid fever on chloramphenicol therapy. *J Lab Clin Med* 1971;77(2):177-184.
90. Constantopoulos A, Economopoulos P, Kandylas J. Fulminant diarrhoea and acute haemolysis due to G.-6-P.D. deficiency in salmonellosis. *Lancet* 1973;1(7818):1522.
91. Hersko C, Vardy PA. Haemolysis in typhoid fever in children with G-6-PD deficiency. *Br Med J* 1967;1(534):214-215.
92. Mengel CE, Metz E, Yancey WS. Anemia during acute infections. Role of glucose-6-phosphate dehydrogenase deficiency in Negroes. *Arch Intern Med* 1967;119(3):287-290.
93. Whelton A, Donadio JV Jr, Elisberg BL. Acute renal failure complicating Rickettsial infections in glucose-6-phosphate dehydrogenase-deficient individuals. *Ann Intern Med* 1968;69(2):323-328.
94. Phillips SM, Silvers NP. Glucose-6 phosphate dehydrogenase deficiency, infectious hepatitis, acute hemolysis, and renal failure. *Ann Intern Med* 1969;70(1):99-104.
95. Salen G, et al. Acute hemolytic anemia complicating viral hepatitis in patients with glucose-6-phosphate dehydrogenase deficiency. *Ann Intern Med* 1966;65(6):1210-1220.
96. Baehner RL, Nathan DG, Castle WB. Oxidant injury of Caucasian glucose-6-phosphate dehydrogenase-deficient red blood cells by phagocytosing leukocytes during infection. *J Clin Invest* 1971;50(12):2466-2473.
97. Gellady AM, Greenwood RD. G-6-PD hemolytic anemia complicating diabetic ketoacidosis. *J Pediatr* 1972;80(6):1037-1038.
98. Glader BE. Role of elevated glucose concentrations in the hemolysis of glucose-6-phosphate dehydrogenase deficient erythrocytes (38474). *Proc Soc Exp Biol Med* 1975;148(1):50-53.

99. Beutler E, Guinto E. Mechanism of stimulation of the hexose monophosphate shunt of erythrocytes by pyruvate. *Enzyme* 1974;18(1):7-18.
100. Szeinberg A, Asher Y, Sheba C. Studies on glutathione stability in erythrocytes of cases with past history of favism or sulfa drug-induced hemolysis. *blood* 1958;13:348-358.
101. Vulliamy T, Luzzatto L. Glucose-6-Phosphate dehydrogenase deficiency and related disorders in blood. In: *Principles and Practice of Hematology*. Handin R, Lux S, Stossel T, eds. Philadelphia, PA: Lippincott, Williams & Wilkins, 2003:1921-1950.
102. Galiano S, et al. Favism in the African type of glucose-6-phosphate dehydrogenase deficiency (A-). *BMJ* 1990;300(6719):236.
103. Kattamis CA, Kyriazakou M, Chaidas S. Favism: clinical and biochemical data. *J Med Genet* 1969;6(1):34-41.
104. Corchia C, et al. Favism in a female newborn infant whose mother ingested fava beans before delivery. *J Pediatr* 1995;127(5):807-808.
105. Mentzer WC, Collier E. Hydrops fetalis associated with erythrocyte G-6-PD deficiency and maternal ingestion of fava beans and ascorbic acid. *J Pediatr* 1975;86(4):565-567.
106. Luisada A. Favism. *Medicine* 1941;20:229-250.
107. Stamatoyannopoulos G, et al. On the familial predisposition to favism. *Am J Hum Genet* 1966;18(3):253-263.
108. Chevion M, et al. The chemistry of favism-inducing compounds. The properties of isouramil and divicine and their reaction with glutathione. *Eur J Biochem* 1982;127(2):405-409.
109. Razin A, et al. The oxidant effect of isouramil on red cell glutathione and its synergistic enhancement by ascorbic acid or 3,4-dihydroxyphenylalanine. Possible relation to the pathogenesis of favism. *Isr J Med Sci* 1968;4(4): 852-857.
110. De Flora A, et al. Favism: disordered erythrocyte calcium homeostasis. *Blood* 1985;66(2):294-297.
111. Maisels MJ. Neonatal jaundice. *Pediatr Rev* 2006;27(12):443-454.
112. Valaes T. Severe neonatal jaundice associated with glucose-6-phosphate dehydrogenase deficiency: pathogenesis and global epidemiology. *Acta Paediatr Suppl* 1994;394:58-76.
113. Kaplan M, Hammerman C. Glucose-6-phosphate dehydrogenase deficiency: a hidden risk for kernicterus. *Semin Perinatol* 2004;28(5):356-364.
114. Kaplan M, et al. PredischARGE bilirubin screening in glucose-6-phosphate dehydrogenase-deficient neonates. *Pediatrics* 2000;105(3 Pt 1):533-537.
115. Kaplan M, Hammerman C, Beutler E. Hyperbilirubinaemia, glucose-6-phosphate dehydrogenase deficiency and Gilbert syndrome. *Eur J Pediatr* 2001;160:195.
116. Kaplan M, Algur N, Hammerman C. Onset of jaundice in glucose-6-phosphate dehydrogenase-deficient neonates. *Pediatrics* 2001;108(4):956-959.
117. Poon MC, et al. G6PD Viangchan: a new glucose 6-phosphate dehydrogenase variant from Laos. *Hum Genet* 1988;78(1):98-99.
118. Tan KL. Phototherapy for neonatal jaundice in erythrocyte glucose-6-phosphate dehydrogenase-deficient infants. *Pediatrics* 1977;59(Suppl 6 Pt 2):1023-1026.
119. Huang CS, et al. Neonatal jaundice and molecular mutations in glucose-6-phosphate dehydrogenase deficient newborn infants. *Am J Hematol* 1996;51(1):19-25.
120. Kaplan M, Hammerman C. Glucose-6-phosphate dehydrogenase-deficient neonates: a potential cause for concern in North America. *Pediatrics* 2000;106(6):1478-1479.
121. Kaplan M, et al. Glucose-6-phosphate dehydrogenase activity in term and near-term, male African American neonates. *Clin Chim Acta* 2005;355(1-2): 113-117.
122. Oyebola DD. Care of the neonate and management of neonatal jaundice as practised by Yoruba traditional healers of Nigeria. *J Trop Pediatr* 1983;29(1):18-22.
123. Slusher TM, et al. Glucose-6-phosphate dehydrogenase deficiency and carboxyhemoglobin concentrations associated with bilirubin-related morbidity and death in Nigerian infants. *J Pediatr* 1995;126(1):102-108.

124. Johnson L, et al. Clinical report from the pilot USA Kernicterus Registry (1992 to 2004). *J Perinatol* 2009;29(Suppl 1):S25-S45.
125. Drew JH, Kitchen WH. Jaundice in infants of Greek parentage: the unknown factor may be environmental. *J Pediatr* 1976;89(2):248-252.
126. Brown AK. Hyperbilirubinemia in black infants. Role of glucose-6-phosphate dehydrogenase deficiency. *Clin Pediatr (Phila)* 1992;31(12):712-715.
127. Valaes T. Pathophysiology of spontaneous neonatal bilirubinemia associated with glucose-6-phosphate dehydrogenase deficiency. *J Pediatr* 1996; 128(6):863-864.
128. Kaplan M, et al. Contribution of haemolysis to jaundice in Sephardic Jewish glucose-6-phosphate dehydrogenase deficient neonates. *Br J Haematol* 1996;93(4):822-827.
129. Kaplan M, et al. Neonatal hyperbilirubinemia in glucose-6-phosphate dehydrogenase-deficient heterozygotes. *Pediatrics* 1999;104(1 Pt 1):68-74.
130. Rattazzi MC, et al. G6PD deficiency and chronic hemolysis: four new mutants-relationships between clinical syndrome and enzyme kinetics. *Blood* 1971;38(2):205-218.
131. BenBassat J, Ben-Ishay D. Hereditary hemolytic anemia associated with glucose-6-phosphate dehydrogenase deficiency (Mediterranean type). *Isr J Med Sci* 1969;5:1053-1059.
132. Corrons J, Feliu E, Pujades MA, et al. Severe glucose-6-phosphate dehydrogenase (G6PD) deficiency associated with chronic hemolytic anemia, granulocyte dysfunction, and increased susceptibility to infections: description of a new molecular variant (G6PD Barcelona). *Blood* 1982;59:428-434.
133. Beutler E. *Red cell metabolism: a manual of biochemical methods*. New York, NY: Grune & Stratton, 1984.
134. Fairbanks V, Beutler E. A simple method for detection of erythrocyte glucose-6-phosphate dehydrogenase (G-6-PD spot test). *Blood* 1962;20:591-601.
135. Brewer G, Tarlov AR, Alving AS. The methemoglobin reduction test for primaquine-type sensitivity of erythrocytes. *JAMA* 1962;180:386-388.
136. Gall J. Studies of glucose-6-phosphate dehydrogenase activity of individual erythrocytes: the methemoglobin elution test for identification of females heterozygous for G6PD deficiency. *Am J Hum Genet* 1965;17:359-368.
137. Brewer G, Zarafonitis CJD. The haemolytic effect of various regimens of primaquine with chloroquine in American Negroes with G6PD deficiency and the lack of an effect of various antimalarial suppressive agents on erythrocyte metabolism. *Bull World Health Organ* 1976;36:303-308.
138. Balinsky D, et al. Glucose-6-phosphate dehydrogenase Johannesburg: a new variant with reduced activity in a patient with congenital non-spherocytic haemolytic anaemia. *Br J Haematol* 1973;25(3):385-392.
139. Corash L, et al. Reduced chronic hemolysis during high-dose vitamin E administration in Mediterranean-type glucose-6-phosphate dehydrogenase deficiency. *N Engl J Med* 1980;303(8):416-420.
140. Hafez M, et al. Improved erythrocyte survival with combined vitamin E and selenium therapy in children with glucose-6-phosphate dehydrogenase deficiency and mild chronic hemolysis. *J Pediatr* 1986;108(4):558-561.
141. Spielberg SP, et al. Improved erythrocyte survival with high-dose vitamin E in chronic hemolyzing G6PD and glutathione synthetase deficiencies. *Ann Intern Med* 1979;90(1):53-54.
142. Johnson GJ, et al. High-dose vitamin E does not decrease the rate of chronic hemolysis in glucose-6-phosphate dehydrogenase deficiency. *N Engl J Med* 1983;308(17):1014-1017.
143. Kappas A, Drummond GS, Valaes T. A single dose of Sn-mesoporphyrin prevents development of severe hyperbilirubinemia in glucose-6-phosphate dehydrogenase-deficient newborns. *Pediatrics* 2001;108(1):25-30.
144. DeSandre GH, et al. The effectiveness of oral tin mesoporphyrin prophylaxis in reducing bilirubin production after an oral heme load in a transgenic mouse model. *Biol Neonate* 2006;89(3):139-146.
145. Meloni T, Forteleoni G, Meloni GF. Marked decline of favism after neonatal glucose-6-phosphate dehydrogenase screening and health education: the northern Sardinian experience. *Acta Haematol* 1992;87(1-2):29-31.

146. Beutler E. Red blood cell enzyme disorders. In: Bern MFF, ed. Hematologic disorders in maternal-fetal medicine. New York, NY: Wiley-Liss, Inc, 1990:199.
147. McCurdy PR, Morse EE. Glucose-6-phosphate dehydrogenase deficiency and blood transfusion. *Vox Sang* 1975;28(3):230-237.
148. Shalev O, Manny N, Sharon R. Posttransfusional hemolysis in recipients of glucose-6-phosphate dehydrogenase-deficient erythrocytes. *Vox Sang* 1993;64(2):94-98.
149. Mimouni F, Shohat S, Reisner SH. G6PD-deficient donor blood as a cause of hemolysis in two preterm infants. *Isr J Med Sci* 1986;22(2):120-122.
150. Kumar P, Sarkar S, Narang A. Acute intravascular haemolysis following exchange transfusion with G-6-PD deficient blood. *Eur J Pediatr* 1994;153(2):98-99.
151. Jaffe ER. Hereditary hemolytic disorders and enzymatic deficiencies of human erythrocytes. *Blood* 1970;35(1):116-134.
152. Beutler E. Effect of flavin compounds on glutathione reductase activity: in vivo and in vitro studies. *J Clin Invest* 1969;48(10):1957-1966.
153. Beutler E, Srivastava SK. Relationship between glutathione reductase activity and drug-induced haemolytic anaemia. *Nature* 1970;226(247):759-760.
154. Loos H, et al. Familial deficiency of glutathione reductase in human blood cells. *Blood* 1976;48(1):53-62.
155. Kamerbeek NM, et al. Molecular basis of glutathione reductase deficiency in human blood cells. *Blood* 2007;109(8):3560-3566.
156. Necheles TF, et al. Homozygous erythrocyte glutathione-peroxidase deficiency: clinical and biochemical studies. *Blood* 1969;33(2):164-169.
157. Necheles TF, Steinberg MH, Cameron D. Erythrocyte glutathione-peroxidase deficiency. *Br J Haematol* 1970;19(5):605-612.
158. Steinberg M, Brauer MJ, Necheles TF. Acute hemolytic anemia associated with erythrocyte glutathione-peroxidase deficiency. *Arch Intern Med* 1970;125(2):302-303.
159. Nishimura Y, et al. Homozygous glutathione-peroxidase deficiency of erythrocytes and leukocytes. *Tohoku J Exp Med* 1972;108(3):207-217.
160. Beutler E, Matsumoto F. Ethnic variation in red cell glutathione peroxidase activity. *Blood* 1975;46(1):103-110.
161. Perona G, et al. In vivo and in vitro variations of human erythrocyte glutathione peroxidase activity as result of cells ageing, selenium availability and peroxide activation. *Br J Haematol* 1978;39(3):399-408.
162. Thomson CD, et al. Selenium concentrations and glutathione peroxidase activities in whole blood of New Zealand residents. *Br J Nutr* 1977;37(3):457-460.
163. Konrad PN, et al. Glutamyl-cysteine synthetase deficiency. A cause of hereditary hemolytic anemia. *N Engl J Med* 1972;286(11):557-561.
164. Prins HK, et al. Congenital nonspherocytic hemolytic anemia, associated with glutathione deficiency of the erythrocytes. Hematologic, biochemical and genetic studies. *Blood* 1966;27(2):145-166.
165. Beutler E, et al. Gamma-glutamylcysteine synthetase deficiency and hemolytic anemia. *Blood* 1990;75(1):271-273.
166. Beutler E, et al. The molecular basis of a case of gamma-glutamylcysteine synthetase deficiency. *Blood* 1999;94(8):2890-2894.
167. Ristoff E, et al. A missense mutation in the heavy subunit of gamma-glutamylcysteine synthetase gene causes hemolytic anemia. *Blood* 2000;95(7):2193-2196.
168. Manu Pereira M, et al. Chronic non-spherocytic hemolytic anemia associated with severe neurological disease due to gamma-glutamylcysteine synthetase deficiency in a patient of Moroccan origin. *Haematologica* 2007;92(11):e102-e105.
169. Boivin P, Galand C. Glutathione synthesis during congenital hemolytic anemia with reduced glutathione deficiency. Congenital erythrocytic glutathione synthetase deficiency? *Nouv Rev Fr Hematol* 1965;5(5):707-720.

170. Corrons JL, et al. Hereditary non-spherocytic haemolytic anaemia due to red blood cell glutathione synthetase deficiency in four unrelated patients from Spain: clinical and molecular studies. *Br J Haematol* 2001;112(2):475-482.
171. Lo SS, Marti HR, Hitzig WH. Hemolytic anemia associated with decreased concentration of reduced glutathione in red cells. *Acta Haematol* 1971;46(1): 14-23.
172. Beutler E, Gelbart T, Pegelow C. Erythrocyte glutathione synthetase deficiency leads not only to glutathione but also to glutathione-S-transferase deficiency. *J Clin Invest* 1986;77(1):38-41.
173. Prchal JT, et al. Hemolytic anemia, recurrent metabolic acidosis, and incomplete albinism associated with glutathione synthetase deficiency. *Blood* 1983;62(4):754-757.
174. Hirono A, et al. Three cases of hereditary nonspherocytic hemolytic anemia associated with red blood cell glutathione deficiency. *Blood* 1996;87(5): 2071-2074.
175. Jellum E, et al. Pyroglutamic aciduria—a new inborn error of metabolism. *Scand J Clin Lab Invest* 1970;26(4):327-335.
176. Skullerud K, et al. The cerebral lesions in a patient with generalized glutathione deficiency and pyroglutamic aciduria (5-oxoprolinuria). *Acta Neuropathol (Berl)* 1980;52(3):235-238.
177. Minnich V, et al. Glutathione biosynthesis in human erythrocytes. I. Identification of the enzymes of glutathione synthesis in hemolysates. *J Clin Invest* 1971;50(3):507-513.
178. Mohler DN, et al. Glutathione synthetase deficiency as a cause of hereditary hemolytic disease. *N Engl J Med* 1970;283(23):1253-1257.
179. Tanaka KR, Zerez CR. Red cell enzymopathies of the glycolytic pathway. *Semin Hematol* 1990;27(2):165-185.
180. Eber SW. Disorders of erythrocyte glycolysis and nucleotide metabolism. In: Handin R, Lux S, Stossel T, eds. *Blood: principles and practice of hematology*. Philadelphia, PA: Lippincott, Williams & Wilkins, 2003:1887-1920.
181. Zanella A, Bianchi P, Fermo E. Pyruvate kinase deficiency. *Haematologica* 2007;92(6):721-723.
182. Zanella A, et al. Pyruvate kinase deficiency: the genotype-phenotype association. *Blood Rev* 2007;21(4):217-231.
183. Tanaka KR, Paglia DE. Pyruvate kinase deficiency. *Semin Hematol* 1971;8(4):367-396.
184. Zanella A, Bianchi P. Red cell pyruvate kinase deficiency: from genetics to clinical manifestations. *Baillieres Best Pract Res Clin Haematol* 2000;13(1):57-81.
185. Fung RH, Keung YK, Chung GS. Screening of pyruvate kinase deficiency and G6PD deficiency in Chinese newborn in Hong Kong. *Arch Dis Child* 1969;44(235):373-376.
186. Bowman H. Pyruvate kinase deficient hemolytic anemia in an Amish isolate. *Am J Hum Genet* 1965;17:1-8.
187. Muir WA, Beutler E, Wasson C. Erythrocyte pyruvate kinase deficiency in the Ohio Amish: origin and characterization of the mutant enzyme. *Am J Hum Genet* 1984;36(3):634-639.
188. Kanno H, et al. Molecular abnormality of erythrocyte pyruvate kinase deficiency in the Amish. *Blood* 1994;83(8):2311-2316.
189. Christensen RD, et al. Pyruvate kinase deficiency as a cause of extreme hyperbilirubinemia in neonates from a polygamist community. *J Perinatol* 2010 Mar;30(3):233-236.
190. Beutler E, Gelbart T. Estimating the prevalence of pyruvate kinase deficiency from the gene frequency in the general white population. *Blood* 2000;95(11):3585-3588.
191. Tani K, et al. Human M2-type pyruvate kinase: cDNA cloning, chromosomal assignment and expression in hepatoma. *Gene* 1988;73(2):509-516.
192. Noguchi T, Inoue H, Tanaka T. The M1- and M2-type isozymes of rat pyruvate kinase are produced from the same gene by alternative RNA splicing. *J Biol Chem* 1986;261(29):13807-13812.
193. Tani K, et al. Human liver type pyruvate kinase: cDNA cloning and chromosomal assignment. *Biochem Biophys Res Commun* 1987;143(2):431-438.
194. Kahn A, et al. The genetic system of the L-type pyruvate kinase forms in man. Subunit structure, interrelation and kinetic characteristics of the pyruvate kinase enzymes from erythrocytes and liver. *Biochim Biophys Acta* 1978;523(1):59-74.

195. Imamura K, Tanaka T. Multimolecular forms of pyruvate kinase from rat and other mammalian tissues. I. Electrophoretic studies. *J Biochem (Tokyo)* 1972;71(6):1043-1051.
196. Takegawa S, Shinohara T, Miwa S. Hemin-induced conversion of pyruvate kinase isozymes in K562 cells. *Blood* 1984;64(3):754-757.
197. Bigley RH, Koler RD. Liver pyruvate kinase (PK) isozymes in a PK-deficient patient. *Ann Hum Genet* 1968;31(4):383-388.
198. Imamura K, et al. Studies on pyruvate kinase (PK) deficiency. II. Electrophoretic, kinetic and immunological studies on pyruvate kinase of erythrocytes and other tissues. *J Biochem (Tokyo)* 1973;74(6):1165-1175.
199. Nakashima K, et al. Characterization of pyruvate kinase from the liver of a patient with aberrant erythrocyte pyruvate kinase, PK Nagasaki. *J Lab Clin Med* 1977;90(6):1012-1020.
200. Zanella A, et al. Red cell pyruvate kinase deficiency: molecular and clinical aspects. *Br J Haematol* 2005;130(1):11-25.
201. Bianchi P, Zanella A. Hematologically important mutations: red cell pyruvate kinase (Third update). *Blood Cells Mol Dis* 2000;26(1):47-53.
202. Baronciani L, Beutler E. Analysis of pyruvate kinase-deficiency mutations that produce nonspherocytic hemolytic anemia. *Proc Natl Acad Sci U S A* 1993;90(9):4324-4327.
203. Lenzner C, et al. Mutations in the pyruvate kinase L gene in patients with hereditary hemolytic anemia. *Blood* 1994;83(10):2817-2822.
204. Christensen RD, et al. Six children with pyruvate kinase deficiency from one small town: molecular characterization of the PK-LR gene. *J Pediatr* 2011;159(4):695-697.
205. Baronciani L, Beutler E. Molecular study of pyruvate kinase deficient patients with hereditary nonspherocytic hemolytic anemia. *J Clin Invest* 1995;95(4):1702-1709.
206. Miwa S. Pyruvate kinase variants characterized by the methods recommended by the International Committee for Standardization in Haematology. *Hemoglobin* 1980;4(5-6):627-633.
207. Miwa S, et al. Seven pyruvate kinase variants characterized by the ICSH recommended methods. *Br J Haematol* 1980;45(4):575-583.
208. Miwa S, et al. Four new pyruvate kinase (PK) variants and a classical PK deficiency. *Br J Haematol* 1975;29(1):157-169.
209. Baronciani L, et al. Study of the molecular defects in pyruvate kinase deficient patients affected by nonspherocytic hemolytic anemia. *Blood Cells Mol Dis* 1995;21(1):49-55.
210. Beutler E, Forman L, Rios-Larain E. Elevated pyruvate kinase activity in patients with hemolytic anemia due to red cell pyruvate kinase "deficiency". *Am J Med* 1987;83(5):899-904.
211. Shinohara K, Tanaka KR. Pyruvate kinase deficiency hemolytic anemia: enzymatic characterization studies in twelve patients. *Hemoglobin* 1980; 4(5-6):611-625.
212. Grimes A, Meisler A, Dacie JV. Hereditary non-spherocytic haemolytic anaemia. A study of red-cell carbohydrate metabolism in twelve cases of pyruvatekinase deficiency. *Br J Haematol* 1964;10:403-411.
213. Oski FA, et al. The role of the left-shifted or right-shifted oxygen-hemoglobin equilibrium curve. *Ann Intern Med* 1971;74(1):44-46.
214. Keitt AS. Pyruvate kinase deficiency and related disorders of red cell glycolysis. *Am J Med* 1966;41(5):762-785.
215. Mentzer WC Jr, et al. Selective reticulocyte destruction in erythrocyte pyruvate kinase deficiency. *J Clin Invest* 1971;50(3):688-699.
216. Nathan D, Oski FA, Sidel VW, et al. Extreme hemolysis and red-cell distortion in erythrocyte pyruvate kinase deficiency. *N Engl J Med* 1965;272:118-123.
217. Nathan DG, et al. Life-span and organ sequestration of the red cells in pyruvate kinase deficiency. *N Engl J Med* 1968;278(2):73-81.
218. Hennekam RC, et al. Hydrops fetalis associated with red cell pyruvate kinase deficiency. *Genet Couns* 1990;1(1):75-79.

219. Ferreira P, et al. Hydrops fetalis associated with erythrocyte pyruvate kinase deficiency. *Eur J Pediatr* 2000;159(7):481-482.
220. Matthay KK, Mentzer WC. Erythrocyte enzymopathies in the newborn. *Clin Haematol* 1981;10(1):31-55.
221. Volpato S, Vigi V, Cattarozzi G. Nonspherocytic haemolytic anaemia and severe jaundice in a newborn with partial pyruvate kinase deficiency. *Acta Paediatr Scand* 1968;57(1):59-64.
222. Oski F, Nathan DG, Sidel VW, et al. Extreme hemolysis and red-cell distortion in erythrocyte pyruvate kinase deficiency. *N Engl J Med* 1964;270: 1023-1030.
223. Tanaka K, Valentine W, Miwa S. Pyruvate kinase (PK) deficiency hereditary nonspherocytic hemolytic anemia. *Blood* 1962;19:267-295.
224. Blacklock HA, Mortimer PP. Aplastic crisis and other effects of the human parvovirus infection. *Clin Haematol* 1984;13(3):679-691.
225. Duncan JR, et al. Aplastic crisis due to parvovirus infection in pyruvate kinase deficiency. *Lancet* 1983;2(8340):14-16.
226. Becker MH, et al. Roentgenographic manifestations of pyruvate kinase deficiency hemolytic anemia. *Am J Roentgenol Radium Ther Nucl Med* 1971;113(3):491-498.
227. Muller-Soyano A, et al. Pyruvate kinase deficiency and leg ulcers. *Blood* 1976;47(5):807-813.
228. Vives-Corrans JL, et al. Hereditary erythrocyte pyruvate-kinase (PK) deficiency and chronic hemolytic anemia: clinical, genetic and molecular studies in six new Spanish patients. *Hum Genet* 1980;53(3):401-408.
229. Wax JR, et al. Pyruvate kinase deficiency complicating pregnancy. *Obstet Gynecol* 2007;109(2 Pt2):553-555.
230. Rider NL, et al. Erythrocyte pyruvate kinase deficiency in an old-order Amish cohort: longitudinal risk and disease management. *Am J Hematol* 2011;86(10):827-834.
231. Salem HH, Van Der Weyden MB, Firkin BG. Iron overload in congenital erythrocyte pyruvate kinase deficiency. *Med J Aust* 1980;1(11):531-532.
232. Nagai H, et al. An autopsy case of pyruvate kinase deficiency anemia associated with severe hemochromatosis. *Intern Med* 1994;33(1):56-59.
233. Rowbotham B, Roeser HP. Iron overload associated with congenital pyruvate kinase deficiency and high dose ascorbic acid ingestion. *Aust N Z J Med* 1984;14(5):667-669.
234. Nathan DG, et al. Studies of erythrocyte spicule formation in haemolytic anaemia. *Br J Haematol* 1966;12(4):385-395.
235. Beutler E. Editorial: why has the autohemolysis test not gone the way of the cephalin flocculation test? *Blood* 1978;51(1):109-110.
236. Hanel HK. Pyruvate kinase in human erythrocytes. *Scand J Haematol* 1969;6(3):173-174.
237. Baronciani L, Beutler E. Prenatal diagnosis of pyruvate kinase deficiency. *Blood* 1994;84(7):2354-2356.
238. Weiden PL, et al. Severe hereditary haemolytic anaemia in dogs treated by marrow transplantation. *Br J Haematol* 1976;33(3):357-362.
239. Morimoto M, et al. Pyruvate kinase deficiency of mice associated with nonspherocytic hemolytic anemia and cure of the anemia by marrow transplantation without host irradiation. *Blood* 1995;86(11):4323-4330.
240. Tanphaichitr VS, et al. Successful bone marrow transplantation in a child with red blood cell pyruvate kinase deficiency. *Bone Marrow Transplant* 2000;26(6):689-690.
241. Tani K, et al. Retrovirus-mediated gene transfer of human pyruvate kinase (PK) cDNA into murine hematopoietic cells: implications for gene therapy of human PK deficiency. *Blood* 1994;83(8):2305-2310.
242. Meza NW, et al. Rescue of pyruvate kinase deficiency in mice by gene therapy using the human isoenzyme. *Mol Ther* 2009;17(12):2000-2009.
243. Altay C, Alper CA, Nathan DG. Normal and variant isoenzymes of human blood cell hexokinase and the isoenzyme patterns in hemolytic anemia. *Blood* 1970;36(2):219-227.
244. Daniele A, et al. Mapping of human hexokinase 1 gene to 10q11—qter. *Hum Hered* 1992;42(2):107-110.
245. Kanno H, Hexokinase: gene structure and mutations. *Baillieres Best Pract Res Clin Haematol* 2000;13(1):83-88.

246. Rijksen G, et al. Generalized hexokinase deficiency in the blood cells of a patient with nonspherocytic hemolytic anemia. *Blood* 1983;61(1):12-18.
247. Beutler E, Dymont PG, Matsumoto F. Hereditary nonspherocytic hemolytic anemia and hexokinase deficiency. *Blood* 1978;51(5):935-940.
248. Valentine WN, et al. Hereditary hemolytic anemia with hexokinase deficiency. Role of hexokinase in erythrocyte aging. *N Engl J Med* 1967;276(1):1-11.
249. Keitt AS. Hemolytic anemia with impaired hexokinase activity. *J Clin Invest* 1969;48(11):1997-2007.
250. Necheles TF, Rai US, Cameron D. Congenital nonspherocytic hemolytic anemia associated with an unusual erythrocyte hexokinase abnormality. *J Lab Clin Med* 1970;76(4):593-602.
251. Siimes MA, Rahiala EL, Leisti J. Hexokinase deficiency in erythrocytes: a new variant in 5 members of a Finnish family. *Scand J Haematol* 1979;22(3):214-218.
252. Board PG, et al. Congenital nonspherocytic hemolytic anemia with an unstable hexokinase variant. *Blood* 1978;51(1):111-118.
253. Magnani M, et al. Hereditary nonspherocytic hemolytic anemia due to a new hexokinase variant with reduced stability. *Blood* 1985;66(3):690-697.
254. Newman P, Muir A, Parker AC. Non-spherocytic haemolytic anaemia in mother and son associated with hexokinase deficiency. *Br J Haematol* 1980;46(4):537-547.
255. Bianchi M, Magnani M. Hexokinase mutations that produce nonspherocytic hemolytic anemia. *Blood Cells Mol Dis* 1995;21(1):2-8.
256. van Wijk R, et al. HK Utrecht: missense mutation in the active site of human hexokinase associated with hexokinase deficiency and severe nonspherocytic hemolytic anemia. *Blood* 2003;101(1):345-347.
257. Rijksen G, Staal GE. Human erythrocyte hexokinase deficiency. Characterization of a mutant enzyme with abnormal regulatory properties. *J Clin Invest* 1978;62(2):294-301.
258. Delivoria-Papadopoulos M, Oski FA, Gottlieb AJ. Oxygen-hemoglobin dissociation curves: effect of inherited enzyme defects of the red cell. *Science* 1969;165(893):601-602.
259. Beutler E. Red cell enzyme defects as nondiseases and as diseases. *Blood* 1979;54(1):1-7.
260. Baughan MA, et al. Hereditary hemolytic anemia associated with glucose-phosphate isomerase (GPI) deficiency—a new enzyme defect of human erythrocytes. *Blood* 1968;32(2):236-249.
261. Arnold H, et al. Glucose phosphate isomerase deficiency with congenital nonspherocytic hemolytic anemia: a new variant (type Nordhorn). II. Purification and biochemical properties of the defective enzyme. *Pediatr Res* 1974;8(1):26-30.
262. Beutler E, et al. Glucosephosphate-isomerase (GPI) deficiency: GPI elyria. *Ann Intern Med* 1974;80(6):730-732.
263. Hutton JJ, Chilcote RR. Glucose phosphate isomerase deficiency with hereditary nonspherocytic hemolytic anemia. *J Pediatr* 1974;85(4):494-497.
264. Valentine WN. Deficiencies associated with Embden-Meyerhof pathway and other metabolic pathways. *Semin Hematol* 1971;8(4):348-366.
265. Kugler W, Lakomek M. Glucose-6-phosphate isomerase deficiency. *Baillieres Best Pract Res Clin Haematol* 2000;13(1):89-101.
266. Paglia DE, et al. Occurrence of defective hexosephosphate isomerization in human erythrocytes and leukocytes. *N Engl J Med* 1969;280(2):66-71.
267. Xu W, Beutler E. The characterization of gene mutations for human glucose phosphate isomerase deficiency associated with chronic hemolytic anemia. *J Clin Invest* 1994;94(6):2326-2329.
268. Fujii H, et al. Hematologically important mutations: molecular abnormalities of glucose phosphate isomerase deficiency. *Blood Cells Mol Dis* 1996;22(2):96-97.
269. Beutler E, et al. Glucosephosphate isomerase (GPI) deficiency mutations associated with hereditary nonspherocytic hemolytic anemia (HNSHA). *Blood Cells Mol Dis* 1997;23(3):402-409.

270. Schroter W, et al. Glucose phosphate isomerase deficiency with congenital nonspherocytic hemolytic anemia: a new variant (type Nordhorn). I. Clinical and genetic studies. *Pediatr Res* 1974;8(1):18-25.
271. Zanella A, et al. The first stable variant of erythrocyte glucose-phosphate isomerase associated with severe hemolytic anemia. *Am J Hematol* 1980;9(1):1-11.
272. Baronciani L, et al. Study of the molecular defects in glucose phosphate isomerase-deficient patients affected by chronic hemolytic anemia. *Blood* 1996;88(6):2306-2310.
273. Yuan PM, et al. A deletion mutation in glucosephosphate isomerase (GPI Denton). *Clin Chim Acta* 1979;92(3):481-489.
274. Van Biervliet JP, et al. A new variant of glucosephosphate isomerase deficiency. *Humangenetik* 1975;30(1):35-40.
275. Whitelaw AG, et al. Congenital haemolytic anaemia resulting from glucose phosphate isomerase deficiency: genetics, clinical picture, and prenatal diagnosis. *J Med Genet* 1979;16(3):189-196.
276. Ravindranath Y, Paglia DE, Warrier I, et al. Glucose phosphate isomerase deficiency as a cause of hydrops fetalis. *N Engl J Med* 1987;316:258-261.
277. Kahn A, et al. Phosphofructokinase (PFK) isozymes in man. I. Studies of adult human tissues. *Hum Genet* 1979;48(1):93-108.
278. Meienhofer MC, et al. Phosphofructokinase in human blood cells. *Blood* 1979;54(2):389-400.
279. Vora S, et al. Isozymes of human phosphofructokinase: identification and subunit structural characterization of a new system. *Proc Natl Acad Sci U S A* 1980;77(1):62-66.
280. Vora S, et al. Assignment of the human gene for muscle-type phosphofructokinase (PFKM) to chromosome 1 (region cen leads to q32) using somatic cell hybrids and monoclonal anti-M antibody. *Somatic Cell Genet* 1982;8(1):95-104.
281. Yamasaki T, et al. Structure of the entire human muscle phosphofructokinase encoding gene: a two-promoter system. *Gene* 1991;104(2):277-282.
282. Nakajima H, et al. Cloning of human muscle phosphofructokinase cDNA. *FEBS Lett* 1987;223(1):113-116.
283. Vaisanen PA, et al. Cloning and characterization of the human muscle phosphofructokinase gene. *DNA Cell Biol* 1992;11(6):461-470.
284. Van Keuren M, et al. Regional assignment of human liver-type 6-phosphofructokinase to chromosome 21q22.3 by using somatic cell hybrids and a monoclonal anti-L antibody. *Hum Genet* 1986;74(1):34-40.
285. Elson A, et al. The structure of the human liver-type phosphofructokinase gene. *Genomics* 1990;7(1):47-56.
286. Levanon D, et al. Construction of a cDNA clone containing the entire coding region of the human liver-type phosphofructokinase. *Biochem Biophys Res Commun* 1987;147(3):1182-1187.
287. Vora S, et al. Regional assignment of the human gene for platelet-type phosphofructokinase (PFKP) to chromosome 10p: novel use of polyspecific rodent antisera to localize human enzyme genes. *Hum Genet* 1983;63(4):374-379.
288. Valentine WN, Paglia DE. Erythrocyte enzymopathies, hemolytic anemia, and multisystem disease: an annotated review. *Blood* 1984;64(3):583-591.
289. Layzer RB, Rowland LP, Ranney H. Muscle phosphofructokinase deficiency. *Trans Am Neurol Assoc* 1967;92:99-101.
290. Tarui S, et al. Enzymatic basis for the coexistence of myopathy and hemolytic disease in inherited muscle phosphofructokinase deficiency. *Biochem Biophys Res Commun* 1969;34(1):77-83.
291. Fujii H, Miwa S. Other erythrocyte enzyme deficiencies associated with non-haematological symptoms: phosphoglycerate kinase and phosphofructokinase deficiency. *Baillieres Best Pract Res Clin Haematol* 2000;13(1): 141-148.
292. Tani K, et al. Phosphofructokinase deficiency associated with congenital nonspherocytic hemolytic anemia and mild myopathy: biochemical and morphological studies on the muscle. *Tohoku J Exp Med* 1983;141(3):287-293.
293. Vora S, et al. Heterogeneity of the molecular lesions in inherited phosphofructokinase deficiency. *J Clin Invest* 1983;72(6):1995-2006.
294. Tarui S, et al. Hereditary and acquired abnormalities in erythrocyte phosphofructokinase activity: the close association with altered 2,3-diphosphoglycerate levels. *Hemoglobin* 1980;4(5-6):581-592.

295. Kahn A, et al. Erythrocyte phosphofructokinase deficiency associated with an unstable variant of muscle phosphofructokinase. *Clin Chim Acta* 1975;61(3):415-419.
296. Waterbury L, Frenkel EP. Hereditary nonspherocytic hemolysis with erythrocyte phosphofructokinase deficiency. *Blood* 1972;39(3):415-425.
297. Etiemble J, et al. A liver-type mutation in a case of pronounced erythrocyte phosphofructokinase deficiency without clinical expression. *Biochim Biophys Acta* 1983;759(3):236-242.
298. Etiemble J, et al. Inherited erythrocyte phosphofructokinase deficiency: molecular mechanism. *Hum Genet* 1980;55(3):383-390.
299. Penhoet E, Rajkumar T, Rutter WJ. Multiple forms of fructose diphosphate aldolase in mammalian tissues. *Proc Natl Acad Sci U S A* 1966;56(4):1275-1282.
300. Izzo P, et al. Human aldolase A gene. Structural organization and tissue-specific expression by multiple promoters and alternate mRNA processing. *Eur J Biochem* 1988;174(4):569-578.
301. Sakakibara M, Mukai T, Hori K. Nucleotide sequence of a cDNA clone for human aldolase: a messenger RNA in the liver. *Biochem Biophys Res Commun* 1985;131(1):413-420.
302. Kukita A, et al. Molecular gene mapping of human aldolase A (ALDOA) gene to chromosome 16. *Hum Genet* 1987;76(1):20-26.
303. Beutler E, et al. Red cell aldolase deficiency and hemolytic anemia: a new syndrome. *Trans Assoc Am Physicians* 1973;86:154-166.
304. Miwa S, et al. Two cases of red cell aldolase deficiency associated with hereditary hemolytic anemia in a Japanese family. *Am J Hematol* 1981;11(4): 425-437.
305. Kreuder J, et al. Brief report: inherited metabolic myopathy and hemolysis due to a mutation in aldolase A. *N Engl J Med* 1996;334(17):1100-1104.
306. Neufeld N, et al. Hemolytic anemia and severe rhabdomyolysis due to compound heterozygous mutations of the gene for erythrocyte/muscle Isozyme of Aldolase: ALDOA(Arg303X/Cys338Tyr). *Blood* 2002;100:225(a).
307. Kishi H, et al. Human aldolase A deficiency associated with a hemolytic anemia: thermolabile aldolase due to a single base mutation. *Proc Natl Acad Sci U S A* 1987;84(23):8623-8627.
308. Takasaki Y, et al. Human aldolase A of a hemolytic anemia patient with Asp-128—Gly substitution: characteristics of an enzyme generated in *E. coli* transfected with the expression plasmid pHAAD128G. *J Biochem (Tokyo)* 1990;108(2):153-157.
309. Yuan PM, Talent JM, Gracy RW. Molecular basis for the accumulation of acidic isozymes of triosephosphate isomerase on aging. *Mech Ageing Dev* 1981;17(2):151-162.
310. McKusick VA. The anatomy of the human genome. *Am J Med* 1980;69(2): 267-276.
311. Daar IO, et al. Human triose-phosphate isomerase deficiency: a single amino acid substitution results in a thermolabile enzyme. *Proc Natl Acad Sci U S A* 1986;83(20):7903-7907.
312. Schneider A, et al. Triosephosphate isomerase deficiency: repetitive occurrence of point mutation in amino acid 104 in multiple apparently unrelated families. *Am J Hematol* 1995;50(4):263-268.
313. Schneider A, Cohen-Solal M. Hematologically important mutations: triosephosphate isomerase. *Blood Cells Mol Dis* 1996;22(1):82-84.
314. Schneider AS. Triosephosphate isomerase deficiency: historical perspectives and molecular aspects. *Baillieres Best Pract Res Clin Haematol* 2000;13(1):119-140.
315. Schneider A, Valentine WN, Hattori M, et al. Hereditary hemolytic anemia with triosephosphate isomerase deficiency. *N Engl J Med* 1965;272:229-235.
316. Mohrenweiser HW, Fielek S. Elevated frequency of carriers for triosephosphate isomerase deficiency in newborn infants. *Pediatr Res* 1982;16(11): 960-963.
317. Valentine W, Schneider AS, Baughan MA, et al. Hereditary hemolytic anemia with triosephosphate isomerase deficiency. *Am J Med* 1966;41:27-41.

318. Harris S, Paglia DE, Jaffe ER, et al. Triosephosphate isomerase deficiency in an adult. *Clin Res* 1970;18:529-530.
319. Hollan S, et al. Hereditary triosephosphate isomerase (TPI) deficiency: two severely affected brothers one with and one without neurological symptoms. *Hum Genet* 1993;92(5):486-490.
320. Hollan S, et al. Search for the pathogenesis of the differing phenotype in two compound heterozygote Hungarian brothers with the same genotypic triosephosphate isomerase deficiency. *Proc Natl Acad Sci U S A* 1997;94(19):10362-10366.
321. Arya R, et al. Prenatal diagnosis of triosephosphate isomerase deficiency. *Blood* 1996;87(11):4507-4509.
322. Pekrun A, et al. Triosephosphate isomerase deficiency: biochemical and molecular genetic analysis for prenatal diagnosis. *Clin Genet* 1995; 47(4):175-179.
323. Valentine WN, et al. Hereditary hemolytic anemia associated with phosphoglycerate kinase deficiency in erythrocytes and leukocytes. A probable X-chromosome-linked syndrome. *N Engl J Med* 1969;280(10):528-534.
324. Konrad PN, et al. Erythrocyte and leukocyte phosphoglycerate kinase deficiency with neurologic disease. *J Pediatr* 1973;82(3):456-460.
325. Chen SH, et al. Phosphoglycerate kinase: an X-linked polymorphism in man. *Am J Hum Genet* 1971;23(1):87-91.
326. Beutler E. PGK deficiency. *Br J Haematol* 2007;136(1):3-11.
327. Dodgson SJ, et al. Erythrocyte phosphoglycerate kinase deficiency: enzymatic and oxygen binding studies. *Aust N Z J Med* 1980;10(6):614-621.
328. Hjelm M, Wadam B, Yoshida A. A phosphoglycerate kinase variant, PGK Uppsala, associated with hemolytic anemia. *J Lab Clin Med* 1980;96(6): 1015-1021.
329. Kraus AP, Langston MF Jr, Lynch BL. Red cell phosphoglycerate kinase deficiency. A new cause of non-spherocytic hemolytic anemia. *Biochem Biophys Res Commun* 1968;30(2):173-177.
330. Svirklys LG, O'Sullivan WJ. Tissue levels of glycolytic enzymes in phosphoglycerate kinase deficiency. *Clin Chim Acta* 1980;108(2):309-315.
331. Miwa S, et al. Phosphoglycerate kinase (PKG) deficiency hereditary nonspherocytic hemolytic anemia: report of a case found in a Japanese family. *Nippon Ketsueki Gakkai Zasshi* 1972;35(4):511-514.
332. Fujii H, et al. A single amino acid substitution (157 Gly—Val) in a phosphoglycerate kinase variant (PGK Shizuoka) associated with chronic hemolysis and myoglobinuria. *Blood* 1992;79(6):1582-1585.
333. Guis MS, Karadsheh N, Mentzer WC. Phosphoglycerate kinase San Francisco: a new variant associated with hemolytic anemia but not with neuromuscular manifestations. *Am J Hematol* 1987;25(2):175-182.
334. Rosa R, et al. A new case of phosphoglycerate kinase deficiency: GK Creteil associated with rhabdomyolysis and lacking hemolytic anemia. *Blood* 1982;60(1):84-91.
335. Harkness D. A new erythrocytic enzyme defect with hemolytic anemia. Glyceraldehyde-3-phosphate dehydrogenase deficiency. *J Lab Clin Med* 1966;68:879-880.
336. Oski F, Whaun J. Hemolytic anemia and red cell glyceraldehyde-3-phosphate dehydrogenase (G-3-PD) deficiency. *Clin Res* 1969;17:427.
337. Rosa R, Gaillardon J, Rosa J. Diphosphoglycerate mutase and 2,3-diphosphoglycerate phosphatase activities of red cells: comparative electrophoretic study. *Biochem Biophys Res Commun* 1973;51(3):536-542.
338. Rosa R, et al. The first case of a complete deficiency of diphosphoglycerate mutase in human erythrocytes. *J Clin Invest* 1978;62(5):907-915.
339. Cartier P, et al. Familial diphosphoglycerate mutase deficiency: hematological and biochemical study. *Nouv Rev Fr Hematol* 1972;12(3):269-287.
340. Travis SF, et al. Study of a kindred with partial deficiency of red cell 2,3-diphosphoglycerate mutase (2,3-DPGM) and compensated hemolysis. *Blood* 1978;51(6):1107-1116.
341. Stefanini M. Chronic hemolytic anemia associated with erythrocyte enolase deficiency exacerbated by ingestion of nitrofurantoin. *Am J Clin Pathol* 1972;58(4):408-414.
342. Kitamura M, et al. Hereditary deficiency of subunit H of lactate dehydrogenase. *Clin Chim Acta* 1971;34(3):419-423.

343. Mollison P. Blood transfusion in clinical medicine, vol. 10. Oxford: Blackwell Scientific Publications, 1997.
344. Glader BE, Sullivan DW. The red blood cell as a biopsy tool. *Clin Haematol* 1981;10(1):209-222.
345. Giblett ER, et al. Adenosine-deaminase deficiency in two patients with severely impaired cellular immunity. *Lancet* 1972;2(7786):1067-1069.
346. Giblett ER, et al. Nucleoside-phosphorylase deficiency in a child with severely defective T-cell immunity and normal B-cell immunity. *Lancet* 1975;1(7914):1010-1013.
347. Paglia DE, Valentine WN, Brockway RA. Identification of thymidine nucleotidase and deoxyribonucleotidase activities among normal isozymes of 5'-nucleotidase in human erythrocytes. *Proc Natl Acad Sci U S A* 1984;81(2):588-592.
348. Paglia DE, et al. Pyrimidine nucleotidase deficiency with active dephosphorylation of dTMP: evidence for existence of thymidine nucleotidase in human erythrocytes. *Blood* 1983;62(5):1147-1149.
349. Swallow DM, et al. Analysis of human erythrocyte 5'-nucleotidases in healthy individuals and a patient deficient in pyrimidine 5'-nucleotidase. *Ann Hum Genet* 1983;47(Pt 1):19-23.
350. Vives-Corrans JL. Chronic non-spherocytic haemolytic anaemia due to congenital pyrimidine 5' nucleotidase deficiency: 25 years later. *Baillieres Best Pract Res Clin Haematol* 2000;13(1):103-118.
351. Ericson A, et al. Erythrocyte nucleotide pattern in two children in a Norwegian family with pyrimidine 5'-nucleotidase deficiency. *Clin Chim Acta* 1983;134(1-2):25-33.
352. Swanson MS, et al. 31P NMR study of erythrocytes from a patient with hereditary pyrimidine-5'-nucleotidase deficiency. *Proc Natl Acad Sci U S A* 1983;80(1):169-172.
353. Valentine WN, et al. Studies on human erythrocyte nucleotide metabolism. II. Nonspherocytic hemolytic anemia, high red cell ATP, and ribosephosphate pyrophosphokinase (RPK, E.C.2.7.6.1) deficiency. *Blood* 1972;39(5):674-684.
354. Valentine WN, et al. Nonspherocytic haemolytic anaemia with increased red cell adenine nucleotides, glutathione and basophilic stippling and ribosephosphate pyrophosphokinase (RPK) deficiency: studies on two new kindreds. *Br J Haematol* 1973;24(2):157-167.
355. Ben-Bassat I, et al. A family with red cell pyrimidine 5'-nucleotidase deficiency. *Blood* 1976;47(6):919-922.
356. Marinaki AM, et al. Genetic basis of hemolytic anemia caused by pyrimidine 5' nucleotidase deficiency. *Blood* 2001;97(11):3327-3332.
357. Zanella A, et al. Hereditary pyrimidine 5'-nucleotidase deficiency: from genetics to clinical manifestations. *Br J Haematol* 2006;133(2):113-123.
358. Chiarelli LR, et al. Hereditary erythrocyte pyrimidine 5'-nucleotidase deficiency: a biochemical, genetic and clinical overview. *Hematology* 2006;11(1):67-72.
359. Paglia DE, Valentine WN. Hereditary and acquired defects in the pyrimidine nucleotidase of human erythrocytes. *Curr Top Hematol* 1980;3:75-109.
360. Valentine WN, et al. Hereditary hemolytic anemia with human erythrocyte pyrimidine 5'-nucleotidase deficiency. *J Clin Invest* 1974;54(4):866-879.
361. Beutler E, et al. Hemolytic anemia due to pyrimidine-5'-nucleotidase deficiency: report of eight cases in six families. *Blood* 1980;56(2):251-255.
362. Paglia DE, et al. Selective accumulation of cytosol CDP-choline as an isolated erythrocyte defect in chronic hemolysis. *Proc Natl Acad Sci U S A* 1983;80(10):3081-3085.
363. Swanson MS, et al. Identification of cytidine diphosphodiesterases in erythrocytes from a patient with pyrimidine nucleotidase deficiency. *Blood* 1984;63(3):665-670.
364. Tomoda A, et al. Hemolytic anemia in hereditary pyrimidine 5'-nucleotidase deficiency: nucleotide inhibition of G6PD and the pentose phosphate shunt. *Blood* 1982;60(5):1212-1218.
365. Rees DC, et al. Interaction of hemoglobin E and pyrimidine 5' nucleotidase deficiency. *Blood* 1996;88(7):2761-2767.
366. Paglia DE, Valentine WN, Dahlgren JG. Effects of low-level lead exposure on pyrimidine 5'-nucleotidase and other erythrocyte enzymes. Possible role of pyrimidine 5'-nucleotidase in the pathogenesis of lead-induced anemia. *J Clin Invest* 1975;56(5):1164-1169.

367. Valentine WN, et al. Lead poisoning: association with hemolytic anemia, basophilic stippling, erythrocyte pyrimidine 5'-nucleotidase deficiency, and intraerythrocytic accumulation of pyrimidines. *J Clin Invest* 1976;58(4): 926-932.
368. Lachant NA, Tomoda A, Tanaka KR. Inhibition of the pentose phosphate shunt by lead: a potential mechanism for hemolysis in lead poisoning. *Blood* 1984;63(3):518-524.
369. Paglia DE, Valentine WN. Red cell nucleotide abnormalities. *Prog Clin Biol Res* 1984;165:213-225.
370. Paglia DE, Valentine WN. Haemolytic anaemia associated with disorders of the purine and pyrimidine salvage pathways. *Clin Haematol* 1981;10(1): 81-98.
371. Cowan MJ, Ammann AJ. Immunodeficiency syndromes associated with inherited metabolic disorders. *Clin Haematol* 1981;10(1):139-159.
372. Meuwissen HJ, Pollara B, Pickering RJ. Combined immunodeficiency disease associated with adenosine deaminase deficiency. Report on a workshop held in Albany, New York, October 1, 1973. *J Pediatr* 1975;86(2):169-181.
373. Valentine WN, et al. Hereditary hemolytic anemia with increased red cell adenosine deaminase (45- to 70-fold) and decreased adenosine triphosphate. *Science* 1977;195(4280):783-785.
374. Miwa S, et al. A case of red-cell adenosine deaminase overproduction associated with hereditary hemolytic anemia found in Japan. *Am J Hematol* 1978;5(2):107-115.
375. Chottiner EG, et al. Erythrocyte adenosine deaminase overproduction in hereditary hemolytic anemia. *Blood* 1989;74(1):448-453.
376. Fujii H, et al. Overproduction of structurally normal enzyme in man: hereditary haemolytic anaemia with increased red cell adenosine deaminase activity. *Br J Haematol* 1982;51(3):427-430.
377. Fujii H, Miwa S, Suzuki K. Purification and properties of adenosine deaminase in normal and hereditary hemolytic anemia with increased red cell activity. *Hemoglobin* 1980;4(5-6):693-705.
378. Paglia D, Valentine WN, Tartaglia AP, et al. Perturbations in erythrocyte adenine nucleotide metabolism: a dominantly inherited hemolytic disorder with implications regarding normal mechanisms of adenine nucleotide preservation. *Blood* 1976;48:959.
379. Glader BE, Backer K, Diamond LK. Elevated erythrocyte adenosine deaminase activity in congenital hypoplastic anemia. *N Engl J Med* 1983;309(24):-1486-1490.
380. Glader BE, Backer K. Elevated red cell adenosine deaminase activity: a marker of disordered erythropoiesis in Diamond-Blackfan anaemia and other haematologic diseases. *Br J Haematol* 1988;68(2):165-168.
381. Beutler E, et al. Metabolic compensation for profound erythrocyte adenylate kinase deficiency. A hereditary enzyme defect without hemolytic anemia. *J Clin Invest.* 1983;72(2):648-655.
382. Matsuura S, et al. Human adenylate kinase deficiency associated with hemolytic anemia. A single base substitution affecting solubility and catalytic activity of the cytosolic adenylate kinase. *J Biol Chem* 1989;264(17):10148-10155.
383. Szeinberg A, et al. Hereditary deficiency of adenylate kinase in red blood cell. *Acta Haematol* 1969;42(2):111-126.
384. Boivin P, et al. A new erythroenzymopathy: congenital non-spherocytic hemolytic anemia and hereditary erythrocytic adenylate kinase deficiency. *Presse Med* 1971;79(6):215-218.
385. Miwa S, et al. Red cell adenylate kinase deficiency associated with hereditary nonspherocytic hemolytic anemia: clinical and biochemical studies. *Am J Hematol* 1983;14(4):325-333.
386. Lachant NA, et al. Hereditary erythrocyte adenylate kinase deficiency: a defect of multiple phosphotransferases? *Blood* 1991;77(12):2774-2784.
387. Toren A, et al. Congenital haemolytic anaemia associated with adenylate kinase deficiency. *Br J Haematol* 1994;87(2):376-380.
388. Quattieri A, et al. Severe erythrocyte adenylate kinase deficiency due to homozygous A ->G substitution at codon 164 of human AK1 gene associated with chronic haemolytic anaemia. *Br J Haematol* 1997;99(4):770-776.
389. Bianchi P, et al. A case of complete adenylate kinase deficiency due to a nonsense mutation in AK-1 gene (Arg 107 -> Stop, CGA -> TGA) associated with chronic haemolytic anaemia. *Br J Haematol* 1999;105(1):75-79.

390. Vives-Corrons JL, et al. Red cell adenylate kinase deficiency. Molecular study of three new mutations (118 G→A, 190 G→A, and GAC deletion) associated with nonspherocytic hemolytic anemia. *Blood* 2003;102:353-356.

Chapter 29 Autoimmune Hemolytic Anemia

> Table of Contents > Part IV - Disorders of Red Cells > Section 3 - Hemolytic Anemia > Chapter 29 - Autoimmune Hemolytic Anemia

Chapter 29

Autoimmune Hemolytic Anemia

Richard C. Friedberg

Vandita P. Johari

CLASSIFICATION

In autoimmune hemolytic anemia (AIHA), pathologic antibodies (autoantibodies) attach to and lead to the destruction (hemolysis) of endogenous erythrocytes (red blood cells, RBCs) resulting in anemia. By definition, both autoantibodies and associated RBC consumption must be identified. AIHA is readily subclassified according to the characteristic temperature activity of the responsible antibodies (Table 29.1). Cold-active antibodies typically have little, if any, activity at body temperature but have greater affinity for RBCs as the temperature decreases toward 0°C. Conversely, warm-active antibodies have their greatest affinity at 37°C. Generally speaking, cold-active antibodies are typically IgM, fix complement, and lead to immediate intravascular RBC destruction or hepatic-mediated clearance. In contrast, warm-active antibodies are typically IgG, may or may not fix complement, and primarily lead to RBC loss by splenic-mediated clearance of sensitized cells. Patients who express both (mixed) cold- and warm-active antibodies are particularly troublesome clinically because of the dual impact from severe RBC destruction and characteristically poor response to therapy.¹ Drug-induced immune hemolytic anemia (DI-IHA) is caused by warm-active antibodies that may be clinically and serologically indistinguishable from the idiopathic warm autoimmune type (α -methyl-dopa type), or may be dependent on the presence of the drug in serologic studies to demonstrate attachment of the antibody to the RBC. The clinical spectrum of drug-induced antibody attachment to RBCs ranges from asymptomatic positive serologic studies to life-threatening massive hemolysis.² Finally, a different type of immune-mediated hemolytic anemia can occur as a complication of organ transplantation. Because the antibodies are generated from donor-derived lymphocytes, the disorder is not truly of “auto”-immune origin, but can be thought of as a graft-versus-host disorder.

Etiology of the Immune Response in Autoimmune Hemolytic Anemia

Immunologic tolerance is a state in which the individual is incapable of developing an immune response to a specific antigen. Self-tolerance refers to lack of responsiveness to an individual's own (self) antigens, which is the normal state. Autoimmunity results from a loss of self-tolerance leading to T-cells or antibodies reacting against self-antigens and the consequent tissue injury. In AIHA, autoantibodies are directed against targets on the individual's own RBCs (“self-antigens”), leading to their enhanced clearance through F_c-receptor-mediated phagocytosis (“extravascular hemolysis”) or complement-mediated breakdown (“intravascular hemolysis”). AIHA may be in large part due to self-reactive antibodies against erythrocyte band 3, an anion transporter found in the RBC membrane that is involved in RBC senescence.^{3, 4}

Central Tolerance

Central tolerance refers to the normal deletion of self-reactive T- and B-lymphocyte clones during their maturation in the central lymphoid organs (thymus for T-cells; bone marrow for B-cells).⁵ Central tolerance prevents widespread autoimmunity by preferentially selecting nonautoreactive (i.e., “normal”) T-cells for circulation into the periphery (“intrathymic negative selection”). Central tolerance is not complete, and a population of T-cells with intermediate avidity for self-antigens invariably escapes into the circulation. Under certain conditions these cells can become activated and lead to organ-specific or systemic autoimmune disease.^{6, 7}

Peripheral Tolerance

The mechanisms by which self-reactive T-cells that escape intrathymic negative selection and are deleted in the peripheral tissues constitute peripheral tolerance, including anergy, suppression by regulatory T-cells, and clonal deletion by activation-induced cell death (see Fig. 29.1).

Energy refers to prolonged or irreversible functional inactivation of lymphocytes. Activation of antigen-specific T-cells requires two signals: (i) recognition of peptide antigen in association with self-MHC (major histocompatibility complex) molecules on the surface of antigen-presenting cells and (ii) a set of costimulatory signals provided by antigen-presenting cells (the co-stimulators B7-1 and B7-2). In the absence of costimulators, a negative signal is delivered, and the T-lymphocyte becomes anergic. Anergic lymphocytes cannot be activated even if the relevant antigen is presented by antigen-presenting cells (e.g., dendritic cells) that can deliver co-stimulation. Anergy also affects B-cells as they encounter antigen in the absence of

P.747

specific helper T-cells. They become unable to respond to subsequent antigenic stimulation and may be excluded from lymphoid follicles.⁶

TABLE 29.1 CLASSIFICATION OF IMMUNE HEMOLYTIC ANEMIAS

Cold-active antibodies

Cold agglutinin disease (CAD)

Primary or idiopathic Secondary

Lymphoproliferative diseases Autoimmune disorders Infections

Mycoplasma pneumoniae Infectious mononucleosis Other viruses

Paroxysmal cold hemoglobinuria (PCH)

Syphilis

Measles, mumps, other viruses

Mixed cold- and warm-active antibodies

Warm-active antibodies

Idiopathic autoimmune hemolytic anemia Secondary autoimmune hemolytic anemia

Lymphoproliferative disorders

Autoimmune and immunodeficiency disorders Malignancy

Viral infections

Drug-induced immune hemolytic anemia (DI-IHA)

Drug adsorption type (penicillin)

Neoantigen type (quinidine/stibophen)

Autoimmune type (α -methyldopa)

Nonimmune type (first-generation cephalosporins)

Transplant-associated hemolytic anemia

Hematopoietic stem cell transplant

Minor ABO group mismatch

Major ABO group mismatch

Passive antibody transfer

Solid organ transplant

Passenger lymphocyte syndrome

Passive antibody transfer

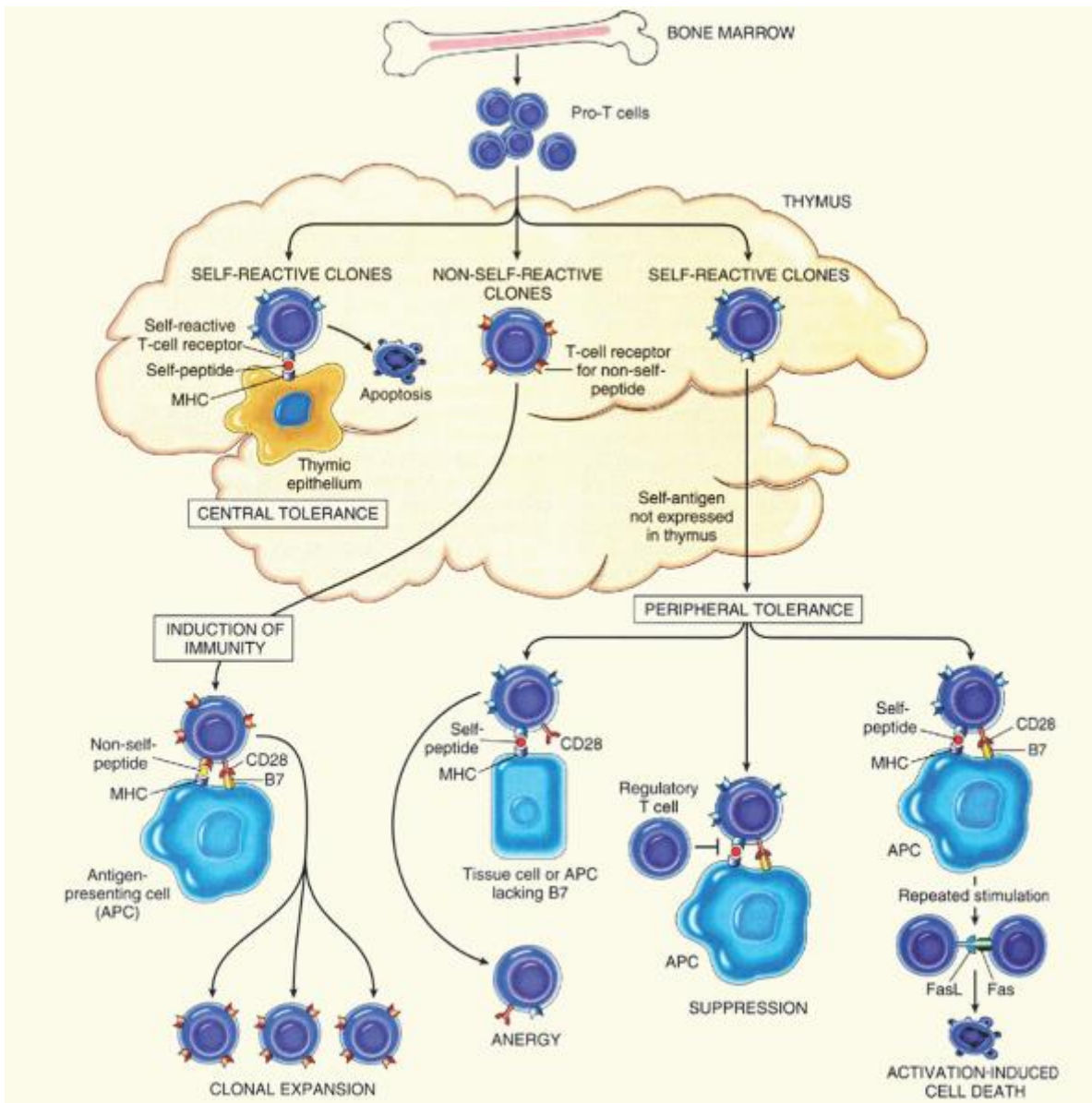

FIGURE 29.1. Schematic illustration of the mechanisms involved in central and peripheral tolerance. The principal mechanisms of tolerance in $CD4^+$ T-cells are shown. APC: antigen-presenting cell. (Used with permission from Abbas AK, Diseases of immunity. In: Kumar V, Abbas A, Fausto N, eds. Robbins and Cotran pathologic basis of disease, 7th ed. Philadelphia, PA: Elsevier Saunders, 2005:223-225.)

Suppression by regulatory T-cells involves $CD4^+$ cells that co-express CD25, the α chain of the interleukin-2 (IL-2) receptor, but some $CD4^+$ cells that lack CD25 may also induce peripheral tolerance by suppression. These T-cells can suppress (inhibit) lymphocyte activation and effector functions in part by the secretion of cytokines such as interleukin-10 (IL-10) and transforming growth factor- β (TGF- β). However, the precise mechanism of their action is unknown.

Clonal deletion by activation-induced cell death refers to the process by which $CD4^+$ T-cells that are activated by self-antigens may receive signals that cause apoptosis. Lymphocytes express Fas (CD95), a member of the tumor necrosis factor (TNF)-receptor family, and activated lymphocytes express FasL, a membrane protein that is structurally homologous to the cytokine TNF. The engagement of Fas by FasL induces apoptosis of activated autoreactive T-cells. Self-antigens that are abundant in peripheral tissues cause repeated and persistent stimulation of self-antigen-specific T-cells, leading eventually to their elimination via Fas-mediated apoptosis. FasL on T-cells engaging Fas on the B-cells may also delete self-reactive B-cells.⁶

Factors Affecting Initiation of Autoimmunity

Autoimmunity can be affected by a number of different factors, including the nature of the autoantigens, genetic associations, and environmental factors. In AIHA, autoantigenic T-cell epitopes have been mapped for the RhD autoantigen.⁸ Although these autoantigenic sites may be a potential target for novel therapeutic interventions, the precise mechanism of disease initiation remains unclear. In addition, MHC class I and class II genes may predispose individuals to certain types of autoimmune disease. For example, the human HLA-DQ-6 molecule has been associated with AIHA. However, the genetic association is multifactorial as with most other autoimmune diseases. Finally, inflammatory stimuli such as viral and bacterial infections have

P.748

been implicated as environmental triggers of autoimmunity, possibly because of antigenic mimicry leading to tolerance breakdown, i.e., environmental or infectious agents may have molecular structures similar to self-antigens. Other possible mechanisms involve production of interferon γ during viral infection that causes up-regulation of F_cRI . Alternatively, viral infection may cause a change in the expression pattern of F_c receptors as a result of transcriptional activation or other mechanisms (discussed further under section "IgG-Mediated Red Blood Cell Destruction").⁹

Mechanism of Immune-mediated Red Blood Cell Lysis

The most important features of RBC destruction by IgM and IgG antibodies are summarized in Table 29.2.

IgM-mediated Red Blood Cell Destruction

Destruction of erythrocytes sensitized with IgM antibodies is mediated by the complement system, either directly by cytolysis or indirectly via interaction of RBC-bound activation and degradation fragments of C3 with specific receptors on reticuloendothelial cells, principally liver macrophages (Kupffer cells).

The pentameric structure of IgM enables efficient complement activation. High-titer IgM antibodies can cause direct intravascular hemolysis by generating the cytolytic membrane attack complex (MAC) of complement on the RBC surface. With sufficient antibody density, complement activation may be robust enough to overwhelm the inhibitory activity of the complement-regulatory proteins DAF (CD55) and MIRL (CD59) on the RBC surface and result in hemolysis.¹⁰ However, in most clinical situations, IgM antierythrocyte antibodies are present in sublytic quantities. Under these conditions, DAF (CD55) and MIRL (CD59) are able to prevent direct RBC lysis. Nonetheless, some C3b is deposited on the RBC surface as a consequence of the IgM-induced complement activation, and interactions of C3b and its ligand iC3b with their specific complement receptors (CR) on liver macrophages (Kupffer cells) are ultimately responsible for the immune destruction of RBCs under sublytic conditions. Table 29.3 summarizes the characteristics of various complement receptors.^{10, 11, 12}

Although ligation of erythrocyte-bound C3b to CR1 on Kupffer cells may mediate some of the clearance, interaction between RBC-bound iC3b and macrophage CR3 is probably the principal mediator of extravascular destruction of complement-sensitized erythrocytes. Clearance of the complement-sensitized RBCs is likely mediated by phagocytosis, because the liver lacks the unique anatomy of the spleen and is thus unable to sequester cells. Once RBC-bound iC3b has been converted to C3dg (ligand for CR2), the RBCs are no longer subject to immune destruction because phagocytic cells do not express the specific receptor for C3dg. Thus, erythrocytes bearing only C3dg have a normal life span.^{13, 14}

TABLE 29.2 RED CELL DESTRUCTION BY IgM AND IgG ANTIBODIES

Antibody	Extravascular			Complement Dependence	Hemoglobinuria	Bilirubinemia	Specificity of Antiglobulin Test
	Intravascular Clearance	Liver Clearance	Spleen Clearance				
IgM Low-titer ^a	+	+	-	+	±	+	Complement
IgM High-titer ^a	+	-	-	+	+	+	Complement
IgG Low-	-	-	+	-	-	+	Immunoglobulin

titer ^b							
IgG	-	±	+	-	±	+	Immunoglobulin
High-titer ^b							lin

^a Anti-A or anti-B blood group antibodies are examples of IgM antibodies that can be present at low or high concentrations.

^b Anti-Rh₀(D) is an example of an IgG antibody that can be present at low or high concentration.

IgG-mediated Red Blood Cell Destruction

IgG is a relatively ineffective initiator of activation of the classical complement pathway. Consequently, direct complement-mediated cytolysis of RBCs induced by IgG antibodies is unusual (a notable exception is the D-L antibody of paroxysmal cold hemoglobinuria [PCH]). In the absence of complement activation, clearance of IgG-sensitized erythrocytes is primarily splenic. Two distinct processes appear to be involved. First, binding to F_c receptors expressed by tissue macrophages in the red pulp of the spleen can mediate direct and complete phagocytosis. Second, partial phagocytosis, in which the phagocytes remove a portion of the membrane, results in a decrease in the surface area-to-volume ratio and the consequent generation of spherocytes, the classic morphologic hallmark of immune hemolytic anemia. The loss of deformability as a consequence of spherocyte formation results in sequestration of the abnormal RBCs in the red pulp because the consequent rigidity limits their ability to traverse the splenic cords into the sinuses. The trapped spherocytes are vulnerable to phagocytosis by macrophages that are found in abundance in the splenic cords. In addition, the life span of the sequestered RBCs is shortened by the unfavorable metabolic environment found in the splenic cords (splenic conditioning). Once trapped, RBC destruction is complete within minutes.

The liver clears IgG-coated RBCs less efficiently than the spleen. Nevertheless, the liver plays a clinically significant role in RBC destruction. The quantity of antibody fixed to the RBC roughly correlates with the site of destruction (smaller amounts of antibody lead mainly to splenic sequestration whereas larger amounts of antibody lead to increased sequestration within the liver).^{15, 16} The more rapid clearance of RBCs sensitized with a higher density of IgG antibodies and the shift in clearance from the spleen to the liver are due to complement activation.¹⁶ Although IgG alone can mediate RBC clearance, the concomitant presence of RBC-bound C3 fragments greatly enhances the rate of immune-mediated destruction.

Phagocytosis of IgG-coated RBCs occurs in the spleen and is mediated by surface receptors for the F_cγ region of the IgG molecule. There are three different classes of F_cγ receptors. F_cγRI mediates in vitro cytotoxic activity. F_cγRII inhibits B-lymphocyte and mast-cell activation. F_cγRIII is responsible for phagocytosis, endocytosis, and antibody-dependent cell-mediated cytotoxicity and therefore plays a key role in hemolysis. The characteristics of F_cγR are summarized in Table 29.4.

Of the four subclasses of IgG, IgG₃ has the highest affinity for the F_cγR and therefore is most efficient at causing extravascular

P.749

hemolysis (IgG₃ > IgG₁ > IgG₄ >>> IgG₂).^{17, 18} The critical role of F_cγ receptors in immune destruction in vivo is further demonstrated by the therapeutic approach to management of AIHA and immune thrombocytopenic purpura (ITP). Treatment with corticosteroids, intravenous IgG (IVIg), anti-D, and/or splenectomy is aimed at reducing the capacity of reticuloendothelial cells to mediate immune clearance of IgG-sensitized RBCs.¹⁹ Administration of monoclonal antibody 2.4G2 in mice, which binds to and blocks mouse F_cγRII and F_cγRIII, allows rapid recovery after induction of AIHA, suggesting that alteration of the balance of stimulatory to inhibitory F_cγ receptors has a marked effect on disease progression and susceptibility. Understanding the detailed structure of the F_cγ receptors may lead to the development of novel therapeutic strategies. For example, molecules that inhibit the binding of the F_cγR to an IgG-coated RBC or those that might inhibit the F_cγ receptor signaling at the different steps leading to phagocytosis may be useful therapeutic tools. Treatments that decrease expression of the activating F_cγ receptor or increase expression of the inhibitory F_cγ receptor may also be effective.⁹

TABLE 29.3 CHARACTERISTICS OF COMPLEMENT RECEPTORS

Receptor	Characteristics	Complement Ligand	Cellular Distribution	Function
CR1 (CD35)	210-330 kDa Four allotypes Single-chain glycoprotein 30 SCRs	C3b (high affinity) C4b iC3b (weak affinity)	RBCs; neutrophils; monocytes; macrophages; B- and some T-cells, follicular dendritic cells; Langerhans cells; Kupfer phagocyte CR1 cells	Regulates C3, C4, and C5 convertase of classic and alternative pathways of complements; factor 1 cofactor, RBC CR1, phagocyte CR1
CR2 (CD21)	145 kDa; integral membrane glycoprotein 15 SCRs	C3dg, C3d	B-cells; follicular dendritic cells	Immune modulation; cellular receptor for the Epstein-Barr virus
CR3 (CD11b/CD18)	165 kDa (CD11b); 95 kDa (CD18); heterodimer	iC3b	Neutrophils; monocytes; macrophages; NK cells; cytotoxic T-cells	Adherence and phagocytosis of opsonized RBCs
CR4 (CD11c/CD18)	150 kDa (CD11c); 95 kDa (CD18); heterodimer	iC3b	Neutrophils; monocytes; macrophages; NK cells; cytotoxic T-cells	Undefined

RBCs, red blood cells; SCR, short consensus repeat.

TABLE 29.4 CHARACTERISTICS OF F_cγ RECEPTORS

Receptor	Characteristics	Affinity for IgG	Cellular Distribution	Function
F _c γRI (CD64)	72 kDa; integral membrane glycoprotein IgG	High (1-3 × 10 ⁻⁸ L/M)	Monocytes; tissue macrophages; neutrophils	Binds monomeric IgG interferon-γ stimulated ADCC and resetting of IgG-coated RBCs; not essential for phagocytosis
F _c γRII (CDw32)	40 kDa; integral membrane glycoprotein	Low (2 × 10 ⁻⁵ L/M)	Monocytes; tissue macrophages; neutrophils; platelets; B-cells	Binds aggregated IgG; mediates ADCC; weak mediator of resetting; important for phagocytosis
F _c γRIII (CD16)	50-80 kDa; both integral membrane (F _c γRIIIa) and glycosyl phosphatidylinositol-anchored (F _c γRIIIb) forms	Low (5 × 10 ⁻⁵ L/M)	Neutrophils (F _c γRIIIb); tissue macrophages; NK cells (F _c γRIIIa)	Binds aggregates IgG; important for clearance of IgG-sensitized RBCs

ADCC, antibody-dependent cell-mediated cytotoxicity; NK, natural killer; RBCs, red blood cells.

Laboratory Diagnosis

Two criteria must be met to diagnose AIHA: clinical or laboratory evidence of hemolysis and serologic evidence of an autoantibody.

Common Laboratory Features

The basic tests to evaluate hemolysis include a complete blood count (CBC) with peripheral smear, bilirubin, lactate dehydrogenase (LDH, particularly isoenzyme 1), haptoglobin, and urine hemoglobin or hemosiderin. Universal signs of hemolysis include decreased serum hemoglobin and hematocrit, increased serum LDH and unconjugated bilirubin, and

polychromasia and reticulocytosis given adequate hematopoietic reserve. Haptoglobin is typically reduced, although sequential levels should be assessed because the protein is an acute-phase reactant and thereby dependent on both hepatic function and systemic stress. Intravascular hemolysis further manifests with increased free hemoglobinemia, increased hemoglobinuria, hemosiderinuria, methemalbuminemia, and decreased serum haptoglobin. Hemoglobinemia is usually evident in the specimen collection tube as a distinctly red- or pink-tinged serum or plasma. Hemolysis in AIHA can be either intravascular or extravascular. Typically, intravascular hemolysis is rapid and aggressive, whereas extravascular hemolysis is milder. The peripheral blood smear may reveal spherocytes in warm AIHA or RBC agglutination in cold AIHA.

Serologic Investigation

The demonstration of RBC surface-bound immunoglobulin or evidence of complement fixation supports the diagnosis of immunemediated RBC destruction. IgM-coated RBCs may spontaneously agglutinate because the pentameric antibody can directly cross-link RBCs. The capability for IgM antibodies to agglutinate saline-suspended RBCs without additional reagents led to the traditional terminology of “complete” antibodies. In contrast, IgG antibodies typically require antihuman globulin (AHG) as a co-factor to agglutinate saline-suspended RBCs and are thus termed “incomplete” antibodies.

P.750

The explanation for this serologic difference lies in the physical properties of the RBCs and the antibody molecules involved. Erythrocytes have a strong net negative surface charge (“zeta potential”) produced by the sialoglycoprotein coat, such that the shortest separation attainable between two RBCs is approximately 18 nm. Other factors may also play a role in maintaining the separation distance, such as water that is tightly bound to the surface of the RBCs. IgM molecules, with their large pentameric structure, create a 30-nm distance between adjacent binding sites and can therefore bridge two RBCs. The smaller IgG can accommodate a span of only 12 nm between antigen-recognition sites and thus usually cannot lead to agglutination alone.²⁰ Exogenous AHG can bridge IgG molecules, which explains the term “incomplete” above. However, some IgG antibodies can indeed agglutinate RBCs (e.g., anti-A, anti-B, and anti-M), revealing the influence on agglutination of the number of antigen sites per RBC²¹ and how far the antigenic determinants project from the surface of the RBC. The blood group-defining A and B oligosaccharides extend well beyond the lipid bilayer membrane.²² In addition to their relative abundance, they are also close together on the RBC surface, potentiating agglutination. The critical number of IgG molecules required to agglutinate RBCs is approximately 7,000 to 20,000 per RBC, whereas the requisite number of IgM molecules is only 25 to 50 per RBC.^{23, 24} Although serologic tricks such as enzyme treatment, centrifugation, and addition of substances such as albumin, polyvinylpyrrolidone (PVP), and dextran have been used to enhance agglutination by IgG antibodies, the most common way to determine the presence of immune system components on RBCs is with the direct antiglobulin test (DAT, direct Coombs).

Direct Antiglobulin Test (Direct Coombs Test)

In 1908, Moreschi described antiglobulin reactions as an aid to RBC agglutination.²⁵ This work remained largely unnoticed until 1945, when the investigation of anti-RBC antibodies was revolutionized with the development of the antiglobulin test by Coombs et al.²⁶ and its role in the identification of maternal IgG on fetal RBCs in hemolytic disease of the newborn (HDN) in 1946.²⁷ The principle of the DAT is quite simple. In order to ascertain if RBCs carry surface-bound immunoglobulin and/or complement, antisera with reactivity to human immunoglobulin and/or complement molecules is added to a suspension of the RBCs in question, providing the necessary cross-link to elicit agglutination. Figure 29.2 illustrates the principle of the test.²⁸ An ethylenediaminetetra-acetic acid (EDTA)-collected sample from the patient is used to prevent subsequent complement adherence to the RBC membrane *in vitro*. The test is performed by first washing the RBCs to remove nonspecifically adhered proteins. Following the addition of AHG, the mixture is centrifuged to enhance agglutination. The result is interpreted by resuspending the RBCs gently and observing carefully for clumps. Magnifying mirrors or lowpower microscopy may aid in discerning weak reactions. Negative reactions are further incubated at room temperature, centrifuged, and read again, as this additional incubation promotes positive reactions in the presence of complement.²⁹ Initial testing is done with polyspecific AHG (antisera), which contain anti-IgG, anti-C3d, and, occasionally, some anti-light-chain activity. Monospecific reagents differentiate between IgG and C3d to further define the specificity. Other monospecific antisera are available for C3b, C4b, C4d, and IgG heavy chain.³⁰ Specific antiserum for IgM or IgA is rarely used, as IgM is not usually found attached to the RBC surface *ex vivo*, and IgA is very rarely a cause of immunoglobulin coating by itself.^{31, 32} The U.S. Food and Drug Administration (FDA) has licensed monoclonal reagents, the most common of which is anti-C3d, which do not cross-react with other complement components.³⁰

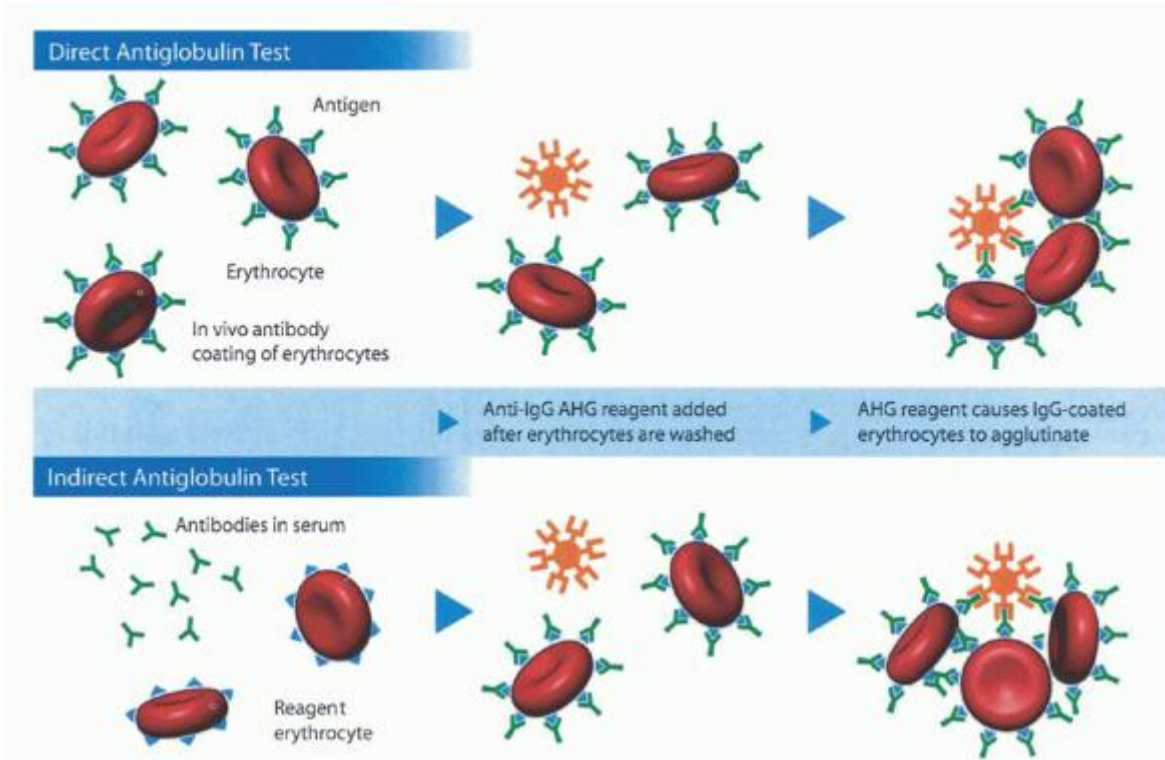

FIGURE 29.2. Direct antiglobulin test (DAT) and indirect antiglobulin test (IAT). The DAT reflects in vivo antibody sensitization of RBCs. Erythrocytes are washed to remove any unbound antibodies, and anti-IgG AHG reagent (AHG: antihuman globulin) is then added. IgG antibodies cannot cause direct RBC agglutination, but IgG-coated RBCs will agglutinate in the presence of AHG containing anti-IgG. This test can also be performed using anticomplement AHG reagent. If it is present, RBC-bound IgG can be eluted for specificity determination. The IAT is used to detect the presence of IgG antibodies in serum (in vitro sensitization). Reagent RBCs are incubated in the presence of serum that may contain antibodies. If they are present, antibodies bind to their target antigens on the reagent RBCs. After incubation, the RBCs are washed to remove unbound antibodies. Anti-IgG AHG reagent is added and will cause IgG-coated erythrocytes to agglutinate. (From Zarandona JM, Yazer MH. Teaching case report. The role of the Coombs test in evaluating hemolysis in adults. *Can Med Assoc J* 2006;174:305-307.)

Early DAT methodology suffered from relative insensitivity. More recent developments have improved the sensitivity for P.751

RBC-bound immunoglobulin and complement. The traditional tube method described above detects a lower limit of 150 to 200 IgG molecules per RBC.³³ With PVP enhancement and an autoanalyzer, the detection limit decreases to as few as 8 IgG per RBC producing 5% agglutination. If bromelain is added as well, the sensitivity increases even further, with 1 IgG per RBC producing 5% agglutination and 3 IgG per RBC producing 50% agglutination.³⁴ Additional acceptable techniques include flow cytometry, enzymelinked antiglobulin tests (ELISA), radioimmunoassays (RIA) using ¹²⁵I-labeled anti-IgG or staphylococcal protein A, solid-phase techniques using microtiter plates, and gel testing.³⁵ However, only the tube test, solid-phase test, and gel tests are in common use. Of these, the solid-phase and gel tests are the most standardized and have largely replaced older tube testing technology.

A positive DAT does not always mean decreased RBC survival. Most patients with a positive DAT have no obvious clinical signs of hemolytic anemia. DAT interpretation must consider the context of clinical history and other laboratory findings. Outside of AIHA, a positive DAT may also be seen with (i) alloantibodies in a recipient of RBC or plasma transfusion, (ii) antibodies from maternal circulation that cross the placenta and coat the fetal RBCs, (iii) antibodies directed against certain drugs that bind to the RBC membrane (e.g., penicillin), (iv) nonspecifically adsorbed proteins including immunoglobulins and Wharton's jelly, (v) RBC-bound complement, and (vi) antibodies produced by passenger lymphocytes in transplanted organs or hematopoietic components. Further evaluation of a positive DAT in a patient with clinical and laboratory evidence of hemolysis includes testing for clinically significant antibodies to RBC antigens and testing the eluate. Figure 29.3 illustrates an approach to the evaluation of a positive DAT.²⁹ A negative DAT, on the other

hand, does not exclude AIHA. Possible causes of a negative DAT with clinical evidence of hemolysis include an IgA or IgM autoantibody, insufficient antibody molecules for detection, and low-affinity autoantibodies.³⁵ Repeat testing, enhancement techniques, and the use of nonroutine reagents may be required when the clinical suspicion is strong.²⁹

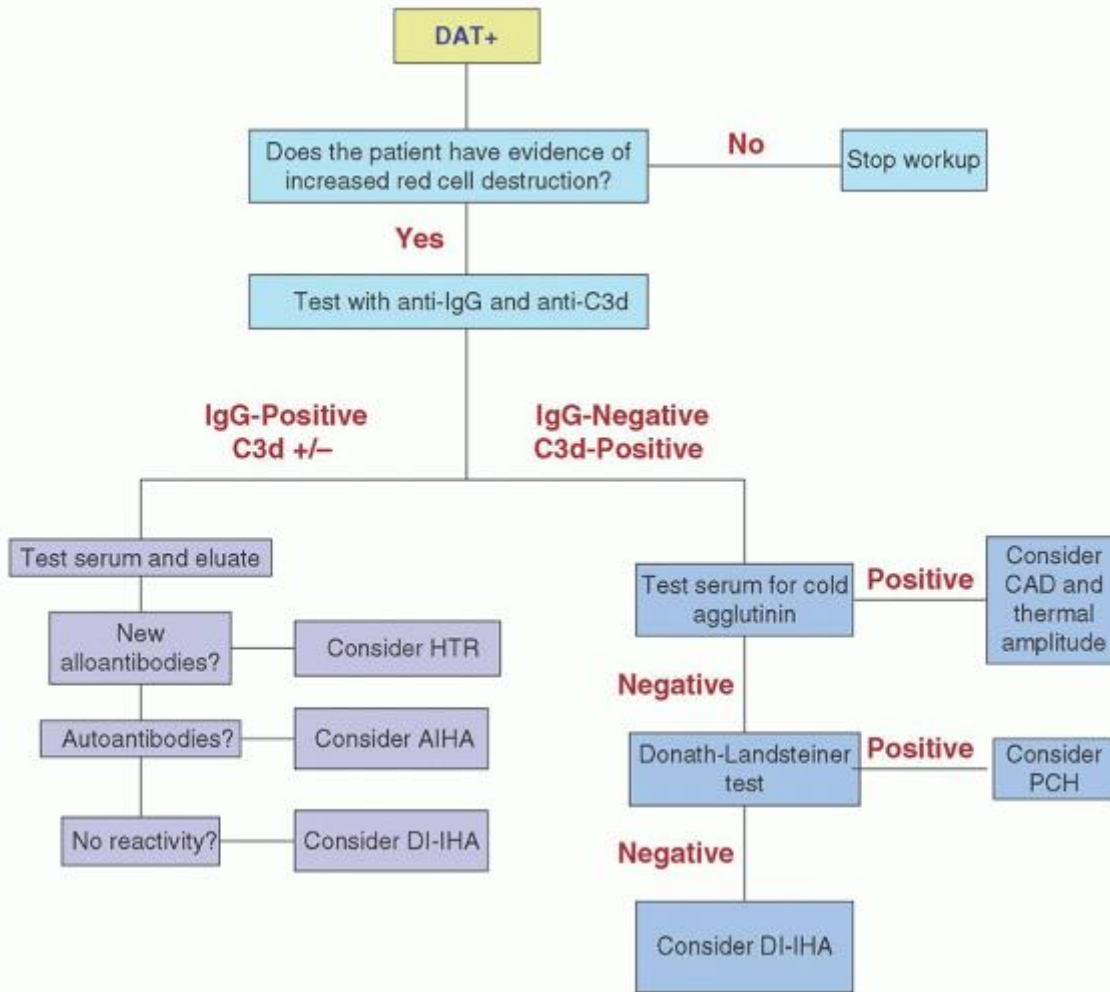

FIGURE 29.3. Flowchart suggesting a rational clinical laboratory approach for investigating a positive DAT. AIHA: autoimmune hemolytic anemia; CAD: cold agglutinin disease; DI-IHA: drug-induced immune hemolytic anemia; HTR: hemolytic transfusion reaction; PCH: paroxysmal cold hemoglobinuria. (Modified from Brecher ME, ed. Technical manual, 15th ed. Bethesda, MD: American Association of Blood Banks, 2005:480.)

Indirect Antiglobulin Test (Indirect Coombs Test)

Approximately 80% of patients with AIHA have autoantibodies in their serum as well as on their RBCs.³⁶ The antibodies in their serum or plasma and the antibodies eluted from their RBCs (the “eluate”) are detected by the indirect antiglobulin test (IAT; more commonly known as the antibody screen). Unlike the DAT, which uses patient RBCs with reagent serum, the IAT tests patient serum against reagent RBCs. Immunoglobulin from the patient serum attaches to the reagent RBCs and is detected with antiglobulin sera, which cross-link the RBCs together and produce agglutination, as in the DAT. See Figure 29.2.²⁸

P.752

Warm autoantibodies are typically panagglutinins, reacting with all cells in the diagnostic RBC panel (i.e., panreactive). Formerly, panagglutinins were believed to react with a basic determinant of the Rh antigen system as they do not react with the very rare Rh_{null} RBCs which do not express Rh antigens.³⁷ However, as more eluates are studied with a broader population of rare null phenotypes, it has been shown that, in addition to Rh, autoantibodies react to LW antigens,

glycophorins A, B, C, and D, and, very rarely, Kidd or Kell blood group system antigens.³⁸ A small number of case reports exist describing AIHA associated with ABO antigens.^{39, 40}

Elution

If the DAT is positive for RBC-bound antibody, that antibody can be eluted (removed) from the RBC with the aid of acid or xylene, and any binding specificities can be further investigated with a reagent red cell panel. Elutions are not typically performed on DAT specimens positive only for complement, as these molecules do not exhibit antigen specificity. Occasionally, however, when antibody presence is suspected but perhaps at too low a concentration to be detected on the RBCs, eluates may show reactivity. Elution tends to produce a more concentrated antibody solution, so reactions are often stronger. Once the antibody is in solution, indirect antiglobulin techniques may help define the antibody characteristics.²⁹

Other Serologic Techniques

Generally, autoantibodies are panreactive, whereas alloantibodies exhibit antigen specificity, reacting only with specific antigen-positive RBCs. In certain situations an autoantibody may mimic an alloantibody. For example, an alloantibody to a high-incidence antigen in a post-transfusion setting can mimic an autoantibody with a positive DAT (mixed field) and reactions with all panel cells. In addition, autoantibodies may exhibit apparent specificity. Autoadsorption and antigenic phenotyping can help differentiate autoantibodies and alloantibodies, especially if the patient has not been transfused recently. Autoadsorption uses autologous RBCs to adsorb autoantibodies prior to repeating serum testing for alloantibodies. If an antibody exhibits specificity, demonstration that autologous RBCs are negative for the corresponding antigen confirms the alloantibody; in the absence of a recent transfusion, a positive result suggests that it is an autoantibody. Autoadsorption can also be used to cross-match donor RBC units for patients with warm autoantibodies who have not been recently transfused.²⁹

IMMUNE HEMOLYTIC ANEMIAS CAUSED BY COLD-ACTIVE ANTIBODIES

Cold-active antibodies exhibit greater titer and RBC-binding activity as the temperature decreases toward 0°C. Two different clinical syndromes are manifested from cold autoimmune antibodies. Cold agglutinin disease (CAD) is associated with IgM antibodies usually directed at the RBC I antigen. CAD typically occurs in adult patients and may be primary or secondary to another disease process, usually infectious. In contrast, PCH is caused by an IgG hemolysin, the Donath-Landsteiner (D-L) antibody.⁴¹ Both PCH and CAD are less common than warm AIHA and make up approximately 20% or less of AIHAs. See Tables 29.5 and 29.6.

Cold Agglutinin Disease

Although Landsteiner first described cold agglutinins in 1903,⁴² it was not until the late 1940s and early 1950s that the connection between cold autoantibodies and RBC destruction was firmly made. In the 1950s, Schubothe coined the term "CAD," and the disorder became recognized as a separate entity from other acquired hemolytic processes.⁴³ The responsible pathologic IgM antibodies are distinguished from naturally occurring cold autoantibodies by their titer and thermal amplitude, a term describing the range of temperatures over which the antibody is reactive. Natural cold autoantibodies occur with titers less than 1:64 at 4°C and have little to no activity at higher temperatures. However, pathologic cold agglutinins typically have titers well over 1:512 and may react at 28°C to 31°C (peripheral body temperature) or even up to 37°C.³¹ See Table 29.6 and Figure 29.4.

TABLE 29.5 COLD AUTOANTIBODIES

	Primary Cold Agglutinin Disease	Secondary Cold Autoantibodies	Paroxysmal Cold Hemoglobinuria
Immunoglobulin	IgM	IgM	IgG
Clonality	Monoclonal	Monoclonal or polyclonal	Polyclonal
Direct antiglobulin test	C3	C3	C3
Hemolysis	Chronic, mild	Self-limited, mild to severe	Episodic, self-limited, mild to severe
Target RBC antigen	<i>I</i>	<i>I, i</i>	<i>P</i>

RBC, red blood cell.

Primary versus Secondary Cold Agglutinin Disease

Primary or idiopathic CAD is typically an affliction of older adults, with a peak incidence around age 70.⁴³ Both sexes are affected, but women predominate.⁴⁴ A monoclonal IgMk antibody is the usual culprit, and, as with other monoclonal gammopathies of unknown significance, may be a harbinger of future B-cell neoplasms. Most commonly, patients tolerate a relatively benign, waxing and waning hemolytic anemia.

Patients with Waldenstrom macroglobulinemia or other B-cell neoplasms may produce monoclonal anti-RBC antibodies with cold reactivity. As in primary CAD, they are nearly always IgMk. This type of secondary cold agglutinin may be effectively treated with antineoplastic chemotherapy. A return of hemolysis may herald a tumor relapse. Other non-B-cell tumors reported in association with cold antibody production include squamous cell carcinoma of the lung, metastatic adrenal adenocarcinoma, metastatic adenocarcinoma of the colon, basal cell carcinoma, and a mixed parotid tumor.⁴⁵

Another scenario of secondary cold autoantibody hemolysis occurs after Mycoplasma pneumoniae infection or infectious mononucleosis and is more commonly seen in younger adults. This transient, self-limited process is mediated by polyclonal IgM (κ or λ), lasts a few weeks, and seldom requires more than supportive care. In rare cases, massive intravascular hemolysis and acute renal failure may be seen. See Table 29.7.

Antibody Characteristics

Immunochemistry and Origin

As stated earlier, nearly all cold agglutinins are IgM. A few reports of IgG or IgA agglutinins are recorded, and a mixed IgM-IgG has been seen in infectious mononucleosis and angioimmunoblastic lymphadenopathy.⁴⁶ Those patients with non-IgM antibodies are more likely to have cold autoantibody hemolysis secondary to another disease and are less likely to display specificity for the I antigen.^{44, 47}

P.753

TABLE 29.6 SEROLOGIC OVERVIEW OF HEMOLYTIC ANEMIAS

	Cold Agglutinin Disease	Paroxysmal Cold Hemoglobinuria	Mixed Warm and Cold Autoimmune Hemolytic Anemia	Warm Autoimmune Hemolytic Anemia	Drug-Induced Hemolytic Anemia
Percentage of cases	16-32%	32% (children); rare in adults	7-8%	40-70%	12-18%
Direct antiglobulin test	C3	C3	IgG ± complement	IgG ± C3; rarely C3 alone	IgG or C3; occasionally IgG ± C3
Ig	IgM	IgG	IgG, IgM	IgG, occasionally with IgA or IgM	IgG
RBC eluate	Nonreactive	Nonreactive	IgG	IgG	IgG or nonreactive
Antibody specificity	<i>I > i >> Pr</i>	<i>P</i>	Panreactive	Panagglutinin	Rh-related
			Unclear > <i>I</i> > others	Rarely Rh	Drug-dependent

RBC, red blood cell.

Anti-idiotypic antibodies and direct nucleotide sequencing of the rearranged immunoglobulin variable-region genes have revealed significant cross-reactivity and homologies among cold autoantibodies with similar specificity.^{48, 49} For instance,

the monoclonal anti-idiotypic antibody 9G4 recognizes an idiotypic determinant present on the heavy chains of both anti-I and anti-i cold agglutinins as well as the responsible neoplastic B-cells.⁵⁰ Essentially all pathologic anti-I and anti-i cold agglutinins are derived from a distinct subset of heavy-chain variable-region genes called V_H4 family genes, specifically V_H4-21.⁵¹ In ~40% of the patients, a circulating B-cell clone can be identified with a distinctive karyotypic marker (trisomy 3q11-q29; trisomy 12; or 48XX+3+12). The chromosomal abnormalities were associated with chronic idiopathic cold agglutinin syndrome as well as with monoclonal cold agglutinins secondary to a neoplasm.^{52, 53, 54} In addition, the cold agglutinins have the same serologic specificity and isoelectric focusing spectrotpe and are therefore likely derived from a pre-neoplastic or neoplastic B-cell clone.⁷

I/i Blood Group System Specificity

More than 90% of cold-active antibodies have the I antigen as their target on the RBC, and the i antigen is the binding site for a significant portion of the remaining 10%.³¹ The closely related I/i antigens are high-frequency carbohydrates similar to the ABO antigens. The RBC surface densities of I and i are inversely proportional, with neonatal RBCs exclusively expressing large amounts of i antigen, usually converting to exclusively I antigen by 18 months of age. Consequently, adult RBCs are used to detect anti-I agglutinins and cord RBCs are needed to detect anti-i agglutinins. Extremely rare adults have been described who never express I antigen on the RBCs. Other uncommon but reported antigen

P.754

targets include Pr. Anti-Pr cold agglutinins tend to be high-titer, with a wide thermal range, and cause symptomatic anemia.^{55, 56} Other infrequent targets are Gd, Fl, Vo, Li, Sa, Lud, M, N, Me, Om, D, Sd^x, and P.^{38, 44, 57} The fact that *M. pneumoniae* induces anti-I antibodies in the majority of patients is potentially related to the finding that sialylated I/i antigens serve as specific *Mycoplasma* receptors.⁵⁸ Minor modification of this antigen may incite autoantibodies. Another theory suggests that an I-like antigen appears on the organism itself, and cross-reacting antibodies lead to RBC lysis.⁵⁹ Despite the high rate of antibody production, clinically significant hemolysis occurs in very few patients.⁶⁰ Infectious mononucleosis is also associated with CAD, but to a much lesser degree than *Mycoplasma*. Only 0.1% to 3.0% of mononucleosis patients have clinical hemolysis,⁶¹ although anti-i is present in 8% to 69% of sera post-infection.^{62, 63, 64} Therefore, the majority of patients with antibodies are asymptomatic. Anti-I activity is usually noted as well, but not to the same degree. Also, anti-Pr and anti-N have been reported.⁶⁵ Both IgM and IgG antibodies as well as IgM rheumatoid-like factors reacting with IgG may act as cold agglutinins after infectious mononucleosis.^{66, 67} See Table 29.7 for a list of other infectious diseases associated with cold agglutinins, most of which are anti-I, although anti-i has been seen in cytomegalovirus infections and in lymphomas.⁶⁸

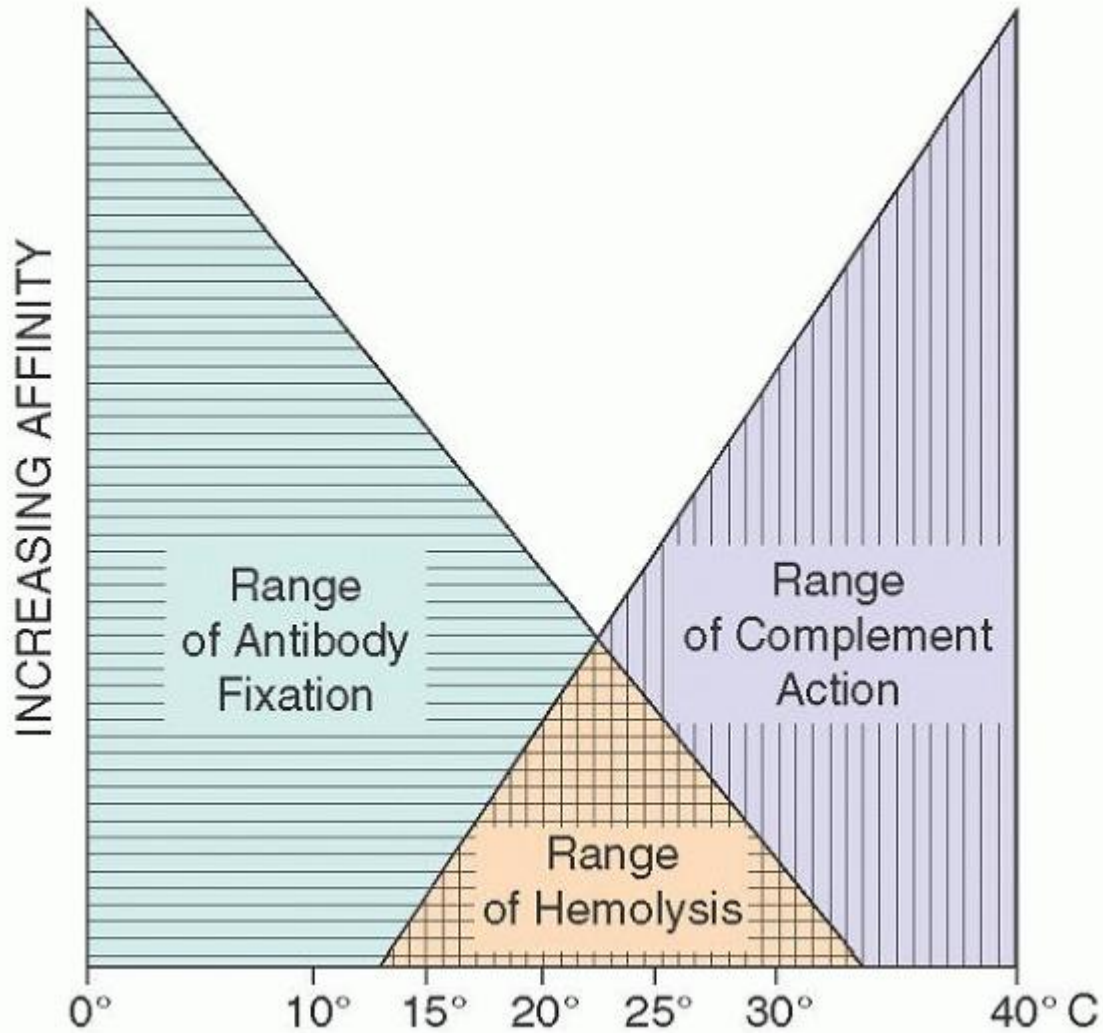

FIGURE 29.4. Temperature ranges for cold agglutinin fixation and lytic complement action. (From Schuboth H. The cold hemagglutinin disease. *Semin Hematol* 1966;3:27-47, with permission.)

TABLE 29.7 SECONDARY COLD AGGLUTININ DISEASE

Neoplasms

Waldenstrom macroglobulinemia

Angioimmunoblastic lymphoma

Other lymphomas

Chronic lymphocytic leukemia

Kaposi sarcoma

Myeloma

Nonhematologic malignancy (rare)

Infections

Mycoplasma pneumoniae

Mononucleosis (Epstein-Barr virus)

Adenovirus
 Cytomegalovirus
 Encephalitis
 Influenza viruses
 Rubella
 Varicella
 Human immunodeficiency virus
 Mumps
 Ornithosis
 Legionnaires' disease
Escherichia coli
 Subacute bacterial endocarditis
 Listeriosis
 Syphilis
 Trypanosomiasis
 Malaria
 Other
 Autoimmune diseases
 Tropical eosinophilia
 Functional Characteristics

Cold agglutinins attach to the RBC in the cooler peripheral circulation. As the blood returns to the warmer core circulation, the antibody dissociates from the RBC. Antibodies that attach, fix complement, and then dissociate are free to attack another erythrocyte and begin the process again.⁶⁹ Complement fixation and activation, which are responsible for the destruction of the RBCs, are far more efficient at the warmer core temperatures. However, with a high antibody titer and a wide thermal amplitude, there may be sufficient temperature overlap to produce hemolysis at $22\pm 10^{\circ}\text{C}$.⁴³ See Figure 29.4. Because of this diversity of temperature requirements for optimal activity of the antibody and complement, RBC destruction is usually not particularly severe with cold autoantibodies. Quite impressive exceptions occur, and these are typically the antibodies with either high titers ($>1:1,000$) or activity up to 37°C even in the face of modest titers. Thermal amplitude is a better predictor of hemolysis than titer.^{46, 70} High-titer cold agglutinins with a narrow thermal amplitude may produce a clinical picture with bursts of hemolysis associated with exposure to cold, often manifested as intermittent hemoglobinuria between quiescent periods.⁶⁹

A frequent misconception about cold agglutinins is the assumption that they are cryoglobulins, whereas in fact they are two distinct disease processes. Both may cause cyanosis and Raynaud phenomenon in cooler temperatures. However, cryoglobulins do not fix complement on the RBCs or lead to hemolysis.

Clinical Manifestations

Mild, chronic hemolytic anemia with exacerbations in the winter is the general rule for CAD. Rarely does the hemoglobin drop below 7 g/dl.⁷¹ Pallor and jaundice may occur if the rate of hemolysis is greater than the endogenous capability to metabolize bilirubin.⁴⁴ Some patients have intermittent bursts of hemolysis associated with hemoglobinemia and hemoglobinuria on exposure to cold and may be forced to move to warmer climates to minimize attacks. Acrocyanosis can occur from agglutination of RBCs in the cooler vessels of the hands, ears, nose, and feet.^{31, 44} Digits may become cold, stiff, painful, or numb and may turn purplish. Limbs may manifest livedo reticularis, a mottled appearance that is readily reversible upon warming of the affected area. Only rarely does actual gangrene of digits develop, and nearly all of these cases have an associated cryoglobulin.⁷² A minority of chronic CAD patients have mild splenomegaly or hepatomegaly. The

spleen may be enlarged or more frequently palpable in secondary cold agglutinins due to lymphoma or infectious mononucleosis.⁴⁴

If hemolysis does occur after Mycoplasma infections, it typically begins during the post-pneumonia recovery period when cold autoantibody titers are at peaking. The process, even if severe, resolves spontaneously within 1 to 3 weeks.³¹ Hemolytic anemia after infectious mononucleosis may begin with the onset of illness or within the next 3 weeks.⁴⁴ The self-limited, post-infectious CAD tends to affect younger patients, whereas the chronic idiopathic form is a disease of the elderly, with peak incidence at ~age 70 years.⁴³

Laboratory Features

Mild chronic anemia is the rule, but the hemoglobin may fall to 5 to 6 g/dl, especially in the winter months in cold climates. The peripheral smear, if not obtained from a carefully collected prewarmed specimen properly maintained warm until spread on a warm slide, may show significant agglutination and RBC clumping under magnification. Occasionally, clumping is so extensive as to be grossly visible without magnification and may even preclude an adequate smear examination. Agglutinates are frequently visible in the specimen tube and can appear to be a large clot. Dissolution with warming demonstrates that the clumped and clotted appearance is a result of a cold agglutinin rather than Rouleaux formation or fibrin strands. Often, the first suspicion of a cold agglutinin comes from a failed attempt to obtain a valid RBC count and indices on an automated CBC. The initially reported RBC count is often artifactually low and the MCV artifactually high, producing a spuriously high MCHC. The reticulocyte count is modestly elevated except in rare cases of concomitant marrow failure, such as those due to parvovirus B19 infection.⁷³ Spherocytosis is not pronounced as in warm AIHA. WBC and platelet counts are usually normal, but low levels of both have been reported, as has leukocytosis.⁴⁴ Bilirubin is mildly elevated, rarely >3 mg/dl. LDH may be increased (reflecting RBC destruction), and complement and haptoglobin are often low or absent. During brisk hemolysis, hemoglobinuria and hemoglobinemia are manifest. The DAT is positive with polyspecific and anticomplement antisera. As above, IgM has dissociated and is not detectable. In extremely rare cases, the antibody involved is IgG or IgA, either alone or in addition to IgM.^{31, 44} Mixed warm and cold autoantibodies are not rare (discussed later). Titers measured at 4°C may range from 1:1,000 to 1:1,000,000, although typical values are between 1:1,000 and 1:500,000. Much lower levels can be clinically significant if activity is measurable at 37°C. Post-infectious CAD titers are lower (<1:4,000) than the chronic idiopathic or lymphoma-associated varieties. In patients with monoclonal IgM, evaluation of serum proteins frequently reveals an M spike, shown by serial observations to be stable in the chronic idiopathic disease.⁷⁴

Management

Primary Cold Agglutinin Disease

Because of the mild chronic nature of the anemia, the majority of patients need no specific therapy other than the general principle of avoiding temperatures below those at which their antibody shows activity. In some cases this may necessitate a move to a warmer climate. For patients with more severe anemia and cardiovascular compromise, aggressive therapy is indicated.

Immunosuppressive Therapy: The ideal therapy would only suppress production of the pathologic antibody. Until that becomes an option, a common approach in treating symptomatic CAD is to use cyclophosphamide or chlorambucil. A minority of patients respond, and in these cases transfusions can be avoided. One alternative is chlorambucil, beginning with 2 to 4 mg/day and increasing by 2 mg every 2 months until either a response is

P.755

obtained or unacceptable myelotoxicity results. Twice-weekly blood counts plus reticulocyte count should be monitored for toxicity.^{31, 75} Pulse therapy with cyclophosphamide (250 mg/day) and prednisone (100 mg/day x4 days) every 2 to 3 weeks, blood counts permitting, or a large dose regimen of cyclophosphamide (1,000 mg), and intravenous methylprednisolone (500 mg) may adequately control hemolysis.⁷⁶ In addition, α -interferon has reportedly produced significant remissions.⁷⁷ However, recent studies have shown that rituximab is the most effective form of treatment and can be used as first line.

Rituximab: Rituximab, a chimeric human/murine monoclonal CD20 antibody, has been used with success in CAD in several case reports and series. The proposed mechanism of action involves complement-dependent cytotoxicity, antibody-dependent cellular cytotoxicity, direct apoptotic effects, and inhibition of B-cell proliferation. The most effective and best-evaluated treatment is rituximab in standard lymphoma dose (375 mg/m² each week for 4 weeks). Berentsen et al., in an open, uncontrolled prospective phase 2 study of rituximab in CAD showed that 20 of 27 patients responded with a median

duration of response of 11 months.⁷⁸ Most relapsed patients responded to retreatment with rituximab. Similar results were obtained by other studies.⁷⁹ Some pediatric patients were successful with just two infusions.⁸⁰ This evidence suggests that rituximab can be used as first-line treatment in symptomatic CAD.

Plasmapheresis: Given the predominantly intravascular distribution of IgM, a logical conclusion would be that plasmapheresis or plasma exchange should provide rapid relief from hemolysis due to cold autoantibodies. Unfortunately, the results have been somewhat disappointing.^{81, 82} Simply removing the circulating antibody does not diminish ongoing endogenous antibody production, so improvements are transient at best. In patients with chronic CAD, plasmapheresis should probably be combined with immunosuppressive therapy in an attempt to decrease antibody production.⁸³ Successful use of plasmapheresis to temporarily decrease cold agglutinin titers in order to permit safe coronary artery bypass surgery has been reported.⁸⁴ Other reports of successful cardiac surgery involving warm cardioplegia have circumvented the need for cold exposure and thus the risk of hemolysis.^{85, 86} Cryofiltration apheresis has been used for acute exacerbations and for surgical procedures requiring hypothermia, such as coronary artery bypass surgery with cardioplegia. In one small study, two of five such patients who received cryofiltration apheresis had a favorable response with a reduction in titer.⁸⁷

Blood Transfusion: Although most patients with CAD have mild anemia and do not need transfusion, RBC support may be required in patients who are clinically symptomatic or severely anemic.⁸⁸ Patients with high-titer or wide-thermal-amplitude antibodies can pose extremely difficult serologic problems for the blood bank laboratory. Testing needs to be performed carefully at 37°C to minimize the effects of the cold agglutinin so that a search for alloantibodies may be properly performed.³¹ This still does not eliminate interference from some particularly pesky autoantibodies. Time-consuming and technically challenging cold autoadsorptions may be necessary to rule out the presence of underlying alloantibodies. Occasionally, incompatible units may need to be issued because of residual agglutination from the cold autoantibody. Most cold agglutinins are directed at the I antigen, which is present on nearly all adult donor RBCs. Locating i adult RBCs (i.e., I-negative) is not practical because of their extreme rarity. Reports have documented i adult RBCs effectiveness and lack thereof.^{89, 90} If transfusion is necessary to treat significant cardiovascular compromise, RBC infusion through an in-line blood warmer at 37°C is recommended.⁹¹ Uncontrolled heating of RBC products is quite dangerous because of the damaging effects of excessive heat and should be avoided. If blood warmers are not available, transfusion may still be accomplished by the slow infusion of room temperature RBCs into a large vein while keeping the patient warm.^{31, 44}

Steroids: Unlike their effectiveness in treating warm AIHA, steroids have little or no place as monotherapy in the treatment of CAD but are often a component in multidrug regimens. The few reports of a response have been suspect in their serologic evaluations or have required such high maintenance doses of prednisone that side effects of therapy were intolerable.⁹²

Splenectomy: Given that most CAD-induced RBC destruction is hepatic, it should be no surprise that splenectomy has been quite ineffective in treating CAD and is therefore not advised. In the rare patient who has the unusual serologic characteristic of hemolysins reactive at 37°C as well as agglutinating activity at cooler temperatures, splenectomy may be of some benefit.³¹

Newer Agents: Because the hemolytic anemia of cold reactive antibodies is mediated by complement, the use of anti-C5 reagents (e.g., eculizumab) and other complement-modifying agents may be of benefit.⁹³

Secondary Cold Agglutinin Disease

Hemolysis from infection-associated cold agglutinins lasts for 2 to 3 weeks, and therapy is typically not required. Given the transient nature of the antibody, even in the rare patient with significant hemolysis, supportive measures such as transfusion and plasmapheresis should suffice. Attempts to alter antibody production with immunosuppressives are generally not indicated. Patients with cold agglutinins and malignancies should have their treatment regimens directed at their underlying disease with the addition of supportive measures as the clinical situation dictates.

Paroxysmal Cold Hemoglobinuria

PCH was the first hemolytic anemia to be described because of its dramatic presentation of intermittent attacks of pain, fever, and hemoglobinuria following exposure to cold. In their classic 1904 paper, Donath and Landsteiner⁴¹ described an antibody that produces the characteristic syndrome. The Donath-Landsteiner antibody is a hemolysin that binds to RBCs at low temperatures in the periphery and fixes complement. When the RBCs return to the warm central body core, they are destroyed by complement lysis. The D-L antibody occurs in three clinical syndromes: (i) chronic PCH associated with late-stage or congenital syphilis, (ii) acute transient PCH occurring after an infectious illness, and (iii) chronic idiopathic PCH. The first type was formerly the most common, but because there are now effective treatments for syphilis, it is now

quite rare. Chronic idiopathic PCH has always been uncommon. The acute transient variety is believed to be one of the most common causes of acute hemolytic anemia of children.^{94, 95} See Table 29.6.

Antibody Characteristics

Immunochemistry and Origin

Typically, PCH antibodies are polyclonal IgG.⁹⁶ Originally described in patients with advanced or congenital syphilis, the antibody is not cross-reactive in syphilis serology tests in patients with syphilis or in those who manifest the acute transient variety of PCH.^{97, 98} PCH has been reported in family members, suggesting a genetic predisposition.⁴⁴ The origin or stimulus for antibody production is likely micro-organism antigen(s) that induce antibodies that cross-react with the P blood group system.⁹⁹

P Antigen Specificity

The antibody in PCH is directed against the P antigen, which is a glycosphingolipid globoside found on the RBCs of most P.756

individuals.^{100, 101} The P antigen is similar to the Forssman glycolipids present in many micro-organisms.⁹⁹ This similarity suggests that infectious agents may elicit D-L antibodies as a result of cross-reactivity.

Functional Characteristics

The D-L IgG antibody is a potent hemolysin, causing significant RBC destruction even in low titers. The D-L antibody is classically described as a "biphasic" hemolysin. This is based on the test for the antibody originally described by Donath and Landsteiner, whereby the patient's serum is incubated with RBCs at 0°C to 4°C and then warmed to 37°C to produce lysis. The antibody requires the cooler temperatures to bind to the RBC, but complement-mediated lysis does not proceed until the temperature is raised. For optimal lysis, complement C1 should be available when the antibody initially binds.^{97, 98} Upon warming, C4, C2, and the remainder of the complement cascade bind and disrupt the membrane, producing lysis. Some D-L antibodies have a wider thermal amplitude and bind to the RBC at temperatures compatible with complement activity. These seem to be "monophasic" hemolysins, in that cooling is not necessary to produce binding activity. Some believe that the distinction between biphasic and monophasic activity is unwarranted, representing only differences in thermal amplitude.⁴⁴ Also, other cold-active antibodies that vigorously fix complement may produce in vitro hemolysis biphasically but yet not have the distinguishing characteristics (IgG, anti-P specificity) that qualify them as true D-L antibodies.

Clinical Manifestations

Although uncommon, PCH may not be as rare as initial reports suggested. In series of all hemolytic anemias, the incidence has ranged from 1.7% to 10.0%.^{31, 61, 102} PCH may account for more than 40% of immune hemolytic anemias in children <5 years of age.¹⁰³ The sudden onset of fever, back or leg pain, and hemoglobinuria after exposure to the cold are the hallmarks of PCH. Cold exposure may be only a few minutes, and symptoms may follow shortly or several hours later. Fever to 40°C is not unusual. Other symptoms may include pain or aching in the back, legs, or abdomen, cramps, headache, nausea, vomiting, and diarrhea. The first urine voided after the onset is dark red-to-black and typically clears in a few hours. Rarely, it persists for a few days. The spleen may be palpable during an attack and shortly thereafter, and mild jaundice may appear.⁴⁴ Vasomotor phenomena manifest as cold urticaria, tingling of hands and feet, cyanosis, and Raynaud phenomenon, and even gangrene has been reported.^{104, 105} Systemic symptoms may appear without the hemoglobinuria and vice versa.

There does not appear to be any racial or gender predilection in PCH. Children are almost exclusively affected by the acute transient syndrome.^{31, 44} An antecedent upper respiratory infection in children is usually identified, although the responsible organism may not be determined. Attacks have been associated with measles, measles vaccinations, mumps, Mycoplasma pneumonia, influenza A, adenovirus, varicella, cytomegalovirus, Haemophilus influenzae, and infectious mononucleosis.^{106, 107, 108, 109, 110, 111} Although episodes are typically self-limited and nonrecurring, they can be quite severe and even life-threatening without supportive care.

The original chronic PCH associated with syphilis has all but disappeared. The diagnosis of chronic PCH now should prompt an investigation for occult syphilis infection and, in its absence, should be considered the idiopathic variety.

Laboratory Features

Hematologic findings in PCH are typical for acute, severe intravascular hemolysis. Hemoglobin levels <5 g/dl can be seen.^{103, 106, 107, 111} The peripheral smears may show spherocytes, nucleated RBCs, polychromatophilia, anisocytosis, poikilocytosis,³¹ and erythrophagocytosis by neutrophils.^{107, 108, 110} The WBC count may be depressed very early in the attack, but is usually normal or high. Platelet counts are usually normal. Reticulocytopenia is quite common early in the episode, and reticulocytosis appears in the recovery phase.⁴⁴ Once haptoglobin is exhausted, hemoglobinuria results. The plasma is frequently tinged red, reflecting the free hemoglobin. As in other instances of hemolysis, the LDH and bilirubin (mostly unconjugated) are elevated. Complement levels are depressed.

Urine tests are positive for hemoglobin and methemoglobin, giving it its dark red-to-black appearance. Occasionally, RBCs are found in the sediment, but the discoloration is primarily pigment. Rarely does the patient have renal insufficiency with elevated blood urea nitrogen and creatinine.¹¹² Hemosiderinuria is found in patients with the chronic variety.

The Donath-Landsteiner test is a simple procedure involving incubating patient serum in melting ice with washed group O, P-positive RBCs, and fresh normal serum as a source of complement. Later, the tube is transferred to 37°C for a second incubation. Lysis visible to the naked eye after the warm incubation is a positive test.²⁹ Appropriate controls should be run simultaneously. Other serologic testing in the blood bank should reveal a positive DAT with anticomplement antisera. The anti-IgG DAT is rarely positive, because of dissociation of the antibody from the RBC at warmer temperatures. If the blood specimen is processed at cold temperatures, RBC surface-bound IgG can occasionally be demonstrated.³¹ The D-L antibody may be demonstrated using the IAT. The method of using an ice-cold saline wash to avoid elution of the antibody and then testing with monospecific antisera for IgG is a sensitive indicator for antibody presence.³¹ Differentiation between cold agglutinins and the D-L antibody can be made by careful characterization of the antibody involved, including specificity and immunoglobulin class. The classic age discrepancy and the rare occurrence of cold agglutinins in children may lend clinical support to the diagnosis.

Management

Treatment of acute attacks is essentially supportive. Given the transient nature of the syndrome, little else is indicated. In severely anemic children, steroids are usually given, although their benefit has not been documented.^{103, 108} Blood transfusion may be safely accomplished with standard banked blood even though essentially all donor units are P-antigen-positive. Delaying a needed transfusion to locate the rare unit of pp blood (i.e., P-negative) among 200,000 units²⁹ may put the patient in far more danger than transfusing readily available units. Warming both the patient and the blood is advisable. The hemoglobin rises the expected amount in most situations. In the rare patient in whom the hemoglobin does not rise, rare-donor files may be able to locate pp or Tj(a-) units. When this pp unit is available, transfusion results have been excellent.¹¹³ As with other immune hemolytic anemias, critical situations may be ameliorated by plasmapheresis.¹¹⁴ Chronic PCH is best treated by the avoidance of cold and rarely requires any other therapy. Patients who have documented syphilis should be appropriately treated, and most show response.¹¹⁵

IMMUNE HEMOLYTIC ANEMIAS CAUSED BY MIXED COLD- AND WARM-ACTIVE ANTIBODIES

Some patients with warm AIHA also possess a cold agglutinin. Although the majority of these cold agglutinins are not clinically significant, they may occasionally demonstrate sufficient thermal amplitude ($>30^{\circ}\text{C}$) or high titer ($>1:1,000$ at 0°C to 4°C) to

P.757

indicate CAD. Similar to the separate entities, mixed-type AIHA can be either idiopathic or secondary to lymphoproliferative disorders or systemic lupus erythematosus (SLE). Patients usually have a chronic course interrupted by severe exacerbations, which can result in a hemoglobin level <5 g/dl. These exacerbations do not appear to be associated with cold exposure, and they do not result in acrocyanosis or Raynaud phenomenon.¹¹⁶

The laboratory work-up demonstrates a DAT that is positive for both IgG and C3. As with the separate diseases, the mixed-type AIHA produces difficulties with the antibody screen and the cross-match. The RBC eluate typically indicates a panreactive warm IgG autoantibody. The cold autoantibody usually exhibits specificity against the I antigen, but reactivity against i has been reported.^{116, 117} Because of technical difficulties associated with performing the cross-match, due to the autoantibody interference, cross-match-incompatible units may have to be transfused in situations where patients are severely symptomatic or severely anemic.⁸⁸ Mixed-type AIHA appears to respond to treatment in a similar manner as warm AIHA. Patients generally respond to steroids, and immunosuppressive agents and splenectomy have been employed successfully as well. Associated diseases, if present, also need to be treated to optimize recovery.¹¹⁶ See Table 29.6.

IMMUNE HEMOLYTIC ANEMIAS CAUSED BY WARM-ACTIVE ANTIBODIES

Autoantibodies with greatest activity at 37°C are responsible for the majority of patients with AIHA. Excluding drug-induced autoantibodies, ~70% of all AIHA patients have the warm-antibody type.^{31, 61} In general, these autoantibodies are IgG, may or may not fix complement, and typically destroy RBCs by extravascular hemolysis in the spleen (exceptions do occur). They may be secondary to an underlying disease, or in some cases, no underlying process is ever identified, and are labeled idiopathic. Certain drugs may induce development of warm-active antibodies, even generating a true autoantibody in the absence of a distinct autoimmune disorder. See Table 29.6.

Primary versus Secondary Autoimmune Hemolytic Anemia

Warm autoantibodies are responsible for 48% to 70% of AIHA cases.^{31, 118} Primary or idiopathic warm AIHA accounts for less than half of the cases. It can occur in any age group, and females predominate (2:1) in most series.^{61, 96, 119} There is no racial predilection, but a genetic predisposition is suggested by intrafamilial occurrences.⁴⁴ No blood group has been consistently shown to be selectively affected. HLA-A1, -B7, and -B8 recur in the literature as being overrepresented in this population, though not all series have reached this conclusion.^{120, 121, 122, 123} The incidence of AIHA has been reported to be in the range of 1:50,000 to 75,000,^{92, 118} rising with age, but most of the increase is in the secondary hemolytic anemias as opposed to idiopathic. The immune system abnormality that leads to the production of the pathologic antibody in either primary or secondary hemolytic anemia is still not completely understood.

With an aggressive search and long follow-up, most patients with warm autoantibodies are found to have an underlying associated condition. Lymphoproliferative disorders such as chronic lymphocytic leukemia (CLL), Hodgkin lymphoma, non-Hodgkin lymphoma, and Waldenström macroglobulinemia are the leading causes of secondary cases.¹²⁴ Other secondary causes include autoimmune disorders (e.g., SLE, rheumatoid arthritis, scleroderma, and ulcerative colitis), nonlymphoid neoplasms (e.g., ovarian dermoid cysts, teratomas, and carcinomas), immunodeficiency disorders (e.g., AIDS, dysglobulinemia, and hypogammaglobulinemia), and childhood viral illnesses.¹²⁴ As a result of these secondary causes, the incidence of warm AIHA increases starting around 40 years of age. Children have a peak incidence in the first 4 years of life. See Table 29.8.

TABLE 29.8 DISEASES OR CONDITIONS ASSOCIATED WITH WARM AUTOIMMUNE ANTIBODIES

Autoimmune disorders

Systemic lupus erythematosus

Rheumatoid arthritis

Scleroderma

Ulcerative colitis

Antiphospholipid antibodies

Lymphoproliferative disorders

Chronic lymphocytic leukemia

Acute myelocytic leukemia

Hodgkin's lymphoma

Non-Hodgkin's lymphoma

Waldenström macroglobulinemia

Other lymphoproliferative disorders

Multiple myeloma

Other neoplastic disorders

Thymoma

Ovarian dermoid cyst

Teratoma

Kaposi sarcoma

Carcinoma

Viral infections

Epstein-Barr virus

Hepatitis C virus

HIV/AIDS

Other

Diphtheria-pertussis-tetanus

vaccinations

Pregnancy

Bone marrow transplantation

Congenital immune deficiency states

Hypogammaglobulinemia

Dysglobulinemia

Antibody Characteristics

Immunochemistry and Origin

Most antibodies are IgG with a preponderance of IgG₁ and, to a lesser extent, IgG₃.¹²⁵ The subtypes vary in their efficiency at causing hemolysis because of the higher affinities of the macrophage F_c receptors for the IgG₁ and IgG₃ subclasses.^{126, 127} Various combinations of IgG subclasses may occur together. Although it is uncommon for IgA or IgM to occur in concert with IgG, it is even less common for them to occur singly.^{31, 32} See Tables 29.4 and 29.6.

Blood Group Specificity

Warm autoantibodies are panagglutinins, reacting with all the RBCs in the diagnostic panel. Of the reported specificities, Rh is by far the most common (70%), including all but the Rh_{null} erythrocytes. Occasionally, the IAT identifies an antibody with relative Rh specificity for a particular Rh antigen such as e. It is extremely rare for antibodies of true specificity to occur in the absence of those of broader specificity. Thus, little is to be gained by transfusing antigen-negative blood to these patients. Other blood group specificities that have been reported include Wright (Wr^b), En^a, Duffy (Fy^b), Gerbich (Ge), Kidd (Jk^a), Kell (K), Lutheran (Lu), LW, M, N, S, Pr, A, B, I^T, Sc3, U, Vel, and Xg^a.^{38, 44}

P.758

Clinical Manifestations

Warm AIHA has a highly variable clinical presentation. Typically, patients insidiously develop anemic symptoms such as weakness, dizziness, fatigue, and dyspnea on exertion. Other, less specific symptoms include fever, bleeding, coughing, abdominal pain, and weight loss.¹²⁸ Cases with insidious onset generally follow a chronic waxing and waning course. In patients with fulminant hemolysis, the anemic symptoms can be accompanied by jaundice, pallor, edema, and dark urine (hemoglobinuria). Splenomegaly, hepatomegaly, and lymphadenopathy may accompany the anemia. This more acute, potentially life-threatening presentation is usually associated with viral infections, especially in children. Post-infectious acute-onset hemolysis tends to be short-lived.⁴⁴ In cases of secondary disease, the symptoms of AIHA may precede the recognition of the underlying illness by months to years, but ultimately the symptoms of the underlying disorder predominate. When presentation includes massive splenomegaly or lymphadenopathy, an underlying lymphoproliferative disorder should be considered. Symptoms can be precipitated by trauma, surgery, infection, pregnancy, and psychological stress. See Table 29.9.

Pregnancy

The rate of autoantibody formation in pregnant women has been reported at 1:50,000, fivefold greater than in an age-comparable control population.¹²⁹ Hemolysis tends to increase during the pregnancy and may remit after delivery of the

infant. Maternal hemoglobin levels <5 g/dl have been reported.¹³⁰ Infants born to mothers with hemolytic anemia may or may not suffer any hemolysis. Fetal and neonatal IgG are of maternal origin, and diminish post-partum naturally with clearance. Maternal antibody-producing lymphocytes do not typically cross the placenta. Even if difficulties are encountered initially, the infant should normalize in a matter of weeks, as there is no endogenous ongoing neonatal production of pathologic antibodies.^{131, 132}

Infancy and Childhood

AIHA in infancy and childhood can be quite different from that in adults. The disease onset is more likely to be sudden and severe, usually preceded by a viral prodrome. There is a slight male predominance, and the prognosis is relatively good for a complete and lasting remission within several weeks of the onset. Most children respond well to steroids, and rarely is splenectomy considered.⁴⁴ A particular association of childhood vaccines and hemolytic anemia has been documented.^{133, 134}

TABLE 29.9 WARM AUTOIMMUNE HEMOLYTIC ANEMIA: PRESENTING SIGNS AND SYMPTOMS

Sign	Frequency (%)	Symptom	Frequency (%)
Splenomegaly	82	Weakness	88
Hepatomegaly	45	Dizziness	50
Lymphadenopathy	34	Fever	37
Jaundice	21	Bleeding	10
Thyromegaly	10	Dyspnea	9
Edema	6	Cough	6
Cardiac failure	5	Weight loss	5
Pallor	4	Gastrointestinal disturbance	5
		Anorexia	4
		Dark urine	3
		Angina	2
		Confusion	2

Modified from Pirofsky B. Clinical aspects of autoimmune hemolytic anemia. *Semin Hematol* 1976;12:251-265.

Evans Syndrome

Children can have very severe Evans syndrome, the concomitant occurrence of warm AIHA and immune thrombocytopenic purpura (ITP) described in 1949.^{135, 136, 137} The thrombocytopenia may precede, coincide with, or follow the AIHA.¹¹⁰ This is more common in children and is less likely to respond well to therapy.^{138, 139} Multiagent protocols have shown some success.^{140, 141} Recent use of rituximab also has demonstrated clinical utility (see management).

Laboratory Features

Hemoglobin and hematocrit values at presentation can vary from essentially normal in the compensated hemolyzing patient to extremely low in the rare patient with fulminant RBC destruction. The MCV is usually elevated, reflecting the increased proportion of young RBCs and perhaps a relative folate deficiency in patients with chronic hemolysis. Reticulocyte counts are usually elevated as well, sometimes remarkably so, but may be depressed early in the course.¹⁴² Reticulocytopenia may have myriad causes, including marrow shutdown from intervening infection, malignancy myelophthisis, parvovirus B19 infection, or the possibility of the autoimmune antibody being directed at antigens in great concentration on the reticulocytes themselves.^{44, 143, 144, 145} The bone marrow is usually hyperplastic even in the face of reticulocytopenia.¹⁴² The peripheral smear typically reflects the reticulocytosis with polychromatophilia and macrocytosis, as well as nucleated RBCs. Spontaneous agglutination is uncommon with warm autoantibodies but may occur if the RBCs are strongly sensitized with immunoglobulin. Spherocytes are produced in varying quantity. Albeit unusual, the presence of erythrophagocytosis by monocytes, or rarely neutrophils, on the peripheral smear is an indication of AIHA.¹⁴⁶

WBC counts are usually slightly elevated but may be depressed. Thrombocytopenia should raise the consideration of Evans syndrome.¹⁴² Both leukopenia and thrombocytopenia may be immune-mediated, as shown in some cases by the presence of antileukocyte and antiplatelet antibodies.¹⁴⁷ Platelet dysfunction may occur as well.¹⁴⁸ Serum bilirubin is elevated but rarely >5 mg/dl in the absence of concomitant liver disease, with the major fraction unconjugated.¹⁴⁹ Hemoglobinemia and depressed or absent haptoglobin can be seen in rapid hemolysis, even if extravascular. Urobilinogens are increased, and hemoglobinuria and hemosiderinuria may follow severe hemolysis. Resultant renal failure has been reported.¹⁵⁰ Stercobilinogens may turn the stool dark. Biologic false-positive syphilis tests are common, and other abnormal antibodies have been reported, including antithyroid antibodies, rheumatoid factors, and anticardiolipin antibodies. Serum immunoglobulin abnormalities have been reported with both elevated or depressed levels, but with no consistent pattern.^{151, 152}

The hallmark of immune-mediated hemolytic anemia is the presence of immunoglobulin, complement, or both on the surface of the RBCs. In >95% of warm AIHA cases, the DAT is positive. Series vary in their DAT results. Between 20% and 66% have only IgG on the surface, 24% to 63% have IgG and C3, 7% to 14% have only C3, and 1% to 4% are DAT-negative.^{31, 118, 153} Patients with SLE are particularly prone to positive tests for complement on their RBCs.

IgG₁ predominates, either alone or in combination with other subclasses, and IgG₄ is uncommon. In rare cases of warm hemolysins, IgM antibodies that fix complement and are associated with severe, life-threatening hemolysis have been reported.¹⁵⁴ It is even more uncommon for IgG antibodies to act as hemolysins.¹⁵⁵ The severity of hemolysis is loosely correlated with the quantity of antibody bound to the RBC and the strength of

P.759

the DAT.^{156, 157} However, other factors play a large role in the significance of the clinical picture, such as the immunoglobulin subclass, with IgG₃ being the most efficient at binding to F_c receptors.

Still other characteristics remain undefined to explain why immune hemolysis occurs in DAT-negative patients, and why some other patients with RBC-bound immunoglobulin have no increase in RBC turnover. If standard techniques do not demonstrate a positive DAT, other, more sensitive techniques may be successful. The antibody screen reveals the presence of the panagglutinin in the serum in 80% of cases. Specificity for other antigens can be sought as described earlier but is difficult to obtain accurately without a large selection of rare, antigen-negative RBCs and is of marginal clinical benefit.

Management

General principles of treatment are guided by the severity of hemolysis. Those patients with a positive DAT, mild reticulocytosis, and normal hematocrit are not routinely subjected to steroid therapy. Folate deficiency can be prevented with daily supplements, which probably should be given to any patient with hemolysis. When the RBC life span shortens beyond the point of marrow compensation and a consequent anemia appears, intervention is indicated. Given the high proportion of secondary hemolytic anemias, a search for an underlying disorder that requires specific therapy, such as a lymphoproliferative disorder, is indicated. See Table 29.8. Treatment of the secondary disorder may also bring the AIHA under control. However, in some situations, each disorder must be addressed separately. Many treatment options exist for these patients, who can have vast differences in the severity of their disease.^{158, 159, 160}

First-Line Treatment

Steroids: Glucocorticoids are the initial therapy of choice for warm AIHA, usually on the order of 1.0 to 1.5 mg/kg or 40 mg/m²/day of prednisone or its equivalent. Higher daily doses or high-dose pulsed therapy may be efficacious.^{159, 161} Response may not be evident for 3 to 4 days but should be noticeable by 7 days. Reticulocyte counts may increase, and the hemoglobin should rise 2 to 3 g/dl per week. Once the hemoglobin reaches 10 g/dl, weaning of the steroid can begin, at a rate to parallel the response. Rapid responders can reduce their dose by 50% over 4 to 6 weeks. Beyond this point, tapering should proceed more slowly over 3 to 4 months. Some even continue a low dose for prolonged periods thereafter to prevent relapse, although no data exist to support this practice fully. This schedule should be adjusted for the individual response to the treatment and for any significant side effects that result. Side effects include increased susceptibility to infection, hypertension, fluid retention, diabetes, myopathy, peptic ulceration, osteoporosis, and even reversible facial cosmetic changes, and may be intolerable. Alternate-day steroid therapy decreases some of the side effects and may still be effective. Consideration should be given to concomitant prophylactic antacids, bisphosphonates, vitamin D, and calcium according to the recommendation of the American College of Rheumatology. Careful monitoring of blood glucose and aggressive treatment of diabetes is recommended because diabetes is a major risk factor for treatment-related deaths from infections.¹⁶²

The mechanism of action of steroids is multifactorial. Initially, steroids act through tissue macrophages delaying the reticuloendothelial clearance of IgG- and C3-coated RBCs.¹⁶³ Steroids may act by reducing antibody avidity,¹⁶⁴ and eventually may actually decrease antibody production.¹⁶⁵ Initial responses to steroids are generally excellent, with >80% of patients having a prompt reduction in hemolysis. In one series, only 7% took longer than 2 weeks, and even fewer more than 3 weeks. Therefore, if there has been no improvement after 3 weeks of therapy, the patient may be considered a steroid treatment failure. Recurrence of hemolysis after remission is usually gradual, especially if the steroids were weaned over a prolonged period.

Relapse of warm AIHA occurs in the vast majority of patients. Approximately 40% to 50% of patients require maintenance doses of prednisone (5 to 20 mg/day).¹⁶⁶ If the maintenance prednisone dose is >15 mg/day, other measures should be considered. Free autoantibody in the serum (positive IAT or antibody screen) may disappear, but the DAT remains positive in most patients, although perhaps weaker.⁴⁴ Complete and lasting remission rates from steroids alone are reported as occurring in only 16% to 35% of patients,^{167, 168} so the majority of patients with warm AIHA require additional therapy.

Second-Line Treatment

Second-line treatment is indicated in those surgical candidates who have not responded to prednisone, require prednisone doses >10 to 20 mg/day to maintain remission, or have suffered intolerable side effects.

Splenectomy: The rationale for splenectomy is twofold. The spleen is the major site of RBC sequestration and destruction in warm AIHA, resulting from the interaction of IgG antibodies with the macrophage F_c receptors. Splenectomy has little effect on the clearance of IgM-coated RBCs and therefore would not be indicated in the unusual patient with a warm-active IgM antibody. The spleen is also believed to be a major producer of IgG antibodies.^{31, 32} Overall responses are probably ~60% to 75%, but many of these patients relapse or remain on steroids, albeit at lower, more tolerable doses.^{31, 169, 170} The likelihood of response to splenectomy may be higher in idiopathic AIHA than in secondary AIHA.¹⁷¹ The complications of splenectomy are those inherent in major abdominal surgery and also include subdiaphragmatic abscess, pulmonary embolism, and increased susceptibility to infections, especially in children.^{44, 172} Pneumococcal, meningococcal, and Haemophilus influenzae vaccinations should be given, preferably administered preoperatively.¹⁷³ Subsequent to splenectomy, patients should be given antibiotics promptly with any febrile illness.

Rituximab: Rituximab may be used as a second-line treatment option in patients who refuse splenectomy or are at high surgical risk. Rituximab is a chimeric human/murine monoclonal anti-CD20 antibody approved for use in lymphoma. Successful rituximab use in refractory warm AIHA and Evans syndrome has been documented in several case reports and series.^{174, 175, 176, 177, 178} Regimens identical to the lymphoma treatment (375 mg/m²/week × 4 weeks) have produced remissions in some patients who were refractory to other therapeutic regimens. A response rate of 87% was reported for one series of refractory pediatric patients. Twenty-three percent of the responders relapsed, but subsequent courses of rituximab induced additional remissions.¹⁷⁸ Thus far, few side effects have been reported, but rare reactions to the infusion have been documented.¹⁷⁹ B-cell counts remain low for months after treatment, raising the risk of infections due to poor immune response.¹⁸⁰ The efficacy and toxicity of rituximab monotherapy was tested in additional retrospective studies in a mixed population of refractory primary or secondary AIHA. These studies have been summarized in a review by Lechner et al.¹⁸¹ Overall response rate was 82%. Safety data available are limited and adverse events include two patients with severe infections and one patient with myocardial infarction.¹⁸² The most severe potential long-term complication of rituximab treatment was progressive multifocal leukoencephalopathy (PML), which, however, has been observed in only two patients with AIHA.¹⁸¹ If remissions remain durable and potential side effects are less harmful than other treatments for warm AIHA, such as prolonged steroid use or splenectomy, rituximab may become accepted second-line therapy.

Immunosuppressive Therapy

Immunosuppressive therapy is indicated for patients who have failed to respond to splenectomy and/or rituximab therapy.¹⁸¹

P.760

Cyclophosphamide is an effective immunosuppressive agent with capability to suppress the immune response, even if administered after antigen presentation.¹⁸³ This is particularly desirable for administration after the onset of immune hemolysis. Beneficial effects of cyclophosphamide therapy are reported in reviews.^{166, 168, 169} Blood counts should be followed closely. Other significant side effects from the antimetabolites and cyclophosphamide include hemorrhagic cystitis, bladder fibrosis, secondary malignancies, sterility, and alopecia.^{31, 166, 184, 185} No properly controlled trial exists from which to draw conclusions, but the reviews and case reports suggest a response rate of approximately 40% to 60% in

those patients who did not respond to steroids and splenectomy.^{168, 169, 170} A reasonable immunosuppressive regimen might include azathioprine (80 mg/m²/day) or cyclophosphamide (60 mg/m²/day), concomitantly with prednisone (40 mg/m²/day). Prednisone may be tapered over 3 months or so, and the cytotoxic agent continued for 6 months before reducing the dose gradually.¹⁶⁶ Bone marrow suppression may dictate minor dose adjustments. Rapid withdrawal has led to rebound immune response.¹⁸⁶ Alternatively, high-dose cyclophosphamide (50 mg/kg/day ×4 days) has produced a complete remission in 66% of patients who were refractory to other therapies. Severe myelotoxicity and its attendant potential for complications are expected.¹⁷³

Mycophenolate mofetil, an inhibitor of inosine 5'-monophosphate dehydrogenase, is an immunosuppressant initially employed to treat allograft rejection. It has been shown to induce complete or partial remission of hemolysis in case reports. Doses begin at 1 g/day and are then increased to 2 g/day. In cases of partial remission, reduction in doses of other immunosuppressives was possible without sacrificing efficacy. Long-term side effects are not fully established. Short-term side effects consist primarily of gastrointestinal intolerance and mild myelosuppression.^{176, 177, 187, 188}

Cyclosporine A has been used both successfully and unsuccessfully in refractory hemolytic anemia patients, as were many of the other immunosuppressive medications previously described. Doses of 3 mg/kg/day with target serum levels of 200 to 400 ng/ml produced remissions.^{178, 189} It has also been used in combination with other remedies with some success, including danazol and prednisone.^{141, 179, 180, 190, 191}

Transfusion

As with CAD, red cell transfusion support may be required in patients who are clinically symptomatic or severely anemic. Patients with WAIHA should be tested for the presence of coexisting alloantibodies, which may have developed following pregnancies or prior transfusions. Alloantibodies, rather than autoantibodies, may cause major transfusion reactions in such patients if not discovered. However, identifying an alloantibody in the presence of an autoantibody takes additional time. Thus, if the patient needs to be transfused emergently, transfusion should be given prior to the availability of the results. Most patients will tolerate even serologically incompatible blood. Blood bank personnel should be involved early in the decision to transfuse to minimize delays and possible confusion.¹⁹²

Other Therapies

Intravenous immunoglobulin (IVIG) has not enjoyed the success in AIHA that it has in immune thrombocytopenia (ITP). Case reports of success^{193, 194, 195} and failure^{196, 197} have appeared. Escalating the dose from the standard 0.4 to 1.0 g/kg/day (×5 days) may be helpful. In one refractory patient, weekly maintenance infusions of 800 mg/kg/week helped to control transfusion requirements.¹⁹⁸ The mechanism of action of IVIG is not completely clear. Recent evidence suggests that IVIG exerts inhibitory effects on dendritic cells by down-regulating costimulatory molecules, blocking maturation, and modifying their interactions with lipopolysaccharide and cytokines.¹⁹⁹ Other postulated mechanisms include modulating expression and function of F_c receptors, interfering with the activation of complement, modulating immune response through anti-idiotypic antibodies, and effects on B- and T-cells.²⁰⁰

Plasmapheresis has been used with limited success in attempts to remove the antibody.^{31, 201, 202} However, in some patients fulminant hemolysis proceeds unchecked and plasmapheresis may serve as a temporizing measure until other immunosuppressive therapies can take effect. Selective removal of IgG with staphylococcal protein A columns has also been reported with some benefit.²⁰³

Stem cell transplantation (SCT) has been described for many severe, life-threatening autoimmune syndromes, including hemolytic anemia and Evans syndrome. Sources of the stem cells have been autologous, HLA-matched sibling, and cord blood.^{204, 205} Relapses and the expected range of complications, including death, have occurred. For very severe and refractory cases of Evans syndrome, SCT offers the only chance of long-term cure. Available data suggest that allogeneic SCT may be superior to autologous SCT, but both carry risks of severe morbidity and of transplant-related mortality. As more refractory patients are seen, stem cell reconstitution after high-dose immune suppressive regimens will no doubt expand. Cure of Evans syndrome following reduced-intensity conditioning has been reported and should be considered for younger patients in the context of controlled clinical trials.²⁰⁶

Alemtuzumab is a humanized anti-CD52 monoclonal antibody that is an effective therapy for B-CLL, mycosis fungoides, and T-cell prolymphocytic leukemia. There have been recent case reports that suggest alemtuzumab may be useful for the treatment of AIHA in B-CLL patients who have failed other treatments.^{207, 208}

Complications

Hoffmann suggests that venous thromboembolism is an underrecognized complication of AIHA and may in some instances be related to co-existent antiphospholipid antibodies.²⁰⁹ Although it is premature to recommend anticoagulant

prophylaxis in general for patients with AIHA hemolytic episodes, consideration might be given to those at particularly high risk, such as those with evidence of co-existing antiphospholipid antibodies.

DRUG-INDUCED IMMUNE HEMOLYTIC ANEMIA

Drugs can produce hemolysis by both immune and nonimmune mechanisms. In the 1970s and 1980s, α -methyldopa and high-dose penicillin were responsible for the majority of cases of drug-induced immune hemolytic anemia (DI-IHA). In recent years there has been a significant decline in DI-IHA due to α -methyldopa and high-dose penicillin because of declining use of those medications. More recent estimates of the incidence of DI-IHA are approximately 1 per million.²¹⁰ Second- and third-generation cephalosporins, especially cefotetan and ceftriaxone, have been associated increasingly with cases of immune hemolytic anemia, accounting for ~80% of the DI-IHA.²¹¹ Rarely, these cases of cephalosporin-induced immune hemolytic anemia are fatal. Other antibiotic agents associated with immune hemolytic anemia include β -lactamase inhibitors (clavulanate, sulbactam, and tazobactam) found in combination with β -lactam antibiotics in Timentin (ticarcillin/clavulanate), Unasyn (ampicillin/sulbactam), Zosyn (piperacillin/tazobactam), and piperacillin.²¹¹ AIHA has been noted with increased incidence in patients receiving purine nucleoside analogs such as fludarabine, cladribine, and pentostatin for hematologic malignancies.²⁰⁹ The mechanism by which these drugs cause AIHA is unclear. See Figure 29.4 and Tables 29.6 and 29.10.

P.761

TABLE 29.10 DRUGS ASSOCIATED WITH IMMUNE HEMOLYSIS OR AUTOANTIBODIES

Acetaminophen	Doxepin	Omeprazole
Aminopyrine	“Ecstasy”	Oxaliplatin
Amphotericin B	Elliptinium acetate	<i>p</i> -Aminosalicylic acid
Ampicillin	Erythromycin	Penicillin G
Antazoline	Etodolac	Phenacetin
Apazone (azapropazone)	Fenfluramine	Podophyllotoxin
Buthiazide (butazide)	Fenoprofen	Probenecid
Carbenicillin	Fludarabine	Procainamide
Carbimazole	Fluorescein	Propyphenazone
Carboplatin	5-Fluorouracil	Pyramidon
Catergen	Glafenine	Quinidine
Cefotaxime	Hydralazine	Quinine
Cefotetan	Hydrochlorothiazide	Ranitidine
Cefoxitin	Ibuprofen	Rifampin (rifampicin)
Ceftazidime	Insecticides	Sodium pentothal
Ceftriaxone	Insulin	Stibophen
Cephaloridine	Interferon- α	Streptomycin
Cephalothin	Intravenous contrast media	Sulfonamides
Chaparral	Isoniazid	Sulfonylurea derivative
Chlorambucil	Latamoxef	Sulindac
Chlorinated hydrocarbons	Levodopa	Suprofen
2-Chlorodeoxyadenosine	Mefenamic acid	Suramin

Chlorpromazine	Mefloquine	Teniposide
Chlorpropamide	Melphalan	Tetracycline
Cianidanol	6-Mercaptopurine	Thiazides
Ciproflaxin	Mephenytoin	Thiopental
Cisplatin	Methadone	Thioridazine
Cladribine	Methicillin	Tolbutamide
Cyclofenil	Methotrexate	Tolmetin
Diclofenac	Methyldopa	Triamterene
Diethylstilbestrol	Nafcillin	Trimellitic anhydride
Diglycoaldehyde	Nalidixic acid	Zomepirac
Dipyrrone	Nomifensine	

Modified from Arndt PA, Garratty G. The changing spectrum of drug-induced hemolytic anemia. *Semin Hematol* 2005;42:137-144.

Mechanisms

Drug-induced antibodies can be divided into two main groupings based on the requirement for the drug in detection. Drug-dependent antibodies (penicillin type or immune complex type) require the presence of the drug in the test system, whereas drug-independent antibodies (autoantibodies) do not. See Table 29.11 and Figure 29.5.

Drug-dependent antibodies may be true autoantibodies with serology that is identical to warm AIHA. There are three major mechanisms by which drugs can cause immune hemolysis in vivo²¹² (see Fig. 29.5):

- The drug adsorption mechanism, in which the antibody reacts with a drug tightly bound to the RBC membrane
- The neoantigen or immune complex mechanism, in which the drug combines loosely with the RBC membrane and the antibody reacts with new antigenic site(s) created by the combination of drug and membrane
- The autoimmune mechanism, which is indistinguishable from true AIHA without drug exposure

Some medications may produce hemolysis by more than one mechanism, and differentiating among them is not always possible. Nonimmunologic adsorption of proteins to the RBC membrane can also cause a positive DAT, but is not associated with increased RBC destruction.

Drug Adsorption Mechanism (Penicillin Type)

In a penicillin-type drug adsorption mechanism, the drug binds tightly to the RBC membrane and the antibody attaches to the drug without direct interaction with the erythrocyte. Penicillin binds to the RBC membrane covalently and can be demonstrated on the RBC in most patients receiving high doses of the drug, even in the absence of antibody.²¹³ Attachment of only the drug does not harm the erythrocyte. However, when the drug is given in large doses (>10 million units/day), it can induce production of IgG antibody, which attaches to the membrane-bound drug, thus producing a positive DAT with AHG sera.²¹³ Eluates from these RBCs do not react with RBC panels, in stark contrast to the previously discussed true autoimmune antibodies, which display panagglutinin activity. The explanation lies in the fact that penicillin-induced antibodies are attached to the drug alone and not to membrane components of the erythrocyte. If reagent cell suspensions are first coated with penicillin, agglutination occurs with all RBCs, thus providing a diagnostic testing strategy when drug-induced hemolysis is suspected.³¹

The benzylpenicilloyl determinant is the primary antigenbinding site. High-titered IgG antibenzylpenicilloyl antibodies are responsible for the positive DAT and appear in ~3% of patients receiving high doses of the drug.²¹⁴ Only some of these patients develop hemolysis.³¹ Rare exceptions of complement fixation to the RBCs exist in patients on penicillin. These have been associated with IgG attachment, and the DAT is positive with both anti-IgG and anti-C3 sera.^{215, 216}

RBC destruction in the drug adsorption mechanism of hemolysis is through sequestration by splenic macrophages of the IgG-coated RBCs.^{217, 218} Rarely, when associated with complement fixation, the RBCs may be lysed (intravascular hemolysis).²¹⁹ Anemia develops gradually over ~7 to 10 days and can be life-threatening if not recognized and the drug discontinued. Once the medication is stopped, the hemolysis resolves over the ensuing couple of weeks. However, the

DAT may remain positive for several weeks. Of clinical importance is the observation that other signs of penicillin hypersensitivity, such as urticaria and airway reactivity, are usually absent.³¹

Other drugs can also cause hemolysis by this mechanism. Cephalosporins,^{220, 221, 222, 223, 224} tetracycline,^{225, 226} tolbutamide,²²⁷ and semisynthetic penicillins^{228, 229} can cause DI-IHA by this mechanism.

Neoantigen Mechanism (Quinidine/Stibophen Type)

The neoantigen mechanism is also known as the immune complex mechanism. The antibody is specific for a combination antigen, or neoantigen, created jointly by the drug and RBCs. Investigations with rare antigen-negative RBCs revealed that 2 antibodies have specific sites on the RBC membrane to which they attach along with the drug.^{230, 231}

The neoantigen mechanism differs from the drug adsorption mechanism in a few key areas. Unlike the penicillin model, these drugs bind very loosely to the RBC membrane. Only a small dose of the medication is required for hemolysis to occur, as opposed to the very large doses of penicillin required. Hemolysis is usually sudden, severe, and accompanied by hemoglobinuria² instead of the subacute anemia typically seen with the drug adsorption type. Renal failure is a frequent occurrence in the neoantigen mechanism.^{232, 233} The effector phase is mediated predominantly by complement

P.762

fixation and subsequent intravascular hemolysis. Some sequestration of RBCs occurs in splenic macrophages or the liver via complement receptors. The DAT is positive only for the presence of complement, and IgM or IgG are rarely still attached to the RBC.³¹ Therefore, eluates are nonreactive primarily because there is no immunoglobulin to elute. In vitro, serum reacts with RBCs only in the presence of the drug or a reactive metabolite.³¹ These drugs may also induce thrombocytopenia by similar mechanisms.^{234, 235}

TABLE 29.11 MECHANISMS OF DRUG-INDUCED HEMOLYSIS OR POSITIVE DIRECT ANTIGLOBULIN TEST

	Drug Adsorption	Neoantigen	Autoimmune	Nonimmune Adsorption
Prototype drug	Penicillin	Quinidine/stibophen	α -Methyldopa	First-generation cephalosporins
Role of drug	Cell-bound hapten	Antibody binds drug + RBC	Induces drug-independent RBC antibody	Modifies RBC membrane; adsorbs proteins nonspecifically
Typical direct antiglobulin test	IgG	Complement	IgG	Non-Ig
Antibody reactions	Reacts only with drug-coated cells	Reacts only with drug present	Drug-independent panagglutinin	No antibody present
Typical clinical presentation	Subacute onset; mild to severe hemolysis	Acute onset; severe hemolysis	Insidious onset; chronic mild hemolysis	No hemolysis

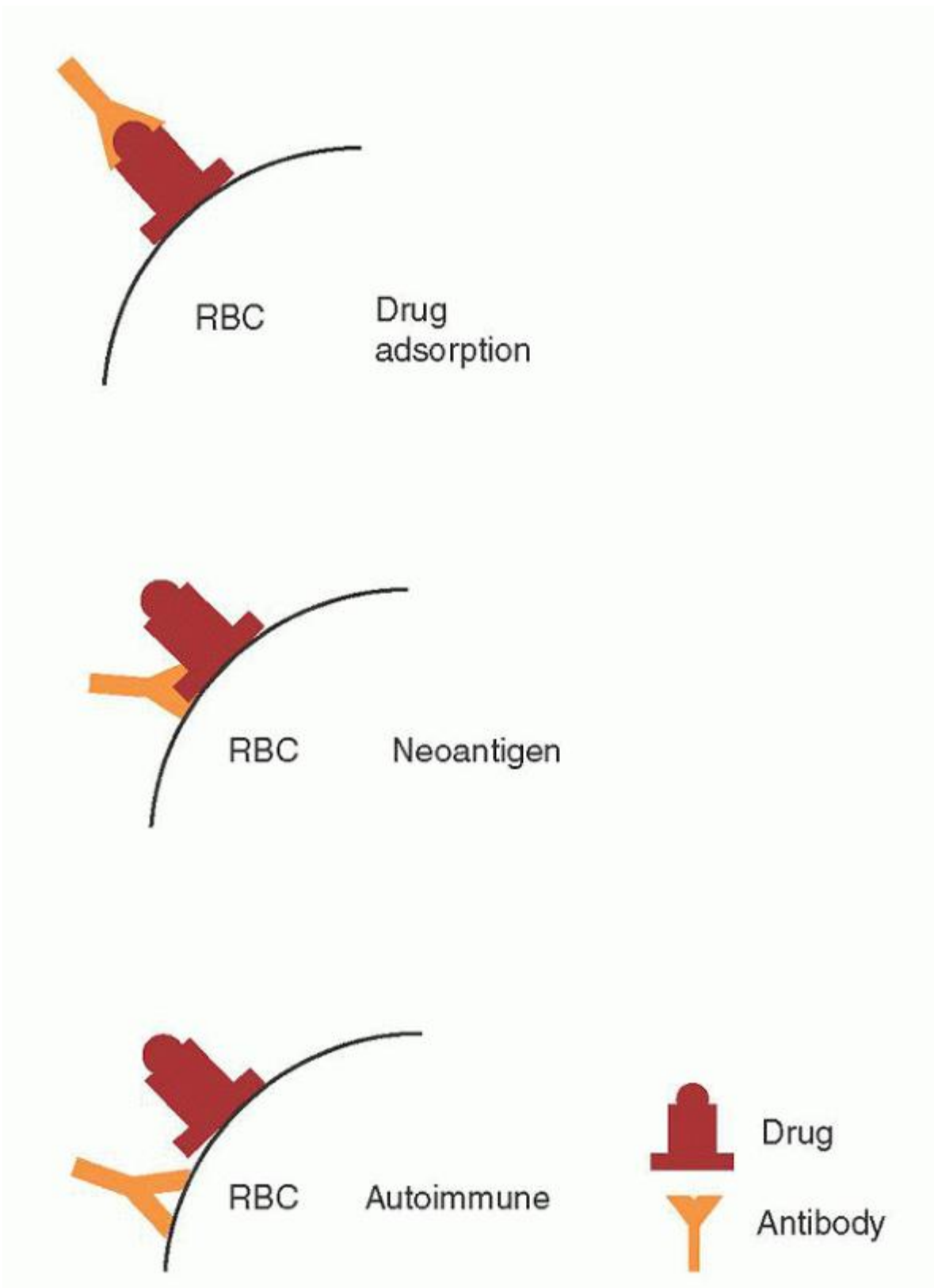

FIGURE 29.5. A proposed theory of drug-induced antibody reactions. A: The antibody attaches only to the drug, which is tightly bound to the red blood cell (RBC) membrane (penicillin type). B: The antibody attaches to a neoantigen created by components of both the drug and the RBC membrane (quinidine/stibophen type). C: The antibody attaches mainly to the membrane, not requiring the presence of the drug (α -methyldopa type). (Adapted from Habibi B. Drug induced red blood cell autoantibodies co-developed with drug specific antibodies causing haemolytic anaemias. *Br J Haematol* 1985;61:139-

143.)

Autoimmune Mechanism (α -Methyldopa Type)

Unlike the previous two mechanisms, which require the presence of the offending drug for antibody reaction with the RBC membrane, hemolysis induced by α -methyldopa is truly autoimmune in nature. Antibodies bind to erythrocyte membrane antigens in a manner indistinguishable from the sporadic AIHA discussed earlier. With declining use of α -methyldopa, these antibodies are now seen in association with cladribine, fludarabine, levodopa, mefenamic acid, and procainamide.²¹¹ The etiology of these antibodies is unknown, but the drugs likely directly stimulate the immune system to mimic an autoimmune disease. The DAT is positive with anti-IgG and is usually negative with anti-C3. The eluate shows a panreactive antibody. The characteristics of the IgG antibody eluted from the RBCs are strikingly similar to those in idiopathic warm AIHA. They are polyclonal²³⁶ and bind as a panagglutinin to reagent cells even in the absence of the drug. As in warm AIHA, these antibodies have a predilection for Rh antigens, with some specific anti-c and anti-e documented.^{236, 237}

Despite a high incidence of immunoglobulin coating of RBCs, only a minority of patients actually develop clinical hemolysis.² Explanations of this phenomenon have been unsatisfactory. The amount of antibody on the RBC correlates poorly with in vivo hemolysis, and no threshold has been well established.^{61, 238}

Nonimmunologic Protein Adsorption Mechanism

Proteins other than immunoglobulins may attach nonspecifically to the RBC membrane and cause positive antiglobulin reactions. These do not cause increased RBC destruction and are of importance only because of the need to differentiate them from those of clinical significance. This is most commonly seen in patients on cephalosporins, which produce a positive DAT in ~3% of patients.^{239, 240} Other drugs that have been associated with this mechanism include cefotetan, cisplatin, diglycoaldehyde, oxaliplatin, suramin, and the β -lactamase inhibitors clavulanate, sulbactam, and tazobactam.²¹¹ Many different RBC-bound proteins have been detected within a few days of instituting the medication, including fibrinogen, albumin, complement, immunoglobulins, and α_2 -macroglobulin.²⁴⁰ Clinical distinction between this benign finding and other, potentially significant ones involves the demonstration of a nonreactive eluate with cephalosporin-treated RBCs and the absence or low titer of antidrug antibodies in the serum.³¹ In the absence of hemolysis, a positive DAT is not a cause for discontinuing the medication.

Multiple Mechanisms—Unifying Hypothesis

Many medications have been implicated in producing hemolysis by more than one mechanism, sometimes simultaneously in the

P.763

same patient. Arndt and Garratty have referred to a unifying hypothesis in their review.²¹¹ The drug or its metabolites interact with the constituents of the RBC membrane, resulting in production of different populations of antibodies. Of these antibodies, some react with drug epitopes alone (drug adsorption). Other antibodies may react with drug and membrane components (neoantigen mechanism), and others with RBC membrane components (autoantibody mimickers). See Figure 29.6.

Clinical Manifestations

The clinical features of DI-IHA are similar to those found in idiopathic AIHA, including pallor, jaundice, and easy fatigability. Splenomegaly is not uncommon, but lymphadenopathy and hepatomegaly should not be attributed to drug-related hemolysis.²⁴¹ The severity of these symptoms depends on the rate of hemolysis, which is, in part, dependent on the mechanism involved. Those patients with the neoantigen mechanism are at the greatest risk for plummeting hemoglobins, hemoglobinuria, and renal failure.^{2, 232, 242} Cefotetan has been implicated in many severe hemolytic reactions.^{243, 244, 245} Fatal reactions are rare but may occur.^{224, 246} Cefotetan, ceftriaxone, and fludarabine have been associated with fatalities.^{211, 247} The drug adsorption and autoimmune varieties are typically characterized by insidious onset of hemolysis over days to weeks. A careful medication history is necessary to evaluate the possibility of a culprit drug in all patients with AIHA.

Laboratory Features

Just as with idiopathic AIHA, anemia with reticulocytosis and a positive DAT are hallmarks of the condition. Elevated indirect bilirubin and LDH are common findings. Rampant RBC destruction leads to hemoglobinemia, hemoglobinuria, and elevated creatinine levels. Distinguishing the mechanisms involved can be accomplished by the serologic results. One can

differentiate the neoantigen mechanism from cold autoantibodies by the absence of high-titer cold agglutinins or D-L antibodies in the drug-induced cases. Drug-induced antibodies also do not react in the absence of the drug or a metabolite in IATs. Only a careful history and resolution of the hemolysis after discontinuation of the drug can separate the α -methyl dopa variety from true autoimmune antibodies. Antibodies to cefotetan react to very high titers against drug-treated RBCs and at lower titers with untreated RBCs with or without drug present. Antibodies to ceftriaxone are the immune complex type.²¹¹ The positive DAT may persist for a few weeks to months after stopping the medication responsible, especially with the autoimmune mechanism.³¹

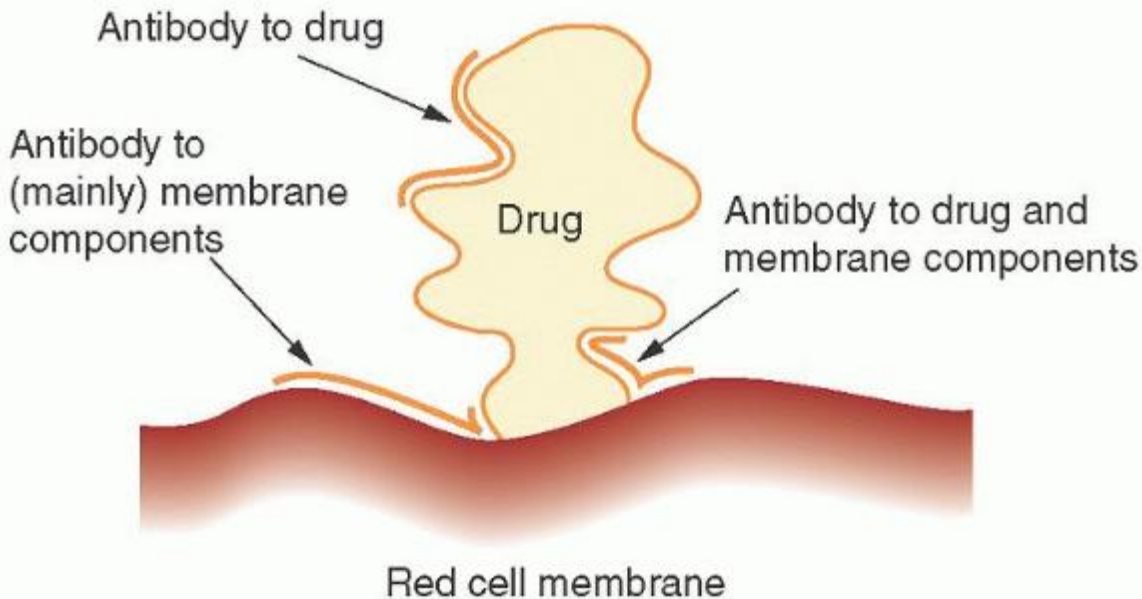

FIGURE 29.6. Proposed unifying hypothesis for drug-induced antibody reactions. The thicker darker lines represent antigen-binding sites on the F_{ab} region of the drug-induced antibody. Drugs (haptens) bind loosely (or firmly) to cell membranes, and antibodies can be made to (a) the drug (producing in vitro reactions typical of a drug adsorption [penicillin-type] reaction); (b) membrane components, or mainly membrane components (producing in vitro reactions typical of autoantibody); or (c) part-drug, part-membrane components (producing an in vitro reaction typical of the so-called immune complex mechanism). (From Garratty G. Target antigens for red-cell bound autoantibodies. In: Nance SJ, ed. Clinical and basic science aspects of immunohematology. Arlington, VA: American Association of Blood Banks, 1991:33-72.)

Management

A careful drug history, including over-the-counter medications, nutritional or dietary supplements, and illicit drugs, is imperative. Discontinuing the implicated medication is usually all that is necessary in management of drug-induced hemolytic anemia. Problems may arise when a positive DAT occurs and uncertainty exists as to whether significant RBC destruction is occurring. As previously described, many medications may be associated with a positive DAT test and yet not cause hemolysis. The drug need not be stopped in these patients.

In cases of brisk hemolysis associated with the neoantigen mechanism, stopping the offending agent can be life-saving. Although the helpfulness of prednisone therapy is questionable,²⁴⁸ it has been used with some success in fludarabine-associated DI-IHA.²⁴⁷ Transfusion can be accomplished, usually without difficulty in cross-matching, as the antibodies in the drug adsorption and neoantigen mechanisms are drug-dependent. However, patients with the autoimmune mechanism may encounter the same difficulties as previously discussed in the section on warm AIHA. It is important to keep in mind that transfused RBCs may be destroyed at the same rate as endogenous RBCs if drug or active metabolites are still circulating. Prognosis is typically excellent for these patients after discontinuation of the drug. With the variety of choices of pharmaceuticals available, alternative therapies are nearly always accessible to treat the underlying condition adequately.

TRANSPLANT-ASSOCIATED IMMUNE HEMOLYTIC ANEMIAS

Although it is not technically an autoimmune hemolytic process, the immune hemolysis associated with transplantation is analogous in many ways. In both cases, antibodies are generated against endogenous self-antigens; the key distinction lies in the source of the antibody-producing lymphocytes. That source can be either the lymphocytes and their precursors contained in a stem cell product being utilized for hematopoietic reconstitution, or they can be lymphocytes that are merely passengers contained in the vascular and perivascular regions of a solid organ being transplanted.²⁴⁹ See Table 29.12.

Hematopoietic Stem Cell Transplants

Hematopoietic stem cell transplants can be ABO-compatible or ABO-mismatched. The mismatch can include major, minor, or both major and minor ABO incompatibilities.²⁵⁰ ABO-compatible stem cell transplants have the same ABO type for the donor and recipient. A major ABO mismatch implies the introduction of a foreign ABO antigen, as would be seen with a group O recipient of a group A, B, or AB donor stem cell product. A minor ABO mismatch implies the introduction of a foreign ABO antibody(isohemagglutinin), as would be seen with a group A, B, or AB recipient of a group O donor stem cell product. Both major and minor incompatibilities would be seen with a group A recipient of a group B donor product or a group B recipient of a group A donor product. Appropriate selection of RBC- and plasma-containing blood products can help minimize the complications of passive antibody transfer.²⁵⁰ The acute impact of a minor incompatible stem cell transplant is ameliorated with a simple washing of the donor product to prevent passive transfer of pre-existing antibodies. However, when there is a minor incompatibility, the novel hematopoietic stem cells will eventually produce lymphocytes that generate antibodies against the recipient's original remaining RBCs. This immune hemolysis

P.764

may begin 7 to 10 days post-transplant and can be abrupt and severe. As the patient's original—but now incompatible—RBCs are destroyed, they are replaced by a combination of transfused cells and post-engraftment novel donor-type RBCs. Consequently, the immune-mediated RBC destruction is limited by the residual original-type RBCs remaining.

TABLE 29.12 TIMING OF POST-TRANSPLANT IMMUNE HEMOLYTIC ANEMIA

Immediate	Days-Weeks-Months
Hemolysis of original RBCs due to ABO antibodies in the donor stem cell product (minor ABO group mismatch)	Passenger lymphocyte syndrome
Passive transfer of ABO antibodies: infusion of plasma, platelets, IVIG, intravenous anti-D, and antilymphocyte globulin	Passive transfer of ABO antibodies: infusion of plasma, platelets, IVIG, intravenous anti-D, and antilymphocyte globulin
Hemolysis of donor RBCs contained in stem cell product by original preexisting ABO antibodies (major ABO group mismatch)	Hemolysis of donor RBCs produced by the newly engrafted marrow caused by residual ABO antibodies (major ABO group mismatch) Alloantibodies produced by residual cells of the original immune system Alloantibodies produced by engrafted cells of the donor's immune system (weeks-months)
Autoimmune hemolytic anemia	Autoimmune hemolytic anemia

IVIG, Intravenous immunoglobulin; RBC, red blood cell.

Solid Organ Transplants and the Passenger Lymphocyte Syndrome

The immune hemolysis associated with solid organ transplantation is typically due to a passenger lymphocyte syndrome. This situation can be seen with just about any solid organ being transplanted, as long as the donor and recipient share an RBC incompatibility. The classic example involves a group O organ transplanted into a group A recipient. Donor lymphocytes that are merely passengers in the transplanted organ react to recipient (endogenous) RBCs and generate antirecipient RBC antibodies. The consequent hemolytic anemia is more frequent with transplanted organs containing significant lymphoid mass. The incidence is lowest in kidney transplant recipients (9% to 17%), intermediate among liver

transplant recipients (29% to 40%), and highest in heart-lung transplant recipients (70%).^{250, 251, 252, 253} Extensive perfusion of transplanted organs does not necessarily prevent this passenger lymphocyte syndrome, implying extravascular lymphocyte sequestration. Unlike the hemolysis associated with minor ABO-incompatible hematopoietic stem cell transplants, the target RBCs are not replaced by transfusion and a novel engrafted marrow. Consequently, the immune-mediated RBC destruction is limited only by the survival of the passenger lymphocytes.

REFERENCES

1. Sokol RG, Hewitt S, Stamps BK. Autoimmune haemolysis. Mixed warm and cold antibody type. *Acta Haematol* 1983;69:266-274.
2. Worledge SM. Immune drug-induced hemolytic anemias. *Semin Hematol* 1969;6:181-200.
3. De Angelis, De Matteis MC, Cozzi MR, et al. Abnormalities of membrane protein composition in patients with autoimmune hemolytic anemia. *Br J Haematol* 1996;95:273-277.
4. Shen CR, Youssef AR, Devine A. Peptides containing a dominant T-cell epitope from red cell band 3 have in vivo immunomodulatory properties in NZB mice with autoimmune hemolytic anemia. *Blood* 2003;102:3800-3806.
5. Shlomchik MJ. Mechanisms of immune self-tolerance and how they fail in autoimmune disease. In: Silberstein L, ed. *Autoimmune disorders of blood*. Bethesda, MD: American Association of Blood Banks, 1996:1-34.
6. Abbas AK. Diseases of immunity. In: Kumar V, Abbas A, and Fausto N, eds. *Robbins and Cotran pathologic basis of disease*, 7th ed. Philadelphia, PA: Elsevier Saunders, 2005;223-225.
7. Semple JW, Freedman J. Autoimmune pathogenesis and autoimmune hemolytic anemia. *Semin Hematol* 2005;42:122-130.
8. Hall AM, Ward FJ, Vickers MA, et al. Interleukin mediated regulatory T-cell responses to epitopes on a human red blood cell autoantigen. *Blood* 2002;100:4529-4536.
9. Worth GR, Jones BA, Schreiber AD. F_c receptor structure/function and role in immune complex-mediated autoimmune disease. *Hematology (Am Soc Hematol Educ Prog)* 2004;54-58.
10. Brown EJ. Complement receptors, adhesion, and phagocytosis. *Infect Agents Dis* 1992;2:63-70.
11. Cooper NR, Moore MD, Nemerow GR. Immunobiology of CR2, the B lymphocyte receptor for Epstein-Barr virus and the C3d complement fragment. *Annu Rev Immunol* 1988;6:85-113.
12. Ross GD, Medof ME. Membrane complement receptors specific for bound fragments of C3. *Adv Immunol* 1985;37:217-267.
13. Frank MM, Fries LF. The role of complement in inflammation and phagocytosis. *Immunol Today* 1991;12:322-326.
14. Lachmann PJ, Voak D, Oldroyd RG, et al. Use of monoclonal anti-C3 antibodies to characterize the fragments of C3 that are found on erythrocytes. *Vox Sang* 1983;45:367-372.
15. Logue G, Rosse WF. Immunologic mechanisms in autoimmune hemolytic disease. *Semin Hematol* 1976;13:277-289.
16. Frank MM, Schreiber AD, Atkinson JP. NIH conference. Pathophysiology of immune hemolytic anemia. *Ann Intern Med* 1977;87:210-222.
17. Unkless JC. Function and heterogeneity of human Fc receptors for immunoglobulin G. *J Clin Invest* 1989;83:355-361.
18. van de Winkel JGJ, Anderson CL. Biology of human immunoglobulin G Fc receptors. *J Leukoc Biol* 1991;49:511-524.
19. Anderson DR, Kelton JG. Mechanisms of intravascular and extravascular cell destruction. In: Nance SJ, ed. *Immune destruction of red cells*. Arlington, VA: American Association of Blood Banks, 1989:1-52.
20. van Oss CJ, Absolom DR. Hemagglutination and the closest distance approach of normal, neuraminidase, and papain-treated erythrocytes. *Vox Sang* 1983;47:250-256.
21. Leikola J, Pasanen VJ. Influence of antigen receptor density on agglutination of red blood cells. *Int Arch Allergy Appl Immunol* 1970;39:352-360.
22. Fukuda M, Fukuda MV, Hakomori S-I. Developmental change and genetic defect in the carbohydrate structure of band 3 glycoprotein of human erythrocyte membrane. *J Biol Chem* 1979;254:3700-3703.
23. Economidou J, Hughes-Jones NC, Gardner B. The functional activities of IgG and IgM anti-A and anti-B. *Immunol* 1967;13:227-234.

24. Greenbury CL, Moore D, Nunn LAC. Reaction of 7S and 19S components of immune rabbit antisera with human group A and AB red cells. *Immunology* 1963;6:421.
25. Moreschi C. Neue Tatsachen über die Blut Körperchenagglutination. *Zentralbl Bakt* 1908;46:49-51.
26. Coombs RRA, Mourant AE, Race RR. A new test for the detection of weak and "incomplete" Rh agglutinins. *Br J Exp Pathol* 1945;26:255-266.
27. Coombs RRA, Mourant AE, Race RR. In vivo isosensitization of red cells in babies with haemolytic disease. *Lancet* 1946;1:264-266.
28. Zarandona JM, Yazer MH. Teaching case report. The role of the Coombs test in evaluating hemolysis in adults. *Can Med Assoc J* 2006;174:305-307.
29. Brecher ME, ed. Technical manual, 15th ed. Bethesda, MD: American Association of Blood Banks, 2005.
30. South SF. Use of the direct antiglobulin test in routine testing. In: Wallace M, Levitt J, eds. Current applications and interpretations of the direct antiglobulin test. Arlington, VA: American Association of Blood Banks, 1988:25-45.
31. Petz LD, Garratty G. Acquired immune hemolytic anemias. New York, NY: Churchill Livingstone, 1980.
32. Sokol RJ, Booker DJ, Stamps R, et al. IgA red cell autoantibodies and autoimmune hemolysis. *Transfusion* 1997;37:175-181.
33. Garratty G. Novel mechanisms for immune destruction of circulating autologous cells. In: Silberstein L, ed. Autoimmune disorders of blood. Bethesda, MD: American Association of Blood Banks, 1996:79-114.
34. Burkhart P, Rosenfield RE, Hsu TC. Instrumental PVP-augmented antiglobulin tests I. Detection of allogeneic antibodies coating otherwise normal erythrocytes. *Vox Sang* 1974;26:289-304.
35. Garratty G. Immune hemolytic anemia associated with negative routine serology. *Semin Hematol* 2005;42:156-164.
36. Issitt PD, Pavone BG, Goldfinger D, et al. Anti Wrb and other autoantibodies responsible for positive direct antiglobulin tests in 150 individuals. *Br J Haematol* 1976;34:5-18.
37. Weiner W, Vox GH. Serology of acquired hemolytic anemias. *Blood* 1963;22:606-613.
38. Garratty G. Target antigens for red-cell-bound autoantibodies. In: Nance SJ, ed. Clinical and basic science aspects of immunohematology. Arlington, VA: American Association of Blood Banks, 1991:33-72.
39. Szymanski IO, Roberts PL, Rosenfield RE. Anti-A autoantibody with severe intravascular hemolysis. *N Engl J Med* 1976;294:995-996.
40. Sokol RJ, Hewitt S, Booker DJ, et al. Patients with red cell autoantibodies: selection of blood for transfusion. *Clin Lab Haematol* 1988;10:257-264.
41. Donath J, Landsteiner K. Ueber Paroxysmal Hämoglobinurie. *Münch Med Wschr* 1904;51:1590-1593.
42. Landsteiner K. Über Beziehungen zwischen dem Blutserum und den Körperzellen. *Munch Med Wochenschr* 1903;50:1812.
43. Schubothe H. The cold hemagglutinin disease. *Semin Hematol* 1966;3:27-47.
44. Dacie J. The auto-immune haemolytic anaemias, 3rd ed. Edinburgh: Churchill Livingstone, 1992.
45. Wortman J, Rosse W, Logue G. Cold agglutinin autoimmune hemolytic anemia in nonhematologic malignancies. *Am J Hematol* 1979;6:275-283.
46. Pruzanski W, Shumak KH. Biologic activity of cold reactive autoantibodies. *N Engl J Med* 1977;297:538-542.
47. Roelcke D, Hack H, Kreft H, et al. IgA cold agglutinins recognize Pr and Sa antigens expressed on glycoporphins. *Transfusion* 1993;33:472-475.
48. Williams R, Kunkel H, Capra J. Antigenic specificities related to the cold agglutinin activity of gamma M globulins. *Science* 1968;161:379.
49. Silberstein LE, Jefferies LC, Goldman J, et al. Variable region gene analysis of pathologic human auto-antibodies to the related i and I red blood cell antigens. *Blood* 1991;73:2372-2386.
50. Stevenson F, Smith G, North J, et al. Identification of normal B-cell counterparts of neoplastic CLLs which secrete cold agglutinins of anti-I and anti-i specificity. *Br J Haematol* 1989;72:9-15.

51. Pascual V, Victor K, Spellerberg M, et al. VH restriction among human cold agglutinins. The VH4-21 gene segment is required to encode anti-I and anti-i specificities. *J Immunol* 1992;149:2337-2344.
52. Michaux L, Dierlamm J, Wlodarska L, et al. Trisomy 3q11-q29 is recurrently observed in B-cell non-Hodgkin's lymphomas associated with cold agglutinin syndrome. *Ann Hematol* 1998;76:201-204.
53. Silberstein LE, Robertson GA, Harris AC, et al. Etiologic aspects of cold agglutinin disease: evidence for cytogenetically defined clones of lymphoid cells and the demonstration that an anti-Pr cold autoantibody is derived from a chromosomally aberrant B cell clone. *Blood* 1986;67:1705-1709.
54. Silberstein LE, Goldman J, Kant JA, et al. Comparative biochemical and genetic characterization of clonally related human B-cell lines secreting pathogenic anti-Pr2 cold agglutinins. *Arch Biochem Biophys* 1988;264: 244-252.
55. Roelcke D. Cold agglutination. *Transfus Med Rev* 1989;3:140-166.
56. Konig AL, Schabel A, Sugg U, et al. Autoimmune hemolytic anemia caused by IgG lambda-monotypic cold agglutinins of anti-Pr specificity after rubella infection. *Transfusion* 2001;41:488-492.
57. von dem Borne AE, Mol JJ, Joustra-Maas N, et al. Autoimmune haemolytic anaemia with monoclonal IgM(k) anti-P cold autohaemolysins. *Br J Haematol* 1982;50:345-350.
58. Loomes LM, Uemure K-I, Childs RA, et al. Erythrocyte receptors for *Mycoplasma pneumoniae* are sialylated oligosaccharides of Ii antigen type. *Nature* 1984;307:560-563.
59. Costea N, Yakulis V, Heller P. Inhibition of cold agglutinins (anti-I) by *M. pneumoniae* antigens. *Proc Soc Exp Biol Med* 1972;139:476-479.
60. Tanowitz HB, Robbins N, Leidich N. Hemolytic anemia associated with severe *Mycoplasma pneumoniae* pneumonia. *N Y State J Med* 1978;78:2231-2232.
61. Dacie JV, Worlledge SM. Autoimmune hemolytic anemias. In: Brown EB, Moore CV, eds. *Progress in hematology VI*. New York, NY: Grune & Stratton, 1969:82-120.
62. Jenkins WJ, Koster HG, Marsh WL, et al. Infectious mononucleosis: an unsuspected source of anti-i. *Br J Haematol* 1965;11:480-483.
63. Hossaini AA. Anti-i infectious mononucleosis. *Am J Clin Pathol* 1970;53: 198-203.
64. Horwitz CA, Moulds J, Henle W, et al. Cold agglutinins in infectious mononucleosis and heterophil-antibody-negative mononucleosis-like syndromes. *Blood* 1977;50:195-200.
65. Bowman HS, Marsh WL, Schumacher HR, et al. Auto anti-N immunohemolytic anemia in infectious mononucleosis. *Am J Clin Pathol* 1974;61:465-472.
66. Goldberg L, Barnett E. Mixed IgG-IgM cold agglutinin. *J Immunol* 1967;99:803-809.
67. Gronemeyer P, Chaplin H, Ghazarian V, et al. Hemolytic anemia complicating infectious mononucleosis due to the interaction of an IgG cold anti-i and an IgM cold rheumatoid factor. *Transfusion* 1981;21:715-718.
68. Horwitz CA, Skradski K, Reece E, et al. Haemolytic anaemia in previously healthy adult patients with CMV infections: report of two cases and an evaluation of subclinical haemolysis in CMV mononucleosis. *Scand J Haematol* 1984;33:35-42.
69. Evans RS, Turner E, Bingham M. Studies with radioiodinated cold agglutinins of ten patients. *Am J Med* 1965;38:378.
70. Rosse WF, Adams JP. The variability of hemolysis in the cold agglutinin syndrome. *Blood* 1980;56:409-416.
71. Evans RS, Bingham M, Turner E, et al. Autoimmune hemolytic disease: observations of serological reactions and disease activity. *Ann N Y Acad Sci* 1965;124:422-440.
72. Ferriman DG, Dacie JV, Kelle KD, et al. The association of Raynaud's phenomena, chronic haemolytic anaemia, and the formation of cold antibodies. *Q J Med N S* 1951;20:275-292.
73. Chitnavis VN, Patou G, Makar YF, et al. B19 parvovirus-induced red cell aplasia complicating acute cold antibody-mediated haemolytic anaemia. *Br J Haematol* 1990;76:433-434.

74. Harboe M, Torvick H. Protein abnormalities in the cold haemagglutinin syndrome. *Scand J Haematol* 1969;6:416-426.
75. Hippe E, Jensen KB, Olesen H, et al. Chlorambucil treatment of patients with cold agglutinin syndrome. *Blood* 1970;35:68-72.
76. Foerster J. Autoimmune hemolytic anemias. In: Lee G, Bithell TC, Foerster J, Athens JW, Lukens JN, eds. *Wintrobe's clinical hematology*, 9th ed. Philadelphia, PA: Lea & Febiger, 1993:1170-1196.
77. Fest T, de Wazieres B, Lamy B, et al. Successful response to alpha-interferon 2b in a refractory IgM autoagglutinin-mediated hemolytic anemia. *Ann Hematol* 1994;69:147-149.
78. Berentsen S, Ulvestad E, Gjertsen BT, et al. Rituximab for primary chronic cold agglutinin disease: a prospective study of 37 courses of therapy in 27 patients. *Blood* 2004;103(8):2925-2928.
79. Schollkopf C, Kjeldsen L, Bjerrum OW, et al. Rituximab in chronic cold agglutinin disease: a prospective study of 20 patients. *Leuk Lymphoma* 2006;47(2):253-260.
80. Hongeng S, Tardtong P, Worapongpaiboon S, et al. Successful treatment of refractory autoimmune haemolytic anaemia in a post-unrelated bone marrow transplant paediatric patient with rituximab. *Bone Marrow Transplant* 2002;29:871-872.
81. Taft EG, Propp RP, Sullivan SA. Plasma exchange for cold agglutinin hemolytic anemia. *Transfusion* 1977;17:173-176.
82. Rodenhuis S, Maas A, Hazenberg CA, et al. Inefficacy of plasma exchange in cold agglutinin hemolytic anemia—a case study. *Vox Sang* 1985;49:20-25.
83. Nydegger UE, Kazatchkine MD, Miescher PA. Immunopathologic and clinical features of hemolytic anemia due to cold agglutinins. *Semin Hematol* 1991;28:66-77.
84. Zoppi M, Oppliger R, Althaus U, et al. Reduction of plasma cold agglutinin titers by means of plasmapheresis to prepare a patient for coronary bypass surgery. *Infusionstherap Transfusionsmed* 1993;20:19-22.
85. Innet LM, Lester JL 3rd, Tait N. Cold agglutinins: preoperative diagnosis leads to an uneventful perfusion. *Perfusion* 1995;10:343-345.
86. Agarwal SK, Ghosh PK, Gupta D. Cardiac surgery and cold-reactive proteins. *Ann Thorac Surg* 1995;60:1143-1150.
87. Siami FS, Siami GA. A last resort modality using cryofiltration apheresis for the treatment of cold hemagglutinin disease in a Veterans Administration hospital. *Ther Apher Dial* 2004;8:398-403.
88. McCullough J. *Transfusion medicine*, 2nd ed. Philadelphia, PA: Elsevier, 2005:341.
89. Woll JE, Smith CM, Nusbacher J. Treatment of acute cold agglutinin hemolytic anemia with transfusion of adult i RBCs. *JAMA* 1974;229:1779-1780.
90. Bell CA, Zwicker H, Sacks HJ. Autoimmune hemolytic anemia: routine serologic evaluation in a general hospital population. *Am J Clin Pathol* 1973;60:903-911.
91. Rosenfield RE, Jagathambal. Transfusion therapy for autoimmune hemolytic anemia. *Semin Hematol* 1976;13:311-321.
92. Schreiber AD, Herskovitz BS, Goldwein M. Low-titer cold-hemagglutinin disease. *N Engl J Med* 1977;296:1490-1494.
93. Hillmen P, Hall C, Marsh JC, et al. Effect of eculizumab on hemolysis and transfusion requirements in patients with paroxysmal nocturnal hemoglobinuria. *N Engl J Med* 2004;350:552-559.
94. Heddle NM. Acute paroxysmal cold hemoglobinuria. *Transfus Med Rev* 1989;3:219-229.
95. Göttsche B, Salama A, Mueller-Eckhardt C. Donath-Landsteiner autoimmune hemolytic anemia in children. A study of 22 cases. *Vox Sang* 1990;58: 281-286.
96. Gelfand EW, Abramson N, Segel GB, et al. Buffy-coat observations and red cell antibodies in acquired hemolytic anemia. *N Engl J Med* 1971;284: 1250-1252.
97. Hinz CB Jr, Picken ME, Lepow IH. Studies on immune human hemolysis. I. The kinetics of the Donath-Landsteiner reaction and the requirement for complement in the reaction. *J Exp Med* 1961;113:177-192.
98. Hinz CF Jr. Serologic and physicochemical characterization of Donath-Landsteiner antibodies from six patients. *Blood* 1963;22:600-605.

99. Schwarting GA, Kundu SK, Marcus DM. Reaction of antibodies that cause paroxysmal cold hemoglobinuria (PCH) with globoside and Forssman glycosphingolipids. *Blood* 1979;53:186-192.
100. Levine P, Celano MJ, Falkowski F. The specificity of the antibody in paroxysmal cold hemoglobinuria. *Transfusion* 1963;3:278-280.
101. Levine P, Celano MJ, Falkowski F. The specificity of the antibody in paroxysmal cold hemoglobinuria (P.C.H.). *Ann N Y Acad Sci* 1966;124:456-461.
102. van Loghem JJ, van der Hart M, Dorfmeier H. Serological studies in acquired hemolytic anemia. In: Sixth International Congress of the International Society of Hematology, 1958. New York: Grune & Stratton, 1958.
103. Sokol RJ, Hewitt S, Stamps BK. Autoimmune haemolysis associated with Donath-Landsteiner antibodies. *Acta Haematol (Basel)* 1982;68:268-277.
104. Hernandez JA, Steane SM. Erythrophagocytosis by segmented neutrophils in paroxysmal cold hemoglobinuria. *Am J Clin Pathol* 1984;81:787-789.
105. Hunt JH. The Raynaud phenomena: a critical review. *Q J Med* 1936;5: 399-444.
106. O'Neill BJ, Marshall WC. Paroxysmal cold haemoglobinuria and measles. *Arch Dis Child* 1967;42:183-186.
107. Bunch DF, Schwarz DM, Bird GWG. Paroxysmal cold haemoglobinuria following measles immunization. *Arch Dis Child* 1972;47:299-300.
108. Colley EW. Paroxysmal cold haemoglobinuria after mumps. *Br Med J* 1964;i:1552-1553.
109. Boccardi V, D'Annibali S, DiNatale G, et al. Mycoplasma pneumoniae infection complicated by paroxysmal cold hemoglobinuria with anti-P specificity of biphasic hemolysin. *Blut* 1977;34:211-214.
110. Sokol RJ, Hewitt S, Stamps BK. Autoimmune haemolysis in childhood and adolescence. *Acta Haematol (Basel)* 1984;72:245-257.
111. Wolach B, Hedde N, Barr RD, et al. Transient Donath-Landsteiner haemolytic anaemia. *Br J Haematol* 1981;48:425-434.
112. Mohler DH, Farris BL, Pearre AA. Paroxysmal cold hemoglobinuria with acute renal failure. *Arch Intern Med* 1963;112:36-40.
113. Rausen AR, LeVine R, Hsu TCS, et al. Compatible transfusion therapy for paroxysmal cold hemoglobinuria. *Pediatrics* 1975;55:275-278.
114. Roy-Burman A, Glader BE. Resolution of severe Donath-Landsteiner autoimmune hemolytic anemia temporally associated with institution of plasmapheresis. *Crit Care Med* 2002;30:931-934.
115. Nelson MG, Nicholl B. Paroxysmal cold haemoglobinuria. *Ir J Med Sci, Sixth Ser* 1960;410:49-57.
116. Shulman IA, Branch DR, Nelson JM, et al. Autoimmune hemolytic anemia with both cold and warm autoantibodies. *JAMA* 1985;253:1746-1748.
117. Kajii E, Miura Y, Ikemoto S. Characterization of autoantibodies in mixed type autoimmune hemolytic anemia. *Vox Sang* 1991;60:45-52.
118. Sokol R, Hewitt S, Stamps BK. Autoimmune haemolysis: an 18 year study of 865 cases referred to a regional transfusion centre. *Br Med J Clin Res Educ* 1981;282:2023-2027.
119. Dausset J, Colombani J. The serology and the prognosis of 128 cases of auto-immune hemolytic anemia. *Blood* 1959;14:1280-1301.
120. Da Costa JAG, White AG, Parker AC, et al. Increased incidence of HL-A1 and 8 in patients showing IgG or complement coating on their red cells. *J Clin Pathol* 1974;27:353-355.
121. Clauvel JP, Marcelli-Barge A, Gautier Coggia I, et al. HLA antigens and idiopathic autoimmune hemolytic anemias. *Transplant Proc* 1974;6:447-448.
122. Abdel-Khalik A, Paton L, White AG, et al. Human leucocyte antigens A, B, C and DRW in idiopathic "warm" autoimmune haemolytic anaemia. *Br Med J* 1980;280:760-761.
123. Toolis F, Parker AC, White A, et al. Familial autoimmune haemolytic anaemia. *Br Med J* 1977;1:1392.

124. Dacie J. Secondary or symptomatic haemolytic anaemias, 3rd ed. Edinburgh: Churchill Livingstone, 1995.
125. Engelfriet CP, Overbeeke MA, von dem Borne AE. Autoimmune hemolytic anemia. *Semin Hematol* 1992;29:3-12.
126. Ravetch J, Kinet J-P. Fc receptors. *Annu Rev Immunol* 1991;9:457-492.
127. Anderson CL, Looney RJ. Human leukocyte IgG Fc receptors. *Immunol Today* 1986;7:264.
128. Pirofsky B. Clinical aspects of autoimmune hemolytic anemia. *Semin Hematol* 1976;13:251-265.
129. Sokol RJ, Hewitt S, Stamps B. Erythrocyte autoantibodies, autoimmune haemolysis and pregnancy. *Vox Sang* 1982;43:169-176.
130. Chaplin H Jr, Cohen R, Bloomberg G, et al. Pregnancy and idiopathic autoimmune haemolytic anaemia: a prospective study during 6 months gestation and 3 months post-partum. *Br J Haematol* 1973;24:219-229.
131. Starksen NF, Bell WE, Kickler TS. Unexplained hemolytic anemia associated with pregnancy. *Am J Obstet Gynecol* 1983;146:617-622.
132. Burt RL, Prichard RW. Acquired hemolytic anaemia in pregnancy: report of a case. *Obstet Gynecol* 1957;10:444-450.
133. Johnson ST, McFarland JG, Kelly KJ, et al. Transfusion support with RBCs from an Mk homozygote in a case of autoimmune hemolytic anemia following diphtheria-pertussis-tetanus vaccination. *Transfusion* 2002;42: 567-571.
134. Downes KA, Domen RE, McCarron KF, et al. Acute autoimmune hemolytic anemia following DTP vaccination: report of a fatal case and review of the literature. *Clin Pediatr* 2001;40:355-358.
135. Muwakkit S, Rachid R, Bazarbachi A, et al. Treatment-resistant infantile Evans syndrome. *Pediatr Int* 2001;43:502-504.
136. Evans RS, Duane RT. Acquired hemolytic anaemia. I. The relation of antibody activity to activity of the disease. II. The significance of thrombocytopenia and leukopenia. *Blood* 1949;4:1196-1213.
137. Evans RS, Takahashi K, Duane RT, et al. Primary thrombocytopenic purpura and acquired hemolytic anaemia. Evidence for a common etiology. *Arch Intern Med* 1951;87:48-65.
138. Crosby WH, Rappaport H. Autoimmune hemolytic anaemia. I. Analysis of hematologic observations with particular reference to their prognostic value. A survey of 57 cases. *Blood* 1957;12:42-55.
139. Wang WC. Evans syndrome in childhood: pathophysiology, clinical course, and treatment. *Am J Pediatr Hematol Oncol* 1988;10:330-338.
140. Scaradavou A, Bussel J. Evans syndrome results of a pilot study utilizing a multiagent treatment protocol. *J Pediatr Hematol Oncol* 1995;17:290-295.
141. Ucar B, Akgun N, Aydogdu SD, et al. Treatment of refractory Evans' syndrome with cyclosporine and prednisone. *Pediatr Int* 1999;41:104-107.
142. Liesveld JL, Rowe JM, Lichtman MA. Variability of the erythropoietic response in autoimmune hemolytic anemia: analysis of 189 cases. *Blood* 1987;69:820-826.
143. Mangan KF, Besa EC, Shaddock RK, et al. Demonstration of two distinct antibodies in autoimmune hemolytic anemia with reticulocytopenia and red cell aplasia. *Exp Hematol* 1984;12:788-793.
144. Hauke G, Fauser AA, Weber S, et al. Reticulocytopenia in severe auto-immune hemolytic anemia (AIHA) of the warm antibody type. *Blut* 1983;46:321-327.
145. Lefrère J-J, Couroucé A-M, Bertrand Y, et al. Human parvovirus and aplastic crisis in chronic hemolytic anemias: a study of 24 observations. *Am J Hematol* 1986;23:271-275.
146. Zinkham WH, Diamond LK. In vitro erythrophagocytosis in acquired hemolytic anemia. *Blood* 1952;7:592-601.
147. Fagiolo E. Platelet and leukocyte antibodies in autoimmune hemolytic anemia. *Acta Haematol (Basel)* 1976;56:97-106.
148. Russell NH, Keenan JP, Fraiss MA. Thrombocytopenia associated with autoimmune hemolytic anemia. *Br Med J* 1978;2:604.
149. Tisdale WA, Klatskin G, Kinsella ED. Significance of the indirect-reacting fraction of serum bilirubin in hemolytic jaundice. *Am J Med* 1959;26:214-227.

150. Payne R, Spaet TH, Aggeler PM. An unusual antibody pattern in a case of idiopathic acquired hemolytic anemia. *J Lab Clin Med* 1955;46:245-254.
151. Kretschmer V, Mueller-Eckhardt C. Autoimmune hemolytic anemias. II. Immunoglobulins and b1-globulin in the serum with special regard to the immunochemical type of autoantibodies and the course of the disease. *Blut* 1972;25:159-168.
152. Mueller-Eckhardt C, Möhring F, Kretschmer V, et al. Reappraisal of the clinical and etiologic significance of immunoglobulin deviations in autoimmune hemolytic anemia ("warm type"). *Blut* 1977;34:39-47.
153. Chaplin H Jr. Clinical usefulness of specific antiglobulin reagents in autoimmune hemolytic anemias. *Prog Hematol* 1973;7:25-49.
154. Araguás C, Martí-n-Vega C, Massagué I, et al. "Complete" warm hemolysins producing an autoimmune hemolytic anemia. *Vox Sang* 1990;59:125-126.
155. Wolf MW, Roelcke D. Incomplete warm hemolysins. *Clin Immunol Immunopathol* 1989;51:68-76.
156. Lalezari P. Serologic profile in autoimmune hemolytic disease: pathophysiologic and clinical interpretations. *Semin Hematol* 1976;13:291-310.
157. Van der Meulen FW, de Bruin HG, Goosen PC, et al. Quantitative aspects of the destruction of red cells sensitized with IgG1 autoantibodies: an application of flow cytofluorometry. *Br J Haematol* 1980;46:47-56.
158. Gehrs BC, Friedberg RC. Autoimmune hemolytic anemia. *Am J Hematol* 2002;69:258-271.
159. Petz LD. Treatment of autoimmune hemolytic anemias. *Curr Opin Hematol* 2001;8:411-416.
160. Dacie SJ. The immune haemolytic anaemias: a century of exciting progress in understanding. *Br J Haematol* 2001;114:770-785.
161. Meyer O, Stahl D, Beckhove P, et al. Pulsed high-dose dexamethasone in chronic autoimmune haemolytic anaemia of warm type. *Br J Haematol* 1997;98:860-862.
162. Nakasone H, Kako S, Endo H, et al. Diabetes mellitus is associated with high early-mortality and poor prognosis in patients with autoimmune hemolytic anemia. *Hematology*. 2009;14(6):361-365.
163. King KE, Ness PM. Treatment of autoimmune hemolytic anemia. *Semin Hematol* 2005;42:131-136.
164. Rosse WF. Quantitative immunology of immune hemolytic anemia II. The relationship of cell bound antibody of hemolysis and the effect of treatment. *J Clin Invest* 1971;50:734-743.
165. Zupanska B, Sylwestrowicz T, Pawelsi S. The results of prolonged treatment of autoimmune hemolytic anemia. *Hematologia* 1971;4:425-433.
166. Murphy S, LoBuglio AF. Drug therapy in autoimmune hemolytic anemia. *Semin Hematol* 1976;13:323-334.
167. Allgood JW, Chaplin H. Idiopathic acquired autoimmune hemolytic anemia: a review of forty-seven cases treated from 1955 through 1965. *Am J Med* 1967;43:254-273.
168. Zupanska B, Sylwestrowicz T, Pawelsi S. The results of prolonged treatment of autoimmune hemolytic anemia. *Hematologia* 1971;4:425-433.
169. Gibson J. Autoimmune hemolytic anemia: current concepts. *Aust N Z J Med* 1988;18:625-637.
170. Pirofsky B, Bardana EJ Jr. Autoimmune hemolytic anemia: II. Therapeutic aspects. *Ser Haematol* 1974;7:376-385.
171. Akpek G, McAneny D, Weintraub L. Comparative response to splenectomy in Coombs-positive autoimmune hemolytic anemia with or without associated disease. *Am J Hematol* 1999;61:98-102.
172. Heisel MA, Ortega JA. Factors influencing prognosis in childhood autoimmune hemolytic anemia. *Am J Pediatr Hematol Oncol* 1983;5:147-152.
173. Moyo VM, Smith D, Brodsky I, et al. High-dose cyclophosphamide for refractory autoimmune hemolytic anemia. *Blood* 2002;100:704-706.
174. Ahrens N, Kingreen D, Seltsam A, et al. Treatment of refractory autoimmune haemolytic anaemia with anti-CD20 (rituximab). *Br J Haematol* 2001;114:244-245.

175. Quartier P, Brethon B, Philippet P, et al. Treatment of childhood autoimmune haemolytic anaemia with rituximab. *Lancet* 2001;358:1511-1513.
176. Perrotta S, Locatelli F, La Manna A, et al. Anti-CD20 monoclonal antibody (rituximab) for life-threatening autoimmune haemolytic anaemia in a patient with systemic lupus erythematosus. *Br J Haematol* 2002;116:465-467.
177. McMahan C, Babu L, Hodgson A, et al. Childhood refractory autoimmune haemolytic anaemia: is there a role for anti-CD20 therapy (rituximab)? *Br J Haematol* 2002;117:480-483.
178. Zecca M, Nobili B, Ramenghi U, et al. Rituximab for the treatment of refractory autoimmune hemolytic anemia in children. *Blood* 2003;101:3857-3861.
179. Kunkel L, Wong A, Maneatis T, et al. Optimizing the use of rituximab for treatment of B-cell non-Hodgkin's lymphoma: a benefit-risk update. *Semin Oncol* 2000;27(Suppl 12):53-61.
180. van der Kolk LE, Baars JW, Prins MH, et al. Rituximab treatment results in impaired secondary humoral immune responsiveness. *Blood* 2002;100: 2257-2259.
181. Lechner K, Jager U. How I treat autoimmune hemolytic anemias in adults *Blood*. 2010;116(11):1831-1838
182. Bussone G, Ribeiro E, Dechartres A, et al. Safety of rituximab in adults with warm antibody autoimmune haemolytic anemia: retrospective analysis of 27 cases. *Am J Hematol*. 2009;84(3):153-157.
183. Floersheim GL. A comparative study of the effects of anti-tumor and immunosuppressive drugs on antibody forming and erythropoietic cells. *Clin Exp Immunol* 1970;6:861-870.
184. Johnson WW, Meadows DC. Urinary bladder fibrosis and telangiectasia associated with long-term cyclophosphamide therapy. *N Engl J Med* 1971;284:290-294.
185. Kumar R, Biggart JD, McEvoy J, et al. Cyclophosphamide and reproductive function. *Lancet* 1972;1:1212-1214.
186. Cheema AR, Hersh EM. Patient survival after chemotherapy and its relationship to in vitro lymphocyte blastogenesis. *Cancer* 1971;28:851-855.
187. Howard J, Hoffbrand AV, Prentice HG, et al. Mycophenolate mofetil for the treatment of refractory auto-immune haemolytic anaemia and auto-immune thrombocytopenia purpura. *Br J Haematol* 2002;117:712-715.
188. Zimmer-Molsberger B, Knauf W, Thiel E. Mycophenolate mofetil for severe autoimmune haemolytic anemia. *Lancet* 1997;350:1003-1004.
189. Emilia G, Messori C, Longo G, et al. Long-term salvage treatment by cyclosporin in refractory autoimmune haematological disorders. *Br J Haematol* 1996;93:341-344.
190. Chemlal K, Wyplosz B, Grange MJ, et al. Salvage therapy and long-term remission with danazol and cyclosporine in refractory Evan's syndrome. *Am J Hematol* 1999;62:200.
191. Rackoff WR, Manno CS. Treatment of refractory Evans syndrome with alternate-day cyclosporine and prednisone. *Am J Pediatr Hematol Oncol* 1994;16:156-159.
192. Garratty G, Petz LD. Approaches to selecting blood for transfusion to patients with autoimmune hemolytic anemia. *Transfusion* 2002;42(11):1390.
193. Bussell JB, Cunningham-Rundles C, Abraham C. Intravenous treatment of autoimmune hemolytic anemia with very high dose gammaglobulin. *Vox Sang* 1986;51:264-269.
194. Leickly FE, Buckley RH. Successful treatment of auto-immune hemolytic anemia in common variable immunodeficiency with high-dose intravenous gamma globulin. *Am J Med* 1987;82:159-162.
195. Majer RV, Hyde RD. High-dose intravenous immunoglobulin in the treatment of autoimmune haemolytic anaemia. *Clin Lab Haematol* 1988;10:391-395.
196. Salama A, Mahn I, Neuzner J, et al. IgG therapy in autoimmune haemolytic anaemia of warm type. *Blut* 1984;48:391-392.
197. Weinblatt ME. Treatment of immune hemolytic anemia with gammaglobulin [letter]. *J Pediatr* 1987;110:817.
198. Vandenberghe P, Zachee P, Verstraete S, et al. Successful control of refractory and life-threatening autoimmune hemolytic anemia with intravenous immunoglobulins in a man with the primary antiphospholipid syndrome. *Ann Hematol* 1996;73:253-256.

199. Bayry J, Lacroix-Desmazes S, Carbonneil C, et al. Inhibition of maturation and function of dendritic cells by intravenous immunoglobulin. *Blood* 2003;101:758-765.
200. Mackay IR, Rosen FS. Immunomodulation of autoimmune and inflammatory diseases with intravenous immune globulin. *N Engl J Med* 2001;345: 747-755.
201. Anderson O, Taaning E, Rosenkvist J, et al. Autoimmune haemolytic anaemia treated with multiple transfusion, immunosuppressive therapy, plasma exchange, and desferrioxamine. *Acta Paediatr Scand* 1984;73:145-148.
202. Kutti J, Wadenvik H, Safai-Kutti S, et al. Successful treatment of refractory autoimmune haemolytic anaemia by plasmapheresis. *Scand J Haematol* 1984;32:149-152.
203. Jaweed M, Nifong TP, Domen RE, et al. Durable response to combination therapy including staphylococcal protein A immunoabsorption in life threatening refractory autoimmune hemolysis. *Transfusion* 2002;42:1217-1220.
204. Seeliger S, Baumann M, Mohr M, et al. Autologous peripheral blood stem cell transplantation and anti-B-cell directed immunotherapy for refractory auto-immune haemolytic anaemia. *Eur J Pediatr* 2001;160:492-496.
205. Raetz E, Beatty PG, Adams RH. Treatment of severe Evans syndrome with an allogeneic cord blood transplant. *Bone Marrow Transplant* 1997;20:427-429.
206. Norton A, Roberts I. Management of Evans syndrome. *Br J Haematol* 2006;132:125-137.
207. Lundin J, Karlsson C. Alemtuzumab therapy for severe autoimmune hemolysis in a patient with B-cell chronic lymphocytic leukemia. *Med Oncol* 2006;23:137-139.
208. Cheung WW, Hwang GY. Alemtuzumab induced complete remission of auto-immune hemolytic anemia refractory to corticosteroids, splenectomy and rituximab. *Haematologica* 2006 May;91(Suppl 5):ECR13.
209. Hoffmann P. Immune hemolytic anemia—selected topics. *Hematology (Am Soc Hematol Educ Prog)* 2006;13-18.
210. Petz LD, Garratty G. *Immune hemolytic anemias*, 2nd ed. Philadelphia, PA: Churchill Livingstone, 2004.
211. Arndt PA, Garratty G. The changing spectrum of drug-induced hemolytic anemia. *Semin Hematol* 2005;42:137-144.
212. Habibi B. Drug induced red blood cell autoantibodies co-developed with drug specific antibodies causing haemolytic anaemias. *Br J Haematol* 1985;61:139-143.
213. Levine BB, Redmond A. Immunochemical mechanisms of penicillin induced Coombs positivity and hemolytic anemia in man. *Int Arch Allergy Appl Immunol* 1967;31:594-606.
214. Petz LD. Immunologic cross-reactivity between penicillins and cephalosporins: a review. *J Infect Dis* 1978;137S:S74-S79.
215. Kerr RO, Caramone J, Dalmaso AP, et al. Two mechanisms of erythrocyte destruction in penicillin-induced hemolytic anemia. *N Engl J Med* 1972;287:1322-1325.
216. Ries CA, Rosenbaum TJ, Garratty G, et al. Penicillin-induced immune hemolytic anemia. *JAMA* 1975;233:432-435.
217. Swanson MA, Chanmougan D, Schwartz RS. Immuno-hemolytic anemia due to anti-penicillin antibodies. *N Engl J Med* 1966;274:178-181.
218. Nesmith LW, Davis JW. Hemolytic anemia caused by penicillin. *JAMA* 1968;203:27-30.
219. Funicella T, Weinger RS, Moake JL, et al. Penicillin-induced immuno-hemolytic anemia associated with circulating immune complexes. *Am J Hematol* 1977;3:219-223.
220. Gralnick HR, Wright LD, McGinniss MH. Coombs' positive reactions associated with sodium cephalothin therapy. *JAMA* 1967;199:725-726.
221. Gralnick HR, McGinniss MH, Elton W, et al. Hemolytic anemia associated with cephalothin. *JAMA* 1971;217:1193-1197.
222. Branch DR, Berkowitz LR, Becker RL, et al. Extravascular hemolysis following the administration of cefamandole. *Am J Hematol* 1985;18:213-219.
223. Chambers LA, Donovan BA, Kruskall MS. Ceftazidime-induced hemolysis patient with drug-dependent antibodies reactive by immune complex and drug adsorption mechanisms. *Am J Clin Pathol* 1991;95:393-396.
224. Garratty G, Nance S, Lloyd M, et al. Fatal immune hemolytic anemia due to cefotetan. *Transfusion* 1992;32:269-271.

225. Simpson MB, Pryzbylik J, Innis B, et al. Hemolytic anemia after tetracycline therapy. *N Engl J Med* 1985;312:840-842.
226. Wenz B, Klein RL, Lalezari P. Tetracycline-induced immune hemolytic anemia. *Transfusion* 1974;14:265-269.
227. Malacarne P, Castaldi G, Bertusi M, et al. Tolbutamide-induced hemolytic anemia. *Diabetes* 1977;26:156-158.
228. Tuffs L, Manoharan A. Flucloxacillin-induced haemolytic anaemia. *Med J Aust* 1986;144:559-560.
229. Seldon MR, Bain B, Johnson CA, et al. Ticarcillin-induced immune haemolytic anaemia. *Scand J Haematol* 1982;28:459-460.
230. Habibi B, Bretagne Y. Blood group antigens may be the receptors for specific drug-antibody complexes reacting with red blood cells. *C R Acad Sci (Paris)* 1983;296:693-696.
231. Salama A, Mueller-Eckhardt C. On the mechanisms of sensitization and attachment of antibodies to RBC in drug-induced immune hemolytic anemia. *Blood* 1987;69:1006-1010.
232. Muirhead EE, Halden ER, Groves M. Drug-dependent Coombs' (antiglobulin) test and anemia. *Arch Intern Med* 1958;101:87.
233. Muirhead EF, Groves M, Guy R, et al. Acquired hemolytic anemia, exposures to insecticides and positive Coombs' test dependent on insecticide preparations. *Vox Sang* 1959;4:277.
234. Christie DJ, Mullen PC, Aster RH. Fab-mediated binding of drug-dependent antibodies to platelets in quinidine- and quinine-induced thrombocytopenia. *J Clin Invest* 1985;75:310-314.
235. Smith ME, Reid DM, Jones CE, et al. Binding of quinine- and quinidine dependent drug antibodies to platelets is mediated by the Fab domain of immunoglobulin G and is not Fc dependent. *J Clin Invest* 1987;79: 912-917.
236. Bakemeier RF, Leddy JP. Erythrocyte autoantibody associated with alpha methyl dopa: heterogeneity of structure and specificity. *Blood* 1968;32:1-14.
237. LoBuglio AF, Jandl JH. The nature of the alpha-methyl dopa red-cell antibody. *N Engl J Med* 1967;276:658-665.
238. Garratty G, Nance SJ. Correlation between in vivo hemolysis and the amount of red cell-bound IgG measured by flow cytometry. *Transfusion* 1990;30: 617-631.
239. Abraham GN, Petz LD, Fudenberg HH. Immunohaematological cross-allergenicity between penicillin and cephalothin in humans. *Clin Exp Immunol* 1968;3:343-357.
240. Spath P, Garratty G, Petz LD. Studies on the immune response to penicillin and cephalothin in humans. II. Immunohematologic reactions to cephalothin administration. *J Immunol* 1971;107:860-869.
241. Worlledge SM, Carstairs KC, Dacie JV. Autoimmune haemolytic anaemia associated with alpha-methyl dopa therapy. *Lancet* 1966;2:135-139.
242. MacGibbon BH, Loughridge LW, Hourihane DB, et al. Autoimmune haemolytic anaemia with acute renal failure due to phenacetin and p-aminosalicylic acid. *Lancet* 1960;1:7.
243. Garratty G, Leger RM, Arndt PA. Severe immune hemolytic anemia associated with prophylactic use of cefotetan in obstetric and gynecologic procedures. *Am J Obstet Gynecol* 1999;181:103-104.
244. Naylor CS, Steele L, Hsi R, et al. Cefotetan-induced hemolysis associated with antibiotic prophylaxis for cesarean delivery. *Am J Obstet Gynecol* 2000;182:1427-1428.
245. Ray EK, Warkentin TE, O'Hoski PL, et al. Delayed onset of life-threatening immune hemolysis after perioperative antimicrobial prophylaxis with cefotetan. *Can J Surg* 2000;43:461-462.
246. Garratty G, Postoway N, Schwellenbach J, et al. A fatal case of ceftriaxone (Rocephin)-induced hemolytic anemia associated with intravascular immune hemolysis. *Transfusion* 1991;31:176-179.
247. Borthakur G, O'Brien S, Wierda WG, et al. Immune anemias in patients with chronic lymphocytic leukaemia treated with fludarabine, cyclophosphamide and rituximab-incidence and predictors. *Br J Haematol*. 2007;136(6): 800-805.
248. Petz LD. Drug-induced autoimmune hemolytic anemia. *Transfus Med Rev* 1993;7:242-254.
249. Petz LD. Immune hemolysis associated with transplantation. *Semin Hematol* 2005;42:145-155.
250. Friedberg RC. Transfusion therapy in the patient undergoing hematopoietic stem cell transplantation. *Hematol Oncol Clin North Am* 1994;8: 1105-1116.

251. Ramsey G. Red cell antibodies arising from solid organ transplants. *Transfusion* 1991;31:76-86.
252. Magrin GT, Street AM, Williams TJ, Esmore DS. Clinically significant anti-A derived from B lymphocytes after single lung transplantation. *Transplantation* 1993;56:466-467.
253. Ramsey GE, Sherman LA. Transfusion therapy in solid organ transplantation. *Hematol Oncol Clin North Am* 1994;8:1117-1129.

Chapter 30 Hemolytic Disease of the Fetus and Newborn

> Table of Contents > Part IV - Disorders of Red Cells > Section 3 - Hemolytic Anemia > Chapter 30 - Hemolytic Disease of the Fetus and Newborn

Chapter 30

Hemolytic Disease of the Fetus and Newborn

Charles T. Quinn

Anne F. Eder

Catherine S. Manno

Hemolytic disease of the fetus and newborn (HDFN) results from the destruction of red blood cells by maternal immunoglobulin (Ig) G antibodies that gain access to the fetal circulation during pregnancy. These antibodies may be directed against Rhesus (Rh) or other blood group antigens on fetal red blood cells, inherited from the father and not present on the mother's red blood cells. HDFN associated with blood group antibodies has a broad spectrum of effects, ranging from mild anemia and hyperbilirubinemia in an infant to life-threatening complications before birth.¹ Clinical manifestations of severe hemolytic disease before birth include profound fetal anemia, hepatosplenomegaly, generalized edema, massive ascites, and congestive heart failure. The accelerated destruction of fetal red blood cells elicits extramedullary hematopoiesis and release of nucleated and other immature red blood cells into the peripheral circulation (erythroblastosis fetalis). Ongoing hemolysis of red blood cells after birth results in neonatal hyperbilirubinemia that may cause kernicterus and permanent neurologic injury or death.

HISTORICAL BACKGROUND

In the 20th century, HDFN was recognized as a distinct clinical entity, its pathogenesis was delineated, and an effective strategy for preventing its most common form was introduced. Case reports in the early 1900s (and before) described edematous (hydropic) stillborns and anemic infants with marked jaundice who died within days of birth. Not until 1932 were these phenomena realized to be the same hematologic disease process when Diamond et al. described the interrelationship of neonatal anemia, jaundice, and edema as symptoms that occur in varying degrees and combinations in erythroblastosis fetalis.²

The precise etiology of the disease remained obscure until seminal observations on blood group antigens and incompatibility in pregnancy were made in the 1940s. Landsteiner and Weiner first used immune sera raised in rabbits against red blood cells from Rhesus monkeys to agglutinate human red blood cells, thus discovering the Rhesus factor.³ This antigen, now known as the D antigen of the Rhesus blood group in humans, is present exclusively on red blood cells of Rh-positive individuals. In the year before this discovery, Levine and Stetson recognized that a woman could become immunized against paternally inherited red blood cell determinants of the fetus during pregnancy.⁴ Using Landsteiner's anti-Rh antisera to investigate cases of erythroblastosis fetalis, Levine et al. subsequently demonstrated that 90% of the mothers were Rh negative, and all the fathers and infants were Rh positive.⁵ This statistical association as well as the presence of Rh agglutinins in the blood of mothers with affected infants supported their theory that alloimmunization and transplacental passage of these antibodies caused destruction of fetal red blood cells.⁵ The inciting stimulus for red blood cell alloimmunization in pregnancy, the passage of fetal red blood cells into the maternal circulation or fetal-maternal hemorrhage (FMH), was directly demonstrated by Chown in 1954.⁶

Methods to monitor alloimmunized pregnancies and to treat affected fetuses and infants were first introduced in the late 1940s. Neonatal exchange transfusion enabled simultaneous correction of the anemia and reduction of bilirubin concentration in affected infants.^{1, 7} In 1961, Liley described the relationship between the concentration of bilirubin in amniotic fluid and the degree of destruction of fetal red blood cells, providing a tool to assess the severity of intrauterine hemolytic disease.⁸ Two years later, Liley introduced the technique of intraperitoneal transfusion of anemic fetuses, which was used for more than 20 years before it was largely supplanted with intravascular transfusion techniques.⁹

Primary prevention of D alloimmunization became possible with the advent of anti-D immune prophylaxis. The ability of passively transferred antibodies to effectively block active immunization to foreign antigens was first demonstrated by Von Dungern in 1900.¹ Experimental studies in the 1960s applied this approach to D alloimmunization, revealing that Rh-negative men could be protected if administered anti-D immune globulin (RhIG) before transfusion with Rh-positive red blood cells.^{10, 11} Between 1963 and 1968, clinical trials involving Rh-negative pregnant women demonstrated that administration of RhIG within 72 hours of delivery was successful in reducing the incidence of D alloimmunization from 7% to 15% to 1% to 2%.^{12, 13, 14, 15, 16, 17} Metaanalysis of clinical trials of postpartum RhIG administration confirms a >90% reduction in the alloimmunization rate among treated women compared to untreated women (Table 30.1).¹⁷ The recognition that FMH occurring primarily in the third trimester contributed to residual risk of alloimmunization during pregnancy led to the clinical observation that additional, antenatal RhIG prophylaxis could further reduce the risk of D alloimmunization to <1%.^{18, 19} Meta-analysis of two randomized controlled trials involving more than 4,500 women confirms the effectiveness of antenatal administration of RhIG at 28 weeks and 32 weeks of pregnancy (Table 30.1).^{20, 21, 22}

By 1971, the administration of RhIG to D-negative women after delivery of a D-positive infant and after abortion was recommended by the World Health Organization and rapidly became widespread practice.²³ Recommendations for antenatal administration of RhIG were more controversial in some countries because of supply concerns and economic cost-benefit arguments, but were introduced in Canada and the United States in 1979 to 1980 and in the United Kingdom in 1998.^{24, 25, 26, 27} In the United States, the incidence of HDFN due to anti-D decreased from 40.5 to 10.6 cases per 10,000 total births between 1970 and 1986.^{28, 29} RhIG accounted for most of this improvement, but the trend toward smaller families and improved quality of perinatal care also contributed to the decline in the incidence of anti-D in pregnant women and related perinatal mortality, respectively.³⁰

Despite all preventive efforts, HDFN due to anti-D continues to occur in about 6.7 of 1,000 live births in the United States.³¹ Failure to prevent maternal D alloimmunization is usually due to inadvertent failure to administer RhIG, or, less commonly, to production of anti-D antibodies early in pregnancy before an antenatal dose of RhIG. No prophylactic measures are available to prevent sensitization to other blood group antigens in pregnancy, most notably Rhesus (c), Kell (K1), and Duffy (Fy^a), and the corresponding maternal alloantibodies can cause severe HDFN.^{32, 33}

PATHOPHYSIOLOGY

The risk of maternal alloimmunization to blood group antigens is related to the frequency of blood group alleles in the population, volume of incompatible red blood cell exposure, immunogenicity of the sensitizing red blood cell antigen, and maternal immune responsiveness. The propensity of maternal red blood cell antibodies to cause HDFN and the severity of the disease in individual cases are affected by the inherent characteristics of the red blood cell antibodies and the compensatory physiologic reaction to the anemia in the infant.

P.767

TABLE 30.1 META-ANALYSIS OF ANTI-D IMMUNE GLOBULIN (RHIG) CLINICAL TRIALS

	Treatment	Control	Odds Ratio, 95% Confidence Interval
Postpartum RhIG (Treatment) vs. No Treatment (Control)			
Immunization after 6 mo (5 RCTs)	10/4,756 (0.2%)	204/2,824 (7%)	0.08 (0.06, 0.11)
Immunization in a subsequent pregnancy (4 RCTs)	11/682 (1.6%)	57/389 (14.6%)	0.12 (0.70, 0.19)
Postpartum and Antenatal RhIG (Treatment) vs. Postpartum RhIG (Control)			
Immunization in pregnancy after birth of Rh-positive infant (2 RCTs)	5/1,112 (0.4%)	13/1,185 (1.1%)	0.44 (0.18, 1.12)

Immunization at 2-12 mo, primigravidae 0/362 (0) 4/360 (0.7%) 0.13 (0.02, 0.96)
(1 RCT)

RCT, randomized controlled trial.

Data from Lee D, Rawlinson VI. Multicentre trial of antepartum low dose anti-D immunoglobulin. *Transfus Med* 1995;5:15-19; and Hensleigh PA. Preventing rhesus isoimmunization: antepartum Rh immune globulin prophylaxis versus a sensitive test for risk identification. *Am J Obstet Gynecol* 1983;146:749-755; Crowther C, Middleton P. Anti-D administration after childbirth for preventing Rhesus alloimmunization. *Cochrane Database Syst Rev.* 2000;(2):CD000021.

Fetal-Maternal Hemorrhage

Although the fetal circulation is separated from the maternal circulation by placental membranes and fetal capillaries, blood cells pass between the fetal and maternal bloodstreams throughout gestation. FMH occurs in 3% of pregnancies in the first trimester, 12% in the second trimester, 45% in the third trimester, and 64% to 100% after delivery.^{34, 35} The total volume of fetal cells in the maternal circulation is usually small and does not exceed 0.1 to 0.25 ml in most cases.³⁶ Large-volume FMH occurs less often, with more than 15 ml of fetal red blood cells (approximately 30 ml whole blood) detected at a rate of 1.6% after cesarean section or complicated vaginal delivery and 0.7% after spontaneous vaginal delivery.³⁷ Invasive procedures, clinical maneuvers, or other traumatic events during pregnancy may also elicit sufficient FMH to induce or augment the production of alloantibodies against red blood cells in susceptible pregnant women (Table 30.2).^{38, 39, 40}

Maternal Alloimmunization to Blood Group Antigens

The likelihood of a relevant blood group incompatibility occurring in pregnancy depends on the frequency of blood group alleles in the population.⁴¹ Among Caucasians and African Americans in the United States, approximately 15% and 8%, respectively, of women are D negative and lack a functional D gene on both chromosomes.⁴¹ Incompatibility with respect to the D antigen occurs in approximately 10% of pregnancies; among D-negative women, approximately 60% to 70% of pregnancies yield D-positive infants. American Indians and Asians are almost all D positive; consequently, D alloimmunization is extremely rare among these populations.⁴¹ Although virtually all pregnant women are exposed to fetal red blood cells with childbirth, alloimmunization to blood group antigens occurs in only a fraction of incompatible pregnancies. Approximately one in six multiparous D-negative women developed anti-D antibodies without RhIG prophylaxis in incompatible pregnancies. The risk of alloimmunization to the D antigen has been estimated for other obstetric interventions (Table 30.2).^{38, 39, 40}

TABLE 30.2 FETAL-MATERNAL HEMORRHAGE AND RHD ALLOIMMUNIZATION: RATES AMONG RH-NEGATIVE WOMEN WITH D-POSITIVE INFANTS, WHO DO NOT RECEIVE ANTI-D IMMUNE GLOBULIN

	Fetal-Maternal Hemorrhage (%)	Primary RhD Alloimmunization (%)
Pregnancy and delivery		
Before 29 week of gestation	3-12	0.3-1.9
35 week to delivery	65-100	7-15
Abortion		
Induced abortion	4-30	4-5
Spontaneous abortion	3-12	1.5-2.0
Threatened abortion	10	ND
Ectopic pregnancy	24	Case reports
Amniocentesis	7-15	2-5
Cordocentesis	57	ND
Chorionic villus sampling	14	1-2

External cephalic version	2-28	ND
Abdominal trauma	28	Case reports

ND, not determined.

Data from Huchet J, Dallemagne S, Huchet C, et al. The antepartum use of anti-D immunoglobulin in rhesus negative women. Parallel evaluation of fetal blood cells passing through the placenta. The results of a multicenter study carried out in the region of Paris. *J Gynecol Obstet Biol Reprod (Paris)* 1987;16:101-111; Medearis AL, Hensleigh PA, Parks DR, et al. Detection of fetal erythrocytes in maternal blood postpartum with the fluorescence-activated cell sorter. *Am J Obstet Gynecol* 1984;148:290-295; Ness PM, Baldwin ML, Niebyl JR. Clinical high-risk designation does not predict excess fetal-maternal hemorrhage. *Am J Obstet Gynecol* 1987;156:154-158; American College of Obstetricians and Gynecologists. Prevention of RhD alloimmunization. Washington, DC: ACOG Practice Bulletin No. 4, May 1999.

A primary determinant of the risk of red blood cell alloimmunization is the volume of incompatible red blood cell exposure. Less than 1 ml of D-positive, fetal red blood cells is sufficient to induce anti-D antibody formation in 0.3% to 1.9% of D-negative women before delivery, whereas transfusion of a unit of D-positive red blood cells (300 ml) immunizes approximately 70% of D-negative individuals.^{16, 41} Host factors also influence the risk of red blood cell alloimmunization. Concomitant ABO and D incompatibility between the mother and fetus (e.g., a type O, D-negative mother with a type A, B, or AB, D-positive fetus) results in an almost ninefold reduction in the risk of alloimmunization to the D antigen in a first pregnancy.^{18, 42} ABO incompatibility does not prevent a secondary immune response in a sensitized individual in subsequent pregnancies. The D antigen is one of the most potent immunogens among red blood cell antigens, but even after incompatible blood transfusion or multiple D-positive pregnancies, approximately 30% of D-negative individuals do not produce anti-D antibodies and are called "nonresponders."⁴¹ Complex genetic factors regulate immune responses, and the basis of this variability to red blood cell immunization among individuals is not well understood.

The overall frequency of alloimmunization to clinically significant blood group antigens among women ranges from 0.04% to 0.3%.^{43, 44, 45, 46, 47} The variability in these rates may be due to geographic differences in blood group antigen expression, national blood transfusion practice, and higher-order birth and abortion rates in the population,

P.768

as well as the sensitivity of laboratory methods used in prenatal antibody screening.^{43, 44, 45, 46, 47, 48} Anti-D is still among the most frequently detected antibodies in sensitized pregnancies despite a precipitous decline in its incidence after the introduction of RhIG prophylaxis (Table 30.3).^{43, 44} In recent decades, other red blood cell alloantibodies have accounted for proportionately more cases of maternal alloimmunization and HDFN. The K1 antigen surpassed the D antigen as the leading cause of alloimmunization among women in a recent series, occurring at a rate of 3.2 in 1,000 compared to 2.7 in 1,000 for anti-D.⁴³ Women who develop anti-K1 antibodies in pregnancy often have a history of blood transfusion as the immunizing stimulus.⁴⁸ In another series of 1,133 Dutch women with positive antibody screens, anti-E was the most common antibody detected (23%) followed by anti-K (18.8%), anti-D (18.7%), and anti-c (10.4%).⁴⁷

ABO Blood Group Isoagglutinins

ABO incompatibility occurs statistically in one of every five pregnancies. ABO isoagglutinins are present in the sera of all individuals whose red blood cells lack the corresponding antigen and are usually of the IgM class. High titers of IgG antibodies are more likely to occur in group O individuals than in group A or B individuals, and increased antibody production after antigenic stimulation can occur.⁴¹ Consequently, group O mothers with potent IgG anti-A, -B, or -A,B are at greatest risk of having affected infants. Among group A or B infants born to group O mothers, 30% to 50% have detectable maternal IgG antibody bound to their red blood cells compared to 5% among all infants.⁴⁹ Because ABO IgG antibodies can occur without prior red blood cell exposure, they can result in hemolytic disease of the newborn (HDN) in a first pregnancy. However, ABO antigens are not fully developed on red blood cells at birth, and similar carbohydrate antigens occur on other tissues that effectively neutralize anti-A, anti-B, and anti-A,B antibodies to a large extent, thereby mitigating their effect. At birth, neonatal anemia due to ABO HDN is usually mild. Antibodies directed against other carbohydrate blood group antigens (Lewis, I, P) are naturally occurring IgM antibodies that are inconsequential in pregnancy because IgM is not transported across the placenta.

TABLE 30.3 RED BLOOD CELL ALLOANTIBODIES: OCCURRENCE IN WOMEN AND ASSOCIATION WITH HEMOLYTIC DISEASE

OF THE FETUS AND NEWBORN (HDFN)

Antibody Incidence (Number per 1,000 Samples)

Blood Group System	1967 ⁴⁴	1996 ⁴³	Association with HDFN
Rhesus (Rh)			
D	43.3	2.7	Mild to severe HDFN, hydrops fetalis
C	0.1	0.7	Mild to severe HDFN, hydrops fetalis
c	1.2	0.9	Mild to severe HDFN, hydrops fetalis
E	1.3	2.0	Mild to severe HDFN, hydrops fetalis
e	0.05	0	Mild to severe HDFN, hydrops fetalis (rare)
Other			Other Rh specificities in rare cases of moderate to severe fetal anemia: C ^w , C ^x , Go ^a , RH36 (Berrens, Be ^a), RH37 (Evans), RH32
Kell			
K1	2.1	3.0	Mild to severe HDFN, hydrops fetalis
K2	0	0.03	Other Kell specificities in rare cases of moderate to severe fetal anemia: k ([Cellano; K2] [rare]), Js ^a , Js ^b , Ku
Lewis (Le^a, Le^b)	2.2	3.0	Not a cause of HDFN
Duffy			
Fy ^a	0.4	0.8	Mild to severe HDFN, hydrops fetalis
Fy ^b	0.02	0.03	Not a cause of HDF; no or mild HDN
MNS			
M	0.7	0.5	Rare cases of moderate to severe HDF
N	0.1	0.03	Not a cause of HDF; no or mild HDN
S	0.2	0.1	Rare cases of moderate to severe HDF
Other			Other MNS specificities in rare cases of moderate to severe fetal anemia: s, U, Mt ^a
Lutheran (Lu^a, Lu^b)	0.02	0.1	No or mild HDFN
Ii	0.3	0.1	Not a cause of HDFN
Kidd			
Jk ^a	0.2	0.2	Mild to severe HDFN
Jk ^b	0	0	Mild to severe HDFN (rare)
P (P1)	0.6	0.03	Not a cause of HDFN
			Other P group specificities in rare cases of moderate to severe fetal anemia: PP ₁ P ^k
Other	0.3	0.03	HLA (Bg ^a , Bg ^b , Bg ^c): Not a cause of HDFN Other blood group specificities in rare cases of moderate to severe fetal

anemia: Diego (Di^a), Cartwright (Yt^a), Biles (Bi), Radin (Rd), Wright (Wr^a)

Fetal and Neonatal Immune-mediated Anemia

In contrast to naturally occurring antibodies against carbohydrate blood group antigens, antibodies against Rhesus, Kell, and other

P.769

protein blood group antigens only rarely occur without exposure to incompatible red blood cells.⁴¹ IgM may be detected in the primary immune response after the initial stimulus, but IgG may be the only immunoglobulin found and is typically present 5 to 15 weeks after FMH. Because FMH usually occurs late in the third trimester or at delivery, IgG antibodies against red blood cell alloantigens usually do not reach appreciable concentration to cause significant disease in a first pregnancy. Upon re-exposure to the red blood cell antigen, however, an anamnestic immune response rapidly produces IgG with enhanced avidity for target fetal red blood cells, translating to earlier onset and greater severity of hemolytic disease in subsequent incompatible pregnancies.

Maternal IgG red blood cell antibodies bind to their target red blood cells and cause Fc-receptor-mediated extravascular destruction by splenic macrophages and other cytotoxic effector cells in the reticuloendothelial system. Progressive removal of portions of the red blood cell membrane by macrophages and other phagocytic cells in the spleen can produce spherocytes in the peripheral circulation. Anti-D is usually high-affinity IgG1 and IgG3, which are the typical IgG subclass responses to protein antigens, and involve T-helper (Th) cells for their production.⁵⁰ The immunoglobulin subclasses IgG1 and IgG3 have greater affinity for Fc receptors on phagocytic cells than IgG2 and IgG4, which may account for their association with more severe hemolytic disease.^{41, 50} The concomitant presence of maternal antihumanleukocyte antigen (HLA) and anti-D is associated with a mild course of HDFN, possibly due to the competitive binding of the HLA antibodies to Fc receptors on cytotoxic effector cells.⁵¹

Extravascular destruction of red blood cells often cannot account completely for the degree of fetal anemia due to anti-K1, unlike most cases of HDF due to anti-D and other red blood cell alloantibodies. Severe fetal anemia may occur with anti-K1 despite low maternal antibody titers and falsely reassuring concentrations of bilirubin in amniotic fluid.^{48, 52} In Kell-sensitized pregnancies, affected fetuses often have fewer reticulocytes and normoblasts in their peripheral circulation than infants with comparable anemia caused by anti-D, which suggests impaired production of red blood cells.^{53, 54} Anti-K1 was shown to inhibit specifically the growth of K1-positive erythroid progenitor cells in vitro, whereas anti-D exhibited no effect with D-positive precursors in the same assay.⁵⁵ These observations support the dual action of maternal anti-Kell in eliciting both peripheral red blood cell destruction and erythropoietic suppression to produce fetal anemia.

Most cases of severe fetal anemia are caused by anti-D, anti-c, and anti-K1; rarely, anti-Fy^a or other IgG red blood cell alloantibodies are associated with severe HDFN (Table 30.3). Compensatory hematopoiesis in the bone marrow and extramedullary hematopoiesis primarily in the liver and spleen result in the release of nucleated red blood cells, reticulocytes, normoblasts, and other immature erythrocytes in the fetal circulation. Severely affected fetuses have marked hepatosplenomegaly due to the extramedullary hematopoiesis, which can lead to portal and umbilical venous obstruction, portal hypertension, and hepatocellular damage.¹ Production of albumin and other plasma proteins by the liver is markedly impaired, and hypoproteinemia results. Severe anemia and hepatic dysfunction with hypoproteinemia and portal hypertension may also lead to the development of congestive heart failure. Hydrops fetalis describes the ultimate outcome of these physiologic insults, with the development of generalized edema (anasarca), marked ascites, and pleural and pericardial effusions. Although the pathogenesis of hydrops fetalis is not clearly defined, the extent of hepatic damage rather than the degree of anemia more consistently correlates with the severity of the condition.¹

Neonatal Immune-mediated Hyperbilirubinemia

Immune-mediated destruction of fetal red blood cells results in increased serum concentration of free heme, which is further metabolized to unconjugated (indirect) bilirubin. During gestation, unconjugated bilirubin and other metabolites are transported across the placenta and eliminated by the mother. When the umbilical cord is severed at birth, unconjugated bilirubin begins to accumulate because infants have immature liver function and are not capable of efficiently metabolizing bilirubin.

Unconjugated bilirubin is transported in the plasma bound to albumin, but when its concentration exceeds the plasmabinding capacity or when it is displaced from carrier proteins, the lipophilic free molecule can cross cell membranes and impair mitochondrial function to cause cell death. Preterm infants are at greater risk for developing bilirubin

encephalopathy than are term infants because of the immaturity of their blood-brain barrier as well as their more pronounced hepatic deficiency. Bilirubin toxicity is potentiated by factors that displace bound bilirubin or otherwise increase circulating levels of unbound bilirubin, such as decreased albumin concentration, free heme molecules, acidosis, increased levels of free fatty acids, or drugs such as sulfonamides and sodium benzoate.¹ Infants with severe unconjugated hyperbilirubinemia may develop nerve deafness or the spectrum of kernicterus, leading to severe brain damage, mental retardation, spastic choreoathetosis, or, in many cases, death.

CLINICAL FEATURES

The clinical spectrum of HDFN ranges from the ominous intrauterine development of hydrops fetalis to varying degrees of neonatal hyperbilirubinemia and anemia. Approximately one half of infants with detectable maternal anti-D are unaffected or only mildly affected, whereas 30% have moderate disease in the neonatal period, and approximately 20% are severely affected in utero (Table 30.4).^{1, 56} The onset of intrauterine disease occurs before 34 weeks' gestation in approximately one half of the cohort of severely affected fetuses, or approximately 9% of affected pregnancies, overall.⁵⁶ Similar trends are observed when anti-c, anti-K1, and anti-Fy^a are detected in pregnancy, in that many fetuses are unaffected, and most of the rest have only mild or moderate disease, but a small number have hydrops fetalis or severe anemia necessitating intrauterine transfusion (Table 30.4).^{31, 32, 33, 48, 56, 57} Maternal IgG antibodies with other specificities have been implicated in cases of severe fetal anemia or life-threatening HDN in rare cases.^{31, 32, 33, 57, 58, 59}

Severely affected newborn infants have cord blood hemoglobin concentrations <12 g/dl and cord bilirubin concentrations >5 mg/dl. If intrauterine transfusions have been given, the course of hemolytic disease in the neonatal period may be relatively mild and the blood type at birth may reflect the ABO and D-negative type of the transfused red blood cells. Infants transfused before birth are at risk for developing late anemia at several weeks of age because intrauterine transfusion may suppress erythropoiesis and persistent circulating maternal alloantibody may cause ongoing hemolysis for 4 to 8 weeks. Infants with moderate disease have 12 to 14 g/dl hemoglobin in cord blood and 7 to 12 g/dl hemoglobin in the first days of life. The bilirubin level in cord blood rarely exceeds 5 mg/dl due to maternal clearance. After birth, however, jaundice may occur within the first 24 to 36 hours of life, earlier than the "physiologic jaundice" otherwise associated with immature liver function, and the bilirubin concentration peaks between 3 and 5 days of life. Mild HDN is characterized by cord blood hemoglobin of 14 g/dl or greater and only slightly increased bilirubin (<4 mg/dl).

The most common cause of HDN is maternal ABO antibodies, although only a minority of infants with detectable maternal ABO antibodies have clinical signs of hemolysis. Exceedingly rare cases of fetal anemia due to ABO antibodies have been reported, but nonimmune hydrops superimposed on ABO incompatibility could not be excluded.¹ Nonimmune hydrops fetalis may be caused by

P.770

intrauterine infection, cardiac disease, or chromosomal disorders (Table 30.5). Because the neonatal anemia is usually mild, the compensatory hematopoietic activity in ABO HDN is not as pronounced as in HDN due to anti-D or anti-K1. Consequently, nucleated red blood cells and erythropoietic progenitors may be evident, but spherocytes predominate in the peripheral blood smear of infants with ABO HDN (Fig. 30.1). The failure to recognize hemolysis due to ABO blood group incompatibility or other risk factors for hyperbilirubinemia resulted in 90 cases of kernicterus in a 17-year period.⁶⁰ This contemporary tragedy underscores the ongoing importance of monitoring progressive jaundice in all infants.

TABLE 30.4 CLINICAL SERIES OF RHESUS, KELL, AND DUFFY ALLOANTIBODIES IN PREGNANCY

Antibodies (Number)	Affected Pregnancies (Number)	None or Mild (%)	Severity (% Affected Pregnancies Resulting in Mild, Moderate, or Severe Disease)			Reference
			Mild-Moderate (e.g., Phototherapy and/or Neonatal Exchange Transfusion) (%)	Severe (e.g., Intrauterine Transfusion, Hydrops, or Perinatal Death) (%)		
Rhesus						
D	566	257	51	30	19	1, 56
c, cE	302	164	70	23	7	1

E	633	162	89	11	—	1
C, Ce, C ^w , e	193	50	86	14	—	1
Kell	478	16	50	37	13	1
K1	127	13	30	30	38	48
Duffy	35	6	67	16	16	1
Fy ^a	68	47	94	2	4	57

TABLE 30.5 DIFFERENTIAL DIAGNOSIS OF HYDROPS FETALIS AND NEONATAL HYPERBILIRUBINEMIA

Hydrops fetalis (fetal edema, anemia)

Hemolytic disease of the fetus due to maternal anti-D, -c, -K1, -Fy^a, or other blood group antibodies

Homozygous α -thalassemia

Twin-to-twin or fetomaternal transfusion

High-output cardiac failure

Congenital infection (e.g., parvovirus, cytomegalovirus, toxoplasmosis, syphilis)

Genetic disorders (e.g., Turner syndrome, 45, X)

Idiopathic

Neonatal hyperbilirubinemia (nonphysiologic)*Unconjugated (indirect) hyperbilirubinemia*

Hemolysis

Hemolytic disease of the newborn due to maternal ABO isohemagglutinins, anti-D, or other blood group antibodies

Hereditary spherocytosis

Glucose-6-phosphate dehydrogenase deficiency, pyruvate kinase deficiency α -Thalassemia

Extravascular blood loss/accumulation (e.g., cephalohematoma)

Genetic disorders (e.g., Crigler-Najjar syndrome, Gilbert syndrome)

Endocrine disease (e.g., hypothyroidism)

Conjugated (direct) hyperbilirubinemia

Infection, sepsis

Metabolic disorders (e.g., Dubin-Johnson syndrome, cystic fibrosis)

Hepatic disease and anatomic abnormalities (e.g., biliary atresia)

Cholestasis from total parenteral nutrition or antibiotics (e.g., ceftriaxone)

LABORATORY EVALUATION

All pregnant women should have their ABO/Rh type and antibody screen determined at the first visit to the obstetrician.⁶¹ These initial tests identify women as candidates for RhIG administration or for additional monitoring during pregnancy. After detection of clinically significant red blood cell alloantibodies, further testing may be required for evaluation of FMH, antenatal assessment of fetal anemia, and detection of neonatal anemia and hyperbilirubinemia. The principles of these laboratory tests and controversies surrounding their use are described below; specific practice recommendations for prevention and treatment of HDFN are described in the subsequent sections entitled "Prevention of Maternal D Alloimmunization with Rh Immune Globulin,"

“Management of Red Blood Cell Alloimmunization in Pregnancy,” and “Treatment of the Newborn Infant.”

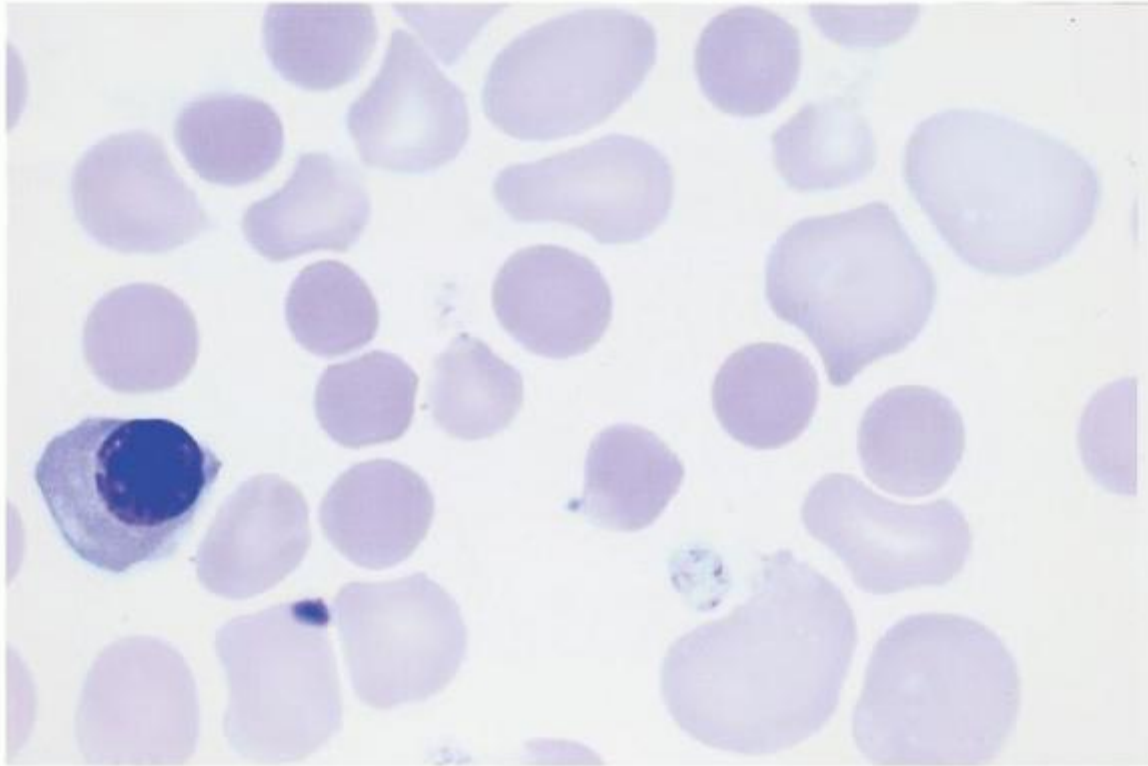

FIGURE 30.1. ABO hemolytic disease of the newborn (HDN). Peripheral blood from an infant with ABO HDN, with numerous spherocytes, occasional nucleated red blood cells, anisocytosis, and polychromasia (Wright-Giemsa stain). (©2002 American Society for Clinical Pathology. Used with permission.)

Maternal ABO/Rh Type and Antibody Screen

The red blood cell ABO/Rh type is assigned in the forward group reaction by incubating the patient's red blood cells with specific IgM or IgG antibodies that cause their immediate and visible agglutination if they express the corresponding A, B, or D antigens. The ABO reverse group identifies plasma reactivity due to ABO isoagglutinins and should confirm the forward, red blood cell typing reactions. The forward reaction for the D antigen may include an additional phase with antihuman globulin to enhance red blood cell agglutination and detect weak expression of the D antigen on the red blood cells.

Formerly known as Du, weak D phenotypes are due to quantitative or qualitative alterations in D antigen expression. The need to test D-negative pregnant women for weak expression of D has been controversial. Weak D occurs in as much as 1% to 3% of the general population, but the majority (90%) of weak D individuals (types 1, 2, 3) possess a normal D antigen, only produced in lower quantities on the red blood cell surface, and cannot be immunized to make anti-D.^{24, 62, 63} The remaining 10% of weak D individuals express aberrant D proteins, and are recognized as partial D phenotypes, many of whom will develop anti-D after exposure to D-positive red blood cells.^{63, 64} Most D-positive individuals with anti-D belong to partial D category D^{VI}, which occurs in 0.02% to 0.05% of Caucasians.⁶³ The AABB (American Association of Blood Banks) considers testing pregnant women for weak D to be optional, and the American College of Obstetricians and Gynecologists (ACOG) recommends against administration of RhIG to weak-D-positive women.^{38, 61}

Although severe HDF in women with weak D is rare, women with known partial D phenotypes (e.g., D^{VI}) are at risk of D alloimmunization, and fatal HDF has occurred as a result.^{65, 66} If pregnant women are tested for weak D, consideration should be given to using a method that accurately distinguishes between those individuals with D variants who are not at risk of anti-D alloimmunization from those who are at risk and may benefit from RhIG prophylaxis.^{63, 64} The alternative is not to test pregnant women (or transfusion recipients) for weak D, which would result in these individuals being classified as D-negative and candidates for RhIG prophylaxis. This presents a challenge to countries that do not have a sufficient

supply of RhIG, and not surprisingly, in a recent survey, international practices on testing for weak D and RhIG administration diverge from practice in the United States.⁴⁰ Eight of ten countries reported that they perform further testing for weak D or D variants if the woman types as D negative or if the typing results are anomalous, to limit administration of RhIG to women with partial D at risk of developing anti-D.⁴⁰ The relative effectiveness of RhIG in preventing the sensitization of partial D women compared to D-negative women is not yet known.

The antibody screen detects maternal antibody in plasma by hemagglutination in an indirect antiglobulin test, formerly called the indirect Coombs' test. The reaction conditions should allow detection of clinically significant IgG alloantibodies that are reactive at 37°C in the antiglobulin phase. Conditions that permit identification of IgM antibodies are not required in the setting of obstetric testing, because IgM antibodies cannot cross the placenta. If IgM antibodies cause interference in the antibody screen, reducing agents such as dithiothreitol can be used to eliminate their reactivity in the assay and allow for specific detection of IgG antibodies. If the initial antibody screen is negative, the need to repeat testing at 28 weeks' gestation is currently debatable. Arguments for eliminating this testing include the extremely low probability that anti-D or other antibodies are formed during pregnancy.^{46, 67}

Serologic and Molecular Testing for Paternal/Fetal Blood Group Antigens

If a potentially significant red blood cell alloantibody is detected in a pregnant woman, the blood type of the biologic father may be investigated to assess the risk of HDFN. Three possibilities exist: the father lacks the antigen, and the fetus is not at risk; the father is heterozygous for the antigen, and the fetus may be at risk; or the father is homozygous for the antigen, and the fetus is definitely at risk. Because no antithetic allele for RhD exists, paternal zygosity cannot be definitively determined by serologic testing for the D antigen but RH D inheritance is closely linked to Rh antigens C/c and E/e. The probability that the father is heterozygous for D can be deduced by serologic determination of the extended Rhesus phenotype (D, Cc, Ee) and most probable combination of haplotypes given the gene frequencies in different ethnic populations and the Rh type of previous children.⁶⁸ Another indirect approach to determine paternal zygosity involves parallel quantitative amplification of RHD- and RHCE-specific sequence.⁶⁹ The development of direct, D-allele-specific molecular assays is complicated by the genetic diversity of the D locus and the variety of insertions, deletions, and missense and nonsense mutations in the RHD gene that can produce the D-negative phenotype. Recently, a molecular test specifically to detect the most prevalent D-negative allele in white populations, the complete RHD deletion, was developed.⁷⁰ This approach may be amenable to routine use in most laboratories, but its clinical application will be limited until modification allows for detection of other common D-negative alleles in ethnically and racially heterogeneous donor populations. Determining the paternal genotype of other blood group determinants is more straightforward with the currently available allele-specific assays for other Rh (C/c, E/e), Kell (K1/K2), Duffy (Fy^a/Fy^b), Kidd (Jk^a/Jk^b), and other red blood cell loci.^{47, 69}

If paternal testing indicates that the father may carry a clinically significant red blood cell antigen, fetal testing should be performed to determine if the allele is present. Considerable genetic diversity underlies aberrant RH alleles associated with the Rh-negative phenotype, which has important implications for fetal testing.^{47, 69} The most prevalent D-negative genotype in Caucasian populations is the complete deletion of RHD; in African blacks and African Americans, other variant RHD genes are more likely to be found.³² The RHD pseudogene, which contains all ten exons but a stop codon between exons 3 and 4 that blocks transcription of the gene, is found in 69% of South African blacks and 24% of African Americans.³² Similarly, the variant RHD gene r's (Cde⁵) underlies serologic RhD negativity in 22% of African Americans. The presence of one of these genes in the fetus can lead to a false-positive result (i.e., the fetus types as RHD-positive by molecular methods but is found to be D negative by serology after birth) and unnecessary prenatal intervention. A maternal blood sample should be analyzed in parallel with the fetal sample. False-negative results (i.e., the fetus types as RHD negative, but is found to be D positive by serology at birth) have been attributed to erroneous paternity or rearrangement at the paternal RHD gene locus. If no paternal sample is available, an RHD-negative fetal blood type determined by molecular methods should be interpreted with caution, and the pregnancy should be monitored to ensure that maternal anti-D titers do not increase.³²

The most common method to obtain fetal DNA for molecular testing is still amniocentesis in the United States, because noninvasive alternatives are not yet routinely available.^{32, 71, 72} Amniocentesis is performed at 24 weeks' gestation and is relatively safe, but is associated with a pregnancy loss rate of about 0.3%.⁷³ This risk is avoided with noninvasive methods to obtain fetal cells or fetal cell-free DNA from the maternal circulation, and maternal blood has been used routinely for RHD fetal typing in Europe.^{47, 71, 72} Fetal DNA can be isolated from maternal plasma as early as 32 days' gestation, and constitutes 3% to 6%

of the plasma DNA pool in the second and third trimesters.⁴⁷ Cell-free fetal DNA is rapidly cleared, and does not persist into subsequent pregnancies in contrast to the potential for long-term persistence of fetal leukocytes that can complicate analysis of cell-associated fetal DNA.⁷⁴ Several groups have demonstrated 96% to 100% accuracy in predicting the RHD phenotype with over 200 pregnancies tested.^{40, 47} False positives were due to the presence of a pseudogene or D variant, and false negatives from the failure to isolate sufficient fetal DNA. When negative results are obtained (e.g., no RHD-specific signal is detected), the presence of fetal DNA in the plasma should be confirmed by another fetus-specific DNA sequence from a highly polymorphic paternal antigen or from the Y chromosome for male fetuses (e.g., SRY). There are no reported strategies for Kell typing or Rh typing other than RHD using a sample of maternal blood, which likely reflects the difficulty of developing a sensitive assay for subtle allelic differences that will still be specific in the presence of an excess of maternal DNA.^{40, 47}

Maternal Red Blood Cell Alloantibody Titers

If molecular testing suggests the fetus is at risk for HDFN, or if molecular testing cannot be performed, determination of the maternal red blood cell alloantibody concentration may be used as a screening test to guide further clinical management.⁷⁵ The concept of a "critical titer" of maternal antibody has been criticized based on the poor predictive accuracy for severe HDN.^{76, 77} However, critical titers are used not to predict the development of severe hemolytic disease after birth, but rather to predict its absence during gestation, because titers below "critical" thresholds are unlikely to require aggressive intervention in utero. In a classic study almost 50 years ago, Allen et al. followed 174 pregnancies with no history of affected fetuses or infants and with antibody titers of 32 or lower and reported 174 (96%) had live infants at 37 weeks' gestation.⁷⁸ The observation that significant intrauterine disease is unlikely to occur when the antiglobulin titer remains low has been substantiated in recent studies and maternal antibody titers are a useful screening tool in a woman's first alloimmunized pregnancy.⁷⁵

Antibody titers are determined with the indirect antiglobulin test by making several dilutions of maternal serum in saline, adding reagent red blood cells and anti-IgG, and observing for macroscopic agglutination in the tubes. The titer is reported as the reciprocal of the highest dilution at which this endpoint is observed; for example, agglutination with a serum dilution of 1:16 but not 1:32 would be reported as an antibody titer of 16. Alternatively, a 12-point scoring system that takes into account the strength of agglutination as well as the dilution factor may be a more specific indication of severe fetal anemia, but it is used less commonly than simple tube titration in current practice.^{41, 75}

Because serial measurements of maternal antibody titer are necessary, an initial maternal sample should be frozen for comparison in subsequent titers determined with the same method, technique, and reagent red blood cells.⁶¹ A difference of greater than two dilutions or a score increase of more than 10 should be considered a significant change in titer.^{61, 75} For anti-D, the critical titer is considered by most experts to be 32 (range, 8 to 32).⁶¹ Critical titers for antibodies other than anti-D have been suggested, based on cumulative clinical experience at a center or historical published data. The utility of antibody titers in monitoring Kell-sensitized pregnancies is limited because the severity of intrauterine disease may not correlate with antibody concentration, and severe HDFN has occurred with low anti-K1 titers (e.g., 8).⁵³ In contrast, other antibodies are less likely than anti-D or anti-K1 to cause hemolytic disease at low titers, and higher thresholds have been proposed for anti-Fy^a (titer, 64), anti-M (titer, 32 to 64), and anti-U (titer, 128).^{33, 75} Anti-M often demonstrates IgG and IgM components that can be distinguished with the use of reducing agents in titration studies, and anti-M-sensitized pregnancies are managed on the basis of the titer of the IgG component.³³

Investigated as an alternative to maternal antibody titer, antibody functional assays, such as the monocyte monolayer assay, the antibody-dependent cellular cytotoxicity assay, and the chemiluminescence test, examine the behavior of potentially significant red blood cell antibodies in vitro.^{77, 79} These assays evaluate the ability of the maternal IgG antibody to interact with target red blood cells and effector cells expressing Fc receptors, such as lymphocytes or monocytes, to cause adherence, phagocytosis, or cytotoxic lysis. The antibody-dependent cell-mediated cytotoxicity assay showed a higher specificity than maternal antibody titer for prediction of fetal disease and may be more useful in guiding decisions about invasive testing for D alloimmunization in pregnancy.⁷⁷ Antibody functional assays, however, have not been as widely used in the United States as in Europe, primarily because prenatal testing is not centralized in highly specialized laboratories in the United States, and the technical complexities of the tests precludes their use at most American centers.⁶¹

Tests for Fetal-Maternal Hemorrhage

An assessment of the volume of fetal cells in the peripheral circulation of a D-negative woman is performed to determine the adequacy of the dose of administered RhIG after delivery of a D-positive infant and in other obstetric situations.^{38, 39}

^{40, 80} A common approach to evaluating FMH is the rosette test to screen for the presence of fetal cells followed by the Kleihauer-Betke acid elution method to quantify the magnitude of the bleed. The rosette test is a modified antiglobulin reaction, based on detection of the fetal (D-positive) red blood cells in a maternal (D-negative) blood sample. On reaction with reagent anti-D Ig, fetal (D-positive) red blood cells form small clumps or rosettes around indicator D-positive red blood cells (Fig. 30.2).⁴¹ The presence of rosettes is a sensitive qualitative screen for FMH. A positive test is obtained in 75% of women with FMH of 2.5 ml of D-positive red blood cells (5 ml whole blood) and all women with FMH of 5 ml of D-positive red blood cells (10 ml whole blood) or more.^{80, 81} If it is determined that an infant has the weak D phenotype, the rosette test is not reliable, and FMH should be evaluated with tests that do not rely on detection of the expression of the D antigen, such as the Kleihauer-Betke acid elution method.⁶¹ Rarely, maternal anti-D is present at such high concentration on the surface of fetal red

P.773

blood cells that interaction with the reagent anti-D is blocked, and the rosette assay produces a false-negative result.

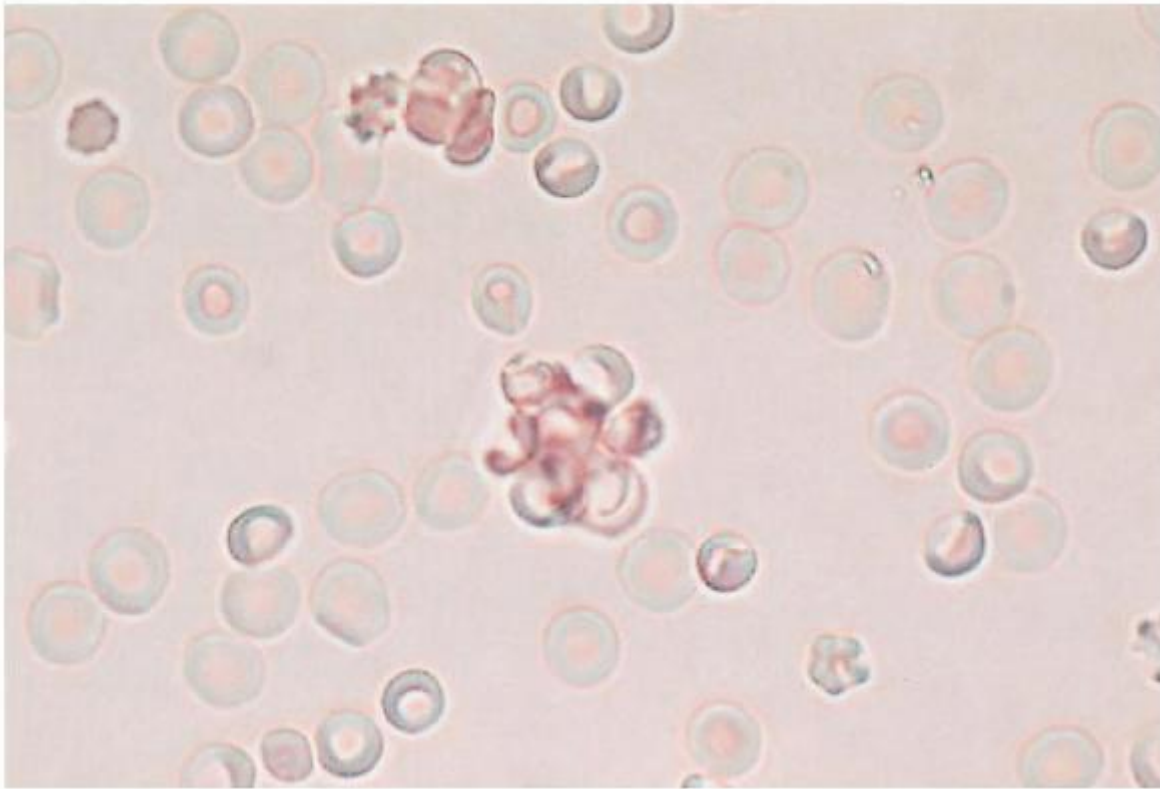

FIGURE 30.2. Rosette assay for fetal-maternal hemorrhage (FMH). D-positive red blood cells are identified in a background of D-negative red blood cells by the formation of rosettes in this screening test for FMH. There are two rosettes in this field: a large one in the center and a smaller one above it; unagglutinated red blood cells appear as refractile biconcave (unstained) disks.

The Kleihauer-Betke acid elution method provides a quantitative estimate of the volume of FMH based on the different solubility properties of fetal hemoglobin (HbF) and adult hemoglobin (HbA). On a peripheral blood smear treated with an acidic solution and counterstained, red blood cells containing acid-soluble HbA appear as pale ghosts compared to the deeply stained red blood cells containing acid-resistant HbF (Fig. 30.3). The Kleihauer-Betke test result is reported as the percentage of HbF-stained fetal cells present on the smear.⁸⁰ The corresponding magnitude of FMH is calculated by multiplying the percentage of fetal cells, expressed as a fraction, by the maternal blood volume, which is 70 to 75 ml/kg or approximately 5,000 ml for an average pregnant woman. For example, a Kleihauer-Betke result of 1.4% indicates the presence of 70 ml of fetal whole blood ($0.014 \times 5,000$ ml). The Kleihauer-Betke test is sensitive to bleeds between 0.01% and 0.06% or 0.2 to 1.0 ml, but samples containing at least 0.5% fetal cells are detected more reliably.^{81, 82} Kleihauer-Betke results that exceed the total predicted fetal blood volume based on gestational age (i.e., 3 ml at 12 weeks; 30 ml at 20 weeks) may reflect the inherent technical imprecision of the method or may reveal precedent maternal conditions

associated with increases in HbF-containing red blood cells such as hereditary persistence of HbF. Notably, the levels of HbF often increase during pregnancy in as many as 25% of women.⁸³ In addition to these false-positives, the Kleihauer-Betke test tends to overestimate the quantity of hemorrhage, resulting in administration of more RhIG than is necessary.⁸² This inherent potential for “overdosing” RhIG is not a problem from a medical standpoint given the safety record of the drug, but it is a concern to countries coping with RhIG shortages or those striving for the most cost-effective use of RhIG.⁴⁰

Alternative methods to quantify FMH include flow cytometry and the enzyme-linked antiglobulin test.^{84, 85} Most flow cytometric assays for FMH are based on detection of the D antigen on fetal red blood cells, but detection of HbF-containing fetal red blood cells is also possible.⁸⁴ Flow cytometric methods are sensitive to FMH of 0.1% or 1.8 ml and can be used to detect events as rare as 1 fetal cell in 10,000 maternal cells.⁸² The enzyme-linked antiglobulin test is a modified enzyme-linked immunosorbent assay and detects D-positive red blood cells in a maternal D-negative background by successive incubations with anti-D, anti-IgG conjugated with the enzyme alkaline phosphatase, and an enzyme substrate.⁸⁵ This test is sensitive to 0.25% or 3 ml FMH.^{41, 85} Both the enzyme-linked antiglobulin test and flow cytometry are reproducible and reliable but are not as commonly used in practice as the Kleihauer-Betke test for quantifying FMH in the United States.⁴⁰

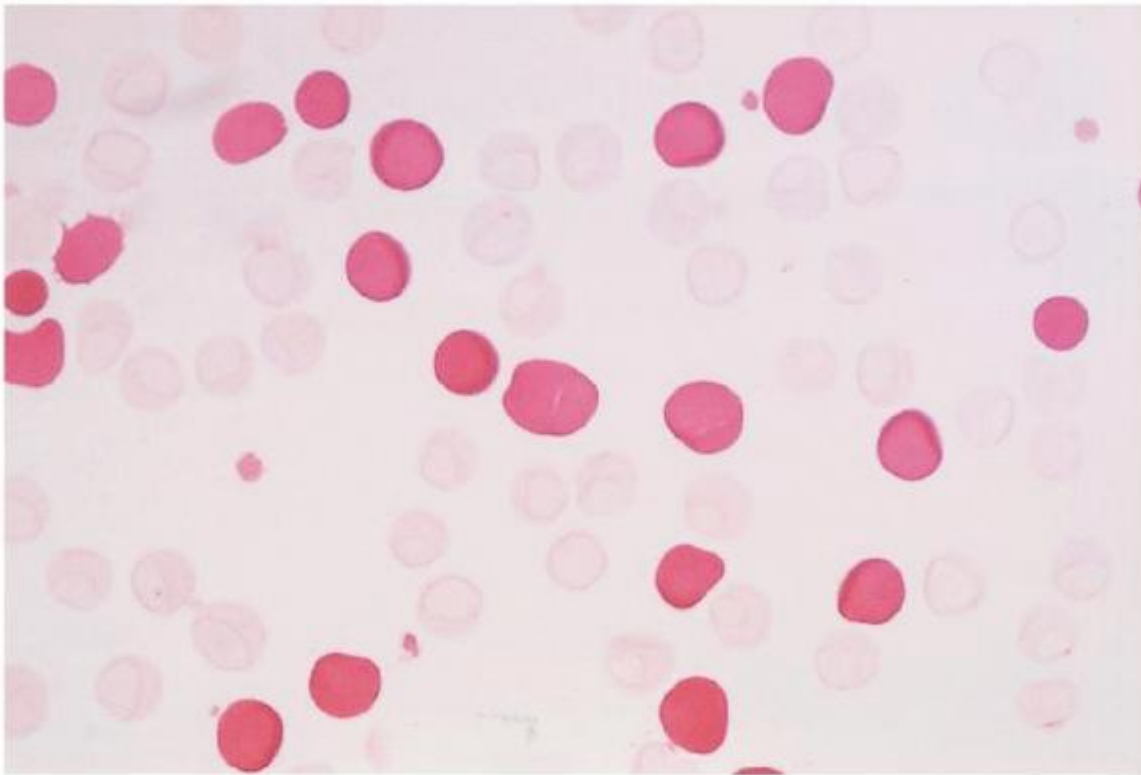

FIGURE 30.3. Kleihauer-Betke acid elution for fetal hemoglobin (Hb). Cord blood was mixed with blood from a healthy adult to simulate fetal-maternal hemorrhage, and a Kleihauer-Betke was performed. Red blood cells containing HbF are deeply stained red; red blood cells containing HbA appear as pale pink ghosts.

Amniotic Fluid Analysis

Amniotic fluid analysis by spectrophotometry, introduced by Liley in 1961 as an indirect marker of fetal red blood cell destruction, is still a cornerstone of obstetric management of alloimmunized pregnancies more than 40 years later.⁸ The principle of the test is based on the characteristic light absorbance by amniotic fluid between 365-nm and 535-nm wavelengths in unaffected pregnancies and the observed deviation from this linear baseline in alloimmunized pregnancies when bilirubin or other optically active compounds are present. An increase in optical density at 450 nm (ΔOD_{450}) relative to the normal baseline is proportional to the amount of bilirubin present in the amniotic fluid. Liley correlated the ΔOD_{450} values to clinical outcomes in 101 Rh-sensitized pregnancies from 27 weeks' gestation to term, generating what is commonly referred to as the Liley curve (Fig. 30.4).⁸ Values in the lowest zone of the Liley curve, zone I, are reassuring because these infants have only a 10% chance of needing treatment after birth.⁸ In contrast, readings in zone III predict severe hemolytic disease with the risk of impending hydrops and imminent fetal death (within 7 to 10 days) with 98%

accuracy.⁸ The presence of contaminating meconium, blood, or the porphyrin-containing breakdown products of red blood cells interferes with the analysis in approximately 10% of cases but can be remedied with chloroform extraction of the amniotic fluid, reducing this rate to 1%.⁸⁶ Amniotic fluid analysis may also be affected by fetal conditions other than hemolytic disease, such as congenital hepatitis, and maternal diseases, such as sickle cell anemia.

In most cases, Liley's method accurately reflects the severity of HDF due to anti-D after 27 weeks' gestation. Extrapolating Liley curves for gestation ages earlier than 27 weeks has been used to manage alloimmunized pregnancies in the second trimester, but this approach has been shown to be unreliable in some studies.^{86, 87, 88, 89} Queenan et al. developed a modified ΔOD_{450} curve for this situation, by evaluating amniotic fluid in 520 unaffected

P.774

pregnancies from 14 to 40 weeks' gestation and in 75 D-immunized pregnancies to develop four zones to guide management decisions in the second trimester (Fig. 30.5).⁸⁹ The upper two zones represent the infants at greatest risk in the Rh-positive (affected) zone and the intrauterine death zone. Analyzing the trends in the four zones was successfully used to manage pregnancies complicated by alloimmunization to the D antigen as well as the simultaneous presence of multiple blood group antibodies.^{89, 90} The controversy over appropriate management of second-trimester alloimmunized pregnancies spurred development of alternate management strategies that relied solely on fetal blood sampling that was, in turn, met with resistance because of the risks associated with cordocentesis.^{91, 92} The increasing use of Doppler ultrasonography to monitor alloimmunized pregnancies has largely quenched this debate, and most centers have implemented a less invasive strategy for management of alloimmunized pregnancies, reserving fetal blood sampling for patients with elevated ΔOD_{450} values or elevated peak middle cerebral artery (MCA) Doppler velocities.³²

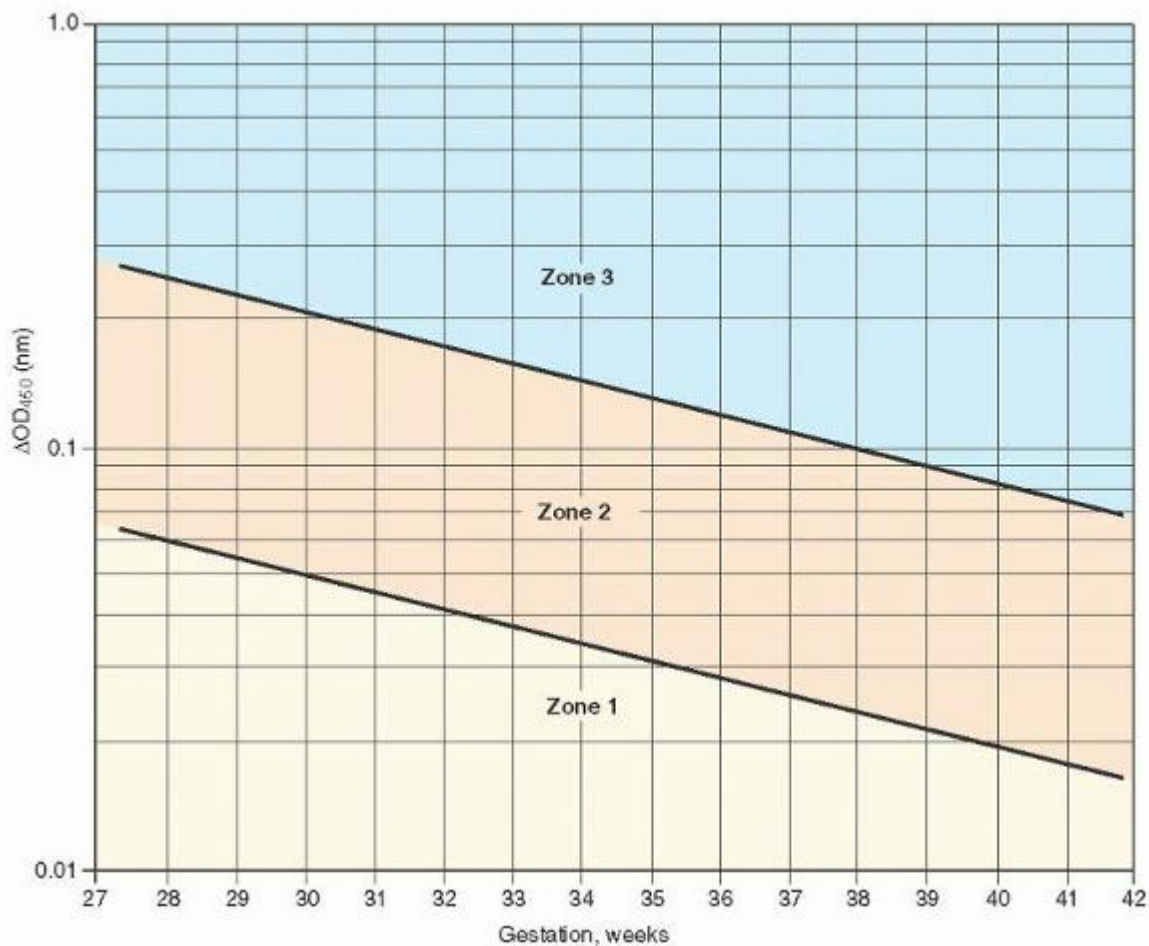

FIGURE 30.4. Liley graph and management zones for alloimmunized pregnancies, based on amniotic fluid increase in optical density at 450 nm (ΔOD_{450}) determination. Patients in zone I or low zone II are allowed to proceed to term, patients in the middle of zone II can progress to 36 to 38 weeks of gestation in most cases; patients in zone III or with a rising value in the upper part of zone II should be delivered or the fetus should receive intrauterine blood transfusion,

depending on gestational age. (Reprinted from Liley AW. Liquor amnii analysis in management of pregnancy complicated by rhesus sensitization. *Am J Obstet Gynecol* 1961;82:1359-1370. Copyright ©1961, with permission from Elsevier.)

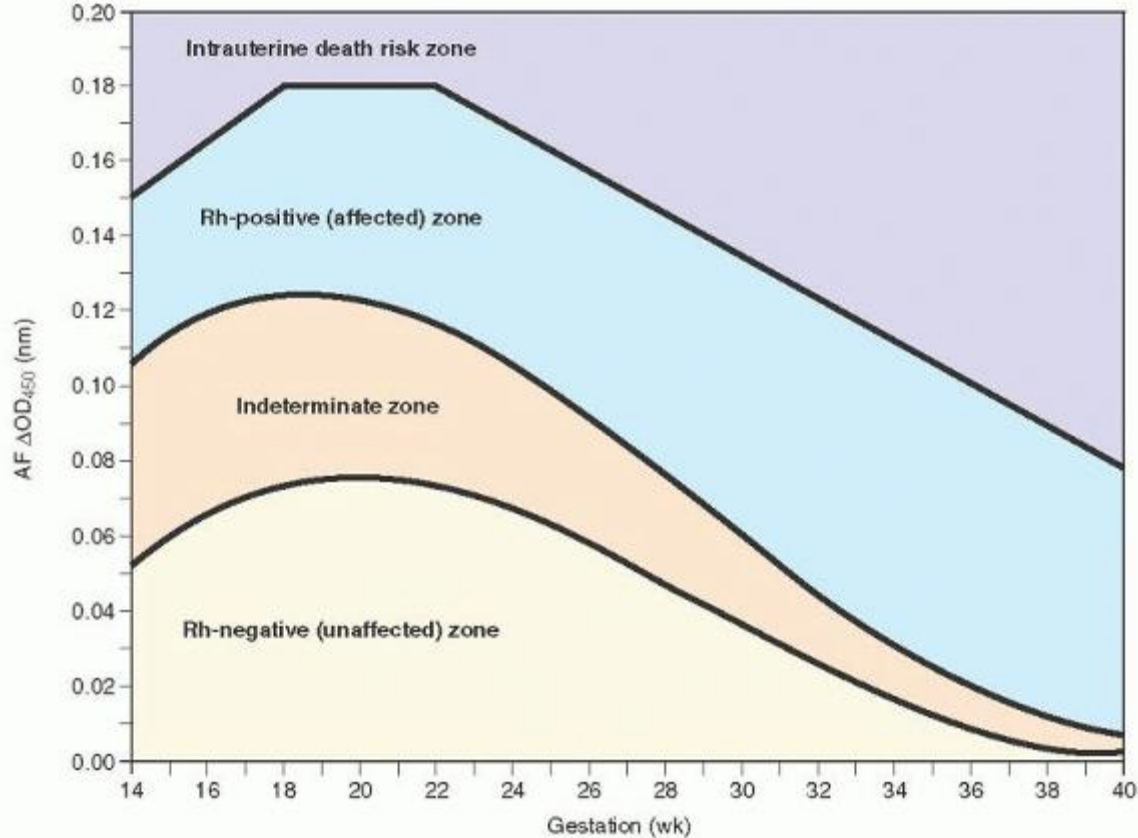

FIGURE 30.5. Queenan graph and clinical approach to D-alloimmunized pregnancies, based on amniotic fluid (AF) increase in optical density at 450 nm (ΔOD_{450}) determination. (Reprinted from Queenan JT, Tomai TP, Ural SH, et al. Deviation in amniotic fluid optical density at a wavelength of 450 nm in Rh-immunized pregnancies from 14 to 40 weeks' gestation: a proposal for clinical management. *Am J Obstet Gynecol* 1993;168:1370-1376; Copyright ©1993; with permission from Elsevier.)

Noninvasive Fetal Monitoring

An important advance in the management of alloimmunized pregnancies has been the use of ultrasonography to predict the severity of anemia. Ultrasonography can accurately establish gestational age and evaluate fetal development, and can detect signs of hydrops fetalis, by the presence of extracellular fluid in two body compartments. Ascites is often the first sign of hydrops, and other sonographic signs of severe or worsening fetal anemia include increases in the size of the fetal liver or spleen, an increase in placental thickness, the presence of effusions or polyhydramnios, visualization of both sides of the fetal bowel, and abnormalities of pulsed Doppler flow velocity waveforms in fetal vessels.⁹³

The increase in blood flow velocity that occurs with anemia can be measured by Doppler ultrasonography of the fetal MCA. In the largest prospective, multicenter study of 165 fetuses with maternal red blood cell alloimmunization (anti-D, -c, -E, or -Fy^a), an increase in peak velocity in the MCA expressed as more than 1.5 multiples of the median (MoM) had a sensitivity of 88% and a specificity of 82% for severe fetal anemia.⁹⁴ The performance of Doppler ultrasonography was better than amniocentesis using the Liley curve, but similar to amniocentesis with Queenan's method. Doppler ultrasonography has also been used to manage Kell-sensitized pregnancies, and is preferred to amniocentesis, which is often unreliable when HDF is caused by anti-K1, because these antibodies not only cause hemolysis, but also suppress erythropoiesis as reflected by falsely reassuring ΔOD_{450} values in the setting of profound fetal anemia.³³ Fetal blood sampling to measure fetal hematologic parameters directly is generally undertaken after Doppler ultrasonography of the MCA suggests the presence of severe or worsening fetal anemia.

Fetal Blood Sampling

Fetal blood sampling (percutaneous umbilical blood sampling, cordocentesis) provides direct access to the fetal circulation for laboratory measurements and transfusion.⁹⁵ With ultrasonographic guidance, a needle (22- or 20-gauge spinal needle) can be introduced into an umbilical vessel as it enters the placenta or, rarely, at other points in its course. Fetal blood sampling permits direct measurement of HbF, hematocrit, reticulocyte count, and bilirubin, and normal values for these variables have been determined for fetuses from 15 weeks' gestational age onward. In addition, the fetal blood cells can be typed for the antigen in question, and, if positive, the presence of the corresponding maternal red blood cell antibody on the surface of fetal red blood cells can be assessed by the direct antiglobulin test.

The risk of fetal loss is generally greater with cordocentesis (1.0% to 2.7%)^{95, 96, 97} than amniocentesis (0.3%),⁷³ but their comparative risk has not been systematically evaluated. As experience with these invasive procedures increases at an institution, the risk of procedure-related morbidity and mortality decreases. Both amniocentesis and cordocentesis may cause FMH with consequent increases in maternal antibody titers that could potentially accelerate the course of HDF. Other complications of fetal blood sampling include fetal bradycardia, chorioamnionitis, placenta trauma, infection, cord hematoma, thrombosis, bleeding from the puncture site, and rupture of the membranes.⁹⁷

Laboratory Testing of Newborn Infants

Infants born to women with potentially significant red blood cell antibodies or those demonstrating clinical signs of hemolytic disease despite a negative maternal antibody screen should have their ABO and D blood type determined and a direct antiglobulin test (DAT) performed at birth.⁶¹ Anti-A and anti-B are not detected in the antibody screen because the reagent red blood cells are type O but can be detected in an indirect antiglobulin test using reagent group A or B red blood cells. The DAT involves mixing cord red blood cells directly with antihuman globulin (anti-IgG) and observing for visible agglutination, which reveals the presence of maternal antibodies on the surface of the newborn's red blood cells.⁴¹ A negative DAT does not exclude the possibility of immune-mediated hemolytic anemia and may reflect a low surface concentration on fetal red blood cells or low avidity of the offending antibody under the reaction conditions. In many cases, maternal antibody may be concentrated by elution from the surface of the fetal cells, facilitating its detection. If HDN is still suspected in the absence of both ABO incompatibility and detectable maternal antibody, the maternal serum or an eluate prepared from the infant's red blood cells can be tested against the biologic father's red blood cells.⁴¹ This procedure may detect a maternal antibody directed against a low-incidence red blood cell antigen that has been associated with severe HDN in rare cases, such as anti-Wr^a (Wright), but is not represented on most red blood cell panels used for antibody identification.^{41, 61}

AABB does not endorse routine immunohematologic testing of infants in the absence of clinically significant maternal antibodies or without a clinical suspicion of HDN.⁶¹ Despite these

P.775

recommendations, some institutions continue to perform ABO/D typing and DATs on all newborn infants; others perform selective testing for infants born to group O mothers. The latter strategy is intended to identify infants at risk of ABO HDN, whose hospital discharge may be planned at <24 hours, but it has been criticized because all newborn infants should be monitored for jaundice during the first weeks of life.⁶¹

Jaundice is the visible manifestation of increased serum bilirubin concentration, and it becomes apparent when levels exceed 5 mg/dl. Laboratory detection of total, direct (conjugated), and indirect (unconjugated) bilirubin provides important diagnostic information regarding the cause of the jaundice (Table 30.5). In immune-mediated hemolytic disease, the total serum bilirubin concentration may be routinely assayed to guide clinical management, because it is almost entirely unconjugated (indirect) bilirubin. Under investigation are transcutaneous bilirubin measurements as well as measurements of unbound bilirubin, such as the bilirubin-to-albumin ratio, serum-free bilirubin, bilirubin reserve binding capacity, bilirubin saturation index, and other signs of elevated bilirubin production such as the carboxyhemoglobin level and exhaled carbon monoxide levels. These tests may be used in addition to, but not in lieu of, total serum bilirubin in managing infants with immune-mediated hemolytic anemia.

PREVENTION OF MATERNAL D ALLOIMMUNIZATION WITH RH IMMUNE GLOBULIN

RhIG prophylaxis is an international standard in obstetric care.⁴⁰ Although the efficacy of RhIG in preventing alloimmunization to the D antigen is unequivocal, the mechanism by which it inhibits the primary immune response is not entirely known. Immune-mediated immunosuppression by passively transferred anti-D antibodies may occur in part by rapid macrophage-mediated clearance of anti-D coated red blood cells in the red pulp of the spleen.^{98, 99} RhIG, however, does not result in complete clearance of fetal red blood cells but is effective even though fetal red blood cells persist in the maternal circulation.⁹⁸ Similarly, the theory that administered RhIG blocks the antigenic stimulus by coating D-positive

red blood cells (i.e., epitope masking) is not supported by the fact that immunosuppressive doses of RhIG bind only to a small fraction of the available antigen sites on red blood cells.⁹⁸

RhIG most likely prevents alloimmunization to the D antigen both by rapid clearance of anti-D coated red blood cells by macrophages in the red pulp of the spleen and by down-regulation of immune response, which blocks antibody production by B cells before development of the anti-D response occurs.⁹⁹ The two molecular interactions responsible for B-cell inhibition occur between the B-cell receptor (membrane IgG) and the D antigen on the red blood cell and between the B-cell Fc γ receptor and the Fc portion of the bound anti-D on the red blood cell surface. In a primary immune response, naive B cells are stimulated to produce antibody when B-cell receptors alone are activated by antigen (Fig. 30.6A). In the presence of RhIG, this signal is overridden, and apoptosis occurs when Fc receptors are simultaneously aggregated in the complex by their association with the red-blood-cell-bound anti-D antibodies (Fig. 30.6B). Memory B cells differ from naive B cells in that they can be activated to produce antibody even in the presence of pre-existing antibodies. This model is consistent with the observation that RhIG prevents the primary immune response, and is not effective for preventing a secondary or anamnestic immune response in a previously sensitized woman.

Interestingly, immune suppression to the D antigen can be induced not only by anti-D, but also by other passively transferred antibodies to a co-expressed blood group antigen, as long as the Fc γ receptor is complexed with the B-cell receptor and the antigen (Fig. 30.6C). This phenomenon of co-inhibition was supported by the observation that passively administered anti-K1 IgG antibodies suppressed anti-D antibody formation in D-negative/K1-negative human subjects given D-positive/K1-positive red blood cells.¹⁰⁰ Finally, animal models of antibody-mediated immune suppression suggest the existence of Fc-receptor-independent pathways.⁹⁸ For example, RhIG may bind and localize factors to the B cell that inhibit antibody production and induce apoptosis, such as transforming growth factor- β (Fig. 30.6D). The immune response is regulated by cellular (e.g., dendritic cells) and soluble mediators (e.g., cytokines), which affect the potential for immunogenicity or tolerance. Down-regulation of immature dendritic cells may also prevent development of the primary immune response after RhIG administration. A role for immunomodulatory cytokines was suggested by Branch et al., who reported an increased plasma concentration of two anti-inflammatory cytokines, TGF- β and prostaglandin E₂ (PGE₂), in D-negative women after antenatal administration of 300 μ g of RhIG.¹⁰¹ TGF- β is a powerful negative modulator of immune responses, and the finding that the cytokine is elevated after RhIG administration is consistent with a role in the prevention of the primary immune response to D fetal red blood cells.^{99, 101}

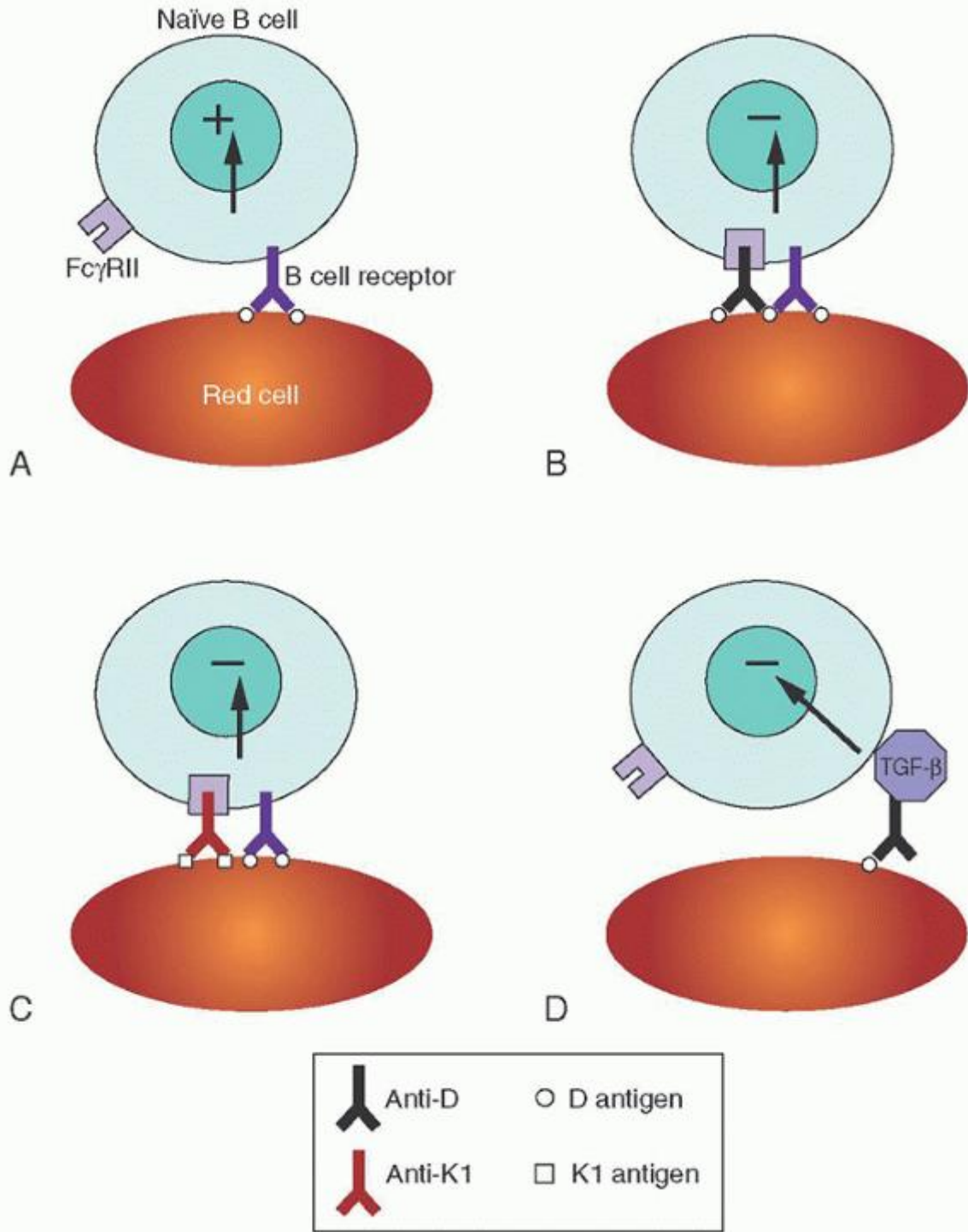

FIGURE 30.6. Mechanisms of anti-D immune globulin (RhIG) immune prophylaxis. A: Alloimmunization. Activation of naive B-cells in a D-negative individual occurs with exposure to D-positive red blood cells through interaction of the B-cell receptor (surface immunoglobulin) and D antigen. B: RhIG immune suppression. Inhibition of B-cells is mediated by passively transferred anti-D (RhIG), which cross-links the B-cell receptor and Fc γ receptor (Fc γ RII). C: Specificity of immune suppression. Inhibition of B-cells from a D-negative, K1-negative individual occurs despite exposure to D-positive, K1-positive red blood cells with the administration of anti-K1, in lieu of RhIG, through formation of the same receptor configuration as in (B) (i.e., cross-linking the Fc γ RII receptor and B-cell receptor for the D antigen). D: Fc-receptor-independent pathways for RhIG immune suppression. Inhibition or apoptosis of B cells may occur through interaction between the Fc portion of anti-D antibodies (RhIG) and immune complex formation on the surface of D-positive red blood

cells. TGF, transforming growth factor.

P.776

Rh Immune Globulin Viral Safety Record

All commercially available RhIG products approved for clinical use are polyclonal anti-D preparations derived from the plasma of immunized human donors (Table 30.6). Subsequent to the realization in the 1980s that human immunodeficiency virus (HIV) could be transmitted through blood product transfusion was the demonstration that the Cohn-Onclay fractionation process used for producing some of the RhIG formulations (e.g., RhoGAM) effectively partitioned and inactivated HIV. To further improve the safety of plasma derivatives, a serologic test to screen plasma donors for HIV was first implemented in 1985; a serologic test for hepatitis C virus (HCV) was introduced in 1991; and nucleic acid testing for both HIV and HCV was added to the repertoire in 2000. As a further precaution, specific viral removal steps, such as sizeexclusion filtration (e.g., RhoGAM), or viral inactivation methods, such as solvent-detergent treatment (e.g., Rhophylac), have been added to the manufacturing process (Table 30.6). Despite these measures, every RhIG product derived from human plasma carries the warning that the potential for disease transmission has not been eliminated.

More than 500,000 doses of RhIG are given to an estimated 350,000 women each year, and no cases of hepatitis or HIV transmission attributed to RhIG have been documented in the United States.^{102, 103} In Ireland and the former East Germany, however, hepatitis C was transmitted to several hundred women by different batches of contaminated intravenous RhIG in the late 1970s, before the introduction of routine donor screening for anti-HCV antibodies in 1991.¹⁰⁴ In 1994, HCV RNA was also detected in batches of RhIG manufactured in Ireland between 1991 and 1994, and a single donor was implicated in contributing the infectious plasma to the pool.¹⁰⁴ A large-scale retrospective investigation screened more than 19,000 recipients of anti-D in this timeframe and identified 19 women with the same strain of HCV as the implicated donor.¹⁰⁴

HCV transmission was linked in 1993 and 1994 to two brands of intravenous immune globulin (IVIg) (Gammagard and Polygam), and these infections were the impetus for introducing viral inactivation steps for all plasma derivatives, including RhIG. No cases of viral transmission have been documented in the United States to any plasma derivative since 1995.^{105a} Another precautionary step recently taken in the United Kingdom is the importation of all source plasma for anti-D products from the United States, in light of a potential risk of transmission of variant Creutzfeldt-Jacob disease from plasma collected in Europe.⁴⁰ Four cases of human variant Creutzfeldt-Jacob disease transmission have been attributed to red blood cell transfusion to date, all in the United Kingdom.^{105b} To decrease the reliance on human plasma, monoclonal antibodies directed against D antigen epitopes have been developed with recombinant technology and appear to compare favorably to RhIG in preventing D alloimmunization but are not commercially available.^{106a} Rozrolimupab, a mixture of 25 different fully human recombinant anti-D monoclonal antibodies, is currently in clinical testing.^{106b}

TABLE 30.6 ANTI-D IMMUNE GLOBULIN PRODUCTS AVAILABLE IN THE UNITED STATES IN 2012

Route of Administration/Brand Name	Manufacturer	Fractionation and Viral Inactivation	Dose	Coverage of D-Positive Red Blood Cells (Whole Blood)	Labeled Indications
IM					
RhoGAM	Ortho-Clinical	Cold alcohol fractionation; size-	300	15 ml (30	Pregnancy/obstetric; D-incompatible transfusion
MicRhoGAM	Diagnostics, Raritan, NJ	exclusion filtration ^a	μg (1,500 IU)	ml) 2.5 ml (5 ml)	
			50 μg (250		

BayRho-D full dose	Bayer Biological, Cold ethanol		300	15 ml (30	Pregnancy/obstetric;
BayRho-D mini dose	Elkhart, IN	fractionation;	μg	ml)	D-incompatible
		solvent-detergent	(1,500	2.5 ml (5	transfusion
		and heat	IU)	ml)	
		treatment ^b	50 μg		
			(250		
			IU)		
IV or IM					
WinRho SDF	Cangene Corporation, Winnipeg, Canada; distributed by Nabi, Boca Raton, FL	Ion exchange chromatography; solvent-detergent and filtration	120 μg (600 IU)	6 ml (12 ml) 15 ml (30 ml) Not for obstetric use	Pregnancy/obstetric; D-incompatible transfusion; immune thrombocytopenia (ITP)
			300 μg (1,500 IU)		
			1,000 μg (5,000 IU)		
Rhophylac	CSL Behring LLC, Kankakee, IL	Ion exchange chromatography; solvent-detergent and filtration ^c	300 μg (1,500 IU)	15 ml (30 ml)	Pregnancy/obstetric; D-incompatible transfusion; immune thrombocytopenia (ITP)

^a Filtration reduces levels of enveloped (e.g., hepatitis C, hepatitis B, human immunodeficiency virus) and non-lipid-enveloped viruses (e.g., parvovirus, hepatitis A).

^b Solvent-detergent and heat treatment removes and inactivates enveloped and nonenveloped viruses.

^c Solvent-detergent treatment inactivates enveloped viruses, and filtration removes some non-lipid-enveloped viruses.

RhIG Dosage and Administration

The effective dose of RhIG to prevent sensitization (20 $\mu\text{g}/\text{ml}$ D-positive red blood cells) was determined experimentally by challenging D-negative male volunteers with incompatible blood.¹⁰⁷ Dosage formulations of different preparations of RhIG are based on this conversion, with the "standard" 300 μg (1,500 IU) sufficient to protect against FMH of 15 ml D-positive red blood cells (30 ml fetal whole blood) (Table 30.6).⁸⁰ The intravenous preparation (WinRho) is used more often for treating immune thrombocytopenia (ITP) than for preventing D alloimmunization, but it is effective for both indications. Dosage adjustments must be made for FMH that exceeds the volume covered by a dose of RhIG⁴¹:

- Multiply the percentage of fetal cells in maternal circulation (expressed as a fraction) by the maternal blood volume (approximately 5,000 ml) to determine the volume (ml) fetal whole blood in the maternal circulation (Kleihauer-Betke result of 1.4%: $0.014 \times 5,000 \text{ ml} = 70 \text{ ml}$ fetal whole blood).

- Divide by the volume of D-positive whole blood covered and round off by standard convention to determine required number of 300- μ g vials of RhIG (70 ml fetal whole blood \div 30 ml whole blood per 300- μ g vial = 2.3 vials).

Given the inherent imprecision in calculating FMH with the Kleihauer-Betke test, some American authorities advocate administering one additional vial of RhIG than this calculated dose to ensure administration of sufficient RhIG.^{41, 80} For example, if the number of vials is calculated to be 2.3, round off to 2.0 vials, but administer 3.0 vials. If the number of vials is calculated to be 2.5, round off to 3.0 vials, but administer 4.0 vials.⁴¹

RhIG is indicated for antenatal and post-natal prophylaxis as well as any clinical situation in which FMH is demonstrated or suspected in D-negative pregnant women. RhIG may also be administered to D-negative women of childbearing potential who inadvertently or unavoidably receive incompatible D-positive red blood cells or cellular components (e.g., platelets) prepared from D-positive whole blood in an attempt to prevent D alloimmunization.¹⁰⁸ RhIG should not be administered to infants or to the following pregnant women^{41, 80}:

- A D-negative woman whose infant is D-negative
- Any D-positive woman, including women with known weak D phenotype
- A D-negative woman known to be immunized to D

Although the appropriate dose of RhIG to administer was determined experimentally in red blood cell challenge experiments, the dosing interval of <72 hours after exposure was an arbitrary decision in early clinical trials but has been universally adopted. RhIG has been shown to be effective if administered 13 days, and possibly as late as 28 days, after exposure to D-positive red blood cells.¹⁰⁹ Consequently, RhIG should be administered within 72 hours of potentially sensitizing events, but it should still be given if this interval is exceeded, as soon as the oversight is recognized. Depending on the administered dose and sensitivity of the laboratory tests, RhIG is detectable in maternal circulation for up to 6 months, with an average half-life of approximately 24 days. Cases of D alloimmunization in post-date pregnancies have been reported when delivery occurred more than 12 weeks after the antenatal dose of RhIG, although the residual circulating RhIG after the standard antenatal dose of 300 μ g should still protect against 1 to 2 ml of D-positive fetal red blood cells at 40 weeks.²⁴

Serious adverse reactions to RhIG are extremely rare but include anaphylaxis in IgA-deficient individuals. More commonly, mild to moderate discomfort may occur at the site of intramuscular injection. Products labeled only for intramuscular injection must not be given intravenously, because they may contain immune complexes that could activate circulating complement proteins and subsequently cause a systemic inflammatory response. The anti-D antibodies in RhIG preparations can cross the placenta and bind to fetal cells but do not cause significant hemolysis.¹¹⁰ Although the possible effects on infants were not consistently examined in previous clinical trials of RhIG, no short-term or long-term detriment to infants whose mothers received RhIG during pregnancy has been demonstrated.¹¹¹

Rh Immune Globulin Immunoprophylaxis Guidelines in Different Countries

ACOG recommends an antenatal RhIG dose of 300 μ g at 28 weeks of gestation for nonsensitized, D-negative women and another 300 μ g after delivery of a D-positive infant, based primarily on data reviewed at the 1977 McMaster Conference revealing the high success rate associated with this regimen (Table 30.7).^{16, 38} Current recommendations from the Royal College of Obstetricians and Gynaecologists (United Kingdom) differ from those from ACOG in that antenatal prophylaxis is given as 100- μ g (500-IU) doses at both 28 weeks and 34 weeks of gestation, and another 100 μ g (500 IU) is given after delivery of a D-positive infant.³⁹ Compared to the American strategy, the British approach achieves similar low rates of alloimmunization with less RhIG [300 μ g (1,500 IU) vs. 600 μ g (3,000 IU)].^{39, 40} This approach also avoids the risk of alloimmunization if delivery occurs more than 12 weeks after administration of the antenatal dose.²⁴ A potential drawback, however, is the additional clinic visit required for the third injection at 34 weeks of gestation. Routine antenatal prophylaxis has not been implemented in all countries⁴⁰; other differences in practices include indications and methods for testing for FMH, availability of noninvasive pre-natal diagnosis for D, and testing D-negative women for weak D to determine eligibility for RhIG.⁴⁰

TABLE 30.7 RECOMMENDATIONS FOR PROPHYLACTIC ANTI-D IMMUNE GLOBULIN (RHIG) ADMINISTRATION TO D-NEGATIVE WOMEN WITHOUT ANTI-D WITHIN 72 HOURS OF DELIVERY, ABORTION, OR EVENT

Antenatal	300 μ g RhIG at 28 weeks' gestation unless father of baby is known to be D-negative
Postpartum	300 μ g RhIG after the delivery of a D-positive infant. American College of Obstetricians and Gynecologists acknowledges American Association of Blood Banks' recommendation for routine FMH screening in this situation to identify FMH >15 ml

	D-positive red blood cells requiring larger dose of RhIG.
Abortion	50 μ g RhIG in the first trimester; 300 μ g RhIG after the first trimester; for induced or spontaneous abortion, ectopic pregnancy
Potentially sensitizing events	50 μ g RhIG in the first trimester; 300 μ g RhIG after the first trimester. This includes chorionic villus sampling, amniocentesis, and fetal blood sampling. RhIG should be considered in cases of threatened abortion, second- or third-trimester antenatal bleeding, external cephalic version, and abdominal trauma.

FMH, fetal-maternal hemorrhage.

Data from Crowther C, Middleton P. Anti-D administration after childbirth for preventing Rhesus alloimmunization. *Cochrane Database Syst Rev.* 2000;(2):CD000021; Lee D, Rawlinson VI. Multicentre trial of antepartum low dose anti-D immunoglobulin. *Transfus Med* 1995;5:15-19; and Hensleigh PA. Preventing rhesus isoimmunization: antepartum Rh immune globulin prophylaxis versus a sensitive test for risk identification. *Am J Obstet Gynecol* 1983;146:749-755.

All international medical authorities, however, emphasize the importance of recognizing potentially sensitizing events and appropriately administering RhIG after amniocentesis, chorionic villus sampling, percutaneous umbilical blood sampling, and obstetric complications, including abdominal trauma, manual removal of placenta, and antepartum vaginal bleeding (Table 30.2).^{38, 39, 40} Smaller doses of anti-D immune globulin can be administered after first-trimester events and procedures, because of the small total red blood cell mass of the fetus before 12 weeks' gestation. Consequently, ACOG recommends 50 μ g to protect against sensitization by 2.5 ml of red blood cells in the first trimester (\leq 13 weeks' gestation) and the standard 300- μ g dose after 12 weeks.

Unfortunately, the sensitization rate among D-negative women is higher than theoretically achievable rates, suggesting a failure to follow recommended prophylactic regimens.²⁹ Although postpartum doses were almost always administered, anti-D immune globulin was less consistently administered after abortion (88% to 94%), antepartum hemorrhage (31%), and amniocentesis (14%) in a 1985 study.¹¹² Deficiencies were noted as recently as 1994 in a series of more than 900 women in which RhIG administration followed only 60% of invasive procedures or other events associated with FMH.¹¹³ Ongoing vigilance in public health care is required

P.778

to ensure effective use of RhIG given the potential severity of HDFN due to D alloimmunization.

MANAGEMENT OF RED BLOOD CELL ALLOIMMUNIZATION IN PREGNANCY

Management of red blood cell alloimmunization depends first on whether the woman has had one or more pregnancies, because HDFN is usually mild in a first pregnancy but likely to increase in severity in subsequent pregnancies. Although an obstetrician may provide routine pre-natal care to an alloimmunized pregnant woman in her first pregnancy and follow antibody titers, perform serial ultrasounds, and initiate amniotic fluid studies (if needed), referral to specialty centers experienced in Doppler ultrasonography and intrauterine transfusion is recommended by fetal-maternal specialists for optimal clinical management.^{32, 94}

Certain red blood cell antibodies are far more often implicated in cases of alloimmune fetal hydrops (e.g., anti-D, -c, -Kl, and -Fy^a) than others (e.g., anti-E and anti-M).^{32, 58, 114} Other IgG red blood cell antibodies have demonstrated the potential in rare cases to cause severe fetal anemia or life-threatening HDN (Table 30.3), and still more IgG red blood cell antibodies have been reported to cause mild HDN. Although anecdotal reporting introduces bias toward the most severe cases, the previous behavior of non-D antibodies in sensitized pregnancies influences clinical management. If the antibody screen at the initial obstetric visit detects the presence of anti-D or other potentially significant red blood cell alloantibodies, additional monitoring is necessary during the pregnancy, and pre-natal intervention may be required. An algorithm for clinical management of a patient with red blood cell sensitization in a first affected pregnancy contains decision points based on maternal antibody titer, paternal phenotype, and serial fetal MCA Doppler or serial amniocentesis beginning at 24 weeks' gestation³² (Fig. 30.7). If the fetus is suspected to be antigen positive, and MCA Doppler reaches 1.5 MoM or greater, cordocentesis should be performed at an experienced referral center, and blood should be available for intrauterine transfusion if the fetal hematocrit is found to be $<$ 30%.³² If serial amniocentesis is performed instead of MCA Doppler, Δ OD₄₅₀ values rising into the upper portion of the Rh-positive, affected zone of the

Queenan curve (Fig. 30.5) or the 80th percentile of zone 2 of the Liley curve (Fig. 30.4) should trigger fetal blood sampling, with preparation for intrauterine transfusion if necessary.³² Women with significant red blood cell alloantibodies who have had a prior affected pregnancy, involving either intrauterine transfusion or neonatal exchange transfusion, should be referred to a tertiary care center experienced in the management of severe HDFN. Maternal antibody titers are not indicated because they do not predict the degree of fetal anemia. Amniocentesis can be performed at 15 weeks' gestation to determine fetal antigen status for patients with a history of a severely affected fetus. Serial MCA Doppler assessment has been recommended starting at 18 weeks' gestation with repeated assessments every 1 to 2 weeks.³² Alternatively, serial amniocentesis for measurement of ΔOD_{450} against the Queenan curves can begin at 18 weeks' gestation. Subsequent management decisions follow the same algorithm for a first affected pregnancy (Fig. 30.7).³²

Intrauterine Fetal Transfusion

Intrauterine transfusion is performed to alleviate symptoms and extend gestation until the developing infant is mature enough to survive after delivery. Generally indicated if the fetal hematocrit falls below 30%, intrauterine transfusion can be given as early as 17 weeks' gestation by the intraperitoneal route and at approximately 20 weeks by the intravascular route.^{114, 115} The only access before 17 weeks' gestation, the intracardiac route, is only an option in extreme circumstances, and most transfusions are given after 20 weeks by the intravascular or intraperitoneal routes.¹¹⁵

Intraperitoneal transfusions are given by injecting blood into the abdominal cavity of the fetus, which is then absorbed into the fetal circulation by the subdiaphragmatic lymphatic system.¹¹⁵ The presence of ascites, however, interferes with absorption, limiting the benefit to the most severely affected infants. Intravascular transfusion directly into the fetal circulation has largely supplanted the intraperitoneal method. The obvious advantage of the intravascular approach was the potential benefit offered to infants with hydrops and the ability to directly evaluate hematologic parameters after the transfusion.^{115, 116, 117} A combined approach using both intravascular and intraperitoneal transfusion may produce more stable hematocrits and permit longer intervals between transfusions.^{116, 117}

The red blood cell volume to administer to a fetus during an intrauterine transfusion depends on the technique, the initial hematocrit, the target hematocrit, and the gestational age.⁴¹ For intraperitoneal transfusion, the volume of red blood cells is calculated by the following equation, which assumes the hematocrit of the donor red blood cell unit is approximately 75%: (gestational age in weeks = 20) \times 10 ml.¹¹⁴ In a nonhydropic fetus, the rate of absorption is approximately 10% to 15% per 24 hours.¹¹⁴ Intravascular intrauterine transfusions are usually given as simple transfusions of small aliquots of red blood cells ranging in volume from 50 to 100 ml, and not as exchange transfusions, due to the technical complexity of the latter. Several equations have been developed to calculate the dose of red blood cells to transfuse for intravascular transfusion, including the following method^{41, 118}:

- Calculate the fetoplacental volume (ml): Ultrasound estimated fetal weight (g) \times 0.14.
- Calculate the volume to transfuse (ml): Fetoplacental volume \times [(desired hematocrit — pretransfusion hematocrit) \div donor unit hematocrit]

The red blood cells used for intrauterine transfusion should be type O, D-negative, and antigen-negative if other clinically significant maternal alloantibodies are present, and they should be crossmatched against maternal serum. If antigen-negative red blood cells are needed but cannot be located, maternal red blood cells can be transfused to the infant if ABO/Rh compatible and after reducing the amount of antibody-containing plasma.¹¹⁹ All red blood cell units for intrauterine transfusion should also be collected from cytomegalovirus (CMV)-seronegative donors or leukocyte-reduced to reduce the risk of CMV transmission, should lack hemoglobin S as a precaution against the potential for red blood cell sickling in hypoxic tissue beds, and should be γ -irradiated to prevent transfusion-associated graft-versus-host disease.⁴¹

Fetal blood is usually aspirated at the conclusion of intravascular transfusions to determine the final hematocrit and adequacy of the treatment. The goal of transfusions is usually to keep the fetal hematocrit around 27% to 30%.^{41, 114} Based on the association of increased umbilical cord venous pressure and mortality after transfusion, some authors recommend that in a severely anemic fetus, the final hematocrit after intravascular transfusion should not exceed a value of 25% or a fourfold increase from the pre-transfusion value.¹²⁰ Repeat transfusions are planned, based on an approximate 1% decline per day in hematocrit after intravascular transfusion.⁴¹ Ongoing brisk hemolysis of fetal cells with severe disease often necessitates a shorter interval between the first and second transfusion, usually 7 to 14 days, compared to subsequent transfusions, usually 21 to 28 days.¹¹⁴

Complications of intrauterine transfusions in general include infection, premature rupture of membranes, premature labor, fetal hemorrhage, FMH resulting in increased maternal antibody titers and accelerated course of fetal hemolytic

disease, and the risks of allogeneic blood components including virus transmission and graft-versus-host disease.¹¹⁵ The risk of virus transmission

P.779

with blood collected from repeat donors in the United States is currently estimated as 1 in 200,000-500,000 units for hepatitis B; 1 in 1,390,000 units for hepatitis C; and <1 in 2,000,000 units for HIV.^{121a, 121b, 121c} The risk of physical injury during intrauterine transfusion, such as damage to fetal viscera with the intraperitoneal approach or umbilical cord damage with the intravascular approach, is minimized with the use of paralytic agents (i.e., vecuronium) to reduce fetal movement during intrauterine transfusions.^{114, 115} The procedure-related risk of fetal loss with intravascular transfusion is estimated as 4% to

P.780

9%.¹¹⁴ Complications of intravascular transfusion, not previously reported with intraperitoneal transfusion, include umbilical cord hematoma, fetal bradycardia, and porencephalic cysts.^{114, 115} The procedure-related risks of intrauterine transfusion must be weighed against the risks of pre-term delivery and prematurity, and transfusions are rarely performed after completion of 34 gestational weeks.¹¹⁴

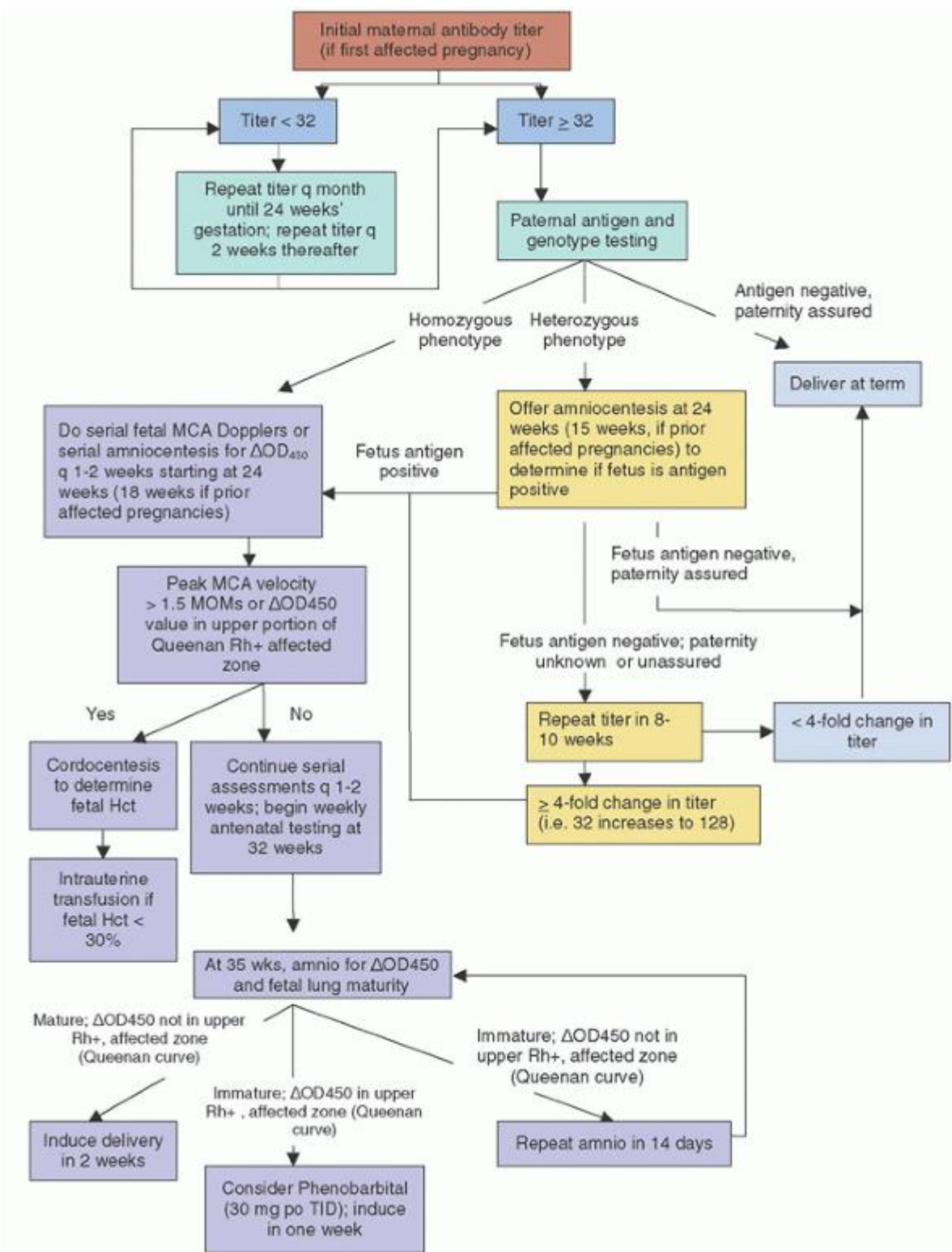

FIGURE 30.7. Algorithm for clinical management of a patient with red blood cell sensitization. Maternal titers are performed for a first affected pregnancy (shaded boxes). If a woman has a history of a previously affected fetus or infant, maternal antibody titers are not predictive of degree of fetal anemia and the patient should be referred to a tertiary care center for early intervention to determine fetal antigen status and initiate middle cerebral artery (MCA) Doppler assessment. MoMs, multiples of the median; ΔOD_{450} , optical density at 450 nm. (Modified from Moise KJ. Red blood cell alloimmunization in pregnancy. *Semin Hematol* 2005;42:169-178, with permission from Elsevier.)

Investigational Strategies to Prevent or Treat Hemolytic Disease of the Fetus and Newborn

Investigational treatment strategies for HDF aim to modulate the maternal immune response and delay or avert the need for intrauterine transfusion by administering pre-natal IVIG or performing therapeutic plasma exchange. Results with therapeutic plasma exchange in red blood cell alloimmunized pregnancies are variable, and in many cases, the maternal anti-D titer was not affected or rebounded to even higher levels after treatment.¹²² Pre-natal intravenous IVIG administration, to either the mother or fetus, is not efficacious and is not recommended for routine use for management of HDF.¹²³ For an alloimmunized woman with multiple fetal losses facing her reproduction options with a man heterozygous for the implicated blood group antigen, pre-implantation diagnosis after in vitro fertilization may provide a means to identify antigen-negative embryos.¹²⁴ Another investigational approach proposes to immunize these high-risk women against paternal HLA antigens before conception, citing the apparent mitigating effect of HLA antibodies on HDFN caused by anti-D.⁵¹ Research to suppress selectively the maternal B cells that produce red blood cell alloantibodies is ongoing.¹¹⁴ Finally, recombinant human antibodies directed against D antigen epitopes are being tested to decrease the reliance on human plasma for Rh immunoprophylaxis.^{106a, 106b}

TREATMENT OF THE NEWBORN INFANT

The therapeutic approach to anemia and jaundice after birth due to HDFN depends on the gestational age at delivery, severity of disease, and other factors.^{125, 126} Treatment of each affected infant must be individualized after a detailed history, physical examination, and laboratory investigation. An infant born with hydrops requires intensive and immediate supportive care. A thorough physical examination may reveal findings of pallor, tachycardia, and tachypnea, which reflect neonatal anemia. The infant must be monitored for worsening jaundice and neurologic findings of bilirubin toxicity. In contrast to “physiologic” jaundice developing on the second or third day of life, early jaundice appearing in the first 24 hours of life is always pathologic and may signify hemolysis. Initial laboratory assessment should include ABO/D blood typing and a direct antiglobulin test, as well as bilirubin measurement and a complete blood count for assessment of hemoglobin, hematocrit, reticulocyte count, and red blood cell morphology (polychromasia, spherocytes, and nucleated red blood cells). Early erythrocyte precursors and nucleated red blood cells may be prominent in the peripheral blood smear with hemolytic disease due to anti-D, whereas spherocytes predominate in ABO HDN. Serial tests of bilirubin concentration are recommended to follow the rate of the rise in bilirubin and to determine the most appropriate form of treatment.¹²⁵ Ongoing hemolysis increases the concentration of unconjugated bilirubin; the concentration of conjugated bilirubin is usually normal or not >0.5 mg/dl and should not be subtracted from the total bilirubin for treatment decisions. Conjugated bilirubin above the upper limit of the normal range in HDN may indicate mild cholestasis or “inspissated” bile.¹²⁵ Infants with jaundice due to immune-mediated hemolysis are generally considered at greater risk for bilirubin encephalopathy than infants with jaundice due to other causes, at any given serum unconjugated bilirubin concentration.¹²⁵ Acid-base disturbances, asphyxia, free heme groups, and other by-products of hemolysis may potentiate the toxic effects of bilirubin in infants with alloimmune hemolysis.^{125, 126} The bilirubin-to-albumin ratio is also taken into consideration, because serum bilirubin is transported in the plasma tightly bound to albumin and the portion that is unbound or loosely bound can more readily leave the intravascular space and cross the intact blood-brain barrier.

Phototherapy

Phototherapy is the first line of treatment for neonatal jaundice and can avert the need for an exchange transfusion in infants with HDN. Light exposure converts insoluble unconjugated bilirubin into a water-soluble photoisomer, permitting more rapid excretion through the urine or bile without conjugation. Factors affecting optimal phototherapy include the dose of light, its spectral emission curve, the infant's exposed surface area, the depth of penetration of the light, and characteristics of the infant's skin and tissues. The effective wavelength of light for transcutaneous degradation of unconjugated bilirubin is in the range of 430 to 490 nm, found at high irradiance in blue light.¹²⁷ Conventional phototherapy uses banks of lights, whereas fiberoptic light systems contain optical fibers in a blanket or band that is wrapped around the infant. The fiberoptic light systems expose greater surface area to light, are convenient to use, and are less disruptive to parent-child bonding than conventional phototherapy. Double phototherapy uses both fiberoptic and conventional phototherapy and lowers serum bilirubin faster than conventional phototherapy alone.^{125c} Intensive phototherapy implies irradiance in the blue-green spectrum (wavelengths of approximately 430 to 490 nm) of at least 30 $\mu\text{W}/\text{cm}^2$ per nm (measured at the infant's skin directly below the center of the phototherapy unit) and delivered to as much of the infant's surface area as possible.¹²⁶

Clinical practice guidelines from the American Academy of Pediatrics (AAP) treat infants with jaundice caused by immunemediated hemolysis more aggressively than infants with “physiologic” jaundice, with comparable serum unconjugated bilirubin concentration.¹²⁶ Treatment of jaundiced pre-term infants and jaundice on the first day of life in any infant requires individualized treatment decisions. In general, phototherapy should be initiated in term infants if bilirubin increases by 0.5 mg/dl/hour or more, or if total bilirubin exceeds the established parameters, which are

determined by gestational age and the presence of risk factors such as hemolysis, sepsis, or acidosis. Premature infants are treated earlier in the course of disease at lower bilirubin concentrations than term infants. Earlier initiation of therapy, at lower bilirubin concentrations, may also be clinically indicated in other scenarios. For example, infants who required extensive pre-natal treatment may be started on optimal phototherapy after birth. High-dose IVIG may block binding of antibody-coated red blood cells to Fc receptors on reticuloendothelial cells, thereby blunting the destruction of red blood cells.^{126, 128} The AAP recommends administration of IVIG (0.5 to 1 g/kg over 2 hours) if the total serum bilirubin is rising despite intensive phototherapy or the total serum bilirubin level is within 2 to 3 mg/dl (34 to 51 μmol/L) of the exchange level (Fig. 30.8).

Adverse effects of phototherapy include increased insensible water loss, diarrhea, photosensitization, overheating, and hyperpigmentation. Because of the potential for retinal damage with phototherapy, protective eye devices must be used.¹²⁷

Exchange Transfusion

Exchange transfusion is usually needed when phototherapy, IVIG, or both fail to adequately decrease bilirubin concentration

P.781

or the initial serum bilirubin concentration places the infant at high risk for developing kernicterus. Classical criteria for early exchange transfusion within 12 hours of birth are a cord bilirubin concentration exceeding 3 to 5 mg/dl for pre-term infants and 5 to 7 mg/dl for term infants or a rate of rise of 0.5 mg/dl/hour or greater.¹²⁵

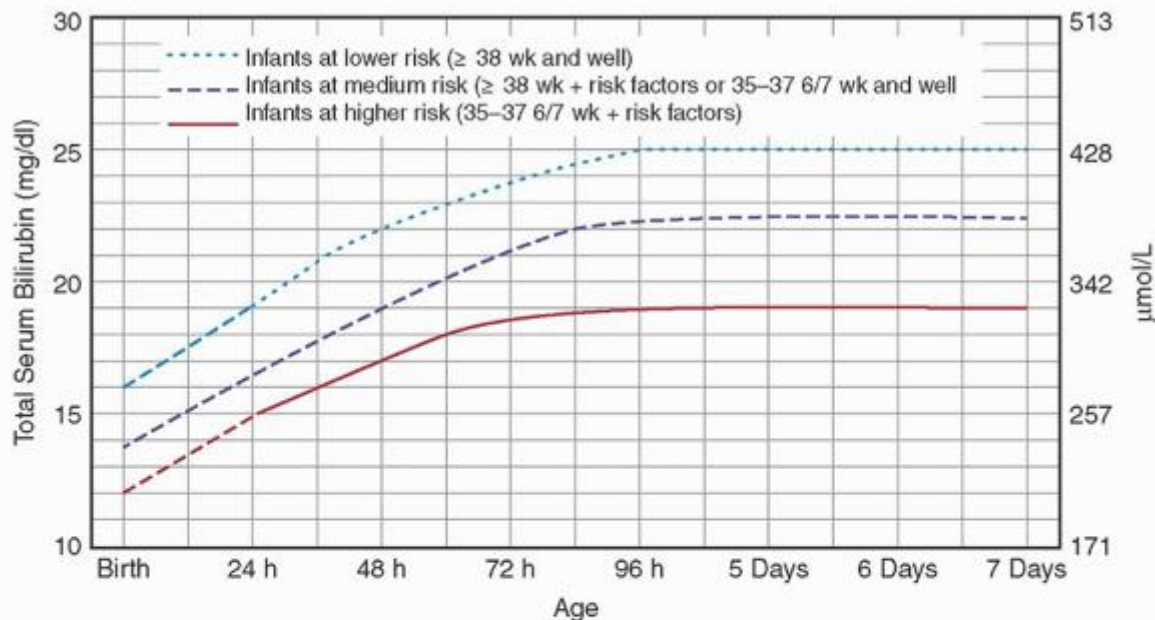

- The dashed lines for the first 24 hours indicate uncertainty due to a wide range of clinical circumstances and a range of responses to phototherapy.
- Immediate exchange transfusion is recommended if infant shows signs of acute bilirubin encephalopathy (hypertonia, arching, retrocollis, opisthotonos, fever, high pitched cry) or if TSB is ≥5mg/dl (85 μmol/L) above these lines.
- Risk factors - isoimmune hemolytic disease, G6PD deficiency, asphyxia, significant lethargy, temperature instability, sepsis, acidosis.
- Measure serum albumin and calculate B/A ratio (See legend)
- Use total bilirubin. Do not subtract direct reacting or conjugated bilirubin
- If infant is well and 35–37 6/7 wk (median risk) can individualize TSB levels for exchange based on actual gestational age.

FIGURE 30.8. Guidelines for exchange transfusion in infants 35 weeks or more. B/A, bilirubin to albumin; G6PD, glucose-6-phosphate dehydrogenase; TSB, total serum bilirubin. (Reproduced with permission from American Academy of Pediatrics, Subcommittee on Hyperbilirubinemia, "Management of hyperbilirubinemia in the newborn infant 35 or more

weeks of gestation." Pediatrics 2004;114:297-316. Copyright ©2004 by the American Academy of Pediatrics.)

Treatment decisions after the first 24 hours for pre-term infants are guided by weight, bilirubin concentration, the rate of its increase (>0.5 mg/dl/hour), and the presence of comorbid factors such as hemolysis, asphyxia, significant lethargy, temperature instability, sepsis, or acidosis.

For infants at 35 weeks' or more gestation, exchange transfusion is recommended when the total serum bilirubin rises to threshold levels despite intensive phototherapy, based on the gestational age and the presence of risk factors (Fig. 30.8).¹²⁶ It is also a clinical option to use the bilirubin-to-albumin ratio together with, but not in lieu of, the total serum bilirubin level as an additional factor in determining the need for exchange transfusion.¹²⁶ Immediate exchange transfusion is recommended if infants show signs of acute bilirubin encephalopathy (e.g., hypertonia, arching, fever, high-pitched cry) or if total serum bilirubin is 25 mg/dl (428 μ mol/L) or higher.¹²⁶

If exchange transfusion is indicated, a transfusion volume approximately twice the infant's total blood volume (85 ml/kg \times 2 for a term infant; 100 ml/kg \times 2 for a pre-term infant) is administered incrementally while removing aliquots of the infant's blood over a period of 1 to 2 hours. The procedure either involves a push-pull method with a single vascular access or an isovolemic method that requires two catheters to allow for simultaneous withdrawal and infusion.^{1, 125} The umbilical artery is usually used for withdrawing blood, and the umbilical vein is usually used for infusion. The isovolemic method may be preferable because mean arterial pressure and cerebral blood volume may be more stable than during the single-catheter, push-pull method.¹²⁵ An exchange of approximately two blood volumes removes approximately 85% of red blood cells but only approximately 45% of plasma bilirubin because the latter re-equilibrates between intravascular and extravascular spaces. Consequently, infants with aggressive hemolytic disease may require more than one exchange transfusion before an acceptable bilirubin concentration is achieved.

Red blood cell units chosen for neonatal exchange transfusion should be O, Rh negative, or ABO/Rh type specific; should lack the blood group antigen implicated in hemolytic disease (e.g., ABO hemolytic disease requires the use of type O red blood cells); and should be compatible with maternal serum. Maternal serum or plasma is usually used in crossmatching red blood cells for infants because it contains the implicated antibody in high concentration and is available in large quantity. If a maternal sample is not available, the infant's plasma or serum can be used for compatibility testing; however, the concentration of circulating antibody may be low if most is bound to the infant's red blood cells. In this case, the bound antibody can be eluted from the surface of the infant's red blood cells, and the resulting eluate can be used for crossmatching. Rarely, HDN is due to an antibody to a high-incidence blood group antigen present in almost all persons, and no compatible units can be identified.⁴¹ In this case, maternal blood can be collected and washed to remove incompatible plasma for the infant.

Any blood component collected from biologic relatives must be irradiated as a precaution against transfusion-associated graft-versus-host disease, as well as blood components transfused to infants who received intrauterine transfusion or who are otherwise immunocompromised due to premature birth or severe primary immune deficiency. Because of the difficulty in identifying all high-risk newborn infants, many transfusion services provide γ -irradiated blood for all infants until the age of 4, 6, or 12 months.¹²⁹ Another common standard of practice is the use of either leukocyte-reduced cellular components or units selected from CMV-seronegative donors to reduce the risk of CMV transmission to newborn infants.¹²⁹ Most blood banks also transfuse only units that lack hemoglobin S to infants to avoid the potential for hypoxia-induced sickling in a critically ill infant and fresh (<5 to 7 days old) or washed red blood cell units to avoid the risk of potassium-mediated cardiac toxicity with large transfusion volumes.^{41, 129} To prepare a two-blood volume exchange transfusion, red blood cells should be reconstituted with ABO-compatible

P.782

plasma to the desired total volume and hematocrit. Albumin infusion before or during exchange in an effort to enhance bilirubin removal is controversial.¹²⁵

Severe reactions related to the neonatal exchange transfusion have been reported in about 5% to 10% of infants, and include citrate-related arrhythmias, bleeding caused by dilutional coagulopathy or thrombocytopenia, catheter-related infection, and bacterial sepsis.¹²⁶ The mortality rate among term infants within 6 hours of exchange transfusion was estimated as 3 to 4 per 1,000.¹²⁶ Adverse reactions during the transfusion are more often related to the infant's underlying disease rather than the transfusion. In a study involving 331 exchanges given to 190 infants, there was only one death within 6 hours of an exchange transfusion, an infant who was critically ill before the procedure.¹³⁰ Procedure-related reactions during exchange transfusion were noted in $<10\%$ of infants (22 of 328) and included transient mild bradycardia.¹³⁰ Other potential complications of neonatal exchange transfusion include hypervolemia and volume

overload, cardiac toxicity due to citrate or hyperkalemia, air emboli or thrombosis in the umbilical vein, necrotizing enterocolitis, bleeding due to dilutional coagulopathy or thrombocytopenia, bacterial sepsis, or viral transmission, as previously described for fetal blood component transfusion.¹

Transfusion for Late-onset Neonatal Anemia

Infants who respond to phototherapy alone or those who receive intrauterine transfusion may also require straight red blood cell transfusion between 2 and 10 weeks of life due to anemia developing as a result of low-grade hemolysis or erythropoietic suppression. Maternal antibody persists in the infant's circulation for approximately 6 weeks, and resultant hemolysis is usually associated with a marked reticulocytosis. In contrast, the late anemia associated with intrauterine transfusion is characterized by sustained suppression of erythropoiesis and decreased to absent reticulocytes and low erythropoietin concentrations.¹³¹ Erythropoietic suppression also occurs with anti-K1 and anti-D, irrespective of intrauterine transfusion.^{125, 132} To counter this late hypoproliferative anemia, erythropoietin treatment resulted in increased reticulocyte count and hemoglobin concentration and avoided the need for transfusion in some infants with HDN.^{131, 132}

Infants with circulating red blood cell antibodies should be closely monitored for at least 8 to 10 weeks to identify the development of late anemia. Hemoglobin concentrations below 7 to 10 g/dl have been proposed as transfusion "triggers." In general, the decision to transfuse should be guided, most importantly, by the infant's condition, such as lethargy, poor feeding, or failure to thrive, rather than the hemoglobin concentration and reticulocyte count in isolation.

Adjunctive and Experimental Treatment

Whereas phototherapy and exchange transfusion effectively eliminate bilirubin in most infants with HDN, experimental strategies are aimed at preventing hyperbilirubinemia by blocking its production. Metalloporphyrins are heme analogs that block the rate-limiting enzyme, heme oxygenase, in the heme metabolic pathway. Tin (Sn)-mesoporphyrin (SnMP) was used to treat two infants with severe immune-mediated hyperbilirubinemia after their parents refused exchange transfusion because of their religious convictions as Jehovah's Witnesses.¹³³ In both cases, phototherapy failed to achieve adequate control, but SnMP effectively halted the progression of hyperbilirubinemia. Without such extenuating circumstances, however, the use of SnMP is not recommended.¹²⁵ Other agents investigated as means to decrease serum bilirubin include phenobarbital, clofibrate, cholestyramine, agar, and charcoal.¹²⁵ The clinical effectiveness and the potential toxicity of these various treatments require further study before they can be recommended for treatment of immune-mediated hemolytic disease.

CLINICAL OUTCOMES OF TREATMENT FOR HEMOLYTIC DISEASE OF THE FETUS AND NEWBORN

The survival rate among infants who required intrauterine transfusion varies with institution and experience, but infants without signs of hydrops have a relatively favorable prognosis. A survey of 16 institutions in the United States and Canada involving 1,087 intrauterine intravascular transfusions given to 389 fetuses revealed a survival rate of 90% for nonhydropic fetuses and 82% in cases of hydrops.¹¹⁴ The degree of hydrops, and not merely its presence, is predictive of the outcome of alloimmunized pregnancies.¹³⁴ In 2001, Van Kamp et al. reported that 41 of 42 fetuses with mild hydrops (98%) survived, compared to only 21 of 55 fetuses with severe hydrops (55%).¹³⁴ Hydrops can be reversed in 60 to 70% of fetuses after intrauterine transfusion, and almost all fetuses with resolved hydrops survived, whereas persistent hydrops was more often associated with an unfavorable outcome.¹³⁴ The long-term neurodevelopmental outcome of infants successfully treated in utero with red blood cell transfusion compares favorably to other high-risk, very-low-birthweight infants.¹³⁵ The majority of surviving infants who received intrauterine transfusion demonstrate normal development and neurologic function; <10% exhibit mild to severe developmental delays or cerebral palsy (spastic tetraparesis or hemiplegia).^{135, 136, 137a} The most recent and largest study of neurodevelopmental outcome of children treated with intrauterine transfusion for HDF to date is the LOTUS study, a national cohort study from Leiden University Medical Center, The Netherlands.^{137b} The overall incidence of neurodevelopmental impairment was 4.8% (14 of 291 children), and the risk factors for neurodevelopmental impairment were the presence of fetal hydrops, the number of intrauterine transfusions, and severe neonatal morbidity.^{137b}

Uncertainties persist regarding the degree and duration of hyperbilirubinemia that place an infant at risk for bilirubin encephalopathy and kernicterus. In the early 1950s before effective treatment was available, approximately one half of infants with bilirubin concentrations >30 mg/dl developed kernicterus. An overall decrease in the incidence of kernicterus has been observed, but evidence for the efficacy of current treatment for neonatal hyperbilirubinemia and the effect of high levels of bilirubin on behavioral and neurodevelopmental outcomes is limited.^{125, 138} Recently, a prospective blinded study compared 140 term and near-term infants with total serum bilirubin levels of 25 mg/dl (428 μmol/L) or more to 419 control subjects and found no significant differences between the two groups in neurodevelopmental outcomes.¹³⁹

However, the subgroup of infants with hyperbilirubinemia resulting from immune-mediated hemolytic disease had lower IQ scores than the control group. This study corroborates previous observations that hemolysis enhances the risk of bilirubin-induced central nervous system injury, and supports the rationale for more aggressive treatment of infants with hyperbilirubinemia associated with HDFN than other infants with physiologic jaundice.

CONCLUSION

Before discovery of RhIG, HDFN from anti-D was a significant cause of perinatal mortality or long-term disability. The incidence of D alloimmunization among D-negative women decreased from 14% to 1 to 2% with the widespread use of postpartum RhIG in the late 1960s, and further decreased to 0.1% with the use of

P.783

routine antenatal RhIG prophylaxis after 1979. Smaller family size in recent decades also contributed to the decline in the number of cases, but HDFN due to anti-D continues to occur at a low rate in the United States, which likely reflects inadvertent failure to administer RhIG prophylaxis, inadequate pre-natal care, or antenatal sensitization prior to RhIG administration at 28 weeks' gestation. Maternal alloimmunization to other red blood cell alloantigens in the Rhesus, Kell, or other blood groups currently cannot be routinely prevented and also cause HDFN. Advances in pre-natal care, noninvasive monitoring, and intrauterine transfusion have improved clinical outcomes to the extent that survival rates for nonhydropic fetuses with alloimmune hemolysis currently approach 90%, and those with hydrops fetalis can be effectively treated in most cases.

REFERENCES

1. Bowman JM. Hemolytic disease of the newborn. In: Garratty G, ed. Immunobiology of transfusion medicine. New York: Marcel Dekker, 1994:553-595.
2. Diamond LK, Blackfan KD, Baty JM. Erythroblastosis fetalis and its association with universal edema of the fetus, icterus gravis neonatorum and anemia of the newborn. *J Pediatr* 1932;1:269-309.
3. Landsteiner K, Wiener AS. An agglutinable factor in human blood recognized by immune sera for rhesus blood. *Proc Soc Exp Biol Med* 1940;43:223.
4. Levine P, Stetson RE. An unusual case of intra-group agglutination. *JAMA* 1939;113:126-127.
5. Levine P, Katzin EM, Burnham L. Isoimmunization in pregnancy: its possible bearing on the etiology of erythroblastosis fetalis. *JAMA* 1941;116:825-827.
6. Chown B. Anemia from bleeding of the fetus into the mother's circulation. *Lancet* 1954;1:1213-1215.
7. Diamond LK, Allen FH Jr, Thomas WO. Erythroblastosis fetalis. VII. Treatment with exchange transfusion. *N Engl J Med* 1951;244:39-49.
8. Liley AW. Liquor amnii analysis in the management of the pregnancy complicated by rhesus sensitization. *Am J Obstet Gynecol* 1961;82:1359-1370.
9. Liley AW. Intrauterine transfusion of foetus in haemolytic disease. *BMJ* 1963;2:1107-1109.
10. Clarke CA, Donohoe WTA, McConnell RB, et al. Further experimental studies in the prevention of Rh-haemolytic disease. *BMJ* 1963;1:979-984.
11. Freda VJ, Gorman JG, Pollack W. Successful prevention of experimental Rh sensitization in man with an anti-Rh gamma2-globulin antibody preparation: a preliminary report. *Transfusion* 1964;4:26-32.
12. Combined study. Prevention of Rh-haemolytic disease: results of the clinical trial. A combined study from centres in England and Baltimore. *BMJ* 1966;2:901-910.
13. Pollack W, Gorman JG, Freda VJ, et al. Results of clinical trials with RhoGAM in women. *Transfusion* 1968;8:151-153.
14. Chown B, Duff AM, James J, et al. Prevention of primary Rh immunization. First report of the Western Canadian Trial. *Can Med Assoc J* 1969;100:1021-1024.
15. Freda VJ, Gorman JG, Pollack W, et al. Prevention of Rh hemolytic disease—ten years' experience with Rh immune globulin. *N Engl J Med* 1975;292:1014-1016.
16. McMaster Conference on Prevention of Rh Immunization. 28-30 September 1977. *Vox Sang* 1979;36:50-64.

17. Crowther C, Middleton P. Anti-D administration after childbirth for preventing Rhesus alloimmunization. *Cochrane Database Syst Rev.* 2000;(2):CD000021.
18. Zipursky A. The universal prevention of Rh immunization. *Clin Obstet Gynecol* 1971;14:869-884.
19. Bowman JM, Chown B, Lewis M, et al. Rh isoimmunization during pregnancy: antenatal prophylaxis. *Can Med Assoc J* 1978;118:623-627.
20. Crowther CA, Keirse MJ. Anti-D administration in pregnancy for preventing rhesus alloimmunisation. *Cochrane Database Syst Rev.* 2000;(2):CD000020.
21. Huchet J, Dallemagne S, Huchet C, et al. The antepartum use of anti-D immunoglobulin in rhesus negative women. Parallel evaluation of fetal blood cells passing through the placenta. The results of a multicenter study carried out in the region of Paris. *J Gynecol Obstet Biol Reprod (Paris)* 1987;16:101-111.
22. Lee D, Rawlinson VI. Multicentre trial of antepartum low dose anti-D immunoglobulin. *Transfus Med* 1995;5:15-19.
23. Prevention of Rh sensitization: report of WHO Scientific group. WHO Technical Report Series 468, 1971.
24. Bowman JM. Controversies in Rh prophylaxis. Who needs Rh immune globulin and when should it be given? *Am J Obstet Gynecol* 1985;151:289-294.
25. Hensleigh PA. Preventing rhesus isoimmunization: antepartum Rh immune globulin prophylaxis versus a sensitive test for risk identification. *Am J Obstet Gynecol* 1983;146:749-755.
26. Tovey LA, Taverner JM. A case for the antenatal administration of anti-D immunoglobulin to primigravidae. *Lancet* 1981;878-881.
27. Statement from the consensus conference on anti-D prophylaxis 7 and 8 April 1997. The Royal College of Physicians of Edinburgh. Royal College of Obstetricians and Gynaecologists. *Vox Sang* 1998;74:127-128.
28. Centers for Disease Control. Rh hemolytic disease: Connecticut, United States, 1970-1979. *MMWR Morb Mortal Wkly Rep* 1981;30:13-15.
29. Chavez GF, Mulinare J, Edmonds LD. Epidemiology of Rh hemolytic disease of the newborn in the United States. *JAMA* 1991;265:3270-3274.
30. Joseph KS, Kramer MS. The decline in Rh hemolytic disease: should Rh prophylaxis get all the credit? *Am J Public Health* 1998;88:209-215.
31. Martin JA, Hamilton BE, Sutton PD, et al. Births: final data for 2002. *Natl Vital Stat Rep* 2002;52:1-116.
32. Moise KJ. Red cell alloimmunization in pregnancy. *Semin Hamatol* 2005;42:169-178.
33. Moise KJ. Non-anti-D antibodies in red-cell alloimmunization. *Eur J Obstet Gynecol Reprod Biol* 2000;92:75-81.
34. Bowman JM, Pollock JM, Penston LE. Fetomaternal transplacental hemorrhage during pregnancy and after delivery. *Vox Sang* 1986;51:117-121.
35. Medearis AL, Hensleigh PA, Parks DR, et al. Detection of fetal erythrocytes in maternal blood postpartum with the fluorescence-activated cell sorter. *Am J Obstet Gynecol* 1984;148:290-295.
36. Zipursky A, Isreals LG. The pathogenesis and prevention of Rh immunization. *Can Med Assoc J* 1967;97:1245-1257.
37. Ness PM, Baldwin ML, Niebyl JR. Clinical high-risk designation does not predict excess fetal-maternal hemorrhage. *Am J Obstet Gynecol* 1987;156:154-158.
38. Prevention of RhD alloimmunization. ACOG Practice Bulletin Number 4. Washington, DC: American College of Obstetricians and Gynecologists (ACOG), May 1999.
39. Royal College of Obstetricians and Gynaecologists. Use of anti-D immunoglobulin for Rh prophylaxis guidelines. www.rcog.org. Accessed July 17, 2008.
40. de Silva M, Engelfriet CP, Reesink HW. Current status of immunoprophylaxis with anti-D immunoglobulin. *Vox Sang* 2003;85:328-337.
41. Brecher ME, ed. Technical manual, 14th ed. Bethesda, MD: American Association of Blood Banks, 2002.
42. Woodrow JC, Donohoe WTA. Rh immunization by pregnancy: results of a survey and their relevance to prophylactic therapy. *BMJ* 1968;4:139.

43. Geifman-Holtzman O, Wojtowycz M, Kosmas E, et al. Female alloimmunization with antibodies known to cause hemolytic disease. *Obstet Gynecol* 1997;89:272-275.
44. Polesky HF. Blood group antibodies in prenatal sera. *Minn Med* 1967;50: 601-603.
45. Filbey D, Hanson U, Wesströöm G. The prevalence of red cell antibodies in pregnancy correlated to the outcome of the newborn: a 12 year study in central Sweden. *Acta Obstet Gynecol Scand* 1995;74:687-692.
46. Heddle NM, Klama L, Frassetto R, et al. A retrospective study to determine the risk of red cell alloimmunization and transfusion during pregnancy. *Transfusion* 1993;23:217-220.
47. Van der Schoot CE, Tax GH, Rijnders RJ, et al. Prenatal typing of Rh and Kell blood group system antigens: the edge of a watershed. *Transfus Med Rev* 2003;17:31-44.
48. Caine ME, Mueller-Heubach E. Kell sensitization in pregnancy. *Am J Obstet Gynecol* 1986;154:85-90.
49. Toy PT, Reid ME, Papenfus L, et al. Prevalence of ABO maternal-infant incompatibility in Asians, Blacks, Hispanics and Caucasians. *Vox Sang* 1988;54:181-183.
50. Contreras M, Garner SF, de Silva M. Prenatal testing to predict the severity of hemolytic disease of the fetus and newborn. *Curr Opin Hematol* 1996;3: 480-484.
51. Neppert J, Witzleben-Schurholz E, Zupanska B, et al. High incidence of maternal HLA A, B and C antibodies associated with a mild course of haemolytic disease of the newborn. Group for the Study of Protective Maternal HLA Antibodies in the Clinical Course of HDN. *Eur J Haematol* 1999;63: 120-125.
52. Bowman JM, Pollock JM, Manning FA, et al. Maternal Kell blood group alloimmunization. *Obstet Gynecol* 1992;79:239-244.
53. Vaughan JI, Manning M, Letsky EA, et al. Erythropoietic suppression in fetal anemia because of Kell alloimmunization. *Am J Obstet Gynecol* 1994;171:247-252.
54. Weiner CP, Widness JA. Decreased fetal erythropoiesis and hemolysis in Kell hemolytic anemia. *Am J Obstet Gynecol* 1996;174:547-551.
55. Vaughan JI, Manning M, Warwick RM, et al. Inhibition of erythroid progenitor cells by anti-K antibodies in fetal alloimmune anemia. *N Engl J Med* 1998;338:798-803.
56. Bowman JM, Pollock JM. Rh immunization in Manitoba: progress in prevention and management. *Can Med Assoc J* 1983;129:343-345.
57. Weinstein L, Taylor ES. Hemolytic disease of the neonate secondary to anti-Fya. *Am J Obstet Gynecol* 1975;121:643-645.
58. De Young-Owens A, Kennedy M, Rose RL, et al. Anti-M isoimmunization: management anti-M isoimmunization: management and outcome at the Ohio State University from 1969 to 1995. *Obstet Gynecol* 1997;90:962-966.
59. Moran P, Robson SC, Reid MM. Anti-E in pregnancy. *Br J Obstet Gynecol* 2000;107:1436-1438.
60. Joint Commission on Accreditation of Healthcare Organizations. Kernicterus threatens healthy newborns. *Sentinel Event Alert* 2001;18:1-4.
61. Judd WJ. Practice guidelines for prenatal and perinatal immunohematology, revisited. *Transfusion* 2001;41:1445-1452.
62. Domen RE. Policies and procedures related to weak D phenotype testing and Rh immune globulin administration. *Arch Pathol Lab Med* 2000;124: 118-1121.
63. Garratty G. Do we need to be more concerned about weak D antigens? *Transfusion* 2005;45:97-101.
64. Denomme GA, Wagner FF, Fernandes BJ, et al. Partial D, weak D types and novel RHD alleles among 33,864 multiethnic patients: implications for anti-D alloimmunization and prevention. *Transfusion* 2005;45:1554-1560.
65. Cannon M, Pierce R, Taber EB, et al. Fatal hydrops fetalis caused by anti-D in a mother with partial D. *Obstet Gynecol* 2003;102:1143-1145. *Comments: Obstet Gynecol* 2004;104:193-195.
66. Lacey PA, Caskey CR, Werner DJ, et al. Fatal hemolytic disease of the newborn due to anti-D in an Rh-positive Du variant mother. *Transfusion* 1983;23:91-94.
67. Rothenberg JM, Weirermiller B, Dirig K, et al. Is a third trimester antibody screen in Rh+ women necessary? *Am J Manag Care* 1999;5:1145-1150.

68. Kanter MH. Derivation of new mathematic formulas for determining whether a D-positive father is heterozygous or homozygous for the D antigen. *Am J Obstet Gynecol* 1992;166:61-63.
69. Avent ND, Finning KM, Martin PG, et al. Prenatal determination of fetal blood group status. *Vox Sang* 2000;78:155-162.
70. Wagner FF, Flegel WA. RHD gene deletion occurred in the Rhesus box. *Blood* 2000;95:3662-3668.
71. Lo YMD, Hjelm NM, Fidler C, et al. Prenatal diagnosis of fetal RhD status by molecular analysis of maternal plasma. *N Engl J Med* 1998;339:1734-1738.
72. Bianchi DW, Avent ND, Costa JM, et al. Noninvasive prenatal diagnosis of fetal Rhesus D: ready for Prime(r) time. *Obstet Gynecol* 2005;106:682-683.
73. Heckerling PS, Verp MS. Amniocentesis or chorionic villus sampling for prenatal genetic testing: a decision analysis. *J Clin Epidemiol* 1991;44:457-470.
74. Bianchi DW, Zickwolf GK, Weil GJ, et al. Male fetal progenitor cells persist in maternal blood for as long as 27 years postpartum. *Proc Natl Acad Sci U S A* 1996;93:705-708.
75. Moise KJ, Perkins JT, Sosler DS, et al. The predictive value of maternal serum testing for detection of fetal anemia in red blood cell alloimmunization. *Am J Obstet Gynecol* 1995;172:1003-1009.
76. Van Dijk BA, Dooren MC, Overbeeke MA. Red cell antibodies in pregnancy: there is no "critical titre." *Transfus Med* 1995;5:199-202.
77. Hadley AG, Kumpel BM, Leader KA, et al. Correlation of serologic, quantitative and cell-mediated functional assays of maternal alloantibodies with the severity of haemolytic disease of the newborn. *Br J Haematol* 1991;77: 221-228.
78. Allen LH, Diamond LK, Jones AR. Erythroblastosis fetalis: IX. Problems of stillbirth. *N Engl J Med* 1954;251:453-456.
79. Oepkes D, van Kamp IL, Simon MJG, et al. Clinical value of an antibody-dependent cell-mediated cytotoxicity assay in the management of Rh D alloimmunization. *Am J Obstet Gynecol* 2001;184:1015-1020.
80. Hartwell EA. Use of Rh immune globulin ASCP Practice Parameter. *Am J Clin Pathol* 1998;110:281-292.
81. Bayliss KM, Kueck BD, Johnson ST, et al. Detecting fetomaternal hemorrhage: a comparison of five methods. *Transfusion* 1991;31:303-307.
82. Sebring ES, Polesky HF. Comparison of fetomaternal hemorrhage detection methods and Rh immune globulin usage. *Am J Clin Pathol* 1979;72: 358-362.
83. Pembrey ME, Weatherall DJ, Clegg JB. Maternal synthesis of hemoglobin F in pregnancy. *Lancet* 1973;1:1350-1354.
84. Davis BH, Olsen S, Bigelow NC, et al. Detection of fetal red cells in fetomaternal hemorrhage using a fetal hemoglobin monoclonal antibody by flow cytometry. *Transfusion* 1998;38:749-756.
85. Ness PM. The assessment of fetal-maternal hemorrhage by an enzyme-linked antiglobulin test for Rh immune globulin recipients. *Am J Obstet Gynecol* 1982;143:788-792.
86. Spinnato JA, Clark AL, Ralston KK, et al. Hemolytic disease of the fetus: a comparison of the Queenan and extended Liley methods. *Obstet Gynecol* 1998;92:441-445.
- P.784
87. Queenan JT. Management of Rh-immunized pregnancies. *Prenat Diagn* 1999;19:852-855.
88. Nicolaides KH, Rodeck CH, Mibashan RS, et al. Have Liley charts outlived their usefulness? *Am J Obstet Gynecol* 1986;155:90-94.
89. Queenan JT, Tomai TP, Ural SH, et al. Deviation in amniotic fluid optical density at a wavelength of 450 nm in Rh-immunized pregnancies from 14 to 40 weeks' gestation: a proposal for clinical management. *Am J Obstet Gynecol* 1993;168:1370-1376.
90. Spong CY, Porter AE, Queenan JT. Management of isoimmunization in the presence of multiple maternal antibodies. *Am J Obstet Gynecol* 2001;185:481-484.

91. Weiner CP, Williamson RA, Wenstrom KD, et al. Management of fetal hemolytic disease by cordocentesis, I: prediction of fetal anemia. *Am J Obstet Gynecol* 1991;165:546-553.
92. Weiner CP, Williamson RA, Wenstrom, KD, et al. Management of fetal hemolytic disease by cordocentesis. II Outcome of treatment. *Am J Obstet Gynecol* 1991;165:1302-1307.
93. Mari G, Deter RL, Carpenter RL, et al. Noninvasive diagnosis by Doppler ultrasonography of fetal anemia due to maternal red-cell alloimmunization. Collaborative Group for Doppler Assessment of the Blood Velocity in Anemic Fetuses. *N Engl J Med* 2000;342:9-14.
94. Oepkes D, Seaward PG, Vandenbussche F, et al. Doppler ultrasonography versus amniocentesis to predict fetal anemia. *N Engl J Med* 2006;355: 156-164.
95. Daffos F, Capella-Povolovsky M, Forstier F. Fetal blood sampling during pregnancy with use of a needle guided by ultrasound. A study of 606 consecutive cases. *Am J Obstet Gynecol* 1985;153:655-660.
96. Ghidini A, Spulveda W, Lockwood CJ, et al. Complications of fetal blood sampling. *Am J Obstet Gynecol* 1993;168:1339-1344.
97. Ludomirsky A. Intrauterine fetal blood sampling—a multicenter registry evaluation of 7462 procedures between 1987-1991. *Am J Obstet Gynecol* 1993;168:318.
98. Kumpel BM, Elson CJ. Mechanism of anti-D mediated immune suppression—a paradox awaiting resolution? *Trends Immunol* 2001;22:26-31.
99. Kumpel BM. On the immunologic basis of Rh immune globulin (anti-D) prophylaxis. *Transfusion* 2006;46:1271-1275.
100. Woodrow JC, Clarke CA, Donohoe WTA, et al. Mechanism of Rh prophylaxis: an experimental study on specificity of suppression. *BMJ* 1975;2:57-59.
101. Branch DR, Shabani F, Lund N, et al. Antenatal administration of Rh-immune globulin causes significant increases in the immunomodulatory cytokines transforming growth factor- β and prostaglandin E2. *Transfusion* 2006;46:1316-1322.
102. CDC. Lack of transmission of human immunodeficiency virus through Rho(D) immune globulin (human). *MMWR Morb Mortal Wkly Rep* 1987;36: 728-729.
103. Wantanabe KK, Busch MP, Schreiber GB, et al. Evaluation of the safety of Rh immunoglobulin by monitoring viral markers among Rh-negative female blood donors. *Vox Sang* 2000;78:1-6.
104. Smith DB, Lawlor E, Power J, et al. A second outbreak of hepatitis C virus infection from anti-D immunoglobulin in Ireland. *Vox Sang* 1999;76: 175-180.
- 105a. CDC. Outbreak of hepatitis C associated with intravenous immunoglobulin administration—United States, October 1993-June 1994. *MMWR Morb Mortal Wkly Rep* 1994;43:505-509.
- 105b. Gillies M, Chohan G, Llewelyn CA, et al. A retrospective case note review of deceased recipients of vCJD-implicated blood transfusions. *Vox Sang* 2009;97:211-218.
- 106a. Kumpel BM, Goodrick J, Pamphilon DH, et al. Human Rh D monoclonal antibodies (BRAD-3 and BRAD-5) cause accelerated clearance of Rh D+ red blood cells and suppression of Rh D immunization in Rh D- volunteers. *Blood* 1995;86:1701-1709.
- 106b. Stasi R. Rozrolimupab, symphobodies against rhesus D, for the potential prevention of hemolytic disease of the newborn and the treatment of idiopathic thrombocytopenic purpura. *Curr Opin Mol Ther* 2010;12:734-740.
107. Pollack W, Ascari W, Kochesky RJ, et al. Studies on Rh prophylaxis. 1. Relationship between doses of anti-Rh and size of antigenic stimulus. *Transfusion* 1971;11:333-339.
108. Anderson B, Shad AT, Gootenberg JE, et al. Successful prevention of post-transfusion Rh alloimmunization by intravenous Rho(D) immune globulin (WinRhoSD). *Am J Hematol* 1999;60:245-247.
109. Samson D, Mollison PL. Effect on primary Rh immunization of delayed administration of anti-Rh. *Immunology* 1975;28:349-357.
110. Maayan-Metzger A, Schwartz T, Sulkes J, et al. Maternal anti-D prophylaxis during pregnancy does not cause neonatal haemolysis. *Arch Dis Child Fetal Neonatal Ed* 2001;84(1):F60-62.

111. Thornton JG, Page C, Foote G, et al. Efficacy and long term effects of antenatal prophylaxis with anti-D immunoglobulin. *BMJ* 1989;298:1671-1673.
112. Huchcroft S, Gunton P, Bowen T. Compliance with postpartum Rh isoimmunization prophylaxis in Alberta. *Can Med Assoc J* 1985;133:871-875.
113. Howard HL, Marlew VJ, McFadyen IR, et al. Preventing Rhesus D haemolytic disease of the newborn by giving anti-D immunoglobulin: are the guidelines being adequately followed? *Br J Obstet Gynaecol* 1997;104:37-41.
114. Management of isoimmunization in pregnancy. ACOG Educational Bulletin Number 227. Washington, DC: American College of Obstetricians and Gynecologists (ACOG), August 1996.
115. Abdalla MGK, Beattie B, Alfirevic Z. Intrauterine transfusion techniques in fetuses with Rhesus incompatibility (Protocol for a Cochrane Review). In: *The Cochrane Library*. John Wiley & Sons Ltd, Chichester, UK, 2004;2:9.
116. Moise KJ, Carpenter RJ, Kirshon B, et al. Comparison of four types of intrauterine transfusion: effect on fetal hematocrit. *Fetal Ther* 1989;4:126-137.
117. Nicolini U, Kochenour NK, Greco P, et al. When to perform the next intra-uterine transfusion in patient with Rh allo-immunization: combined intravascular and intraperitoneal transfusion allows longer intervals. *Fetal Ther* 1989;4:14-20.
118. Giannina G, Moise KJ, Dorman K. A simple method to estimate volume for fetal intravascular transfusion. *Fetal Diagn Ther* 1998;13:94-97.
119. Gonsoulin WJ, Moise KJ Jr, Milam JD, et al. Serial maternal blood donations for intrauterine transfusion. *Obstet Gynecol* 1990;75:158-162.
120. Radunovic N, Lockwood CJ, Alvarez M, et al. The severely anemic and hydropic isoimmune fetus: changes in fetal hematocrit associated with intrauterine death. *Obstet Gynecol* 1992;79:390-393.
- 121a. Dodd RY, Notari EP, Stramer SL. Current prevalence and incidence of infectious disease markers and estimated window-period risk in the American Red Cross blood donor population. *Transfusion* 2002;42:975-979.
- 121b. Stramer S. Current risks of transfusion-transmitted agents-A Review. *Arch Pathol Lab Med*. 2007;131:702-707.
- 121c. Zou S, Stramer SL, Notari EP, et al. Current Incidence and residual risk of hepatitis B infection among blood donors in the United States. *Transfusion* 2009;49:1609-1620.
122. Grima KM. Therapeutic apheresis in hematological and oncological diseases. *J Clin Apher* 2000;15:42.
123. University HealthSystem Consortium. Technology assessment: intravenous immunoglobulin preparations. Oak Brook, IL: University HealthSystem Consortium, 2001:25-30.
124. Van den Veyver IB, Chong SS, Cota J, et al. Single-cell analysis for the RhD blood type for use in preimplantation diagnosis in the prevention of severe hemolytic disease of the newborn. *Am J Obstet Gynecol* 1995;172:533-540.
125. Peterec SM. Management of neonatal Rh disease. *Clin Perinat Hematol* 1995;22:561-592.
126. American Academy of Pediatrics, Subcommittee on Hyperbilirubinemia. Clinical Practice Guideline: management of hyperbilirubinemia in the newborn infant 35 or more weeks of gestation. *Pediatrics* 2004;114:297-316.
127. Mills JF, Tudehope D. Fiberoptic phototherapy for neonatal jaundice. *Cochrane Database Syst Rev*. 2001;(1):CD002060.
128. Rubo J, Albrecht K, Lasch P, et al. High-dose intravenous immune globulin therapy for hyperbilirubinemia caused by Rh hemolytic disease. *J Pediatr* 1992;121:93-97.
129. Strauss RG. Data-driven blood banking practices for neonatal RBC transfusion. *Transfusion* 2000;40:1528-1540.
130. Keenan WJ, Novak KK, Sutherland JM, et al. Morbidity and mortality associated with exchange transfusion. *Pediatrics* 1985;75:417-441.
131. Scaradavou A, Inglis S, Peterson P, et al. Suppression of erythropoiesis by intrauterine transfusion in hemolytic disease of the newborn: use of erythropoietin to treat the late anemia. *J Pediatr* 1993;123:279-284.
132. Dhodapkar KM, Blei F. Treatment of hemolytic disease of the newborn caused by anti-Kell antibody with recombinant erythropoietin. *J Pediatr Hematol Oncol* 2001;23:69-70.
133. Kappas A, Drummond GS, Munson DP, et al. Sn-Mesoporphyrin interdiction of severe hyperbilirubinemia in Jehovah's Witness newborns as an alternative to exchange transfusion. *Pediatrics* 2001;108:1374-1377.

134. van Kamp IL, Klumper FJCM, Bakkum RSLA, et al. The severity of immune fetal hydrops is predictive of fetal outcome after intrauterine treatment. *Am J Obstet Gynecol* 2001;185:668-673.
135. Janssens HM, de Haan MJJ, van Kamp IL, et al. Outcome for children treated with fetal intravascular transfusions because of severe blood group antagonism. *J Pediatr* 1997;131:373-380.
136. Doyle LW, Kelley EA, Rickards AL, et al. Sensorineural outcome at 2 years for survivors of erythroblastosis treated with fetal intravascular transfusions. *Obstet Gynecol* 1993;81:931-935.
- 137a. Hudon L, Moise KJ, Hegemier SE, et al. Long-term neurodevelopmental outcome after intrauterine transfusion for the treatment for fetal hemolytic disease. *Am J Obstet Gynecol* 1998;179:858-863.
- 137b. Lindenburg IT, Smits-Wintjens VE, van Klink JM, et al; on behalf of the LOTUS study group. Long-term neurodevelopmental outcome after intrauterine transfusion for hemolytic disease of the fetus/newborn: the LOTUS study. *Am J Obstet Gynecol* 2012;206:141.e1-e8.
138. Ip S, Chung M, Kulig J, et al., and the Subcommittee on Hyperbilirubinemia, American Academy of Pediatrics. An evidence-based review of important issues concerning neonatal hyperbilirubinemia. *Pediatrics* 2004;114:e130-e153. <http://pediatrics.aappublications.org.easyaccess1.lib.cuhk.edu.hk/content/114/1/e130.abstract>. Accessed April 1, 2013.
139. Newman TB, Liljestrand P, Jeremy RJ, et al. Outcomes among newborns with total serum bilirubin levels of 25 mg per deciliter or more. *N Engl J Med* 2006;354:1889-1900.

Chapter 31 Paroxysmal Nocturnal Hemoglobinuria

> Table of Contents > Part IV - Disorders of Red Cells > Section 3 - Hemolytic Anemia > Chapter 31 - Paroxysmal Nocturnal Hemoglobinuria

Chapter 31

Paroxysmal Nocturnal Hemoglobinuria

Charles J. Parker

Russell E. Ware

INTRODUCTION

Definition

Although usually classified as a hemolytic anemia, paroxysmal nocturnal hemoglobinuria (PNH) is a disease of the hematopoietic stem cell. PNH arises as a result of nonmalignant clonal expansion of one or several hematopoietic stem cells that have acquired a somatic mutation of PIGA (phosphatidylinositol glycan-class A). The PIGA gene is located on the X chromosome, and it encodes an enzyme that is an essential component of the complex biosynthetic pathway that generates glycosyl phosphatidylinositol (GPI). The GPI moiety serves as a membrane anchor for more than 20 proteins of diverse function that are normally expressed on hematopoietic cells. As a consequence of somatic mutation of PIGA, progeny of affected stem cells are deficient in all GPI-anchored proteins (GPI-APs). Among the GPI-APs normally expressed on hematopoietic cells are the complement regulatory proteins CD55 (decay accelerating factor [DAF]) and CD59 (membrane inhibitor of reactive lysis [MIRL]), and it is the deficiency of these two proteins that accounts for the complement-mediated intravascular hemolysis that is the primary clinical manifestation of the disease. In addition to complement-mediated intravascular hemolysis, an element of bone marrow failure is present in all patients, and PNH frequently arises in association with a defined bone marrow failure process, particularly aplastic anemia and, to a lesser extent, low-grade myelodysplastic syndrome (MDS). Thrombophilia is a major cause of morbidity and mortality in PNH.¹

PNH is characterized, in the classic case, by macroscopic hemoglobinuria. When intravascular hemolysis occurs at night, while the patient is asleep, hemoglobin accumulates in the bladder, and the patient becomes alarmed the following morning by the startlingly abnormal appearance of the first voided urine. The hemoglobinuria is painless and ranges in color from red to brown to black. Typically the gross hemoglobinuria resolves during the course of the day. In most patients, however, the classic pattern is absent at diagnosis. In these patients, the disease is characterized by symptoms of lethargy, malaise, and asthenia, and by laboratory evidence of chronic, low-grade intravascular hemolysis that may or may not be punctuated by episodes of macroscopic hemoglobinuria, usually occurring in association with infection or unusual stress such as trauma or surgery. Thrombocytopenia, leukopenia, and thrombosis involving unusual sites are other notable clinical characteristics of PNH. As cited above, a close association exists between PNH and certain bone marrow failure syndromes, particularly aplastic anemia, but the basis of this association is incompletely understood.

The history of PNH has been chronicled.^{2, 3, 4, 5} Strübling published a remarkable paper on PNH in 1882, clearly recognizing the uniqueness of the disease and providing laboratory support for his prescient hypothesis on the etiology of nocturnal hemoglobinuria (positing that it was caused by the acidosis that resulted from carbon dioxide accumulation associated with sleep-related hypoventilation). Marchiafava and Nazari (1911) and Micheli (1931) subsequently detailed the clinical characteristics of the disease (in some older literature, PNH is called Marchiafava-Micheli syndrome). By 1953, at least 162 cases had been collected. Although the advent of flow cytometry has greatly improved diagnostic sensitivity and specificity, undoubtedly some cases go undiagnosed as the classical signs and symptoms are often absent initially. Even today there may be a significant time lapse between the onset of clinical symptoms and the correct diagnosis. Failure to distinguish hemoglobinuria (when present) from hematuria; the rarity of the disease, which limits familiarity with its protean clinical manifestation; and the absence of gross hemoglobinuria at presentation in many cases are the primary factors that account for the delay in diagnosis.

It can be argued that the term paroxysmal nocturnal hemoglobinuria is imprecise because it describes only one feature of the illness—a feature, moreover, that is found in only one-quarter of affected individuals at presentation. Nonetheless, the term has been established through long, popular use and consequently is part of the essence of the disease.

ETIOLOGY AND PATHOGENESIS

Sensitivity to Complement-mediated Lysis

The chronic intravascular hemolysis that is the clinical hallmark of PNH is due to the abnormal sensitivity of the erythrocytes to complement-mediated lysis. From 1937 to 1939, Ham and Dingle made the seminal observations that connected the hemolysis to complement.⁵ Those studies demonstrated that the abnormal cells are hemolyzed when incubated in acidified serum and that the hemolysis is complement-dependent. The lysis of the defective cells in acidified serum (a process that activates the alternative pathway of complement) became the standard technique for the diagnosis of PNH; and appropriately, the assay was called Ham's test. Approximately 10 years after the studies of Ham and Dingle, cross-transfusion studies confirmed that hemolysis in PNH results from an intrinsic abnormality of the red cell. In those studies, Dacie reported that normal erythrocytes survive normally in patients with PNH, whereas the life span of PNH erythrocytes is shortened both in the patient and in a normal recipient. Not all PNH red cells are equally sensitive to complement-mediated lysis, however, and cohorts of relatively long-lived and very short-lived cells can be distinguished in red cell survival studies. Moreover, the proportions of complement-sensitive and complement-insensitive cells vary greatly among patients. Generally, the percentage of abnormal cells remains stable in an individual patient, although there are clearly exceptions. The percentage of markedly complement-sensitive cells correlates with the clinical course of each patient with respect to the hemolytic component of the disease and perhaps to thrombotic propensity.

A defining feature of PNH is phenotypic mosaicism based on sensitivity of the erythrocytes to complement-mediated lysis. This remarkable characteristic was first clearly elucidated by Rosse and Dacie in 1966,⁶ and Rosse further refined the analysis in 1973.⁷ Using an *in vitro* test that quantitates the sensitivity of erythrocytes to complement-mediated lysis (the complement lysis sensitivity assay), three phenotypes of PNH erythrocytes were identified (Table 31.1; Figs. 31.1 and 31.2). One of the phenotypes (designated PNH I) was characterized by normal or nearnormal sensitivity to complement, whereas another phenotype (designated PNH III) was 15 to 25 times more susceptible to lysis. A third phenotype (PNH II) was of intermediate sensitivity, about 3 to 5 times more susceptible than normal cells. Most patients have a mixture of type I and type III cells, but mosaics of type I, type II, and type III, as well as type I and type II, are also observed.

As noted above, the proportion of complement-sensitive and -insensitive cells varies greatly among patients. For example, the

P.786

erythrocytes of one patient (hypothetical patient A) may be comprised of 10% PNH III cells and 90% PNH I cells, whereas another patient (hypothetical patient B) may have 75% PNH III cells and 25% PNH I cells. The intensity of the hemolytic component of the disease is related to the size of the PNH III population.⁸ The proportions of sensitive and insensitive cells usually remain stable for long periods (years to decades); but population shifts may be observed during the course of the disease, and in some patients, the abnormal clone remits spontaneously.^{9, 10} The threshold for biochemical evidence of intravascular hemolysis is crossed when the population of GPI-deficient PMNs (as a measure of the PNH clone size) is 20% to 25% or greater.¹¹ Patients with a clone size of 20% to 25% usually have 3% to 5% PNH erythrocytes (the population of PNH III cells is smaller than the clone size because the complement-sensitive red cells are selectively destroyed intravascularly). As a rule, visible hemoglobinuria is absent when PNH III erythrocytes constitute less than 20% of the red cell population (corresponding to a PNH clone size of 40% to 60%).⁸ Paroxysms of gross hemoglobinuria occur when the

PNH III population ranges from 20% to 50% of the population (corresponding to a PNH clone size of 60% to 90%), and constant hemoglobinuria is associated with greater than 50% PNH III erythrocytes (PNH clone

P.787

size >90%). PNH II cells (the erythrocytes of intermediate sensitivity to complement), even when present in high proportions, are associated with no visible hemoglobinuria.

TABLE 31.1 PNH PHENOTYPES

Phenotypic Designation	Complement Sensitivity^a	GPI-AP Expression by Flow Cytometry^b	Type of <i>PIGA</i> Mutation
PNH I	Normal	Normal	None
PNH II	Moderately sensitive (3-4 times normal)	Dim positive	Missense (partial <i>PIGA</i> inactivation)
PNH III	Markedly sensitive (15-20 times normal)	Negative	Nonsense, frameshifts, deletions, insertions (complete inactivation of <i>PIGA</i>)

GPI-AP, glycosyl phosphatidylinositol-anchored proteins; *PIGA*, phosphatidylinositol glycan-class A; PNH, paroxysmal nocturnal hemoglobinuria.

^aBased on the complement lysis sensitivity assay of Rosse and Dacie.

^bBased on flow cytometric analysis of GPI-AP expression of erythrocytes.

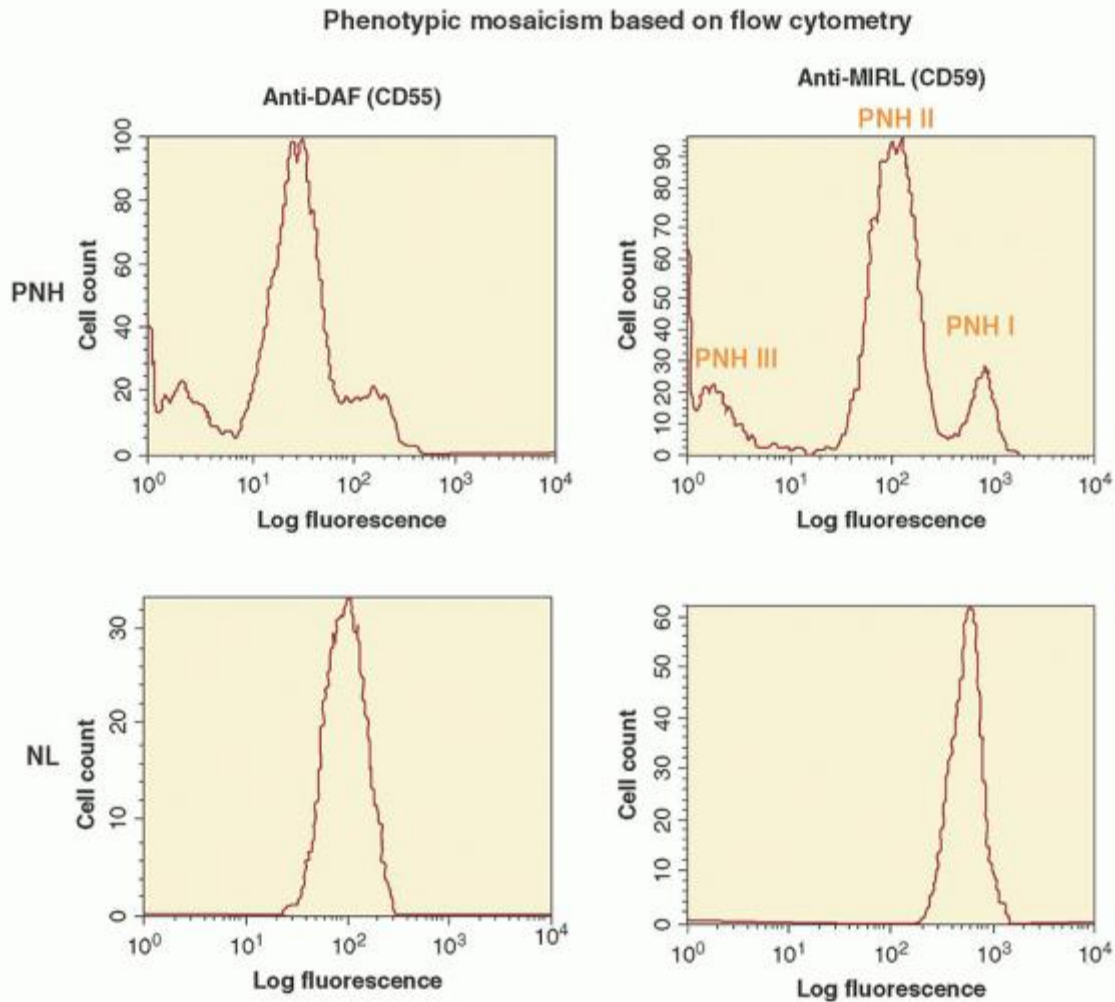

FIGURE 31.1. Phenotypic mosaicism in PNH. Erythrocytes from a patient with PNH and from a normal volunteer donor (NL) were analyzed by flow cytometry using anti-DAF (CD55) and anti-MIRL (CD59) as primary antibodies. The histogram of the erythrocytes from the normal donor shows uniformly positive staining with both antibodies. In contrast, the patient's histogram (PNH) suggests three discrete populations of cells (a negative population [called PNH III], a population with partial expression [called PNH II], and a population with normal expression [called PNH I]). Statistical analysis of the three groups of cells from the patient showed that the negative population contributed 14% to the total, the intermediate population contributed 75%, and the normal population contributed 11%. From Endo M, Ware RE, Vreeke TM, et al. Molecular basis of the heterogeneity of expression of glycosyl phosphatidylinositol-anchored proteins in paroxysmal nocturnal hemoglobinuria. *Blood* 1996;87:2546-2557.

The proportion of abnormal cells is greater in the marrow than in the blood and, among circulating erythrocytes, is greatest in young cell populations (the percentage of GPI-deficient reticulocytes is similar to the percentage of GPI-deficient PMNs).

PNH is not an immune-mediated hemolytic anemia that arises as a consequence of the development of autoantibodies. Rather, the failure to regulate an alternative pathway of complement activation on the erythrocyte surface underlies the hemolysis of PNH (Fig. 31.3). Under physiologic conditions, the alternative pathway is in a state of continuous, low-grade activation. Normal erythrocytes are not hemolyzed as a result of this low-grade alternative pathway activation because specific cell-surface proteins have evolved that inhibit the activity of complement (Fig. 31.3). In contrast, PNH erythrocytes are deficient in the two most important membrane regulators of complement (CD55 and CD59), and consequently, they are subject to chronic, spontaneous hemolysis *in vivo* (Fig. 31.3). Failure to inhibit alternative pathway activation has a profound effect on red cell survival, as studies have shown that the half-life of complement-sensitive PNH cells is approximately 6 days (compared to 60 days for normal erythrocytes).

A. Erythrocytes

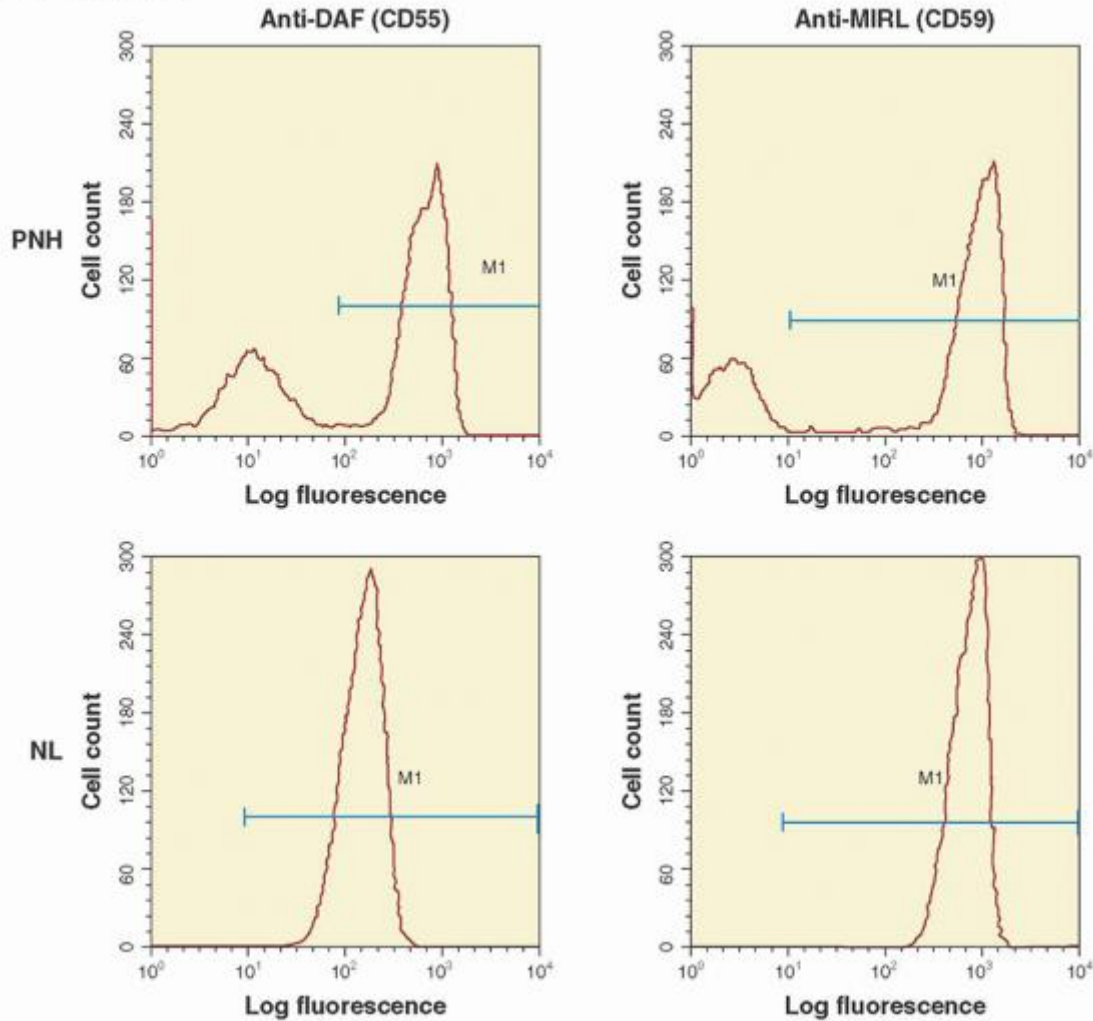

FIGURE 31.2. Analysis of glycosyl phosphatidylinositol-anchored proteins (GPI-AP) on erythrocytes (A) and granulocytes (B) from a patient with PNH. Erythrocytes and isolated granulocytes from a patient with PNH and from a normal volunteer donor (NL) were analyzed by flow cytometry using anti-DAF (CD55), anti-MIRL (CD59), or anti-FcγRIIIb (CD16b) (granulocytes only) as primary antibodies. The histograms of the cells from the normal donor show uniformly positive staining with both antibodies. In contrast, the patient's histograms (PNH) demonstrate two discrete populations of cells. In the case of the erythrocytes (A), 30% of the cells are negative for DAF and MIRL expression, and 70% show normal expression. In the case of the granulocytes (B), 65% are negative for DAF and MIRL expression. The same population of cells shows abnormal expression of FcγRIIIb, but the deficiency is partial rather than absolute. Together, these results demonstrate three characteristic features of PNH: (1) The hematopoietic cells are a mosaic of normal and GPI-AP-deficient cells; (2) the proportion of abnormal granulocytes is greater than the proportion of abnormal erythrocytes; (3) the deficiency of FcγRIIIb is partial rather than absolute.

Rosse and colleagues reported the first clear evidence of the nature of the aberrant interactions of PNH erythrocytes with complement in 1973 and 1974.^{12, 13} Those investigators showed that when complement is activated *in vitro* by either the classical or the alternative pathway, PNH erythrocytes bind much greater amounts of activated C3 than normal erythrocytes. The difference in C3 deposition was particularly striking when acidified serum was used to activate the alternative pathway. Subsequent studies showed that PNH red cells lacked the capacity to regulate the formation and stability of the amplification C3 convertases of complement,^{14, 15} thus accounting for the greater binding of activated C3. A second defect was suggested by experiments demonstrating that PNH erythrocytes also failed to regulate the activity of the cytolytic membrane attack complex of complement.^{16, 17} Collectively these observations indicated that PNH erythrocytes had two complement regulatory defects, one that affected regulation of the C3 convertases and a second that affected regulation of the membrane attack complex (Fig. 31.3).

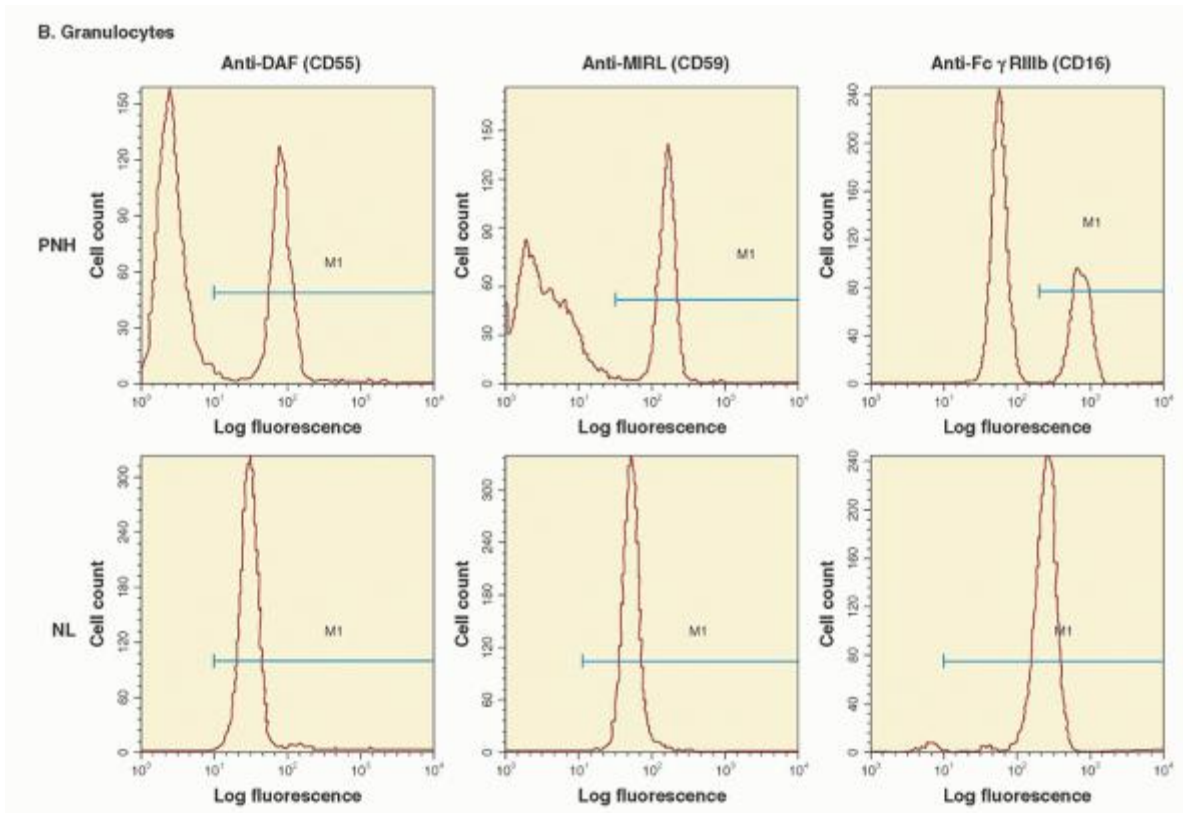

FIGURE 31.2. (continued)

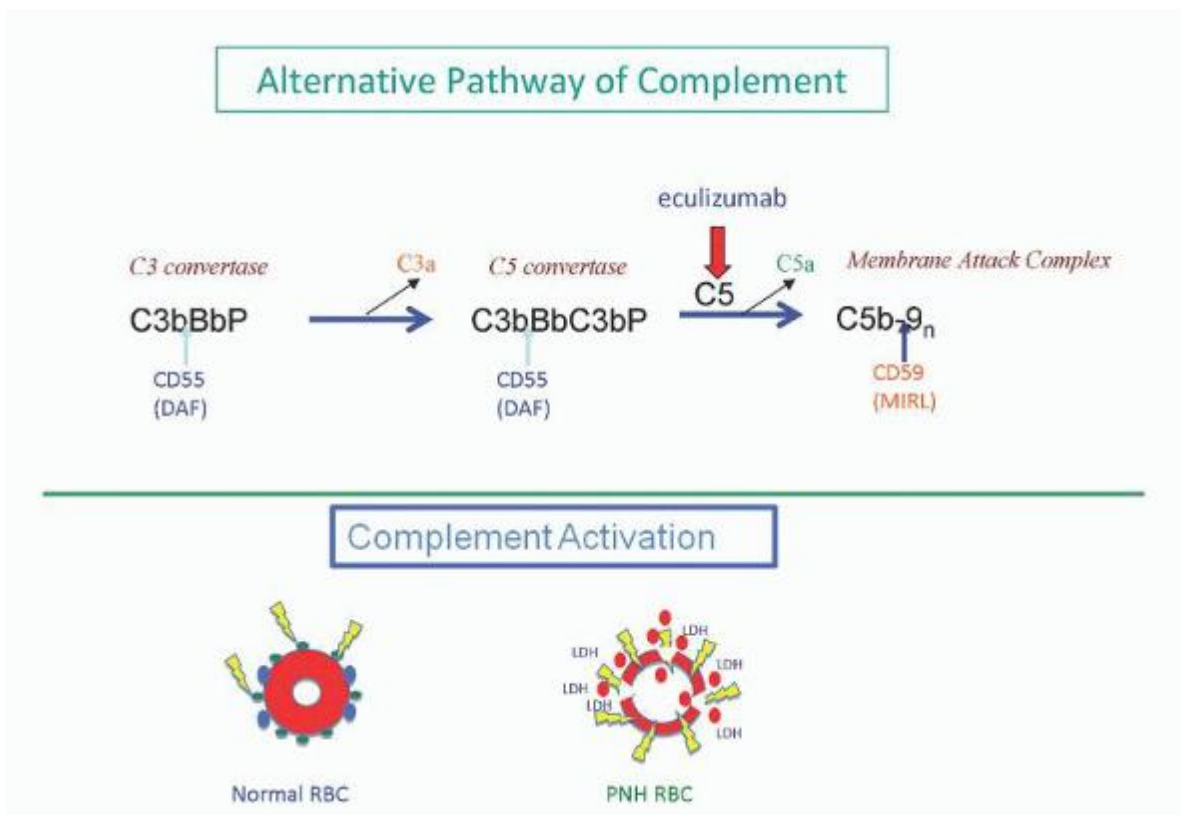

FIGURE 31.3. Complement-mediated lysis of PNH erythrocytes. Upper panel: The hemolytic anemia of PNH is Coombs-negative because the process is mediated by the antibody-independent alternative pathway of complement. The GPI-anchored complement regulatory protein CD55 (DAF) restricts formation of both the C3 and the C5 amplification convertases, whereas CD59 (MIRL) blocks formation of the cytolytic membrane attack complex (C5b-9). Inhibition of formation of the cytolytic membrane attack complex of complement (C5b-9) by the humanized monoclonal anti-C5 antibody eculizumab ameliorates the hemolytic anemia in patients with PNH. Lower panel: Normal erythrocytes are protected against complement-mediated lysis (lightning bolts) primarily by CD55 (blue filled circles) and CD59 (green filled circles). Deficiency of these GPI-anchored complement regulatory proteins results in complement activation on PNH erythrocytes. The membrane attack complex forms a pore in the red cell membrane resulting in colloid osmotic lysis and release of red cell contents including hemoglobin and LDH into the intravascular space.

Erythrocyte Membrane Protein Deficiencies

Acetylcholinesterase

While Beck and Valentine reported in 1951 that neutrophils from patients with PNH were deficient in leukocyte alkaline phosphatase,¹⁸ the first erythrocyte membrane protein that was found to be deficient in PNH was acetylcholinesterase.¹⁹ In 1959, Auditore and Hartmann¹⁹ presented evidence that the extent of the acetylcholinesterase deficiency correlated with the severity of the hemolysis. More detailed studies by others²⁰ showed that PNH I red cells had a relatively normal amount of acetylcholinesterase, while PNH III erythrocytes were profoundly deficient. Although the deficiency of acetylcholinesterase plays no role in the abnormal susceptibility of PNH red cells to complement-mediated lysis, ultimately the observations that the red cells lack acetylcholinesterase and that the neutrophils lack alkaline phosphatase provided important insights into the fundamental defect that underlies PNH.

Decay Accelerating Factor (CD55)

In 1983, two groups reported that PNH erythrocytes were deficient in DAF (CD55).^{21, 22} DAF, first identified by Hoffman^{23, 24} in 1969 and subsequently purified by Nicholson-Weller and colleagues in 1982,²⁵ is a 70 kD protein that inhibits the formation and stability of the C3 convertases of complement (Fig. 31.3). Thus, the absence of DAF provided a plausible explanation for the greater binding of activated C3 to PNH erythrocytes. Detailed studies, however,

demonstrated that DAF does not regulate the activity of the membrane attack complex of complement. Those results implied that PNH erythrocytes were deficient in a second complement regulatory protein that was functionally distinct from DAF.

Membrane Inhibitor of Reactive Lysis (CD59)

In 1989, Holguin et al.²⁶ reported the isolation from normal erythrocytes of an 18 kD protein called MIRL (CD59) that protected PNH III red cells against complement-mediated lysis (Fig. 31.3). As anticipated, PNH cells were found to be deficient in MIRL, and additional studies by those investigators and others demonstrated that MIRL inhibits complement-mediated lysis by blocking the assembly of the membrane attack complex^{26, 27, 28, 29} (Fig. 31.3).

By comparing expression of DAF and MIRL on PNH I, PNH II, and PNH III erythrocytes, the functional basis of the different complement sensitivity phenotypes was determined.³⁰ Those studies showed that PNH III cells are completely deficient in both DAF and MIRL, whereas PNH II cells are partially deficient in the two complement regulatory proteins, and PNH I cells have normal expression. Thus, the variability in sensitivity to lysis among the different phenotypes is explained by quantitative differences in expression of DAF and MIRL. Additional experiments demonstrated that the combined deficiency of DAF and MIRL was sufficient to explain the enhanced susceptibility of PNH erythrocytes to hemolysis in acidified serum.³¹

Of the two complement regulatory proteins, MIRL is more important than DAF in protecting cells from complement-mediated lysis *in vivo*. Antigens of the Cromer-related blood group complex are located on DAF, and rare cases of a null phenotype called Inab have been reported.³² Like PNH cells, Inab erythrocytes are deficient in DAF, but unlike PNH erythrocytes, MIRL expression is normal on Inab red cells.³³ Although Inab erythrocytes bind more activated C3 when exposed to acidified serum,³³ they undergo little or no hemolysis. Further, subjects with the Inab phenotype have no known hematologic abnormalities, and in particular, they have no clinical evidence of hemolysis.^{28, 32} These observations show that isolated deficiency of DAF does not produce the PNH syndrome. In contrast, a patient with an inherited, isolated deficiency of MIRL (CD59) had a syndrome that was indistinguishable from PNH.^{34, 35} Clinically, the patient experienced recurrent episodes of hemoglobinuria, suggesting that MIRL is essential for protecting erythrocytes against complement-mediated lysis *in vivo*. Recurrent thromboembolic events were also observed in this patient. That patient had normal DAF expression, but *in vitro*, his cells were susceptible to hemolysis in acidified serum, implying that MIRL deficiency accounts primarily for the positive Ham's test in PNH.³¹ While the above studies provide interesting insights into the individual function of DAF and MIRL *in vivo*, it is important to remember that in PNH, both proteins are deficient (because both are GPI-anchored). Therefore, it is the combined deficiency of DAF and MIRL that results in the markedly abnormal susceptibility of the red cells of PNH to complement-mediated lysis.

Basis of the Protein Deficiencies in Paroxysmal Nocturnal Hemoglobinuria

If only DAF or only MIRL were deficient in PNH, it would have been logic to hypothesize that the disease was due to mutations affecting the gene that encodes the particular protein. That PNH cells were deficient in multiple proteins (MIRL, DAF, and acetylcholinesterase on red cells and leukocyte alkaline phosphatase on neutrophils), however, eliminated the possibility that the gene for each protein was mutant. Rather, a more plausible hypothesis was that the PNH defect involved a post-translational modification common to all of the proteins that are deficient in PNH. In 1984, Medof and colleagues³⁶ reported that isolated DAF spontaneously reincorporated into erythrocyte membranes. This property of DAF had actually been appreciated by Hoffman in 1969.^{23, 24} Working with the butanol-saturated aqueous phase of a crude extract prepared from normal human erythrocyte stroma, he showed that the sample contained a factor capable of inhibiting complement-mediated lysis by accelerating the decay of the C3 convertase. He further showed that this substance (that he called decay accelerating factor of stroma [DAF-S]) had the capacity to reincorporate into red cells and remain functionally active. In 1980, Low and Zilversmit³⁷ demonstrated that alkaline phosphatase that had been solubilized from cells by butanol extraction exhibited the capacity to bind to phospholipid vesicles. In this case, the incorporation was thought to be due to the attachment of a phosphatidylinositol moiety to the enzyme. Subsequent experiments demonstrated that isolated acetylcholinesterase also spontaneously reincorporated into cell membranes. Previous studies had shown that alkaline phosphatase, acetylcholinesterase, and 5'-ectonucleotidase (another protein that is deficient in PNH) were released from the cell surface by treatment with phosphatidylinositol-specific phospholipase C (PIPLC). The cumulative work of a number of investigators showed that both the capacity to reincorporate into membranes and susceptibility to cleavage by PIPLC was characteristic of a group of amphipathic membrane proteins that shared the common structural feature of being anchored to the cell surface through a GPI moiety. The structural link between DAF and acetylcholinesterase, alkaline phosphatase, and 5'-ectonucleotidase was made in 1986 by Davitz et al.³⁸ and Medof et al.,³⁹ when those investigators presented evidence that DAF is a GPI-

anchored protein. Subsequent studies confirmed that MIRL is also a GPI-anchored protein.⁴⁰ The results of those studies suggested the following paradigm: all proteins that are deficient in PNH are GPI-anchored, and all GPI-anchored proteins that are expressed by hematopoietic cells are deficient in PNH. All data to date are consistent with this postulate.

GPI-anchored proteins are functionally diverse. In addition to the complement regulatory proteins (DAF [CD55] and MIRL [CD59]) and enzymes (acetylcholinesterase, alkaline phosphatase, and 5'-ectonucleotidase [CD73]) discussed above, proteins with a variety of receptor, adhesion, and immune modulatory functions (e.g., FcγRIIIb [CD16b], urokinase receptor [CD87], endotoxinbinding protein receptor [CD14], and LFA-3 [CD58]) are also GPI-anchored. Further, a number of proteins whose function is unknown are GPI-anchored. Over 80 eukaryotic proteins have been shown to be GPI-anchored and approximately 30 of these are found in humans. Currently the list of proteins deficient in PNH numbers at least 23 (Table 31.2). This number is less than the total number of GPI-anchored human proteins because PNH is an acquired disease that affects only hematopoietic cells. Thus, GPI-anchored proteins that are present on somatic tissues other than hematopoietic cells are expressed normally in patients with PNH. Despite the fact that PNH cells lack a number of functionally diverse membrane constituents, the only pathologic component of the disease that is unequivocally causally related to GPI-anchored protein deficiency is the abnormal susceptibility of the erythrocytes to complement-mediated lysis.

Molecular Basis of Paroxysmal Nocturnal Hemoglobinuria

The observation that, based on sensitivity to complement, the peripheral blood of PNH patients is a mosaic comprised of both normal and abnormal cells suggested that the abnormal cells were the progeny of a mutant clone and that they coexisted with the progeny of residual normal stem cells. Further, that PNH is an acquired rather than an inherited disease implied that the abnormal clone arises as a consequence of a somatic mutation. In 1970, Oni et al.⁴¹ analyzed G6PD isoforms in both the complement-sensitive and the complement-insensitive erythrocytes of a female PNH patient who was heterozygous at the G6PD locus.

P.790

The complement-insensitive cells expressed both G6PD isoforms, indicating a polyclonal origin for this cohort. In contrast, the complement-sensitive cells expressed only one isoform, a finding consistent with monoclonality. These studies provided the first experimental evidence in support of the clonal hypothesis of PNH. In 1969, Aster and Enright⁴² reported that a portion of both the platelet and granulocyte populations from patients with PNH was abnormally sensitive to complement-mediated cytolysis. This publication represented another watershed event in the understanding of the origins of PNH, because it indicated that the mutation arose in a primitive hematopoietic stem cell that has the capacity to differentiate along myeloid lines. Subsequent studies showed that monocytes are also affected, and, in most patients, affected lymphocytes were demonstrated. Together with the observation that all proteins that are deficient in PNH are GPI-anchored, these studies suggested that PNH arises as a result of a somatic mutation affecting a pluripotent hematopoietic stem cell and that the gene that is mutant is essential for the normal biosynthesis of the GPI anchor.

TABLE 31.2 GLYCOSYL PHOSPHATIDYLINOSITOL-ANCHORED PROTEINS DEFICIENT IN PAROXYSMAL NOCTURNAL HEMOGLOBINURIA

Protein

Leukocyte alkaline phosphatase

Acetylcholinesterase

Decay accelerating factor (DAF, CD55)

Membrane inhibitor of reactive lysis (MIRL, CD59)

FcγRIIIb (CD16b)

Lymphocyte function-associated antigen 3 (LFA-3, CD58)

Endotoxin binding protein (CD14)

CAMPATH-1 (CD52)

5'-Ectonucleotidase (CD73)

Urokinase plasminogen activator receptor (CD87)

JMH-bearing protein (CD108)

CD66b (formerly CD67)

CD66c

p50-80

CD24

CD48

Thy-1 (CD90)

CD109

CD157

GP500

GP175

Folate receptor

Cellular prion protein^a

^aDeficient on resting platelets, but putative transmembrane form expressed on activated platelets.

The GPI anchor is a complex structure with at least 25 proteins being essential for assembly of the moiety.^{43, 44} Hypothetically, the PNH phenotype would result if any of these proteins were nonfunctional, because if the GPI anchor is not synthesized, GPI-anchored proteins are not expressed. Accordingly, it seemed probable that PNH would be found to be heterogeneous at the molecular level as mutations affecting any one of several genes that encode elements critical for GPI anchor assembly would produce the disease phenotype. In 1992⁴⁵ and 1993,⁴⁶ however, two groups published the surprising finding that GPI-protein deficient lymphocyte cell lines derived from different patients with PNH all belonged to the same complementation class (Class A) of GPI-AP-deficient cell lines. Additional experiments confirmed that the PNH cell lines had the same biochemical defect as the complementation Class A mutants. Like the Class A mutants, the PNH cell lines failed to synthesize N-acetylglucosaminyl-phosphatidylinositol (GlcNAc-PI), the first intermediate in the pathway of GPI anchor assembly (Fig. 31.4).

A gene that restores normal expression of GPI-anchored proteins in the complementation Class A PNH cell lines was identified by Kinoshita and colleagues in 1993.^{47, 48} As predicted by the studies cited above, the gene, called PIGA, encodes a protein that is essential for the normal synthesis of GlcNAc-PI.⁴⁷ Subsequently, Takeda et al.⁴⁸ showed that PIGA complements the deficient expression of GPI-anchored proteins in PNH lymphoblastoid cell lines and that those cell lines harbored somatic mutations in PIGA. Together, those studies defined both the biochemical and the molecular basis of the deficiency of GPI-anchored proteins in PNH (Fig. 31.4).

Additionally, Takeda and colleagues observed that a heterozygous mutation was sufficient to produce the PNH phenotype.⁴⁸ As presaged by the studies of Hyman et al.,⁴⁹ the dominant expression of the somatic mutation was explained when PIGA was mapped to chromosome Xp22.1. As males have a single X chromosome, any functionally significant mutation affecting PIGA is expressed. Females are functionally haploid due to X-inactivation. Therefore, somatic mutations in PIGA appear dominant when they occur on the active X chromosome. To date, somatic mutations affecting PIGA account for the PNH phenotype in all patients in whom the genetic basis has been identified. PIGA mutations have not been identified in all patients studied, but this apparent discrepancy is likely a technical artifact rather than a true difference in etiology. The chromosomal location of PIGA provides the most logical explanation for the uniformity of the molecular defect in PNH. This interpretation supposes that all other genes that are essential for synthesis of the GPI moiety are autosomal, a supposition supported by available data.

Analysis of PIGA has revealed that the same mutation can be identified in isolated neutrophils, monocytes, and lymphocytes from individual patients with PNH, confirming that the disease involves the hematopoietic stem cell.^{48, 50} More than 150 PIGA mutations have been identified in affected cells of patients with PNH. Only three large deletions have been observed^{51, 52} (Fig. 31.5). The remaining mutations consist of nucleotide substitutions of the missense or nonsense types, or small deletions or insertions that cause frameshifts and introduce premature termination codons (Fig. 31.5). The

mutations are distributed randomly over the entire coding region and at splice junctions (Fig. 31.5). At least 19 mutations have been observed in more than one patient. Absence of repetitive mutations indicates that PIGA lacks molecular hot spots. The simplest explanation for these observations is that clonal selection and expansion depends on complete or nearly complete inactivation of PIGA such that expression of GPI-AP proteins is below a critical threshold. Therefore all PIGA mutations in PNH are loss-of-function mutations.

Studies of PIGA mutations have also provided insights into the molecular basis of the phenotypic mosaicism of PNH.⁵⁰ Cloned lymphocyte cell lines were established from the peripheral blood of a patient whose erythrocytes were a mixture of PNH I, PNH II, and PNH III cells (Fig. 31.1). Based on expression of GPI-anchored proteins, lymphocyte clones with four different phenotypes were observed. Analysis of clones with normal expression of GPI-AP revealed no somatic PIGA mutations. In contrast, among the three phenotypically distinct lymphocyte clones with abnormal GPI-AP expression, four discrete PIGA mutations were identified. In the lymphocyte clones with the PNH II phenotype, a missense mutation that changed a highly conserved amino acid was found. This finding suggests that cells with partial expression of GPI-anchored proteins (PNH II) are derived from stem cells with mutations that

P.791

incompletely inactivate PIGA. In the case of the lymphocyte clones with the PNH III phenotype, three separate mutations were identified, each of which was expected to inactivate completely the PIGA gene product. Collectively, these experiments demonstrate that the phenotypic mosaicism that is characteristic of PNH is a consequence of genotypic mosaicism. Further, because any mutation that completely inactivates PIGA results in PNH III cells, phenotypically identical cells can have different PIGA genotypes (Fig. 31.6).

Pathophysiology of PNH Is Known

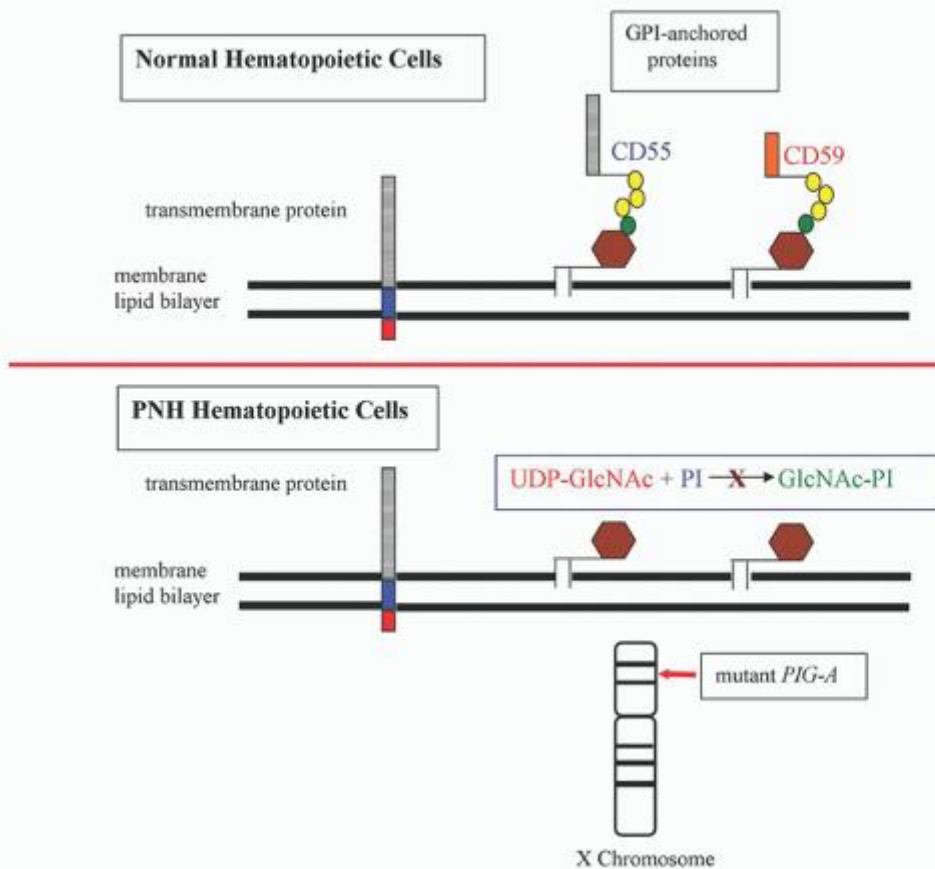

FIGURE 31.4. The PNH defect. Transmembrane proteins have three domains: an ectoplasmic domain (rectangle with horizontal lines), a transmembrane domain (blue rectangle), and a cytoplasmic domain (red rectangle). In contrast, glycosyl phosphatidylinositol (GPI)-anchored proteins lack the cytoplasmic and transmembrane domains. This class of proteins is anchored to the cell by a GPI moiety consisting of phosphatidylinositol (brown hexagon), glucosamine (green

circle), and three mannose (yellow circles) residues. The GPI moiety is linked to the COOH-terminus of the protein portion of the molecule by ethanolamine. The PIGA gene product is essential for the transfer of the nucleotide sugar uridine diphosphate-N-acetylglucosamine (UDP-GlcNAc) to phosphatidylinositol (PI) to form GlcNAc-PI, the first intermediate in the synthesis of the GPI anchor. PIGA is located on the short arm of the X chromosome. Hematopoietic cells in PNH are deficient in all proteins that are GPI-anchored because a somatic mutation in a hematopoietic stem cell partially or completely inactivates the PIGA gene product. Consequently, the GPI moiety is not synthesized.

Studies of the pattern of X chromosomal inactivation indicated that, in the female patient with four different PIGA mutations, the abnormal clones were not derived from a common ancestor.⁵⁰ Further, that each of the mutations was discrete demonstrated that the mutational events occurred independently rather than by clonal evolution. These results demonstrate that PNH is not strictly a monoclonal process and that they have important implications for the origins of the disease.

Studies of mutational frequency in PNH have produced conflicting results. Some of the disparity is almost certainly due to differences in experimental design and interpretation of data. While an abnormally high mutational rate may contribute to generation of multiple PIGA-mutant clones, a selective advantage for GPI-AP-deficient stem cells and variable extent of expansion of the mutant clones appears to be necessary to explain the outgrowth of multiple PNH clones, some of which dominate hematopoiesis and some of which persist subclinically.

The Pathophysiology of Paroxysmal Nocturnal Hemoglobinuria Is Unique

Despite the progress that has been made in determining the basis of the abnormal sensitivity of the erythrocytes to complement-mediated lysis and the global absence of GPI-anchored proteins (GPI-AP) from hematopoietic cells, an issue that is fundamental to a more complete understanding of PNH remains largely enigmatic. In order for PNH to become clinically evident, the hematopoietic

P.792

stem cells bearing the mutant PIGA must expand so that progeny sufficient to produce symptoms and signs of the disease are generated. In many instances, GPI-AP-deficient (GPI-AP⁻) cells dominate hematopoiesis in patients with PNH, suggesting that the mutant stem cell has either a greater proliferative capacity or a survival advantage relative to GPI-AP sufficient (GPI-AP⁺) stem cells. That PIGA mutations are necessary for the development of PNH is incontrovertible. At issue is whether PIGA mutations are both necessary and sufficient to account for the PNH syndrome and whether the PIGA mutation provides an absolute or a conditional growth/survival advantage.

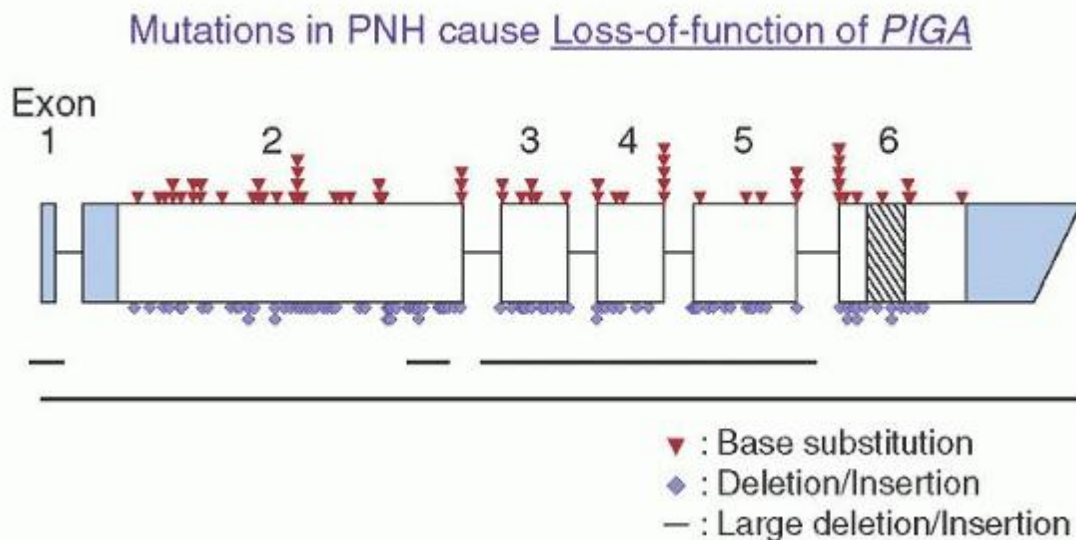

FIGURE 31.5. Diagram of the human PIGA gene and the locations of somatic mutations reported in patients with PNH. The boxes represent exons within the PIGA gene, and the blackened areas denote noncoding regions. Lines connecting the exons represent introns. The hatched region within exon six indicates the putative PIGA transmembrane domain. Single nucleotide substitutions are indicated above the gene as inverted triangles, while small nucleotide deletions and insertions are identified beneath the gene by diamonds. Large DNA deletions and insertions are denoted by horizontal

lines below the gene. (From Nishimura J, Murakami Y, Kinoshita T. Paroxysmal nocturnal hemoglobinuria: an acquired genetic disease. *Am J Hematol* 1999;62:175-182, with permission of Wiley-Liss.)

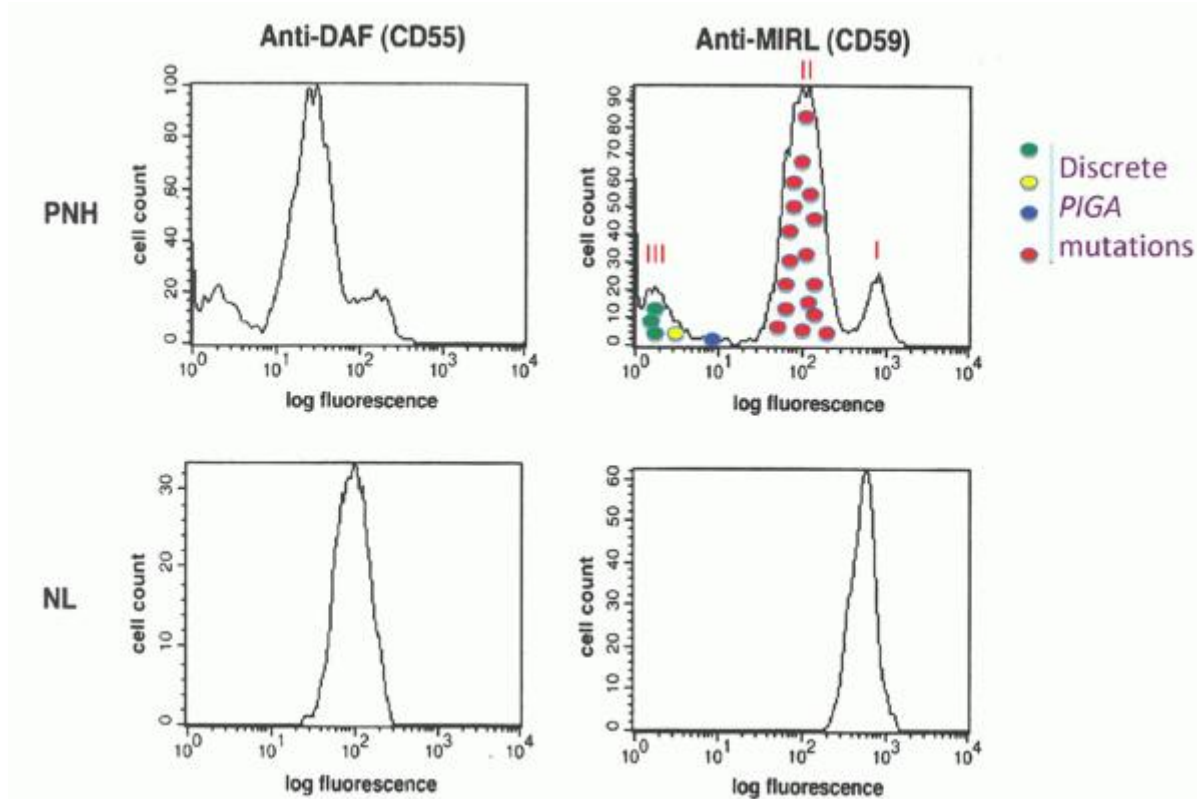

FIGURE 31.6. PIGA genotype determines PNH phenotype. A flow cytometry histogram modeled after that of a patient with PNH (Fig. 31.1) is shown. In this case, approximately 75% of the patient's hematopoiesis was derived from a clone (red filled circles) with a PIGA missense mutation that produced the PNH II phenotype. Three discrete PI-A mutations that produced a null phenotype were found among the PNH III cells (green, yellow, and blue filled circles). These three clones together contributed 11% of the patient's hematopoiesis. In this case, the PNH II clone has expanded much more than any of the PNH III clones.

PNH differs from monoclonal hematopoietic stem cell disorders such as chronic myelogenous leukemia in which the t(9;21) that generates the fusion protein BCR-ABL is sufficient to account for the proliferative advantage of the mutant cell, and in which all normal hematopoiesis is progressively and invariably displaced as a consequence of the uncontrolled proliferation of a transformed clone. In PNH, the peripheral blood is a mosaic of normal and abnormal cells and the proportion of GPI-AP⁻:GPI-AP⁺ cells varies greatly among patients; that ratio tends to remain fixed over long periods of observations. PNH is, therefore, more aptly characterized as having deregulated cellular proliferation and expansion, rather than cellular transformation.

The oligoclonal nature of PNH⁵⁰ suggests that a powerful selection process that is most likely based on phenotype is at work in the bone marrow. According to this hypothesis, stem cells with mutant PIGA have an advantage because of some pathological process (perhaps immune-mediated) that involves a GPI-AP. For example, an autoimmune process could arise in which the target antigen is a GPI-AP expressed on hematopoietic stem cells. Under those circumstances, PIGA-mutant stem cells (lacking GPI-AP) would escape immune-mediated destruction because the target antigen is absent.

P.793

Hematopoietic cells express a relatively large number of functionally diverse GPI-AP (Table 31.2). Thus, absence of all GPI-AP is probably not required for the clonal selection of the mutant stem cells. Rather, the selective advantage may be dependent on the absence of a single protein that is GPI-anchored, and the reason for the global deficiency of GPI-AP is that PIGA is located on the X chromosome. According to this supposition, an autosomal gene encodes the GPI-AP that is conditionally detrimental (e.g., an antigen targeted for immune destruction or a receptor for a negative growth regulator).

Inasmuch as two alleles rather than one must be mutated, the probability of inactivating an autosomal gene through somatic mutagenesis is remote compared with the probability of inactivating an X-linked gene. Therefore, stem cells with a deficiency of the detrimental GPI-AP are most likely to arise as a consequence of PIGA mutations, as is the case in patients with CLL treated with Campath1H (anti-CD52).⁵³ Assuming that the GPI-AP complement regulatory proteins are not the targets of the underlying pathologic process, the hemolytic anemia that is the clinical hallmark of PNH may represent an epiphenomenon related to the chromosomal location of PIGA.

Although a compelling case can be made in support of the paradigm that the PIGA mutation bestows a conditional growth advantage upon the affected stem cell, the hypothesis that the mutant stem cells have an absolute growth or survival advantage must also be considered. Data that both support and challenge this hypothesis can be found.^{54, 55, 56} The most compelling argument against an intrinsic growth or survival advantage for PIGA-mutant cells is made by the results of studies using transgenic mice.⁵⁷ By using homologous recombination, Kawagoe et al.⁵⁸ disrupted *Piga* (the murine homologue of PIGA). Only mice with a low degree of chimerism survived. Among those animals, the percentage of GPI-AP⁻ erythrocytes ranged from ~1% to 5%. During 10 months of observation, the ratio of GPI-AP⁻: GPI-AP⁺ peripheral blood cells did not increase. Studies by others using conditional knockout technology have confirmed these observations.⁵⁷

What Is the Origin of the PIGA-Mutant Stem Cells?

Patients with PNH often have more than one PIGA-mutant clone.^{50, 59} A tenet of the Darwinian selection hypothesis as it applies to PNH is that PIGA-mutant hematopoietic stem cells are present during the time when the selection pressure is applied to the bone marrow. PIGA-mutant hematopoietic elements have been identified in the peripheral blood and bone marrow of normal volunteers, providing experimental support for this concept, although whether the GPI-AP-deficient cells identified in normal individuals originate from hematopoietic stem cells with mutant PIGA has been questioned.⁶⁰ While there is experimental data that suggest that the mutational frequency of the gene is abnormally high,⁶⁰ the fact that PIGA is located on the X chromosome (so that only one allele need be mutated for the phenotype to become apparent) likely accounts primarily for the existence of multiple discrete clones in many patients with PNH.

A Two-Step Model of Paroxysmal Nocturnal Hemoglobinuria Pathogenesis

Studies by Inoue and colleagues suggest that a two-step mechanism may account for the unique pathophysiology of PNH.⁶¹ Those investigators identified two patients whose PIGA-mutant cells had a concurrent, acquired rearrangement of chromosome 12. Detailed analysis showed that in both cases, the chromosome 12 rearrangement resulted in disruption of the 3' untranslated region of HMGA2. As a consequence, a negative regulatory region of the locus was disrupted, resulting in ectopic expression of the gene. HMGA2 is a member of the high mobility group of proteins (HMGA1a, HMGA1b, HMGA2) that function as architectural transcription factors. HMG members possess no intrinsic transcriptional activity. Instead, these nonhistone phosphoproteins orchestrate assembly of stereospecific transcriptional regulatory proteins into enhanceosomes. The cellular targets of HMGA2 are incompletely defined but appear to include cyclin A and E2F1.

Molecular studies established a causal role for HMGA2 in benign mesenchymal tumors. Rearrangement of 12q13-15 is observed in these neoplasms, but tumorigenesis does not depend on generation of chimeric proteins derived from fusion of HMGA2 with specific translocation partners. Rather, clonal expansion induced by HMGA2 appears to result from deregulated expression of the protein. For the two PNH patients, ectopic expression was a consequence of gain-of-function mutational events caused by disruption of the 3'UTR shown to contain elements that negatively regulate HMGA2 mRNA stability, including the microRNA let-7a.^{62, 63} Additional studies will be required to determine whether aberrant expression of HMGA2 underlies clonal expansion in PNH patients without structural abnormalities of 12q13-15, but studies by Murakami and colleagues support this hypothesis.⁶⁴

In contrast to a disorder characterized by cellular transformation and malignant cellular growth, PNH manifests many of the characteristics of a benign tumor, since there is limited expansion of PIGA-mutant clones (the peripheral blood of patients is a relatively stable mosaic of normal and abnormal cells); PIGA-mutant cells respect tissue boundaries (there is no invasion of non-hematopoietic tissues); PIGA-mutant cells respond appropriately to signals that normally regulate hematopoiesis (function is not autonomous); and transformation into acute leukemia occurs rarely (PNH is not a premalignant condition).⁶⁵ The studies of Inoue and colleagues⁶¹ suggest the concept of PNH as a benign tumor of the bone marrow with aberrant expression of HMGA2 acting in concert with mutant PIGA (and the consequent deficiency of GPI-APs) to produce the proliferative phenotype that underlies clonal expansion. These studies did not define how the aberrant expression of HMGA2 works additively or synergistically with mutant PIGA to produce the proliferative phenotype.

The findings of Inoue et al. provide new insights into the etiology of the nonmalignant clonal hematopoiesis of PNH. These studies support a two-step process consisting of (i) clonal selection based on phenotype (i.e., GPI-AP deficiency resulting

from mutant PIGA) and (ii) clonal expansion as a consequence of a second somatic mutation that bestows an additional growth/survival advantage. Clonal selection may induce the exit of PIGA-mutant stem cells from a dormant state, thereby favoring acquisition of the second mutation that underlies clonal expansion. The variable expansion of PIGA-mutant clones among patients and among mutant clones in the same patient could be explained by heterogeneity involving the second genetic event that partners with mutant PIGA. According to this hypothesis, mutant PIGA is promiscuous with respect to the second mutant gene with which it partners. But the benign nature of PNH suggests that genes involved in clonal expansion of PIGA-mutant stem cells are different from those that underlie malignant clonal diseases such as acute leukemia.

In summary, the basis of the clonal dominance in PNH is incompletely understood; however, available evidence supports a two-step model of pathogenesis. Step 1 of this model is clonal selection. In this case, a loss-of-function mutation affecting PIGA causes deficiency of GPI-APs on affected stem cells. These mutant stem cells have a relative growth or survival advantage that is likely enhanced in the setting of bone marrow failure (e.g., aplastic

P.794

anemia). Thus, principles of Darwinian evolution may apply to development of PNH. Clonal expansion, step 2 of the PNH pathogenesis model, is envisioned as a consequence of clonal evolution in which a second somatic (gain-of-function) mutation working in concert with the consequences of mutant PIGA bestows upon the double mutant stem cell an absolute proliferative advantage.⁶¹ The extent of expansion of a particular mutant clone and the dominance of one PIGA-mutant clone in the presence of other PIGA mutants may be mediated by the nature of the second event that may be molecularly heterogeneous. Alternatively, a limited number of second mutations may partner with mutant PIGA, and the extent of clonal expansion may be determined by how the second mutation affects gene function.

Aplastic Anemia and Paroxysmal Nocturnal Hemoglobinuria

Patients with clinical PNH can be divided into the following two groups: those without a preceding history of aplastic anemia (classic PNH); and those with an antecedent history of aplastic anemia who subsequently develop PNH (PNH/aplastic anemia).¹ An association between aplastic anemia and PNH has been recognized at least since 1961, and numerous subsequent studies have confirmed the association. The probability is negligible that these two rare diseases would occur together so frequently by chance. Therefore, a pathophysiologic link between PNH and aplastic anemia must exist.

Hillmen et al.⁶⁵ reported that 23 of 80 PNH patients (29%) had an antecedent history of aplastic anemia, and in a series of 220 French patients with PNH, Socié and colleagues identified 65 (30%) in whom the diagnosis of aplastic anemia preceded that of PNH.⁶⁶ The latter group of investigators also found that 10% of PNH patients with no antecedent history of aplastic anemia developed pancytopenia during the period of observation covered by the study (median follow-up of 2 years). The estimated cumulative incidence of pancytopenia was 8.2% (\pm 2.4%, SE) at 2 years and 14.2% (\pm 3.3%, SE) at 4 years.⁶⁶ This incidence appears to be somewhat higher than that observed in the study reported by Hillmen et al. in which 5 of 80 patients (6%) with PNH subsequently developed aplasia.⁶⁵

On the other hand, the proportion of patients with aplastic anemia who subsequently develop PNH varies widely among studies, in part because the criteria for diagnosis of PNH are not uniform. In some cases, a positive Ham's test or sucrose lysis test was required for diagnosis, and in other cases, identification by flow cytometry of a population of peripheral blood cells with GPI-AP deficiency was used to classify patients. A recent study reported that PNH cells were found in the BM in 89% of 115 patients with aplastic anemia at some point during the course of their illness.⁶⁷ Two other studies reported 38% (11 of 29 patients)⁶⁸ and 32% (12 of 37 patients)⁶⁹ for the portion of patients with aplastic anemia treated with immunosuppression who developed laboratory evidence of PNH during the course of their disease. In the latter study, 23% of patients had clinical signs and symptoms of PNH. Therefore, in most patients with aplastic anemia, evidence of PNH is subclinical or transient. These results suggest that the selective pressure that favors PIGA-mutant cells occurs frequently in the setting of aplastic anemia, but that the clinical syndrome occurs at a significantly lower frequency.

The time between the diagnosis of aplastic anemia and the development of PNH varies from a few months to several years. In the series reported by Socié et al.,⁶⁶ the median time between diagnosis of aplastic anemia and laboratory evidence of PNH was 3.1 years (range 0.17 to 15 years). Using an assay with the capacity to detect 0.004% GPI-AP-deficient erythrocytes, Mukhina et al. reported that 61% of patients with aplastic anemia had detectable PNH cells prior to therapy.⁷⁰ Similar results were obtained in more recent studies using high-resolution flow cytometry.⁷¹ In most of these cases, the GPI-AP-deficient cells would be undetected by conventional flow cytometry, in which the sensitivity threshold for detecting cells with the PNH phenotype is 1% to 3%. Identification of very small populations of GPI-AP-deficient cells

by high-resolution flow cytometry has led to a new class of PNH, termed subclinical PNH (PNH-sc).¹ Patients with PNH-sc have no clinical or laboratory evidence of hemolysis. Small populations of GPI-AP-deficient hematopoietic cells (peripheral blood erythrocytes, granulocytes, or both) are detected by very sensitive flow cytometric analysis. PNH-sc is observed in association with bone marrow failure syndromes, particularly aplastic anemia and the refractory anemia variant of MDS.

In summary, while 40% to 60% of patients with aplastic anemia have small, subclinical populations of GPI-AP⁻ hematopoietic cells at diagnosis,⁷¹ only 10% to 15% subsequently develop clinically apparent PNH.^{72, 73} In the remainder, GPI-AP⁻ cells persist subclinically or disappear,^{71, 74} suggesting that mutant PIGA (and the consequent deficiency of GPI-APs) is necessary for clonal selection but is insufficient to account for the clonal expansion required for clinical manifestations of PNH to become apparent. The simplest interpretation of these observations is that factors in addition to mutant PIGA contribute to the development of clinical signs and symptoms of PNH by affecting the extent to which the PIGA-mutant stem cells expand.

As expansion of the mutant clones occurs later in the course of aplastic anemia, the process could be influenced directly or indirectly by therapy. Although many patients with aplastic anemia who develop PNH are treated with immunosuppressive therapy (e.g., anti-thymocyte globulin and cyclosporin), there is no evidence that immunosuppression causes PNH.⁷³ Patients with aplastic anemia who respond to androgens appear equally likely to develop PNH.⁶⁶

The basis of the relationship between PNH and aplastic anemia is speculative. Essentially all patients with PNH have some evidence of bone marrow failure (e.g., thrombocytopenia, leukopenia, or both) during the course of their disease. Therefore, bone marrow injury may play a central role in the development of PNH by providing the conditions that favor the growth/survival of PIGA-mutant, GPI-AP-deficient stem cells. Currently, there is no evidence that the types of PIGA mutations that occur in PNH/aplastic anemia are different from those observed in classic PNH.⁷⁵ Further, a distinction between classic PNH and PNH/aplastic anemia may be artificial, as the underlying pathophysiologic process could be the same. According to this hypothesis, in classic PNH, the aplastic or hypoplastic component is subclinical and short-lived, with disease noted only after the PIGA-mutant clone has expanded sufficiently to dominate hematopoiesis.

Leukocytes and Platelets

Deficiency of GPI-AP on neutrophils, monocytes, platelets, and lymphocytes has been demonstrated in the peripheral blood of patients with PNH, and identical PIGA mutations have been identified in neutrophils, monocytes, and lymphocytes from the same patient.^{48, 50} Together, these studies indicate that the somatic mutation that gives rise to PNH affects a hematopoietic stem cell. Most PNH patients have pancytopenia or either neutropenia or thrombocytopenia in combination with anemia at some point during the course of their illness. The neutropenia and thrombocytopenia, however, are due to abnormal hematopoiesis rather than to increased peripheral, complement-mediated destruction, as *in vivo* studies have demonstrated normal survival of neutrophils and platelets in patients with PNH. That absence of GPI-anchored complement regulatory proteins from PNH neutrophils and platelets does not affect their survival implies that these cell types (unlike erythrocytes) have mechanisms in addition to those provided by CD55 and CD59 that protect them from complement-mediated destruction *in vivo*.

P.795

In vitro studies have shown functional abnormalities of PNH leukocytes and platelets. Further, deficiency of some of the GPI-AP from PNH leukocytes and platelets would seem to have important functional consequences (e.g., deficiency of FcγRIIIb from neutrophils, deficiency of urokinase-type plasminogen activator receptor from monocytes and neutrophils, deficiency of LFA-3 from lymphocytes, or deficiency of the folate receptor from hematopoietic stem cells) (Table 31.2). However, evidence that deficiency of GPI-APs other than erythrocyte CD55 and CD59 contributes to the pathophysiologic manifestations of PNH is largely conjectural. At least in some cases, functional redundancy appears to account for the lack of untoward consequences associated with GPI-AP deficiency.

Hematopoietic Stem Cells

The PNH defect can be demonstrated in erythroid and granulocytic precursors grown *in vitro* (i.e., CFU-E, BFU-E, and CFU-GM).⁶⁰ Two populations of colonies can be identified in such studies, and they differ from one another in complement sensitivity and expression of acetylcholinesterase.⁷⁶ These latter observations support the concept of a clonal process originating from a mutant hematopoietic stem cell.

Cytogenetic studies on hematopoietic cells of patients with PNH have yielded mixed results. The issue is complicated because patients with aplastic anemia can have karyotypic abnormalities. Araten and colleagues reported karyotypic

abnormalities in 11/46 (24%) of PNH patients examined in a retrospective study.⁷⁷ In 7 of those patients, there was evidence of clonal regression, and none of the patients developed an excess of blasts or a transformation into acute leukemia. These findings suggest that karyotypic abnormalities in PNH do not predict progression into a malignant phenotype. To date, the only nonrandom chromosomal abnormality specific for PNH involves rearrangement of 12q13-15 that results in ectopic expression of HMGA2.⁷⁸ A systematic study of a large number of patients is needed to determine if other nonrandom karyotypic abnormalities that contribute to the clonal expansion of PIGA-mutant cells exist.

Uncommonly (~1%), patients with PNH develop acute leukemia.^{65, 66} In some cases, the leukemic clone arises from the PNH clone because the blasts are GPI-AP-deficient.⁷⁹ Similar observations have been made in MDS arising in the setting of PNH.⁸⁰ However, in other cases, PNH cells disappear following the onset of the leukemia⁸¹ or myelodysplasia.⁸² While transformation into acute leukemia or other clonal myelopathies is uncommon in PNH, the incidence is probably higher than in the general population. Therefore, an element of genetic instability may be associated with PNH or the process that underlies PNH.

CLINICAL MANIFESTATIONS

PNH usually begins insidiously with the abrupt onset of clinically apparent hemoglobinuria being the presenting symptom in only 25% of cases.^{83, 84} The course is chronic with a generally stable clinical pattern in a given individual. The illness ranges in severity from a mild, clinically benign process to a chronically debilitating, potentially lethal disease. The diagnosis is made most frequently in the fourth to fifth decades of life,^{65, 66, 84} but PNH is also encountered in childhood⁸⁵ and in old age (age range 16 to 75 years⁶⁵ and 6 to 82 years⁶⁶ in two large series). Both genders are affected, with perhaps a slight female predominance, and PNH has been described in many racial groups. The disease has no familial tendency. Inherited cases due to global deficiency of GPI-AP have not been reported, suggesting that germ line mutations of PIGA are embryonically lethal. This hypothesis is supported by the lack of success in producing a homozygous or hemizygous knockout mouse using a targeted mutation of Piga.⁵⁸ Observations in humans also support the hypothesis. An X-linked lethal disorder characterized by cleft palate, neonatal seizures, contractures, and central nervous system structural malformations was investigated using whole exome sequencing.⁸⁶ In that case, a germ line mutation of PIGA was identified, but the PNH phenotype was not observed. In vitro studies indicated that the mutant PIGA had partial function, thereby accounting for the absence of hemolysis. Similarly, two unrelated kindreds with germ line mutations in the promoter of the autosomal gene PIGM were identified. Homozygotes were characterized by a propensity toward venous thrombosis and seizures, but clinically significant hemolysis was not observed. The lack of hemolysis was explained by flow cytometric analysis that showed only partial deficiency of GPI-anchored complement regulatory proteins on the red cells.⁸⁷ Together, these observations indicate that germ line deficiency of GPI-APs sufficient to produce the PNH phenotype is not compatible with life. As previously noted, a patient with an inherited deficiency of MIRL (CD59) had a syndrome that was clinically indistinguishable from PNH, but other GPI-APs were expressed normally by that patient.³⁵

Most commonly, patients with classic PNH complain initially of malaise, lethargy, and asthenia. Yellowish discoloration of the skin (jaundice) and sclera (icterus) may be observed by astute family members.

Hemoglobinuria

Although essentially all patients with classic PNH have episodes of hemoglobinuria sometime during their illness, this defining symptom is reported as part of the initial evaluation in only one-quarter of all patients (Table 31.3). Nocturnal hemoglobinuria appears to result from an increase in the rate of hemolysis that occurs during sleep. It is not related to time of day, however, because the pattern can be reversed if the patient is kept awake at night and allowed to sleep during the day. In patients with nocturnal hemoglobinuria, the urine is usually darkly discolored in the morning and clears gradually over the course of the day. When hemolysis is intense, however, hemoglobinuria persists throughout the day.

The cause of the nocturnal exacerbation is poorly understood. Retention of CO₂ causing a slight fall in plasma pH sufficient to activate the alternative pathway of complement is a possible explanation, but this hypothesis has been challenged.

TABLE 31.3 PRESENTING FEATURES IN 80 PATIENTS WITH PAROXYSMAL NOCTURNAL HEMOGLOBINURIA

Signs and Symptoms	Number of Patients (%)
Symptoms of anemia	28 (35)
Hemoglobinuria	21 (26)
Hemorrhagic signs and symptoms	14 (18)
Aplastic anemia	10 (13)

Gastrointestinal symptoms	8 (10)
Hemolytic anemia and jaundice	7 (9)
Iron deficiency anemia	5 (6)
Thrombosis or embolism	5 (6)
Infections	4 (5)
Neurologic signs and symptoms	3 (4)

From Dacie JV, Lewis SM. Paroxysmal nocturnal haemoglobinuria: clinical manifestations, haematology, and nature of the disease. *Ser Haematol* 1972;5:3-23.

P.796

Episodic Hemolysis

In addition to the sleep-related pattern, most patients with classic PNH experience irregular but recurrent exacerbations of hemolysis and hemoglobinuria. Paroxysms may be precipitated by a wide variety of events, including infections (even minor ones), surgery, transfusions, iron supplementation, vaccinations, and menstruation. Attacks of hemoglobinuria are unrelated to cold exposure, thus distinguishing PNH clinically from paroxysmal cold hemoglobinuria.

Mild hemolytic episodes often pass without significant symptoms, but more severe attacks may be associated with substernal, lumbar, or abdominal pain together with drowsiness, malaise, fever, and headaches. The abdominal pain may be colicky and may last for 1 to 2 days. The abdomen may be tender, especially in the left upper quadrant, with guarding and rebound tenderness. The back pain resembles that noted in patients with other types of intravascular hemolysis (such as in an ABO incompatible transfusion reaction) and is most severe in the lumbar region. Headaches may be excruciating and sometimes last for days.

Marrow Hypoplasia

Because many patients with PNH/aplastic anemia have only a small proportion of complement-sensitive cells, few of the changes usually associated with hemolytic anemia are obvious. Therefore, the PNH/aplastic syndrome is probably underdiagnosed. Clinicians need to maintain a high degree of suspicion, and any evidence of hemolysis (e.g., elevated serum lactate dehydrogenase [LDH]) in a patient with aplastic anemia warrants evaluation for PNH. In one series of 80 European patients with PNH, aplastic anemia was the first diagnosis in 23 cases (29%)^{65, 83}; the same was true of 26 of 85 patients (31%) from Thailand⁸⁸ and 65 of 220 French patients (30%).⁶⁶ In some instances, the diagnosis of hemolysis is made first, and pancytopenia develops subsequently.

Thromboembolic Complications

PNH is associated with a striking predisposition toward intravascular thromboses, especially within the venous circulation.^{65, 66, 89} Intra-abdominal veins are the most commonly affected. Cerebral vein and superficial dermal vein thrombosis also appear to be represented disproportionately. Thrombotic disease accounts for about 50% of all deaths in patients with PNH. Fatal thromboses usually involve the portal system or the brain.

Recurrent abdominal pain is the dominant clinical manifestation in some patients with PNH (Table 31.3). The cause of the pain is often obscure but may be severe enough to suggest an acute abdomen warranting emergency surgery. The possibility that a thrombosis in the portal or mesenteric veins is the cause of the pain should be considered in this setting. Both transient intestinal ischemia and intestinal infarction due to thrombosis involving the microcirculation are other possible causes.

Hepatic venous thrombosis (Budd-Chiari syndrome) is a serious, potentially fatal complication of PNH.^{90, 91} In various series, 15% to 30% of patients with PNH had hepatic venous thrombosis, and this complication might be even more common because affected individuals can be asymptomatic when Budd-Chiari syndrome is in its early stage.⁹² The clinical manifestations include nausea, abdominal pain, variable degrees of ascites, variceal bleeding, and signs of liver failure. Often the liver increases abruptly in size, but hepatomegaly is not always noted. Three pathophysiologic stages of hepatic venous thrombosis have been defined.⁹² In the early or mildest stage, only venules or small hepatic veins are involved. Patients may be asymptomatic and therefore the condition may go unrecognized. Mild, easily controlled ascites is

detected in some patients. In the second stage, larger hepatic veins are partially occluded. Ascites is noted in most patients with such abnormalities. Some individuals develop variceal bleeding, and a few become jaundiced. The third or advanced stage is characterized by complete occlusion of large hepatic veins. Ascites is almost always present, jaundice is common, and variceal bleeding occurs in a few patients. This stage is often fatal.

An increase in the level of serum LDH, alanine aminotransferase, and aspartate aminotransferase may be an early clue to the presence of hepatic vein thrombosis. Plasma concentration of conjugated bilirubin also may increase, but other biochemical tests of liver function are of limited value. Ultrasonography is the most effective noninvasive method for early detection of hepatic vein thrombosis, with a sensitivity and specificity of 85% or more.^{93, 94} Computed tomographic and magnetic resonance imaging (MRI) scans are more sensitive than ultrasound. MRI is better for visualizing the whole length of the vena cava and may permit differentiation of the acute form from the subacute form of the disease.⁹⁴ Radioactive isotope scanning demonstrates patchy uptake in most of the liver, except for a normally functioning, hypertrophied caudate lobe that is spared because of its separate venous drainage. Hepatic venography is definitive, but this procedure carries more risk than noninvasive techniques. Biopsy may demonstrate congestion and liver cell loss, but the procedure is hazardous and not always informative.

Small-vessel thromboses may cause severe and refractory headaches or they presage progressive cerebrovascular thrombosis.⁹⁵ Isotopic brain scanning and electroencephalography usually are of little help in monitoring PNH patients with headaches.

Renal Abnormalities

Both acute and chronic renal insufficiency occurs in patients with PNH.^{96, 97} Acute renal insufficiency is associated with hemoglobinuric crises and may resolve without residual damage. In one series of 19 patients with PNH, however, 12 individuals had reduced values for creatinine clearance while their underlying disease was stable. Furthermore, at least three of these patients had progressive renal insufficiency. Patients with PNH may also have hematuria, proteinuria, hypertension, an inability to concentrate their urine, or some combination of these abnormalities. The kidneys usually are enlarged when examined radiographically, and MRI may reveal hemosiderin deposition. The renal abnormalities probably result from repeated thrombotic episodes involving small venules.

Dysphagia and Male Impotence

When closely questioned, many patients with PNH complain of painful or difficult swallowing. The symptom is often worse in the morning and appears to be exacerbated during hemolytic episodes. Studies of peristalsis have shown that the esophageal contractions that occur in this setting have 9 to 10 times the normal force. The pathogenesis of these esophageal complaints is speculative. Inasmuch as hemoglobin binds nitric oxide, it has been proposed that the plasma free hemoglobin that is a consequence of the chronic intravascular hemolysis characteristic of PNH acts as a sump for nitric oxide.⁹⁸ Esophageal (and intestinal spasm) may ensue because of consumption by plasma free hemoglobin of the smooth muscle-relaxing activity of nitric oxide. This hypothesis is supported by observations that patients receiving artificial hemoglobin also experience dysphagia and odynophagia.⁹⁹

Male impotence is common in patients with PNH and is worse during hemolytic exacerbations. As is the case with dysphagia, nitric oxide deficiency that is a consequence of the sump effect of plasma free hemoglobin may underlie the erectile dysfunction.

Infections

The apparent increased incidence of infections in patients with PNH may be attributable to leukopenia, to treatment with P.797

corticosteroids, or to functional defects in leukocytes (although compelling experimental support is lacking). Even mild infections may constitute a serious hazard because they may precipitate a hemolytic exacerbation.

Physical Examination

Findings are largely nonspecific (related to anemia, thrombocytopenia, or neutropenia). Jaundice may be observed in patients with brisk hemolysis. Moderate splenomegaly and mild to moderate hepatomegaly are sometimes observed and should raise concerns about hepatic or splenic vein thrombosis.

LABORATORY FINDINGS

Blood

Essentially all patients with PNH are anemic, and in many, the anemia is severe. The red cells are usually macrocytic, as observed in other bone marrow failure syndromes, but the MCV varies considerably among patients. Occasionally, the red cells may appear hypochromic and microcytic because of iron deficiency resulting from chronic and acute hemoglobinuria. Moderate anisocytosis and poikilocytosis are common but spherocytes are not observed in the peripheral blood film. Polychromatophilia, reflecting reticulocytosis, is observed unless bone marrow failure is severe. Relative reticulocytosis may be marked, but the absolute reticulocyte count is often lower than that found in association with other hemolytic disorders at comparable degrees of anemia. This discrepancy reflects underlying marrow dysfunction that is invariably a component of the disease. Normoblasts (nucleated red blood cells) may also be found in the peripheral blood film. The osmotic and mechanical fragility of the erythrocytes is normal, and the reaction to the direct antiglobulin (Coombs') test is negative (although it may become positive in patients treated with eculizumab, see below).

Leukopenia is often observed and may be marked, especially in the setting of PNH/aplastic anemia. The leukopenia is a consequence of bone marrow rather than complement-mediated destruction.¹⁰⁰ Neutrophil alkaline phosphatase (a GPI-AP) expression is low or absent. Functional leukocyte defects have been demonstrated but their clinical relevance is conjectural.

Thrombocytopenia of moderate to severe degree is common, but platelet life span and function generally are normal.¹⁰¹ Thus, like the leukopenia, the thrombocytopenia of PNH is a consequence of bone marrow failure. Bleeding due to severe thrombocytopenia may contribute to the morbidity and mortality of the disease.

Plasma

The plasma may be golden brown, reflecting the presence of increased levels of unconjugated bilirubin, hemoglobin, and methemalbumin. Predictably, serum haptoglobin concentration is low and LDH concentration is markedly elevated, reflecting intravascular hemolysis.

Urine

When the rate of blood destruction is increased, the urine contains increased amounts of urobilinogen. In addition, intravascular hemolysis leads to depletion of serum haptoglobin, which results in the continuous presence of hemoglobin in the glomerular filtrate of the kidney. The cells of the proximal convoluted tubules that reabsorb much of the hemoglobin become heavily laden with iron. The excretion of this iron in the form of granules gives rise to hemosiderinuria. In addition, spectroscopic examination may reveal variable amounts of free hemoglobin. The continuous loss of relatively large amounts of iron in the urine can result in iron deficiency. Average daily losses of up to 16 mg have been observed, and as much as 4 mg of iron excreted in 24 hours has been demonstrated even in the absence of gross hemoglobinuria. Albuminuria has been detected immediately before and after an episode of hemoglobinuria, and long-term study of PNH patients has shown an unexpectedly high incidence of functional renal abnormalities, such as hematuria, hyposthenuria, tubular malfunction, and declining creatinine clearance.^{96, 97}

Bone Marrow

In patients with classic PNH, normoblastic hyperplasia is a characteristic finding. As many as 50% of the nucleated cells may be normoblasts, but only occasionally are megaloblastic changes evident. The absence of morphologic changes consistent with megaloblastic anemia suggests that deficiency of the GPI-anchored form of the folate receptor (Table 31.2) does not result in abnormalities in folate metabolism that are clinically significant. The number of megakaryocytes may be decreased. When pancytopenia is evident, a hypoplastic marrow is usually observed, although in some patients, pancytopenia is associated with a cellular marrow, a feature that is more consistent with the ineffective hematopoiesis associated with a myelodysplastic process.

Cytogenetic Studies

Although a number of karyotypic abnormalities have been reported in PNH,⁷⁷ the only nonrandom chromosomal aberrations specific for PNH involve rearrangement of the HMGA2 locus on 12q13-15.⁶¹ Apparently, the presence of karyotypically abnormal bone marrow cells is not a negative prognostic factor in PNH.⁷⁷

Diagnostic Tests

Until the early 1990s, the diagnosis of PNH was based on the results of special tests that exploited the abnormal sensitivity of PNH red cells to lysis by complement. Among the available assays, Ham's test (acidified serum lysis) and the sucrose lysis test (sugar water test of Hartmann) were most commonly used for the clinical diagnosis of PNH. While these tests are sensitive and specific when properly performed, and relatively simple in both theory and practice, their accuracy is strongly operator-dependent. Therefore, in the hands of an inexperienced technician, results are not always reliable. This

problem is compounded by the fact that the tests are usually performed on a sporadic basis in most clinical laboratories because the diagnosis of PNH is entertained relatively uncommonly.

The recognition that deficiency of GPI-AP underlies PNH has resulted in the development of a simple, reliable method for diagnosing the disease.¹⁰² By analyzing expression of GPI-AP on hematopoietic cells using monoclonal antibodies and flow cytometry, the abnormal cells can be readily identified (Figs. 31.1 and 31.2). The simplest method is to analyze expression of MIRL (CD59) on erythrocytes (Fig. 31.1). Because it is normally present in relatively high density, red cells with either complete or partial deficiency of MIRL are easily distinguished from normal (Fig. 31.1). Therefore, PNH I (normal expression), PNH II (partial expression), and PNH III (negative expression) erythrocytes can be identified by analyzing the flow cytometry histogram (Fig. 31.1). Analysis of erythrocyte DAF (CD55) expression is also informative. Because erythrocytes express ~6 to 8-fold less DAF (CD55) than MIRL (CD59), however, separation into discrete populations may be less obvious when anti-DAF is used as the primary antibody. By using both antibodies, the diagnosis can be confirmed (Figs. 31.1 and 31.2A).

The size of the PNH clone is best determined by analysis of GPI-AP expression on granulocytes. Unlike the life span of

peripheral blood RBCs that is markedly shortened as a consequence of deficiency of the GPI-anchored complement regulatory proteins CD55 and CD59, the life span of PIGA-mutant, GPI-AP-deficient PMNs is normal.¹⁰⁰

Therefore, the percentage of GPI-AP-deficient PMNs is believed to be an accurate reflection of the contribution of the mutant clone(s) to hematopoiesis. The value of determining the size of the PNH clone is that some of the clinical manifestations of the disease, particularly the risk of thromboembolic complications, appear to be proportional to clone size.^{103, 104} Analysis of GPI-AP on granulocytes is technically more challenging than on erythrocytes, because of the difficulties associated with shipping, processing, and analyzing these fragile cells. Further, granulocyte expression must be analyzed within 24 to 48 hours after the blood sample is acquired, whereas erythrocytes can be analyzed 1 to 2 weeks after the blood is obtained if the sample is properly stored at 4°C.

GPI-AP-deficient populations that comprise >1% to 3% of the red cells can be identified by standard flow cytometry. Concern that recent red cell transfusion might result in a false-negative result seems unfounded. Because the assay is very sensitive and because the proportion of GPI-AP-deficient cells is greater in the reticulocyte population than in the peripheral blood as a whole, massive transfusion that both replaces essentially all of the patient's blood volume and also completely suppresses hematopoiesis would be required to produce a false-negative result. Transfusion will have an impact on the percentage of GPI-AP-deficient cells that are observed, but the possibility that the diagnosis would be obscured is remote. Conversely, it is unlikely that a recent hemolytic episode would result in a false-negative result because all the abnormal cells are destroyed. However, when documenting the proportion of affected cells and determining the precise erythrocyte phenotype, the analysis is best done when the patient has not been recently transfused, as well as when the patient is not experiencing a hemolytic crisis related to infection or some other cause.

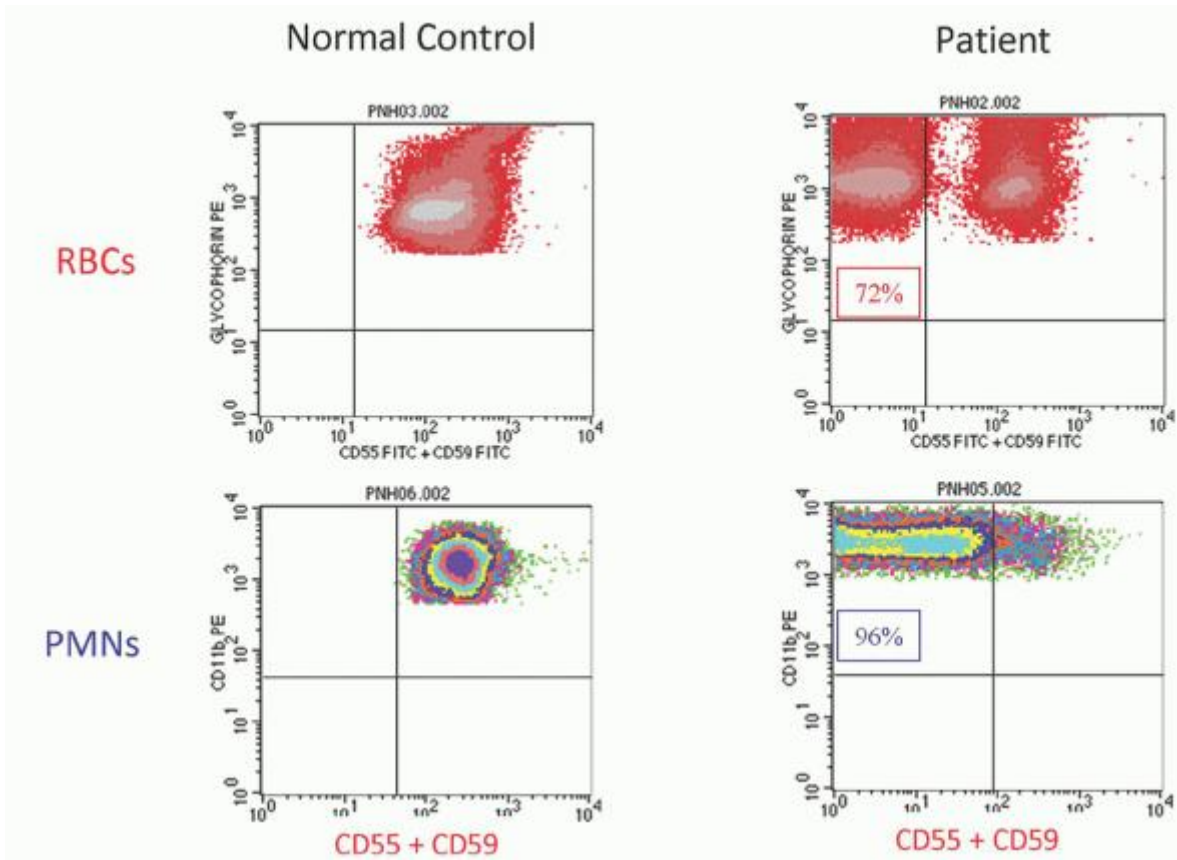

FIGURE 31.7. High sensitivity flow cytometry for diagnosis of PNH. A: Two-color flow cytometry histogram of erythrocytes (upper panels) and neutrophils (lower panels) from a normal volunteer (left) and from a patient with classic PNH (right). Erythrocytes were stained with phycoerythrin (PE)-labeled anti-glycophorin A (vertical axis) and a combination of fluorescein isothiocyanate (FITC)-labeled anti-CD55 and anti-CD59 (horizontal axis). Neutrophils were stained with PE-labeled CD11b (vertical axis) and FITC-labeled anti-CD55 and anti-CD59 (horizontal axis). No GPI-AP-deficient erythrocytes or neutrophils were among ~100,000 cells counted in this analysis for the normal control, whereas the patient had 72% GPI-AP-deficient erythrocytes and 96% GPI-AP-deficient neutrophils. B: Two-color flow cytometry histogram of erythrocytes and neutrophils from two patients with aplastic anemia but with no clinical evidence of PNH. In the example on the left, approximately 0.077% of the erythrocytes and 0.74% of the neutrophils failed to express CD55 and CD59. In the example on the right, 3% of the erythrocytes and 21% of the neutrophils failed to express CD55 and CD59.

By careful gating and by using triple-antibody staining techniques, the sensitivity of flow cytometry can be enhanced by about three orders of magnitude, such that as few as 0.003% GPI-AP-deficient cells (RBCs and WBCs) can be consistently and reproducibly detected⁷¹ (Fig. 31.7). This high-resolution analysis is used to identify patients with PNH-sc (Fig. 31.7B). Patients with PNH-sc in the setting of aplastic anemia and the refractory anemia variant of MDS appear to have a more benign clinical course than patients without PNH-sc.^{71, 105, 106} In addition, some^{71, 105, 106} but

P.799

not all¹⁰⁷ studies suggest that patients with PNH-sc respond more favorably to immunosuppressive therapy.

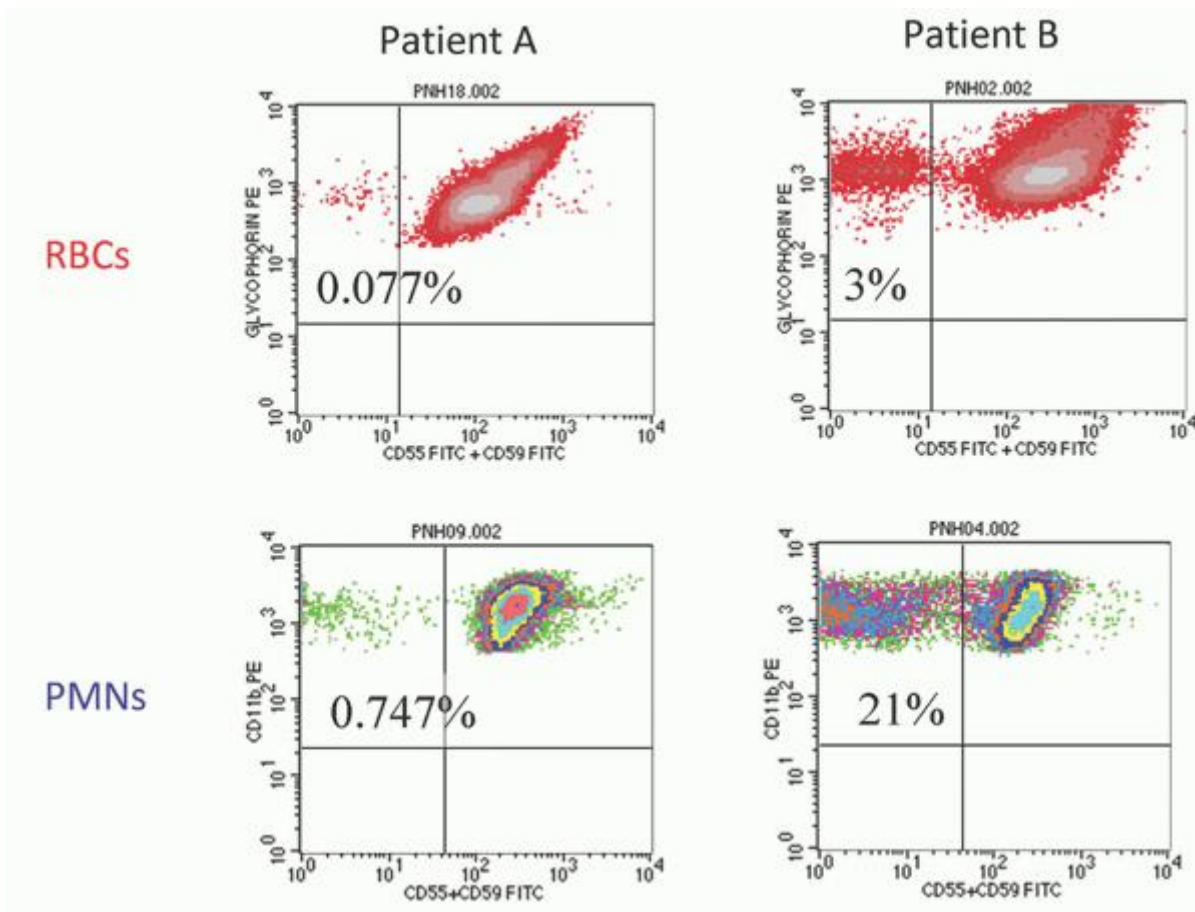

FIGURE 31.7. (continued)

A diagnostic assay for PNH using fluorescent aerolysin (FLAER) that exploits the unique properties of the bacterial toxin aerolysin has been developed.¹⁰⁸ This channel-forming protein binds directly to the GPI anchor. By fluorochrome labeling of a modified recombinant form of the protein that does not cause lysis, this reagent can be used to detect leukocytes with the PNH phenotype.¹⁰⁸ The primary advantage of this assay is that because it detects all GPI-APs, it is specific for PNH. The primary disadvantage is that the FLAER reagent does not bind well to RBCs. Thus FLAER cannot be used to characterize GPI-AP expression on erythrocytes.

Analysis of expression of GPI-AP on erythrocytes is a highly specific test for PNH. There is no other known disease in which the erythrocytes include a mosaic of both GPI-AP⁺ and GPI-AP⁻ cells. Subjects with isolated deficiency of either DAF (the Inab phenotype) or MIRL (CD59) will be identified by this method (assuming that anti-DAF and anti-MIRL antibodies are used). Such patients are extremely rare, however, and their flow cytometry histograms are readily distinguishable from patients with PNH because 100% of the cells are abnormal and expression of only one GPI-AP is deficient. Patients with inherited abnormalities of GPI-AP synthesis would be distinguished from patients with PNH because in the former case, mosaicism would not be observed.

DIFFERENTIAL DIAGNOSIS

The diagnosis of PNH must be considered in any patient who has the following: (1) signs and symptoms of intravascular hemolysis (manifested by an abnormally high LDH) of undefined cause (i.e., Coombs-negative) with or without macroscopic hemoglobinuria often accompanied by iron deficiency; (2) pancytopenia in association with hemolysis; (3) venous thrombosis affecting unusual sites, especially intra-abdominal, cerebral, or dermal locations accompanied by evidence of hemolysis; (4) unexplained recurrent bouts of abdominal pain, low backache, or headache in the presence of chronic hemolysis; and (5) Budd-Chiari syndrome.

It is important to document evidence of hemolysis before proceeding with tests more specific for clinical PNH. As discussed above, a history of gross hemoglobinuria (nocturnal or otherwise) is not part of the initial clinical presentation in approximately three-fourths of patients with PNH (Table 31.3). However, except for patients with PNH-sc, laboratory evidence of hemolysis is a relatively constant feature of the disease. Quantitation of serum LDH is particularly informative

because intravascular hemolysis results in markedly elevated values. If LDH concentrations are difficult to interpret because of other comorbid conditions (e.g., liver disease), then alternative evidence for chronic intravascular hemolysis should be sought (e.g., low serum haptoglobin, urine hemosiderin).

P.800

Without evidence of hemolysis, more specific tests for clinical PNH are generally unwarranted. PNH must be differentiated from antibody-mediated hemolytic anemias, especially paroxysmal cold hemoglobinuria and the cold agglutinin syndrome, and from HEMPAS (Hereditary Erythroblastic Multinuclearity with a Positive Acidified Serum Lysis Test, or Congenital Dyserythropoietic Anemia type II). The mechanism that underlies the abnormal susceptibility of HEMPAS erythrocytes to acidified serum lysis is different from that of PNH.¹⁰⁹ By using flow cytometry, there is no difficulty distinguishing PNH from other hemolytic diseases because deficiency of GPI-APs affecting a portion of the erythrocytes is diagnostic of PNH.

By definition, patients with PNH-sc have no clinical or laboratory evidence of hemolysis. PNH-sc is diagnosed by using high-resolution flow cytometry. Patients with aplastic anemia and the refractory anemia variant of MDS should undergo screening for PNH-sc at diagnosis and yearly thereafter. Finding PNH-sc appears to have important prognostic and therapeutic implications, as patients with PNH-sc/aplastic anemia or PNH-sc/MDS-RA may have a more benign clinical course and a higher rate of response to immunosuppressive therapy than those without PNH-sc.^{71, 105, 106}

TREATMENT

The size of the PNH clone and the type and severity of the bone marrow failure component of the disease are the main factors that determine the clinical course. Some patients have a relatively benign clinical course with only a moderate degree of anemia and minimal hemolysis, and in such patients, no PNH-specific treatment is required. Other patients have severe anemia punctuated by hemolytic crises and thromboembolic complications; in such patients, treatment of the complement-mediated hemolytic anemia is clearly warranted. In other patients, the disease is dominated by bone marrow failure rather than by hemolysis, and in those patients, the focus of treatment should be on the underlying marrow failure process. By taking into account the size of the PNH clone and the type and severity of the bone marrow failure component of the disease, a classification has been developed that provides a rational basis for management.

Clinical Classification

The basic approach to classifying PNH is straightforward. Flow cytometric analysis of peripheral blood erythrocytes and granulocytes (± monocytes) is needed to determine the phenotype of the red cells and the size of the PNH clone (based on the percentage of GPI-AP-deficient granulocytes (± monocytes)). CBC, reticulocyte count, serum concentration of LDH, bilirubin (fractionated), haptoglobin, and iron stores are needed to assess the degree of marrow failure and hemolysis and whether iron deficiency is present. Bone marrow aspirate and biopsy and cytogenetic analysis are needed to characterize the status of the bone marrow. Once the basic evaluation is complete, patients should be classified based on the categories developed by the International PNH Interest Group.¹

Classification of PNH*					
Category	Rate of Intravascular Hemolysis†	Bone Marrow	Flow Cytometry	Benefit from Eculizumab	
Clinical PNH	Classic	Flourid (markedly abnormal LDH often with episodic macroscopic hemoglobinuria)	Hypocellular with erythroid hyperplasia and normal or near-normal morphology‡‡	Large population (>50%) of GPI-AP deficient PMNs¶	Yes
	PNH in the setting of another bone marrow failure syndrome§	Mild (often with minimal abnormalities of biochemical markers of hemolysis)	Evidence of a concomitant bone marrow failure syndrome§	Although variable, the percentage of GPI-AP deficient PMNs is usually relatively small (25%-50%)	Typically no, but some patients have clinically significant hemolysis and benefit from treatment
	Subclinical	No clinical or biochemical evidence of intravascular hemolysis	Evidence of a concomitant bone marrow failure syndrome§	Small (<1%) population of GPI-AP deficient PMNs detected by high-resolution flow cytometry	No

* Based on recommendations of the International PNH Interest Group (Blood 2005;106:3699-3709)
 † Based on macroscopic hemoglobinuria, serum LDH concentration and reticulocyte count
 ‡‡ Karyotypic abnormalities are uncommon
 § Aplastic anemia or low risk myelodysplastic syndrome
 ¶ Analysis of PMNs is more informative than analysis of RBCs due to selective destruction GPI-AP deficient RBCs

FIGURE 31.8. Classification of PNH. This classification is modified based on the recommendations of the International PNH Interest Group.

The three categories are as follows (Figure 31.8):

Classic PNH. Patients with classic PNH have clinical evidence of intravascular hemolysis (reticulocytosis, abnormally high concentration of serum LDH and indirect bilirubin, and abnormally low concentration of serum haptoglobin), but have no evidence of another defined bone marrow abnormality. A cellular marrow with erythroid hyperplasia and normal or near-normal morphology, but without nonrandom karyotypic abnormalities, is consistent with classic PNH. The PNH clone is large (>50% and often >90%). Patients with a large population of PNH II erythrocytes, however, will have minimal hemolysis.

PNH in the setting of another specified bone marrow disorder. This subcategory of patients has at least laboratory evidence of hemolysis but also has concomitantly a defined underlying marrow abnormality. Bone marrow analysis and cytogenetics are used to determine if PNH arose in association with aplastic anemia or MDS. Standard criteria are used for diagnosis of the bone marrow abnormality (e.g., aplastic anemia, low-risk MDS). Finding nonrandom karyotypic abnormalities that are associated with a specific bone marrow abnormality may contribute diagnostically (e.g., abnormalities of chromosomes 5q, 7, and 20q are associated with MDS). The large majority of patients with PNH/AA and PNH/MDS have relatively small PNH clones (<50%), and require no specific PNH therapy; and in these cases, treatment should focus on the underlying bone marrow failure syndrome.⁷³

Approximately half of the patients with clinical PNH in the setting of bone marrow failure will require therapy (eculizumab for hemolysis or anticoagulation for thrombosis).⁷³ **Subclinical PNH (PNH-sc).** Patients with PNH-sc have no clinical or laboratory evidence of hemolysis. Small populations of GPI-AP-deficient hematopoietic cells (peripheral blood erythrocytes, granulocytes, or both) are detected by sensitive flow cytometric analysis.⁷⁴ PNH-sc is observed in association with bone marrow failure syndromes, particularly aplastic anemia and refractory anemia-MDS. In approximately 80% of these cases, the proportion of GPI-AP-deficient cells is <1.0%.⁷⁴ These patients require no

P.801

PNH-specific therapy; however, as noted above, finding a population of GPI-AP-deficient erythrocytes in patients with aplastic anemia may be clinically relevant, as some^{71, 105, 106} but not all¹⁰⁷ studies suggest that these patients have a particularly high probability of responding to immunosuppressive therapy with a more rapid rate of onset of response compared with patients with aplastic anemia without a population of GPI-AP-deficient erythrocytes. Treatment with immunosuppressive therapy appears to have no influence on the size of the PNH clone.⁷³

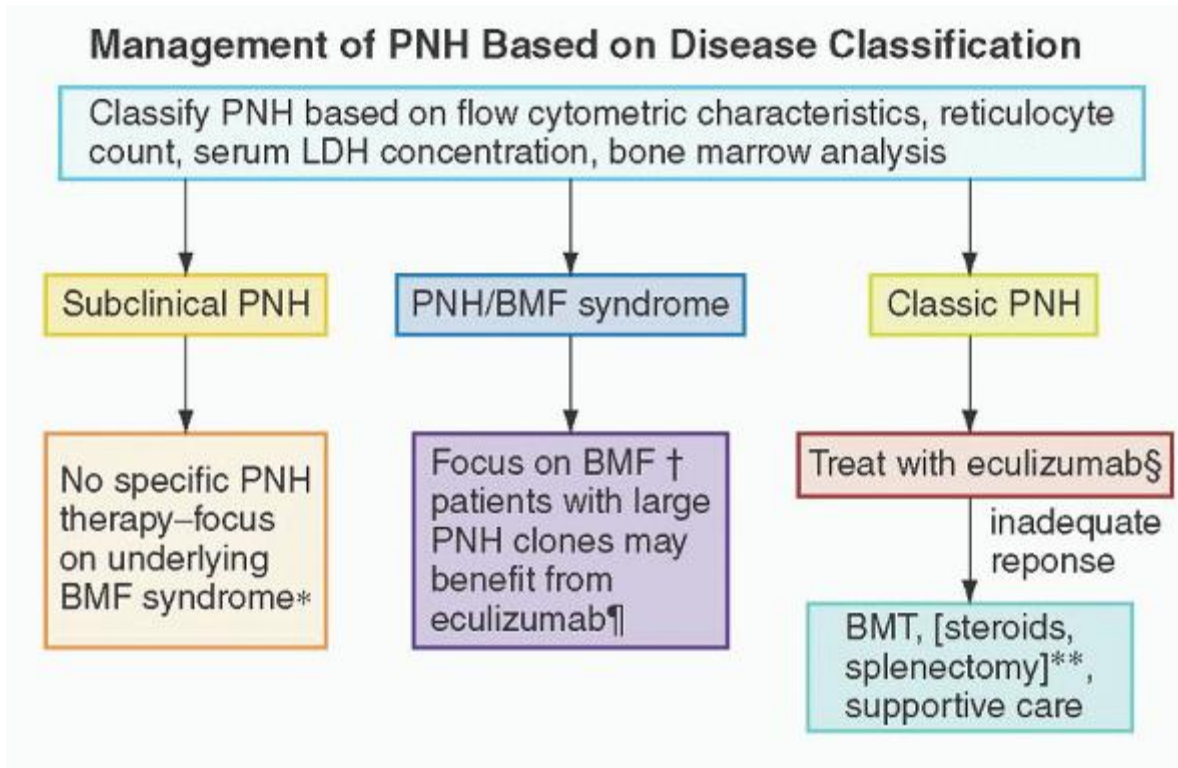

FIGURE 31.9. Algorithm for management of PNH based on disease classification. Disease classification is based on the

recommendations of the International PNH Interest Group (Fig 31.8). *Some, but not all, studies suggest a favorable response to immunosuppressive therapy (IST). †BMT eradicates the PNH clone, and typically, treatment with IST does not affect PNH clone size (<10% of patients with PNH/BMF have PNH clone size >50%). §Some patients respond to danazol as first line therapy. **Consider for patients with clinically significant extravascular hemolysis. BMF, bone marrow failure (aplastic anemia and low-risk MDS); BMT, bone marrow transplant. (Reproduced from Parker CJ. Management of paroxysmal nocturnal hemoglobinuria in the era of complement inhibitory therapy. *Hematology Am Soc Hematol Educ Program* 2011:21-29, with permission of the author).

An algorithmic approach to management of PNH based on the above disease classification is shown (Fig. 31.9).

Management of the Anemia of Paroxysmal Nocturnal Hemoglobinuria

Coombs-negative hemolytic anemia is the clinical hallmark of PNH, but because the disease usually arises in the setting of an underlying abnormality of the bone marrow, hemolysis may account for only part of a patient's anemia. Further, the erythrocytes of PNH are a mosaic of normal and abnormal cells, and the portion of GPI-AP-deficient RBCs varies among patients (Figs. 31.1 and 31.2). For example, in hypothetical patient A, only 15% of the circulating RBC may be GPI-AP-deficient while, in hypothetical patient B, 75% GPI-AP-deficient erythrocytes may be observed (Fig. 31.10). In the former, hemolysis would contribute modestly to an observed anemia, while in the latter, a significant hemolytic component would be expected (Fig. 31.10). Another complicating factor is that deficiency of GPI-AP may be partial rather than complete (Figs. 31.1 and 31.10), and partial expression of CD55 and CD59 is sufficient to protect PNH II cells from spontaneous complement-mediated lysis *in vivo*.³⁰ Therefore, even if a patient has a high proportion of PNH II cells, only modest evidence of spontaneous hemolysis is usually observed (Fig. 31.10). But brisk hemolysis can occur in patients with predominantly PNH II erythrocytes in situations where complement activation is enhanced (e.g., by infection, trauma, surgery, pregnancy, or unusual stress).

Prior to initiating therapy, an effort should be made to determine how much of the anemia is a consequence of hemolysis and how much is due to impaired erythropoiesis (Table 31.4). Review of the complete blood count is informative because evidence of thrombocytopenia, leukopenia, or both suggests stem cell dysfunction. The capacity of the marrow to respond to the anemia can be inferred from the reticulocyte count. An element of marrow failure is likely a contributing factor in a patient with PNH who has anemia with an inappropriately low reticulocyte count.

Biochemical parameters of hemolysis should be assessed (Table 31.4). Normal or minimal elevation of LDH argues against hemolysis as a major contributing factor to the anemia. The presence of urine hemosiderin suggests chronic intravascular hemolysis but provides no quantitative information, while gross hemoglobinuria indicates clinically significant intravascular hemolysis.

The concentration of erythropoietin should be determined, as renal dysfunction may complicate PNH.⁹⁶ Iron deficiency due to hemosiderinuria/hemoglobinuria is common.

Treatment of anemia that is primarily a consequence of bone marrow failure should be aimed at the underlying disease (e.g., aplastic anemia, MDS). Patients with PNH/aplastic anemia or PNH/RA-MDS appear to have a favorable response to immunosuppressive therapy.^{71, 105, 106} If absolute or relative erythropoietin deficiency is thought to contribute to the anemia, replacement with the recombinant protein is warranted, but patients should be closely monitored, as erythropoietin supplementation could exacerbate hemolysis by increasing production of GPI-AP-deficient erythrocytes (patients treated with eculizumab would be protected against such a hemolytic exacerbation). There are also anecdotal reports of patients responding to pharmacologic doses of erythropoietin even when the endogenous concentration is high.¹¹⁰ Androgens may also be beneficial in patients with PNH who have a hypoproliferative component to their anemia.¹¹¹ Complement inhibitory therapy (i.e., eculizumab) would not be expected to have efficacy in the treatment of anemia due to marrow failure.

Complement Inhibitory Therapy

Patients with evidence of clinically significant intravascular hemolysis (markedly elevated LDH, macroscopic hemoglobinuria, reticulocytosis, or transfusion dependence) are candidates for treatment with eculizumab (Soliris, Alexion Pharmaceuticals Inc.). However, patients need not be transfusion-dependent to benefit from eculizumab, as the debilitating symptoms of lethargy, malaise, and asthenia that accompany the chronic, complement-mediated intravascular hemolysis of PNH are ameliorated by treatment with eculizumab. Eculizumab is a humanized monoclonal antibody that binds complement C5, preventing its activation to C5b by the APC C5 convertase and thereby inhibiting MAC formation (Fig. 31.1).¹¹² In 2007, eculizumab was approved by both the US FDA and the European Union Commission for treatment of the hemolysis of PNH. The drug is now available in countries outside of North American and Europe. Treatment of patients with classic PNH with eculizumab reduces transfusion requirements, ameliorates the anemia of

PNH, and improves quality of life.^{10, 113, 114} Following treatment, serum LDH concentration returns to normal or near-normal, with approximately one-half to two-thirds of patients achieving transfusion independence,⁸⁴ but mild to moderate anemia, hyperbilirubinemia, and reticulocytosis persist in essentially all treated patients. Eculizumab appears to reduce the risk of thromboembolic complications.¹¹⁵ For patients being treated with eculizumab who have no prior history of thromboembolic complications, prophylactic anticoagulation may

P.802

be unnecessary, while it is recommended that anticoagulation continue for those patients who experienced a thromboembolic event prior to initiating therapy with eculizumab.⁸⁴ Eculizumab is expensive (~\$400,000/year in the United States), and it has no effect either on the underlying stem cell abnormality or on the associated bone marrow failure. Consequently, treatment must continue indefinitely and leukopenia, thrombocytopenia, and reticulocytopenia, if present, persist. Patients treated with eculizumab are at risk for infection with *Neisseria* organisms, and vaccination against *Neisseria meningitidis* is required prior to initiation of therapy. Nonetheless, deaths from meningococcal sepsis have been observed in patients being treated with eculizumab. Some advocate the use of prophylactic penicillin in patients treated with eculizumab, as the currently available vaccine does not protect against some species of meningococcus.⁸⁴ Treatment with eculizumab appears to have a favorable impact on survival, as a recent study of 79 patients treated between 2002 and 2010 showed the same survival as that of age- and sex-matched controls from the general population.⁸⁴ However, the contribution of eculizumab to survival in this study cannot be quantified accurately as a control patient group was not included.

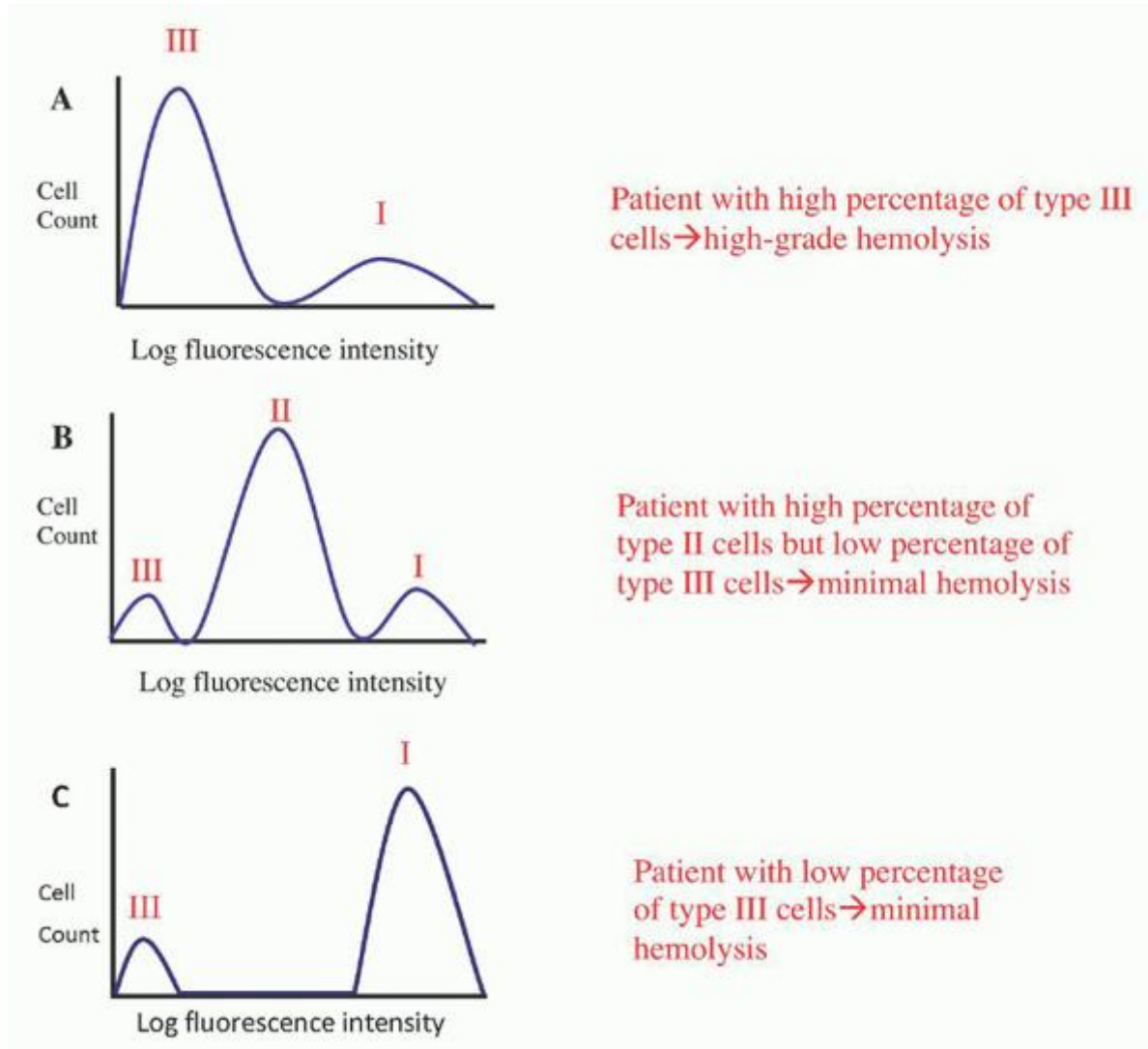

FIGURE 31.10. Impact of phenotype and degree of mosaicism on the hemolytic anemia of PNH. Hypothetical histograms of

erythrocytes from patients with PNH stained with anti-CD59 are illustrated. The proportion and type of abnormal erythrocytes varies greatly among patients with PNH and these characteristics are important determinants of clinical manifestations. In general, patients with a high percentage of type III erythrocytes have clinically apparent hemolysis (panel A). If the erythrocytes are partially deficient in GPI-AP, hemolysis may be modest even if the percentage of the affected cells is high (panel B). A patient may have a diagnosis of PNH, but if the proportion of type III cells is low, only biochemical evidence of hemolysis may be observed (panel C). (Modified from Parker C, Omine M, Richards S, et al. Diagnosis and management of paroxysmal nocturnal hemoglobinuria. *Blood* 2005;106:3699-3709.)

TABLE 31.4 INFORMATION USEFUL FOR MANAGING ANEMIA IN PATIENTS WITH PAROXYSMAL NOCTURNAL HEMOGLOBINURIA

- Complete blood count
- Reticulocyte count
- Serum concentration of lactate dehydrogenase (LDH), bilirubin (total and direct fractions), and haptoglobin
- Urine hemosiderin^a
- Flow cytometric analysis of erythrocytes and granulocytes for expression of glycosyl phosphatidylinositol-anchored proteins (GPI-AP)
- Serum erythropoietin concentration
- Serum concentration of blood urea nitrogen and creatinine
- Serum iron studies (iron concentration, total iron binding capacity, transferrin saturation index, and ferritin concentration)

^a Indicative of chronic hemolysis but provides no quantitative information.

Modified from Parker C, Omine M, Richards S, et al. Diagnosis and management of paroxysmal nocturnal hemoglobinuria. *Blood* 2005;106:3699-3709.

Reasons for Eculizumab Failure

The recommended maintenance dose of eculizumab is fixed (900 mg every 2 weeks \pm 2 days), rather than being based on weight or body surface area. Due to differences in the rate of drug metabolism, some patients may show evidence of breakthrough intravascular hemolysis (i.e., a rise in LDH and development of constitutional symptoms) near the end of a treatment cycle. In these cases, breakthrough hemolysis can be ameliorated by reducing the length of the treatment cycle from 14 days to 13 days or 12 days, and in some instances, the maintenance dose of eculizumab may also have to be increased. All patients with PNH have an element of bone marrow failure, and patients treated with eculizumab who have higher degrees of relative reticulocytopenia may remain anemic or even transfusion-dependent despite excellent control of intravascular hemolysis. Iron stores and serum erythropoietin concentration should be quantified in these patients, and if iron stores are adequate, and serum erythropoietin concentration is inappropriately low, a trial of recombinant erythropoietin is warranted in patients who have symptomatic anemia or who are transfusion-dependent. Following treatment with eculizumab, serum LDH returns to normal or nearnormal, but mild to moderate anemia and laboratory evidence of hemolysis persist in essentially all treated patients.¹¹³ A small subgroup of eculizumab-treated patients experiences little or no improvement in either anemia or constitutional symptoms. In these patients, hemolysis is mediated by opsonization of the PNH erythrocytes by activation and degradation products of complement C3, and when tested, they are found to be Coombs'-positive for C3 but not IgG.^{116, 117, 118, 119} The known pathophysiology of PNH predicts that CD55 deficiency would result in ongoing extravascular hemolysis of PNH erythrocytes as a consequence of C3

P.803

opsonization (Fig. 31.3), as eculizumab does not block the activity of the APC C3 convertase that is unregulated because of DAF deficiency (Fig. 31.3). Support for this hypothesis is provided by the studies of Risitano and colleagues,¹¹⁹ who showed that in patients treated with eculizumab, a portion of the PNH erythrocytes (i.e., the CD59-deficient population) had complement C3 bound. Those studies also confirmed the Coombs'-negative designation of PNH, as no C3 was found bound to PNH erythrocytes prior to initiation of treatment with eculizumab, implying that PNH erythrocytes upon which

complement has been activated are destroyed directly as a consequence of MAC-mediated cytolysis. Thus, those studies provide a plausible explanation for the persistent hemolytic anemia observed in PNH patients treated with eculizumab. By inhibiting formation of the MAC, eculizumab prevents direct cytolysis of PNH erythrocytes, allowing the manifestations of DAF deficiency to become apparent in the form of aberrant regulation of the APC C3 convertase and the consequent deposition of activated C3 on the cell surface (Fig. 31.3).¹²⁰ Covalently bound activation and degradation products of C3 then serve as opsonins that are recognized by specific receptors on reticuloendothelial cells resulting in extravascular hemolysis. The extravascular hemolysis of patients with PNH receiving eculizumab does not require treatment in the absence of constitutional symptoms, symptoms of anemia, or transfusion dependence. As the process is extravascular, splenectomy or corticosteroids may ameliorate the hemolysis in symptomatic or transfusion-dependent patients by removing or inhibiting the function of phagocytic cells. Long-term use of corticosteroids is associated with significant toxicity, however, and concerns about both postoperative and late complications temper enthusiasm for splenectomy. It is also conceivable that the primary site of phagocytosis is hepatic rather than splenic. In such cases, response to splenectomy would likely be inadequate. Based on experience in the treatment of refractory autoimmune hemolytic anemia, a trial of danazol can be considered, however, Rituxan is not indicated, as the process is mediated by C3 opsonization rather than opsonization by IgG antibody.

Androgenic Steroids, Cortical Steroids, and Immunosuppressive Therapy

Although efficacy is controversial,¹ some patients with PNH respond to treatment with androgenic steroids and prednisone.¹¹¹

Approximately one-third of patients appear to respond to androgen therapy with an increase in hemoglobin concentration, a reduction in transfusion requirement, or both; however, attempting to identify the responders in advance is problematic. The mechanism by which androgenic steroids ameliorate the anemia of PNH is not understood, although the rapid onset of action is consistent with complement inhibition.¹²¹ The adverse effects of androgen therapy can be substantial, ranging from virilization in women and acne in both sexes to serious liver disease, including peliosis hepatitis and hepatocellular carcinoma. Although neither of the last two complications has been reported in androgen-treated patients with PNH, some suggest androgens might predispose to an insidious form of hepatic vein thrombosis.¹¹¹ These considerations make prudent institution of androgen therapy for 6 to 8 weeks with discontinuation if no clear response is observed. Oral preparations such as fluoxymesterone (5 to 30 mg/day) or oxymetholone (10 to 50 mg/day) have been used most commonly. Because of fewer virilizing adverse effects, the synthetic androgen danazol (400 to 800 mg/day in two divided doses) is an attractive alternative to anabolic steroids. Once hemolysis is controlled, a dose of 200 to 400 mg/day may be sufficient to sustain the response. Monitoring of liver function studies is mandatory, but prolonged use of danazol appears to be safe in most patients.

Corticosteroids have been used as treatment for both chronic hemolysis and acute hemolytic exacerbations. As is the case with androgenic steroids, treatment is empiric, and there is no experimental data that provides a plausible explanation for why steroids should ameliorate the hemolysis of PNH. Nonetheless, some patients appear to respond rapidly and dramatically to glucocorticoids (given in the dosage range of 0.25 to 1.0 mg/kg/d of prednisone). The rapid response (often within 24 hours of initiating therapy) suggests that complement inhibition accounts for the anti-hemolytic activity of glucocorticoid therapy. Such an effect could be direct (the result of inhibition of the activity of some component of the alternative pathway of complement) or indirect (the result of dampening a process, such as inflammation, that stimulates activation of complement).

The main value of corticosteroids may be in attenuating acute hemolytic exacerbations.¹ Under these circumstances, brief pulses of prednisone may reduce the severity and duration of the crisis while avoiding the untoward consequences associated with long-term use. The value of steroids in treating chronic hemolysis is limited by toxicity, and the harm that can accrue from long-term use cannot be overemphasized. An every other day schedule may attenuate some of the adverse effects of chronic steroid use, but patients may note worsening of symptoms on the off day. Careful follow-up is essential and both bacterial prophylaxis and prophylaxis against steroid-induced osteopenia are recommended. Awareness of the potentially debilitating effects of steroid myopathy and sensitivity to the disfiguring consequences of iatrogenic Cushing's syndrome are essential for proper management.

Responses to immunosuppressive therapy with cyclosporin and anti-thymocyte globulin have been reported.^{122, 123, 124} This approach to management has been applied primarily to patients with PNH/aplastic anemia, and as noted above, immunosuppressive therapy appears to have no effect on the size of the PNH clone.⁷³ Use of high-dose cyclophosphamide for treatment of PNH and PNH/aplastic anemia has been investigated.¹¹

Transfusions

Blood transfusions may be required for treatment of anemia. The recommendation that the blood be given in the form of saline-washed or frozen-thawed, deglycerolized red cells in order to avert a hemolytic episode has been questioned.¹²⁵ But hemofiltration is recommended to prevent transfusion reactions resulting from interaction between donor leukocytes and recipient antibodies. Transfused red cells survive normally in patients with PNH, and transfusion to nearly normal hemoglobin levels can produce short-lived "remissions." Clinical improvement may result from a temporary decrease in the production of abnormal cells with a consequent reduction of hemolysis and other disease-associated epiphenomena. Iatrogenic hemochromatosis can occur from chronic transfusions, but may be delayed because of iron loss from hemoglobinuria and hemosiderinuria. In fact, iron overload in patients with classic PNH is rare. But iron overload remains a concern in patients who require chronic transfusion when the anemia is primarily a consequence of marrow failure rather than hemolysis.

Iron

As a result of chronic hemoglobinuria and hemosiderinuria, iron deficiency eventually develops in most patients (even in heavily transfused patients).¹²⁶ The amount of iron lost should be replaced, since iron-limited erythropoiesis may contribute to the anemia, and hemolysis appears to be exacerbated by iron deficiency. Most patients tolerate oral iron therapy well, but hemolytic episodes have been precipitated by such treatment. This phenomenon probably results from the outpouring of a cohort of young erythrocytes, a larger proportion of which is more complement-sensitive. Parenteral iron repletion is generally safe. If hemoglobinuria after iron therapy is troublesome, hematopoiesis can be suppressed by a brief period of transfusion during which iron stores are repleted. Alternatively, a short course of high doses

P.804

of prednisone given during the early phases of iron replacement therapy may ameliorate the hemolytic exacerbation. For patients treated with eculizumab, a hemolytic exacerbation would not be induced by iron replacement, and iron deficiency should not develop in patients on eculizumab, as inhibition of hemolysis eliminates hemoglobinuria and the consequent iron loss.

Splenectomy

The role of splenectomy in the management of patients with PNH is debatable. Reports of amelioration of hemolysis and improvement in cytopenias following splenectomy are anecdotal. Concerns about lack of proven efficacy and the potential for postoperative complications, particularly thrombosis, limit enthusiasm for splenectomy in the management of PNH.¹

Folate

Although most normal western diets supply adequate folate, supplemental folate (1 to 5 mg/day) is recommended to ensure compensation for increased utilization associated with heightened erythropoiesis that is a consequence of hemolysis.

Bone Marrow Transplantation

Bone marrow or other forms of stem cell transplantation has been used in the treatment of PNH for nearly 40 years.¹²⁷ The unique pathophysiology of PNH should be taken into account when planning a transplant strategy. PNH is a nonmalignant clonal disease, and observation of a patient who underwent a syngeneic stem cell transplant¹²⁸ underscores two important differences in response to transplant compared with malignant clonal myelopathies such as acute leukemia. First, cytoreduction of the "tumor" cell burden prior to transplant conditioning is not required, whereas the success of transplant for acute leukemia (and other malignant clonal myelopathies) is dependent on maximum pretransplant tumor debulking. Second, graft vs. tumor effect is not essential for eradication of the PNH clone, whereas graft vs. tumor effect plays a critical role in the outcome of transplant for malignant disorders.

The optimal transplant conditioning regimen for PNH should be made on a case-by-case basis.¹ Clearly some conditioning is essential, as infusion of syngeneic donor marrow without conditioning has limited, transient, efficacy.¹²⁹ Using a nonmyeloablative regimen, Childs and colleagues reported that eradication of the PNH clone was incomplete without any graft vs. tumor effect,¹³⁰ but as noted above, a myeloablative regimen can completely eradicate the PNH clone without graft vs. tumor effect.¹²⁸ Together, these observations can be used in planning a transplant strategy for patients with PNH, depending upon the anticipated or desired role of graft vs. tumor effect in the therapeutic process.

While allogeneic BMT is potentially curative, the benefits must be weighed against the significant morbidity and mortality associated with the procedure. The experience of the International Bone Marrow Transplant Registry (IBMTR) was reviewed in 1999.¹³¹ A total of 57 patients were included in that study, with 48 receiving HLA-identical sibling transplants.

The 2-year probability of survival for this group was 56%. Only 1 of 7 patients who underwent unrelated donor transplant was alive after 5 years of follow-up. However, improvements in HLA matching using molecular techniques may improve outcomes with unrelated donors, though unlikely to reach those observed for transplant using stem cells from HLA-identical sibling donors. Successful treatment of patients with PNH using nonmyeloablative stem cell transplantation has been reported.^{130, 132, 133}

When BMT is used to treat patients with PNH/aplastic anemia or PNH-sc/aplastic anemia, the decision on transplantation should be guided primarily by recommendations for management of that particular marrow failure syndrome, typically based on the degree of aplasia and transfusion dependence. For patients with classic PNH, both recurrent life-threatening thrombosis and refractory, transfusion-dependent hemolytic anemia are indications for transplantation. In the pre-eculizumab era PNH patients who had thrombosis at presentation had only a 40% survival rate at 4 years.⁶⁶ Progression to pancytopenia was also a risk factor that negatively affected survival,⁶⁶ as did development of MDS or acute leukemia, age over 55 at diagnosis, and thrombocytopenia at diagnosis (Table 31.5). Surprisingly, however, an antecedent history of aplastic anemia has been reported to influence favorably survival in a multivariate analysis (Table 31.5).⁶⁶ That rarely some patients with PNH undergo spontaneous remission must also be taken into account when deciding on the appropriateness of allogeneic BMT as treatment for PNH.^{65, 134}

In the unusual circumstance in which the patient has a syngeneic twin, bone marrow transplantation is the most appropriate therapy for classic PNH because absence of graft vs. host disease greatly reduces transplant-associated morbidity and mortality, while graft vs. tumor effect is not necessary for eradication of the PIGA-mutant clone.^{128, 135} Syngeneic transplantation without preconditioning has been unsuccessful because abnormal hematopoiesis usually returns, suggesting that the residual PIGA-mutant stem cells have a survival or proliferative advantage relative to the transplanted GPI-AP⁺ cells.¹²⁹ This same phenomenon may limit the efficacy of gene therapy, as transducing PIGA-mutant stem cells with normal PIGA would hypothetically eliminate the conditional growth or survival advantage. An attractive alternative approach to gene therapy would take advantage of the fact that the hematopoietic stem cells of patients with PNH are a mosaic. Conceivably, the GPI-AP⁺ cells can be selected and used for marrow rescue following myeloablation. The success of this approach depends upon developing a method for separating uniformly and efficiently the GPI-AP⁺ population from the GPI-AP⁻ population and acquiring GPI-AP⁺ stem cells sufficient to repopulate the ablated marrow. Fluorescence-activated cell sorting may be useful for this purpose, as CD34⁺, CD38⁻ hematopoietic stem cells express both CD55 and CD59.¹³⁶

The question now arises regarding when and how best to perform transplant in the eculizumab era. Short-term treatment with eculizumab may provide an opportunity to reduce hemolysis and

P.805

stabilize the blood counts, prior to a planned transplant. In one recent report, eculizumab was used until 2 weeks before a highly lymphoablative conditioning regimen, with good success.¹³⁷

TABLE 31.5 RISK FACTORS AFFECTING SURVIVAL BEFORE THE AVAILABILITY OF ECULIZUMAB

Factor	Relative Risk of Disease-Related Mortality (95% Confidence Interval)	p value
Development of thrombosis	10.2 (6.0-17)	<0.0001
Progression to pancytopenia	5.5 (2.8-11)	<0.0001
Myelodysplastic disease or acute leukemia	19.1 (7.3-50)	<0.001
Age over 55	4.0 (2.4-6.9)	<0.0001
More than one treatment	2.1 (1.3-3.6)	<0.003
Thrombocytopenia at diagnosis	2.2 (1.3-3.8)	<0.003
Aplastic anemia antedating paroxysmal nocturnal hemoglobinuria	0.32 (0.14-0.72)	<0.023

Modified from Socié G, Mary J-Y, deGramont A, et al. Paroxysmal nocturnal haemoglobinuria: long-term follow-up and prognostic factors. *Lancet* 1996;348:573-577.

Before the availability of eculizumab, the primary indications for transplantation for PNH were bone failure, recurrent life-threatening thrombosis, and uncontrollable hemolysis.¹ The latter process can be eliminated by treatment with eculizumab, and the thrombophilia of PNH may also respond to inhibition of intravascular hemolysis by eculizumab.¹³⁸ Nonetheless, transplantation is the only curative therapy for PNH; and the availability of molecularly defined, matched unrelated donors, less toxic conditioning regimens, reductions in transplantation-related morbidity and mortality, and improvements in post-transplantation supportive care make this option a viable alternative to medical management.¹³⁸ The decision of who should receive a transplantation and when it should be performed is complex, however, and requires an understanding of the unique pathobiology of PNH and the input of physicians experienced in transplantation and medical management of PNH.¹³⁹ The recent studies of Kelly et al.⁸⁴ showing normal survival for patients with PNH treated with eculizumab make the decision concerning medical management versus transplantation even more challenging.

Prevention and Treatment of Thrombosis

In contrast to our thorough understanding of the basis of the hemolysis, much less is known about the mechanism that underlies the thrombophilia of PNH⁸⁹ (Table 31.6).

A recent review of 13 retrospective studies of PNH in nonpregnant patients revealed considerable variation in the reported rate of thromboembolic disease; however, overall 14.4% (95% confidence interval 7.6 to 25.5) of the patients included in these studies were affected.¹⁴⁰ Thromboembolic complications of PNH appear to be more common among patients from western countries (with the exception of Mexico¹⁴¹), with intra-abdominal (hepatic and mesenteric veins) and cerebral veins being the most commonly involved sites (Table 31.6). Nine of these studies described cause of death, with 22% of the mortality being due to venous thrombosis (higher among westerners).

TABLE 31.6 THROMBOSIS AND PAROXYSMAL NOCTURNAL HEMOGLOBINURIA (PNH)

The pathogenesis of the thrombophilia of PNH is incompletely understood

- Sites of thrombosis that are disproportionately represented in PNH
- Hepatic vein (Budd-Chiari syndrome)
- Mesenteric veins
- Portal vein
- Cerebral veins
- Dermal veins
- Propensity toward thrombosis appears roughly proportional to the size of the PNH clone^a
- The risk of thromboembolic disease appears higher in Caucasian and African-American patients than in patients of Asian/Pacific Island or Hispanic ancestry even when adjusted for clone size
- Caucasian and African-American patients with >50% GPI-AP-deficient granulocytes who have no contraindications are candidates for prophylactic anticoagulation with warfarin^b
- Patients with PNH who have experienced a thromboembolic event should remain anticoagulated indefinitely^c

^a The size of the PNH clone is determined by flow cytometric analysis of expression of GPI-AP on peripheral blood granulocytes.

^b Standard intensity warfarin therapy (INR 2.0-3.0) is recommended for chronic therapy.

^c Long-term anticoagulation should be reassessed in any patient who undergoes a spontaneous remission or in whom the PNH clone size falls to below 50%.

Modified from Parker C, Omine M, Richards S, et al. Diagnosis and management of paroxysmal nocturnal hemoglobinuria. *Blood* 2005;106:3699-3709.

Clinicians should be particularly alert for thrombotic disease in patients with indwelling catheters, after surgical procedures, during prolonged sedentary periods, and during the puerperium (pregnancy and PNH are discussed below). Female patients should avoid the use of estrogen-containing oral contraceptives because these agents increase the risk of serious thrombotic disease.

Treatment of thromboembolic complications of Paroxysmal Nocturnal Hemoglobinuria

Anticoagulation is required for treatment of venous thrombosis (including cerebral vein thrombosis) associated with PNH, with thrombolytic therapy being advocated for extensive acute or life-threatening hepatic vein thrombosis (see below). Mild to moderate thrombocytopenia (platelet count between 50,000 and 100,000/ μ l) is not a contraindication to anticoagulation; however, platelet transfusion may be required for patients with counts $< 50,000/\mu$ l. Occasional episodes of hemolysis coincident with the administration of heparin have been reported,¹¹¹ and this phenomenon has been attributed to activation of the alternative pathway of complement by heparin. This complication is rare, however, and concern for exacerbation of hemolysis by heparin should not deter its use in standard pharmacologic doses in situations where anticoagulation is warranted. Once adequately anticoagulated with heparin, Coumadin therapy should be initiated with a goal of maintaining the international normalized ratio between 2.0 and 2.5. Although data on recurrence rates have not been generated, patients with PNH who experience a thromboembolic episode probably warrant life-long anticoagulation.

For hepatic vein thrombosis or other life-threatening conditions, prompt treatment with heparin or thrombolytic agents is recommended.^{91, 142} Even with heparin therapy, extensive hepatic vein thrombosis is associated with a poor prognosis.^{95, 142} Experience with thrombolytic therapy in this setting is limited, but success has been reported with the use of streptokinase, urokinase, and tissue plasminogen activator.^{142, 143} A recent review of nine patients receiving intravenous tissue plasminogen activator on 15 occasions reported serious hemorrhagic complications in three, so thrombolysis must be considered a high-risk intervention.¹⁴⁴ A PNH patient with chronic hepatic vein thrombosis markedly improved following bone marrow transplantation.¹³⁵

Prophylactic anticoagulation

In the study of Socié et al. that antedated the use of eculizumab,⁶⁶ 30% of French patients experienced an episode of thrombosis within 8 years of the diagnosis of PNH, and based on Kaplan-Meier estimates, approximately 50% of patients were predicted to have this complication within 15 years. Because of the relatively high incidence of thrombosis (particularly among westerners) and its associated morbidity and mortality, an argument can be made for prophylactic anticoagulation in patients without contraindications such as severe thrombocytopenia.¹⁰⁴ A nonrandomized study with a relatively short follow-up period suggested a significant reduction in thrombotic events when PNH patients with $\geq 50\%$ GPI-AP-deficient granulocytes received prophylactic anticoagulation with Coumadin¹⁰⁴ (Table 31.6). A second, more recent retrospective study supports the use of prophylactic anticoagulation for patients with large PNH clones ($>50\%$ to 60%).¹⁰³ The benefits of prophylactic anticoagulation, however, must be weighed against potential adverse effects of long-term anticoagulation. Patients at risk for cerebral vein thrombosis and portal/hepatic vein thrombosis would likely derive the greatest benefit from prophylactic anticoagulation. A method for identifying that subgroup of patients, however, has not been developed.

P.806

Eculizumab appears to reduce the risk of thromboembolic complications.¹¹⁵ For patients being treated with eculizumab who have no prior history of thromboembolic complications, prophylactic anticoagulation may be unnecessary.⁸⁴ Because PNH patients with prior thrombosis are at higher risk for recurrent thrombosis, anticoagulation for eculizumab-treated patients who experienced a prior thromboembolic event should be continued.^{84, 138}

Pregnancy and Paroxysmal Nocturnal Hemoglobinuria

Pregnancy is often hazardous in PNH;^{145, 146, 147} however, patients with PNH can have successful, uncomplicated pregnancies^{147, 148, 149, 150}. De Gramont and colleagues¹⁴⁷ reported that approximately one-third of 38 pregnancies observed in 28 patients with PNH were uncomplicated and that life-threatening complications in mothers are uncommon. Complications experienced by mothers in that series were mainly hemorrhage and acute hemolysis. However, 45% of the pregnancies resulted in either spontaneous miscarriage or elective termination. Other studies¹⁴⁵ have reported a maternal mortality of $\sim 6\%$, with the major complications being related to thrombosis (particularly Budd-Chiari syndrome). Fetal wastage and prematurity were also reported to be relatively common. Based upon a review of 20 published reports that

described the outcome of 33 pregnant women with PNH, Ray and colleagues¹⁴⁰ calculated an all-cause maternal mortality rate of 20.8% (95% confidence intervals 7.3 to 39.0). Approximately half of all infants were delivered preterm. Three deaths were reported among 34 live births (perinatal mortality of 8.8% with 95% confidence intervals of 1.9 to 23.7).

When possible, patients with PNH who are contemplating pregnancy should be counseled about the potential for both maternal and fetal complications. However, in approximately 25% of cases of PNH and pregnancy, PNH is first diagnosed during pregnancy.¹⁴⁰ The care of a pregnant patient with PNH requires the combined expertise of an experienced hematologist and an obstetrician who specializes in the management of high-risk pregnancies.¹⁵¹

Unless there is an absolute contraindication, patients should receive therapeutic doses of subcutaneous heparin during pregnancy. Low-molecular-weight heparin may be advantageous because it is associated with a lower incidence of drug-induced thrombocytopenia compared with unfractionated heparin. Nonetheless, the platelet count should be monitored frequently (weekly), as thrombocytopenia frequently complicates PNH during pregnancy. Patients should undergo hepatic ultrasound monthly to monitor the patency of hepatic veins. Anticoagulation should be initiated as soon as the pregnancy is documented and should continue 4 to 6 weeks into the postpartum period.¹⁴⁰ Coumadin should be used for anticoagulation during the postpartum period.

In the eculizumab treatment era, the question has arisen regarding the safety of treating a pregnant woman with PNH. Since eculizumab is a hybrid of IgG2 and IgG4, little antibody is believed to cross the placenta. Two reports have documented the safety of treatment throughout gestation for both mother and baby.^{152, 153}

Pediatric Paroxysmal Nocturnal Hemoglobinuria

PNH can occur in the young (about 10% of patients are younger than 21),^{1, 65, 66, 154} but is often misdiagnosed and mismanaged.^{85, 155} A retrospective analysis of 26 cases⁸⁵ underscored the many similarities between childhood and adult PNH. Signs and symptoms of hemolysis, bone marrow failure, and thrombosis dominate the clinical picture, with hemoglobinuria occurring less often in young patients. A generally good response to immunosuppressive therapy (6 of 9 patients) was observed. However, based on the lack of spontaneous remissions and poor long-term survival (80% at 5 years, 60% at 10 years, and only 28% at 20 years), sibling-matched stem cell transplantation is the recommended treatment for childhood PNH. A recent Dutch study confirmed the common presentation of bone marrow failure in 11 children with PNH,¹⁵⁵ and reported that five patients eventually received BMT (three matched unrelated donors and two matched family donors) of whom four are alive. A recent cohort of 12 children with PNH documented five with myelodysplastic features without excess blasts or malignant transformation.¹⁵⁶ Mortality appears high in young patients with PNH treated with transplantation using unrelated donors, although surviving cases have been reported.^{133, 155}

Dysphagia, Male Impotence, Abdominal Pain

Many patients with PNH are troubled by dysphagia and odynophagia, especially during hemolytic exacerbations.¹ These symptoms appear to be a consequence of esophageal spasm. The cause of the spasm is speculative, but may be due to acquired deficiency of nitric oxide (NO), a bioactive molecule that mediates smooth muscle relaxation.⁹⁹ Males with PNH may experience episodes of impotence, particularly during hemolytic exacerbations. The cause of the impotence may also be a consequence of decreased bioavailability of NO. Sildenafil citrate has shown efficacy in the treatment of hypercontractile motility disorders of the esophagus, including idiopathic achalasia, where the mechanism of disease appears to be impaired NO production similar to that reported for erectile dysfunction.^{157, 158, 159} Therefore, sildenafil citrate and pharmacologically related compounds are candidate therapies for both the dysphagia/odynophagia and male impotence of PNH. Agents such as oral or dermal nitroglycerine that supply NO pharmacologically have also shown efficacy.

Some patients with PNH are debilitated by recurrent episodes of colicky abdominal pain.¹ The etiology of the abdominal pain is largely speculative, but thrombosis of mesenteric vessels appears to play a role in some cases. Vascular spasm may also contribute to this process. Vigorous hydration and pain control are the mainstays of management, but mesenteric vein thrombosis can result in intestinal infarction necessitating surgical intervention. Still to be determined are the roles of anticoagulation, complement inhibition, and NO supplementation in the management of abdominal pain of PNH.

Geographic/Ethnic Differences

The natural history of PNH appears different for Americans and Europeans compared with Asian/Pacific Islanders and Hispanics.^{88, 134, 141, 160, 161} In general, the manifestations of bone marrow failure are more common in Asians/Pacific Islanders and Hispanics. In contrast, thrombosis and infection appear more common in American and European patients (Table 31.6). The basis of these phenotypic differences is unknown, but the relationship of ethnicity and geography to the natural history of PNH should be considered when formulating a management plan.

DISEASE COURSE AND PROGNOSIS

PNH is a chronic disease. Retrospective studies that antedated the use of eculizumab suggested a median survival of 10 to 15 years.^{65, 66} Approximately 25% of patients survive for 25 years or longer after diagnosis.⁶⁵ The major causes of morbidity and mortality are thrombosis, bleeding, and infections. The latter two complications are due to thrombocytopenia and neutropenia, respectively, which are consequences of the abnormal hematopoiesis that underlies this stem cell disorder. The salutary effects of eculizumab therapy on both hemolysis and thrombosis should also help reduce the early mortality of PNH, but long-term data have not been reported to date.⁸⁴

In some PNH patients, the severity of the illness lessens with time, and (in one series) approximately one-third of patients who survived 10 years experienced a spontaneous clinical remission.⁶⁵ These cases suggest that, in time, the abnormal clone(s) can gradually lose their relative proliferative or survival advantage.

P.807

That the disease spontaneously remits in some instances provides a basis for hope for both patient and physician. Additionally, this feature of the disease should enter into management decisions, particularly when the patient is a candidate for allogeneic bone marrow transplantation.⁶⁵ Spontaneous remission, however, appears to occur primarily in patients with PNH/aplastic anemia, with such remission being unlikely in patients with classic PNH.

Development of other clonal myelopathies, including myelodysplastic disease and acute leukemia, adversely affect prognosis.⁶⁶ The incidence of acute leukemia in association with PNH appears to be in the range of 1%,⁶⁶ although higher (7.7% in a study of Japanese patients¹⁶⁰ and lower (0 of 80 patients in a study from England⁶⁵) incidences have been reported. The rate of myelodysplastic disease in association with PNH is on the order of 5%.⁶⁶ Other clonal myelopathies that have been reported in association with PNH include myelofibrosis, chronic lymphocytic leukemia, chronic myelocytic leukemia, polycythemia vera, and erythroleukemia. In some instances, the clonal myelopathy arises in the PNH clone,^{79, 80} whereas in other instances it arises in a GPI-AP+ clone.^{81, 82} The association of PNH with other stem cell disorders, particularly myelodysplasia and acute leukemia, suggests that genetic instability is a component of the disease.¹⁶² This process may be a consequence of the as yet undefined bone marrow injury that underlies PNH.

Future Directions for Clinical and Basic Research

Among the important issues that need to be addressed through careful clinical studies are the following:

- Guidelines for management of the thrombophilia of PNH
- Guidelines for bone marrow and stem cell transplantation
- Guidelines for how best to use eculizumab
- Guidelines for management of pregnancy and PNH
- Clearer definitions of the effects of ethnic/geographic differences on the natural history of PNH

An international observational study designed to generate data on the natural history and treatment of PNH is currently open to enrollment (<http://www.pnhregistry.com>).

Basic research into the mechanism of the thrombophilia of PNH and the basis of clonal selection and clonal dominance will likely produce new insights into the pathobiology of PNH and the physiology of benign and malignant clonal hematopoiesis.

REFERENCES

1. Parker C, Omine M, Richards S, et al. Diagnosis and management of paroxysmal nocturnal hemoglobinuria. *Blood* 2005;106:3699-3709.
2. Crosby WH. Paroxysmal nocturnal hemoglobinuria: a classic description by Paul Strübling in 1882, and a bibliography of the disease. *Blood* 1951;6: 270-284.
3. Rosse W. A brief history of PNH. Neal S. Young and Joel Moss, Eds. In: PNH and the GPI-linked proteins. San Diego, CA: Academic Press, 2000:1-20.
4. Parker CJ. Historical aspects of paroxysmal nocturnal haemoglobinuria: "defining the disease". *Br J Haematol* 2002;117:3-22.

5. Parker CJ. Paroxysmal nocturnal hemoglobinuria: an historical overview. *Hematology Am Soc Hematol Educ Program* 2008;93-103.
6. Rosse WF, Dacie JV. Immune lysis of normal human and paroxysmal nocturnal hemoglobinuria (PNH) red blood cells. II. The role of complement components in the increased sensitivity of PNH red cells to immune lysis. *J Clin Invest* 1966;45:749-757.
7. Rosse WF. Variations in the red cells in paroxysmal nocturnal haemoglobinuria. *Br J Haematol* 1973;24:327-342.
8. Rosse WF. Paroxysmal nocturnal hemoglobinuria—present status and future prospects. *West J Med* 1980;132:219-228.
9. Nishimura J, Hirota T, Kanakura Y, et al. Long-term support of hematopoiesis by a single stem cell clone in patients with paroxysmal nocturnal hemoglobinuria. *Blood* 2002;99:2748-2751.
10. Hillmen P, Young NS, Schubert J, et al. The complement inhibitor eculizumab in paroxysmal nocturnal hemoglobinuria. *N Engl J Med* 2006;355: 1233-1243.
11. Pu JJ, Mukhina G, Wang H, Savage WJ, Brodsky RA. Natural history of paroxysmal nocturnal hemoglobinuria clones in patients presenting as aplastic anemia. *Eur J Haematol* 2011;87:37-45.
12. Logue GL, Rosse WF, Adams JP. Mechanisms of immune lysis of red blood cells in vitro. I. Paroxysmal nocturnal hemoglobinuria cells. *J Clin Invest* 1973;52:1129-1137.
13. Rosse WF, Logue GL, Adams J, Crookston JH. Mechanisms of immune lysis of the red cells in hereditary erythroblastic multinuclearity with a positive acidified serum test and paroxysmal nocturnal hemoglobinuria. *J Clin Invest* 1974;53:31-43.
14. Pangburn MK, Schreiber RD, Trombold JS, Muller-Eberhard HJ. Paroxysmal nocturnal hemoglobinuria: deficiency in factor H-like functions of the abnormal erythrocytes. *J Exp Med* 1983;157:1971-1980.
15. Parker CJ, Baker PJ, Rosse WF. Increased enzymatic activity of the alternative pathway convertase when bound to the erythrocytes of paroxysmal nocturnal hemoglobinuria. *J Clin Invest* 1982;69:337-346.
16. Packman CH, Rosenfeld SI, Jenkins DE Jr, Thiem PA, Leddy JP. Complement lysis of human erythrocytes. Differing susceptibility of two types of paroxysmal nocturnal hemoglobinuria cells to C5b-9. *J Clin Invest* 1979;64:428-433.
17. Parker CJ, Wiedmer T, Sims PJ, Rosse WF. Characterization of the complement sensitivity of paroxysmal nocturnal hemoglobinuria erythrocytes. *J Clin Invest* 1985;75:2074-2084.
18. Beck WS, Valentine WN. Biochemical studies on leucocytes. II. Phosphatase activity in chronic lymphatic leukemia, acute leukemia, and miscellaneous hematologic conditions. *J Lab Clin Med* 1951;38:245-253.
19. Auditore JV, Hartmann RC. Paroxysmal nocturnal hemoglobinuria II. Erythrocyte acetylcholinesterase defect. *Am J Med* 1959;27:401-410.
20. Kunstling TR, Rosse WF. Erythrocyte acetylcholinesterase deficiency in paroxysmal nocturnal hemoglobinuria (PNH). A comparison of the complement-sensitive and insensitive populations. *Blood* 1969;33:607-616.
21. Nicholson-Weller A, March JP, Rosenfeld SI, Austen KF. Affected erythrocytes of patients with paroxysmal nocturnal hemoglobinuria are deficient in the complement regulatory protein, decay accelerating factor. *Proc Natl Acad Sci U S A* 1983;80:5066-5070.
22. Pangburn MK, Schreiber RD, Muller-Eberhard HJ. Deficiency of an erythrocyte membrane protein with complement regulatory activity in paroxysmal nocturnal hemoglobinuria. *Proc Natl Acad Sci U S A* 1983;80:5430-5434.
23. Hoffmann EM. Inhibition of complement by a substance isolated from human erythrocytes. II. Studies on the site and mechanism of action. *Immunochemistry* 1969;6:405-419.
24. Hoffmann EM. Inhibition of complement by a substrate isolated from human erythrocytes: I. Extraction from human erythrocyte stroma. *Immunochemistry* 1969;6:391-403.
25. Nicholson-Weller A, Burge J, Fearon DT, Weller PF, Austen KF. Isolation of a human erythrocyte membrane glycoprotein with decay-accelerating activity for C3 convertases of the complement system. *J Immunol* 1982;129: 184-189.
26. Holguin MH, Fredrick LR, Bernshaw NJ, Wilcox LA, Parker CJ. Isolation and characterization of a membrane protein from normal human erythrocytes that inhibits reactive lysis of the erythrocytes of paroxysmal nocturnal hemoglobinuria. *J Clin Invest* 1989;84:7-17.

27. Lehto T, Meri S. Interactions of soluble CD59 with the terminal complement complexes. CD59 and C9 compete for a nascent epitope on C8. *J Immunol* 1993;151:4941-4949.
28. Merry AH, Rawlinson VI, Uchikawa M, Daha MR, Sim RB. Studies on the sensitivity to complement-mediated lysis of erythrocytes (Inab phenotype) with a deficiency of DAF (decay accelerating factor). *Br J Haematol* 1989;73: 248-253.
29. Rollins SA, Zhao J, Ninomiya H, Sims PJ. Inhibition of homologous complement by CD59 is mediated by a species-selective recognition conferred through binding to C8 within C5b-8 or C9 within C5b-9. *J Immunol* 1991;146:2345-2351.
30. Holguin MH, Wilcox LA, Bernshaw NJ, Rosse WF, Parker CJ. Relationship between the membrane inhibitor of reactive lysis and the erythrocyte phenotypes of paroxysmal nocturnal hemoglobinuria. *J Clin Invest* 1989;84: 1387-1394.
31. Wilcox LA, Ezzell JL, Bernshaw NJ, Parker CJ. Molecular basis of the enhanced susceptibility of the erythrocytes of paroxysmal nocturnal hemoglobinuria to hemolysis in acidified serum. *Blood* 1991;78:820-829.
32. Telen MJ, Green AM. The Inab phenotype: characterization of the membrane protein and complement regulatory defect. *Blood* 1989;74:437-441.
33. Holguin MH, Martin CB, Bernshaw NJ, Parker CJ. Analysis of the effects of activation of the alternative pathway of complement on erythrocytes with an isolated deficiency of decay accelerating factor. *J Immunol* 1992;148:498-502.
34. Motoyama N, Okada N, Yamashina M, Okada H. Paroxysmal nocturnal hemoglobinuria due to hereditary nucleotide deletion in the HRF20 (CD59) gene. *Eur J Immunol* 1992;22:2669-2673.
35. Yamashina M, Ueda E, Kinoshita T, et al. Inherited complete deficiency of 20-kilodalton homologous restriction factor (CD59) as a cause of paroxysmal nocturnal hemoglobinuria. *N Engl J Med* 1990;323:1184-1189.
36. Medof ME, Kinoshita T, Nussenzweig V. Inhibition of complement activation on the surface of cells after incorporation of decay-accelerating factor (DAF) into their membranes. *J Exp Med* 1984;160:1558-1578.
37. Low MG, Zilversmit DB. Role of phosphatidylinositol in attachment of alkaline phosphatase to membranes. *Biochemistry* 1980;19:3913-3918.
38. Davitz MA, Low MG, Nussenzweig V. Release of decay-accelerating factor (DAF) from the cell membrane by phosphatidylinositol-specific phospholipase C (PIPLC). Selective modification of a complement regulatory protein. *J Exp Med* 1986;163:1150-1161.
39. Medof ME, Walter EI, Roberts WL, Haas R, Rosenberry TL. Decay accelerating factor of complement is anchored to cells by a C-terminal glycolipid. *Biochemistry* 1986;25:6740-6747.
40. Holguin MH, Wilcox LA, Bernshaw NJ, Rosse WF, Parker CJ. Erythrocyte membrane inhibitor of reactive lysis: effects of phosphatidylinositol-specific phospholipase C on the isolated and cell-associated protein. *Blood* 1990;75:284-289.
41. Oni SB, Osunkoya BO, Luzzatto L. Paroxysmal nocturnal hemoglobinuria: evidence for monoclonal origin of abnormal red cells. *Blood* 1970;36:145-152.
42. Aster RH, Enright SE. A platelet and granulocyte membrane defect in paroxysmal nocturnal hemoglobinuria: usefulness for the detection of platelet antibodies. *J Clin Invest* 1969;48:1199-1210.
43. Murakami Y, Siripanyaphinyo U, Hong Y, Tashima Y, Maeda Y, Kinoshita T. The initial enzyme for glycosylphosphatidylinositol biosynthesis requires PIG-Y, a seventh component. *Mol Biol Cell* 2005;16:5236-5246.
44. Kinoshita T, Inoue N, Takeda J. Defective glycosyl phosphatidylinositol anchor synthesis and paroxysmal nocturnal hemoglobinuria. *Adv Immunol* 1995;60:57-103.
45. Armstrong C, Schubert J, Ueda E, et al. Affected paroxysmal nocturnal hemoglobinuria T lymphocytes harbor a common defect in assembly of N-acetyl-D-glucosamine inositol phospholipid corresponding to that in class A Thy-1-murine lymphoma mutants. *J Biol Chem* 1992;267:25347-25351.
46. Takahashi M, Takeda J, Hirose S, et al. Deficient biosynthesis of N-acetylglucosaminyl-phosphatidylinositol, the first intermediate of glycosyl phosphatidylinositol anchor biosynthesis, in cell lines established from patients with paroxysmal nocturnal hemoglobinuria. *J Exp Med* 1993;177:517-521.
47. Miyata T, Takeda J, Iida Y, et al. The cloning of PIG-A, a component in the early step of GPI-anchor biosynthesis. *Science* 1993;259:1318-1320.
48. Takeda J, Miyata T, Kawagoe K, et al. Deficiency of the GPI anchor caused by a somatic mutation of the PIG-A gene in paroxysmal nocturnal hemoglobinuria. *Cell* 1993;73:703-711.

49. Hyman R, Cunningham K, Stallings V. Evidence for a genetic basis for the Class A Thy-1-defect. *Immunogenetics* 1980;10:261-271.
50. Endo M, Ware RE, Vreeke TM, et al. Molecular basis of the heterogeneity of expression of glycosyl phosphatidylinositol anchored proteins in paroxysmal nocturnal hemoglobinuria. *Blood* 1996;87:2546-2557.
51. Luzzatto L, Nafa K. Genetics of PNH. In: Young NS, Moss, J., ed. Paroxysmal nocturnal hemoglobinuria and the glycosylphosphatidylinositol-linked proteins. San Diego, CA: Academic Press, 2000:21-47.
52. Nishimura J, Murakami Y, Kinoshita T. Paroxysmal nocturnal hemoglobinuria: an acquired genetic disease. *Am J Hematol* 1999;62:175-182.
- P.808
53. Hertenstein B, Wagner B, Bunjes D, et al. Emergence of CD52-, phosphatidylinositolglycan-anchor-deficient T lymphocytes after in vivo application of Campath-1H for refractory B-cell non-Hodgkin lymphoma. *Blood* 1995;86:1487-1492.
54. Iwamoto N, Kawaguchi T, Horikawa K, et al. Preferential hematopoiesis by paroxysmal nocturnal hemoglobinuria clone engrafted in SCID mice. *Blood* 1996;87:4944-4948.
55. Brodsky RA, Vala MS, Barber JP, Medof ME, Jones RJ. Resistance to apoptosis caused by PIG-A gene mutations in paroxysmal nocturnal hemoglobinuria. *Proc Natl Acad Sci U S A* 1997;94:8756-8760.
56. Chen R, Nagarajan S, Prince GM, et al. Impaired growth and elevated fas receptor expression in PIGA(+) stem cells in primary paroxysmal nocturnal hemoglobinuria. *J Clin Invest* 2000;106:689-696.
57. Kinoshita T, Bessler M, Takeda J. Animal models of PNH. In: Young NS, Moss J, eds. Paroxysmal nocturnal hemoglobinuria and the glycosylphosphatidylinositol-linked proteins. San Diego, CA: Academic Press, 2000:139-158.
58. Kawagoe K, Kitamura D, Okabe M, et al. Glycosylphosphatidylinositol-anchor-deficient mice: implications for clonal dominance of mutant cells in paroxysmal nocturnal hemoglobinuria. *Blood* 1996;87:3600-3606.
59. Mortazavi Y, Merk B, McIntosh J, Marsh JC, Schrezenmeier H, Rutherford TR. The spectrum of PIG-A gene mutations in aplastic anemia/paroxysmal nocturnal hemoglobinuria (AA/PNH): a high incidence of multiple mutations and evidence of a mutational hot spot. *Blood* 2003;101:2833-2841.
60. Hu R, Mukhina GL, Piantadosi S, Barber JP, Jones RJ, Brodsky RA. PIG-A mutations in normal hematopoiesis. *Blood* 2005;105:3848-3854.
61. Inoue N, Izui-Sarumaru T, Murakami Y, et al. Molecular basis of clonal expansion of hematopoiesis in 2 patients with paroxysmal nocturnal hemoglobinuria (PNH). *Blood* 2006;108:4232-4236.
62. Ikeda K, Mason PJ, Bessler M. 3'UTR-truncated Hmga2 cDNA causes MPNlike hematopoiesis by conferring a clonal growth advantage at the level of HSC in mice. *Blood* 2011;117:5860-5869.
63. Cavazzana-Calvo M, Payen E, Negre O, et al. Transfusion independence and HMGA2 activation after gene therapy of human beta-thalassaemia. *Nature* 2010;467:318-322.
64. Murakami Y, Inoue N, Shichishima T, et al. Deregulated expression of HMGA2 is implicated in clonal expansion of PIGA deficient cells in paroxysmal nocturnal haemoglobinuria. *Br J Haematol* 2012;156:383-387.
65. Hillmen P, Lewis SM, Bessler M, Luzzatto L, Dacie JV. Natural history of paroxysmal nocturnal hemoglobinuria. *N Engl J Med* 1995;333:1253-1258.
66. Socie G, Mary JY, de Gramont A, et al. Paroxysmal nocturnal haemoglobinuria: long-term follow-up and prognostic factors. *French Society of Haematology. Lancet* 1996;348:573-577.
67. Nissen C, Tichelli A, Gratwohl A, et al. High incidence of transiently appearing complement-sensitive bone marrow precursor cells in patients with severe aplastic anemia—a possible role of high endogenous IL-2 in their suppression. *Acta Haematol* 1999;101:165-172.
68. Schubert J, Vogt HG, Zielinska-Skowronek M, et al. Development of the glycosylphosphatidylinositol-anchoring defect characteristic for paroxysmal nocturnal hemoglobinuria in patients with aplastic anemia. *Blood* 1994;83:2323-2328.

69. Griscelli-Bennaceur A, Gluckman E, Scrobohaci ML, et al. Aplastic anemia and paroxysmal nocturnal hemoglobinuria: search for a pathogenetic link. *Blood* 1995;85:1354-1363.
70. Mukhina GL, Buckley JT, Barber JP, Jones RJ, Brodsky RA. Multilineage glycosylphosphatidylinositol anchor-deficient haematopoiesis in untreated aplastic anaemia. *Br J Haematol* 2001;115:476-482.
71. Sugimori C, Chuhjo T, Feng X, et al. Minor population of CD55-CD59-blood cells predicts response to immunosuppressive therapy and prognosis in patients with aplastic anemia. *Blood* 2006;107:1308-1314.
72. Frickhofen N, Heimpel H, Kaltwasser JP, Schrezenmeier H. Antithymocyte globulin with or without cyclosporin A: 11-year follow-up of a randomized trial comparing treatments of aplastic anemia. *Blood* 2003;101:1236-1242.
73. Scheinberg P, Marte M, Nunez O, Young NS. Paroxysmal nocturnal hemoglobinuria clones in severe aplastic anemia patients treated with horse antithymocyte globulin plus cyclosporine. *Haematologica* 2010;95:1075-1080.
74. Sugimori C, Mochizuki K, Qi Z, et al. Origin and fate of blood cells deficient in glycosylphosphatidylinositol-anchored protein among patients with bone marrow failure. *Br J Haematol* 2009;147:102-112.
75. Nagarajan S, Brodsky RA, Young NS, Medof ME. Genetic defects underlying paroxysmal nocturnal hemoglobinuria that arises out of aplastic anemia. *Blood* 1995;86:4656-4661.
76. Rotoli B, Robledo R, Scarpato N, Luzzatto L. Two populations of erythroid cell progenitors in paroxysmal nocturnal hemoglobinuria. *Blood* 1984;64: 847-851.
77. Araten DJ, Swirsky D, Karadimitris A, et al. Cytogenetic and morphological abnormalities in paroxysmal nocturnal haemoglobinuria. *Br J Haematol* 2001;115:360-368.
78. Inoue N, Murakami Y, Kinoshita T. Molecular genetics of paroxysmal nocturnal hemoglobinuria. *Int J Hematol* 2003;77:107-112.
79. Devine DV, Gluck WL, Rosse WF, Weinberg JB. Acute myeloblastic leukemia in paroxysmal nocturnal hemoglobinuria. Evidence of evolution from the abnormal paroxysmal nocturnal hemoglobinuria clone. *J Clin Invest* 1987;79:314-317.
80. Longo L, Bessler M, Beris P, Swirsky D, Luzzatto L. Myelodysplasia in a patient with pre-existing paroxysmal nocturnal haemoglobinuria: a clonal disease originating from within a clonal disease. *Br J Haematol* 1994;87:401-403.
81. Krause JR. Paroxysmal nocturnal hemoglobinuria and acute non-lymphocytic leukemia. A report of three cases exhibiting different cytologic types. *Cancer* 1983;51:2078-2082.
82. van Kamp H, Smit JW, van den Berg E, Ruud Halie M, Vellenga E. Myelodysplasia following paroxysmal nocturnal haemoglobinuria: evidence for the emergence of a separate clone. *Br J Haematol* 1994;87:399-400.
83. Dacie JV, Lewis SM. Paroxysmal nocturnal haemoglobinuria: clinical manifestations, haematology, and nature of the disease. *Ser Haematol* 1972;5:3-23.
84. Kelly RJ, Hill A, Arnold LM, et al. Long-term treatment with eculizumab in paroxysmal nocturnal hemoglobinuria: sustained efficacy and improved survival. *Blood* 2011;117:6786-6792.
85. Ware RE, Hall SE, Rosse WF. Paroxysmal nocturnal hemoglobinuria with onset in childhood and adolescence. *N Engl J Med* 1991;325:991-996.
86. Johnston JJ, Gropman AL, Sapp JC, et al. The phenotype of a germline mutation in PIGA: the gene somatically mutated in paroxysmal nocturnal hemoglobinuria. *Am J Hum Genet* 2012;90:295-300.
87. Almeida AM, Murakami Y, Layton DM, et al. Hypomorphic promoter mutation in PIGM causes inherited glycosylphosphatidylinositol deficiency. *Nat Med* 2006;12:846-851.
88. Kruatrachue M, Wasi P, Na-Nakorn S. Paroxysmal nocturnal haemoglobinuria in Thailand with special reference to an association with aplastic anaemia. *Br J Haematol* 1978;39:267-276.
89. Sloand EM, Young NS. Thrombotic complications in PNH. In: Young NS, Moss, J., ed. *Paroxysmal nocturnal hemoglobinuria and the glycosylphosphatidylinositol-linked proteins*. San Diego, CA: Academic Press, 2000:101-112.
90. Hartmann RC, Luther AB, Jenkins DE, Jr., Tenorio LE, Saba HI. Fulminant hepatic venous thrombosis (Budd-Chiari syndrome) in paroxysmal nocturnal hemoglobinuria: definition of a medical emergency. *Johns Hopkins Med J* 1980;146:247-254.

91. Leibowitz AI, Hartmann RC. The Budd-Chiari syndrome in paroxysmal nocturnal haemoglobinuria—revisited. *Br J Haematol* 1981;49:659-660.
92. Valla D, Dhumeaux D, Babany G, et al. Hepatic vein thrombosis in paroxysmal nocturnal hemoglobinuria. A spectrum from asymptomatic occlusion of hepatic venules to fatal Budd-Chiari syndrome. *Gastroenterology* 1987;93:569-575.
93. Birgens HS, Hancke S, Rosenklint A, Hansen NE. Ultrasonic demonstration of clinical and subclinical hepatic venous thrombosis in paroxysmal nocturnal haemoglobinuria. *Br J Haematol* 1986;64:737-743.
94. Menon KV, Shah V, Kamath PS. The Budd-Chiari syndrome. *N Engl J Med* 2004;350:578-585.
95. Peytremann R, Rhodes RS, Hartmann RC. Thrombosis in paroxysmal nocturnal hemoglobinuria (PNH) with particular reference to progressive, diffuse hepatic venous thrombosis. *Ser Haematol* 1972;5:115-136.
96. Hillmen P, Elebute M, Kelly R, et al. Long-term effect of the complement inhibitor eculizumab on kidney function in patients with paroxysmal nocturnal hemoglobinuria. *Am J Hematol* 2010;85:553-559.
97. Clark DA, Butler SA, Braren V, Hartmann RC, Jenkins DE Jr. The kidneys in paroxysmal nocturnal hemoglobinuria. *Blood* 1981;57:83-89.
98. Hill A, Sapsford RJ, Scally A, et al. Under-recognized complications in patients with paroxysmal nocturnal haemoglobinuria: raised pulmonary pressure and reduced right ventricular function. *Br J Haematol* 2012;158:409-414.
99. Murray JA, Ledlow A, Launspach J, Evans D, Loveday M, Conklin JL. The effects of recombinant human hemoglobin on esophageal motor functions in humans. *Gastroenterology* 1995;109:1241-1248.
100. Brubaker LH, Essig LJ, Mengel CE. Neutrophil life span in paroxysmal nocturnal hemoglobinuria. *Blood* 1977;50:657-662.
101. Devine DV, Siegel RS, Rosse WF. Interactions of the platelets in paroxysmal nocturnal hemoglobinuria with complement. Relationship to defects in the regulation of complement and to platelet survival in vivo. *J Clin Invest* 1987;79:131-137.
102. Borowitz MJ, Craig FE, Digiuseppe JA, et al. Guidelines for the diagnosis and monitoring of paroxysmal nocturnal hemoglobinuria and related disorders by flow cytometry. *Cytometry B Clin Cytom* 2010;78:211-230.
103. Moyo VM, Mukina GL, Barrett ES, Brodsky RA. Natural history of paroxysmal nocturnal haemoglobinuria using modern diagnostic assays. *Br J Haematol* 2004;126:133-138.
104. Hall C, Richards S, Hillmen P. Primary prophylaxis with warfarin prevents thrombosis in paroxysmal nocturnal hemoglobinuria (PNH). *Blood* 2003;102:3587-591.
105. Ishiyama K, Chuhjo T, Wang H, Yachie A, Omine M, Nakao S. Polyclonal hematopoiesis maintained in patients with bone marrow failure harboring a minor population of paroxysmal nocturnal hemoglobinuria-type cells. *Blood* 2003;102:1211-1216.
106. Wang H, Chuhjo T, Yasue S, Omine M, Nakao S. Clinical significance of a minor population of paroxysmal nocturnal hemoglobinuria-type cells in bone marrow failure syndrome. *Blood* 2002;100:3897-3902.
107. Scheinberg P, Wu CO, Nunez O, Young NS. Predicting response to immunosuppressive therapy and survival in severe aplastic anaemia. *Br J Haematol* 2009;144:206-216.
108. Brodsky RA, Mukhina GL, Li S, et al. Improved detection and characterization of paroxysmal nocturnal hemoglobinuria using fluorescent aerolysin. *Am J Clin Pathol* 2000;114:459-466.
109. Tomita A, Parker CJ. Aberrant regulation of complement by the erythrocytes of hereditary erythroblastic multinuclearity with a positive acidified serum lysis test (HEMPAS). *Blood* 1994;83:250-259.
110. Balleari E, Gatti AM, Mareni C, Massa G, Marmont AM, Ghio R. Recombinant human erythropoietin for long-term treatment of anemia in paroxysmal nocturnal hemoglobinuria. *Haematologica* 1996;81:143-147.
111. Rosse WF. Treatment of paroxysmal nocturnal hemoglobinuria. *Blood* 1982;60:20-23.
112. Parker C. Eculizumab for paroxysmal nocturnal haemoglobinuria. *Lancet* 2009;373:759-767.
113. Hillmen P, Hall C, Marsh JC, et al. Effect of eculizumab on hemolysis and transfusion requirements in patients with paroxysmal nocturnal hemoglobinuria. *N Engl J Med* 2004;350:552-559.

114. Brodsky RA, Young NS, Antonioli E, et al. Multicenter phase 3 study of the complement inhibitor eculizumab for the treatment of patients with paroxysmal nocturnal hemoglobinuria. *Blood* 2008;111:1840-1847.
115. Hillmen P, Muus P, Duhrsen U, et al. Effect of the complement inhibitor eculizumab on thromboembolism in patients with paroxysmal nocturnal hemoglobinuria. *Blood* 2007;110:4123-4128.
116. Berzuini A, Montanelli F, Prati D. Hemolytic anemia after eculizumab in paroxysmal nocturnal hemoglobinuria. *N Engl J Med* 2010;363:993-994.
117. Risitano AM, Notaro R, Luzzatto L, Hill A, Kelly R, Hillmen P. Paroxysmal nocturnal hemoglobinuria—hemolysis before and after eculizumab. *N Engl J Med* 2010;363:2270-2272.
118. Risitano AM, Notaro R, Luzzatto L, Hill A, Kelly R, Hillmen P. Paroxysmal nocturnal hemoglobinuria—hemolysis before and after eculizumab. *N Engl J Med* 2011;363:2270-2272.
119. Risitano AM, Notaro R, Marando L, et al. Complement fraction 3 binding on erythrocytes as additional mechanism of disease in paroxysmal nocturnal hemoglobinuria patients treated by eculizumab. *Blood* 2009;113:4094-4100.
120. Lindorfer MA, Pawluczkwycz AW, Peek EM, Hickman K, Taylor RP, Parker CJ. A novel approach to preventing the hemolysis of paroxysmal nocturnal hemoglobinuria: both complement-mediated cytolysis and C3 deposition are blocked by a monoclonal antibody specific for the alternative pathway of complement. *Blood* 2010;115:2283-2291.
121. Hartmann RC, Jenkins DE Jr, McKee LC, Heyssel RM. Paroxysmal nocturnal hemoglobinuria: clinical and laboratory studies relating to iron metabolism and therapy with androgen and iron. *Medicine (Baltimore)* 1966;45:331-363.
122. Schubert J, Scholz C, Geissler RG, Ganser A, Schmidt RE. G-CSF and cyclosporin induce an increase of normal cells in hypoplastic paroxysmal nocturnal hemoglobinuria. *Ann Hematol* 1997;74:225-230.
123. Stoppa AM, Vey N, Sainty D, et al. Correction of aplastic anaemia complicating paroxysmal nocturnal haemoglobinuria: absence of eradication of the PNH clone and dependence of response on cyclosporin A administration. *Br J Haematol* 1996;93:42-44.
124. van Kamp H, van Imhoff GW, de Wolf JT, Smit JW, Halie MR, Vellenga E. The effect of cyclosporine on haematological parameters in patients with paroxysmal nocturnal haemoglobinuria. *Br J Haematol* 1995;89:79-82.
125. Rosse WF. Transfusion in paroxysmal nocturnal hemoglobinuria: to wash or not to wash. *Transfusion* 1989;29:663-664.
126. Hartmann RC, Kolhouse JF. Viewpoints on the management of paroxysmal nocturnal hemoglobinuria (PNH). *Ser Haematol* 1972;5:42-60.
127. Antin JH, Ginsburg D, Smith BR, Nathan DG, Orkin SH, Rapoport JM. Bone marrow transplantation for paroxysmal nocturnal hemoglobinuria: eradication of the PNH clone and documentation of complete lymphohematopoietic engraftment. *Blood* 1985;66:1247-1250.
128. Frei-Lahr D, Inoue N, Wittwer C, et al. Molecular complete remission of clonal hematopoiesis in a patient with paroxysmal nocturnal hemoglobinuria (PNH) after syngeneic stem cell transplant (SCT). *Blood* 2006;108:5362 (abst).
129. Endo M, Beatty PG, Vreeke TM, Wittwer CT, Singh SP, Parker CJ. Syngeneic bone marrow transplantation without conditioning in a patient with paroxysmal nocturnal hemoglobinuria: in vivo evidence that the mutant stem cells have a survival advantage. *Blood* 1996;88:742-750.
130. Takahashi Y, McCoy JP Jr, Carvallo C, et al. In vitro and in vivo evidence of PNH cell sensitivity to immune attack after nonmyeloablative allogeneic hematopoietic cell transplantation. *Blood* 2004;103:1383-1390.
131. Saso R, Marsh J, Cevreska L, et al. Bone marrow transplants for paroxysmal nocturnal haemoglobinuria. *Br J Haematol* 1999;104:392-396.
132. Suenaga K, Kanda Y, Niiya H, et al. Successful application of nonmyeloablative transplantation for paroxysmal nocturnal hemoglobinuria. *Exp Hematol* 2001;29:639-642.
133. Woodard P, Wang W, Pitts N, et al. Successful unrelated donor bone marrow transplantation for paroxysmal nocturnal hemoglobinuria. *Bone Marrow Transplant* 2001;27:589-592.
134. Nishimura JI, Kanakura Y, Ware RE, et al. Clinical course and flow cytometric analysis of paroxysmal nocturnal hemoglobinuria in the United States and Japan. *Medicine (Baltimore)* 2004;83:193-207.

135. Graham ML, Rosse WF, Halperin EC, Miller CR, Ware RE. Resolution of Budd-Chiari syndrome following bone marrow transplantation for paroxysmal nocturnal haemoglobinuria. *Br J Haematol* 1996;92:707-710.
136. Prince GM, Nguyen M, Lazarus HM, Brodsky RA, Terstappen LW, Medof ME. Peripheral blood harvest of unaffected CD34+ CD38- hematopoietic precursors in paroxysmal nocturnal hemoglobinuria. *Blood* 1995;86:3381-3386.
137. Taniguchi K, Okada M, Yoshihara S, et al. Strategy for bone marrow transplantation in eculizumab-treated paroxysmal nocturnal hemoglobinuria. *Int J Hematol* 2011;94:403-407.
138. Parker CJ. Management of paroxysmal nocturnal hemoglobinuria in the era of complement inhibitory therapy. *Hematology Am Soc Hematol Educ Program* 2011;2011:21-29.
139. Parker CJ. Bone marrow failure syndromes: paroxysmal nocturnal hemoglobinuria. *Hematol Oncol Clin North Am* 2009;23:333-346.
140. Ray JG, Burows RF, Ginsberg JS, Burrows EA. Paroxysmal nocturnal hemoglobinuria and the risk of venous thrombosis: review and recommendations for management of the pregnant and nonpregnant patient. *Haemostasis* 2000;30:103-117.
141. Gongora Bianchi RA. Paroxysmal nocturnal hemoglobinuria: the Mexican experience. *Rev Invest Clin* 1997;49:85S-88S.
142. McMullin MF, Hillmen P, Jackson J, Ganly P, Luzzatto L. Tissue plasminogen activator for hepatic vein thrombosis in paroxysmal nocturnal haemoglobinuria. *J Intern Med* 1994;235:85-89.
143. Sholar PW, Bell WR. Thrombolytic therapy for inferior vena cava thrombosis in paroxysmal nocturnal hemoglobinuria. *Ann Intern Med* 1985;103:539-541.
144. Araten DJ, Notaro R, Thaler HT, et al. Thrombolytic therapy is effective in paroxysmal nocturnal hemoglobinuria: a series of nine patients and a review of the literature. *Haematologica* 2012;97:344-352.
145. Bais J, Pel M, von dem Borne A, van der Lelie H. Pregnancy and paroxysmal nocturnal hemoglobinuria. *Eur J Obstet Gynecol Reprod Biol* 1994;53:211-214.
146. Bais JM, Pel M. Late maternal mortality due to paroxysmal nocturnal hemoglobinuria and pregnancy. *Eur J Obstet Gynecol Reprod Biol* 1995;58:211.
147. De Gramont A, Krulik M, Debray J. Paroxysmal nocturnal haemoglobinuria and pregnancy. *Lancet* 1987;1:868.
148. Beresford CH, Gudex DJ, Symmans WA. Paroxysmal nocturnal haemoglobinuria and pregnancy. *Lancet* 1986;2:1396-1397.
149. Jacobs P, Wood L. Paroxysmal nocturnal haemoglobinuria and pregnancy. *Lancet* 1986;2:1099.
150. Svigos JM, Norman J. Paroxysmal nocturnal haemoglobinuria and pregnancy. *Aust N Z J Obstet Gynaecol* 1994;34:104-106.
151. Melo A, Gorgal-Carvalho R, Amaral J, et al. Clinical management of paroxysmal nocturnal haemoglobinuria in pregnancy: three case reports. *Blood Transfus* 2011;9:99-103.
152. Kelly R, Arnold L, Richards S, et al. The management of pregnancy in paroxysmal nocturnal haemoglobinuria on long term eculizumab. *Br J Haematol* 2010;149:446-450.
153. Marasca R, Coluccio V, Santachiara R, et al. Pregnancy in PNH: another eculizumab baby. *Br J Haematol* 2010;150:707-708.
154. Nishimura J, Kanakura Y, Ware RE, et al. Clinical course and flow cytometric analysis of paroxysmal nocturnal hemoglobinuria in the United States and Japan. *Medicine (Baltimore)* 2004;83:193-207.
155. van den Heuvel-Eibrink MM, Bredius RG, te Winkel ML, et al. Childhood paroxysmal nocturnal haemoglobinuria (PNH), a report of 11 cases in the Netherlands. *Br J Haematol* 2005;128:571-577.
156. Curran KJ, Kernan NA, Prockop SE, et al. Paroxysmal nocturnal hemoglobinuria in pediatric patients. *Pediatr Blood Cancer* 2012;59(3):525-529.
157. Bortolotti M, Mari C, Lopilato C, Porrizzo G, Miglioli M. Effects of sildenafil on esophageal motility of patients with idiopathic achalasia. *Gastroenterology* 2000;118:253-257.

158. Bortolotti M, Pandolfo N, Giovannini M, Mari C, Miglioli M. Effect of Sildenafil on hypertensive lower oesophageal sphincter. *Eur J Clin Invest* 2002;32:682-685.
159. Eherer AJ, Schwetz I, Hammer HF, et al. Effect of sildenafil on oesophageal motor function in healthy subjects and patients with oesophageal motor disorders. *Gut* 2002;50:758-764.
160. Fujioka S, Takayoshi T. Prognostic features of paroxysmal nocturnal hemoglobinuria in Japan. *Acta Haematol Japan* 1989;52:1386-1394.
161. Araten DJ, Thaler HT, Luzzatto L. High incidence of thrombosis in African-American and Latin-American patients with paroxysmal nocturnal haemoglobinuria. *Thromb Haemost* 2005;93:88-91.
162. Horikawa K, Kawaguchi T, Ishihara S, et al. Frequent detection of T cells with mutations of the hypoxanthine-guanine phosphoribosyl transferase gene in patients with paroxysmal nocturnal hemoglobinuria. *Blood* 2002;99:24-29.

Chapter 32 Acquired Nonimmune Hemolytic Disorders

> Table of Contents > Part IV - Disorders of Red Cells > Section 3 - Hemolytic Anemia > Chapter 32 - Acquired Nonimmune Hemolytic Disorders

Chapter 32

Acquired Nonimmune Hemolytic Disorders

Robert T. Means, Jr.

Bertil Glader

Hemolysis occurs when red blood cells (RBCs) are exposed to a variety of infectious agents, chemicals, or physical stresses. In some cases these effects are antibody mediated (Chapters 29 and 30). In other patients, such as those with glucose-6-phosphate dehydrogenase (G6PD) deficiency (Chapter 28) or those with unstable hemoglobins (Chapter 35), there is an underlying propensity of the RBCs to be more susceptible to injury. In still other cases, such as paroxysmal nocturnal hemoglobinuria (PNH), hemolysis occurs as a consequence of an acquired clonal abnormality in the RBC membrane (Chapter 31). Hemolytic anemia also occurs when otherwise normal red cells are injured directly by infectious agents, chemicals, thermal injury, mechanical stresses, or altered metabolites. These etiologies of hemolysis are the focus of this chapter.

HEMOLYSIS DUE TO INFECTION

A variety of infectious processes can lead to hemolytic destruction of normal RBCs. In some cases, such as in *Mycoplasma pneumoniae* infection or with infections related to paroxysmal cold hemoglobinuria, hemolysis is related to antibody-mediated cell destruction (Chapter 29). With the infections described in this section, hemolysis is largely the result of direct nonimmune effects on erythrocytes. Some of the infections discussed here are not major problems in North America or Europe; however, to the extent that there is significant international travel to and from endemic areas, recognition of these infections is important for medical personnel worldwide.

Malaria

Malaria is an acute, chronic, or recurrent febrile disease caused in humans by four species of *Plasmodia*: *Plasmodia vivax*, *Plasmodia falciparum*, *Plasmodia malariae*, and *Plasmodia ovale*. Infections with *P. falciparum* are the major form of malaria in Africa and Southeast Asia, whereas *P. vivax* is most common in Central America and India. These protozoan microorganisms are capable of parasitizing erythrocytes and other body tissues. Malaria is spread by female mosquitoes of the genus *Anopheles* (Fig. 32.1). The sexual phase of the *Plasmodium* life cycle takes place within the mosquito. The semitropical and tropical endemic distribution of malaria corresponds to the distribution of the vector.

On a worldwide basis, malaria is the most prevalent of all serious diseases; it has been estimated that approximately 2.5 billion people are at risk for malaria, and that approximately 500 million people are infected with *P. falciparum*.^{1, 2} Ninety percent of the deaths is in African children.³ Malaria has not been endemic in the United States since the 1940s, but approximately 1,000 cases have been reported each year since 1985, and there has been a steady increase in the number of cases reported annually.⁴ Malaria can also be transmitted by blood transfusions⁵ or by sharing needles among intravenous drug abusers.^{6, 7}

Clinical Manifestations

After the initial exposure to malaria, some patients are completely asymptomatic, whereas others have nonspecific flulike symptoms that mimic a viral illness.⁸ Classically, the most prominent clinical manifestations are recurrent paroxysms of chills and fever with temperatures as high as 105° to 106°F (40.5° to 41°C) associated with malaise, headache, vomiting, and other systemic symptoms. The paroxysms tend to recur regularly every 36 to 72 hours. They are most prominent with *P. malariae* infections and much less with *P. falciparum*. Splenomegaly is noted in about one half of patients during early stages of disease⁸ and becomes more common later. Jaundice and hepatomegaly may develop in later stages of the illness.

Of the various malaria species, *P. falciparum* infection causes the most morbidity and mortality. In the acute stage, it can be associated with increasing parasitemia, hypotension, malignant hyperthermia, and death. In addition, *P. falciparum* malaria is associated with cerebral, pulmonary, and renal complications.⁹ The overall mortality from a study of over 1,800 children with malaria in Kenya was 3.5%; in 84% of cases death occurred within 24 hours of admission.¹⁰ The most important prognostic factors for death were impaired consciousness and respiratory distress (Fig. 32.2). Severe anemia alone did not affect prognosis.^{3, 10}

Anemia is common in malaria.^{11, 12, 13, 14} It is particularly characteristic of *P. falciparum* malaria because of the greater extent of red cell parasitization with this species. With uncomplicated *P. falciparum* malaria, moderately severe anemia is seen in approximately 20% of previously healthy patients during or after the first infection.¹⁵ Complete eradication of malaria parasites from the blood may take months to years, particularly in areas of high transmission; immunity to malaria is slowly acquired. In tropical areas, anemia tends to be most prevalent and most severe in children from 1 to 5 years of age,¹⁶ whereas only moderate anemia is usually noted in adolescents and adults.

In children, the circulating parasite count is inversely proportional to the hematocrit.¹⁷ Leukocyte numbers may be normal, but patients often have leukopenia. Thrombocytopenia has been observed in about two thirds of patients with *P. falciparum* malaria,^{9, 16} often associated with splenomegaly.¹⁸

The most serious hematologic complication of malaria is acute intravascular hemolytic anemia (blackwater fever), which occurs as a rare event in the course of infection by *P. falciparum*. The clinical manifestations are fulminating, the intravascular hemolysis being associated with prostration, vomiting, chills, and fever. Hemoglobinemia, hemoglobinuria, and hyperbilirubinemia are consistent features, and in the most severe episodes, acute oliguric renal failure supervenes.

Pathogenesis

After a bite from the female *Anopheles* mosquito, sporozoites introduced into the circulation go to the liver parenchyma where they proliferate into thousands of merozoites (Fig. 32.1). The duration of this liver development stage varies between species. The infected hepatocytes next release merozoites into the bloodstream where they invade erythrocytes.

The ability of various Plasmodia to infect red cells is related to their attachment to specific membrane receptors. Of the species that infect humans, *P. vivax* and *P. ovale* invade only reticulocytes. *P. malariae* invades mature red cells, and *P. falciparum* invades erythrocytes of all ages. As a result, the proportion of cells parasitized in *P. vivax* malaria rarely exceeds 1%, whereas as many as 50% of cells may be affected in *P. falciparum* malaria. It is of interest that *P. vivax* invades only Duffy blood-group-positive red cells¹⁹; in West Africa where the Duffy antigen is missing on red cells, *P. vivax* malaria is nonexistent. *P. falciparum* apparently has two receptors: one that binds to sialic acid groups on the erythrocyte membrane protein glycophorin and another that

P.810

binds to a trypsin-sensitive, nonsialated ligand.^{20, 21, 22} Other proposed parasite receptors include surface heparinlike molecules²³ and complement receptor type-1.²⁴

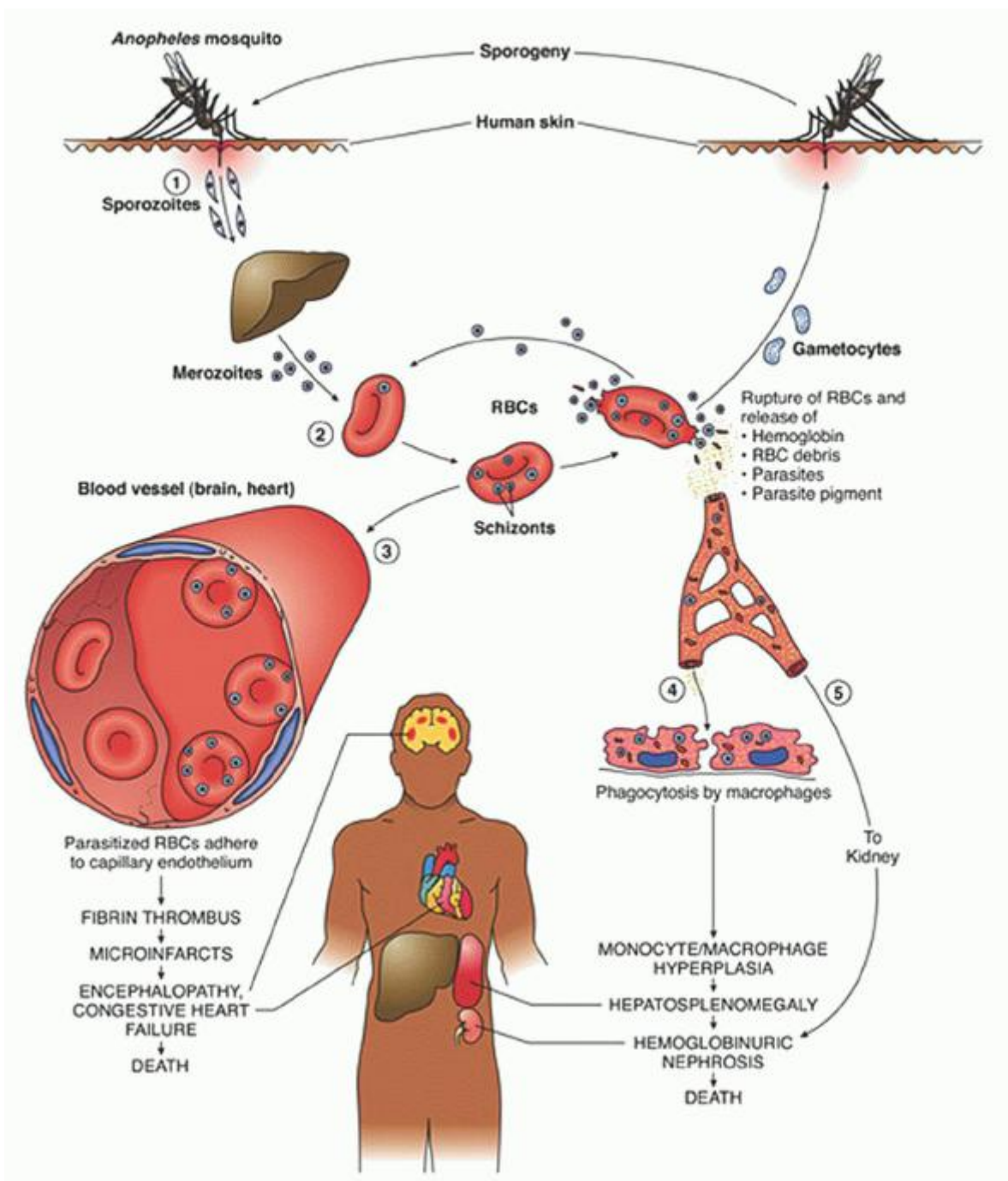

FIGURE 32.1. Life cycle of malaria. An *Anopheles* mosquito bites an infected person, taking blood that contains micro- and macrogametocytes (sexual forms). In the mosquito, sexual multiplication (“sporogony”) produces infective sporozoites in the salivary glands. (1) During the mosquito bite, sporozoites are inoculated into the bloodstream of the vertebrate host. Some sporozoites leave the blood and enter the hepatocytes, where they multiply asexually (exoerythrocytic schizogony), and form thousands of uninucleated merozoites. (2) Rupture of hepatocytes releases merozoites, which penetrate erythrocytes and become trophozoites, which then divide to form numerous schizonts (intraerythrocytic schizogony). Schizonts divide to form more merozoites, which are released on the rupture of erythrocytes and re-enter other erythrocytes to begin a new cycle. After several cycles, subpopulations of merozoites develop into micro- and macrogametocytes, which are taken up by another mosquito to complete the cycle. (3) Parasitized erythrocytes obstruct capillaries of the brain, heart, kidney, and other deep organs. Adherence of parasitized erythrocytes to capillary endothelial cells causes fibrin thrombi, which produce microinfarcts. These result in encephalopathy, congestive heart failure, pulmonary edema, and frequently death. Ruptured erythrocytes release hemoglobin, erythrocyte debris, and

malarial pigment. (4) Phagocytosis leads to monocyte/macrophage hyperplasia and hepatosplenomegaly. (5) Released hemoglobin produces hemoglobinuric nephrosis, which may be fatal. (From Rubin E, Farber JL. Pathology, 3rd ed. Philadelphia, PA: Lippincott Williams & Wilkins, 1999.)

Further development of the parasite within red cells is along one of two pathways, either asexual or sexual differentiation (Fig. 32.1). Sexual forms, or gametocytes, continue their development within mosquitoes. The asexual differentiation of parasites in red cells proceeds from young ring forms through trophozoites to produce schizonts containing 6 to 32 merozoites (Fig. 32.3). In the process, parasites use 25% to 75% of the hemoglobin of the cell.²⁵ The intraerythrocytic phase lasts 24 to 72 hours, depending on the species. The schizonts then lyse, the cell ruptures, and the merozoites are released to invade other cells, thereby continuing the erythrocyte cycle. The simultaneous rupture of billions of schizonts from red cells is associated with the classic paroxysms of malarial fever.

Erythrocytes parasitized by certain strains of *P. falciparum* develop electron-dense knobs that mediate the attachment of the infected red cells to venules.^{26, 27, 28} Such sequestration of parasite-infected RBC creates an obstruction to tissue perfusion. In addition, the sequestration in venules prevents parasitized cells from entering the splenic circulation, thereby evading destruction and enhancing merozoite development; this phenomenon may be a factor in the rapid development of anemia in severe infections.²⁹

The anemia in malaria is due to a combination of factors that include parasite-mediated RBC destruction, splenic removal of

P.811

infected RBCs, and decreased red cell production (Table 32.1). Hemoglobin digestion and cell disruption by the parasite are clearly the major causes of hemolysis.^{11, 12, 30} The malarial pigment hemozoin, a product of hemoglobin degradation,²⁵ also inhibits erythropoiesis.^{31, 32}

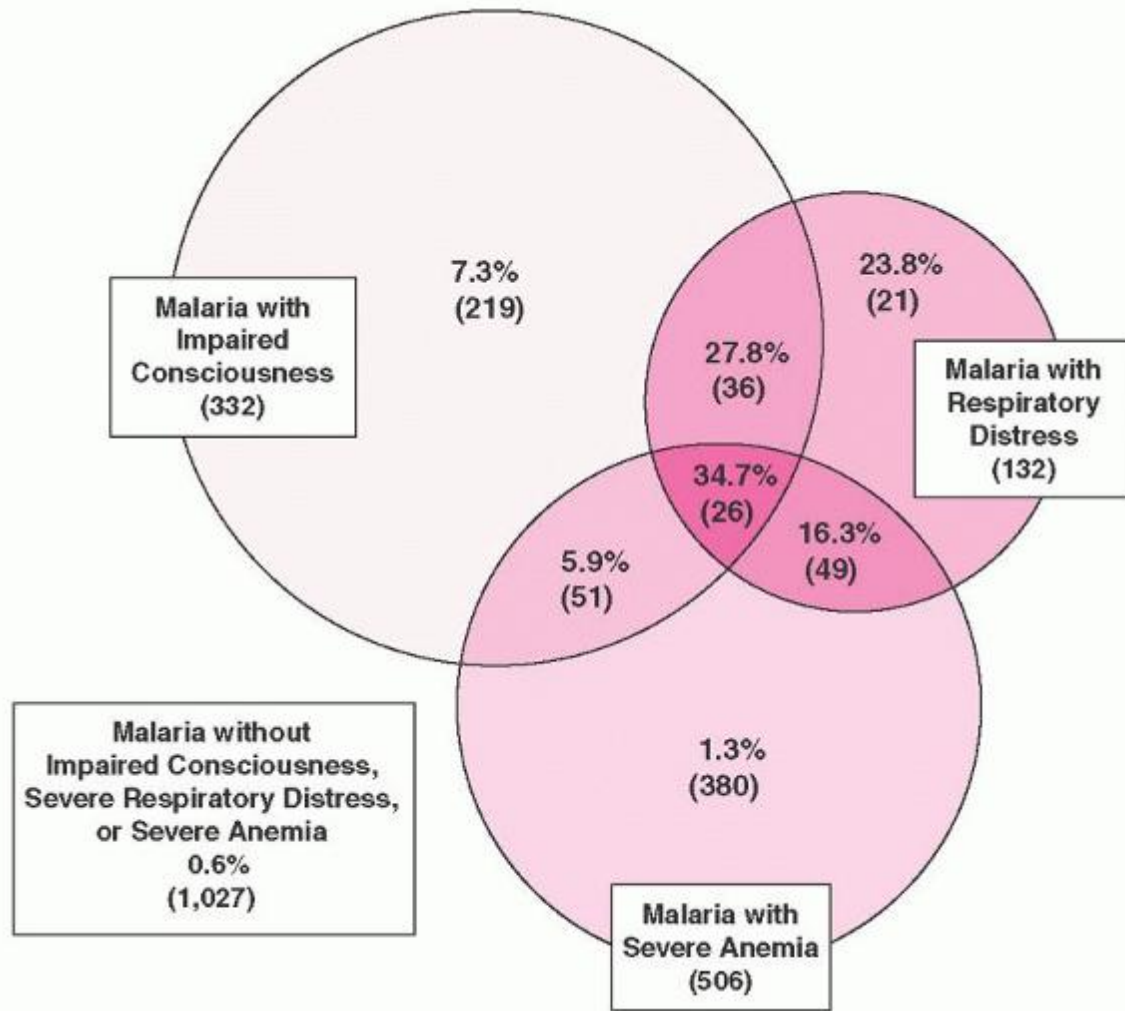

FIGURE 32.2. Prevalence, overlap, and mortality for major clinical subgroups of severe malaria in 1,809 African children. In 1,027 of these children, malaria was present without signs of impaired consciousness, respiratory distress, or severe anemia. In a subset of all children presenting with malaria (782 patients; approximately 40% of total) there was evidence of severe anemia (hemoglobin <5 g/dl), severe respiratory distress, impaired consciousness, and/or some combination of these clinical findings. Almost all deaths occurred in the children who presented with combinations of these clinical abnormalities. Total numbers of patients are given in parentheses. Mortality is given as a percentage. (Modified from Marsh K, Forster D, Waruiru C, et al. Indicators of life-threatening malaria in African children. *N Engl J Med* 1995;332(21):1399-1404.)

The role of the spleen in red cell destruction is related to the decreased deformability of RBCs infected with *Plasmodia*,³³ erythrocyte retention in the red pulp, prolonged exposure to splenic macrophages, and removal of parasitized cells or “pitting” of the parasite, with consequent damage to the cell.^{36, 37, 38} A similar process of macrophage-mediated destruction of parasitized RBCs occurs in the marrow sinusoids.³⁹ Moreover, normal nonparasitized RBCs have a shorter survival in malaria, presumably a consequence of hypersplenism and hyperactive macrophages.⁴⁰

Even after complete clearance of the parasites, hemolysis may persist for 4 to 5 weeks.⁴¹ A complement-mediated process may be responsible in part, and the direct antiglobulin test is often positive.⁴²

Dyserythropoiesis with characteristic morphologic findings also occurs in malaria. It is thought that this contributes to the slow recovery seen after a single malarial attack and also to the persistence of anemia in individuals with chronic parasitemia.^{13, 43, 44}

Anemia often persists for weeks following treatment of malaria, and this results in part from relative marrow failure, as occurs in association with other forms of infection (see Chapter 41).^{12, 41} Abnormalities in several of the cytokine

mediators of the anemia of chronic disorders (tumor necrosis factor, interferon gamma) have been reported in patients with severe *P. falciparum* malaria.^{45, 46, 47, 48, 49}

Serum erythropoietin levels often are inadequate for the degree of anemia.^{50, 51, 52} The bone marrow response to erythropoietin also appears to be impaired.⁵³ Circulating concentration of the iron regulatory peptide hepcidin, a key mediator of the anemia of chronic disease, is elevated early in the course of malaria.^{54, 55} This results in impaired iron mobilization.^{56, 57}

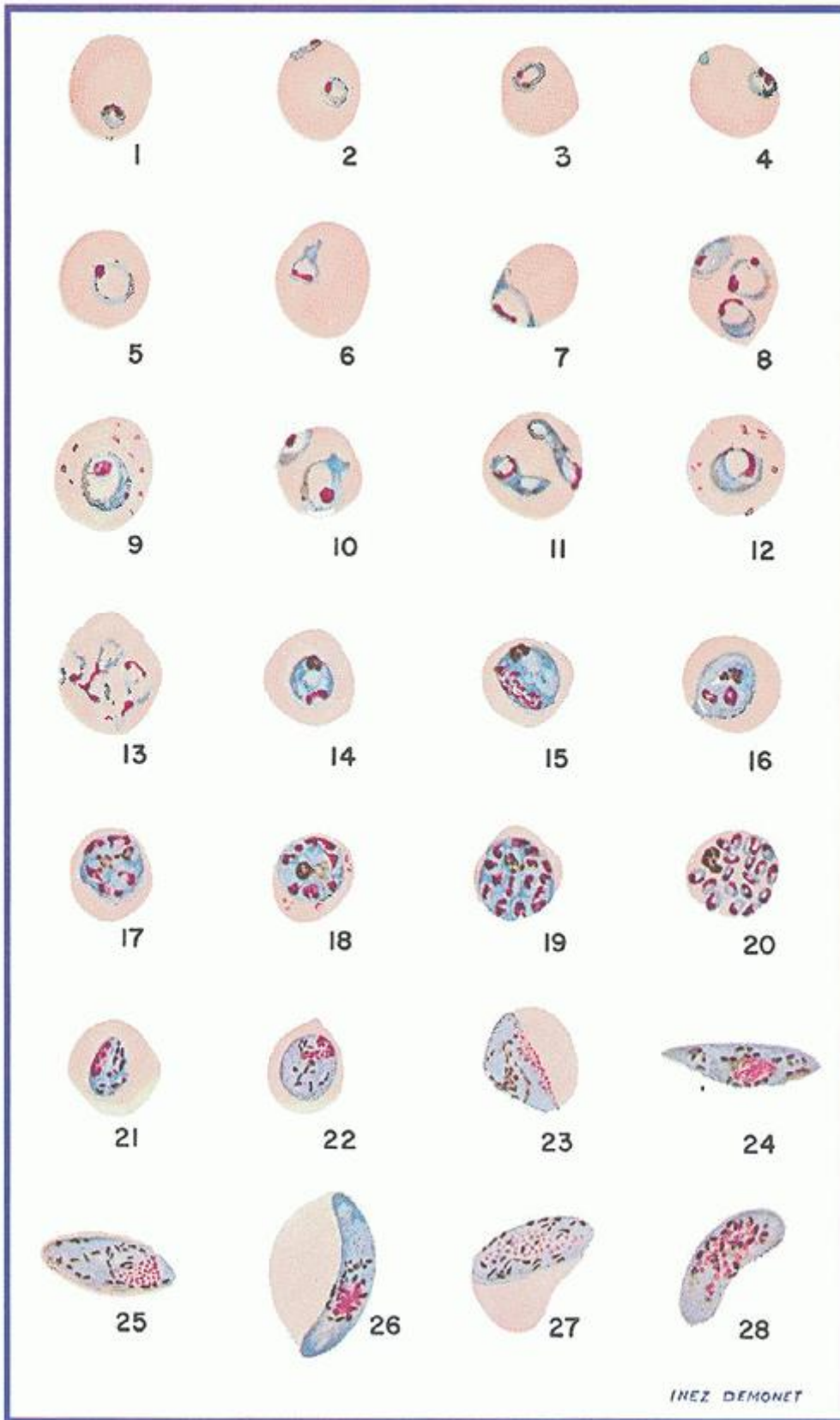

FIGURE 32.3. *Plasmodium falciparum*. 1: Very young ring form trophozoite. 2: Double infection of single cell with young trophozoites, one a marginal form, the other a signet ring form. 3,4: Young trophozoites showing double chromatin dots.

5-7: Developing trophozoites. 8: Three medium trophozoites in one cell. 9: Trophozoite showing pigment in a cell containing Maurer spots. 10,11: Two trophozoites in each of two cells, showing variation of forms that parasites may assume. 12: Almost mature trophozoite showing haze of pigment throughout cytoplasm. 13: Aestivo-autumnal slender forms. 14: Mature trophozoite, showing clumped pigment. 15: Parasite in the process of initial chromatin division. 16-19: Various phases of the development of the schizont. 20: Mature schizont. 21-24: Successive forms in the development of the gametocyte, usually not found in the circulation. 25: Immature macrogametocyte. 26: Mature macrogametocyte. 27: Immature microgametocyte. 28: Mature microgametocyte. (Reproduced from Wilcox A. Manual for the microscopical diagnosis of malaria in man. National Institutes of Health Bulletin No. 180.)

The percentage of reticulocytes tends to be low during active infection and increases transiently after effective treatment. In *P. vivax* malaria, however, the low reticulocyte count may be explained in part by the increased affinity of the organism for immature erythroid precursors and reticulocytes.⁵⁸ Infection by *P. vivax* appears to be restricted to reticulocytes.⁵⁹

The pathogenesis of acute intravascular hemolysis (blackwater fever) remains uncertain, and currently this complication is less commonly seen, although it still occurs.^{60, 61} Blackwater fever does not reflect an unusual degree of parasitemia. In many historical cases, the acute intravascular hemolysis appears to have been precipitated by quinine ingestion^{62, 63}; quinine, for many years the primary treatment agent for malaria, may act as

P.812

a hapten, becoming antigenic after interacting with the red cell. However, cases involving untreated individuals also have been reported.⁹ Some episodes thought to represent blackwater fever may have resulted from the use of primaquinolike drugs in G6PD-deficient people.

TABLE 32.1 FACTORS CONTRIBUTING TO ANEMIA IN MALARIA

Accelerated red blood cell (RBC) destruction

Direct parasite destruction of red cells

Decreased deformability of parasitized RBCs and destruction by splenic macrophages

Macrophage-mediated destruction of parasitized RBCs in marrow and liver sinusoids

Destruction of nonparasitized cells by immune mechanisms

Destruction of nonparasitized cells by hypersplenism and hyperactive macrophages

Hapten (quinine)-induced intravascular hemolysis (blackwater fever)

Decreased RBC production

Bone marrow suppression due to inflammatory cytokines

Inadequate erythropoietin production

Dyserythropoiesis

Modified from Menendez C, Fleming AF, et al. Malaria-related anaemia. *Parasitol Today* 2000;16(11):469-476.

Certain inherited red cell disorders appear to confer resistance to malaria, either by inhibiting parasitic invasion or by slowing intracellular growth. It is thought that these phenomena may contribute to increased prevalence of such inherited diseases because of their effects on survival (balanced polymorphism). These disorders include sickle cell trait,^{64, 65, 66} G6PD deficiency,^{67, 68, 69, 70} thalassemia,^{71, 72} hemoglobin E variants,⁷⁰ hemoglobin C variants,⁷³ ovalocytosis of the Melanesian (Malayan) type,⁷⁴ and lack of the Duffy blood group antigen.¹⁹

Diagnosis

Diagnosis of malaria in the United States is often delayed because it is not suspected.^{8, 75} Such delays are dangerous because the early mortality rate from *P. falciparum* malaria approaches 10%, and these deaths can be prevented with adequate treatment. Malaria should be considered in the differential diagnosis of any febrile patient returning from an endemic zone.

Diagnosis traditionally has required identification of parasites on the blood smear (Fig. 32.3). They can be recognized on ordinary Wright-stained smears, but the chances for detection and identification of species are enhanced by the use of thick smears. Single negative smears do not exclude the disease with certainty in patients with low-grade infections. Parasites may be detected in blood during any phase of the illness, but the chances of detection are greatest during afebrile periods. *P. falciparum* disease is distinguished from that caused by other strains by heavy parasitemia involving all ages of erythrocytes and by the lack of trophozoites and schizonts; usually, only ring forms and the distinctive, banana-shaped gametocytes are apparent (Fig. 32.2).

Simple test strips that take 10 to 15 minutes are available for diagnosis of malaria from a drop of fingerstick blood. The sensitivity of these tests is probably as good as microscopy. Diagnosis by rapid polymerase chain reaction is also available.^{76, 77, 78} Regardless of the method used, it is important to distinguish *P. falciparum* malaria from other malaria species because of therapeutic considerations, and because only *P. falciparum* infection has the potential for being rapidly fatal.⁹

Management

Therapeutic considerations for malaria include supportive medical care for anemia and other complications. Administration of folate to patients with malaria is controversial; its use is associated with higher hematocrits, but may also prolong parasitemia.⁷⁹ Chemoprophylaxis should be recommended to all people traveling to an endemic area.^{80, 81} Because of the spread of drug-resistant strains of *P. falciparum*, however, no single regimen is completely effective. Knowledge of the characteristics of the malaria strains in the sites to be visited is essential. Because of changes in drug resistance and the development of new agents, before recommending a regimen to a prospective traveler, physicians should become familiar with current guidelines from the U.S. Centers for Disease Control and Prevention (CDC), Atlanta, Georgia. See the CDC website (<http://www.cdc.gov/travel/malinfo.htm>).

Babesiosis

Infection by tick-borne protozoans of the genus *Babesia* is rare in humans.^{82, 83, 84} The infection has been reported in Nantucket and other islands off the northeastern U.S. shore, as well as in neighboring coastal areas of New England. It also is found in north central states, Washington, and California.⁸⁵ Most cases of babesiosis described in Europe have occurred in asplenic individuals.^{84, 86} In the United States, *Babesia microti* is the causative agent, whereas *Babesia divergens* is the species identified in Europe, and the latter cases are usually more severe.^{82, 87} Babesiosis also can be transmitted by blood transfusion.⁸⁸

Babesiosis is characterized by an acute febrile illness and hemolytic anemia, very similar to malaria. In most cases it is a mild self-limited disorder that goes undiagnosed, and thus is not reported. It is likely the true incidence of babesiosis in healthy hosts is underrecognized. However, in asplenic individuals it can produce serious, often fatal illness with hemolytic anemia, renal failure, or pulmonary edema.^{82, 84, 89}

Laboratory features include hemoglobinuria, hyperbilirubinemia, normocytic anemia, thrombocytopenia, and sometimes leukopenia.⁸² Both *B. microti* and *B. divergens* can be seen in RBCs on the peripheral blood smear and can be confused with malaria.⁸² Serologic antibody tests and polymerase chain reaction-based assays are available to aid in diagnosis.⁹⁰

In mild cases of babesiosis no treatment may be necessary. In more severe cases, the combinations of atovaquone and azithromycin or of clindamycin and quinine are useful. The atovaquone/azithromycin is reportedly better tolerated.^{90, 91} Red cell exchange transfusions have been used also.^{90, 91, 92}

Trypanosomiasis

Moderate to severe hemolytic anemia is a regular feature of African trypanosomiasis (sleeping sickness).^{93, 94, 95} This often fatal illness is caused by *Trypanosoma brucei gambiense* or *T. brucei rhodesiense*. The diseases induced by the two subspecies are similar except that *T. brucei gambiense* infection follows a more chronic course. The organisms are transmitted to humans and domestic animals by the bite of the tsetse fly.

Normocytic anemia with reticulocytosis is prominent. Red cell survival is shortened and autoagglutination of erythrocytes with accelerated erythrocyte sedimentation characteristically is observed. The results of the direct antiglobulin (Coombs) test may be positive. Erythrophagocytosis by macrophages is seen throughout the reticuloendothelial system.⁹⁶

The toxic effects of the parasite and immunologic mechanisms both are implicated in the destruction of red cells. The intensity of the hemolytic anemia may fluctuate with the degree of parasitemia. Transient hepatosplenomegaly and decreased serum complement levels accompany the episodes. Marrow failure often supervenes during the terminal phases of the illness. Diagnosis

P.813

depends on serologic tests or demonstration of the parasite in the blood.⁹⁷

Visceral Leishmaniasis (Kala-Azar)

Leishmaniasis is an infection caused by intracellular protozoan parasites transmitted by sandflies. There are three main forms of *Leishmania* infections in humans: cutaneous, mucocutaneous, and visceral. The major hematologic problems occur with the visceral infection (kala-azar) and involve the lymph nodes, liver, spleen, and bone marrow. The disorder is caused by *Leishmania donovani*, and is found throughout Asia and Africa, affecting individuals of all ages. A variant parasite, *L. donovani infantum* is the form that causes kala-azar in southern Europe and North Africa, and it primarily affects young children and infants. Visceral leishmaniasis mainly occurs in local endemic areas; however, it may be contracted on short-term visits. It has been recognized in Europe in travelers returning from Mediterranean holidays.⁹⁸ Both cutaneous and visceral leishmaniasis have been reported in military personnel returning from deployment in the Persian Gulf.^{99, 100}

Following an incubation period of 1 to 3 months, there is the insidious onset of fever, sweating, malaise, and anorexia, but these acute symptoms gradually abate. Next, hepatosplenomegaly gradually evolves, and this stage of illness is associated with anemia, neutropenia, and thrombocytopenia. In young children with acute visceral leishmaniasis, particularly in Mediterranean populations, the clinical and hematologic features may be more aggressive with a rapid onset of severe hemolytic anemia.¹⁰¹

The bone marrow is hyperplastic with dyserythropoietic changes, and the diagnosis can usually be made by finding macrophages containing intracellular parasites (*Leishman-Donovan* bodies). The overall hematologic picture is typical of hypersplenism. Red cell survival studies indicate that hemolysis is the major cause of anemia in leishmaniasis.^{101, 102}

In most cases there is no evidence of immune hemolysis, although both immunoglobulin G (IgG) and complement occasionally are found on the red cells. Similar to what is seen in malaria, nonsensitized red cells are destroyed by macrophages recruited to the spleen and liver as part of the inflammatory response to the parasite.

Bartonellosis (Carrion's Disease)

A severe, acute hemolytic anemia is produced in humans by *Bartonella bacilliformis*, a flagellated bacillus.¹⁰³ The infection is limited to South America, particularly in the Andean valleys of Peru, Ecuador, and Columbia, at elevations of 500 to 3,000 m.^{104, 105, 106, 107} The bacillus is transmitted by the sand fly (*Phlebotomus*) and probably by other arthropods. After a 2- to 3-week incubation period, the acute phase of the illness, known as Oroya fever, begins. It is marked by malaise, headache, muscle pains, remittent fever, chills, and rapid onset of severe anemia. The disease has existed in Peru since pre-Incan times.^{103, 108} The highest rates of infection are in children.^{104, 107}

The findings in the blood are characteristic of acute extravascular blood destruction.^{103, 109} As viewed in Wright- or Giemsa-stained blood smears, numerous *Bartonella* organisms are apparent in the erythrocyte.¹⁰³ The organisms are rod shaped (1 to 2 m in length and 0.2 to 0.5 m in width) or round (0.3 to 1.0 m in diameter).

In patients who recover from the acute phase, a quiescent period ensues during which the organisms disappear from the blood. A chronic eruptive stage follows, *verruca peruviana*, a benign condition characterized by hemangioma-like lesions of the skin but without hematologic manifestations.¹⁰⁹

Bartonella infection can be treated by antibiotic combinations containing chloramphenicol and other antibiotics, often a beta lactam. *Verruca peruviana* is typically treated with streptomycin-containing regimens. In the era prior to antibiotics, the only available treatment was blood transfusion.^{104, 110}

Clostridial Sepsis

Clostridium perfringens septicemia occurs after septic abortion or in association with a diseased biliary tree, traumatic wound infections, cancer, leukemia, endocarditis, gastrointestinal arteriovenous malformations, or necrotizing enterocolitis of newborns.^{111, 112, 113, 114, 115, 116, 117} Sometimes no underlying disease is identified.^{118, 119, 120} Profound, often fatal hemolytic anemia is a regular feature of clostridial sepsis.^{118, 121} Signs of intravascular red cell destruction are prominent, and many microspherocytes are found in the blood. The hemolysis can be rapid and massive, with hematocrit values falling to very low levels in a matter of hours.^{119, 120} Hemolysis is thought to result from the elaboration of a clostridial toxin, a phospholipase that attacks erythrocyte membrane lipids to form highly lytic lysolecithins.^{122, 123} The diagnosis should be suspected when fever, jaundice, and intravascular hemolysis occur together in a patient with a history of previous gastrointestinal or genitourinary surgery, a recent wound, cancer, or other disease. Clostridial infections

respond to antibiotic therapy, but in order to affect outcome, treatment must be started quickly, usually before culture results are available.¹²⁴

Other Bacterial Infections

Acute hemolytic anemia with bacterial infection is common, especially in childhood, and has been reported with streptococcal, staphylococcal, or pneumococcal septicemia or endocarditis.^{125, 126, 127, 128} Intravascular hemolysis with hemoglobinuria has been reported in patients with cholera¹²⁹ and with typhoid fever.¹³⁰ *Escherichia coli* O157 gastroenteritis can cause the hemolytic-uremic syndrome, but can also bring about hemolytic anemia with no renal involvement or red cell fragmentation.¹³¹ Severe hemolytic anemia not attributable to autoimmune mechanisms is observed occasionally in patients with miliary tuberculosis.^{126, 132} Certain spirochetal infections are also associated with hemolytic anemia, including relapsing fever caused by *Borrelia recurrentis*¹³³ and leptospirosis.¹³⁴

The pathogenesis of hemolysis in most cases cited above is uncertain. In some it is thought that anemia is due to direct action of the infectious agent or its products on erythrocytes. Adsorption of microbial antigens to red cells has been detected by immunofluorescent techniques,¹³⁵ and this phenomenon may lead to phagocytosis or complement-mediated erythrocyte destruction. The capsular polysaccharide of *Haemophilus influenzae* type b, polyribosyl ribitol phosphate (PRP), is released from growing organisms during human infection and can be found in body fluids including red cells. It has been proposed that the hemolytic anemia that occurs during *H. influenzae* type b infection may be due to absorption of PRP to red cells and immune destruction of sensitized erythrocytes.¹³⁶

In other cases, serious bacterial infections are associated with disseminated intravascular coagulation and a microangiopathic hemolytic anemia. Also, as discussed above, *C. perfringens* may release phospholipases that can lead to red cell membrane injury and cell destruction. Of interest, some bacteria release neuraminidase, an enzyme that cleaves red cell sialic acid residues, thereby exposing a cryptic "T antigen."¹³⁷ These "T-activated" red cells can react with anti-T IgM antibodies present in most human adult plasma, thereby resulting in RBC agglutination and possible hemolysis in vivo.¹³⁷ The main bacteria that release neuraminidase are *C. perfringens* and *Streptococcus pneumoniae*; however, *Bacteroides*, *E. coli*, *Actinomyces*, and *Vibrio cholerae* also have been implicated.¹³⁸

P.814

HEMOLYSIS DUE TO DRUGS AND CHEMICALS

Many drugs and chemicals injure normal red cells to cause hemolytic anemia. Some of the more common occurrences are summarized below. (Drug-induced immune hemolysis is discussed in Chapter 29.)

Oxidant Drugs and Chemicals

Certain chemical agents can bring about the oxidative denaturation of hemoglobin, leading to the sequential formation of methemoglobin, sulfhemoglobin, and Heinz bodies. In some cases, the chemical itself acts as an oxidizing agent; more often, however, it interacts with oxygen to form free radicals or peroxides. These free radicals or peroxides, if produced in quantities too great to be detoxified by the glutathione-dependent reduction system, denature hemoglobin and damage other cellular structures, such as the cell membrane.¹³⁹ Individuals deficient in G6PD or other components of glutathione-dependent detoxification processes (Chapter 28) are particularly sensitive to the hemolytic effects of oxidant compounds (Table 32.2). These agents may also unmask otherwise insignificant defects in the metabolic pathways that defend the erythrocyte against oxidative stress.¹⁴⁰ However, some of these agents are powerful enough to overcome the defense mechanisms of otherwise normal erythrocytes, and can cause hemolysis if given to healthy subjects in higher than usual doses or if renal failure leads to unusually high blood levels.

Hemolytic anemia caused by oxidant drugs varies considerably in severity. Usually the anemia is noted within 1 to 2 weeks after drug therapy is initiated with laboratory findings of low hemoglobin, reticulocytosis, hyperbilirubinemia, and low serum haptoglobin. Also, in some cases, hemoglobinemia and hemoglobinuria may be apparent. Cyanosis with methemoglobinemia or sulfhemoglobinemia is sometimes noted. The hemolytic process usually disappears within 1 to 3 weeks after use of the offending drug has been discontinued.

TABLE 32.2 DRUGS AND CHEMICALS THAT CAUSE HEMOLYTIC ANEMIA IN PATIENTS WITH NORMAL ERYTHROCYTES

Sulfonamides³⁷⁵

Sulfones³⁷⁶

Phenazopyridine (Pyridium)¹⁴²Nitrofurantoin (Furadantin)³⁷⁷Phenacetin³⁷⁸Acetylsalicylic acid³⁷⁹Phenol³⁸⁰Cresol (Lysol, penetrating oil)³⁸¹Naphthalene (mothballs)³⁸²Nitrobenzene³⁸³Aniline³⁸⁴Phenylsemicarbazide³⁸⁵Phenylhydrazine¹⁴³Chlorates³⁸⁶Nitrates³⁸⁷Oxygen³⁸⁸Hydroxylamine³⁸⁹Methylene blue (in infants)³⁹⁰Hematin³⁹¹Pentachlorophenol³⁹²Cisplatin, Carboplatin³⁹³

Morphologic findings characteristic of hemolytic anemia caused by oxidant drugs and chemicals include the following: Heinz bodies (seen with brilliant cresyl blue supravital stains of blood during hemolytic episodes) (Fig. 32.4A); "bite cells" (seen in routine Wright-stained blood smear) as erythrocytes that look as if a semicircular bite has been taken from one edge (Fig. 32.4B)^{141, 142}; and hemighosts¹⁴³ or eccentrocytes,¹⁴⁴ erythrocytes that look as if the hemoglobin has shifted to one side of the cell, leaving the other side clear (Fig. 32.4C). These hemighosts also are referred to as "blister cells" and may appear to contain a large vacuole. These RBCs contain a coagulum of hemoglobin that has separated from the membrane, often leaving an unstained non-hemoglobin-containing cell membrane.¹⁴⁵ Hemighosts appear only when hemolysis is brisk,^{141, 143} and probably indicate a particularly severe degree of oxidant damage. All of these morphologic alterations are consequences of oxidative assault on hemoglobin.

Although the treatment of drug-induced nonimmune hemolysis is largely supportive, erythropoietin has been used in cases associated with a blunted erythropoietic response, particularly in the hemolytic anemia that is observed in hepatitis C patients treated with ribavirin.¹⁴⁶

Arsine Poisoning

Arsine (AsH₃) is the most acutely toxic form of arsenic. It is a colorless, nonirritating, highly toxic gas that is produced by the action of water on a metallic arsenide. Arsine poisoning is associated most often with the use of acids in refining, extracting, or otherwise processing crude metals that contain arsenic as an impurity.^{147, 148} Industrial processes such as galvanizing, soldering, etching, and lead plating can expose workers to this noxious gas.¹⁴⁹ Arsine is also used in the transistor industry to stabilize silicon, and leakage from cylinders in which the gas is transported can lead to accidental poisoning.¹⁵⁰

Manifestations of poisoning appear 2 to 24 hours after exposure and include abdominal pain, nausea, and vomiting; the passage of dark-red urine; jaundice; anemia; reticulocytosis; leukocytosis; and other signs of acute hemolytic anemia. Hemoglobinemia and hemoglobinuria are found, and acute, oliguric renal failure may ensue. The antiglobulin test result is negative. The mortality rate can approach 20%.^{150, 151} The mechanism of red cell injury is not known for certain. Interactions between arsine and oxyhemoglobin may be involved.^{152, 153} Also, arsine-induced membrane injury with altered ion transport has been proposed.^{152, 154}

The treatment of choice for acute toxicity is exchange transfusion to remove the arsenic-containing erythrocytes and to restore the blood hemoglobin levels.^{155, 156}

Copper Toxicity

Hemolytic episodes due to copper toxicity have been noted in humans after accidental exposure to toxic amounts of copper sulfate.^{157, 158, 159} Moreover, copper has been implicated in hemolytic episodes after hemodialysis due to faulty copper tubing and increased levels of the metal in dialysis fluid.^{160, 161}

When inorganic copper enters the blood in large amounts, much of it accumulates in RBCs.^{162, 163} Within RBCs it may damage the cell membrane, accelerate oxidation of hemoglobin, and inactivate enzymes of the pentose-phosphate and glycolytic pathways.¹⁶³ Which of these abnormalities is responsible for shortened RBC survival is not known.

The release of inorganic copper into the circulation accounts for the hemolytic anemia that is observed in patients with Wilson disease (hepatolenticular degeneration).^{164, 165, 166, 167, 168, 169, 170, 171} This inherited illness, characterized by a lifelong tendency to accumulate

P.815

copper, is due to defects in the copper transporting intracellular ATPase ATP7B, which leads to a deficiency of ceruloplasmin, the plasma copper transport protein.^{172, 173} It usually becomes symptomatic in the teens or early 20s, when copper concentration in the liver or nervous system reaches toxic levels.¹⁷⁴ Hemolytic anemia can be associated with the early stages of Wilson disease¹⁷⁵ and occasionally may be the first manifestation of the disorder,^{170, 171, 176, 177, 178} or it may be associated with hepatic decompensation.¹⁶⁷ However, it may appear late in the course of the disease if chelation therapy is discontinued.^{164, 165} The hemolytic episodes in Wilson disease usually are transient and self-limited, but they may be severe and recurrent. When they occur with hepatic decompensation, death from liver failure often follows.¹⁶⁷ The true incidence of copper-induced hemolysis in Wilson disease is not known: reported frequencies range from 2% to 50%.^{177, 178, 179} Treatment of this complication may require plasma exchange transfusion.¹⁸⁰

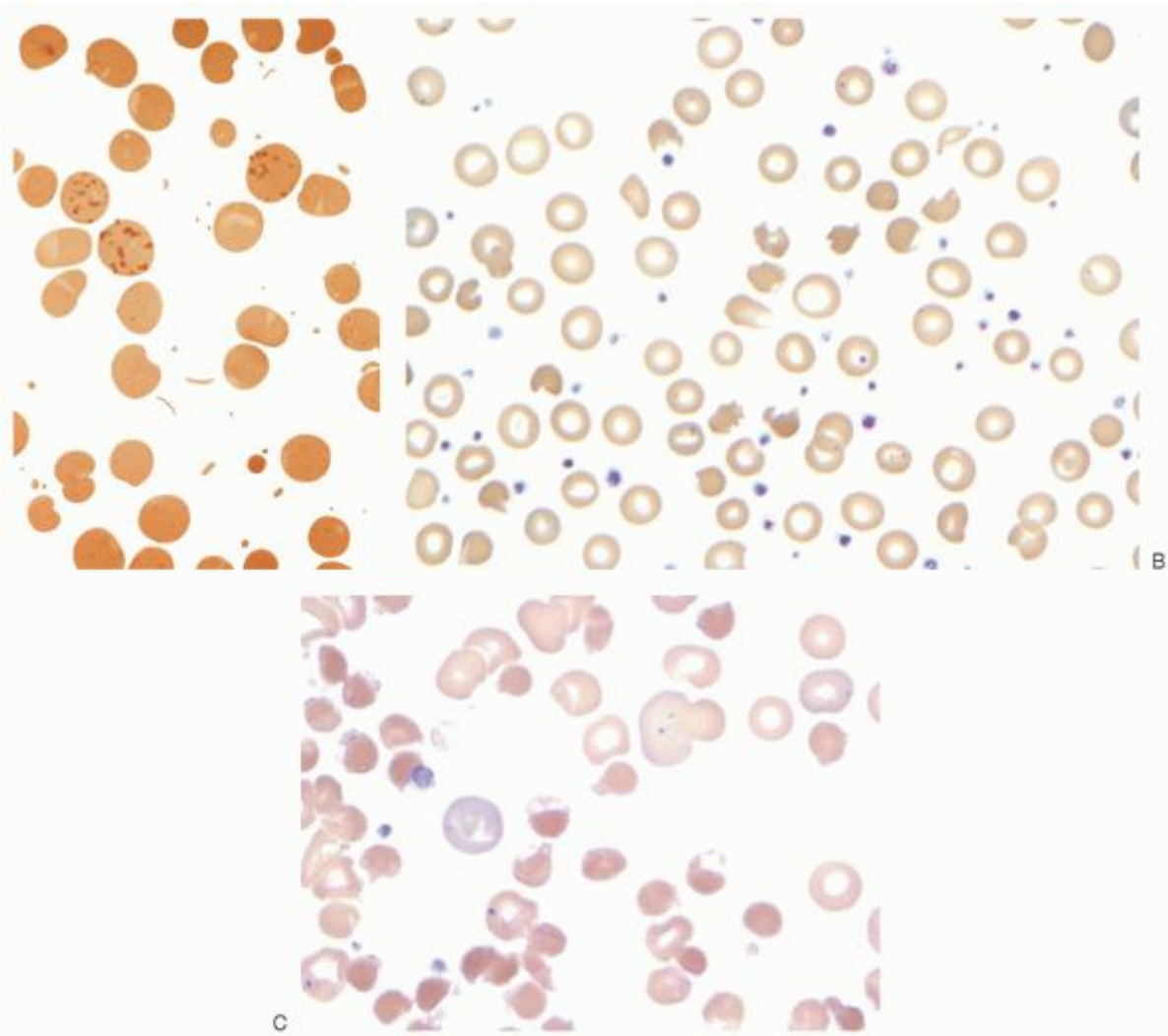

FIGURE 32.4. Morphologic findings characteristic of hemolytic anemia caused by oxidant drugs and chemicals. A: Heinz bodies (seen with brilliant cresyl blue supravital stains of blood during hemolytic episodes). B: “Bite cells” (seen in routine Wright-stained blood smear) as erythrocytes that look as if a semicircular bite has been taken from one edge. C: “Blister cells” or hemighosts (seen in routine Wright-stained blood smear) appear as if hemoglobin has shifted to one side of the cell, leaving the other side clear. These blister red blood cells contain a coagulum of hemoglobin that has separated from the membrane, leaving an unstained non-hemoglobin-containing cell membrane. This image is from a patient receiving Pyridium. (Courtesy of Irma Pereira, MT [ASCP]SH.)

Lead Toxicity

Risk factors for lead toxicity are related to occupational hazards in adults and environmental exposure in children.^{181, 182, 183} Occupational hazards include the manufacturing of batteries, paint or pigments, mining, or smelting; the primary route of assimilation is by inhalation. Environmental exposures in children occur by ingestion of lead from ceramics, paint, gasoline, or water from lead pipes, or having a parent who works in a high-lead environment. Lead poisoning through use of herbal or traditional medicines has also been reported.^{184, 185}

Acute toxicity occurs when lead accidentally gets into a food or water source. Such acute poisoning leads to lead encephalopathy (headache, confusion, stupor, coma, and seizures) and in addition there is abdominal colic, hypertension, and hemolytic anemia. Chronic exposure over time also is associated with a variety of neurologic, gastrointestinal, reproductive, and hematologic complications.

P.816

The peripheral smear shows extensive coarse basophilic stippling and reticulocytosis. Red cell morphology is not otherwise characteristic. The diagnosis of lead-related hemolysis can be made from the history of lead exposure, the physical finding of the gingival lead sulfide line, and the coarse basophilic stippling of red cells. The diagnosis is confirmed by measuring the blood and urine lead levels.

Lead inhibits two steps in heme synthesis: d-aminolevulinic acid dehydratase and heme synthetase (or ferrochelatase). The latter enzyme catalyzes the insertion of iron into protoporphyrin IX to form heme. The lead-induced inhibition of ferrochelatase is responsible for the increase in free erythrocyte protoporphyrin seen in this disorder and also is the basis of a simple screening test for lead toxicity.

The explanation for hemolysis in acute lead toxicity is not known for sure, but it is intriguing that the basophilic stippling seen in acute lead poisoning is similar to that found in hereditary deficiency of the enzyme pyrimidine 5'-nucleotidase (P5'N) (Chapter 28). In the enzyme-deficient cells, intracellular aggregates form as a consequence of impaired ribosomal degradation; these aggregates appear as basophilic stippling on Wright-stained peripheral blood smears. Of interest, the P5'N enzyme is readily inactivated by heavy metals such as lead, and it has been proposed that the basophilic stippling in lead poisoning is secondary to acquired P5'N deficiency.^{186, 187, 188, 189} As blood lead levels approach 200- $\mu\text{g}/\text{dl}$ packed red cells, P5'N activity decreases to levels comparable to those associated with the homozygous deficiency state, intracellular pyrimidine nucleotides accumulate, and basophilic stippling can be demonstrated.^{187, 190}

Water (Osmotic Hemolysis)

There are anecdotal reports of hemolysis following inadvertent injection of water and other hypotonic fluids.¹⁹¹ Hemoglobinuria, renal failure, and death were observed in association with transurethral resection of the prostate when distilled water was used for irrigation. Apparently, the water entered the bloodstream by way of the lymphatic and venous channels opened during the operation.¹⁹² Hemolysis also has been noted in survivors of near-drowning in fresh water.¹⁹³ The entry of more than 0.6 L of water into the circulation produces hemoglobinemia and hemoglobinuria as a result of osmotic hemolysis.

HEMOLYSIS WITH VENOMS

Spider Bites

Certain spider bites produce severe, necrotic, gangrenous lesions ("necrotic arachnidism") that may be associated with hemolytic anemia or disseminated intravascular coagulation, and occasionally renal failure.^{194, 195, 196, 197, 198} In South America and the south-western part of the United States, the spiders implicated are the brown recluse spider (*Loxosceles reclusa*) and other *Loxosceles* species.^{198, 199} In the northwestern United States, a similar picture follows the bite of the hobo spider, *Tegenaria agrestis*.^{200, 201}

The initially painless *Loxosceles* bite develops into a painful, edematous, necrotic lesion that may progress to an extensive, slowly healing, gangrenous process, necrotic arachnidism.^{199, 202, 203} In a few patients, systemic manifestations, including intravascular hemolytic anemia, develop within several hours to 5 days later. Hemoglobinuria and severe anemia are characteristic findings; spherocytes and leukocytosis are found in the blood. Thrombocytopenia also has been observed, sometimes associated with diffuse intravascular coagulation.²⁰⁴ In some cases, red cells are coated with complement and the direct antiglobulin test is positive.^{203, 205, 206} Most often, the hemolytic episode subsides spontaneously in about 1 week, but occasionally severe reactions occur with renal failure and death.

The spider venom primarily attacks endothelium and secondarily activates granulocytes with adhesion and discharge of their granular contents.²⁰⁷ Granulocytes are required for the necrotic process to ensue. The spider venom also causes complement-dependent intravascular hemolysis associated with cleavage of glycophorin from the red cell membrane.^{202, 205, 208} These events occur because *Loxosceles* venom contains sphingomyelinase activity that activates a membrane-bound metalloproteinase.^{209, 210, 211} Recombinant *Loxosceles* neutral sphingomyelinase is the target antigen in an experimental antivenom for brown recluse bite.²¹²

Treatment of spider-bite-induced hemolysis is largely supportive.

Snake bites

Snake bites are a significant health problem worldwide, especially in parts of Asia where thousands of people die from them annually.²¹³ The composition of snake venom varies considerably between species, between the same species living in different geographical locations, and in the same snake at different times of the year. Most venoms contain a mixture of active ingredients.^{214, 215} The problems resulting from snake venoms include neurotoxicity, myotoxicity, renal failure, edema, bleeding due to activation of clotting proteins, and intravascular hemolysis. Hemolysis is seen following

evenomation with most poisonous snakes including cobras,^{216, 217} Australian king brown snakes,²¹⁸ the Tunisian sawscaled (carpet) viper,²¹⁹ North American rattlesnakes,²²⁰ habu snakes²²¹ (191), and the several species of Russell viper (*Daboia russelli*) found throughout India and the rest of Asia.^{213, 214, 215, 222} Much of our information regarding the pathophysiology of envenomization comes from studies of the Russell viper in Asia.²¹⁵

The clinical presentation of intravascular hemolysis from snake bites can be acute and fulminant, or the effects can be delayed for a few hours to days. Hemoglobinemia and hemoglobinuria are present, the severity of which varies with the degree of evenomation and species of snake. There are a variety of components in venom which may be contributing to hemolysis. The best studied of these is phospholipase A₂, which has direct toxicity for many tissues including the red cell membrane.^{215, 223} Venom from the habu snake contains enzymes that activate complement and cleaves CD55 and CD59 from the red cell membrane, thus leaving the red cell susceptible to complement-induced lysis.²²¹ Other snake venoms contain protein kinase C inhibitors implicated in hemolysis.²²⁴

Bee Stings

Africanized honey bees (*Apis mellifera*) were originally a problem in Brazil²²⁵ where these bees were accidentally released in the 1950s. By 1990, they were reported in Texas and are now distributed through the United States as far north as the Canadian border.²²⁶ These bees are aggressive and their attacks are usually massive.²²⁷

The effects of bee stings can be immediate or delayed. "Immediate" reactions are related to anaphylaxis. "Delayed" reactions refer to patients who are asymptomatic after massive bee evenomation, but 12 to 24 hours later, have evidence of hemolysis, disseminated intravascular coagulation, thrombocytopenia, rhabdomyolysis, liver dysfunction, or renal failure.^{228, 229} The delayed effects are related to the degree of evenomation, and it is thought that problems in an adult occur after 100 to 500 stings, although as few 30 to 50 stings can be problematic in a child.²³⁰ In one instance, a 3-year-old child stung 200 to 300 times by honeybees died after the development of intravascular hemolysis and oliguric renal failure.²³¹ The venom contains melittin and phospholipase A₂, which together disrupt the red cell membrane and cause hemolysis.²²⁷ Hemolytic reactions to bee stings appear to be rare. Renal failure is a much more significant problem than hemolytic anemia.

P.817

HEMOLYSIS WITH THERMAL INJURY

Burns

Acute hemolytic anemia has been observed after extensive thermal burns.^{232, 233, 234} Signs of intravascular hemolysis are associated with schistocytes, spherocytes, and echinocytes in the blood along with increased osmotic and mechanical fragility of the erythrocytes.^{234, 235} The severity of the reaction is related to the area of body surface affected. In one series, hemoglobinuria was found in 11 of 14 patients who were moderately to severely burned with more than 15% of the body surface involved in most cases.²³⁴ In another series, hemolysis was apparent in patients with third-degree burns affecting more than 20% of the body surface.²³⁶

Hemolysis occurs during the first 24 to 48 hours after the burn²³⁵ and as much as 30% of the circulating red cell mass may be destroyed in this 2-day period.²³⁷ After the acute hemolytic episode, anemia develops and may last for many weeks,²³² although signs of hemolysis disappear. This later stage of the anemia of thermal injury is probably a form of the anemia of chronic disorders (see Chapter 41).^{238, 239, 240, 241}

The acute hemolytic reaction in burned patients results from the direct effects of heat on erythrocytes. When red cells are heated to temperatures >47°C, irreversible morphologic and functional abnormalities occur, the severity of which is related to the temperature and the duration of exposure.^{242, 243} The major alterations are fragmentation of the cells and the development of spherocytes, accompanied by an increase in osmotic and mechanical fragility. These changes result from irreversible denaturation of the cytoskeletal protein spectrin.^{244, 245, 246} Mildly heat-damaged erythrocytes are removed predominantly by the spleen, and with greater degrees of damage, the red cells also are destroyed in the liver.^{243, 247}

Heated Fluids and Blood

Overheating of biologic fluids is another clinical circumstance resulting in thermal red cell damage. One reported example of this was the overheating of dialysis solution due to failure of thermostatic controls on the hemodialysis equipment.²⁴⁸ It

is also recognized that direct microwave warming of blood prior to transfusion can damage red cells and cause hemolytic anemia following infusion.^{249, 250, 251} Similarly, the heating of intravenous tubing has resulted in hemolysis.²⁵²

The U.S. Food and Drug Administration-approved inline blood warmers, equipped with thermometers and alarms, and close adherence to the manufacturer's specific directions should provide a safety level that prevents the accidental overheating of blood.

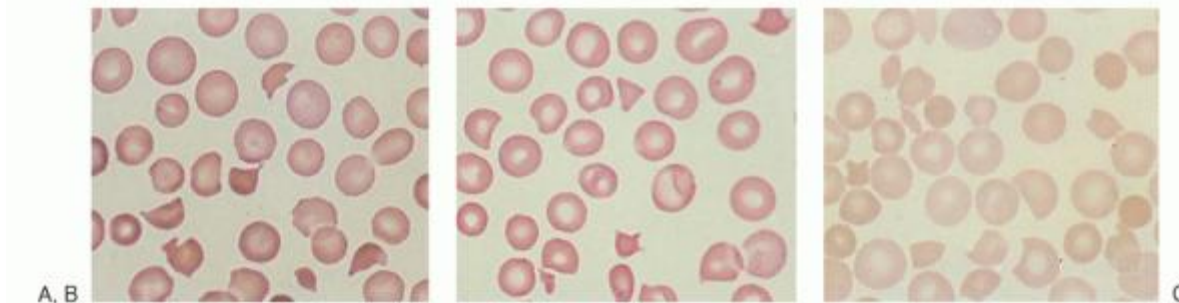

FIGURE 32.5. Schistocytes in patients with (A) thrombotic thrombocytopenic purpura, (B) disseminated intravascular coagulation, and (C) aortic valve replacement.

FRAGMENTATION HEMOLYSIS

When red cells are subjected to excessive physical trauma, they may undergo premature fragmentation and intravascular hemolysis, thereby resulting in hemoglobinemia, hemoglobinuria, and hemosiderinuria. The hallmark of this type of hemolysis is the fragmented red cell or schistocyte, and these cells take the form of crescents, helmets, triangles, and/or microspherocytes (Fig. 32.5). Hemolytic anemias resulting from red cell fragmentation are associated with abnormalities of the heart and great vessels, diseases of small vessels, disseminated intravascular coagulation, and hypertension (Table 32.3). In most of these conditions hemolysis is one of many clinical findings, and usually not the major problem.

Cardiac and Large Vessel Abnormalities

Etiology

Soon after the advent of open-heart surgery came the realization that the postoperative course of some patients was complicated by the development of anemia of varying severity. The discovery of fragmented red cells as a characteristic feature of this type of anemia was made in 1961, when Sayed et al. described these morphologic alterations in a patient who developed severe and persistent intravascular hemolysis after repair of an ostium primum defect with Teflon.²⁵³ It is now well recognized that fragmented erythrocytes with intravascular hemolysis are commonly associated with a wide variety of structural defects of the heart or great vessels (Table 32.3). Surgically inserted prosthetic devices, particularly heart valves, furnish the most striking examples of red cell fragmentation. Most of the prosthetic valves associated with hemolytic disease are of the aortic variety,^{254, 255, 256, 257} but cases of hemolysis caused by mitral valve replacement^{258, 259, 260, 262, 263, 264, 265} unsuccessful mitral valvoplasties,^{266, 267} and repair of ruptured chordae tendineae²⁶⁸ also have been reported. The use of bioprostheses has reduced the risk of hemolysis greatly, although red cell fragmentation still occurs after the insertion of porcine xenografts or bioprostheses constructed from bovine tissues.^{261, 269, 270, 271, 272, 273} In these patients, hemolysis usually is associated with a paravalvular leak,²⁷⁰ a torn cusp,²⁷¹ or other manifestations of valvular dysfunction,²⁶⁹ including infective endocarditis or calcification.²⁷⁴

Intracardiac patch repairs of various types also may lead to intravascular hemolysis^{253, 275, 276}; typical cases involve patients with Teflon patches used in the repair of ostium primum defects.

Mechanical ventricular assist devices and other similar pumpbased technologies employed as a bridge to cardiac transplantation are also associated with mechanical hemolysis.^{277, 278}

Last, although red cell fragmentation is associated most strikingly with intracardiac surgical procedures, intravascular

P.818

hemolysis occurs in many patients with valvular heart disease who have not had surgery.^{279, 280, 281, 282} Most often, this red cell fragmentation is noted in patients suffering from severe aortic valve disease, especially aortic stenosis; occasionally, however, patients with mitral valve involvement are affected. Intravascular hemolysis also has been reported in patients with a ruptured aneurysm of the sinus of Valsalva,²⁸³ coarctation of the aorta,²⁸⁴ coarctation with a bicuspid aortic

valve,²⁸⁵ and a ventricular septal defect in conjunction with a patent ductus arteriosus.²⁸⁶ The hemolysis accompanying valvular heart disease that has not been treated surgically is usually minor and rarely severe.

TABLE 32.3 CAUSES OF RED CELL FRAGMENTATION

Associated with abnormalities of the heart and great vessels

Synthetic valvular prostheses

Valve homografts

Valve xenografts and xenobioprostheses

Autograft valvoplasties

Ruptured chordae tendineae

Intracardiac patch repairs

Unoperated valve disease (especially aortic stenosis)

Coarctation of the aorta

Associated with small vessel disease: microangiopathic hemolytic anemia

Thrombotic thrombocytopenic purpura (TTP)

Hemolytic-uremic syndrome (HUS)

HUS/TTP-related disorders

Disseminated carcinoma

Chemotherapy/drugs

Transplant-associated microangiopathy

Pregnancy and postpartum period

HELLP syndrome

TTP/HUS

Malignant hypertension

Disseminated intravascular coagulation

Immune mechanisms

Lupus erythematosus

Acute glomerulonephritis

Scleroderma

Wegener granulomatosis

Hemangiomas

Giant hemangioma (Kasabach-Merritt syndrome)

Hemangioendothelioma of the liver

Plexiform lesions in pulmonary hypertension

March hemoglobinuria

HELLP, hemolysis, elevated liver enzymes, and low platelet counts.

Incidence

Clinically significant hemolytic disease is reported in 5% to 25% of patients with various types of valvular prostheses,^{254, 287, 288} usually involving replacement of defective aortic valves, and in about 5% of patients with Teflon repairs of ostium primum defects.²³¹ The incidence of clinically detectable hemolysis in patients with mitral valve prostheses is considerably lower, although the incidence of hemolysis with ring repair of mitral valve defects was 3.8% in one series.²⁶⁵ When more sensitive techniques are used to detect red cell destruction, such as red cell survival studies^{279, 281, 289} or haptoglobin levels,^{282, 290, 291, 292} most patients with aortic valvular prostheses have evidence of mild intravascular hemolysis. Undoubtedly, the severity of the valvular disease is an important variable.

Pathogenesis

Several mechanisms may account for the intravascular nature of the hemolysis and the appearance of the characteristic fragmented cells.

Direct mechanical trauma, for instance by the closure of prosthetic valves, has been postulated; it is known also to occur in other conditions, such as march hemoglobinuria.²⁹³ However, it is unlikely that valve closure itself is responsible for RBC fragmentation inasmuch as many patients with prosthetic valves do not have clinically significant hemolysis. It also is unlikely that the presence of prosthetic materials per se contributes to red cell fragmentation,^{254, 294} although Teflon that is not covered by endothelium^{253, 276} has been found at reoperation in some patients. In all likelihood, therefore, both hemolysis and the lack of endothelialization depend on the presence of a third factor, such as turbulence.

The most common feature in recorded cases of hemolysis occurring after the insertion of prosthetic devices is the existence of some form of hemodynamic defect, such as regurgitation through or around valvular prostheses^{254, 263, 270} or mitral insufficiency after Teflon patch repair of atrioventricular canal defects.²⁷⁵ Teflon patch-associated hemolysis has become less common as the use of biomaterial and autologous patches has increased.^{295, 296} Extreme turbulence is a common factor in all of these patients and can routinely generate shearing stress $>3,000$ dyn/cm²,^{259, 297, 298} leading to mechanical hemolysis in vitro²⁹⁹ and in vivo, such as in the presence of regurgitant defects between the aorta and the left ventricle, when the lumen of the aortic prosthesis is small relative to the stroke volume or when the ball of a ball valve is large relative to the diameter of the aorta.

Clinical Manifestations

No distinctive clinical features are noted, with the exception of those related to pre-existent heart disease or cardiac surgery. The development of hemolysis sometimes coincides with severe deterioration of cardiac function because of the tear of a valve cusp or the loosening of valve attachments. When the hemolysis is clinically significant, jaundice often is obvious, but hemoglobinuria may not be detectable by the naked eye.

Laboratory Findings

The blood findings of these patients vary widely, depending on the severity of the hemolytic process. The hemoglobin level may be normal if the hemolysis is compensated, or it may be extremely low. Most cells are normocytic and normochromic, but there also are variable numbers of fragmented erythrocytes, and these are identical to the schistocytes seen in patients with microangiopathic hemolytic anemia (Fig. 32.5). The number of fragmented cells apparent in the blood smear directly reflects the severity of the hemolytic process.³⁰⁰ In patients with long-standing hemolysis, iron stores may be depleted because of hemoglobinuria and hemosiderinuria, and the red cells may appear hypochromic due to iron deficiency. Hemosiderinuria is present in many patients when hemoglobinuria is not detectable. The serum bilirubin level is slightly or moderately raised. Serum haptoglobin is reduced or absent. Lactic dehydrogenase (LDH) levels usually are elevated. The reaction to the antiglobulin test is usually, but not always, negative. A positive direct antiglobulin test is observed occasionally in a few patients with prosthetic valves^{301, 302, 303} and occasionally in patients with severe aortic valve disease in the absence of

P.819

surgical intervention.³⁰⁴ It is possible that mechanical damage may expose subsurface antigens, which then elicit the production of autoantibodies.

Treatment

A marked degree of anemia and elevated LDH often indicate wear or malfunction of a valvular prosthesis,^{258, 300} and under these circumstances, prompt surgical intervention and valve replacement are usually indicated. Only occasionally does the condition causing hemolysis improve spontaneously.²⁵⁶ Severity of the hemolytic process increases with physical activity.³⁰⁵ When iron deficiency has developed because of prolonged hemosiderinuria, iron therapy is indicated.

Erythropoietin has been used to reduce the need for blood transfusion.³⁰⁶ Folate supplementation may also assist in maintaining an adequate erythropoietic response to hemolysis.

Small Vessel Disease (Microangiopathic Hemolytic Anemia)

In 1952, Symmers introduced the term microangiopathic hemolytic anemia to describe a clinical syndrome now commonly called thrombotic thrombocytopenic purpura (TTP).³⁰⁷ Brain et al. subsequently popularized the term,³⁰⁸ and it is now used to designate any hemolytic anemia related to red cell fragmentation occurring in association with small vessel disease (Table 32.3).

The term thrombotic microangiopathy also is used to describe syndromes characterized by hemolytic anemia with red cell fragmentation, thrombocytopenia, and thrombotic lesions in small blood vessels.³⁰⁹

TTP and the hemolytic-uremic syndrome (HUS) are similar disorders included in this category. They share many laboratory and clinical features, and the clinical distinction between TTP and HUS is not always clear. There are also TTP/HUS-related conditions seen with pregnancy, cancer, collagen vascular disease, drug therapy, tissue transplantation, and other disorders (Table 32.3). A detailed discussion of TTP, HUS, and related disorders can be found in Chapter 48, and TTP related to pregnancy is discussed in Chapter 42.

Hemolysis due to Malignant Hypertension

An association between red cell fragmentation and malignant hypertension was first recorded in 1954 and has since been confirmed in many other studies.^{310, 311} The pathogenesis of microangiopathic hemolytic anemia in malignant hypertension is attributed to the presence of fibrinoid necrosis within the arterioles,³⁰⁸ which in turn appears to depend on the presence of hypertension.

Hemolysis due to Disseminated Intravascular Coagulation

Microangiopathic hemolytic anemia is associated with a variety of disorders characterized by disseminated intravascular coagulation (DIC), including sepsis,^{312, 313} purpura fulminans,³¹⁴ heat stroke,³¹⁵ and abruptio placentae.³¹⁶ In all of these clinical conditions, red cell fragmentation is thought to result from the deposition of fibrin within the microvasculature. Fortunately, hemolysis often is not severe and may not contribute significantly to the morbidity of the disease. As the underlying disease comes under control with appropriate therapy, the fragmentation of red cells also ceases.

The generation of RBC fragmentation with DIC is supported by classical experimental animal data. When intravascular coagulation is induced in rabbits by the infusion of endotoxin³⁰⁸ or thrombin,³¹⁷ the onset of red cell fragmentation and hemoglobinemia is closely linked to the development of renal glomerular thrombosis. These findings indicate a link between the deposition of platelet and fibrin thrombi and red cell fragmentation, and this is supported by histologic studies that associate hemolysis with a loose fibrin network to which red cells adhere.³¹⁸ From in vitro experiments it has been observed that when red cells are forced through a loose fibrin clot within a slide chamber, they attach to fine fibrin threads and fold around these razor-sharp strands (Fig. 32.6).³¹⁹ As other cells flow past the attached RBCs, they cause either their release or their fragmentation, often with resealing of the membrane, and thus the formation of red cell fragments described. Similar results are obtained when nylon or glass fibers are used in artificial circuits.³¹⁹

Fragmentation Hemolysis with Immune Disorders

Microangiopathic hemolytic anemia may be a feature of diseases in which the microvasculature is damaged by immune mechanisms. Connective tissue diseases characterized by vasculitis, which occasionally lead to red cell fragmentation, include lupus erythematosus³²⁰ and perhaps rheumatoid arthritis, Sjögren syndrome, and polyarteritis nodosa.³⁰⁹ Red cell fragmentation also has been observed in association with polymyositis,³⁰⁹ scleroderma,³²¹ Wegener granulomatosis,^{322, 323} giant cell arteritis,³²⁴ and Still disease.³²⁵ The diverse symptomatology of vasculitic disorders, along with the presence of microangiopathic hemolysis, may lead to these disorders being confused with TTP. ADAMTS13 activity levels, although often lower in vasculitic disorders than in healthy patients, are rarely as low as is typical for TTP (discussed in Chapter 48).^{326, 327}

Circulating immune complexes trigger the coagulation cascade,³²⁸ leading to fibrin deposition, which in turn stimulates the proliferation of endothelial cells. Fibrin deposition and endothelial changes, including immune-complex-mediated damage of endothelial cells, are probably responsible for the red cell fragmentation that occurs in disorders characterized by the presence of circulating immune complexes. Such complexes, together with red cell fragmentation, have been found in patients with a variety of disorders, including TTP, subacute bacterial endocarditis,³²⁹ and glomerulonephritis.^{330, 331} The significance of this association is unclear, however, because immune complexes are commonly

found in patients with some of these conditions, whereas red cell fragmentation and other manifestations of thrombotic microangiopathy are much less common.

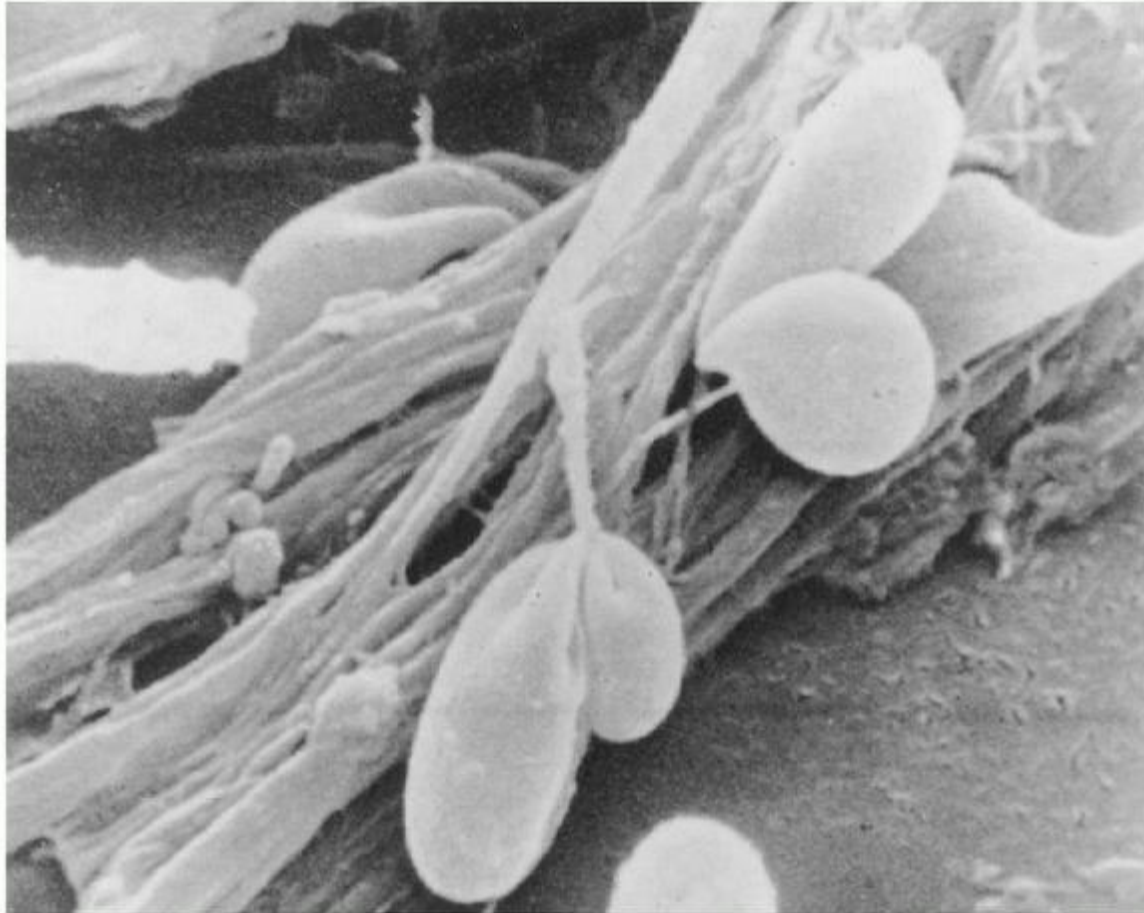

FIGURE 32.6. Scanning electron micrograph. Red cells are “clotheslined” over fine fibrin strands (in vitro model). Other cells, moving past these trapped erythrocytes, may cause their fragmentation. Thicker fibrin strands in background do not cause this injury. (From Bull BS, Kuhn IH. The production of schistocytes by fibrin strands. *Blood* 1970;35:104.)

Giant Hemangiomas and Hemangioendotheliomas

Microangiopathic hemolytic anemia has been identified in patients with giant hemangiomas^{332, 333, 334} and in patients with hemangioendotheliomas of the liver.^{335, 336} Microangiopathic hemolytic anemia also has been described in the blue rubber-bleb nevus syndrome, a rare disorder characterized by subcutaneous and gastrointestinal hemangiomas.³³⁷ It is thought that local coagulation in the abnormal blood vessels plays a role in red cell fragmentation.³³² Therapeutic resolution of the hemangioma cures the microangiopathic hemolytic anemia and consumption coagulopathy.³³³

March Hemoglobinuria

March hemoglobinuria is an unusual hemolytic disorder in which transient hemoglobinemia and hemoglobinuria develop in susceptible individuals after strenuous exercise that involves forceful contact of the body with a hard surface. Although red cell fragmentation is not always evident, the condition carries all the hallmarks of acute intravascular hemolysis, which presumably results from the mechanical disruption of circulating red cells. Few cases have been reported since Fleischer described the first case in 1881.²⁹³ Clinically inapparent hemoglobinemia may be more common.

March hemoglobinuria primarily affects young males.^{293, 338} Hemoglobinuria is precipitated by prolonged marches or competitive running, but the syndrome has also been noted in conga drum players^{339, 340} and people participating in karate exercises.³⁴¹ Passage of red or dark urine after physical exertion is often the only complaint. Occasionally, symptoms include nausea; vague abdominal, back, or thigh pain; or a burning feeling in the soles of the feet.

Hemoglobinuria characteristically occurs immediately after exercise and lasts for only a few hours. March hemoglobinuria most commonly affects athletes at the beginning of a running career or on resumption of road training.³⁴²

Laboratory studies show evidence of intravascular hemolysis, specifically hemoglobinemia and a decreased serum haptoglobin concentration. Significant anemia is uncommon. The bilirubin concentration rarely exceeds 2 mg/dl. Serum lactic dehydrogenase levels may be elevated. The urine contains hemoglobin; after recurrences, it also may contain hemosiderin. Long-distance runners may develop iron deficiency attributable to hemosiderinuria, although the possibility of exercise-associated gastrointestinal bleeding in long-distance runners must also be considered.³⁴³ Swimmers, who do not sustain comparable trauma, have a similar situation.³⁴⁴

Hemoglobinuria can be prevented by the use of shoes with thicker and more resilient soles than those usually worn. Thus, one postulate was that susceptible individuals destroy red cells in the soles of their feet while running. Confirmation came from the ingenious experiments of Davidson, who inserted polyvinyl tubes containing blood into the running shoes of susceptible individuals and showed that these runners destroyed their own and the control blood at about the same rate, and to a greater degree than control subjects running on the same surface.³⁴⁵ Whether hemolysis is entirely attributable to the type of exercise and the style of running or whether other factors make the red cells of some people particularly susceptible to hemolysis is not clear.³⁴⁶

No specific therapy is usually needed for individuals with march hemoglobinuria. Attacks may be prevented by wearing shoes with more resilient soles and by changing to a less traumatic running style. Banfi and colleagues have reported that immersion of the legs in cold water for several minutes, either before or after training, prevents hemolysis and hemoglobinuria in rugby players.³⁴⁷

OTHER CAUSES OF HEMOLYSIS

Hemolytic anemia is also seen in association with a number of nonhematologic systemic disorders, and in most cases there are several etiologies to the anemia.

Hypersplenism

Normal functions of the spleen include the monitoring and processing of "old" and "damaged" red cells. These culling and pitting functions are executed by macrophages that line reticuloendothelial sinuses of the spleen, and also the liver and bone marrow (Chapter 65). Macrophages have receptors that recognize immunoglobulin and complement molecules on the RBC surface, and possibly receptors that detect alterations in the outer portion of the phospholipid bilayer. The spleen is considered to be the most stringent of the reticuloendothelial filters, and this is aided by the slow rate of blood flow through the splenic red pulp.

Broadly defined, the term hypersplenism refers to sequestration and/or destruction of blood cells occurring in an enlarged spleen, associated with peripheral anemia and/or neutropenia and/or thrombocytopenia. In experimental animals with splenomegaly induced by methyl cellulose injections, there is accelerated destruction of normal erythrocytes.³⁴⁸ Also, in humans, it is generally held that splenomegaly from any cause can be associated with increased filtering, extended macrophage attack, and increased erythrocyte destruction.³⁴⁹ Rarely does hypersplenism cause significant hemolysis. However, under conditions where macrophages are activated, there may be increased red cell destruction, and this may explain the accelerated hemolysis commonly seen with infections, in particular with malaria.³⁵⁰

Massive splenomegaly often is associated with an increased plasma volume, and in these cases the low hemoglobin or hematocrit gives a falsely low estimate of the true red cell mass.

Liver Disease

Anemia in liver disease has many causes including hemolysis (Chapter 41). One component of this shortened red cell survival relates to portal hypertension and associated splenomegaly. However, the hemolysis occurring under these conditions is usually mild, with varying degrees of a compensatory increase in red cell production.

Another cause of hemolysis in liver disease is associated with the formation of "spur cells," a variant form of acanthocytes. In patients with liver disease, abnormalities in lipid metabolism result in RBCs becoming selectively loaded with excess cholesterol. The cholesterol-loaded RBCs have impaired ability to repair peroxidized membrane lipids,³⁵⁰ and thus they undergo oxidative damage. As a consequence, they become rigid and nondeformable, and are rapidly cleared by the reticuloendothelial system, in particular the spleen^{351, 352} (see Chapter 41).

Attempts to correct portal hypertension have utilized angiographic techniques to create a communication between the intrahepatic portal vein and the hepatic vein. The placement of these transjugular intrahepatic portosystemic shunts

(TIPS) avoids the anesthetic and surgical risks of other shunting procedures; however, some 10% of patients develop mild intravascular hemolysis.³⁵³ The hemolysis usually is self-limited and rarely requires intervention.

Renal Disease

Hemolytic anemia and renal failure together can occur with the thrombotic microangiopathies (Chapter 48). Anemia also P.821

is a frequent complication of primary renal disease, the most common cause being due to impaired erythropoietin production (Chapter 41). However, in some cases there also is a hemolytic component^{354, 355} that is thought to be a consequence of uremia. Classic cross-transfusion studies demonstrated that normal erythrocytes have a shortened survival in uremic patients, whereas red cells from uremic patients survive normally when transfused into healthy control individuals.^{356, 357} RBC survival is decreased in proportion to the blood urea nitrogen concentration,³⁵⁸ and it improves significantly following intensive hemodialysis.³⁵⁹ The exact uremic metabolite responsible for red cell injury is not known and the specific uremia-induced RBC injury that causes shortened RBC survival also is not defined. Of interest, it has also been observed that uremic red cells have increased expression of phosphatidylserine (PS) on the outer membrane surface, and incubation of normal RBC in uremic plasma also induces increased expression of PS on the outer cell surface.^{360, 361} These observations are important because it is now thought that one mechanism for macrophage recognition of damaged RBCs may be the loss of phospholipid asymmetry across the membrane, particularly the appearance of PS on the external side of the membrane^{362, 363} (Chapter 6).

Hypophosphatemia

Severe hypophosphatemia can occur in patients undergoing prolonged antacid therapy, in those receiving intravenous hyperalimentation without phosphorus supplementation, in debilitated and starved people, and in alcoholics. In addition to confusion, weakness, anorexia, malaise, paresthesias, and electroencephalographic and electromyographic changes, hypophosphatemia also has been noted to cause hemolytic anemia.^{364, 365, 366, 367, 368, 369, 370, 371} The anemia is characterized by reticulocytosis and microspherocytosis seen on the peripheral smear.³⁶⁵ In affected individuals, the serum phosphorus concentration invariably is very low.

POSTPERFUSION SYNDROME

Cardiopulmonary bypass sometimes is associated with several adverse reactions including acute intravascular hemolysis, leukopenia, a hemostatic deficit, and nonspecific systemic inflammatory reactions, collectively referred to as the postperfusion syndrome. This systemic dysfunction may result in acute respiratory distress syndrome and shock.

After cardiopulmonary bypass, intravascular hemolysis can occur with hemoglobinemia. The mechanism of hemolysis associated with this syndrome was thought to be due to mechanical factors during surgery.³⁷² However, it now is recognized that complement is activated during the procedure³⁷³ and the terminal C5b-9 complement complexes are deposited on both erythrocytes and polymorphonuclear neutrophilic leukocytes.³⁷⁴ In one interesting study utilizing lysed erythrocyte membranes recovered from blood of patients at the end of bypass surgery, C5b-9 components were identified on the red cell ghosts but not on intact erythrocytes. Moreover, the appearance of ghosts carrying C5b-9 neoantigens always coincided with hemolysis.³⁷⁴ Thus, it now is thought that complement activation occurs as blood flows through the oxygenator, and the resultant deposition of C5b-9 on red cells leads to immediate intravascular hemolysis. The same reactions presumably lead to granulocyte activation and sequestration in the lungs.³⁷³

The hemolytic process is transient. Hematologic treatment is directed toward RBC support as needed until spontaneous resolution occurs.

REFERENCES

1. Hay SI, Guerra CA, Gething PW, et al. A world malaria map: Plasmodium falciparum endemicity in 2007. *PLoS Med* 2009;6(3):e1000048.
2. Guerra CA, Snow RW, Hay SI. Mapping the global extent of malaria in 2005. *Trends Parasitol* 2006;22(8):353-358.
3. Taylor TE, Molyneux ME. Something new out of Africa. *N Engl J Med* 1995;332(21):1441-1442.
4. Jerrard DA, Broder JS, Hanna JR, et al. Malaria: a rising incidence in the United States. *J Emerg Med* 2002;23(1):23-33.
5. Allain JP. Malaria and transfusion: a neglected subject coming back to the forefront. *Clin Infect Dis* 2010;51(10):1199-1200.

6. Isaacson M. Airport malaria: a review. *Bull World Health Organ* 1989;67(6):737-743.
7. Friedmann CT, Dover AS, Roberto RR, Kearns OA. A malaria epidemic among heroin users. *Am J Trop Med Hyg* 1973;22(3):302-307.
8. Kean BH, Reilly PC Jr. Malaria—the mime. Recent lessons from a group of civilian travellers. *Am J Med* 1976;61(2):159-164.
9. Fitzgerald FT. Malaria: a modern dilemma. *West J Med* 1982;136(3): 220-226.
10. Marsh K, Forster D, Waruiru C, et al. Indicators of life-threatening malaria in African children. *N Engl J Med* 1995;332(21):1399-1404.
11. Conrad ME. Pathophysiology of malaria. Hematologic observations in human and animal studies. *Ann Intern Med* 1969;70(1):134-141.
12. Menendez C, Fleming AF, Alonso PL. Malaria-related anaemia. *Parasitol Today* 2000;16(11):469-476.
13. Abdalla S, Weatherall DJ, Wickramasinghe SN, Hughes M. The anaemia of *P. falciparum* malaria. *Br J Haematol* 1980;46(2):171-183.
14. Wickramasinghe SN, Abdalla SH. Blood and bone marrow changes in malaria. *Bailliere's best practice & research. Clin Haematol* 2000;13(2):277-299.
15. Canfield CJ. Renal and hematologic complications of acute falciparum malaria in Vietnam. *Bull N Y Acad Med* 1969;45(10):1043-1057.
16. Perrin LH, Mackey LJ, Miescher PA. The hematology of malaria in man. *Semin Hematol* 1982;19(2):70-82.
17. Okafor HU, Nwaiwu O. Anemia of persistent malarial parasitemia in Nigerian children. *J Trop Pediatr* 2001;47(5):271-275.
18. Niazi GA. Haematological aspect of malaria in a population based hospital, Saudi Arabia. *J Egypt Soc Parasitol* 1995;25(3):787-793.
19. Miller LH, Mason SJ, Clyde DF, McGinniss MH. The resistance factor to *Plasmodium vivax* in blacks. The Duffy-blood-group genotype, FyFy. *N Engl J Med* 1976;295(6):302-304.
20. Hadley TJ, Klotz FW, Pasvol G, et al. Falciparum malaria parasites invade erythrocytes that lack glycophorin A and B (MkMk). Strain differences indicate receptor heterogeneity and two pathways for invasion. *J Clin Invest* 1987;80(4):1190-1193.
21. Mitchell GH, Hadley TJ, McGinniss MH, Klotz FW, Miller LH. Invasion of erythrocytes by *Plasmodium falciparum* malaria parasites: evidence for receptor heterogeneity and two receptors. *Blood* 1986;67(5):1519-1521.
22. Pasvol G, Jungery M, Weatherall DJ, Parsons SF, Anstee DJ, Tanner MJ. Glycophorin as a possible receptor for *Plasmodium falciparum*. *Lancet* 1982;2(8305):947-950.
23. Boyle MJ, Richards JS, Gilson PR, Chai W, Beeson JG. Interactions with heparin-like molecules during erythrocyte invasion by *Plasmodium falciparum* merozoites. *Blood* 2010;115(22):4559-4568.
24. Tham WH, Schmidt CQ, Hauhart RE, et al. *Plasmodium falciparum* uses a key functional site in complement receptor type-1 for invasion of human erythrocytes. *Blood* 2011;118(7):1923-1933.
25. Goldberg DE. Hemoglobin degradation in *Plasmodium*-infected red blood cells. *Seminars in cell biology* 1993;4(5):355-361.
26. Gritzmacher CA, Reese RT. Reversal of knob formation on *Plasmodium falciparum*-infected erythrocytes. *Science* 1984;226(4670):65-67.
27. Wyler DJ. Malaria—resurgence, resistance, and research (First of two parts). *N Engl J Med* 1983;308(15):875-878.
28. Wyler DJ. Malaria—resurgence, resistance, and research (second of two parts). *N Engl J Med* 1983;308(16):934-940.
29. Davis TM, Krishna S, Looareesuwan S, et al. Erythrocyte sequestration and anemia in severe falciparum malaria. Analysis of acute changes in venous hematocrit using a simple mathematical model. *J Clin Invest* 1990;86(3):793-800.
30. Phillips RE, Pasvol G. Anaemia of *Plasmodium falciparum* malaria. *Baillieres Clin Haematol* 1992;5(2):315-330.

31. Awandare GA, Kempaiah P, Ochiel DO, Piazza P, Keller CC, Perkins DJ. Mechanisms of erythropoiesis inhibition by malarial pigment and malaria-induced proinflammatory mediators in an in vitro model. *Am J Hematol* 2011;86(2):155-162.
32. Skorokhod OA, Caione L, Marrocco T, et al. Inhibition of erythropoiesis in malaria anemia: role of hemozoin and hemozoin-generated 4-hydroxynonenal. *Blood* 2010;116(20):4328-4337.
33. Miller LH, Usami S, Chien S. Alteration in the rheologic properties of *Plasmodium knowlesi*—infected red cells. A possible mechanism for capillary obstruction. *J Clin Invest* 1971;50(7):1451-1455.
35. Dondorp AM, Kager PA, Vreeken J, White NJ. Abnormal blood flow and red blood cell deformability in severe malaria. *Parasitol Today* 2000;16(6):228-232.
36. Looareesuwan S, Ho M, Wattanagoon Y, et al. Dynamic alteration in splenic function during acute falciparum malaria. *N Engl J Med* 1987;317(11): 675-679.
37. Schnitzer B, Sodeman TM, Mead ML, Contacos PG. An ultrastructural study of the red pulp of the spleen in malaria. *Blood* 1973;41(2):207-218.
38. Wyler DJ, Quinn TC, Chen LT. Relationship of alterations in splenic clearance function and microcirculation to host defense in acute rodent malaria. *J Clin Invest* 1981;67(5):1400-1404.
39. Wickramasinghe SN, Phillips RE, Looareesuwan S, Warrell DA, Hughes M. The bone marrow in human cerebral malaria: parasite sequestration within sinusoids. *Br J Haematol* 1987;66(3):295-306.
40. Looareesuwan S, Merry AH, Phillips RE, et al. Reduced erythrocyte survival following clearance of malarial parasitaemia in Thai patients. *Br J Haematol* 1987;67(4):473-478.
41. Woodruff AW, Ansdell VE, Pettitt LE. Cause of anaemia in malaria. *Lancet* 1979;1(8125):1055-1057.
42. Abdalla S, Weatherall DJ. The direct antiglobulin test in *P. falciparum* malaria. *Br J Haematol* 1982;51(3):415-425.
43. Wickramasinghe SN, Looareesuwan S, Nagachinta B, White NJ. Dyserythropoiesis and ineffective erythropoiesis in *Plasmodium vivax* malaria. *Br J Haematol* 1989;72(1):91-99.
44. Clark IA, Chaudhri G. Tumour necrosis factor may contribute to the anaemia of malaria by causing dyserythropoiesis and erythrophagocytosis. *Br J Haematol* 1988;70(1):99-103.
45. Anyona SB, Kempaiah P, Raballah E, et al. Functional promoter haplotypes of interleukin-18 condition susceptibility to severe malarial anemia and childhood mortality. *Infect Immun* 2011;79(12):4923-4932.
46. Ong'echa JM, Davenport GC, Vulule JM, Hittner JB, Perkins DJ. Identification of inflammatory biomarkers for pediatric malarial anemia severity using novel statistical methods. *Infect Immun* 2011;79(11):4674-4680.
47. Wenisch C, Parschalk B, Narzt E, Looareesuwan S, Graninger W. Elevated serum levels of IL-10 and IFN-gamma in patients with acute *Plasmodium falciparum* malaria. *Clin Immunol Immunopathol* 1995;74(1):115-117.
48. Grau GE, Taylor TE, Molyneux ME, et al. Tumor necrosis factor and disease severity in children with falciparum malaria. *N Engl J Med* 1989;320(24):1586-1591.
49. Kern P, Hemmer CJ, van Damme J, Gruss HJ, Dietrich M. Elevated tumor necrosis factor alpha and interleukin-6 serum levels as markers for complicated plasmodium falciparum malaria. *Am J Med* 1989;87:139-143.
50. Burgmann H, Looareesuwan S, Kapiotis S, et al. Serum levels of erythropoietin in acute *Plasmodium falciparum* malaria. *Am J Trop Med Hyg* 1996;54(3):280-283.
51. el Hassan AM, Saeed AM, Fandrey J, Jelkmann W. Decreased erythropoietin response in *Plasmodium falciparum* malaria-associated anaemia. *Eur J Haematol* 1997;59:299-304.
52. Leowattana W, Krudsood S, Tangpukdee N, Brittenham G, Looareesuwan S. Defective erythropoietin production and reticulocyte response in acute *Plasmodium falciparum* malaria-associated anemia. *Southeast Asian J Trop Med Public Health* 2008;39(4):581-588.
53. Kurtzhals JA, Rodrigues O, Addae M, Commey JO, Nkrumah FK, Hviid L. Reversible suppression of bone marrow response to erythropoietin in *Plasmodium falciparum* malaria. *Br J Haematol* 1997;97(1):169-174.
54. Casals-Pascual C, Huang H, Lakhal-Littleton S, et al. Hepcidin demonstrates a biphasic association with anemia in acute *Plasmodium falciparum* malaria. *Haematologica* 2012;97(11):1695-1698.

55. de Mast Q, Syafruddin D, Keijmel S, et al. Increased serum hepcidin and alterations in blood iron parameters associated with asymptomatic *P. falciparum* and *P. vivax* malaria. *Haematologica* 2010;95(7):1068-1074.
56. de Mast ECQ. Mild increases in serum hepcidin and interleukin-6 concentrations impair iron incorporation in haemoglobin during an experimental human malaria infection. *Br J Haematol* 2009;145(5):657-664.
57. Nweneka CV, Doherty CP, Cox S, Prentice A. Iron delocalisation in the pathogenesis of malarial anaemia. *Trans R Soc Trop Med Hyg* 2010;104(3):175-184.
58. Tamez PA, Liu H, Fernandez-Pol S, Halder K, Wickrema A. Stage-specific susceptibility of human erythroblasts to *Plasmodium falciparum* malaria infection. *Blood* 2009;114(17):3652-3655.
59. Hadley TJ. Invasion of erythrocytes by malaria parasites: a cellular and molecular overview. *Annu Rev Microbiol* 1986;40:451-477.
60. Van den Ende J, Coppens G, Verstraeten T, et al. Recurrence of blackwater fever: triggering of relapses by different antimalarials. *Trop Med Int Health* 1998;3(8):632-639.
61. Bruneel F, Gachot B, Wolff M, et al. Resurgence of blackwater fever in longterm European expatriates in Africa: report of 21 cases and review. *Clin Infect* 2001;32(8):1133-1140.
62. Fernan-Nunez M. Blackwater fever: a clinical review of fifty-two cases. *Ann Intern Med* 1936;9(9):1203-1212.
63. Blackie WK. Blackwater fever. *Clin Proc* 1944;3:272-312.
64. Roth EF Jr, Friedman M, Ueda Y, Tellez I, Trager W, Nagel RL. Sickling rates of human AS red cells infected in vitro with *Plasmodium falciparum* malaria. *Science* 1978;202(4368):650-652.
65. Friedman MJ. Erythrocytic mechanism of sickle cell resistance to malaria. *Proc Natl Acad Sci U S A* 1978;75(4):1994-1997.
66. Hassell KL. Population estimates of sickle cell disease in the U.S. *Am J Prev Med* 2010;38(Suppl 4):S512-S521.
67. Luzzatto L. Genetics of red cells and susceptibility to malaria. *Blood* 1979;54(5):961-976.
68. Roth E Jr, Raventos Suarez C, Rinaldi A, Nagel RL. The effect of X chromosome inactivation on the inhibition of *Plasmodium falciparum* malaria growth by glucose-6-phosphate-dehydrogenase-deficient red cells. *Blood* 1983;62(4):866-868.
69. Roth EF Jr, Ruprecht RM, Schulman S, Vanderberg J, Olson JA. Ribose metabolism and nucleic acid synthesis in normal and glucose-6-phosphate dehydrogenase-deficient human erythrocytes infected with *Plasmodium falciparum*. *J Clin Invest* 1986;77(4):1129-1135.
70. Nagel RL, Roth EF Jr. Malaria and red cell genetic defects. *Blood* 1989;74(4):1213-1221.
71. Ifediba TC, Stern A, Ibrahim A, Rieder RF. *Plasmodium falciparum* in vitro: diminished growth in hemoglobin H disease erythrocytes. *Blood* 1985;65(2):452-455.
72. Udomsangpetch R, Sueblinvong T, Pattanapanyasat K, Dharmkrong-at A, Kittikalayawong A, Webster HK. Alteration in cytoadherence and rosetting of *Plasmodium falciparum*-infected thalassemic red blood cells. *Blood* 1993;82(12):3752-3759.
73. Friedman MJ, Roth EF, Nagel RL, Trager W. The role of hemoglobins C, S, and Nbal in the inhibition of malaria parasite development in vitro. *Am J Trop Med Hyg* 1979;28(5):777-780.
74. Mohandas N, Lie-Injo LE, Friedman M, Mak JW. Rigid membranes of Malayan ovalocytes: a likely genetic barrier against malaria. *Blood* 1984;63(6): 1385-1392.
75. Kyriacou DN, Spira AM, Talan DA, Mabey DC. Emergency department presentation and misdiagnosis of imported *falciparum* malaria. *Ann Emerg Med* 1996;27(6):696-699.
76. Runsewe-Abiodun IT, Efunshile M, Ghebremedhin B, et al. Malaria diagnostics: a comparative study of blood microscopy, a rapid diagnostic test and polymerase chain reaction in the diagnosis of malaria. *J Trop Pediatr* 2012;58(2):163-164.
77. Maltha J, Gillet P, Cnops L, et al. Evaluation of the rapid diagnostic test SDFK40 (Pf-pLDH/pan-pLDH) for the diagnosis of malaria in a non-endemic setting. *Malar J* 2011;10:7.

78. Alam MS, Mohon AN, Mustafa S, et al. Real-time PCR assay and rapid diagnostic tests for the diagnosis of clinically suspected malaria patients in Bangladesh. *Malar J* 2011;10:175.
79. Mulenga M, Malunga P, Bennett S, et al. Folic acid treatment of Zambian children with moderate to severe malaria anemia. *Am J Trop Med Hyg* 2006;74(6):986-990.
80. Shanks GD, Kain KC, Keystone JS. Malaria chemoprophylaxis in the age of drug resistance. II. Drugs that may be available in the future. *Clin Infect Dis* 2001;33(3):381-385.
81. Shingadia D, Ladhani S. UK treatment of malaria. *Archives of disease in childhood. Education and practice edition* 2011;96(3):87-90.
82. Homer MJ, Aguilar-Delfin I, Telford SR 3rd, Krause PJ, Persing DH. Babesiosis. *Clinical microbiology reviews* 2000;13(3):451-469.
83. Filbin MR, Mylonakis EE, Callegari L, Legome E. Babesiosis. *J Emerg Med* 2001;20(1):21-24.
84. Gorenflot A, Moubri K, Precigout E, Carcy B, Schetters TP. Human babesiosis. *Annals of tropical medicine and parasitology* 1998;92(4):489-501.
85. Jerant AF, Arline AD. Babesiosis in California. *West J Med* 1993;158(6): 622-625.
86. Browne S, Ryan Y, Goodyer M, Gilligan O. Fatal babesiosis in an asplenic patient. *Br J Haematol* 2010;148(4):494.
87. Rowin KS, Tanowitz HB, Rubinstein A, Kunkel M, Wittner M. Babesiosis in asplenic hosts. *Trans R Soc Trop Med Hyg* 1984;78(4):442-444.
88. Cable RG, Leiby DA. Risk and prevention of transfusion-transmitted babesiosis and other tick-borne diseases. *Curr Opin Hematol* 2003;10(6):405-411.
89. Bredt AB, Weinstein WM, Cohen S. Treatment of babesiosis in asplenic patients. *JAMA* 1981;245(19):1938-1939.
90. Krause PJ. Babesiosis diagnosis and treatment. *Vector borne and zoonotic diseases* Spring 2003;3(1):45-51.
91. Vannier E, Krause PJ. Human babesiosis. *N Engl J Med* 2012;366(25): 2397-2407.
92. Evenson DA, Perry E, Kloster B, Hurley R, Stroncek DF. Therapeutic apheresis for babesiosis. *J Clin Apher* 1998;13:32-36.
93. Wery M, Mulumba PM, Lambert PH, Kazyumba L. Hematologic manifestations, diagnosis, and immunopathology of African trypanosomiasis. *Semin Hematol* 1982;19(2):83-92.
94. Rickman WJ, Cox HW. Association of autoantibodies with anemia, splenomegaly, and glomerulonephritis in experimental African trypanosomiasis. *J Parasitol* 1979;65(1):65-73.
95. Woodruff AW, Ziegler JL, Hathaway A, Gwata T. Anaemia in African trypanosomiasis and "big spleen disease" in Uganda. *Trans R Soc Trop Med Hyg* 1973;67(3):329-337.
96. Fleming AF. Haematological manifestations of malaria and other parasitic diseases. *Clin Haematol* 1981;10(3):983-1011.
97. Radwanska M. Emerging trends in the diagnosis of human African Trypanosomiasis. *Parasitology* 2010;137(14):1977-1986.
98. Buonomano R, Brinkmann F, Leupin N, et al. Holiday souvenirs from the Mediterranean: three instructive cases of visceral leishmaniasis. *Scand J Infect Dis* 2009;41(10):777-781.
99. Willard RJ, Jeffcoat AM, Benson PM, Walsh DS. Cutaneous leishmaniasis in soldiers from Fort Campbell, Kentucky returning from Operation Iraqi Freedom highlights diagnostic and therapeutic options. *J Am Acad Dermatol* 2005;52(6):977-987.
100. Halsey ES, Bryce LM, Wortmann GW, Weina PJ, Ryan JR, DeWitt CC. Visceral leishmaniasis in a soldier returning from Operation Enduring Freedom. *Mil Med* 2004;169(9):699-701.
101. Li Volti S, Fischer A, Musumeci S. Hematological and serological aspects of Mediterranean kala-azar in infancy and childhood. *Acta Tropica* 1980;37(4):351-365.
102. Woodruff AW, Topley E, Knight R, Downie CG. The anaemia of kala-azar. *Br J Haematol* 1972;22(3):319-329.
103. Reynafarje C, Ramos J. The hemolytic anemia of human bartonellosis. *Blood* 1961;17:562-578.

104. Ellis BA, Rotz LD, Leake JA, et al. An outbreak of acute bartonellosis (Oroya fever) in the Urubamba region of Peru, 1998. *Am J Trop Med Hyg* 1999;61(2):344-349.
105. Gray GC, Johnson AA, Thornton SA, et al. An epidemic of Oroya fever in the Peruvian Andes. *Am J Trop Med Hyg* 1990;42(3):215-221.
106. Cooper P, Guderian R, Orellana P, et al. An outbreak of bartonellosis in Zamora Chinchipe Province in Ecuador. *Trans R Soc Trop Med Hyg* 1997;91(5):544-546.
107. Chamberlin J, Laughlin LW, Romero S, et al. Epidemiology of endemic Bartonella bacilliformis: a prospective cohort study in a Peruvian mountain valley community. *J Infect Dis* 2002;186(7):983-990.
108. Schultz MG. A history of bartonellosis (Carrion's disease). *Am J Trop Med Hyg* 1968;17(4):503-515.
109. Ricketts WE. Bartonella bacilliformis anemia (Oroya fever); a study of 30 cases. *Blood* 1948;3(9):1025-1049.
110. Rolain JM, Brouqui P, Koehler JE, Maguina C, Dolan MJ, Raoult D. Recommendations for treatment of human infections caused by Bartonella species. *Antimicrob Agents Chemother* 2004;48(6):1921-1933.
111. Barrett JP, Whiteside JL, Boardman LA. Fatal clostridial sepsis after spontaneous abortion. *Obstet Gynecol* 2002;99(5 Pt 2):899-901.
112. Soper DE. Abortion and clostridial toxic shock syndrome. *Obstet Gynecol* 2007;110(5):970-971.
113. Boggs DR, Frei E 3rd, Thomas LB. Clostridial gas gangrene and septicemia in four patients with leukemia. *N Engl J Med* 1958;259(26):1255-1258.
114. Terebelo HR, McCue RL, Lenneville MS. Implication of plasma free hemoglobin in massive clostridial hemolysis. *JAMA* 1982;248(16):2028-2029.
115. Warren S, Schreiber JR, Epstein MF. Necrotizing enterocolitis and hemolysis associated with Clostridium perfringens. *Am J Dis Child* 1984;138(7):686-688.
116. Wynne JW, Armstrong D. Clostridial septicemia. *Cancer* 1972;29(1):215-221.
117. Ghosh K, Jacob M, Hassanein AA. Clostridial septicaemia with intense hemolysis complicating septic abortion. *Blut* 1990;61(6):381-382.
118. Alvarez A, Rives S, Nomdedeu B, Pereira A. Massive hemolysis in Clostridium perfringens infection. *Haematologica* 1999;84(6):571-573.
119. Meyerhoff A, Renzi RM, Wehbe T, Opal SM. Fatal clostridial sepsis in a previously healthy woman. *Clin Infect Dis* 1995;20(4):1066-1067.
120. Gutierrez A, Florencio R, Ezpeleta C, Cisterna R, Martinez M. Fatal intravascular hemolysis in a patient with Clostridium perfringens septicemia. *Clin Infect Dis* 1995;20(4):1064-1065.
121. Singer AJ, Migdal PM, Oken JP, Chale SN, Moll UM. Clostridium perfringens septicemia with massive hemolysis in a patient with Hodgkin's lymphoma. *Am J Emerg Med* 1997;15(2):152-154.
122. Ikezawa H, Murata R. Comparative kinetics of hemolysis of mammalian erythrocytes by Clostridium Perfringens alpha-toxin (phospholipase C). *J Biochem* 1964;55:217-224.
123. Hubl W, Mostbeck B, Hartleb H, Pointner H, Kofler K, Bayer PM. Investigation of the pathogenesis of massive hemolysis in a case of Clostridium perfringens septicemia. *Ann Hematol* 1993;67(3):145-147.
124. Batge B, Filejski W, Kurowski V, Kluter H, Djonlagic H. Clostridial sepsis with massive intravascular hemolysis: rapid diagnosis and successful treatment. *Intensive Care Med* 1992;18(8):488-490.
125. Castle WB, Daland GA, Gottlieb L, Wallerstein RO. Hematologic observations in bacterial endocarditis, especially the prevalence of histiocytes and the elevation and variation of the white cell count in blood from the ear lobe. *J Lab Clin Med* 1956;48(6):827-845.
126. Jandl JH, Jacob HS, Daland GA. Hypersplenism due to infection. A study of five cases manifesting hemolytic anemia. *N Engl J Med* 1961;264:1063-1071.
127. Inada T, Shirono K, Tsuda H. Hemolytic anemia in a patient with subacute bacterial endocarditis due to Streptococcus sanguis. *Acta Haematol* 1995;94:95-97.

128. Huang HL, Lin FC, Hung KC, Wang PN, Wu D. Hemolytic anemia in native valve infective endocarditis: a case report and literature review. *Jpn Circ J* 1999;63(5):400-403.
129. De SNS KP, Chanda NN. Intravascular haemolysis in cholera; the effect of oxytetracycline. *Lancet* 1954;266(6816):807-809.
130. Retief FP, Hofmeyr NG. Acute haemolytic anaemia as a complication of typhoid fever. *South African medical journal = Suid-Afrikaanse tydskrif vir geneeskunde* 1965;39:96-97.
131. Pennings CM, Seitz RC, Karch H, Lenard HG. Haemolytic anaemia in association with *Escherichia coli* O157 infection in two sisters. *Eur J Pediatr* 1994;153(9):656-658.
132. Lindeboom GA. Rare forms of symptomatic hemolytic anemia. *Acta Haematol* 1950;4(6):343-350.
133. Banwell JG, Kibukamusoke JW. Haemolytic anaemia and relapsing fever. *East African medical journal* 1963;40:124-126.
134. Trowbridge AA, Green JB 3rd, Bonnett JD, Shohet SB, Ponnappa BD, McCombs WB 3rd. Hemolytic anemia associated with leptospirosis. Morphologic and lipid studies. *Am J Clin Pathol* 1981;76(4):493-498.
135. Seitz RC, Buschermohle G, Dubberke G, Herbrand R, Maiwald M, Hellwege HH. The acute infection-associated hemolytic anemia of childhood: immunofluorescent detection of microbial antigens altering the erythrocyte membrane. *Ann Hematol* 1993;67:191-196.
136. Shurin SB, Anderson P, Zollinger J, Rathbun RK. Pathophysiology of hemolysis in infections with *Hemophilus influenzae* type b. *Eur J Clin Invest* 1986;77:1340-1348.
137. Ramasetu J, Luban N. T activation. *Br J Haematol* 2001;112(2):259-263.
138. Russo TA, Thompson JS, Godoy VG, Malamy MH. Cloning and expression of the *Bacteroides fragilis* TAL2480 neuraminidase gene, nanH, in *Escherichia coli*. *J Bacteriol* 1990;172(5):2594-2600.
139. De Franceschi L, Fattovich G, Turrini F, et al. Hemolytic anemia induced by ribavirin therapy in patients with chronic hepatitis C virus infection: role of membrane oxidative damage. *Hepatology* 2000;31(4):997-1004.
140. Grattagliano I, Russmann S, Palmieri VO, Portincasa P, Palasciano G, Lauterburg BH. Glutathione peroxidase, thioredoxin, and membrane protein changes in erythrocytes predict ribavirin-induced anemia. *Clin Pharmacol Ther* 2005;78(4):422-432.
141. Ward PC, Schwartz BS, White JG. Heinz-body anemia: "bite cell" variant—a light and electron microscopic study. *Am J Hematol* 1983;15(2):135-146.
142. Greenberg MS. Heinz body hemolytic anemia. "Bite cells" -a clue to diagnosis. *Arch Intern Med* 1976;136(2):153-155.
143. Chan TK, Chan WC, Weed RI. Erythrocyte hemighosts: a hallmark of severe oxidative injury in vivo. *Br J Haematol* 1982;50(4):575-582.
144. Ham TH, Grauel JA, Dunn RF, Murphy JR, White JG, Kellermeyer RW. Physical properties of red cells as related to effects in vivo. IV. Oxidant drugs producing abnormal intracellular concentration of hemoglobin (eccentricocytes) with a rigid-red-cell hemolytic syndrome. *J Lab Clin Med* 1973;82(6):898-910.
145. Arese P, De Flora A. Pathophysiology of hemolysis in glucose-6-phosphate dehydrogenase deficiency. *Semin Hematol* 1990;27(1):1-40.
146. Balan V, Schwartz D, Wu GY, et al. Erythropoietic response to anemia in chronic hepatitis C patients receiving combination pegylated interferon/ribavirin. *Am J Gastroenterol* 2005;100(2):299-307.
147. Fowler BA, Weissberg JB. Arsine poisoning. *N Engl J Med* 1974;291(22): 1171-1174.
148. Jenkins GC, Ind JE, Kazantzis G, Owen R. Arsine poisoning: massive haemolysis with minimal impairment of renal function. *Br Med J* 1965;2(5453): 78-80.
149. Romeo L, Apostoli P, Kovacic M, Martini S, Brugnone F. Acute arsine intoxication as a consequence of metal burnishing operations. *Am J Ind Med* 1997;32(3):211-216.
150. Kleinfeld MJ. Arsine poisoning. *J Occup Med* 1980;22(12):820-821.
151. Phoon WH, Chan MO, Goh CH, et al. Five cases of arsine poisoning. *Ann Acad Med Singapore* 1984;13(Suppl 2):394-398.

152. Rael LT, Ayala-Fierro F, Carter DE. The effects of sulfur, thiol, and thiol inhibitor compounds on arsine-induced toxicity in the human erythrocyte membrane. *Toxicol Sci* 2000;55(2):468-477.
153. Hatlelid KM, Brailsford C, Carter DE. Reactions of arsine with hemoglobin. *J Toxicol Environ Health* 1996;47(2):145-157.
154. Winski SL, Barber DS, Rael LT, Carter DE. Sequence of toxic events in arsine-induced hemolysis in vitro: implications for the mechanism of toxicity in human erythrocytes. *Fundam Appl Toxicol* 1997;38(2):123-128.
155. Song Y, Wang D, Li H, Hao F, Ma J, Xia Y. Severe acute arsine poisoning treated by plasma exchange. *Clin Toxicol* 2007;45(6):721-727.
156. Hesdorffer CS, Milne FJ, Terblanche J, Meyers AM. Arsine gas poisoning: the importance of exchange transfusions in severe cases. *Br J Ind Med* 1986;43(5):353-355.
157. Chuttani HK, Gupta PS, Gulati S, Gupta DN. Acute copper sulfate poisoning. *Am J Med* 1965;39(5):849-854.
158. Fairbanks VF. Copper sulfate-induced hemolytic anemia. Inhibition of glucose-6-phosphate dehydrogenase and other possible etiologic mechanisms. *Arch Intern Med* 1967;120(4):428-432.
159. Sontz E, Schwieger J. The "green water" syndrome: copper-induced hemolysis and subsequent acute renal failure as consequence of a religious ritual. *Am J Med* 1995;98(3):311-315.
160. Klein WJ Jr, Metz EN, Price AR. Acute copper intoxication. A hazard of hemodialysis. *Arch Intern Med* 1972;129(4):578-582.
161. Manzler AD, Schreiner AW. Copper-induced acute hemolytic anemia. A new complication of hemodialysis. *Ann Intern Med* 1970;73(3):409-412.
162. Oski FA. Chickee, the copper. *Ann Intern Med* 1970;73(3):485-486.
163. Metz EN, Sagone AL Jr. The effect of copper on the erythrocyte hexose mono-phosphate shunt pathway. *J Lab Clin Med* 1972;80(3):405-413.
164. Deiss A, Lee GR, Cartwright GE. Hemolytic anemia in Wilson's disease. *Ann Intern Med* 1970;73(3):413-418.
165. Forman SJ, Kumar KS, Redeker AG, Hochstein P. Hemolytic anemia in Wilson disease: clinical findings and biochemical mechanisms. *Am J Hematol* 1980;9(3):269-275.
166. Robitaille GA, Piscatelli RL, Majeski EJ, Gelehrter TD. Hemolytic anemia in Wilson's disease. A report of three cases with transient increase in hemoglobin A2. *JAMA* 1977;237(22):2402-2403.
167. Roche-Sicot J, Benhamou JP. Acute intravascular hemolysis and acute liver failure associated as a first manifestation of Wilson's disease. *Ann Intern Med* 1977;86(3):301-303.
168. Shimon I, Moses B, Sela BA, Dolev E. Hemolytic episode in a patient with Wilson's disease treated with zinc. *Isr J Med Sci* 1993;29(10):646-647.
169. Zandman-Goddard G, Weiss P, Avidan B, Bar-Meir S, Shoenfeld Y. Acute varicella infection heralding Wilsonian crisis. *J Clin Gastroenterol* 1994;18(3):265-266.
170. Dabrowska E, Jablonska-Kaszewska I, Ozieblowski A, Falkiewicz B. Acute haemolytic syndrome and liver failure as the first manifestations of Wilson's disease. *Med Sci Monit* 2001;7(Suppl 1):246-251.
171. Michel M, Lafaurie M, Noel V, et al. [Hemolytic anemia disclosing Wilson's disease. Report of 2 cases]. *La Revue de medecine interne / fondee ... par la Societe nationale francaise de medecine interne* 2001;22(3):280-283.
172. Loudianos G, Gitlin JD. Wilson's disease. *Seminars in liver disease* 2000;20(3):353-364.
173. Lutsenko S, Efremov RG, sivkovskii R, alker JM. Human copper-transporting ATPase ATP7B (the Wilson's Disease protein): biochemical properties and regulation. *J Bioenerg Biomembr* 2002;34(5):351-362.
174. Rosencrantz R, Schilsky M. Wilson disease: pathogenesis and clinical considerations in diagnosis and treatment. *Semin Liver Dis* 2011;31(3):245-259.
175. Deiss A, Lynch RE, Lee GR, Cartwright GE. Long-term therapy of Wilson's disease. *Ann Intern Med* 1971;75(1):57-65.
176. Buchanan GR. Acute hemolytic anemia as a presenting manifestation of Wilson disease. *J Pediatr* 1975;86(2):245-247.

177. Hogland HC, Goldstein NP. Hematologic (cytopenic) manifestations of Wilson's disease (hepatolenticular degeneration). *Mayo Clinic proceedings*. Mayo Clinic 1978;53(8):498-500.
178. Walshe JM. Wilson's disease. The presenting symptoms. *Arch Dis Child* 1962;37:253-256.
179. Nazer H, Ede RJ, Mowat AP, Williams R. Wilson's disease in childhood. Variability of clinical presentation. *Clin Pediatr (Phila)* 1983;22(11): 755-757.
180. Matsumura A, Hiraishi H, Terano A. Plasma exchange for hemolytic crisis in Wilson disease. *Ann Intern Med* 1999;131(11):866.
181. Landrigan PJ, Todd AC. Lead poisoning. *West J Med* 1994;161(2):153-159.
182. D'Souza H S, Dsouza SA, Menezes G, Venkatesh T. Diagnosis, evaluation, and treatment of lead poisoning in general population. *Indian J Clin Biochem* 2011;26(2):197-201.
183. Chandran L, Cataldo R. Lead poisoning: basics and new developments. *Pediatr Rev* 2010;31(10):399-405; quiz 406.
184. Ibrahim AS, Latif AH. Adult lead poisoning from a herbal medicine. *Saudi Med J* 2002;23(5):591-593.
185. Gupta N, Goswami B, Singh N, Koner BC, Garg R. Lead poisoning associated with Ayurvedic drug presenting as intestinal obstruction: a case report. *Clin Chim Acta* 2011;412(1-2):213-214.
186. Paglia DE, Valentine WN, Dahlgren JG. Effects of low-level lead exposure on pyrimidine 5'-nucleotidase and other erythrocyte enzymes. Possible role of pyrimidine 5'-nucleotidase in the pathogenesis of lead-induced anemia. *J Clin Invest* 1975;56(5):1164-1169.
187. Valentine WN, Paglia DE, Fink K, Madokoro G. Lead poisoning: association with hemolytic anemia, basophilic stippling, erythrocyte pyrimidine 5'-nucleotidase deficiency, and intraerythrocytic accumulation of pyrimidines. *J Clin Invest* 1976;58(4):926-932.
188. Paglia DE, Valentine WN. Characteristics of a pyrimidine-specific 5'-nucleotidase in human erythrocytes. *J Biol Chem* 1975;250(20):7973-7979.
189. Paglia DE, Valentine WN, Fink K. Lead poisoning. Further observations on erythrocyte pyrimidine-nucleotidase deficiency and intracellular accumulation of pyrimidine nucleotides. *J Clin Invest* 1977;60(6):1362-1366.
190. Paglia DE, Valentine WN, Keitt AS, Brockway RA, Nakatani M. Pyrimidine nucleotidase deficiency with active dephosphorylation of dTMP: evidence for existence of thymidine nucleotidase in human erythrocytes. *Blood* 1983;62(5):1147-1149.
191. Pendergrast JM, Hladunewich MA, Richardson RM. Hemolysis due to inadvertent hemodialysis against distilled water: perils of bedside dialysate preparation. *Crit Care Med* 2006;34(10):2666-2673.
192. Landsteiner EK, Finch CA. Hemoglobinemia accompanying transurethral resection of the prostate. *N Engl J Med* 1947;237(9):310-312.
193. Rath CE. Drowning hemoglobinuria. *Blood* 1953;8(12):1099-1104.
194. Ginsburg CM, Weinberg AG. Hemolytic anemia and multiorgan failure associated with localized cutaneous lesion. *J Pediatr* 1988;112(3):496-499.
195. Sezerino UM, Zannin M, Coelho LK, et al. A clinical and epidemiological study of *Loxosceles* spider envenoming in Santa Catarina, Brazil. *Trans R Soc Trop Med Hyg* 1998;92(5):546-548.
196. Futrell JM. *Loxoscelism*. *Am J Med Sci* 1992;304(4):261-267.
197. Bey TA, Walter FG, Lober W, Schmidt J, Spark R, Schlievert PM. *Loxosceles arizonica* bite associated with shock. *Ann Emerg Med* 1997;30(5):701-703.
198. Murray LM, Seger DL. Hemolytic anemia following a presumptive brown recluse spider bite. *Journal of toxicology. Clin Toxicol* 1994;32(4):451-456.
199. Nance WE. Hemolytic anemia of necrotic arachnidism. *Am J Med* 1961;31:801-807.
200. Prevention CfDC. Necrotic arachnidism—Pacific Northwest, 1988-1996. *MMWR Morb Mortal Wkly Rep* 1996;45(21):433-436.
201. Fisher RG, Kelly P, Krober MS, Weir MR, Jones R. Necrotic arachnidism. *West J Med* 1994;160(6):570-572.

202. Foil LD, Norment BR. Envenomation by *Loxosceles reclusa*. *J Med Entomol* 1979;16(1):18-25.
203. Leung LK, Davis R. Life-threatening hemolysis following a brown recluse spider bite. *J Tenn Med Assoc* 1995;88(10):396-397.
204. Wasserman GS, Anderson PC. Loxoscelism and necrotic arachnidism. *Journal of toxicology. Clin Toxicol* 1983;21(4-5):451-472.
205. Eichner ER. Spider bite hemolytic anemia: positive Coombs' test, erythrophagocytosis, and leukoerythroblastic smear. *Am J Clin Pathol* 1984;81(5): 683-687.
206. Lane DR, Youse JS. Coombs-positive hemolytic anemia secondary to brown recluse spider bite: a review of the literature and discussion of treatment. *Cutis* 2004;74(6):341-347.
207. Patel KD, Modur V, Zimmerman GA, Prescott SM, McIntyre TM. The necrotic venom of the brown recluse spider induces dysregulated endothelial cell-dependent neutrophil activation. Differential induction of GM-CSF, IL-8, and E-selectin expression. *J Clin Invest* 1994;94(2):631-642.
208. Tambourgi DV, Magnoli FC, Von Eickstedt VR, Benedetti ZC, Petricevich VL, da Silva WD. Incorporation of a 35-kilodalton purified protein from *Loxosceles intermedia* spider venom transforms human erythrocytes into activators of autologous complement alternative pathway. *J Immunol* 1995;155(9):4459-4466.
209. Tambourgi DV, De Sousa Da Silva M, Billington SJ, et al. Mechanism of induction of complement susceptibility of erythrocytes by spider and bacterial sphingomyelinases. *Immunology* 2002;107(1):93-101.
210. Tambourgi DV, Morgan BP, de Andrade RM, Magnoli FC, van Den Berg CW. *Loxosceles intermedia* spider envenomation induces activation of an endogenous metalloproteinase, resulting in cleavage of glycoporphins from the erythrocyte surface and facilitating complement-mediated lysis. *Blood* 15 2000;95(2):683-691.
211. Van Den Berg CW, De Andrade RM, Magnoli FC, Marchbank KJ, Tambourgi DV. *Loxosceles* spider venom induces metalloproteinase mediated cleavage of MCP/CD46 and MHCI and induces protection against C-mediated lysis. *Immunology* 2002;107(1):102-110.
212. Olvera A, Ramos-Cerrillo B, Estevez J, et al. North and South American *Loxosceles* spiders: development of a polyvalent antivenom with recombinant sphingomyelinases D as antigens. *Toxicon* 2006;48(1):64-74.
213. Warrell DA. Snake venoms in science and clinical medicine. 1. Russell's viper: biology, venom and treatment of bites. *Trans R Soc Trop Med Hyg* 1989;83(6):732-740.
214. Hung DZ, Wu ML, Deng JF, Lin-Shiau SY. Russell's viper snakebite in Taiwan: differences from other Asian countries. *Toxicon* 2002;40(9):1291-1298.
215. Mukherje AK, Ghosal SK, Maity CR. Some biochemical properties of Russell's viper (*Daboia russelli*) venom from Eastern India: correlation with clinico-pathological manifestation in Russell's viper bite. *Toxicon* 2000;38(2):163-175.
216. Reid HA. Cobra-Bites. *Br Med J* 1964;2(5408):540-545.
217. Perkash A, Sarup BM. Red cell abnormalities after snake bite. *J Trop Med Hyg* 1972;75(5):85-90.
218. Campbell CH. Myotoxic paralysis and hemolytic anemia due to king brown snake bite. *Aust N Z J Med* 1984;14(2):169.
219. Gillissen A, Theakston RD, Barth J, B, Krieg M, Warrell DA. Neurotoxicity, haemostatic disturbances and haemolytic anaemia after a bite by a Tunisian saw-scaled or carpet viper (*Echis "pyramidum"-complex*): failure of antivenom treatment. *Toxicon* 1994;32(8):937-944.
220. Gibly RL, Walter FG, Nowlin SW, Berg RA. Intravascular hemolysis associated with North American crotalid envenomation. *J Toxicol Clin Toxicol* 1998;36(4):337-343.
221. Yamamoto C, Tsuru D, Oda-Ueda N, Ohno M, Hattori S, Kim ST. Trimeresurus flavoviridis (habu snake) venom induces human erythrocyte lysis through enzymatic lipolysis, complement activation and decreased membrane expression of CD55 and CD59. *Pharmacol Toxicol* 2001;89(4):188-194.
222. Phillips RE, Theakston RD, Warrell DA, et al. Paralysis, rhabdomyolysis and haemolysis caused by bites of Russell's viper (*Vipera russelli pulchella*) in Sri Lanka: failure of Indian (Haffkine) antivenom. *Q J Med* 1988;68(257): 691-715.
223. Condrea E, Mammon Z, Aloff S, Devries A. Susceptibility of erythrocytes of various animal species to the hemolytic and phospholipid splitting action of snake venom. *Biochim Biophys Acta* 1964;84:365-375.

224. Chiou SH, Chuang MH, Hung CC, et al. Inhibition of protein kinase C by snake venom toxins: comparison of enzyme inhibition, lethality and hemolysis among different cardiotoxin isoforms. *Biochem Mol Biol Int* 1995;35(5):1103-1112.
225. Franca FO, Benvenuti LA, Fan HW, et al. Severe and fatal mass attacks by "killer" bees (Africanized honey bees—*Apis mellifera scutellata*) in Brazil: clinicopathological studies with measurement of serum venom concentrations. *Q J Med* 1994;87(5):269-282.
226. Ferreira RS Jr, Almeida RA, Barraviera SR, Barraviera B. Historical perspective and human consequences of Africanized bee stings in the Americas. *J Toxicol Environ Health Part B Crit Rev* 2012;15(2):97-108.
227. Munoz-Arizpe R, Valencia-Espinoza L, Velasquez-Jones L, Abarca-Franco C, Gamboa-Marrufo J, Valencia-Mayoral P. Africanized bee stings and pathogenesis of acute renal failure. *Nephron* 1992;61(4):478.
228. Kolecki P. Delayed toxic reaction following massive bee envenomation. *Ann Emerg Med* 1999;33(1):114-116.
229. Vetter RS, Visscher PK, Camazine S. Mass envenomations by honey bees and wasps. *West J Med* 1999;170(4):223-227.
230. Bresolin NL, Carvalho LC, Goes EC, Fernandes R, Barotto AM. Acute renal failure following massive attack by Africanized bee stings. *Pediatr Nephrol* 2002;17(8):625-627.
231. Dacie JV. *The Haemolytic anaemias, congenital and acquired*, vol III, 2nd ed. Philadelphia, PA: Grune & Stratton; 1967.
232. Moore FD, Peacock WC, et al. The anemia of thermal burns. *Ann Surg* 1946;124:811-839.
233. Lawrence C, Atac B. Hematologic changes in massive burn injury. *Crit Care Med* 1992;20(9):1284-1288.
234. Shen SC, Ham TH, Fleming EM. Studies on the destruction of red blood cells. *N Engl J Med* 1943;229(19):701-713.
235. Topley E. The usefulness of counting "heat-affected" red cells as a guide to the risk of the later disappearance of red cells after burns. *J Clin Pathol* 1961;14:295-297.
236. James GW 3rd, Purnell OJ, Evans EI. The anemia of thermal injury. I. Studies of pigment excretion. *J Clin Invest* 1951;30(2):181-190.
237. Davies JW, Topley E. The disappearance of red cells in patients with burns. *Clin Sci (Lond)* 1956;15(1):135-148.
238. James GW 3rd, Abbot LD Jr, Brooks JW, Evans EI. The anemia of thermal injury. III. Erythropoiesis and hemoglobin metabolism studied with N15-glycine in dog and man. *J Clin Invest* 1954;33(2):150-162.
239. Andes WA, Rogers PW, Beason JW, Pruitt BA Jr. The erythropoietin response to the anemia of thermal injury. *J Lab Clin Med* 1976;88(4):584-592.
240. Robinson H, Monafó WW, Saver SM, Gallagher NI. The role of erythropoietin in the anemia of thermal injury. *Ann Surg* 1973;178(5):565-572.
241. Wallner SF, Vautrin RM, Buerk C, Robinson WA, Peterson VM. The anemia of thermal injury: studies of erythropoiesis in vitro. *J Trauma* 1982;22(9): 774-780.
242. Ham TH, Shen SC, et al. Studies on the destruction of red blood cells; thermal injury; action of heat in causing increased spheroidicity, osmotic and mechanical fragilities and hemolysis of erythrocytes; observations on the mechanisms of destruction of such erythrocytes in dogs and in a patient with a fatal thermal burn. *Blood* 1948;3(4):373-403.
243. Kimber RJ, Lander H. The effect of heat on human red cell morphology, fragility, and subsequent survival in vivo. *J Lab Clin Med* 1964;64:922-933.
244. Brandts JF, Erickson L, Lysko K, Schwartz AT, Taverna RD. Calorimetric studies of the structural transitions of the human erythrocyte membrane. The involvement of spectrin in the A transition. *Biochemistry* 1977;16(15): 3450-3454.
245. Rakow AL, Hochmuth RM. Effect of heat treatment on the elasticity of human erythrocyte membrane. *Biophys J* 1975;15(11):1095-1100.
246. Jacob HS. Editorial: tightening red-cell membranes. *N Engl J Med* 1976;294(22):1234-1235.
247. Wagner HN Jr, Razzak MA, Gaertner RA, Caine WP Jr, Feagin OT. Removal of erythrocytes from the circulation. *Arch Intern Med* 1962;110:90-97.
248. Lynn KL, Boots MA, Mitchell TR. Haemolytic anaemia caused by overheated dialysate. *Br Med J* 1979;1(6159):306-307.

249. Phillips WA, Pottenger LA, DeWald RL. Extracorporeal hemolysis in orthopedic patients. Report of two cases. *Clin Orthop Relat Res* 1989(238):241-244.
250. McCullough J, Polesky HF, Nelson C, Hoff T. Iatrogenic hemolysis: a complication of blood warmed by a microwave device. *Anesth Analg* 1972;51(1): 102-106.
251. Staples PJ, Griner PF. Extracorporeal hemolysis of blood in a microwave blood warmer. *N Engl J Med* 1971;285(6):317-319.
252. Opitz JC, Baldauf MC, Kessler DL, Meyer JA. Hemolysis of blood in intravenous tubing caused by heat. *J Pediatr* 1988;112(1):111-113.
253. Sayed HM, Dacie JV, Handley DA, Lewis SM, Cleland WP. Haemolytic anaemia of mechanical origin after open heart surgery. *Thorax* 1961;16:356-360.
254. Marsh GW, Lewis SM. Cardiac haemolytic anaemia. *Semin Hematol* 1969;6(2):133-149.
255. Decesare W, Rath C, Hufnagel C. Hemolytic anemia of mechanical origin with aortic-valve prosthesis. *N Engl J Med* 1965;272:1045-1050.
256. Dave KS, Madan CK, Pakrashi BC, Roberts BE, Ionescu MI. Chronic hemolysis following fascia lata and Starr-Edwards aortic valve replacement. *Circulation* 1972;46(2):240-249.
257. Lund O. Late chronic hemolysis after valve replacement for aortic stenosis. Relation to residual hypertrophy and impaired left ventricular function. *Angiology* 1990;41(10):836-847.
258. Clark RE, Grubbs FL, McKnight RC, Ferguson TB, Roper CL, Weldon CS. Late clinical problems with Beall model 103 and 104 mitral valve prostheses: hemolysis and valve wear. *Ann Thorac Surg* 1976;21(6):475-482.
259. Garcia MJ, Vandervoort P, Stewart WJ, et al. Mechanisms of hemolysis with mitral prosthetic regurgitation. Study using transesophageal echocardiography and fluid dynamic simulation. *J Am Coll Cardiol* 1996;27(2):399-406.
260. Hashimoto K, Arai T, Takeuchi N, et al. Valvular (external hinge) leakage of the CarboMedics mitral valve. *J Thorac Cardiovasc Surg* 1996;111(1): 277-278.
261. Reddy SB, Pater JL, Pym J, Armstrong PW. Hemolytic anemia following insertion of Ionescu-Shiley mitral valve bioprosthesis. *Can Med Assoc J* 1984;131(12):1469-1470.
262. Smith RE, Berg D. Occult paravalvular leak in a clinically normal St. Jude's mitral valve presenting with life-threatening microangiopathic hemolytic anemia. *J Cardiovasc Surg* 1991;32(1):56-58.
263. Weiss GB, Nienhuis AW, McIntosh CL, Klein HG. Traumatic cardiac hemolytic anemia: a late complication of a Starr-Edwards mitral valve prosthesis. *Arch Intern Med* 1979;139(3):374-375.
264. Barmada H, Starr A. Clinical hemolysis with the St. Jude heart valve without paravalvular leak. *Med Prog Technol* 1994;20(3-4):191-194.
265. Demirsoy E, Yilmaz O, Sirin G, et al. Hemolysis after mitral valve repair: a report of five cases and literature review. *J Heart Valve Dis* 2008;17(1):24-30.
266. O'Regan S, Newman AJ. Cardiac hemolytic anemia resolving after second mitral annuloplasty. *Can Med Assoc J* 1976;115(5):419-420.
267. Ziperovich S, Paley HW. Severe mechanical hemolytic anemia due to valvular heart disease without prosthesis. *Ann Intern Med* 1966;65(2):342-346.
268. Gupta SC, Suryaprasad AG. Mechanical hemolytic anemia after repair of ruptured chordae tendineae of mitral valve apparatus. *Angiology* 1979;30(11):776-779.
269. Enzenauer RJ, Berenberg JL, Cassell PF Jr. Microangiopathic hemolytic anemia as the initial manifestation of porcine valve failure. *South Med J* 1990;83(8):912-917.
270. Rao KR, Patel AR, Patel RN, Kumaraiah V, Towne WD. Erythrocyte survival in patients with porcine xenograft aortic and mitral valves. *South Med J* 1982;75(3):296-297.
271. Schaer DH, Cheng TO, Aaron BL. Hemolytic anemia and acute mitral regurgitation caused by a torn cusp of a porcine mitral prosthetic valve 7 years after its implantation. *Am Heart J* 1987;113(2 Pt 1):404-406.

272. Terada Y, Mitsui T, Tsutsui T, Asakura T, Abe M. The hole in the valve: presentation with haemolytic anaemia. *Med J Aust* 1994;161(11-12):674.
273. Mecozzi G, Milano AD, De Carlo M, et al. Intravascular hemolysis in patients with new-generation prosthetic heart valves: a prospective study. *J Thorac Cardiovasc Surg* 2002;123(3):550-556.
274. Weesner KM, Rocchini AP, Rosenthal A, Behrendt D. Intravascular hemolysis associated with porcine mitral valve calcification in children. *Am J Cardiol* 1981;47(6):1286-1288.
275. Sigler AT, Forman EN, Zinkham WH, Neill CA. Severe Intravascular Hemolysis Following Surgical Repair of Endocardial Cushion Defects. *Am J Med* 1963;35:467-480.
276. Verdon TA Jr, Forrester RH, Crosby WH. Hemolytic anemia after open-heart repair of ostium-primum defects. *N Engl J Med* 1963;269:444-446.
277. Gopalan RS, Arabia FA, Noel P, Chandrasekaran K. Hemolysis from aortic regurgitation mimicking pump thrombosis in a patient with a HeartMate II left ventricular assist device: a case report. *ASAIO J* 2012;58(3):278-280.
278. Luckraz H, Woods M, Large SR, Papworth VADG. And hemolysis goes on: ventricular assist device in combination with veno-venous hemofiltration. *Ann Thorac Surg* 2002;73(2):546-548.
279. Brodeur MT, Sutherland DW, Koler RD, Griswold HE. Hemolytic anemia and valvular disease. *N Engl J Med* 1965;272:104-105.
280. Dupont B, Wennevold A. Mechanical hemolytic anemia in unoperated aortic valve disease. *Acta Med Scand* 1968;184(5):353-357.
281. Grosse-Brockhoff F, Gehrman G. Mechanical hemolysis in patients with valvular heart disease and valve prosthesis. *Am Heart J* 1967;74(1):137-139.
282. Veneziale CM, McGuckin WF, Hermans PE, Mankin HT. Hypohaptoglobinemia and valvular heart disease: association with hemolysis after insertion of valvular prostheses and in cases in which operation had not been performed. *Mayo Clinic proceedings. Mayo Clin* 1966;41(10):657-662.
283. Ellman L, Knox-Macauley H. Traumatic hemolysis with rupture of aneurysm of sinus of Valsalva. *Arch Intern Med* 1970;126(6):1019-1021.
284. Ravenel SD, Johnson JD, Sigler AT. Intravascular hemolysis associated with coarctation of the aorta. *J Pediatr* 1969;75(1):67-73.
285. Westphal RG, Azen EA. Macroangiopathic hemolytic anemia due to congenital cardiovascular anomalies. *JAMA* 1971;216(9):1477-1478.
- P.822
286. Daubeney PE, Milne AE, Salmon AP. Hemolytic anemia: an unusual presentation of congenital heart disease. *Arch Pediatr Adolesc Med* 1996;150(1): 109-111.
287. Straub PW, Rothlin M. [Severe traumatic hemolysis and endocarditis in fascia aortic valvuloplasty. Correction with ball valve]. *Dtsch Med Wochenschr* 1969;94(43):2212-2214.
288. Kloster FE, Bristow JD, Griswold HE. Medical Problems in Mitral and Multiple Valve Replacement. *Prog Cardiovasc Dis* 1965;7:504-530.
289. Yacoub MH, Keeling DH. Chronic haemolysis following insertion of ball valve prostheses. *Br Heart J* 1968;30(5):676-678.
290. Bell RE, Petuoglu S, Fraser RS. Chronic haemolysis occurring in patients following cardiac surgery. *Br Heart J* 1967;29(3):327-332.
291. Andersen MN, Gabrieli E, Zizzi JA. Chronic hemolysis in patients with ball-valve prostheses. *J Thorac Cardiovasc Surg* 1965;50(4):501-510.
292. Cullhed I. Serum haptoglobin in cases with Starr-Edwards ball-valve prosthesis. *Acta Med Scand* 1967;181(3):321-325.
293. Davidson RJ. March or exertional haemoglobinuria. *Semin Hematol* 1969;6(2):150-161.

294. Neill CA. Postoperative hemolytic anemia in endocardial cushion defects. *Circulation* 1964;30:801-802.
295. McMillan WD, Leville CD, Hile CN. Bovine pericardial patch repair in infected fields. *J Vasc Surg* 2012;55(6):1712-1715.
296. Kawase I, Ozaki S, Yamashita H, et al. Angioplasty with autologous pericardium for bilateral coronary ostial stenosis in Takayasu disease. *Ann Thorac Surg* 2012;93(2):645-647.
297. Hasenkam JM, Nygaard H, Giersiepen M, Reul H, Stodkilde-Jorgensen H. Turbulent stress measurements downstream of six mechanical aortic valves in a pulsatile flow model. *J Biomech* 1988;21(8):631-645.
298. Yoganathan AP, Sung HW, Woo YR, Jones M. In vitro velocity and turbulence measurements in the vicinity of three new mechanical aortic heart valve prostheses: Bjork-Shiley Monostrut, Omni-Carbon, and Duromedics. *J Thorac Cardiovasc Surg* 1988;95(5):929-939.
299. Nevaril CG, Lynch EC, Alfrey CP Jr, Hellums JD. Erythrocyte damage and destruction induced by shearing stress. *J Lab Clin Med* 1968;71(5): 784-790.
300. Ducrou W, Harding PE, Kimber RJ, Kutkaite D. Traumatic haemolysis after heart valve replacement: a comparison of haematological investigations. *Aust N Z J Med* 1972;2(2):118-123.
301. Hjelm M, Hoegman CF, Finnson M, Malers E. Transient auto-antibody formation in a case of open heart surgery with no signs of increased red-cell destruction. *Vox Sang* 1964;9:505-509.
302. Pirofsky B. Aortic valve surgery and autoimmune hemolytic anemia. *Am Heart J* 1965;70:426-428.
303. Pirofsky B, Sutherland DW, Starr A, Griswold HE. Hemolytic anemia complicating aortic-valve surgery. an autoimmune syndrome. *N Engl J Med* 1965;272:235-239.
304. Westring DW. Aortic Valve Disease and Hemolytic Anemia. *Ann Intern Med* 1966;65(2):203-209.
305. Sears DA, Crosby WH. Intravascular hemolysis due to intracardiac prosthetic devices: diurnal variations related to activity. *Am J Med* 1965;39:341-354.
306. Gitler B. Treatment of hemolytic anemia due to red blood cell fragmentation using recombinant human erythropoietin. *JAMA* 1995;274(4):300-301.
307. Symmers WS. Thrombotic microangiopathic haemolytic anaemia (thrombotic microangiopathy). *Br Med J* 1952;2(4790):897-903.
308. Brain MC, Dacie JV, Hourihane DO. Microangiopathic haemolytic anaemia: the possible role of vascular lesions in pathogenesis. *Br J Haematol* 1962;8:358-374.
309. Kwaan HC. Miscellaneous secondary thrombotic microangiopathy. *Semin Hematol* 1987;24(3):141-147.
310. Baker LR, Sevitt LH, Wrong OM. Vascular lesions in malignant hypertension. *Lancet* 1969;2(7620):593.
311. Capelli JP, Wesson GL Jr, Erslev AV. Malignant hypertension and red cell fragmentation syndrome. Report of a case. *Ann Intern Med* 1966;64(1):128-136.
312. Rosner F, Rubenberg ML. Erythrocyte fragmentation in consumption coagulopathy. *N Engl J Med* 1969;280(4):219-220.
313. Rubenberg ML, Baker LR, McBride JA, Sevitt LH, Brain MC. Intravascular coagulation in a case of *Clostridium perfringens* septicaemia: treatment by exchange transfusion and heparin. *Br Med J* 1967;4(5574):271-274.
314. Hollingsworth JH, Mohler DN. Microangiopathic hemolytic anemia caused by purpura fulminans. *Ann Intern Med* 1968;68(6):1310-1314.
315. Stefanini M, Spicer DD. Hemostatic breakdown, fibrinolysis, and acquired hemolytic anemia in a patient with fatal heatstroke: pathogenetic mechanisms. *Am J Clin Pathol* 1971;55(2):180-186.
316. Sher G, Statland BE. Abruptio placentae with coagulopathy: a rational basis for management. *Clin Obstet Gynecol* 1985;28(1):15-23.
317. Brain MC, Esterly JR, Beck EA. Intravascular haemolysis with experimentally produced vascular thrombi. *Br J Haematol* 1967;13(6):868-891.
318. Rubenberg ML, Regoezi E, Bull BS, Dacie JV, Brain MC. Microangiopathic haemolytic anaemia: the experimental production of haemolysis and red-cell fragmentation by defibrination in vivo. *Br J Haematol* 1968;14(6):627-642.

319. Bull BS, Rubenberg ML, Dacie JV, Brain MC. Microangiopathic haemolytic anaemia: mechanisms of red-cell fragmentation: in vitro studies. *Br J Haematol* 1968;14(6):643-652.
320. Neshar G, Hanna VE, Moore TL, Hersh M, Osborn TG. Thrombotic microangiographic hemolytic anemia in systemic lupus erythematosus. *Semin Arthritis Rheum* 1994;24(3):165-172.
321. Salyer WR, Salyer DC, Heptinstall RH. Scleroderma and microangiopathic hemolytic anemia. *Ann Intern Med* 1973;78(6):895-897.
322. Crummy CS, Perlin E, Moquin RB. Microangiopathic hemolytic anemia in Wegener's granulomatosis. *Am J Med* 1971;51(4):544-548.
323. Jordan JM, Manning M, Allen NB. Multiple unusual manifestations of Wegener's granulomatosis: breast mass, microangiopathic hemolytic anemia, consumptive coagulopathy, and low erythrocyte sedimentation rate. *Arthritis Rheum* 1986;29(12):1527-1531.
324. Zauber NP, Echikson AB. Giant cell arteritis and microangiopathic hemolytic anemia. *Am J Med* 1982;73(6):928-930.
325. Quemeneur T, Noel LH, Kyndt X, et al. Thrombotic microangiopathy in adult Still's disease. *Scand J Rheumatol* 2005;34(5):399-403.
326. Liu F, Feys HB, Dong N, Zhao Y, Ruan C. Alteration of ADAMTS13 antigen levels in patients with idiopathic thrombotic thrombocytopenic purpura, idiopathic thrombocytopenic purpura and systemic lupus erythematosus. *Thromb Haemost* 2006;95(4):749-750.
327. George JN, Vesely SK, James JA. Overlapping features of thrombotic thrombocytopenic purpura and systemic lupus erythematosus. *South Med J* 2007;100(5):512-514.
328. Bull BS, Kuhn IN. The production of schistocytes by fibrin strands (a scanning electron microscope study). *Blood* 1970;35(1):104-111.
329. Bayer AS, Theofilopoulos AN, Eisenberg R, Friedman SG, Guze LB. Thrombotic thrombocytopenic purpura-like syndrome associated with infective endocarditis. A possible immune complex disorder. *JAMA* 1977;238(5):408-410.
330. Medani CR, Pearl PL, Hall-Craggs M. Acute renal failure, hemolytic anemia, and thrombocytopenia in poststreptococcal glomerulonephritis. *South Med J* 1987;80(3):370-373.
331. Michael AF Jr, Drummond KN, Good RA, Vernier RL. Acute poststreptococcal glomerulonephritis: immune deposit disease. *J Clin Invest* 1966;45(2):237-248.
332. Inceman S, Tangun Y. Chronic defibrination syndrome due to a giant hemangioma associated with microangiopathic hemolytic anemia. *Am J Med* 1969;46(6):997-1002.
333. Shimizu M, Miura J, Itoh H, Saitoh Y. Hepatic giant cavernous hemangioma with microangiopathic hemolytic anemia and consumption coagulopathy. *Am J Gastroenterol* 1990;85(10):1411-1413.
334. Propp RP, Scharfman WB. Hemangioma-thrombocytopenia syndrome associated with microangiopathic hemolytic anemia. *Blood* 1966;28(5):623-633.
335. Alpert LI, Benisch B. Hemangioendothelioma of the liver associated with microangiopathic hemolytic anemia. Report of four cases. *Am J Med* 1970;48(5):624-628.
336. Yohannan MD, Abdulla AM, Patel PJ. Neonatal hepatic haemangioendothelioma: presentation with jaundice and microangiopathic haemolytic anaemia. *Eur J Pediatr* 1990;149(11):804-805.
337. Hofhuis WJ, Oranje AP, Bouquet J, Sinaasappel M. Blue rubber-bleb naevus syndrome: report of a case with consumption coagulopathy complicated by manifest thrombosis. *Eur J Pediatr* 1990;149(8):526-528.
338. Streeton JA. March haemoglobinuria. *Br Med J* 1970;1(5695):567.
339. Kaden WS. Traumatic haemoglobinuria in conga-drum players. *Lancet* 1970;760(1):1341-1342.
340. Caro XJ, Sutherland PW, Mitchell DB, Glazener FS. Traumatic hemoglobinuria associated with conga drumming. *West J Med* 1975;123(2):141-144.
341. Streeton JA. Traumatic haemoglobinuria caused by karate exercises. *Lancet* 1967;2(7508):191-192.
342. Eichner ER. Runner's macrocytosis: a clue to footstrike hemolysis. Runner's anemia as a benefit versus runner's hemolysis as a detriment. *Am J Med* 1985;78(2):321-325.

343. Buckman MT. Gastrointestinal bleeding in long-distance runners. *Ann Intern Med* 1984;101(1):127-128.
344. Pelliccia A, Di Nucci GB. Anemia in swimmers: fact or fiction? Study of hematologic and iron status in male and female top-level swimmers. *Int J Sports Med* 1987;8(3):227-230.
345. Pellicano R, Rizzetto M. Is hepcidin the bridge linking *Helicobacter pylori* and anemia of chronic infection? A research proposal. *Panminerva Med* 2004;46(3):165-169.
346. Banga JP, Pinder JC, Gratzer WB, Linch DC, Huehns ER. An erythrocyte membrane-protein anomaly in march haemoglobinuria. *Lancet* 1979;2(8151):1048-1049.
347. Banfi G, Melegati G. Effect on sport hemolysis of cold water leg immersion in athletes after training sessions. *Lab Hematol* 2008;14(2):15-18.
348. Brabec V, Sebestik V. Blood volume changes in "hypersplenic" rats. *Haematologia* 1975;9(1-2):97-102.
349. Rosse WF. The spleen as a filter. *N Engl J Med* 1987;317(11):704-706.
350. Allen DW, Manning N. Cholesterol-loading of membranes of normal erythrocytes inhibits phospholipid repair and arachidonoyl-CoA:1-palmitoyl-snglycero-3-phosphocholine acyl transferase. A model of spur cell anemia. *Blood* 1996;87(8):3489-3493.
351. Cooper RA. Hemolytic syndromes and red cell membrane abnormalities in liver disease. *Semin Hematol* 1980;17(2):103-112.
352. Cooper RA, Kimball DB, Durocher JR. Role of the spleen in membrane conditioning and hemolysis of spur cells in liver disease. *N Engl J Med* 1974;290(23):1279-1284.
353. Sanyal AJ, Freedman AM, Purdum PP, Shiffman ML, Luketic VA. The hematologic consequences of transjugular intrahepatic portosystemic shunts. *Hepatology* 1996;23(1):32-39.
354. Eschbach JW, Funk D, Adamson J, Kuhn I, Scribner BH, Finch CA. Erythropoiesis in patients with renal failure undergoing chronic dialysis. *N Engl J Med* 1967;276:653-658.
355. Bonomini M, Sirolli V. Uremic toxicity and anemia. *J Nephrol* 2003;16(1): 21-28.
356. Loge JP, Lange RD, Moore CV. Characterization of the anemia associated with chronic renal insufficiency. *Am J Med* 1958;24(1):4-18.
357. Kaye M. The anemia associated with renal disease. *J Lab Clin Med* 1958;52:83.
358. Shaw AB. Haemolysis in chronic renal failure. *Br Med J* 1967;2(5546): 213-216.
359. Koch KM, Patyna WD, Shaldon S, Werner E. Anemia of the regular hemodialysis patient and its treatment. *Nephron* 1974;12(5):405-419.
360. Bonomini M, Sirolli V, Settefrati N, Dottori S, Di Liberato L, Arduini A. Increased erythrocyte phosphatidylserine exposure in chronic renal failure. *J Am Soc Nephrol* 1999;10(9):1982-1990.
361. Bonomini M, Sirolli V, Reale M, Arduini A. Involvement of phosphatidylserine exposure in the recognition and phagocytosis of uremic erythrocytes. *Am J Kidney Dis* 2001;37(4):807-814.
362. Connor J, Pak CC, Schroit AJ. Exposure of phosphatidylserine in the outer leaflet of human red blood cells. Relationship to cell density, cell age, and clearance by mononuclear cells. *J Biol Chem* 1994;269(4):2399-2404.
363. McEvoy L, Williamson P, Schlegel RA. Membrane phospholipid asymmetry as a determinant of erythrocyte recognition by macrophages. *Proc Natl Acad Sci U S A* 1986;83(10):3311-3315.
364. Adams KF, Johnson G Jr, Hornowski KE, Lineberger TH. The effect of copper on erythrocyte deformability: a possible mechanism of hemolysis in acute copper intoxication. *Biochim Biophys Acta* 1979;550(2):279-287.
365. Jacob HS, Amsden T. Acute hemolytic anemia with rigid red cells in hypophosphatemia. *N Engl J Med* 1971;285(26):1446-1450.
366. Klock JC, Williams HE, Mentzer WC. Hemolytic anemia and somatic cell dysfunction in severe hypophosphatemia. *Arch Intern Med* 1974;134(2): 360-364.
367. Melvin JD, Watts RG. Severe hypophosphatemia: a rare cause of intravascular hemolysis. *Am J Hematol* 2002;69(3):223-224.

368. Shilo S, Werner D, Hershko C. Acute hemolytic anemia caused by severe hypophosphatemia in diabetic ketoacidosis. *Acta Haematol* 1985;73(1): 55-57.
369. Altuntas Y, Innice M, Basturk T, Seber S, Serin G, Ozturk B. Rhabdomyolysis and severe haemolytic anaemia, hepatic dysfunction and intestinal osteopathy due to hypophosphataemia in a patient after Billroth II gastrectomy. *Eur J Gastroenterol Hepatol* 2002;14(5):555-557.
370. Kaiser U, Barth N. Haemolytic anaemia in a patient with anorexia nervosa. *Acta Haematol* 2001;106(3):133-135.
371. Poesen R, Dierickx D, Evenepoel P. Hemolytic anemia associated with severe hypophosphatemia in a renal transplant recipient. *Transpl Int* 2012;25(2):e27-e28.
372. Andersen MN, Kuchiba K. Blood trauma produced by pump oxygenators: a comparative study of five different units. *J Thorac Cardiovasc Surg* 1969;57(2):238-244.
373. Chenoweth DE, Cooper SW, Hugli TE, Stewart RW, Blackstone EH, Kirklin JW. Complement activation during cardiopulmonary bypass: evidence for generation of C3a and C5a anaphylatoxins. *N Engl J Med* 1981;304(9):497-503.
374. Salama A, Hugo F, Heinrich D, et al. Deposition of terminal C5b-9 complement complexes on erythrocytes and leukocytes during cardiopulmonary bypass. *N Engl J Med* 1988;318(7):408-414.
375. Eklund SG, Johansson SV, Lins LE, Strandberg O. Sulphonamide as hemolysis-promoting factor in uremia. *Scand J Urol Nephrol* 1980;14(3): 275-277.
376. Mayer K, Ley AB. Hemolysis of red cells due to sulfone. *Ann Intern Med* 1970;72(5):711-714.
377. Pritchard JA, Scott DE, Mason RA. Severe anemia with hemolysis and megaloblastic erythropoiesis. A reaction to nitrofurantoin administered during pregnancy. *JAMA* 1965;194(4):457-459.
378. Schnitzer B. Analgesics, hemolysis, and splenomegaly. *Ann Intern Med* 1971;75(2):320-321.
379. Shahidi NT, Westring DW. Acetylsalicylic acid—induced hemolysis and its mechanism. *J Clin Invest* 1970;49(7):1334-1340.
380. Bukowska B, Kowalska S. Phenol and catechol induce prehemolytic and hemolytic changes in human erythrocytes. *Toxicol Lett* 2004;152(1):73-84.
381. Chan TK, Mak LW, Ng RP. Methemoglobinemia, Heinz bodies, and acute massive intravascular hemolysis in lysol poisoning. *Blood* 1971;38(6): 739-744.
382. Todisco V, Lamour J, Finberg L. Hemolysis from exposure to naphthalene mothballs. *N Engl J Med* 1991;325(23):1660-1661.
383. Schimelman MA, Soler JM, Muller HA. Methemoglobinemia: nitrobenzene ingestion. *Jacep* 1978;7(11):406-408.
384. Centers for Disease C, Prevention. Severe methemoglobinemia and hemolytic anemia from aniline purchased as 2C-E (4-ethyl-2,5-dimethoxyphenethylamine), a recreational drug, on the Internet—Oregon, 2011. *MMWR Morb Mortal Wkly Rep* 2012;61(5):85-88.
385. Andre R, Dreyfus B, Malassenet R, Sultan C. [2 cases of acute hemolytic anemia following intake of phenylsemicarbazide. Remarks on poikilocytosis and review of literature]. *Nouvelle revue francaise d'hematologie* 1965;5(3): 431-444.
386. Lee DB, Brown DL, Baker LR, Littlejohns DW, Roberts PD. Haematological complications of chlorate poisoning. *Br Med J* 1970;2(5700):31-32.
387. Wolfhagen FH. [Methemoglobinemia due to ingestion of isobutyl nitrite (“poppers”)]. *Nederlands tijdschrift voor geneeskunde* 2003;147(10):468-469.
388. Larkin EC, Williams WT, Ulvedal F. Human hematologic responses to 4 hr of isobaric hyperoxic exposure (100% oxygen at 760 mm Hg). *J Appl Physiol* 1973;34(4):417-421.
389. Scott GL, Rasbridge MR. The in vitro action of dapsone and its derivatives on normal and G6PD-deficient red cells. *Br J Haematol* 1973;24(3):307-317.
390. Sills MR, Zinkham WH. Methylene blue-induced Heinz body hemolytic anemia. *Arch Pediatr Adolesc Med* 1994;148(3):306-310.
391. Petersen JM, Pierach CA. Hematin-induced hemolysis in acute porphyria. *Ann Intern Med* 1984;101(6):877-878.

392. Hassan AB, Seligmann H, Bassan HM. Intravascular haemolysis induced by pentachlorophenol. *Br Med J (Clin Res Ed)* 1985;291(6487):21-22.

393. Maloisel F, Kurtz JE, Andres E, Gorodetsky C, Dufour P, Oberling F. Platin salts-induced hemolytic anemia: cisplatin and the first case of carboplatin-induced hemolysis. *Anticancer Drugs* 1995;6(2):324-326.

Section 4 - Hereditary Disorders of Hemoglobin Structure and Synthesis

Chapter 33 Sickle Cell Anemia and Other Sickling Syndromes

> Table of Contents > Part IV - Disorders of Red Cells > Section 4 - Hereditary Disorders of Hemoglobin Structure and Synthesis > Chapter 33 - Sickle Cell Anemia and Other Sickling Syndromes

Chapter 33

Sickle Cell Anemia and Other Sickling Syndromes

Jane S. Hankins

Winfred C. Wang

This chapter discusses hemoglobin (Hb) variants that cause alterations in erythrocyte morphology and rheology. Hb S, or sickle Hb, is a variant Hb of tremendous clinical importance due to its high prevalence and worldwide distribution. Homozygous Hb SS (sickle cell anemia) alone is the most common heritable hematologic disease affecting humans.

Long before they were recognized in the Western hemisphere, sickling disorders were known in Africa by onomatopoeic names denoting the recurrent, unrelenting, and painful nature of the crises.^{1, 2} Although symptoms of sickle cell anemia (SCA) could be traced in one Ghanaian family to the year 1670,³ disorders of Hb synthesis went unrecognized by the scientific community until 1910, when Herrick, a Chicago cardiologist, recorded observations made during investigation of anemia in a 20-year-old West Indian student.⁴ Herrick's report led not only to the recognition of hundreds of abnormalities of Hb synthesis, but also to a series of remarkable scientific advances involving protein chemistry, molecular biology, physiology, and genetics. The term sickle cell anemia was first used in 1922, when it was recognized that a common African ancestry was present in all initial cases described.⁵ In 1949, Linus Pauling and collaborators demonstrated for the first time that an abnormal protein could be causally linked to a disease.⁶ A historical review has been published summarizing the major developments related to sickle cell disease in the first 100 years since the disease's description.⁷

The genetic basis for Hb synthesis is discussed in Chapter 22. Each major hemoglobinopathy occurs in both a heterozygous and a homozygous form. In the heterozygous state, red cells contain both normal adult Hb (Hb A) and the variant Hb. Because they rarely have phenotypic expressions of clinical significance, heterozygotes are said to have the trait for that abnormality, for example, sickle cell trait. In the homozygous state, Hb A is totally lacking, and clinical manifestations are of variable severity; individuals so affected have SCA. In addition, disease may result from the combination of two variant hemoglobins or from a variant Hb and an interacting thalassemia gene. These doubly heterozygous states are designated by both aberrant gene products, such as Hb SC disease or Hb S/ β^0 -thalassemia. The term sickle cell disease is used in a generic sense to refer to all of the sickling syndromes, although the compound heterozygous HbS/ β^0 -thalassemia is commonly classified as SCA, due to phenotypic similarity to HbSS.

EPIDEMIOLOGY

Hb S, so-called because of the sickle shape it imparts to deoxygenated red cells, is responsible for a wide spectrum of disorders that vary with respect to degree of anemia, frequency of crises, extent of organ injury, and duration of survival. Some of the sickling syndromes lack significant pathologic potential, but they are easily confused with clinically aggressive disorders on the basis of laboratory evaluation; consequently, precision in diagnosis is essential both to proper clinical management and to meaningful genetic counseling.

The highest prevalence of Hb S in the world is in sub-Saharan Africa, followed by the Arabian and Indian subcontinents. It occurs with lower frequency in the rest of the world as the result of voluntary or forced population migration from high prevalence areas. Results of studies of DNA polymorphisms linked to the β^S gene suggest that it arose from three

independent mutations in tropical Africa.^{8, 9} The most common β^S chromosome is found in Benin and central West Africa. A second haplotype is prevalent in Senegal and the African West Coast, and a third haplotype is seen in the Central African Republic (Bantu-speaking Africa). The same three haplotypes are associated with the β^S gene in black Americans and Jamaicans.¹⁰ The Hb S gene in the eastern province of Saudi Arabia and in Central India is associated with a different DNA structure that is not encountered in Africa and probably represents a fourth independent occurrence of the sickle cell mutation.⁹ Only the Benin and Senegal haplotypes are prevalent among North Africans, Greeks, and Italians, suggesting that the β^S mutation spread to the Mediterranean basin from West Africa.^{10, 11} In some parts of Africa, as many as 25% of the population have sickle cell trait, whereas in the United States,^{12, 13} Latin America, and the Caribbean,¹⁴ the prevalence of the sickle gene varies from approximately 2% to 8% (Table 33.1). In the United States, the expected incidence of SCA (Hb SS) at birth is 1 in 625. Taking into account recent trends of decreased mortality among children, approximately 100,000 cases of sickle cell disease would be expected among African Americans in the United States.¹⁵

Before this century, most individuals with SCA died before the age of reproduction. Without selective advantage to Hb S trait, the sickle gene would have been eliminated. The most widely accepted theory to account for the remarkable stability of the sickle gene in Africa is that of balanced polymorphism.^{16, 17} Recognition that sickle cell trait has its highest prevalence in areas that are hyperendemic for malaria suggested that Hb S afforded selective protection against lethal forms of malaria (Fig. 33.1).¹⁸ Preferential sickling of parasitized cells has been observed in the blood of children with sickle cell trait and malaria.¹⁷ Selective removal of sickled cells from the circulation probably reduces the degree of parasitemia and substantially limits the infectious process.

PATHOPHYSIOLOGY

The sickle mutation substitutes thymine for adenine in the sixth codon of the β gene (GAG → GTG), thereby encoding valine instead of glutamic acid in the sixth position of the β chain. This ostensibly minor change in structure is responsible for profound changes in molecular stability and solubility.

Molecular Basis of Sickling

An abundance of information indicates that the distortion of cells containing Hb S is the result of Hb polymerization.¹⁹ Deoxy Hb S polymers in the cell exist in a spectrum of forms from scattered individual fibers to highly ordered fiber aggregates that essentially fill the cell and distort it into the classic sickle shape or other elongated forms. It is the presence of polymer that causes the

P.824

reversible, oxygen-linked changes in the rheologic properties of the sickle erythrocyte that characterizes the disease. Upon oxygenation, these polymers dissolve or “melt,” and the sickle erythrocyte loses most of those pathologic properties caused by the presence of polymer. If the concentration of Hb S in such solutions or in the red cell approaches 30 g/dl, a semisolid gel forms.

TABLE 33.1 WORLDWIDE PREVALENCE OF SICKLE CELL TRAIT AND DISEASE

Region	Trait Prevalence (%)	Disease Prevalence (%)	Reference
Africa			
Nigeria	24.5	2	1043, 1044
Republic of Congo	23.3	0.96	1045
Tanzania	13.0		691
Burkina Faso		1.75	1046
India	0-34 varies with region		1047, 1048, 1049
South America			
Brazil	4-9.8	0.08-0.1	1050
Venezuela	2.5		1051
Central America			

Jamaica	10.0		1052
North America			
United States			
(African Americans)	8.0	0.16	1053
Europe			
Belgium		0.07	1054
France	0.7	0.06	1055, 1056
England		0.05	1057
Spain		0.001-0.03	1058
Greece	0.9-4		792, 1059
East Mediterranean			
Turkey	0.5-10		1060, 1061, 1062, 1063
Arab Peninsula			
Oman	6.0		1064
Saudi Arabia	2-27	0.2-1.4	1065, 1066

Structure of Hemoglobin S Polymer

The structure of the deoxygenated Hb S polymer has been deduced from studies involving the use of electron microscopy (Fig. 33.2)²⁰ and x-ray diffraction.²¹ The polymerized Hb fiber is a helical structure with 14 Hb tetramers in each layer; these form a central core of four strands and an outer sheath of 10 additional strands with a diameter of ~21 nm.²² Only one of the two b6 Val residues appears to participate in the intermolecular contact; it fits into a hydrophobic pocket formed by a b^{85 Phe} and a b^{88 Leu} residue on a β chain of a nearby Hb S tetramer. Bonds between contact points include both hydrophobic and electrostatic forces.

Physiologic Determinants of Polymerization

The equilibrium of Hb S between its liquid and solid phases is determined by four variables: oxygen tension, Hb S concentration, temperature, and hemoglobins other than Hb S. Polymerization occurs only with deoxygenation, which results in a fall in oxygen affinity, thereby stabilizing the deoxy state. An increase in 2,3-diphosphoglycerate decreases the affinity of Hb S for oxygen and enhances gelation.²³ Likewise, a decrease in pH decreases oxygen affinity via the Bohr effect, thereby increasing the amount of deoxy Hb S at any given oxygen tension. There is a positive correlation between Hb S concentration and gelation.²⁴ Under standard laboratory conditions, gelation occurs as the concentration of deoxy Hb S is raised above 20.8 g/dl.²⁵ Because the mean Hb concentration of the red cell is normally >30 g/dl, intracellular gelation of Hb S is a predictable consequence of deoxygenation.

The influence of other hemoglobins on Hb S polymerization is variable. Both Hb A and Hb F have an inhibitory effect on gelation.²⁶ When these hemoglobins are deoxygenated, they enter the sickle polymer less readily than does deoxy Hb S, thereby retarding gelation by a dilutional effect. Because there are 20 surface amino acid differences between b^S and g chains and only a single residue difference between b^S and b^A chains, it is not surprising that Hb F is excluded from Hb S polymers to a greater extent than Hb A. Other hemoglobins interfere with polymer formation less well. By measuring the minimum gelling concentration of various mixtures of hemoglobins, the extent of interaction can be quantitated. Deoxy Hb S molecules copolymerize most effectively with other Hb S molecules and, in decreasing order, with Hb C, D, O Arab, A, J, and F.²⁷ These in vitro observations predict the clinical severity of disorders involving these variants. In contrast, the doubly heterozygous state for Hb S and hereditary persistence of fetal Hb (HPFH), in which red cells contain approximately 70% Hb S and 30% Hb F, is not associated with clinical disease.^{28, 29, 30, 31} It is possible to estimate how much inhibition of polymerization would result from therapeutic interventions such as altering Hb S solubility, which might be accomplished by modifying polymer structure, lowering mean corpuscular Hb concentration (MCHC), or elevating the fraction of Hb F.³² Recently, the primary significance of polymerization has been called into question because modulators of polymerization, such as the Hb F level, neither correlate with the frequency nor predict the onset of pain crises, nor do they address the initiation of acute vascular occlusion.³³

Kinetics of Sickling

Sickling is not an instantaneous phenomenon; the kinetics of sickling suggest that molecular polymerization occurs in stages. The delay period between deoxygenation and polymerization is attributed to nucleation processes, in which Hb S tetramers form small aggregates without modification of internal viscosity. When these aggregates reach a critical mass, a rapid addition of free Hb units occurs to form fibers that then undergo alignment to form a tactoid.³⁴ A red cell spends ~1 to 2 seconds in the arterial circulation and 1 second in the microcirculation; it then takes ~15 seconds returning to the lungs.³⁵ If the delay time is >15 seconds, the cell can return to the lungs and be reoxygenated before any significant polymerization has begun, but if the delay time is between 1 and 15 seconds, gelation occurs while the cell is in the venous circulation. Sickling in the large veins does not produce vaso-occlusion, but the cell membrane may be damaged, resulting in a loss of water and a shorter delay time in subsequent trips through the circulation. If the delay time is less than 1 second, gelation can occur while the cell is in one of the narrow vessels of the microcirculation. Because the cell is much less deformable, it may not be able to “squeeze” through and may become transiently or permanently stuck. Under physiologic conditions, the delay between complete deoxygenation and erythrocyte sickling is ~2 seconds. Small increments in deoxyhemoglobin concentration (e.g., those that occur with loss of cell water) profoundly shorten the delay time,³⁶ thereby potentiating sickling. The delay time, however, is strongly influenced by changes in Hb concentration, the presence of hemoglobins other than Hb S, temperature, pH, and 2,3-diphosphoglycerate.³⁷ Increased intracellular 2,3-diphosphoglycerate decreases the oxygen-binding affinity of

P.825

Hb, thereby inducing sickling. In a study of cultured human red cells and mice, the induction of adenosine A(2B) receptor led to increased levels of 2,3-diphosphoglycerate in the cells, consequently inducing more sickling.³⁸ Recent findings point to the role of free heme in the kinetics of sickling; increasing amounts of free heme added to dialyzed Hb S solutions enhances polymerization.³⁹

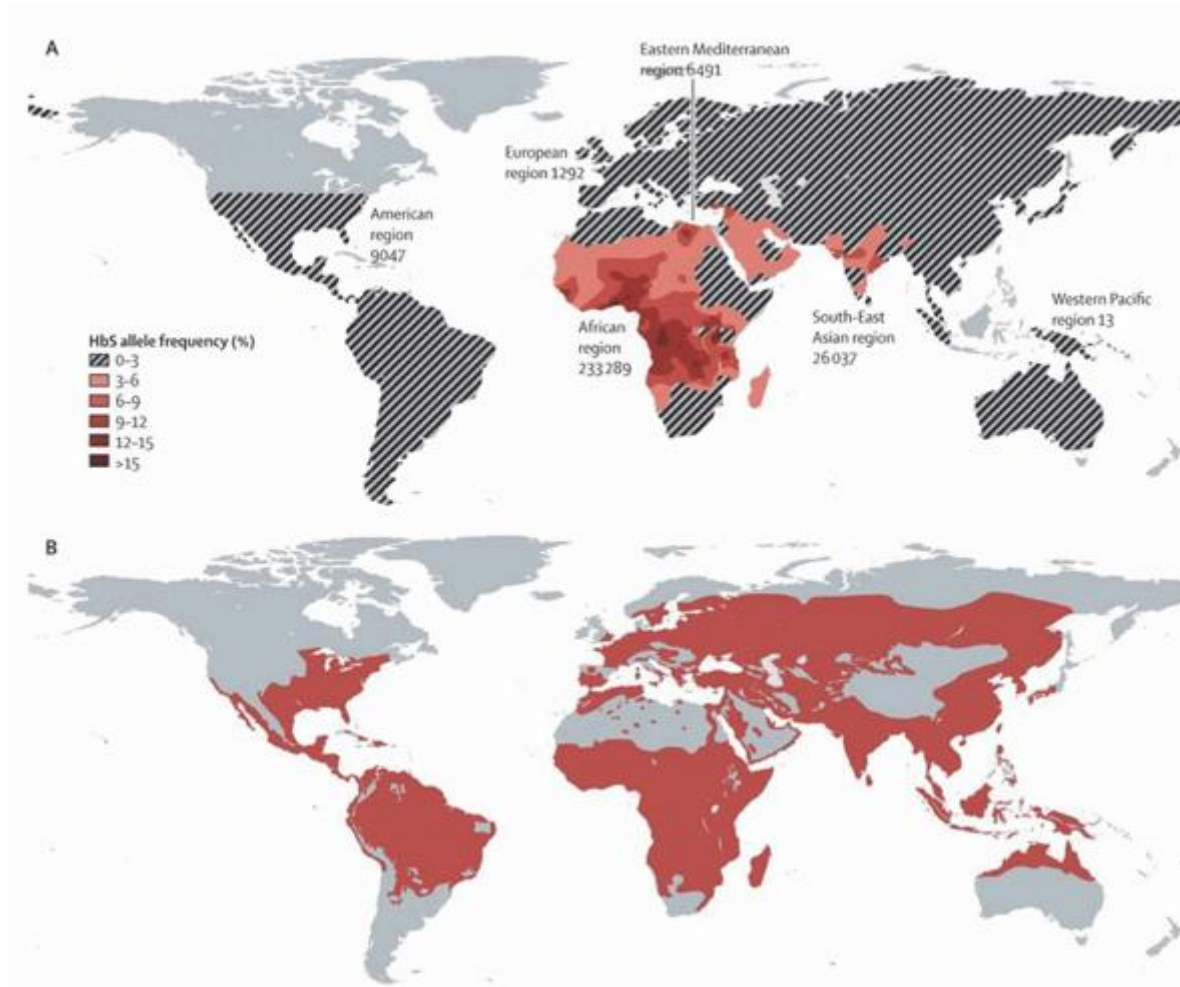

FIGURE 33.1. Global distributions of Hb S and malaria. This map shows the distribution of the Hb S allele. Part A indicates estimates for the combined yearly total number of individuals affected by Hb SS, Hb SC, and Hb S β -thalassemia by World Health Organization region. Part B shows the global distribution of malaria (red) before intervention to control malaria. From Rees DC, Williams TN, and Gladwin MT. *Lancet*. 2010 Dec 11;376(9757):2018-2031, with permission.

Cellular Pathology

Red cells containing Hb S acquire the sickle-shape deformity upon deoxygenation because of the intracellular polymerization of Hb. This phenomenon may be monitored directly with light or scanning electron microscopy (Fig. 33.3) and indirectly by measuring changes in viscosity or filterability.⁴⁰ Electron micrographs demonstrate filaments in parallel array, some of which extend into the protuberances of sickled cells.⁴¹ The membrane is secondarily involved by repeated or prolonged sickling. Irreparable damage to membrane structures obviates resumption of the normal disc shape despite solubilization of intracellular polymers and thus produces the irreversibly sickled cell (ISC).⁴² Both Hb polymerization and membrane injury contribute to the pathophysiology of the sickling syndromes.

Red Cell Sickling

The sickling of erythrocytes containing Hb S is induced by the same physicochemical perturbations as those responsible for the gelation of Hb S solutions. Arterial blood, having a high oxygen saturation, contains fewer sickle cells than blood collected from various sites in the venous circulation.⁴³ The oxygen affinity is abnormally sensitive to pH fluctuations in the physiologic range; a decrease in pH from 7.4 to 7.2 results in twice the normal decrement in oxygen affinity.⁴⁴ Sickling is greatly potentiated by increasing the intracellular concentration of Hb S. Predictably, red cells containing relatively more Hb F sickle less readily and survive longer than cells containing little Hb F.

Membrane Alterations

Red cell sickling is associated with reversible membrane changes. With repeated cycles of sickling and unsickling, aberrations in membrane function and structure become increasingly pronounced, culminating in fixation of the membrane in the sickled configuration.⁴⁵

P.826

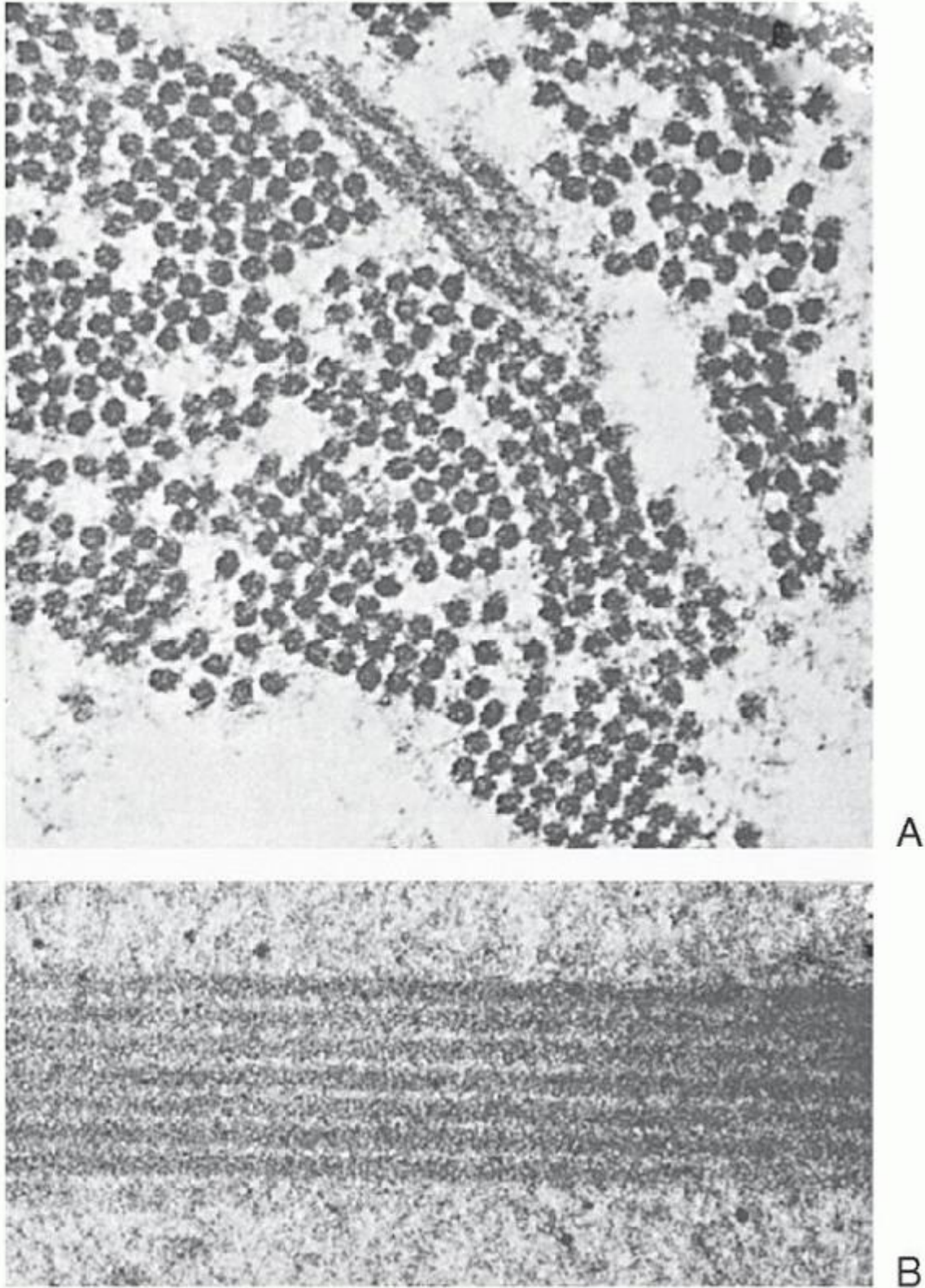

FIGURE 33.2. Electron photomicrographs of cell-free pellets of deoxyhemoglobin (Hb S). A: Transverse section through fibers of polymerized Hb S ($\times 97,000$). B: Longitudinal section through same ($\times 102,000$). From Finch JT, Perutz MF, Bertles JF, et al. Structure of sickled erythrocytes and of sickle-cell hemoglobin fibers. *Proc Natl Acad Sci U S A* 1973;70:718, with permission.

Reversibly and Irreversibly Sickled Cells

When red cells are sickled, they leak K^+ and gain Na^+ , a phenomenon previously ascribed to partial failure of the Na^+ , K^+ -adenosine triphosphatase (ATPase) pump.⁴⁶ Because the net flux of Na^+ and K^+ is approximately equal in reversibly sickled cells, no change occurs in intracellular hydration or Hb concentration.⁴⁷ The intracellular concentration of Ca^{2+} is increased during sickling, owing in part to increased membrane permeability for Ca^{2+} and possibly to impairment of the ATPase-dependent Ca^{2+} pump.⁴⁸

From 5% to 50% of cells from individuals with SCA are ISCs, permanently stabilized in their abnormal crescent or oval shape.⁴⁹ ISCs contain substantially less Hb F than reversibly sickled cells,⁵⁰ and their endowment of Hb F appears to be the primary determinant of irreversible sickling. In the ISC, the quantity of membrane lipids is decreased consistent with membrane loss, probably as a result of vesiculation.⁵¹ The normal phospholipid organization of the red cell membrane (phosphatidyl choline and sphingomyelin in the outer monolayer and phosphatidyl ethanolamine and phosphatidyl serine [PS] in the inner monolayer) is altered by deoxygenation, resulting in negatively charged PS on the red cell surface. This phospholipid may initiate blood clotting by enhancing the conversion of prothrombin to thrombin, as suggested by the findings of increased plasma levels of fragment 1.2 in the circulation.⁵²

Dehydration

Two pathways play a major role in formation of dense cells: the Ca^{2+} -activated K^+ channel (Gardos pathway) and the K-Cl cotransport channel (KCC). KCC regulates RBC volume, especially in reticulocytes, and its dominant isoform is KCC3.⁵³ The transient increase in free Ca^{2+} induced by red cell deoxygenation and sickling leads to activation of the Gardos pathway and subsequent activation of KCC with further K^+ loss. In ISCs, unlike reversibly sickled cells, K^+ loss exceeds Na^+ gain, and there is overall loss of cell water and increased concentration of intracellular Hb S. Although total cellular Ca^{2+} is increased, it is compartmentalized in cytoplasmic vesicles, resulting in normal levels of free cytoplasmic Ca^{2+} and prevention of dysfunction of the inner membrane.⁵⁴

The rate of dehydration of sickle cells is uneven, and those destined to become ISCs dehydrate by a fast-track process. Reversible permeability pathways for Na^+ , K^+ , Mg^{2+} , and Ca^{2+} , sometimes referred to as the sickling-induced pathway, are the result of ionic shifts affecting cell hydration (58). The combined activity of the Gardos channel and K-Cl co-transport leads to rapid dehydration of a relatively young subpopulation of sickle cells, many with the characteristics of ISCs. The antimycotic agent clotrimazole is an inhibitor of the Gardos channel and prevents dehydration of sickle cells in vitro and in vivo.^{55, 56} An analog of clotrimazole (ICA 17043, Senicapoc) with greater potency and fewer side effects has been shown to prevent dehydration of red cells in a transgenic sickle mouse model⁵⁷ and was tested in clinical trials (see the section "Reduction of Red Cell Hemoglobin Concentration").

In vitro, KCC is activated by cell swelling, low pH, or urea.^{58, 59} When activated, K^+ and Cl^- leave the cell via facilitated diffusion down their concentration gradients. Water follows their efflux, leading to cell dehydration. The activity of the KCC is abnormally increased in SCA^{58, 60}; regulation of its activity involves phosphorylation and dephosphorylation reactions in membranebound serine/threonine kinases and phosphatases. Magnesium is abnormally reduced in sickle erythrocytes, and increasing cell magnesium produces a marked decrease in the activity of K-Cl cotransport.⁵⁶ Still another approach to prevention of red cell dehydration has been to inhibit chloride conductance with a reversible anion conductance inhibitor.⁶¹ The sickling-induced permeability pathway may be affected by transport inhibitors, including dipyrindamole at pharmacologic levels.⁶²

Adhesion

Sickle red cells demonstrate abnormal adherence to vascular endothelium,^{63, 64, 65} monocytes, macrophages, and model lipid membranes. Compared with normal red cells, sickle cells are 2 to 10 times more adherent to bovine and human endothelial cells.⁶³ This property of sickle blood is imparted by deformable sickle cells rather than by ISCs,^{66, 67} perhaps because rigid cells are unable to form multiple surface contacts with endothelial cells. Furthermore, red cell deformability has a strong positive correlation with the frequency and severity of pain crises.^{66, 68} Individuals who generate a relatively greater number of ISCs have decreased red cell deformability and milder disease compared with those whose red cells are more deformable. Presumably, rigid ISCs are unable to enter capillaries or to adhere tenaciously to capillary endothelium, whereas deformable sickle cells enter capillaries readily, adhere to the endothelium, and compromise blood flow.

When examined under dynamic conditions, red cell adherence is noted primarily at sites of turbulence rather than where flow is laminar.⁶⁹ Several mechanisms for increased adherence have been proposed.⁷⁰ The repellent force of the red cell is thought to reside in negatively charged sialic acid residues that are homogeneously distributed over the surface of the membrane. The distribution of negative charges on membranes of sickle red cells is patchy and interrupted,⁶³ creating surface areas that may have an electrostatic attraction for other cells. Alternatively, abnormal adherence may be a

derivative of cellular dehydration, which induces an abnormality of negative charge distribution in normal red cells similar to that of sickle red cells.⁷¹ Auto-oxidation of sickle red cells is yet another possible mechanism for increased adherence. Induction of excessive free radical generation in normal red cells is associated with increased adherence under conditions that allow the influx of calcium.⁷²

Conditions and factors that promote the expression of adhesion receptors by endothelial cells include hypoxia, thrombin, tissue necrosis factor, platelet-activated factor, and interleukin-1.⁷³

P.827

These conditions/factors also cause increased adhesion of sickle cells to endothelium in vitro. Thrombospondin may be an important plasma adhesogen because of its ability to bridge CD36 expressed on sickle reticulocytes.⁷⁴ Thrombospondin-mediated adherence occurs under flow conditions with both microvascular and large-vessel endothelial cell assays. Thrombospondin levels are elevated in sickle cell patients during crisis,⁷⁵ perhaps as a result of platelet activation. Fibronectin may link endothelial receptors with the fibronectin receptor $\alpha_4 \beta_1$ (VLA-4) expressed on sickle reticulocytes.⁷⁶,⁷⁷ Ultralarge forms of von Willebrand factor are postulated to promote adherence through nonreceptor mechanisms such as by binding with co-clustered hemichrome-band 3 aggregates on sickle membranes.⁷⁸ Erythrocyte membrane sulfatide, a sulfated glycosphingolipid, may also play an important role in adhesion and its blockage with specific antibodies significantly prevents endothelial adhesion.⁷⁹ Different mechanisms may predominate under various circumstances or in different parts of the circulation. Coagulopathy might cause thrombospondin release and precipitate vaso-occlusion in microvessels, and dehydration-induced vasopressin elevation might stimulate von Willebrand factor release and precipitate vaso-occlusion in large postcapillary venules. The increased sickle cell adherence to injured endothelium, the role of platelet and leukocyte receptors, and the possible stimulation of nitric oxide (NO) production by adherent red cells all require further evaluation.

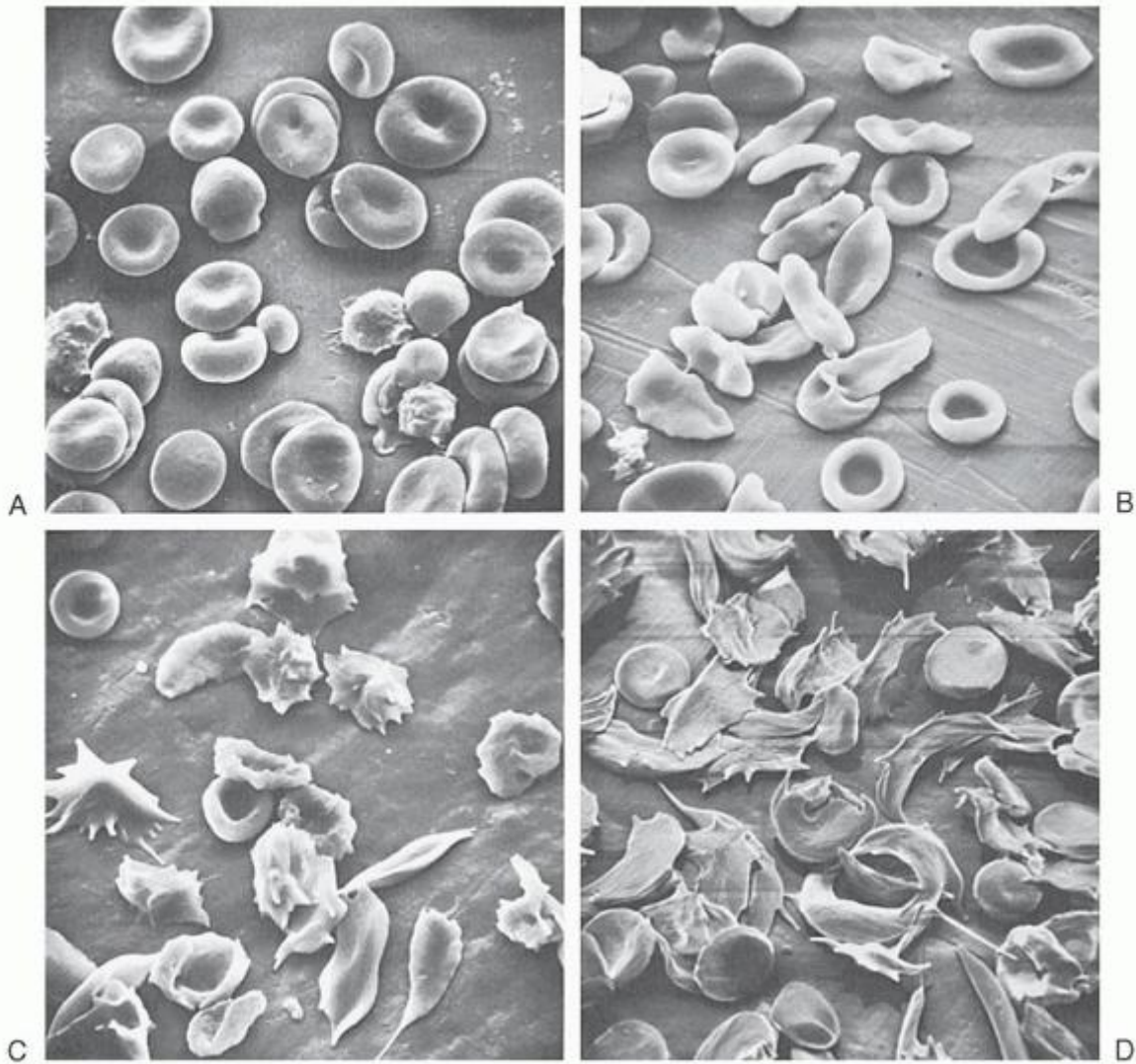

FIGURE 33.3. Erythrocytes from a patient with sickle cell anemia (SCA) examined with scanning electron microscopy. A: Oxygenated blood. Red cells appear normal except for one microspherocyte. Three leukocytes are evident in the field. B: Oxygenated irreversibly sickled cells are smooth in texture and outline but are ovoid or boatlike in shape. C: Partial deoxygenation causes the cells to assume bizarre shapes with spikes, spicules, and filaments that protrude from the cells. D: More complete deoxygenation causes the cells to assume sickled shapes with longitudinal surface striations.

Circulating activated endothelial cells have been assayed using immunohistochemical examination of buffy coat smears with antiendothelial cell antibodies.⁸⁰ In one study patients with SCA who had acute painful episodes had higher levels of circulating endothelial cells than patients with no recent events, who, in turn, had higher levels than controls. Circulating endothelial cells were predominantly microvascular (CD36⁺) and expressed markers of endothelial cell activation (intercellular adhesion molecule [ICAM]-1, vascular cell adhesion molecule [VCAM]-1, E-selectin, and P-selectin). This suggested that vascular endothelium is activated in patients with SCA and that adhesion proteins on the cells may have a role in the vascular pathology. Using an animal model with the ex vivo rat mesocecum venules and human sickle cells, two monoclonal antibodies were demonstrated to inhibit interactions between sickle cells and endothelial cells by blocking ligand binding to integrin $\alpha_v\beta_3$, a molecule that binds to several adhesion proteins, including von Willebrand factor and thrombospondin.⁷³ P-selectin may also mediate SS red cell adhesion to endothelial cells in vitro.⁸¹

Rheology of Sickle Cells

The clinical features of SCA are directly or indirectly related to increased blood viscosity. The viscosity of plasma in sickle cell subjects is slightly higher than that of plasma from normal subjects because of higher total protein concentration.⁸² However, at all shear rates, the viscosity of oxygenated sickle blood is lower than that of normal blood, mainly as a result

of lower hematocrit values.⁸³ The viscosity of a sickle blood sample increases with decreased oxygen saturation, primarily because of reduced cellular deformability.^{82, 84} When the cell concentration of sickle blood is raised in vitro to 45%, viscosity becomes higher than that of normal blood. The extent to which membrane rigidity,⁸⁵ Hb polymerization,⁸⁶ and increased intracellular Hb concentration⁸³

P.828

contribute to altered blood flow depends in part on the method used to study the properties of sickle red cells. Reduction in the cellular deformability of oxygenated sickle red cells has been demonstrated by increased viscosity of sickle blood (viscometry),⁸³ decreased filtration of dilute cell suspensions through narrow pores,⁸⁷ decreased ability of cells to undergo deformation in shear fields (ektacytometry),⁸⁸ and increased aspiration pressures needed to induce entry of cells into micropipets.⁸⁹ Cellular dehydration, as well as the resulting increase in cytoplasmic viscosity, is a major determinant of abnormal rheologic behavior of oxygenated sickled red cells. Sickled red cell membranes demonstrate extensional rigidity and persistent deformation, as documented by videomicrographs of micropipet aspiration.⁸⁹ The rheologic properties of oxygenated sickle cells are strongly influenced by the state of cell hydration and the increased propensity for oxidative damage to the membrane.^{90, 91} The already compromised deformability of oxygenated sickle cells is dramatically reduced further after deoxygenation. Under conditions of high shear stress, increased internal viscosity appears to determine the rheologic behavior of ISCs, whereas at low shear rates, membrane rigidity assumes greater significance.⁹² Under physiologic conditions, increased viscosity results primarily from cellular dehydration. The poor deformability of ISCs, as measured by ektacytometry, can be rectified by osmotically hydrating them to a normal MCHC. The membrane rigidity of oxygenated sickle cells also can be returned to a normal level by replacing Hb S with Hb A, suggesting that the interaction of Hb S with the cell membrane is an important determinant of cellular rigidity.⁹³ Peripheral vascular resistance is increased in proportion to ISC numbers, the extent of ISC deoxygenation, and ISC density.⁹⁴ The functional significance of the impaired flow properties of sickle red cells has been demonstrated by measuring exercise tolerance before and after partial exchange transfusion. By increasing the relative number of cells containing Hb A without increasing the total Hb concentration, exercise capacity improved significantly.⁹⁵

Pathogenetic Role of Hemolysis

Intravascular hemolysis results from the lysis of complement-sensitive red cells⁹⁶ and Hb lost during sickling- or shear-induced membrane fragmentation.⁹⁷ Extravascular hemolysis may occur by two mechanisms: monocyte and macrophage recognition and phagocytosis of red cells that have undergone sickling- or oxidation-induced membrane changes⁹⁸ and physical entrapment of rheologically compromised red cells.⁹⁹ Intravascular and extravascular patterns of hemolysis are believed to account for 1/3 and 2/3 of sickle hemolysis, respectively;¹⁰⁰ however, this information has not been re-evaluated using more modern diagnostic methods. The multiple mechanisms for intra- and extravascular hemolysis in SCA result in complex interactions involving red cell dehydration, sickling, increased sensitivity to complement-mediated lysis,¹⁰¹ and clustering of membrane protein band 3 leading to accumulation of IgG and complement on the cell surface,¹⁰² collectively leading to red cell trapping and fragmentation, osmotic lysis, and erythrophagocytosis.¹⁰³

Hemolysis can be quantitated utilizing different biomarkers, but the accepted measures of hemolytic rate are the direct red cell survival (red cell lifespan) assessment or the amount of plasma Hb. Traditional red cell survival measurement involves exposure to radioactive chromium 51; however, more recent methods utilizing erythrocyte labeling with different biotin densities may be safer.¹⁰⁴ Several factors bear a strong relationship to the rate of hemolysis. Of greatest significance is the relative number of ISCs.¹⁰⁵ The extent of Hb polymer formation, calculated from the MCHC and the relative proportion of Hb fractions, also correlates closely with the severity of hemolysis.¹⁰⁶ Of particular interest is the relationship between hemolytic rate and adherence of sickle cells to macrophages.¹⁰⁷

Cell-free Hb, a direct result of hemolysis, is a known cause of consumption of nitric oxide, although other mechanisms may also result in low NO levels, such as increased plasma arginase levels, and increased levels of an NO inhibitor, asymmetric dimethylarginine (ADMA).^{108, 109} SCA individuals are recognized to be NO-deficient, but the role of NO deficiency in the development of vasculopathy and endothelial dysfunction, is still incompletely understood. Because of the multitude of mechanisms involved in the pathophysiology of SCA (inflammation, adhesion, hemolysis, hypoxia-reperfusion injury, etc.), the contribution of NO consumption in the genesis of vascular dysfunction in SCA is not completely defined.

Two distinct clinical phenotypes have been proposed to classify patients based on the type of disease complications and the pathophysiologic role of hemolysis. The first includes clinical manifestations of sickle cell disease linked to hyperviscosity: vaso-occlusive pain crises and acute chest syndrome (ACS), which are associated with high white blood cell counts and relatively elevated steady-state hemoglobin levels.¹¹⁰ The second encompasses clinical complications

attributed to hemolysis-induced “dysregulation of NO metabolism” leading to endothelial dysfunction (vasculopathy), and includes pulmonary hypertension (PHT), leg ulceration, priapism, and possibly stroke. This classification has recently been called into question, as classic biomarkers of intravascular hemolysis, such as lactate dehydrogenase (LDH) and reticulocyte count, are not consistently elevated in all cases of “hyperhemolysis.” Furthermore, in other conditions where intravascular hemolysis is marked, such as paroxysmal nocturnal hemoglobinuria, there is no significant increase in leg ulcers or stroke.^{103, 111, 112} Additional mechanisms other than hemolysis-induced low NO levels may be involved in the promotion of endothelial dysfunction. For instance, the pathophysiology of renal dysfunction may be related to induction of heme oxygenase-1, release of heme, and HbS instability.¹¹³

Pathogenesis of Vaso-occlusion

Possible factors involved in the development of sickle cell vaso-occlusion include Hb S polymerization, sickle cell deformability, sickle blood viscosity, the fraction of dense cells, sickle cell-endothelial cell adherence, endothelial cell activation, hemostatic activation, vascular tone, white blood cell and platelet activation, enhanced local and regional inflammatory response, ischemia and reperfusion injury, and oxidative stress.^{114, 115, 116} These processes and events are highly interconnected, leading to clinically significant outcomes, and often reinforcing or producing a “vicious cycle” of vaso-occlusion.¹¹⁷ The mechanisms of vaso-occlusion may vary with anatomic site and with different circumstances. For example, there is functional heterogeneity of endothelial cells from large-vessel and microvessel sources, and there are organo-organ differences in microvascular architecture.¹¹⁸ During inflammation, increased white blood cell interactions with endothelium could be a triggering event. Under other circumstances, platelet activation might result in an elevation in thrombospondin level or clinical dehydration might lead to an increased release of von Willebrand factor, thus promoting vaso-occlusion.

Because of their higher Hb S concentration, the densest cells are least deformable and are at greatest risk for intracellular polymerization. Obstruction by these cells develops at the arteriolar-capillary junctions in model systems.^{118, 119} The role of dense cells may be to create a “logjam” behind an obstruction rather than to initiate the vascular plug. The proportion of dense cells increases immediately before an acute pain crisis and falls during the first few days afterward.^{120, 121} Initiation of vaso-occlusion by adherent cells may explain the fractional reduction in the least dense, most adherent cells during the initial stages of a vaso-occlusive pain crisis. This is consistent with a correlation of the frequency of painful events and better red cell deformability, rather than poorer deformability as might be expected.

P.829

The abnormal interaction between sickle cells and vascular endothelium may be of greater relevance for vaso-occlusive events than alterations in red cell morphology or viscosity. Although endothelial adherence does not correlate with standard hematologic measurements, it correlates significantly with the severity of pain crises.¹²² Likewise, patients with clinically less severe sickling disorders, such as Hb SC disease, tend to have less adherent red cells.¹²³ When red cells from patients with SCA are suspended in autologous plasma, however, dramatic increases in adherence are noted at the onset of vaso-occlusive events. Both plasma fibrinogen and fibronectin have been implicated as factors modulating adherence.¹²⁴ These findings from in vitro studies complement the classic clinical observation of a temporal relationship between infections and pain crises¹²⁵ and the demonstration of increased plasma fibrinogen levels during vaso-occlusive crises. Red cell adherence is also augmented by hyperosmolar conditions and by endothelial injury. Together, these observations suggest that alterations in the environment of the red cell predispose to vaso-occlusion by amplifying the abnormal attraction of sickle red cells to vascular endothelium.

Sickled red cells may adversely affect local regulation of vascular tone. Normal endothelial-cell-derived vasoactive factors include nitric oxide and prostacyclins (vasodilators) and endothelin-1 and platelet-derived growth factor- β (vasoconstrictors). These agents act on vascular smooth muscle cells and inhibit or stimulate platelet aggregation and adhesion. Vascular tone is also modulated by local oxygen tension and shear forces. An abnormal state of vasodilation and low vascular resistance in subjects with sickle cell disease occurs during steady-state periods, but during crisis states there is a decrease in the levels of vasodilator substances such as the prostacyclins and an increase in vasoconstrictor substances including endothelin and prostaglandins. This shift in the balance of vascular tone toward vasoconstriction results in slowing of vascular flow, further obstruction, and more profound deoxygenation of sickled red cells.¹²⁶ A family of enzymes termed nitric oxide synthase (NOS) catalyzes arginine and produces NO,¹²⁷ the major endothelium-derived relaxing factor in normal physiology. NO plays a central role in vascular homeostasis by maintaining vasomotor tone and limiting ischemia-reperfusion injury.¹²⁸ Plasma levels of the NO metabolites (nitrite and nitrate) and plasma arginine levels

are depressed in sickle cell patients during vaso-occlusive crisis and the acute chest syndrome.^{129, 130} The rate of NO depletion correlates with the severity of hemolysis and is associated with the release of cell-free hemoglobin, which scavenges NO. The effect of scavenging is compounded by decreased bioavailability of the arginine substrate, which is rapidly consumed by erythrocyte arginase after its release from the hemolyzed red blood cell.^{131, 132} Downstream effects of intravascular hemolysis and NO consumption include increased endothelin-1 expression, heme- and free-iron-mediated oxygen radical generation, platelet activation, and increased endothelial adhesion-molecule expression.¹³³ Low arginine levels in sickle cell patients with vaso-occlusive crisis and ACS provide a rationale for arginine therapy in these conditions.¹³⁴

Adhesion of red cells to endothelial cells alters vascular flow as described earlier. Specific ligands that may mediate adhesion of sickled red cells to endothelium include von Willebrand factor, thrombospondin, fibrinogen, fibronectin, laminin, and vitronectin.^{135, 136} Factors that act as vasoconstrictors, such as free radicals, prostaglandins (PGI₂ and PGD₂), and endothelin-1, may enhance adhesion of sickled red cells to the endothelium. Infection or tissue inflammation may exacerbate erythrocyte adhesion through inflammatory cytokines such as tumor necrosis factor.¹³⁷

Alterations in the number and function of white blood cells may contribute to vaso-occlusive events.^{138, 139} Changes in chemotaxis and adhesion and increased stickiness of neutrophil membranes also have been observed in crisis states.^{140, 141} Leukocytes may interfere with microvascular flow by lodging in the capillary entrance or adhering to venous or capillary endothelium.¹⁴² Increased white blood cell counts in patients with sickle cell disease have been associated with increased mortality¹⁴³ and SCI in the brain.¹⁴⁴ The beneficial effect of hydroxyurea in the Multi-Center Study of Hydroxyurea was associated with its effect in reducing leukocyte counts.¹⁴⁵ Data from the Cooperative Study of Sickle Cell Disease (CSSCD) showed that increased baseline white blood cell counts in infants are a predictive factor for severe manifestations of sickle cell disease in later childhood.¹⁴⁶ Furthermore, acute infection, possibly because of the attendant leukocytosis, is often a triggering mechanism for vaso-occlusive pain events. In addition, four separate reports have linked the administration of granulocyte colony-stimulating factor (G-CSF) or granulocyte-macrophage colony-stimulating factor (GM-CSF) to the initiation of severe or even fatal sickle cell crisis.^{147, 148, 149, 150} An experimental *in vivo* model using blood flow in the cremasteric muscle of sickle cell mice has indicated that leukocytes that are adherent to the vessel wall can contribute directly to vascular occlusion by means of their interaction with sickle red cells; inhibition of leukocyte adhesion by targeted disruption of P- and E-selectin expression can prevent vaso-occlusion.¹⁵¹ Leukocytes may cause further tissue damage by release of inflammatory mediators and oxygen radicals. Endothelium adhesion molecules such as E-selectin, VCAM-1, and ICAM-1 mediate leukocyte recruitment and promote an inflammatory response, as may the release of heme from red cell lysis.¹⁵²

It has been postulated that patients with sickle cell disease live in a state of "chronic inflammation." The heightened state of inflammation results from different factors, including constant red cell sickling, increased white and red blood cell adhesion and damage to endothelium, increased cytokine generation, or ischemia-reperfusion injury, all causing more vaso-occlusion and repeated endothelial damage (Fig. 33.4).¹¹⁶ In sickle cell transgenic mice, induction of hypoxia followed by re-oxygenation enhances peroxide production and increases leukocyte recruitment.¹⁵³ In addition, ischemia-reperfusion injury causes inhibition of oxygen-sensing prolyl hydroxylase enzymes, leading to activation of hypoxia and inflammatory signaling cascades, altering the stability of transcriptional factors hypoxia-inducible factor (HIF) and nuclear factor- κ B (NF- κ B).^{154, 155} An inhibitor to the nuclear factor- κ B was shown in a sickle cell mouse model to reduce the expression of ICAM-1 and VCAM-1 on circulating endothelial cells of patients with sickle cell disease.¹⁵⁶ Examples of biomarkers of inflammation that are elevated in sickle cell disease are C-reactive protein (CRP), erythrocyte sedimentation rate (ESR), interleukins, and secretory phospholipase A₂, (linked to the development of ACS), among others.^{117, 157, 158}

Consistent alterations in platelet number and function have suggested the involvement of platelets in vaso-occlusive events. Abnormalities include increased platelet counts, increased platelet volume,¹⁵⁹ decreased platelet survival,¹⁶⁰ and decreased platelet aggregation.¹⁶¹ The latter has been attributed to a refractory state resulting from *in vivo* platelet activation. In support of this interpretation is the demonstration that plasma β -thromboglobulin, a measure of release activity from platelet α -granules, is elevated in the steady state and increases further during vaso-occlusive crises.¹⁶² Elevated urinary levels of thromboxane metabolites and depressed platelet thrombospondin content provide evidence for platelet activation in steady-state sickle cell patients.^{163, 164} The levels of the contact factors (factor XII, prekallikrein, and high-molecular-weight kininogen) are low and decrease further during crises.¹⁶⁵ The coagulation inhibitors protein C and free protein S are reduced in steady-state sickle cell disease;^{166, 167} antithrombin III activity levels have been variable, but increased thrombin-antithrombin III complexes and plasma factor VII levels indicate increased tissue factor activity during the steady state.¹⁶⁸ Plasma prostacyclin activity, thought to be generated from vessel wall PG, is increased.¹⁶⁹ The level of fibrin d-dimer, a breakdown

fragment of cross-linked fibrin, increases during vaso-occlusive crises and returns to normal after crisis resolution.¹⁷⁰ Platelet activation is profoundly inhibited by NO, and this inhibition is blocked by plasma hemoglobin-mediated NO scavenging.¹⁷¹ Whether these alterations in hemostasis and fibrinolysis are of pathogenic significance or are simply epiphenomena remains to be determined.

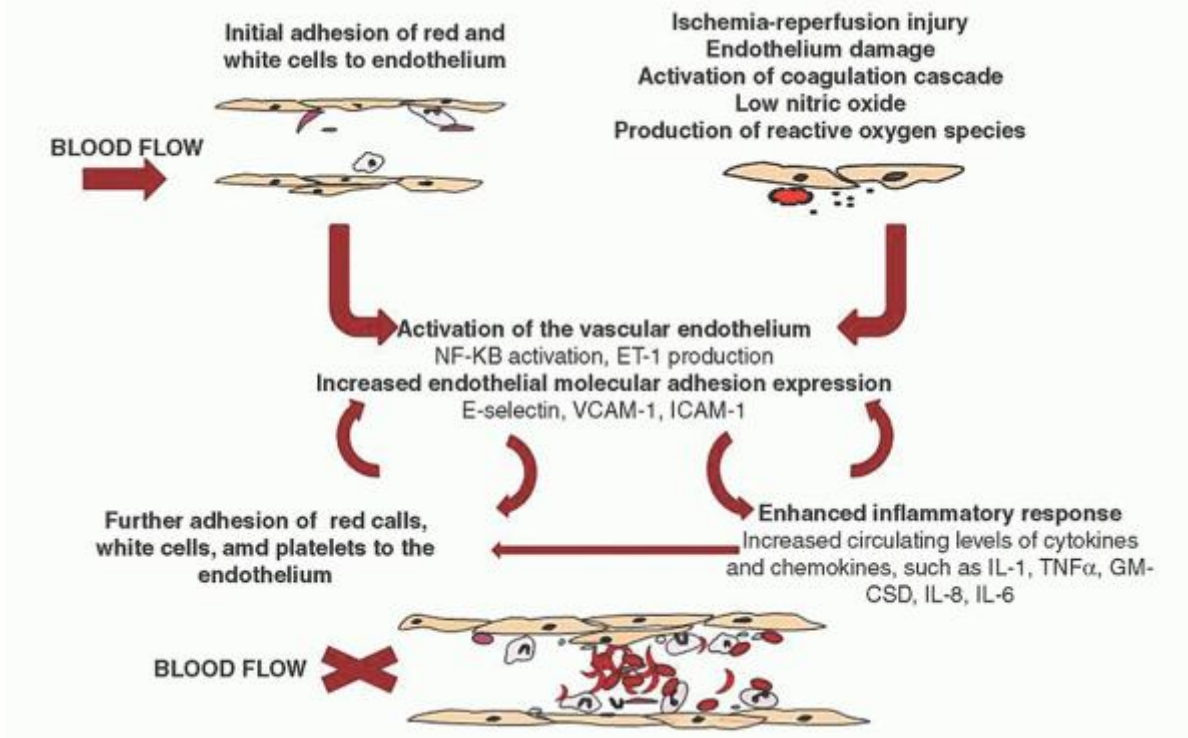

FIGURE 33.4. The chronic inflammatory state and vaso-occlusion. Hemoglobin S polymer formation leads red blood cell membrane surface exposure of glycolipids and protein epitopes. Red and white cell adhesion to the endothelium, coupled with endothelial damage due to cell-free hemoglobin and ischemia reperfusion injury, low nitric oxide bioavailability, and activation of the coagulation cascade by glycolipids, lead to activation of the vascular endothelium. Endothelial activation augments NFκB activity and endothelin-1 production, in association with increased surface adhesion molecule expression. Further adhesive interactions between the endothelium and red cells, leukocytes, and platelets are induced, coupled with a pan-cellular activation that results in an up-regulation of numerous inflammatory mediators. As such, a vicious circle of repeated cell activation, cellular adhesion, and inflammatory molecule production perpetuates the chronic inflammatory state that has a fundamental role in the vaso-occlusive process. Modified from Conran N, Franco-Penteado CF, Costa FF. Hemoglobin. 2009;33(1):1-16.

SICKLE CELL ANEMIA (HEMOGLOBIN SS)

Clinical Features

The clinical features of SCA result more from the vaso-occlusive consequences of sickle cells than from the anemia itself. These features may be divided into those that characteristically are acute and episodic and those that are chronic and often progressive. Although signs and symptoms attributed to Hb S have been observed in early infancy,¹⁷² affected individuals characteristically are asymptomatic until the second half of the first year of life. The lack of clinical expression of the Hb SS genotype during fetal and early postnatal life is explained by the production of a sufficient quantity of Hb F to limit clinically important sickling. Because erythrocytes contain increasing amounts of Hb S and proportionally decreasing amounts of Hb F over the first several months of life, the conditions for sickling under physiologic conditions gradually are met. Prospective studies of affected infants followed from birth indicate a close temporal relationship between the postnatal decline in Hb F and evolution of anemia.^{173, 174, 175, 176} Mild hemolytic anemia is apparent by 10 to 12 weeks of age (Fig. 33.5).^{176, 177}

Clinical features change with age. In the first year of life splenomegaly (usually noted after 6 months of age), dactylitis, and ACS are commonly seen.¹⁷³ Loss of function of the spleen has been documented as early as 5 months of age,^{176, 178} and death from overwhelming infection is an increased risk before 12 months of age.¹⁷⁵ The first vaso-occlusive episode is experienced before 4 years of age by the majority,¹⁷⁵ but not until late childhood or adulthood by a few. During adolescent and especially young adult years, organ dysfunction (e.g., renal, pulmonary, cardiac, and hepatic dysfunction) becomes more prevalent and, in older adults frequently causes mortality.^{143, 179}

The Cooperative Study of Sickle Cell Disease and the Jamaican Cohort Study, the two largest prospective sickle cell cohorts to date, have generated information regarding the “natural history” of sickle cell disease in thousands of pediatric and adult patients. More recently, the Dallas Cohort has offered important data about survival and risk factors in sickle cell disease.¹⁸⁰

Compound heterozygote states, such as Hb SC and Hb S β^+ -thalassemia, can exhibit any of the clinical features seen in Hb SS, but often do so with lesser frequency and severity. Hb S β^0 -thalassemia has a very similar phenotype to Hb SS, and is often considered together with Hb SS in the literature, sometimes with both conditions being referred to as SCA. The term sickle cell disease is used to describe all clinically significant genotypes that involve Hb S.

Acute Events: Characteristics, Management, Prevention

Vaso-occlusive Events: Dactylitis and Pain

The term sickle cell crisis was introduced to describe a recurring attack of pain involving the skeleton, chest, abdomen, or all three. Using the term in a broader sense, vaso-occlusive “crises” comprise a variety of syndromes that are typically recurrent and potentially catastrophic. Clinical manifestations are sudden in onset and are directly attributable to obstruction of the

P.831

microcirculation by intravascular sickling. Modest exacerbation of anemia and increased leukocytosis are common. Infections often precede vaso-occlusive episodes in children, suggesting that fever, dehydration, and acidosis may be contributing factors. In adults, a triggering event is not often identified, however.

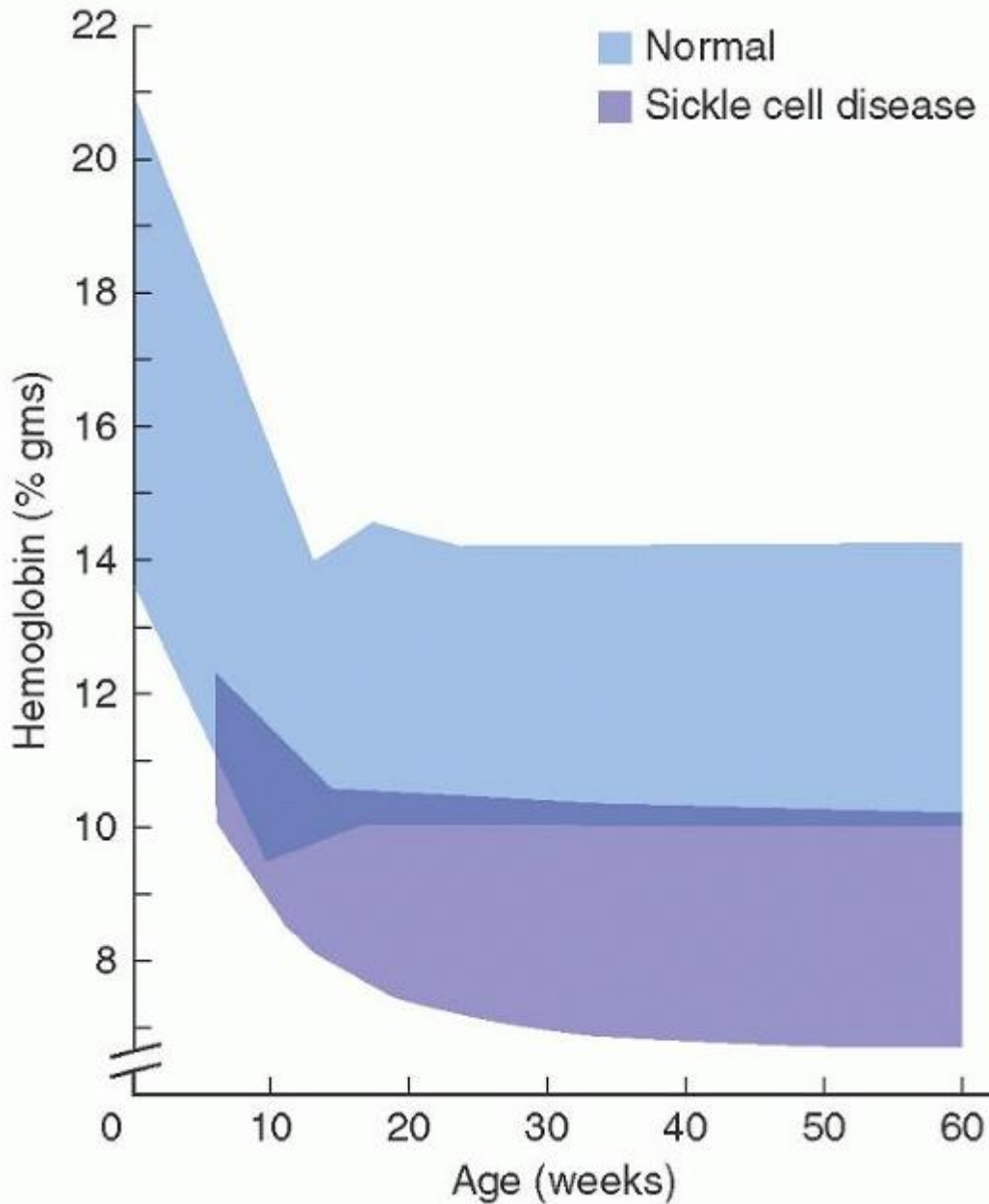

FIGURE 33.5. Hemoglobin concentration as a function of age in infants with sickle cell anemia (SCA). From O'Brien RT, McIntosh S, Aspnes GT, et al. Prospective study of sickle cell anemia in infancy. *J Pediatr* 1976;89:205, with permission.

The initial vaso-occlusive episode in infants, named hand-foot syndrome or dactylitis, often involves the small bones of the hands and feet. By 2 years of age, nearly 50% of Jamaican children and 25% of American children with SCA have experienced at least one episode of dactylitis.^{173, 181} Typically, the dorsa of the hands and/or feet are swollen, nonerythematous, and exquisitely painful. Fever and leukocytosis are common. Radiographic changes are limited initially to soft-tissue swelling; cortical thinning and destruction of metacarpals, metatarsals, and phalanges appear 2 to 3 weeks after the onset of symptoms. Dactylitis is sudden in onset and may last 1 or 2 weeks. It may recur on one or more occasions until the patient is ~3 years of age.¹⁸¹

Usually, after the first few years of life, interruption of blood flow occurs in the larger bones of the extremities, spine, rib cage, and periarticular structures, producing painful crises of the bones and joints.^{182, 183} The sinusoidal circulation of the bone marrow provides an ideal vascular bed for the sickling phenomenon.

In the CSSCD, epidemiologic features of pain crises were analyzed in a large group of patients with sickle cell disease.¹⁸⁴ The average rate of pain was 0.8 episode/patient-year in Hb SS, 1.0 episode/patient-year in Hb S β^0 -thalassemia, and 0.4

episode/patient-year in Hb SC disease and Hb S β^+ -thalassemia. However, the rate varied widely from patient to patient: 39% of patients with SCA had no episodes of pain, but 1% had more than six episodes per year. With Hb SS patients 5% accounted for almost one third of all the episodes. The pain rate increased moderately from childhood to the third decade of life. A higher rate of pain events has been associated with low nocturnal oxygen saturation detected by continuous monitoring during sleep.¹⁸⁵ When children with a history of asthma experience an episode of pain, antecedent or concurrent respiratory symptoms (cough, wheeze, tachypnea, retractions, or grunting) occur more frequently than in children without a history of asthma, suggesting that involvement of the respiratory system is a risk factor for these events.¹⁸⁶

Pain resulting from ischemia of the bone marrow is gnawing and progressive in severity. Although pain can affect any bone in the body, the most frequent sites are the humerus, tibia, and femur. Involvement of facial bones is less common but is well documented. The swelling associated with infarction of the orbital bone may be sufficient to produce proptosis and ophthalmoplegia.¹⁸⁷ Swelling of the elbows or knees may mimic rheumatic fever or septic arthritis.¹⁸⁸ Infarcts involving deep bones are usually not associated with detectable swelling, erythema, or surface temperature change. Laboratory findings, too, are inconstant and nonspecific. The radiographic features of bone infarction and periostitis usually do not appear until after the resolution of symptoms. Increased signal with T2-weighted images is seen by magnetic resonance imaging (MRI) in approximately one third of pain crises.¹⁸⁹ Discrete areas of decreased localization of ⁹⁹Tc-sulfur colloid identify areas of decreased marrow blood flow, and ⁸⁵Sr or ⁹⁹Tc-phosphate localizes the increased osteoblastic activity that occurs with healing.¹⁹⁰ Although radionuclide bone and bone marrow scans theoretically enable differentiation of bone infarcts from osteomyelitis, in practice they are of limited value.¹⁸² Unlike osteomyelitis, bone infarcts are associated with no more than a low-grade fever, little or no left shift in the leukocyte differential, and only occasional edema. As a cause of bone pain, infarction is >50 times as common as osteomyelitis.¹⁸²

An abdominal pain crisis, a diagnosis of exclusion, is attributed to small infarcts of the mesentery and abdominal viscera. An abdominal pain crisis is characterized by severe abdominal pain and signs of peritoneal irritation; however, the differential diagnosis of other causes of abdominal pain (e.g., cholecystitis, pancreatitis, constipation) should always be considered. The persistence of bowel sounds differentiates pain crises from acute intra-abdominal disorders requiring surgical intervention. Diagnosis is facilitated by prior experience with the patient, because the pattern of pain tends to repeat itself from crisis to crisis. Atypical clinical or laboratory features should suggest one of several complications to which patients with SCA are especially susceptible, such as ACS, urinary tract infection, or cholecystitis.

On average, painful crises persist for 4 or 5 days, although protracted episodes may last for weeks, especially among adults. Data from the CSSCD indicate that an increased frequency of painful events is associated with a high hematocrit and a low Hb F level.¹⁸⁴ Adults with high rates of pain episodes tend to die earlier than those with low rates.¹⁸⁴ Of therapeutic significance, it was noted in the CSSCD that even when the Hb F level was low, a small increase was associated with an ameliorating effect on the pain rate and potentially improved survival.

No specific form of therapy has proven effective for acute vaso-occlusive crises. None of the many medications and manipulations that have been touted as beneficial have withstood critical scrutiny. Low-molecular-weight dextran, phenothiazines, fibrinolytic agents, bicarbonate and other alkalis, and urea solutions, when evaluated in controlled clinical studies, were found to be without apparent effect.^{191, 192, 193, 194, 195, 196} Other therapeutic strategies, although not subjected to randomized clinical trials, have enjoyed only fleeting popularity. These strategies have included carbonic anhydrase inhibitors,¹⁹⁷ vasodilators, anticoagulants, progesterone,¹⁹⁸ testosterone,¹⁹⁹ papaverine,²⁰⁰ antithyroid drugs,²⁰¹ and hyperbaric oxygen.²⁰² Studies of pentoxifylline, an agent that increases red blood cell deformability and inhibits platelet aggregation,²⁰³ and cetiedil, a smooth muscle relaxant that inhibits sickling and cell dehydration,²⁰⁴ suggested a reduction in duration of painful crises, but results have not been substantiated by further trials. Poloxamer-188, a nonionic surfactant compound, reduced total analgesic use, but a Phase III trial demonstrated only a slight shortening of the duration of pain crises.²⁰⁵ Phase II and III randomized, placebo-controlled, double-blind studies investigating the Gardos channel blocker Senicapoc (ICA-17043), showed improvement of anemia and reduction of dense erythrocytes and reticulocytes when compared to placebo; however, they

P.832

failed to demonstrate reduction of painful crises.^{206, 207} Despite encouraging results in Phase II trials, a prospective, multicenter, double-blind, randomized, placebo-controlled clinical trial for up to 72 hours of inhaled NO gas failed to demonstrate benefit in reducing duration of pain crisis or amount of narcotic use.²⁰⁸ Vitamin D levels are reported low in the majority of individuals with sickle cell disease, and there are reports linking chronic pain with vitamin D insufficiency and deficiency.^{209, 210, 211, 212} Replacement of vitamin D has been reported in a few patients to improve symptoms of

chronic pain.^{213, 214} The duration and severity of pain crises are notoriously variable, and the natural course is one of spontaneous improvement. Consequently, uncontrolled reports of effective therapies must be viewed with skepticism, especially if the proposed treatment entails an element of risk.

The cornerstones of present-day therapy are fluids and analgesics. The volume of fluids administered should be sufficient to abolish any deficit, correct hypertonicity, and fully compensate for ongoing losses imposed by fever, hyposthenuria, vomiting, or diarrhea. Typically 150% maintenance intravenous hypotonic fluids are used in the first 12 to 24 hours of the pain event, and subsequently reduced gradually. Precipitants of the crisis should be sought and eliminated. Infection, a common precipitating cause in children, may require antibiotic therapy. Acidosis is corrected readily with intravenous administration of sodium bicarbonate, but its etiology should be investigated and treated. Oxygen therapy in the absence of documented hypoxemia is without benefit and triggers an increase in the number of ISCs when discontinued.²¹⁵ Red blood cell transfusions are not indicated in the treatment of the acute pain crisis, unless there is associated accentuated anemia (e.g., parovirus B19 induced "aplastic crisis"). Furthermore, because fever and back pain are common features of pain crises, transfusion reactions may escape early recognition.²¹⁶

Control of pain requires the liberal use of analgesics,²¹⁷ but narcotic addiction is unlikely as long as analgesics are closely monitored. Nonsteroidal inflammatory drugs (NSAIDs) used in association with opioids offer benefit, but should be used with caution in patients with renal dysfunction. Regardless of the use of opioids and/or NSAIDs, pain should be treated promptly (within 60 minutes from initial assessment) and re-evaluated within 30 minutes from first dose of analgesic, according to published quality of care indicators.²¹⁸ The use of patient-controlled analgesia enables patients to administer opioids to themselves as needed and provides an element of self-control in pain management.^{219, 220} Patient-to-patient variability in the response to pain treatment is common, and there has been great interest in developing individualized pain therapy to improve the efficacy of treatment, as well as patient experience and satisfaction.²²¹ Some of this individual variation may be explained by polymorphic enzyme cytochrome P450 (CYP) 2D6 variant alleles that are commonly observed among African Americans and may lead to impaired codeine conversion to morphine.²²² Nonpharmacologic management of pain, such as with self-hypnosis, has been used successfully for pain control in selected subjects.²²³ Local use of warm packs may be beneficial in some. Prophylactic approaches to pain management are discussed later in this chapter.

Central Nervous System Events

Stroke is a catastrophic complication of SCA that affects 6% to 17% of children and young adults.^{224, 225} Data from the CSSCD, in which ~4,000 patients were followed for an average of 5 years, indicated that infarctive stroke was most frequent in children and older adults with Hb SS, whereas hemorrhagic stroke had the highest incidence in patients 20 to 29 years of age.²²⁴ The mortality rate was 26% after hemorrhagic stroke, but 0% after infarctive stroke. Severe anemia, a history of recent or recurrent acute chest syndrome, previous transient ischemic attack (TIA), and hypertension were independent risk factors for ischemic stroke; anemia and leukocytosis were independent risk factors for hemorrhagic stroke.²²⁴ The risk of stroke is increased in patients with Hb F levels <8%²²⁶ and in patients with siblings who have had strokes. Data from the CSSCD also revealed that silent cerebral infarcts (SCI, areas of increased signal intensity, primarily in deep white matter or watershed areas of the cerebral cortex, not attributed to an overt neurologic event or finding) on MRI were a strong independent risk factor for stroke.^{227, 228} In addition, nocturnal hypoxemia is a risk factor for acute neurologic events (stroke, TIA, or seizures).²²⁹ By far the best predictor of stroke risk at this time, however, is transcranial Doppler (TCD) velocity.²³⁰

The pathogenesis of cerebral vascular disease is incompletely understood (Fig. 33.6). Pathologically, vascular narrowing (stenosis) results from segmental proliferation and fragmentation of the intima. The internal elastic lamina may show degenerative changes, and the tunica media may be disrupted by fibrosis and hemorrhage. Occlusion is the result of progressive proliferation of vascular smooth muscle, superimposed thrombosis, or embolus.^{231, 232} Increased adherence of sickle red cells to the endothelium of vessel walls and decreased cerebral vessel CO₂ responsiveness (reflecting diminished reserve capacity for vasodilatation), may be additional mechanisms.^{233, 234} Aneurysms can be demonstrated in some patients who have sustained intracranial hemorrhage and may be observed as an incidental finding in children with cerebral vaso-occlusive disease.²³³

The distal internal carotid and proximal middle and anterior cerebral arteries are stenotic or occluded in sickle cell patients who have experienced a stroke.²³⁵ In response to chronic anemia and hypoxemia, cerebral blood flow is markedly increased.²³⁶ TCD velocities in the major cerebral arteries are influenced by both of these factors and are abnormally elevated in patients at high risk for stroke.^{230, 237} There are several factors that appear to modulate TCD velocities and stroke risk. Hb desaturation is linked to elevated TCD velocities and stroke,^{238, 239} whereas G6PD deficiency and elevated markers of hemolysis increase the risk of elevated TCD velocities.²⁴⁰ The most common sites of ischemic stroke are the

parenchymal areas supplied by the anterior and middle cerebral arteries and the border zones between their distal circulations.^{241, 242} When acute or chronic conditions arise leading to diminished oxygen availability (e.g., an episode of ACS, an aplastic crisis, nocturnal hypoxemia), the increased hypoxic stress coupled with the inability of the cerebrovasculature to undergo further dilatation leads to ischemia.²²⁹

Increasing evidence for genetic modifiers of stroke has accumulated. In a clinical epidemiology study, 42 sibships of patients with SCA in which one sibling had had a stroke revealed a greater than expected number of families having two or more children with a stroke.²⁴³ In another study, children with SCA were far more likely to have an abnormally elevated flow velocity on TCD if they had a sibling with an abnormal TCD.²⁴⁴ Specific β -S-globin gene haplotypes have been associated with increased stroke risk, but findings have been inconsistent.^{245, 246} Certain HLA alleles and the presence of alpha thalassemia are recognized protective factors for cerebrovascular disease.^{240, 247, 248} Genes regulating immune function and inflammation, including Fc γ receptor and tumor necrosis factor- α (TNF- α), have not contributed to an increased risk of stroke, whereas single nucleotide polymorphisms (SNPs) within the vascular cell adhesion molecule (VCAM)-1 gene may influence this risk.^{249, 250} Other SNPs shown to be associated with increased stroke risk are ANXA2, TGFBR3, and TEK, whereas SNPs in the ADCY9 gene were linked to decreased stroke risk.²⁴⁸

A novel approach to “disentangling the web of interactions among genes, environment, and phenotype” has been the use of a Bayesian network, a multivariate dependency model that accounts for simultaneous associations and interactions among multiple genes and their interplay with clinical and physiologic factors.²⁵¹ Using data and stored samples from the CSSCD, 108 SNPs in 39 candidate genes from almost 1,400 individuals were analyzed. Candidate genes were involved in vasoregulation, inflammation,

P.833

cell adhesion, coagulation, hemostasis, cell proliferation, oxidative biology, and other functions. In 92 patients who had had an overt stroke, the network was used to determine 11 genes whose variants had a direct effect modulated by hemoglobin F levels and 9 genes whose variants were indirectly associated with stroke.

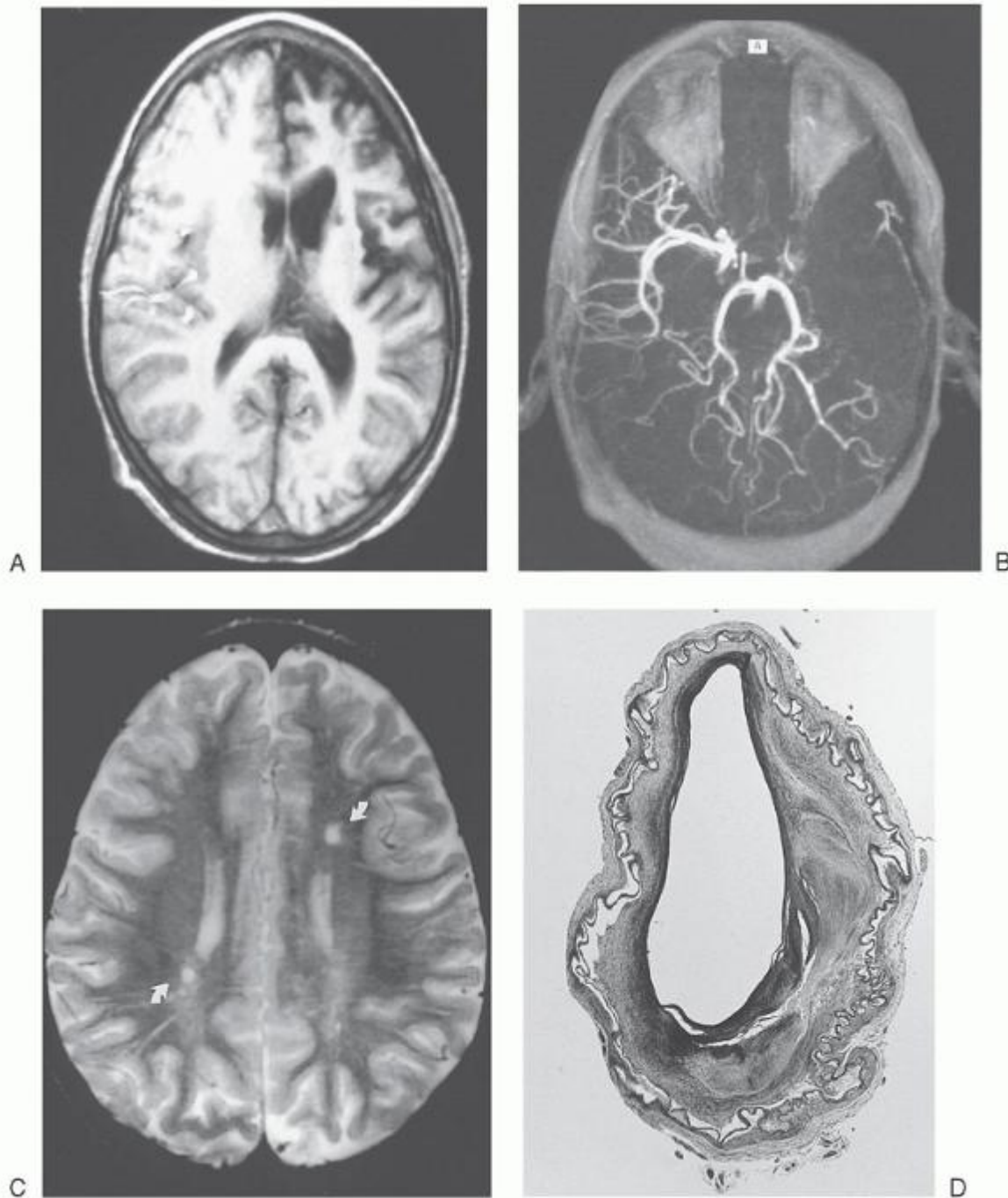

FIGURE 33.6. Vaso-occlusive effects in the central nervous system. **A:** T1-weighted magnetic resonance imaging (MRI) in a 6-year-old girl with hemoglobin (Hb) SS and a history of stroke. There is extensive atrophy involving the distributions of the left anterior and middle cerebral arteries with compensatory enlargement of the left lateral ventricle. **B:** Magnetic resonance angiography in the same patient showing occlusion of left middle cerebral artery and diminished flow through both anterior cerebral arteries. **C:** T2-weighted sagittal MRI in a 4-year-old boy with “silent infarcts.” Small areas of leukomalacia are seen in deep white matter in frontal and parietal areas (arrows). **D:** Pathologic section of internal carotid artery showing fibrinous thrombus with parallel layers of fibrin deposited on intimal surfaces and atrophic media. Courtesy of Dr. J. J. Jenkins, St. Jude Children's Research Hospital.

Clinically, strokes are characterized by the abrupt onset of hemiparesis, aphasia, seizures, sensory deficits, and altered consciousness, occurring singly or together. The patient may make a full recovery, but incomplete resolution of neurologic deficits may happen. Diffusion weighted imaging (DWI) MRI permits noninvasive and early visualization of focal ischemia.

Emergent treatment of stroke includes vigorous hydration, simple transfusion, patient stabilization, followed by exchange transfusion once Hb concentration is at least 8 g/dl.

Strokes tend to be repetitive because of the progressive nature of cerebral vascular disease. Patients with moyamoya are more than twice as likely to incur subsequent stroke or transient ischemic attack despite transfusion treatment.²⁵² In general, unless patients begin a long-term transfusion program, they are at risk for recurrent cerebral infarctions with progressive neurologic deterioration. Chronic transfusion therapy designed to maintain the level of Hb S at <30% reduces the risk of recurrent strokes (within 36 months) from approximately 70% to 90% to 10% to 20%.²³³ Interruption or termination of treatment, even after 8 years of chronic transfusion, is associated with a stroke recurrence rate similar to that of untransfused patients,^{253, 254} suggesting that transfusion therapy for secondary stroke prophylaxis should be continued indefinitely. However, reduction of the intensity of chronic transfusion to allow pretransfusion Hb S levels to reach 50% appears safe after the first few years of prophylaxis^{255, 256} and is routinely utilized by many sickle cell centers.²⁵⁷ Many chronically transfused children have transfusions

P.834

discontinued when they reach adulthood. In one series of nine adult patients who stopped transfusion after a median of 6 years, none suffered recurrent stroke.²⁵⁸ In an initial report, long-term treatment with hydroxyurea appeared to prevent stroke recurrence in children who were treated with relatively high doses (30 to 40 mg/kg/day).^{259, 260} In a larger prospective trial, 35 children with SCA and stroke had transfusions discontinued and hydroxyurea started.²⁶¹ Initially, transfusion was stopped before hydroxyurea therapy was started, but later, transfusion was overlapped until full-dose hydroxyurea therapy was tolerated. Overall, stroke reoccurred at a rate of 5.7 events per 100 patient-years, but children receiving overlapping therapy had only 3.6 events per 100 patient-years. In a cohort from Jamaica, where blood supply is limited, hydroxyurea therapy was the only reliable treatment option and was shown to prevent stroke recurrence in children with prior stroke events.²⁶² These findings led to the Stroke with Transfusions Changing to Hydroxyurea (SWITCH) study, a phase III randomized, multicenter clinical trial, which compared standard treatment (transfusions with iron chelation) to alternative treatment (hydroxyurea with phlebotomy) for stroke prophylaxis in children who had experienced prior stroke.^{263, 264, 265} SWITCH was a noninferiority trial with a composite primary endpoint of stroke and hepatic iron overload. This study was interrupted early because more strokes were observed in the hydroxyurea/phlebotomy arm and only equivalence in liver iron content was seen in the two arms. Chronic transfusion therapy and iron chelation remains the standard treatment for secondary prevention of stroke in children with SCA. Unfortunately, chronic blood transfusion does not prevent progression of brain vasculopathy or silent cerebral infarcts in children receiving this therapy for secondary stroke prevention, which makes blood transfusion an imperfect choice for this indication.^{263, 264}

In a series of studies led by Robert Adams, an abnormal transcranial Doppler ultrasound examination (defined by a timeaveraged mean maximum velocity ≥ 200 cm/s in the distal internal carotid or proximal middle cerebral artery) was predictive of a 40% stroke risk in HbSS patients.²³⁰ In the Stroke Prevention in Sickle Cell Anemia (STOP) trial, 130 patients with abnormal TCD velocities were prospectively randomized to receive chronic transfusion or standard observation.²⁶⁶ A 92% reduction in the risk of stroke occurred in the patients receiving chronic transfusion. The appropriate length of time for transfusion for primary stroke prevention in patients with abnormal TCD velocities was addressed by the STOP II Trial.²⁶⁷ Patients enrolled in STOP II had had an initial abnormal TCD velocity and transfusion for at least 30 months, during which time the TCD velocity became normal (<170 cm/s). Patients were then randomly assigned to continue or stop transfusion, and the primary endpoint was stroke or a reversion to an abnormal TCD exam. Among the 41 children enrolled in the discontinuation-of-transfusion group, abnormal TCD results developed in 14 and stroke in 2 others within a mean of 4.5 months (range 2.1 to 10.1 months) of the last transfusion. None of these endpoint events occurred in the 38 children who continued to receive transfusions. A recent analysis of the participants of the STOP II trial demonstrated that among children who discontinued transfusions there was significant progression of SCI in comparison with those who continued transfusions.^{268, 268} In a separate cohort of children who were receiving chronic transfusion therapy for primary stroke prevention after having had abnormal TCD velocities, transfusions were successful in preventing progression of vasculopathy.²⁶⁹ As discussed earlier, the same protection does not seem to be conferred by transfusions to children with prior overt strokes.

Overall, among 209 total patients who underwent randomization in STOP and STOP II, 20 strokes occurred. In all cases, the last TCD examination before the stroke showed an abnormal velocity.²⁷⁰ The estimated stroke risk for untreated patients was 10% per year for an abnormal TCD and 2% to 5% per year for a conditional TCD. Extrapolation from these data has led to recommendations for the frequency of TCD screening in children with HbSS/S β^0 thalassemia between the ages of 2 and

16 years (Table 33.2).²⁷¹ Information regarding utility of TCD examination in adults is extremely limited, although velocities are probably intermediate between those found in children with sickle cell disease and normal adult controls.²⁷²

Since the results of the STOP trials, TCD programs have led to a dramatic reduction of stroke incidence in some centers.^{271, 273, 274} However, despite the well-publicized results of the STOP Trials, performance of TCD screening has been variable. Preliminary data from the C-Data Registry of the Comprehensive Sickle Cell Centers indicate that a TCD exam was performed in the past year in only 42% of 2- to 12-year-old children with HbSS and Hb Sβ⁰ thalassemia, the genotypes at greatest risk for stroke.²⁷⁵ The greatest perceived barrier to TCD screening in children with sickle cell disease was poor patient adherence to TCD appointments, which in part was attributable to the second most common obstacle: distance to a “vascular laboratory.”²⁷⁶ There also has been concern about complications of chronic transfusion, particularly the risk of iron overload. The availability of oral iron chelators, may partially alleviate that concern.

The use of hydroxyurea for primary stroke prevention is currently under investigation. In a French study, 6 of 10 patients with abnormal TCD whose velocities normalized on transfusion were switched successfully to treatment with hydroxyurea.²⁷⁷ In a Belgian study, patients with abnormal TCD were treated with hydroxyurea and observed for a total of 96 patient-years.²⁷⁸ Only a single neurologic event, a seizure, was observed. In two different cohorts of children with SCA, hydroxyurea treatment resulted in significant decrease in TCD velocities.^{279, 280} In addition, hydroxyurea treatment of adult patients with sickle cell disease resulted in improved, but not normalized, cerebral oxygen levels.²⁸¹ The ongoing phase III multicenter randomized TCD with Transfusions Changing to Hydroxyurea (TWiTCH) trial aims at maintaining or lowering TCD velocities in children who have received blood transfusions for abnormal TCD velocities for at least 12 months. In the TWiTCH trial, children with abnormal TCD velocities are randomized to continue transfusions, or to discontinue transfusions and begin hydroxyurea after a period of overlap between the two treatment arms (clinicaltrials.gov # NCT01425307).

Although the relative risk of primary stroke is lower among patients with conditional TCD velocities (time-averaged mean maximum velocity 170 to 199 cm/sec) than those with abnormal velocities (risk 2 to 5 vs. 9% per year), more children have conditional TCD velocities (17% vs. 9% prevalence), so the absolute number at risk for stroke without therapy is comparable. The risk of conversion from a conditional to abnormal TCD velocity is

P.835

highest in children under 10 years of age.^{282, 283} Currently, conditional TCD velocity is not an indication for treatment, but the ongoing phase III multicenter Sparing Conversion to Abnormal TCD elevation (SCATE) study is investigating whether hydroxyurea therapy in children under age 11 years with conditional TCD will be less likely to develop abnormal TCD velocities than those who are observed (clinicaltrials.gov # NCT01531387).

TABLE 33.2 RECOMMENDED TRANSCRANIAL DOPPLER (TCD) SCREENING SCHEDULE IN CHILDREN WITH SICKLE CELL DISEASE

Initial TCD Result ^a	Frequency of Testing		
	Age (years)		
	2-5	6-11	12-16
Normal	Yearly	Yearly × 3	Yearly × 2
Low conditional	Every 6 mo	Every 6 mo	Every 6 mo
High conditional	Every 3 mo	Every 3 mo	Every 3 mo
Abnormal	Within 1 mo	Within 1 mo	Within 1 mo

^a TCD result: normal, <170 cm/s; low conditional, 170 to 184 cm/s; high conditional, 185 to 199 cm/s; abnormal, ≥200 cm/s.

SCI occurs in 27% of children with SCA under 6 years of age,²⁸⁴ and 37% by their 14th birthday.²⁸⁵ Data from the CSSCD have shown that children with SCI had an increased incidence of new stroke and new or more extensive SCI²²⁷ and that SCIs were the strongest independent predictor of stroke.²²⁸ Data from the STOP trial indicated that those who had SCI as well as abnormal velocities were at higher risk for developing a new SCI or stroke than those whose MRI showed no abnormality.²⁸⁶ However, a comparison of patients who were in both the CSSCD and STOP studies indicated that those who had abnormal TCDs did not have an unusually high frequency of MRI abnormality; conversely, those who had SCI did

not have an unusually high frequency of abnormal TCD velocities, suggesting that those findings represent different aspects of the pathophysiology of the brain in children with sickle cell disease.²⁸⁷ The ongoing Silent Cerebral Infarct Transfusion (SIT) trial is a phase III multicenter randomized study aiming at determining whether blood transfusion therapy will limit overt clinical strokes or new or progressive SCI in children with SCA and SCI identified by MRI screening in comparison with children randomized to observation (clinicaltrials.gov # NCT00072761).²⁸⁸ Baseline results of the SIT trial showed that lower Hb concentration and higher systolic blood pressure were associated with SCI in children with SCA.²⁸⁹

Acute Chest Syndrome

Acute chest syndrome (ACS) is an acute illness characterized by fever and/or respiratory symptoms, accompanied by a new pulmonary infiltrate on a chest X-ray.²⁹⁰ ACS remains one of the most common causes for hospitalization, critical care utilization, and mortality in children and adults with sickle cell disease.^{291, 292} The term acute chest syndrome was coined because it is not usually possible to determine the relative importance of vascular occlusion and infection in the acute pulmonary process in any given patient. Infection tends to predominate in children and infarction in adults, but the two processes are often interrelated and concurrent.²⁹³ Impaired access of oxygen to infected segments of the lung likely enhances local sickling, with resulting focal microvascular thrombotic disease. Data from the CSSCD indicate that patients with Hb SS have an incidence of ACS of ~13/100 patient-years; the rate is highest in children 2 to 4 years of age (25/100 patient-years) and decreases gradually with increasing age to that seen in adults (9/100 patient-years).²⁹⁴ A higher ACS rate is associated with a higher rate of mortality from all causes. The risk of ACS is associated with a lower fetal Hb level and a higher steady-state hematocrit and leukocyte count.²⁹⁵

Before the availability of pneumococcal vaccines and the widespread use of penicillin prophylaxis, pulmonary events in children typically were the result of bacterial infection.^{276, 296} *Streptococcus pneumoniae* was the most common causative organism. Infiltrates often affected multiple lobes, and resolution was slower than in the general population.²⁹⁷ Identified infectious agents have included *Mycoplasma pneumoniae*,²⁹⁸ *Chlamydia pneumoniae*,²⁹⁹ parvovirus B19,³⁰⁰ and respiratory viruses. The National Acute Chest Syndrome Study Group reported causes and outcomes based on analysis of 671 episodes of ACS.³⁰¹ Nearly half of the patients were initially admitted for another reason, primarily pain. The mean length of hospitalization was 10.5 days; 13% required mechanical ventilation, and 3% died. Patients who were 20 years of age or older had a more severe course. A specific cause of ACS was identified in 38% of all episodes and in 70% of episodes with complete data (Table 33.3).³⁰¹ The most common specific causes were pulmonary fat embolism, chlamydia, mycoplasma, miscellaneous viruses, and bacterial infections resulting from coagulase-positive *Staphylococcus aureus* and *Streptococcus pneumoniae*. Recently, influenza, especially H1N1, was shown to be associated with increased risk and severity of ACS, and therefore should be prevented whenever an outbreak or epidemic is detected.³⁰² In adults, an infectious basis for lobar consolidation is established less often than in children, and antibiotic therapy is without apparent effect on the duration or severity of symptoms.³⁰³ In situ vaso-occlusion owing to erythrocyte stasis appears to be the more common primary event. Interestingly, an association between smoking and increased rate of ACS and pain events has been observed among adults with sickle cell disease.³⁰⁴

The relationship of asthma/reactive airway disease to ACS has been examined. In children with Hb SS, asthma is associated with an increased incidence of sickle-cell-related morbidity,

P.836

including ACS and pain episodes, and mortality.^{305, 306} A similar relationship was observed between asthma and the incidence of ACS in pediatric patients with Hb SC.³⁰⁷ Sickle cell patients with a history of asthma were four times more likely to develop ACS during a hospital admission for pain and had a substantially longer duration of hospitalization.³⁰⁸ Similarly, children with pulmonary function test (PFT)-documented lower airway obstruction had a greater risk for pain and ACS hospitalization (risk ratio 2.0, CI: 1.3 to 3.3).³⁰⁹ In Jamaican children with sickle cell disease, asthma and bronchiolar hyperreactivity were more common than in ethnic-matched controls and were associated with recurrent ACS.³¹⁰ Much less information is available for adult patients, but a high prevalence of airway hyperresponsiveness to methacholine challenge was noted in those with a history of reactive airway disease.³¹¹ Hematologically, ACS is characterized by a sudden drop in Hb concentration and an increase in the number of platelets and leukocytes.³¹² Rib infarcts are a primary trigger of ACS when bone pain is followed by soft-tissue reaction, pleuritis, splinting, hypoventilation, atelectasis, and the typical radiologic picture.³¹³ Incentive spirometry with the use of maximal inspirations every 2 hours has been shown to prevent ACS in patients with sickle cell disease who were hospitalized with chest or back pain.³¹⁴ Lung crises may result from embolization of fat from infarcted bone marrow (pulmonary fat emboli)³¹⁵ or deep-vein thrombi. Occlusion of major pulmonary vessels is a recognized cause of sudden death. Pulmonary

fat emboli are found more commonly than previously appreciated when a diagnosis is sought by fat staining of pulmonary macrophages obtained by bronchoalveolar lavage.³¹⁵ Fat emboli are associated with bone pain, chest pain, neurologic symptoms, acute decreases in Hb level and platelet count, and prolonged hospitalization. Secretory phospholipase A₂ (sPLA₂), an inflammatory mediator that liberates free fatty acids and lysophospholipids and may be responsible for acute lung injury, is markedly elevated in sickle cell patients 24 to 48 hours before the diagnosis of ACS in patients presenting with a pain event^{316, 317} and in most patients at the time of diagnosis of ACS.³¹⁸ A clinical trial involved patients hospitalized for pain who developed fever and elevated sPLA₂ and were randomized to receive transfusion or observation.¹⁵⁸ Because of slow accrual, conclusions could not be reached regarding the effect of transfusion to pre-emptively avert an ACS event, but information regarding the sensitivity of this test was provided; a threshold level of sPLA₂ ≥ 48 ng/ml offered 73% sensitivity and 71% specificity.

TABLE 33.3 CAUSES OF ACUTE CHEST SYNDROME

Cause	(N = 670)	Age at Episode of Acute Chest Syndrome			
		Percentage	0-9 years (N = 329)	10-19 years (N = 188)	≥20 years (N = 153)
Fat embolism, with or without infection	59	8.8	24	16	19
Chlamydia	48	7.2	19	15	14
Mycoplasma	44	6.6	29	7	8
Virus	43	6.4	36	5	2
Bacteria	30	4.5	13	5	12
Mixed infections	25	3.7	16	6	3
Legionella	4	0.6	3	0	1
Miscellaneous infections	3	0.4	0	3	0
Infarction	108	16.1	50	43	15
Unknown	306	45.7	139	88	79

Modified from Vichinsky EP, Neumayr LD, Earles AN, et al. Causes and outcomes of the acute chest syndrome in sickle cell disease. National Acute Chest Syndrome Study Group. *New Engl J Med* 2000;342:1855-1865.

A comprehensive review of the management of ACS in children has been recently published and is a useful guideline for treatment of this complication.³¹⁹ Because the relative importance of infection and infarction is difficult to ascertain, broad-spectrum parenteral antibiotics, such as a third- or fourth-generation cephalosporin, should be provided for children with ACS. A macrolide antibiotic is indicated to cover Mycoplasma and Chlamydia. Of utmost importance is the correction of hypoxemia. If the arterial PO₂ value is <75 mm Hg or the O₂ saturation by pulse oximetry is significantly below baseline, the clinician should consider prompt simple or partial exchange transfusion.³²⁰

Intravenous dexamethasone was shown to result in a shorter hospital stay and reduced need for blood transfusion and oxygen when compared to placebo in children with ACS.³²¹ Because there appeared to be a high risk of recurrent symptoms and readmission to the hospital after dexamethasone was abruptly discontinued, a recent randomized study investigated the use of tapered oral dexamethasone for ACS treatment.³²² Despite a very small number of participants, this trial showed a reduction in hospitalization duration in the dexamethasone arm, but higher rates of rebound pain. sL-selectin was found elevated among patients with rebound pain and could be a useful biomarker during ACS. Nitric oxide inhalation has been utilized in the regulation of hypoxic pulmonary vasoconstriction,³²³ but definitive trials have not yet substantiated its therapeutic role.

Priapism

Priapism is an unwanted, painful, and persistent erection of the penis. Useful reviews of this topic have been published.^{324, 325} The incidence of priapism in patients with sickle cell disease has been reported to be between 3% and 45%^{326, 327}; it has a bimodal distribution of age of onset, with peaks at 5 to 13 years of age and at 21 to 29 years of age.³²⁸ Most priapism episodes begin during sleep³²⁹ or early in the morning; they may be associated with physiologic dehydration and hypoventilation, which results in metabolic acidosis followed by increases in sickling and stagnation of blood within the penile sinusoids or the corpora cavernosa. In data from the CSSCD, subjects with priapism had significantly lower levels of hemoglobin and higher levels of bilirubin, reticulocytes, white blood cells, and platelets, suggesting an association of priapism with increased hemolysis, perhaps related to a diminished availability of circulating NO, which plays an important role in erectile function.³³⁰ Although priapism is usually self-limited and of relatively short duration, it is often recurrent and may become chronic. "Stuttering" priapism refers to multiple episodes, each <4 hours in duration, which may occur several times a week and may herald a prolonged event. Usually, these do not require medical intervention. Typically, priapism results from engorgement of the paired cavernosal bodies with sparing of the glans and corpus spongiosum and is maintained by the partial obstruction of venous drainage. However, tricorporal priapism may occur, especially in postpubertal patients, and is associated with a poor prognosis.³³¹ Although it occurs with approximately equal frequency in prepubertal and postpubertal males, priapism is more difficult to manage in the latter group.^{332, 333} Numerous ISCs and clots are found in the distended sinuses when needle aspiration or incisional drainage is performed.³³⁴ The repetitive trapping of cells in the corpora cavernosa, with or without surgical intervention, may lead to fibrosis of the septa and impotence.

Penile blood gas measurements and technetium-99 penile scintigraphy scans have been used to define intracorporeal hemodynamics and to guide therapy. However, these modalities are not readily available, and a more conventional approach to treatment is necessary. Of particular concern is an increased rate of impotence reported in sickle cell patients whose attacks lasted >24 hours^{335, 336}. As with other complications resulting from the sludging of sickled erythrocytes, aggressive hydration and adequate analgesia are of primary importance and should be pursued within the first few hours of symptoms. If no response is seen within 12 to 24 hours, partial exchange transfusion to lower the Hb S level to <30% may be performed; this is occasionally sufficient.³³⁷ However, an association of sickle cell disease, priapism, exchange transfusion, and neurologic events, including seizures and obtundation, referred to as ASPEN syndrome, is of concern.^{338, 339} If no resolution occurs within another 12 to 24 hours, corporal aspiration and irrigation with saline may be indicated through such means as a Winter procedure,³⁴⁰ in which a fistula between the glans penis and the corpora cavernosa is created using a biopsy needle. The Dallas program reported rapid complete detumescence in 35 of 37 consecutive episodes of prolonged priapism in pediatric patients treated with aspiration and irrigation with a dilute epinephrine solution.³⁴¹ If penile aspiration is unsuccessful, creation of a cavernosa spongiosum shunt³⁴² or a venous bypass may be considered.

Prevention of recurrent priapism has been accomplished in some patients with chronic transfusion, particularly through exchange transfusion. α -Adrenergic agonists increase contraction of the smooth muscle of the trabecular arteries of the cavernosa and facilitate venous outflow from the corpora, promoting detumescence. α -Adrenergic agents including etilefrine, pseudoephedrine, and phenylephrine may be administered either orally or by intracavernous injection.^{343, 344} Other approaches have been the administration of diethylstilbestrol,³⁴⁵

P.837

the gonadotropin-releasing hormone analog leuprolide acetate,³⁴⁶ low-dose antiandrogens,³⁴⁷ finasteride,³⁴⁸ and oral phosphodiesterase 5 inhibitor.³⁴⁹ Sildenafil is reported to improve priapism, but can trigger pain as a side effect.³⁵⁰ A polyethylene glycolmodified adenosine deaminase (PEG-ADA) has been used in transgenic sickle mice to reduce adenosine levels and promoted increased cavernosal relaxation, suggesting a possible new avenue of treatment for priapism.³⁵¹ Despite either conservative or aggressive treatment, >25% of patients have some degree of impotence³⁵² and may be candidates for a penile prosthesis after 6 to 12 months.³⁵³

Exacerbation of Anemia

Hematologic "crises," characterized by sudden exaggeration of anemia, are pathogenetically and temporally unrelated to vaso-occlusive crises. If they are unrecognized or untreated, the decrease in Hb concentration may be so precipitous and severe as to cause heart failure and death within hours.

Aplastic Crises. Aplastic crises are the most common of the hematologic complications. The pathogenesis and course of aplastic crises in SCA are similar to those of other chronic hemolytic states. Several characteristics are indicative of an infectious basis: the crises are characteristically preceded by or associated with febrile illnesses; several members of

families with congenital hemolytic anemia may have concurrent aplasia;³⁵⁴ recurrence of crisis within the same individual is not observed,³⁵⁵ and most aplastic episodes occur during childhood.³⁵⁶ Epidemiologic studies clearly implicate human parvovirus B19 as the cause for almost all aplastic crises.^{355, 356} Aplasia is the result of direct cytotoxicity of the parvovirus to erythroid precursors, especially colony-forming units, erythroid (CFU-E).³⁵⁷ However, not all parvovirus infections result in problems; serologic evidence of previous infection was found in 71% of subjects with SCA who reached adulthood, but only 27% had a previous clinically recognized aplastic crisis.³⁵⁸

In the early phase of an aplastic crisis, peripheral blood reticulocytes and bone marrow normoblasts disappear or are greatly reduced in number. Because red cell survival in Hb SS is no more than 10 to 20 days, cessation of erythropoiesis is followed by a rapid decrease in Hb concentration. The process is self-limited, however; within 10 days, red cell production resumes spontaneously, and large numbers of reticulocytes and nucleated erythrocytes appear in the peripheral blood. Thereafter, the Hb concentration returns to its precrisis level. Often, the patient is first seen early in the recovery phase, when differentiation from a hemolytic crisis may be difficult. Although leukocytes and platelets are usually normal, all marrow elements may be affected.³⁵⁹ Treatment consists of supportive care with red cell transfusion when necessary.

Susceptible hospital workers exposed to patients with aplastic crises are at high risk of contracting nosocomial erythema infectiosum.³⁶⁰ Because infection during the midtrimester of pregnancy may result in hydrops fetalis and stillbirth, respiratory isolation precautions are a necessity if an aplastic crisis is suspected.³⁶¹

In addition to causing aplastic crisis, an acute parvovirus event not infrequently will lead to a prolonged vaso-occlusive pain crisis or it may trigger acute splenic sequestration.^{362, 363, 364} Less frequently, it is associated with long-term problems, such as glomerulonephritis, which may cause end-stage renal failure, cardiac dysfunction, and stroke.^{365, 366}

Splenic Sequestration. Splenic sequestration is characterized by sudden trapping of blood in the spleen. A splenic sequestration crisis is defined by a decrease in the steady-state Hb concentration of at least 2 g/dl, evidence of compensatory marrow erythropoiesis, and an acutely enlarging spleen.³⁶⁷ This complication occurs in infants and young children whose spleens are chronically enlarged before autoinfarction and fibrosis. Although splenic sequestration has been documented in infants as young as 3 to 4 months of age,³⁶⁸ it is observed most commonly during the second 6 months of life and is a less frequent finding after 2 years of age; however, it has been reported in adults.^{367, 369} In a large pediatric French cohort study, the risk of recurrence decreased with age: when the first episode occurred after 2 years, the risk was lower than when it occurred before 1 year of age (hazard ratio, 0.60).³⁷⁰

Children experiencing splenic sequestration may have an earlier onset of splenomegaly and a lower level of Hb F at 6 months of age.³⁷¹ Crises often are associated with respiratory tract infections or with parvovirus B19, usually in conjunction with an aplastic crisis.^{372, 373} The already enlarged spleen rapidly increases in size at the expense of blood volume; hypovolemic shock and death may occur within hours.³⁷⁴ The sole pertinent postmortem finding is engorgement of splenic sinusoids with sickled cells. Individuals who survive have a tendency for recurrent episodes until 5 or 6 years of age, by which time sufficient fibrosis of the spleen has occurred to limit its expansion. There has been wide variability in the long-term management of patients with splenic sequestration, and currently, no consensus exists. Chronic transfusion and surgical splenectomy have both been used in an effort to avoid recurrence. Due to concerns with invasive encapsulated organisms, often monthly erythrocyte transfusions are used and total splenectomy is delayed until an age after which the risk of sepsis is lower. Partial splenectomy has also been used in an attempt to preserve immunologic function in children with SCA and severe splenic sequestration,³⁷⁵ but the indications for this procedure and long-term outcomes are still under investigation. Although it is encountered much less frequently, sudden trapping of blood in the liver (hepatic sequestration crisis) also occurs.³⁷⁶

Hemolytic Crises (Hyperhemolytic Crises). Hemolytic (hyperhemolytic) crises result from a sudden acceleration of the hemolytic process. They have been described in association with co-inherited hereditary spherocytosis³⁷⁷ and concurrent mycoplasma infection.²⁹⁸ Other causes of hyperhemolytic crisis include acute or delayed hemolytic transfusion reactions (usually Coombs test positive),³⁷⁸ and drug-induced hemolysis.³⁷⁹ Although ~10% of black male patients with SCA have the unstable A variant of glucose 6-phosphate dehydrogenase (G6PD),³⁸⁰ they have no more severe anemia and no greater frequency of acute hemolytic episodes than those with normal levels of G6PD, even when challenged with oxidant drugs and infections, because of the young mean age of sickle red blood cells.³⁸¹

Megaloblastic Crises. Megaloblastic crises result from the sudden arrest of erythropoiesis by folate depletion.³⁸² Chronic erythroid hyperplasia imposes a drain on folate reserves, and biochemical evidence of mild folate deficiency has been demonstrated with high frequency in subjects with SCA.³⁸³ Megaloblastic crises likely occur when food consumption is interrupted by illness or alcoholism or when the folate requirement is augmented by rapid growth or pregnancy. The inverse relationship between plasma homocysteine concentration and folate status has led to a series of reports

describing homocysteine levels and the possible need for folate supplementation. However, both elevated homocysteine levels³⁸⁴ and normal homocysteine levels have been reported.³⁸⁵ Currently, folic acid deficiency, as a cause of exaggerated anemia in sickle cell disease, appears to be extremely rare in the United States. Nevertheless, it is common practice to prescribe prophylactic folic acid (1 mg/day) to patients with sickle cell disease in areas of the world where folate is not routinely added to grain-derived products.

Infections

Overwhelming infection may be the presenting manifestation of SCA in early childhood. Acute infection has been one of the most

P.838

common causes of hospitalization and previously was the most frequent cause of death, particularly during the first 3 years of life. *S. pneumoniae* is the usual infecting organism; the blood and spinal fluid are the major sites of infection.³⁸⁶,³⁸⁷ Previously, the incidence of invasive infection with *S. pneumoniae* was ~7/100 patient-years in children with SCA who were <5 years of age; this rate was 30 to 100 times that which would be expected in a healthy population of this age.³⁸⁷,³⁸⁸ More than 70% of meningitis in children with SCA also resulted from *S. pneumoniae*.³⁸⁹ The mortality rate of pneumococcal sepsis was as high as 35%, but widespread improvement in parental education and aggressive management of the febrile child have greatly improved the likelihood of surviving a septic event.³⁹⁰ Furthermore, penicillin prophylaxis and pneumococcal vaccines have dramatically lowered the risk of invasive pneumococcal infection. Despite the dramatic decline in the rate of pneumococcal sepsis in recent decades (secondary to widespread use of pneumococcal immunization and penicillin prophylaxis), invasive pneumococcal infection still exists and may be life threatening.³⁹¹,³⁹² A major threat to continued success in prevention and management of *S. pneumoniae* invasive infection has been the emergence of antibiotic-resistant pneumococcal organisms over the past two decades.³⁹¹,³⁹²

Beyond 5 years of age, Gram-negative bacteria replace *S. pneumoniae* as the major infectious agents.²⁹⁵,³⁸⁷ In contrast to infections in young children, those in older children and adults generally have an identifiable source or focus (e.g., *Escherichia coli* associated with urinary tract infection).³⁸⁷,³⁹³ Osteomyelitis, sometimes involving multiple sites, occurs with increased frequency at all ages. The increased risk of osteomyelitis may stem from tissue ischemia and infarction associated with pain crises; these provide a potential nidus for infection in the long bones. Although >80% of hematogenous osteomyelitis in the general population is caused by *Staphylococcus*, most cases of osteomyelitis occurring in individuals with SCA are caused by *Salmonella*.³⁹⁴,³⁹⁵ Serum antibody levels against *Salmonella* antigens are normal, but microinfarcts of the intestinal mucosa may predispose to invasive infections.³⁹⁶ A positive blood culture for *Salmonella* in a patient with SCA strongly suggests the diagnosis of osteomyelitis. *Staphylococcal* bone infection, clinically indistinguishable from *Salmonella* infection, also occurs with increased frequency in sickle cell disease.³⁹⁷

Bloodstream infections in hospitalized adults with sickle cell disease have been increasingly recognized. In one series,³⁹⁸ 28% were caused by *Staphylococcus aureus*, the majority of which were methicillin-resistant. Gram-negative organisms, anaerobes, and yeast were also found and >80% of the infections were considered to be catheter-related. Bloodstream infections frequently are associated with bone and joint infection.³⁹⁹

The pathophysiologic basis for increased susceptibility to aggressive infection relates in large part to the loss of spleen function.⁴⁰⁰ During the first few years of life, recurrent perivascular hemorrhage and infarction reduce the spleen to a small siderofibrotic vestige.⁴⁰¹ Despite the frequent occurrence of splenomegaly in the first few years, spleen function often is impaired by 6 to 12 months of age.¹⁷⁶ Howell-Jolly bodies and "pits" (depressions in the red blood cell membrane) are seen in peripheral blood erythrocytes,⁴⁰² and radiolabeled sulfur colloid is not cleared,⁴⁰³ Spleen function is temporarily restored by transfusion therapy in early life, suggesting that functional asplenia is a consequence of altered perfusion imposed by intrasplenic sickling.⁴⁰⁴ In the absence of spleen function, bloodborne particulate antigens fail to elicit an expected antigenic response.⁴⁰⁵ Spleen function is necessary for effective host response to *S. pneumoniae* in the absence of preformed antibodies; in the presence of antibody, organisms are trapped effectively at extrasplenic sites. Because the acquisition of pneumococcal antibodies occurs with advancing age, young children without spleen function fare less well than older children and adults. However, responses to conjugated *Haemophilus influenzae* vaccine in young infants with SCA were appropriate.⁴⁰⁶ Other mechanisms may contribute to the vulnerability of children with sickle cell disease to infectious crises. Serum IgM levels are decreased.⁴⁰⁷ The alternative pathway for complement activation may be defective.⁴⁰⁸ Alterations of B- and T-lymphocyte number and function and of the function of neutrophils and monocytes are of uncertain significance.⁴⁰⁹,⁴¹⁰

Prevention of Infection. The use of penicillin prophylaxis has been a major advance in the management of sickle cell disease. Two controlled trials, one in Jamaica and the other organized by the National Institutes of Health, led to the widespread acceptance of penicillin prophylaxis as standard therapy.^{411, 412} In the latter trial (PROPS), twice-daily oral penicillin V resulted in an 84% reduction in the incidence of pneumococcal bacteremia in infants <36 months of age. Current recommendations are to initiate penicillin prophylaxis by 3 months of age and to continue it at least until 5 years of age in children with Hb SS or Hb Sβ⁰-thalassemia (or longer if there was a history of surgical splenectomy, incomplete pneumococcal immunization, or invasive pneumococcal infection). A multi-institutional controlled trial found no further advantage of penicillin in the prevention of invasive pneumococcal infection in children >5 years of age.⁴¹³ The use of prophylaxis in young children with Hb SC disease or Hb Sβ¹-thalassemia is controversial,⁴¹⁴ but many centers maintain all children with sickle cell disease on penicillin until 5 years of age. Of concern has been the question of whether prophylaxis might increase the risk of penicillin-resistant pneumococcal organisms. Its usage reduces nasopharyngeal colonization with *S. pneumoniae*, but the effect on the development of antibiotic resistance has been equivocal.^{415, 416, 417}

Unfortunately, the pneumococcal serotypes that are most prevalent in the community and most highly virulent (types 6A, 14, 19, and 23F) are least immunogenic.^{418, 419} Although the immunologic response of children 2 years of age and older to polysaccharide-conjugated pneumococcal vaccine is comparable to that of the general population,⁴²⁰ antibody titers fall more rapidly than in adults. Children with sickle cell disease should receive a primary immunization with the 23-valent polysaccharide vaccine at 2 years of age and a booster immunization 3 to 5 years later⁴²¹; the vaccine is ineffective in children <2 years of age. Administration of booster doses of this vaccine to older children and adults with sickle cell disease is controversial, but a booster is administered to teenagers and adults once every 10 years in many centers.

In contrast, the seven-valent protein-conjugated pneumococcal vaccine (PCV-7) is immunogenic in the first few months of life and is routinely administered to infants in the United States. This vaccine (which includes serotypes 4, 6B, 9V, 14, 18C, 19F, and 23F) is administered at 2, 4, 6, and 12 months of age (same immunization schedule as in the general pediatric population) and produces adequate antibody concentrations in the same range as those achieved among infants without sickle cell disease.^{422, 423} In addition, significant rises are seen in antibody concentration to all seven protein-conjugated pneumococcal vaccine serotypes after the administration of polysaccharide-conjugated pneumococcal vaccine at 24 months of age. Recently, the protein-conjugated vaccine has been reported to lower the incidence of invasive pneumococcal disease between 65% and to >90% in children with sickle cell disease,^{424, 425} but it has not completely eliminated invasive pneumococcal infection.³⁹¹ In 2010 the 13-valent pneumococcal conjugate (PCV13) vaccine replaced PCV-7 in the United States and the United Kingdom; PCV13 has the additional serotypes 1, 3, 5, 6A, 7F, and 19A.⁴²⁶ It is unclear whether addition of the serotypes included in the PCV13 vaccine will significantly improve protection as replacement colonization has been with predominantly non-PCV13 serotypes, and a resurgence of invasive disease has been seen in some areas with predominantly non-PCV13 serotypes.³⁹¹

P.839

The conjugated *H. influenzae* type B vaccine induces protective antibody levels in young infants with SCA^{390, 406} and has virtually eliminated invasive *H. influenzae* infection in this population. Yearly influenza virus vaccine (including H1N1 strains) and the complete series with 3 doses of hepatitis B vaccine offers further protection. Meningococcal polysaccharide diphtheria toxoid-conjugated vaccine offers protection against groups A, C, Y, and W-135 meningococcus and is recommended in children with sickle cell disease at age 2 with a booster at 5 years of age. It is unclear if adults should receive a booster of the meningococcus vaccination, but some centers offer boosters every 5 years. For updated information regarding the recommended schedule of immunization in children and adults in the United States, the Centers of Disease Control website (www.CDC.gov) should be consulted. The high frequency of parvovirus B19 infections in children with sickle cell disease, their life-threatening nature, and the associated risk of complications indicate the need for a vaccine that would confer lifelong immunity. A vaccine for parvovirus B19 (viral particles 1 and 2 proteins expressed in a baculovirus system with adjuvant MF-59) has been developed and undergone pilot testing, but side effects have stalled further studies.⁴²⁷

Management of Fever. Any fever $\geq 38.5^{\circ}\text{C}$ in a child with SCA must be considered a medical emergency because of the potential risk of overwhelming pneumococcal sepsis, especially during the high-risk period between 6 months and 3 years of age. Previously, routine hospitalization of every febrile patient with SCA was standard management, to deliver intravenous antibiotic coverage until blood cultures were demonstrated to be negative. More recently, the majority of febrile patients have been managed in the emergency department and the outpatient setting if they do not have high-risk characteristics (e.g., toxic appearance, very high fever, serious localized infection, exceptionally high or low white blood

cell count, a history of invasive infection, or inadequate capacity for close follow-up).^{390, 428, 429, 430} These children may be managed with prompt assessment, rapid administration of ceftriaxone, observation for at least 2 hours, and close outpatient follow-up.

Chronic Organ Damage

Growth and Development

The sickling syndromes profoundly affect growth and development. Growth curves for the height, weight, and sexual development of children with SCA were constructed in the 1980s to permit the identification of individuals whose growth delay was greater than what could be accounted for by the hemoglobinopathy (Fig. 33.7).^{431, 432} Although normal at birth, the heights and weights of children with SCA were significantly delayed by 2 years of age.^{431, 432, 433} The growth curves maintain a relatively normal configuration but deviate progressively from the normal curves. Increases in velocity of adolescent height and weight growth occur later, and the magnitude of the growth spurt is substantially less than in healthy children. Puberty also is delayed. Menarche occurs 2 to 3 years later than in the general population (median age, 14.0 to 15.5 years),⁴³⁴ and Tanner stage V is not achieved until the median ages of 17.3 and 17.6 years for girls and boys, respectively.⁴³² As in normal subjects, progression through Tanner stages is orderly and appropriate for bone age, and the age of menarche correlates closely with age and weight. By adulthood, both men and women with sickle cell disease appear to acquire normal or near-normal heights, but their mean weights are still lower than those of controls.⁴³² Investigations in small numbers of subjects show that growth hormone, thyroid hormone, adrenocorticotrophic hormone and cortisol levels, and pituitary responses to growth-hormone-releasing factor are normal.⁴³⁵ Transient hypogonadism may occur in adolescence. The normal relationship of puberty and growth pattern seen in most patients suggests that the delay in skeletal maturation represents constitutional delay rather than gonadal or pituitary failure.⁴³²

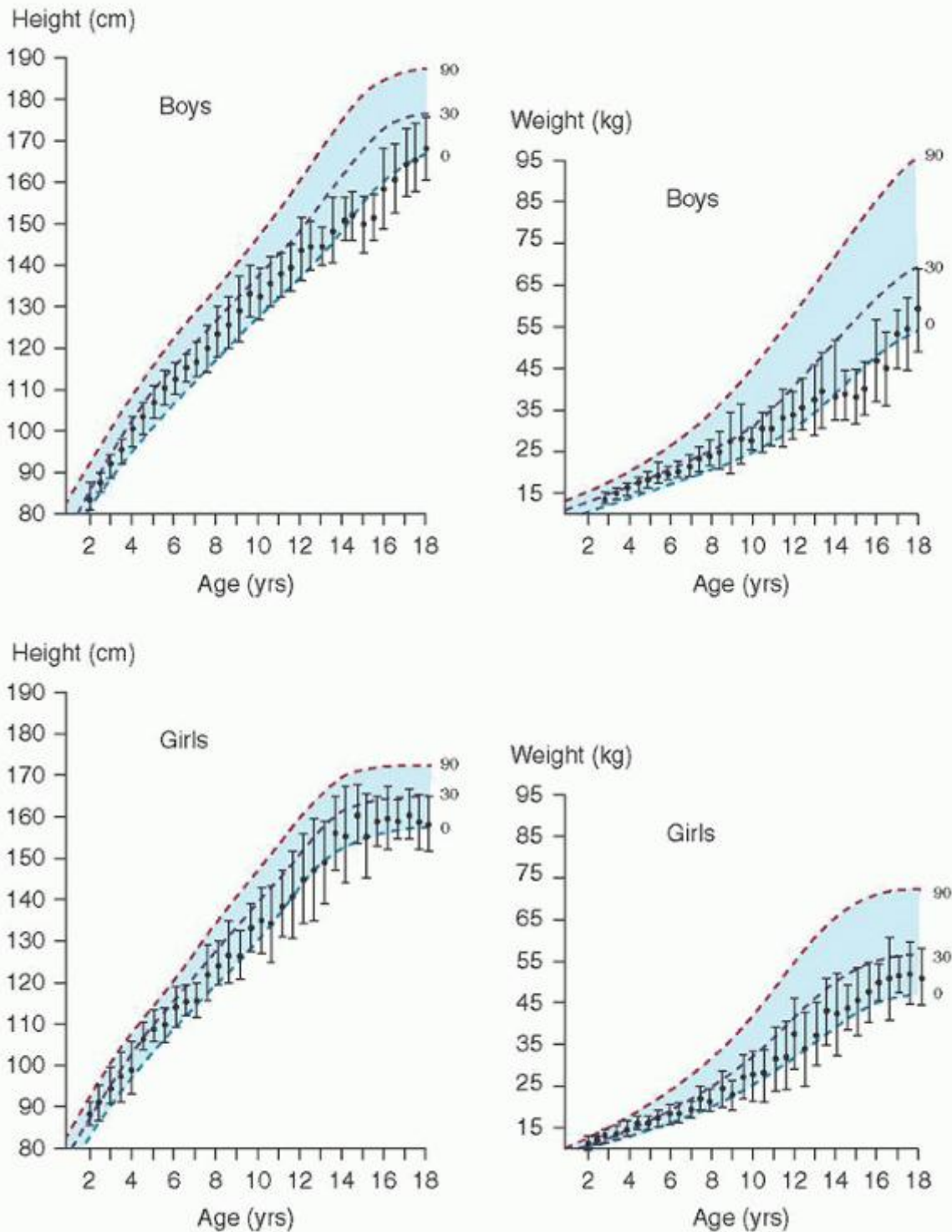

FIGURE 33.7. Height and weight (mean, ± 1 standard deviation) of American boys and girls with sickle cell anemia (SCA) compared with National Center for Health Statistics growth percentiles. From Phebus CK, Gloninger MF, Maciak BJ. Growth patterns by age and sex in children with sickle cell disease. *J Pediatr* 1984;105:28, with permission.

Low weight appears to be the most critical variable influencing differences in physical maturation among the sickling syndromes.⁴³² The basis for delay in weight gain is not fully understood, although it has been hypothesized that chronic hemolysis leads to a state of high protein turnover and increased basal metabolic requirements.⁴³⁶ Recent studies have shown that decreased growth velocity in children with SCA was independently associated with decreased Hb concentration and increased total resting energy expenditure (REE).⁴³⁷ REE measured by indirect calorimetry is 15% to

20% greater in Hb SS patients.^{436, 438, 439} Increased whole-body protein breakdown and protein synthesis may be related to increased bone turnover.⁴⁴⁰ Prepubertal children with sickle cell disease do not compensate for their higher resting energy expenditure by increasing their energy intake, measured by weighing all food consumed during a 3-day period.⁴⁴¹ Furthermore, caloric intake is significantly decreased at the time of an admission for acute illness, contributing to an overall energy deficit.⁴⁴² When body composition of children and adolescents with sickle cell disease is measured by bioelectrical impedance analysis, male subjects have significantly lower fatfree mass and body fat compared with controls.⁴⁴³ Response to nasogastric dietary supplementation has been reported.⁴⁴⁴

Other studies have suggested increased requirements for zinc, folate, riboflavin, vitamin B₆, ascorbate, and the fat-soluble vitamins A and E, but consistent correlations between deficiencies and growth retardation have not been established.^{438, 445, 446, 447} A relationship between zinc deficiency and hypogonadism in adults with SCA has been suggested.⁴⁴⁸ Defective growth hormone secretion, decreased insulinlike growth factor-1, and partial resistance to growth hormone in short children with sickle cell disease were reported.^{449, 450}

P.840

Bones and Joints

In addition to the acute episodes of skeletal pain described previously, chronic and progressive destruction of the bones and joints may take place in the absence of clearly defined episodes of pain. The most prominent changes evolve slowly from the cumulative effect of recurrent small episodes of ischemia or infarction within the spongiosa of bone. Radiographs of the long bones of adults show a mottled strandlike increase in density randomly distributed within the medullary region (Fig. 33.8). These irregular areas of increased density are produced by new bone laid down on devitalized trabeculae.⁴⁵¹ Because the bone is weakened during the early stages of repair, weight bearing may collapse the femoral head, producing the clinical and radiologic features of osteonecrosis, which affects patients with all the genotypes of sickle cell disease but occurs most often in those with Hb SS and α -thalassemia (4.5 cases/100 patient-years).⁴⁵² The overall prevalence of osteonecrosis of the hip in persons with sickle cell disease is approximately 10%, but it occurs in 50% in those >35 years of age.⁴⁵² The prevalence of osteonecrosis of the humeral head is approximately one half as much.⁴⁵³ Typically, the pain from osteonecrosis of the hip begins insidiously, is brought on by walking or quick movements, and is localized to the groin or buttock. After several months, radiographs may show areas of increased density mixed with areas of increased lucency, followed by the appearance of a "crescent sign," segmental collapse, molding of the femoral head, loss of joint space, involvement of the acetabulum, and complete degeneration of the joint. When osteonecrosis occurs in the femoral capital epiphysis before closure, healing with minimal destruction may occur. However, long-term follow-up shows that in the majority of cases, the hip is painful and permanently damaged.⁴⁵⁴ Because weight bearing is not required of the shoulder joint, the prognosis of osteonecrosis of the humeral head is substantially better. Only ~20% of patients have pain or limited range of movement at the time of diagnosis,⁴⁵³ but functional abnormalities of the shoulder may be a long-term consequence in adults.⁴⁵⁵

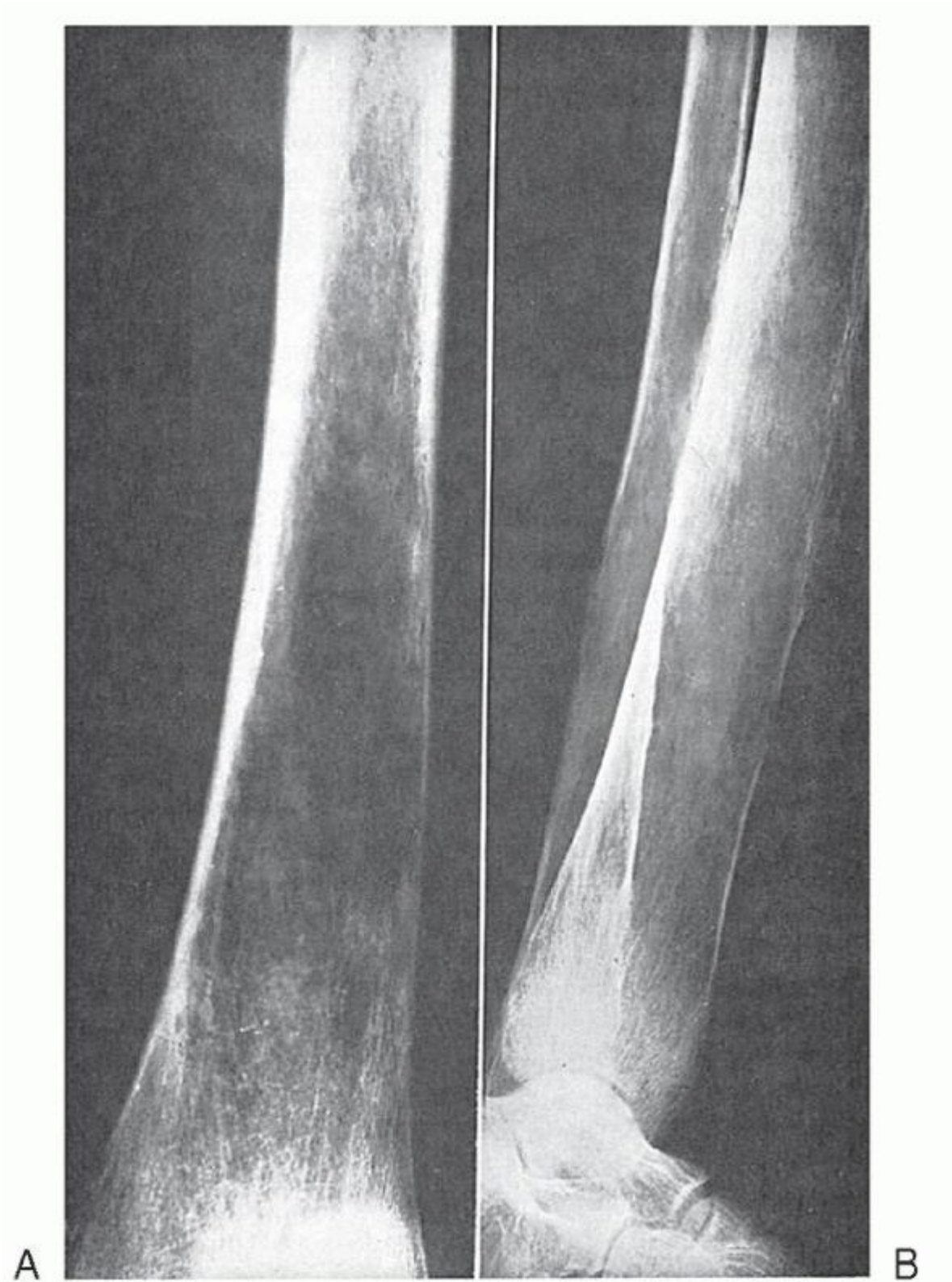

FIGURE 33.8. Sickle cell anemia. A: Femur. The cortex is thinned, and the normal bony architecture is disturbed. Adjoining small areas of translucency are areas of sclerosis. B: Tibia and fibula. Marked thinning of the cortex of the bones as well as periosteal reaction and disarrangement of the trabeculae. The latter changes and the extensive coarseness of the cortical layers suggest the bone is involved from within.

Avoidance of weight bearing in the early phases of bone necrosis may permit sufficient repair to preserve reasonable joint function. More often, however, the deformity is progressively crippling. Total hip replacement is usually recommended for the painful hip in stage III or IV or for restoration of joint movement, if this is desired. However, the prognosis for hip replacement has been suboptimal, with a 30% chance that arthroplasty will require revision within 4 to 5 years.^{456, 457} For stage I and II osteonecrosis, core decompression, in which a core of cancellous bone ~8 mm in diameter is removed from the neck and head of the femur through an incision in the lateral cortex, has been of benefit.^{458, 459} In a prospective randomized trial, physical therapy alone appeared to be as effective as hip core decompression followed by physical therapy, improving hip function and postponing the need for additional surgical intervention at a mean of 3 years after treatment.⁴⁶⁰ Grafting with autologous bone marrow obtained from the iliac crest is a possible new option for osteonecrosis of the hip.⁴⁶¹ This technique, which is currently investigational, appears most effective in the early stages of osteonecrosis, before subchondral collapse has occurred, and provides progenitor cells to the proximal femur which stimulate bone remodeling.

Another characteristic bone change develops in the vertebral column of some individuals during the second decade of life. Recurrent infarcts of the main vertebral arteries lead to ischemic damage of the central portion of the vertebral body growth plates. Because the outer portion of the plates is supplied by numerous apophyseal arteries, vertebral growth is irregular, producing a "fish-mouth" deformity in which symmetric cuplike depressions are confined to the central three fifths of the vertebral plates.⁴⁶² Other skeletal changes result from expansion of medullary cavities owing to long-standing erythroid hyperplasia. Radiographs of the skull show a thickening of the diploë and thinning of the outer table of the calvaria in the frontal and parietal regions. Gnathopathy (prominent maxillary overbite) may result from overgrowth of maxillary bone and frequently leads to significant malocclusion.⁴⁶³

Low bone mass density (osteopenia and osteoporosis) has been recognized in adults and more recently in children.^{209, 464} and has been associated with the severity of hemolysis.⁴⁶⁵ Vitamin D replacement in those cases of vitamin D deficiency has been reported to offer salutary effects on bone mass density.⁴⁶⁶

Joints may be affected by avascular necrosis of adjacent bone.⁴⁶⁷ The joint effusion, pain, fever, and leukocytosis accompanying such infarcts make differentiation from septic arthritis difficult. Numerous neutrophils and sickled erythrocytes are found in the joint fluid.⁴⁶⁸ Less commonly, joint disease is related to infection,⁴⁶⁹ gout,⁴⁷⁰ or synovial hemosiderosis. Adults may have deformities of the hands and feet with shortening of the digits, the remote sequelae of dactylitis during early childhood.⁴⁷¹

Cognitive Function

Multiple studies have reported deficits in global and specific neuropsychologic functioning in school-aged children with sickle cell disease when compared with their siblings or healthy children.^{472, 473, 474} Children with SCA who have experienced an overt stroke have significant cognitive impairment, reduced language function, and problems in adjustment.⁴⁷⁵ Diminished performance has been noted in the areas of visual-motor integration, attention and concentration, arithmetic, memory, and reading. Similarly to children, adults with SCA have poorer cognitive performance when compared with healthy controls, even without a history of prior stroke.⁴⁷⁶ Significant areas of deficit in adults with SCA were in working memory, processing speed, and measures of executive function.

P.841

MRI data from several studies investigating the central nervous system of children with Hb SS without a history of overt stroke show a prevalence of SCI varying from 11% to 37%.^{284, 285, 477, 478} Data from the CSSCD gathered over a 10-year period of follow-up of school-aged children with Hb SS indicated that those with SCI had significantly lower scores for math and reading achievement, full-scale intelligence quotient (IQ), verbal IQ, and performance IQ, when compared with individuals with normal MRI of the brain.⁴⁷² However, even in children with normal MRI findings, the scores for verbal IQ and math achievement declined with increasing age.⁴⁷⁹ A meta-analysis of 17 reports of cognitive functioning in children concluded that sickle cell disease is associated with detrimental effects even in the absence of cerebral infarction on MRI.⁴⁸⁰ Direct effects of sickle cell disease on brain function or indirect effects of chronic illness may be important. A multi-institutional study from France in which children with sickle cell disease were compared to sibling controls reported impaired cognitive function in patients both with a history of stroke and with SCI.⁴⁸¹ In addition, a hematocrit <20% and a platelet count $>500 \times 10^9/L$ were independent risk factors for cognitive deficiency. Patients with infarction in the frontal lobe differed from their peers in measures of attention, executive function, and memory.^{482, 483} In another study, children with SCI had twice the rate of school difficulties as those without infarcts, including poor educational attainment, defined

as repeating a grade in school because of lack of educational progress, a requirement for special educational services, or both.⁴⁸⁴

Lower Hb concentration is a reported risk factor for both the development of SCI and neurocognitive impairments.^{289, 485, 486} Other recognized risk factors for decreased cognitive function are hypoxemia and age. Nocturnal hemoglobin oxygen desaturation has been examined in a small group of children with SCA and found to be associated with lower neuropsychological measures of executive function.⁴⁸⁷ In addition, elevated blood flow velocity by TCD in children with SCA was associated with decreased language function (syntactical skills), even when controlling for the degree of anemia.⁴⁸⁸

New MRI modalities that examine cerebral blood flow, such as arterial spin-labeled (ASL) perfusion, and the effect of oxygenation on the magnetic properties of blood Hb, such as blood oxygenation level-dependent (BOLD) signal changes, deserve further investigation, but may prove useful in diagnosing and monitoring brain microvasculature damage in sickle cell disease.^{489, 490, 491}

Interventions for improving neurocognitive performance in patients with sickle cell disease are lacking. An association of oral hydroxyurea (HU) therapy with improved cognitive functioning on tests of verbal comprehension, fluid reasoning, and general cognitive ability has been seen in a small group of children with sickle cell disease and may be an effect of improved blood and oxygen supply to the brain or reduced fatigue and illness related to HU treatment.⁴⁹² Because several reports support the hypothesis that the severity of anemia is related to cognitive functioning,^{481, 493, 494} a multicenter study has been performed to determine whether short-term transfusion results in improved neurocognitive performance in adults with sickle cell disease; however, results are not yet available. In addition, neuropsychologic performance in patients who have undergone successful bone marrow transplants has been measured, and it appears that full-scale IQ levels have at least stabilized.^{495, 496}

Cardiovascular System

Cardiac enlargement, particularly an increase in left ventricular (LV) dimensions and mass, results from an increase in cardiac output imposed by chronic anemia and has its onset in early childhood.⁴⁹⁷ The typical physical examination reveals cardiomegaly, a hyperdynamic precordium, and a grade II-III (out of VI) systolic ejection murmur with wide radiation. An ejection click from pulmonary artery dilatation and an S3 or apical diastolic rumble also may be heard. Autopsies have revealed that right and left ventricular dilation is common in both children and adults.⁴⁹⁸ Right ventricular (RV) preload and systolic function do not worsen during childhood; however, RV mass index and the prevalence of PHT increase, consistent with rising pulmonary vascular resistance.⁴⁹⁹ Significant LV dilatation and LV hypertrophy due to abnormal loading conditions was also found in children.⁵⁰⁰ Echocardiography, performed on adult sickle cell patients from the CSSCD in their baseline state, showed striking left atrial and biventricular enlargement, normal shortening fraction, prolonged ejection time, and increased stroke volume.⁵⁰¹ Adult sickle cell patients may have RV enlargement and dysfunction (decreased RV ejection fraction) even in the absence of overt PHT.⁵⁰² Brain natriuretic peptide (BNP) mediates natriuresis and vasodilation and its elevation is associated with diminished exercise tolerance and poor prognosis in patients with LV cardiac failure. Increased BNP in patients with sickle cell disease reflects the increased cardiac chamber volume and pressure overload. Elevation of N-terminal (NT)-proBNP is observed in the setting of PHT and is associated with functional impairment and increased mortality.^{503, 504}

Systolic dysfunction is rare in young patients with sickle cell disease, but diastolic dysfunction is common and easily diagnosed and monitored using new tissue Doppler and speckle tracking echocardiography techniques.^{505, 506} LV diastolic dysfunction is associated with hemoglobin concentration, but not with iron deposition in the myocardium.⁵⁰⁷ Diastolic dysfunction, as reflected by a low E/A ratio, was associated with mortality with a risk ratio of 3.5, even after adjustment for tricuspid regurgitation jet velocity (TRV). The presence of both diastolic dysfunction and PHT conferred a risk ratio for death of 12.0.⁵⁰⁸

In general, there is an absence of atherosclerotic heart disease, although one study reported myocardial infarction and fibrosis in 17% of patients.⁵⁰⁹ Adults with sickle cell disease may present with clinical signs of acute myocardial infarction in the absence of atherosclerosis or coronary occlusion, but this is uncommon.⁵¹⁰ In children, rare cases of myocardial infarction and transient ventricular dysfunction have been reported,^{511, 512} although myocardial perfusion abnormality measured by thallium-201 single-photon emission computed tomography may be relatively frequent.^{513, 514, 515} Congestive heart failure generally does not occur in the absence of extracardiac complications of sickle cell disease.⁵⁰¹ However, physical performance is severely compromised; adults are usually unable to exceed 50% of expected work capacity,^{516, 517} and children and adolescents have 60% to 70% work capacities.^{518, 519, 520} This is the result of a high cardiac output at rest and an inability to increase output as an adaptive response under stress and increased physical demand.

Electrophysiology changes have also been noted in patients with sickle cell disease. In a screening study of sickle cell subjects between the ages of 10 and 24 years, prolongation of the QTc interval was observed in 29/76 (38%) subjects, and was not associated with the presence of LV hypertrophy.⁵²¹

Other factors may compound the cardiac embarrassment resulting from anemia. The shunting of blood through infarcted, nonaerated segments of the lung compromises arterial oxygen saturation, and sludging of sickled erythrocytes in small pulmonary arteries may result in PHT. Myocardial injury or infarction may be associated with fat embolism.⁵²² Myocardial hemosiderosis, the consequence of long-standing transfusion therapy, may be responsible for intractable heart failure, but is an uncommon finding in patients with sickle cell disease compared to patients with thalassemia major, who frequently develop this complication.

Pulmonary System

Chronic pulmonary disease, an event more commonly observed in adults with sickle cell disease, is presumably related to recurring episodes of ACS, and is characterized by lung fibrosis on high-resolution chest computerized tomography, decreased radiolucency of the lungs, and impairment of pulmonary function,

P.842

primarily in a restrictive pattern.^{523, 524} Typically, the vital capacity and total lung capacity are reduced, and gas mixing and exchange are compromised. Less often, obstructive lung disease is noted. Blood is shunted through poorly aerated or collapsed segments of the lung, creating a disparity between ventilation and perfusion. The resulting reduction in the functional pulmonary vascular tree is responsible for a decrease in arterial oxygen tension (70 to 90 mm Hg) and desaturation of arterial blood. Hb oxygen saturation is lower in children with Hb SS/Sβ⁰ thalassemia compared with those with Hb SC/Sβ⁺ thalassemia.^{525, 526, 527} Although pulse oximetry may underestimate true arterial saturation, pulse oximetry values correlate positively with Hb and fetal Hb levels in patients with Hb SS.^{528, 529, 530}

There is a high prevalence of asthma and airway responsiveness among pediatric patients with sickle cell disease.^{310, 531, 532} The morbidity of asthma among adults is less defined; however, wheezing (without necessarily a formal diagnosis of asthma) has been associated with increased pain and ACS events.⁵³³ Because of the high prevalence of asthma and airway hyperresponsiveness in sickle cell disease, the overlap of symptoms of asthma exacerbation and ACS, and the inheritance pattern of asthma within families of patients with sickle cell disease, it is hypothesized that the asthma (or airway hyperresponsiveness) symptoms are in fact part of the pathophysiology of sickle cell disease, rather than there being two separate co-morbid conditions.⁵³⁴ Further investigation is needed to confirm this hypothesis.

Sleep disordered breathing (obstructive sleep apnea, snoring) may be increased among patients with sickle cell disease, although most studies did not utilize polysomnography to confirm findings, but relied on validated sleep disorder questionnaires.²⁶³ Further investigation in this area might establish supportive therapeutic options to reduce nightly oxygen desaturation. Pulmonary hypertension (PHT) is a major cause of morbidity and mortality among adults with sickle cell disease.^{535, 536, 537, 538} It is not known why PHT was rarely recognized as a complication of sickle cell disease in earlier studies, but it is possible that the high frequency seen in older patients reflects current success in preventing mortality in severely affected children and young adults.^{536, 539} PHT is defined by a mean pulmonary artery pressure ≥ 25 mmHg, and includes pulmonary arterial hypertension (PAH), pulmonary venous hypertension (PVH) (which results from LV dysfunction), or a combination of both (mixed disease). It is important to note that high cardiac output can also elevate pulmonary artery pressure, adding to the complex and multifactorial pathophysiology of PHT in sickle cell disease. Tricuspid regurgitant jet velocity (TRV) has been a noninvasive surrogate measure of PHT. Specifically, TRV values ≥ 2.5 m/s measured by Doppler echocardiography are suggestive of PHT, and values ≥ 3.0 m/s are highly indicative of PHT.¹³² In a landmark study, 32% of adults with Hb SS had TRV ≥ 2.5 m/s; this was associated with a tenfold increase in risk of death and a mortality rate of $\sim 16\%$ at 18 months and 40% at 40 months of follow-up. Subsequently, other studies utilizing TRV as a noninvasive screening test also found significant associations between elevated TRV and increased mortality.^{540, 541} Markers of hemolytic anemia, including low hemoglobin level, high reticulocyte count, and high LDH, were associated with elevated TRV, as were a history of renal or cardiovascular complications, increased systemic systolic blood pressure, and priapism. In subsequent studies, TRV was validated against direct right heart catheterization in adults, and 25% to 65.5% were shown to have true PHT, for a prevalence of PHT in the total screened population varying from 6% to 10%.^{539, 542, 543} TRV as measured by echocardiogram should not be used alone to establish a diagnosis of PHT. Definitive diagnosis requires right heart catheterization and a mean pulmonary artery pressure ≥ 25 mmHg. A potential screening for PHT in adults with sickle cell disease has been proposed utilizing a combination of TRV, NT-proBNP, and 6-minute walk tests results.⁵²⁴ TRV elevation has been reported in children; however, it does not seem associated with increased mortality and

it is unclear if it truly reflects PHT in children.⁵⁴⁴ It is possible that TRV elevation reflects increased cardiac output in children,⁵⁴⁵ therefore there is no recommendation at present for using TRV as a screening test in children with sickle cell disease.

PHT may represent one element of generalized vasculopathy seen in some patients with sickle cell disease (associated with systemic hypertension, renal dysfunction, priapism, and cerebrovascular events), but it is not associated with markers of inflammation, fetal hemoglobin level, or platelet count.¹³³ There is growing evidence that altered arginine metabolism is involved, in particular, the intravascular release of arginase activity from ongoing hemolysis.^{108, 536}

Therapeutic intervention for PHT has been limited. Arginine supplementation lowered pulmonary artery pressures by >15% after 5 days of therapy in a pilot study;⁵⁴⁶ however, a larger study failed to show benefit (unpublished). Sildenafil, a phosphodiesterase 5-inhibitor, resulted in decreased pulmonary artery systolic pressure and increased exercise tolerance in a small group of adults.⁵⁴⁷ Sildenafil was tested in a large multicenter placebo-controlled double-blinded trial of adults with sickle cell disease with elevated TRV and low exercise capacity by the 6-minute walk distance test (walk-PHaSST study); however, the trial was stopped early due to a higher percentage of subjects experiencing serious adverse events (pain) in the sildenafil arm.⁵⁴⁸ There was no evidence of a treatment effect on the 6-minute walk distance test, TRV, or N-terminal pro-BNP. It is unclear why sildenafil increased the incidence of painful events, but lowering of the pain threshold has been postulated as a possible explanation. Other management considerations include endothelin receptor agonists (ambrisentan and bosentan), hydroxyurea treatment, chronic transfusion therapy (especially for severe PHT), and various forms of prostaglandin therapy.¹³³ Endothelin receptor agonists were tested in 2 clinical trials (ASSET studies), but due to low accrual rate, the studies were interrupted early, and were therefore underpowered to show any benefit.⁵⁴⁹ Treatment of risk factors such as hypoxemia, severe anemia, or LV systolic and diastolic dysfunction is indicated.

Hepatobiliary and Gastrointestinal Systems

Liver enlargement is present by 1 year of age and persists to a moderate degree throughout life. Analysis of histologic sections reveals distention of sinusoids with sickled cells, Kupffer cell erythrophagocytosis, and varying degrees of periportal fibrosis and hemosiderin pigment.⁵⁵⁰ Sickle cell disease may be associated with disturbance in hepatic function.⁵⁵¹ Acute enlargement of the liver, such as may occur with sequestration of sickle cells, subcapsular infarction, or hepatic vein thrombosis,^{552, 553, 554} is associated with tenderness or right upper quadrant pain. Intrahepatic infarcts may be complicated by abscess formation. In addition, hepatic function as assessed by lidocaine metabolism is impaired in patients with sickle cell disease, suggesting caution when using hepatically metabolized medication in these patients.⁵⁵⁵

It is not unusual for hyperbilirubinemia (with increases in both direct and indirect bilirubin) to punctuate the course of SCA. These episodes may result from hemolysis, intercurrent infectious hepatitis, intrahepatic sickling (hepatic crisis, "sickle hepatopathy"), or choledocholithiasis. It has been suggested that coexistent glucose 6-phosphate dehydrogenase deficiency may be a contributing factor.⁵⁵⁶

The clinical picture of acute viral hepatitis is similar to that seen in non-sickle-cell patients except for the remarkable elevation of serum bilirubin concentration (which may reach 100 mg/dl).⁵⁵⁷ Hepatitis A virus may be a frequent cause of acute icteric hepatitis in endemic areas and may result in fulminant hepatic failure and death.⁵⁵⁸ Sickle cell patients respond normally to hepatitis B vaccine,⁵⁵⁹ although surface antibody titers after immunization

P.843

should be measured to identify those who do not convert and require booster injections.⁵⁶⁰ Evidence of prior hepatitis C virus infection has been found in 10% to 21% of SCA patients,^{561, 562} but since the advent of screening of transfused blood for hepatitis C, new cases of this infection have become extremely rare. Liver biopsies may show progression to chronic active hepatitis and cirrhosis. Orthotopic liver transplantation has been used in a few patients with sickle cell disease with success; however, the frequency of neurologic complications during the transplant may be disproportionately high.⁵⁶³

The histologic consequences of intrahepatic sickling include impaction of hepatic sinusoids with sickled erythrocytes, patchy areas of hepatocellular necrosis, engorgement of Kupffer cells, and bile stasis.^{550, 564} In a recent report, sickle hepatopathy was defined by a total serum bilirubin concentration >13 mg/dl, not explained by severe acute hemolysis, viral hepatitis, extrahepatic obstruction, or hepatic sequestration.⁵⁶⁵ In children, manifestations of sickle hepatopathy are relatively mild and transient. These include right upper quadrant pain, hepatomegaly, fever and leukocytosis, mild elevation of serum transaminase levels, and moderate to marked elevation of serum bilirubin and alkaline phosphatase levels.⁵⁶⁶ Although the course in children is benign and symptoms usually resolve in 1 to 3 weeks, progression to fulminant hepatic failure, generalized bleeding, and death are much more frequent in adults⁵⁶⁵ and are occasionally seen in

adolescents.⁵⁶⁷ Prompt exchange transfusion and, occasionally, chronic transfusion have been the only effective therapies in these patients.^{567, 568, 569}

Because of a sustained increase in heme catabolism, the frequency of pigmentary gallstones in sickle cell disease is high. These stones, which may be either radiolucent or radio-opaque, have been documented in children <5 years of age.^{570, 571} The incidence of gallstones increases with age, from 12% in the 2- to 4-year-old age group to 42% in the 15- to 18-year-old age group and 60% in adults.⁵⁷² In Jamaica, the prevalence of gallstones was 53% at 23 years of age in Hb SS and 20% in Hb SC.⁵⁷³ When ultrasonography is used routinely, the finding of gallbladder sludge with or without concurrent stones is common;⁵⁷⁴ even if it is not present initially, patients with sludge eventually develop stones. Genetic variations in the uridine diphosphate-glucuronosyltransferase 1a promoter significantly influence serum bilirubin levels and the development of symptomatic cholelithiasis in children with SCA.⁵⁷⁵ Chronic transfusion, even if used for prolonged periods, does not seem to prevent the development of gallstones.⁵⁷⁶ Although patients are not always able to distinguish the pain of choledocholithiasis from that of abdominal vaso-occlusive crises, elective cholecystectomy may be followed by a dramatic decrease in the frequency of abdominal crises.⁵⁷⁷ Laparoscopic cholecystectomy has replaced open cholecystectomy in most centers because it results in shorter hospitalization and decreased post-operative pain and other complications.^{578, 579, 580}

Although duodenal ulcer disease has been reported in patients with SCA,⁵⁸¹ there is no clear evidence that it is more common than in the general population. Gastric acid output is not increased in patients with duodenal ulcers.⁵⁸² Severe ischemic colitis has been reported in several patients,^{583, 584, 585} and pancreatitis has been a rare problem in sickle cell disease.⁵⁸⁶

The chronic use of blood transfusions will eventually lead to accumulation of iron in the liver (hemosiderosis). Although iron initially accumulates in reticuloendothelial cells of the liver (sinusoids), with continued transfusions, it is incorporated in parenchymal cells (hepatocytes), increasing the risk of liver injury with hepatocyte damage, synthetic dysfunction, fibrosis, and eventually cirrhosis.⁵⁸⁷

Kidneys

A variety of defects in renal function has been described,⁵⁸⁸ and a number of histologic alterations noted.⁵⁸⁹ Even in the absence of clinically apparent renal disease, small cortical infarcts of varying ages are evident,⁵⁹⁰ hemosiderin is deposited in the epithelium of proximal convoluted tubules, glomerular arterioles are dilated and congested, glomerular surface area relative to kidney size is increased,⁵⁸⁹ and varying degrees of juxtamedullary glomerular hypertrophy and sclerosis are seen. Symmetric enlargement of the kidneys is a regular feature, and distortion of the collecting system has been a common finding on intravenous pyelograms.⁵⁹⁰ Frank papillary necrosis may occur.

Hyposthenuria^{591, 592} and a limited capacity for hydrogen ion excretion^{593, 594, 595} are a result of tubular damage, and are present after 6 to 12 months of age. Hyposthenuria may be corrected temporarily by red cell transfusions until up to 15 years, but not thereafter.⁵⁹¹ Disruption of the countercurrent multiplication system owing to sludging of sickle cells in the more hypertonic portions of the renal medulla has been proposed as the mechanism responsible for the concentrating defect.⁵⁹¹ The demonstrated obliteration of a portion of the vasa rectae is in keeping with this hypothesis.⁵⁹⁰ Presumably because of the large fluid consumption necessitated by the renal-concentrating defect, most patients experience enuresis.⁵⁹⁶ Enuretic sickle cell patients have nocturnal urine osmolality equivalent to that of nonenuretic patients but may respond to desmopressin.^{597, 598} In addition, enuretic patients have a higher rate of psychosocial problems than sibling controls.⁵⁹⁹

Urinary acidification is abnormal in sickle cell patients, probably resulting from an incomplete form of distal tubular acidosis attributable to diminished ability of the collecting duct to maintain hydrogen ion gradient.^{593, 595} Impaired potassium excretion by the kidney and subsequent hyperkalemia, increased phosphate reabsorption, and increased uric acid clearance have also been described.^{600, 601, 602}

Hematuria is common and may be both brisk and prolonged. Bleeding may originate in one kidney or both, or it may take place in an alternating fashion. The most common lesion is an ulcer in the renal pelvis at the site of a papillary infarct.^{603, 604} The possibility that painless hematuria may be the result of poststreptococcal glomerulonephritis,⁶⁰⁵ renal medullary carcinoma,⁶⁰⁶ or other disorders unrelated to the hemoglobinopathy should not be overlooked. Idiopathic hematuria rarely requires more than symptomatic treatment. The risk of clotting within the collecting system is best minimized with a high fluid intake. Although there is no controlled study of its use, ε-aminocaproic acid is said to shorten the duration of hematuria in both SCA and sickle trait patients.^{607, 608} Its use, however, is attended by a risk of ureteral obstruction resulting from blood clots.

The nephrotic syndrome is an infrequent but well-documented complication of SCA that occurs in adolescents and adults. The syndrome may be associated with hypertension, hematuria, parvovirus B19 infection,³⁶⁶ and progressive renal insufficiency culminating in renal failure. Pathologic lesions include glomerular enlargement and focal segmental glomerulosclerosis.^{564, 609} In more advanced disease, a lesion that resembles membranoproliferative glomerulopathy has been described,⁶¹⁰ immune complex nephropathy has also been reported.⁶¹¹ Glomerular enlargement is secondary to the increased glomerular filtration rate and effective renal plasma flow that are found in children but that decline to subnormal levels with increasing age or from adverse effects of nonsteroidal anti-inflammatory agents.^{612, 613} In addition, the increased cardiac output and vasodilation from increased production of prostacyclins contributes to the glomerular hyperfiltration. Glomerular damage in adults is very common and associated with albuminuria and progressive renal failure.⁶¹⁴ Glomerular hyperfiltration also occurs in children, with a prevalence of 76% in one pediatric cohort, progressive decrease with age, and inverse association with cystatin-C levels and systolic blood pressure.⁶¹⁵ Microalbuminuria occurs commonly in adults (37%),⁶¹⁶ but in children its prevalence is lower and is reported from 16% to 18%.^{615, 617} The use of angiotensin-converting enzyme inhibitors (ACEi) might be beneficial in preventing progression of microalbuminuria and proteinuria in sickle cell disease, but prospective studies have

P.844

not been conducted. In addition, hydroxyurea, used in conjunction with ACEi or alone, might offer additional benefit in reducing proteinuria and improving renal urine concentrating ability.^{618, 619} However, chronic red cell transfusion begun at an early age may be protective against microalbuminemia.⁶²⁰ Approximately one fourth of adult sickle cell patients have at least 1+ proteinuria, and 7% have serum creatinine concentrations above the normal range.⁶²¹ The overall incidence of hypertension in patients with Hb SS is low (2% to 6%), compared with a published incidence of 28% for the black population in the United States.⁶²² Data from the CSSCD confirmed that individuals with sickle cell disease have a significantly lower blood pressure than the general population, but hypertension is still a risk factor for stroke and increased mortality.⁶²³ Intermittent hypertension occurring during sickle cell crises and associated with transient elevation of plasma renin activity has been attributed to the reversible sludging of red cells in the small vessels of the kidney.

Renal failure, which occurs in ~4% of patients with SCA at a median age of onset of 23 years,^{624, 179} is a significant cause of mortality in adults.¹⁴³ The preazotemic manifestations of hypertension, proteinuria, and increasingly severe anemia predict end-stage renal failure with an average survival (despite dialysis) of 4 years after diagnosis.⁶²⁴ Potentially valuable newer measures of declining renal function include serum cystatin-C and markers of tubular damage (increased serum β 2 microglobulin, increased urinary N-acetylglucosaminidase or endothelium-1).^{625, 626} In addition, 2 genes (MYH9 and APOL1) have been identified as having SNPs associated with proteinuria and end-stage renal disease.^{627, 628} Management of renal failure is the same as that for renal insufficiency resulting from other causes. Both hemodialysis⁶²⁹ and peritoneal dialysis, when used in conjunction with a transfusion program, are efficacious in transiently correcting uremic complications. The role of renal transplantation has not been well established because of limited numbers of patients and posttransplant problems of increased pain crises, graft thrombosis, and recurrence of sickle nephropathy.⁶³⁰ A report from the North American Pediatric Transplant Cooperative Society described nine patients with end-stage sickle cell nephropathy for whom graft survival was 71% at 2 years after transplant.⁶³¹ In another report, 82 patients with end-stage sickle cell nephropathy received renal allografts.⁶³² The short-term result was similar to that seen with other causes of end-stage renal disease, and this approach seems to improve survival in comparison with those patients managed with chronic dialysis.⁶³³ Pharmacologic doses of exogenous erythropoietin have been effective in correcting anemia,⁶³⁴ but higher hematocrits have been associated with increased pain crises.⁶³⁵

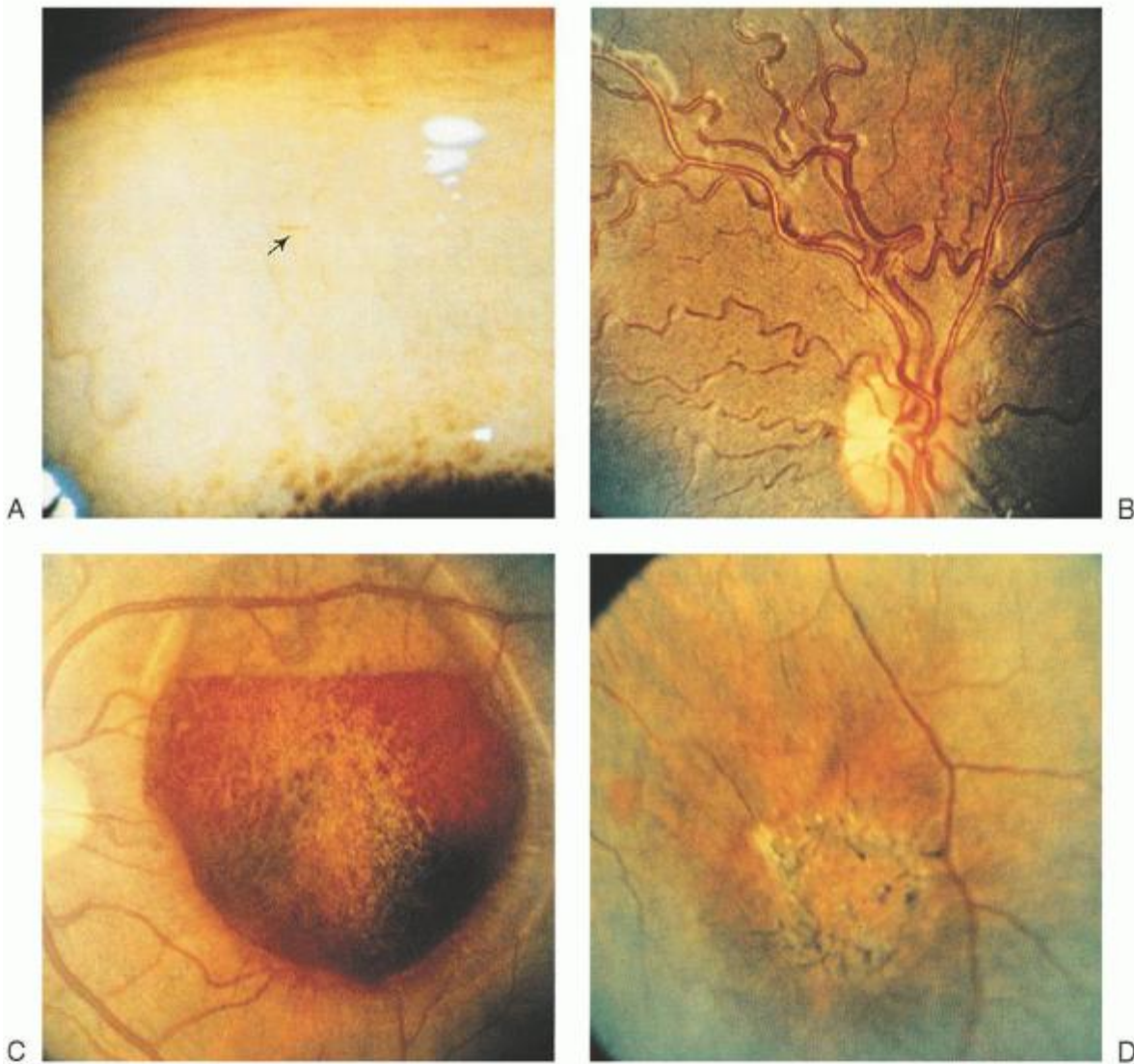

FIGURE 33.9. Ocular abnormalities in sickle cell anemia. A: “Comma” vascular sign: superficial conjunctival vessel that contains densely packed sickled cells (arrow). B: Widened veins and tortuous large vessels of the retina. C: Large preretinal hemorrhage of approximately 2 weeks' duration. There is partial resorption and exposure of a darkened area that was the probable site of intraretinal hemorrhage. D: Old pigmented chorioretinal scar. Photographs by Professor Mansour Armaly, The George Washington University Medical Center.

Eyes

A variety of ocular lesions results from occlusion of the small vessels of the eye by sickled erythrocytes (Fig. 33.9). The prominence of end arterioles within the retina renders this tissue especially vulnerable to irreversible injury after vascular occlusion.

Sludging of blood in conjunctival vessels is responsible for the so-called conjunctival sign,⁶³⁶ which consists of dark red, commashaped, or corkscrew-shaped vascular fragments that appear to be isolated from other vessels. The anomalous segments are seen most often in that part of the temporal bulbar conjunctiva covered by the lower lid. A direct relationship between the prominence of these saccular segments and the number of ISCs on blood smears has been noted.^{637, 638}

P.845

Vaso-occlusive disease of the retina is responsible for both nonproliferative and proliferative (neovascular) changes.^{639, 640} The former consist of “salmon patches,” produced by small intraretinal hemorrhages; iridescent spots, representing collections of iron-loaded retinal macrophages; and schisis cavities, left after resorption of blood. Hemorrhages that break into the potential space between the sensory retina and pigment epithelium stimulate pigment production and migration, giving rise to black, discshaped scars known as “black sunbursts.” Proliferative changes begin with the formation of arteriovenous anastomoses, followed by the development of vascular fronds resembling sea fans.⁶⁴¹ Immunohistochemical techniques have been used to demonstrate the association of vascular endothelial growth factor and fibroblast growth factor with sea fan formation.⁶⁴² Vessels grow anteriorly toward the pre-equatorial, ischemic portion of the retina. Inspection of sea fans with ultraviolet light after the intravenous injection of fluorescein usually reveals small leaks into the vitreous. Major hemorrhages from sea fans that extend into the visual axis can generate visual symptoms. More often, however, they are confined to the peripheral portions of the retina and go undetected except by ophthalmoscopy. With time, repeated vitreous hemorrhages cause vitreous degeneration and vitreoretinal traction, which in turn produces retinal holes, tears, and detachment. Although these changes may culminate in loss of vision, they do so less often in association with Hb SS than in association with Hb SC disease.^{641, 643, 644}

The prevalence of sickle retinopathy (both proliferative and nonproliferative) increases with age and is more common among patients with HbSC than those with HbSS. In a large study of sickle cell patients, the prevalence of sickle retinopathy was 54.6% and 18.1% in patients with HbSC and HbSS, respectively, and was more common among men than women.⁶⁴⁵ No correlation has been found between retinopathy and various hematologic parameters except Hb F level, which is higher in less-affected patients.⁶⁴⁶ Screening for sickle retinopathy is recommended beginning at 10 years of age, and should be done annually for HbSC or bi-annually for other genotypes.

Diagnosis and monitoring of sickle retinopathy generally has been performed with noncontact wide-field fundus photography (Fig. 33.9). However, current technology utilizing wide-field angiography offers a 200° field of view in a single frame, allowing better visualization of peripheral proliferative changes, and a scanning laser ophthalmoscope; this requires a bolus dose of 5 ml of 10% sodium fluorescein. In a small study of 6 patients with this technique, peripheral vascular changes were detected that would have been missed using standard techniques.⁶⁴⁷

Proliferative retinal disease may be arrested by laser photocoagulation or cryocoagulation,⁶³⁷ to seal off the feeder vessels of neovascular patches and coagulate vascular leaks. However, because the long-term complication rate is relatively high, most retinal specialists have abandoned feeder vessel treatment in favor of scatter photocoagulation, except in recalcitrant cases with repetitive bleeding.⁶⁴⁸ Vitreous hemorrhages can be removed by pars plana vitrectomy followed by photocoagulation. Retinal detachment is treated by scleral buckling surgery, although potential complications include persistent intraocular hemorrhage, hyphema with secondary glaucoma, infarctions of the macula and optic nerve from elevated intraocular pressure, and the potential for intraoperative sickling crises.⁶⁴⁸

An additional ocular complication of sickle cell disease is hyphema. Bleeding into the anterior chamber leads to trapping of sickled red cells, mechanical obstruction of the outflow apparatus, compromised circulation of the aqueous humor, and increased intraocular pressure, which may result in sudden blindness.⁶⁴⁹ This complication, which also can occur with sickle cell trait red cells, may be managed effectively by lowering intraocular pressure through anterior-chamber paracentesis.

Mild edema of the eyelids is frequently seen in association with vaso-occlusive pain crises, but more significant sickle “orbitopathy” has been described in approximately 20 patients.^{650, 651} A vaso-occlusive process in the marrow space around the orbit may result in frontal headache, fever, eyelid edema, and orbital compression. Subperiosteal hematomas are common and appear to result from bone marrow infarction. Although supportive care is usually adequate, the presence of optic nerve dysfunction or unusually large hematomas may require surgical evacuation to prevent loss of vision.⁶⁵⁰

Leg Ulcers

Breakdown of the skin over the malleoli and distal portions of the legs is a recurring problem during adult life (Fig. 33.10).⁶⁵² Stasis of blood in the small vessels supplying these areas may interfere with the healing of minor traumatic abrasions. Venous incompetence detected by Doppler ultrasonography was more frequent in Jamaican patients with Hb SS than in controls and was highly associated with leg ulcers.⁶⁵³ These were observed in 2.5% of sickle cell patients >10 years of age in North America,⁶⁵⁴ but they affect as many as 75% of adults with SCA who live in tropical areas.⁶⁵⁵ A number of other risk factors have been identified. Ulcers are common in patients with Hb SS but quite rare in those with Hb SC disease or Hb Sβ⁺-thalassemia.⁶⁵⁴ They are more common in men than in women and in those >20 years of age. There is a positive correlation with a low steady-state Hb concentration and with a low level of Hb F.⁶⁵⁴ Recently, associations with

severity of hemolysis and with single-nucleotide polymorphisms in the Klotho gene and TGF- β pathway genes have been reported.¹¹²

The ulcers typically form a shallow depression with a smooth and slightly elevated margin; often, they have a surrounding area of edema. There may be exudation, crusting, and granulation at the base. Secondary infection of the ulcer with undermining of the edges and progressive extension are common. Single or multiple bacterial organisms may be cultured from the lesions and may contribute to their refractoriness. Healing leaves a thinned depigmented epithelium that is often surrounded by areas of hyperpigmentation and hyperkeratosis. This fragile epithelium is likely to break down with minimal trauma or edema, leading to recurrence rates >70%.⁶⁵⁶

Healing of leg and ankle ulcerations is facilitated by bed rest, elevation of the affected extremities, wet-to-dry dressings, and eradication of documented wound infections with systemically administered antibiotics. When acute inflammation has subsided, occlusive zinc-oxide-impregnated gel boots (Unna boots) are applied, and partial ambulation is permitted. In refractory

P.846

or progressive cases, the healing process may be enhanced if the level of Hb S is maintained at <40% with transfusions. Splitthickness skin grafting may be necessary.⁶⁵⁷ A number of alternative approaches have also been described in recent years. Zinc deficiency has been invoked to explain slow tissue healing,⁶⁵⁸ and oral zinc therapy may hasten healing in some patients.⁶⁵⁹ Erythropoietin and hydroxyurea may improve healing by increasing fetal or total Hb levels (or both).^{660, 661} Hydroxyurea has been linked to the development of leg ulcers anecdotally, but larger studies have not found this association. The use of collagen-matrix dressings (RGD peptide matrix) resulted in greater ulcer closure in a controlled collaborative trial.⁶⁶² Recently a phase II clinical trial in 23 adults with refractory leg ulcers compared standard care with arginine butyrate (500 mg/kg, 5 d/week) plus standard care.⁶⁶³ Healing of the ulcers was significantly better in the arginine butyrate arm.



FIGURE 33.10. Chronic leg ulcers in an adult patient with sickle cell anemia (SCA).

Pregnancy

Pregnancy poses potentially serious problems for the woman with SCA, as well as for the fetus and neonate.^{664, 665, 666} In the absence of medical supervision, the mortality for mother and infant has been as high as 20% and 50%, respectively.⁶⁶⁷ With optimal care, mortality and morbidity are reduced substantially, even in difficult settings in Africa.⁶⁶⁸ The jeopardy imposed by pregnancy is explained in part by marginal health status before conception and in part by the sinusoidal circulation of the placenta, whereby a high degree of oxygen extraction provides an excellent milieu for sickling, stasis, and infarction. Although life-threatening complications generally are not encountered until the third trimester, an increased incidence of pyelonephritis, hematuria, and thrombophlebitis is noted throughout pregnancy.⁶⁶⁹ Anemia is more severe and may be compounded by folate deficiency. During late pregnancy and the postpartum period, major infarctions may involve the lungs, kidneys, or brain. Toxemia, heart failure, and postpartum puerperal endometritis occur with greater frequency in women with SCA than in the general population.^{669, 670, 671}

The risk to the fetus is serious; fetal wastage results from a combination of abortion and stillbirth.⁶⁶⁹ The incidence of congenital malformations or susceptibility to complications is comparable to that shared by all preterm infants.⁶⁷² Opiates are not associated with teratogenicity, congenital malformations, or toxic effects other than transient suppression of movement and variability in fetal heart tones.⁶⁷³ Hydroxyurea, even when used throughout pregnancy, has not been associated with teratogenic changes, both in a small number of pregnancies, and among adults who participated in the MSH trial and were followed for up to 17 years.^{674, 675} Nevertheless, it is a teratogen in animals and should be stopped once pregnancy is recognized.⁶⁶⁴

Infants born to women with SCA are at greater risk of preterm birth, low birth weight, being small for gestational age, and neonatal jaundice,⁶⁷⁰ but since 1980, the neonatal mortality rate has ranged from 0% to 10%.⁶⁶⁴ According to a CSSCD report 21% of infants were small for their gestational age.⁶⁷¹ Possible etiologic factors are severe maternal anemia; frequent episodes of vaso-occlusion leading to hypoperfusion and hypoxia of the placenta; increased risks of abruptio placentae, placenta previa, and toxemia of pregnancy; diminished maternal nutrition; and increased narcotic use in the mother. Pre-eclampsia and acute anemic events were risk factors identified by the CSSCD.⁶⁷¹ The increased risk of preterm labor and prematurity may be caused by similar factors, including anemia, abruptio placentae, placenta previa, toxemia, and narcotic use, as well as increased urinary tract infection and chorioamnionitis. A high maternal Hb F level may have an ameliorating effect on perinatal mortality.⁶⁷⁶ Treatment of sickle cell disease during pregnancy may include repeated blood transfusions, but this is not indicated in all cases (see "Treatment" section).

The efficacy and safety of various methods of contraception have not been investigated systematically in women with sickle cell disease. Despite a theoretical possibility of enhancing thrombotic risk, low-estrogen-dose birth control pills are sometimes recommended. Studies in Nigeria and Brazil found no adverse effects from the progestational contraceptive implant and a possible improvement in fetal Hb level.^{677, 678} An association of pain crises and menstrual periods seen in 37% of women suggests the use of a continuous combined contraceptive pill regimen or medroxyprogesterone (Depo-Provera) to induce amenorrhea in severe cases.⁶⁷⁹ A review of progesterone-only contraceptive use suggested that they are safe and result in less frequent and severe painful crises.⁶⁸⁰

Prognosis

The prognosis for persons with SCA has undergone dramatic change as a result of early diagnosis, improved patient education, and effective therapeutic interventions. In a retrospective review of autopsy cases from the United States in 1972, 20% to 30% were <5 years of age at the time of death.³³⁴ The median age at death was 14 years, and survival beyond 40 years of age was unusual. In a 1976 report of a screening program that used cord blood samples, 31% of children diagnosed at birth died before 15 years of age at a mean age of 2 years.⁶⁸¹ The disproportionate number of reported deaths occurring in early childhood was the result of overwhelming bacterial infections and splenic sequestration crises.^{175, 682}

Newborn screening for sickle cell disease and greater awareness of the unique needs of affected infants and children have resulted in an improved prognosis.^{683, 684} The simple adoption of a standardized protocol for the management of febrile illnesses reduced the mortality in children with SCA 0 to 5 years of age from 3.2/100 patient-years to 1.4/100 patient-years.³⁹⁰ In 1989, the CSSCD documented an 85% survival rate at 20 years of age.⁶⁸⁵ In that study, peak incidence of death (mostly resulting from infections) occurred between 1 and 3 years of age. Cerebrovascular accidents and traumatic events exceeded infections as a cause of death in the second decade of life. Mortality data for young children with Hb SS born in the early 1990s in three large states with newborn hemoglobinopathy screening indicated that 1% died as a result of sickle cell disease related causes during the first 3 years of life.⁶⁸⁶ In the Dallas newborn cohort study, infants identified by newborn screening were followed for up to 18 years.⁶⁸⁷ The cumulative overall, sickle cell related, and stroke-free survival

rates were approximately 86%, 94%, and 88.5% by age 18 years. It was concluded that childhood mortality from sickle cell disease is decreasing and that a smaller proportion of deaths are from infection.

In a report from the CSSCD,¹⁴³ causes of death for 209 adult patients who died during the study were analyzed. Among adults with Hb SS, the median age at death was 42 years for males and 48 years for females. However, among those with Hb SC disease, the median age at death was 60 years for males and 68 years for females. Only 18% of deaths occurred in patients with chronic organ failure; of these, 58% had chronic renal failure, 29% had chronic congestive failure, and 23% had chronic debilitating stroke. One third of the deaths occurred in the context of hospitalization for an acute painful episode, ACS, or stroke, which was predominantly hemorrhagic. Six percent died from infection, 6% had perioperative deaths, and 6% died from trauma. Miscellaneous causes included cancer, gastrointestinal bleeding, and fulminant hepatic failure. In ~23%, the exact cause of death was unknown. Statistical modeling revealed that in patients with SCA, ACS, renal failure, seizures, baseline white cell count >15,000/mm³, and a low level of fetal Hb were associated with an increased risk of early death. It was concluded that a high level of fetal Hb is a relatively reliable childhood forecaster of improved adult life expectancy.

P.847

In a four-decade prospective cohort study from Los Angeles involving more than 1,000 patients, it was noted that children born after 1975 had an 89% survival to age 20 years.^{179, 688} A higher rate of hospitalization for sickle cell pain crises in adults was associated with increased rates of avascular necrosis, leg ulcers, chronic lung disease, renal failure, and early death. Of the patients who died, 73% had one or more forms of irreversible organ damage. By the fifth decade, nearly one half of the surviving patients had documented irreversible organ damage, including end-stage renal disease, chronic pulmonary disease with PHT, retinopathy, and cerebral infarctions, underscoring the need for preventive therapy to ameliorate the progression of sickle vasculopathy.

Overall, although mortality in children with sickle cell disease has progressively decreased in developed nations, the burden of mortality in sickle cell disease is increasingly shifting to adults, particularly among young adults (18 to 30 years) who have recently transitioned out of pediatric sickle cell programs.^{15, 180, 689} Mortality during childhood years, especially before 5 years of age, remains elevated in developing nations, however.^{690, 691}

Determinants of Severity

Extensive data from the CSSCD highlighting frequency/incidence and risk factors for various complications of sickle cell disease have been published.⁶⁹² Because of the large number of patients involved and the efforts to avoid patient selection bias, these data represent an ambitious attempt to describe the natural history of sickle cell disease. A large, carefully followed cohort of sickle cell patients from Jamaica described in numerous publications and a textbook provides another major source of data for prognostic analysis.¹⁴

SCA is remarkably variable in its clinical expression, even among affected members of the same family. Whereas many individuals have recurrent severe complications, others enjoy a relatively benign, virtually symptom-free course.⁶⁹³ Occasionally, patients with apparently mild SCA are found on further study to be doubly heterozygous for Hb S and another Hb variant having the same electrophoretic mobility as Hb S or to be heterozygous for both Hb S and HPFH. That clinical heterogeneity is related to genetic variables is suggested by the tendency for differences in disease severity to follow selected geographic and ethnic lines. In the eastern oases of Saudi Arabia, for example, SCA is clinically benign,^{694, 695} whereas in western Saudi Arabia, it is comparable in severity to that seen in African Americans.⁶⁹⁶ Several important modulators of hematologic and clinical severity have been identified; however, Hb F level, the presence of α -thalassemia, and the β -globin gene cluster haplotype are the most important ones.^{240, 245, 697, 698, 699}

Because Hb F is excluded from the Hb S polymer, individuals with relatively greater amounts of Hb F should have less severe disease than those with less Hb F. The level of Hb F in patients with SCA is determined by the number of red cells containing Hb F (F cells), the Hb F concentration within F cells, and the survival of F cells.⁷⁰⁰ The proportion of reticulocytes containing Hb F is relatively constant over time, but it varies greatly among affected individuals (2% to 50%). Other confounding factors in studies to determine the prognostic significance of Hb F include the variability in techniques used to measure fetal Hb and the fact that Hb F levels in sickle cell patients gradually decline over a long period of childhood and do not reach equilibrium until 12 years of age. The expression of high levels of Hb F and F reticulocytes may be inherited as an autosomal dominant characteristic.^{701, 702}

In the eastern province of Saudi Arabia^{694, 703} and in Kuwait,⁷⁰⁴ Iran,⁷⁰⁵ India,⁷⁰⁶ and the West Indies,⁷⁰⁷ mild disease is associated with Hb F levels of 15% to 30%. Levels of Hb F influence the age at which symptoms develop²⁷⁷ and partially determine the risk of acute splenic sequestration,^{174, 371} stroke,^{233, 235} ACS,²⁹⁴ leg ulcers,⁶⁵⁴ pain crises,¹⁸¹ loss of spleen function,²⁷⁷ and mortality.⁷⁰⁸ Among patients of West African ancestry, higher levels of Hb F are associated with an improvement in hematologic features,^{181, 709} but an improvement in measures of clinical severity related to increased Hb F has been difficult to establish. One study concluded that Hb F levels substantially <20% conferred minimal benefit on disease severity, indicating a threshold effect.⁷⁰⁹ However, evidence from the CSSCD indicates that even when the fetal Hb level is low, small increments in the level may have an ameliorating effect on the pain rate and may ultimately improve survival.¹⁸⁴ The limited capacity of Hb F levels to predict disease severity, however, does not negate the importance of Hb F production. Hb F levels are determined not only by synthetic rates but also by the extent to which F cells are enriched by differential cell survival. Thus, high levels of Hb F may reflect increased synthesis, resulting in mild disease, or greater amplification through accelerated destruction of cells containing no Hb F, a manifestation of more severe disease.⁷⁰⁰

Co-inheritance of SCA and α -thalassemia is not an unusual event. Nearly 30% of black Americans have a single α -gene deletion, and in ~2%, deletion of two of the four α -globin genes has been found. Hematologic studies provide support for the clinical relevance of α -thalassemia. Subjects with SCA and α -thalassemia have a higher Hb concentration, lower MCV and MCHC, fewer ISCs, a lower reticulocyte count, lower serum bilirubin concentration, and relatively more Hb A² than subjects without concurrent α -thalassemia.^{698, 710, 711, 712, 713} The α -gene deletion also is associated with improved cell deformability,⁷¹⁴ a decreased fraction of dense cells,^{714, 715} protection against cation leak,⁷¹⁶ and improved red cell survival.⁷¹⁷ There is relatively little effect of α -thalassemia on Hb F levels,^{711, 712} although in patients with the Senegal haplotype, Hb F levels are higher.⁷¹⁸ The mechanism responsible for these differences in hematologic status is probably mediated by a decrease in the MCHC, because the extent and the rate of Hb S polymerization are highly dependent on the cellular concentration of Hb S.

Data from the CSSCD demonstrated that coexistent α -thalassemia is associated with a diminished mortality risk in patients >20 years of age.¹⁴³ In addition, stroke risk is decreased in the presence of alpha thalassemia.^{240, 247, 248} The rheologic benefits of more deformable α -thalassemic sickle cells are offset by rheologic impairment associated with the greater viscosity of a higher hematocrit induced by α -thalassemia.⁷¹⁹ Thus, α -thalassemia is associated with more frequent vaso-occlusive pain crises by virtue of its effect on hematocrit.¹⁸⁴ Osteonecrosis and perhaps sickle retinopathy occur more often in sickle cell subjects with coexistent α -thalassemia.^{720, 721, 722} Sickle cell trait is also influenced by α -thalassemia.⁷²³ Subjects with lower fractional content of Hb S associated with α -thalassemia have less severely impaired urinary-concentrating ability.⁷²⁴

Genetic factors that modulate the phenotype of sickle cell disease are associated with restriction fragment length polymorphic sites within the β -globin-like gene cluster.⁷²⁵ These β -globin gene haplotypes are characteristic of different populations; most patients with SCA in the United States have the Benin haplotype, with fewer having the Bantu (Central African Republic) and Senegal types. The origin of these genes in malarial regions of Africa is shown in Figure 33.1.¹⁸ In Mediterranean populations, the b^s gene is usually associated with a Benin haplotype, whereas the haplotype found in eastern Saudi Arabia and parts of India resembles but is distinct from that of Senegal. The Senegal haplotype is associated with higher levels of Hb F^{718, 726, 727, 728} and with fewer hospitalizations and painful episodes.^{245, 729} By contrast, the Bantu haplotype has been associated with the highest incidence of organ damage, particularly renal failure.²⁴⁵

Fetal Hb levels in both sickle cell patients and normal individuals have been found to be partially controlled by an X-linked gene located at Xp22.2, the F-cell production locus.⁶⁹⁷ Female

P.848

gender increases the expression of Hb F in patients with SCA and in normal individuals.⁶⁹⁷ Multiple regression analysis in one study showed that the F-cell production locus was the strongest predictor of Hb F level, although not accounting for approximately one half of the variation.⁷³⁰ When β -globin haplotype and gender were considered together, the Hb F level in female patients of all haplotype groupings was higher than that in male patients, with the highest level occurring in female patients with one Senegal haplotype chromosome (Hb F, 12.8%).⁷³¹ Thus, gender and β -globin gene cluster haplotype interact in the modulation of Hb F and Hb level in SCA. Recent discoveries demonstrate physical interactions between the β locus control region and the downstream structural γ - and β -globin genes, and with transcription factors and chromatin remodeling complexes. These interactions all play roles in globin gene expression and globin switching at the human β -globin locus.⁷³² In Jamaica, high levels of Hb F (and a normal α -globin gene complement) have been associated with benign disease, which occurred in 15% of patients.⁷⁰⁰

A cohort of 392 infants with Hb SS or Hb S β^0 -thalassemia from the CSSCD were followed for an average of 10 years beginning at <6 months of age. Eighteen percent had an adverse outcome, defined as death, stroke, frequent pain, or recurrent ACS.¹⁴⁶ Three statistically significant predictors of an adverse outcome could be identified at 2 years of age: Hb level <7 g/dl, leukocytosis in the absence of infection, and an episode of dactylitis before 1 year of age. However, in a report from the Dallas newborn cohort, hospitalizations in the first 3 years of life for pain (other than dactylitis), ACS, and dactylitis did not predict death or stroke.⁷³³ Nevertheless, early pain and ACS both predicted a modest increase in later pain episodes, and early ACS strongly increased the odds of more frequent ACS throughout childhood.

Sickle cell disease should no longer be considered a single-gene disorder,⁷³⁴ because a number of epistatic and pleiotropic genes have been defined.^{735, 736} Genomewide association studies (GWAS), which have been used to identify common genetic factors that influence health and disease, are hard to perform in sickle cell disease due to the large datasets required. The few GWAS studies that have been conducted in patients with SCA have examined SNPs associated with elevated bilirubin levels, cholelithiasis, fetal hemoglobin levels, and disease severity.^{737, 738, 739, 740} Some SNPs appear to be significant from these studies, such as SNPs in KCNK6 (a potassium channel gene) and telomere length regulator gene TNKS, which were both associated with increased disease severity.⁷³⁹ The most striking and potentially important information from recent GWAS studies has been the discovery of 3 loci with large effects on HbF production: the gene encoding B-cell lymphoma/leukemia (BCL) 11A (chromosome 2), genes encoding HB1SL (chromosome 6), and Myb, a transcription factor.^{741, 742, 743, 744} Together these 3 loci explain 40% of the variation in the amount of HbF produced.⁷⁴¹ Understanding the role of BCL-11A and other loci, and their relationship with the globin switch that occurs early in life may potentiate the development of treatment compounds and gene therapy strategies that reactivate HbF production.^{745, 746}

Laboratory Features

Red Blood Cells

In SCA, a moderately severe normocytic, normochromic anemia manifests by 3 months of age⁶⁷⁰ and persists throughout life.¹⁷⁶ The average Hb concentration is 8 g/dl, with a range from ~6 to 10 g/dl. Mean Hb levels vary with gender and with age; they are higher in adult men compared with women and higher in males between the ages of 20 and 39 years.⁷⁴⁷ In adults with Hb SS, the mean MCV is ~90 fl, and the mean MCHC is ~34.0 g/dl.⁷⁴⁷ The MCV and MCHC are substantially lower (means 72 fl and 32.5 g/dl, respectively) in patients with concurrent α -thalassemia minor ($-\alpha/-\alpha$ genotype) and in children with incidental iron deficiency.⁷⁴⁸ The MCV in males with SCA is less than that for females in almost all age groups;⁷⁴⁹ this may reflect the higher Hb F concentration seen in female patients. Automated blood cell counters (based on aperture and impedance or light-scatter techniques) may result in overestimation of the MCV and underestimation of the MCHC⁷⁵⁰ because of the inability of dehydrated, dense sickled red cells to deform like normal cells as they pass through the narrow counter aperture. However, the use of two-angle light-scattering technology permits accurate measurement of MCV and MCHC and generation of histograms of these properties.⁷⁵¹ This allows quantitation of the percentage of dense, dehydrated red cells.

Blood smears contain variable numbers of sickled forms, target cells, and ovalocytes (Fig. 37.11). The great variety of sickle cells is best appreciated by scanning electron microscopy (Fig. 37.2). The morphologic features of accelerated erythropoiesis, which include polychromatophilia, basophilic stippling, and normoblastosis, are prominent. The mean reticulocyte count is ~10%, with a range of 4% to 24%.⁷⁴⁷ Howell-Jolly bodies reflect functional asplenia. Numerous pits in red cell membranes, also a feature of the asplenic state, require phase-interference contrast microscopy for visualization.⁴⁰² With transmission electron microscopy, dense aggregates of Hb can be seen adjacent to red cell membranes.⁷⁵²

Erythrokinetic studies performed in the steady state indicate a four- to fivefold increase in red cell production and erythron iron turnover and a comparable shortening of red cell survival. The curves of cell survival obtained with ³H- or ³²P-labeled diisopro-pylfluorophosphate indicate a random rather than a senescent mode of cell destruction.⁷⁵³ This pattern of cell loss is explained by the lack of dependence of ISC formation on cell age.¹⁰⁵ Chronic

P.849

hemolysis, some of which is intravascular, is responsible for an increase in endogenous carbon monoxide generation and for elevated serum levels of unconjugated bilirubin and heme proteins.⁷⁵⁴ Serum immunoreactive erythropoietin levels are lower than those noted in association with other anemias of comparable severity.⁷⁵⁵

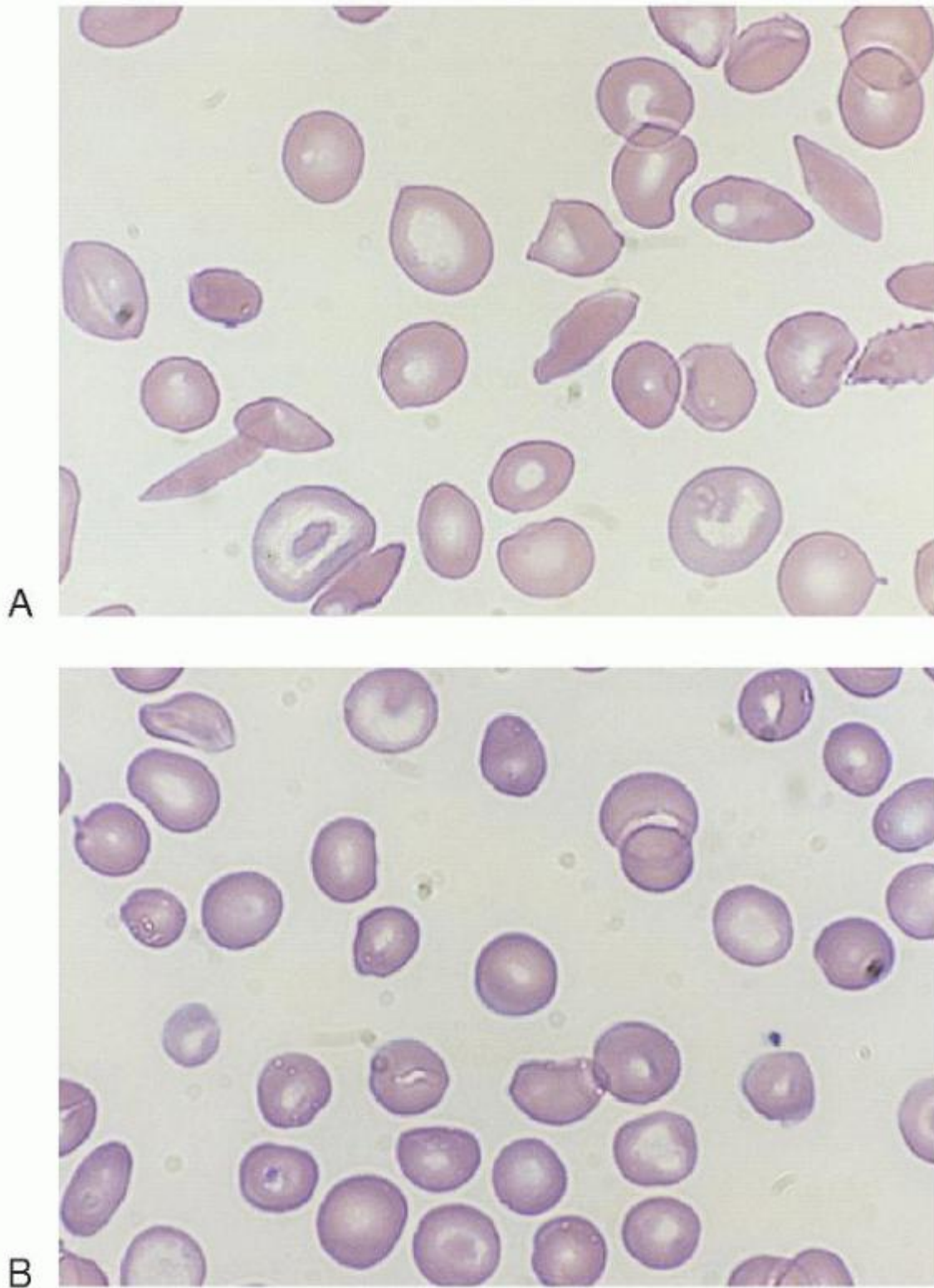

FIGURE 33.11. Blood smears of patients with hemoglobin (Hb) SS and Hb SC disease. A: Red blood cell morphology in sickle cell anemia (SCA) is characterized by sickled forms (dense elongated cells with pointed ends), target cells, ovalocytes, and polychromatophilia. B: Hb SC disease is characterized by target cells, relatively few sickled forms, and a small proportion of cells that contain dark blunt protuberances (hemoglobin “crystals”).

White Blood Cells

The white blood cell count is consistently elevated owing to an increase in the number of mature granulocytes. The mean leukocyte count under steady-state conditions is 12 to $15 \times 10^9/L$, with a range of 6 to $20 \times 10^9/L$.⁷⁴⁹ This increase is explained to a large extent by a shift of granulocytes from the marginated to the circulating compartments.¹³⁸ Both total and segmented leukocyte numbers increase during vaso-occlusive crises and infections, but only with bacterial infections does a consistent increase occur in bands (nonsegmented neutrophils), often to levels $>1 \times 10^9/L$.¹³⁹

Platelets and Coagulation

The platelet count is increased (mean, approximately $440 \times 10^9/L$), reflecting reduced or absent splenic trapping.^{159, 749, 756} Totals of both platelets and megathrombocytes decrease during vaso-occlusive crises.^{159, 160} Platelet aggregation is decreased, the likely result of in vivo platelet activation.^{161, 757} The plasma β -thromboglobulin level is elevated.¹⁶² The contact factors are decreased,¹⁶⁵ whereas factor VIII activity, fibrinogen concentration, and fibrinolytic activity are increased.^{758, 759, 760} Some of these alterations likely reflect vascular endothelial damage inflicted by the sickling process and not primary perturbations responsible for crises.

Other Laboratory Tests

Inflammatory markers are increased in sickle cell disease and reflect the "heightened inflammatory state" of the disease. Inflammatory markers, such as CRP, sPLA₂, fibrinogen, Von Willebrand factor, interleukines, serum ferritin, and TNF α , are all elevated,^{117, 761} in addition to elevation of WBC. The sedimentation rate is difficult to interpret due to the presence of anemia, hyperfibrinogenemia, and the failure of sickle cells to undergo rouleaux formation.

Diagnosis

The diagnosis of SCA (HbSS) rests on the electrophoretic or chromatographic separation of hemoglobins in hemolysates prepared from peripheral blood. The predominant hemoglobin is S; Hb F is present in varying concentrations; and Hb A² is normal. There is no Hb A. Electrophoresis using cellulose acetate and an alkaline buffer is rapid, inexpensive, and effective in the separation of normal hemoglobins from common variants. Whole blood, blood specimens dried on filter paper, or Hb solutions may be used.⁷⁶² However, several relatively rare Hb variants have an electrophoretic mobility identical to that of Hb S on cellulose acetate. Because most of these variants do not co-polymerize with Hb S on deoxygenation, the doubly heterozygous states are seldom associated with the clinical and hematologic features of sickling. The interaction of Hb S with β^0 -thalassemia also gives an electrophoretic pattern that is indistinguishable from that of homozygous SCA, except for an increase in Hb A₂. In general, the appropriate diagnosis can be made by taking into consideration associated hematologic data (Table 33.4). However, detailed family studies, Hb separation by isoelectric focusing or high-performance liquid chromatography (HPLC), globin-chain electrophoresis, or structural analysis of Hb [by protein chemistry, mass spectrometry, or sequencing of polymerase chain reaction (PCR)-amplified DNA] may be required to characterize accurately the genotypic basis for a sickling disorder.

TABLE 33.4 DIFFERENTIAL DIAGNOSIS OF ELECTROPHORETIC PATTERN OF HEMOGLOBIN (HB) SS AT PH 8.6

Diagnosis	Symptoms	Anemia	Red Blood Cell Morphology	Distinguishing Features
Sickle cell anemia (Hb SS)	Present	Moderate or severe	ISCs, target cells	—
Hb S/ β^0 -thalassemia disease	Present	Moderate or severe	ISCs, target cells, hypochromia, microcytosis	Hb A ₂ increased; mean cell volume and mean corpuscular Hb concentration decreased
Hb S/hereditary persistence of fetal Hb	Absent	Absent	Target cells	Hb F evenly distributed in erythrocytes
Hb S/D-Punjab disease	Present	Moderate	ISCs, target cells	Hb S and D separable on citrate agar at acid pH

ISC, irreversibly sickled cell.

A variety of simple tests permits detection of Hb S. The sickling phenomenon can be induced by sealing a drop of blood under a coverslip to exclude oxygen or by adding agents that induce chemical deoxygenation, such as 2% sodium metabisulfite or sodium dithionite.⁷⁶³ The decreased solubility of deoxy Hb S forms the basis for tests in which blood is

added to a buffered solution of a reducing agent such as sodium dithionite. Hb S is insoluble and precipitates in solution, rendering it turbid, whereas solutions containing hemoglobins other than Hb S remain clear. Hyperglobulinemia and other sickling hemoglobins may cause false positive results;⁷⁶⁴ false negatives may result from the addition of an inadequate number of red cells. Neither the sickle cell preparation nor solubility tests differentiate SCA from sickle cell trait or detect Hb variants that interact with Hb S. Thus, they should never be used as a primary screening test. Their principal value has been as an adjunct to electrophoretic identification of Hb S.

Quantitation of Hb A₂ is performed by HPLC. Quantitation of Hb F can be carried out by alkali denaturation, HPLC, or radioimmunoassay.^{752, 765} The distribution of Hb F in red cells may be analyzed by its resistance to acid elution or, more precisely, by Hb F-specific antibodies that measure the number of "F cells."⁷⁶⁶

Although the diagnosis of Hb SC disease is straightforward, that of Hb Sβ⁰-thalassemia may sometimes be problematic. In Hb Sβ⁺-thalassemia, there is a preponderance of Hb S, with Hb A comprising 5% to 30% of the total, and elevation of HbA₂. This must be distinguished from sickle cell trait, in which Hb A exceeds Hb S, and from the presence of Hb A resulting from red blood cell transfusions within the previous 3 to 4 months. Hb Sβ⁰-thalassemia produces an electrophoretic pattern that is

P.850

visually indistinguishable from that of SCA, but a diagnosis can be made by the presence of an elevated Hb A₂ level and a decreased MCV. In addition, upon exam of the peripheral blood, both HbSβ⁺-thalassemia and HbSβ⁰-thalassemia display large numbers of target cells. However, because SCA with coincident α-thalassemia also has a phenotype with reduced MCV and mildly elevated Hb A₂, family- or DNA-based studies may be necessary to make this distinction.

Neonatal Diagnosis

The first statewide newborn hemoglobinopathy screening program was initiated in New York in 1975,⁷⁶⁷ but the impetus for universal screening came from the demonstration that early diagnosis and comprehensive care could reduce morbidity and mortality in infants with SCA through the prevention of pneumococcal sepsis with penicillin prophylaxis.⁴¹¹ A National Institutes of Health Consensus Conference concluded that every child should be screened early for sickle cell disease,⁷⁶⁸ leading to statewide newborn screening programs in all 50 states.⁷⁶⁹ Universal rather than targeted screening is necessary to ensure that all with disease are identified and none are discriminated against or stigmatized.⁷⁶⁸

It is estimated that between 2,000 and 3,000 children are born yearly with sickle cell disease in the United States,¹⁵ and approximately 280,000 worldwide.⁷⁷⁰ Most newborn screening programs use dried blood spots on filter paper, because Hb testing can easily be integrated into existing metabolic programs with established methods of sample collection, specimen processing, data management, and quality control.⁷⁷¹ A comparison of liquid cord blood and heel-puncture blood on filter paper showed that both systems were subject to a small error rate, primarily involving carrier phenotypes, but cord blood testing was more prone to lead to inconclusive results and noncompliance in sample collection.⁷⁷² Isoelectric focusing and HPLC have replaced cellulose acetate electrophoresis in most screening programs.⁷⁷³

The primary goal of newborn screening for sickle syndromes is reduction of morbidity and mortality by identifying affected infants at birth, referring them to treating centers, initiating prophylactic penicillin early, and providing ongoing care by knowledgeable health professionals.⁷⁷¹ The number of early deaths avoided has been estimated at 0.6 to 1.2/100 births.⁷⁷⁴ All cases of suspected disease still must be confirmed with a separate sample from the infant, because clerical errors may be encountered.⁷⁷² A common problem is the need to establish a mechanism for educating and counseling parents of carriers detected by testing at birth.⁷⁶⁸ Using public health and state genetic program resources, it is possible to provide parents with individual counseling, education, and extended family testing.⁷⁷⁵ Prenatal education for expectant mothers, which includes information about newborn sickle cell screening, significantly increases the follow-up rate for infants with sickle cell trait and contributes to a greater retention of information.⁷⁷⁶

Each of these techniques allows the detection of minor Hb components in the presence of large amounts of Hb F. The pattern in infants destined to develop SCA comprises Hb F, a relatively small amount of Hb S, and no Hb A. Neonates who are doubly heterozygous for Hb S and β⁰-thalassemia and for Hb S and HPFH have a Hb "FS" separation pattern indistinguishable from that for Hb SS. They may be differentiated by hemoglobinopathy testing of the parents or by repeat testing of the infant at a later age, when the production of HbA₂ will be high enough to allow detection of its elevation above the normal range. Another potential pitfall is misdiagnosis of Hb Sβ⁺-thalassemia by incorrect identification of an FS or FAS (sickle cell trait) pattern rather than the correct FSA pattern.⁷⁷⁷ Molecular genetic analysis using PCR-based techniques may provide reliable confirmatory testing (e.g., for distinguishing Hb Sβ⁰-thalassemia from Hb SS).^{778, 779} The combination of isoelectric focusing and HPLC also is an effective strategy for dramatically reducing the risk of errors.⁷⁸⁰

Prenatal Diagnosis

The clinical application of recombinant DNA techniques to the prenatal diagnosis of SCA permits a high level of diagnostic accuracy with relatively little risk to the fetus.⁷⁸¹ Guidelines for the ethical application of prenatal diagnosis have been developed,⁷⁸² and the use of routinely incorporating screening and counseling into the early prenatal care of populations at risk has been demonstrated.⁷⁸³

Initially, prenatal diagnosis required fetal blood sampling. Subsequently developed assays permit the use of DNA prepared from amniotic fluid cells obtained at 15 to 20 weeks' gestation or from a biopsy of chorionic villi obtained at 10 to 12 weeks' gestation. The latter technique is an outpatient procedure that involves passing a catheter through the cervix with ultrasonographic guidance.^{784, 785} It provides earlier diagnostic information, thereby permitting termination of pregnancy in the first trimester, when it is simpler, safe, and less psychologically stressful. The least invasive method of prenatal diagnosis uses fetal cells from the maternal circulation isolated by a variety of techniques such as flow cytometry.⁷⁸⁶ Preimplantation genetic diagnosis (PGD) allows couples who are sickle cell carriers to select unaffected embryos prior to in vitro fertilization. In some cases, PGD has been performed in combination with HLA typing, allowing the delivery of an unaffected child who is also HLA identical to an affected sibling, therefore providing an ideal stem cell donor for the affected child.⁷⁸⁷ However, PGD is expensive and has a pregnancy success rate of only 13% to 30%.^{787, 788, 789, 790} Although prenatal diagnosis of fetuses conceived by couples at risk of having children with sickle cell disease is widely accepted in some countries,⁷⁹¹ use of this technology has been infrequently requested by couples at risk in the United States. Reduction in the rate of affected births has not been observed in the United States, despite genetic counseling efforts by sickle cell programs. Recently Greece has observed a decline in the number of new births with sickle cell disease and thalassemia, which has been attributed to aggressive education and early pregnancy termination.⁷⁹²

Several strategies have been used successfully for the analysis of fetal DNA. Methods that involve the use of restriction fragment length polymorphisms are indirect and suitable only for those cases in which the parents at risk can be shown to carry the appropriate linked polymorphism.⁷⁹³ The most widely used approach is based on the fact that the DNA mutation in the β^S gene is itself a cleavage site for the restriction enzyme Mst II,^{794, 795} which cleaves DNA at the normal sixth codon and, therefore, generates abnormally long DNA fragments with base mutations involving this codon. Synthetic oligonucleotides that are specific for the β^S nucleotide substitution also permit direct, rapid, and sensitive detection of the β^S gene.⁷⁹⁶ The use of the PCR to amplify β -globin sequences enzymatically before restriction enzyme or oligonucleotide analysis greatly increases the sensitivity and speed of the procedure, making it possible to provide genetic diagnoses within a few hours.^{796, 797} The dot-blot method of allele-specific hybridization uses fixation of PCR-amplified target β -globin DNA to filters and hybridization of the filters with labeled probes complementary to β^A and β^S sequences.⁷⁹⁸ Prenatal screening of single-gene disorders from maternal blood is possible using cellfree fetal DNA obtained from maternal plasma.⁷⁹⁹

Treatment

In addition to prophylactic measures aimed at preventing specific complications of sickle cell disease, three treatment options have been used increasingly for overall management: chronic blood transfusion, hydroxyurea, and stem cell transplantation. Gene therapy remains a future goal.

P.851

Preventive Measures

Until a safe and widely applicable mechanism for the prevention of intravascular sickling is found, a high priority must be placed on the prevention of complications. Because vaso-occlusive crises are precipitated by infection, fever, dehydration, acidosis, hypoxemia, and cold exposure, measures to prevent or remedy these conditions assume importance. Optimal hydration is essential, especially during febrile illnesses. In estimating fluid requirements, the hyposthenuria of SCA, as well as increased insensible losses, must be considered. Because the liberal use of salicylates imposes an acid load, acetaminophen is the preferred antipyretic. Sudden transition to high altitude and exposure to situations likely to cause chilling should be avoided.

The high risk of overwhelming pneumococcal disease in children mandates the use of penicillin prophylaxis and pneumococcal vaccination. Preventive measures and early medical intervention for febrile illnesses substantially reduce mortality.³⁸⁶ Effective primary prevention of stroke through the use of TCD screening has been discussed above.

Blood Transfusion

One of the most effective therapeutic measures presently available is the transfusion of normal red cells.^{800, 801} However, because of the complications of transfusion therapy, it is reserved for selected indications, such as severe anemia, stroke prevention, pregnancy, progressive or recurrent organ damage, preparation for surgery, and certain severe acute vaso-occlusive events. Transfusion therapy facilitates improved blood and tissue oxygenation, reduces the propensity for vaso-occlusion by diluting host cells, and temporarily suppresses the production of red cells containing Hb S. With chronic transfusion support, splenic involution and fibrosis are reversed in some patients.⁸⁰² The viscosity of deoxygenated sickle cell blood is disproportionately reduced by the addition of normal red cells. A mixture of one-fourth Hb A cells and three-fourths Hb S cells reduces the viscosity of deoxygenated blood by 50%.⁸⁶ Accordingly, the relative number of Hb S-containing cells needs to be reduced only to ~40% to prevent most clinically significant vaso-occlusive events.⁸⁰³ Replacement of patient cells with donor cells is readily accomplished by a limited exchange transfusion, in which patient blood is removed before or during packed cell transfusion.^{804, 805} Repeated partial exchange transfusion, which can be performed through erythrocytapheresis, greatly reduces the net gain of iron.^{806, 807} However, the long-term central venous access, which is often required, may be associated with an unusually high rate of catheter infection, thrombosis, and premature removal of the central line.^{808, 809} Repeated simple transfusions are probably equally effective in terminating the consequences of in vivo sickling. Packed red cell transfusions at 3- to 4-week intervals generally are sufficient to maintain the relative number of donor cells in the circulation at >70%, but Hb S is more easily suppressed in some patients than others.⁸¹⁰ Furthermore, chronic transfusion may result in recurrent splenomegaly and the additional problem of hypersplenism.⁸¹¹

Although it is effective in circumventing the numerous complications of SCA,⁸¹² chronic transfusion therapy is limited by logistic and toxicologic considerations. The requisite commitment of personnel and blood resources is considerable, and the risks of alloimmunization and hemosiderosis are cumulative and potentially life-limiting. Among individuals with SCA, 18% to 36% become alloimmunized, considerably more than with other forms of anemia.^{813, 814} The greater risk of alloimmunization in SCA is primarily a result of racial differences between the blood donor and recipient populations. The development of multiple antibodies is a relatively common problem;⁸¹⁴ antibodies against C, E, and Kell (K) antigens account for most of the alloantibodies. The use of racially matched and selected minor blood-group antigen-matched blood for chronically transfused patients with sickle cell disease has been recommended to prevent alloimmunization.^{812, 814} Hemolytic transfusion reactions are associated with as many as 3% of transfusions. Most occur several days after the transfusion and are accompanied by a falling hematocrit, hemoglobinuria, increased jaundice, and, frequently, a pain episode.^{216, 815} In some cases, a delayed hemolytic transfusion reaction may lead to a fall in Hb level to a level lower than before transfusion, with a life-threatening or fatal outcome resulting from attempts to provide further transfusions.

Iron overload has been an inevitable result if chronic transfusion is not performed by partial exchange methodology, such as erythrocytapheresis. The severity of iron overload has traditionally been monitored with serum ferritin concentration, and there is a strong inpatient correlation between ferritin levels and volumes transfused.⁸¹⁶ However, there is wide interpatient variability, indicating a need to assess iron stores more directly, such as by liver biopsy, to determine the necessity for iron chelation.^{816, 817} As little as 10 units of packed red blood cells (PRBCs) per year will increase the liver iron concentration (LIC) obtained by biopsy above 3 mg Fe/g of dry weight liver, the normal upper limit of LIC.⁸¹⁸ Calibration studies have shown excellent correlation between LIC and quantitative MRI (both R2* and R2) at low and moderate LIC values.^{819, 820, 821} These noninvasive MR methods to measure iron levels have improved the clinical management of iron overload in target organs such as the liver and, more recently, the heart.^{820, 821, 822} The superconducting quantum interference device (SQUID) also has been utilized successfully for monitoring liver iron but has limited availability.⁸²³

With repeated transfusions, iron will accumulate progressively in several organs in addition to the liver, including the heart, pancreas, kidneys, pituitary, and gonads. Iron endocrinopathy and myocardial hemosiderosis have not been as problematic in SCA as in thalassemia major.^{507, 824} Similarly, liver fibrosis is less common in sickle cell disease than thalassemia major, but does occur.^{587, 825} Reasons for these differences are not completely understood, but might be related to the age when transfusions are initiated, total cumulative volume of transfusion, differences in iron metabolism (e.g., lower nontransferrin bound iron levels in sickle cell disease), and the chronic inflammatory state of sickle cell disease, which might confer hepcidin-mediated protection against the toxic effects of iron on the tissues.^{826, 827}

Although chelation with desferrioxamine (Desferal) has reduced organ damage and significantly prolonged life expectancy in transfused thalassemia patients, its use has several serious limitations. The administration of desferrioxamine as a life-long, daily, subcutaneous, or intravenous infusion is cumbersome and has caused logistical hardships that promote inconsistent adherence to treatment.⁸²⁸ In addition, vision and hearing need to be monitored yearly due to the potential of the drug for ototoxicity and retinal damage.

Deferiprone (L1; Ferriprox), an oral chelator licensed in the United States in 2011, is a small molecule with a short half-life that is believed to have better access to intracellular iron. It is administered three times a day and its side effects are well recognized: agranulocytosis occurring in 0.6/100 patients per year, and, more commonly, transient neutropenia, arthropathy, zinc deficiency, increased transaminase levels, and gastrointestinal symptoms.⁸²⁹ Encouraging preliminary reports suggestive of effective penetration into cardiac cells prompted a large retrospective study, which showed a significantly lower rate of cardiac death and cardiac events in patients treated by deferiprone (75 mg/kg/day) compared to those treated by standard subcutaneous desferrioxamine.⁸³⁰ Randomized prospective trials have shown an advantage of deferiprone over desferrioxamine in decreasing myocardial iron as measured by T2* MRI and in improving LV function in thalassemia patients.^{831, 832}

P.852

The tridentate chelator deferasirox (ICL670; Exjade) is given as a single daily oral dose because of its long half-life. The dissolvable powder has a recommended daily dose ranging from 20 to 40 mg/kg/day. Deferasirox was studied extensively in murine models and in adults and children >2 years old,^{833, 834} and was approved in the United States in 2005 for transfusion-induced iron overload. Several clinical trials have shown its efficacy in reducing LIC, and recent evidence points toward use of higher doses of deferasirox (30 to 40 mg/kg/day) to produce adequate liver iron clearance.^{835, 836, 837} In addition, there is some evidence to support the efficacy of deferasirox in reducing myocardial iron and improving function.^{838, 839, 840} However, a comparison in a prospective randomized trial of deferasirox and deferiprone for removing cardiac iron has not been performed. Common side effects of deferasirox included rash (11%) and transient gastrointestinal symptoms (10% to 15%), in addition, many patients complain of unpleasant drug taste (personal communication). The drug combination of an oral chelator and desferrioxamine has been used in patients with thalassemia major and provided improved negative iron balance,⁸⁴¹ but no large trials have been conducted in patients with sickle cell disease. A phase II trial of a new tridentate oral iron chelator, FBS0701, has been completed in adult patients with thalassemia. The drug has also shown efficacy in reducing LIC without serious drug-related side effects.⁸⁴² FBS0701 is available in capsule form, potentially reducing the inconvenience of unpalatable taste.

Although oral chelators have the potential to improve therapy for iron overload by improving compliance and therefore clinical response, suboptimal adherence has been reported.^{843, 844} Current recommendations for the management of iron overload in sickle cell disease are to monitor serum ferritin and LIC (by liver biopsy or MRI) longitudinally, and to initiate iron chelation when LIC becomes ≥ 7 mg Fe/g of dry weight liver. During ongoing transfusion therapy LIC at least should be maintained between 5 and 7 mg Fe/g of dry weight liver.^{845, 846}

Indications for Transfusions

Anemia. Anemia with Hb levels as low as 5 g/dl generally is well tolerated and requires no therapy. During hematologic crises, however, the Hb concentration may fall precipitously, requiring rapid correction. An aplastic crisis caused by parvovirus infection often requires a single packed red cell transfusion before erythropoiesis eventually returns. A severe splenic sequestration crisis may require an immediate transfusion to restore blood volume and oxygen-carrying capacity. If the patient does not have an elective splenectomy, chronic transfusion therapy to maintain splenic function has been used as an alternative. However, recurrences of sequestration have occurred despite transfusion.⁸⁴⁷ The experimental use of polymerized bovine Hb in adult patients and polymerized human Hb along with erythropoietin in a sickle cell patient with multiple red cell antibodies has been described,⁸⁴⁸ but overall evidence of efficacy is lacking and there is concern about effects on NO metabolism.

Progressive Organ Damage. The risks and expense of a long-term transfusion program are justified if progressive or recurrent vaso-occlusive events threaten major organ function.⁸⁴⁹ Chronic transfusion therapy minimizes the risk of recurrent or progressive neurologic deterioration in children who have had a stroke.^{233, 850, 851} In addition transfusions have a role in primary stroke prevention.²⁶⁶ Progressive retinopathy, sickle cell renal disease, and cardiac decompensation may also be arrested with repeated transfusions. Short-term transfusion therapy may be of benefit for a variety of complications, including ACS, pain events, priapism, protracted hematuria, and chronic skin ulcerations.⁸⁵²

Surgery. Anesthesia, surgery, and postsurgical convalescence expose patients to the formidable consequences of hypoventilation, hypotension, cooling, dehydration, acidosis, and immobilization. Although recommendations regarding the preparation of patients for surgery have varied, simple transfusions before elective procedures and partial exchange transfusions before emergency surgery have been used.⁸⁵³ The CSSCD noted a perioperative mortality rate over a 10-year period of 1.1%.⁸⁵⁴ A large multicenter prospective trial compared the rates of perioperative complications among patients

randomly assigned to receive either an aggressive transfusion regimen (to decrease the Hb S level to <30%) or a conservative regimen (to increase the Hb level to 10 g/dl).⁸⁵⁵ Perioperative complications, including ACS, were similar in the two groups except for transfusion-associated complications, which were more common in the aggressively treated group. It was concluded that with good perioperative management, it is unnecessary to reduce markedly the Hb S level before surgery.⁸⁵⁵ In a recent national survey of practice in the United Kingdom, it was found that most patients undergoing cholecystectomy and adenoidectomy do so without preoperative blood transfusion, whereas almost all patients undergoing hip arthroplasty are prepared by exchange transfusion.⁸⁵⁶ There was no difference in the rate of postoperative complications in patients who received a transfusion and those who did not.⁸⁵⁷

Pregnancy. As do women who are hematologically normal, women with SCA experience a decrease in Hb concentration during pregnancy as a consequence of hemodilution. In general, however, the minor aggravation of anemia is without symptomatic consequence, and no therapy is indicated. However, the final weeks of pregnancy are often complicated by vaso-occlusive events that may have devastating consequences for both mother and fetus. In an attempt to prevent progressive placental infarction and premature delivery, some authors advocate the use of transfusion therapy during the third trimester.^{671, 858} In the only randomized study of its effectiveness, however, prophylactic transfusion therapy did not have a favorable impact on maternal morbidity (other than a reduction in the number of pain crises) or fetal wastage.⁸⁵⁹

Pharmacotherapy

Hemoglobin F Inducers

Reversal of ontogeny with re-institution of Hb F synthesis⁸⁶⁰ is a long-standing objective that appears increasingly attainable. This therapeutic strategy is based on the observation that clinical expression of the sickle gene is prevented by Hb F synthesis in the perinatal period, as well as throughout life in individuals with HPFH.

Initial attempts to augment γ -globin synthesis were based on the observation that DNA in the vicinity of a wide variety of expressed genes is undermethylated relative to the DNA flanking inactive genes.^{861, 862} 5-Azacytidine, a cytidine analog that blocks DNA methylation, reactivated dormant genes in cultured cells and increased Hb F synthesis in anemic baboons.⁸⁶³ When given to patients with severe SCA, 5-azacytidine caused a four- to sixfold increase in net γ -globin synthesis, a marked increase in the proportion of reticulocytes containing Hb F (F reticulocytes), and a precipitous decrease in the number of ISCs and dense red cells.^{864, 865}

Because of the known carcinogenic potential of 5-azacytidine, alternative stimulants of fetal Hb were sought. Hydroxyurea, a cytotoxic drug that has no known effect on DNA methylation, also increases Hb F production in anemic primates⁸⁶⁶ and in patients with severe SCA.^{867, 868} Hydroxyurea preferentially arrests the development of the more mature erythroid precursors, perhaps resulting in the recruitment of earlier erythroid progenitors with a greater capacity for Hb F synthesis.⁸⁶⁹ Alternatively, hydroxyurea may have a direct effect on "reprogramming" globin synthesis by early erythroid progenitors, a suggestion that is supported by the fact that the increase in F-reticulocyte numbers

P.853

that follows hydroxyurea administration occurs sooner (within 2 to 3 days) than would be expected if the effect represented recovery from bone marrow suppression.^{867, 868, 870} Alterations in the physical properties of red cells produced under the influence of 5-azacytidine and hydroxyurea appear to be out of proportion to modest changes in the level of Hb F. This disparity is attributed in part to reduced β^S -globin synthesis and in part to increased formation of $\alpha_2\beta^S$ tetramers, which do not participate in polymer formation.

Patients taking hydroxyurea consistently develop macrocytosis, which may occur before any change in Hb F takes place (Fig. 33.12). They also show a rapid correction toward normal red cell density distribution and improved whole-blood viscosity. The density profile is characterized by the disappearance of two red cell populations: the densest, most dehydrated, ISC-enriched fraction and the least dense, most hydrated cells.⁶⁶¹ The least dense cells tend to adhere most tenaciously to the endothelium, and the most dense cells are the least deformable. It is possible that these changes in red cell density distribution may be unrelated to the increased Hb F induced by hydroxyurea therapy.⁸⁷¹ Hydroxyurea therapy is associated with the intravascular and intraerythrocytic generation of NO, which may have a role in the clinical response that precedes the improvement in fetal Hb level.^{872, 873, 874}

In 1995, a double-blind multi-institutional trial of hydroxyurea versus placebo (Multicenter Study of Hydroxyurea, MSH trial) in ~300 adults with moderate to severe SCA was concluded with convincing evidence of clinical benefit from the drug.⁸⁷⁵ Patients treated with hydroxyurea had ~50% lower rates of pain crises, ACS, hospitalization, and transfusion. There was wide variability in drug tolerance and clinical response, but the primary toxicity and dose-limiting factor was

mild neutropenia. In addition to reducing acute events, hydroxyurea therapy has been reported to reduce mortality among adult patients with SCA. Patients with absolute HbF levels above 0.5 g/dl, in response to hydroxyurea therapy, had a 40% reduction in mortality.⁸⁷⁶ Data from an extended (17 years of follow-up) nonrandomized prospective study of adults with sickle cell disease in Greece showed that mortality could be reduced by 73% through hydroxyurea therapy.⁸⁷⁷ Because of the favorable outcome in the majority of treated patients, hydroxyurea has become widely used in the treatment of adult patients who experience frequent vaso-occlusive crises⁸⁷⁸ and was approved by the Federal Drug Administration in the United States for this indication.

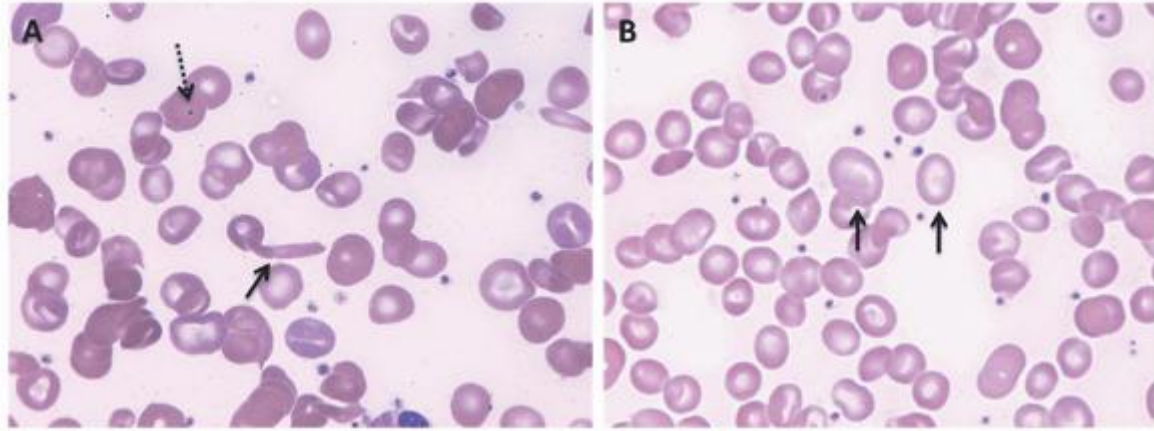

FIGURE 33.12. Effect of hydroxyurea on red blood cells. A. Peripheral blood smear of patient with Hb SS prior to treatment with hydroxyurea showing sickle forms (solid arrow), polychromasia, Howell-Jolly body (dashed arrow), and anisocytosis. B. Peripheral blood smear of same patient after 12 months of hydroxyurea therapy shows significant decrease in number of sickle forms, macrocytosis (solid arrows), and decreased polychromasia.

A multicenter phase I-II trial indicated that school-aged children treated with hydroxyurea had increases in fetal Hb, Hb concentration, and MCV similar to those of adults and suggested that clinical benefit and toxicity may also be similar.^{879, 880, 881, 882, 883} Long-term hydroxyurea therapy at a maximum tolerated dose (MTD) (average dose 25 mg/kg/d) was well tolerated by pediatric patients and had sustained hematologic efficacy with apparent long-term safety.⁸⁸⁴ Preliminary studies have pointed to a possible beneficial effects on organ function. A return of splenic function was noted in several patients treated with hydroxyurea,^{878, 885, 886} and lack of progression of silent cerebral infarcts was also noted in children.⁸⁸⁷ Hydroxyurea can be utilized as an oral solution (100 mg/ml), which is especially convenient for young children.⁸⁸⁸ Pilot trials suggested that hydroxyurea with or without concurrent phlebotomy may be substituted for chronic transfusion in the prevention of recurrent stroke;^{260, 261} however, a randomized phase III trial (SWITCH study) comparing hydroxyurea versus transfusions did not support this initial observation (see above).²⁶⁵

Studies in young children, 6 to 24 months of age at onset of treatment and 2 to 5 years of age, have not indicated unusual toxicity from hydroxyurea.^{889, 890} Further follow-up of the younger group indicated that after 4 years, hydroxyurea was associated with increased Hb concentration, percentage of Hb F, and MCV, and decreased reticulocytes, WBC, and platelets. In general, infants with SCA tolerated prolonged hydroxyurea therapy with sustained hematologic benefits, fewer ACS events, and improved growth.⁸⁹¹ The phase III randomized placebo-controlled trial for infants (ages 9 to 18 months) with SCA (BABY HUG study) assessed the effect of hydroxyurea therapy on organ dysfunction and clinical complications, and examined laboratory findings and toxic effects.⁸⁹² Ninety-six patients received hydroxyurea and 97 placebo. Hydroxyurea significantly decreased pain, dactylitis, ACS, hospitalization rates, and transfusion requirement. Spleen and renal functions were not improved when assessed by ⁹⁹Tc-spleen scan and ⁹⁹Tc- DTPA clearance, respectively. Analysis of secondary endpoints of the BABY HUG study, however, did show reduction of pitted cell and Howell-Jolly body counts, suggesting improvement of splenic function in the hydroxyurea-treated arm. In addition, urine specific gravity improved and total kidney volume decreased at study exit, suggesting preservation of renal function. Toxicity was limited to mild-to-moderate neutropenia. The positive results of the BABY HUG study warrant consideration of hydroxyurea for all children with SCA.

P.854

Hydroxyurea has led to weight gain and improved exercise performance in adults⁸⁹³ and growth in children.⁸⁹⁴ A modified dose based on hydroxyurea pharmacokinetics in patients with renal dysfunction has been recommended.⁸⁹⁵

Cross-sectional and prospective studies of hydroxyurea treatment have examined potential acquisition of genotoxicity with chromosomal karyotype, illegitimate VDJ recombination events, white cell cytostasis and cytotoxicity development, and micronucleated reticulocyte formation. These have not shown significant increases in genotoxicity compared with the measurements prior to initiation of therapy or those performed on placebo-controlled sickle cell disease subjects.^{896, 897, 898, 899} Although caution about the long-term carcinogenic and teratogenic potential of hydroxyurea needs to be exercised, to date there is no evidence that the drug leads to an increased cancer risk or to congenital anomalies in offspring of women who inadvertently became pregnant while taking hydroxyurea.^{900, 901} Prediction of fetal Hb response in patients with sickle cell disease receiving hydroxyurea has been difficult,⁹⁰² but the multicenter phase I-II trial found that baseline Hb F and Hb concentrations, maximum tolerated dose, compliance, and therapy-related changes in blood counts had predictive value.⁹⁰³

Increased levels of Hb F during stress erythropoiesis result from premature maturation of early erythroid progenitor cells under the influence of high concentrations of erythropoietin.⁹⁰⁴ In patients with SCA, doses of erythropoietin >1,000 units/kg were shown to increase Hb F levels modestly.⁹⁰⁵ In one study, erythropoietin given in combination with hydroxyurea failed to show any additional effect on Hb F production,⁹⁰⁶ but another trial in which hydroxyurea was alternated with erythropoietin and supplemental iron did result in a significant further increase in Hb F level.⁹⁰⁷ A recent report suggests that erythropoietin therapy may allow more aggressive HU dosing in high-risk sickle cell patients and in the setting of mild renal insufficiency, common to the older sickle cell population.⁹⁰⁸ Furthermore, erythropoietin appears to be safe when used in conjunction with hydroxyurea.

Butyrate is a short-chain fatty acid known to induce gene expression by inhibiting histone deacetylase and changing chromatin structure.⁹⁰⁹ Butyrate was found to be the likely cause of the delayed γ - to β -globin switch in infants of mothers with poorly controlled diabetes.⁹¹⁰ Subsequently, parenteral infusions of butyrate were shown to augment Hb F production in primates.⁹¹¹ Short courses of intravenous arginine butyrate administered to children with SCA were associated with increases in F reticulocytes and relative rates of γ -globin synthesis,⁹¹² but administration of the drug over a 10-week period did not demonstrate a hematologic response.⁹¹³ Subsequently, intermittent or pulse dosing of butyrate for 4 days at a time resulted in a sustained increase in Hb F in most patients.⁹¹⁴ Oral sodium phenylbutyrate has also been shown to increase fetal Hb levels,⁹¹⁵ as has the antiepileptic drug valproic acid.⁹¹⁶ In a phase II clinical trial of arginine butyrate there was improvement of refractory leg ulcers.⁶⁶³

Decitabine, an azacytidine analog (5-aza-2'-deoxycytidine), causes induction of Hb F through DNA hypomethylation.⁹¹⁷ In recent small-scale clinical trials in patients with sickle cell disease, treatment with decitabine resulted in significant increases in mean γ -globin synthesis, Hb F levels, and the number of F cells (RBC that contain Hb F).^{917, 918, 919} Interestingly, increased Hb F levels were observed in 100% of patients with sickle cell disease who received decitabine, including patients who had previously failed to respond to hydroxyurea.⁹²⁰ A current clinical trial is testing decitabine in adults with sickle cell disease who do not tolerate hydroxyurea due to hematologic or other toxicities (clinicaltrials.gov # NCT01375608).

Recent findings from GWAS studies have identified BCL11A as a critical modulator of the fetal-to-adult hemoglobin switch in humans and a silencing factor for the γ -globin genes.^{745, 921, 922} Down-regulation of BCL11A results in robust induction of fetal hemoglobin,⁹²¹ and suggests developing strategies to down-regulate or inhibit BCL11A function.

Antisickling Agents Acting on Membrane

Poloxamer-188, also known as RheothRx, is a nonionic copolymer emulsifying agent that may counteract the tendency of sickle cells to adhere to endothelium by decreasing the interaction between red cells and fibrinogen.⁹²³ In phase II trials the duration of painful episodes was reduced, particularly in younger patients and in those receiving hydroxyurea.^{205, 924}

Reduction of Red Cell Density

Therapy designed to reduce the MCHC is based on the fact that small decrements in the MCHC significantly delay the rate of deoxy Hb S polymerization and inhibit red cell sickling. The delay time of gelation of deoxy Hb S is inversely proportional to the 30th power of Hb S concentration.⁹²⁵ Anecdotal accounts of patients with a low MCHC on the basis of iron deficiency led to the suggestion that symptomatic crises were fewer⁹²⁶ and red cell survival was longer.⁹²⁷ One approach to reduction of the MCHC used the long-acting antidiuretic hormone desmopressin, salt restriction, and water loading. When combined, these measures induced sufficient hyponatremia and osmotic swelling of red cells to reduce the MCHC by 2 to 3 g/dl,⁹²⁸ but clinical testing uncovered problems related to poor compliance, fluctuating levels of serum sodium, neurologic complications, and lack of efficacy.⁹²⁹

The Ca^{2+} -activated K^+ channel (Gardos channel) contributes to the deleterious dehydration of sickle cells. One of the membrane-active agents, cetiedil, appears to inhibit sickling by inducing red cell swelling and decreasing the MCHC as a result of inhibiting the Gardos pathway and increasing passive Na^+ influx more than K^+ efflux. In a placebo-controlled study, cetiedil appeared to shorten the duration of pain crises but had no effect on the total analgesic requirement.²⁰⁴ Clotrimazole and other imidazole antimycotics also prevent sickle cell dehydration by inhibiting the Gardos pathway. In a small group of sickle cell patients, clotrimazole resulted in reduced red cell dehydration, increased cell potassium content, and increased Hb levels.⁸¹⁷ A more potent analog, ICA-17043 (Senicapoc) was developed and shown to decrease the RBC membrane cation permeability by decreasing the Gardos channel activity and calcium-induced K^+ efflux. ICA-17043 was shown to reduce RBC density in mice in comparison with untreated controls, even in the setting of hypoxia-induced RBC dehydration.⁹³⁰ These preliminary results, coupled with the long half-life of ICA-17043 (allowing once-daily dosing) and minimal side effects, fostered further investigation in a clinical trial of adults with sickle cell disease.⁹³¹ A phase II clinical trial randomized 90 adult patients with sickle cell disease to receive a loading dose of 150 mg of ICA-17043 followed by 10 mg daily, a lower loading dose of 100 mg followed by 6 mg daily, or placebo.²⁰⁶ Study participants were treated for 12 weeks, and hematologic efficacy was demonstrated in the higher dose treatment arm by a significant increase in Hb concentration, and decrease in LDH, bilirubin, reticulocyte count, and dense RBCs. In this phase II study, the activity of the Gardos channel decreased significantly and hemolysis was reduced. However, in a phase III multicenter clinical trial, ICA-17043, failed to reduce the frequency of painful events, leading to an early closure of the study. Because the K-Cl co-transporter is a major determinant of sickle cell dehydration and is inhibited by increasing red cell magnesium, phase I and II trials of oral magnesium pidolate in adult sickle cell patients have been conducted.^{932, 933} In 10 adult patients with Hb SS, a 4-week course of oral magnesium supplementation (using magnesium pidolate) resulted in increased red cell Mg^{2+} and K^+ concentrations, a reduction in K-Cl co-transport activity, and a decrease in the number of dense Hb SS erythrocytes.⁹³² A subsequent study on 20 patients with Hb SS involved the administration of magnesium pidolate for 6 months.⁹³³ In this

P.855

unblinded study, a reduction in the number of pain crises was noted during the period of magnesium supplementation. In both studies, a significant decrease in red cell density was noted and clinical toxicity was absent except for mild reversible diarrhea. The combination approach of oral hydroxyurea and magnesium treatment was used in children with SCA in a phase I study.⁹³⁴ The maximum tolerated dose of magnesium pidolate when used in combination with hydroxyurea was 125 mg/kg/day. K-Cl co-transporter activity significantly declined after 3 months of magnesium pidolate.

Anti-inflammatory Agents

Sickle cell disease patients live in a state of “baseline heightened inflammation,” which contributes to and sustains the pathophysiologic cycle of vaso-occlusion and tissue damage. Attenuation of the inflammatory response in sickle cell disease could potentially ameliorate symptoms of the disease.

Adenosine is a purine nucleoside that modulates many intracellular processes, such as signal transduction and energy transfer. The concentration of adenosine rises rapidly in response to cellular damage, such as tissue ischemia. Adenosine functions through signaling of four receptor subtypes: A_1 , A_{2A} , A_{2B} , and A_3 .⁹³⁵ There is evidence of excessive adenosine signaling in sickle cell disease, as both adenosine and 2,3-diphosphoglycerate (DPG) concentrations were elevated in individuals with sickle cell disease and induce sickling in vitro.³⁸ Adenosine A_{2A} receptor activation in invariant natural killer T (iNKT) and natural killer (NK) cells reduced inflammation and lung injury in sickle cell mice.⁹³⁶ A current phase I trial is evaluating the safety and maximum tolerated dose of an adenosine A_{2A} receptor agonist (Lexiscan) in adolescents and adults with SCA (clinicaltrials.gov # NCT01085201).

Adenosine A_{2B} receptor-mediated induction of 2,3-DPG decreases the oxygen binding affinity of Hb and induces erythrocyte sickling (caused by excess adenosine) in cultured human RBCs and in sickle cell disease transgenic mice,³⁸ suggesting a possible role of excessive adenosine signaling through the A_{2B} receptor in the pathogenesis of sickle cell disease. A_{2A} receptor activation or A_{2B} receptor blocking could be two new avenues of therapy for sickle cell disease that have the potential of reducing its exaggerated inflammatory response.

Bone Marrow (Hematopoietic Stem Cell) Transplantation

Bone marrow transplantation has the potential to normalize Hb synthesis in patients with SCA and is currently the only curative treatment for sickle cell disease. The first transplant was performed in a child with both SCA and acute myeloblastic leukemia in 1984; bone marrow from an HLA-identical sibling abolished both diseases.⁹³⁷ Since then, hundreds of patients with severe SCA have been transplanted using human leukocyte antigen (HLA)-identical sibling donors. The four largest HLA-matched sibling donor transplant series collectively have shown excellent results, with

overall survival ranging from 92% to 94%, event-free survival 82% to 86%, and rejection rate 7% to 13%.^{495, 938, 939, 940} The incidence of graft-versus-host disease (GVHD) has varied from 10% to 20%. Treatment-related mortality has ranged from 2% to 7%, and the most common causes of death have been complications of GVHD, sepsis, and stroke (primarily hemorrhagic). These four reports have described myeloablative regimens utilizing pretransplant conditioning regimens of busulfan, methotrexate, cyclophosphamide, and antithymocyte globulin (ATG) in most cases.

Current indications for stem cell transplant in sickle cell disease are broad, but have in common increased disease severity (e.g., stroke, recurrent ACS, intractable pain, red cell alloimmunization, AVN of the hip). Abnormal TCD velocities are another potential indication for transplant, although there is not a consensus among hematologists regarding this.⁹⁴¹

Previous reports have indicated the effectiveness of conventional stem cell transplants in preventing recurrence of CNS events following transplant.⁴⁹⁵ Brain parenchymal damage has been reported in a study of nine children with severe sickle cell disease in whom CNS evaluations were performed serially before and after transplant.⁴⁹⁶ Neurologic examinations and neuropathologic tests were stable, but serial MRI/magnetic resonance angiogram (MRA) studies showed that new brain parenchymal lesions occurred in all seven patients who had pretransplant lacunae or infarcts.

The possibility of infertility is a concern among patients undergoing myeloablative conditioning regimens for stem cell transplant. Recently ovarian stimulation followed by oocyte retrieval and cryopreservation provided fertility preservation in an adolescent with severe sickle cell disease scheduled to undergo a hematopoietic stem cell transplant.⁹⁴² This approach, along with sperm banking, can be alternatives for young sickle cell patients who will undergo stem cell transplant and aspire to have families in the future.

The availability and the relative success of bone marrow transplantation worldwide have raised a number of social and ethical questions about its use. For example, how severe must sickle cell disease be to justify a transplant-associated mortality rate of 5% to 10%? In the United States, only 6% of patients with SCA met the criteria for transplantation specified in the study protocol; furthermore, a survey of children with SCA in the San Francisco area estimated that only 18% would have sibling donors.⁹⁴³ Although these criteria would result in approximately 1% of American children with SCA being eligible for transplantation, criteria used in Belgium were based on the poor prognosis of children with sickle cell disease who were returning to a setting of limited medical care in central Africa.⁷⁴⁷ Another point of view has been that transplantation is warranted in virtually all patients for whom a suitable donor is available,⁹⁴⁴ particularly before organ dysfunction and transfusion exposure occur. It has been noted that the transplant enrollment criteria parallel those of studies using hydroxyurea treatment.⁹⁴⁵ When these two modalities are compared, transplantation offers a definitive cure for SCA but a significant risk of mortality, whereas hydroxyurea offers amelioration of the clinical symptoms with short-term complications that appear to be reversible and small. When transplantation, periodic prophylactic blood transfusion, and hydroxyurea were compared in a decision analysis study for children with severe sickle cell disease, bone marrow transplant was the strategy treatment of choice.⁹⁴⁶

Other approaches to transplantation have been developed outside of sickle cell disease. Cord blood stem cells harvested from HLA-identical newborn sibs, as well as unrelated donors, have been successfully transplanted.^{947, 948} Directed donor banking of cord blood from a sibling of a child with a disorder treatable by stem cell transplantation provided a cord blood allograft that was successful in 16 of 17 cases.⁹⁴⁹ Unrelated donor cord blood stem cell transplants, on the other hand, have not had favorable outcomes, likely due to the HLA mismatches that result from ethnic and racial differences between donors and recipients.^{950, 951}

When stable mixed chimerism is established after stem cell transplant, even a minority of donor cells with a selective advantage may overcome a genetic defect. In an analysis of 50 patients with successful allografts, five had chimerism with a relatively low proportion of donor cells (range, 11% to 74%). These five patients had normal Hb levels and much lower Hb S fractions than the proportion of donor chimerism, suggesting that donor erythroid progenitors or erythrocytes had a survival advantage over their recipient sickle cell counterparts.⁹⁵² Because these patients were also clinically asymptomatic, it appears that full-donor chimerism is not necessary to cure nonmalignant disorders, and reduced intensity regimens that allow mixed chimerism may be effective.^{952, 953} In fact, reduced intensity stem cell transplantation

P.856

from matched donors has been described in 10 adults with sickle cell disease, and sustainable marrow engraftment with stable mixed chimerism was achieved in 9 out of the 10 subjects. This regimen utilized low-dose total body irradiation, alemtuzumab, and sirolimus, and appears to be a viable option for patients who would otherwise not be able to tolerate an aggressive conditioning regimen.⁹⁵⁴

Worldwide, hematopoietic stem cell transplant is underutilized in patients with sickle cell disease, a multifactorial phenomenon resulting from high costs, lack of expertise, lack of available HLA-matched donors, insufficient referral to transplant centers, and increased use of disease-modifying therapies (hydroxyurea, erythrocyte transfusions) among other reasons. Therapy preference and decision making among patients with severe SCA and their families was analyzed after they received standardized nondirective presentations and educational materials. Ten percent expressed preference for stem cell transplant, 17% for chronic transfusion, and 70% for hydroxyurea.⁹⁵⁵ However, many patients and families still perceive this treatment to be dangerous in comparison with other therapies, such as hydroxyurea and chronic transfusions, and choose not to pursue transplant even when a matched HLA sibling donor is available.^{955, 956}

Gene Therapy

Gene therapy offers great promise as a potential cure for sickle cell disease, but there are currently concerns about random genomic insertion that must be resolved.⁹⁵⁷ In the past, low efficiency of gene transfer to stem cells and suboptimal globin gene expression, as well as safety concerns, have limited progress. The insertion of a therapeutic globin gene does not necessarily confer selective advantage to transduced stem cells, therefore complex DNA regulatory sequences have to be preset within the transfer vector for proper gene expression. Recent use of lentiviral vectors derived from the HIV genome have allowed more efficient transduction of human cells. Two transgenic mouse strains with human SS disease have been transduced using lentiviral vectors using globin genes linked to regulatory elements of the LCR, resulting in reduced sickling, improved renal-concentrating capacity, and human β -globin synthesis at 10% to 50% of the level of endogenous β -globin production.⁹⁵⁸ Proof of concept of gene therapy as a viable strategy for hemoglobinopathies has been shown in an adult with thalassemia (HbE β^0 -thalassemia) who has remained transfusion-independent 33 months after lentiviral β -globin gene transfer.⁹⁵⁹

SICKLE CELL TRAIT

Sickle cell trait, the heterozygous state for the Hb S gene, is present in ~8% of black Americans and in as many as 20% of some African populations (Table 33.1). The red cells of such individuals contain both Hb A and Hb S, but there is always more Hb A than Hb S.

Clinical Features

Sickle cell trait is known to confer a better prognosis from malarial infection.⁹⁶⁰ It rarely is associated with clinical or hematologic manifestations of significance. Individuals have no anemia, and red cell morphology is normal. Growth and development proceed normally,⁹⁶¹ and no increased frequency of bone and joint disease is observed.⁹⁶² A prospective study of pregnant women with sickle cell trait documented an overall incidence of complications and a distribution of birth weights similar to those of a control group.⁹⁶³ Life expectancy and overall mortality rate for persons with sickle cell trait are the same as for the general population. The prevalence of the trait among professional football players is the same as that in the black population, suggesting that it imposes no limitation in physical capabilities.⁹⁶⁴ Nevertheless, most of the complications associated with SCA have been described in individuals with sickle cell trait. In such reports, the presence of Hb S was likely an incidental finding, unrelated to the observed deficit. For example, studies of sudden death in soldiers and athletes undergoing strenuous physical conditioning lack pertinent information concerning the relative amounts of Hb A and Hb S and the presence of potential but undetected underlying illness.^{965, 966} Nevertheless, a comprehensive analysis of sudden unexplained deaths among more than 2 million recruits undergoing basic training in the United States Armed Forces demonstrated a small increase of such deaths, especially those related to exertional heat illness (EHI), in association with sickle cell trait.⁹⁶⁷ Following this finding, an interventional trial examined the hypothesis that preventing EHI would reduce mortality for all recruits, including those with sickle cell trait.^{968, 969} The intervention consisted of monitoring of core temperature, minimizing efforts in hot weather, increasing water consumption, and use of light clothing, among other measures. No deaths among individuals with or without sickle cell trait were observed when precautionary measures were undertaken, which was a significant decline from the predicted 13 deaths among recruits with sickle cell trait. Currently, sickle cell trait is not a disqualifying condition for entry into the United States Armed Forces, and universal precautions against EHI have been fully implemented.

A study of almost 2 million National Collegiate Athletic Association (NCAA) athletes found 273 deaths between 2004 and 2008, with five (2%) of these deaths occurring in athletes with the sickle cell trait, all in association with heat exertion (exertional deaths).⁹⁷⁰ The study concluded that the risk of exertional death was 37 times greater in athletes with sickle cell trait than that among those without it. This study, however, did not have information of the sickle cell trait status of the entire cohort, and estimated trait prevalence based on prior epidemiologic studies (1:12 African Americans are sickle cell trait carriers). The results of this study prompted the NCAA to adopt a policy requiring Division I institutions to perform testing for sickle cell trait in all incoming athletes in the United States. Because the risk under even the most

adverse circumstances is low (1 in 3,200 in the Armed Forces study), it is important that the millions of black individuals, including aspiring athletes, with sickle cell trait not be stigmatized or labeled as sick. Due to this concern, the American Society of Hematology (ASH) released a statement in 2012 opposing testing or disclosure of sickle cell trait status as a prerequisite for participation in athletic activities. This position was subsequently adopted by the Sickle Cell Disease Association of America (SCDAA) among other professional societies.

Other complications of the trait are well documented but relatively rare: hematuria, urinary tract infection, and splenic infarction. The former generally is transient and probably is related to poor perfusion of the renal papillae.^{588, 607, 971} Frank renal papillary necrosis has been described.⁶⁰⁴ Renal medullary carcinoma is a rare malignancy of the renal medulla; most of the reported cases have occurred in individuals with sickle cell trait.^{606, 972} Urine-concentrating ability also is impaired, although renal acidification is normal.⁹⁷³ A Jamaican study of older adult women showed an increased frequency of bacteriuria in those with sickle cell trait.⁹⁷⁴ During pregnancy, women with sickle cell trait have increases in bacteriuria and pyelonephritis.⁹⁷⁵ There are numerous reports of splenic infarction in individuals with sickle cell trait who were exposed to altitudes of 10,000 feet or more in unpressurized aircraft, but this has not been reported in commercial flights, in which cabin pressure is equivalent to ~8,000 feet.⁹⁷⁶ Individuals with sickle cell trait, especially whites, have suffered splenic infarction at mountain altitudes.⁹⁷⁷ Most individuals with sickle cell trait, however, tolerate simulated high

P.857

altitude with impunity.⁹⁷⁸ A case control study identified sickle cell trait as a risk factor for venous thromboembolism;⁹⁷⁹ however, further investigation linking thrombosis risk and sickle cell trait is necessary to establish this association.

Diagnosis

Sickle cell trait is characterized by an electrophoretic pattern containing both Hb A and Hb S, with more Hb A than Hb S. The interaction of α -thalassemia with sickle cell trait is responsible for a trimodal distribution of Hb S with means of ~41%, 35%, and 28%, corresponding to the $\alpha\alpha/\alpha\alpha$, $-\alpha/\alpha\alpha$, and $-\alpha/-\alpha$ genotypes, respectively.^{980, 981} The positive correlation between the proportion of Hb S and the output of a genes indicates the greater affinity of β^A chains than of β^S chains for a chains in the formation of Hb tetramers. Excess β^S chains presumably are destroyed by proteolysis.⁹⁸² The relative amount of Hb S is also decreased by iron⁹⁸³ and folate⁹⁸⁴ deficiencies.

Screening Programs

There are two possible reasons to screen groups for the presence of sickle cell trait: (a) to inform affected persons of health risks and (b) to provide information that might affect an individual's reproductive decisions. Most hemoglobinopathy screening is now done to identify sickle cell disease in neonates. Therefore, identification of sickle cell trait occurs at a time when counseling of the affected individual is impossible. Counseling of family members of newborns with sickle cell trait may be of value but is only performed sporadically in most states.

The technique chosen for screening should be genetically diagnostic and should clearly differentiate between sickle cell trait and those disorders of Hb that have implications for health. Conventional Hb electrophoresis⁹⁸⁵ and thin-layer isoelectric focusing on acrylamide gel⁹⁸⁶ and high-performance liquid chromatography have been adapted satisfactorily to mass screening. Because solubility tests do not detect β -thalassemia trait, Hb C, and other Hb variants that interact with Hb S to cause disease, they should not be used for screening.

OTHER SICKLING SYNDROMES

Several of the doubly heterozygous states for Hb S and a second disorder of Hb synthesis are characterized by clinical and hematologic aberrations that to some extent mimic the features of SCA. The clinically significant disorders resulting from double heterozygosity for Hb S and a second Hb variant are considered to be forms of sickle cell disease.

Hemoglobin SC Disease

The sickling disorder known as hemoglobin SC disease results from the inheritance of an Hb S gene from one parent and an Hb C gene from the other parent. Red cells contain approximately equal amounts of the two hemoglobins. Hb A is absent, and Hb F is normal or slightly increased. The disorder occurs with an approximate frequency of 1 in 1,100 births among black Americans⁷⁶⁷ and 1 in 1,400 births in Jamaica.⁹⁸⁷ In Ghana, the presumed site of origin of the Hb C mutation,⁹⁸⁸ Hb SC disease is as prevalent as SCA, and in some regions it affects as many as 25% of the population.¹

The clinical and laboratory features of Hb SC disease cannot be explained by co-polymerization of Hb C with Hb S.⁹⁸⁹ The solubility of mixtures of deoxy Hb S and Hb C is no different from that of mixtures of Hb S and Hb A.⁹⁹⁰ Differences in the sickling properties of sickle trait cells and Hb SC cells are related to two factors: a higher proportion of Hb S and a higher

concentration of hemoglobin in Hb SC cells compared with Hb AS cells.^{989, 991} The 10%-to-15% greater proportion of Hb S in Hb SC cells is the result of differences in rates of subunit assembly, which, in turn, are determined by the net surface charges of β^A , β^S , and β^C .⁹⁸⁹ The higher MCHC of Hb SC cells is the result of Hb C inducing, by mechanisms not fully understood, an increase in the activity of K-Cl co-transport, which causes loss of K^+ and consequently of intracellular water.⁹⁹²

Clinical Features

The clinical manifestations of Hb SC disease are similar to, but on average less frequent than, those of SCA.^{14, 992} Growth and sexual development are delayed compared to normal children, but less so than in children with SCA.⁴³⁵ Symptoms in the first year are rare, and one fourth of affected individuals remain asymptomatic throughout the first decade of life.^{992, 993} The most common symptom is episodic abdominal or skeletal pain, qualitatively similar to that caused by vaso-occlusive events in SCA. The average number of painful episodes per year for Hb SC patients is approximately one half that for persons with SCA (0.4 vs. 0.8 episodes per year).¹⁸⁴ Moderate enlargement of the spleen is present in approximately two thirds of children and often persists into adult life. Spleen perfusion is intact, however, and as a result, symptomatic splenic infarction⁹⁹⁴ and acute splenic sequestration^{995, 996, 997} may occur in adults as well as in children. Loss of spleen function is more gradual and occurs at a later age than occurs in SCA.¹⁷⁸ The frequency of infections of patients with Hb SC disease is increased, but fatal pneumococcal septicemia, although well documented,⁹⁹⁸ is less of a risk than is noted in SCA.⁹⁹⁹ In contrast to the infectious complications of SCA, those of Hb SC disease are characteristically associated with a primary focus, tend not to recur, and respond promptly to therapy.^{1000, 1001} *S. pneumoniae* is the most common bacterial isolate, and the respiratory tract is the most common focus.^{1000, 1001, 1002} The incidence of bacteremia drops abruptly after 2 years of age, a contrasting pattern to SCA, in which the incidence declines gradually between 2 and 6 years of age.³⁸⁷ Because bacteremia rarely progresses to septicemia and a fatal outcome in young children with Hb SC disease, some investigators believe that prophylactic penicillin is not necessary.⁴¹⁴ However, fatal pneumococcal septicemia was reported in a series of seven children with Hb SC, six of whom were >3 years of age.¹⁰⁰³ Central nervous system deficits, asymptomatic hematuria, ankle ulceration, priapism, and other complications of sickling occur with Hb SC disease but are infrequent events. In the United States, the median lifespan for male and female Hb SC patients is 60 and 68 years of age, respectively.¹⁴³

Because of the frequency with which they occur, certain complications of Hb SC disease deserve special comment. Proliferative retinopathy is more common and more severe than in SCA.^{641, 643, 644} Progressive loss of vision may have its onset early in the second decade, and patients should be encouraged to have an annual ophthalmologic examination starting at 10 years of age. Aseptic necrosis of the femoral head has been reported to have a greater frequency in Hb SC disease than in Hb SS, but the age-adjusted prevalence is lower.⁴⁵² ACS, attributed to fat emboli after bone marrow infarction, occurs most commonly during the final months of pregnancy^{1004, 1005} in women with Hb SC. The exaggerated vulnerability of individuals with Hb SC disease to certain complications is thought to be a function of the higher viscosity of the blood relative to that in SCA. Two analyses of adults with Hb SC disease^{688, 1006} have re-emphasized the common clinical features of pain crises, avascular necrosis of the hip, proliferative sickle retinopathy, and splenic infarction/sequestration. In one series, it was noted that co-morbidity of obesity, hypertension, and type 2 diabetes mellitus were common.¹⁰⁰⁶ In the other, decreased morbidity was noted in patients who had concurrent α -thalassemia 2.⁶⁸⁸

P.858

Moderately severe complications of in vivo sickling occur in Hb SC-Harlem disease¹⁰⁰⁷ and in the Hb SC/ α -thalassemia syndrome.¹⁰⁰⁸ Combined Hb SC disease and hereditary spherocytosis was documented as the cause of recurrent splenic sequestration crises.¹⁰⁰⁹

Laboratory Features

Anemia is mild or nonexistent; 75% of children 2 to 15 years of age have a hematocrit between 28 and 38, and 75% of adults have a hematocrit between 28 and 42 (with males having higher levels than females).⁷⁴⁹ Compared with Hb SS, the MCV may be decreased (10 to 15 fl lower), and the MCHC may be increased owing to cellular dehydration.^{749, 1010} Reticulocytes are modestly increased in number. Blood films contain as many as 50% target cells. Although sickled cells are relatively rare, cells containing Hb "crystals" are noted regularly.¹⁰¹¹ These hyperchromic shrunken cells are distorted into pyramidal or elongated contours by condensed aggregates of Hb (Fig. 33.11). The white blood cell count and leukocyte differential are normal.¹³⁹

Treatment

Unlike the extensive investigations of the use of hydroxyurea in adults and children with Hb SS, data in patients with Hb SC disease are lacking. One study involving six adult Hb SC disease patients noted that hydroxyurea resulted in an increase in hematocrit and MCV, improved cell hydration, and no significant difference in Hb F level.¹⁰¹² In a study of six severely affected children with Hb SC disease, MCV and Hb F increased, and patients improved clinically, but Hb concentration did not change after hydroxyurea treatment.¹⁰¹³ One symptomatic patient with a high hematocrit responded to recurrent phlebotomy.¹⁰¹⁴ The first randomized clinical trial specifically targeting individuals with Hb SC was a phase II multicenter double-blinded trial comparing the effects of hydroxyurea and magnesium (pidolate).¹⁰¹⁵ Subjects were randomized to hydroxyurea + placebo, magnesium + placebo, hydroxyurea + magnesium, or placebo + placebo. The primary endpoint was the proportion of hyperdense red blood cells after 8 weeks of treatment. Thirty-six subjects were evaluable, but the study was terminated early because of slow enrollment. In the combined hydroxyurea groups, MCV and HbF were increased, but differences were not seen in hyperdense red cells or vasoocclusive events.

Hemoglobin S- β -Thalassemia

The doubly heterozygous condition of Hb S and β -thalassemia is designated as S β^0 -thalassemia if there is no β -globin synthesis from the affected allele and S β^+ -thalassemia if β -globin synthesis is present but reduced. The clinical manifestations are quite variable, and patients may be nearly asymptomatic or have problems similar to those occurring in the worst cases of SCA.¹⁰¹⁶ In general, Hb S β^0 -thalassemia resembles Hb SS in severity (and therefore is sometimes included under the designation "sickle cell anemia"), and Hb S β^+ -thalassemia is somewhat milder than Hb SC disease. Patients with Hb S β^0 -thalassemia have a slightly higher Hb level, a greater Hb A₂ level (4% to 6%), and a smaller MCV (65 to 75 fl) than those with Hb SS. Hb S β^+ -thalassemia patients have a higher Hb level and lower reticulocyte count than those with Hb S β^0 -thalassemia.^{1016, 1017} In children with Hb S β^0 -thalassemia, splenic dysfunction measured by pit cell counts occurs within the first year of life, but only 20% of those with Hb S β^+ -thalassemia have elevated pit counts by 20 years of age.¹⁰¹⁸ Patients with Hb S β^+ -thalassemia, unlike those with SCA, often have splenomegaly beyond the first few years of childhood.

Hemoglobin S/Hereditary Persistence of Fetal Hemoglobin

In HPFH, Hb F levels are elevated relative to the patient's age. Deletional mutations typically involve large segments of DNA and result in a pancellular distribution of Hb F. Approximately 1 in 1,000 African Americans carry the deletion HPFH gene. Nondeletion mutations result in more variable levels of Hb F (4% to 30%) and heterocellular or pancellular distribution. The doubly heterozygous condition for Hb S and HPFH results in a heterogeneous disorder that is generally extremely mild and associated with a pancellular distribution of Hb F, normal blood counts, microcytosis, target cells, and 20% to 30% Hb F.^{14, 30, 31} Overall, there is ~1 case of Hb S/HPFH for every 100 cases of Hb SS, but it is important to identify this condition because of its extremely good prognosis.

Hemoglobin SE Disease

Hb E is characterized by the substitution of lysine for glutamic acid at position 26 of the β chain and results in a mild β -thalassemia phenotype. Because of the increase in the Asian population in the United States, the doubly heterozygous condition of Hb SE is now occasionally seen. Patients with Hb SE may have mild anemia and microcytosis along with ~30% Hb E, but blood smears look relatively normal (except for target cells), and patients are usually asymptomatic.^{31, 1019}

Hemoglobin SD Disease

Of the 16 variants fulfilling the electrophoretic and solubility criteria for Hb D or Hb G, at least nine have been recognized in association with Hb S.¹⁰²⁰ With one exception, the doubly heterozygous states for Hb S and Hb D or Hb G are clinically silent. Hb D-Punjab (Hb D-Los Angeles) interacts with Hb S to produce mild hemolytic anemia and symptoms that mimic those of mild sickle cell disease. The Hb SD-Punjab syndrome was first detected in a Caucasian man¹⁰²¹ whose case had been previously reported as an instance of SCA in the white race. Subsequently, Hb SD-Punjab disease was recognized in a number of subjects, most of African origin.^{1022, 1023} In each of these subjects, the clinical and hematologic features were those of mild sickle cell disease. Elevation of Hb F, however, is not protective among individuals with Hb SD as it is for those with Hb SS. For example, in Middle Eastern Kuwaiti sickle cell patients, elevated Hb F level was not protective against pain events in patients with Hb SD.¹⁰²⁴

Hemoglobin SO-Arab Disease

Hb O-Arab interacts strongly with Hb S in vitro. As would be predicted, the doubly heterozygous state is clinically and hematologically indistinguishable from SCA.^{27, 1025, 1026} Functional asplenia occurs at an early age and is followed by progressive splenic infarction. The disorder is differentiated readily from Hb SC disease, with which it is confused on

electrophoretic grounds, by the greater prominence of symptoms, the severity of the anemia, and the presence of numerous ISCs on blood smears.¹⁰²⁷

Hemoglobin C Disorders

In Hb C, lysine replaces glutamic acid in the sixth position of the β -chain. The positive charge resulting from this substitution gives the variant a slow electrophoretic mobility at both an acid and an alkaline pH. This variant appears to have originated on the west coast of Africa,¹⁰²⁷ where the carrier rate is as high as 25%. Although less convincing than for Hb S, the distribution of Hb C in Africa suggests that it also may have conferred a survival advantage in areas endemic for malaria. Among the Dogon of West Africa, where the gene frequency of Hb C is high and

P.859

that of Hb S is low, cerebral malaria and other forms of severe malaria are uncommon in those having Hb C.¹⁰²⁸ Although not providing full protection against malaria, Hb C appears to minimize the risk of severe infection. These clinical observations are supported by in vitro studies that demonstrate the inability of Hb CC red cells to release merozoites by cell lysis at the appropriate stage of parasite development.¹⁰²⁹ The heterozygous state is noted in 2% to 3% of blacks, and homozygous Hb C disease affects ~1 in 5,000.¹³ As with Hb S, Hb C has been identified in individuals with no known African ancestry.¹⁰³⁰ The β^C gene can be identified in fetal DNA by using restriction fragment length polymorphisms⁷²⁵ and by sequence-specific oligonucleotide probes.¹⁰³¹

Hemoglobin C Trait

The heterozygous state for Hb C (Hb AC) is clinically silent. Although the hemoglobin concentration is within the broad range of normal, the mean for groups of subjects is low. The red cell mass and red cell survival also may be decreased.¹⁰³² Reticulocyte numbers, however, are not increased. The physiologic basis for the apparent failure of appropriate erythropoietic response to shortened cell survival is probably similar to that operative in Hb CC disease. The peripheral blood smear contains moderate numbers (5% to 30%) of target cells. By electrophoretic analysis, 30% to 40% of the hemoglobin is Hb C, and 50% to 60% is Hb A; Hb A₂ (separated chromatographically) is increased slightly. The relative amount of Hb C with coexistent α -thalassemia is less, reflecting the higher affinity of β^A -compared with β^C -globin for limited amounts of α -globin during hemoglobin assembly.¹⁰³³

Hemoglobin C Disease

Hemoglobin C disease (Hb CC) is a mild disorder that characteristically is detected through newborn hemoglobinopathy screening programs or during the investigation of an unrelated medical problem.¹⁰³⁴ Growth and development are appropriate, and pregnancy and surgery are well tolerated. Mild intermittent abdominal discomfort, arthralgia, and headaches are noted in some reports, but their relationship to the hemoglobinopathy, if any, is unclear. The spleen is enlarged in many affected individuals, and spontaneous rupture of the organ has been reported.¹⁰³⁵ Spleen function is unaffected, however, and unusual infectious problems are not observed. As with other hemolytic disorders, cholelithiasis occurs with increased frequency.

Anemia is mild to moderate in severity.¹⁰³⁶ The mean packed cell volume is 33%; individual values often fall within the normal range. Reticulocyte counts are elevated only slightly (2% to 6%). Erythrocyte morphology is strikingly abnormal, with microcytosis, target cells ($\geq 90\%$), occasional spherocytes, and cells distorted by what appear to be crystals of hemoglobin.^{1011, 1037} Target cells appear more plump and smaller in diameter than those seen in individuals with liver disease, although their resistance to osmotic lysis is similar to that of other target cells.¹⁰³⁷ Red blood cell survival is shortened with evidence of splenic sequestration. Considering the relative indolence of the hemolytic process, it is surprising that anemia is not fully compensated by a greater erythropoietic effort. This apparent inconsistency is explained by a decrease in the oxygen affinity of hemoglobin of Hb CC erythrocytes, which have an intracellular pH lower than that of normal cells.¹⁰³⁸ The right-shifted oxygen dissociation curve of whole blood permits normal tissue oxygenation in spite of a smaller than normal red blood cell mass. Shortened red cell survival probably is related to the decreased solubility of deoxy-Hb C, a consequence of electrostatic interactions between positively charged β -6 amino groups and negatively charged groups on adjacent molecules.¹⁰³⁷ When suspended in hypertonic medium, Hb CC cells form intracellular crystals, a process that begins along the membrane¹⁰³⁹ and is enhanced by deoxygenation.¹⁰³⁷ Intracellular aggregates of hemoglobin limit cell deformability by increasing internal viscosity,¹⁰⁴⁰ thereby predisposing to fragmentation, spherocyte formation, and splenic sequestration. Diagnosis rests on the electrophoretic or chromatographic analysis of hemoglobin. The major fraction is Hb C, Hb A is absent, and Hb F is slightly increased. Relatively more Hb F (to 22%) is present in individuals who have coexistent Hb CC disease and α -thalassemia.¹⁰⁴¹ Therapy is neither available nor needed; however, genetic counseling and clinical monitoring are advised.

KEY POINTS

- Sickle cell disease is a common worldwide genetic disorder with an autosomal recessive pattern.
- Sickle cell disease is a chronic condition with intermittent and unpredictable acute vaso-occlusive episodes (e.g., pain, ACS, splenic sequestration, priapism, etc.).
- The most common and also the most severe genotype is Hb SS (sickle cell anemia). HbS β^0 -thalassemia is frequently classified with Hb SS due to its similar phenotype.
- Pathophysiology involves a complex intertwined array of processes including vaso-occlusion in the microcirculation, hypoxia-reperfusion injury, chronic hemolysis, increased endothelial adhesion, hypercoagulability, and enhanced inflammatory response.
- All tissues can be affected, causing progressive organ dysfunction and eventually organ failure.
- The overall survival in sickle cell disease has improved in the last few decades due to early diagnosis, prophylaxis against infection, and use of disease-modifying therapies.
- Effective therapies include hydroxyurea, chronic blood transfusion, and stem cell transplantation.

WEBSITES OF INTEREST

The following websites offer useful information about sickle cell disease, both for patients and medical providers:

- www.NHLBI.gov
- www.CDC.gov
- www.SCDAA.org

The website www.clinicaltrials.gov offers information about prospective clinical trials. Using the search option, trials investigating sickle cell disease can be retrieved. In addition to these websites, two textbooks offer particularly extensive information about sickle cell disease.^{14, 1042}

REFERENCES

1. Konotey-Ahulu FID. The effects of environment on sickle cell disease in West Africa. In: Abramson H, Bertles JF, Wethers DL, eds. Sickle cell disease: diagnosis, management, education, and research. St. Louis, MO: Mosby, 1973:20-38.
2. Edelstein SJ. The sickled cell: from myths to molecules. Cambridge, MA: Harvard University Press, 1986.
3. Konotey-Ahulu FI. The sickle cell diseases. Clinical manifestations including the "sickle crisis". Arch Intern Med 1974;133(4):611-619.
4. Herrick JB. Peculiar elongated and sickle-shaped red blood corpuscles in a case of severe anemia. 1910. Yale J Biol Med 2001;74(3):179-184.
5. Mason VR. Sickle cell anemia. JAMA 1922;79:1318-1320.
6. Strasser BJ. Linus Pauling's "molecular diseases": between history and memory. Am J Med Genet 2002;115(2):83-93.
7. Serjeant GR. One hundred years of sickle cell disease. Br J Haematol 2010;151(5):425-429.
8. Pagnier J, Mears JG, Dunda-Belkhdja O, et al. Evidence for the multicentric origin of the sickle cell hemoglobin gene in Africa. Proc Natl Acad Sci U S A 1984;81(6):1771-1773.
9. Serjeant GR. The geography of sickle cell disease: opportunities for understanding its diversity. Ann Saudi Med 1994;14:237-246.
10. Antonarakis SE, Boehm CD, Serjeant GR, Theisen CE, Dover GJ, Kazazian HH Jr. Origin of the beta S-globin gene in blacks: the contribution of recurrent mutation or gene conversion or both. Proc Natl Acad Sci U S A 1984;81(3):853-856.
11. Mears JG, Beldjord C, Benabadji M, et al. The sickle gene polymorphism in North Africa. Blood 1981;58(3):599-601.
12. Motulsky AG. Frequency of sickling disorders in U.S. blacks. N Engl J Med 1973;288(1):31-33.
13. Schneider RG, Hightower B, Hosty TS, et al. Abnormal hemoglobins in a quarter million people. Blood 1976;48(5):629-637.
14. Serjeant GR. Sickle cell disease, 2nd ed. New York: Oxford University Press, 1992.

15. Hassell KL. Population estimates of sickle cell disease in the U.S. *Am J Prev Med* 2010;38(Suppl 4):S512-S521.
 16. Allison AC. Protection afforded by sickle cell trait against subtertian malarial infection. *BMJ* 1954;1:290.
 17. Luzzatto L. Genetics of red cells and susceptibility to malaria. *Blood* 1979;54(5):961-976.
 18. Rees DC, Williams TN, Gladwin MT. Sickle-cell disease. *Lancet* 2010;376(9757):2018-2031.
 19. Schechter AN, Noguchi CT. Sickle hemoglobin polymer: structure-function correlates. In: Embury SH, Hebbel RP, Mohandas N, Steinberg MH, eds. *Sickle cell disease: basic principles and clinical practice*. New York: Raven Press, 1994:33-51.
 20. Finch JT, Perutz MF, Bertles JF, Dobler J. Structure of sickled erythrocytes and of sickle-cell hemoglobin fibers. *Proc Natl Acad Sci U S A* 1973;70(3):718-722.
- P.860
21. Magdoff-Fairchild B, Swerdlow PH, Bertles JF. Intermolecular organization of deoxygenated sickle haemoglobin determined by x-ray diffraction. *Nature* 1972;239(5369):217-219.
 22. Dykes G, Crepeau RH, Edelstein SJ. Three-dimensional reconstruction of the fibres of sickle cell haemoglobin. *Nature* 1978;272(5653):506-510.
 23. Briehl RW, Ewert S. Effects of pH, 2,3-diphosphoglycerate and salts on gelation of sickle cell deoxyhemoglobin. *J Mol Biol* 1973;80(3):445-458.
 24. May A, Huehns ER. The concentration dependence of the oxygen affinity of haemoglobin S. *Br J Haematol* 1975;30(3):317-335.
 25. Singer K, Singer L. Studies on abnormal hemoglobins. VIII. The gelling phenomenon of sickle hemoglobin: its biological and diagnostic significance. *Blood* 1953;8:1008.
 26. Bookchin RM, Nagel RL. Interactions between human hemoglobins: sickling and related phenomena. *Semin Hematol* 1974;11(4):577-595.
 27. Charache S, Conley CL. Rate of sickling of red cells during deoxygenation of blood from persons with various sickling disorders. *Blood* 1964;24:25-48.
 28. Conley CL. Hereditary persistence of fetal hemoglobin: a study of 79 affected persons in 15 Negro families in Baltimore. *Blood* 1963;21:261.
 29. Reed LJ, Bradley TB Jr, Ranney HM. The effect on amelioration of anemia of the synthesis of fetal hemoglobin in sickle cell anemia. *Blood* 1965;25(1):37-48.
 30. Murray N, Serjeant BE, Serjeant GR. Sickle cell-hereditary persistence of fetal haemoglobin and its differentiation from other sickle cell syndromes. *Br J Haematol* 1988;69(1):89-92.
 31. Kinney TR, Ware RE. Compound heterozygous states. In: Embury SH, Hebbel RP, Mohandas N, Steinberg MH, eds. *Sickle cell disease: basic principles and clinical practice*. New York: Raven Press, 1994:437-451.
 32. Noguchi CT, Rodgers GP, Serjeant G, Schechter AN. Levels of fetal hemoglobin necessary for treatment of sickle cell disease. *N Engl J Med* 1988;318(2):96-99.
 33. Embury SH. The not-so-simple process of sickle cell vasoocclusion. *Microcirculation* 2004;11(2):101-113.
 34. Hofrichter J. Kinetics of sickle hemoglobin polymerization. III. Nucleation rates determined from stochastic fluctuations in polymerization progress curves. *J Mol Biol* 1986;189(3):553-571.
 35. Eaton WA, Hofrichter J. Sickle hemoglobin polymerization. In: Embury SH, Hebbel RP, Mohandas N, Steinberg MH, eds. *Sickle cell disease: basic principles and clinical practice*. New York: Raven Press, 1994:53-87.
 36. Hofrichter J, Ross PD, Eaton WA. Kinetics and mechanism of deoxyhemoglobin S gelation: a new approach to understanding sickle cell disease. *Proc Natl Acad Sci U S A* 1974;71(12):4864-4868.
 37. Harris JW, Bensusan HB. The kinetics of the sol-gel transformation of deoxyhemoglobin S by continuous monitoring of viscosity. *J Lab Clin Med* 1975;86(4):564-575.

38. Zhang Y, Dai Y, Wen J, et al. Detrimental effects of adenosine signaling in sickle cell disease. *Nat Med* 2011;17(1):79-86.
39. Uzunova VV, Pan W, Galkin O, Vekilov PG. Free heme and the polymerization of sickle cell hemoglobin. *Biophys J* 2010;99(6):1976-1985.
40. Usami S, Chien S, Bertles JF. Deformability of sickle cells as studied by micro-sieving. *J Lab Clin Med* 1975;86(2):274-279.
41. White JG. Ultrastructural features of erythrocyte and hemoglobin sickling. *Arch Intern Med* 1974;133(4):545-562.
42. Shen SC, Fleming EM, Castle WB. Studies on the destruction of red blood cells; irreversibly sickled erythrocytes; their experimental production in vitro. *Blood* 1949;4(5):498-504.
43. Serjeant GR, Petch MC, Serjeant BE. The in vivo sickle phenomenon: a reappraisal. *J Lab Clin Med* 1973;81(6):850-856.
44. Bookchin RM, Balazs T, Landau LC. Determinants of red cell sickling. Effects of varying pH and of increasing intracellular hemoglobin concentration by osmotic shrinkage. *J Lab Clin Med* 1976;87(4):597-616.
45. Nash GB, Johnson CS, Meiselman HJ. Rheologic impairment of sickle RBCs induced by repetitive cycles of deoxygenation-reoxygenation. *Blood* 1988;72(2):539-545.
46. Clark MR, Morrison CE, Shohet SB. Monovalent cation transport in irreversibly sickled cells. *J Clin Invest* 1978;62(2):329-337.
47. Fales FW. Water distribution in blood during sickling of erythrocytes. *Blood* 1978;51(4):703-709.
48. Anderson DR, Davis JL, Carraway KL. Calcium-promoted changes of the human erythrocyte membrane. Involvement of spectrin, transglutaminase, and a membrane-bound protease. *J Biol Chem* 1977;252(19):6617-6623.
49. Smith CM, Krivit W, White JG. The irreversibly sickled cell. *Am J Pediatr Hematol Oncol* 1982;4(3):307-315.
50. Serjeant GR, Serjeant BE, Desai P, Mason KP, Sewell A, England JM. The determinants of irreversibly sickled cells in homozygous sickle cell disease. *Br J Haematol* 1978;40(3):431-438.
51. Allan D, Raval P. Some morphological consequences of uncoupling the lipid bilayer from the plasma membrane skeleton in intact erythrocytes. *Biomed Biochim Acta* 1983;42(11-12):S11-S16.
52. Kuypers FA, Yee M, Vichinsky E, Lubin BH. Activation of the prothrombinase complex in sickle cell anemia. *Blood* 1992;80:75.
53. Pan D, Kalfa TA, Wang D, et al. K-Cl cotransporter gene expression during human and murine erythroid differentiation. *J Biol Chem* 2011;286(35):30492-30503.
54. Lew VL, Hockaday A, Sepulveda MI, et al. Compartmentalization of sickle-cell calcium in endocytic inside-out vesicles. *Nature* 1985;315(6020):586-589.
55. Brugnara C, De Franceschi L, Alper SL. Inhibition of Ca²⁺-dependent K⁺ transport and cell dehydration in sickle erythrocytes by clotrimazole and other imidazole derivatives. *J Clin Invest* 1993;92(1):520-526.
56. Brugnara C. Therapeutic strategies for prevention of sickle cell dehydration. *Blood Cells Mol Dis* 2001;27(1):71-80.
57. Stocker JW, De Franceschi L, McNaughton-Smith G, et al. A novel Gardos channel inhibitor, ICA-17043, prevents red blood cell dehydration in vitro and in a mouse model (SAD) of sickle cell disease. *Blood* 2000;96:486a. Ref Type: Abstract
58. Brugnara C, Bunn HF, Tosteson DC. Regulation of erythrocyte cation and water content in sickle cell anemia. *Science* 1986;232(4748):388-390.
59. Brugnara C, Van HT, Tosteson DC. Acid pH induces formation of dense cells in sickle erythrocytes. *Blood* 1989;74(1):487-495.
60. Fathallah H, Sauvage M, Romero JR, Canessa M, Giraud F. Effects of PKC alpha activation on Ca²⁺ pump and K(Ca) channel in deoxygenated sickle cells. *Am J Physiol* 1997;273(4 Pt 1):C1206-C1214.
61. Bennekou P, De Franceschi L, Pedersen O, et al. Treatment with NS3623, a novel Cl-conductance blocker, ameliorates erythrocyte dehydration in trans-genic SAD mice: a possible new therapeutic approach for sickle cell disease. *Blood* 2001;97(5):1451-1457.
62. Joiner CH, Jiang M, Claussen WJ, Roszell NJ, Yasin Z, Franco RS. Dipyridamole inhibits sickling-induced cation fluxes in sickle red blood cells. *Blood* 2001;97(12):3976-3983.

63. Hebbel RP, Yamada O, Moldow CF, Jacob HS, White JG, Eaton JW. Abnormal adherence of sickle erythrocytes to cultured vascular endothelium: possible mechanism for microvascular occlusion in sickle cell disease. *J Clin Invest* 1980;65(1):154-160.
64. Mohandas N, Evans E. Adherence of sickle erythrocytes to vascular endothelial cells: requirement for both cell membrane changes and plasma factors. *Blood* 1984;64(1):282-287.
65. Kanavaki I, Makrythanasis P, Lazaropoulou C, et al. Adhesion molecules and high-sensitivity C-reactive protein levels in patients with sickle cell betathalassaemia. *Eur J Clin Invest* 2012;42(1):27-33.
66. Ballas SK, Larner J, Smith ED, Surrey S, Schwartz E, Rappaport EF. Rheologic predictors of the severity of the painful sickle cell crisis. *Blood* 1988;72(4):1216-1223.
67. Barabino GA, McIntire LV, Eskin SG, Sears DA, Udden M. Endothelial cell interactions with sickle cell, sickle trait, mechanically injured, and normal erythrocytes under controlled flow. *Blood* 1987;70(1):152-157.
68. Lande WM, Andrews DL, Clark MR, et al. The incidence of painful crisis in homozygous sickle cell disease: correlation with red cell deformability. *Blood* 1988;72(6):2056-2059.
69. Burns ER, Wilkinson WH, Nagel RL. Adherence properties of sickle erythrocytes in dynamic flow systems. *J Lab Clin Med* 1985;105(6):673-678.
70. Hebbel RP, Schwartz RS, Mohandas N. The adhesive sickle erythrocyte: cause and consequence of abnormal interactions with endothelium, monocytes/macrophages and model membranes. *Clin Haematol* 1985;14(1):141-161.
71. Marikovsky Y, Khodadad JK, Weinstein RS. Influence of red cell shape on surface charge topography. *Exp Cell Res* 1978;116(1):191-197.
72. Hebbel RP. Erythrocyte autoxidation and the membrane abnormalities of sickle red cells. *Prog Clin Biol Res* 1984;159:219-225.
73. Hebbel RP. Blockade of adhesion of sickle cells to endothelium by monoclonal antibodies. *N Engl J Med* 2000;342(25):1910-1912.
74. Sugihara K, Sugihara T, Mohandas N, Hebbel RP. Thrombospondin mediates adherence of CD36+ sickle reticulocytes to endothelial cells. *Blood* 1992;80(10):2634-2642.
75. Brittain HA, Eckman JR, Swerlick RA, Howard RJ, Wick TM. Thrombospondin from activated platelets promotes sickle erythrocyte adherence to human microvascular endothelium under physiologic flow: a potential role for platelet activation in sickle cell vaso-occlusion. *Blood* 1993;81(8):2137-2143.
76. Joneckis CC, Ackley RL, Orringer EP, Wayner EA, Parise LV. Integrin alpha 4 beta 1 and glycoprotein IV (CD36) are expressed on circulating reticulocytes in sickle cell anemia. *Blood* 1993;82(12):3548-3555.
77. Swerlick RA, Eckman JR, Kumar A, Jeitler M, Wick TM. Alpha 4 beta 1-integrin expression on sickle reticulocytes: vascular cell adhesion molecule-1-dependent binding to endothelium. *Blood* 1993;82(6):1891-1899.
78. Wick TM, Moake JL, Udden MM, Eskin SG, Sears DA, McIntire LV. Unusually large von Willebrand factor multimers increase adhesion of sickle erythrocytes to human endothelial cells under controlled flow. *J Clin Invest* 1987;80(3):905-910.
79. Zhou Z, Thiagarajan P, Udden M, Lopez JA, Guchhait P. Erythrocyte membrane sulfatide plays a crucial role in the adhesion of sickle erythrocytes to endothelium. *Thromb Haemost* 2011;105(6):1046-1052.
80. Solovey A, Lin Y, Browne P, Choong S, Wayner E, Hebbel RP. Circulating activated endothelial cells in sickle cell anemia. *N Engl J Med* 1997;337(22): 1584-1590.
81. Matsui NM, Borsig L, Rosen SD, Yaghami M, Varki A, Embury SH. P-selectin mediates the adhesion of sickle erythrocytes to the endothelium. *Blood* 2001;98(6):1955-1962.
82. Chien S, King RG, Kaperonis AA, Usami S. Viscoelastic properties of sickle cells and hemoglobin. *Blood Cells* 1982;8(1):53-64.
83. Chien S, Usami S, Bertles JF. Abnormal rheology of oxygenated blood in sickle cell anemia. *J Clin Invest* 1970;49(4):623-634.
84. Danish EH, Harris JW. Viscosity studies of deoxyhemoglobin S: evidence for formation of microaggregates during the lag phase. *J Lab Clin Med* 1983;101(4):515-526.

85. Messmann R, Gannon S, Sarnaik S, Johnson RM. Mechanical properties of sickle cell membranes. *Blood* 1990;75(8):1711-1717.
86. Murphy JR, Wengard M, Brereton W. Rheological studies of Hb SS blood: influence of hematocrit, hypertonicity, separation of cells, deoxygenation, and mixture with normal cells. *J Lab Clin Med* 1976;87(3):475-486.
87. Schmalzer EA, Manning RS, Chien S. Filtration of sickle cells: recruitment into a rigid fraction as a function of density and oxygen tension. *J Lab Clin Med* 1989;113(6):727-734.
88. Clark MR, Mohandas N, Shohet SB. Deformability of oxygenated irreversibly sickled cells. *J Clin Invest* 1980;65(1):189-196.
89. Evans E, Mohandas N, Leung A. Static and dynamic rigidities of normal and sickle erythrocytes. Major influence of cell hemoglobin concentration. *J Clin Invest* 1984;73(2):477-488.
90. Clark MR. Mean corpuscular hemoglobin concentration and cell deformability. *Ann N Y Acad Sci* 1989;565:284-294.
91. Hebbel RP, Leung A, Mohandas N. Oxidation-induced changes in microrheologic properties of the red blood cell membrane. *Blood* 1990;76(5): 1015-1020.
92. Schmid-Schonbein H. Continuous viscous deformation of red blood cells in flow and their disturbance in sickle cell disease. *Blood Cells* 1982;8(1):29-51.
93. Evans EA, Mohandas N. Membrane-associated sickle hemoglobin: a major determinant of sickle erythrocyte rigidity. *Blood* 1987;70(5):1443-1449.
94. Kaul DK, Fabry ME, Windisch P, Baez S, Nagel RL. Erythrocytes in sickle cell anemia are heterogeneous in their rheological and hemodynamic characteristics. *J Clin Invest* 1983;72(1):22-31.
95. Miller DM, Winslow RM, Klein HG, Wilson KC, Brown FL, Statham NJ. Improved exercise performance after exchange transfusion in subjects with sickle cell anemia. *Blood* 1980;56(6):1127-1131.
96. Test ST, Kleman K, Lubin B. Characterization of the complement sensitivity of density-fractionated sickle cells. *Blood* 1991;78(Suppl):202a. Ref Type: Abstract
97. Platt OS. Exercise-induced hemolysis in sickle cell anemia: shear sensitivity and erythrocyte dehydration. *Blood* 1982;59(5):1055-1060.
98. Galili U, Clark MR, Shohet SB. Excessive binding of natural anti-alpha-galactosyl immunoglobulin G to sickle erythrocytes may contribute to extravascular cell destruction. *J Clin Invest* 1986;77(1):27-33.
99. Kaul DK, Fabry ME, Nagel RL. Vaso-occlusion by sickle cells: evidence for selective trapping of dense red cells. *Blood* 1986;68(5):1162-1166.
100. Bensinger TA, Gillette PN. Hemolysis in sickle cell disease. *Arch Intern Med* 1974;133(4):624-631.
101. Test ST, Woolworth VS. Defective regulation of complement by the sickle erythrocyte: evidence for a defect in control of membrane attack complex formation. *Blood* 1994;83(3):842-852.
102. Waugh SM, Willardson BM, Kannan R, Labotka RJ, Low PS. Heinz bodies induce clustering of band 3, glycophorin, and ankyrin in sickle cell erythrocytes. *J Clin Invest* 1986;78(5):1155-1160.
103. Hebbel RP. Reconstructing sickle cell disease: a data-based analysis of the "hyperhemolysis paradigm" for pulmonary hypertension from the perspective of evidence-based medicine. *Am J Hematol* 2011;86(2):123-154.
104. Mock DM, Matthews NI, Zhu S, et al. Red blood cell (RBC) survival determined in humans using RBCs labeled at multiple biotin densities. *Transfusion* 2011;51(5):1047-1057.
105. Serjeant GR, Serjeant BE, Milner PF. The irreversibly sickled cell; a determinant of haemolysis in sickle cell anaemia. *Br J Haematol* 1969;17(6): 527-533.
106. Noguchi CT, Schechter AN. Non-uniformity of intracellular polymer formation in sickle erythrocytes: possible correlation with severity of hemolytic anemia. *Am J Pediatr Hematol Oncol* 1984;6(1):46-50.
107. Miller WJ, Hebbel RP. Erythrophagocytosis as a determinant of hemolytic rate in sickle disease. *Prog Clin Biol Res* 1984;165:85-92.
108. Morris CR, Kato GJ, Poljakovic M, et al. Dysregulated arginine metabolism, hemolysis-associated pulmonary hypertension, and mortality in sickle cell disease. *JAMA* 2005;294(1):81-90.

109. Schnog JB, Teerlink T, van der Dijs FP, Duits AJ, Muskiet FA. Plasma levels of asymmetric dimethylarginine (ADMA), an endogenous nitric oxide synthase inhibitor, are elevated in sickle cell disease. *Ann Hematol* 2005;84(5): 282-286.
110. Kato GJ, Gladwin MT, Steinberg MH. Deconstructing sickle cell disease: reappraisal of the role of hemolysis in the development of clinical subphenotypes. *Blood Rev* 2007;21(1):37-47.
111. Bunn HF, Nathan DG, Dover GJ, et al. Pulmonary hypertension and nitric oxide depletion in sickle cell disease. *Blood* 2010;116(5):687-692.
112. Nolan VG, Adewoye A, Baldwin C, et al. Sickle cell leg ulcers: associations with haemolysis and SNPs in Klotho, TEK and genes of the TGF-beta/BMP pathway. *Br J Haematol* 2006;133(5):570-578.
113. Nath KA, Katusic ZS. Vasculature and kidney complications in sickle cell disease. *J Am Soc Nephrol* 2012.
114. Embury SH, Hebbel RP, Steinberg MH, Mohandas N. Pathogenesis of vasoocclusion. In: Embury SH, Hebbel RP, Mohandas N, Steinberg MH, eds. *Sickle cell disease: basic principles and clinical practice*. New York: Raven Press, 1994:311-326.
115. Siciliano A, Malpeli G, Platt OS, et al. Abnormal modulation of cell protective systems in response to ischemic/reperfusion injury is important in the development of mouse sickle cell hepatopathy. *Haematologica* 2011;96(1):24-32.
116. Conran N, Franco-Penteado CF, Costa FF. Newer aspects of the pathophysiology of sickle cell disease vaso-occlusion. *Hemoglobin* 2009;33(1):1-16.
117. Rees DC, Gibson JS. Biomarkers in sickle cell disease. *Br J Haematol* 2012;156(4):433-445.
118. Kurantsin-Mills J, Klug PP, Lessin LS. Vaso-occlusion in sickle cell disease: pathophysiology of the microvascular circulation. *Am J Pediatr Hematol Oncol* 1988;10(4):357-372.
119. Kaul DK, Fabry ME, Nagel RL. Microvascular sites and characteristics of sickle cell adhesion to vascular endothelium in shear flow conditions: pathophysiological implications. *Proc Natl Acad Sci U S A* 1989;86(9):3356-3360.
120. Akinola NO, Stevens SM, Franklin IM, Nash GB, Stuart J. Rheological changes in the prodromal and established phases of sickle cell vaso-occlusive crisis. *Br J Haematol* 1992;81(4):598-602.
121. Fabry ME, Benjamin L, Lawrence C, Nagel RL. An objective sign in painful crisis in sickle cell anemia: the concomitant reduction of high density red cells. *Blood* 1984;64(2):559-563.
122. Hebbel RP, Boogaerts MA, Eaton JW, Steinberg MH. Erythrocyte adherence to endothelium in sickle-cell anemia. A possible determinant of disease severity. *N Engl J Med* 1980;302(18):992-995.
123. Hebbel RP, Moldow CF, Steinberg MH. Modulation of erythrocyte-endothelial interactions and the vasoocclusive severity of sickling disorders. *Blood* 1981;58(5):947-952.
124. Wautier JL, Pintigny D, Wautier MP, et al. Fibrinogen, a modulator of erythrocyte adhesion to vascular endothelium. *J Lab Clin Med* 1983;101(6):911-920.
125. Diggs LW. Sickle cell crises. *Am J Clin Pathol* 1965;44:1.
126. Faller DV. Vascular modulation. In: Embury SH, Hebbel RP, Mohandas N, Steinberg MH, eds. *Sickle cell disease: basic principles and clinical practice*. New York: Raven Press, 1994:235-246.
127. Setty BN, Stuart MJ. Vascular cell adhesion molecule-1 is involved in mediating hypoxia-induced sickle red blood cell adherence to endothelium: potential role in sickle cell disease. *Blood* 1996;88(6):2311-2320.
128. Reiter CD, Gladwin MT. An emerging role for nitric oxide in sickle cell disease vascular homeostasis and therapy. *Curr Opin Hematol* 2003;10(2):99-107.
129. Stuart MJ, Setty BN. Sickle cell acute chest syndrome: pathogenesis and rationale for treatment. *Blood* 1999;94(5):1555-1560.
130. Morris CR, Kuypers FA, Larkin S, Vichinsky EP, Styles LA. Patterns of arginine and nitric oxide in patients with sickle cell disease with vaso-occlusive crisis and acute chest syndrome. *J Pediatr Hematol Oncol* 2000;22(6):515-520.
131. Castro O. Systemic fat embolism and pulmonary hypertension in sickle cell disease. *Hematol Oncol Clin North Am* 1996;10(6):1289-1303.

132. Aldrich TK, Dhuper SK, Patwa NS, et al. Pulmonary entrapment of sickle cells: the role of regional alveolar hypoxia. *J Appl Physiol* 1996;80(2):531-539.
133. Gladwin MT, Kato GJ. Cardiopulmonary complications of sickle cell disease: role of nitric oxide and hemolytic anemia. *Hematology Am Soc Hematol Educ Program* 2005;51-57.
134. Morris CR, Kuypers FA, Larkin S, et al. Arginine therapy: a novel strategy to induce nitric oxide production in sickle cell disease. *Br J Haematol* 2000;111(2):498-500.
135. Mohandas N, Evans E. Rheological and adherence properties of sickle cells. Potential contribution to hematologic manifestations of the disease. *Ann N Y Acad Sci* 1989;565:327-337.
136. Ginsburg V, Roberts DD. Glycoconjugates and cell adhesion: the adhesive proteins laminin, thrombospondin and von Willebrand's factor bind specifically to sulfated glycolipids. *Biochimie* 1988;70(11):1651-1659.
137. Vordermeier S, Singh S, Biggerstaff J, et al. Red blood cells from patients with sickle cell disease exhibit an increased adherence to cultured endothelium pretreated with tumour necrosis factor (TNF). *Br J Haematol* 1992;81(4):591-597.
138. Boggs DR, Hyde F, Srodes C. An unusual pattern of neutrophil kinetics in sickle cell anemia. *Blood* 1973;41(1):59-65.
139. Buchanan GR, Glader BE. Leukocyte counts in children with sickle cell disease. Comparative values in the steady state, vaso-occlusive crisis, and bacterial infection. *Am J Dis Child* 1978;132(4):396-398.
140. Akenzua GI, Amienheme OR. Inhibitor of in vitro neutrophil migration in sera of children with homozygous sickle cell gene during pain crisis. *Br J Haematol* 1981;47(3):345-352.
141. Boghossian SH, Wright G, Webster AD, Segal AW. Investigations of host defence in patients with sickle cell disease. *Br J Haematol* 1985;59(3): 523-531.
142. Bagge U, Amundson B, Lauritzen C. White blood cell deformability and plugging of skeletal muscle capillaries in hemorrhagic shock. *Acta Physiol Scand* 1980;108(2):159-163.
143. Platt OS, Brambilla DJ, Rosse WF, et al. Mortality in sickle cell disease. Life expectancy and risk factors for early death. *N Engl J Med* 1994;330(23): 1639-1644.
144. Kinney TR, Sleeper LA, Wang WC, et al. Silent cerebral infarcts in sickle cell anemia: a risk factor analysis. The Cooperative Study of Sickle Cell Disease. *Pediatrics* 1999;103(3):640-645.
145. Charache S, Barton FB, Moore RD, et al. Hydroxyurea and sickle cell anemia. Clinical utility of a myelosuppressive "switching" agent. The Multicenter Study of Hydroxyurea in Sickle Cell Anemia. *Medicine (Baltimore)* 1996;75(6):300-326.
146. Miller ST, Sleeper LA, Pegelow CH, et al. Prediction of adverse outcomes in children with sickle cell disease. *N Engl J Med* 2000;342(2):83-89.
147. Adler BK, Salzman DE, Carabasi MH, Vaughan WP, Reddy VV, Prchal JT. Fatal sickle cell crisis after granulocyte colony-stimulating factor administration. *Blood* 2001;97(10):3313-3314.
148. Grigg AP. Granulocyte colony-stimulating factor-induced sickle cell crisis and multiorgan dysfunction in a patient with compound heterozygous sickle cell/beta+ thalassemia. *Blood* 2001;97(12):3998-3999.
149. Abboud M, Laver J, Blau CA. Granulocytosis causing sickle-cell crisis. *Lancet* 1998;351(9107):959.
150. Pieters RC, Rojer RA, Saleh AW, Saleh AE, Duits AJ. Molgramostim to treat SS-sickle cell leg ulcers. *Lancet* 1995;345(8948):528.
151. Turhan A, Weiss LA, Mohandas N, Coller BS, Frenette PS. Primary role for adherent leukocytes in sickle cell vascular occlusion: a new paradigm. *Proc Natl Acad Sci U S A* 2002;99(5):3047-3051.
152. Wagener FA, Eggert A, Boerman OC, et al. Heme is a potent inducer of inflammation in mice and is counteracted by heme oxygenase. *Blood* 2001;98(6):1802-1811.
153. Kaul DK, Hebbel RP. Hypoxia/reoxygenation causes inflammatory response in transgenic sickle mice but not in normal mice. *J Clin Invest* 2000;106(3): 411-420.
154. Eltzschig HK, Carmeliet P. Hypoxia and inflammation. *N Engl J Med* 2011;364(7):656-665.
155. Eltzschig HK, Eckle T. Ischemia and reperfusion—from mechanism to translation. *Nat Med* 2011;17(11):1391-1401.
156. Solovey AA, Solovey AN, Harkness J, Hebbel RP. Modulation of endothelial cell activation in sickle cell disease: a pilot study. *Blood* 2001;97(7):1937-1941.

157. Styles L, Wager CG, Labotka RJ, et al. Refining the value of secretory phospholipase A2 as a predictor of acute chest syndrome in sickle cell disease: results of a feasibility study (PROACTIVE). *Br J Haematol* 2012;157(5):627-636.
158. Styles LA, Aarsman AJ, Vichinsky EP, Kuypers FA. Secretory phospholipase A(2) predicts impending acute chest syndrome in sickle cell disease. *Blood* 2000;96(9):3276-3278.
159. Freedman ML, Karpatkin S. Elevated platelet count and megathrombocyte number in sickle cell anemia. *Blood* 1975;46(4):579-582.
160. Haut MJ, Cowan DH, Harris JW. Platelet function and survival in sickle cell disease. *J Lab Clin Med* 1973;82(1):44-53.
161. Mehta P, Mehta J. Abnormalities of platelet aggregation in sickle cell disease. *J Pediatr* 1980;96(2):209-213.
162. Mehta P. Significance of plasma beta-thromboglobulin values in patients with sickle cell disease. *J Pediatr* 1980;97(6):941-944.
163. Browne PV, Mosher DF, Steinberg MH, Hebbel RP. Disturbance of plasma and platelet thrombospondin levels in sickle cell disease. *Am J Hematol* 1996;51(4):296-301.
164. Kurantsin-Mills J, Ibe BO, Natta CL, Raj JU, Siegel RS, Lessin LS. Elevated urinary levels of thromboxane and prostacyclin metabolites in sickle cell disease reflects activated platelets in the circulation. *Br J Haematol* 1994;87(3):580-585.
165. Gordon EM, Klein BL, Berman BW, Strandjord SE, Simon JE, Coccia PF. Reduction of contact factors in sickle cell disease. *J Pediatr* 1985;106(3): 427-430.
166. Karayalcin G, Lanzkowsky P. Plasma protein C levels in children with sickle cell disease. *Am J Pediatr Hematol Oncol* 1989;11(3):320-323.
167. Francis RB Jr. Protein S deficiency in sickle cell anemia. *J Lab Clin Med* 1988;111(5):571-576.
168. Kurantsin-Mills J, Ofosu FA, Safa TK, Siegel RS, Lessin LS. Plasma factor VII and thrombin-antithrombin III levels indicate increased tissue factor activity in sickle cell patients. *Br J Haematol* 1992;81(4):539-544.
169. Mehta P, Albiol L. Prostacyclin and platelet aggregation in sickle cell disease. *Pediatrics* 1982;70(3):354-359.
170. Devine DV, Kinney TR, Thomas PF, Rosse WF, Greenberg CS. Fragment D-dimer levels: an objective marker of vaso-occlusive crisis and other complications of sickle cell disease. *Blood* 1986;68(1):317-319.
171. Radomski MW, Palmer RM, Moncada S. Endogenous nitric oxide inhibits human platelet adhesion to vascular endothelium. *Lancet* 1987;2(8567): 1057-1058.
172. Hegyi T, Delphin ES, Bank A, Polin RA, Blanc WA. Sickle cell anemia in the newborn. *Pediatrics* 1977;60(2):213-216.
173. Gill FM, Sleeper LA, Weiner SJ, et al. Clinical events in the first decade in a cohort of infants with sickle cell disease. Cooperative Study of Sickle Cell Disease. *Blood* 1995;86(2):776-783.
174. Stevens MC, Hayes RJ, Vaidya S, Serjeant GR. Fetal hemoglobin and clinical severity of homozygous sickle cell disease in early childhood. *J Pediatr* 1981;98(1):37-41.
175. Powars DR. Natural history of sickle cell disease—the first ten years. *Semin Hematol* 1975;12(3):267-285.
176. O'Brien RT, McIntosh S, Aspnes GT, Pearson HA. Prospective study of sickle cell anemia in infancy. *J Pediatr* 1976;89(2):205-210.
177. Brown AK, Sleeper LA, Miller ST, Pegelow CH, Gill FM, Waclawiw MA. Reference values and hematologic changes from birth to 5 years in patients with sickle cell disease. Cooperative Study of Sickle Cell Disease. *Arch Pediatr Adolesc Med* 1994;148(8):796-804.
178. Pearson HA, McIntosh S, Ritchey AK, Lobel JS, Rooks Y, Johnston D. Developmental aspects of splenic function in sickle cell diseases. *Blood* 1979;53(3):358-365.
179. Powars DR, Chan LS, Hiti A, Ramicone E, Johnson C. Outcome of sickle cell anemia: a 4-decade observational study of 1056 patients. *Medicine (Baltimore)* 2005;84(6):363-376.
180. Quinn CT, Rogers ZR, McCavit TL, Buchanan GR. Improved survival of children and adolescents with sickle cell disease. *Blood* 2010;115(17): 3447-3452.
181. Stevens MC, Padwick M, Serjeant GR. Observations on the natural history of dactylitis in homozygous sickle cell disease. *Clin Pediatr (Phila)* 1981;20(5):311-317.

182. Keeley K, Buchanan GR. Acute infarction of long bones in children with sickle cell anemia. *J Pediatr* 1982;101(2):170-175.
183. Milner PF, Brown M. Bone marrow infarction in sickle cell anemia: correlation with hematologic profiles. *Blood* 1982;60(6):1411-1419.
184. Platt OS, Thorington BD, Brambilla DJ, et al. Pain in sickle cell disease. Rates and risk factors. *N Engl J Med* 1991;325(1):11-16.
185. Hargrave DR, Wade A, Evans JP, Hewes DK, Kirkham FJ. Nocturnal oxygen saturation and painful sickle cell crises in children. *Blood* 2003;101(3):846-848.
186. Glassberg J, Spivey JF, Strunk R, Boslaugh S, DeBaun MR. Painful episodes in children with sickle cell disease and asthma are temporally associated with respiratory symptoms. *J Pediatr Hematol Oncol* 2006;28(8):481-485.
187. Blank JP, Gill FM. Orbital infarction in sickle cell disease. *Pediatrics* 1981;67(6):879-881.
188. Schumacher HR, Andrews R, McLaughlin G. Arthropathy in sickle-cell disease. *Ann Intern Med* 1973;78(2):203-211.
189. Mankad VN, Williams JP, Harpen MD, et al. Magnetic resonance imaging of bone marrow in sickle cell disease: clinical, hematologic, and pathologic correlations. *Blood* 1990;75(1):274-283.
190. Rao S, Solomon N, Miller S, Dunn E. Scintigraphic differentiation of bone infarction from osteomyelitis in children with sickle cell disease. *J Pediatr* 1985;107(5):685-688.
191. Mann JR, Deeble TJ, Breeze GR, Stuart J. Ancrod in sickle-cell crisis. *Lancet* 1972;1(7757):934-937.
192. Clinical trials of therapy for sickle cell vaso-occlusive crises. Cooperative urea trials group. *JAMA* 1974;228(9):1120-1124.
193. Pearson HA, Noyes WD. Failure of phenothiazines in sickle cell anemia. *JAMA* 1967;199(1):33-34.
194. Oski F, Call FL, Lessen L. Failure of promazine HCl to prevent the painful episodes in sickle cell anemia. *J Pediatr* 1968;73(2):265-266.
195. Opio E, Barnes PM. Intravenous urea in treatment of bone-pain crises of sickle-cell disease. A double-blind trial. *Lancet* 1972;2(7769):160-162.
196. Oski F, Viner ED, Purugganan H, McElfresh AE. Low molecular weight dextran in sickle cell crisis. *JAMA* 1965;191(1):43.
197. Finney RAJ, Hatch FE Jr. Effect of carbonic anhydrase inhibitor (Dichlorphenamide) on sickle cell anemia. *Am J Med Sci* 1965;250:154.
198. Isaacs WA, Effiong CE, Ayeni O. Steroid treatment in the prevention of painful episodes in sickle-cell disease. *Lancet* 1972;1(7750):570-571.
199. Lundh B, Gardner FH. The haematological response to androgens in sickle cell anaemia. *Scand J Haematol* 1970;7(5):389-397.
200. Diggs LW, Williams DL. Treatment of painful sickle cell crises with papaverine: preliminary report. *South Med J* 1963;56:472.
201. Seward CW, Eaton JW, Chaplin H Jr. Artificially induced thyroid suppression in sickle cell disease. *Blood* 1972;40(6):905-913.
202. Reynolds JD. Painful sickle cell crisis. Successful treatment with hyperbaric oxygen therapy. *JAMA* 1971;216(12):1977-1978.
203. Sherer JT, Glover PH. Pentoxifylline for sickle-cell disease. *Ann Pharmacother* 2000;34(9):1070-1074.
204. Benjamin LJ, Berkowitz LR, Orringer E, et al. A collaborative, double-blind randomized study of cetiedil citrate in sickle cell crisis. *Blood* 1986;67(5):1442-1447.
205. Orringer EP, Casella JF, Ataga KI, et al. Purified poloxamer 188 for treatment of acute vaso-occlusive crisis of sickle cell disease: a randomized controlled trial. *JAMA* 2001;286(17):2099-2106.
206. Ataga KI, Smith WR, De Castro LM, et al. Efficacy and safety of the Gardos channel blocker, senicapoc (ICA-17043), in patients with sickle cell anemia. *Blood* 2008;111(8):3991-3997.

207. Ataga KI, Reid M, Ballas SK, et al. Improvements in haemolysis and indicators of erythrocyte survival do not correlate with acute vaso-occlusive crises in patients with sickle cell disease: a phase III randomized, placebo-controlled, double-blind study of the Gardos channel blocker senicapoc (ICA-17043). *Br J Haematol* 2011;153(1):92-104.
208. Gladwin MT, Kato GJ, Weiner D, et al. Nitric oxide for inhalation in the acute treatment of sickle cell pain crisis: a randomized controlled trial. *JAMA* 2011;305(9):893-902.
209. Chapelon E, Garabedian M, Brousse V, Souberbielle JC, Bresson JL, de MM. Osteopenia and vitamin D deficiency in children with sickle cell disease. *Eur J Haematol* 2009;83(6):572-578.
210. Jackson TC, Krauss MJ, DeBaun MR, Strunk RC, Arbelaez AM. Vitamin D deficiency and comorbidities in children with sickle cell anemia. *Pediatr Hematol Oncol* 2012;29(3):261-266.
211. Osunkwo I, Hodgman EI, Cherry K, et al. Vitamin D deficiency and chronic pain in sickle cell disease. *Br J Haematol* 2011;153(4):538-540.
212. Sadat-Ali M, Al-Elq A, Al-Turki H, Sultan O, Al-Ali A, AlMulhim F. Vitamin D level among patients with sickle cell anemia and its influence on bone mass. *Am J Hematol* 2011;86(6):506-507.
213. Arya SC, Agarwal N. Apropos "complete resolution of sickle cell chronic pain with high-dose vitamin D therapy: a case report and review of the literature". *J Pediatr Hematol Oncol* 2012;34(4):e172-e173.
214. Osunkwo I. Complete resolution of sickle cell chronic pain with high dose vitamin D therapy: a case report and review of the literature. *J Pediatr Hematol Oncol* 2011;33(7):549-551.
215. Embury SH, Garcia JF, Mohandas N, Pennathur-Das R, Clark MR. Effects of oxygen inhalation on endogenous erythropoietin kinetics, erythropoiesis, and properties of blood cells in sickle-cell anemia. *N Engl J Med* 1984;311(5): 291-295.
216. Diamond WJ, Brown FL Jr, Bitterman P, Klein HG, Davey RJ, Winslow RM. Delayed hemolytic transfusion reaction presenting as sickle-cell crisis. *Ann Intern Med* 1980;93(2):231-234.
217. Ballas S. *Sickle Cell Pain*. IASP, Progress in pain research and management. Seattle: IASP Press; 1998.
218. Wang CJ, Kavanagh PL, Little AA, Holliman JB, Sprinz PG. Quality-of-care indicators for children with sickle cell disease. *Pediatrics* 2011;128(3): 484-493.
219. Shapiro BS, Cohen DE, Howe CJ. Patient-controlled analgesia for sickle-cell-related pain. *J Pain Symptom Manage* 1993;8(1):22-28.
220. McPherson E, Perlin E, Finke H, Castro O, Pittman J. Patient-controlled analgesia in patients with sickle cell vaso-occlusive crisis. *Am J Med Sci* 1990;299(1):10-12.
221. Ballas SK. Update on pain management in sickle cell disease. *Hemoglobin* 2011;35(5-6):520-529.
222. Kirchheiner J, Schmidt H, Tzvetkov M, et al. Pharmacokinetics of codeine and its metabolite morphine in ultra-rapid metabolizers due to CYP2D6 duplication. *Pharmacogenomics J* 2007;7(4):257-265.
223. Zeltzer L, Dash J, Holland JP. Hypnotically induced pain control in sickle cell anemia. *Pediatrics* 1979;64(4):533-536.
224. Ohene-Frempong K, Weiner SJ, Sleeper LA, et al. Cerebrovascular accidents in sickle cell disease: rates and risk factors. *Blood* 1998;91(1):288-294.
225. Powars D, Wilson B, Imbus C, Pegelow C, Allen J. The natural history of stroke in sickle cell disease. *Am J Med* 1978;65(3):461-471.
226. Powars DR, Schroeder WA, Weiss JN, Chan LS, Azen SP. Lack of influence of fetal hemoglobin levels or erythrocyte indices on the severity of sickle cell anemia. *J Clin Invest* 1980;65(3):732-740.
227. Pegelow CH, Macklin EA, Moser FG, et al. Longitudinal changes in brain magnetic resonance imaging findings in children with sickle cell disease. *Blood* 2002;99(8):3014-3018.
228. Miller ST, Macklin EA, Pegelow CH, et al. Silent infarction as a risk factor for overt stroke in children with sickle cell anemia: a report from the Cooperative Study of Sickle Cell Disease. *J Pediatr* 2001;139(3):385-390.
229. Kirkham FJ, Hewes DK, Prengler M, Wade A, Lane R, Evans JP. Nocturnal hypoxaemia and central-nervous-system events in sickle-cell disease. *Lancet* 2001;357(9269):1656-1659.

230. Adams R, McKie V, Nichols F, et al. The use of transcranial ultrasonography to predict stroke in sickle cell disease. *N Engl J Med* 1992;326(9): 605-610.
231. Tuohy AM, McKie V, Mancini EA, Adams RJ. Internal carotid artery occlusion in a child with sickle cell disease: case report and immunohistochemical study. *J Pediatr Hematol Oncol* 1997;19(5):455-458.
232. Boros L, Thomas C, Weiner WJ. Large cerebral vessel disease in sickle cell anaemia. *J Neurol Neurosurg Psychiatry* 1976;39(12):1236-1239.
233. Russell MO, Goldberg HI, Hodson A, et al. Effect of transfusion therapy on arteriographic abnormalities and on recurrence of stroke in sickle cell disease. *Blood* 1984;63(1):162-169.
234. Nur E, Kim YS, Truijen J, et al. Cerebrovascular reserve capacity is impaired in patients with sickle cell disease. *Blood* 2009;114(16):3473-3478.
235. Stockman JA, Nigro MA, Mishkin MM, Oski FA. Occlusion of large cerebral vessels in sickle-cell anemia. *N Engl J Med* 1972;287(17):846-849.
236. Prohovnik I, Pavlakis SG, Piomelli S, et al. Cerebral hyperemia, stroke, and transfusion in sickle cell disease. *Neurology* 1989;39(3):344-348.
237. Adams RJ, Nichols FT, III, Aaslid R, et al. Cerebral vessel stenosis in sickle cell disease: criteria for detection by transcranial Doppler. *Am J Pediatr Hematol Oncol* 1990;12(3):277-282.
238. Quinn CT, Variste J, Dowling MM. Haemoglobin oxygen saturation is a determinant of cerebral artery blood flow velocity in children with sickle cell anaemia. *Br J Haematol* 2009;145(4):500-505.
239. Quinn CT, Sargent JW. Daytime steady-state haemoglobin desaturation is a risk factor for overt stroke in children with sickle cell anaemia. *Br J Haematol* 2008;140(3):336-339.
240. Bernaudin F, Verlhac S, Chevret S, et al. G6PD deficiency, absence of alpha-thalassemia, and hemolytic rate at baseline are significant independent risk factors for abnormally high cerebral velocities in patients with sickle cell anemia. *Blood* 2008;112(10):4314-4317.
241. Pavlakis SG, Bello J, Prohovnik I, et al. Brain infarction in sickle cell anemia: magnetic resonance imaging correlates. *Ann Neurol* 1988;23(2):125-130.
242. Adams RJ, Nichols FT, McKie V, McKie K, Milner P, Gammal TE. Cerebral infarction in sickle cell anemia: mechanism based on CT and MRI. *Neurology* 1988;38(7):1012-1017.
243. Driscoll MC, Hurler A, Styles L, et al. Stroke risk in siblings with sickle cell anemia. *Blood* 2003;101(6):2401-2404.
244. Kwiatkowski JL, Hunter JV, Smith-Whitley K, Katz ML, Shults J, Ohene-Frempong K. Transcranial Doppler ultrasonography in siblings with sickle cell disease. *Br J Haematol* 2003;121(6):932-937.
245. Powars DR. Beta s-gene-cluster haplotypes in sickle cell anemia. Clinical and hematologic features. *Hematol Oncol Clin North Am* 1991;5(3):475-493.
246. Sarnaik SA, Ballas SK. Molecular characteristics of pediatric patients with sickle cell anemia and stroke. *Am J Hematol* 2001;67(3):179-182.
247. Belisario AR, Rodrigues CV, Martins ML, Silva CM, Viana MB. Coinheritance of alpha-thalassemia decreases the risk of cerebrovascular disease in a cohort of children with sickle cell anemia. *Hemoglobin* 2010;34(6):516-529.
248. Flanagan JM, Frohlich DM, Howard TA, et al. Genetic predictors for stroke in children with sickle cell anemia. *Blood* 2011;117(24):6681-6684.
249. Hoppe C, Klitz W, Cheng S, et al. Gene interactions and stroke risk in children with sickle cell anemia. *Blood* 2004;103(6):2391-2396.
250. Taylor JG, Tang DC, Savage SA, et al. Variants in the VCAM1 gene and risk for symptomatic stroke in sickle cell disease. *Blood* 2002;100(13):4303-4309.
251. Sebastiani P, Ramoni MF, Nolan V, Baldwin CT, Steinberg MH. Genetic dissection and prognostic modeling of overt stroke in sickle cell anemia. *Nat Genet* 2005;37(4):435-440.
252. Dobson SR, Holden KR, Nietert PJ, et al. Moyamoya syndrome in childhood sickle cell disease: a predictive factor for recurrent cerebrovascular events. *Blood* 2002;99(9):3144-3150.

253. Wilimas J, Goff JR, Anderson HR Jr, Langston JW, Thompson E. Efficacy of transfusion therapy for one to two years in patients with sickle cell disease and cerebrovascular accidents. *J Pediatr* 1980;96(2):205-208.
254. Wang WC, Kovnar EH, Tonkin IL, et al. High risk of recurrent stroke after discontinuance of five to twelve years of transfusion therapy in patients with sickle cell disease. *J Pediatr* 1991;118(3):377-382.
255. Cohen AR, Martin MB, Silber JH, Kim HC, Ohene-Frempong K, Schwartz E. A modified transfusion program for prevention of stroke in sickle cell disease. *Blood* 1992;79(7):1657-1661.
256. Miller ST, Jensen D, Rao SP. Less intensive long-term transfusion therapy for sickle cell anemia and cerebrovascular accident. *J Pediatr* 1992;120(1): 54-57.
257. Aygun B, McMurray MA, Schultz WH, et al. Chronic transfusion practice for children with sickle cell anaemia and stroke. *Br J Haematol* 2009;145(4): 524-528.
258. Rana S, Houston PE, Surana N, Shalaby-Rana EI, Castro OL. Discontinuation of long-term transfusion therapy in patients with sickle cell disease and stroke. *J Pediatr* 1997;131(5):757-760.
259. Sumoza A, de Bisotti R, Sumoza D, Fairbanks V. Hydroxyurea (HU) for prevention of recurrent stroke in sickle cell anemia (SCA). *Am J Hematol* 2002;71(3):161-165.
260. Ware RE, Zimmerman SA, Schultz WH. Hydroxyurea as an alternative to blood transfusions for the prevention of recurrent stroke in children with sickle cell disease. *Blood* 1999;94(9):3022-3026.
261. Ware RE, Zimmerman SA, Sylvestre PB, et al. Prevention of secondary stroke and resolution of transfusional iron overload in children with sickle cell anemia using hydroxyurea and phlebotomy. *J Pediatr* 2004;145(3):346-352.
262. Ali SB, Moosang M, King L, Knight-Madden J, Reid M. Stroke recurrence in children with sickle cell disease treated with hydroxyurea following first clinical stroke. *Am J Hematol* 2011;86(10):846-850.
263. Brousse V, Hertz-Pannier L, Consigny Y, et al. Does regular blood transfusion prevent progression of cerebrovascular lesions in children with sickle cell disease? *Ann Hematol* 2009;88(8):785-788.
264. Hulbert ML, McKinstry RC, Lacey JL, et al. Silent cerebral infarcts occur despite regular blood transfusion therapy after first strokes in children with sickle cell disease. *Blood* 2011;117(3):772-779.
265. Ware RE, Helms RW. Stroke With Transfusions Changing to Hydroxyurea (SWITCH). *Blood* 2012;119(17):3925-3932.
266. Adams RJ, McKie VC, Hsu L, et al. Prevention of a first stroke by transfusions in children with sickle cell anemia and abnormal results on transcranial Doppler ultrasonography. *N Engl J Med* 1998;339(1):5-11.
267. Adams RJ, Brambilla D. Discontinuing prophylactic transfusions used to prevent stroke in sickle cell disease. *N Engl J Med* 2005;353(26):2769-2778.
268. Abboud MR, Yim E, Musallam KM, Adams RJ. Discontinuing prophylactic transfusions increases the risk of silent brain infarction in children with sickle cell disease: data from STOP II. *Blood* 2011;118(4):894-898.
269. Bishop S, Matheus MG, Abboud MR, et al. Effect of chronic transfusion therapy on progression of neurovascular pathology in pediatric patients with sickle cell anemia. *Blood Cells Mol Dis* 2011;47(2):125-128.
270. Lee MT, Piomelli S, Granger S, et al. Stroke Prevention Trial in Sickle Cell Anemia (STOP): extended follow-up and final results. *Blood* 2006;108(3): 847-852.
271. McCarville MB, Goodin GS, Fortner G, et al. Evaluation of a comprehensive transcranial doppler screening program for children with sickle cell anemia. *Pediatr Blood Cancer* 2008;50(4):818-821.
272. Silva GS, Vicari P, Figueiredo MS, et al. Transcranial Doppler in adult patients with sickle cell disease. *Cerebrovasc Dis* 2006;21:38-41.
273. Fullerton HJ, Adams RJ, Zhao S, Johnston SC. Declining stroke rates in Californian children with sickle cell disease. *Blood* 2004;104(2):336-339.
274. Enniful-Eghan H, Moore RH, Ichord R, Smith-Whitley K, Kwiatkowski JL. Transcranial Doppler ultrasonography and prophylactic transfusion program is effective in preventing overt stroke in children with sickle cell disease. *J Pediatr* 2010;157(3):479-484.
275. Rogers ZR, Lieff S, McMurray M, et al. Collaborative Data Project [C-DATA] of the Comprehensive Sickle Cell Centers Program. *ASH Annu Meet Abstr* 2006;108(11):1200.

276. Fullerton HJ, Gardner M, Adams RJ, Lo LC, Johnston SC. Obstacles to primary stroke prevention in children with sickle cell disease. *Neurology* 2006;67(6):1098-1099.
277. Bernaudin F, Verlhac S, Coic L, Lesprit E, Brugieres P, Reinert P. Long-term follow-up of pediatric sickle cell disease patients with abnormal high velocities on transcranial Doppler. *Pediatr Radiol* 2005;35(3):242-248.
278. Gulbis B, Haberman D, Dufour D, et al. Hydroxyurea for sickle cell disease in children and for prevention of cerebrovascular events: the Belgian experience. *Blood* 2005;105(7):2685-2690.
279. Kratovil T, Bulas D, Driscoll MC, Speller-Brown B, McCarter R, Minniti CP. Hydroxyurea therapy lowers TCD velocities in children with sickle cell disease. *Pediatr Blood Cancer* 2006;47(7):894-900.
280. Zimmerman SA, Schultz WH, Burgett S, Mortier NA, Ware RE. Hydroxyurea therapy lowers transcranial Doppler flow velocities in children with sickle cell anemia. *Blood* 2007;110(3):1043-1047.
281. Tavakkoli F, Nahavandi M, Wyche MQ, Castro O. Effects of hydroxyurea treatment on cerebral oxygenation in adult patients with sickle cell disease: an open-label pilot study. *Clin Ther* 2005;27(7):1083-1088.
282. Adams RJ, Brambilla DJ, Granger S, et al. Stroke and conversion to high risk in children screened with transcranial Doppler ultrasound during the STOP study. *Blood* 2004;103(10):3689-3694.
283. Hankins JS, Fortner GL, McCarville MB, et al. The natural history of conditional transcranial doppler flow velocities in children with sickle cell anaemia. *Br J Haematol* 2008;142(1):94-99. PMID: 18477038.
284. Kwiatkowski JL, Zimmerman RA, Pollock AN, et al. Silent infarcts in young children with sickle cell disease. *Br J Haematol* 2009;146(3):300-305.
285. Bernaudin F, Verlhac S, Arnaud C, et al. Impact of early transcranial Doppler screening and intensive therapy on cerebral vasculopathy outcome in a newborn sickle cell anemia cohort. *Blood* 2011;117(4):1130-1140.
286. Pegelow CH, Wang W, Granger S, et al. Silent infarcts in children with sickle cell anemia and abnormal cerebral artery velocity. *Arch Neurol* 2001;58(12):2017-2021.
287. Wang WC, Gallagher DM, Pegelow CH, et al. Multicenter comparison of magnetic resonance imaging and transcranial Doppler ultrasonography in the evaluation of the central nervous system in children with sickle cell disease. *J Pediatr Hematol Oncol* 2000;22(4):335-339.
288. Casella JF, King AA, Barton B, et al. Design of the silent cerebral infarct transfusion (SIT) trial. *Pediatr Hematol Oncol* 2010;27(2):69-89.
289. DeBaun MR, Sarnaik SA, Rodeghier MJ, et al. Associated risk factors for silent cerebral infarcts in sickle cell anemia: low baseline hemoglobin, sex, and relative high systolic blood pressure. *Blood* 2012;119(16):3684-3690.
290. Ballas SK, Loeff S, Benjamin LJ, et al. Definitions of the phenotypic manifestations of sickle cell disease. *Am J Hematol* 2010;85(1):6-13.
291. Gardner K, Bell C, Bartram JL, et al. Outcome of adults with sickle cell disease admitted to critical care—experience of a single institution in the UK. *Br J Haematol* 2010;150(5):610-613.
292. Bartram JL, Thein SL, Gardner K, et al. Outcome of children with sickle cell disease admitted to intensive care—a single institution experience. *Br J Haematol* 2010;150(5):614-617.
293. Barrett-Connor E. Pneumonia and pulmonary infarction in sickle cell anemia. *JAMA* 1973;224(7):997-1000.
294. Castro O, Brambilla DJ, Thorington B, et al. The acute chest syndrome in sickle cell disease: incidence and risk factors. The Cooperative Study of Sickle Cell Disease. *Blood* 1994;84(2):643-649.
295. Barrett-Connor E. Acute pulmonary disease and sickle cell anemia. *Am Rev Respir Dis* 1971;104(2):159-165.
296. Cappellini MD, Cohen A, Piga A, et al. A phase 3 study of deferasirox (ICL670), a once-daily oral iron chelator, in patients with beta-thalassemia. *Blood* 2006;107(9):3455-3462.
297. Shulman ST, Bartlett J, Clyde WA Jr, Ayoub EM. The unusual severity of Mycoplasma pneumoniae in children with sickle-cell disease. *N Engl J Med* 1972;287(4):164-167.
298. Miller ST, Hammerschlag MR, Chirgwin K, et al. Role of Chlamydia pneumoniae in acute chest syndrome of sickle cell disease. *J Pediatr* 1991;118(1): 30-33.

299. Lowenthal EA, Wells A, Emanuel PD, Player R, Prchal JT. Sick cell acute chest syndrome associated with parvovirus B19 infection: case series and review. *Am J Hematol* 1996;51(3):207-213.
300. Vichinsky EP, Neumayr LD, Earles AN, et al. Causes and outcomes of the acute chest syndrome in sickle cell disease. National Acute Chest Syndrome Study Group. *N Engl J Med* 2000;342(25):1855-1865.
301. Charache S, Scott JC, Charache P. "Acute chest syndrome" in adults with sickle cell anemia. Microbiology, treatment, and prevention. *Arch Intern Med* 1979;139(1):67-69.
302. Strouse JJ, Reller ME, Bundy DG, et al. Severe pandemic H1N1 and seasonal influenza in children and young adults with sickle cell disease. *Blood* 2010;116(18):3431-3434.
303. Davies SC, Luce PJ, Win AA, Riordan JF, Brozovic M. Acute chest syndrome in sickle-cell disease. *Lancet* 1984;1(8367):36-38.
304. Cohen RT, DeBaun MR, Blinder MA, Strunk RC, Field JJ. Smoking is associated with an increased risk of acute chest syndrome and pain among adults with sickle cell disease. *Blood* 2010;115(18):3852-3854.
305. Boyd JH, Macklin EA, Strunk RC, DeBaun MR. Asthma is associated with acute chest syndrome and pain in children with sickle cell anemia. *Blood* 2006;108(9):2923-2927.
306. Boyd JH, Macklin EA, Strunk RC, DeBaun MR. Asthma is associated with increased mortality in individuals with sickle cell anemia. *Haematologica* 2007;92(8):1115-1118.
307. Poulter EY, Truszkowski P, Thompson AA, Liem RI. Acute chest syndrome is associated with history of asthma in hemoglobin SC disease. *Pediatr Blood Cancer* 2011;57(2):289-293.
308. Boyd JH, Moinuddin A, Strunk RC, DeBaun MR. Asthma and acute chest in sickle-cell disease. *Pediatr Pulmonol* 2004;38(3):229-232.
309. Boyd JH, DeBaun MR, Morgan WJ, Mao J, Strunk RC. Lower airway obstruction is associated with increased morbidity in children with sickle cell disease. *Pediatr Pulmonol* 2009;44(3):290-296.
310. Knight-Madden JM, Forrester TS, Lewis NA, Greenough A. Asthma in children with sickle cell disease and its association with acute chest syndrome. *Thorax* 2005;60(3):206-210.
311. Vendramini EC, Vianna EO, De LA, I, De Castro FB, Martinez JA, Terra-Filho J. Lung function and airway hyperresponsiveness in adult patients with sickle cell disease. *Am J Med Sci* 2006;332(2):68-72.
312. Poncz M, Greenberg J, Gill FM, Cohen A. Hematologic changes during acute chest syndrome in sickle cell disease. *Am J Pediatr Hematol Oncol* 1985;7(1):96-99.
313. Rucknagel DL, Kalinyak KA, Gelfand MJ. Rib infarcts and acute chest syndrome in sickle cell diseases. *Lancet* 1991;337(8745):831-833.
314. Bellet PS, Kalinyak KA, Shukla R, Gelfand MJ, Rucknagel DL. Incentive spirometry to prevent acute pulmonary complications in sickle cell diseases. *N Engl J Med* 1995;333(11):699-703.
315. Vichinsky E, Williams R, Das M, et al. Pulmonary fat embolism: a distinct cause of severe acute chest syndrome in sickle cell anemia. *Blood* 1994;83(11):3107-3112.
316. Styles LA, Schalkwijk CG, Aarsman AJ, Vichinsky EP, Lubin BH, Kuypers FA. Phospholipase A2 levels in acute chest syndrome of sickle cell disease. *Blood* 1996;87(6):2573-2578.
317. Naprawa JT, Bonsu BK, Goodman DG, Ranalli MA. Serum biomarkers for identifying acute chest syndrome among patients who have sickle cell disease and present to the emergency department. *Pediatrics* 2005;116(3):e420-e425.
318. Ballas SK, Files B, Luchtman-Jones L, et al. Secretory phospholipase A2 levels in patients with sickle cell disease and acute chest syndrome. *Hemoglobin* 2006;30(2):165-170.
319. Miller ST. How I treat acute chest syndrome in children with sickle cell disease. *Blood* 2011;117(20):5297-5305.
320. Mallouh AA, Asha M. Beneficial effect of blood transfusion in children with sickle cell chest syndrome. *Am J Dis Child* 1988;142(2):178-182.
321. Bernini JC, Rogers ZR, Sandler ES, Reisch JS, Quinn CT, Buchanan GR. Beneficial effect of intravenous dexamethasone in children with mild to moderately severe acute chest syndrome complicating sickle cell disease. *Blood* 1998;92(9):3082-3089.

322. Quinn CT, Stuart MJ, Kesler K, et al. Tapered oral dexamethasone for the acute chest syndrome of sickle cell disease. *Br J Haematol* 2011;155(2): 263-267.
323. Gladwin MT, Schechter AN, Shelhamer JH, Ognibene FP. The acute chest syndrome in sickle cell disease. Possible role of nitric oxide in its pathophysiology and treatment. *Am J Respir Crit Care Med* 1999;159(5 Pt 1):1368-1376.
324. Rogers ZR. Priapism in sickle cell disease. *Hematol Oncol Clin North Am* 2005;19(5):917-28, viii.
325. Burnett AL. Therapy insight: priapism associated with hematologic dyscrasias. *Nat Clin Pract Urol* 2005;2(9):449-456.
326. Bruno D, Wigfall DR, Zimmerman SA, Rosoff PM, Wiener JS. Genitourinary complications of sickle cell disease. *J Urol* 2001;166(3):803-811.
327. Furtado PS, Costa MP, Ribeiro dP V, et al. The prevalence of priapism in children and adolescents with sickle cell disease in Brazil. *Int J Hematol*. 2012 Jun;95(6):648-651. doi:10.1007/s12185-012-1083-0. Epub 2012 Apr 27.
328. Hamre MR, Harmon EP, Kirkpatrick DV, Stern MJ, Humbert JR. Priapism as a complication of sickle cell disease. *J Urol* 1991;145(1):1-5.
329. Mantadakis E, Cavender JD, Rogers ZR, Ewalt DH, Buchanan GR. Prevalence of priapism in children and adolescents with sickle cell anemia. *J Pediatr Hematol Oncol* 1999;21(6):518-522.
330. Nolan VG, Wyszynski DF, Farrer LA, Steinberg MH. Hemolysis-associated priapism in sickle cell disease. *Blood* 2005;106(9):3264-3267.
331. Sharpsteen JR Jr, Powars D, Johnson C, Rogers ZR, Williams WD, Posch RJ. Multisystem damage associated with tricorporal priapism in sickle cell disease. *Am J Med* 1993;94(3):289-295.
332. Rothfeld SH, Mazor D. Priapism in children: a complication of sickle cell disease. *J Urol* 1971;105(2):307-308.
333. Miller ST, Rao SP, Dunn EK, Glassberg KI. Priapism in children with sickle cell disease. *J Urol* 1995;154(2 Pt 2):844-847.
334. Diggs LW. Anatomic lesions in sickle disease. In: Abramson H, Bertles JF, Wethers DL, eds. *Sickle cell disease: diagnosis, management, education, and research*. St. Louis, MO: Mosby, 1973:189-229.
335. Emond AM, Holman R, Hayes RJ, Serjeant GR. Priapism and impotence in homozygous sickle cell disease. *Arch Intern Med* 1980;140(11):1434-1437.
336. Burnett AL, Allen RP, Tempany CM, Dover GJ, Brendler CB. Evaluation of erectile function in men with sickle cell disease. *Urology* 1995;45(4):657-663.
337. Seeler RA. Intensive transfusion therapy for priapism in boys with sickle cell anemia. *J Urol* 1973;110(3):360-363.
338. Siegel JF, Rich MA, Brock WA. Association of sickle cell disease, priapism, exchange transfusion and neurological events: ASPEN syndrome. *J Urol* 1993;150(5 Pt 1):1480-1482.
339. Rackoff WR, Ohene-Frempong K, Month S, Scott JP, Neahring B, Cohen AR. Neurologic events after partial exchange transfusion for priapism in sickle cell disease. *J Pediatr* 1992;120(6):882-885.
340. Winter CC. Priapism cured by creation of fistulas between glans penis and corpora cavernosa. *J Urol* 1978;119(2):227-228.
341. Mantadakis E, Ewalt DH, Cavender JD, Rogers ZR, Buchanan GR. Outpatient penile aspiration and epinephrine irrigation for young patients with sickle cell anemia and prolonged priapism. *Blood* 2000;95(1):78-82.
342. Quackels R. Cure of a patient suffering from priapism by cavernospongiosal anastomosis. *Acta Urol Belg* 1964;32:5-7.
343. Okpala I, Westerdale N, Jegede T, Cheung B. Etilerfrine for the prevention of priapism in adult sickle cell disease. *Br J Haematol* 2002;118(3):918-921.
344. Gbadoe AD, Atakouma Y, Kusiaku K, Assimadi JK. Management of sickle cell priapism with etilefrine. *Arch Dis Child* 2001;85(1):52-53.
345. Gbadoe AD, Assimadi JK, Segbena YA. Short period of administration of diethylstilbestrol in stuttering priapism in sickle cell anemia. *Am J Hematol* 2002;69(4):297-298.
346. Levine LA, Guss SP. Gonadotropin-releasing hormone analogues in the treatment of sickle cell anemia-associated priapism. *J Urol* 1993;150 (2 Pt 1):475-477.
347. Dahm P, Rao DS, Donatucci CF. Antiandrogens in the treatment of priapism. *Urology* 2002;59(1):138.

348. Rachid-Filho D, Cavalcanti AG, Favorito LA, Costa WS, Sampaio FJ. Treatment of recurrent priapism in sickle cell anemia with finasteride: a new approach. *Urology* 2009;74(5):1054-1057.
349. Burnett AL, Bivalacqua TJ, Champion HC, Musicki B. Long-term oral phosphodiesterase 5 inhibitor therapy alleviates recurrent priapism. *Urology* 2006;67(5):1043-1048.
350. Lane A, Deveras R. Potential risks of chronic sildenafil use for priapism in sickle cell disease. *J Sex Med* 2011;8(11):3193-3195.
351. Wen J, Jiang X, Dai Y, et al. Adenosine deaminase enzyme therapy prevents and reverses the heightened cavernosal relaxation in priapism. *J Sex Med* 2010;7(9):3011-3022.
352. Fowler JE Jr, Koshy M, Strub M, Chinn SK. Priapism associated with the sickle cell hemoglobinopathies: prevalence, natural history and sequelae. *J Urol* 1991;145(1):65-68.
353. Bertram RA, Carson CC, III, Webster GD. Implantation of penile prostheses in patients impotent after priapism. *Urology* 1985;26(4):325-327.
354. Leikin SL. The aplastic crises of sickle cell disease. Occurrence in several members of a family. *Am J Dis Child* 1957;93:128.
355. Pattison JR, Jones SE, Hodgson J, et al. Parvovirus infections and hypoplastic crisis in sickle-cell anaemia. *Lancet* 1981;1(8221):664-665.
356. Serjeant GR, Topley JM, Mason K, et al. Outbreak of aplastic crises in sickle cell anaemia associated with parvovirus-like agent. *Lancet* 1981;2(8247):595-597.
357. Young N. Hematologic and hematopoietic consequences of B19 parvovirus infection. *Semin Hematol* 1988;25(2):159-172.
358. Zimmerman SA, Davis JS, Schultz WH, Ware RE. Subclinical parvovirus B19 infection in children with sickle cell anemia. *J Pediatr Hematol Oncol* 2003;25(5):387-389.
359. Kim KY, Karayalcin G, Rosner F, Aballi A. Pancytopenia in a patient with sickle cell anemia. *Am J Dis Child* 1975;129(10):1195-1196.
360. Bell LM, Naides SJ, Stoffman P, Hodinka RL, Plotkin SA. Human parvovirus B19 infection among hospital staff members after contact with infected patients. *N Engl J Med* 1989;321(8):485-491.
361. Anand A, Gray ES, Brown T, Clewley JP, Cohen BJ. Human parvovirus infection in pregnancy and hydrops fetalis. *N Engl J Med* 1987;316(4):183-186.
362. Krishnamurti L, Lanford L, Munoz R. Life threatening parvovirus B19 and herpes simplex virus associated acute myocardial dysfunction in a child with homozygous sickle cell disease. *Pediatr Blood Cancer* 2007;49(7):1019-1021.
363. Godeau B, Galacteros F, Schaeffer A, et al. Aplastic crisis due to extensive bone marrow necrosis and human parvovirus infection in sickle cell disease. *Am J Med* 1991;91(5):557-558.
364. Yates AM, Hankins JS, Mortier NA, Aygun B, Ware RE. Simultaneous acute splenic sequestration and transient aplastic crisis in children with sickle cell disease. *Pediatr Blood Cancer* 2009;53(3):479-481.
365. Balkaran B, Char G, Morris JS, Thomas PW, Serjeant BE, Serjeant GR. Stroke in a cohort of patients with homozygous sickle cell disease. *J Pediatr* 1992;120(3):360-366.
366. Quek L, Sharpe C, Dutt N, et al. Acute human parvovirus B19 infection and nephrotic syndrome in patients with sickle cell disease. *Br J Haematol* 2010;149(2):289-291.
367. Topley JM, Rogers DW, Stevens MC, Serjeant GR. Acute splenic sequestration and hypersplenism in the first five years in homozygous sickle cell disease. *Arch Dis Child* 1981;56(10):765-769.
368. Walterspiel JN, Rutledge JC, Bartlett BL. Fatal acute splenic sequestration at 4 months of age. *Pediatrics* 1984;73(4):507-508.
369. Tavare AN, Wrench D, Cooper N. Acute splenic sequestration crisis in an adult with sickle cell anaemia. *Br J Hosp Med (Lond)* 2012;73(3):168-169.
370. Brousse V, Elie C, Benkerrou M, et al. Acute splenic sequestration crisis in sickle cell disease: cohort study of 190 paediatric patients. *Br J Haematol* 2012;156(5):643-648.

371. Emond AM, Collis R, Darvill D, Higgs DR, Maude GH, Serjeant GR. Acute splenic sequestration in homozygous sickle cell disease: natural history and management. *J Pediatr* 1985;107(2):201-206.
372. Mallouh AA, Qudah A. Acute splenic sequestration together with aplastic crisis caused by human parvovirus B19 in patients with sickle cell disease. *J Pediatr* 1993;122(4):593-595.
373. Smith-Whitley K, Zhao H, Hodinka RL, et al. Epidemiology of human parvovirus B19 in children with sickle cell disease. *Blood* 2004;103(2):422-427.
374. Seeler RA, Shwiaki MZ. Acute splenic sequestration crises (ASSC) in young children with sickle cell anemia. Clinical observations in 20 episodes in 14 children. *Clin Pediatr (Phila)* 1972;11(12):701-704.
375. Mouttalib S, Rice HE, Snyder D, et al. Evaluation of partial and total splenectomy in children with sickle cell disease using an internet-based registry. *Pediatr Blood Cancer*. 2012 Jul 15;59(1):100-104. doi: 10.1002/pbc.24057. Epub 2012 Jan 11.
376. Hatton CS, Bunch C, Weatherall DJ. Hepatic sequestration in sickle cell anaemia. *Br Med J (Clin Res Ed)* 1985;290(6470):744-745.
377. Maurer HS, Vida LN, Honig GR. Homozygous sickle cell disease with coexistent hereditary spherocytosis in three siblings. *J Pediatr* 1972;80(2):235-242.
378. de MM, Dumont MD, Heilbronner C, et al. Delayed hemolytic transfusion reaction in children with sickle cell disease. *Haematologica* 2011;96(6):801-807.
379. Goyal M, Donoghue A, Schwab S, Hasbrouck N, Khojasteh S, Osterhoudt K. Severe hemolytic crisis after ceftriaxone administration. *Pediatr Emerg Care* 2011;27(4):322-323.
380. Bienzle U, Sodeinde O, Effiong CE, Luzzatto L. Glucose 6-phosphate dehydrogenase deficiency and sickle cell anemia: frequency and features of the association in an African community. *Blood* 1975;46(4):591-597.
381. Steinberg MH, West MS, Gallagher D, Mentzer W. Effects of glucose-6-phosphate dehydrogenase deficiency upon sickle cell anemia. *Blood* 1988;71(3):748-752.
382. Lopez R, Shimizu N, Cooperman JM. Recurrent folic acid deficiency in sickle cell disease. *Am J Dis Child* 1973;125(4):544-548.
383. Pearson HA. Folic acid studies in sickle cell anemia. *J Lab Clin Med* 1964;64:913.
384. van der Dijs FP, Schnog JJ, Brouwer DA, et al. Elevated homocysteine levels indicate suboptimal folate status in pediatric sickle cell patients. *Am J Hematol* 1998;59(3):192-198.
385. Rodriguez-Cortes HM, Griener JC, Hyland K, et al. Plasma homocysteine levels and folate status in children with sickle cell anemia. *J Pediatr Hematol Oncol* 1999;21(3):219-223.
386. Seeler RA, Metzger W, Mufson MA. Diplococcus pneumoniae infections in children with sickle cell anemia. *Am J Dis Child* 1972;123(1):8-10.
387. Zarkowsky HS, Gallagher D, Gill FM, et al. Bacteremia in sickle hemoglobinopathies. *J Pediatr* 1986;109(4):579-585.
388. Wong WY, Overturf GD, Powars DR. Infection caused by Streptococcus pneumoniae in children with sickle cell disease: epidemiology, immunologic mechanisms, prophylaxis, and vaccination. *Clin Infect Dis* 1992;14(5): 1124-1136.
389. Overturf GD, Powars D, Baraff LJ. Bacterial meningitis and septicemia in sickle cell disease. *Am J Dis Child* 1977;131(7):784-787.
390. Powars D, Overturf G, Weiss J, Lee S, Chan L. Pneumococcal septicemia in children with sickle cell anemia. Changing trend of survival. *JAMA* 1981;245(18):1839-1842.
391. McCavit TL, Quinn CT, Techasaensiri C, Rogers ZR. Increase in invasive Streptococcus pneumoniae infections in children with sickle cell disease since pneumococcal conjugate vaccine licensure. *J Pediatr* 2011;158(3):505-507.
392. Hsu KK, Shea KM, Stevenson AE, Pelton SI. Changing serotypes causing childhood invasive pneumococcal disease: Massachusetts, 2001-2007. *Pediatr Infect Dis J* 2010;29(4):289-293.
393. Robinson MG, Halpern C. Infections, Escherichia coli, and sickle cell anemia. *JAMA* 1974;230(8):1145-1148.
394. Givner LB, Luddy RE, Schwartz AD. Etiology of osteomyelitis in patients with major sickle hemoglobinopathies. *J Pediatr* 1981;99(3):411-413.

395. Hook EW, Campbell CG, Weens HS, Cooper GR. Salmonella osteomyelitis in patients with sickle cell anemia. *N Engl J Med* 1957;257(9):403-409.
396. Hand WL, King NL. Serum opsonization of salmonella in sickle cell anemia. *Am J Med* 1978;64(3):388-395.
397. Syrogiannopoulos GA, McCracken GH Jr, Nelson JD. Osteoarticular infections in children with sickle cell disease. *Pediatrics* 1986;78(6):1090-1096.
398. Chulamokha L, Scholand SJ, Riggio JM, Ballas SK, Horn D, DeSimone JA. Bloodstream infections in hospitalized adults with sickle cell disease: a retrospective analysis. *Am J Hematol* 2006;81(10):723-728.
399. Zarrouk V, Habibi A, Zahar JR, et al. Bloodstream infection in adults with sickle cell disease: association with venous catheters, Staphylococcus aureus, and bone-joint infections. *Medicine (Baltimore)* 2006;85(1):43-48.
400. Johnston RB Jr. Increased susceptibility to infection in sickle cell disease: review of its occurrence and possible causes. *South Med J* 1974;67(11): 1342-1348.
401. Diggs LW. Siderofibrosis of the spleen in sickle cell anemia. *JAMA* 1939;112:695.
402. Casper JT, Koethe S, Rodey GE, Thatcher LG. A new method for studying splenic reticuloendothelial dysfunction in sickle cell disease patients and its clinical application: a brief report. *Blood* 1976;47(2):183-188.
403. Pearson HA, Spencer RP, Cornelius EA. Functional asplenia in sickle-cell anemia. *N Engl J Med* 1969;281(17):923-926.
404. Pearson HA, Cornelius EA, Schwartz AD, Zelson JH, Wolfson SL, Spencer RP. Transfusion-reversible functional asplenia in young children with sickle-cell anemia. *N Engl J Med* 1970;283(7):334-337.
405. Schwartz AD, Pearson HA. Impaired antibody response to intravenous immunization in sickle cell anemia. *Pediatr Res* 1972;6(2):145-149.
406. Gigliotti F, Feldman S, Wang WC, Day SW, Brunson G. Immunization of young infants with sickle cell disease with a Haemophilus influenzae type b saccharide-diphtheria CRM197 protein conjugate vaccine. *J Pediatr* 1989;114(6):1006-1010.
407. Gavriliis P, Rothenberg SP, Guy R. Correlation of low serum IgM levels with absence of functional splenic tissue in sickle cell disease syndromes. *Am J Med* 1974;57(4):542-545.
408. Bjornson AB, Lobel JS. Direct evidence that decreased serum opsonization of Streptococcus pneumoniae via the alternative complement pathway in sickle cell disease is related to antibody deficiency. *J Clin Invest* 1987;79(2): 388-398.
409. Strauss RG, Johnston RB Jr, Asbrock T, Moreno H, Lehmyer JE. Neutrophil oxidative metabolism in sickle cell disease. *J Pediatr* 1976;89(3):391-394.
410. Wang W, Herrod H, Presbury G, Wilimas J. Lymphocyte phenotype and function in chronically transfused children with sickle cell disease. *Am J Hematol* 1985;20(1):31-40.
411. Gaston MH, Verter JI, Woods G, et al. Prophylaxis with oral penicillin in children with sickle cell anemia. A randomized trial. *N Engl J Med* 1986;314(25):1593-1599.
412. John AB, Ramlal A, Jackson H, Maude GH, Sharma AW, Serjeant GR. Prevention of pneumococcal infection in children with homozygous sickle cell disease. *Br Med J (Clin Res Ed)* 1984;288(6430):1567-1570.
413. Falletta JM, Woods GM, Verter JI, et al. Discontinuing penicillin prophylaxis in children with sickle cell anemia. Prophylactic Penicillin Study II. *J Pediatr* 1995;127(5):685-690.
414. Rogers ZR, Buchanan GR. Bacteremia in children with sickle hemoglobin C disease and sickle beta(+)-thalassemia: is prophylactic penicillin necessary? *J Pediatr* 1995;127(3):348-354.
415. Daw NC, Wilimas JA, Wang WC, et al. Nasopharyngeal carriage of penicillin-resistant Streptococcus pneumoniae in children with sickle cell disease. *Pediatrics* 1997;99(4):E7.
416. Steele RW, Warriar R, Unkel PJ, et al. Colonization with antibiotic-resistant Streptococcus pneumoniae in children with sickle cell disease. *J Pediatr* 1996;128(4):531-535.
417. Woods GM, Jorgensen JH, Waclawiw MA, et al. Influence of penicillin prophylaxis on antimicrobial resistance in nasopharyngeal S. pneumoniae among children with sickle cell anemia. The Ancillary Nasopharyngeal Culture Study of Prophylactic Penicillin Study II. *J Pediatr Hematol Oncol* 1997;19(4): 327-333.

418. Ahonkhai VI, Landesman SH, Fikrig SM, et al. Failure of pneumococcal vaccine in children with sickle-cell disease. *N Engl J Med* 1979;301(1):26-27.
419. Kaplan J, Frost H, Sarnaik S, Schiffman G. Type-specific antibodies in children with sickle cell anemia given polyvalent pneumococcal vaccine. *J Pediatr* 1982;100(3):404-406.
420. Overturf GD, Rigau-Perez JG, Selzer J, et al. Pneumococcal polysaccharide immunization of children with sickle cell disease. I. Clinical reactions to immunization and relationship to preimmunization antibody. *Am J Pediatr Hematol Oncol* 1982;4(1):19-23.
421. Weintrub PS, Schiffman G, Addiego JE Jr, et al. Long-term follow-up and booster immunization with polyvalent pneumococcal polysaccharide in patients with sickle cell anemia. *J Pediatr* 1984;105(2):261-263.
422. Nowak-Wegrzyn A, Winkelstein JA, Swift AJ, Lederman HM. Serum opsonic activity in infants with sickle-cell disease immunized with pneumococcal polysaccharide protein conjugate vaccine. The Pneumococcal Conjugate Vaccine Study Group. *Clin Diagn Lab Immunol* 2000;7(5):788-793.
423. O'Brien KL, Swift AJ, Winkelstein JA, et al. Safety and immunogenicity of heptavalent pneumococcal vaccine conjugated to CRM(197) among infants with sickle cell disease. Pneumococcal Conjugate Vaccine Study Group. *Pediatrics* 2000;106(5):965-972.
424. Halasa NB, Shankar SM, Talbot TR, et al. Incidence of invasive pneumococcal disease among individuals with sickle cell disease before and after the introduction of the pneumococcal conjugate vaccine. *Clin Infect Dis* 2007;44(11):1428-1433.
425. McCavit TL, Xuan L, Zhang S, Flores G, Quinn CT. Hospitalization for invasive pneumococcal disease in a national sample of children with sickle cell disease before and after PCV7 licensure. *Pediatr Blood Cancer* 2012;58(6):945-949.
426. Jefferies JM, Macdonald E, Faust SN, Clarke SC. 13-valent pneumococcal conjugate vaccine (PCV13). *Hum Vaccin* 2011;7(10):1012-1018.
427. Bernstein DI, El Sahly HM, Keitel WA, et al. Safety and immunogenicity of a candidate parvovirus B19 vaccine. *Vaccine* 2011;29(43):7357-7363.
428. Rogers ZR, Morrison RA, Vedro DA, Buchanan GR. Outpatient management of febrile illness in infants and young children with sickle cell anemia. *J Pediatr* 1990;117(5):736-739.
429. Wilimas JA, Flynn PM, Harris S, et al. A randomized study of outpatient treatment with ceftriaxone for selected febrile children with sickle cell disease. *N Engl J Med* 1993;329(7):472-476.
430. Williams LL, Wilimas JA, Harris SC, Day SW, Dancy RM, Wang WC. Outpatient therapy with ceftriaxone and oral cefixime for selected febrile children with sickle cell disease. *J Pediatr Hematol Oncol* 1996;18(3):257-261.
431. Phebus CK, Gloninger MF, Maciak BJ. Growth patterns by age and sex in children with sickle cell disease. *J Pediatr* 1984;105(1):28-33.
432. Platt OS, Rosenstock W, Espeland MA. Influence of sickle hemoglobinopathies on growth and development. *N Engl J Med* 1984;311(1):7-12.
433. Stevens MC, Maude GH, Cupidore L, Jackson H, Hayes RJ, Serjeant GR. Prepubertal growth and skeletal maturation in children with sickle cell disease. *Pediatrics* 1986;78(1):124-132.
434. Jimenez CT, Scott RB, Henry WL, Sampson CC, Ferguson AD. Studies in sickle cell anemia. XXVI. The effects of homozygous sickle cell disease on the onset of menarche, pregnancy, fertility, pubescent changes, and body growth in Negro subjects. *Am J Dis Child* 1966;111(5):497-504.
435. Landefeld CS, Schambelan M, Kaplan SL, Embury SH. Clomiphene-responsive hypogonadism in sickle cell anemia. *Ann Intern Med* 1983;99(4):480-483.
436. Borel MJ, Buchowski MS, Turner EA, Peeler BB, Goldstein RE, Flakoll PJ. Alterations in basal nutrient metabolism increase resting energy expenditure in sickle cell disease. *Am J Physiol* 1998;274(2 Pt 1):E357-E364.
437. Rhodes M, Akohoue SA, Shankar SM, et al. Growth patterns in children with sickle cell anemia during puberty. *Pediatr Blood Cancer* 2009;53(4): 635-641.
438. Barden EM, Zemel BS, Kawchak DA, Goran MI, Ohene-Frempong K, Stallings VA. Total and resting energy expenditure in children with sickle cell disease. *J Pediatr* 2000;136(1):73-79.

439. Kopp-Hoolihan LE, van Loan MD, Mentzer WC, Heyman MB. Elevated resting energy expenditure in adolescents with sickle cell anemia. *J Am Diet Assoc* 1999;99(2):195-199.
440. Buchowski MS, de la Fuente FA, Flakoll PJ, Chen KY, Turner EA. Increased bone turnover is associated with protein and energy metabolism in adolescents with sickle cell anemia. *Am J Physiol Endocrinol Metab* 2001;280(3):E518-E527.
441. Singhal A, Parker S, Linsell L, Serjeant G. Energy intake and resting metabolic rate in preschool Jamaican children with homozygous sickle cell disease. *Am J Clin Nutr* 2002;75(6):1093-1097.
442. Fung EB, Malinauskas BM, Kawchak DA, et al. Energy expenditure and intake in children with sickle cell disease during acute illness. *Clin Nutr* 2001;20(2):131-138.
443. VanderJagt DJ, Harmatz P, Scott-Emuakpor AB, Vichinsky E, Glew RH. Bioelectrical impedance analysis of the body composition of children and adolescents with sickle cell disease. *J Pediatr* 2002;140(6):681-687.
444. Heyman MB, Vichinsky E, Katz R, et al. Growth retardation in sickle-cell disease treated by nutritional support. *Lancet* 1985;1(8434):903-906.
445. Gee BE, Platt OS. Growth and development. In: Embury SH, Hebbel RP, Mohandas N, Steinberg MH, eds. *Sickle cell disease: basic principles and clinical practice*. New York: Raven Press, 1994:589-597.
446. Nelson MC, Zemel BS, Kawchak DA, et al. Vitamin b6 status of children with sickle cell disease. *J Pediatr Hematol Oncol* 2002;24(6):463-469.
447. Westerman MP, Zhang Y, McConnell JP, et al. Ascorbate levels in red blood cells and urine in patients with sickle cell anemia. *Am J Hematol* 2000;65(2):174-175.
448. Prasad AS, Abbasi AA, Rabbani P, DuMouchelle E. Effect of zinc supplementation on serum testosterone level in adult male sickle cell anemia subjects. *Am J Hematol* 1981;10(2):119-127.
449. Luporini SM, Bendit I, Manhani R, Bracco OL, Manzella L, Giannella-Neto D. Growth hormone and insulin-like growth factor I axis and growth of children with different sickle cell anemia haplotypes. *J Pediatr Hematol Oncol* 2001;23(6):357-363.
450. Soliman AT, el Banna N, alSalmi I, De S, V, Craig A, Asfour M. Growth hormone secretion and circulating insulin-like growth factor-I (IGF-I) and IGF binding protein-3 concentrations in children with sickle cell disease. *Metabolism* 1997;46(11):1241-1245.
451. Reynolds J. Radiologic manifestations of sickle cell hemoglobinopathy. *JAMA* 1977;238(3):247-250.
452. Milner PF, Kraus AP, Sebes JI, et al. Sickle cell disease as a cause of osteonecrosis of the femoral head. *N Engl J Med* 1991;325(21):1476-1481.
453. Milner PF, Kraus AP, Sebes JI, et al. Osteonecrosis of the humeral head in sickle cell disease. *Clin Orthop* 1993;(289):136-143.
454. Hernigou P, Galacteros F, Bachir D, Goutallier D. Deformities of the hip in adults who have sickle-cell disease and had avascular necrosis in childhood. A natural history of fifty-two patients. *J Bone Joint Surg Am* 1991;73(1): 81-92.
455. Hernigou P, Allain J, Bachir D, Galacteros F. Abnormalities of the adult shoulder due to sickle cell osteonecrosis during childhood. *Rev Rhum Engl Ed* 1998;65(1):27-32.
456. Clarke HJ, Jinnah RH, Brooker AF, Michaelson JD. Total replacement of the hip for avascular necrosis in sickle cell disease. *J Bone Joint Surg Br* 1989;71(3):465-470.
457. Hanker GJ, Amstutz HC. Osteonecrosis of the hip in the sickle-cell diseases. Treatment and complications. *J Bone Joint Surg Am* 1988;70(4):499-506.
458. Styles LA, Vichinsky EP. Core decompression in avascular necrosis of the hip in sickle-cell disease. *Am J Hematol* 1996;52(2):103-107.
459. Mukisi-Mukaza M, Manicom O, Alexis C, Bashoun K, Donkerwolcke M, Burny F. Treatment of sickle cell disease's hip necrosis by core decompression: a prospective case-control study. *Orthop Traumatol Surg Res* 2009;95(7): 498-504.
460. Neumayr LD, Aguilar C, Earles AN, et al. Physical therapy alone compared with core decompression and physical therapy for femoral head osteonecrosis in sickle cell disease. Results of a multicenter study at a mean of three years after treatment. *J Bone Joint Surg Am* 2006;88(12):2573-2582.

461. Hernigou P, Poignard A, Zilber S, Rouard H. Cell therapy of hip osteonecrosis with autologous bone marrow grafting. *Indian J Orthop* 2009;43(1):40-45.
462. Reynolds J. A re-evaluation of the "fish vertebra" sign in sickle cell hemoglobinopathy. *Am J Roentgenol Radium Ther Nucl Med* 1966;97(3):693-707.
463. Oredugba FA, Savage KO. Anthropometric finding in Nigerian children with sickle cell disease. *Pediatr Dent* 2002;24(4):321-325.
464. Sarrai M, Duroseau H, D'Augustine J, Moktan S, Bellevue R. Bone mass density in adults with sickle cell disease. *Br J Haematol* 2007;136(4):666-672.
465. Baldanzi G, Traina F, Marques Neto JF, Santos AO, Ramos CD, Saad ST. Low bone mass density is associated with hemolysis in brazilian patients with sickle cell disease. *Clinics (Sao Paulo)* 2011;66(5):801-805.
466. Adewoye AH, Chen TC, Ma Q, et al. Sickle cell bone disease: response to vitamin D and calcium. *Am J Hematol* 2008;83(4):271-274.
467. Alavi A, Schumacher HR, Dorwart B, Kuhl DE. Bone marrow scan evaluation of arthropathy in sickle cell disorders. *Arch Intern Med* 1976;136(4): 436-440.
468. Goldberg MA. Sickle cell arthropathy: analysis of synovial fluid in sickle cell anemia with joint effusion. *South Med J* 1973;66(8):956-958.
469. Palmer DW, Ellman MH. Septic arthritis and Reiter's syndrome in sickle cell disorders: case reports and implications for management. *South Med J* 1976;69(7):902-904.
470. Ball GV, Sorensen LB. The pathogenesis of hyperuricemia and gout in sickle cell anemia. *Arthritis Rheum* 1970;13(6):846-848.
471. Serjeant GR, Ashcroft MT. Delayed skeletal maturation in sickle cell anemia in Jamaica. *Johns Hopkins Med J* 1973;132(2):95-102.
472. Armstrong FD, Thompson RJ Jr, Wang W, et al. Cognitive functioning and brain magnetic resonance imaging in children with sickle Cell disease. *Neuropsychology Committee of the Cooperative Study of Sickle Cell Disease. Pediatrics* 1996;97(6 Pt 1):864-870.
473. Fowler MG, Whitt JK, Lallinger RR, et al. Neuropsychologic and academic functioning of children with sickle cell anemia. *J Dev Behav Pediatr* 1988;9(4):213-220.
474. Swift AV, Cohen MJ, Hynd GW, et al. Neuropsychologic impairment in children with sickle cell anemia. *Pediatrics* 1989;84(6):1077-1085.
475. Hariman LM, Griffith ER, Hurtig AL, Keehn MT. Functional outcomes of children with sickle-cell disease affected by stroke. *Arch Phys Med Rehabil* 1991;72(7):498-502.
476. Vichinsky EP, Neumayr LD, Gold JI, et al. Neuropsychological dysfunction and neuroimaging abnormalities in neurologically intact adults with sickle cell anemia. *JAMA* 2010;303(18):1823-1831.
477. Wang WC, Langston JW, Steen RG, et al. Abnormalities of the central nervous system in very young children with sickle cell anemia. *J Pediatr* 1998;132(6):994-998.
478. Wang WC, Pavlakis SG, Helton KJ, et al. MRI abnormalities of the brain in one-year-old children with sickle cell anemia. *Pediatr Blood Cancer* 2008;51(5):643-646.
479. Wang W, Enos L, Gallagher D, et al. Neuropsychologic performance in school-aged children with sickle cell disease: a report from the Cooperative Study of Sickle Cell Disease. *J Pediatr* 2001;139(3):391-397.
480. Schatz J, Finke RL, Kellett JM, Kramer JH. Cognitive functioning in children with sickle cell disease: a meta- analysis. *J Pediatr Psychol* 2002;27(8):739-748.
481. Bernaudin F, Verlhac S, Freard F, et al. Multicenter prospective study of children with sickle cell disease: radiographic and psychometric correlation. *J Child Neurol* 2000;15(5):333-343.
482. Brown RT, Davis PC, Lambert R, Hsu L, Hopkins K, Eckman J. Neurocognitive functioning and magnetic resonance imaging in children with sickle cell disease. *J Pediatr Psychol* 2000;25(7):503-513.

483. Watkins KE, Hewes DK, Connelly A, et al. Cognitive deficits associated with frontal-lobe infarction in children with sickle cell disease. *Dev Med Child Neurol* 1998;40(8):536-543.
484. Schatz J, Brown RT, Pascual JM, Hsu L, DeBaun MR. Poor school and cognitive functioning with silent cerebral infarcts and sickle cell disease. *Neurology* 2001;56(8):1109-1111.
485. Hijmans CT, Grootenhuis MA, Oosterlaan J, Heijboer H, Peters M, Fijnvandraat K. Neurocognitive deficits in children with sickle cell disease are associated with the severity of anemia. *Pediatr Blood Cancer* 2011;57(2):297-302.
486. Lebensburger JD, Hilliard LM, McGrath TM, Fineberg NS, Howard TH. Laboratory and clinical correlates for magnetic resonance imaging (MRI) abnormalities in pediatric sickle cell anemia. *J Child Neurol* 2011;26(10):1260-1264.
487. Hollocks MJ, Kok TB, Kirkham FJ, et al. Nocturnal oxygen desaturation and disordered sleep as a potential factor in executive dysfunction in sickle cell anemia. *J Int Neuropsychol Soc* 2012;18(1):168-173.
488. Sanchez CE, Schatz J, Roberts CW. Cerebral blood flow velocity and language functioning in pediatric sickle cell disease. *J Int Neuropsychol Soc* 2010;16(2):326-334.
489. Helton KJ, Paydar A, Glass J, et al. Arterial spin-labeled perfusion combined with segmentation techniques to evaluate cerebral blood flow in white and gray matter of children with sickle cell anemia. *Pediatr Blood Cancer* 2009;52(1):85-91.
490. Zou P, Helton KJ, Smeltzer M, et al. Hemodynamic responses to visual stimulation in children with sickle cell anemia. *Brain Imaging Behav* 2011;5(4):295-306.
491. Gevers S, Nederveen AJ, Fijnvandraat K, et al. Arterial spin labeling measurement of cerebral perfusion in children with sickle cell disease. *J Magn Reson Imaging* 2012;35(4):779-787.
492. Puffer E, Schatz J, Roberts CW. The association of oral hydroxyurea therapy with improved cognitive functioning in sickle cell disease. *Child Neuropsychol* 2007;13(2):142-154.
493. Berkelhammer LD, Williamson AL, Sanford SD, et al. Neurocognitive sequelae of pediatric sickle cell disease: a review of the literature. *Child Neuropsychol* 2007;13(2):120-131.
494. Steen RG, Xiong X, Mulhern RK, Langston JW, Wang WC. Subtle brain abnormalities in children with sickle cell disease: relationship to blood hematocrit. *Ann Neurol* 1999;45(3):279-286.
495. Walters MC, Storb R, Patience M, et al. Impact of bone marrow transplantation for symptomatic sickle cell disease: an interim report. Multicenter investigation of bone marrow transplantation for sickle cell disease. *Blood* 2000;95(6):1918-1924.
496. Woodard P, Helton KJ, Khan RB, et al. Brain parenchymal damage after haematopoietic stem cell transplantation for severe sickle cell disease. *Br J Haematol* 2005;129(4):550-552.
497. Lindsay J Jr, Meshel JC, Patterson RH. The cardiovascular manifestations of sickle cell disease. *Arch Intern Med* 1974;133(4):643-651.
498. Gerry JL, Bulkley BH, Hutchins GM. Clinicopathologic analysis of cardiac dysfunction in 52 patients with sickle cell anemia. *Am J Cardiol* 1978;42(2):211-216.
499. Qureshi N, Joyce JJ, Qi N, Chang RK. Right ventricular abnormalities in sickle cell anemia: evidence of a progressive increase in pulmonary vascular resistance. *J Pediatr* 2006;149(1):23-27.
500. Lamers L, Ensing G, Pignatelli R, et al. Evaluation of left ventricular systolic function in pediatric sickle cell anemia patients using the end-systolic wall stress-velocity of circumferential fiber shortening relationship. *J Am Coll Cardiol* 2006;47(11):2283-2288.
501. Covitz W, Espeland M, Gallagher D, Hellenbrand W, Leff S, Talner N. The heart in sickle cell anemia. The Cooperative Study of Sickle Cell Disease (CSSCD). *Chest* 1995;108(5):1214-1219.
502. Raman SV, Simonetti OP, Cataland SR, Kraut EH. Myocardial ischemia and right ventricular dysfunction in adult patients with sickle cell disease. *Haematologica* 2006;91(10):1329-1335.
503. Machado RF, Hildesheim M, Mendelsohn L, Remaley AT, Kato GJ, Gladwin MT. NT-pro brain natriuretic peptide levels and the risk of death in the cooperative study of sickle cell disease. *Br J Haematol* 2011;154(4):512-520.
504. Aliyu ZY, Suleiman A, Attah E, et al. NT-proBNP as a marker of cardiopulmonary status in sickle cell anaemia in Africa. *Br J Haematol* 2010;150(1): 102-107.

505. Eddine AC, Alvarez O, Lipshultz SE, Kardon R, Arheart K, Swaminathan S. Ventricular structure and function in children with sickle cell disease using conventional and tissue Doppler echocardiography. *Am J Cardiol* 2012;109(9):1358-1364.
506. Ahmad H, Gayat E, Yodwut C, et al. Evaluation of myocardial deformation in patients with sickle cell disease and preserved ejection fraction using three-dimensional speckle tracking echocardiography. *Echocardiography*. 2012 Sep; 29(8):962-969. doi: 10.1111/j.1540-8175.2012.01710.x. Epub 2012 May 8.
507. Hankins JS, McCarville MB, Hillenbrand CM, et al. Ventricular diastolic dysfunction in sickle cell anemia is common but not associated with myocardial iron deposition. *Pediatr Blood Cancer* 2010;55(3):495-500.
508. Sachdev V, Machado RF, Shizukuda Y, et al. Diastolic dysfunction is an independent risk factor for death in patients with sickle cell disease. *J Am Coll Cardiol* 2007;49(4):472-479.
509. Martin C, Cobb C, Johnson C. Cardiovascular pathology in sickle cell disease. *J Am Coll Cardiol* 1983;1:723.
510. Barrett O Jr, Saunders DE Jr, McFarland DE, Humphries JO. Myocardial infarction in sickle cell anemia. *Am J Hematol* 1984;16(2):139-147.
511. Deymann AJ, Goertz KK. Myocardial infarction and transient ventricular dysfunction in an adolescent with sickle cell disease. *Pediatrics* 2003;111(2):E183-E187.
512. Johnson WH Jr, McCrary RB, Mankad VN. Transient left ventricular dysfunction in childhood sickle cell disease. *Pediatr Cardiol* 1999;20(3):221-223.
513. Acar P, Sebahoun S, de Pontual L, Maunoury C. Myocardial perfusion in children with sickle cell anaemia. *Pediatr Radiol* 2000;30(5):352-354.
514. de MM, Maunoury C, Acar P, Brousse V, Sidi D, Lenoir G. Myocardial ischaemia in children with sickle cell disease. *Arch Dis Child* 2004;89(4): 359-362.
515. Maunoury C, Acar P, de Montalembert M, Sidi D. Myocardial perfusion in children with sickle cell disease. *Am J Cardiol* 2003;91(3):374-376.
516. Brown J, Geer M, Covitz W, et al. Electrocardiographic responses to exercise in sickle cell anemia. In: Doyle EG, Engle MA, Gersony WM, eds. *Pediatric cardiology*. New York: Springer-Verlag, 1986:1111-1116.
517. Callahan LA, Woods KF, Mensah GA, Ramsey LT, Barbeau P, Gutin B. Cardiopulmonary responses to exercise in women with sickle cell anemia. *Am J Respir Crit Care Med* 2002;165(9):1309-1316.
518. Alpert BS, Gilman PA, Strong WB, et al. Hemodynamic and ECG responses to exercise in children with sickle cell anemia. *Am J Dis Child* 1981;135(4):362-366.
519. Batra AS, Acherman RJ, Wong WY, et al. Cardiac abnormalities in children with sickle cell anemia. *Am J Hematol* 2002;70(4):306-312.
520. Covitz W, Eubig C, Balfour IC, et al. Exercise-induced cardiac dysfunction in sickle cell anemia. A radionuclide study. *Am J Cardiol* 1983;51(3):570-575.
521. Liem RI, Young LT, Thompson AA. Prolonged QTc interval in children and young adults with sickle cell disease at steady state. *Pediatr Blood Cancer* 2009;52(7):842-846.
522. Dang NC, Johnson C, Eslami-Farsani M, Haywood LJ. Myocardial injury or infarction associated with fat embolism in sickle cell disease: a report of three cases with survival. *Am J Hematol* 2005;80(2):133-136.
523. Knight-Madden JM, Forrester TS, Lewis NA, Greenough A. The impact of recurrent acute chest syndrome on the lung function of young adults with sickle cell disease. *Lung* 2010;188(6):499-504.
524. Miller AC, Gladwin MT. Pulmonary complications of sickle cell disease. *Am J Respir Crit Care Med* 2012;185(11):1154-1165.
525. Homi J, Levee L, Higgs D, Thomas P, Serjeant G. Pulse oximetry in a cohort study of sickle cell disease. *Clin Lab Haematol* 1997;19(1):17-22.
526. Pianosi P, Charge TD, Esseltine DW, Coates AL. Pulse oximetry in sickle cell disease. *Arch Dis Child* 1993;68(6):735-738.
527. Quinn CT, Ahmad N. Clinical correlates of steady-state oxyhaemoglobin desaturation in children who have sickle cell disease. *Br J Haematol* 2005;131(1):129-134.

528. Blaisdell CJ, Goodman S, Clark K, Casella JF, Loughlin GM. Pulse oximetry is a poor predictor of hypoxemia in stable children with sickle cell disease. *Arch Pediatr Adolesc Med* 2000;154(9):900-903.
529. Comber JT, Lopez BL. Evaluation of pulse oximetry in sickle cell anemia patients presenting to the emergency department in acute vasoocclusive crisis. *Am J Emerg Med* 1996;14(1):16-18.
530. Fitzgerald RK, Johnson A. Pulse oximetry in sickle cell anemia. *Crit Care Med* 2001;29(9):1803-1806.
531. Field JJ, Stocks J, Kirkham FJ, et al. Airway hyperresponsiveness in children with sickle cell anemia. *Chest* 2011;139(3):563-568.
532. Ozbek OY, Malbora B, Sen N, Yazici AC, Ozyurek E, Ozbek N. Airway hyper-reactivity detected by methacholine challenge in children with sickle cell disease. *Pediatr Pulmonol* 2007;42(12):1187-1192.
533. Cohen RT, Madadi A, Blinder MA, DeBaun MR, Strunk RC, Field JJ. Recurrent, severe wheezing is associated with morbidity and mortality in adults with sickle cell disease. *Am J Hematol* 2011;86(9):756-761.
534. Field JJ, DeBaun MR. Asthma and sickle cell disease: two distinct diseases or part of the same process? *Hematology Am Soc Hematol Educ Program* 2009;45-53.
535. Castro O, Hoque M, Brown BD. Pulmonary hypertension in sickle cell disease: cardiac catheterization results and survival. *Blood* 2003;101(4):1257-1261.
536. Castro O, Gladwin MT. Pulmonary hypertension in sickle cell disease: mechanisms, diagnosis, and management. *Hematol Oncol Clin North Am* 2005;19(5):881-96, vii.
537. Haque AK, Gokhale S, Rampy BA, Adegboyega P, Duarte A, Saldana MJ. Pulmonary hypertension in sickle cell hemoglobinopathy: a clinicopathologic study of 20 cases. *Hum Pathol* 2002;33(10):1037-1043.
538. Sutton LL, Castro O, Cross DJ, Spencer JE, Lewis JF. Pulmonary hypertension in sickle cell disease. *Am J Cardiol* 1994;74(6):626-628.
539. Fonseca GH, Souza R, Salemi VM, Jardim CV, Gualandro SF. Pulmonary hypertension diagnosed by right heart catheterisation in sickle cell disease. *Eur Respir J* 2012;39(1):112-118.
540. De Castro LM, Jonassaint JC, Graham FL, Ashley-Koch A, Telen MJ. Pulmonary hypertension associated with sickle cell disease: clinical and laboratory endpoints and disease outcomes. *Am J Hematol* 2008;83(1):19-25.
541. Ataga KI, Moore CG, Jones S, et al. Pulmonary hypertension in patients with sickle cell disease: a longitudinal study. *Br J Haematol* 2006;134(1):109-115.
542. Parent F, Bachir D, Inamo J, et al. A hemodynamic study of pulmonary hypertension in sickle cell disease. *N Engl J Med* 2011;365(1):44-53.
543. Mehari A, Gladwin MT, Tian X, Machado RF, Kato GJ. Mortality in adults with sickle cell disease and pulmonary hypertension. *JAMA* 2012;307(12): 1254-1256.
544. Minniti CP, Sable C, Campbell A, et al. Elevated tricuspid regurgitant jet velocity in children and adolescents with sickle cell disease: association with hemolysis and hemoglobin oxygen desaturation. *Haematologica* 2009;94(3):340-347.
545. Chaudry RA, Cikes M, Karu T, et al. Paediatric sickle cell disease: pulmonary hypertension but normal vascular resistance. *Arch Dis Child* 2011;96(2): 131-136.
546. de Gouw HW, Hendriks J, Woltman AM, Twiss IM, Sterk PJ. Exhaled nitric oxide (NO) is reduced shortly after bronchoconstriction to direct and indirect stimuli in asthma. *Am J Respir Crit Care Med* 1998;158(1):315-319.
547. Tsao PS, McEvoy LM, Drexler H, Butcher EC, Cooke JP. Enhanced endothelial adhesiveness in hypercholesterolemia is attenuated by L-arginine. *Circulation* 1994;89(5):2176-2182.

P.861

548. Machado RF, Barst RJ, Yovetich NA, et al. Hospitalization for pain in patients with sickle cell disease treated with sildenafil for elevated TRV and low exercise capacity. *Blood* 2011;118(4):855-864.
549. Barst RJ, Mubarak KK, Machado RF, et al. Exercise capacity and haemodynamics in patients with sickle cell disease with pulmonary hypertension treated with bosentan: results of the ASSET studies. *Br J Haematol* 2010;149(3):426-435.

550. Johnson CS, Omata M, Tong MJ, Simmons JF Jr, Weiner J, Tatter D. Liver involvement in sickle cell disease. *Medicine (Baltimore)* 1985;64(5):349-356.
551. Hilkovitz G, Jacobson A. Hepatic dysfunction and abnormalities of serum proteins and serum enzymes in sickle cell anemia. *J Lab Clin Med* 1961;57:856.
552. Jeng MR, Rieman MD, Naidu PE, et al. Resolution of chronic hepatic sequestration in a patient with homozygous sickle cell disease receiving hydroxyurea. *J Pediatr Hematol Oncol* 2003;25(3):257-260.
553. Norris WE. Acute hepatic sequestration in sickle cell disease. *J Natl Med Assoc* 2004;96(9):1235-1239.
554. Sty JR. Ultrasonography: hepatic vein thrombosis in sickle cell anemia. *Am J Pediatr Hematol Oncol* 1982;4(2):213-215.
555. Gremse DA, Fillingim E, Hoff CJ, Wells DJ, Boerth RC. Hepatic function as assessed by lidocaine metabolism in sickle cell disease. *J Pediatr* 1998;132(6):989-993.
556. Smits HL, Oski FA, Brody JI. The hemolytic crisis of sickle cell disease: the role of glucose-6-phosphate dehydrogenase deficiency. *J Pediatr* 1969;74(4):544-551.
557. Barrett-Connor E. Sickle cell disease and viral hepatitis. *Ann Intern Med* 1968;69(3):517-527.
558. Yohannan MD, Arif M, Ramia S. Aetiology of icteric hepatitis and fulminant hepatic failure in children and the possible predisposition to hepatic failure by sickle cell disease. *Acta Paediatr Scand* 1990;79(2):201-205.
559. Sarnaik SA, Merline JR, Bond S. Immunogenicity of hepatitis B vaccine in children with sickle cell anemia. *J Pediatr* 1988;112(3):429-430.
560. Hord J, Windsor B, Koehler M, Blatt J, Janosky J, Mirro J. Diminished antibody response to hepatitis B immunization in children with sickle cell disease. *J Pediatr Hematol Oncol* 2002;24(7):548-549.
561. DeVault KR, Friedman LS, Westerberg S, Martin P, Hosein B, Ballas SK. Hepatitis C in sickle cell anemia. *J Clin Gastroenterol* 1994;18(3):206-209.
562. Hasan MF, Marsh F, Posner G, et al. Chronic hepatitis C in patients with sickle cell disease. *Am J Gastroenterol* 1996;91(6):1204-1206.
563. Hurtova M, Bachir D, Lee K, et al. Transplantation for liver failure in patients with sickle cell disease: challenging but feasible. *Liver Transpl* 2011;17(4):381-392.
564. Rosenblate HJ, Eisenstein R, Holmes AW. The liver in sickle cell anemia. A clinical-pathologic study. *Arch Pathol* 1970;90(3):235-245.
565. Ahn H, Li CS, Wang W. Sickle cell hepatopathy: clinical presentation, treatment, and outcome in pediatric and adult patients. *Pediatr Blood Cancer* 2005;45(2):184-190.
566. Buchanan GR, Glader BE. Benign course of extreme hyperbilirubinemia in sickle cell anemia: analysis of six cases. *J Pediatr* 1977;91(1):21-24.
567. Stephan JL, Merpit-Gonon E, Richard O, Raynaud-Ravni C, Freycon F. Fulminant liver failure in a 12-year-old girl with sickle cell anaemia: favourable outcome after exchange transfusions. *Eur J Pediatr* 1995;154(6): 469-471.
568. O'Callaghan A, O'Brien SG, Ninkovic M, et al. Chronic intrahepatic cholestasis in sickle cell disease requiring exchange transfusion. *Gut* 1995;37(1): 144-147.
569. Shao SH, Orringer EP. Sickle cell intrahepatic cholestasis: approach to a difficult problem. *Am J Gastroenterol* 1995;90(11):2048-2050.
570. Karayalcin G, Hassani N, Abrams M, Lanzkowsky P. Cholelithiasis in children with sickle cell disease. *Am J Dis Child* 1979;133(3):306-307.
571. Lachman BS, Lazerson J, Starshak RJ, Vaughters FM, Werlin SL. The prevalence of cholelithiasis in sickle cell disease as diagnosed by ultrasound and cholecystography. *Pediatrics* 1979;64(5):601-603.
572. Sarnaik S, Slovis TL, Corbett DP, Emami A, Whitten CF. Incidence of cholelithiasis in sickle cell anemia using the ultrasonic gray-scale technique. *J Pediatr* 1980;96(6):1005-1008.
573. Walker TM, Hambleton IR, Serjeant GR. Gallstones in sickle cell disease: observations from The Jamaican Cohort study. *J Pediatr* 2000;136(1):80-85.

574. Winter SS, Kinney TR, Ware RE. Gallbladder sludge in children with sickle cell disease. *J Pediatr* 1994;125(5 Pt 1):747-749.
575. Passon RG, Howard TA, Zimmerman SA, Schultz WH, Ware RE. Influence of bilirubin uridine diphosphate-glucuronosyltransferase 1A promoter polymorphisms on serum bilirubin levels and cholelithiasis in children with sickle cell anemia. *J Pediatr Hematol Oncol* 2001;23(7):448-451.
576. McCarville MB, Rogers ZR, Sarnaik S, et al. Effects of chronic transfusions on abdominal sonographic abnormalities in children with sickle cell anemia. *J Pediatr* 2012;160(2):281-285.
577. Cameron JL, Maddrey WC, Zuidema GD. Biliary tract disease in sickle cell anemia: surgical considerations. *Ann Surg* 1971;174(4):702-710.
578. Al Mulhim AS, Al Mulhim FM, Al Suwayigh AA. The role of laparoscopic cholecystectomy in the management of acute cholecystitis in patients with sickle cell disease. *Am J Surg* 2002;183(6):668-672.
579. Haberkern CM, Neumayr LD, Orringer EP, et al. Cholecystectomy in sickle cell anemia patients: perioperative outcome of 364 cases from the National Preoperative Transfusion Study. Preoperative Transfusion in Sickle Cell Disease Study Group. *Blood* 1997;89(5):1533-1542.
580. Ware RE, Kinney TR, Casey JR, Pappas TN, Meyers WC. Laparoscopic cholecystectomy in young patients with sickle hemoglobinopathies. *J Pediatr* 1992;120(1):58-61.
581. Rao S, Royal JE, Conrad HA Jr, Harris V, Ahuja J. Duodenal ulcer in sickle cell anemia. *J Pediatr Gastroenterol Nutr* 1990;10(1):117-120.
582. Lee MG, Thirumalai CH, Terry SI, Serjeant GR. Endoscopic and gastric acid studies in homozygous sickle cell disease and upper abdominal pain. *Gut* 1989;30(5):569-572.
583. Karim A, Ahmed S, Rossoff LJ, Siddiqui R, Fuchs A, Multz AS. Fulminant ischaemic colitis with atypical clinical features complicating sickle cell disease. *Postgrad Med J* 2002;78(920):370-372.
584. Green BT, Branch MS. Ischemic colitis in a young adult during sickle cell crisis: case report and review. *Gastrointest Endosc* 2003;57(4):605-607.
585. Qureshi A, Lang N, Bevan DH. Sickle cell "girdle syndrome" progressing to ischaemic colitis and colonic perforation. *Clin Lab Haematol* 2006;28(1): 60-62.
586. Kumar A, Posner G, Marsh F, Bellvue R, Dosik H. Acute pancreatitis in sickle cell crisis. *J Natl Med Assoc* 1989;81(1):91-92.
587. Hankins JS, Smeltzer MP, McCarville MB, et al. Patterns of liver iron accumulation in patients with sickle cell disease and thalassemia with iron overload. *Eur J Haematol* 2010;85(1):51-57.
588. Buckalew VM Jr, Someren A. Renal manifestations of sickle cell disease. *Arch Intern Med* 1974;133(4):660-669.
589. Efenbein IB, Patchefsky A, Schwartz W, Weinstein AG. Pathology of the glomerulus in sickle cell anemia with and without nephrotic syndrome. *Am J Pathol* 1974;77(3):357-374.
590. Khademi M, Marquis JR. Renal angiography in sickle-cell disease. A preliminary report correlating the angiographic and urographic changes in sickle-cell nephropathy. *Radiology* 1973;107(1):41-46.
591. Keitel HG. Hyposthenuria in sickle cell anemia. A reversible renal defect. *J Clin Invest* 1956;35:998.
592. Perillie P, Epstein FH. Sickling phenomenon produced by hypertonic solutions: a possible explanation for the hyposthenuria of sickle cell anemia. *J Clin Invest* 1963;42:570.
593. Goossens JP, Stadius van Eps LW, Schouten H, Giterson AL. Incomplete renal tubular acidosis in sickle cell disease. *Clin Chim Acta* 1972;41:149-156.
594. Hatch FE, Culbertson JW, Diggs LW. Nature of the renal concentrating defect in sickle cell disease. *J Clin Invest* 1967;46(3):336-345.
595. Ho PK, Alleyne GA. Defect in urinary acidification in adults with sickle-cell anaemia. *Lancet* 1968;2(7575):954-955.
596. Suster G, Oski FA. Enuresis in sickle cell anemia. *Am J Dis Child* 1967;113(3):311.
597. Figueroa TE, Benaim E, Griggs ST, Hvizdala EV. Enuresis in sickle cell disease. *J Urol* 1995;153(6):1987-1989.

598. Readett DR, Morris J, Serjeant GR. Determinants of nocturnal enuresis in homozygous sickle cell disease. *Arch Dis Child* 1990;65(6):615-618.
599. Jordan SS, Hilker KA, Stoppelbein L, Elkin TD, Applegate H, Iyer R. Nocturnal enuresis and psychosocial problems in pediatric sickle cell disease and sibling controls. *J Dev Behav Pediatr* 2005;26(6):404-411.
600. de Jong PE, de Jong-van den Berg LT, Stadius van Eps LW. The tubular reabsorption of phosphate in sickle-cell nephropathy. *Clin Sci Mol Med* 1978;55(5):429-434.
601. DeFronzo RA, Taufield PA, Black H, McPhedran P, Cooke CR. Impaired renal tubular potassium secretion in sickle cell disease. *Ann Intern Med* 1979;90(3):310-316.
602. Diamond HS, Meisel A, Sharon E, Holden D, Cacatian A. Hyperuricosuria and increased tubular secretion of urate in sickle cell anemia. *Am J Med* 1975;59(6):796-802.
603. Allen TD. Sickle cell disease and hematuria: a report of 29 cases. *J Urol* 1964;91:177.
604. Harrow BR, Sloane JA, Liebman NC. Roentgenologic demonstration of renal papillary necrosis in sickle-cell trait. *N Engl J Med* 1963;268(18):969-976.
605. Susmano S, Lewy JE. Sickle cell disease and acute glomerulonephritis. *Am J Dis Child* 1969;118(4):615-618.
606. Davis CJ Jr, Mostofi FK, Sesterhenn IA. Renal medullary carcinoma. The seventh sickle cell nephropathy. *Am J Surg Pathol* 1995;19(1):1-11.
607. Bennett MA, Heslop RW, Meynell MJ. Massive haematuria associated with sickle-cell trait. *Br Med J* 1967;1(541):677-679.
608. Black WD, Hatch FE, Acchiardo S. Aminocaproic acid in prolonged hematuria of patients with sickle cell anemia. *Arch Intern Med* 1976;136(6):678-681.
609. Bhathena DB, Sondheimer JH. The glomerulopathy of homozygous sickle hemoglobin (SS) disease: morphology and pathogenesis. *J Am Soc Nephrol* 1991;1(11):1241-1252.
610. Bakir AA, Hathiwalla SC, Ainis H, et al. Prognosis of the nephrotic syndrome in sickle glomerulopathy. A retrospective study. *Am J Nephrol* 1987;7(2): 110-115.
611. Strauss J, Pardo V, Koss MN, Griswold W, McIntosh RM. Nephropathy associated with sickle cell anemia: an autologous immune complex nephritis. I. Studies on nature of glomerular-bound antibody and antigen identification in a patient with sickle cell disease and immune deposit glomerulonephritis. *Am J Med* 1975;58(3):382-387.
612. Allon M, Lawson L, Eckman JR, Delaney V, Bourke E. Effects of nonsteroidal antiinflammatory drugs on renal function in sickle cell anemia. *Kidney Int* 1988;34(4):500-506.
613. Hatch FE Jr, Azar SH, Ainsworth TE, Nardo JM, Culbertson JW. Renal circulatory studies in young adults with sickle cell anemia. *J Lab Clin Med* 1970;76(4):632-640.
614. Guasch A, Navarrete J, Nass K, Zayas CF. Glomerular involvement in adults with sickle cell hemoglobinopathies: prevalence and clinical correlates of progressive renal failure. *J Am Soc Nephrol* 2006;17(8):2228-2235.
615. Aygun B, Mortier NA, Smeltzer MP, Hankins JS, Ware RE. Glomerular hyperfiltration and albuminuria in children with sickle cell anemia. *Pediatr Nephrol* 2011;26(8):1285-1290.
616. Day TG, Drasar ER, Fulford T, Sharpe CC, Thein SL. Association between hemolysis and albuminuria in adults with sickle cell anemia. *Haematologica* 2012;97(2):201-205.
617. King L, Moosang M, Miller M, Reid M. Prevalence and predictors of microalbuminuria in Jamaican children with sickle cell disease. *Arch Dis Child* 2011;96(12):1135-1139.
618. Alvarez O, Miller ST, Wang WC, et al. Effect of hydroxyurea treatment on renal function parameters: results from the multi-center placebo-controlled baby hug clinical trial for infants with sickle cell anemia. *Pediatr Blood Cancer* 2012.
619. Fitzhugh CD, Wigfall DR, Ware RE. Enalapril and hydroxyurea therapy for children with sickle nephropathy. *Pediatr Blood Cancer* 2005;45(7):982-985.
620. Alvarez O, Montane B, Lopez G, Wilkinson J, Miller T. Early blood transfusions protect against microalbuminuria in children with sickle cell disease. *Pediatr Blood Cancer* 2006;47(1):71-76.

621. Falk RJ, Scheinman J, Phillips G, Orringer E, Johnson A, Jennette JC. Prevalence and pathologic features of sickle cell nephropathy and response to inhibition of angiotensin-converting enzyme. *N Engl J Med* 1992;326(14):910-915.
622. van Eps LW, De Long P. Sickle cell disease. In: Schrier R, Gottschalk C, eds. *Diseases of the kidney*, 6th ed. Boston, MA: Little Brown & Co., 1997:561.
623. Pegelow CH, Colangelo L, Steinberg M, et al. Natural history of blood pressure in sickle cell disease: risks for stroke and death associated with relative hypertension in sickle cell anemia. *Am J Med* 1997;102(2):171-177.
624. Powars DR, Elliott-Mills DD, Chan L, et al. Chronic renal failure in sickle cell disease: risk factors, clinical course, and mortality. *Ann Intern Med* 1991;115(8):614-620.
625. Scheinman JI. Tools to detect and modify sickle cell nephropathy. *Kidney Int* 2006;69(11):1927-1930.
626. Tharaux PL, Hagege I, Placier S, et al. Urinary endothelin-1 as a marker of renal damage in sickle cell disease. *Nephrol Dial Transplant* 2005;20(11):2408-2413.
627. Ashley-Koch AE, Okocha EC, Garrett ME, et al. MYH9 and APOL1 are both associated with sickle cell disease nephropathy. *Br J Haematol* 2011;155(3):386-394.
628. Freedman BI, Kopp JB, Langefeld CD, et al. The apolipoprotein L1 (APOL1) gene and nondiabetic nephropathy in African Americans. *J Am Soc Nephrol* 2010;21(9):1422-1426.
629. Friedman EA, Rao TK, Sprung CL, et al. Uremia in sickle-cell anemia treated by maintenance hemodialysis. *N Engl J Med* 1974;291(9):431-435.
630. Montgomery R, Zibari G, Hill GS, Ratner LE. Renal transplantation in patients with sickle cell nephropathy. *Transplantation* 1994;58(5):618-620.
631. Warady BA, Sullivan EK. Renal transplantation in children with sickle cell disease: a report of the North American Pediatric Renal Transplant Cooperative Study (NAPRTCS). *Pediatr Transplant* 1998;2(2):130-133.
632. Ojo AO, Govaerts TC, Schmouder RL, et al. Renal transplantation in end-stage sickle cell nephropathy. *Transplantation* 1999;67(2):291-295.
633. Sharpe CC, Thein SL. Sickle cell nephropathy—a practical approach. *Br J Haematol* 2011;155(3):287-297.
634. Steinberg MH. Erythropoietin for anemia of renal failure in sickle cell disease. *N Engl J Med* 1991;324(19):1369-1370.
635. Breen CP, Macdougall IC. Improvement of erythropoietin-resistant anaemia after renal transplantation in patients with homozygous sickle-cell disease. *Nephrol Dial Transplant* 1998;13(11):2949-2952.
636. Fink AI. Vascular fine structure changes in the bulbar conjunctiva associated with sickle cell disease. *Am J Ophthalmol* 1970;69(4):563-572.
637. Nagpal KC, Goldberg MF, Rabb MF. Ocular manifestations of sickle hemoglobinopathies. *Surv Ophthalmol* 1977;21(5):391-411.
638. Serjeant GR, Serjeant BE, Condon PI. The conjunctival sign in sickle cell anemia. A relationship with irreversibly sickled cells. *JAMA* 1972;219(11):1428-1431.
639. Armaly MF. Ocular manifestations in sickle cell disease. *Arch Intern Med* 1974;133(4):670-679.
640. Condon PI, Serjeant GR. Ocular findings in homozygous sickle cell anemia in Jamaica. *Am J Ophthalmol* 1972;73(4):533-543.
641. Goldberg MF. Natural history of untreated proliferative sickle retinopathy. *Arch Ophthalmol* 1971;85(4):428-437.
642. Cao J, Mathews MK, McLeod DS, Merges C, Hjelmeland LM, Luty GA. Angiogenic factors in human proliferative sickle cell retinopathy. *Br J Ophthalmol* 1999;83(7):838-846.
643. Condon PI, Serjeant GR. Ocular findings in hemoglobin SC disease in Jamaica. *Am J Ophthalmol* 1972;74(5):921-931.
644. Downes SM, Hambleton IR, Chuang EL, Lois N, Serjeant GR, Bird AC. Incidence and natural history of proliferative sickle cell retinopathy: observations from a cohort study. *Ophthalmology* 2005;112(11):1869-1875.
645. Leveziel N, Lalloum F, Bastuji-Garin S, et al. [Sickle-cell retinopathy: retrospective study of 730 patients followed in a referral center]. *J Fr Ophtalmol* 2012;35(5):343-347.

646. Kent D, Arya R, Aclimandos WA, Bellingham AJ, Bird AC. Screening for ophthalmic manifestations of sickle cell disease in the United Kingdom. *Eye* 1994;8(Pt 6):618-622.
647. Cho M, Kiss S. Detection and monitoring of sickle cell retinopathy using ultra wide-field color photography and fluorescein angiography. *Retina* 2011;31(4):738-747.
648. Emerson GG, Luty GA. Effects of sickle cell disease on the eye: clinical features and treatment. *Hematol Oncol Clin North Am* 2005;19(5):957-973, ix.
649. Deutsch TA, Weinreb RN, Goldberg MF. Indications for surgical management of hyphema in patients with sickle cell trait. *Arch Ophthalmol* 1984;102(4):566-569.
650. Curran EL, Fleming JC, Rice K, Wang WC. Orbital compression syndrome in sickle cell disease. *Ophthalmology* 1997;104(10):1610-1615.
651. Garty I, Koren A, Garzosi H. Frontal and orbital bone infarctions causing periorbital swelling in patients with sickle cell anemia. *Arch Ophthalmol* 1984;102(10):1486-1488.
652. Trent JT, Kirsner RS. Leg ulcers in sickle cell disease. *Adv Skin Wound Care* 2004;17(8):410-416.
653. Clare A, FitzHenley M, Harris J, Hambleton I, Serjeant GR. Chronic leg ulceration in homozygous sickle cell disease: the role of venous incompetence. *Br J Haematol* 2002;119(2):567-571.
654. Koshy M, Entsuaeh R, Koranda A, et al. Leg ulcers in patients with sickle cell disease. *Blood* 1989;74(4):1403-1408.
655. Serjeant GR. Leg ulceration in sickle cell anemia. *Arch Intern Med* 1974;133(4):690-694.
656. Akinyanju O, Akinsete I. Leg ulceration in sickle cell disease in Nigeria. *Trop Geogr Med* 1979;31(1):87-91.
657. Wolfort FG, Krizek TJ. Skin ulceration in sickle cell anemia. *Plast Reconstr Surg* 1969;43(1):71-77.
658. Hallbook T, Lanner E. Serum-zinc and healing of venous leg ulcers. *Lancet* 1972;2(7781):780-782.
659. Serjeant GR, Galloway RE, Gueri MC. Oral zinc sulphate in sickle-cell ulcers. *Lancet* 1970;2(7679):891-892.
660. al Momen AK. Recombinant human erythropoietin induced rapid healing of a chronic leg ulcer in a patient with sickle cell disease. *Acta Haematol* 1991;86(1):46-48.
661. Charache S, Dover GJ, Moore RD, et al. Hydroxyurea: effects on hemoglobin F production in patients with sickle cell anemia. *Blood* 1992;79(10):2555-2565.
662. Wethers DL, Ramirez GM, Koshy M, et al. Accelerated healing of chronic sickle-cell leg ulcers treated with RGD peptide matrix. RGD Study Group. *Blood* 1994;84(6):1775-1779.
663. McMahon L, Tamary H, Askin M, et al. A randomized phase II trial of Arginine Butyrate with standard local therapy in refractory sickle cell leg ulcers. *Br J Haematol* 2010;151(5):516-524.
664. Hassell K. Pregnancy and sickle cell disease. *Hematol Oncol Clin North Am* 2005;19(5):903-viii.
665. Serjeant GR, Loy LL, Crowther M, Hambleton IR, Thame M. Outcome of pregnancy in homozygous sickle cell disease. *Obstet Gynecol* 2004;103(6):1278-1285.
666. Wilson NO, Ceesay FK, Hibbert JM, et al. Pregnancy outcomes among patients with sickle cell disease at Korle-Bu Teaching Hospital, Accra, Ghana: retrospective cohort study. *Am J Trop Med Hyg* 2012;86(6):936-942.
667. Pritchard JA, Scott DE, Whalley PH, Cunningham FG, Mason RA. The effects of maternal sickle cell hemoglobinopathies and sickle cell trait on reproductive performance. *Am J Obstet Gynecol* 1973;117(5):662-670.
668. Rahimy MC, Gangbo A, Adjou R, Deguenon C, Goussanou S, Alihonou E. Effect of active prenatal management on pregnancy outcome in sickle cell disease in an African setting. *Blood* 2000;96(5):1685-1689.
669. Horger EO, III. Sickle cell and sickle cell-hemoglobin C disease during pregnancy. *Obstet Gynecol* 1972;39(6):873-879.
670. Brown AK, Sleeper LA, Pegelow CH, Miller ST, Gill FM, Waclawiw MA. The influence of infant and maternal sickle cell disease on birth outcome and neonatal course. *Arch Pediatr Adolesc Med* 1994;148(11):1156-1162.
671. Smith JA, Espeland M, Bellevue R, Bonds D, Brown AK, Koshy M. Pregnancy in sickle cell disease: experience of the Cooperative Study of Sickle Cell Disease. *Obstet Gynecol* 1996;87(2):199-204.
672. Perkins RP. Inherited disorders of hemoglobin synthesis and pregnancy. *Am J Obstet Gynecol* 1971;111(1):120-159.

673. Koshy M, Chisum D, Burd L, Orlina A, How H. Management of sickle cell anemia and pregnancy. *J Clin Apher* 1991;6(4):230-233.
674. Diav-Citrin O, Hunnisett L, Sher GD, Koren G. Hydroxyurea use during pregnancy: a case report in sickle cell disease and review of the literature. *Am J Hematol* 1999;60(2):148-150.
675. Ballas SK, McCarthy WF, Guo N, et al. Exposure to hydroxyurea and pregnancy outcomes in patients with sickle cell anemia. *J Natl Med Assoc* 2009;101(10):1046-1051.
676. Morris JS, Dunn DT, Poddar D, Serjeant GR. Haematological risk factors for pregnancy outcome in Jamaican women with homozygous sickle cell disease. *Br J Obstet Gynaecol* 1994;101(9):770-773.
677. Ladipo OA, Falusi AG, Feldblum PJ, Osotimehin BO, Otolorin EO, Ojengbede OA. Norplant use by women with sickle cell disease. *Int J Gynaecol Obstet* 1993;41(1):85-87.
678. Nascimento ML, Ladipo OA, Coutinho EM. Norgestrel acetate contraceptive implant use by women with sickle cell disease. *Clin Pharmacol Ther* 1998;64(4):433-438.
679. Yoong WC, Tuck SM. Menstrual pattern in women with sickle cell anaemia and its association with sickling crises. *J Obstet Gynaecol* 2002;22(4): 399-401.
680. Legardy JK, Curtis KM. Progestogen-only contraceptive use among women with sickle cell anemia: a systematic review. *Contraception* 2006;73(2): 195-204.
681. Gilman PA, McFarlane JM, Huisman THJ. Natural history of sickle cell anemia: reevaluation of a 15 year cord blood testing program. *Pediatr Res* 1976;10:376. Ref Type: Abstract
682. Vichinsky E, Hurst D, Earles A, Kleman K, Lubin B. Newborn screening for sickle cell disease: effect on mortality. *Pediatrics* 1988;81(6):749-755.
683. Mortality among children with sickle cell disease identified by newborn screening during 1990-1994—California, Illinois, and New York. *MMWR Morb Mortal Wkly Rep* 1998;47(9):169-172.
684. Githens JH, Lane PA, McCurdy RS, Houston ML, McKinna JD, Cole DM. Newborn screening for hemoglobinopathies in Colorado. The first 10 years. *Am J Dis Child* 1990;144(4):466-470.
685. Leikin SL, Gallagher D, Kinney TR, Sloane D, Klug P, Rida W. Mortality in children and adolescents with sickle cell disease. Cooperative Study of Sickle Cell Disease. *Pediatrics* 1989;84(3):500-508.
686. Davis H, Schoendorf KC, Gergen PJ, Moore RM Jr. National trends in the mortality of children with sickle cell disease, 1968 through 1992. *Am J Public Health* 1997;87(8):1317-1322.
687. Quinn CT, Rogers ZR, Buchanan GR. Survival of children with sickle cell disease. *Blood* 2004;103(11):4023-4027.
688. Powars DR, Hiti A, Ramicone E, Johnson C, Chan L. Outcome in hemoglobin SC disease: a four-decade observational study of clinical, hematologic, and genetic factors. *Am J Hematol* 2002;70(3):206-215.
689. van der Plas EM, van den Tweel XW, Geskus RB, et al. Mortality and causes of death in children with sickle cell disease in the Netherlands, before the introduction of neonatal screening. *Br J Haematol* 2011;155(1):106-110.
690. Fernandes AP, Januario JN, Cangussu CB, Macedo DL, Viana MB. Mortality of children with sickle cell disease: a population study. *J Pediatr (Rio J)* 2010;86(4):279-284.
691. Makani J, Cox SE, Soka D, et al. Mortality in sickle cell anemia in Africa: a prospective cohort study in Tanzania. *PLoS One* 2011;6(2):e14699.
692. Bonds DR. Three decades of innovation in the management of sickle cell disease: the road to understanding the sickle cell disease clinical phenotype. *Blood Rev* 2005;19(2):99-110.
693. Steinberg MH, Hebbel RP. Clinical diversity of sickle cell anemia: genetic and cellular modulation of disease severity. *Am J Hematol* 1983;14(4):405-416.
694. Pembrey ME, Wood WG, Weatherall DJ, Perrine RP. Fetal haemoglobin production and the sickle gene in the oases of Eastern Saudi Arabia. *Br J Haematol* 1978;40(3):415-429.
695. Perrine RP, Pembrey ME, John P, Perrine S, Shoup F. Natural history of sickle cell anemia in Saudi Arabs. A study of 270 subjects. *Ann Intern Med* 1978;88(1):1-6.

696. Acquaye JK, Omer A, Ganeshaguru K, Sejeny SA, Hoffbrand AV. Non-benign sickle cell anaemia in western Saudi Arabia. *Br J Haematol* 1985;60(1):99-108.
697. Dover GJ, Smith KD, Chang YC, et al. Fetal hemoglobin levels in sickle cell disease and normal individuals are partially controlled by an X-linked gene located at Xp22.2. *Blood* 1992;80(3):816-824.
698. Steinberg MH, Embury SH. Alpha-thalassemia in blacks: genetic and clinical aspects and interactions with the sickle hemoglobin gene. *Blood* 1986;68(5):985-990.
699. Steinberg MH, Hsu H, Nagel RL, et al. Gender and haplotype effects upon hematological manifestations of adult sickle cell anemia. *Am J Hematol* 1995;48(3):175-181.
700. Dover GJ, Boyer SH, Charache S, Heintzelman K. Individual variation in the production and survival of F cells in sickle-cell disease. *N Engl J Med* 1978;299(26):1428-1435.
701. Boyer SH, Dover GJ, Serjeant GR, et al. Production of F cells in sickle cell anemia: regulation by a genetic locus or loci separate from the beta-globin gene cluster. *Blood* 1984;64(5):1053-1058.
702. Milner PF, Leibfarth JD, Ford J, Barton BP, Grenett HE, Garver FA. Increased HbF in sickle cell anemia is determined by a factor linked to the beta S gene from one parent. *Blood* 1984;63(1):64-72.
703. Miller BA, Salameh M, Ahmed M, et al. Analysis of hemoglobin F production in Saudi Arabian families with sickle cell anemia. *Blood* 1987;70(3):716-720.
704. Ali SA. Milder variant of sickle-cell disease in Arabs in Kuwait associated with unusually high level of foetal haemoglobin. *Br J Haematol* 1970;19(5): 613-619.
705. Haghshenass M, Ismail-Beigi F, Clegg JB, Weatherall DJ. Mild sickle-cell anaemia in Iran associated with high levels of fetal haemoglobin. *J Med Genet* 1977;14(3):168-171.
706. Kar BC, Satapathy RK, Kulozik AE, et al. Sickle cell disease in Orissa State, India. *Lancet* 1986;2(8517):1198-1201.
707. Serjeant GR. Fetal haemoglobin in homozygous sickle cell disease. *Clin Haematol* 1975;4(1):109-122.
708. McBurney PG, Hanevold CD, Hernandez CM, Waller JL, McKie KM. Risk factors for microalbuminuria in children with sickle cell anemia. *J Pediatr Hematol Oncol* 2002;24(6):473-477.
709. Powars DR, Weiss JN, Chan LS, Schroeder WA. Is there a threshold level of fetal hemoglobin that ameliorates morbidity in sickle cell anemia? *Blood* 1984;63(4):921-926.
710. Embury SH, Dozy AM, Miller J, et al. Concurrent sickle-cell anemia and alpha-thalassemia: effect on severity of anemia. *N Engl J Med* 1982;306(5): 270-274.
711. Higgs DR, Aldridge BE, Lamb J, et al. The interaction of alpha-thalassemia and homozygous sickle-cell disease. *N Engl J Med* 1982;306(24):1441-1446.
712. Steinberg MH, Rosenstock W, Coleman MB, et al. Effects of thalassemia and microcytosis on the hematologic and vasoocclusive severity of sickle cell anemia. *Blood* 1984;63(6):1353-1360.
713. Stevens MC, Maude GH, Beckford M, et al. Alpha thalassemia and the hematology of homozygous sickle cell disease in childhood. *Blood* 1986;67(2): 411-414.
714. Embury SH, Clark MR, Monroy G, Mohandas N. Concurrent sickle cell anemia and alpha-thalassemia. Effect on pathological properties of sickle erythrocytes. *J Clin Invest* 1984;73(1):116-123.
715. Fabry ME, Mears JG, Patel P, et al. Dense cells in sickle cell anemia: the effects of gene interaction. *Blood* 1984;64(5):1042-1046.
716. Embury SH, Backer K, Glader BE. Monovalent cation changes in sickle erythrocytes: a direct reflection of alpha-globin gene number. *J Lab Clin Med* 1985;106(1):75-79.
717. De Ceulaer K, Higgs DR, Weatherall DJ, Hayes RJ, Serjeant BE, Serjeant GR. alpha-Thalassemia reduces the hemolytic rate in homozygous sickle-cell disease. *N Engl J Med* 1983;309(3):189-190.
718. Schroeder WA, Powars DR, Kay LM, et al. Beta-cluster haplotypes, alpha-gene status, and hematological data from SS, SC, and S-beta-thalassemia patients in southern California. *Hemoglobin* 1989;13(4):325-353.
719. Serjeant BE, Mason KP, Kenny MW, et al. Effect of alpha thalassaemia on the rheology of homozygous sickle cell disease. *Br J Haematol* 1983;55(3): 479-486.

720. Fox PD, Higgs DR, Serjeant GR. Influence of alpha thalassaemia on the retinopathy of homozygous sickle cell disease. *Br J Ophthalmol* 1993;77(2): 89-90.
721. Hawker H, Neilson H, Hayes RJ, Serjeant GR. Haematological factors associated with avascular necrosis of the femoral head in homozygous sickle cell disease. *Br J Haematol* 1982;50(1):29-34.
722. Hayes RJ, Condon PI, Serjeant GR. Haematological factors associated with proliferative retinopathy in homozygous sickle cell disease. *Br J Ophthalmol* 1981;65(1):29-35.
723. Kennedy AP, Walsh DA, Nicholson R, Adams JG, III, Steinberg MH. Influence of HbS levels upon the hematological and clinical characteristics of sickle cell trait. *Am J Hematol* 1986;22(1):51-54.
724. Gupta AK, Kirchner KA, Nicholson R, et al. Effects of alpha-thalassemia and sickle polymerization tendency on the urine-concentrating defect of individuals with sickle cell trait. *J Clin Invest* 1991;88(6):1963-1968.
725. Orkin SH, Kazazian HH Jr, Antonarakis SE, et al. Linkage of beta-thalassaemia mutations and beta-globin gene polymorphisms with DNA polymorphisms in human beta-globin gene cluster. *Nature* 1982;296(5858):627-631.
726. Nagel RL, Fabry ME, Pagnier J, et al. Hematologically and genetically distinct forms of sickle cell anemia in Africa. The Senegal type and the Benin type. *N Engl J Med* 1985;312(14):880-884.
727. Nagel RL, Erlingsson S, Fabry ME, et al. The Senegal DNA haplotype is associated with the amelioration of anemia in African-American sickle cell anemia patients. *Blood* 1991;77(6):1371-1375.
728. Rieder RF, Safaya S, Gillette P, et al. Effect of beta-globin gene cluster haplotype on the hematological and clinical features of sickle cell anemia. *Am J Hematol* 1991;36(3):184-189.
729. Powars DR. Sickle cell anemia: beta s-gene-cluster haplotypes as prognostic indicators of vital organ failure. *Semin Hematol* 1991;28(3):202-208.
730. Chang YC, Smith KD, Moore RD, Serjeant GR, Dover GJ. An analysis of fetal hemoglobin variation in sickle cell disease: the relative contributions of the X-linked factor, beta-globin haplotypes, alpha-globin gene number, gender, and age. *Blood* 1995;85(4):1111-1117.
731. Adams JG, Benjamin L, Fryd S, et al. Gender and haplotype effects upon hematological and clinical manifestations of sickle cell anemia. *Clin Res* 1992;40:378a.
732. Bank A. Regulation of human fetal hemoglobin: new players, new complexities. *Blood* 2006;107(2):435-443.
733. Quinn CT, Shull EP, Ahmad N, Lee NJ, Rogers ZR, Buchanan GR. Prognostic significance of early vaso-occlusive complications in children with sickle cell anemia. *Blood* 2007;109(1):40-45.
734. Chui DH, Dover GJ. Sickle cell disease: no longer a single gene disorder. *Curr Opin Pediatr* 2001;13(1):22-27.
735. Nagel RL. Pleiotropic and epistatic effects in sickle cell anemia. *Curr Opin Hematol* 2001;8(2):105-110.
736. Steinberg MH, Rodgers GP. Pathophysiology of sickle cell disease: role of cellular and genetic modifiers. *Semin Hematol* 2001;38(4):299-306.
737. Bhatnagar P, Purvis S, Barron-Casella E, et al. Genome-wide association study identifies genetic variants influencing F-cell levels in sickle-cell patients. *J Hum Genet* 2011;56(4):316-323.
738. Solovieff N, Milton JN, Hartley SW, et al. Fetal hemoglobin in sickle cell anemia: genome-wide association studies suggest a regulatory region in the 5' olfactory receptor gene cluster. *Blood* 2010;115(9):1815-1822.
739. Sebastiani P, Solovieff N, Hartley SW, et al. Genetic modifiers of the severity of sickle cell anemia identified through a genome-wide association study. *Am J Hematol* 2010;85(1):29-35.
740. Milton JN, Sebastiani P, Solovieff N, et al. A genome-wide association study of total bilirubin and cholelithiasis risk in sickle cell anemia. *PLoS One* 2012;7(4):e34741.
741. Orkin SH, Higgs DR. Medicine. Sickle cell disease at 100 years. *Science* 2010;329(5989):291-292.
742. Menzel S, Garner C, Gut I, et al. A QTL influencing F cell production maps to a gene encoding a zinc-finger protein on chromosome 2p15. *Nat Genet* 2007;39(10):1197-1199.
743. Menzel S, Jiang J, Silver N, et al. The HBS1L-MYB intergenic region on chromosome 6q23.3 influences erythrocyte, platelet, and monocyte counts in humans. *Blood* 2007;110(10):3624-3626.

744. Uda M, Galanello R, Sanna S, et al. Genome-wide association study shows BCL11A associated with persistent fetal hemoglobin and amelioration of the phenotype of beta-thalassemia. *Proc Natl Acad Sci U S A* 2008;105(5): 1620-1625.
745. Sankaran VG, Xu J, Ragoczy T, et al. Developmental and species-divergent globin switching are driven by BCL11A. *Nature* 2009;460(7259):1093-1097.
746. Zhou D, Liu K, Sun CW, Pawlik KM, Townes TM. KLF1 regulates BCL11A expression and gamma- to beta-globin gene switching. *Nat Genet* 2010;42(9):742-744.
747. Hayes RJ, Beckford M, Grandison Y, Mason K, Serjeant BE, Serjeant GR. The haematology of steady state homozygous sickle cell disease: frequency distributions, variation with age and sex, longitudinal observations. *Br J Haematol* 1985;59(2):369-382.
748. Vichinsky E, Kleman K, Embury S, Lubin B. The diagnosis of iron deficiency anemia in sickle cell disease. *Blood* 1981;58(5):963-968.
749. West MS, Wethers D, Smith J, Steinberg M. Laboratory profile of sickle cell disease: a cross-sectional analysis. The Cooperative Study of Sickle Cell Disease. *J Clin Epidemiol* 1992;45(8):893-909.
750. Marvel JS, Sutera SP, Krogstad DJ, Zarkowsky HS, Williamson JR. Accurate determination of mean cell volume by isotope dilution in erythrocyte populations with variable deformability. *Blood Cells* 1991;17(3):497-512.
751. Mohandas N, Johnson A, Wyatt J, et al. Automated quantitation of cell density distribution and hyperdense cell fraction in RBC disorders. *Blood* 1989;74(1):442-447.
752. Chudwin DS, Rucknagel DL. Immunological quantification of hemoglobins F and A2. *Clin Chim Acta* 1974;50:413-419.
753. McCurdy PR. 32-DFP and 51-Cr for measurement of red cell life span in abnormal hemoglobin syndromes. *Blood* 1969;33(2):214-224.
754. Naumann HN, Diggs LW, Barreras L, Williams BJ. Plasma hemoglobin and hemoglobin fractions in sickle cell crisis. *Am J Clin Pathol* 1971;56(2): 137-147.
755. Sherwood JB, Goldwasser E, Chilcote R, Carmichael LD, Nagel RL. Sickle cell anemia patients have low erythropoietin levels for their degree of anemia. *Blood* 1986;67(1):46-49.
756. Schwartz AD. The splenic platelet reservoir in sickle cell anemia. *Blood* 1972;40(5):678-683.
757. Stuart MJ, Stockman JA, Oski FA. Abnormalities of platelet aggregation in the vaso-occlusive crisis of sickle-cell anemia. *J Pediatr* 1974;85(5):629-632.
758. Abildgaard CF, Simone JV, Schulman I. Factor-8 (antihemophilic factor) activity in sickle-cell anaemia. *Br J Haematol* 1967;13(1):19-27.
759. Leslie J, Langler D, Serjeant GR, Serjeant BE, Desai P, Gordon YB. Coagulation changes during the steady state in homozygous sickle-cell disease in Jamaica. *Br J Haematol* 1975;30(2):159-166.
760. Rickles FR, O'Leary DS. Role of coagulation system in pathophysiology of sickle cell disease. *Arch Intern Med* 1974;133(4):635-641.
761. Mohammed FA, Mahdi N, Sater MA, Al-Ola K, Almawi WY. The relation of C-reactive protein to vasoocclusive crisis in children with sickle cell disease. *Blood Cells Mol Dis* 2010;45(4):293-296.
762. Garrick MD, Dembure P, Guthrie R. Sickle-cell anemia and other hemoglobinopathies. Procedures and strategy for screening employing spots of blood on filter paper as specimens. *N Engl J Med* 1973;288(24):1265-1268.
763. Schneider RG, Alperin JB, Lehmann H. Sickling tests. Pitfalls in performance and interpretation. *JAMA* 1967;202(5):419-421.
764. Canning DM, Huntsman RG. An assessment of Sickledex as an alternative to the sickling test. *J Clin Pathol* 1970;23(8):736-737.
765. Wilson JB, Headlee ME, Huisman TH. A new high-performance liquid chromatographic procedure for the separation and quantitation of various hemoglobin variants in adults and newborn babies. *J Lab Clin Med* 1983;102(2):174-186.
766. Dover GJ, Boyer SH. Quantitation of hemoglobins within individual red cells: asynchronous biosynthesis of fetal and adult hemoglobin during erythroid maturation in normal subjects. *Blood* 1980;56(6):1082-1091.

767. Grover R, Wethers D, Shahidi S, Grossi M, Goldberg D, Davidow B. Evaluation of the expanded newborn screening program in New York City. *Pediatrics* 1978;61(5):740-749.
768. Consensus conference. Newborn screening for sickle cell disease and other hemoglobinopathies. *JAMA* 1987;258(9):1205-1209.
769. Hoppe CC. Newborn screening for hemoglobin disorders. *Hemoglobin* 2011;35(5-6):556-564.
770. Modell B, Darlison M. Global epidemiology of haemoglobin disorders and derived service indicators. *Bull World Health Organ* 2008;86(6):480-487.
771. Eckman JR. Neonatal screening. In: Embury SH, Hebbel RP, Mohandas N, Steinberg MH, eds. *Sickle cell disease: basic principles and clinical practice*. New York: Raven Press, 1994:309-315.
772. Papadea C, Eckman JR, Kuehnert RS, Platt AF. Comparison of liquid and dried blood for neonatal hemoglobinopathy screening: laboratory and programmatic issues. *Pediatrics* 1994;93(3):427-432.
773. Galacteros F, Kleman K, Caburi-Martin J, Beuzard Y, Rosa J, Lubin B. Cord blood screening for hemoglobin abnormalities by thin layer isoelectric focusing. *Blood* 1980;56(6):1068-1071.
774. Karnon J, Zeuner D, Ades AE, Efimba W, Brown J, Yardumian A. The effects of neonatal screening for sickle cell disorders on lifetime treatment costs and early deaths avoided: a modelling approach. *J Public Health Med* 2000;22(4):500-511.
775. Day SW, Brunson GE, Wang WC. Successful newborn sickle cell trait counseling program using health department nurses. *Pediatr Nurs* 1997;23(6): 557-561.
776. Yang YM, Andrews S, Peterson R, Shah A, Cepeda M. Prenatal sickle cell screening education effect on the follow-up rates of infants with sickle cell trait. *Patient Educ Couns* 2000;39(2-3):185-189.
777. Strickland DK, Ware RE, Kinney TR. Pitfalls in newborn hemoglobinopathy screening: failure to detect beta(+)-thalassemia. *J Pediatr* 1995;127(2): 304-308.
778. Old JM. Screening and genetic diagnosis of haemoglobin disorders. *Blood Rev* 2003;17(1):43-53.
779. Zhang YH, McCabe LL, Wilborn M, Therrell BL Jr, McCabe ER. Application of molecular genetics in public health: improved follow-up in a neonatal hemoglobinopathy screening program. *Biochem Med Metab Biol* 1994;52(1):27-35.
780. Ducrocq R, Pascaud O, Bevier A, Finet C, Benkerrou M, Elion J. Strategy linking several analytical methods of neonatal screening for sickle cell disease. *J Med Screen* 2001;8(1):8-14.
781. Alter BP. Advances in the prenatal diagnosis of hematologic diseases. *Blood* 1984;64(2):329-340.
782. Powledge TM, Fletcher J. Guidelines for the ethical, social, and legal issues in prenatal diagnosis: a report from the Genetics Research Group of the Hastings Center, Institute of Society, Ethics and the Life Sciences. *N Engl J Med* 1979;300:168.
783. Rucknagel DL. A decade of screening in the hemoglobinopathies: is a national program to prevent sickle cell anemia possible? *Am J Pediatr Hematol Oncol* 1983;5(4):373-377.
784. Goossens M, Dumez Y, Kaplan L, et al. Prenatal diagnosis of sickle-cell anemia in the first trimester of pregnancy. *N Engl J Med* 1983;309(14):831-833.
785. Rhoads GG, Jackson LG, Schlesselman SE, et al. The safety and efficacy of chorionic villus sampling for early prenatal diagnosis of cytogenetic abnormalities. *N Engl J Med* 1989;320(10):609-617.
786. Price JO, Elias S, Wachtel SS, et al. Prenatal diagnosis with fetal cells isolated from maternal blood by multiparameter flow cytometry. *Am J Obstet Gynecol* 1991;165(6 Pt 1):1731-1737.
787. Rechitsky S, Kuliev A, Tur-Kaspa I, Morris R, Verlinsky Y. Preimplantation genetic diagnosis with HLA matching. *Reprod Biomed Online* 2004;9(2): 210-221.
788. Oyewo A, Salubi-Udu J, Khalaf Y, et al. Preimplantation genetic diagnosis for the prevention of sickle cell disease: current trends and barriers to uptake in a London teaching hospital. *Hum Fertil (Camb)* 2009;12(3):153-159.
789. Gonzalez-Merino E, Emiliani S, Pichon B, et al. [Preimplantation genetic diagnosis (PGD): the Erasme Hospital experience]. *Rev Med Brux* 2008;29(6): 527-534.

790. Kuliev A, Pakhalchuk T, Verlinsky O, Rechitsky S. Preimplantation genetic diagnosis for hemoglobinopathies. *Hemoglobin* 2011;35(5-6):547-555.
791. Dorticos-Balea A, Martin-Ruiz M, Hechevarria-Fernandez P, et al. Reproductive behaviour of couples at risk for sickle cell disease in Cuba: a follow-up study. *Prenat Diagn* 1997;17(8):737-742.
792. Voskaridou E, Ladis V, Kattamis A, et al. A national registry of haemoglobinopathies in Greece: deduced demographics, trends in mortality and affected births. *Ann Hematol.* 2012 Sep;91(9):1451-1458. Epub 2012 Apr 19.
793. Boehm CD, Antonarakis SE, Phillips JA, III, Stetten G, Kazazian HH Jr. Prenatal diagnosis using DNA polymorphisms. Report on 95 pregnancies at risk for sickle-cell disease or beta-thalassemia. *N Engl J Med* 1983;308(18):1054-1058.
794. Chang JC, Kan YW. A sensitive new prenatal test for sickle-cell anemia. *N Engl J Med* 1982;307(1):30-32.
795. Orkin SH, Little PF, Kazazian HH Jr, Boehm CD. Improved detection of the sickle mutation by DNA analysis: application to prenatal diagnosis. *N Engl J Med* 1982;307(1):32-36.
796. Saiki RK, Chang CA, Levenson CH, et al. Diagnosis of sickle cell anemia and beta-thalassemia with enzymatically amplified DNA and nonradioactive allele-specific oligonucleotide probes. *N Engl J Med* 1988;319(9):537-541.
797. Embury SH, Scharf SJ, Saiki RK, et al. Rapid prenatal diagnosis of sickle cell anemia by a new method of DNA analysis. *N Engl J Med* 1987;316(11): 656-661.
798. Saiki RK, Bugawan TL, Horn GT, Mullis KB, Erlich HA. Analysis of enzymatically amplified beta-globin and HLA-DQ alpha DNA with allele-specific oligonucleotide probes. *Nature* 1986;324(6093):163-166.
799. Sekizawa A, Saito H. Prenatal screening of single-gene disorders from maternal blood. *Am J Pharmacogenomics* 2001;1(2):111-117.
800. Vichinsky E. Transfusion therapy. In: Embury SH, Heibel RP, Mohandas N, Steinberg MH, eds. *Sickle cell disease: basic principles and clinical practice*. New York: Raven Press Ltd, 1994:781-798.
801. Wayne AS, Kevy SV, Nathan DG. Transfusion management of sickle cell disease. *Blood* 1993;81(5):1109-1123.
802. Buchanan GR, McKie V, Jackson EA, Vedro DA, Hamner S, Holtkamp CA. Splenic phagocytic function in children with sickle cell anemia receiving longterm hypertransfusion therapy. *J Pediatr* 1989;115(4):568-572.
803. Anderson R, Cassell M, Mullinax GL, Chaplin H. Effect of normal cells on viscosity of sickle cell blood. *Arch Intern Med* 1963;111(3):286-294.
804. Klein HG, Garner RJ, Miller DM, Rosen SL, Statham NJ, Winslow RM. Automated partial exchange transfusion in sickle cell anemia. *Transfusion* 1980;20(5):578-584.
805. Lanzkowsky P, Shende A, Karayalcin G, Kim YJ, Aballi AJ. Partial exchange transfusion in sickle cell anemia. Use in children with serious complications. *Am J Dis Child* 1978;132(12):1206-1208.
806. Adams DM, Schultz WH, Ware RE, Kinney TR. Erythrocytapheresis can reduce iron overload and prevent the need for chelation therapy in chronically transfused pediatric patients. *J Pediatr Hematol Oncol* 1996;18(1):46-50.
807. Kim HC, Dugan NP, Silber JH, et al. Erythrocytapheresis therapy to reduce iron overload in chronically transfused patients with sickle cell disease. *Blood* 1994;83(4):1136-1142.
808. Abdul-Rauf A, Gauderer M, Chiarucci K, Berman B. Long-term central venous access in patients with sickle cell disease. Incidence of thrombotic and infectious complications. *J Pediatr Hematol Oncol* 1995;17(4):342-345.
809. Jeng MR, Feusner J, Skibola C, Vichinsky E. Central venous catheter complications in sickle cell disease. *Am J Hematol* 2002;69(2):103-108.
810. Zinkham WH, Seidler AJ, Kickler TS. Variable degrees of suppression of hemoglobin S synthesis in subjects with hemoglobin SS disease on a longterm transfusion regimen. *J Pediatr* 1994;124(2):215-219.
811. Cohen AR, Buchanan GR, Martin M, Ohene-Frempong K. Increased blood requirements during long-term transfusion therapy for sickle cell disease. *J Pediatr* 1991;118(3):405-407.
812. Tahhan HR, Holbrook CT, Braddy LR, Brewer LD, Christie JD. Antigen-matched donor blood in the transfusion management of patients with sickle cell disease. *Transfusion* 1994;34(7):562-569.
813. Rosse WF, Gallagher D, Kinney TR, et al. Transfusion and alloimmunization in sickle cell disease. The Cooperative Study of Sickle Cell Disease. *Blood* 1990;76(7):1431-1437.

814. Vichinsky EP, Earles A, Johnson RA, Hoag MS, Williams A, Lubin B. Alloimmunization in sickle cell anemia and transfusion of racially unmatched blood. *N Engl J Med* 1990;322(23):1617-1621.
815. Petz LD, Calhoun L, Shulman IA, Johnson C, Herron RM. The sickle cell hemolytic transfusion reaction syndrome. *Transfusion* 1997;37(4):382-392.
816. Files B, Brambilla D, Kutlar A, et al. Longitudinal changes in ferritin during chronic transfusion: a report from the Stroke Prevention Trial in Sickle Cell Anemia (STOP). *J Pediatr Hematol Oncol* 2002;24(4):284-290.
817. Harmatz P, Butensky E, Quirolo K, et al. Severity of iron overload in patients with sickle cell disease receiving chronic red blood cell transfusion therapy. *Blood* 2000;96(1):76-79.
818. Inati A, Musallam KM, Wood JC, Taher AT. Iron overload indices rise linearly with transfusion rate in patients with sickle cell disease. *Blood* 2010;115(14):2980-2981.
819. Hankins JS, McCarville MB, Loeffler RB, et al. R2* magnetic resonance imaging of the liver in patients with iron overload. *Blood* 2009;113(20): 4853-4855.
820. St Pierre TG, Clark PR, Chua-anusorn W, et al. Noninvasive measurement and imaging of liver iron concentrations using proton magnetic resonance. *Blood* 2005;105(2):855-861.
821. Wood JC, Enriquez C, Ghugre N, et al. MRI R2 and R2* mapping accurately estimates hepatic iron concentration in transfusion-dependent thalassemia and sickle cell disease patients. *Blood* 2005;106(4):1460-1465.
822. Pennell DJ. T2* magnetic resonance and myocardial iron in thalassemia. *Ann N Y Acad Sci* 2005;1054:373-378.
823. Fischer R, Piga A, Harmatz P, Nielsen P. Monitoring long-term efficacy of iron chelation treatment with biomagnetic liver susceptometry. *Ann N Y Acad Sci* 2005;1054:350-357.
824. Noetzli LJ, Coates TD, Wood JC. Pancreatic iron loading in chronically transfused sickle cell disease is lower than in thalassaemia major. *Br J Haematol* 2011;152(2):229-233.
825. Ghugre NR, Gonzalez-Gomez I, Butensky E, et al. Patterns of hepatic iron distribution in patients with chronically transfused thalassemia and sickle cell disease. *Am J Hematol* 2009;84(8):480-483.
826. Inati A, Musallam KM, Cappellini MD, Duca L, Taher AT. Nontransferrinbound iron in transfused patients with sickle cell disease. *Int J Lab Hematol* 2011;33(2):133-137.
827. Walter PB, Fung EB, Killilea DW, et al. Oxidative stress and inflammation in iron-overloaded patients with beta-thalassaemia or sickle cell disease. *Br J Haematol* 2006;135(2):254-263.
828. Morris CR, Singer ST, Walters MC. Clinical hemoglobinopathies: iron, lungs and new blood. *Curr Opin Hematol* 2006;13(6):407-418.
829. Cohen AR, Galanello R, Piga A, De S, V, Tricta F. Safety and effectiveness of long-term therapy with the oral iron chelator deferiprone. *Blood* 2003;102(5):1583-1587.
830. Borgna-Pignatti C, Cappellini MD, De SP, et al. Cardiac morbidity and mortality in deferoxamine- or deferiprone-treated patients with thalassemia major. *Blood* 2006;107(9):3733-3737.
831. Pennell DJ, Berdoukas V, Karagiorga M, et al. Randomized controlled trial of deferiprone or deferoxamine in beta-thalassemia major patients with asymptomatic myocardial siderosis. *Blood* 2006;107(9):3738-3744.
832. Maggio A, Vitrano A, Lucania G, et al. Long-term use of deferiprone significantly enhances left-ventricular ejection function in thalassemia major patients. *Am J Hematol* 2012;87(7):732-733.
833. Galanello R, Piga A, Alberti D, Rouan MC, Bigler H, Sechaud R. Safety, tolerability, and pharmacokinetics of ICL670, a new orally active iron-chelating agent in patients with transfusion-dependent iron overload due to betathalassemia. *J Clin Pharmacol* 2003;43(6):565-572.
834. Hershko C, Konijn AM, Nick HP, Breuer W, Cabantchik ZI, Link G. ICL670A: a new synthetic oral chelator: evaluation in hypertransfused rats with selective radioiron probes of hepatocellular and reticuloendothelial iron stores and in iron-loaded rat heart cells in culture. *Blood* 2001;97(4):1115-1122.
835. Vichinsky E, Bernaudin F, Forni GL, et al. Long-term safety and efficacy of deferasirox (Exjade) for up to 5 years in transfusional iron-overloaded patients with sickle cell disease. *Br J Haematol* 2011;154(3):387-397.

836. Meerpohl JJ, Antes G, Rucker G, Fleeman N, Niemeyer C, Bassler D. Deferasirox for managing transfusional iron overload in people with sickle cell disease. *Cochrane Database Syst Rev* 2010;(8):CD007477.
837. Taher A, Cappellini MD, Vichinsky E, et al. Efficacy and safety of deferasirox doses of >30 mg/kg per d in patients with transfusion-dependent anaemia and iron overload. *Br J Haematol* 2009;147(5):752-759.
838. Wood JC, Kang BP, Thompson A, et al. The effect of deferasirox on cardiac iron in thalassemia major: impact of total body iron stores. *Blood* 2010;116(4):537-543.
839. Pennell DJ, Porter JB, Cappellini MD, et al. Continued improvement in myocardial T2* over two years of deferasirox therapy in beta-thalassemia major patients with cardiac iron overload. *Haematologica* 2011;96(1): 48-54.
840. Pennell DJ, Porter JB, Cappellini MD, et al. Deferasirox for up to 3 years leads to continued improvement of myocardial T2* in patients with betathalassemia major. *Haematologica* 2012;97(6):842-848.
841. Kwiatkowski JL. Real-world use of iron chelators. *Hematology Am Soc Hematol Educ Program* 2011;2011:451-458.
842. Neufeld EJ, Galanello R, Viprakasit V, et al. A phase 2 study of the safety, tolerability, and pharmacodynamics of FBS0701, a novel oral iron chelator, in transfusional iron overload. *Blood* 2012;119(14):3263-3268.
843. Raphael JL, Bernhardt MB, Mahoney DH, Mueller BU. Oral iron chelation and the treatment of iron overload in a pediatric hematology center. *Pediatr Blood Cancer* 2009;52(5):616-620.
844. Alvarez O, Rodriguez-Cortes H, Robinson N, et al. Adherence to deferasirox in children and adolescents with sickle cell disease during 1-year of therapy. *J Pediatr Hematol Oncol* 2009;31(10):739-744.
845. Inati A, Khoriaty E, Musallam KM. Iron in sickle-cell disease: what have we learned over the years? *Pediatr Blood Cancer* 2011;56(2):182-190.
846. Brittenham GM. Iron-chelating therapy for transfusional iron overload. *N Engl J Med* 2011;364(2):146-156.
847. Kinney TR, Ware RE, Schultz WH, Filston HC. Long-term management of splenic sequestration in children with sickle cell disease. *J Pediatr* 1990;117(2 Pt 1):194-199.
848. Gonzalez P, Hackney AC, Jones S, et al. A phase I/II study of polymerized bovine hemoglobin in adult patients with sickle cell disease not in crisis at the time of study. *J Investig Med* 1997;45(5):258-264.
849. Milner PF. Chronic transfusion regimens in sickle cell disease. *Prog Clin Biol Res* 1982;98:97-107.
850. Pegelow CH, Adams RJ, McKie V, et al. Risk of recurrent stroke in patients with sickle cell disease treated with erythrocyte transfusions. *J Pediatr* 1995;126(6):896-899.
851. Scothorn DJ, Price C, Schwartz D, et al. Risk of recurrent stroke in children with sickle cell disease receiving blood transfusion therapy for at least five years after initial stroke. *J Pediatr* 2002;140(3):348-354.
852. Telen MJ. Principles and problems of transfusion in sickle cell disease. *Semin Hematol* 2001;38(4):315-323.
853. Spigelman A, Warden MJ. Surgery in patients with sickle cell disease. *Arch Surg* 1972;104(6):761-764.
854. Koshy M, Weiner SJ, Miller ST, et al. Surgery and anesthesia in sickle cell disease. Cooperative Study of Sickle Cell Diseases. *Blood* 1995;86(10): 3676-3684.
855. Vichinsky EP, Haberkern CM, Neumayr L, et al. A comparison of conservative and aggressive transfusion regimens in the perioperative management of sickle cell disease. The Preoperative Transfusion in Sickle Cell Disease Study Group. *N Engl J Med* 1995;333(4):206-213.
856. Buck J, Casbard A, Llewelyn C, Johnson T, Davies S, Williamson L. Preoperative transfusion in sickle cell disease: a survey of practice in England. *Eur J Haematol* 2005;75(1):14-21.
857. Buck J, Davies SC. Surgery in sickle cell disease. *Hematol Oncol Clin North Am* 2005;19(5):897-902, vii.
858. Cunningham FG, Pritchard JA, Mason R, Chase G. Prophylactic transfusions of normal red blood cells during pregnancies complicated by sickle cell hemoglobinopathies. *Am J Obstet Gynecol* 1979;135(7):994-1003.
859. Koshy M, Burd L, Wallace D, Moawad A, Baron J. Prophylactic red-cell transfusions in pregnant patients with sickle cell disease. A randomized cooperative study. *N Engl J Med* 1988;319(22):1447-1452.
860. Atweh GF, Schechter AN. Pharmacologic induction of fetal hemoglobin: raising the therapeutic bar in sickle cell disease. *Curr Opin Hematol* 2001;8(2):123-130.

861. Busslinger M, Hurst J, Flavell RA. DNA methylation and the regulation of globin gene expression. *Cell* 1983;34(1):197-206.
862. Felsenfeld G, McGhee J. Methylation and gene control. *Nature* 1982;296(5858):602-603.
863. DeSimone J, Heller P, Hall L, Zwiers D. 5-Azacytidine stimulates fetal hemoglobin synthesis in anemic baboons. *Proc Natl Acad Sci U S A* 1982;79(14):4428-4431.
864. Charache S, Dover G, Smith K, Talbot CC Jr, Moyer M, Boyer S. Treatment of sickle cell anemia with 5-azacytidine results in increased fetal hemoglobin production and is associated with nonrandom hypomethylation of DNA around the gamma-delta-beta-globin gene complex. *Proc Natl Acad Sci U S A* 1983;80(15):4842-4846.
865. Ley TJ, DeSimone J, Noguchi CT, et al. 5-Azacytidine increases gamma-globin synthesis and reduces the proportion of dense cells in patients with sickle cell anemia. *Blood* 1983;62(2):370-380.
866. Letvin NL, Linch DC, Beardsley GP, McIntyre KW, Nathan DG. Augmentation of fetal-hemoglobin production in anemic monkeys by hydroxyurea. *N Engl J Med* 1984;310(14):869-873.
867. Platt OS, Orkin SH, Dover G, Beardsley GP, Miller B, Nathan DG. Hydroxyurea enhances fetal hemoglobin production in sickle cell anemia. *J Clin Invest* 1984;74(2):652-656.
868. Veith R, Galanello R, Papayannopoulou T, Stamatoyannopoulos G. Stimulation of F-cell production in patients with sickle-cell anemia treated with cytarabine or hydroxyurea. *N Engl J Med* 1985;313(25):1571-1575.
869. Torrealba-de Ron A, Papayannopoulou T, Knapp MS, Fu MF, Knitter G, Stamatoyannopoulos G. Perturbations in the erythroid marrow progenitor cell pools may play a role in the augmentation of Hb F by 5-azacytidine. *N Engl J Med* 1984;63:201.
870. Humphries RK, Dover G, Young NS, et al. 5-Azacytidine acts directly on both erythroid precursors and progenitors to increase production of fetal hemoglobin. *J Clin Invest* 1985;75(2):547-557.
871. Orringer EP, Parker JC. Hydroxyurea and sickle cell disease. *Hematol Pathol* 1992;6(4):171-178.
872. Gladwin MT, Shelhamer JH, Ognibene FP, et al. Nitric oxide donor properties of hydroxyurea in patients with sickle cell disease. *Br J Haematol* 2002;116(2):436-444.
873. Glover RE, Ivy ED, Orringer EP, Maeda H, Mason RP. Detection of nitrosyl hemoglobin in venous blood in the treatment of sickle cell anemia with hydroxyurea. *Mol Pharmacol* 1999;55(6):1006-1010.
874. Huang J, Hadimani SB, Rupon JW, Ballas SK, Kim-Shapiro DB, King SB. Iron nitrosyl hemoglobin formation from the reactions of hemoglobin and hydroxyurea. *Biochemistry* 2002;41(7):2466-2474.
875. Charache S, Terrin ML, Moore RD, et al. Effect of hydroxyurea on the frequency of painful crises in sickle cell anemia. Investigators of the Multicenter Study of Hydroxyurea in Sickle Cell Anemia. *N Engl J Med* 1995;332(20):1317-1322.
876. Steinberg MH, Barton F, Castro O, et al. Effect of hydroxyurea on mortality and morbidity in adult sickle cell anemia: risks and benefits up to 9 years of treatment. *JAMA* 2003;289(13):1645-1651.
877. Voskaridou E, Christoulas D, Bilalis A, et al. The effect of prolonged administration of hydroxyurea on morbidity and mortality in adult patients with sickle cell syndromes: results of a 17-year, single-center trial (LaSHS). *Blood* 2010;115(12):2354-2363.
878. Ferguson RP, Arun A, Carter C, Walker SD, Castro O. Hydroxyurea treatment of sickle cell anemia in hospital-based practices. *Am J Hematol* 2002;70(4):326-328.
879. de Montalembert M, Belloy M, Bernaudin F, et al. Three-year follow-up of hydroxyurea treatment in severely ill children with sickle cell disease. The French Study Group on Sickle Cell Disease. *J Pediatr Hematol Oncol* 1997;19(4):313-318.
880. Ferster A, Vermynen C, Cornu G, et al. Hydroxyurea for treatment of severe sickle cell anemia: a pediatric clinical trial. *Blood* 1996;88(6):1960-1964.
881. Jayabose S, Tugal O, Sandoval C, et al. Clinical and hematologic effects of hydroxyurea in children with sickle cell anemia. *J Pediatr* 1996;129(4): 559-565.
882. Kinney TR, Helms RW, O'Branski EE, et al. Safety of hydroxyurea in children with sickle cell anemia: results of the HUG-KIDS study, a phase I/II trial. Pediatric Hydroxyurea Group. *Blood* 1999;94(5):1550-1554.

883. Scott JP, Hillery CA, Brown ER, Misiewicz V, Labotka RJ. Hydroxyurea therapy in children severely affected with sickle cell disease. *J Pediatr* 1996;128(6):820-828.
884. Zimmerman SA, Schultz WH, Davis JS, et al. Sustained long-term hematologic efficacy of hydroxyurea at maximum tolerated dose in children with sickle cell disease. *Blood* 2004;103(6):2039-2045.
885. Claster S, Vichinsky E. First report of reversal of organ dysfunction in sickle cell anemia by the use of hydroxyurea: splenic regeneration. *Blood* 1996;88(6):1951-1953.
886. Vichinsky EP, Lubin BH. A cautionary note regarding hydroxyurea in sickle cell disease. *Blood* 1994;83(4):1124-1128.
887. Hankins JS, Helton KJ, McCarville MB, Li CS, Wang WC, Ware RE. Preservation of spleen and brain function in children with sickle cell anemia treated with hydroxyurea. *Pediatr Blood Cancer* 2008;50(2):293-297.
888. Heeney MM, Whorton MR, Howard TA, Johnson CA, Ware RE. Chemical and functional analysis of hydroxyurea oral solutions. *J Pediatr Hematol Oncol* 2004;26(3):179-184.
889. Hoppe C, Vichinsky E, Quirolo K, van Warmerdam J, Allen K, Styles L. Use of hydroxyurea in children ages 2 to 5 years with sickle cell disease. *J Pediatr Hematol Oncol* 2000;22(4):330-334.
890. Wang WC, Wynn LW, Rogers ZR, Scott JP, Lane PA, Ware RE. A two-year pilot trial of hydroxyurea in very young children with sickle-cell anemia. *J Pediatr* 2001;139(6):790-796.
891. Hankins JS, Ware RE, Rogers ZR, et al. Long-term hydroxyurea therapy for infants with sickle cell anemia: the HUSOFT extension study. *Blood* 2005;106(7):2269-2275.
892. Wang WC, Ware RE, Miller ST, et al. Hydroxycarbamide in very young children with sickle-cell anaemia: a multicentre, randomised, controlled trial (BABY HUG). *Lancet* 2011;377(9778):1663-1672.
893. Hackney AC, Hezier W, Gullede TP, et al. Effects of hydroxyurea administration on the body weight, body composition and exercise performance of patients with sickle-cell anaemia. *Clin Sci (Lond)* 1997;92(5):481-486.
894. Wang WC, Helms RW, Lynn HS, et al. Effect of hydroxyurea on growth in children with sickle cell anemia: results of the HUG-KIDS Study. *J Pediatr* 2002;140(2):225-229.
895. Yan JH, Ataga K, Kaul S, et al. The influence of renal function on hydroxyurea pharmacokinetics in adults with sickle cell disease. *J Clin Pharmacol* 2005;45(4):434-445.
896. McGann PT, Flanagan JM, Howard TA, et al. Genotoxicity associated with hydroxyurea exposure in infants with sickle cell anemia: results from the BABY-HUG phase III clinical trial. *Pediatr Blood Cancer*. 2012 Aug;59(2):254-257. doi:10.1002/pbc.23365. Epub 2011 Oct 19.
897. McGann PT, Howard TA, Flanagan JM, Lahti JM, Ware RE. Chromosome damage and repair in children with sickle cell anaemia and long-term hydroxycarbamide exposure. *Br J Haematol* 2011;154(1):134-140.
898. Khayat AS, Antunes LM, Guimaraes AC, et al. Cytotoxic and genotoxic monitoring of sickle cell anaemia patients treated with hydroxyurea. *Clin Exp Med* 2006;6(1):33-37.
899. Maluf S, Pra D, Friedrisch JR, et al. Length of treatment and dose as determinants of mutagenicity in sickle cell disease patients treated with hydroxyurea. *Environ Toxicol Pharmacol* 2009;27(1):26-29.
900. Byrd DC, Pitts SR, Alexander CK. Hydroxyurea in two pregnant women with sickle cell anemia. *Pharmacotherapy* 1999;19(12):1459-1462.
901. de Montalembert M, Begue P, Bernaudin F, Thuret I, Bachir D, Micheau M. Preliminary report of a toxicity study of hydroxyurea in sickle cell disease. French Study Group on Sickle Cell Disease. *Arch Dis Child* 1999;81(5):437-439.
902. Valafar H, Valafar F, Darvill A, et al. Predicting the effectiveness of hydroxyurea in individual sickle cell anemia patients. *Artif Intell Med* 2000;18(2):133-148.
903. Ware RE, Eggleston B, Redding-Lallinger R, et al. Predictors of fetal hemoglobin response in children with sickle cell anemia receiving hydroxyurea therapy. *Blood* 2002;99(1):10-14.
904. Papayannopoulou T, Brice M, Stamatoyannopoulos G. Hemoglobin F synthesis in vitro: evidence for control at the level of primitive erythroid stem cells. *Proc Natl Acad Sci U S A* 1977;74(7):2923-2927.
905. Nagel RL, Vichinsky E, Shah M, et al. F reticulocyte response in sickle cell anemia treated with recombinant human erythropoietin: a double-blind study. *Blood* 1993;81(1):9-14.

906. Goldberg MA, Brugnara C, Dover GJ, Schapira L, Charache S, Bunn HF. Treatment of sickle cell anemia with hydroxyurea and erythropoietin. *N Engl J Med* 1990;323(6):366-372.
907. Rodgers GP, Dover GJ, Uyesaka N, Noguchi CT, Schechter AN, Nienhuis AW. Augmentation by erythropoietin of the fetal-hemoglobin response to hydroxyurea in sickle cell disease. *N Engl J Med* 1993;328(2):73-80.
908. Little JA, McGowan VR, Kato GJ, et al. Combination erythropoietin-hydroxyurea therapy in sickle cell disease: experience from the National Institutes of Health and a literature review. *Haematologica* 2006;91(8):1076-1083.
909. Raphael RI. Pathophysiology and treatment of sickle cell disease. *Clin Adv Hematol Oncol* 2005;3(6):492-505.
910. Perrine SP, Greene MF, Faller DV. Delay in the fetal globin switch in infants of diabetic mothers. *N Engl J Med* 1985;312(6):334-338.
911. Blau CA, Constantoulakis P, Shaw CM, Stamatoyannopoulos G. Fetal hemoglobin induction with butyric acid: efficacy and toxicity. *Blood* 1993;81(2):529-537.
912. Perrine SP, Ginder GD, Faller DV, et al. A short-term trial of butyrate to stimulate fetal-globin-gene expression in the beta-globin disorders. *N Engl J Med* 1993;328(2):81-86.
913. Sher GD, Ginder GD, Little J, Yang S, Dover GJ, Olivieri NF. Extended therapy with intravenous arginine butyrate in patients with beta-hemoglobinopathies. *N Engl J Med* 1995;332(24):1606-1610.
914. Pace BS, Chen YR, Thompson A, Goodman SR. Butyrate-inducible elements in the human gamma-globin promoter. *Exp Hematol* 2000;28(3):283-293.
915. Resar LM, Segal JB, Fitzpatrick LK, Friedmann A, Brusilow SW, Dover GJ. Induction of fetal hemoglobin synthesis in children with sickle cell anemia on low-dose oral sodium phenylbutyrate therapy. *J Pediatr Hematol Oncol* 2002;24(9):737-741.
916. Collins AF, Dover GJ, Luban NL. Increased fetal hemoglobin production in patients receiving valproic acid for epilepsy. *Blood* 1994;84(5):1690-1691.
917. DeSimone J, Koshy M, Dorn L, et al. Maintenance of elevated fetal hemoglobin levels by decitabine during dose interval treatment of sickle cell anemia. *Blood* 2002;99(11):3905-3908.
918. Koshy M, Dorn L, Bressler L, et al. 2-deoxy 5-azacytidine and fetal hemoglobin induction in sickle cell anemia. *Blood* 2000;96(7):2379-2384.
919. Sauntharajah Y, Hillery CA, Lavelle D, et al. Effects of 5-aza-2'-deoxycytidine on fetal hemoglobin levels, red cell adhesion, and hematopoietic differentiation in patients with sickle cell disease. *Blood* 2003;102(12):3865-3870.
920. Frenette PS, Atweh GF. Sickle cell disease: old discoveries, new concepts, and future promise. *J Clin Invest* 2007;117(4):850-858.
921. Sankaran VG, Menne TF, Xu J, et al. Human fetal hemoglobin expression is regulated by the developmental stage-specific repressor BCL11A. *Science* 2008;322(5909):1839-1842.
922. Sankaran VG, Nathan DG. Reversing the hemoglobin switch. *N Engl J Med* 2010;363(23):2258-2260.
923. Smith CM, Hebbel RP, Tukey DP, Clawson CC, White JG, Vercellotti GM. Pluronic F-68 reduces the endothelial adherence and improves the rheology of liganded sickle erythrocytes. *Blood* 1987;69(6):1631-1636.
924. Adams-Graves P, Kedar A, Koshy M, et al. RheothRx (poloxamer 188) injection for the acute painful episode of sickle cell disease: a pilot study. *Blood* 1997;90(5):2041-2046.
925. Eaton WA, Hofrichter J, Ross PD. Editorial: delay time of gelation: a possible determinant of clinical severity in sickle cell disease. *Blood* 1976;47(4): 621-627.
926. Haddy TB, Castro O. Overt iron deficiency in sickle cell disease. *Arch Intern Med* 1982;142(9):1621-1624.
927. Castro O, Haddy TB. Improved survival of iron-deficient patients with sickle erythrocytes. *N Engl J Med* 1983;308(9):527.
928. Rosa RM, Bierer BE, Thomas R, et al. A study of induced hyponatremia in the prevention and treatment of sickle-cell crisis. *N Engl J Med* 1980;303(20):1138-1143.
929. Charache S, Walker WG. Failure of desmopressin to lower serum sodium or prevent crisis in patients with sickle cell anemia. *Blood* 1981;58(5):892-896.

930. Stocker JW, de FL, Naughton-Smith GA, Corrocher R, Beuzard Y, Brugnara C. ICA-17043, a novel Gardos channel blocker, prevents sickled red blood cell dehydration in vitro and in vivo in SAD mice. *Blood* 2003;101(6): 2412-2418.
931. Ataga KI, Orringer EP, Styles L, et al. Dose-escalation study of ICA-17043 in patients with sickle cell disease. *Pharmacotherapy* 2006;26(11):1557-1564.
932. De Franceschi L, Bachir D, Galacteros F, et al. Oral magnesium supplements reduce erythrocyte dehydration in patients with sickle cell disease. *J Clin Invest* 1997;100(7):1847-1852.
933. De Franceschi L, Bachir D, Galacteros F, et al. Oral magnesium pidolate: effects of long-term administration in patients with sickle cell disease. *Br J Haematol* 2000;108(2):284-289.
934. Hankins JS, Wynn LW, Brugnara C, Hillery CA, Li CS, Wang WC. Phase I study of magnesium pidolate in combination with hydroxycarbamide for children with sickle cell anaemia. *Br J Haematol* 2008;140(1):80-85.
935. Fredholm BB, IJerman AP, Jacobson KA, Klotz KN, Linden J. International Union of Pharmacology. XXV. Nomenclature and classification of adenosine receptors. *Pharmacol Rev* 2001;53(4):527-552.
936. Wallace KL, Linden J. Adenosine A2A receptors induced on iNKT and NK cells reduce pulmonary inflammation and injury in mice with sickle cell disease. *Blood* 2010;116(23):5010-5020.
937. Johnson FL, Look AT, Gockerman J, Ruggiero MR, Dalla-Pozza L, Billings FT, III. Bone-marrow transplantation in a patient with sickle-cell anemia. *N Engl J Med* 1984;311(12):780-783.
938. Bernaudin F, Socie G, Kuentz M, et al. Long-term results of related myeloablative stem-cell transplantation to cure sickle cell disease. *Blood* 2007;110(7):2749-2756.
939. Panepinto JA, Walters MC, Carreras J, et al. Matched-related donor transplantation for sickle cell disease: report from the Center for International Blood and Transplant Research. *Br J Haematol* 2007;137(5):479-485.
940. Vermynen C, Cornu G, Ferster A, et al. Haematopoietic stem cell transplantation for sickle cell anaemia: the first 50 patients transplanted in Belgium. *Bone Marrow Transplant* 1998;22(1):1-6.
941. Locatelli F, Pagliara D. Allogeneic hematopoietic stem cell transplantation in children with sickle cell disease. *Pediatr Blood Cancer* 2012;59(2): 372-376.
942. Dovey S, Krishnamurti L, Sanfilippo J, et al. Oocyte cryopreservation in a patient with sickle cell disease prior to hematopoietic stem cell transplantation: first report. *J Assist Reprod Genet* 2012;29(3):265-269.
943. Mentzer WC, Heller S, Pearle PR, Hackney E, Vichinsky E. Availability of related donors for bone marrow transplantation in sickle cell anemia. *Am J Pediatr Hematol Oncol* 1994;16(1):27-29.
944. Pionelli S. Bone marrow transplantation in sickle cell diseases: a plea for a rational approach. *Bone Marrow Transplant* 1992;10(Suppl 1):58-61.
945. Platt OS, Guinan EC. Bone marrow transplantation in sickle cell anemia—the dilemma of choice. *N Engl J Med* 1996;335(6):426-428.
946. O'Brien SH, Hankins JS. Decision analysis of treatment strategies in children with severe sickle cell disease. *J Pediatr Hematol Oncol* 2009;31(11): 873-878.
947. Brichard B, Vermynen C, Ninane J, Cornu G. Persistence of fetal hemoglobin production after successful transplantation of cord blood stem cells in a patient with sickle cell anemia. *J Pediatr* 1996;128(2):241-243.
948. Gore L, Lane PA, Quinones RR, Giller RH. Successful cord blood transplantation for sickle cell anemia from a sibling who is human leukocyte antigen-identical: implications for comprehensive care. *J Pediatr Hematol Oncol* 2000;22(5):437-440.
949. Reed W, Smith R, Dekovic F, et al. Comprehensive banking of sibling donor cord blood for children with malignant and nonmalignant disease. *Blood* 2003;101(1):351-357.
950. Adamkiewicz TV, Szabolcs P, Haight A, et al. Unrelated cord blood transplantation in children with sickle cell disease: review of four-center experience. *Pediatr Transplant* 2007;11(6):641-644.
951. Ruggeri A, Eapen M, Scaravadou A, et al. Umbilical cord blood transplantation for children with thalassemia and sickle cell disease. *Biol Blood Marrow Transplant* 2011;17(9):1375-1382.

952. Walters MC, Patience M, Leisenring W, et al. Stable mixed hematopoietic chimerism after bone marrow transplantation for sickle cell anemia. *Biol Blood Marrow Transplant* 2001;7(12):665-673.
953. Gaziev J, Lucarelli G. Stem cell transplantation for hemoglobinopathies. *Curr Opin Pediatr* 2003;15(1):24-31.
954. Hsieh MM, Kang EM, Fitzhugh CD, et al. Allogeneic hematopoietic stem-cell transplantation for sickle cell disease. *N Engl J Med* 2009;361(24): 2309-2317.
955. Hankins J, Hinds P, Day S, et al. Therapy preference and decision-making among patients with severe sickle cell anemia and their families. *Pediatr Blood Cancer* 2007;48(7):705-710.
956. Hansbury EN, Schultz WH, Ware RE, Aygun B. Bone marrow transplant options and preferences in a sickle cell anemia cohort on chronic transfusions. *Pediatr Blood Cancer* 2012;58(4):611-615.
957. Sadelain M. Recent advances in globin gene transfer for the treatment of betathalassemia and sickle cell anemia. *Curr Opin Hematol* 2006;13(3):142-148.
958. Pawliuk R, Westerman KA, Fabry ME, et al. Correction of sickle cell disease in transgenic mouse models by gene therapy. *Science* 2001;294(5550): 2368-2371.
959. Cavazzana-Calvo M, Payen E, Negre O, et al. Transfusion independence and HMGA2 activation after gene therapy of human beta-thalassaemia. *Nature* 2010;467(7313):318-322.
960. Williams TN, Mwangi TW, Wambua S, et al. Sickle cell trait and the risk of *Plasmodium falciparum* malaria and other childhood diseases. *J Infect Dis* 2005;192(1):178-186.
961. Kramer MS, Rooks Y, Pearson HA. Growth and development in children with sickle-cell trait. A prospective study of matched pairs. *N Engl J Med* 1978;299(13):686-689.
962. Dorwart BB, Goldbert MA, Schumacher HR, Alavi A. Absence of increased frequency of bone and joint disease with hemoglobin AS and AC. *Ann Intern Med* 1977;86(1):66-67.
963. Blattner P, Dar H, Nitowsky HM. Pregnancy outcome in women with sickle cell trait. *JAMA* 1977;238(13):1392-1394.
964. Murphy JR. Sickle cell hemoglobin (Hb AS) in black football players. *JAMA* 1973;225(8):981-982.
965. Cooper MR, Toole JF. Sickle-cell trait: benign or malignant? *Ann Intern Med* 1972;77(6):997-998.
966. Jones SR, Binder RA, Donowho EM Jr. Sudden death in sickle-cell trait. *N Engl J Med* 1970;282(6):323-325.
967. Kark JA, Posey DM, Schumacher HR, Ruehle CJ. Sickle-cell trait as a risk factor for sudden death in physical training. *N Engl J Med* 1987;317(13):781-787.
968. Grant AM, Parker CS, Jordan LB, et al. Public health implications of sickle cell trait: a report of the CDC meeting. *Am J Prev Med* 2011;41(6 Suppl 4): S435-S439.
969. Goldsmith JC, Bonham VL, Joiner CH, Kato GJ, Noonan AS, Steinberg MH. Framing the research agenda for sickle cell trait: building on the current understanding of clinical events and their potential implications. *Am J Hematol* 2012;87(3):340-346.
970. Harmon KG, Drezner JA, Klossner D, Asif IM. Sickle cell trait associated with a RR of death of 37 times in National Collegiate Athletic Association football athletes: a database with 2 million athlete-years as the denominator. *Br J Sports Med* 2012;46(5):325-330.
971. Goodwin WE, Alston EF, Semans JH. Hematuria and sickle cell disease: unexplained, gross unilateral renal hematuria in Negroes coincident with the blood sickling trait. *J Urol* 1950;63:79.
972. Watanabe IC, Billis A, Guimaraes MS, et al. Renal medullary carcinoma: report of seven cases from Brazil. *Mod Pathol* 2007;20(9):914-920.
973. Oster JR, Lee SM, Lesprier LE, Pellegrini EL, Vaamonde CA. Renal acidification in sickle cell trait. *Arch Intern Med* 1976;136(1):30-35.
974. Ashcroft MT, Miall WE, Milner PF. A comparison between the characteristics of Jamaican adults with normal hemoglobin and those with sickle cell trait. *Am J Epidemiol* 1969;90(3):236-243.
975. Baill IC, Witter FR. Sickle trait and its association with birthweight and urinary tract infections in pregnancy. *Int J Gynaecol Obstet* 1990;33(1): 19-21.
976. Sears DA. The morbidity of sickle cell trait: a review of the literature. *Am J Med* 1978;64(6):1021-1036.

977. Lane PA, Githens JH. Splenic syndrome at mountain altitudes in sickle cell trait. Its occurrence in nonblack persons. *JAMA* 1985;253(15):2251-2254.
978. McKenzie JM. Vocational options for those with sickle cell trait: questions about hypoxemia and the industrial environment. *Am J Pediatr Hematol Oncol* 1982;4(2):172-178.
979. Austin H, Key NS, Benson JM, et al. Sickle cell trait and the risk of venous thromboembolism among blacks. *Blood* 2007;110(3):908-912.
980. Embury SH, Dozy AM. Correlation of alpha-globulin genotype with hematologic parameters in sickle cell trait. *Blood* 1979;54(Suppl):53a. Ref Type: Abstract
981. Huisman TH. Trimodality in the percentages of beta chain variants in heterozygotes: the effect of the number of active Hbalpha structural loci. *Hemoglobin* 1977;1(4):349-382.
982. Shaeffer JR, Kleve LJ, DeSimone J. betaS Chain turnover in reticulocytes of sickle trait individuals with high or low concentrations of haemoglobin S. *Br J Haematol* 1976;32(3):365-372.
983. Levere RD, Levine J, Lichtman HC. Effect of iron deficiency anaemia on the metabolism of the heterogenic haemoglobins in sickle cell trait. *Nature* 1964;202(493):499-501.
984. Heller P, Yakulis VJ, Epstein RB, Friedland S. Variation in the amount of hemoglobin S in a patient with sickle cell trait and megaloblastic anemia. *Blood* 1963;21(4):479.
985. Barnes MG, Komarmy L, Novack AH. A comprehensive screening program for hemoglobinopathies. *JAMA* 1972;219(6):701-705.
986. Basset P, Beuzard Y, Garel MC, Rosa J. Isoelectric focusing of human hemoglobin: its application to screening, to the characterization of 70 variants, and to the study of modified fractions of normal hemoglobins. *Blood* 1978;51(5):971-982.
987. Serjeant GR, Richards R, Barbor PR, Milner PF. Relatively benign sickle-cell anaemia in 60 patients aged over 30 in the West Indies. *Br Med J* 1968;3(610):86-91.
988. Eddington GM, Laing WN. Relationships between haemoglobin C and S and malaria in Ghana. *Br Med J* 1957;2:143-145.
989. Bunn HF. Subunit assembly of hemoglobin: an important determinant of hematologic phenotype. *Blood* 1987;69(1):1-6.
990. Bookchin RM, Balazs T. Ionic strength dependence of the polymer solubilities of deoxyhemoglobin S + C and S + A mixtures. *Blood* 1986;67(4):887-892.
991. Bunn HF, Noguchi CT, Hofrichter J, Schechter GP, Schechter AN, Eaton WA. Molecular and cellular pathogenesis of hemoglobin SC disease. *Proc Natl Acad Sci U S A* 1982;79(23):7527-7531.
992. Nagel RL, Fabry ME, Steinberg MH. The paradox of hemoglobin SC disease. *Blood Rev* 2003;17(3):167-178.
993. Williams S, Maude GH, Serjeant GR. Clinical presentation of sickle cell-hemoglobin C disease. *J Pediatr* 1986;109(4):586-589.
994. Yeung KY, Lessin LS. Splenic infarction in sickle cell-hemoglobin C disease. Demonstration by selective splenic arteriogram and scintillation scan. *Arch Intern Med* 1976;136(8):905-911.
995. Geola F, Kukreja SC, Schade SG. Splenic sequestration with sickle cell-C disease. *Arch Intern Med* 1978;138(2):307-308.
996. Githens JH, Gross GP, Eife RF, Wallner SF. Splenic sequestration syndrome at mountain altitudes in sickle/hemoglobin C disease. *J Pediatr* 1977;90(2):203-206.
997. Koduri PR, Nathan S. Acute splenic sequestration crisis in adults with hemoglobin S-C disease: a report of nine cases. *Ann Hematol* 2006;85(4):239-243.
998. Chilcote RR, Dampier C. Overwhelming pneumococcal septicemia in a patient with HbSC disease and splenic dysfunction. *J Pediatr* 1984;104(5):734-736.
999. Barrett-Connor E. Infection and sickle cell-C disease. *Am J Med Sci* 1971;262(3):162-169.
1000. Buchanan GR, Smith SJ, Holtkamp CA, Fuseler JP. Bacterial infection and splenic reticuloendothelial function in children with hemoglobin SC disease. *Pediatrics* 1983;72(1):93-98.

1001. Topley JM, Cupidore L, Vaidya S, Hayes RJ, Serjeant GR. Pneumococcal and other infections in children with sickle-cell hemoglobin C (SC) disease. *J Pediatr* 1982;101(2):176-179.
1002. Chusid MJ, Lachman BS, Lazerson J. Severe Mycoplasma pneumonia and vesicular eruption in SC hemoglobinopathy. *J Pediatr* 1978;93(3):449-451.
1003. Lane PA, Rogers ZR, Woods GM, et al. Fatal pneumococcal septicemia in hemoglobin SC disease. *J Pediatr* 1994;124(6):859-862.
1004. Chmel H, Bertles JF. Hemoglobin S/C disease in a pregnant woman with crisis and fat embolization syndrome. *Am J Med* 1975;58(4):563-566.
1005. Davey RJ, Esposito DJ, Jacobson RJ, Corn M. Partial exchange transfusion as treatment for hemoglobin SC disease in pregnancy. *Arch Intern Med* 1978;138(6):937-939.
1006. Koduri PR, Agbemadzo B, Nathan S. Hemoglobin S-C disease revisited: clinical study of 106 adults. *Am J Hematol* 2001;68(4):298-300.
1007. Moo-Penn W, Bechtel K, Jue D, et al. The presence of hemoglobin S and C Harlem in an individual in the United States. *Blood* 1975;46(3):363-367.
1008. Honig GR, Gunay U, Mason RG, Vida LN, Ferenc C. Sickle cell syndromes. I. Hemoglobin SC-alpha-thalassemia. *Pediatr Res* 1976;10(6):613-620.
1009. Warkentin TE, Barr RD, Ali MA, Mohandas N. Recurrent acute splenic sequestration crisis due to interacting genetic defects: hemoglobin SC disease and hereditary spherocytosis. *Blood* 1990;75(1):266-270.
1010. Ballas SK, Lerner J, Smith ED, Surrey S, Schwartz E, Rappaport EF. The xerocytosis of Hb SC disease. *Blood* 1987;69(1):124-130.
1011. Diggs LW, Bell A. Intraerythrocytic hemoglobin crystals in sickle cell hemoglobin C disease. *Blood* 1965;25:218.
1012. Steinberg MH, Nagel RL, Brugnara C. Cellular effects of hydroxyurea in Hb SC disease. *Br J Haematol* 1997;98(4):838-844.
1013. Miller MK, Zimmerman SA, Schultz WH, Ware RE. Hydroxyurea therapy for pediatric patients with hemoglobin SC disease. *J Pediatr Hematol Oncol* 2001;23(5):306-308.
1014. Markham MJ, Lottenberg R, Zumberg M. Role of phlebotomy in the management of hemoglobin SC disease: case report and review of the literature. *Am J Hematol* 2003;73(2):121-125.
1015. Wang W, Brugnara C, Snyder C, et al. The effects of hydroxycarbamide and magnesium on haemoglobin SC disease: results of the multi-centre CHAMPS trial. *Br J Haematol* 2011;152(6):771-776.
1016. Serjeant GR, Ashcroft MT, Serjeant BE, Milner PF. The clinical features of sickle-cell- thalassaemia in Jamaica. *Br J Haematol* 1973;24(1):19-30.
1017. Stevens MC, Maude GH, Beckford M, et al. Haematological change in sickle cell-haemoglobin C disease and in sickle cell-beta thalassaemia: a cohort study from birth. *Br J Haematol* 1985;60(2):279-292.
1018. Pearson HA, Gallagher D, Chilcote R, et al. Developmental pattern of splenic dysfunction in sickle cell disorders. *Pediatrics* 1985;76(3):392-397.
1019. Rey KS, Unger CA, Rao SP, Miller ST. Sickle cell-hemoglobin E disease: clinical findings and implications. *J Pediatr* 1991;119(6):949-951.
1020. McCurdy PR, Lorkin PA, Casey R, Lehmann H, Uddin DE, Dickson LG. Hemoglobin S-G (S-D) syndrome. *Am J Med* 1974;57(4):665-670.
1021. Sturgeon P, Itano HA, Bergreu WR. Clinical manifestations of hemoglobin-S with hemoglobin-D. The interaction of hemoglobin-S with hemoglobin-D. *Blood* 1955;10:389.
1022. Cawein MJ, Lappat EJ, Brangle RW, Farley CH. Hemoglobin S-D disease. *Ann Intern Med* 1966;64(1):62-70.
1023. Schneider RG, Ueda S, Alperin JB, Levin WC, Jones RT, Brimhall B. Hemoglobin D Los Angeles in two Caucasian families: hemoglobin SD disease and hemoglobin D thalassemia. *Blood* 1968;32(2):250-259.
1024. Adekile A, Mullah-Ali A, Akar NA. Does elevated hemoglobin F modulate the phenotype in Hb SD-Los Angeles? *Acta Haematol* 2010;123(3):135-139.

1025. Charache S, Zinkham WH, Dickerman JD, Brimhall B, Dover GJ. Hemoglobin SC, SS/GPhiladelphia and SOArab diseases diagnostic importance of an integrative analysis of clinical, hematologic and electrophoretic findings. *Am J Med* 1977;62(3):439-446.
1026. Maeda K, Kini RK, Saeed SM, Rucknagel DL. Hemoglobin SO Arab and hemoglobin CO Arab diseases. Clinical and laboratory study. *Am J Pediatr Hematol Oncol* 1983;5(2):127-131.
1027. Kan YW, Dozy AM. Evolution of the hemoglobin S and C genes in world populations. *Science* 1980;209(4454):388-391.
1028. Agarwal A, Guindo A, Cissoko Y, et al. Hemoglobin C associated with protection from severe malaria in the Dogon of Mali, a West African population with a low prevalence of hemoglobin S. *Blood* 2000;96(7):2358-2363.
1029. Olson JA, Nagel RL. Synchronized cultures of *P falciparum* in abnormal red cells: the mechanism of the inhibition of growth in HbCC cells. *Blood* 1986;67(4):997-1001.
1030. Galbraith PA, GREEN PT. Hemoglobin C disease in an Anglo-Saxon family. *Am J Med* 1960;28:969-972.
1031. Loukopoulos D, Voskaridou E, Kalotychou V, Schina M, Loutradi A, Theodoropoulos I. Reduction of the clinical severity of sickle cell/beta-thalassemia with hydroxyurea: the experience of a single center in Greece. *Blood Cells Mol Dis* 2000;26(5):453-466.
1032. Prindle KH Jr, McCurdy PR. Red cell lifespan in hemoglobin C disorders (with special reference to hemoglobin C trait). *Blood* 1970;36(1):14-19.
1033. Liebhaber SA, Cash FE, Cornfield DB. Evidence for posttranslational control of Hb C synthesis in an individual with Hb C trait and alpha-thalassemia. *Blood* 1988;71(2):502-504.
1034. Olson JF, Ware RE, Schultz WH, Kinney TR. Hemoglobin C disease in infancy and childhood. *J Pediatr* 1994;125(5 Pt 1):745-747.
1035. Lipshutz M, McQueen DA, Rosner F. Spontaneous rupture of the spleen in homozygous hemoglobin C disease. *JAMA* 1977;237(8):792-793.
1036. Redetzki JE, Bickers JN, Samuels MS. Homozygous hemoglobin C disease: clinical review of fifteen patients. *South Med J* 1968;61(3):238-242.
1037. Charache S, Conley CL, Waugh DF, Ugoretz RJ, Spurrell JR. Pathogenesis of hemolytic anemia in homozygous hemoglobin C disease. *J Clin Invest* 1967;46(11):1795-1811.
1038. Murphy JR. Hemoglobin CC erythrocytes: decreased intracellular pH and decreased O₂ affinity—anemia. *Semin Hematol* 1976;13(3):177-180.
1039. Lessin LS, Jensen WN, Ponder E. Molecular mechanism of hemolytic anemia in homozygous hemoglobin C disease. Electron microscopic study by the freeze-etching technique. *J Exp Med* 1969;130(3):443-466.
1040. Mohandas N, Clark MR, Jacobs MS, Shohet SB. Analysis of factors regulating erythrocyte deformability. *J Clin Invest* 1980;66(3):563-573.
1041. Steinberg MH. Haemoglobin C/alpha thalassaemia: haematological and biosynthetic studies. *Br J Haematol* 1975;30(3):337-342.
1042. Embury SH, Hebbel RP, Steinberg MH, Mohandas N. Sickle cell disease: basic principles and clinical practice. New York: Raven Press, 1994.
1043. Taiwo IA, Oloyede OA, Dosumu AO. Frequency of sickle cell genotype among the Yorubas in Lagos: implications for the level of awareness and genetic counseling for sickle cell disease in Nigeria. *J Community Genet* 2011;2(1):13-18.
1044. Akinyanju OO. A profile of sickle cell disease in Nigeria. *Ann N Y Acad Sci* 1989;565:126-136.
1045. Agasa B, Bosunga K, Opara A, et al. Prevalence of sickle cell disease in a northeastern region of the Democratic Republic of Congo: what impact on transfusion policy? *Transfus Med* 2010;20(1):62-65.
1046. Kafando E, Sawadogo M, Cotton F, Vertongen F, Gulbis B. Neonatal screening for sickle cell disorders in Ouagadougou, Burkina Faso: a pilot study. *J Med Screen* 2005;12(3):112-114.
1047. Ramasamy S, Balakrishnan K, Pitchappan RM. Prevalence of sickle cells in Irula, Kurumba, Paniya & Mullukurumba tribes of Nilgiris (Tamil Nadu, India). *Indian J Med Res* 1994;100:242-245.

1048. Balgir RS. Spectrum of hemoglobinopathies in the state of Orissa, India: a ten years cohort study. *J Assoc Physicians India* 2005;53:1021-1026.
1049. Mohanty D, Mukherjee MB. Sickle cell disease in India. *Curr Opin Hematol* 2002;9(2):117-122.
1050. Lobo C, Bueno LM, Moura P, Castilho S, Carvalho SMF, Ogeda LL. Triagem neonatal para hemoglobinopatias no Rio de Janeiro, Brasil. *Pan Am J Public Health* 2003;13(2/3):154-159.
1051. Gimenez OG, Torrealba MC, Urquiola MB, et al. [Diagnosis of hemoglobinopathies in newborns in Venezuela hospitals]. *An Pediatr (Barc)* 2009;71(4): 314-318.
1052. Hanchard NA, Hambleton I, Harding RM, McKenzie CA. The frequency of the sickle allele in Jamaica has not declined over the last 22 years. *Br J Haematol* 2005;130(6):939-942.
1053. Michlitsch J, Azimi M, Hoppe C, et al. Newborn screening for hemoglobinopathies in California. *Pediatr Blood Cancer* 2009;52(4):486-490.
1054. Le PQ, Ferster A, Cotton F, et al. Sickle cell disease from Africa to Belgium, from neonatal screening to clinical management. *Med Trop (Mars)* 2010;70(5-6):467-470.
1055. Berthet S, Monpoux F, Soummer AM, Berard E, Sarles J, Badens C. [Neonatal screening for sickle cell disease at the Nice University Hospital: the last 8 years]. *Arch Pediatr* 2010;17(12):1652-1656.
1056. Thuret I, Sarles J, Merono F, et al. Neonatal screening for sickle cell disease in France: evaluation of the selective process. *J Clin Pathol* 2010;63(6):548-551.
1057. Streetly A, Latinovic R, Hall K, Henthorn J. Implementation of universal newborn bloodspot screening for sickle cell disease and other clinically significant haemoglobinopathies in England: screening results for 2005-7. *J Clin Pathol* 2009;62(1):26-30.
1058. Manu PM, Corrons JL. Neonatal haemoglobinopathy screening in Spain. *J Clin Pathol* 2009;62(1):22-25.
1059. Kalleas C, Anagnostopoulos K, Sinopoulou K, et al. Phenotype and genotype frequency of beta-thalassemia and sickle cell disease carriers in Halkidiki, Northern Greece. *Hemoglobin* 2012;36(1):64-72.
1060. Canatan D, Kose MR, Ustundag M, Haznedaroglu D, Ozbas S. Hemoglobinopathy control program in Turkey. *Community Genet* 2006;9(2):124-126.
1061. Bircan I, Sisli S, Guven A, et al. Hemoglobinopathies in the district of Antalya, Turkey. *Pediatr Hematol Oncol* 1993;10(3):289-291.
1062. Kocak R, Alparslan ZN, Agridag G, Baslamisli F, Aksungur PD, Koltas S. The frequency of anaemia, iron deficiency, hemoglobin S and beta thalassemia in the south of Turkey. *Eur J Epidemiol* 1995;11(2):181-184.
1063. Tuncbilek E, Ozguc M. Application of medical genetics in Turkey. *Turk J Pediatr* 2007;49(4):353-359.
1064. Al-Riyami A, Ebrahim GJ. Genetic Blood disorders survey in the Sultanate of Oman. *J Trop Pediatr* 2003;49(Suppl 1):i1-i20.
1065. Al-Qurashi MM, El-Mouzan MI, Al-Herbish AS, Al-Salloum AA, Al-Omar AA. The prevalence of sickle cell disease in Saudi children and adolescents. A community-based survey. *Saudi Med J* 2008;29(10):1480-1483.
1066. Jastaniah W. Epidemiology of sickle cell disease in Saudi Arabia. *Ann Saudi Med* 2011;31(3):289-293.

Chapter 34 Thalassemias and Related Disorders: Quantitative Disorders of Hemoglobin Synthesis

Caterina Borgna-Pignatti

Renzo Galanello*

Dedication: We wish to dedicate this chapter to Rino Vullo and Antonio Cao who passed away on June 22, 2010, and June 21, 2012, respectively.

Rino Vullo in Ferrara and Antonio Cao in Cagliari pioneered a new way of approaching thalassemia, believing in the power of science to change the fate of what was considered for many decades a hopeless disease. Their scientific and human contributions will remain in the history of hematology.

* Dr. Renzo Galanello died on May 13, 2013. He was a pediatrician, a hematologist and a geneticist of enormous competence. We will miss his enthusiastic approach to science, to medicine, to life itself.

The thalassemias are a group of congenital anemias that have in common deficient synthesis of one or more of the globin subunits of the normal human hemoglobins (Hbs). The primary defect is usually quantitative, consisting of the reduced or absent synthesis of normal globin chains, but there are mutations resulting in structural variants produced at reduced rate (e.g., HbE, Hb Lepore) and mutations producing hyperunstable hemoglobin variants with a thalassemia phenotype (thalassemic hemoglobinopathies). Therefore, a rigid differentiation from the qualitative changes of hemoglobin structure that characterize the hemoglobinopathies is no longer appropriate. According to the chain whose synthesis is impaired, the most common thalassemias are called α -, β -, γ -, or $\delta\beta$ -thalassemias. These subgroups have in common an imbalanced globin synthesis, with the consequence that the globin produced in excess is responsible for ineffective erythropoiesis (intramedullary destruction of erythroid precursors) and hemolysis (peripheral destruction of red cells). In the last few years, the advances of DNA analysis have permitted understanding the basic aspects of gene structure and function and the characterization of the molecular basis for deficient globin synthesis. The thalassemias result from the effect of a large number of different molecular defects, which may interact, leading to a variety of clinical and hematologic phenotypes.

PREVALENCE, GEOGRAPHIC DISTRIBUTION, AND THE ROLE OF MALARIA

Thalassemia is considered one of the most common genetic disorders worldwide. It occurs in a particularly high frequency in a broad belt extending from the Mediterranean basin through the Middle East, Indian subcontinent, Burma, Southeast Asia, Melanesia, and the islands of the Pacific. According to data collected through the Hereditary Disease Program of the World Health Organization and based on local surveys and reports by visiting experts, the carriers of hemoglobin disorders in the world are estimated to be 269 million.¹ Recent global epidemiologic data on the demographics and prevalence of hemoglobinopathies have established that these disorders represent a significant health problem in 71% of 229 countries and that around 1.1% of couples worldwide are at risk for having children with a hemoglobin disorder.² From data available it has been estimated that the annual number of births is 22,989 for β -thalassemia major; 5,183 for Hb Bart hydrops fetalis syndrome; 9,568 for hemoglobin H disease (the intermediate form of α -thalassemia); and 19,128 for HbE/ β -thalassemia.^{2, 3}

Diseases caused by α -thalassemia are encountered commonly in Southeast Asia and China with up to 40% of the regional population being carriers, and less commonly in India, Kuwait, the Middle East, Greece, Italy, and Northern Europe.⁴ Southeast Asia is the area of the world where the frequency of α -thalassemia is so high as to cause a major public health problem, because of the increased number of patients with severe HbH disease and fetuses with Hb Bart hydrops fetalis. In the eastern oasis of Saudi Arabia, more than 50% of the population appears to have a clinically silent form of α -thalassemia, and HbH disease is recognized with increasing frequency.⁵ In a random population sample, the gene frequency of deletion-type α -thalassemia-2 ($-\alpha$) was 0.18 in Sardinians and 0.07 in Greek Cypriots; the occurrence of nondeletion α -thalassemia is estimated to be one-third that of the deletion-type.⁶ In African-Americans, α -thalassemia is relatively common, but rarely is it of clinical significance. Of 211 healthy African-Americans in whom the α -globin genotype was characterized, 27.5% lacked a single α -globin gene, and 1.9% lacked two of the four α -globin genes.⁷ With the rise in Asian immigration to North America over the past few decades the prevalence of α -thalassemia and other hemoglobinopathies has increased steadily.⁸ The epidemiologic changes in the prevalence of hemoglobin disorders have important implications for public health programs, including new laboratory strategies, newborn screening, counseling, and patient management.^{9, 10} About 3% of the world's population (150 million people) carry β -thalassemia genes. In Europe they are particularly prevalent in inhabitants of Italy and Greece. In Italy, the highest prevalence of the carrier state, in descending order, has been found in Sardinia (10.3%), the Delta region of the Po River near Ferrara (8%), and Sicily (5.9% with an almost equal distribution over the entire island).^{11, 12, 13} In Greece, the prevalence varies considerably, ranging from <5% to nearly 15% in the southern and central areas.^{32, 33} In Cyprus, one individual in seven is a carrier of β -thalassemia and one individual in 1,000 is currently homozygous.¹ In Sardinia the incidence of homozygous β -thalassemia is 1 in 250 live births. There are an estimated 3,500 individuals with thalassemia major in Greece and 4,300 in Italy¹⁴ (Cianciulli personal communication). β -Thalassemia is encountered less often in the northern and western parts of Africa. In the Maghreb (African countries opening on the Mediterranean) frequencies vary from 3% in Algeria to 7% in Morocco and Lybia.¹⁵ In Egypt, thalassemia represents a serious health problem, with a predicted 1,000 new patients born each year.¹⁶ In Turkey, the frequency varies from 0.8% to 10.8%.¹⁷ It has been described in high frequencies (10% to 20%) in Indian and Kurdish Jews.¹⁸ In Arabs it averages 2%.¹⁹ Few data are available for Pakistan.²⁰ Among Indians, frequencies between 3.5% and 14.9% have been reported.²¹ In North America, thalassemia used to affect mainly individuals of Mediterranean origin and African-Americans, but is, at present, most frequently observed in Asians. In fact, increases in Asian immigration and births in the United States, particularly in California, have led to a prevalence rate of HbE/ β -

thalassemia among Southeast Asians of ~1 in 2,200.²² In one survey of healthy black men, heterozygous β -thalassemia was documented in 1.4%.²³ β -Thalassemia in Jamaica may have its origin in both the African and Asian immigrant populations.²⁴ In sporadic cases, β -thalassemia has been noted in Northern Europeans with no apparent Mediterranean or Asian ancestry.¹⁵ Although well documented in natives of Southeast Asia and southern China, β -thalassemia is far less prevalent in these regions than is α -thalassemia.²⁵ HbE, the hallmark of Southeast Asia, is most frequently found at the border of Thailand, Laos, and Cambodia, where the frequencies may reach 50% to 60%. In Great Britain, which today is a multiethnic society due to substantial

P.863

migration from Cyprus, the Indian subcontinent, Southeast Asia, and the Middle East, it is estimated that 0.37 per 1,000 fetuses have a major hemoglobin disorder, 20% being thalassemias and 80% being sickle cell disease. A formal patient register was also recently established in Great Britain in 1997. At the end of 1999, 807 patients with thalassemia major were alive and residing in the United Kingdom, most of whom were of Pakistani or of Cypriot origin.²⁶ Detailed information on the frequency of thalassemia in different world regions is available from Modell and Darlison,² and Galanello et al.²⁷

The Role of Malaria

Even in the first description from Italy of children affected by thalassemia, Maccanti observed that all the patients came from malarial areas and, 20 years later, Vezzoso noted that the distribution of Cooley's anemia in Italy coincided with that of malaria.^{28, 29} The hypothesis that malaria had an influence in maintaining the high prevalence of hemoglobinopathies in the world was first suggested in 1949 by Haldane, who also proposed that the small red cells of the carriers of thalassemia could be more resistant to the malaria parasites.³⁰ A few years earlier, Neel and Valentine had calculated that, in the absence of some kind of selective pressure, the mutation rate for thalassemia had to be in the order of 1 in 2,500.³¹ Carcassi et al. and Siniscalco et al. in Sardinia obtained suggestive epidemiologic data on the distribution of thalassemia and malaria, but their results were not confirmed in other populations.³² Molecular biology studies helped to clarify at least some aspects of the problem. In fact, they revealed the very high number of β -thalassemia mutations that are, for the most part, regionally specific, as well as the association of particular mutations with specific β -globin gene haplotypes. The regional specificity of mutations suggests local processes for their elevation to high frequencies, while the close association with specific haplotypes suggests a recent cause. These observations point to the conclusion that the selective pressure of malaria has amplified the β -thalassemia genes to high frequency so recently that neither migration, recombination, nor genetic drift could have had sufficient time to bring them into spatial or genetic equilibrium with their background.³³

The mechanism by which the thalassemia heterozygote could be protected from malaria is still not clear. Several studies have demonstrated reduced red cell invasion by malaria parasites in the severe forms of thalassemia, but the results in the heterozygous states for α - and β -thalassemia have been contradictory.^{34, 35, 36} A provocative study performed in newborns with α -thalassemia revealed an increased susceptibility to infection by *Plasmodium vivax*, a less severe form of malaria, and suggested that this could confer permanent cross-species protection against *Plasmodium falciparum*.³⁷ Both parasites invade preferentially young circulating red cells, and early infection in a period of life when maternal antibodies are still present could protect them from later severe disease. Also, some form of immunologic mechanism could be involved in protecting carriers of thalassemia from malaria and possibly from other diseases as well.³⁸ However, recent in vitro studies using red blood cells (RBCs) with common hemoglobinopathies (e.g., α - and β -thalassemias, HbS, HbC, HbE) and enzyme (glucose-6-phosphate dehydrogenase [G6PD]) defects have shown a reduced parasite invasion/growth and an increased susceptibility to phagocytosis of the infected RBC as a malaria-protective effect.^{39, 40} A recent systematic review and meta-analysis of studies that estimated the risk of malaria in patients with and without hemoglobinopathies, showed a decreased risk of severe *P. falciparum* malaria in sickle cell carriers, homozygous and heterozygous hemoglobin C, and homozygous and heterozygous α -thalassemia.⁴¹ These hemoglobinopathies differ substantially in the degree of protection provided and confer mild or no protection against uncomplicated malaria and asymptomatic parasitemia.

Moreover, evidence has been obtained for complex epistatic interactions among different inherited hemoglobin disorders with respect to malaria protection, at least partly explaining some profound differences in their distribution among different populations.³

GENETIC MECHANISMS AND MOLECULAR PATHOLOGY

Synthesis of hemoglobin, the molecule used for oxygen transport, is directed by two gene clusters: The α locus, which contains the embryonic ζ gene, plus the two adult α genes; and the β cluster, which contains the embryonic ζ , the fetal G γ

and $\text{A}\gamma$, and the adult δ and β genes (Fig. 34.1). Different hemoglobins are produced during development and two globin gene switches take place: the embryonic to fetal switch (ϵ to γ and ζ to α), which starts very early in pregnancy and is completed at 10 weeks of gestation; and the fetal to adult switch (γ to β), which occurs during the perinatal period.⁴² The globin gene switches, besides the changes in hemoglobin composition, come with changes in other morphologic and biochemical characteristics of the erythropoietic cell line, including the shift from the nucleated megaloblast to macrocyte and to the definitive normocyte; the shift in the site of erythropoiesis from the yolk sac to liver, spleen, and bone marrow; and changes in the membrane antigenic profile and in the red cell glycolytic activity.⁴³ Recent discoveries about transcriptional regulation of fetal hemoglobin represent a major advance in understanding the switching mechanisms and for developing targeted approaches to ameliorate the severity of β -hemoglobinopathies. Genetic linkage and genome-wide association studies have led to the identification of a variety of nuclear factors acting as multiprotein complexes, involved in globin gene regulation and switching.^{44, 45, 46, 47, 48, 49} The most relevant are BCL11A and KLF1. BCL11A is a zinc-finger transcription factor necessary for normal B and T lymphopoiesis, that in cooperation with other transcriptional factors, acts also as a direct developmental stage-specific repressor of fetal hemoglobin expression.⁵⁰ KLF1 is a zinc-finger erythroid-specific transcriptional regulator, known as an activator of the β -globin gene through direct binding to the critical CACCC box promoter element, that activates BCL11A expression by associating with the BCL11A promoter.^{48, 51} Therefore, KLF1 has a dual role in globin gene regulation, functioning as a direct activator of the β -globin gene and an indirect repressor of the γ -globin gene.^{52, 53, 54} Protein-protein and protein-DNA interactions, involving the β -globin gene cluster and the locus controlling region (LCR), result in complex developmental-related chromatin modifications that activate or repress the different globin genes (Fig. 34.2). The globin genes are relatively small and composed of three exons, coding for functional domains of the hemoglobin, and two intervening sequences (introns).⁴³ The different globin gene expression during development is controlled through the action of transcription factors and regulatory elements (promoters, enhancers, and silencers) that flank each globin gene, and of more remote sequences important for the regulation of all of the cluster (see below). The promoter of each globin gene contains sequences that act as binding sites for erythroid-restricted or ubiquitously expressed transcription factors responsible for tissue-specific and developmental-specific regulation of the globin genes. Particularly relevant promoter sequences are the TATA box, situated 30 bp upstream of the initiation site, and the CAAT and CACCC boxes at approximately -70 and -110 bp from the initiation site, respectively. Among the transcription factors, some have been studied in detail for their role in the regulation of globin gene expression. GATA-1 is the first of a family of DNA-binding proteins, whose binding sites are present in one or more copies in almost all the regulatory elements of the globin genes.⁵⁵ Nuclear factor-erythroid 2 (NFE2), EKLF, FOG-1, and SP1 are other transcription factors involved in the expression

P.864

of the β -globin gene.^{56, 57, 58, 59} Like other genes, globin genes possess a series of motifs critical for their expression: the CAP site, which indicates the start of transcription; the AGT initiation codon, which is the signal for starting translation in messenger RNA (mRNA); the donor and acceptor splice sites, which are involved in the processing (splicing) of mRNA; the termination codon, which interrupts translation; and the polyadenylation signal, which is crucial for the addition of a poly (A) tail to the mRNA. The importance of these critical sequences is underscored by the fact that nucleotide substitutions that either alter them or create new similar consensus sequences in a globin gene cause abnormal mRNA processing and constitute the molecular basis for most types of thalassemia. Detailed information on positions, genotypes, and phenotypes for the known globin gene variants are available at the websites listed at the end of this chapter. Essentially the process of globin gene expression consists of the following steps: Transcription of DNA into a primary mRNA transcript; processing of the primary mRNA, involving modifications at both its 5' (capping) and 3' (polyadenylation) ends together with removal of the introns and joining of the exons (splicing) to produce mature mRNA, the final template for protein synthesis; and translation of mRNA in the globin protein. Transcription and RNA processing occur in the nucleus, while translation occurs in the cytoplasm [for review, see (15, 60)]. Thalassemia syndromes result from a large series of molecular defects, which alter the expression of one or more globin genes.

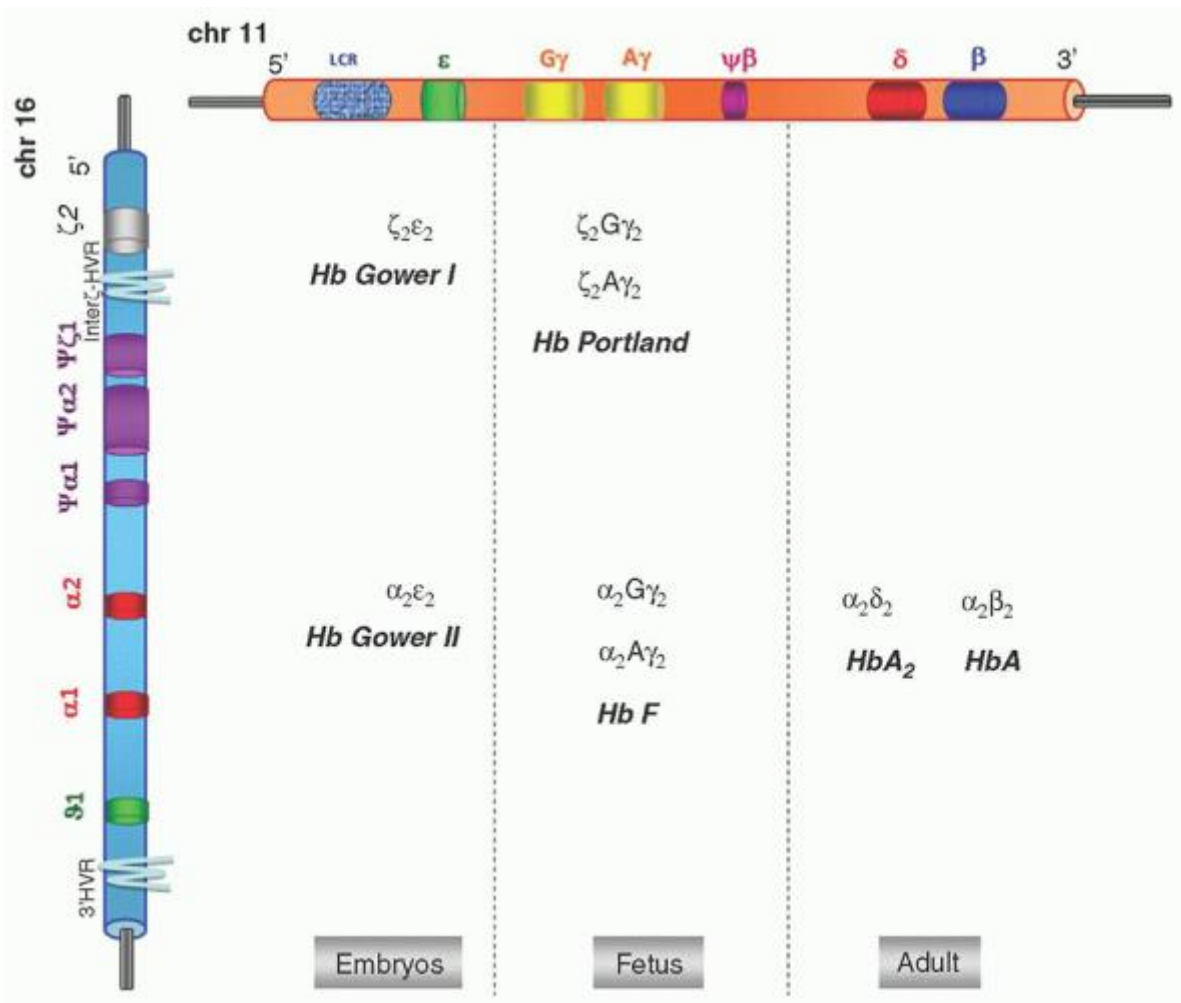

FIGURE 34.1. α - and β -globin gene cluster and hemoglobins (Hbs) produced during development. LCR, locus control region.

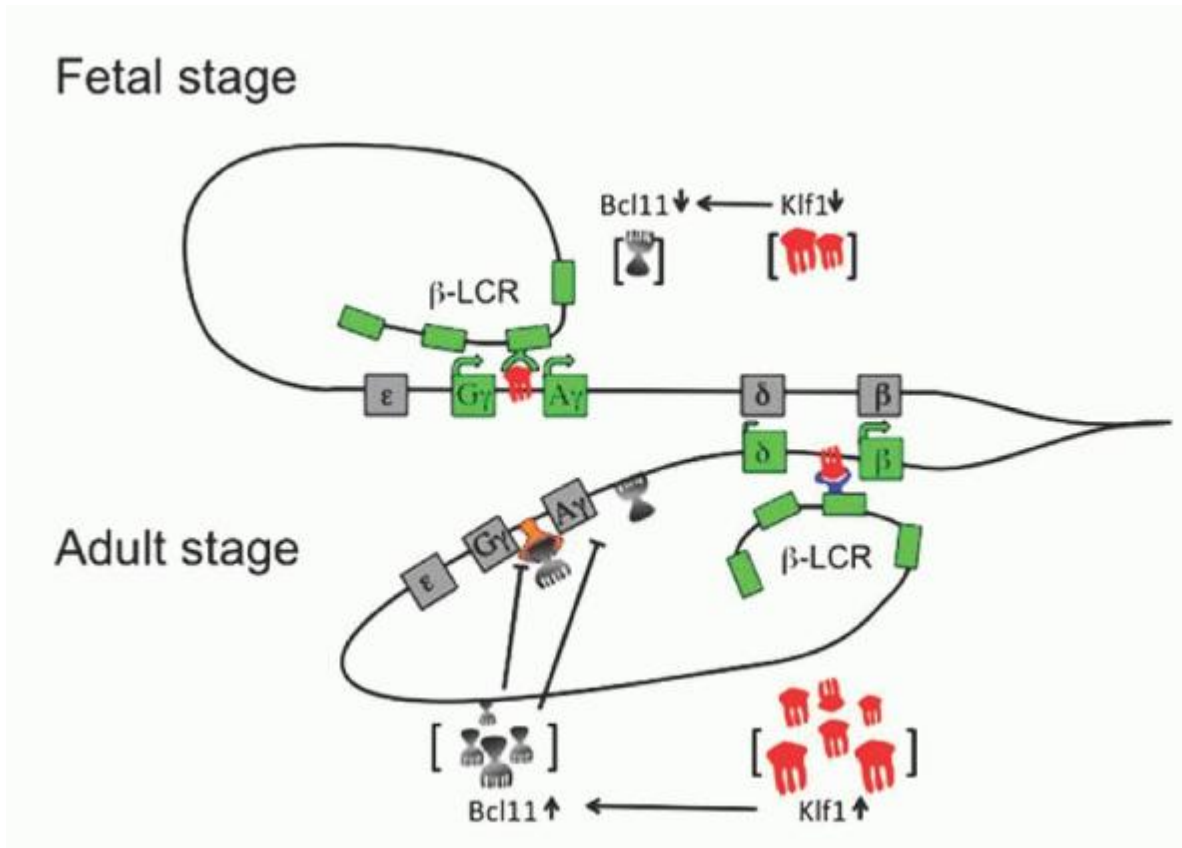

FIGURE 34.2. Current hemoglobin switching model. Bcl11A, B cell lymphoma 11; KLF, Krueppel-like factor; LCR, locus control region. (Reprinted with permission of Cao A, Moi P, Galanello R. Recent advances in β -thalassemias. *Pediatr Rep* 2011;3:e17.)

α -Thalassemia

The α -globin genes are duplicated and located in the telomeric region of chromosome 16 (16p13.3) in a cluster containing an embryonic α -like gene (ζ_2) and three pseudogenes (pseudo ζ_1 , pseudo α_1 , pseudo α_2) (Fig. 34.1).⁶¹ A gene (θ) with unknown function, but whose mRNA can be found through all stages of development, is part of the α cluster. Several regions of the cluster contain tandem arrays of short GC-rich sequences (minisatellites), identified as hypervariable regions, and many Alu family repeats.^{62, 63} The α cluster is surrounded by widely expressed genes (MPG, C16 orf 35 and Luc 7L). Upstream of the α cluster there are four highly conserved noncoding sequences or multispecies conserved sequences (MCS), called MCS-R1-R4, that are involved in the regulation of the α -like globin genes.⁶⁴ When the multipotent hemopoietic progenitors committed to the erythroid lineage start their differentiation to mature erythrocytes, several specific erythroid transcription factors, including GATA-1, GATA-2, SCL NF-E2, and cofactors, such as FOG, pCAF, and p300, bind to the MCS-R elements and the α -like globin gene promoters, causing extended modifications associated with chromatin activation. Then, RNA polymerase II is engaged both at the upstream regulatory regions and at the globin gene promoters beginning transcription in erythroid progenitors.⁶⁴ The importance of the MCS as regulatory elements is suggested by the presence of rare deletions of this region that produce α -thalassemia, although both

P.865

α genes on each chromosome are intact (see below). The human α -globin gene cluster of apparently normal individuals contains a series of DNA sequence variations (e.g., single nucleotide polymorphism [SNP], variations in the number of tandem repeats [VNTRs]; and copy number variants [CNVs], which have been of considerable value in the analysis of evolutionary aspects of the gene cluster, in defining the origin of many of the α -thalassemia mutations, and in identifying functionally important areas of the cluster).^{65, 66} The α complex is arranged in the order in which it is expressed during development: $5'\zeta_2 \dots \alpha_2\text{-}\alpha_1$. There is a very high homology between α_2 and α_1 genes; they differ only in the IVS-2 (two base substitutions and a 7-bp insertion/deletion) and in the 3' noncoding region (18 base substitutions and a single-base deletion in the 3' untranslated region).^{67, 68} This remarkable homology has been maintained during evolution through

repeated rounds of gene conversion.^{67, 68, 69} The embryonic ζ gene shows only 58% homology with the α genes in the coding region. The level of transcription of the two α genes differs: the α_2 gene expresses two to three times more α -globin than α_1 .^{70, 71} This would imply that the globin structural variants of the α_2 gene should represent about 35% of the total hemoglobin, while the α_1 globin mutants should represent about 15%. However, contrasting results have been reported on this point. Shakin and Liebhaber have reported identical translation profiles of α_2 - and α_1 -mRNA, and higher percentages of α_2 -globin variants (24% to 40% as compared to 11% to 23% for the α_1 -globin variants).⁷² Molchanova et al. confirmed the average ratio of 2.6:1, observed for α_2 - and α_1 -mRNA, but reported an average percentage of the abnormal hemoglobin in heterozygotes with α_2 mutations (23.5%) to be only slightly higher than that in heterozygotes with α_1 mutations (19.7%), suggesting a less efficient translation of α_2 -mRNA.⁷³ It should be pointed out that, besides the rate of transcription and efficiency of translation, other factors, such as the stability of the variant, the affinity of the variant for β -chains, and the number of active α genes, may influence the final level of the abnormal hemoglobin. The issue of different expression of the two α genes is important not only for the α -globin structural variants, but also for the pathophysiology of the deletional and nondeletional forms of α -thalassemia. Normal individuals have usually four α -globin genes, but as a result of unequal genetic exchange, some may have five or six α genes while still being phenotypically normal.^{74, 75, 76} Multiple arrangements with three to six ζ -like embryonic genes have also been reported.^{77, 78}

The α -thalassemias are classified generally into the α^0 thalassemias, in which there is absence of α -chain production from the affected chromosome, and the α^+ thalassemias, in which the production of the α -chains from the mutated chromosome is reduced.

Deletion α -Thalassemia

α -Thalassemia is caused most frequently by deletions of DNA that involve one or both α -globin genes. The α -globin genes are embedded within two highly homologous regions extending for about four kb, whose sequence homology has been maintained by gene conversion and unequal crossover events.^{61, 79} Three homologous subsegments (X, Y, and Z) separated by nonhomologous elements have been defined. Reciprocal recombination between Z boxes, which are 3.7 kb apart, and between X boxes, which are 4.2 kb apart, gives rise to chromosomes with only one α -gene. These α -thalassemia determinants, which are the most common, are referred to as $-\alpha$ 3.7 kb rightward deletion and $-\alpha$ 4.2 kb leftward deletion, respectively (Fig. 34.3).⁸⁰ Based on the exact location within the Z box where the crossover took place, the $-\alpha$ 3.7 kb deletion is further subdivided into $-\alpha$ 3.7 I, $-\alpha$ 3.7 II, and $-\alpha$ 3.7 III.⁶⁹ Besides the deletion α -thalassemia determinants, the nonreciprocal crossover produces chromosomes with three α -globin genes: $\alpha\alpha\alpha$ anti-3.7 and $\alpha\alpha\alpha$ anti-4.2.^{81, 82} More complex recombination events result in chromosomes with four or five α genes.⁷³ In addition to the common $-\alpha$ 3.7 kb and $-\alpha$ 4.2 kb deletions, an increasing number of deletions that produce α^+ -thalassemia have been reported.^{83, 84} Most of the deletions are rare or highly region-specific. The result of a single α -globin gene deletion is a reduced production of α -chains from the affected chromosome (α^+ -thalassemia). Measurements of α -globin mRNA in patients with $-\alpha$ 4.2 determinants suggest that there is a compensatory increase in expression of the remaining α_1 gene, while in the chromosome with $-\alpha$ 3.7 deletion, the remaining α gene is expressed roughly halfway between a normal α_2 and α_1 gene.^{85, 86} These differences in expression most likely are a consequence of changes in the rate of transcription, due to the new combinations of flanking sequences, to the modification in chromatin structure resulting from the deletion, or to variation in the interaction with the HS-40 (MCS-R2) regulatory element.⁸⁷ Deletions that remove all or part of the α -globin gene cluster, including both α genes (entirely or in part) and sometimes the embryonic ζ_2 gene, result in α^0 -thalassemia. The extent of the deletions, completely removing both α -globin genes, is from 100 kb to over 250 kb and sometimes other flanking genes, such as a DNA repair enzyme, a protein disulphide isomerase, and several anonymous housekeeping genes, are removed (Fig. 34.3).^{66, 84} However, interestingly, in subjects with these large deletions, the only phenotypical manifestation is α -thalassemia. Several molecular mechanisms (illegitimate recombination, reciprocal translocation, truncation of chromosome 16) have been described as responsible for these large deletions.⁶³ The associated phenotype is the α^0 -thalassemia phenotype. At present approximately 50 deletions completely or partially deleting both α -globin genes, therefore resulting in α^0 thalassemia, have been reported.^{64, 66} A series of naturally occurring human deletions that remove MCS regulatory elements have been identified.^{88, 89, 90} Despite the presence of intact α -globin genes of carriers, these deletions have the α^0 thalassemia phenotype. As shown by human deletions and by studies of transgenic mice, among the four regulatory elements (MCS-R1 to R4), the most relevant for α -globin gene expression is MCS-R2, located 40 kb upstream from the ζ globin gene.⁹¹ An interesting patient with a severe hemoglobin H disease phenotype and all four α intact genes, but lacking MCS-R2 in both chromosomes and also MCS-R1 and R3 in one chromosome, has been recently described.⁹² This report proves that the complete loss of the major MCS-R2 regulatory element severely downregulates α -globin gene expression but is not associated with the complete absence of α -chain production. A novel deletion involving the α_1 and θ gene that inactivates the intact α_2 gene has been reported.⁹³ Subsequent studies have shown that the deletion juxtaposes to the structural normal α_2 globin gene a downstream widely

expressed gene (Luc 7L).⁹⁴ Transcription of antisense in RNA from Luc 7L through the α_2 gene mediates methylation of the associated CpG island with silencing of α_2 globin gene expression. These findings identify a new mechanism underlying human genetic disease.

Nondeletion α -Thalassemia

Single nucleotide mutations or oligonucleotide deletions/insertions in regions critical for α -globin gene expression produce α -thalassemia. Nondeletional α^+ -thalassemia are relatively common, except the Constant Spring mutation, which is quite frequent in Southeast Asia. Several molecular mechanisms (mutations affecting RNA splicing, the poly [A] addition signal, the initiation of mRNA translation, chain termination mutations, in-frame deletions, frameshift mutations) and at least 72 well-defined types of nondeletion α -thalassemia have been described.⁸⁴ The majority (50) of nondeletional mutants occur in the α_2 gene and, as expected, have a more severe effect on α -globin gene expression, while 17 have been reported in the α_1 gene, and 5 on a - α chromosome. Hb Constant Spring (α 142 TAA \rightarrow CAA, StopSGIn) is the most common of the nine potential chain termination mutants, which

P.866

change the stop codon to one amino acid, allowing mRNA translation to continue to the next in phase stop codon located within the polyadenylation signal. The result of this class of mutation is the production of a very low amount (~1%) of an α -chain variant elongated by 31 amino acids. It has been suggested that the reason for the reduced production of the elongated variants is the instability of the mRNA due to disruption of the 3' untranslated region.⁹⁵ Other extended α -chain variants are Hb Icaria (α 142 Lys), Koya Dora (α 142 Ser), Seal Rock (α 142 Glu), and Paksé (α 142 Tyr). Heterozygotes for α -globin elongated chains, besides the presence of a very small amount of the hemoglobin variant, have the phenotype of α -thalassemia. Mutations of α -globin genes, which result in the production of highly unstable globin variants such as Hb Quong Sze (α 125 Leu \rightarrow Pro), Hb Heraklion (α 37 Pro \rightarrow 0) and Hb Agrinio (α 29 Leu \rightarrow Pro), unable to assemble in stable tetramers and thus rapidly degraded, produce the phenotype of α -thalassemia.⁹⁶ A regularly updated overview of these variants can be found at the Hb Var website. A novel mechanism for nondeletion α -thalassemia has been suggested to explain the α -thalassemia phenotype with intact α genes in some Melanesian patients.⁶⁴ Among 283 single nucleotide polymorphisms (SNP) identified by resequencing of approximately 213 Kb of DNA containing the α cluster and the surrounding regions, one SNP creating a GATA-1 binding site, always linked with α -thalassemia phenotype, has been identified.⁹⁷ This new GATA-1 site, which binds transcription factors in vivo and is activated in erythroid cells because it is located closer to MCS elements, competes most efficiently with the α -globin promoters, thereby causing α -thalassemia.

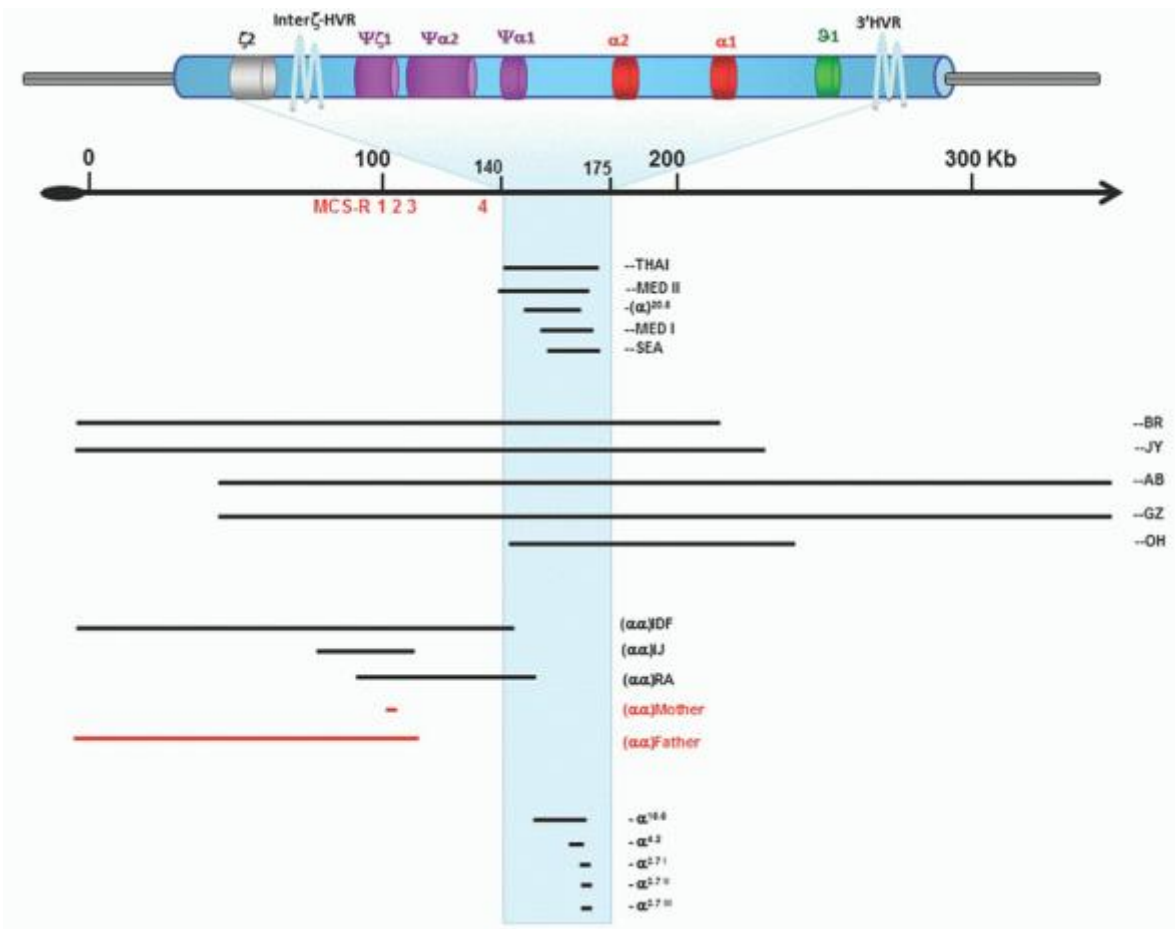

FIGURE 34.3. Most common deletional α -thalassemia defects.

β -Thalassemia

The β -globin gene is located in the short arm of chromosome 11 in a region containing also the δ gene, the embryonic ϵ gene, the fetal γ and δ genes, and the pseudogene $\beta 1$ (Fig. 34.1).⁹⁸ The five functional globin genes are arranged in the order of their developmental expression. The complete sequencing of the β -globin gene complex has shown interspersed repetitive sequences (microsatellite repeats of [CA]_n, an [ATTTT]_n repeat, AluI and KpnI families of repeat DNA sequences), which may play a role in the generation of the deletions of the β cluster. The region also contains many polymorphic base substitutions, which produce restriction fragment length polymorphisms (RFLPs), combined in a restricted number of haplotypes in linkage disequilibrium with β -thalassemia mutations.⁹⁹ Haplotype analysis provides information relevant for population genetics of the hemoglobinopathies. A1 with the α -like globin genes, variations in the number of β cluster genes, mostly involving the γ genes (which may be present in one to five copies), have been reported.^{100, 101} Like the α genes, β -globin genes are

P.867

subject to a very complex regulatory mechanism, acting at the level of single genes as well as of the entire β cluster.

The appropriate expression of the different β -like globin genes in erythroid tissues during development depends on a major regulatory region highly conserved in mammals named the locus control region (LCR), located 5 to 25 kb upstream from the ϵ -globin gene.¹⁰² Five DNAase hypersensitive sites (HSs) have been described in this region and each HS contains one or more binding motifs for erythroid-specific transcriptional activator1 (GATA-1 and NF-E2) and for ubiquitous DNA-binding proteins.¹⁰³ The importance of the LCR for the control of β -like globin gene expression has also been suggested by a series of naturally occurring deletions that totally or partially remove the HS sites and result in the inactivation of the intact downstream β -globin gene.^{104, 105} β -Thalassemia mutations result in either a complete absence of β -globin chains (β^0 -thalassemia) or in a largely variable reduction of β -globin output (β^+ -thalassemia). More than 200 different mutations producing β -thalassemia have been so far described; the large majority are point mutations in functionally important

sequences of the β -globin gene; while, in contrast to α -thalassemia, gene deletion is a rare cause of β -thalassemia (Table 34.1). A complete updated list of β -thalassemia mutations has been published and is also available through the globin gene server websites (see the end of the chapter).

Nondeletion β -Thalassemia

Point mutations resulting in β -thalassemia are single nucleotide substitutions or oligonucleotide insertions/deletions that affect the β gene expression by a variety of mechanisms (Table 34.1).

Three main categories can be identified: (a) mutations altering β gene transcription (promoter and 5' untranslated region mutants); (b) mutations affecting mRNA processing (splice junction and consensus sequence mutants, exon and intron cryptic site mutants, the polyadenylation site and other 3' untranslated region mutants); and (c) mutations resulting in abnormal mRNA translation (nonsense, frameshift, and initiation codon mutants).

Transcription Mutations

Promoter Mutations

Several mutations have been described in or around the conserved motifs in the 5' flanking sequence of β -globin genes (TATA box, proximal and distal CACCC box). They reduce binding of RNA polymerase, thereby reducing the rate of mRNA transcription to 20%-30% of normal. They result in a moderate decrease of β -globin chain output (β^+ -thalassemia) and hence in a mild phenotype. One mutation C→T at position -101 to the β -globin gene (distal CACCC box) is unusually mild and associated with a silent phenotype in carriers and in a very mild thalassemia intermedia clinical picture in genetic compounds with severe β -thalassemia mutations.^{106, 107} The promoter mutations -28 A→G and -29 A→G are relatively common in Chinese and black populations, while -87 C→G and the silent -101 C→T have been described in the Mediterranean population. The first mutation in the conserved CCAAT box at positions -76 to -72 of the β -globin gene (-73 A→T) has been described in a Chinese patient.¹⁰⁸

5' Untranslated Region Mutations

Several mutations (single-base substitution and minor deletions) have been reported in this 50-nucleotide region; all have mild effects on gene transcription. Heterozygotes have normal or borderline red cell indices and HbA₂; and compound heterozygotes, with severe β -thalassemia alleles, usually have a mild phenotype. The only homozygous state for a mutation at the β -globin gene mRNA capsite (Cap +1 ASC) shows hematologic values of a thalassemia trait.¹⁰⁹

TABLE 34.1 MUTATIONS CAUSING β -THALASSEMIA

Transcriptional Mutants	Phenotype	Number of Mutations
Promoter	Silent	3
	Mild	6
	β^+	17
5'-UTR	Silent	4
	Mild	1
	β^+	2
RNA Processing		
Splice junction	β^o	27
Consensus splice sites	Silent	2
	β^o	1
	Mild	1
	β^+	8
Cryptic splice sites in introns	β^o/β^+	1
	β^o	1
	β^+	3

Cryptic splice sites in exons	Mild	2
	β^+	3
3'-UTR RNA cleavage: Poly (A) signal	Silent	1
	Mild	4
	β^+	5
Others	Silent	1
	Mild	1
	β^+	1

RNA Translation

	Initiation codon β^o	9
Nonsense codons	β^o	16
Frameshift	β^o	72
Deletions	β^o	15

Dominant β -Thalassemi

Missense mutations	β^o	12
Deletion or insertion of intact codons	β^o	9
Premature termination	β^o	2
Frameshift or aberrant splicing	β^o	23

UTR, untranslated region.

Data from Thein and Wood¹²⁹.

Mutations Affecting mRNA Processing

RNA processing essentially consists in the removal of the intervening sequences and in the splicing of the coding regions to produce functional mRNA. The precision of this process relies on critical sequences present at intron/exon boundaries: the invariant dinucleotides —GT— at the 5' (donor) and —AG— at the 3' (acceptor) splice junctions and the flanking sequences (consensus sequences) that are rather well conserved.¹¹⁰

Splice Junction and Consensus Sequence Mutants

Mutations of the invariants 5'—GT— and 3'—AG— dinucleotides completely abolish normal splicing and result in β^o -thalassemia. Twenty-seven base substitutions or short deletions involving the invariant dinucleotides have been identified. Other cryptic

P.868

splice sites present elsewhere in precursor mRNA are used for alternative splicing, but the misspliced mRNA cannot be translated into functional β -globin.^{111, 112} The efficiency of normal splicing may be decreased by mutations within the consensus sequences immediately adjacent to the splice junctions. The reduction of β -globin production is quite variable and the resulting phenotypes range from mild to severe. For example, the mutations at position five of IVS-1 (G→C, G→T, G→A) produce a consistent reduction of β -globin synthesis and hence a severe β^+ -thalassemia phenotype; while the IVS-1-6 T→C mutation (Portuguese mutation), quite common in Mediterraneans, only mildly affects normal splicing and results in a mild thalassemia intermedia clinical picture.¹¹³ Even in the consensus sequence mutations, abnormal alternative splicing using neighboring cryptic sites may occur.¹¹²

Cryptic Site Mutants in Introns and Exons

Along introns and exons there are sequences similar to those found at the intron/exon boundaries, which normally are not used for splicing ("cryptic" splice sites). A number of nucleotide substitutions involving these sequences transform a

cryptic site into a legitimate one. This new splice signal competes with the normal consensus sequence for splicing and, in some cases, is used preferentially (up to 90% in the IVS-1-110 G→A substitution and almost 100% in the IVS-1-116 T→G substitution), resulting in a severe β^+ - or β^0 -thalassemia phenotype.^{114, 115} Two cryptic splice site mutations in IVS-1 and three in IVS-2 have been described. In the exons, three cryptic splice sites can be activated by nucleotide substitution: one at codon (cd) 10 (C→A), a second at codon 19 (A→G), and a third by mutations at codons 24 (T→A), 26 (G→A), 26 (A→C), or 27 (G→T). The nucleotide substitutions partially activate the cryptic splice sites, resulting in both normally and abnormally spliced β -mRNA. Mutations at codon 19, 26, and 27 result in the production of abnormal hemoglobins (cd 19, Hb Malay [Asn→Ser], cd 26 HbE [Glu→Lys], cd26 Hb Tripoli [Glu→Ala] cd 27 Hb Knossos [Ala→Ser]) and are associated with a mild or silent phenotype because of the preferential use of the normal splice sites.^{112, 116, 117, 118}

Poly (A) and Other 3'UTR Mutants

Downstream of the mRNA terminal codon there is a highly conserved AAUAAA sequence, which represents a signal for cleavage and polyadenylation reaction, as a part of the RNA transcript processing. Since polyadenylation is important in determining the stability of mRNA, mutations at the AAUAAA sequence affect the efficiency of translation, resulting in β^+ -thalassemia of variable, but usually mild, severity. Seven nucleotide substitutions at different positions, two oligonucleotide deletions (of two and five bases), and one deletion of the total AATAAA sequence have been described. Other mutations in the 3' untranslated region (+1480 C→G) also produce β^+ -silent thalassemia.

Mutations Affecting mRNA Translation

A very large group of mutations alter the different steps of mRNA translation. Three categories of mRNA translation mutations can be identified: initiation codon mutations, nonsense mutations, and frameshift mutations.

Initiation Codon Mutations

The initiator codon ATG, which encodes for methionine, is a critical signal for starting translation. Nine different point mutations of the initiation codon have been reported as a cause of β^0 -thalassemia.

Nonsense Mutations

Single nucleotide substitutions may change a codon for a given amino acid to one of the three possible chain termination codons: TAA, TAG, or TGA. The result is a premature interruption of mRNA translation, with absence of β -globin production (β^0 -thalassemia). A very low level of β -mRNA has been detected in erythroid cells affected by mutations in exons 1 and 2 as a consequence of rapid degradation of the mutant β -mRNA.^{119, 120} This process is referred to as nonsense-mediated decay and may be a mechanism to eliminate mRNAs encoding truncated polypeptides, with potential harmful effects for the erythroid cell.^{121, 122} Nonsense mutations in exon 3 are associated with β -mRNA levels comparable with normal levels. The protective process does not occur, and mutant β -mRNA is probably translated to produce the abnormal globin (see Hyperunstable Globins, below).¹²³

The most common nonsense mutation in the Mediterranean population, particularly in Sardinians, where it accounts for more than 95% of the cases of β -thalassemia, is the C→T base substitution at codon 39, while the nonsense mutation at codon 17 A→T shows a high frequency in the Chinese and Thai populations.^{124, 125}

Frameshift Mutations

Insertion or deletion of one or a few nucleotides (other than three or multiples of three) alters the reading frame of the encoded mRNA starting at the site of the mutation. The new reading frame usually results in a novel abnormal amino acid sequence and in a premature termination further downstream. The mutant globin chain is rapidly degraded and the final result is a β^0 -thalassemia. The frameshift resulting from a single-base deletion at codon 6 (-A) is relatively common in the Mediterranean population, while the -4 nucleotides deletion at codons 41 and 42 are particularly common in Chinese and Asian Indian populations.¹²⁶ The position of the premature termination (in exon 1, 2, or 3) caused by the frameshift mutation affects the mutant mRNA level and processing as previously reported for nonsense mutations.

β -Globin Gene Deletions

Several deletions affecting only the β -globin gene and ranging in size from 290 bp to about 67 kb have been reported. Only one, the 619-bp deletion, removing the 3' end of the β -globin gene, is relatively common in the Sind and Punjab populations of India and Pakistan.¹²⁷ All the others are extremely rare and have in common the deletion of the promoter region and at least part of the β -globin gene. The phenotype is that of β^0 -thalassemia with unusually high levels of HbA2 and F in heterozygotes. This is probably the result of the removal of competition for the upstream LCR, thus allowing an increased interaction between the LCR and the γ and δ gene in cis, with a consequently more efficient expression of these genes.¹²⁸ Other deletions causing β -thalassemia remove either the whole β -globin cluster or the LCR. Total deletions of

the β cluster result in lack of any globin production and, hence, in $(\epsilon \text{ G}\gamma \text{ A}\gamma \delta\beta)^0$ -thalassemia. Deletions of the β -LCR leaving the β gene intact inactivate the β gene. To date a total of ten deletions removing the whole β -globin cluster and eight removing the upstream LCR have been reported [original references in (129)]. These deletions confirm, *in vivo*, the critical importance of the LCR for the control of expression of the β -globin genes.

β -Thalassemic Hemoglobinopathies

This group includes some structurally abnormal hemoglobins associated with a thalassemia phenotype. They can be classified according to the molecular mechanism in:

- $\delta\beta$ hybrid genes,
- activation of cryptic splice sites,
- hyperunstable β -globins, and
- unknown mechanism.

P.869

$\delta\beta$ Hybrid Genes

Unequal crossing over between the homologous δ - and β -globin genes results in the formation of hybrid $\delta\beta$ and $\beta\delta$ genes, referred to as Lepore and anti-Lepore genes, respectively. The Lepore hemoglobins contain the N-terminal amino acid sequence of the normal δ -chain and the C-terminal sequence of the normal β -chain, and depending on the point of transition from δ to β sequence, three different variants of Hb Lepore have been described: Boston or Washington ($\delta 87/\beta \text{IVS-2-8}$), Baltimore ($\delta 68/\beta 84$), and Hollandia ($\delta 22/\beta \text{IVS-1-16}$).^{130, 131, 132, 133} The rate of production of the Lepore hemoglobins (about 10% in the carriers) likely depends on the structure of the hybrid gene, which has the promoter of the δ gene (this would explain the lower Hb Lepore amount as compared to normal HbA); and the IVS-2 of the β gene, which probably contains an enhancer (this would explain the higher level of Hb Lepore as compared with HbA2). Moreover, a relative instability of the Lepore mRNA may be responsible for the low level of synthesis. Nonhomologous crossing over between the β and δ genes also results in the production of a hybrid $\beta\delta$ gene in a chromosome also containing the normal β and δ genes. These anti-Lepore genes produce about 15% to 20% of the abnormal hemoglobin. Based on the position of the fusion point, several anti-Lepore hemoglobins have been identified (Hb Miyada, P Congo, P Nilotic, and Hb Lincoln Park, which has in addition a valine residue deleted at position 137), and carriers have normal hemoglobin levels and normal red cell indices.

A similar nonhomologous crossing over involving the $\text{A}\gamma$ - and β -globin gene produces an abnormal hybrid chain, which contains γ and β sequences (Hb Kenya). Restriction enzyme analysis in these patients shows a deletion of about 22.5 kb and the loss of sequences extending from exon 2 of the $\text{A}\gamma$ gene to exon 2 of the β gene.¹³⁴

Activation of Cryptic Splice Sites

This group, including the HbE, Hb Malay, and Hb Knossos, has been previously described.

Hyperunstable Globins

A singular group of β -globin gene mutants are characterized by amino acid substitutions, additions, or deletions in the β -globin chain associated with a clinically detectable thalassemic phenotype in the heterozygous state. For this reason, these forms are also referred to as dominantly inherited β -thalassemia. The molecular lesions include 12 missense mutations, 9 small deletions or insertions of intact codons resulting in severe β -globin destabilization, 2 premature terminations, and 23 frameshift or aberrant splicing producing elongated or truncated β -globin chains. Most of these mutations are located in the exon 3.¹³⁵

In contrast with the typical recessively inherited forms of β -thalassemia, which lead to a reduced synthesis of normal β -globin chains, this group of mutations results in the production of β -globin variants, which are extremely unstable. These hyperunstable globins fail to form functional tetramers and precipitate in the erythroid precursors, leading to ineffective erythropoiesis, which is exacerbated by the concomitant relative excess of α -chains. Most of the patients present the phenotype of thalassemia intermedia; a few patients have a thalassemia trait; and some may even have a severe anemia requiring red blood cell transfusions. Laboratory findings consist of varying degrees of hypochromic microcytic anemia, increased HbA2 and an imbalanced α - to β -globin synthesis ratio. In most of the cases the hemoglobin variant cannot be detected in the peripheral blood.

Unknown Mechanism

Adams et al. reported a patient with 8% of an abnormal hemoglobin (Hb Vicksburg $\beta 75 \text{ Leu} \rightarrow 0$) and the phenotype of thalassemia intermedia.¹³⁶ The reason for the thalassemia intermedia phenotype associated with Hb Vicksburg has not yet been defined.

The original patient has been re-examined and, despite the use of the new technologies of DNA analysis, the predicted Hb Vicksburg deletion was not present.¹³⁷ Moreover, even the Hb variant was not detected on two occasions, while HbA, absent at the beginning, has now been found. DNA analysis showed that the patient was a compound heterozygote for the -88 C \rightarrow T β^+ allele and IVS-2-849 A \rightarrow G mutation that causes β^0 -thalassemia.^{137, 138} It has been proposed that Hb Vicksburg arose as a stem cell mutation on the β^+ -thalassemia chromosome. The variable hemoglobin composition at different ages suggests that over time there were at least two clones of erythroid progenitors contributing to erythropoiesis.^{137, 138} A phenotype of mild heterozygous β -thalassemia with microcytosis and increased levels of HbA2 has been reported in patients with two hemoglobin variants: Hb North Shore ($\beta 134 \text{ Val} \rightarrow \text{Glu}$) and Hb Woolwich ($\beta 132 \text{ Lys} \rightarrow \text{Glu}$).^{138, 139} In both cases, a mild deficit of β -globin chain synthesis has been reported. DNA analysis of these patients has not been performed and the mechanism responsible for the thalassemic phenotype remains unknown.

δ -Thalassemia

Several mutations of the δ -globin gene, which result in reduced (δ^+ -thalassemia) or absent (δ^0 -thalassemia) production of δ -globin chains, have been described. These conditions do not have clinical relevance, but the coinheritance with β -thalassemia mutations may create problems in β -carrier identification, since the HbA2 may be normal or borderline. The classes of mutations are similar to those responsible for β -thalassemia. Some δ -thalassemia mutations have been described in cis to β -thalassemia. The $\delta^+ 27 \text{ C} \rightarrow \text{T}$, fairly common in the Mediterranean population, has been reported in cis to $\beta^+ \text{IVS-2-745 C} \rightarrow \text{G}$, $\beta^0 39 \text{ C} \rightarrow \text{T}$, and $\beta^+ 27 \text{ G} \rightarrow \text{T}$ (Hb Knossos).^{140, 141, 142} Also the Corfu deletion (-7.2 kb) has been reported isolated or associated with the $\beta^+ \text{IVS-1-5 G} \rightarrow \text{A}$ mutation.^{143, 144}

$\delta\beta$ -Thalassemia

$\delta\beta$ -Thalassemia includes a group of disorders characterized by reduced or absent production of both δ - and β -globin chains and by a variable increase in γ -chain synthesis, which is only partially able to balance the δ - and β -chain deficiency. The most common molecular mechanism consists of deletions of variable extent of the β -like globin cluster, which involve the δ - and β -globin genes. Based on the presence of one ($G\gamma$) or both ($G\gamma$ and $A\gamma$) globin genes, and hence on the residual synthesis of only $G\gamma$ - or both $G\gamma$ - and $A\gamma$ -globin chains, two groups of $\delta\beta^0$ -thalassemia have been identified: $G\gamma (A\gamma \delta\beta^0)^0$ - and $G\gamma A\gamma(\delta\beta^0)$ -thalassemia. In Table 34.2 the different varieties with the size of the deletion are summarized. Some have been described in a single family or a few families, while others, such as the Sicilian, the Spanish $G\gamma$.

$A\gamma(\delta\beta^0)$, and the black $G\gamma (A\gamma \delta\beta^0)^0$, are more common. Homozygotes have been reported as well. For some deletions, the 3' breakpoint has not been defined. The majority of the deletions that result in $\delta\beta$ -thalassemia are due to illegitimate recombination. Similar but more complex mechanisms have been invoked to explain other $\delta\beta^0$ -thalassemias such as Macedonian/Turkish $G\gamma A\gamma(\delta\beta^0)$ thalassemia, which is characterized by a double deletion/inversion rearrangement.^{145, 146} The reasons for the increased expression of the γ genes in $\delta\beta^0$ -thalassemia and for the differences between $\delta\beta^0$ -thalassemia

P.870

and hereditary persistence of fetal hemoglobin (HPFH, see below) have not been defined. Juxtaposition to the globin genes of new sequences as a result of the deletion; removal of intergene sequences critical for control of γ -globin gene expression; and altered spatial relationships between the LCR and the genes of the β cluster (with changes in LCR/globin gene promoter interaction and competition) have been postulated to explain the upregulation of the γ -globin genes and the phenotypic differences between $\delta\beta$ -thalassemia and deletion HPFH. It is possible that a combination of the above mechanisms plays a role, and that a balance between regulatory sequences, with positive or negative effects on the γ gene expression, may finally determine the amount of HbF in the red cells. A recent study of three families with elevated HbF identified using comparative genomic hybridization, breakpoint DNA sequencing, and chromatin immunoprecipitation identified a 3.5 kb intergenic region near the 5' end of the β -globin gene, which is necessary for γ -globin gene silencing.¹⁴⁷ This region binds the fetal hemoglobin silencing factor BCL11A and its partners in the chromatin of adult erythroid cells. The Corfu $\delta\beta$ -thalassemia is characterized by a deletion of 7.2 kb, which removes the δ gene associated with the β -IVS-1-5 G \rightarrow A mutation.¹⁴⁸ Carriers for this mutation have the unusual hematologic phenotype of heterozygous β -thalassemia with normal levels of HbA2, while homozygotes have relatively high levels of HbF and a mild clinical phenotype.¹⁴⁴ The 7.2-kb deletion has been reported isolated as a deletion form of δ -thalassemia not associated with increased HbF.^{144, 145} Two

varieties of nondeletion $\delta\beta$ -thalassemia have also been described. One, relatively common in Sardinia, is of the $\delta\beta^0$ type and presents two mutations in cis: the common $\beta^{039} C\rightarrow T$ nonsense mutation, and a point mutation at position -196 in the $A\gamma$ gene promoter, which is responsible for the Italian/Chinese nondeletion $A\gamma$ HPFH (see below).¹⁴⁹ The other, reported in two Chinese families and characterized by decreased expression of the β -globin gene and increased expression of both $G\gamma$ and $A\gamma$ globin genes ($\delta\beta^+$ -thalassemia), showed no deletion in the β -globin cluster.¹⁵⁰ In one of these families, the -29 $A\rightarrow G$ mutation in the promoter of the β gene (a mild β^+ allele) and a non-polymorphic $C\rightarrow T$ substitution in the $3A\gamma$ enhancer have been identified.^{151, 152}

TABLE 34.2 MUTATIONS RESPONSIBLE FOR DELETIONAL AND NONDELETIONAL $\delta\beta$ -THALASSEMIA**Deletion Size (kb) *Deletion sizes from (129)*****Deletional** **$G\gamma A\gamma(\delta\beta)^0$ -thalassemia**

Mediterranean	13.378
Southeast Asian	12.584
Eastern European	9.124
Black	11.767
Macedonian/Turkish	11.465
Macedonian/Turkish	1.593
Indian	32.621
Spanish	~95
Japanese	113.629
Turkish	~30

 $G\gamma(A\gamma \delta\beta)^0$ -thalassemia

Black	35.811
Chinese	78.847
Indian	0.834
Indian	7.460
Italian	~52
Belgian	~50
Yunnanese	~88
German	~52
Turkish	36.211
SE Asian	79.208
Malaysian 2	~42

Nondeletional

Sardinian	$A\gamma$ -196 $C\rightarrow T/\beta^{039}$
Chinese	Not defined

Hereditary Persistence of Fetal Hemoglobin

HPFH is characterized by the presence of increased levels of HbF in adult life in the absence of relevant hematologic abnormalities. The amount of HbF is quite variable, ranging in the carriers from 2.0% to 30%, and this variability reflects a

marked molecular heterogeneity. Both deletion and nondeletion defects have been identified. The deletions resulting in HPFH, listed in Table 34.3, extend from 13 kb (HPFH-5 or Sicilian HPFH) to about 106 kb (HPFH-1 or black HPFH).^{153, 154} They remove δ - and β -globin genes, but spare both $G\gamma$ and $A\gamma$ genes. As in $\delta\beta^0$ -thalassemia, the most common mechanism producing deletions is an illegitimate recombination followed by unequal crossing over. Nondeletion HPFH usually is the result of mutations in the promoter regions of $G\gamma$ and $A\gamma$ genes (Table 34.3). Most of these mutations are single nucleotide substitutions in or very close to the conserved sequences that bind various regulatory transcription factors. As a consequence, there are changes in the binding of repressor or activator proteins that may modify the balance of the competition between the promoter and the LCR, ultimately resulting in increased HbF synthesis in adult life.¹²⁹ In some families, mostly with interacting β -thalassemia or sickle cell anemia, it has been shown that HPFH may segregate unlinked to the β -globin cluster.^{155, 156, 157} Several patterns of inheritance have been identified: autosomal or X-linked dominant and autosomal recessive. The locus for the X-linked form seems to reside at Xp22.2-22.3.¹⁵⁸ Craig et al., by using polymorphic markers covering the whole genome to study a single very large family, localized a putative locus for HPFH at 6q22.3-q24.¹⁵⁷ Candidate-gene association studies and genome-wide association studies allowed the identification of common single nucleotide polymorphism (SNPs) in the HBS1L-MYB intergenic region on chromosome 6p23, and in the IVS2 of BCL11A gene in chromosome 2p16.1, associated with increased HbF levels in healthy subjects, in β -thalassemia, and in sickle cell anemia.^{45, 159, 160, 161}

These SNPs explain a significant proportion of the inter-individual variation of HbF levels and of the thalassemia severity, and represent potential therapeutic targets for HbF induction.^{162, 163, 164}

Unusual Causes of β -Thalassemia

Insertion of a transposable element into IVS2 of the β -globin gene, resulting in the expression of approximately 15% of normal β -globin mRNA, has been reported with the phenotype of β -thalassemia.¹⁶⁵ Mutations in the general transcription factor TFIIF, involved in basal transcription and DNA repair, cause trichothiodystrophy and are frequently associated with the

P.871

phenotype of the β -thalassemia trait.¹⁶⁶ Some mutations in the erythroid transcription factor GATA have been reported as a cause of β -thalassemia associated with thrombocytopenia.^{167, 168} Large somatic deletions at chromosome 11 p15.5, including the β -globin cluster and leading to thalassemia intermedia, have been reported in heterozygous β -thalassemia patients.^{169, 170} The deletion in a subpopulation of erythroid cells resulted in a somatic mosaic with 10% to 20% of erythroid cells heterozygous with one normal copy of the β -globin gene, and the rest homozygous without any normal β -globin gene.

TABLE 34.3 MUTATIONS RESPONSIBLE FOR HEREDITARY PERSISTENCE OF FETAL HEMOGLOBIN (HPFH)

Deletion Size (kb) <i>Deletion sizes from (129)</i>	
Deletional	
$\gamma\beta$ Fusion	
Hb Kenya	22.675
$G\gamma A (\delta \beta)^0$ -thalassemia	
Black	84.918
Ghanaian	83.679
Indian	47.733
Italian	~40
Sicilian	12.910
Southeast Asian	~28
Nondeletional	
$G\gamma$ mutations	

Black	-202 C→G
Tunisian	-200+C
Black/Sardinian/British	-175 T→C
Japanese	-114 C→T
Australian	-114 C→G
Aγ mutations	
Black	-202 C→T
British	-198 T→C
Italian/Chinese	-196 C→T
Brazilian	-195 C→G
Black	-175 T→C
Greek/Black	-117 G→A
Black	-114 to -102 del
Georgia	-114 C→T

PATHOPHYSIOLOGY

Pathophysiology of the thalassemia syndromes is extremely complex and encompasses intracellular processes as well as their consequences for the organism as a whole. The complete comprehension of the pathophysiology of the thalassemias is essential for the understanding of the differences in clinical expression between α - and β -thalassemia, the high variability of the clinical phenotypes, and potential therapeutic treatment.

β -Thalassemia

The basic defect in β -thalassemia is a reduced or absent production of β -globin chains with relative excess of α -chains. The direct consequences are a net decrease of hemoglobin production and an imbalance of the globin chain synthesis. The former is more evident in carriers, leading to a reduction of mean cell hemoglobin (MCH) and mean cell volume (MCV), and has a minor clinical significance. The latter has dramatic effects on the red cell precursors, ultimately resulting in their extensive premature destruction in the bone marrow and in the extramedullary sites. This process is referred to as ineffective erythropoiesis and is the hallmark of β -thalassemia. Using ferrokinetic analysis, it has been shown that in β -thalassemia patients only 15% of ^{59}Fe was incorporated in circulating erythrocytes, indicating that ineffective erythropoiesis could account for as much as 60% to 75% of total erythropoiesis.^{171, 172} Hemolysis of the erythrocytes containing inclusions that reach peripheral blood is a minor cause of anemia, particularly in thalassemia major (Fig. 34.4).

The excess α -chains may, in minor amounts, combine with residual β - (in β^+ -thalassemia) and γ -chains (whose synthesis persists usually in small quantity after birth), undergo proteolysis, or in large part become associated with the erythroid precursors and red cell membrane, with deleterious effects on erythroid maturation and survival. Therefore, the main determinant of the clinical severity is the extent of the relative excess of α -chains in red cell precursors and hence the degree of α /non- α imbalance. In 1966, Fessas et al. described the presence of inclusion bodies in erythroblasts of thalassemic patients, suggesting that they were precipitated by α -chains.¹⁷⁴ The composition of inclusion bodies in β -thalassemia, completely consisting of precipitated α -chains, has been confirmed by immunoelectron microscopy.¹⁷⁵ Oxidation of excess α -chains results in the formation of hemichromes, whose basic structure consists of the covalent binding of distal histidine E7 to the sixth coordination site of the heme iron. Irreversible hemichromes and denatured α -chains precipitate as inclusion bodies early during differentiation and throughout erythroid maturation.¹⁷⁶ α -Chain precipitation in the red cell membrane causes structural and functional alterations with changes in deformability, stability, and red cell hydration.^{174, 177} Isolated red cell membranes from β -thalassemia intermedia, particularly from splenectomized patients, are rigid and unstable. Protein 4.1, a major component of the cytoskeleton, undergoes partial oxidation in β -thalassemia, resulting in its defective capability to mediate the formation of the spectrin-protein 4.1-actin complex, which is critical to maintain cytoskeleton stability.¹⁷⁸ In vitro experiments, using purified α -chains released within normal red blood cells, support the role of aggregated α -chains in causing red cell membrane rigidity.¹⁷⁹ A further consequence of the membrane-bound hemichromes is their association with the cytoplasmic domain

of protein band 3, creating a neoantigen, which is subjected to opsonization with autologous immunoglobulin G (IgG) and complement and immune removal of the cell by macrophages.^{180, 181} Red blood cells in β -thalassemia lose K^+ , store Ca^{2+} , and are dehydrated, resulting in altered deformability.¹⁷⁴ Besides oxidation, free α -chains are subjected to degradation, resulting in the formation of denatured α -globin protein, heme, and free iron. These degradation products play a role in damaging erythroid precursors and red cell membranes.

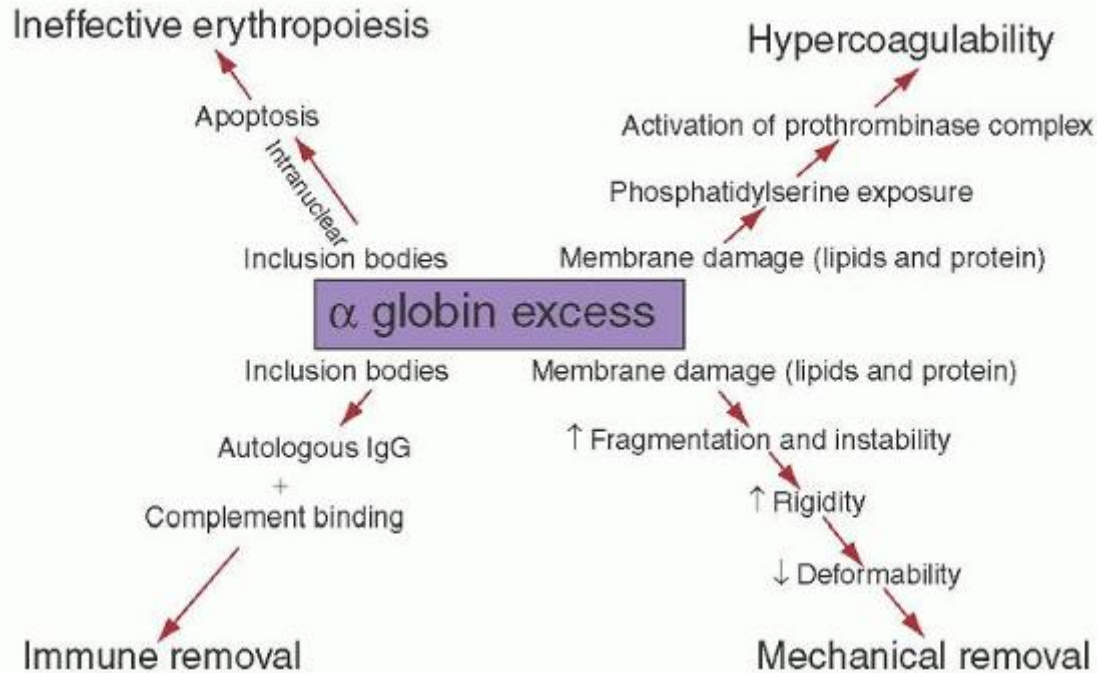

FIGURE 34.4. Pathophysiology of β -thalassemia. Ig, immunoglobulin.

Free iron, via the Fenton reaction, generates reactive oxygen species, which cause lipid and protein peroxidation with consequent damage to red cell membranes and intracellular organelles.¹⁸² High levels of iron, closely associated with denatured hemoglobin, have been found in the membrane of β -thalassemic red cells.¹⁸³ In vitro and in vivo experiments (in humans and animals) have shown that the oral iron chelator deferiprone, which may enter the cells, is able to remove free iron from thalassemic red cells, resulting in an improvement of red cell survival.^{184, 185} These results confirm the role of free iron in damaging the red cell membrane structure. Also, heme, and its oxidized form hemin, produce oxidative damage to the different components of the red cell membrane with consequent structural and functional alterations.^{177, 186} Recently a new protein relevant for α -globin stabilization has been discovered and its function deeply analyzed.¹⁸⁷ This protein, named α -hemoglobin-stabilizing protein (AHSP), is an abundant erythroid protein that specifically binds free α -globin chains, stabilizes their structure, and limits their ability to participate in chemical reactions that generate reactive oxygen species.¹⁸⁸

All the above-reported alterations of erythroid precursors cause their extensive premature death by apoptosis in the bone marrow, significantly contributing to ineffective erythropoiesis.¹⁸⁹ Of the two major pathways of apoptosis, the mitochondrial pathway and the cell surface death domain pathway, the death domain pathway seems to be mainly involved.¹⁹⁰ Both FAS and FAS ligand appear to be upregulated at all stages of β -thalassemic erythroid progenitors. Procaspase 8, one of the initiator caspases, whose activation is a hallmark of the death receptor domain pathway, is also activated.¹⁹⁰ In turn, caspases inactivate GATA-1, a transcription factor necessary for erythroid growth maturation, thereby suppressing and limiting the thalassemic erythropoiesis.¹⁹¹ Other recent studies in mouse models of β -thalassemia have shown that increased or excessive activation of the Jak2/STAT5 pathway promotes unnecessary disproportionate proliferation of erythroid progenitors, exacerbating ineffective erythropoiesis.¹⁹²

The ineffective erythropoiesis and anemia have several consequences in the organism as a whole, producing the clinical picture of the disease. The first response to anemia is an increased production of erythropoietin, causing a marked

erythroid hyperplasia, which may range between 10 and 30 times normal.¹⁷² Anemia may produce cardiac enlargement and sometimes severe cardiac failure. Erythroid expansion produces skeletal deformities, osteoporosis, and occasionally extramedullary masses, and contributes to splenomegaly. Untreated or undertreated thalassemia major patients have retarded growth as a result of anemia and the excessive metabolic burden imposed by erythroid expansion. Environmental factors, such as poor nutrition and infections, may contribute to growth failure. The high vascularization of expanded marrow results in an increase in plasma volume, which, associated with splenomegaly, aggravates the anemia. Ineffective erythropoiesis is associated with increased iron absorption, whose mechanism has been recently clarified.¹⁹³ Expression of growth differentiation factor-15 (GDF-15), a TGF- β superfamily member, usually associated with cellular stress or apoptosis, has been found at particularly high levels in the serum of patients with thalassemia and other conditions associated with ineffective erythropoiesis. Elevated levels of GDF-15 contribute to the suppression of hepcidin, a small peptide produced in the liver, considered the major regulator of iron.¹⁹⁴ Low levels of hepcidin result in increased intestinal iron absorption and most of that excess iron is stored in the liver.¹⁹⁵ A second novel erythroid regulator of hepcidin expression, i.e., twisted gastrulation factor 1 (TWSG1), has been recently identified in thalassemic and human cells.¹⁹⁶ In transfusion-dependent patients, iron overload is largely increased by repeated blood transfusions (see Complications of Transfusions). Iron overload damages several organs (myocardium, liver, endocrine glands), leading to severe complications. Removal of the abnormal red blood cells by the reticuloendothelial elements of the spleen results in splenomegaly and hypersplenism, which, when severe, may exacerbate anemia and cause thrombocytopenia and leukopenia.

A further consequence of the red blood cell membrane damage is the loss of the normal asymmetric distribution and increased surface exposure of the procoagulant, negatively charged phospholipids phosphatidylserine and phosphatidylethanolamine. Perturbation of the cell membrane causes thalassemic RBCs to become rigid and deformed, increasing their cohesiveness and tendency to aggregate.¹⁹⁷ The anionic phospholipids increase thrombin generation, which leads to activation of platelets and endothelial cells.^{198, 199, 200} Further evidence of the chronic platelet activation has been well documented in patients with thalassemia, as evidenced by increased platelet aggregation and expression of CD62P (P-selectin) and CD 63, shorter platelet survival, and elevated levels of urinary metabolites of prostacyclin (PGI₂) and thromboxane A₂ (TXA₂), two markers of hemostasis.^{197, 201, 202} Moreover, thrombocytosis and increased platelet aggregation associated with splenectomy contribute to the higher risk of thromboembolic events. Decreased levels of naturally occurring anticoagulants, such as protein C and protein S, and elevated plasma levels of the thrombin-antithrombin III complex, have been reported.^{203, 204} It has also been shown that adherence of thalassemic red cells to endothelial cells is markedly enhanced as compared to that of normal red cells, and elevated levels of endothelial adhesion proteins (intracellular adhesion molecule-1, E-selectin, vascular cell adhesion molecule-1, von Willebrand factor) in the serum and plasma of thalassemic patients have been described.^{205, 206} Activated monocytes and granulocytes, found in patients with thalassemia, could contribute to the endothelial damage and the hypercoagulable state.^{207, 208}

α -Thalassemia

As in the case of β -thalassemia, the primary defect of α -thalassemia is the imbalance of globin biosynthesis, with an excess of β -and/or γ -globin chains. Unlike α -chains, which are highly unstable and unable to form soluble tetramers, excess γ -chains in fetal life and β -chains in extrauterine life associate to form relatively soluble γ_4 tetramers (Hb Bart) and β_4 tetramers (HbH), respectively. These excess non- α -chains damage mostly mature red cells and to a lesser extent erythroid precursors, leading mainly to hemolysis and minimally to ineffective erythropoiesis. The different characteristics of the excess chains in α -thalassemia are of great importance in determining its pathophysiology; but in addition, the functional properties of HbH and Hb Bart and the number of α genes contribute to the difference in severity of α -thalassemia as compared to β -thalassemia syndromes. Red blood cells in α -thalassemia are rigid, as in β -thalassemia, but unlike β -thalassemia, they are hyperhydrated and have red cell membranes that are hyperstable. The reason for hyperhydration has not been clearly defined, but is likely a consequence of the effect of β -chain excess on the KCl cotransporter system. Membrane skeletal-bound β -globins become partially oxidized, with consequent membrane damage. In vitro studies have shown that entrapment of β -chains in normal red cells does not result in any significant change in membrane protein function or thiol concentrations, but rather produces changes in red cell deformability,

P.873

as reported in vivo in patients with HbH disease.^{209, 210} Interaction of excess β -globin with the cytoplasmic domain of protein band 3 is abnormal in erythrocytes of patients with HbH disease, since β_4 tetramers tend to adhere tightly to protein band 3.²¹¹ β -Globin tetramers precipitate as the red cell becomes old, forming inclusions. These inclusions can be induced in vitro by vital stains, such as brilliant cresyl blue or new methylene blue, and are more common in

splenectomized patients.²¹² Studies using monoclonal antibodies have shown that red cell inclusions in HbH disease are composed of β -globin. Membrane-bound inclusion bodies perturb the flow velocity during transit through the spleen capillaries, ultimately resulting in mechanical trapping and macrophagic phagocytosis.²¹³ Red cell hemolysis is a significant pathophysiologic mechanism of HbH disease, but ineffective erythropoiesis is a component, even if moderate. This has been suggested by morphologic and ferrokinetic studies and by the analysis of plasma levels of the transferrin receptor.^{214, 215} Excess β -chains accumulate and precipitate not only in old red cells, but also in marrow erythroid precursors, where they may cause some intramedullary cell death. β_4 inclusion bodies alter the normal membrane phospholipid bilayer, exposing phosphatidylserine, which represents a signal for the development of apoptosis and red cell removal by the macrophages in the spleen and other reticuloendothelial organs.^{216, 217} Programmed cell death has been found moderately increased in patients with HbH disease. Red cell membrane deformability and stability is even more affected in patients with HbH/Hbcs.²¹⁸ As compared with patients with HbH disease, HbH/Hbcs patients have a higher amount of HbH and a higher percentage of erythrocytes with inclusion bodies and with translocated phosphatidylserine.^{213, 217, 219} All these characteristics may account for the increased hematologic severity of HbH/Hbcs disease. γ -Globin tetramers (Hb Bart) are much less prone than β -globin tetramers to precipitate and form inclusions.²²⁰ Besides the characteristics of excess β - and γ -globin chains discussed above, other functionally abnormal properties are important in determining the pathophysiology of α -thalassemia. HbH and, even more, Hb Bart, have a very high oxygen affinity and show no heme/heme interaction or Bohr effect, hence severely reducing their oxygen-carrying capacity.^{221, 222} Some α -globin chain variants barely symptomatic in the heterozygous state, are either unstable because of folding defects and/or defective in binding to α -hemoglobin-stabilizing protein (AHSP) and are associated with the α -thalassemia phenotype.⁹⁶ When the patients are homozygous for such variants or compound heterozygotes with another α -thalassemic defect, they present the phenotype of HbH disease or chronic hemolytic anemia or even hydrops fetalis syndrome.

GENOTYPE-PHENOTYPE CORRELATION IN THALASSEMIA

Progress in molecular biology and the wide availability of methods for DNA analysis have allowed for the definition of globin gene defects in thalassemia syndromes and for the understanding of the mechanisms of globin gene regulation and expression, and have partially elucidated the relationship between genotype and phenotype. This knowledge is helpful in clinical practice for planning the management of the patients, and in genetic counseling for the prediction of phenotype from genotype in couples at risk. In patients, the differentiation at presentation between thalassemia major and intermedia is essential to design the appropriate treatment. In fact, the prediction of a mild phenotype may avoid unnecessary transfusions and their complications, while the diagnosis of thalassemia major will allow an early start of the transfusion program, thus preventing hypersplenism and the red cell sensitization often associated with a delayed start of red cell administration.²²³ As reported above, in β -thalassemia the globin chain imbalance is the main determinant of clinical severity. Therefore, the presence of factors able to reduce the globin chain imbalance results in a milder form of thalassemia. These factors are the coinheritance of α -thalassemia or of genetic determinants that increase γ -chain production and the presence of silent or mild β -thalassemia alleles, associated with a high residual output of β -globin. Examples of these alleles are the silent -101 C \rightarrow T and the mild IVS-1-6 T \rightarrow C mutation in the Mediterranean population and the -29 A \rightarrow G in Africans. Deletion and nondeletion HPFH mutations, associated with a high HbF level in carriers, when in genetic compounds with severe β -thalassemia alleles, result in mild thalassemia intermedia. A mild phenotype may also be determined by coinheritance of genetic determinants associated with γ -chain production, mapping outside the β -globin cluster. Several single nucleotide polymorphisms (SNPs) at the BCL11A gene on 2 p16.1 and HBS1L-MYB intergenic region on 6q23.3 have been associated with variable HbF levels in patients with thalassemia and sickle cell disease.^{45, 160, 224} The effect of α -thalassemia determinants in ameliorating the disease severity is less consistent, but the coinheritance of the deletion of two α -globin genes with homozygous β^+ -thalassemia, and sometimes even with β^0 -thalassemia, produces the clinical picture of thalassemia intermedia.^{15, 225} Variants at the three main quantitative trait loci (QTLs) regulating HbF levels (i.e., BCL11A, HBS1L-MYB intergenic region, Xmn1 CG - γ gene) and α -thalassemia have been associated with the mild thalassemia intermedia phenotype and with a delayed need for transfusions in patients with homozygous β zero thalassemia.^{163, 226}

The precise definition of the phenotype from the genotype is helpful also in genetic counseling, since it may avoid prenatal diagnosis in cases of expected very mild thalassemia intermedia in the fetus. Prenatal diagnosis in at-risk couples where the -101 C \rightarrow T mutation is present should not be considered and the same applies to the coinheritance of the triple α -gene arrangement or of the HPFH mutations associated with high levels of HbF. The ameliorating effect that results from the presence of mild β -thalassemia alleles is less constant. The mild β -thalassemia allele IVS-1-6 T \rightarrow C, common in the Mediterranean population, shows remarkable phenotypic diversity in some populations, such as the Jewish population.²²⁷ Despite the progress in better defining genetic determinants able to influence the clinical severity of β -

thalassemia, phenotype prediction from genotype is not always accurate. However, the information obtained from extended genetic analysis may be used for planning appropriate management and for providing adequate genetic counseling, and may also reveal potential new targets for therapeutic intervention. As reported above, the wide range of phenotypic manifestations of thalassemia results from the heterogeneity of the primary mutation and from the coinheritance of other globin gene-associated determinants, which may ameliorate or worsen the disease severity.²²⁸ However, other known or unknown genetic determinants may modify the clinical expression of the thalassemia syndromes. Several secondary genetic modifiers have been identified in the recent years. The presence of (TA)₇ polymorphism in the promoter region of the uridine diphosphoglucuronosyltransferase gene, which in the homozygous state is associated with Gilbert syndrome, is a risk factor for the development of cholelithiasis in thalassemia major and intermedia patients and in patients with HbE/ β -thalassemia.^{229, 230} Other candidate genes for modification of the thalassemia phenotype are the apolipoprotein E ϵ 4 allele, which seems to be a genetic risk factor for left ventricular failure in homozygous β -thalassemia.²³¹ Less consistent data have been reported for genes involved in iron metabolism (C282Y and H63D HFE gene mutations), probably because their effect on iron overload is hidden as a result of treatment (e.g., secondary iron overload from red cell transfusion and iron chelation).^{232, 233}

In α -thalassemia, the symptomatic form of HbH disease shows a wide phenotypic diversity. The phenotype varies depending on the number of α genes affected and on the type of mutation

P.874

present.^{234, 235} Studies that have correlated hematologic and clinical findings with α -globin genotypes indicate that HbH patients with nondeletion α -thalassemia defects have a more severe clinical expression (see below).^{236, 237, 238, 239}

Unlike with β -thalassemia, limited progress has been made in the search for genetic modifiers of HbH disease.²³⁸ One type of genetic modification is coinheritance of β -thalassemia mutations, also referred to as the HbH/ β -thalassemia trait. Subjects with this genotype have severe hypochromia, microcytosis, and anemia, and do not present HbH at the electrophoresis.²⁴⁰

CLINICAL AND LABORATORY FEATURES

α -Thalassemia: Clinical Forms

Despite the large number of different α -thalassemia alleles (overall more than 100) only four hematologic and clinical conditions of increasing severity are recognized: silent carrier, α -thalassemia trait, HbH disease, and Hb Bart hydrops fetalis.^{241, 242}

Silent Carrier

This condition results from the presence of a single α -globin gene defect associated with the 3.7 or 4.2 kb deletion ($-\alpha/\alpha$) and from nondeletion defects. This genotype is characterized in the newborn period by a very mild increased percentage (1% to 2%) of Hb Bart, a tetramer of four γ -globin chains (γ_4), which is produced when there is an excess of γ -chains in relation to α -chains. However, failure to demonstrate Hb Bart in cord blood does not exclude the silent carrier state.^{243, 244} Among black Americans, the incidence of the silent carrier state determined by gene mapping is about 27%, yet Hb Bart is detected in only 12% of cord samples. Similar trends have been found in Mediterranean and Saudi Arabian populations.^{245, 246}

Adult individuals with three functional α genes may have a completely silent phenotype (normal red blood cell indices) or present a moderate thalassemia-like hematologic picture (reduced MCV and MCH and very mild anemia) with normal HbA₂ and F.^{241, 242} Analysis of globin chain synthesis in vitro in peripheral blood reticulocytes displays a reduced α : β ratio in the range of 0.8 to 0.9. It has been shown that, at birth, children with the $-\alpha_{4.2}$ deletion, which removes the α_2 gene, have a more severe phenotype than children with the $-\alpha_{3.7}$ deletion, which deletes most of the less productive α_1 gene, resulting in a hybrid gene consisting of the 5' part of the α_2 gene linked to the 3' part of the α_1 gene.^{86, 246} However, with increasing age, the two genotypic forms become phenotypically indistinguishable, presumably because of upregulation of α -globin production by the α_1 -gene in subjects with the $-\alpha_{4.2}$ deletion.^{87, 247}

α -Thalassemia Trait

This condition is characterized in the newborn by more markedly increased levels of Hb Bart (5% to 6%) and in the adult by thalassemia-like red cell indices, normal HbA₂ and F, and a reduced α : β -globin chain synthesis ratio in the range of 0.7 to 0.8.^{241, 242} Subjects with two residual functional α genes, either in cis on the same chromosome ($-\alpha/\alpha$ or α^0 -thalassemia carriers) or in trans in opposite chromosomes ($-\alpha/-\alpha$, homozygous α^+ -thalassemia), clearly show the α -thalassemia carrier

state. Carriers of nondeletion defects have quite variable hematologic phenotypes ranging from the α -thalassemia trait to the silent carrier state (see above). Double heterozygotes for $-\alpha/$ and nondeletion α -thalassemia ($-\alpha/[\alpha\alpha]T$) and homozygotes for nondeletion defects ($[[aa]T/[aa]T$) have the typical phenotype of the α -thalassemia carrier state. However, homozygotes for some nondeletional forms of α -thalassemia may have a mild HbH disease.²⁴⁸ It should be pointed out that homozygotes for the Hb Constant Spring mutation, the most common nondeletion defect in the Asian population, have a clinical syndrome that is similar to HbH disease (see below).²⁴⁹ The α -thalassemia carrier state should be differentiated from iron deficiency and from δ - and β -thalassemia interaction (see carrier detection). This differentiation has important practical consequences.

Hemoglobin H Disease

HbH disease is common in Southeast Asia and relatively frequent in Mediterranean countries and parts of the Middle East, while occurring rarely in populations of African descent. This clinical condition results from the presence of only one functional α gene, usually as a consequence of the compound heterozygous state for α^0 -thalassemia/ α^+ -thalassemia ($-/\alpha$ or $-/\alpha T\alpha$). As a consequence of the relative excess of β -chains, individuals with HbH disease produce a variable amount of this abnormal hemoglobin, a tetramer of β -globin chains (β_4). The HbH is unstable and precipitates inside the red cells and to some extent in erythroid precursors, causing membrane damage and premature erythrocyte destruction. As reported above, both hemolysis and ineffective erythropoiesis contribute to anemia in HbH disease, but the predominant mechanism is hemolysis. HbH has a much higher oxygen affinity than HbA and this may worsen the severity of anemia in patients with HbH disease. In the neonatal period, subjects with the HbH disease genotype have a consistently elevated Hb Bart (~25%), which may still be detected in small amounts in some adults with HbH disease. The syndrome of HbH disease shows a considerable variability in clinical and hematologic severity. The majority of patients have minor disability, a few are severely affected requiring regular blood transfusions, and rare cases of HbH disease have been described with the hydrops fetalis clinical picture (see below).^{15, 65} The most relevant features are microcytic and hypochromic hemolytic anemia, hepatosplenomegaly, jaundice, and moderate thalassemia-like skeletal modifications.^{65, 237, 238, 239} The hemoglobin concentration is usually in the range of 7 to 10 g/dl and the MCV varies with age (being around 58 fl in childhood and around 64 fl in adulthood), while the MCH is around 18 pg irrespective of age. Reticulocytes range between 5% and 10%, and the α : β -globin chain synthesis ratio is markedly reduced, in the order of 0.20 to 0.60. Hemoglobin electrophoresis at alkaline pH shows a fast-moving band (HbH) in amounts ranging from 1% to 40%. Sometimes, because of the low quantity and the possible loss due to instability in the preparation of the hemolysate, HbH may escape detection. The most sensitive method to detect HbH consists of the incubation of peripheral blood cells for 1 to 2 hours at 37°C in the presence of supravital dyes (brilliant cresyl blue or methyl violet), which induce precipitation of the abnormal hemoglobin as inclusion bodies, easily recognizable at the microscope (Fig. 34.5). Determination of the α -globin genotype may be useful for prognosis of HbH disease, because the nondeletion forms are more severe than the deletion forms. Anemia is accentuated during pregnancy and may worsen quite dramatically with infections, fever, ingestion of oxidant drugs, aplastic anemia associated with Parvovirus B19, and hypersplenism.²³⁷ A variable spleen enlargement is almost always present, while liver enlargement is less common. A mild phenotype of HbH disease may result from the homozygous state for nondeletional α -thalassemia. Although the phenotype in some cases is closer to that of the homozygous state for α^+ -thalassemia, the degree of anemia and hypochromia may be more severe.²⁵⁰ In particular, homozygotes for the elongated α -chain variant Hb Constant Spring are asymptomatic, but show mild pallor and jaundice with liver and spleen enlargement in about 50% of the cases.^{15, 251} The hemoglobin level ranges from 9 to 11 g/dl and the MCV tends to be normal (88 ± 6 fl), while the MCH is slightly reduced (26 ± 3 pg). The peripheral blood contains HbA₂, A, Hb Constant Spring, and traces of Hb Bart

P.875

rather than HbH.¹⁵ The severity of HbH disease shows a good correlation with the degree of α -chain deficiency. Thus, the more severe and variable phenotypes are associated with interactions involving nondeletion α -thalassemia defects that affect the dominant α_2 gene, including ($-/\alpha$ Constant Spring α), ($-/\alpha$ Ncol α) and ($-/\alpha$ Hphl α).^{237, 238, 239} Patients with the nondeletional genotypes present earlier, with more severe hemolytic anemia, significant growth delay, dysmorphic facial features, and more marked hepatosplenomegaly; they require more transfusions. Few patients with HbH disease resulting from the interaction of α^+ -thalassemia ($-\alpha$) with the deletion of the MCS regulatory region have been reported.⁶⁶ A severe case of HbH disease due to deletions of variable extent of both upstream MCS-Rs while all four downstream α -globin genes are intact has been recently described.⁹²

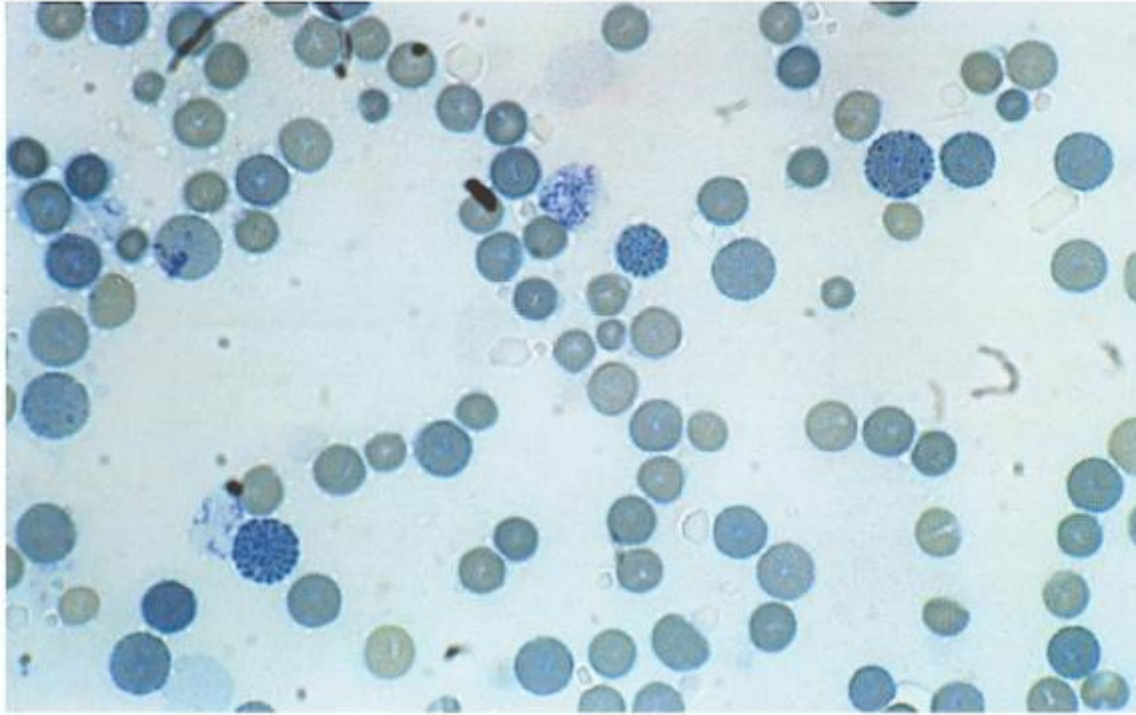

FIGURE 34.5. Hemoglobin H inclusion bodies.

A very few cases of unusually severe HbH disease associated with hydrops fetalis due to coinheritance of α^0 - and α^+ -thalassemia have been described.^{65, 252, 253, 254} In four cases, the α^+ -thalassemia alleles were mutations of the α_2 gene associated with hyperunstable α -globin variants. The interaction between two relatively common forms of α -thalassemia ($-\text{Med}/\alpha^{\text{TSaudi}}\alpha$) can present with HbH hydrops fetalis.²⁵⁵ In these families, prenatal diagnosis can be indicated.

Patients with HbH disease may develop complications including hypersplenism, leg ulcers, gallstones, and abnormal left ventricular dysfunction. Hypersplenism has been reported in 10% of Thai patients with HbH disease, but seems to be rare elsewhere.²⁵⁶ Iron overload as assessed by serum ferritin is increased in a large proportion (50% to 75%) of patients and is significantly correlated with age.^{237, 239, 257} Some patients develop increased liver iron concentration.

In general, patients with HbH disease do not need any treatment. Some clinicians recommend folic acid supplementation as for other hemolytic anemias. Patients should be advised to avoid oxidant drugs because of the risk of hemolytic crisis. Occasional blood transfusions may be required when the hemoglobin level suddenly drops as a consequence of hemolytic or aplastic crisis. Pregnant women with HbH disease need careful monitoring of the hemoglobin levels. Splenectomy may be indicated in the presence of hypersplenism, but the potential complication of venous thrombosis, reported in some patients with HbH disease following splenectomy, should be considered.^{258, 259} Chelation therapy should be initiated in patients with elevated serum ferritin and/or liver iron concentration.

Hemoglobin Bart Hydrops Fetalis Syndrome

Hb Bart hydrops fetalis syndrome is the most severe α -thalassemia clinical condition, often associated with the absent function of all four α -globin genes (homozygous α^0 -thalassemia or $-/-$). A few cases of hydrops fetalis have been reported in infants with very low levels of α -chain synthesis, resulting from interaction of common α^0 -thalassemia determinants with uncharacterized nondeletion defects.^{253, 254, 256} Hb Bart hydrops fetalis syndrome is relatively common in Southeast Asia, while in Mediterranean populations it is relatively rare due to the low frequency of α^0 -thalassemia.^{15, 260, 261} Because of the extreme rarity of the $-/\alpha\alpha$ genotype, this disorder rarely, if ever, affects infants of African descent. A fetus homozygous for α^0 -thalassemia produces mainly Hb Bart (γ_4), which is functionally useless for oxygen transport, and his or her survival to late pregnancy is due to the presence of small amounts of embryonic hemoglobins Portland 1 ($\zeta_2\gamma_2$) and Portland 2 ($\zeta_2\beta_2$). There is a marked variability in the intrauterine clinical course of fetuses with Hb Bart hydrops fetalis. Many pregnancies terminate unnoticed or early in gestation. In some cases pregnancy proceeds to term, but the fetus is stillborn or severely ill; in others the fetus does not become hydropic and is born normally.^{262, 263} The clinical features of this syndrome are those of a very severe anemia (Hb level range, 3 to 8 g/dl), with marked hepatosplenomegaly,

generalized edema, signs of cardiac failure, and extensive extramedullary erythropoiesis in many organs.^{15, 264} Other congenital abnormalities, particularly of the skeletal, cardiovascular, and urogenital system, have been reported. Complications during pregnancy are common and include severe and mild pre-eclampsia (hypertension, fluid retention with or without proteinuria), polyhydramnios or oligohydramnios (increased or reduced accumulation of amniotic fluid, respectively), and antepartum hemorrhage. Postpartum complications include placenta retention, eclampsia (fits and coma), hemorrhage, anemia, and sepsis. At present there is no effective treatment for the Hb Bart hydrops fetalis syndrome. Early treatment with intrauterine transfusions after noninvasive monitoring by Doppler ultrasonography or in utero hematopoietic stem cell transplantation have been attempted, but may not be justified because of the unknown future risks for infants of severe developmental abnormalities.^{265, 266, 267, 268, 269} Given the severity of this syndrome and of the maternal obstetric complications, early termination of at-risk pregnancies is recommended and several regions have initiated universal prenatal screening programs to address homozygous α -thalassemia.^{270, 271}

Unusual Forms of α -Thalassemia

There are two unusual forms of α -thalassemia: one is the acquired HbH disease associated with myelodysplasia, and other is the α -thalassemia associated with mental retardation syndrome.

α -Thalassemia/Myelodysplasia Syndrome (OMIM catalog #300448)

Patients with myelodysplasia may rarely develop an unusual form of HbH disease characterized by the presence of classic HbH inclusion bodies in red blood cells, often detectable levels of HbH (1% to 57%), and a severe microcytic and hypochromic anemia with anisopoikilocytosis.²⁷² The α - to β -globin mRNA ratio, studied in a few patients, showed a marked reduction (0.06 to 0.50), and the α - to β -globin chain synthesis ratio was similarly reduced (α : β ratio = 0.28).²⁷³ Structural analysis of the α -globin genes and of their flanking regions has revealed no abnormalities in such patients.²⁷⁴ Recent studies have shown that some patients with α -thalassemia/myelodysplasia syndrome have point mutations and/or splicing abnormalities in the ATRX gene (see below).²⁷⁵ In one patient a large deletion of the telomeric region of the short arm of one allele of chromosome 16, including both α -globin genes, was reported.²⁷⁶

α -Thalassemia and Mental Retardation Syndromes

There are two different syndromes in which α -thalassemia is associated with mental retardation.^{235, 277} The first is characterized by a relatively mild mental retardation and a variety of facial and

P.876

skeletal abnormalities. These subjects have extended (1 to 2 megabases) deletions resulting from rearrangements of the short arm of chromosome 16. The deletions remove both α -globin genes and up to 52 other genes.²⁷⁸ Two common patterns of α -thalassemia have been described: One is characterized by parents with a normal α -globin genotype ($\alpha\alpha/\alpha\alpha$) whose affected offspring have the phenotype of severe α -thalassemia trait (genotype $-/\alpha\alpha$). In the other, one parent has the phenotype of the mild thalassemia trait and the child has HbH disease. This condition is called ATR-16 syndrome (OMIM catalog #141750).

The second group of patients has a complex phenotype characterized by severe mental retardation, quite uniform clinical features (hypertelorism, flat nasal bridge, triangular upturned nose, wide mouth, urogenital abnormalities), other developmental abnormalities, and defective α -globin synthesis, resulting in a relatively mild form of HbH disease. No structural changes of the α cluster or 16p chromosome have been found in these patients and the transmission is X-linked. Recently it has been shown that this syndrome is associated with mutations in an X-encoded gene, the ATRX gene, a member of the DNA helicase family.^{279, 280, 281} To date 128 acquired and/or inherited mutations predominantly lying in 2 highly conserved domains of the ATRX protein have been identified.²⁸² ATRX, a large protein with 2492 residues, is a member of the snf2 family of ATP-dependent remodeling proteins and a key regulatory component of nucleosomal dynamics and higher order chromatin conformation. ATRX protein plays a prominent role in the control of gene transcription and in the maintenance of chromosome stability.^{283, 284} Mutations in this gene downregulate the expression of the α -globin genes and of other unidentified genes, producing the complex phenotype. This condition is referred to as Atrx syndrome (OMIM catalog #301040).

More detailed information about the forms of α -thalassemia associated with mental retardation or myelodysplasia and about the role of ATRX are reported in published reviews.^{272, 282}

α -Thalassemia in Association with Structural Variants

A number of syndromes result from the interaction of α -thalassemia genes with those producing structurally abnormal hemoglobins. In some disorders, thalassemia genes that otherwise would have gone unnoticed are given clinical expression by the variant hemoglobin; in others, the relative amount of the variant hemoglobin is altered by the thalassemia gene. Features common to all these syndromes are red cell hypochromia and microcytosis, in addition to the presence of a hemoglobin variant. Some of the mutations causing α -chain structural variants appear to have occurred in chromosomes with only a single α -globin gene. Thus, Q/α^0 -thalassemia has a clinical phenotype similar to that of HbH disease.²⁸⁵ Affected subjects synthesize no HbA. This disorder has been described in individuals from Thailand, China, Iran, and India.^{286, 287} The mutation responsible for HbG-Philadelphia sometimes occurs on a chromosome with a single α -globin gene and other times on a chromosome containing both α genes. This variant is encountered primarily in black individuals.²⁸⁸ In persons with a normal α -globin gene on the same chromosome containing the HbG mutation, HbG-Philadelphia/ α^0 -thalassemia ($\alpha G\alpha/-$) is characterized clinically by α -thalassemia minor; whereas in individuals with no normal α -gene cis to the α^G -gene ($-\alpha^G/-$), the doubly heterozygous state resembles clinically HbH disease. The variant hemoglobin constitutes approximately 40% of the total concentration of hemoglobin in the former situation, and more than 90% in the latter.³⁷ HbI/ α -thalassemia has been reported in a black patient.²⁸⁹ That the gene for HbI is not linked in cis with an α -thalassemia gene is indicated by the presence of 30% HbA. The combination of α -thalassemia with β -chain variants is associated with a decrease in the relative amount of the variant hemoglobin and a clinical picture similar to that of the heterozygous state for the structural variant.¹⁵ The lower than usual percentage of the variant hemoglobin is attributed to the preferential binding of α -chains with β A-chains. The β -chain variants noted in association with α -thalassemia include HbS, HbC, HbE, and HbJ Bangkok.¹⁵ The interaction of α -thalassemia and the HbS trait produces a trimodal distribution in the relative amount of HbS. Individuals with a full complement of α -globin genes have more than 35% HbS, compared with 28% to 35% in those with the ($-\alpha/\alpha$) genotype, 25% to 30% in those with the ($-\alpha/-\alpha$) genotype, and no more than 20% in those with the rare ($-/-\alpha$) genotype.^{290, 291} Reductions in MCV and MCH are also observed. α -Thalassemia modifies some of the hematologic consequences of homozygous sickle cell anemia. Subjects with the ($-\alpha/-\alpha$) genotype have a higher hemoglobin concentration, lower red cell indices, fewer irreversibly sickled cells, a lower reticulocyte count, and lower serum bilirubin levels than subjects without concurrent α -thalassemia.^{292, 293, 294} The ameliorating effect of α -thalassemia is probably mediated by a decreased red cell concentration of HbS. α -Thalassemia fails, however, to temper significantly the clinical expression of sickle cell anemia. More information on the effects of α -thalassemia on sickle cell anemia can be found in Steinberg MH⁶⁶ and in the chapter on sickle cell anemia in this book. For the interaction of α -thalassemia and HbE, see Hemoglobin E Syndromes in this chapter.

β -THALASSEMIA MAJOR

From a clinical point of view, the β -thalassemia syndromes represent the most relevant forms of thalassemia. The designations commonly used to describe the β -thalassemia syndromes are based on clinical severity. The most severe form is defined as β -thalassemia major and is characterized by transfusion-dependent anemia. Thalassemia intermedia is the term used to designate a form of anemia that, independently from the genotype, does not require transfusion, or only sporadic or intermittent transfusions. Thalassemia minor indicates the heterozygous state, which is usually completely asymptomatic. Thalassemia minima was used in the Italian literature to indicate a carrier in whom no hematologic or clinical symptoms were recognizable, but the term should probably be abandoned. Some authors use the term thalassemia minima to indicate the condition of silent carrier.

History

Originally, there was a disease called anemia splenica infantum that included several conditions, often not well distinguished from one another. Syphilis was considered a possible cause, as were tuberculosis and leishmaniasis. These children were usually born normally and grew normally until the second half of the first year, when they were noticed to become paler and paler, and to develop an enormous abdomen, containing a spleen that could extend from a few centimeters below the left costal margin to the iliac crest and below, sometimes visible from the outside. At this time in the disease course, the patients liked to be left alone and to lie down "in a monotonous morbid state."²⁸ Bone deformities, especially of the skull, soon appeared, giving the children a distinctive "Mongolian" appearance.^{295, 296} The disease was often present in more than one sibling; or, more frequently, other siblings had previously died of the same disease. The first systematic descriptions of what was going to be identified as thalassemia major came from Cooley and Lee²⁹⁵ from Michigan, who observed the disease in Italian and Greek children, and from Maccanti, a pediatrician from Ferrara, Italy, who also noted that the children were often coming from malarial areas near the Po river.^{28, 295} Anemia, leukocytosis, and normoblastemia were always present. Both groups tried unsuccessfully the entire armamentarium of therapies then available (arsenium, fresh veal bone marrow, sunshine, the

quartz lamp, cod liver oil, and, of course, iron) and even blood transfusions, which were helpful but short-lasting in one patient but caused increased hemolysis in another.²⁸ This is not surprising, considering the very limited blood matching available at the time and the already enormous size of the spleen at presentation. Splenectomy and Roentgen irradiation of the spleen were also performed without benefit. All the children died shortly after presentation. Detailed autopsic data, showing peculiar abnormalities in the bones and spleen fibrosis, are available. Almost at the same time, Rietti, also from Ferrara, had reported three adult patients, two of whom were father and son, who presented with "primitive hemolytic jaundice" associated with decreased osmotic fragility.²⁹⁷ Anemia, microcytosis, anisocytosis, and basophilic stippling were noted. The syndrome was probably a form of thalassemia intermedia, and for a long time the eponymic title of Rietti-Greppi-Micheli was used in Italy, from the names of those who in those years described similar clinical pictures. In 1932, in consideration of the Mediterranean origin of the patients affected by Cooley anemia, Whipple and Bradford proposed the name of thalassemia, from the Greek word *thalassa*, meaning sea.²⁹⁸ Subsequently, the severe and the mild form of thalassemia were denominated thalassemia major and minor, respectively.²⁹⁹

Unfortunately, the lack of communication between the two sides of the Atlantic made the research in this field, as in others, proceed slowly in parallel.^{300, 301} In 1940, Wintrobe reported the presence of a familial hemopoietic disorder in adolescents and adults of Italian origin, while in Italy, between 1943 and 1947, Silvestroni and Bianco defined the hematologic, clinical, and epidemiologic characteristics of thalassemia minor and its relationship with thalassemia major.³⁰² A detailed report of that research can be found in a comprehensive book on thalassemia by Ida Bianco Silvestroni.³⁰³ The picture was further clarified by the identification of HbA₂ and its increase in the parents of patients affected by thalassemia major.^{304, 305} The patients, on the other hand, were found to be completely devoid of HbA and to have, in addition to HbA₂, only an alkali-resistant variant usually found in the newborn, HbF.³⁰⁶ The newly born erythrokinetic technique defined the enormous and ineffective erythropoiesis present in this disease.³⁰⁷ Between 1956 and 1961 the chemical structure of hemoglobin was described, and soon the complete sequences of globin chains were clarified.³⁰⁸

The idea of thalassemia resulting from a defect in the production of adult hemoglobin is due to the contribution of several authors. Globin chain synthesis was able to confirm this hypothesis.³⁰⁹ The developments in molecular biology are recent history and continue to clarify more aspects of the disease.

Clinical Features

The clinical picture of β -thalassemia major includes features that are due to the disease itself and others that represent the consequences of therapy and are, in a sense, iatrogenic.

Anemia

The early symptoms of the disease appear usually in the first year of life, at the time when the synthesis of γ -chains is not replaced by the synthesis of β -chains. In an ethnically composite population of transfusion-dependent children diagnosed in the United Kingdom, the mean age at presentation was reported to be 6 months, while in a study from Greece the age was 13.1 months, ranging from 2 to 36 months.^{310, 311} In a study from Sardinia the disease was recognized at around 8 months in patients with transfusion-dependent thalassemia but at age 2 years in non-transfusion-dependent children.³¹² The age at diagnosis is influenced by the molecular defect and by the degree of suspicion of the treating physician. Pallor is usually the first sign, accompanied by splenomegaly of various severity, fever, and failure to thrive.

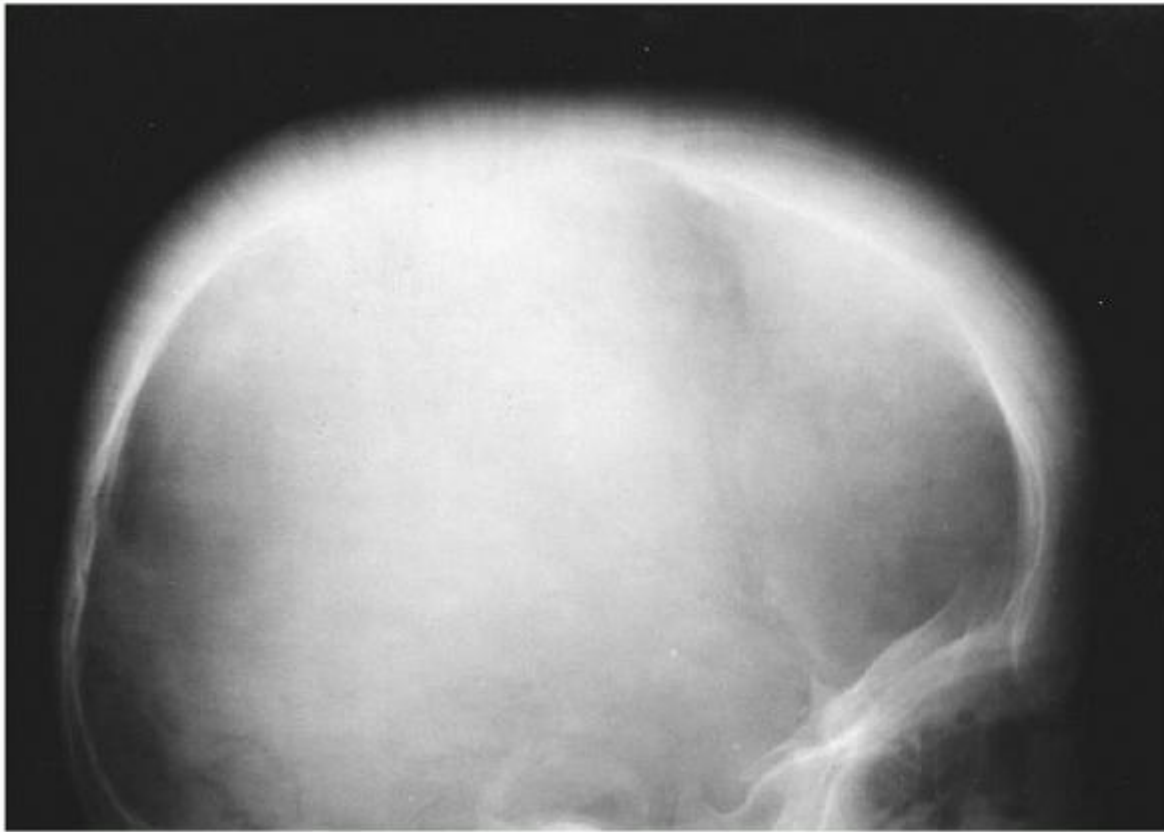

FIGURE 34.6. Radiograph of the skull. In the frontal area, the bone has a lamellated structure, parallel to the inner table of the diploe. In the parietal area, erythroid hyperplasia has perforated the outer table, producing a characteristic “hair on end” appearance. (Courtesy of Dr. C. Orzincolo.)

Bone Deformities

Untransfused or poorly transfused patients with thalassemia develop typical bone abnormalities that were described even in the first reports of the disease and that are due to the extremely increased erythropoiesis, with consequent expansion of the bone marrow to 15 to 30 times normal. The skull is large and deformed by frontal and posterior bossing with the diploe increased in thickness to several times normal. The outer and inner tables are thin and the trabeculae are arranged in vertical striations, resulting in a “hair on end” appearance. A peculiar, stratified appearance of the skull has been reported (Fig. 34.6).³¹³ The zygomatic bones are prominent, the base of the nose is depressed and pneumatization of the sinuses is delayed. Overgrowth of the maxilla produces severe malocclusion, with a rodent-like appearance. Metatarsal and metacarpal bones are the first to expand as a consequence of increased erythropoiesis (Fig. 34.7). The ribs are broad, often with a “rib-within-rib” appearance, and the vertebral bodies are square. The trabeculation of the medullary space gives the bones a mosaic pattern. Shortening of long bones is frequent, as a result of premature fusion of the humeral and femoral epiphyseal lines.^{314, 315} Extramedullary erythropoiesis gives rise to masses that protrude from bones where red marrow persists.³¹⁶

Overgrowth from the vertebral bodies can cause cord compression and paraparesis.³¹⁷ Ear impairment due to extramedullary marrow growing in the middle ear, and progressive visual loss caused by compressive optic neuropathy have been reported.^{318, 319} This kind of picture is more often present in patients with thalassemia intermedia, in whom transfusions are avoided at the price of intense autologous marrow hyperactivity. Improvement in the radiologic bone appearance in the cohorts of patients who have undergone regular transfusions from an early age has been striking. The lack of severe skull deformities is reflected in the mildness of thalassemic features that are now observed in most patients. However, bone lesions of a different nature are often observed as a consequence of excessive deferoxamine (DFO) therapy.

Osteoporosis

Reduced bone mineral density and consequent susceptibility to fractures have been observed in thalassemia patients and, in recent years, have been the subject of intense research. Mineral density is usually investigated with dual-energy x-ray

absorptiometry (DEXA) at the spinal (L1 to L4) and femoral neck level. Osteoporosis is defined as a decrease in bone mineral density

P.878

≥ 2.5 SD below the young adult mean value, while a decrease between -1 and -2.5 SD is defined as osteopenia.³²⁰ Osteoporosis in thalassemia has been found to affect 48% of the patients, with an additional 44% affected by osteopenia.³²¹ Although more frequent and severe in males than in females, this complication represents an important cause of morbidity in adult patients of both sexes.³²¹ The pathogenesis of osteoporosis in thalassemia major is multifactorial and results from a variety of genetic and acquired factors. The polymorphism at the Sp1 site of the collagen type I gene (COL1A1) has been associated with severe osteoporosis and pathologic fractures of the spine and the hip.^{321, 322, 323} Moreover, the vitamin D receptor (VDR) Bsm1 and Fok1 polymorphisms were found to be risk factors for bone mineral damage, low bone mineral density, and short stature in prepubertal and pubertal patients.³²⁴ However, different studies of genetic polymorphisms have given contradictory results.^{322, 325} Acquired factors include the primary disease itself, causing ineffective hematopoiesis with progressive bone marrow expansion; and several secondary factors such as endocrine dysfunction, iron overload and chelation therapy, vitamin deficiencies, and decreased physical activity.^{326, 327} In particular, vitamin D deficiency is frequent among adolescents.³²⁸ Male sex, lack of spontaneous puberty, and diabetes represent significant risk factors for osteoporosis, while transfusional history, chelation, and erythropoietic activity do not.³²⁹



FIGURE 34.7. Mosaic pattern produced by trabeculation in the bones of the hand of a patient with thalassemia major. Note the rectangular contour of the metacarpals.

Defective osteoblastic activity is thought to be the major pathogenetic mechanism for osteoporosis. There are data demonstrating in thalassemia patients increased serum levels of Dickkopf-1, a soluble inhibitor of osteoblast differentiation that correlates with reduced bone mineral density. Also sclerostin, an inhibitor of osteoblast function, is increased and correlates with bone mineral density of the spine, radius, and femoral neck.³³⁰ In addition, there is evidence of increased osteoclast activation. Elevated markers of bone resorption, such as urinary N-terminal peptides of collagen type I and serum tartrate-resistant acid phosphatase isoform 5b, have been demonstrated.^{331, 332} The increased osteoclast

activity seems to be due to an overproduction of cytokines that are involved in osteoclast differentiation and function.³³³ There is evidence that the receptor activator of nuclear factor kappa B ligand (RANKL)/osteoprotegerin (OPG) pathway mediates osteoclast proliferation in thalassemia and contributes to the pathogenesis of osteoporosis.³³⁴ The hypothesis that the RANKL/OPG system is involved in mediating the action of sex steroids on bone³³⁴ has not been confirmed.³³⁵ Fractures, often secondary to mild or moderate trauma, are more frequent in thalassemia patients than in the general population. In a retrospective study, 12% of patients with thalassemia major were found to have suffered from fractures, with an equal distribution between males and females. Prevalence increased with age. The presence of other endocrinopathies, anthropometric parameters, heart disease, or hepatitis C were not significant independent predictors of fractures.^{336, 337} Bone pain of varying severity is a common complaint among adult patients and has been attributed to expanded bone marrow with consequent pressure on the cortical bone.³³⁸ Magnetic resonance imaging (MRI) in these cases may show the reappearance of hypercellular areas in bones previously replaced by fatty marrow. Reduced and irregular mineralization of the bone has been found using microradiography and X-rays in thalassemic patients with and without clinically evident bone abnormalities.³³⁹ Back pain is sometimes associated with compression fractures and intervertebral disc degeneration.^{327, 340}

In a recent study, pain was found to be associated with low vitamin D, lower bone density, and bisphosphonate use.³⁴¹ Osteoporosis is a progressive disease, thus early detection, prevention, and treatment are essential for effective control of this potentially debilitating condition.³²⁶ Annual follow-up should be started during adolescence.³⁴² Therapy includes sex hormone replacement therapy, regular exercise, and a diet rich in calcium and vitamin D. In consideration of the pathogenetic data suggesting that in thalassemia patients the reduced osteoblastic activity is accompanied by a comparable or even greater increase in bone resorption, antiresorptive drugs such as bisphosphonates are being increasingly used. To date, alendronate, pamidronate, and zoledronate have been reported to be effective in increasing bone mineral density and normalizing bone turnover.^{343, 344, 345} Neridronate has improved bone mineral density and reduced back pain in a cohort of thalassemia patients with osteoporosis.³⁴⁶ One study evaluating the effect of calcitonin on bone mass showed that it prevented bone pain, improved radiologic findings, and decreased the number of fractures.³⁴⁷ Other agents, like teriparatide and strontium ranelate, are being studied, but their effects remain to be proven.³⁴²

Cholelithiasis

Gallstones have been reported in patients with thalassemia^{348, 349} (Fig. 34.8). The percentages found were variable, depending on the transfusion regimens and consequent residual inefficient erythropoiesis and hemolysis, on the time of splenectomy, and, more importantly, on the associated presence of the (TA)⁷ promoter mutation of the gene of uridindiphosphoglucuronyl-transferase.³⁵⁰ A recent cooperative study including 858 patients with transfusion-dependent thalassemia found a prevalence of cholelithiasis of 30%. The Gilbert genotype [homozygosity for (TA)⁷ motif] influenced both the prevalence of cholelithiasis and the age at which it developed.³⁵¹ Ultrasonography of the gallbladder should be checked regularly. If gallstones are present at the time of splenectomy, cholecystectomy should be performed at the same time.

Thromboembolic Complications

Numerous reports of thromboembolic complications in thalassemia have been published. In a multicenter study the

P.879

frequency of thromboembolic events was found to be 4% in patients with thalassemia major and 10% in patients with thalassemia intermedia.³⁵² Other groups have reported similar prevalences.³⁵³ In a large study of 8860 patients from different countries, female sex, previous splenectomy, and profound anemia were found to represent risk factors.³⁵⁴ A chronic hypercoagulable state has been observed even in childhood.²⁰⁵ The mechanisms underlying hypercoagulability in thalassemia are still unclear. Several authors^{197, 200} have suggested that the presence of a chronic hypercoagulable state could be due to the procoagulant effect of the anionic phospholipids exposed on the surface of the damaged circulating red blood cells and to endothelial derangement occurring as a consequence of an inflammatory state associated with the disease. Also, blood cells and platelets have an important role in increasing the thrombotic risk in thalassemia.³⁵⁵



FIGURE 34.8. Spine of a 35-year-old patient with thalassemia major. Reduced mineral bone density is evident, in addition to a gallstone-filled gallbladder.

In addition, vascular endothelial cell injury and the peroxidative status due to iron overload are possible pathogenetic mechanisms.^{198, 206, 356}

Concomitant prothrombotic conditions are frequently present in thalassemia patients after the first decade of life: insulin-independent diabetes, estrogen therapy, atrial fibrillation, and postsplenectomy thrombocytosis, among others. Prophylactic measures are necessary when additional risk factors (e.g., surgery, parturition, immobilization) are present.³⁵⁴ (See also thalassemia intermedia.)

Pseudoxanthoma Elasticum

Pseudoxanthoma Elasticum (PXE) is an autosomal recessive multisystem disorder affecting elastic tissues. In the majority of families affected by PXE the gene carrying mutations is the ABCC6 gene, encoding a transmembrane transporter protein probably involved in calcium and phosphate homeostasis and primarily expressed in the liver, the kidneys, and the intestine. More than 300 mutations have been identified and lead to the absence of a functional ABCC6 protein. This absence results in a deficiency of circulating factors which should prevent aberrant mineralization, and induces the accumulation of calcium phosphate in skin, eye, and vascular lesions.^{357, 358} Clinically it is characterized by typical lesions of the skin (small yellowish papules or larger coalescent plaques), eyes (breaks of the elastic lamina of Bruch's membrane called angioid streaks), and arteries (degeneration of the elastic lamina of the arterial wall often accompanied by arterial calcification).^{359, 360} An acquired PXE-like syndrome has been described in several hemolytic disorders.^{361, 362} The first reports of typical skin lesions, angioid streaks in the retina, calcified arterial walls, and aortic valve disease in two patients affected by thalassemia was published by Aessopos et al. in 1989.³⁶³ Several subsequent reports have confirmed the existence of a clinical syndrome resembling PXE in thalassemia patients.^{364, 365, 366, 367} It appears to be age-dependent and it is more common in thalassemia intermedia than in thalassemia major. In a study published in 1998 and including patients affected by thalassemia intermedia older than 30 years, arterial calcifications were found in 55%, skin lesions in 20%, and ocular alterations in 52%. Eighty-five percent had at least one of the three typical lesions.³⁶⁸

In PXE-like syndromes, lesions are structurally indistinguishable from those of the inherited form. The typical histopathologic features are the abnormal, mineralized, and fragmented elastic fibers (elastorrhexia) in skin, eyes, and arterial blood vessels. Nevertheless, β -thalassemia patients do not harbour mutations in the ABCC6 gene,^{366, 369} and the pathophysiology remains unclear. At first, it was suggested that, like so many other complications of the disease, this syndrome could be the result of an iron-induced oxidative tissue damage, caused by hemolysis and iron overload.^{368, 370} Recently, it has been demonstrated that a significant, progressive, liver-specific downregulation of Abcc6 expression can be found in the mouse model of β -thalassemia. Despite the fact that these mice do not develop connective mineralization, they could represent a model for clarifying the increased susceptibility to dystrophic mineralization in dermal, ocular, and vascular tissue of β -thalassemia patients.³⁷¹ The abnormalities in elastic fibers of arterial walls may lead to several serious and life-threatening vascular complications in both the inherited and acquired forms. In the thalassemic population several cases of cardiac involvement have been reported, including rupture of chordae tendineae and aneurysmatic dilatation of the ascending aorta.^{368, 372, 373, 374, 375} In an Italian study, five out of 14 thalassemia patients with a PXE-like syndrome died because of cardiovascular complications. Thrombotic events and gastrointestinal and intracranial bleeding, which preclude the use of platelet antiaggregants, can also complicate the clinical course.³⁷⁶ Close surveillance of these patients is therefore mandatory.

No effective therapy is available for PXE and PXE-like syndromes. Several promising avenues for the treatment are currently being explored. The phosphate binders, a group of drugs given in the attempt to limit the intestinal absorption of phosphate, and consequently normalizing the serum calcium phosphate product, could offer a means of reducing the calcium/phosphate load in patients with PXE. Histopathologic regression of skin calcifications was demonstrated in 3 out of six patients treated with aluminum hydroxide for 1 year, and in all six no progression of the ocular angioid streaks was observed.³⁷⁷ In a knocked-out ABCC6 gene (Abcc6 -/-) mouse model of PXE, a magnesium carbonate-enriched diet completely prevented mineralization of the vibrissae,

P.880

an early biomarker of the mineralization process.³⁷⁸ The mechanisms by which magnesium may prevent calcium phosphate deposition in tissues are not clear, but a marked increase in the urinary output of calcium, with concomitant reduction in phosphate, has been obtained in these mice.^{378, 379}

These results suggest that changes in diet, and specifically changes in dietary magnesium and phosphate binders, may offer a potential treatment modality for this so far intractable disease.³⁸⁰ Recent reports on the use of intraocular injection

of antiangiogenic agents targeting vascular endothelial growth factor in age-associated macular degeneration have suggested that significant improvements in visual acuity could also be achieved in patients with PXE.^{381, 382}

Molecular strategies based on specific mutations identified in the ABCC6 gene, gene therapy approaches targeting a transgene to restore its function in the liver, and anti-mineralization factors with a potential role as modifiers (fetuin-A, for example) are still being tested.

Secondary Gout

Hyperuricemia is not unusual in thalassemia patients, but gouty arthritis has rarely been reported.³⁸³

Laboratory Findings and Diagnosis

Laboratory data at presentation are characterized by HbF levels ranging from 10% to 100%; HbA2 may be normal or increased up to 5% to 7%; and the remaining percentage is constituted by HbA. HbF is heterogeneously distributed among red cells. The reticulocyte count is low, usually below 1%. MCV is typically 60 to 70 fl and MCH is 12 to 18 pg/cell. In the peripheral blood smear a great variation in size and shape of the erythrocytes is always evident. Microcytes, tear drop cells, and nucleated red cells are present, together with large and pale target cells (Fig. 34.9). The Hb composition varies mainly accordingly to the patient's genotype. Homozygotes for β^0 -thalassemia mutations have only HbF (93% to 97%) and HbA2 (3% to 7%) and no HbA, while homozygotes for β^+ -thalassemia mutations and β^0/β^+ genetic compounds have HbA, HbA2, and a variable, but always significantly elevated, amount of HbF (10% to 90%). HbA2 in homozygous β -thalassemia may be normal or increased and so of no diagnostic value. Hb separation to determine the hemoglobin pattern can be performed with different methods (electrophoresis at alkaline or acidic pH, isoelectric focusing, high performance liquid chromatography [for details, see (384, 385)]). In the case of transfused patients, diagnosis can be made by globin chain synthesis analysis from peripheral blood reticulocytes, which shows a severe α /non- α imbalance (usually higher than 2), or by β -globin gene analysis to identify the various DNA mutations (details on DNA methods can be found in specific surveys and laboratory manuals).³⁸⁶

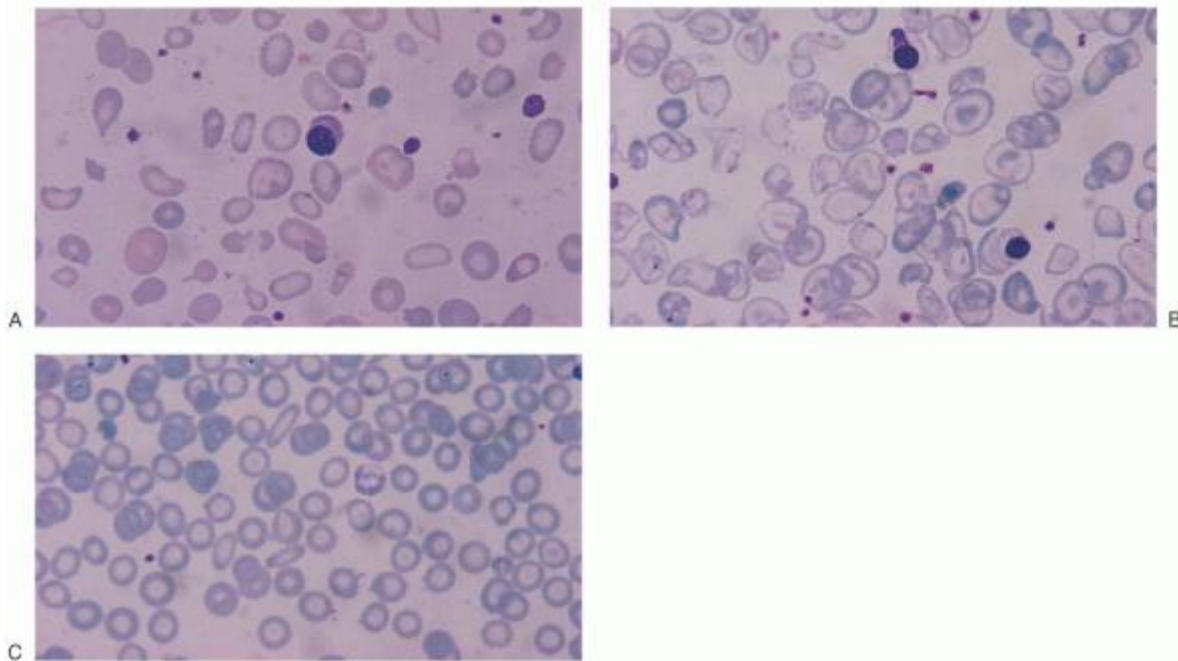

FIGURE 34.9. Peripheral blood smears in β -thalassemia major (A) and intermedia (B) and in heterozygous β -thalassemia (C).

Therapy

Blood Transfusion

The decision on whether and when to start transfusion therapy in a child with thalassemia is not an easy one and should be based on a precise molecular diagnosis indicating the severity of the thalassaemic defect, on the level of hemoglobin, and on general conditions and satisfactory growth. Evidence of increasing splenomegaly, of bony expansion, and of consequent modification of facial features should also be considered. The age at which starting transfusion becomes

necessary in thalassemia varies according to the prevalent genotypes in a particular ethnicity. Delaying the age of transfusion increases the risk of developing allo- and autoantibodies.²²³

For many years after the description of thalassemia major as a clinical entity, therapy was limited to blood transfusion when symptoms of anemia were so severe as to incapacitate the patient. The corresponding levels of hemoglobin (Hb) were different in different patients, but varied between 6 and 7 g/dl. As a consequence of continuous anemia, erythropoiesis, although inefficient, was intense, the bone marrow underwent an enormous expansion, and the plasma volume increased greatly. In addition, the liver and spleen increased in size as a consequence

P.881

of both extramedullary erythropoiesis and hemolytic activity in the reticuloendothelial tissue. The bone deformities caused by the expanded marrow are typical of thalassemia and gave to all the poorly transfused patients similar features (see above). In the 1960s, however, the superiority of regular and methodically repeated transfusions was recognized, first by Orsini in France, and later by Wolman in Philadelphia and Piomelli in New York, who started a program of chronic transfusion directed at maintaining a baseline Hb level adequate to eliminate hypoxia and thus suppress its consequences.^{387, 388, 389} It was calculated then that the amount of iron administered to maintain a minimum Hb of 9.5 g/dl was only 50% greater than that resulting from a baseline Hb of 6 g/dl, and that the additional iron intake could be counterbalanced in part by the reduction of intestinal iron absorption. This kind of regimen, that never allowed Hb level to fall below 9.5 to 10 g/dl, was termed "hypertransfusion." Complete bone marrow suppression, however, is seldom obtained at these Hb levels, and therefore some bone remodeling and expansion of the blood volume persist. To completely correct the effects of anemia, Propper et al. in 1980 launched what was called a "supertransfusion" regimen, where the pretransfusion hematocrit was kept at $\geq 35\%$.³⁹⁰ The hypothesis was that, as a consequence of the reduction of the blood volume, the amount of blood needed to maintain a higher baseline would not have been greater than the blood volume used for the lower baseline. A few papers from Europe confirmed the data; but, since the blood that is destroyed between transfusions and that needs replacing is a percentage of the patient's red cell mass, patients kept at a higher baseline Hb level require a larger amount of blood and therefore accumulate more iron.^{391, 392, 393} In a study of patients kept at a pretransfusion hemoglobin level between 9 and 10 g/dl, the erythroid marrow activity, evaluated through the measurement of serum transferrin receptor, did not exceed two to three times normal levels. On the basis of these studies, the majority of centers choose to transfuse at a Hb level of 9 to 10.5 g/dl.³⁹⁴ The recommended post transfusion Hb is 14 to 15 g/dl. Leuko-reduced packed red cells are recommended for eliminating the adverse reactions attributed to contaminating white cells and for preventing platelet alloimmunization. The number of residual leukocytes should not be higher than 1×10^5 . At present the preferred method for leukoreduction is prestorage filtration of whole blood with an inline filter within 8 hours after blood collection. Alternatively, laboratory filtration can be used pretransfusion. With this method, packed red blood cells are prepared from donor whole blood, then filtered prior to release from the blood bank. Finally, the packed red cell unit can be filtered at the bedside.

The current recommended practice is to use red cell units that have not been stored more than 2 weeks. Extended red cell antigen typing, including at least the Rh antigens, Duffy, Kidd, and Kell, is recommended before the patient is started on a transfusion regimen. Transfusion of young red cells (neocytes) obtained by centrifugation has been proposed in the attempt to reduce the total blood requirement, but the results obtained were not sufficient to justify the increased cost and the exposure to a larger number of donors.^{395, 396}

In general, the transfusion rate is 5 to 6 ml/kg/hour. In the case of patients with cardiac failure, blood should be infused at a slower rate (no more than 3 to 4 ml/Kg/h), and the administration of diuretics before transfusion is advised. The recommended interval between transfusions should take into account the patient's practical needs, as long as a pretransfusional Hb ranging between 9 and 10.5 g/dl is maintained. It is important to keep an accurate record of the amount transfused, in order to calculate the iron intake of the patient. The annual intake is expressed in ml/kg/yr of pure red cells, assuming that 1 ml of pure red cells contains 1.08 mg of iron.³⁹⁷ It has been observed that the level of Hb maintained during the warm months is lower than that during the cold months. Possible mechanisms include expansion of plasma volume with resultant hemodilution in the patient, and lower hemoglobin content in donor blood.³⁹⁸

For the comfort and safety of the patient, there should be a designated area at the hospital where transfusions will be administered and supervised by regular staff, well known to the patients and their families. It is often necessary for the center to be able to provide after hours transfusions, especially for children going to school and for working patients.

Complications of Transfusions

Although blood transfusions are life-saving for thalassemia patients, who no longer die of anemia, they can be complicated by transfusion reactions, alloimmunization, infections, and hemosiderosis.

Febrile Nonhemolytic Transfusion Reactions. A cooperative effort conducted 20 years ago, the CooleyCare initiative, reviewing more than one hundred thousand red cell transfusions in Italy and Greece, found that transfusion reactions complicated 1% of all transfusional events in 16% of the patients.³⁹⁹ About 90% of the red cell units infused were leukocyte-poor. Chills, fever, urticaria, headache, and chest pain accounted for more than 80% of symptoms reported, and in two-thirds of cases, reactions were reported during transfusion.⁴⁰⁰ Alloimmunization to HLA-antigens on leukocytes is the most common cause of febrile reaction in multiply transfused thalassemic patients. If blood is not filtered prestorage, cytokines may develop during storage and be responsible for the reaction. Treatment includes acetaminophen or hydrocortisone. Allergic reactions, due to plasma proteins and manifesting as hives, pruritus, and more rarely edema, are best treated with an antihistaminic drug.

Alloimmunization. Alloimmunization and autoimmunization can complicate transfusion therapy. The frequency of alloimmunization against red cells is variable, the lower percentages being found in patients who received blood matched for the ABO, Rhesus, and Kell systems from their first transfusion. In a multicenter study, allo- and autoantibodies were reported in 16.5% and 4.9% of patients, respectively. Splenectomized patients were 2.5 times more likely to have developed alloantibodies.⁴⁰¹

Another study from a single large center found that 19.5% of the thalassemia patients developed alloantibodies, 94% of them being against the Rhesus or Kell antigens. Older age, higher transfusion frequency, and splenectomy were risk factors for alloimmunization.⁴⁰²

The risk of developing alloantibodies is not uniform and is probably genetically determined. Transfusion in infancy seems to induce immune tolerance.²²³ Asians appear to be at a higher risk of developing allo- and autoantibodies.⁴⁰³ In addition, the risk of alloimmunization is higher in individuals from ethnic minorities that, in general, donate less. In the US, the donation rates of African-American are 25% to 50% of that of white individuals.⁴⁰⁴

This phenomenon is present also in Europe, where the immigrant population, potentially at risk for hemoglobinopathies, is increasing in recent years. Donation by minorities should be encouraged to prevent the formation of red blood cell alloantibodies, which can result in hemolytic transfusion reactions and difficulty in finding appropriate red blood cells for future transfusions.

Infections. The risk of transfusion-transmitted viral infection is well known. Among the most frequent and clinically relevant are the widely diffused hepatotropic viruses hepatitis B and C (HBV, HCV). The prevalence of infection of these viruses in multitransfused patients is different in different parts of the world and is directly related to the frequency in that population. Worldwide, from 0.3% to 5.7% of thalassemia patients are hepatitis B surface antigen (HBsAg)-positive⁴⁰⁵,⁴⁰⁶,⁴⁰⁷ and from 4.4% to 85% are positive for anti-hepatitis C antibodies.⁴⁰⁸,⁴⁰⁹ The prevalence of HBV chronic infection is higher in countries in Asia and Southeast

P.882

Asia, whereas HCV chronic infection is widespread throughout the world. The DNA-recombinant vaccine against hepatitis B virus, safe and effective, is available and should be administered to all patients who have not yet been infected. Hepatitis G virus and GB virus C (GBV-C) are RNA viruses that were independently identified in 1995, and were subsequently found to be two isolates of the same virus. Together with transfusion-transmitted (TT) virus, they are common among thalassemia patients but have not been found to contribute to chronic hepatocellular damage.⁴¹⁰ West Nile Virus infection has become of concern in recent years. Epidemics have been reported, and the virus can be transmitted through blood transfusion.⁴¹¹,⁴¹² In the United States, testing for West Nile virus antibodies has been implemented in 2003,⁴¹³ and nucleic acid testing is widely used in Europe in endemic areas.

CMV is widespread in most populations. A European collaborative study revealed a positive CMV IgG test in two-thirds of the thalassemia patients examined.⁴¹⁴

HIV infection was acquired almost exclusively before the systematic screening of blood donation. In 1987 the prevalence of HIV in thalassemia patients from 13 European or Mediterranean countries was found to be 1.56%. Two years later no HIV seroconversion was observed in the same areas when a total of 2,972 patients affected by thalassemia who had received 96,518 blood units were examined.⁴¹⁵ Since 2004, several cases of transfusion-associated variant Creutzfeldt-Jacobs Disease (vCJD) have been reported and linked to blood collected from preclinically affected donors. Animal data suggest that all blood components are vectors for prion disease transmission.⁴¹⁶ Malaria can be transmitted by transfusion

in endemic areas.⁴¹⁷ A screening program for *Trypanosoma cruzi*, a parasitic infection endemic in Central and South America, which is spreading into nonendemic countries with the migration of infected individuals, was developed in 1998 in the United Kingdom⁴¹⁸ and in 2007 in the United States.⁴¹³ Although significant improvements have been made to further decrease the incidence of transfusion-transmitted infections, risks remain for infectious disease agents specific to red blood cell concentrates including emerging viruses, bacteria, protozoa, and residual contaminating leukocytes.^{419, 420, 421} Pathogen and leukocyte inactivation of red blood cells is therefore of potential relevance in order to transfuse patients with completely pathogen-inactivated blood units. A pathogen inactivation system for red blood cells, based on a nucleic acid (DNA and RNA) targeting and crosslinking compound, is being actively developed and is reaching clinical application.⁴²²

In a recent review, the major results from more than 150 articles published by the Retrovirus Epidemiology Donor Study (REDS), conducted from 1989 to 2001, and the REDS-II, conducted from 2004 to 2012, were reported. These were National Heart, Lung, and Blood Institute-funded, multicenter programs focused on improving blood safety and availability in the United States. REDS-II also included Brazil and China, while the just launched REDS-III will also include South Africa. The three major research domains of REDS/REDS-II have been evaluation of infectious risk, blood donation availability, and blood donor characterization. Blood safety studies have included protocols evaluating epidemiologic and/or laboratory aspects of human immunodeficiency virus, human T-lymphotropic virus 1/2, hepatitis C virus, hepatitis B virus, West Nile virus, cytomegalovirus, human herpesvirus 8, parvovirus B19, malaria, Creutzfeldt-Jakob disease, influenza, and *Trypanosoma cruzi* infections.⁴²³

Predisposing factors for bacterial infections include prior splenectomy, iron overload, and use of the iron chelator deferoxamine. Despite the availability of prophylactic measures against encapsulated organisms, the risk of severe, sometimes fatal, infections is still high in splenectomized patients.⁴²⁴ Iron overload and deferoxamine favor the growth of organisms such as *Yersinia enterocolitica* and *Klebsiella pneumoniae*, *Yersinia* being more prevalent in temperate regions and *Klebsiella* in tropical and subtropical areas. *Yersinia* infection should be suspected in the presence of fever, diarrhea, right-lower-quadrant abdominal pain, and a palpable abdominal mass. Abdominal suppurative complications have been reported.⁴²⁵ Deferoxamine, but not deferiprone or deferasirox, increases growth of *Yersinia* both in vivo and in vitro. In fact, being a siderophore, deferoxamine can be used by this organism as a source of iron. Growth of *Klebsiella*, on the contrary is only moderately enhanced by DFO in vitro and not at all by deferiprone or deferasirox. Several reports have described infection with *Aeromonas hydrophila* in Asia. The growth of *Aeromonas hydrophila*, however, does not seem to be affected by any of the three chelators.⁴²⁶

Hemosiderosis

In patients who undergo transfusional therapy for several years, the accumulation of iron, if untreated, causes considerable morbidity and ultimately leads to death. Since each unit of blood contains approximately 200 milligrams of iron, a patient who receives 25 to 30 units of blood a year, by the third decade of life, in the absence of chelation, will accumulate over 70 g of iron.⁴²⁷ In addition to the iron administered through blood transfusions, a hyperactive bone marrow will favor increased intestinal iron absorption that will contribute, although marginally, to the total body load. This mechanism has recently been clarified. Duodenal iron absorption is regulated by the hepcidin-ferroportin axis, and hepcidin, in turn, is regulated by plasma iron concentration and iron stores. Hepcidin is a 25-amino acid peptide, synthesized in the hepatocytes, that controls the concentration of ferroportin on the intestinal epithelium. Ferroportin is the primary means of cellular iron efflux and a key component of iron metabolism. Hepcidin regulates ferroportin activity by inducing its internalization and degradation. Low levels of hepcidin correlate with higher levels of ferroportin, resulting in increased intestinal iron absorption.

In addition, hepcidin is homeostatically regulated by the iron requirements of erythroid precursors for hemoglobin synthesis. In iron-loading anemias associated with ineffective erythropoiesis, hepcidin production is suppressed by a signal mediated by growth differentiation factor 15 (GDF15), which is expressed at high levels in conditions of intense erythropoietic drive.⁴³⁰ As a consequence, in β -thalassemia, whenever the bone marrow is not completely suppressed by blood transfusions, iron absorption is increased, even in the presence of iron overload.^{195, 428, 429, 430, 431}

Excessive iron may damage the cell by several mechanisms. In patients who have fully saturated transferrin, a significant fraction of the total iron in plasma circulates in the form of low molecular weight complexes not bound to transferrin.⁴³² Although the exact mechanism of tissue damage remains unclear, the most important pathogenetic factor appears to be iron-induced peroxidative injury to the phospholipids of lysosomes and mitochondria. The redox active component of non-transferrin-bound iron is referred to as the labile plasma iron and it can be identified with oxidantsensitive fluorescent methods.^{433, 434, 435}

Control of circulating labile plasma iron is crucial to prevent oxidative damage and to decrease the risk of organ dysfunction. At present, an easy method for serial labile plasma iron measurements is not available.^{436, 437}

Excessive iron stores lead to depletion of substances that defend against free radical attack, e.g., among others, ascorbic acid, which is oxidized to oxalate, and vitamin E.⁴³⁸ This in turn causes sequestration of the iron in the reticuloendothelial system, somehow protecting tissues from siderosis.⁴³⁹ At suboptimal concentration, ascorbic acid is a pro-oxidant and enhances the catalytic effect of iron in free radical formation. The presence of the genetic hemochromatosis mutations does not seem to influence the degree of iron overload and its consequences in regularly transfused and chelated patients with thalassemia major.²³²

P.883

Assessment of Iron Stores. The iron status of multitransfused patients can be assessed by several methods. The use of two or more parameters will usually provide a good estimate of the total amount of iron accumulated. Serum iron is always elevated. Transferrin saturation correlates reasonably well with serum ferritin.^{440, 441} After only a few years of transfusion, however, transferrin is completely saturated in the majority of patients. In thalassemia major, serum ferritin has, in general, been found to correlate well with iron stores, as measured by phlebotomy, and with liver iron, either measured directly by liver biopsy or by MRI.^{195, 429} (Fig. 34.10) Significantly higher ferritin levels are present in patients with endocrinopathies,^{442, 443} cardiac failure, and arrhythmias than in patients without such complications. Levels above 2,500 ng/dl have been reported to be associated with a four-fold higher risk of death.⁴⁴⁴

Several variables can interfere with the reliability of ferritin as a marker of iron overload. Ferritin, being an acute phase reactant, is increased in chronic disease, malignancy, or inflammatory disorders. A ferritin concentration of 4,000 mcg/L is considered the maximum level of physiologic synthesis, while higher values would represent the release of intracellular ferritin from damaged cells.⁴⁴⁵ Ascorbic acid deficiency can lead to decreased synthesis and release of ferritin. This can therefore lead to ferritin levels that are only mildly elevated, even in the presence of massive iron stores.⁴⁴⁶ A low level of hepcidin also results in iron depletion of macrophages, decreasing their secretion of ferritin and, therefore, serum ferritin levels. This phenomenon is particularly evident in thalassemia intermedia.¹⁹⁵ Conversely, patients with active liver disease may have high levels of serum ferritin that do not mirror the body iron load.⁴⁴⁷ Despite all this, serial measurements of serum ferritin remain a reliable means, and the easiest one, to evaluate iron overload and efficacy of chelation therapy. The measurement of iron excretion over 24 hours, after an intramuscular injection of 500 mg of desferrioxamine was, in the past, used largely to establish the time to start chelation therapy or to evaluate the iron burden. Unfortunately, the correlation between urinary excretion and body iron is not very good, as many factors, including dose of chelator administered per unit of weight of the patient and vitamin C status, contribute to influence iron excretion.

The total iron burden can be estimated by direct measurement of iron concentration in the liver. Needle biopsy specimens of 1 mg dry weight are adequate. The measurement is done by atomic absorption spectrometry on ashed or lyophilized samples and correlates well with the total amount of blood transfused and with the extent of hepatic fibrosis.⁴⁴⁸ Removal of body iron by phlebotomy after bone marrow transplantation has demonstrated that total body iron stores (in milligrams per kilogram of body weight) are equivalent to 10.6 times the hepatic iron concentration (in milligrams per gram of liver, dry weight). The correlation's standard error is <7.9. In the absence of cirrhosis, the correlation is linear up to a body iron burden of 250 mg/kg.⁴⁴⁸

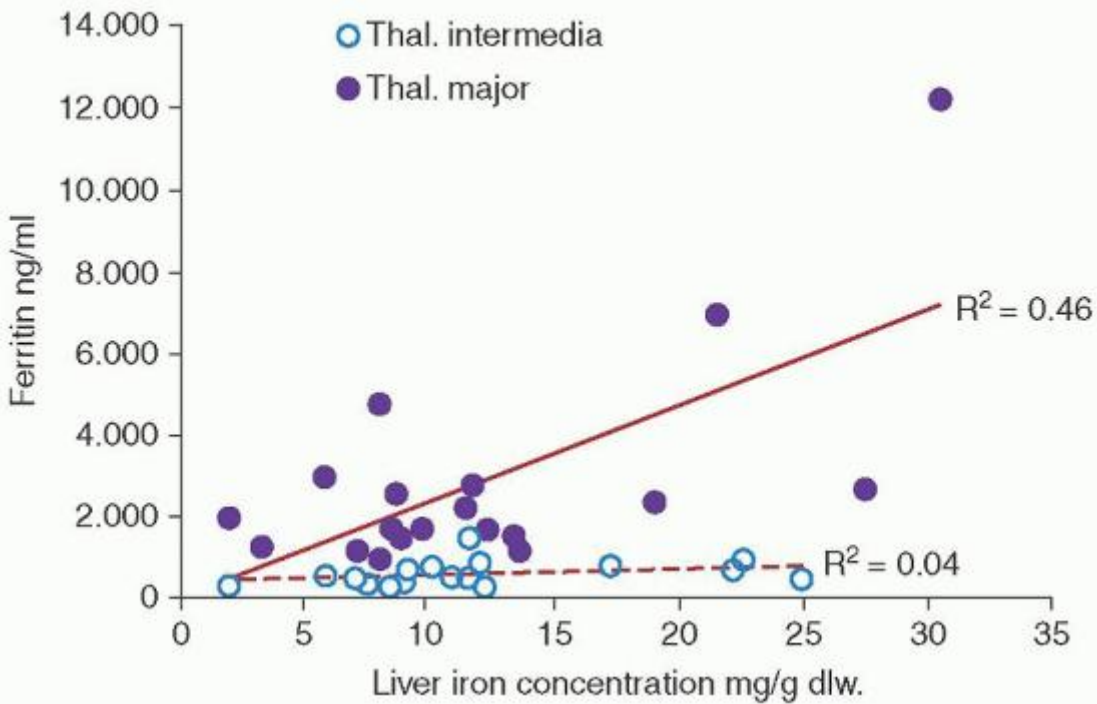

FIGURE 34.10. Correlation between liver iron concentration and serum ferritin in patients with β -thalassemia. The solid line represents the linear regression for thalassemia major ($n = 22$), and the dashed line that for thalassemia intermedia ($n = 22$). (Reprinted with permission of Origa R, Galanello R, Ganz T, et al. Liver iron concentrations and urinary hepcidin in β -thalassemia. *Haematologica* 2007;92:583-588.)

The variation in iron concentration throughout the liver, however, increases with the iron loading and in the presence of cirrhosis. The coefficient of variation for multiple needle biopsy measurements ranges from an average of 19% for disease-free liver to more than 40% for end-stage cirrhosis.^{450, 451} Magnetic susceptometry, a noninvasive method, is based on the magnetic response of ferritin and hemosiderin iron contained in the liver.^{452, 453} The equipment necessary for this measurement (SQUID: superconducting quantum interference device) is available in two sites in the US, one in Germany, and one in Italy.

At present, MRI $R2^*$ assessed clinically via its reciprocal, $T2^*$, is widely used for the evaluation of iron in myocardium and liver. The $T2^*$ technique for the measurement of tissue iron, was developed in 2001 by Anderson and colleagues, and validated by chemical estimation of iron in patients undergoing liver biopsy.⁴⁵⁴

$T2^*$ is a magnetic relaxation property of any tissue and is inversely related to intracellular iron stores. Iron deposits shorten $T1$, $T2$, and $T2^*$. $T2^*$ has become the most widely used because it is the most sensitive to iron deposition. Measurement is simple, quick, and robust, and has high reproducibility. An additional advantage of the technique that makes it particularly helpful for measuring heart iron is its ability to measure ventricular function. As myocardial iron increases, there is a progressive decline in ejection fraction. In the original study all patients with ventricular dysfunction had a myocardial $T2^*$ of <20 ms.

Iron calibration in humans for cardiovascular magnetic resonance $R2^*$ against myocardial iron concentration has been reported.⁴⁵⁵ An MRI multislice multi-echo $T2^*$ technique for global and segmental measurement of iron overload in the heart, whose reproducibility has been validated, is in use in most Italian centers.^{454, 456, 457}

A validated, noninvasive method of measuring and imaging liver iron concentration in vivo using a magnetic resonance imaging unit (MRI) was reported by St. Pierre et al.⁴⁵⁰ High degrees of sensitivity and specificity of mean liver proton transverse relaxation rates ($R2$) were found at clinically significant liver iron concentrations. Although most 1.5 Tesla magnets are able to perform iron estimation measurements, specialized software and local expertise are required for accurate assessment. As a result, some centers have chosen to purchase commercial software or outsource their image analysis to a central facility where the data are sent by telemedicine.

More recently MRI T2* was used for assessing iron in the pancreas,⁴⁵⁸, ⁴⁵⁹, ⁴⁶⁰ hypophysis,⁴⁶¹ and kidneys.⁴⁶², ⁴⁶³

Clinical Manifestations of Iron Overload

Heart

Cardiac complications are frequent and heart failure and arrhythmias are responsible for 70% of the deaths of patients treated with deferoxamine⁴⁴². A recent Italian cooperative study, performed as a part of the MIOT (Myocardial Iron Overload in Thalassemia) initiative, demonstrated that out of 776 thalassemia major patients, 22% had a diagnosis of one or more cardiac problems, including heart dysfunction (66%), arrhythmias (14%), and both heart dysfunction and arrhythmias (19%).

P.884

The prevalence of heart dysfunction and/or arrhythmias is significantly higher in males than in females.⁴⁶⁴

Heart disease, a consequence of iron overload, is mediated through the labile iron-induced peroxidative injury to the phospholipids of lysosomes and mitochondria, demonstrated both in vitro and in the experimental animal.⁴³⁴, ⁴⁶⁵ In the absence of chelation, subclinical dysfunction appears in the second decade of life, or when approximately 20 grams of iron have been accumulated. Subsequently, cardiomegaly and left ventricular deterioration progress to congestive heart failure. Arrhythmias can cause sudden death.⁴⁶⁶ In asymptomatic thalassemia patients with normal myocardial mass, diastolic dysfunction appears to be an early event, even when the systolic function is only mildly impaired. The classic picture of end-stage iron-induced cardiomyopathy is a combination of left ventricular diastolic dysfunction, pulmonary hypertension, and right ventricular dilatation.⁴⁶⁷

Although chelation has a crucial role in preventing or correcting the cardiac damage, iron accumulation has been documented in patients with good compliance and low ferritin and liver iron concentration.⁴⁶⁸, ⁴⁶⁹

The measurement of cardiac iron, until recently, was difficult to obtain. The results of endomyocardial biopsies are not accurate,⁴⁷⁰ and traditional diagnostic tools (ECG, 24-hour tracings, echocardiography, nuclear studies), although routinely utilized, are not predictive of subsequent cardiac dysfunction. When positive, the cardiomyopathy is often advanced. As mentioned above, the cardiovascular magnetic resonance relaxation parameter R2* (assessed clinically via its reciprocal, T2*) measured in the ventricular septum has greatly increased the amount of information obtainable on heart iron content and function. A fast spin-echo sequence is available to permit acquisition of multiple images in one breathhold.⁴⁷¹ The technique has recently been validated against 12 human hearts from transfusion-dependent patients.⁴⁴⁵

The predictive value of cardiac T2* for heart failure and arrhythmia in thalassemia has been assessed on 652 thalassemia major patients from 21 UK centers. The relative risk of developing heart failure within 1 year was 160 with cardiac T2* values <10 ms (compared with >10 ms) and 270 with a T2* <6 ms. Cardiac T2* was <10 ms in 98% of patients who developed heart failure and had a greater predictive value than serum ferritin and liver iron concentration.⁴⁷² (Fig. 34.11).

Right ventricular dysfunction, which mirrors the decrease in left ventricular function, has been demonstrated with worsening of cardiac iron loading.⁴⁷³, ⁴⁷⁴

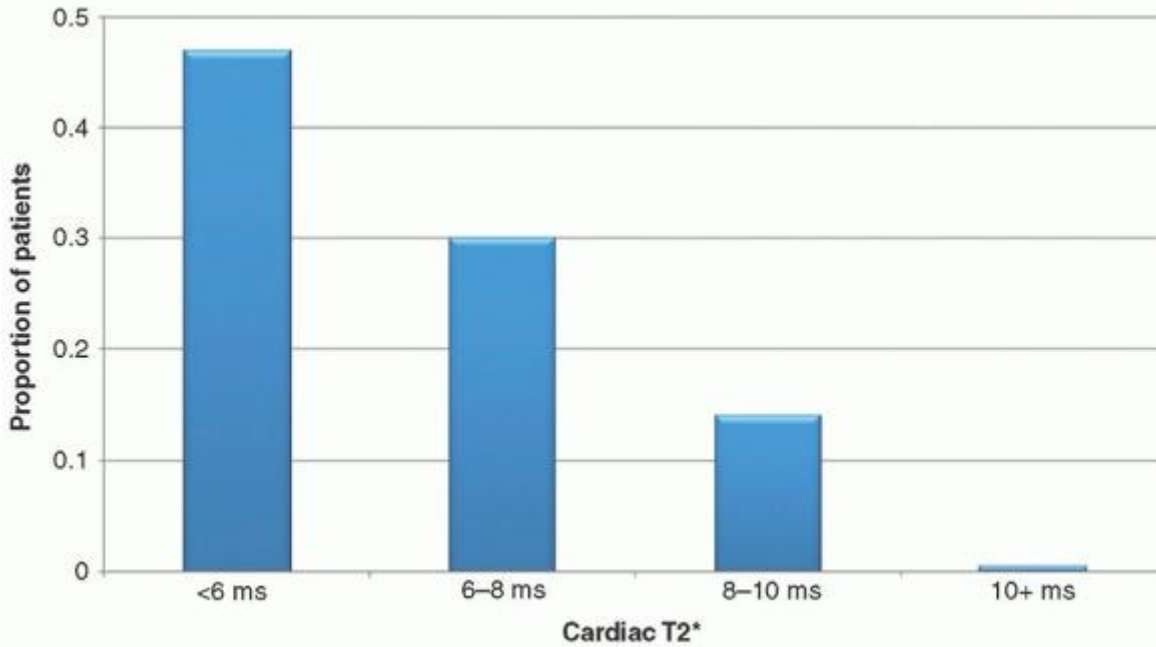

FIGURE 34.11. Proportion of patients developing heart failure after 1 year, according to different baseline cardiac T2* values. (Adapted from Kirk P, Roughton M, Porter JB, et al. Cardiac T2* magnetic resonance for prediction of cardiac complications in thalassemia major. *Circulation* 2009;120:1961-1968.)

A poor correlation between myocardial and liver iron has been clearly documented⁴⁶⁸ (Fig. 34.12).

The prognosis for thalassemic patients with heart failure has always been considered dismal.⁴⁷⁵ More recently, however, the availability of more intensive chelation regimens, particularly effective on the cardiac iron load, has modified the course of the disease, and cardiac failure and arrhythmias can be considered reversible complications in a large number of patients. Improvements of as little as 2% to 3% in ejection fraction, measured by MRI, have been found to reduce significantly the risk of cardiac failure within a year.⁴⁷⁶

Deferoxamine has been crucial in improving survival and decreasing iron-induced heart disease. However, with the introduction of MRI T2*, myocardial siderosis was found in two-thirds of thalassemia major patients on deferoxamine treatment and was associated with a high prevalence of left ventricular dysfunction.⁴⁶⁹

It has been suggested that deferiprone is more effective than deferoxamine in chelating iron from the heart. In a 9-year study, we observed 52 cardiac events, including ten cardiac deaths, in patients treated with deferoxamine only, while no cardiac event developed in patients who were switched to deferiprone.⁴⁴⁴ No data are yet available on the efficacy of deferasirox on life expectancy, but continuous treatment with deferasirox for 2 years at a high dose has been shown to remove iron from the heart in patients with mild, moderate, and severe cardiac siderosis.⁴⁷⁷

In another MRI study, monotherapy with deferasirox was effective in patients with mild to moderate iron stores, but failed to remove cardiac iron in patients with severe hepatic iron burdens, and the left ventricular ejection fraction was unchanged. At present, for patients with severe myocardial siderosis and impaired left ventricular function, combined chelation therapy with subcutaneous deferoxamine and oral deferiprone is indicated. There are data, in fact, that combined therapy reduces myocardial iron and improves cardiac function.⁴⁷⁸

In a long-term study from Cyprus, combined therapy with deferoxamine and deferiprone was shown to prevent deaths related to iron overload.⁴⁷⁹ Results of multivariable analysis demonstrated a 7.4-fold improved survival for each year on combination therapy.⁴⁸⁰

Similarly, a Greek study reported a risk of cardiac death of 9.5 per 1,000 patient-years for deferoxamine, 2.5 for deferiprone, and 1.4 for combination therapy. In the deferasirox group no cardiac deaths were recorded. The risk for a de novo cardiac event for patients on DFO was 9.1 times greater than for patients

on DFP and 23.6 times greater than for those on the combination of DFP and DFO. For DFX, there was one cardiac event over 269 patient-years.⁴⁸¹

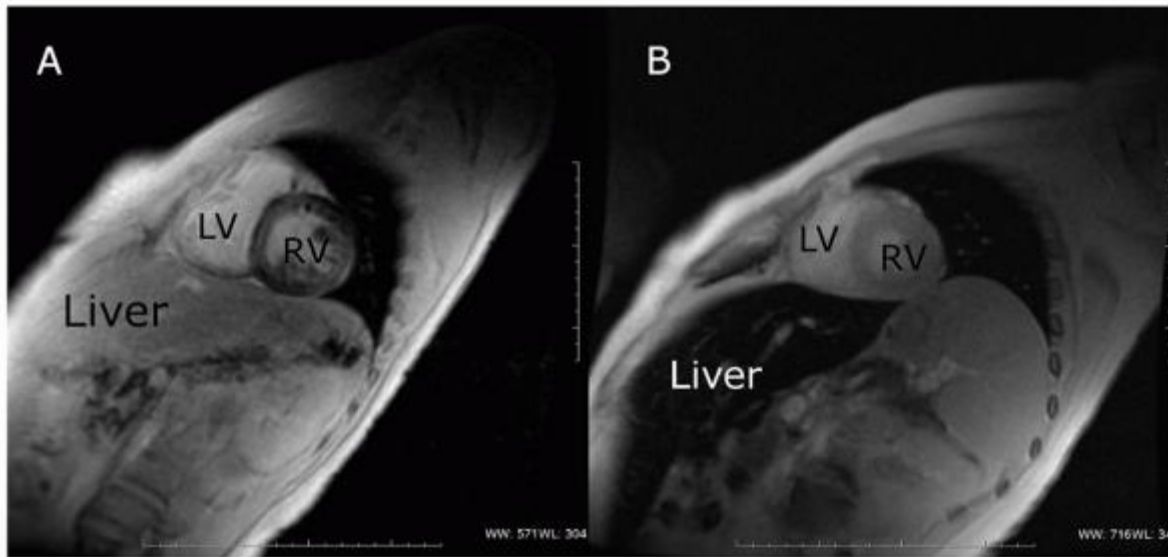

FIGURE 34.12. Heart multislice multi-echo MRI T2* obtained with a 1.5 T scanner. Short axis plane shows discordance of liver and heart iron deposition. A: Heart iron deposition, in contrast with minimal liver iron load. B: Severe hepatic iron overload and normal heart iron. (Courtesy of Alessia Pepe, Magnetic Resonance Unit Fondazione G. Monasterio CNR, Tuscany Region, Italy.)

In addition, the striking reduction in cardiac deaths observed in the United Kingdom in the last decade has been attributed to the combined benefits of T2*, which identifies myocardial siderosis, and of tailored intensification of chelation therapy.⁴⁸²

Acute episodes of sterile pericarditis were seen, in the prechelation era, in about half of the patients with massive iron overload, but are now uncommon in regularly transfused patients.⁴⁸³

Diabetes represents a risk of cardiac complications even when other variables have been accounted for. The presence of iron overload in the pancreas predicts heart siderosis.⁴⁵⁹

Pulmonary hypertension is a possible concomitant cause.⁴⁸⁴ An elevated tricuspid regurgitant jet velocity has been described in one-third of transfusion-dependent thalassemia patients, both adults and children. Age, splenectomy, hepatitis C, and smoking were significant univariate risk factors.⁴⁸⁵

However, the use of tricuspid regurgitant jet velocity as a surrogate marker of pulmonary hypertension could be inadequate in patients with chronic anemia and hyperdynamic cardiac activity.⁴⁸⁶

A recent review of Italian patients by means of a shared Internet database, found that approximately 19% of regularly transfused and chelated thalassemia major patients needed cardiovascular drug therapy. This subgroup was characterized by a dilated and mildly hypokinetic left ventricle when compared with the majority of thalassemia major patients, who did not need cardioactive drugs.⁴⁸⁷ Management of cardiac complications in patients with thalassemia major has been described.⁴⁸⁸ In asymptomatic or minimally symptomatic patients with left ventricular dysfunction, the angiotensin-converting enzyme inhibitor enalapril produced significant improvement in systolic and diastolic function as demonstrated by echocardiography.⁴⁸⁹ The treatment of arrhythmias is difficult and the risk of pro-arrhythmic effects of antiarrhythmic drugs is high. The help of a cardiac electrophysiologist is often necessary. Heart transplantation has been attempted with variable results. This kind of treatment, however, should no longer be necessary, except for older patients who could not benefit from the effective chelation and supportive therapy available nowadays.^{490, 491}

Liver

Liver disease is a major complication of thalassemia major and is due to the damage produced by iron overload and, in a large proportion of older patients, to the effects of transfusion-transmitted viral infections. Liver iron can be assessed by different methods. Today the method of choice is the MRI R2 or its reciprocal T2. A correlation between T2* and liver iron concentration, as measured by biopsy, has been observed with a relatively good sensitivity and specificity for levels above

3.2 mg Fe/g dry tissue. Sensitivity and specificity for higher liver iron concentrations are less satisfactory (e.g., at 7 mg Fe/g, dry tissue sensitivity and specificity are 70% and 88%, respectively). The R2 (1/T2) technique (Ferriscan®) has been registered in the European Union, and can be done on a standard MRI scanner, with data sent electronically to a commercial organization for analysis.^{450, 492}

Hepatic siderosis in the absence of chelation is present from the very early stages of iron loading and progresses to fibrosis and cirrhosis.⁴⁹³

The mechanisms responsible for the effects of iron are not completely clear. Data in rats suggest that peroxidation of intracellular organelles (lysosomes and mitochondria) and membrane components by reactive oxygen species is the major cause of tissue toxicity and organ damage. Iron mediated oxidation, and the consequent loss of integrity of RNA is considered an important contributing factor to disease development.⁴⁹⁴

Also, an interplay between iron and calcium has been demonstrated in isolated rat liver in a laboratory setting and could be considered as an important mechanism of iron toxicity in liver cells.

Liver biopsy is still considered the gold standard to assess liver inflammation and fibrosis. The degree of liver fibrosis is best documented histologically by the Ishak score.^{495, 496}

However, liver biopsy is an invasive procedure associated with some discomfort, and its accuracy for the evaluation of liver fibrosis is questionable in relation to inadequate tissue sampling and

P.886

intraobserver and interobserver variability.⁴⁹⁷ Transient elastography, a technique that uses both ultrasound and low-frequency elastic waves whose propagation velocity is directly related to the elasticity of the liver tissue, is widely used to measure liver stiffness in chronic hepatitis C and appears to be a reasonably accurate method for detection of cirrhosis in thalassemia patients, regardless of the degree of iron overload.^{495, 498, 499, 500}

Fibrosis of the liver directly correlates with age, number of units of blood transfused, and liver iron concentration.⁵⁰¹

HCV infection is widely diffused among thalassemia patients who had been transfused before 1989 when the virus was identified and before a systematic screening of blood units was performed.⁵⁰² The most common genotype is the genotype 1b.^{409, 503, 504, 505} In the United States, a third of the transfusion-dependent thalassemia patients were found to have antibodies against HCV. Of these, one-third were RNA positive.⁴⁰⁷ The residual risk of transfusion-transmitted infections associated with the window-period donations is extremely low in industrialized countries, especially after the introduction of NAT technology to screen blood donations, but it remains significant where the prevalence of infection in the population is high.^{506, 507, 508} Other hepatotropic viruses, such as GB virus C and transfusion-transmitted (TT) virus, are also common among thalassemia patients but have not been found to contribute to chronic hepatocellular damage. HCV hepatitis becomes chronic in 70% to 80% of infected individuals. It has been calculated that 20% of HCV chronically infected patients will develop cirrhosis within 10 years and that their risk of developing hepatocellular carcinoma is increased.⁵⁰⁹ Transaminase levels typically fluctuate between normal and slightly elevated values, with a good correlation being demonstrated between transaminase levels and viral load measured by quantitative polymerase chain reaction.⁵⁰²

Recommendations on the management of chronic hepatitis in patients with thalassemia have recently been published.⁵⁰³

According to these recommendations, the standard of care for the treatment of chronic hepatitis C and compensated cirrhosis is the combination of a pegylated interferon (Peg-interferon α_2a or Peg-interferon α_2b) and ribavirin. Treatment should be administered for 48 weeks to patients infected by genotype 1 or 4, and for 24 weeks to patients infected by genotype 2 or 3. International guidelines recommend stopping antiviral therapy after 12 weeks in patients infected with genotype 1 or 4 if serum HCV-RNA levels have not decreased by at least two log units compared with baseline, on the basis of strong evidence that such patients have a small likelihood of achieving sustained viral response after 48 weeks of treatment.⁵¹⁰ Small series have also been reported from the US Thalassemia Clinical Research Network.⁵¹¹

Also, direct-acting antiviral (DAA) agents are becoming available for the optimal treatment regimen of genotype 1 chronic HCV infection.⁵¹²

Single nucleotide polymorphisms (SNPs) associated with IL28B influence the outcome of peginterferon- $\alpha\pm$ /ribavirin therapy of chronic HCV infection. Polymorphisms in IL28B are strongly associated with the first phase viral decline during peginterferon- $\alpha\pm$ /ribavirin therapy of chronic HCV infection, irrespective of HCV genotype.⁵¹³

Hepatocellular carcinoma represents the first cause of death in patients with genetic hemochromatosis in whom liver cirrhosis has already developed at the time of diagnosis, and it frequently complicates the course of cirrhosis due to

chronic HCV and HBV hepatitis. As a consequence of the numerous risk factors present in multitransfused patients, the development of the tumor is to be expected with advancing age of the thalassemia patients. In fact, several such cases have been reported.⁵¹⁴

Surveillance is of great importance. Because α -fetoprotein determination lacks adequate sensitivity and specificity for effective surveillance and for diagnosis, all patients with chronic HBV hepatitis and patients with HCV and cirrhosis should undergo liver ultrasound every 6 months. Diagnosis of hepatocellular carcinoma should then be based on imaging techniques and/or biopsy.⁵¹⁵ In fact, when diagnosed and treated early this once invariably fatal tumor can be effectively treated.

Kidney

Renal function has not been extensively studied until recently. Renal failure had been described in association with toxicity due to very high doses of deferoxamine.⁵¹⁶ In a small series, 40% of the patients on subcutaneous deferoxamine developed a clinically significant decrease in glomerular filtration rate.⁵¹⁷

The advent of novel measures of renal function facilitating early detection of kidney disease, in addition to the introduction of a chelator that can induce nephrotoxicity,^{518, 519} have produced a flurry of interest in the subject. In a study from the US Thalassemia Clinical Research Network, regular transfusions were associated with a decrease in creatinine clearance and almost one-third of the patients had hypercalciuria. Albuminuria was found in over half of patients, but was not consistently associated with transfusion therapy.⁵²⁰ Other studies have shown impaired renal function with elevated cystatin C levels, glomerular dysfunction with proteinuria, and tubulopathy with hypercalciuria increasing with age and duration of blood transfusion. In a study, most adults with thalassemia major followed for 10 years maintained the estimated glomerular filtration rate within the normal range. However, some patients with tubular dysfunction secondary to either thalassemia major or its treatment developed an abnormal estimated glomerular filtration rate.⁵²¹ Renal tubular dysfunction may be related to the disease itself, to the effects of iron overload or to the chelator (see below). Some patients demonstrated an increased creatinine clearance leading to hyperfiltration.⁵²²

Iron can be demonstrated in kidneys. Nevertheless, kidney MRI T2* correlates weakly with liver and cardiac T2*.⁴⁶²

Endocrine Glands

Iron deposition is the main cause of damage to the endocrine glands, directly or through the hypothalamic-pituitary axis. Direct damage to almost all endocrine glands has been demonstrated histologically and by MRI. High ferritin levels, poor compliance with chelation, and splenectomy increase the risk of being affected by all endocrinopathies.^{442, 443, 525}

Intensive iron chelation can normalize the iron load and thereby prevent or even reverse multiple endocrine complications.⁵²⁶

Growth Retardation. Stunted growth is common in thalassemia and it is typically characterized by normal growth during childhood, decreased growth velocity at the end of the first decade of life, and evident growth failure at the expected age of puberty in those patients who lack sexual maturation. Poor pubertal growth, however, was found to be present also in a group of thalassaemic patients regardless of hypogonadism.⁵²⁷

Sitting height is reduced as a consequence of spinal growth abnormalities. A recent survey from the US found that approximately 25% of patients with a thalassemia syndrome³²⁸ had short stature. In children, however, growth was mildly affected and final height was close to midparental height. A report from India, where the majority of adult patients reached a height below 150 cm, highlights the importance of adequate hemoglobin levels and regular transfusion from childhood for normal growth,⁵²⁸ confirming observations made in the United States and Europe before the introduction of hypertransfusion.³⁸⁷

Between 12% and 54% of short children with thalassemia major have been found to have growth hormone (GH) deficiency.^{328, 529} Dysfunction of the GH-IGF-1 axis, hypothyroidism and hypogonadism, chronic liver disease, and in some patients zinc deficiency, undernutrition, and psychosocial stress can contribute to the growth disturbance. In clinical practice, regular

P.887

growth assessment in both standing and sitting positions every 4 to 6 months, annual determination of bone age, and annual pubertal staging should be performed from the age of 11 years. Treatment with recombinant human GH improves height velocity, but most patients remain below their target height.⁵³⁰

Adults with GH deficiency have a decreased life expectancy. Therefore the role of treatment with GH in selected deficient adults who present with cardiomyopathy or severe bone disease needs to be evaluated.⁵³¹ Desferrioxamine (DFO) toxicity is responsible in some cases of reduced or absent growth velocity, platyspondyly with short trunk, metaphyseal irregularity of long bones, and widened growth plates, in particular of the wrist and knee.^{532, 533} These abnormalities were first reported in patients who had started high-dose subcutaneous DFO before the age of 3 years, but were later confirmed also in patients on a standard dose of DFO.⁵³⁴ A negative correlation between the maximum dose of DFO received and height was later described in a group of adolescent patients.⁵³⁵

Hypogonadism. Hypogonadism is very common, affecting in all series more than 50% of the patients.⁴⁰⁷ It ranges from complete lack of sexual maturation to arrested or delayed puberty. Secondary amenorrhea affects 65% of the women who had had spontaneous menarche.⁵³⁶ Significant improvement in spontaneous sexual maturation has been observed in patients born after 1975, suggesting a crucial role for adequate chelation.⁴⁴² A quarter of sexually mature men go on to develop impotence.⁵³⁶ Hypogonadism is hypogonadotropic in origin and is probably due to the free radical oxidative damage caused by iron deposition in the anterior pituitary and/or in the hypothalamus.⁵³⁷ Investigations for the diagnosis of pubertal hypogonadism include bone age measured by x-ray of the wrist and hand, study of the hypothalamic-pituitary-gonadal axis (GnRH test), dosage of sex steroids, and pelvic ultrasound in females.

Hormonal replacement therapy consists in the administration of small doses of oral conjugated estrogens or transdermal 17 β -estradiol, plus cyclic or continuous gestagen administration and progesterone to females; testosterone enanthate in males. Therapy is initially given for a period of 3 to 6 months. If puberty does not develop spontaneously within 6 months after the end of treatment, sex steroids are reintroduced at increasing doses. Hormone replacement, in addition to inducing the secondary sexual characters, enhances height velocity, contributes to the prevention of osteoporosis, and has enormous psychological benefits. Fertility is normal in female patients with normal menstrual function, or it can be induced with human menopausal gonadotropin or FSH.⁵³⁸ In men with thalassemia major, sperm count, sperm motility, and proportion of sperm with normal morphology are significantly lower than in control individuals.⁵³⁹

Gonadotropin treatment, using human chorionic gonadotropin plus human FSH or Gn-RH, is given to stimulate spermatogenesis and induce fertility.^{540, 541}

Pregnancy. In women with hypogonadotropic hypogonadism, gonadal function is usually intact and fertility is therefore retrievable. Hundreds of pregnancies have now taken place and severe obstetric complications have been quite rare.^{542, 543, 544} Ninety-one percent of the pregnancies recently reported by an Italian cooperative group resulted in successful delivery, and no secondary complications of iron overload developed or worsened during pregnancy.⁵⁴⁵ Anemia should be avoided to protect the fetus from hypoxia (Hb levels suggested 10 g/dl), and chelation therapy should be discontinued because of concerns regarding teratogenicity. However, over 80 cases have been reported in which desferrioxamine was given in various periods of gestation without evidence of teratogenic effects.⁵⁴⁶

Preexisting cardiomyopathy, expanded plasma volume, increased cardiac output, continuous iron accumulation in the absence of chelation, and reduced glucose tolerance can deteriorate maternal health in the course of pregnancy. A few cases of cardiac failure, even fatal, have been observed, but care by an expert multidisciplinary team should now be able to prevent serious complications. Delivery has been performed by elective Cesarean section in approximately half of the cases reported. As a consequence of gonadotropin-induced ovulation, multiple pregnancies and preterm births are not rare.⁵⁴⁷ To decrease the risk of thromboembolic events, the use of low molecular weight heparin is recommended peripartum, especially in splenectomized women with thrombocytosis. Low-dose aspirin is indicated during the entire pregnancy for women with high platelet counts. Genetic counseling is mandatory before conception.

Hypothyroidism. Hypothyroidism is the second most common endocrine disorder after hypogonadism, having been reported in 5.6% to 17% of patients.^{407, 442, 443}

The majority of patients have subclinical or mild forms, while approximately one-third have the overt form. Central hypothyroidism is less frequent. No difference in the mean level of serum ferritin concentration was found between patients with or without hypothyroidism. Regular assessment of FT4 and TSH is recommended after the first decade of life. Thyroid ultrasonography can show irregular echo pattern and thickening of the capsule. Abnormal thyroid function has been reversed to normal by means of intensive chelation therapy with DFO alone or in combination with deferiprone.⁵²⁶

Hypoparathyroidism. Hypoparathyroidism affects 3% to 10% of thalassemia patients and it is attributed to iron deposition in the parathyroids.⁴⁰⁷ Males seem to be affected more often than females.

Early detection requires periodic estimation of calcium homeostasis. Serum calcium levels below 8 mg/dl (2 mmol/L), phosphorus above 7 mg/dl (2.6 mmol/L), and low 1,25-dihydroxy vitamin D are suggestive of hypoparathyroidism.

Symptoms are usually mild and include paresthesias, muscle pain, and, when severe, tetany and even convulsions. Extreme hypocalcemia is a late event. Intracranial calcifications have been reported in 40% of patients with hypoparathyroidism in the absence of symptoms and independently from the severity of the hormonal deficit.⁵⁴⁷ In mild forms the treatment of choice to normalize calcium and phosphate is calcitriol at a dosage of 0.25 to 1 µg twice daily, carefully monitoring serum calcium.

Adrenal. No clinically symptomatic adrenal insufficiency has been reported,^{548, 549} but dynamic hormonal testing has given conflicting results. Some authors found integrity of the pituitary adrenal axis,⁵⁴⁹ while others found subclinical hypoadrenalism, which might become clinically relevant in case of major stressful events, in up to 46% of patients.^{550, 551}

Diabetes. Diabetes mellitus has been reported with a frequency variable between 4.9%⁵⁵² and 14%,³²⁸ with a mean age at diagnosis of 18 to 22 years. The reported prevalence of insulin-dependent diabetes and of impaired glucose tolerance is significantly lower in patients born after 1975, probably as a result of chelation therapy.^{553, 554} The peak incidence of diabetes was observed in 1986 (3.9%), decreasing to 0.8% in 2007 in parallel with the progressive decrease of the annual mean serum ferritin levels.⁵⁵⁵ Patients with a serum ferritin level >2,500 µg/L were 3.5 times more likely to have diabetes mellitus.⁴⁴³ Iron deposition in the pancreas resulting in excess collagen deposition, fibrosis, and fatty degeneration with progressive β cell destruction can be demonstrated histologically.⁵⁵⁶ Pancreatic iron, as evaluated by MRI, is the strongest predictor of β cell toxicity, but total body iron burden, age, and body habitus also influence glucose regulation.⁵⁵⁷

P.888

It has been suggested that liver damage could contribute to the impairment of islet cells' function.⁵⁵⁸ HCV infection may induce insulin resistance by a direct effect on insulin-signaling pathways and may cause a direct cytopathic effect at the islet cell level, reducing insulin release.⁵⁵⁹ In a survey, 36% of HCV positive patients had either a diagnosis of diabetes or an abnormal fasting blood glucose, a percentage significantly higher than in HCV negative patients.³²⁸ Impaired glucose tolerance characterized by insulin resistance can precede the appearance of symptoms by a few months to several years and can be followed by progressive insulin deficiency leading to overt diabetes.⁵⁶⁰ Impaired β cell function, as reflected by a reduction in the insulin secretion index, can be found in normoglycemic patients.⁵⁶¹

Asymptomatic hyperglycemia is the presenting sign in the overwhelming majority of patients. Ketoacidosis is uncommon, and retinopathy develops in a quarter of patients, a percentage that is approximately half that of age- and sex-matched diabetic controls without thalassemia.⁵⁶² Intensive chelation may reverse glucose intolerance and postpone the onset of insulin-dependent diabetes.⁵²⁶

Impaired glucose tolerance is often responsive to oral hypoglycemic drugs. In the insulin-dependent form, therapy needs to be closely monitored, as glucose control is often difficult.

Exocrine Glands

Low serum levels of chymotrypsin and lipase have been described in patients with thalassemia, and have been attributed to hemosiderosis of the pancreatic acinar tissue.⁵⁶³ An ultrasonographic study demonstrated hyperechogenicity of the pancreas and significantly decreased size of the gland when compared to controls, both of which were significantly correlated with patient's age and duration of transfusion therapy. Serum concentrations of trypsin and lipase were significantly lower in patients than in controls.⁵⁶⁴

Eye

Ocular involvement is not rare, but it is usually of moderate severity. In a recent report from India, more than half of the patients had some eye problems. Lenticular opacities were the most common ocular finding (44%).⁵⁶⁵ It has been known for a long time that retinal pigmentary changes may complicate hemochromatosis. Accordingly, retinal hyperpigmentation detected in a group of thalassemia patients was attributed to iron overload. Also reported were abnormal electroretinographic potentials, similar to those observed in experimental siderosis bulbi.⁵⁶⁶ Their severity was directly correlated with iron overload. The presence of retinal angioid streaks should raise the suspicion of pseudoxanthoma elasticum.^{367, 567} Nevertheless, most eye problems in patients with thalassemia major are a consequence of DFO toxicity and will be discussed below.

Pulmonary Problems

Pulmonary problems, mainly due to ventilatory restrictive impairment, have been reported in patients with thalassemia major. Iron deposition in the respiratory system has been proposed as a potential cause.⁵⁶⁸ However, no correlation was found between restrictive impairment and iron deposition in the respiratory system evaluated by MRI.⁵⁶⁹

Chelation

To prevent hemosiderosis, iron needs to be chelated and excreted. Iron balance is obtained when the daily excretion is sufficient to eliminate the iron introduced by transfusion. This amount approximates, in most patients, 0.3 to 0.5 mg/Kg. The two main sources of chelatable iron are (1) the intracellular labile pool, derived from lysosomal catabolism of ferritin and from transferrin- and nontransferrin-bound iron, and (2) the iron derived from red cell catabolism in macrophages.^{434, 570} The first contributes chiefly to the hepatocellular load and is excreted as fecal iron, while the second is the major source of urinary iron. Ferric iron has six coordination sites, which need to be chelated completely, for the generation of harmful free radicals to be prevented. Three chelators are presently in use: deferoxamine (DFO), deferiprone, and deferasirox. (Fig. 34.13) DFO is hexadentate and therefore forms stable iron-chelate complexes using a single molecule, while the molecules of deferiprone and deferasirox, being bidentate and tridentate, respectively, could, in theory, dissociate from iron at suboptimal concentrations and promote, rather than prevent, iron toxicity.⁵⁷¹

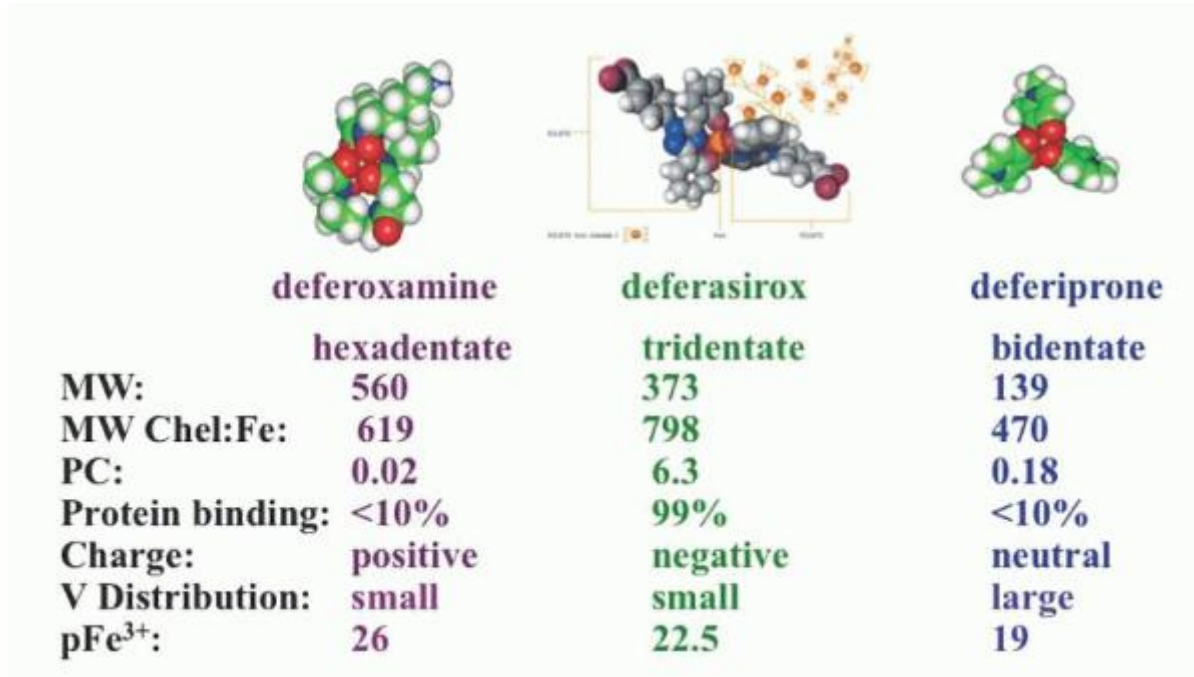

FIGURE 34.13. Molecular structure and chemical properties of the three chelators presently available.

Adherence to chelation therapy and persistence with it is challenging, as the benefits of therapy are not perceived immediately. Children are the most compliant (not being directly responsible for the drug administration), followed by adolescents and adults. Compliance appears to be better with oral chelation (deferasirox in a study), but switching from one chelator to another increases adherence.^{572, 573} A strict relationship between the patient and the health team is necessary to maintain or improve adherence.⁵⁷³

Deferoxamine B

DFO, a trihydroxamic acid produced by *Streptomyces pilosus* was first used for the treatment of transfusional hemosiderosis in 1962.⁵⁷⁴ Because of its large molecular weight, it is not efficiently absorbed from the gut and it cannot, therefore, be administered orally. At the beginning, the drug was given by intramuscular injection, but, because of its short half-life and the finite chelatable iron pool available at any given time, negative iron balance was not obtained.⁵⁷⁵ In a seminal study performed in the United Kingdom, it was found that patients treated with DFO had, after 7 years, lower ferritin levels and lower liver iron concentration than those not chelated.^{576, 577} It was only with the administration of prolonged parenteral infusions, however, intravenous at first, and then subcutaneous, that negative iron balance was achieved.^{578, 579} Today, DFO is most frequently administered subcutaneously, by means of a portable battery-operated pump (Fig. 34.14), at a dose ranging between 20 and 60 mg/kg/day over 8 to 12 hours at night.

Pharmacokinetic studies have shown that a plateau is reached within 4 to 8 hours after starting the infusion and that, at the end of it, plasma levels fall rapidly.⁵⁸⁰ Nontransferrin-bound iron (NTBI) is efficiently bound by DFO, so that the effects of free radical formation and lipid peroxidation are prevented.⁵⁸¹ The efficacy of DFO in reducing the iron burden, in improving organ function, and in improving survival has been repeatedly demonstrated.^{442, 582}

In order to avoid severe effects on growth and bone metabolism, DFO should be started when ferritin levels reach 1,000 ng/ml, or after 10 to 15 units of blood have been given.^{583, 584}

P.889

A discrete variability was demonstrated between patients, but the mean liver iron concentration after 1.3 years of transfusions was found to be 8.5 mg/g, slightly above the limit of 7 mg/g, which, in patients with idiopathic hemochromatosis, is considered compatible with a normal life expectancy.⁵⁸⁵ Decreasing growth velocity is an indication to lower the dose of the chelator. The adequacy of therapy is monitored by repeated measurements of serum ferritin and by more direct quantification of heart and liver iron, usually by magnetic resonance.



FIGURE 34.14. Deferoxamine needs to be administered by subcutaneous infusion by means of a pump. The available models are different in technical characteristics, size, and price.

In the case of cardiac dysfunction and gross iron overload, continuous 24-hour deferoxamine infusion, delivered via an intravenous catheter implanted in a large vein, has been used with good results,⁵⁸⁶ although the drug is more efficient on the liver than on the heart.⁵⁸⁷ Improvement of cardiac performance can usually be demonstrated even before the total iron load is significantly reduced, probably as an effect of the binding of the toxic labile plasma iron. The more frequent catheter-related complications are infection and thromboembolism at a rate of 1.15 and 0.48 per 1,000 catheter days, respectively.⁵⁸⁸ In heart cell cultures, studies have demonstrated that DFO removes the iron directly from iron-loaded heart cells, inhibits lipid peroxidation, and reverses the abnormalities in cellular contractility and rhythmicity induced by the iron.^{589, 590} Recently, the efficacy of DFO on the heart has been found to be insufficient. In fact, myocardial iron loading ($T2^* < 20$ ms), was demonstrated in 65% of patients treated by subcutaneous deferoxamine therapy investigated by MRI. In 13% the iron overload was severe ($T2^* < 8$ ms)⁴⁶⁹ (Fig. 34.15).

The administration of DFO by twice daily subcutaneous bolus injection has been demonstrated to induce the same urinary iron excretion as the slow, pump-mediated infusion and to be well accepted, especially by older patients.^{352, 591, 592} The main limit of DFO is the inconvenience of parenteral administration. The patients' adherence therefore, is often erratic, especially during the teenage years.

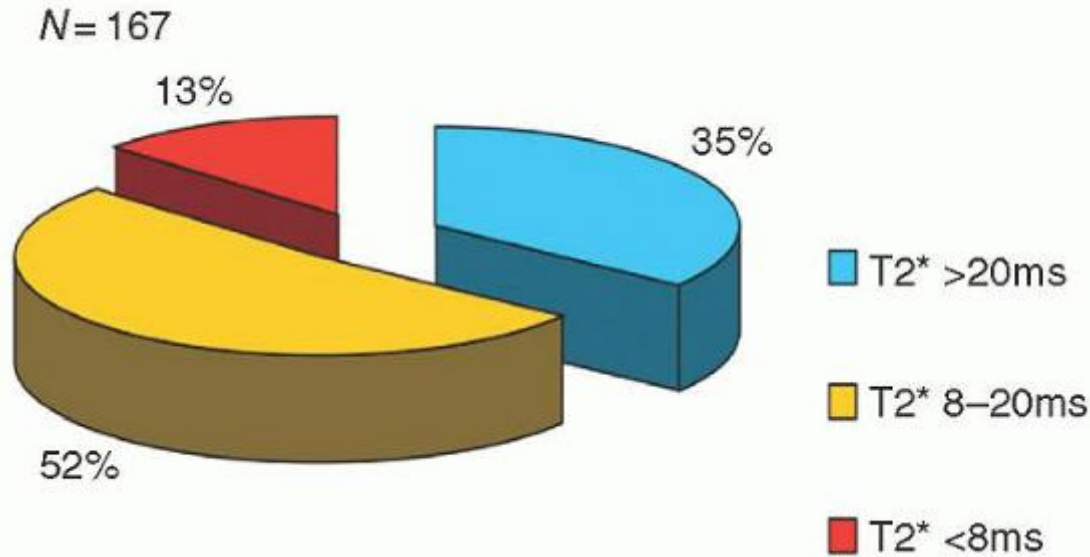

FIGURE 34.15. Myocardial iron loading in patients on long-term deferoxamine treatment.

Deferoxamine B Toxicity. The most common side effects of DFO are represented by local redness and soreness at the site of infusion. Inflammation, necrosis, and even ulceration can be caused by the intradermal insertion of the needle. If the reaction persists after appropriate needle placement in the subcutaneous tissue, hydrocortisone (5 to 10 mg) can be added in the syringe. The direct and rapid injection of DFO in a vessel can cause brief episodes of nausea, hypotension, and collapse. Systemic allergic reactions and, occasionally, anaphylaxis require desensitization or changing chelator.^{593, 594}

Retinal and optic nerve disturbances, manifesting as loss of central vision, night blindness, and finally amaurosis, were reported in patients treated with high-dose intravenous or subcutaneous DFO.^{595, 596} All the cases reported were reversible upon discontinuation of therapy and the resumption of treatment was well tolerated. High frequency sensorineural hearing loss was observed in a large percentage of patients during intensive DFO therapy. The defect was correlated with the total monthly dose of DFO received, and it was more frequent in younger patients with low serum ferritin levels.⁵⁹⁷ Auditory toxicity can often be prevented by keeping a therapeutic index devised for that purpose (mean daily dose of DFO [mg/kg] divided by the serum ferritin [ng/L]) below 0.025.⁵⁹⁸ The hearing defect should be detected early, by performing an audiogram at least yearly, or whenever symptoms, even subtle, are reported. In fact, significant improvement has been observed after reduction of the DFO dose in patients with a mild defect, whereas only a small benefit has been gained by those severely affected.⁵⁹⁹

Stunted growth and rickets-like bone abnormalities have been described when treatment was initiated early, at a dosage higher than 40 mg/kg, or when the iron burden was not severe.^{533, 600} Sitting height is more often affected than standing height, as a consequence of vertebral growth impairment or flatness of vertebral bodies. Cupping of the ulnar, radial, and tibial metaphyses, which are poorly ossified and with irregular sclerotic margins, can be demonstrated radiographically and, when more advanced, can produce severe deformity of the knees and elbows (Fig. 34.16). Reduction of the DFO dose is sufficient to reestablish normal growth velocity, but orthopedic surgery has sometimes been required for correction of advanced varus and valgus deformities of the knees.⁵³⁴ An acute, often lethal, pulmonary infiltration syndrome has been observed in patients treated intensively with very high doses of DFO (10 to 20 mg/kg/h).^{601, 602} Renal failure has also been reported in this context.^{516, 517} Infection with *Yersinia enterocolitica* is a well-known complication of hemosiderosis. The presence of DFO in plasma and tissues facilitates the growth of the organism, which uses the drug as a siderophore.⁶⁰³ Fever and gastrointestinal symptoms are an indication to temporarily discontinue DFO. Antibiotic therapy is indicated as *Yersinia* infection can be severe and even life-threatening.⁶⁰⁴ *Klebsiella*, whose growth is only moderately favored by DFO,⁴²⁶ is becoming more frequent in thalassemia, especially in tropical and subtropical countries.

Deferiprone

Deferiprone (DFP) is a member of the family of the hydroxypyridin-4-one chelators that have been intensively studied during the past two decades in order to find an orally active alternative to DFO for the treatment of transfusional iron overload. Because each molecule provides two coordination sites, three molecules of deferiprone are required to fully

bind the six coordination sites of an iron atom. The iron-chelate complex that is formed has a lower stability than the one formed by DFO. The sources of chelatable iron are both parenchymal and reticulo-endothelial cells. In addition, iron is mobilized from transferrin, lactoferrin, and hemosiderin. The drug is excreted in the urine within 3 to 4 hours after having been glucuronidated in the liver. Three doses a day are therefore necessary. The recommended dosage is

P.890

75 mg/kg/day in three subdoses given 1 hour before meals. DFP is easily absorbed from the gut and a peak concentration is reached in the plasma 45 minutes after ingestion.^{605, 606} Food reduces the rate of absorption but not the total amount absorbed. DFP is available as film coated, immediate-release tablets containing either 500 or 1,000 mg of the active agent and as a liquid formulation containing 100 mg/ml. The majority of iron is excreted in the urine, while fecal excretion ranges between 5% and 20%. The dose of 75 mg/kg/day has been shown to induce a urinary iron excretion equivalent to that achieved with 40 mg/kg/day of DFO.⁴⁴⁵ Greater excretion can be obtained with a dose of 100 mg/kg/day, and no more side effects occur at this dose.⁶⁰⁷ Ascorbic acid has no effect on iron excretion in response to deferiprone. A decrease in NTBI was demonstrated in a small series of patients.⁶⁰⁸ Deferiprone, as well as the other oral chelator, deferasirox, were found to be efficient scavengers of the labile iron pools of cardiomyocytes, and to restore contractility impaired by iron overload.⁶⁰⁹



FIGURE 34.16. A: Desferrioxamine toxicity. The growth plate of the distal ulna is wide, and the metaphysis exhibits a cuplike deformity with sclerotic and irregular borders. B: A similar picture is present in the metaphyses of the femur and fibula. (Courtesy of Dr. C. Orzincolo.)

Deferiprone was licensed for clinical use in India in 1995 and in Europe in 1999. The FDA approved the drug in the United States in 2011. In a randomized trial comparing the efficacy over 1 year of DFO and deferiprone, the latter was found to be significantly more effective than deferoxamine in improving asymptomatic myocardial siderosis. Left ventricular ejection fraction also increased significantly more with deferiprone than with DFO.⁶¹⁰ The efficacy of deferiprone in removing iron from the heart has been suggested also by a recent MRI study.⁶¹¹

Finally, in the setting of a large natural history study involving all the thalassemia major patients treated in seven Italian centers over 9 years, deferiprone therapy was associated with significantly greater cardiac protection than DFO.⁴⁴⁴

Numerous experiences around the world have been reported on the effectiveness of combining deferiprone and DFO therapy.⁶¹² Results have usually demonstrated an additive effect of combination therapy because the two drugs access different pools of iron. It has been suggested that deferiprone, being able to pass through membranes, could “shuttle” tissue iron to DFO in the bloodstream and then be reused.⁶¹³ Combination therapy is now being widely used.^{479, 614, 615} A randomized, placebo-controlled clinical trial demonstrated that, in comparison to the standard chelation monotherapy of

DFO, combination treatment with additional deferiprone reduced myocardial iron and improved ejection fraction and endothelial function in thalassemia major patients with mild to moderate cardiac iron loading.⁶¹⁶

A small non-randomized study and several case reports have confirmed the efficacy of combined therapy in the context of severe cardiac iron overload.^{617, 618, 619}

Several studies have documented the efficacy of such therapy to rapidly decrease ferritin levels and cardiac iron, as measured by T2*, at the same time improving cardiac function in severely iron-overloaded patients. Reversal of some endocrinopathies was observed after normalization of iron stores with intensive combined iron chelation.⁵²⁶

In Cyprus, mortality due to cardiac causes decreased sharply after combined therapy was implemented in the majority of thalassemia patients.^{479, 480}

Alternating deferiprone and DFO can improve adherence and, in a long-term prospective study, decreased mortality in comparison to DFO alone.^{612, 620}

Deferiprone Toxicity. The most frequent adverse effects are gastrointestinal discomfort or nausea, reported by 33% of the patients in the first year and decreasing to 3% thereafter. The intensity is usually mild to moderate and few patients have abandoned the treatment because of that. The new liquid formulation seems to cause a lower incidence of gastrointestinal side effects. The most severe adverse effects observed with deferiprone are agranulocytosis and neutropenia. In a prospective multicenter study the overall frequency of agranulocytosis was 0.5% and the incidence was 0.2 per 100 patient-years. Milder neutropenia occurred in 8.5% of patients.⁶²¹

Neutropenia occurred more frequently in non-splenectomized patients.⁶²² The complication usually appears shortly after inception of therapy, but a case has been reported after 9 years. Rechallenge with the drug can produce relapse of the agranulocytosis and is contraindicated.⁶²³ The concomitant administration of drugs that can induce neutropenia (e.g., interferon, hydroxyurea) should be avoided.

Arthropathy, particularly of the knee, occurs in 6% to 39% of patients and it appears to be more frequent in patients who have more severe iron overload.^{621, 622, 624} It has been hypothesized that the formation of 1:1 or 1:2 deferiprone iron complexes can induce inflammatory changes, possibly mediated by free radicals. Other, less severe, unwanted effects include excessive appetite, zinc deficiency, and fluctuation in liver enzymes, affecting 7% of the patients, more commonly if HCV positive.⁶²⁵ Progressive liver fibrosis was reported in 5 out of 14 patients treated with deferiprone for over 2 years.⁶²⁶ However, a large multicenter study, involving 56 patients over 3.5 years, whose

P.891

liver biopsies were evaluated in blinded fashion, did not confirm an effect of deferiprone on hepatic fibrosis.⁶²⁷ Reversible neurologic symptoms were elicited in 2 patients when a dose three times higher than suggested was mistakenly given for over 2 years.

Deferasirox

This compound is a member of a new class of tridentate ironselective synthetic chelators, the bis-hydroxyphenyl-triazoles. As a tridentate chelator, two molecules of deferasirox bind one molecule of iron. The plasma half-life is 8 to 16 hours.

Deferasirox (Exjade) is available as tablets for oral suspension containing 125 mg, 250 mg, or 500 mg. It should be administered orally once daily on an empty stomach (≥ 30 minutes before eating), preferably at the same time each day. It should not be administered with aluminum-containing antacid preparations, since the absorption of deferasirox may be decreased. In a large randomized trial comparing the two drugs, deferasirox was shown to be as effective as deferoxamine when administered at doses of 20 and 30 mg/kg. The rate of transfusional iron intake, however, strongly influences the effectiveness of deferasirox. For most patients with transfusional iron intake averaging <0.3 mg/kg/day, a dose of 20 mg/kg of deferasirox is effective in reducing liver iron concentration, while an iron intake of >0.5 mg/kg/day requires doses >30 mg/kg/day.³⁹⁷

Careful assessment of the patient's blood consumption, of ferritin trends and liver iron content during treatment is important to regulate the dose of deferasirox to be administered. Currently, doses of deferasirox of up to 40 mg/kg/day are approved for use.

Cardiac iron removal is crucial to reduce morbidity and mortality in thalassemia. Clinical data suggest that deferasirox is able to remove cardiac iron. Myocardial T2*, assessed by cardiovascular magnetic resonance, was measured in patients on a mean deferasirox dose of 33.6 ± 9.8 mg/kg per day. After 3 years, 68% of patients with baseline T2* from 10 to <20

ms normalized their value, and 50% of patients with baseline T2* >5 to <10 ms improved to 10 to <20 ms. Left ventricular ejection fraction did not vary significantly throughout.⁴⁷⁷

The safety and efficacy of deferasirox in pediatric patients reported in a study⁵¹⁹ was similar to that of adult patients, and younger pediatric patients responded similarly to older pediatric patients. The recommended starting dose and dosing modifications are the same for children and adults. A recent study reporting on 111 children concluded that deferasirox is at least as effective as DFO in maintaining safe serum ferritin levels and normal growth progression. The height and weight standard deviation scores in children treated with deferasirox did not differ from those of patients treated with DFO. Fluctuations in liver enzymes and non-progressive increases in serum creatinine were the most common adverse events.⁶²⁸ Deferasirox was approved in 2005 by the Food and Drug Administration in the United States, and in 2006 in Europe, for use in patients 2 years of age and older.

Deferasirox Toxicity. The most common adverse effects are related to gastrointestinal discomfort, including nausea, vomiting, and abdominal pain.^{629, 630}

Because lactose monohydrate is among the inactive ingredients of the tablet, some cases of diarrhea can be attributed to coexistence in the patient of congenital or acquired lactose intolerance.

A skin rash can develop, usually within the first month of treatment (Fig. 34.17). For rashes of mild to moderate severity, the drug may be continued without dose adjustment, since the rash often resolves spontaneously. In severe cases, it may be interrupted and reintroduced at a lower dose with escalation, in combination with a short period of oral steroid administration.

Approximately one-third of patients are reported to develop increases in serum creatinine >33% above baseline on two separate occasions.⁵¹⁹ In two-thirds of cases the creatinine level returns to normal without dose adjustment. Therapy should not be started in patients with a creatinine clearance below 40 ml/min or with a serum creatinine >2 times the age-appropriate upper limit of normal.

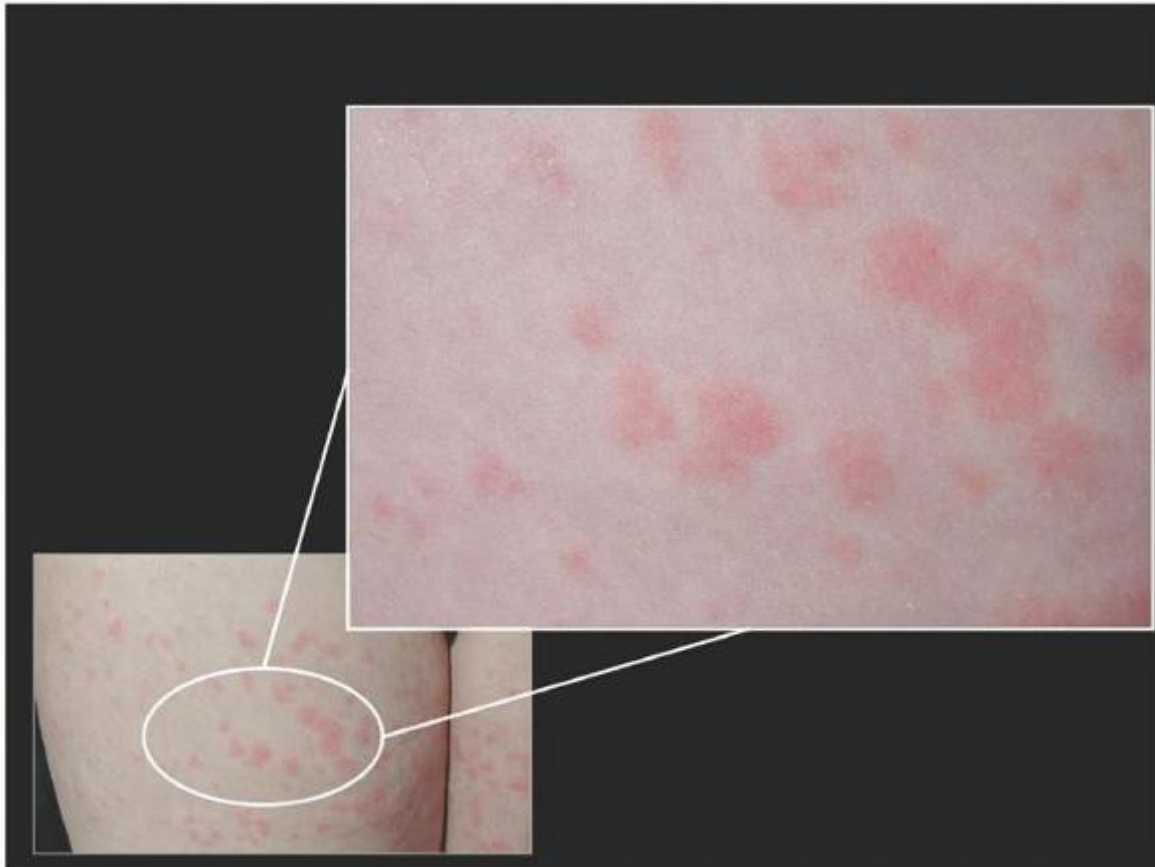

FIGURE 34.17. Typical rash appearing in patients on deferasirox therapy.

Several cases of Fanconi syndrome have been reported with the use of deferasirox.^{518, 631, 632, 633}

Fanconi syndrome is secondary to generalized dysfunction of the renal proximal tubule and results in renal losses of phosphate, amino acids, bicarbonate, glucose, urate, and other molecules.

Although no conclusive pathogenetic explanation to deferasirox-related serum creatinine increase and proximal tubulopathy has been found, careful monitoring of renal function and serum ferritin levels in patients receiving deferasirox is mandatory. Regarding hepatic toxicity, in the original phase 3 study, 6% of patients treated with deferasirox developed elevations in ALT levels >5 times the upper limit of normal at two consecutive occasions. Of these, two patients had drug-induced hepatitis, proven by liver biopsy.⁶²⁹

Increased ALT levels >10 times above the upper limits of normal were reported in 1.0% of patients.⁵¹⁹

There have been postmarketing reports (both spontaneous and from clinical trials) of cytopenias, including agranulocytosis, neutropenia, and thrombocytopenia.⁶³⁴ The relationship of these episodes to treatment with deferasirox is uncertain. Interruption of treatment should be considered in patients who develop unexplained cytopenia.

Reintroduction of therapy with deferasirox may be considered, once the cause of the cytopenia has been elucidated. Non-fatal upper gastrointestinal tract irritation, ulceration, and gastrointestinal bleeding have been reported in patients, including children and adolescents, receiving deferasirox. Caution should be used when the drug is prescribed in association with non-steroidal anti-inflammatory drugs, corticosteroids, oral bisphosphonates, or anticoagulants. Gastrointestinal symptoms, increases in serum creatinine, and skin rash are dose related, while increases in transaminases are not. Alternating deferasirox with deferiprone has been used successfully to overcome intolerance to both drugs.⁶³⁵ Combining the two drugs is also a promising alternative for the treatment of severe cardiac iron overload.^{636, 637}

New Chelators

Despite the availability of three iron chelators, morbidity and mortality are still a major problem for transfusion-dependent patients. Iron chelators in current use (see above) are efficacious in many

P.892

patients, but each has limitations relating to safety, ease of administration, patient acceptance, and compliance.⁶³⁸

FBS0701 is a novel, orally available iron chelator, a member of the desazadesferriothicin class of siderophore-related tridentate chelators. The results of a multicenter phase-2 study designed to assess safety, tolerability, and pharmacodynamics of FBS0701 have been published. The compound seems promising, having a good chelating efficacy and a safety and tolerability profile at therapeutic doses that compare favorably to other oral chelators.⁶³⁸

Vitamin Supplementation

Vitamins and trace minerals represent key buffers against the oxidative stress due to iron overload. Chronic demands on oxidative buffering capacity may produce deficiencies in key amino acids and enzymatic cofactors.⁶³⁹ Siderosis of the exocrine pancreas sometimes causes a decrease in circulating pancreatic trypsin and stool elastase levels^{640, 641} that results in vitamin malabsorption. In addition, liver damage may play a role in the depletion of lipidsoluble antioxidants, such as vitamins E and A.⁶⁴²

A large cooperative survey of dietary habits revealed dietary inadequacy, that increased with increasing age for vitamins A, C, E, B-6, folate, thiamin, calcium, magnesium and zinc. Also, circulating levels of serum 25-OH vitamin D remained insufficient in the majority of subjects despite daily supplementation.⁶³⁹

Vitamin D is essential for intestinal calcium absorption and plays a critical role in global calcium homeostasis and bone metabolism.⁶⁴³ Nevertheless, its receptors are found in nearly all tissues and therefore the vitamin is now believed to play a systemic role. Cardiac iron loading was found to be more common in thalassemia patients with vitamin D deficiency and secondary PTH elevation, but the association of this deficit with left ventricular dysfunction is still unproven.⁶⁶⁴

Vitamin D deficiency is also inversely related to hepatic iron concentration and ferritin, as previously described in hereditary hemochromatosis, because of inhibition of hepatic 25-hydroxylation by excess iron.⁶⁴⁵

In conclusion, chronically transfused thalassemia major patients have broad spectrum nutritional deficiencies of both water- and fat-soluble nutrients. It is therefore advisable to perform periodic nutritional evaluation and supplement as necessary.⁶³⁹

Hemosiderotic patients are often ascorbate deficient and a case of frank scurvy has been reported.^{438, 439}

DFO-induced iron excretion is enhanced by ascorbic acid supplementation because of the expansion of the chelatable iron pool which DFO can access.^{434, 646}

However, ascorbate, a natural reducing agent, accelerates iron-induced lipid peroxidation in biologic systems at low concentrations and it has been shown to alter the function of rat myocardial cells in culture. In addition, anecdotal echocardiographic observations have in the past suggested cardiotoxicity.⁶⁴⁷

Vitamin C supplementation is therefore recommended only for patients not affected by cardiomyopathy, with unsatisfactory iron excretion and demonstrated ascorbate deficiency. When necessary, 50 mg per day of ascorbate in children up to 10 years and 100 mg per day thereafter should be sufficient. Vitamin C should be given when DFO infusion is already under way. Alfatocopherol, a lipid-soluble antioxidant, is able to interrupt the membrane lipid peroxidation process. Supplementation with Vitamin E is therefore often suggested, but data demonstrating its efficacy are lacking. Folic acid deficiency was reported in early studies from Thailand.⁶⁴⁸ Folate supplementation is advised for patients with a hyperactive bone marrow, like those with thalassemia intermedia, and during pregnancy. Zinc has been found to be low in patients with thalassemia major. Nevertheless, these patients have a normal zinc binding capacity, which is generally increased in nutritional zinc deficiency.^{649, 650} Zinc supplementation can become necessary when desferrioxamine and deferiprone are given in combination.⁶¹⁵

Splenectomy

Splenectomy, associated with sporadic blood transfusions, has for many years represented the mainstay of therapy in thalassemia. It was often performed shortly after diagnosis because the spleen soon reached an enormous size and caused severe hypersplenism, frequently leading to profound neutropenia and thrombocytopenia. A cooperative observational study involving 872 regularly transfused thalassemia patients born between 1960 and 1999 found that, overall, 67% of the patients had not been splenectomized, but the probability of having undergone the procedure was strongly influenced by the date of birth⁶⁵¹ (Fig. 34.18). For patients born in 1960 and in 1980 the probability of being splenectomized was 57% and 7%, respectively. No patient younger than 5 years was splenectomized after 1987. This trend toward a delay in spleen removal is likely due to the improvement in global management of thalassemia, and may represent an important protection against the risks associated with the splenectomy, e.g., infections, thromboembolic complications, and pulmonary hypertension (see below). Rational criteria for splenectomy were first indicated by Modell.⁶⁵² She suggested that surgery should be performed when blood consumption increased over 50% above the average consumption of the splenectomized population—in practice, when more than 200 to 250 ml/kg/year of pure red cells are required to maintain a pre-transfusional Hb of 9 to 9.5 g/dl. Splenectomy reduces the transfusion requirement to approximately 150 ml/kg/year, with some variation from patient to patient, and the effect has been demonstrated to be long-lasting.⁶⁵³

Attempts at recognizing the appropriate time for splenectomy by the study of Tc-99 sulfur colloid or Tc-99 red blood cell uptake have not proven of great practical use. Cytopenias and physical encumbrances remain strong indications. Risks associated with splenectomy include an increased susceptibility to infections with encapsulated bacteria and an increase in thromboembolic events. Laparoscopic splenectomy, when possible, avoids the disfiguring scar created by laparotomy, reduces the hospital stay, and, in the end, does not seem to have a higher financial cost.⁶⁵⁴ However, the large size of the spleen when splenectomy is considered

P.893

necessary, makes laparoscopic surgery difficult. In addition, the risk of thrombosis of the portal vein seems to be higher.^{655, 656}

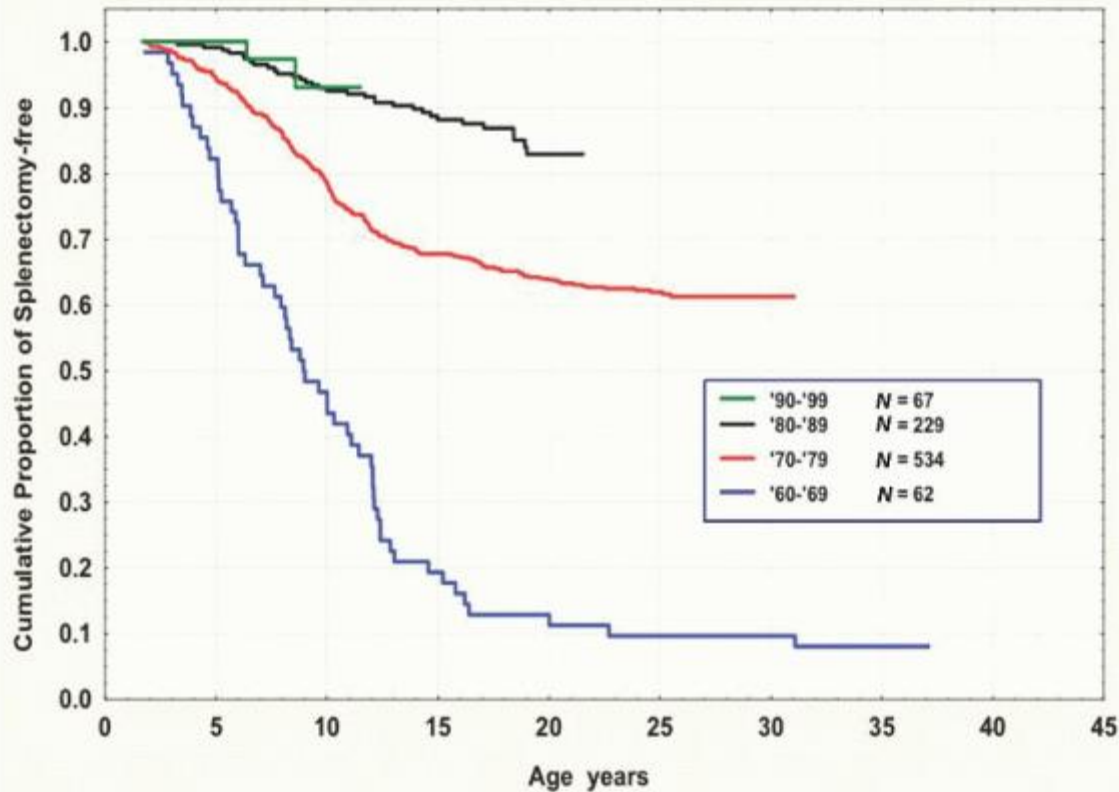

FIGURE 34.18. Cumulative proportion of splenectomy-free survival in different birth cohorts (1960-1969, 1970-1979, 1980-1989, and 1990-1999). During the period of observation, 284 patients (32.6%) were splenectomized, whereas 588 patients (67.4%) still had their spleen in at the end of the study ($P < 0.0001$).

The problem of postsplenectomy sepsis with encapsulated organisms has been recognized for many years.^{657, 658, 659} These infections are often abrupt in onset and rapidly fatal. The clinical spectrum of serious bacterial postsplenectomy infections among patients with hemoglobinopathies includes sepsis (the most common and severe complication), bacteremia, pneumonia, skin and liver abscesses, and urinary tract infections.^{424, 660} Overwhelming postsplenectomy sepsis (OPSI) results from the removal of a major site of antibody production (in particular the splenic marginal zone) and, possibly, the long-term decrease of T cell subsets of functional relevance for primary immune responses. Splenic macrophages are critical in clearing opsonized encapsulated bacteria and intraerythrocytic parasites such as those causing malaria and babesiosis, which explains the fulminant nature of these infections in persons with anatomic or functional asplenia.^{661, 662, 663, 664}

The most frequently responsible bacteria are *Streptococcus pneumoniae*, *Hemophilus influenzae*, and *Neisseria meningitidis*, but cases have been reported in which *E. coli* and *Staphylococcus aureus* were the causative agents.⁶⁶⁵ A recent study from Israel reported that 35% of splenectomized patients with hemoglobinopathies, despite being vaccinated against *Streptococcus pneumoniae* and on prophylactic penicillin, developed serious infections, two of which were fatal. The most common germ involved was *E. coli*, followed by *Streptococcus pneumoniae* and *Campylobacter*.⁴²⁴

Klebsiella appears to be an increasingly common cause of infection, particularly in Asia.^{666, 667}

Capnocytophaga canimorsus, a Gram-negative rod, present as a commensal organism in the saliva of cats and dogs, has also caused severe infections in asplenic and splenectomized individuals.⁶⁶⁸

The risk of severe infections is greatest in younger children and in the first years after splenectomy, but it never disappears. It has been suggested that thalassemia patients are exposed to a higher risk than other non-immunodeficient patients splenectomized for different causes.⁶⁶⁹ From a review of the literature, Singer found that 25% of patients undergoing splenectomy for thalassemia developed postsplenectomy sepsis.⁶⁷⁰ Later, however, in Thai patients, the

frequency was found to be 4%, but the mortality associated was 89%. Guidelines for the prevention of postsplenectomy infections were published by the British Committee for Standards in Haematology in 1996 and updated in 2011.⁶⁷¹

The guidelines recommend antibiotic prophylaxis with penicillin, amoxicillin, or erythromycin for the first 2 years after surgery, and for children until age 16 years. Compliance with penicillin prophylaxis can be a problem and requires continuous reinforcement.^{672, 673} Polysaccharidic antipneumococcal immunization (PPSV23) should be given 2 weeks before the procedure, or whenever possible after it. Re-immunization of asplenic patients is currently recommended every 5 years. According to these guidelines, for older children and adults who may or may not have received previous pneumococcal conjugate vaccine (PCV), there is insufficient evidence to recommend a change in policy from PPSV to PCV either for primary immunization or for boosting. On the contrary, the American Academy of Pediatrics recommends that children 6 through 18 years of age who are at increased risk of invasive pneumococcal disease because of anatomic or functional asplenia, should receive a single dose of the recently developed, 13 valent conjugated antipneumococcal vaccine regardless of whether they have previously received the seven valent conjugated vaccine or PPSV23.⁶⁷⁴

The efficacy of antipneumococcal immunization in conjunction with early antibiotic therapy has been demonstrated in children, but infection by serotypes not included in the vaccine or poorly immunogenic has been reported.⁶⁷⁵

Immunization against *Haemophilus influenzae* is also recommended.⁶⁷⁶ Previous recommendations did not include meningococcal vaccination, but the revised guidelines recommend meningococcal four-valent conjugated vaccine against serogroups A, C, Y e W135 for unimmunized patients. Patients should also be offered annual influenza vaccination. The risk, already increased, of thrombotic events, can be exacerbated by splenectomy.³⁵³

Thrombocytosis, due at least in part to the presence in the circulation of platelets previously marginated in the spleen, develops in 75% of the splenectomized patients, and in 15% it reaches 1,000,000/mm³ or more, peaking between 8 days and 4 months after surgery.^{677, 678} A correlation between splenectomy and pulmonary hypertension has been suggested on the basis of the high prevalence of asplenia found among patients with unexplained pulmonary hypertension, and confirmed by case series reports.⁶⁷⁹ Recurrent lung thromboembolism could be responsible for the phenomenon.⁶⁸⁰

In the attempt to avoid the above mentioned complications of surgical splenectomy, several alternatives have been proposed, with mixed results. Partial splenectomy and partial dearterialization of the spleen have been reported to have an immediate beneficial effect, but of short duration.⁶⁸¹ Partial embolization of the spleen has been successfully performed with long-lasting results, but it has sometimes led to complications.^{682, 683} It has the advantage of not requiring general anesthesia and not leaving a scar. The procedure is followed by severe pain lasting a few days and requiring spinal anesthesia. The theory that a residual portion of spleen protects the patient from infections and thrombotic events is tempting, but still unproven. It has been hypothesized that the spleen could represent a reservoir for the transfused iron and that splenectomy would, therefore, expose the patient to the risk of more massive siderosis of the liver.⁶⁸⁴ However, the iron content of the spleen at splenectomy is low, amounting to no more than one-fifth to one-tenth of the liver iron content.⁶⁸⁵ As demonstrated by modern MRI techniques, splenic iron content plateaus at 1 to 1.5 g, even as hepatic content continues to grow.⁶⁸⁶ In addition, no difference has been observed, in terms of liver fibrosis, between splenectomized and non-splenectomized patients.⁶⁸⁷

Prognosis with Conventional Therapy

The improved survival of patients with thalassemia major has been reported in several countries and has been attributed to better transfusion therapy, more adequate chelation, the availability of magnetic resonance for the evaluation of cardiac iron overload, and the referral of patients to centers of excellence. Between 1949 and 1957, in Ferrara, only 9% of the patients reached age 6 years, and at the end of the 1970s half of the Italian patients had already died at age 12. A review of the fate of patients followed between 1960 and 1976 at Cornell Medical Center reported a median survival of 17.1 years for patients transfused at low hemoglobin level and not chelated, while for hypertransfused and well-chelated ones, median survival was 31 years. Today, at least in developed countries, most patients will reach the age of employment and marriage.^{688, 689}

A large cooperative Italian study, including 977 uniformly treated patients, demonstrated significantly better survival for patients born in more recent years and for females (Fig. 34.19), but mortality remains increased compared to the general population. In 2010, 68% of the patients were alive at the age of 35 years, with 67% of the deaths being due to heart disease. Infections represented the second cause of death, being responsible for 15% of the deaths, followed by liver disease and thromboembolic events, both at 4%. Similar data are reported from most world centers. In a report of 1,044 Greek patients, the overall survival at the age of 50 years was 65%. The standardized mortality ratio compared to the general population improved significantly from 28.9 in 1990-1999, to 13.5 in 2000-2008, while the standardized cardiac mortality ratio decreased from 323 to 107, respectively.⁶⁹⁰

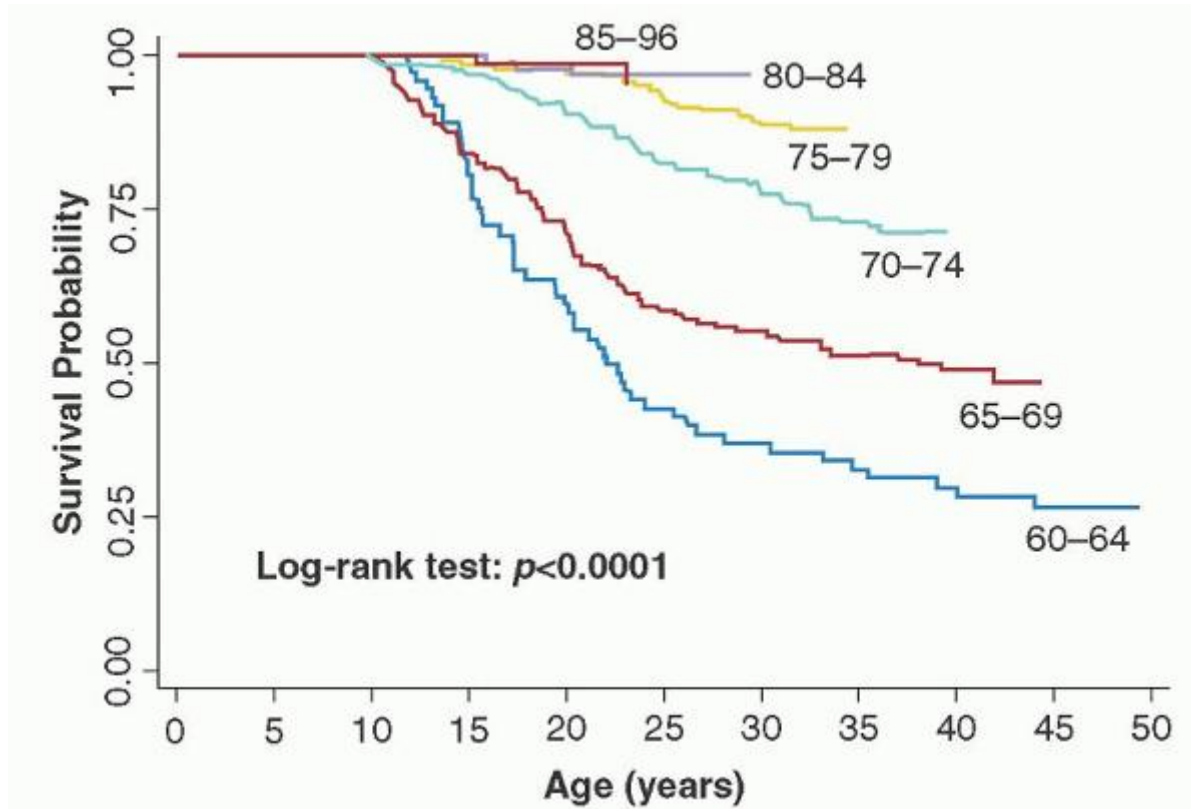

FIGURE 34.19. Kaplan-Meier survival curve after the first decade of life, subdivided by cohort of birth of patients from an Italian cooperative study. The survival data were collected in 2009. The role of the cohort of birth is evident.

The importance of good chelation in improving life expectancy has been repeatedly demonstrated. In fact, lower ferritin levels are associated with a lower probability of heart failure and with prolonged survival, using a cut-off as low as 1,000 ng/ml.⁴⁴⁴ Both in the Italian and in the Greek series, birth cohort had a significant effect on survival ($P < 0.001$). In Cyprus, where mortality of thalassemia patients had been high, a marked improvement in survival was noted for patients of all ages since 2000,⁴⁷⁹ an observation also made in the United Kingdom^{476, 482} and in Italy (Fig. 34.20). The use of MRI and the introduction of oral iron chelation have produced significant improvement in terms of reduction of iron overload among US patients.⁶⁹¹

Complications remain frequent and for the most part are due to the oxidative damage mediated by labile iron. Surveillance, prophylaxis, and prompt treatment of infection remain essential, and chronic hepatitis should be managed with the best available current therapies.

With extended survival, new complications are appearing that will change the classical picture of thalassemia and will require new therapeutic approaches.

Several studies investigating the effects of thalassemia on psychosocial adjustment have given contradictory results. According to a survey from Greece, 42% of the patients examined had psychiatric problems, while other authors demonstrated that thalassaemic adults have normal psychological development and better social adjustment and self-esteem than their normal peers.^{692, 693} A study from the Thalassemia Clinical Research Network, comparing health-related quality of life of 264 patients with thalassemia over age 14 to US normals, found that patients reported a statistically significant worse quality of life on five of the eight subscales (physical functioning, role-physical, general health, social functioning, and role-emotional). Women, older patients, and those with more disease complications and side effects from chelation fared worse.⁶⁹⁴ Cultural and economic variables probably influence the acceptance of the chronic problems of thalassemia.⁶⁹⁵ Psychological support seems appropriate as an adjunct in treatment. However, no randomized controlled trials assessing the effectiveness of specific psychological interventions have so far been performed.⁶⁹⁶

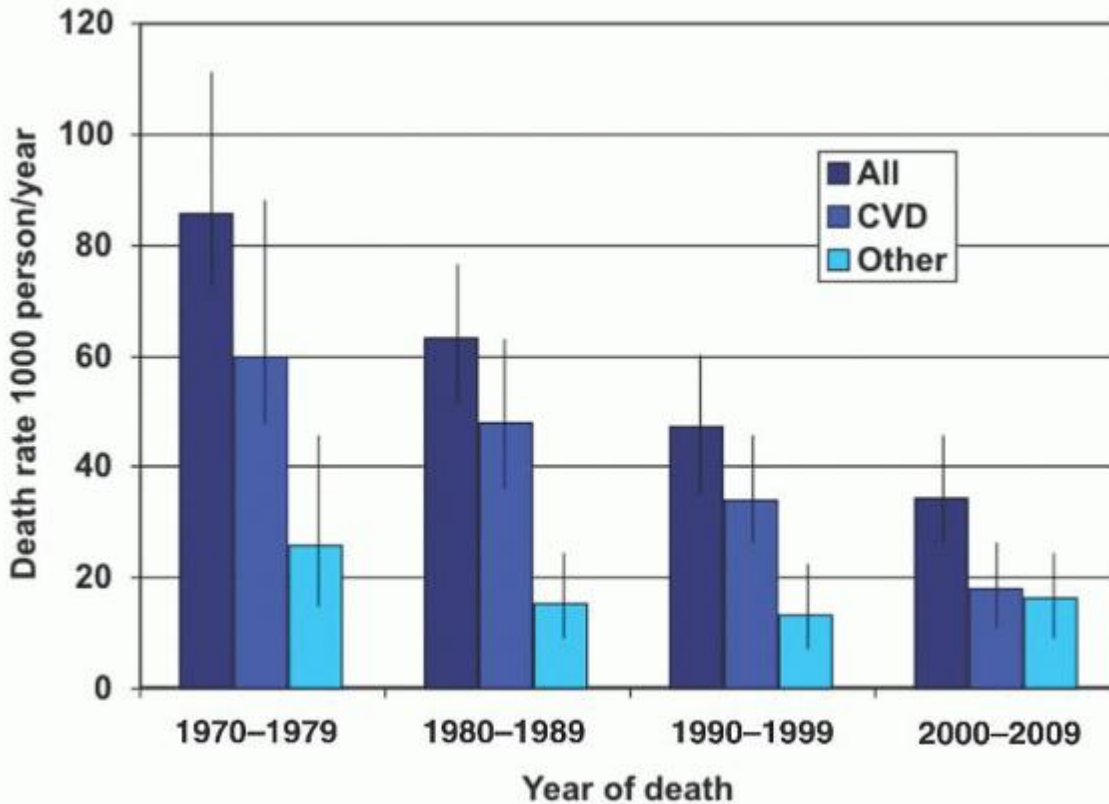

FIGURE 34.20. Decrease in death rate in a multitransfused population of Italian thalassemia patients by year at death. Death constantly decreased, because of the decrease of cardiac causes. (Data collected in 2009 as part of the 7 Centers Study.)

A recent survey of the education and employment status of patients with thalassemia in the United States and Canada revealed that 70% of adults were employed, of whom 67% reported working full-time. Sixty percent had a college degree and 14% had achieved some post-college education. Eighty-two percent of school age children were at expected grade level. Neither transfusion nor chelation was associated with lower employment or educational achievement.⁶⁹⁷

In this chapter we have described the course and therapy of thalassemia major as we see it now in developed countries with adequate economic and health resources. However, the disease is widely diffused in countries where sanitary problems are enormous and the resources required for the management of thalassemia are not available. In third world countries, many thalassemia patients are rarely, if ever, transfused and chelated. Their survival is therefore severely limited and their quality of life poor.⁶⁹⁸

Some countries have adopted a genetic control program according to WHO recommendations, while the poorest and least developed countries have not yet acknowledged the magnitude of the problem.^{699, 700}

There are countries in Asia, where South-South partnerships are being created to link centers with expertise to centers where competence and expertise need to be developed.⁷⁰¹

Stem Cell Transplantation

Hematopoietic stem cell transplantation (HSCT) is an accepted approach to the treatment of thalassemia major, and so far the only curative one. The first bone marrow transplant for thalassemia was performed in Seattle in 1981.⁷⁰²

Thousands of patients have since received transplants worldwide. The vast majority were affected by thalassemia major, while a few had thalassemia intermedia, HbE/ β -thalassemia, or HbH disease. The largest experience has been recorded in Italy by Lucarelli and his group, who, on the basis of their experience, suggested that patients be classified into three levels of transplantation risk, based on the presence or absence of portal fibrosis, hepatomegaly, and regular chelation.^{703, 704} The lowest risk is present in patients regularly chelated and without liver fibrosis or hepatomegaly. Patients poorly chelated, with hepatomegaly and portal fibrosis, have the highest risk, while the intermediate risk group includes patients with one or two risk factors. The ideal donor is an HLA-identical donor. At present the prognosis for HSCT from an HLA-

matched sibling donor is excellent. A recent review by the European Bone Marrow Transplantation Group of 1,061 thalassemia patients of a median age of 7 years, from 28 countries, reported overall survival and thalassemia-free survival of 91% and 83%, respectively. The age threshold for better results was 14 years. In a multicenter study reporting on 179 young thalassemia major patients, 7 years was found to be the age

P.895

above which mortality risk was higher.⁷⁰⁵ In adult patients, transplant-related mortality remains elevated. Lucarelli and his group transplanted 107 adult patients with a probability of survival, event-free survival, nonrejection mortality, and rejection of 66%, 62%, 37%, and 4%, respectively, with a median follow-up of 12 years.⁷⁰⁶ A second group of 15 patients with a median age of 21 years was treated with a reduced-dose intensity-conditioning regimen that produced some improvement in thalassemia-free survival (67%) and lower, but still elevated, transplant-related mortality (27%). In addition, the risk of developing chronic GVHD remained high.⁷⁰⁷

Alternative Donors

An HLA-compatible sibling is available for only 25% to 30% of thalassemia patients. Therefore, alternative donors have been used as a source of hematopoietic cells. HLA-identical relatives can be found in families coming from small ethnic communities or where inbreeding is common. A higher risk of rejection mortality, infection, and GVHD was reported in eight patients transplanted from an HLA-identical parent.⁷⁰⁸ While HSCT from HLA mismatched family members has given disappointing results, matched unrelated donors can be considered a viable alternative when a matched sibling is not available. In fact, approximately 30% of Caucasian patients with thalassemia major who started the search found a suitable donor in one of the international hematopoietic stem cell donor registries that now include more than 18 million volunteers worldwide. Initially, these HSCTs were aggravated by high risk of death and GvHD, but more precise characterization of HLA alleles using stringent criteria of compatibility with the recipient (i.e., identity or single allelic disparity for HLA-A, B, C, DRB1, and DQB1 loci) and high-resolution molecular typing for both class I and class II loci can reduce the risk of immune-mediated complications and fatal events.⁷⁰⁹ The probability of cure after HSCT was about 85% for children belonging to classes I and II of the Pesaro classification, and 65% for children belonging to class III and for adults.

Additional genetic characteristics have been reported to be of prognostic value in choosing the potential donor more accurately.⁷¹⁰

Conditioning Regimen

The bone marrow of thalassemia patients is hypercellular. The ideal conditioning regimen should therefore be capable of eradicating the thalassemic marrow and be sufficiently immunosuppressive to permit sustained engraftment. For many years after inception of HSCT for thalassemia, the preparatory regimen included IV dimethyl busulfan or oral busulfan at the dose of 14 mg/kg plus 120 to 200 mg/kg of cyclophosphamide. More recently, the introduction of conditioning regimens including intravenous busulfan or treosulfan associated with thiotepa and fludarabine has improved results. In a study of 60 thalassemia patients (median age 7 years, range 1 to 37) who underwent allogeneic HSCT, a conditioning regimen combining thiotepa/treosulfan/fludarabine proved to be safe and effective. Neither the class of risk nor the donor used influenced outcome.⁷¹¹

Reduced-intensity preparative regimens have resulted in minimal toxicity, but in a high percentage of incomplete engraftment and graft rejection, confirming the need for a myeloablative regimen.⁷¹²

GVHD prophylaxis consisting in cyclosporine and short course methotrexate is effective in preventing acute and chronic GvHD. Antithymocyte globulin is often added to reinforce immunosuppression, in particular for transplants from unrelated donors or when an HLA disparity is present.

Rejection can appear in different patterns.⁷¹³ The patients can have no take, develop aplasia, or, more often, have autologous reconstitution of the thalassemic marrow after engraftment. The most common transplant-related cause of death is infection, especially in patients who remain aplastic after graft rejection. A few splenectomized patients have died, after transplant, of overwhelming sepsis.

Persistent mixed chimerism was observed, over a period of time varying between 2 and 11 years after BMT, in 11% of patients transplanted for thalassemia.^{714, 715} Despite the presence of large numbers of residual host cells, these patients no longer required red blood cell transfusions, producing levels of Hb A ranging from 8.3 to 14.7 g/dl. The mechanisms underlying this apparent state of immunologic tolerance or education are not clear. However, these observations may be useful in defining optimal strategies for gene therapy and in utero hematopoietic stem cell transplantation.

Cord Blood Transplantation

Umbilical cord blood has rapidly become a valuable alternative stem cell source for allogeneic HSCT. In thalassemia patients, related cord blood transplantation appears to have a probability of success comparable to that offered by bone marrow transplantation; and, in addition to avoiding general anesthesia to the donor, it is associated with lower risks of transplant-related mortality, chronic GVHD, and transmission of viral infections. A large, ongoing international study, retrospectively comparing cord blood to bone marrow recipients, (Locatelli, personal communication) has revealed overall survival and thalassemia-free survival to be very similar in the two groups, in the order of 95% and 88%, respectively, while acute and chronic GVHD were almost double in bone marrow recipients (20% and 12% vs 10%, and 5% for cord blood recipients). The mean age in the two groups were similar, 8 vs. 6 years, and almost all patients belonged to good-risk classes. The main disadvantage of cord blood is represented by the longer time necessary to reach safe platelet and neutrophil counts. Studies have shown that the number of nucleated cells infused is the most significant predictor of success.^{716, 717}

These results support targeted efforts to bank family cord blood units that can be used for a sibling diagnosed with thalassemia or other diseases which can be cured by allogeneic hematopoietic stem cell transplantation.⁷¹⁸

Umbilical Cord Blood Transplantation

Umbilical cord blood is less restricted with regards to HLA matching, so that a mismatch at 1 or 2 loci is usually tolerated without a significant increase in GVHD or impaired survival.

The use of unrelated cord blood as a source of stem cells for thalassemia patients has not been explored in well-designed clinical trials. In a recent report of 35 unrelated transplants, the 5-year overall survival and thalassemia-free survival were 88% and 74%, respectively. However, 40% of the patients developed chronic skin GVHD.⁷¹⁹

Other reports have been less favorable,⁷²⁰ suggesting that unrelated cord blood transplantation in thalassemia is still an experimental, high-risk approach.

Peripheral blood stem cell transplantation has been tried in patients with thalassemia.^{705, 721} The results showed that major outcomes obtained with this source of hematopoietic cells are not statistically different from those obtained with bone marrow in terms of rejection and disease-free survival. However, an increased risk of chronic graft-versus-host disease was observed.

Side Effects of Stem Cell Transplantation

Chronic Graft-versus-Host Disease. Chronic graft-versus-host disease (cGVHD) a multiorgan disorder with features of an autoimmune disease, is particularly feared when transplanting patients, such as those with thalassemia, who undergo transplantation more to improve their quality of life than to avoid an impending risk of death. In an historic series the incidence of cGVHD was 27%.⁷²² Among Middle Eastern patients transplanted in Italy, the incidence

P.896

of chronic GVHD was 18%.⁷²³ In a group of patients treated with reduced-toxicity conditioning regimen, only one out of 56 patients at risk developed chronic GVHD.⁷¹¹ The risk of GVHD is lower after cord blood transplantation. After grafting from an unrelated donor chosen according to stringent criteria of HLA-compatibility, the risk of GVHD is not higher.⁷²⁴

Growth, Development, and Fertility. Short stature is present in a significant percentage of children transplanted for thalassemia. There appears to be a strict correlation between age at the time of transplant and final adult height. In a study, the patients whose age at transplant was <7 years reached their genetic target for height, while those who were >7 years did not.⁷²⁵ This is in contrast with most studies in children transplanted for hematologic malignancies that have demonstrated that the younger the patient was at the time of HSCT, the greater the loss in height. Probably the deleterious effects on growth of iron and desferrioxamine, at an early age, are even more profound than the effects of pretransplant conditioning.⁷²⁶ Results on pubertal maturation remain unsatisfactory after HSCT. In a series of 50 prepubertal patients with thalassemia major, who had been transplanted during childhood or in the peripubertal period, clinical and hormonal evidence of gonadal dysfunction was found, and normal puberty developed in only 40% of patients. There was no correlation between pubertal maturation and age at HSCT or serum ferritin levels.⁷²⁷ Sterility from pretransplant conditioning is also considered a possible side effect of the procedure. In fact, the myeloablative conditioning regimen including busulfan and cyclophosphamide may induce gonadal dysfunction in males and females, especially when high doses of busulfan are used. Nevertheless, a few successful cases of spontaneous pregnancy and paternity have been reported in patients transplanted for thalassemia.⁷²⁸

Counseling is mandatory, as artificial reproductive techniques are available.⁷²⁹ In postpubertal male patients, sperm can be stored, while for prepubertal males, immature testicular tissue cryopreservation is still an experimental procedure.⁷³⁰

Cryopreservation of ovary tissue collected before transplantation is feasible and can maintain fertility even after a long period of time. Several pregnancies have been recorded following autologous reimplantation of frozen ovarian tissue harvested after puberty.⁷³¹

Malignancies. A few solid tumors and several cases of early and late non-Hodgkin lymphoma have been observed in patients transplanted for thalassemia. The overall frequency has been calculated to be less than 7/100,000 per year.⁷³²,
⁷³³ ⁷³⁴

Regular screening for oral squamous cell carcinoma should be performed in patients experiencing chronic graft-versus-host disease secondary to HSCT, as malignant lesions of the buccal mucosa can appear decades after the transplant.⁷³⁵

Iron Depletion

The hemochromatosis present at the time of grafting will not disappear after transplantation without some kind of intervention. After HSCT, ferritin increases, reaching a peak around the third month after the procedure, probably as a consequence of bone marrow aplasia and shifting of iron to the storage compartment.

The conditioning regimen can contribute to the increase in NTBI levels. In one study, NTBI peaked as early as 4 days prior to transplantation, and was detectable for 6 to 18 days in all patients.⁷³⁶

Normally, endogenous antioxidants play a role in scavenging toxic free radicals and preventing cell damage.⁷³⁷ However, in patients undergoing HSCT, chemotherapy-based conditioning regimens can result in a pro-oxidant status, as indicated by a reduced total radical antioxidant parameter of plasma.⁷³⁸ ⁷³⁹

After transplant, ferritin usually returns to pretransplant levels. In the absence of therapy, the iron content of the body remains stable, potentially for many years. One study demonstrated that ferritin levels normalized only in moderate-to-severely ironoverloaded pediatric patients as a result of the use of storage iron for growth.⁷⁴⁰ The effects of persistent iron overload on the longterm morbidity of HSCT recipients (particularly as it relates to late organ dysfunction) have not been investigated.

Considering the damage that iron induces in non-transplanted thalassemia patients, phlebotomy is indicated for patients with high ferritin levels and/or high parenchymal iron concentration measured before transplant. Bimonthly venesections should be performed starting at least 18 months after grafting. Their effectiveness in reducing ferritin level, median liver iron concentration, and liver enzymes has been repeatedly demonstrated.⁴⁴⁹

Monthly erythrocytaphereses are equally effective. This technique has the advantage of saving plasma and mononucleated cells, but it is more costly and time consuming. Cirrhosis of the liver can be reversed after iron depletion by phlebotomy.⁷⁴¹

In one report deferasirox was used in seven patients transplanted for thalassemia without negative effects on donor chimerism or liver function. Serum ferritin levels decreased while serum creatinine significantly increased, but it remained within normal limits in all patients.⁷⁴²

Deferoxamine can also be used to reduce the iron burden in patients in whom low levels of hemoglobin after transplantation or difficult venous access prevent phlebotomy.⁷⁴³ Chelation with deferoxamine should not be started too soon after transplant, because this chelator has been reported to interfere with grafting. Deferiprone is contraindicated in this setting for its potential toxicity on the myeloid cell line.

Quality of Life after Hematopoietic Stem Cell Transplantation

The long-term prognosis of thalassemia patients who are treated according to modern criteria is satisfactory and continuously improving. Therefore the choice to undergo HCST must be motivated by serious arguments. On one hand, the freedom from transfusion and chelation, and, if the transplant is done early enough, from the consequences of iron overload; on the other, the immediate risks of death and of acute and chronic GVHD and possibly of the long-term effects of toxic conditioning regimens need to be considered.

Not many data are available in this regard. In a report of 28 children with β -thalassemia from Middle Eastern countries who underwent allogeneic HSCT in Italy, child-self and parent-proxy reports were collected to prospectively evaluate health-related quality of life. The study demonstrated that physical functioning declined significantly from the time of transplant to 3 months after it but then increased significantly up to 18 months after the procedure. As expected, chronic GVHD was significantly associated with lower scores.⁷²³

The results of this study, however, collected in poorly treated patients, may not be applicable to a population of patients enjoying adequate conventional therapy.

Hemoglobin F Reactivation

For patients with homozygous β -thalassemia, an increased γ -globin chain production would result in a more balanced α /non- α ratio and an amelioration of the severity of the anemia. In fact, γ -chains can neutralize the harmful excess of α -chains and allow a better survival of erythroid precursors in the bone marrow and of the red cells in the peripheral blood. Effective procedures to enhance red cell production could reduce or even eliminate the need for transfusions and would represent a major advance in the treatment of homozygous β -thalassemia. Toward this aim, many efforts in the last decades have focused on the pharmacologic induction of fetal hemoglobin in patients with hemoglobinopathies. Three different therapeutic classes of

P.897

γ -globin inducers have been investigated, including cytostatic-hypomethylating agents (e.g., hydroxyurea, 5-azacytidine, and decitabine); short-chain fatty acid derivatives, some of which are histone deacetylase inhibitors (e.g., sodium phenylbutyrate, arginine butyrate, and isobutyrate); and recombinant erythropoietin.^{744, 745, 746} These classes of compounds act through complex distinct mechanisms, only partially clarified. Cytostatic-hypomethylating compounds, preferentially killing dividing cells, alter the kinetics of erythropoiesis and induce γ -globin gene hypomethylation. Accelerated erythropoiesis is associated with the emergence of primitive erythroid progenitors, which are more committed to HbF synthesis.⁷⁴⁷ Because heavily methylated genes, as are γ -globin genes in the adult, cannot be transcribed and are therefore effectively silenced, demethylation results in transcriptional activation.⁷⁴⁸ Small clinical trials have been conducted with 5-azacytidine with some apparent clinical benefit, but the carcinogenic risk of the drug has discouraged its use.^{749, 750} Recent clinical trials with a more tolerable deoxycytidine analog, decitabine, have shown a modest but significant increase in total hemoglobin and in absolute fetal hemoglobin.^{751, 752} The largest experience has been reported with hydroxyurea (HU), a potent inhibitor of ribonucleotide reductase that interferes with DNA synthesis and promotes cell death, resulting in perturbation of the kinetics of erythroid differentiation. Several studies suggested that HU may induce HbF synthesis through the guanosine 3',5'-cyclic monophosphate (CGMP) signaling pathway.⁷⁵³ HU has been given in many different regimens and doses, alone or in combination with other drugs, including erythropoietin. In some patients with thalassemia intermedia and HbE/ β -thalassemia, there has been a modest to moderate effect on total hemoglobin concentration and HbF, but not in all patients.^{754, 755, 756} A 13-year experience in a large group of Iranian patients with β -thalassemia showed that HU at a dose of 8 to 15 mg/kg/day was effective in decreasing or determining cessation of the need for regular blood transfusions without any major side effects.⁷⁵⁷ HU has also been used effectively in thalassemia intermedia to reduce the size of extramedullary erythropoietic masses when these compress vital organs or tissues.^{316, 758} Recombinant human erythropoietin (Epo) and the new synthetic form, darbepoetin, with a longer half-life, have been used to stimulate erythropoiesis and promote erythroid cell survival. The results have been modest and variable among the patients.^{759, 760, 761}

The use of compounds that further stimulate erythropoietic expansion is questionable. Combined use of agents that counterbalance their effects (e.g., Epo and HU) may offer a better therapeutic potential.

Butyrate and its analogs, including short-chain fatty acid derivatives, have been used to induce HbF production in hemoglobinopathies, with variable responses.^{762, 763} This class of compounds increases γ -globin gene expression by promoting histone acetylation (through histone deacetylase inhibition), which is associated with transcriptional activation and increased mRNA translation.^{745, 764, 765} Butyrate and other histone deacetylase inhibitors have shown other epigenetic mechanisms, namely, decreased DNA methylation, signaling activation through the soluble guanylate cyclase and p38MAP kinase pathway as well as ERKMAP kinase inhibition (for review, see Ref. 745). Clinical trials with these agents in patients with β -thalassemia have shown a modest effectiveness and a variability in response among patients.^{762, 766, 767, 768, 769} Moreover, the inconveniently frequent administration of high doses makes this treatment intolerable for many patients. In general, the small-scale studies of the induction of fetal hemoglobin in thalassemia major have been unsuccessful, probably because the magnitude of activation of the γ -globin genes is not sufficient to correct the severe chain imbalance characteristic of the disease.⁷⁷⁰ Moreover, there are concerns about the potential for serious side effects from the long-term use of chemotherapeutic agents like 5-azacytidine and HU. Therefore, the use of HbF inducers remains experimental and cannot be recommended outside of clinical trials.

Recent discoveries using new technologies of DNA analysis have further elucidated the mechanism of human fetal hemoglobin regulation.^{771, 772, 773} Physical interactions between the β -LCR and the downstream γ - and β -globin genes with

transcription factors and chromatin-remodeling complexes have been shown to play a role in globin gene switching. These insights might lead to the design of new therapeutic approaches to enhance fetal hemoglobin expression in adult erythroid cells.

Gene Therapy

β -Thalassemias were among the first diseases to be considered for gene therapy. In principle, the tissue to be corrected (i.e., the bone marrow) can be removed, treated, and reinfused into the patient. Moreover, the gene and the molecular lesions responsible for the disease are well known. Therefore, genetically based strategies, aimed to insert a normal copy of the human β -globin gene, along with key regulatory sequences into autologous hematopoietic stem cells (HSCs), represent a feasible alternative to bone marrow transplantation to definitively cure β -thalassemia. However, this approach has been impeded over the last decade by challenging obstacles, including the extremely complex regulation of the globin genes, the isolation and the biology of the optimal target cell (i.e., the pluripotent self-renewing hematopoietic stem cell), a safe and efficient transduction, and a stable and effective transgene expression.

For at least two decades gene transfer vectors based on the Moloney murine leukemia retrovirus (MLV) have been used to transfect HSCs, but the transfection was at a very low rate and the transfused globin genes were unstable and only rarely integrated intact into the genome, thus losing any therapeutic efficacy.^{774, 775} The main problems associated with the use of retroviral vectors for gene therapy include the inability of these vectors to target non-dividing HSCs, the possibility of accommodating only small segments of DNA, and the risk of insertional activation of protooncogenes.

To obtain gene therapy for the hemoglobinopathies, vectors must target HSCs because these are the only cells capable of self-maintenance as well as erythroid differentiation. Because of the complexity of globin gene regulation, relatively large segments of DNA need to be integrated into the genome of gene-transduced target human HSCs, if good levels of globin expression have to be attained. The corrective construct should contain the structural human β -globin gene as well as its promoter and critical elements of the human β -LCR (locus control region). Experience from treating X-linked severe combined immunodeficiency (X-SCID) showed that several patients, cured of their disease, developed leukemia as a result of insertional mutagenesis.⁷⁷⁶

Results from trials performed in Paris and London reported in 5 out of 20 patients with X-SCID treated with specific gene therapy, the occurrence of leukemia, which was associated with oncogene transactivation by the vector's transcriptional control elements.^{776, 777}

To solve these problems, the use of lentiviral vectors was first introduced in the early 2000s.^{778, 779, 780} The major advantages of these vectors were the ability to infect quiescent hematopoietic stem cells at higher rates and to export unspliced the vector RNA from nuclei, thereby ensuring the integrity of the expression cassette. In the year 2000, the group led by Sadelain published the first study in which a murine model of thalassemia intermedia was efficiently cured with a lentiviral globin vector.⁷⁸⁰ Soon after, therapeutic efficacy was demonstrated in a murine model of sickle cell disease,⁷⁸¹ and even in a murine model of thalassemia major.⁷⁸² In the following years different laboratories confirmed and extended these initial results, demonstrating the efficacy of lentiviral gene therapy with xenotransplants of P.898

genetically corrected human thalassemic HSCs into recipient SCID mice.⁷⁸³

After many animal experiments, the first human gene therapy trial for β -thalassemia and sickle cell anemia began in France in 2006.⁷⁸⁴ Two patients with thalassemia were treated. In the first patient, the gene-corrected bone marrow failed to reconstitute and the patient required a rescue with untransduced back-up bone marrow. The second patient had recently been reported to be free of transfusion for more than 3 years of post-gene therapy follow-up, maintaining a hemoglobin level between 9 and 10 g/dl.⁷⁸⁴ However, further analysis of the patient discovered a dominant cell clone with integration site into the HMGA2 gene, a potential oncogene.^{785, 786} The patient continues to be strictly monitored to anticipate a potential evolution into a leukemic state. A more extended follow-up and larger numbers of patients are needed to confirm the initial positive results, as well as to insure that the globin lentiviral vectors are sufficiently safe and offer to thalassemia patients a better option than the traditional transfusion and chelation therapy. In recent years, a new, highly promising technology has been developed that allows derivation of patient-specific embryonic-like stem cells from adult differentiated cells (e.g., skin fibroblast). These reprogrammed cells, produced by transduction with the transcription factors Sox2, Oct3/4, Myc, and Klf4, are called induced pluripotent stem cells (iPS) because they have the ability to differentiate into all embryonic tissues. iPS can be easily obtained and have the great advantage of being expandable in large amounts and indefinitely. Moreover, the possibility of making them amenable to gene correction by homologous recombination renders these cells highly attractive for gene therapy. A proof of principle of this use has

recently been provided by employing iPS to correct a murine model of sickle cell anemia.⁷⁸⁷ The field is very exciting and rapidly developing, and in the near future has the potential to completely revolutionize the field of gene therapy and regenerative medicine. However, some major challenges need to be overcome before iPS can be considered for clinical use, including the improvement of the efficiency with which somatic cells are reprogrammed and the demonstration that genetically engineered iPS have no potential to undergo subsequent malignant transformation.⁷⁸⁸

THALASSEMIA MINOR

Classical Form: Clinical Picture

The classical heterozygous carrier of β -thalassemia is usually asymptomatic, and the diagnosis is made by chance, because of positive family history or during population screening. Several series have been published on the clinical and hematologic features of people with thalassemia minor.^{789, 790} Anemia is mild or absent. In pregnancy, anemia can be more severe than in normal women, and folate supplementation, at the dose of 5 mg daily, is recommended.^{791, 792} Iron absorption is increased, and frank iron overload has been reported. Inappropriate administration of iron has been proposed as a possible cause in some of the patients.⁷⁹³ In addition, it has been observed that the β -thalassemia trait aggravates the clinical picture of hemochromatosis in individuals homozygous for the mutations C282Y and H63D, favoring higher rates of iron accumulation and the possible development of iron-related complications.⁷⁹³ On the other hand, the H63D mutation has been reported to increase iron overload in β -thalassemia carriers.⁷⁹⁴ Iron deficiency anemia occurs less frequently in children heterozygous for β -thalassemia as compared to normal controls, but its clinical expression, at similar levels of iron depletion, is more severe. The hemoglobin nadir at the end of the first trimester of life is also deeper and more prolonged in carriers of the trait.⁷⁹⁵ Serum bilirubin levels present considerable variation. Homozygosity for the mutation typical of Gilbert syndrome is one of the factors determining hyperbilirubinemia in these individuals.⁷⁹⁶ Increased risk of gallstones has also been observed in women with the β -thalassemia trait as compared to controls.⁷⁹⁷ Data from Sicily seem to indicate that heterozygotes for β -thalassemia have a longer life expectancy.⁷⁹⁸ Men have a lower risk of myocardial infarction than the general population.⁷⁹⁹ A partially improved cardiovascular risk profile has been observed in terms of low hematocrit, low-density lipoprotein (LDL) cholesterol, and apo-B in carriers of β -thalassemia.⁸⁰⁰ The LDL lowering effect of the thalassemia trait is evident even in patients with familial hypercholesterolemia.⁸⁰¹

Laboratory Features

The reported mean hemoglobin concentration in affected Italian men and women was 12.7 and 10.9 g/dl, respectively; in Greek men, 13.9 g/dl⁸⁰²; and in Oriental men and women, 12.1 and 10.8 g/dl, respectively.^{790, 791, 793, 803} A slightly lower hemoglobin concentration was noted in Jamaicans with heterozygous β^0 -thalassemia (11.3 g/dl) compared with those having heterozygous β^+ -thalassemia (12.5 g/dl).⁸⁰⁴ Hemoglobin is less markedly decreased in Africans than in Mediterraneans.⁸⁰⁵ The red cell count is elevated, and the MCV and MCH values are reduced. The mean cell hemoglobin concentration (MCHC) is normal or only slightly decreased. In one series of 244 cases of β^0 -thalassemia carriers, the MCV was 67 ± 4.6 fl (mean \pm 1 SD), the MCH was 22.4 ± 1.6 pg, and the MCHC was 32.9 ± 0.8 g/dl red blood cells.⁷⁹¹ The degree of reduction in the MCV is directly related to the degree of reduction in β -globin production.⁸⁰⁶ The MCVs produced by β^0 mutations are lower than those produced by β^+ mutations.⁸⁰⁷ Heterozygotes for mild β -thalassemia mutations, as a group, have higher MCV and MCH as compared to the severe β^0 and β^+ alleles. Microcytosis and hypochromia, associated with variation in size and shape of the erythrocytes, are commonly observed in the peripheral blood smear. Basophilic stippling is frequently found in heterozygous individuals from the Mediterranean, but not in Africans or Orientals.^{808, 809} Reticulocytes are generally increased to twice the normal numbers and have been found to correlate with the hemoglobin level.⁷⁹³ In children, the MCV is lower than in adults and normally increases with age; in thalassemia carriers, the correlation with age is less evident.⁸¹⁰ The evolution of hematologic parameters in children at various ages is reported in Table 34.4.⁸¹¹ Free erythrocyte protoporphyrin is normal or slightly increased. Osmotic fragility is decreased. Red cell survival, measured by ⁵¹Cr, shows mild ineffective erythropoiesis,

P.899

rather than peripheral hemolysis.⁸¹² HbA2 is constantly elevated in heterozygous carriers of β -thalassemia in all the ethnic groups studied. The values range from 3.5% to 7% with a mean of 5%.¹⁵ This increase appears to be determined by an increased output of δ -chains from both loci, in cis and in trans, to the thalassemia gene. HbF is increased in half of the patients, but the values observed are generally in the range of 1% to 3%. The distribution within the red cells is usually heterogeneous.^{813, 814} A minority of carriers show unusually high levels of HbA2 (>6.5%) associated with a variable increase of HbF. The molecular basis of these forms is large deletions of the β -globin gene, which remove its 5' promoter region. Globin chain synthesis analysis in heterozygous β -thalassemia shows variable imbalance correlated to the severity

of the β -globin chain defect.¹⁵ The physiologic decrease of HbF in the first weeks of life is slower in β -thalassemia heterozygotes (Table 34.4).

TABLE 34.4 MAIN HEMATOLOGIC PARAMETERS OF β -THALASSEMIA CARRIERS ACCORDING TO AGE

Age	Hb (g/dl)	MCV (fl)	HbA ₂ (%)	HbF (%)
At birth	18.3 ± 2.3	99 ± 8	0.5 ± 0.2	73.8 ± 10.1
4 mo	10.1 ± 1.1	70 ± 6	3.2 ± 0.7	27.0 ± 10.5
7 mo	10.5 ± 0.8	59 ± 4	4.8 ± 0.7	8.2 ± 4.0
9-10 mo	11.1 ± 0.9	59 ± 2	5.1 ± 0.5	4.4 ± 2.1
2 y	11.2 ± 0.9	58 ± 2	4.8 ± 0.4	4.1 ± 2.1
2-6 y	10.7 ± 1.0	61 ± 4	5.3 ± 0.6	nd
6-12 y	11.0 ± 1.0	62 ± 5	5.2 ± 0.6	nd
Adult male	13.3 ± 0.8	67 ± 6	5.0 ± 0.5	1.0 ± 0.5
Adult female	11.8 ± 0.9	66 ± 4	5.0 ± 0.5	0.9 ± 0.6

Hb, hemoglobin; MCV, mean corpuscular volume; nd, not determined.

Atypical Carriers

The typical phenotype of the β -thalassemia trait, essentially characterized by reduced MCV and MCH, and increased HbA₂, may be modified by several genetic and acquired factors, causing problems in carrier identification. The coinheritance of heterozygous β -thalassemia with homozygous α^+ -thalassemia ($-\alpha/-\alpha$) or heterozygous α^0 -thalassemia ($-/\alpha\alpha$) has a substantial effect on MCV and MCH, which increase sometimes up to normal values (Fig. 34.21).⁸¹⁵ However, the HbA₂ in these double heterozygotes remains in the carrier range, thus allowing their identification. Atypical carriers with reduced MCV and MCH and normal or borderline HbA₂ include double heterozygotes for δ - and β -thalassemia and carriers of some mild mutation, such as the -87 C→G, the -29 A→G, and IVS-1-6 T→C (Table 34.5). The differential diagnosis includes iron deficiency and α -thalassemia trait. Specific tests and sometimes family studies allow correct identification (see below).^{699, 816} A third group of atypical β -thalassemia carriers is represented by heterozygotes for very mild or silent β -thalassemia mutations (Table 34.5). As a result of minimal deficiency of β -globin production, these carriers have normal MCV and MCH and normal or borderline HbA₂.^{816, 817} The α - to β -globin chain synthesis ratio is normal or slightly higher than 1, confirming that these mutations cause only a very mild reduction in the expression of the β -globin gene. In this group also, the carriers of the triple α -globin gene arrangement ($\alpha\alpha\alpha/\alpha\alpha$), which for the excess of α -globin chain produced may be considered a very mild β -thalassemia allele, should be included.^{77, 818} Identification of these silent carriers is usually retrospective in parents of patients with mild thalassemia intermedia. An extreme, although rare, instance of complex thalassemia gene combination that may lead to an almost silent phenotype is the coinheritance of α -, δ -, and β -thalassemia.⁸¹⁸ Acquired factors able to modify the typical phenotype of β -thalassemia trait are iron deficiency anemia and folate deficiency. Iron deficiency anemia, when severe, may decrease the high HbA₂ levels typical of heterozygous β -thalassemia, and folate deficiency may increase the MCV up to normal values.⁸¹⁹ When these deficiency anemias are present, other tests, such as DNA analysis to identify the β -globin gene mutation or retesting after correction of the anemia, are warranted to make a correct diagnosis.

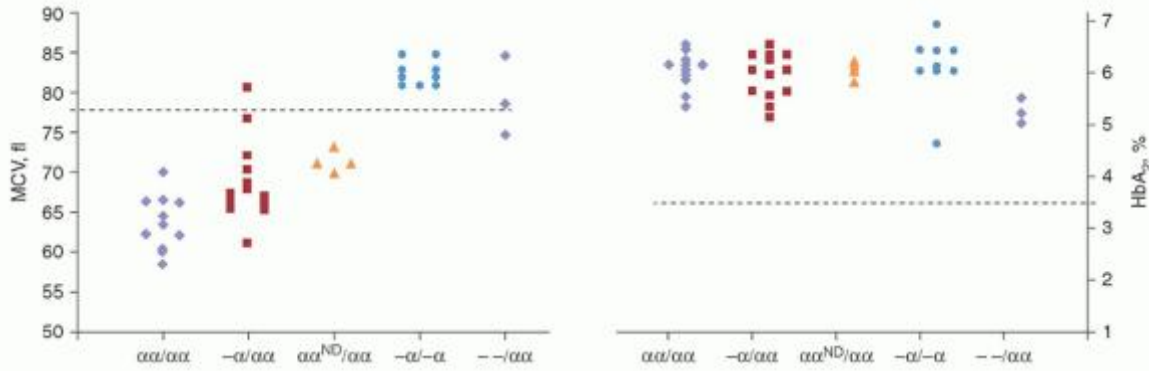

FIGURE 34.21. Effect of coinheriting of different α -thalassemia alleles in β -thalassemia carriers. Hb, hemoglobin; MCV, mean cell volume.

TABLE 34.5 GENOTYPE AND PHENOTYPE OF ATYPICAL β -THALASSEMIA CARRIERS

Phenotype	Genotype
Normal MCV and MCH, high HbA ₂	Coinheriting of α -thalassemia
Reduced MCV and MCH, borderline/normal HbA ₂	Some mild β -thalassemia alleles Coinheriting of δ -thalassemia ϵ - γ - δ - β -thalassemia Corfu δ - β -thalassemia
Normal MCV-MCH, and borderline/normal HbA ₂	Very mild/silent alleles Triplicated α -globin gene KLF1 mutations
Significant clinical phenotype	Coinheriting of α -globin gene defects: triple alpha locus and HbH disease genotype ($-/-\alpha$) Hyperunstable globins

Hb, Hemoglobin; MCH, mean cell hemoglobin; MCV, mean cell volume.

Iron deficiency, diagnosed on the basis of serum ferritin and mild anemia, has been reported to cause mild reduction of HbA₂, hence reducing its reliability for β -thalassemia carrier identification.^{820, 821}

$\delta\beta$ and Hereditary Persistence of Fetal Hemoglobin Carriers

$\delta\beta^0$ -Thalassemia carriers show red blood cell changes milder than those observed in β -thalassemia trait. Overall, MCV and MCH are around 70 fl and 24 pg, respectively. HbA₂ is normal or reduced, and HbF is increased (5% to 20%) and heterogeneously distributed among red cells. The degree of globin chain imbalance is mild (α to non- α ratio around 1.5). Heterozygotes for deletional HPFH are characterized mostly by normal MCV, MCH, and HbA₂. Only in some cases is there a mild reduction of red cell indices and

P.900

HbA₂. HbF ranges from 15% to 30% with pancellular distribution. α -/ n - α -globin synthesis is normal or mildly unbalanced.⁸²² Nondeletional HPFH heterozygotes have red cell indices, HbA₂, and α - to non- α ratios similar to those of deletional HPFH carriers, while mean HbF levels vary from 1.5% to 27%.

Carrier Detection

β -Thalassemia and $\delta\beta$ -Thalassemia

Carrier detection methods should be able to identify typical and atypical heterozygous β -thalassemia as well as $\delta\beta$ -thalassemia and the hemoglobin variants, such as HbS and HbE, which, by interacting with β -thalassemia, may result in

the production of clinically significant syndromes. As compared to most genetic diseases, carrier detection in hemoglobinopathies is relatively easy because it may be achieved through hematologic examination rather than DNA analysis. However, DNA analysis is needed for the identification of globin gene mutation, which is essential for prenatal diagnosis. Basic hematology methods for carrier detection consist of red blood cell indices determination and hemoglobin pattern analysis. More specialized tests (including iron status determination and globin chain synthesis analysis) and eventually DNA analysis are required in some cases for definitive diagnosis.^{384, 386, 823}

The recommended method for blood count is the electronic measurement of red cell indices. All red cell indices are important in the evaluation, but the most useful for thalassemia carrier identification are MCV and MCH, with cut-off values of <78 fl and 27 pg, respectively. Hemoglobin pattern analysis can be obtained in a single step by high-pressure liquid chromatography (HPLC). This method gives an accurate quantitation of HbA₂ and HbF and detects the large majority of Hb variants.^{824, 825} Several automatic devices for hemoglobin separation and quantitation are available, and a comparative study has shown that all provide reliable detection of hemoglobin variants and good HbA₂ quantification.⁸²⁶ Alternatively, cellulose acetate electrophoresis or isoelectric focusing can be used for detecting Hb variants, but quantitation of HbA₂ and HbF should be performed, respectively, by microchromatography and alkali denaturation. Elution of HbA₂ and HbF bands after electrophoresis is an accurate but time-consuming method. Appropriate tests for iron status determination and globin chain synthesis analysis are supplementary hematologic methods useful in carrier detection procedures.⁸²³ Family studies may be helpful in some atypical cases, particularly in genetic compounds for two different alleles. The carrier detection procedure should be designed in order not to miss any carrier or couple at risk. Based on the frequency and heterogeneity of thalassemia types present in a population, appropriate screening programs are set out. The most used flow chart in Mediterranean populations, where thalassemias are common and heterogeneous, is reported in Figure 34.22.¹¹ In addition to MCV and MCH, the first set of tests includes HbA₂ quantitation to avoid missing double heterozygotes for α - and β -thalassemia with normal MCV and MCH. Globin chain synthesis analysis is performed to differentiate α -thalassemia trait from δ -+ β -thalassemia or mild β -thalassemia alleles. With this relatively complex flow chart, only the truly silent β -thalassemia carrier and the triple α -globin gene arrangement may be missed.

P.901

In populations with low frequency of thalassemia the initial screening IVS-1-6 T→C Poly A site AACCCC AATGAA cd, codon; UTR, untranslated region can be performed by the evaluation of red cell indices modification, followed by the hemoglobin pattern analysis to confirm the presence of a thalassaemic allele. The osmotic fragility test, less expensive than MCV and MCH determination, is a simple approach to screening for thalassemia.⁸²⁷ However, this test is sensitive but not specific, is difficult to standardize, and does give false negative results. Several mathematical indices derived from red cell parameters, measured using electronic counters, have been proposed to identify β -thalassemia carriers, discriminating thalassemia trait from iron deficiency (Mentzer, England and Fraser, Shine and Lal). However, these indices turned out to be inaccurate, particularly in pregnant women, in children, and in α -thalassemia- β -thalassemia interaction, predicting the correct diagnosis only in 80% to 90% of the patients.⁸²⁸ Therefore, their use is not appropriate, particularly in populations with a high frequency of β -thalassemia, where missing a carrier may have serious consequences.

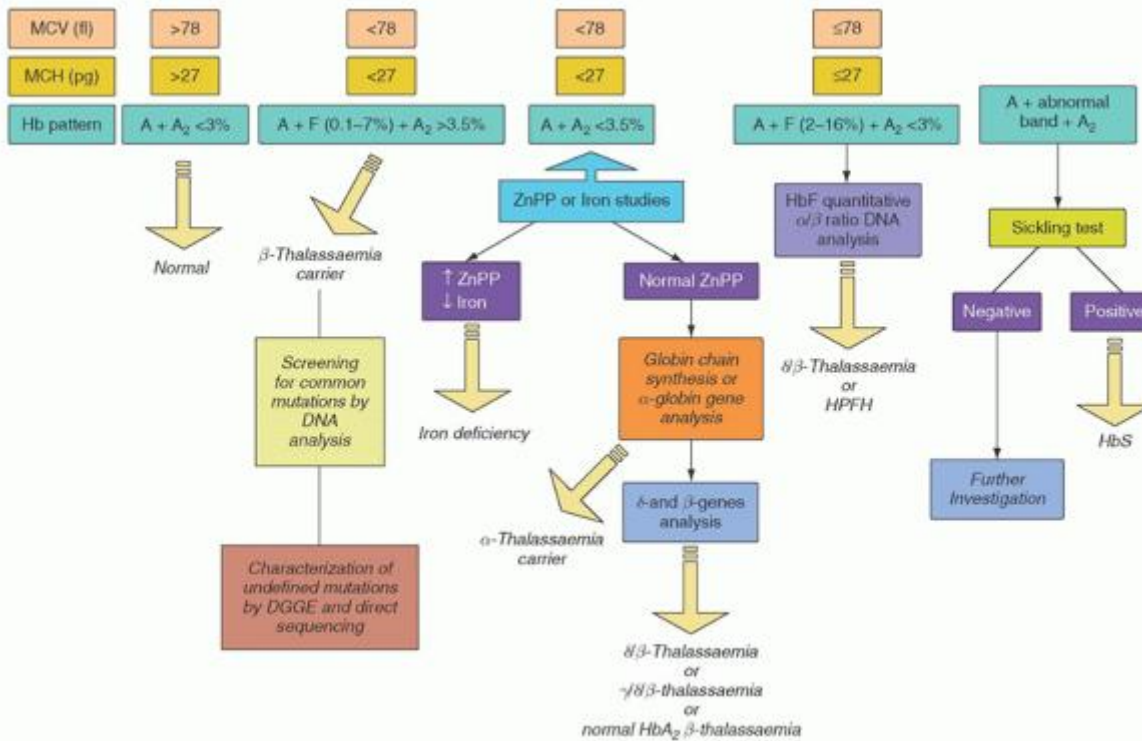

FIGURE 34.22. Flow chart for the diagnosis of thalassemia syndromes. Hb, hemoglobin; HPFH, hereditary persistence of fetal hemoglobin; MCH, mean cell hemoglobin; MCV, mean cell volume; THAL, thalassemia. (Reprinted with permission of Cao A, Congiu R, Sollaino MC, et al. Thalassaemia and glucose-6-phosphate dehydrogenase screening in 13- to 14-year-old students of the Sardinian population: preliminary findings. *Community Genet* 2008;11:121-128.)

Two common problems in screening for β -thalassemia are the presence of borderline HbA₂ values (i.e., HbA₂ = 3.2% to 3.8%) and the differential diagnosis of microcytosis with normal to borderline HbA₂.^{816, 818} Borderline HbA₂ may be associated with low or normal MCV and MCH. Several β -thalassemia genotypes have been associated with borderline HbA₂ including mild β^+ thalassemia mutations (i.e., HBB c.92+6 TC), coinherited δ - and β -thalassemia, and β promoter mutations (i.e., HBB c.-142 CT).⁸²⁹ However, all these determinants explain only a limited proportion of borderline HbA₂ levels, and the unexplained cases pose relevant screening and genetic counseling problems. Recently, mutations of the KLF1 gene have been described in a consistent proportion of subjects with borderline HbA₂, and this facilitates carrier detection and genetic counseling.⁸³⁰ A phenotype characterized by microcytosis, hypochromia, normal or borderline HbA₂, and normal HbF may result from iron deficiency, α -thalassemia, δ + β -thalassemia interaction, mild β -thalassemia, or, very rarely, $\epsilon\gamma\delta\beta$ -thalassemia. After exclusion of iron deficiency by erythrocyte zinc protoporphyrin determination and/or evaluation of transferrin saturation, the different thalassemia determinants leading to this phenotype are discriminated by globin chain synthesis analysis and eventually by α -, δ -, and β -globin gene analysis.

$\delta\beta^0$ -thalassemia carriers and HPFH heterozygotes, both characterized by increased HbF levels, can be clearly differentiated by globin chain synthesis analysis, showing an α /non- α imbalance in the former. Identification of the molecular defect by globin gene DNA analysis may be requested to confirm the diagnosis.

The presence of the Hb Lepore can be suspected in the presence of an abnormal slow Hb band on the electrophoretic pattern associated with reduced MCV, MCH, and HbA₂ and usually a mild increase (~2% to 5%) of HbF. The diagnosis is confirmed by DNA analysis of the β -globin gene cluster. In couples at risk identified by the carrier detection procedures described above, the specific mutation is defined by globin gene DNA analysis using polymerase chain reaction (PCR)-based methods. There are now many different PCR-based techniques that can be used to detect globin gene mutations, including dot blot analysis, reverse dot blot analysis, the amplification refractory mutation system (ARMS), denaturing gradient gel electrophoresis (DGGE), mutagenically separated polymerase chain reaction, gap-PCR, restriction endonuclease (RE) analysis, real-time PCR, Sanger sequencing, pyrosequencing, multiplex ligation-dependent probe amplification (MLPA), and gene array systems.^{831, 832, 833, 834} Each method has advantages and disadvantages and the choice depends not only on the technical expertise of the laboratory, but also on the type and variety of the mutations likely to be encountered in the populations being tested. In fact, despite the marked heterogeneity of thalassemia

mutations, a limited number of molecular defects are prevalent in each population (Table 34.6). This information is very useful in practice because the most appropriate probes or primers can be selected according to the carriers' ethnic origin. It is advisable for any diagnostic laboratory to have at least two alternative methods for detecting mutations.

TABLE 34.6 MOST COMMON SILENT AND MILD β -THALASSEMIA MUTATIONS

Silent

-101 C→T

-92 C→T

IVS-2-2-844 C→G

6'-UTR mutants

3'-UTR mutants

Mild

Transcriptional mutants

Proximal CACCC box

-88 C→T

-87 C→G

TATA box

-30 T→A

-29 A→G

Alternative splicing site

cd 19 A→C

cd 24 T→A

cd 27 G→T

Consensus splicing sequence

IVS-1 -6 T→C

Poly A site

AACCCC

AATGAA

Cd, codon; UTR, untranslated region.

α -Thalassemia

α -Thalassemia carriers are more difficult to identify than β - or $\delta\beta$ -thalassemia carriers because they do not have typical changes in HbA2 or HbF levels. MCV and MCH are always reduced in carriers of $-\alpha/-\alpha$ and $-\alpha/\alpha$ genotypes, while $-\alpha/\alpha$ carriers often have normal or sometimes a mild reduction of MCV and MCH values. The hemoglobin pattern in adult α -thalassemia carriers is normal, although as a group they have slightly lower levels of HbA2. In the newborn the electrophoretic detection of Hb Bart (γ_4), a fast-moving band, is useful for diagnosis of α -thalassemia trait. α^+ -Thalassemia carriers usually show up to 3% of Hb Bart, and α^0 -thalassemia carriers ($-\alpha/\alpha$) and α^+ -thalassemia homozygotes ($-\alpha/-\alpha$) may have 3% to 8%. However, in some carriers Hb Bart may be undetectable.^{244, 246}

A simple test for detecting α -thalassemia carriers is the incubation of the peripheral blood with brilliant cresyl blue; the smear examination may show rare red blood cells with HbH inclusion bodies, although their absence does not exclude α -thalassemia carrier status.²⁴⁶ Globin chain synthesis is used to identify α -thalassemia carriers that show an $\alpha:\beta$ ratio lower than 0.9. This test is helpful in the presence of microcytosis with normal HbA2 to differentiate the α -thalassemia trait from the δ -+ β -thalassemia interaction (see β -Thalassemia Carrier Detection). Definitive diagnosis of α -thalassemia carriers can

also be achieved with DNA analysis of the α -globin genes. The methods used depend upon the type of mutations expected in each population and are divided into those that detect deletions (gap-PCR and sometimes Southern blotting) and those that detect point mutations, that is,

P.902

nondeletion α -thalassemia (direct detection by restriction enzyme analysis, allele-specific oligonucleotide hybridization, DGGE, and DNA sequencing).^{391, 835, 836} The α^0 -thalassemia phenotype can be detected with an anti- ζ globin monoclonal antibody, since small amounts of embryonic ζ globin are produced in adult life by chromosomes lacking both α -globin genes.⁸³⁷ Detection of α^0 -thalassemia carriers is important for prevention of Hb Bart hydrops fetalis syndrome, for which prenatal diagnosis is always indicated, also to avoid the severe toxemic maternal complications during pregnancy. HbH disease is not considered to be among the hemoglobinopathies targeted for prevention.

Hemoglobin E

The diagnosis of heterozygous HbE is based on the hemoglobin pattern analysis by electrophoresis or HPLC separation. At alkaline pH (8.4), HbE moves at the same position as HbA2 and can be distinguished by its high concentration; usually 25% to 30% HbE has the same elution time of HbA2 at HPLC.⁸³⁸ Lower proportions of HbE in carriers indicate the presence of coinheritance α -thalassemia or of iron deficiency anemia. The blue dye dichlorophenolindophenol (DCIP) can be used as a screening test for HbE, which will dissociate and precipitate at the bottom of the tube upon incubation with this dye at 37°C.⁸³⁹

Prenatal Diagnosis

The availability of prenatal diagnosis added a new option to couples at risk for a major hemoglobinopathy, leading to a significant change in the effectiveness of screening and counseling in hemoglobinopathy prevention.⁸⁴⁰ Prenatal diagnosis of both α - and β -thalassemia was carried out for the first time in the 1970s using globin chain synthesis analysis in fetal blood, obtained by fetoscopy or placental aspiration around the 19th week of gestation.⁸⁴¹ The advent of DNA analysis and the introduction of chorionic villus sampling resulted in a notable improvement in prenatal diagnosis that can now be performed within the first trimester of pregnancy, generally at 10 to 12 weeks of gestation.^{842, 843} Fetal DNA can be obtained also from amniocytes at 15 to 17 weeks of pregnancy. Chorionic villus sampling is carried out transcervically or transabdominally and the risk of fetal loss with this procedure has given contrasting results, ranging from 0.5% to 4.5%.^{844, 845} However, in experienced hands, the fetal loss rate appears to be 0.5% to 1%, similar to natural wastage for pregnancies of this duration.⁸⁴⁶ After sampling, fetal DNA analysis is performed by the PCR-based methods. Methods aimed at identifying the mutations are traditionally separated into direct (those designed to interrogate samples for the presence/absence of specific candidate mutations known to be present in the population) or indirect methods (those that screen regions of genes to identify/exclude sequence variation of genes within each gene region (for review see 832)). As a consequence of recent immigrations and the admixture of different ethnic groups, the spectrum of mutations, particularly in western countries, has increased. In this context, more generic methods such as DNA sequencing, are more appropriate. In general, the mutation to be detected in the fetus is first identified in the parents. The results of DNA analysis are very accurate, but misdiagnosis may occur for several reasons (e.g., failure to amplify the target DNA fragment, mispaternity, maternal contamination, and sample exchange). However, the risk of misdiagnosis can be significantly reduced using a number of precautionary measures, such as the fetal DNA analysis for selected polymorphic markers.^{844, 847} The advent of DNA amplification has made it possible to define the genotype of a single cell biopsied from cleaving embryos (preimplantation diagnosis), and to analyze the polar body obtained during the maturation of the oocyte (preconception diagnosis).^{848, 849} These procedures avoid the need to terminate affected pregnancies through identification and transfer only of healthy embryos, established from in vitro fertilization. Successful experiences in many couples with this approach have been reported in hemoglobinopathies.^{850, 851, 852} However, preimplantation genetic diagnosis (PGD) is a technically challenging, intensive procedure, which requires the close collaboration of a team of specialists. PGD is now an established reproductive alternative to prenatal diagnosis, offered in several specialized centers throughout the world (<http://www.eshre.com>).⁸³² PDG requires close collaboration between experts in assisted reproductive techniques and DNA-experienced laboratories. Hemoglobinopathies are the monogenic disease for which PGD has been used more frequently.⁸⁵³ PGD performed in combination with HLA typing for selecting unaffected and histocompatible embryos to facilitate bone marrow transplantation raises relevant bioethical problems. The ultimate success (an unaffected baby suitable as a bone marrow donor), based on genetic combinations, success of implantation, and frequency of delivery rate, is very limited in practice, rarely surpassing about 10% for any cycle.^{854, 855, 856} In the last decades there have been efforts in developing noninvasive methods for prenatal diagnosis, analyzing fetal cells or fetal free DNA present in maternal blood during pregnancy.^{857, 858} The rarity of fetal erythroblasts in the maternal circulation

has limited the practicality of this approach, while the use of fetal DNA holds promise for the noninvasive prenatal diagnosis of various hemoglobinopathies.^{859, 860}

β -thalassemia prevention programs adapted to meet the need of different communities have been implemented in several at-risk countries across the world.⁸⁶¹ These programs are based on education, carrier screening, and genetic counseling associated, in most but not all countries, with prenatal diagnosis. As for the timing, carrier screening can be premarital, preconceptual, or antenatal, each one offering different options to the carrier couples at risk.^{11, 862, 863, 864, 865}

Hemoglobinopathy screening programs are mostly offered on a voluntary basis, but in some countries, including Saudi Arabia and Palestinian territories laws in place make premarital screening mandatory.^{865, 866}

The incidence of thalassemia major has decreased significantly after the introduction of prevention programs in several areas, including Sardinia, Cyprus, Taiwan, Iran, India, and Guangdong (China) (Fig. 34.23).^{271, 863, 867, 868, 869, 870}

THALASSEMIA INTERMEDIA

Genetic Determinants

The remarkable clinical diversity of thalassemia intermedia may be produced by a great variety of genotypes. Thalassemia intermedia most commonly is associated with a homozygous or compound heterozygous state for two β -thalassemia alleles.^{15, 871, 872, 873} However, several patients with this mild clinical picture have only a single β -globin gene affected and are considered heterozygotes for β -thalassemia. It has been clearly established that the severity of the β -thalassemias is related to the degree of globin chain imbalance. Therefore, in homozygous β -thalassemia, any inherited or acquired factor able to reduce the degree of globin imbalance may produce milder clinical forms (Fig. 34.24). On the other hand, in simple β -thalassemia heterozygotes, the worsening of globin chain imbalance may turn the asymptomatic carrier state into a significant clinical phenotype (Table 34.5).

Homozygotes or compound heterozygotes for mild β -thalassemia mutations, characterized by a residual high β -globin chain production, usually have thalassemia intermedia. Examples are the homozygous state for -29 A \rightarrow G in black patients and the IVS-1-6 T \rightarrow C in Mediterranean

P.903

patients.^{114, 874, 875} Compound heterozygotes for a mild and a severe mutation may cover a remarkably broad clinical spectrum of severity.^{227, 815} This variability can be related to the presence of α -thalassemia or of genetic determinants able to increase the γ -chain production.²²⁷ Few homozygotes for silent mutations have been reported (e.g., β CAP + 1 ASC, IVS-2-844 C \rightarrow G); they have the hematologic and clinical characteristics of β -thalassemia trait.^{110, 876} Compound heterozygotes for a silent and a severe mutation usually have a very mild thalassemia intermedia, but exceptions with a severe phenotype have been reported.^{108, 236, 817, 818, 877, 878, 879} Coinheritance of α -thalassemia with homozygous β -thalassemia leads to a reduction in the excess of the α -chain pool and in the imbalance of the globin chain (Fig. 34.24A). Interacting α -thalassemia has been reported in patients with β -thalassemia intermedia from the Mediterranean and Southeast Asia.^{880, 881, 882, 883} However, the ameliorating effect depends both on the type of coinherited α -thalassemia (the presence of two α genes deleted being more effective) and on the severity of the β -thalassemia allele (α -thalassemia being less effective in ameliorating the homozygous β^0 -thalassemia). Genetic determinants maintaining a high γ -chain synthesis after birth result in a reduction of the α /non- α -chain imbalance, thus producing a mild phenotype when coinherited with homozygous severe β -thalassemia. Moreover, a high γ -chain synthesis produces a net increase in total hemoglobin synthesis. Rarely, the increase of γ -chain output depends on the type of thalassemia mutations per se, as it occurs in $\delta\beta$ -thalassemias, caused by deletions of variable extent in the β -globin gene cluster, or in deletions removing the β -globin gene promoter. Most commonly the persistence of HbF production depends on the co-transmission of specific determinants associated with quantitative trait loci linked or unlinked to the β -globin cluster. The most common of these loci is -158 C \rightarrow T G γ promoter substitution, which is in linkage disequilibrium with several β^0 -thalassemia mutations (cd 6 [-A], cd 8 [-AA], IVS-2-1 G \rightarrow A).^{871, 884} This mutation leads to enhanced γ -chain production under conditions of erythropoietic stress and partially compensates for the absence of β -chain synthesis with consequent amelioration of the α /non- α imbalance and of the clinical phenotype. The -158 G γ C \rightarrow T substitution has been

P.904

found occasionally in patients with β^+ IVS-1-6 T \rightarrow C and with the severe β^0 39 C \rightarrow T mutation.⁸⁸⁵ Genetic determinants capable of sustaining a continuous increased production of HbF in adult life and mapping outside the β -globin gene cluster have been identified on chromosome 2p16 (BCL11A gene) and on chromosome 6q23 (HBS1L-MYB intergenic region).^{44, 45}

¹⁵⁹ Several polymorphisms at these loci have been associated with increased HbF levels in patients with different hemoglobinopathies (e.g., β -thalassemia, sickle cell anemia, HbE/ β -thalassemia) belonging to different populations (Sardinians, Chinese, Thais, African-Americans).^{45, 160, 886} Coinheritance of these determinants and α -thalassemia contributes to the amelioration of the phenotype of homozygous β -thalassemia, resulting in a thalassemia intermedia phenotype.^{163, 164} However, in some patients with thalassemia intermedia homozygotes or compound heterozygotes for severe β -thalassemia mutations, even of the β^0 type, the inherited modifying factors able to ameliorate the clinical features are still unknown. Less commonly, the phenotype of thalassemia intermedia has been reported in subjects carrying only one β -globin gene defect. The worsening of the globin chain imbalance which converts the asymptomatic carrier state into a significant clinical phenotype depends on several mechanisms (Fig. 34.24B). Among them, five groups have been defined: (1) the dominantly inherited β -thalassemia mutations (also reported as hyperunstable globins or inclusion body thalassemias);^{887, 888} (2) compound heterozygosity for severe β -thalassemia with both deletion and nondeletion pancellular HPFH; (3) compound heterozygosity for β -thalassemia and some structural β -chain variants (HbD-Los Angeles β 121 GluSer, HbC β 6 Glu→Lys, HbO-Arab β 121 Glu→Lys);⁸⁸⁹ (4) coexistence of somatic deletions of a region of chromosome 11 p15;^{169, 170} and (5) coinheritance of triplicated α -globin gene with excessive α -globin production.^{76, 890, 891} This is the most common group. Recently, cases have also been reported of simple β -thalassemia heterozygosity presenting with an intermediate to severe phenotype because of duplication of the complete α -globin gene cluster, including the upstream regulatory element HS-40, resulting in α -globin gene quadruplication.^{892, 893} However, it should be pointed out that several patients, heterozygotes for β -thalassemia with the typical thalassemia intermedia clinical picture, have been reported in whom extensive analysis of β - and α -globin gene cluster and family studies fail to identify any other associated molecular defect.^{894, 895} Recently, a new protein has been identified that binds to α -globin, preventing its precipitation.¹⁸⁷ This protein belongs to the group of molecular chaperones and is referred to as AHSP. Transgenic mice, lacking functional AHSP, showed red blood cell changes consistent with damage caused by excess α -chains. Unexplained cases of thalassemia intermedia in β -thalassemia heterozygotes might result from mutations in AHSP that would cause the α -chain excess to be more detrimental.⁸⁹⁶ However, few and discordant results have been reported.^{892, 893}

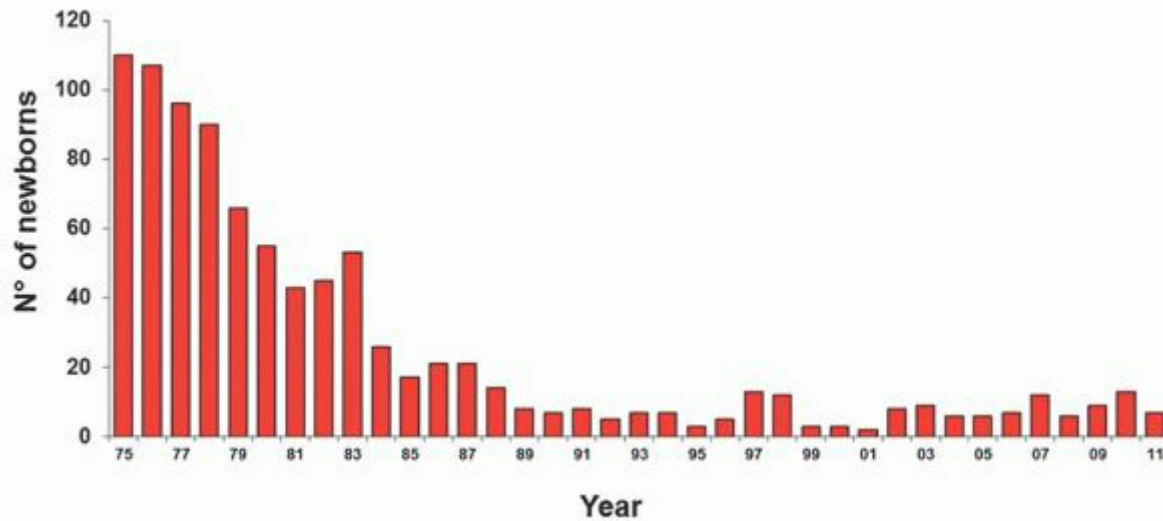

FIGURE 34.23. Fall in the birth rate of infants with homozygous β -thalassemia in Sardinia.

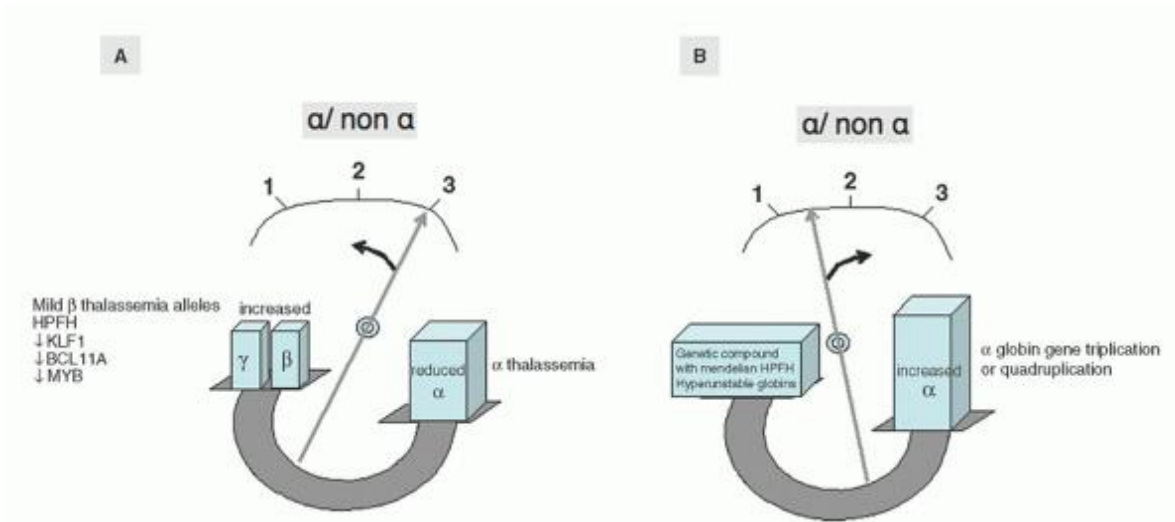

FIGURE 34.24. Mechanisms of β -thalassemia intermedia. A: Reduced globin chain imbalance. B: Increased globin chain imbalance. HPFH, hereditary persistence of fetal hemoglobin.

TABLE 34.7 β -THALASSEMIA MUTATIONS OCCURRING IN SPECIFIC POPULATIONS WITH HIGH FREQUENCY

Population	Alleles
African American	-88 C→T -29A→G
Italians	IVS -1 -1 G→A IVS -1 -6 T→C IVS -1 -110 G→A cd 39 C→T IVS -2 -745 C→G
Greek	IVS -1 -1 G→A IVS -1 -6 T→C IVS -1 -110 G→A cd 39 C→T IVS -2 -745 C→G
Indian	cd 8/9 +G IVS -1 -1 G→T IVS -1 -5 G→C cd 41/42-TTCT 619-base pair deletion
Thai	-28 A→G cd 17 A→T cd 19 A→G IVS -1 -1 G→T IVS -1 -5 G→C

	cd 41/42-TTCT
	IVS -2 -645 C→T
Chinese	-28 A→G
	cd 17 A→T
	cd 41/42-TTCT
	IVS -2 -645 C→T
Middle East	cd 8 -AA
	cd 8/9 +G
	IVS -1 -5 G→C
	cd 39 C→T
	cd 44 - C
	IVS -2 -1 G→A
Israeli	-28 A→G
	IVS -1 -110 G→A
	cd 39 C→T
	cd 44 - C
	IVS -2 -1 G→A
North African	Cd 6 -A
	IVS -1 -1 G→A
	IVS -1 -110 G→A
	cd 39 C→T

cd, codon.

Clinical Features

The clinical spectrum of thalassemia intermedia is heterogenous and variable in severity, ranging from mild anemia and jaundice to a thalassemia major-like clinical picture. It is usually diagnosed later compared to thalassemia major. Modell and Berdoukas reported that only 11% of patients with thalassemia intermedia presented in the first year of life, 30% in the second year, and 59% later in life.³¹⁰

Conventionally, thalassemia intermedia is considered transfusion-independent if hemoglobin is spontaneously maintained at or above 7 to 7.5 g/dl.⁸⁹⁷

However, regular transfusions often become necessary with advancing age, while in other cases they are required only occasionally (infections, hypersplenism, and pregnancy).⁸⁹⁸ It is not easy to predict which patients will become transfusion-dependent and when. Age at presentation seems to represent a good indicator of future transfusion independency. Cao et al., describing a group of 34 patients with thalassemia intermedia, observed that those who became transfusion-dependent were diagnosed at a mean age of 8.5 ± 1.8 months, while those who remained transfusion-independent were diagnosed at 17.4 ± 11.8 months.⁸⁹⁹

Patients with truly transfusion-independent forms may be completely asymptomatic until adulthood, experiencing anemia of various degrees and mild jaundice, while growth and development are not impaired. In severely affected patients, thalassemia intermedia generally presents between the ages of 2 and 6 years, and although many are able to survive without regular transfusions, growth and development can be delayed.

P.905

The spleen is palpable in the majority of the patients and its size increases with time. Hypersplenism may develop, causing a decrease in hemoglobin levels and sometimes thrombocytopenia and neutropenia.

Bone deformities are common and include frontal bossing, prominence of the zygomatic bones, depression of the base of the nose, shortening of long bones, cortical thinning, and dilatation of the medullary cavities, as described for thalassemia major.⁸⁹⁷ The more severe skeletal abnormalities indicate excessive marrow activity secondary to anemia and are an indication to begin transfusions.

Osteoporosis is frequently found in thalassemia intermedia and along with cortical thinning is responsible for pathologic fractures of long bones and vertebrae. The pathophysiology of bone disease is complex and is due to bone marrow expansion, endocrine dysfunction, genetic factors, direct iron toxicity to osteoblasts, and increased osteoclast activity.³²⁷ Vitamin D deficiency has an important role.⁹⁰⁰ The development of osteoporosis in some patients has been associated with specific polymorphisms in candidate genes (vitamin D receptor, estrogen receptor, calcitonin receptor, and collagen type 1 α_1), but the hypothesis has not been confirmed.³²¹ Bone and joint pains are also frequently reported.

Extramedullary erythropoiesis is common in thalassemia intermedia and can produce all sorts of bizarre symptoms.^{902, 903} It is found in up to 65% of patients with thalassemia intermedia, compared to thalassemia major patients on regular transfusions, where the prevalence remains below 1%.⁸⁹⁷

Symptoms are usually reported during the third and fourth decades of life; however, there have been reports in children.^{904, 905}

Ectopic erythropoietic masses may be found in various body sites, including spleen, liver, lymph nodes, and kidneys, but also in paravertebral, intrathoracic, pelvic, and intracranial locations.^{316, 906}

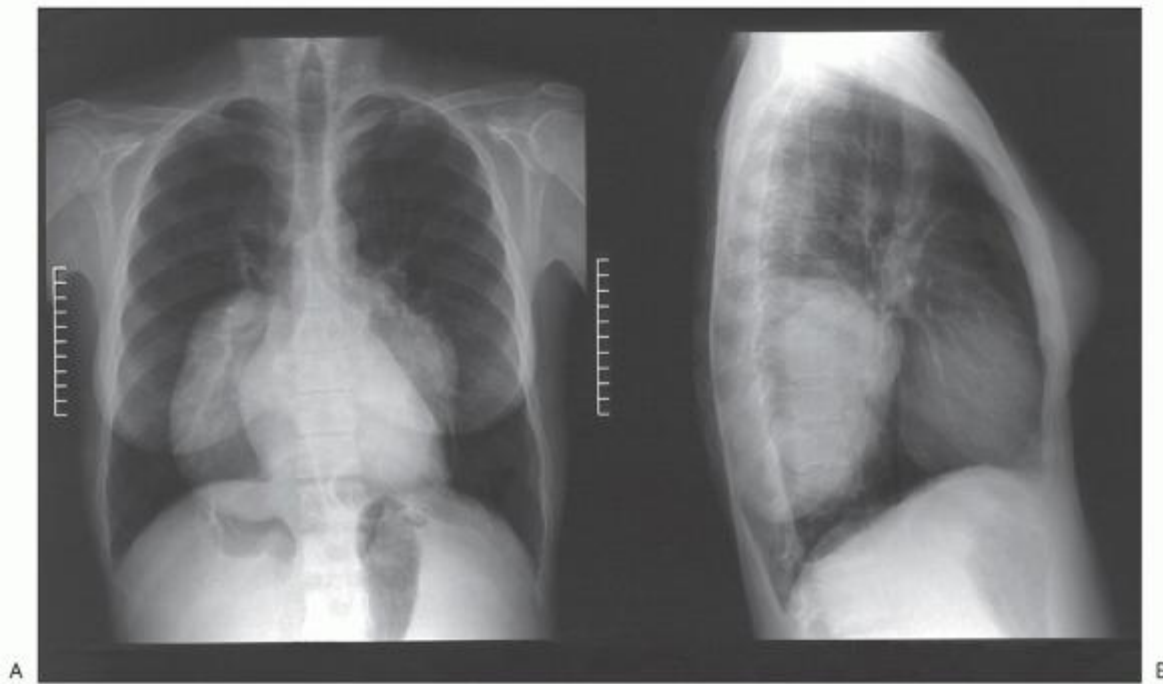

FIGURE 34.25. Extramedullary erythropoiesis manifesting as bulky space-occupying masses in the chest. The patient was a 34-year-old woman, untransfused by her choice. Molecular defect was heterozygous β^0 thalassemia plus α gene duplication. A: Antero-posterior projection. B: Lateral projection.

Most cases remain asymptomatic and are usually diagnosed incidentally by radiologic techniques, while others lead to compression of adjacent structures as tumor-like masses.

Paraspinal involvement occurs in 11% to 15% of cases and may present with a variety of neurologic symptoms, including back pain, paraparesis, paraplegia, urinary urgency, and bowel incontinence.^{906, 907} (Fig. 34.26) Spinal cord compression causing paraparesis and cauda equina syndrome requires urgent treatment.

The intrathoracic location is often asymptomatic; however, it may present with pleural effusion or mediastinal syndrome.^{908, 909, 910} (Fig. 34.25)

There is currently no consensus on the best treatment strategy for extramedullary erythropoiesis. Hydroxyurea and transfusions have proven to be effective,^{908, 911} but when rapid regression is required, surgical treatment and/or radiotherapy may be indicated.^{912, 913, 914}

Magnetic resonance imaging (MRI) is considered the method of choice for the diagnosis and follow-up of extramedullary erythropoiesis, especially for paraspinal localizations.^{907, 908, 915}

Transfusion Therapy

Thalassemia intermedia, is, by definition, transfusion-independent. However, at some time during the life of a patient the decision to initiate transfusion therapy may need to be made. In general, transfusion becomes necessary when the sense of well-being of the patient decreases to a level inadequate to the activities of a normal life. This usually occurs at levels of hemoglobin below 7 g/dl. In children, in addition to the level of hemoglobin, the main indicators are stunted growth, poor general condition, and skeletal deformities.

Also, it is important to consider the consequences of withholding transfusions in terms of medullary and extramedullary hyperplasia. Other circumstances that may require transfusion therapy include infections, hypersplenism, periods of rapid growth, and

P.906

pregnancy. Parvovirus B19 infections can cause aplastic crises, characterized by peripheral reticulocytopenia and giant and bizarre pronormoblasts in the bone marrow and, sometimes, transient pancytopenia. Anemia is often severe enough to require blood transfusion.



FIGURE 34.26. CT scan of the spine of a 40-year-old patient with thalassemia intermedia showing an extramedullary mass compressing the spinal marrow.

In adult patients who have been transfusion-independent for decades, transfusions can become necessary because of reduced marrow activity and development of severe anemia. This phenomenon has been attributed by some authors to a decreased production of erythropoietin, but further research is necessary to confirm this hypothesis. When the decision to transfuse is made, the transfusion regimen should be similar to the one generally adopted for thalassemia major. A level of pretransfusional Hb around 9.5 to 10 mg/dl is usually sufficient to adequately suppress the bone marrow activity,

promoting better growth and decreasing iron absorption from the gut. Several authors believe that patients with more severe forms of thalassemia intermedia, mimicking thalassemia major, should be transfused immediately following diagnosis.⁸⁹⁸

In the OPTIMAL CARE study, a large cooperative effort including heterogeneous patients from the Middle East, Iran, and Italy, and in several observational studies, transfused thalassemia intermedia patients experienced fewer complications related to chronic anemia, ineffective erythropoiesis, and hemolysis (extramedullary hematopoiesis, pulmonary hypertension, and thromboembolic events), while suffering higher rates of iron overload-related endocrinopathy.⁹⁰⁰

The introduction of transfusions earlier in life will probably increase iron accumulation overload, that can, however, be controlled by effective iron-chelating drugs.⁹¹⁶

Another reason to start transfusion early is that the risks of alloimmunization and autoimmunization seem to be lower if transfusions are initiated early in life. In a report, 34% of 139 patients with thalassemia intermedia developed this complication,⁹¹⁷ and a Greek study reported a frequency of alloimmunization of 21% versus 47.5% in patients transfused before and after the age of 3 years.²²³

The consequences can be dramatic when the autoimmune hemolytic anemia develops during pregnancy, causing severe anemia incompatible with survival of the fetus.⁵⁴⁵

The pathogenesis of allo- and autoimmunization is unclear, and it has been attributed to "hidden" antigens from peripheral red blood cell fragmentation. Transfusion of blood phenotypically matched at least for the ABO, Rh, and Kell systems is necessary and can prevent alloimmunization in many cases.⁹¹⁸

Therapy with immune suppressants, intravenous immunoglobulins, hydroxyurea, and even splenectomy can be attempted. Remission of the hemolytic process has been reported with allogeneic bone marrow transplantation.⁹¹⁹ Hypersplenism is an almost inevitable complication of thalassemia intermedia, often leading to transfusion dependency that is usually reversed by splenectomy. An exception is represented by the association of duplication of α genes plus heterozygous β -thalassemia, in which splenectomy can aggravate the hemolytic process.⁹²⁰

In any case, the risks of postsplenectomy infection and thrombosis should always be kept in mind.

Iron Overload

Iron overload in thalassemia intermedia can be caused by two mechanisms: increased intestinal absorption and, more rarely, transfusions. In non-transfused patients iron overload develops more slowly and accumulates in different sites. The role of hepcidin in this process is being unveiled. Hepcidin is a 25-amino acid peptide synthesized in the hepatocytes that controls the concentration of ferroportin on the intestinal epithelium. Low levels of hepcidin correlate with higher levels of ferroportin, resulting in increased intestinal iron absorption that for the most part is stored in the liver (Fig. 34.27). The lack of hepcidin results in hyperabsorption of dietary iron, but also in iron depletion of macrophages, lowering their secretion of ferritin and, consequently, serum ferritin levels. Therefore, reliance on serum ferritin alone may delay adequate treatment^{195, 428, 429} (Fig. 34.10).

In thalassemia intermedia, the high erythropoietic drive induces hepcidin deficiency, in large part mediated by growth differentiation factor 15 (GDF15). GDF15, identified as a hepcidin suppressor factor, is expressed at high levels in patients with ineffective erythropoiesis.⁴³⁰ Data suggesting that Janus kinase-2 (Jak2) may affect iron metabolism, regulating ferroportin degradation,¹⁹² have not been confirmed.^{458, 921}

Iron Chelation

Studies performed by magnetic resonance have shown that, in thalassemia intermedia, iron tends to accumulate in the liver, while the heart is usually spared.

Iron assessment in thalassemia intermedia should include direct liver iron concentration by MRI or, if necessary, by biopsy.^{922, 923, 924}

The decision to start iron chelation in patients with thalassemia intermedia depends on several factors: degree of iron overload, rate of iron accumulation, duration of exposure to excess iron, and various other factors, including compliance.⁹⁰⁶ In a study, elevated liver iron concentration was associated with an increased rate of morbidity in patients with phenotypes of any severity. An increase in 1 mg Fe/g dry weight in liver iron concentration was independently and significantly associated with higher odds of thrombosis, pulmonary hypertension, hypothyroidism, osteoporosis, and hypogonadism.⁹²⁵

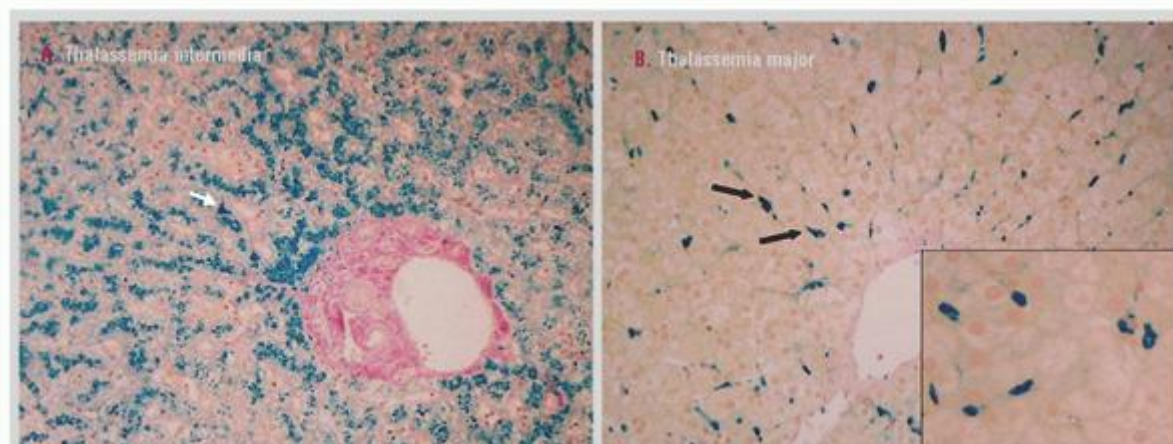

FIGURE 34.27. Iron distribution in the liver of thalassemia intermedia (A) and major (B) patients. A: Stored iron is found mainly at the biliary pole of hepatocytes. Only sporadic iron-loaded hypertrophic Kupffer cells are observed (arrow) (Perls' stain, original magnification is $\times 250$). B: Stored iron is observed mainly in hypertrophic Kupffer cells (arrows) (Perls' stain, original magnification is $\times 250$). At higher magnification ($\times 400$, insert), fine hemosiderin granules are also seen in the cytoplasm of hepatocytes. (Reprinted with permission of Origa R, Galanello R, Ganz T, et al. Liver iron concentrations and urinary hepcidin in β -thalassemia. *Haematologica* 2007;92:583-588.)

It is suggested that chelation therapy should be initiated if liver iron concentration exceeds 7 mg/g dry weight of liver tissue.⁹²⁶ However, lower levels of liver iron concentration for initiation of chelation therapy may also be considered, especially if oral chelators are available.⁹⁰⁶

Three chelating agents are currently available: desferrioxamine (DFO), deferiprone (DFP), and deferasirox (DFX).

Deferoxamine has demonstrated significant benefits in terms of morbidity and mortality in iron-overloaded thalassemia major patients.^{442, 690} However, data on safety and efficacy in thalassemia intermedia are limited. In the past, in a small study of ten transfusion-independent patients treated with DFO for 6 months, a significant reduction of serum ferritin, accompanied by iron excretion, was seen.⁹²⁷

Data on the use of the first available oral iron chelator, DFP, in thalassemia intermedia are also limited. A small clinical trial using deferiprone in nine intermittently transfused thalassemia intermedia patients demonstrated significant reductions in mean serum ferritin, hepatic iron, red cell membrane iron, and serum nontransferrin-bound iron levels. Adverse events were mostly mild and included gastrointestinal symptoms and joint pain.⁹²⁸

Deferiprone is known to be more effective than desferrioxamine in removing cardiac iron,^{444, 610} and these two agents in combination are used for intensive chelation in the presence of severe iron overload.^{480, 526} However, data for thalassemia intermedia patients are not yet available and, considering that cardiac iron overload is virtually absent in thalassemia intermedia, intensive combination treatment may rarely be necessary.^{924, 929, 930}

A recent, randomized, double-blind, placebo-controlled study of 1 year duration assessed the efficacy and safety of deferasirox in 166 thalassemia intermedia patients. Liver iron concentration and serum ferritin decreased and the frequency of adverse events compared favorably with placebo.⁹³¹

In the rare patients with sufficiently high hemoglobin levels, phlebotomy could be used to decrease the iron overload accumulated with previous transfusions or through the gastrointestinal tract.⁹³² A few patients have been treated by bone marrow transplantation.^{728, 919}

Endocrine Complications

Endocrine complications are rare in patients with thalassemia intermedia, but hypogonadism, diabetes, and hypothyroidism have been reported.⁹²⁵ Although patients generally experience delayed puberty, they have normal sexual development, and fertility is usually preserved. Hundreds of children have been born to women and men with thalassemia intermedia, mostly after spontaneous conception. However, pregnancy may be complicated by miscarriage, preterm delivery, intrauterine growth restriction, and thromboembolic events.^{538, 545, 933} In some series, miscarriages seem to be more frequent than in the normal population, especially if severe anemia is present.⁵⁴³

Anemia becomes more severe during pregnancy, especially during the first and second trimester and, in order to prevent fetal growth restriction due to hypoxia, blood transfusion is often required.^{906, 916}

However, transfusions in previously untransfused women may induce alloimmunization, which contributes to worsening of anemia.^{495, 897} Alternative approaches, such as erythropoietin administration, have been suggested.⁹³⁴

Sometimes splenomegaly can interfere with uterus enlargement and splenectomy can become necessary.

The risk of thrombosis is high enough to warrant antithrombotic therapy before and after delivery.^{356, 933}

Folic acid deficiency, a risk factor for neural tube defects, is common in thalassemia intermedia. Therefore, oral folic acid supplementation is recommended during pregnancy. Caesarean section is often chosen as a method of delivery, especially when a fetopelvic disproportion, not rare in these women, is present.

Leg Ulcers

Trophic leg ulcers developing above the medial malleolus are a common and distressing finding in older patients with thalassemia intermedia (Fig. 34.28). The pathophysiology is still unclear, but it seems that the low hemoglobin levels associated with abnormal red cell rheology and increased hemoglobin F levels that cause reduced oxygen release determine tissue hypoxia. This promotes thinning of the skin and subcutaneous fragility, which in turn increase the risk of lesions both spontaneous and from minimal trauma.^{935, 936} Hemolysis-induced low arginine and nitric oxide bioavailability, associated with oxidative stress and hypercoagulability have been demonstrated in patients with thalassemia intermedia. These factors contribute to endothelial dysfunction and development of vasculopathy, which have been implicated in the pathogenesis of pulmonary hypertension, stroke, priapism, and also leg ulcers.^{680, 937, 938}

P.908



FIGURE 34.28. Large malleolar ulcer in a patient with thalassemia intermedia. After numerous unsuccessful attempts the lesion was cured with compressive bandages.

Treatment is often unsatisfactory, as leg ulcers are difficult to heal and frequently recur. It may include simple measures, like pressure dressing⁹³⁹ and elevation of legs and feet for a few hours during the day or at night, or, in more complicated cases, skin grafting.⁹³⁵ Regular blood transfusion, associated with hydroxyurea, may be useful in persistent cases.⁹⁴⁰ In one report, a transfusion-independent patient suffering from persistent leg ulcerations responded to 1-year therapy with exchange transfusions, which reduced the percentage of HbF from 70% to 35%.⁹⁴¹ Other reported treatments include topical G-CSF, as well as platelet growth factor, zinc supplementation, and local hyperbaric oxygen sessions.⁹⁴²

Thromboembolic Disease

Hypercoagulability and thromboembolic events have been reported in all thalassemia syndromes. However, they appear to be more common in thalassemia intermedia compared to a normal age- and sex-matched population and to thalassemia major patients.²⁰⁰ In a report on 8,860 thalassemia patients from the Mediterranean countries and Iran, thromboembolism occurred in 4% of 2,190 patients with thalassemia intermedia compared to 0.9% of 6,670 patients with thalassemia major. In the thalassemia intermedia group, these events primarily occurred in the venous system and included deep vein thrombosis (40%), portal vein thrombosis (19%), stroke (9%), pulmonary embolism (12%), and others (20%).³⁵⁴

In an Italian multicenter study, the prevalence of thromboembolic events was found to be 9.6% in patients with thalassemia intermedia as compared to 4% in patients with thalassemia major.⁹⁴³

In a large cooperative study thrombosis was the fifth most common complication, affecting 14% of the patient population. On multivariate analysis, splenectomy, age above 35 years, and a serum ferritin level $\geq 1,000$ $\mu\text{g/l}$ were associated with a higher risk for thrombosis. Conversely, a positive history of transfusion and a hemoglobin level ≥ 9 g/dl were found to be protective against thrombosis.⁹⁰⁰

Thrombosis of the portal vein after splenectomy has been reported.⁹⁴⁴

In addition, a magnetic resonance imaging study described the presence of silent white matter lesions in the brains of as many as 60% of splenectomized adults. The occurrence and multiplicity of the lesions were associated with older age and transfusion naivety (83% of lesion-positive patients had never had a transfusion vs. 25% of lesion negative patients).⁹⁴⁵

The pathogenesis of the chronic hypercoagulable state is complex. Circulating damaged red cells and erythroid precursors and red cell remnants expose negatively charged phosphatidyl-serine through the "flip-flop" phenomenon and subsequently activate thrombosis. Splenectomy favors the persistence of these damaged red cells in the circulation, especially in non-transfused patients.⁹⁴⁶ Endothelial cells are also activated and damaged by the oxidative stress due to hemolysis and iron overload, leading to increased expression of adhesion molecules and impaired nitric oxide production. Furthermore, increased platelet numbers and aggregation are common in thalassemia.²⁰⁰ Higher plasma levels of markers of coagulation and of fibrinolysis activation are present in splenectomized thalassemia intermedia patients compared to thalassemia major and to healthy individuals.³⁵⁶ Also, splenectomy, as well as liver dysfunction, cause deficiency of natural anticoagulants, such as protein C and protein S and increased levels of thrombin-ATIII complex.¹⁹⁸

It has been suggested, on the basis of data from a large multicenter study, that splenectomized patients who will develop thromboembolic events may be identified early on by the high number of circulating nucleated red blood cells and platelet counts, evidence of pulmonary hypertension, and transfusion naivety.⁹⁴⁷

In a subanalysis of a large cooperative study, platelet counts over $500 \times 10^9/\text{l}$ were an independent and significant predictor of thrombosis in splenectomized thalassemia intermedia patients.⁹¹⁶ Therefore, platelet antiaggregants should be given early in the disease, particularly in splenectomized patients. High counts of nucleated red blood cells and evidence of pulmonary hypertension were also predictive of development of thromboembolic events in splenectomized thalassemia intermedia patients.⁹⁴⁷

Finally, a model for assessing the risk of thrombosis in thalassemia has been proposed to estimate the thrombotic risk as a function of intrinsic (thalassemia type and number of circulating red blood cells) and extrinsic (infection, surgery, and splenectomy) factors.¹⁹⁷

Recommended treatment options include platelet anti-aggregants, such as aspirin, in patients with thrombocytosis or anticoagulant agents, such as low molecular weight heparin, in patients undergoing surgery, and in the peripartum period. Heparin therapy, followed by long-term oral anticoagulants or antiplatelet agents is indicated after thromboembolic events. Although reasonable and widely applied, these recommendations are not supported by compelling evidence from the literature.^{897, 906}

Liver Disease

Hepatocellular carcinoma has been reported in adult patients with thalassemia intermedia as a consequence of iron overload and chronic viral infection.⁹⁴⁸

Gallstones are more common in thalassemia intermedia than in thalassemia major because of greater ineffective erythropoiesis and peripheral hemolysis, in the absence of regular transfusions. Coinheritance of the Gilbert's syndrome (mutation of the A[TA] nTAA motif of the promoter of the bilirubin in UDP-glucuronosyltransferase gene) increases the indirect bilirubin level and the risk of gallstones in thalassemia syndromes.³⁷³ The effect is even more evident in thalassemia intermedia patients, in whom the prevalence of gallstones seems to be related to allele dosage: 27% in patients with normal (TA)6/(TA)6 genotype, 68% in heterozygous patients for the mutated (TA)7, and 80% in homozygotes (TA)7/(TA)7.²²⁹

Pronounced jaundice is a frequent consequence of hemolysis, especially in patients with coexistent Gilbert's syndrome, and is often found disturbing for esthetical reasons.

Cardiac Disease

While heart disease, as a consequence of iron overload, is the first cause of death in thalassemia major, patients with thalassemia

P.909

intermedia are usually not affected by severe hemosiderosis and are therefore less prone to cardiac problems. MRI data have demonstrated that in patients with thalassemia intermedia cardiac iron overload is virtually absent.^{924, 929, 930} Nevertheless, a large multicenter study of 110 Greek patients found that 5.4% had congestive heart failure, 8% acute pericarditis, 34% chronic pericardial changes, and more than half had some kind of valvular defect.³⁷³

Chronically high cardiac output in non-transfused patients has an important role in left ventricular remodeling, which has been demonstrated to be more pronounced than in regularly transfused thalassemia major patients.⁹⁴⁹ Regular transfusions seem to be protective toward the development of heart failure.⁹⁰⁰ However, pulmonary hypertension is known to be the leading cause of cardiac failure in thalassemia intermedia.

Pulmonary Hypertension

Pulmonary hypertension is defined as systolic pulmonary artery pressure >25 mmHg at rest and >30 mmHg during exercise with a normal pulmonary artery wedge pressure <15 mmHg and an increased pulmonary vascular resistance greater than three Wood units. It is now considered the leading cause of cardiac failure in thalassemia intermedia.

In the previously mentioned Greek study, pulmonary hypertension was found in 59% of cases and all the patients with congestive heart failure had severe pulmonary hypertension with normal systolic left ventricular function.³⁷³ Risk factors for pulmonary hypertension have been identified as being splenectomized, having high nucleated red blood cell counts, not being transfused, and not being treated with hydroxyurea or iron chelation. In addition, a risk factor is a previous history of thromboembolism.⁹⁵⁰

The mechanisms underlying pulmonary hypertension in thalassemia intermedia are unclear. There is evidence that chronic hemolysis, through the induction of nitric oxide and arginine depletion, may lead to vasoconstriction, vessel wall hypertrophy, hypercoagulability, local thrombosis, and increase of thromboxane and endothelin, resulting in chronic organ damage and endothelial dysfunction.⁹⁵¹

Platelet activation has been shown to be significantly higher in thalassemia intermedia compared to thalassemia major.⁹⁵² Complex interactions between platelets, coagulation factors, erythrocytes, and endothelial cells with inflammatory and vascular mediators may also contribute to the endothelial dysfunction and subsequent pulmonary vascular remodeling.^{952, 953}

For all the above mentioned reasons, screening for pulmonary hypertension is an essential part of the diagnostic follow-up in patients with thalassemia intermedia.

Regular transfusions associated with adequate iron chelation reduce tissue hypoxia, ineffective erythropoiesis, and circulation of damaged erythrocytes, therefore preventing hemolysis and hypercoagulability, which contribute to the development of pulmonary hypertension.⁶³⁷

However, the preventive role of transfusion is still controversial. Pulmonary hypertension has been described also among transfused thalassemia major patients, mostly after splenectomy, implying that in some cases regular transfusions do not prevent the disease.

Many authors recommend regular transfusions and iron chelation in thalassemia intermedia patients when early signs of pulmonary hypertension appear.^{373, 906, 954}

Hydroxyurea prevents hemolysis and hypercoagulability by increasing hemoglobin F synthesis and reducing thrombocytosis. A retrospective study found no pulmonary hypertension in 50 thalassemia intermedia patients treated with hydroxyurea for 7 years.^{900, 955}

Specific treatments for pulmonary hypertension are being studied. New agents, like prostacyclin analogs (epoprostenol, iloprost, oral beraprost), endothelin receptor antagonists (bosentan, sitaxsentan), and phosphodiesterase 5 inhibitors (sildenafil) have been successfully used to treat pulmonary hypertension. Some of these have been used in patients with hemoglobinopathies.

Bosentan is often used with good results, but it sometimes needs to be discontinued because of hepatotoxicity or inadequate efficacy.

Sildenafil citrate was first successfully used in a 34-year-old transfusion-dependent man with thalassemia intermedia⁹⁵⁶ and, more recently, in four patients who during therapy experienced reduction of pulmonary pressure, improvement of cardiovascular function, and better exercise tolerance.⁹⁵⁷

Unfortunately, there are no randomized, controlled trials demonstrating the long-term safety and efficacy of these new treatments in patients with hemoglobinopathies. Two randomized trials in sickle cell disease, one using sildenafil and the other bosentan, were discontinued because of the increase of painful crises in one and lack of beneficial effects in both.^{958, 959}

Further studies including larger groups of patients are necessary to establish the long-term safety and efficacy of these new agents in patients with thalassemia intermedia.

Pseudoxanthoma Elasticum

Pseudoxanthoma elasticum (PXE) is an autosomal recessive, multisystem disorder affecting elastic tissues, because of a mutation on chromosome 16p13.1. The gene encodes the membrane transport protein ABCC6 and more than 300 mutations have been described. Clinically it is characterized by typical lesions of the skin (small yellowish papules or larger coalescent plaques), eyes (breaks of the elastic lamina of Brush membrane named angioid streaks), and arteries (degeneration of the elastic lamina of the arterial wall often accompanied by arterial calcification). Acquired PXE-like syndromes have been described in several hemolytic disorders.

Typical skin lesions, angioid streaks in the retina, calcified arterial walls, and aortic valve disease resembling PXE have been reported in patients affected by thalassemia.^{367, 367}

It appears to be age-dependent and it is more common in thalassemia intermedia than in thalassemia major. In a study published in 1998 and including patients affected by thalassemia intermedia older than 30 years, arterial calcifications were found in 55%, skin lesions in 20%, and ocular alterations in 52%. Eightyfive percent had at least one of the three typical lesions.³⁶⁸

The presence of PXE is usually suspected because of the characteristic skin lesions.

The typical histopathologic features of PXE both in the inherited and the acquired form are the abnormal, mineralized, and fragmented elastic fibers (elastorrhexia) in skin, eyes, and arterial blood vessels; however, the genetic mutations of the inherited form are not present in patients with PXE and thalassemia.³⁶⁹

The pathophysiology remains unclear and it is attributed to iron-induced oxidative tissue damage, caused by hemolysis and iron overload.

Thrombotic events and gastrointestinal and intracranial bleeding, which preclude the use of platelet antiaggregants, can complicate the clinical course.³⁷⁶

Although no effective therapy is available, phosphate binders, a group of drugs given in the attempt to limit the intestinal absorption of phosphate and consequently normalizing the serum calcium phosphate product, could offer a means of reducing the calcium/phosphate load in patients with PXE. Histopathologic regression of skin calcifications was demonstrated in 3 out of six patients treated with aluminum hydroxide for 1 year and in all six no progression of the ocular angioid streaks was observed.³⁷⁷

In a knock-out mouse model of PXE, obtained by silencing the *Abcc6* gene, a magnesium carbonate-enriched diet completely prevented mineralization of the vibrissae, an early biomarker of the mineralization process. These results suggest that phosphate binders may offer a potential treatment modality for this so far intractable disease.³⁷⁸

Other Complications

Folic acid deficiency can be present^{960, 961} because of increased folate utilization by the hyperactive bone marrow. Daily supplementation with 1 mg of folic acid is advised for patients with thalassemia intermedia.⁹⁶²

β -THALASSEMIA IN ASSOCIATION WITH β -CHAIN STRUCTURAL VARIANTS

Hemoglobin S Thalassemia Syndromes

The term sickle cell disease refers, not only to homozygous HbSS, but also to all genotypes in which HbS interacts with other globin gene mutations, including β^0 -thalassemia, β^+ -thalassemia, $\delta\beta$ -thalassemia, HPFH, and HbLepore. The clinical course of these phenotypes is extremely variable; however, the thalassemia gene is expressed with some degree of microcytosis, hypochromia, and variation in the relative proportions of HbA2 and HbF. Sickling symptoms, if present, are often milder than those noted in patients with homozygous sickle cell anemia.

Hemoglobin S- β -Thalassemia

The double heterozygous state for HbS and β -thalassemia is the most common variant of sickle cell disease in individuals of Mediterranean ancestry and the second most common sickling disorder. In the U.S. it is estimated to affect about 1 in 1667 Americans at birth.⁹⁶³ HbS/ β^0 -thalassemia occurs approximately once in every 23,000 Afro-Americans⁹⁶⁴ and in Jamaica has a frequency of one in 6,750.⁹⁶⁵

HbS/ β -thalassemia is clinically more similar to sickle cell disease than to thalassemia major or intermedia. The severity depends on the type of β -thalassemia mutation. Patients who inherit a β^0 gene are clinically indistinguishable from those with homozygous sickle cell anemia and have very low levels of HbA, while patients with β^+ genes present milder phenotypes and may even be asymptomatic because of the higher levels of HbA.^{966, 967}

Hematologically HbS/ β -thalassemia presents with higher red blood cell counts and HbA2 levels and lower MCV and MCH values (mean 68 fl and 20 pg, respectively) compared to HbSS.⁹⁶⁸

The risk of stroke in patients with HbS/ β^0 -thalassemia is considered high and therefore transcranial Doppler screening is recommended, as in homozygous HbSS.⁹⁶⁹

Complications of both diseases are frequently seen, including delayed growth and puberty, vaso-occlusive events, and acute chest syndrome.

Splenomegaly is more common in patients with HbS/ β -thalassemia, compared to HbSS, and the spleen tends to remain enlarged and functional in adulthood. As a consequence, several cases of fatal splenic sequestration have been reported in patients with HbS- β^+ -thalassemia.^{970, 971, 972}

Avascular necrosis of the femoral head is more frequent and appears earlier in sickling disorders with higher hematocrits, like HbS/ β^+ -thalassemia.⁹⁷³

Proliferative sickle retinopathy also seems to be more common and severe in sickle-thalassemia than in homozygous HbSS.^{974, 975}

While antibiotic prophylaxis is highly recommended in HbSS and HbS/ β^0 -thalassemia, in patients with HbS/ β^+ -thalassemia its use is controversial, because their splenic function is not usually impaired and they are not considered at high risk of having pneumococcal septicemia.⁹⁷⁶

Various phenotypes of sickle cell disease may have a milder course when associated with a concomitant α -thalassemia trait as a result of a decrease in the MCHC, which lowers HbS polymer formation.⁹⁷⁷

Other genetic modifiers can influence the phenotype, as hypothesized on the basis of the discordance of symptoms in affected members of a single family.⁹⁷⁸

In particular, the relative amount of HbF plays an important role in disease severity.⁹⁷⁹

Precise diagnosis is important to predict the clinical course and prognosis, and to perform correct genetic counseling.

In HbS/ β -thalassemia, HbS is the most abundant hemoglobin, HbA2 is increased, and HbF may be normal or variably increased. HbA accounts for less than 30% of the total amount of hemoglobin in patients with β^+ gene mutations, while it is virtually absent in HbS- β^0 -thalassemia.^{968, 980}

The electrophoretic picture of HbS/ β^+ -thalassemia and sickle cell trait may be similar, but usually the relative proportions of HbS and HbA allow a correct diagnosis. On the other hand, HbS- β^0 -thalassemia and homozygous sickle cell anemia may be indistinguishable.

Although consistently elevated by 1 year of age, HbA₂ may be difficult to measure accurately with electrophoresis because of its proximity to the HbS band, and with HPLC because of co-elution of minor components with HbA₂ (secondary to post-translational modifications of HbS).^{824, 981}

Hemoglobin S- $\delta\beta$ -Thalassemia

$\delta\beta$ -thalassemia is a condition characterized by high levels of HbF. The coinheritance with sickle cell disease has been described in African-Americans, Indians, and individuals of Mediterranean origin.^{982, 983, 984, 985}

Patients are usually asymptomatic and may show signs only of mild anemia or hematologic alterations, which include microcytosis, presence of target cells, and rare sickled cells. The electrophoretic pattern is characterized by the prevalence of HbS and elevated HbF (15% to 40%), associated with the absence of HbA and decreased HbA₂. Some patients however may present with a severe clinical course, because of heterogenous distribution of HbF among peripheral red blood.⁹⁸⁵

Hemoglobin S-Hereditary Persistence of Fetal Hemoglobin

Compound heterozygosity for HbS and HPFH is characterized by a relatively benign clinical picture. A recent study demonstrated that, in patients with HbS-HPFH, HbF levels are 50% to 90% during infancy and tend to decline steeply within the first few years of life, stabilizing at approximately 30% between ages 3 and 5 years. Furthermore, hematologic parameters are nearly normal, with average hemoglobin concentration being 13 ± 1 g/dl and average MCV 75 ± 4 fl.⁹⁸⁶

In adults the electrophoretic pattern is similar to that of homozygous sickle cell anemia: HbS 70% to 80% of the total hemoglobin, Hb F 20% to 30%, decreased HbA₂, and absent HbA.

In HbS-HPFH patients, all red blood cells contain uniformly distributed HbF in sufficient concentration to dilute HbS and inhibit its polymerization despite the high percentage of HbS.

A correct diagnosis is necessary in order to allow appropriate counseling and alleviate anxiety associated with the diagnosis of sickle cell disease. Therefore, in sickle cell patients with elevated HbF levels after the age of 1 year, molecular testing should be performed.

Hemoglobin S Hemoglobin Lepore

The double heterozygosity for sickle hemoglobin with Lepore hemoglobin is a relatively rare condition. The Hb Lepore gene alone or in combination with the HbS gene manifests as microcythemia; therefore the Hb S/Hb Lepore is similar to microdrepanocytosis. This syndrome is usually characterized by a disorder of

P.911

moderate severity, with chronic hemolytic anemia, splenomegaly, and few painful crises.^{987, 988, 989, 990}

The electrophoretic mobility of HbLepore at an alkaline pH is identical to that of HbS; therefore the condition can be confused with sickle cell anemia. At an acid pH, however, Hb Lepore migrates with HbA. HbS accounts for 60% to 80% of the hemoglobin, Hb Lepore for approximately 10%, and HbF for 9% to 25%. HbA₂ is decreased and HbA is absent.

Hemoglobin C Thalassemia

The association of HbC with β -thalassemia, especially with β^+ -thalassemia in Africans (more common than β^0 -thalassemia in this ethnic group) results in a clinical picture similar to homozygous HbCC, with mild hemolytic anemia, splenomegaly, and a benign clinical course.⁹⁹¹ However, unlike the homozygous state, Hb C/ β -thalassemia is a microcythemic condition. The diagnosis is based on the presence of target cells, specific intraerythrocytic Hb C crystals in blood smear and Hb C level at 100%.

In Italian, North African, and Turkish individuals HbC may be coinherited with β^0 -thalassemia, resulting in a more severe clinical course, similar to thalassemia intermedia.⁹⁹²

Hb C-Hb Lepore has been described in an African-American and in an Algerian family.^{993, 994}

Hemoglobin E Syndromes

HbE is the most common abnormal hemoglobin of Southeast Asia, but it has recently been reported from other Asian regions, like Pakistan⁹⁹⁵ and India.⁹⁹⁶

In southern China thousands of patients are affected.¹ It is estimated that 30 million people are heterozygous for HbE and that one million are homozygous.⁹⁹⁷

As a consequence of migratory fluxes, the epidemiology of thalassemia has changed in most industrialized countries. In North America hemoglobin E- β -thalassemia affects 13% of patients with a hemoglobinopathy and it is more common in the Western states.⁹⁹⁸

HbE is a thalassemic hemoglobinopathy because the nucleotide substitution G \rightarrow A at codon 26 of the β gene changes the encoded amino acid (Lys \rightarrow Glu) and creates a new alternative splice site in exon 1.¹¹⁷ This results in the synthesis of structurally abnormal variant hemoglobin HbE by the normally spliced β -mRNA and in a β^+ -thalassemia phenotype because of the use of the new splice site. Its molecular and clinical features have been reviewed.^{999, 1000} When HbE is present, alone or in different combinations with α - and β -thalassemia or with other abnormal hemoglobins, many different HbE syndromes are observed, which can be divided into asymptomatic and symptomatic forms.

Asymptomatic Forms

HbE heterozygotes are clinically normal with only minimal hematologic changes. Red blood cells are normocytic or slightly microcytic with minor morphologic changes, such as target cell morphology. HbE constitutes 25% to 30% of the total hemoglobin and this amount is reduced by the coexistence of α -thalassemia.⁸³⁹

Patients homozygous for HbE are usually asymptomatic and have normal hemoglobin levels, although in some cases mild anemia may be present. They show microcytosis and 20% to 80% of target red cells at peripheral blood smear examination. Hemoglobin analysis reveals 85% to 95% of HbE with the remainder being HbF. The α /non- α -globin chain synthesis ratio is around 2.0.¹⁰⁰¹

Symptomatic Forms

The clinical spectrum of the disease is very heterogeneous, ranging from a mild phenotype to a severe transfusion-dependent anemia.^{1002, 1003, 1004} This heterogeneity depends only in part on the different interacting β -thalassemia alleles.¹⁰⁰⁵ HbE- β^0 -thalassemia is characterized by HbE and F, only while in Hb- β^+ -thalassemia, some HbA is detected in addition to HbE and HbF. HbE in association with β -thalassemia is considered to represent one-half of all the severe thalassemia syndromes worldwide.

A large study has been going on since 1997 in Sri Lanka, attempting to define the genetic and environmental factors that modify the severity of HbE thalassemia.¹⁰⁰⁶ Considerable phenotypic heterogeneity occurred within a relatively narrow range of hemoglobin values. Major genetic factors included the type of β -thalassemia mutation, the coinheritance of α -thalassemia, and polymorphisms associated with increased synthesis of fetal hemoglobin. The presence of the Xmn-1 polymorphism in the promoter region of the γ gene explained the variation of Hb F production. Among the environmental factors, coinfection with the malaria parasite, previous splenectomy, a variable increase in response to erythropoietin, and attenuation of this response with time appear to be important. The remarkable variation and instability of clinical phenotypes requires periodic reassessment of the need for transfusion therapy.^{1004, 1006}

As a consequence of the interaction of HbE with HbH disease and Hb Constant Spring, three symptomatic syndromes have been identified:^{1007, 1008}

- HbAE Bart's disease, resulting from the interaction of HbH disease with heterozygous HbE;
- HbEF Bart's disease, which is due to the interaction of HbH disease with homozygous HbE or HbE- β -thalassemia;
- homozygous HbE with homozygous Hb Constant Spring syndrome.

The anemia in these forms is moderate to severe and the various genotypes can be suspected on the basis of the hemoglobin pattern and/or family studies, but DNA analysis is required for the definition of the exact genotype. Phenotypes similar to thalassemia major can be predicted from the early onset of clinical symptoms and the requirement of regular blood transfusion from infancy.

Clinical Picture

Most HbE β -thalassemia patients are not transfused or are transfused very little, and iron chelation is rarely administered. Erythropoiesis is markedly increased, and extramedullary masses are common.⁹¹¹ As is the case in other forms of sporadically transfused thalassemias, allo- and autoimmune hemolytic anemia develops frequently.¹⁰⁰⁹

Infections, mostly due to gram-negative bacteria, are a major complication and cause of death in patients with Hb E β -thalassemia, especially after splenectomy.¹⁰⁰⁴ Prospective studies indicate increased susceptibility to bacterial, fungal, and viral infections.^{1010, 1011} *Pythium insidiosum* (a type of water mold which is now classified within the kingdom Chromista

together with algae) has been reported to have caused arterial occlusion and gangrene of the legs.⁴⁰⁶ Gallstones are present in 50% of the patients and are strongly associated with the 7/7 genotype of the UGT1A1 promoter.^{1004, 1012} The clinical syndrome of hypertension, convulsions, and cerebral hemorrhage occurring immediately or as late as 2 weeks after multiple blood transfusions in Hb E β -thalassemia is a possible complication.¹⁰¹³ Monitoring blood pressure during and after blood transfusion is, therefore, necessary, as prompt therapy with anti-hypertensive drugs will reduce mortality from cerebral hemorrhage. In a group of nontransfusion-dependent β -thalassemia/HbE patients, nontransferrin-bound iron (labile plasma iron and directly chelatable iron) was found to be increased and to respond to treatment with deferiprone.¹⁰¹⁴ An increased risk of thrombosis reported in these patients, especially after splenectomy, can be explained by chronic low-grade coagulation and platelet activation, chronic low-grade

P.912

inflammation, endothelial cell injury, impaired fibrinolysis, and decreased naturally occurring anticoagulants.¹⁰¹⁵ Hypoxemia is observed in the majority of splenectomized patients.¹⁰¹⁶ The underlying mechanism is unknown, but it has been attributed to increased aggregation of platelets in the pulmonary vessels, based on the autoptic finding of pulmonary arterial occlusion in a large number of such patients.¹⁰¹⁷ Accordingly, the administration of aspirin can ameliorate the degree of hypoxemia in the majority of cases. Stem cell transplantation, be it bone marrow or cord blood, has proven effective.^{1018, 1019} Some, but not all, β -thalassemia/HbE patients respond to hydroxyurea treatment.¹⁰²⁰ In an Indian trial, patients who responded showed an increase in hemoglobin, mean corpuscular volume, mean cell hemoglobin content, fetal hemoglobin, and F cells.¹⁰²¹ In a study, membrane deformability and cell hydration, whose improvement is important for extending the life span of erythrocytes, did not change significantly, except in splenectomized patients.¹⁰²²

Pregnancy in women affected by β -thal/HbE disease is possible, but the cases reported were significantly associated with an increased risk of fetal growth restriction, preterm birth, and low birth weight.¹⁰²³

Survival of patients with β -thalassemia/HbE in Thailand has been reported to be 30 years, significantly longer than the 10 years reported for homozygous β -thalassemia.¹⁰²⁴

WEBSITE

<http://www.bx.psu.edu>

<http://phencode.bx.psu.edu>

<http://www.fda.gov/downloads/AdvisoryCommittees/CommitteesMeetingMaterials/Drugs/OncologicDrugsAdvisoryCommittee/UCM271538.pdf>

<http://www.pharma.us.novartis.com/product/pi/pdf/exjade.pdf>

<http://www.eshre.com>

REFERENCES

1. Angastiniotis M, Modell B. Global epidemiology of hemoglobin disorders. *Ann N Y Acad Sci* 1998;850:251-269.
2. Modell B, Darlison M. Global epidemiology of haemoglobin disorders and derived service indicators. *Bull World Health Organ* 2008;036673.
3. Weatherall DJ. The inherited diseases of hemoglobin are an emerging global health burden. *Blood* 2010;115:4331-4336.
4. Bernini L. Geographic distribution of alpha-thalassemia. In: Steinberg MH, Forget BG, Higgs DR, Nagel RL, eds. *Disorders of hemoglobin*, 1st ed. New York: Cambridge University Press, 2001:878-894.
5. Al-Awamy BH. Thalassemia syndromes in Saudi Arabia. Meta-analysis of local studies. *Saudi Med J* 2000;21:8-17.
6. Pirastu M, Lee KY, Dozy AM, et al. Alpha-thalassemia in two Mediterranean populations. *Blood* 1982;60:509-512.
7. Dozy AM, Kan YW, Embury SH, et al. Alpha-globin gene organisation in blacks precludes the severe form of alpha-thalassaemia. *Nature* 1979;280:605-607.
8. Anderson HM, Ranney HM. Southeast Asian immigrants: the new thalassemias in Americans. *Semin Hematol* 1990;27:239-246.
9. Hoppe CC. Newborn screening for non-sickling hemoglobinopathies. *Hematology (Am Soc Hematol Educ Program)* 2009:19-25.

10. Michlitsch J, Azimi M, Hoppe C, et al. Newborn screening for hemoglobinopathies in California. *Pediatr Blood Cancer* 2009;52:486-490.
11. Cao A, Congiu R, Sollaino MC, et al. Thalassaemia and glucose-6-phosphate dehydrogenase screening in 13- to 14-year-old students of the Sardinian population: preliminary findings. *Community Genet* 2008;11:121-128.
12. Barrai I, Rosito A, Cappellozza G, et al. Beta-thalassemia in the Po Delta: selection, geography, and population structure. *Am J Hum Genet* 1984;36:1121-1134.
13. Schilirò G, Di Gregorio F, Samperi P, et al. Genetic heterogeneity of betathalassemia in southeast Sicily. *Am J Hematol* 1995;48:5-11.
14. Loukopoulos D. Current status of thalassemia and the sickle cell syndromes in Greece. *Semin Hematol* 1996;33:76-86.
15. Weatherall D, Clegg J. *The thalassemia syndromes*, 4th ed. Hoboken, NJ: Blackwell Science Ltd, 2001:1-827.
16. Hussein IR, Temtamy SA, el-Beshlawy A, et al. Molecular characterization of beta-thalassemia in Egyptians. *Hum Mutat* 1993;2:48-52.
17. Aksoy M, Kutlar A, Kutlar F, et al. Survey on haemoglobin variants, beta thalassaemia, glucose-6-phosphate dehydrogenase deficiency, and haptoglobin types in Turks from western Thrace. *J Med Genet* 1985;22:288-290.
18. Horowitz A, Cohen T, Goldschmidt E, Levene C. Thalassaemia types among Kurdish Jews in Israel. *Br J Haematol* 1966;12:555-568.
19. White JM, Byrne M, Richards R, et al. Red cell genetic abnormalities in Peninsular Arabs: sickle haemoglobin, G6PD deficiency, and alpha and beta thalassaemia. *J Med Genet* 1986;23:245-251.
20. Hashmi JA, Farzana F. Thalassaemia trait, abnormal haemoglobins, and raised fetal haemoglobin in Karachi. *Lancet* 1976;1:206.
21. Mehta BC, Dave VB, Joshi SR, et al. Study of hematological and genetical characteristics of Cutchhi Bhanushali community. *Indian J Med Res* 1972;60:305-311.
22. Lorey F. Asian immigration and public health in California: thalassemia in newborns in California. *J Pediatr Hematol Oncol* 2000;22:564-566.
23. Pierce HI, Kurachi S, Sofroniadou K, Stamatoyannopoulos G. Frequencies of thalassemia in American blacks. *Blood* 1977;49:981-986.
24. Ahern E, Herbert R, Mclver C, et al. Beta-thalassaemia of clinical significance in adult Jamaican Negroes. *Br J Haematol* 1975;30:197-213.
25. Wasi P, Na-Nakorn S, Pootrakul S, et al. Alpha- and beta-thalassemia in Thailand. *Ann N Y Acad Sci* 1969;165:60-82.
26. Modell B, Khan M, Darlison M, et al. A national register for surveillance of inherited disorders: beta thalassaemia in the United Kingdom. *Bull World Health Organ* 2001;79:1006-1013.
27. Galanello R, Eleftheriou A, Traeger-Synodinos J. *Prevention of thalassemia and other haemoglobin disorders*, vol 1. Cyprus: Thalassaemia International Federation, 2001.
28. Maccanti A. Contributo alla conoscenza dell'anemia splenica infantile a tipo familiare. *Riv Clin Pediatr* 1928;26:620-640.
29. Vezzoso B. Influenza della malaria sulla mortalità infantile per anemia con speciale riguardo al morbo di Cooley. *Riv Malarial* 1946;XXV:61.
30. Haldane J. The rate of mutation of human genes. *Proc VIII Int Cong Genet Hereditas* 1949;35:267.
31. Neel JV, Valentine WN. Further studies on the genetics of thalassemia. *Genetics* 1947;32:38-63.
32. Siniscalco M, Bernini L, Filippi G, et al. Population genetics of haemoglobin variants, thalassaemia and glucose-6-phosphate dehydrogenase deficiency, with particular reference to the malaria hypothesis. *Bull World Health Organ* 1966;34:379-393.
33. Fullerton SM, Harding RM, Boyce AJ, Clegg JB. Molecular and population genetic analysis of allelic sequence diversity at the human beta-globin locus. *Proc Natl Acad Sci U S A* 1994;91:1805-1809.
34. Udomsangpetch R, Sueblinvong T, Pattanapanyasat K, et al. Alteration in cytoadherence and rosetting of Plasmodium falciparum-infected thalassemic red blood cells. *Blood* 1993;82:3752-3759.

35. Pasvol G, Weatherall DJ, Wilson RJ. Effects of foetal haemoglobin on susceptibility of red cells to *Plasmodium falciparum*. *Nature* 1977;270:171-173.
36. Senok AC, Li K, Nelson EA, et al. Invasion and growth of *Plasmodium falciparum* is inhibited in fractionated thalassaemic erythrocytes. *Trans R Soc Trop Med Hyg* 1997;91:138-143.
37. Williams TN, Maitland K, Bennett S, et al. High incidence of malaria in alpha-thalassaemic children. *Nature* 1996;383:522-525.
38. O'Donnell A, Premawardhena A, Arambepola M, et al. Interaction of malaria with a common form of severe thalassemia in an Asian population. *Proc Natl Acad Sci U S A* 2009;106:18716-18721.
39. Min-oo G, Gros P. Microreview Erythrocyte variants and the nature of their malaria protective effect. *Cell Microbiol* 2005;7:753-763.
40. Weatherall DJ. Genetic variation and susceptibility to infection: the red cell and malaria. *Br J Haematol* 2008;141:276-286.
41. Taylor SM, Parobek C, Fairhurst RM. Haemoglobinopathies and the clinical epidemiology of malaria: a systematic review and meta-analysis. *Lancet Infect Dis* 2012;12:457-468.
42. Stamatoyannopoulos G, Grosfeld F. The molecular basis of blood disease. In: Stamatoyannopoulos G, Majeurs P, Perlmutter R, eds. *Hemoglobin Switching*, 3rd ed. Philadelphia, PA: Saunders, 2001:135-182.
43. Go M. Correlation of DNA exonic regions with protein structural units in haemoglobin. *Nature* 1981;291:90-92.
44. Menzel S, Garner C, Gut I, et al. A QTL influencing F cell production maps to a gene encoding a zinc-finger protein on chromosome 2p15. *Nat Genet* 2007;39:1197-1199.
45. Uda M, Galanello R, Sanna S, et al. Genome-wide association study shows BCL11A associated with persistent fetal hemoglobin and amelioration of the phenotype of beta-thalassemia. *Proc Natl Acad Sci U S A* 2008;105:1620-1625.
46. Manfredini R, Vergine G, Boari B, et al. Circadian and seasonal variation of first febrile seizures. *J Pediatr* 2004;145:838-839.
47. Borg J, Papadopoulos P, Georgitsi M, et al. Haploinsufficiency for the erythroid transcription factor KLF1 causes hereditary persistence of fetal hemoglobin. *Nat Genet* 2010;42:801-805.
48. Zhou D, Liu K, Sun C-W, et al. KLF1 regulates BCL11A expression and gamma- to beta-globin gene switching. *Nat Genet* 2010;42:742-744.
49. Wilber A, Nienhuis AW, Persons DA. Transcriptional regulation of fetal to adult hemoglobin switching: new therapeutic opportunities. *Blood* 2011;117:3945-3953.
50. Sankaran VG, Menne TF, Xu J, et al. Human fetal hemoglobin expression is regulated by the developmental stage-specific repressor BCL11A. *Science (New York, NY)* 2008;322:1839-1842.
51. Bieker JJ. Probing the onset and regulation of erythroid cell-specific gene expression. *Mt Sinai J Med* 2005;72:333-338.
52. Sankaran VG, Nathan DG. Reversing the hemoglobin switch. *N Engl J Med* 2010;363:2258-2260.
53. Satta S, Perseu L, Moi P, et al. Compound heterozygosity for KLF1 mutations associated with remarkable increase of fetal hemoglobin and red cell protoporphyrin. *Haematologica* 2011;96:767-770.
54. Cao A, Moi P, Galanello R. Recent advances in beta-thalassemsias. *Pediatr Rep* 2011;3:e17.
55. Orkin SH. GATA-binding transcription factors in hematopoietic cells. *Blood* 1992;80:575-581.
56. Ney PA, Sorrentino BP, Lowrey CH, Nienhuis AW. Inducibility of the HS II enhancer depends on binding of an erythroid specific nuclear protein. *Nucleic Acids Res* 1990;18:6011-6017.
57. Miller IJ, Bieker JJ. A novel, erythroid cell-specific murine transcription factor that binds to the CACCC element and is related to the Krüppel family of nuclear proteins. *Mol Cell Biol* 1993;13:2776-2786.
58. Feng WC, Southwood CM, Bieker JJ. Analyses of beta-thalassemia mutant DNA interactions with erythroid Krüppel-like factor (EKLF), an erythroid cell-specific transcription factor. *J Biol Chem* 1994;269:1493-1500.
59. Cantor AB, Orkin SH. Transcriptional regulation of erythropoiesis: an affair involving multiple partners. *Oncogene* 2002;21:3368-3376.

60. Forget B. Molecular genetics of the human globin genes. In: Steinberg M, Forget B, Higgs D, eds. Disorders of hemoglobin: genetics, pathophysiology, and clinical management. Cambridge: Cambridge University Press, 2001:117-130.
61. Higgs DR, Goodbourn SE, Wainscoat JS, et al. Highly variable regions of DNA flank the human alpha globin genes. *Nucleic Acids Res* 1981;9:4213-4224.
62. Higgs DR, Hill AV, Bowden DK, et al. Independent recombination events between the duplicated human alpha globin genes; implications for their concerted evolution. *Nucleic Acids Res* 1984;12:6965-6977.
63. Higgs DR, Vickers MA, Wilkie AO, et al. A review of the molecular genetics of the human alpha-globin gene cluster. *Blood* 1989;73:1081-1104.
64. Higgs DR, Gibbons R. The molecular basis of α -thalassemia: a model for understanding human molecular genetics. *Hematol Oncol Clin North Am* 2010;24:1033-1054.
65. Chui DHK, Fucharoen S, Chan V. Hemoglobin H disease: not necessarily a benign disorder. *Blood* 2003;101:791-800.
66. Higgs D. The molecular basis of a thalassemia. In: Steinberg MH FB, Higgs DR et al., eds. Disorders of hemoglobin, 2nd ed. Cambridge: Cambridge University Press, 2009:241.
67. Michelson AM, Orkin SH. The 3' untranslated regions of the duplicated human alpha-globin genes are unexpectedly divergent. *Cell* 1980;22:371-377.
68. Liebhaber SA, Goossens M, Kan YW. Homology and concerted evolution at the alpha 1 and alpha 2 loci of human alpha-globin. *Nature* 1981;290:26-29.
69. Nicholls RD, Fischel-Ghodsian N, Higgs DR. Recombination at the human alpha-globin gene cluster: sequence features and topological constraints. *Cell* 1987;49:369-378.
70. Orkin SH, Goff SC. The duplicated human alpha-globin genes: their relative expression as measured by RNA analysis. *Cell* 1981;24:345-351.
71. Liebhaber SA, Cash FE, Ballas SK. Human alpha-globin gene expression. The dominant role of the alpha 2-locus in mRNA and protein synthesis. *J Biol Chem* 1986;261:15327-15333.
72. Shakin SH, Liebhaber SA. Translational profiles of alpha 1-, alpha 2-, and beta-globin messenger ribonucleic acids in human reticulocytes. *J Clin Invest* 1986;78:1125-1129.
73. Molchanova TP, Pobedimskaya DD, Huisman TH. The differences in quantities of alpha 2- and alpha 1-globin gene variants in heterozygotes. *Br J Haematol* 1994;88:300-306.
74. Higgs DR, Old JM, Pressley L, et al. A novel alpha-globin gene arrangement in man. *Nature* 1980;284:632-635.
75. Gu YC, Landman H, Huisman TH. Two different quadruplicated alpha globin gene arrangements. *Br J Haematol* 1987;66:245-250.
76. Galanello R, Ruggeri R, Paglietti E, et al. A family with segregating triplicated alpha globin loci and beta thalassemia. *Blood* 1983;62:1035-1040.
77. Winichagoon P, Higgs DR, Goodbourn SE, et al. Multiple arrangements of the human embryonic zeta globin genes. *Nucleic Acids Res* 1982;10:5853-5868.
78. Felice AE, Cleek MP, Marino EM, et al. Different zeta globin gene deletions among black Americans. *Hum Genet* 1986;73:221-224.
79. Michelson AM, Orkin SH. Boundaries of gene conversion within the duplicated human alpha-globin genes. Concerted evolution by segmental recombination. *J Biol Chem* 1983;258:15245-15254.
80. Embury SH, Miller JA, Dozy AM, et al. Two different molecular organizations account for the single alpha-globin gene of the alpha-thalassemia-2 genotype. *J Clin Invest* 1980;66:1319-1325.
81. Goossens M, Dozy AM, Embury SH, et al. Triplicated alpha-globin loci in humans. *Proc Natl Acad Sci U S A* 1980;77:518-521.
82. Trent RJ, Higgs DR, Clegg JB, Weatherall DJ. A new triplicated alpha-globin gene arrangement in man. *Br J Haematol* 1981;49:149-152.

83. Lacerra G, Fioretti G, De Angioletti M, et al. (Alpha)alpha 5.3: a novel alpha(+)-thalassemia deletion with the breakpoints in the alpha 2-globin gene and in close proximity to an Alu family repeat between the psi alpha 2- and psi alpha 1-globin genes. *Blood* 1991;78:2740-2746.
84. Harteveld CL, Higgs D. Alpha-thalassaemia. *Orphanet J Rare Dis* 2010;5:13.
85. Bowden DK, Hill AV, Higgs DR, et al. Different hematologic phenotypes are associated with the leftward (-alpha 4.2) and rightward (-alpha 3.7) alpha+-thalassemia deletions. *J Clin Invest* 1987;79:39-43.
86. Liebhaber SA, Cash FE, Main DM. Compensatory increase in alpha 1-globin gene expression in individuals heterozygous for the alpha-thalassemia-2 deletion. *J Clin Invest* 1985;76:1057-1064.
87. Proudfoot NJ. Transcriptional interference and termination between duplicated alpha-globin gene constructs suggests a novel mechanism for gene regulation. *Nature* 1986;322:562-565.
88. Hatton CS, Wilkie AO, Drysdale HC, et al. Alpha-thalassemia caused by a large (62 kb) deletion upstream of the human alpha globin gene cluster. *Blood* 1990;76:221-227.
89. Harteveld CL, Voskamp A, Phylipsen M, et al. Nine unknown rearrangements in 16p13.3 and 11p15.4 causing alpha- and beta-thalassaemia characterised by high resolution multiplex ligation-dependent probe amplification. *J Med Genet* 2005;42:922-931.
90. Phylipsen M, Vogelaar IP, Schaap RAC, et al. A new alpha(0)-thalassemia deletion found in a Dutch family (- (AW)). *Blood Cells* 2010;45:133-135.
91. Vernimmen D, Marques-Kranc F, Sharpe JA, et al. Chromosome looping at the human alpha-globin locus is mediated via the major upstream regulatory element (HS-40). *Blood* 2009;114:4253-4260.
92. Sollaino M, Paglietti M, Loi D, et al. Homozygous deletion of the major alphaglobin regulatory element (MCS-R2) responsible for a severe case of hemoglobin H disease. *Blood* 2010;116:2193-2194.
93. Indrak K, Gu YC, Novotny J, Huisman TH. A new alpha-thalassemia-2 deletion resulting in microcytosis and hypochromia and in vitro chain imbalance in the heterozygote. *Am J Hematol* 1993;43:144-145.
94. Tufarelli C, Stanley J a S, Garrick D, et al. Transcription of antisense RNA leading to gene silencing and methylation as a novel cause of human genetic disease. *Nat Genet* 2003;34:157-165.
95. Hunt DM, Higgs DR, Winichagoon P, et al. Haemoglobin constant spring has an unstable alpha chain messenger RNA. *Br J Haematol* 1982;51:405-413.
96. Wajcman H, Traeger-Synodinos J, Papassotiriou I, et al. Unstable and thalassaemic alpha chain hemoglobin variants: a cause of Hb H disease and thalassemia intermedia. *Hemoglobin* 2008;32:327-349.
97. De Gobbi M, Viprakasit V, Hughes JR, et al. A regulatory SNP causes a human genetic disease by creating a new transcriptional promoter. *Science (New York, NY)* 2006;312:1215-1217.
98. Fritsch EF, Lawn RM, Maniatis T. Molecular cloning and characterization of the human beta-like globin gene cluster. *Cell* 1980;19:959-972.
99. Antonarakis SE, Boehm CD, Giardina PJ, Kazazian HH. Nonrandom association of polymorphic restriction sites in the beta-globin gene cluster. *Proc Natl Acad Sci U S A* 1982;79:137-141.
100. Fei YJ, Kutlar F, Harris HF, et al. A search for anomalies in the zeta, alpha, beta, and gamma globin gene arrangements in normal black, Italian, Turkish, and Spanish newborns. *Hemoglobin* 1989;13:45-65.
101. Huisman TH, Kutlar F, Gu LH. Gamma chain abnormalities and gammaglobin gene rearrangements in newborn babies of various populations. *Hemoglobin* 1991;15:349-379.
102. Forrester WC, Thompson C, Elder JT, Groudine M. A developmentally stable chromatin structure in the human beta-globin gene cluster. *Proc Natl Acad Sci U S A* 1986;83:1359-1363.
103. Talbot D, Grosveld F. The 5'HS2 of the globin locus control region enhances transcription through the interaction of a multimeric complex binding at two functionally distinct NF-E2 binding sites. *EMBO J* 1991;10:1391-1398.
104. Van der Ploeg LH, Konings A, Oort M, et al. Gamma-beta-thalassaemia studies showing that deletion of the gamma- and delta-genes influences betaglobin gene expression in man. *Nature* 1980;283:637-642.

105. Curtin P, Pirastu M, Kan YW, et al. A distant gene deletion affects beta-globin gene function in an atypical gamma delta beta-thalassemia. *J Clin Invest* 1985;76:1554-1558.
106. Gonzalez-Redondo JM, Stoming TA, Kutlar A, et al. A C—T substitution at nt-101 in a conserved DNA sequence of the promotor region of the betaglobin gene is associated with “silent” beta-thalassemia. *Blood* 1989;73: 1705-1711.
107. Maragoudaki E, Kanavakis E, Traeger-Synodinos J, et al. Molecular, haematological and clinical studies of the -101 C → T substitution of the beta-globin gene promoter in 25 beta-thalassaemia intermedia patients and 45 heterozygotes. *Br J Haematol* 1999;107:699-706.
108. Chen X-W, Mo Q-H, Li Q, et al. A novel mutation of -73(A→T) in the CCAAT box of the beta-globin gene identified in a patient with the mild beta-thalassemia intermedia. *Ann Hematol* 2007;86:653-657.
109. Wong C, Dowling CE, Saiki RK, et al. Characterization of beta-thalassaemia mutations using direct genomic sequencing of amplified single copy DNA. *Nature* 1987;330:384-386.
110. Mount SM. A catalogue of splice junction sequences. *Nucleic Acids Res* 1982;10:459-472.
111. Treisman R, Orkin SH, Maniatis T. Specific transcription and RNA splicing defects in five cloned beta-thalassaemia genes. *Nature* 1983;302:591-596.
112. Cheng TC, Orkin SH, Antonarakis SE, et al. Beta-thalassemia in Chinese: use of in vivo RNA analysis and oligonucleotide hybridization in systematic characterization of molecular defects. *Proc Natl Acad Sci U S A* 1984;81: 2821-2825.
113. Tamagnini GP, Lopes MC, Castanheira ME, et al. Beta + thalassemia—Portuguese type: clinical, haematological and molecular studies of a newly defined form of beta thalassaemia. *Br J Haematol* 1983;54:189-200.
114. Spritz RA, Jagadeeswaran P, Choudary PV, et al. Base substitution in an intervening sequence of a beta+-thalassemic human globin gene. *Proc Natl Acad Sci U S A* 1981;78:2455-2459.
115. Metherall JE, Collins FS, Pan J, et al. Beta zero thalassemia caused by a base substitution that creates an alternative splice acceptor site in an intron. *EMBO J* 1986;5:2551-2557.
116. Orkin SH, Kazazian HH, Antonarakis SE, et al. Abnormal RNA processing due to the exon mutation of beta E-globin gene. *Nature* 1982;300:768-769.
117. Orkin SH, Antonarakis SE, Loukopoulos D. Abnormal processing of beta Knossos RNA. *Blood* 1984;64:311-313.
118. Yang KG, Kutlar F, George E, et al. Molecular characterization of beta-globin gene mutations in Malay patients with Hb E-beta-thalassaemia and thalassaemia major. *Br J Haematol* 1989;72:73-80.
119. Baserga SJ, Benz EJ. Nonsense mutations in the human beta-globin gene affect mRNA metabolism. *Proc Natl Acad Sci U S A* 1988;85:2056-2060.
120. Nagy E, Maquat LE. A rule for termination-codon position within introncontaining genes: when nonsense affects RNA abundance. *Trends Biochem Sci* 1998;23:198-199.
121. Sachs AB. Messenger RNA degradation in eukaryotes. *Cell* 1993;74:413-421.
122. Zhang J, Sun X, Qian Y, Maquat LE. Intron function in the non-sense-mediated decay of beta-globin mRNA: indications that pre-mRNA splicing in the nucleus can influence mRNA translation in the cytoplasm. *RNA (New York, NY)* 1998;4:801-815.
123. Hall GW, Thein S. Nonsense codon mutations in the terminal exon of the beta-globin gene are not associated with a reduction in beta-mRNA accumulation: a mechanism for the phenotype of dominant beta-thalassemia. *Blood* 1994;83:2031-2037.
124. Cao A, Rosatelli C, Pirastu M, Galanello R. Thalassemias in Sardinia: molecular pathology, phenotype-genotype correlation, and prevention. *Am J Pediatr Hematol Oncol* 1991;13:179-188.
125. Liang R, Liang S, Jiang NH, et al. Alpha and beta thalassaemia among Chinese children in Guangxi Province, P.R. China: molecular and haematological characterization. *Br J Haematol* 1994;86:351-354.
126. Chang JC, Alberti A, Kan YW. A beta-thalassemia lesion abolishes the same Mst II site as the sickle mutation. *Nucleic Acids Res* 1983;11:7789-7794.

127. Thein SL, Old JM, Wainscoat JS, et al. Population and genetic studies suggest a single origin for the Indian deletion beta thalassaemia. *Br J Haematol* 1984;57:271-278.
128. Popovich BW, Rosenblatt DS, Kendall AG, Nishioka Y. Molecular characterization of an atypical beta-thalassemia caused by a large deletion in the 5' beta-globin gene region. *Am J Hum Genet* 1986;39:797-810.
129. Thein S, Wood W. The molecular basis of beta thalassemia, deltabeta thalassemia and hereditary persistence of fetal hemoglobin. In: Steinberg M, Forget B, Higgs D, Weatherall D, eds. *Disorders of hemoglobin: genetics, pathophysiology and clinical management*. Cambridge: Cambridge University Press, 2009:323-356.
130. Baglioni C. The fusion of two peptide chains in hemoglobin Lepore and its interpretation as a genetic deletion. *Proc Natl Acad Sci U S A* 1962;48: 1880-1886.
131. Baird M, Driscoll C, Schreiner H, et al. A nucleotide change at a splice junction in the human beta-globin gene is associated with beta 0-thalassemia. *Proc Natl Acad Sci U S A* 1981;78:4218-4221.
132. Miranda SR, Figueiredo MS, Kerbauy J, et al. Hb Lepore Baltimore (delta 50Ser beta 86Ala) identified by DNA analysis in a Brazilian family. *Acta Haematol* 1994;91:7-9.
133. Waye JS, Eng B, Coleman MB, et al. Delta beta-thalassemia in an African-American: identification of the deletion endpoints and PCR-based diagnosis. *Hemoglobin* 1994;18:389-399.
134. Ojwang PJ, Nakatsuji T, Gardiner MB, et al. Gene deletion as the molecular basis for the Kenya-G gamma-HPFH condition. *Hemoglobin* 1983;7:115-123.
135. Efremov G. Dominantly inherited beta-thalassemia. *Hemoglobin* 2007;31:193-207.
136. Adams JG, Steinberg MH, Newman MV, et al. Beta-thalassemia present in cis to a new beta-chain structural variant, Hb Vicksburg [beta 75 (E19)Leu leads to O]. *Proc Natl Acad Sci U S A* 1981;78:469-473.
137. Adams JG, Hardy CL, Steinberg MH. Disappearance of the protein of a somatic mutation: a possible example of stem cell inactivation. *Am J Physiol* 1991;261:C448-54.
138. Lang A, Lehmann H, King-Lewis PA. Hb K Woolwich the cause of a thalassaemia. *Nature* 1974;249:467-469.
139. Smith CM, Hedlund B, Cich JA, et al. Hemoglobin North Shore: a variant hemoglobin associated with the phenotype of beta-thalassemia. *Blood* 1983;61:378-383.
140. Pirastu M, Ristaldi MS, Loudianos G, et al. Molecular analysis of atypical betathalassemia heterozygotes. *Ann N Y Acad Sci* 1990;612:90-97.
141. Oggiano L, Guiso L, Frogheri L, et al. A novel Mediterranean "delta betathalassemia" determinant containing the delta (+) 27 and beta (0) 39 point mutations in cis. *Am J Hematol* 1994;45:81-84.
142. Loudianos G, Cao A, Pirastu M, et al. Molecular basis of the delta thalassemia in cis to hemoglobin Knossos variant. *Blood* 1991;77:2087-2088.
143. Traeger-Synodinos J, Tzetis M, Kanavakis E, et al. The Corfu delta beta thalassaemia mutation in Greece: haematological phenotype and prevalence. *Br J Haematol* 1991;79:302-305.
144. Galanello R, Melis MA, Podda A, et al. Deletion delta-thalassemia: the 7.2 kb deletion of Corfu delta beta-thalassemia in a non-beta-thalassemia chromosome. *Blood* 1990;75:1747-1749.
145. Kulozik AE, Bellan-Koch A, Kohne E, Kleihauer E. A deletion/inversion rearrangement of the beta-globin gene cluster in a Turkish family with delta beta zero-thalassemia intermedia. *Blood* 1992;79:2455-2459.
146. Craig JE, Barnetson RA, Prior J, et al. Rapid detection of deletions causing delta beta thalassemia and hereditary persistence of fetal hemoglobin by enzymatic amplification. *Blood* 1994;83:1673-1682.
147. Sankaran VG, Xu J, Byron R, et al. A functional element necessary for fetal hemoglobin silencing. *N Engl J Med* 2011;365:807-814.
148. Kulozik AE, Yarwood N, Jones RW. The Corfu delta beta zero thalassemia: a small deletion acts at a distance to selectively abolish beta globin gene expression. *Blood* 1988;71:457-462.
149. Pirastu M, Kan YW, Galanello R, Cao A. Multiple mutations produce delta beta 0 thalassemia in Sardinia. *Science (New York, NY)* 1984;223:929-930.

150. Zeng YT, Huang SZ, Chen B, et al. Hereditary persistence of fetal hemoglobin or (delta beta)0-thalassemia: three types observed in South-Chinese families. *Blood* 1985;66:1430-1435.
151. Atweh GF, Zhu XX, Brickner HE, et al. The beta-globin gene on the Chinese delta beta-thalassemia chromosome carries a promoter mutation. *Blood* 1987;70:1470-1474.
152. Balta G, Brickner HE, Takegawa S, et al. Increased expression of the G gamma and A gamma globin genes associated with a mutation in the A gamma enhancer. *Blood* 1994;83:3727-3737.
153. Camaschella C, Serra A, Gottardi E, et al. A new hereditary persistence of fetal hemoglobin deletion has the breakpoint within the 3' beta-globin gene enhancer. *Blood* 1990;75:1000-1005.
154. Collins FS, Cole JL, Lockwood WK, Iannuzzi MC. The deletion in both common types of hereditary persistence of fetal hemoglobin is approximately 105 kilobases. *Blood* 1987;70:1797-1803.
155. Thein S, Weatherall D. A non-deletion hereditary persistence of fetal hemoglobin (HPFH) determinant not linked to the beta-globin gene complex. In: Stamatoyannopoulos G, Nierhuis A, eds. *Hemoglobin switching: cellular and molecular mechanism*. New York: Alan R Liss, 1989:97-111.
156. Seltzer WK, Abshire TC, Lane PA, et al. Molecular genetic studies in black families with sickle cell anemia and unusually high levels of fetal hemoglobin. *Hemoglobin* 1992;16:363-377.
157. Craig JE, Rochette J, Fisher CA, et al. Dissecting the loci controlling fetal haemoglobin production on chromosomes 11p and 6q by the regressive approach. *Nat Genet* 1996;12:58-64.
158. Dover GJ, Smith KD, Chang YC, et al. Fetal hemoglobin levels in sickle cell disease and normal individuals are partially controlled by an X-linked gene located at Xp22.2. *Blood* 1992;80:816-824.
159. Thein SL, Menzel S, Peng X, et al. Intergenic variants of HBS1L-MYB are responsible for a major quantitative trait locus on chromosome 6q23 influencing fetal hemoglobin levels in adults. *PNAS* 2007;104:1-6.
160. Lettre G, Sankaran VG, Bezerra MAC, et al. From the cover: DNA polymorphisms at the BCL11A, HBS1L-MYB, and -globin loci associate with fetal hemoglobin levels and pain crises in sickle cell disease. *Proc Natl Acad Sci* 2008;105:11869-11874.
161. Creary LE, Ulug P, Menzel S, et al. Genetic variation on chromosome 6 influences F cell levels in healthy individuals of African descent and HbF levels in sickle cell patients. *PLoS one* 2009;4:e4218.
162. Thein S, Menzel S, Lathrop M, Garner C. Control of fetal hemoglobin: new insights emerging from genomics and clinical implications. *Hum Mol Genet* 2009;18(R2):R216-23.
163. Galanello R, Sanna S, Perseu L, et al. Amelioration of Sardinian beta0 thalassemia by genetic modifiers. *Blood* 2009;114:3935-3937.
164. Danjou F, Anni F, Perseu L, et al. Genetic modifiers of beta-thalassemia and clinical severity assessed by age at first transfusion. *Haematologica* 2012;97(7):989-993.
165. Kimberland ML, Divoky V, Prchal J, et al. Full-length human L1 insertions retain the capacity for high frequency retrotransposition in cultured cells. *Hum Mol Genet* 1999;8:1557-1560.
166. Viprakasit V, Gibbons RJ, Broughton BC, et al. Mutations in the general transcription factor TFIID result in beta-thalassaemia in individuals with trichothiodystrophy. *Hum Mol Genet* 2001;10:2797-2802.
167. Mehaffey MG, Newton AL, Gandhi MJ, et al. X-linked thrombocytopenia caused by a novel mutation of GATA-1. *Cell* 2001;98:2681-2688.
168. Yu C, Niakan KK, Matsushita M, et al. X-linked thrombocytopenia with thalassemia from a mutation in the amino finger of GATA-1 affecting DNA binding rather than FOG-1 interaction. *Blood* 2002;100:2040-2045.
169. Badens C, Mattei MG, Imbert AM, et al. A novel mechanism for thalassaemia intermedia. *Lancet* 2002;359:132-133.
170. Galanello R, Perseu L, Perra C, et al. Somatic deletion of the normal beta-globin gene leading to thalassaemia intermedia in heterozygous beta-thalassaemic patients. *Br J Haematol* 2004;127:604-606.
171. Finch CA, Deubelbeiss K, Cook JD, et al. Ferrokinetics in man. *Medicine* 1970;49:17-53.

172. Rachmilewitz EA, Schrier SL. Pathophysiology of beta thalassemia. In: Steinberg MH, Forget B, Higgs D, et al., eds. Disorders of hemoglobin: genetics, pathophysiology, and clinical management. Cambridge: Cambridge University Press, 2001:233-251.
173. Oner R, Kutlar F, Gu LH, Huisman TH. The Georgia type of nondeletional hereditary persistence of fetal hemoglobin has a C→T mutation at nucleotide-114 of the A gamma-globin gene. *Blood* 1991;77:1124-1125.
174. Fessas P, Loukopoulos D, Kaltsoya A. Peptide analysis of the inclusions of erythroid cells in beta-thalassemia. *Biochim Biophys Acta* 1966;124:430-432.
175. Wickramasinghe SN, Lee MJ, Furukawa T, et al. Composition of the intraerythroblastic precipitates in thalassaemia and congenital dyserythropoietic anaemia (CDA): identification of a new type of CDA with intra-erythroblastic precipitates not reacting with monoclonal antibodies to alpha- and beta-glob. *Br J Haematol* 1996;93:576-585.
176. Polliack A, Yataganas X, Rachmilewitz EA. Ultrastructure of the inclusion bodies and nuclear abnormalities in beta-thalassemic erythroblasts. *Ann N Y Acad Sci* 1974;232:261-282.
177. Schrier SL, Rachmilewitz E, Mohandas N. Cellular and membrane properties of alpha and beta thalassemic erythrocytes are different: implication for differences in clinical manifestations. *Blood* 1989;74:2194-2202.
178. Shinar E, Rachmilewitz EA, Lux SE. Differing erythrocyte membrane skeletal protein defects in alpha and beta thalassemia. *J Clin Invest* 1989;83:404-410.
179. Scott MD, Rouyer-Fessard P, Ba MS, et al. Alpha- and beta-haemoglobin chain induced changes in normal erythrocyte deformability: comparison to beta thalassaemia intermedia and Hb H disease. *Br J Haematol* 1992;80:519-526.
180. Yuan J, Kannan R, Shinar E, et al. Isolation, characterization, and immunoprecipitation studies of immune complexes from membranes of beta-thalassemic erythrocytes. *Blood* 1992;79:3007-3013.
181. Mannu F, Arese P, Cappellini MD, et al. Role of hemichrome binding to erythrocyte membrane in the generation of band-3 alterations in beta-thalassemia intermedia erythrocytes. *Blood* 1995;86:2014-2020.
182. Grinberg LN, Rachmilewitz EA, Kitrossky N, Chevion M. Hydroxyl radical generation in beta-thalassemic red blood cells. *Free Radic Biol Med* 1995;18:611-615.
183. Repka T, Shalev O, Reddy R, et al. Nonrandom association of free iron with membranes of sickle and beta-thalassemic erythrocytes. *Blood* 1993;82:3204-3210.
184. Shalev O, Repka T, Goldfarb A, et al. Deferiprone (L1) chelates pathologic iron deposits from membranes of intact thalassemic and sickle red blood cells both in vitro and in vivo. *Blood* 1995;86:2008-2013.
185. Browne PV, Shalev O, Kuypers FA, et al. Removal of erythrocyte membrane iron in vivo ameliorates the pathobiology of murine thalassemia. *J Clin Invest* 1997;100:1459-1464.
186. Chiu D, Lubin B. Oxidative hemoglobin denaturation and RBC destruction: the effect of heme on red cell membranes. *Semin Hematol* 1989;26:128-135.
187. Kihm AJ, Kong Y, Hong W, et al. An abundant erythroid protein that stabilizes free alpha-haemoglobin. *Nature* 2002;417.
188. Weiss MJ, Zhou S, Feng L, et al. Role of alpha-hemoglobin-stabilizing protein in normal erythropoiesis and beta-thalassemia. *Ann N Y Acad Sci* 2005;1054:103-117.
189. Schrier SL. Pathophysiology of thalassemia. *Curr Opin Hematol* 2002;9: 123-126.
190. Schrier SL, Centis F, Verneris M, et al. The role of oxidant injury in the pathophysiology of human thalassemias. *Redox Rep* 2003;8:241-245.
191. De Maria R, Testa U, Luchetti L, et al. Apoptotic role of Fas/Fas ligand system in the regulation of erythropoiesis. *Blood* 1999;93:796-803.
192. Rivella S. The role of ineffective erythropoiesis in non-transfusion-dependent thalassemia. *Blood Rev* 2012;26:S12-S15.
193. Tanno T, Bhanu NV, Oneal PA, et al. High levels of GDF15 in thalassemia suppress expression of the iron regulatory protein hepcidin. *Sci Technol* 2007;13:1096-1101.
194. Ganz T. Hepcidin—a regulator of intestinal iron absorption and iron recycling by macrophages. *Best Pract Res Clin Haematol* 2005;18:171-182.

195. Origa R, Galanello R, Ganz T, et al. Liver iron concentrations and urinary hepcidin in beta-thalassemia. *Haematologica* 2007;92:583-588.
196. Tanno T, Porayette P, Sripichai O, et al. Identification of TWSG1 as a second novel erythroid regulator of hepcidin expression in murine and human cells. *Blood* 2009;114:181-186.
197. Cappellini MD, Motta I, Musallam KM, Taher A. Redefining thalassemia as a hypercoagulable state. *Ann N Y Acad Sci* 2010;1202:231-236.
198. Borenstain-Ben Yashar V, Barenholz Y, Hy-Am E, et al. Phosphatidylserine in the outer leaflet of red blood cells from beta-thalassemia patients may explain the chronic hypercoagulable state and thrombotic episodes. *Am J Hematol* 1993;44:63-65.
199. Helley D, Eldor A, Girot R, et al. Increased procoagulant activity of red blood cells from patients with homozygous sickle cell disease and beta-thalassemia. *J Thromb Haemost* 1996;76:322-327.
200. Eldor A, Rachmilewitz E. The hypercoagulable state in thalassemia. *Blood* 2002;99:36-43.
201. Eldor A, Krausz Y, Atlan H, et al. Platelet survival in patients with betathalassemia. *Am J Hematol* 1989;32:94-99.
202. Cappellini MD, Musallam K, Poggiali E, Taher AT. Hypercoagulability in nontransfusion-dependent thalassemia. *Blood Rev* 2012;26:S20-S23.
203. Musumeci S, Leonardi S, Di Dio R, et al. Protein C and antithrombin III in polytransfused thalassaemic patients. *Acta Haematol* 1987;77:30-33.
204. Eldor A, Durst R, Hy-Am E, et al. A chronic hypercoagulable state in patients with beta-thalassaemia major is already present in childhood. *Br J Haematol* 1999;107:739-746.
205. Butthep P, Bunyaratvej A, Funahara Y, et al. Alterations in vascular endothelial cell-related plasma proteins in thalassaemic patients and their correlation with clinical symptoms. *J Thromb Haemost* 1995;74:1045-1049.
206. Hovav T, Goldfarb A, Artmann G, et al. Enhanced adherence of beta-thalassaemic erythrocytes to endothelial cells. *Br J Haematol* 1999;106:178-181.
207. Deo SS, Merchant SM, Kapadia AC. Elevated polymorphonuclear phagocytic function in thalassemia patients by chemiluminescence. *Indian J Pediatr* 1994;61:395-399.
208. Wiener E, Wanachiwanawin W, Chinprasertsuk S, et al. Increased serum levels of macrophage colony-stimulating factor (M-CSF) in alpha- and betathalassaemia syndromes: correlation with anaemia and monocyte activation. *Eur J Haematol* 1996;57:364-369.
209. Scott MD, Rouyer-Fessard P, Lubin BH, Beuzard Y. Entrapment of purified alpha-hemoglobin chains in normal erythrocytes. A model for beta thalassemia. *J Biol Chem* 1990;265:17953-17959.
210. Shalev O, Shinar E, Lux SE. Isolated beta-globin chains reproduce, in normal red cell membranes, the defective binding of spectrin to alpha-thalassaemic membranes. *Br J Haematol* 1996;94:273-278.
211. Shinar E, Rachmilewitz EA. Haemoglobinopathies and red cell membrane function. *Baillieres Clin Haematol* 1993;6:357-369.
212. Bunyaratvej A, Sahaphong S, Bhamarapravati N, Wasi P. Different patterns of intraerythrocytic inclusion body distribution in the two types of haemoglobin H disease. An ultrastructural study. *Acta Haematol* 1983;69:314-318.
213. Higgs D, Viprakasit V, Bowden D. Pathophysiology and clinical features of alpha thalassemia. In: Steinberg M, Forget B, Higgs D, eds. *Disorders of hemoglobin: genetic, pathophysiology and clinical management*. Cambridge: Cambridge University Press, 2009:266-295.
214. Wickramasinghe SN, Hughes M, Fucharoen S, Wasi P. The fate of excess beta-globin chains within erythropoietic cells in alpha-thalassaemia 2 trait, alpha-thalassaemia 1 trait, haemoglobin H disease and haemoglobin Q-H disease: an electron microscope study. *Br J Haematol* 1984;56:473-482.
215. Papassotiriou I, Traeger-Synodinos J, Kanavakis E, et al. Erythroid marrow activity and hemoglobin H levels in hemoglobin H disease. *J Pediatr Hematol Oncol* 1998;20:539-544.
216. Kuypers FA, Yuan J, Lewis RA, et al. Membrane phospholipid asymmetry in human thalassemia. *Blood* 1998;91:3044-3051.

217. Naito M, Nagashima K, Mashima T, Tsuruo T. Phosphatidylserine externalization is a downstream event of interleukin-1 beta-converting enzyme family protease activation during apoptosis. *Blood* 1997;89:2060-2066.
218. Schrier SL, Bunyaratvej A, Khuhapinant A, et al. The unusual pathobiology of hemoglobin constant spring red blood cells. *Blood* 1997;89:1762-1769.
219. Adirojnanon P, Wasi P. Levels of haemoglobin H and proportions of red cells with inclusion bodies in the two types of haemoglobin H disease. *Br J Haematol* 1980;46:507-509.
220. Chui DH, Wayne JS. Hydrops fetalis caused by alpha-thalassemia: an emerging health care problem. *Blood* 1998;91:2213-2222.
221. Benesh RE, Ranney HM, Benesh R, Smith GM. The chemistry of the Bohr effect. II. Some properties of hemoglobin H. *J Biol Chem* 1961;236:2926-2929.
222. Horton BF, Thompson RB, Dozy AM, et al. Inhomogeneity of hemoglobin. VI. The minor hemoglobin components of cord blood. *Blood* 1962;20:302-314.
223. Spanos T, Karageorga M, Ladis V, et al. Red cell alloantibodies in patients with thalassemia. *Vox Sang* 1990;58:50-55.
224. Thein SL, Menzel S, Peng X, et al. Intergenic variants of HBS1L-MYB are responsible for a major quantitative trait locus on chromosome 6q23 influencing fetal hemoglobin levels in adults. *Proc Natl Acad Sci U S A* 2007;104:11346-11351.
225. Galanello R, Cao A. Relationship between genotype and phenotype. Thalassemia intermedia. *Ann N Y Acad Sci* 1998;850:325-333.
226. Danjou F, Anni F, Perseu L, et al. Genetic modifiers of beta-thalassemia and clinical severity as assessed by age at first transfusion. *Haematologica* 2012;97(7):989-993.
227. Rund D, Oron-Karni V, Filon D, et al. Genetic analysis of beta-thalassemia intermedia in Israel: diversity of mechanisms and unpredictability of phenotype. *Am J Hematol* 1997;54:16-22.
228. Weatherall DJ. Single gene disorders or complex traits: lessons from the thalassaemias and other monogenic diseases. *BMJ (Clinical research ed)* 2000;321:1117-1120.
229. Galanello R, Piras S, Barella S, et al. Cholelithiasis and Gilbert's syndrome in homozygous beta-thalassaemia. *Br J Haematol* 2001;115:926-928.
230. Premawardhena A, Fisher CA, Fathiu F, et al. Genetic determinants of jaundice and gallstones in haemoglobin E beta thalassaemia. *Lancet* 2001;357:1945-1946.
231. Economou-Petersen E, Aessopos a, Kladi a, et al. Apolipoprotein E epsilon4 allele as a genetic risk factor for left ventricular failure in homozygous betathalassemia. *Blood* 1998;92:3455-3459.
232. Borgna-Pignatti C, Solinas A, Bombieri C, et al. The haemochromatosis mutations do not modify the clinical picture of thalassaemia major in patients regularly transfused and chelated. *Br J Haematol* 1998;103:813-816.
233. Longo F, Zecchina G, Sbaiz L, et al. The influence of hemochromatosis mutations on iron overload of thalassemia major. *Haematologica* 1999;84:799-803.
234. Vichinsky E. Complexity of alpha thalassemia: growing health problem with new approaches to screening, diagnosis, and therapy. *Ann N Y Acad Sci* 2010;1202:180-187.
235. Galanello R. Recent advances in the molecular understanding of non-transfusion-dependent thalassemia. *Blood Rev* 2012;26(Suppl 1):s7-s11.
236. Galanello R, Pirastu M, Melis MA, et al. Phenotype-genotype correlation in haemoglobin H disease in childhood. *J Med Genet* 1983;20:425-429.
237. Origa R, Sollaino MC, Giagu N, et al. Clinical and molecular analysis of haemoglobin H disease in Sardinia: haematological, obstetric and cardiac aspects in patients with different genotypes. *Br J Haematol* 2007;136: 326-332.
238. Fucharoen S, Viprakasit V. Hb H disease: clinical course and disease modifiers. *Hematology (Am Soc Hematol Educ Program)* 2009:26-34.
239. Lal A, Goldrich ML, Haines DA, et al. Heterogeneity of hemoglobin H disease in childhood. *N Engl J Med* 2011;364:710-718.

240. Galanello R, Paglietti E, Giagu L, et al. Phenotypic manifestations of heterozygous non-deletion alpha-thalassaemia (alpha alpha/(alpha alpha)th) in Sardinians. *Br J Haematol* 1983;55:711-713.
241. Galanello R, Cao A. Gene test review. Alpha-thalassemia. *Genet Med* 2011;13:83-88.
242. Higgs D. The pathophysiology and clinical features of alpha thalassemia. In: Steinberg MH, Forget B, Higgs D, Weatherall D, eds. *Disorders of hemoglobin: genetic, pathophysiology and clinical management*. Cambridge: Cambridge University Press, 2009:266-295.
243. Higgs DR, Lamb J, Aldridge BE, et al. Inadequacy of Hb Bart's as an indicator of alpha thalassaemia. *Br J Haematol* 1982;51:177-178.
244. Galanello R, Maccioni L, Ruggeri R, et al. Alpha thalassaemia in Sardinian newborns. *Br J Haematol* 1984;58:361-368.
245. Higgs DR. Gene regulation in hematopoiesis: new lessons from thalassemia. *Hematology (Am Soc Hematol Educ Program)* 2004:1-13.
246. Ganczakowski M, Bowden DK, Maitland K, et al. Thalassaemia in Vanuatu, south-west Pacific: frequency and haematological phenotypes of young children. *Br J Haematol* 1995;89:485-495.
247. Williams TN, Maitland K, Ganczakowski M, et al. Red blood cell phenotypes in the alpha + thalassaemias from early childhood to maturity. *Br J Haematol* 1996;95:266-272.
248. Galanello R, Monne MI, Paderi L, et al. Homozygous non-deletion alpha 2 globin gene mutation (initiation codon mutation): clinical and haematological phenotype. *Br J Haematol* 1991;79:117-119.
249. Pootrakul P, Winichagoon P, Fucharoen S, et al. Homozygous haemoglobin Constant Spring: a need for revision of concept. *Hum Genet* 1981;59:250-255.
250. Paglietti E, Galanello R, Moi P, et al. Molecular pathology of haemoglobin H disease in Sardinians. *Br J Haematol* 1986;63:485-496.
251. Singer S, Kim H-Y, Olivieri N, et al. Hemoglobin H-constant spring in North America: an alpha thalassemia with frequent complications. *Am J Hematol* 2009;84:759-761.
252. Chan V, Chan TK, Liang ST, et al. Hydrops fetalis due to an unusual form of Hb H disease. *Blood* 1985;66:224-228.
253. Ko TM, Hsieh FJ, Hsu PM, Lee TY. Molecular characterization of severe alpha-thalassemsias causing hydrops fetalis in Taiwan. *American J Med Genet* 1991;39:317-320.
254. Lorey F, Charoenkwan P, Witkowska HE, et al. Hb H hydrops foetalis syndrome: a case report and review of literature. *Br J Haematol* 2001;115:72-78.
255. Viprakasit V, Green S, Height S, et al. Hb H hydrops fetalis syndrome associated with the interaction of two common determinants of a thalassaemia (-MED/a TSaudi a). *Br J Haematol* 2002;759-762.
256. Wasi P, Na-Nakorn S, Pootrakul S. The alpha thalassaemias. *Clin Haematol* 1974;3:383-410.
257. Chen FE, Ooi C, Ha SY, et al. Genetic and clinical features of hemoglobin H disease in Chinese patients. *N Engl J Med* 2000;343:544-550.
258. Tso SC, Chan TK, Todd D. Venous thrombosis in haemoglobin H disease after splenectomy. *Aust N Z J Med* 1982;12:635-638.
259. Sonakul D, Fucharoen S. Pulmonary thromboembolism in thalassaemic patients. *Southeast Asian J Trop Med Public Health* 1992;23(Suppl 2):25-28.
260. Kattamis C, Metaxotou-Mavromati A, Tsiarta E, et al. Haemoglobin Bart's hydrops syndrome in Greece. *Br Med J* 1980;281:268-270.
261. Galanello R, Sanna MA, Maccioni L, et al. Fetal hydrops in Sardinia: implications for genetic counselling. *Clin Genet* 1990;38:327-331.
262. Srisupundit K, Piyamongkol W, Tongsong T. Comparison of red blood cell hematology among normal, alpha-thalassaemia-1 trait, and hemoglobin Bart's fetuses at mid-pregnancy. *Am J Hematol* 2008;83:908-910.
263. Lee SYR, Chow CB, Li CK, Chiu MC. Outcome of intensive care of homozygous alpha-thalassaemia without prior intra-uterine therapy. *J Paediatr Child Health* 2007;43:546-550.
264. Pootrakul S, Wasi P, Na-Nakorn S. Haemoglobin Bart's hydrops foetalis in Thailand. *Ann Hum Genet* 1967;30:293-311.

265. Diukman R, Golbus MS. In utero stem cell therapy. *J Reprod Med* 1992;37:515-520.
266. Westgren M, Ringden O, Eik-Nes S, et al. Lack of evidence of permanent engraftment after in utero fetal stem cell transplantation in congenital hemoglobinopathies. *Transplantation* 1996;61:1176-1179.
267. Vichinsky EP. Alpha thalassemia major—new mutations, intrauterine management, and outcomes. *Hematology (Am Soc Hematol Educ Program)* 2009:35-41.
268. Moise KJ. The usefulness of middle cerebral artery Doppler assessment in the treatment of the fetus at risk for anemia. *Am J Obstet Gynecol* 2008;198:161.e1-161.e4.
269. Yi JS, Moertel CL, Baker KS. Homozygous alpha-thalassemia treated with intrauterine transfusions and unrelated donor hematopoietic cell transplantation. *J Pediatr* 2009;154:766-768.
270. Leung KY, Lee CP, Tang MHY, et al. Cost-effectiveness of prenatal screening for thalassaemia in Hong Kong. *Prenat Diagn* 2004;24:899-907.
271. Liao C, Mo Q-H, Li J, et al. Carrier screening for alpha- and beta-thalassemia in pregnancy: the results of an 11-year prospective program in Guangzhou Maternal and Neonatal hospital. *Prenat Diagn* 2005;25:163-171.
272. Higgs D, Buckle V, Gibbons R, Steensma D. Unusual types of alpha thalassemia. In: Steinberg M, Forget B, Higgs D, Weatherall D, eds. *Disorders of hemoglobin: genetics, pathophysiology and clinical management*. Cambridge: Cambridge University Press, 2009:296-321.
273. Higgs DR, Wood WG, Barton C, Weatherall DJ. Clinical features and molecular analysis of acquired hemoglobin H disease. *Am J Med* 1983;75:181-191.
274. Craddock C. *Normal and abnormal regulation of human α globin expression*. Oxford: University of Oxford, 1994.
275. Gibbons RJ, Pellagatti A, Garrick D, et al. Identification of acquired somatic mutations in the gene encoding chromatin-remodeling factor ATRX in the alpha-thalassemia myelodysplasia syndrome (ATMDS). *Nat Genet* 2003;34:446-449.
276. Steensma DP, Viprakasit V, Hendrick A, et al. Deletion of the alpha-globin gene cluster as a cause of acquired alpha-thalassemia in myelodysplastic syndrome. *Blood* 2004;103:1518-1520.
277. Wilkie AO, Zeitlin HC, Lindenbaum RH, et al. Clinical features and molecular analysis of the alpha thalassemia/mental retardation syndromes. II. Cases without detectable abnormality of the alpha globin complex. *Am J Hum Genet* 1990;46:1127-1140.
278. Gibbons RJ, Higgs DR. ATRX: taming tandem repeats. *Cell cycle (Georgetown, Tex)* 2010;9:4605-4606.
279. Gibbons R. Alpha thalassaemia-mental retardation, X-linked. *Orphanet J Rare Dis* 2006;1:15.
280. Picketts DJ, Higgs DR, Bachoo S, et al. ATRX encodes a novel member of the SNF2 family of proteins: mutations point to a common mechanism underlying the Atrx syndrome. *Hum Mol Genet* 1996;5:1899-1907.
281. Gibbons R, Higgs D. The alpha thalassemia/mental retardation syndromes. In: MH S, BG F, Higgs DR et al., eds. *Disorders of hemoglobin: genetics, pathophysiology and clinical management*. Cambridge: Cambridge University Press, 2001:470-488.
282. Gibbons RJ, Wada T, Fisher CA, et al. Mutations in the chromatin-associated protein ATRX. *Hum Mutat* 2008;29:796-802.
283. De La Fuente R, Baumann C, Viveiros MM. Role of ATRX in chromatin structure and function: implications for chromosome instability and human disease. *Reproduction (Cambridge, England)* 2011;142:221-234.
284. Mitson M, Kelley LA, Sternberg ME, et al. Functional significance of mutations in the Snf2 domain of ATRX. *Hum Mol Genet* 2011;20:2603-2610.
285. Lie-Injo LE, Dozy AM, Kan YW, et al. The alpha-globin gene adjacent to the gene for HbQ-alpha 74 Asp replaced by His is deleted, but not that adjacent to the gene for HbG-alpha 30 Glu replaced by Gln; three-fourths of the alpha-globin genes are deleted in HbQ-alpha-thalassemia. *Blood* 1979;54: 1407-1416.
286. Lieinjo L E, Pillay RP, Thuraisingham V. Further cases of Hb Q-H disease (Hb Q-alpha thalassemia). *Blood* 1966;28:830-839.

287. Sukumaran PK, Merchant SM, Desai MP, et al. Haemoglobin Q India (alpha 64(E13) aspartic acid histidine) associated with beta-thalassemia observed in three Sindhi families. *J Med Genet* 1972;9:436-442.
288. Rieder RF, Woodbury DH, Rucknagel DL. The interaction of alpha-thalassaemia and haemoglobin G Philadelphia. *Br J Haematol* 1976;32:159-165.
289. Atwater J, Schwartz IR, Erslev AJ, et al. Sickling of erythrocytes in a patient with thalassemia-hemoglobin-I disease. *N Engl J Med* 1960;263:1215-1223.
290. Felice AE, Cleek MP, McKie K, et al. The rare alpha-thalassemia-1 of blacks is a zeta alpha-thalassemia-1 associated with deletion of all alpha- and zeta globin genes. *Blood* 1984;63:1253-1257.
291. Matthay KK, Mentzer WC, Dozy AM, et al. Modification of hemoglobin H disease by sickle trait. *J Clin Invest* 1979;64:1024-1032.
292. Kulozik AE, Kar BC, Serjeant GR, et al. The molecular basis of alpha thalassemia in India. Its interaction with the sickle cell gene. *Blood* 1988;71: 467-472.
293. Embury SH, Dozy AM, Miller J, et al. Concurrent sickle-cell anemia and alpha-thalassemia: effect on severity of anemia. *N Engl J Med* 1982;306: 270-274.
294. Higgs DR, Aldridge BE, Lamb J, et al. The interaction of alpha-thalassemia and homozygous sickle-cell disease. *N Engl J Med* 1982;306:1441-1446.
295. Cooley T, Lee P. A series of cases of splenomegaly in children with anemia and peculiar bone changes. *Trans Am Pediatr Soc* 1925;39:29-34.
296. Cooley T, Witwer E. Anemia in children with splenomegaly and peculiar changes in the bones. Report of cases. *Am J Dis Child* 1927;34:347.
297. Rietti F. Sugli itteri emolitici primitivi. Comunicazione all'Accademia delle Scienze Naturali di Ferrara 1924;II.
298. Whipple G, Bradford W. Racial and familial anemia of children. *Am J Dis Child* 1932;44:336.
299. Valentine W, Neel J. Hematologic and genetic study of the transmission of thalassemia. *Arch Int Med* 1944:185.
300. Ravenna F, Canella C. Una forma nuova di grave anemia infantile associata ad osteoporosi diffusa. *Policlinico* 1934;41:807-814.
301. Caminopetros J. L'anémie Erythroblastique. *Monographies. Acad d'Athènes* 1937;6:3.
302. Wintrobe M, Mathews E. A familial hemopoietic disorder in Italian adolescents and adults resembling Mediterranean disease (thalassemia). *JAMA* 1940;114:1530.
303. Bianco Silvestroni I. Le talassemie. Un problema medico-sociale: ieri e oggi. *Ist Ital Di Med Soc Ed Roma* 1998:163-167.
304. Kunkel HG, Wallenius G. New hemoglobin in normal adult blood. *Science (New York, NY)* 1955;122:288.
305. Silvestroni E, Bianco I, Modiano G. Sul valore discriminante dell'Hb A2 tra soggetti normali e microcitemici. *Il Prog Med* 1957;13:772.
306. Vecchio F. Sulla resistenza della emoglobina alla denaturazione alcalina in alcune sindromi emopatiche. *Pediatria* 1946;54:545.
307. Finch CA, Sturgeon P. Erythrokinetics in Cooley's anemia. *Blood* 1957;12: 64-73.
308. Perutz MF. Structure of hemoglobin. *Brookhaven Symp Biol* 1960;13: 165-183.
309. Weatherall DJ, Clegg JB, Naughton MA. Globin synthesis in thalassaemia: an in vitro study. *Nature* 1965;208:1061-1065.
310. Modell C, Berdoukas V. The clinical approach to thalassaemia. New York: Grune and Stratton, 1984.
311. Kattamis CA, Kattamis AC. Management of thalassemias: growth and development, hormone substitution, vitamin supplementation, and vaccination. *Semin Hematol* 1995;32:269-279.
312. Cao A, Galanello R, Rosatelli MC, et al. Clinical experience of management of thalassemia: the Sardinian experience. *Semin Hematol* 1996;33:66-75.

313. Orzincolo C, Castaldi G, Scutellari PN, Franceschini F. The "lamellated" skull in beta-thalassaemia. *Skeletal Radiol* 1989;18:373-376.
314. Wonke B. Bone disease in beta-thalassaemia major. *Br J Haematol* 1998;103:897-901.
315. Colavita N, Orazi C, Danza SM, et al. Premature epiphyseal fusion and extra-medullary hematopoiesis in thalassemia. *Skeletal Radiol* 1987;16:533-538.
316. Eskazan AE, Ar MC, Baslar Z. Intracranial extramedullary hematopoiesis in patients with thalassemia: a case report and review of the literature. *Transfusion* 2012.
317. Tunaci M, Tunaci A, Engin G, et al. Pictorial review. Imaging features of thalassemia. 1999;1809:1804-1809.
318. Sheikha A, Kameswaran M, Okafor BC, al-Saigh AA. Otological manifestations of thalassaemia intermedia: evidence of temporal bone involvement and report of a unique cholesteatoma-like lesion. *J Laryngol Otol* 1992;106: 316-321.
319. Aarabi B, Haghshenas M, Rakeii V. Visual failure caused by suprasellar extra-medullary hematopoiesis in beta thalassemia: case report. *Neurosurgery* 1998;42:922-925; discussion 925-926.
320. W.H.O. Who scientific group on the assessment of osteoporosis at primary health. Summary Meeting Report 2004;May.
321. Origa R, Fiumana E, Gamberini MR, et al. Osteoporosis in beta-thalassemia: clinical and genetic aspects. *Ann N Y Acad Sci* 2005;1054:451-456.
322. Perrotta S, Cappellini MD, Bertoldo F, et al. Osteoporosis in beta-thalassaemia major patients: analysis of the genetic background. *Br J Haematol* 2000;111:461-466.
323. Guzeloglu-Kayisli O, Cetin Z, Keser I, et al. Relationship between SP1 polymorphism and osteoporosis in beta-thalassemia major patients. *Pediatr Int* 2008;50:474-476.
324. Dresner Pollack R, Rachmilewitz E, Blumenfeld A, et al. Bone mineral metabolism in adults with beta-thalassaemia major and intermedia. *Br J Haematol* 2000;111:902-907.
325. Wonke B, Jensen C, Hanslip JJ, et al. Genetic and acquired predisposing factors and treatment of osteoporosis in thalassaemia major. *J Pediatr Endocrinol Metab* 1998;11(Suppl 3):795-801.
326. Haidar R, Musallam KM, Taher AT. Bone disease and skeletal complications in patients with beta thalassemia major. *Bone* 2011;48:425-432.
327. Voskaridou E, Terpos E. New insights into the pathophysiology and management of osteoporosis in patients with beta thalassaemia. *Br J Haematol* 2004;127:127-139.
328. Vogiatzi MG, Macklin EA, Trachtenberg FL, et al. Differences in the prevalence of growth, endocrine and vitamin D abnormalities among the various thalassaemia syndromes in North America. *Br J Haematol* 2009;146: 546-556.
329. Jensen CE, Tuck SM, Agnew JE, et al. High prevalence of low bone mass in thalassaemia major. *Br J Haematol* 1998;103:911-915.
330. Voskaridou E, Christoulas D, Plata E, et al. High circulating sclerostin is present in patients with thalassemia-associated osteoporosis and correlates with bone mineral density. *Horm Metab Res* 2012;44(12):909-913.
331. Voskaridou E, Kyrtsolis MC, Terpos E, et al. Bone resorption is increased in young adults with thalassaemia major. *Br J Haematol* 2001;112:36-41.
332. Angelopoulos NG, Goula A, Katounda E, et al. Markers of bone metabolism in eugonadal female patients with beta-thalassemia major. *Pediatr Hematol Oncol* 24:481-491.
333. Morabito N, Russo GT, Gaudio A, et al. The "lively" cytokines network in betathalassemia Major-related osteoporosis. *Bone* 2007;40:1588-1594.
334. Morabito N, Gaudio A, Lasco A, et al. Osteoprotegerin and RANKL in the pathogenesis of thalassemia-induced osteoporosis: new pieces of the puzzle. *J Bone Miner Res* 2004;19:722-727.
335. Pietrapertosa AC, Minenna G, Colella SM, et al. Osteoprotegerin and RANKL in the pathogenesis of osteoporosis in patients with thalassaemia major. *Panminerva med* 2009;51:17-23.
336. Michelson J, Cohen A. Incidence and treatment of fractures in thalassemia. *J Orthop Trauma* 1988;2:29-32.

337. Vogiatzi MG, Macklin EA, Fung EB, et al. Bone disease in thalassemia: a frequent and still unresolved problem. *J Bone Miner Res* 2009;24:543-557.
338. Angastiniotis M, Pavlides N, Aristidou K, et al. Bone pain in thalassaemia: assessment of DEXA and MRI findings. *J Pediatr Endocrinol Metab* 1998;11(Suppl 3):779-784.
339. de Sanctis V, Savarino L, Stea S, et al. Microstructural analysis of severe bone lesions in seven thalassemic patients treated with deferoxamine. *Calcif Tissue Int* 2000;67:128-133.
340. Desigan S, Hall-Craggs MA, Ho C-P, et al. Degenerative disc disease as a cause of back pain in the thalassaemic population: a case-control study using MRI and plain radiographs. *Skeletal Radiol* 2006;35:95-102.
341. Trachtenberg F, Foote D, Martin M, et al. Pain as an emergent issue in thalassemia. *Am J Hematol* 2010;85:367-370.
342. Terpos E, Voskaridou E. Treatment options for thalassemia patients with osteoporosis. *Ann N Y Acad Sci* 2010;1202:237-243.
343. Voskaridou E, Terpos E, Spina G, et al. Pamidronate is an effective treatment for osteoporosis in patients with beta-thalassaemia. *Br J Haematol* 2003;123:730-737.
344. Pennisi P, Pizzarelli G, Spina M, et al. Quantitative ultrasound of bone and clodronate effects in thalassemia-induced osteoporosis. *J Bone Miner Metab* 2003;21:402-408.
345. Voskaridou E, Christoulas D, Konstantinidou M, et al. Continuous improvement of bone mineral density two years post zoledronic acid discontinuation in patients with thalassemia-induced osteoporosis: long-term follow-up of a randomized, placebo-controlled trial. *Haematologica* 2008;93:1588-1590.
346. Forni GL, Perrotta S, Giusti A, et al. Neridronate improves bone mineral density and reduces back pain in beta-thalassaemia patients with osteoporosis: results from a phase 2, randomized, parallel-arm, open-label study. *Br J Haematol* 2012;158(2):274-282.
347. Canatan D, Akar N, Arcasoy A. Effects of calcitonin therapy on osteoporosis in patients with thalassemia. *Acta Haematol* 1995;93:20-24.
348. Borgna-Pignatti C, De Stefano P, Pajno D, et al. Cholelithiasis in children with thalassemia major: an ultrasonographic study. *J Pediatr* 1981;99:243-244.
349. Dewey KW, Grossman H, Canale VC. Cholelithiasis in thalassemia major. *Radiology* 1970;96:385-388.
350. Borgna-Pignatti C, Rigon F, Merlo L, et al. Thalassemia minor, the Gilbert mutation, and the risk of gallstones. *Haematologica* 2003;88:1106-1109.
351. Origa R, Galanello R, Perseu L, et al. Cholelithiasis in thalassemia major. *Eur J Haematol* 2009;82:22-25.
352. Borgna-Pignatti C, Franchini M, Gandini G, et al. Subcutaneous bolus injection of deferoxamine in adult patients affected by onco-hematologic diseases and iron overload. *Haematologica* 1998;83:788-790.
353. Moratelli S, De Sanctis V, Gemmati D, et al. Thrombotic risk in thalassemic patients. *J Pediatr Endocrinol Metab* 1998;11(Suppl 3):915-921.
354. Taher A, Isma'eel H, Mehio G, et al. Prevalence of thromboembolic events among 8,860 patients with thalassaemia major and intermedia in the Mediterranean area and Iran.
355. Tripodi A, Cappellini MD, Chantarangkul V, et al. Hypercoagulability in splenectomized thalassemic patients detected by whole-blood thromboelastometry, but not by thrombin generation in platelet-poor plasma. *Haematologica* 2009;94:1520-1527.
356. Cappellini MD, Robbiolo L, Bottasso BM, et al. Venous thromboembolism and hypercoagulability in splenectomized patients with thalassaemia intermedia. *Br J Haematol* 2000;111:467-473.
357. Jiang Q, Endo M, Dibra F, et al. Pseudoxanthoma elasticum is a metabolic disease. *J Invest Dermatol* 2009;129:348-354.
358. Uitto J, Li Q, Jiang Q. Pseudoxanthoma elasticum: molecular genetics and putative pathomechanisms. *J Invest Dermatol* 2010;130:661-670.
359. Chassaing N, Martin L, Calvas P, et al. Pseudoxanthoma elasticum: a clinical, pathophysiological and genetic update including 11 novel ABCC6 mutations. *J Med Genet* 2005;42:881-892.

360. Hu X, Plomp AS, van Soest S, et al. Pseudoxanthoma elasticum: a clinical, histopathological, and molecular update. *Surv Ophthalmol* 2003;48:424-438.
361. Paton D. Angioid streaks and sickle cell anemia: a report of two cases. *Arch Ophthalmol* 1959;62:852-858.
362. Suerig K, Siefert F. Pseudoxanthoma elasticum and sickle cell anemia. *Arch Intern Med* 1964;113:135-141.
363. Aessopos A, Stamatelos G, Savvides P, et al. Pseudoxanthoma elasticum and angioid streaks in two cases of beta-thalassaemia. *Clin Rheumatol* 1989;8:522-527.
364. Aessopos A, Savvides P, Stamatelos G, et al. Pseudoxanthoma elasticumlike skin lesions and angioid streaks in beta-thalassemia. *Am J Hematol* 1992;41:159-164.
365. Aessopos A, Voskaridou E, Kavouklis E, et al. Angioid streaks in sicklethalassemia. *Am J Ophthalmol* 1994;117:589-592.
366. Baccarani-Contri M, Bacchelli B, Boraldi F, et al. Characterization of pseudoxanthoma elasticum-like lesions in the skin of patients with beta-thalassemia. *J Am Acad Dermatol* 2001;44:33-39.
367. Fabbri E, Forni GL, Guerrini G, Borgna-Pignatti C. Pseudoxanthomaelasticum-like syndrome and thalassemia: an update. *Dermatol Online J* 2009;15:7.
368. Aessopos A, Samarkos M, Voskaridou E, et al. Arterial calcifications in betathalassemia. *Angiology* 1998;49:137-143, 176.
369. Hamlin N, Beck K, Bacchelli B, et al. Acquired Pseudoxanthoma elasticum-like syndrome in beta-thalassaemia patients. *Br J Haematol* 2003;122:852-854.
370. Aessopos A, Farmakis D, Loukopoulos D. Elastic tissue abnormalities in inherited haemolytic syndromes. *Eur J Clin Invest* 2002;32:640-642.
371. Martin L, Douet V, VanWart CM, et al. A mouse model of beta-thalassemia shows a liver-specific down-regulation of Abcc6 expression. *Am J Pathol* 2011;178:774-783.
372. Farmakis D, Deftereos S, Giakoumis A, et al. Rupture of chordae tendineae in patients with beta-thalassemia. *Eur J Haematol* 2004;72:296-298.
373. Aessopos A, Farmakis D, Karagiorga M, et al. Cardiac involvement in thalassemia intermedia: a multicenter study. *Blood* 2001;97:3411-3416.
374. Farmakis D, Moysakis I, Perakis A, et al. Unstable angina associated with coronary arterial calcification in a thalassemia intermedia patient with a pseudoxanthoma elasticum-like syndrome. *Eur J Haematol* 2003;70: 64-66.
375. Farmakis D, Vesleme V, Papadogianni A, et al. Aneurysmatic dilatation of ascending aorta in a patient with beta-thalassemia and a pseudoxanthoma elasticum-like syndrome. *Ann Hematol* 2004;83:596-599.
376. Cianciulli P, Sorrentino F, Maffei L, et al. Cardiovascular involvement in thalassaemic patients with pseudoxanthoma elasticum-like skin lesions: a long-term follow-up study. *Eur J Clin Invest* 2002;32:700-706.
377. Sherer DW, Singer G, Uribarri J, et al. Oral phosphate binders in the treatment of pseudoxanthoma elasticum. *J Am Acad Dermatol* 2005;53:610-615.
378. Li Q, Larusso J, Grand-Pierre AE, Uitto J. Magnesium carbonate-containing phosphate binder prevents connective tissue mineralization in Abcc6(-/-) mice-potential for treatment of pseudoxanthoma elasticum. *Clin Translation Sci* 2009;2:398-404.
379. LaRusso J, Li Q, Jiang Q, Uitto J. Elevated dietary magnesium prevents connective tissue mineralization in a mouse model of pseudoxanthoma elasticum (Abcc6(-/-)). *J Invest Dermatol* 2009;129:1388-1394.
380. Gorgels TGMF, Waarsing JH, de Wolf A, et al. Dietary magnesium, not calcium, prevents vascular calcification in a mouse model for pseudoxanthoma elasticum. *J Mol Med (Berlin, Germany)* 2010;88:467-475.
381. Finger RP, Charbel Issa P, Schmitz-Valckenberg S, et al. Long-term effectiveness of intravitreal bevacizumab for choroidal neovascularization secondary to angioid streaks in pseudoxanthoma elasticum. *Retina (Philadelphia, PA)* 2011;31:1268-1278.

382. Uitto J, Bercovitch L, Terry SF, Terry PF. Pseudoxanthoma elasticum: progress in diagnostics and research towards treatment: summary of the 2010 PXE International Research Meeting. *American J Med Genet Part A* 2011;155A:1517-1526.
383. Paik CH, Alavi I, Dunea G, Weiner L. Thalassemia and gouty arthritis. *JAMA* 1970;213:296-297.
384. Ryan K, Bain B, Worthington D, et al. Significant haemoglobinopathies: guidelines for screening and diagnosis. *Br J Haematol* 2010;149:35-49.
385. Old J, Traeger-Synodinos J, Galanello R, et al. Prevention of thalassemias and other haemoglobin disorders. Cyprus: Thalassemia International Federation, 2012.
386. Old JM. Screening and genetic diagnosis of haemoglobinopathies. *Scand J Clin Lab Invest* 2007;67:71-86.
387. Wolman IJ. Transfusion therapy in Cooley's anemia: growth and health as related to long-range hemoglobin levels. A progress report. *Ann N Y Acad Sci* 1964;119:736-747.
388. Wolman IJ, Ortolani M. Some clinical features of Cooley's anemia patients as related to transfusion schedules. *Ann N Y Acad Sci* 1969;165:407-414.
389. Piomelli S, Danoff SJ, Becker MH, et al. Prevention of bone malformations and cardiomegaly in Cooley's anemia by early hypertransfusion regimen. *Ann N Y Acad Sci* 1969;165:427-436.
390. Propper RD, Button LN, Nathan DG. New approaches to the transfusion management of thalassemia. *Blood* 1980;55:55-60.
391. Gabutti V, Piga A, Nicola P, et al. Haemoglobin levels and blood requirement in thalassaemia. *Arch Dis Child* 1982;57:156-158.
392. Piomelli S. Management of Cooley's anaemia. *Baillieres Clin Haematol* 1993;6:287-298.
393. Cazzola M, Borgna-Pignatti C, Locatelli F, et al. A moderate transfusion regimen may reduce iron loading in beta-thalassemia major without producing excessive expansion of erythropoiesis. *Transfusion* 1997;37:135-140.
394. Cappellini M, Cohen A, Eleftheriou A, et al. Guidelines for the clinical management of thalassemia. *Thalassaemia International Federation* 2008, November.
395. Cohen AR, Schmidt JM, Martin MB, et al. Clinical trial of young red cell transfusions. *J Pediatr* 1984;104:865-868.
396. Marcus RE, Wonke B, Bantock HM, et al. A prospective trial of young red cells in 48 patients with transfusion-dependent thalassaemia. *Br J Haematol* 1985;60:153-159.
397. Cohen AR, Glimm E, Porter JB. Effect of transfusional iron intake on response to chelation therapy in beta-thalassemia major. *Blood* 2008;111:583-587.
398. Borgna-Pignatti C. Seasonal variation of pretransfusion hemoglobin levels in patients with thalassemia major. *Blood* 2006;107:355-357.
399. Rebutta P, Modell B. Transfusion requirements and effects in patients with thalassaemia major. *CooleyCare Programme*. *Lancet* 1991;337:277-280.
400. Rebutta P. Transfusion reactions in thalassemia. A survey from the CooleyCare programme. The CooleyCare Cooperative Group. *Haematologica* 1990;75(Suppl 5):122-127.
401. Thompson AA, Cunningham MJ, Singer ST, et al. Red cell alloimmunization in a diverse population of transfused patients with thalassaemia. *Br J Haematol* 2011;153:121-128.
402. el-Danasoury AS, Eissa DG, Abdo RM, Elalfy MS. Red blood cell alloimmunization in transfusion-dependent Egyptian patients with thalassemia in a limited donor exposure program. *Transfusion* 2012;52:43-47.
403. Singer ST, Wu V, Mignacca R, et al. Alloimmunization and erythrocyte autoimmunization in transfusion-dependent thalassemia patients of predominantly Asian descent. *Blood* 2000;96:3369-3373.
404. Shaz BH, Hillyer CD. Minority donation in the United States: challenges and needs. *Curr Opin Hematol* 2010;17:544-549.
405. Mirmomen S, Alavian S-M, Hajarizadeh B, et al. Epidemiology of hepatitis B, hepatitis C, and human immunodeficiency virus infections in patients with betathalassemia in Iran: a multicenter study. *Arch Iran Med* 2006;9:319-323.

406. Wanachiwanawin W, Thianprasit M, Fucharoen S, et al. Fatal arteritis due to *Pythium insidiosum* infection in patients with thalassaemia. *Trans R Soc Trop Med Hyg* 1993;87:296-298.
407. Cunningham MJ. Complications of thalassemia major in North America. *Blood* 2004;104:34-39.
408. Al-Kubaisy WA, Al-Naib KT, Habib M. Seroprevalence of hepatitis C virus specific antibodies among Iraqi children with thalassaemia. *East Mediterr Health J* 2006;12(1-2):204-210.
409. Wonke B, Hoffbrand AV, Brown D, Dusheiko G. Antibody to hepatitis C virus in multiply transfused patients with thalassaemia major. *J Clin Pathol* 1990;43:638-640.
410. Gamberini MR, Francesconi R, Fortini M, et al. HCV and HGV infection, iron overload and liver disease in multitransfused patients with thalassaemia and persistently normal or abnormal transaminase levels. *Pediatr Endocrinol Rev* 2004;2(Suppl 2):259-266.
411. Francis RO, Strauss D, Williams JD, et al. West Nile virus infection in blood donors in the New York City area during the 2010 seasonal epidemic. *Transfusion* 2012. doi:10.1111/j.1537-2995.2012.03639.x.
412. Barzon L, Pacenti M, Cusinato R, et al. Human cases of West Nile Virus infection in north-eastern Italy, 15 June to 15 November 2010. *Euro Surveill* 2011;16:pii: 19949.
413. Dodd R. Managing the microbiological safety of blood for transfusion: a US perspective. *Future Microbiol* 2009;4:807-818.
414. de Montalembert M, Girot R, Mattlinger B, Lefrère JJ. Transfusion-dependent thalassemia: viral complications (epidemiology and follow-up). *Semin Hematol* 1995;32:280-287.
415. Lefrère JJ, Girot R. Risk of HIV infection in polytransfused thalassaemia patients. *Lancet* 1989;2:813.
416. McCutcheon S, Alejo Blanco AR, Houston EF, et al. All clinically-relevant blood components transmit prion disease following a single blood transfusion: a sheep model of vCJD. *PLoS One* 2011;6:e23169.
417. Choudhury NJ, Dubey ML, Jolly JG, et al. Post-transfusion malaria in thalassaemia patients. *Blut* 1990;61:314-316.
418. Kitchen AD, Hewitt PE, Chiodini PL. The early implementation of *Trypanosoma cruzi* antibody screening of donors and donations within England: preempting a problem. *Transfusion* 2012;52(9):1931-1939.
419. Leiby DA. Babesiosis and blood transfusion: flying under the radar. *Vox Sang* 2006;90:157-165.
420. Mohammed H, Linnen JM, Muñoz-Jordán JL, et al. Dengue virus in blood donations, Puerto Rico, 2005. *Transfusion* 2008;48:1348-1354.
421. Nichols WG, Price TH, Gooley T, et al. Transfusion-transmitted cytomegalovirus infection after receipt of leukoreduced blood products. *Blood* 2003;101:4195-4200.
422. Henschler R, Seifried E, Mufti N. Development of the S-303 pathogen inactivation technology for red blood cell concentrates. *Infusionsther Transfusionsmed* 2011;38:33-42.
423. Kleinman S, King MR, Busch MP, et al. The National Heart, Lung, and Blood Institute Retrovirus Epidemiology Donor Studies (Retrovirus Epidemiology Donor Study and Retrovirus Epidemiology Donor Study-II): twenty years of research to advance blood product safety and availability. *Transfus Med Rev* 2012;26(4):281-304, 304.e1-e2.
424. Sakran W, Levin C, Kenes Y, et al. Clinical spectrum of serious bacterial infections among splenectomized patients with hemoglobinopathies in Israel: a 37-year follow-up study. *Infection* 2012;40:35-39.
425. Adamkiewicz TV, Berkovitch M, Krishnan C, et al. Infection due to *Yersinia enterocolitica* in a series of patients with beta-thalassemia: incidence and predisposing factors. *Clin Infect Dis* 1998;27:1362-1366.
426. Chan GC-F, Chan S, Ho P-L, Ha S-Y. Effects of chelators (deferoxamine, deferiprone and deferasirox) on the growth of *Klebsiella pneumoniae* and *Aeromonas hydrophila* isolated from transfusion-dependent thalassemia patients. *Hemoglobin* 2009;33:352-360.
427. Piomelli S. The management of patients with Cooley's anemia: transfusions and splenectomy. *Semin Hematol* 1995;32:262-268.
428. Ganz T, Nemeth E. The hepcidin-ferroportin system as a therapeutic target in anemias and iron overload disorders. *Hematology (Am Soc Hematol Educ Program)* 2011;2011:538-542.

429. Taher A, El Rassi F, Isma'eel H, et al. Correlation of liver iron concentration determined by R2 magnetic resonance imaging with serum ferritin in patients with thalassemia intermedia. *Haematologica* 2008;93: 1584-1586.
430. Tanno T, Miller JL. Iron loading and overloading due to ineffective erythropoiesis. *Adv Hematol Oncol* 2010;2010:358283.
431. Gardenghi S, Marongiu MF, Ramos P, et al. Ineffective erythropoiesis in beta-thalassemia is characterized by increased iron absorption mediated by down-regulation of hepcidin and up-regulation of ferroportin. *Blood* 2007;109:5027-5035.
432. Hershko C, Graham G, Bates GW, Rachmilewitz EA. Non-specific serum iron in thalassaemia: an abnormal serum iron fraction of potential toxicity. *Br J Haematol* 1978;40:255-263.
433. Bacon BR, Britton RS. The pathology of hepatic iron overload: a free radical—mediated process? *Hepatology* (Baltimore, MD) 1990;11:127-137.
434. Esposito BP, Breuer W, Sirankapracha P, et al. Labile plasma iron in iron overload: redox activity and susceptibility to chelation. *Blood* 2003;102:2670-2677.
435. Breuer W, Shvartsman M, Cabantchik ZI. Intracellular labile iron. *Int J Biochem* 2008;40:350-354.
436. Zanninelli G, Breuer W, Cabantchik ZI. Daily labile plasma iron as an indicator of chelator activity in thalassaemia major patients. *Br J Haematol* 2009;147:744-751.
437. Wood JC, Glynos T, Thompson a., et al. Relationship between labile plasma iron, liver iron concentration and cardiac response in a deferasirox mono-therapy trial. *Haematologica* 2011;96:1055-1058.
438. Link G, Pinson A, Kahane I, Hershko C. Iron loading modifies the fatty acid composition of cultured rat myocardial cells and liposomal vesicles: effect of ascorbate and alpha-tocopherol on myocardial lipid peroxidation. *J Lab Clin Med* 1989;114:243-249.
439. Cohen A, Cohen IJ, Schwartz E. Scurvy and altered iron stores in thalassemia major. *N Engl J Med* 1981;304:158-160.
440. Lipschitz DA, Cook JD, Finch CA. A clinical evaluation of serum ferritin as an index of iron stores. *Nutrition* (Burbank, Los Angeles County, CA) 1974;8:443-447; discussion 448.
441. Dadone MM, Kushner JP, Edwards CQ, et al. Hereditary hemochromatosis. Analysis of laboratory expression of the disease by genotype in 18 pedigrees. *Am J Clin Pathol* 1982;78:196-207.
442. Borgna-Pignatti C, Rugolotto S, De Stefano P, et al. Survival and complications in patients with thalassemia major treated with transfusion and deferoxamine. *Haematologica* 2004;89:1187-1193.
443. Belhoul KM, Bakir ML, Saned M-S, et al. Serum ferritin levels and endocrinopathy in medically treated patients with beta thalassemia major. *Ann Hematol* 2012.
444. Borgna-Pignatti C, Cappellini MD, De Stefano P, et al. Cardiac morbidity and mortality in deferoxamine- or deferiprone-treated patients with thalassemia major. *Blood* 2006;107:3733-3737.
445. Worwood M, Cragg SJ, Jacobs A, et al. Binding of serum ferritin to concanavalin A: patients with homozygous beta thalassaemia and transfusional iron overload. *Br J Haematol* 1980;46:409-416.
446. Chapman RW, Hussain MA, Gorman A, et al. Effect of ascorbic acid deficiency on serum ferritin concentration in patients with beta-thalassaemia major and iron overload. *J Clin Pathol* 1982;35:487-491.
447. De Virgiliis S, Cornacchia G, Sanna G, et al. Chronic liver disease in transfusion-dependent thalassemia: liver iron quantitation and distribution. *Acta Haematol* 1981;65:32-39.
448. Angelucci E, Brittenham GM, McLaren CE, et al. Hepatic iron concentration and total body iron stores in thalassemia major. *N Engl J Med* 2000;343:327-331.
449. Angelucci E, Muretto P, Lucarelli G, et al. Phlebotomy to reduce iron overload in patients cured of thalassemia by bone marrow transplantation. Italian Cooperative Group for Phlebotomy Treatment of Transplanted Thalassemia Patients. *Blood* 1997;90:994-998.

450. Pierre TGS, Clark PR, Chua-anusorn W, et al. Noninvasive measurement and imaging of liver iron concentrations using proton magnetic resonance. *Liver* 2005;105:855-861.
451. Emond MJ, Bronner MP, Carlson TH, et al. Quantitative study of the variability of hepatic iron concentrations. *Clin Chem* 1999;45:340-346.
452. Brittenham GM, Farrell DE, Harris JW, et al. Magnetic-susceptibility measurement of human iron stores. *N Engl J Med* 1982;307:1671-1675.
453. Fischer R, Tiemann CD, Engelhardt R, et al. Assessment of iron stores in children with transfusion siderosis by biomagnetic liver susceptometry. *Am J Hematol* 1999;60:289-299.
454. Anderson LJ, Holden S, Davis B, et al. Cardiovascular T2-star (T2*) magnetic resonance for the early diagnosis of myocardial iron overload. *Eur Heart J* 2001;22:2171-2179.
455. Carpenter J-P, He T, Kirk P, et al. On T2* magnetic resonance and cardiac iron. *Circulation* 2011;123:1519-1528.
456. Positano V, Pepe A, Santarelli MF, et al. Multislice multiecho T2* cardiac magnetic resonance for the detection of heterogeneous myocardial iron distribution in thalassaemia patients. *NMR Biomed* 2009;22:707-715.
457. Ramazzotti A, Pepe A, Positano V, et al. Multicenter validation of the magnetic resonance T2* technique for segmental and global quantification of myocardial iron. *J Magn Reson Imaging* 2009;30:62-68.
458. Restaino G, Meloni A, Positano V, et al. Regional and global pancreatic T*2 MRI for iron overload assessment in a large cohort of healthy subjects: normal values and correlation with age and gender. *Magn Reson Med* 2011;65:764-769.
459. Noetzli LJ, Papudesi J, Coates TD, Wood JC. Pancreatic iron loading predicts cardiac iron loading in thalassemia major. *Blood* 2009;114:4021-4026.
460. Au W-Y, Lam WW-M, Chu W, et al. A T2* magnetic resonance imaging study of pancreatic iron overload in thalassemia major. *Haematologica* 2008;93: 116-119.
461. Noetzli LJ, Panigrahy A, Mittelman SD, et al. Pituitary iron and volume predict hypogonadism in transfusional iron overload. *Am J Hematol* 2011. doi:10.1002/ajh.22247.
462. Hashemieh M, Azarkeivan A, Akhlaghpour S, et al. T2-star (T2 *) Magnetic resonance imaging for assessment of kidney iron overload in thalassaemic patients. *Arch Iran Med* 2012;15:91-94.
463. Kirk P, He T, Anderson LJ, et al. International reproducibility of single breath-hold T2* MR for cardiac and liver iron assessment among five thalassemia centers. *J Magn Reson Imaging* 2010;32:315-319.
464. Marsella M, Borgna-Pignatti C, Meloni a., et al. Cardiac iron and cardiac disease in males and females with transfusion-dependent thalassemia major: a T2* magnetic resonance imaging study. *Haematologica* 2011;96:515-520.
465. Link G, Athias P, Grynberg A, et al. Effect of iron loading on transmembrane potential, contraction, and automaticity of rat ventricular muscle cells in culture. *J Lab Clin Med* 1989;113:103-111.
466. Ehlers KH, Levin AR, Markenson AL, et al. Longitudinal study of cardiac function in thalassemia major. *Ann N Y Acad Sci* 1980;344:397-404.
467. Jessup M, Manno CS. Diagnosis and management of iron-induced heart disease in Cooley's anemia. *Ann N Y Acad Sci* 1998;850:242-250.
468. Anderson LJ, Westwood MA, Prescott E, et al. Development of thalassaemic iron overload cardiomyopathy despite low liver iron levels and meticulous compliance to desferrioxamine. *Acta Haematol* 2006;115:106-108.
469. Tanner M, Galanello R, Dessi C, et al. Myocardial iron loading in patients with thalassemia major on deferoxamine chelation. *J Cardiovasc Magn Reson* 2006;8:543-547.
470. Barosi G, Arbustini E, Gavazzi A, et al. Myocardial iron grading by endomyocardial biopsy. A clinico-pathologic study on iron overloaded patients. *Eur J Haematol* 1989;42:382-388.
471. He T, Gatehouse PD, Anderson LJ, et al. Development of a novel optimized breathhold technique for myocardial T2 measurement in thalassemia. *J Magn Reson Imaging* 2006;24:580-585.
472. Kirk P, Roughton M, Porter JB, et al. Cardiac T2* magnetic resonance for prediction of cardiac complications in thalassemia major. *Circulation* 2009;120:1961-1968.

473. Carpenter J-P, Alpendurada F, Deac M, et al. Right ventricular volumes and function in thalassemia major patients in the absence of myocardial iron overload. *J Cardiovasc Magn Reson* 2010;12:24.
474. Alpendurada F, Carpenter J-P, Deac M, et al. Relation of myocardial T2* to right ventricular function in thalassaemia major. *Eur Heart J* 2010;31:1648-1654.
475. Kremastinos DT, Tsetsos GA, Tsiapras DP, et al. Heart failure in beta thalassemia: a 5-year follow-up study. *Am J Med* 2001;111:349-354.
476. Pennell DJ, Carpenter JP, Roughton M, Cabantchik Z. On improvement in ejection fraction with iron chelation in thalassemia major and the risk of future heart failure. *J Cardiovasc Magn Reson* 2011;13:45.
477. Pennell DJ, Porter JB, Cappellini MD, et al. Deferasirox for up to 3 years leads to continued improvement of myocardial T2* in patients with betathalassemia major. *Haematologica* 2012;97(6):842-848.
478. Wood JC, Kang BP, Thompson A, et al. The effect of deferasirox on cardiac iron in thalassemia major: impact of total body iron stores. *Blood* 2010;116:537-543.
479. Telfer P, Coen PG, Christou S, et al. Survival of medically treated thalassemia patients in Cyprus. Trends and risk factors over the period 1980-2004. *Haematologica* 2006;91:1187-1192.
480. Telfer PT, Warburton F, Christou S, et al. Improved survival in thalassemia major patients on switching from desferrioxamine to combined chelation therapy with desferrioxamine and deferiprone. *Haematologica* 2009;94:1777-1778.
481. Ladis V, Chouliaras G, Berdoukas V, et al. Relation of chelation regimes to cardiac mortality and morbidity in patients with thalassaemia major: an observational study from a large Greek Unit. *Eur J Haematol* 2010;85:335-344.
482. Modell B, Khan M, Darlison M, et al. Improved survival of thalassaemia major in the UK and relation to T2* cardiovascular magnetic resonance. *J Cardiovasc Magn Reson* 2008;10:42.
483. Schlesinger BE. Acute benign pericarditis in thalassaemia major. *J R Soc Med* 1962;55:236-237.
484. Aessopos A, Stamatelos G, Skoumas V, et al. Pulmonary hypertension and right heart failure in patients with beta-thalassemia intermedia. *Chest* 1995;107:50-53.
485. Morris CR, Kim H-Y, Trachtenberg F, et al. Risk factors and mortality associated with an elevated tricuspid regurgitant jet velocity measured by Doppler-echocardiography in thalassemia: a Thalassemia Clinical Research Network report. *Blood* 2011;118:3794-3802.
486. Nathan DG. Guilt by association. *Blood* 2011;118:3758-3759.
487. Derchi G, Formisano F, Balocco M, et al. Clinical management of cardiovascular complications in patients with thalassaemia major: a large observational multicenter study. *Eur J Echocardiogr* 2011;12:242-246.
488. Cogliandro T, Derchi G, Mancuso L, et al. Guideline recommendations for heart complications in thalassemia major. *J Cardiovasc Med (Hagerstown, MD)* 2008;9:515-525.
489. Karvounis HI, Zaglavara TA, Parharidis GE, et al. An angiotensin-converting enzyme inhibitor improves left ventricular systolic and diastolic function in transfusion-dependent patients with beta-thalassemia major. *Am Heart J* 2001;141:281.
490. Perrimond H, Michel G, Orsini A, et al. First Report of a cardiac transplantation in a patient with thalassaemia major. *Br J Haematol* 1991;78:467-467.
491. Caines AE, Kpodonu J, Massad MG, et al. Cardiac transplantation in patients with iron overload cardiomyopathy. *J Heart Lung Transplant* 2005;24: 486-488.
492. Anderson LJ. Assessment of iron overload with T2* magnetic resonance imaging. *Prog Cardiovasc Dis* 2001;54:287-294.
493. Lisboa PE. Experimental hepatic cirrhosis in dogs caused by chronic massive iron overload. *Gut* 1971;12:363-368.
494. Poulsen HE, Specht E, Broedbaek K, et al. RNA modifications by oxidation: a novel disease mechanism? *Free Radic Biol Med* 2012;52(8):1353-1361.
495. Fraquelli M, Cassinerio E, Roghi A, et al. Transient elastography in the assessment of liver fibrosis in adult thalassemia patients. *Am J Hematol* 2010;85:564-568.
496. Ishak K, Baptista A, Bianchi L, et al. Histological grading and staging of chronic hepatitis. *J Hepatol* 1995;22:696-699.

497. Angelucci E, Baronciani D, Lucarelli G, et al. Needle liver biopsy in thalassaemia: analyses of diagnostic accuracy and safety in 1184 consecutive biopsies. *Br J Haematol* 1995;89:757-761.
498. Castera L, Fornis X, Alberti A. Non-invasive evaluation of liver fibrosis using transient elastography. *J Hepatol* 2008;48:835-847.
499. Friedrich-Rust M, Ong M-F, Martens S, et al. Performance of transient elastography for the staging of liver fibrosis: a meta-analysis. *Gastroenterology* 2008;134:960-974.
500. Di Marco V, Bronte F, Cabibi D, et al. Noninvasive assessment of liver fibrosis in thalassaemia major patients by transient elastography (TE)—lack of interference by iron deposition. *Br J Haematol* 2010;148:476-479.
501. Angelucci E, Muretto P, Nicolucci A, et al. Effects of iron overload and hepatitis C virus positivity in determining progression of liver fibrosis in thalassemia following bone marrow transplantation. *Blood* 2002;100:17-21.
502. Kuo G, Choo QL, Alter HJ, et al. An assay for circulating antibodies to a major etiologic virus of human non-A, non-B hepatitis. *Science (New York, NY)* 1989;244:362-364.
503. Di Marco V, Capra M, Angelucci E, et al. Management of chronic viral hepatitis in patients with thalassemia: recommendations from an international panel. *Blood* 2010;116:2875-2883.
504. Adinolfi LE, Utili R, Andreana A, et al. Relationship between genotypes of hepatitis C virus and histopathological manifestations in chronic hepatitis C patients. *Eur J Gastroenterol Hepatol* 2000;12:299-304.
505. Prati D, Zanella A, Farma E, et al. A multicenter prospective study on the risk of acquiring liver disease in anti-hepatitis C virus negative patients affected from homozygous beta-thalassemia. *Blood* 1998;92:3460-3464.
506. Seed CR, Kiely P, Keller AJ. Residual risk of transfusion transmitted human immunodeficiency virus, hepatitis B virus, hepatitis C virus and human T lymphotropic virus. *Intern Med J* 2005;35:592-598.
507. Velati C, Fomiatti L, Baruffi L, et al. Impact of nucleic acid amplification technology (NAT) in Italy in the three years following implementation (2001-2003). *Euro Surveill* 2005;10:12-14.
508. Heyns A du P, Benjamin RJ, Swanevelder JPR, et al. Prevalence of HIV-1 in blood donations following implementation of a structured blood safety policy in South Africa. *JAMA* 2006;295:519-526.
509. Resnick RH, Koff R. Hepatitis C-related hepatocellular carcinoma. Prevalence and significance. *Arch Intern Med* 1993;153:1672-1677.
510. Ghany MG, Strader DB, Thomas DL, Seeff LB. Diagnosis, management, and treatment of hepatitis C: an update. *Hepatology (Baltimore, MD)* 2009;49:1335-1374.
511. Harmatz P, Jonas MM, Kwiatkowski JL, et al. Safety and efficacy of pegylated interferon alpha-2a and ribavirin for the treatment of hepatitis C in patients with thalassemia. *Haematologica* 2008;93:1247-1251.
512. Ghany MG, Nelson DR, Strader DB, et al. An update on treatment of genotype 1 chronic hepatitis C virus infection: 2011 practice guideline by the American Association for the Study of Liver Diseases. *Hepatology (Baltimore, MD)* 2011;54:1433-1444.
513. Osaki R, Nishimura T, Shioya M, et al. Interleukin-28B genotypes determine response to pegylated-interferon plus ribavirin therapy in patients with hepatitis C virus infection. *Mol Med Rep* 2012;5:525-528.
514. Mancuso A. Hepatocellular carcinoma in thalassemia: a critical review. *World J Hepatol* 2010;2:171-174.
515. Bruix J, Sherman M. Management of hepatocellular carcinoma: an update. *Hepatology (Baltimore, MD)* 2011;53:1020-1022.
516. Koren G, Bentur Y, Strong D, et al. Acute changes in renal function associated with deferoxamine therapy. *Am J Dis Child* 1989;143:1077-1080.
517. Koren G, Kochavi-Atiya Y, Bentur Y, Olivieri NF. The effects of subcutaneous deferoxamine administration on renal function in thalassemia major. *Int J Hematol* 1991;54:371-375.
518. Grangé S, Bertrand DM, Guerrot D, et al. Acute renal failure and Fanconi syndrome due to deferasirox. *Nephrol Dial Transplant* 2010;25:2376-2378.

519. Cappellini MD, Bejaoui M, Agaoglu L, et al. Thalassemia major: efficacy and safety during 5 years' follow-up iron chelation with deferasirox in adult and pediatric patients with thalassemia major: efficacy and safety during 5 years' follow-up. *Blood* 2011;884-893.
520. Quinn CT, Johnson VL, Kim H-Y, et al. Renal dysfunction in patients with thalassaemia. *Br J Haematol* 2011;153:111-117.
521. Lai ME, Spiga A, Vacquer S, et al. Renal function in patients with betathalassaemia major: a long-term follow-up study. *Nephrol Dial Transplant* 2012;27:3547-3551.
522. Bhandari S, Galanello R. Renal aspects of thalassaemia a changing paradigm. *Eur J Haematol* 2012;89(3):187-197.
523. Jalali A, Khalilian H, Ahmadzadeh A, et al. Renal function in transfusion-dependent pediatric beta-thalassemia major patients. *Hematology (Amsterdam, Netherlands)* 2011;16:249-254.
524. Economou M, Printza N, Teli A, et al. Renal dysfunction in patients with betathalassemia major receiving iron chelation therapy either with deferoxamine and deferiprone or with deferasirox. *Acta Haematol* 2010;123:148-152.
525. Shalitin S, Carmi D, Weintrob N, et al. Serum ferritin level as a predictor of impaired growth and puberty in thalassemia major patients. *Eur J Haematol* 2005;74:93-100.
526. Farmaki K, Tzoumari I, Pappa C, et al. Normalisation of total body iron load with very intensive combined chelation reverses cardiac and endocrine complications of thalassaemia major. *Br J Haematol* 2010;148:466-475.
527. Caruso-Nicoletti M, De Sanctis V, Raiola G, et al. No difference in pubertal growth and final height between treated hypogonadal and non-hypogonadal thalassemic patients. *Horm Res* 2004;62:17-22.
528. Prakash A, Aggarwal R. Thalassemia major in adults: short stature, hyperpigmentation, inadequate chelation, and transfusion-transmitted infections are key features. *N Am J Med Sci* 2012;4:141-144.
529. Poggi M, Pascucci C, Monti S, et al. Prevalence of growth hormone deficiency in adult polytransfused beta-thalassemia patients and correlation with transfusional and chelation parameters. *J Endocrinol Invest* 2010;33: 534-538.
530. Cavallo L, De Sanctis V, Cisternino M, et al. Final height in short polytransfused thalassemia major patients treated with recombinant growth hormone. *J Endocrinol Invest* 2005;28:363-366.
531. van Bunderen CC, van Nieuwpoort IC, Arwert LI, et al. Does growth hormone replacement therapy reduce mortality in adults with growth hormone deficiency? Data from the Dutch National Registry of Growth Hormone Treatment in adults. *J Clin Endocrinol Metab* 2011;96:3151-3159.
532. Piga A, Luzzatto L, Capalbo P, et al. High-dose desferrioxamine as a cause of growth failure in thalassemic patients. *Eur J Haematol* 1988;40:380-381.
533. De Virgiliis S, Congia M, Frau F, et al. Deferoxamine-induced growth retardation in patients with thalassemia major. *J Pediatr* 1988;113:661-669.
534. De Sanctis V, Pinamonti A, Di Palma A, et al. Growth and development in thalassaemia major patients with severe bone lesions due to desferrioxamine. *Eur J Pediatr* 1996;155:368-372.
535. De Sanctis V, Roos M, Gasser T, et al. Impact of long-term iron chelation therapy on growth and endocrine functions in thalassaemia. *J Pediatr Endocrinol Metab* 2006;19:471-480.
536. Gamberini MR, De Sanctis V, Gilli G. Hypogonadism, diabetes mellitus, hypothyroidism, hypoparathyroidism: incidence and prevalence related to iron overload and chelation therapy in patients with thalassaemia major followed from 1980 to 2007 in the Ferrara Centre. *Pediatr Endocrinol Rev* 2008;6(Suppl 1):158-169.
537. Wood JC, Noetzel L, Hyderi A, et al. Predicting pituitary iron and endocrine dysfunction. *Ann N Y Acad Sci* 2010;1202:123-128.
538. Skordis N, Christou S, Koliou M, et al. Fertility in female patients with thalassemia. *J Pediatr Endocrinol Metab* 1998;11(Suppl 3):935-943.
539. Safarinejad MR. Evaluation of semen quality, endocrine profile and hypothalamus-pituitary-testis axis in male patients with homozygous beta-thalassemia major. *J Urol* 2008;179:2327-2332.
540. Cisternino M, Manzoni SM, Coslovich E, Autelli M. Hormonal replacement therapy with HCG and HU-FSH in thalassaemic patients affected by hypogonadotropic hypogonadism. *J Pediatr Endocrinol Metab* 1998;11 (Suppl 3):885-890.

541. Bajoria R, Chatterjee R. Hypogonadotrophic hypogonadism and diminished gonadal reserve accounts for dysfunctional gametogenesis in thalassaemia patients with iron overload presenting with infertility. *Hemoglobin* 2011;35:636-642.
542. Tampakoudis P, Tsatalas C, Mamopoulos M, et al. Transfusion-dependent homozygous beta-thalassaemia major: successful pregnancy in five cases. *Eur J Obstet Gynecol Reprod Biol* 1997;74:127-131.
543. Savona-Ventura C, Bonello F. Beta-thalassemia syndromes and pregnancy. *Obstet Gynecol Surv* 1994;49:129-137.
544. Tuck SM, Jensen CE, Wonke B, Yardumian A. Pregnancy management and outcomes in women with thalassaemia major. *J Pediatr Endocrinol Metab* 1998;11(Suppl 3):923-928.
545. Origa R, Piga A, Quarta G, et al. Pregnancy and beta-thalassemia: an Italian multicenter experience. *Haematologica* 2010;95:376-381.
546. Singer ST, Vichinsky EP. Deferoxamine treatment during pregnancy: is it harmful? *Am J Hematol* 1999;60:24-26.
547. Karimi M, Rasekhi AR, Rasekh M, et al. Hypoparathyroidism and intracerebral calcification in patients with beta-thalassemia major. *Eur J Radiol* 2009;70:481-484.
548. De Sanctis V, Vullo C, Bagni B, Chiccoli L. Hypoparathyroidism in betathalassemia major. Clinical and laboratory observations in 24 patients. *Acta Haematol* 1992;88:105-108.
549. Sklar CA, Lew LQ, Yoon DJ, David R. Adrenal function in thalassemia major following long-term treatment with multiple transfusions and chelation therapy. Evidence for dissociation of cortisol and adrenal androgen secretion. *Am J Dis Child* 1987;141:327-330.
550. Scacchi M, Danesi L, Cattaneo A, et al. The pituitary-adrenal axis in adult thalassaemic patients. *Eur J Endocrinol* 2010;162:43-48.
551. Srivatsa A, Marwaha RK, Muraldharan R, Trehan A. Assessment of adrenal endocrine function in Asian thalasseemics. *Indian Pediatr* 2005;42:31-35.
552. Anon. Multicentre study on prevalence of endocrine complications in thalassaemia major. Italian Working Group on Endocrine Complications in Non-Endocrine Diseases. *Clin Endocrinol* 1995;42:581-586.
553. Brittenham GM, Griffith PM, Nienhuis AW, et al. Efficacy of deferoxamine in preventing complications of iron overload in patients with thalassemia major. *N Engl J Med* 1994;331:567-573.
554. Gamberini MR, Fortini M, Gilli G, et al. Epidemiology and chelation therapy effects on glucose homeostasis in thalassaemic patients. *J Pediatr Endocrinol Metab* 1998;11(Suppl 3):867-869.
555. Borgna-Pignatti C, Gamberini MR. Complications of thalassemia major and their treatment. *Expert Rev Hematol* 2011;4:353-366.
556. Iancu TC. Biological and ultrastructural aspects of iron overload: an overview. *Pediatr Pathol* 1990;10:281-296.
557. Noetzli LJ, Mittelman SD, Watanabe RM, et al. Pancreatic iron and glucose dysregulation in thalassemia major. *Am J Hematol* 2011. doi:10.1002/ajh.22223.
558. De Sanctis V, D'Ascola G, Wonke B. The development of diabetes mellitus and chronic liver disease in long term chelated beta thalassaemic patients. *Postgrad Med J* 1986;62:831-836.
559. Sougleri M, Labropoulou-Karatza C, Paraskevopoulou P, et al. Chronic hepatitis C virus infection without cirrhosis induces insulin resistance in patients with alpha-thalassaemia major. *Eur J Gastroenterol Hepatol* 2001;13: 1195-1199.
560. Merkel PA, Simonson DC, Amiel SA, et al. Insulin resistance and hyperinsulinemia in patients with thalassemia major treated by hypertransfusion. *N Engl J Med* 1988;318:809-814.
561. Angelopoulos NG, Zervas A, Livadas S, et al. Reduced insulin secretion in normoglycaemic patients with beta-thalassaemia major. *Diabet Med* 2006;23:1327-1331.
562. Incorvaia C, Parmeggiani F, Mingrone G, et al. Prevalence of retinopathy in diabetic thalassaemic patients. *J Pediatr Endocrinol Metab* 1998;11 (Suppl 3):879-883.
563. Hussain M, Dandona P, Fedail SS, et al. Serum immunoreactive trypsin in beta-thalassaemia major. *J Clin Pathol* 1981;34:970-971.

564. Gullo L, Corcioni E, Brancati C, et al. Morphologic and functional evaluation of the exocrine pancreas in beta-thalassemia major. *Pancreas* 1993;8:176-180.
565. Taneja R, Malik P, Sharma M, Agarwal MC. Multiple transfused thalassemia major: ocular manifestations in a hospital-based population. *Indian J Ophthalmol* 58:125-130.
566. Gelmi C, Borgna-Pignatti C, Franchin S, et al. Electroretinographic and visual-evoked potential abnormalities in patients with beta-thalassemia major. *Ophthalmologica* 1988;196:29-34.
567. Aessopos A, Farmakis D, Loukopoulos D. Elastic tissue abnormalities resembling pseudoxanthoma elasticum in beta thalassemia and the sickling syndromes. *Blood* 2002;99:30-35.
568. Bourli E, Dimitriadou M, Economou M, et al. Restrictive pulmonary dysfunction and its predictors in young patients with beta-thalassaemia major. *Pediatr Pulmonol* 2012;47(8):801-807.
569. Sohn EY, Noetzli LJ, Gera A, et al. Pulmonary function in thalassaemia major and its correlation with body iron stores. *Br J Haematol* 2011;155:102-105.
570. Hershko C, Rachmilewitz EA. Mechanism of desferrioxamine-induced iron excretion in thalassaemia. *Br J Haematol* 1979;42:125-132.
571. Hershko C. Oral iron chelators: new opportunities and new dilemmas. *Haematologica* 2006;91(10):1307-1312.
572. Trachtenberg F, Vichinsky E, Haines D, et al. Iron chelation adherence to deferoxamine and deferasirox in thalassemia. *Am J Hematol* 2011;86: 433-436.
573. Porter JB, Evangelini M, El-Beshlawy A. Challenges of adherence and persistence with iron chelation therapy. *Int J Hematol* 2011;94:453-460.
574. Smith RS. Iron excretion in thalassaemia major after administration of chelating agents. *Br Med J* 1962;2:1577-1580.
575. Barry M, Flynn DM, Letsky EA, Risdon RA. Long-term chelation therapy in thalassaemia major: effect on liver iron concentration, liver histology, and clinical progress. *Br Med J* 1974;2:16-20.
576. Letsky EA, Flynn DM, Barry M. The effect of treatment with long-term chelating agents on iron overload in thalassaemia. *Br J Haematol* 1973;25:285.
577. Letsky EA. A controlled trial of long-term chelation therapy in homozygous beta-thalassemia. *Birth Defects Orig Artic Ser* 1976;12:31-41.
578. Propper RD, Cooper B, Rufo RR, et al. Continuous subcutaneous administration of deferoxamine in patients with iron overload. *N Engl J Med* 1977;297:418-423.
579. Pippard MJ, Letsky EA, Callender ST, Weatherall DJ. Prevention of iron loading in transfusion-dependent thalassaemia. *Lancet* 1978;1:1178-1181.
580. Porter JB, Abeysinghe RD, Marshall L, et al. Kinetics of removal and reappearance of non-transferrin-bound plasma iron with deferoxamine therapy. *Blood* 1996;88:705-713.
581. Breuer W, Ronson a, Slotki IN, et al. The assessment of serum nontransferrin-bound iron in chelation therapy and iron supplementation. *Blood* 2000;95:2975-2982.
582. Cohen A, Martin M, Schwartz E. Depletion of excessive liver iron stores with desferrioxamine. *Br J Haematol* 1984;58:369-373.
583. Rodda CP, Reid ED, Johnson S, et al. Short stature in homozygous betathalassaemia is due to disproportionate truncal shortening. *Clin Endocrinol* 1995;42:587-592.
584. Olivieri NF, Brittenham GM. Iron-chelating therapy and the treatment of thalassemia. *Blood* 1997;89:739-761.
585. Cartwright GE, Edwards CQ, Kravitz K, et al. Hereditary hemochromatosis. Phenotypic expression of the disease. *N Engl J Med* 1979;301:175-179.
586. Cohen AR, Mizanin J, Schwartz E. Rapid removal of excessive iron with daily, high-dose intravenous chelation therapy. *J Pediatr* 1989;115:151-155.
587. Anderson LJ, Westwood MA, Holden S, et al. Myocardial iron clearance during reversal of siderotic cardiomyopathy with intravenous desferrioxamine: a prospective study using T2* cardiovascular magnetic resonance. *Br J Haematol* 2004;127:348-355.

588. Davis BA, Porter JB. Long-term outcome of continuous 24-hour deferoxamine infusion via indwelling intravenous catheters in high-risk beta-thalassemia. *Blood* 2000;95:1229-1236.
589. Link G, Pinson A, Hershko C. Heart cells in culture: a model of myocardial iron overload and chelation. *J Lab Clin Med* 1985;106:147-153.
590. Hershko C, Link G, Pinson A. Modification of iron uptake and lipid peroxidation by hypoxia, ascorbic acid, and alpha-tocopherol in iron-loaded rat myocardial cell cultures. *J Lab Clin Med* 1987;110:355-361.
591. Borgna-Pignatti C, Cohen A. Evaluation of a new method of administration of the iron chelating agent deferoxamine. *J Pediatr* 1997;130:86-88.
592. Franchini M, Gandini G, de Gironcoli M, et al. Safety and efficacy of subcutaneous bolus injection of deferoxamine in adult patients with iron overload. *Blood* 2000;95:2776-2779.
593. Cianciulli P, Sorrentino F, Maffei L, Amadori S. Continuous low-dose subcutaneous desferrioxamine (DFO) to prevent allergic manifestations in patients with iron overload. *Ann Hematol* 1996;73:279-281.
594. Bousquet J, Navarro M, Robert G, et al. Rapid desensitisation for desferrioxamine anaphylactoid reaction. *Lancet* 1983;2:859-860.
595. Davies S, Hungerford JL, Arden GB, et al. Ocular toxicity of high-dose intravenous desferrioxamine. *The Lancet* 1983;322:181-184.
596. Borgna-Pignatti C, De Stefano P, Broglia AM. Visual loss in patient on high-dose subcutaneous desferrioxamine. *Lancet* 1984;1:681.
597. Olivieri NF, Buncic JR, Chew E, et al. Visual and auditory neurotoxicity in patients receiving subcutaneous deferoxamine infusions. *N Engl J Med* 1986;314:869-873.
598. Porter JB, Jaswon MS, Huehns ER, et al. Desferrioxamine ototoxicity: evaluation of risk factors in thalassaemic patients and guidelines for safe dosage. *Br J Haematol* 1989;73:403-409.
599. Gallant T, Boyden MH, Gallant LA, et al. Serial studies of auditory neurotoxicity in patients receiving deferoxamine therapy. *Am J Med* 1987;83: 1085-1090.
600. Olivieri NF, Koren G, Harris J, et al. Growth failure and bony changes induced by deferoxamine. *Am J Pediatr Hematol Oncol* 1992;14:48-56.
601. Freedman MH, Grisaru D, Olivieri N, et al. Pulmonary syndrome in patients with thalassemia major receiving intravenous deferoxamine infusions. *Am J Dis Child* 1990;144:565-569.
602. Castriota Scanderbeg A, Izzi GC, Butturini A, Benaglia G. Pulmonary syndrome and intravenous high-dose desferrioxamine. *Lancet* 1990;336:1511.
603. Robins-Browne RM, Prpic JK, Stuart SJ. Yersinia and iron. A study in host-parasite relationships. *Contrib Microbiol Immunol* 1987;9:254-258.
604. Gallant T, Freedman MH, Vellend H, Francombe WH. Yersinia sepsis in patients with iron overload treated with deferoxamine. *N Engl J Med* 1986;314:1643.
605. al-Refaie FN, Sheppard LN, Nortey P, et al. Pharmacokinetics of the oral iron chelator deferiprone (L1) in patients with iron overload. *Br J Haematol* 1995;89:403-408.
606. Kontoghiorghes GJ, Goddard JG, Bartlett AN, Sheppard L. Pharmacokinetic studies in humans with the oral iron chelator 1,2-dimethyl-3-hydroxypyrid-4-one. *Clin Pharmacol Ther* 1990;48:255-261.
607. Hoffbrand AV. Oral iron chelation. *Semin Hematol* 1996;33:1-8.
608. Cabantchik ZI, Breuer W, Zanninelli G, Cianciulli P. LPI-labile plasma iron in iron overload. *Best Pract Res Clin Haematol* 2005;18:277-287.
609. Glickstein H, El RB, Link G, et al. Action of chelators in iron-loaded cardiac cells: accessibility to intracellular labile iron and functional consequences. *Blood* 2006;108:3195-3203.
610. Pennell DJ, Berdoukas V, Karagiorga M, et al. Randomized controlled trial of deferiprone or deferoxamine in beta-thalassemia major patients with asymptomatic myocardial siderosis. *Blood* 2006;107:3738-3744.

611. Pepe A, Meloni A, Capra M, et al. Deferasirox, deferiprone and desferrioxamine treatment in thalassemia major patients: cardiac iron and function comparison determined by quantitative magnetic resonance imaging. *Haematologica* 2011;96:41-47.
612. Maggio A, Vitrano A, Capra M, et al. Blood cells, molecules, and diseases improving survival with deferiprone treatment in patients with thalassemia major: a prospective multicenter randomised clinical trial under the auspices of the Italian Society for Thalassemia and Hemoglobinopathies. *Blood Cell Mol Dis* 2009;42:247-251.
613. Link G, Konijn AM, Breuer W, et al. Exploring the "iron shuttle" hypothesis in chelation therapy: effects of combined deferoxamine and deferiprone treatment in hypertransfused rats with labeled iron stores and in iron-loaded rat heart cells in culture. *J Lab Clin Med* 2001;138:130-138.
614. Farmaki K, Angelopoulos N, Anagnostopoulos G, et al. Effect of enhanced iron chelation therapy on glucose metabolism in patients with beta-thalassaemia major. *Br J Haematol* 2006;134:438-444.
615. Origa R, Bina P, Agus A, et al. Combined therapy with deferiprone and desferrioxamine in thalassemia major. *Haematologica* 2005;90:1309-1314.
616. Tanner MA, Galanello R, Dessi C, et al. A randomized, placebo-controlled, double-blind trial of the effect of combined therapy with deferoxamine and deferiprone on myocardial iron in thalassemia major using cardiovascular magnetic resonance. *Circulation* 2007;115:1876-1884.
617. Tanner MA, Galanello R, Dessi C, et al. Combined chelation therapy in thalassemia major for the treatment of severe myocardial siderosis with left ventricular dysfunction. *J Cardiovasc Magn Reson* 2008;10:12.
618. Porcu M, Landis N, Salis S, et al. Effects of combined deferiprone and desferrioxamine iron chelating therapy in beta-thalassemia major end-stage heart failure: a case report. *Eur J Heart Fail* 2007;9:320-322.
619. Tsironi M, Deftereos S, Andriopoulos P, et al. Reversal of heart failure in thalassemia major by combined chelation therapy: a case report. *Eur J Haematol* 2005;74:84-85.
620. Galanello R, Kattamis A, Piga A, et al. A prospective randomized controlled trial on the safety and efficacy of alternating deferoxamine and deferiprone in the treatment of iron overload in patients with thalassemia. *Haematologica* 2006;91:1241-1243.
621. Cohen AR, Galanello R, Piga A, et al. Safety and effectiveness of longterm therapy with the oral iron chelator deferiprone. *Blood* 2003;102: 1583-1587.
622. Cohen a R, Galanello R, Piga A, et al. Safety profile of the oral iron chelator deferiprone: a multicentre study. *Br J Haematol* 2000;108:305-312.
623. Hoffbrand AV, Bartlett AN, Veys PA, et al. Agranulocytosis and thrombocytopenia in patient with blackfan-diamond anaemia during oral chelator trial. *Lancet* 1989;334:457.
624. Agarwal MB, Gupte SS, Viswanathan C, et al. Long-term assessment of efficacy and safety of L1, an oral iron chelator, in transfusion dependent thalassaemia: Indian trial. *Br J Haematol* 1992;82:460-466.
625. al-Refaie FN, Wonke B, Wickens DG, et al. Zinc concentration in patients with iron overload receiving oral iron chelator 1,2-dimethyl-3-hydroxypyrid-4-one or desferrioxamine. *J Clin Pathol* 1994;47:657-660.
626. Olivieri NF, Brittenham GM, McLaren CE, et al. Long-term safety and effectiveness of iron-chelation therapy with deferiprone for thalassemia major. *N Engl J Med* 1998;339:417-423.
627. Wanless IR, Sweeney G, Dhillon AP, et al. Lack of progressive hepatic fibrosis during long-term therapy with deferiprone in subjects with transfusion-dependent beta-thalassemia. *Engl J* 2002;100:1566-1569.
628. Aydinok Y, Unal S, Oymak Y, et al. Observational study comparing longterm safety and efficacy of deferasirox with desferrioxamine therapy in chelation-naïve children with transfusional iron overload. *Eur J Haematol* 2012;88:431-438.
629. Cappellini MD. A phase 3 study of deferasirox (ICL670), a once-daily oral iron chelator, in patients with beta-thalassemia. *Blood* 2006;107:3455-3462.
630. Vichinsky E, Onyekwere O, Porter J, et al. A randomised comparison of deferasirox versus deferoxamine for the treatment of transfusional iron overload in sickle cell disease. *Br J Haematol* 2007;136:501-508.
631. Rafat C, Fakhouri F, Ribeil J-A, et al. Fanconi syndrome due to deferasirox. *Am J Kidney Dis* 2009;54:931-934.

632. Rheault MN, Bechtel H, Neglia JP, Kashtan CE. Reversible Fanconi syndrome in a pediatric patient on deferasirox. *Pediatr Blood Cancer* 2011;56:674-676.
633. Wei H-Y, Yang C-P, Cheng C-H, Lo F-S. Fanconi syndrome in a patient with beta-thalassemia major after using deferasirox for 27 months. *Transfusion* 2011;51:949-954.
634. Grandvuillemin A, Audia S, Leguy-Seguin V, et al. [Severe thrombocytopenia and mild leucopenia associated with deferasirox therapy]. *Thérapie* 2009;64:405-407.
635. Balocco M, Carrara P, Pinto V, Forni GL. Daily alternating deferasirox and deferiprone therapy for "hard-to-chelate" beta-thalassemia major patients. *Am J Hematol* 2010;85:460-461.
636. Berdoukas V, Carson S, Nord A, et al. Combining two orally active iron chelators for thalassemia. *Ann Hematol* 2010;89:1177-1178.
637. Farmakis D, Aessopos A. Pulmonary hypertension associated with hemoglobinopathies: prevalent but overlooked. *Circulation* 2011;123:1227-1232.
638. Neufeld EJ, Galanello R, Viprakasit V, et al. A phase 2 study of the safety, tolerability, and pharmacodynamics of FBS0701, a novel oral iron chelator, in transfusional iron overload. *Blood* 2012;119:3263-3268.
639. Claster S, Wood JC, Noetzli L, et al. Nutritional deficiencies in iron overloaded patients with hemoglobinopathies. *Am J Hematol* 2009:344-348.
640. Midiri M, Lo Casto A, Sparacia G, et al. MR imaging of pancreatic changes in patients with transfusion-dependent beta-thalassemia major. *AJR Am J Roentgenol* 1999;173:187-192.
641. Montalto G, D'Angelo P, Lo Casto A, et al. Serum and fecal pancreatic enzymes in beta-thalassemia major. *Int J Pancreatol* 1997;22:131-135.
642. Livrea MA, Tesoriere L, Pintaudi AM, et al. Oxidative stress and antioxidant status in beta-thalassemia major: iron overload and depletion of lipid-soluble antioxidants. *Blood* 1996;88:3608-3614.
643. Holick MF, Chen TC, Lu Z, Sauter E. Vitamin D and skin physiology: a D-Lightful Story. *J Bone Miner Res* 2007;22:28-33.
644. Noetzli LJ, Carson S, Coates TD, Wood JC. Revisiting the relationship between vitamin D deficiency, cardiac iron and cardiac function in thalassemia major. *Eur J Haematol* 2011;86:176-177.
645. Chow LH, Frei JV, Hodsman AB, Valberg LS. Low serum 25-hydroxyvitamin D in hereditary hemochromatosis: relation to iron status. *Gastroenterology* 1985;88:865-869.
646. Pippard MJ, Callender ST, Weatherall DJ. Intensive iron-chelation therapy with desferrioxamine in iron-loading anaemias. *Clin Sci Mol Med* 1978;54:99-106.
647. Nienhuis AW. Vitamin C and iron. *N Engl J Med* 1981;304:170-171.
648. Vatanavicharn S, Anuvatanakulchai M, Na-Nakorn S, Wasi P. Serum erythrocyte folate levels in thalassaemic patients in Thailand. *Scand J Haematol* 1979;22:241-245.
649. Arcasoy A, Canata D, Sinav B, et al. Serum zinc levels and zinc binding capacity in thalassemia. *J Trace Elem Med Biol* 2001;15:85-87.
650. Silprasert A, Laokuldilok T, Kulapongs P. Zinc deficiency in beta-thalassaemic children. *Birth Defects Orig Artic Ser* 1987;23:473-476.
651. Piga A, Serra M, Longo F, et al. Changing patterns of splenectomy in transfusion-dependent thalassemia patients. *Am J Hematol* 2011;86:808-810.
652. Modell B. Total management of thalassaemia major. *Arch Dis Child* 1977;52:489-500.
653. Cohen A, Gayer R, Mizanin J. Long-term effect of splenectomy on transfusion requirements in thalassemia major. *Am J Hematol* 1989;30:254-256.
654. Luks FI, Logan J, Breuer CK, et al. Cost-effectiveness of laparoscopy in children. *Arch Pediatr Adolesc Med* 1999;153:965-968.
655. Rossi E, Michelini ME, Pignatti CB, et al. A case of portal vein thrombosis after laparoscopy-assisted splenectomy and cholecystectomy in a child. *J Pediatr Surg* 2007;42:1449-1451.

656. Winslow ER, Brunt LM, Drebin JA, et al. Portal vein thrombosis after splenectomy. *Am J Surg* 2002;184:631-635; discussion 635-636.
657. Smith CH, Erlandson ME, Stern G, Hilgartner M. Postsplenectomy infection in Cooley's anemia. An appraisal of the problem in this and other blood disorders, with a consideration of prophylaxis. *N Engl J Med* 1962;266: 737-743.
658. Smith CH, Erlandson ME, Stern G, Hilgartner MW. Postsplenectomy infection in Cooley's anemia. *Ann N Y Acad Sci* 1964;119:748-757.
659. Erickson WD, Burgert EO, Lynn HB. The hazard of infection following splenectomy in children. *Am J Dis Child* 1968;116:1-12.
660. Yapp AR, Lindeman R, Gilroy N, et al. Infection outcomes in splenectomized patients with hemoglobinopathies in Australia. *Int J Infect Dis* 2009;13: 696-700.
661. Looreesuwan S, Suntharasamai P, Webster HK, Ho M. Malaria in splenectomized patients: report of four cases and review. *Clin Infect Dis* 1993;16: 361-366.
662. Martin F, Oliver AM, Kearney JF. Marginal zone and B1 B cells unite in the early response against T-independent blood-borne particulate antigens. *Immunity* 2001;14:617-629.
663. Wolf HM, Eibl MM, Georgi E, et al. Long-term decrease of CD4+CD45RA+ T cells and impaired primary immune response after post-traumatic splenectomy. *Br J Haematol* 1999;107:55-68.
664. Ram S, Lewis LA, Rice PA. Infections of people with complement deficiencies and patients who have undergone splenectomy. *Clin Microbiol Rev* 2010;23:740-780.
665. Issaragrisil S, Wanachiwanawin W, Bhuripanyo K, et al. Infection in thalassemia: a retrospective study of 1,018 patients with beta-thalassemia/Hb E disease. *Birth Defects Orig Artic Ser* 1987;23:505-511.
666. Wang S-C, Lin K-H, Chern JPS, et al. Severe bacterial infection in transfusion-dependent patients with thalassemia major. *Clin Infect Dis* 2003;37:984-988.
667. Vento S, Cainelli F, Cesario F. Infections and thalassaemia. *Lancet Infect Dis* 2006;6:226-233.
668. Yu RK, Shepherd LE, Rapson DA. *Capnocytophaga canimorsus*, a potential emerging microorganism in splenectomized patients. *Br J Haematol* 2000;109:679.
669. Hansen K, Singer DB. Asplenic-hyposplenic overwhelming sepsis: postsplenectomy sepsis revisited. *Pediatr Dev Pathol* 2001;4:105-121.
670. Singer DB. Postsplenectomy sepsis. *Perspect Pediatr Pathol* 1973;1:285-311.
671. Davies JM, Lewis MPN, Wimperis J, et al. Review of guidelines for the prevention and treatment of infection in patients with an absent or dysfunctional spleen: prepared on behalf of the British Committee for Standards in Haematology by a working party of the Haemato-Oncology Task Force. *Br J Haematol* 2011;155:308-317.
672. Borgna-Pignatti C, De Stefano P, Barone F, Concia E. Penicillin compliance in splenectomized thalassems. *Eur J Pediatr* 1984;142:83-85.
673. Buchanan GR, Siegel JD, Smith SJ, DePasse BM. Oral penicillin prophylaxis in children with impaired splenic function: a study of compliance. *Pediatrics* 1982;70:926-930.
674. Anon. Recommendations for the prevention of *Streptococcus pneumoniae* infections in infants and children: use of 13-valent pneumococcal conjugate vaccine (PCV13) and pneumococcal polysaccharide vaccine (PPSV23). *Pediatrics* 2010;126:186-190.
675. Konradsen HB, Henrichsen J. Pneumococcal infections in splenectomized children are preventable. *Acta Paediatr Scand* 1991;80:423-427.
676. Li Volti S, Sciotto A, Fisichella M, et al. Immune responses to administration of a vaccine against *Haemophilus influenzae* type B in splenectomized and non-splenectomized patients. *J Infect* 1999;39:38-41.
677. Slater PP, Sherlock EC. Splenectomy, thrombocytosis, and venous thrombosis. *Am Surg* 1957;23:549-554.
678. Hathirat P, Mahaphan W, Chuansumrit A, et al. Platelet counts in thalassemic children before and after splenectomy. *Southeast Asian J Trop Med Public Health* 1993;24(Suppl 1):213-215.

679. Hoepfer MM, Niedermeyer J, Hoffmeyer F, et al. Pulmonary hypertension after splenectomy? *Ann Intern Med* 1999;130:506-509.
680. Morris CR, Vichinsky EP. Pulmonary hypertension in thalassemia. *Ann N Y Acad Sci* 2010;1202:205-213.
681. de Montalembert M, Girot R, Revillon Y, et al. Partial splenectomy in homozygous beta thalassaemia. *Arch Dis Child* 1990;65:304-307.
682. Politis C, Spigos DG, Georgiopolou P, et al. Partial splenic embolisation for hypersplenism of thalassaemia major: five year follow up. *Br Med J (Clinical Research ed)* 1987;294:665-667.
683. Pinca A, Di Palma A, Soriani S, et al. Effectiveness of partial splenic embolization as treatment for hypersplenism in thalassaemia major: a 7-year follow up. *Eur J Haematol* 1992;49:49-52.
684. Okon E, Levij IS, Rachmilewitz EA. Splenectomy, iron overload and liver cirrhosis in beta-thalassemia major. *Acta Haematol* 1976;56:142-150.
685. Borgna-Pignatti C, De Stefano P, Bongo IG, et al. Spleen iron content is low in thalassemia. *The American J Pediatr Hematol Oncol* 1984;6:340-343.
686. Brewer CJ, Coates TD, Wood JC. Spleen R2 and R2* in iron-overloaded patients with sickle cell disease and thalassemia major. *J Magn Reson Imaging* 2009;29:357-364.
687. Risdon RA, Barry M, Flynn DM. Transfusional iron overload: the relationship between tissue iron concentration and hepatic fibrosis in thalassaemia. *J Pathol* 1975;116:83-95.
688. Borgna-Pignatti C. The life of patients with thalassemia major. *Haematologica* 2010;95:345-348.
689. Ehlers KH, Giardina PJ, Lesser ML, et al. Prolonged survival in patients with beta-thalassemia major treated with deferoxamine. *J Pediatr* 1991;118: 540-545.
690. Ladis V, Chouliaras G, Berdoukas V, et al. Survival in a large cohort of Greek patients with transfusion-dependent beta thalassaemia and mortality ratios compared to the general population. *Eur J Haematol* 2011;86:332-338.
691. Kwiatkowski JL, Kim H-Y, Thompson AA, et al. Chelation use and iron burden in North American and British thalassemia patients: a report from the Thalassemia Longitudinal Cohort. *Blood* 2012;119:2746-2753.
692. Palma A, Vullo C, Zani B, Facchini A. Psychosocial integration of adolescents and young adults with thalassemia major. *Ann N Y Acad Sci* 1998;850: 355-360.
693. Politis C, Di Palma A, Fisfis M, et al. Social integration of the older thalassaemic patient. *Arch Dis Child* 1990;65:984-986.
694. Sobota A, Yamashita R, Xu Y, et al. Quality of life in thalassemia: a comparison of SF-36 results from the thalassemia longitudinal cohort to reported literature and the US norms. *Am J Hematol* 2011;86:92-95.
695. Tsiantis J, Dragonas T, Richardson C, et al. Psychosocial problems and adjustment of children with beta-thalassemia and their families. *Eur Child Adolesc Psychiatry* 1996;5:193-203.
696. Anie KA, Massaglia P. Psychological therapies for thalassaemia. *Cochrane Database System Rev* 2001:CD002890.
697. Pakbaz Z, Treadwell M, Kim H-Y, et al. Education and employment status of children and adults with thalassemia in North America. *Pediatr Blood Cancer* 2010;55:678-683.
698. Wahab IA, Naznin M, Nora MZ, et al. Thalassaemia: a study on the perception of patients and family members. *Med J Malaysia* 2011;66:326-334.
699. Cao A, Galanello R, Rosatelli MC. Prenatal diagnosis and screening of the haemoglobinopathies. *Baillieres Clin Haematol* 1998;11:215-238.
700. Angastiniotis M, Modell B, Englezos P, Boulyjenkov V. Prevention and control of haemoglobinopathies. *Bull World Health Organ* 1995;73:375-386.
701. Colah R, Gorakshakar A, Nadkarni A. Global burden, distribution and prevention of beta-thalassaemias and hemoglobin E disorders. *Expert Rev Hematol* 2010;3:103-117.
702. Thomas ED, Buckner CD, Sanders JE, et al. Marrow transplantation for thalassaemia. *Lancet* 1982;2:227-229.
703. Lucarelli G, Clift RA, Galimberti M, et al. Marrow transplantation for patients with thalassemia: results in class 3 patients. *Blood* 1996;87:2082-2088.

704. Lucarelli G, Galimberti M, Polchi P, et al. Bone marrow transplantation in patients with thalassemia. *N Engl J Med* 1990;322:417-421.
705. Sabloff M, Chandy M, Wang Z, et al. HLA-matched sibling bone marrow transplantation for beta-thalassemia major. *Blood* 2011;117:1745-1750.
706. Lucarelli G, Clift RA, Galimberti M, et al. Bone marrow transplantation in adult thalassemic patients. *Blood* 1999;93:1164-1167.
707. Gaziev J, Sodani P, Polchi P, et al. Bone marrow transplantation in adults with thalassemia: treatment and long-term follow-up. *Ann N Y Acad Sci* 2005;1054:196-205.
708. Gaziev D, Galimberti M, Lucarelli G, et al. Bone marrow transplantation from alternative donors for thalassemia: HLA-phenotypically identical relative and HLA-nonidentical sibling or parent transplants. *Bone Marrow Transplant* 2000;25:815-821.
709. La Nasa G, Littera R, Locatelli F, et al. Status of donor-recipient HLA class I ligands and not the KIR genotype is predictive for the outcome of unrelated hematopoietic stem cell transplantation in beta-thalassemia patients. *Biol Blood Marrow Transplant* 2007;13:1358-1368.
710. Orrù S, Orrù N, Manolagos E, et al. Recipient CTLA-4*CT60-AA genotype is a prognostic factor for acute graft-versus-host disease in hematopoietic stem cell transplantation for thalassemia. *Hum Immunol* 2012;73:282-286.
711. Bernardo ME, Piras E, Vacca A, et al. Allogeneic hematopoietic stem cell transplantation in thalassemia major: results of a reduced-toxicity conditioning regimen based on the use of treosulfan. *Blood* 2012;120(2):473-476.
712. Bertaina A, Bernardo ME, Mastronuzzi A, et al. The role of reduced intensity preparative regimens in patients with thalassemia given hematopoietic transplantation. *Ann N Y Acad Sci* 2010;1202:141-148.
713. Galimberti M, Andreani M, Lucarelli G, et al. Patterns of graft rejection after bone marrow transplant in thalassemia. *Prog Clin Biol Res* 1989;309: 223-229.
714. Andreani M, Nesci S, Lucarelli G, et al. Long-term survival of ex-thalassemic patients with persistent mixed chimerism after bone marrow transplantation. *Bone Marrow Transplant* 2000;25:401-404.
715. Andreani M, Manna M, Lucarelli G, et al. Persistence of mixed chimerism in patients transplanted for the treatment of thalassemia. *Blood* 1996;87: 3494-3499.
716. Gluckman E, Koegler G, Rocha V. Human leukocyte antigen matching in cord blood transplantation. *Semin Hematol* 2005;42:85-90.
717. Wagner JE, Barker JN, DeFor TE, et al. Transplantation of unrelated donor umbilical cord blood in 102 patients with malignant and nonmalignant diseases: influence of CD34 cell dose and HLA disparity on treatment-related mortality and survival. *Blood* 2002;100:1611-1618.
718. Gluckman E, Ruggeri A, Rocha V, et al. Family-directed umbilical cord blood banking. *Haematologica* 2011;96:1700-1707.
719. Jaing T-H, Hung I-J, Yang C-P, et al. Unrelated cord blood transplantation for thalassaemia: a single-institution experience of 35 patients. *Bone Marrow Transplant* 2012;47:33-39.
720. Ruggeri A, Eapen M, Scaravadou A, et al. Umbilical cord blood transplantation for children with thalassemia and sickle cell disease. *Biol Blood Marrow Transplant* 2011;17:1375-1382.
721. Ghavamzadeh A, Irvani M, Ashouri A, et al. Peripheral blood versus bone marrow as a source of hematopoietic stem cells for allogeneic transplantation in children with class I and II beta thalassemia major. *Biol Blood Marrow Transplant* 2008;14:301-308.
722. Gaziev D, Polchi P, Galimberti M, et al. Graft-versus-host disease after bone marrow transplantation for thalassemia: an analysis of incidence and risk factors. *Transplantation* 1997;63:854-860.
723. Caocci G, Efficace F, Ciotti F, et al. Prospective assessment of health-related quality of life in pediatric patients with beta-thalassemia following hematopoietic stem cell transplantation. *Biol Blood Marrow Transplant* 2011;17:861-866.
724. Locatelli F, Littera R, Pagliara D, et al. Outcome of unrelated donor bone marrow transplantation for thalassemia major patients. *ASH Ann Meet Abstr* 2011;118:149.

725. De Simone M, Verrotti A, Iughetti L, et al. Final height of thalassemic patients who underwent bone marrow transplantation during childhood. *Bone Marrow Transplant* 2001;28:201-205.
726. Cohen A, Rovelli A, Bakker B, et al. Final height of patients who underwent bone marrow transplantation for hematological disorders during childhood: a study by the Working Party for Late Effects-EBMT. *Blood* 1999;93:4109-4115.
727. De Sanctis V, Galimberti M, Lucarelli G, et al. Pubertal development in thalassaemic patients after allogenic bone marrow transplantation. *Eur J Pediatr* 1993;152:993-997.
728. Borgna-Pignatti C, Marradi P, Rugolotto S, Marcolongo A. Successful pregnancy after bone marrow transplantation for thalassaemia. *Bone Marrow Transplant* 1996;18:235-236.
729. Babb A, Farah N, Lyons C, et al. Uptake and outcome of assisted reproductive techniques in long-term survivors of SCT. *Bone Marrow Transplant* 2012;47:568-573.
730. Sharma V. Sperm storage for cancer patients in the UK: a review of current practice. *Hum Reprod* 2011;26:2935-2943.
731. Donnez J, Silber S, Andersen CY, et al. Children born after autotransplantation of cryopreserved ovarian tissue. A review of 13 live births. *Ann Med* 2011;43:437-450.
732. Erer B, Angelucci E, Muretto P, et al. Kaposi's sarcoma after allogeneic bone marrow transplantation. *Bone Marrow Transplant* 1997;19:629-631.
733. Baronciani D, Angelucci E, Polchi P, et al. An unusual marrow transplant complication: cardiac myxoma. *Bone Marrow Transplant* 1998;21:825-827.
734. Polchi P, Lucarelli G, Galimberti M, Moretti L. Cyclosporine in children. *Prog Clin Biol Res* 1989;309:333-348.
735. Montebugnoli L, Gissi DB, Marchetti C, Foschini MP. Multiple squamous cell carcinomas of the oral cavity in a young patient with graft-versus-host disease following allogenic bone marrow transplantation. *Int J Oral Maxillofac Surg* 2011;40:556-558.
736. Sahlstedt L, Ebeling F, von Bonsdorff L, et al. Non-transferrin-bound iron during allogeneic stem cell transplantation. *Br J Haematol* 2001;113:836-838.
737. Evens a M, Mehta J, Gordon LI. Rust and corrosion in hematopoietic stem cell transplantation: the problem of iron and oxidative stress. *Bone Marrow Transplant* 2004;34:561-571.
738. Dürken M, Herrring C, Finckh B, et al. Impaired plasma antioxidative defense and increased nontransferrin-bound iron during high-dose chemotherapy and radiochemotherapy preceding bone marrow transplantation. *Free Radic Biol Med* 2000;28:887-894.
739. Pullarkat V. Iron overload in patients undergoing hematopoietic stem cell transplantation. *Adv Hematol Oncol* 2010. doi:10.1155/2010/345756.
740. Lucarelli G, Angelucci E, Giardini C, et al. Fate of iron stores in thalassaemia after bone-marrow transplantation. *Lancet* 1993;342:1388-1391.
741. Muretto P, Angelucci E, Lucarelli G. Reversibility of cirrhosis in patients cured of thalassemia by bone marrow transplantation. *Ann Intern Med* 2002;136:667-672.
742. Yesilipek MA, Karasu G, Kazik M, et al. Posttransplant oral iron-chelating therapy in patients with beta-thalassemia major. *Pediatr Hematol Oncol* 2010;27:374-379.
743. Giardini C, Galimberti M, Lucarelli G, et al. Desferrioxamine therapy accelerates clearance of iron deposits after bone marrow transplantation for thalassaemia. *Br J Haematol* 1995;89:868-873.
744. Testa U. Fetal hemoglobin chemical inducers for treatment of hemoglobinopathies. *Ann Hematol* 2009;88:505.
745. George A., Fathallah H. Pharmacologic induction of fetal hemoglobin production. *Hamatol Oncol Clin N Am* 2010;24:1131-1144.
746. Thein S. The emerging role of fetal hemoglobin induction in non-transfusiondependent thalassemia. *Blood Rev* 2012;26S:S35-S39.
747. Torrealba-de Ron A, Papayannopoulou T, Knapp M, et al. Perturbations in the erythroid marrow progenitor cell pools may play a role in the augmentation of HbF by 5-azacytidine. *Blood* 1984;63:201-210.

748. DeSimone J, Heller P, Hall L, Zwiers D. 5-Azacytidine stimulates fetal hemoglobin synthesis in anemic baboons. *Proc Natl Acad Sci U S A* 1982;79: 4428-4431.
749. Carr BI, Reilly JG, Smith SS, et al. The tumorigenicity of 5-azacytidine in the male Fischer rat. *Carcinogenesis* 1984;5:1583-1590.
750. Hsiao WL, Gattoni-Celli S, Weinstein IB. Effects of 5-azacytidine on the progressive nature of cell transformation. *Mol Cell Biol* 1985;5:1800-1803.
751. Sauntharajah Y, Hillery CA, Lavelle D, et al. Effects of 5-aza-2'-deoxycytidine on fetal hemoglobin levels, red cell adhesion, and hematopoietic differentiation in patients with sickle cell disease. *Blood* 2003;102:3865-3870.
752. Olivieri NF, Sauntharajah Y, Thayalasuthan V, et al. A pilot study of subcutaneous decitabine in beta-thalassemia intermedia. *Blood* 2011;118: 2708-2711.
753. Cokic VP, Andric SA, Stojilkovic SS, et al. Hydroxyurea nitrosylates and activates soluble guanylyl cyclase in human erythroid cells. *Blood* 2008;111:1117-1123.
754. Singer S, Kuypers F, Olivieri N, et al. Fetal haemoglobin augmentation in E/beta(0) thalassaemia: clinical and haematological outcome. *Br J Haematol* 2005;131:378-388.
755. Koren A, Levin C, Dgany O, et al. Response to hydroxyurea therapy in betathalassemia. *Am J Hematol* 2008;83:366-370.
756. Dixit A, Chatterjee TC, Mishra P, et al. Hydroxyurea in thalassemia intermedia—a promising therapy. *Ann Hematol* 2005;84:441-446.
757. Karimi M, Haghpanah S, Farhadi A, Yavarian M. Genotype-phenotype relationship of patients with beta-thalassemia taking hydroxyurea: a 13-year experience in Iran. *Int J Hematol* 2012;95:51-56.
758. Saxon BR, Rees D, Olivieri NF. Regression of extramedullary haemopoiesis and augmentation of fetal haemoglobin concentration during hydroxyurea therapy in beta thalassaemia. *Br J Haematol* 1998;101:416-419.
759. Rachmilewitz EA, Goldfarb A, Dover G. Administration of erythropoietin to patients with beta-thalassemia intermedia: a preliminary trial. *Blood* 1991;78:1145-1147.
760. Olivieri NF, Freedman MH, Perrine SP, et al. Trial of recombinant human erythropoietin: three patients with thalassemia intermedia. *Blood* 1992;80: 3258-3260.
761. Singer S, Vichinsky E, Sweeters N, Rachmilewitz E. Darbepoetin alfa for the treatment of anaemia in alpha- or beta-thalassaemia intermedia syndromes. *Br J Haematol* 2011;154:281-284.
762. Perrine SP, Ginder GD, Faller DV, et al. A short-term trial of butyrate to stimulate fetal-globin-gene expression in the beta-globin disorders. *N Engl J Med* 1993;328:81-86.
763. Sher GD, Ginder GD, Little J, et al. Extended therapy with intravenous arginine butyrate in patients with beta-hemoglobinopathies. *N Engl J Med* 1995;332:1606-1610.
764. Cao H. Pharmacological induction of fetal hemoglobin synthesis using histone deacetylase inhibitors. *Hematology (Amsterdam, Netherlands)* 2004;9: 223-233.
765. Weinberg RS, Ji X, Sutton M, et al. Butyrate increases the efficiency of translation of gamma-globin mRNA. *Blood* 2005;105:1807-1809.
766. Perrine SP, Castaneda SA, Boosalis MS, et al. Induction of fetal globin in betathalassemia: cellular obstacles and molecular progress. *Ann N Y Acad Sci* 2005;1054:257-265.
767. Domenica Cappellini M, Graziadei G, Ciceri L, et al. Oral isobutyramide therapy in patients with thalassemia intermedia: results of a phase II open study. *Blood Cells* 2000;26:105-111.
768. Gille G, Reichmann H. Iron-dependent functions of mitochondria—relation to neurodegeneration. *J Neural Transm* 2011:349-359.
769. Reich S, Bühner C, Henze G, et al. Oral isobutyramide reduces transfusion requirements in some patients with homozygous beta-thalassemia. *Blood* 2000;96:3357-3363.
770. Fathallah H, Sutton M, Atweh GF. Pharmacological induction of fetal hemoglobin: why haven't we been more successful in thalassemia? *Ann N Y Acad Sci* 2005;1054:228-237.

771. Bank A. Regulation of human fetal hemoglobin: new players, new complexities. *Blood* 2006;107:435-443.
772. Thein SL, Menzel S, Lathrop M, Garner C. Control of fetal hemoglobin: new insights emerging from genomics and clinical implications. *Hum Mol Genet* 2009;18:R216-23.
773. Sankaran VG. Targeted therapeutic strategies for fetal hemoglobin induction. *Hematology (Am Soc Hematol Educ Program)* 2011:459-465.
774. Moi P, Sadelain M. Towards the genetic treatment of beta-thalassemia: new disease models, new vectors, new cells. *Haematologica* 2008;93:325-330.
775. Case SS, Price MA, Jordan CT, et al. Stable transduction of quiescent CD34(+) CD38(-) human hematopoietic cells by HIV-1-based lentiviral vectors. *Proc Natl Acad Sci U S A* 1999;96:2988-2993. 202
776. Hacein-Bey-Abina S, Garrigue A, Wang GP, et al. Insertional oncogenesis in 4 patients after retrovirus-mediated gene therapy of SCID-X1. *J Clin Invest* 2008;118:3132-3142.
777. Hacein-Bey-Abina S, Hauer J, Lim A, et al. Efficacy of gene therapy for X-linked severe combined immunodeficiency. *N Engl J Med* 2010;363: 355-364.
778. May C, Rivella S, Callegari J, et al. Therapeutic haemoglobin synthesis in betathalassaemic mice expressing lentivirus-encoded human beta-globin. *Nature* 2000;406:82-86.
779. Imren S, Fabry ME, Westerman KA, et al. High-level beta-globin expression and preferred intragenic integration after lentiviral transduction of human cord blood stem cells. *J Clin Invest* 2004;114:953-962.
780. May C, Sadelain M. A promising genetic approach to the treatment of betathalassaemia. *Trends Cardiovasc Med* 2001;11:276-280.
781. Pawliuk R, Westerman KA, Fabry ME, et al. Correction of sickle cell disease in transgenic mouse models by gene therapy. *Science (New York, NY)* 2001;294:2368-2371.
782. Rivella S, May C, Chadburn A, et al. A novel murine model of Cooley anemia and its rescue by lentiviral-mediated human beta-globin gene transfer. *Blood* 2003;101:2932-2939.
783. Puthenveetil G, Scholes J, Carbonell D, et al. Successful correction of the human beta-thalassemia major phenotype using a lentiviral vector. *Blood* 2004;104:3445-3453.
784. Cavazzana-Calvo M, Payen E, Negre O, et al. Transfusion independence and HMGA2 activation after gene therapy of human beta-thalassaemia. *Nature* 2010;467:318-322.
785. Italiano A, Bianchini L, Keslair F, et al. HMGA2 is the partner of MDM2 in well-differentiated and dedifferentiated liposarcomas whereas CDK4 belongs to a distinct inconsistent amplicon. *Int J Cancer* 2008;122:2233-2241.
786. Mayr C, Hemann MT, Bartel DP. Disrupting the pairing between let-7 and Hmga2 enhances oncogenic transformation. *Science (New York, NY)* 2007;315:1576-1579.
787. Hanna J, Wernig M, Markoulaki S, et al. Treatment of sickle cell anemia mouse model with iPS cells generated from autologous skin. *Science (New York, NY)* 2007;318:1920-1923.
788. Rivière I, Dunbar CE, Sadelain M. Hematopoietic stem cell engineering at a crossroads. *Blood* 2012;119:1107-1116.
789. Pootrakul P, Wasi P, Na-Nakorn S. Haematological data in 312 cases of -thalassaemia trait in Thailand. *Br J Haematol* 1973;24:703-712.
790. Galanello R, Melis MA, Ruggeri R, et al. Beta 0 thalassemia trait in Sardinia. *Hemoglobin* 1979;3:33-46.
791. Cooley JR, Kitay DZ. Heterozygous beta-thalassemia in pregnancy. *J Reprod Med* 1984;29:141-142.
792. Leung CF, Lao TT, Chang AM. Effect of folate supplement on pregnant women with beta-thalassaemia minor. *Eur J Obstet Gynecol Reprod Biol* 1989;33:209-213.
793. Van der Weyden MB, Fong H, Hallam LJ, Harrison C. Red cell ferritin and iron overload in heterozygous beta-thalassemia. *Am J Hematol* 1989;30:201-205.
794. Melis MA, Cau M, Deidda F, et al. H63D mutation in the HFE gene increases iron overload in beta-thalassemia carriers. *Haematologica* 2002;87:242-245.
795. Galanello R, Turco MP, Barella S, et al. Iron stores and iron deficiency anemia in children heterozygous for beta-thalassemia. *Haematologica* 1990;75: 319-322.

796. Galanello R, Perseu L, Melis MA, et al. Hyperbilirubinaemia in heterozygous beta-thalassaemia is related to coinherited Gilbert's syndrome. *Br J Haematol* 1997;99:433-436.
797. Borgna-Pignatti C, De Stefano P, Bongo I. Cholelithiasis in thalassemia minor: an epidemiological study on Italian women. *Int J Gastroenterol* 1983;15:228-230.
798. Schiliro G, Li Volti S, Marino S, et al. Increase with age in the prevalence of beta-thalassemia trait among Sicilians. *N Engl J Med* 1989;321:762.
799. Gallerani M, Scapoli C, Cicognani I, et al. Thalassaemia trait and myocardial infarction: low infarction incidence in male subjects confirmed. *J Intern Med* 1991;230:109-111.
800. Maioli M, Vigna GB, Tonolo G, et al. Plasma lipoprotein composition, apolipoprotein(a) concentration and isoforms in beta-thalassemia. *Atherosclerosis* 1997;131:127-133.
801. Deiana L, Garuti R, Pes GM, et al. Influence of beta(0)-thalassemia on the phenotypic expression of heterozygous familial hypercholesterolemia: a study of patients with familial hypercholesterolemia from Sardinia. *Arterioscler Thromb Vasc Biol* 2000;20:236-243.
802. Labie D, Bennani C, Beldjord C. Beta-thalassemia in Algeria. *Ann N Y Acad Sci* 1990;612:43-54.
803. Livingstone FB. Abnormal hemoglobins in human populations. Chicago: Aldine, 1967.
804. Millard DP, Mason K, Serjeant BE, Serjeant GR. Comparison of haematological features of the beta0 and beta+ thalassaemia traits in Jamaican Negroes. *Br J Haematol* 1977;36:161-170.
805. Charache S, Conley CL, Doebelin TD, Bartalos M. Thalassaemia in black Americans. *Ann N Y Acad Sci* 1974;232:125-134.
806. Rund D, Filon D, Strauss N, et al. Mean corpuscular volume of heterozygotes for beta-thalassemia correlates with the severity of mutations. *Blood* 1992;79:238-243.
807. Rosatelli M, Leoni G, Tuveri T, et al. Heterozygous beta-thalassemia: relationship between the hematological phenotype and the type of beta-thalassemia mutation. *Am J Hematol* 1992;39:1-4.
808. Mazza U, Saglio G, Cappio FC, et al. Clinical and haematological data in 254 cases of beta-thalassaemia trait in Italy. *Br J Haematol* 1976;33:91-99.
809. Weatherall DJ. Biochemical phenotypes of thalassemia in the American negro population. *Ann N Y Acad Sci* 1964;119:450-462.
810. Borgna-Pignatti C, Zonta L, Bongo I, De Stefano P. Red blood cell indices in adults and children with heterozygous beta-thalassemia. *Haematologica* 1983;68:149-156.
811. Galanello R, Melis MA, Ruggeri R, Cao A. Prospective study of red blood cell indices, hemoglobin A2, and hemoglobin F in infants heterozygous for betathalassemia. *J Pediatr* 1981;99:105-108.
812. Pippard MJ, Wainscoat JS. Erythrokinetics and iron status in heterozygous beta thalassaemia, and the effect of interaction with alpha thalassaemia. *Br J Haematol* 1987;66:123-127.
813. Shepard MK, Weatherall DJ, Conley CL. Semi-quantitative estimation of the distribution of fetal hemoglobin in red cell populations. *Bull Johns Hopkins Hosp* 1962;110:293-310.
814. Wood WG, Stamatoyannopoulos G, Lim G, Nute PE. F-cells in the adult: normal values and levels in individuals with hereditary and acquired elevations of Hb F. *Blood* 1975;46:671-682.
815. Melis MA, Pirastu M, Galanello R, et al. Phenotypic effect of heterozygous alpha and beta 0-thalassemia interaction. *Blood* 1983;62:226-229.
816. Galanello R, Barella S, Ideo A, et al. Genotype of subjects with borderline hemoglobin A2 levels: implication for beta-thalassemia carrier screening. *Am J Hematol* 1994;46:79-81.
817. Bianco I, Cappabianca M, Foglietta E, et al. Silent thalassemsias: genotypes and phenotypes. *Haematologica* 1997;82:269-280.
818. Galanello R, Paglietti ME, Addis M, et al. Pitfalls in genetic counselling for beta-thalassemia: an individual with 4 different thalassemia mutations. *Clin Genet* 1988;33:151-155.
819. Harthoorn-Lasthuizen EJ, Lindemans J, Langenhuijsen MM. Influence of iron deficiency anaemia on haemoglobin A2 levels: possible consequences for beta-thalassaemia screening. *Scand J Clin Lab Invest* 1999;59:65-70.

820. Passarello C, Giambona A, Cannata M, et al. Iron deficiency does not compromise the diagnosis of high HbA(2) beta thalassemia trait. *Haematologica* 2012;97:472-473.
821. Verhovsek M, So C-C, O'Shea T, et al. Is HbA2 level a reliable diagnostic measurement for beta-thalassemia trait in people with iron deficiency? *Am J Hematol* 2012;87:114-116.
822. Gianni AM, Bregni M, Cappellini MD, et al. A gene controlling fetal hemoglobin expression in adults is not linked to the non-alpha globin cluster. *EMBO J* 1983;2:921-925.
823. Traeger-Synodinos J, Old JM, Petrou M, Galanello R. Best practice guidelines for carrier identification and prenatal diagnosis of haemoglobinopathies. 2002. European Molecular Genetics Quality Network. http://www.emqn.org/emqn/digitalAssets/0/235_HB_eu.pdf
824. Galanello R, Barella S, Gasperini D, et al. Evaluation of an automatic HPLC analyser for thalassemia and haemoglobin variants screening. *J Auto Chem* 1995;17:73-76.
825. Clarke GM, Higgins TN. Laboratory investigation of hemoglobinopathies and thalassemias: review and update. *Clin Chem* 2000;46:1284-1290.
826. Van Delft P, Lenters E, Bakker-Verweij M, et al. Evaluating five dedicated automatic devices for haemoglobinopathy diagnostics in multi-ethnic populations. *Int J Lab Hematol* 2009;31:484-495.
827. Kattamis C, Efremov G, Pootrakul S. Effectiveness of one tube osmotic fragility screening in detecting beta-thalassaemia trait. *J Med Genet* 1981;18:266-270.
828. d'Onofrio G, Zini G, Ricerca BM, et al. Automated measurement of red blood cell microcytosis and hypochromia in iron deficiency and beta-thalassemia trait. *Arch Pathol Lab Med* 1992;116:84-89.
829. Mosca A, Paleari R, Galanello R, et al. New analytical tools and epidemiological data for the identification of HbA2 borderline subjects in the screening for beta-thalassemia. *Bioelectrochemistry (Amsterdam, Netherlands)* 2008;73:137-140.
830. Perseu L, Satta S, Moi P, et al. KLF1 gene mutations cause borderline HbA(2). *Blood* 2011;118:4454-4458.
831. Old J, Henderson S. Molecular diagnosis for haemoglobinopathies. *Expert Opin Med Diagn* 2010;4:225-240.
832. Hartevelde CL, Kleanthous M, Traeger-Synodinos J. Prenatal diagnosis of hemoglobin disorders: present and future strategies. *Clin Biochem* 2009;42:1767-1779.
833. Mand F, Old J. Laboratory methods for diagnosis and evaluation of hemoglobin disorders. In: Steinberg M, Forget B, Higgs D, Weatherall D, eds. *Disorders of hemoglobin: genetics, pathophysiology and clinical management*. Cambridge: Cambridge University Press, 2009:658-686.
834. Old J. Prenatal diagnosis of the hemoglobinopathies. In: Milunsky A, Milunsky J, eds. *Genetic disorders and the fetus*, 6th ed. Oxford: Blackwell Publishing, 2010:646-679.
835. Hartevelde KL, Heister AJ, Giordano PC, et al. Rapid detection of point mutations and polymorphisms of the alpha-globin genes by DGGE and SSCP. *Hum Mutat* 1996;7:114-122.
836. Galanello R, Sollaino C, Paglietti E, et al. Alpha-thalassemia carrier identification by DNA analysis in the screening for thalassemia. *Am J Hematol* 1998;59:273-278.
837. Luo HY, Clarke BJ, Gaudie J, et al. A novel monoclonal antibody based diagnostic test for alpha-thalassemia-1 carriers due to the (-SEA/) deletion. *Blood* 1988;72:1589-1594.
838. Fucharoen S, Winichagoon P, Thonglairuam V. Beta-thalassemia associated with alpha-thalassemia in Thailand. *Hemoglobin* 1988;12:581-592.
839. Frischer H, Bowman J. Hemoglobin E, an oxidatively unstable mutation. *J Lab Clin Med* 1975;85:531-539.
840. Cao A, Galanello R, Saba L, Rosatelli M. Beta-thalassemia: molecular diagnosis, carrier screening and prevention. A review for clinicians. *JAMA* 1997;278:11273-11277.
841. Kan YW, Golbus MS, Klein P, Dozy AM. Successful application of prenatal diagnosis in a pregnancy at risk for homozygous beta-thalassemia. *N Engl J Med* 1975;292:1096-1099.
842. Hogge WA, Schonberg SA, Golbus MS. Chorionic villus sampling: experience of the first 1000 cases. *Am J Obstet Gynecol* 1986;154:1249-1252.

843. Cao A, Cossu P, Monni G, Rosatelli MC. Chorionic villus sampling and acceptance rate of prenatal diagnosis. *Prenat Diagn* 1987;7:531-533.
844. Monni G, Ibba RM, Lai R, et al. Early transabdominal chorionic villus sampling in couples at high genetic risk. *Am J Obstet Gynecol* 1993;168: 170-173.
845. Jauniaux E, Pahal GS, Rodeck CH. What invasive procedure to use in early pregnancy? *Baillieres Best Pract Res Clin Obstet* 2000;14:651-662.
846. Kuliev AM, Modell B, Jackson L, et al. Risk evaluation of CVS. *Prenat Diagn* 1993;13:197-209.
847. Old J, Petrou M, Varnavides L, et al. Accuracy of prenatal diagnosis for haemoglobin disorders in the UK: 25 years' experience. *Prenat Diagn* 2000;20:986-991.
848. Monk M, Holding C. Amplification of a beta-haemoglobin sequence in individual human oocytes and polar bodies. *Lancet* 1990;335:985-988.
849. Handyside AH, Lesko JG, Tarín JJ, et al. Birth of a normal girl after in vitro fertilization and preimplantation diagnostic testing for cystic fibrosis. *N Engl J Med* 1992;327:905-909.
850. Kuliev A, Rechitsky S, Verlinsky O, et al. Preimplantation diagnosis of thalassemias. *J Assist Reprod Genet* 1998;15:219-225.
851. Palmer GA, Traeger-Synodinos J, Davies S, et al. Pregnancies following blastocyst stage transfer in PGD cycles at risk for beta-thalassaemic haemoglobinopathies. *Hum Reprod* 2002;17:25-31.
852. Kanavakis E, Traeger-Synodinos J. Preimplantation genetic diagnosis in clinical practice. *J Med Genet* 2002;39:6-11.
853. Harper JC, Wilton L, Traeger-Synodinos J, et al. The ESHRE PGD Consortium: 10 years of data collection. *Hum Reprod Update* 2012;18:234-247.
854. Edwards G. Ethics of PGD: thoughts on the consequences of typing HLA in embryos. *Reprod Biomed Online* 2004;9:222-224.
855. Burgio GR, Locatelli F. Programming a hematopoietic stem cell donor: the evolution of a project over time. *Haematologica* 2006;91:1015-1016.
856. Qureshi N, Foote D, Walters MC, et al. Outcomes of preimplantation genetic diagnosis therapy in treatment of beta-thalassemia: a retrospective analysis. *Ann N Y Acad Sci* 2005;1054:500-503.
857. Cheung MC, Goldberg JD, Kan YW. Prenatal diagnosis of sickle cell anaemia and thalassaemia by analysis of fetal cells in maternal blood. *Nat Genet* 1996;14:264-268.
858. Lo YM, Corbetta N, Chamberlain PF, et al. Presence of fetal DNA in maternal plasma and serum. *Lancet* 1997;350:485-487.
859. Lo YMD, Chiu RWK. Noninvasive approaches to prenatal diagnosis of hemoglobinopathies using fetal DNA in maternal plasma. *Hematol Oncol Clin North Am* 2010;24:1179-1186.
860. Traeger- J, Vrettou C, Kanavakis E. Prenatal, noninvasive and preimplantation genetic diagnosis of inherited disorders: hemoglobinopathies. *Rev Lit Arts Am* 2011:299-312.
861. Cousens NE, Gaff CL, Metcalfe SA, Delatycki MB. Carrier screening for beta-thalassaemia: a review of international practice. *Eur J Hum Genet* 2010;18:1077-1083.
862. Mitchell JJ, Capua A, Clow C, Scriver CR. Twenty-year outcome analysis of genetic screening programs for Tay-Sachs and beta-thalassemia disease carriers in high schools. *Am J Hum Genet* 1996;59:793-798.
863. Angastiniotis MA, Hadjiminias MG. Prevention of thalassaemia in Cyprus. *Lancet* 1981;1:369-371.
864. Karimi M, Jamalian N, Yarmohammadi H, et al. Premarital screening for beta-thalassaemia in Southern Iran: options for improving the programme. *J Med Screen* 2007;14:62-66.
865. Alhamdan NA, Almazrou YY, Alswaidi FM, Choudhry AJ. Premarital screening for thalassemia and sickle cell disease in Saudi Arabia. *Genet Med* 2007;9:372-377.
866. Tarazi I, Al Najjar E, Lulu N, Sirdah M. Obligatory premarital tests for betathalassaemia in the Gaza Strip: evaluation and recommendations. *Int J Lab Hematol* 2007;29:111-118.
867. Cao A. Carrier screening and genetic counselling in beta-thalassemia. *Int J Hematol* 2002;76(Suppl 2):105-113.

868. Chern JPS, Lin K-H, Su Y-N, et al. Impact of a national beta-thalassemia carrier screening program on the birth rate of thalassemia major. *Pediatr Blood Cancer* 2006;46:72-76.
869. Khorasani G, Kosaryan M, Vahidshahi K, et al. Results of the national program for prevention of beta-thalassemia major in the Iranian Province of Mazandaran. *Hemoglobin* 2008;32:263-271.
870. Tamhankar PM, Agarwal S, Arya V, et al. Prevention of homozygous beta thalassemia by premarital screening and prenatal diagnosis in India. *Prenat Diagn* 2009;29:83-88.
871. Ho P, Hall G, Luo L, et al. Beta-thalassaemia intermedia: is it possible consistently to predict phenotype from genotype? *Br J Haematol* 1998;100:70-78.
872. Wainscoat J, Thein S, Weatherall D. Thalassaemia intermedia. *Blood Rev* 1987;1:273-279.
873. Galanello R. Recent advances in the molecular understanding of non-transfusion-dependent thalassemia. *Blood Rev* 2012;26:S7-S11.
874. Gonzalez-Redondo J, Stoming T, Lanclos K, et al. Clinical and genetic heterogeneity in black patients with homozygous beta-thalassemia from the southeastern United States. *Blood* 1988;72:1007-1014.
875. Safaya S, Rieder R, Dowling C, et al. Homozygous beta-thalassemia without anemia. *Blood* 1989;73:324-328.
876. Rosatelli M, Pischedda A, Meloni A, et al. Homozygous beta-thalassaemia resulting in the beta-thalassaemia carrier state phenotype. *Br J Haematol* 1994;88:562-565.
877. Ristaldi M, Murru S, Loudianos G, et al. The C-T substitution in the distal CACCC box of the beta-globin gene promoter is a common cause of silent beta thalassaemia in the Italian population. *Br J Haematol* 1990;74:480-486.
878. Jankovic L, Dimovski A, Kollia P, et al. A C—G mutation at nt position 6 3' to the terminating codon may be the cause of a silent beta-thalassemia. *Int J Hematol* 1991;54:289-293.
879. Maragoudaki E, Vrettou C, Kanavakis E, et al. Molecular, haematological and clinical studies of a silent beta-gene C—>G mutation at 6 bp 3' to the termination codon (+1480 C—>G) in twelve Greek families. *Br J Haematol* 1998;103:45-51.
880. Wainscoat J, Kanavakis E, Wood WG, et al. Thalassaemia intermedia in Cyprus: the interaction of alpha and beta thalassaemia. *Br J Haematol* 1983;53:411-416.
881. Winichagoon P, Fucharoen S, Weatherall D, Wasi P. Concomitant inheritance of alpha-thalassemia in beta 0-thalassemia/Hb E disease. *Am J Hematol* 1985;20:217-222.
882. Thein S, Hesketh C, Wallace R, Weatherall D. The molecular basis of thalassaemia major and thalassaemia intermedia in Asian Indians: application to prenatal diagnosis. *Br J Haematol* 1988;70:225-231.
883. Galanello R, Dessi E, Melis M, et al. Molecular analysis of beta zero-thalassemia intermedia in Sardinia. *Blood* 1989;74:823-827.
884. Gilman J, Huisman T. DNA sequence variation associated with elevated fetal G gamma globin production. *Blood* 1985;66:783-787.
885. Efremov D, Dimovski A, Baysal E, et al. Possible factors influencing the haemoglobin and fetal haemoglobin levels in patients with beta-thalassaemia due to a homozygosity for the IVS-I-6 (T—>C) mutation. *Br J Haematol* 1994;86:824-830.
886. Sedgewick A, Timofeev N, Sebastiani P, et al. BCL11A is a major HbF quantitative trait locus in three different populations with beta-hemoglobinopathies. *Blood Cells* 2008;41:255-258.
887. Thein S. Structural variants with a beta-thalassemia phenotype. In: Steinberg M, Forget B, Higgs D, Nagel R, eds. *Disorders of hemoglobin: genetic, pathophysiology and clinical management*. Cambridge: Cambridge University Press, 2001:342-355.
888. Fei Y, Stoming T, Kutlar A, et al. One form of inclusion body beta-thalassemia is due to a GAA—TAA mutation at codon 121 of the beta chain. *Blood* 1989;73:1075-1077.
889. Huisman TH. Silent beta-thalassemia and thalassemia intermedia. *Haematologica* 1990;75(Suppl 5):1-8.
890. Camaschella C, Kattamis AC, Petroni D, et al. Different hematological phenotypes caused by the interaction of triplicated alpha-globin genes and heterozygous beta-thalassemia. *Am J Hematol* 1997;55:83-88.
891. Traeger-Synodinos J, Kanavakis E, Vrettou C, et al. The triplicated alphaglobin gene locus in beta-thalassaemia heterozygotes: clinical, haematological, biosynthetic and molecular studies. *Br J Haematol* 1996;95:467-471.

892. Hartevelde C, Refaldi C, Cassinero E, et al. Segmental duplications involving the alpha-globin gene cluster are causing beta-thalassemia intermedia phenotypes in beta-thalassemia heterozygous patients. *Blood Cells* 40:312-316.
893. Sollaino M, Paglietti M, Perseu L, et al. Association of α globin gene quadruplication and heterozygous beta thalassemia in patients with thalassemia intermedia. *Haematologica* 2009;94:1445-1448.
894. Gasperini D, Perseu L, Melis MA, et al. Heterozygous beta-thalassemia with thalassemia intermedia phenotype. *Am J Hematol* 1998;57:43-47.
895. Ho PJ, Hall G, Watt S, et al. Unusually severe heterozygous beta-thalassemia: evidence for an interacting gene affecting globin translation. *Blood* 1998;92:3428-3435.
896. Luzzatto L, Notaro R. Haemoglobin's chaperone. *Nature* 2002;417:703-705.
897. Borgna-Pignatti C, Marsella M, Zanforlin N. The natural history of thalassemia intermedia. *Ann N Y Acad Sci* 2010;1202:214-220.
898. Aessopos A, Kati M, Meletis J. Thalassemia intermedia today: should patients regularly receive transfusions? *Transfusion* 2007;47:792-800.
899. Cao A. Diagnosis of beta-thalassemia intermedia at presentation. *Birth Defects Orig Artic Ser* 1988;23:219-226.
900. Taher AT, Musallam KM, Karimi M, et al. Overview on practices in thalassemia intermedia management aiming for lowering complication rates across a region of endemicity: the OPTIMAL CARE study. *Blood* 2010;115: 1886-1892.
901. Genovese MG, Neretto G, Poti A, Benincasa A. [A case of mediastinal extra-medullary hemopoiesis (MEH) in a patient with intermediate thalassemia]. *Minerva Med* 1979;70:981-986.
902. Yu YC, Kao EL, Chou SH, et al. Intrathoracic extramedullary hematopoiesis simulating posterior mediastinal mass—report of a case in patient with betathalassemia intermedia. *Kaohsiung J Med Sci* 1991;7:43-48.
903. Mancuso P, Zingale A, Basile L, et al. Cauda equina compression syndrome in a patient affected by thalassemia intermedia: complete regression with blood transfusion therapy. *Childs Nerv Syst* 1993;9:440-441.
904. Ileri T, Azik F, Ertem M, et al. Extramedullary hematopoiesis with spinal cord compression in a child with thalassemia intermedia. *J Pediatr Hematol Oncol* 2009;31:681-683.
905. Chehal A, Aoun E, Koussa S, et al. Hypertransfusion: a successful method of treatment in thalassemia intermedia patients with spinal cord compression secondary to extramedullary hematopoiesis. *Spine* 2003;28:E245-9.
906. Taher A, Isma'eel H, Cappellini MD. Thalassemia intermedia: revisited. *Blood Cells* 2006;37:12-20.
907. Haidar R, Mhaidli H, Taher AT. Paraspinal extramedullary hematopoiesis in patients with thalassemia intermedia. *Eur Spine J* 2010;19:871-878.
908. Meo A, Cassinero E, Castelli R, et al. Effect of hydroxyurea on extramedullary haematopoiesis in thalassaemia intermedia: case reports and literature review. *Int J Lab Hematol* 2008;30:425-431.
909. Taher A, Skouri H, Jaber W, Kanj N. Extramedullary hematopoiesis in a patient with beta-thalassemia intermedia manifesting as symptomatic pleural effusion. *Hemoglobin* 2001;25:363-368.
910. Nastri G, Cappelletti M, Cappellini MD, et al. [Thoracic localizations of extra-medullary erythropoiesis]. *La Radiol Med* 1992;84:576-581.
911. Aliberti B, Patrikiou A, Terentiou A, et al. Spinal cord compression due to extramedullary haematopoiesis in two patients with thalassaemia: complete regression with blood transfusion therapy. *J Neurol* 2001;248:18-22.
912. Khen-Dunlop N, Girot R, Brunelle F, et al. Surgical treatment of an unusual case of pelvic extramedullary hematopoiesis. *J Pediatr Surg* 2006;41:e13-5.
913. da Fonseca SF, Figueiredo MS, Cançado RD, et al. Spinal cord compression in beta-thalassemia: follow-up after radiotherapy. *Rev Paul Med* 1998;116:1879-1881.
914. Lee CM, Salzman KL, Blumenthal DT, Gaffney DK. Intracranial extramedullary hematopoiesis: brief review of response to radiation therapy. *Am J Hematol* 2005;78:151-152.
915. Chourmouzi D, Pistevou-Gompaki K, Plataniotis G, et al. MRI findings of extramedullary haemopoiesis. *Eur Radiol* 2001;11:1803-1806.

916. Taher AT, Musallam KM, Cappellini MD, Weatherall DJ. Optimal management of beta thalassaemia intermedia. *Br J Haematol* 2011;152:512-523.
917. Kruatrachue M, Sirisinha S, Pacharee P, et al. An association between thalassaemia and autoimmune haemolytic anaemia (AIHA). *Scand J Haematol* 1980;25:259-263.
918. Hmida S, Mojaat N, Maamar M, et al. Red cell alloantibodies in patients with haemoglobinopathies. *Nouv Rev Fr Hematol* 1994;36:363-366.
919. De Stefano P, Zecca M, Giorgiani G, et al. Resolution of immune haemolytic anaemia with allogeneic bone marrow transplantation after an unsuccessful autograft. *Br J Haematol* 1999;106:1063-1064.
920. Graziadei G, Refaldi C, Barcellini W, et al. Does absolute excess of alpha chains compromise the benefit of splenectomy in patients with thalassemia intermedia? *Haematologica* 2011;97:151-153.
921. Ross SL, Tran L, Winters A, et al. Molecular mechanism of hepcidin-mediated ferroportin internalization requires ferroportin lysines, not tyrosines or JAKSTAT. *Cell Metab* 2012;15:905-917.
922. Wood JC, Enriquez C, Ghugre N, et al. MRI R2 and R2* mapping accurately estimates hepatic iron concentration in transfusion-dependent thalassemia and sickle cell disease patients. *Blood* 2005;106:1460-1465.
923. Voskaridou E, Douskou M, Terpos E, et al. Magnetic resonance imaging in the evaluation of iron overload in patients with beta thalassaemia and sickle cell disease. *Br J Haematol* 2004;126:736-742.
924. Taher AT, Musallam KM, Wood JC, Cappellini MD. Magnetic resonance evaluation of hepatic and myocardial iron deposition in transfusion-independent thalassemia intermedia compared to regularly transfused thalassemia major patients. *Am J Hematol* 2010;85:288-290.
925. Musallam KM, Cappellini MD, Wood JC, et al. Elevated liver iron concentration is a marker of increased morbidity in patients with beta thalassemia intermedia. *Haematologica* 2011;96:1605-1612.
926. Taher A, Hershko C, Cappellini MD. Iron overload in thalassaemia inter-media: reassessment of iron chelation strategies. *Br J Haematol* 2009;147: 634-640.
927. Cossu P, Toccafondi C, Vardeu F, et al. Iron overload and desferrioxamine chelation therapy in beta-thalassemia intermedia. *Eur J Pediatr* 1981;137: 267-271.
928. Pootrakul P, Sirankapracha P, Sankote J, et al. Clinical trial of deferiprone iron chelation therapy in beta-thalassaemia/haemoglobin E patients in Thailand. *Br J Haematol* 2003;122:305-310.
929. Origa R, Barella S, Argiolas G, et al. No evidence of cardiac iron in 20 never- or minimally-transfused patients with thalassemia intermedia. *Haematologica* 2008;93:1095-1096.
930. Roghi A, Cappellini MD, Wood JC, et al. Absence of cardiac siderosis despite hepatic iron overload in Italian patients with thalassemia intermedia: an MRI T2* study. *Ann Hematol* 2010;89:585-589.
931. Taher A, Porter J, Viprakasit V, et al. Deferasirox significantly reduces iron overload in non-transfusion-dependent thalassemia: 1-year results from a prospective, randomized, double-blind, placebo-controlled study. *Blood* 2012;blood-2012-02-412692-.
932. Camba L. Phlebotomy in beta-thalassemia intermedia and secondary hemosiderosis. *Haematologica* 2000;85:E05.
933. Nassar AH, Naja M, Cesaretti C, et al. Pregnancy outcome in patients with beta-thalassemia intermedia at two tertiary care centers, in Beirut and Milan. *Haematologica* 2008;93:1586-1587.
934. Bennett M, Macri CJ, Bathgate SL. Erythropoietin use in a pregnant Jehovah's witness with anemia and beta-thalassemia: a case report. *J Reprod Med* 2005;50:135-137.
935. Gimmon Z, Wexler MR, Rachmilewitz EA. Juvenile leg ulceration in betathalassemia major and intermedia. *Plast Reconstr Surg* 1982;69:320-325.
936. Camaschella C, Cappellini MD. Thalassemia intermedia. *Haematologica* 1995;80:58-68.
937. Kato GJ, McGowan V, Machado RF, et al. Lactate dehydrogenase as a biomarker of hemolysis-associated nitric oxide resistance, priapism, leg ulceration, pulmonary hypertension, and death in patients with sickle cell disease. *Blood* 2006;107:2279-2285.

938. Morris CR. Mechanisms of vasculopathy in sickle cell disease and thalassemia. *Hematology (Am Soc Hematol Educ Program)* 2008;177-185.
939. Fracchia E, Elkababri M, Cantello C, et al. Venous-like leg ulcers without venous insufficiency in congenital anemia: successful treatment using compression bandages. *Dermatol Surg* 2010;36:1336-1340.
940. Levin C, Koren A. Healing of refractory leg ulcer in a patient with thalassemia intermedia and hypercoagulability after 14 years of unresponsive therapy. *Isr Med Assoc J* 2011;13:316-318.
941. Aessopos A, Kati M, Tsironi M, et al. Exchange blood transfusions for the treatment of leg ulcerations in thalassemia intermedia. *Haematologica* 2006;91:ECR11.
942. Josifova D, Gatt G, Aquilina A, et al. Treatment of leg ulcers with platelet-derived wound healing factor (PDWHFS) in a patient with beta thalassaemia intermedia. *Br J Haematol* 2001;112:527-529.
943. Borgna-Pignatti C, Carnelli V, Caruso V, et al. Thromboembolic events in beta thalassemia major: an Italian multicenter study. *Acta Haematol* 1998;99: 76-79.
944. Skarsgard E, Doski J, Jaksic T, et al. Thrombosis of the portal venous system after splenectomy for pediatric hematologic disease. *J Pediatr Surg* 1993;28:1109-1112.
945. Taher AT, Musallam KM, Nasreddine W, et al. Asymptomatic brain magnetic resonance imaging abnormalities in splenectomized adults with thalassemia intermedia. *J Thromb Haemost* 2010;8:54-59.
946. Cappellini MD, Grespi E, Cassinerio E, et al. Coagulation and splenectomy: an overview. *Ann N Y Acad Sci* 2005;1054:317-324.
947. Taher AT, Musallam KM, Karimi M, et al. Splenectomy and thrombosis: the case of thalassemia intermedia. *J Thromb Haemost* 2010;8:2152-2158.
948. Borgna-Pignatti C, Vergine G, Lombardo T, et al. Hepatocellular carcinoma in the thalassaemia syndromes. *Br J Haematol* 2004;124:114-117.
949. Vaccari M, Crepez R, Fortini M, et al. Left ventricular remodeling, systolic function, and diastolic function in young adults with beta-thalassemia inter-media: a Doppler echocardiography study. *Chest* 2002;121:506-512.
950. Karimi M, Musallam KM, Cappellini MD, et al. Risk factors for pulmonary hypertension in patients with beta thalassemia intermedia. *Eur J Intern Med* 2011;22:607-610.
951. Morris CR, Gladwin MT, Kato GJ. Nitric oxide and arginine dysregulation: a novel pathway to pulmonary hypertension in hemolytic disorders. *Curr Mol Med* 2008;8:620-632.
952. Singer S, Kuypers F, Styles L, et al. Pulmonary hypertension in thalassemia: association with platelet activation and hypercoagulable state. *Am J Hematol* 2006;81:670-675.
953. Atichartakarn V, Likittanasombat K, Chuncharunee S, et al. Pulmonary arterial hypertension in previously splenectomized patients with beta-thalassemic disorders. *Int J Hematol* 2003;78:139-145.
954. O'Driscoll A, Mackie IJ, Porter JB, Machin SJ. Low plasma heparin cofactor II levels in thalassaemia syndromes are corrected by chronic blood transfusion. *Br J Haematol* 1995;90:65-70.
955. Karimi M, Borzouee M, Mehrabani A, Cohan N. Echocardiographic finding in beta-thalassemia intermedia and major: absence of pulmonary hypertension following hydroxyurea treatment in beta-thalassemia intermedia. *Eur J Haematol* 2009;82:213-218.
956. Littera R, La Nasa G, Derchi G, et al. Long-term treatment with sildenafil in a thalassemic patient with pulmonary hypertension. *Blood* 2002;100: 1516-1517.
957. Derchi G, Forni GL, Formisano F, et al. Efficacy and safety of sildenafil in the treatment of severe pulmonary hypertension in patients with hemoglobinopathies. *Haematologica* 2005;90:452-458.
958. Machado RF, Barst RJ, Yovetich NA, et al. Hospitalization for pain in patients with sickle cell disease treated with sildenafil for elevated TRV and low exercise capacity. *Blood* 2011;118:855-864.
959. Barst RJ, Mubarak KK, Machado RF, et al. Exercise capacity and haemodynamics in patients with sickle cell disease with pulmonary hypertension treated with bosentan: results of the ASSET studies. *Br J Haematol* 2010;149:426-435.

960. Danel P, Girot R, Tchernia G. [Thalassemia major manifested by megaloblastic anemia caused by folate deficiency]. *Arch Fr Pediatr* 1983;40:799-801.
961. Ortuño F, Remacha A, Martin S, et al. Prevalence of folate deficiency in beta and delta-beta heterozygous thalassemia. *Haematologica* 1990;75:585.
962. Mojtahedzadeh F, Kosaryan M, Mahdavi M-R, Akbari J. The effect of folic acid supplementation in beta-thalassemia major: a randomized placebo-controlled clinical trial. *Arch Iran Medicine* 2006;9:266-268.
963. Motulsky AG. Frequency of sickling disorders in U.S. blacks. *N Engl J Med* 1973;288:31-33.
964. Steinberg MH, Dreiling BJ. Clinical, hematologic and biosynthetic studies in sickle cell-beta⁰-thalassemia: a comparison with sickle cell anemia. *Am J Hematol* 1976;1:35-44.
965. Serjeant G, Serjeant B. Neonatal screening for sickle hemoglobin. *Am J Clin Pathol* 1979;72:251.
966. Tyagi S, Choudhry VP, Saxena R. Subclassification of HbS syndrome: is it necessary? *Clin Lab Haematol* 2003;25:377-381.
967. Galanello R, Origa R. Beta-thalassemia. *Orphanet J Rare Dis* 2010;5:11.
968. Stevens MC, Maude GH, Beckford M, et al. Haematological change in sickle cell-haemoglobin C disease and in sickle cell-beta thalassaemia: a cohort study from birth. *Br J Haematol* 1985;60:279-292.
969. Goldstein LB, Adams R, Becker K, et al. Primary prevention of ischemic stroke: a statement for healthcare professionals from the Stroke Council of the American Heart Association. *Stroke* 2001;32:280-299.
970. Koduri PR, Kovarik P. Acute splenic sequestration crisis in an adult with sickle beta-thalassemia. *Ann Hematol* 2006;85:633-635.
971. Hutchins KD, Ballas SK, Phatak D, Natarajan GA. Sudden unexpected death in a patient with splenic sequestration and sickle cell-beta+ thalassemia syndrome. *J Forensic Sci* 2001;46:412-414.
972. Aslam AF, Aslam AK, Dipillo F. Fatal splenic sequestration crisis with multiorgan failure in an adult woman with sickle cell-beta+ thalassemia. *Am J Med Sci* 2005;329:141-143.
973. Milner PF, Kraus AP, Sebes JI, et al. Sickle cell disease as a cause of osteonecrosis of the femoral head. *N Engl J Med* 1991;325:1476-1481.
974. Condon PI, Serjeant GR. Ocular findings in sickle cell thalassemia in Jamaica. *Am J Ophthalmol* 1972;74:1105-1109.
975. Clarkson JG. The ocular manifestations of sickle-cell disease: a prevalence and natural history study. *Trans Am Ophthalmol Soc* 1992;90:481-504.
976. Rogers ZR, Buchanan GR. Bacteremia in children with sickle hemoglobin C disease and sickle beta(+)-thalassemia: is prophylactic penicillin necessary? *J Pediatr* 1995;127:348-354.
977. Embury SH, Clark MR, Monroy G, Mohandas N. Concurrent sickle cell anemia and alpha-thalassemia. Effect on pathological properties of sickle erythrocytes. *J Clin Invest* 1984;73:116-123.
978. Joishy SK, Griner PF, Rowley PT. Sickle beta-thalassemia: identical twins differing in severity implicate nongenetic factors influencing course. *Am J Hematol* 1976;1:23-33.
979. Shaeffer JR, Moake JL. Sickle cell—beta⁰ thalassemia variant with high hemoglobin F and mild clinical course. *Am J Med* 1976;61:437-438.
980. Serjeant BE, Mason KP, Serjeant GR. The development of haemoglobin A2 in normal negro infants and in sickle cell disease. *Br J Haematol* 1978;39: 259-265.
981. Higgins TN, Khajuria A, Mack M. Quantification of HbA(2) in patients with and without beta-thalassemia and in the presence of HbS, HbC, HbE, and HbD Punjab hemoglobin variants: comparison of two systems. *Am J Clin Pathol* 2009;131:357-362.
982. Kinney TR, Friedman S, Cifuentes E, et al. Variations in globin synthesis in delta-beta-thalassaemia. *Br J Haematol* 1978;38:15-22.
983. Zelkowitz L, Torres C, Bhoopalam N, et al. Double heterozygous -thalassemia in Negroes. *Arch Intern Med* 1972;129:975-979.

984. Stamatoyannopoulos G, Sofroniadou C, Akrivakis A. Absence of hemoglobin A in a double heterozygote for F-thalassemia and hemoglobin S. *Blood* 1967;30:772-776.
985. Patel DK, Patel M, Mashon RS, et al. Clinical and molecular characterization of beta(S) and (G) γ ((A) γ δ beta)0-thalassemia in eastern India. *Hemoglobin* 2010;34:604-609.
986. Ngo DA, Aygun B, Akinsheye I, et al. Fetal haemoglobin levels and haematological characteristics of compound heterozygotes for haemoglobin S and deletional hereditary persistence of fetal haemoglobin. *Br J Haematol* 2012;156:259-264.
987. Sangare A, Sanogo I, Meite M, et al. [Clinical and hematological profile of Lepore Hemoglobin in Ivory Coast]. *Med Trop (Mars)* 1994;54:43-46.
988. Seward DP, Ware RE, Kinney TR. Hemoglobin sickle-Lepore: report of two siblings and review of the literature. *Am J Hematol* 1993;44:192-195.
989. Voskaridou E, Konstantopoulos K, Kollia P, et al. Hb Lepore (Pylos)/Hb S compounds heterozygosity in two Greek families. *Am J Hematol* 1995;49: 131-134.
990. Romana M, Diara JP, Merghoub T, et al. Hemoglobin sickle-lepore: an unusual case of sickle cell disease. *Acta Haematol* 1997;98:170-171.
991. Konotey-Ahulu FI, Ringelhan B. Sickle-cell anaemia, sickle-cell thalassaemia, sickle-cell haemoglobin C disease, and asymptomatic haemoglobin C thalassaemia in one Ghanaian family. *Br Med J* 1969;1:607-612.
992. Cao A, Galanello R. Beta-thalassemia. *Genet Med* 2010;12:61-76.
993. Francina A, Dorleac E, Aubry M, et al. Hb Lepore-Hb C and Hb Lepore-beta 0-thalassemia compound heterozygotes in an Algerian family. *Hemoglobin* 1985;9:505-508.
994. Ranney HM, Jacobs AS. Simultaneous Occurrence of H α emoglobins C and Lepore in an Afro-American. *Nature* 1964;204:163-166.
995. Moiz B, Hashmi MR, Nasir A, et al. Hemoglobin E syndromes in Pakistani population. *BMC Blood Disord* 2012;12:3.
996. Chandrashekar V, Soni M. Hemoglobin disorders in South India. *ISRN Hematol* 2011;2011:748939.
997. Modell B, Darlison M. Global epidemiology of haemoglobin disorders and derived service indicators. *Bull World Health Organ* 2008;86:480-487.
998. Vichinsky EP, MacKlin EA, Wayne JS, et al. Changes in the epidemiology of thalassemia in North America: a new minority disease. *Pediatrics* 2005;116:e818-e825.
999. Fucharoen S, Winichagoon P. Clinical and hematologic aspects of hemoglobin E beta-thalassemia. *Curr Opin Hematol* 2000;7:106-112.
1000. Olivieri NF, Pakbaz Z, Vichinsky E. HbE/beta-thalassemia: basis of marked clinical diversity. *Hematol Oncol Clin North Am* 2010;24:1055-1070.
1001. Wasi P, Winichagoon P, Baramée T, Fucharoen S. Globin chain synthesis in heterozygous and homozygous hemoglobin E. *Hemoglobin* 1982;6:75-78.
1002. Fucharoen S, Winichagoon P, Pootrakul P, et al. Variable severity of Southeast Asian beta 0-thalassemia/Hb E disease. *Birth Defects Orig Artic Ser* 1987;23:241-248.
1003. Rees DC, Styles L, Vichinsky EP, et al. The hemoglobin E syndromes. *Ann N Y Acad Sci* 1998;850:334-343.
1004. Premawardhana A, Fisher CA, Olivieri NF, et al. Haemoglobin E beta thalassaemia in Sri Lanka. *Lancet* 2005;366:1467-1470.
1005. Winichagoon P, Fucharoen S, Chen P, Wasi P. Genetic factors affecting clinical severity in beta-thalassemia syndromes. *J Pediatr Hematol Oncol* 22: 573-580.
1006. Olivieri NF. Treatment strategies for hemoglobin E beta-thalassemia. *Blood Rev* 2012;26(Suppl 1):S28-30.
1007. Fucharoen S, Winichagoon P, Thonglairuam V, Wasi P. EF Bart's disease: interaction of the abnormal alpha- and beta-globin genes. *Eur J Haematol* 1988;40:75-78.
1008. Fucharoen S, Piankijagum A, Wasi P. Deaths in beta-thalassemia/Hb E patients secondary to infections. *Birth Defects Orig Artic Ser* 1987;23: 495-500.

1009. Malasit P, Mahasorn W, Mongkolsapaya J, et al. Presence of immunoglobulins, C3 and cytolytic C5b-9 complement components on the surface of erythrocytes from patients with beta-thalassaemia/HbE disease. *Br J Haematol* 1997;96:507-513.
1010. Aswapokee N, Aswapokee P, Fucharoen S, Wasi P. A study of infective episodes in patients with beta-thalassaemia/Hb E disease in Thailand. *Birth Defects Orig Artic Ser* 1987;23:513-520.
1011. Aswapokee P, Aswapokee N, Fucharoen S, et al. Severe infection in thalassaemia: a prospective study. *Birth Defects Orig Artic Ser* 1987;23:521-526.
1012. Chandrcharoensin-Wilde C, Chairongruang S, Jitnuson P, et al. Gallstones in thalassaemia. *Birth Defects Orig Artic Ser* 1988;23:263-267.
1013. Wasi P, Pootrakul P, Piankijagum A, et al. A syndrome of hypertension, convulsion, and cerebral haemorrhage in thalassaemic patients after multiple blood-transfusions. *Lancet* 1978;312:602-604.
1014. Pootrakul P, Breuer W, Sametband M, et al. Labile plasma iron (LPI) as an indicator of chelatable plasma redox activity in iron-overloaded beta-thalassaemia/HbE patients treated with an oral chelator. *Blood* 2004;104:1504-1510.
1015. Angchaisuksiri P, Atichartakarn V, Aryurachai K, et al. Hemostatic and thrombotic markers in patients with hemoglobin E/beta-thalassaemia disease. *Am J Hematol* 2007;82:1001-1004.
1016. Fucharoen S, Youngchaiyud P, Wasi P. Hypoxaemia and the effect of aspirin in thalassaemia. *Southeast Asian J Trop Med Public Health* 1981;12:90-93.
1017. Winichagoon P, Fucharoen S, Wasi P. Increased circulating platelet aggregates in thalassaemia. *Southeast Asian J Trop Med Public Health* 1981;12:556-560.
1018. Pakakasama S, Hongeng S, Chaisiripoomkere W, et al. Allogeneic peripheral blood stem cell transplantation in children with homozygous beta-thalassaemia and severe beta-thalassaemia/hemoglobin E disease. *J Pediatr Hematol Oncol* 2004;26:248-252.
1019. Suvatte V, Tanphaichitr VS, Visuthisakchai S, et al. Bone marrow, peripheral blood and cord blood stem cell transplantation in children: ten years' experience at Siriraj Hospital. *Int J Hematol* 1998;68:411-419.
1020. Watanapokasin Y, Chuncharunee S, Sanmund D, et al. In vivo and in vitro studies of fetal hemoglobin induction by hydroxyurea in beta-thalassaemia/hemoglobin E patients. *Exp Hematol* 2005;33:1486-1492.
1021. Italia KY, Jijina FF, Merchant R, et al. Effect of hydroxyurea on the transfusion requirements in patients with severe HbE-beta-thalassaemia: a genotypic and phenotypic study. *J Clin Pathol* 2010;63:147-150.
1022. Singer S, Vichinsky E, Larkin S, et al. Hydroxycarbamide-induced changes in E/beta thalassaemia red blood cells. *Am J Hematol* 2008;83:842-845.
1023. Luewan S, Srisupundit K, Tongsong T. Outcomes of pregnancies complicated by beta-thalassaemia/hemoglobin E disease. *Int J Gynaecol Obstet* 2009;104:203-205.
1024. Riewpaiboon A, Nuchprayoon I, Torcharus K, et al. Economic burden of betathalassaemia/Hb E and beta-thalassaemia major in Thai children. *BMC Res Notes* 2010;3:29.

Chapter 35 Hemoglobins with Altered Oxygen Affinity, Unstable Hemoglobins, M-Hemoglobins, and Dyshemoglobinemias

> Table of Contents > Part IV - Disorders of Red Cells > Section 4 - Hereditary Disorders of Hemoglobin Structure and Synthesis > Chapter 35 - Hemoglobins with Altered Oxygen Affinity, Unstable Hemoglobins, M-Hemoglobins, and Dyshemoglobinemias

Chapter 35

Hemoglobins with Altered Oxygen Affinity, Unstable Hemoglobins, M-Hemoglobins, and Dyshemoglobinemias

Martin H. Steinberg

More than 1,100 mutations affecting the globin subunits of hemoglobin have been described (<http://globin.cse.psu.edu/>), and among these, sickle cell disease along with hemoglobinopathies associated with HbE, HbC, and the β - and α -thalassemias are mankind's most common single-gene disorders (see Chapters 33 and 34). Much less common are hemoglobin mutations discussed in this chapter that affect the ability of the molecule to bind and release oxygen, that reduce its stability, and that allow its heme iron to be oxidized. Exogenous agents can also oxidize hemoglobin, interfering with oxygen transport.

HEMOGLOBINS WITH ALTERED OXYGEN AFFINITY

The affinity of hemoglobin for oxygen is characterized by the amount of oxygen bound at any given oxygen tension. Oxygen affinity is usually designated by the P_{50} , which is the partial pressure of oxygen at which hemoglobin is 50% saturated. Oxygen affinity can be modified by pH, temperature, and organic phosphates. The normal co-operativity of hemoglobin, or heme-heme interactions in the hemoglobin tetramer, determines the sigmoidal shape of the hemoglobin-oxygen dissociation curve. This is a result of the fact that the deoxygenated T (tense) form of hemoglobin has a lower affinity for oxygen than the oxygenated R (relaxed) form (see Chapter 6). Consequently, globin gene mutations that alter areas of the molecule involved with T-R interactions can lead to alterations in oxygen affinity. Both high- and low-oxygen-affinity hemoglobin variants are encountered and all globin genes have been affected.

High-oxygen-Affinity Hemoglobins

Globin gene mutations can increase the affinity of the hemoglobin molecule for oxygen and cause erythrocytosis. More than 90 high-oxygen-affinity variants have been reported in <http://globin.cse.psu.edu/> and Wajcman and Galacteros.¹ Familial erythrocytosis is a valuable clue to the presence of a high-oxygen-affinity hemoglobin variant; isolated cases are caused by new mutations. These α - or β -globin chain mutations are dominant disorders, expressed clinically in the heterozygote. They may be lethal in homozygotes if they affect the α -globin chain and are expressed in utero. One γ -globin variant (HbF-Monserrato-Sassari, HBG2 cys93arg) in a normal newborn and a possible δ -globin variant (Hb Noah Mehmet Oesteurk, HBD his143tyr) have been described.

Several homozygotes for β -globin high-oxygen-affinity variants have been described and these individuals can have more severe disease.^{2, 3, 4, 5} Compound heterozygotes with a high-oxygen-affinity hemoglobin and β^0 -thalassemia have also been described, mimicking the homozygous state as normal adult hemoglobin A (HbA) is not present.

Pathophysiology

Stabilization of the R state of the hemoglobin tetramer ($\alpha_2\beta_2$), with its high affinity for oxygen, or destabilization of the low-oxygen-affinity T state is caused by globin gene mutations in critical areas that can effect the R \rightarrow T transition (Table 35.1).⁶ The increased avidity for oxygen (low P_{50}) of these variants reduces oxygen delivery to tissues, thereby stimulating erythropoietin production and increasing red cell mass. Patients with high-oxygen-affinity hemoglobins with erythrocytosis usually have normal urine erythropoietin levels. However, erythropoietin levels increase when they are phlebotomized to a normal red cell mass.^{7, 8} Individuals with these hemoglobin variants appear to be reasonably compensated for the low P_{50} by the increased red cell mass. Oxygen consumption and arterial pO_2 are normal, but in some cases there is reduced mixed venous pO_2 and decreased resting cardiac output.

Not unexpectedly, the JAK2 V617F mutation found in some individuals with polycythemia vera is absent in patients with high-oxygen-affinity hemoglobin variant induced erythropoiesis.⁹

Diagnosis

The differential diagnosis of increased red cell mass is discussed in Chapter 44. The diagnosis of high-oxygen-affinity hemoglobins is suspected by finding isolated erythrocytosis without accompanying leukocytosis, thrombocytosis, and splenomegaly, as might be expected in cases of polycythemia vera. A family history of erythrocytosis is also suggestive of a high-oxygen-affinity hemoglobin variant. Other disorders expressed in the erythrocyte that cause isolated erythrocytosis include 2,3-diphosphoglycerate (2,3-DPG) mutase mutations that reduce the synthesis of this modulator of hemoglobin-oxygen affinity, some instances of methemoglobinemia, and chronic carbon monoxide (CO) poisoning.

Determination of the red cell oxygen equilibrium curve is the benchmark for the diagnosis of erythrocytosis due to high-oxygen-affinity hemoglobins. The oxygen-binding characteristics of hybrid tetramers ($\alpha_2\beta^A\beta^{var}$) are likely to be intermediate between purified HbA and purified variant, and the shape of the hemoglobin-oxygen dissociation curve can at times be biphasic. Measurement of blood P_{50} confirms the shift in the hemoglobin-oxygen dissociation curve. Rarely, the whole-blood P_{50} is normal, requiring study of dialyzed purified hemoglobin. An accurate P_{50} value is difficult to "calculate" from pO_2 data, and it is best to measure the pO_2 and hemoglobin saturation directly. P_{50} measurements are not widely available but can be done with several instruments.

High oxygen affinity is observed in both erythrocytes and purified dialyzed hemoglobin. The concentration of 2,3-DPG is normal, indicating that altered oxygen affinity is not caused by reduced levels of this modulator of hemoglobin function. This is in contrast to what is seen in the rare instance of red cell 2,3-DPG mutase deficiency, where both erythrocytes and whole blood have high oxygen affinity, and the oxygen affinity of the purified hemolysate stripped of 2,3-DPG is normal.¹⁰

High-performance liquid chromatography (HPLC) studies may reveal an abnormal hemoglobin, but normal studies do not exclude the possibility of a high-affinity hemoglobin that migrates with normal HbA. As with all evaluations for abnormal hemoglobins, determining the DNA sequence of the globin genes provides the definitive information.

Examples of high-oxygen-affinity hemoglobins that illustrate the varying mechanisms and heterogeneous clinical findings seen with these variants are discussed in the following. A detailed

P.915

understanding of the structure of hemoglobin and the importance of each residue in determining function allows a molecular explanation of most of the clinical abnormalities observed.

TABLE 35.1 SITES OF GLOBIN MUTATION ASSOCIATED WITH INCREASED OXYGEN AFFINITY^a

$\alpha_1\beta_2$ interface contacts (sliding contact) connecting $\alpha_1\beta_1$ and $\alpha_2\beta_2$ dimers

$\alpha_1\beta_1$, $\alpha_2\beta_2$ interface

Mutations that reduce 2,3-diphosphoglycerate (2,3-DPG) binding

Heme pocket mutations

Miscellaneous

^aOther than single amino acid substitutions, these mutations can include small deletions and insertions of amino acids, reading frameshifts, fusion globins, and elongated globin chains.

α -Globin Chain Variants

Because there are four α -globin genes, most stable α -globin variants form 25% or less of the total hemoglobin, compared with 40% to 50% for β -globin variants. As a result, the clinical effects of α -globin variants are less striking than those of β -globin variants. However, the coincident inheritance of a β -thalassemia gene can modulate the concentration of high-affinity α -variant hemoglobins and homozygosity for a high-oxygen-affinity variant affecting α -globin chains has been described.

Hb Chesapeake (HBA arg92leu) was the first reported high-affinity hemoglobin variant.¹¹ It was discovered in an 81-year-old patient with erythrocytosis, an abnormal hemoglobin detected by hemoglobin electrophoresis, and erythrocytes with increased oxygen affinity. Fifteen members of the proband's family were similarly affected. Hb Chesapeake represented ~20% of the total hemoglobin. With a P_{50} of 19 mm Hg (normal ~26 mm Hg), Hb Chesapeake produced moderate erythrocytosis. The mutation affected an invariant residue that stabilizes the R state at the $\alpha_1\beta_2$ area of contact, making the T conformer less favored.

Hb Nunobiki (HBA1 arg141cys), is one of four mutations of this invariant residue, all of which exhibit high oxygen affinity and moderate to mild erythrocytosis.¹² This group of mutations represents an interesting cluster of variants that illustrates the effects of different mutations at the same amino acid residue. As a mutant of the 3'-HBA1 gene that is expressed to a lesser extent than the 5'-HBA2 gene, Hb Nunobiki makes up ~13% of the hemolysate and is accompanied by only mild erythrocytosis. High oxygen affinity is a result of the breaking of the C terminal-to-C terminal salt bridge that is indispensable for the stabilization of the T state, favoring the R state.

β -Globin Chain Variants

All possible single-base mutations of the $\beta 99$ site disturbing the $\alpha_1\beta_2$ area of contact have been described and include Hb Kempsey (HBB asp99asn), Hb Yakima (asp99his), Hb Radcliffe (asp99ala), Hb Ypsilanti (asp99tyr), Hb Hotel-Dieu (asp99gly), Hb Chemilly (asp99val), and Hb Coimbra (asp99glu). As expected for stable β -globin chain variants, all are present at 40% to 50% of the hemolysate, exhibit moderately high oxygen affinity, and are characterized clinically by erythrocytosis. Hbs Kempsey, Radcliffe, and Hotel Dieu have a decreased response to 2,3-DPG. Hbs Ypsilanti and Radcliffe form stable hybrid tetramers in the hemolysates in which the abnormal β chains coexist with normal β chains.

Six of the possible seven mutations of the C-terminal CAC (tyr) codon have also been described. One of them, Hb Cochin-Port Royal (tyr146arg), has nearly normal oxygen affinity but decreased 2,3-DPG interaction and Bohr effect.¹³

Three mutations of β 82 lys have been described: Hb Rahere (lys82thr), Hb Helsinki (lys82met), and Hb Providence (lys82asn). All have moderately high oxygen affinity and moderate erythrocytosis.

These mutants have drastically reduced 2,3-DPG binding as a result of the elimination of one of the normal binding sites for this allosteric effector. Hb Porto Alegre (HBB ser9cys) has high oxygen affinity and a tendency to aggregate, but erythrocytosis is not present.¹⁴ Polymerization of Hb Porto Alegre is based on the formation of disulfide bonds in oxygenated samples and is different from HbS polymerization. Polymerization of this mutant diminishes heme-heme interaction and increases the oxygen affinity.

Hb Tak (HBB 147(+AC), modified C-terminal sequence: 147thr-lys-leu-ala-phe-leu-leu-ser-asn-phe-157tyr-COOH), is elongated by 11 amino acid residues.^{15, 16} It forms 40% of the hemolysate, has a very high oxygen affinity with no cooperativity, and no allosteric interaction with pH or 2,3-DPG. The C terminus of the β -globin chain is actively involved in the conformational changes of the hemoglobin molecule by stabilizing the T state. By having these stabilizing interactions disrupted, Hb Tak is totally frozen in the R state. Hb Tak is also slightly unstable. In spite of these severe functional abnormalities, a heterozygous patient did not have erythrocytosis. The extreme biphasic nature of the hemoglobin-oxygen affinity curve observed in mixtures of Hb Tak and HbA suggests that hybrid tetramer ($\alpha_2\beta^A\beta^{\text{Tak}}$) formation is absent. The top portion of the oxygen equilibrium curve is normal, and it begins to be abnormal only at <40% saturation. Because physiologic oxygen exchange occurs most commonly above that level of saturation, the tissues may not be hypoxic, removing the stimulus for increased erythropoiesis.

Clinical Features

Patients with high-affinity hemoglobins and erythrocytosis have a benign clinical course and rarely have complications, apart from a ruddy complexion. Splenomegaly is typically absent. Hemoglobin concentration and hematocrit are increased variably, and usually only moderately, suggesting that modulation by variations in other genes might affect the physiologic response to hypoxia. Some patients with Hb Malmo (HBB his97gln) have been reported to be symptomatic and to benefit from phlebotomy and the transfusion of normal blood, but this clinical course is an exception.¹⁷

Many cases of high-oxygen-affinity hemoglobins are diagnosed during a routine hematologic examination or when the family of a proband known to have erythrocytosis is examined. In very limited studies, exercise capacity in the laboratory and the indices of working capacity and cardiac tolerance were similar in patients with high-oxygen-affinity hemoglobins and in controls.¹⁸ It has been suspected that carriers of these variants may have enhanced athletic performance under some circumstances, and this has led to the unfortunate and sometimes fatal use of erythropoietin or transfusion to enhance performance in competitive athletics.

In a population-based study of erythrocytosis, high-oxygen-affinity variants accounted for 3% of all cases.¹⁹ By early diagnosis of high-affinity hemoglobins, unnecessary invasive diagnostic procedures and inappropriate therapeutic interventions, such as cardiac catheterization, can be avoided. Patients have received ³²P treatment based on a mistaken diagnosis of polycythemia vera.

Increased morbidity or mortality in mothers with high-oxygen-affinity hemoglobins or their offspring has not been observed, suggesting that the affinity of the mother's hemoglobin is irrelevant with respect to oxygen delivery to the fetus.¹⁸ Low ambient pO_2 , as in unpressurized airplanes and ascent to altitude, do not represent a risk, because high-affinity hemoglobins are avid for oxygen.

Hypothetically, carriers should be less prone to "the bends" during deep sea diving, because of slower oxygen release during ascension.

P.916

Treatment

Patients with high-oxygen-affinity hemoglobins have reasonable compensation for their abnormality, with adequate tissue oxygen delivery despite increases in blood viscosity. Intervention is therefore rarely required. Exercise studies before and after phlebotomy in patients with Hb Osler (HBB tyr145asn), a variant with a P_{50} of 10 to 11 mm Hg and a hemoglobin concentration of ~22 g/dl, did not show an impairment after phlebotomy.¹⁸ Limited studies have suggested that phlebotomy generally does not improve exercise performance. However, rare individuals appear to have benefited from

phlebotomy, and thus other unknown factors may be interfering with their normal compensation for high hemoglobin - oxygen affinity, and increased blood viscosity may have become a burden. Prudence dictates that before embarking on a regimen of chronic phlebotomy, one should be conservative and review the hematologic and physiologic findings at 6-month intervals during the first few years after diagnosis. In older patients, special attention should be directed to blood flow to the heart and central nervous system. Thrombosis has been reported in individuals with high-oxygen-affinity variants but a causal relationship has not been established. In an example of a patient with a high-oxygen-affinity hemoglobin with concurrent β -thalassemia, treatment with hydroxyurea reduced the PCV from 61% to 39%, increased HbF from 3.6% to 30%, and P_{50} from 6 to 10 mm Hg.²⁰ This case should not be a recommendation for routine treatment of erythrocytosis due to high-oxygen-affinity hemoglobins with cytostatic agents.

Low-oxygen-Affinity Hemoglobins

Hemoglobin variants with reduced affinity for oxygen are in many respects the converse of high-oxygen-affinity variants. About half as many low-oxygen-affinity variants have been described compared to high-oxygen-affinity variants. They are expressed in the heterozygote, with homozygosity likely to be embryonic lethal. A major clinical feature is anemia that, at times, is accompanied by cyanosis.

Pathophysiology

Alterations of critical molecular regions involved directly in the R-T transition result in the stabilization of the deoxy T state or destabilization of the oxy R state. Low-oxygen-affinity hemoglobins deliver more O_2 to the tissues per gram of hemoglobin, and this is reflected by an oxygen-hemoglobin dissociation curve shifted toward the right of normal and an increase in P_{50} . When hemoglobin has a right-shifted or low-affinity curve, the difference between oxygen binding in the lungs at PO_2 levels of 100 mm Hg and unloading in the tissues at 40 mm Hg can be twice as great as the differences in a hemoglobin with a normal oxygen equilibrium curve. Patients with a moderately right-shifted oxygen equilibrium curve (P_{50} between 35 and 55 mm Hg) may be mildly anemic, but some individuals with very right-shifted oxygen equilibrium curves ($P_{50} \sim 80$) are not anemic. A right-shifted oxygen equilibrium curve leads to an increase in the synthesis of 2,3-DPG and a decrease in its destruction.

Diagnosis

The first report of a low-oxygen-affinity hemoglobin was Hb Kansas (HBB asn102thr), which presented with asymptomatic cyanosis without anemia or hemolysis.²¹ Detection of a lowoxygen-affinity hemoglobin is part of the differential diagnosis of patients with cyanosis (see later). Before undertaking extensive diagnostic procedures in cases of cyanosis that are not clearly the result of cardiovascular or pulmonary disease, fractionating hemoglobin by HPLC and measuring blood P_{50} is advisable. A search for low-affinity hemoglobins as an explanation for anemia without cyanosis is less compelling, but if other investigations prove fruitless, unexplained normocytic anemia without reticulocytosis might be evaluated by measuring P_{50} .

A simple bedside test can distinguish cyanosis resulting from low-oxygen-affinity hemoglobins or cardiopulmonary cyanosis from that occurring with methemoglobinemia, M hemoglobins, or sulfhemoglobinemia. When blood from carriers of low-oxygen-affinity hemoglobins or patients with cardiopulmonary disease is exposed to ambient oxygen, it will turn from purple-greenish to bright red. In contrast, blood of patients with methemoglobinemia, sulfhemoglobinemia, or M hemoglobins will remain abnormally colored.

Clinically apparent cyanosis is observed only in carriers of low-oxygen-affinity variants with greatly right-shifted curves and where the variant comprises a substantial portion of the hemolysate. Cyanosis is present from birth in some low-oxygen-affinity hemoglobins due to α -globin chain mutants. In carriers of β -globin chain mutants, cyanosis may appear from the middle to the end of the first year of life as γ -globin gene expression and HbF synthesis wanes and is replaced by β -globin gene expression and HbA. Neonatal cyanosis has been associated with γ -globin variants that have low oxygen affinity.²² Globin gene sequencing is the sole means of definitive diagnosis.

Clinical Features

Three low-oxygen-affinity variants have been described at $\beta 102$. Hb Kansas, the best-studied variant, has a whole-blood P_{50} of ~ 70 mm Hg, decreased co-operativity, and a normal Bohr effect.²¹ The $\beta 102$ asn residue is invariant among β -globin chains and participates in the only hydrogen bond between asn 102 and asp 94 across the $\alpha_1\beta_2$ interface in oxyhemoglobin. This bond is broken when the molecule assumes the T state. The new thr residue is incapable of forming this bond, and low oxygen affinity results from destabilization of the R conformer. The changes induced by this substitution at the $\alpha_1\beta_2$ interface allow Hb Kansas to dissociate into $\alpha\beta$ dimers, the near opposite of the high-oxygen-affinity Hb Chesapeake.

Hb Beth Israel (HBB asn102ser) was found in a patient with cyanosis of the fingers, lips, and nail beds.²³ The P_{50} was 88 mm Hg, and arterial blood was only 63% saturated despite a normal pO_2 . The hemolysate also had a low oxygen affinity and a normal Bohr effect. Erythrocyte 2,3-DPG was mildly elevated. The molecular mechanism of reduced oxygen affinity is the same as for Hb Kansas, although the defect may be more disruptive locally, because the serine side chain is shorter than that of threonine.

Hb Bologna (HBB lys61met) is informative because it was present as a compound heterozygote with β^0 -thalassemia and comprised 90% of the hemolysate.²⁴ Adults were neither cyanotic nor anemic despite having a P_{50} of 37.6 mm Hg. During gestation, the high concentration of HbF makes it doubtful that this mutation would have an effect on fetal development.

Hb Bruxelles (HBB phe42del) is a deletion of the most conserved amino acid residue of hemoglobin.^{25, 26} Phenylalanine residues at $\beta 41$ and $\beta 42$ are conserved in all normal mammalian non- α -globin chains and are indispensable for the structural integrity and oxygen-binding functions of the molecule. From age 4 years, the index case of Hb Bruxelles had severe hemolytic anemia and cyanosis, requiring blood transfusion once. Later in life, her hemoglobin concentration stabilized at 10 g/dL. Reasons for this "switch" of phenotype are unknown. Other mutations of $\beta 41$ and $\beta 42$, which are predominately unstable hemoglobins, are discussed later.

Treatment

Treatment is not needed for these variants. The importance of early diagnosis is to avoid unnecessary work-up and to alleviate concern for the patient and family.

P.917

UNSTABLE HEMOGLOBINS

The unstable hemoglobins result from globin chain mutations that cause hemoglobin tetramer instability and intracellular precipitation of its globin subunits. These intraerythrocytic precipitates are detectable by supravital staining and appear as globular aggregates called Heinz bodies. These inclusions reduce the life of the erythrocyte by binding to the membrane, decreasing cell deformability, and increasing membrane permeability. The resultant hemolytic disorder is sometimes called congenital Heinz body hemolytic anemia. Heinz bodies and hemolysis also occur with certain hereditary erythrocyte enzyme deficiencies (see Chapter 28). More than 140 unstable variants of both the β - and α -globin chains with widely varying clinical severity have been reported, almost always as heterozygotes for the mutation, although some homozygous cases have been reported. The major clinical features are anemia, reticulocytosis, pigmenturia, and splenomegaly.

Pathophysiology

The pathophysiology of unstable hemoglobins relates to the specific mutations leading to altered heme-globin interaction, the process of Heinz body formation, and destruction of red cells containing denatured hemoglobin.

Mutations That Alter Heme-Globin Interaction

Mutations that change the primary structure (amino acid sequence) of globin, depending on the substitution and its location, can alter the secondary structure (α -helical), the tertiary structure (folding of the globin chain), or the quaternary structure (interactions within the hemoglobin tetramer). The mechanisms that can lead to this hemoglobin instability are listed in Table 35.2.

Heme-globin interactions are vital for oxygen delivery but also contribute to molecular stability and intracellular solubility. For example, introduction of a charged amino acid residue into the heme pocket, a site normally formed by residues with nonpolar side chains, results in hemoglobin instability (e.g., Hb Bristol). Mutations involving residues that interact directly with heme, such as those near the (F8) proximal histidine that reacts with heme-iron (e.g., Hb Köln), are associated with hemoglobin instability. Also, mutations associated with nontyrosine substitutions of the (E7) distal histidine (e.g., Hb Zürich) cause molecular instability. An interesting effect of this is that the ligand-binding properties of iron are changed, and Hb Zürich has a much higher affinity for CO.^{27, 28}

Disruption of the secondary structure reduces subunit solubility and is often a result of the introduction of proline residue that cannot be accommodated into the α -helix except in its first two positions. α -Helices comprise ~70% of a globin subunit and must be folded into a globin motif. Introduction of water into the molecule destroys its stability, and this can be caused by substitution of a charged residue, for example, alanine, for a nonpolar residue, such as proline (e.g., Hb Brockton).²⁹

TABLE 35.2 SITES OF GLOBIN MUTATION ASSOCIATED WITH UNSTABLE HEMOGLOBINS^a

Weakening or modification heme-globin interactions

Interference with the secondary structure of a globin subunit

Interference with the tertiary structure of the subunit

Altered subunit interactions interfering with the quaternary structure

^aOther than single amino acid substitutions, these mutations can include small deletions and insertions of amino acids, reading frameshifts, fusion globins, and elongated globin chains.

Loss of intersubunit contact hydrogen bonds or salt bridges in the $\alpha_1\beta_1$ contact area will interfere with hemoglobin quaternary structure and also reduce stability. Dissociation of $\alpha_1\beta_1$ contacts normally does not occur in red cells, whereas dissociation of $\alpha_1\beta_2$ contact does take place. Dissociation of $\alpha_1\beta_1$ dimers into monomers is normally minimal, as it generates methemoglobin and consequent instability. Dissociation of chains along the $\alpha_1\beta_1$ contact generates α - and β -globin chains that uncoil, loosening their heme-globin interaction and favoring methemoglobin formation. Mutations affecting the $\alpha_1\beta_1$ interface tend to be more unstable than those affecting the $\alpha_1\beta_2$ contact. Examples of unstable hemoglobin mutations that are due to decreased $\alpha_1\beta_1$ contact include Hb Philly,³⁰ Hb Peterborough,³¹ and Hb Stanmore.³²

α -Hemoglobin-stabilizing protein (AHSP) binds free α -globin chains, protecting them from precipitation (see Chapter 6). In vitro studies suggest that the impaired interaction of AHSP with α -globin variants when the mutation lies in the molecular sites where AHSP binds α -globin might affect the stability of the variant. In these studies, recombinant Hb Groen Hart (HBA pro119ser), Hb Diamant (HBA pro119leu), and α -globin termination mutants had impaired interactions with AHSP. These observations suggest an additional mechanism for unstable α -globin variants.^{33, 34}

Heinz Body Formation

Heme loss is inhibited by maintaining heme iron in the reduced ferrous (Fe^{2+}) state by the action of methemoglobin reductases and detoxification of oxygen radicals. Therefore, dimerization and the dispersion and precipitation of free heme is minimized. Hemoglobin dimers autoxidize and lose heme more readily than tetramers. Generation of methemoglobin increases the thermostability of hemoglobin, suggesting that the pathways and events accompanying the conversion of ferrous to ferric heme are important for hemoglobin stability.

Heinz bodies are the product of hemoglobin denaturation. First suggested to be heme-depleted globin chains, these inclusions were subsequently identified as hemichromes, derivatives of ferric hemoglobin that have the sixth coordination position occupied by a ligand provided by the globin. Hemichromes are generated when heme is dissociated from the heme pocket and rebinds elsewhere in the globin after the α - or the β -chains have denatured. Irreversible hemichromes are a stage in the formation of Heinz bodies (also see Chapter 6). Membranes prepared from the red cells of patients with Hb Köln (HBB val98met) who have had splenectomies contain aggregates composed of disulfide-linked spectrin, Band 3, globin, and high-molecular-weight complexes composed in part of denatured spectrin.

Red Cell Destruction

Red blood cells containing Heinz bodies have a shortened lifespan. Hemichrome can bind to Band 3 of the erythrocyte membrane. Decreased deformability of the erythrocyte leads to preferential trapping in the spleen, where Heinz bodies are removed. The coincident loss of small amounts of membrane gradually converts discoid cells into spherocytes that are eventually removed from the circulation. Membrane damage might also result from lipid peroxidation and protein cross-linking because of free-radical formation that is a result of Fenton chemistry.

Hyperunstable hemoglobins are an uncommon class of variants in which the mutation, usually in the third exon of the globin gene, leads often to a truncated globin that is barely detectable or is undetectable.^{35, 36} These hemoglobins, presumably synthesized normally, are rapidly destroyed, creating the phenotype of dominantly inherited thalassemia.

P.918

Diagnosis

Patients with unstable hemoglobins may have characteristically dark urine or pigmenturia. This is a result of the presence of dipyrroles that are also present in Heinz bodies. The absence of pigmenturia does not exclude the diagnosis of unstable hemoglobin, and the severity of the hemolysis is unrelated to pigmenturia. For example, carriers of Hb Köln and Hb Zürich

(HBB his63arg) both can have pigmenturia, but hemolysis with Hb Köln can be severe whereas it is usually very mild with Hb Zürich. The P_{50} of unstable hemoglobins is variable and can be normal, low, or high. This is a result of different mutations variously affecting heme-globin interaction, and the tertiary and quaternary structures of the molecule.

Blood Smear

Abnormalities of the blood smear are nonspecific. They can include anisocytosis, basophilic stippling, Howell-Jolly bodies, nucleated red blood cells, and microspherocytes. Fragmented cells appear to have had a "bite" taken from them and are thought to result from the phagocytosis of Heinz bodies during passage of the cell through the spleen. The mean corpuscular hemoglobin concentration may be as low as 25 g/dl because of heme loss or Heinz body formation. Some reported values for reticulocytes may be factitiously high, as inclusion bodies are mistaken for reticulocytes.

Heinz Body Preparation

Heinz bodies in circulating red cells are usually seen only after splenectomy or during an acute hemolytic episode. Under such circumstances, >50% of the cells typically contain one or more large, spherical inclusions. Heinz body detection requires the incubation of erythrocytes with a supravital stain such as new methylene blue or crystal violet. The Heinz bodies appear as single or multiple inclusions of 2 μm in diameter or less and often appear attached to the membrane. Heinz bodies may be found in fresh blood, but usually, incubation for 24 hours without glucose is required for their formation. A normal control should always be run simultaneously.

Hemoglobin Stability Tests

The isopropanol test is a good screening test for unstable hemoglobins, but it can give false-positive results when the sample contains >5% HbF.³⁷ In the heat denaturation test, a hemolysate is incubated for 1 or 2 hours at 50°C, and hemoglobin instability is suggested by the development of a visible precipitate.³⁸ Although the test is simple, the results can vary because of different concentrations of the abnormal variant and different temperatures needed for denaturation. Controls with a normal stable hemolysate must be run simultaneously.

Hemoglobin High-performance Liquid Chromatography

When the mutation is such that heme dissociates from the abnormal globin chain, as in the example of Hb Köln, the partially heme-deficient molecule is susceptible to reversible and irreversible hemichrome formation with subsequent denaturation. Precipitates tend to be pale, and the pattern found during hemoglobin separation is characterized by lack of discrete peaks and multiple diffuse bands when electrophoresis is used, unless stabilized by the addition of hemin. Dipyrroluria is present, suggesting that free heme was converted to dipyrroles rather than bilirubin.

About a quarter of unstable hemoglobins are not detectable by commonly used methods of hemoglobin separation. On HPLC, some unstable hemoglobins such as Hb Köln, Hb Zurich, and Hb Hasharon demonstrate characteristic elution times.

Detection of the Variant Hemoglobin and Mutation Analysis

If clinical and hematologic studies suggest an unstable variant, the determination of the molecular defect becomes the final step in diagnosis. DNA analysis is the ultimate approach to defining the globin mutation. New mutations are common, so a family history need not be present.

Clinical Features

The presence of an unstable hemoglobin should always be considered when hemolytic anemia is present and its cause is not clearly defined. Chronic hemolysis as a result of unstable hemoglobins can be associated with all of the known complications of hemolysis, including aplastic crisis, jaundice with cholelithiasis, leg ulcers, splenomegaly, and hypersplenism and pulmonary hypertension.³⁹ A special feature of unstable hemoglobins is pigmenturia. Similar to glucose-6-phosphate dehydrogenase (G6PD) deficiency, increased hemolysis often is associated with fever, infections, and ingestion of certain drugs (see Chapter 28). Dusky cyanosis has been described in some patients with unstable hemoglobins predisposed to methemoglobin formation. In one case in which the γ -globin chain of HbF was affected (HbF-Poole; HBG2 trp130gly), hemolytic anemia was present in the newborn but disappeared as the γ - to β -globin switch was completed.⁴⁰ Sometimes the disease is seen in early childhood; it can be found in adults incidentally, or when fever or drug treatment induces hemolysis.

Many unstable hemoglobin variants produce mild hemolytic disease with minimal or no anemia. In the steady state, reticulocyte counts range between 4% and 10%. Splenomegaly may be present. Most patients with mild disease are first seen during a hemolytic crisis induced by drugs or infection. More than one half of the unstable variants are associated with no hematologic abnormality and are detected through screening programs (<http://globin.cse.psu.edu>).

Just as in all other chronic hemolytic anemias, B19 parvovirus infection can temporarily shut down erythropoiesis, rapidly worsening the anemia and resulting in an aplastic crisis. Anemia may also increase during infection and after treatment with oxidant drugs such as sulfonamides. The intensity of hemolysis is variable and is dependent on the mutation and fraction of abnormal hemoglobin present.

Hb Köln, described in multiple kindreds, is the most common unstable hemoglobin and is characterized by anemia, reticulocytosis, splenomegaly, and 10% to 25% Hb Köln.⁴¹ It is not associated with oxidant-drug-induced hemolysis. The independent occurrence of this variant in so many apparently unrelated individuals suggests that the Hb Köln mutation, located at a methylated CpG dinucleotide sequence of the β -globin gene, can act as a "hotspot" for mutation through the deamination of the methylcytosine nucleotide to form thymine.

Hb Zürich has also been reported on multiple occasions.⁴² This variant, forming ~25% of the hemolysate, is accompanied by mild anemia exacerbated by oxidant drugs, pigmenturia, and, as discussed previously, an increased affinity for CO. The latter protects the β -globin heme group from oxidation and increased instability. Carriers have a special susceptibility to sulfonamide-induced hemolytic crisis. Investigation of the basis for variation in drug-related hemolysis of family members with Hb Zürich disease suggested that tobacco smoking ameliorated hemolysis, probably because the high affinity of Hb Zürich for CO stabilized the hemoglobin tetramer.^{43, 44}

Hb Hasharon (HBA2 asp47his) is another more common variant affecting the α -globin chain, found in Ashkenazi Jews and P.919

causing hemolysis in newborns but not in most adults.^{45, 46} This variant comprises 15% to 20% of the hemolysate, and inclusion bodies are not found.

Some unstable hemoglobins are linked to α - or β -thalassemia genes: the α -chain mutants Hb Suan-Dok (HBA2 leu109arg) and Hb Petah Tikva (HBA ala110asp) coexist in cis with α -thalassemia and some β -chain mutants such as Hb Leiden (HBB glu6 or 7del), Hb Duarte (HBB ala62pro), and HbG-Ferrara (HBB asn57lys) coexist with a β^0 -thalassemia mutation in trans.

Pulmonary Hypertension

Altered nitric oxide (NO) bioavailability has become recognized as a common occurrence in hemolytic anemia and might account for a commonality of clinical findings in what are very different pathophysiologic entities.^{47, 48} Because a variable fraction of hemolysis occurs within the vasculature, heme and arginase released from the erythrocyte into blood consume NO and deplete supplies of arginine, the substrate of the NO synthases. Pulmonary hypertension and priapism, common complications of hemolytic anemia, have been described in patients with unstable hemoglobins.^{49, 50}

Miscellaneous

In a case of hemolytic anemia resulting from Hb Bristol-Alesha (HBB val68met), moyamoya and transient ischemic attacks occurred in a 10-year-old girl.⁵¹ The authors suggested that chronic hypoxemia may be the cause of occlusive moyamoya in unstable hemoglobinopathies or in hemoglobins with altered oxygen affinity.

Hyperunstable Hemoglobin

Some uncommon globin mutations are hyperunstable. Although these mutants are synthesized in normal amounts, they are unable to form stable tetramers or even dimers and are rapidly catabolized. These variants therefore have features of both unstable hemoglobins and thalassemias, and they have been called thalassemic hemoglobinopathies. The phenotype is that of severe, dominantly inherited β -thalassemia rather than unstable hemoglobin disease, because the affected globin chain fails to accumulate and participate in tetramer formation. In the first recognized example of this phenotype, three generations of a family had a dominantly transmitted hemolytic anemia with splenomegaly, gross abnormalities of the erythrocytes, dyserythropoiesis, and large inclusion bodies in bone marrow erythroblasts and in nucleated red cells of the peripheral blood.^{35, 36}

Dominantly inherited β -thalassemias (sometimes the α -globin chain is similarly affected) have been identified in many ethnic groups and are caused by missense mutations, deletions or insertions of intact codons, single-base substitutions leading to premature termination of translation (nonsense mutations), and mutations causing frameshifts or aberrant splicing. Most of the mutations are in exon 3 of the affected gene, and this location might permit globin mRNA to escape nonsense-mediated decay and allow enough denatured protein, along with the uninvolved globin chain, to accumulate and damage the developing erythroblast.

Treatment

Unstable hemoglobinopathies are generally mild disorders and do not require therapy except supportive and preventive measures. As with other hemolytic anemias, Parvovirus B19 infections can cause the development of severe acute anemia. Administration of folic acid to prevent megaloblastic arrest of erythropoiesis might be warranted, although access to a nutritious diet is probably satisfactory. The possibility of fever-associated hemolysis should be recognized, and avoidance of oxidant drugs, including acetaminophen and sulfonamides, are other management considerations. Chronic hemolysis is associated with a high incidence of cholelithiasis.

Severe hemolysis raises the question of splenectomy because the spleen undoubtedly plays an important pathophysiologic role in the destruction of Heinz-body-containing red cells. As in other chronic hemolytic anemias, the decision to perform a splenectomy must be balanced with the role of the spleen as a defense against pneumococcal infections early in life and the need for antipneumococcal vaccines and prophylactic penicillin in cases where splenectomy is performed in childhood. On balance, splenectomy might be beneficial for individuals with severe unstable hemoglobinopathies, and partial correction of the anemia is sometimes achieved. Nevertheless, predicting the response to splenectomy is difficult. Hydroxyurea has been used to stimulate HbF production and help repair anemia in two cases of unstable hemoglobin disease.⁵²

M HEMOGLOBINS

The M (met) hemoglobins are characterized by heme-iron oxidation. Heme iron is more stable in the ferric than the ferrous state. Erythrocyte methemoglobin reductive capacity cannot effectively compensate for this instability of ferrous heme. The major clinical feature of these disorders is cyanosis. They are not noted for clinical severity. The misdiagnosis of other causes of cyanosis and unneeded treatment are the major hazards of these rare variants.

Pathophysiology

In the M hemoglobins, the mutant globin chain creates an abnormal microenvironment for the heme iron, displacing the equilibrium toward the oxidized or ferric (Fe³⁺) state. A combination of Fe³⁺ and its abnormal coordination with the substituted amino acid generates a visible spectrum that resembles, but is clearly different from, methemoglobin that is not due to a globin gene mutation, in which the heme iron is oxidized but there is no associated amino acid substitution.

In the Iwate prefecture of Japan, “black children” had been observed for more than 160 years, and this was associated with a brownish-colored hemoglobin in the hemolysate of a patient that was eventually characterized as HbM Iwate (HBA his87tyr).⁵³ Six β-, two α-, and two γ-globin HbM variants have been reported. In five of the eight described HbM variants, the mutation involves the substitution of the distal (E7) or proximal (F8) histidine interacting with the heme iron via tyrosine (<http://globin.cse.psu.edu>). With HbM Milwaukee (HBB val67glu), the longer side chain of the glutamic acid residue can reach and perturb the heme iron. In two novel variants that form methemoglobin, an amino acid deletion was suspected to alter the orientations of the distal and proximal histidine residues.⁵⁴ Properties of some M hemoglobins are shown in Table 35.3. The strength of attachment of ferric heme to globins differs among M hemoglobins.

HbM Milwaukee is an example of an M hemoglobin that is not caused by mutation of the proximal or distal histidine residues, but by the nearby β67 (E11) val (<http://globin.cse.psu.edu>). When this residue is replaced by a glutaminy residue, it perturbs the heme iron and generates an M hemoglobin. Of interest, other mutations of that site, such as Hb Bristol (val67asp) or Hb Sidney (val67ala), are unstable or have low affinity but do not lead to heme-iron oxidation. X-ray crystallography shows that the carboxylic group of the new glutaminy residue in Hb Milwaukee occupies the sixth coordination position of the iron, and that the proximal histidine maintains its role as the tenant of the fifth coordinating position, stabilizing the abnormal ferric state of HbM Milwaukee.

P.920

TABLE 35.3 HEMATOLOGIC FEATURES OF SOME HβM VARIANTS OF THE α- AND β-GLOBIN GENES

Variant	PercentHb (g/dl)	Reticulocytes (%)	P₅₀	Bohr Effect
HbM Hyde Park (Milwaukee-2)(β)	23-32	10-13	4-6	Normal Present
HbM Iwate (α)	19	17	—	DecreasedDecreased
HbM Boston (α)	20-30	—	—	DecreasedDecreased
HbM Milwaukee (β)	50	14-15	1-2	DecreasedPresent

HbM Saskatoon (β)	35	13-16	0.8-3.2	Normal	Present
HbM Chile (β)	17	13.2	1.2	—	—

Oxygen-binding Properties and the R \rightarrow T Transition of M Hemoglobins

HbM Milwaukee, HbM Hyde Park (HBB his92tyr), and HbM Boston (HBA his58tyr) all adopt deoxy or deoxylike conformation upon the deoxygenation of the two normal chains, although the abnormal chains cannot off-load oxygen. This, and crystallographic, electron paramagnetic resonance, and nuclear magnetic resonance (NMR) spectroscopy, and 2,3-DPG-binding studies affirm that after two heme groups become deoxygenated, the entire molecule adopts the deoxy T conformation.

With HbM Milwaukee, Hb M Saskatoon (HBB his63tyr), and HbM Hyde Park, a normal Bohr effect and P_{50} strongly suggest that the hemoglobin adopts the R state when the two normal chains are oxygenated. NMR studies of HbM Milwaukee support the notion that the conformational changes take place when the normal heme groups are oxygenated. In contrast, HbM Iwate is in the crystallographic T configuration when its normal heme groups are in the ferric state, explaining its decreased oxygen affinity; the molecule does not shift to the R state when the normal heme groups are liganded and remains in the low-affinity T state. A similar situation probably exists in HbM Boston, as the habit of the deoxy crystal remains intact after oxygenation, suggesting that no conformational change has occurred that would require a different crystal structure.

HbM Saskatoon and HbM Boston have different properties despite the common substitution of the distal histidine. This occurs because HbM Saskatoon does not change its conformation when oxygenated, whereas the latter variant does. Why properties of the β -globin chains differ from those of the α -globin chain when their distal histidine is substituted is unresolved.

Iron Oxidation and Spectral Characteristics

In M hemoglobins, the affected heme groups are stabilized in the ferric state and have an abnormal microenvironment. They exhibit an abnormal visible absorption spectrum that is easily distinguished from methemoglobin. This characteristic separates these variants from some unstable hemoglobin mutants that also have a tendency to form methemoglobin.

Heme iron in the abnormal subunits of the M hemoglobin exhibit abnormally low redox potential. They are oxidized more rapidly by molecular oxygen and are resistant, to a variable degree, to reduction by dithionite. Differences also exist in the rate of reduction of the five M hemoglobins with NADH-cytochrome b_5 reductase (CYB5R3). HbM Iwate, HbM Hyde Park, and HbM Boston are not reduced at all, whereas HbM Milwaukee is reduced slowly and HbM Saskatoon is reduced normally by this reductase. These last two variants might be less oxidized in vivo than expected. Full ferric conversion might occur only in vitro, because of the high autoxidation rate of these abnormal hemoglobins. Older red cells might, nevertheless, have fully oxidized abnormal chains consistent with the presence of clinically apparent cyanosis.

Clinical Features and Diagnosis

Clinically, the skin and mucous membranes of HbM carriers have an appearance similar to, but not identical with, cyanosis, sometimes called pseudocyanosis. Pseudocyanosis is not associated with dyspnea or clubbing. Skin and mucosal surfaces are brownish/slate-colored, more like methemoglobinemia, but not as slate blue-purple as true cyanosis. This distinction is subtle and might not be apparent without comparing the two conditions at the same time. Skin reflects hemoglobin molecules with an abnormal ferric heme and abnormal spectrum, whereas cyanosis is caused by the presence of more than 5 g/dl of deoxyhemoglobin. Pseudocyanosis is present from birth in α -globin-chain abnormalities and from the middle of the first year of life in the β -chain mutants. The γ -globin gene HbM variants, HbF-M Osaka (HBG2 his63tyr) and HbF-M Fort Ripley (HBG his92tyr), have been associated with neonatal "cyanosis" that disappears as γ -globin-chain synthesis wanes.^{55, 56} A mixture of the abnormal pigment and true cyanosis, resulting from hemoglobin desaturation of the normal chains, is observed in the low-oxygen-affinity HbM Boston and HbM Hb Iwate.

A mild hemolytic anemia and reticulocytosis have been observed in HbM Hyde Park and can be explained by the instability of the hemoglobin induced by partial heme loss.

HbM should be considered in all patients with abnormal homogeneous coloration of the skin and mucosa, particularly if pulmonary and cardiac functions are normal. The diagnosis can be suspected by observing an abnormal brown coloration of the blood in a tube. To distinguish this coloration from methemoglobin, the addition of KCN to the hemolysate is useful. KCN will turn blood containing methemoglobin red but has little if any effect on HbM-containing hemolysates. Lack of color conversion with KCN is diagnostic of HbM.

A spectrophotometric recording of the visible spectrum of the hemolysate is critical for the diagnosis, and the mutation is confirmed by DNA analysis. M hemoglobins do not have an absorbance peak at 630 to 635 nm which is typical of methemoglobin. In the presence of HbM, accurate measurement of oxygen saturation and CO hemoglobin is difficult with most instruments. Absorption maxima at different wavelengths of all hemoglobin M variants have been reported.

Treatment

Treatment for individuals with HbM is neither necessary nor possible. A correct diagnosis is most important, because this will forestall therapeutic and diagnostic misadventures.

P.921

METHEMOGLOBINEMIA UNRELATED TO GLOBIN GENE MUTATIONS

Normally, small amounts of hemoglobin are continually being oxidized by endogenous agents, including oxygen itself (autooxidation). When oxygen reacts with deoxygenated hemoglobin to produce oxyhemoglobin, one electron from heme-iron (Fe^{2+}) is transferred to the bound oxygen, thereby forming a ferric-superoxide anion complex ($\text{Fe}^{3+}\text{-O}_2^-$). Subsequently, when hemoglobin is deoxygenated, most oxygen is released as O_2 , but a small amount leaves as superoxide anion (O_2^-). The partially transferred electron is not returned to iron, leaving the heme-iron as Fe^{3+} (methemoglobin). Increased temperature and low pH promote auto-oxidation.⁶ Usually, methemoglobin levels are <1% of the total hemoglobin, because erythrocytes contain cytochrome b5 reductase that catalyzes its reduction (see Chapter 6). Genetically determined methemoglobinemia, unrelated to globin gene mutations, occurs in individuals with hereditary deficiency of cytochrome b5 reductase. Acquired methemoglobinemia occurs in normal individuals exposed to drugs and chemicals that oxidize hemoglobin iron at a rate that exceeds the capacity for enzymatic reduction.

Cyanosis

Cyanosis most often is due to cardiac or pulmonary disease, but genetic and acquired disorders of hemoglobin can result in significant arterial desaturation. In the M hemoglobins and with sulfhemoglobin and methemoglobin, the altered visible spectrum of the abnormal pigments is responsible for the brownish/slate skin color. The spectral properties of sulfhemoglobin versus methemoglobin are such that patients can be markedly "cyanotic," with 0.5 g/dl of sulfhemoglobin; 1.5 g/dl of methemoglobin is required to produce "cyanosis"; true cyanosis requires 10 times this concentration of deoxyhemoglobin.

Although dyspnea is not a feature of M hemoglobins, it can be present even with relatively low levels of methemoglobinemia. Because the altered hemes in HbM, sulfhemoglobin, and methemoglobin do not transport oxygen, affected individuals with all three conditions may have normal hemoglobin concentrations but are functionally anemic, simply because of insufficient operational heme groups. This effect is clinically significant only in extreme cases of methemoglobinemia and sulfhemoglobinemia or when the overall hemoglobin level is low. With HbM, the proportion of normal to abnormal heme is genetically determined and fixed, so that decreased oxygen delivery is problematical only when superimposed on underlying anemia.

The clinical effects of nonfunctional heme groups are not limited to an inability to transport oxygen. Small amounts of nonfunctional heme can have clinical significance if their presence produces a physiologically dysfunctional shift in the oxygenation of neighboring unmodified subunits. This is the molecular basis of the left-shifted oxygenation curve, the impaired oxygen delivery to the tissues, and the resulting respiratory distress seen in relatively mild degrees of methemoglobinemia. This phenomenon, called the Darling-Roughton effect, occurs as oxidized subunits in partially oxidized tetramers are held in an R-like conformation, increasing the oxygen affinity of the remaining subunits. Although mixed venous blood is unusually saturated, the abnormal spectrum of the methemoglobin dominates this effect, causing cyanosis. An analogous left shift in the oxygenation curve, but to a more pronounced degree, is present with CO poisoning and impaired oxygen delivery exacerbates dyspnea.

Cytochrome b5 Reductase Deficiency

Mutations of the cytochrome b5 reductase 3 gene (CYB5R3; 22q13) cause decreased activity of the soluble form of this erythrocyte enzyme and hereditary methemoglobinemia. CYB5R3 is a transferase that facilitates electron transfer from NADH to cytochrome b5, which then directly reduces methemoglobin. A second erythrocyte enzyme is NADPH-methemoglobin reductase, which by itself is unable to reduce methemoglobin effectively, and individuals lacking this

enzyme do not have methemoglobinemia. However, in the presence of redox compounds such as methylene blue, NADPH methemoglobin reductase rapidly reduces methemoglobin. Thus this agent is useful in treating methemoglobinemia.

Cytochrome b5 reductase enzyme deficiency is a recessive trait, and only homozygotes or individuals who are compound heterozygotes for two different gene mutations express the disease. Of interest, however, heterozygotes can be at risk for acquired methemoglobinemia when exposed to oxidant drugs.^{57, 58} Two forms of cytochrome b5 reductase deficiency are recognized, types I and II.

Type I deficiency is limited to erythrocytes and is manifested by methemoglobinemia only. Patients are more cyanotic than sick, in the worst cases complaining of fatigue with strenuous exercise. They have normal survival and have normal pregnancies. Methemoglobin levels vary from 20% to 40%. When exposed to methemoglobin-inducing drugs or chemicals, these patients are at risk for developing further methemoglobinemia symptoms. Enzymatic activity of the NADH-dependent methemoglobin reductase system is reduced in the erythrocyte.

Type II deficiency is a generalized form cytochrome b5 reductase deficiency, affecting 10% to 15% of patients. It is a severe and lethal disease, with a strong neurologic component. Although the methemoglobinemia can be treated, the neurologic syndrome is refractory. The disease is secondary to homozygosity or compound heterozygosity for defective cytochrome b5 reductase in all tissues.

At least 33 mutations of CYB5R3 have been associated with methemoglobinemia.⁶² Seventeen exon mutations were associated with type 1 disease, 15 with type II, and 1 with both types of disease. Missense, nonsense, deletions, and other classes of mutation have been described.

A high incidence of hereditary methemoglobinemia is found among Alaskan Eskimos, Northwest Indians, Navajo Indians, and natives of Yakusk, Siberia, groups that might have common ancestry. In one report from Alaska, the gene frequency was 0.07, but these results were based on enzyme assay and not detection of the gene. Cytochrome b5 reductase deficiency has also been observed sporadically among Puerto Ricans and in Mediterranean populations.

Acquired (Toxic) Methemoglobinemia

Many chemical agents and drugs can induce methemoglobinemia in normal people (Table 35.4). Dapsone- and primaquine-induced methemoglobinemia, at levels of 15% to 33%, have been reported in human immunodeficiency virus (HIV)-infected patients. Nitrites also are common offenders, and recreational use of amyl, butyl, or isobutyl nitrites is a cause of acquired methemoglobinemia. Infections that release toxins (including nitrites) can produce methemoglobin. Aniline dyes and aniline reduce molecular oxygen and generate methemoglobin. Phenylhydroxylamine, after reducing oxyhemoglobin, can generate nitrosobenzene, which is reduced again to phenylhydroxylamine by red cell enzymes. The cycle can then, in turn, generate more methemoglobin. Henna, a natural product used worldwide as a hair dye and to stain skin and nails, contains a chemical, 2-hydroxy-1,4-naphthoquinone, that can increase methemoglobin production, especially in G6PD-deficient individuals. Use of benzocaine as a topical anesthetic is often associated with methemoglobinemia. Certain medications used to treat diaper rash that contain benzocaine and resorcinol have been reported to produce methemoglobin levels as high as 35%.^{57, 58, 59, 60, 61, 62, 63, 64}

P.922

TABLE 35.4 DRUGS AND AGENTS THAT CAN CAUSE METHEMOGLOBINEMIA

Local anesthetics

Benzocaine

Lidocaine

Procaine

Prilocaine

Aniline dyes

Chlorates

Dapsone

Diarylsulfonylureas (sulofenur)

Primaquine

Rasburicase

Nitrates and nitrites

Nitroglycerine

Cerium nitrate

Amyl nitrate

Isobutyl

Nitrobenzines

Nitrofurans

Pyridium

Primaquine

Sulfonamides

Acetaminophen/phenacetin

Newborn infants are at increased risk for methemoglobinemia because of a transient decrease in NADH cytochrome reductase activity during the neonatal period; normal adult enzyme activity is present by 3 to 4 months of age. Infantile methemoglobinemia has occurred in association with nitrate contamination of the water supply.⁶⁰ Children with septic shock also can have methemoglobinemia, presumably because of increased circulating nitrite/nitrate levels. In children with *Plasmodium falciparum* malaria, mean methemoglobin levels are increased, and this is related to disease and anemia severity.⁶¹ Because malaria itself produces hypoxia, the additional reduction in oxygen-carrying capacity because of the presence of methemoglobinemia might be particularly critical for the subgroup of patients who are anemic or acidotic.

Diagnosis

The possibility of acquired methemoglobinemia should be considered in anyone with recent or sudden apparent cyanosis who is unresponsive to 100% oxygen and without cardiopulmonary pathology. Sulfhemoglobinemia (see later) should also be considered in these cases. Acquired methemoglobinemia is not rare; it is much more common than any of the genetic causes of methemoglobinemia. In a retrospective study of acquired methemoglobinemia (methemoglobin level >2%), 138 cases were encountered over a period of 28 months.⁶⁴ Patients' ages ranged from 4 days to 86 years, and there was one fatality and three near-fatalities. Dapsone was the most common etiology of acquired methemoglobinemia, accounting for 42% of all cases. The mean peak methemoglobin level among these individuals was 7.6%. In five of the patients with the most severely elevated levels, 20% benzocaine spray was the causative agent and was associated with a mean peak methemoglobin level of 44%. Eleven pediatric patients developed methemoglobinemia either from exogenous exposure, such as drugs, or because of serious illness, such as gastrointestinal infections with dehydration. Ninety-four percent of patients with methemoglobinemia were anemic.

Long-standing symptoms, or symptoms in siblings, is suggestive of a hereditary methemoglobinemia. Because the enzyme deficiency is inherited as a recessive trait, clinical disease is not expected in the parents. The differential diagnosis includes the HbM variants and low-oxygen-affinity hemoglobins. Because of the "dominance" of the HbM genes, one parent often has the same symptoms.

The diagnosis of cytochrome b5 reductase deficiency is made by direct assay of the enzyme. Genetic ascertainment is available for the known mutations. Pre-natal diagnosis is available for type II congenital methemoglobinemia.

Treatment

Acquired methemoglobin is treated by stopping the offending agent once it is identified. Direct drug intervention with intravenous methylene blue is indicated in patients with 40% to 60% methemoglobin, particularly when symptoms are present. Methemoglobin levels of 70% can be fatal. The usual dose of methylene blue is 1 to 2 mg/kg, and the maximum dose is 7 mg/kg. It can be given intravenously in acute methemoglobinemia. For intravenous administration, it should be given slowly over 35 minutes to avoid high concentrations and paradoxical methemoglobin production. Rapid

improvement in cyanosis and normalization of methemoglobin level usually occurs 30 to 60 minutes after methylene blue injection. If there is coexistent G6PD deficiency, methylene blue is not effective, because of the lack of NADPH production, and its use may result in hemolysis. A transient drop of pulse oximeter arterial oxygen saturation can be seen following methylene blue injection, a result of interference by methylene blue with the light-wave emission of the pulse oximeter. Methemoglobin levels can increase again following successful treatment.⁶⁵ In type I cytochrome b5 reductase deficiency, treatment is mainly for cosmetic purposes. Oral methylene blue, 100 to 300 mg daily, can maintain methemoglobin levels of 5% to 10%. Ascorbic acid, 200 to 500 mg daily, also can reverse cyanosis in patients with type I methemoglobinemia.

In aniline-induced methemoglobinemia, methylene blue can couple with oxyhemoglobin to generate free radicals and has sometimes produced hemolysis. In these cases, dosing should be limited.

Automated red blood cell exchange has been used successfully when methylene blue is ineffective and may be superior to manual exchange transfusion.⁶⁶

PULSE OXIMETRY

Virtually all of the classes of hemoglobin variants and methemoglobinemia discussed above have been associated with unexpected low oxygen saturations when this is measured by pulse oximetry. Some low-oxygen-affinity variants have both a low pulse oximeter measured oxygen saturation and a low arterial oxygen saturation although the arterial oxygen pressure was normal.^{67, 68, 69, 70} These anomalies are due to the altered absorption spectrum of the hemoglobin variant that confounds the settings of the pulse oximeter which uses set wavelengths of light to calculate oxygen saturation. Attention should be paid to measurement of blood oxygen saturation when any hemoglobin variant is present. Blood oxygen saturation can be measured using an arterial blood gas analyzer, by pulse oximetry, or by using a CO-oximeter. The first method measures blood partial pressure of dissolved oxygen and provides the PaO₂ and SaO₂. The convenient pulse oximeter provides a transcutaneous measure of absorbance at two wavelengths (660 and 940 nm) but is inaccurate when dyshemoglobins, such as methemoglobin (hemoglobin with oxidized [Fe³⁺] heme iron), carboxyhemoglobin, and sulfhemoglobin, are present. CO-oximetry, the most accurate of all the methods, can be inaccurate in cases of M hemoglobins.

P.923

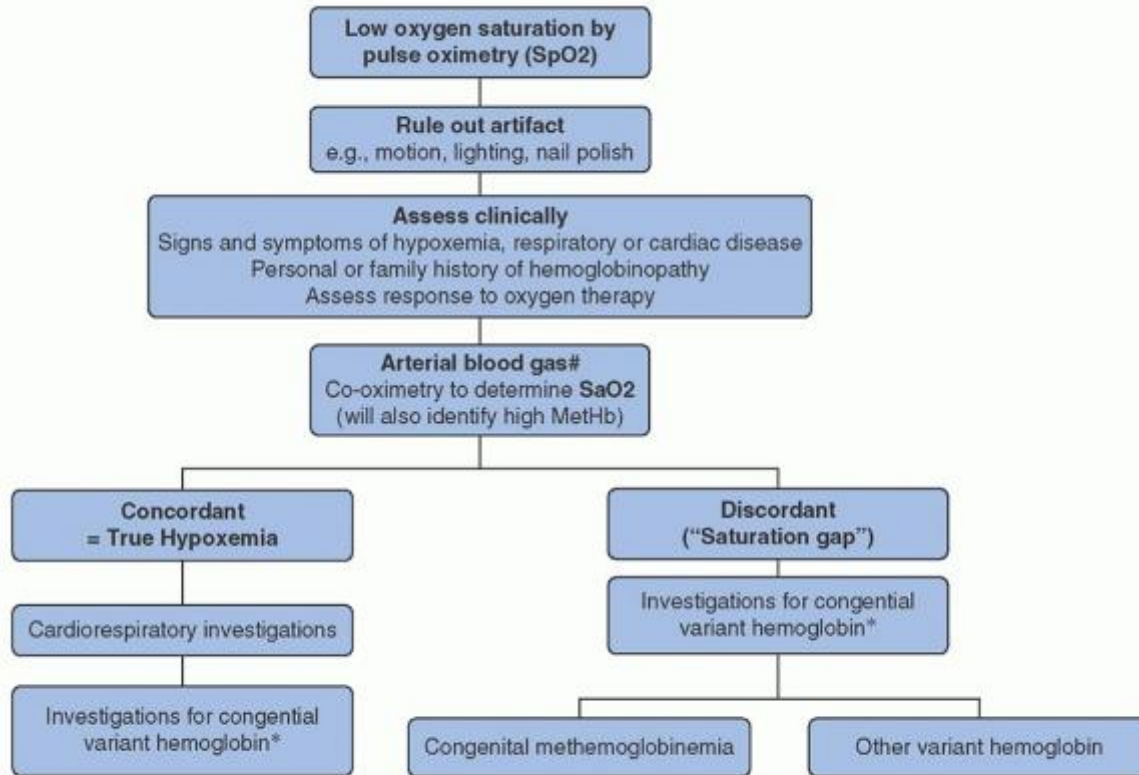

* Evaluation for variant hemoglobins are discussed in Chapters 33–35.

FIGURE 35.1. An algorithm for evaluation of low SpO₂. Arterial blood gas should be done on room air and with simultaneous SpO₂ measurement. (Redrawn from Ref. 70.)

Oxygen saturation calculated from pH and PO₂ should be interpreted with caution, because the algorithms used assume normal hemoglobin oxygen affinity, normal 2,3-DPG concentrations, and no dyshemoglobins such as methemoglobin or hemoglobinopathies. CO-oximeter reports should include the dyshemoglobin fractions in addition to the oxyhemoglobin fraction. In cases of increased methemoglobin fraction, pulse oximeter values trend toward 85%, underestimating the actual oxygen saturation. Hemoglobin M variants may yield normal methemoglobin levels and increased carboxyhemoglobin or sulfhemoglobin fractions measured by CO-oximetry.

In a systematic review, 25 publications and 4 unpublished reports representing 45 patients with low SpO₂ and a confirmed variant hemoglobin were identified.⁷⁰ Fifty-seven family members of patients had a confirmed or suspected variant hemoglobin. Three low-oxygen-affinity variant hemoglobins had concordantly low SpO₂ and SaO₂. Eleven variant hemoglobins were associated with unexpectedly low SpO₂ measurements but normal SaO₂. Most variant hemoglobins were associated with spuriously low SpO₂. The differential diagnosis of possible variant hemoglobin should be considered in asymptomatic patients found to have unexpectedly low SpO₂. Otherwise these patients might be subjected to unneeded extensive cardiopulmonary investigations in search of the cause of their “hypoxemia.” A approach to the evaluation of low oxygen saturation is shown in Figure 35.1.

DYSHEMOGLOBINEMIAS: CARBOXY-, SULF-, AND NITROSOHEMOGLOBINS

CO and NO are present in normal red cells in very low concentrations, and both can bind to hemoglobin to form carboxyhemoglobin (CO hemoglobin) and nitrosohemoglobin (NO hemoglobin), respectively. Carboxyhemoglobin avidly binds oxygen and cannot release it to the tissues. Nitrosohemoglobin may have critical physiologic functions. In addition to these normally occurring liganded hemoglobins, sulfur compounds can bind to the pyrrole ring of heme, forming a thiochlorin, referred to as sulfhemoglobin (see Chapter 6). Mutations or environmental conditions can increase the concentrations of all these liganded or oxidized hemoglobins, thereby producing dyshemoglobinemias. Sometimes, increased levels of dyshemoglobins are life-threatening, and because effective treatments are available, their presence should be identified promptly.

Carbon Monoxide Poisoning: Carboxyhemoglobinemia

CO, a toxic gas, is odorless, colorless, and tasteless, has a low solubility in water, and is relatively inert. It combines with hemoglobin heme with high affinity and with lesser affinities to myoglobin and cytochrome heme. Under physiologic conditions, its affinity for hemoglobin is ~240 times greater than that of oxygen. Once CO is bound to heme, its "off" rate is very slow, producing a very high affinity constant of CO for heme and a life-threatening danger for organisms exposed to high levels of CO.

Further endangering those exposed to CO, once two molecules of CO are bound to hemoglobin, the molecule switches to the R state, and the two globin chains that can bind oxygen will be in their high-affinity conformation. This high ligand affinity makes the delivery of oxygen to the tissues by the remaining oxygen-binding sites more difficult (Darling-Roughton effect). Consequently, the oxygen equilibrium curve of blood is shifted to the left with increasing CO levels.

In the absence of increased environmental CO, the blood of adults contains ~1% to 2% CO hemoglobin. This endogenous CO is derived from heme catabolism, specifically, the first enzymatic reaction catalyzed by heme oxygenase (see Chapter 6). Caloric restriction, dehydration, and Japanese

P.924

and Amerindians seem to generate higher endogenous levels of CO. Hemolytic anemia, hematomas, and infection tend to increase CO production up to threefold. Fetuses and newborns have double the normal adult levels of CO hemoglobin, and this increases further in the presence of neonatal hemolysis. Exogenous sources of CO include atmospheric CO, which is a product of incomplete combustion and oxidation of hydrocarbons, and natural sources.

The most commonly used instrument for the detection and quantification of carboxyhemoglobins is the CO-oximeter, which also provides the levels of oxy-, deoxy-, and methemoglobin.

Chronic CO Intoxication

It has been estimated that CO intoxication is responsible for upward of 50,000 emergency room visits yearly.⁷¹ Symptoms of CO hemoglobinemia can include irritability, nausea, lethargy, headache, and sometimes a flulike condition. A study of more than 1,000 CO-poisoned patients suggested that symptoms might not correlate well with blood levels of CO hemoglobin.⁷² Higher CO hemoglobin levels produce somnolence, palpitations, cardiomegaly, and hypertension, and might contribute to atherosclerosis. Long-term neuropsychological symptoms can persist and even be permanent.⁷¹ Chronic CO poisoning can produce erythrocytosis, the magnitude of which varies with the level of CO hemoglobin. By increasing red cell production, chronic CO poisoning can mask the mild anemia of thalassemia trait or other acquired or genetic hemolytic disorders.

The most frequent exogenous source of CO is cigarette smoking, which can increase carboxyhemoglobin to 15%. Waterpipes have also been associated with CO hemoglobinemia. Pregnant women, fetuses, neonates, and infants are particularly susceptible to CO poisoning from smoking. Because CO hemoglobin increases hemoglobin-O₂ affinity, this may cause erythrocytosis, especially in smokers. The second most common cause of chronic CO exposure is defective heating exhaust systems and vehicles that leak CO into the passenger compartment. Occupational exposure is seen in garage workers, toll booth attendants, tunnel workers and other situations and occupations with poor ventilation, firefighters, and workers with industrial exposure.

Acute CO Intoxication

Carboxyhemoglobin levels >20% are usually required before symptoms appear. Accidental exposures to high environmental levels of CO or suicide attempts by deliberate exposure to a CO source are the most frequent causes of acute poisoning in the United States, responsible for ~4,000 adult deaths a year. Acute CO intoxication in children is responsible for ~400 deaths a year, is more severe, and sometimes has unique symptomatology. Children are more likely to have severe sequelae such as leukoencephalopathy, white-matter destruction, and severe myocardial ischemia. Carboxyhemoglobinemia has been associated with high doses of sodium nitroprusside in children, with levels of 5.5% to 7.7%.⁷³ The mechanism is unclear but is hypothesized to be the induction of heme oxygenase, the first enzyme in heme catabolism that generates CO.⁷⁴

CO rapidly affects the central and peripheral nervous system and cardiopulmonary functions. Cerebral edema is common, as are alterations of sensory and peripheral nerve function. CO induces increased permeability in the lung, resulting in acute pulmonary edema. Cardiac arrhythmia, generalized hypoxemia, and respiratory failure are the common causes of CO-related death. Carboxyhemoglobin levels >40% are present in these cases. In survivors, considerable neurologic deficits may remain.

Less severe acute cases present with the same types of symptoms as patients with chronic intoxication. Arrhythmias, myocardial ischemia, lactic acidosis, convulsions, and coma also can occur. An interesting complication observed several days after the exposure to CO are patches of necrotic skin induced by localized hypoxia. The levels of carboxyhemoglobin that can elicit any of these symptoms vary widely among patients.

Treatment

Treatment of chronic exposure is principally rapid removal of the patient from the source of environmental CO and if needed, breathing 100% O₂ will increase the rate of CO removal. Hyperbaric oxygen, whose efficacy is unproven,^{71, 74} perhaps because of the almost inevitable delay in its institution, should be reserved for exceptional cases of CO intoxication.⁷⁴ In acute exposure, after identification and removal of the source of CO, 100% O₂ should be administered.

Sulfhemoglobinemia

Sulfhemoglobin is a green-pigmented protein with a sulfur atom incorporated into the heme ring. It is first suspected in a cyanotic patient with near-normal oxygen tension who is felt to have methemoglobinemia but does not respond to therapy with methylene blue. Although it shares a similar absorption peak with methemoglobin, the absorption peak of methemoglobin, unlike that of sulfhemoglobin, is abolished by cyanide. At low concentrations, sulfurated tetramers are shifted toward the deoxy or T form, producing a right shift of the oxygen equilibrium curve. This shift in the hemoglobin-oxygen dissociation curve reduces the likelihood of dyspnea unless the concentrations of sulfhemoglobin are exceptionally high.

Sulfhemoglobin has been associated with the use of certain "oxidant" medications, although mostly when used in doses higher than recommended, during drug abuse, with occupational exposure to sulfur compounds and with exposure to polluted air.⁷⁵ Sulfhemoglobin and methemoglobin have been reported to coexist in some cases of drug-induced hemoglobinopathy, and chemicals and drugs reported to produce these syndromes are similar. Congenital sulfhemoglobinemia is rare and has been described with an unstable hemoglobin. It is likely, that, because of drug-related and industrial exposure to sulfur, this condition is underdiagnosed. For equivalent amounts of abnormal pigment, the patient with sulfhemoglobinemia appears bluer than the patient with methemoglobinemia, and concentrations of 0.5 g/dl can produce cyanosis. These individuals are less symptomatic than those with methemoglobinemia, as cyanosis occurs at a sulfhemoglobin concentration 10 times lower than the methemoglobin level needed to cause cyanosis. Treatment is rarely required in addition to withdrawal from the putative offending agent. Exchange transfusion is the sole therapeutic option for symptomatic cases.

Nitrosohemoglobins

NO is generated from L-arginine by nitric oxide synthases (see Chapter 6). NO diffuses out of the originating cells and into nearby target cells, where it binds the heme groups of enzymes and hemoglobin. The reaction of free NO with erythrocytes is diffusion-limited. It has been proposed that S-nitrosylhemoglobin is formed in the lungs, whereas in tissues NO is liberated from hemoglobin leading to vasodilation. It is hypothesized that by sensing the physiologic oxygen gradient in tissues, hemoglobin exploits conformation-associated changes in the position of β 93 cys to bring local blood flow into line with oxygen requirements.^{76, 77, 78, 79, 80, 81} This hypothesis is controversial, however, and there is little direct evidence that NO is liberated from the β 93 cys site as hemoglobin assumes the T state.

P.925

REFERENCES

1. Wajcman H, Galacteros F. Hemoglobins with high oxygen affinity leading to erythrocytosis. New variants and new concepts. *Hemoglobin* 2005;29:91-106.
2. Papassotiriou I, Traeger-Synodinos J, Marden MC, et al. The homozygous state for Hb Crete [β 129 (H7) Ala→Pro] is associated with a complex phenotype including erythrocytosis and functional anemia. *Blood Cells Mol Dis* 2005;34:229-234.
3. Tanphaichitr VS, Viprakasit V, Veerakul G, et al. Homozygous hemoglobin Tak causes symptomatic secondary polycythemia in a Thai boy. *J Pediatr Hematol Oncol* 2003;25:261-265.
4. Venkateswaran L, Swanson KC, Hoyer JD. Homozygous hemoglobin Abruzzo in a North American child. *J Pediatr Hematol Oncol* 2005;27:618-620.

5. Williamson D, Beresford CH, Langdown JV, et al. Polycythaemia associated with homozygosity for the abnormal haemoglobin Sherwood Forest (beta 104 (G6)Arg→Thr). *Br J Haematol* 1994;86:890-892.
6. Bunn H, ed. Hemoglobin: molecular, genetic and clinical aspects. Philadelphia, PA: WB Saunders, 1986.
7. Adamson JW, Hayashi A, Stamatoyannopoulos G, et al. Erythrocyte function and marrow regulation in hemoglobin Bethesda (β 145 histidine). *J Clin Invest* 1972;51:2883.
8. Adamson JW, Finch CA. Erythroprotein and the polycythemia. *Ann N Y Acad Sci* 1968;149:560.
9. McClure RF, Hoyer JD, Mai M. The JAK2 V617F mutation is absent in patients with erythrocytosis due to high oxygen affinity hemoglobin variants. *Hemoglobin* 2006;30:487-489.
10. Rosa R, Prehu MO, Beuzard Y, et al. The first case of a complete deficiency of diphosphoglycerate mutase in human erythrocytes. *J Clin Invest* 1978;62:907.
11. Charache S, Weatherall DJ, Clegg JB. Polycythemia associated with a hemoglobinopathy. *J Clin Invest* 1966;45:813-822.
12. Shimasaki S. A new hemoglobin variant, hemoglobin Nunobiki [α 141 (HC3) Arg—Cys]. Notable influence of the carboxy-terminal cysteine upon various physico-chemical characteristics of hemoglobin. *J Clin Invest* 1985;75:695-701.
13. Wajcman H, Kilmartin JV, Najman A, et al. Hemoglobin Cochin-Port-Royal: consequences of the replacement of the beta chain C-terminal by an arginine. *Biochim Biophys Acta* 1975;400:354-364.
14. Tondo C, Bonaventura J, Bonaventura J, et al. Functional properties of hemoglobin Porto Alegre (α 2A β 2 9Ser leads to Cys) and the reactivity of its extra cysteinyl residue. *Biochim Biophys Acta* 1974;342:15-20.
15. Flatz G, Kinderlerer JL, Kilmartin JV, et al. Haemoglobin Tak: a variant with additional residues at the end of the beta-chains. *Lancet* 1971;1(7702): 732-733.
16. Imai K, Lehmann H. The oxygen affinity of haemoglobin Tak, a variant with an elongated beta chain. *Biochim Biophys Acta* 1975;412:288-294.
17. Giordano PC, Hartevelde CL, Brand A, et al. Hb Malmo [β 97(FG-4) His→Gln] leading to polycythemia in a Dutch family. *Ann Hematol* 1996;73:183-188.
18. Charache S, Achuff S, Winslow R, et al. Variability of the homeostatic response to altered p50. *Blood* 1978;52:1156-1162.
19. Percy MJ, Butt NM, Crotty GM, et al. Identification of high oxygen affinity hemoglobin variants in the investigation of patients with erythrocytosis. *Haematologica* 2009;94:1312-1322.
20. Gaudreau P-O, Weng X, Cournoyer G, et al. Treatment with hydroxyurea in a patient compound heterozygote for a high oxygen affinity hemoglobin and β -thalassemia minor. *Am J Hematol* 2009;84:766-768.
21. Bonaventura J, Riggs A. Hemoglobin Kansas, a human hemoglobin with a neutral amino acid substitution and an abnormal oxygen equilibrium. *J Biol Chem* 1968;243:980-991.
22. Crowley MA, Mollan TL, Abdulmalik OY, et al. A hemoglobin variant associated with neonatal cyanosis and anemia. *N Engl J Med* 2011;364: 1837-1843.
23. Nagel RL, Lynfield J, Johnson J, et al. Hemoglobin Beth Israel. A mutant causing clinically apparent cyanosis. *N Engl J Med* 1976;295:125-130.
24. Marinucci M, Giuliani A, Maffi D, et al. Hemoglobin bologna (α 2 β 2 61 (E5) lys replaced by met). An abnormal human hemoglobin with low oxygen affinity. *Biochim Biophys Acta* 1981;668:209-215.
25. Blouquit Y, Bardakdjian J, Lena-Russo D, et al. Hb Bruxelles: α 2A β 2 (2)41 or 42(C7 or CD1)Phe deleted. *Hemoglobin* 1989;13:465-474.
26. Griffon N, Badens C, Lena-Russo D, et al. Hb Bruxelles, deletion of Phe β 42, shows a low oxygen affinity and low cooperativity of ligand binding. *J Biol Chem* 1996;271:25916-25920.
27. Williamson D. The unstable haemoglobins. *Blood Rev* 1993;7:146-163.
28. Ohba Y. Unstable hemoglobins. *Hemoglobin* 1990;14:353-388.
29. Moo-Penn WF, Jue DL, Johnson MH, et al. Hemoglobin Brockton (β 138 (H16) Ala—Pro): an unstable variant near the C-terminus of the beta-subunits with normal oxygen-binding properties. *Biochemistry* 1988;27:7614-7619.

30. Rieder RF, Oski FA, Clegg JB. Hemoglobin Philly (beta 35 tyrosine phenylalanine): studies in the molecular pathology of hemoglobin. *J Clin Invest* 1969;48:1627-1642.
31. King MA, Wiltshire BG, Lehmann H, et al. An unstable haemoglobin with reduced oxygen affinity: haemoglobin Peterborough, 3 (G13) Valine lead to Phenylalanine, its interaction with normal haemoglobin and with haemoglobin Lepore. *Br J Haematol* 1972;22:125-134.
32. Como PF, Wylie BR, Trent RJ, et al. A new unstable and low oxygen affinity hemoglobin variant: Hb Stanmore [beta 111(G13)Val—Ala]. *Hemoglobin* 1991;15:53-65.
33. Vasseur-Godbillon C, Marden MC, Giordano P, et al. Impaired binding of AHSP to alpha chain variants: Hb Groene Hart illustrates a mechanism leading to unstable hemoglobins with alpha thalassemic like syndrome. *Blood Cells Mol Dis* 2006;37:173-179.
34. Turbpaiboon C, Limjindaporn T, Wongwiwat W, et al. Impaired interaction of alpha-haemoglobin-stabilising protein with alpha-globin termination mutant in a yeast two-hybrid system. *Br J Haematol* 2006;132:370-373.
35. Stamatoyannopoulos G, Woodson R, Papayannopoulou T, et al. Inclusion-body beta-thalassemia trait. A form of beta thalassemia producing clinical manifestations in simple heterozygotes. *N Engl J Med* 1974;290:939-943.
36. Steinberg, M. H., Adams, J. G. Thalassaemic hemoglobinopathies. *Am J Pathol* 1983;113:396.
37. Carrell RW, Kay R. A simple method for the detection of unstable haemoglobins. *Br J Haematol* 1972;23:615-619.
38. Grimes AJ, Meisler A, Dacie JV. Congenital Heinz-body anaemia, further evidence on the cause of Heinz-body production in red cells. *Br J Haematol* 1964;10:281-290.
39. Kato GJ and Taylor JG 6th. Pleiotropic effects of intravascular haemolysis on vascular homeostasis. *Br J Haematol* 2010;148:690-701.
40. Lee-Potter JP, Deacon-Smith RA, Simpkins MJ, et al. A new cause of haemolytic anaemia in the newborn. A description of an unstable fetal haemoglobin: F Poole, alpha2-G-gamma2 130 trptophan yields glycine. *J Clin Pathol* 1975;28:317-320.
41. Miller DR, Weed RI, Stamatoyannopoulos G, et al. Hemoglobin Koln disease occurring as a fresh mutation: erythrocyte metabolism and survival. *Blood* 1971;38:715-729.
42. Tucker PW, Phillips SE, Perutz MF, et al. Structure of hemoglobins Zurich [His E7(63)beta replaced by Arg] and Sydney [Val E11(67)beta replaced by Ala] and role of the distal residues in ligand binding. *Proc Natl Acad Sci U S A* 1978;75:1076-1080.
43. Zinkham WH, Houtchens RA, Caughey WS. Carboxyhemoglobin levels in an unstable hemoglobin disorder (Hb Zurich): effect on phenotypic expression. *Science* 1980;209:406-408.
44. Zinkham WH, Houtchens RA, Caughey WS. Relation between variations in the phenotypic expression of an unstable hemoglobin disorder (hemoglobin Zurich) and carboxyhemoglobin levels. *Am J Med* 1983;74:23-29.
45. Levine RL, Lincoln DR, Buchholz WM, et al. Hemoglobin Hasharon in a premature infant with hemolytic anemia. *Pediatr Res* 1975;9:7.
46. Tassis B, Dosik H, Rieder R, et al. Hemoglobin Hasharon: severe hemolytic anemia and hypersplenism associated with a mildly unstable hemoglobin. *Birth Defects* 1972;8:25.
47. Dejam A, Hunter CJ, Schechter AN, et al. Emerging role of nitrite in human biology. *Blood Cells Mol Dis* 2004;32:423-429.
48. Gladwin MT, Crawford JH, Patel RP. The biochemistry of nitric oxide, nitrite, and hemoglobin: role in blood flow regulation. *Free Radic Biol Med* 2004;36:707-717.
49. Andrieu V, Dumonceau O, Grange MJ. Priapism in a patient with unstable hemoglobin: hemoglobin Koln. *Am J Hematol* 2003;74:73-74.
50. Lode HN, Krings G, Schulze-Neick I, et al. Pulmonary hypertension in a case of Hb-Mainz hemolytic anemia. *J Pediatr Hematol Oncol* 2007;29:173-177.
51. Brockmann K, Stolpe S, Fels C, et al. Moyamoya syndrome associated with hemolytic anemia due to Hb Alesha. *J Pediatr Hematol Oncol* 2005;27: 436-440.

52. Rose C, Bauters F, Galacteros F. Hydroxyurea therapy in highly unstable hemoglobin carriers. *Blood* 1996;88:2807-2808.
53. Percy MJ, McFerran NV, Lappin TR. Disorders of oxidised haemoglobin. *Blood Rev* 2005;19:61-68.
54. Kutlar F, Hilliard LM, Zhuang L, et al. Hb M Dothan [β 25/26 (B7/B8)/(GGT/GAG→GAG//Gly/Glu→Glu)]; a new mechanism of unstable methemoglobin variant and molecular characteristics. *Blood Cells Mol Dis* 2009;43: 235-238.
55. Glader BE, Zwerdling D, Kutlar F, et al. Hb F-M-Osaka or alpha 2G gamma 2(63)(E7)His—Tyr in a Caucasian male infant. *Hemoglobin* 1989;13:769-773.
56. Priest JR, Watterson J, Jones RT, et al. Mutant fetal hemoglobin causing cyanosis in a newborn. *Pediatrics* 1989;83:734-736.
57. Cohen RJ, Sachs JF, Wicker DJ, et al. Methemoglobinemia provoked by malarial chemoprophylaxis in Vietnam. *N Engl J Med* 1968;279:1127-1131.
58. Umbreit J. Methemoglobin—it's not just blue: a concise review. *Am J Hematol* 2007;82:134-144.
59. Linz AJ, Greenham RK, Fallon LF Jr. Methemoglobinemia: an industrial outbreak among rubber molding workers. *J Occup Environ Med* 2006;48: 523-528.
60. Greer FR, Shannon M. Infant methemoglobinemia: the role of dietary nitrate in food and water. *Pediatrics* 2005;116:784-786.
61. Uko EK, Udoh AE, Etukudoh MH. Methaemoglobin profile in malaria infected children in Calabar. *Niger J Med* 2003;12:94-97.
62. Coleman MD, Coleman NA. Drug-induced methaemoglobinaemia. Treatment issues. *Drug Safety* 1996;14:394-405.
63. Mansouri A, Lurie AA. Concise review: methemoglobinemia. *Am J Hematol* 1993;42:7-12.
64. Ash-Bernal R, Wise R, Wright SM. Acquired methemoglobinemia: a retrospective series of 138 cases at 2 teaching hospitals. *Medicine (Balt)* 2004;83: 265-273.
65. Fitzsimons MG, Gaudette RR, Hurford WE. Critical rebound methemoglobinemia after methylene blue treatment: case report. *Pharmacotherapy* 2004;24:538-540.
66. Golden PJ, Weinstein R. Treatment of high-risk, refractory acquired methemoglobinemia with automated red blood cell exchange. *J Clin Apher* 1998;13:28-31.
67. Bruns CM, Thet LA, Woodson RD, et al. Hemoglobinopathy case finding by pulse oximetry. *Am J Hematol* 2003;74:142-143.
68. Deyell R, Jackson S, Spier S, et al. Low oxygen saturation by pulse oximetry may be associated with a low oxygen affinity hemoglobin variant, hemoglobin Titusville. *J Pediatr Hematol Oncol* 2006;28:100-102.
69. Haymond S, Cariappa R, Eby CS, et al. Laboratory assessment of oxygenation in methemoglobinemia. *Clin Chem* 2005;51:434-444.

P.926

70. Verhovsek M, Henderson MP, Cox G, et al. Unexpectedly low pulse oximetry measurements associated with variant hemoglobins: a systematic review. *Am J Hematol* 2011;86:722-725.
71. Weaver LK. Carbon monoxide poisoning. *N Engl J Med* 2009;360:1217-1225
72. Hampson NB, Dunn SL. Symptoms of carbon monoxide poisoning do not correlate with the initial carboxyhemoglobin level. *Undersea Hyperb Med* 2012;39:657-685.
73. Lopez-Herce J, Borrego R, Bustinza A, et al. Elevated carboxyhemoglobin associated with sodium nitroprusside treatment. *Intensive Care Med* 2005;31:1235-1238
74. Fisher JA, Iscoe S, Fedorko L, Duffin J. Rapid elimination of CO through the lungs: coming full circle 100 years on. *Exp Physiol* 2011;96:1262-1269.

75. Gopalachar AS, Bowie VL, Bharadwaj P. Phenazopyridine-induced sulfhemoglobinemia. *Ann Pharmacother* 2005;39:1128-1130.
76. Gow AJ. The biological chemistry of nitric oxide as it pertains to the extrapulmonary effects of inhaled nitric oxide. *Proc Am Thorac Soc* 2006;3:150-152.
77. Gow AJ, Singel D. NO, SNO, and hemoglobin: lessons in complexity. *Blood* 2006;108:3224-3225; author reply 3226-3227.
78. Gow AJ, Stamler JS. Reactions between nitric oxide and haemoglobin under physiological conditions. *Nature* 1998;391:169-173.
79. Jia L, Bonaventura C, Bonaventura J, et al. S-nitrosohaemoglobin: a dynamic activity of blood involved in vascular control. *Nature* 1996;380:221-226.
80. Kim-Shapiro DB, Schechter AN, Gladwin MT. Unraveling the reactions of nitric oxide, nitrite, and hemoglobin in physiology and therapeutics. *Arterioscler Thromb Vasc Biol* 2006;26:697-705.
81. Stamler JS, Jia L, Eu JP, et al. Blood flow regulation by S-nitrosohemoglobin in the physiological oxygen gradient. *Science* 1997;276:2034-2037.

Section 5 - Other Red Cell Disorders

Chapter 36 Megaloblastic Anemias: Disorders of Impaired Dna Synthesis

> Table of Contents > Part IV - Disorders of Red Cells > Section 5 - Other Red Cell Disorders > Chapter 36 - Megaloblastic Anemias: Disorders of Impaired Dna Synthesis

Chapter 36

Megaloblastic Anemias: Disorders of Impaired Dna Synthesis

Ralph Carmel

HISTORICAL BACKGROUND

The story of megaloblastic anemia, its causes, and how they were decoded is a wonderfully instructive chapter of medicine. Clinical observations set the stage for a series of insightful clinical investigations that converted a dreaded “pernicious” condition into one that is now easily treated.

A puzzling illness with anemia, debilitation, languor, and, finally, torpor and death was described by Addison¹ in 1849. Although possibly similar cases were reported earlier and Addison believed the anemia to be related to adrenal dysfunction, this is generally taken as the first description of pernicious anemia. Neuropathy was noted by Osler and Gardner in 1877, and Lichtheim associated it with myelopathy 10 years later. In 1880, Ehrlich identified megaloblasts and proposed them as the precursors of the “giant blood corpuscles” described in the peripheral blood by Hayem.

The clinical breakthrough occurred in 1926 when Minot and Murphy,² using the then new technique of reticulocyte assessment, showed that the manifestations could be reversed and held in abeyance by eating prodigious amounts of liver; for this, they shared the Nobel Prize. Three years later, Castle,³ building on earlier descriptions of achylia gastrica, demonstrated that gastric juice contains an “intrinsic factor” (IF) that combines with an “extrinsic factor” in meat and allows it to be absorbed. Several decades later, the extrinsic factor, vitamin B₁₂, was synthesized,^{4, 5} and its structure was demonstrated by Hodgkin,⁶ who was awarded a Nobel Prize for her crystallographic work.

Studies by Wills,⁷ who treated macrocytic anemia with yeast, and by many others defined the need for folate, which was isolated and characterized by 1948.⁸ The ability of nutritional folate deficiency to cause megaloblastic anemia was proven in a notable selfexperiment by Herbert.⁹ The stories of these and other discoveries are available in several highly readable books and articles.^{10, 11, 12, 13}

Cure is so simple now that the once deadly diseases are considered domesticated. That gratifying development has been so successful that the potential for clinical neglect has emerged,^{14, 15, 16} even as major metabolic and molecular advances

continue. The definitions of insufficiency have expanded,¹⁷ and accurate and accessible biochemical tools have facilitated exploration of potential impact on public health. This has not been free of controversy.

NORMAL PHYSIOLOGY AND PATHOPHYSIOLOGY

Megaloblastic anemia is, most often, a product of folate or cobalamin (vitamin B₁₂) deficiency. These metabolically intertwined vitamins, whose disorders are sometimes difficult to differentiate, require very distinct diagnostic and therapeutic approaches. The two are discussed separately throughout this chapter, which signals the need to always differentiate between them.

Biochemistry and Metabolism

Folate

Folate, or pteroylglutamate, consists of a pteridine ring, paraminobenzoate, and one or more glutamate side chains (Fig. 36.1). Folates vary in their reduction states, one-carbon moieties, and glutamation states. Polyglutamated folates, with three or more γ -carboxyl-linked glutamate residues, predominate intracellularly; they are better retained in cells than monoglutamated forms, which traverse membranes more easily.¹⁸ Polyglutamated forms are also more effective participants in enzymatic reactions, although N5-methyltetrahydrofolate (methylTHF), the major folate in the body, tends to be a poor substrate for polyglutamation.

Folic acid is pharmacologically stable but must be reduced to be active. Folates reduced to tetrahydrofolate (THF) at positions N5 through N8 (Fig. 36.1) function as one-carbon group donors, acceptors, or modifiers. THFs with varying one-carbon moieties at the N5, N10, or both positions, attach to enzymes and serve as co-substrates in cytoplasmic or mitochondrial one-carbon group transfers involving amino acids (Fig. 36.2, reactions 4, 5, and 7),

P.928

purines (reactions 10 and 11), and pyrimidines (reaction 2). By indirectly contributing to S-adenosylmethionine (AdoMet) generation, folate is linked to important methylations, including methylation of DNA cytosine (Fig. 36.2, reaction 13). Cellular folate metabolism and its compartments are reviewed elsewhere.^{18, 19}

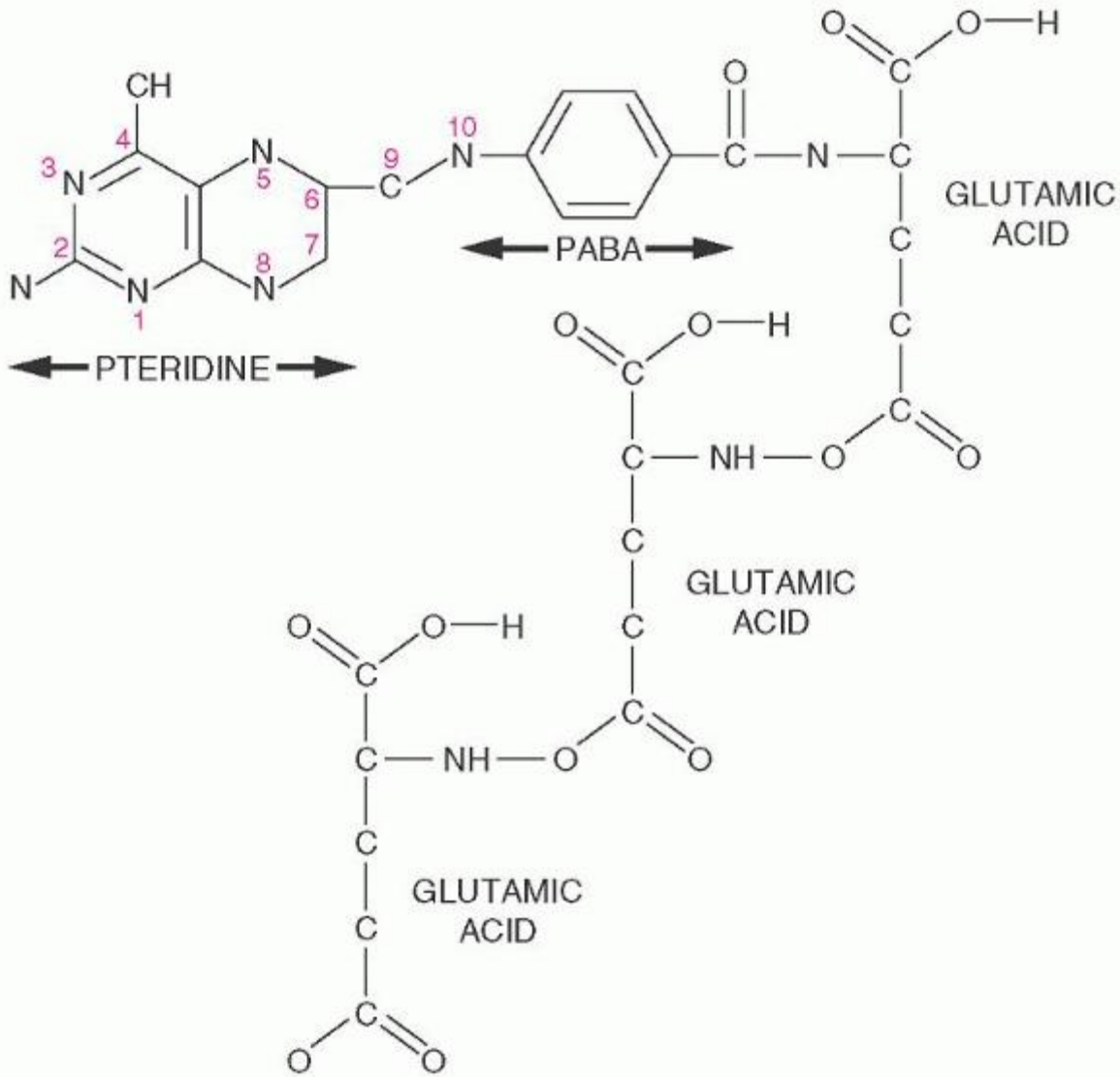

FIGURE 36.1. Folate structure. The constituents are, from left to right, pteridine and p-aminobenzoic acid (PABA), which constitute the pteroyl moiety, and one or more glutamates that are attached by γ -carboxyl linkage (in this diagram, three glutamates are linked). Metabolic activity requires reduction to tetrahydrofolate at positions 5, 6, 7, and 8. Various one-carbon moieties are attached to the nitrogen at position 5 (N5-methyl, N5-formyl, or N5-formimino) or 10 (N10-formyl), or bridging 5 and 10 (N5,10-methylene or N5,10-methenyl). Each folate participates in specific reactions by transferring, accepting, or transforming its one-carbon moiety.

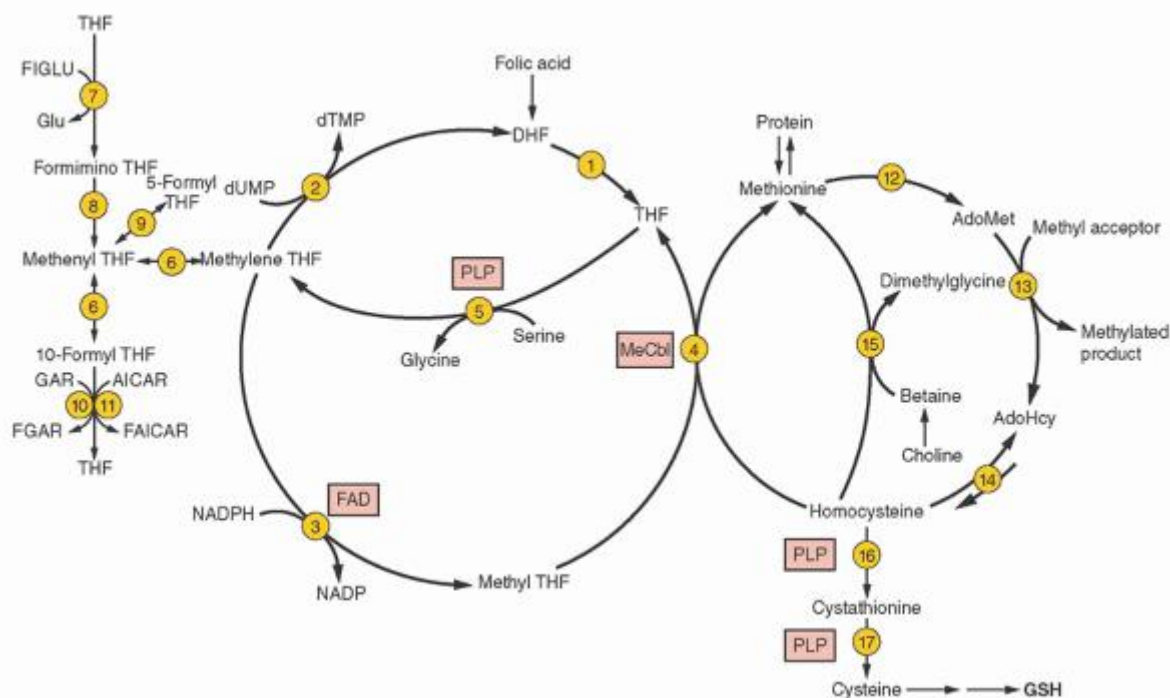

FIGURE 36.2. Folate metabolism and its linkage with cobalamin (reaction 4) to homocysteine and methionine metabolism (right). Vitamin co-factors are highlighted in boxes. Not all bidirectional reactions are noted as such, but the unidirectional nature of reaction 3 is the basis for the methyltetrahydrofolate trap hypothesis. The enzymes for the reactions include the following: (1) dihydrofolate (DHF) reductase; (2) thymidylate synthase; (3) methylene tetrahydrofolate (THF) reductase; (4) methionine synthase (maintained by a reductive system mediated by methionine synthase reductase); (5) serine hydroxymethyltransferase; (6) two sequential reactions mediated by two enzymatic activities of a single protein (methylene-THF dehydrogenase and methenyl-THF cyclohydrolase); (7) glutamate formiminotransferase; (8) formiminotetrahydrofolate cyclodeaminase; (9) methenyl-THF synthase; (10) glycinamide ribonucleotide (GAR) transformylase; (11) 5-aminoimidazole-4-carboxamide ribonucleotide (AICAR) transformylase; (12) methionine adenosyltransferase; (13) diverse S-adenosylmethionine (AdoMet)-dependent methyltransferases; (14) S-adenosylhomocysteine (AdoHcy) hydrolase (kinetics usually favor synthesis of AdoHcy); (15) betaine:homocysteine methyltransferase; (16) cystathionine β -synthase; (17) cystathionine γ -lyase. dTMP, deoxythymidine monophosphate; dUMP, deoxyuridine monophosphate; FAD, flavin adenine dinucleotide (riboflavin); FAICAR, formylAICAR; FGAR, formylGAR; FIGLU, formiminoglutamic acid; Glu, glutamic acid; MeCbl, methylcobalamin; PLP, pyridoxal 5'-phosphate.

Cobalamin

Cobalamin, a 1,355-Da member of the corrin family, is an organometallic co-factor. Four nitrogens of its planar tetrapyrrole anchor a central cobalt atom linked with a nucleotide (5,6-dimethylbenzimidazole) below and a variable prosthetic moiety above the pyrrole plane (Fig. 36.3). Specific cobalamins are named for their prosthetic moiety: methylcobalamin, which predominates in plasma and cytoplasm, and 5'-deoxyadenosylcobalamin, which predominates in mitochondria. Vitamin B₁₂, used popularly as a synonym for cobalamin, was the name given to cyanocobalamin,⁴ a stable pharmacologic preparation that must be converted to other forms for utilization. Noncobalamin corrinoids, often with major structural changes or deletions, are ubiquitous in microbial metabolism, but cannot be used by humans. Some noncobalamin analogs are nevertheless bound avidly by transcobalamin (TC) I (also called haptocorrin)^{20, 21} and are found in the gut, plasma, and, much less often, tissues.²²

To serve as an active co-enzyme, cobalamin requires reduction of its cobalt to the monovalent cob(I)alamin or divalent cob(II) alamin.²³ Reduced cobalamin has two known roles in humans. Attached to methionine synthase, it accepts the methyl group from methyl-THF as methylcobalamin and transfers it to homocysteine (Fig. 36.2, reaction 4). Cobalamin activity for this reaction is maintained by methionine synthase reductase²⁴ and requires AdoMet. In cobalamin's other role, reduced mitochondrial cobalamin accepts 5'-deoxyadenosyl from adenosine triphosphate and binds to methylmalonyl coenzyme A (CoA) mutase. This mutase mediates an intramolecular rearrangement of L-methylmalonyl CoA to succinyl CoA in propionate metabolism.²⁵

Cobalamin deficiency has a major impact on folate, homocysteine, and methionine metabolism by impairing the methionine synthase reaction. Most evidence supports the concept that cobalamin deficiency thereby “traps” methylTHF, which has no alternative metabolic role or route.^{26, 27} Feedback mechanisms activate methyleneTHF reductase (Fig. 36.2, reaction 3) in an effort to mobilize more methylTHF but only end up diverting even more methyleneTHF from its other roles and into the trap. A paralysis of folate metabolism spreads as THF and other active folates decrease. An alternative to the trap hypothesis emphasizes that the failure of methionine synthesis ultimately leads to formate “starvation,”²⁸ with depletion of formylTHF, methenylTHF, and methyleneTHF.

Homocysteine and Methionine

Folate and cobalamin participate intimately in homocysteine and methionine metabolism. The eventual generation of AdoMet (Fig. 36.2, reaction 12) serves several major functions. AdoMet helps regulate the metabolism of folate and disposition of homocysteine

P.929

by inhibiting both methyleneTHF reductase (reaction 3) and betaine hydroxymethyltransferase (an alternate remethylator of homocysteine [reaction 15] confined to liver and perhaps kidney and lens), and by activating cystathionine β -synthase (reaction 16).²⁹

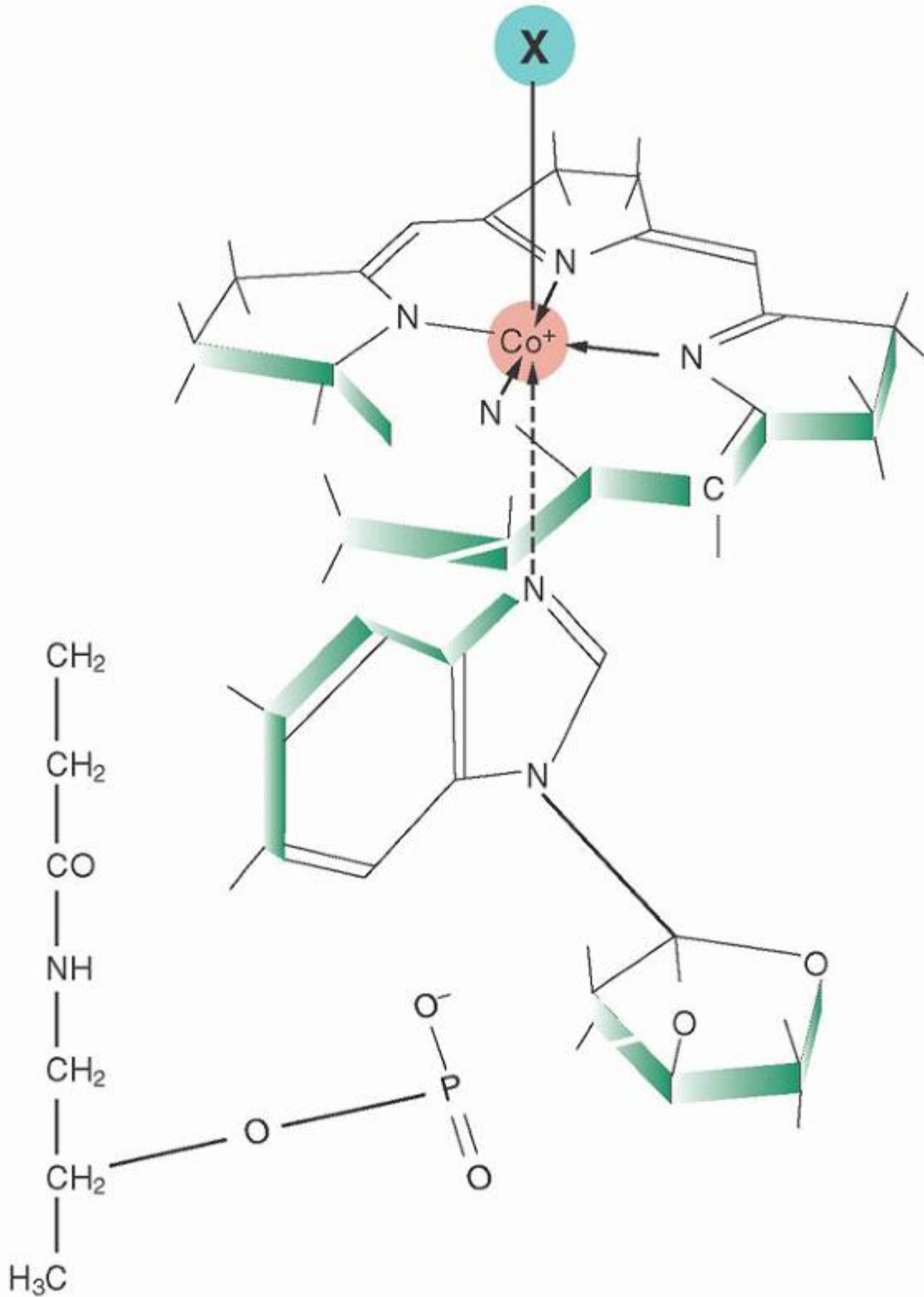

FIGURE 36.3. Cobalamin structure. Attached to the central cobalt atom of the corrin tetrapyrrole and to one of the pyrrole rings is the α -ligand, the 5,6-dimethylbenzimidazole nucleotide, extending below the corrin plane. The β -ligand (marked as X in the diagram) above the plane can be any one of several moieties, such as methyl, 5'-deoxyadenosyl, hydroxyl, or cyanide.

Even more importantly, AdoMet is the methyl donor for most cellular methylation reactions affecting proteins, nucleic acids, histones, phospholipids, and neurotransmitters, all mediated by various methyltransferases (Fig. 36.2, reaction 13).³⁰ DNA hypomethylation, which contributes to neoplasia, can result from AdoMet deficiency. In the methylation reactions, S-adenosylhomocysteine (AdoHcy) is formed. AdoHcy, which in excess inhibits AdoMet activity, can be hydrolyzed to homocysteine; under normal conditions, however, the direction of this reaction favors AdoHcy synthesis (reaction 14).

An alternate fate of homocysteine is its transsulfuration to cystathionine and then to cysteine; both of these steps require pyridoxal 5'-phosphate (reactions 16 and 17). This is the major catabolic pathway for homocysteine, which is cytotoxic in concentrations normal for other amino acids. The pathway also influences redox activity by generating glutathione, a major intracellular reducing agent.

Normal Folate Physiology

Nutritional Characteristics

Folate, named for green leafy vegetables, exists in nearly all classes of foods. Organ meats (e.g., liver and kidney) and yeast are particularly rich, although not frequently eaten, sources. More common sources are other meats, nuts, beans, orange juice, dairy products, grains, and cereals. However, food folate, mostly methylTHF and formylTHF, is labile. Large losses occur with storage and some cooking processes,³¹ especially when the water is discarded.⁹

Fortification of the American food supply in 1998 with 140 µg folic acid/100 g in grain and cereal products was mandated to lower the risk of neural tube defect births. Many food producers exceeded that amount, increasing the average folate intake by 190 µg/day.³² Folate levels have risen sharply, reducing the frequency of subnormal red cell folate from 37.6% to 4.5% in young women.³³ Supplement use has also grown in Western societies, especially among women and the aged.³⁴ However, overall folate intake remains poor in other countries.

Dietary recommendations³⁵ take into account folate bioavailability, which is highest for synthetic folic acid and lower for food folate, which tends to be polyglutamated and requires conversion to monoglutamate for optimal absorption. Recommended intake is therefore expressed in dietary folate equivalents, in which 0.5 µg of folic acid supplement or 0.85 µg folic-acid-fortified food delivers the dietary equivalent of 1 µg of food folate. The recommended dietary folate equivalent intake is 400 µg daily for adults, 600 µg for pregnant women, 500 µg for lactating women, and lesser amounts scaled for age in children. Women of reproductive age are advised to take 400 µg of folic acid as an additional supplement to prevent neural tube defect births.

Physiologic Cycle of Assimilation

Folate Absorption

The absorption combines specific saturable processes that tend to predominate in the upper small intestine and nonsaturable ones that predominate in the ileum.³⁶ Luminal binding proteins appear not to be involved. The saturable process allows absorption of all folates, usually after the polyglutamated forms are hydrolyzed to monoglutamated ones by glutamate carboxypeptidase II in the jejunal brush borders. Two transmembrane, high-affinity members of the solute carrier superfamily mediate the saturable absorption of reduced folates in the upper small intestine. The main one, the proton-coupled folate transporter, has optimal affinity for folate at the duodenal pH of 5.5.^{36, 37, 38} The reduced folate carrier has a higher affinity at pH 7.4 and thus has a lesser duodenal role.³⁶ Both these carriers exist in other tissues also. Conversion of absorbed folate to methylTHF appears to occur in the intestinal cell, which then exports the methylTHF into portal blood via carrier-mediated basolateral membrane transport, but some have proposed later hepatic conversion instead.³⁹ The liver either polyglutamates and stores the folate, secretes it for biliary enterohepatic recycling, or exports it for delivery elsewhere. Folate achieves peak levels in the blood 1 hour after ingestion.

Nonsaturable ileal absorption of folate assumes a dominant role whenever more than 200 µg of folate, which exceeds the capacity of the jejunal process, is ingested.³⁵ Such absorption of nearly unlimited amounts of unreduced monoglutamates may explain why oral folic acid is effective even when the more specific jejunal mechanisms fail in some malabsorptive disorders.

Folate Binders and Receptors

The various specific and nonspecific folate binders are incompletely understood and may not be mandatory for cellular uptake of folate. Specific binding proteins in the blood bind only a small fraction of circulating folate. Secretions, especially milk, also contain specific binding protein whose role is unclear but may withhold folate from bacteria.

The reduced folate carrier belongs to the SLC19 family of transporters, some members of which transport thiamine, and transports reduced folates (and methotrexate) into cells by a process linked to organic anions.³⁶ With its high activity at neutral

P.930

pH and operating at higher concentrations of folate, reduced folate carrier assumes major responsibility for folate uptake from the blood by the liver, kidney, leukocytes, placenta, and parts of the brain.

Folate receptor- α (FR- α or FR1) and FR- β (or FR2), are specific, partially homologous receptors in epithelial cells, placenta, hematopoietic cells, renal tubular cells, and malignant cells.^{36, 40} Their related genes lie on chromosome 11q13. FR- α and FR- β are covalently linked to glycosylphosphatidyl inositol anchors on cell membranes, bind and internalize methylTHF by endocytosis via clathrin-coated pits, and are recycled.⁴¹ FR- γ is confined to hematopoietic cells but lacks glycosylphosphatidyl inositol anchoring and is therefore readily secreted.⁴² The roles of these FR isoforms are not known, but FR α is active in renal tubular reabsorption of excreted folates. Some FR is found intracellularly, and some circulating folate-binding proteins appear to derive from FR. FRs are being explored as enhancers of drug delivery and cellular imaging because of their high expression in malignant and inflammatory cells. FR- α is also a co-factor for entry of Marburg and Ebola viruses into cells.⁴³

Folate Transport and Cellular Utilization

Dietary folate and reabsorbed biliary folate enter the bloodstream and are rapidly cleared to tissues.⁴⁴ The rapid flux probably explains why plasma folate declines within 3 weeks when intake is reduced. Plasma folate, which is mostly methylTHF, is bound nonspecifically and with low affinity to proteins such as albumin, but approximately one third circulates unbound and a tiny fraction is bound specifically by the previously discussed FR-derived binding proteins. None of the circulating proteins plays any obvious role in cell uptake of folates.

Cellular uptake of monoglutamated folate occurs via either membrane FR or reduced folate carrier, the details varying among cell types and conditions.^{18, 36} Passive diffusion also occurs. In the cell, folates are rapidly polyglutamated by folylpoly- γ -glutamate synthetase, which enhances cellular retention and promotes attachment to enzymes. The folate is transported by saturable mechanisms into organelles; 35% of intracellular folate is in mitochondria.

Folate Stores and Turnover

A classic depletion study in one volunteer suggests that body stores of folate can be depleted in a few months to levels that do not support normal hematopoiesis,⁹ but precise data are scarce. Old data estimate that normal liver folate content exceeds 7.5 mg.⁴⁵ The liver concentrates much of the body's folate and is a major site of one-carbon metabolism. Several folate pools exist, with different turnover rates ranging up to 100 days.⁴⁶ Enterohepatic recycling involves as much as 100 μ g of folate daily.⁴⁴

Approximately 200 μ g of folate is excreted fecally every day. However, that amount includes not only the endogenous losses via sloughed intestinal cells and nonreabsorbed biliary folate but also external folates, such as unabsorbed food folate and folate synthesized by intestinal bacteria.⁴⁶ Approximately 1 mg of folate is filtered daily in the glomerulus but is largely reabsorbed as its folate-binding protein attaches to megalin, the multiligand receptor in proximal tubules.⁴⁷ Oxidatively degraded folate is lost, primarily in urine. Daily losses thus approximate 1% to 2% of body stores, which is compatible with the folate depletion rate reported in a normal person after 2 to 3 months of dietary restriction.⁹

Normal Cobalamin Physiology

Nutritional Characteristics

Humans obtain their cobalamin secondhand from animals and fish, which ingested the bacteria that synthesize cobalamin, or from animal products, such as milk.^{45, 48} The more prodigious bacteria ingestors, such as ruminants and oysters, are rich sources. Plants do not contain cobalamin. Bioavailability varies with different foods^{45, 48, 49, 50} and is at least as important as content. Cereals, fortified with cobalamin, dairy products, and fish provide better cobalamin bioavailability than meat.^{49, 50} Cobalamin supplement use, often as part of a multivitamin, has grown.^{49, 51}

When absorption is normal, the recommended daily requirement of 2.4 μ g in adults⁵² provides more than 1 μ g cobalamin to compensate for the approximate daily loss. In children, recommended daily intake rises from 0.4 μ g in infancy to 1.8 μ g in preadolescence. A survey in 1995 indicated that typical daily intake of cobalamin in the United States is 4.0 to 6.2 μ g.⁵³ European surveys suggested that metabolic sufficiency plateaus at intakes of 4.2 μ g or higher, depending on the population surveyed.^{50, 54, 55}

Physiologic Cycle of Assimilation

Intestinal absorption and tissue uptake (Fig. 36.4) are designed to internalize and concentrate available cobalamin efficiently while excluding possibly harmful nonfunctional analogs. The process is tightly regulated by a system of binding proteins and receptors.^{56, 57, 58} Whether food-bound or as a free supplement, cobalamin that exceeds the capacity of IF-mediated uptake is poorly absorbed,⁵⁹ unlike the ready absorption of excess, free folic acid. IF mediates the absorption of more than 75% of the typically small cobalamin load in a meal but can accommodate little more than a total of 1 to 2 μg at a time.⁴⁵

Cobalamin-binding Proteins

Three proteins with nonoverlapping roles bind cobalamin with high affinity^{56, 57, 58, 60} (Table 36.1). IF and TC II (called TC by authors who eschew TC I and TC II terminology) share moderate structural homology but their genes are located on different chromosomes.^{61, 62} Crystallographic analysis of TC II has defined key functional regions⁶³ that may be shared by IF. Each protein binds cobalamin specifically and ferries it into cells by endocytosis via its specific receptor; neither protein binds nonfunctional corrinoid analogs avidly.²⁰ IF, which originates in parietal cells although chief cells may synthesize it ectopically in patients with gastritis,⁶⁴ is confined to the gastrointestinal tract. TC II is synthesized by endothelial and other cells and is found in plasma and other fluids (Table 36.1). Holo-TC II (TC II with bound cobalamin) is cleared quickly by cellular uptake; its half-life in plasma is 90 minutes.⁶⁵ Plasma levels of total TC II tend to rise in inflammatory and other disorders, suggesting an acute-phase reactant character unrelated to cobalamin status,^{56, 66, 67} but correlation with C-reactive protein levels is poor.⁶⁸ A common missense polymorphism of the TCN2 gene, C776G, displays no consistent phenotypic impact,^{69, 70, 71} but the less common A67G mutation was associated with lower holo-TC II without affecting metabolic cobalamin status.⁷¹

TC I (also called haptocorrin, R binder, or cobalophilin) is heavily glycosylated.⁵⁶ Its carbohydrate variability is prominent and affects major physicochemical characteristics.^{56, 72} Some carbohydrate variations led to ill-advised isoelectric point demarcation of a "TC III" subset of TC I, but others may substantively alter TC I clearance from plasma. TC I is synthesized in the specific granules of late myeloid precursors⁷³ and in exocrine gland epithelium.⁵⁶ TC I has only 33% to 36% homology to IF and TC II.^{62, 74} It also differs from them in two important ways: it binds nonfunctional corrinoid analogs as avidly as cobalamin, and it lacks specific receptors for cellular delivery. As a result, plasma TC I exists largely saturated with cobalamin (i.e., holo-TC I) and has a half-life of 9 to 10 days.⁶⁵ Thus, TC I carries more than 70% of cobalamin^{75, 76} and virtually 100% of analogs in plasma,^{20, 77} whose concentrations are nearly equal. Only 10% to 30% of plasma cobalamin is holo-TC II at any moment, which greatly underestimates the heavy but rapidly turning over holo-TC II traffic.

P.931

Holoprotein proportions can vary widely in some disorders, and the reason is not always known.^{76, 78} Desialylated TC I is cleared nonspecifically by hepatic receptors for asialoglycoproteins,⁷⁹ whereby some of its cobalamin is cleared in bile.

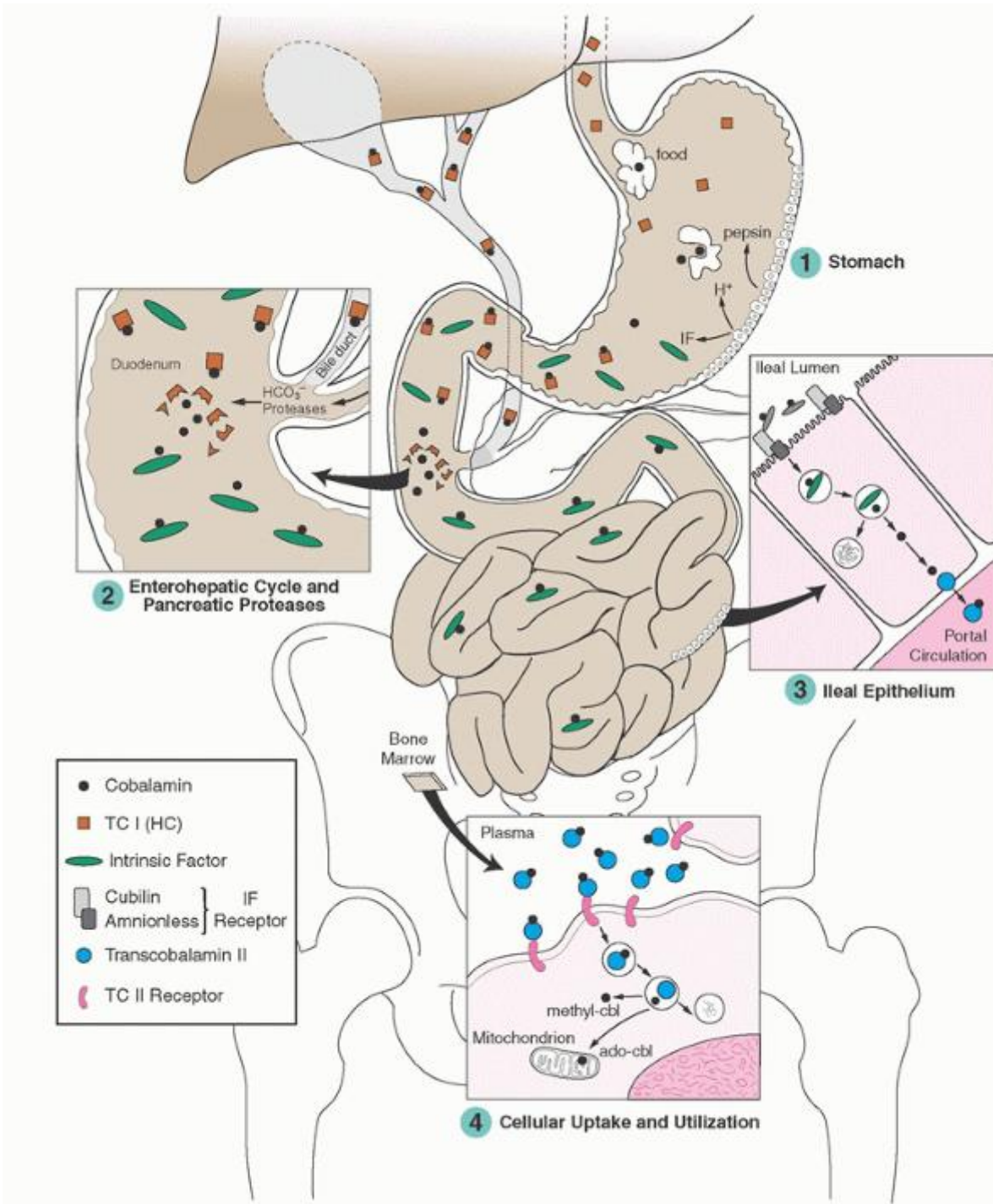

FIGURE 36.4. Assimilation and utilization of cobalamin. ado-cbl, 5'-deoxyadenosylcobalamin; IF, intrinsic factor; methyl-cbl, methylcobalamin; TC I (HC), transcobalamin I (haptocorrin); TC II, transcobalamin II. (Modified from Carmel R. Cobalamin deficiency. In Carmel R, Jacobsen DW, eds. Homocysteine in health and disease. Cambridge, MA: Cambridge University Press, 2001:289-305, with permission.)

TC I concentrations in all secretions exceed plasma levels manyfold.⁵⁶ TC I carries nearly all the cobalamin in breast milk, salivary TC I is the first protein to bind ingested cobalamin, and biliary TC I is involved in enterohepatic recycling of cobalamin. These facts suggest that much of the TC I role lies outside the bloodstream. It is plausible to suggest that TC I, whose role is considered unknown, is the primary “withholder” of excess cobalamin and, perhaps more important, all analogs that are used by

the vast human microbiome in the gut and elsewhere, as well as withholding unusable analogs from human cells.⁸⁰ The subject requires careful study. Several minor cobalamin-binding proteins and complexes have also been described in plasma, but their roles are unknown.^{56, 79, 81, 82, 83}

TABLE 36.1 COBALAMIN-BINDING PROTEINS

	Intrinsic Factor	TC II (TC)	TC I (Haptocorrin)
Gene	<i>GIF</i> (chr. 11q13)	<i>TCN2</i> (chr. 22q12.2)	<i>TCNI</i> (chr. 11q11-q12.3)
Cbl-related role	Promotes ileal uptake	Promotes uptake by all cells	Sequesters Cbl and nonfunctional corrinoids, withholding them from cellular uptake; carries all Cbl in milk and bile and most Cbl in blood; initial acceptor of Cbl in stomach
Cbl binding	High affinity and specificity for Cbl; low affinity for corrinoid analogs	High affinity and specificity for Cbl; low affinity for corrinoid analogs	High affinity for Cbl; high affinity for corrinoid analogs
Cells of origin	Gastric parietal cell ^a	Endothelial cell; fibroblast; ?ileal cell; ?hepatocyte	Neutrophil; exocrine gland epithelial and ductal cells
Distribution in fluids	Gastric juice	Plasma, CSF, semen, amniotic fluid	Plasma, all exocrine secretions, ^b CSF, semen
Protein structure	48-kDa glycoprotein (15% carbohydrate)	43-kDa polypeptide	66-kDa glycoprotein (33-40% carbohydrate)
Receptors	Cubilin-amnionless complex ("cubam")	TC II receptor; ^c Megalin ^d	None identified ^e
Consequence of Cbl binder deficiency	Cbl malabsorption	Severe cellular Cbl deficiency	Low serum Cbl level without Cbl deficiency

Cbl, cobalamin; chr., chromosome; CSF, cerebrospinal fluid; TC, transcobalamin.

^aEctopic production of intrinsic factor by chief cells occurs in patients with gastritis.

^bSecretions include saliva, breast milk, bronchial secretions, and tears.

^cThis specific receptor is ubiquitous and internalizes holo-TC II for cobalamin utilization. Its gene is *TCBIR/CD320*.

^dMultiligand receptor in proximal renal tubule, intestine, choroid plexus, type 2 pneumocyte, and yolk sac; renal role involves cobalamin salvage but roles elsewhere are uncertain. Its gene is *LRP2*.

^eDesialylated TC I may undergo nonspecific clearance by asialoglycoprotein receptors in the liver.

Cobalamin Absorption

Cobalamin is released from food by pepsin at an acid pH in the stomach and binds preferentially to salivary TC I rather than IF at this pH (Fig. 36.4, panel 1). Pancreatic secretions entering the duodenum neutralize the pH and provide proteases to degrade TC I.⁸⁴ The released cobalamin, including biliary cobalamin,²¹ thus becomes available to IF (Fig. 36.4, panel 2).

The IF-cobalamin complex eventually attaches to the cubilin receptor for IF in the ileum (Fig. 36.4, panel 3). Cubilin is a 460-kDa glycoprotein whose 27 CUB domains provide binding sites for many other ligands, such as vitamin-D-binding protein, transferrin, immunoglobulin light chain, albumin, and apolipoprotein A1;⁴⁷ it also exists in yolk sac, renal proximal tubules, and elsewhere. Cubilin lacks a transmembrane domain but is anchored by amnionless, a 45-kDa transmembrane protein that provides cell signaling for the “cubam” receptor complex.^{85, 86, 87} After endocytosis, the cubilin-IF-cobalamin complex is split, and cobalamin exits the ileal cell into the bloodstream several hours after its oral ingestion. Whether the exit is mediated by TC II or multidrug resistance protein-1⁸⁸ is unclear.

Plasma Transport and Cellular Utilization

Some of the portal blood holo-TC II is internalized by hepatocytes via TC II receptors.²¹ The remainder finds its way to other tissues for calcium-dependent, TC II receptor-mediated cellular endocytosis^{89, 90} (Fig. 36.4, panel 4). After lysosomal degradation of the TC II, its cobalamin is released for attachment to cytoplasmic methionine synthase and conversion to methylcobalamin and to mitochondria for conversion to adenosylcobalamin.

Specific uptake of holo-TC II also occurs in yolk sac, gut, and especially in the proximal renal tubule by a second receptor, megalin, a 600-kDa glycoprotein member of the low-density lipoprotein receptor family.⁴⁷ As is cubilin, with which it sometimes co-localizes, megalin is a multiligand receptor, but it has a considerably greater clientele of ligands; these include additional vitamin-binding proteins (such as folate-binding protein and retinol-binding protein), several lipoproteins, carrier proteins (such as albumin, lactoferrin, and transthyretin), hormones, enzymes, hemoglobin, and myoglobin. Most information on megalin derives from studies in the proximal renal tubule, which is rich in the protein, and in knockout mice. Megalin prevents the urinary loss of many filtered proteins, and virtually completely reabsorbs the 1.5- μ g cobalamin load in the holo-TC II that is filtered by the glomerulus daily.

Body Stores and Turnover

Cobalamin stores exceed daily requirement more than 1,000-fold. This contrast with the much smaller ratio for folate explains why cobalamin depletion takes years whereas folate depletion takes weeks to months. The total body content of cobalamin approximates 2.5 mg (2,500 μ g) in adults⁹¹ and only approximately 1 μ g is lost daily. Some of the loss occurs by biliary excretion of 1.4 μ g daily, but two thirds of that is reabsorbed via the IF mechanism.²¹ If the IF mechanism fails, as in pernicious anemia, biliary reabsorption ceases. Urinary loss of cobalamin is minor because of reabsorption by megalin (however, if plasma cobalamin exceeds TC II capacity, as happens after cobalamin injection, the free cobalamin escapes renal reabsorption).

It bears mention that corrinoid analogs outnumber cobalamin 98-fold in the colon,⁹² whereas they approximately equal cobalamin content in the plasma.⁷⁷ The extent of cobalamin conversion to analog in the body is unknown.

CLINICAL AND LABORATORY FEATURES

The hematologic consequences are identical in folate and cobalamin deficiency. So are many nonhematologic manifestations, with the notable exception of neurologic dysfunction. Some clinical variations reflect the ways in which the two deficiencies arise. Folate deficiency typically evolves rapidly, and it is often

P.933

associated with broad malnutrition and with alcohol abuse. In contrast, the evolution of cobalamin deficiency is usually measured in years, and it tends to be a purer deficiency state because malabsorption is often restricted to cobalamin alone.

Megaloblastic Anemia in Cobalamin and Folate Deficiency

Biochemistry

Deficiency of folate compromises the methylation of deoxyuridylate to deoxythymidylate (Fig. 36.2, reaction 2), and deficiency of cobalamin does so indirectly. However, impaired de novo thymidylate synthesis only partially explains megaloblastic anemia. Observations in nonanemic patients with cobalamin deficiency^{93, 94, 95, 96} and animal models⁹⁷ show that thymidylate synthase impairment alone need not lead to anemia. Other steps contribute.⁹⁸ The excess uracil from deoxyuridylate is misincorporated into DNA in place of thymine and active excision repair produces many single-strand breaks.⁹⁹ When excisions coincide at opposing DNA strand sites, double-stranded breaks result, which may explain the nuclear defects of megaloblastic anemia. The end result appears to be an arrest at various stages of interphase in hematopoietic precursors.¹⁰⁰ Even so, the details are incomplete and megaloblastic anemia is not restricted to cobalamin or folate deficiency.

Hematopathology

Megaloblastic anemia is a panmyelosis, even though its name suggests a disorder limited to red cells and erythroid hyperplasia is a prominent feature. Indeed, the immature appearance of megaloblastic nuclei and the occasionally intense myeloid proliferation in the marrow have led to a misdiagnosis of leukemia in rare cases. The morphologic hallmark is nuclear-cytoplasmic dissociation, which is best appreciated in precursor cells in the bone marrow aspirate (Fig. 36.5). Megaloblastic nuclei are larger than normoblastic nuclei, and their chromatin appears abnormally dispersed due to its retarded condensation. Random chromosomal abnormalities are seen, including centromere spreading,¹⁰¹ but nonrandom changes may also occur.^{102, 103} Cytoplasmic maturation appears unremarkable.

Giant band cells and metamyelocytes with large and often misshapen nuclei are typical. Neutrophils with characteristic hypersegmented nuclei (Fig. 36.6) appear in the blood early in the course,^{9, 104} but they do not arise directly from the giant metamyelocytes.⁹⁸ The mechanism of hypersegmentation and why it persists in the blood for more than a week after therapy¹⁰⁵ are unknown. As megaloblastic anemia worsens, neutropenia and thrombocytopenia develop. These can be severe in advanced cases but are uncommon when anemia is mild.⁴⁵ Platelets are often functionally impaired,¹⁰⁶ although megakaryocytes do not show definable morphologic changes. The same may apply to lymphocytes.¹⁰⁷

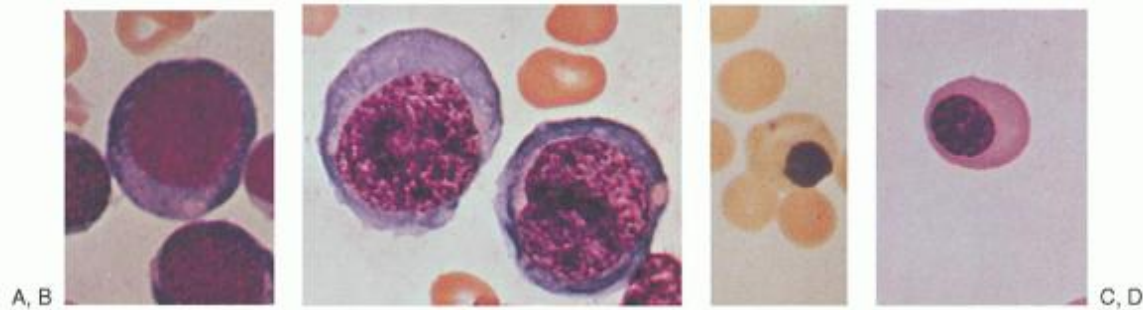

FIGURE 36.5. Normal and megaloblastic precursor cells in the bone marrow. A: Pronormoblast. B: Megaloblastic equivalent of cell in plate A. C: Late normoblast. D: Megaloblastic equivalent of cell in plate C. (From Lee RG, Foerster J, Lukens J, et al., eds. Wintrobe's clinical hematology, 10th ed. Philadelphia: Lippincott Williams & Wilkins, 1999:913, with permission.)

Erythroid macrocytosis (Fig. 36.6) is an early change. Individual macrocytes appear first, as detectable by hemoglobin and cell size measurements confined to reticulocytes,¹⁰⁸ followed by a gradual rise in overall mean corpuscular hemoglobin (MCH) and then mean corpuscular volume (MCV) that eventually crosses the line into abnormality (>97 fl) before the hemoglobin levels fall.⁹ In cobalamin deficiency, with its slow progression, macrocytosis precedes anemia by months.^{14, 15} Macro-ovalocytes are especially characteristic of megaloblastic anemia but are not specific.¹⁰⁹ Early megaloblastic changes in the bone marrow precede the macrocytosis but are easily missed. Eventually, poikilocytosis becomes more pronounced with teardrop cells. Nucleated red cells, Howell-Jolly bodies, and even Cabot rings appear in the blood in severe megaloblastosis.

As anemia progresses, iron and transferrin receptor levels, sideroblast counts, and the ferritin content of erythroid precursors and macrophages increase.^{45, 110, 111} Erythropoietin levels correlate with the severity of anemia but can vary widely.¹¹²

Megaloblastic anemia is the chief exemplar of ineffective hematopoiesis in all three hematopoietic cell lines; bone marrow hyperplasia is intense but reticulocytosis does not occur.^{45, 98, 100} Precursor cells are arrested at various stages in interphase but continue to mature. As megaloblastosis advances, most precursors die within the hypercellular bone marrow and are phagocytosed. Whether early cell death is primarily apoptotic or not is controversial and may depend on the model studied.^{100, 113, 114} Advanced megaloblastic anemia has a poorly understood component of intravascular hemolysis also; survival of normal red cells transfused into cobalamin-deficient patients is short.¹¹⁵ Serum glutathione, an antioxidant, appears to be the most significant metabolic predictor of anemia in cobalamin deficiency.¹¹⁶ Abnormalities of red cell membrane proteins, including spectrin, have also been described.¹¹⁷

The evolution of hematologic changes has been detailed elsewhere⁴⁵ and its laboratory characteristics are detailed further in the section "Hematologic Assessment." With progressive anemia also come fatigue, hypervolemia, and cardiovascular symptoms, as well as the pallor combined with hyperbilirubinemia that gives a classic lemon yellow skin color, and even retinal hemorrhages and, on occasion, pseudotumor cerebri.

Neurologic Dysfunction

Cobalamin Deficiency

Pathophysiology

Demyelination with subsequent axonal disruption and gliosis can affect all parts of the central nervous system. Peripheral nerves, however, tend to show axonal degeneration without

P.934

demyelination.^{118, 119} The classic myelopathic syndrome is subacute combined degeneration, in which posterior and lateral column damage predominates; dorsal, pyramidal, and spinocerebellar tracts are affected. The earliest changes appear in the cervical or thoracic spine and can be detected by magnetic resonance imaging (MRI) as hyperintensity on T2-weighted images (Fig. 36.7). Larger, more heavily myelinated fibers tend to be affected most often.¹²⁰

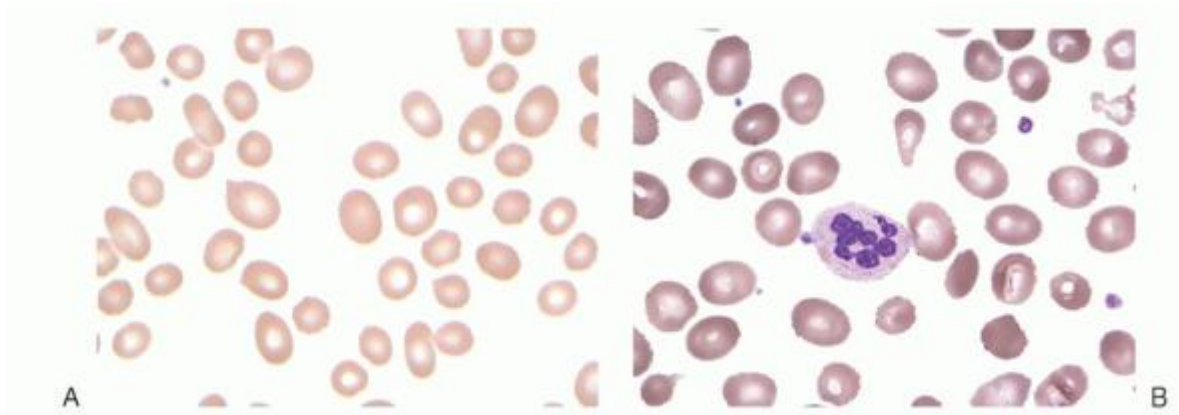

FIGURE 36.6. Blood smear from a patient with megaloblastic anemia due to cobalamin deficiency. Note characteristic large macro-ovalocytes (A) and hypersegmented neutrophils (B). (Courtesy of Irma Pereira MT [ASCP]SH.)

The biochemical mechanisms are unknown. Because myeloneuropathy is much more prominent in cobalamin deficiency than in folate deficiency, suspicion fell on the folate-unrelated role of adenosylcobalamin in propionate metabolism and its possible consequences to fatty acids in myelin. Most evidence now points to methionine synthase impairment and its effects on methionine metabolism and methylations instead.¹²¹ Animal data suggested that methionine ameliorates cobalamin deficiency-induced neurologic dysfunction, preliminary cerebrospinal fluid studies in humans described low AdoMet levels, and high AdoHcy-to-AdoMet ratios suggested inhibition of AdoMet's methylation activity by AdoHcy. Plasma homocysteine-related metabolite comparisons in neurologically impaired versus hematologically impaired patients with pernicious anemia suggest even greater complexity:¹¹⁶ cysteine levels were significantly higher in the neurologically affected patients and, surprisingly, AdoMet levels were actually higher in neurologically impaired patients. Neurologically impaired patients also had significantly higher serum folate levels than those without neurologic problems.^{116, 122, 123} It is unclear if these differences represent cause, concurrence, or consequence.

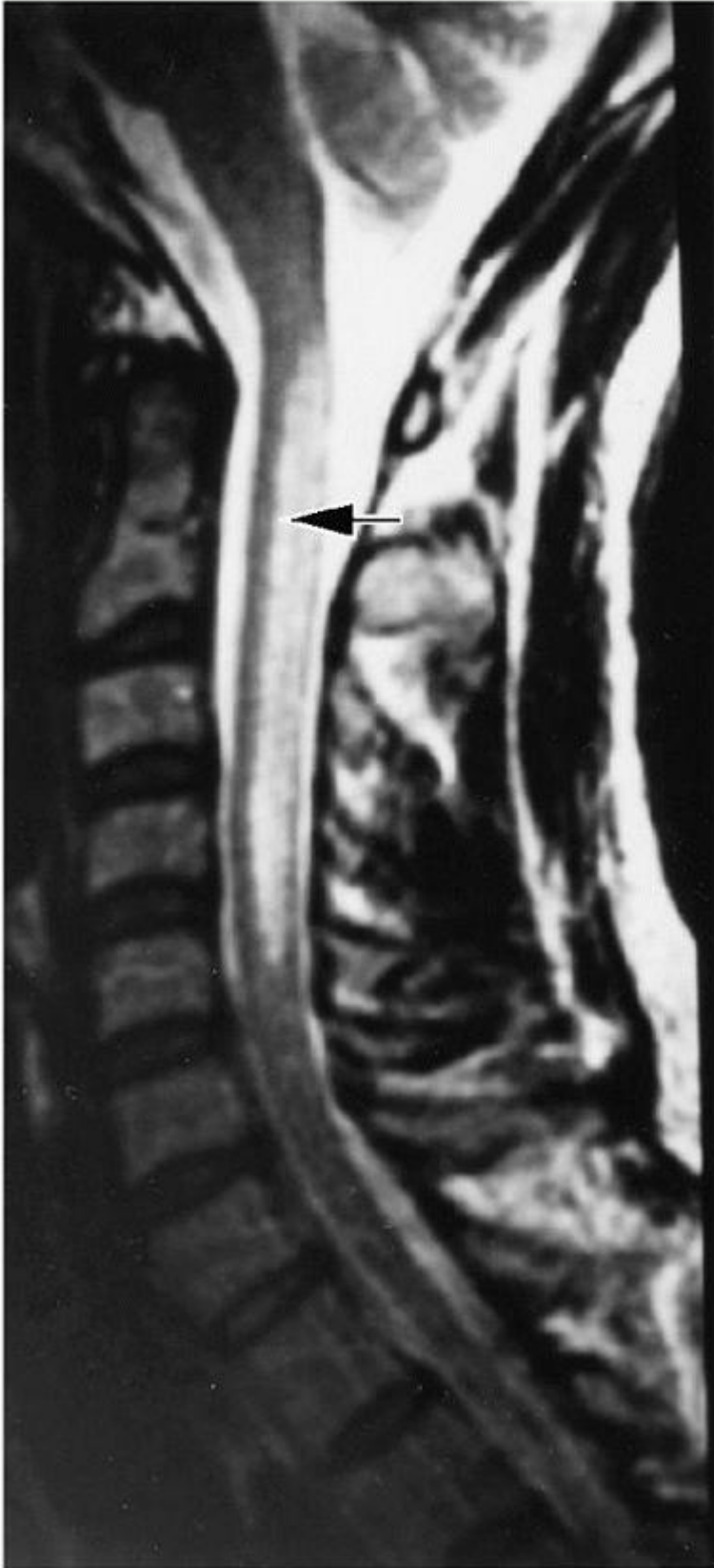

FIGURE 36.7. Magnetic resonance imaging (T2 weighted) of a sagittal section of the cervical spine of a man with pernicious anemia and severe myelopathy. Note the posterior localization of the high signal intensity lesion (arrow). (From Larner AJ,

Zeman AZ, Allen CMC, et al. MRI appearances in subacute combined degeneration of the spinal cord due to vitamin B₁₂ deficiency. *J Neurol Neurosurg Psychiatry* 1997;62:99-101, with permission.)

Clinical Features

The frequency of neurologic involvement in cobalamin deficiency is presumed lower than the frequency of anemia but is undefined (perhaps because it is not as explicit and quantifiable as anemia and because of patient selection biases). Often regarded as a late development, neurologic changes can precede anemia instead.^{124, 125, 126} Interestingly, the extents of neurologic and hematologic expressions of cobalamin deficiency tend to vary inversely in patients,^{116, 126} and the predilection tends to recur when deficiency relapses.^{126, 127, 128} Although genetic influences on clinical expression seem plausible, methyleneTHF reductase polymorphisms that increase folate availability for thymidylate synthase over methionine synthase did not predispose to neurologic manifestations in pernicious anemia.¹²⁹

Neuromyelopathy is the most common neurologic feature of cobalamin deficiency,^{120, 126, 130, 131} but it is not specific to it; copper deficiency, for example, produces similar findings,¹³² as well as macrocytosis.¹³³ Sensory changes in cobalamin deficiency include position sense disturbance and dysesthesia; pyramidal tract signs include spasticity and a Babinski reflex; neuropathy is exemplified by loss of tendon reflexes; and gait disturbances are common signs of advanced involvement. Manifestations tend to be symmetrical. Neuropathy, which is usually sensory but can be sensorimotor,¹³⁴ can be hard to differentiate clinically from posterior column involvement.^{126, 130, 135, 136}

The earliest manifestations are loss of vibratory sense in the feet and numbness, tingling, and loss of fine sensation. Others include loss of proprioception and, depending on the balance between myelopathy and neuropathy, hyperactive or diminished deep tendon reflexes. Involvement ascends up the legs, and, eventually, hands are affected as well. Muscle weakness and tenderness have been described sometimes. Ataxia, spasticity, gait disturbances, positive Babinski reflex, impotence, and bladder¹³⁷ and bowel dysfunction appear in advanced cases.

Cerebral symptoms, notably cognitive and emotional changes, can be severe in some cases^{124, 126} or so mild as to be recognized

P.935

only in retrospect after treatment. MRI reveals focal and diffuse changes in the brain¹³⁸ (Fig. 36.8). Tensor diffusion imaging also shows white matter changes in adjacent areas that seem normal on MRI.¹³⁹ Nevertheless, despite low cobalamin levels in 10% to 20% of patients with chronic dementias,^{95, 140} the low levels usually reflect only subclinical cobalamin deficiency (SCCD) and appear unrelated to chronic dementias, which rarely improve with cobalamin therapy.¹⁴¹ In very young children, however, some cobalamin deficiencies can cause developmental delay, lethargy, cerebral atrophy, and seizures.¹⁴²

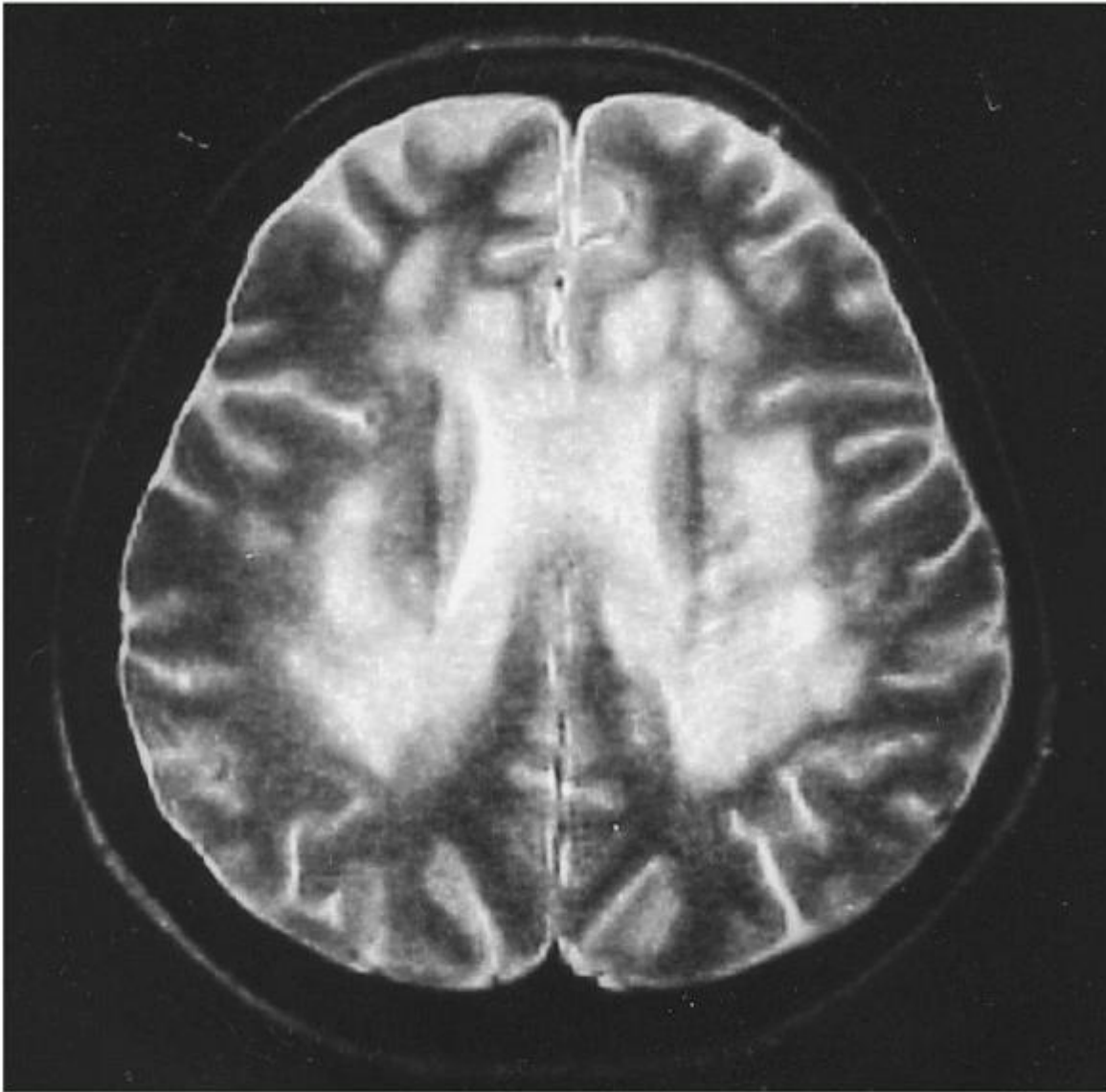

FIGURE 36.8. Magnetic resonance imaging (T2 weighted) of the brain in a woman with pernicious anemia and cognitive dysfunction. Large confluent and focal areas of increased signal intensities are seen, predominating around the ventricles. The changes improved after therapy. (From Stojsavljevic N, Levic Z, Drulovic J, et al. A 44-month clinical-brain MRI follow-up in a patient with B₁₂ deficiency. *Neurology* 1997;49:878-881, with permission.)

Autonomic dysfunction is sometimes demonstrable with deficiency.^{118, 143, 144, 145} Other neurologic manifestations include visual changes, optic neuritis, which predominates in men, and disturbances of smell or taste.^{126, 146} Classic motor dysfunction is rare, other than that caused by spasticity and proprioceptive loss, but abnormal central motor conduction times have been described.¹³⁴ At early or late stages, MRI (Figs. 36.7 and 36.8) and functional electrophysiologic tests, such as electroencephalography, evoked potentials, and nerve conduction, show abnormalities.^{134, 138, 147, 148, 149, 150, 151}

Unlike anemia, neurologic dysfunction does not always reverse after cobalamin therapy. Residual deficits persist in 6% of patients;¹²⁶ they are not always predictable but tend to accompany more extensive involvement and longer duration before treatment begins.^{45, 130} Mistaken folate therapy has also been tied to the risk of neurologic irreversibility in patients with clinical cobalamin deficiency. The delayed cobalamin treatment when the anemia responds to folate presumably allows neurologic abnormalities to appear, progress, and, in occasional reports,¹⁵² perhaps even accelerate. The events are more ambiguous than assumed. Hematologic improvement after folate is usually neither complete nor long lived in pernicious anemia,^{152, 153} and transient neurologic responses to folate may occur too.¹⁵³ Nevertheless, the anecdotal reports of clinical acceleration cannot be completely dismissed and cannot be studied prospectively in

pernicious anemia. Folate should never be given alone to cobalamin-deficient patients, even those whose deficiency is subclinical and lacks convincing evidence for adverse effects.¹⁵⁴

Folate Deficiency

Neurologic defects occur in only occasional adults with folate deficiency^{155, 156, 157} and are rarely as severe as in cobalamin deficiency. Although myelopathy has been reported,¹⁵⁸ it is exceptional. Mild mental changes, such as forgetfulness and irritability,⁹ and mild neuropathy have been better accepted. A causative association with depression is controversial.^{159, 160} Attributions of any neurologic changes to folate deficiency, which often occurs in a setting of malnutrition, require high standards of proof, including consideration of alternative explanations such as alcohol abuse.

In sharp contrast, however, children with inborn errors of folate metabolism often have severe myelopathy and brain dysfunction, including seizures and mental retardation.^{142, 161, 162} The explanations for the neurologic differences between folate and cobalamin deficiency or between acquired and hereditary folate disorders are unknown.

Other Manifestations

Miscellaneous Clinical Findings

Atrophy of tongue papillae is common with cobalamin deficiency and sometimes gives rise to a beefy red tongue that may or may not cause symptoms.^{45, 163} Aphthous stomatitis and oral soreness can be prominent in some patients, including some without anemia. However, glossitis occurs with folate deficiency and other deficiencies also. The glossitis of cobalamin deficiency does not respond to folate.¹⁶⁴ Mucosal changes occur elsewhere too, including megaloblastic changes in buccal epithelium, cervical cells, and intestinal villi;^{45, 165, 166} the latter apparently caused temporary malabsorption of cobalamin and other nutrients.^{167, 168} Other reversible but unexplained clinical changes in pernicious anemia include: impaired osteoblastic activity,¹⁶⁹ although reports of bone density changes and risk of fractures have been inconsistent; darkening of nails and skin and change of hair color in severely deficient non-Caucasians;^{170, 171, 172} and sometimes marked weight loss.¹⁷³

Miscellaneous Laboratory Abnormalities

Platelet function is sometimes impaired,¹⁰⁶ but neutrophil dysfunction has been variable. Hemoglobin A₂ levels rise slightly.¹⁷⁴ Occasional patients with sickle cell trait have shown striking changes in hemoglobin S and F levels when folate-deficient.¹⁷⁵ Cobalamin deficiency also affects some nonhematologic serum analytes: bone alkaline phosphatase is often decreased¹⁶⁹ and immunoglobulin levels sometimes decline.¹⁷⁶ An adolescent with severe megaloblastic anemia had reduced ADAMTS13 activity.¹⁷⁷

Subclinical Deficiency and Indirect Consequences of Altered Vitamin Status

Automated metabolic tests have simplified identification of asymptomatic, nonanemic vitamin deficiency. The high frequency of these early subclinical states has opened them to scrutiny as possible public health issues, with varying outcomes. The uncertainties apply especially to cobalamin, because SCCD is widespread, dominates epidemiologic surveys, and is often confused with clinical deficiency, yet has unclear health implications and, therefore, unknown need for intervention.^{17, 178, 179}

Subclinical Cobalamin Deficiency

Many patients and healthy people—especially, but not exclusively, the elderly—have low cobalamin levels but are asymptomatic and have normal blood counts. These low serum levels were thought artifactual until sensitive deoxyuridine suppression tests

P.936

showed in 1985 that most of them reflected mild biochemical insufficiency that responded to cobalamin and, equally important, rarely involved IF-related malabsorption.^{94, 95, 96, 180} None of the subjects had cobalamin-related anemia although bone marrow cells displayed reversible metabolic defects. Similarly, none had clinical neurologic findings although some,^{96, 141, 181} but not all,¹⁸² displayed mild, reversible electrophysiologic changes.

Widespread methylmalonic acid (MMA) and homocysteine testing^{183, 184, 185} next showed that asymptomatic nonanemic SCCD was much more common than clinical deficiency.^{17, 186, 187, 188} Thus, a survey of community-dwelling elderly subjects found that 12% had biochemical insufficiency¹⁸⁸ but only 2% of them had IF antibody-positive pernicious anemia¹⁸⁹ and, by extrapolation, 1% to 2% more may have had undetected antibody-negative disease. Readers must be aware that epidemiologic data apply to SCCD alone because too few subjects have clinical deficiency.¹⁹⁰ Moreover, falsely low

cobalamin levels (i.e., with normal MMA and homocysteine) also outnumber clinical deficiency in surveys.¹⁹¹ Nevertheless, the mild metabolic abnormalities in some asymptomatic subjects with low-normal cobalamin levels led many laboratories to raise the cutpoint for “suspicious” cobalamin levels from 200 to 300 or 350 ng/L to capture more cases.¹⁸⁶ The change is open to criticism because nearly 70% of cases added thereby have normal MMA and homocysteine levels and are not cobalamin-deficient. The influx of suspected SCCD expanded the concept of cobalamin deficiency at the cost of overdiagnosis based on often nonspecific biochemical findings whose need for therapy was unclear.^{17, 179, 190, 192, 193}

Assumptions that SCCD, especially when unaccompanied by malabsorption, progresses inevitably to clinical deficiency are untested.^{179, 190} Asymptomatic persons without malabsorption have been free of symptoms and anemia for 10 years despite persistently low cobalamin levels,¹⁹⁴ and metabolic monitoring over 1 to 4 years showed infrequent progression of mildly elevated MMA levels.¹⁹² Only a small minority of people with SCCD have early pernicious anemia,¹⁸⁹ whose progression to clinical deficiency is very predictable. Most persons with SCCD have no identifiable cause for it,^{17, 178} and the likelihood of progression in the 30% to 40% who have food-cobalamin malabsorption appears limited.¹⁹⁵

TABLE 36.2 COMPARISON BETWEEN CLINICAL AND SUBCLINICAL COBALAMIN DEFICIENCY STATES

Characteristics	Clinical Deficiency	Subclinical Deficiency
Biochemical abnormalities	Often severe	Usually mild
Clinical abnormalities	Megaloblastic anemia is present in >75% of cases Neurologic or cognitive changes are present in >50% of cases Electrophysiologic (neurologic) abnormalities are usually present	Anemia is absent ^a Neurologic changes are absent ^a Mild electrophysiologic changes are sometimes present
Cobalamin absorption status	IF-related malabsorption causes >90% of cases ^b FBCM is uncommon Normal absorption is uncommon (e.g., veganism)	IF-related malabsorption is usually absent ^b FBCM is present in <50% of cases Most persons have normal absorption
Diagnostic criteria	Almost always one or more clinical abnormalities At least one abnormal biochemical finding	No clinical signs of cobalamin deficiency Ideally, at least two abnormal biochemical findings should be demonstrated
Likelihood of progression of deficiency	Very high because of the usual presence of IF-related malabsorption	Unknown, but probably small Any progression to symptoms (i.e., clinical deficiency) is likely to be very slow
Need for cobalamin therapy	Urgent in all cases	Unknown
Medical implications	Clinical deficiency indicates that medical management is needed	None known, but if SCCD is found during medical evaluation it must be evaluated medically
Public health implications	None known	Unclear at present ^c

FBCM, food-bound cobalamin malabsorption; IF, intrinsic factor; SCCD, subclinical cobalamin

deficiency.

^a Any anemia or neurologic findings found in a patient with suspected SCCD must have a cobalamin-unrelated cause (otherwise it is clinical deficiency and cannot be considered SCCD).

^b IF-related malabsorption refers to absence of IF (which defines pernicious anemia) or inability of IF to promote intestinal absorption (e.g., intestinal disease). If such malabsorption is present, SCCD is likely to progress to clinical expression.

^c Active research into potential public health issues requiring preventive interventions is ongoing but still inconclusive. High-dose cobalamin, folic acid, and pyridoxine may slow progression of cognitive decline in some elderly persons, but it is unknown whether SCCD is a factor.

SCCD is compared and contrasted with clinical cobalamin deficiency in Table 36.2.

Subclinical Folate Deficiency

Subclinical folate deficiency is less explicitly defined than SCCD for several reasons: folate status fluctuates more readily than cobalamin status because folate turnover is rapid;³⁵ folate deficiency tends to be accompanied by other deficiencies; and attention is often diverted from the deficiency to its hyperhomocysteinemia. The latter, and growing pharmacogenetic and gene-nutrient data, suggest that subclinical variations of folate status below the level of deficiency may subtly influence many health issues, which are discussed next.

Vitamins and Public Health Risks

Subclinical Cobalamin Deficiency and Cognition

Many epidemiologic associations with SCCD have been pursued but clinical trials have been infrequent. Cognitive decline in the elderly has undergone the most active study because neurologic manifestations are frequent in clinical deficiency. The most consistent associations for cognitive dysfunction have been with homocysteine status, with variable links to folate and, to often lesser extent, cobalamin status. As reviewed elsewhere,^{179, 196, 197} early clinical trials were inadequate or inconclusive.^{198, 199, 200, 201, 202} However, two long-term randomized clinical trials in Europe, where dietary fortification is not mandatory, reported reduced progression of brain atrophy and cognitive decline. One found that 0.8 mg of folic acid daily was effective.²⁰³ The second demonstrated that three vitamins (0.8 mg folic acid, 500 µg cobalamin,

P.937

and 25 mg pyridoxine) slowed brain atrophy by 30%²⁰⁴ and reduced cognitive decline.²⁰⁵ Its important features were that the subjects were mildly cognitively impaired at baseline (which predicts likely progression, but avoids the irreversibility of dementia), the responders were hyperhomocysteinemic, and it is not clear which of the three vitamins was the beneficial one.

Folate and Neural Tube Defect Prevention

Supplementation with folic acid has also been scrutinized for prevention of conditions not directly attributable to folate deficiency. Of the many studied targets and associations, such as cancer, vascular and thrombotic disease, osteoporosis, cognitive dysfunction, and birth defects, the only unambiguous effect has been on neural tube defect (NTD). Folate supplementation reduces a woman's risk of having a child with NTD,^{206, 207} but the benefit seems pharmacologic rather than amelioration of folate inadequacy. Genetic and other susceptibilities related to folate, cobalamin, or homocysteine probably underlie the NTD risk, more so than does maternal folate deficiency. For example, the MTHFR C677T polymorphism increases the risk of NTD.²⁰⁸ High rates of antibody to FR have also been reported in women with NTD pregnancies²⁰⁹ and deficiency of FR-α in mice is associated with neural tube and other birth defects.²¹⁰

Folate prophylaxis must begin at conception because the neural tube closes at approximately 3 weeks. Daily doses of 400 µg are effective, with 4 mg recommended for women who use anticonvulsants or have a history of previous NTD. All grain and cereal foods have been fortified with folic acid since 1998 in the United States, Canada, and a few other countries. NTD rates have fallen but not disappeared, leading some experts to urge additional fortification.²¹¹ The benefits must be weighed against the consequences of chronic use of high folic acid doses, as discussed in the section "Preventive and Other Uses of Supplements."

Considerable human and animal data associated lower folate status with increased risk of cancer, best demonstrated with colon cancer. However, the associations are complex, may include double-edged folate impact that depends on neoplastic status and details as much as on folate status, and are beyond the scope of this chapter. These issues are discussed in the section "Preventive and Other Uses of Supplements" at the end of the chapter.

Hyperhomocysteinemia

Extrapolation from inborn errors of homocysteine metabolism suggested that severe hyperhomocysteinemia may predispose to thrombotic manifestations.²¹² Extensive epidemiologic data associated even mild hyperhomocysteinemia with increased risks for coronary, cerebral, and peripheral vascular complications, although the associations were less firm in prospective, rigorously designed studies than in retrospective ones.^{213, 214} Genetic polymorphisms, primarily of methyleneTHF reductase, contribute to 9% of homocysteine level variation,²¹⁵ but even in the absence of vitamin deficiency folate, cobalamin, and vitamin B₆ often reverse the hyperhomocysteinemia. Indeed, folic acid fortification reduced the frequency of hyperhomocysteinemia from 20% to 32% to 5% to 14% in the elderly.²¹⁶ Nevertheless, the outcomes of large interventional vitamin trials on coronary and cerebrovascular disease prevention have been disappointing.²¹⁷ Indeed, some trials even suggested adverse effects.^{218, 219, 220, 221, 222}

Laboratory Evaluation

Laboratory evaluation must have two separate targets: documenting hematologic, metabolic, and clinical chemistry changes that identify cobalamin or folate deficiency, and documenting the underlying condition or disease that caused the deficiency.

Hematologic Assessment

The mechanisms of megaloblastosis were discussed in the section "Hematopathology." The classic blood count findings in cobalamin or folate deficiency are anemia, a high MCV and MCH, and, in more advanced cases, thrombocytopenia and neutropenia. Patients are often identifiable at an early stage in which they have MCV and MCH elevation alone, which precedes anemia by months in cobalamin deficiency¹⁵ but only by a few weeks in the more rapidly developing folate deficiency.⁹ At first, the MCV and MCH may simply be higher than the patient's baseline, without being explicitly abnormal (e.g., an MCV of 90 fl replacing one of 85 fl). An early anisocytosis as new macrocytes begin to emerge can be detected by measuring the MCV or hemoglobin content of reticulocytes¹⁰⁸ or by an elevated red cell distribution width, which, however, is not invariable in early deficiency.²²³ Red cell counts decline before hemoglobin and packed cell volume levels.

Megaloblastic anemia is not the only cause of macrocytic anemia, however, or even the most common (Table 36.3). A hospital survey found 64% of MCV values >100 fl to be due to chemotherapy, antiretroviral therapy, or alcohol abuse.¹⁰⁹ Cobalamin and folate deficiencies caused only 6% of the high MCV values but accounted for most MCV values above 110 fl.

Absolute reticulocyte counts typically fall slightly. The laboratory signs of ineffective erythropoiesis, serum lactate dehydrogenase and indirect bilirubin levels, are initially inapparent but rise as the hemoglobin approaches 10 g/dl.⁴⁵ As anemia worsens, lactate dehydrogenase levels may reach thousands of units per liter as intravascular hemolysis is added to ineffective erythropoiesis. Other markers include rising serum transferrin receptor, iron, ferritin, nontransferrin-bound iron, and methemalbumin levels, as well as low serum haptoglobin levels. Platelet and neutrophil counts usually decline only as the anemia progresses. The pancytopenia can ultimately mimic aplastic anemia, which too is usually macrocytic (but does not display the bilirubin and lactate dehydrogenase elevations).

Most of the hematologic variability is dictated by the stage at which the patient is discovered.⁴⁵ However, not every patient expresses the same degree of anemia for the degree of cobalamin deficiency. Many severely deficient patients have surprisingly mild anemia or even lack it.¹²⁵ The reasons are usually unknown but some may be linked to the unexplained tendency for inverse association between anemia and neurologic dysfunction.^{124, 125} Another influence on hematologic expression is coexisting iron deficiency or thalassemia that produces normal or low MCV in approximately 7% of patients with pernicious anemia;²²⁴ these MCVs are above baseline for the patients and fall after vitamin therapy.²²⁵ Iron deficiency sometimes also blunts the erythroid megaloblastic changes themselves, both morphologically and by deoxyuridine suppression testing.^{226, 227} Iron studies in untreated megaloblastic anemia often do not reveal the coexisting iron deficiency.⁴⁵ Because all marrow and blood indicators of iron status fall within 24 to 48 hours of vitamin therapy, sometimes transiently to low levels before rebounding, it is advisable to wait several days for the tests to stabilize and reveal the patient's true iron status.

Hypersegmentation of neutrophil nuclei is a constant feature but is variably defined⁴⁵ and may be unreliable in inexperienced hands. The most serviceable criteria are finding one or more neutrophils with six or more nuclear lobes or showing that at

least 4% to 5% of neutrophils have five lobes. Calculating lobe averages is considered the gold standard but comparison against published reference ranges is unreliable because interobserver variation is great. Hypersegmentation often precedes anemia,^{9, 104} but it is not found in subclinical deficiency.²²⁸ Hypersegmented neutrophils are not specific for cobalamin or folate deficiency; they are found in patients receiving chemotherapeutic drugs such as 5-fluorouracil or hydroxyurea, in some patients receiving steroid therapy for immune thrombocytopenic purpura,²²⁹ and in rare

P.938

patients with myelofibrosis or chronic myelogenous leukemia. It is unclear whether iron deficiency can cause hypersegmentation.²³⁰ Neutrophil segmentation is normally greater in blacks than in whites.²²⁸

TABLE 36.3 CAUSES OF MACROCYTOSIS, DEFINED AS MEAN CORPUSCULAR VOLUME (MCV) GREATER THAN 97 FL^a

Causes of Macrocytosis (MCV >97 fl)	Likelihood of Severe Macrocytosis (MCV >110 fl)
Megaloblastic anemia	
Cobalamin or folate deficiency	High
Some metabolic disorders (e.g., thiamine-responsive anemia)	High
Cytotoxic drugs (e.g., hydroxyurea, 5-fluorouracil)	High
Some immunosuppressive drugs (e.g., azathioprine)	High
Alcohol^b	
Without liver disease	Low
With liver disease	Moderate
Drugs^b	
Antiviral drugs	Moderate
Anticonvulsant drugs	Low
Disorders of red cell production^b	
Aplastic anemia; pure red cell aplasia	High
Myelodysplastic syndromes	Moderate
Myeloproliferative disease; leukemia	Low
Sideroblastic anemia (hereditary or acquired)	Low
Congenital dyserythropoietic anemia; ? Fanconi anemia; Blackfan-Diamond anemia	
Copper deficiency anemia	Moderate
Reticulocytosis^b	
Hemolytic anemia	Moderate
Nonhematologic disease^b	
Liver disease (alcohol unrelated)	Low

Physiologic^b	Hypothyroidism	Low
	Red cells are enlarged in the first 4 wk of life	Low
Idiopathic^b	Pregnancy	Low
	Chronic lung disease; smoking	Low
	Cancer	Low
	Multiple myeloma	Low
Artifact of electronic cell sizing^b	Cold agglutinins	High
	Severe hyperglycemia	High
	Hyponatremia	?
	Stored blood	?
	Warm antibody to red blood cells	?

^aMacrocytosis can be diagnosed when an MCV is not yet >97 fl, if the MCV is higher than in the past. The second column estimates the likelihood of finding severe macrocytosis (>110 fl in adults).

^bMacrocytosis is not accompanied by megaloblastic changes.

Laboratory Tests of Deficiency

Cobalamin and folate levels are measurable in serum and cells. The original microbiologic methods exploited the cobalamin or folate requirements of various micro-organisms, including differential sensitivities to specific forms of folate.^{45, 231, 232} Although rarely used today, microbiologic assays remain the gold standard. Radioisotope dilution competitive-binding assays for cobalamin and folate gave way to automated chemiluminescence-based competitive-binding assays a decade ago. Technical ease and demand have grown, but transparency, documentation, and validation of assay performance have diminished.^{233, 234} Long suspected of critical failures to identify low cobalamin levels, and sometimes producing results above 1,000 ng/L,^{234, 235} many automated assays have misidentified 22% to 35% of sera from untreated patients with pernicious anemia.²³⁶ The errors appear to involve failure to inactivate serum autoantibodies to IF, but at present the manufacturers' corrections are awaited.

No single biochemical test is diagnostically definitive for either cobalamin or folate deficiency.¹⁹⁰ In most clinical settings, the cobalamin test, when free of error, nevertheless suffices if the clinical picture is clear.¹⁹³ Several metabolic tests are available to clarify the vitamin levels (Table 36.4), and can be clinically decisive in difficult cases. However, a clinical "picture" is unavailable in SCCD, and all tests lack sufficient specificity.¹⁹⁰ Therefore, a panel evaluating cobalamin testing in epidemiologic research²³⁷ recommended that the diagnosis of SCCD should be based on finding at least two abnormalities, one metabolic (e.g., MMA or homocysteine) and one quantitating cobalamin content (e.g., serum cobalamin

P.939

or holo-TC II).¹⁹⁰ Metabolic tests are essential in the diagnosis of inborn errors of metabolism, in which vitamin levels are often normal. Metabolites are also ideal for monitoring response of deficiency to therapy because their levels do not change unless the therapy was effective, whereas vitamin levels (serum cobalamin, holo-TC II, or folate) rise upon vitamin entry into the bloodstream regardless of efficacy. Metabolite improvement is also delayed for several days, allowing a post-therapy window of time for diagnostic reassessment if needed.

TABLE 36.4 BIOCHEMICAL TESTS FOR THE DIAGNOSIS AND DIFFERENTIATION OF CLINICALLY RELEVANT COBALAMIN AND FOLATE DEFICIENCIES

Test	Test Finding in			
	Cobalamin Deficiency	Folate Deficiency	Sensitivity of Abnormal Test Result ^a	Specificity of Abnormal Test Result ^a
Serum cobalamin	Low	N or Low	Very good ^b	Poor
Serum folate	N or High	Low	Very good	Poor
Red cell folate	N or Low	Low	Good	Moderate
Serum methylmalonic acid	High	N	Very good	Poor
Serum 2-methylcitric acid ^c	High	N	Good	Nd
Plasma homocysteine	High	High	Very good	Poor
Plasma cystathionine ^c	High	High	Nd	Nd
Serum holo-transcobalamin II	Low	N	Presumably very good	Poor
Deoxyuridine suppression test ^{c, d}	Abnormal ^d	Abnormal ^d	Very good	Nd

N, normal result; Nd, not determined.

^a The sensitivity and specificity estimates (very good, >90%; good, 80% to 90%; poor <70%) apply only to clinically expressed cobalamin deficiency. They do not apply to subclinical cobalamin deficiency, in which sensitivity and specificity tend to be lower than in clinical deficiency, are usually determined only against other biochemical tests, or are unknown.

^b Automated chemiluminescence cobalamin assays, however, appear prone to falsely normal results when serum contains antibody to intrinsic factor.

^c The test is available only in research laboratories.

^d The discriminatory diagnostic power arises from including testing with vitamin additives in vitro.

Awareness of major pre-analytic influences on some tests, such as whether supplements must be interrupted during testing, whether plasma or serum must be used, and processing requirements, can be helpful. Interpretation is affected by common confounders, such as renal failure, which affects all cobalamin-related test values, and uncertainties, such as variations in reference intervals that can create or blur mildly abnormal results and compromise comparability between laboratories and methods.^{190, 238, 239, 240} Cutpoint variations are common among clinical laboratories,¹⁹³ and may also explain discrepancies and controversies in epidemiologic research.¹⁹⁰

Cobalamin Levels

In cobalamin deficiency, serum cobalamin levels fall below the generally accepted cutpoint of 200 to 250 ng/L (often expressed as 148 to 185 pmol/L; 1 ng = 0.738 pmol.) Despite a frequently cited study's unreproduced claim that serum cobalamin is insensitive to clinical deficiency,²⁴¹ diagnostic sensitivity has been 90% to 97% in clinical practice.^{183, 190, 242, 243} The lower the cobalamin level, the more likely is clinically noteworthy deficiency to exist,^{231, 232} but exceptions exist even at levels below 100 ng/L. Approximately 20% to 40% of low cobalamin levels are falsely low^{17, 190} (Table 36.4), which makes routine equation of low serum cobalamin with deficiency risky, especially when clinical findings are absent or equivocal. Although sensitivity and positive predictive value are poor in epidemiologic surveys involving SCCD,²⁴⁴ subnormal cobalamin levels in patients coming to medical attention require pursuit, as does any patient with a surprisingly normal level.¹⁹³

Many persons with SCCD have unexplained normal cobalamin levels,^{186, 242, 243} and homocysteine and MMA abnormalities compatible with deficiency outnumber low cobalamin levels in surveys of healthy elderly people.^{186, 188, 191} These observations led some authors to raise the cobalamin cutpoint for deficiency to 350 ng/L.¹⁸⁶ However, abnormal homocysteine and MMA have too many confounders to provide conclusive proof of deficiency, especially in asymptomatic patients with normal cobalamin levels (Table 36.4).

The causes of low cobalamin levels are listed in Table 36.5. Serum cobalamin frequently falls in folate deficiency, becoming subnormal in approximately 10% of cases, and recovers after folate therapy⁴⁵; such cases must be differentiated from combined deficiency of both vitamins. Cobalamin levels also decline during pregnancy, affecting 35% of women by the last trimester.^{45, 245} Levels can fall below 100 ng/L, but recover within days after delivery. The explanation is unknown, and metabolic studies do not find cobalamin deficiency.^{245, 246} Unexplained low cobalamin levels, most often without evidence of deficiency, also occur in patients with human immunodeficiency virus (HIV) infection,^{247, 248, 249} but the incidence has fallen from 27% to 8.7% because of high supplementation rates and more active retroviral therapy. Other conditions associated with unexplained low cobalamin levels include multiple myeloma^{250, 251} and multiple sclerosis.²⁵² An unexplained association with obesity²⁵³ may result from expanded plasma volume. Hereditary TC I deficiency is a frequent cause of low cobalamin levels^{80, 254} but acquired TC I deficiency, such as in severe neutropenic states²⁵⁵ and aplastic anemia, can also do so. Drugs, such as oral contraceptives and metformin, also cause mildly low cobalamin levels without inducing deficiency.^{256, 257, 258}

Elevated cobalamin levels are more frequent than low ones in clinical practice and are often unexplained.⁷⁸ The most common association of high levels was with renal failure,⁷⁸ although patients undergoing chronic high-flux hemodialysis have low levels.²⁵⁹ Other causes include liver disease²⁶⁰ and recent cobalamin therapy. A host of uncommon diseases with high plasma TC I levels, either because TC I is overproduced or because abnormally glycosylated TC I is cleared slowly, accumulate high cobalamin levels secondarily.^{72, 78, 79, 260} The diseases include chronic myelogenous and acute promyelocytic leukemias,⁵⁶ metastatic cancer,²⁶¹ fibrolamellar hepatoma,²⁶² and adult-onset Still's disease.²⁶³

P.940

In autoimmune lymphoproliferative syndrome, lymphocytes surprisingly contained TC I.²⁶⁴ When chronic myelogenous leukemia coexists with pernicious anemia, cobalamin levels are normal, not low.²⁶⁵ Spontaneous⁸² or therapy-acquired²⁶⁶ autoantibodies to TC II retain holo-TC II, leading to elevated cobalamin levels. Some blood-collection tubes containing separator gel produce higher cobalamin levels.²⁶⁷ Like TC I and TC II levels, cobalamin levels tend to be higher in blacks than in whites and Asians,²⁶⁸ which may have a genetic basis. Serum cobalamin is also mildly elevated in homozygotes for the common G461A nonsense mutation of the $\alpha^1, 2$ -fucosyltransferase gene FUT2, which regulates Lewis ABO(H) antigen expression,^{269, 270} but the mechanism whereby it affects the cobalamin level is unknown. *H. pylori* status was unrelated,²⁷⁰ making initial assumptions that FUT2 polymorphism affected cobalamin levels via *H. pylori*-related malabsorption unlikely.

TABLE 36.5 CAUSES OF LOW SERUM COBALAMIN LEVELS

Clinical cobalamin deficiency

Pernicious anemia (atrophic gastritis with loss of IF)

Hereditary IF deficiency

Post-gastrectomy state

Acquired intestinal disease with cobalamin malabsorption

Imerslund-Grösbeck syndrome

Small bowel bacterial overgrowth

Veganism

Infant exclusively breast-fed by mother with veganism or PA

Subclinical (biochemical) cobalamin deficiency

Food-cobalamin malabsorption (e.g., non-PA gastritis, gastric surgery)

Drugs

Vegetarianism

Idiopathic

Conditions associated with unexplained low cobalamin levels^a

Pregnancy

Folate deficiency

Cobalamin transport changes

Hereditary TC I deficiency

Acquired TC I deficiency (e.g., severe granulocyte disorders, ?metformin therapy)

Congenital specific-granule deficiency

Unexplained associations^a

Disorders with pancytopenia (e.g., aplastic anemia, myelodysplasia, PNH, hairy cell leukemia)

Other diseases (e.g., HIV infection, multiple myeloma, multiple sclerosis)

Drugs (e.g., oral contraceptives,^b anticonvulsants)

Pre-analytic influences^a

Inappropriately high cutpoint and reference range selection^c Hemodilution

IF, intrinsic factor; PA, pernicious anemia; PNH, paroxysmal nocturnal hemoglobinuria; TC I, transcobalamin I (haptocorrin).

^a Evidence of metabolically or clinically defined cobalamin deficiency or malabsorption has been found in only some cases in these categories.

^b Does not apply to post-menopausal hormone replacement.

^c Frequencies of “low levels” depend greatly on cutpoint selection, which is often arbitrary.

The impact can be great; for example, the frequency of “low levels” increases twofold or more following the shift of the cobalamin cutpoint from 200 ng/L to 300 ng/L.

Red cell cobalamin has little diagnostic value because levels are low in many other anemias; reticulocyte counts influence red cell cobalamin strongly.⁴⁵

Serum Folate

Folate deficiency, using megaloblastic anemia as a criterion, is traditionally defined by a serum folate level below 2.5 µg/L (also expressed as 5.7 nmol/L; 1 µg = 2.266 nmol.) However, using homocysteine elevation as the criterion implicates serum folate below 4.5 to 5.0 µg/L^{271, 272} or even 6.5 µg/L.²⁷³ These findings justify viewing serum folate levels between 2.5 and 5.0 µg/L with suspicion, especially in countries using folic acid fortification.

Pre-analytic influences abound. Ascorbate must be added to protect samples stored for a few days against oxidative damage. Spuriously high levels occur in hemolyzed blood samples, which release red cell folate into serum. Serum folate, which is mostly methylTHF, also tends to rise as cobalamin deficiency advances, and it becomes high in approximately 30% of cases^{45, 46} (Table 36.4). The new generation of automated nonisotopic assays is inadequately documented compared with older methods. Assay imprecision is frequently unexplained.²⁷⁴ Following dietary fortification and growing supplement use, subnormal results have become rare.

Red Blood Cell (Whole Blood) Folate

MethylTHF (60%) and formylTHF (26%) are the major folates in red cells.²⁷⁵ A red cell's folate content is constant and is viewed as a truer indicator of tissue folate than are serum levels, which fluctuate with changes in folate intake. Red cell levels below 160 µg/L are usually considered low,^{45, 276} but the reference intervals vary among laboratories and methods.

Red cell folate results cannot differentiate between folate and cobalamin deficiency (Table 36.4). Levels were low in 63% of cobalamin-deficient patients²⁷⁶ because the accumulating methyl-THF fraction is less easily polyglutamated and therefore poorly retained by cells. Because reticulocytes are rich in folate, red cell folate is high in states of intense reticulocytosis such as hemolytic anemia.²⁷⁶ Red cell folate, much of it bound to hemoglobin,²⁷⁷ is also slightly higher in deoxygenated than oxygenated cells. Transfusion, of course, invalidates red cell folate results. The greater variability and methodologic difficulties than with serum folate^{45, 238, 274} have led to divergent views about the usefulness of red cell folate assay.^{233, 278}

Plasma Total Homocysteine

Homocysteine rises with either folate or cobalamin deficiency (Table 36.4) and in many other conditions (Table 36.6). This nonspecificity limits its diagnostic value, but a normal result helps to exclude clinically relevant deficiency. The sensitivity exceeds 95% in clinically expressed cobalamin deficiency, with levels often above 50 µmol/L in pernicious anemia, but sensitivity is only 86% in clinical folate deficiency.²⁷⁹ Milder elevations and poorer sensitivity characterize its performance in subclinical deficiency of either vitamin.^{240, 280} Homocysteine falls several days after appropriate treatment of deficiency and becomes normal within a week.²⁴²

Plasma total homocysteine, which consists of reduced homocysteine and its oxidized forms, homocystine and mixed disulfides, can be measured by various chromatographic and automated immune or enzyme-based methods. Unfortunately, results vary among laboratories,²⁸¹ as do reference intervals. Major preanalytic influences include the requirement for plasma, as well as its immediate separation from blood cells, to minimize artificial cellular release of homocysteine, but many laboratories use serum for convenience and cost saving. Fasted samples are not necessary as long as a large meal is avoided. Age and sex affect normal levels.²⁸² Homocysteine values double between childhood and old age.²⁸¹ Levels above 12 to 14 µmol/L in women and 14 to 15 µmol/L in men are generally regarded as elevated. However, even normal levels can often be reduced by giving folate,²⁸³ which may reflect either unrecognized depletion or interaction with genetic and other influences.

As reviewed elsewhere,²⁸¹ homocysteine rises in many acquired and genetic conditions (Table 36.6). Folate intake and serum creatinine levels (even if still within the normal range) are major determinants of homocysteine status; creatinine measurement is advisable whenever the homocysteine level is high. Cobalamin levels assume greater influence in the elderly,^{282, 284} and the influence has increased in countries with folate fortification.

Levels of both cystathionine, a product of homocysteine transsulfuration, and AdoHcy, a product of remethylation, also rise in

P.941

folate and cobalamin deficiencies.²⁸⁴ Methionine levels, surprisingly, are usually unremarkable.^{116, 284}

TABLE 36.6 CAUSES OF ELEVATED HOMOCYSTEINE LEVELS

Causes	Degree of Homocysteine Elevation^a
Vitamin deficiency states	
Clinical cobalamin deficiency (acquired or hereditary ^b)	Mild to severe
Subclinical cobalamin deficiency	Mild or none
Folate deficiency (acquired or hereditary ^c)	Mild to severe
Vitamin B ₆ deficiency	Mild or none ^d
Riboflavin deficiency	Mild or none
Medical conditions	
Renal failure ^e	Mild to moderate
Post-transplantation	Mild to moderate
Hypothyroidism	Mild

Acute lymphocytic leukemia	Mild
Psoriasis	Mild
Drugs and toxins	
Alcohol abuse	Mild to severe
Methotrexate and other antifols	Mild to severe
Trimethoprim; anticonvulsants; fenofibrate; cyclosporine A	Mild
Drugs affecting vitamin B ₆ (e.g., niacin, azauridine)	Mild ^d
Levodopa	Mild
Nitrous oxide toxicity (causes cobalamin inactivation)	Mild to severe

Genetic disorders

Cystathionine β -synthase deficiency	Severe
Methylene tetrahydrofolate reductase polymorphisms (homozygous C677T or A1298C mutations)	Mild or none ^f

Physiologic and lifestyle factors^g

Male sex; older age	Mild
Coffee, smoking	Mild

Artifact

Use of serum sample instead of plasma; delay in centrifugation	Mild, but can be variable
Selection of inappropriately low cutpoint	Variable

^a Homocysteine elevations are categorized arbitrarily here as mild (15 to 25 $\mu\text{mol/L}$), moderate (25 to 50 $\mu\text{mol/L}$), and severe (>50 $\mu\text{mol/L}$).

^b Homocysteine elevation does not occur in genetic cobalamin disorders in which methylcobalamin function is spared.

^c Plasma homocysteine elevation does not occur in cerebral folate deficiency.

^d Often inapparent unless post-methionine-loading measurement is done.

^e Homocysteine elevation may occur even with serum creatinine changes within the reference interval.

^f Often inapparent unless folate status is also compromised.

^g It is not always known if other influences contribute to the differences attributed to these factors.

Methylmalonic Acid

MMA, a product of accumulated D-methylmalonyl CoA, increases in serum and urine in cobalamin deficiency but not in folate deficiency, making MMA a more specific test for cobalamin deficiency than homocysteine. MMA is also subject to fewer pre-analytic influences. Serum levels are elevated in 98.4% of patients with clinical deficiency, such as pernicious anemia.²⁷⁹ Most laboratories consider MMA elevated above 280 nmol/L (0.28 $\mu\text{mol/L}$), but published cutpoints have varied between 210 and 480 nmol/L,²⁸⁵ which predictably affects the diagnostic frequency of abnormality.^{190, 191} Levels often exceed 1,000 nmol/L in clinical deficiency but are usually only mildly elevated in SCCD. MMA becomes normal within a week after cobalamin therapy;²⁴² folate therapy has no effect.

Elevated MMA is often used as sole evidence of cobalamin deficiency in epidemiologic studies²⁸⁶ and in validating the performance of other biomarkers, such as holo-TC II.¹⁹⁰ However, despite a high sensitivity that allows a normal MMA level to exclude the possibility of cobalamin deficiency, MMA susceptibility to many cobalamin-unrelated influences (Table 36.7) disqualifies it as a diagnostic gold standard.^{190, 192} Independent influences on the MMA level include not only cobalamin status but also serum creatinine, age, and sex, but these account for only 16% of MMA variation.²⁸⁷ Some MMA elevations are unexplained, and mild, isolated, and often spontaneously fluctuating elevations are common in SCCD.^{192, 240} The observation that nonelevated MMA levels can fall after antibiotic therapy^{242, 288} suggests intestinal bacteria contribute to serum MMA, perhaps through bacterial propionate metabolism. High MMA levels are common during the first year of life but they are transient.²⁸⁹ Their explanation is unknown, but the MMA levels respond to cobalamin therapy also.²⁹⁰

Serum MMA assay is now automated and increasingly available in reference laboratories. Less information is available about urine MMA assay. An alternative product of propionyl CoA metabolism, 2-methylcitric acid, rises in cobalamin deficiency.²⁹¹

P.942

TABLE 36.7 CAUSES OF ELEVATED METHYLMALONIC ACID LEVELS

Cobalamin deficiency

High-normal serum creatinine

Renal failure

Old age

Unexplained transient elevation in normal babies in first year of life^a

Hereditary disorders of cobalamin metabolism in which methylmalonate metabolism is affected

Hereditary disorders of methylmalonate metabolism (e.g., methylmalonyl CoA mutase deficiency)

Methylmalonate metabolism polymorphisms

? Bacterial contamination of the small bowel^b

Idiopathic

^cApplication of a liberal cutpoint for methylmalonic acid assay

^aIt is unclear if subclinical cobalamin deficiency exists in some cases.

^bReduction of methylmalonic acid levels has been described after antibiotic therapy in patients with bacterial contamination of the small bowel. The phenomenon has been attributed to propionate metabolism by bacteria.

^cThe optimal cutpoint for methylmalonic acid has not been defined. Laboratories and studies that use lower cutpoints than usual (e.g., 210 nmol/L) identify greater numbers of subjects with “high” or “abnormal” levels.

Holo-transcobalamin II

Holo-TC II, which carries all cobalamin available to cells, is conceptually attractive as a substitute for measuring total cobalamin, most of which is carried by TC I and unavailable to cells.²⁹² It is presumed to be very sensitive to cobalamin depletion because it is more often abnormal than other markers of cobalamin status. Serum levels are thought to represent a balance between holo-TC II entering the bloodstream, from the gut and perhaps elsewhere, and its very rapid uptake by tissues. However, it is unclear whether serum holo-TC II, whose half-life is measured in minutes, is more sensitive to intermittent transport fluxes than to the long-term changes in cobalamin stores that lead to cobalamin deficiency;¹⁹⁰ for example, it is unknown if temporarily reduced (i.e., 1 or 2 weeks) inflow from the gut, due to transiently

reduced dietary intake or transient malabsorption caused by drugs, may reduce serum holo-TC II without there being any cobalamin depletion, which takes years. The contribution of holo-TC II reabsorbed in the renal tubule is also unknown.

Moreover, holo-TC II validation rests largely on comparisons against cobalamin assay, with MMA as the (unsatisfactory) arbiter of cobalamin status in surveys of subjects with SCCD.^{244, 293} As reviewed elsewhere,¹⁹⁰ these analyses showed marginal superiority of holo-TC II to total cobalamin in SCCD, but clinical assessment has been insufficient and some clinical studies identified shortcomings. Chief among the shortcomings has been poor holo-TC II specificity.^{190, 244, 294} Reported confounding causes of low holo-TC II include oral contraceptive use,²⁵⁶ a common TCN2 A67G polymorphism,⁷¹ alcoholism and various hematologic disorders such as myelodysplasia,²⁹⁵ and an effect of malabsorption independent of cobalamin adequacy.²⁹⁶ Much work remains to be done²⁹⁷ before recommendations that holo-TC II become the primary tool to determine cobalamin status²⁹⁸ can be accepted.

Other Tests

Loss of the normal ability of added deoxyuridine to suppress thymidine incorporation into DNA by bone marrow cells deficient in cobalamin or folate²⁹⁹ is as sensitive a test for cobalamin deficiency as homocysteine or MMA assay.³⁰⁰ The test served to first document and define SCCD.^{94, 95, 96, 180} Adding cobalamin or folates to the cells can usually differentiate between the two deficiencies.^{299, 301} This labor-intensive test has been replaced by metabolite testing.

Formal diagnostic trials of reticulocyte response to a dose of folic acid or cobalamin small enough to ensure the specificity of response to it³⁰² are no longer needed. Nevertheless, objective documentation of the clinical response to therapy often has diagnostic value and is an important part of management.

SPECIFIC DISORDERS CAUSING COBALAMIN OR FOLATE DEFICIENCY

Diagnostic evaluation must include identification of the specific condition responsible for the deficiency. Identification of the cause helps confirm the diagnosis of deficiency, ascertains the prognosis, and is invaluable for management. The underlying cause predicts the rate at which deficiency, especially of cobalamin, progresses or relapses. Often, the cause itself can also be treated directly.

Causes of Cobalamin Deficiency

The discussion of causes follows the order of the cobalamin assimilation and utilization steps illustrated in Figure 36.4. The overwhelming majority of clinically apparent cobalamin deficiencies are malabsorptive in origin, of which pernicious anemia is the most common.

Dietary Insufficiency

Adults

The circumscribed dietary source for cobalamin and the huge ratio of body stores to daily loss protect most adults from becoming severely deficient on a purely dietary basis. Malnutrition limited to a few weeks or months does not produce cobalamin deficiency. The adults at risk tend to be committed, long-term vegetarians, especially vegans, but even they seldom become sufficiently depleted to develop megaloblastic anemia or myelopathy. A study of vegetarian women showed that their cobalamin intake was 1.68 ± 1.60 $\mu\text{g}/\text{day}$, one half that of nonvegetarian controls.³⁰³ Surveys of vegetarians identify little or no change in MCV,^{304, 305} and macrocytic anemia is uncommon. Most often, vegetarians display SCCD, with mild biochemical abnormalities.^{306, 307, 308} The risks are greater in those with lifelong dietary inadequacy in developing countries, such as India, where public health measures may be warranted.³⁰⁹ Sometimes, metabolic abnormalities persist even after the diet has been liberalized.³⁰⁷ Coexisting disorders, such as malabsorption, should be explored in vegetarian adults who actually develop symptoms of deficiency.^{310, 311}

Children

Young children, who must negotiate normal neurologic development and normal expansion of cobalamin stores simultaneously often have more serious consequences of dietary restriction. Children in macrobiotic communities show persistent metabolic abnormalities³¹² and an often suspect cognitive performance,³¹³ even years after starting cobalamin supplementation. Phenylketonuric diets restricted in animal protein may predispose to mild biochemical cobalamin deficiency.^{314, 315}

The consequences can be much more catastrophic for babies born to and exclusively breast-fed by mothers who are strict vegetarians or have undiagnosed pernicious anemia.^{170, 315, 316, 317, 318} It is instructive of the cobalamin differences between adults and children that the mothers are asymptomatic and only mildly deficient, whereas the children have severe neurologic and developmental abnormalities, often including movement disorders, which may increase just after therapy is begun.³¹⁹ Long-term deficits may persist.³²⁰ Although the frequency of the syndrome in at-risk babies is

unknown, maternal deficiency is thought to be the most common cause of cobalamin deficiency in childhood.¹⁴² The impact on growth and developmental retardation is unclear but preventive efforts are warranted.

P.943

Malabsorption

Pernicious Anemia

The defect that defines pernicious anemia is not the anemia but the loss of IF that produces severe malabsorption of all forms of cobalamin. The atrophic gastritis that is universal in acquired pernicious anemia differs from the more common atrophic gastritis, which maintains IF secretion long after acid secretion ceases.^{321, 322}

With its loss of the parietal cells that synthesize IF, pernicious anemia is irreversible and many features suggest its autoimmune nature.^{45, 322, 323} At least one of two autoantibodies to gastric antigens is found in 85% of cases, one directed against IF and one against the parietal cell; the gastric histology suggests an inflammatory disorder, cell-mediated immune abnormalities have been reported, steroid therapy sometimes restores IF secretion, and other autoimmune disorders often coexist.

The gastritis has been subdivided into types A and B.³²⁴ Type A gastritis is found in 80% to 90% of patients with pernicious anemia, although it is the less common gastritis form in the general population; it is characterized by the presence of parietal cell antibody and is limited to the fundus while sparing the antrum, which is often hypertrophic. Type B pangastritis usually results from *Helicobacter pylori* infection and lacks such autoantibodies. Although it is the most common gastritis generally, only 10% to 20% of patients with pernicious anemia have it, suggesting that its role in pernicious anemia is infrequent.³²⁵

Pernicious anemia appears to have a familial predisposition, and relatives have increased frequencies of atrophic gastritis, antibodies to parietal cells, and thyroid disease.^{45, 326} Pernicious anemia is diagnosed most often after the age of 60 years,⁴⁵ although the gastritis begins many years earlier.³²⁷ A survey of the elderly in Los Angeles found that 1.9% had unrecognized, often pre-clinical pernicious anemia.¹⁸⁹ Earlier surveys in Scandinavia reported prevalences of 0.13% to 0.2% among all ages.⁴⁵ Women are affected almost 50% more often than men in most surveys.^{45, 328} Although northern Europeans have the highest rates, pernicious anemia is universal.^{45, 189, 268, 328, 329, 330, 331, 332} The frequency in blacks may approach that in whites.¹⁸⁹ The reason why black women develop the disease more often before 50 years of age than do whites and have antibody to IF more often is unknown;³²⁸ American Hispanics display a less significantly younger age trend for pernicious anemia.^{268, 331} Even in whites, approximately 10% of cases occur at a young age, sometimes in childhood or adolescence.⁴⁵ Called juvenile pernicious anemia in children, it is accompanied by especially high rates of gastric antibodies, immune endocrinopathy, and a positive family history.

In addition to causing relentless cobalamin deficiency, pernicious anemia carries many disease-specific associations and prognostic implications. The most serious is an increased risk for two gastric tumors, both predominating in the fundus.³²² A Swedish registry showed a 26.4-fold increased risk of gastric carcinoid and a 2.2-fold increased risk for gastric adenocarcinoma.³³³ The carcinoid tumors metastasize in only 20% of cases, however.^{322, 334} The increased risk for gastric carcinoma has been widely but not unanimously accepted.^{45, 322, 335, 336, 337, 338} Many authors recommend endoscopy at the time of diagnosis in every patient with pernicious anemia,³³⁹ but routine re-examinations are not advised. An increased risk of esophageal squamous cell carcinoma³³³ is controversial.

Iron deficiency affects 21% of patients at diagnosis of pernicious anemia and another 23% develop it later.³⁴⁰ An independent cause is not always found, suggesting that iron malabsorption due to gastritis and achlorhydria plays a role.³⁴¹ Bacterial contamination of the stomach and upper small bowel, presumably abetted by achlorhydria, has been described in pernicious anemia.³⁴² An increased frequency of gallstones has also been suggested.³⁴³

At some point, approximately 10% of patients develop clinical or latent thyroid disease, most often hypothyroidism.³⁴⁴ Related autoimmune disorders associated with pernicious anemia include vitiligo, hypoparathyroidism, hypoadrenalism, and myasthenia gravis.⁴⁵ An unusual coexistence is with agammaglobulinemia or common variable immunodeficiency;³⁴⁵ the patients are young, have type B gastritis, often have bacterial overgrowth, and are at very high risk for gastric cancer. Other immune associations of pernicious anemia may include immune thrombocytopenia, immune hemolytic anemia, transient red cell aplasia, diabetes mellitus, biliary cirrhosis, chronic lymphocytic leukemia, and renal tubular acidosis.^{45, 346, 347, 348, 349, 350, 351} Links have also been suggested with myelodysplasia, leukemia, and myeloproliferative diseases,^{265,}

^{338, 352, 353, 354} and perhaps with sickle cell anemia. ^{355, 356} An increased rate of tuberculosis was reported in Asian Indians and Chinese with pernicious anemia. ^{330, 332}

Hereditary Intrinsic Factor Deficiency

Also called congenital pernicious anemia, this autosomal recessive disorder is characterized by an absent, unstable, or nonfunctional gastric IF^{142, 357, 358, 359} (Table 36.8). Gastric status is otherwise normal, although unexplained basal hypochlorhydria sometimes occurs.³⁵⁷ Several mutations of the GIF gene have been found,^{360, 361} some in patients originally misdiagnosed to have Imerslund-Grösbeck syndrome because of spurious Schilling test results. Hereditary deficiencies of IF and TC I, whose genes lies near each other, coexisted in one family.³⁶² Patients with hereditary IF deficiency usually develop anemia, myelopathy, and, occasionally, developmental delay in the first few years of life as cobalamin stores from birth become depleted. Infrequently, diagnosis is delayed until adolescence or later.³⁵⁷

Food-cobalamin Malabsorption

Studies in 1973 demonstrated that absorption testing with free crystalline cyanocobalamin, such as in the Schilling test, failed to identify defective release of food-bound cobalamin.³⁶³ As reviewed elsewhere,¹⁹⁵ tests using food vehicles revealed that many patients could not absorb food-bound cobalamin while absorbing free cobalamin normally, the disparity that is diagnostic for food-cobalamin malabsorption (when free cobalamin absorption fails, as in pernicious anemia, of course, food-bound cobalamin cannot be absorbed either).

The crux in food-cobalamin malabsorption appears to be the loss of pepsin and the acid secretion needed for optimal pepsin activity, without losing IF secretion³⁶⁴ (Fig. 36.4, panel 1). Most prominent among patients with food-cobalamin malabsorption were those with partial gastrectomy, other gastric surgery, or gastritis, all of whom had intact IF secretion. However, the gastric disorders are heterogeneous. Some patients have severe autoimmune gastritis and achlorhydria but others have *H. pylori* induced gastritis.³⁶⁵ Although it may have therapeutic implications as a reversible cause of malabsorption,³⁶⁵ the association with *H. pylori* infection lacks sufficient diagnostic sensitivity and specificity to be equated with food-cobalamin malabsorption.^{240, 366, 367} Food-cobalamin malabsorption improves after antibiotic therapy sometimes, but whether this reflects the disappearance of *H. pylori*³⁶⁵ or anaerobic bacteria,³⁶⁸ or both, was not proven directly. Reported cures of cobalamin deficiency anemia solely by eradicating *H. pylori* require more documentation.²⁴⁰ Patients taking acid-suppressive drugs, such as omeprazole, also malabsorb food cobalamin;^{195, 369} cobalamin deficiency is infrequent in them, although low cobalamin levels were reported in a retrospective study of patients who may have had other predispositions to low levels.³⁷⁰

Food-cobalamin malabsorption need not cause cobalamin deficiency, perhaps because it is sometimes reversible and because it may not abrogate reabsorption of biliary cobalamin, but it affects 30% to 40% of people with SCCD.¹⁹⁵ Severe deficiency occurs much less often.^{96, 195, 311, 371, 372} Progression to pernicious anemia with loss of IF has been reported in a few cases.^{311, 371}

P.944

TABLE 36.8 HEREDITARY DISORDERS OF COBALAMIN AND COBALAMIN-RELATED METABOLISM

Disorder	Defect (and Affected Gene)	Megaloblastic				
		Cbl	Hcys	MMA	Anemia	
					Myeloneuropathy	Other
Hereditary IF deficiency	IF synthesis (<i>GIF</i>)	↓	↑	↑	Yes	Often
Imerslund-Gräsbeck syndrome	IF receptor (<i>CUB</i> or <i>AMN</i>)	↓	↑	↑	Yes	Often
TC II deficiency	TC II synthesis (<i>TCN2</i>)	N	↑	N-↑	Yes	Occasional
TC II receptor	TC II receptor synthesis	N	N	↑	No	No

deficiency	(<i>TCblR/CD320</i>)							
TC I (HC) deficiency	TC I (HC) synthesis (<i>TCNI</i>)	↓	N	N	No	No		
CblA defect	Mitochondrial reduction of cobalamin (<i>MMAA</i>)	N	N	↑	No	No	Failure to thrive, lethargy, hypotonia, acidosis	
CblB defect	Cob(I)alamin adenosyl transferase (<i>MMAB</i>)	N	N	↑	No	No	Failure to thrive, lethargy, hypotonia, acidosis	
CblC defect	?Cytoplasmic reduction of cobalamin (<i>MMACHC</i>)	N	↑	↑	Yes	Yes	Developmental delay, microcephaly, seizures, retinopathy	
CblD defect-combined	?Cytoplasmic reduction of cobalamin (<i>MMADHC</i>)	N	↑	↑	Varies	Varies	Thrombosis	
CblD-variant 1	CblD defect affects only methylcobalamin (<i>MMADHC</i>)	N	↑	N	Mild to mod	Yes	Cerebral defects, seizures	
CblD-variant 2	CblD defect affects only adenosylcobalamin (<i>MMADHC</i>)	N	N	↑	No	No	Mental changes, seizures	
CblE defect	Methionine synthase reductase (<i>MTRR</i>)	N	↑	N	Yes	Yes	Developmental delay, cerebral atrophy, seizures, hypotonia	
CblF defect	Cobalamin release from lysosome (<i>LMBRD1</i>)	N	↑	↑	Mild	No	Poor feeding, growth retardation	
CblG defect	Methionine synthase (<i>MTR</i>)	N	↑	N	Yes	Yes	Behavior changes, seizures	
CblJ defect	Cobalamin release from lysosome (ATP-binding cassette transporter; <i>ABCD4</i>)	N	↑	↑	Yes	No	Developmental delay, microcephaly, hypotonia, lethargy	

Mut ⁰ defect	Absent MM-CoA mutase (<i>MUT</i>)	N	N	↑	No	No	Failure to thrive, lethargy, hypotonia, acidosis
Mut ⁻ defect	Decreased MM-CoA mutase (<i>MUT</i>)	N	N	↑	No	No	Failure to thrive, lethargy, hypotonia, acidosis
MM-CoA epimerase deficiency	MM-CoA epimerase deficiency (<i>MCEE</i>)	N	N	↑	No	No	

↑, increased levels; ↓, decreased levels; ado-cbl, adenosylcobalamin; Cbl, cobalamin; HC, haptocorrin; Hcys, homocysteine; IF, intrinsic factor; MMA, methylmalonic acid; MM-CoA, methylmalonyl coenzyme A; mod, moderate; N, normal levels; TC, transcobalamin.

Gastric Surgery

Subtotal gastrectomy eventuates in cobalamin deficiency in 15% to 30% of patients.^{45, 373, 374} Some of these patients develop clinical deficiency with megaloblastic anemia and neuropsychiatric problems. However, absorption of free cobalamin (Schilling test) most often remains normal,³⁷⁵ and most patients have only food-cobalamin malabsorption and SCCD.^{195, 363} Iron deficiency and folate malabsorption may also develop.^{376, 377} Food-cobalamin malabsorption and SCCD complicate other gastric procedures too, such as bariatric surgery.^{378, 379}

Pancreatic Insufficiency

Pancreatic proteases degrade TC I and release its cobalamin for transfer to IF.⁸⁴ One half of patients with chronic pancreatic insufficiency have abnormal Schilling test results, requiring exogenous pancreatic extract for correction. It is unclear why such apparently severe malabsorption rarely, if ever, eventuates in clinically apparent cobalamin deficiency.

Bacterial Overgrowth of the Small Bowel

Large enough numbers of bacteria may accumulate in the upper small bowel if anatomical abnormalities (e.g., fistulas, strictures, large diverticula) or motility disorders exist (e.g., autonomic dysfunction in diabetes). Bacteria take up cobalamin and, in that location, may compete with IF for it.³⁸⁰ Bacteria also generate nonfunctional corrinoid analogs,³⁸¹ whose contribution to the cobalamin deficiency is unclear. The deficiency can be clinically overt and is sometimes the only obvious manifestation of bacterial

P.945

overgrowth. Antibiotics reverse the malabsorption, but relapse occurs if the cause of bacterial overgrowth persists.

Parasitic Infestation

The classic parasitic cause of cobalamin deficiency is *Diphyllobothrium latum*, which infests freshwater fish.^{45, 382} The tapeworms in the upper small intestine compete avidly for cobalamin. Most patients are asymptomatic, but cobalamin levels are often low.³⁸³ It is uncertain whether the worm load or coexisting conditions, such as a frequent atrophic gastritis, determine the extent of deficiency. The infection is rare in the United States. *Giardia lamblia* has been associated with cobalamin malabsorption, particularly in children and immunocompromised patients, but it is unclear if the association is a causal one. Low cobalamin levels have been reported in heavy *Strongyloides stercoralis* infection.³⁸²

Gastrinoma

The Zollinger-Ellison syndrome can cause cobalamin malabsorption. The basis appears to be the low pH in the intestine.³⁸⁴ Ileal uptake of the IF-cobalamin complex requires a neutral pH.

Ileal Diseases

If they involve enough of the ileum, acquired diseases impair receptor-mediated absorption of IF-bound cobalamin (Fig. 36.4, panel 3). Schilling tests had successfully demonstrated malabsorption refractory to oral IF or antibiotics and led to a

diagnostic pursuit of the specific ileal disease. The tests' disappearance has made these malabsorptive diagnoses inaccessible.

Tropical sprue is endemic in the Caribbean, South Asia, and elsewhere. Manifestations can appear long after a person has emigrated. Cobalamin deficiency occurs in chronic cases and is sometimes the sole clinical finding.^{385, 386} Some patients have folate deficiency instead, especially early in the course, or have both deficiencies. The vitamin differences may vary regionally, as does the often impermanent response of tropical sprue to folate and antibiotics. As in all acquired ileal diseases, other nutrients are often at risk also. The disease's prevalence appears to be declining but a subclinical tropical enteropathy may exist.³⁸⁷

The frequency of cobalamin malabsorption and deficiency varies in celiac disease, inflammatory bowel disease, and dermatitis herpetiformis.^{388, 389} Deficiency often depends on the extent of ileal involvement, and resections that exceed 20 cm make deficiency more likely.³⁹⁰ Atrophic gastritis may sometimes contribute to the deficiency. Ileal malabsorption has been associated with acquired immunodeficiency syndrome but does not explain most of the low cobalamin levels (see the "Cobalamin Levels" section of "Laboratory Tests of Deficiency").

As noted, the risk of cobalamin malabsorption and deficiency after ileal surgery appears to be proportional to its extent. Long-term malabsorption occurs with jejunioileal bypass for obesity.^{391, 392} Deficiency has also been attributed to malabsorption with ileal reservoirs for the ureters in patients with bladder cancer^{393, 394} and for restorative proctocolectomy in ulcerative colitis.³⁹⁵ Puzzlingly, however, Schilling tests have been normal with ileal reservoirs.³⁹⁵

Imerslund-Gräsbeck Syndrome (Megaloblastic Anemia Type 1)

Selective malabsorption of cobalamin arises from genetic defects affecting the ileal IF receptor (Table 36.8). Two mutations of the cubilin gene have been identified in Finnish families;^{396, 397} some Norwegian families have mutations of the amnionless gene,³⁹⁸ and other mutations of these genes have been reported in the Mediterranean area and elsewhere.³⁹⁹ The malabsorption is limited to cobalamin and usually produces classical clinical signs of deficiency in the first few years of life.^{142, 400, 401} Diagnosis is occasionally delayed and, with disappearance of the Schilling test, differentiation from hereditary IF deficiency can be difficult. The disorder is often accompanied by mild and apparently benign proteinuria because cubilin, a multiligand receptor, also reabsorbs albumin in renal tubular cells.^{402, 403}

Drugs, Toxins, and Related Toxicities

Many drugs and toxins interfere with cobalamin absorption, usually by unknown mechanisms. Examples include alcohol, colchicine, neomycin, cholestyramine, paraaminosalicylic acid, and slow-release potassium, but the true list of offending drugs is probably longer. Cobalamin deficiency rarely occurs with any of them because exposure and malabsorption must be uninterrupted and last for several years in order to deplete cobalamin stores. Few drugs fulfill those criteria. The low cobalamin levels in metformin users have been widely equated with cobalamin deficiency, yet MMA levels are normal;²⁵⁷ the low cobalamin may represent acquired TC I deficiency instead.²⁵⁸

Transport and Cellular Defects

Most disorders of cobalamin transport to cells and cellular utilization are genetic in origin and usually affect children. In contrast with malabsorptive and dietary disorders, their effects usually develop rapidly and serum cobalamin levels are usually normal.

Transcobalamin II Deficiency and Transcobalamin II Receptor Defect

Deficiency of TC II impairs cobalamin delivery to cells, although some cobalamin enters cells by unknown, presumably nonspecific means (Table 36.8). TC I-bound cobalamin continues to circulate, so normal cobalamin levels are maintained, with rare exceptions.⁴⁰⁴ The children typically have megaloblastic anemia and failure to thrive in the first year of life.¹⁴² Neurologic dysfunction is less frequent⁴⁰⁵ and may appear chiefly when treatment is inadequate.⁴⁰⁶ Some children also have infections suggesting immune hypofunction.⁴⁰⁷ Schilling test results have often been abnormal, perhaps because TC II must take up the absorbed cobalamin. The diagnosis requires immunoassay of total TC II, but a nonfunctional TC II has also been described.⁴⁰⁸ Several TCN2 mutations have been identified.^{409, 410} Patients respond to frequent cobalamin injections. Oral therapy has been used after stabilization, but complications have also been attributed to undertreatment.⁴¹¹

The phenotype is very different in deficiency of TC II receptor caused by homozygous TCbIR/CD320 nonsense mutation:⁴¹² moderate methylmalonic aciduria is the lone finding and there are no symptoms. The explanation for this paradoxical presentation is unknown.

Transcobalamin I (Haptocorrin) Deficiency

This disorder, often mistaken for and treated as cobalamin deficiency, is typically uncovered in adults with unexplained low cobalamin levels (Table 36.8). Serum cobalamin is low because 70% or more of it is carried by TC I. Cellular and metabolic cobalamin status is normal.^{83, 254, 413, 414, 415} Corrinoid analogs, typically carried by TC I, appear to be absent in severely TC I-deficient plasma;⁸⁰ tissue analog content is unknown. A few patients have had atypical, probably unrelated neurologic dysfunction that was unaffected by cobalamin therapy,^{254, 415} and probably reflects coincidence or selection bias for cobalamin testing (which led to TC I testing). The diagnosis requires demonstration of TC I absence in plasma and secretions, such as saliva, which is typical of severe deficiency. Nine severely deficient patients, all non-Caucasians, have been identified, and the frequency in a prospective survey of samples with low cobalamin levels appears to be 0.6%.²⁵⁴ A combined deficiency of TC I and lactoferrin, which are synthesized together in specific granules of myeloid cells and in exocrine gland epithelium, was found in a family;⁴¹⁵ interestingly, the affected patients were not predisposed to infection. Another family had coexisting deficiencies of TC I and IF, whose genes are not far apart.³⁶²

P.946

TC I deficiency was thought rare until a mild deficiency identical to that seen in obligate heterozygous relatives of severely deficient patients,⁴¹⁵ was found in 15% of patients with low cobalamin levels.²⁵⁴ Such patients have low or low-normal levels of plasma TC I and saliva TC I. The diagnosis requires ruling out cobalamin deficiency and measuring plasma TC I (serum often provides spuriously normal TC I results). Four heterozygous TCN1 mutations,^{356, 416, 417} also seen in severely deficient patients with homozygous or compound heterozygous mutations, were found in 34 affected members in 24 families.⁸⁰

Nitrous Oxide Toxicity

Nitrous oxide oxidizes cob(I)alamin, irreversibly inactivating the methionine synthase to which the cobalamin is bound.⁴¹⁸ Because exposure during dental and surgical procedures is brief and enzyme is regenerated quickly, clinical expression does not occur despite mild metabolic abnormalities lasting a few days.^{419, 420} There are two exceptions to the benign consequences. One is repetitive exposure,^{421, 422} such as "recreational" abuse of the gas. The other is when a patient with unrecognized, clinical cobalamin deficiency is exposed to nitrous oxide during lengthy or repeated surgery.^{423, 424, 425, 426} Within days, megaloblastic anemia results but neuropsychiatric dysfunction is often especially severe.

Nitric oxide also reacts with cobalamin and inhibits methionine synthase,⁴²⁷ but no clinical impact is known.

Cbl Mutations

Inborn errors affecting intracellular cobalamin metabolism, designated cbl mutations (Table 36.8), are sorted by their metabolic changes, whether homocystinuria, methylmalonic aciduria, or both. The disorders are then differentiated by complementation studies in which the metabolic behaviors of patients' fibroblasts fused with known-disease fibroblasts are compared. Most genes are known but the proteins coded by some of them are unknown.¹⁴²

Homocystinuria without MMA elevation marks the cblE defect, caused by methionine synthase reductase deficiency; the cblG defect, caused by methionine synthase deficiency; and the cblD-variant 1. Megaloblastic anemia and prominent neurologic problems occur, usually in the first few years of life,⁴²⁸ but diagnosis can sometimes be delayed.⁴²⁹ Therapy is generally effective, although the neurologic problems are difficult to reverse unless treated early.

Isolated methylmalonic acidurias (cblA, cblB, cblD-variant 2, mutase, and epimerase defects) affect adenosylcobalamin, which is required in the methylmalonyl CoA mutase reaction, or other methylmalonyl enzymes. The cblB defect affects adenosyltransferase, whereas mitochondrial reduction of cobalamin appears to be defective in cblA and cblD-variant 2.¹⁴² These disorders cause lethargy, vomiting, dehydration, failure to thrive, hypotonia, and acidosis but do not produce megaloblastic anemia.⁴³⁰ Presentation is in the first months of life, but the course and response to cobalamin may vary. The clinical picture in cblD-variant 2 was complicated by an intracranial hemorrhage at birth. The two mutase defects affect the methylmalonyl CoA mutase enzyme itself: muto, characterized by enzyme deficiency, and mut-, with abnormal enzyme. Methylmalonyl CoA epimerase (racemase) deficiency was described in a patient with mild MMA elevation.⁴³¹ The mutase and epimerase defects do not involve cobalamin or respond to it, have either no clinical manifestations or just the mild ones seen in other methylmalonic acidurias, and are mentioned only for the differential diagnosis of methylmalonic aciduria.

The combined homocystinuria-methylmalonic acidurias include the cblC, cblD, cblF, and cblJ defects, which affect both methylcobalamin and adenosylcobalamin. Megaloblastic anemia is prominent in cblC, often with a microangiopathic and thrombocytopenic process resembling the hemolytic uremic syndrome,⁴³² but megaloblastic anemia is muted in cblD and

cbfF defects.⁹³ Many children with cblC, the most common of the cbl disorders, have severe courses marked by neurologic dysfunction, acidosis, perimacular degeneration, and thromboses.⁴³³ Prognosis is often poor. The cblD defect can vary in hematologic and neurologic severity and includes venous thromboses.^{93, 434} The defect involves the MMADHC gene, which has a cobalamin binding motif and a putative mitochondrial targeting sequence.⁴³⁴ CblD is puzzling because, despite complementation identity, different mutations of the gene can produce homocystinuria, methylmalonic aciduria, or both;^{434, 435} each is discussed within its metabolic group. Variable presentations are seen in the cblF and cblJ defects, in which lysosomal export appears defective.^{436, 437, 438}

Increased Requirements

High demand for cobalamin in hypermetabolic and increased cell turnover states has been proposed, but its documentation is incomplete. Patients with clinical consequences have yet to be identified satisfactorily.

Old Age

Normal aging does not cause cobalamin deficiency but common disorders of aging, such as gastritis and gastric atrophy, predispose to it.^{178, 322, 439} The elderly are at increased risk for both clinically expressed and subclinical deficiencies, including the most common causes of each form, pernicious anemia and food-cobalamin malabsorption, respectively. Although frequencies vary with the studied population and the test cutpoint selection, most studies estimate that 10% or more of the elderly are affected, with SCCD outnumbering clinical deficiency severalfold. The frequency of low cobalamin levels outnumbers low folate levels^{191, 440}.

Elevated cobalamin levels appear to be independent predictors of mortality in elderly patients with or without cancer.^{441, 442} The explanation is unknown.

Causes of Folate Deficiency

The origin of folate deficiency is often multifactorial. Limited intake may not be able to compensate for increased folate demand, or a drug or genetic polymorphism that mildly inhibits folate metabolism can convert borderline folate intake into frank deficiency. That being said, the landscape of folate deficiency has changed dramatically as a result of food fortification and folate supplement use. The incidence of deficiency has decreased sharply. Between 1988-1994 and 2001-2002, the frequency of serum folate levels below 3 µg/L declined from 18.4% to 0.2% of the American population and that of red cell folate below 160 µg/L declined from 45.8% to 7.1%, across all economic and demographic strata.⁴⁴³ Other studies reported even greater impact in those who also took folate supplements.⁴⁴⁴ The folate status of American elderly leapfrogged that of younger adults, largely because of higher rates of supplement use,⁴⁴³ whereas Europeans, with less exposure to fortification and supplements, showed metabolic signs of folate deficiency as they aged further.⁴⁴⁵

Dietary Insufficiency

The relatively small ratio of folate stores to daily requirement makes it possible to become folate-deficient after only a few months of poor intake, and the likelihood and speed of deficiency are enhanced when other causes coexist. The most common of these is abuse of alcohol,⁴⁴⁶ especially hard liquor, which also contains little folate.

Children

Delivery of maternal folate to the fetus is efficient,⁴⁵ so folate deficiency is rare at birth. Folate levels decline thereafter, and problems arise in some children in whom growth demands and limited diet combine. Premature infants have especially high requirements.⁴⁴⁷ The availability of folate from milk is limited.⁴⁵ Deficiency can appear in babies whose diet depends heavily on milk and who do not receive folate-fortified foods or supplements.

P.947

Folate deficiency can also occur with restricted diets, such as those given for phenylketonuria.

Malabsorption

Intestinal Malabsorption

Documented in only 2% of folate-deficient patients in one study,²⁷⁹ malabsorption is a distant second to malnutrition and alcoholism as a cause of folate deficiency. Deficiency appears early in tropical sprue, which can feature marked gastrointestinal symptoms and other absorptive defects.^{385, 386} The intestinal lesion itself can remit with folate therapy, although the remission can be limited. Celiac disease also causes folate malabsorption and deficiency in some patients, with or without cobalamin deficiency.^{389, 448} Inflammatory bowel disease, such as Crohn disease, which involves ileum most prominently, produces folate deficiency less often.⁴⁴⁹ Folate malabsorption has been described in patients with

dermatitis herpetiformis. The impact, if any, of food fortification on folate deficiency in patients with malabsorption requires study.

Other Malabsorptive Mechanisms

Folate absorption is reduced in atrophic gastritis and other gastric disorders or with drugs that cause achlorhydria.^{377, 450, 451, 452} It is not clear how often deficiency results.⁴⁵¹ Similarly, folate absorption diminishes when oral pancreatic replacement therapy, which buffers pH, is given for pancreatic insufficiency,⁴⁵³ whereas cobalamin absorption may improve.

Drugs and Toxins

Alcohol abuse is a major contributor to folate deficiency⁴⁴⁶ and should be suspected even when other causes of deficiency are found. The risk is highest in alcoholics who eat poorly, but alcohol also has direct effects on folate metabolism and transport. The latter include interruption of the enterohepatic recycling of hepatic methylTHF, direct toxicity to enterocytes, formation of aldehyde adducts, and increased degradation of folates.^{454, 455, 456, 457}

Sulfasalazine interferes with folate absorption and perhaps with folate-related enzymes.⁴⁵⁸ Hydantoins, and to a lesser extent other anticonvulsants, have been associated with macrocytosis and low folate levels, but megaloblastic anemia is uncommon.⁴⁵ The mechanisms are unclear. Valproic acid inhibits mitochondrial folate metabolism and affects fetal folate metabolism.⁴⁵⁹ Antifolates, such as methotrexate, inhibit folate binding to dihydrofolate reductase and thus limit the availability of THF (Fig. 36.2, reaction 1). Their effect can be bypassed by administering reduced folates such as 5-formylTHF (leucovorin; folinic acid). Trimethoprim-sulfamethoxazole and pyrimethamine are potent inhibitors of bacterial dihydrofolate reductase but weak inhibitors of the human enzyme. They cause megaloblastic anemia infrequently but appear to do so especially in patients with other limitations of folate status.⁴⁶⁰ Oral contraceptive use has been associated with diminished serum folate levels, but deficiency has not been well documented.

Inborn Errors of Folate Transport and Metabolism

Methylene Tetrahydrofolate Reductase Deficiency

Homozygous deficiency of this enzyme (Fig. 36.2, reaction 3), to be distinguished from the common polymorphism that causes no disease, produces severe neurologic dysfunction, including myelopathy, developmental delay, seizures, and microcephaly.¹⁴² Thrombosis may also occur. Symptoms usually arise in the first year, but mild cases may not be diagnosed until adulthood. Anemia does not develop because methyleneTHF remains available for thymidylate synthesis (reaction 2). Serum folate is low because methyleneTHF cannot be converted to methylTHF, the main circulating form of folate. The diagnosis is made by measuring enzyme activity in fibroblasts or leukocytes, which correlates with disease severity. Many mutations of the reductase gene have been identified.¹⁴² Early treatment, which includes betaine, is essential.⁴⁶¹

Hereditary Folate Malabsorption

This rare disorder is characterized by impaired transport of folate across both the intestinal mucosa and the choroid plexus because of mutations affecting the proton-coupled folate transporter, which is located at both those sites.^{36, 37} As a result, serum, red cell, and cerebrospinal fluid folate levels are very low. Megaloblastic anemia and severe neurologic dysfunction, including seizures, appear in the first few months of life.¹⁶¹ Diarrhea, mucositis, immunodeficiency, and failure to thrive also occur. Intensive parenteral and even intrathecal therapy have often been used, but some patients respond well to oral folinic acid.^{37, 161}

Cerebral Folate Deficiency

Cerebral folate deficiency is characterized by decreased cerebrospinal fluid methylTHF, whereas, unlike in hereditary folate malabsorption, folate absorption and systemic metabolism are normal.¹⁶² Thus, it features mental and neurologic manifestations similar to hereditary malabsorption but lacks low serum and red cell folate levels and megaloblastic anemia. Many affected children display mutations of the FOLR1 gene that codes for FR- α , which regulates methylTHF transport across the choroid plexus.^{462, 463} Others have autoantibody to FR- α instead,^{162, 464} including one middle-aged adult.⁴⁶⁵ Unrelated conditions can produce varying degrees of the same cerebral methylTHF deficiency without apparent mutations or FR- α abnormality.^{162, 466} These miscellaneous conditions await clarification. As illustrated in the next section, various hereditary disorders can produce similar pictures. The cerebral folate deficiency often responds to folinic acid;^{162, 467} folic acid is contraindicated.

Miscellaneous Folate Disorders

Five members from two families with megaloblastic anemia, seizures, microcephaly, and developmental delay had dihydrofolate reductase deficiency. They had normal serum folate and cobalamin levels but displayed a cerebral folate deficiency syndrome, with methylTHF deficiency and tetrahydrobiopterin deficiency limited to cerebrospinal fluid.^{467, 468} Hematologic improvement rapidly followed folinic acid therapy, but neurologic improvement was incomplete.

A mutation of the MTHFD1 gene, which encodes a single protein with three enzyme activities in folate metabolism (Fig. 36.2, reaction 6), was identified in a child with megaloblastic anemia, atypical hemolytic uremic syndrome, immunodeficiency, and homocystinuria.⁴⁶⁹

A single report of familial aplastic anemia with defective cellular uptake of folate⁴⁷⁰ remains a mystery.

Genetic Polymorphisms

No clinical consequences have been confirmed for many missense mutation polymorphisms affecting genes for folate-related enzymes and transport proteins.⁷⁰ The best-studied exception is the gene for methyleneTHF reductase, whose C677T and, to a lesser extent, A1298C mutations are common in most populations except blacks. These polymorphisms produce mildly diminished enzyme activity and no direct symptoms. However, mild hyperhomocysteinemia is seen if folate intake or levels are diminished in persons homozygous for the C677T mutation. Consequences such as increased risks for neural tube defect births and cardiovascular risks have been described and often appear tied to lower levels of folate intake.⁴⁷¹ It is interesting that reduced leukemia and colorectal cancer risks have been associated with this mutation.⁴⁷²

Increased Demand or Increased Losses

Fetal needs divert maternal folate via placental receptors. Other settings for increased demand for folate are lactation, chronic hemolytic anemia, and perhaps psoriasis and myeloproliferative

P.948

diseases. Evidence for stress on folate metabolism by increased requirements exists but lacks clear metabolic proof of depletion.^{35, 473, 474, 475, 476} Deficiency usually results when dietary intake cannot compensate adequately or disorders such as alcohol abuse or malabsorption supervene. Folic acid is often given routinely to pregnant women and patients with chronic hemolysis. However, a frequent mild elevation of homocysteine in sickle cell anemia appears unrelated to folate status or supplementation,⁴⁷⁷ and a randomized supplementation trial in sickle cell anemia failed to show clinical benefits.⁴⁷⁸ The increased detection of pernicious anemia in patients with sickle hemoglobinopathy suggests that monitoring is advisable by physicians who routinely prescribe folic acid.^{355, 356}

Folate is lost during dialysis, and supplements are often given. Alcohol abuse, anticonvulsants, and oral contraceptives have been proposed to cause increased folate catabolism and loss.⁴⁷⁹

Syndromes of Unknown Cause

A syndrome of acute deficiency, megaloblastic changes in bone marrow (but not peripheral blood), and pancytopenia was described in severely ill patients in intensive care units;⁴⁸⁰ serum folate levels have been normal. The entity is unclear because such patients have many illnesses and receive many drugs.

Causes of Megaloblastic Anemia Other than Cobalamin or Folate Deficiency

Thiamine-responsive Megaloblastic Anemia

A familial syndrome of megaloblastic anemia, diabetes mellitus, and sensorineural deafness can occur during childhood or adolescence.^{481, 482} Some patients may have additional features.⁴⁸³ The megaloblastic anemia and diabetes improve at least partially with thiamine therapy. Neither folate nor cobalamin has a known causative or therapeutic role. Several mutations of the thiamine transporter-1 gene have been found.^{483, 484, 485, 486} The patients have no evidence of thiamine deficiency.

Hereditary Orotic Aciduria

Megaloblastic anemia unrelated to folate or cobalamin accompanies developmental delay, orotic acid crystalluria, and ureteral problems in affected children.⁴⁸⁷ There is clinical heterogeneity. Some patients also have congenital malformations and immune deficiency. The defect usually involves the gene for both orotate phosphoribosyltransferase and orotidine 5'-monophosphate decarboxylase, which catalyze uridine-5-monophosphate synthesis. Oral uridine is effective.

Miscellaneous Causes

Chemotherapeutic agents that affect nucleoprotein synthesis, such as hydroxyurea and 5-fluorouracil, cause megaloblastic anemia. More easily distinguishable from megaloblastic anemia are the bizarre nuclear changes in arsenic toxicity.

Myelodysplastic syndromes occasionally feature nuclear characteristics that resemble megaloblastic change, but hyposegmentation of neutrophil nuclei ("pseudo-Pelger-Huet") is more common than hypersegmentation. Erythroleukemia and some cases of acute myelogenous leukemia also show megaloblastlike nuclear dysplasia in erythroid precursors.

Laboratory Diagnosis of the Causes of Deficiency

Cobalamin Deficiency

Malabsorption is the main suspect when evaluating causes because approximately 94% of cases of clinical cobalamin deficiency in adults have gastrointestinal origins.²⁷⁹ The situation has been modified by the increasing, often accidental identifications of patients with the usually clinically irrelevant SCCD, which is much less often associated with malabsorption.^{178, 179}

Although malabsorptive disorders in children, whether classically acquired as in adults or hereditary, are not unusual, the diagnostic approach in children differs and depends on age and other issues. Genetic metabolic disorders tend to present in early childhood but can be delayed; MMA and homocysteine must usually be measured because cobalamin levels may be normal. Maternal cobalamin status must also be part of the evaluation of very young children.

Direct Tests of Cobalamin Absorption

The classic absorption test, the Schilling test, assessed absorption of free crystalline cobalamin by measuring urinary excretion of an oral dose of ⁵⁷Co-labeled cyanocobalamin that approximated the amount in a meal.^{45, 488} If excreted radioactivity was subnormal, the test was repeated with an oral dose of IF. Correction of an abnormal result by IF diagnosed pernicious anemia; lack of correction suggested an intestinal problem. If results became normal upon re-testing after antibiotic treatment or with an oral pancreatic extract, intestinal bacterial overgrowth or pancreatic insufficiency, respectively, were likely. The Schilling test and all its variants have disappeared because of concerns about isotope use, limited and suspect sources of IF, and the tests' inconvenience and occasional unreliabilities.⁴⁸⁸

Probably contributing to the test's disappearance were misperceptions that diagnosing malabsorption was clinically irrelevant, which may have been reinforced by the large influx of new patients with SCCD, whose results were consistently normal.⁴⁸⁸ A new absorption test measuring serum holo-TC II response to oral cobalamin⁴⁸⁹ has not been convincingly validated.

Several food-cobalamin absorption tests have identified impaired release of ingested cobalamin from its binding to food proteins, using ⁵⁷Co-labeled cobalamin attached to egg, egg yolk, or chicken serum as vehicles in a procedure otherwise identical to the Schilling test which tested only absorption of free cobalamin.^{195, 363, 375} These tests have disappeared as well. Substitution of often mistaken, indirect criteria for direct foodcobalamin absorption testing has generated a series of unreliable reports by some authors, as noted elsewhere.⁴⁸⁸ Blood tests for gastritis/gastric atrophy or *H. pylori* status are also unreliable surrogate markers.^{240, 366}

Autoantibody to Intrinsic Factor

Testing serum for antibody to IF sometimes permits the diagnosis of pernicious anemia without having to resort to the Schilling test. Type I antibody, which blocks the cobalamin-binding site of IF, is slightly more frequent and more easily tested than type II antibody, which complexes with a nonbinding IF epitope. Antibody is found in 50% to 70% of patients with pernicious anemia, with the higher frequencies when more sensitive assays are used.^{490, 491, 492} Some groups of patients have higher rates; 96% of black women with pernicious anemia are positive.³²⁸ With the disappearance of Schilling tests, IF antibody, whose specificity exceeds 95%,^{45, 493} is the only practical option for diagnosing pernicious anemia, despite its poor sensitivity. However, serum containing excess free cobalamin often produces false-positive IF antibody results; blood samples obtained within days after a cobalamin injection must be avoided.⁴⁹⁴

Autoantibody to Gastric Parietal Cell

Parietal cell antibody is directed to the membrane H⁺,K⁺-adenosine triphosphatase pump subunits pre-existing in cytoplasmic tubulovesicles.^{323, 495} The antibody occurs in 80% to 90% of patients with pernicious anemia. However, it is specific for immune gastritis, not for pernicious anemia.⁴⁹⁶ Moreover, the

antibody tends to disappear with time,⁴⁹⁷ and it is not as sensitive as IF antibody in many types of patients, such as the young and some ethnic groups.^{332, 491}

Functional Blood Tests of Gastritis and Gastric Atrophy

Serum gastrin is elevated in 80% to 90% of patients with pernicious anemia,⁴⁹⁸ reflecting their gastric achlorhydria and frequent antral hypertrophy.^{322, 324} Levels tend to be very high, often in the thousands, particularly in women.^{491, 498} However, hypergastrinemia has many, more frequent causes, such as nonpernicious anemia atrophic gastritis or omeprazole use. Serum pepsinogens also reflect gastric status. Pepsinogen I, derived from fundic chief cells, is usually decreased in pernicious anemia, whereas pepsinogen II, which derives from fundus and antrum, is normal or elevated because of antral sparing in most patients with pernicious anemia.⁴⁹⁹ A low pepsinogen I-to-II ratio or low pepsinogen I level, or both, may be the most sensitive blood tests for pernicious anemia⁴⁹⁸ but have limited specificity. None of the tests mentioned in this section are diagnostically reliable in food-bound cobalamin malabsorption either.³⁶⁶

Direct Gastric Tests

Measuring IF content in stimulated gastric juice is the most reliable test for pernicious anemia but requires gastric intubation and is not generally available. Measuring gastric acid secretion has some diagnostic value because the presence of acid rules out Addisonian pernicious anemia.

Tests of Intestinal Function

Without the Schilling test, intestinal malabsorption of cobalamin is not identifiable. Today, intestinal malabsorption can only be suggested if other gastroenterologic tests, such as blood tests for celiac disease or ileal biopsy, identify a specific disease. Duodenal biopsy is more accessible than ileal biopsy but has much less diagnostic relevance to cobalamin.

Cobalamin-binding Proteins

Serum TC II assay identifies TC II deficiency in children with unexplained cobalamin deficiency (usually, but not always, accompanied by normal cobalamin levels) but is rarely needed when evaluating adults. TC I assay (testing plasma, and never serum) is useful in patients of all ages with unexplained low cobalamin levels who are asymptomatic or have equivocal symptoms.²⁵⁴ Measuring apoproteins with cobalamin-binding capacity assays is not as useful as immunoassays for total TC II or TC I, and becomes unreliable after cobalamin injection which saturates apoproteins, rendering them unmeasurable. TC I assays, and to a lesser extent TC II assays, can sometimes also help explain high cobalamin levels.^{56, 78, 260}

Folate Deficiency

Because dietary insufficiency, alcohol abuse, and drug effects often contribute to folate deficiency,²⁷⁹ a careful history is usually the most effective diagnostic test. Malabsorption must be considered when a dietary cause is not apparent. Tests of folate absorption are unavailable, and response to oral folic acid does not rule out malabsorption.

Acquired causes of deficiency predominate in children too. Dietary deficiency may occur in specific settings and can be aggravated by the demands of growth and development. Hereditary disorders are rare but can be severe.¹⁴² They may feature low folate levels, as in methyleneTHF reductase deficiency or hereditary malabsorption, or normal levels. Relevant enzymes can be measured and genetic mutations are increasingly identifiable. If neurologic symptoms exist, measuring cerebrospinal fluid folate, including methylTHF, can be diagnostically helpful whether serum levels are normal or not.

MANAGEMENT

Management of cobalamin and folate deficiencies extends beyond giving the right vitamin and can be complex.¹⁹³ It can be undermined by patient noncompliance¹²⁷ and by physician error, which most often involves underestimation of the disorder and its requirements, especially the value of precise diagnosis of underlying causes. Management goals are to reverse symptoms; select the appropriate dose, route, and duration of vitamin replacement; ensure that the vitamin deficiency was identified correctly and that the patient responded appropriately; identify the underlying disorder that caused the deficiency and treat it directly, if possible, define its prognosis, and manage its complications; and provide patient education. These goals do not apply easily to SCCD, whose need for therapy is undefined.¹⁹³

Reversal of Presenting Symptoms

Course

Megaloblastic anemia reverses quickly with the correct vitamin. The patient often begins to feel better within a day, before anemia improves. New reticulocytes appear in 2 to 3 days. Effective hematopoiesis replaces ineffective hematopoiesis, as lactate dehydrogenase and bilirubin decline and maturation of erythroid precursors becomes more normoblastic. Although neutrophil hypersegmentation persists for 2 weeks or more,¹⁰⁵ white blood cell and platelet counts rise in the first week if they had been decreased. Peak reticulocytosis occurs at 7 to 10 days. As new normocytic cells accumulate, which can be detected with reticulocyte-specific profiling,¹⁰⁸ the MCV declines. The blood count becomes fully normal before 8 weeks have elapsed. In most cases, neurologic improvement becomes noticeable in the first few weeks.

There are no signs or symptoms to reverse in patients with SCCD, but occasionally mild signs can be identified retroactively upon their improvement after cobalamin therapy.

Monitoring the Response

Homocysteine and MMA levels begin to fall within a few days of therapy and can be used to monitor response;^{183, 184} monitoring vitamin levels, whether cobalamin, holo-TC II, or serum folate, has little value because plasma levels rise passively regardless of therapeutic effectiveness. Reticulocyte response can be assessed best at the end of the first week, and it is always useful to determine completeness of hematologic response after 8 weeks. An incomplete response at either time usually indicates a coexisting anemia, perhaps one that was initially inapparent; most often, the cause is iron deficiency, which can be masked in megaloblastic anemia. A poor response can also indicate that the original diagnosis was incorrect.

The extent of neurologic improvement cannot always be predicted. In general, the likelihood of full reversal with cobalamin is inversely related to the duration of symptoms before therapy was started and the extent of the original dysfunction. Whatever reversal can be expected is usually completed by 6 months, but improvement occasionally continues until a year or more. Progression despite therapy throws doubt on cobalamin deficiency as its cause.

Blood Transfusion

Patients with megaloblastic anemia tend to compensate for even severe anemia surprisingly well⁵⁰⁰ and usually can be managed supportively until cobalamin therapy takes effect. The temptation

P.950

to transfuse should be resisted unless coexisting conditions or worrisome symptoms and signs (e.g., cardiopulmonary or cerebrovascular) require immediate intervention. If transfusion is given, care must be taken to avoid aggravating the pre-existing volume overload.

Vitamin Replacement

Unless folate and cobalamin deficiency coexist, using both vitamins together has uncertain benefits and, done reflexively, can muddy the specificity of the response and the patient's understanding of the medical condition.

Cobalamin Deficiency

Rapid reversal of anemia or neurologic dysfunction is achieved most reliably with intramuscular cobalamin. Cyanocobalamin use predominates in the United States and is the model here, although hydroxocobalamin is more physiologic and its better retention allows less frequent injection.⁵⁰¹ Methylcobalamin can also be used but its advantages are unclear. As little as 1 to 2 µg of cobalamin produces quick hematologic response, but a series of 1,000-µg injections is usually given during the first few weeks. Because nonspecific intestinal absorption of cobalamin is very limited, many details of subsequent therapy depend on whether the IF mechanism is intact. When absorption is normal, oral cyanocobalamin can usually be used, and doses of 2 to 5 µg do not substantially exceed IF capacity. Intranasal and sublingual preparations, which bypass IF, have no proven advantages, and may be ineffective if rhinitis or other mucosal conditions exist.

If free cobalamin cannot be absorbed, as in pernicious anemia, most maintenance regimens call for 100 to 1,000 µg cyanocobalamin given intramuscularly once a month. Most of the 1,000-µg dose is excreted rapidly in the urine, but the amount retained (100 to 150 µg) is greater than with 100-µg doses (55 µg retained). Very high oral doses, long known to be effective even in patients with pernicious anemia,⁵⁹ have been resurrected with daily oral doses of 1,000 µg (or even 2,000 µg) as a suitable alternative,⁵⁰² although clinical response has not been consistently optimal.⁵⁰³ The advantage of oral therapy is avoidance of injection, with its discomfort, costs, and inconvenience. This must be weighed against the need to take a large dose every day, often for life; the need to monitor periodically because daily compliance is surely

poorer in daily practice than it has been among research volunteers; and the incomplete documentation of equivalence of neurologic improvement after oral and parenteral cobalamin.¹⁹³ Because relapse occurs sooner when oral rather than parenteral therapy is discontinued,¹²⁸ repletion of stores by injection before embarking on oral maintenance is advisable.

Cobalamin replacement must continue for as long as the underlying cause persists. Occasional patients seem to require more frequent injections for unknown reasons^{59, 193} and should be allowed to do so or be given hydroxocobalamin. The only known side effects of cobalamin are rare allergic or even anaphylactic reactions, sometimes to the preservative. Some patients treated with depot preparations of hydroxocobalamin form anti-TC II antibodies, which seem to produce no effects other than very high serum cobalamin levels.²⁶⁶ Isolated British reports of high rates of sudden death during treatment of severe megaloblastic anemia, attributed to the transient hypokalemia in early hematologic response to therapy (in fact, similar hypokalemia accompanies treatment of iron deficiency anemia), have not been confirmed.⁵⁰⁴ Giving potassium preventively is unnecessary unless special circumstances dictate it.

The optimal treatment of elderly patients (or anyone) with SCCD is unclear. Oral 6- μ g doses, typical of most multivitamins, are not always effective.^{378, 379} Controlled trials of graded oral doses in elderly persons with SCCD reported persistent MMA abnormalities until daily doses exceeded 50 to 500 μ g^{505, 506, 507} but did not document absorption status or why the poor responses occurred.²⁴⁰ The assumption that food-cobalamin malabsorption allows normal absorption of free cobalamin when taken with meals is untested and may be mistaken.¹⁹³

Hereditary disorders require individually tailored therapy and close monitoring because expression, severity, and response vary even in the same disorder. Other sources can be consulted for relevant details.¹⁴²

Folate Deficiency

Oral synthetic folic acid is stable and efficiently absorbed.³⁵ Daily doses of 1 mg usually suffice, and it is better absorbed than food folate, even by patients with malabsorptive disorders. Monitoring the response can determine if higher doses or intramuscular injections are needed. Body stores can be repleted within a month or two. The need to continue longer is guided by the underlying disorder, its persistence or likelihood of recurrence, and the patient's dietary, medical, and social details.

Treatment of children with inborn errors of folate metabolism calls for larger doses, often given parenterally, and may require specialized regimens.¹⁴² Folinic acid is needed for disorders that require reduced folic acid, such as cerebral folate deficiency, and in patients using drugs that inhibit dihydrofolate reductase.

Direct toxicity of folic acid is minimal.⁵⁰⁸ Seizure disorders have worsened in some patients receiving large doses intravenously.⁵⁰⁹ Concern about folate administration to someone with unrecognized and untreated clinical cobalamin deficiency has engaged attention because of adverse experiences in patients with pernicious anemia. The anemia of cobalamin deficiency usually responds at least partially to folic acid, although relapse occurs eventually.^{152, 153} In the meantime, unchecked neurologic progression can occur. This issue with diverse ramifications is discussed further in the section, "Preventive and Other Uses of Supplements."

Assurance of Response

The diagnosis of deficiency is often made with varying degrees of certainty, especially in minimally symptomatic patients. The less clear the original evidence, the greater is the value of monitoring therapeutic response.

Managing Underlying Disorders Causing the Deficiency

Pernicious anemia is the most likely cause for clinically obvious cobalamin deficiency, but other malabsorptive causes account for at least 25% of cases.²⁷⁹ This sizeable minority includes independently treatable causes whose identification may be simple (e.g., the history of gastric surgery) or require greater effort (e.g., pursuing bacterial overgrowth). An important goal is to determine how long therapy must continue. As to pernicious anemia, conclusive diagnosis has tangible clinical value despite the disease's irreversibility. For example, it confers the confidence to recommend endoscopy to screen for cancer and to insist upon lifelong cobalamin therapy. Ironically, many patients (and some physicians) attribute cobalamin deficiency to dietary inadequacy, which accounts for only 1% of clinically expressed cases. The dietary inadequacy needed to create clinically overt deficiency is usually dramatic and obvious.

The diagnostic pursuit of causes of folate deficiency is diametrically different. Poor diet is by far the most common cause and malabsorption is among the least common.²⁷⁹ The post-fortification era has removed much of the folate deficiency attributable to inadequate intake alone.^{443, 510} The causes today need to be reexamined to determine if fortification has left behind mostly the

deficiencies requiring medical interventions, such as alcoholism, small bowel disease, and drugs affecting folate status.

Patient Education

Pernicious anemia is a prototype of the ideal medical encounter: a disease with potentially disastrous consequences that is easily and safely treated. Yet, therapy is frequently discontinued.¹²⁷ Patient education about cause, course, and prognosis is critical. Noncompliance occurs in many serious diseases throughout medical practice, especially those with toxic or inconvenient therapies. Just the opposite may be operative in pernicious anemia; its simple vitamin therapy may lull patients (and sometimes physicians) into complacency about its medical importance.^{511 512}

Preventive and Other Uses of Supplements

Nonmedical vitamin use is widespread, especially among the elderly, women, whites, and the affluent. Thirty-five percent of American adults report recent supplement use,⁵¹³ and 38% of the elderly have folate levels above 20 µg/L.⁵¹⁰ Both folate and cobalamin are generally viewed as beneficial and innocuous. However, experience with chronic supplementation using high daily doses in minimally deficient and nondeficient persons is limited.

Folic Acid

Folic acid fortification has successfully reduced NTD rates, leading to advocacy for raising fortification levels further to maximize the prevention²¹¹ and for raising cobalamin intake.⁵¹⁴ Self-supplementation is popular for purposes of varying validity, and the 1 mg folic acid intake limit advised by the Food and Drug Administration to reduce the likelihood of masking undiagnosed cobalamin deficiency³⁵ is often exceeded with supplements.

Three categories of adverse consequences are being investigated, with still tentative conclusions. First, epidemiologic studies have not provided consistent answers about folate-related neurologic and cognitive risks in persons with SCCD,^{154, 179, 515, 516, 517, 518, 519, 520, 521} Second, levels of unmetabolized folic acid appear to be high as serum folate levels several times normal have become common in the general population.^{520, 522, 523, 524} Whether folic acid poses adverse oxidative risks has been inconclusive.^{522, 525, 526} Third, folate deficiency is linked with higher cancer risk, especially well documented in colorectal cancer,⁵²⁷ and high folate intake has decreased that risk.^{528, 529} Yet, folate may also accelerate precancerous conditions, such as colonic adenomatous polyps.⁵²⁷ All this suggests a binary folate effect, reducing risk of new neoplasia and accelerating transformation of precancerous lesions. To this have been added unexpected data, including clinical trials, linking high folic acid intake, with or without cobalamin and pyridoxine, with risks of other cancers, such as breast cancer,^{530, 531, 532} but other studies disagree.^{533, 534}

A homocysteine-lowering trial in patients with diabetic nephropathy found that folic acid, cobalamin, and pyridoxine unexpectedly worsened renal function and vascular complications.⁵³⁵ It seems clear that safety issues of high folate intakes need careful study.^{527, 536}

Cobalamin

The public health debate about cobalamin supplementation programs for SCCD is in its early stages.¹⁷⁹ Most supplements contain 6 µg of cyanocobalamin, but many contain 25 µg or more. However, these usual doses may not suffice in the elderly or in persons with food-cobalamin malabsorption. Studies, including clinical trials, have reported many persons whose SCCD does not fully correct despite supplements of 100 µg or more.^{51, 240, 378, 379, 505, 506, 507} The absorptive or other limitations impairing responsiveness in the elderly need to be defined.

Evidence that high-dose cobalamin, folic acid, and pyridoxine supplementation may slow the progression of brain atrophy and cognitive decline^{204, 205} is of great interest. The mechanisms of these promising findings need elucidation, but so do concerns whether chronic intake of high daily doses of vitamins has any negative consequences.

The value of dietary fortification with cobalamin to circumvent the cobalamin deficiency-related risks of folate fortification is also unclear. Fortification with cobalamin must grapple with the paradox that bioavailability may be limited precisely in those who might benefit most, whereas those needing it the least absorb cobalamin efficiently (and may have been responsible for most of the seeming responsiveness to oral doses that studies of supplementation have reported). Studies must examine critical subsets, not just overall population-wide data. The efficacy and practicality of fortifying are not obvious currently, especially if high doses prove necessary.^{537, 538} The risks of chronic, daily intake of high doses are unknown, but accumulation of inactive cyanocobalamin in cells has been reported.⁵³⁹

REFERENCES

1. Addison T. Anaemia—disease of the supra-renal capsules. *Lond Med Gaz* 1849;43:517-518.

2. Minot GR, Murphy WP. Treatment of pernicious anemia by a special diet. *JAMA* 1926;87:470-476.
3. Castle WB. Observations on the etiologic relationship of achylia gastrica to pernicious anemia. I. The effect of the administration to patients with pernicious anemia of the contents of the normal human stomach recovered after the ingestion of beef muscle. *Am J Med Sci* 1929;178:748-764.
4. Rickes EL, Brink NG, Koniuszy FR, et al. Crystalline vitamin B₁₂. *Science* 1948;107:396-397.
5. Smith EL, Parker LFJ. Purification of anti-pernicious anaemia factor. *Biochem J* 1948;43:viii-ix.
6. Hodgkin DC, Kamper J, Mackay M, et al. Structure of vitamin B₁₂. *Nature* 1956;178:64-66.
7. Wills L. Treatment of "pernicious anaemia of pregnancy" and "tropical anaemia," with special reference to yeast extract as curative agent. *BMJ* 1931;1:1059-1064.
8. Jukes TH, Stokstad TLR. Pteroylglutamic acid and related compounds. *Physiol Rev* 1948;28:51-106.
9. Herbert V. Experimental nutritional folate deficiency in man. *Trans Assoc Am Phys* 1962;75:307-320.
10. Kass L. Pernicious anemia. Philadelphia: WB Saunders, 1976.
11. Wintrobe MM. Blood, pure and eloquent: a story of discovery, of people, and of ideas. New York, NY: McGraw-Hill, 1980.
12. Chanarin I. A history of pernicious anemia. *Br J Haematol* 2000;111: 407-415.
13. Hoffbrand AV, Weir DG. The history of folic acid. *Br J Haematol* 2001;113: 579-589.
14. Hall CA. The nondiagnosis of pernicious anemia. *Ann Intern Med* 1965;63:951-954.
15. Carmel R. Macrocytosis, mild anemia and delay in diagnosis of pernicious anemia. *Arch Intern Med* 1979;139:47-50.
16. Carmel R, Karnaze DS. Physician response to low serum cobalamin levels. *Arch Intern Med* 1986;146:1161-1165.
17. Carmel R. Current concepts in cobalamin deficiency. *Annu Rev Med* 2000;51:357-375.
18. Shane B. Folate chemistry and metabolism. In: Bailey LB, ed. *Folate in health and disease*, 2nd ed. Boca Raton, FL: CRC Press, 2009:1-24.
19. Stover PJ. Folate biochemical pathways and their regulation. In: Bailey LB, ed. *Folate in health and disease*, 2nd ed. Boca Raton, FL: CRC Press, 2009:49-74.
20. Kolhouse JF, Kondo H, Allen NC, et al. Cobalamin analogues are present in human plasma and can mask cobalamin deficiency because current radioisotope dilution assays are not specific for true cobalamin. *N Engl J Med* 1978;299:785-792.
21. el Kholty S, Guéant JL, Bressler L, et al. Portal and biliary phases of enterohepatic circulation of corrinoids in humans. *Gastroenterology* 1991;101: 1399-1408.
22. Kondo H, Kolhouse JF, Allen RH. Presence of cobalamin analogues in animal tissues. *Proc Natl Acad Sci U S A* 1980;77:817-821.
23. Banerjee R. B₁₂ trafficking in mammals: a case for coenzyme escort service. *ACS Chem Biol* 2006;1:149-159.
24. Leclerc D, Wilson A, Dumas R, et al. Cloning and mapping of a cDNA for methionine synthase reductase, a flavoprotein defective in patients with homocystinuria. *Proc Natl Acad Sci U S A* 1998;95:3059-3064.
25. Fenton WA, Hack AM, Helfgott D, et al. Biogenesis of the mitochondrial enzyme methylmalonyl-CoA mutase: synthesis and processing of a precursor in a cell-free system and in cultured cells. *J Biol Chem* 1984;259:6616-6621.
26. Noronha JM, Silverman M. On folic acid, vitamin B₁₂, methionine und formiminoglutamic acid metabolism. In: Heinrich HC, ed. *Vitamin B₁₂ and intrinsic factor 2. Europäisches symposion*. Stuttgart: Enke, 1962:728-736.
27. Herbert V, Zalusky R. Interrelations of vitamin B₁₂ and folic acid metabolism: folic acid clearance studies. *J Clin Invest* 1962;41:1263-1276.
28. Chanarin I, Deacon R, Lumb M, et al. Cobalamin and folate: recent developments. *J Clin Pathol* 1992;45:277-283.
29. Finkelstein J. Homocysteine: a history in progress. *Nutr Rev* 2000;58: 193-204.
30. Clarke S, Banfield K. S-Adenosylmethionine-dependent methyltransferases. In: Carmel R, Jacobsen DW, eds. *Homocysteine in health and disease*. Cambridge, MA: Cambridge University Press, 2001:65-80.

31. McKillop DJ, Pentieva K, Daly D, et al. The effect of different cooking methods on folate retention in various foods that are major contributors to folate intake in the UK diet. *Br J Nutr* 2002;88:681-688.
32. Choukmenowitch SF, Selhub J, Wilson PWF, et al. Folic acid intake from fortification in United States exceeds predictions. *J Nutr* 2002;132:2792-2798.
33. McDowell MA, Lacher DA, Pfeiffer CM, et al. Blood folate levels: the latest NHANES results. NCHS data briefs, no. 6. Hyattsville, MD: National Center for Health Statistics, 2008.
34. Rock CL. Multivitamin-multimineral supplements: who uses them? *Am J Clin Nutr* 2007;85(Suppl):277S-279S.
35. Panel on folate, other B vitamins, and choline; Institute of Medicine. Folate. In: Dietary reference intakes: thiamin, riboflavin, niacin, vitamin B₆, folate, vitamin B₁₂, pantothenic acid, biotin, and choline. Washington, DC: National Academy of Sciences, 1998:196-305.
36. Zhao R, Matherly RH, Goldman ID. Membrane transporters and folate homeostasis: intestinal absorption and transport into systemic compartments and tissues. *Exp Rev Mol Med* 2009;11:e4.
37. Qiu A, Jansen M, Sakaris A, et al. Identification of an intestinal folate transporter and the molecular basis for hereditary folate malabsorption. *Cell* 2006;127:917-928.
38. Nakai Y, Inoue K, Abe N, et al. Functional characterization of human proton-coupled folate transporter/heme carrier protein 1 heterologously expressed in mammalian cells as a folate transporter. *J Pharmacol Exp Ther* 2007;322:469-476.
39. Wright AJA, Dainty JR, Finglas PM. Folic acid metabolism in human subjects revisited: potential implications for proposed mandatory folic acid fortification in the UK. *Br J Nutr* 2007;98:667-675.
40. Maziarz KM, Monaco HL, Shen F, et al. Complete mapping of divergent amino acids responsible for differential ligand binding of folate receptors α and β . *J Biol Chem* 1999;274:11086-11091.
41. Rijnboutt S, Jansen G, Posthuma G, et al. Endocytosis of GPI-linked membrane folate receptor- α . *J Cell Biol* 1996;132:35-47.
42. Shen F, Ross JF, Wang X, et al. Identification of a novel folate receptor, a truncated receptor, and receptor type β in hematopoietic cells: cDNA cloning, expression, immunoreactivity, and tissue specificity. *Biochem* 1994;33: 1209-1215.
43. Chan SY, Empig CJ, Welte FJ, et al. Folate receptor- α is a cofactor for cellular entry by Marburg and Ebola viruses. *Cell* 2001;106:117-126.
44. Steinberg SE, Campbell CL, Hillman RS. Kinetics of the normal folate enterohepatic cycle. *J Clin Invest* 1979;64:83-88.
45. Chanarin I. The megaloblastic anaemias, 2nd ed. Oxford: Blackwell Scientific, 1979.
46. Stites TE, Bailey LB, Scott KC, et al. Kinetic modeling of folate metabolism through the use of chronic administration of deuterium-labeled folic acid in men. *Am J Clin Nutr* 1997;65:53-60.
47. Birn H. The kidney in vitamin B₁₂ and folate homeostasis: characterization of receptors for tubular uptake of vitamins and carrier proteins. *Am J Physiol Renal Physiol* 2006;291:F22-F36.
48. Watanabe F. Vitamin B₁₂ sources and bioavailability. *Exp Biol Med* 2007;232: 1266-1274.
49. Tucker KL, Rich S, Rosenberg I, et al. Plasma vitamin B₋₁₂ concentrations relate to intake source in the Framingham offspring study. *Am J Clin Nutr* 2000;71:514-522.
50. Vogiatzoglou A, Smith AD, Nurk E, et al. Dietary sources of vitamin B₋₁₂ and their association with plasma vitamin B₋₁₂ concentrations in the general population: the Hordaland homocysteine study. *Am J Clin Nutr* 2009;89:1078-1087.
51. Howard JM, Azen C, Jacobsen DW, et al. Dietary intake of cobalamin in elderly people who have abnormal serum cobalamin, methylmalonic acid and homocysteine levels. *Eur J Clin Nutr* 1998;52:582-587.
52. Panel on folate, other B vitamins, and choline; Institute of Medicine. Vitamin B₁₂. In: Dietary reference intakes: thiamin, riboflavin, niacin, vitamin B₆, folate, vitamin B₁₂, pantothenic acid, biotin, and choline. Washington, DC: National Academy of Sciences, 1998:306-356.
53. Life Sciences Research Office. Third report on nutrition monitoring in the United States, vol. 2. Washington, DC: US Government Printing Office, 1996.
54. Bor MV, Lydeking-Olsen E, Moller J, Nexø E. A daily intake of approximately 6 μ g vitamin B₋₁₂ appears to saturate all the vitamin B-12-related variables in Danish postmenopausal women. *Am J Clin Nutr* 2006;83:52-58.

55. Bor MV, von Castel-Roberts KM, Kauwell GPA, et al. Daily intake of 4 to 7 µg dietary vitamin B₁₂ is associated with steady concentrations of vitamin B₁₂-related biomarkers in a healthy young population. *Am J Clin Nutr* 2010;91:571-577.
56. Carmel R. Cobalamin-binding proteins in man. In: Silber R, Gordon AS, LoBue J, et al., eds. *Contemporary hematology-oncology*, vol. 2. New York, NY: Plenum Publishing, 1981:79-129.
57. Seetharam B. Receptor-mediated endocytosis of cobalamin (vitamin B₁₂). *Annu Rev Nutr* 1999;19:173-195.
58. Quadros EV. Advances in the understanding of cobalamin assimilation and metabolism. *Br J Haematol* 2009;148:195-204.
59. Berlin H, Berlin R, Brante G. Oral treatment of pernicious anaemia with high doses of vitamin B₁₂ without intrinsic factor. *Acta Med Scand* 1968;184: 247-258.
60. Rothenberg SP, Quadros EV, Regec A. Transcobalamin II. In: Banerjee R, ed. *Chemistry and biochemistry of B₁₂*. New York, NY: Wiley-Interscience, 1999:441-473.
61. Hewitt JE, Gordon MM, Taggart RT, et al. Human gastric intrinsic factor: characterization of cDNA and genomic clones and localization to human chromosome 11. *Genomics* 1991;10:432-440.
62. Li N, Seetharam S, Seetharam B. Genomic structure of human transcobalamin II: comparison to human intrinsic factor and transcobalamin I. *Biochem Biophys Res Commun* 1995;208:756-764.
63. Wuerges J, Garau G, Geremia S, et al. Structural basis for mammalian vitamin B₁₂ transport by transcobalamin. *Proc Natl Acad Sci U S A* 2006;103: 4386-4391.
64. Shao JS, Carmel R, Alpers DH. Production of ectopic gastric intrinsic factor in gastric mucosa of humans with chronic gastritis. *Dig Dis Sci* 2011;56: 3209-3219.
65. Hom BL. Plasma turnover of ⁵⁷ cobalt-vitamin B₁₂ bound to transcobalamin I and II. *Scand J Haematol* 1967;4:321-332.
66. Carmel R, Hollander D. Extreme elevation of transcobalamin II levels in multiple myeloma and other disorders. *Blood* 1978;51:1057-1063.
67. Fräter-Schröder M, Hitzig WH, Grob PJ, et al. Increased unsaturated transcobalamin II in active autoimmune disease. *Lancet* 1978;2:238-239.
68. Nexø E, Christensen AL, Petersen TE, et al. Measurement of transcobalamin by ELISA. *Clin Chem* 2000;46:1643-1649.
69. Namour F, Olivier J-L, Abdelmouttaleb I, et al. Transcobalamin codon 259 polymorphism in HT-29 and Caco-2 cells and in Caucasians: relation to transcobalamin and homocysteine concentration in blood. *Blood* 2001;97: 1092-1098.
70. Gellekink H, den Heijer M, Heil SG, et al. Genetic determinants of plasma total homocysteine. *Semin Vasc Med* 2005;5:98-109.
71. Riedel BM, Molloy AM, Meyer K, et al. Transcobalamin polymorphism 67A>G, but not 776C>G, affects serum holotranscobalamin in a cohort of healthy middle-aged men and women. *J Nutr* 2011;141:1784-1790.
72. Burger RL, Mehlman CS, Allen RH. Human plasma R-type vitamin B₁₂ binding proteins. I. Isolation and characterization of transcobalamin I, transcobalamin III, and the normal granulocyte vitamin B₁₂-binding protein. *J Biol Chem* 1975;250:7700-7706.
73. Cowland JB, Borregaard N. The individual regulation of granule protein mRNA levels during neutrophil maturation explains the heterogeneity of neutrophil granules. *J Leukoc Biol* 1999;66:989-995.
74. Johnston J, Yang-Feng T, Berliner N. Genomic structure and mapping of the chromosomal gene for transcobalamin I (TCN1): comparison to human intrinsic factor. *Genomics* 1992;12:459-464.
75. Hall CA. Transcobalamins I and II as natural transport proteins of vitamin B₁₂. *J Clin Invest* 1975;56:1125-1131.
76. Carmel R. The distribution of endogenous cobalamin among cobalamin-binding proteins in the blood in normal and abnormal states. *Am J Clin Nutr* 1985;41:713-719.
77. Hardlei TF, Nexø E. A new principle for measurement of cobalamin and corrinoids, used for studies of cobalamin analogs on serum haptocorrin. *Clin Chem* 2009;55:1002-1010.
78. Carmel R, Vasireddy H, Aurangzeb I, et al. High serum cobalamin levels in the clinical setting: clinical associations and holo-transcobalamin changes. *Clin Lab Haematol* 2001;23:365-371.

79. Burger RL, Schneider RJ, Mehlman CS, et al. Human plasma R-type vitamin B₁₂ binding proteins. II. The role of transcobalamin I, transcobalamin III and the normal granulocyte vitamin B₁₂-binding protein in the plasma transport of vitamin B₁₂. *J Biol Chem* 1975;250:7707-7713.
80. Carmel R, Parker J, Kelman Z. Transcobalamin I (TC I) deficiency, a common cause of falsely low serum cobalamin (Cbl), is usually genetic, and plasma corrinoid analogs are decreased: is "withholding" Cbl and its analogs from human cells and the microbiome the chief biological role for TC I? *FASEB J* 2013 27:246.8
81. Carmel R. Large vitamin B₁₂-binding proteins and complexes in human serum. In: Zagalak B, Friedrich W, eds. *Vitamin B₁₂. Proceedings of the third European symposium on vitamin B₁₂ and intrinsic factor*. Berlin: Walter de Gruyter, 1979:777-790.
82. Carmel R, Tatsis B, Baril L. Circulating antibody to transcobalamin II causing retention of vitamin B₁₂ in the blood. *Blood* 1977;49:987-1000.
83. Carmel R. A new case of deficiency of the R binder for cobalamin, with observations on minor cobalamin-binding proteins in serum and saliva. *Blood* 1982;59:152-156.
84. Allen RH, Seetharam B, Podell E, et al. Effect of proteolytic enzymes on the binding of cobalamin to R protein and intrinsic factor. In vitro evidence that a failure to partially degrade R protein is responsible for cobalamin malabsorption in pancreatic insufficiency. *J Clin Invest* 1978;61:47-54.
85. He Q, Madsen M, Kilkenny A, et al. Amnionless function is required for cubilin brush-border expression and intrinsic factor-cobalamin (vitamin B₁₂) absorption in vivo. *Blood* 2005;106:1447-1453.
86. Coudroy G, Gburek J, Kozyraki R, et al. Contribution of cubilin and amnion-less to processing and membrane targeting of cubilin-amnionless complex. *J Am Soc Nephrol* 2005;16:2330-2337.
87. Pedersen GA, Chakraborty S, Steinhauer AL, Traub LM, Madsen M. AMN directs endocytosis of the intrinsic factor-vitamin (B₁₂) receptor cubam by engaging ARH or Dab2. *Traffic* 2010;11:706-720.
88. Beedholm-Ebsen R, van de Wetering K, Hardlei T, et al. Identification of multidrug resistance protein 1 (MRP/ABCC1) as a molecular gate for cellular export of cobalamin. *Blood* 2010;115:1632-1639.
- P.952
89. Quadros EV, Nakayama Y, Sequeira JM. The binding properties of the human receptor for the cellular uptake of vitamin B₁₂. *Biochem Biophys Res Comm* 2005;327:1006-1010.
90. Jiang W, Sequeira JM, Nakayama Y, Lai SC, Quadros EV. Characterization of the promoter region of TCbIR/CD320 gene, the receptor for cellular uptake of transcobalamin-bound cobalamin. *Gene* 2010;466:49-55.
91. Adams JF, Tankel HI, MacEwan F. Estimation of the total body vitamin B₁₂ in the live subject. *Clin Sci* 1970;39:107-113.
92. Allen RH, Stabler SP. Identification and quantitation of cobalamin and cobalamin analogues in human feces. *Am J Clin Nutr* 2008;87:1324-1335.
93. Carmel R, Goodman SI. Abnormal deoxyuridine suppression test in congenital methylmalonic aciduria-homocystinuria without megaloblastic anemia: divergent biochemical and morphological bone marrow manifestations of disordered cobalamin metabolism in man. *Blood* 1982;59:306-311.
94. Carmel R, Karnaze DS. The deoxyuridine suppression test identifies subtle cobalamin deficiency in patients without typical megaloblastic anemia. *JAMA* 1985;253:1284-1287.
95. Karnaze DS, Carmel R. Low serum cobalamin levels in primary degenerative dementia: do some patients harbor atypical cobalamin deficiency states? *Arch Intern Med* 1987;147:429-431.
96. Carmel R, Sinow RM, Karnaze DS. Atypical cobalamin deficiency: subtle biochemical evidence of deficiency is commonly demonstrable in patients without megaloblastic anemia and is often associated with protein-bound cobalamin malabsorption. *J Lab Clin Med* 1987;109:454-463.
97. Goodman AM, Harris JW. Studies in B₁₂-deficient monkeys with combined system disease. I. B₁₂-deficient patterns in bone marrow deoxyuridine suppression tests without morphologic or functional abnormalities. *J Lab Clin Med* 1980;96:722-733.

98. Wickramasinghe SN. The wide spectrum and unresolved issues of megaloblastic anemia. *Semin Hematol* 1999;36:3-18.
99. Blount BC, Mack MM, Wehr CM, et al. Folate deficiency causes uracil misincorporation into human DNA and chromosome breakage: implications for cancer and neuronal damage. *Proc Natl Acad Sci U S A* 1997;94: 3290-3295.
100. Wickramasinghe SN. Morphology, biology, and biochemistry of cobalamin- and folate-deficient bone marrow cells. *Baillieres Clin Haematol* 1995;8: 441-459.
101. Keller R, Lindstrand K, Norden A. Chromosome studies in megaloblastic anaemia before and after treatment. *Scand J Haematol* 1971;8:309-320.
102. Wollman MR, Penchansky L, Shekhter-Levin S. Transient 7q- in association with megaloblastic anemia due to dietary folate and B₁₂ deficiency. *J Pediatr Hematol Oncol* 1996;18:162-165.
103. Chintagumpala MM, Dreyer ZE, Steuber CP, et al. Pancytopenia with chromosomal fragility: vitamin B₁₂ deficiency. *J Pediatr Hematol Oncol* 1996;18:166-170.
104. Lindenbaum J, Nath BJ. Megaloblastic anemia and neutrophil hypersegmentation. *Br J Haematol* 1980;44:511-513.
105. Nath BJ, Lindenbaum J. Persistence of neutrophil hypersegmentation during recovery from megaloblastic granulopoiesis. *Ann Intern Med* 1979;90: 757-760.
106. Ingeberg S, Stoffersen E. Platelet dysfunction in patients with vitamin B₁₂ deficiency. *Acta Haematol* 1979;61:75-79.
107. Tamura J, Kubota K, Murakami H, et al. Immunomodulation by vitamin B₁₂: augmentation of CD8⁺ T lymphocytes and natural killer (NK) cell activity in vitamin B₁₂-deficient patients by methyl-B₁₂ treatment. *Clin Exp Immunol* 1999;116:28-32.
108. Ceylan C, Miskiouglu M, Colak H, Kilicciouglu B, Ozdemir E. Evaluation of reticulocyte parameters in iron deficiency, vitamin B₁₂ deficiency, and β -thalassemia minor patients. *Int J Lab Hem* 2007;29:327-334.
109. Savage DG, Ogundipe A, Allen RH, et al. Etiology and diagnostic evaluation of macrocytosis. *Am J Med Sci* 2000;319:343-352.
110. Hodgetts J, Peters SW, Hoy TG, et al. The ferritin content of normoblasts and megaloblasts from human bone marrow. *Clin Sci* 1986;70:47-51.
111. Carmel R, Skikne BS. Serum transferrin receptor in the megaloblastic anemia of cobalamin deficiency. *Eur J Haematol* 1992;49:246-250.
112. Carmel R, MacPhee RD Jr. Erythropoietin levels in cobalamin deficiency: comparison of anemic and nonanemic, subtly deficient patients. *Eur J Haematol* 1992;48:159-162.
113. Ingram CF, Davidoff AN, Marais E, et al. Evaluation of DNA analysis for evidence of apoptosis in megaloblastic anaemia. *Br J Haematol* 1997;96: 576-583.
114. Koury MJ, Ponka P. New insights into erythropoiesis: the role of folate, vitamin B₁₂, and iron. *Annu Rev Nutr* 2004;24:105-131.
115. Hamilton HE, Sheets RF, DeGowin EL. Studies with inagglutinable erythrocyte counts. VII. Further investigation of the hemolytic mechanism in untreated pernicious anemia and the demonstration of a hemolytic property in the plasma. *J Lab Clin Med* 1958;51:942-955.
116. Carmel R, Melnyk S, James SJ. Cobalamin deficiency with and without neurologic abnormalities: differences in homocysteine and methionine metabolism. *Blood* 2003;101:3302-3308.
117. Ballas SK. Abnormal erythrocyte membrane protein pattern in severe megaloblastic anemia. *J Clin Invest* 1978;61:1097-1101.
118. McCombe PA, McLeod JG. The peripheral neuropathy of vitamin B₁₂ deficiency. *J Neurol Sci* 1984;66:117-126.
119. Tomoda H, Shibasaki H, Hirata I, et al. Central vs peripheral nerve conduction. Before and after treatment of subacute combined degeneration. *Arch Neurol* 1988;45:526-529.
120. Pant SS, Asbury AK, Richardson EP Jr. The myelopathy of pernicious anemia. A neurological reappraisal. *Acta Neurol Scand* 1968;44(Suppl 35):1-36.
121. Weir D, Scott J. The biochemical basis of the neuropathy in cobalamin deficiency. *Baillieres Clin Haematol* 1995;8:479-497.

122. Waters AH, Mollin DL. Observations on the metabolism of folic acid in pernicious anaemia. *Br J Haematol* 1963;9:319-327.
123. Magnus EM. Whole blood folate values in pernicious anaemia: relation to treatment. *Eur J Haematol* 1987;39:39-43.
124. Lindenbaum J, Healton EB, Savage DG, et al. Neuropsychiatric disorders caused by cobalamin deficiency in the absence of anemia or macrocytosis. *N Engl J Med* 1988;318:1720-1728.
125. Carmel R. Pernicious anemia: the expected findings of very low serum cobalamin levels, anemia and macrocytosis are often lacking. *Arch Intern Med* 1988;148:1712-1714.
126. Healton EB, Savage DG, Brust JC, et al. Neurologic aspects of cobalamin deficiency. *Medicine* 1991;70:229-245.
127. Savage D, Lindenbaum J. Relapses after interruption of cyanocobalamin therapy in patients with pernicious anemia. *Am J Med* 1983;74:765-772.
128. Magnus EM. Cobalamin and unsaturated transcobalamin values in pernicious anaemia: relation to treatment. *Scand J Haematol* 1986;36:457-465.
129. Carmel R, Pullarkat V. Gene polymorphisms associated with diminished activity of 5,10-methylenetetrahydrofolate reductase do not explain the clinical manifestations of cobalamin deficiency. *Br J Haematol* 2003;120:907-908.
130. Rundles RW. Prognosis in the neurologic manifestations of pernicious anemia. *Blood* 1946;1:209-219.
131. Victor M, Lear AA. Subacute combined degeneration of spinal cord. Current concepts of the disease process. Value of serum vitamin B₁₂ determinations in clarifying some of the common clinical problems. *Am J Med* 1956;20: 896-911.
132. Kumar N, Gross JB Jr, Ahlskog JE. Copper deficiency myelopathy produces a clinical picture like subacute combined degeneration. *Neurology* 2004;63: 33-39.
133. Carmel R. Nutritional anemias and the elderly. *Sem Hematol* 2008;45: 225-234.
134. Hemmer B, Glocker FX, Schumacher M, et al. Subacute combined degeneration: clinical, electrophysiological, and magnetic resonance imaging findings. *J Neurol Neurosurg Psychiatry* 1998;65:822-827.
135. Steiner I, Kidron D, Soffer D, et al. Sensory peripheral neuropathy of vitamin B₁₂ deficiency: a primary demyelinating disease? *J Neurol* 1988;235: 163-164.
136. Saperstein DS, Wolfe GI, Gronseth GS, et al. Challenges in the identification of cobalamin-deficiency polyneuropathy. *Arch Neurol* 2003;60:1296-1301.
137. Misra UK, Kalita J, Kumar G, Kapoor R. Bladder dysfunction in subacute combined degeneration. A clinical, MRI, and urodynamic study. *J Neurol* 2008;255:1881-1888.
138. Stojsavljevic N, Levic Z, Drulovic J, et al. A 44-month clinical-brain MRI follow-up in a patient with B₁₂ deficiency. *Neurology* 1997;49:878-881.
139. Kealey SM, Provenzale JM. Tensor diffusion imaging in B₁₂ leukoencephalopathy. *J Comput Assist Tomogr* 2002;26:952-955.
140. Levitt A, Karlinsky H. Folate, vitamin B₁₂ and cognitive impairment in patients with Alzheimer's disease. *Acta Psychiatr Scand* 1992;86:301-305.
141. Carmel R, Gott PS, Waters CH, et al. The frequently low cobalamin levels in dementia usually signify treatable metabolic, neurologic and electrophysiologic abnormalities. *Eur J Haematol* 1995;54:245-253.
142. Watkins D, Rosenblatt DS. Inherited disorders of folate and cobalamin transport and metabolism. In: Valle D, Beaudet AL, Vogelstein B, et al., eds. *The online metabolic and molecular bases of inherited disease*. New York, NY: McGraw-Hill, 2011, Part 17, Chap 155. <http://www.ommbid.com/part17/ch155>.
143. White WB, Reik L Jr, Cutlip DE. Pernicious anemia seen initially as orthostatic hypotension. *Arch Intern Med* 1981;141:1543-1544.
144. Beitzke M, Pfister P, Fortin J, et al. Autonomic dysfunction and hemodynamics in vitamin-B₁₂ deficiency. *Auton Neurol* 2002;97:45-54.
145. Moore A, Ryan J, Watts M, et al. Orthostatic tolerance in older patients with vitamin B₁₂ deficiency before and after vitamin B₁₂ replacement. *Clin Auton Res* 2004;14:67-71.
146. Adams P, Chalmers T, Foulds W, et al. Megaloblastic anaemia and vision. *Lancet* 1967;1:229-231.

147. Bassi SS, Bulundwe KK, Greeff GP, et al. MRI of the spinal cord in myelopathy complicating vitamin B₁₂ deficiency: two additional cases and a review of the literature. *Neuroradiology* 1999;41:271-274.
148. Wallace P, Westmoreland B. The electroencephalogram in pernicious anemia. *Mayo Clin Proc* 1976;51:281-285.
149. Zegers de Beyl D, Delecluse F, Verbanck P, et al. Somatosensory conduction in vitamin B₁₂ deficiency. *Electroencephalogr Clin Neurophysiol* 1988;69: 313-318.
150. Fine EJ, Soria E, Paroski MW, et al. The neurophysiological profile of vitamin B₁₂ deficiency. *Muscle Nerve* 1990;13:158-164.
151. Misra UK, Kalita J, Das A. Vitamin B₁₂ deficiency neurological syndromes: a clinical, MRI and electrodiagnostic study. *Electromyogr Clin Neurophysiol* 2003;43:57-64.
152. Ross JF, Belding H, Paegel BL. The development and progression of subacute combined degeneration of the spinal cord in patients with pernicious anemia treated with synthetic pteroylglutamic (folic) acid. *Blood* 1948;3:68-90.
153. Schwartz SO, Kaplan SR, Armstrong BE. The long-term evaluation of folic acid in the treatment of pernicious anemia. *J Lab Clin Med* 1950;35: 894-898.
154. Carmel R. Does high folic acid intake affect unrecognized cobalamin deficiency, and how will we know it when we see it? *Am J Clin Nutr* 2009;90:1449-1450.
155. Reynolds EH, Rothfeld P, Pincus J. Neurological disease associated with folate deficiency. *BMJ* 1973;2:398-400.
156. Manzoor M, Runcie J. Folate responsive neuropathy: reports of ten cases. *BMJ* 1976;1:1176-1178.
157. Shorvon SD, Carney MWP, Chanarin I, et al. The neuropsychiatry of megaloblastic anaemia. *BMJ* 1980;281:1036-1038.
158. Lever EG, Elwes RDC, Williams A, et al. Subacute combined degeneration of the cord due to folate deficiency: response to methyl folate treatment. *J Neurol Neurosurg Psychiatry* 1986;49:1203-1207.
159. Alpert J, Fava M. Nutrition and depression: the role of folate. *Nutr Rev* 1997;55:145-149.
160. Penninx BWJH, Guralnik JM, Ferrucci L, et al. Vitamin B₁₂ deficiency and depression in physically disabled older women: epidemiologic evidence from the Women's Health and Aging Study. *Am J Psychiatry* 2000;157:715-721.
161. Geller J, Kronn D, Jayabose S, et al. Hereditary folate malabsorption. Family report and review of the literature. *Medicine* 2002;81:51-68.
162. Hyland K, Shoffner J, Heales SJ. Cerebral folate deficiency. *J Inherit Metab Dis* 2010;33:563-570.
163. Hjorting-Hansen E, Bertram U. Oral aspects of pernicious anaemia. *Br Dent J* 1968;125:266-270.
164. Wagley PF. Neurologic disturbances with folic acid therapy. *N Engl J Med* 1948;238:11-15.
165. Berg N, Dahlqvist A, Lindberg T, et al. Morphology, dipeptidases and disaccharidases of small intestinal mucosa in vitamin B₁₂ and folic acid deficiency. *Scand J Haematol* 1972;9:167-173.
166. Titenko-Holland N, Jacob RA, Shang N, et al. Micronuclei in lymphocytes and exfoliated buccal cells of postmenopausal women with dietary changes in folate. *Mutat Res* 1998;417:101-114.
167. Carmel R, Herbert V. Correctable intestinal defect of vitamin B₁₂ absorption in pernicious anemia. *Ann Intern Med* 1967;67:1201-1207.
168. Lindenbaum J, Pezzimenti J, Shea N. Small-intestinal function in vitamin B₁₂ deficiency. *Ann Intern Med* 1974;80:326-331.
169. Carmel R, Lau KHW, Baylink DJ, et al. Cobalamin and osteoblast-specific proteins. *N Engl J Med* 1988;319:70-75.
170. Jadhav M, Webb JKG, Vaishnav S, et al. Vitamin B₁₂ deficiency in Indian infants: a clinical syndrome. *Lancet* 1962;2:903-907.
171. Gough KR, Read AE, McCarthy CF, et al. Megaloblastic anaemia due to nutritional deficiency of folic acid. *QJM* 1963;32:243-257.
172. Carmel R. Hair and fingernail changes in acquired and congenital pernicious anemia. *Arch Intern Med* 1985;145:484-485.
173. Seaton DA, Goldberg A. Weight-loss in pernicious anaemia. *Lancet* 1960;1:1002-1004.

174. Henshaw L, Tizzard J, Booth K, et al. Haemoglobin A₂ levels in vitamin B₁₂ and folate deficiency. *J Clin Pathol* 1978;31:960-962.
175. Grode H, Laszlo J. Sickle cell trait, refractory anemia, and nutritional anemia with variable expression of A and S hemoglobin. *Ann Intern Med* 1966;65:321-324.
176. Kafetz K. Immunoglobulin deficiency responding to vitamin B₁₂ in two elderly patients with megaloblastic anaemia. *Postgrad Med J* 1985;61:1065-1066.
177. Dimond AS, George JN, Hastings C. Severe vitamin B₁₂ deficiency in a child mimicking thrombotic thrombocytopenic purpura. *Pediatr Blood Cancer* 2009;52:420-422.
178. Carmel R. Cobalamin, the stomach and aging. *Am J Clin Nutr* 1997;66: 750-759.
179. Carmel R. Subclinical cobalamin deficiency. *Curr Opin Gastroenterol* 2012;28:151-158.
180. Carmel R. Reversal by cobalamin therapy of minimal defects in the deoxyuridine suppression test in patients without anemia: further evidence for a subtle metabolic cobalamin deficiency. *J Lab Clin Med* 1992;119:240-244.
181. Karnaze DS, Carmel R. Neurological and evoked potential abnormalities in subtle cobalamin deficiency states, including those without anemia and with normal absorption of free cobalamin. *Arch Neurol* 1990;47:1008-1012.
182. Gilois C, Wierzbicki A, Hirani N, et al. The hematological and electrophysiological effects of cobalamin. Deficiency secondary to vegetarian diets. *Ann N Y Acad Sci* 1992;669:345-348.
183. Stabler SP, Marcell PD, Podell ER, et al. Assay of methylmalonic acid in the serum of patients with cobalamin deficiency using capillary gas chromatography mass spectrometry. *J Clin Invest* 1986;77:1606-1612.
184. Stabler SP, Marcell PD, Podell ER, et al. Elevation of total homocysteine in the serum of patients with cobalamin and folate deficiency detected by capillary gas chromatography-mass spectrometry. *J Clin Invest* 1988;81:466-474.
185. Rasmussen K. Solid-phase sample extraction for rapid determination of methylmalonic acid in serum and urine by a stable-isotope dilution method. *Clin Chem* 1989;35:260-264.
186. Lindenbaum J, Rosenberg IH, Wilson PWF, et al. Prevalence of cobalamin deficiency in the Framingham elderly population. *Am J Clin Nutr* 1994;60: 2-11.
187. Metz J, Bell AH, Flicker L, et al. The significance of subnormal vitamin B₁₂ concentration in older people: a case control study. *J Am Geriatr Soc* 1996;44:1355-1361.
188. Carmel R, Green R, Jacobsen DW, et al. Serum cobalamin, homocysteine and methylmalonic acid concentrations in a multiethnic elderly population: ethnic and sex differences in cobalamin and metabolite abnormalities. *Am J Clin Nutr* 1999;70:904-910.
189. Carmel R. Prevalence of undiagnosed pernicious anemia in the elderly. *Arch Intern Med* 1996;156:1097-1100.
190. Carmel R. Biomarkers of cobalamin (vitamin B-12) status in the epidemiologic setting: a critical overview of context, applications, and performance characteristics of cobalamin, methylmalonic acid, and holotranscobalamin II. *Am J Clin Nutr* 2011;94:348S-358S.
191. Bailey R, Carmel R, Green R, et al. Monitoring of vitamin B-12 nutritional status in the United States by using plasma methylmalonic acid and serum vitamin B-12. *Am J Clin Nutr* 2011;94:552-561.
192. Hvas A-M, Ellegaard J, Nexø E. Increased plasma methylmalonic acid level does not predict clinical manifestations of vitamin B₁₂ deficiency. *Arch Intern Med* 2001;161:1534-1541.
193. Carmel R. How I treat cobalamin (vitamin B₁₂) deficiency. *Blood* 2008;112: 2214-2221.
194. Waters WE, Withey JL, Kilpatrick GS, et al. Serum vitamin B₁₂ concentrations in the general population: a ten-year follow-up. *Br J Haematol* 1971;20: 521-526.
195. Carmel R. Malabsorption of food cobalamin. *Baillieres Clin Haematol* 1995;8: 639-655.
196. Smith DA. The worldwide challenge of the dementias: a role for B vitamins and homocysteine? *Food Nutr Bull* 2008;29(Suppl):143-172.
197. Clarke RJ, Bennett DA. B vitamins for prevention of cognitive decline. *JAMA* 2008;300:1819-1821.
198. McMahon JA, Green TJ, Skeaff CM, et al. A controlled trial of homocysteine lowering and cognitive performance. *N Engl J Med* 2006;354:2764-2772.

199. Balk EM, Raman G, Tatsioni A, et al. Vitamin B₆, B₁₂, and folic acid supplementation and cognitive function. A systematic review of randomized trials. *Arch Intern Med* 2007;167:21-30.
200. Aisen PS, Schneider LS, Sano M, et al. High-dose B vitamin supplementation and cognitive decline in Alzheimer disease. A randomized controlled trial. *JAMA* 2008;300:1774-1783.
201. Wald DS, Kasturiratne A, Simmonds M. Effect of folic acid, with or without other B vitamins, on cognitive decline: meta-analysis of randomized trials. *Am J Med* 2010;123:522-527.
202. Ho RCM, Cheung MWL, Fu E, et al. Is high homocysteine level a risk factor for cognitive decline in the elderly? A systematic review, meta-analysis, and meta-regression. *Am J Geriatr Psychiatry* 2011;19:607-617.
203. Durga J, van Boxtel MPJ, Schouten EG, et al. Effect of 3-year folic acid supplementation on cognitive function in older adults in the FACIT trial. *Lancet* 2007;369:208-216.
204. Smith AD, Smith SM, de Jager CA, et al. Homocysteine-lowering by B vitamins slows the rate of accelerated brain atrophy in mild cognitive impairment: a randomized controlled trial. *PLoS One* 2010;5:e12244.
205. de Jager CA, Oulhaj A, Jacoby R, et al. Cognitive and clinical outcomes of homocysteine-lowering B-vitamin treatment in mild cognitive impairment: a randomized controlled trial. *Int J Geriatr Psychiatry* 2012;27:592-600.
206. MRC Vitamin Study Research Group. Prevention of neural tube defects: results of the MRC Vitamin Study. *Lancet* 1991;338:131-137.
207. Czeizel AE, Dudas I. Prevention of the first occurrence of neural tube defects by periconceptional vitamin supplementation. *N Engl J Med* 1992;327: 1832-1835.
208. Brouns R, Ursem N, Lindemans J, et al. Polymorphisms in genes related to folate and cobalamin metabolism and the associations with complex birth defects. *Prenat Diagn* 2008;28:485-493.
209. Rothenberg SP, da Costa MP, Sequeira JM, et al. Autoantibodies against folate receptors in women with a pregnancy complicated by a neural-tube defect. *N Engl J Med* 2004;350:134-142.
210. Tang LS, Finnell RH. Neural and orofacial defects in Folbp1 knockout mice. *Birth Defects Res* 2003;67:209-218.
211. Wald NJ. Folic acid and the prevention of neural tube defects. *N Engl J Med* 2004;350:101-103.
212. McCully KS. Vascular pathology of homocysteinemia: implications for the pathogenesis of arteriosclerosis. *Am J Pathol* 1969;56:111-128.
213. Verhoef P, Stampfer M. Epidemiology of vascular and thrombotic associations. In: Carmel R, Jacobsen DW, eds. *Homocysteine in health and disease*. Cambridge, MA: Cambridge University Press, 2001:357-370.
214. The Homocysteine Studies Collaboration. Homocysteine and the risk of ischemic heart disease and stroke: a meta-analysis. *JAMA* 2002;288:2015-2022.
215. Kluijtmans LAJ, Young IS, Boreham CA, et al. Genetic and nutritional factors contributing to hyperhomocysteinemia in young adults. *Blood* 2003;101:2483-2488.
216. Pfeiffer CM, Osterloh JD, Kennedy-Stephenson J, et al. Trends in circulating concentrations of total homocysteine among US adolescents and adults: findings from the 1991-1994 and 1999-2004 National health and nutrition examination surveys. *Clin Chem* 2008;54:801-813.
217. Clarke R, Halsey J, Lewington S, et al. Effects of lowering homocysteine levels with B vitamins on cardiovascular disease, cancer, and cause-specific mortality. Meta-analysis of 8 randomized trials involving 37485 individuals. *Arch Intern Med* 2010;170:1622-1631.
218. Toole JF, Malinow MR, Chambless LE, et al. Lowering homocysteine in patients with ischemic stroke to prevent recurrent stroke, myocardial infarction, and death: the vitamin intervention for stroke prevention randomized controlled trial. *JAMA* 2004;291:565-575.
219. Lange H, Suryapranata H, De Luca G, et al. Folate therapy and in-stent restenosis after coronary stenting. *N Engl J Med* 2004;350:2673-2681.
220. The Heart Outcomes Prevention Evaluation (HOPE) 2 Investigators. Homocysteine lowering with folic acid and B vitamins in vascular disease. *N Engl J Med* 2006;354:1567-1577.

221. Bona KH, Njolstad I, Ueland PM, et al. Homocysteine lowering and cardiovascular events after myocardial infarction. *N Engl J Med* 2006;354:1578-1588.
222. Bazzano LA, Reynolds K, Holder KN, et al. Effect of folic acid supplementation on risk of cardiovascular diseases. A meta-analysis of randomized controlled trials. *JAMA* 2006;296:2720-2726.
223. Saxena S, Weiner JM, Carmel R. Red cell distribution width in untreated pernicious anemia. *Am J Clin Pathol* 1988;89:660-663.
224. Chan CWJ, Liu SYH, Kho CSB, et al. Diagnostic clues to megaloblastic anaemia without macrocytosis. *Int J Lab Hematol* 2007;29:163-171.
225. Green R, Kuhl W, Jacobson R, et al. Masking of macrocytosis by alpha-thalassemia in blacks with pernicious anemia. *N Engl J Med* 1982;307:1322-1325.
226. van der Weyden M, Rother M, Firkin B. Megaloblastic maturation masked by iron deficiency: a biochemical basis. *Br J Haematol* 1972;22:299-307.
227. Spivak J. Masked megaloblastic anemia. *Arch Intern Med* 1982;142: 2111-2114.
228. Carmel R, Green R, Jacobsen DW, et al. Neutrophil nuclear segmentation in mild cobalamin deficiency: relation to metabolic tests of cobalamin status and observations on ethnic differences in neutrophil segmentation. *Am J Clin Pathol* 1996;106:57-63.
229. Eichacker P, Lawrence C. Steroid-induced hypersegmentation in neutrophils. *Am J Hematol* 1985;18:41-45.
230. Westerman DA, Evans D, Metz J. Neutrophil hypersegmentation in iron deficiency anaemia: a case-control study. *Br J Haematol* 1999;107:512-515.
231. Adams J, Boddy K, Douglas A. Interrelation of serum vitamin B₁₂, total body vitamin B₁₂, peripheral blood morphology and the nature of erythropoiesis. *Br J Haematol* 1972;23:297-305.
232. Mollin DL, Anderson BB, Burman JF. The serum vitamin B₁₂ level: its assay and significance. *Clin Haematol* 1976;5:521-546.
233. Zittoun J, Zittoun R. Modern clinical testing strategies in cobalamin and folate deficiency. *Semin Hematol* 1999;36:35-46.
234. Carmel R, Brar S, Agrawal A, et al. Failure of assay to identify low cobalamin concentrations. *Clin Chem* 2000;46:2017-2018.
235. Vlasveld LT, van't Wout JW, Meeuwissen P, et al. High measured cobalamin (vitamin B₁₂) concentration attributable to an analytic problem in testing serum from a patient. *Clin Chem* 2006;52:157-158.
236. Carmel R, Agrawal YP. Failures of cobalamin assays in pernicious anemia. *N Engl J Med* 2012;367:385-386.
237. Yetley EA, Pfeiffer CM, Phinney KW, et al. Biomarkers of vitamin B-12 status in NHANES: a roundtable summary. *Am J Clin Nutr* 2011;94(Suppl): 313S-321S.
238. Gunter EW, Bowman BA, Caudill SP, et al. Results of an international round robin for serum and whole-blood folate. *Clin Chem* 1996;42:1689-1694.
239. Morkbak AL, Heimdal RM, Emmens K, et al. Evaluation of the technical performance of novel holotranscobalamin assays in a multicenter European demonstration project. *Clin Chem Lab Med* 2005;43:1058-1064.
240. Carmel R, Sarrai M. Diagnosis and management of clinical and subclinical cobalamin deficiency: advances and controversies. *Curr Hematol Rep* 2006;5: 23-33.
241. Solomon LR. Cobalamin-responsive disorders in the ambulatory care setting: unreliability of cobalamin, methylmalonic acid, and homocysteine testing. *Blood* 2005;105:978-985.
242. Lindenbaum J, Savage DG, Stabler SP, et al. Diagnosis of cobalamin deficiency. II. Relative sensitivities of serum cobalamin, methylmalonic acid, and total homocysteine concentrations. *Am J Hematol* 1990;34:99-107.
243. Bolann BJ, Solli JD, Schneede J, et al. Evaluation of indicators of cobalamin deficiency defined as cobalamin-induced reduction in increased serum methylmalonic acid. *Clin Chem* 2000;46:1744-1750.
244. Clarke R, Sherliker P, Hin H, et al. Detection of vitamin B₁₂ deficiency in older people by holotranscobalamin, the active fraction of vitamin B₁₂. *Clin Chem* 2007;53:963-970.

245. Koebnick C, Heins UA, Dagnelie PC, et al. Longitudinal concentrations of vitamin B₁₂ and B₁₂-binding proteins during uncomplicated pregnancy. *Clin Chem* 2002;48:928-933.
246. Metz J, McGrath K, Bennett M, et al. Biochemical indices of vitamin B₁₂ nutrition in pregnant patients with subnormal serum vitamin B₁₂ levels. *Am J Hematol* 1995;48:251-255.
247. Burkes RL, Cohen H, Krailo M, et al. Low serum cobalamin levels occur frequently in the acquired immune deficiency syndrome and related disorders. *Eur J Haematol* 1987;38:141-147.
248. Remacha AF, Cadafalch J. Cobalamin deficiency in patients infected with the human immunodeficiency virus. *Semin Hematol* 1999;36:75-87.
249. Remacha AF, Cadafalch J, Sardà P, et al. Vitamin B₁₂ metabolism in HIV-infected patients in the age of highly active antiretroviral therapy: role of homocysteine in assessing vitamin B₁₂ status. *Am J Clin Nutr* 2003;77: 420-424.
250. Hansen O, Drivsholm A, Hippe E. Vitamin B₁₂ metabolism in myelomatosis. *Scand J Haematol* 1977;18:395-402.
251. Vlasveld LT. Low cobalamin (vitamin B₁₂) levels in multiple myeloma: a retrospective study. *Neth J Med* 2003;61:249-252.
252. Zhu Y, He ZY, Liu HN. Meta-analysis of the relationship between homocysteine, vitamin B₁₂, folate, and multiple sclerosis. *J Clin Neurosci* 2011;18:933-938.
253. Pinhas-Hamiel O, Doron-Panush N, Reichman B, et al. Obese children and adolescents. A risk group for low vitamin B₁₂ concentrations. *Arch Pediatr Adolesc Med* 2006;160:933-936.
254. Carmel R. Mild transcobalamin I (haptocorrin) deficiency and low serum cobalamin concentrations. *Clin Chem* 2003;49:1367-1374.
255. Carmel R, Coltman CA Jr, Brubaker LH. Serum vitamin B₁₂-binding proteins in neutropenia. *Proc Soc Exp Biol Med* 1975;148:1217-1222.
256. Riedel B, BJORKE Monsen AL, Ueland PM, Schneede J. Effects of oral contraceptives and hormone replacement therapy on markers of cobalamin status. *Clin Chem* 2005;51:778-781.
257. Carlsen SM, Folling I, Grill V, et al. Metformin increases total serum homocysteine levels in non-diabetic male patients with coronary heart disease. *Scand J Clin Lab Invest* 1997;57:521-527.
258. Leung S, Mattman A, Snyder F, et al. Metformin induces reductions in plasma cobalamin and haptocorrin bound cobalamin levels in elderly diabetic patients. *Clin Biochem* 2010;43:759-760.
259. Chandna SM, Tattersall JE, Nevett GE, et al. Low serum vitamin B₁₂ levels in chronic high-flux haemodialysis patients. *Nephron* 1997;75:259-263.
260. Arendt JFB, Nexo E. Cobalamin related parameters and disease patterns in patients with increased serum cobalamin levels. *PLoS ONE* 2012;7:e45979.
261. Carmel R. Extreme elevation of serum transcobalamin I in patients with metastatic cancer. *N Engl J Med* 1975;292:282-284.
262. Lildballe DL, Nguyen KQ, Poulsen SS, Nielsen HO, Nexo E. Haptocorrin as marker of disease progression in fibrolamellar hepatocellular carcinoma. *Eur J Surg Oncol* 2011;37:72-79.
263. Kalyoncu U, Buyukasik Y, Akdogan A, et al. Increased serum vitamin B₁₂ levels are associated with adult-onset still's disease with reactive macrophage activation syndrome. *Joint Bone Spine* 2010;77:131-134.
264. Bowen RAR, Dowdell KC, Dale JK, et al. Elevated vitamin B₁₂ levels in auto-immune lymphoproliferative syndrome attributable to elevated haptocorrin in lymphocytes. *Clin Biochem* 2012;45:490-492.
265. Corcino JJ, Zalusky R, Greenberg M, et al. Coexistence of pernicious anaemia and chronic myeloid leukaemia: an experiment of nature involving vitamin B₁₂ metabolism. *Br J Haematol* 1971;20:511-520.
266. Skouby A, Hippe E, Olesen H. Antibody to transcobalamin II and B₁₂ binding capacity in patients treated with hydroxocobalamin. *Blood* 1971;38:769-774.
267. Lowrey I, Smith G. Elevated results in a vitamin B₁₂ assay when using serum blood collection tubes. *Ann Clin Biochem* 2003;50:560-562.
268. Carmel R. Ethnic and racial factors in cobalamin metabolism and its disorders. *Semin Hematol* 1999;36:88-100.

269. Hazra A, Kraft P, Selhub J, et al. Common variants of FUT2 are associated with plasma vitamin B₁₂ levels. *Nat Genet* 2008;40:1160-1162.
270. Ousalah A, Besseau C, Chery C, et al. Helicobacter pylori serologic status has no influence on the association between fucosyltransferase 2 polymorphism (FUT2 461 G>A) and vitamin B-12 in Europe and West Africa. *Am J Clin Nutr* 2012;95:514-521.
271. Selhub J, Jacques PF, Wilson PWF, et al. Vitamin status and intake as primary determinants of homocysteinemia in an elderly population. *JAMA* 1993;270:2693-2698.
272. Brouwer DAJ, Welten HTME, Reijngoud DJ, et al. Plasma folic acid cutoff value derived from its relationship with homocyst(e)ine. *Clin Chem* 1998;44:1545-1550.
273. Lewis CA, Pancharuniti N, Sauberlich HE. Plasma folate adequacy as determined by homocysteine level. *Ann N Y Acad Sci* 1992;669:360-362.
274. Owen WE, Roberts WL. Comparison of five automated serum and whole blood folate assays. *Am J Clin Pathol* 2003;120:121-126.
275. Luccock M, Yates Z. Measurement of red blood cell methylfolate. *Lancet* 2002;360:1021-1022.
276. Hoffbrand AV, Newcombe BFA, Mollin DL. Method of assay of red cell folate activity and the value of the assay as a test for folate deficiency. *J Clin Pathol* 1966;19:17-28.
277. Benesch R, Kwong S, Benesch R, et al. The binding of folyl- and antifolylpolyglutamates to hemoglobin. *J Biol Chem* 1985;260:14653-14658.
278. Jaffe JP, Schilling RF. Erythrocyte folate levels: a clinical study. *Am J Hematol* 1991;36:116-121.
279. Savage DG, Lindenbaum J, Stabler SP, et al. Sensitivity of serum methylmalonic acid and total homocysteine determinations for diagnosing cobalamin and folate deficiencies. *Am J Med* 1994;96:239-246.
280. Pennypacker LC, Allen RH, Kelly JP, et al. High prevalence of cobalamin deficiency in elderly outpatients. *J Am Geriatr Soc* 1992;40:1197-1204.
281. Refsum H, Smith AD, Ueland PM, et al. Facts and recommendations about total homocysteine determinations: an expert opinion. *Clin Chem* 2004;50: 3-32.
282. Selhub J, Jacques PF, Rosenberg IH, et al. Serum total homocysteine concentrations in the Third National Health and Nutrition Examination Survey (1991-1994): population reference ranges and contribution of vitamin status to high serum concentrations. *Ann Intern Med* 1999;131:331-339.
283. Rasmussen K, Moller J, Lyngbak M, et al. Age- and gender-specific reference intervals for total homocysteine and methylmalonic acid in plasma before and after vitamin supplementation. *Clin Chem* 1996;42:630-636.
284. Carmel R. Cobalamin deficiency. In: Carmel R, Jacobsen DW, eds. *Homocysteine in health and disease*. Cambridge, MA: Cambridge University Press, 2001:289-305.
285. Hvas A-M, Ellegaard J, Lous J, Nexø E. Health technology assessment in clinical biochemistry. Methylmalonic acid: a Danish showcase. *Scand J Clin Lab Invest* 2003;63:319-330.
286. Morris MS, Jacques PF, Rosenberg IH, et al. Elevated serum methylmalonic acid concentrations are common among elderly Americans. *J Nutr* 2002;132:2799-2803.
287. Vogiatzoglou A, Oulhaj A, Smith AD, et al. Determinants of plasma methylmalonic acid in a large population.: implications for assessment of vitamin B₁₂ status. *Clin Chem* 2009;55:2198-2206.
288. Sentongo TA, Azzam R, Charrow J. Vitamin B₁₂ status, methylmalonic acidemia, and bacterial overgrowth in short bowel syndrome. *J Pediatr Gastroenterol Nutr* 2009;48:495-497.
289. Bjorke Monsen ALB, Refsum H, Ueland PM, et al. Cobalamin status and its biochemical markers methylmalonic acid and homocysteine in different age groups from 4 days to 19 years. *Clin Chem* 2003;49:2067-2075.
290. Bjorke-Monsen AL, Torsvik I, Saetran H, Markestad T, Ueland PM. Common metabolic profile in infants indicating impaired cobalamin status responds to cobalamin supplementation. *Pediatrics* 2008;122:83-19.
291. Allen RH, Stabler SP, Savage DG, Lindenbaum J. Elevation of 2-methylcitric acid I and II levels in serum, urine, and cerebrospinal fluid of patients with cobalamin deficiency. *Metabolism* 1993;42:978-988.

292. Lindemans J, Schoester M, van Kapel J. Application of a simple immunoabsorption assay for the measurement of saturated and unsaturated transcobalamin II and R-binders. *Clin Chim Acta* 1983;132:53-61.
293. Miller JW, Garrod MG, Rockwood AL, et al. Measurement of total vitamin B₁₂ and holotranscobalamin, singly and in combination, in screening for metabolic vitamin B₁₂ deficiency. *Clin Chem* 2006;52:278-285.
294. Schrempf W, Eulitz M, Neumeister V, et al. Utility of measuring vitamin B₁₂ and its active fraction, holotranscobalamin, in neurological vitamin B₁₂ deficiency syndromes. *J Neurol* 2011;258:393-401.
295. Wickramasinghe SN, Ratnayaka ID. Limited value of serum holo-transcobalamin II measurements in the differential diagnosis of macrocytosis. *J Clin Pathol* 1996;49:755-758.
296. Chen X, Remacha AF, Sarda MP, Carmel R. Influence of cobalamin deficiency compared with that of cobalamin absorption on serum holo-transcobalamin II. *Am J Clin Nutr* 2005;81:110-114.
297. Carmel R. On measuring and interpreting holotranscobalamin (holotranscobalamin II). *Clin Chem* 2002;48:407-409.
298. Hvas AM, Nexø E. Holotranscobalamin—a first choice assay for diagnosing early vitamin B₁₂ deficiency? *J Intern Med* 2005;257:289-298.
299. Metz J, Kelly A, Swett VC, et al. Deranged DNA synthesis by bone marrow from vitamin B₁₂-deficient humans. *Br J Haematol* 1968;14:575-592.
300. Carmel R, Rasmussen K, Jacobsen DW, et al. Comparison of the deoxyuridine suppression test with serum levels of methylmalonic acid and homocysteine in mild cobalamin deficiency. *Br J Haematol* 1996;93:311-318.
301. Wickramasinghe S. The deoxyuridine suppression test: biochemical basis and diagnostic applications. *Blood Rev* 1988;2:168-177.
302. Hansen HA, Weinfeld A. Metabolic effects and diagnostic value of small doses of folic acid and B₁₂ in megaloblastic anemias. *Acta Med Scand* 1962;172:427-443.
303. Barry SI, Broughton TM. Relative weight, weight loss efforts and nutrient intakes among health-conscious vegetarian, past vegetarian and nonvegetarian women ages 18 to 50. *J Am Coll Nutr* 2000;19:781-788.
304. Sanders TAB, Ellis FR, Dickerson JWT. Haematological studies on vegans. *Br J Nutr* 1978;40:9-15.
305. Haddad EH, Berk LS, Kettering JD, et al. Dietary intake and biochemical, hematologic, and immune status of vegans compared with nonvegetarians. *Am J Clin Nutr* 1999;70(Suppl):586S-593S.
306. Refsum H, Yajnik CS, Gadkari M, et al. Hyperhomocysteinemia and elevated methylmalonic acid indicate a high prevalence of cobalamin deficiency in Asian Indians. *Am J Clin Nutr* 2001;74:233-241.
307. Carmel R, Mallidi PV, Vinarskiy S, et al. Hyperhomocysteinemia and cobalamin deficiency in young Asian Indians in the United States. *Am J Hematol* 2002;70:107-114.
308. Obeid R, Geisel J, Schorr H, et al. The impact of vegetarianism on some haematological parameters. *Eur J Haematol* 2002;69:275-279.
309. Antony AC. Vegetarianism and vitamin B-12 (cobalamin) deficiency. *Am J Clin Nutr* 2003;78:3-6.
310. Schloesser LL, Schilling RF. Vitamin B₁₂ absorption studies in a vegetarian with megaloblastic anemia. *Am J Clin Nutr* 1963;12:70-74.
311. Carmel R. Subtle cobalamin malabsorption in a vegan patient: evolution into classical pernicious anemia with anti-intrinsic factor antibody. *Arch Intern Med* 1982;142:2206-2207.
312. van Dusseldorp M, Schneede J, Refsum H, et al. Risk of persistent cobalamin deficiency in adolescents fed a macrobiotic diet in early life. *Am J Clin Nutr* 1999;69:664-671.
313. Louwman MWJ, van Dusseldorp M, van den Vijver FJR, et al. Signs of impaired cognitive function in adolescents with marginal cobalamin status. *Am J Clin Nutr* 2000;72:762-769.
314. Hanley WB, Feigenbaum AS, Clarke JT, et al. Vitamin B₁₂ deficiency in adolescents and young adults with phenylketonuria. *Eur J Pediatr* 1996;155(Suppl 1): S145-S147.
315. Hvas AM, Nexø E, Nielsen JB. Vitamin B₁₂ and vitamin B₆ supplementation is needed among adults with phenylketonuria (PKU). *J Inher Metab Dis* 2006;29:47-53.

316. Higginbottom MC, Sweetman L, Nyhan WL. A syndrome of methylmalonic aciduria, homocystinuria, megaloblastic anemia and neurologic abnormalities in a vitamin B₁₂-deficient breast-fed infant of a strict vegetarian. *N Engl J Med* 1978;299:317-323.
317. Neurologic impairment in children associated with maternal dietary deficiency of cobalamin—Georgia, 2001. *MMWR Morb Mortal Wkly Rep* 2003;52:61-64.
318. Honzik T, Adamovicova M, Smolka V, et al. Clinical presentation and metabolic consequences in 40 breastfed infants with nutritional vitamin B12 deficiency—what have we learned? *Eur J Paediatr Neurol* 2010;14:488-495.
319. Grattan-Smith PJ, Wilcken B, Procopis PG, et al. The neurological syndrome of infantile cobalamin deficiency: developmental regression and involuntary movements. *Mov Disord* 1997;12:39-46.
320. Graham SM, Arvela OM, Wise GA. Long-term neurologic consequences of nutritional vitamin B₁₂ deficiency. *J Pediatr* 1992;121:710-714.
321. Poliner IJ, Spiro HM. The independent secretion of acid, pepsin, and “intrinsic factor” by the human stomach. *Gastroenterology* 1958;34:196-209.
322. Carmel R. Pernicious anemia: definitions, expressions, and the long-term consequences of atrophic gastritis. In: Holt PR, Russell RM, eds. *Chronic gastritis and hypochlorhydria in the elderly*. Boca Raton, FL: CRC Press, 1993:99-114.
323. Toh B-H, van Driel IR, Gleeson PA. Pernicious anemia. *N Engl J Med* 1997;337:1441-1448.
324. Strickland RG, Mackay IR. A reappraisal of the nature and significance of atrophic gastritis. *Am J Dig Dis* 1973;18:426-440.
325. Fong TL, Dooley CP, Dehesa M, et al. *Helicobacter pylori* infection in pernicious anemia: a prospective controlled study. *Gastroenterology* 1991;100:328-332.
326. Banka S, Ryan K, Thomson W, Newman WG. Pernicious anaemia—genetic insights. *Autoimmun Rev* 2011;10:455-459.
327. Irvine WJ, Cullen DR, Mawhinney H. Natural history of autoimmune achlorhydric atrophic gastritis. A 1-15 year follow-up study. *Lancet* 1974;2: 482-485.
328. Carmel R, Johnson CS. Racial patterns in pernicious anemia: early age of onset and increased frequency of intrinsic factor antibody in black women. *N Engl J Med* 1978;298:647-650.
329. Sievers ML, Metzger AL, Goldberg LS, et al. Pernicious anemia in Southwestern American Indians. *Blood* 1973;41:309-317.
330. Chanarin I, Malkowska V, O'Hea AM, et al. Megaloblastic anaemia in a vegetarian Hindu community. *Lancet* 1985;2:1168-1172.
331. Carmel R, Johnson CS, Weiner JM. Pernicious anemia in Latin Americans is not a disease of the elderly. *Arch Intern Med* 1987;147:1995-1996.
332. Au WY, Hui CH, Chan LC, et al. Clinicopathological features of megaloblastic anaemia in Hong Kong: a study of 84 Chinese patients. *Clin Lab Haematol* 1998;20:217-219.
333. Ye W, Nyrén O. Risk of cancers of the oesophagus and stomach by histology or subsite in patients hospitalised for pernicious anaemia. *Gut* 2003;52:938-941.
334. Gilligan CJ, Lawton GP, Tang LH, et al. Gastric carcinoid tumors: the biology and therapy of an enigmatic and controversial lesion. *Am J Gastroenterol* 1995;90:338-352.
335. Eriksson S, Clase L, Moquist-Olsson I. Pernicious anemia as a risk factor in gastric cancer. The extent of the problem. *Acta Med Scand* 1981;210: 481-484.
336. Schafer LW, Larson DE, Melton LJ III, et al. Risk of development of gastric carcinoma in patients with pernicious anemia: a population-based study in Rochester, Minnesota. *Mayo Clin Proc* 1985;60:444-448.
337. Borch K. Epidemiologic, clinicopathologic and economic aspects of gastroscopy screening of patients with pernicious anemia. *Scand J Gastroenterol* 1986;21:21-30.
338. Hsing AW, Hansson LE, McLaughlin JK, et al. Pernicious anemia and subsequent cancer: a population-based cohort study. *Cancer* 1993;71:745-750.

339. Kokkola A, Sjoblom SM, Haapianien R, et al. The risk of gastric carcinoma and carcinoid tumours in patients with pernicious anaemia. *Scand J Gastroenterol* 1998;33:88-92.
340. Carmel R, Weiner JM, Johnson CS. Iron deficiency occurs frequently in patients with pernicious anemia. *JAMA* 1987;257:1081-1083.
341. Hershko C, Ronson A, Souroujon M, et al. Variable hematologic presentation of autoimmune gastritis: age-related progression from iron deficiency to cobalamin depletion. *Blood* 2006;107:1673-1679.
342. Stockbruegger RW, Cotton PB, Menon GG, et al. Pernicious anaemia, intragastric bacterial overgrowth, and possible consequences. *Scand J Gastroenterol* 1984;19:355-364.
343. Aydogdu I, Sari R, Ulu R, et al. The frequency of gallbladder stones in patients with pernicious anemia. *J Surg Res* 2001;101:120-123.
344. Carmel R, Spencer CA. Clinical and subclinical thyroid disorders associated with pernicious anemia. Observations on abnormal thyroid-stimulating hormone levels and on a possible association of blood group O with hyperthyroidism. *Arch Intern Med* 1982;142:1465-1469.
345. Twomey JJ, Jordan PH, Jarrold T, et al. The syndrome of immunoglobulin deficiency and pernicious anemia: a study of ten cases. *Am J Med* 1969;47:340-350.
346. Pezzimenti J, Lindenbaum J. Megaloblastic anemia associated with erythroid hypoplasia. *Am J Med* 1972;53:748-754.
347. Chanarin I, Loewi G, Tavill AS, et al. Defect of renal tubular acidification with antibody to loop of Henle. *Lancet* 1974;2:317-318.
348. Rabinowitz AP, Sacks Y, Carmel R. Autoimmune cytopenias in pernicious anemia: a report of four cases and review of the literature. *Eur J Haematol* 1990;44:18-23.
349. Dan K, Ito T, Nomura T. Pure red cell aplasia following pernicious anemia. *Am J Hematol* 1990;33:148-150.
350. Takahashi T, Honma T, Ishizuka K, et al. A female with asymptomatic biliary cirrhosis associated with pernicious anemia. *J Gastroenterol Hepatol* 2001;16:1420-1424.
351. Landgren O, Engels EA, Caporaso NE, et al. Patterns of autoimmunity and subsequent chronic lymphocytic leukemia in Nordic countries. *Blood* 2006;108:292-296.
352. Blackburn EK, Callender ST, Dacie JV, et al. Possible association between pernicious anaemia and leukaemia: a prospective study of 1625 patients with a note on the very high incidence of stomach cancer. *Int J Cancer* 1968;3:163-170.
353. Brinton JA, Gridley G, Hrubec Z, et al. Cancer risk following pernicious anaemia. *Br J Cancer* 1989;59:810-813.
354. Drabick JJ, Davis BJ, Byrd JC. Concurrent pernicious anemia and myelodysplastic syndrome. *Ann Hematol* 2001;80:243-245.
355. Dhar M, Bellevue R, Carmel R. Pernicious anemia with neuropsychiatric dysfunction in a patient with sickle cell anemia treated with folate supplementation. *N Engl J Med* 2003;348:2204-2207.
356. Carmel R, Bellevue R, Kelman Z. Low cobalamin levels associated with sickle cell disease: contrasting origins and clinical meanings in two instructive patients. *Am J Hematol* 2010;85:436-439.
357. Carmel R. Gastric juice in congenital pernicious anemia contains no immunoreactive intrinsic factor molecule: study of three kindreds with variable ages at presentation, including a patient first diagnosed in adulthood. *Am J Hum Genet* 1983;35:67-77.
358. Katz M, Lee SK, Cooper BA. Vitamin B₁₂ malabsorption due to a biologically inert intrinsic factor. *N Engl J Med* 1972;287:425-429.
359. Yang YM, Ducos R, Rosenberg AJ, et al. Cobalamin malabsorption in three siblings due to an abnormal intrinsic factor that is markedly susceptible to acid and proteolysis. *J Clin Invest* 1985;76:2057-2065.
360. Yassin F, Rothenberg SP, Rao S, et al. Identification of a 4-base deletion in the gene in inherited intrinsic factor deficiency. *Blood* 2004;103:1515-1517.
361. Tanner SM, Li Z, Perko JD, et al. Hereditary juvenile cobalamin deficiency caused by mutations in the intrinsic factor gene. *Proc Natl Acad Sci U S A* 2005;102:4130-4133.

362. Zittoun J, Léger J, Marquet J, et al. Combined congenital deficiencies of intrinsic factor and R binder. *Blood* 1988;72:940-943.
363. Doscherholmen A, Swaim WR. Impaired assimilation of egg Co⁵⁷ vitamin B₁₂ in patients with hypochlorhydria and achlorhydria and after gastric resection. *Gastroenterology* 1973;64:913-919.
364. del Corral A, Carmel R. Transfer of cobalamin from the cobalamin-binding protein of egg yolk to R binder of human saliva and gastric juice. *Gastroenterology* 1990;98:1460-1466.
365. Cohen H, Weinstein WM, Carmel R. The heterogeneity of gastric histology and function in food cobalamin malabsorption: absence of atrophic gastritis and achlorhydria in some patients with severe malabsorption. *Gut* 2000;47:638-645.
366. Carmel R, Aurangzeb I, Qian D. Associations of food-cobalamin malabsorption with ethnic origin, age, *Helicobacter pylori* infection, and serum markers of gastritis. *Am J Gastroenterol* 2001;96:63-70.
367. Dierkes J, Ebert M, Malfertheimer P, et al. *Helicobacter pylori* infection, vitamin B₁₂ and homocysteine. *Dig Dis* 2003;21:237-244.
368. Suter PM, Golner BB, Goldin BR, et al. Reversal of protein-bound vitamin B₁₂ malabsorption with antibiotics in atrophic gastritis. *Gastroenterology* 1991;101:1039-1045.
369. Schenk BE, Festen HPM, Kuipers EJ, et al. Effect of short- and long-term treatment with omeprazole on the absorption and serum levels of cobalamin. *Aliment Pharmacol Ther* 1996;10:541-545.
370. Valuck RJ, Ruscini JM. A case-control study on adverse effects: H₂ blocker or proton pump inhibitor use and risk of vitamin B₁₂ deficiency in older adults. *J Clin Epidemiol* 2004;57:422-428.
371. Dawson DW, Sawers AH, Sharma RK. Malabsorption of protein bound vitamin B₁₂. *BMJ* 1984;288:675-678.
372. Jones BP, Broomhead AF, Kwan YL, et al. Incidence and clinical significance of protein-bound vitamin B₁₂ malabsorption. *Eur J Haematol* 1987;38:131-136.
373. Rygvold O. Hypovitaminosis B₁₂ following partial gastrectomy by the Billroth II method. *Scand J Gastroenterol* 1974;9(Suppl 29):57-64.
374. Sumner AE, Chin MM, Abraham JL, et al. Elevated methylmalonic acid and total homocysteine levels show high prevalence of vitamin B₁₂ deficiency after gastric surgery. *Ann Intern Med* 1996;124:469-476.
375. Mahmud K, Ripley D, Doscherholmen A. Vitamin B₁₂ absorption tests. Their unreliability in postgastrectomy states. *JAMA* 1971;216:1167-1171.
376. Hines JD, Hoffbrand AV, Mollin DL. The hematologic complications following partial gastrectomy. A study of 292 patients. *Am J Med* 1967;43:555-569.
377. Elsborg L. Malabsorption of folic acid following partial gastrectomy. *Scand J Gastroenterol* 1974;9:271-274.
378. Schilling RF, Gohdes PN, Hardie GH. Vitamin B₁₂ deficiency after gastric bypass surgery for obesity. *Ann Intern Med* 1984;101:501-502.
379. Rhode BM, Arseneau P, Cooper BA, et al. Vitamin B₁₂ deficiency after gastric surgery for obesity. *Am J Clin Nutr* 1996;63:103-109.
380. Rana CV, Bhardwa SB. Small intestinal bacterial overgrowth. *Scand J Gastroenterol* 2008;43:1030-1037.
381. Brandt LJ, Bernstein LH, Wagle A. Production of vitamin B₁₂ analogues in patients with small-bowel bacterial overgrowth. *Ann Intern Med* 1977;87:546-551.
382. Brasitus TA. Parasites and malabsorption. *Am J Med* 1979;67:1058-1065.
383. Editorial. Anaemia and the fish tapeworm. *Lancet* 1977;1:292.
384. Shimoda S, Saunders D, Rubin C. The Zollinger-Ellison syndrome with steatorrhea. II. The mechanism of fat and vitamin B₁₂ malabsorption. *Gastroenterology* 1968;55:705-723.
385. Baker SJ. Idiopathic small intestinal disease in the tropics. *Crit Rev Trop Med* 1982;1:197-245.
386. Haghighi P, Wolf PL. Tropical sprue and subclinical enteropathy: a vision for the nineties. *Crit Rev Clin Lab Sci* 1997;34:313-341.

387. Rosenberg IH. Tropical enteritis: nutritional consequences and connections with the riddle of cholera. *J Nutr* 2003;133:333S-335S.
388. Fausa O. Vitamin B₁₂ absorption in intestinal diseases. (Coeliac disease, dermatitis herpetiformis, ulcerative colitis, Crohn's disease, jejunoileal shunting). *Scand J Gastroenterol* 1974;9(Suppl):75-79.
389. Halfdanarson TR, Litzow MR, Murray JA. Hematologic manifestations of celiac disease. *Blood* 2007;129:412-421.
390. Duerksen DR, Fallows G, Bernstein CN. Vitamin B₁₂ malabsorption in patients with limited ileal resection. *Nutrition* 2006;22:1210-1213.
391. Hocking M, Duerson M, O'Leary J, et al. Jejunoileal bypass for morbid obesity. Late follow-up in 100 cases. *N Engl J Med* 1983;308:995-999.
392. Rasmussen I, Enblad P, Arosenius KE. Jejunoileal bypass for morbid obesity. Report of a series with long-term results. *Acta Chir Scand* 1989;155:401-407.
393. Nilsson L, Myrvold H, Swolin B, et al. Vitamin B₁₂ in plasma in patients with continent ileostomy and long observation time. *Scand J Gastroenterol* 1984;19:369-374.
394. Pannek J, Haupt G, Schulze H, et al. Influence of continent ileal urinary diversion on vitamin B₁₂ absorption. *J Urol* 1996;155:1206-1208.
395. Coull DB, Tait RC, Anderson JH, McKee RF, Finlay IG. Vitamin B₁₂ deficiency following restorative proctocolectomy. *Colorect Dis* 2007;9:562-566.
396. Aminoff M, Carter JE, Chadwick RB, et al. Mutations in CUBN, encoding the intrinsic factor-vitamin B₁₂ receptor, cubilin, cause hereditary megaloblastic anaemia 1. *Nat Genet* 1999;21:309-313.
397. Kristiansen M, Aminoff M, Jacobsen C, et al. Cubilin P1297L mutation associated with hereditary megaloblastic anemia 1 causes impaired recognition of intrinsic factor-vitamin B₁₂ by cubilin. *Blood* 2000;96:405-409.
398. Tanner SM, Aminoff M, Wright FA, et al. Amnionless, essential for mouse gastrulation, is mutated in recessive hereditary megaloblastic anemia. *Nat Genet* 2003;33:426-429.
399. Tanner SM, Li Z, Bisson R, et al. Genetically heterogeneous selective intestinal malabsorption of vitamin B₁₂: founder effects, consanguinity, and high clinical awareness explain aggregations in Scandinavia and the Middle East. *Hum Mutat* 2004;23:327-333.
400. Imerslund O. Idiopathic chronic megaloblastic anemia in children. *Acta Paediatr* 1960;49(Suppl):1-115.
401. Gräsbeck R, Gordin R, Kantero I, et al. Selective vitamin B₁₂ malabsorption and proteinuria in young people. A syndrome. *Acta Med Scand* 1960;167: 289-296.
402. Wahlstedt-Fröberg V, Pettersson T, Aminoff M, et al. Proteinuria in cubilind deficient patients with selective vitamin B₁₂ malabsorption. *Pediatr Nephrol* 2003;18:417-421.
403. Amsellem S, Gburek J, Hamard G, et al. Cubilin is essential for albumin reabsorption in the renal proximal tubule. *J Am Soc Nephrol* 2010;21:1859-1867
404. Carmel R, Ravindranath Y. Congenital transcobalamin II deficiency presenting atypically with a low serum cobalamin level: studies demonstrating the coexistence of a circulating transcobalamin I (R binder) complex. *Blood* 1984;63:598-605.
405. Hall CA. The neurologic aspects of transcobalamin II deficiency. *Br J Haematol* 1992;80:117-120.
406. Schiff MM, Ogier de Baulny H, Bard G, et al. Should transcobalamin deficiency be treated aggressively? *J Inher Metab Dis* 2010;33:223-229.
407. Hitzig WH, Fräter-Schröder M, Seger R. Immunodeficiency due to transcobalamin II deficiency. In: Elliott K, Whelan J, eds. Enzyme defects and immune dysfunction. Ciba Foundation Symposium 68, 1979:77-91.
408. Haurani F, Hall CA, Rubin R. Megaloblastic anemia as a result of an abnormal transcobalamin II (Cardeza). *J Clin Invest* 1979;64:1253-1259.
409. Li N, Rosenblatt DS, Kamen BA, et al. Identification of two mutant alleles of transcobalamin II in an affected family. *Hum Mol Genet* 1994;3:1835-1840.
410. Li N, Rosenblatt DS, Seetharam B. Nonsense mutations in human transcobalamin II deficiency. *Biochem Biophys Res Commun* 1994;204:1111-1118.

411. Monagle PT, Tauro GP. Long term follow-up of patients with transcobalamin II deficiency. *Arch Dis Child* 1995;72:237-238.
412. Quadros EV, Lai SC, Nakayama Y, et al. Positive newborn screen for methylmalonic aciduria identifies the first mutation in TCBLR/CD320, the gene for cellular uptake of transcobalamin-bound vitamin B₁₂. *Hum Mut* 2010;31:924-929.
413. Carmel R, Herbert V. Deficiency of vitamin B₁₂-binding alpha globulin in two brothers. *Blood* 1969;33:1-12.
414. Carmel R. R binder deficiency: a clinically benign cause of cobalamin pseudo-deficiency. *JAMA* 1983;250:1886-1890.
415. Lin JC, Borregaard N, Liebman HA, Carmel R. Deficiency of the specific granule proteins, R binder/transcobalamin I and lactoferrin, in plasma and saliva: a new disorder. *Am J Med Genet* 2001;100:145-151.
416. Carmel R, Parker J, Kelman Z. Genomic mutations associated with mild and severe deficiencies of transcobalamin I (haptocorrin) that cause mildly and severely low serum cobalamin levels. *Br J Haematol* 2009;147:386-391.
417. Carmel R, Parker J, Kelman Z: Mutations of TCN1 cause transcobalamin I deficiency with low serum cobalamin levels that are indistinguishable from cobalamin deficiency. *Blood* 2009;114(Suppl):787.
418. Guttormsen AB, Refsum H, Ueland PM. The interaction between nitrous oxide and cobalamin. Biochemical effects and clinical consequences. *Acta Anaesthesiol Scand* 1994;38:753-756.
419. Ermens AAM, Refsum H, Ruprecht J, et al. Monitoring cobalamin inactivation during nitrous oxide anesthesia by determination of homocysteine and folate in plasma and urine. *Clin Pharmacol Ther* 1991;49:385-393.
420. Carmel R, Rabinowitz AP, Mazumder A. Metabolic evidence of cobalamin deficiency in bone marrow cells harvested for transplantation from donors given nitrous oxide. *Eur J Haematol* 1993;50:228-233.
421. Layzer RB, Fishman RA, Schafer JA. Neuropathy following abuse of nitrous oxide. *Neurology* 1978;28:504-506.
422. Ng J, Frith R. Nanging. *Lancet* 2002;360:384.
423. Schilling RF. Is nitrous oxide a dangerous anesthetic for vitamin B₁₂-deficient subjects? *JAMA* 1986;255:1605-1606.
424. Flippo TS, Holder WD. Neurologic degeneration associated with nitrous oxide anesthesia in patients with vitamin B₁₂ deficiency. *Arch Surg* 1993;128: 1391-1395.
425. Rosener M, Dichgans J. Severe combined degeneration of the spinal cord after nitrous oxide anesthesia in a vegetarian. *J Neurol Neurosurg Psychiatry* 1996;60:354.
426. Sesso RMCC, Iunes Y, Melo ACP. Myeloneuropathy following nitrous oxide anesthesia in a patient with macrocytic anaemia. *Neuroradiology* 1999;41:588-590.
427. Danishpajoo IO, Gudi T, Chen Y, et al. Nitric oxide inhibits methionine synthase activity in vivo and disrupts carbon flow through the folate pathway. *J Biol Chem* 2001;276:27296-27303.
428. Watkins D, Rosenblatt DS. Functional methionine synthase deficiency (cblE and cblG): clinical and biochemical heterogeneity. *Am J Med Genet* 1989;34:427-434.
429. Carmel R, Watkins D, Goodman SI, et al. A hereditary defect of cobalamin metabolism (cblG mutation) presenting as a neurologic disorder in adulthood. *N Engl J Med* 1988;318:1738-1741.
430. Matsui SM, Mahoney MJ, Rosenberg LE. The natural history of the inherited methylmalonic acidemias. *N Engl J Med* 1983;308:857-861.
431. Dobson CM, Gradinger A, Longo N, et al. Homozygous nonsense mutations in the MCEE gene and siRNA suppression of methylmalonyl-CoA epimerase expression: a novel cause of mild methylmalonic aciduria. *Mol Genet Metab* 2006;88:327-333.
432. Geraghty MT, Perlman EJ, Martin LS, et al. Cobalamin C defect associated with hemolytic-uremic syndrome. *J Pediatr* 1992;120:934-937.
433. Rosenblatt DS, Aspler AL, Shevell MI, et al. Clinical heterogeneity and prognosis in combined methylmalonic aciduria and homocystinuria (cblC). *J Inherit Metab Dis* 1997;20:528-538.
434. Coelho D, Suormala T, Stucki M, et al. Gene identification for the cblD defect of vitamin B₁₂ metabolism. *N Engl J Med* 2008;358:1454-1464.
435. Suormala T, Baumgartner MR, Coelho D, et al. The cblD defect causes either isolated or combined deficiency of methylcobalamin and adenosylcobalamin synthesis. *J Biol Chem* 2004;279:42742-42749.

436. MacDonald MR, Wiltse HE, Bever JL, et al. Clinical heterogeneity in two patients with cblF disease. *Am J Hum Genet* 1992;51:A353.
437. Rutsch F, Gailus S, Suormala T, Fowler B. LMBRD1: the gene for the cblF defect of vitamin B₁₂ metabolism. *J Inher Metab Dis* 2011;34:121-126.
438. Coelho D, Kim JC, Miousse IR, et al. Mutations in ABCD4 cause a new inborn error of vitamin B₁₂ metabolism. *Nat Genet* 2012;44:1152-1155.
439. Nilsson-Ehle H. Age-related changes in cobalamin (vitamin B₁₂) handling. Implications for therapy. *Drugs Aging* 1998;12:277-292.
440. Herrmann W, Quast S, Ullrich M, et al. Hyperhomocysteinemia in high-aged subjects: relation of B-vitamins, folic acid, renal function, and the methylenetetrahydrofolate reductase mutation. *Atherosclerosis* 1999;144:91-101.
441. Geissbühler P, Mermillod B, Rapin C-H. Elevated serum vitamin B₁₂ levels associated with CRP as a predictive factor of mortality in palliative care cancer patients: a prospective study over five years. *J Pain Sympt Manage* 2000;20:93-103.
442. Hemmersbach-Miller M, Conde-Martel A, Betancor-Léon P. Vitamin B₁₂ as a predictor of mortality in elderly patients. *J Am Geriatr Soc* 2005;53: 2035-2036.
443. Ganji V, Kafai MR. Trends in serum folate, RBC folate, and circulating total homocysteine concentrations in the United States: analysis of data from National Health and Nutrition Examination Surveys, 1988-1994, 1999-2000, and 2001-2002. *J Nutr* 2006;136:153-158.
444. Jacques PF, Selhub J, Bostom AG, et al. The effect of folic acid fortification on plasma folate and total homocysteine concentrations. *N Engl J Med* 1999;340:1449-1454.
445. Clarke R, Evans JG, Schneede J, et al. Vitamin B₁₂ and folate deficiency in later life. *Age Ageing* 2004;33:34-41.
446. Lindenbaum J, Roman MJ. Nutritional anemia in alcoholism. *Am J Clin Nutr* 1980;33:2727-2735.
447. Worthington-White DA, Behnke M, Gross S. Premature infants require additional folate and vitamin B₁₂ to reduce the severity of the anemia of prematurity. *Am J Clin Nutr* 1994;60:930-935.
448. Hallert C, Tobiasson P, Walan A. Serum folate determinations in tracing adult coeliacs. *Scand J Gastroenterol* 1981;16:263-267.
449. Elsborg L, Larsen L. Folate deficiency in chronic inflammatory bowel disease. *Scand J Gastroenterol* 1979;14:1019-1024.
450. MacKenzie JF, Russell RI. The effect of pH on folic acid absorption in man. *Clin Sci Mol Med* 1976;51:363-365.
451. Russell RM, Krasinski SD, Samloff IM, et al. Folic acid malabsorption in atrophic gastritis: possible compensation by bacterial folate synthesis. *Gastroenterology* 1986;91:1476-1482.
452. Russell RM, Golner BB, Krasinski SD, et al. Effect of antacid and H₂ receptor antagonists on the intestinal absorption of folic acid. *J Lab Clin Med* 1988;112:458-463.
453. Russell RM, Dutta S, Oaks E, et al. Impairment of folic acid absorption by oral pancreatic extracts. *Dig Dis Sci* 1980;25:369-373.
454. Steinberg S, Campbell C, Hillman R. The toxic effects of alcohol on folate metabolism. *Clin Toxicol* 1980;17:407-411.
455. Halsted CH. Folate deficiency in alcoholism. *Am J Clin Nutr* 1980;33: 2736-2740.
456. Guynn R, Labaume L, Henkin J. Equilibrium constants under physiologic conditions for the condensation of acetaldehyde with tetrahydrofolic acid. *Arch Biochem Biophys* 1982;217:181-190.
457. Shaw S, Jayatilleke E, Herbert V, et al. Cleavage of folates during ethanol metabolism. Role of acetaldehyde/xanthine oxidase-generated superoxide. *Biochem J* 1989;257:277-280.
458. Selhub J, Dhar J, Rosenberg IH. Inhibition of folate enzymes by sulfasalazine. *J Clin Invest* 1978;61:221-224.
459. Wegner C, Nau H. Alteration of embryonic folate metabolism by valproic acid during organogenesis: implications for mechanism of teratogenesis. *Neurology* 1992;42(Suppl 5):17-24.
460. Kobrinsky L, Ramsay N. Acute megaloblastic anemia induced by high-dose trimethoprim-sulfamethoxazole. *Ann Intern Med* 1981;94:780-781.

461. Ronge E, Kjellman B. Long term treatment with betaine in methylenetetrahydrofolate reductase deficiency. *Arch Dis Child* 1996;74:239-241.
462. Cario H, Bode H, Debatin KM, Opladen T, Schwarz K. Congenital null mutations of the FOLR1 gene—a progressive neurologic disease and its treatment. *Neurology* 2009;73:2127-2129.
463. Steinfeld R, Grapp M, Kraetzner R, et al. Folate receptor alpha defect causes cerebral folate transport deficiency: a treatable neurodegenerative disorder associated with disturbed myelin metabolism. *Am J Hum Genet* 2009;85:354-363.
464. Ramaekers VT, Rothenberg SP, Sequeira JM, et al. Autoantibodies to folate receptors in the cerebral folate deficiency syndrome. *N Engl J Med* 2005;352:1985-1991.
465. Sadighi Z, Butler IJ, Koenig MK. Adult-onset cerebral folate deficiency. *Arch Neurol* 2012;69:778-779.
466. Perez-Duenas B, Ormazabal A, Toma C, et al. Cerebral folate deficiency syndromes in childhood. Clinical, analytic, and etiologic aspects. *Arch Neurol* 2011;68:615-621.

P.953

467. Banka S, Blom HJ, Walter J, et al. Identification and characterization of an inborn error of metabolism caused by dihydrofolate reductase deficiency. *Am J Hum Genet* 2012;88:216-225.
468. Cario H, Smith DEC, Blom H, et al. Dihydrofolate reductase deficiency due to a homozygous mutation causes megaloblastic anemia and cerebral folate deficiency leading to severe neurologic disease. *Am J Hum Genet* 2012;88:226-231.
469. Watkins D, Schwartzentruber JA, Ganesh J, et al. Novel inborn error of folate malabsorption: identification by exome capture and sequencing of mutations in the MTHFD1 gene in a single proband. *J Med Genet* 2011;48:590-592.
470. Branda RF, Moldow CF, MacArthur JR, et al. Folate-induced remission in aplastic anemia with familial defect of cellular folate uptake. *N Engl J Med* 1978;298:469-475.
471. Klerk M, Verhoef P, Clarke R, et al. MTHFR 677C>T polymorphism and risk of coronary heart disease. A meta-analysis. *JAMA* 2002;288:2023-2031.
472. Robien K, Ulrich CM. 5,10-methylenetetrahydrofolate reductase polymorphisms and leukemia risk: a HuGE minireview. *Am J Epidemiol* 2003;157:571-582.
473. Lindenbaum J. Folic acid requirement in situations of increased need. In: Folic acid. Biochemistry and physiology in relation to the human nutrition requirement. (Food and Nutrition Board, National Research Council.) Washington, DC: National Academy of Sciences, 1977:256-276.
474. McPartlin J, Halligan A, Scott JM, et al. Accelerated folate breakdown in pregnancy. *Lancet* 1993;341:148-149.
475. Mackey AD, Picciano MF. Maternal folate status during extended lactation and the effect of supplemental folic acid. *Am J Clin Nutr* 1999;69:285-292.
476. Ramlau-Hansen CH, Moller UK, Henriksen TB, et al. Folate and vitamin B₁₂ in relation to lactation: a 9-month postpartum follow-up study. *Eur J Clin Nutr* 2006;60:120-128.
477. Dhar M, Bellevue R, Brar S, et al. Mild hyperhomocysteinemia in adult patients with sickle cell disease: a common finding unrelated to folate and cobalamin status. *Am J Hematol* 2004;76:114-120.
478. Rabb L, Grandison Y, Mason K, et al. A trial of folate supplementation in children with homozygous sickle cell disease. *Br J Haematol* 1983;54:589-594.
479. Suh JR, Herbig AK, Stover PJ. New perspectives on folate catabolism. *Annu Rev Nutr* 2001;21:255-282.
480. Amos R, Amess J, Hinds C, et al. Incidence and pathogenesis of acute megaloblastic bone-marrow change in patients receiving intensive care. *Lancet* 1982;2:835-839.
481. Rogers LE, Porter FS, Sidbury JBJ. Thiamine-responsive megaloblastic anemia. *J Pediatr* 1969;74:494-504.
482. Haworth C, Evans DIK, Mitra J, et al. Thiamine responsive anaemia: a study of two further cases. *Br J Haematol* 1982;50:549-561.

483. Bergmann AK, Sahai I, Falcone JF, et al. Thiamine-responsive megaloblastic anemia: identification of novel compound heterozygotes and mutation update. *J Pediatr* 2009;155:888-892.
484. Labay V, Raz T, Baron D, et al. Mutations in SLC19A2 cause thiamine-responsive megaloblastic anaemia associated with diabetes mellitus and deafness. *Nat Genet* 1999;22:300-304.
485. Fleming J, Tartaglino E, Schorderet D, et al. The gene mutated in thiamine-responsive anaemia with diabetes and deafness (TRMA) encodes a functional thiamine transporter. *Nat Genet* 1999;22:305-308.
486. Diaz G, Banikazemi M, Oishi K, et al. Mutations in a new gene encoding a thiamine transporter cause thiamine-responsive megaloblastic anaemia syndrome. *Nat Genet* 1999;22:309-312.
487. Nyhan WL. Disorders of purine and pyrimidine metabolism. *Mol Genet Metab* 2005;86:25-33.
488. Carmel R. The disappearance of cobalamin absorption testing: a critical diagnostic loss. *J Nutr* 2007;137:2481-2484.
489. Hvas AM, Morkbak AL, Hardlei TF, Nexø E. The vitamin B₁₂ absorption test, CobaSorb, identifies patients requiring vitamin B₁₂ injection therapy. *Scand J Clin Lab Invest* 2011;71:432-438.
490. Nimo RE, Carmel R. Increased sensitivity of detection of the blocking (type I) anti-intrinsic factor antibody. *Am J Clin Pathol* 1987;88:729-733.
491. Carmel R. Reassessment of the relative prevalences of antibodies to gastric parietal cell and to intrinsic factor in patients with pernicious anaemia: influence of patient age and race. *Clin Exp Immunol* 1992;89:74-77.
492. Waters HM, Dawson DW, Howarth JE, et al. High incidence of type II autoantibodies in pernicious anaemia. *J Clin Pathol* 1993;46:45-47.
493. Conn D. Intrinsic factor antibodies in relation to disease. *Med Lab Sci* 1986;43:220-224.
494. Muckerheide M, Wolfman J, Rohde D, et al. Studies on a radioassay for intrinsic factor antibody: comparison of methods and false positive results due to elevated serum B₁₂ levels. *Am J Clin Pathol* 1984;82:300-304.
495. Callaghan JM, Khan MA, Alderuccio F, et al. α and β subunits of the gastric H⁺/K⁺-ATPase are concordantly targeted by parietal cell autoantibodies associated with autoimmune gastritis. *Autoimmunity* 1993;16:289-295.
496. Kaye M. Immunological aspects of gastritis and pernicious anaemia. *Baillieres Clin Gastroenterol* 1987;1:487-506.
497. Davidson RJL, Atrah HI, Sewell HF. Longitudinal study of circulating gastric antibodies in pernicious anaemia. *J Clin Pathol* 1989;42:1092-1095.
498. Carmel R. Pepsinogens and other serum markers in pernicious anemia. *Am J Clin Pathol* 1988;90:442-446.
499. Samloff IM, Varis K, Ihamaki T, et al. Relationships among serum pepsinogen I, serum pepsinogen II, and gastric mucosal histology. A study in relatives of patients with pernicious anemia. *Gastroenterology* 1982;83:204-209.
500. Carmel R, Shulman IA. Blood transfusion in medically treatable chronic anemia: pernicious anemia as a model for transfusion overuse. *Arch Pathol Lab Med* 1989;113:995-997.
501. Skouby AP. Hydroxocobalamin for initial and long-term therapy for vitamin B₁₂ deficiency. *Acta Med Scand* 1987;221:399-402.
502. Kuzminski AM, Del Giacco EJ, Allen RH, et al. Effective treatment of cobalamin deficiency with oral cobalamin. *Blood* 1998;92:1191-1198.
503. Kondo H. Haematological effects of oral cobalamin preparations on patients with megaloblastic anaemia. *Acta Haematol* 1998;99:200-205.
504. Carmel R. Treatment of severe pernicious anemia: no association with sudden death. *Am J Clin Nutr* 1988;48:1443-1444.
505. Seal EC, Metz J, Flicker L, et al. A randomized double-blind, placebo-controlled study of oral vitamin B₁₂ supplementation in older patients with subnormal or borderline serum vitamin B₁₂ concentrations. *J Am Geriatr Soc* 2002;50:146-151.
506. Garcia A, Paris-Pombo A, Evans L, et al. Is low-dose oral cobalamin enough to normalize cobalamin function in older people? *J Am Geriatr Soc* 2002;50:1401-1404.
507. Rajan S, Wallace JI, Brodtkin KI, et al. Response of elevated methylmalonic acid to three dose levels of oral cobalamin in older adults. *J Am Geriatr Soc* 2002;50:1789-1795.

508. Butterworth CE Jr, Tamura T. Folic acid safety and toxicity: a brief review. *Am J Clin Nutr* 1989;50:353-358.
509. Ch'ien LT, Krumdieck CL, Scott CW Jr, et al. Harmful effect of megadoses of vitamins: electroencephalogram abnormalities and seizures induced by intravenous folate in drug-treated epileptics. *Am J Clin Nutr* 1975;28:51-58.
510. Pfeiffer CM, Caudill SP, Gunter EW, Osterloh J, Sampson EJ. Biochemical indicators of B vitamin status in the US population after folic acid fortification: results from the National Health and Nutrition Examination Survey 1999-2000. *Am J Clin Nutr* 2005;82:442-450.
511. Fraser RC, Cathcart M, Seivewright H. Audit of the use of vitamin B₁₂ in general practice. *BMJ* 1983;287:729-731.
512. Taylor MP. Response to paper "Audit of the use of vitamin B₁₂ in general practice." *BMJ* 1984;288:1275.
513. Radimer K, Bidenwald B, Hughes J, et al. Dietary supplement use by United States adults: data from the National Health and Nutrition Examination Survey, 1999-2000. *Am J Epidemiol* 2004;160:339-349.
514. Molloy AM, Kirke PN, Troendle JF, et al. Maternal vitamin B₁₂ status and risk of neural tube defects in a population with high neural tube defect prevalence and no folic acid fortification. *Pediatrics* 2009;123:917-923.
515. Morris MC, Evans DA, Bienias JL, et al. Dietary folate and vitamin B₁₂ intake and cognitive decline among community-dwelling older persons. *Arch Neurol* 2005;62:641-645.
516. Selhub J, Morris MS, Jacques PF. In vitamin B₁₂ deficiency, higher serum folate is associated with increased total homocysteine and methylmalonic acid concentrations. *Proc Natl Acad Sci USA* 2007;104:19995-20000.
517. Morris MS, Jacques PF, Rosenberg IH, Selhub J. Folate and vitamin B-12 status in relation to anemia, macrocytosis, and cognitive impairment in older Americans in the age of folic acid fortification. *Am J Clin Nutr* 2007;85: 193-200.
518. Clarke R, Sherliker P, Hin H, et al. Folate and vitamin B₁₂ status in relation to cognitive impairment and anaemia in the setting of voluntary fortification in the UK. *Br J Nutr* 2008;100:1054-1059.
519. Miller JW, Garrod MG, Allen LH, Haan MN, Green R. Metabolic evidence of vitamin B₁₂ deficiency, including high homocysteine and methylmalonic acid and low holotranscobalamin, is more pronounced in older adults with elevated plasma folate. *Am J Clin Nutr* 2009;90:1586-1592.
520. Morris MS, Jacques PF, Rosenberg IH, Selhub J. Circulating unmetabolized folic acid and 5-methyltetrahydrofolate in relation to anemia, macrocytosis, and cognitive test performance in American seniors. *Am J Clin Nutr* 2010;91:1733-1744.
521. Mills JL, Carter TC, Scott JM, et al. Do high blood folate concentrations exacerbate metabolic abnormalities in people with low vitamin B₁₂ status? *Am J Clin Nutr* 2011;94:495-500.
522. Troen AM, Mitchell B, Sorensen B, et al. Unmetabolized folic acid in plasma is associated with reduced natural killer cell cytotoxicity among postmenopausal women. *J Nutr* 2006;136:189-194.
523. Sweeney MR, Staines A, Daly L, et al. Persistent circulating unmetabolised folic acid in a setting of liberal voluntary folic acid fortification. Implication for further mandatory fortification. *BMC Publ Health* 2009;9:925.
524. Bailey RL, Mills JL, Yetley EA, et al. Unmetabolized serum folic acid and its relation to folic acid intake from diet and supplements in a nationally representative sample of adults aged ≥60 y in the United States. *Am J Clin Nutr* 2010;92:383-389.
525. Kelly P, McPartlin J, Goggins M, et al. Unmetabolized folic acid in serum: acute studies in subjects consuming fortified foods and supplements. *Am J Clin Nutr* 1997;65:1790-1795.
526. Boilson A, Staines A, Kelleher CC, et al. Unmetabolized folic acid prevalence is widespread in the older Irish population despite the lack of a mandatory fortification program. *Am J Clin Nutr* 2012;96:613-621.
527. Kim Y-I. Folate: a magic bullet or a double edged sword for colorectal cancer prevention? *Gut* 2006;55:1387-1389.
528. Lee JE, Willett WC, Fuchs CS, et al. Folate intake and risk of colorectal cancer and adenoma: modification by time. *Am J Clin Nutr* 2011;93:817-825.
529. Gibson TM, Weinstein SJ, Pfeiffer RM, et al. Pre- and postfortification intake of folate and risk of colorectal cancer in a large prospective cohort study in the United States. *Am J Clin Nutr* 2011;94:1053-1062.
530. Stultzenberg-Solomon RZ, Chang SC, Leitzmann MF, et al. Folate intake, alcohol use, and postmenopausal breast cancer risk in the prostate, lung, colorectal, and ovarian cancer screening trial. *Am J Clin Nutr* 2006;83: 895-904.

531. Lin J, Lee IM, Cook NR, et al. Plasma folate, vitamin B-6, vitamin B-12, and risk of breast cancer in women. *Am J Clin Nutr* 2008;87:734-743.
532. Ebbing M, Bonna KH, Nygard O, et al. Cancer incidence and mortality after treatment with folic acid and vitamin B₁₂. *JAMA* 2009;302:2119-2126.
533. Zhang SM, Cook NR, Albert CM, et al. Effect of combined folic acid, vitamin B₆, and vitamin B₁₂ on cancer risk in women. A randomized trial. *JAMA* 2008;300:2012-2021.
534. Marutti SS, Ulrich CM, White E. Folate and one-carbon metabolism nutrients from supplements and diet in relation to breast cancer risk. *Am J Clin Nutr* 2009;89:624-633.
535. House AA, Eliasziw M, Cattran DC, et al. Effect of B-vitamin therapy on progression of diabetic nephropathy. A randomized controlled trial. *JAMA* 2010;303:1603-1609. CH/544. Mason J. *Am J Clin Nutr* 2011.
536. Ulrich CM, Potter JD. Folate supplementation: too much of a good thing? *Cancer Epidemiol Biomarkers Prev* 2006;15:189-193.
537. Carmel R. Efficacy and safety of fortification and supplementation with vitamin B₁₂: biochemical and physiological effects. *Food Nutr Bull* 2008;29(Suppl):S177-S187.
538. Carmel R. Mandatory fortification of the food supply with cobalamin: an idea whose time has not yet come. *J Inherit Metab Dis* 2011;34:67-73.
539. Gimsing P, Hippe E, Helleberg-Rasmussen I, et al. Cobalamin forms in plasma and tissues during treatment of vitamin B₁₂ deficiency. *Scand J Haematol* 1982;29:311-318.

Chapter 37 Inherited Aplastic Anemia Syndromes

> Table of Contents > Part IV - Disorders of Red Cells > Section 5 - Other Red Cell Disorders > Chapter 37 - Inherited Aplastic Anemia Syndromes

Chapter 37

Inherited Aplastic Anemia Syndromes

Akiko Shimamura

Blanche P. Alter

The inherited bone marrow failure syndromes may primarily affect a single or multiple hematopoietic lineages. Four inherited bone marrow failure syndromes associated with aplastic anemia will be discussed in this chapter: Fanconi anemia (FA), dyskeratosis congenita (DC), Shwachman-Diamond syndrome (SDS), and congenital amegakaryocytic thrombocytopenia (CAMT). The congenital bone marrow failure disorders affecting primarily one cell line are discussed elsewhere in this text (Diamond Blackfan anemia, Chapter 39; Congenital Neutropenias, Chapter 57). While the inherited marrow failure disorders are rare, early diagnosis is important for optimal medical management, cancer surveillance, and family planning. Some of the disorders are associated with sensitivity to chemotherapy and radiation, and thus diagnosis of those underlying disorders prior to initiation of treatment of aplastic anemia or associated malignancies is crucial.

A careful medical and family history together with a thorough physical examination may provide important clues to distinguish acquired from inherited bone marrow failure.¹ A family history suggestive of cancer predisposition, such as malignancies at an unusually young age, may be obtained. A history of excessive toxicity following treatment with genotoxic agents may be present. A family history of congenital anomalies or stigmata characteristic of the inherited bone marrow failure syndromes may provide additional clues. Other potential etiologies for cytopenias should be ruled out. Once the diagnosis of an inherited bone marrow failure syndrome is made, it is important to test all family members at risk for the disease regardless of clinical symptoms since manifestations may vary widely among family members.

These disorders are increasingly being recognized in adults, who often manifest milder clinical phenotypes and whose first manifestation of an underlying inherited bone marrow failure syndrome may be aplastic anemia or malignancy.² With the advent of genetic and laboratory diagnostic testing, the diseases are also increasingly recognized in patients who lack the characteristic physical stigmata conventionally associated with the disease. Genetic test results must be interpreted critically and within the clinical context of the patient. Methodologic limitations of genetic testing and the distinction between functional mutations versus rare polymorphisms are important considerations.

FANCONI ANEMIA

FA is an inherited chromosomal instability syndrome with a variable clinical presentation that includes congenital anomalies, progressive pancytopenia, and cancer susceptibility. Guido Fanconi first reported a familial syndrome of pancytopenia and congenital physical abnormalities in 1927.^{3, 4} The diagnostic hallmark of FA is increased chromosomal breakage in response to DNA damaging agents such as mitomycin C (MMC) or diepoxybutane (DEB). Remarkable advances in the last few years have elucidated the molecular pathways disrupted in FA cells. Potential clinical implications of recent molecular studies will be discussed.

Clinical Features

FA should be considered in patients with congenital anomalies, aplastic anemia, or a family history of bone marrow failure or cancer susceptibility. The International Fanconi Anemia Registry (IFAR) analysis of 370 patients found that nearly 40% of patients had no reported physical findings.⁵ Aplastic anemia or malignancy may be the presenting sign of the underlying diagnosis of FA in the absence of physical anomalies or prior family history. The manifestations of FA can vary between affected members of the same family, suggesting that additional genetic, epigenetic, or environmental factors likely influence the disease course.

A wide range of congenital anomalies has been reported in FA patients (reviewed in Refs. 1, 6) (Table 37.1). Skin pigmentary changes, short stature, and radial bone and thumb abnormalities are the most common manifestations associated with FA, although these may be seen in some of the other inherited bone marrow failure syndromes as well. Abnormalities of the skeletal, ocular, renal, genital, aural, gastrointestinal (GI), cardiac, and central nervous systems have also been reported with high frequency.

The hematologic complications of FA typically present within the first decade of life. Early manifestations include moderate single or bilineage cytopenia with red cell macrocytosis. Elevated levels of fetal hemoglobin (Hb F) help to distinguish inherited from acquired aplastic anemia. Marrow failure may range in severity from mild asymptomatic cytopenias to severe aplastic anemia. This is in contrast to other chromosomal instability syndromes, such as ataxia telangiectasia, or Bloom syndrome, which are not typically associated with bone marrow failure.

Patients with FA are at increased risk of developing myelodysplasia (MDS) or acute myeloid leukemia (AML).^{7, 8} In a cohort study of 145 patients with FA, the cumulative incidence of AML reached 10% by age 24 years and plateaued thereafter.⁸ Patients with FA are also at increased risk of developing solid tumors, particularly squamous cell carcinomas of the head and neck, skin, GI tract, and genital tract.⁹ The cumulative incidence of solid tumors was low in younger patients but progressively increased with age starting at around 20 years of age, and reached 29% by age 48 years.⁸ FA patients, particularly those who have received

P.955

androgen treatment, are also at increased risk of liver tumors. Treatment of malignancies is limited by the low tolerance of FA patients to chemotherapy and radiation. Myeloid malignancies in FA patients have been successfully treated with hematopoietic stem cell transplantation (HSCT), though patient numbers are small and follow-up is limited. The role of pretransplant chemotherapy is unclear.¹⁰ For solid tumors, surgical resection is the mainstay of therapy. Regular and frequent surveillance for cancers is particularly important in this population and is discussed further in the section "Supportive Care." Patients with the FANCD1/BRCA2 subtype manifest an especially high rate of early onset AML and specific solid tumors (brain and Wilms) compared with other FA subtypes.^{11, 12, 13}

TABLE 37.1 PHYSICAL FINDINGS ASSOCIATED WITH FA

Skeletal

Short stature

Radial ray anomalies (thumbs, hands, radii)

Hip and spine anomalies

Skin

Hyperpigmentation (Café au lait spots)

Hypopigmentation

Genitourinary

Renal structural anomalies

Hypogonadism

Craniofacial

Microcephaly ophthalmic anomalies (microphthalmia, epicanthal folds)

Otic anomalies (external and middle ear anomalies, deafness)

Genitourinary

Hypogonadism

Renal anomalies

Gastrointestinal malformations

Esophageal atresia or tracheoesophageal fistula

Imperforate anus

Cardiac malformations

Growth hormone deficiency has been observed in rare FA patients,¹⁴ and treatment with growth hormone improved growth in a subset of these patients¹⁵; its use is controversial because of a hypothetical risk of cancer or leukemia.¹⁶ Additional endocrine disorders associated with FA include hypothyroidism with or without thyroid hormone binding globulin deficiency, abnormal glucose tolerance, and diabetes mellitus.^{14, 17} Although FA is associated with short stature, endocrine evaluation is important to rule out treatable endocrine causes that might further contribute to poor growth.

There are currently 15 known FA subtypes (A, B, C, D1 [BRCA2], D2, E, F, G, I, J [BRIP1, BACH1], L, M, N [PALB2], O [RAD51C], and P [SLX4]). With the exception of subtype B, which is X-linked recessive, all the other FA subtypes follow an autosomal recessive pattern of inheritance.^{18, 19} FA is found with similar frequencies in both genders and has no known ethnic restriction. The heterozygote carrier frequency has been recently reestimated at 1 in 181 in the United States and is higher in regions with founder effects such as Israel.²⁰ The mean age at diagnosis is generally reported to be between 7 and 9 years of age, with 75% of cases diagnosed between the ages of 4 and 14; however, FA has been diagnosed in neonates as well as in adults in their fifties.

Differential Diagnosis

Other inherited and acquired causes of bone marrow failure should be considered (see Chapter 41). FA may be considered in patients with characteristic congenital anomalies and may be the underlying diagnosis in patients with VACTERL-H (vertebral anomalies, anal atresia, cardiovascular malformations, tracheoesophageal fistula, renal and limb anomalies, plus hydrocephalus, MIM 276950).²¹ Cells derived from patients with other chromosomal breakage syndromes or syndromes with similar constitutional findings, such as Bloom syndrome or ataxia telangiectasia, may also exhibit high rates of spontaneous chromosomal breakage; however, they do not generally show increased chromosomal breakage in response to DNA crosslinkers such as MMC or DEB. Other chromosomal breakage syndromes are not typically associated with marrow failure. The exception is Nijmegen breakage syndrome, which may be associated with some increased chromosomal breakage with MMC and may be confused with FA.²² FA may also be considered in patients with a family history suggestive of cancer predisposition, patients presenting with cancers at an unusually young age, or patients who experience severe toxicity with chemotherapy or radiation.

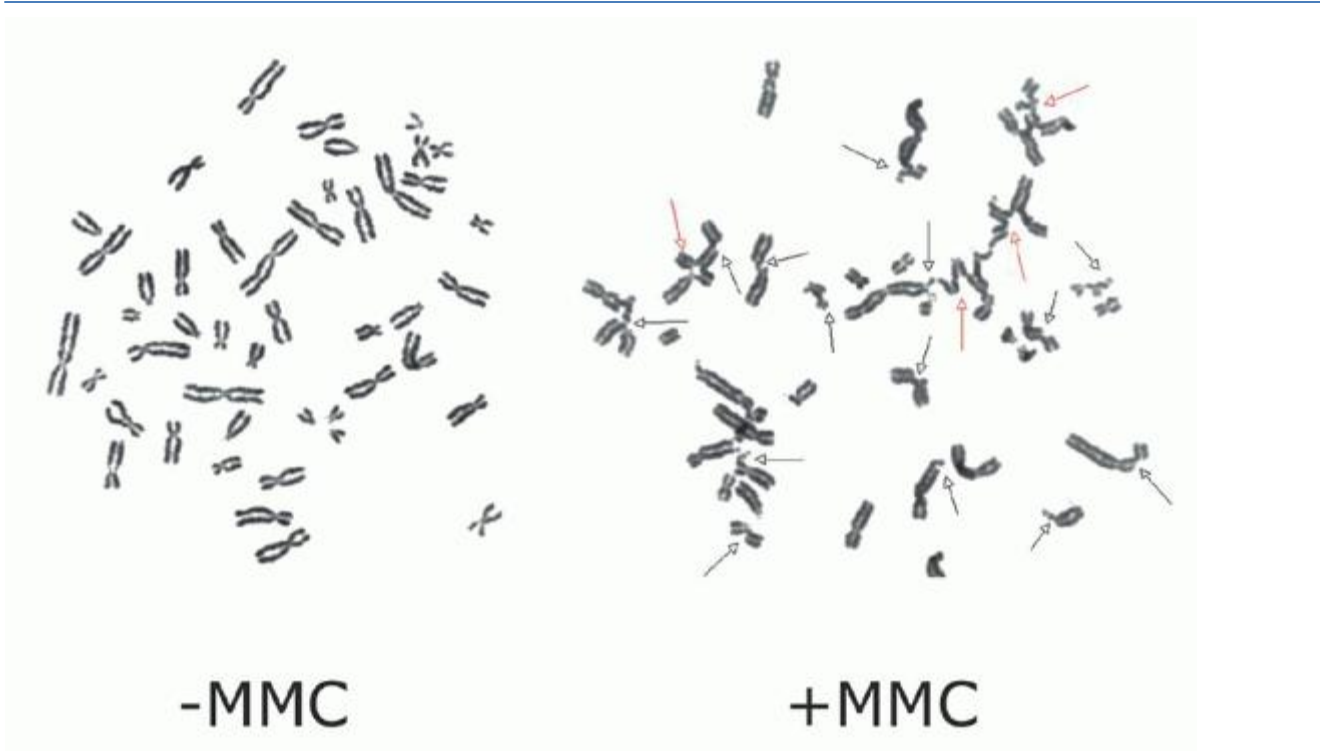

FIGURE 37.1. Chromosomal breakage in FA. Peripheral blood lymphocytes from a FA patient were cultured without (left panel) or with (right panel) mitomycin C (MMC). The black arrows indicate chromosomal breaks. The red arrows indicate radial chromosomal fusions characteristic of FA. (Courtesy of Lisa Moreau, Dana Farber Cancer Institute, Boston, MA.)

Laboratory

Cell morphology on peripheral blood smear is typically unremarkable except for red cell macrocytosis and mild anisocytosis, though these are variably present. Thrombocytopenia or leukopenia typically precede anemia. Pancytopenia may be progressive over time. Erythrocyte macrocytosis and increased Hb F levels may be present even in the absence of cytopenias.

Bone marrow biopsy findings vary from normal cellularity to frank aplasia. Morphologic examination of the bone marrow aspirate may show dysplastic features, with nuclear-cytoplasmic maturation disynchrony. Dyserythropoiesis with multinucleate forms or nuclear fragmentation may be seen. Bone marrow aspirates should be sent for cytogenetic analysis, as FA patients are at high risk for malignant transformation. The appearance of cytogenetic clones of unclear clinical significance in the absence of morphologic evidence of MDS must be considered carefully, since cases of persistent or transient clonal abnormalities without apparent progression to leukemia have been reported.²³ At a minimum, patients with persistent unexplained changes in blood counts or new cytogenetic marrow abnormalities should be monitored closely with serial blood counts and a follow-up bone marrow examination to assess for possible malignant evolution. Amplification or gains of chromosome 3q26q29 were shown to correlate with increased risk of MDS and AML in one study.²⁴

The diagnosis of FA is based on the demonstration of increased chromosomal breakage in the presence of DNA cross-linking agents, such as MMC or DEB.^{25, 26} (Fig. 37.1) DEB is preferred in some centers since it is associated with less variability in chromosomal breakage among normal controls. The chromosomal breakage test is usually performed on metaphase spreads of peripheral blood lymphocytes cultured with MMC or DEB. A total of 50 metaphase cells are analyzed for chromosomal

P.956

breakage, including the formation of radial figures—a hallmark of this disease. Results are compared to a normal control and a positive control that have been run in parallel. Results are generally reported as aberrations per cell and the number of cells with breaks or radial forms. Increased spontaneous chromosomal breakage may be observed in some FA patients¹²; nonetheless, the rate of breakage is markedly enhanced by exposure to MMC or DEB regardless of patient

phenotype or severity of disease. Chromosomal breakage in response to MMC/DEB can also be assessed in fetal cells obtained for prenatal diagnosis by amniocentesis or chorionic villus sampling.^{27, 28} If the disease-causing mutation is known for a given family, these assays can be used for prenatal diagnosis or preimplantation genetic diagnosis.²⁹ FA patient cells also exhibit cell cycle abnormalities with G2 phase prolongation and arrest by flow cytometry.^{30, 31} Studies comparing results of DEB chromosomal breakage with cell cycle analyses of patients referred for FA testing showed close correlation between the results of these two tests.³² Constitutive elevation of serum alpha-fetoprotein (AFP) has been reported in FA patients,³³ although variations in AFP levels determined by different methodologies and the lack of specificity has limited the diagnostic utility of this test so far.³⁴ FA heterozygous carriers cannot be reliably detected by testing for chromosomal breakage. Genetic mutation testing is available for the FA genes.³⁵

Clonal somatic reversion to wild-type has been observed in a subset of cells from some FA patients. Increased chromosomal breakage may be limited to a subpopulation of lymphocytes in such patients. The reversion to normal cellular phenotype has been attributed to recombination or gene conversion events leading to selective growth advantage of the reverted cells^{36, 37}; somatic reversion has been reported in early hematopoietic lineages.³⁸ Patients with a high degree of wild-type mosaicism may be difficult to diagnose. In cases with a high degree of suspicion for FA and normal blood breakage analysis, the MMC/DEB test should be performed on skin fibroblasts, since somatic mosaicism has not been observed in fibroblasts.

Pathophysiology

Models of the FA biochemical pathway have emerged from molecular studies of the cloned FA gene products. The reader is referred to recent excellent reviews of this rapidly evolving field.^{39, 40, 41} At least 15 different FA complementation groups (A, B, C, D1 [BRCA2], D2, E, F, G, I, J [BRIP1, BACH1], L, M, N [PALB2], O [RAD51C], and P [SLX4]) have been identified, and the corresponding genes have also been identified⁴² (Table 37.2). The gene for Fanconi subtype D1 is the previously identified tumor suppressor gene, BRCA2.⁴³ Biallelic mutations in BRCA2 are associated with an increased risk of early onset leukemia¹¹ and solid tumors, particularly Wilms and midline brain tumors.^{12, 13} The FANCI/BACH1/BRIP1 gene encodes a DNA helicase, which is an enzyme that unwinds DNA. The FANCM (Hef) gene shares regions of homology with both helicases and endonucleases, though these functions have yet to be directly demonstrated. FANCM may function in DNA translocation. The FANCL/PHF9/POG gene shares homology with other E3 ubiquitin ligases. The most common FA subtype is FA-A (60%), followed by FA-C (14%) and FA-G (10%)⁴⁴; the other FA subtypes are rare. The types of mutations associated with FA are highly variable.

TABLE 37.2 FA GENES

Subtype	Gene	FA patients (Estimated) %	Inheritance Pattern	Chromosome Location	Ubiquitinated FANCD2
A	<i>FANCA</i>		60 Autosomal recessive	16q24.3	Absent
B	<i>FANCB</i>		2 X-linked recessive	Xp22.31	Absent
C	<i>FANCC</i>		14 Autosomal recessive	9q22.3	Absent
D1	<i>FANCD1/BRCA2</i>		3 Autosomal recessive	13q12-13	Present
D2	<i>FANCD2</i>		3 Autosomal recessive	3p25.3	NA
E	<i>FANCE</i>		3 Autosomal recessive	6p21-22	Absent
F	<i>FANCF</i>		2 Autosomal recessive	11p15	Absent
G	<i>FANCG</i>		10 Autosomal recessive	9p13	Absent

I	<i>FANCI</i>	1 Autosomal recessive	15q25-q26	Absent
J	<i>FANCI/BACH1/BRIP1</i>	2 Autosomal recessive	17q22-q24	Present
L	<i>FANCL/PHF9/POG</i>	<1 Autosomal recessive	2p16.1	Absent
M	<i>FANCM/Hef</i>	<1 Autosomal recessive	14q21.3	Absent
N	<i>FANCN/PALB2</i>	<1 Autosomal recessive	16p12	Present
O	<i>FANCO/RAD51C</i>	<1 Autosomal recessive	17q22	Present
P	<i>FANCP/SLX4</i>	<1 Autosomal recessive	16p13 .3	Present

The FA genes function coordinately in a common molecular pathway to regulate DNA repair. Loss of function of any FA gene results in sensitivity to DNA interstrand crosslinks, which block the progression of DNA replication. The FA proteins FANCA, FANCB, FANCC, FANCE, FANCF, FANCG, FANCL, and FANCM associate into a nuclear complex ("FA complex") together with proteins FAAP24 and FAAP100 and the E2 ubiquitin conjugating enzyme UBE2T. A model (Fig. 37.2) has emerged whereby stimuli such as S phase entry, or DNA damage by agents such as MMC, or ionizing radiation leads to activation of the FA complex, which functions as an E3 ubiquitin ligase to covalently attach a ubiquitin protein (monoubiquitinate) to the FANCI and FANCD2 proteins. The monoubiquitinated FANCD2/FANCI dimer translocates to nuclear foci with BRCA1, a known cancer susceptibility gene product implicated in DNA repair, as well as FANCD1/BRCA2, FANCN/PALB2, RAD51, ATR, NBS1, and FANCI/BACH1/BRIP1. Monoubiquitination of FANCD2 and FANCI is required for MMC resistance and is dependent on the functional integrity of the upstream Fanconi proteins. FANCD2 monoubiquitination remains intact in bone marrow failure syndromes other than FA.⁴⁵ FANCD2 monoubiquitination can be assessed on a Western blot and serves as a useful biochemical diagnostic screen for FA.¹³ FANCM, in complex with FAAP24 and MHF, binds to stalled replication forks at sites of unresolved interstrand crosslinks. FANCM recruits the FA complex, which in turn monoubiquitinates the FANCD2/FANCI dimer. Ubiquitinated FANCD2/FANCI associates

P.957

with the nuclease FAN1 which can cleave and release the crosslink to allow DNA replication to proceed by translesion synthesis. RAD51 functions in homologous recombination. FANCI/BRIP1 is a DNA helicase that is important for homologous recombination repair. FANCP/SLX4 interacts with and stimulates the DNA repair endonucleases XPF-ERCC1, MUS81-EME1, and SLX1, and may be important for resolution of homologous recombination intermediates. Elucidation of the Fanconi biochemical pathway in turn led to the identification of interactions between the Fanconi proteins and other known tumor suppressor pathways. These findings provide biochemical support for a role of the Fanconi pathway in tumorigenesis. For example, FANCD2 was subsequently shown to be phosphorylated by ATM kinase at a serine residue at amino acid position 222.⁴⁶ This phosphorylation is required for the cell cycle S phase checkpoint in response to radiation.⁴⁶ ATM function is disrupted in the chromosomal instability syndrome ataxia telangiectasia. Thus, FANCD2 links two DNA repair pathways, the Fanconi pathway and the ataxia telangiectasia pathway. Dysfunction of the Fanconi pathway or the ATM pathway is associated with increased cancer susceptibility. The Fanconi biochemical pathway was further implicated in DNA repair by the identification of the gene for FANCD1 as the tumor suppressor gene, BRCA2.⁴³ The FA pathway also interacts with other DNA damage checkpoint proteins including ATR, CHK1, and γ -H2AX.

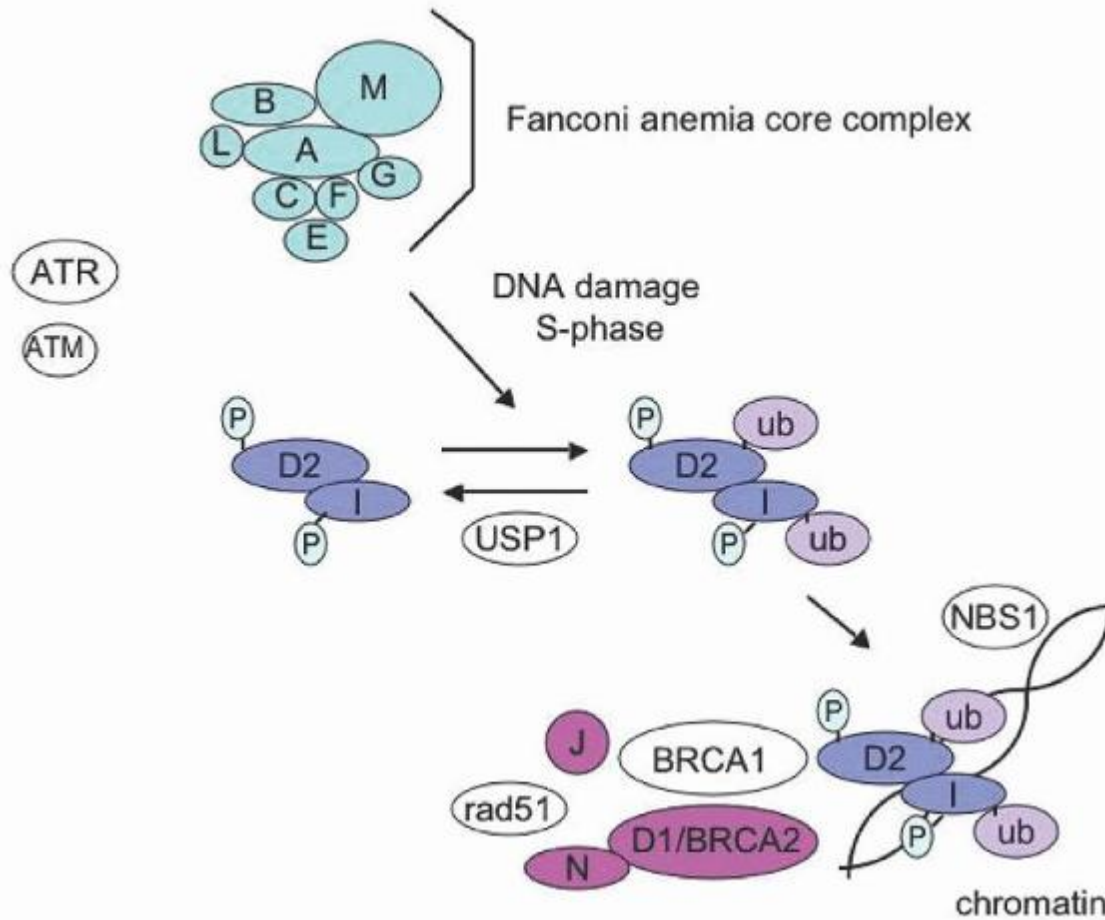

FIGURE 37.2. Schematic diagram of the Fanconi anemia (FA) pathway. FA proteins (A, B, C, D1, D2, E, F, G, I, J, L, M, N) are depicted with shaded circles. Additional DNA repair proteins interacting with the FA pathway are denoted in non-shaded circles. Following activation of the FA core complex by DNA damage or the cell cycle, the D2 and I proteins are monoubiquitinated. Monoubiquitinated D2/I are translocated to chromatin where they colocalize with additional DNA repair proteins to participate in interstrand DNA crosslink repair. Ub, ubiquitin; P, phosphorylation.

Given the compelling biochemical data linking the Fanconi pathway to other known DNA repair pathways functioning in tumor suppression, the question of whether asymptomatic FA heterozygotes carry an increased risk of developing malignancies is a subject of active investigation. Heterozygous BRCA2 mutations are associated with increased risks of breast and ovarian cancer.⁴⁷ The reason why breast and ovarian cancer is uncommon in the FA patient population is not known, but may be related to decreased estrogen levels in these patients. Currently, not all FANCD1/BRCA2 mutations reported in FA patients have been associated with increased cancer risk in heterozygous carriers in the general population, and it is currently unclear whether all the FANCD1/BRCA2 mutations leading to FA (when both alleles are mutated) will also confer cancer predisposition in family members in whom only one BRCA2 allele may be mutant.¹³ Counseling of family members of patients with the FA-D1 subtype must currently be tempered with caution. Cancers have been reported in some heterozygous carriers of different FA genes (FANCD1/BRCA2 FANDJ/BRIP and FANCN/PALB2) with loss of heterozygosity of the FA gene in the tumor consistent with a tumor suppressor gene model (reviewed in Ref. 48).

In addition to a nuclear role in DNA repair, numerous studies suggest additional potential functions for the FA proteins. FA cells are sensitive to many different extracellular apoptotic signals, such as interferon- γ , TNF- α , and double-stranded RNA.^{49, 50, 51, 52} Furthermore, Fanconi proteins such as FANCC may have additional roles in other signaling pathways.⁵³

Studies also suggest a role for the FA proteins in mediating oxidative stress.^{54, 55} DEB, a clastogen to which Fanconi cells are especially susceptible, can cause oxidative DNA damage. FA cells may exhibit increased susceptibility to oxidative damage, and reactive oxygen species can damage DNA and lead to DNA crosslinks and double-stranded breaks.

The molecular etiology of marrow failure in FA remains an area of active investigation. A recent study reports p53 hyperactivation in hematopoietic stem/progenitor cells deficient in FA gene expression resulting in cell cycle arrest.⁵⁶ This

finding is further supported by the demonstration that knockdown of p53 expression in a zebrafish model of FA rescues the developmental abnormalities.⁵⁷ Since p53 knockdown rescues the hematopoietic abnormalities in other marrow failure syndromes, p53 may represent a final common pathway for cellular stress or DNA damage in marrow failure syndromes. Abrogation of DNA damage checkpoints has been associated with a milder marrow failure phenotype; however, these FA patients remained at risk for malignant transformation to leukemia.⁵⁸ A potential role for environmental toxins in the severity of the FA phenotype has been demonstrated in murine models where disruption of the FA pathway results in increased sensitivity to reactive aldehydes associated with an increased risk of developmental anomalies and a propensity to develop leukemias.⁵⁹

Supportive Care

Cancer surveillance and education play an important role in the management of FA patients. Physicians should counsel patients regarding established behavioral and environmental risk factors associated with increased cancer risk. Since FA patients have a defect in DNA repair, imaging studies should minimize exposure to ionizing radiation. For example, when clinically feasible, it is reasonable to use MRI scans or ultrasound rather than CT scans for FA patients.

Because of the increased risk of MDS and leukemia in patients with bone marrow failure syndromes, frequent complete blood counts and annual bone marrow aspirates and biopsies with cytogenetic analysis are recommended, particularly since hematopoietic stem cell transplant outcomes are superior for patients transplanted prior to emergence of leukemia. FA patients are at risk for clonal cytogenetic abnormalities (reviewed in Ref. 60). Assessment of the clinical significance of a cytogenetic clonal abnormality requires consideration of the specific clone, the number of chromosomal abnormalities, the presence of significant marrow dysplasia (some baseline mild dysplasia is common in FA), and whether there are concomitant progressive peripheral cytopenias.^{23, 61} Chromosomal abnormalities common in AML, such as t(8:21), inv(16), or trisomy 8, have not been reported in FA.^{23, 62} Amplifications of 3q are common in FA but rarely seen in AML. FA AML also had a higher frequency of 1q amplification, loss of part or all of chromosome 7, and gain of 13q and del 20q.^{62, 63}

For patients on androgen therapy, regular physical examinations for liver size, liver ultrasound for masses or abnormalities every 6 to 12 months, and frequent liver enzyme tests are recommended. Annual examination by an otolaryngologist for leukoplakia or other signs of squamous cell carcinoma of the

P.958

oral cavity and oropharynx is important for patients with FA, DC, and those FA patients previously treated with bone marrow transplantation. Annual endoscopy can be considered in older FA and DC patients. Regular dental exams are important both for maintenance of oral hygiene and for detecting leukoplakia. Patients should be evaluated immediately for symptoms of pain in the mouth or throat, difficulty swallowing, changes in voice, anorexia, or weight loss. Suspicious lesions should be biopsied immediately, since early surgical excision is the mainstay of cancer therapy in FA patients. Annual gynecologic examinations, including Pap smears and HPV (human papilloma virus) exams, are recommended at puberty or after the age of 16. Counseling regarding sexual activity should be provided. Barrier methods of contraception may be particularly pertinent for the FA patients who are already at risk of cervical and vulvar malignancies. Regular breast exams are also recommended, although it is not clear what role mammography should play in cancer screening of these patients. HPV, which may be associated with an increased risk of squamous cell carcinoma of the head and neck, exhibits increased proliferation and epithelial cell expansion secondary to elevated levels of the viral E7 protein when the FA pathway has been disrupted.⁶⁴ Vaccination against HPV should be offered to all FA patients, males and females, in accordance with current guidelines.

Regular endocrinology evaluations are important, particularly in the pediatric population if the patient exhibits poor growth or delayed puberty. Hypothyroidism and diabetes are not infrequent in FA patients. A recent study reported one or more endocrine abnormalities in more than 70% of patients with FA.^{17, 65} GI symptoms may present in FA patients, necessitating prompt referral to a gastroenterologist.

Treatment

HSCT is the only curative therapy for the hematologic manifestations of FA. Patients with FA are exquisitely sensitive to the toxicity of the usual chemotherapy and radiation regimens used in preparation for BMT,⁶⁶ particularly organ toxicity and graft-versus-host disease (GVHD). In addition, these regimens confer an increased risk of subsequent malignancies, primarily squamous cell carcinomas of the head and neck.^{67, 68} Reduced dose conditioning regimens are used for FA patients (reviewed in Ref. 69). An appropriate conditioning regimen combined with use of a matched sibling donor has resulted in survivorship of up to 80%.^{70, 71, 72} Post-HSCT malignancies, especially squamous cell carcinomas of the head and neck, remain a long-term risk. Acute and chronic GVHD and radiation are risk factors for post-transplant squamous

cell carcinomas.^{67, 68, 73, 74} Regimens with the goal of reducing transplant-related toxicity and long-term cancer risk are under investigation.^{75, 76, 77} Clinical trials replacing radiation with fludarabine, a potent immunosuppressive agent with less cytotoxicity, have reported successful engraftment using either HLA-matched family member donors or alternative donors.^{78, 79, 80, 81, 82, 83, 84} Some families opt to pursue preimplantation genetic diagnosis to provide a donor for patients who lack an unaffected HLA-identical sibling donor.⁸⁵ Treatment of AML in FA patients is challenging,¹⁰ and HSCT is generally the treatment of choice for eligible candidates.

Medical therapies are available for patients who either lack a suitable HSCT donor or for whom the risk of HSCT is high. Androgens may improve the blood counts in approximately 50% of patients with FA. Experience is greatest with oxymetholone, but widespread use is limited by its associated virilizing side effects, which are particularly problematic for female patients or very young patients. In a recent study, improvement in anemia and thrombocytopenia were noted in 7 of 8 patients with FA treated with danazol with minimal side effects.⁸⁶ Suggested treatment guidelines have been proposed by a consensus committee of the FA Research Foundation, although these guidelines must be individualized for each patient and undergo continuous modification as new data emerge. The suggestion of the committee is to consider an allogeneic stem cell transplant or androgen therapy if the hemoglobin falls below 8g/dl, if anemia is symptomatic, if the platelet count falls below 30,000/mm³, or if the neutrophil count falls below 500/mm³.⁸⁷ The earliest and most frequent response to androgens is seen in red cells, with reticulocytosis and increase in hemoglobin generally occurring within the first 1 to 2 months of treatment. Responses in the white cell count and platelet count are variable and may not be seen until after 6 to 12 months of therapy. Resistance to therapy may develop over time (generally years). A common starting androgen regimen consists of oxymetholone 2 to 5 mg/kg/day given orally. Androgen doses may be slowly tapered to the minimal effective dose with careful monitoring of the blood counts. Side effects of androgen administration include liver toxicity, such as elevated liver enzymes, cholestasis, peliosis hepatis, and increased propensity to develop hepatic tumors (benign adenomas and malignant hepatomas). Other side effects of androgens include acne, oily skin, enlarged penis/clitoris, hoarseness/voice deepening, hair growth or hair loss, behavioral changes, hot flashes, breast enlargement or tenderness, amenorrhea, fluid retention, and secondary hypertension.

Hematopoietic growth factors such as G-CSF or GM-CSF have been shown to improve the neutrophil count in the majority of treated patients.^{88, 89} In a few patients, platelet or red cell counts also improved following treatment with G-CSF.⁸⁹ Growth factor treatment is generally not recommended for patients with MDS and is generally avoided for those with a clonal cytogenetic abnormality of the bone marrow, although there are no available data that directly address whether G-CSF increases leukemia risk. It is reasonable to perform a bone marrow aspirate and biopsy as well as cytogenetic studies prior to the initiation of growth factor therapy and monitor regularly throughout therapy.

Results of a gene therapy trial for FA-C patients were reported.⁹⁰ Three FA-C patients underwent 3 to 4 cycles of retroviral transduction of G-CSF-mobilized peripheral blood CD34⁺ mononuclear cells (MNC), while a fourth patient received a single infusion of transduced cells. The transduced wild-type FANCC gene was detected in peripheral blood and bone marrow MNC in association with increased hematopoietic colony growth in vitro. Transient improvement in bone marrow cellularity accompanied these findings and two patients experienced a transient improvement in blood counts. While the selective advantage of corrected cells makes FA an appealing candidate for gene therapy,⁹¹ potential limitations include low CD34⁺ cell numbers,⁹² poor ex vivo expansion of hematopoietic stem/progenitor cells,⁹³ and the residual risk of leukemia associated with the remaining noncorrected hematopoietic cells.³⁸ The development of leukemia in a few patients receiving gene therapy for X-linked SCIDS⁹⁴ raises concerns about the potential growth advantage theoretically conferred by gene correction of a preleukemic hematopoietic stem/progenitor cell in FA patients. In a *Fancc*^{-/-} mouse model, ex vivo cultured stem/progenitor cells exhibited a propensity to develop cytogenetic abnormalities and myeloid malignancies.⁹⁵ Additional studies to optimize ex vivo expansion of hematopoietic stem cells are ongoing.

Published data to guide management of leukemia in FA are scarce. Patients are susceptible to severe mucositis, end-organ toxicities, and prolonged or intractable cytopenias with chemotherapy. Outcomes with chemotherapy alone are poor, so the current treatment of choice for leukemia is a hematopoietic stem cell transplant. Successful treatment of solid tumors is typically best attained with surgical excision of localized tumors. Treatment of solid tumors with chemotherapy or radiation is limited by the high rates of toxic side effects such as mucositis or prolonged or intractable marrow suppression.

P.959

DYSKERATOSIS CONGENITA

DC is an inherited disorder classically characterized by lacey reticular skin pigmentation, nail dystrophy, and leukoplakia (the diagnostic triad). The advent of genetic testing and telomere length analysis revealed a broad spectrum of clinical phenotypes; indeed, the classical clinical triad is absent in a subset of patients.⁹⁶ X-linked recessive, autosomal dominant, and autosomal recessive inheritance patterns have been reported. Patients exhibit a predisposition to bone marrow failure, malignancy, and pulmonary dysfunction. See excellent recent reviews for additional details.^{97, 98}

Clinical Features

The DC registry established in 1995 undertook a comprehensive study of the clinical features associated with DC.⁹⁹ By 1999, the registry included 92 families from 20 countries. There were 148 DC patients, of whom 127 were male and 21 were female. Twentyfive families showed an X-linked recessive pattern of inheritance, while 51 families had sporadic affected males. Sixteen families included one or more affected females, representing both autosomal dominant and autosomal recessive forms of the disease.

The severity of the clinical phenotype can vary widely in affected members of the same family. The classic triad of skin, nail, and oral findings may be lacking. A variety of other clinical features have also been described in patients with DC (Table 37.3). The range of physical findings in female patients is similar to that reported in male patients.⁹⁹ Most of the somatic abnormalities are not present early in life but develop progressively with age. The skin pigmentation is typically reticular and mottled in appearance, and may be localized or widespread. The classical triad of abnormal skin pigmentation, nail dystrophy, and leukoplakia generally appears between the ages of 5 and 10 years, with a median age of onset between 6 and 8 years (range 0.5 to 26 years).⁹⁹ Both the tempo of symptom progression as well as symptom severity are highly variable between patients. For example, nail dystrophy can range from minimal nail irregularities to progressive atrophy and even complete nail loss.

Peripheral cytopenias of two or more peripheral lineages were affected in the majority of registry patients, though single lineage cytopenias were also reported.⁹⁹ The median age of onset of pancytopenia was 8 years, with 50% developing pancytopenia below the age of 10.⁹⁹ The bone marrow is typically hypocellular, though cellularity may be normal or even increased early in the disease. Bone marrow failure or its associated complications accounted for the majority of deaths (67%).

Approximately 20% of patients develop pulmonary disease with reduced diffusion capacity and/or restrictive pulmonary disease.^{99, 100, 101} Pulmonary complications account for nearly 10% of deaths.⁹⁹ Postmortem studies reveal pulmonary fibrosis and abnormalities in the pulmonary microvasculature. Similarly, a high incidence of early and late fatal bone marrow transplant-associated pulmonary complications has also been reported in DC patients.¹⁰²

Immunologic abnormalities, including low or high immunoglobulins, reduced numbers of B or T cells, and reduced stimulation by phytohemagglutinin, have been described in some DC patients.^{99, 103} Opportunistic infections such as *Pneumocystis carinii* pneumonia have been reported.^{104, 105}

Malignancies were noted in 13 out of 148 patients (8.8%) in the DC registry.⁹⁹ These developed in older patients, generally after the second decade of life. It is possible that a higher incidence of cancers might have been observed had not many patients succumbed to aplastic anemia at an earlier age. An increased incidence of MDS and AML has also been observed.⁹⁹ Eight cases of carcinomas were reported in patients aged 20 to 56 years.⁹⁹ A recent report from the National Cancer Institute cohort identified similar cancer risks in FA and DC, with cumulative incidences of solid tumors of 20% to 30% by age 50 years, and 10% AML for age 40 years. The majority of the tumors in DC are HNSCC.^{106, 107}

TABLE 37.3 CLINICAL FEATURES ASSOCIATED WITH DC

Skin pigmentary abnormalities

Nail dystrophy

Leukoplakia

Epiphora

Cognitive/developmental delay

Pulmonary disease

Short stature

Dental caries/tooth loss

- Esophageal stricture
- Hair loss/grey hair/sparse eyelashes
- Hyperhidrosis
- Intrauterine growth retardation
- Gastrointestinal (GI) disorders
- Ataxia
- Hypogonadism/undescended testes
- Microcephaly
- Urethral stricture/Phimosis
- Osteoporosis/aseptic necrosis/scoliosis
- Deafness
- Bone marrow failure
- Malignancy
- Pathophysiology

Reduced hematopoietic progenitor cell colonies have been described for all three hematopoietic lineages compared with controls.^{108, 109, 110, 111} DC patients show a reduction in the proliferative capacity of myeloid progenitors as measured by secondary colony formation following replating.¹¹² Bone marrow cells from DC patients show poor growth in long-term bone marrow culture assays. The defect is intrinsic to the hematopoietic stem cells since DC stromal cells are able to support hematopoietic cells from normal controls, while DC hematopoietic cells grow poorly on normal control stroma.¹¹¹

The X-linked recessive form of DC was linked to Xq28 and the gene was identified by positional cloning and named DKC1¹¹³ (Table 37.4). DKC1 encodes a ubiquitously expressed protein, dyskerin. Dyskerin also interacts with TERC, which is the H/ACA RNA component of the human telomerase complex.¹¹⁴ Cells from DC patients manifest abnormally shortened telomeres and reduced telomerase activity.¹¹⁵ In further support of a telomerase defect in DC, the mutations responsible for some cases of the autosomal dominant form of DC were found to reside in the RNA template, TERC, itself,¹¹⁶ and in TERT, the telomerase reverse transcriptase^{117, 118} (Table 37.4). Telomerase is an enzyme that adds DNA sequences to the ends of chromosomes (the telomeres) to prevent loss of terminal repeats (TTAGG) during DNA replication (reviewed in Ref. 119). Telomeres are important for the prevention of chromosomal fusions and rearrangements. Spontaneous unbalanced chromosomal rearrangements have been described in fibroblasts and bone marrow cells from DC patients.¹²⁰ While telomerase activity is abundant early in development, it is later detectable only in a subset of tissues with dividing cells, including the progenitor cells of the hematopoietic system, the basal layer of the epidermis, intestinal cells, and hair follicles. These tissues

P.960

mirror those most severely affected in DC patients. Telomere loss has also been implicated in contributing to the process of aging, and DC may represent a form of premature aging of tissues with a high replicative requirement.^{121, 122} The gene(s) responsible for some of the sporadic or autosomal dominant as well as the autosomal recessive forms of DC have not yet been identified. Sequence alternations in TERT have also been described in some patients with aplastic anemia in the absence of the characteristic physical findings of DC.^{118, 123} Mutations in additional components of telomerase NOP10 (NOLA3)¹²⁴ and NHP2 (NOLA2)¹²⁵ as well as TERT and CTC1¹²⁶ are found in patients with autosomal recessive DC. In further support of DC as a telomere disorder, mutations in TIN2, a component of the shelterin complex that binds and protects telomeres, cause an autosomal dominant form of DC.¹²⁷ WRAP53, which encodes the TCAB1 protein, functions in the intracellular translocation of telomerase to the Cajal bodies for assembly.¹²⁸

TABLE 37.4 SUMMARY OF BONE MARROW FAILURE SYNDROMES

Clinical Features	Inheritance Pattern	Gene	Additional Laboratory	Associated Malignancies
-------------------	---------------------	------	-----------------------	-------------------------

			Testing		
Fanconi anemia	Radial ray, skin, craniofacial, genitourinary, gastrointestinal, cardiac	Autosomal recessive	<i>FANCA</i> , <i>FANCC</i> , <i>FANCD1</i> , <i>FANCD2</i> , <i>FANCE</i> , <i>FANCF</i> , <i>FANCG</i> , <i>FANCI</i> , <i>FANCI</i> , <i>FANCL</i> , <i>FANCM</i> , <i>FANCN</i> , <i>FANCO</i> , <i>FANCP</i> , <i>FANCB</i>	Chromosome breakage	AML, carcinomas (head and neck, gynecologic); brain and Wilms in <i>D1/BRCA2</i>
Dyskeratosis congenita	Abnormal nails, reticular rash, leukoplakia	X-linked recessive	<i>DKC1</i>	Telomere length	AML, carcinomas (head and neck, anogenital)
		Autosomal dominant	<i>TERC</i> <i>TERT</i> <i>TINF2</i>		
		Autosomal recessive	<i>NHP2</i> <i>NOP10</i> <i>TERT</i> <i>WRAP53</i> <i>CTCI</i>		
Shwachman-Diamond syndrome	Short stature, fat malabsorption, skeletal anomalies	Autosomal recessive	<i>SBDS</i>	Serum trypsinogen, pancreatic isoamylase	AML
Congenital amegakaryocytic thrombocytopenia		Autosomal recessive	<i>C-MPL</i>		AML

AML, acute myeloid leukemia

Dyskerin also exhibits strong homology to two previously characterized proteins: *Saccharomyces cerevisiae* Cbf5p^{129, 130} and rat NAP57.¹³¹ Like Cbf5p and NAP57, dyskerin is localized primarily in the nucleolus and shares some homology with RNA pseudouridine synthases. Pseudouridine synthases together with small nucleolar RNAs (snoRNAs) isomerize uridine bases in ribosomal RNAs (rRNAs) to pseudouridine. In the absence of Cbf5p, yeast rRNA processing is defective.¹³⁰ Impaired translation initiation from internal ribosome entry site sequences has been observed in *Dkc1^m* mice and in cells from DC patients.¹³²

It is increasingly apparent that the classical clinical syndrome of DC represents only the most severe form of the disease. Previously unrecognized milder forms exhibiting only isolated findings or marrow failure alone may now be identified through telomere length measurement and genetic testing.

Differential Diagnosis

DC must be distinguished from other inherited bone marrow failure syndromes that also present with aplastic anemia, congenital anomalies, and cancer predisposition, such as FA. In contrast to FA, cells from DC patients do not manifest increased chromosomal breakage in response to MMC or DEB.¹³³ Literature reports differ over whether cells from DC patient cells exhibit increased chromosomal breakage in response to DNA damaging agents.^{134, 135, 136, 137, 138} Since DC patients may develop aplastic anemia in the first decade of life prior to the manifestation of skin or nail abnormalities, their underlying diagnosis may be missed. DC may mimic graft-versus-host disease in patients previously transplanted for aplastic anemia. Patients with DC typically present with very short telomeres for age; this assay is a clinically approved test.⁹⁶

Laboratory Findings

In addition to peripheral cytopenias, red cell macrocytosis and elevated Hb F may be seen in patients with DC.¹³⁹ However, these signs of stress erythropoiesis are nonspecific, as they are seen in many patients with any of the inherited bone marrow failure syndromes. As noted above, immunologic abnormalities have also been described in some patients.^{99, 103}

Primary DC skin fibroblasts grow slowly in culture and exhibit abnormal morphology. X-chromosome inactivation patterns in female obligate carriers showed complete skewing, consistent with a growth or survival disadvantage for cells expressing only the defective X-chromosome allele.^{140, 141, 142} Spontaneous unbalanced chromosomal translocations have been observed.^{120, 143}

P.961

Telomere length analysis is a useful diagnostic screen for DC since patients with DC exhibit very short (<first percentile of age-matched controls) telomeres in multiple lymphocyte subsets by multicolor flow cytometric fluorescent in situ hybridization (Flow-FISH).^{96, 144} Since over half of patients diagnosed clinically with DC lack mutations in the DC genes known to date, telomere length provides a useful diagnostic screen. Experience with telomere length testing is still limited, and must be interpreted within the clinical context of the patient. Genetic testing is clinically available, but negative genetic testing does not rule out the diagnosis of DC.

Supportive Care

Supportive care for DC patients is similar to that outlined for aplastic anemia and FA patients. Annual pulmonary function testing is recommended, given the risk of developing pulmonary fibrosis. Exposure to pulmonary toxins, such as cigarettes, should be avoided. Regular endocrinology visits are particularly important, since DKC patients are at increased risk of osteoporosis, and their diet, vitamin D, and parathyroid hormone levels and calcium status should be monitored. Patients with significant immunologic dysfunction resulting in reduced immunoglobulin levels may benefit from IVIG therapy.

Treatment

The only curative treatment for bone marrow failure MDS or AML in DC remains allogeneic stem cell transplantation (SCT).^{102, 145, 146, 147, 148, 149, 150, 151, 152} Although long-term survivors have been reported, early and late fatal pulmonary and vascular complications after SCT remain a significant problem.^{102, 145, 148, 149, 153} In one case, a successful lung transplant followed several years after bone marrow transplantation for aplastic anemia due to DC that had not been diagnosed.¹⁵⁴ The avoidance of drugs associated with pulmonary toxicity and the use of radiation-sparing conditioning regimens may provide useful avenues for future study. DC may be mistaken for chronic GVHD in patients transplanted for aplastic anemia.^{155, 156} Treatment with ATG and cyclosporin is generally not effective in these patients.¹⁵⁷ Improvement in peripheral blood counts has been described in some patients following treatment with the androgen oxymetholone.¹⁵⁸ Improved neutrophil counts in response to GM-CSF^{159, 160} or G-CSF^{161, 162} have been reported. Combined treatment with G-CSF and erythropoietin led to improved neutrophil and red cell counts in one case report.¹⁶³

SHWACHMAN-DIAMOND SYNDROME

Clinical Features

SDS is characterized clinically by the combination of exocrine pancreatic insufficiency and bone marrow failure (see Refs. 164, 165, 166 for recent reviews). The differential diagnosis includes other inherited and acquired causes of marrow failure as well as other causes of exocrine pancreatic insufficiency, such as cystic fibrosis, Pearson syndrome, and cartilage hair hypoplasia.

Exocrine pancreatic insufficiency typically presents in infancy with failure to thrive and loose, foul-smelling stools consistent with steatorrhea. Fecal fat measurements may be helpful, but a normal test does not rule out the diagnosis of SDS, since exocrine pancreatic function may improve in a subset of patients. Exocrine pancreatic insufficiency may improve with age to become clinically asymptomatic in a subset of patients. The pancreas in patients with SDS shows fatty replacement of the pancreatic acini, with sparing of the ducts and islets. Fat-soluble vitamin deficiencies (vitamins A, D, E, and K) may be seen. Neutropenia is the most common feature of marrow failure in SDS. Neutropenia may be either intermittent or persistent.¹⁶⁷ Patients are predisposed to infections, particularly bacterial and fungal. Abnormalities of T or B cells have also been reported and may contribute to infectious complications.¹⁶⁸ Anemia and/or thrombocytopenia may also be seen and a subset of SDS patients develop aplastic anemia. The red blood cells may be macrocytic.

There is no pathognomonic feature of the bone marrow in SDS patients; nonetheless, a bone marrow examination with aspirate, biopsy, and cytogenetics is important to rule out other causes of cytopenias. Marrow cellularity may be normal, low, or high. As with other inherited bone marrow failure syndromes, mild dysplastic features may be seen in the erythroid, myeloid, and megakaryocytic lineages. There is a risk for progression to pancytopenia and aplastic anemia (20% to 25%) or myelodysplastic syndrome/AML (5% to 33%).^{6, 167, 169} Hb F is elevated at some stage in approximately 80% of patients.¹⁶⁷

Marrow cytogenetic abnormalities may be seen, such as abnormalities of chromosome 7 (monosomy 7, deletions/translocations of 7q, isochromosome 7) as well as 20q-, which are particularly common. In the absence of morphologic evidence for MDS, the clinical significance of most cytogenetic abnormalities is unclear. These cytogenetic clonal populations may wax and wane over time or even disappear.¹⁷⁰

Additional features that may be variably associated with SDS include: skeletal abnormalities, including metaphyseal dysostosis and osteopenia, failure to thrive despite early institution of pancreatic enzyme supplementation (see below), hepatic abnormalities, and abnormal dentition.¹⁶⁵

Laboratory Findings

SDS is the second most common cause of inherited pancreatic insufficiency, after cystic fibrosis.¹⁷¹ Sweat chloride is normal and serves to distinguish these patients from those with cystic fibrosis. Serum trypsinogen is generally depressed in SDS patients at any age, although it may improve with time.¹⁷² Isoamylase levels remain low after the age of 3 and are useful in this older age group.¹⁷² Other tests for exocrine pancreatic function include pancreatic stimulation or elevated fecal fat measurement, though the latter test is not specific for pancreatic dysfunction. Imaging studies may reveal a fatty, atretic pancreas. Fecal elastase may be decreased, but the sensitivity of this test as a screen for SDS remains to be ascertained. Fat-soluble vitamin levels (vitamins A, D, E, and K) may be low secondary to malabsorption. Skeletal imaging studies may reveal a wide variety of abnormalities, which are often asymptomatic, although metaphyseal dysostosis may require treatment.¹⁷³

Over 90% of patients who meet clinical criteria for SDS harbor autosomal recessive mutations in the SBDS gene. While the presence of biallelic pathogenic SBDS mutations is helpful in confirming the diagnosis, the absence of mutations does not rule out the diagnosis of SDS if the patient meets diagnostic criteria on clinical grounds.¹⁶⁶

Pathophysiology

SDS is an autosomal recessive disorder with an estimated incidence of 1 in 75,000.¹⁷⁴ In the majority (90%) of affected patients reported, mutations have been detected in the Shwachman-Bodian-Diamond syndrome (SBDS) gene located on chromosome 7q11.^{175, 176} SBDS is highly conserved throughout evolution and is expressed in all human tissues tested to date.¹⁷⁶ The human SBDS protein is found in both the nucleus and cytoplasm, and shuttles in and out of the nucleolus in a cell cycle-dependent fashion.¹⁷⁷

SBDS has been implicated in multiple cellular functions. Attention has focused on its role in ribosome biogenesis. Human SBDS associates with the 60S ribosomal precursor but not with the mature 80S ribosome.¹⁷⁸ Yeast failing to express the SBDS ortholog Sdo1 grows poorly. This slow growth is rescued by

mutations in Tif6, the yeast ortholog of eIF6 which functions in ribosome biogenesis and ribosomal subunit joining.¹⁷⁹ Deletion of murine Sbds results in early embryonic lethality.¹⁸⁰ Using conditional Sbds knockout murine models, Sbds was shown to function in coupling the GTPase Efl1 to the release of eIF6 from the nascent 60S ribosomal subunit.¹⁸¹ eIF6 sterically hinders the association of the 60S ribosomal subunit to the 40S subunit^{182, 183}; thus, eIF6 release is required for final assembly of a translationally active 80S ribosomal subunit. SBDS has also been implicated in additional molecular pathways including mitotic spindle stabilization,¹⁸⁴ cellular stress response,¹⁸⁵ actin dynamics,¹⁸⁶ and signaling downstream of RANK for osteoclast differentiation.¹⁸⁷

Supportive Care

Regular monitorings of the peripheral blood counts and periodic bone marrow examinations are recommended. Fevers in the setting of neutropenia warrant prompt medical evaluation for appropriate cultures and treatment with broad spectrum antibiotics. Hematopoietic growth factors (such as recombinant human granulocyte colony-stimulating factor [rhG-CSF]) may stabilize or improve the neutropenia. The main indication for G-CSF therapy is serious bacterial or fungal infection related to neutropenia, though some centers opt to initiate treatment based on the neutrophil counts. Patients with a history of recurrent or severe bacterial infections may benefit from prophylactic G-CSF. Although there is a theoretical risk that G-CSF might stimulate the growth or progression of leukemic clones, there is no direct evidence to address this.^{169, 188} Transfusion support with red cells or platelets should be provided as clinically indicated for severe or symptomatic anemia and thrombocytopenia. There are no published reports to support the use of erythropoietin therapy unless erythropoietin levels are low.

Endocrinology evaluation is useful in these patients to rule out treatable comorbid conditions that could further exacerbate short stature or osteopenia. Dietary counseling may be helpful to ensure adequate intake of calcium and vitamin D.

Treatment

Therapy in SDS is initiated based on clinical manifestations. Fat malabsorption is treated with the administration of oral pancreatic enzymes. Exocrine pancreatic functions may vary over time, and thus regular assessment by a gastroenterologist is recommended.^{189, 190, 191} Patients benefit from supplementation with water-soluble versions of vitamins A, D, E, and K. Fecal fat measurements, vitamin levels, and prothrombin time provide useful measures of exocrine pancreatic function.

Bone marrow transplantation can cure the hematologic aspects of SDS and has been evaluated as a potential therapy in SDS patients with marrow failure, MDS, or AML.^{192, 193, 194, 195, 196, 197} The results in the published literature, consisting largely of case reports, point to an increased risk of complications from end-organ dysfunction, particularly hepatic, cardiac, and pulmonary, as well as transplant-associated problems. Indications for transplant include severe or symptomatic cytopenias, high risk MDS, and leukemia. Outcomes for leukemia remain poor with standard chemotherapy regimens, and thus transplant is the treatment of choice. SDS patients receiving cytotoxic therapies are at risk for prolonged or intractable cytopenias, so appropriate preparations for stem cell support are warranted. As with the other inherited marrow failure syndromes, potential sibling donors regardless of clinical phenotype should be tested for pathogenic mutations identified in the proband. Reported survival rates are lower for patients transplanted for overt leukemia.^{194, 195} For this reason, regular surveillance of blood counts and bone marrow exams have been recommended to increase the likelihood of detecting early signs of malignant transformation.

CONGENITAL AMEGAKARYOCYTIC THROMBOCYTOPENIA

Clinical Features

Patients with CAMT typically present in the neonatal period with petechiae, purpura, or bleeding typically involving the skin, mucous membranes, or GI tract.¹⁹⁸ Intracranial bleeding has also been reported. Bleeding may be life threatening. Thrombocytopenia at birth is usually severe with platelet counts typically less than 50,000 and often less than 20,000. A family history of miscarriages has been reported.¹⁹⁸ Patients are at risk for developing cytopenias in all three hematopoietic lineages and may progress to severe aplastic anemia, which develops later in childhood, with a median age of 3.7 years.¹⁹⁸ A recent retrospective study reported pancytopenia in 14 out of 20 patients at a median age of 38 months with a range between 6 and 53 months.¹⁹⁸ Two clinical forms of CAMT have been described.¹⁹⁹ Patients in CAMT group I are characterized by severe, persistent thrombocytopenia and early onset of pancytopenia. Patients in CAMT group II are characterized by transient increases in platelet counts to over 50,000/ μ l early in life and either a delayed onset of pancytopenia or lack of pancytopenia to date.¹⁹⁹ The development of AML or MDS has been reported in patients with CAMT.¹⁹⁸

Skeletal abnormalities are not typically seen in patients with CAMT. In a recent report, two patients with cardiac abnormalities and six with failure to thrive were reported.¹⁹⁸ Cerebral malformations have been detected, but the possibility that some of these may represent sequelae of prior intracranial hemorrhage could not be excluded. The presence of congenital anomalies together with thrombocytopenia should prompt diagnostic workup for other disorders such as FA, thrombocytopenia-absent-radii (TAR) syndrome, amegakaryocytic thrombocytopenia with radioulnar synostosis (ATRUS), Paris-Trousseau syndrome, or the Hoyeraal-Hreidarsson variant of DC. Mutations in MPL have been identified as one of many causes of familial aplastic anemia.

Differential Diagnosis

Complete blood counts and evaluation of the blood smear should be performed. In cases where primary marrow dysfunction appears likely, a bone marrow examination with cytogenetics is indicated. Thrombocytopenia in the neonate may be secondary to other causes such as infections (e.g., TORCH: toxoplasmosis, rubella, cytomegalovirus, herpes simplex, other viruses), sepsis, Kasabach-Merritt syndrome, thrombosis, or medications. Infants may exhibit transient thrombocytopenia in the setting of maternal HELLP syndrome. Immune-mediated thrombocytopenia from transplacentally acquired maternal alloantibodies or autoantibodies is also common in the neonatal period. Other rare causes of thrombocytopenia include the giant platelet syndromes: Bernard-Soulier syndrome, Glanzmann's thrombocythemia, and May-Hegglin disease. Additional inherited syndromes associated with thrombocytopenia, such as GATA-1 mutations²⁰⁰ or other inherited bone marrow failure syndromes, must also be considered. The absence of radial ray anomalies distinguishes CAMT from TAR. While patients with TAR exhibit thrombocytopenia at an early age, platelet counts generally improve with age, though counts may fluctuate. Aplastic anemia has not been reported in TAR patients, although AML or MDS has been reported.^{201, 202, 203}

Laboratory Findings¹⁹⁸

The platelets in CAMT are of normal size and morphology but low in number, typically in the 20,000/ μ l range, but higher platelet counts do not rule out the diagnosis. Laboratory tests for platelet

P.963

function are also normal. The red cells may be normocytic or macrocytic. Mean platelet volume is typically normal. The bone marrow initially shows normal cellularity but exhibits reduced or absent megakaryocytes. Thrombopoietin (TPO) levels are typically elevated (see below). Genetic testing for mutations in the c-Mpl gene is available.

Pathophysiology

CAMT is an autosomal recessively inherited disorder associated with mutations in the c-Mpl gene, which encode the receptor for TPO.^{204, 205} Mutations may be located throughout the gene and include nonsense, missense, and splicing mutations. A correlation between clinical severity and mutation classification has been observed.¹⁹⁹ Patients in the more severe CAMT group I carry mutations predicted to abrogate the production of a full length c-mpl protein. Patients in CAMT group II carry missense mutations that appear to represent hypomorphic alleles retaining some residual activity resulting in the milder clinical phenotype.¹⁹⁹

CAMT patients exhibit high TPO serum levels,²⁰⁶ and their endogenous serum TPO appears functional.²⁰⁷ TPO is important for megakaryocyte development but also for hematopoietic stem cell survival. Mice deficient in either TPO or c-Mpl exhibit both thrombocytopenia as well as reduced numbers of hematopoietic stem cells and progenitors.²⁰⁸ Stem cell dependency on TPO likely contributes to the development of aplastic anemia in CAMT patients.

Supportive Care

Indications for platelet transfusions vary, but generally they are reserved for patients who are experiencing bleeding symptoms. Prophylactic platelet transfusions may be considered for patients posing a high bleeding risk (e.g., prior to surgery). Antifibrinolytic medications such as aminocaproic acid or tranexamic acid may be helpful in stabilizing clots, particularly for mucous membrane bleeding such as oral or nasal bleeding. These agents inhibit plasminogen activation within the clot. Agents that inhibit platelet function, such as aspirin or nonsteroidal antiinflammatory agents should be avoided. Desmopressin acetate (DDAVP) has been used in some patients with thrombocytopenia, though side effects such as SIADH (syndrome of inappropriate antidiuretic hormone secretion) must be monitored.

Treatment

Currently, the only curative therapy for CAMT is a hematopoietic stem cell transplant.^{198, 209, 210, 211, 212, 213} Testing for biallelic c-mpl mutations is a consideration prior to choosing a sibling transplant donor. Whether c-mpl carrier status

affects transplant outcomes is unclear. Abnormal platelet production has been noted in a sibling who was heterozygous for c-mpl mutation and exhibited decreased megakaryocyte colony formation in vitro despite normal platelet counts,²¹⁴ but a good short-term outcome using one sibling carrier donor has been reported.²¹⁰ Considerations for timing of transplant include minimizing the risk of allosensitization from donor blood products or infectious complications secondary to neutropenia. The reader is referred to several recent comprehensive reviews for additional information.^{215, 216}

Acknowledgments

This research was supported in part by the Intramural Research Program of the National Cancer Institute of the National Institutes of Health (B.P.A.) and by the National Institutes of Health (A.S.).

REFERENCES

1. Shimamura A, Alter BP. Pathophysiology and management of inherited bone marrow failure syndromes. *Blood Rev* 2010;24:101-122.
2. Alter BP, Joenje H, Oostra AB, Pals G. Fanconi anemia: adult head and neck cancer and hematopoietic mosaicism. *Arch Otolaryngol Head Neck Surg* 2005;131:635-639.
3. Fanconi G. Familiäre infantile perniziosaartige anämie (pernizioses blutbild und konstitution). *Z Kinderheilkunde* 1927;117:257.
4. Fanconi G. Familial constitutional panmyelocytopenia, Fanconi's anemia (FA). I. Clinical aspects. *Semin Hematol* 1967;4:233-240.
5. Giampietro PF, Adler-Brecher B, Verlander PC, Pavlakis SG, Davis JG, Auerbach AD. The need for more accurate and timely diagnosis in Fanconi anemia. A report from the International Fanconi Anemia Registry. *Pediatrics* 1993;91:1116-1120.
6. Alter BP. Inherited bone marrow failure syndromes. In: Nathan DG, Orkin SH, Ginsburg D, Look AT, eds. *Nathan and Oski's hematology of infancy and childhood*. Philadelphia, PA: W.B. Saunders, 2003:280-365.
7. Butturini A, Gale RP, Verlander PC, Adler Brecher B, Gillio A, Auerbach AD. Hematologic abnormalities in Fanconi anemia. An International Fanconi Anemia Registry study. *Blood* 1994;84:1650-1655.
8. Rosenberg PS, Greene MH, Alter BP. Cancer incidence in persons with Fanconi anemia. *Blood* 2003;101:822-826.
9. Alter BP. Cancer in Fanconi anemia, 1927-2001. *Cancer* 2003;97:425-440.
10. Mehta PA, Ileri T, Harris RE, et al. Chemotherapy for myeloid malignancy in children with Fanconi anemia. *Pediatr Blood Cancer* 2006;48:668-672.
11. Wagner JE, Tolar J, Levrán O, et al. Germline mutations in BRCA2: shared genetic susceptibility to breast cancer, early onset leukemia, and Fanconi anemia. *Blood* 2004;103:3226-3229.
12. Hirsch B, Shimamura A, Moreau L, et al. Association of biallelic BRCA2/ FANCD1 mutations with spontaneous chromosomal instability and solid tumors of childhood. *Blood* 2004;103:2554-2559.
13. Alter BP, Rosenberg PS, Brody LC. Clinical and molecular features associated with biallelic mutations in FANCD1/BRCA2. *J Med Genet* 2007;44:1-449.
14. Wajnrajch MP, Gertner J, Huma Z, Popovic J, et al. Evaluation of growth and hormonal status in patients referred to the International Fanconi Anemia Registry. *Pediatrics* 2001;107:744-754.
15. Dupuis-Girod S, Gluckman E, Souberbielle JC, Brauner R. Growth hormone deficiency caused by pituitary stalk interruption in Fanconi's anemia. *J Pediatr* 2001;138:129-133.
16. Alter BP. Growth hormone and the risk of malignancy. *Pediatr Blood Cancer* 2004;43:534-535.
17. Giri N, Batista DL, Alter BP, Stratakis CA. Endocrine abnormalities in patients with Fanconi anemia. *J Clin Endocrinol Metab* 2007;92:2624-2631.
18. Schroeder TM, Tilgen D, Kruger J, Vogel F. Formal genetics of Fanconi's anaemia in the genetics of neoplasia. *Nature* 1976;230:370-373.
19. Rogatko A, Auerbach AD. Segregation analysis with uncertain ascertainment: application to Fanconi anemia. *Am J Hum Genet* 1988;42:889.

20. Rosenberg PS, Tamary H, Alter BP. How high are carrier frequencies of rare recessive syndromes? Contemporary estimates for Fanconi anemia in the United States and Israel. *Am J Med Genet A* 2011;155A:1877-1883.
21. Faivre L, Portnoi MF, Pals G, et al. Should chromosome breakage studies be performed in patients with VACTERL association? *Am J Med Genet A* 2005;137:55-58.
22. Nakanishi K, Taniguchi T, Ranganathan V, et al. Interaction of FANCD2 and NBS1 in the DNA damage response. *Nat Cell Biol* 2002;4:913-920.
23. Alter BP, Caruso JP, Drachtman RA, Uchida R, Velagaleti GVN, Elghetany MT. Fanconi anemia: myelodysplasia as a predictor of outcome. *Cancer Genet Cytogenet* 2000;117:125-131.
24. Tonnies H, Huber S, Kuhl JS, Gerlach A, Ebell W, Neitzel H. Clonal chromosomal aberrations in bone marrow cells of Fanconi anemia patients: gains of the chromosomal segment 3q26q29 as an adverse risk factor. *Blood* 2003;101:3872-3874.
25. Sasaki MS, Tonomura A. A high susceptibility of Fanconi's anemia to chromosome breakage by DNA cross linking agents. *Cancer Res* 1973;33:1829-1836.
26. Auerbach AD, Wolman SR. Susceptibility of Fanconi's anemia fibroblasts to chromosome damage by carcinogens. *Nature* 1976;261:494-496.
27. Auerbach AD, Adler B, Chaganti RSK. Prenatal and postnatal diagnosis and carrier detection of Fanconi anemia by a cytogenetic method. *Pediatrics* 1981;67:128.
28. Auerbach AD, Alter BP. Prenatal and postnatal diagnosis of aplastic anemia. In: Alter BP, ed. *Methods in hematology: perinatal hematology*. Edinburgh: Churchill Livingstone, 1989:225.
29. Verlinsky Y, Rechitsky S, Schoolcraft W, Strom C, Kuliev A. Preimplantation diagnosis for Fanconi anemia combined with HLA matching. *JAMA* 2001;285:3130-3133.
30. Kubbies M, Schindler D, Hoehn H, Schinzel A, Rabinovich PS. Endogenous blockage and delay of the chromosome cycle despite normal recruitment and growth phase explain poor proliferation and frequent edomitosis in Fanconi anemia cells. *Am J Hum Genet* 1985;37:1022-1030.
31. Dutrillaux B, Aurias A, Dutrillaux AM, Buriot D, Prieur M. The cell cycle of lymphocytes in Fanconi anemia. *Hum Genet* 1982;62:327.
32. Seyschab H, Schindler D, Friedl R, et al. Simultaneous measurement, using flow cytometry, of radiosensitivity and defective mitogen response in ataxia telangiectasia and related syndromes. *Eur J Pediatr* 1992;151:756-760.
33. Cassinat B, Guardiola P, Chevret S, et al. Constitutive elevation of serum alpha-fetoprotein in Fanconi anemia. *Blood* 2000;96:859-863.
34. Cassinat B, Darsin D, Guardiola P, et al. Intermethod discordance for alphafetoprotein measurements in Fanconi anemia. *Clin Chem* 2001;47:1405-1409.
35. Ameziane N, Sie D, Dentro S, et al. Diagnosis of Fanconi anemia: mutation analysis by next-generation sequencing. *Anemia* 2012;2012:132856.
36. Lo Ten Foe JR, Kwee ML, Roomans MA, et al. Somatic mosaicism in Fanconi anemia: molecular basis and clinical significance. *Eur J Hum Genet* 1997;5:137-148.
37. Waisfisz Q, Morgan NV, Savino M, et al. Spontaneous functional correction of homozygous Fanconi anaemia alleles reveals novel mechanistic basis for reverse mosaicism. *Nat Genet* 1999;22:379-383.
38. Gregory JJ Jr, Wagner JE, Verlander PC, et al. Somatic mosaicism in Fanconi anemia: evidence of genotypic reversion in lymphohematopoietic stem cells. *Proc Natl Acad Sci U S A* 2001;98:2532-2537.
39. Kee Y, D'Andrea AD. Expanded roles of the Fanconi anemia pathway in preserving genomic stability. *Genes Dev* 2010;24:1680-1694.
40. Huang M, D'Andrea AD. A new nuclease member of the FAN club. *Nat Struct Mol Biol* 2010;17:926-928.
41. Cybulski KE, Howlett NG. FANCP/SLX4: A swiss army knife of DNA interstrand crosslink repair. *Cell Cycle* 2011;10:1757-1763.
42. Taniguchi T, D'Andrea AD. Molecular pathogenesis of Fanconi anemia: recent progress. *Blood* 2006;107:4223-4233.

43. Howlett NG, Taniguchi T, Olson S, et al. Biallelic inactivation of BRCA2 in Fanconi anemia. *Science* 2002;297:606-609.
 44. Levitus M, Roomans MA, Steltenpool J, et al. Heterogeneity in Fanconi anemia: evidence for two new genetic subtypes. *Blood* 2003;103:2498-2503.
 45. Shimamura A, Montes De Oca R, Svenson JL, et al. A novel diagnostic screen for defects in the Fanconi anemia pathway. *Blood* 2002;100:4649-4654.
 46. Taniguchi T, Garcia-Higuera I, Xu B, et al. Convergence of the Fanconi anemia and ataxia telangiectasia signaling pathways. *Cell* 2002;109:459-472.
 47. King MC, Marks JH, Mandell JB. Breast and ovarian cancer risks due to inherited mutations in BRCA1 and BRCA2. *Science* 2003;302:643-646.
 48. Kennedy RD, D'Andrea AD. The Fanconi anemia/BRCA pathway: new faces in the crowd. *Genes Dev* 2005;19:2925-2940.
 49. Cumming RC, Liu JM, Youssoufian H, Buchwald M. Suppression of apoptosis in hematopoietic factor-dependent progenitor cell lines by expression of the FA-C gene. *Blood* 1996;88:4558-4567.
 50. Rathbun R, Christianson T, Faulkner G, et al. Interferon-gamma-induced apoptotic responses of Fanconi anemia group C hematopoietic progenitor cells involve caspase 8-dependent activation of caspase 3 family members. *Blood* 2000;96:4204-4211.
 51. Fagerlie SR, Diaz J, Christianson T, et al. Functional correction of FA-C cells with FANCC suppresses the expression of interferon gamma-inducible genes. *Blood* 2001;97:3017-3024.
 52. Pang Q, Keeble W, Christianson TA, Faulkner GR, Bagby GC. FANCC interacts with HSP70 to protect hematopoietic cells from IFNgamma/TNF-mediated cytotoxicity. *EMBO J* 2001;20:4478-4489.
 53. Pang Q, Christianson TA, Keeble W, et al. The Fanconi anemia complementation group C gene product: structural evidence of multifunctionality. *Blood* 2001;98:1392-1401.
 54. Cumming RC, Lightfoot J, Beard K, Youssoufian H, O'Brien PJ, Buchwald M. Fanconi anemia group C protein prevents apoptosis in hematopoietic cells through redox regulation of GSTP1. *Nat Med* 2001;7:814-820.
 55. Pagano G. Mitomycin c and diepoxybutane action mechanisms and FANCC protein functions: further insights into the role for oxidative stress in Fanconi's anaemia phenotype. *Carcinogenesis* 2000;21:1067-1068.
 56. Ceccaldi R, Parmar K, Mouly E, et al. Bone marrow failure in Fanconi anemia is triggered by an exacerbated p53/p21 DNA damage response that impairs hematopoietic stem and progenitor cells. *Cell Stem Cell* 2012;11:36-49.
 57. Liu TX, Howlett NG, Deng M, et al. Knockdown of zebrafish Fancd2 causes developmental abnormalities via p53-dependent apoptosis. *Dev Cell* 2003;5:903-914.
 58. Ceccaldi R, Briot D, Larghero J, et al. Spontaneous abrogation of the G(2) DNA damage checkpoint has clinical benefits but promotes leukemogenesis in Fanconi anemia patients. *J Clin Invest* 2011;121:184-194.
 59. Langevin F, Crossan GP, Rosado IV, Arends MJ, Patel KJ. FANCD2 counteracts the toxic effects of naturally produced aldehydes in mice. *Nature* 2011;475:53-58.
 60. Meyer S, Neitzel H, Tonnies H. Chromosomal aberrations associated with clonal evolution and leukemic transformation in Fanconi anemia: clinical and biological implications. *Anemia* 2012;2012:349837.
 61. Cioc AM, Wagner JE, MacMillan ML, DeFor T, Hirsch B. Diagnosis of myelodysplastic syndrome among a cohort of 119 patients with Fanconi anemia: morphologic and cytogenetic characteristics. *Am J Clin Pathol* 2010;133: 92-100.
 62. Rochowski A, Olson SB, Alonzo TA, Gerbing RB, Lange BJ, Alter BP. Patients with Fanconi anemia and AML have different cytogenetic clones than de novo cases of AML. *Pediatr Blood Cancer* 2012;59:922-924.
- P.964
63. Quentin S, Cuccuini W, Ceccaldi R, et al. Myelodysplasia and leukemia of Fanconi anemia are associated with a specific pattern of genomic abnormalities that includes cryptic RUNX1/AML1 lesions. *Blood* 2011;117:e161-e170.

64. Hoskins EE, Morreale RJ, Werner SP, et al. The Fanconi anemia pathway limits human papillomavirus replication. *J Virol* 2012;86:8131-8138.
65. Rose SR, Myers KC, Rutter MM, et al. Endocrine phenotype of children and adults with Fanconi anemia. *Pediatr Blood Cancer* 2012;59:690-696.
66. Gluckman E, Devergie A, Schaison G, et al. Bone marrow transplantation in Fanconi anaemia. *Br J Haematol* 1980;45:557-564.
67. Guardiola P, Socie G, Li X, et al. Acute graft-versus-host disease in patients with Fanconi anemia or acquired aplastic anemia undergoing bone marrow transplantation from HLA-identical sibling donors: risk factors and influence on outcome. *Blood* 2004;103:73-77.
68. Rosenberg PS, Socie G, Alter BP, Gluckman E. Risk of head and neck squamous cell cancer and death in patients with Fanconi anemia who did and did not receive transplants. *Blood* 2005;105:67-73.
69. MacMillan ML, Wagner JE. Haematopoietic cell transplantation for Fanconi anaemia—when and how? *Br J Haematol* 2010;149:14-21.
70. Gluckman E, Auerbach AD, Horowitz MM, et al. Bone marrow transplantation for Fanconi anemia. *Blood* 1995;86:2856-2862.
71. Kohli-Kumar M, Morris C, Delaat C, et al. Bone marrow transplantation in Fanconi anemia using matched sibling donors. *Blood* 1994;84:2050-2054.
72. Dufour C, Rondelli R, Locatelli F, et al. Stem cell transplantation from HLA-matched related donor for Fanconi's anaemia: a retrospective review of the multicentric italian experience on behalf of AIEOP-GITMO. *Br J Haematol* 2001;112:796-805.
73. Deeg HJ, Socie G. Malignancies after hematopoietic stem cell transplantation: many questions, some answers. *Blood* 1998;91:1833-1844.
74. Socie G, Devergie A, Girinski T, et al. Transplantation for Fanconi's anaemia: long-term follow-up of fifty patients transplanted from a sibling donor after low-dose cyclophosphamide and thoraco-abdominal irradiation for conditioning. *Br J Haematol* 1998;103:249-255.
75. Guardiola P, Pasquini R, Dokal I, et al. Outcome of 69 allogeneic stem cell transplantations for Fanconi anemia using HLA-matched unrelated donors: a study on behalf of the European Group for Blood and Marrow Transplantation. *Blood* 2000;95:422-429.
76. Ayas M, Al-Jefri A, Al-Mahr M, et al. Stem cell transplantation for patients with Fanconi anemia with low-dose cyclophosphamide and antithymocyte globulins without the use of radiation therapy. *Bone Marrow Transplant* 2005;35:463-466.
77. Torjemane L, Ladeb S, Ben Othman T, Abdelkefi A, Lakhel A, Ben Abdeladhim A. Bone marrow transplantation from matched related donors for patients with Fanconi anemia using low-dose busulfan and cyclophosphamide as conditioning. *Pediatr Blood Cancer* 2006;46:496-500.
78. de la Fuente J, Reiss S, McCloy M, et al. Non-TBI stem cell transplantation protocol for Fanconi anaemia using HLA-compatible sibling and unrelated donors. *Bone Marrow Transplant* 2003;32:653-656.
79. Maschan AA, Trakhtman PE, Balashov DN, et al. Fludarabine, low-dose busulfan and antithymocyte globulin as conditioning for Fanconi anemia patients receiving bone marrow transplantation from HLA-compatible related donors. *Bone Marrow Transplant* 2004;34:305-307.
80. George B, Mathews V, Shaji RV, Srivastava V, Srivastava A, Chandy M. Fludarabine-based conditioning for allogeneic stem cell transplantation for multiply transfused patients with Fanconi's anemia. *Bone Marrow Transplant* 2005;35:341-343.
81. Tan PL, Wagner JE, Auerbach AD, Defor TE, Slungaard A, Macmillan ML. Successful engraftment without radiation after fludarabine-based regimen in Fanconi anemia patients undergoing genotypically identical donor hematopoietic cell transplantation. *Pediatr Blood Cancer* 2006;46:630-636.
82. Bitan M, Or R, Shapira MY, et al. Fludarabine-based reduced intensity conditioning for stem cell transplantation of Fanconi anemia patients from fully matched related and unrelated donors. *Biol Blood Marrow Transplant* 2006;12:712-718.

83. Yabe M, Shimizu T, Morimoto T, et al. Matched sibling donor stem cell transplantation for Fanconi anemia patients with T-cell somatic mosaicism. *Pediatr Transplant* 2012;16:340-345.
84. Maekawa K, Yoshimitsu M, Fujiwara H, et al. Successful allo-HSCT with a minimal myeloablative conditioning regimen in an adult patient with Fanconi's anemia. *Bone Marrow Transplant* 2012;47:159-160.
85. Grewal SS, Kahn JP, MacMillan ML, Ramsay NK, Wagner JE. Successful hematopoietic stem cell transplantation for Fanconi anemia from an unaffected HLA-genotype-identical sibling selected using preimplantation genetic diagnosis. *Blood* 2004;103:1147-1151.
86. Scheckenbach K, Morgan M, Filger-Brillinger J, et al. Treatment of the bone marrow failure in Fanconi anemia patients with danazol. *Blood Cells Mol Dis* 2012;48:128-131.
87. Shimamura A. Treatment of hematologic abnormalities in Fanconi anemia. In: Eiler ME, Frohnmayer D, Frohnmayer L, Larsen K, Owen J, eds. *Fanconi anemia guidelines for diagnosis and management*, 3rd ed. Eugene: Fanconi Anemia Research Fund, 2008:49-75.
88. Guinan EC, Lopez KD, Huhn RD, Felser JM, Nathan DG. Evaluation of granulocyte-macrophage colony-stimulating factor for treatment of pancytopenia in children with Fanconi anemia. *J. Pediatr* 1994;124:144.
89. Rackoff WR OA, Robinson CA, Cooper RJ, et al. Prolonged administration of granulocyte colony-stimulating factor (filgrastim) to patients with Fanconi anemia: a pilot study. *Blood* 1996;88:1588-1593.
90. Liu JM, Kim S, Read EJ, et al. Engraftment of hematopoietic progenitor cells transduced with the Fanconi anemia group C gene (FANCC). *Human Gene Therapy* 1999;10:2337-2346.
91. Mankad A, Taniguchi T, Cox B, et al. Natural gene therapy in monozygotic twins with Fanconi anemia. *Blood* 2006;107:3084-3090.
92. Croop JM, Cooper R, Fernandez C, et al. Mobilization and collection of peripheral blood CD34⁺ cells from patients with Fanconi anemia. *Blood* 2001;98:2917-2921.
93. Habi O, Delisle MC, Messier N, Carreau M. Lack of self-renewal capacity in FancC^{-/-} stem cells after ex vivo expansion. *Stem Cells* 2005;23:1135-1141.
94. Hacein-Bey-Abina S, von Kalle C, Schmidt M, et al. A serious adverse event after successful gene therapy for X-linked severe combined immunodeficiency. *N Engl J Med* 2003;348:255-256.
95. Li X, Le Beau MM, Ciccone S, et al. Ex vivo culture of FANCC^{-/-} stem/progenitor cells predisposes cells to undergo apoptosis, and surviving stem/progenitor cells display cytogenetic abnormalities and an increased risk of malignancy. *Blood* 2005;105:3465-3471.
96. Alter BP, Rosenberg PS, Giri N, Baerlocher GM, Lansdorp PM, Savage SA. Telomere length is associated with disease severity and declines with age in dyskeratosis congenita. *Haematologica* 2012;97:353-359.
97. Savage SA, Bertuch AA. The genetics and clinical manifestations of telomere biology disorders. *Genet Med* 2010;12:753-764.
98. Mason PJ, Bessler M. The genetics of dyskeratosis congenita. *Cancer Genet* 2011;204:635-645.
99. Dokal I. Dyskeratosis congenita in all its forms. *Br J Haematol* 2000;110: 768-779.
100. Paul SR, Perez-Atayde A, Williams DA. Interstitial pulmonary disease associated with dyskeratosis congenita. *Am J Pediatr Hematol/Oncol* 1992;14: 89-92.
101. Verra F, Kouzan S, Saiag P, Bignon J, deCremoux H. Bronchoalveolar disease in dyskeratosis congenita. *Eur Respir J* 1992;5:497-499.
102. Rocha V, Devergie A, Socie G, Ribaud P, Esperou H, Parquet N, E. G. Unusual complications after bone marrow transplantation for dyskeratosis congenita. *Br J Haematol* 1998;103:243-248.
103. Solder B, Weiss M, Jager A, Belohradsky BH. Dyskeratosis congenita: multisystem disorder with special consideration of immunologic aspects. *Clin Pediatr* 1998;19:32-38.
104. Wiedemann HP, McGuire J, Dwyer JM, et al. Progressive immune failure in dyskeratosis congenita. Report of an adult in whom pneumocystis carinii and fatal disseminated candidiasis developed. *Arch Intern Med* 1984;144: 397-399.

105. Rose C, Kern WV. Another case of pneumocystic carinii pneumonia in a patient with dyskeratosis congenita (Zinsser-Cole-Engman syndrome). *Clin Infect Dis* 1992;15:1056-1057.
106. Alter BP, Giri N, Savage SA, Rosenberg PS. Cancer in dyskeratosis congenita. *Blood* 2009;113:6549-6557.
107. Alter BP, Giri N, Savage SA, et al. Malignancies and survival patterns in the National Cancer Institute Inherited Bone Marrow Failure syndromes cohort study. *Br J Haematol* 2010;150:179-188.
108. Colvin BT, Baker H, Hibbin JA, Gordon-Smith EC, Gordon MY. Haemopoietic progenitor cells in dyskeratosis congenita. *Br J Haematol* 1984;56: 513-515.
109. Friedland M, Lutton JD, Spitzer R, Levere RD. Dyskeratosis congenita with hypoplastic anemia: a stem cell defect. *Am J Hematol* 1985;20:85-87.
110. Alter BP, Knoblock ME, He L, Gillio AP, O'Reilly RJ, Reilly LK. Effect of stem cell factor on in vitro erythropoiesis in patients with bone marrow failure syndromes. *Blood* 1992;80:3000-3008.
111. Marsh JCW, Will AJ, Hows JM, et al. "Stem cell" origin of the hematopoietic defect in dyskeratosis congenita. *Blood* 1992;79:3138-3144.
112. Marley SB, Lewis JL, Davidson RJ, et al. Evidence for a continuous decline in haemopoietic cell function from birth: application to evaluating bone marrow failure in children. *Br J Haematol* 1999;106:162-166.
113. Heiss NS, Knight SW, Vulliamy TJ, et al. X-linked dyskeratosis congenita is caused by mutations in a highly conserved gene with putative nucleolar functions. *Nature Genet* 1998;19:32-38.
114. Mitchell JR, Cheng J, Collins K. A box H/ACA small nucleolar RNA-like domain at the human telomerase RNA 3' end. *Mol Cell Biol* 1999;19:567-576.
115. Mitchell JR, Wood E, Collins K. A telomerase component is defective in the human disease dyskeratosis congenita. *Nature* 1999;402:551-555.
116. Vulliamy T, Marrone A, Goldman F, et al. The RNA component of telomerase is mutated in autosomal dominant dyskeratosis congenita. *Nature* 2001;413:432-435.
117. Armanios M, Chen JL, Chang YP, et al. Haploinsufficiency of telomerase reverse transcriptase leads to anticipation in autosomal dominant dyskeratosis congenita. *Proc Natl Acad Sci U S A* 2005;102:15960-15964.
118. Savage SA, Stewart BJ, Weksler BB, et al. Mutations in the reverse transcriptase component of telomerase (TERT) in patients with bone marrow failure. *Blood Cells Mol Dis* 2006;37:134-136.
119. Collins K, Mitchell JR. Telomerase in the human organism. *Oncogene* 2002;21:564-579.
120. Dokal I, Bungey J, Williamson P, Oscier D, Hows J, Luzzatto L. Dyskeratosis congenita fibroblasts are abnormal and have unbalanced chromosomal rearrangements. *Blood* 1992;80:3090-3096.
121. Marciniak RA, Johnson FB, Guarente L. Dyskeratosis congenita, telomeres, and human aging. *Trends Genet* 2000;16:193-195.
122. Shay JW, Wright WE. Mutant dyskerin ends relationship with telomerase. *Science* 1999;286:2284-2285.
123. Yamaguchi H, Calado RT, Ly H, et al. Mutations in TERT, the gene for telomerase reverse transcriptase, in aplastic anemia. *N Engl J Med* 2005;352: 1413-1424.
124. Vulliamy T, Beswick R, Kirwan M, et al. Mutations in the telomerase component NHP2 cause the premature ageing syndrome dyskeratosis congenita. *Proc Natl Acad Sci U S A* 2008;105:8073-8078.
125. Walne AJ, Vulliamy TJ, Beswick R, Kirwan M, Dokal I. TINF2 mutations result in very short telomeres: analysis of a large cohort of patients with dyskeratosis congenita and related bone marrow failure syndromes. *Blood* 2008;112: 3594-3600.
126. Keller RB, Gagne KE, Usmani GN, et al. CTC1 mutations in a patient with dyskeratosis congenita. *Pediatr Blood Cancer* 2012;59:311-314.
127. Savage SA, Giri N, Baerlocher GM, Orr N, Lansdorp PM, Alter BP. TINF2, a component of the shelterin telomere protection complex, is mutated in dyskeratosis congenita. *Am J Hum Genet* 2008;82:501-509.
128. Zhong F, Savage SA, Shkreli M, et al. Disruption of telomerase trafficking by TCAB1 mutation causes dyskeratosis congenita. *Genes Dev* 2011;25:11-16.

129. Jiang W, Middleton K, Yoon H-J, Fouquet C, Carbon J. An essential yeast protein, Cbf5p, binds in vitro to centromeres and microtubules. *Mol Cell Biol* 1993;13:4884-4893.
130. Cadwell C, Yoon H-J, Zebrarjadian Y, Carbon J. The yeast nucleolar protein Cbf5p is involved in rRNA biocynthesis and interacts genetically with the RNA polymerase I transcription factor Rrn3. *Mol Cell Biol* 1997;17: 6175-6183.
131. Meier UT, Blobel G. NAP57, a mammalian nucleolar protein with a putative homologue in yeast and bacteria. *J Cell Biol* 1994;127:1505-1514.
132. Yoon A, Peng G, Brandenburg Y, et al. Impaired control of IRES-mediated translation in X-linked dyskeratosis congenita. *Science* 2006;312:902-906.
133. Coulthard S, Chase A, Pickard J, Goldman J, Dokal I. Chromosome breakage analysis in dyskeratosis congenita peripheral blood lymphocytes. *Br J Haematol* 1998;102:1162-1164.
134. Pai GS, Yan Y, DeBauche DM, Stanley WS, Paul SR. Bleomycin hypersensitivity in dyskeratosis congenita fibroblasts, lymphocytes and transformed lymphoblasts. *Cytogenet Cell Genet* 1989;52:186-189.
135. DeBauche DM, Pai GS, Stanley WS. Enhanced G2 chromatid radiosensitivity in dyskeratosis congenita fibroblasts. *Am J Hum Genet* 1990;46:350-357.
136. Ning Y, Yongshan Y, Pai GS, Gross AJ. Heterozygote detection through bleomycin-induced G2 chromatid breakage in dyskeratosis congenita families. *Ca Genet Cytogenet* 1992;60:31-34.
137. Sirinavin C, Trowbridge AA. Dyskeratosis congenita: clinical features and genetic aspects: report of a family and review of the literature. *J Med Genet* 1975;12:339-354.
138. Drachtman RA, Alter BP. Dyskeratosis congenita: clinical and genetic heterogeneity: report of a new case and review of the literature. *Am J Pediatr Hematol/Oncol* 1992;14:297-304.
139. Reichel M, Grix A, Isseroff R. Dyskeratosis congenita associated with elevated fetal hemoglobin, X-linked ocular albinism, and juvenile-onset diabetes mellitus. *Pediatr Dermatol* 1992;9:103-106.
140. Devriendt K, Matthijs G, Legius E, et al. Skewed X-chromosome inactivation in female carriers of dyskeratosis congenita. *Am J Hum Genet* 1997;60: 581-587.
141. Ferraris AM, Forni GL, Mangeini R, Gaetani GF. Nonrandom X-chromosome inactivation in hematopoietic cells from carriers of dyskeratosis congenita. *Am J Hum Genet* 1997;61:458-461.
142. Vulliamy TJ, Knight SW, Dokal I, Mason PJ. Skewed X-inactivation in carriers of X-linked dyskeratosis congenita. *Blood* 1997;90:2213-2216.
143. Scappaticci S, Fraccaro M, Cerimele D. Chromosomal abnormalities in dyskeratosis congenita. *Am J Med Genet* 1989;34:609-610.
144. Alter BP, Baerlocher GM, Savage SA, et al. Very short telomere length by flow fluorescence in situ hybridization identifies patients with dyskeratosis congenita. *Blood* 2007;110:1439-1447.
145. Berthou C, Devergie A, D'Agay MF, Sonsino E, Scrobhaci ML, Loirat C, E. G. Late vascular complications after bone marrow transplantation for dyskeratosis congenita. *Br J Haematol* 1991;79:335-336.
146. Phillips RJ, Judge M, Webb D, Harper JI. Dyskeratosis congenita: delay in diagnosis and successful treatment of pancytopenia by bone marrow transplantation. *Br J Dermatol* 1992;127:278-280.
147. Forni GL, Melevendi C, Fappelli S, Rasore-Quartino A. Dyskeratosis congenita: unusual presenting features within a kindred. *Pediatr Hematol Oncol* 1993;10:145-149.
148. Langston AA, Sanders JE, Deeg HJ, et al. Allogeneic marrow transplantation for aplastic anaemia associated with dyskeratosis congenita. *Br J Haematol* 1996;92:758-765.
149. Knight S, Vulliamy T, Copplestone A, Gluckman E, Mason PJ, Dokal I. Dyskeratosis congenita (DC) registry: identification of new features of DC. *Br J Haematol* 1998;103:990-996.
150. Lau YL, Ha SY, Chan DF, Lee ACW, Liang RHS, Yuen HL. Bone marrow transplant for dyskeratosis congenita. *Br J Haematol* 1999;105:571.
151. Ghavamzadeh A, Alimoghadam K, Nasser P, Jahani M, Khodabandeh A, Ghahremani G. Correction of bone marrow failure in dyskeratosis congenita by bone marrow transplantation. *Bone Marrow Transplant* 1999;23:299-301.

152. Dietz AC, Orchard PJ, Baker KS, et al. Disease-specific hematopoietic cell transplantation: nonmyeloablative conditioning regimen for dyskeratosis congenita. *Bone Marrow Transplant* 2011;46:98-104.
153. Yabe M, Yabe H, Hattori K, et al. Fatal interstitial pulmonary disease in a patient with DC after allogeneic bone marrow transplantation. *Bone Marrow Transplant* 1997;19:389-392.
154. Giri N, Lee R, Faro A, et al. Lung transplantation for pulmonary fibrosis in dyskeratosis congenita: case report and systematic literature review. *BMC Blood Disord* 2011;11:3.
155. Ling NS, Fenske NA, Julius RL, Espinosa CG, Drake LA. Dyskeratosis congenita in a girl simulating chronic graft-versus-host disease. *Arch Dermatol* 1985;121:1424-1428.
156. Ivker RA, Woosley J, Resnick SD. Dyskeratosis congenita or chronic graft-versus-host disease? A diagnostic dilemma in a child eight years after bone marrow transplantation for aplastic anemia. *Pediatr Dermatol* 1993;10:362-365.
157. Al-Rahawan MM, Giri N, Alter BP. Intensive immunosuppression therapy for aplastic anemia associated with dyskeratosis congenita. *Int J Hematol* 2006;83:275-276.
158. Smith CM, Ramsay NKC, Branda RF, Nesbit ME, Krivit W. Response to androgens in the constitutional aplastic anemia of dyskeratosis congenita. *Pediatr Res* 1979;13:441.
159. Russo CL, Glader BE, Israel RJ, Galasso F. Treatment of neutropenia associated with dyskeratosis congenita with granulocyte-macrophage colony-stimulating factor. *Lancet* 1990;336:751-752.
160. Putterman C, Safadi R, Zolotogora J, Banura R, Eldor A. Treatment of the hematological manifestations of dyskeratosis congenita. *Ann Hematol* 1993;66:209-212.
161. Pritchard SL, Junker AK. Positive response to granulocyte colony-stimulating factor in dyskeratosis congenita before matched unrelated bone marrow transplantation. *Am J Pediatr Hematol Oncol* 1994;16:186-187.
162. Oehler L, Reiter E, Friedl J, et al. Effective stimulation of neutropoiesis with rh G-CSF in dyskeratosis congenita: a case report. *Ann Hematol* 1994;69: 325-327.
163. Alter BP, Gardner EH, Hall RE. Treatment of dyskeratosis congenita with granulocyte macrophage colony-stimulating factor and erythropoietin. *Br J Haematol* 1997;97:309-311.
164. Dror Y. Shwachman-Diamond syndrome. *Pediatr Blood Cancer* 2005;45: 892-901.
165. Burroughs L, Woolfrey A, Shimamura A. Shwachman-Diamond syndrome: a review of the clinical presentation, molecular pathogenesis, diagnosis, and treatment. *Hematol Oncol Clin North Am* 2009;23:233-248.
166. Dror Y, Donadieu J, Kogmeier J, et al. Draft consensus guidelines for diagnosis and treatment of Shwachman-Diamond syndrome. *Ann N Y Acad Sci* 2011;1242:40-55.
167. Smith OP, Hann IM, Chessells JM, Reeves BR, Milla P. Haematological abnormalities in Shwachman-Diamond syndrome. *Br J Haematol* 1996;94: 279-284.
168. Dror Y, Ginzberg H, Dalal I, et al. Immune function in patients with Shwachman-Diamond syndrome. *Br J Haematol* 2001;114:712-717.
169. Donadieu J, Leblanc T, Bader Meunier B, et al. Analysis of risk factors for myelodysplasias, leukemias and death from infection among patients with congenital neutropenia. Experience of the French Severe Chronic Neutropenia Study Group. *Haematologica* 2005;90:45-53.
170. Dror Y, Durie P, Ginzberg H, et al. Clonal evolution in marrows of patients with Shwachman-Diamond syndrome: a prospective 5-year follow-up study. *Exp Hematol* 2002;30:659-669.
171. Cipolli M. Shwachman-Diamond syndrome: clinical phenotypes. *Pancreatol* 2001;1:543-548.
172. Ip WF, Dupuis A, Ellis L, et al. Serum pancreatic enzymes define the pancreatic phenotype in patients with Shwachman-Diamond syndrome. *J Pediatr* 2002;141:259-265.
173. Makitie O, Ellis L, Durie PR, et al. Skeletal phenotype in patients with Shwachman-Diamond syndrome and mutations in SBDS. *Clin Genet* 2004;65:101-112.
174. Goobie S, Popovic M, Morrison J, et al. Shwachman-Diamond syndrome with exocrine pancreatic dysfunction and bone marrow failure maps to the centromeric region of chromosome 7. *Am J Hum Genet* 2001;68: 1048-1054.

175. Woloszynek JR, Rothbaum RJ, Rawls AS, et al. Mutations of the SBDS gene are present in most patients with Shwachman-Diamond syndrome. *Blood* 2004;104:3588-3590.
176. Boocock GR, Morrison JA, Popovic M, et al. Mutations in SBDS are associated with Shwachman-Diamond syndrome. *Nat Genet* 2003;33:97-101.
177. Austin KM, Leary RJ, Shimamura A. The Shwachman-Diamond SBDS protein localizes to the nucleolus. *Blood* 2005;106:1253-1258.
178. Ganapathi KA, Austin KM, Lee CS, et al. The human Shwachman-Diamond syndrome protein, SBDS, associates with ribosomal RNA. *Blood* 2007;110:1458-1465.
179. Menne TF, Goyenechea B, Sanchez-Puig N, et al. The Shwachman-Bodian-Diamond syndrome protein mediates translational activation of ribosomes in yeast. *Nat Genet* 2007;39:486-495.
180. Zhang S, Shi M, Hui CC, Rommens JM. Loss of the mouse ortholog of the Shwachman-Diamond syndrome gene (SBDS) results in early embryonic lethality. *Mol Cell Biol* 2006;26:6656-6663.
181. Finch A, Hilcenko C, Basse N, et al. Uncoupling of GTP hydrolysis from Eif6 release on the ribosome causes Shwachman-Diamond syndrome. *Genes Dev* 2011;25:917-929.
182. Ceci M, Gaviraghi C, Gorrini C, et al. Release of EIF6 (p27BBP) from the 60S subunit allows 80S ribosome assembly. *Nature* 2003;426:579-584.
183. Gartmann M, Blau M, Armache JP, Mielke T, Topf M, Beckmann R. Mechanism of EIF6-mediated inhibition of ribosomal subunit joining. *J Biol Chem* 2010;285:14848-14851.
184. Austin KM, Gupta ML, Coats SA, et al. Mitotic spindle destabilization and genomic instability in Shwachman-Diamond syndrome. *J Clin Invest* 2008;118:1511-1518.
185. Ball HL, Zhang B, Riches JJ, et al. Shwachman-Bodian Diamond syndrome is a multi-functional protein implicated in cellular stress responses. *Hum Mol Genet* 2009;18:3684-3695.
186. Orelia C, Kuijpers TW. Shwachman-Diamond syndrome neutrophils have altered chemoattractant-induced F-actin polymerization and polarization characteristics. *Haematologica* 2009;94:409-413.
187. Leung R, Cuddy K, Wang Y, Rommens J, Glogauer M. SBDS is required for RAC2-mediated monocyte migration and signaling downstream of RANK during osteoclastogenesis. *Blood* 2011;117:2044-2053.
188. Rosenberg PS, Alter BP, Bolyard AA, et al. The incidence of leukemia and mortality from sepsis in patients with severe congenital neutropenia receiving long-term G-CSF therapy. *Blood* 2006;107:4628-4635.
189. Mack DR. Shwachman-Diamond syndrome. *J Pediatr* 2002;141:164-165.
190. Rothbaum R, Perrault J, Vlachos A, et al. Shwachman-Diamond syndrome: report from an international conference. *J Pediatr* 2002;141:266-270.
191. Cipolli M, D'Orazio C, Delmarco A, Marchesini C, Miano A, Mastella G. Shwachman's syndrome: pathomorphosis and long-term outcome. *J Pediatr Gastroenterol Nutr* 1999;29:265-272.
192. Okcu F, Roberts WM, Chan KW. Bone marrow transplantation in Shwachman-Diamond syndrome: report of two cases and review of the literature. *Bone Marrow Transplant* 1998;21:849-851.
193. Hsu JW, Vogelsang G, Jones RJ, Brodsky RA. Bone marrow transplantation in Shwachman-Diamond syndrome. *Bone Marrow Transplant* 2002;30:255-258.
194. Cesaro S, Oneto R, Messina C, et al. Haematopoietic stem cell transplantation for Shwachman-Diamond disease: a study from the European Group for Blood and Marrow Transplantation. *Br J Haematol* 2005;131:231-236.
195. Donadieu J, Michel G, Merlin E, et al. Hematopoietic stem cell transplantation for Shwachman-Diamond syndrome: experience of the French Neutropenia Registry. *Bone Marrow Transplant* 2005;36:787-792.
196. Vibhakar R, Radhi M, Rumelhart S, Tatman D, Goldman F. Successful unrelated umbilical cord blood transplantation in children with Shwachman-Diamond syndrome. *Bone Marrow Transplant* 2005;36:855-861.
197. Bhatla D, Davies SM, Shenoy S, et al. Reduced-intensity conditioning is effective and safe for transplantation of patients with Shwachman-Diamond syndrome. *Bone Marrow Transplant* 2008;42(3):159-65.

198. King S, Germeshausen M, Strauss G, Welte K, Ballmaier M. Congenital amegakaryocytic thrombocytopenia: a retrospective clinical analysis of 20 patients. *Br J Haematol* 2005;131:636-644.
199. Germeshausen M, Ballmaier M, Welte K. MPL mutations in 23 patients suffering from congenital amegakaryocytic thrombocytopenia: the type of mutation predicts the course of the disease. *Hum Mutat* 2006;27:296-301.
200. Nichols KE, Crispino JD, Poncz M, et al. Familial dyserythropoietic anaemia and thrombocytopenia due to an inherited mutation in GATA1. *Nat Genet* 2000;24:266-270.
201. Camitta BM, Rock A. Acute lymphoid leukemia in a patient with thrombocytopenia/absent radii (TAR) syndrome. *Am J Pediatr Hematol Oncol* 1993;15:335-337.
202. Fadoo Z, Naqvi SM. Acute myeloid leukemia in a patient with thrombocytopenia with absent radii syndrome. *J Pediatr Hematol Oncol* 2002;24:134-135.
203. Go RS, Johnston KL. Acute myelogenous leukemia in an adult with thrombocytopenia with absent radii syndrome. *Eur J Haematol* 2003;70:246-248.
204. Ballmaier M, Germeshausen M, Schulze H, et al. C-MPL mutations are the cause of congenital amegakaryocytic thrombocytopenia. *Blood* 2001;97: 139-146.
205. Ihara K, Ishii E, Eguchi M, et al. Identification of mutations in the C-MPL gene in congenital amegakaryocytic thrombocytopenia. *Proc Natl Acad Sci U S A* 1999;96:3132-3136.
206. Mukai HY, Kojima H, Todokoro K, et al. Serum thrombopoietin (TPO) levels in patients with amegakaryocytic thrombocytopenia are much higher than those with immune thrombocytopenic purpura. *Thromb Haemost* 1996;76:675-678.
207. Cremer M, Schulze H, Linthorst G, et al. Serum levels of thrombopoietin, IL-11, and IL-6 in pediatric thrombocytopenias. *Ann Hematol* 1999;78: 401-407.
208. Murone M, Carpenter DA, de Sauvage FJ. Hematopoietic deficiencies in c-Mpl and Tpo knockout mice. *Stem Cells* 1998;16:1-6.
209. Lonial S, Bilodeau PA, Langston AA, et al. Acquired amegakaryocytic thrombocytopenia treated with allogeneic BMT: a case report and review of the literature. *Bone Marrow Transplant* 1999;24:1337-1341.
210. Muraoka K, Ishii E, Ihara K, et al. Successful bone marrow transplantation in a patient with c-MPL-mutated congenital amegakaryocytic thrombocytopenia from a carrier donor. *Pediatr Transplant* 2005;9:101-103.
211. Steele M, Hitzler J, Doyle JJ, et al. Reduced intensity hematopoietic stem-cell transplantation across human leukocyte antigen barriers in a patient with congenital amegakaryocytic thrombocytopenia and monosomy 7. *Pediatr Blood Cancer* 2005;45:212-216.
212. Al-Ahmari A, Ayas M, Al-Jefri A, Al-Mahr M, Rifai S, El-Solh H. Allogeneic stem cell transplantation for patients with congenital amegakaryocytic thrombocytopenia (CAT). *Bone Marrow Transplant* 2004;33:829-831.
213. Yesilipek MA, Hazar V, Kupesiz A, Yegin O. Peripheral stem cell transplantation in a child with amegakaryocytic thrombocytopenia. *Bone Marrow Transplant* 2000;26:571-572.
214. Tonelli R, Scardovi AL, Pession A, et al. Compound heterozygosity for two different amino-acid substitution mutations in the thrombopoietin receptor (C-MPL gene) in congenital amegakaryocytic thrombocytopenia (CAMT). *Hum Genet* 2000;107:225-233.
215. Geddis AE. Congenital amegakaryocytic thrombocytopenia. *Pediatr Blood Cancer* 2011;57:199-203.
216. Ballmaier M, Germeshausen M. Congenital amegakaryocytic thrombocytopenia: clinical presentation, diagnosis, and treatment. *Semin Thromb Hemost* 2011;37:673-681.

Chapter 38 Acquired Aplastic Anemia

> Table of Contents > Part IV - Disorders of Red Cells > Section 5 - Other Red Cell Disorders > Chapter 38 - Acquired Aplastic Anemia

Chapter 38

Acquired Aplastic Anemia

Robert A. Brodsky

HISTORICAL BACKGROUND

The earliest case description of aplastic anemia was by Dr. Paul Ehrlich in 1888.¹ He described a young woman who died following an abrupt illness that manifested as severe anemia, bleeding, hyperpyrexia, and a markedly hypocellular bone marrow. The term aplastic anemia was first introduced in 1904 by Chauffard. In 1972, a patient with aplastic anemia became the first recipient of successful allogeneic bone marrow transplantation.² The development of bone marrow transplantation and potent immunosuppressive therapy in the 1970s greatly improved the prognosis of an illness that was almost uniformly fatal within a few years of diagnosis. Although aplastic anemia remains a potentially devastating illness, with prompt intervention most patients now survive the disease.

ACQUIRED VERSUS CONSTITUTIONAL APLASTIC ANEMIA

Acquired aplastic anemia can occur in any age group and is usually the consequence of an autoimmune attack against hematopoietic stem cells. Awareness of the less common inherited forms of bone marrow failure is critical in the assessment of any new patient with aplastic anemia (Chapter 37). These inherited disorders can masquerade as acquired aplastic anemia, but rarely respond to immunosuppressive therapies; management usually consists of supportive care or in severe cases bone marrow transplantation (BMT).^{3, 4} Inherited forms of bone marrow failure generally present in the first decade of life and are often associated with physical anomalies, (e.g., short stature, upper-limb anomalies, hypogonadism, café-au-lait spots); however, inherited forms of bone marrow failure may present well into adulthood. Some patients have a positive family history of cytopenias, highlighting the importance of taking a careful family history when evaluating aplastic anemia patients.

Fanconi anemia, the most common form of inherited bone marrow failure, is usually an autosomal recessive disorder that is characterized by defects in DNA repair and a predisposition to leukemia and solid tumors.⁵ Recently, a rare, X-linked form of Fanconi anemia has been described.⁶ Dyskeratosis congenita (DKC) is an inherited bone marrow failure syndrome that results from loss of function mutations of telomerase components and displays considerable clinical and genetic heterogeneity. Although DKC classically presents with the triad of abnormal skin pigmentation, nail dystrophy, and mucosal leukoplakia, these findings can be subtle.^{7, 8} X-linked recessive, autosomal dominant and autosomal recessive forms of DKC are recognized.^{9, 10} Telomerase reverse transcriptase (TERT) and the RNA component of telomerase (TERC) form the core of the active telomerase complex. Autosomal dominant DKC can result from mutations of TERC¹¹ or TERT.¹² The X-linked recessive DKC results from mutations in the gene *DKC1*, whose gene product, dyskerin, is important for stabilizing the telomerase RNA-protein complex.^{13, 14} Mutations of the *TINF2* gene can also lead to DKC. *TINF2* mutations result in dysfunction of the shelterin complex, interfering with its protection of telomeres and leading to reduced telomere length. Accelerated telomere shortening leads to bone marrow failure, genetic instability, and premature aging.

Inherited amegakaryocytic thrombocytopenia is characterized by severe thrombocytopenia and megakaryocyte absence at birth. Missense or nonsense mutations in the *c-mpl* gene are present in most patients. A high percentage of these patients subsequently develop multilineage bone marrow failure in the second decade of life.¹⁵ Shwachman-Diamond syndrome is an autosomal recessive disorder characterized by pancreatic exocrine dysfunction, metaphyseal dysostosis, and bone marrow failure.¹⁶ Similar to Fanconi anemia, there is an increased risk of developing myelodysplasia or leukemia at an early age. Hypomorphic mutations in the Shwachman-Bodian-Diamond Syndrome (SBDS) gene on chromosome 7 have been found in roughly 85% of cases.¹⁷ The SBDS gene is important for ribosome biogenesis, but how this leads to bone marrow failure is unclear. These inherited forms of aplastic anemia are described in more detail in Chapter 37. The remainder of this chapter focuses on acquired aplastic anemia, hereafter referred to as aplastic anemia.

EPIDEMIOLOGY

Incidence, Age, and Geographic Distribution

Precise estimates of the incidence of aplastic anemia are confounded by the imprecision in establishing the diagnosis. The International Aplastic Anemia and Agranulocytosis Study (IAAAS), conducted in Europe and Israel, is the largest and most comprehensive epidemiologic study of bone marrow failure.¹⁸ This prospective study (performed between 1980 and 1984) reported that the overall incidence of aplastic anemia was 2 cases per 1 million people; however, the incidence may be two to threefold higher in Southeast Asia.¹⁹

Aplastic anemia most commonly presents in children and young adults, but there is a second smaller peak in incidence after age 60.^{20, 21} Similar to other autoimmune diseases, certain histocompatibility locus specificities, especially HLA-DR2, are associated with an underlying predisposition to aplastic anemia.²² Although aplastic anemia has been causally associated with many agents, including drugs, benzene exposure, insecticides, and viruses, no etiologic agent can be

identified in most cases.^{23, 24} A population-based case-control study of aplastic anemia in Thailand found that drugs were the most commonly implicated cause, but they explained only 5% of newly diagnosed cases.²³

Benzene and Environmental Toxins

The medical literature is replete with case reports of aplastic anemia associated with environmental exposures, most notably benzene or radiation exposure. However, rigorous epidemiologic studies supporting an association between environmental toxins and aplastic anemia are lacking. A major confounder is that benzene and other toxins predispose people to myelodysplastic syndromes (MDS) and leukemia. Older literature was unlikely to have been able to distinguish different types of marrow failure, such as aplastic anemia, MDS, and hypoplastic leukemia, leading to an overestimation of the association between benzene and aplastic anemia. Although the magnitude of the risk remains uncertain, benzene is probably not a major risk factor for aplastic anemia in countries with modern standards of industrial hygiene. A large case-controlled study in Thailand employing modern diagnostic and epidemiologic methods found that individuals of lower economic status and younger age are at greater risk for developing aplastic anemia than their counterparts in other countries following exposure to solvents, glues, and hepatitis A. Grain farmers were also found to have a higher risk of developing aplastic

P.966

anemia (relative risk = 2.7) regardless of whether they used insecticides.¹⁹ These same investigators noted marked differences in incidence between northern and southern rural regions of Thailand and among Bangkok suburbs, implicating potential environmental factors in causing the disease.²⁵

Radiation

Ionizing radiation is directly toxic to bone marrow stem/progenitor cells, and high doses (>1.5 Gy to the whole body) can lead to severe pancytopenia within 2 to 4 weeks after exposure; the LD₅₀ has been estimated at about 4.5 Gy, and a dose of 10 Gy or greater is thought to have 100% mortality.^{26, 27} Although pancytopenia is common after a single high dose of radiation, an increased risk of aplastic anemia is not well documented as a delayed event from atomic bomb survivors.²⁸ Although the principles of managing pancytopenia following radiation exposure are similar to those of aplastic anemia, it is important to recognize that the mechanism of bone marrow failure is different. Bone marrow failure in most cases of community acquired aplastic anemia is due to autoimmune destruction of bone marrow stem/progenitor cells; however, radiation-induced bone marrow failure is dose dependent and is a consequence of direct toxicity to stem and progenitor cells. Supportive care with blood transfusions, granulocyte colony-stimulating factor, and antibiotics is the mainstay of therapy for radiation-induced bone marrow failure, inasmuch as autologous reconstitution will occur in most patients who survive the immediate consequences of radiation exposure.

Drugs and Chemicals

A plethora of case reports and small series have implicated drugs as the cause of bone marrow failure; however, proving a causal association in these rare idiosyncratic reactions is difficult. The more common classes of drugs implicated in causing aplastic anemia are listed in Table 38.1. Nevertheless, drugs were not found to be a common cause of aplastic anemia in two large, controlled, population-based studies.^{18, 29} An epidemiologic study in Thailand examined 541 patients and 2,261 controls. Exposures were determined by in-person interview. The investigators observed significantly elevated relative risk estimates for sulfonamides (5.6), thiazides (3.8), and mebendazole (3.0). Interestingly, no increased risk was associated with chloramphenicol, perhaps the most widely implicated drug in case reports; however, chloramphenicol use in this study was infrequent.²⁹

When drugs are implicated in causing aplastic anemia, it is important to recognize that unlike agranulocytosis and drug-induced thrombocytopenia, stopping the putative drug does not usually lead to hematopoietic recovery. Most cases of drug-induced aplastic anemia lead to an idiosyncratic immune response directed against hematopoietic stem cells and are managed similarly to those with idiopathic aplastic anemia. Notable exceptions include patients who receive high doses of cytotoxic chemotherapy drugs (e.g., alkylating agents, antimetabolites, antimetotics) or rare individuals who have thiopurine methyltransferase deficiency (TPMT). TPMT catalyzes the S-methylation of 6-mercaptopurine, 6-thioguanine, and azathioprine.³⁰ Most individuals have high or intermediate activity of TPMT; however, there are rare individuals (<0.1% of the population) with undetectable levels of TPMT. Exposure to even low dosages of 6-thioguanine, azathioprine, or 6-mercaptopurine, as used in inflammatory bowel disease and lupus, can result in severe bone marrow failure within weeks of starting the drug. Withdrawal of the drug usually leads to hematopoietic recovery in 2 to 4 weeks. Reliable polymerase chain reaction-based methods are now available for detecting the major inactivating mutations at the human TPMT locus.^{31, 32}

TABLE 38.1 CLASSIFICATION OF DRUGS MOST COMMONLY IMPLICATED IN CAUSING APLASTIC ANEMIA

Nonsteroidal Analgesics

Phenylbutazone, indomethacin, ibuprofen, sulindac, diclofenac, piroxicam

Anticonvulsants

Hydantoins, carbamazepine, phenacemide

Antibiotics

Sulfonamides, chloramphenicol

Antiprotozoals

Quinacrine, chloroquine

Antithyroid Drugs

Methimazole, propylthiouracil

Gold

Viruses

Viruses, similarly to drugs, are often implicated, but seldom proven to cause aplastic anemia. Viral infections, especially in chronically ill patients, often lead to transient cytopenias, but frank aplastic anemia is uncommon. These transient cytopenias can be due directly to infection and cytolysis of hematopoietic cells or indirectly through the elaboration of inhibitory cytokines. True aplastic anemia following viruses also appears to result usually from an idiosyncratic immune response directed against hematopoietic stem cells. Acute infection with Epstein-Barr virus (EBV) is often associated with peripheral blood cytopenias. Rarely, acute EBV infection can be complicated by the development of aplastic anemia.^{33, 34, 35} There is no convincing data that B19 parvovirus causes aplastic anemia, but this virus is often linked with aplastic anemia due to the unfortunate term “aplastic crisis,” used to describe the transient red cell aplasia and severe anemia that occurs in sickle cell anemia patients who are acutely infected with B19 parvovirus. The only known natural host cell of parvovirus B19 is the human erythroid progenitor.³⁶ The receptor for the virus is a neutral glycolipid, globoside, also known as the erythrocyte P antigen.³⁷ Globoside is expressed on erythroid progenitors, erythrocytes, fetal myocardium, placenta, some megakaryocytes, and endothelial cells; it is not present on hematopoietic stem cells. Other viruses, including a variety of herpes viruses and the human immunodeficiency virus have been implicated in triggering aplastic anemia, but convincing causal data are lacking. Spontaneous recovery, response to immunosuppression, and response to antiviral therapy have all been described; however, for those with severe disease, conventional therapy (immunosuppression or bone marrow transplantation) should be initiated early.

Seronegative (non-A through non-G) hepatitis precedes the diagnosis of aplastic anemia in 3% to 5% of cases and is recognized as hepatitis-associated aplastic anemia.³⁸ After orthotopic liver transplantation for fulminant seronegative hepatitis, up to 30% of patients will develop aplastic anemia (HAA).^{39, 40} In most cases, the hepatitis resolves spontaneously; however, when severe aplastic anemia (SAA) follows, it is often fatal and presents within a few months after the onset of hepatitis.⁴¹ The pathophysiology of HAA is unknown, but is thought to be immune mediated because it responds to immunosuppressive therapy.⁴¹ Furthermore, patients with HAA have a skewed T-cell repertoire, and liver biopsies from these patients show lymphocytic infiltration.⁴²

Pregnancy

Pregnancy-associated aplastic anemia is a rare entity, and despite numerous case reports, the association is not well understood.^{1, 43, 44}

P.967

The onset of aplastic anemia can occur during pregnancy or shortly after delivery. Moreover, in women with a history of aplastic anemia who had been treated into remission with immunosuppressive therapy, there is an increased risk for relapse of aplastic anemia during pregnancy. The European Group for Blood and Marrow Transplantation performed a retrospective study on the outcome of pregnancy in 36 women who had received immunosuppressive therapy to treat aplastic anemia.⁴⁵ Seven of the pregnancies (19%) were complicated by relapse of aplastic anemia. In contrast to idiopathic aplastic anemia, pregnancy-associated aplastic anemia is often associated with spontaneous remissions.

However, in patients with severe disease, therapy should be initiated promptly, because maternal and fetal mortality are not uncommon.^{43, 44, 45}

PATHOPHYSIOLOGY

Autoimmunity

Aplastic anemia was originally thought to result from a direct toxic effect on hematopoietic stem cells. In the late 1960s, Mathé and colleagues were among the first to postulate an autoimmune basis for aplastic anemia.⁴⁶ After administering antilymphocyte globulin for conditioning, they performed bone marrow transplantation in aplastic anemia patients using partially mismatched donors. Although the transplanted marrow failed to engraft, some patients experienced autologous recovery of hematopoiesis, suggesting that growth and differentiation of the patient's hematopoietic stem cells were being suppressed by the immune system. An analysis by the International Bone Marrow Transplant Registry of identical twin bone marrow transplants in aplastic anemia patients also suggests an autoimmune etiology for the majority of patients. Attempts to treat aplastic anemia by simple transfusion of bone marrow from an identical twin fails to reconstitute hematopoiesis in about 70% of patients.⁴⁷ However, repeating the procedure following a high-dose cyclophosphamide conditioning regimen is successful in most patients.⁴⁸

The first laboratory evidence of autoimmunity in aplastic anemia was provided by experiments showing that lymphocytes from aplastic anemia patients inhibit allogeneic and autologous hematopoietic colony formation *in vitro*.⁴⁹ Subsequently, cytotoxic T lymphocytes were found to mediate the destruction of hematopoietic stem cells in aplastic anemia.^{50, 51} These cytotoxic T cells are more conspicuous in the bone marrow of aplastic anemia patients than in the peripheral blood,^{52, 53, 54} and they overproduce interferon- γ and tumor necrosis factor (TNF).⁵⁵ TNF and interferon- γ are direct inhibitors of hematopoiesis and appear to up-regulate Fas expression on CD34⁺ cells.⁵⁶ Immortalized CD4⁺ and CD8⁺ T-cell clones from aplastic anemia patients also secrete Th1 cytokines and are directly toxic to autologous CD34 cells.^{50, 51} There is also evidence for a humoral autoimmune response in aplastic anemia; autoantibodies against kinectin, a 1,300 amino acid molecule expressed on human hematopoietic cells, liver, ovary, testis, and brain cells have been found in approximately 40% of aplastic anemia patients.⁵⁷ Antidiazepam-binding related protein-1 is another putative autoantibody found in some patients with aplastic anemia;⁵⁸ however, the relevance of these autoantibodies to the pathophysiology of aplastic anemia is unclear. Studies in aplastic anemia patients examining T-cell diversity using complementarity-determining region (CDR3) spectratyping further implicate an autoimmune pathophysiology in aplastic anemia. T cells from aplastic anemia patients have limited T-cell receptor β -chain heterogeneity, suggesting oligoclonal T-cell expansion in response to a specific, but as yet unrecognized, antigen.^{51, 59}

Stem Cells

A reduction in the number of hematopoietic stem/progenitor cells is a universal laboratory finding in aplastic anemia. CD34⁺ cells, assayable hematopoietic progenitors, and long-term culture-initiating cells are strikingly reduced in aplastic anemia.^{60, 61} However, some healthy hematopoietic stem cells persist in most patients with aplastic anemia inasmuch as complete recovery of normal hematopoiesis can occur with effective immunosuppressive therapy.^{62, 63} T cells from aplastic anemia patients kill hematopoietic stem cells in an HLA-DR restricted manner^{50, 51} via Fas ligand.⁵⁶ Hematopoietic stem cells represent several classes of cells with varying capacity for long-term production of the different hematopoietic lineages and variable expression of Fas ligand and HLA-DR.⁶⁴ The most primitive hematopoietic stem cells express little or no HLA-DR^{64, 65} or Fas,^{66, 67} and the expression of both HLA-DR and Fas increases as the stem cells mature. Thus, the primitive hematopoietic stem cells, which normally represent less than 10% of the total CD34⁺ cells, may be relatively invisible to the autoreactive T cells; conversely, the more mature hematopoietic stem cells may be the principal targets of the immune attack in aplastic anemia.⁶⁸ The primitive hematopoietic stem cells eluding the autoimmune attack may be responsible for the slow hematopoietic recovery that occurs in aplastic anemia patients following immunosuppressive therapy.

Clonality and Aplastic Anemia

Clonal hematopoietic stem cell disorders such as paroxysmal nocturnal hemoglobinuria (PNH) and MDS frequently arise from aplastic anemia. Even before the widespread use of immunosuppressive therapy, 5% of patients with aplastic anemia progressed to clonal hematopoiesis. This suggests that the increase in MDS and PNH following immunosuppressive therapy is not a direct consequence of treatment. Rather, the increased survival following immunosuppressive therapy allows time for these underlying clones to develop and expand.^{69, 70}

MDS is a clonal hematopoietic stem cell disorder that produces multilineage hematologic cytopenias (Chapter 79). It is associated with heterogeneous karyotypic abnormalities, often involving chromosomes 5, 7, or 8. Up to 15% of children and adults with aplastic anemia will develop MDS following immunosuppressive therapy, with monosomy 7 being the

most common chromosomal abnormality to emerge.^{71, 72} PNH results from the expansion of an abnormal hematopoietic stem cell that harbors a somatic mutation of the X-linked gene, PIGA.^{73, 74} The PIGA gene product is required for glycosylphosphatidylinositol (GPI) anchor biosynthesis; consequently, PNH cells are deficient in all GPI-anchored proteins (GPI-AP). The GPI-APs (CD59 and CD55) protect cells from complement-mediated destruction; their absence explains the complement-mediated intravascular hemolysis associated with PNH.

Small to moderate PNH clones are found in up to 70% of patients with aplastic anemia.^{69, 75} Typically, less than 20% GPI-AP-deficient granulocytes are detected in aplastic anemia patients at diagnosis, but occasional patients may have larger clones. DNA sequencing of the GPI-AP-deficient cells from aplastic anemia patients reveals clonal PIGA gene mutations.⁷⁶ Moreover, many of these patients exhibit expansion of the PIGA mutant clone and progress to clinical PNH. Although it was once thought that PNH evolving from aplastic anemia is more benign than classical PNH, this observation may be a consequence of lead time bias, inasmuch as many of these patients eventually develop classical PNH symptoms after the PIGA mutant clone expands. Interestingly, the PNH clone can regress, remain stable, or expand in aplastic anemia patients treated with immunosuppressive therapy; however, expansion of the PNH clone is commonly associated with relapse.^{77, 78}

The mechanism whereby PNH clones expand is not entirely clear; however, a preponderance of data suggests that the PNH stem cell has a conditional growth advantage in the setting of aplastic anemia. Specifically, it has been suggested that PNH cells

P.968

may be relatively resistant to an autoimmune attack on the bone marrow, possibly because they are deficient in GPI-anchored UL binding proteins (ULBP) that serve as receptors for NKG2D, a ligand that is important for natural killer cells and T cells.^{79, 80} Alternatively, it has been proposed that “second hit” mutations may also give the PNH clone a growth advantage.⁸¹ These hypotheses are not mutually exclusive.

CLINICAL FEATURES AND DIAGNOSIS

Aplastic anemia can present abruptly over days, or insidiously over weeks to months. Clinical manifestations are proportional to the peripheral blood cytopenias and may include dyspnea on exertion, fatigue, easy bruising, petechia, epistaxis, gingival bleeding, heavy menses, headache, and fever. A complete blood count, leukocyte differential, reticulocyte count, and a bone marrow aspirate and biopsy can establish the diagnosis. Peripheral blood flow cytometry to rule out PNH^{82, 83} and bone marrow karyotyping to help exclude hypoplastic myelodysplastic syndromes (hMDS) should be performed on all patients. Flow cytometric assays to detect PNH cells can be performed with either monoclonal antibodies⁸³ or a fluorescein-conjugated proaerolysin variant known as FLAER.⁸⁴ Unlike monoclonal antibodies that bind the protein portion of a GPI-anchored protein, FLAER binds to the glycan portion of the GPI anchor and is highly sensitive and specific for detecting PNH cells.^{69, 82} Patients less than 40 years of age should be screened for Fanconi anemia using the clastogenic agents diepoxybutane or mitomycin C that test for increased chromosomal breakage.⁵ Up to 10% of patients with Fanconi anemia will have a false negative chromosomal breakage analysis due to mosaicism. In these patients, fibroblasts from a skin biopsy or buccal smear can be used to establish the diagnosis. A family history of cytopenias or pulmonary fibrosis should raise suspicion for an inherited disorder, even when physical abnormalities are not present.

A hypocellular bone marrow is required for the diagnosis of aplastic anemia (Table 38.2). Spicules from an aspirate may be surprisingly cellular in some patients despite overall marrow hypocellularity as most patients will have residual pockets of ongoing hematopoiesis. Thus, a 1- to 2-cm core biopsy is essential for assessing cellularity. Mild dyserythropoiesis is not uncommon in aplastic anemia, especially in cases with simultaneous small-to moderate-sized PNH populations; however, the presence of a small percentage of myeloid blasts or dysplastic features in the myeloid or megakaryocyte lineages favors a diagnosis of hMDS (Table 38.3). Distinguishing between aplastic anemia and hMDS is often challenging, especially in older patients where hMDS is more common. The percentage of CD34⁺ cells in the bone marrow is often helpful.^{85, 86} CD34 is expressed on hematopoietic progenitors and is fundamental to the pathophysiology of both diseases; in MDS clonal expansion emanates from a CD34⁺ stem cell, and in aplastic anemia the CD34⁺ stem cells are the target of an autoimmune attack (Fig. 38.1). Accordingly, the percentage of CD34⁺ cells is usually ≤0.3% in aplastic anemia, whereas the CD34 percentage is either normal (0.5% to 1.0%) or elevated in hMDS.⁸⁵

TABLE 38.2 DIFFERENTIAL DIAGNOSIS OF PANCYTOPENIA WITH A HYPOCELLULAR BONE MARROW

Acquired aplastic anemia

Inherited aplastic anemia
 Fanconi anemia
 Dyskeratosis congenita
 Shwachman-Diamond syndrome
 Amegakaryocytic thrombocytopenia
 Reticular dysgenesis
 Hypoplastic myelodysplastic syndromes
 Large granular lymphocytic leukemia (rare)
 Hypoplastic PNH (PNH/aplastic anemia)
 PNH, paroxysmal nocturnal hemoglobinuria.

TABLE 38.3 BONE MARROW FINDINGS THAT HELP TO DISCRIMINATE APLASTIC ANEMIA FROM MYELODYSPLASIA

Characteristic	Myelodysplastic Syndromes	Aplastic Anemia
Cellularity	Usually increased or normal ^a	Decreased
CD34 count	Normal to increased	Decreased
Erythropoiesis		
Megaloblastosis	Common	Common
Dyserythropoiesis	Common	Sometimes
Ringed sideroblasts	Common	Never
Myelopoiesis		
Increased blasts	Common	Never
Megakaryocytes		
Dysplastic	Common	Never

^a A hypocellular bone marrow is found in up to 15% of cases of myelodysplastic syndromes.

Classification

As do most autoimmune diseases, aplastic anemia encompasses a wide spectrum of disease activity ranging from mild to severe. The risk of morbidity and mortality from aplastic anemia correlates best with the severity of the cytopenias rather than bone marrow cellularity. Thus, acquired aplastic anemia is classified as nonsevere (NSAA), severe (SAA), or very severe (VSAA) based on the degree of peripheral blood pancytopenia (Table 38.4). A bone marrow cellularity of less than 25% and markedly decreased values of at least two of three hematopoietic lineages (neutrophil count <500/μl, platelet count <20,000/μl, and absolute reticulocyte count of <60,000/μl) define SAA. VSAA satisfies the above criteria except the neutrophil count is <200/μl, whereas NSAA is characterized by a hypocellular bone marrow, but with cytopenias that do not meet the criteria for severe disease. The 2-year mortality rate with supportive care alone for patients with SAA or VSAA approaches 80%,⁸⁷ with invasive fungal infections and overwhelming bacterial sepsis being the most frequent causes of death. NSAA is seldom life-threatening and in many instances requires no therapy.

SUPPORTIVE CARE

Transfusions

Patients with symptomatic anemia and/or thrombocytopenia associated with wet purpura or bleeding require immediate blood transfusions. All transfusions in patients with suspected aplastic anemia should be irradiated to prevent transfusion-associated GVHD. If the patient is a potential BMT candidate and is cytomegalovirus (CMV)-negative or the CMV status is unknown, CMV transmission should be avoided by either leukoreduction or the use of CMV-negative products. Blood donation from family

members should be avoided to prevent alloimmunization that could also complicate future BMT. After stabilization of the patient, blood products should be used judiciously to prevent cardiopulmonary compromise and to reduce the risk of hemorrhage; a platelet goal of 10,000/ μL will suffice for most patients, although some patients will tolerate even lower platelet goals without bleeding or petechiae.

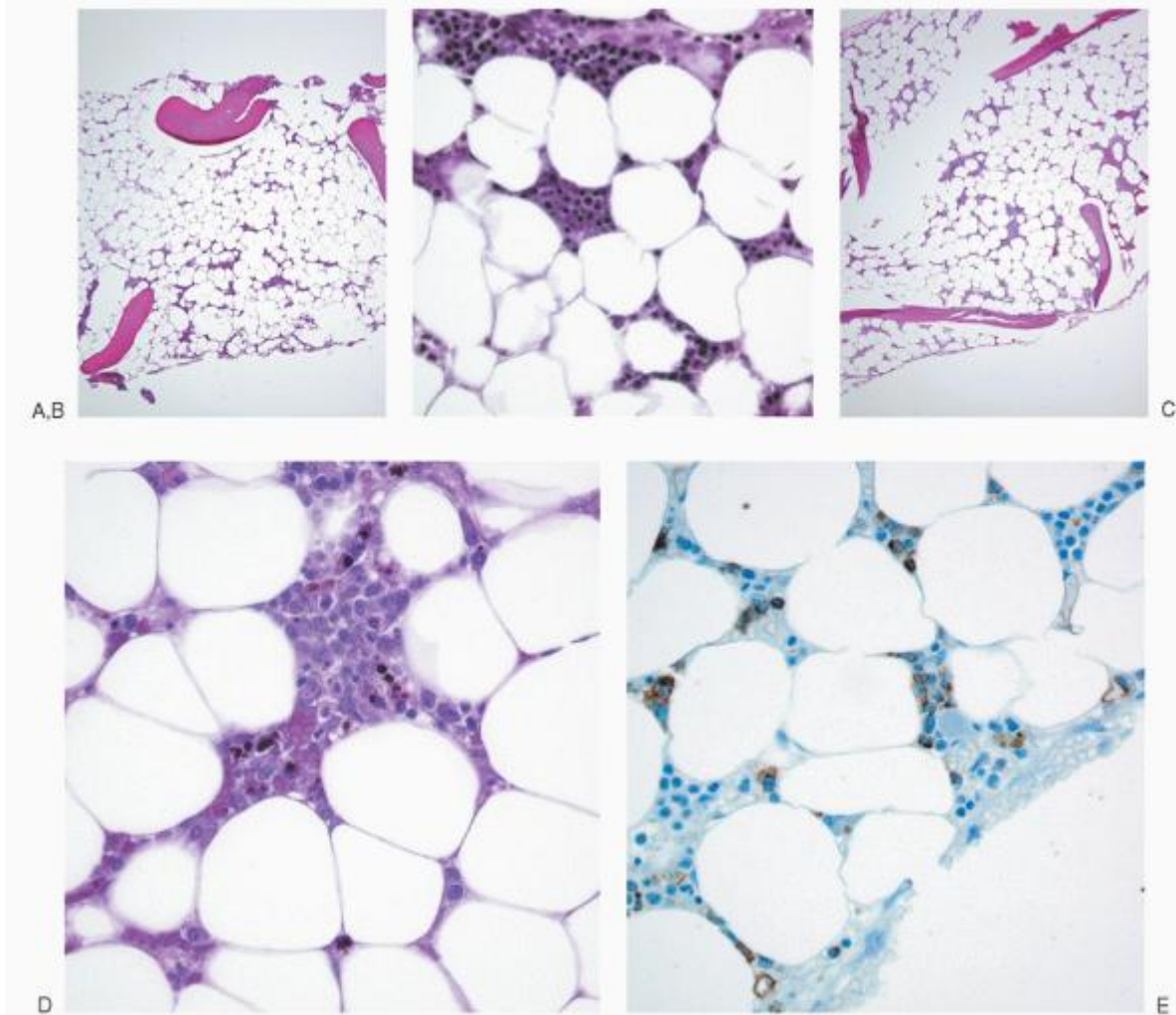

FIGURE 38.1. Aplastic anemia versus hypoplastic myelodysplastic syndrome (hMDS). A: Bone marrow biopsy from patient with aplastic anemia. B: Higher power of biopsy from A showing cluster of nucleated red cells. C: Low-power view of biopsy from a patient with hMDS. D: High-power view of bone marrow from patient in C showing small blast population. Brown pigment represents iron. E: CD34 immunoperoxidase stain (brown) of marrow from patient with hMDS.

TABLE 38.4 CLASSIFICATION OF APLASTIC ANEMIA BASED ON SEVERITY OF PANCYTOPENIA

Severe aplastic anemia (SAA)

Bone marrow cellularity <25%

Two of three peripheral blood criteria:

Absolute neutrophil count <500/ mm^3

Platelet count <20,000/ mm^3

Reticulocyte count <60,000/ mm^3 or <1% corrected reticulocyte count

Very severe aplastic anemia (vSAA)

Same as SAA with absolute neutrophil count $<200/\text{mm}^3$

Nonsevere (moderate aplastic anemia)

Bone marrow cellularity $<25\%$

Peripheral blood cytopenias do not fulfill criteria for SAA

Antibiotics

Overwhelming sepsis caused by bacteria or fungus (especially aspergillus) is the most frequent cause of death from aplastic anemia. In most circumstances, prophylactic antibiotics are unnecessary. However, for patients with absolute neutrophil counts that are consistently $<200/\mu\text{L}$, prophylaxis with oral antibiotics, such as a quinolone and a triazole antifungal, is reasonable. Patients with febrile neutropenia should be treated promptly with broad-spectrum antibiotics; in patients with persistent fever after the initiation of antibacterial antibiotics, aspergillus coverage should be added. Prophylaxis for *Pneumocystis carinii* pneumonia should be given to

P.970

all patients for at least 6 months after immunosuppressive therapy, BMT, or high-dose cyclophosphamide therapy.

Growth Factors

Hematopoietic growth factor deficiency (such as erythropoietin, granulocyte colony-stimulating factor, thrombopoietin, or granulocyte-monocyte colony-stimulating factor) is not responsible for the bone marrow failure in aplastic anemia; levels of measurable hematopoietic growth factors are markedly elevated in aplastic anemia patients in a compensatory attempt to increase blood production. Hence, these factors should not be used in lieu of definitive therapy. Hematopoietic growth factors are often used after immunosuppressive therapy or high-dose cyclophosphamide therapy to accelerate hematopoietic recovery, but their use has not been shown to improve survival.

DEFINITIVE TREATMENT

Nonsevere (Moderate) Aplastic Anemia

There are limited data on the long-term prognosis of patients with moderate aplastic anemia. Although moderate aplastic anemia can progress, many patients will remain stable for years, and some may spontaneously improve, even in the absence of specific treatment.⁸⁸ Treatment should be based on the degree of cytopenia, not bone marrow cellularity. Patients with asymptomatic cytopenias probably require no therapy. Patients with more significant cytopenias, such as symptomatic anemia, may benefit from a trial of immunosuppressive therapy with antithymocyte globulin and cyclosporine (ATG/CSA)⁸⁹ or CSA alone.⁹⁰ Daclizumab, a humanized monoclonal antibody to the interleukin-2 receptor, improved blood counts in 6 of 16 patients with moderate aplastic anemia.⁹¹ However, it is not clear that treatment of moderate aplastic anemia will effect survival.

Definitive Therapy for Severe Aplastic Anemia

Bone Marrow Transplantation

Allogeneic BMT from an HLA-matched sibling donor is the treatment of choice at most centers for young patients with SAA (Table 38.5). A major advantage of BMT over standard immunosuppressive therapy is a marked reduction in the risk of relapse and the outgrowth of late clonal disorders such as MDS and PNH.⁹² Cyclophosphamide (50 mg/kg/day \times 4 days) with or without ATG, is commonly used for conditioning before stem cell transplantation. Although this regimen is nonmyeloablative, the immunosuppression is sufficient to allow engraftment in most cases.^{93, 94, 95} Avoidance of total body irradiation and busulfan reduces transplant-related complications such as mucositis, graft-versus-host disease (GVHD), second malignancies, and infertility. Alternative regimens using fludarabine, cyclophosphamide and antithymocyte globulin are increasingly being used.⁹⁶ Survival rates following matched sibling allogeneic BMT have steadily improved since the 1970s largely because of improved supportive care, improved typing, and better GVHD prophylaxis.⁹⁷ Late BMT-related complications such as chronic GVHD occur in up to one third of patients, with many of these patients requiring long-term therapy for their GVHD.⁹⁸ Patient age and the type of allograft (HLA-matched sibling, unrelated, or mismatched donors) are the most important factors influencing outcome. In patients under 30 years of age, the cure rate after HLA-matched sibling BMT ranges from 70% to 90%.^{98, 99, 100} However, the risk of GVHD steadily increases with age, leading to reduced survival.

TABLE 38.5 REPRESENTATIVE RESULTS FROM LARGE MATURE STUDIES OF BONE MARROW TRANSPLANTATION FOR

SEVERE APLASTIC ANEMIA USING MATCHED SIBLING DONORS

Institution	Years	N	Median Age (Range)	Engraftment (%)	Survival (%)	Median Follow-Up (Years)	Acute GVHD (%)	Chronic GVHD (%)
IBMTR ¹⁰⁰	1988-1992	47120	(1-51)	84	66	3		1932
EBMT ¹⁴⁴	1991-1998	7119	(4-46)	97	86	5		3035
Seattle ⁹⁵	1988-2004	8125	(2-63)	96	88	9		2426
Seoul ¹⁴⁵	1995-2001	11328	(16-50)	85	89	6		1112
Taipei ¹⁴⁶	1985-2001	7922	(4-43)	92	74	5		735
Sao Paulo ¹⁴⁷	1993-2001	8124	(3-53)	82	56	6		3739
EBMT ⁹⁶	1998-2007	23942	(30-67)	86	61	4		2025

EBMT, European Group for Blood and Marrow Transplantation; IBMTR, International Bone Marrow Transplant Registry.

Alternative Donor Bone Marrow Transplantation

Unrelated donors and mismatched transplants have almost twice the transplant-related mortality and risk of GVHD as matched sibling donor transplants (Table 38.6).²⁴ Less than 30% of patients will have an HLA-matched sibling donor. Thus, bone marrow transplantation from unrelated or mismatched donors is usually reserved for patients who fail to respond to one or more courses of immunosuppressive therapy. The best results with unrelated and mismatched transplants are seen in patients under 21 with disease duration of less than 1 year.^{101, 102, 103} The International Bone Marrow Transplant Registry reported on the results of 318 alternative donor transplants between 1988 and 1998.¹⁰⁴ Most patients in this series were young, heavily transfused, and of poor performance status. The probability of graft failure was 20% and the survival probability at 5 years was less than 40%. The Fred Hutchinson Cancer Research Center reported on the results of unrelated allogeneic bone marrow transplantation in aplastic anemia after conditioning with low-dose total body irradiation, high-dose cyclophosphamide, and ATG.¹⁰³ The median age was 19 years, and with a median follow-up of 7 years, 61% of HLA-identical and 40% of HLA nonidentical transplant recipients survived the procedure; however, more than 70% of patients acquired acute GVHD, and over 50% developed chronic GVHD. However, improved typing, newer conditioning regimens, and better GVHD prophylaxis are leading to better survival, higher engraftment rates, and less GVHD. EBMT data using fludarabine, cyclophosphamide, and ATG conditioning ± total body irradiation (TBI) demonstrated survival rates as high as 75%.¹⁰⁵ Survival is best

P.971

in children and in patients who undergo BMT within 2 years of diagnosis. Another promising approach to facilitate engraftment and to mitigate the risk of GVHD is the use of post-transplant cyclophosphamide for GVHD prophylaxis.^{106, 107}

TABLE 38.6 REPRESENTATIVE RESULTS FROM LARGE MATURE STUDIES OF BONE MARROW TRANSPLANTATION FROM ALTERNATIVE DONORS

Institution	Years	N	Median Age (Range)	Donor Source	Survival	Median Follow-Up (Years)	Acute GVHD	Chronic GVHD
--------------------	--------------	----------	---------------------------	---------------------	-----------------	---------------------------------	-------------------	---------------------

IBMTR ^{a,104}	1988-1998	31816 (1-55)	MUD 181; MMRD 86; MMUD 51	39% for MUD	5	48% for MUD	29% for MUD
Seattle ¹⁰³	1988-2004	8719 (1-53)	MUD 62; MMUD 25	55%	5	70%	52%
Japan Marrow Donor Program ¹⁴⁸	1993-2000	15417 (1-46)	MUD 79; MMUD 75	56%	5	29%	30%
EBMT ¹⁰⁵	1998-2007	10020 (3-53)	MUD 87; MMRD 13	77%	3.5	10%	43%

EBMT, European Group for Blood and Marrow Transplantation; GVHD, graft-versus-host disease; IBMTR, International Bone Marrow Transplant Registry; MUD, matched unrelated donor; MMRD, mismatched-related donor; MMUD, mismatched unrelated donor.

Immunosuppressive Therapy

Immunosuppressive therapy with ATG/CSA is used in patients who are not candidates for bone marrow transplantation because of older age or lack of a matched sibling donor. ATG is produced by immunizing animals (horse or rabbit) against human thymocytes and kills human T cells through its cytolytic activity. The largest experience is with horse ATG, although rabbit ATG has recently been approved for use in the United States. CSA suppresses T-cell function by inhibiting the expression of nuclear regulatory proteins. Both single-agent ATG and single-agent CSA⁹⁰ can induce remissions in acquired aplastic anemia; however, the combination ATG/CSA leads to a higher response rate and a greater likelihood of achieving transfusion independence.^{89, 108} A randomized controlled trial demonstrated that horse ATG/CSA is superior to rabbit ATG/CSA. However, difficulties in maintaining quality control have led to the withdrawal of horse ATG in Europe since June of 2007.

The response rates to ATG/CSA range between 60% and 80% (Table 38.7), with 5-year survival rates comparable to BMT.¹⁰⁹ However, in contrast to BMT, most patients are not cured of their disease. Most patients respond within 6 to 12 weeks after receiving ATG/CSA. ATG is usually given over 4 days but CSA must be continued for at least 6 to 12 months before tapering the drug. Persistent cytopenia is common and many patients relapse, become dependent on cyclosporine, or develop secondary clonal disease such as PNH or MDS.^{71, 89, 110, 111} The European Group for Blood and Marrow Transplantation (EBMT) SAA working party performed a retrospective analysis of 468 patients treated with immunosuppressive therapy between 1975 and 1986.¹¹² Patients who survived more than 2 years (n = 223) were classified as long-term survivors. The actuarial mortality rate for long-term survivors was 22% at 8 years, and the actuarial risks of developing PNH and MDS were 13% and 15%, respectively, at 7 years. Bacigalupo and colleagues reported a response rate and overall survival of 77% and 87%, respectively, in 100 patients (median age, 16 years) treated with ATG/CSA, prednisolone, and granulocyte colony-stimulating factor.⁶² The risk of relapse was 9% and cytogenetic abnormalities developed in 11%, but the actuarial probability of discontinuing cyclosporine therapy was only 38% at 5 years. The National Institutes of Health (NIH) treated 122 patients (median age, 35 years) with the combination of ATG/CSA and methylprednisolone and followed them over a period of 8 years.⁷¹ The response rate was 58% and actuarial survival at 7 years was 55%; 13% of patients died within 3 months of treatment,

P.972

mostly from fungal infections. The relapse rate for responders was 40% and 13 patients developed MDS. In an attempt to improve response rate and survival, and to decrease the relapse rate and secondary MDS that occurs after ATG/CSA, the NIH added mycophenolate (1 gram twice daily for 18 months) to the standard ATG/CSA regimen. This three-drug regimen resulted in a 62% response rate, but 37% of the responders relapsed (most while taking mycophenolate) and 9% progressed to either MDS or leukemia; thus, the addition of mycophenolate did not improve response or survival.¹¹³ Sirolimus and Tacrolimus have also been used as alternatives to cyclosporine but no clear advantage in terms of response, relapse, or secondary clonal disease has been demonstrated. Alemtuzumab is another active immunosuppressive therapy for SAA but response rates in untreated patients are less than 30%.

TABLE 38.7 REPRESENTATIVE RESULTS TRIALS OF IMMUNOSUPPRESSIVE THERAPY FOR SEVERE APLASTIC ANEMIA

Study	Regimen	Years	Median Age (Range)	Survival (%)	Response (%)	Relapse (%)	Median Follow-Up	MDS or Leukemia (%)
German ^{89, 149}	ATG with or without CSA	1986-1989	8432 (7-80)	58	70	38	11 y	8
EGBMT ⁶²	ALG, CSA, pred, G-CSF	1991-1999	10016 (1-72)	87	77	12	3 y	3
NIH ^{71, 110}	ATG, CSA, pred	1991-1998	12235	55	61	35	7 y	11
NIH ¹¹³	ATG, CSA, MMF, pred	1995-2001	10330 (3-76)	80	62	37	2 y	9
Japan ¹⁵⁰	ATG, CSA, danazol	1992-1997	1199 (1-16)	84	68	30	4 y	3
Johns Hopkins ¹²⁸	High-dose CY, G-CSF	1996-2008	4432 (2-68)	88	71	7	5 y	5

ATG, antithymocyte globulin; CSA, cyclosporine; CY, cyclophosphamide; EGBMT, European Group for Blood and Marrow Transplantation; G-CSF, granulocyte colony-stimulating factor; MMF, mycophenolic acid; NIH, National Institutes of Health; pred, prednisone.

High-dose Cyclophosphamide

High-dose cyclophosphamide remains (often in conjunction with ATG) the most commonly used BMT conditioning regimen for aplastic anemia.^{93, 114} Interestingly, complete reconstitution of autologous hematopoiesis occurs in 10% to 15% of patients undergoing allogeneic BMT for aplastic anemia.^{115, 116, 117} Most of these patients have maintained long-term remissions despite autologous reconstitution. The EMBT reported that 10% of SAA patients experience autologous reconstitution following BMT using a cyclophosphamide + ATG conditioning regimen. Interestingly, 10-year survival (84%) in patients with autologous recovery was equivalent or better than in patients who engrafted (74%).¹¹⁸

Cyclophosphamide is a prodrug and is converted to 4-hydroxycyclophosphamide and its tautomer, aldophosphamide, by the hepatic cytochrome P-450 system.¹¹⁹ These compounds diffuse into cells and are converted into the active alkylating compound, phosphoramidate mustard, through simple intracellular decomposition. The major mechanism of cyclophosphamide detoxification appears to be inactivation of aldophosphamide by cellular aldehyde dehydrogenase to form the inert compound, carboxyphosphamide. ALDH1A1, previously called class I ALDH or cytosolic ALDH, ALDH1, or retinaldehyde dehydrogenase 1, appears to be the aldehyde dehydrogenase most responsible for cyclophosphamide detoxification.¹²⁰ ALDH1A1 also plays an important role in ethanol metabolism, but its major function appears to be the biosynthesis of retinoic acid from vitamin A (retinol).¹²⁰ After alcohol dehydrogenase oxidizes retinol to retinaldehyde, ALDH1A1 oxidizes retinaldehyde to retinoic acid. Retinoic acid is essential for cellular growth and differentiation. Cells with high proliferative potential, such as hematopoietic stem cells, express high levels of ALDH1A1 because of their requirement for retinoic acid and are thus resistant to cyclophosphamide.^{121, 122} Conversely, lymphocytes have low levels of aldehyde dehydrogenase and are rapidly killed by high doses of cyclophosphamide. High-dose cyclophosphamide is therefore highly immunosuppressive, but not myeloablative, allowing endogenous hematopoietic stem cells to reconstitute hematopoiesis.

High-dose cyclophosphamide without BMT has been used to treat aplastic anemia patients who lack a suitable donor.^{63, 123, 124, 125, 126, 127, 128} In a pilot study, 7 of 10 patients achieved durable complete remissions. No relapse or clonal evolution was observed with a median follow-up of 10.8 (range, 7.3 to 17.8) years. Investigators at the National Institutes of Health initiated a randomized trial of high-dose cyclophosphamide plus CSA versus ATG/CSA.¹²⁶ This trial closed after enrolling 31 patients (17% of the planned accrual) because early toxicity appeared to be higher in the cyclophosphamide plus CSA arm. However, no stopping rules were met, and there were no statistical differences in response rate, survival, or secondary clonal disorders.

Subsequently, a large mature study has confirmed the efficacy of high-dose cyclophosphamide for treating SAA.¹²⁸ Investigators from Johns Hopkins treated 67 SAA patients with high-dose cyclophosphamide; 44 patients were treatment naïve and 23 were refractory to one or more previous immunosuppressive regimens. At 10 years, the overall actuarial survival, response rate, and event-free survival was 88%, 71%, and 58%, respectively, for the 44 treatment-naïve patients. Patients with refractory SAA fared less well: at 10 years, overall actuarial survival, response, and event-free survival rates were 62%, 48%, and 27%, respectively. For treatment-naïve patients, the median time to a neutrophil count of $0.5 \times 10^9/L$ was 60 (range, 28 to 104) days, the median time to last platelet and red cell transfusion was 117 and 186 days, respectively. Relapse occurred in just 2 of the treatment-naïve patients, one of whom was retreated with high-dose cyclophosphamide into a second complete remission. Despite the high response rate and low risk of relapse and secondary clonal disease, many investigators are unwilling to accept the relatively long period of aplasia associated with this therapy. Additional large series and/or future randomized trials will be necessary to fully define the role of this promising therapy.

Relapsed and Refractory Severe Aplastic Anemia

There is no standard algorithm for managing patients with SAA who fail to respond, or relapse, after treatment with ATG/CSA; however, inasmuch as 30% to 40% of patients do not respond to initial therapy and another 20% to 40% of responding patients relapse, these patients pose a common treatment dilemma. Therapeutic options include allogeneic bone marrow transplant (usually from an unrelated or mismatched donor), re-treatment with ATG/CSA, alemtuzumab, or high-dose cyclophosphamide. Alternative donor allogeneic BMT probably offers the best chance for cure in children and young adults, but is associated with substantial morbidity and mortality in older patients. Patients with relapsed aplastic anemia are more likely to respond to a second course of ATG/CSA or to high-dose cyclophosphamide than patients with primary refractory disease. Response rates to a second course of horse or rabbit ATG/CSA ranges from 20% to 70% with the weighted average closer to 30%.^{129, 130, 131, 132, 133} High-dose cyclophosphamide or alemtuzumab may also salvage up to 30% of patients with refractory SAA.^{134, 135, 136} All of these potential options should be discussed with patients; however, patient age, performance status, timing and availability of a bone marrow donor, insurance coverage, and institutional expertise are factors in the decision process.

Treatment of Hepatitis-associated Severe Aplastic Anemia

There are no large prospective series to determine the best treatment for HAA, in part due to the rarity of the disease. Most reports consist of registry data, case series, or single case reports. Because HAA predominantly occurs in children, allogeneic BMT from an HLA-identical sibling is usually considered as first-line therapy. In patients without an HLA-identical sibling, ATG/CSA and high-dose cyclophosphamide have produced durable remissions.^{41, 137} The EBMT performed a retrospective cohort study from 257 centers to assess the epidemiology and treatment of HAA.¹³⁸ They identified 214 patients managed between 1990 and 2007. The incidence of HAA was 5% and the response rate and outcome did not appear to differ from idiopathic SAA. Similar results were reported by the Japan Childhood Aplastic Anemia Study Group who analyzed the outcome of 44 children with HAA. They reported a 70% response rate with immunosuppressive therapy and an 88% overall survival at 10 years.¹³⁹

Other Therapies

Numerous reports suggest that anabolic steroids are effective in treating aplastic anemia;^{140, 141, 142} however, for SAA, controlled

P.973

clinical trials have shown no benefit in terms of hematopoietic improvement¹⁴³ or survival.⁸⁷ Although it is clear that androgens should not be used as first-line therapy in SAA, a 3- to 6-month trial is not unreasonable in patients with refractory disease. Danazol, oxymetholone, and decanoate are often tried in such cases. Careful monitoring of liver function tests and vigilance for other hepatic complications (adenomas, tumors, etc.) are required. Eculizumab is a humanized monoclonal antibody that blocks terminal complement activity and prevents intravascular hemolysis in PNH.⁷⁴ The drug is FDA approved for the treatment of PNH but it does not improve bone marrow function; thus it should not be used to treat aplastic anemia.

REFERENCES

1. Ehrlich P. Ueber einem Fall von Anamie mit Bemer-kungen uber regenerative Veranderungen des Knochenmarks. Charite-Annalen 1888;13:301-309.
2. Thomas ED, Storb R, Fefer A, et al. Aplastic anaemia treated by marrow transplantation. Lancet 1972;i:284-289.

3. Dufour C, Rondelli R, Locatelli F, et al. Stem cell transplantation from HLA-matched related donor for Fanconi's anaemia: a retrospective review of the multicentric Italian experience on behalf of AIEOP-GITMO. *Br J Haematol* 2001;112:796-805.
4. Hsu JW, Vogelsang G, Jones RJ, Brodsky RA. Bone marrow transplantation in Shwachman-Diamond syndrome. *Bone Marrow Transplant* 2002;30: 255-258.
5. Bagby GC Jr. Genetic basis of Fanconi anemia. *Curr Opin Hematol* 2003;10:68-76.
6. Meetei AR, Levitus M, Xue Y, et al. X-linked inheritance of Fanconi anemia complementation group B. *Nat Genet* 2004;36:1219-1224.
7. Vulliamy T, Marrone A, Dokal I, Mason PJ. Association between aplastic anaemia and mutations in telomerase RNA. *Lancet* 2002;359:2168-2170.
8. Yamaguchi H, Baerlocher GM, Lansdorp PM, et al. Mutations of the human telomerase RNA gene (TERC) in aplastic anemia and myelodysplastic syndrome. *Blood* 2003;102:916-918.
9. Dokal I, Vulliamy T. Dyskeratosis congenita: its link to telomerase and aplastic anaemia. *Blood Rev* 2003;17:217-225.
10. Elliott AM, Graham GE, Bernstein M, Mazer B, Teebi AS. Dyskeratosis congenita: an autosomal recessive variant. *Am J Med Genet* 1999;83:178-182.
11. Ly H, Schertzer M, Jastaniah W, et al. Identification and functional characterization of 2 variant alleles of the telomerase RNA template gene (TERC) in a patient with dyskeratosis congenita. *Blood* 2005;106:1246-1252.
12. Armanios M, Chen JL, Chang YP, et al. Haploinsufficiency of telomerase reverse transcriptase leads to anticipation in autosomal dominant dyskeratosis congenita. *Proc Natl Acad Sci U S A* 2005;102:15960-15964.
13. Heiss NS, Knight SW, Vulliamy TJ, et al. X-linked dyskeratosis congenita is caused by mutations in a highly conserved gene with putative nucleolar functions. *Nat Genet* 1998;19:32-38.
14. Hassock S, Vetrie D, Giannelli F. Mapping and characterization of the X-linked dyskeratosis congenita (DKC) gene. *Genomics* 1999;55:21-27.
15. Ballmaier M, Germeshausen M, Krukemeier S, Welte K. Thrombopoietin is essential for the maintenance of normal hematopoiesis in humans: development of aplastic anemia in patients with congenital amegakaryocytic thrombocytopenia. *Ann N Y Acad Sci* 2003;996:17-25.
16. Ginzberg H, Shin J, Ellis L, et al. Shwachman syndrome: phenotypic manifestations of sibling sets and isolated cases in a large patient cohort are similar. *J Pediatr* 1999;135:81-88.
17. Boocock GR, Morrison JA, Popovic M, et al. Mutations in SBDS are associated with Shwachman-Diamond syndrome. *Nat Genet* 2003;33:97-101.
18. Kaufman DW, Kelly JP, Levy M, Shapiro S. The drug etiology of agranulocytosis and aplastic anemia. New York: Oxford University Press, Inc., 1991:1-404.
19. Issaragrisil S, Chansung K, Kaufman DW, Sirijirachai J, Thamprasit T, Young NS. Aplastic anemia in rural Thailand: its association with grain farming and agricultural pesticide exposure. Aplastic Anemia Study Group. *Am J Public Health* 1997;87:1551-1554.
20. Bottiger LE. Epidemiology and aetiology of aplastic anemia. *Haematol Blood Transfus* 1979;24:27-37.
21. Davies SM, Walker DJ. Aplastic anaemia in the Northern Region 1971-1978 and follow-up of long term survivors. *Clin Lab Haematol* 1986;8:307-313.
22. Nimer SD, Ireland P, Meshkinpour A, Frane M. An increased HLA DR2 frequency is seen in aplastic anemia patients. *Blood* 1994;84:923-927.
23. Issaragrisil S, Kaufman DW, Anderson T, et al., The Aplastic Anemia Study Group. Low drug attributability of aplastic anemia in Thailand. *Blood* 1997;89:4034-4039.
24. Bacigalupo A, Oneto R, Bruno B, et al. Current results of bone marrow transplantation in patients with acquired severe aplastic anemia. Report of the European Group for Blood and Marrow transplantation. On behalf of the Working Party on Severe Aplastic Anemia of the European Group for Blood and Marrow Transplantation. *Acta Haematol* 2000;103:19-25.
25. Issaragrisil S, Leaverton PE, Chansung K, et al. Regional patterns in the incidence of aplastic anemia in Thailand. The Aplastic Anemia Study Group. *Am J Hematol* 1999;61:164-168.

26. Baverstock KF, Ash PJ. A review of radiation accidents involving whole body exposure and the relevance to the LD50/60 for man. *Br J Radiol* 1983;56:837-844.
27. Mole RH. The LD50 for uniform low LET irradiation of man. *Br J Radiol* 1984;57:355-369.
28. Ichimaru M, Ishimaru T, Tsuchimoto T, Kirshbaum JD. Incidence of aplastic anemia in A-bomb survivors. Hiroshima and Nagasaki, 1946-1967. *Radiat Res* 1972;49:461-472.
29. Issaragrisil S, Kaufman DW, Anderson T, et al. The epidemiology of aplastic anemia in Thailand. *Blood* 2006;107:1299-1307.
30. Weinshilboum RM. Pharmacogenetics of methyl conjugation. *Prog Clin Biol Res* 1983;135:167-181.
31. Krynetski EY, Schuetz JD, Galpin AJ, Pui CH, Relling MV, Evans WE. A single point mutation leading to loss of catalytic activity in human thiopurine S-methyltransferase. *Proc Natl Acad Sci U S A* 1995;92:949-953.
32. Yates CR, Krynetski EY, Loennechen T, et al. Molecular diagnosis of thiopurine S-methyltransferase deficiency: genetic basis for azathioprine and mercaptopurine intolerance. *Ann Intern Med* 1997;126:608-614.
33. Lazarus KH, Baehner RL. Aplastic anemia complicating infectious mononucleosis: a case report and review of the literature. *Pediatrics* 1981;67:907-910.
34. Baranski BG, Young NS. Autoimmune aspects of aplastic anemia. *in vivo* 1988;2:91-94.
35. Lau YL, Srivastava G, Lee CW, Kwong KY, Yeung CY. Epstein-Barr virus associated aplastic anaemia and hepatitis. *J Paediatr Child Health* 1994;30:74-76.
36. Young NS, Brown KE. Parvovirus B19. *N Engl J Med* 2004;350:586-597.
37. Brown KE, Anderson SM, Young NS. Erythrocyte P antigen: cellular receptor for B19 parvovirus. *Science* 1993;262:114-117.
38. Hagler L, Pastore RA, Bergin JJ, Wrensch MR. Aplastic anemia following viral hepatitis: report of two fatal cases and literature review. *Medicine* 1975;54:139-164.
39. Tzakis AG, Arditi M, Whittington PF, et al. Aplastic anemia complicating orthotopic liver transplantation for non-A, non-B hepatitis. *N Engl J Med* 1988;319:393-396.
40. Cattral MS, Langnas AN, Markin RS, et al. Aplastic anemia after liver transplantation for fulminant liver failure. *Hepatology* 1994;20:813-818.
41. Brown KE, Tisdale J, Barrett AJ, Dunbar CE, Young NS. Hepatitis-associated aplastic anemia [see comments]. *N Engl J Med* 1997;336:1059-1064.
42. Lu J, Basu A, Melenhorst JJ, Young NS, Brown KE. Analysis of T-cell repertoire in hepatitis-associated aplastic anemia. *Blood* 2004;103:4588-4593.
43. Choudhry VP, Gupta S, Gupta M, Kashyap R, Saxena R. Pregnancy associated aplastic anemia—a series of 10 cases with review of literature. *Hematology* 2002;7:233-238.
44. Deka D, Malhotra N, Sinha A, Banerjee N, Kashyap R, Roy KK. Pregnancy associated aplastic anemia: maternal and fetal outcome. *J Obstet Gynaecol Res* 2003;29:67-72.
45. Tichelli A, Socie G, Marsh J, et al. Outcome of pregnancy and disease course among women with aplastic anemia treated with immunosuppression. *Ann Intern Med* 2002;137:164-172.
46. Mathe G, Amiel JL, Schwarzenberg L, et al. Bone marrow graft in man after conditioning by antilymphocytic serum. *Br Med J* 1970;2:131-136.
47. Hinterberger W, Rowlings PA, Hinterberger-Fischer M, et al. Results of transplanting bone marrow from genetically identical twins into patients with aplastic anemia [see comments]. *Ann Intern Med* 1997;126:116-122.
48. Champlin RE, Feig SA, Sparkes RS, Galen RP. Bone marrow transplantation from identical twins in the treatment of aplastic anaemia: implication for the pathogenesis of the disease. *Br J Haematol* 1984;56:455-463.
49. Hoffman R, Zanjani ED, Lutton JD, Zalusky R, Wasserman LR. Suppression of erythroid-colony formation by lymphocytes from patients with aplastic anemia. *N Engl J Med* 1977;296:10-13.
50. Nakao S, Takami A, Takamatsu H, et al. Isolation of a T-cell clone showing HLA-DRBI*0405-restricted cytotoxicity for hematopoietic cells in a patient with aplastic anemia. *Blood* 1997;89:3691-3699.

51. Zeng W, Maciejewski JP, Chen G, Young NS. Limited heterogeneity of T cell receptor BV usage in aplastic anemia. *J Clin Invest* 2001;108:765-773.
52. Zoumbos NC, Gascón P, Djeu JY, Trost SR, Young NS. Circulating activated suppressor T lymphocytes in aplastic anemia. *N Engl J Med* 1985;312: 257-265.
53. Maciejewski JP, Hibbs JR, Anderson S, Katevas P, Young NS. Bone marrow and peripheral blood lymphocyte phenotype in patients with bone marrow failure. *Exp Hematol* 1994;22:1102-1110.
54. Melenhorst JJ, van Krieken JHJM, Dreef E, Landegent JE, Willemze R, Fibbe WE. T cells selectively infiltrate bone marrow areas with residual haemopoiesis of patients with acquired aplastic anaemia. *Br J Haematol* 1997;99: 517-519.
55. Nakao S, Yamaguchi M, Shiobara S, et al. Interferon-gamma gene expression in unstimulated bone marrow mononuclear cells predicts a good response to cyclosporine therapy in aplastic anemia. *Blood* 1992;79:2532-2535.
56. Maciejewski JP, Selleri C, Sato T, Anderson S, Young NS. Increased expression of Fas antigen on bone marrow CD34⁺ cells of patients with aplastic anaemia. *Br J Haematol* 1995;91:245-252.
57. Hirano N, Butler MO, Bergwelt-Baildon MS, et al. Autoantibodies frequently detected in patients with aplastic anemia. *Blood* 2003;102:4567-4575.
58. Feng X, Chuhjo T, Sugimori C, et al. Diazepam-binding inhibitor-related protein 1: a candidate autoantigen in acquired aplastic anemia patients harboring a minor population of paroxysmal nocturnal hemoglobinuria-type cells. *Blood* 2004;104:2425-2431.
59. Melenhorst JJ, Fibbe WE, Struyk L, van der Elsen PJ, Willemze R, Landegent JE. Analysis of T-cell clonality in bone marrow of patients with acquired aplastic anaemia. *Br J Haematol* 1997;96:85-91.
60. Bacigalupo A, Figari O, Tong J, et al. Long-term marrow culture in patients with aplastic anemia compared with marrow transplant recipients and normal controls. *Exp Hematol* 1992;20:425-430.
61. Schrezenmeier H, Jenal M, Herrmann F, Heimpel H, Raghavachar A. Quantitative analysis of cobblestone area-forming cells in bone marrow of patients with aplastic anemia by limiting dilution assay. *Blood* 1996;88: 4474-4480.
62. Bacigalupo A, Bruno B, Saracco P, et al. Antilymphocyte globulin, cyclosporine, prednisolone, and granulocyte colony-stimulating factor for severe aplastic anemia: an update of the GITMO/EBMT study on 100 patients [In Process Citation]. *Blood* 2000;95:1931-1934.
63. Brodsky RA, Sensenbrenner LL, Jones RJ. Complete remission in acquired severe aplastic anemia following high-dose cyclophosphamide. *Blood* 1996;87:491-494.
64. Van Zant G, de Haan G, Rich IN. Alternatives to stem cell renewal from a developmental viewpoint. *Exp Hematol* 1997;25:187-192.
65. Rusten LS, Jacobsen SE, Kaalhus O, Veiby OP, Funderud S, Smeland EB. Functional differences between CD34- and DR-subfractions of CD34+ bone marrow cells. *Blood* 1994;84:1473-1481.
66. Nagafuji K, Shibuya T, Harada M, et al. Functional expression of Fas antigen (CD95) on hematopoietic progenitor cells. *Blood* 1995;86:883-889.
67. Kim H, Whartenby KA, Georgantas RW, III, Wingard J, Civin CI. Human CD34+ hematopoietic stem/progenitor cells express high levels of FLIP and are resistant to Fas-mediated apoptosis. *Stem Cells* 2002;20:174-182.
68. Brodsky RA, Jones RJ. Aplastic anaemia. *Lancet* 2005;365:1647-1656.
69. Mukhina GL, Buckley JT, Barber JP, Jones RJ, Brodsky RA. Multilineage glycosylphosphatidylinositol anchor deficient hematopoiesis in untreated aplastic anemia. *Br J Haematol* 2001;115:476-482.
70. Brodsky RA, Jones RJ. Riddle: what do aplastic anemia, promyelocytic leukemia, and chronic myeloid leukemia have in common? *Leukemia* 2004;18(10):1740-1742.
71. Rosenfeld S, Follmann D, Nunez O, Young NS. Antithymocyte globulin and cyclosporine for severe aplastic anemia: association between hematologic response and long-term outcome. *JAMA* 2003;289:1130-1135.
72. Ohara A, Kojima S, Hamajima N, et al. Myelodysplastic syndrome and acute myelogenous leukemia as a late clonal complication in children with acquired aplastic anemia. *Blood* 1997;90:1009-1013.

73. Brodsky RA. Narrative review: paroxysmal nocturnal hemoglobinuria: the physiology of complement-related hemolytic anemia. *Ann Intern Med* 2008;148:587-595.
74. Brodsky RA. How I treat paroxysmal nocturnal hemoglobinuria. *Blood* 2009;(26):6522-8527.
75. Wang H, Chuhjo T, Yasue S, Omine M, Nakao S. Clinical significance of a minor population of paroxysmal nocturnal hemoglobinuria-type cells in bone marrow failure syndrome. *Blood* 2002;100:3897-3902.
76. Nagarajan S, Brodsky R, Young NS, Medof ME. Genetic defects underlying paroxysmal nocturnal hemoglobinuria that arises out of aplastic anemia. *Blood* 1995;86:4656-4661.
77. Scheinberg P, Marte M, Nunez O, Young NS. Paroxysmal nocturnal hemoglobinuria clones in severe aplastic anemia patients treated with horse anti-thymocyte globulin plus cyclosporine. *Haematologica* 2010;95: 1075-1080.
78. Pu JJ, Mukhina G, Wang H, Savage WJ, Brodsky RA. Natural history of paroxysmal nocturnal hemoglobinuria clones in patients presenting as aplastic anemia. *Eur J Haematol* 2011;87:37-45.
79. Hanaoka N, Kawaguchi T, Horikawa K, Nagakura S, Mitsuya H, Nakakuma H. Immunoselection by natural killer cells of PIGA mutant cells missing stress-inducible ULBP. *Blood* 2006;107:1184-1191.
80. Savage WJ, Barber JP, Mukhina GL, et al. Glycosylphosphatidylinositolanchored protein deficiency confers resistance to apoptosis in PNH. *Exp Hematol* 2009;37:42-51.
81. Inoue N, Izui-Sarumaru T, Murakami Y, et al. Molecular basis of clonal expansion of hematopoiesis in two patients with paroxysmal nocturnal hemoglobinuria (PNH). *Blood* 2006;108(13):4232-4236.
82. Brodsky RA, Mukhina GL, Li S, et al. Improved detection and characterization of paroxysmal nocturnal hemoglobinuria using fluorescent aerolysin. *Am J Clin Pathol* 2000;114:459-466.
83. Hall SE, Rosse WF. The use of monoclonal antibodies and flow cytometry in the diagnosis of paroxysmal nocturnal hemoglobinuria. *Blood* 1996;87: 5332-5340.
84. Brodsky RA, Mukhina GL, Nelson KL, Lawrence TS, Jones RJ, Buckley JT. Resistance of paroxysmal nocturnal hemoglobinuria cells to the glycosylphosphatidylinositol-binding toxin aerolysin. *Blood* 1999;93:1749-1756.
85. Matsui WH, Brodsky RA, Smith BD, Borowitz MJ, Jones RJ. Quantitative analysis of bone marrow CD34 cells in aplastic anemia and hypoplastic myelodysplastic syndromes. *Leukemia* 2006.
86. Orazi A, Albitar M, Heerema NA, Haskins S, Neiman RS. Hypoplastic myelodysplastic syndromes can be distinguished from acquired aplastic anemia by CD34 and PCNA immunostaining of bone marrow biopsy specimens. *Am J Clin Pathol* 1997;107:268-274.
87. Camitta BM, Thomas ED, Nathan DG, et al. A prospective study of androgens and bone marrow transplantation for treatment of severe aplastic anemia. *Blood* 1979;53:504-514.
88. Howard SC, Naidu PE, Hu XJ, et al. Natural history of moderate aplastic anemia in children. *Pediatr Blood Cancer* 2004;43:545-551.
89. Frickhofen N, Kaltwasser JP, Schrezenmeier H, et al. Treatment of aplastic anemia with antilymphocyte globulin and methylprednisolone with or without cyclosporine. *N Engl J Med* 1991;324:1297-1304.
90. Maschan A, Bogatcheva N, Kryjanovskii O, et al. Results at a single centre of immunosuppression with cyclosporine A in 66 children with aplastic anaemia. *Br J Haematol* 1999;106:967-970.
91. Maciejewski JP, Sloand EM, Nunez O, Boss C, Young NS. Recombinant humanized anti-IL-2 receptor antibody (daclizumab) produces responses in patients with moderate aplastic anemia. *Blood* 2003;102:3584-3586.
92. Socie G, Henry-Amar M, Bacigalupo A, et al. Malignant tumors occurring after treatment of aplastic anemia. *N Engl J Med* 1993;329:1152-1157.
93. May WS, Sensenbrenner LL, Burns WH, et al. BMT for severe aplastic anemia using cyclosporin. *Bone Marrow Trans* 1993;11:459-464.
94. Storb R, Leisenring W, Anasetti C, et al. Long-term follow-up of allogeneic marrow transplants in patients with aplastic anemia conditioned by cyclophosphamide combined with antithymocyte globulin. *Blood* 1997;89:3890-3891.

95. Kahl C, Leisenring W, Deeg HJ, et al. Cyclophosphamide and antithymocyte globulin as a conditioning regimen for allogeneic marrow transplantation in patients with aplastic anaemia: a long-term follow-up. *Br J Haematol* 2005;130:747-751.
96. Maury S, Bacigalupo A, Anderlini P, et al. Improved outcome of patients older than 30 years receiving HLA-identical sibling hematopoietic stem cell transplantation for severe acquired aplastic anemia using fludarabinebased conditioning: a comparison with conventional conditioning regimen. *Haematologica* 2009;94:1312-1315.
97. Bacigalupo A. Bone marrow transplantation for severe aplastic anemia from HLA identical siblings. *Haematologica* 1999;84:2-4.
98. Storb R, Blume KG, O'Donnell MR, et al. Cyclophosphamide and antithymocyte globulin to condition patients with aplastic anemia for allogeneic marrow transplantations: the experience in four centers. *Biol Blood Marrow Transplant* 2001;7:39-44.
99. Ades L, Mary JY, Robin M, et al. Long-term outcome after bone marrow transplantation for severe aplastic anemia. *Blood* 2004;103:2490-2497.
100. Horowitz MM. Current status of allogeneic bone marrow transplantation in acquired aplastic anemia. *Semin Hematol* 2000;37:30-42.
101. Deeg HJ, Amylon ID, Harris RE, et al. Marrow transplants from unrelated donors for patients with aplastic anemia: minimum effective dose of total body irradiation. *Biol Blood Marrow Transplant* 2001;7:208-215.
102. Margolis D, Camitta B, Pietryga D, et al. Unrelated donor bone marrow transplantation to treat severe aplastic anaemia in children and young adults. *Br J Haematol* 1996;94:65-72.
103. Deeg HJ, O'Donnell M, Tolar J, et al. Optimization of conditioning for marrow transplantation from unrelated donors for patients with aplastic anemia after failure of immunosuppressive therapy. *Blood* 2006;108:1485-1491.
104. Passweg JR, Perez WS, Eapen M, et al. Bone marrow transplants from mismatched related and unrelated donors for severe aplastic anemia. *Bone Marrow Transplant* 2006;37:641-649.
- P.974
105. Bacigalupo A, Socie' G, Lanino E, et al. Fludarabine, cyclophosphamide, antithymocyte globulin, with or without low dose total body irradiation, for alternative donor transplants, in acquired severe aplastic anemia: a retrospective study from the EBMT-SAA working party. *Haematologica* 2010;95:976-982.
106. Luznik L, Fuchs EJ. High-dose, post-transplantation cyclophosphamide to promote graft-host tolerance after allogeneic hematopoietic stem cell transplantation. *Immunol Res* 2010;47:65-77.
107. Dezern AE, Luznik L, Fuchs EJ, Jones RJ, Brodsky RA. Post-transplantation cyclophosphamide for GVHD prophylaxis in severe aplastic anemia. *Bone Marrow Transplant* 2010.
108. Marsh J, Schrezenmeier H, Marin P, et al. Prospective randomized multicenter study comparing cyclosporin alone versus the combination of antithymocyte globulin and cyclosporin for treatment of patients with nonsevere aplastic anemia: a report from the European Blood and Marrow Transplant (EBMT) Severe Aplastic Anaemia Working Party. *Blood* 1999;93:2191-2195.
109. Bacigalupo A, Broccia G, Corda G, et al. Antilymphocyte globulin, cyclosporin, and granulocyte colony-stimulating factor in patients with acquired severe aplastic anemia (SAA): A pilot study of the EMBT SAA Working Party. *Blood* 1995;85:1348-1353.
110. Rosenfeld SJ, Kimball J, Vining D, Young NS. Intensive immunosuppression with antithymocyte globulin and cyclosporin as treatment for severe aplastic anemia. *Blood* 1995;85:3058-3065.
111. Bacigalupo A, Bruno B, Saracco P, et al. Antilymphocyte globulin, cyclosporine, prednisolone, and granulocyte colony-stimulating factor for severe aplastic anemia: an update of the GITMO/EBMT study on 100 patients. European Group for Blood and Marrow Transplantation (EBMT) Working Party on Severe Aplastic Anemia and the Gruppo Italiano Trapianti di Midollo Osseo (GITMO). *Blood* 2000;95:1931-1934.
112. de Planque MM, Bacigalupo A, Wursch A, et al. Long-term follow-up of severe aplastic anaemia patients treated with antithymocyte globulin. *Br J Haematol* 1989;73:121-126.

113. Scheinberg P, Nunez O, Wu C, Young NS. Treatment of severe aplastic anaemia with combined immunosuppression: anti-thymocyte globulin, cyclosporin and mycophenolate mofetil. *Br J Haematol* 2006;133:606-611.
114. Storb R, Etzioni R, Anasetti C, et al. Cyclophosphamide combined with antithymocyte globulin in preparation for allogeneic marrow transplants in patients with aplastic anemia. *Blood* 1994;84:941-949.
115. Thomas ED, Storb R, Giblett ER, et al. Recovery from aplastic anemia following attempted marrow transplantation. *Exp Hematol* 1976;4:97-102.
116. Sensenbrenner LL, Steele AA, Santos GW. Recovery of hematologic competence without engraftment following attempted bone marrow transplantation for aplastic anemia: report of a case with diffusion chamber studies. *Exp Hematol* 1977;77:51-58.
117. Gmur J, von Felten A, Phyner K, Frick PG. Autologous hematologic recovery from aplastic anemia following high dose cyclophosphamide and HLA-matched allogeneic bone marrow transplantation. *Acta Haematol* 1979;62:20-24.
118. Piccin A, McCann S, Socie G, et al. Survival of patients with documented autologous recovery after SCT for severe aplastic anemia: a study by the WPSAA of the EBMT. *Bone Marrow Transplant* 2010;45:1008-1013.
119. Emadi A, Jones RJ, Brodsky RA. Cyclophosphamide and cancer: golden anniversary. *Nat Rev Clin Oncol* 2009;6:638-647.
120. Duester G. Genetic dissection of retinoid dehydrogenases. *Chem Biol Interact* 2001;130-132:469-480.
121. Hilton J. Role of aldehyde dehydrogenase in cyclophosphamide-resistant L1210 leukemia. *Cancer Res* 1984;44:5156-5160.
122. Jones RJ, Barber JP, Vala MS, et al. Assessment of aldehyde dehydrogenase in viable cells. *Blood* 1995;85:2742-2746.
123. Baran DT, Griner PF, Klemperer MR. Recovery from aplastic anemia after treatment with cyclophosphamide. *N Engl J Med* 1976;295:1522-1523.
124. Brodsky RA, Sensenbrenner LL, Smith BD, et al. Durable Treatment-Free Remission Following High-Dose Cyclophosphamide for Previously Untreated Severe Aplastic Anemia. *Ann Intern Med* 2001;135:477-483.
125. Jaime-Perez JC, Gonzalez-Llano O, Gomez-Almaguer D. High-dose cyclophosphamide in the treatment of severe aplastic anemia in children. *Am J Hematol* 2001;66:71.
126. Tisdale JF, Dunn DE, Geller N, et al. High-dose cyclophosphamide in severe aplastic anaemia: a randomised trial. *Lancet* 2000;356:1554-1559.
127. Li Z, Yin S, Xie S, Ma L, Nie D, Xsu L. Treatment of severe aplastic anemia using high-dose cyclophosphamide alone in China. *Haematologica* 2000;85:E06.
128. Brodsky RA, Chen AR, Dorr D, et al. High-dose cyclophosphamide for severe aplastic anemia: long-term follow-up. *Blood* 2010;115:2136-2141.
129. Tichelli A, Passweg J, Nissen C, et al. Repeated treatment with horse antilymphocyte globulin for severe aplastic anaemia. *Br J Haematol* 1998;100:393-400.
130. Marsh JC, Hows JM, Bryett KA, Al-Hashimi S, Fairhead SM, Gordon-Smith EC. Survival after antilymphocyte globulin therapy for aplastic anemia depends on disease severity. *Blood* 1987;70:1046-1052.
131. Stein RS, Means RT Jr, Krantz SB, Flexner JM, Greer JP. Treatment of aplastic anemia with an investigational antilymphocyte serum prepared in rabbits. *Am J Med Sci* 1994;308:338-343.
132. Means RT Jr, Krantz SB, Dessypris EN, et al. Re-treatment of aplastic anemia with antithymocyte globulin or antilymphocyte serum. *Am J Med* 1988;84:678-682.
133. Di Bona E, Rodeghiero F, Bruno B, et al. Rabbit antithymocyte globulin (r-ATG) plus cyclosporine and granulocyte colony stimulating factor is an effective treatment for aplastic anaemia patients unresponsive to a first course of intensive immunosuppressive therapy. Gruppo Italiano Trapianto di Midollo Osseo (GITMO). *Br J Haematol* 1999;107:330-334.
134. Brodsky RA, Chen AR, Brodsky I, Jones RJ. High-dose cyclophosphamide as salvage therapy for severe aplastic anemia. *Exp Hematol* 2004;32:435-440.
135. Audino AN, Blatt J, Carcamo B, et al. High-dose cyclophosphamide treatment for refractory severe aplastic anemia in children. *Pediatr Blood Cancer* 2010;54:269-272.

136. Risitano AM, Selleri C, Serio B, et al. Alemtuzumab is safe and effective as immunosuppressive treatment for aplastic anaemia and single-lineage marrow failure: a pilot study and a survey from the EBMT WPSAA. *Br J Haematol* 2010;148:791-796.
137. Savage WJ, DeRusso PA, Resar LM, et al. Treatment of hepatitis-associated aplastic anemia with high dose cyclophosphamide. *Blood* 2006;108:291a.
138. Locasciulli A, Bacigalupo A, Bruno B, et al. Hepatitis-associated aplastic anaemia: epidemiology and treatment results obtained in Europe. A report of The EBMT aplastic anaemia working party. *Br J Haematol* 2010;149:890-895.
139. Osugi Y, Yagasaki H, Sako M, et al. Antithymocyte globulin and cyclosporine for treatment of 44 children with hepatitis associated aplastic anemia. *Haematologica* 2007;92:1687-1690.
140. Shahidi NT, Diamond LK. Testosterone-induced remission in aplastic anemia. *Am J Dis Child* 1959;98:293-302.
141. Shahidi NT, Diamond LK. Testosterone-induced remission in aplastic anemia of both acquired and congenital types. Further observations in 24 cases. *N Engl J Med* 1961;264:953-967.
142. Gardner FH, Juneja HS. Androstane therapy to treat aplastic anaemia in adults: an uncontrolled pilot study. *Br J Haematol* 1987;65:295-300.
143. Young N, Griffith P, Brittain E, et al. A multicenter trial of antithymocyte globulin in aplastic anemia and related diseases. *Blood* 1988;72: 1861-1869.
144. Locatelli F, Bruno B, Zecca M, et al. Cyclosporin A and short-term methotrexate versus cyclosporin A as graft versus host disease prophylaxis in patients with severe aplastic anemia given allogeneic bone marrow transplantation from an HLA-identical sibling: results of a GITMO/EBMT randomized trial. *Blood* 2000;96:1690-1697.
145. Ahn MJ, Choi JH, Lee YY, et al. Outcome of adult severe or very severe aplastic anemia treated with immunosuppressive therapy compared with bone marrow transplantation: multicenter trial. *Int J Hematol* 2003;78:133-138.
146. Bai LY, Chiou TJ, Liu JH, et al. Hematopoietic stem cell transplantation for severe aplastic anemia—experience of an institute in Taiwan. *Ann Hematol* 2004;83:38-43.
147. Dullely FL, Vigorito AC, Aranha FJ, et al. Addition of low-dose busulfan to cyclophosphamide in aplastic anemia patients prior to allogeneic bone marrow transplantation to reduce rejection. *Bone Marrow Transplant* 2004;33:9-13.
148. Kojima S, Matsuyama T, Kato S, et al. Outcome of 154 patients with severe aplastic anemia who received transplants from unrelated donors: the Japan Marrow Donor Program. *Blood* 2002;100:799-803.
149. Frickhofen N, Heimpel H, Kaltwasser JP, Schrezenmeier H. Antithymocyte globulin with or without cyclosporin A: 11-year follow-up of a randomized trial comparing treatments of aplastic anemia. *Blood* 2003;101: 1236-1242.
150. Kojima S, Horibe K, Inaba J, et al. Long-term outcome of acquired aplastic anaemia in children: comparison between immunosuppressive therapy and bone marrow transplantation. *Br J Haematol* 2000;111:321-328.

Chapter 39 Red Cell Aplasia: Acquired and Congenital Disorders

> Table of Contents > Part IV - Disorders of Red Cells > Section 5 - Other Red Cell Disorders > Chapter 39 - Red Cell Aplasia: Acquired and Congenital Disorders

Chapter 39

Red Cell Aplasia: Acquired and Congenital Disorders

Jeffrey M. Lipton

Bertil Glader

Robert T. Means, Jr.

ACQUIRED RED CELL APLASIA

Pure red cell aplasia (PRCA) is an acquired syndrome characterized by normochromic normocytic anemia, severe reticulocytopenia (reticulocyte count <1%), and an almost complete absence of erythroblasts from the bone marrow

(erythroblasts <0.5%).^{1, 2} In contrast to aplastic anemia, in which the aplasia involves all three cell lines, in PRCA the aplasia is selective for the erythroid cell line so that patients have normal leukocyte and platelet counts.³ PRCA is a rare disorder that affects any age group and both males and females equally.

This disorder was first described by Kaznelson in 1922⁴ and has appeared in the literature under a variety of different names, including pure aplastic anemia, erythrophthisis, chronic hypoplastic anemia, aplastic crisis, erythroblastopenia, erythropoiesis imperfecta, Blackfan-Diamond syndrome, pure red cell agenesis, and primary red cell anemia.¹ Today the term PRCA is used primarily to describe this disorder in adults, although some of the causes of RBC aplasia in adults also are seen in children. Diamond-Blackfan anemia (DBA) refers to a pathophysiologically different congenital syndrome of children. Transient erythroblastopenia of childhood (TEC) describes a typically self-limited PRCA variant that occurs most commonly in infants and children and is discussed below. It must be noted, however, that DBA can present in adulthood and should be considered in the differential diagnosis of PRCA at any age.

PRCA may be primary or may be secondary to a variety of neoplastic, autoimmune, or infectious diseases (Table 39.1). Primary acquired PRCA affects individuals of any age in the absence of any underlying disorder. It may run an acute and usually self-limited course or may persist chronically as a form of refractory anemia. In adults the acute form of primary PRCA is very rare and the chronic form of this disorder predominates. Acute PRCA in adults escapes diagnosis because acute arrest of erythropoiesis of short duration does not lead to symptoms of anemia, as a result of the long lifespan of the red cells.

Etiology and Pathogenesis

PRCA may occur as a primary disorder or may develop as a hematologic complication in the course of a variety of diseases (Table 39.1). In the section that follows, differing etiologies of PRCA and their associated pathogenetic mechanisms are described. Secondary etiologies are arranged in approximate order of clinical significance or frequency.

Primary Acquired (Autoimmune) Pure Red Cell Aplasia

In primary acquired PRCA and TEC, multiple studies have indicated that the arrest of erythropoiesis is caused by the presence in the patient's plasma of an erythropoietic inhibitor. Early studies in mice have shown that injection of patients' plasma leads to a significant suppression of *in vivo* erythropoiesis as measured by ⁵⁹Fe incorporation into newly formed red cells.^{101, 102} Evaluation of the response of patients' marrow cells to erythropoietin by measuring heme synthesis *in vitro* showed that, in the presence of normal plasma, PRCA marrow responds normally to erythropoietin, but in the presence of a patient's autologous plasma, a significant decline in heme synthesis is observed, suggesting the presence in the patient's plasma of an inhibitor acting on erythroid cells.^{103, 104} In about 60% of cases, patients' marrow cells respond to erythropoietin in a normal way by increasing the rate of heme synthesis by 2- to 9-fold and in about 40% an inhibitor of erythropoiesis can be detected in their plasma. This inhibitor has been localized to the IgG fraction, and it disappears from the plasma after remission of PRCA.^{103, 104, 105}

The stage of erythropoiesis at which the arrest occurs has been studied by assaying PRCA marrow cells in semisolid media for erythroid progenitors. Despite a conspicuous absence of erythroblasts from the PRCA marrow, in at least 60% of patients, normal numbers of early burst-forming unit erythroid (BFU-E) and late colony-forming unit erythroid (CFU-E) erythroid progenitors can be detected, indicating that the arrest occurs at any level between CFU-E and basophilic erythroblasts. In the remainder of patients the erythroid cell compartment is affected at a stage earlier than the CFU-E, so that the CFU-E and/or BFU-E marrow pools are significantly reduced.^{1, 106, 107, 108} The presence of normal numbers of erythroid progenitors has been associated with a favorable outcome of immunosuppressive therapy.^{106, 108} The patient's serum IgG inhibits maturation and differentiation of erythroid progenitors into erythroblasts *in vitro*. The inhibition is dose-dependent and is no longer present in the IgG fraction of the patient's plasma collected after remission.¹⁰⁵ The inhibitory effect of the IgG is specific for erythroid cells, because no effect on myeloid progenitor cell growth is detected.^{107, 108, 109}

The target antigen and mode of action of the IgG inhibitor of erythropoiesis has been investigated in a number of cases of primary autoimmune PRCA, but appears to be variable. As discussed above, it may target erythroid CFU-E and/or BFU-E progenitors or it may be directed against morphologically recognizable erythroblasts.^{110, 111} The molecule(s) on the erythroid cell membrane with which the PRCA IgG inhibitor interacts has not yet been defined. In rare cases, endogenous erythropoietin itself appears to be the target antigen.^{112, 113} In some cases of autoimmune hemolytic anemia, concurrent with PRCA, the antibody causing hemolysis can also suppress erythroid progenitor colony formation,⁷⁵ while in other cases the two processes result from two different antibodies.^{76, 77}

In addition to antibody-mediated PRCA, cases of PRCA have been reported in which the immunologic mechanism is T cell mediated. These cases appear to be particularly associated with thymomas.^{114, 115, 116, 117, 118, 119, 120, 121} There are also

cases of PRCA in which no immune pathogenic mechanism or other known mechanism can be established by in vitro assays. These cases are classified as idiopathic PRCA. However, failure to demonstrate an immune mechanism does not necessarily exclude an immune pathogenesis, since the outcome of treatment seems to be the same among autoimmune and idiopathic cases.¹

Transient Erythroblastopenia of Childhood

This is a common cause of acquired red cell aplasia in young children^{122, 123} due to a transient antibody-mediated suppression of normal erythropoiesis.^{124, 125} The disorder is characterized by the gradual (over weeks) development of anemia (hemoglobin level of 2 to 8 g/dl), reticulocytopenia, and a pronounced reduction of bone marrow erythroblasts. The platelet count is normal to increased. The leukocyte count is usually normal, although 20% of children

P.976

may have significant neutropenia (less than 1,000 neutrophils per dl). The disorder uniquely occurs in previously healthy young children from 6 months to 4 years of age and is seen with equal frequency in boys and girls. Occasionally cases of the disorder occur in clusters, suggesting it may be a consequence of some seasonal environmental toxin or virus. To date, however, serologic studies have failed to reveal exposure to a common virus. The natural history of TEC is that all patients recover spontaneously in a few weeks and there are no long-term hematologic sequelae. In many children with the disorder, particularly if there is evidence of recovery at the time of diagnosis, no specific therapy other than careful observation is necessary. Erythrocyte transfusions are indicated only if a child is symptomatic from the anemia, and rarely is more than one transfusion needed. Neither iron nor steroid therapy have any role in the management of this disorder. The diagnosis often is confused with that of iron deficiency anemia, although the erythrocytes in patients with TEC are normocytic (mean corpuscular volume [MCV] 70 to 85 fl, which is normal for children), whereas iron deficiency anemia is characterized by microcytosis (MCV, 50 to 70 fl). TEC also may be confused with DBA, although the latter generally presents before 6 months of age, often is associated with congenital abnormalities, and usually is characterized by macrocytic erythrocytes with many fetal-like features. (See section "Diamond-Blackfan Anemia.")

TABLE 39.1 CLASSIFICATION OF PURE RED CELL APLASIA

Congenital

Inherited

Diamond-Blackfan anemia

Not inherited

Pearson syndrome

Acquired PRCA

Primary

Autoimmune (includes TEC)

Preleukemic

Idiopathic

Secondary, associated with

Thymoma^{1, 5, 6, 7}

Hematologic malignancies

Chronic lymphocytic leukemia

B cell type^{1, 8, 9, 10}

T cell type^{1, 11}

Hodgkin disease¹²

Non-Hodgkin lymphomas^{13, 14, 15}

Angioimmunoblastic lymphadenopathy^{16, 17, 18, 19, 20}
Multiple myeloma^{21, 22}
Waldenström macroglobulinemia²³
Chronic myelogenous leukemia^{24, 25}
Chronic myelomonocytic leukemia⁹
Myelofibrosis with myeloid metaplasia^{1, 26, 27}
Essential thrombocythemia^{28, 29}
Acute lymphoblastic leukemia^{30, 31, 32}
Chronic eosinophilic leukemia³³
Solid tumors¹
Gastric cancer³⁴
Breast cancer³⁵
Biliary cancer³⁶
Primary lung cancer³⁷
Primary skin cancer^{38, 39}
Thyroid cancer⁴⁰
Thymus cancer⁴¹
Renal cell carcinoma⁴²
Carcinoma of unknown primary site¹
Kaposi sarcoma^{43, 44}
Infections
Human B19 parvovirus^{45, 46, 47, 48, 49, 50}
Human immunodeficiency virus⁵¹
T cell leukemia-lymphoma virus⁵²
Infectious mononucleosis^{53, 54}
Viral hepatitis^{55, 56, 57, 58, 59}
Mumps¹
Cytomegalovirus⁶⁰
Bacterial infections^{1, 61, 62, 63}
Leishmaniasis⁶⁴
Chronic hemolytic anemias^{65, 66}
Collagen vascular/Autoimmune diseases
Systemic lupus erythematosus^{67, 68, 69, 70, 71}
Rheumatoid arthritis⁷²
Mixed connective tissue disease⁷³
Autoimmune multiple endocrine gland insufficiency⁷⁴

Autoimmune hemolytic anemia^{75, 76, 77}

Autoimmune hepatitis^{78, 79}

Primary sclerosing cholangitis⁸⁰

Inflammatory bowel disease⁷⁸

Pregnancy^{81, 82, 83, 84, 85, 86}

Severe renal failure⁸⁷

Severe nutritional deficiencies^{61, 88}

Vitamin B12 deficiency⁸⁹

Riboflavin deficiency^{88, 90}

Folate deficiency⁹¹

Miscellaneous

Post-ABO-incompatible stem cell transplantation^{92, 93, 94, 95, 96}

Castleman's disease^{97, 98}

Anti-Epo antibodies after treatment with Epo^{99, 100}

Epo, erythropoietin; PRCA, pure red cell aplasia; TEC, transient erythroblastopenia of childhood.

Myelodysplastic Primary Pure Red Cell Aplasia

A small percentage of cases of idiopathic PRCA, usually refractory to treatment, may evolve into acute leukemia, and these cases are classified as preleukemic or myelodysplastic.^{1, 126} In a sense, such cases should be regarded not as part of a PRCA syndrome but rather as myelodysplastic morphologically resembling PRCA.

Parvovirus-induced Pure Red Cell Aplasia

It has been known for many years that human B19 parvovirus is responsible for the aplastic crisis seen in patients with chronic hemolytic anemia.^{127, 128, 129, 130, 131} It was subsequently demonstrated that B19 parvovirus can produce chronic PRCA in immunocompromised patients, such as those with HIV, posttransplantation, or on immunosuppressive drugs.^{45, 46, 47, 132, 133, 134, 135, 136, 137, 138, 139, 140, 141}

B19 parvovirus directly infects human erythroid progenitors by a process requiring the red cell surface P antigen (globoside).^{142, 143} Individuals who do not express P antigen are not susceptible to parvovirus infection.¹⁴⁴ B19 parvovirus induces apoptosis in erythroid progenitors.¹⁴⁵ The precise mechanism by which this occurs is unclear, but appears to involve viral nonstructural protein 1.^{146, 147} Hypoxia-inducible factor-1 appears to upregulate expression of viral messages in infected cells.¹⁴⁸

Recombinant Erythropoietin-induced Immune Pure Red Cell Aplasia

As noted earlier, autoimmune PRCA caused by antibodies against endogenous Epo has been described infrequently.^{112, 113, 149} Beginning in the mid- to late 1990s, cases of PRCA associated with antibodies against recombinant human (rh) Epo began to appear.

These cases occurred in patients with end-stage renal disease receiving rhEpo for anemia management.^{99, 150, 151, 152, 153, 154, 155, 156} These cases were unusual in that more than 90% of cases involved a particular rhEpo product, it was primarily associated with subcutaneous treatment, the vast majority of cases occurred outside the United States, and there was wide nation-to-nation variation, even allowing for use of specific rhEpo products.^{99, 157, 158, 159, 160, 161, 162, 163, 164, 165}

Eventually the process was attributed to packaging features of the rhEpo product (such as adjuvant effects of the material used in syringes).^{157, 166, 167, 168, 169, 170} In response to changed packaging, the problem has largely resolved.

P.977

It has been suggested that the low level immunogenicity of rhEpo might be enhanced in specific patients by the presence of Epospecific CD4⁺ T cells, or by HLA-DRB1*09.^{92, 171, 172, 173, 174}

Thymoma

The association between thymic neoplasms and PRCA has been known for many years.^{5, 6, 7, 40, 175, 176, 177, 178} PRCA may precede the development of thymoma, coexist with thymoma, or develop even years after the surgical removal of a thymoma. The incidence of PRCA among patients with thymoma was earlier estimated to be as high as 15%; however, in more recent reports the incidence was found to be close to 4%.^{1, 179} Approaching it from the other perspective, the presence of a thymoma among patients presenting with PRCA was initially reported to be as high as 50%, but in more recent series it was estimated to be close to 9%.^{1, 61, 118, 175, 180} The pathogenetic mechanism involved is uncertain but presumably related to T cell-mediated processes.^{118, 120, 181, 182}

Lymphoproliferative Disorders

Various lymphoproliferative syndromes have been associated with severe erythroid aplasia (see Table 39.2), with chronic lymphocytic leukemia (CLL) of B cell, T cell type, or with the large granular lymphocyte (LGL) type, the last being the most frequent.^{8, 183} The incidence of severe erythroid aplasia among patients with CLL may be as high as 6%, with many cases missed because severe normochromic anemia and reticulocytopenia is a frequent manifestation of advanced-stage CLL and is usually attributed to the primary disease process. The development of erythroid aplasia does not affect the prognosis of CLL and in the majority of cases does not seem to be related to previous cytotoxic chemotherapy.^{1, 8} PRCA has been also described in association with Hodgkin¹² and non-Hodgkin lymphomas,¹³ multiple myeloma,²¹ Waldenström's macroglobulinemia,²³ angioimmunoblastic lymphadenopathy,¹⁶ and Castleman's disease.⁹⁷

TABLE 39.2 DRUGS AND CHEMICALS ASSOCIATED WITH PURE RED CELL APLASIA

Allopurinol	Isoniazid
α-Methyldopa	Lamivudine
Aminopyrine	Leuprolide
Anagryne	Linezolid
Arsphenamine	Maloprim (dapsone and pyrimethamine)
Azathioprine	Mepacrine
Benzene hexachloride	Methazolamide
	Micafungin
Bromsulphalein	Mycophenolate mofetil
Calomel	Penicillin
Campath-1H	
Carbamazepine	D-Penicillamine
Cephalothin	Pentachlorophenol
Chenopodium	Phenobarbital
Cladribine	Phenylbutazone
Chloramphenicol	Procainamide
Chlormadinone	Salicylazosulfapyridine
Chlorpropamide	Santonin
Co-trimoxazole	Sodium dipropylacetate
Diphenylhydantoin Erythropoietin (recombinant)	Sodium valproate
Estrogens	Sulfasalazine
Fenbufen	Sulfathiazole
Fenoprofen	Sulindac

FK506	Tacrolimus
Fludarabine	Thiamphenicol
Gold	Tolbutamide
Halothane	Rifampicin
Interferon- α	Zidovudine

Most pathophysiologic studies have been performed in CLL-associated PRCA. PRCA appears to derive from immune suppression, but not typically through inhibitory antibodies.¹⁴ Various studies have demonstrated that in T cell CLL (including LGL type), the T lymphocytes are responsible for the suppression of erythropoiesis.^{11, 184, 185} The suppression is mediated by direct cell-to-cell interaction, mainly between a subset of T cells expressing receptors for the γ chain of IgG (T γ cells) and erythroid progenitors, and it is HLA-DR restricted.¹⁸⁴ The suppression is selective for the erythroid cells and is not detectable after remission of the PRCA.^{184, 185} Similar findings have been reported in B cell CLL, in which there seems to be a progressive increase in the marrow of T γ cells, which, when they reach a critical concentration, suppress erythropoiesis and cause red cell aplasia.^{116, 117, 121} In LGL lymphocytosis, clonal expansion of LGLs of the γ/δ type expressing killer-cell inhibitory receptors for Class I HLA antigens has been shown to be responsible for lysis of erythroblasts, most likely related to the declining density, with eventual disappearance of HLA-I antigens in late marrow erythroid cells. However, the role of killer-cell inhibitory receptors in the pathogenesis of PRCA in large granular lymphocytosis remains unclear, since such receptors are also detectable in large granular lymphocytosis patients without PRCA.^{186, 187} Expansion of the marrow population of CD8⁺/perforin⁺ memory T cells has also been noted in thymoma-associated PRCA patients.¹⁸⁸

Other Hematologic Malignancies

PRCA has been reported in association with chronic myelogenous leukemia,^{24, 25} chronic myelomonocytic leukemia,⁹ chronic eosinophilic leukemia,³³ primary myelofibrosis,^{26, 27} essential thrombocythemia,²⁸ and acute lymphoblastic leukemia.^{30, 31} Few cases have been studied in detail, but in general the course of PRCA appears to run independently of the associated disease and may reflect a coincident autoimmune disorder.²⁴

Nonthymic Solid Tumors

There have been a number of reports of PRCA observed in patients with nonthymic, nonhematologic malignancies (see Table 39.1).

Given that these reports are rare and that the primary malignancy and PRCA typically run independent courses,¹ it is likely that the association is coincidental.

Autoimmune Disorders/Collagen Vascular Disease

It should not be surprising that PRCA is a hematologic complication of various autoimmune diseases, including collagen vascular diseases, such as systemic lupus erythematosus,^{67, 68} rheumatoid arthritis,⁷² mixed connective tissue disease,⁷³ Sjögren syndrome,^{6, 189} autoimmune hemolytic anemia,^{75, 76, 77} multiple endocrine gland insufficiency,⁷⁴ autoimmune hypothyroidism,^{190, 191} inflammatory bowel disease,⁷⁸ autoimmune liver disease,^{79, 80} pyoderma gangrenosum,¹⁹² and pernicious anemia.⁸⁹ PRCA may occur prior to, during, or after the onset of these disorders. When investigated in detail, cases of PRCA associated with autoimmune or collagen vascular diseases are typically found to be mediated by antibodies which inhibit erythropoiesis.^{193, 194}

P.978

ABO-incompatible Stem Cell Transplantation

PRCA may occur as a consequence of ABO-incompatible bone marrow or stem cell transplantation.^{93, 94, 195, 196, 197} In one series, this complication occurred in 26% of ABO-incompatible transplants and was most common in circumstances where a blood group O recipient was transplanted from a blood group A donor.¹⁹⁷ Erythroid precursors express surface blood group antibodies, and anti-A or anti-B isoagglutinins from recipient plasma cells are the etiologic agents.⁹⁴ There is a 60% to 70% frequency of spontaneous recovery, but the remainder may develop sustained PRCA requiring treatment.¹⁹⁷

Pure Red Cell Aplasia with Infections Other Than Parvovirus

Acute, self-limited PRCA may develop in the course of various infections.^{1, 51, 53, 55, 60, 62, 64, 199, 200} Viral hepatitis and infectious mononucleosis in particular have been reported many times in association with PRCA. In general, PRCA remits with treatment or the resolution of the underlying infection. Studies on the pathogenesis of PRCA in the course of viral hepatitis, infectious mononucleosis, and HTLV-1 infection have suggested that the suppression of erythropoiesis is mediated by cytotoxic T lymphocytes.

Drugs and Chemicals

Many drugs and chemicals have been reported as causes of PRCA^{38, 92, 139, 201, 202, 203, 204, 205, 206, 207, 208, 209, 210, 211, 212, 213, 214, 215, 216, 217, 218, 219, 220, 221, 222, 223, 224, 225, 226} (Table 39.2). Drug-induced PRCA is usually an acute disorder that remits soon after discontinuation of the drug or cessation of exposure to the chemical. It may appear after the first exposure to the drug or a significant time after its initiation. In most instances, the association of a drug with PRCA is circumstantial and is based on the evidence that PRCA remits after discontinuation of the drug.^{1, 227} Diphenylhydantoin, azathioprine, chlorpropamide, and isoniazid have been repeatedly implicated as causes of PRCA, and in certain instances their association with PRCA has been proven by recurrence of anemia upon reinstatement of therapy.¹

Different drugs cause erythroid aplasia through different mechanisms. Studies on direct drug effects on erythroid cell growth in vitro may be confusing because many drugs may have nonspecific effects on hematopoietic colony formation in vitro. IgG inhibitors of erythropoiesis have been shown for diphenylhydantoin and rifampin.^{206, 228} Isoniazid and procainamide appear to use a different mechanism.^{229, 230}

Pregnancy

Pregnancy also has been associated with PRCA that usually but not always, remits after delivery.^{81, 82, 83, 84, 85, 86} Development of PRCA during one pregnancy does not necessarily predict recurrence of the disease in subsequent pregnancies. This syndrome is also discussed in Chapter 42.

Miscellaneous Disorders

In rare cases, PRCA has been associated with renal failure,⁸⁷ severe malnutrition producing marasmus and/or kwashiorkor,^{61, 88} and riboflavin,^{88, 90} vitamin B₁₂,^{89, 91} and folic acid deficiencies.⁹¹

Clinical Presentation

There are no clinical features or physical findings characteristic of PRCA other than the signs and symptoms of anemia. Since a complete arrest of erythropoiesis would cause a decline of red cell mass of roughly 1% a day, so the development of anemia in PRCA is gradual, allowing for physiologic compensation which would mitigate symptomatology for any given degree of anemia. In secondary cases, physical findings related to the underlying disease may be present. Patients with chronic PRCA requiring transfusion support may have findings suggesting iron overload.

Laboratory Evaluation

Peripheral Blood Counts

In acquired PRCA the erythrocytes are normochromic and normocytic. There is a complete absence of polychromatophilic red cells on the smear, and the reticulocyte count is between 0% and 1%. A reticulocyte count >1% should raise serious doubt about the correctness of the diagnosis. The white cell count and the differential count are usually normal. Occasionally, mild leukopenia, lymphocytosis, and/or eosinophilia may be present. The platelet count is usually normal. Mild thrombocytopenia of 100,000 to 150,000 platelets/ μ l is occasionally seen, and some patients may have a mild reactive thrombocytosis. When present, these abnormalities typically reflect a state of immune activation.

Bone Marrow

The hallmark of PRCA is the absence of erythroblasts from an otherwise normal marrow. The cellularity of the marrow is normal or slightly increased. Markedly increased cellularity with elimination of fat spaces should lead away from the diagnosis of PRCA. In typical cases the erythroblasts are either totally absent, or they constitute <1% on the marrow differential count (Fig. 39.1A). In a small number of cases, a few proerythroblasts and/or basophilic erythroblasts may be seen, not exceeding 5% of the differential count.^{1, 231} The presence of large proerythroblasts ("giant pronormoblasts") with vacuolated cytoplasm and pseudopodia formation may raise the suspicion of an active B19 parvovirus infection but are not diagnostic.^{232, 233, 234}

In some cases a phase of ineffective erythropoiesis characterized by erythroid hyperplasia with maturation arrest at the stage of proerythroblasts or basophilic erythroblasts in the marrow and reticulocytopenia in the blood may precede the development of PRCA, develop during the course of PRCA, or appear after partial response to treatment and before the

return of erythropoiesis to normal.^{235, 236} While this morphologic picture in the absence of dysplastic changes in other lineages or cytogenetic abnormalities should raise suspicion of PRCA, bone marrow examination would need to be repeated at a later time to confirm the diagnosis.

The myeloid cells and the megakaryocytes in the marrow are normal and exhibit full maturation. An increased number of lymphocytes on marrow smear, or an increased number of lymphoid aggregates in marrow biopsy, or a mild increase in plasma cells, eosinophils, or mast cells may be seen. These findings are presumed to reflect inflammatory/immune activation. Iron stores are increased and normally distributed, but during recovery or the phase of ineffective erythropoiesis, a few ring sideroblasts may be seen.¹

Cytogenetics

Cytogenetic studies on marrow cells in PRCA are normal. An abnormal karyotype indicates a preleukemic/myelodysplastic disorder with the morphologic appearance of erythroid hypoplasia.^{126, 237, 238} Such patients do not respond well to immunosuppression.^{126, 239}

Ferrokinetics

Ferrokinetic studies show a prolonged clearance of ⁵⁹Fe, no accumulation of iron in the sacral bone, and almost undetectable incorporation into red cells, findings consistent with an almost

P.979

complete arrest of erythropoiesis. Ferrokinetic parameters return to normal after full hematologic recovery except in adult patients in partial remission, in whom ineffective erythropoiesis may be present.²³⁵ Bone marrow imaging by the use of ⁵⁹Fe or ⁹⁸In shows little or no uptake, but returns to normal upon remission. In both children and adults with PRCA, ⁵¹Cr red cell survival is mildly shortened to a degree inadequate to explain the severity of the anemia.^{235, 236, 240} Patients who are refractory to treatment and who are supported by regular red cell transfusions may develop a significant hemolytic component after alloimmunization or development of hypersplenism.¹

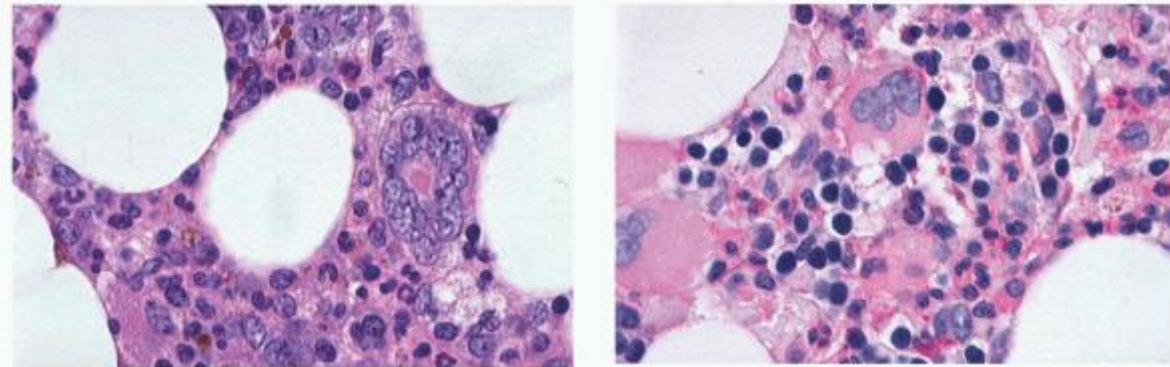

FIGURE 39.1. A: Characteristic bone marrow biopsy from a Pure red cell aplasia (PRCA) patient. B: Bone marrow biopsy from same patient after successful response to immunosuppression. Note easily identifiable erythroblasts.

Other Laboratory Abnormalities

Vitamin B₁₂, folic acid, ferritin, serum iron, and saturation of transferrin are normal or elevated. Serum erythropoietin levels are increased in proportion to the severity of the anemia.³ A number of different immunologic abnormalities have been reported in patients with chronic PRCA, including hypogammaglobulinemia, monoclonal gammopathies, pyroproteins, decreased complement, antinuclear antibodies, decreased or increased B cells, and impaired PHA-induced lymphocyte cytotoxicity.^{1, 3, 120, 241} More recently, in a number of patients the presence of lymphocytes with γ or δ T cell receptor gene rearrangement has been described.^{114, 116, 119, 121, 182, 242, 243} Some of these cases certainly represent PRCA secondary to a T cell lymphoproliferative disorder and not primary PRCA.

Evaluation and Treatment

PRCA, myelodysplastic syndromes (MDSs), and other primary marrow failure disorders are suspected in similar clinical circumstances, and the initial diagnostic approach is bone marrow examination. Specimens should be sent for cytogenetics and flow cytometry as well as routine pathology. In PRCA, a normocellular marrow in which there is almost a complete absence of erythroblasts but with normal myeloid cells and megakaryocytes is expected. A hypocellular marrow

with trilineage hypoplasia suggests aplastic anemia; dyspoietic marrow morphology, or ringed sideroblasts, suggests an MDS.

In all patients with PRCA, polymerase chain reaction (PCR) testing for parvovirus DNA should be performed.^{244, 245} Parvovirus serology may be of value in immunocompetent patients, but is misleading in the immunocompromised.²⁴⁵ For that reason, PCR on peripheral blood is the test of choice. If parvovirus testing is negative, computerized tomography should be performed on all adult patients to rule out thymoma. Flow cytometry studies performed on the diagnostic bone marrow will identify a lymphoproliferative disorder as the possible etiology of PRCA. Abnormal cytogenetics would indicate an MDS. Patients with renal failure who develop PRCA while being treated with rhEpo should be evaluated for anti-Epo antibodies. Testing for underlying autoimmune disorders can be performed if otherwise clinically indicated, but typically would not alter therapy.

Immunosuppressive/Immunomodulatory Therapy

Drugs should be reviewed as possible contributors to PRCA, and any active infection should be treated. Underlying malignancies should be treated. MDSs appearing as PRCA should be managed as MDSs (Chapter 79). Otherwise, in the absence of documented parvovirus infection or thymoma, the initial approach to PRCA is immunosuppression or immunomodulation (Table 39.3). Figures 39.1A and 39.1B display bone marrow biopsy results from a patient before and after immunosuppression. Approximately two-thirds of PRCA patients will respond to an immunosuppression approach.^{1, 108, 239, 246, 247, 248}

Corticosteroids

Corticosteroids are the traditional first line drugs. Prednisone is given orally at a dose of 1 mg/kg/day until a remission is induced. As indicated in Table 39.3, approximately 40% of patients will have a remission on steroids. Corticosteroid-induced remission usually occurs within 4 weeks and continuation of a trial with prednisone longer than 12 weeks is not recommended.²⁴⁶ The effect of treatment can be assessed by weekly reticulocyte counts and measurements of hemoglobin concentration. A rising reticulocyte count and/or stabilization of the hematocrit are the first laboratory findings indicating response to treatment. Once the hematocrit reaches a level of 35%, the dose of prednisone can be tapered very slowly and the drug can be eventually discontinued, preferably after 3 to 4 months. Rapid tapering of prednisone may lead to recurrence of anemia. A number of responders may be prednisone-dependent, requiring small doses of the drug to maintain a normal hematocrit.^{246, 249, 250} The dependence of the response on low-dose prednisone can be assessed during the period of slow tapering, and the minimum dose required can be easily determined.

For patients who do not respond to prednisone within 2 to 3 months, the dose should be rapidly tapered to approximately 20 to 30 mg daily, and the use of a second agent considered.

Cyclosporine

Cyclosporine appears to be the single most effective immunosuppressive used for PRCA (Table 39.3), and it has been P.980

suggested that it should be considered the immunosuppressive drug of choice for this disorder.²⁴⁷ Figure 39.2 shows the response of a patient refractory to several other agents prior to cyclosporine therapy.¹⁰⁵ Cyclosporine is substantially more expensive than prednisone, and requires monitoring of drug levels and of renal function.

TABLE 39.3 RESPONSE OF PURE RED CELL APLASIA (PRCA) TO VARIOUS IMMUNOSUPPRESSIVE THERAPIES

• Study	• Dessypris ¹	• Lacy et al. ²³⁹	• Charles et al. ¹⁰⁸	• Sawada et al. ²⁴⁷	• Total
• Number of patients	• 49	• 47	• 37	• 62	• 195
• Primary PRCA	• 32	• 25	• 18	• 62	• 137
• Secondary PRCA	• 17	• 22	• 19	• 0	• 58
• Corticosteroids	• 18/41 ^a	• 9/29	• 9/36	• 14/22	• 50/128 (39%)
• Cytotoxic agents ^b	• 24/54	• 14/29	• 8/27	• 0/3	• 46/113 (41%)

• Antithymocyte γ -globulin	• 2/6	• 0/1	• 8/12	• —	• 10/19 (53%)
• Cyclosporine	• 3/4	• 4/5	• 2/3	• 28/36	• 37/48 (77%)
• Intravenous immunoglobulin G	• —	• 1/2	• 2/8	• —	• 3/10 (30%)
• Plasmapheresis	• —	• —	• 0/2	• —	• 0/2 (0%)
• Splenectomy	• 4/23	• 0/1	• 0/1	• —	• 4/25 (16%)
• Multiple treatments	• 35/49	• 28/47	• 28/37	• —	• 91/133 (68%)

Note: Many patients did not respond to treatment or suffered relapses, so one patient may be included in more than one treatment modality.

^a Number of responders/number of patients treated.

^b Including cyclophosphamide, azathioprine, or methotrexate, each given either alone or in combination with prednisone.

Cyclosporine may be used as a single agent or concurrently with low-dose prednisone (usually 30 mg prednisone/day or less). The usual starting dose of cyclosporine is 6 mg/kg/day, although initial doses as much as 12 mg/kg/day have been used.^{105, 248, 251, 252} Target trough levels are 150 to 2,500 ng/ml.²⁴⁸ When the hematocrit approaches target levels (usually 35% to 36%), a slow taper is begun. Some patients may require maintenance therapy. If a patient has not responded in 3 to 4 months, cyclosporine should be tapered off and another agent started.

Although cyclosporine is not leukemogenic as are some of the cytotoxic drugs used for PRCA, there are reports of lymphoma development in PRCA patients treated with cyclosporine.¹⁰⁵ Whether these cases represented treatment-induced lymphomas or were cases of lymphoma-associated PRCA is not clear.

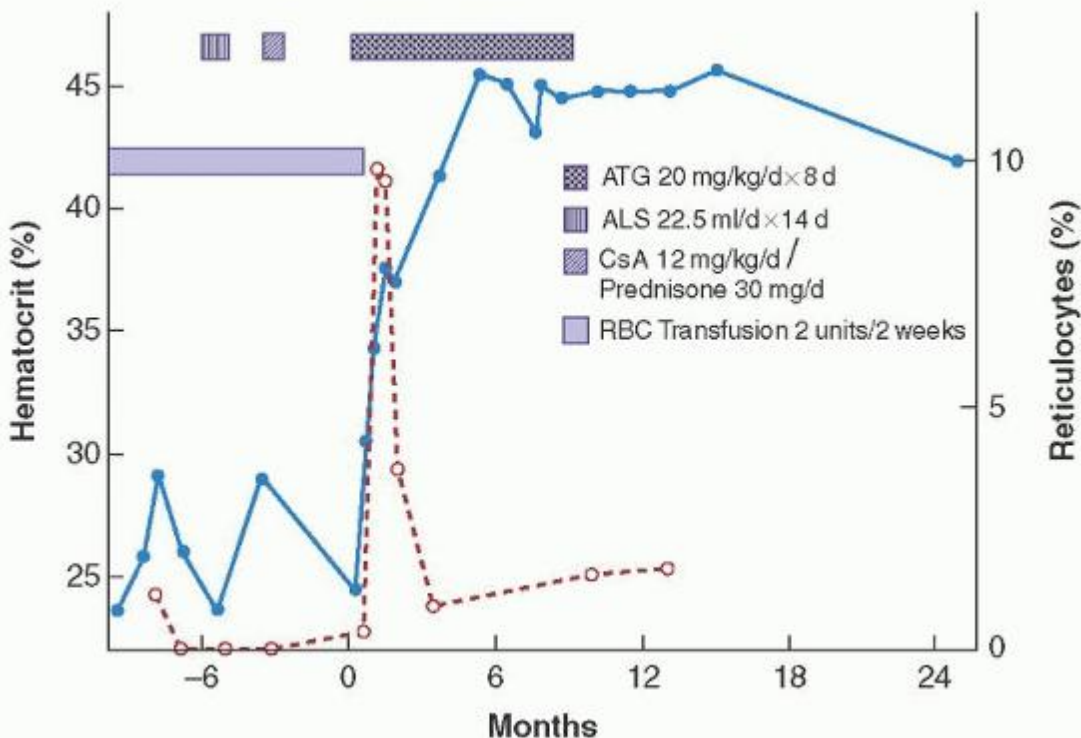

FIGURE 39.2. Time course of response of patient 9 to Cyclosporine A (CsA). Hematocrit (closed circles) and uncorrected reticulocyte count (open circles) are shown. Treatments administered in the 8 months prior to CsA (equine antithymocyte globulin [ATG] and rabbit antilymphocyte serum [ALS]), and the duration of CsA therapy, are indicated on the figure. Prior to beginning CsA (time 0), the patient had required biweekly transfusion to maintain his hematocrit at the levels indicated. No transfusions have been required subsequently. Reproduced with permission from Means et al. *Br J Haematol* 1991;78:114-119. RBC, Red blood cells.

Cytotoxic Agents

In patients not responding to prednisone, cyclosporine, or both, cyclophosphamide or azathioprine can be given alone, or with small doses of prednisone, which seems to increase the effectiveness of treatment. The overall response rate to cytotoxic agent-based therapy is approximately 40% (Table 39.3). The initial dose of either agent is 50 mg po daily. If the white blood and platelet counts allow it, it is increased by 50 mg weekly or biweekly to a maximum of 150 mg daily until remission occurs or bone marrow suppression develops. The mean time to response is about 11 to 12 weeks, with a broad range of 2 to 26 weeks.^{1, 108, 239, 246} If response occurs, prednisone is tapered and then the dose of cytotoxic agent is progressively decreased and eventually discontinued. If bone marrow toxicity develops, the drug is discontinued and the marrow is allowed to recover. If, after 3 months of treatment, no response and no marrow toxicity is seen, the dose can be increased progressively (by 50 mg biweekly) to a maximum tolerable or 250 mg daily under close monitoring of the blood counts. If reticulocytosis or stabilization of the hematocrit is noticed, the dose is gradually reduced. If the absolute neutrophil count decreases to <1,000/ μ l or the platelet count drops to <100,000/ μ l, the cytotoxic drug is discontinued. In a number of patients, with the return of granulocytes and platelets to normal, a reticulocytosis is seen, followed by a return of erythropoiesis to normal. If no response occurs, another type of immunosuppressive treatment should be initiated.

Other Immunosuppressive/Immunomodulatory Modalities

Rituximab, a humanized monoclonal antibody against CD20, has been reported to be effective in PRCA whether primary/autoimmune or associated with lymphoproliferative disorders.^{10, 15, 68, 137, 163, 253, 254, 255, 256} It has also been used effectively in PRCA following ABO-incompatible stem cell transplantation.^{15, 95, 96, 257, 258, 259, 260} In isolated case reports, successful treatment of PRCA by Campath-1H²⁶¹ or alemtuzamab^{262, 263, 264} have been reported.

P.981

High-dose intravenous γ -globulin is primarily used for the treatment of parvovirus-induced PRCA (below). It has also been shown to be effective in patients with immune-mediated PRCA, whether primary or secondary.^{265, 266, 267, 268} Donor lymphocyte infusion has been reported to be effective in PRCA following ABOincompatible stem cell transplantation.^{95, 269, 270}

There are a number of immunomodulatory modalities used primarily in PRCA patients who are refractory to other approaches. Plasmapheresis may be considered in patients who have failed other immunosuppressive approaches. Since the IgG inhibitor of erythropoiesis removed by plasmapheresis is distributed in both intravascular and extravascular spaces, an aggressive approach to plasmapheresis is required, often in concert with immunosuppression.^{271, 272, 273, 274} Antithymocyte globulin (ATG), formerly the routine therapy after corticosteroids and cytotoxic agents, is used uncommonly in refractory patients. The overall response rate to ATG is approximately 50% (Table 39.3). ATG is given on the same treatment schedule as is used for aplastic anemia (Chapter 38).^{108, 239, 246, 275}

Splenectomy has also been used as a final therapeutic maneuver in patients who are refractory to all other forms of treatment. Responses to splenectomy have been reported in ~17% of such recalcitrant-to-treatment cases within the first 2 to 3 postoperative months.^{1, 240, 276, 277, 278, 279} After splenectomy, patients may become responsive to agents against which they were previously resistant.

There are a small number of case reports of PRCA treated by bone marrow or stem cell transplantation.^{280, 281}

Parvovirus-associated Pure Red Cell Aplasia

As was discussed earlier, in immunocompetent individuals B19 parvovirus infection produces transient and self-limited erythroid suppression that is generally unnoticed except in patients with chronic hemolytic disorders. In immunocompromised patients, parvovirus infection can lead to chronic PRCA. Patient with PRCA and documented parvovirus infection (best demonstrated by PCR on peripheral blood) should be treated with high-dose intravenous

γglobulin, which confers passive immunity.^{45, 245, 268, 282, 283} If the immunocompromised state persists, periodic retreatment may be necessary. In HIV patients, relapses of parvovirus-induced PRCA are rare in patients with CD4 lymphocyte count greater than 300/μl.²⁸³

Thymoma-associated Pure Red Cell Aplasia

In the presence of a thymoma, thymectomy should be performed before the initiation of any immunosuppressive treatment. In 30% to 40% of patients with thymoma, erythropoiesis returns to normal within 4 to 8 weeks after thymectomy.^{5, 175, 284, 285, 286, 287, 288} In patients who either do not respond to thymectomy or recur after thymectomy, immunosuppressive therapy is frequently effective. Thymectomy in the absence of thymoma is not recommended.¹ Responses to octreotide and tacrolimus have been reported in thymoma-associated PRCA.^{289, 290}

Anti-Epo Antibody-associated Pure Red Cell Aplasia

As noted earlier, many cases of anti-Epo antibody-mediated PRCA induced by rhEpo therapy in renal failure patients have been reported. Such patients should be managed with immunosuppression, like other immune-mediated PRCA patients.^{92, 156, 158, 161, 267, 274, 291, 292, 293, 294, 295, 296} The overall response rate to immunosuppression has been reported to be 78%, with cyclosporine being the most effective agents, and steroids the least effective.^{156, 294} Patients who undergo renal transplantation appear to have remission of PRCA.^{155, 156} In one series, no patient who did not receive immunosuppression (with or without renal transplantation) developed a remission,¹⁵⁶ while there are case reports of eventual recovery with no therapy apart from cessation of rhEpo therapy and transfusion support.^{150, 297}

The issue of whether or not a patient who has experienced anti-Epo antibody-induced PRCA can ever be retreated with rhEpo or a different rhEpo product remains an open one. The reported antibodies appear to cross react with all available rhEpo agents.⁹⁹ While there are several case reports of successful rechallenge with epoetin or darbepoetin, and even of recovery while continuing rhEpo therapy,^{92, 298, 299, 300, 301, 302} the practice is not recommended.^{303, 304}

Continuous Epo receptor agonist (CERA) is a peptide which is not immunologically similar to rhEpo but activates the Epo receptor. CERA has been proposed as a treatment for rhEpo-induced PRCA.³⁰⁵ In a study of 14 patients, 13 became transfusion-independent, and anti-Epo antibodies became undetectable in 6. However, half the patients studied developed grade 3 or 4 toxicity.³⁰⁵

Refractory Pure Red Cell Aplasia

For patients who respond and relapse, retreatment is often effective. Despite the variety of therapeutic modalities available, there will be some PRCA patients who do not respond to therapy. These individuals will require transfusion support, with chelation management to minimize complications of iron overload.

The survival of patients with primary PRCA is estimated to be 14 years.²⁴⁶ A poorer prognosis is associated with myelodysplastic PRCA variants. The 3% to 5% of PRCA patients who develop acute myeloid leukemia (AML) typically fall into this latter category.^{126, 246, 306} Development of subsequent aplastic anemia in PRCA patients has been reported but is rare.³⁰⁷

DIAMOND-BLACKFAN ANEMIA

DBA (Online Mendelian Inheritance in Man, OMIM, #105,650), first recognized as a discrete clinical entity in 1938,³⁰⁸ is one of a rare group of genetic disorders known as the inherited bone marrow failure syndromes (IBMFS).³⁰⁹ These disorders share a predilection to bone marrow failure, birth defects, and cancer and are characterized by proapoptotic and/or prosenescent hematopoiesis. Furthermore, almost in defiance of their rarity, the IBMFS have provided extraordinary insights into DNA repair, telomerase function, the misfolded protein response, signal transduction and, in the case of Shwachman-Diamond syndrome and DBA, ribosome biogenesis and function (see Chapter 37).

With the discovery of a number of "DBA genes" and the availability of highly annotated patient databases, the diagnostic criteria for DBA have evolved considerably. The classical diagnostic criteria, established 75 years ago³⁰⁸ and refined decades later,³¹⁰ are (a) normochromic, usually macrocytic, and occasionally normocytic anemia developing in early childhood; (b) reticulocytopenia; (c) normocellular bone marrow with selective deficiency of erythroid precursors; (d) normal or only slightly decreased granulocyte count; and (e) normal or slightly increased platelet count. However, with the identification of the first gene known to be mutated in DBA it has become evident that there exist many not as strictly defined cases. Ongoing gene discovery will no doubt classify patients that today are only considered to have probable or even possible DBA.³¹¹ DBA is frequently associated with a variety of somatic malformations and rarely with developmental delay, usually in the setting of a large genetic deletion. Approximately 80% of patients respond to corticosteroids with an

improvement in, or complete remission of, their anemia.^{311, 312} However, prolonged corticosteroid treatment has been problematic for many patients.³¹²

P.982

Since the first description of this syndrome 75 years ago, a number of theories have been put forth regarding its etiology. The myriad discarded explanations have included humoral³¹³ or cellular^{314, 315} suppression of erythropoiesis, a microenvironmental defect,³¹⁶ and accessory cell failure.³¹⁷ In the late 1970s the concept of erythroid failure as a consequence of a block in the erythroid maturation pathway was introduced,^{2, 318} and it rapidly became evident that the erythroid failure in DBA results from an intrinsic erythroid progenitor/precursor-cell defect,^{2, 318, 319, 320} rather than an extrinsic immune or microenvironmental abnormality. Convincing data show that there is a defective pathway from the multipotent bone marrow progenitor to the mature CFU-E, and most prominently through terminal differentiation to the proerythroblast and beyond,^{319, 320} in which an intrinsic defect in erythroid progenitors and precursors render them highly sensitive to death by apoptosis.^{321, 322} It is now clear that in at least 60% to 70% of cases, proapoptotic or prosenescent erythropoiesis and many of the other manifestations of DBA are consequences of faulty ribosome assembly or function.³²³ Exactly how ribosome dysfunction leads to tissue specific red cell failure, poor growth, birth defects and cancer remains a topic of intense inquiry. However, only approximately 70% of patients with DBA can be explained by either sequence changes or deletions in either small or large subunit-associated ribosomal protein (RP) genes.³²⁴ David Nathan suggested decades ago that DBA should result from faulty transcription regulation of erythropoiesis. Virtually unpredictably, however, DBA is in the majority of instances a ribosomopathy. However, the recent discovery of a mutation in the erythroid transcription regulator GATA1 in a family with clinical DBA³²⁵ suggests that DBA is not only a ribosomopathy but also, as predicted by Nathan, a "transcriptionopathy."

Etiology and Pathogenesis

Normal erythropoiesis is dependent upon interactions between erythroid progenitors and accessory cells, the bone marrow stroma, and their locally acting cytokines.³²⁶ Thus, the erythroid failure in DBA could have arisen from an absence of, or failure in,³²⁷ any one of these elements to act or to respond appropriately. Some early investigators described a marrow microenvironmental defect³¹⁶ or implicated accessory cell dysfunction.³¹⁷ Others seemingly found evidence that the red cell failure in DBA was due to the presence of cytotoxic or autoreactive T cells,^{314, 315} or humoral inhibitors of erythropoiesis.³¹³ These findings were never substantiated,^{2, 318, 319, 327, 328, 329} and it is now accepted that DBA results from an intrinsic progenitor defect.^{2, 318, 319, 320, 321, 322, 329, 330, 331} Freedman et al.² first suggested that some patients had decreased numbers of CFU-E; whereas studies by Nathan et al.,³¹⁸ using chronically affected either multiply-transfused or steroid-dependent patients, suggested a block in maturation between the earliest committed multipotent myeloid progenitor and the immature BFU-E. In addition, these investigators found that the progenitors expressed in culture were relatively insensitive to erythropoietin,^{330, 331} reiterated the concept of progenitor hyporesponsiveness to erythropoietin, and suggested that this abnormality could be corrected in part by the addition of glucocorticoids in vitro, implying a relationship between clinical response to corticosteroids and in vitro progenitor response. A series of studies by Lipton and colleagues confirmed these observations. In these studies, some patients expressed normal, or nearly normal, numbers of BFU-E-derived colonies but had decreased numbers of CFU-E-derived colonies in the presence of exogenous cytokines and erythropoietin; while other patients demonstrated normal numbers of (albeit small and poorly differentiated) colonies derived from both BFU-E and CFU-E.³¹⁹ These data suggested that DBA is a heterogeneous disorder in which erythropoiesis may be blocked at different stages of erythroid differentiation. This observation was later confirmed in studies by McGuckin and colleagues.³³²

Further investigations confirm that DBA is due to an intrinsic disorder of the erythroid progenitor that involves its inability to respond normally to inducer(s) of erythroid proliferation and differentiation,³²⁰ resulting in accelerated apoptosis,³²¹ and that the effect could be ameliorated by corticosteroids.³²² The mechanism of steroid action in DBA is not clear but it is likely that the steroid response is not related to the DBA-specific defect. Recent studies by Varricchio and colleagues³³³ suggest that variations in alternatively spliced species of the glucocorticoid receptor (GR) may explain how GR polymorphisms are an important modifier of disease severity and response to corticosteroids. It needs to be explored whether specific GR polymorphisms are predictive of steroid response in DBA. Clearly, the variable expression of both the hematologic and nonhematologic manifestations of DBA, particularly within multiplex families, strongly suggests robust interactions with modifying genes.

The intrinsic defect in the erythron has not been found to be associated with any abnormalities in erythropoietin or its receptor.^{334, 335} A mildly decreased leukocyte count and the development of pancytopenia, bone marrow hypoplasia, and reduced clonogenic cell output in lymphocyte assays,³³⁶ as well as hypogammaglobulinemia and T cell abnormalities,^{317, 337} support this contention in many but not all cases. Furthermore, other studies show that, in addition to erythroid progenitors, a defect in CFU-GM can be found in a subset of patients.³³² These in vitro studies are consistent with the observation that neutropenia and even aplastic anemia occur in some DBA patients. The response of erythroid cell growth and differentiation to a variety of cytokines in addition to erythropoietin, such as SCF and IL-3, has been evaluated, with no abnormalities of the cytokines or their receptors being identified.^{338, 339, 340, 341, 342} Moreover, somatic malformations, growth failure, and cancer predisposition cannot be easily explained by an abnormality in erythropoietin or cytokine receptors. However, for approximately 30% of patients there is not yet an identified gene. Furthermore, there are sufficient numbers of patients, in addition to those described by Gazda and colleagues as harboring a GATA1 mutation,³²⁵ lacking described nonhematologic manifestations of DBA to imply that rare cases may indeed involve erythroid-restricted pathways. Additionally, the discovery by Ebert and colleagues that an acquired RPS14 mutation can explain the erythroid failure in 5q- MDS³⁴³ suggests that some cases of DBA may be the consequence of acquired somatic, rather than germ line, mutations.³⁴⁴

With the identification of the first DBA gene, RPS19, a gene that encodes an RP located at chromosome 19q13.2,^{345, 346} and a second gene coding for RPS24,³⁴⁷ it became obvious that other RP genes would be implicated in the molecular pathogenesis of DBA. Based upon the original technique used to describe RPS19 (cloning of a cytogenetic abnormality from an informative patient), linkage analysis, resequencing of the known ribosome-associated protein genes, or most recently, a variety of techniques for the detection of copy number variants in the genome,^{324, 348} a number of additional RP gene mutations/deletions have been identified, accounting for approximately 70% of all cases of DBA. Currently, the RP genes confirmed to be mutated in DBA are RPL5, RPL11, RPL35A, RPS7, RPS10, RPS17, RPS19, RPS24, and RPS26.^{324, 345, 346, 347, 348, 349, 350, 351} Rarer abnormalities of less certain significance have been identified in isolated patients or families. These likely DBA genes include RPL3, RPL7, RPL9, RPL14, RPL19, RPL23A, RPL26, RPL25, RPL36, RPS8, RPS15, and RPS27A.^{351, 352, 353, 354} The nature of the mutations studied thus far suggests that there is either complete loss of function or nonexpression of the mutated allele. Thus, current evidence strongly supports that in patients with RPS19 (the most studied) and other small or large ribosomal subunit-associated protein gene mutations, DBA results from RP protein haploinsufficiency.³⁵⁵ When the gene is knocked down in cellular models,^{356, 357} there is resulting failure of erythropoiesis. In the in vitro models this defect can also be corrected

P.983

when the normal gene is overexpressed, resulting in increased RPS19 protein expression and restoration of erythropoiesis.³⁵⁸ Furthermore, a number of mouse and fish models have been developed confirming the role of RP haploinsufficiency in erythroid failure.^{359, 360, 361, 362} But despite the discovery of at least 9, and likely more, small and large subunit-associated RP gene mutations, the mechanism of erythroid failure and the other clinical manifestations of DBA are only partially explained. Much work needs to be done in order to connect faulty ribosome function with red cell failure, the congenital anomalies associated with DBA, as well as the clear recognition of DBA as a cancer-predisposition syndrome.^{363, 364} A number of theories have been proposed to account for the pathophysiology of DBA. Time will allow for the elucidation of the perhaps myriad explanations necessary to explain the pathophysiology of the DBA non-ribosomopathies. With regard to the DBA ribosomopathies, it is likely that at least one explanation provides the fundamental explanation for DBA-associated proapoptotic erythropoiesis, congenital anomalies, and cancer predisposition. While it appears that RP haploinsufficiency leads to aberrant ribosomal RNA (rRNA) processing of uncertain significance, the fundamental lesion appears to be a faulty translational apparatus created by RP haploinsufficiency leading to nucleolar stress signaling. This results from RPL5, RPL11, and 5S rRNA binding to MDM2 (murine double minute) and its human ortholog HDM2, leading to a decrease in its ubiquitin ligase activity essential for p53 degradation, thereby stabilizing p53 and resulting in accelerated apoptosis.^{360, 361, 365} The regulatory pathway utilizing RPL5 and RPL11 to bind to HDM2, reducing its ubiquitin ligase activity, seems central to this stress signaling; so much so that even when small ribosome-associated proteins are deficient, offering no excess of RPL5 and RPL11, as is the case for large subunit-associated haploinsufficiency resulting in degraded large subunits, the RPL5 and RPL11 TOP (terminal oligopyrimidine tract) mRNAs are translationally upregulated. The fact that both RPL5 and RPL11 are known as "DBA" genes and that they represent a severe congenital anomaly phenotype³⁵¹ tells us that there is much more to be learned about how HDM2 is regulated when their encoding genes are haploinsufficient. Furthermore, the tissue specificity of defects manifested by a germ line mutation in a ribosome-associated protein, as opposed to a relatively more erythroid-restricted transcription regulator such as GATA1, particularly in the erythron, begs for explanation. One explanation suggests that certain proteins

that are canonically translated are favored over others and that those proteins may be overrepresented in the erythron.³⁶⁶ The other supports the notion that the makeup of ribosomes is tissue specific (i.e., not all 80 RPs are required in every tissue), favoring translation in some tissues and not others as a consequence of any particular RP haploinsufficiency.³⁶⁷ Likely there are multiple explanations related to the complexity of tissue specific translation. Regardless, the knockdown of p53 in DBA animal models ameliorates the erythroid failure,^{361, 368, 369} making the therapeutic targeting of p53 in DBA an intriguing although potentially risky approach. Elucidating all the downstream events leading to accelerated cell death and understanding the interdicting mutations that lead to cancer in DBA are important subjects of inquiry.

Clinical Presentation

DBA usually presents in infancy. Severe anemia is recognized at birth in 25% of patients, with 65% diagnosed by 6 months of age and 90% within the first year of life.^{311, 312} DBA presenting as hydrops fetalis has been reported.³⁷⁰ The disease may also present in older children and adults.^{311, 371} Although rare instances of X-linked inheritance have been reported, the incidence in males equals that in females. The majority of cases are reported in whites, but the disorder has been reported in virtually all ethnic groups.³¹¹

Josephs in 1936,³⁷² and Diamond and Blackfan in 1938,³⁰⁸ were the first to describe red cell failure in infants. The variety of descriptive names for what is now preferably called DBA include “congenital pure red cell hypoplastic anemia,” “congenital red cell aregenerative anemia,” “erythrogenesis imperfecta,” “chronic erythroblastopenia,” “primary red cell aplasia,” and “Josephs-Diamond-Blackfan anemia.”^{310, 311} The classical diagnostic criteria for DBA reflect the careful clinical analysis performed by Diamond and colleagues³¹⁰ and, more recently, by Alter.^{309, 373} Recently, however, a consensus conference took place during which, as a consequence of robust gene discovery, the diagnostic criteria for DBA were expanded to account for nonclassical presentations.³¹¹ For a still valuable compilation of the clinical syndrome of DBA that is beyond the scope of this chapter, interested readers are referred to Young and Alter's classic monograph.³⁰⁹

The Diamond Blackfan Anemia Registry of North America (DBAR), a database of >600 patients, was established in 1991 and has been described in detail.^{311, 312, 374} The DBAR has provided important information regarding the epidemiology and biology of DBA.^{312, 364, 375} The male-to-female ratio of cases is approximately 1:1. The median age at presentation is 8 weeks, with a median age at diagnosis of 12 weeks. More than 90% of the reported cases present clinically by 1 year of age. The mainstays of therapy, as described below, remain red cell transfusions and corticosteroids. Physical anomalies, not including short stature, are found in nearly 50% of patients. Short stature is clearly a constitutional feature of DBA, but may also be due to chronic anemia, iron overload, corticosteroid administration, or a combination of all these. Thus it is difficult to always ascribe growth failure directly to the disorder. The constellation of physical anomalies found in the 47% of affected patients with typical hematologic manifestations includes a high percentage of craniofacial anomalies (50% of patients with anomalies) as well as upper limb and hand, in particular thumb (38%), as well as genitourinary (39%) and cardiac (30%) abnormalities. Table 39.4 enumerates the congenital anomalies collected in a series by Alter.³⁷⁵ Of interest, there appears to be no genotype-phenotype correlation with regard to steroid responsiveness, remission, or cancer predisposition. However, mutations in RPL5 and RPL11 are disproportionately associated with orofacial and thumb anomalies.^{351, 376} Figure 39.3 illustrates typical thumb abnormalities in a patient with DBA as the consequence of an RPL11 gene mutation.

Laboratory Evaluation

With the discovery of genetic mutations there are numerous “patients” recognized with minimal or no hematologic manifestations. With that in mind, classical DBA is characterized by severe anemia, with hemoglobin levels at presentation as low as 2 to 3g/dl. There is a marked reticulocytopenia, frequently as low as zero. There are usually no significant abnormalities in other cell lines. Occasionally, there is mild to moderate neutropenia and infrequently severe neutropenia requiring G-CSF support^{311, 375, 377, 378} or thrombocytopenia.³⁷⁹ However, thrombocytosis in the range of 400,000 to 700,000 is more common.³⁷⁹ Although originally described as a normochromic, normocytic anemia, macrocytosis was noted at presentation in ~30% of cases reviewed by Alter³⁷⁸ in patients for whom data were available. The percentage of patients with macrocytosis increases with the age of the patient, as the disease becomes chronic when the normal red cell MCV would decrease during the first year of life. Indeed, the persistence of “fetal-like” red cells, with macrocytosis, “i” antigen, increased fetal hemoglobin (HbF), and red cell glycolytic and hexose-monophosphate (HMP) shunt enzyme activities characteristic of fetal cells are a consistent finding. The HbF is typical of fetal cells,^{377, 378} with an elevated glycine-to-alanine ratio at position 136 of the γ chain. Of note is that the fetal-like characteristics

P.984

are not concordant; cells with high HbF are not necessarily those with the “i” antigen. Although red cells contain

significant HbF, as determined by hemoglobin electrophoresis, the distribution is uneven as evaluated by the Kleihauer-Betke method. Alter points out that red cells contain both fetal and adult hemoglobin and that the "re-expression of fetal erythropoiesis is thus incomplete, and not clonal."³⁷⁸ Although glycolytic and HMP shunt enzymes have a fetal pattern, erythrocyte adenosine deaminase (eADA), a purine salvage pathway enzyme, is increased in activity in DBA patients but not in normal fetal or cord blood erythrocytes.³⁸⁰ When compared to controls with normal eADA activity obtained from patients with hemolytic anemia, Fanconi anemia, and those with steroid-dependent nephrosis, as well as virtually all patients with TEC, approximately 85% of the patients with typical DBA have elevated eADA activity.^{380, 381, 382} In some DBA patients with normal eADA activity there is markedly elevated orotidine decarboxylase activity.^{380, 383} Although abnormalities in purine or pyrimidine biosynthesis are consistent findings in most DBA patients and in some animal models and serve as a valuable screening tool, this observation has not yet been helpful in understanding the pathophysiology of DBA. Red cells of some patients with acute leukemia, adult-type chronic myelogenous leukemia, myeloproliferative disorder with Down syndrome, dyskeratosis congenita with pancytopenia, and megaloblastic anemia were also found occasionally to have increased eADA activity.³⁸¹ This may suggest an association of elevated eADA activity with abnormal progenitor function. Also of interest is the observation that W/W^v and S1/S1^d mice, with genetically determined red cell failure, have elevated erythrocyte nucleoside deaminase activity.³⁸⁴ Further advances in this area must await a detailed understanding of the biochemistry of hematopoiesis. However, from a practical prospective, eADA activity determinations provide a reasonably useful means for distinguishing ~85% of DBA from TEC (see section "Differential Diagnosis"). To date none of the described hematologic abnormalities have been linked to a specific pathophysiology, and they have no predictive value in distinguishing steroid responding from nonresponding patients.

TABLE 39.4 PHYSICAL ABNORMALITIES IN PATIENTS WITH DIAMOND-BLACKFAN ANEMIA

Low birth weight
 Short stature, no steroids
 Head and face:
 "Cathie" facies
 Other facies
 Small head
 Large head
 Jaw and mouth
 Small jaw alone
 Small jaw plus cleft palate
 (Pierre-Robin syndrome)
 Cleft palate alone
 Cleft palate and lip
 Cleft lip alone
 Macroglossia
 Flat nasal bridge
 Abnormal ears
 Abnormal eyes:
 Hypertelorism
 Epicanthal folds
 Ptosis
 Strabismus

Blue sclera
Congenital cataracts
Microphthalmia
Glaucoma
Neck:
Short
Webbed
Thumb:
Triphalangeal
Duplicated or bifid
Subluxed
Hypoplastic
Renal

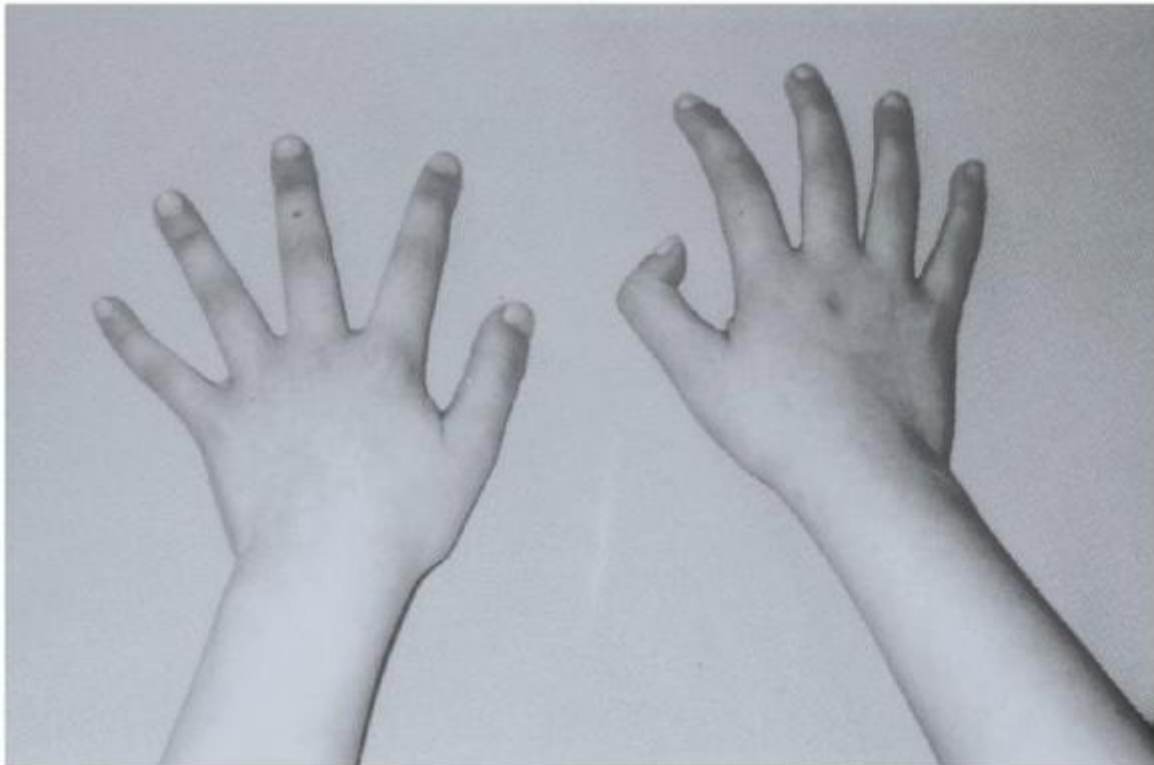

FIGURE 39.3. Typical displaced and “trigger” thumbs in a patient with Diamond-Blackfan anemia.

Vitamin B₁₂, folate, serum iron, and transferrin saturation are elevated or normal in patients with DBA.^{310, 380} Erythropoietin levels seem to reflect the degree of anemia, or may be elevated for the degree of anemia and remain elevated even in steroidresponsive patients.^{310, 378} Approximately one-third of patients evaluated by Alter had hypogammaglobulinemia, consistent with the finding of in vitro immunologic abnormalities in some DBA patients.^{317, 378, 385} Recently an association of hypogammaglobulinemia with RP haploinsufficiency³⁸⁶ has been described, perhaps explaining this observation.

Examination of the bone marrow biopsy and aspirate at diagnosis in childhood usually reveals normal cellularity with a paucity of erythroid precursors. Myeloid and megakaryocyte lineages appear normal. Myeloid-to-erythroid (M:E) ratios at diagnosis are usually around 10:1 and with time may become as high as 100:1.³¹⁰ This progression of erythroid failure

(with time) seems to parallel the more severe abnormalities in *in vitro* progenitor differentiation observed in older chronically affected patients as compared to those newly diagnosed.³¹⁹ The heterogeneity of the disorder is reflected in the marrow. In one series of 9 patients, all had marked erythroid hypoplasia; 4 had virtually no erythroid precursors, 2 had erythroid maturation up to the polychromatophilic or orthochromatic normoblast stage, and 3 had a maturation arrest at the proerythroblast stage, with 2% to 7% of the total nucleated cells being proerythroblasts.³¹⁹ In Alter's review, 28 of 29 DBA patients had erythroid hypoplasia. One had erythroid hyperplasia with a maturation arrest. Several of Alter's patients had normal numbers of proerythroblasts but no differentiation beyond that stage. In a series of patients studied by Bernard et al., 90% had erythroid hypoplasia, 5% had normal erythroid precursors, and 5% had erythroid hyperplasia.³⁸⁷ Although all patients have a profound reticulocytopenia, the erythroid arrest in DBA has been demonstrated by progenitor assays, or morphologically, to occur at all stages of maturation from the multipotent myeloid progenitor to the late normoblast. These and other observations³³⁶ suggest that the defect may become more profound with age and that the arrest in erythropoiesis moves to an earlier stage of differentiation

P.985

as patients get older. This is, however, somewhat confounding in light of the presence of remissions.³¹²

Imaging studies are useful to help delineate congenital abnormalities that may be present in patients with DBA. Skeletal surveys and, in particular, CT scans are not usually warranted in light of the increased risk of cancer in DBA, but selected radiographs may define suspected bony anomalies. Renal and cardiac ultrasonography is warranted and may detect suspected and perhaps significant anomalies.

Genetics

Prior to the identification of causative mutations Alter estimated that there is more than one affected family member in ~10% of cases.³⁷⁵ Early data from the DBAR provided a comparable or even slightly higher rate when robust clinical and hematologic data were available. Early case reports are representative of the now known genetics of DBA. In these families there were reports of affected same- and opposite-sex siblings,^{376, 388, 389, 390} including identical twins,³⁹¹ and maternal or paternal half-siblings.^{392, 393, 394, 395} There were also instances of parental transmission.^{395, 396, 397, 398} Striking evidence of autosomal dominant inheritance is illustrated in one case report of DBA in a male infant who had an affected mother and maternal grandfather.³⁹⁹ Thus, the clinical evidence is consistent with the known majority of cases of autosomal dominant inheritance resulting from RP haploinsufficiency and the rare X-linked inheritance caused by a mutation in GATA1.

The genetics of the majority of cases of DBA have become firmly established since 1997, when after studying a patient with a 19:X translocation, Gustavsson and colleagues^{345, 346, 400} used linkage analysis to show that DBA mapped to chromosome 19q13.2. That observation led to the cloning of a gene that encodes a ribosomal protein, RPS 19. Studies have shown that the RPS19 mutation accounts for only ~20% to 25% of familial as well as sporadic cases. With the description of a second "DBA gene," RPS 24, also a component of the 40S ribosomal subunit,³⁴⁷ and the subsequent identification of mutations or deletions in both small and large subunit-associated RP genes in approximately 70% of patients,^{349, 350, 351, 352, 353, 354} as well as a rare causative mutation in the transcription regulator GATA1,³²⁵ about 30% of patients remain genetically unclassified at this time. Thus the majority of familial cases are of dominant inheritance, with sporadic cases representing new dominant mutations. Within the identified pedigrees there is marked heterogeneity in the expression of the DBA phenotype. This heterogeneity exists for both the hematologic and nonhematologic manifestations of DBA. Thus the DBA phenotype appears to be the result of complex interactions between DBA and non-DBA genes. A family with discordant hematologic manifestations including a nonhematologically affected phenotype as well as discordance of craniofacial anomalies in affected family members has been reported.⁴⁰¹ The incidence of genetically determined cases is no doubt underestimated because of the apparent variable penetrance of the autosomal dominant cases in which an elevated HbF, MCV, or erythrocyte ADA activity may be the only abnormality in a parent or sibling of a child with typical DBA.^{311, 312} Indeed, in the case described, the mothers of affected cousins had none of these hematologic or nonhematologic abnormalities.⁴⁰¹ By tracing RPS19 mutations in families, the UK group has shown that nearly half of all patients have autosomal dominantly inherited DBA.⁴⁰² Therefore, in the absence of a molecular diagnosis for all DBA genotypes, families of affected individuals should be evaluated to determine HbF levels, MCV, and eADA activity. A number of cases currently felt to be sporadic or autosomal recessive in nature will no doubt be recategorized, but recessive inheritance as a mode of transmission is far from ruled out. The appearance of DBA in the male and female children of unaffected parents has also been observed. Reported gonadal mosaicism in DBA is rare.⁴⁰³ Furthermore, parental consanguinity has been observed,^{404, 405} supporting an, as of yet unconfirmed, autosomal recessive mode of

inheritance. That approximately 30% of DBA cases have not been assigned a genetic cause supports the possibility that additional cases consistent with novel recessive modes of inheritance will be described in the future.

The absence of a phenotype is a particularly distressing finding, as the use of such potential hematopoietic stem cell transplantation (HSCT) donors with such a “silent phenotype” may result in transplant failure.⁴⁰⁶ Furthermore, genetic counseling in these instances is inherently imprecise.⁴⁰⁷

The vast majority of DBA patients have a normal karyotype, but the few reported abnormal cases, in particular leading to the discovery of the first⁴⁰⁰ and other genes,³⁵⁰ have been of great importance; thus, karyotypic analysis is suggested as part of the initial evaluation.

Differential Diagnosis

The differential diagnosis of classical DBA includes the normochromic, normocytic (or macrocytic) anemias that present from birth through the first year of life. These anemias are pathophysiologically distinct from the majority of causes of PRCA seen in adults that are frequently associated with an underlying disorder (Table 39.1). However, it is clear that DBA does present in adulthood and these cases are often undiagnosed as such. Conversely, a patient presenting with red cell failure at age 5 and diagnosed with atypical DBA was confirmed to have 5q- MDS some 20 years later.³⁴⁴ And the association of PRCA with thymoma, as described in adults, has not been described in infancy, although it has been observed in a 5-year-old girl.⁴⁰⁸ Thus an index of suspicion for DBA should be maintained with regard to all cases of PRCA presenting at any age. In classical cases the differential almost always consists of DBA versus TEC (Table 39.5). Of note, patients with Pearson syndrome, resulting from large deletions of the mitochondrial genome, may present with pure red cell failure. Clinical suspicion or the presence of vacuolated erythroid precursors in the marrow should prompt a stain for ringed sideroblasts and the evaluation for a mitochondrial DNA deletion. A careful history, physical examination, and examination of the peripheral blood smear can usually rule out hemorrhage, myelosuppression resulting from infection, renal failure, infiltrative disease, severe

P.986

protein malnutrition, or drug-related red cell failure, as well as the aplastic crisis of a chronic hemolytic anemia (such as sickle cell anemia or hereditary spherocytosis). Because folate deficiency as a cause of the hypoplastic crises associated with chronic hemolytic anemia is prevented by prophylactic administration of the vitamin, acquired hypoplastic anemia in these patients is now most frequently a consequence of human parvovirus B19 infection. Evidence of human parvovirus B19 infection (see Parvovirus-induced pure red cell aplasia) has been found in patients with all congenital hemolytic disorders.^{127, 128, 129, 130, 142, 409, 410, 411} Red cell aplasia in otherwise normal neonates resulting in fetal hydrops, and in a patient on treatment for acute lymphoblastic leukemia, has also been described, apparently due to parvovirus infection.⁴¹² Chronic red cell aplasia due to parvovirus B19 after 10 years of transfusion-dependent anemia has been eradicated by the use of intravenous immunoglobulin.⁴⁵ Thus, parvovirus infection should be ruled out in all atypical instances of red cell failure in children. This can be best accomplished by PCR analysis, as IgM and IgG antibody evidence will be lacking in the presence of significant immunodeficiency.

TABLE 39.5 DIFFERENTIAL DIAGNOSIS OF DIAMOND-BLACKFAN ANEMIA (DBA) VERSUS TRANSIENT ERYTHROBLASTOPENIA OF CHILDHOOD (TEC)

	DBA	TEC
Pure red cell aplasia	Present	Present
Age	<1 y	>1 y
Inheritance	Sporadic and dominant or possibly but unlikely recessive inheritance Mutation analysis available for known DBA genes	Not inherited
Congenital anomalies	Present	Absent
Mean corpuscular volume	Elevated	Normal
Fetal hemoglobin	Elevated	Normal

i RBC antigen	Present	Absent
Erythrocyte ADA activity	Elevated	Normal

ADA, adenosine deaminase; RBC, red blood cell.

All RBC characteristics except ADA activity are helpful only when tested in a reticulocytopenic child. During recovery from TEC, a transient wave of fetal-like erythropoiesis may be detected.

A bone marrow examination revealing red cell aplasia or severe hypoplasia with no abnormalities in myeloid or megakaryocyte lineages, as well as no evidence of infiltrative disease, congenital dyserythropoietic anemia, vacuolated precursors, or ringed sideroblasts in an infant or young child, suggests either DBA or TEC. Table 39.4 outlines the important features that distinguish TEC, a temporary immune-mediated suppression of erythropoiesis that frequently follows a viral infection, from DBA. There is a moderate to severe anemia with reticulocytopenia. The disease is not familial, and there are no associated anomalies. The age of onset is usually a bit older than for congenital PRCA. One key point in differentiating between DBA and TEC is the presence of fetal characteristics in the erythrocytes of many patients with DBA (see section "Laboratory Evaluation"). As previously described, these characteristics include an elevated MCV for age, elevated levels of HbF and "i" antigen, and a fetal erythrocyte glycolytic and HMP shunt enzyme pattern.⁴¹³ The presence of "fetal-like" cells is much less reliable in differentiating DBA from TEC in very young infants, in whom red cells normally possess fetal characteristics. However, this is a situation where measuring eADA may be useful, because the activity of this enzyme is the same in neonates and older children. Even in typical DBA, only 30% of patients have "fetal-like" erythrocytes at diagnosis. Recovery from TEC is characterized by "stress erythropoiesis," giving rise to erythrocytes with fetal characteristics."⁴¹⁴ Making a diagnosis of TEC retrospectively after a long course of corticosteroids subjects the child to needless toxicity. As previously described, studies by Glader and coworkers^{380, 381, 382} have demonstrated that elevated eADA activity can be used to distinguish DBA from TEC. Unfortunately, many patients are transfused prior to consideration of the diagnosis, making an accurate eADA activity determination impossible. A molecular diagnosis can be made about 70% of patients and these assays are now commercially available. Based on the differences listed in Table 39.4, a high index of suspicion of TEC should prompt avoidance of steroids, minimal red cell transfusions, and alleviation of parental concern. Cases that are atypical or those who do not recover spontaneously deserve a genetic evaluation.

Treatment

If the diagnosis of DBA versus TEC is in doubt and the child has symptomatic anemia, the patient should be modestly transfused to a hemoglobin level of 7 to 8 g/dl so that erythropoiesis will not be suppressed, delaying recovery in those patients who have TEC. The use of corticosteroids in TEC is ineffective and should be assiduously avoided. In 1951, corticosteroid treatment in the form of ACTH was first shown to be effective in DBA^{415, 416}; however, the transfusion of packed red blood cells is the initial treatment. Transfusions should continue until 1 year of age if possible. The ability to defer corticosteroid treatment is dependent upon the availability of a safe blood supply and the ability to maintain appropriate venous access. The current approach is to start all patients on prednisone, 2 mg/kg/day orally in 3 to 4 divided doses, sometime as close to 1 year of age as can be accomplished. By delaying the start of corticosteroids, it is anticipated that many of the significant side effects associated with early steroid administration (growth retardation, developmental delay, osteopenia, hyperglycemia, hypertension, etc.) can be avoided.³¹¹ A reticulocyte response usually occurs within 1 to 2 weeks. The clinical response to prednisone therapy is variable. Data from the DBAR reveal that 79% of patients were initially responsive to corticosteroids, 17% were nonresponsive, and 4% were never treated with steroids.³⁷⁴ At the time of the analysis only 37% of patients were using corticosteroids. Steroid-related side effects were observed in most patients, at least transiently, with 48%, 22%, and 12% manifesting cushingoid features, pathologic fractures, and cataracts, respectively. Thirty-one percent of the patients were receiving red cell transfusions. Some patients respond rapidly and can be tapered off prednisone, remaining in remission for extended periods of time; others respond but require continued therapy, with erythropoiesis ceasing rapidly if steroids are discontinued. Thus the ability of responders to achieve an effective every-otherday dose schedule is variable. Of the transfused patients enrolled in the DBAR, 35% were never steroid-responsive, 22% became steroid-refractory, 33% could not be weaned to an acceptable dose, and 5% were never on steroids. A small number were transfused for unspecified reasons. Some patients may be tapered off steroids even after many years. Indeed, the actuarial likelihood of remission is 20% by age 25 years, with 72% entering remission during the first decade of life. Patients appear to remit equally from steroid and transfusion therapy. Almost 75% of these patients have what appears to be a sustained remission. Although high-dose corticosteroid pulses may evoke an erythroid response in some patients,^{417, 418} the potential side effects and the need for repeat pulses and the failure of this modality in subsequent studies⁴¹⁹ have limited its utility. Likewise, trials of cyclosporine (CsA), erythropoietin,

interleukin-3, metoclopramide, etc., despite anecdotal reports in DBA, have not been particularly encouraging (reviewed in Ref. 311). Furthermore, the potential toxicity of this agent makes it less preferable to red cell transfusions for those patients who cannot be weaned to an acceptable corticosteroid dose. In some patients who fail to respond to prednisone there may be a response when oxymetholone (2.0 to 5.0 mg/kg/day) is added. However, experienced clinicians do not advocate the use of androgens in infants and young children because of their limited effectiveness and considerable side effects. If there is no response within a month, prednisone is discontinued in favor of transfusion and iron chelation. These patients may receive periodic prednisone trials, because they may respond at a later date.

For patients in whom there is a response, the hemoglobin is followed until a level of 10 g/dl is achieved. The steroid dose is then tapered until the patient is on the smallest possible alternateday dose. A Monday-Wednesday-Friday dose schedule is usually effective and easier to comply with than a strict every-other-day regimen. The dosage in a Monday-Wednesday-Friday schedule may range from a few milligrams even in adolescents to as much as 40 to 50 mg. The target dose is 0.5 mg/kg/day or 1 mg/kg every other day. Arbitrary discontinuation of therapy should be discouraged, because reestablishment of erythropoiesis after discontinuation of an effective every-other-day course of prednisone requires reinstitution of the original daily dose. For patients who are steroid-refractory or in whom the dose cannot be tapered to an alternate-day regimen and thus require high daily doses that cause toxicity, chronic transfusion is instituted. Data from the DBAR and accumulated international experience demonstrate

P.987

that more patients than originally anticipated have significant steroid-related side effects even on a low-dose, every-other-day schedule. These are in addition to pathologic fractures and cataracts, and include poor growth, osteoporosis, and osteonecrosis, and may require the discontinuation of corticosteroids in favor of chronic transfusion therapy. Patients must be carefully monitored and steroid therapy discontinued when morbid side effects ensue, even if the dose is within the "accepted" range.

In recent years, HSCT has been used in DBA patients with good results. The first successful transplant for DBA was performed by August and colleagues in 1976.⁴²⁰ In a 1998 review of stem cell transplantation in DBA by Alter that analyzed 35 of the 37 cases reported to that date in the literature, the actuarial survival for predominantly allogeneic HLA-matched donor transplants was 66%.⁴²¹ Two more recent studies suggest that the actuarial survival is in the range of 90% for matched related HSCT in young, otherwise healthy patients.^{422, 423} The historical substantial risks associated with alternative-donor bone marrow transplantation favor transfusion and chelation in those patients unable to achieve an every-other-day steroid schedule; however, the hesitancy to use unrelated donors is changing as recent results from patients transplanted since 2000 are dramatically better, likely as the result of more precise high-resolution HLA-typing, an expanded donor pool, and better pretransplant management of iron overload.⁴²² Modern chelation regimens seem to be very effective in reducing the consequences of iron overload in chronically transfused patients, but the long-term results of these programs are currently not known. The recent availability of an oral chelating agent promises to improve compliance with better-tolerated chelation regimens than the traditional nightly continuous subcutaneous infusions. This uncertainty and the other risks of transfusion (i.e., sensitization and infection) make the decision regarding bone marrow transplantation (when a suitable alternative donor exists) versus chelation therapy for DBA patients who are steroidrefractory or steroid-intolerant, one that must be individualized and constantly reevaluated. In particular, poor compliance with chelation regimens has resulted in significant morbidity and mortality in young adult patients with transfusion-dependent DBA.³¹¹ A recent "How I Treat" article by Vlachos and Muir⁴²⁴ provides a highly annotated approach to the treatment of DBA.

Prognosis

The DBAR describes an overall actuarial survival rate at ~40 years of age as 75.1% ± 4.8%, with 86.7% ± 7.0% for corticosteroidmaintainable patients, and 57.2% ± 8.9% for transfusiondependent patients. There is a statistically significant survival advantage for steroid-maintainable versus transfusion-dependent patients.^{311, 312} Deaths due to infection in splenectomized patients with DBA are now dramatically reduced through the use of pneumococcal and Hemophilus influenzae vaccines, prophylactic penicillin, and careful follow-up and management. In addition, splenectomy is performed only for hypersplenism and an increased transfusion requirement, not as specific therapy for DBA. However, despite modern chelation schemes, transfusion-related hemosiderosis is a significant cause of death in DBA. Deaths from infection (Pneumocystis jiroveci pneumonia, varicella pneumonia, Pseudomonas pneumonia, sepsis, and one unknown infection), vascular access device complications, hematopoietic stem cell transplant complications, aplastic anemia, and malignancy^{311, 312} are described. Seventy percent of deaths were treatment-related, with alternative-donor HSCT the leading cause of death in DBA. Only one HLA-matched related and one alternative-donor HSCT recorded by the DBAR

were done for the indication of severe aplastic anemia. The major indication was either steroid nonresponsiveness or intolerance. Since that publication, the results for unrelated HSCT have improved significantly, and this modality is under constant evaluation on a case-by-case basis. The most recent analysis from the DBAR reports an overall HLA-matched related-donor transplant survival of $76.9\% \pm 8.4\%$, with a $93.8\% \pm 6.1\%$ survival for patients equal to or less than 9 years of age. For unrelated donor transplants the overall survival has improved from $32.1\% \pm 11.7\%$ (1994 to 1999) to $85.7\% \pm 13.2\%$ (2000 to present).

For several years, it has been recognized that DBA is a syndrome predisposing to cancer, both hematopoietic and nonhematopoietic malignancies. A recent analysis of the prospective cohort of 608 patients enrolled in the DBAR since 1991 was performed to provide the first quantitative assessment of cancer incidence in DBA patients.³⁶⁴ Among the 608 patients, there were 9,458 person-years of follow-up. There were 15 solid tumors, 2 cases of AML, and 2 cases of MDS diagnosed at a median age of 41 years. The cancer incidence in DBA is significantly elevated, with an observed-to-expected (O/E) ratio of 5.4 for all cancers and 287 for MDS, 28 for AML, 36 for colon cancer, 33 for osteogenic sarcoma, and 12 for female genital cancers, respectively. Clearly, in addition to understanding the mechanism of cancer predisposition in DBA, surveillance strategies must be considered for this at-risk population.

Future Directions

Advances in cellular and molecular biology have dramatically increased our understanding of the pathophysiology of DBA. DBA has been shown to be the consequence of an intrinsic progenitor cell defect and in the majority of cases the consequence of abnormal ribosome assembly/function. At least nine and likely more RP genes as well as the transcription regulator GATA1 have been implicated. Careful clinical investigation has defined the syndrome, and the study of the cellular biology of the disorder has borrowed from and contributed to the understanding of the mechanism of hematopoietic progenitor cell differentiation. Using the DBAR and other international databases, important epidemiologic, clinical, and laboratory observations have been made with regard to the clinical presentation and inheritance of DBA. These databases have yielded other important observations on the genetics of congenital malformations in DBA, the therapeutic outcomes including the efficacy of HSCT, and the recognition of DBA as a cancer-predisposing syndrome. In particular, they have provided the essential substrate of well-characterized patients and multiplex families necessary for gene discovery. Robust gene discovery will no doubt permit the molecular classification of all cases of DBA.

Dr. Louis Diamond, whose career spanned over 60 years and who had been a teacher to many and an inspiration to the rest,⁴²⁵ would be pleased to know that from his description of an esoteric little disease has arisen fundamental new knowledge that has allowed extraordinary insights into the regulation of hematopoiesis and morphogenesis and the mechanisms of oncogenesis.

Acknowledgments

The authors acknowledge the contributions of Dr. Emmanuel Dessypris, whose excellent work on previous editions of this chapter served as the template for the current version.

REFERENCES

1. Dessypris EN. Pure red cell aplasia. Baltimore, MD: Johns Hopkins University Press, 1988:1-156.
2. Freedman MH, Amato D, Saunders EF. Erythroid colony growth in congenital hypoplastic anemia. *J Clin Invest* 1976;57(3):673-677.
3. Krantz SB. Pure red-cell aplasia. *N Engl J Med* 1974;291(7):345-350.
4. Kaznelson P, Zur entstehung der blutplättchen. *Verh Dtsch Ges Inn Med* 1922;34:557-558.
5. Bhargava R, Dolai TK, Singhal D, et al. Pure red cell aplasia associated with thymoma: is thymectomy the cure? *Leuk Res* 2009;33(3):e17-e18.
6. Fujii K, Kanno R, Shio Y, et al. Triad of thymoma, myasthenia gravis and pure red cell aplasia combined with Sjögren's syndrome. *Jpn J Thorac Cardiovasc Surg* 2004;52(7):345-348.
7. Jain D, Varma N, Vaiphei K, et al. Pure red cell aplasia with malignant thymoma: a rarity. *Indian J Pathol Microbiol* 2006;49(4):553-554.
8. Chikkappa G, Zarrabi MH, Tsuan MF. Pure red cell aplasia in patients with chronic lymphocytic leukemia. *Medicine (Baltimore)* 1986;65:339-351.

9. Tanna S, Ustun C. Immunosuppressive treatment in patient with pure red cell aplasia associated with chronic myelomonocytic leukemia: harm or benefit? *Int J Hematol* 2009;90(5):597-600.
10. D'Arena G, Cascavilla N. Chronic lymphocytic leukemia-associated pure red cell aplasia. *Int J Immunopathol Pharmacol* 2009;22(2):279-286.
11. Hoffman R, Kopel S, Hsu SD, et al. T cell chronic lymphocytic leukemia: presence in bone marrow and peripheral blood of cells that suppress erythropoiesis in vitro. *Blood* 1978;52(1):255-260.
12. Morgan E, Pang KM, Goldwasser E. Hodgkin disease and red cell aplasia. *Am J Hematol* 1978;5(1):71-75.
13. Vlachaki E, Diamantidis MD, Klonizakis P, et al. Pure red cell aplasia and lymphoproliferative disorders: an infrequent association. *SciWorld J* 2012;2012:475313.
14. Hirokawa M, Sawada K, Fujishima N, et al. Acquired pure red cell aplasia associated with malignant lymphomas: a nationwide cohort study in Japan for the PRCA Collaborative Study Group. *Am J Hematol* 2009;84(3):144-148.
15. Anastasiadis A, Margaritis D, Kotsianidis I, et al. Pure red cell aplasia as first manifestation of splenic marginal zone lymphoma-successful treatment with rituximab: a case report. *Cases J* 2009;2:6913.
16. Tsujimura H, Sakai C, Takagi T. Pure red cell aplasia complicated by angioimmunoblastic T-cell lymphoma: humoral factor plays a main role in the inhibition of erythropoiesis from CD34(+) progenitor cells. *Am J Hematol* 1999;62(4):259-260.
17. Al Hilali M, Joyner MV. Pure red-cell aplasia secondary to angioimmunoblastic lymphadenopathy. *J R Soc Med* 1983;76(10):894-895.
18. Alberti E, Aldovini D, Mazzon C, et al. Angioimmunoblastic lymphadenopathy with dysproteinemia. Report of a case with pure red cell aplasia. *Haematologica* 1982;67(6):919-925.
19. Choi JH, Oh YH, Park IK. A case of pure red cell aplasia associated with angioimmunoblastic T-cell lymphoma. *Cancer Res Treat* 2010;42(2):115-117.
20. Lynch JW, Eifenbein GJ, Noyes WD, et al. Pure red cell aplasia associated with angioimmunoblastic lymphadenopathy with dysproteinemia. *Am J Hematol* 1994;46(2):72-78.
21. Orchard J, Myint H, Hamblin TJ. A patient with myeloma who still has pure red cell aplasia despite the most intensive immune modulation. *Leuk Res* 1997;21(4):353-354.
22. Gilbert EF, Harley JB, Anido V, et al. Thymoma, plasma cell myeloma, red cell aplasia and malabsorption syndrome. *Am J Med* 1968;44(5):820-829.
23. Masauzi N, Tanaka J, Watanabe M, et al. Primary Waldenström's macroglobulinemia associated with pure red cell aplasia in which Ts/c lymphocytes inhibiting erythroid precursors were detected. *Rinsho Ketsueki* 1993;34(3):355-361.
24. Dessypris EN, McKee CL Jr, Metzantonakis C, et al. Red cell aplasia and chronic granulocytic leukaemia. *Br J Haematol* 1981;48(2):217-225.
25. Hirri HM, Green PJ. Pure red cell aplasia in a patient with chronic granulocytic leukaemia treated with interferon-alpha. *Clin Lab Haematol* 2000;22(1):53-54.
26. Barosi G, Baraldi A, Cazzola M, et al. Red cell aplasia in myelofibrosis with myeloid metaplasia. A distinct functional and clinical entity. *Cancer* 1983;52(7):1290-1296.
27. Howarth JE, Waters HM, Geary CG. Red cell aplasia in myelofibrosis. *Br J Haematol* 1989;72(1):114.
28. Sarode R, Bamberg P, Marwaha N, et al. Pure red cell aplasia associated with essential thrombocythemia (a case report). *Indian J Cancer* 1990;27(3): 138-142.
29. Brafield AJ, Verbov J. A case of thrombocythaemia with red cell aplasia. *Postgrad Med J* 1966;42(490):525-526.
30. Zhang M, Hu S, Ashwani N, et al. Pediatric T-cell acute lymphoblastic leukemia with transient pure red cell aplasia. *Pediatr Blood Cancer* 2012;58(6): 1002-1003.
31. Nishioka R, Nakajima S, Morimoto Y, et al. T-cell acute lymphoblastic leukemia with transient pure red cell aplasia associated with myasthenia gravis and invasive thymoma. *Intern Med* 1995;34(2):127-130.
32. Imamura N, Kuramoto A, Morimoto T, et al. Pure red cell aplasia associated with acute lymphoblastic leukaemia of pre-T-cell origin. *Med J Aust* 1986;144(13):724.

33. Tanaka H, Iwato K, Asou H, et al. Pure red cell aplasia associated with imatinib-treated FIP1L1-PDGFR α positive chronic eosinophilic leukemia. *Intern Med* 2010;49(12):1195-200.
34. Gajwani B, Zinner EN. Pure red-cell aplasia. Associated with adenocarcinoma of stomach. *N Y State J Med* 1976;76(13):2177-2179.
35. Harris SJ, Seah JA, Barnett F, et al. Inflammatory breast cancer and secondary pure red cell aplasia. *Acta Oncol* 2011;50(5):727-728.
36. Lee CH, Clark AR, Thorpe ME, et al. Bile duct adenocarcinoma with Leser-Trelat sign and pure red blood cell aplasia. *Cancer* 1980;46(7):1657-1660.
37. Tauchi T, Iwama H, Kaku H, et al. Remission of pure-red-cell aplasia associated with operative cure of lung cancer. *Am J Hematol* 1999;61(2):157-158.
38. Gordon IO, Wade T, Chin K, et al. Immune-mediated red cell aplasia after anti-CTLA-4 immunotherapy for metastatic melanoma. *Cancer Immunol Immunother* 2009;58(8):1351-1353.
39. Carneiro BA, Watkin WG, Mehta UK, et al. Metastatic basal cell carcinoma: complete response to chemotherapy and associated pure red cell aplasia. *Cancer Invest* 2006;24(4):396-400.
40. Iannucci A, Perini A, Pizzolo G. Acquired pure red cell aplasia associated with thyroid carcinoma: case report. *Acta Haematol* 1983;69(1):62-63.
41. Fong PH, Wee A, Chan HL, et al. Primary thymic carcinoma and its association with dermatomyositis and pure red cell aplasia. *Int J Dermatol* 1992;31(6): 426-428.
42. Maekawa K, Shibata J, Nakagawa S, et al. Pure red cell aplasia associated with renal cell carcinoma. *Nihon Naika Gakkai Zasshi* 1989;78(7): 1002-1003.
43. Ketata W, Fouzi S, Msaad S, et al. Thymoma associated with pure red cell aplasia and Kaposi's sarcoma. *Rev Mal Respir* 2009;26(1):78-82.
44. Shimm DS, Logue GL, Rohlfs MB, et al. Primary amyloidosis, pure red cell aplasia, and Kaposi's sarcoma in a single patient. *Cancer* 1979;44(4): 1501-1503.
45. Kurtzman G, Frickhofen N, Kimball J, et al. Pure red-cell aplasia of 10 years' duration due to persistent parvovirus B19 infection and its cure with immunoglobulin therapy. *N Engl J Med* 1989;321(8):519-523.
46. Frickhofen N, Chen ZJ, Young NS, et al. Parvovirus B19 as a cause of acquired chronic pure red cell aplasia. *Br J Haematol* 1994;87(4):818-824.

P.988

47. Abkowitz JL, Brown KE, Wood RW, et al. Clinical relevance of parvovirus B19 as a cause of anemia in patients with human immunodeficiency virus infection. *J Infect Dis* 1997;176(1):269-273.
48. Kaneko H, Shimura K, Nishida K, et al. Pure red cell aplasia caused by parvovirus B19 in two patients without chronic hemolysis. *J Infect Chemother* 2011;17(2):268-271.
49. Young N. Hematologic and hematopoietic consequences of B19 parvovirus infection. *Semin Hematol* 1988;25:159-172.
50. Frickhofen N, Young NS. Persistent parvovirus B19 infections in humans. *Microb Pathog* 1989;7(5):319-327.
51. Gottlieb F, Deutsch J. Red cell aplasia responsive to immunoglobulin therapy as initial manifestation of human immunodeficiency virus infection. *Am J Med* 1992;92(3):331-333.
52. Hisano S, Morioka E, Murakami G, et al. Adult T-cell leukemia associated with pure red cell aplasia-like lesion. *Rinsho Ketsueki* 1990;31(11):1831-1835.
53. Purtilo DT, Zelkowitz L, Harada S, et al. Delayed onset of infectious mononucleosis associated with acquired agammaglobulinemia and red cell aplasia. *Ann Intern Med* 1984;101(2):180-186.
54. Bruyn GA, Schelfhout LJ. Transient syndrome of inappropriate antidiuretic hormone secretion in a patient with infectious mononucleosis and pure red cell aplasia. *Neth J Med* 1986;29(5):167-169.

55. Li C, Wang HF. Hepatitis E virus-related acute liver failure associated with pure red cell aplasia. *Hepatobiliary Pancreat Dis Int* 2011;10(5):557-558.
56. Aterini S, Fusco I, Amato M. Pure red-cell aplasia in a peritoneal dialysis patient with HCV-related cryoglobulinemia in the absence of neutralizing antierythropoietin antibodies. *J Nephrol* 2004;17(5):744-746.
57. Lee TH, Oh SJ, Hong S, et al. Pure red cell aplasia caused by acute hepatitis A. *Chonnam Med J* 2011;47(1):51-53.
58. Ohno Y, Itakura A, Sano M, et al. Pure red cell aplasia and acute hepatitis during pregnancy. *Gynecol Obstet Invest* 2002;53(2):112-113.
59. Yoon YK, Park DW, Sohn JW, et al. Corticosteroid treatment of pure red cell aplasia in a patient with hepatitis A. *Acta Haematol* 2012;128(1):60-63.
60. Kumar V, Gupta S, Singh S, et al. Pure red cell aplasia associated with cytomegalovirus infection. *J Pediatr Hematol Oncol* 2010;32(4):315-316.
61. Sinha AK, Agarwal A, Lakhey M, et al. Pure red cell aplasia—report of 11 cases from eastern Nepal. *Indian J Pathol Microbiol* 2003;46(3):405-408.
62. Ozkaynak MF, Ortega JA, Miller J. Concurrence of transient asplenia and pure red cell aplasia. *Eur J Pediatr* 1990;149(8):542-544.
63. Mewawalla P, Bauer F, Dasanu CA. Lemierre syndrome caused by group C streptococci and associated with red cell aplasia and immune thrombocytopenia. *South Med J* 2011;104(3):244-246.
64. Solano C, Gomez-Reino F, Fernandez-Ranada JM. Pure red cell aplasia in kala-azar. *Acta Haematol* 1984;72(3):205-207.
65. Figueiredo S, Pio D, Martins M, et al. Transient pure red blood cell aplasia as clinical presentation of congenital hemolytic anemia: a case report. *Cases J* 2009;2:6814.
66. Scaramucci L, Niscola P, Ales M, et al. Pure red cell aplasia associated with hemolytic anemia refractory to standard measures and resolved by rituximab in an elderly patient. *Int J Hematol* 2008;88(3):343-344.
67. Arcasoy MO, Chao NJ. T-cell-mediated pure red-cell aplasia in systemic lupus erythematosus: response to cyclosporin A and mycophenolate mofetil. *Am J Hematol* 2005;78(2):161-163.
68. Gupta RK, Ezeonyeji AN, Thomas AS, et al. A case of pure red cell aplasia and immune thrombocytopenia complicating systemic lupus erythematosus: response to rituximab and cyclophosphamide. *Lupus* 2011;20(14):1547-1550.
69. Chan AY, Li EK, Tam LS, et al. Successful treatment of pure red cell aplasia associated with systemic lupus erythematosus with oral danazol and steroid. *Rheumatol Int* 2005;25(5):388-390.
70. Iwadate H, Kobayashi H, Shio K, et al. A case of systemic lupus erythematosus complicated by pure red cell aplasia and idiopathic portal hypertension after thymectomy. *Mod Rheumatol* 2006;16(2):109-112.
71. Orbach H, Ben-Yehuda A, Ben-Yehuda D, et al. Successful treatment of pure red cell aplasia in systemic lupus erythematosus with erythropoietin. *J Rheumatol* 1995;22(11):2166-2169.
72. Banavali SD, Parikh PM, Charak BS, et al. Corticosteroid-responsive pure red cell aplasia in rheumatoid arthritis and its association with pregnancy: a case report. *Am J Hematol* 1989;31(1):58-61.
73. Julkunen H, Jantti J, Pettersson T. Pure red cell aplasia in mixed connective tissue disease. *J Rheumatol* 1989;16(10):1385-1386.
74. Myers TJ, Bower BF, Hild DH. Pure red cell aplasia and the syndrome of multiple endocrine gland insufficiency. *Am J Med Sci* 1980;280(1):29-34.
75. Meyer RJ, Hoffman R, Zanjani ED. Autoimmune hemolytic anemia and periodic pure red cell aplasia in systemic lupus erythematosus. *Am J Med* 1978;65(2):342-345.
76. Mangan KF, Besa EC, Shaddock RK, et al. Demonstration of two distinct antibodies in autoimmune hemolytic anemia with reticulocytopenia and red cell aplasia. *Exp Hematol* 1984;12(10):788-793.
77. Taniguchi S, Shibuya T, Morioka E, et al. Demonstration of three distinct immunological disorders on erythropoiesis in a patient with pure red cell aplasia and autoimmune haemolytic anaemia associated with thymoma. *Br J Haematol* 1988;68(4):473-477.

78. Fox RM, Firkin FC. Sequential pure red cell and megakaryocyte aplasia associated with chronic liver disease and ulcerative colitis. *Am J Hematol* 1978;4(1):79-85.
79. Trinchet JC, Lacombe C, Islam S, et al. Association of autoimmune chronic active hepatitis and acquired erythroblastopenia cured by cyclophosphamide. *Gastroenterol Clin Biol* 1986;10(12):841-844.
80. Kawano Y, Katayama Y, Okamura A, et al. Pure red cell aplasia with primary sclerosing cholangitis. *Int J Hematol* 2008;88(5):599-601.
81. Aggio MC, Zunini C. Reversible pure red-cell aplasia in pregnancy. *N Engl J Med* 1977;297(4):221-222.
82. Majer RV, Green PJ. Recurrent reversible pure red cell aplasia in pregnancy. *Clin Lab Haematol* 1988;10(1):101-103.
83. Bamberg P, Varma N, Varma S, et al. Prolonged, pregnancy-related pure red cell aplasia; a case report. *Eur J Obstet Gynecol Reprod Biol* 1991;42(3):233-235.
84. Baker RI, Manoharan A, de Luca E, et al. Pure red cell aplasia of pregnancy: a distinct clinical entity. *Br J Haematol* 1993;85(3):619-622.
85. Miller AC, Rashid RM. Three episodes of acquired pure red cell aplasia restricted to pregnancy. *J Perinat Med* 2008;36(3):270-271.
86. Kashyap R, Pradhan M. Maternal and fetal outcome in pregnancy-associated pure red cell aplasia. *J Obstet Gynaecol* 2010;30(7):733-734.
87. Saeki A, Kaito K, Kobayashi M, et al. Pure red cell aplasia complicated with polyarthritis, angitis, and acute renal failure. *Rinsho Ketsueki* 1993;34(11):1480-1485.
88. Foy H, Kondi A, Macdougall L. Pure red-cell aplasia in marasmus and kwashiorkor treated with riboflavine. *Br Med J* 1961;1(5230):937-941.
89. Dan K, Ito T, Nomura T. Pure red cell aplasia following pernicious anemia. *Am J Hematol* 1990;33(2):148-150.
90. Alfrey CP, Lane M. The effect of riboflavin deficiency on erythropoiesis. *Semin Hematol* 1970;7(1):49-54.
91. Chanarin I. Investigation and management of megaloblastic anaemia. *Clin Haematol* 1976;5:747-763.
92. Agrawal A, Parrott NR, Riad HN, et al. Azathioprine-induced pure red cell aplasia: case report and review. *Transplant Proc* 2004;36(9):2689-2691.
93. Fujisawa S, Maruta A, Sakai R, et al. Pure red cell aplasia after major ABO-incompatible bone marrow transplantation: two case reports of treatment with recombinant human erythropoietin. *Transpl Int* 1996;9(5): 506-508.
94. Mueller RJ, Stussi G, Odermatt B, et al. Major ABO-incompatible hematopoietic stem cell transplantation: study of post-transplant pure red cell aplasia and endothelial cell chimerism. *Xenotransplantation* 2006;13(2):126-132.
95. Helbig G, Stella-Holowiecka B, Wojnar J, et al. Pure red-cell aplasia following major and bi-directional ABO-incompatible allogeneic stem-cell transplantation: recovery of donor-derived erythropoiesis after long-term treatment using different therapeutic strategies. *Ann Hematol* 2007;86(9):677-683.
96. Sora F, De Matteis S, Piccirillo N, et al. Rituximab for pure red cell aplasia after ABO-mismatched allogeneic peripheral blood progenitor cell transplantation. *Transfusion* 2005;45(4):643-645.
97. Funabiki K, Kaneko S, Terajima M, et al. A case of multicentric Castleman's disease associated with renal amyloidosis and pure red cell aplasia. *Am J Nephrol* 1998;18(3):247-250.
98. Hattori K, Irie S, Isobe Y, et al. Multicentric Castleman's disease associated with renal amyloidosis and pure red cell aplasia. *Ann Hematol* 1998;77(4):179-181.
99. Casadevall N, Nataf J, Viron B. Pure red-cell aplasia and antierythropoietin antibodies in patients treated with recombinant erythropoietin. *N Engl J Med* 2002;346:469-475.
100. Macdougall IC. Epoetin-induced pure red cell aplasia: diagnosis and treatment. *Curr Opin Nephrol Hypertens* 2007;16(6):585-588.
101. Jepson JH, Lowenstein L. Inhibition of erythropoiesis by a factor present in the plasma of patients with erythroblastopenia. *Blood* 1966;27(4):425-434.
102. Zalusky R, Zanjani ED, Gidari AS, et al. Site of action of a serum inhibitor of erythropoiesis. *J Lab Clin Med* 1973;81(6):867-875.

103. Krantz SB, Kao V. Studies on red cell aplasia. II. Report of a second patient with an antibody to erythroblast nuclei and a remission after immunosuppressive therapy. *Blood* 1969;34(1):1-13.
104. Krantz SB, Kao V. Studies on red cell aplasia. I. Demonstration of a plasma inhibitor to heme synthesis and an antibody to erythroblast nuclei. *Proc Natl Acad Sci U S A* 1967;58(2):493-500.
105. Means RT, Dessypris EN, Krantz SB. Treatment of refractory pure red cell aplasia with cyclosporine A: in vitro correlation of clinical response. *Br J Haematol* 1991;78:114-119.
106. Lacombe C, Casadevall N, Muller O, et al. Erythroid progenitors in adult chronic pure red cell aplasia: relationship of in vitro erythroid colonies to therapeutic response. *Blood* 1984;64(1):71-77.
107. Katz LJ, Hoffman R, Ritchey AK, et al. The proliferative capacity of pure red cell aplasia bone marrow cells. *Yale J Biol Med* 1981;54(2):89-94.
108. Charles RJ, Sabo KM, Kidd PG, et al. The pathophysiology of pure red cell aplasia: implications for therapy. *Blood* 1996;87(11):4831-4838.
109. Dessypris EN, Krantz SB, Roloff JS, et al. Mode of action of the IgG inhibitor of erythropoiesis in transient erythroblastopenia of childhood. *Blood* 1982;59: 114-123.
110. Krantz SB, Moore WH, Zaentz SD. Studies on red cell aplasia. V. Presence of erythroblast cytotoxicity in G-globulin fraction of plasma. *J Clin Invest* 1973;52(2):324-336.
111. Zaentz SD, Luna JA, Baker AS, et al. Detection of cytotoxic antibody to erythroblasts. *J Lab Clin Med* 1977;89:851-860.
112. Peschle C, Marmont AM, Marone G, et al. Pure red cell aplasia: studies on an IgG serum inhibitor neutralizing erythropoietin. *Br J Haematol* 1975;30(4):411-417.
113. Jepson JH, Lowenstein L. Panhypoplasia of the bone marrow. I. Demonstration of a plasma factor with anti-erythropoietin-like activity. *Can Med Assoc J* 1968;99(3):99-101.
114. Hara T, Mizuno Y, Nagata M, et al. Human gamma delta T-cell receptor-positive cell-mediated inhibition of erythropoiesis in vitro in a patient with type I autoimmune polyglandular syndrome and pure red blood cell aplasia. *Blood* 1990;75(4):941-950.
115. Mangan KF. T-cell-mediated suppression of hematopoiesis. *N Engl J Med* 1985;312(5):306-307.
116. Mangan KF, Chikkappa G, Farley PC. T gamma (T gamma) cells suppress growth of erythroid colony-forming units in vitro in the pure red cell aplasia of B-cell chronic lymphocytic leukemia. *J Clin Invest* 1982;70(6):1148-1156.
117. Mangan KF, Chikkappa G, Scharfman WB, et al. Evidence for reduced erythroid burst (BFUE) promoting function of T lymphocytes in the pure red cell aplasia of chronic lymphocytic leukemia. *Exp Hematol* 1981;9(5): 489-498.
118. Masuda M, Arai Y, Okamura T, et al. Pure red cell aplasia with thymoma: evidence of T-cell clonal disorder. *Am J Hematol* 1997;54(4):324-328.
119. Masuda M, Teramura M, Matsuda A, et al. Clonal T cells of pure red-cell aplasia. *Am J Hematol* 2005;79(4):332-333.
120. Soler J, Estivill X, Ayats R, et al. Chronic T-cell lymphocytosis associated with pure red cell aplasia, thymoma and hypogammaglobulinemia. *Br J Haematol* 1985;61(3):582-584.
121. Abkowitz JL, Kadin ME, Powell JS, et al. Pure red cell aplasia: lymphocyte inhibition of erythropoiesis. *Br J Haematol* 1986;63(1):59-67.
122. Wranne L. Transient erythroblastopenia in infancy and childhood. *Scand J Haematol* 1970;7(2):76-81.
123. Glader BE. Transient erythroblastopenia of childhood. *West J Med* 1988;149(4):453-454.
124. Dessypris EN, Krantz SB, Roloff JS, et al. Mode of action of the IgG inhibitor of erythropoiesis in transient erythroblastopenia of children. *Blood* 1982;59(1): 114-123.
125. Koenig HM, Lightsey AL, Nelson DP, et al. Immune suppression of erythropoiesis in transient erythroblastopenia of childhood. *Blood* 1979;54(3):742-746.
126. Dessypris EN, Fogo A, Russell M, et al. Studies on pure red cell aplasia. X. Association with acute leukemia and significance of bone marrow karyotype abnormalities. *Blood* 1980;56(3):421-426.
127. Pattison JR, Jones SE, Hodgson J, et al. Parvovirus infections and hypoplastic crisis in sickle-cell anaemia. *Lancet* 1981;1(8221):664-665.

128. Anderson MJ, Davis LR, Hodgson J, et al. Occurrence of infection with a parvovirus-like agent in children with sickle cell anaemia during a two-year period. *J Clin Pathol* 1982;35(7):744-749.
129. Serjeant GR, Topley JM, Mason K, et al. Outbreak of aplastic crises in sickle cell anaemia associated with parvovirus-like agent. *Lancet* 1981;2(8247):595-597.
130. Duncan JR, Potter CB, Cappellini MD, et al. Aplastic crisis due to parvovirus infection in pyruvate kinase deficiency. *Lancet* 1983;2(8340):14-16.
131. Kelleher JF Jr, Luban NL, Cohen BJ, et al. Human serum parvovirus as the cause of aplastic crisis in sickle cell disease. *Am J Dis Child* 1984;138(4): 401-403.
132. Frickhofen N, Arnold R, Hertenstein B, et al. Parvovirus B19 infection and bone marrow transplantation. *Ann Hematol* 1992;64(Suppl):A121- A124.
133. Soutar RL, Birnie DH, Bennett B. Parvovirus B19 induced red cell aplasia in myelofibrosis. *Br J Haematol* 1993;85(3):623-624.
134. Plentz A, Hahn J, Holler E, et al. Long-term parvovirus B19 viraemia associated with pure red cell aplasia after allogeneic bone marrow transplantation. *J Clin Virol* 2004;31(1):16-19.
135. Hayes-Lattin B, Seipel TJ, Gatter K, et al. Pure red cell aplasia associated with parvovirus B19 infection occurring late after allogeneic bone marrow transplantation. *Am J Hematol* 2004;75(3):142-145.
136. Garewal G, Ahluwalia J, Varma N, et al. Parvovirus B19 infection-associated red-cell aplasia in renal-transplant recipients: clues from the bone marrow. *Transplantation* 2004;77(2):320-321.
137. Helbig G, Stella-Holowiecka B, Krawczyk-Kulis M, et al. Successful treatment of pure red cell aplasia with repeated, low doses of rituximab in two patients after ABO-incompatible allogeneic haematopoietic stem cell transplantation for acute myeloid leukaemia. *Haematologica* 2005;90(Suppl): ECR33.
138. Vales-Albertos LJ, Garcia-Cardenas M, Chavez-Becerra S, et al. Pure red cell aplasia associated with parvovirus B19 infection in renal transplantation: the first case report in Mexico. *Transplantation* 2005;79(6):739.
139. Pitchaipillai S, Kelsey P, Haeney M. Persistent pure red cell aplasia due to parvovirus B19 infection in a patient with Turner's syndrome. *Clin Lab Haematol* 2006;28(5):347-350.
140. Intalapaporn P, Poovorawan Y, Suankratay C. Immune reconstitution syndrome associated with parvovirus B19-induced pure red cell aplasia during highly active antiretroviral therapy. *J Infect* 2006;53(2):e79-e82.
141. Poplar S, Allford S, Rooney N. Chronic parvovirus B19 infection leading to red cell aplasia following treatment of Hodgkin lymphoma. *Br J Haematol* 2010;148(5):671.
142. Young N, Harrison M, Moore J, et al. Direct demonstration of the human parvovirus in erythroid progenitor cells infected in vitro. *J Clin Invest* 1984;74(6):2024-2032.
143. Brown KE, Anderson SM, Young NS. Erythrocyte P antigen: cellular receptor for B19 parvovirus. *Science* 1993;262(5130):114-117.
144. Brown KE, Hibbs JR, Gallinella G, et al. Resistance to parvovirus B19 infection due to lack of virus receptor (erythrocyte P antigen). *N Engl J Med* 1994;330(17):1192-1196.
145. Yaegashi N, Niinuma T, Chisaka H, et al. Parvovirus B19 infection induces apoptosis of erythroid cells in vitro and in vivo. *J Infect* 1999;39(1):68-76.
146. Morita E, Nakashima A, Asao H, et al. Human parvovirus B19 nonstructural protein (NS1) induces cell cycle arrest at G(1) phase. *J Virol* 2003;77(5): 2915-2921.
147. Sol N, Le Junter J, Vassias I, et al. Possible interactions between the NS-1 protein and tumor necrosis factor alpha pathways in erythroid cell apoptosis induced by human parvovirus B19. *J Virol* 1999;73(10):8762-8770.
148. Pillet S, Le GN, Hofer T, et al. Hypoxia enhances human B19 erythrovirus gene expression in primary erythroid cells. *Virology* 2004;327(1):1-7.
149. Casadevall N, Dupuy E, Molho-Sabatier P, et al. Brief report: autoantibodies against erythropoietin in a patient with pure red-cell aplasia. *N Engl J Med* 1996;334(10):630-633.

150. Prabhakar SS, Muhlfelder T. Antibodies to recombinant human erythropoietin causing pure red cell aplasia. *Clin Nephrol* 1997;47(5):331-335.
151. Gershon SK, Luksenburg H, Cote TR, et al. Pure red-cell aplasia and recombinant erythropoietin. *N Engl J Med* 2002;346(20):1584-1586.
152. Nigg L, Schanz U, Ambuhl PM, et al. Prolonged course of pure red cell aplasia after erythropoietin therapy. *Eur J Haematol* 2004;73(5):376-379.
153. Panchapakesan U, Austin SK, Shafransky A, et al. Recovery of pure red-cell aplasia secondary to antierythropoietin antibodies after cessation of recombinant human erythropoietin. *Intern Med J* 2003;33(9-10):468-471.
154. Quint L, Casadevall N, Giraudier S, Pure red cell aplasia in patients with refractory anaemia treated with two different recombinant erythropoietins. *Br J Haematol* 2004;124(6):842.
155. Snanoudj R, Beaudreuil S, Arzouk N, et al. Recovery from pure red cell aplasia caused by anti-erythropoietin antibodies after kidney transplantation. *Am J Transplant* 2004;4(2):274-277.
156. Vergeist D, Rossert J, Casadevall N, et al. Treatment of erythropoietin-induced pure red cell aplasia: a retrospective study. *Lancet* 2004;363:1768-1771.
157. Boven K, Knight J, Bader F, et al. Epoetin-associated pure red cell aplasia in patients with chronic kidney disease: solving the mystery. *Nephrol Dial Transplant* 2005;20(Suppl 3):iii33- iii40.
158. Bennett CL, Cournoyer D, Carson KR, et al. Long-term outcome of individuals with pure red cell aplasia and antierythropoietin antibodies in patients treated with recombinant epoetin: a follow-up report from the Research on Adverse Drug Events and Reports (RADAR) Project. *Blood* 2005;106(10):3343-3347.
159. Bennett CL, Luminari S, Nissenson AR, et al. Pure red-cell aplasia and epoetin therapy. *N Engl J Med* 2004;351(14):1403-1408.
160. Berliner N, Rose MG. The incidence and characteristics of recombinant erythropoietin-associated pure red-cell aplasia. *Curr Hematol Rep* 2005;4(2):93-94.
161. Casadevall N, Cournoyer D, Marsh J, et al. Recommendations on haematological criteria for the diagnosis of epoetin-induced pure red cell aplasia. *Eur J Haematol* 2004;73(6):389-396.
162. Collins AJ, Li S, Adamson JW, et al. Assessment of pure red cell aplasia in US dialysis patients: the limits of the Medicare data. *Am J Kidney Dis* 2004;43(3):464-470.
163. D'Arena G, Vigliotti ML, Dell'Olio M, et al. Rituximab to treat chronic lymphoproliferative disorder-associated pure red cell aplasia. *Eur J Haematol* 2009;82(3):235-239.
164. Evens AM, Bennett CL, Luminari S. Epoetin-induced pure red-cell aplasia (PRCA): preliminary results from the Research on Adverse Drug Events and Reports (RADAR) group. *Best Pract Res Clin Haematol* 2005;18(3):481-489.
165. Macdougall IC. Pure red cell aplasia with anti-erythropoietin antibodies occurs more commonly with one formulation of epoetin alfa than another. *Curr Med Res Opin* 2004;20(1):83-86.
166. Boven K, Stryker S, Knight J, et al. The increased incidence of pure red cell aplasia with an Eprex formulation in uncoated rubber stopper syringes. *Kidney Int* 2005;67(6):2346-2353.
167. Locatelli F, Aljama P, Barany P, et al. Erythropoiesis-stimulating agents and antibody-mediated pure red-cell aplasia: where are we now and where do we go from here? *Nephrol Dial Transplant* 2004;19(2):288-293.
168. Schellekens H. Immunologic mechanisms of EPO-associated pure red cell aplasia. *Best Pract Res Clin Haematol* 2005;18(3):473-480.
169. Schellekens H. Erythropoietic proteins and antibody-mediated pure red cell aplasia: a potential role for micelles. *Nephrol Dial Transplant* 2004;19(9):2422.
170. Schellekens H, Jiskoot W. Eprex-associated pure red cell aplasia and leachates. *Nat Biotechnol* 2006;24(6):613-614.
171. Delluc S, Ravot G, Maillere B. Quantification of the preexisting CD4 T-cell repertoire specific for human erythropoietin reveals its immunogenicity potential. *Blood* 2010;116(22):4542-4545.
172. Macdougall IC. Antibody-mediated pure red cell aplasia (PRCA): epidemiology, immunogenicity and risks. *Nephrol Dial Transplant* 2005;20(Suppl 4):iv9- iv15.

173. Praditpornsilpa K, Kupatawintu P, Mongkonsritagoon W, et al. The association of anti-r-HuEpo-associated pure red cell aplasia with HLA-DRB1*09-DQB1*0309. *Nephrol Dial Transplant* 2009;24(5):1545-1549.
174. Praditpornsilpa K, Tiranathanagul K, Kupatawintu P, et al. Biosimilar recombinant human erythropoietin induces the production of neutralizing antibodies. *Kidney Int* 2011;80(1):88-92.
175. al-Mondhiry H, Zanjani ED, Spivack M, et al. Pure red cell aplasia and thymoma: loss of serum inhibitor of erythropoiesis following thymectomy. *Blood* 1971;38(5):576-582.
176. Hirst E, Roberstson TI. The syndrome of thymoma and erythroblastopenic anemia: a review of 56 cases including 3 cases reports. *Medicine (Baltimore)* 1967;46:225.
177. Parry EH, Kilpatrick GS, Hardisty RM. Red-cell aplasia and benign thymoma; studies on a case responding to prednisone. *Br Med J* 1959;1(5130): 1154-1156.
178. Hirokawa M, Sawada K, Fujishima N, et al. Long-term response and outcome following immunosuppressive therapy in thymoma-associated pure red cell aplasia: a nationwide cohort study in Japan by the PRCA collaborative study group. *Haematologica* 2008;93(1):27-33.
179. Thompson CA. Pure red cell aplasia and thymoma. *J Thorac Oncol* 2007;2(4):263-264.
180. Srinivas U, Mahapatra M, Saxena R, et al. Thirty-nine cases of pure red cell aplasia: a single center experience from India. *Hematology* 2007;12(3): 245-248.
181. Mangan KF, Volkin R, Winkelstein A. Autoreactive erythroid progenitor-T suppressor cells in the pure red cell aplasia associated with thymoma and panhypogammaglobulinemia. *Am J Hematol* 1986;23(2):167-173.
182. Fujishima N, Hirokawa M, Fujishima M, et al. Oligoclonal T cell expansion in blood but not in the thymus from a patient with thymoma-associated pure red cell aplasia. *Haematologica* 2006;91(12 Suppl):ECR47.
183. Fujishima N, Sawada K, Hirokawa M, et al. Long-term responses and outcomes following immunosuppressive therapy in large granular lymphocyte leukemia-associated pure red cell aplasia: a Nationwide Cohort Study in Japan for the PRCA Collaborative Study Group. *Haematologica* 2008;93(10):1555-1559.
184. Lipton JM, Nadler LM, Canellos GP, et al. Evidence for genetic restriction in the suppression of erythropoiesis by a unique subset of T lymphocytes in man. *J Clin Invest* 1983;72(2):694-706.
185. Nagasawa T, Abe T, Nakagawa T. Pure red cell aplasia and hypogammaglobulinemia associated with Tr-cell chronic lymphocytic leukemia. *Blood* 1981;57(6):1025-1031.
186. Handgretinger R, Geiselhart A, Moris A, et al. Pure red-cell aplasia associated with clonal expansion of granular lymphocytes expressing killer-cell inhibitory receptors. *N Engl J Med* 1999;340(4):278-284.
187. Casado LF, Granados E, Algara P, et al. High expression of the ILT2 (LIR-1) inhibitory receptor for major histocompatibility complex class I molecules on clonal expansions of T large granular lymphocytes in asymptomatic patients. *Haematologica* 2001;86(5):457-463.
188. Nitta H, Mihara K, Sakai A, et al. Expansion of CD8+/perforin+ effector memory T cells in the bone marrow of patients with thymoma-associated pure red cell aplasia. *Br J Haematol* 2010;150(6):712-715.
189. Assimakopoulos SF, Michalopoulou S, Melachrinou M, et al. Primary Sjögren syndrome complicated by autoimmune hemolytic anemia and pure red cell aplasia. *Am J Med Sci* 2007;334(6):493-496.
190. Franzen P, Friman C, Pettersson T, et al. Combined pure red cell aplasia and primary autoimmune hypothyroidism in systemic lupus erythematosus. *Arthritis Rheum* 1987;30(7):839-840.
191. Francis DA. Pure red-cell aplasia: association with systemic lupus erythematosus and primary autoimmune hypothyroidism. *Br Med J (Clin Res Ed)* 1982;284(6309):85.
192. Balasubramanian S, Kaarthigeyan K, Rajkumar J, et al. Pyoderma gangrenosum with pure red cell aplasia. *Indian Pediatr* 2010;47(6):529-531.
193. Dessypris EN, Baer MR, Sergeant JS, et al. Rheumatoid arthritis and pure red cell aplasia. *Ann Intern Med* 1984;100(2):202-206.
194. Cavalcant J, Shadduck RK, Winkelstein A, et al. Red-cell hypoplasia and increased bone marrow reticulin in systemic lupus erythematosus: reversal with corticosteroid therapy. *Am J Hematol* 1978;5(3):253-263.

195. Fang B, Song Y, Zhao RC, et al. Treatment of resistant pure red cell aplasia after major ABO-incompatible bone marrow transplantation with human adipose tissue-derived mesenchymal stem cells. *Am J Hematol* 2007;82(8):772-773.
196. Tsai HJ, Lin SF, Liu TC, et al. Pure red cell aplasia after ABO major-mismatched allogeneic peripheral blood stem cell transplantation successfully treated with plasma exchange and low-dose steroid: two case reports. *Kaohsiung J Med Sci* 2004;20(3):128-132.
197. Zhu KE, Li JP, Zhang T, et al. Clinical features and risk factors of pure red cell aplasia following major ABO-incompatible allogeneic hematopoietic stem cell transplantation. *Hematology* 2007;12(2):117-121.
198. Lagadinou ED, Marangos M, Liga M, et al. Human herpesvirus 6-related pure red cell aplasia, secondary graft failure, and clinical severe immune suppression after allogeneic hematopoietic cell transplantation successfully treated with foscarnet. *Transpl Infect Dis* 2010;12(5):437-440.
199. Koiso H, Kobayashi S, Ueki K, et al. Pure red cell aplasia accompanied by autoimmune hemolytic anemia in a patient with type A viral hepatitis. *Rinsho Ketsueki* 2009;50(5):424-429.
200. Sung HJ, Kim SJ, Lee JH, et al. Persistent anemia in a patient with diffuse large B cell lymphoma: pure red cell aplasia associated with latent Epstein-Barr virus infection in bone marrow. *J Korean Med Sci* 2007;22(Suppl):S167- S170.
201. MacCullough D, Jackson JM, Venerys J. Drug-induced red cell aplasia. *Br Med J* 1974;4:163.
202. Gollan JL, Hussein S, Hoffbrand AV, et al. Red cell aplasia following prolonged d-penicillamine therapy. *J Clin Pathol* 1976;29:135.
203. Dunn AM, Kerr GD. Pure red cell aplasia associated with sulfasalazine. *Lancet* 1981;2:1288.
204. Nicholls MD, Concannon AJ. Maloprim-induced agranulocytosis and red cell aplasia. *Med J Aust* 1982;2:564.
205. Claiborne RA, Dutt AK. Isoniazid-induced pure red cell aplasia. *Am Rev of Respir Dis* 1985;131:947.
206. Dessypris EN, Redline S, Harris JW, et al. Diphenylhydantoin-induced pure red cell aplasia. *Blood* 1985;65:789.
207. Tsuda H, Kuniyasu W, Fukuda K, et al. Pure red cell aplasia caused by chlormadinone. *Lancet* 1994;344(8933):1370-1371.
208. Arcasoy MO, Rockey DC, Heneghan MA. Pure red cell aplasia following pegylated interferon alpha treatment. *Am J Med* 2004;117(8):619-620.
209. The T, Kolla R, Dawkins F, et al. Pure red cell aplasia after 13 years of sodium valproate, and bone marrow suppression after 17 years of carbamazepine. *PLoS Med* 2004;1(2):e51.
210. Yamamoto N, Shiraki K, Saitou Y, et al. Ticlopidine induced acute cholestatic hepatitis complicated with pure red cell aplasia. *J Clin Gastroenterol* 2004;38(1):84.
211. Borrás-Blasco J, Conesa-García V, Navarro-Ruiz A, et al. Pure red cell aplasia associated with dapsone therapy. *Ann Pharmacother* 2005;39(6):1137-1138.
212. Chao SC, Yang CC, Lee JY. Hypersensitivity syndrome and pure red cell aplasia following allopurinol therapy in a patient with chronic kidney disease. *Ann Pharmacother* 2005;39(9):1552-1556.
213. Weinkove R, Rangarajan S, van der Walt J, et al. Zidovudine-induced pure red cell aplasia presenting after 4 years of therapy. *AIDS* 2005;19(17):2046-2047.
214. Hodo Y, Tsuji K, Mizukoshi E, et al. Pure red cell aplasia associated with concomitant use of mycophenolate mofetil and ribavirin in post-transplant recurrent hepatitis C. *Transpl Int* 2006;19(2):170-171.
215. Pasha SF, Pruthi RK. Procainamide-induced pure red cell aplasia. *Int J Cardiol* 2006;110(1):125-126.
216. Elimelakh M, Dayton V, Park KS, et al. Red cell aplasia and autoimmune hemolytic anemia following immunosuppression with alemtuzumab, mycophenolate, and daclizumab in pancreas transplant recipients. *Haematologica* 2007;92(8):1029-1036.
217. Bartakke S, Abdelhaleem M, Carcao M. Valproate-induced pure red cell aplasia and megakaryocyte dysplasia. *Br J Haematol* 2008;141(2):133.
218. John MA, Rhemtula YA, Menezes CN, et al. Lamivudine-induced red cell aplasia. *J Med Microbiol* 2008;57(Pt 8):1032-1035.

219. Hassan A, Babadoko AA, Mamman AI, et al. Zidovudine induced pure red cell aplasia: a case report. *Niger J Med* 2009;18(3):332-333.
220. Balakrishnan A, Valsalan R, Sheshadri S, et al. Zidovudine-induced reversible pure red cell aplasia. *Indian J Pharmacol* 2010;42(3):189-191.
221. Nakamura H, Okada A, Kawakami A, et al. Isoniazid-triggered pure red cell aplasia in systemic lupus erythematosus complicated with myasthenia gravis. *Rheumatol Int* 2010;30(12):1643-1645.
222. Chang CS, Yan SL, Lin HY, et al. Pure red cell aplasia caused by pegylated interferon-alpha-2a plus ribavirin in the treatment of chronic hepatitis C. *World J Gastroenterol* 2011;17(16):2155-2158.
223. Bennett CL, Starko KM, Thomsen HS, et al. Linking drugs to obscure illnesses: lessons from pure red cell aplasia, nephrogenic systemic fibrosis, and Reye's syndrome. A report from the Southern Network on Adverse Reactions (SONAR). *J Gen Intern Med* 2012;27:1687-1703.
224. Waki F, Ohnishi H, Shintani T, et al. Linezolid-induced pure red cell aplasia in a patient with *Staphylococcus epidermidis* infection after allogeneic stem cell transplantation. *Transpl Infect Dis* 2012.
225. Reid G, Patterson AC. Pure red-cell aplasia after gold treatment. *Br Med J* 1977;2(6100):1457.
226. Jurgensen JC, Abraham JP, Hardy WW. Erythroid aplasia after halothane hepatitis. Report of a case. *Am J Dig Dis* 1970;15(6):577-581.
227. Geary CG. Drug-related red-cell aplasia. *Br Med J* 1978;1(6104):51-52.
228. Mariette X, Mitjavila MT, Moulinie JP, et al. Rifampicin-induced pure red cell aplasia. *Am J Med* 1989;87(4):459-460.
229. Giannone L, Kugler JW, Krantz SB. Pure red cell aplasia associated with administration of sustained-release procainamide. *Arch Intern Med* 1987;147(6):1179-1180.
230. Hoffman R, McPhedran P, Benz EJ Jr, et al. Isoniazid-induced pure red cell aplasia. *Am J Med Sci* 1983;286(1):2-9.
231. Dessypris EN. The biology of pure red cell aplasia. *Semin Hematol* 1991;28(4):275-284.
232. Chim CS, Ma SK. Giant pronormoblasts in parvovirus-associated pure red cell aplasia. *Am J Hematol* 2000;65(4):289.
233. Au WY, Cheng VC, Wan TS, et al. Myelodysplasia masquerading as parvo-virus-related red cell aplasia with giant pronormoblasts. *Ann Hematol* 2004;83(10):670-671.
234. Kho L-K. Erythroblastopenia with giant pro-erythroblasts in kwashiorkor. *Blood* 1957;12(2):171-182.
235. Wibulyachainunt S, Price R, Brill AB, et al. Studies on red-cell aplasia: IX. Ferrokinetics during remission of the disease. *Am J Hematol* 1978;4(3): 233-244.
236. Keefer MJ, Solanki DL. Dyserythropoiesis and erythroblast-phagocytosis preceding pure red cell aplasia. *Am J Hematol* 1988;27(2):132-135.
237. Inui Y, Yamamoto K, Okamura A, et al. Isolated isochromosome 17q in myelodysplastic syndromes with pure red cell aplasia and basophilia. *Intern Med* 2012;51(12):1579-1584.
238. Garcia-Suarez J, Pascual T, Munoz MA, et al. Myelodysplastic syndrome with erythroid hypoplasia/aplasia: a case report and review of the literature. *Am J Hematol* 1998;58(4):319-325.
239. Lacy MQ, Kurtin PJ, Tefferi A. Pure red cell aplasia: association with large granular lymphocyte leukemia and the prognostic value of cytogenetic abnormalities. *Blood* 1996;87(7):3000-3006.
240. Beard ME, Krantz SB, Johnson SA, et al. Pure red cell aplasia. *Q J Med* 1978;47(187):339-348.
241. Holborow EJ, Asherson GL, Johnson GD, et al. Antinuclear factor and other antibodies in blood and liver diseases. *Br Med J* 1963;1(5331):656-658.
242. Bai LY, Liu JH, Kau JP. T-cell clonal disorder in acquired primary pure red cell aplasia. *Ann Hematol* 2004;83(8):544-546.
243. Froland SS, Wisloff F, Stavem P. Abnormal lymphocyte populations in pure red cell aplasia. *Scand J Haematol* 1976;17(4):241-250.
244. Frickhofen N, Young NS. Polymerase chain reaction for detection of parvovirus B19 in immunodeficient patients with anemia. *Behring Inst Mitt* 1990(85): 46-54.

245. Frickhofen N, Abkowitz JL, Safford M, et al. Persistent B19 parvovirus infection in patients infected with human immunodeficiency virus type 1 (HIV-1): a treatable cause of anemia in AIDS. *Ann Intern Med* 1990;113(12):926-933.
246. Clark DA, Dessypris EN, Krantz SB. Studies on pure red cell aplasia. XI. Results of immunosuppressive therapy of 37 patients. *Blood* 1984;63: 277-286.
247. Sawada K, Fujishima N, Hirokawa M. Acquired pure red cell aplasia: updated review of treatment. *Br J Haematol* 2008;142(4):505-514.
248. Sawada K, Hirokawa M, Fujishima N, et al. Long-term outcome of patients with acquired primary idiopathic pure red cell aplasia receiving cyclosporine A, a nationwide cohort study in Japan for the PRCA Collaborative Study Group. *Haematologica* 2007;92(8):1021-1028.
249. Zaentz SD, Krantz SB, Brown EB. Studies on pure red cell aplasia. Maintenance therapy with immunosuppressive drugs. *Br J Haematol* 1976;32(1):47-54.
250. Finkel HE, Kimber RJ, Dameshek W. Corticosteroid-responsive acquired pure red cell aplasia in adults. *Am J Med* 1967;43(5):771-776.
251. Williams DL, Mageed AS, Findley H, et al. Cyclosporine in the treatment of red cell aplasia. *Am J Pediatr Hematol Oncol* 1987;9(4):314-316.
252. Totterman TH, Nisell J, Killander A, et al. Successful treatment of pure red-cell aplasia with cyclosporin. *Lancet* 1984;2(8404):693.
253. Auner HW, Wolfer A, Beham-Schmid C, et al. Restoration of erythropoiesis by rituximab in an adult patient with primary acquired pure red cell aplasia refractory to conventional treatment. *Br J Haematol* 2002;116:727-728.
254. Behler CM, Terrault NA, Etzell JE, et al. Rituximab therapy for pure red cell aplasia due to anti-epoetin antibodies in a woman treated with epoetin-alfa: a case report. *J Med Case Rep* 2009;3:7335.
255. Mandreoli M, Finelli C, Lopez A, et al. Successful resumption of epoetin alfa after rituximab treatment in a patient with pure red cell aplasia. *Am J Kidney Dis* 2004;44(4):757-761.
256. Zecca M, De SP, Nobili B, et al. Anti-CD20 monoclonal antibody for the treatment of severe, immune-mediated, pure red cell aplasia and hemolytic anemia. *Blood* 2001;97(12):3995-3997.
257. Jung SH, Ahn JS, Yang DH, et al. Successful treatment of pure red cell aplasia with rituximab in patients after ABO-compatible allogeneic hematopoietic stem cell transplantation. *Case Rep Oncol* 2012;5(1):110-113.
258. Park JH, Spitzer T, Kuter DJ. Successful treatment of pure red cell aplasia with autologous stem cell transplantation. *Am J Hematol* 2007;82(9): 812-814.
259. Verhopen F, Stalder M, Helg C, et al. Resistant pure red cell aplasia after allogeneic stem cell transplantation with major ABO mismatch treated by escalating dose donor leukocyte infusion. *Eur J Haematol* 2004;73(6):441-446.
260. Woo HY, Min CK, Lee SM, et al. Resistant pure red cell aplasia after allogeneic bone marrow transplantation with major ABO mismatch treated by purified CD34+ cell infusion. *Eur J Haematol* 2006;76(2):160-163.
261. Dungarwalla M, Marsh JC, Tooze JA, et al. Lack of clinical efficacy of rituximab in the treatment of autoimmune neutropenia and pure red cell aplasia: implications for their pathophysiology. *Ann Hematol* 2007;86(3):191-197.
262. Antonio MR, Carmine S, Bianca S, et al. Alemtuzumab is safe and effective as immunosuppressive treatment for aplastic anaemia and single-lineage marrow failure: a pilot study and a survey from the EBMT WPSAA. *Br J Haematol* 2009;9999(9999).
263. Au WY, Lam CC, Chim CS, et al. Alemtuzumab induced complete remission of therapy-resistant pure red cell aplasia. *Leuk Res* 2005;29(10):1213-1215.
264. Schutzing C, Gaiger A, Thalhammer R, et al. Remission of pure red cell aplasia in T-cell receptor gammadelta-large granular lymphocyte leukemia after therapy with low-dose alemtuzumab. *Leukemia* 2005;19(11):2005-2008.
265. Clauvel JP, Vainchenker W, Herrera A, et al. Treatment of pure red cell aplasia by high dose intravenous immunoglobulins. *Br J Haematol* 1983;55(2): 380-382.
266. Katakhar SB. Pure red blood cell aplasia: response to intravenous immunoglobulins, a blocking antibody. *Arch Intern Med* 1986;146(11):2288.

267. McGuire WA, Yang HH, Bruno E, et al. Treatment of antibody-mediated pure red-cell aplasia with high-dose intravenous gamma globulin. *N Engl J Med* 1987;317(16):1004-1008.
268. Mouthon L, Guillevin L, Tellier Z. Intravenous immunoglobulins in autoimmune- or parvovirus B19-mediated pure red-cell aplasia. *Autoimmun Rev* 2005;4(5):264-269.
269. Bavaro P, Di Girolamo G, Olioso P, et al. Donor lymphocyte infusion as therapy for pure red cell aplasia following bone marrow transplantation. *Br J Haematol* 1999;104(4):930-931.
270. Musso M, Porretto F, Crescimanno A, et al. Donor lymphocyte infusions for refractory pure red cell aplasia relapsing after both autologous and nonmyeloablative allogeneic peripheral stem cell transplantation. *Bone Marrow Transplant* 2004;33(7):769-771.
271. Messner HA, Fauser AA, Curtis JE, et al. Control of antibody-mediated pure red-cell aplasia by plasmapheresis. *N Engl J Med* 1981;304(22):1334-1338.
272. Ohta S, Yokoyama H, Ise T, et al. Apheresis therapy for prolonged red cell aplasia after major ABO-mismatched bone marrow transplantation. *Intern Med* 1997;36(7):487-491.
273. Or R, Naparstek E, Mani N, et al. Treatment of pure red-cell aplasia following major ABO-mismatched T-cell-depleted bone marrow transplantation. Two case reports with successful response to plasmapheresis. *Transpl Int* 1991;4(2): 99-102.
274. Freund LG, Hippe E, Strandgaard S, et al. Complete remission in pure red cell aplasia after plasmapheresis. *Scand J Haematol* 1985;35(3):315-318.
275. Abkowitz JL, Powell JS, Nakamura JM, et al. Pure red cell aplasia: response to therapy with anti-thymocyte globulin. *Am J Hematol* 1986;23(4): 363-371.
276. Zaentz DS, Krantz SB, Sears DA. Studies on pure red cell aplasia. VII. Presence of proerythroblasts and response to splenectomy: a case report. *Blood* 1975;46(2):261-270.
277. Kurstjens R, Haanen C. Remission of pure red cell aplasia obtained by splenectomy after failure of thymectomy and immunosuppressive treatment. *Ned Tijdschr Geneesk* 1978;122(33):1221-1225.
278. Sawada K, Koyanagawa Y, Deno M, et al. A case of pure red cell aplasia of which remission was obtained by splenectomy alone (author's transl.). *Rinsho Ketsueki* 1981;22(12):1955-1961.
279. Yamaguchi H, Muto K, Kamihira S, et al. A case of pure red cell aplasia with excellent response to splenectomy (author's transl.). *Rinsho Ketsueki* 1976;17(5):562-568.
280. Muller BU, Tichelli A, Passweg JR, et al. Successful treatment of refractory acquired pure red cell aplasia (PRCA) by allogeneic bone marrow transplantation. *Bone Marrow Transplant* 1999;23(11):1205-1207.
281. Kochethu G, Baden HS, Jaworska E, et al. Reduced intensity conditioning bone marrow transplantation for pure red cell aplasia: successful outcome but difficult post transplant course. *Bone Marrow Transplant* 2005;36(1): 81-82.
282. Subtirelu MM, Flynn JT, Schechner RS, et al. Acute renal failure in a pediatric kidney allograft recipient treated with intravenous immunoglobulin for parvovirus B19 induced pure red cell aplasia. *Pediatr Transplant* 2005;9(6):801-804.
283. Koduri PR, Kumapley R, Valladares J, et al. Chronic pure red cell aplasia caused by parvovirus B19 in AIDS: use of intravenous immunoglobulin—a report of eight patients. *Am J Hematol* 1999;61(1):16-20.
284. Jiang D, Wu M. Thymectomy resulted in complete remission of pure red cell aplasia when associated with thymoma. *Thorac Cardiovasc Surg* 2010;58(4):235-236.
285. Krantz SB. Thymoma and red-cell aplasia. *N Engl J Med* 1973;288(22): 1185-1186.
286. Peschle C, Condorelli M. Pure red cell aplasia associated with thymoma. Demonstration of an autoimmune serum factor inhibiting erythropoiesis and remission induced by cyclophosphamide. *Haematologica* 1972;58(9): 553-559.
287. Thompson CA, Steensma DP. Pure red cell aplasia associated with thymoma: clinical insights from a 50-year single-institution experience. *Br J Haematol* 2006;135(3):405-407.
288. van der Marel J, Pahlplatz PV, Steup WH, et al. Thymoma with paraneoplastic syndromes, Good's syndrome, and pure red cell aplasia. *J Thorac Oncol* 2007;2(4):325-326.

289. Yoshida S, Konishi T, Nishizawa T, et al. Effect of tacrolimus in a patient with pure red-cell aplasia. *Clin Lab Haematol* 2005;27(1):67-69.
290. Zaucha R, Zaucha JM, Jassem J. Resolution of thymoma-related pure red cell aplasia after octreotide treatment. *Acta Oncol* 2007;46(6):864-865.
291. Carson KR, Evens AM, Bennett CL, et al. Clinical characteristics of erythropoietin-associated pure red cell aplasia. *Best Pract Res Clin Haematol* 2005;18(3):467-472.
292. Casadevall N. Epoetin-induced autoimmune pure red cell aplasia. *Hematol J* 2004;5(Suppl 3):S104- S109.
293. Duffield JS, Mann S, Horn L, et al. Low-dose cyclosporin therapy for recombinant erythropoietin-induced pure red-cell aplasia. *Nephrol Dial Transplant* 2004;19(2):479-481.
294. Fraer M, Campbell A, Sawaya BP. Response to cyclosporine A in a patient with pure red cell aplasia due to antierythropoietin-alpha antibodies. *Semin Dial* 2006;19(3):251-254.
295. Shinohara K. Pure red cell aplasia caused by antibody to erythropoietin successfully treated by cyclosporine administration. *Am J Hematol* 2007;82(3): 247-248.
296. Westerlund P, Kurkus J, Segelmark M. Rapid resolution of EPO-induced pure red cell aplasia after a course of immunoadsorption therapy using protein A columns. *Am J Kidney Dis* 2005;45(6):e97- e99.
297. Katagiri D, Shibata M, Katsuki T, et al. Antierythropoietin antibody-related pure red cell aplasia: successful remission with cessation of recombinant erythropoietin alone. *Clin Exp Nephrol* 2010;14(5):501-505.
298. Andrade J, Taylor PA, Love JM, et al. Successful reintroduction of a different erythropoiesis-stimulating agent after pure red cell aplasia: relapse after successful therapy with prednisone. *Nephrol Dial Transplant* 2005;20(11): 2548-2551.
299. Asari A, Gokal R. Pure red cell aplasia secondary to epoetin alpha responding to darbepoetin alpha in a patient on peritoneal dialysis. *J Am Soc Nephrol* 2004;15(8):2204-2207.
300. Lee H, Yang J, Kim H, et al. Improvement in erythropoiesis-stimulating agent-induced pure red-cell aplasia by introduction of darbepoetin-alpha when the anti-erythropoietin antibody titer declines spontaneously. *J Korean Med Sci* 2010;25(11):1676-1679.
301. Summers SA, Matijevic A, Almond MK, Successful re-introduction of recombinant human erythropoietin following antibody induced pure red cell aplasia. *Nephrol Dial Transplant* 2004;19(8):2137-2139.
302. Vartia A, Asola MR, Tertti R, et al. Two haemodialysis patients with epoetin alfa-induced pure red-cell aplasia recovered despite treatment with another epoetin preparation. *Nephrol Dial Transplant* 2004;19(5):1313-1316.
303. Summers S, Holdsworth S, Sharples E. The (re)challenging question of erythropoiesis-stimulating agents inducing pure red cell aplasia. *Nephrol Dial Transplant* 2008;23(10):3053-3055.
304. Praditpornsilpa K, Tiranathagul K, Kupatawintu P. Biosimilar recombinant human erythropoietin induces the production of neutralizing antibodies. *Kidney Int* 2011;80:88-92.
305. Macdougall IC, Rossert J, Casadevall N, et al. A peptide-based erythropoietin-receptor agonist for pure red-cell aplasia. *N.Engl.J.Med* 2009;361(19): 1848-1855.
306. Baer AN, Dessypris EN, Goldwasser E, et al. Blunted erythropoietin response to anaemia in rheumatoid arthritis. *Br J Haematol* 1987;66:559-564.
307. McMahan JN, Egan EL. Aplastic anaemia in a patient with pure red cell aplasia. *Ir J Med Sci* 1980;149(5):212-214.
308. Diamond LK, Blackfan KD. Hypoplastic anemia. *Am J Dis Child* 1938;56:464.
309. Young NS, Alter BP. *Aplastic anemia acquired and inherited*. Philadelphia: WB Saunders Co, 1994.
310. Diamond LK, Wang WC, Alter BP. Congenital hypoplastic anemia. *Adv Pediatr* 1976;22:349-378.
311. Vlachos A, Ball S, Dahl N, et al. Diagnosing and treating Diamond Blackfan anaemia: results of an international clinical consensus conference. *Br J Haematol* 2008;142(6):859-876.
312. Vlachos A, Klein GW, Lipton JM. The Diamond Blackfan Anemia Registry: tool for investigating the epidemiology and biology of Diamond-Blackfan anemia. *J Pediatr Hematol Oncol* 2001;23(6):377-382.
313. Ortega JA, Shore NA, Dukes PP, et al. Congenital hypoplastic anemia inhibition of erythropoiesis by sera from patients with congenital hypoplastic anemia. *Blood* 1975;45(1):83-89.

314. Hoffman R, Zanjani ED, Vila J, et al. Diamond-Blackfan syndrome: lymphocyte-mediated suppression of erythropoiesis. *Science* 1976;193(4256): 899-900.
315. Sawada K, Koyanagawa Y, Sakurama S, et al. Diamond-Blackfan syndrome: a possible role of cellular factors for erythropoietic suppression. *Scand J Haematol* 1985;35(2):158-165.
316. Ershler WB, Ross J, Finlay JL, et al. Bone-marrow microenvironment defect in congenital hypoplastic anemia. *N Engl J Med* 1980;302(24):1321-1327.
317. Finlay JL, Shahidi NT, Horowitz S, et al. Lymphocyte dysfunction in congenital hypoplastic anemia. *J Clin Invest* 1982;70(3):619-626.
318. Nathan DG, Clarke BJ, Hillman DG, et al. Erythroid precursors in congenital hypoplastic (Diamond-Blackfan) anemia. *J Clin Invest* 1978;61(2):489-498.
319. Lipton JM, Kudisch M, Gross R, et al. Defective erythroid progenitor differentiation system in congenital hypoplastic (Diamond-Blackfan) anemia. *Blood* 1986;67(4):962-968.
320. Tsai PH, Arkin S, Lipton JM. An intrinsic progenitor defect in Diamond-Blackfan anaemia. *Br J Haematol* 1989;73(1):112-120.
321. Perdahl EB, Naprstek BL, Wallace WC, et al. Erythroid failure in Diamond-Blackfan anemia is characterized by apoptosis. *Blood* 1994;83(3):645-650.
322. Ohene-Abuakwa Y, Orfali KA, Marius C, et al. Two-phase culture in Diamond Blackfan anemia: localization of erythroid defect. *Blood* 2005;105(2): 838-846.
323. Lipton JM, Ellis SR. Diamond Blackfan anemia 2008-2009: broadening the scope of ribosome biogenesis disorders. *Curr Opin Pediatr* 2010;22(1):12-19.
324. Farrar JE, Vlachos A, Atsidaftos E, et al. Ribosomal protein gene deletions in Diamond-Blackfan anemia. *Blood* 2011;118(26):6943-6951.
325. Sankaran VG, Ghazvinian R, Do R, et al. Exome sequencing identifies GATA1 mutations resulting in Diamond-Blackfan anemia. *J Clin Invest* 2012;122(7):2439-2443.
326. Lipton JM, Nathan DG. Cell-cell interactions in the regulation of erythropoiesis. *Br J Haematol* 1983;53(3):361-367.
327. Geller G, Drivit W, Zalusky R, et al. Lack of erythropoietic inhibitory effect of serum from patients with congenital pure red cell aplasia. *N Engl J Med* 1975;292(9):198-201.
328. Freedman MH, Saunders EF. Diamond-Blackfan syndrome: evidence against cell-mediated erythropoietic suppression. *Blood* 1978;51(6):1125-1128.
329. Nathan DG, Hillman DG, Chess L, et al. Normal erythropoietic helper T cells in congenital hypoplastic (Diamond-Blackfan) anemia. *N Engl J Med* 1978;298(19):1049-1051.
330. Chan HS, Saunders EF, Freedman MH. Diamond-Blackfan syndrome. I. Erythropoiesis in prednisone responsive and resistant disease. *Pediatr Res* 1982;16(6):474-476.
331. Chan HS, Saunders EF, Freedman MH. Diamond-Blackfan syndrome. II. In vitro corticosteroid effect on erythropoiesis. *Pediatr Res* 1982;16(6):477-478.
332. McGuckin CP, Ball SE, Gordon-Smith EC. Diamond-Blackfan anaemia: three patterns of in vitro response to haemopoietic growth factors. *Br J Haematol* 1995;89(3):457-464.
333. Varricchio L, Godbold J, Scott SA, et al. Increased frequency of the glucocorticoid receptor A3669G (rs6198) polymorphism in patients with Diamond-Blackfan anemia. *Blood* 2011;118(2):473-474.
334. Dianzani I, Garelli E, Dompe C, et al. Mutations in the erythropoietin receptor gene are not a common cause of Diamond-Blackfan anemia. *Blood* 1996;87(6):2568-2572.
335. Bagnara GP, Zauli G, Vitale L, et al. In vitro growth and regulation of bone marrow enriched CD34+ hematopoietic progenitors in Diamond-Blackfan anemia. *Blood* 1991;78(9):2203-2210.
336. Giri N, Kang E, Tisdale JF, et al. Clinical and laboratory evidence for a trilineage haematopoietic defect in patients with refractory Diamond-Blackfan anaemia. *Br J Haematol* 2000;108(1):167-175.

337. van Diemen PC, Maasdam D, Darroudi F, et al. X-ray-sensitivity of lymphocytes of aplastic- and Diamond-Blackfan anemia patients as detected by conventional cytogenetic and chromosome painting techniques. *Mutat Res* 1997;373(2): 225-235.
338. Abkowitz JL, Sabo KM, Nakamoto B, et al. Diamond-Blackfan anemia: in vitro response of erythroid progenitors to the ligand for c-kit. *Blood* 1991;78(9):2198-2202.
339. Sieff CA, Yokoyama CT, Zsebo KM, et al. The production of steel factor mRNA in Diamond-Blackfan anaemia long-term cultures and interactions of steel factor with erythropoietin and interleukin-3. *Br J Haematol* 1992;82(4): 640-647.
340. Spritz RA, Freedman MH. Lack of mutations of the MGF and KIT genes in Diamond-Blackfan anemia. *Blood* 1993;81(11):3165.
341. Scopes J, Daly S, Ball SE, et al. The effect of human flt-3 ligand on committed progenitor cell production from normal, aplastic anaemia and Diamond-Blackfan anaemia bone marrow. *Br J Haematol* 1995;91(3):544-550.
342. McGuckin CP, Uhr MR, Liu WM, et al. The use of recombinant SCF protein for rapid determination of c-kit expression in normal and abnormal erythropoiesis. *Eur J Haematol* 1996;57(1):72-78.
343. Ebert BL, Pretz J, Bosco J, et al. Identification of RPS14 as a 5q-syndrome gene by RNA interference screen. *Nature* 2008;451(7176):335-339.
344. Vlachos A, Farrar J, Atsidaftos E, et al. 5q-myelodysplastic syndrome, in Diamond Blackfan Anemia (DBA) and responding to lenalidomide. *Blood* 2010;16. Late Breaking Abstract Session.
345. Gustavsson P, Willing TN, van Haeringen A, et al. Diamond-Blackfan anaemia: genetic homogeneity for a gene on chromosome 19q13 restricted to 1.8 Mb. *Nat Genet* 1997;16(4):368-371.
346. Draptchinskaia N, Gustavsson P, Andersson B, et al. The gene encoding ribosomal protein S19 is mutated in Diamond-Blackfan anaemia. *Nat Genet* 1999;21(2):169-175.
347. Gazda HT, Grabowska A, Merida-Long LB, et al. Ribosomal protein S24 gene is mutated in Diamond-Blackfan anemia. *Am J Hum Genet* 2006;79(6): 1110-1118.
348. Kuramitsu M, Sato-Otsubo A, Morio T, et al. Extensive gene deletions in Japanese patients with Diamond-Blackfan anemia. *Blood* 2012;119(10): 2376-2384.
349. Cmejla R, Cmejlova J, Handrkova H, et al. Ribosomal protein S17 gene (RPS17) is mutated in Diamond-Blackfan anemia. *Hum Mutat* 2007;28(12): 1178-1182.
350. Farrar JE, Nater M, Caywood E, et al. Abnormalities of the large ribosomal subunit protein, Rpl35a, in Diamond-Blackfan anemia. *Blood* 2008;112(5):1582-1592.
- P.989
351. Gazda HT, Sheen MR, Vlachos A, et al. Ribosomal protein L5 and L11 mutations are associated with cleft palate and abnormal thumbs in Diamond-Blackfan anemia patients. *Am J Hum Genet* 2008;83(6):769-780.
352. Gazda HT, Sheen M, Doherty L, et al. Ribosomal protein genes S10 and S26 are commonly mutated in Diamond-Blackfan anemia. *Blood* 2010;114:175.
353. Doherty L, Sheen MR, Vlachos A, et al. Ribosomal protein genes RPS10 and RPS26 are commonly mutated in Diamond-Blackfan anemia. *Am J Hum Genet* 2010;86(2):222-228.
354. Gazda HT, Landowski M, Buros C, et al. Array comparative hybridization of ribosomal protein genes in Diamond-Blackfan anemia patients RPS8, RPS14 and RPL15 with large deletion of duplication (abstract). *Blood* 2010;116:1007.
355. Gazda HT, Zhong R, Long L, et al. RNA and protein evidence for haplo-insufficiency in Diamond-Blackfan anaemia patients with RPS19 mutations. *Br J Haematol* 2004;127(1):105-113.
356. Flygare J, Kiefer T, Miyake K, et al. Deficiency of ribosomal protein S19 in CD34+ cells generated by siRNA blocks erythroid development and mimics defects seen in Diamond-Blackfan anemia. *Blood* 2005;105(12):4627-4634.

357. Ebert BL, Lee MM, Pretz JL, et al. An RNA interference model of RPS19 deficiency in Diamond-Blackfan anemia recapitulates defective hematopoiesis and rescue by dexamethasone: identification of dexamethasone-responsive genes by microarray. *Blood* 2005;105(12):4620-4626.
358. Hamaguchi I, Ooka A, Brun A, Richter J, Dahl N, Karlsson S. Gene transfer improves erythroid development in ribosomal protein S-19 deficient Diamond-Blackfan anemia. *Blood* 2005;100:2724-2731.
359. Devlin EE, Dacosta L, Mohandas N, et al. A transgenic mouse model demonstrates a dominant negative effect of a point mutation in the RPS19 gene associated with Diamond-Blackfan anemia. *Blood* 2010;116(15): 2826-2835.
360. McGowan KA, Li JZ, Park CY, et al. Ribosomal mutations cause p53-mediated dark skin and pleiotropic effects. *Nat Genet* 2008;40(8):963-970.
361. Danilova N, Sakamoto KM, Lin S. Ribosomal protein S19 deficiency in zebrafish leads to developmental abnormalities and defective erythropoiesis through activation of p53 protein family. *Blood* 2008;112(13):5228-5237.
362. Uechi T, Nakajima Y, Chakraborty A, et al. Deficiency of ribosomal protein S19 during early embryogenesis leads to reduction of erythrocytes in a zebrafish model of Diamond-Blackfan anemia. *Hum Mol Genet* 2008;17(20):3204-3211.
363. Lipton JM, Federman N, Khabbaze Y, et al. Osteogenic sarcoma associated with Diamond-Blackfan anemia: a report from the Diamond-Blackfan Anemia Registry. *J Pediatr Hematol Oncol* 2001;23(1):39-44.
364. Vlachos A, Rosenberg PS, Atsidaftos E, et al. Incidence of neoplasia in Diamond Blackfan anemia: a report from the Diamond Blackfan Anemia Registry. *Blood* 2012;119(16):3815-3819.
365. Fumagalli S, Thomas G. The role of p53 in ribosomopathies. *Semin Hematol* 2011;48(2):97-105.
366. Horos R, Ijspeert H, Pospisilova D, et al. Ribosomal deficiencies in Diamond-Blackfan anemia impair translation of transcripts essential for differentiation of murine and human erythroblasts. *Blood* 2012;119(1): 262-272.
367. Xue S, Barna M. Specialized ribosomes: a new frontier in gene regulation and organismal biology. *Nature reviews. Mol Cell Biol* 2012;13(6):355-369.
368. McGowan KA, Mason PJ. Animal models of Diamond Blackfan anemia. *Semin Hematol* 2011;48(2):106-116.
369. Scimeca PG, Weinblatt ME, Slepowitz G, et al. Diamond-Blackfan syndrome: an unusual cause of hydrops fetalis. *Am J Pediatr Hematol Oncol* 1988;10(3): 241-243.
370. Balaban EP, Buchanan GR, Graham M, et al. Diamond-Blackfan syndrome in adult patients. *Am J Med* 1985;78(3):533-538.
371. Josephs H. Anemia of infancy and early childhood. *Medicine* 1936;15:307.
372. Alter BP. Modern review of congenital hypoplastic anemia. *J Pediatr Hematol Oncol* 2001;23(6):383-384.
373. Lipton JM, Atsidaftos E, Zyskind I, et al. Improving clinical care and elucidating the pathophysiology of Diamond Blackfan anemia: an update from the Diamond Blackfan Anemia Registry. *Pediatr Blood Cancer* 2006;46(5):558-564.
374. Vlachos A, Federman N, Reyes-Haley C, et al. Hematopoietic stem cell transplantation for Diamond Blackfan anemia: a report from the Diamond Blackfan Anemia Registry. *Bone Marrow Transplant* 2001;27(4):381-386.
375. Alter BP. The bone marrow failure syndromes. In: Nathan DG, ed. *Hematology of infancy and childhood*, 3rd ed. Philadelphia: W.B. Saunders, 1987:159-241.
376. Aase JM, Smith DW. Congenital anemia and triphalangeal thumbs: a new syndrome. *J Pediatr* 1969;74(3):471-474.
377. Schroeder WA, Huisman THJ, Brown AD, et al. Postnatal changes in the chemical heterogeneity of human fetal hemoglobin. *Pediatr Res* 1971;9:493.
378. Alter BP. Childhood red cell aplasia. *Am J Pediatr Hematol Oncol* 1980;2:121.
379. Buchanan GR, Alter BP, Holtkamp CA, et al. Platelet number and function in Diamond-Blackfan anemia. *Pediatrics* 1981;68(2):238-241.
380. Glader BE, Backer K. Comparative activity of erythrocyte adenosine deaminase and orotidine decarboxylase in Diamond-Blackfan anemia. *Am J Hematol* 1986;23(2):135-139.
381. Glader BE, Backer K. Elevated red cell adenosine deaminase activity: a marker of disordered erythropoiesis in Diamond-Blackfan anaemia and other haematologic diseases. *Br J Haematol* 1988;68(2):165-168.

382. Glader BE, Backer K, Diamond LK. Elevated erythrocyte adenosine deaminase activity in congenital hypoplastic anemia. *N Engl J Med* 1983;309(24): 1486-1490.
383. Zielke HR, Ozand PT, Luddy RE, et al. Elevation of pyrimidine enzyme activities in the RBC of patients with congenital hypoplastic anaemia and their parents. *Br J Haematol* 1979;42(3):381-390.
384. Harrison DE, Malathi VG, Silber R. Elevated erythrocyte nucleoside deaminase levels in genetically anemic W/W^v and Sl/Sl^d mice. *Blood Cells* 1975;1:605.
385. Brookfield EG, Singh P. Congenital hypoplastic anemia associated with hypogammaglobulinemia. *J Pediatr* 1974;85(4):529-531.
386. Khan S, Pereira J, Darbyshire PJ, et al. Do ribosomopathies explain some cases of common variable immunodeficiency? *Clin Exp Immunol* 2011;163(1):96-103.
387. Bernard J, Seligmann M, Chassigneux J, et al. Blackfan-Diamond anemia. *Nouv Rev Fr Hematol* 1962;2:721-739.
388. Gordon RR, Varadi S. Congenital hypoplastic anaemia (pure red-cell anaemia) with periodic erythroblastopenia. *Lancet* 1962;1:296-299.
389. Sensenbrenner J. Congenital hypoplastic anemia of Blackfan and Diamond in sibs. In: Bergsma D, ed. *The clinical delineation of birth defects*. Baltimore, MD: Williams and Wilkins, 1972.
390. Starling KA, Fernbach DJ. Hypoplastic anemia. *J Pediatr* 1973;82:735.
391. Waterkotte GW, McElfresh AE. Congenital pure red cell hypoplasia in identical twins. *Pediatrics* 1974;54(5):646-647.
392. Altman AC, Gross S. Severe congenital hypoplastic anemia. Transmission from a healthy female to opposite sex step-siblings. *Am J Pediatr Hematol Oncol* 1983;5(1):99-101.
393. Forare SA. Pure red cell anemia in step siblings. *Acta Paediatr* 1963;52: 159-160.
394. Hunter RE, Hakami N. The occurrence of congenital hypoplastic anemia in half brothers. *J Pediatr* 1972;81(2):346-348.
395. Mott MG, Apley J, Raper AB. Congenital (erythroid) hypoplastic anaemia: modified expression in males. *Arch Dis Child* 1969;44(238):757-760.
396. Hamilton PJ, Dawson AA, Galloway WH. Congenital erythroid hypoplastic anaemia in mother and daughter. *Arch Dis Child* 1974;49(1):71-73.
397. Lawton JW, Aldrich JE, Turner TL. Congenital erythroid hypoplastic anaemia: autosomal dominant transmission. *Scand J Haematol* 1974;13(4):276-280.
398. Michelson AD. Inheritance of Diamond-Blackfan anemia. *Med J Aust* 1982;2(9):409-410.
399. Gray PH. Pure red-cell aplasia. Occurrence in three generations. *Med J Aust* 1982;1(12):519-521.
400. Gustavsson P, Skeppner G, Johansson B, et al. Diamond-Blackfan anaemia in a girl with a de novo balanced reciprocal X;19 translocation. *J Med Genet* 1997;34(9):779-782.
401. Gripp KW, McDonald-McGinn DM, La Rossa D, et al. Bilateral microtia and cleft palate in cousins with Diamond-Blackfan anemia. *Am J Med Genet* 2001;101(3):268-274.
402. Orfali KA, Ohene-Abuakwa Y, Ball SE. Diamond Blackfan anaemia in the UK: clinical and genetic heterogeneity. *Br J Haematol* 2004;125(2):243-252.
403. Cmejla R, Blafkova J, Stopka T, et al. Ribosomal protein S19 gene mutations in patients with diamond-blackfan anemia and identification of ribosomal protein S19 pseudogenes. *Blood Cells Mol Dis* 2000;26(2):124-132.
404. Tada K, Kudo T, Nakagawa I, et al. [Not Available] [Article in French] *Arch Fr Pediatr* 1958;15(2):183-194.
405. Diamond LK, Allen DM, Magill FB. Congenital (erythroid) hypoplastic anemia. A 25-year study. *Am J Dis Child* 1961;102:403-415.
406. Orfali KA, Wynn RF, Stevens R, et al. Failure of red cell production following allogeneic BMT for Diamond-Blackfan anaemia (DBA) illustrates functional significance of high erythrocyte adenosine deaminase (eADA) activity in the donor. *Blood* 1999;94:414a.

407. Vlachos A, Dahl N, Dianzani I, et al. Clinical utility gene card for: Diamond Blackfan anemia. *Eur J Hum Genet* 2013 Mar 6 doi:10.1038/ejhg.2013.34 [E pub ahead of print].
408. Talerman A, Amigo A. Thymoma associated with aregenerative and aplastic anemia in a five-year-old child. *Cancer* 1968;21(6):1212-1218.
409. Young N, Mortimer P. Viruses and bone marrow failure. *Blood* 1984;63(4): 729-737.
410. Young NS, Mortimer PP, Moore JG, et al. Characterization of a virus that causes transient aplastic crisis. *J Clin Invest* 1984;73(1):224-230.
411. Kelleher JF, Luban NL, Mortimer PP, et al. Human serum "parvovirus": a specific cause of aplastic crisis in children with hereditary spherocytosis. *J Pediatr* 1983;102(5):720-722.
412. Van Horn DK, Mortimer PP, Young N, et al. Human parvovirus-associated red cell aplasia in the absence of underlying hemolytic anemia. *Am J Pediatr Hematol Oncol* 1986;8(3):235-239.
413. Wang WC, Mentzer WC. Differentiation of transient erythroblastopenia of childhood from congenital hypoplastic anemia. *J Pediatr* 1976;88(5):784-789.
414. Link MP, Alter BP. Fetal-like erythropoiesis during recovery from transient erythroblastopenia of childhood. *Pediatr Res* 1981;15:1036.
415. Gasser C. Aplastic anemia (chronic erythroblastopenia) and cortisone. *Schweiz Med Wochenschr* 1951;81(50):1241-1242.
416. Hill JM, HR. ACTH therapy in refractory anemias. Proceedings of the Second Clinical ACTH Conference, New York, NY, 1987.
417. Ozsoylu S. High-dose intravenous corticosteroid treatment for patients with Diamond-Blackfan syndrome resistant or refractory to conventional treatment. *Am J Pediatr Hematol Oncol* 1988;10(3):217-223.
418. Ozsoylu S, Coskun T, Minassazi S. High dose intravenous glucocorticoid in the treatment of childhood acquired aplastic anaemia. *Scand J Haematol* 1984;33(3):309-316.
419. Buchanan GR. Oral megadose methylprednisolone therapy for refractory Diamond-Blackfan anemia. International Diamond-Blackfan Anemia Study Group. *J Pediatr Hematol Oncol* 2001;23(6):353-356.
420. August CS, King E, Githens JH, et al. Establishment of erythropoiesis following bone marrow transplantation in a patient with congenital hypoplastic anemia (Diamond-Blackfan syndrome). *Blood* 1976;48(4):491-498.
421. Alter BP. Bone marrow transplant in Diamond-Blackfan anemia. *Bone Marrow Transplant* 1998;21(9):965-966.
422. Aghalar J, Atsidaftos E, Lipton JM, Vlachos A. Improved outcomes in Diamond Blackfan anemia treated via stem cell transplantation since the year 2000. *ASH Annu Meeting Abstr* 2009;114:3202.
423. Willig TN, Niemeyer CM, Leblanc T, et al. Identification of new prognosis factors from the clinical and epidemiologic analysis of a registry of 229 Diamond-Blackfan anemia patients. DBA group of Société d'Hématologie et d'Immunologie Pédiatrique (SHIP), Gesellschaft für Pädiatrische Onkologie und Hämatologie (GPOH), and the European Society for Pediatric Hematology and Immunology (ESPHI). *Pediatr Res* 1999;46(5):553-561.
424. Vlachos A, Muir E. How I treat Diamond-Blackfan anemia. *Blood* 2010; 116(19):3715-3723.
425. Lipton JM, de Alarcon PA, Louis K. Diamond: an incomparable legacy. *J Pediatr Hematol/Oncol* 2001;23(6):371-372.

Chapter 40 Congenital Dyserythropoietic Anemias

> Table of Contents > Part IV - Disorders of Red Cells > Section 5 - Other Red Cell Disorders > Chapter 40 - Congenital Dyserythropoietic Anemias

Chapter 40

Congenital Dyserythropoietic Anemias

Gary Kupfer

Linette Bosques

Bertil Glader

The congenital dyserythropoietic anemias (CDAs) are a heterogeneous group of inherited blood disorders characterized by anemia and morphologic abnormalities of erythroid precursors in the bone marrow, a consequence of dyserythropoiesis and ineffective erythropoiesis.^{1, 2} These disorders principally affect the erythroid lineage, whereas other nonerythroid hematopoietic lineages seem to be unaffected. On the basis of morphologic abnormalities of the bone marrow, CDAs were classified into three different types: type I, type II, and type III. However, additional variants requiring further characterization have also been identified.³ Approximately 600 cases of CDA have been reported worldwide, CDA II being the most common.³ CDA I and II are inherited in an autosomal recessive pattern, and CDA III exhibits autosomal dominant inheritance and a sporadic form.⁴ The disease-related genes for CDA I, II, and III have been localized by linkage analysis, and the disease-causing genes have been identified for CDA I and II.

CDA patients display marked ineffective erythropoiesis and dyserythropoiesis.^{5, 6} Ineffective erythropoiesis may lead to intermittent jaundice, splenomegaly, hepatomegaly, and iron overload.^{2, 7} Iron overload is also a result of blood transfusion therapy, although even transfusion-independent patients may develop iron overload due to increased iron absorption.⁸ Dyserythropoiesis results in a variety of dysplastic features of erythroblasts in the bone marrow: internuclear chromatin bridges, karyorrhectic nuclei, binuclearity, multinuclearity, vacuolation of the cytoplasm, and duplication of the plasma membrane.⁹ Diagnosis of CDA relies on light and electron microscopy analyses to identify the characteristic morphologic abnormalities of the erythroblasts in the bone marrow.¹⁰ Mutation analysis is becoming available for some CDAs.

CDA should be suspected in any individual with a chronic anemia that is largely due to ineffective erythropoiesis, as well as in individuals with unexplained iron overload. The presence of ineffective erythropoiesis is characterized by a low absolute reticulocyte count for the degree of anemia despite erythroid hyperplasia in the marrow. Further suggestive laboratory data include a low serum haptoglobin level and increased serum lactic dehydrogenase (LDH) activity. Generally, the anemia is mildly or moderately macrocytic in CDA I, normocytic in CDA II, and mildly macrocytic in CDA III.

CONGENITAL DYSERYTHROPOIETIC ANEMIA TYPE I (CDA I)

CDA I is inherited in an autosomal recessive pattern and it represents the second most common form of CDA.⁶ It is most prevalent among Western Europeans, Middle Easterners (Israeli Bedouins, Lebanese, Kuwaitis, Saudi Arabians), Indians, and Japanese, with more than 150 reported cases.²

Clinical Features

Observations on CDA I have been enhanced by studies on a large cluster of cases in Israeli Bedouin families^{11, 12, 13} and on cases in the German CDA registry.¹⁴ The anemia varies from mild to severe, with the most severe cases presenting in infancy and the milder cases presenting in adolescence or later in life. Some degree of anemia is present in about two thirds of neonates, often requiring transfusion, but less than 10% of cases remain transfusion dependent later in life.^{14, 15} Occasionally, severe anemia in the fetus causes hydrops fetalis with pericardial and pleural effusions and edema.^{16, 17} Jaundice and splenomegaly are common findings at all ages. Gallstones may develop and require cholecystectomy. In addition, distal limb malformations, such as syndactyly, absence of phalanges and nails, an additional phalanx, and duplication or hypoplasia of the metatarsals, have been reported in several cases of CDA I.¹⁸ Other congenital abnormalities found include café au lait spots, short stature, flattened vertebral bodies, hypoplastic rib, Madelung deformity, and deafness.² Deterioration of vision with retinal angioid streaks and macular degeneration has been described in two cases.^{19, 20}

Laboratory Features

CDA I patients usually have a macrocytic anemia with MCV values up to 115; normocytic CDA I patients still display macrocytes and thus an increased RDW. Anisocytosis, poikilocytosis (including teardrop-shaped poikilocytes), and basophilic stippling are other features of the peripheral blood smear (Fig. 40.1). Increased hemoglobin A₂ levels and unbalanced globin chain synthesis are found in some cases in the absence of β -thalassemia mutations.¹³ Bone marrow examination reveals marked erythroid hyperplasia with megaloblastic erythroblasts. One of the defining features of CDA I is the presence of thin internuclear chromatin bridges between nearly completely separated erythroblasts in 0.6% to 2.8% of cells^{6, 10} (Fig. 40.2). In only one well-documented case were such bridges not seen.¹⁹ A small proportion of erythroblasts are binucleate and occasional cells have three or four nuclei. Other abnormalities include RBC basophilic stippling, irregular nuclear outlines, and karyorrhexis.

A second defining structural feature of CDA I is multiple rounded electron-lucent areas within the electron-dense heterochromatin seen in up to 60% of erythroblasts, giving the nucleus a spongy or "Swiss cheese" appearance^{10, 21} (Fig. 40.3B,C). In some erythroblasts, there are also marked invaginations or evaginations of the nuclear envelope, and the

invaginations carry cytoplasm and cytoplasmic organelles such as mitochondria into the nucleus (Fig. 40.3C).²² Bone marrow macrophages contain phagocytosed morphologically abnormal erythroblasts (Fig. 40.4).

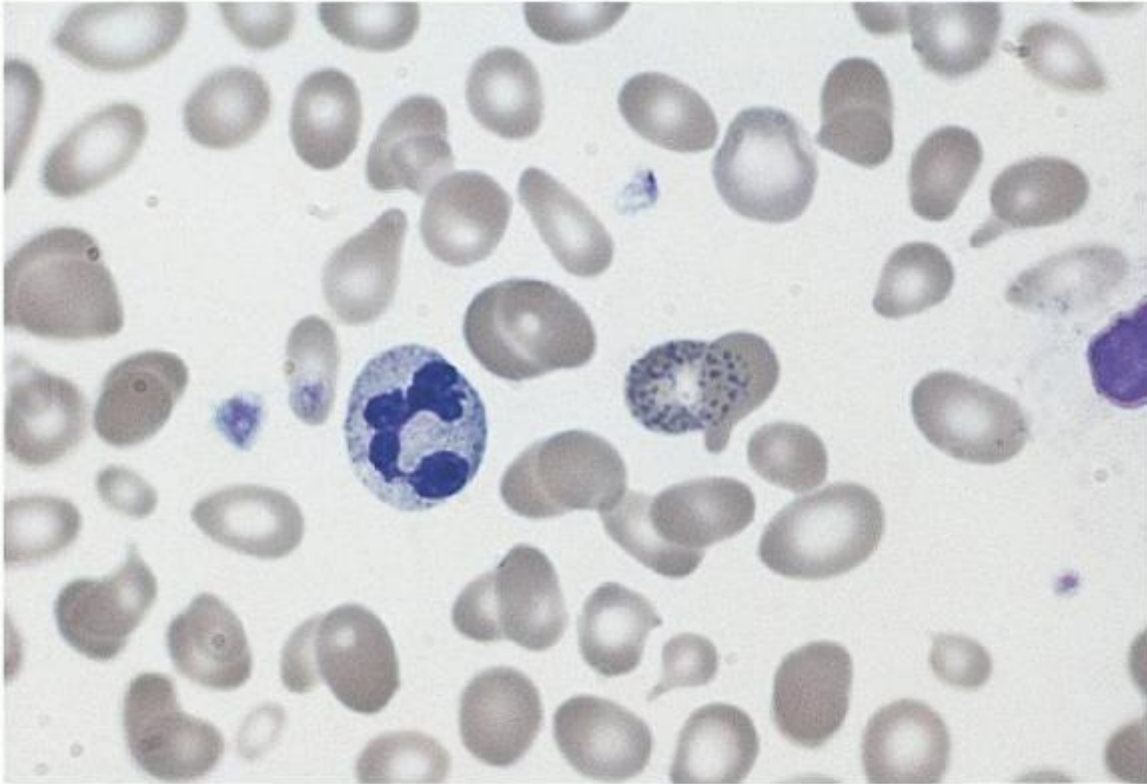

FIGURE 40.1. Blood smear from a patient with congenital dyserythropoietic anemia type I. (From Wickramasinghe SN. Congenital dyserythropoietic anemias. In: Wickramasinghe SN, McCullough J, eds. Blood and bone marrow pathology. Edinburgh: Churchill Livingstone, 2003:273-282, with permission.)

P.991

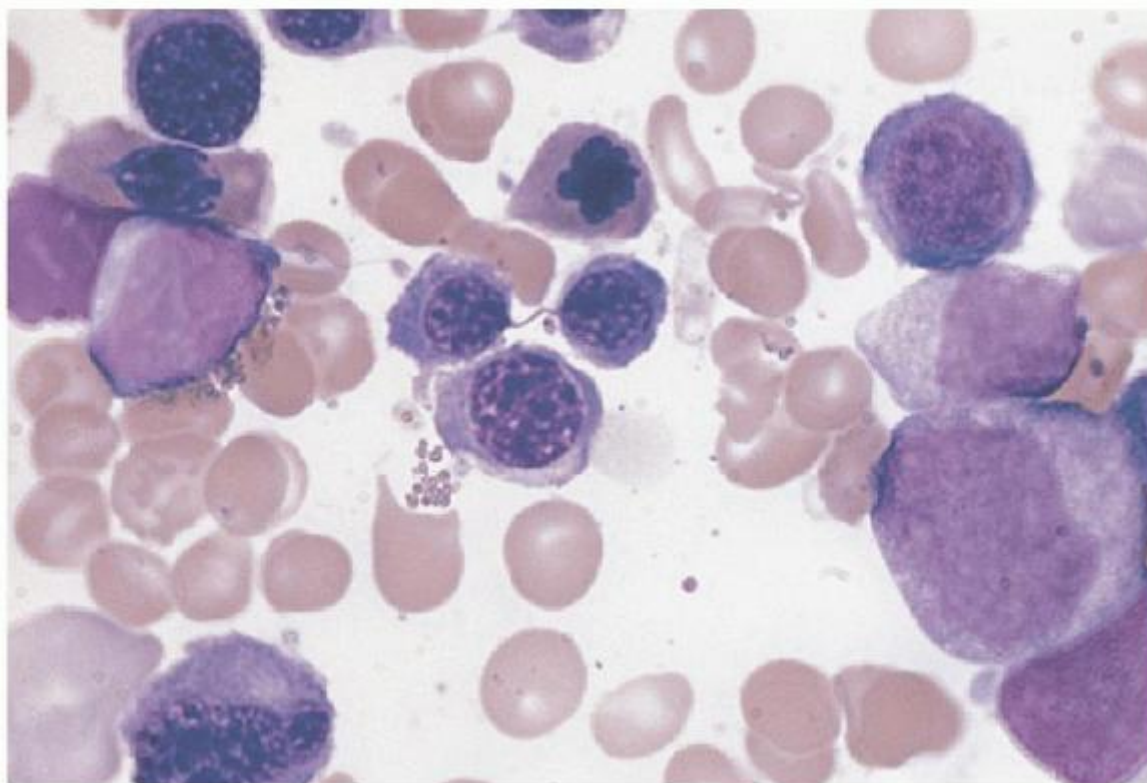

FIGURE 40.2. Bone marrow smear of a patient with congenital dyserythropoietic anemia type I showing an internuclear chromatin bridge. (From Wickramasinghe SN. Congenital dyserythropoietic anemias. In: Wickramasinghe SN, McCullough J, eds. Blood and bone marrow pathology. Edinburgh: Churchill Livingstone, 2003:273-282, with permission.)

Management

CDA I often follows an indolent course, although patients may require red cell transfusions in infancy, with infections, and during pregnancy. Only some patients benefit from splenectomy and this is in contrast to CDA II.^{2, 11, 14} Erythropoietin administration has no effect on the anemia of CDA I.²² Following the fortuitous observation that treatment of hepatitis C in a CDA I patient with interferon- α 2a led to a substantial hematologic improvement, several additional patients, including a severely affected infant, have been treated with interferon- α 2a, interferon- α 2b, or peg-interferon- α 2b, and these patients also have also experienced hematologic improvement.^{16, 24, 25, 26, 27, 28, 29} Interferon- α should be considered in the management of CDA I with severe anemia. In one case, long-term therapy was reported to reduce iron overload.²⁹ Careful monitoring for secondary hemochromatosis is important, at times requiring iron chelation therapy.

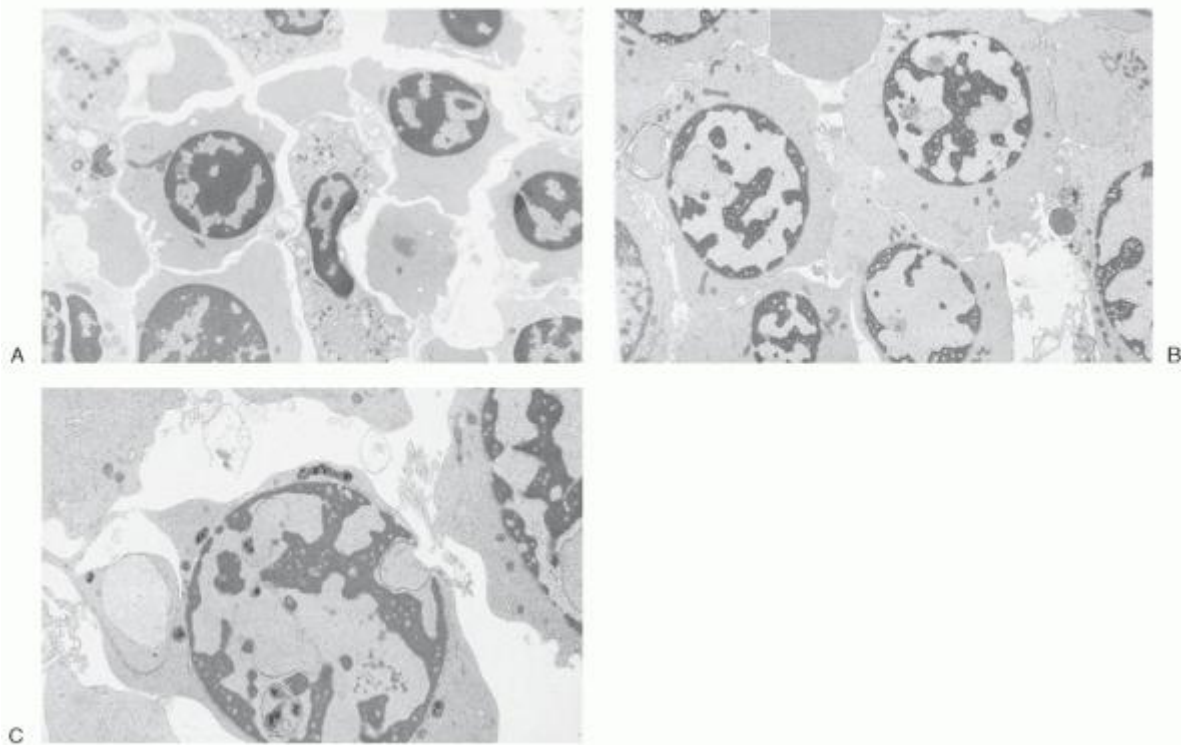

FIGURE 40.3. Ultrastructure of erythroblasts from a normal individual (A) and a patient with congenital dyserythropoietic anemia type i. B and C demonstrate the abnormal “Swiss cheese” appearance of the heterochromatin (compare with A), and C shows invagination of the nuclear membrane and nuclear membrane-bound areas of cytoplasm (containing iron-laden mitochondria) within the nucleus. (From Wickramasinghe SN. Congenital dyserythropoietic anaemias: clinical features, haematologic morphology and new biochemical data. *Blood Rev* 1998;12:178-200, with permission.)

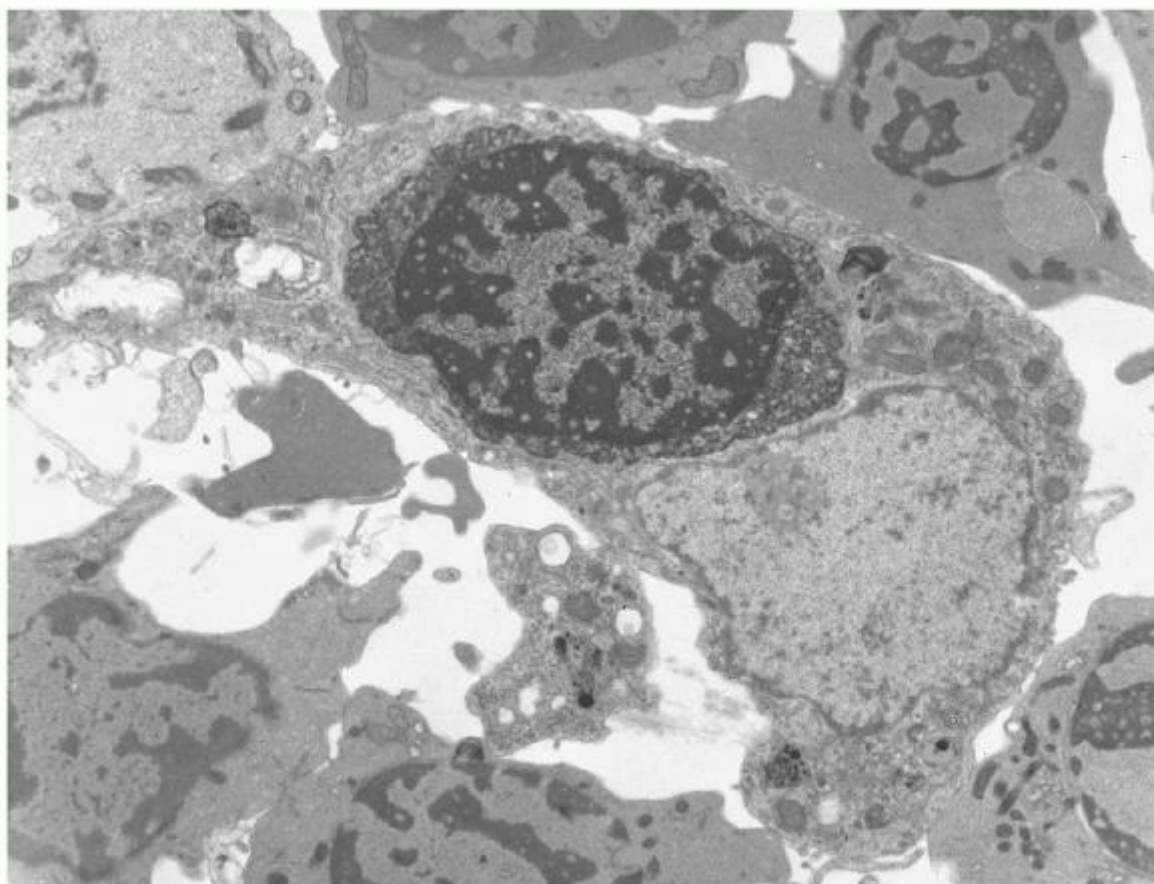

FIGURE 40.4. Bone marrow macrophage from a case of congenital dyserythropoietic anemia type I containing an ingested erythroblast with abnormal heterochromatin.

Molecular Biology of CDA I

In 1998 the gene for CDA I was localized to chromosome 15q15.1-15.3.³⁰ and it is now recognized that CDA I is caused by mutations in the CDAN1 gene.³¹ CDAN1 has 28 exons spanning 15 kb of genomic DNA and encodes a highly conserved protein of unknown function called codanin-1. Mutations in the CDAN1

P.992

gene are mainly located in the 3' half of the gene and no homozygote for null type mutations has been identified, suggesting that the complete absence of codanin-1 may be lethal.³² One founder missense mutation is observed mainly in Israeli Bedouins with CDA I which converts arginine to tryptophan at codon 1,040 and generates an NcoI restriction site.³¹ This same missense mutation was found in 11 individuals with CDA I of two unrelated Lebanese families. A single mutation in CDAN1 has been found in several sporadic cases and in one case, no mutations in CDAN1 were found.³¹

Analysis of codanin-1 orthologs revealed the *Drosophila* homolog, *dlt*, is required for cell survival and cell cycle progression through the S phase.³³ Interestingly, codanin-1 increases during the S phase and is phosphorylated and excluded from condensed chromosomes during mitosis.³⁴ This study demonstrated that codanin-1 localizes to the nucleus, specifically to heterochromatin, during interphase and it is regulated by E2F1 transcription factors.³⁴ Another study confirmed codanin-1 localization to the nucleus, but it revealed that it is more abundant in the cytoplasm.³⁵ Codanin-1 mutations lead to the abnormal accumulation of heterochromatin protein HP1 α in the Golgi apparatus of CDA I erythroblasts but not normal erythroblasts.³⁵ However, overall chromatin structure as indicated by genomewide epigenetic marks of several histone modifications is normal in CDA I erythroblasts.

Recently, codanin-1 was shown to interact with histone chaperone Asf1, which regulates the import of histones during DNA replication.³⁶ Codanin-1 knockdown increases the amount of chromatin-bound Asf1, enhancing DNA synthesis.

Conversely, forced expression of codanin-1 interferes with Asf1 function due to Asf1 sequestration in the cytoplasm. Thus codanin-1 acts as a negative regulator of replication.

This close association with heterochromatin suggests that codanin-1 may be involved in mechanisms controlling gene transcription and chromatin structure remodeling. Thus, a clear understanding of the biochemical behavior of codanin-1 may provide us insight into how this interaction is established.

CONGENITAL DYSERYTHROPOIETIC ANEMIA TYPE II (CDA II)

Type II CDA was first categorized as such by Heimpel and Wendt in 1968. It is the most common type of CDA, and several hundred patients have been described.³ The mode of inheritance is autosomal recessive.

Clinical Features

CDA II is usually a normocytic anemia with evidence of ineffective erythropoiesis and premature peripheral red cell destruction, causing jaundice and hepatosplenomegaly. In very mild cases, the anemia may be so slight as to remain undiscovered until late in adult life, although a majority of patients have a hemoglobin less than 11 g/dl. Overall, a third of affected children require transfusion in the first year of life, but transfusion requirements decrease in subsequent years, and only 5% of patients need regular transfusions in adulthood.³⁷ As in other congenital disorders in which ineffective erythropoiesis is a prominent feature, such as β thalassemia major, complications of extramedullary hematopoiesis may occur, such as dysmorphic facies, particularly in severely affected individuals. Cholelithiasis and secondary hemochromatosis are frequent complications, with iron overload the presenting manifestation in some cases.³⁸ Occasionally, transient red cell aplasia secondary to parvovirus B19 infection may develop.³⁹ Mental retardation,³ hemihypertrophy,³ and piebaldism and vaginal atresia have all been reported.⁴¹

Laboratory Features

Peripheral blood smear features include anisocytosis, poikilocytosis, basophilic stippling, and some irregularly contracted cells (Fig. 40.5). Bone marrow examination reveals marked erythroid hyperplasia without megaloblastosis. The defining erythroblast abnormality is prominent binuclearity. Proerythroblasts are morphologically normal, but basophilic and early and late polychromatic erythroblasts are binucleated, with up to 10% to 35% of late erythroblasts being so (Fig. 40.6). Some of these nuclei have irregular outlines or show karyorrhexis. In many binucleate late polychromatic erythroblasts, the nuclei are equal in size, and each of the two nuclei has a diploid DNA content suggesting the possibility that the cells resulted from a failure of cytokinesis following normal mitosis. The phagocytosis of red cells and erythroblasts by bone marrow macrophages leads to the formation of Gaucher-like macrophages (pseudo-Gaucher cells) in some individuals.

Electron microscopy reveals the characteristic presence of peripheral cisternae in erythroid cells.⁴⁰ These are discontinuous double membranes running parallel to and 40 to 60 nm away from the cell membrane (Fig. 40.7).⁴²

Peripheral cisternae are found in some red cells, a substantial proportion of mononucleate

P.993

and binucleate late polychromatic erythroblasts, and a smaller proportion of early polychromatic erythroblasts. They appear to represent endoplasmic reticulum (ER) as they contain disulfide isomerase that is known to be present in ER.⁴³

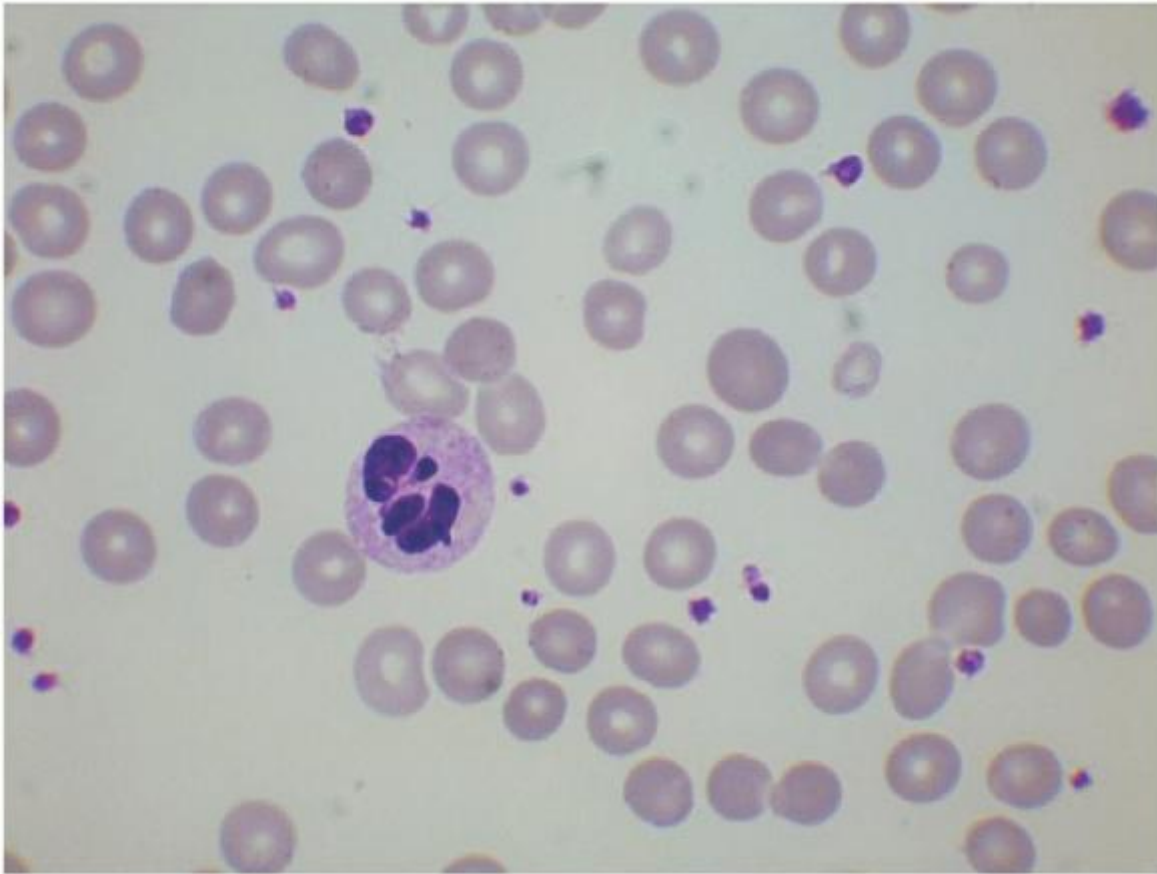

FIGURE 40.5. Blood smear from a patient with congenital dyserythropoietic anemia type II. (Courtesy of Professor B. Bain, London.)

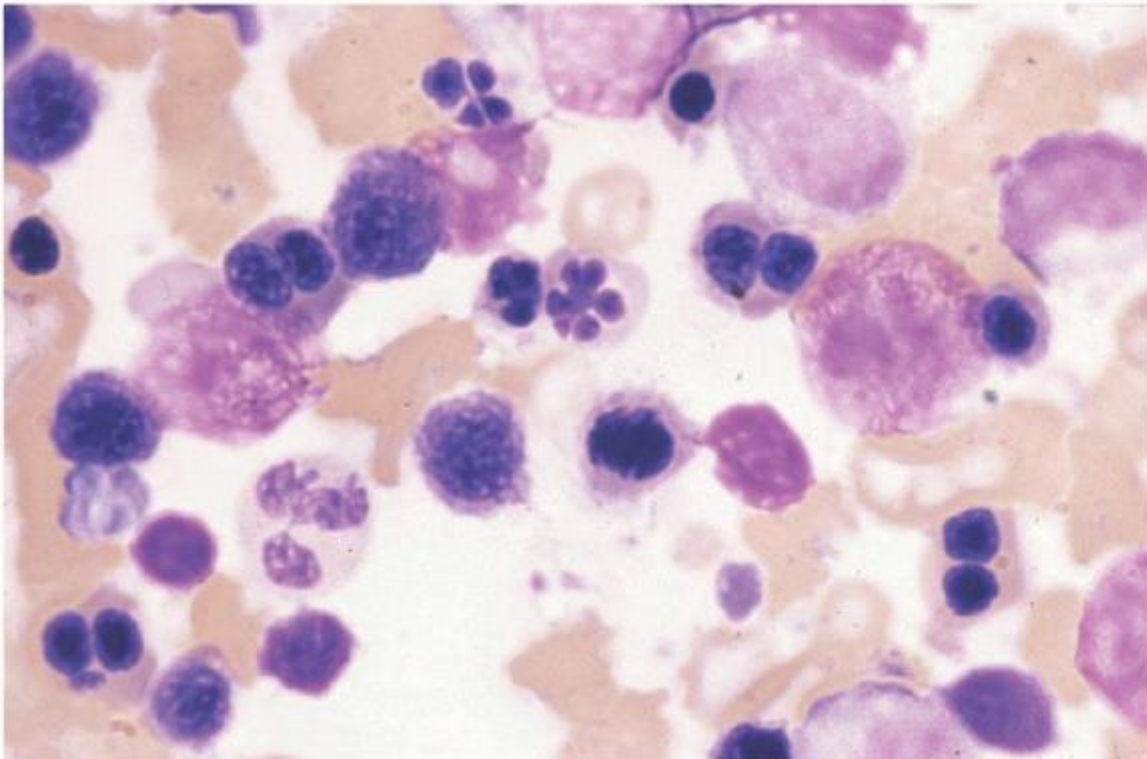

FIGURE 40.6. Bone marrow smear from a patient with congenital dyserythropoietic anemia type II, showing binucleate late polychromatic erythroblasts and karyorrhexis.

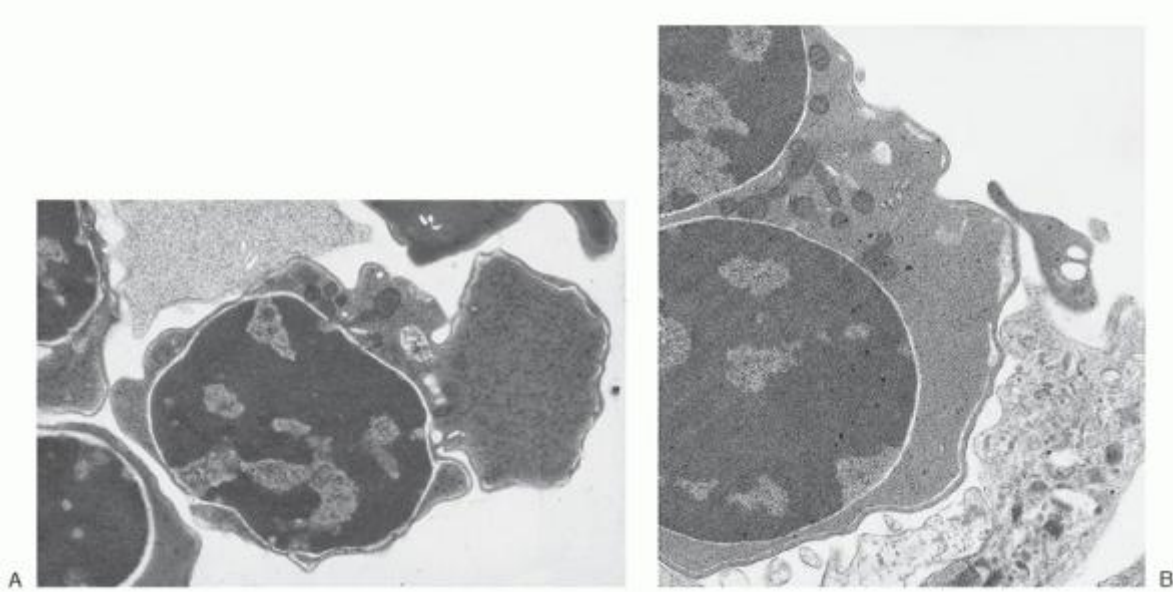

FIGURE 40.7. Electron micrograph of a mononucleate late polychromatic erythroblast (A) and part of a binucleate late polychromatic erythroblast (B) from a case of congenital dyserythropoietic anemia type II showing peripheral cisternae. (Part B from Wickramasinghe SN. Congenital dyserythropoietic anemias. In: Wickramasinghe SN, McCullough J, eds. Blood and bone marrow pathology. Edinburgh: Churchill Livingstone, 2003:273-282, with permission.)

When tested against a panel of ABO-compatible acidified sera (pH 6.8) from normal individuals, about 30% of the sera lyses CDA II red cells (acidified serum lysis test or Ham test). Unlike paroxysmal nocturnal hemoglobinuria (PNH), there is rarely lysis of the patient's red cells by his or her own serum. In addition, CDA II cells do not lyse in isotonic sucrose as PNH cells do. The lysis in acidified heterologous sera is due to a naturally occurring complement-binding immunoglobulin (Ig) M antibody against an unidentified antigen on CDA II cells. The combination of the characteristic morphologic abnormalities and the serologic finding led Crookston et al.⁴⁴ to propose the acronym HEMPAS (hereditary erythroblastic multinuclearity with positive acidified serum test) for CDA II. The acidified serum lysis test previously was most informative and useful to diagnose PNH; however, this test now has been replaced by quantitation of CD55 and CD59 by flow cytometry (see Chapter 35). As a consequence there is decreased availability of the Ham test in clinical laboratories and this test is rarely used to help identify CDA II.

The principal biochemical feature of CDA II is defective N-glycosylation of the erythrocyte membrane proteins, band 3 (anion exchange protein 1) and band 4.5 (glucose transporter 1).^{45, 46, 47} This causes band 3 and band 4.5 to migrate at lower molecular weights on sodium dodecyl sulfate-polyacrylamide gel electrophoresis (SDS-PAGE). During normal maturation of erythroid cells, the erythrocyte membrane proteins are glycosylated with polylactosaminoglycans. Band 3 and band 4.5 proteins normally contain long polylactosamine chains attached to complex N-linked oligosaccharides.⁴⁸ However, in CDA II, erythrocyte membrane proteins carry altered N-glycans with truncated polylactosamine structures.⁴⁸ Instead, glycosylation is shifted to lipid acceptors resulting in the accumulation of polylactosamines as glycolipids. Immunogold electron microscopy analysis using antiband 3 antibodies reveals irregular clustering of underglycosylated band 3 protein in CDA II erythrocyte membranes when compared to normal erythrocytes.⁴⁹ SDS-PAGE of red cell membrane proteins can be used as a diagnostic criterion in lieu of a positive acidified serum lysis test.

Management

Some cases of CDA II follow an indolent course, whereas transfusion-dependent individuals often benefit from splenectomy, usually with a moderate increase in hemoglobin concentration.^{3, 37} Most important, patients should be monitored closely for secondary hemochromatosis, which can occur even in the absence of regular transfusion as a result of ineffective erythropoiesis with increased iron absorption.⁵⁰ The extent of iron overload increases progressively with age,^{3, 37} and about 20% of cases develop cirrhosis.³ Iron chelation therapy may be indicated, or alternatively, phlebotomy may be considered in patients with mild anemia. In one case of CDA II with co-inherited β -thalassemia trait⁵¹ and one of a variant CDA II with a negative Ham test,⁵² allogeneic bone marrow transplantation has been curative.

Molecular Biology of CDA II

Abnormalities in two Golgi enzymes previously were implicated in the pathogenesis of CDA II: N-acetylglucosaminyltransferase II and α -mannosidase II.⁵³ In fact, an α -mannosidase II knockout mouse reproduces a phenotype similar to CDA II.⁵⁴ However, further familial studies have excluded linkage of CDA II to the N-acetylglucosaminotransferase and α -mannosidase II genes.⁵⁵ In addition, it has been found that abnormalities of glycosylation of red cell membrane proteins are not confined to CDA II, being present, albeit to a lesser degree, in both CDA I and III.^{56, 57}

From studying several families, the CDA I1 gene (CDAN2) has been localized to chromosome 20q11.2.^{58, 59} The disease-causing gene in CDA II is SEC23B, which spans approximately 54 kb on chromosome 20p11.23.^{60, 61} It encodes an essential component of the coat protein complex II (COPII)-coated vesicles that transport secretory proteins from the endoplasmic reticulum to the Golgi apparatus. The majority of CDA II patients harbor mutations in the SEC23B gene, although 10% of CDA II patients have no detectable mutations in this gene.^{37, 60, 61} The most frequent SEC23B mutations are the coding region missense mutations, R14W and E109K, and nonsense mutations, R497C and I318T.^{61, 62, 63, 64} Splice-site mutations and frameshift mutations have also been reported.^{63, 64} Compound heterozygosity for a frameshift or nonsense mutation and a missense mutation result in a more severe CDA II phenotype than homozygosity for two missense mutations,

P.994

establishing a genotype-phenotype relationship. However, CDA II patients homozygous for nonsense mutations have never been reported, suggesting that some SEC23B expression is necessary for embryonic viability.^{60, 61} In light of the identification of SEC23B, earlier described abnormalities in two Golgi enzymes implicated in the pathogenesis of CDA II: N-acetylglucosaminyltransferase II and α -mannosidase II are even more compelling.⁵³

CONGENITAL DYSERYTHROPOIETIC ANEMIA TYPE III (CDA III)

This disorder was first described in 1951 in an American family by Wolfe and von Hofe under the name familial erythroid multinuclearity, and in 1962 in a Swedish family by Bergström and Jacobsson as hereditary benign erythroreticulosis.^{65, 66} CDA III represents the rarest CDA variant with a familial and a sporadic form.⁶⁷ The familial form is inherited in an autosomal dominant pattern, and the sporadic form is inherited in an autosomal recessive pattern or may arise de novo as a dominant mutation.^{6, 67} The disease gene has been localized in the Swedish family with CDA III to a 4.5 cM interval on chromosome 15q21-q25.⁶⁸ The possibility of an individual having CDA III is considered in the face of a mild macrocytic anemia not due to other common conditions.

Clinical Features

Individuals may experience fatigue, weakness, and episodes of abdominal pain and jaundice resulting from gallstones. Splenomegaly is absent in the dominantly inherited cases but is present in most sporadic cases. Intravascular hemolysis and consequent hemosiderinuria may be present and occasionally lead to iron deficiency. Iron overload does not develop in the Swedish cases probably because of iron loss from hemosiderinuria.⁶⁹ In the Swedish family, the prevalence of monoclonal gammopathy of unknown significance and myeloma is increased,⁶⁹ and visual disturbances due to macular degeneration and angioid streaks may be seen in older patients.⁷⁰ Single sporadic cases have been reported to develop Hodgkin disease and malignant T-cell lymphoma.^{71, 72}

Laboratory Features

The macrocytic anemia is generally of mild to moderate severity. The peripheral blood smear displays basophilic stippling, irregularly contracted erythrocytes, anisocytosis, and poikilocytosis (Fig. 40.8).² A distinguishing feature of CDA III is markedly abnormal erythroblast proliferation resulting in giant binucleated and multinucleated erythroblasts with up to 12 nuclei (Fig. 40.9A-D) and total DNA content up to 48 N.^{65, 73} Electron microscopy shows multinucleated erythroblasts with multiple nuclear clefts in the heterochromatin, which may lead to nuclear lobulation and karyorrhexis (Fig. 40.10).⁷⁴ Individual nuclei within the same multinucleated cells (with up to 12 nuclei) can display different shapes and sizes and abnormal heterochromatin appearance.⁷⁴ The cytoplasm of many erythroblasts contains large autophagic vacuoles, inclusions containing β globin chains, iron-loaded mitochondria, and myelin figures.

CONGENITAL DYSERYTHROPOIETIC ANEMIA VARIANTS

A category, designated CDA type IV, was proposed to describe cases with bone marrow appearances typical of CDA II, but a negative Ham test with heterologous sera. Some of these cases may simply represent CDA II in which an insufficient number of heterologous sera were used in the test. Examples exist of cases that have been reclassified as CDA II when retested with more sera. The availability of SEC23B gene testing should help define if these are truly CDA II variants.

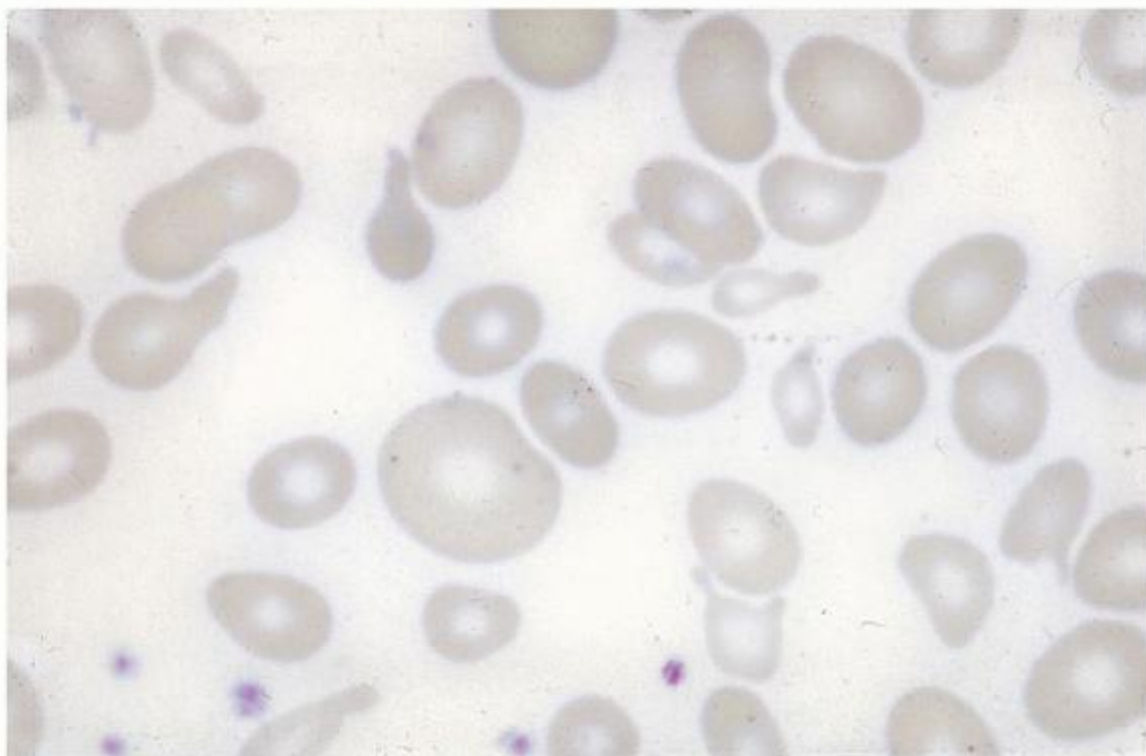

FIGURE 40.8. Blood smear from a patient with congenital dyserythropoietic anemia type III.

Several cases have been reported with features other than those of CDA I, II, or III that seem to represent distinct forms of CDA rather than variants of the three classic types. Most of these have been tentatively assigned to four phenotype-based groups designated CDA group IV, V, VI, and VII and their essential features are shown in Table 40.1;^{2, 6} the majority belong to group IV.^{75, 76} They have been designated as groups rather than types as there is evidence of phenotypic and/or genetic heterogeneity within each group. In addition to these groups, each of which includes three or more families, there are cases with unique features reported in only one or two families.

A father and daughter had a disorder with probable autosomal dominant inheritance characterized by normal hemoglobin values, macrocytes in the blood film, and dyserythropoiesis including internuclear chromatin bridges, but unlike in CDA I, the erythroblast heterochromatin was ultrastructurally normal.⁷⁷ Other single cases have shown large cytoplasmic vacuoles, macrocytosis without anemia, and marked irregularities of nuclear outline in a high proportion of erythroblasts⁷⁸ or transfusion-dependent anemia with gross nonspecific dyserythropoietic changes in many erythroblasts including marked irregularities of nuclear outline.⁷⁹ In two consanguineous Arab families, CDA was associated with microcytosis, many binucleate late erythroblasts, a negative Ham test, and chronic recurrent multifocal osteomyelitis; the inheritance was autosomal recessive and homozygous mutations in the LPIN2 gene on chromosome 18p were present.^{80, 81} A third Arabic patient with this syndrome also had a homozygous mutation in LPIN2.⁸²

A missense mutation of erythroid transcription factor KLF1 has been reported to cause CDA with erythroid hyperplasia and unique ultrastructural abnormalities in the bone marrow.⁸³ A characteristic feature of this CDA variant is the high number of orthochromatic erythroblasts in the peripheral blood that fail to undergo terminal erythroid differentiation and thus retain their nuclei. Furthermore, patient-derived CD34⁺ cells induced down the erythroid lineage in vitro show impaired enucleation. Electron microscopy reveals erythroblasts with endoreplication of nuclear membrane with abnormally large nuclear pores, severe anisopoikilocytosis, and cytoplasmic inclusions. Clinically, the patient described with this mutation required frequent blood transfusions due to hemolytic anemia. Treatment with erythropoietin or interferon- α was ineffective. Following splenectomy, the patient became transfusion-independent and hemoglobin

P.995

levels stabilized. The patient had no mutations in the CDAN1 and SEC23B genes. The disease-causing mutation was discovered to affect exon 3 of the KLF1 gene, converting glutamate 325 to lysine (E325K). The patient displayed

dysregulation of globin gene expression, resulting in the persistence of embryonic and fetal hemoglobins. Additionally, the patient's circulating erythroblasts and mature erythrocytes were deficient in the adhesion molecule CD44 and water channel AQP1. Of interest, a well-studied patient with very similar clinical features had been reported in the 1990s.

This previous patient had a moderate normochromic normocytic anemia, dyserythropoiesis, circulating erythroblasts, ineffective erythropoiesis, and the following features: deficiency of erythroid but not leukocyte CD44, a unique Colton blood group, 50% hemoglobin F, small amounts of ζ - and ϵ -globin chains in some red cells, reduced expression of aquaporin 1 (CHIP), and rounded intraerythroblastic inclusions composed of tightly packed double

P.996

membranes.^{84, 85, 86} More recently, when this earlier patient was reevaluated, she also was found to have the same KLF1 mutation.⁸³

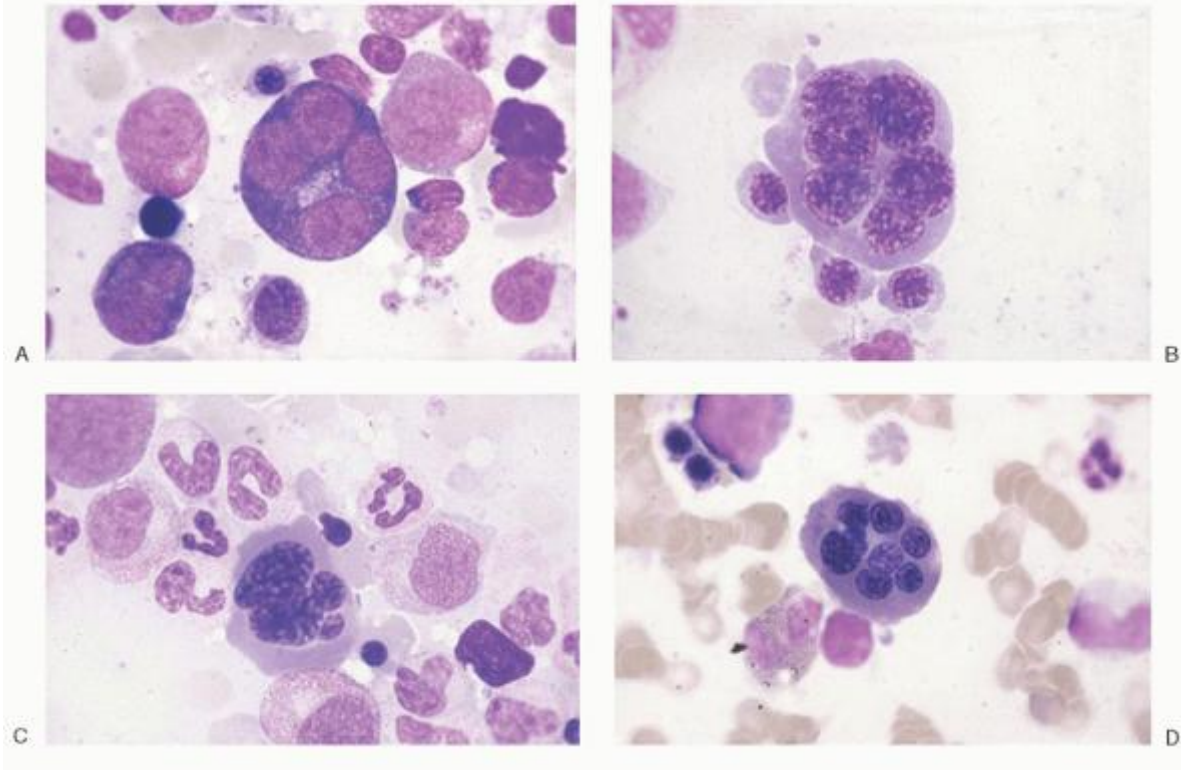

FIGURE 40.9. Multinucleate erythroblasts from the bone marrow of a case of congenital dyserythropoietic anemia type III. A: Tetranucleate basophilic erythropoietic cell. B, C, and D: Polychromatic erythroblasts with six, four, and eight nuclei, respectively.

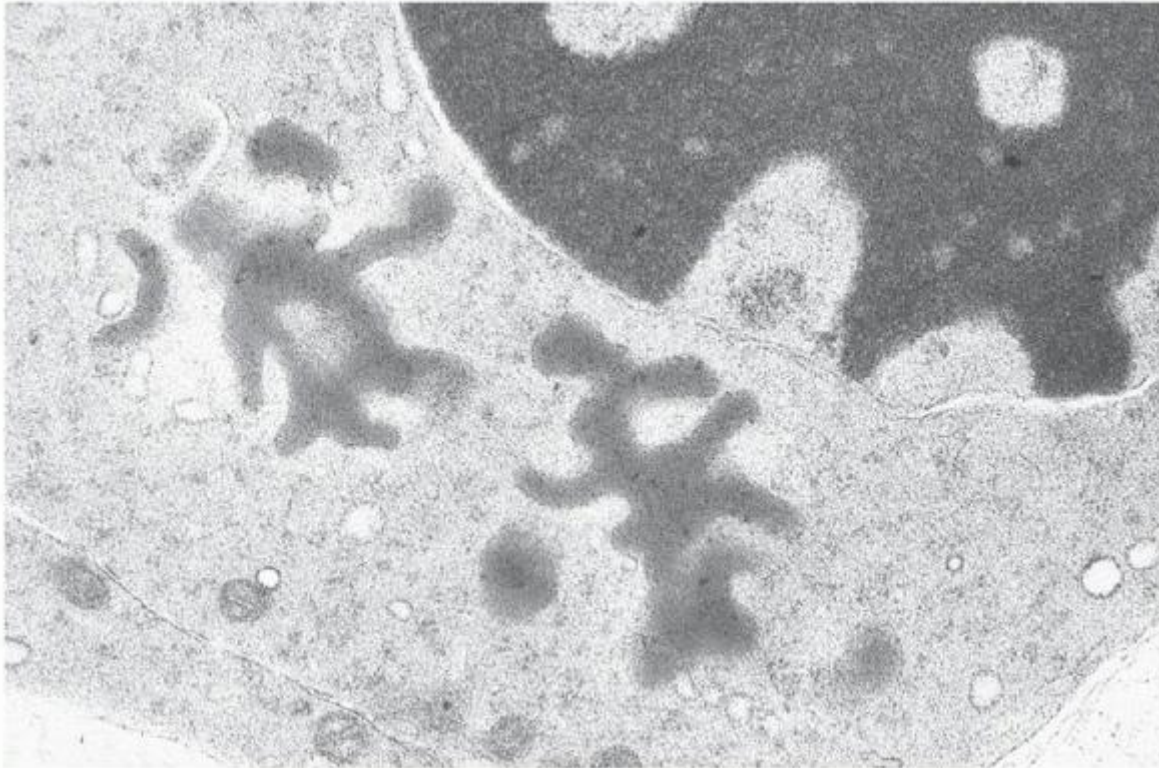

FIGURE 40.10. Erythroblast from a case of congenital dyserythropoietic anemia type III showing stellate intracytoplasmic inclusions. (From Wickramasinghe SN, Wahlin A, Anstee D, et al. Observations on two members of the Swedish family with congenital dyserythropoietic anaemia, type III. *Eur J Haematol* 1993;50:213-221, with permission.)

TABLE 40.1 FEATURES OF CONGENITAL DYSERYTHROPOIETIC ANEMIA (CDA) GROUPS IV-VII^a

Group Defining Features

IV	Severe transfusion-dependent anemia Marked erythroid hyperplasia, usually normoblastic Markedly ineffective erythropoiesis Slight/moderate increase in nonspecific dyserythropoietic changes including markedly irregular or karyorrhectic nuclei Absence of the marrow abnormalities characteristic of CDA I-III Absence of precipitated protein within erythroblasts by electron microscopy (which excludes α -thalassemia syndromes and CDA group VII)
V	Normal or near-normal Hb with normal or slightly increased MCV Predominantly unconjugated hyperbilirubinemia Marked normoblastic/mildly or moderately megaloblastic erythroid hyperplasia Grossly ineffective erythropoiesis Little or no erythroid dysplasia
VI	Normal or near-normal Hb with marked macrocytosis (MCV 119-125 fl) Erythroid hyperplasia with cobalamin and folate-independent florid megaloblastic erythropoiesis and nonspecific dyserythropoiesis

Ineffective erythropoiesis

VII Severe transfusion-dependent anemia

Marked normoblastic erythroid hyperplasia with nonspecific dyserythropoietic changes, especially irregular nuclear shapes, in many polychromatic erythroblasts

Markedly ineffective erythropoiesis

Intraerythroblastic inclusions resembling precipitated globin that do not react with antibodies to α - or β -globin chains (electron microscope studies)

Hb, hemoglobin; MCV, mean corpuscular volume.

^aCDA group IV is distinct from CDA type IV, which is a term that has been used to describe a variant of CDA type II.

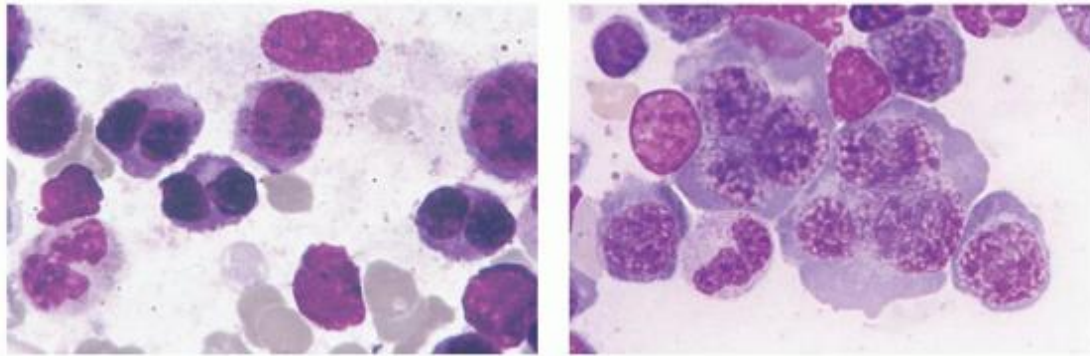

FIGURE 40.11. Bone marrow appearances resembling those of congenital dyserythropoietic anemia. A: Myelodysplastic syndrome with frequent binucleate late polychromatic erythroblasts. B: Thiamine-responsive anemia with multinucleate megaloblasts. (Part B from Wickramasinghe SN. Macrocytic anemia. In: Wickramasinghe SN, McCullough J, eds. Blood and bone marrow pathology. Edinburgh: Churchill Livingstone, 2003:229-247, with permission.)

Congenital dyserythropoiesis is associated with thrombocytopenia in patients with mutations in the gene for the transcription factor GATA1.^{2, 87} However, the presence of thrombocytopenia would generally be considered to exclude such cases from the category of CDAs.

In addition to the congenital dyserythropoietic disorders discussed in this chapter, acquired conditions occasionally can be associated with ineffective erythropoiesis and dyserythropoiesis.^{2, 6, 9} These include vitamin B₁₂ or folate deficiency, severe iron deficiency, thalassemia syndromes, some unstable hemoglobins, sideroblastic anemias, myelodysplastic syndromes, acute myeloid leukemia, aplastic anemia, malaria, Kala azar, alcohol abuse, and liver disease. It is noteworthy that morphologic features characteristic of CDA I, II, and III may be seen in some acquired dyserythropoietic states. For example, internuclear chromatin bridges such as those seen in CDA I may be found occasionally in myelodysplastic syndromes (MDSs), in *Plasmodium falciparum* malaria, and during marrow regeneration following transplantation. A high proportion of binucleate late erythroblasts such as is seen in CDA II may be encountered in MDS (Fig. 40.11A) and marked multinuclearity of erythroblasts as found in CDA III is seen in some cases of erythroleukemia and thiamine-responsive anemia (Fig. 40.11B).

REFERENCES

1. Renella R, Wood WG. The congenital dyserythropoietic anemias. *Hematol Oncol Clin North Am* 2009;23(2):283-306.
2. Wickramasinghe SN, Wood WG. Advances in the understanding of the congenital dyserythropoietic anaemias. *Br J Haematol* 2005;131(4):431-446.
3. Heimpel H, Anselstetter V, Chrobak L, et al. Congenital dyserythropoietic anemia type II: epidemiology, clinical appearance, and prognosis based on long-term observation. *Blood* 2003;102(13):4576-4581.
4. Wickramasinghe SN. Congenital dyserythropoietic anemias. *Curr Opin Hematol* 2000;7(2):71-78.
5. Kamiya T, Manabe A. Congenital dyserythropoietic anemia. *Int J Hematol* 2010;92(3):432-438.

6. Wickramasinghe SN. Congenital dyserythropoietic anaemias: clinical features, haematological morphology and new biochemical data. *Blood Rev* 1998;12(3):178-200.
7. Iolascon A, Russo R, Delaunay J. Congenital dyserythropoietic anemias. *Curr Opin Hematol* 2011;18(3):146-151.
8. Cazzola M, Barosi G, Bergamaschi G, et al. Iron loading in congenital dyserythropoietic anaemias and congenital sideroblastic anaemias. *Br J Haematol* 1983;54(4):649-654.
9. Wickramasinghe SN. Dyserythropoiesis and congenital dyserythropoietic anaemias. *Br J Haematol* 1997;98(4):785-797.
10. Heimpel H, Forteza-Vila J, Queisser W, Spiertz E. Electron and light microscopic study of the erythroblasts of patients with congenital dyserythropoietic anemia. *Blood* 1971;37(3):299-310.
11. Shalev H, Kapleushnik Y, Haeskelzon L, et al. Clinical and laboratory manifestations of congenital dyserythropoietic anemia type I in young adults. *Eur J Haematol* 2002;68(3):170-174.
12. Shalev H, Tamary H, Shaft D, Reznitsky P, Zaizov R. Neonatal manifestations of congenital dyserythropoietic anemia type I. *J Pediatr* 1997;131(1 Pt 1): 95-97.
13. Tamary H, Shalev H, Luria D, et al. Clinical features and studies of erythropoiesis in Israeli Bedouins with congenital dyserythropoietic anemia type I. *Blood* 1996;87(5):1763-1770.
14. Heimpel H, Schwarz K, Ebnother M, et al. Congenital dyserythropoietic anemia type I (CDA I): molecular genetics, clinical appearance, and prognosis based on long-term observation. *Blood* 2006;107(1):334-340.
15. Shalev H, Kapelushnik J, Moser A, Dgany O, Krasnov T, Tamary H. A comprehensive study of the neonatal manifestations of congenital dyserythropoietic anemia type I. *J Pediatr Hematol Oncol* 2004;26(11):746-748.
16. Perez N, Dommergues M, Zupan V, et al. Severe congenital dyserythropoietic anaemia type I: prenatal management, transfusion support and alpha-interferon therapy. *Br J Haematol* 2000;110(2):420-423.
17. Stone P, Zuccollo J. Lethal congenital dyserythropoietic anaemia type I in siblings presenting as pericardial effusions in the second trimester. *Fetal Diagn Ther* 1999;14(1):11-14.
18. Goede JS, Benz R, Fehr J, Schwarz K, Heimpel H. Congenital dyserythropoietic anemia type I with bone abnormalities, mutations of the CDAN I gene, and significant responsiveness to alpha-interferon therapy. *Ann Hematol* 2006;85(9):591-595.
19. Tamary H, Offret H, Dgany O, et al. Congenital dyserythropoietic anaemia, type I, in a Caucasian patient with retinal angioid streaks (homozygous Arg1042Trp mutation in codanin-1). *Eur J Haematol* 2008;80(3):271-274.
20. Roberts E, Madhusudhana KC, Newsom R, Cullis JO. Blindness due to angioid streaks in congenital dyserythropoietic anaemia type I. *Br J Haematol* 2006;133(5):456.
21. Lewis SM, Nelson DA, Pitcher CS. Clinical and ultrastructural aspects of congenital dyserythropoietic anaemia type I. *Br J Haematol* 1972;23(1):113-119.
22. Hiraoka A, Kanayama Y, Yonezawa T, Kitani T, Tarui S, Hashimoto PH. Congenital dyserythropoietic anemia type I: a freeze-fracture and thin section electron microscopic study. *Blut* 1983;46(6):329-338.
23. Tamary H, Shalev H, Pinsk V, Zoldan M, Zaizov R. No response to recombinant human erythropoietin therapy in patients with congenital dyserythropoietic anemia type I. *Pediatr Hematol Oncol* 1999;16(2):165-168.
24. Lavabre-Bertrand T, Blanc P, Navarro R, et al. alpha-Interferon therapy for congenital dyserythropoiesis type I. *Br J Haematol* 1995;89(4):929-932.
25. Virjee S, Hatton C. Congenital dyserythropoiesis type I and alpha-interferon therapy. *Br J Haematol* 1996;94(3):581-582.
26. Wickramasinghe SN. Response of CDA type I to alpha-interferon. *Eur J Haematol* 1997;58(2):121-123.
27. Roda L, Pasche J, Fournier A, et al. Congenital dyserythropoietic anemia, type 1, in a polynesian patient: response to interferon alpha2b. *J Pediatr Hematol Oncol* 2002;24(6):503-506.
28. Heimpel H. Congenital dyserythropoietic anemias: epidemiology, clinical significance, and progress in understanding their pathogenesis. *Ann Hematol* 2004;83(10):613-621.
29. Lavabre-Bertrand T, Ramos J, Delfour C, et al. Long-term alpha interferon treatment is effective on anaemia and significantly reduces iron overload in congenital dyserythropoiesis type I. *Eur J Haematol* 2004;73(5):380-383.

30. Tamary H, Shalmon L, Shalev H, et al. Localization of the gene for congenital dyserythropoietic anemia type I to a <1-cM interval on chromosome 15q15.1-15.3. *American Journal of Human Genetics* 1998;62(5):1062-1069.
31. Dgany O, Avidan N, Delaunay J, et al. Congenital dyserythropoietic anemia type I is caused by mutations in codanin-1. *Am J Hum Genet* 2002;71(6):1467-1474.
32. Tamary H, Dgany O, Proust A, et al. Clinical and molecular variability in congenital dyserythropoietic anaemia type I. *Br J Haematol* 2005;130(4):628-634.
33. Pielage J, Stork T, Bunse I, Klambt C. The *Drosophila* cell survival gene discs lost encodes a cytoplasmic Codanin-1-like protein, not a homolog of tight junction PDZ protein Patj. *Dev Cell* 2003;5(6):841-851.
34. Noy-Lotan S, Dgany O, Lahmi R, et al. Codanin-1, the protein encoded by the gene mutated in congenital dyserythropoietic anemia type I (CDAN1), is cell cycle-regulated. *Haematologica* 2009;94(5):629-637.
35. Renella R, Roberts NA, Brown JM, et al. Codanin-1 mutations in congenital dyserythropoietic anemia type 1 affect HP1 α localization in erythroblasts. *Blood* 2011;117(25):6928-6938.

P.997

36. Ask K, Jasencakova Z, Menard P, Feng Y, Almouzni G, Groth A. Codanin-1, mutated in the anaemic disease CDAl, regulates Asf1 function in S-phase histone supply. *EMBO J* 2012;31(8):2013-2023.
37. Iolascon A, Delaunay J, Wickramasinghe SN, Perrotta S, Gigante M, Camaschella C. Natural history of congenital dyserythropoietic anemia type II. *Blood* 2001;98(4):1258-1260.
38. Greiner TC, Burns CP, Dick FR, Henry KM, Mahmood I. Congenital dyserythropoietic anemia type II diagnosed in a 69-year-old patient with iron overload. *Am J Clin Pathol* 1992;98(5):522-525.
39. Heimpel H, Wilts H, Hirschmann WD, et al. Aplastic crisis as a complication of congenital dyserythropoietic anemia type II. *Acta Haematol* 2007;117(2):115-118.
40. Verwilghen RL, Lewis SM, Dacie JV, Crookston JH, Crookston MC. HEMPAS: congenital dyserythropoietic anaemia (type II). *Q J Med* 1973;42(166): 257-278.
41. Koklu S, Ertugrul D, Onat AM, et al. Piebaldism associated with congenital dyserythropoietic anemia type II (HEMPAS). *Am J Hematol* 2002;69(3): 210-213.
42. Wong KY, Hug G, Lampkin BC. Congenital dyserythropoietic anemia type II: ultrastructural and radioautographic studies of blood and bone marrow. *Blood* 1972;39(1):23-30.
43. Alloisio N, Texier P, Denoroy L, et al. The cisternae decorating the red blood cell membrane in congenital dyserythropoietic anemia (type II) originate from the endoplasmic reticulum. *Blood* 1996;87(10):4433-4439.
44. Crookston JH, Crookston MC, Burnie KL, et al. Hereditary erythroblastic multinuclearity associated with a positive acidified-serum test: a type of congenital dyserythropoietic anaemia. *Br J Haematol* 1969;17(1):11-26.
45. Mawby WJ, Tanner MJ, Anstee DJ, Clamp JR. Incomplete glycosylation of erythrocyte membrane proteins in congenital dyserythropoietic anaemia type II (CDA II). *Br J Haematol* 1983;55(2):357-368.
46. Scartezzini P, Forni GL, Baldi M, Izzo C, Sansone G. Decreased glycosylation of band 3 and band 4.5 glycoproteins of erythrocyte membrane in congenital dyserythropoietic anaemia type II. *Br J Haematol* 1982;51(4):569-576.
47. Fukuda MN, Papayannopoulou T, Gordon-Smith EC, Rochant H, Testa U. Defect in glycosylation of erythrocyte membrane proteins in congenital dyserythropoietic anaemia type II (HEMPAS). *Br J Haematol* 1984;56(1):55-68.
48. Denecke J, Kranz C, Nimtz M, et al. Characterization of the N-glycosylation phenotype of erythrocyte membrane proteins in congenital dyserythropoietic anemia type II (CDA II/HEMPAS). *Glycoconj J* 2008;25(4):375-382.
49. Fukuda MN, Klier G, Yu J, Scartezzini P. Anomalous clustering of underglycosylated band 3 in erythrocytes and their precursor cells in congenital dyserythropoietic anemia type II. *Blood* 1986;68(2):521-529.
50. Halpern Z, Rahmani R, Levo Y. Severe hemochromatosis: the predominant clinical manifestation of congenital dyserythropoietic anemia type 2. *Acta Haematol* 1985;74(3):178-180.

51. Iolascon A, Sabato V, de Mattia D, Locatelli F. Bone marrow transplantation in a case of severe, type II congenital dyserythropoietic anaemia (CDA II). *Bone Marrow Transplant* 2001;27(2):213-215.
52. Remacha AF, Badell I, Pujol-Moix N, et al. Hydrops fetalis-associated congenital dyserythropoietic anemia treated with intrauterine transfusions and bone marrow transplantation. *Blood* 2002;100(1):356-358.
53. Fukuda MN, Masri KA, Dell A, Luzzatto L, Moremen KW. Incomplete synthesis of N-glycans in congenital dyserythropoietic anemia type II caused by a defect in the gene encoding alpha-mannosidase II. *Proc Natl Acad Sci U S A* 1990;87(19):7443-7447.
54. Chui D, Oh-Eda M, Liao YF, et al. Alpha-mannosidase-II deficiency results in dyserythropoiesis and unveils an alternate pathway in oligosaccharide biosynthesis. *Cell* 1997;90(1):157-167.
55. Iolascon A, Miraglia del Giudice E, Perrotta S, Granatiero M, Zelante L, Gasparini P. Exclusion of three candidate genes as determinants of congenital dyserythropoietic anemia type II (CDA-II). *Blood* 1997;90(10):4197-4200.
56. Zdebska E, Golaszewska E, Fabijanska-Mitek J, et al. Glycoconjugate abnormalities in patients with congenital dyserythropoietic anaemia type I, II and III. *Br J Haematol* 2001;114(4):907-913.
57. Wickramasinghe SN, Wahlin A, Anstee D, et al. Observations on two members of the Swedish family with congenital dyserythropoietic anaemia, type III. *Eur J Haematol* 1993;50(4):213-221.
58. Gasparini P, et al. Linkage analysis of 6p21 polymorphic markers and the hereditary hemochromatosis: localization of the gene centromeric to HLA-F. *Hum Mol Genet* 1993;2(5):571-576.
59. Iolascon A, et al. Geographic distribution of CDA-II: did a founder effect operate in Southern Italy? *Haematologica* 2000;85(5):470-474.
60. Schwarz K, Iolascon A, Verissimo F, et al. Mutations affecting the secretory COPII coat component SEC23B cause congenital dyserythropoietic anemia type II. *Nat Genet* 2009;41(8):936-940.
61. Bianchi P, Fermo E, Vercellati C, et al. Congenital dyserythropoietic anemia type II (CDAII) is caused by mutations in the SEC23B gene. *Hum Mutat* 2009;30(9):1292-1298.
62. Russo R, Esposito MR, Asci R, et al. Mutational spectrum in congenital dyserythropoietic anemia type II: identification of 19 novel variants in SEC23B gene. *Am J Hematol* 2010;85(12):915-920.
63. Iolascon A, Russo R, Esposito MR, et al. Molecular analysis of 42 patients with congenital dyserythropoietic anemia type II: new mutations in the SEC23B gene and a search for a genotype-phenotype relationship. *Haematologica* 2010;95(5):708-715.
64. Iolascon A, Russo R, Esposito MR, et al. Congenital dyserythropoietic anaemias: new acquisitions. *Blood Transfus* 2011;9(3):278-280.
65. Wolff JA, Von Hofe FH, Familial erythroid multinuclearity. *Blood* 1951;6(12):1274-1283.
66. Bergstrom I, Jacobsson L. Hereditary benign erythroreticulosis. *Blood* 1962;19:296-303.
67. Sandstrom H, Wahlin A. Congenital dyserythropoietic anemia type III. *Haematologica* 2000;85(7):753-757.
68. Lind L, Sandstrom H, Wahlin A, et al. Localization of the gene for congenital dyserythropoietic anemia type III, CDAN3, to chromosome 15q21-q25. *Hum Mol Genet* 1995;4(1):109-112.
69. Sandstrom H, Wahlin A, Eriksson M, Bergstrom I, Wickramasinghe SN. Intravascular haemolysis and increased prevalence of myeloma and monoclonal gammopathy in congenital dyserythropoietic anaemia, type III. *Eur J Haematol* 1994;52(1):42-46.
70. Sandstrom H, Wahlin A, Eriksson M, Holmgren G, Lind L, Sandgren O. Angioid streaks are part of a familial syndrome of dyserythropoietic anaemia (CDA III). *Br J Haematol* 1997;98(4):845-849.
71. Byrnes RK, Dhru R, Brady AM, Galen WP, Hopper B. Congenital dyserythropoietic anemia in treated Hodgkin's disease. *Hum Pathol* 1980;11(5):485-486.
72. McCluggage WG, Hull D, Mayne E, Bharucha H, Wickramasinghe SN. Malignant lymphoma in congenital dyserythropoietic anaemia type III. *J Clin Pathol* 1996;49(7):599-602.
73. Wickramasinghe SN, Goudsmit R. Some aspects of the biology of multinucleate and giant mononucleate erythroblasts in a patient with CDA, type III. *Br J Haematol* 1979;41(4):485-495.

74. Bjorksten B, Holmgren G, Roos G, Stenling R. Congenital dyserythropoietic anaemia type III: an electron microscopic study. *Br J Haematol* 1978;38(1): 37-42.
75. Wickramasinghe SN, Vora AJ, Will A, et al. Transfusion-dependent congenital dyserythropoietic anaemia with non-specific dysplastic changes in erythroblasts. *Eur J Haematol* 1998;60(2):140-142.
76. Carter C, Darbyshire PJ, Wickramasinghe SN. A congenital dyserythropoietic anaemia variant presenting as hydrops fetalis. *Br J Haematol* 1989;72(2):289-290.
77. Wickramasinghe SN, Spearing RL, Hill GR. Congenital dyserythropoiesis with intererythroblastic chromatin bridges and ultrastructurally normal erythroblast heterochromatin: a new disorder. *Br J Haematol* 1998;103(3):831-834.
78. Woessner S, Trujillo M, Florensa L, Mesa MC, Wickramasinghe SN. Congenital dyserythropoietic anaemia other than type I to III with a peculiar erythroblastic morphology. *Eur J Haematol* 2003;71(3):211-214.
79. Heimpel H, Kohne E, Schrod L, Schwarz K, Wickramasinghe S. A new type of transfusion-dependent congenital dyserythropoietic anemia. *Haematologica* 2007;92(10):1427-1428.
80. Majeed HA, Al-Tarawna M, El-Shanti H, Kamel B, Al-Khalaileh F. The syndrome of chronic recurrent multifocal osteomyelitis and congenital dyserythropoietic anaemia. Report of a new family and a review. *Eur J Pediatr* 2001;160(12):705-710.
81. Ferguson PJ, Chen S, Tayeh MK, et al. Homozygous mutations in LPIN2 are responsible for the syndrome of chronic recurrent multifocal osteomyelitis and congenital dyserythropoietic anaemia (Majeed syndrome). *J Med Genet* 2005;42(7):551-557.
82. Al-Mosawi ZS, Al-Saad KK, Ijadi-Maghsoodi R, El-Shanti HI, Ferguson PJ. A splice site mutation confirms the role of LPIN2 in Majeed syndrome. *Arthritis Rheum* 2007;56(3):960-964.
83. Arnaud L, Saison C, Helias V, et al. A dominant mutation in the gene encoding the erythroid transcription factor KLF1 causes a congenital dyserythropoietic anemia. *Am J Hum Genet* 2010;87(5):721-727.
84. Wickramasinghe SN, Illum N, Wimberley PD. Congenital dyserythropoietic anaemia with novel intra-erythroblastic and intra-erythrocytic inclusions. *Br J Haematol* 1991;79(2):322-330.
85. Parsons SF, Jones J, Anstee DJ, et al. A novel form of congenital dyserythropoietic anemia associated with deficiency of erythroid CD44 and a unique blood group phenotype [In(a-b-), Co(a-b-)]. *Blood* 1994;83(3): 860-868.
86. Agre P, Smith BL, Baumgarten R, et al. Human red cell Aquaporin CHIP. II. Expression during normal fetal development and in a novel form of congenital dyserythropoietic anemia. *J Clin Invest* 1994;94(3):1050-1058.
87. Nichols KE, Crispino JD, Poncz M, et al. Familial dyserythropoietic anaemia and thrombocytopenia due to an inherited mutation in GATA1. *Nat Genet* 2000;24(3):266-270.

Chapter 41 Anemias Secondary to Chronic Disease and Systemic Disorders

> Table of Contents > Part IV - Disorders of Red Cells > Section 5 - Other Red Cell Disorders > Chapter 41 - Anemias Secondary to Chronic Disease and Systemic Disorders

Chapter 41

Anemias Secondary to Chronic Disease and Systemic Disorders

Robert T. Means, Jr.

ANEMIA OF CHRONIC DISEASE

The anemia that is often observed in patients with infectious, inflammatory, or neoplastic diseases that persist for more than 1 or 2 months is called anemia of chronic disease (ACD). The characteristic feature of this syndrome is the occurrence of hypoferrremia in the presence of ample reticuloendothelial iron stores. ACD is defined by the presence of this unique combination of findings.^{1, 2, 3} As so defined, the syndrome does not include anemias caused by marrow replacement, blood loss, hemolysis, renal insufficiency, hepatic disease, or endocrinopathy, even when those disorders are chronic. These other syndromes are discussed in the sections "Anemia of Chronic Renal Insufficiency," "Anemia in Cirrhosis and Other Liver Diseases," and "Anemias Associated with Endocrine Disorders" in this chapter. To further complicate

nomenclature, the acute anemia observed in critically ill patients and that component of postsurgical anemia not attributable to blood loss appear to be pathophysiologically identical to ACD.

As the discussion above suggests, the designation ACD is far from perfect.⁴ The alternate term, anemia of inflammation has become more widely used in recent years,^{4, 5} but also has significant etymologic deficiencies, and the more pathophysiologically correct term cytokine-mediated anemia⁶ is not commonly used. Highly specific descriptive designations, such as anemia of defective iron reutilization,⁷ hypoferrmic anemia with reticuloendothelial siderosis, and thesauric hypoferrmic anemia,⁸ are also rarely used and have the limitation of focusing solely on the iron-related aspects of the syndrome.

Associated Syndromes

ACD is extremely common and, overall, is probably more common than any anemia syndrome other than blood loss with consequent iron deficiency. Cash and Sears evaluated all the anemic individuals admitted to the medical service of a busy municipal hospital during two 2-month periods in 1985 and 1986.⁹ After patients with active bleeding, hemolysis, or known hematologic malignancy were excluded, 52% of anemic patients met laboratory criteria for ACD.⁹ The syndrome is also observed in 27% of outpatients with rheumatoid arthritis¹⁰ and in 58% of new admissions to inpatient rheumatology units.¹¹ However, it should be remembered that 40% of patients in the series reported by Cash and Sears lacked one of the traditional "ACD-associated disorders."⁹ Approximately one-third of this latter group had renal insufficiency, in which pathophysiologic mechanisms implicated in ACD are active.¹² Clinical disorders commonly associated with ACD are listed in Table 41.1.

Clinical and Laboratory Description

Because this type of anemia occurs in association with so many diseases, the clinical manifestations necessarily vary widely. Usually, the signs and symptoms of the underlying disorder overshadow those of the anemia, but on rare occasions, developing anemia provides the first evidence of the primary condition. This situation may be observed particularly in difficult-to-diagnose clinical syndromes, such as temporal arteritis.¹³

Anemia

Development and Severity

Typically, anemia develops during the first 1 to 2 months of illness and thereafter does not progress.² The hematocrit usually is maintained between 0.25 and 0.40,^{2, 14, 15} but significantly lower values are observed in 20% to 30% of patients.^{9, 10} The hemoglobin concentration and hematocrit generally provide an accurate reflection of the extent to which the circulating red cell mass is reduced, although in certain cases, expansion of the total blood volume would mean that the reduction in red cell mass is less than the hemoglobin or hematocrit indicates.^{16, 17}

A general correlation exists between the degree of anemia and the severity of the underlying disease.² For example, infections accompanied by pronounced fever, chills, and suppuration are associated with more severe anemia than those with fewer systemic manifestations.¹⁸ In infected wounds, the degree of anemia

P.999

is related to the number of organisms present.¹⁸ Correlation has also been observed between the severity of the anemia and the activity of rheumatoid arthritis as judged by fever, severity of joint swelling and inflammation, and the erythrocyte sedimentation rate.^{19, 20} In patients with malignant disease, anemia is more severe when metastases are widespread than when the disease is localized; however, the development of anemia does not require or imply neoplastic involvement of the bone marrow.^{21, 22}

TABLE 41.1 CONDITIONS ASSOCIATED WITH ANEMIA OF CHRONIC DISEASE

Chronic Infections^{9, 16}

Pulmonary infections: abscesses, emphysema, tuberculosis, pneumonia

Subacute bacterial endocarditis

Pelvic inflammatory disease

Osteomyelitis

Chronic urinary tract infections

Chronic fungal disease

Meningitis

Human immunodeficiency virus

Chronic, Noninfectious Inflammations

Rheumatoid arthritis^{30, 68, 457}

Rheumatic fever⁴⁵⁸

Systemic lupus erythematosus⁴⁵⁹

Severe trauma⁴⁶⁰

Thermal injury⁴⁶¹

Vasculitis

Malignant Diseases

Carcinoma

Hodgkin disease

Non-Hodgkin lymphoma

Leukemia

Multiple myeloma

Miscellaneous

Alcoholic liver disease

Congestive heart failure^{165, 167}

Thrombophlebitis

Ischemic heart disease

Idiopathic

Typically, the percentage of reticulocytes is normal or reduced,² although on rare occasions it may be slightly increased.¹⁸ The reticulocyte production index is decreased, although not to the same degree seen in primary marrow failure states like aplastic anemia or pure red cell aplasia.

Morphologic Features

The erythrocytes usually are normocytic and normochromic; however, hypochromia and microcytosis may be observed. In older series, microcytosis (mean corpuscular volume [MCV] <80 fl) was observed in 2% to 8% of patients with ACD^{19, 23, 24}; however, other, more recent studies report a frequency of 20% to 40%.^{9, 15} Hypochromia (mean corpuscular hemoglobin concentration, 26 to 32 g/dl) is more common than microcytosis. In various series, hypochromia was observed in 23% to 50% of patients with chronic infection, 50% to 100% of patients with rheumatoid arthritis, and 44% to 64% of patients with cancer.^{2, 15} Overall, it is observed in 40% to 70% of patients with ACD.^{9, 10, 19, 23, 24} Hypochromia may be observed even though the hematocrit remains within normal limits.²⁵ Microcytosis in ACD is usually not as striking as that commonly associated with iron deficiency anemia; values for MCV <72 fl are rare.^{2, 15} Another distinction from iron deficiency is that hypochromia typically precedes microcytosis in ACD but typically follows the development of microcytosis in iron deficiency.² Slight anisocytosis and poikilocytosis may be detected, but such changes tend to be less prominent than in iron-deficient subjects. Routine examination of the blood smear rarely reveals specific morphologic abnormalities. The width of the erythrocyte size distribution curve (red cell distribution width) is typically elevated to a moderate degree, and generally does not help in distinguishing iron deficiency and ACD. Newer parameters calculated by automated hematologic analyzers, such as reticulocyte hemoglobin content (Chr), may assist in distinguishing ACD from iron deficiency.^{26, 27}

Laboratory Markers of Iron Status

Characteristically, serum iron concentration is decreased, total iron-binding capacity (or serum transferrin concentration) is reduced, and transferrin saturation may be below normal, though not to the same degree as in iron deficiency.^{2, 24} In patients with infection, hypoferrremia develops early in the course of the illness, often within 24 hours, and is observed even in acute, self-limited febrile diseases or after experimentally induced fever in humans or animals.^{8, 14, 28, 29} When the infection is of short duration, the serum iron returns to normal and anemia does not develop; in prolonged illnesses, the serum iron level remains low as long as the disease is active. When the disorder subsides, anemia often is relieved before the serum iron level returns to normal. The degree of hypoferrremia is related to the severity of the underlying illness.^{19, 24, 30}

In bone marrow aspirates stained for iron, the number of sideroblasts is reduced to 5% to 20% of the total quantity of normoblasts (normal, 30% to 50%). In contrast, the amount of hemosiderin within macrophages usually is increased; exceptions to this probably represent cases complicated by iron deficiency.²

Serum ferritin level is a useful indicator of iron status in patients without underlying inflammatory disorders. In patients with ACD, however, the serum ferritin level indicative of adequate reticuloendothelial iron stores requires upward adjustment. Serum ferritin values usually increase in patients with inflammatory diseases,³¹ and extreme elevations of serum ferritin may be a nonspecific indicator of significant underlying disease.³²

When iron deficiency coexists, the serum ferritin level falls but may not reach values as low as those found in uncomplicated iron deficiency. Values of 60 to 100 $\mu\text{g/L}$, previously suggested as the appropriate lower limit of normal for serum ferritin in chronic inflammation, may be too low, depending upon the parameters of the ferritin assay used.^{33, 34, 35, 36} At one institution, all patients with serum ferritin levels $<30 \mu\text{g/L}$ were iron-deficient by marrow examination, as were the majority of hospitalized patients with serum ferritin levels of 30 to 100 $\mu\text{g/L}$ and approximately one-third of hospitalized patients with serum ferritin levels between 100 and 200 $\mu\text{g/L}$ (Fig. 41.1).³⁷ Combining the serum ferritin level with other parameters, such as erythrocyte sedimentation rate and C-reactive protein, did not improve its predictive value,³⁸ although it has been suggested that the combination of serum ferritin with red cell ferritin may be more predictive.³⁹ The recognition of iron deficiency in patients with chronic inflammatory states is not a trivial issue: Iron deficiency contributes to anemia in up to 27% of anemic rheumatoid arthritis patients¹⁰ and probably accounts for periodic reports of successful treatment of "the anemia of chronic disease" with iron preparations.⁴⁰ A patient with chronic inflammatory disease and a serum ferritin $<30 \mu\text{g/L}$ is certainly iron-deficient, and a patient with a serum ferritin $>200 \mu\text{g/L}$ is certainly not iron-deficient; in other circumstances, certainty can be provided only by examination of a Prussian blue-stained marrow specimen. Elevated concentration of soluble transferrin receptors (sTfRs) in serum is another way to identify iron-deficient individuals with normal serum ferritin concentrations.⁴¹

Serum or plasma sTfR concentration is elevated in iron deficiency but is not elevated in uncomplicated ACD. It will be elevated in ACD cases complicated by iron deficiency.^{42, 43, 44, 45} sTfR concentration is most accurately interpreted in the context of the serum ferritin concentration,^{41, 46} and is often expressed as a ratio to the log of the serum or plasma ferritin concentration (called the transferrin receptor index or transferrin/ferritin index).⁴⁶

As will be discussed later in this chapter, the iron regulatory peptide hepcidin appears to be a significant driver of the pathogenesis of ACD. Circulating hepcidin concentration is expected to be elevated in ACD.^{5, 47} Well-studied and reproducible assays for hepcidin have been developed,^{48, 49, 50, 51, 52, 53} and while none are available for routine clinical use at present it is reasonable to assume that they will be available in the near future. It has been suggested that serum hepcidin concentration can be plotted against CHr and that the combination of elevated hepcidin and normal CHr will distinguish ACD from both iron deficiency (normal hepcidin, high CHr) and the combined state of ACD and iron deficiency (low CHr, high hepcidin).⁵⁴

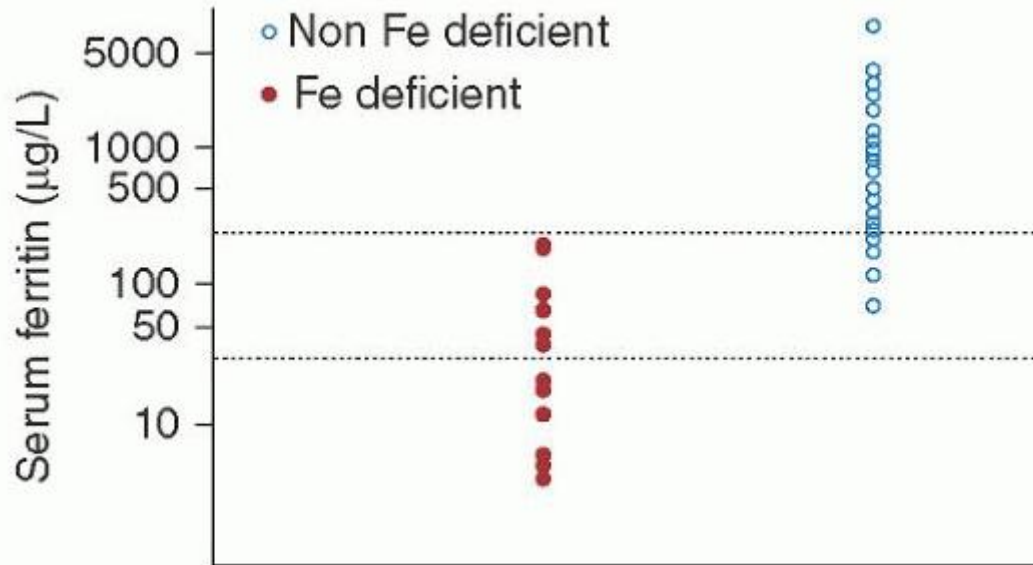

FIGURE 41.1. Comparison of serum ferritin levels from iron-deficient and non-irondeficient patients as identified by bone marrow examination during 1994 to 1995 at the University of Cincinnati Medical Center. Dashed lines indicate the range of normal for the laboratory.

P.1000

Other Biochemical Findings

The concentration of free protoporphyrin in the erythrocytes (FEP) tends to be elevated in patients with ACD.^{14, 55, 56} However, FEP increases more slowly in ACD than it does in iron deficiency, and it does not become clearly abnormal until significant anemia has developed.

A variety of other biochemical changes often are detected in patients with chronic diseases. Many of these changes reflect alteration of levels of particular plasma proteins, often called acute-phase reactants.^{57, 58, 59, 60, 61} The concentrations of certain plasma proteins, such as fibrinogen, ceruloplasmin, haptoglobin, C-reactive protein, orosomucoid, C3, and amyloid A protein, increase^{62, 63, 64}, whereas the concentrations of albumin and transferrin characteristically decrease.⁶⁵ The increase in ceruloplasmin accounts for the increase in serum copper levels often noted in association with chronic diseases.^{2, 14} An elevated fibrinogen level is probably the most important factor in the increased sedimentation rate.

Patients with chronic illness develop accelerated protein catabolism and negative nitrogen balance associated with muscle proteolysis.^{64, 65} Over time, this phenomenon can result in muscle wasting, increased urea excretion, weight loss, and growth impairment in children. However, protein catabolism generates amino acids that can be used by the patient as alternative energy sources or to supply substrates for biosynthetic processes related to host response. In this context, it is perhaps relevant that elevated serum levels of tumor necrosis factor (TNF), a cytokine implicated in the pathogenesis of ACD, are noted in patients with significant malnutrition.^{66, 67}

Kinetic Characteristics

Erythrocyte survival is modestly but significantly reduced in patients with ACD. In two studies comparing red cell survival in anemic patients with rheumatoid arthritis to red cell survival in normal individuals, the mean red cell survivals noted were 81 days versus 98 days, and 90 days versus 114 days, respectively.^{68, 69} In a similar study comparing red cell survivals in 10 anemic patients with a variety of chronic inflammatory states to 10 normal individuals, the mean values observed were 80 days versus 88 days, respectively.⁶⁸ The usual manifestations of increased blood destruction, such as increases in serum bilirubin values and urobilinogen excretion, are not typically observed.^{2, 70}

There is little evidence of a compensatory erythropoietic response to this reduction in red cell survival. The reticulocyte count usually is normal or decreased, and little or no erythroid hyperplasia of the marrow is observed. The pathogenetic significance of these findings is discussed in the following section. Kinetic data indicate that anemia develops because the

bone marrow fails to increase red cell production sufficiently to compensate for a mild decrease in the lifespan of the red cells.^{2, 8, 68} Ferrokinetic studies involving patients with chronic infections,^{71, 72} rheumatoid arthritis,⁷³ and various malignant diseases^{21, 22, 74} reveal that the rate of disappearance of iron from the plasma is rapid, the plasma iron transport rate is normal or slightly increased, the uptake of iron into erythrocytes and the amount of iron turning over through red cells daily are normal or increased, and the fraction of red cells renewed daily is increased.² When techniques that allow the division of marrow iron turnover (a measure of total erythropoiesis) into red cell iron turnover and ineffective iron turnover were used, marrow iron turnover was normal in patients with ACD.^{68, 69, 75, 76} Ineffective iron turnover was also normal, or even less than normal, indicating a lack of ineffective erythropoiesis as traditionally defined.⁶⁸ In iron-deficient subjects, ineffective iron turnover is increased, perhaps because of greater stimulation of the marrow.

Pathogenesis

Efforts to clarify the pathogenesis of ACD have focused on three principal abnormalities: shortened erythrocyte survival, impaired marrow response, and disturbance in iron metabolism. The modest shortening of the erythrocyte survival creates an increased demand for red cell production on the marrow. Normally, the marrow could easily accommodate this demand, but in the setting of ACD, the marrow is unable to respond fully because of a combination of a blunted erythropoietin (Epo) response, an inadequate progenitor response to Epo, and limited iron availability (Fig. 41.2).

Cytokines

ACD is one manifestation of the systemic response to immunologic or inflammatory stress, which results in the production of various cytokines.^{3, 77} The ability to trigger this cytokine response appears to be the common pathogenetic factor shared by the various conditions associated with this anemia syndrome.⁷⁸ The central role of these molecules suggests that ACD may be best understood as a cytokine-mediated process.⁶ The cytokines most often implicated in the pathogenesis of ACD are TNF,^{79, 80, 81} IL-1,^{82, 83} IL-6,⁸⁴ and the interferons,^{85, 86, 87} concentrations of which have been reported to be increased in the serum or plasma of patients with disorders associated with ACD.^{85, 87, 88, 89, 90, 91} Therapeutic administration of TNF or interferon may induce anemia.^{92, 93} The role of IL-6 is complex. IL-6 administration itself does not suppress erythropoiesis but rather is associated with increased plasma volume; therefore there is a dilutional component to any observed anemia.¹⁷ The association of IL-6 with hepatocyte activation may thus explain the dilutional component of the anemia observed in liver disease.^{94, 95, 96} However, IL-6 is also a potent inducer of hepcidin, proposed as a major mediator of the iron abnormalities of ACD.⁵

The Role of Hepcidin

While inflammation-induced cytokine activation is clearly the initial event in the pathogenesis of ACD, the liver-produced antimicrobial peptide hepcidin appears to be the most important mediator through which cytokines exert their effects on the pathogenetic mechanisms of ACD.^{5, 97, 98} Hepcidin is an acute-phase-reacting peptide, largely regulated by IL-6 but also by cytokine pathways not linked to IL-6.^{5, 99, 100} Patients with hepatic adenomas secreting hepcidin exhibit a hypoferremic anemia that resolves with resection of the adenoma.⁹⁷ Urinary hepcidin excretion is strongly correlated with serum ferritin concentration and is markedly elevated in patients with anemia of inflammation (defined as anemia

P.1001

with a characteristic clinical setting and an elevated serum ferritin) compared to iron-deficient patients.⁵ Hepcidin promotes macrophage iron retention by causing internalization of the iron export protein ferroportin.¹⁰¹

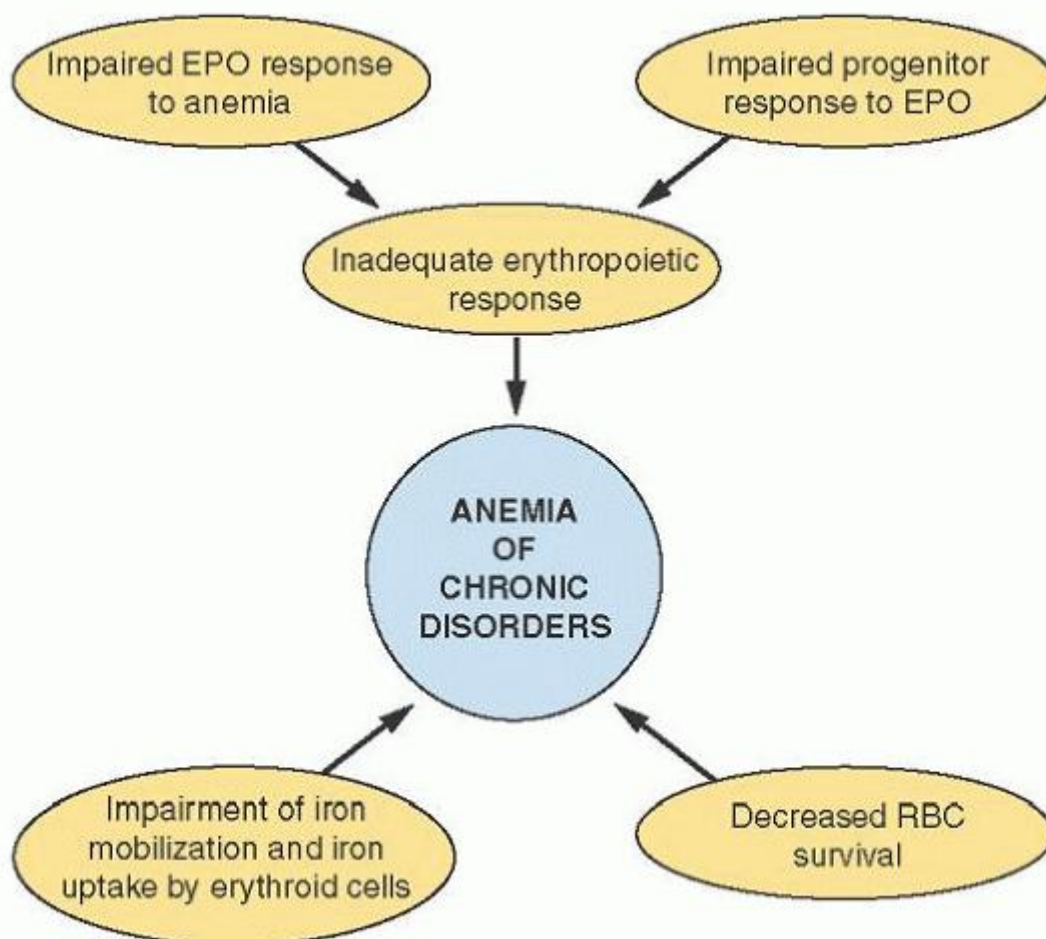

FIGURE 41.2. Schematic diagram representing contributing mechanisms in the pathogenesis of anemia of chronic disease. EPO, erythropoietin; RBC, red blood cell.

Of the pathogenetic mechanisms shown in Figure 41.2, hepcidin clearly drives the abnormalities in iron metabolism. However, it may be linked to other elements as well. Under conditions of limited Epo availability, hepcidin is associated with impaired erythroid colony formation *in vitro*.¹⁰² Increased circulating hepcidin appears to be linked to the degree of resistance to recombinant (rh) Epo therapy in dialysis patients.¹⁰³ Hepcidin and Epo production appear to be regulated in an inverse relationship by hypoxiainducible factor,¹⁰⁴ which may potentially provide some linkage between hepcidin and the relative Epo deficiency of ACD. This latter connection remains to be demonstrated.

Shortened Erythrocyte Survival

The rate of survival of cells from patients with arthritis, when transfused into normal subjects, is normal, and the survival of red cells from normal individuals in the circulation of patients with arthritis is less than the normal rate.^{2, 23} Therefore, shortened red cell survival in patients with chronic inflammatory disorders is attributed to an extracorporeal mechanism.³⁰ IL-1 levels and shortened red cell survival are correlated in anemic patients with rheumatoid arthritis,¹⁰⁵ and mice that become anemic after exposure to TNF *in vivo* also exhibit a shortened red cell survival.¹⁰⁶ Neocytolysis, a selective hemolysis of newly formed erythrocytes associated with Epo deficiency,^{107, 108} has been proposed as a mechanism for shortened red blood cell survival in ACD. Peroxynitrite, derived from the reaction of the cytokine second messenger nitric oxide and superoxide, may contribute to red cell rigidity and thus to decreased survival.¹⁰⁹

Impaired Marrow Response

Normal bone marrow, capable of a six- to eightfold increase in the red cell production rate, should easily compensate for such a modest reduction in erythrocyte survival. Its failure to do so in ACD suggests that impaired production capacity is of fundamental importance in the pathogenesis of this condition. The possible defects in erythropoiesis fall into three categories: inappropriately low Epo secretion, diminished marrow response to Epo, and iron-limited erythropoiesis.

An inverse relationship between serum or plasma Epo levels and hemoglobin normally exists: As the hemoglobin decreases, the Epo level rises.¹¹⁰ A similar inverse relationship between hemoglobin and Epo level exists in anemic individuals with rheumatoid arthritis, cancer, and human immunodeficiency virus infection^{111, 112, 113, 114}; however, for any given anemic patient in these disease categories, the Epo level was lower than that found in equally anemic individuals with iron deficiency, indicating that the Epo response to anemia was blunted. This impaired Epo response is cytokine-mediated. IL-1, TNF- α , and transforming growth factor β inhibit production of Epo by various hepatoma cell lines and by isolated perfused rat kidneys in vitro.^{115, 116} This effect occurs at the messenger RNA level.¹¹⁵ It has been proposed that this inadequate Epo secretion is adaptive; that is, it reflects reduced tissue oxygen use so that normal oxygenation is maintained despite reduced hemoglobin levels. One colorful description of this process is that the "hematologic thermostat has been turned down a bit",⁸ perhaps to allow diversion of substrates normally used in erythropoiesis to more immediately critical activities. Changes that ordinarily signify erythrocyte adaptation to tissue hypoxia, such as increased erythrocyte 2,3-diphosphoglycerate (2,3-DPG) levels, are observed in ACD.¹¹⁷ Hemoglobin oxygen affinity is also slightly decreased in these patients but overlaps the range observed in normal subjects.¹¹⁷

Although the Epo levels of patients with ACD are lower than those observed in equally anemic iron-deficient individuals, they are still higher than are observed in normal individuals who are not anemic. This implies that inhibition of Epo production cannot entirely account for the impaired erythropoiesis associated with ACD, and that the erythroid progenitors themselves exhibit an abnormal response to Epo. Studies of anemic cancer patients support this concept.^{118, 119}

TNF, IL-1, and interferon have all been reported to inhibit erythropoiesis in vivo and in vitro.^{90, 92, 120, 121, 122, 123, 124, 125, 126, 127, 128} TNF inhibits in vitro colony formation by human erythroid colony-forming units (CFU-E) indirectly, through interferon- β and possibly other soluble factors released from marrow accessory cells in response to TNF.^{129, 130} The inhibitory effect of rhIL-1 on human CFU-E colony formation was also indirect and dependent on marrow accessory cells; however, the responsible accessory cells in this case were T lymphocytes, and the mediator was interferon- γ , which also exhibits a direct inhibitory effect on human CFU-E.¹³¹ Although interferon- α and interferon- β share a common receptor, interferon- α does not exert a direct inhibitory effect on human CFU-E colony formation. Instead, its effect is mediated through an unidentified soluble factor released by T lymphocytes.¹³² The inhibitory effects of interferon- α and interferon- β exhibit synergy with interferon- γ .¹³² An important point to consider in reviewing the various models for cytokine effects on erythropoiesis is that none of the systems described operates in isolation in vivo. Thus, TNF induces IL-1 production by macrophages, IL-1 induces interferon- γ production by T lymphocytes, and interferon- γ can exhibit positive or negative feedback on production of IL-1 and TNF.

Treatment with recombinant human Epo (rhEpo) can correct ACD in many cases. Inhibition of in vitro erythroid colony formation by interferon- γ , but not interferon- α and interferon- β , can be corrected by exposure to high concentrations of Epo.^{132, 133} Epo also suppresses hepcidin production.^{134, 135}

Abnormal Iron Metabolism

It has been proposed that lack of iron for erythropoiesis contributes to the inadequate marrow response in ACD. Evidence of a functional iron deficiency in this syndrome includes erythrocyte microcytosis, increased FEP,^{14, 56} reduced transferrin saturation,²⁴ and decreased marrow sideroblasts.²⁴

Ferroketic studies have proved confusing. It has been reported that erythroid iron turnover correlated with serum iron levels, permitting a conclusion that marrow proliferation was limited by availability of iron in ACD.¹¹⁸ Other studies found no correlation between marrow iron turnover and serum iron concentration.^{68, 69, 76, 136}

The major contributor to hypoferrremia in patients with ACD is probably a shift of iron from a transferrin-bound, available circulating state to an intracellular storage state. Iron absorption appears to be normal, but iron tends to remain in the mucosal cell and in hepatocytes.^{137, 138} Macrophages, the major site from which iron is obtained for erythropoiesis, also exhibit increased iron storage. This process is mediated by hepcidin, which downregulates the iron egress regulatory ferroportin, thus trapping iron intracellularly.¹⁰¹

The dominant factor in the iron abnormalities of ACD is clearly hepcidin, discussed above and at greater length in Chapter 23. A number of other processes of less overarching significance may contribute under particular circumstances to the iron anomalies observed. Apoferritin is normally synthesized in response to increased intracellular iron concentration.¹³⁹ It has been suggested that excess apoferritin is made in inflammatory and malignant conditions, and the surplus binds a larger-than-usual amount of iron entering the cell.^{140, 141, 142} In effect, such a mechanism would divert iron from the rapid to the slow pathway of iron release. Rodents injected with recombinant TNF developed

a hypoferremic anemia associated with impaired storage iron release and incorporation into erythrocytes.^{106, 143} It has also been reported that IL-1 increases translation of ferritin messenger RNA and that this additional ferritin could act as a trap for iron that might otherwise be available for erythropoiesis.¹⁰⁵ Nitric oxide, which is a common mediator of cytokine effects, has similar effects on ferritin expression.^{144, 145} Lactoferrin is a transferrinlike protein found in neutrophil-specific granules.^{146, 147} It is released from the neutrophil during phagocytosis or stimulation by IL-1.¹⁴⁸ At low pH, lactoferrin binds iron more avidly than does transferrin.¹⁴⁹ Lactoferrin-bound iron is not immediately available for erythropoiesis¹⁵⁰; rather, it binds to specific receptors on macrophages (particularly in the liver and spleen) and is endocytosed and subsequently incorporated into ferritin.^{151, 152} Thus, lactoferrin transfers iron from its transferrin-bound, circulating state to a storage state, from which it cannot be rapidly mobilized.¹⁵³ One group of investigators found that reducing the available lactoferrin by inducing neutropenia in rats blunted the hypoferremic response to IL-1,¹⁵⁴ but another group found that administration of recombinant IL-1-induced hypoferremia in mice, even in the face of severe neutropenia.¹⁵⁵

In addition to decreased availability of iron, erythroid progenitors may also be unable to fully use the iron available to them. Erythroblasts from anemic patients with rheumatoid arthritis express fewer surface TfR than do erythroblasts from normal individuals. These TfR also exhibit lower binding affinity for transferrin.¹⁵⁶ Furthermore, acute-phase reactants, such as α_1 -antitrypsin, impair transferrin binding to erythroblasts and also inhibit transferrin internalization.¹⁵⁷ rhEpo appears to induce a greater level of TfR expression on erythroid cells.¹⁵⁸

Anemia in Patients with Cancer

Much of the anemia commonly observed in patients with cancer can be attributed to the mechanisms involved in ACD; however, certain processes unique to malignancy may also contribute. Erythroid precursors may be displaced from marrow by metastatic tumor,¹⁵⁹ tumor-induced fibrosis,¹⁶⁰ or tumor-associated marrow necrosis.¹⁶¹ The treatment of cancer can also produce or exacerbate anemia by a variety of mechanisms, including impaired Epo production¹⁶² and cytotoxic effects of therapy on erythroid progenitors.¹⁶³

Diagnosis

Studies suggest that diagnosis of anemia of moderate degree, as is commonly observed in ACD, is often missed.¹⁶⁴ ACD should be considered in anemic patients with associated inflammatory, infectious, or neoplastic states. As described in Table 41.1,⁹ not all cases are associated with a classic chronic disease, but virtually all cases are associated with states of cytokine or immune activation. This is likely the mechanism associated with the increasing number of reports of ACD in congestive heart failure.^{103, 165, 166, 167} The diagnosis is confirmed by demonstrating hypoferremia with adequate reticuloendothelial iron stores in a patient with an appropriate clinical syndrome. Typically, the serum transferrin is either low or low normal, and sTfR concentration is normal in ACD. The major differential diagnosis is iron deficiency anemia. This is not a trivial distinction. The diagnosis of iron deficiency mandates identification of a source of blood loss. Incorrectly labeling a patient with ACD as iron-deficient exposes that patient to intrusive and expensive (although fairly safe) diagnostic procedures and to ineffective therapy. Mislabeling an iron-deficient patient as having ACD may result in failure to diagnose an underlying gastrointestinal malignancy at a curable stage and in failure to offer inexpensive and effective therapy. The diagnosis of iron deficiency is discussed in detail in Chapter 23 and in the section "Abnormal Iron Metabolism." It has been suggested that a marker of inflammation or cytokine activation, such as C-reactive protein or IL-6 should be an element of the diagnosis of ACD.^{168, 169} This may not be necessary in cases of ACD associated with "classic" ACD-related disease, like rheumatoid arthritis, but may be helpful in ACD which are less typical, or perhaps complicated by iron deficiency.

In principle, absence of an elevated serum or plasma hepcidin concentration could rule out ACD. When hepcidin assays become available for routine use in a clinical context, it will be important to carry out well-designed studies to determine whether they will contribute more to diagnosis than currently available clinical markers of iron status.¹⁷⁰

Treatment

The focus of therapy should be on the underlying disorder. The anemia itself is rarely an important clinical problem. Thus, direct approaches to correction of the anemia are rarely necessary. Fewer than 30% of patients have anemia sufficiently severe to necessitate transfusion, and assessment of the symptomatic state should always be considered before administration of blood products.

rhEpo and the rhEpo analog darbepoetin, are effective in ACD but expensive,^{171, 172, 173} and many if not most third-party payers will not reimburse for its use in ACD. It is not currently approved for this purpose in the United States. Limitations on the use of rhEpo in anemic cancer patients for safety reasons (discussed below) limit the use of rhEpo in ACD at present. Because most patients were not symptomatic from their anemia, symptomatic benefit was rarely reported in the

initial studies.^{171, 172} Subsequent studies using more sophisticated evaluation instruments have reported increased quality of life in anemic patients with rheumatoid arthritis¹⁷⁴ or cancer¹⁷⁵ treated with Epo. It can also be used for ACD patients who wish to donate blood for autologous transfusion at elective surgery but are too anemic to do so¹⁷⁶ or to permit autologous blood donation by a patient with ACD and multiple alloantibodies.¹⁷⁷ It has been proposed that rhEpo administration may be of benefit in anemic patients with congestive heart failure.^{178, 179, 180, 181, 182}

It is debated whether or not to administer iron routinely to patients receiving therapy with Epo products. It is this author's practice to do so in the absence of elevated serum ferritin levels. In one study of anemic patients with rheumatoid arthritis, the concurrent use of iron supplementation was a powerful predictor of response to Epo¹⁸³; however, many of the patients in this study may have been iron-deficient. Although there are reports of correction of ACD by intravenous iron without Epo,^{40, 184} normalization of hemoglobin was largely seen in patients who were also iron-deficient.⁴⁰ Iron therapy by itself is likely to be useful only in patients who have concurrent iron deficiency,¹⁰ and then only for the component of anemia caused by iron deficiency. There is no convincing evidence that iron alone corrects ACD per se. Anemic cancer patients treated with concurrent intravenous iron and rhEpo appear to have a better response than those treated with no iron supplementation or with iron supplementation alone.¹⁸⁵

Studies of the use of rhEpo in cancer patients have been associated with increased adverse outcomes in certain cases,^{186, 187, 188, 189, 190} leading to restrictions on circumstances in which rhEpo can be used in cancer therapy. While there is debate in the literature as to whether the observed outcomes reflected unique features of particular rhEpo regimens or of specific patient populations,^{191, 192, 193} the clinician is encouraged to review current guidelines prior to initiating therapy.

As noted earlier, Epo downregulates hepcidin production. Given the significant role of hepcidin in the pathogenesis of ACD, therapy directed against hepcidin would be attractive in principle. Antisense hepcidin has been reported to decrease anemia in an animal inflammation model.¹⁹⁴ At present, however, there are no specific antihepcidin agents available for clinical use.

P.1003

ANEMIA OF CHRONIC RENAL INSUFFICIENCY

Anemia is an almost invariable manifestation of chronic renal failure, often contributing substantially to the morbidity of the condition. It may be considered as typical of the disease as azotemia.¹⁹⁵ In the era before the availability of rhEpo, 98% of patients on hemodialysis were anemic¹⁹⁶; even now, 48% of renal failure patients before dialysis and 28% of hemodialysis patients have hematocrit values <0.30.^{197, 198} The term anemia of chronic renal insufficiency refers to that anemia resulting directly from failure of the endocrine and filtering functions of the kidney. The kidney is the major source of Epo, and the ability to secrete this hormone is lost as the kidney fails. In addition, renal failure is associated with other pathologic processes, including some that may inhibit erythropoiesis and others that may shorten erythrocyte survival. Lack of sufficient Epo is by far the most important of these anemia-causing factors; consequently, the hypoproliferative features of the anemia tend to predominate.¹⁹⁹

In clinical settings associated with chronic renal failure, additional factors may also contribute to the development of anemia, but these should be considered complications rather than fundamental components of the anemia of renal insufficiency itself. In the presence of infection or inflammation, ACD is likely to be observed. Iron deficiency anemia (see Chapter 23) may develop because of blood loss from the gastrointestinal tract or (less frequently) hematuria or from retention of blood in the hemodialysis apparatus tubing.^{199, 200} The megaloblastic anemia of folate deficiency also may occur in patients on dialysis^{201, 202} but is otherwise uncommon.²⁰³ Certain types of renal disease, including the hemolytic-uremic syndrome or thrombotic thrombocytopenic purpura, are associated with microangiopathic hemolytic anemia (see Chapter 48). Finally, aluminum intoxication can cause microcytic anemia in dialysis patients, although this has become rare in modern dialysis practice.²⁰⁴

Clinical Description

Chronic renal failure occurs during the final stages of several renal diseases. As a rule, the nature of the underlying disease bears little relation to the degree of anemia, although anemia may be less severe in patients with hypertensive renal disease²⁰⁵ and is considerably less severe in patients with polycystic disease.^{206, 207} In one series, the mean hematocrit in 12 subjects with polycystic disease was 0.297, compared with 0.212 in 24 subjects with other types of chronic renal failure.²⁰⁷ Apparently, the Epo-secreting function of the kidney is preserved in polycystic disease—even when the filtering

function is lost.^{207, 208} Erythropoietic activity can be found in the cystic fluid and may arise from single interstitial cells juxtaposed to proximal tubular cysts.²⁰⁷

In most instances, the patient seeks medical attention because of symptoms related to the underlying renal disease, and anemia is an incidental finding. Occasionally, however, the renal symptoms are so subtle and so slowly progressive that the patient cites only symptoms of pallor, exertional dyspnea, or other signs of the cardiovascular adjustment to anemia. The severity of the anemia bears a rough relationship to the degree of renal insufficiency. Anemia is not routinely observed until the creatinine clearance falls to <45 ml/minute/ 1.73 m² body surface area, which corresponds roughly to a serum creatinine of 2.0 to 2.5 mg/ml in an average-sized adult.²⁰⁹ At creatinine clearance rates below that, a statistically significant correlation between creatinine clearance and hematocrit has been reported.^{210, 211} However, the variation in the results of these studies is so great that one cannot reliably predict the hemoglobin level in an individual patient on the basis of renal function.

Laboratory Findings

Anemia tends to become more severe as renal failure worsens, but in most patients the hematocrit ultimately stabilizes between 0.15 and 0.30.² Because regulation of body water and electrolyte balance is impaired in renal disease, the apparent degree of anemia may be exaggerated or minimized by alterations in plasma volume.

The erythrocytes usually are normocytic and normochromic, but slight macrocytosis is occasionally observed.²¹² The majority of red cells appear normal on blood smears. Occasionally, however, "burr" cells (Fig. 41.3) are observed along with some triangular, helmet-shaped, or fragmented cells. The reticulocyte count often is within normal limits,²¹³ but it may be moderately increased.^{212, 214} In one study, the numbers of reticulocytes were normal when the blood urea nitrogen (BUN) value was <130 mg/dl; at higher BUN levels, however, their number often was increased.²¹⁵ The highest values (average, 6%) were observed with extreme azotemia (BUN, 300 to 350 mg/dl).

The leukocyte count typically is normal, but slight neutrophilic leukocytosis may be observed. In one series, the leukocyte count averaged 10.7×10^9 /L.²¹³ The platelet count is either normal or slightly increased,²¹³ but platelet function may be severely impaired, resulting in defective hemostasis (see Chapter 52).

The bone marrow tends to be moderately hypercellular, and slight erythroid hyperplasia may be observed. The myeloid-to-erythroid ratio averaged 2.5:1.0 in one study.²¹³ Erythroid maturation appears morphologically normal. In some instances, especially when renal failure is relatively acute, hypoplasia of erythroid elements is noted.^{216, 217} In a study of 100 predialysis renal failure patients with hemoglobin concentrations less than 11 g/dl and not treated with rhEpo, 48% of patients had no detectable bone marrow iron.²¹⁸

The serum bilirubin level was within normal limits in all of the 26 patients in one series.²⁰⁸ The hemolytic index, a measure of urobilinogen excretion in relation to total circulating hemoglobin, was increased in ~40% of patients evaluated.^{212, 219}

Values for serum iron vary considerably in renal disease.^{212, 219} As a rule, the value is normal when renal impairment is mild. With more severe disease, some investigators observe a decrease in serum iron levels,²²⁰ whereas others note hyperferremia.^{220, 221} Whether a characteristic disturbance of serum iron concentration is associated with "uncomplicated" renal failure remains to be determined. One group of investigators has reported that the gastrointestinal absorption of iron is reduced in patients with chronic renal failure.²²² Other researchers, using a different method, found that iron absorption was related to disturbances in iron balance and was unrelated to the degree of anemia, the rate of erythropoiesis, or the degree of azotemia.²²³ FEP may be normal or moderately increased,²¹² but the increased values seem to occur only in patients with hypoferremia.²²⁴ The erythrocyte lactate dehydrogenase level is within normal limits.²²⁵ Serum hepcidin levels in dialysis patients appear to track with iron status, and to be low in the iron-deficient.²²⁶ At any given level of iron stores, higher hepcidin levels appear to predict anemia progression.²²⁷

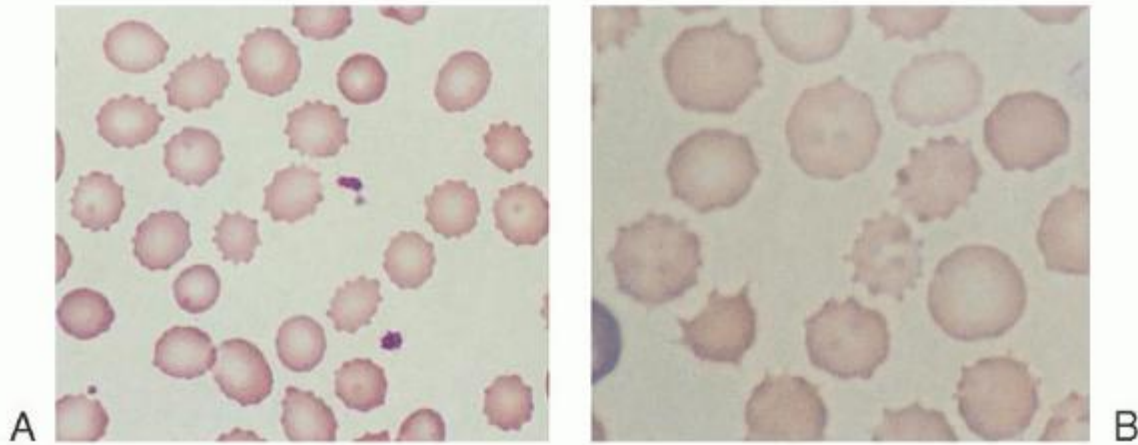

FIGURE 41.3. A: Crenated cells in renal disease ($\times 1,500$). B: Burr cells in renal disease ($\times 3,000$).

P.1004

The glycosylated fraction (A_1) of hemoglobin (the best-known component of which is hemoglobin A_{1c}) tends to increase in chronic renal failure. In uremic patients who have not undergone dialysis, the hemoglobin A_1 value averaged 10.8% of the total hemoglobin, compared with 7.1% in nonuremic individuals.²²⁸ In uremic patients treated with dialysis, the value averaged 8.8%. The increase is thought to result from carbamylation of the hemoglobin molecule by urea-derived cyanate; it can be detected by using column chromatography but not by using certain chemical methods designed for hemoglobin A_{1c} . The magnitude of the increase usually correlates with the average value for BUN over the preceding 2 to 3 months. The increase in the A_1 fraction may continue after successful renal transplantation has brought the azotemia under control; in this case, the increase might reflect disturbed carbohydrate metabolism²²⁹ and probably reflects hemoglobin A_{1c} .

Pathogenesis

It has been known for many years that three factors are involved in the pathogenesis of anemia of chronic renal failure. These factors are Epo deficiency, suppression of marrow erythropoiesis, and shortened red cell survival.^{230, 231, 232} When anemia is severe, ferrokinetic studies typically demonstrate that the plasma iron transport rate is normal, but red cell iron utilization and erythrocyte iron turnover are decreased.^{199, 212} With milder degrees of anemia, ferrokinetic measurements tend to be near normal. In anemic patients, however, such "normal" values indicate an insufficient marrow response to the stimulus of anemia. The success of recombinant Epo in the treatment of anemia of renal failure has caused the other two factors to receive short shrift in recent years.

As renal function deteriorates, renal Epo secretion decreases.^{232, 233} Measured Epo values may be lower than normal, higher than normal, or normal.^{210, 232, 233, 234} However, it is important to remember that even the "increased" Epo concentrations observed in this syndrome are still strikingly low for the degree of anemia.²³⁵ Overall, the usual relationship between Epo and hemoglobin concentrations is lost, indicating a loss of customary feedback mechanisms.²¹¹ Some capacity to induce Epo secretion is preserved, however, because even the very low levels of Epo secretion in renal disease change in response to hemorrhage or transfusion.²³¹ Certain extrarenal sources of erythropoietic hormone account for some of the activity found in serum, especially that found in anephric subjects.^{235, 236} This extrarenal Epo secretion does not, however, appear to increase sufficiently in response to anemia to compensate for deficiencies at the renal source.²³⁷ Elegant studies in sheep²³⁸ and subsequent confirmatory studies in human patients^{239, 240} have established the primacy of Epo deficiency in the pathogenesis of anemia of chronic renal failure.

There is also a significant body of data suggesting that the inadequate marrow response to anemia is not due solely to Epo deficiency. The observation that the rate of erythropoiesis improved in patients treated with dialysis even though Epo levels were unchanged^{214, 241} suggested that retained uremic toxins depress erythropoiesis directly. This field of research has been quite confusing, because not all investigators have been able to confirm the presence of inhibitors or to demonstrate their specificity. Several groups of investigators have shown that plasma from uremic patients can depress heme synthesis,²⁴² or inhibit growth of erythroid colonies in vitro, or both.^{243, 244, 245, 246} The polyamine spermine and

other molecules that accumulate in renal failure have been proposed as candidates.^{244, 245, 247, 248, 249} Inhibitors of multipotential stem cell (colony-forming unit granulocyteerythroid-macrophage-megakaryocyte) growth have also been detected in uremic plasma,²⁵⁰ but they are of uncertain pathophysiologic importance.²⁴⁴ Parathyroid hormone, associated with secondary hyperparathyroidism in renal failure patients, may also contribute to marrow suppression.²⁵¹ The hematocrit increases in approximately one half of the patients with renal failure who undergo parathyroidectomy, although only to a modest degree.^{252, 253, 254} Some, but not all, investigators suggest that levels of parathyroid hormone similar to those found in the serum of uremic patients depress the growth of erythroid colonies in vitro.^{251, 255, 256, 257} Hyperparathyroidism may also exert its effects by causing marrow fibrosis.^{252, 254}

Allen and colleagues have demonstrated that inhibition of erythroid colony formation by uremic serum can be abrogated by neutralizing antibodies to TNF and interferon- γ .¹² These data suggest that cytokine-mediated anemia mechanisms typically associated with ACD may be active in renal failure.²⁵⁸ It is also possible that the excellent response of anemia of renal failure to Epo does not indicate a lack of contributing inhibitors but rather reflects the ability of Epo to overcome an inhibitor, as has been reported for interferon- γ .¹³³

A third pathogenetic factor is hemolysis. Erythrocyte survival, although often within normal limits, may be slightly to moderately reduced.²⁵⁹ Depending on the evaluation technique used, 20% to 70% of uremic patients show shortened red cell survival.^{195, 212, 214, 220} The extent to which red cell survival is decreased is somewhat related to the degree of azotemia.¹⁹⁹ Cross-transfusion studies suggest that the hemolytic factor, when present, is extracorporeal. Survival of normal cells transfused into patients is shortened, whereas patients' cells survive normally in normal recipients.^{195, 212, 220} Less commonly, shortened survival of uremic patients' cells is observed even in normal subjects.²²⁰ In some patients, splenic sequestration of red cells may be a contributory factor.²⁶⁰

The hemolytic factor(s) is presumed to be a toxic substance (or substances) normally excreted or metabolized by the kidney. Guanidine and its derivatives appear to be a subset of the many retained metabolites that adversely affect erythrocyte survival.^{12, 261} The hypothetical factor(s) is apparently not dialyzable.²³⁰ Peroxidation of membrane lipids by free radicals may also contribute to the shortened survival observed.²⁶²

In ~20% of uremic patients not treated with dialysis, the red cell pentose phosphate pathway is impaired as a result of a poorly defined substance in the plasma.^{263, 264} This defect is best detected by using the ascorbate-cyanide test; other tests of pentose phosphate pathway function may yield normal results.²⁶⁵ Administration of glutathione returns the ascorbate-cyanide test to normal.²⁶² Oxidant drugs, such as primaquine or sulfonamides, produce a Heinz body hemolytic anemia in patients with the pentose phosphate pathway defect. Even in the absence of drug exposure, Heinz bodies may be observed in the red cells of uremic patients if they have undergone splenectomy.²⁶⁶ Contamination of dialysate water by chloramines, which inhibit phosphoglyceromutase and thus cause accumulation of glycolytic intermediates, may worsen this defect.^{267, 268} Decreased oxidative stress may also contribute to the observed lower frequency of anemia in patients undergoing peritoneal dialysis compared to those on hemodialysis.²⁶⁹ In one study, use of the antioxidant N-acetylcysteine was associated with improved hematocrit.²⁷⁰

Cation transport may be impaired in uremic red cells: The defect reverts toward normal after dialysis.^{271, 272} When sensitive measures are used, nearly all patients can be shown to have such an abnormality²⁷²; in those most severely affected, the erythrocyte sodium concentration is increased.²⁷¹ Considerable disagreement surrounds the nature of the defect, with various investigators reporting abnormalities in cation pump site number or function^{271, 272} and others reporting the presence (or absence) of soluble, dialyzable inhibitors of pump function.^{273, 274, 275}

Evidence of impaired erythrocyte glycolysis has been found in uremic patients²⁷⁶; however, in most studies, the overall glycolytic rate is increased,^{277, 278} probably because of the elevation in plasma levels of inorganic phosphorus.²⁷⁷ The increase in the glycolytic rate probably accounts for the observed increase in red cell

P.1005

adenosine triphosphate levels.^{277, 279} Hemoglobin oxygen affinity is reduced,²⁸⁰ presumably because of increased erythrocyte adenosine triphosphate and 2,3-DPG levels. Such abnormalities would not be expected to cause reduced red cell survival.

Neocytolysis, the selective hemolysis of newly formed red cells, has been reported after Epo withdrawal in dialysis patients and may contribute to shortened red cell survival in dialysis patients.²⁸¹

Management and Course

Recombinant Human Erythropoietin

rhEpo has been available for treatment of anemia of renal disease since the mid 1980s^{240, 282} and has revolutionized the approach to this disorder. Therapy with this agent or rhEpo analogs such as darbepoetin,²⁸³ is safe and effective, and has been reported to improve quality of life and cognitive function.^{284, 285} It is the treatment of choice for anemia in renal insufficiency, being effective in patients receiving peritoneal or hemodialysis.²⁸⁶ It is equally efficacious in anemia due to renal insufficiency that is not sufficiently advanced to require dialysis, but in which the creatinine clearance is <45 ml/minute/1.73 m² body surface area or the serum creatinine is >2.5 mg/ml.^{210, 232, 287, 288}

Epo can be administered intravenously or subcutaneously. Although Epo was originally given three times weekly (to coincide with dialysis schedules), single weekly or less frequent dosing schedules are similarly efficacious if the dose is increased appropriately.²⁸⁹ A standard starting dose would be 100 to 150 U/kg/week or its equivalent. Higher doses generally result in faster correction of anemia; target hemoglobin is typically attained within 6 to 8 weeks.^{287, 290} Iron supplementation is generally necessary, particularly in patients on hemodialysis. The target hemoglobin range is to be no higher than 11 to 12 g/dl; some reports suggest that higher levels may have an adverse clinical impact.²⁹¹ The long-acting Epo analog darbepoetin (novel erythropoiesis-stimulating protein) appears to be safe and effective in the anemia of renal failure.^{290, 291, 292, 293} The recommended starting dose is 0.45 µg/kg/week for patients on dialysis, and 0.45 µg/kg/ 4 weeks for patients before dialysis.

Continuous Epo receptor activator is a new peptide agent which is not an Epo analog but which activates the Epo receptor. Its role in the management of the anemia of renal failure is under study.²⁹⁴

Side Effects/Adverse Reactions

As noted earlier, rhEpo products are generally safe but complications may occur. When used for anemia in renal disease, increased blood pressure is an important complication, experienced by up to 35% of patients.^{295, 296} Rarely, the hypertension is abrupt and severe with encephalopathy and seizures.²⁹⁷

The occurrence of hypertension appears to be more closely related to the rate of increase in the blood hemoglobin level than the dose of rhEpo.²⁹⁸ It tends to be a transient phenomenon confined to the first 3 to 6 months of treatment. The pathogenesis is incompletely understood and probably multifactorial.²⁹⁸ Because heart rate, stroke volume, and cardiac output decrease as anemia is corrected, an increase in peripheral vascular resistance may be responsible. Daytime vasoconstriction may be a consequence of reduced plasma volume.²⁹⁵ Left ventricular hypertrophy, an important predictor of cardiac morbidity and mortality in renal patients, tends to decrease by ~18% within a year of correction of anemia; this beneficial effect may be diminished by hypertension.²⁹⁶ However, Epo can also contribute to hypertension through vasopressor effects, often mediated by nitric oxide, which appear most active in renal insufficiency.^{299, 300, 301}

In early studies, prolonged or less effective dialysis^{302, 303} and increased thrombotic events were thought to be problems associated with Epo treatment, but these concerns were not borne out in a large study.²⁸⁶ Anaphylaxis in response to Epo has been described but is extremely rare³⁰⁴.

Erythropoietin Resistance

As mentioned earlier, more than one-fourth of hemodialysis patients have a hematocrit <0.30. The failure of patients to respond optimally to Epo therapy or a requirement for unusually high doses is referred to as Epo resistance. The possible causes of Epo resistance are listed in Table 41.2.

Iron deficiency is the most common cause.^{305, 306} Loss of blood in the dialysis apparatus is an important source of iron depletion.³⁰⁷ Most patients require iron supplementation at some time during their course.³⁰⁸ In general, those with serum ferritin levels <100 to 200 µg/L or with transferrin saturation values <20% to 25%^{309, 310, 311} require iron supplementation, but such values may not appear until resistance to rhEpo becomes apparent. In another study, patients with serum ferritin values between 100 and 400 ng/ml were as likely to respond to iron replacement as those with serum ferritin <100 ng/ml.³¹² Other investigators found that a low MCV, but not a low serum ferritin, predicted response to iron replacement.³¹³ The best early predictors of Epo response are serum sTfR concentration and serum fibrinogen.³¹⁴

Response rate approaches 100% when both are low and 29% when both are high, reflecting both the patient's iron status and the presence or absence of inflammation. Some authors recommend routine oral iron supplementation for all patients. However, oral iron administration can be limited by intolerance, so that compliance is relatively poor.³⁰⁸ Efficacy may also be limited. Consequently, intravenous iron replacement is recommended for dialysis patients.^{315, 316, 317} Studies comparing oral versus intravenous iron supplementation generally find that the intravenous replacement group achieves higher hemoglobin levels with lower Epo use.^{313, 318} In order to avoid iron overload, intravenous iron replacement is discontinued or decreased when the ferritin exceeds 500 ng/ml.³¹⁹

Inadequate hemodialysis is associated with Epo resistance.³²⁰ As a general rule, the intensity of dialysis must be sufficient to reduce the BUN by 65% or more to ensure optimal Epo response. Such factors as the frequency and duration of dialysis and characteristics of the dialyzer may need to be adjusted to achieve this goal.^{321, 322} Mortality is also reduced by attention to dialysis

P.1006

intensity. Rates of reimbursement for dialysis in the United States have discouraged optimal intensity, with the result that mortality is higher there than in Western Europe and Japan.

TABLE 41.2 CAUSES OF ERYTHROPOIETIN RESISTANCE

Iron deficiency

Blood loss (in dialysis apparatus, gastrointestinal, genitourinary)

Insufficient iron supplementation

Concurrent cytokine activation

Infection

Inflammation

Neoplasm

Insufficient dialysis intensity

Aluminum toxicity

Secondary hyperparathyroidism

Folate deficiency

Angiotensin-converting enzyme inhibitors

Renal allograft failure

Antierythropoietin antibody-mediated resistance

Pure red cell aplasia

Other

Splenomegaly

As discussed earlier, secondary hyperparathyroidism often accompanies renal failure, and the associated marrow fibrosis may contribute to the anemia^{251, 252, 254} and to Epo resistance. Treatment with vitamin D₃ can decrease rhEpo requirements and improve hemoglobin values.³²³ Aluminum toxicity is an uncommon cause of anemia and responds to chelation therapy.³²⁴

If Epo resistance is associated with an increased MCV, folate supplementation is warranted.²⁰¹ Serum folate levels may not be helpful in this situation. In some cases, iron replacement may unmask folate deficiency in dialysis patients.³¹³

Associated infections or inflammatory states, as in ACD, may provoke cytokine-mediated anemia mechanisms. In addition, there are a number of minor etiologies of Epo resistance. The use of angiotensin-converting enzyme inhibitors in renal failure patients (particularly those undergoing transplantation) may exacerbate Epo resistance.^{325, 326} Splenomegaly may create a requirement for higher Epo dosing: This is resolved by splenectomy.²⁶⁰ Infrequent cases of Epo resistance due to anti-Epo antibodies, including production of pure red cell aplasia, have been reported.^{327, 328, 329} It appears to be a result of packaging and delivery characteristics of particular Epo products (especially in Western Europe and Canada), rather than a reaction to Epo itself. This topic is discussed at length in Chapter 39.

Renal Replacement Therapy

Renal replacement approaches (transplantation and dialysis) aim to restore or substitute for lost renal function. As such, they may have some effects on anemia associated with renal failure.

Renal Transplantation

In many ways, renal transplantation is the most complete and satisfactory treatment for renal insufficiency. With a successful graft, the hematologic response is often striking. Anemia is usually corrected over an 8- to 10-week period.^{330, 331, 332} For the most part, the improvement results from Epo secretion by the grafted kidney. Two peaks of Epo secretion have been documented: an early peak, in which serum Epo levels increase approximately ninefold and then return to normal after ~7 days; and a second, smaller, more sustained increase in Epo levels, which begins on approximately day 8 and is accompanied by reticulocytosis and a gradual increase in hemoglobin levels. Epo values return to normal when the hematocrit reaches 0.32. The early peak is seen only in patients with delayed graft function and is not associated with hematologic improvement.^{330, 332} The second peak is associated with recovery of the graft excretory function and is presumed to be the important factor in the hematologic response.

Approximately 80% of patients experience an increase in blood hemoglobin concentration after renal allograft.³³¹ Failure to respond usually can be explained on the basis of hemorrhage, vigorous immunosuppression, or graft rejection. The rejection phenomenon often is accompanied transiently by increased Epo levels,^{333, 334} but this is followed by a profound reduction in Epo levels and reticulocyte counts.³³⁵ Improvement in erythropoiesis occurs earlier when cyclosporine is used for immunosuppression rather than with antilymphocyte globulin. With the latter, the reticulocyte peak is delayed ~2 days. Cyclosporine immunosuppression, however, may be associated with slower correction of the anemia.³³⁵ In ~20% of transplant patients, erythrocytosis follows correction of the anemia.³³⁰ This complication is discussed in Chapter 48 and can sometimes be avoided by pretransplant use of Epo.³³⁵

Dialysis

Most patients with end-stage renal disease are maintained on dialysis. As a modality for managing anemia, dialysis has been essentially eclipsed by the availability of Epo and is primarily of interest because the mild increment observed in hemoglobin concentration provides circumstantial evidence for the role of circulating inhibitors. Red cell production increases slightly in patients on hemodialysis, with attendant small increases in hematocrit and decreases in transfusion requirement.³³⁶

As a general rule, anemia is less severe in patients receiving peritoneal dialysis, with consequently lower Epo and transfusion requirements.^{337, 338, 339, 340, 341, 342} Increments in hemoglobin in the absence of Epo are gradual and of modest extent: They are accompanied by an increase in red cell mass and a reduction in plasma volume.³⁴⁰ The reasons for the beneficial effects of peritoneal dialysis on erythropoiesis are not firmly established. An increase in Epo production has been reported,³³⁹ whereas other data suggest that removal of inhibitors in the "middle molecule" range (500 to 1,500 daltons) is the important mechanism.³⁴³ Induction of a lower degree of red cell oxidative stress by peritoneal dialysis compared to hemodialysis has been suggested as an alternative explanation.²⁶⁹

In the Epo era, the importance of other treatments for anemia of renal disease, such as androgens, has become of primarily historical interest. Blood transfusion support may still be required for patients who fail to respond to rEpo products. The risks of bloodborne infections and of iron overload are significantly increased by the use of transfusion.³³⁶

ANEMIA IN CIRRHOSIS AND OTHER LIVER DISEASES

Some degree of anemia is commonly observed in patients with liver disease. Although it has been studied most extensively in patients with alcohol-induced cirrhosis (Laennec cirrhosis), changes in red cell morphology and other contributors to anemia have been observed in various other liver diseases, including biliary cirrhosis,³⁴⁴ hemochromatosis,⁹⁶ postnecrotic cirrhosis, and acute hepatitis.³⁴⁵ When the term anemia of liver disease is used, it refers to the mild to moderate anemia associated with liver disease in the absence of any complicating factors such as blood loss, marrow suppression by exogenous agents, or nutritional deficiency. This syndrome apparently results from a combination of intravascular dilution due to volume overload, shortened red cell survival, and impaired ability of the marrow to respond optimally to the anemia. In addition, some patients develop a severe hemolytic anemia associated with morphologically abnormal erythrocytes (spur cells). Hemolytic anemia associated with Wilson disease is discussed in Chapter 32.

The anemia actually observed in patients with liver disease reflects both the "uncomplicated" anemia discussed above and the consequences of factors extrinsic to the liver itself. Alcohol abusers can develop a characteristic sideroblastic anemia, often accompanied by impaired folate metabolism or overt folate deficiency (see Chapter 36), or may have direct suppression of hematopoiesis by alcohol.³⁴⁶ Individuals with cirrhosis of any etiology are at increased risk for hemorrhage. Blood loss occurs in 24% to 70% of patients with alcoholic cirrhosis.⁹⁶ The upper gastrointestinal tract is the major site of bleeding, but loss of blood from the nose, hemorrhoids, and uterus often occurs in association with coagulopathy of hepatic origins.

Prevalence and Clinical Manifestations

Approximately 75% of patients with chronic liver disease develop anemia as defined by a reduction in the hematocrit or hemoglobin level.^{95, 96, 347} The whole blood volume in liver disease (especially cirrhosis) averages 10% to 15% greater than normal but may be as much as 30% to 35% increased; thus, hemodilution tends to exaggerate the prevalence and degree of anemia.^{95, 96, 347, 348}

P.1007

For the same reason, the hematocrit may be decreased despite a normal red cell mass. The majority of cirrhotic patients are described as anemic, but in only 30% to 40% is the red cell mass reduced.^{95, 348} Patients with more severe liver disease and bleeding tend to have reduced red cell mass.⁹⁶ The magnitude of the hypervolemia in cirrhosis appears to be related to the degree of portal hypertension, but not to the presence or absence of ascites (Table 41.3).

The anemia is usually mild to moderate. In cirrhotic patients, the hemoglobin level averages ~12 g/dl or the hematocrit ~0.36.^{96, 348} The hemoglobin level rarely falls below 10 g/dl in the absence of bleeding or severe hemolysis. Approximately 5% of liver disease patients, all of whom have relatively severe hepatocellular disease, develop spur cell hemolytic anemia and hemoglobin concentrations <10 g/dl.³⁴⁹ Spur cell anemia may be seen chronically with cirrhosis, or it may develop rapidly in association with fulminant hepatic failure. Morphologic and hemolytic abnormalities may resolve or diminish if liver function improves. Spur cell anemia can also occur in infants with cholestatic liver disease.³⁵⁰

Episodic hemolysis can occur in association with alcoholic liver disease even before cirrhosis.^{351, 352} These episodes are typically related to binge drinking, are usually mild to moderate in severity, and tend to resolve in 2 to 4 weeks if the patient abstains. Splenomegaly is not a major finding in these patients. When accompanied by jaundice and hyperlipidemia, the condition is known as Zieve syndrome.^{353, 354, 355} It is unclear whether this transient form of hemolysis in liver disease is a syndrome of discrete and characteristic pathogenesis or simply a coincident constellation of abnormalities to which patients with liver disease are prone independently. The clinical diagnosis of hemolysis in alcoholic liver disease is problematic in any event, because interruption of alcohol intake is frequently accompanied by reticulocytosis, and liver disease of any etiology may be associated with jaundice.

Hematologic Findings

More often than not, anemia of liver disease is mildly macrocytic: The MCV rarely exceeds 115 fl in the absence of megaloblastic changes in the bone marrow.^{95, 96} When macrocytosis (particularly with very elevated MCVs) is found in patients with liver disease, complicating folate deficiency or stimulated erythropoiesis must be suspected, but such findings may not explain the macrocytosis observed in patients with milder forms of the disease.³⁵⁶ The reported proportion of patients with liver disease who have increased MCV varies from 33% to 65%.^{96, 347, 357, 358, 359} Even more common is “thin” macrocytosis—an increase in mean cell diameter with a normal mean cell volume. In one study of 222 patients with various kinds of liver disease, the mean cell diameter was increased in 137 (62%).³⁵⁸ The patients were classified into three groups: thin macrocytosis (81 patients), target macrocytosis (39 patients), and thick macrocytosis (17 patients). The MCV was increased only in the last group. In a sense, thin macrocytes and target macrocytes are the mirror image of the microspherocytes observed in autoimmune hemolysis. The latter result from a decreased membrane pulled more tightly over a constant volume; the former result from a membrane that is more abundant.

TABLE 41.3 CHANGES IN BLOOD VOLUME IN PATIENTS WITH CIRRHOSIS

Measurement	Normal Subjects	Patients with Cirrhosis	
		Without Ascites	With Ascites
Hematocrit	0.42	0.35 (-17%)	0.34 (-19%)
Red cell mass (ml/kg)	23	20 (-13%)	19 (-17%)
Plasma volume (ml/kg)	42	57 (+35%)	55 (+31%)
Whole blood volume (ml/kg)	65	74 (+14%)	74 (+14%)

Values are means of 24 normal subjects, 63 patients with cirrhosis and no ascites, and 34 patients with cirrhosis and ascites. All groups included approximately twice as many men as women.

Data modified from Lieberman FL, Reynolds TB. Plasma volume in cirrhosis of the liver. *J Clin Invest* 1967;46:1297-1308.

The reticulocyte count often is increased, but this depends on the point in the natural history of disease at which it is measured. In one series, the mean reticulocyte percent of all anemic cirrhotic patients was only 2.8%.⁹⁵ However, erythropoiesis can be transiently suppressed by alcohol, and after acute alcohol withdrawal, reticulocyte percentages in the 8% to 10% range are not uncommon.^{346, 357, 360} Sustained reticulocytosis of 15% or more is unusual in the absence of hemorrhage, spur cell anemia, or other complicating conditions.

Target cells and cells with increased diameters are evident on blood smear (Fig. 41.4). The cells appear hypochromic, but the appearance is related to the thinness of the cell rather than to reduced hemoglobin concentration. These morphologic changes are accompanied by increased resistance to hemolysis in osmotic fragility tests.³⁵⁸ When spur cell hemolytic anemia supervenes, characteristic acanthocytes—erythrocytes covered with five to ten spike-like projections—are evident. The acanthocytes are morphologically indistinguishable from the distorted erythrocytes found in patients with abetalipoproteinemia. Stomatocytes are sometimes observed in association with the transient hemolytic episodes associated with acute fatty liver disease,³⁶¹ but they are also noted in alcoholics who display no evidence of hemolysis.³⁶²

Approximately 50% of patients with cirrhosis have mild thrombocytopenia, but values $<50 \times 10^9/L$ are uncommon.^{95, 347} A variety of leukocyte abnormalities may be observed; in a study of 25 patients, 16 had lymphopenia, 4 had neutropenia, and 12 had neutrophilia.³⁴⁷

Bone marrow cellularity is normal or increased.^{96, 347, 359} Often, erythroid hyperplasia is observed. Red cell precursors at times have been described as macronormoblasts, a term that implies their size is increased, but their nuclear chromatin appears normal.^{347, 359, 363} Frank megaloblastosis is seen in $<20\%$ of patients.

Pathogenesis

Shortened Erythrocyte Survival

Red cell survival is decreased in approximately two-thirds of patients with alcoholic liver disease. The precise extent to which this occurs varies depending on the technique used to measure survival, but it is usually of only moderate degree.^{95, 96, 345} Shorter survival tends to be observed in more anemic patients.

P.1008

When indirect bilirubinemia is observed in a liver disease patient (elevated total bilirubin with $>70\%$ indirect), erythrocyte survival is particularly likely to be reduced.³⁶⁴ Erythrocyte survival also was significantly shortened in patients with biliary cirrhosis,³⁴⁴ obstructive jaundice, and infectious hepatitis,^{345, 364} even in the absence of anemia.

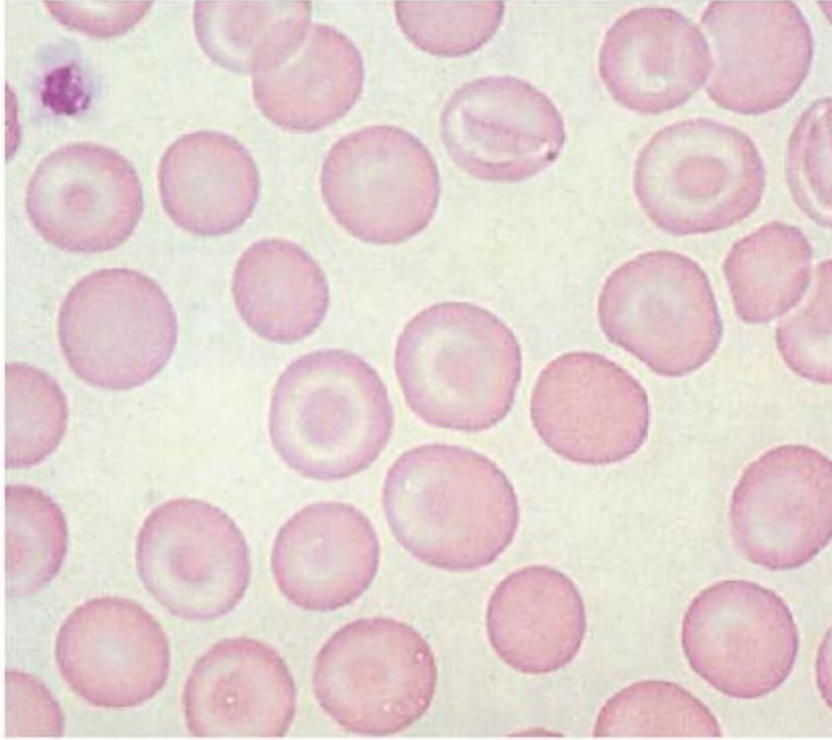

FIGURE 41.4. Macrocytes and target cells in liver disease ($\times 1,500$).

The mechanism for the observed decrease in red cell lifespan is not fully understood; it is most probably multifactorial. Results of cross-transfusion studies demonstrate improved survival when patients' cells are transfused to normal recipients, suggesting that the hemolytic mechanism is extracorporeal (i.e., not intrinsic to the erythrocyte).³⁶⁵ Congestive splenomegaly and splenic sequestration are major suspects in this category,^{96, 351, 357, 366, 367} although they cannot always be demonstrated.⁹⁶ In some cases, correction of the hemolytic process may occur after splenectomy.

Abnormal erythrocyte metabolism is a possible intracorporeal factor leading to reduced erythrocyte survival in liver disease. Activity of the methylene blue-stimulated pentose phosphate shunt is decreased, with consequent glutathione instability and a tendency to form Heinz bodies.^{368, 369} This metabolic abnormality renders the cell sensitive to oxidant hemolysis, but whether this form of hemolysis is an important mechanism of shortened erythrocyte survival in liver disease is uncertain, because a comparable shunt defect in most patients with glucose 6-phosphate dehydrogenase deficiency does not lead to hemolysis unless oxidant drugs are encountered. However, oxidant drugs can produce hemolysis in liver disease, as when patients with hepatitis C are treated with ribavirin.³⁷⁰ Another metabolic abnormality encountered occasionally in liver disease is hypophosphatemia, with reduced erythrocyte adenosine triphosphate levels and consequent hemolysis.³⁷¹

Characteristic alterations in red cell membrane lipids are found in patients with hepatitis, cirrhosis, and obstructive jaundice and may also be another contributor to shortened red cell survival.^{351, 372, 373, 374, 375, 376, 377} In the usual uncomplicated case, a 25% to 50% increase in both cholesterol and lecithin is noted in the membrane. These changes result in an increased cell surface area associated with the target cells or thin macrocytes that are so characteristic of liver disease. The loss of sialic acid from the red cell surface may contribute to impaired viability of the cell.³⁷⁸ Bile duct obstruction leads to an increase in the activity of neuraminidases, enzymes that remove sialic acid. However, it is not proven that such abnormalities shorten red cell survival.³⁵¹

In spur cell hemolytic anemia, the erythrocyte membrane accumulates excess cholesterol without a corresponding increase in lecithin, resulting in the characteristic morphologic abnormality. This change is accompanied by pronounced reduction in erythrocyte survival, probably because the distorted cells are less deformable than normal and thus become trapped by splenic macrophages. Passage through the spleen causes loss of cell surface with transformation of echinocytes to acanthocytes,^{366, 375} but in fact, the spleen is not required for development of spur cells.^{379, 380} Splenectomy may ameliorate severe hemolysis.³⁶⁶ The mechanism whereby the red cell lipid pattern becomes altered is not well understood. One possible factor is an alteration in the cholesterol-to-phospholipid ratio in high-density plasma

lipoproteins, because mature erythrocytes are unable to synthesize lipids and depend largely on plasma lipids for replenishment.³⁸¹ In addition, the process of red cell phospholipid repair appears to be defective in spur cell anemia.^{382, 383} Phospholipid biosynthesis is inhibited and therefore cannot compensate for the increased membrane cholesterol characteristic of liver disease. Other potential contributors to altered erythrocyte membrane lipids in liver disease are changes in plasma lecithin-cholesterol acyltransferase activity, retention of lytic bile acids,³⁸² and an increase in the intrinsic proteolytic activity of the membrane.³⁸⁴

Zieve syndrome has been mentioned earlier. It has been proposed that the transient hemolytic anemia in this syndrome is caused by the lytic action of certain plasma lipids.³⁵⁴ However, hypertriglyceridemia by itself does not cause hemolysis^{353, 376, 377}; erythrocyte lipids in these patients are similar to those described in patients with only a modest hemolytic component³⁷⁷; and hemolytic anemia may occur in patients with acute fatty liver disease even if plasma triglyceride levels are not increased.³⁵² Alcohol-induced vitamin E deficiency with decreased polyunsaturated fatty acids in membrane lipids may play a role in some patients³⁵³; similar findings have been reported in vitamin E-deficient children.³⁸⁵

Erythropoiesis

In addition to the shortened erythrocyte survival, the marrow response to the anemia in patients with liver disease may be inadequate. Plasma iron turnover, red cell iron utilization, and erythrocyte iron turnover were normal or reduced in the majority of patients in one series, whereas these parameters were increased two- to threefold in another.^{96, 386} The presence or absence of complications may explain such discrepancies. Alcohol, in particular, depresses erythropoiesis, and if the patient is studied before the effects of alcohol ingestion subside, marrow function appears depressed.³⁶⁰

Serum from cirrhotic patients can suppress hematopoietic colony formation in vitro,³⁸⁷ and cytokines implicated in inhibition of erythropoiesis have been found to be increased in patients with liver disease.³⁸⁸ Dyserythropoiesis with morphologic abnormalities and intramedullary hemolysis has also been reported in severe liver disease.³⁸⁹ It has been suggested that extrarenal Epo by the liver is abnormal in patients with liver disease, but in fact, the expected inverse relationship between hemoglobin and Epo production has been found to be preserved in liver disease and to result in levels appropriate for the degree of anemia.^{66, 390}

ANEMIAS ASSOCIATED WITH ENDOCRINE DISORDERS

A mild to moderate anemia commonly accompanies disorders affecting the thyroid, adrenals, parathyroids, gonads, or pituitary. It is usually not associated with symptomatology (other than that associated with the underlying endocrinopathy) and in fact may reflect a physiologically appropriate hemoglobin concentration because the hormone deficiency often results in reduced oxygen requirements. The anemia is therefore "adaptive."³⁹¹ In consultative hematology practice, these individuals present as referrals for evaluation of moderate anemia with normal iron, B₁₂, and folate studies, generally with a question from the referring doctor of whether marrow examination is required. The endocrine disorder is typically undiagnosed at time of referral.

Hypothyroidism

Anemia is observed in 21% to 60% of hypothyroid patients and is more common in hypothyroid men than in hypothyroid women.³⁹² The frequency of anemia was 39% in patients with subclinical hypothyroidism, and 43% in patients with overt hypothyroidism in one series.³⁹³ The anemia observed may be normocytic and normochromic, hypochromic and microcytic, or macrocytic. The last category comprises roughly one-third of anemic patients in most reported series; the frequency of the other two morphologic types varies considerably in different reports (Table 41.4).^{391, 394, 395, 396, 397}

The uncomplicated anemia of hypothyroidism is either normocytic or slightly macrocytic, as is suggested by the predominance of these findings in most series.^{392, 395, 396} Hypochromic microcytic anemia found in association with hypothyroidism should

P.1009

be considered iron deficiency until proven otherwise.^{391, 392, 396} Biochemical markers of iron deficiency are present: The microcytic anemia responds (at least in part) to iron therapy, even if thyroid hormone is not administered, but does not typically respond to thyroid hormone without iron.³⁹² Iron deficiency in hypothyroidism may be normocytic, so an important step is to determine the serum iron, transferrin, and ferritin concentrations. Hypothyroid individuals are more likely to become iron-deficient because of predisposition to menorrhagia³⁹⁷ and achlorhydria³⁹⁶ and because thyroid hormone itself may be essential for normal iron absorption.³⁹¹ Severely macrocytic anemia usually results from complicating deficiency of vitamin B₁₂³⁹⁶ or folate.³⁹⁵

TABLE 41.4 INCIDENCE OF VARIOUS TYPES OF ANEMIA MORPHOLOGIES IN PATIENTS WITH MYXEDEMA

Type of Anemia	Reference 396 (%)	Reference 391 (%)
Normocytic, normochromic	4	13.5
Hypochromic, microcytic	14	4.5
Macrocytic	13	8
All anemias	31	26

When patients with iron, folate, or vitamin B₁₂ deficiency are excluded, the remaining individuals should be considered to have “uncomplicated anemia of hypothyroidism,” which is a manifestation of the hormone deficiency itself.^{395, 396} All or nearly all children with anemia and hypothyroidism have the uncomplicated form of the syndrome.³⁹⁸ Anemia usually affects children whose height is below the third-percentile. The anemia usually is mild, with the hematocrit rarely falling below 0.35. The plasma volume often is decreased, which tends to make the reduction in hematocrit less than might be expected for a given decrease in red cell mass.^{396, 399} The degree of anemia is related to both the severity and the duration of the hypothyroidism.⁴⁰⁰ The hematocrit declines for as long as 6 months after thyroidectomy in previously euthyroid subjects, even though the basal metabolic rate remains at a stable reduced level.

The MCV may be increased in hypothyroid patients, even in the absence of anemia (350). Anisocytosis, poikilocytosis, and other red cell morphologic abnormalities are uncommon, but acanthocytes are apparent in ~20% of patients.³⁹¹ Usually, the leukocyte and platelet counts are within the normal range, although both may be slightly reduced.⁴⁰⁰ The bone marrow may be mildly hypoplastic, but the myeloid-to-erythroid ratio is not significantly altered.^{401, 402} Hemoglobin A₂ levels are reduced slightly.⁴⁰³

Pathogenesis

The anemia of hypothyroidism results from decreased red cell production. Erythrocyte survival is normal or even slightly prolonged in humans,^{396, 404} but plasma iron transport and erythrocyte iron turnover rates are reduced, indicating subnormal red cell production.^{221, 404} As noted earlier, the anemia of hypothyroidism is considered “adaptive”—that is, a physiologic adjustment to the reduced needs of the organism for oxygen.³⁹¹ Epo secretion is reduced in hypothyroid patients,⁴⁰⁵ and 2,3-DPG levels are not increased⁴⁰⁶ as occurs in most anemic and hypoxic states. Thyroid hormones can enhance erythropoiesis in vitro and presumably in vivo as well.⁴⁰⁷ The observation that the noncalorigenic D-isomer of triiodothyronine can stimulate erythropoiesis without altering oxygen consumption has been cited as evidence of a hormonal effect that is not oxygen-dependent.⁴⁰⁸

The response of anemia of hypothyroidism to thyroid hormone is gradual. No striking reticulocytosis occurs, and the hematocrit returns to a normal value only gradually over approximately a 6-month period (range, 3 to 12 months).^{392, 396} The MCV almost always decreases, regardless of its initial value or the presence or degree of anemia, and stabilizes after 4 to 6 months or more.⁴⁰⁹

Hyperthyroidism

A mild anemia with no other apparent etiology occurs in 10% to 25% of patients with hyperthyroidism.^{410, 411} Anemia is primarily observed in individuals with severe or prolonged hyperthyroidism.⁴¹⁰ More typically, the hemoglobin value falls somewhat but remains within normal limits.⁴¹⁰ The anemia of hyperthyroidism is in many ways the mirror image of that observed in hypothyroidism. MCV is either normal or modestly decreased and, consistent with the comparison to hypothyroidism, may be decreased even in the absence of anemia.⁴¹⁰ Hemoglobin A₂ levels are slightly increased but not as much as in thalassemia.⁴⁰³ Both the anemia and the microcytosis are corrected when the hyperthyroidism is successfully treated; on average, the hemoglobin increases 0.5 g/dl, and the MCV increases 6 fl.

The pathogenesis of anemia and microcytosis of hyperthyroidism is not well understood. Plasma volume may be increased, suggesting dilution.³⁹⁹ Erythropoiesis usually is accelerated but ineffective.^{411, 412} Some (but not all) investigators report increased levels of erythrocyte 2,3-DPG.^{406, 413, 414, 415} Such a change would reduce oxygen affinity and improve oxygen delivery, thereby compensating for the reduced hemoglobin level. Increased plasma Epo levels have been reported⁴¹⁶—the opposite of what has been described for hypothyroidism.

Adrenal Insufficiency

Although anemia (in the sense of a decreased red cell mass) is common and probably nearly universal in adrenal insufficiency, it may be masked by the dehydration characteristic of this syndrome.^{417, 418} In a series of patients with

untreated Addison disease, the average blood hemoglobin level was 13.2 g/dl (range, 9.4 to 18.0 g/dl).⁴¹⁹ The red cells were normocytic and normochromic. After institution of hormone replacement, the average hemoglobin fell to 10.7 g/dl and the hematocrit from 0.42 to 0.33, presumably reflecting the expansion of plasma volume associated with clinical improvement. Later in the course of the disease, reticulocytosis and a return to normal hemoglobin levels occurred.⁴¹⁹ Pernicious anemia is observed in 3% to 16% of cases of nontuberculous adrenal insufficiency and may complicate 13% of adrenal insufficiency cases associated with the polyglandular autoimmune syndrome type I.^{420, 421}

Androgen Deficiency

After puberty, values for the hematocrit, blood hemoglobin concentration, and red cell count average ~10% to 13% higher in men than in women.⁴²² In castrated men, these values fall to within the normal female range.^{423, 424} This is almost certainly due to a difference in Epo production,⁴²⁵ although the relationship between hemoglobin and Epo concentration does not differ between the sexes. After the sixth decade, male hemoglobin values fall back toward those observed in women.^{422, 426} The anemia in these patients is corrected by androgen replacement.

The differences in red cell parameters between the sexes are accounted for chiefly by the stimulating effect of androgens on erythropoiesis. In addition, some observers suggest that estrogens exert a suppressive effect. Thus, castration of male rats precipitates a decrease in hemoglobin, whereas castration of female rats brings about an increase.^{427, 428} The administration of androgens to castrated males restores male values for hemoglobin concentration. Androgens can also stimulate erythropoiesis in normal subjects (see Chapter 44). In normal men, testosterone enanthate

P.1010

induced an average red cell mass increase of 1.7 to 2.3.⁴²⁹ The increase in hematocrit was of smaller magnitude (from 0.456 to 0.494), probably because the plasma volume also increased. Androgens act by increasing renal synthesis of Epo.^{430, 431} Estrogens produce anemia when given in large amounts to rats.^{432, 433} It has been suggested that this effect results from suppression of hepatic synthesis of Epo, but it may also simply represent opposition to androgen effects in general.

Hypopituitarism

Moderately severe anemia is a well-recognized feature of pituitary insufficiency, regardless of cause. In an extensive review of cases of Simmonds disease in the first half of the 20th century, the average blood hemoglobin concentration was ~10 g/dl, with similar values reported in patients with hypopituitarism that arose from neoplasms.^{434, 435, 436} Anemia is also evident in prepubertal pituitary dwarfs but tends to be underappreciated because of contracted plasma volume.^{437, 438} The anemia usually is normocytic and normochromic, and the red cells appear normal morphologically. In some patients, slight hypochromia or macrocytosis has been observed^{435, 439}; however, complicating deficiencies of iron or folate were not excluded. Results of kinetic studies demonstrate reduced red cell production.⁴³⁷

The anemia of hypopituitarism results chiefly from deficiencies of the hormones of target glands controlled by the pituitary, especially the thyroid and adrenal hormones, but also from a deficiency of androgens. In addition, lack of other pituitary factors, such as growth hormone,^{437, 440} prolactin,⁴⁴¹ or factors characterized less clearly,⁴⁴² may be of importance. The interrelations of these various hormones have been studied experimentally in animals, especially the rat. In this species, hypophysectomy results in a moderately severe, slightly hypochromic and microcytic anemia^{440, 443}, associated with a pronounced decrease in erythroid elements in the bone marrow.⁴⁴⁴ No hemolysis has been reported. Combined adrenalectomy and thyroidectomy results in an anemia that is similar, but not identical, to that noted after hypophysectomy.^{440, 445}

As suggested for the anemia of hypothyroidism, panhypopituitarism probably produces its effects on erythropoiesis chiefly by reducing tissue oxygen consumption.⁴⁴⁰ The organism reacts to this decreased need for oxygen by secreting less Epo, and the red cell mass diminishes until a new equilibrium between oxygen supply and demand is established. This hypothesis is supported by the observations that (a) tissue oxygen consumption is low in the hypophysectomized rat, even if the red cell mass is restored to normal levels⁴⁴⁰; (b) once equilibrium is established, the marrow of the hypophysectomized animal responds to hypoxia, bleeding, or cobalt administration^{440, 446}; (c) correlation between oxygen consumption and rate of erythropoiesis is apparent in hypophysectomized animals given thyroxine or 2,4-dinitrophenol⁴⁴¹; and (d) erythrocyte 2,3-DPG levels, which increase when tissue oxygen delivery is compromised, are normal in patients with panhypopituitarism.⁴⁴⁷

Treatment with a combination of thyroxine, cortisone, and growth hormone corrects both the anemia and the marrow hypoplasia⁴⁴⁰ and is more effective than any single hormone by itself. In one reported case of panhypopituitarism

secondary to craniopharyngioma, anemia persisted and progressed despite replacement hormone therapy. Administration of rhEpo (6,000 IU/day) was followed by correction of the anemia, with the blood hemoglobin level rising from 6 g/dl to normal over a 3-month period.⁴⁴⁸

Hyperparathyroidism

Secondary hyperparathyroidism as a contributor to anemia of renal failure has been discussed earlier. Anemia is a rare complication of primary hyperparathyroidism.^{449, 450} At one institution, 17 of 332 patients (5.1%) with primary hyperparathyroidism were anemic, with hematocrit values ranging from 0.23 to 0.37.⁴⁵¹ None had leukopenia or thrombocytopenia. The anemia was normocytic and normochromic, and no reticulocytosis was evident. Five patients had bone marrow examinations. Four of these patients had 25% or more of their marrow replaced by fibrosis. Anemic patients appeared to have relatively severe hyperparathyroidism as judged by the presence of bone cysts, subperiosteal bone resorption, and particularly high values for serum calcium, alkaline phosphatase, and parathyroid hormone. The hematocrit increased in all seven patients who underwent parathyroidectomy; in six patients, it became normal.⁴⁵¹

The cause of the anemia in these patients remains obscure. Although renal failure and gastrointestinal bleeding occur in association with hyperparathyroidism, they could not be implicated as an etiologic factor in this group of anemic patients, nor was incidental iron deficiency evident. Some authors conclude that parathyroid hormone decreases proliferation of erythroid precursors in culture.²⁵¹ Marrow fibrosis may also be a result of excess hormone levels.^{252, 253} Myelofibrosis is a common finding in bone marrow biopsy specimens, but the usual morphologic signs of myelophthisis are lacking.⁴⁵⁰

When hyperparathyroidism is secondary to renal disease, it is difficult to ascertain the relative importance of the hormone excess versus the Epo deficit characteristic of renal failure as a contributor to the observed anemia. Of note, however, is that medical treatment of hyperparathyroidism with vitamin D₃ can bring about improvement in anemia and decreased requirement for Epo in some patients.³²³

Anorexia Nervosa

Anemia is observed in as many as 84% of patients with anorexia nervosa admitted to the hospital.^{452, 453, 454} A moderate degree of leukopenia or thrombocytopenia may also be observed. The peripheral blood smear shows a striking composite process, and bone marrow examination shows gelatinous transformation with necrosis, as well as decreased cellularity in most cases.^{453, 454, 455} These are essentially the findings observed in starvation, and they return to normal with improved nutrition.^{453, 454, 455} Hemolytic anemia has also been reported in anorexia nervosa.⁴⁵⁶ This was presumed to be a complication of hypophosphatemia (see Chapter 32).

Disclosure

The author is a consultant to Xenon Pharmaceuticals, a company engaged in development of hepcidin-directed therapeutics.

REFERENCES

1. Bentley DP. Anaemia and chronic disease. *Clin Haematol* 1982;11:465-479.
2. Cartwright GE. The anemia of chronic disease. *Semin Hematol* 1966;3: 351-375.
3. Lee GR. The anemia of chronic disease. *Semin Hematol* 1983;20:61-80.
4. Schilling RF. Anemia of chronic disease: a misnomer. *Ann Intern Med* 1991;115:572-573.
5. Nemeth E, Valore EV, Territo M, Schiller G, Lichtenstein A, Ganz T. Hpcidin, a putative mediator of anemia of inflammation, is a type II acute phase protein. *Blood* 2003;101:2461-2463.
6. Means RT. Pathogenesis of the anemia of chronic disease: a cytokine-mediated anemia. *Stem Cells* 1995;13:32-37.
7. Haurani FI, Green D. Primary defective iron reutilization: response to testosterone therapy. *Am J Med* 1967;42(1):151-158.
8. Cartwright GE, Lee GR. The anaemia of chronic disorders. *Br J Haematol* 1971;21:147-152.
9. Cash JM, Sears DA. The anemia of chronic disease: spectrum of associated diseases in a series of unselected hospitalized patients. *Am J Med* 1989;87(6):638-644.
10. Baer AN, Dessypris EN, Krantz SB. The pathogenesis of anemia in rheumatoid arthritis. A clinical and laboratory analysis. *Semin Arthritis Rheum* 1990;14:209-223.

11. Miller RK, Altz-Smith M. Usefulness of serum ferritin in detecting iron deficiency in rheumatoid arthritis (RA). *Arthritis Rheum* 1982;25:S114.
12. Allen DA, Breen C, Yaqoob MM, Macdougall IC. Inhibition of CFU-E colony formation in uremic patients with inflammatory disease: role of IFN- γ and TNF- α . *J Invest Med* 1999;47:204-211.
13. Healey LA, Wilske KR. Presentation of occult giant cell arteritis. *Arthritis Rheum* 1980;23:641-643.
14. Cartwright GE, Wintrobe MM. The anemia of infection. XVII. A review. *Adv Intern Med* 1952;5:165-226.
15. Chernow B, Wallner SF. Is the anemia of chronic disease normocytic and normochromic? *Mil Med* 1978;143:345-346.
16. Schiavone DJ, Rubbo SD. Anaemia associated with *Haemophilus influenzae meningitis*. *Lancet* 1953;265(6788):696-698.
17. Atkins MB, Kappler K, Mier JW, Isaacs RE, Berkman EM. Interleukin-6-associated anemia: determination of the underlying mechanism. *Blood* 1995;86(4):1288-1291.
18. James GW. Studies on prolonged suppurative infection in man. *J Lab Clin Med* 1948;33:1607-1623.
19. Jeffrey MR. Some observations on anemia in rheumatoid arthritis. *Blood* 1953;8(6):502-518.
20. Eastgate JA, Wood NC, DiGiovine FS, Symons JA, Grinlinton FA, Duff GW. Correlation of plasma interleukin1 levels with disease activity in rheumatoid arthritis. *Lancet* 1988;2:706-709.
21. Chodos RB, Emerson CP, Miller A, Ross JF. Studies of the anemia and iron metabolism in cancer. *J Clin Invest* 1956;35(11):1248-1262.
22. Hyman GA, Harvey JE. The pathogenesis of anemia in patients with carcinoma. *Am J Med* 1955;19(3):350-356.
23. Alexander WRM, Richmond J, Roy LMH, Dathie JJR. Nature of anaemia in rheumatoid arthritis II. Survival of transfused erythrocytes in patients with rheumatoid arthritis. *Ann Rheum Dis* 1956;15:12.
24. Bainton DF, Finch CA. The diagnosis of iron deficiency anemia. *Am J Med* 1964;37:62-70.
25. Kyllonen KE. Observations concerning the blood volume, red cells and erythropoiesis in patients with lung cancer. A pre- and postoperative study. *Ann Chir Gynaecol Fenn Suppl* 1961;50(101):1-120.
26. Mast AE, Blinder MA, Dietzen DJ. Reticulocyte hemoglobin content. *Am J Hematol* 2008;83(4):307-310.
27. Thomas C, Kirschbaum A, Boehm D, Thomas L. The diagnostic plot: a concept for identifying different states of iron deficiency and monitoring the response to epoetin therapy. *Med Oncol* 2006;23(1):23-36.
28. Elin RJ, Wolff SM, Finch CA. Effect of induced fever on serum iron and ferritin concentrations in man. *Blood* 1977;49:147-153.
29. Kampschmidt RF, Upchurch HF, Johnson HL. Iron transport after injection of endotoxin in rats. *Am J Physiol* 1965;208:68-72.
30. Freireich EJ, Ross JF, Bayles TB, Emerson CP, Finch SC. Radioactive iron metabolism and erythrocyte survival studies of the mechanism of the anemia associated with rheumatoid arthritis. *J Clin Invest* 1957;36(7):1043-1058.
31. Lipshitz DA, Cook JD, Finch CA. A clinical evaluation of serum ferritin as an index of marrow iron stores. *N Engl J Med* 1974;290:1213-1216.
32. Lee MH, Means RT. Extremely elevated serum ferritin levels in a university hospital: associated diseases and clinical significance. *Am J Med* 1995;98:566-571.
33. Anderson JE, Appelbaum FR, Schoch G, et al. Allogeneic marrow transplantation for refractory anemia: a comparison of two preparative regimens and analysis of prognostic factors. *Blood* 1996;87(1):51-58.
34. Hansen NE. The anaemia of chronic disorders: a bag of unsolved questions. *Scand J Haematol* 1983;31:397-402.
35. Hansen TM, Hansen NE, Birgens HS, Holund B, Lorenzen I. Serum ferritin and the assessment of iron deficiency in rheumatoid arthritis. *Scand J Rheumatol* 1983;12(4):353-359.
36. Witte DL. Can serum ferritin be effectively interpreted in the presence of the acute phase response? *Clin Chem* 1991;37:484-485.

37. North M, Dallalio G, Donath AS, Melink R, Means RT. Serum transferrin receptor levels in patients undergoing evaluation of iron stores: correlation with other parameters, and observed versus predicted results. *Clin Lab Haematol* 1997;19:93-97.
38. Kurer SB, Seifert B, Michel B, Ruegg R, Fehr J. Prediction of iron deficiency in chronic inflammatory rheumatic disease anaemia. *Br J Haematol* 1995;91(4):820-826.
39. Balaban EP, Sheehan RG, Demian SE, Cox JV, Frenkel EP. Evaluation of bone marrow iron stores in anemia associated with chronic disease: a comparative study of serum and red cell ferritin. *Am J Hematol* 1993;42:177-181.
40. Auerbach M, Witt D, Toler W, Fierstein M, Lerner RG, Ballard H. Clinical use of the total dose intravenous infusion of iron dextran. *J Lab Clin Med* 1988;111:566-570.
41. Means RT, Allen J, Sears DA, Schuster SJ. Serum soluble transferrin receptor and the prediction of marrow aspirate results in a heterogeneous group of patients. *Clin Lab Haematol* 1999;21:161-167.
42. Berlin T, Meyer A, Rotman-Pikielny P, Natur A, Levy Y. Soluble transferrin receptor as a diagnostic laboratory test for detection of iron deficiency anemia in acute illness of hospitalized patients. *Isr Med Assoc J* 2011;13(2): 96-98.
43. Chua E, Clague JE, Sharma AK, Horan MA, Lombard M. Serum transferrin receptor assay in iron deficiency anaemia and anaemia of chronic disease in the elderly. *QJM* 1999;92:587-594.
44. Koulaouzidis A, Said E, Cottier R, Saeed AA. Soluble transferrin receptors and iron deficiency, a step beyond ferritin. A systematic review. *J Gastrointest Liver Dis* 2009;18(3):345-352.
45. Punnonen K, Irjala K, Rajam KA. Iron-deficiency anemia is associated with high concentrations of transferrin receptor in serum. *Clin Chem* 1994;40:774-776.
46. Punnonen K, Irjala K, Rajamaeki A. Serum transferrin receptor and its ratio to serum ferritin in the diagnosis of iron deficiency. *Blood* 1997;89(3): 1052-1057.
47. Sasu BJ, Li H, Rose MJ, Arvedson TL, Doellgast G, Molineux G. Serum hepcidin but not prohepcidin may be an effective marker for anemia of inflammation (AI). *Blood Cells Mol Dis* 2010;45(3):238-245.
48. Busbridge M, Griffiths C, Ashby D, et al. Development of a novel immunoassay for the iron regulatory peptide hepcidin. *Br J Biomed Sci* 2009;66(3): 150-157.
49. Ganz T, Olbina G, Girelli D, Nemeth E, Westerman M. Immunoassay for human serum hepcidin. *Blood* 2008;112(10):4292-4297.
50. Grebenchtchikov N, Geurts-Moespot AJ, Kroot JJ, et al. High-sensitive radioimmunoassay for human serum hepcidin. *Br J Haematol* 2009;146(3): 317-325.
51. Kemna E, Tjalsma H, Laarakkers C, Nemeth E, Willems H, Swinkels D. Novel urine hepcidin assay by mass spectrometry. *Blood* 2005;106(9):3268-3270.
52. Koliaraki V, Marinou M, Vassilakopoulos TP, et al. A novel immunological assay for hepcidin quantification in human serum. *PLoS One* 2009;4(2):e4581.
53. Nicolai G, Anneke JG, Joyce JCK, et al. High-sensitive radioimmunoassay for human serum hepcidin. *Br J Haematol* 2009;146(3):317-325.
54. Thomas C, Kobold U, Balan S, Roedddiger R, Thomas L. Serum hepcidin-25 may replace the ferritin index in the Thomas plot in assessing iron status in anemic patients. *Int J Lab Hematol* 2011;33:187-193.
55. Marsh WL Jr, Koenig HM. The laboratory evaluation of microcytic red blood cells. *Crit Rev Clin Lab Sci* 1982;16(3):195-254.
56. Marsh WL, Jr., Nelson DP, Koenig HM. Free erythrocyte protoporphyrin (FEP) II. The FEP test is clinically useful in classifying microcytic RBC disorders in adults. *Am J Clin Pathol* 1983;79(6):661-666.
57. Dinarello CA. Interleukin-1 and the pathogenesis of the acute-phase response. *N Engl J Med* 1984;311(22):1413-1418.
58. Kushner I. The phenomenon of the acute phase response. *Ann N Y Acad Sci* 1982;389:39-48.
59. Morley JJ, Kushner I. Serum C-reactive protein levels in disease. *Ann N Y Acad Sci* 1982;389:406-418.

60. Bornstein DL. Leukocytic pyrogen: a major mediator of the acute phase reaction. *Ann N Y Acad Sci* 1982;389:323-337.
61. Lebreton JP, Joisel F, Raoult JP, Lannuzel B, Rogez JP, Humbert G. Serum concentration of human alpha 2 HS glycoprotein during the inflammatory process: evidence that alpha 2 HS glycoprotein is a negative acute-phase reactant. *J Clin Invest* 1979;64(4):1118-1129.
62. Kushner I. Erythrocyte sedimentation and the acute phase reactants. In: Kelley WN, Harris ED Jr, Ruddy S, et al., eds. *Textbook of rheumatology*. Philadelphia, PA: W.B. Saunders, 1989:719-27.
63. Baracos V, Rodemann HP, Dinarello CA, Goldberg AL. Stimulation of muscle protein degradation and prostaglandin E2 release by leukocytic pyrogen (interleukin-1). A mechanism for the increased degradation of muscle proteins during fever. *N Engl J Med* 1983;308(10):553-558.
64. Beisel WR. Mediators of fever and muscle proteolysis. *N Engl J Med* 1983;308(10):586-587.
65. Clowes GH Jr, George BC, Vilee CA Jr, Saravis CA. Muscle proteolysis induced by a circulating peptide in patients with sepsis or trauma. *N Engl J Med* 1983;308(10):545-552.
66. Means RT, Mendenhall CL, Worden BD, Moritz TE, Chedid A, Department of Veterans Affairs Cooperative Studies G. Erythropoietin and cytokine levels in the anemia of severe alcoholic liver disease. *Alcohol Clin Exp Res* 1996;20:355-358.
67. Dekaris D, Sabioncello A, Mazuran R, et al. Multiple changes of immunologic parameters in prisoners of war. Assessments after release from a camp in Manjaca, Bosnia. *JAMA* 1993;270:595-599.
68. Cavill I, Bentley DP. Erythropoiesis in the anaemia of rheumatoid arthritis. *Br J Haematol* 1982;50(4):583-590.
69. Dinant HJ, de Maat CE. Erythropoiesis and mean red-cell lifespan in normal subjects and in patients with the anaemia of active rheumatoid arthritis. *Br J Haematol* 1978;39(3):437-444.
70. Saifi MF, Vaughan JM. The anaemia associated with infection. *J Pathol Bacteriol* 1944;56(2):189-197.
71. Bush JA, Ashenbrucker H, Cartwright GE, Wintrobe MM. The anemia of infection. XX. The kinetics of iron metabolism in the anemia associated with chronic infection. *J Clin Invest* 1956;35(1):89-97.
72. Haurani FI, Burke W, Martinez EJ. Defective reutilization of iron in the anemia of inflammation. *J Lab Clin Med* 1965;65:560-570.
73. Haurani FI, Burke WM, Martinez EJ. Effective reutilization of iron in the anemia of rheumatoid arthritis. *J Lab Clin Med* 1965;65:560-570.
74. Chodos RB, Miller A, Ross JF, Emerson CP. The mechanism of anemia in cancer. *Acta Unio Int Contra Cancrum* 1956;12(1-2):36-42.
75. Ricketts C, Jacobs A, Cavill I. Ferrokinetics and erythropoiesis in man: the measurement of effective erythropoiesis, ineffective erythropoiesis and red cell lifespan using ⁵⁹Fe. *Br J Haematol* 1975;31(1):65-75.
76. Cavill I, Ricketts C, Napier JA. Erythropoiesis in the anaemia of chronic disease. *Scand J Haematol* 1977;19(5):509-512.
77. Mackness GB. The monocyte in cellular immunity. *Semin Hematol* 1970;7(2):172-184.
78. Means RT, Krantz SB. Progress in understanding the pathogenesis of the anemia of chronic disease. *Blood* 1992;80:1639-1647.
79. Beutler B, Cerami A. Cachectin: more than a tumor necrosis factor. *N Engl J Med* 1987;316:379-385.
80. Tracey KJ, Vlassara H, Cerami A. Cachectin/tumor necrosis factor. *Lancet* 1988;1:1122-1125.
81. Brenner MK. Annotation: tumor necrosis factor. *Br J Haematol* 1988;69: 149-152.
82. Durum SK, Schmidt JA, Oppenheim JJ. Interleukin 1: an immunological perspective. *Annu Rev Immunol* 1985;3:263-287.
83. Dinarello CA. Interleukin-1 and its biologically related cytokines. *Adv Immunol* 1989;44:153-205.
84. Vreugdenhil G, Lowenberg B, van Eijk HG, Swaak AJ. Anaemia of chronic disease in rheumatoid arthritis. Raised serum interleukin-6 (IL-6) levels and effects of IL-6 and anti-IL-6 on in vitro erythropoiesis. *Rheumatol Int* 1990;10(3):127-130.
85. Hooks JJ, Moutsopoulos HM, Geis SA, Stahl NI, Decker JL, Notkins AC. Immune interferon in the circulation of patients with autoimmune disease. *N Engl J Med* 1979;301:5-8.

86. Murray HW. Interferon-gamma, the activated macrophage, and host defense against microbial challenge. *Ann Intern Med* 1988;108:595-608.
87. Vilcek J, Gray PW, Rinderknecht E, Sevastopoulos CG. Interferon (gamma): a lymphokine for all seasons. *Lymphokines* 1985;11:1-32.
88. Balkwill F, Burke F, Talbot D, et al. Evidence for tumor necrosis factor/cachectin production in cancer. *Lancet* 1987;2:1229-1232.
89. Mauritz NJ, Holmdahl R, Jonsson R, Van der Meide PH, Scheynius A, Klarskug L. Treatment with gamma-interferon triggers the onset of collagen arthritis in mice. *Arthritis Rheum* 1988;31:1297-1303.
90. Maury CPJ, Andersson LC, Teppo AM, Partanen S, Javonen E. Mechanism of anaemia in rheumatoid arthritis: demonstration of raised interleukin 1 (beta) concentration in anaemic patients and of interleukin 1 mediated suppression of normal erythropoiesis and proliferation of human erythroleukemia (HEL) cells in vitro. *Ann Rheum Dis* 1988;47:972-978.
91. Maury CPJ, Teppo AM. Tumor necrosis factor in the serum of patients with systemic lupus erythematosus. *Arthritis Rheum* 1989;32:146-150.
92. Blick M, Sherwin SA, Rosenblum M, Gutterman J. Phase I study of recombinant tumor necrosis factor in cancer patients. *Cancer Res* 1987;47:2986-2989.
93. Vadhan-Raj S, Al-Katib A, Bhulla R, et al. Phase I trial of recombinant interferon gamma in cancer patients. *J Clin Oncol* 1986;4:137-146.
94. Hill DB, Marsano L, Cohen D, Allen J, Shedlofsky S, McClain CJ. Increased plasma interleukin-6 concentrations in alcoholic hepatitis. *J Lab Clin Med* 1992;119:547-552.
95. Sheehy TW, Berman A. The anemia of cirrhosis. *J Lab Clin Med* 1960;56:72-82.
96. Kimber C, Deller DJ, Ibbotson RN, Lander H. The mechanism of anemia in chronic liver disease. *Q J Med* 1965;133:33-64.
97. Weinstein DA, Roy CN, Fleming MD, Loda MF, Wolfsdorf JI, Andrews NC. Inappropriate expression of hepcidin is associated with iron refractory anemia: implications for the anemia of chronic disease. *Blood* 2002;100(10):3776-3781.
98. Fleming RE, Sly WS. Hepcidin: a putative iron-regulatory hormone relevant to hereditary hemochromatosis and the anemia of chronic disease. *Proc Natl Acad Sci U S A* 2001;98:8160-8162.
99. Rivera S, Gabayan V, Ganz T. In chronic inflammation, there exists an IL-6-independent pathway for the induction of hepcidin (abstract). *Blood* 2004;104:875a.
100. Armitage AE, Eddowes LA, Gileadi U, et al. Hepcidin regulation by innate immune and infectious stimuli. *Blood* 2011;118(15):4129-4139.
101. Nemeth E, Tuttle MS, Powelson J, et al. Hepcidin regulates iron efflux by binding to ferroportin and inducing its internalization. *Science* 2004;306: 2090-2093.
102. Dallaglio G, Law E, Means Jr RT. Hepcidin inhibits in vitro erythroid colony formation at reduced erythropoietin concentrations. *Blood* 2006;107: 2702-2704.
103. Kato A. Increased hepcidin-25 and erythropoietin responsiveness in patients with cardio-renal anemia syndrome. *Future cardiol* 2010;6(6):769-771.
104. Mastrogriannaki M, Matak P, Mathieu JRR, et al. Hepatic hypoxia-inducible factor-2 down-regulates hepcidin expression in mice through an erythropoietin-mediated increase in erythropoiesis. *Haematologica* 2012;97(6):827-834.
105. Rogers J, Durmowicz G, Kasschau K, Lacroix L, Bridges K. A motif within the 5' non-coding regions of acute phase mRNA mediates control of ferritin translation by IL-1[b] and may contribute to the anemia of chronic disease. *Blood* 1991;78(Suppl 1):361a.
106. Moldawer LL, Marano MA, Wei H, et al. Cachectin/tumor necrosis factor alters red blood cell kinetics and induces anemia in vivo. *FASEB J* 1989;3:1637-1643.
107. Rice L, Alfrey CP, Driscoll T, Whitley CE, Hachey DL, Suki W. Neocytolysis contributes to the anemia of renal disease. *Am J Kidney Dis* 1999;33:59-62.

108. Trial J, Rice L, Alfrey CP. Erythropoietin withdrawal alters interactions between young red blood cells, splenic endothelial cells, and macrophages: an in vitro model of neocytolysis. *J Investig Med* 2001;49:335-345.
109. Deliconstantinos G, Villitou V, Stavrides JC, Salemes N, Gogas J. Nitric oxide and peroxy nitrite production by human erythrocytes: a causative factor of toxic anemia in breast cancer patients. *Anticancer Res* 1995;15:1435-1446.
110. Erslev AJ, Wilson J, Caro J. Erythropoietin titers in anemic, nonuremic patients. *J Lab Clin Med* 1987;109:429-433.
111. Baer AN, Dessypris EN, Goldwasser E, Krantz SB. Blunted erythropoietin response to anaemia in rheumatoid arthritis. *Br J Haematol* 1987;66: 559-564.
112. Hochberg MC, Arnold CM, Hogans BB, Spivak JL. Serum immunoreactive erythropoietin in rheumatoid arthritis: impaired response to anemia. *Arthritis Rheum* 1988;31:1318-1321.
113. Miller CB, Jones RJ, Piantadosi S, Abeloff MD, Spivak JL. Decreased erythropoietin response in patients with the anemia of cancer. *N Engl J Med* 1990;322:1689-1692.
114. Spivak JL, Barnes DC, Fuchs E, Quinn TC. Serum immunoreactive erythropoietin in HIV-infected patients. *JAMA* 1989;261:3104-3107.
115. Faquin WC, Schneider TJ, Goldberg MA. Effect of inflammatory cytokines on hypoxia-induced erythropoietin production. *Blood* 1992;79(8):1987-1994.
116. Jelkmann W, Pagel H, Wolff M, Fandrey J. Monokines inhibiting erythropoietin production in human hepatoma cultures and in isolated perfused rat kidneys. *Life Sci* 1991;50:301-308.
117. Douglas SW, Adamson JW. The anemia of chronic disorders: studies of marrow regulation and iron metabolism. *Blood* 1975;45(1):55-65.
118. Dowlati A, RZik S, Fillet G, Beguin Y. Anaemia of lung cancer is due to impaired erythroid marrow response to erythropoietin stimulation as well as relative inadequacy of erythropoietin production. *Br J Haematol* 1997;97(2):297-299.
119. Carazza F, Beguin Y, Bergmann P, et al. Anemia in children is associated with decreased erythropoietic activity and not with inadequate erythropoietin production. *Blood* 1998;92:1793-1798.
120. Johnson CS, Chang MJ, Furmanski P. In vivo hematopoietic effects of tumor necrosis factor-alpha in normal and erythroleukemic mice: characterization and therapeutic applications. *Blood* 1988;72(6):1875-1883.
121. Johnson CS, Keckler DJ, Topper MI, Braunschweiger PG, Furmanski P. In vivo hematopoietic effects of recombinant interleukin-1 alpha in mice: stimulation of granulocytic, monocytic, megakaryocytic, and early erythroid progenitors, suppression of late-stage erythropoiesis, and reversal of erythroid suppression with erythropoietin. *Blood* 1989;73(3):678-683.
122. Johnson RA, Waddelow TA, Caro J, Oliff A, Roodman GD. Chronic exposure to tumor necrosis factor in vivo preferentially inhibits erythropoiesis in nude mice. *Blood* 1989;74:130-138.
123. Mamus SW, Beck-Schroeder SK, Zanjani ED. Suppression of normal human erythropoiesis by gamma interferon in vitro: role of monocytes and T-lymphocytes. *J Clin Invest* 1985;75:1496-1503.
124. Maury CPJ. Anaemia in rheumatoid arthritis: role of cytokines. *Scand J Rheumatol* 1987;18:3-5.
125. Raefsky EL, Platanius LC, Zoumbos NC, Young NS. Studies of interferon as a regulator of hematopoietic cell proliferation. *J Immunol* 1985;135: 2507-2512.
126. Roodman GD, Bird A, Hutzler D, Montgomery W. Tumor necrosis factor-alpha and hematopoietic progenitors: effects of tumor necrosis factor on the growth of erythroid progenitors CFU-E and BFU-E and the hematopoietic cell lines K562, HL60, HEL cells. *Exp Hematol* 1987;15:928-935.
127. Sugimoto M, Wakabayashi Y, Hirose S, Takaku F. Immunological aspects of the anemia of rheumatoid arthritis. *Am J Hematol* 1987;25:1-11.
128. Tracey KJ, Wei H, Nanogue KR, et al. Cachectin/tumor necrosis factor induces cachexia, anemia, and inflammation. *J Exp Med* 1988;167:1211-1227.
129. Means RT, Dessypris EN, Krantz SB. Inhibition of human colony-forming units erythroid by tumor necrosis factor requires accessory cells. *J Clin Invest* 1990;86:538-541.

130. Means RT, Krantz SB. Inhibition of human erythroid colony-forming units by tumor necrosis factor requires beta interferon. *J Clin Invest* 1993;91: 416-419.
131. Means RT, Dessypris EN, Krantz SB. Inhibition of human erythroid colony-forming units by interleukin-1 is mediated by gamma interferon. *J Cell Physiol* 1992;150:59-64.
132. Means RT, Krantz SB. Inhibition of human erythroid colony-forming units by interferons ... and: differing mechanisms despite shared receptor. *Exp Hematol* 1996;24:204-208.
133. Means RT, Krantz SB. Inhibition of human erythroid colony forming units by gamma interferon can be corrected by recombinant human erythropoietin. *Blood* 1991;78:2564-2567.
134. Nicolas G, Viatte L, Bennoun M, Beaumont C, Kahn A, Vaulmont S. Hepcidin, a new iron regulatory peptide. *Blood Cells Mol Dis* 2002;29:327-335.
135. Pinto JP, Ribeiro S, Pontes H, et al. Erythropoietin mediates hepcidin expression in hepatocytes through EPOR signaling and regulation of C/EBP α . *Blood* 2008;111(12):5727-5733.
136. Al-Ismael S, Cavill I, Evans IH, et al. Erythropoiesis and iron metabolism in Hodgkin's disease. *Br J Cancer* 1979;40:365-370.
137. Hershko C, Cook JD, Finch CA, Storage ik. Storage iron kinetics IV. The effect of inflammation on iron exchange in the rat. *Br J Haematol* 1974;28: 67-75.
138. Schade SG. Normal incorporation of oral iron into intestinal ferritin in inflammation. *Proc Soc Exp Biol Med* 1972;139:620-622.
139. Harrison PM, Arosio P. Ferritins: molecular properties, iron storage function and cellular regulation. *Biochim Biophys Acta Bio-Energ* 1996;1275(3): 161-203.
140. Gelvan D, Fibach E, Meyron-Holtz EG, Konijn AM. Ferritin uptake by human erythroid precursors is a regulated iron uptake pathway. *Blood* 1996;88(8):3200-3207.
141. Konijn AM, Carmel N, Levy R, Hershko C. Ferritin synthesis in inflammation. II. Mechanism of increased ferritin synthesis. *Br J Haematol* 1981;49(3): 361-370.
142. Konijn AM, Hershko C. Ferritin synthesis and inflammation. I. Pathogenesis of impaired iron release. *Br J Haematol* 1977;37:7-16.
143. Alvarez-Hernandez X, Liceaga J, McKay IC, Brock JH. Induction of hypoferremia and modulation of macrophage iron metabolism by tumor necrosis factor. *Lab Invest* 1989;61:319-322.
144. Domachowske JB, Rafferty SP, Singhania N, Mardiney M, III, Malech HL. Nitric oxide alters the expression of gamma-globin, H-ferritin, and transferrin receptor in human K562 cells at the posttranscriptional level. *Blood* 1996;88(8):2980-2988.
145. Recalcati S, Taramelli D, Conte D, Cairo G. Nitric oxide-mediated induction of ferritin synthesis in J774 macrophages by inflammatory cytokines: role of selective iron regulatory protein-2 downregulation. *Blood* 1998;91(3): 1059-1066.
146. Bennett RM, Kokocinski T. Lactoferrin content of peripheral blood cells. *Br J Haematol* 1978;39(4):509-521.
147. Lash JA, Coates TD, Lafuze J, Baehner RL, Boxer LA. Plasma lactoferrin reflects granulocyte activation in vivo. *Blood* 1983;61(5):885-888.
148. Klempner MS, Dinarello CA, Gallin JI. Human leukocytic pyrogen induces release of specific granule contents from human neutrophils. *J Clin Invest* 1978;61(5):1330-1336.
149. Ainscough EW, Brodie AM, Plowman JE, Bloor SJ, Loehr JS, Loehr TM. Studies on human lactoferrin by electron paramagnetic resonance, fluorescence, and resonance Raman spectroscopy. *Biochemistry* 1980;19(17): 4072-4079.
150. Brock JH, Esparza I. Failure of reticulocytes to take up iron from lactoferrin saturated by various methods. *Br J Haematol* 1979;42(3):481-483.
151. Birgens HS, Hansen NE, Karle H, Kristensen LO. Receptor binding of lactoferrin by human monocytes. *Br J Haematol* 1983;54(3):383-391.
152. Friedell GH. Anaemia in Cancer. *Lancet* 1965;1(7381):356-359.

153. Van Snick JL, Masson PL, Heremans JF. The involvement of lactoferrin in the hypsideremia of acute inflammation. *The J Exp Med* 1974;140(4): 1068-1084.
154. Goldblum SE, Cohen DA, Jay M, McClain CJ. Interleukin 1-induced depression of iron and zinc: role of granulocytes and lactoferrin. *Am J Physiol* 1987;252(1 Pt 1):E27-32.
155. Gordeuk VR, Prithviraj P, Dolinar T, Brittenham GM. Interleukin 1 administration in mice produces hypoferrinemia despite neutropenia. *J Clin Invest* 1988;82(6):1934-1938.
156. Feelders RA, Vreugdenhil G, van Dijk JP, Swaak AJ, van Eijk HG. Decreased affinity and number of transferrin receptors on erythroblasts in the anemia of rheumatoid arthritis. *Am J Hematol* 1993;43(3):200-204.
157. Graziadei I, Gaggi S, Kaserbacher R, Braunsteiner H, Vogel W. The acute phase protein ...-1-antitrypsin inhibits growth and proliferation of human early erythroid progenitor cells (burst-forming units-erythroid) and of human erythroleukemic cells (K562) in vitro by interfering with transferrin iron uptake. *Blood* 1994;83:260-268.
158. Weiss G, Houston T, Kastner S, Johrer K, Grunewald K, Brock JH. Regulation of cellular iron metabolism by erythropoietin: activation of iron-regulatory protein and upregulation of transferrin receptor expression in erythroid cells. *Blood* 1997;89(2):680-687.
159. Bezwoda WR, Lewis D, Livini N. Bone marrow involvement in anaplastic small cell lung cancer. Diagnosis, hematologic features, and prognostic implications. *Cancer* 1986;58:1762-1765.
160. Jacobs SC. Spread of prostate cancer to bone. *Urology* 1983;21:337-344.
161. Norgard MJ, Carpenter Jr, Conrad ME. Bone marrow necrosis and degeneration. *Arch Intern Med* 1979;139:905-911.
162. Schapira L, Antin JH, Ransil BJ, et al. Serum erythropoietin levels in patients receiving intensive chemotherapy and radiotherapy. *Blood* 1990;76: 2354-2359.
163. Gastineau DA, Hoaglund HC. Hematologic effects of chemotherapy. *Semin Oncol* 1992;19:543-550.
164. Self KG, Conrady MM, Eichner ER. Failure to diagnose anemia in medical inpatients. Is the traditional diagnosis of anemia a dying art? *Am J Med* 1986;81:786-790.
165. Opasich C, Cazzola M, Scelsi L, et al. Blunted erythropoietin production and defective iron supply for erythropoiesis as major causes of anaemia in patients with chronic heart failure. *Eur Heart J* 2005;26(21):2232-2237.
166. Thomas MC. The high prevalence of anemia in diabetes is linked to functional erythropoietin deficiency. *Semin Nephrol* 2006;26(4):275-282.
167. Kleijn L, Belonje AMS, Voors AA, et al. Inflammation and anaemia in a broad spectrum of patients with heart failure. *Heart* 2012;98(16):1237-1241.
168. Weiss G, Goodnough L. Anemia of chronic disease. *N Engl J Med* 2005;352(10):1011-1023.
169. Vreugdenhil G, Baltus CA, van Eijk HG, Swaak AJ. Anaemia of chronic disease: diagnostic significance of erythrocyte and serological parameters in iron deficient rheumatoid arthritis patients. *Br J Rheumatol* 1990;29(2):105-110.
170. Means RT. Hpcidin and cytokines in anaemia. *Hematology* 2004;9(5-6): 357-362.
171. Means RT, Olsen NJ, Krantz SB, et al. Treatment of the anemia of rheumatoid arthritis with recombinant human erythropoietin: clinical and in vitro studies. *Arthritis Rheum* 1989;32:638-642.
172. Pincus T, Olsen NJ, Russell IJ, et al. Multicenter study of recombinant human erythropoietin in correction of anemia in rheumatoid arthritis. *Am J Med* 1990;89:161-168.
173. Gudbjornsson B, Hallgren R, Wide L, Birgegard G. Response of anemia in rheumatoid arthritis to treatment with subcutaneous recombinant human erythropoietin. *Ann Rheum Dis* 1992;51:747-752.
174. Peeters HR, Jongen-Lavrencic M, Bakker CH, Vreugdenhil G, Breedveld FC, Swaak AJ. Recombinant human erythropoietin improves health-related quality of life in patients with rheumatoid arthritis and anaemia of chronic disease; utility measures correlate strongly with disease activity measures. *Rheumatol Int* 1999;18(5-6):201-206.
175. Qurt I, Robeson C, Lau CY, et al. Epoetin alfa therapy increases hemoglobin levels and improves quality of life in patients with cancer-related anemia who are not receiving chemotherapy and patients with anemia who are receiving chemotherapy. *J Clin Oncol* 2001;19:4126-4134.

176. Means RT. Clinical application of recombinant human erythropoietin in the anemia of chronic disease. *Hematol Oncol Clin North Am* 1994;8:933-944.
177. Thompson FL, Powers JS, Graber SE, Krantz SB. Use of recombinant human erythropoietin to enhance autologous blood donation in a patient with multiple red cell allo-antibodies and the anemia of chronic disease. *Am J Med* 1991;90:398-400.
178. Belonje AM, Voors AA, van Gilst WH, van Veldhuisen DJ. Erythropoietin in chronic heart failure. *Congest Heart Fail* 2007;13(5):289-292.
179. Faraz HA, Zafar SF, Ghali JK. Anemia and the potential role of erythropoiesisstimulating agents in heart failure. *Curr Heart Fail Rep* 2008;5(2):83-90.
180. Iyengar S, Abraham WT. Anemia in chronic heart failure: can EPO reduce deaths? *Cleve Clin J Med* 2005;72(11):1027-1032.
181. Latini R, Brines M, Fiordaliso F. Do non-hemopoietic effects of erythropoietin play a beneficial role in heart failure? *Heart Fail Rev* 2008;13(4):415-423.
182. Mak G, Murphy NF, McDonald K. Anemia in heart failure: to treat or not to treat? *Curr Treat Options Cardiovasc Med* 2008;10(6):455-464.
183. Nordstrom D, Lindroth Y, Marsal L, et al. Availability of iron and degree of inflammation modifies the response to recombinant human erythropoietin when treating anemia of chronic disease in patients with rheumatoid arthritis. *Rheumatol Int* 1997;17:67-73.
184. Martini A, Ravelli A, Di FG, Rosti V, Cazzola M, Barosi G. Intravenous iron therapy for severe anaemia in systemic-onset juvenile chronic arthritis. *Lancet* 1994;344(8929):1052-1054.
185. Auerbach M, Ballard H, Trout JR, et al. Intravenous iron optimizes the response to recombinant human erythropoietin in cancer patients with chemotherapy-related anemia: a multicenter, open-label, randomized trial. *J Clin Oncol* 2004;22:1301-1307.
186. Milano M, Schneider M. EPO in cancer anemia: benefits and potential risks. *Crit Rev Oncol Hematol* 2007;62(2):119-125.
187. Newland AM, Black CD. Tumor progression associated with erythropoiesisstimulating agents. *Ann Pharmacother* 2008;42(12):1865-1870.
188. Rizzo JD, Somerfield MR, Hagerty KL, et al. Use of epoetin and darbepoetin in patients with cancer: 2007 American Society of Hematology/American Society of Clinical Oncology clinical practice guideline update. *Blood* 2008;111(1):25-41.
189. Bennett CL, Silver SM, Djulbegovic B. Venous thromboembolism and mortality associated with recombinant erythropoietin and darbepoetin administration for the treatment of cancer-associated anemia. *JAMA* 2008;299:914-924.
190. Blau CA. Erythropoietin in cancer: presumption of innocence? *Stem Cells* 2007;25(8):2094-2097.
191. Agarwal N, Prchal JT. Erythropoietic agents and the elderly. *Semin Hematol* 2008;45(4):267-275.
192. Nowrousian MR, Dunst J, Vaupel P. Erythropoiesis-stimulating agents: favorable safety profile when used as indicated. *Strahlenther Onkol* 2008;184(3):121-136.
193. Oster HS, Neumann D, Hoffman M, Mittelman M. Erythropoietin: the swinging pendulum. *Leuk Res* 2012;36(8):939-944.
194. Crosby JR, Gaarde WA, Egerston J, et al. Targeting hepcidin with anti-sense oligonucleotides improves anemia endpoints in mice (abstract). *Blood* 2006;108(11):83a-84a.
195. Desforgues JF. Anemia in uremia. *Arch Intern Med* 1970;126(5):808-811.
196. Charles G, Lundin AP 3rd, Delano BG, Brown C, Friedman EA. Absence of anemia in maintenance hemodialysis. *Int J Artif Organs* 1981;4(6):277-279.
197. End Stage Renal Disease Core Indicators P. 1997 Annual Report. Baltimore, MD: US Department of Health and Human Services/Health Care Financing Administration, 1997.
198. Voormolen N, Grootendorst DC, Urlings TA, et al. Prevalence of anemia and its impact on mortality and hospitalization rate in predialysis patients. *Nephron Clin Pract* 2010;115(2):c133-141.

199. Adamson JW, Eschbach J, Finch CA. The kidney and erythropoiesis. *Am J Med* 1968;44(5):725-733.
200. Carter RA, Hawkins JB, Robinson BH. Iron metabolism in the anaemia of chronic renal failure. Effects of dialysis and of parenteral iron. *Br Med J* 1969;3(5664):206-210.
201. Hampers CL, Streiff R, Nathan DG, Snyder D, Merrill JP. Megaloblastic hematopoiesis in uremia and in patients on long-term hemodialysis. *The N Engl J Med* 1967;276(10):551-554.
202. Pronai W, Riegler-Keil M, Silberbauer K, Stockenhuber F. Folic acid supplementation improves erythropoietin response. *Nephron* 1995;71(4):395-400.
203. Paine CJ, Hargrove MD Jr, Eichner ER. Folic acid binding protein and folate balance in uremia. *Arch Intern Med* 1976;136(7):756-760.
204. Touam M, Martinez F, Lacour B, et al. Aluminum induced reversible microcytic anemia in chronic renal failure: clinical and experimental studies. *Clin Nephrol* 1983;19:295-298.
205. Hilden M, Hilden T. Haemoglobin level and renal function in patients with and without hypertension. *Acta Med Scand* 1968;183(3):183-190.
206. Chandra M, Miller ME, Garcia JF, Mossey RT, McVicar M. Serum immunoreactive erythropoietin levels in patients with polycystic kidney disease as compared with other hemodialysis patients. *Nephron* 1985;39(1):26-29.
207. Eckardt KU, Mollmann M, Neumann R, et al. Erythropoietin in polycystic kidneys. *J Clin Invest* 1989;84(4):1160-1166.
208. Walle AJ, Wong GY, Clemons GK, Garcia JF, Niedermayer W. Erythropoietin-hematocrit feedback circuit in the anemia of end-stage renal disease. *Kidney Int* 1987;31(5):1205-1209.
209. Astor BC, Muntner P, Levin A, Eustace JA, Coresh J. Association of kidney function with anemia: the Third National Health and Nutrition Examination Survey (1988-1994). *Arch Intern Med* 2002;162(12):1401-1408.
210. de Klerk G, Wilink JM, Rosengarten PC, Vet RJ, Goudsmit R. Serum erythropoietin (ESF) titers in anemia of chronic renal failure. *J Lab Clin Med* 1982;100(5):720-734.
211. Pavlovic-Kentera V, Clemons GK, Djukanovic L, Biljanovic-Paunovic L. Erythropoietin and anemia in chronic renal failure. *Exp Hematol* 1987;15(7):785-789.
212. Loge JP, Lange RD, Moore CV. Characterization of the anemia associated with chronic renal insufficiency. *Am J Med* 1958;24(1):4-18.
213. Callen IR, Limarzi LR. Blood and bone marrow studies in renal disease. *Am J Clin Pathol* 1950;20(1):3-23, illust.
214. Kurtides ES, Rambach WA, Alt HL, Delgreco F. Effect of hemodialysis on erythrokinetics in anemia of uremia. *J Lab Clin Med* 1964;63:469-479.
215. Shaw AB, Scholes MC. Reticulocytosis in renal failure. *Lancet* 1967;1(7494):799-802.
216. Morgan T, Innes M, Ribush N. The management of the anaemia of patients on chronic haemodialysis. *Med J Aust* 1972;1(17):848-852.
217. Pasternack A, Wahlberg P. Bone marrow in acute renal failure. *Acta Med Scand* 1967;181(4):505-511.
218. Stancu S, Stanciu A, Zugravu A, et al. Bone marrow iron, iron indices, and the response to intravenous iron in patients with non-dialysis-dependent CKD. *Am J Kidney Dis* 2010;55(4):639-647.
219. Eklund SG, Johansson SV, Strandberg O. Anemia in uremia. Hemolysis evaluated by common methods and application of the bilirubin turnover method. *Acta Med Scand* 1971;190:435-443.
220. Kaye M. The anemia associated with renal disease. *J Lab Clin Med* 1958;52(1):83-100.
221. Finch CA, Deubelbeiss K, Cook JD, et al. Ferrokinetics in man. *Medicine (Baltimore)* 1970;49(1):17-53.
222. Boddy K, Lawson DH, Linton AL, Will G. Iron metabolism in patients with chronic renal failure. *Clin Sci* 1970;39(1):115-121.
223. Eschbach JW, Cook JD, Finch CA. Iron absorption in chronic renal disease. *Clin Sci* 1970;38(2):191-196.
224. London GM, Nordmann Y, Safar ME, Metral S, Milliez P. Free erythrocyte protoporphyrin level and nerve conduction velocity in end-stage renal disease. *Br Med J* 1975;4(5992):324-325.

225. Melissinos K, Drivas G, Vlassopoulos K. LDH activity of red cells in chronic renal failure. *Clin Chim Acta Int J Clin Chem* 1972;40(1):165-169.
226. Bratescu LO, Barsan L, Munteanu D, Stancu S, Mircescu G. Is hepcidin-25 a clinically relevant parameter for the iron status in hemodialysis patients? *J Ren Nutr* 2010;20(Suppl 5):S77-S83.
227. Niihata K, Tomosugi N, Uehata T, et al. Serum hepcidin-25 levels predict the progression of renal anemia in patients with non-dialysis chronic kidney disease. *Nephrol Dial Transplantation* 2012. Epub 24/7/12.
228. Fluckiger R, Harmon W, Meier W, Loo S, Gabbay KH. Hemoglobin carbamylation in uremia. *N Engl J Med* 1981;304(14):823-827.
229. Zawada ET, Jr., Johnson M, Mackenzie T, et al. Hemoglobin A1 in renal transplant recipients. *Arch Intern Med* 1985;145(1):82-84.
230. Eschbach JW, Adamson JW. Anemia of end-stage renal disease (ESRD). *Kidney Int* 1985;28:1-5.
231. Sexauer CL, Matson JR. Anemia of chronic renal failure. *Ann Clin Lab Sci* 1981;11(6):484-487.
232. Radtke HW, Claussner A, Erbes PM, Scheuermann EH, Schoeppe W, Koch KM. Serum erythropoietin concentration in chronic renal failure: relationship to degree of anemia and excretory renal function. *Blood* 1979;54(4):877-884.
233. McGonigle RJ, Wallin JD, Shaddock RK, Fisher JW. Erythropoietin deficiency and inhibition of erythropoiesis in renal insufficiency. *Kidney Int* 1984;25(2):437-444.
234. Garcia JF, Ebbe SN, Hollander L, Cutting HO, Miller ME, Cronkite EP. Radioimmunoassay of erythropoietin: circulating levels in normal and polycythemic human beings. *J Lab Clin Med* 1982;99(5):624-635.
235. Caro J, Brown S, Miller O, Murray T, Erslev AJ. Erythropoietin levels in uremic nephric and anephric patients. *J Lab Clin Med* 1979;93(3):449-458.
236. Naets JP, Wittek M. Erythropoiesis in anephric man. *Lancet* 1968;1(7549): 941-943.
237. Zucker S, Lysik RM, Mohammad G. Erythropoiesis in chronic renal disease. *J Lab Clin Med* 1976;88(4):528-535.
238. Eschbach JW, Mladenovic J, Garcia JF, Wahl PW, Adamson JW. The anemia of chronic renal failure in sheep. Response to erythropoietin-rich plasma in vivo. *J Clin Invest* 1984;74(2):434-441.
239. Eschbach JW, Kelly MR, Haley NR, Abels RI, Adamson JW. Treatment of the anemia of progressive renal failure with recombinant human erythropoietin. *N Engl J Med* 1989;321(3):158-163.
240. Winearls CG, Oliver DO, Pippard MJ, Reid C, Downing MR, Cotes PM. Effect of human erythropoietin derived from recombinant DNA on the anaemia of patients maintained by chronic haemodialysis. *Lancet* 1986;2:1175-1178.
241. Mann DL, Donati RM, Gallagher NI. Erythropoietin assay and ferrokinetic measurements in anemic uremic patients. *JAMA* 1965;194(12):1321-1322.
242. Wallner SF, Vautrin RM. The anemia of chronic renal failure. Studies of iron transport in vitro. *J Lab Clin Med* 1980;96(1):67-74.
243. Freedman MH, Cattran DC, Saunders EF. Anemia of chronic renal failure: inhibition of erythropoiesis by uremic serum. *Nephron* 1983;35(1):15-19.
244. Hotta T, Maeda H, Suzuki I, Chung TG, Saito A. Selective inhibition of erythropoiesis by sera from patients with chronic renal failure. *Proc Soc Exp Biol Med* 1987;186(1):47-51.
245. Radtke HW, Rege AB, LaMarche MB, et al. Identification of spermine as an inhibitor of erythropoiesis in patients with chronic renal failure. *J Clin Invest* 1981;67(6):1623-1629.
246. Wallner SF, Vautrin RM, Kurnick JE, Ward HP. The effect of serum from patients with chronic renal failure on erythroid colony growth in vitro. *J Lab Clin Med* 1978;92(3):370-375.
247. Spragg BP, Bentley DP, Coles GA. Anaemia of chronic renal failure. Polyamines are not raised in uraemic serum. *Nephron* 1984;38(1):65-66.
248. Wallner SF, Vautrin RM. The anemia of chronic renal failure: studies of the effect of organic solvent extraction of serum. *J Lab Clin Med* 1978;92(3): 363-369.
249. Gutman RA, Huang AT. Inhibitor of marrow thymidine incorporation from sera of patients with uremia. *Kidney Int* 1980;18(6):715-724.

250. Delwiche F, Segal GM, Eschbach JW, Adamson JW. Hematopoietic inhibitors in chronic renal failure: lack of in vitro specificity. *Kidney Int* 1986;29(3): 641-648.
251. Potasman I, Better OS. The role of secondary hyperparathyroidism in the anemia of chronic renal failure. *Nephron* 1983;33(4):229-231.
252. Barbour GL. Effect of parathyroidectomy on anemia in chronic renal failure. *Arch Intern Med* 1979;139(8):889-891.
253. Podjarny E, Rathaus M, Korzets Z, Blum M, Zevin D, Bernheim J. Is anemia of chronic renal failure related to secondary hyperparathyroidism? *Arch Intern Med* 1981;141(4):453-455.
254. Zingraff J, Druke T, Marie P, Man NK, Jungers P, Bordier P. Anemia and secondary hyperparathyroidism. *Arch Intern Med* 1978;138(11):1650-1652.
255. Meytes D, Bogin E, Ma A, Dukes PP, Massry SG. Effect of parathyroid hormone on erythropoiesis. *J Clin Invest* 1981;67(5):1263-1269.
256. Delwiche F, Garrity MJ, Powell JS, Robertson RP, Adamson JW. High levels of the circulating form of parathyroid hormone do not inhibit in vitro erythropoiesis. *J Lab Clin Med* 1983;102(4):613-620.
257. McGonigle RJ, Wallin JD, Huserl F, et al. Potential role of parathyroid hormone as an inhibitor of erythropoiesis in the anemia of renal failure. *J Lab Clin Med* 1984;104(6):1016-1026.
258. Means RT. Commentary: an anemia of chronic disease, after all? *J Investig Med* 1999;47:203.
259. Shaw AB. Haemolysis in chronic renal failure. *Br Med J* 1967;2(5546):213-216.
260. Hartley LC, Morgan TO, Innis MD, Clunie GJ. Splenectomy for anaemia in patients on regular haemodialysis. *Lancet* 1971;2(7738):1343-1345.
261. Giovannetti S, Balestri PL, Barsotti G. Methylguanidine in uremia. *Arch Intern Med* 1973;131(5):709-713.
262. Zachee P, Ferrant A, Daelemans R, Goossens W, Boogaerts MA, Lins RL. Reduced glutathione for the treatment of anemia during hemodialysis: a preliminary communication. *Nephron* 1995;71(3):343-349.
263. Rosenmund A, Binswanger U, Straub PW. Oxidative injury to erythrocytes, cell rigidity, and splenic hemolysis in hemodialyzed uremic patients. *Ann Intern Med* 1975;82(4):460-465.
264. Yawata Y, Tanaka KR. Red cell glutathione reductase: mechanism of action of inhibitors. *Biochim Biophys Acta* 1973;321(1):72-83.
265. Monti M. Microcalorimetric measurements of heat production in erythrocytes of patients with chronic uraemia. *Scand J Haematol* 1977;18(2):154-162.
266. Albano LM, Zatz M, Kim CA, et al. Friedreich's ataxia: clinical and molecular study of 25 Brazilian cases. *Rev Hosp Clin* 2001;56(5):143-148.
267. Yawata Y, Howe R, Jacob HS. Abnormal red cell metabolism causing hemolysis in uremia. A defect potentiated by tap water hemodialysis. *Ann Intern Med* 1973;79(3):362-367.
268. Eaton JW, Kolpin CF, Swofford HS, Kjellstrand CM, Jacob HS. Chlorinated urban water: a cause of dialysis-induced hemolytic anemia. *Science* 1973;181(4098):463-464.
269. Lucchi L, Bergamini S, Iannone A, et al. Erythrocyte susceptibility to oxidative stress in chronic renal failure patients under different substitutive treatments. *Artif Organs* 2005;29(1):67-72.
270. Hsu SP, Chiang CK, Yang SY, Chien CT. N-acetylcysteine for the management of anemia and oxidative stress in hemodialysis patients. *Nephron Clin Pract* 2010;116(3):c207-216.
271. Cheng JT, Kahn T, Kaji DM. Mechanism of alteration of sodium potassium pump of erythrocytes from patients with chronic renal failure. *J Clin Invest* 1984;74(5):1811-1820.
272. Izumo H, Izumo S, DeLuise M, Flier JS. Erythrocyte Na,K pump in uremia. Acute correction of a transport defect by hemodialysis. *J Clin Invest* 1984;74(2):581-588.
273. Gault MH, Vasdev SC, Longerich LL. Endogenous digoxin-like substance(s) and combined hepatic and renal failure. *Ann Intern Med* 1984;101(4): 567-568.
274. Graves SW, Brown B, Valdes R Jr. An endogenous digoxin-like substance in patients with renal impairment. *Ann Intern Med* 1983;99(5):604-608.

275. Heazlewood VJ, Heazlewood RL, Jellett LB. An endogenous digoxin-like substance and renal failure. *Ann Intern Med* 1984;100(4):618.
276. Morgan JM, Morgan RE. Study of the effect of uremic metabolites on erythrocyte glycolysis. *Metabolism* 1964;13:629-635.
277. Lichtman MA, Miller DR. Erythrocyte glycolysis, 2,3-diphosphoglycerate and adenosine triphosphate concentration in uremic subjects: relationship to extracellular phosphate concentration. *J Lab Clin Med* 1970;76(2):267-279.
278. Wallas CH. Metabolic studies on red cells from patients with chronic renal disease on haemodialysis. *Br J Haematol* 1974;26(1):71-78.
279. Wallas CH. Metabolic studies on the erythrocyte from patients with chronic renal disease on haemodialysis. II. ATP metabolism. *Br J Haematol* 1974;27(1):145-152.
280. Mitchell TR, Pegrum GD. The oxygen affinity of haemoglobin in chronic renal failure. *Br J Haematol* 1971;21(4):463-472.
281. Trial J, Rice L. Erythropoietin withdrawal leads to the destruction of young red cells at the endothelial-macrophage interface. *Curr Pharm Des* 2004;10(2):183-190.
282. Eschbach JW, Egrie JC, Downing MR, Browne JK, Adamson JW. Correction of the anemia of end-stage renal disease with recombinant human erythropoietin. Results of a combined phase I and II clinical trial. *N Engl J Med* 1987;316(2):73-78.
283. Albert MH, Bittner TC, Nonoyama S, et al. X-linked thrombocytopenia (XLT) due to WAS mutations: clinical characteristics, long-term outcome, and treatment options. *Blood* 2010;115(16):3231-3238.
284. Temple RM, Deary IJ, Winney RJ. Recombinant erythropoietin improves cognitive function in patients maintained on chronic ambulatory peritoneal dialysis. *Nephrol Dial Transplant* 1995;10(9):1733-1738.
285. Mayer G, Thum J, Cada EM, Stumvoll HK, Graf H. Working capacity is increased following recombinant human erythropoietin treatment. *Kidney Int* 1988;34:525-528.
286. Eschbach JW, Abdulhadi MH, Browne JK, et al. Recombinant human erythropoietin in anemic patients with end-stage renal disease. Results of a phase III multicenter clinical trial. *Ann Intern Med* 1989;111(12):992-1000.
287. Valderrabano F, Madias NE, Schena FP, et al. Erythropoietin in chronic renal failure. *Kidney Int* 1996;50(4):1373-1391.
288. Branger B, Vecina F, Zabadani B, Balducchi JP, Fourcade J. Subcutaneous erythropoietin administration in predialysis patients: a single centre prospective study. *Nephrol Dial Transplant* 1995;10(Suppl 6):36-39.
289. Lago M, Perez-Garcia R, De VMSG, Anaya F, Valderrabano F. Efficiency of once-weekly subcutaneous administration of recombinant human erythropoietin versus three times a week administration in hemodialysis patients. *Nephron* 1996;72(4):723-724.
290. Locatelli F, Aljama P, Barany P. Revised European best practice guidelines for the management of anaemia in patients with chronic renal failure. *Nephrol Dial Transplant* 2004;19:ii1-ii47.
291. Besarab A, Bolton WK, Browne JK. The effects of normal as compared with low hematocrit values in patients with cardiac disease who are receiving hemodialysis and epoetin [see comment]. *N Eng J Med* 1998;339:584-590.
292. Bacigalupo A, Broccia G, Corda G, et al. Antilymphocyte globulin, cyclosporin, and granulocyte colony-stimulating factor in patients with acquired severe aplastic anemia (SAA): a pilot study of the EBMT SAA Working Party. *Blood* 1995;85(5):1348-1353.
293. Locatelli F, Olivares J, Walker R, et al. Novel erythropoiesis stimulating protein for treatment of anemia in chronic renal insufficiency. *Kidney Int* 2001;60:741-747.
294. Locatelli F, Mann JF, Aldigier JC, et al. C.E.R.A. safety profile: a pooled analysis in patients with chronic kidney disease. *Clin Nephrol* 2010;73(2):94-103.
295. Jones MA, Kingswood JC, Dallyn PE, et al. Changes in diurnal blood pressure variation and red cell and plasma volumes in patients with renal failure who develop erythropoietin-induced hypertension. *Clin Nephrol* 1995;44(3): 193-200.
296. Radermacher J, Koch KM. Treatment of renal anemia by erythropoietin substitution. The effects on the cardiovascular system. *Clin Nephrol* 1995;44(Suppl 1):S56-S60.

297. Beccari M. Seizures in dialysis patients treated with recombinant erythropoietin. Review of the literature and guidelines for prevention. *Int J Artif Organs* 1994;17(1):5-13.
298. Kokot F, Wiecek A. Arterial hypertension in uraemic patients treated with erythropoietin. *Nephron* 1995;71(2):127-132.
299. Vaziri ND, Zhou XJ, Naqvi F, et al. Role of nitric oxide resistance in erythropoietin-induced hypertension in rats with chronic renal failure. *Am J Physiol Endocrinol Metab* 1996;271(1):E113-E122.
300. Vaziri ND, Zhou XJ, Smith J, Oviesi F, Baldwin K, Purdy RE. In vivo and in vitro pressor effects of erythropoietin in rats. *Am J Physiol* 1995;268:F838-F845.
301. Hand MF, Haynes WG, Johnstone HA, Anderton JL, Webb DJ. Erythropoietin enhances vascular responsiveness to norepinephrine in renal failure. *Kidney Int* 1995;48(3):806-813.
302. Ahmad R, Hand M. Recombinant erythropoietin for the anemia of chronic renal failure. *N Engl J Med* 1987;317(3):169-170.
303. Walczyk M. Correction of the anemia of end-stage renal disease with recombinant human erythropoietin. *N Engl J Med* 1987;317(4):249-251.
304. Garcia JE, Senent C, Pascual C, et al. Anaphylactic reaction to recombinant human erythropoietin. *Nephron* 1993;65:636-637.
305. Van Wyck DB, Stivelman JC, Ruiz J, Kirlin LF, Katz MA, Ogden DA. Iron status in patients receiving erythropoietin for dialysis-associated anemia. *Kidney Int* 1989;35(2):712-716.
306. Tarng DC, Chen TW, Huang TP. Iron metabolism indices for early prediction of the response and resistance to erythropoietin therapy in maintenance hemodialysis patients. *Am J Nephrol* 1995;15(3):230-237.
307. Curtis JR, Eastwood JB, Smith EK, et al. Maintenance haemodialysis. *The Q J Med* 1969;38(149):49-89.
308. Wingard RL, Parker RA, Ismail N, Hakim RM. Efficacy of oral iron therapy in patients receiving recombinant human erythropoietin. *Am J Kidney Dis* 1995;25(3):433-439.
309. Neal TF, Holland HK, Baum CK, et al. CD34+ progenitor cells from asymptomatic patients are not a major reservoir for human immunodeficiency virus-1. *Blood* 1995;86:1749-1756.
310. Kalantar-Zadeh K, Hoffken B, Wunsch H, Fink H, Kleiner M, Luft FC. Diagnosis of iron deficiency anemia in renal failure patients during the posterythropoietin era. *Am J Kidney Dis* 1995;26(2):292-299.
311. Phelps KR. Diagnosis of iron deficiency in dialysis patients. *Am J Kidney Dis* 1996;27(5):762-764.
312. Silva J, Andrade S, Ventura H, et al. Iron supplementation in haemodialysis—practical clinical guidelines. *Nephrol Dial Transplant* 1998;13(10):2572-2577.
313. Pollak VE, Lorch JA, Means RT, Jr. Unanticipated favorable effects of correcting iron deficiency in chronic hemodialysis patients. *J Investig Med* 2001;49(2):173-183.
314. Beguin Y, Loo M, R'Zik S, et al. Early prediction of response to recombinant human erythropoietin in patients with the anemia of renal failure by serum transferrin receptor and fibrinogen. *Blood* 1993;82:2010-2016.
315. KDOQI Clinical Practice Guidelines and Clinical Practice Recommendations for Anemia in Chronic Kidney Disease. *Am J Kidney Dis* 2006;47: S11-S145.
316. Drueke TB, Barany P, Cazzola M, et al. Management of iron deficiency in renal anemia: guidelines for the optimal therapeutic approach in erythropoietintreated patients. *Clin Nephrol* 1997;48:1-8.
317. Macdougall IC. Strategies for iron supplementation: oral versus intravenous. *Kidney Int Suppl* 1999;69:S61-S66.
318. Fishbane S, Frei GL, Maesaka J. Reduction in recombinant human erythropoietin doses by the use of chronic intravenous iron supplementation. *Am J Kidney Dis* 1995;26(1):41-46.
319. National Kidney Foundation. KDOQI Clinical Practice Guidelines for Anemia of Chronic Kidney Disease, 2000. *Am J Kidney Dis* 2001;37:S182-S238.
320. Ifudu O, Feldman J, Friedman EA. The intensity of hemodialysis and the response to erythropoietin in patients with end-stage renal disease. *N Engl J Med* 1996;334(7):420-425.

321. Viganò SM, Filippo SD, Milia VL, Pontoriero G, Locatelli F. Prospective randomized pilot study on the effects of two synthetic high-flux dialyzers on dialysis patient anemia. *Int J Artif Organs* 2012;35(5):346-351.
322. Klahr S. Anemia, dialysis, and dollars. *N Engl J Med* 1996;334(7):461-463.
323. Argiles A, Mourad G, Lorho R, et al. Medical treatment of severe hyperparathyroidism and its influence on anaemia in end-stage renal failure. *Nephrol Dial Transplant* 1994;9(12):1809-1812.
324. Goch J, Birgegard G, Danielson BG, Wikstroem B. Treatment of erythropoietin-resistant anaemia with desferrioxamine in patients on haemofiltration. *Eur J Haematol* 1995;55(2):73-77.
325. Gossmann J, Kachel HG, Schoeppe W, Scheuermann EH. Anemia in renal transplant recipients caused by concomitant therapy with azathioprine and angiotensin-converting enzyme inhibitors. *Transplantation* 1993;56(3): 585-589.
326. Sizeland PC, Bailey RR, Lynn KL, Robson RA. Anemia and angiotensin converting enzyme inhibition in renal transplant recipients. *J Cardiovasc Pharmacol* 1990;16(Suppl 7):S117-S119.
327. Adams JR, Elting LS, Lyman GH, et al. Use of erythropoietin in cancer patients: assessment of oncologist's practice patterns in the United States and other countries. *Am J Med* 2004;116:28-34.
328. Bennett CL, Cournoyer D, Carson KR, et al. Long-term outcome of individuals with pure red cell aplasia and antierythropoietin antibodies in patients treated with recombinant epoetin: a follow-up report from the Research on Adverse Drug Events and Reports (RADAR) Project. *Blood* 2005;106(10):3343-3347.
329. Bennett CL, Luminari S, Nissenson AR, et al. Pure red-cell aplasia and epoetin therapy. *N Engl J Med* 2004;351(14):1403-1408.
330. Kessler M. Erythropoietin and erythropoiesis in renal transplantation. *Nephrol Dial Transplant* 1995;10(Suppl 6):114-116.
331. Hoffman GC. Human erythropoiesis following kidney transplantation. *Ann N Y Acad Sci* 1968;149(1):504-508.
332. Abbrecht PH, Greene JA, Jr. Serum erythropoietin after renal homotransplantation. *Ann Intern Med* 1966;65(5):908-921.
333. Sun CH, Ward HJ, Paul WL, Koyle MA, Yanagawa N, Lee DB. Serum erythropoietin levels after renal transplantation. *N Engl J Med* 1989;321(3):151-157.
334. Murphy GP, Mirand EA, Grace JT, Jr. Erythropoietin activity in anephric or renal allotransplanted man. *Ann Surg* 1969;170(4):581-587.
335. Besarab A, Caro J, Jarrell BE, Francos G, Erslev AJ. Dynamics of erythropoiesis following renal transplantation. *Kidney Int* 1987;32(4):526-536.
336. Eschbach JW Jr, Funk D, Adamson J, Kuhn I, Scribner BH, Finch CA. Erythropoiesis in patients with renal failure undergoing chronic dialysis. *N Engl J Med* 1967;276(12):653-658.
337. House AA, Pham B, Page DE. Transfusion and recombinant human erythropoietin requirements differ between dialysis modalities. *Nephrol Dial Transplant* 1998;13:1763-1769.
338. Friedman EA. Critical appraisal of continuous ambulatory peritoneal dialysis. *Annu Rev Med* 1984;35:233-248.
339. Chandra M, McVicar M, Clemons G, Mossey RT, Wilkes BM. Role of erythropoietin in the reversal of anemia of renal failure with continuous ambulatory peritoneal dialysis. *Nephron* 1987;46(3):312-315.
340. De Paeppe MB, Schelstraete KH, Ringoir SM, Lameire NH. Influence of continuous ambulatory peritoneal dialysis on the anemia of endstage renal disease. *Kidney Int* 1983;23(5):744-748.
341. Steiner RW. Characteristics of the hematocrit response to continuous ambulatory peritoneal dialysis. *Arch Intern Med* 1984;144(4):728-732.
342. Zappacosta AR, Caro J, Erslev A. Normalization of hematocrit in patients with end-stage renal disease on continuous ambulatory peritoneal dialysis: the role of erythropoietin. *Am J Med* 1982;72(1):53-57.
343. McGonigle RJ, Husserl F, Wallin JD, Fisher JW. Hemodialysis and continuous ambulatory peritoneal dialysis effects on erythropoiesis in renal failure. *Kidney Int* 1984;25(2):430-436.
344. Hume R, Williamson JM, Whitelaw JW. Red cell survival in biliary cirrhosis. *J Clin Pathol* 1970;23(5):397-401.

345. Pitcher CS, Williams R. Reduced red cell survival in jaundice and its relation to abnormal glutathione metabolism. *Clin Sci* 1963;24:239-252.
346. Eichner ER. The hematologic disorders of alcoholism. *Am J Med* 1973;54(5):621-630.
347. Berman L, Axelrod AR, et al. The blood and bone marrow in patients with cirrhosis of the liver. *Blood* 1949;4(5):511-533.
348. Lieberman FL, Reynolds TB. Plasma volume in cirrhosis of the liver: its relation of portal hypertension, ascites, and renal failure. *J Clin Invest* 1967;46(8):1297-1308.
349. Wallner SF, Kurnick JE, Vautrin RM, White MJ, Chapman RG, Ward HP. Levels of erythropoietin in patients with the anemias of chronic diseases and liver failure. *Am J Hematol* 1977;3:37-44.
350. Cynamon HA, Isenberg JN, Gustavson LP, Gourley WK. Erythrocyte lipid alterations in pediatric cholestatic liver disease: spur cell anemia of infancy. *J Pediatr Gastroenterol Nutr* 1985;4(4):542-549.
351. Cooper RA. Hemolytic syndromes and red cell membrane abnormalities in liver disease. *Semin Hematol* 1980;17(2):103-112.
352. Wisloff F, Boman D. Haemolytic anaemia in alcohol abuse. A review of 14 cases. *Acta Med Scand* 1979;205(3):237-242.
353. Goebel KM, Goebel FD, Schubotz R, Schneider J. Red cell metabolic and membrane features in haemolytic anaemia of alcoholic liver disease (Zieve's syndrome). *Br J Haematol* 1977;35(4):573-585.
354. Zieve L. Jaundice, hyperlipemia and hemolytic anemia: a heretofore unrecognized syndrome associated with alcoholic fatty liver and cirrhosis. *Ann Intern Med* 1958;48(3):471-496.
355. Martin JC, Ross A, Watson D, O'Sullivan MM. A case of Zieve's syndrome presenting with myalgia: not to be confused with polymyalgia rheumatica. *Br J Rheumatol* 1996;35(5):495-496.
356. Unger KW, Johnson D, Jr. Red blood cell mean corpuscular volume: a potential indicator of alcohol usage in a working population. *Am J Med Sci* 1974;267(5):281-289.
357. Jandl JH. The anemia of liver disease: observations on its mechanism. *J Clin Invest* 1955;34(3):390-404.
358. Bingham J. The macrocytosis of hepatic disease. I. Thin macrocytosis. *Blood* 1959;14(6):694-707.
359. Kumar S, Dube B, Mehrotra PN. The macrocytosis in cirrhosis of the liver. A clinical and experimental study. *Acta Haematol* 1966;35(1):30-45.
360. Straus DJ. Hematologic aspects of alcoholism. *Semin Hematol* 1973;10(3): 183-194.
361. Douglass CC, Twomey JJ. Transient stomatocytosis with hemolysis: a previously unrecognized complication of alcoholism. *Ann Intern Med* 1970;72(2): 159-164.
362. Wisloff F, Boman D. Acquired stomatocytosis in alcoholic liver disease. *Scand J Haematol* 1979;23(1):43-50.
363. Nunnally RM, Levine I. Macronormoblastic hyperplasia of the bone marrow in hepatic cirrhosis. *Am J Med* 1961;30:972-975.
364. Felsher BF, Redeker AG, Reynolds TB. Indirect reacting hyperbilirubinemia in cirrhosis: its relation to red cell survival. *Am J Dig Dis* 1968;13(7):598-607.
365. Katz R, Velasco M, Guzman C, Alessandri H. Red cell survival estimated by radioactive chromium in hepatobiliary disease. *Gastroenterology* 1964;46:399-404.
366. Cooper RA, Kimball DB, Durocher JR. Role of the spleen in membrane conditioning and hemolysis of spur cells in liver disease. *N Engl J Med* 1974;290(23):1279-1284.
367. Subhiyah BW, al-Hindawi AY. Red cell survival and splenic accumulation of radiochromium in liver cirrhosis with splenomegaly. *Br J Haematol* 1967;13(5):773-778.
368. Smith JR, Kay NE, Gottlieb AJ, Oski FA. Abnormal erythrocyte metabolism in hepatic disease. *Blood* 1975;46(6):955-964.
369. Smith JR, Kay NE, Gottlieb AJ, Oski FA. Abnormal erythrocyte metabolism in hepatic disease: effect of NADP repletion. *Am J Hematol* 1979;6(4):313-321.

370. Van Vlierbergh H, Delange JR, DeVos M, Leroux-Roel G, Committee BS. Factors influencing ribavirin-induced hemolysis. *J Hepatol* 2001;34:911-916.
371. Wolf PL, Koett J. Hemolytic anemia in hepatic disease with decreased erythrocyte adenosine triphosphate. *Am J Clin Pathol* 1980;73(6):785-788.
372. Cooper RA. Lipids of human red cell membrane: normal composition and variability in disease. *Semin Hematol* 1970;7(3):296-322.
373. Cooper RA, Jandl JH. Bile salts and cholesterol in the pathogenesis of target cells in obstructive jaundice. *J Clin Invest* 1968;47(4):809-822.
374. Neerhout RC. Abnormalities of erythrocyte stromal lipids in hepatic disease. *J Lab Clin Med* 1968;71(3):438-447.
375. Shohet SB. Acanthocytogenesis—or how the red cell won its spurs. *N Engl J Med* 1974;290(23):1316-1317.
376. Shohet SB. Hemolysis and changes in erythrocyte membrane lipids. 2. *N Engl J Med* 1972;286(12):638-644.
377. Shohet SB. Hemolysis and changes in erythrocyte membrane lipids. 1. *N Engl J Med* 1972;286(11):577-583.
378. Powell LW, LaMont JT, Isselbacher KJ. Haemolysis in experimental cholestasis: possible role of erythrocyte sialic acid. *Gut* 1974;15(10):794-798.
379. Greenberg MS, Choi ES. Post-splenectomy spur cell hemolytic anemia. *Am J Med Sci*. Mar-Apr 1975;269(2):277-280.
380. Greenberg MS, Choi ES. Letter: spur cells in splenectomized patient. *N Engl J Med* 1975;292(4):213-214.
381. Owen JS, McIntyre N. Erythrocyte lipid composition and sodium transport in human liver disease. *Biochim Biophys Acta* 1978;510(1):168-176.
382. Allen DW, Manning N. Cholesterol-loading of membranes of normal erythrocytes inhibits phospholipid repair and arachidonoyl-CoA:1-palmitoyl-snglycero-3-phosphocholine acyl transferase. A model of spur cell anemia. *Blood* 1996;87(8):3489-3493.
383. Allen DW, Manning N. Abnormal phospholipid metabolism in spur cell anemia: decreased fatty acid incorporation into phosphatidylethanolamine and increased incorporation into acylcarnitine in spur cell anemia erythrocytes. *Blood* 1994;84(4):1283-1287.
384. Olivieri O, Guarini P, Negri M, et al. Increased proteolytic activity of erythrocyte membrane in spur cell anaemia. *Br J Haematol* 1988;70(4):483-489.
385. Fernandez-Zamorano A, Arnalich F, Codoceo R, et al. Hemolytic anemia and susceptibility to hydrogen peroxide hemolysis in children with vitamin E deficiency and chronic liver disease. *J Med* 1988;19:317-334.
386. Boivin P. [Hematology of cirrhosis]. *La Revue du praticien* 1964;14: 2601-2607.
387. Ohki I, Dan K, Kuriya S, Nomura T. A study on the mechanism of anemia and leukopenia in liver cirrhosis. *Jpn J Med* 1988;27:155-159.
388. Tilg H, Wilmer A, Vogel W, et al. Serum levels of cytokines in chronic liver diseases. *Gastroenterology* 1992;103:264-274.
389. Hadnagy C, Laszlo GA. Acquired dyserythropoiesis in liver disease (letter). *Br J Haematol* 1991;78:283.
390. Pirisi M, Fabris C, Falletti E, et al. Evidence for a multifactorial control of serum erythropoietin concentration in liver disease. *Clin Chim Acta* 1993;219:47-55.
391. Bomford R. Anaemia in myoedema. *The Q J Med* 1938;7:495-536.
392. Horton L, Coburn RJ, England JM, Himsworth RL. The haematology of hypothyroidism. *The Q J Med* 1976;45(177):101-123.
393. Mehmet E, Aybike K, Ganidagli S, Mustafa K. Characteristics of anemia in subclinical and overt hypothyroid patients. *Endoc J* 2012;59(3):213-220.
394. Green ST, Ng JP. Hypothyroidism and anaemia. *Biomed Pharmacother* 1986;40(9):326-331.
395. Hines JD, Halsted CH, Griggs RC, Harris JW. Megaloblastic anemia secondary to folate deficiency associated with hypothyroidism. *Ann Intern Med* 1968;68(4):792-805.

396. Tudhope GR, Wilson GM. Anaemia in hypothyroidism: incidence, pathogenesis, and response to treatment. *Q J Med* 1960;24:513-537.
397. Goldsmith RE, Sturgis SH, Lerman J, Stanbury JB. The menstrual pattern in thyroid disease. *J Clin Endocrinol Metab* 1952;12(7):846-855.
398. Chu JY, Monteleone JA, Peden VH, Graviss ER, Vernava AM. Anemia in children and adolescents with hypothyroidism. *Clin Pediatr (Phila)* 1981;20(11):696-699.
399. Muldowney FP, Crooks J, Wayne EJ. The total red cell mass in thyrotoxicosis and myxoedema. *Clin Sci (Lond)* 1957;16(2):309-314.
400. Stern B, Altschule MD. Hematological Studies in Hypothyroidism Following Total Thyroidectomy. *J Clin Invest* 1936;15(6):633-641.
401. Axelrod AR, Berman L. The bone marrow in hyperthyroidism and hypothyroidism. *Blood* 1951;6(5):436-453.
402. Jones RM. Human sternal bone marrow in hyperthyroid and myxedematous states. *Am J Med Sci* 1940;200(2):211-220.
403. Kuhn JM, Rieu M, Rochette J, et al. Influence of thyroid status on hemoglobin A2 expression. *J Clin Endocrinol Metab* 1983;57(2):344-348.
404. Kiely JM, Purnell DC, Owen CA, Jr. Erythrokinetics in myxedema. *Ann Intern Med* 1967;67(3):533-538.
405. Nakao K, Maekawa T, Shirakura T, Yaginuma M. Anemia due to hypothyroidism. *Isr J Med Sci* 1965;1(4):742-745.
406. Zaroulis CG, Kourides IA, Valeri CR. Red cell 2,3-diphosphoglycerate and oxygen affinity of hemoglobin in patients with thyroid disorders. *Blood* 1978;52(1):181-185.
407. Golde DW, Bersch N, Chopra IJ, Cline MJ. Thyroid hormones stimulate erythropoiesis in vitro. *Br J Haematol* 1977;37:173-177.
408. Meineke HA, Crafts RC. Evidence for a non-calorigenic effect of thyroxin on erythropoiesis as judged by radioiron utilization. *Proc Soc Exp Biol Med* 1964;117:520-524.
409. Haut A, Tudhope GR, Cartwright GE, Wintrobe MM. Studies on the osmotic fragility of incubated normal and abnormal erythrocytes. *J Clin Invest* 1962;41:1766-1775.
410. Nightingale S, Vitek PJ, Himsworth RL. The haematology of hyperthyroidism. *The Q J Med* 1978;47(185):35-47.
411. Rivlin RS, Wagner HN, Jr. Anemia in hyperthyroidism. *Ann Intern Med* 1969;70(3):507-516.
412. Donati RM, Warnecke MA, Gallagher NI. Ferrokinetics in hyperthyroidism. *Ann Intern Med* 1965;63(6):945-950.
413. Miller WW, Delivoria-Papadopoulos M, Miller L, Oski FA. Oxygen releasing factor in hyperthyroidism. *JAMA* 1970;211(11):1824-1826.
414. Snyder LM, Reddy WJ. Mechanism of action of thyroid hormones on erythrocyte 2,3-diphosphoglyceric acid synthesis. *J Clin Invest* 1970;49(11):1993-1998.
415. Snyder LM, Reddy WJ. Thyroid hormone control of erythrocyte 2,3-diphosphoglyceric acid concentrations. *Science* 1970;169(3948):879-880.
416. Das KC, Mukherjee M, Sarkar TK, Dash RJ, Rastogi GK. Erythropoiesis and erythropoietin in hypo- and hyperthyroidism. *J Clin Endocrinol Metab* 1975;40(2):211-220.
417. Ten S, New M, McLaren N. Clinical review 130: Addison's disease 2001. *J Clin Endocrinol Metab* 2001;86:2909-22.
418. Bethune JE. The diagnosis and treatment of adrenal insufficiency. In: DeGroot LJ, ed. *Endocrinology*. Philadelphia, PA: WB Saunders, 1989:1647-59.
419. Irvine WJ, Stewart AG, Scart L. A clinical and immunological study of adrenocortical insufficiency (Addison's disease). *Clin Exp Immunol* 1967;1:31.
420. Neufield M, McLaren NK, Blizzard RM. Two types of autoimmune Addison's disease associated with different polyglandular autoimmune (PGA) syndromes. *Medicine (Baltimore)* 1981;60:355.
421. Baez-Villasenor J, Rath CE, Finch CA. The blood picture in Addison's disease. *Blood* 1948;3(7):769-773.

422. Cheng CK, Chan J, Cembrowski GS, van Assendelft OW. Complete blood count reference interval diagrams derived from NHANES III: stratification by age, sex, and race. *Lab Hematol* 2004;10(1):42-53.
423. Alexanian R. Erythropoietin and erythropoiesis in anemic man following androgens. *Blood* 1969;33(4):564-572.
424. McCullagh EP, Jones R. Effect of androgens on the blood count of men. *J Clin Endocrinol* 1942;2(4):243-251.
425. Krantz SB, Jacobson LO. Erythropoietin and the regulation of erythropoiesis. Chicago: University of Chicago, 1970.
426. Hawkins VW, Speck E, Leonard VG. Variation of the hemoglobin level with sex and age. *Blood* 1954;9:999.
427. Crafts RC. Effects of hypophysectomy, castration, and testosterone propionate on hemopoiesis in the adult male rat. *Endocrinology* 1946;39(6):401-413.
428. Gemzell CA, Sjostrand T. The effect of the gonads on the total amount of haemoglobin and blood volume in rats. *Acta Endocrinol* 1956;21(1):86-96.
429. Gardner FH, Nathan DG, Piomelli S, Cummins JF. The erythrocythaemic effects of androgen. *Br J Haematol* 1968;14(6):611-615.
430. Bessman JD, Gardner FH. Persistence of abnormal RBC and platelet phenotype during recovery from aplastic anemia. *Arch Intern Med* 1985;145: 292-296.
431. Gordon AS, Mirand EA, Wenig J, Katz R, Zanjani ED. Androgen actions on erythropoiesis. *Ann N Y Acad Sci* 1968;149(1):318-335.
432. Dukes PP, Goldwasser E. Inhibition of erythropoiesis by estrogens. *Endocrinology* 1961;69:21-29.
433. Piliero SJ, Medici PT, Haber C. The interrelationships of the endocrine and erythropoietic systems in the rat with special reference to the mechanism of action of estradiol and testosterone. *Ann N Y Acad Sci* 1968;149(1): 336-355.
434. Escamilla RF, Lisser H. Simmonds' disease—A clinical study with review of the literature, differentiation from anorexia nervosa by statistical analysis of 595 cases, 101 of which were proved pathologically. *J Clin Endocrinol* 1942;2(2):65-96.
435. Daughaday WH, Williams RH, Daland GA. The effect of endocrinopathies on the blood. *Blood* 1948;3(12):1342-1366.
436. Greig HB, Metz J, Sunn L. Anaemia in hypopituitarism; treatment with testosterone and cortisone. *S Afr J Lab Clin Med* 1956;2(1):52-61.
437. Jepson JH, McGarry EE. Hemopoiesis in pituitary dwarfs treated with human growth hormone and testosterone. *Blood* 1972;39(2):229-248.
438. Jepson JH, McGarry EE, Lowenstein L. Erythropoietin excretion in a hypo-pituitary patient. Effects of testosterone and vasopressin. *Arch Intern Med* 1968;122(3):265-270.
439. Summers VK. The anaemia of hypopituitarism. *Br Med J* 1952;1(4762): 787-790.
440. Crafts RC, Meineke HA. Influence of the pituitary on hemopoiesis. *Am J Clin Nutr.* Jul-Aug 1957;5(4):453-460.
441. Jepson JH, Lowenstein L. Effect of prolactin on erythropoiesis in the mouse. *Blood* 1964;24:726-738.
442. Lindemann R, Trygstad O, Halvorsen S. Pituitary control of erythropoiesis. *Scand J Haematol* 1969;6(2):77-86.
443. Berlin NI, Van Dyke DC, Siri WE, Williams CP. The effect of hypophysectomy on the total circulating red cell volume of the rat. *Endocrinology* 1950;47(6):429-435.
444. Bozzini CE. Decrease in the number of erythrocytic elements in the blood-forming tissues as the cause of anemia in hypophysectomized rats. *Endocrinology* 1965;77(6):977-984.
445. Contopoulos AN, Simpson ME, Van Dyke DC, Lawrence JH, Evans HM. A comparison of the anemia produced by hypophysectomy with that resulting from combined thyroidectomy, adrenalectomy and gonadectomy. *Endocrinology* 1954;55(4):509-515.
446. Fisher JW, Crook JJ. Influence of several hormones on erythropoiesis and oxygen consumption in the hypophysectomized rat. *Blood* 1962;19:557-565.
447. Rodriguez JM, Shahidi NT. Erythrocyte 2,3-diphosphoglycerate in adaptive red-cell-volume deficiency. *N Engl J Med* 1971;285(9):479-482.
448. Nomiya J, Shinohara K, Inoue H. Improvement of anemia by recombinant erythropoietin in a patient with postoperative hypopituitarism. *Am J Hematol* 1994;47(3):249-250.

449. Mallette LE. Hyporegenerative anemia in primary hyperparathyroidism. *South Med J* 1977;70(10):1199-1201.
450. Mallette LE. Anemia in hypercalcemic hyperparathyroidism. Renewed interest in an old observation. *Arch Intern Med* 1977;137(5):572-573.
451. Boxer M, Ellman L, Geller R, Wang CA. Anemia in primary hyperparathyroidism. *Arch Intern Med* 1977;137(5):588-593.
452. Cleary BS, Gaudiani JL, Mehler PS. Interpreting the complete blood count in anorexia nervosa. *Eating disorders* 2010;18(2):132-139.
453. Mant MJ, Faragher BS. The haematology of anorexia nervosa. *Br J Haematol* 1972;23:737-749.
454. Smith RR, Spivak JL. Marrow cell necrosis in anorexia nervosa and involuntary starvation. *Br J Haematol* 1985;60(3):525-530.
455. Amrein P, Freidman R, Kosinski K, Ellman L. Hematologic changes in anorexia nervosa. *JAMA* 1979;241:2190-2191.
456. Kaiser U, Barth N. Haemolytic anaemia in a patient with anorexia nervosa. *Acta Haematol* 2001;106(3):133-135.
457. Strandberg O. Anemia in rheumatoid arthritis. *Acta Med Scand Suppl* 1966;454:1-153.
458. Hubbard JP, McKee MH. Anemia of rheumatic fever. *J Pediatr* 1939;14:66-73.
459. Beyan E, Beyan C, Turan M. Hematological presentation in systemic lupus erythematosus and its relationship with disease activity. *Hematology* 2007;12(3):257-261.
460. Hobisch-Hagen P, Wiedermann F, Mayr A, et al. Blunted erythropoietic response to anemia in multiply traumatized patients. *Crit Care Med* 2001;29:743-747.
461. Andes WA, Rogers PW, Beason JW, Pruitt BA Jr. The erythropoietin response to the anemia of thermal injury. *J Lab Clin Med* 1976;88(4):584-592.

Chapter 42 Anemias During Pregnancy and The Postpartum Period

> Table of Contents > Part IV - Disorders of Red Cells > Section 5 - Other Red Cell Disorders > Chapter 42 - Anemias During Pregnancy and The Postpartum Period

Chapter 42

Anemias During Pregnancy and The Postpartum Period

Robert T. Means, Jr.

OVERVIEW/EPIDEMIOLOGY

By the second trimester of pregnancy, at least a mild degree of maternal anemia (defined as a hemoglobin concentration or hematocrit below the lower limit of normal for healthy adult females) is almost universal.¹ Significant anemia (defined as a hemoglobin concentration <10 g/dl) occurs with a prevalence ranging between 2% and 26%, depending upon the population studied.^{2, 3, 4} In all populations, but particularly in the less-developed countries of the world, anemia is a major contributor to maternal and fetal morbidity and mortality.^{2, 3, 4, 5, 6}

Anemia in pregnancy represents a combination of various potential etiologies. The common underlying mechanism, encountered routinely, is a consequence of the physiology of pregnancy itself (physiologic anemia of pregnancy). Superimposed on this can be deficiency of nutrients (typically in the context of a preexisting deficiency exacerbated by childbearing), hemolysis, or marrow failure syndromes. It should also be remembered that pregnant women remain susceptible to etiologies of anemia unrelated to their pregnancy.⁷ In some cases, such as sickle cell anemia, the underlying condition has major implications for the management of pregnancy.

MATERNAL ERYTHROPOIESIS

There is an increase in maternal erythropoiesis during the third trimester preceded by an increase in serum erythropoietin concentrations, presumably on the basis of reduced oxygen delivery to maternal renal tissues during the late second and early third trimesters.⁸ Similarly, serum erythropoietin concentrations are elevated in fetuses with anemia, and correlate with hypoxemia.⁹

The biology of erythropoietin and erythropoiesis in the fetus is discussed in Chapter 43. Erythropoietin is also present in human breast milk in concentrations of 10 to 20 mU/ml, essentially the same as in amniotic fluid.¹⁰ Erythropoietin concentrations in the mother's milk do not correlate with erythropoietin concentrations in her blood. In fact, over the first weeks of lactation, maternal serum erythropoietin concentrations fall, whereas milk erythropoietin concentrations increase, reaching the highest concentrations in women breast-feeding for a year or more. The source of erythropoietin in breast milk appears to be mammary gland epithelium. Erythropoietin in human breast milk, like that in amniotic fluid and colostrum, is relatively protected from proteolytic digestion in the fetal and neonatal gastrointestinal tract.¹⁰

PHYSIOLOGIC ANEMIA OF PREGNANCY

Expansion of the plasma volume is the cause of the physiologic anemia of pregnancy (Table 42.1). Expanding the plasma volume reduces the volume-dependent indicators of anemia (the hematocrit, the blood hemoglobin concentration, and the circulating erythrocyte count) but does not reduce the absolute amounts of hemoglobin or of erythrocytes in the circulation as a whole. The mechanisms underlying these changes are uncertain. It has been speculated that the physiologic anemia of pregnancy serves the purpose of reducing maternal blood viscosity, thereby enhancing placental perfusion and facilitating oxygen and nutrient delivery to the fetus. Beginning in approximately the sixth week of pregnancy, the plasma volume increases disproportionately to the red cell mass. Plasma volume generally reaches a maximum value at approximately 24 weeks' gestation¹¹ but may continue increasing as late as the 37th week.¹² At its peak, the plasma volume is about 40% higher among pregnant women than among nonpregnant women.^{13, 14} The reduction in the hematocrit, hemoglobin concentration, and circulating erythrocyte count generally occurs by the seventh to eighth week of pregnancy,^{11, 14} and continues until a new equilibrium is reached at the 16th to 22nd week.^{13, 15} As a result of this new physiologic equilibrium, it has been suggested that a hemoglobin concentration <11 g/dl in the late first trimester and <10 g/dl in the second and third trimesters are the lower limits below which a cause other than the physiologic anemia of pregnancy should be sought.¹⁶ In patients with β -thalassemia trait who have only modest anemia at baseline, hemoglobin concentration may drop significantly after the first trimester of pregnancy.¹⁷

During pregnancy, a 15% to 25% increase in the red cell mass generally occurs but is concealed by the dilutional effect of the increase in plasma volume.^{12, 13} A greater increase in red cell mass occurs if the mother takes iron supplements.¹ Ferrokinetic studies demonstrate accelerated erythropoiesis during pregnancy, supporting the concept of an increase in red cell mass.^{18, 19} Choi and Pai investigated erythropoiesis during pregnancy among 342 women by examining reticulocyte subpopulations using flow cytometry and also by measuring serum transferrin receptor concentrations. They found no differences between prepregnancy and those during the first and second trimesters. However, during the third trimester of pregnancy, reticulocyte maturity index and serum transferrin receptor concentrations increased twofold. After delivery these values decreased, falling to nonpregnant values about 5 weeks after delivery. They concluded that maternal erythropoiesis increases late in gestation and returns to normal by about 1 month after delivery.²⁰

Maternal plasma volume generally decreases during the final weeks of pregnancy, and consequently the hematocrit, hemoglobin, and circulating erythrocyte count increase.^{21, 22} However, studies of maternal blood volume in late pregnancy yield conflicting results depending on whether the patient is supine or in the decubitus position, and the effects of the gravid uterus

P.1013

compressing blood vessels are an additional source of variation. As a result, the results observed may represent only variations within the error of measurement or random occurrences.^{13, 21, 23} The maternal blood volume generally returns to prepregnancy levels within 1 to 3 weeks after delivery, in part reflecting blood loss at delivery.^{19, 24, 25}

TABLE 42.1 FEATURES OF THE PHYSIOLOGIC ANEMIA OF PREGNANCY

Plasma volume begins to increase during the sixth week of pregnancy.

There is no significant increase in erythrocyte production during the first trimester.

Dilutional anemia is first apparent by the seventh to eighth week.

Increase in erythrocyte production is apparent during the second trimester.

Lowest hemoglobin explainable by dilutional effect (the physiologic anemia of pregnancy) is 11 g/dl in the first trimester and 10 g/dl in the second and third trimesters.

Physiologic anemia of pregnancy is normochromic, is normocytic, does not worsen during the third

trimester, and does not require additional evaluation or specific treatment.

IRON DEFICIENCY DURING PREGNANCY

The physiologic anemia of pregnancy is normochromic and normocytic. Therefore, if a pregnant woman has a microcytic hypochromic anemia, nonphysiologic causes must be considered. Iron deficiency is common in women of childbearing age and is certainly the most common cause of nonphysiologic anemia during pregnancy.¹ It is particularly common in economically and socially disadvantaged populations.^{26, 27} The prevalence of iron deficiency ranges from 16% to 55% in pregnant women during the third trimester. This partially reflects utilization of iron by the fetus, and partially reflects pre-existing iron deficiency.^{1, 26, 28} In a Cochrane review, Milman et al. observed that among fertile women, 20% have presumed iron reserves of >500 mg (defined as a serum ferritin concentration >70 µg/L), which is stated as the required minimum during pregnancy; 40% have iron stores of 100 to 500 mg (defined by a serum ferritin concentration 30 to 70 µg/L), and 40% have undetectable iron stores (serum ferritin <30 µg/L).²⁹ The fetus is a privileged recipient of the nutrients required for hemoglobin synthesis. Thus, the hemoglobin concentration of infants born to mothers who have severe iron deficiency anemia is normal, and the serum iron, transferrin saturation, and serum ferritin levels are unrelated to maternal iron status.^{30, 31, 32}

In a study by De Leeuw et al., 84% of women not supplemented with oral iron lacked stainable iron in bone marrow aspirates after delivery at term, whereas 81.5% of women treated with iron had stainable iron present at term.¹ The demand for absorbed iron increases from 0.8 mg/day in early pregnancy to 7.5 mg/day in late pregnancy. An iron supplement of 65 mg/day beginning at or before 20 weeks' gestation generally is adequate to prevent iron deficiency during pregnancy.²⁹

There is evidence that the risks of premature delivery, low birth weight, and infant death are increased by severe iron deficiency. However, it is difficult to distinguish the effects of the iron deficiency itself from the conditions that produced the deficiency. A large case-control study from Venezuela indicated that maternal iron deficiency was associated with increased risk of premature delivery (risk ratio, 1.70; 95% confidence interval, 1.18 to 2.57).³³ However, when Mahomed reviewed 20 trials evaluating the issue of iron supplementation in pregnancy for the Cochrane database, he concluded that iron supplementation during pregnancy resulted in a substantial reduction in women with anemia (a hemoglobin below 10 g/dl late in pregnancy) but had no detectable effect on maternal or fetal outcome.³⁴ Thus, whether maternal iron deficiency adversely influences pregnancy is controversial. In fact, it is not entirely clear whether maternal iron deficiency reduces the fetal iron supply. Harthoorn-Lasthuizen et al. found no significant differences in iron status of neonates born to iron-deficient versus iron-replete women and concluded that the fetal iron supply is not negatively influenced by iron deficiency in the mother.³⁵ In contrast, Turgeon O'Brien et al. reviewed medical records of 202 pregnant women to examine the association of low- and high-ferritin levels and anemia with pregnancy outcome.³⁶ They observed an inverse relationship between firsttrimester anemia and birth weight, but they observed no relationship in the second and third trimesters. They suggested that maternal iron deficiency in early pregnancy was associated with poor fetal weight gain but that maternal iron deficiency later in pregnancy was not. During iron deficiency, the placenta becomes hypertrophied, a possible cause of maternal hypertension. A specific variant of pica, namely (ingestion of baking powder) can lead to symptoms suggesting preeclampsia.³⁷

Recombinant erythropoietin administration, combined with iron replacement, has been reported to be an effective treatment for moderate and severe iron deficiency anemia during pregnancy,^{38, 39} although a meta-analysis of this topic suggests that the benefits from erythropoietin are relatively modest.⁴⁰

The usual criteria for diagnosing iron deficiency are valid during pregnancy (see Chapter 23), including a reduced mean corpuscular volume (MCV), a reduced serum transferrin saturation to ≤15%, and a reduced serum ferritin concentration. Measurement of serum transferrin receptors may be useful in complicated situations in which inflammatory disease makes the serum ferritin value less reliable.⁴¹ Interpretation of serum iron values can be complicated during pregnancy: Even in apparently iron-replete women, serum iron levels progressively decline, and values for serum total iron-binding capacity and free erythrocyte protoporphyrin increase,^{1, 42} findings that usually indicate iron deficiency. Expression of the iron-regulatory peptide hepcidin appears to be suppressed during pregnancy, consistent with an increased iron demand.⁴³

Dietary supplementation with 78 mg of elemental ferrous iron daily during pregnancy increased the hematocrit, hemoglobin concentration, and red cell mass, with the red cell mass rising to nearly twice that found in similar, apparently healthy women not supplemented.¹ At term, the mean hemoglobin concentration averaged 12.4 g/dl in those who received the supplement and 10.9 g/dl in those who did not. In Bantu women, whose diet is habitually high in iron, a significant change in serum iron does not occur, and iron deficiency anemia does not develop during pregnancy.⁴⁴ Some

have recommended that all pregnant women receive iron supplements beginning at 18 to 20 weeks' gestation in doses ranging from 30 to 60 mg/day,²⁶ whereas others recommend that iron supplementation be provided selectively. A typical regimen in this second circumstance is as follows: No iron supplementation if the serum ferritin concentration is $>70 \mu\text{g/L}$; lowlevel iron supplementation (40 mg elemental iron/day) if serum ferritin is between 30 and 70 $\mu\text{g/L}$; and 80 to 100 mg elemental iron/day in women with lower serum ferritin concentrations.⁴⁵

Actual iron deficiency anemia should be treated as in individuals who are not pregnant (see Chapter 23). Constipation may be an especially problematic side effect in pregnant women; therefore, gradual increases in dose until fully therapeutic levels are achieved and an emphasis on taking medication with meals are particularly important precautions. Rarely, parenteral treatment may be necessary.

DEFICIENCY OF FOLATE AND OTHER NUTRIENTS DURING PREGNANCY

Macrocytic anemia of pregnancy is typically megaloblastic and in most cases results from deficiency of folic acid.^{46, 47, 48, 49, 50} In a study from India, macrocytic anemia in pregnancy carried a more negative prognosis for both mother and child than did iron deficiency.⁵¹ Megaloblastic anemia during pregnancy begins most often in either the third trimester or shortly after delivery.⁵² Folate requirements increase during pregnancy, and the diets of many pregnant patients are insufficient to meet the increased need.^{53, 54} Although folate deficiency occurs most often in economically deprived patients, this consequence of inadequate eating habits is not confined to the poor.^{52, 53, 54, 55} Particularly in pregnant adolescents, the diet may provide an inadequate source of folate, regardless of economic status.⁵⁴ In uncomplicated pregnancies, the gastrointestinal absorption of dietary folate (polyglutamate) and of folic

P.1014

acid (monoglutamate) is normal.^{56, 57} Folate deficiency during pregnancy is relatively common, although its frequency depends on the population studied. The prevalence varies from 1% to 50% of pregnant patients.^{48, 52, 55, 58} In North America, the prevalence is 1% to 4%.⁵⁰ Not all patients in whom the serum concentration of folate is low develop megaloblastic anemia. In those who do, often the serum folate concentration was low earlier in pregnancy.⁵²

Pregnant women often have no symptoms with folate deficiency anemia and may be found to have blood hemoglobin levels of 6 to 9 g/dl in the third trimester or postpartum. Folate deficiency is clearly associated with fetal neural tube defects and cleft palate, but these defects are established very early in fetal development, long before maternal megaloblastic anemia is detected.⁵⁰ The association between low serum folate during the first trimester of pregnancy and fetal neural tube defects has been known for over 25 years.⁵⁰ Lumley et al. reviewed this issue for the Cochrane database, examining four trials involving 6,425 women treated with folate or placebo.⁵⁹ Preconceptional folate supplementation reduced the incidence of neural tube defects to a relative risk of 0.28 (95% confidence interval, 0.13 to 0.58). Folate did not increase miscarriage, ectopic pregnancy, or stillbirth. Multivitamins without folate did not prevent neural tube defects, and adding multivitamins to folate supplementation did not produce additional preventive effects. Thompson et al. reported an unexpected but significant reduction in childhood acute lymphoblastic leukemia among offspring of women supplemented with folate during pregnancy.⁶⁰

An association between bacteriuria and folate deficiency was noted in pregnant patients. In experimental systems, infection may induce folate-deficient megaloblastic anemia. Malabsorption (see Chapter 36) may be associated with megaloblastic anemia of pregnancy, even in nontropical areas.⁵⁰

In rare cases, folate-deficient pregnant patients develop erythroblastopenia and bone marrow changes morphologically simulating acute leukemia.⁶¹ Application of current molecular, immunologic, and cytochemical tools for diagnosing leukemia will avoid a mistaken diagnosis.

Megaloblastic anemia during pregnancy, as in the nonpregnant patient, is suggested by an increased MCV with oval macrocytes and hypersegmented granulocytes on blood smear, but a bone marrow examination can be done if doubt exists. Folate deficiency must be distinguished from vitamin B₁₂ deficiency. The latter is rare in pregnancy, and the distinction can often be made on clinical grounds, especially on the basis of a careful nutritional history.

Folate is transported across the placenta against a concentration gradient. Infants born to mothers with the megaloblastic anemia of pregnancy have no anemia and no biochemical evidence of folate deficiency.⁶² The concentration of vitamin B₁₂ also is two to three times higher in cord blood than in maternal blood.⁶³ Nevertheless, this nutritional advantage is insufficient to protect the infant if the mother is vitamin B₁₂ deficient and if the sole source of nutrition is the mother's milk. Megaloblastic anemia accompanied by irreversible neurologic damage has been documented in breast-fed infants of vegan mothers^{64, 65} and in breastfed infants of mothers with subclinical pernicious anemia.^{66, 67}

Dietary supplementation with approximately 0.3 mg of folic acid daily during pregnancy reduces the occurrence of megaloblastic anemia to approximately 0.7% of all pregnant women,^{49, 68, 69} whereas a supplement of only 0.1 to 0.2 mg/day is not adequate to maintain serum folic acid concentration at normal levels.^{70, 71} A supplement of 0.45 mg/day results in supranormal values for serum folate,^{69, 71} but, even with this amount of supplementation, megaloblastic anemia may occur in a pregnant patient in whom the course is complicated by urinary tract infection, hemolysis, or hemorrhage.⁷¹ Nevertheless, because true pernicious anemia caused by a lack of intrinsic factor and vitamin B₁₂ does occur in pregnant patients,⁷² the considerations regarding masking of pernicious anemia with folate doses of 0.40 mg/day or more apply (Chapter 36). Both the American Academy of Pediatrics and the American College of Obstetricians and Gynecologists recommend daily supplements of 0.4 mg of folic acid for pregnant women at low risk for neural tube defects; for pregnant women with a history of previous pregnancies associated with neural tube defects or at otherwise high risk, 4 mg of folic acid daily is recommended.^{73, 74, 75} For patients not at high risk for neural tube defects but at increased risk for folate deficiency, such as those with chronic hemolytic anemia, the supplement may be increased to 1 mg/day.⁵⁰

For established deficiencies, the regimen described in Chapter 36 should be followed. If the possibility of vitamin B₁₂ deficiency cannot be excluded, vitamin B₁₂ injections should be added to the regimen.

Anemia due to zinc deficiency has been associated in some studies with fetal growth restriction, congenital abnormalities, and neurodevelopmental delay. Iodine deficiency during pregnancy is very uncommon in developed countries but can result in fetal wastage, preterm delivery, and neonatal hypothyroidism. Deficiency of magnesium, selenium, copper, and calcium has also been associated with complications of pregnancy and fetal development.^{76, 77} In a study in Nepal, vitamin A supplementation reduced maternal mortality, and suggested that vitamin A influences the synthesis of erythropoietin and thus might decrease maternal anemia, although other studies carried out in pregnant women in Africa have not confirmed this.^{78, 79, 80}

MATERNAL ANEMIA ASSOCIATED WITH PRENATAL INFECTIONS

Most clinically significant infections of the fetus are viral or protozoal, but generally these conditions result in minimal evidence of infection in the mother. Specifically, women carrying a fetus infected with cytomegalovirus, toxoplasmosis, rubella, herpes simplex, or parvovirus B19 generally have no anemia related to the infection. However, certain infectious diseases during pregnancy do result in maternal anemia. For example, intestinal helminth infections, common in certain parts of the world, produce or exacerbate iron deficiency during pregnancy, resulting in anemia. Nurdia et al. reported that 70% of 442 pregnant women from Central Java, Indonesia, had either *Trichuris trichiura*, *Necator americanus*, or *Ascaris lumbricoides* detected during pregnancy.⁸¹ They observed a significant negative association between hookworm infection and serum ferritin in the first trimester and suggested that anthelmintic therapy should be given to infected women before conception as a means of improving their iron status. Similarly, Torlesse and Hodges reported that anthelmintics were useful in Sierra Leone, reducing the decline in hemoglobin concentration during pregnancy by more than 6.5 g/L.⁸²

Syphilis generally does not lead to anemia in pregnancy. Mavrov and Goubenko, from Ukraine, reported on 155 pregnant women with syphilis. They observed that 78% of the women remained asymptomatic throughout pregnancy, although placental and fetal/neonatal pathology were found in about half of cases.⁸³

Malaria can cause maternal and fetal anemia.⁸⁴ This is a significant issue in the less-developed countries of the world. Standard methods of diagnosing malaria are often ineffective during pregnancy.⁸⁴ The anemia is mild in most neonates with malaria, but with a marked placental accumulation of parasites, intrauterine growth retardation can be significant.⁸⁵ Steketee et al. reviewed studies between 1985 and 2000 and summarized the risk of neonatal anemia, low birth weight, and infant mortality associated with maternal malaria. Indeed, maternal malaria was associated with substantial risks for anemia (population attributable risk, 3% to 15% increased), low birth weight (8% to 14% increased risk), and infant mortality (3% to 8% increased risk).

P.1015

They estimated that each year 75,000 to 200,000 infant deaths are associated with maternal malaria.⁸⁶ More recent studies from Nigeria, Benin, and India have shown similar results.^{87, 88, 89}

HEMOLYTIC ANEMIA IN PREGNANCY

Pregnancy-induced Hemolytic Anemia

A variety of hemolytic anemia syndromes can occur in pregnant women just as in nonpregnant women. In fact, pregnancy can exacerbate underlying autoimmune hemolytic anemia.⁹⁰ Thus, hemolytic anemia is not particularly uncommon in

obstetric practice. However, a rare entity has been described in which an idiopathic hemolytic anemia occurs during pregnancy, resolves completely after pregnancy, and recurs during subsequent pregnancy (Table 42.2). The pathogenesis of this anemia is not known. Terms for the condition include idiopathic autoimmune hemolytic anemia of pregnancy, unexplained hemolytic anemia associated with pregnancy, and pregnancy-induced hemolytic anemia. The condition is not homogeneous. In the cases reported by Ng et al. from Kuala Lumpur and Benraad et al. from The Netherlands,^{91, 92} women had immunoglobulin G warm antibodies and were successfully treated with glucocorticoids. In some cases, a positive direct antiglobulin (Coombs) test is not found.^{93, 94, 95} The majority of cases have no identifiable immune mechanisms and have a variable response to glucocorticoids.^{96, 97, 98}

This pregnancy-induced hemolytic anemia becomes apparent in the third trimester of pregnancy and in most cases remits completely within 2 months of delivery, sometimes taking as long as 4 or 5 months. The anemia is usually very severe, even life threatening to mother and fetus. Corticosteroids and intravenous immunoglobulin (IVIG) have been reported to be successful in some cases, but many of the women have been treated with repeated erythrocyte transfusions. Generally, the transfused donor cells have a shortened survival. Neonates born to women with pregnancy-induced hemolytic anemia generally have transient hemolysis, lasting 1 to 2 months; severe jaundice requiring neonatal exchange transfusion has not been reported.

Autoimmune Hemolytic Anemia during Pregnancy

In cases of autoimmune hemolytic anemia during pregnancy, whether idiopathic or of an identified variety, the degree of hemolysis is generally more severe in the mother than that in the fetus.⁹⁹ However, therapy that ameliorates the maternal disease (such as corticosteroids or IVIG) often does not protect the fetus. This is in contrast to autoimmune thrombocytopenia during pregnancy, in which maternal and fetal platelet counts are likely to be concordant.

TABLE 42.2 FEATURES OF IDIOPATHIC PREGNANCY-INDUCED HEMOLYTIC ANEMIA

There is no identifiable mechanism.

Anemia becomes apparent in the third trimester.

Anemia remits completely within 2 mo of delivery.

Anemia generally recurs in subsequent pregnancies.

Anemia is usually severe, even life threatening.

Corticosteroids and intravenous immunoglobulin are sometimes helpful.

Erythrocyte transfusions are the mainstay of treatment for severe anemia.

Donor cells have a shortened survival.

Neonates generally have transient nonsevere hemolysis.

HELLP Syndrome

Preeclampsia is characterized by gestational hypertension and proteinuria or pathologic edema; eclampsia is complicated by the additional occurrence of seizures.^{100, 101} Preeclampsia and eclampsia are systemic diseases involving the kidney, liver, heart, and central nervous system. Hematologic complications have been recognized for some time and include microangiopathic hemolytic anemia with characteristic fragmented red blood cells (RBCs) in the peripheral blood, thrombocytopenia, and well-defined abnormalities of the coagulation system.^{102, 103} This subset of patients with severe preeclampsia/eclampsia is considered to have HELLP syndrome, characterized by hemolysis (H), elevated liver (EL) enzymes, and low platelet (LP) counts (Table 42.3).^{104, 105}

It is thought that RBC fragmentation and thrombocytopenia associated with HELLP are a result of a number of interrelated, largely mechanical factors, including endothelial damage, vasoconstriction coupled with hypertension, and the deposition of fibrin in injured vessels. Women with preeclampsia have abnormalities in coagulation, including signs of chronic intravascular coagulation,¹⁰⁶ shortened platelet lifespan,^{103, 107} decreased plasma antithrombin III activity,^{108, 109} abnormalities in circulating fibrinogen multimers¹¹⁰ and increased fibrin deposition within the kidney and the liver.^{111, 112} Increased rates of factor VIII consumption have been reported by some although not all investigators.^{113, 114, 115} Patients with preeclampsia have decreased hemopexin relative to healthy pregnant mothers.¹¹⁶ Women with preeclampsia also have higher circulating levels of the endogenous vasoconstrictor endothelin and other abnormalities of endothelial function.^{117, 118, 119, 120} Patients with preeclampsia have an imbalance of placental prostacyclin and thromboxane production that favors vasoconstriction.¹²¹

TABLE 42.3 MAJOR CLINICAL CHARACTERISTICS OF HELLP SYNDROME, TTP, AND HUS

Clinical Features	HELLP Syndrome	TTP	HUS
Target organ/system involved	Liver	Neurologic	Renal
Gestational age	Second to third trimester	Second trimester	Postpartum
Platelets	Decreased	Decreased	Decreased
PT/PTT	Normal	Normal	Normal
Hemolysis	Present	Present	Present
Fibrinogen	Normal	Normal	Normal
Creatinine	Normal/increased	Increased	Increased
Liver enzymes	Increased	Normal	Normal
ADAMTS-13	Mild-moderate	Severely	Variable; typically severely
	Decreased	Decreased/absent	Decreased

HELLP, hemolysis (H), elevated liver (EL) enzymes, and low platelet (LP) counts; HUS, hemolytic-uremic syndrome; PT, prothrombin time; PTT, partial thromboplastin time; TTP, thrombotic thrombocytopenic purpura.

Modified from Saphier CJ, Repke JT. Hemolysis, elevated liver enzymes, and low platelets (HELLP) syndrome: A review of diagnosis and management. *Semin Perinatol* 1998; 22(2):118-133.

P.1016

HELLP syndrome reportedly occurs in 20% of women with severe preeclampsia and 10% of women with eclampsia.¹²² The median gestational age at presentation is 32 to 34 weeks, with a range of 24 to 39 weeks.¹²³ Clinical findings at presentation include malaise, right upper quadrant tenderness, hypertension, and edema. Most women with HELLP syndrome are not anemic at presentation, although they may drop their hemoglobin out of proportion to the volume of blood lost at delivery.¹²³

Laboratory features include elevated liver enzymes (i.e., alanine aminotransferase [ALT] and aspartate aminotransferase [AST]), thrombocytopenia with $<100,000/\mu\text{l}$ in most patients, and evidence of compensated hemolysis. The latter is probably the most specific abnormality associated with HELLP syndrome, but sometimes difficult to detect. The peripheral blood smear usually reveals schistocytes and there also may be burr cells and polychromatophilia.¹²³ In one study, however, schistocytes were seen in only a small fraction of patients and it was proposed that the fragmented cells may have been removed by the spleen.¹²⁴ Hemoglobinemia and hemoglobinuria occur in $<10\%$ of cases. The one consistent abnormality noted in women with HELLP syndrome is a decreased serum haptoglobin in virtually all patients, and this may be considered to be a highly sensitive test to detect this RBC abnormality when only a few schistocytes are present on smear.¹²⁴ Patients with HELLP syndrome have been reported to have mild to moderate reduction in the von Willebrand factor cleaving protease ADAMTS-13 compared to nonpregnant women or women experiencing an uncomplicated pregnancy. These reduced levels were not due to inactivating antibodies.¹²⁵ Severely reduced ADAMTS-13 levels would suggest a diagnosis of thrombotic thrombocytopenic purpura (TTP) rather than HELLP.¹²⁶ TTP is also distinguished from HELLP by an increased lactate dehydrogenase (LDH)/AST ratio.¹²⁷

The management of pre-eclampsia with HELLP syndrome is a matter of some obstetric debate, and is beyond the scope of this chapter. In general, the issues relate to immediate delivery or close observation, and these in turn are governed by maternal clinical status and fetal gestational age.^{123, 128} The most common approach is to deliver the fetus as soon as possible or, if it is likely that there is fetal lung immaturity because of gestational age, steroids are administered to the mother for 2 to 3 days, and then the infant is delivered. It is intriguing that a small but significant fraction of women (30%

in one study) spontaneously improves without more aggressive intervention.¹²⁹ In contrast to TTP, there currently are no data indicating a role for plasmapheresis.

One of the most serious complications is hepatic rupture, with 50% maternal and 60% to 70% fetal mortality. Other complications include disseminated intravascular coagulation, renal failure, pulmonary edema, and placental abruption.¹⁰⁵ Overall, maternal mortality ranges from 0% to 4% in different series.¹²³ Hematologic and chemical abnormalities resolve within a few days of delivery. Neonatal mortality is 5% to 20%,^{105, 123} and this is more a reflection of fetal age rather than any specific complication of maternal HELLP issues.

Pregnancy-associated Thrombotic Thrombocytopenic Purpura and Hemolytic-uremic Syndrome

In most reported studies of thrombotic microangiopathy with pregnancy, TTP and hemolytic-uremic syndrome (HUS) have been distinguished on the basis of the predominant symptomatology, neurologic or renal. TTP most commonly occurs antepartum, with a significant majority of cases presenting before 24 weeks' gestation. Postpartum TTP is uncommon.¹³⁰ HUS, on the other hand, typically occurs after a normal delivery and a symptomfree interval, and is characterized by acute-onset renal failure and microangiopathic hemolytic anemia.^{106, 128} Hypertension is almost always found. A small fraction (10% to 15%) of HUS and TTP patients have signs of preeclampsia. Sometimes TTP/HUS is not correctly diagnosed until the patient, thought to have preeclampsia, has an atypical prolonged recovery in the postpartum period.¹³¹

Laboratory results show the expected hemolytic anemia with many RBC fragments. Severe thrombocytopenia usually is present. Fibrin breakdown products are often increased, but the findings of other coagulation studies usually are normal.¹⁰⁶ In postpartum HUS azotemia is the rule, but is rare in TTP.

In an extensive case review, the overall maternal mortality was 44%. The mortality rate was reduced to 0% with plasma therapy, but was 68% if plasma therapy was not instituted.^{106, 131, 132, 133, 134} The pregnancy should not be terminated because this does not cure the disease, and the fetus may survive with successful therapy. The presence of severely reduced ADAMTS-13 activity at the outset of pregnancy in any woman with a history of TTP should suggest a need for plasma exchange during pregnancy.¹²⁶

BONE MARROW FAILURE SYNDROMES ASSOCIATED WITH PREGNANCY

Aplastic Anemia/Pure Red Cell Aplasia

Pregnancy may occur in patients with existing bone marrow failure syndromes,^{135, 136, 137} although this is uncommon and requires cooperation between a high-risk obstetrics expert and a hematologist experienced with bone marrow failure syndromes. Predictors of a poor outcome include thrombocytopenia and aplastic anemia associated with paroxysmal nocturnal hemoglobinuria.¹³⁶ Even more uncommon is aplastic anemia that develops during pregnancy. Whether this is a coincident association in most cases is unclear: The observation that approximately up to 25% of these individuals experience a spontaneous remission after delivery suggests that it is not coincidence.^{138, 139} Patients are generally managed with supportive care during pregnancy, and receive specific immunosuppressive therapy subsequently if necessary.

Pure red cell aplasia may also have its initial onset in pregnancy. These patients should be managed with supportive care also, and the majority will experience a remission after delivery. In some cases, subsequent pregnancies are associated with recurrence.^{140, 141, 142}

Sideroblastic Anemia

There have been a number of case reports and small series of sideroblastic anemia with onset during pregnancy. Some cases appear to represent a coincident association with idiopathic sideroblastic anemia,¹⁴³ whereas others appear to be pregnancy induced, and may recur with subsequent pregnancies.^{144, 145} A pregnancy-associated syndrome with morphologic features of both sideroblastic anemia and amegakaryocytic thrombocytopenia has been described, which responds to immunosuppression, but may also undergo spontaneous remission after delivery.¹⁴⁶

POSTPARTUM ANEMIA

Postpartum anemia is common, particularly among low-income women. Studying nearly 60,000 women who were enrolled in the Special Supplemental Nutrition Program for Women, Infants, and Children, Bodnar et al. reported an overall incidence of postpartum anemia of 27%. However, rates reached 48% among non-Hispanic black women. Prenatal anemia was the best predictor

P.1017

of postpartum anemia. Maternal obesity, multiple births, and formula feeding also predicted postpartum anemia.²⁷

Peripartum hemorrhage is an obvious and common cause of postpartum anemia. An estimated blood loss at delivery in excess of 500 ml is claimed to be a good predictor of postpartum anemia.¹⁴⁷ Unsuccessful vacuum extraction can cause peripartum hemorrhage and subsequent postpartum maternal anemia. Sheiner et al. evaluated over 2,100 cases of delivery by vacuum extraction in Israel between 1990 and 1998¹⁴⁸ and reported that 5.4% of all deliveries were complicated by unsuccessful extraction, with a subsequent cesarean section. Postpartum anemia was much more common in the women following unsuccessful vacuum extraction than in those in whom cesarean sections were not preceded by attempts at vacuum extraction. Maternal blood loss during and after the unsuccessful vacuum extraction procedures was suggested as the cause.

Hemorrhage occurring a week or more after delivery, so-called secondary postpartum hemorrhage, has a high morbidity rate. Hoveyda and MacKenzie analyzed 132 consecutive women presenting with secondary postpartum hemorrhage over a 3-year period at Barrett Maternity Hospital, Northampton, United Kingdom.¹⁴⁹ They observed this complication in just under 1% of women and found that most presented in the second week after delivery. Histories of either primary postpartum hemorrhage or manual removal of the placenta were the only significant risk factors identified. Eighty-four percent of these women were rehospitalized, 63% required surgery, and 17% received blood transfusions.

Peripartum hemolysis is another cause of postpartum anemia. Hemolytic reactions have been described in women receiving second- and third-generation cephalosporins, such as cefotetan, administered prophylactically for cesarean section.^{150, 151}

Recombinant erythropoietin has been used to treat postpartum anemia. Meta-analysis suggests that although erythropoietin treatment is safe and tends to be associated with a more rapid rise in hematocrit, it may not reduce the need for transfusion.¹⁵² Similarly, intravenous iron administration for postpartum anemia is associated with a more rapid hemoglobin increment than oral iron.¹⁵³ However, the relative safety compared to oral iron is not established.¹⁵⁴

REFERENCES

1. de Leeuw NK, Lowenstein L, Hsieh YS. Iron deficiency and hydremia in normal pregnancy. *Medicine (Baltimore)* 1966;45(4):291-315.
2. Levy A, Fraser D, Katz M, Mazor M, Sheiner E. Maternal anemia during pregnancy is an independent risk factor for low birthweight and preterm delivery. *Eur J Obstet Gynecol Reprod Biol* 2005;122(2):182-186.
3. Adebisi OY, Strayhorn G. Anemia in pregnancy and race in the United States: blacks at risk. *Fam Med* 2005;37(9):655-662.
4. Xiong X, Buekens P, Fraser WD, Guo Z. Anemia during pregnancy in a Chinese population. *Int J Gynaecol Obstet* 2003;83(2):159-164.
5. Kozuki N, Lee AC, Katz J; Child Health Epidemiology Reference Group. Moderate to severe, but not mild, maternal anemia is associated with increased risk of small-for-gestational-age outcomes. *J Nutr* 2012;142(2): 358-362.
6. Brabin BJ, Hakimi M, Pelletier D. An analysis of anemia and pregnancy-related maternal mortality. *J Nutr* 2001;131(2S-2):604S-614S.
7. Gangopadhyay R, Karoshi M, Keith L. Anemia and pregnancy: a link to maternal chronic diseases. *Int J Gynaecol Obstet* 2011;115(Suppl 1):S11-S15.
8. Milman N, Graudal N, Nielsen OJ, Agger AO. Serum erythropoietin during normal pregnancy: relationship to hemoglobin and iron status markers and impact of iron supplementation in a longitudinal, placebo-controlled study on 118 women. *Int J Hematol* 1997;66(2):159-168.
9. Bajoria R, Ward S, Sooranna SR. Erythropoietin in monochorionic twin pregnancies in relation to twin—twin transfusion syndrome. *Hum Reprod* 2001;16(3):574-580.
10. Kling PJ, Sullivan TM, Roberts RA, Philipps AF, Koldovsky O. Human milk as a potential enteral source of erythropoietin. *Pediatr Res*. 1998;43(2): 216-221.
11. Lund CJ, Donovan JC. Blood volume during pregnancy. Significance of plasma and red cell volumes. *Am J Obstet Gynecol* 1967;98(3):394-403.
12. Mani S, Duffy TP. Anemia of pregnancy. *Clin Perinatol* 1995;22(3):593-607.

13. Chesley LC. Plasma and red cell volumes during pregnancy. *Am J Obstet Gynecol* 1972;112(3):440-450.
14. Low JA, Johnston EE, McBride RL. Blood volume adjustments in the normal obstetric patient with particular reference to the third trimester of pregnancy. *Am J Obstet Gynecol* 1965;91:356-363.
15. Pritchard JA. Changes in the blood volume during pregnancy and delivery. *Anesthesiology* 1965;26:393-399.
16. Milman N, Byg KE, Agger AO. Hemoglobin and erythrocyte indices during normal pregnancy and postpartum in 206 women with and without iron supplementation. *Acta Obstet Gynecol Scand* 2000;79(2):89-98.
17. Torrance CC. Pregnancy in a case of Mediterranean anemia (thalassemia minor). *Am J Obstet Gynecol*. 1958;75(4):785-787.
18. Pritchard JA, Dams RH. Erythrocyte production and destruction during pregnancy. *Am J Obstet Gynecol* 1960;79:750-757.
19. Pritchard JA, Baldwin RD, Dickey JC. Blood volume changes in pregnancy and puerperium. II. Red blood cell loss and changes in apparent blood volume during and following vaginal delivery, caesarean section, and total hysterectomy. *Am J Obstet Gynecol* 1962;84:1271-1282.
20. Choi JW, Pai SH. Change in erythropoiesis with gestational age during pregnancy. *Ann Hematol* 2001;80(1):26-31.
21. McLennan CE. Plasma volume late in pregnancy. *Am J Obstet Gynecol* 1950;59(3):662-666.
22. McLennan CE, Thouin LG. Blood volume in pregnancy: a critical review and preliminary report of results with a new technique. *Am J Obstet Gynecol* 1948;55(2):189-200.
23. Adair FL, Dieckmann WT, Grant K. Anemia in pregnancy. *Am J Obstet Gynecol* 1939;32:560-570.
24. Verel D, Bury JD, Hope A. Blood volume changes in pregnancy and the puerperium. *Clin Sci (Lond)* 1956;15(1):1-7.
25. Lund CJ, Sisson TR. Blood volume and anemia of mother and baby. *Am J Obstet Gynecol* 1958;76(5):1013-1024.
26. Schwartz WJ III, Thurnau GR. Iron deficiency anemia in pregnancy. *Clin Obstet Gynecol* 1995;38(3):443-454.
27. Bodnar LM, Scanlon KS, Freedman DS, Siega-Riz AM, Cogswell ME. High prevalence of postpartum anemia among low-income women in the United States. *Am J Obstet Gynecol* 2001;185(2):438-443.
28. Berger J, Wieringa FT, Lacroux A, Dijkhuizen MA. Strategies to prevent iron deficiency and improve reproductive health. *Nutr Rev* 2011;69(Suppl 1): S78-S86.
29. Milman N, Graudal N, Agger AO. Iron status markers during pregnancy. No relationship between levels at the beginning of the second trimester, prior to delivery and post partum. *J Intern Med* 1995;237(3):261-267.
30. Lanzkowsky P. The influence of maternal iron-deficiency anaemia on the haemoglobin of the infant. *Arch Dis Child* 1961;36:205-209.
31. van Eijk HG, Kroos MJ, Hoogendoorn GA, Wallenburg HC. Serum ferritin and iron stores during pregnancy. *Clin Chim Acta* 1978;83(1-2):81-91.
32. El-Farrash RA, Ismail EA, Nada AS. Cord blood iron profile and breast milk micronutrients in maternal iron deficiency anemia. *Pediatr Blood Cancer* 2012;58(2):233-238.
33. Marti A, Pena-Marti G, Munoz S, Lanas F, Comunian G. Association between prematurity and maternal anemia in Venezuelan pregnant women during third trimester at labor. *Arch Latinoam Nutr* 2001;51(1):44-48.
34. Mahomed K. Iron supplementation in pregnancy. *Cochrane Database Syst Rev* 2000(2):CD000117.
35. Harthoorn-Lasthuizen EJ, Lindemans J, Langenhuisen MM. Does iron-deficient erythropoiesis in pregnancy influence fetal iron supply? *Acta Obstet Gynecol Scand* 2001;80(5):392-396.
36. Turgeon O'Brien H, Santure M, Maziade J. The association of low and high ferritin levels and anemia with pregnancy outcome. *Can J Diet Pract Res* 2000;61(3):121-127.
37. Barton JR, Riely CA, Sibai BM. Baking powder pica mimicking preeclampsia. *Am J Obstet Gynecol* 1992;167(1):98-99.
38. Sifakis S, Angelakis E, Vardaki E, Koumantaki Y, Matalliotakis I, Koumantakis E. Erythropoietin in the treatment of iron deficiency anemia during pregnancy. *Gynecol Obstet Invest* 2001;51(3):150-156.
39. Krafft A, Breyman C. Iron sucrose with and without recombinant erythropoietin for the treatment of severe postpartum anemia: a prospective, randomized, open-label study. *J Obstet Gynaecol Res* 2011;37(2):119-124.

40. Dodd J, Dare MR, Middleton P. Treatment for women with postpartum iron deficiency anaemia. *Cochrane Database Syst Rev* 2004(4):CD004222.
41. Akinsooto V, Ojwang PJ, Govender T, Moodley J, Connolly CA. Soluble transferrin receptors in anaemia of pregnancy. *J Obstet Gynaecol* 2001;21(3):250-252.
42. Dagg JH, Goldberg A, Lochhead A. Value of erythrocyte protoporphyrin in the diagnosis of latent iron deficiency (sideropenia). *Br J Haematol* 1966;12(3):326-330.
43. Finkenstedt A, Widschwendter A, Brasse-Lagnel CG, et al. Hepcidin is correlated to soluble hemojuvelin but not to increased GDF15 during pregnancy. *Blood Cells Mol Dis* 2012;48(4):233-237.
44. Gerritsen T, Walker AR. The effect of habitually high iron intake on certain blood values in pregnant Bantu women. *J Clin Invest* 1954;33(1):23-26.
45. Milman N. Iron prophylaxis in pregnancy—general or individual and in which dose? *Ann Hematol* 2006;85(12):821-828.
46. Giles C. An account of 335 cases of megaloblastic anaemia of pregnancy and the puerperium. *J Clin Pathol* 1966;19(1):1-11.
47. Lawrence C, Klipstein FA. Megaloblastic anemia of pregnancy in New York City. *Ann Intern Med* 1967;66(1):25-34.
48. Lowenstein L, Cantlie G, Ramos O, Brunton L. The incidence and prevention of folate deficiency in a pregnant clinic population. *Can Med Assoc J* 1966;95(16):797-806.
49. Streiff RR, Little AB. Folic acid deficiency in pregnancy. *N Engl J Med* 1967;276(14):776-779.
50. Campbell BA. Megaloblastic anemia in pregnancy. *Clin Obstet Gynecol* 1995;38(3):455-462.
51. Tripathi R, Tyagi S, Singh T, Dixit A, Manju, Mala YM. Clinical evaluation of severe anemia in pregnancy with special reference to macrocytic anemia. *J Obstet Gynaecol Res* 2012;38(1):203-207.
52. Rae PG, Robb PM. Megaloblastic anaemia of pregnancy: a clinical and laboratory study with particular reference to the total and labile serum folate levels. *J Clin Pathol* 1970;23(5):379-391.
53. Chanarin I, Rothman D, Perry J, Stratfull D. Normal dietary folate, iron, and protein intake, with particular reference to pregnancy. *Br Med J* 1968;2(5602):394-397.
54. Daniel WA Jr, Mounger JR, Perkins JC. Obstetric and fetal complications in folate-deficient adolescent girls. *Am J Obstet Gynecol* 1971;111(2):233-238.
55. Cooper BA, Cantlie GS, Brunton L. The case for folic acid supplements during pregnancy. *Am J Clin Nutr* 1970;23(6):848-854.
56. McLean FW, Heine MW, Held B, Streiff RR. Folic acid absorption in pregnancy: comparison of the pteroylpolyglutamate and pteroylmonoglutamate. *Blood* 1970;36(5):628-631.
57. Iyengar L, Babu S. Folic acid absorption in pregnancy. *Br J Obstet Gynaecol* 1975;82(1):20-23.
58. Iyengar L. Folic acid requirements of Indian pregnant women. *Am J Obstet Gynecol* 1971;111(1):13-16.
59. Lumley J, Watson L, Watson M, Bower C. Periconceptional supplementation with folate and/or multivitamins for preventing neural tube defects. *Cochrane Database Syst Rev* 2001(3):CD001056.
60. Thompson JR, Gerald PF, Willoughby ML, Armstrong BK. Maternal folate supplementation in pregnancy and protection against acute lymphoblastic leukaemia in childhood: a case-control study. *Lancet* 2001;358(9297): 1935-1940.
61. Levine PH, Hamstra RD. Megaloblastic anemia of pregnancy simulating acute leukemia. *Ann Intern Med* 1969;71(6):1141-1147.
62. Grossowicz N, Izak G, Rachmilewitz M. The effect of anemia on the concentration of folate derivatives in paired fetal-maternal blood. *Isr J Med Sci* 1966;2(4):510-512.
63. Rappazzo ME, Salmi HA, Hall CA. The content of vitamin B12 in adult and foetal tissue: a comparative study. *Br J Haematol* 1970;18(4):425-433.
64. Higginbottom MC, Sweetman L, Nyhan WL. A syndrome of methylmalonic aciduria, homocystinuria, megaloblastic anemia and neurologic abnormalities in a vitamin B12-deficient breast-fed infant of a strict vegetarian. *N Engl J Med* 1978;299(7):317-323.

65. Jadhav M, Webb JK, Vaishnav S, Baker SJ. Vitamin B12 deficiency in Indian infants. A clinical syndrome. *Lancet* 1962;2(7262):903-907.
66. Johnson PR Jr, Roloff JS. Vitamin B12 deficiency in an infant strictly breast-fed by a mother with latent pernicious anemia. *J Pediatr* 1982;100(6):917-919.
67. Lampkin BC, Shore NA, Chadwick D. Megaloblastic anemia of infancy secondary to maternal pernicious anemia. *N Engl J Med* 1966;274(21):1168-1171.
68. Lee JI, Lee JA, Lim HS. Effect of time of initiation and dose of prenatal iron and folic acid supplementation on iron and folate nutriture of Korean women during pregnancy. *Am J Clin Nutr* 2005;82(4):843-849.
69. Willoughby ML. An investigation of folic acid requirements in pregnancy. II. *Br J Haematol* 1967;13(4):503-509.
70. Alperin JB, Hutchinson HT, Levin WC. Studies of folic acid requirements in megaloblastic anemia of pregnancy. *Arch Intern Med* 1966;117(5):681-688.
71. Willoughby ML, Jewell FJ. Investigation of folic acid requirements in pregnancy. *Br Med J* 1966;2(5529):1568-1571.
72. Martin JD, Davis RE. Serum folic acid activity and vaginal bleeding in early pregnancy. *J Obstet Gynaecol Br Commonw* 1964;71:400-403.
73. Committee on Genetics AAoP. Folic acid for the prevention of neural tube defects. *Pediatrics* 1999;104:325-327.
74. American College of Obstetricians and Gynecologists (ACOG). Neural tube defects. Washington, DC: American College of Obstetricians and Gynecologists (ACOG), 2003.
75. Aggarwal A, Kumhar GD, Harit D, Faridi MM. Role of folic acid supplementation in prevention of neural tube defects: physicians yet unaware! *J Prev Med Hyg* 2010;51(3):131-132.
76. Black RE. Micronutrients in pregnancy. *Br J Nutr* 2001;85(Suppl 2):S193-S197.
77. Lindstrom E, Hossain MB, Lonnerdal B, Raqib R, El Arifeen S, Ekstrom EC. Prevalence of anemia and micronutrient deficiencies in early pregnancy in rural Bangladesh, the MINIMat trial. *Acta Obstet Gynecol Scand* 2011;90(1):47-56.
78. Semba RD, Kumwenda N, Taha TE, et al. Impact of vitamin A supplementation on anaemia and plasma erythropoietin concentrations in pregnant women: a controlled clinical trial. *Eur J Haematol* 2001;66(6):389-395.
79. van den Broek NR, White SA, Flowers C, et al. Randomised trial of vitamin A supplementation in pregnant women in rural Malawi found to be anaemic on screening by HemoCue. *BJOG* 2006;113(5):569-576.
80. Miller MF, Stoltzfus RJ, Iliff PJ, Malaba LC, Mbuya NV, Humphrey JH. Effect of maternal and neonatal vitamin A supplementation and other postnatal factors on anemia in Zimbabwean infants: a prospective, randomized study. *Am J Clin Nutr* 2006;84(1):212-222.
81. Nurdia DS, Sumarni S, Suyoko, Hakim M, Winkvist A. Impact of intestinal helminth infection on anemia and iron status during pregnancy: a community based study in Indonesia. *Southeast Asian J Trop Med Public Health* 2001;32(1):14-22.
82. Torlesse H, Hodges M. Anthelmintic treatment and haemoglobin concentrations during pregnancy. *Lancet* 2000;356(9235):1083.
83. Mavrov GI, Goubenko TV. Clinical and epidemiological features of syphilis in pregnant women: the course and outcome of pregnancy. *Gynecol Obstet Invest* 2001;52(2):114-118.
84. Mayor A, Moro L, Aguilar R, et al. How hidden can malaria be in pregnant women? Diagnosis by microscopy, placental histology, polymerase chain reaction and detection of histidine-rich protein 2 in plasma. *Clin Infect Dis* 2012;54(11):1561-1568.
85. Thompson D, Pegelow C, Underman A, Powars D. Congenital malaria: a rare cause of splenomegaly and anemia in an American infant. *Pediatrics* 1977;60(2):209-212.
86. Steketee RW, Nahlen BL, Parise ME, Menendez C. The burden of malaria in pregnancy in malaria-endemic areas. *Am J Trop Med Hyg* 2001;64(1-2 Suppl):28-35.
87. Ayoola OO, Whatmore A, Balogun WO, Jarrett OO, Cruickshank JK, Clayton PE. Maternal malaria status and metabolic profiles in pregnancy and in cord blood: relationships with birth size in Nigerian infants. *Malar J* 2012;11:75.
88. Bodeau-Livinec F, Briand V, Berger J, et al. Maternal anemia in Benin: prevalence, risk factors, and association with low birth weight. *Am J Trop Med Hyg* 2011;85(3):414-420.

89. Seal SL, Mukhopadhyay S, Ganguly RP. Malaria in pregnancy. *J Indian Med Assoc.* August 2010;108(8):487-490.
90. Sacks DA, Platt LD, Johnson CS. Autoimmune hemolytic disease during pregnancy. *Am J Obstet Gynecol* 1981;140(8):942-946.
91. Ng SC, Wong KK, Raman S, Bosco J. Autoimmune haemolytic anaemia in pregnancy: a case report. *Eur J Obstet Gynecol Reprod Biol* 1990;37(1):83-85.
92. Benraad CE, Scheerder HA, Overbeeke MA. Autoimmune haemolytic anaemia during pregnancy. *Eur J Obstet Gynecol Reprod Biol.* June 1994;55(3):209-211.
93. Katsuragi S, Sameshima H, Omine M, Ikenoue T. Pregnancy-induced hemolytic anemia with a possible immune-related mechanism. *Obstet Gynecol* 2008;111(2 pt 2):528-529.
94. Gilliland BC, Baxter E, Evans RS. Red-cell antibodies in acquired hemolytic anemia with negative antiglobulin serum tests. *N Engl J Med* 1971;285(5):252-256.
95. Yam P, Wilkinson L, Petz LD, Garratty G. Studies on hemolytic anemia in pregnancy with evidence for autoimmunization in a patient with a negative direct antiglobulin (Coombs') test. *Am J Hematol* 1980;8(1):23-29.
96. Kumar R, Advani AR, Sharan J, Basharutallah MS, Al-Lumai AS. Pregnancy induced hemolytic anemia: an unexplained entity. *Ann Hematol* 2001;80(10):623-626.
97. Craig GA, Turner RL. A case of symptomatic haemolytic anaemia in pregnancy. *Br Med J* 1955;1(4920):1003-1005.
98. Bjornsson S, Brennand JE, Calder AA, et al. Unexplained haemolytic anaemia in successive pregnancies with negative direct antiglobulin test and response to high dose i.v. IgG. *Br J Obstet Gynaecol* 1994;101(1):75-77.
99. Batalias L, Trakakis E, Loghis C, et al. Autoimmune hemolytic anemia caused by cold agglutinins in a young pregnant woman. *J Matern Fetal Neonatal Med* 2006;19(4):251-253.
100. Cunningham FG, Lindheimer MD. Hypertension in pregnancy. *N Engl J Med* 1992;326(14):927-932.
101. Weiner CP. The clinical spectrum of preeclampsia. *Am J Kidney Dis* 1987;9(4):312-316.
102. Cunningham FG, Pritchard JA. Hematologic considerations of pregnancy-induced hypertension. *Semin Perinatol* 1978;2(1):29-38.
103. Inglis TC, Stuart J, George AJ, Davies AJ. Haemostatic and rheological changes in normal pregnancy and pre-eclampsia. *Br J Haematol* 1982;50(3):461-465.
104. Haram K, Svendsen E, Abildgaard U. The HELLP syndrome: clinical issues and management. A review. *BMC Pregnancy Childbirth* 2009;9:8.
105. Rath W, Faridi A, Dudenhausen JW. HELLP syndrome. *J Perinat Med* 2000;28(4):249-260.
106. Weiner CP. Thrombotic microangiopathy in pregnancy and the postpartum period. *Semin Hematol* 1987;24(2):119-129.
107. Rakoczi I, Tallian F, Bagdany S, Gati I. Platelet life-span in normal pregnancy and pre-eclampsia as determined by a non-radioisotope technique. *Thromb Res* 1979;15(3-4):553-556.
108. Weiner CP, Bonsib SM. Relationship between renal histology and plasma anti-thrombin III activity in women with early onset preeclampsia. *Am J Perinatol* 1990;7(2):139-143.
109. Weiner CP, Brandt J. Plasma antithrombin III activity: an aid in the diagnosis of preeclampsia-eclampsia. *Am J Obstet Gynecol* 1982;142(3):275-281.
110. Manten GT, Sikkema JM, Franx A, et al. Increased high molecular weight fibrinogen in pre-eclampsia. *Thromb Res* 2003;111(3):143-147.
111. Vassalli P, McCluskey RT. The coagulation process and glomerular disease. *Am J Med* 1965;39:179-183.
112. Arias F, Mancilla-Jimenez R. Hepatic fibrinogen deposits in pre-eclampsia. Immunofluorescent evidence. *N Engl J Med* 1976;295(11):578-582.
113. Fournie A, Monrozies M, Pontonnier G, Boneu B, Bierme R. Factor VIII complex in normal pregnancy, pre-eclampsia and fetal growth retardation. *Br J Obstet Gynaecol* 1981;88(3):250-254.

114. Calvin S, Corrigan J, Weinstein L, Jeter M. Factor VIII: von Willebrand factor patterns in the plasma of patients with pre-eclampsia. *Am J Perinatol* 1988;5(1):29-32.
115. Witsenburg CP, Rosendaal FR, Middeldorp JM, Van der Meer FJ, Scherjon SA. Factor VIII levels and the risk of pre-eclampsia, HELLP syndrome, pregnancy related hypertension and severe intrauterine growth retardation. *Thromb Res* 2005;115(5):387-392.
116. Bakker WW, Henning RH, van Son WJ, et al. Vascular contraction and pre-eclampsia: downregulation of the angiotensin receptor 1 by hemopexin in vitro. *Hypertension* 2009;53(6):959-964.
117. Sharma D, Singh A, Trivedi SS, Bhattacharjee J. Role of endothelin and inflammatory cytokines in pre-eclampsia—a pilot North Indian study. *Am J Reprod Immunol* 2011;65(4):428-432.
118. Kraayenbrink AA, Dekker GA, van Kamp GJ, van Geijn HP. Endothelial vasoactive mediators in preeclampsia. *Am J Obstet Gynecol* 1993;169(1):160-165.
119. Blaauw J, Graaff R, van Pampus MG, et al. Changes in endothelial function precede the clinical disease in women in whom preeclampsia develops. *Hypertension* 2006;47(3):e14; author reply e14-e15.
120. Donker RB, Molema G, Faas MM, et al. Absence of in vivo generalized pro-inflammatory endothelial activation in severe, early-onset preeclampsia. *J Soc Gynecol Investig* 2005;12(7):518-528.
121. Liu HS, Chu TY, Yu MH, Chang YK, Ko CS, Chao CF. Thromboxane and prostacyclin in maternal and fetal circulation in pre-eclampsia. *Int J Gynaecol Obstet* 1998;63(1):1-6.
122. Sibai BM, Ramadan MK, Usta I, Salama M, Mercer BM, Friedman SA. Maternal morbidity and mortality in 442 pregnancies with hemolysis, elevated liver enzymes, and low platelets (HELLP syndrome). *Am J Obstet Gynecol* 1993;169(4):1000-1006.
123. Curtin WM, Weinstein L. A review of HELLP syndrome. *J Perinatol* 1999;19(2):138-143.
124. Wilke G, Rath W, Schutz E, Armstrong VW, Kuhn W. Haptoglobin as a sensitive marker of hemolysis in HELLP-syndrome. *Int J Gynaecol Obstet* 1992;39(1):29-34.
125. Lattuada A, Rossi E, Calzarossa C, Candolfi R, Mannucci PM. Mild to moderate reduction of a von Willebrand factor cleaving protease (ADAMTS-13) in pregnant women with HELLP microangiopathic syndrome. *Haematologica* 2003;88(9):1029-1034.
126. Ehsanipoor RM, Rajan P, Holcombe RF, Wing DA. Limitations of ADAMTS-13 activity level in diagnosing thrombotic thrombocytopenic purpura in pregnancy. *Clin Appl Thromb Hemost* 2009;15(5):585-587.
127. Keiser SD, Boyd KW, Rehberg JF, et al. A high LDH to AST ratio helps to differentiate pregnancy-associated thrombotic thrombocytopenic purpura (TTP) from HELLP syndrome. *J Matern Fetal Neonatal Med* 2011;25(7):1059-1063.
128. Saphier CJ, Repke JT. Hemolysis, elevated liver enzymes, and low platelets (HELLP) syndrome: a review of diagnosis and management. *Semin Perinatol* 1998;22(2):118-133.
129. van Pampus MG, Wolf H, Westenberg SM, van der Post JA, Bonsel GJ, Treffers PE. Maternal and perinatal outcome after expectant management of the HELLP syndrome compared with pre-eclampsia without HELLP syndrome. *Eur J Obstet Gynecol Reprod Biol* 1998;76(1):31-36.
130. Helou J, Nakhle S, Shoenfeld S, Nasseir T, Shalev E. Postpartum thrombotic thrombocytopenic purpura: report of a case and review of the literature. *Obstet Gynecol Surv* 1994;49(11):785-789.
131. Egerman RS, Witlin AG, Friedman SA, Sibai BM. Thrombotic thrombocytopenic purpura and hemolytic uremic syndrome in pregnancy: review of 11 cases. *Am J Obstet Gynecol* 1996;175(4 pt 1):950-956.
132. Ezra Y, Rose M, Eldor A. Therapy and prevention of thrombotic thrombocytopenic purpura during pregnancy: a clinical study of 16 pregnancies. *Am J Hematol* 1996;51(1):1-6.
133. Rose M, Rowe JM, Eldor A. The changing course of thrombotic thrombocytopenic purpura and modern therapy. *Blood Rev* 1993;7(2):94-103.
134. Scully M, Starke R, Lee R, Mackie I, Machin S, Cohen H. Successful management of pregnancy in women with a history of thrombotic thrombocytopenic purpura. *Blood Coagul Fibrinolysis* 2006;17(6):459-463.
135. Alter BP, Kumar M, Lockhart LL, Sprinz PG, Rowe TF. Pregnancy in bone marrow failure syndromes: Diamond-Blackfan anaemia and Shwachman-Diamond syndrome. *Br J Haematol* 1999;107(1):49-54.

136. Tichelli A, Socie G, Marsh J, et al. Outcome of pregnancy and disease course among women with aplastic anemia treated with immunosuppression. *Ann Intern Med* 2002;137(3):164-172.
137. Faivre L, Meerpohl J, Da CL, et al. High-risk pregnancies in Diamond-Blackfan anemia: a survey of 64 pregnancies from the French and German registries. *Haematologica* 2006;91(4):530-533.
138. Kwon JY, Lee Y, Shin JC, Lee JW, Rha JG, Kim SP. Supportive management of pregnancy-associated aplastic anemia. *Int J Gynaecol Obstet* 2006;95(2): 115-120.
139. Choudhry VP, Gupta S, Gupta M, Kashyap R, Saxena R. Pregnancy associated aplastic anemia—a series of 10 cases with review of literature. *Hematology* 2002;7(4):233-238.
140. Choudry MA, Moffett BK, Laber DA. Pure red-cell aplasia secondary to pregnancy, characterization of a syndrome. *Ann Hematol* 2007;86(4):233-237.
141. Kashyap R, Pradhan M. Maternal and fetal outcome in pregnancy-associated pure red cell aplasia. *J Obstet Gynaecol* 2010;30(7):733-734.
142. Miller AC, Rashid RM. Three episodes of acquired pure red cell aplasia restricted to pregnancy. *J Perinat Med* 2008;36(3):270-271.
143. Barton JR, Shaver DC, Sibai BM. Successive pregnancies complicated by idiopathic sideroblastic anemia. *Am J Obstet Gynecol* 1992;166(2): 576-577.
144. Jackson N, Hamizah I. Sideroblastic anemia recurring during two pregnancies. *Int J Hematol* 1996;65(1):85-88.
145. Impey L, Greenwood C, Taylor A, Redman C, Wainscoat J. Recurrent acquired sideroblastic anemia in a twin pregnancy. *J Matern Fetal Med* 2000;9(4): 248-249.
146. Natelson EA. Pregnancy-induced pancytopenia with cellular bone marrow: distinctive hematologic features. *Am J Med Sci* 2006;332(4):205-207.
147. Swaim LS, Perriatt S, Andres RL, Paradissis J, Watson MN. Clinical utility of routine postpartum hemoglobin determinations. *Am J Perinatol* 1999;16(7):333-337.
148. Sheiner E, Shoham-Vardi I, Silberstein T, Hallak M, Katz M, Mazor M. Failed vacuum extraction. Maternal risk factors and pregnancy outcome. *J Reprod Med* 2001;46(9):819-824.
149. Hoveyda F, MacKenzie IZ. Secondary postpartum haemorrhage: incidence, morbidity and current management. *BJOG* 2001;108(9):927-930.
150. Naylor CS, Steele L, Hsi R, Margolin M, Goldfinger D. Cefotetan-induced hemolysis associated with antibiotic prophylaxis for cesarean delivery. *Am J Obstet Gynecol* 2000;182(6):1427-1428.
151. Garratty G, Leger RM, Arndt PA. Severe immune hemolytic anemia associated with prophylactic use of cefotetan in obstetric and gynecologic procedures. *Am J Obstet Gynecol* 1999;181(1):103-104.
152. Kotto-Kome AC, Calhoun DA, Montenegro R, Sosa R, Maldonado L, Christensen RD. Effect of administering recombinant erythropoietin to women with postpartum anemia: a meta-analysis. *J Perinatol* 2004;24(1):11-15.
153. Armand-Ugon R, Cheong T, Matapandewu G, et al. Efficacy of intravenous iron for treating postpartum anemia in low-resource African countries: a pilot study in Malawi. *J Womens Health* 2011;20(1):123-127.
154. Bhandal N, Russell R. Intravenous versus oral iron therapy for postpartum anaemia. *BJOG* 2006;113(11):1248-1252.

Chapter 43 Anemias Unique to the Fetus and Neonate

> Table of Contents > Part IV - Disorders of Red Cells > Section 5 - Other Red Cell Disorders > Chapter 43 - Anemias Unique to the Fetus and Neonate

Chapter 43

Anemias Unique to the Fetus and Neonate

Robert D. Christensen

Robin K. Ohls

INTRODUCTION

The reference ranges used to define normal hematocrit, hemoglobin, erythrocyte count, and the erythrocyte indices, change considerably during fetal life as well as in the weeks after birth.^{1, 2} Consequently, the laboratory findings that define anemia in a fetus or neonate are highly dependent on the gestational and postnatal age. Once anemia is recognized in a fetus or neonate, the differential diagnosis used to seek for the cause is unique from that at all other ages. In this chapter we display the pertinent reference ranges and review the underlying differences in erythropoiesis, erythrocyte structure, function, and metabolism that make anemias in the fetus and neonate so unique.

ERYTHROPOIETIN BIOLOGY IN THE FETUS AND NEONATE

Erythropoietin has both erythropoietic effects and nonerythropoietic effects during human fetal and neonatal development (Table 43.1).^{3, 4} Although initially described by, and principally known for, its actions on erythroid progenitors, erythropoietin is also an important physiologic growth factor for fetal small intestinal villous enterocytes and neurons.^{4, 5, 6, 7}

Erythropoietin is a constituent of amniotic fluid, in concentrations of 25 to 40 mU/ml. A normal human fetus swallows 200 to 300 ml of amniotic fluid per kilogram body weight per day, and thus swallows 10 to 15 U of erythropoietin/kg/day.⁸ In humans, erythropoietin does not cross the placenta from maternal to fetal circulations, and it appears that the source of the erythropoietin in amniotic fluid is not the maternal circulation. In the second and third trimesters, amniotic fluid is largely derived from fetal urine, with minor constituents from fetal tracheal effluent and the placenta and fetal membranes. However, erythropoietin in amniotic fluid does not appear to come from fetal urine. The fetal kidney makes little erythropoietin before delivery, and the first-voided urine of neonates generally has no detectable erythropoietin.⁸ Studies using *in situ* hybridization and immunohistochemistry indicate that the source of erythropoietin in amniotic fluid is largely maternal: from mesenchymal and endothelial cells in the deciduae and from the amnion.⁸

Erythropoietin is present in human colostrum and breast milk in concentrations of 10 to 20 mU/ml.^{4, 5, 6, 7, 8, 9} Erythropoietin concentrations in mother's milk do not correlate with erythropoietin concentrations in her blood. In fact, over the first weeks of lactation, maternal serum erythropoietin concentrations fall, whereas milk erythropoietin concentrations increase, reaching the highest concentrations in women breast-feeding for a year or more. The source of erythropoietin in breast milk appears to be mammary gland epithelium.^{7, 8}

TABLE 43.1 ACTIONS OF ERYTHROPOIETIN IN THE HUMAN FETUS

Site of Erythropoietin Production	Mechanism of Erythropoietin Delivery to Target Cells	Actions at Target Cells
Hepatocyte/hepatic macrophages	Paracrine	Erythropoiesis/angiogenesis
Glia	Paracrine	Neural migration
Glia	Paracrine	Neural protection from hypoxia
Decidua and amniotic membranes (amniotic fluid)	Swallowed by fetus	Small bowel villous development
Mammary epithelia (breast milk)	Swallowed by neonate	Small bowel villous development

Erythropoietin in human amniotic fluid, colostrum, and breast milk is relatively protected from proteolytic digestion in the fetal and neonatal gastrointestinal tract.⁸ Rather than being absorbed from the gastrointestinal track into the blood, the erythropoietin swallowed by the fetus and neonate binds to erythropoietin receptors on the luminal surface of villous enterocytes, where it serves topically as a growth and development factor. Indeed, experimental animals artificially fed formulas devoid of erythropoietin have retarded villous development, a condition that can be remedied by enteral recombinant erythropoietin and blocked by antierythropoietin antibody.^{4, 5, 6, 7, 8, 9}

Erythropoietin is produced by cells in the developing central nervous system and is present in relatively high concentrations in fetal cerebrospinal fluid (CSF).^{10, 11, 12, 13, 14, 15} Among newborn infants, the highest concentrations of erythropoietin in the CSF are seen in the most premature neonates, and by several years of age CSF erythropoietin concentrations are generally below 1 mU/ml.⁵ Erythropoietin receptors are expressed on human fetal neurons,^{10, 11, 12, 13, 14, 15} and at least small quantities of recombinant erythropoietin, administered intravenously, cross the blood-brain barrier and appear in the CSF fluid.¹⁶ Erythropoietin in the central nervous system is a neuroprotectant from hypoxia. Erythropoietin production increases rapidly in the brain during hypoxia, and when erythropoietin binds to receptors on

neurons, antiapoptotic activity is induced. Cell culture systems and whole animal models illustrate a marked neuroprotective effect of erythropoietin.¹⁷ The clinical utility of recombinant erythropoietin as a neuroprotectant is a topic of recent and ongoing studies.^{18, 19, 20, 21, 22}

The liver is the primary site of erythropoietin production in the fetus. The kidney does not become the primary site until several months after birth. In the human fetus, the kidney produces about 5% of the total erythropoietin during mid-gestation. The developmental mechanisms regulating the switch in erythropoietin production from the liver to the kidney are not completely known but may involve developmental expression of transcription activators such as hypoxia inducible factor and hepatic nuclear factor 4, or developmental methylation of promoter and enhancer regions. Alternatively, the switch might involve the GATA transcription factors, particularly GATA-2 and GATA-3, which are negative regulators of erythropoietin gene transcription.

Erythropoietin ameliorates experimental damage to the placenta and fetal liver induced by lipopolysaccharide.²³ Elevated concentrations of erythropoietin in fetal blood and/or amniotic fluid may indicate fetal hypoxia, and although erythropoietin may have a protective role for some fetal cells, such as neurons, placental, hepatic, and intestinal villous cells, it might also be a marker for poor neurodevelopmental outcome on the basis of severe or chronic hypoxia.^{23, 24, 25, 26}

NORMAL ERYTHROCYTE VALUES DURING HUMAN FETAL DEVELOPMENT

Normal ranges for erythrocyte values of the human fetus and neonate are generally not available. This is because blood is not drawn on healthy neonates to establish such ranges. Instead, reference ranges are used, consisting of the 5th to the 95th

P.1019

percentile values compiled from laboratory tests performed on neonates who were thought to have minimal pathology relevant to the laboratory test, or pathology unlikely to affect the test results significantly. The premise on which the reference range concept is based is that these values approximate normal ranges, although they were admittedly obtained for a clinical reason and not from healthy volunteers.^{1, 2}

Circulating erythrocytes in the mid- and third trimester fetus have features reminiscent of what is called "stress erythropoiesis in adults. These features include marked anisocytosis, poikilocytosis, macrocytosis, and a relatively high percentage of nucleated erythrocytes. Marrow cellularity in the fetus is relatively high, and because the available marrow space is fully cellular, the fetus and newborn infant have little marrow reserve on which to call. Erythroid precursors account for 30% to 65% and myeloid cells 45% to 75% of nucleated marrow cells at birth.²⁷ The myeloid to erythroid ratio at birth is approximately 1.5:1. Marrow cellularity decreases after birth, attaining a density that is normal for adults by 1 to 3 months.²⁸ Initially, this decrease in cellularity results from a rapid decline in red cell precursors. At 1 week of age, erythroid elements account for only 8% to 12% of nucleated cells, and the myeloid to erythroid ratio exceeds 6:1. The normal adult proportion of myeloid to erythroid precursors is not established until the third month. Both the percentage and absolute number of lymphocytes increase during the first 2 months, so that by 3 months of age, they constitute nearly 50% of marrow nucleated cells. Differential counts of bone marrow aspirates from preterm infants are the same as those for term infants.²⁹

Normal reference ranges for the hemoglobin concentration on the day of birth, at gestational ages ranging from 22 to 42 weeks, are shown in Figure 43.1. The reference ranges gradually increase during this period in utero, and there are no differences between genders.³⁰ After birth, the anatomic site of blood sampling to measure the hemoglobin and hematocrit influences the test result.^{1, 2, 31} Perfusion of small vessels in the extremities can be relatively poor, particularly during hypotension or skin cooling, resulting in increased transudation of fluid and hemoconcentration. Consequently, the hemoglobin concentration and packed cell volume of capillary blood are 5% to 10% higher than those of venous blood.² The difference between capillary and venous values is greatest at birth but disappears by 3 months of age. The discrepancy is greatest in preterm infants and in those with hypotension, hypovolemia, and acidosis.³² Differences can be minimized, but not fully resolved, by warming the extremity before sampling, obtaining freely flowing blood, and discarding the first few drops. The interpretation of serial observations necessitates the consistent use of one site of blood sampling.

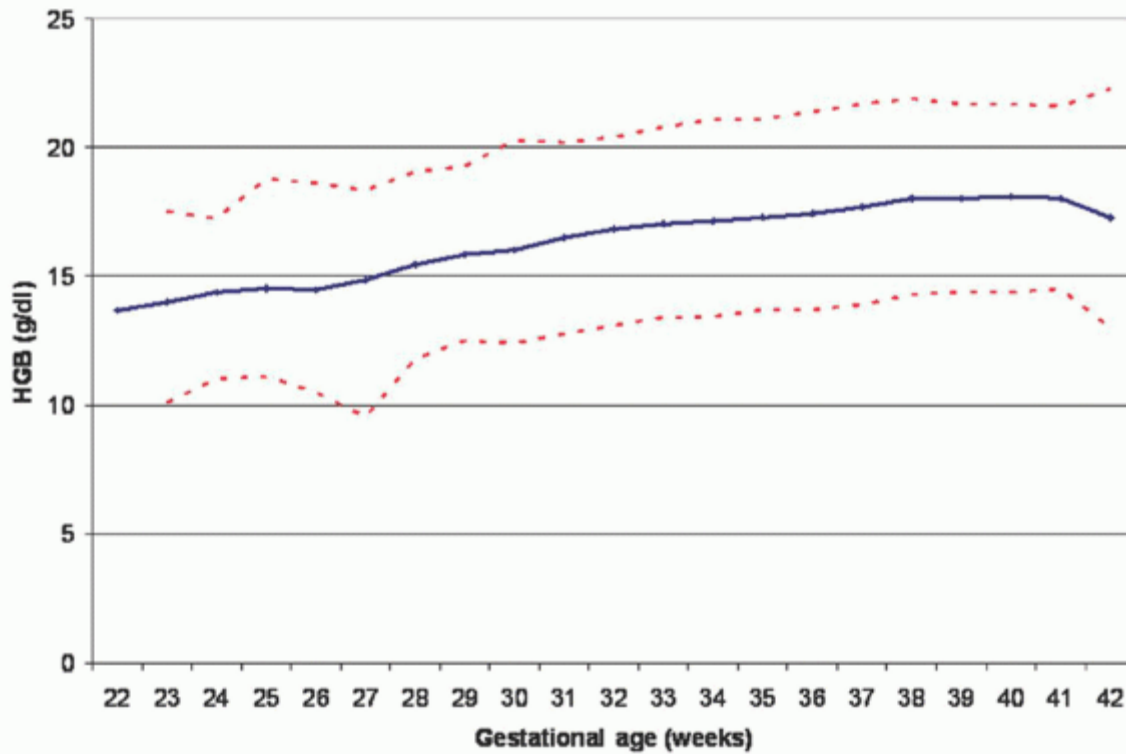

FIGURE 43.1. Reference ranges for blood hemoglobin concentration at birth. Values are shown from 24,416 subjects after 22 to 42 weeks gestation. The solid line shows the mean value and the dashed lines show the 5% and the 95% reference range. (From Jopling et al. Reference ranges for hematocrit and blood hemoglobin concentration during the neonatal period; data from a multihospital healthcare system. *Pediatrics* 2009;123:e333-e337.)

Hemoglobin concentrations increase during the first hours after birth attributable in part to a shift of fluid from the intravascular compartment but also to the transfusion of fetal red cells from the placenta at the time of birth.² After the first day, the reference ranges for hemoglobin and hematocrit gradually decrease, as shown in Figure 43.2 (term and late preterm neonate) and Figure 43.3 (preterm neonates).

The mean corpuscular volume (MCV) at birth is highly dependent on gestational age, as shown in Figure 43.4.³³ Values below the 5th percentile are seen in neonates with α -thalassemia trait or hereditary spherocytosis.^{34, 35, 36} A low MCV at birth due to fetal iron deficiency is less common, but this can occur with chronic fetomaternal hemorrhage or twin-to-twin transfusion syndrome. The mean corpuscular hemoglobin (MCH), like the MCV, is high at birth, by adult standards, and is highly dependent on gestational age. In contrast, the mean corpuscular hemoglobin concentration (MCHC) does not change with gestational age and should be in the range 33 to 35 g/dl in all neonates whether born prematurely or at term. An MCHC value >36 to 36.5 g/dl can suggest hereditary spherocytosis, particularly if accompanied by an MCV below the reference range for gestational age.^{35, 36}

Reticulocytosis and normoblastosis reflect the accelerated nature of fetal erythropoiesis. Reticulocyte counts at birth are approximately 5%, with a range of 4% to 7%.² Counts in preterm infants are slightly higher, averaging 6% to 10%. Reticulocytes remain elevated for the first 1 to 2 days of life, then drop abruptly to 0% to 1%.

Nucleated red blood cells (NRBC) are seen regularly on blood smears during the first day of life. The reference ranges for NRBC, according to gestational age at birth, are shown in Figure 43.5.³⁷ Elevations in NRBC in preterm infants correlate with adverse outcomes of intraventricular hemorrhage (IVH) and periventricular leukomalacia.^{37, 38} Elevations in NRBC in term infants correlate with hypoxic ischemic encephalopathy and with adverse neurodevelopmental outcomes.^{37, 38}

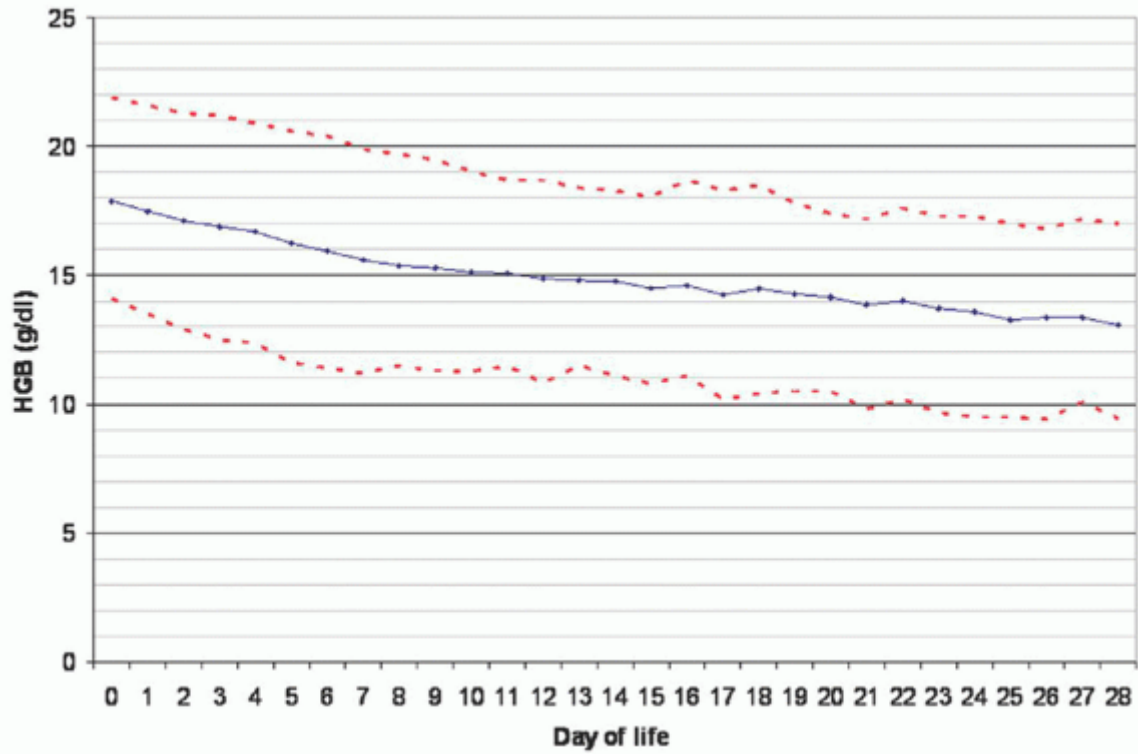

FIGURE 43.2. Reference ranges for blood hemoglobin concentration of term and late preterm neonates during the first month after birth. The solid line shows the mean value and the dashed lines show the 5% and the 95% reference range. (From Jopling et al. Reference ranges for hematocrit and blood hemoglobin concentration during the neonatal period; data from a multihospital healthcare system. *Pediatrics* 2009;123:e333-e337.)

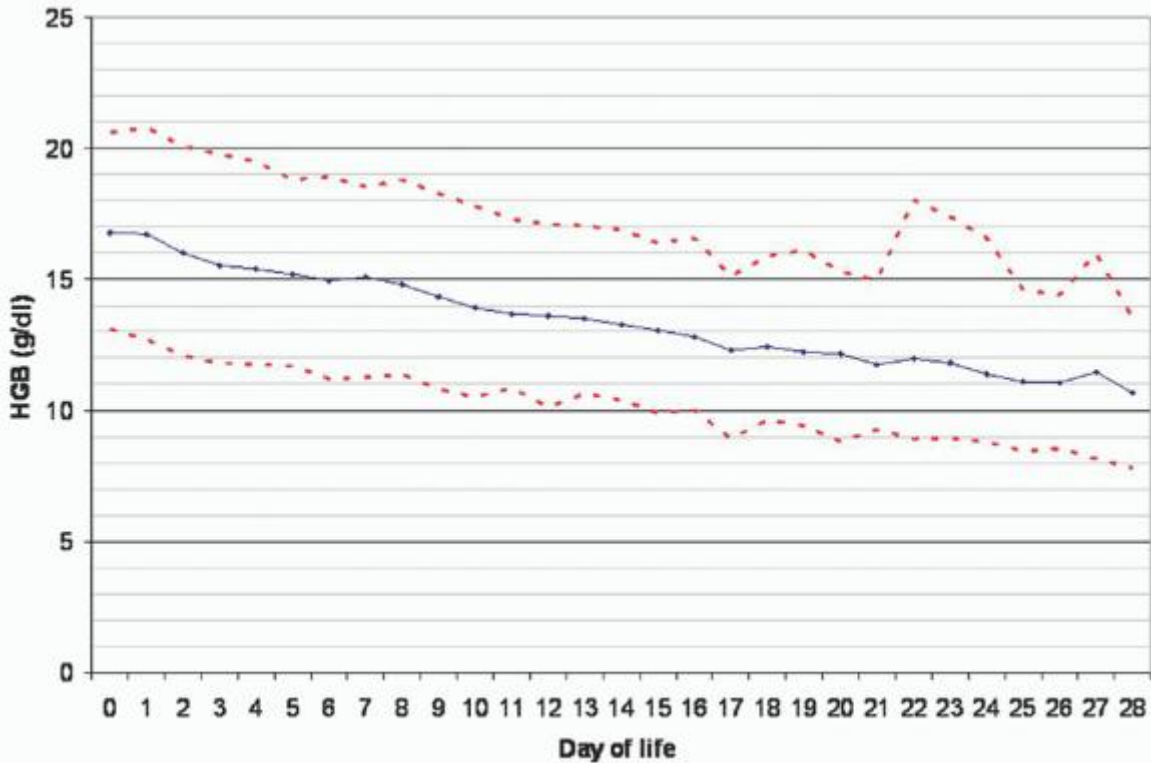

FIGURE 43.3. Reference ranges for blood hemoglobin concentration of neonates 29 to 34 weeks gestation during the first

month after birth. The solid line shows the mean value and the dashed lines show the 5% and the 95% reference range. (From Jopling et al. Reference ranges for hematocrit and blood hemoglobin concentration during the neonatal period; data from a multihospital healthcare system. *Pediatrics* 2009;123:e333-e337.)

Red cell morphology in the newly born preterm or term neonate is characterized by macrocytosis and poikilocytosis. Target cells and irregularly shaped cells are particularly prominent. A high proportion of stomatocytes is noted when viewed by phase contrast microscopy.³⁹ Similarly a high proportion of siderocytes (3.16% vs. normal male adult mean of 0.09%) are seen.⁴⁰ Differential staining of red cells for fetal hemoglobin (HbF) provides a demonstration of the switch in hemoglobin synthesis that precedes birth: the younger macrocytes contain a minimal amount of HbF, whereas the smaller older cells are rich in HbF.⁴¹

Variations in red cell size and shape are somewhat greater than those observed in term infants, and cytoplasmic vacuoles are evident in nearly one-half of all cells when viewed by using interference-contrast microscopy. Red cell survival is shorter in preterm than in term infants. For infants who undergo exchange transfusion or multiple transfusions, both erythropoietin concentrations and reticulocyte counts are lower at any given hemoglobin concentration.⁴² It had been assumed that oxygen delivery is decreased in newborns because of the presence of a high-affinity hemoglobin, but a leftward shift in the hemoglobin-oxygen dissociation curve due to high levels of HbF might actually better maintain oxygen delivery during episodes of severe hypoxemia.⁴³

The capacity of a fetus or neonate to deliver oxygen to tissues is better estimated by the circulating red blood cell volume than by the hematocrit or hemoglobin concentration. However, measuring the circulating red blood cell volume in a fetus or neonate is particularly difficult. Therefore, either the hematocrit or the hemoglobin is often used in making transfusion decisions. Mock

P.1021

et al. used a nonradioactive method, based on in vivo dilution of biotinylated RBC enumerated by flow cytometry, to estimate the correlation between hematocrit and circulating RBC volume in infants below 1,300 grams, between 7 and 79 days of life. They found that venous hematocrit values correlated highly with the circulating erythrocyte volume ($r = 0.907$; $p < 0.0001$).⁴⁴

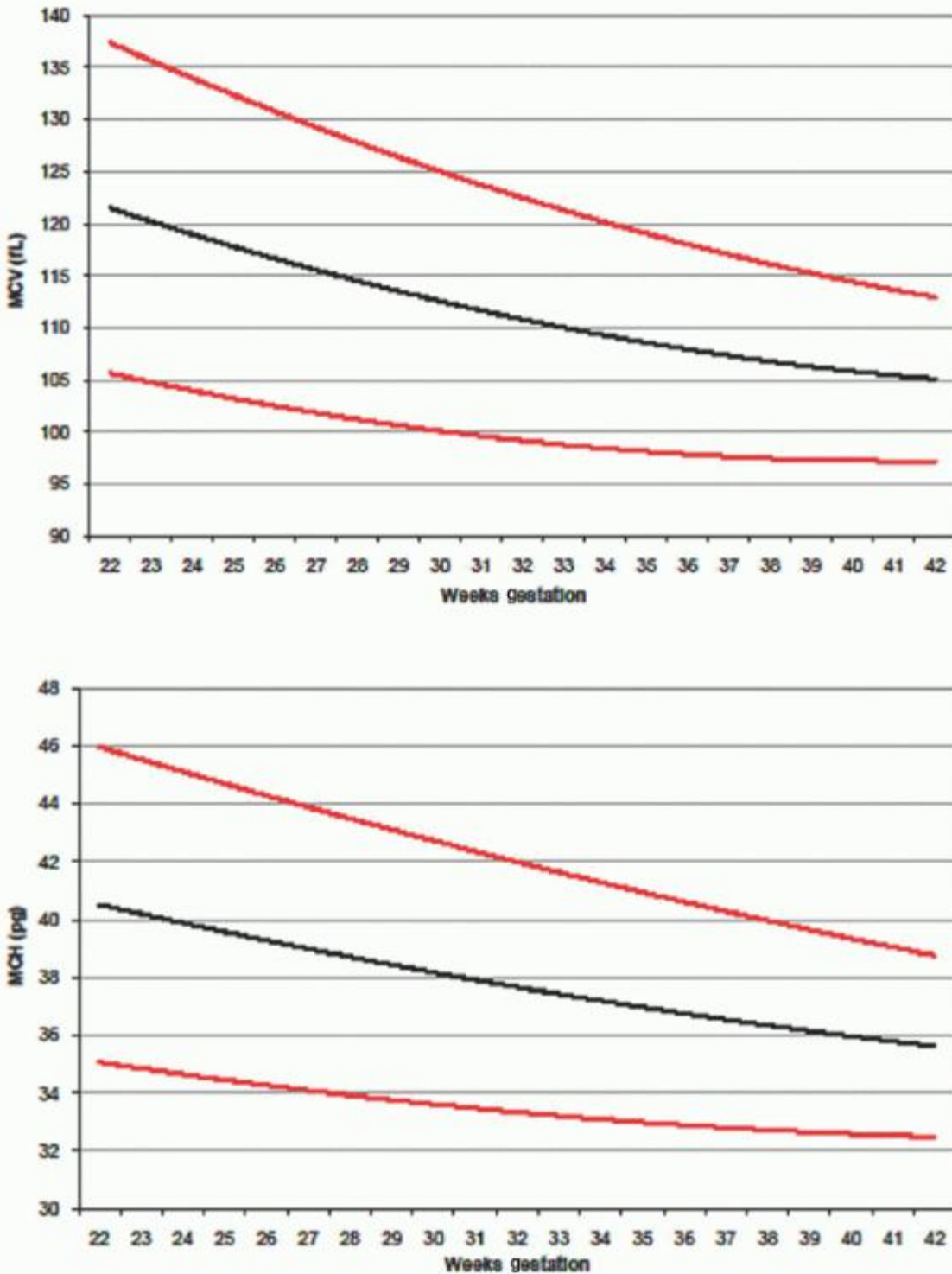

FIGURE 43.4. Reference ranges for mean corpuscular volume (MCV) upper panel, and mean corpuscular hemoglobin (MCH) on the day of birth. Values are shown from subjects after 22 to 42 weeks gestation. The solid line shows the mean value and the dashed lines show the 5% and the 95% reference range. (From Christensen et al. The erythrocyte indices of neonates, defined using data from over 12,000 patients in a multihospital healthcare system. *J Perinatol* 2008;28:24-28.)

Neonates have a shorter red cell survival than do children and adults.⁴⁵ The life span of red cells from term infants is estimated to be 60 to 80 days with use of the ⁵¹Cr method and 45 to 70 days using methods involving ⁵⁹Fe.⁴⁵ Fetal studies using [¹⁴C] cyanatelabeled red cells in sheep revealed an average red cell life span of 63.6 ± 5.8 days.⁴⁶ The mean red cell life span increased linearly from 35 to 107 days as the fetal age increased from 97 days (midgestation) to 136 days (term).

Neonatal red cells transfused into adults have a similarly short survival,⁴⁷ indicating that factors intrinsic to the newborn red cell are responsible. Also, adult red cells survive normally in newborn recipients.⁴⁸ The life span is not parametrically distributed, in that most cells are destroyed before the mean survival is reached. Shortened red cell survival as well as demands imposed by an expanding red cell mass account for erythropoietic rates at birth that are three to five times higher than those of normal adults.

The abrupt transition from the uterus to an oxygen-rich environment triggers responses that have a profound effect on erythropoiesis. During the first 2 months of life, the infant experiences both the highest and lowest hemoglobin concentrations occurring at any time in development. Although quite variable, erythropoietin levels at birth usually are well above the normal adult range. Erythropoietin levels fall in the immediate postnatal period, with a half-life of 2.6 ± 0.5 hours in infants with polycythemia and 3.7 ± 0.9 hours in infants born to mothers with preeclampsia.⁴⁹ By 24 hours, the erythropoietin value is below the normal adult range, where it remains throughout the first month. The decrease in erythropoietin is followed by a decline in the number of bone marrow precursors⁵⁰ and a fall in the reticulocyte count.

The combination of shortened cell survival, decreased production, and growth-related expansion of the blood volume is responsible for a progressive fall of the hemoglobin concentration

P.1022

to a mean of approximately 11 g/dl at 2 months of age.⁵¹ The lower range of normal for infants of this age is approximately 9 g/dl. This nadir is called physiologic anemia, because it is not associated with apparent distress and is not prevented with nutritional supplements. Stabilization of the hemoglobin concentration is heralded by an increase in reticulocytes at 4 to 8 weeks.⁵⁰ Thereafter, the hemoglobin concentration rises to a mean level of 12.5 g/dl, where it remains throughout infancy and early childhood.

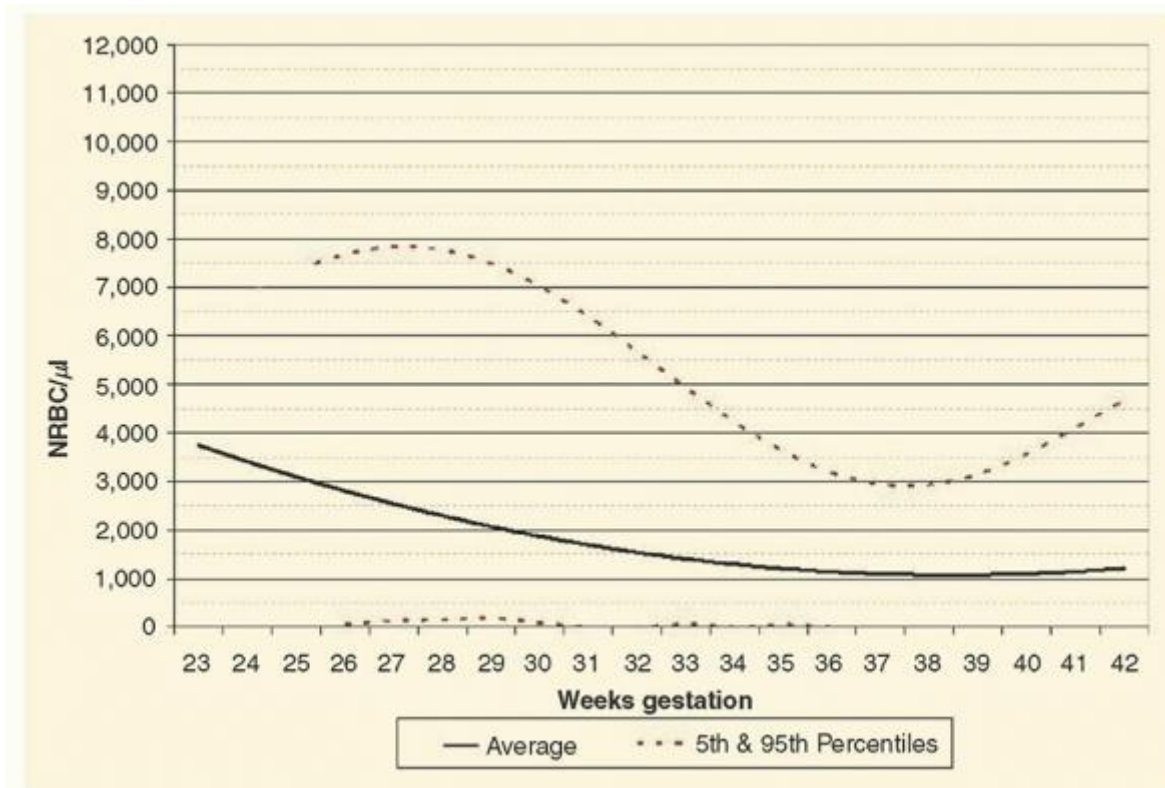

FIGURE 43.5. Reference ranges for blood concentrations of nucleated erythrocytes on the day of birth. Values are shown from subjects after 23 to 42 weeks gestation. The solid line shows the mean value and the dashed lines show the 5% and the 95% referenc range. (From Christensen et al. Neonatal reference ranges for blood concentrations of nucleated red blood cells. *Neonatology* 2010;99:289-294.)

At term, the placenta and umbilical cord contain 75 to 125 ml of blood, or approximately one fourth to one third of the fetal blood volume. The umbilical arteries constrict shortly after birth but the umbilical vein remains dilated, and blood flows in the direction of gravity. Infants held below the level of the placenta can receive half of the placental blood volume

(30 to 50 ml) in 1 minute. Conversely, infants held above the placenta can lose 20 to 30 ml of blood back into the placenta per minute.⁵² The blood volume of infants with early cord clamping averages 72 ml/kg, whereas the volume of infants with delayed cord clamping averages 93 ml/kg. Linderkamp et al. compared postnatal alterations in blood viscosity, hematocrit, plasma viscosity, red cell aggregation, and red cell deformability in the first 5 days in full-term neonates with early (less than 10 seconds) and late (3 minutes) cord clamping.⁵³ The residual placental blood volume decreased from 52 ± 8 ml/kg of neonatal body weight after early cord clamping to 15 ± 4 ml/kg after late cord clamping. The neonatal blood volume was 50% higher in the late cord-clamped infants than in the early cord-clamped infants.

It is possible to promote placental transfer of blood to preterm infants by delaying the clamping of the umbilical cord for 30 seconds. In fact transfer of about 10 ml/kg body wt can be expected using this method.⁵⁴ In a randomized trial by Mercer et al., this maneuver of delayed cord clamping among infants <1,500 grams birth weight resulted in less IVH and less late-onset sepsis.⁵⁵ An alternative approach involves "milking" or "stripping" of the umbilical cord after delivery, while the placenta is still attached to the uterus. This maneuver moves fetal blood toward the fetus before the umbilical cord is clamped. Delayed clamping and cord stripping are roughly equivalent means of providing a small transfusion before birth of a very low birth weight (VLBW) infant, thereby reducing the odds that a donor blood transfusion will be needed during the first days after birth when phlebotomies for laboratory tests commonly result in transfusions to replace the rapidly depleted red cell mass.^{56, 57, 58}

FETAL AND NEONATAL ERYTHROCYTE MEMBRANE AND METABOLISM

The erythrocyte membranes of neonates differ slightly from those of adults.⁵⁹ The percentage of spectrin dimers and the spectrin tryptic peptide patterns are the same as in adult cells⁶⁰ but neonatal cells have more immunoreactive myosin.⁶¹ The quantity and distribution of lipids differ in several respects from adult red cells. Total lipid, phospholipid, and cholesterol are increased out of proportion to the surface area of newborn red cells.^{62, 63} Neonatal cells also exhibit increased endocytosis in response to membraneactive agents, suggesting that the membranes of neonatal cells are less stable and are capable of greater reorganization.⁵⁹

Antigen expression differs from that of adult cells. The A, B, S, and Lutheran antigens are present in decreased amounts. Replacement of the i antigen with its adult counterpart I requires its conversion from a linear poly lactosamine to a branched poly lactosamine.⁵⁹ Reduced A and B antigenicity may result in part from decreased branching and increased stimulation of glycoproteins on neonatal red cells.⁶⁴

At term, red cell deformability and viscoelastic properties are normal.⁶⁵ Similarly, osmotic fragility of erythrocyte from preterm neonates is similar to or even slightly less fragile than erythrocytes of term neonates. However, preterm neonates may have a small subpopulation of cells that are more susceptible to hemolysis, giving preterm infants a greater tendency to develop hemolytic jaundice.⁶⁶

Increased concentrations of certain erythrocyte enzymes in neonates can be explained by the young mean age of red cells. The increase in glycolytic enzymes is comparable in magnitude to that observed in high-reticulocyte adult blood.^{67, 68} Increased glycolytic enzyme activity, in turn, is responsible for increased consumption of glucose and galactose and increased levels of adenosine triphosphate (ATP).⁶⁹ Unique metabolic characteristics of neonatal erythrocytes are summarized in Table 43.2.

P.1023

TABLE 43.2 METABOLIC CHARACTERISTICS OF FETAL/NEONATAL RED BLOOD CELLS

Metabolic characteristics explained by young mean cell age

Increased enzyme activity

Hexokinase

Aldolase

Triosephosphate isomerase

Phosphoglycerate mutase

Pyruvate kinase

Lactate dehydrogenase
 Glucose-6-phosphate dehydrogenase
 6-Phosphogluconate dehydrogenase
 Glutathione reductase
 Glyoxalase I and II
 Galactokinase
 Galactose-1-phosphate uridyl transferase
 Increased glucose and galactose consumption
 Increased levels of ATP
 Metabolic characteristics distinctive for neonatal red cells
 Embden-Meyerhof pathway
 Increased activity of phosphoglycerate kinase, enolase, glucose phosphate isomerase, and glyceraldehyde-3-phosphate dehydrogenase
 Decreased activity of phosphofructokinase
 2,3-Diphosphoglycerate instability
 Pentose phosphate pathway and glutathione metabolism
 Decreased glutathione peroxidase and glutathione synthetase
 Glutathione instability
 ATP and phosphate metabolism
 ATP instability
 Decreased phosphate uptake, slower incorporation of phosphate into ATP and 2,3-diphosphoglycerate
 Nonglycolytic enzymes
 Decreased enzyme activity
 Carbonic anhydrase
 Catalase
 Cholinesterase
 Adenylate kinase
 Phosphoribosyl transferase
 Cytochrome *b*₅ reductase
 ATP, adenosine triphosphate.

The activities of four enzymes in the Embden-Meyerhof pathway—phosphoglycerate kinase, enolase, glucose phosphate isomerase, and glyceraldehyde-3-phosphate dehydrogenase—are increased out of proportion to cell age.^{70, 71} The activity of phosphofructokinase, a rate-controlling enzyme in glycolysis, is only 40% to 70% of that in adult red cells of comparable age.^{68, 69, 71} Low levels of phosphofructokinase may produce a block in glycolysis, resulting in the accumulation of glucose-6-phosphate and fructose-6-phosphate and a decrease in the amounts of 2,3-diphosphoglycerate (2,3-DPG) and phosphoenolpyruvate.⁷¹ Decreased activity of phosphofructokinase is probably explained by accelerated decay of a less stable fetal isoenzyme.⁷² Neonatal red cells contain a homotetramer of liver-type phosphofructokinase subunits rather than the heterotetramer of liver and muscle subunits present in adult cells.⁷³ Differences in the relative proportions of isoenzymes have also been described for hexokinase and enolase.⁷⁴ The concentration of 2,3-DPG falls rapidly during short periods of incubation,⁶⁹ apparently because of accelerated breakdown. Preterm infants have lower 2,3-DPG

concentrations than term infants. These concentrations gradually increase with gestation.^{75, 76} Concentrations can be increased with the use of erythropoietin, thereby shifting the oxygen dissociation curve to the right.⁷⁷

The activities of two key enzymes of the pentose phosphate pathway, glucose-6-phosphate dehydrogenase and 6-phosphogluconate dehydrogenase, are increased by virtue of a young mean red cell age.^{68, 69} The response of the pentose phosphate pathway to oxidant stimuli is normal, and the level of reduced glutathione is equal to or greater than that found in adults.⁷⁰ Despite this, newborn cells exhibit glutathione instability, increased Heinz body formation, and a propensity to increased methemoglobin generation, all indicative of greater susceptibility to oxidant-induced injury.⁶⁷ The basis for this oxidant vulnerability is not known. Although red cells of the newborn infant have low levels of activities of both glutathione peroxidase⁷⁸ and glutathione synthetase,⁷⁹ no apparent relationship exists between these deficiencies and oxidant vulnerability.⁸⁰ Other factors that have been implicated in attempts to explain metabolic differences include deficient catalase activity, decreased numbers of membrane sulfhydryl groups,⁸¹ greater residual membrane hemoglobin,⁸² and other plasma factors.^{83, 84} Studies evaluating the antioxidant capacity of preterm red cells and plasma from infants with respiratory distress syndrome reported no difference in activity between sick and well preterm infants, and antioxidant activity appeared intact. The study did not provide convincing evidence of oxidative damage and diminished antioxidant defenses in preterm infants with neonatal respiratory distress syndrome.⁸⁵

Although elevated at birth, the red cell ATP level falls rapidly during short periods of incubation. The uptake of labeled orthophosphate by cord blood cells is slower than that by adult cells, resulting in delayed incorporation of phosphate into ATP and 2,3-DPG.⁸⁶ This disturbance in energy metabolism has been held responsible for accelerated potassium loss during incubation. Neonatal erythrocytes have increased rates of endocytosis compared to adult erythrocytes; these rates gradually decrease to adult levels with prolonged incubation.⁸⁷ In septic neonates, ATP concentration in red blood cells was significantly lower than in neonates with respiratory distress syndrome and controls, whereas the 2,3-DPG concentration was increased.⁸⁸

The activity of a number of nonglycolytic enzymes differs in neonatal red cells compared to adult red cells. Carbonic anhydrase,⁸⁶ catalase,⁸⁹ acetylcholinesterase,⁹⁰ adenylate kinase,⁹⁰ hypoxanthine-guanine-phosphoribosyl transferase,⁹¹ and cytochrome b₅ reductase⁹² are all less active than in adult red cells. Differences in carbonic anhydrase activity have been exploited by using this enzyme to lyse selectively any contaminating maternal cells from samples of mixed fetal and maternal cells obtained for the prenatal diagnosis of hemoglobinopathies.⁹³ Reduced activity of cytochrome b₅ reductase, the enzyme responsible for methemoglobin reduction, contributes to the infant's vulnerability to methemoglobinemia. This enzyme exists in both soluble and membrane-bound forms. The membrane-bound form is the precursor enzyme that is posttranslationally processed to a smaller soluble form, probably by a calmodulin-dependent endogenous protease.⁹⁴ Neonatal red cells have membrane-bound cytochrome b₅ reductase activity comparable to that of adult cells but are limited in their ability to convert membrane-bound enzyme to the soluble form.

Cord blood contains HbF (α_2, γ_2), HbA (α_2, β_2), and HbA2 (α_2, δ_2), with HbF constituting the major fraction (50% to 85%) at term. Because of this, hemoglobinopathies involving β -chain synthesis, such as sickle cell disease and β -thalassemia, do not present in the neonatal period. The G- γ to A- γ ratio at birth is approximately 3:1, in contrast to a ratio of 2:3 in adults.⁹⁵

P.1024

HbA accounts for 15% to 40% of the hemoglobin at term and HbA2 is present in only trace amounts (mean, 0.3%), but increases slowly after birth, reaching the normal adult level (2% to 3%) by 5 months. The level of HbF at birth is influenced by a number of variables, the most significant of which is gestational age. Premature infants have more HbF and postmature infants less (Fig. 43.6).⁹⁵ Neonates who have survived chronic intrauterine hypoxia, such as occurs with maternal heart and lung disease, have higher levels of HbF. The switch from γ -chain synthesis to β -chain synthesis appears to be developmentally programmed. Neither intrauterine transfusion nor neonatal exchange transfusion affects the synthetic rates of β - and δ -chains.⁹⁶

HbF has an affinity for oxygen that is greater than that of HbA.⁹⁷ The oxygen tension at which the hemoglobin of cord blood is 50% saturated is 19 to 21 mm Hg, 6 to 8 mm Hg lower than that of the hemoglobin of normal adult blood. This shift to the left of the hemoglobin-oxygen dissociation curve results from poor binding of 2,3-DPG by HbF.⁹⁸ The position of the oxygen dissociation curve is determined by both the percentage of HbA and the red cell content of 2,3-DPG.⁹⁹ As the relative proportion of HbA increases, the oxygen dissociation curve shifts by approximately 4 to 6 months of age to a position that is normal for the adult (Fig. 43.7). The increased oxygen affinity of HbF confers a physiologic advantage to the fetus in facilitating the transfer of oxygen from mother to fetus.

HbF is resistant to alkali denaturation, and unlike HbA is not eluted from fixed blood smears immersed in an acid buffer.¹⁰⁰ This property permits the differential staining of HbF and HbA, a technique used to detect fetal cells in the maternal circulation.

FETAL AND NEONATAL ANEMIA DUE TO HEMOLYSIS

Bilirubin is effectively cleared from fetal blood by the placenta and is metabolized by the maternal liver.¹⁰¹ As a result, fetal hemolytic disease does not present with significant jaundice immediately at birth. However, after birth the products of heme catabolism must be processed by the neonate's liver, which is limited in its ability to metabolize bilirubin efficiently, in part because of a relative deficiency of the cytoplasmic acceptor protein ligandin, and in part because of decreased activity of uridine diphosphoglucuronyl transferase.¹⁰²

Causes of hemolytic disease in the newborn are noted in Table 43.3. Worldwide, isoimmunization caused by maternal-fetal blood group incompatibility is the most common cause of hemolytic anemia. Antigens in the ABO, MN, Rh, Kell, Duffy, and Vel systems are well developed on fetal red cells during early intrauterine life.¹⁰³ They are present in the fifth to seventh gestational week and remain constant through the remainder of intrauterine development. Other antigens, such as the Lutheran and XgA systems, develop more slowly but are present at birth, unlike Lewis antigens, which develop after birth. By 2 years of age, red cell and plasma antigens have developed a pattern that is seen throughout the remainder of life.¹⁰⁴

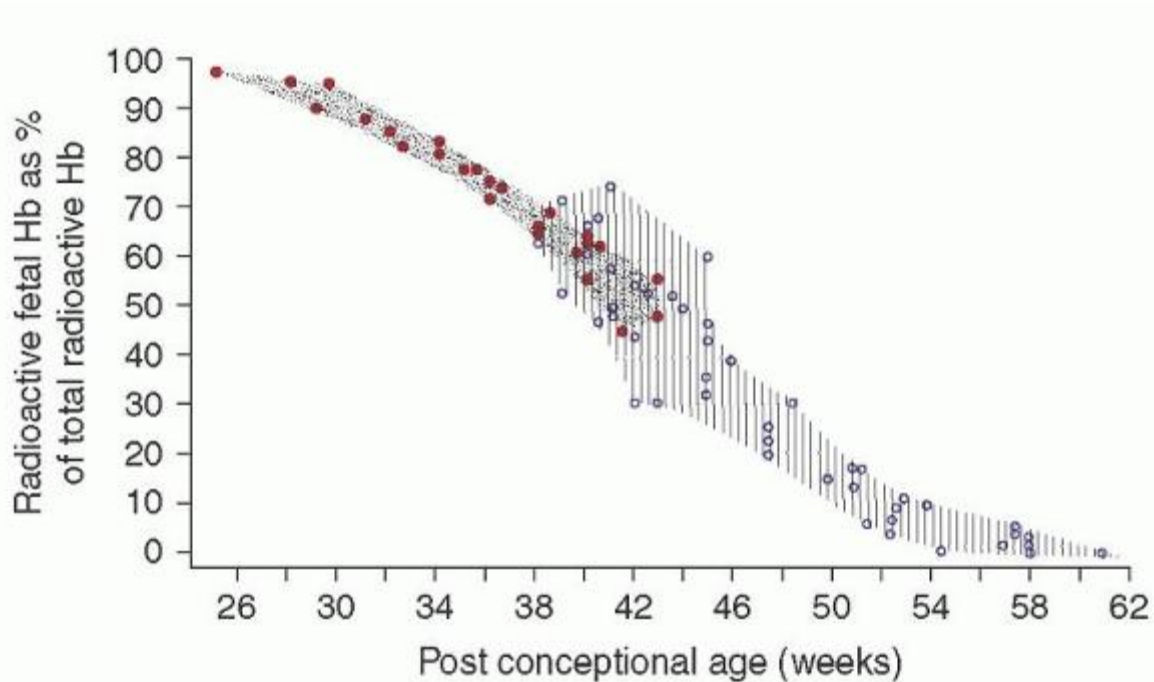

FIGURE 43.6. Decline in fetal hemoglobin synthesis as a function of gestational age. Solid dots represent cord blood samples from preterm infants, open circles are samples from term infants. (From Bard H. The postnatal decline of hemoglobin F synthesis in normal fullterm infants. *J Clin Invest* 1975;55:395-398, with permission.)

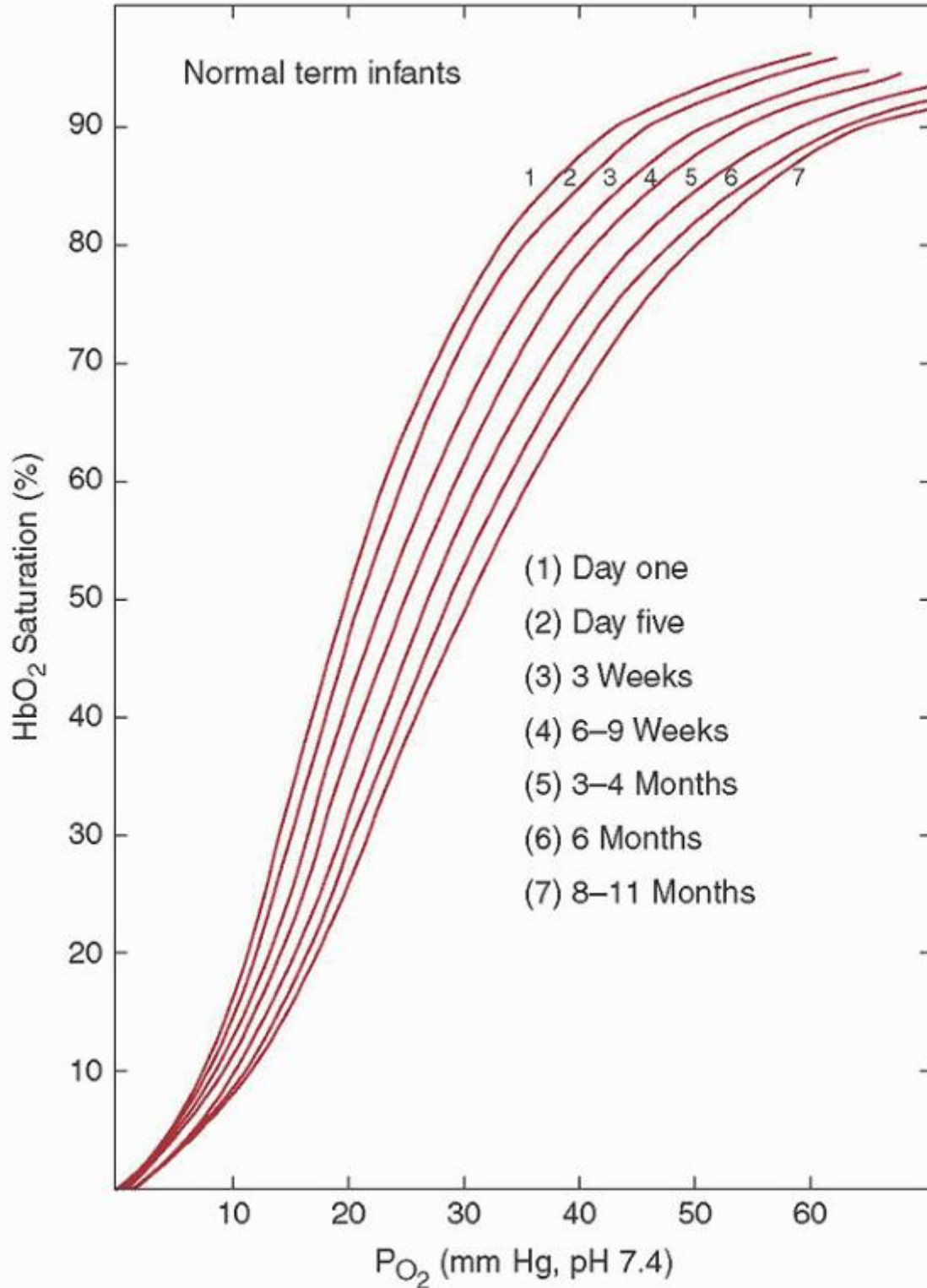

FIGURE 43.7. Oxygen dissociation curves of blood from term infants at different postnatal ages. (From Oski FA, Delivoria-Papadopoulos M. The red cell 2,3-diphosphoglycerate, and tissue oxygen release. *J Pediatr* 1970;77:941-956, with permission.)

Although A and B antigens are present early in utero, A and B isoagglutinin production occurs later during the second and third trimesters.¹⁰⁴ By 30 to 34 weeks gestation, about one half of all fetuses have some measurable anti-A or anti-B

antibodies. The fetal production of such antibodies is not related to maternal blood type, rather, intrauterine exposure to gram-negative organisms whose antigens are chemically related to those of blood groups A and B act as a potent stimulus for antibody development. Isoimmunization due to Rh or ABO incompatibility is the most common cause of hemolytic disease in the newborn period. ABO incompatibility represents a spectrum of hemolytic disease in newborns.

Fetuses with hemolytic anemia due to anti-Kell antibody have lower reticulocyte counts and total serum bilirubin levels than comparable anti-D anemic fetuses.¹⁰⁵ The level of hemolysis caused by anti-Kell antibodies is less than that caused by anti-D antibodies, but fetal erythropoiesis is blunted because Kell sensitization results in both suppression of fetal erythropoiesis and hemolysis. Anti-Kell antibodies cause fetal anemia by suppressing erythropoiesis at the level of erythroid progenitors.

P.1025

TABLE 43.3 CAUSES OF HEMOLYTIC DISEASE IN NEWBORNS

Immune-mediated

- Rh incompatibility (anti-D antibody)
- ABO, c, C, e, E, G incompatibility
- Minor blood group incompatibility:
 - Fya (Duffy), Kell group, Jka, MNS, Vw
- Drug-induced (penicillin, α -methyldopa, cephalosporins)
- Maternal autoimmune hemolytic anemia

Non-Immune mediated

Congenital erythrocyte enzyme defects

- Glucose-6-phosphate dehydrogenase deficiency
- Pyruvate kinase deficiency
- Hexokinase deficiency
- Glucose phosphate isomerase deficiency
- Pyrimidine 5' nucleotidase deficiency

Hereditary erythrocyte membrane disorders

- Spherocytosis
- Elliptocytosis
- Stomatocytosis
- Pyropoikilocytosis
- Other membrane disorders

Infection

- Bacterial sepsis (*Escherichia coli*, group B streptococcus)
- Parvovirus B19 (can present with hydrops fetalis)
- Congenital syphilis
- Congenital malaria
- Congenital TORCH infections (toxoplasmosis, rubella, cytomegalovirus,

disseminated herpes)

Other congenital viral infections

Hemoglobin defects

α -Thalassemia syndromes

γ -Thalassemia syndromes

α - and γ -Chain structural anomalies

Macro- and microangiopathic hemolysis

Cavernous hemangiomas

Arteriovenous malformations

Renal artery stenosis or thrombosis

Other large vessel thrombi

Severe coarctation of the aorta

Severe valvular stenoses

Other causes

Disseminated intravascular coagulation

Hypothyroidism

Galactosemia

Lysosomal storage diseases

Prolonged metabolic acidosis from metabolic disease (amino acid and organic acid disorders)

High titers of anti-C antibody have been associated with neonatal hemolytic disease.¹⁰⁶ However, routine screening of anti-C titers during pregnancy is not warranted, because antibody titers do not accurately reflect the severity of hemolytic disease.¹⁰⁷ C(w) is a low-frequency antigen in the Rh blood group system with a prevalence of about 2% among Caucasian populations. Anti-C(w) is not too uncommon in pregnancy (0.1% incidence), but clinically significant hemolytic disease of the newborn is very unusual.¹⁰⁸

FETAL AND NEONATAL ANEMIA DUE TO HEMORRHAGE

Hemorrhage can occur at any time during the prenatal, perinatal, and postnatal periods (Table 43.4).

Prenatal Hemorrhage

Small numbers of maternal and fetal erythrocytes cross the placental barrier during pregnancy. The volume of fetal blood identified in the maternal circulation, at delivery, is generally on the order of 0.01 to 0.1 ml. However, approximately 1 in 400 pregnancies is associated with a fetal to maternal hemorrhage of 30 ml or more, and approximately 1 in 2,000 pregnancies are associated with a potential fetal transplacental hemorrhage of 100 ml or more.¹⁰⁹ To detect and quantify fetal-maternal hemorrhage, flow cytometric-based methods, quantifying erythrocytes with HbF in the maternal circulation, are more sensitive than the Kleihauer-Betke.¹⁰⁹ Significant fetal-maternal hemorrhage has been described following maternal trauma,¹¹⁰ but most cases have no identified antecedent.

Term neonates born after a large fetomaternal hemorrhage present with pallor and tachypnea but they generally have minimal to no requirement for supplemental oxygen. Hemoglobin concentrations can be extremely low at birth, between 4 and 6 g/dl, and a significant metabolic acidosis is often present as a result of poor perfusion.

Twin-twin transfusion occurs in 5% to 30% of monochorionic twin gestations and involves placental anastomoses that allow net transfer of blood from one twin to the other.¹¹¹ The perinatal mortality rate can be as high as 70% to 100%, depending on severity

and timing of presentation. Approximately 70% of monozygous twin pregnancies have monochorionic placentas.¹¹² Although vascular anastomoses are present in almost all such cases, not all of those develop twin-twin transfusion.

TABLE 43.4 CAUSES OF HEMORRHAGE IN THE FETUS/NEONATE

Prenatal

Chronic and/or acute twin-to-twin transfusion syndrome

Chronic and/or acute fetal-maternal hemorrhage

Hemorrhage into amniotic fluid after periumbilical blood sampling

Traumatic amniocentesis

Maternal trauma

Trauma after external cephalic version

Perinatal

Placental abruption

Placenta previa

Vasa previa

Trauma or incision of placenta during cesarean section

Ruptured normal or abnormal (varices, aneurysms, hematoma) umbilical cord

Placental hematoma

Velamentous insertion of the cord

Nuchal cord

Postnatal

Subgaleal hemorrhage

Cephalohematoma

Hemorrhage associated with disseminated intravascular coagulation/sepsis

Intraventricular/intracranial hemorrhage (prematurity, trauma, isoimmune thrombocytopenia)

Organ trauma (liver, spleen, adrenal, renal, gonadal)

Pulmonary hemorrhage

Iatrogenic blood loss (phlebotomy, central line accidents)

Acute twin-twin transfusion generally results in twins of similar size but with hemoglobin concentrations that vary by more than 5 g/dl. In chronic twin-twin transfusion, the donor twin becomes progressively anemic and growth retarded, whereas the recipient becomes polycythemic, macrosomic, and sometimes hypertensive. Both can develop hydrops fetalis; the donor twin becomes hydropic from profound anemia, and the recipient from congestive heart failure and hypervolemia. The donor twin often has low amniotic fluid volumes, whereas the recipient twin has increased amniotic fluid.

Chronic twin-twin transfusion can be diagnosed by serial prenatal ultrasounds measuring cardiomegaly, discordant amniotic fluid production, and fetal growth discrepancy of >20%. Percutaneous umbilical blood sampling can determine if hemoglobin concentration differences of greater than 5 gm/dl exist between the two fetuses.¹¹³ After birth, the donor twin may require transfusions and can also experience neutropenia, hydrops from severe anemia, growth retardation, congestive heart failure, and hypoglycemia. The recipient twin is often the sicker of the two. Problems include hypertrophic cardiomyopathy, congestive heart failure, polycythemia, hyperviscosity, respiratory difficulties,

hypocalcemia, and hypoglycemia. Neurologic evaluation and imaging are helpful because of the risk of neurologic cerebral lesions in 20% to 30% of both twins.¹¹⁴

Prenatal treatment for twin-twin transfusion consists of close monitoring and reduction amniocenteses to decrease uterine stretch and prolong the pregnancy. Treatment in utero using laser surgery to ablate bridging vessels has become more common in the past decade. Most recent reports conclude an improvement in fetal survival using selective laser ablation.^{115, 116, 117}

Perinatal Hemorrhage

Obstetric complications, such as placenta previa, abruption, incision or tearing of the placenta during cesarean section, and cord evulsion, can result in significant neonatal blood loss. Placental abruption involves premature separation of the placenta from the uterus and occurs in 3 to 6 per 1,000 live births.¹¹⁸ Risk factors for abruption include cigarette smoking, prolonged rupture of the membranes, chorioamnionitis, hypertension (before pregnancy and pregnancy-induced), and advanced maternal age.^{119, 120, 121} The incidence of abruption increases with lower gestational age, and abruption can be a cause of preterm delivery.¹²⁰ Mortality ranges from 0.8 to 2.0 per thousand births, or 15% to 20% of the deliveries in which significant abruption occurs.

Placenta previa involves part or all of the placenta overlying the cervical os. Maternal risk factors for developing a placenta previa are essentially the same as those for abruption.^{122, 123} Vasa previa (anomalous vessels overlying the internal cervix os) can be made with transvaginal color Doppler, and should be suspected in any case of antepartum or intrapartum hemorrhage. Although vasa previa is uncommon (1 in 3,000 deliveries), the perinatal death rate is high, ranging from 33% to 100% when undetected before delivery.¹²⁴

Infants born after placental abruption or previa can be hypovolemic due to prenatal hemorrhage. Although the majority of the blood loss is maternal, loss of fetal blood can also occur, thus in neonates born after abruption or previa it is important to monitor blood pressure, hemoglobin/hematocrit, and tissue perfusion.

Cord rupture can occur during delivery due to traction on a shortened, weakened, or otherwise abnormal umbilical cord. Cord aneurysms, varices, and cysts can all lead to a weakened cord. Cord infections (funisitis) can also weaken the cord and increase the risk of rupture. Hematomas of the cord occur infrequently (1 in 5,000 to 6,000 deliveries) and can be a cause of fetal blood loss and fetal death. Hematomas of the cord can be diagnosed in utero by ultrasound and differentiated from other lesions of the placenta and cord.¹²⁵

Velamentous insertion of the umbilical cord occurs when the cord enters the membranes distant from the placenta, and is present in approximately 0.5% to 2.0% of pregnancies. These vessels are more likely to tear, even in the absence of traction or trauma. The fetal mortality is high in this condition, because rapid detection is difficult.¹²⁶

Postnatal Hemorrhage

Loss of fetal blood during delivery can occur into the placenta. The fetal-placental-umbilical cord unit contains about 120 ml/kg of blood, at term. After delivery, but before the umbilical cord is severed, blood in this unit can flow predominantly toward or away from the neonate. A fetoplacental hemorrhage can occur when the neonate is held significantly higher than the placenta after birth, for instance, on the mother's abdomen. It has been suggested that neonates can lose 10% to 20% of their blood volume when born with a tight nuchal cord, which allows blood to be pumped through umbilical arteries toward the placenta, while constricting flow back from the placenta to the baby, through the umbilical vein, which is more easily constricted due to its thin wall structure. However, in a study of over 200,000 deliveries, those with a tight nuchal cord (6.7%) did not have outcomes different from those with loose nuchal cords or with no nuchal cords.¹²⁷ On that basis, it is not clear that tight nuchal cords typically cause clinical problems.

Hemorrhage into the subgaleal space can be a life-threatening neonatal complication.¹²⁸ However, the spectrum of severity ranges widely, from a small asymptomatic hemorrhage to a massive one causing hypovolemic shock. Associations are well known between vacuum or forceps-assisted delivery and subgaleal hemorrhage, but some cases occur when neither vacuum nor forceps were applied. In 38 neonates recently reported with a subgaleal hemorrhage, 21 occurred after vacuum, two after forceps, four after vacuum followed by forceps, and 11 when neither vacuum nor forceps were used. Thirty-five were admitted to an intensive care unit. Transfusions were given to 13, but no transfusions were given in the group where neither vacuum nor forceps was used, suggesting their hemorrhages were less severe.¹²⁸

Anemia appearing after the first 24 hours of life in a nonjaundiced infant can be a sign of hemorrhage. Visible hemorrhages, such as a cephalohematoma, as well as internal occult hemorrhages, can occur. Breech deliveries may be associated with renal, adrenal, or splenic hemorrhage into the retroperitoneal space. Delivery of macrosomic infants, such

as infants born to diabetic mothers, can result in hemorrhage. Infants with overwhelming sepsis can bleed into soft tissue and organs, such as liver, adrenal glands, and lungs.

The liver in a neonate is prone to iatrogenic rupture, resulting in a high morbidity and mortality.¹²⁹ Infants may appear asymptomatic until the liver ruptures and hemoperitoneum occurs. This can occur in term and preterm infants¹³⁰ and has been associated with chest compressions during cardiopulmonary resuscitation. Surgical intervention involving vascular tamponade has been reported to save some infants; however, the mortality remains high.¹³¹

Splenic rupture can result from birth trauma or as a result of distention caused by extramedullary hematopoiesis. Abdominal distension and discoloration, scrotal swelling, and pallor are clinical signs of splenic rupture; these signs may also be seen with adrenal hemorrhage or hepatic rupture.¹³² Other rare causes of postnatal hemorrhage include hemangiomas of the gastrointestinal tract,¹³³ vascular malformations of the skin, and hemorrhage into soft tumors, such as giant sacrococcygeal teratomas or ovarian cysts.

P.1027

FETAL AND NEONATAL ANEMIA DUE TO CONGENITAL INFECTION

Neonatal bacterial sepsis can cause anemia on the basis of hemolysis, DIC, and/or hemorrhage. Neonates with sepsis are generally jaundiced and have hepatosplenomegaly. Some bacterial organisms responsible for neonatal sepsis produce hemolytic endotoxins that result in accelerated erythrocyte destruction.¹³⁴

Congenital infections due to cytomegalovirus, toxoplasmosis, rubella, syphilis, and herpes simplex can also cause hemolytic anemia. Fetal and neonatal infection with parvovirus B19 can cause severe anemia, hydrops, and fetal demise.¹³⁵ The fetus or neonate generally presents with a hypoplastic anemia, but hemolysis can occur as well. The virus replicates in erythroid progenitor cells and results in red cell aplasia. In utero transfusions for hydropic fetuses can be successful. Intrauterine fetal infusion of B19 IgG-rich high titer gammaglobulin has been reported to be successful.¹³⁶

Other fetal infections associated with neonatal anemia include malaria and HIV. Congenital malaria is seen rarely in the United States, generally in large cities where imported cases of malaria are increasing. In certain African countries, congenital malaria has been reported in up to 20% of neonates.¹³⁷ Congenital HIV infection in a neonate is generally asymptomatic. However, infants born to mothers on zidovudine can have a hypoplastic anemia due to suppressive effects of the drug on fetal erythropoiesis.¹³⁸

ANEMIA OF PREMATURITY AND OTHER HYPOPROLIFERATIVE DISORDERS

Impaired erythrocyte production can occur in a fetus or neonate for a variety of reasons. Lack of an appropriate or sufficient marrow environment (as seen in osteopetrosis), lack of specific substrates or their carriers (e.g., iron, folate, vitamin B₁₂, or transcobalamin II deficiency), and lack of specific growth factors (e.g., decreased erythropoietin production or abnormalities in Epo receptors) can be causative.

Anemia of Prematurity

Infants delivered before 32 completed weeks gestation typically develop a transient and unique anemia known as the anemia of prematurity.¹³⁹ During the first week or two after birth, while in an intensive care unit, anemia secondary to phlebotomy loss is common.¹⁴⁰ However after this period has passed, a second anemia is sometimes seen; it is characterized as a normocytic, normochromic, hyporegenerative anemia, with serum erythropoietin concentrations significantly below those found in adults with similar degrees of anemia.¹⁴¹ This anemia is not responsive to the administration of iron, folate, or vitamin E. Some infants with the anemia of prematurity are asymptomatic, whereas others have clear signs of anemia that are alleviated by erythrocyte transfusion. These signs include tachycardia, rapid tiring with nipple feedings, poor weight gain, increased requirements for supplemental oxygen, episodes of apnea and bradycardia, and elevated serum lactate concentrations.^{139, 140, 141}

The reason preterm infants do not significantly increase serum erythropoietin concentration during this anemia is not known.¹⁴² Indeed, it is unclear whether production of erythropoietin does in fact increase, yet the serum concentration does not. Certainly their erythroid progenitors are sensitive to erythropoietin,^{143, 144} and concentrations of other erythropoietic growth factors appear to be normal.¹⁴⁵

The molecular and cellular mechanisms responsible for the anemia of prematurity are multifactorial, and include the transition from fetal to adult hemoglobin, shortened erythrocyte survival, and hemodilution associated with a rapidly increasing body mass.^{139, 140} It is unknown whether preterm infants rely on erythropoietin produced by the liver (the

source of erythropoietin in utero), or that produced by the kidney, or a combination of the two. Regardless of the mechanism responsible for the anemia of prematurity, exogenous erythropoietin administered to preterm infants accelerates effective erythropoiesis.^{146, 147} A meta-analysis of studies evaluating the use of “late erythropoietin administration to prevent and treat the anemia of prematurity reveals a positive effect on decreasing transfusion requirements in preterm infants.¹⁴⁸ In addition, beneficial neurodevelopmental effects of recombinant erythropoietin administration have been reported in preterm infants.^{17, 18, 19, 20, 149, 150}

Pharmacokinetic studies of darbepoetin, the long-acting erythropoietic stimulator, have been conducted among neonates with the anemia of prematurity, with the speculation that less frequent dosing and cost savings might render darbepoetin a more attractive alternative than recombinant erythropoietin for treating the anemia of prematurity.^{151, 152, 153, 154} Following subcutaneous and intravenous dosing, darbepoetin has a considerably shorter terminal half-life in neonates than in adults (Table 43.5). Intravenous dosing appears to be as effective as subcutaneous dosing.¹⁵³ Newer, long-acting Epo mimetics, such as CERA (continuous erythropoiesis receptor agonist), have yet to be studied in neonates, but may hold promise as potential agents to decrease transfusions and provide neuroprotection. Although a minimal number of clinical studies evaluating darbepoetin administration to preterm infants have been published, numerous RCTs evaluating Epo administration to preterm infants have consistently shown evidence of increased erythropoiesis and a decrease in transfusions.¹⁴¹

A consistent finding in the largest RCTs has been an elevation in hematocrit among Epo-treated infants compared with placebo/controls, despite the implementation of strict transfusion guidelines aimed at maintaining hematocrits in a similar range. For those neonatal practitioners electing to maintain hematocrits at higher levels, the use of Epo can gain a “buffer” of 4% to 6% hematocrit points, decreasing the number of transfusions given. This may benefit preterm infants in a number of ways, given recent studies that have reported associations between RBC transfusions and necrotizing enterocolitis (NEC)¹⁵⁵ and between RBC transfusions and IVH.^{156, 157}

Other Hypoproliferative Anemias

During the neonatal period, hypoproliferative anemias are rare, with the exception of the anemia of prematurity, which is common (Table 43.6). The hypoproliferative anemia Diamond-Blackfan syndrome can be diagnosed at birth, but characteristically is not recognized until after 2 to 3 months of age. In fact, 10% to 25% of infants with Diamond-Blackfan syndrome have at least a mild anemia at birth.¹⁵⁸ Severe anemia with hydrops has been

P.1028

reported in conjunction with this syndrome. Aase syndrome, another congenital hypoplastic anemia syndrome involving marrow and skeletal anomalies,¹⁵⁹ is sometimes classified as a variant of Diamond-Blackfan syndrome. Congenital dyserythropoietic anemia is a rare disorder marked by ineffective erythropoiesis, megaloblastic anemia, and characteristic abnormalities of the nuclear membrane and cytoplasm seen on electron microscopy. Fanconi pancytopenia rarely is manifested during the neonatal period. This autosomal-recessive disorder is characterized by marrow failure and congenital anomalies, including abnormalities in skin pigmentation, gastrointestinal anomalies, renal anomalies, and upper limb anomalies.¹⁶⁰ Approximately one third of patients have no obvious congenital anomalies, and anemia is less common than thrombocytopenia and leukopenia. Five genetic phenotypes of Fanconi pancytopenia have been reported, and two of the genes have been cloned.¹⁶¹ Cells are hypersensitive to DNA cross-linking agents such as diepoxybutane and mitomycin C. The diepoxybutane test represents a sensitive and specific diagnostic test. When Fanconi anemia is recognized in a neonate, it is generally on the basis of the congenital anomalies and not the hematologic abnormalities. However, congenital thrombocytopenia, manifested during the immediate newborn period, progressing to pancytopenia has rarely been reported.¹⁶² Erythropoietin concentrations are usually elevated, and HbF production is increased. A significant percentage of patients develop myelodysplastic syndrome or acute myelogenous leukemia later in life. Treatment of Fanconi pancytopenia includes androgen therapy, and, in many cases, bone marrow transplantation has been successful.

TABLE 43.5 TERMINAL T ½ OF DARBEPOETIN AMONG ADULTS, CHILDREN, AND NEONATES AFTER SUBCUTANEOUS OR INTRAVENOUS DOSING

	After Subcutaneous Dosing (hours)	After Intravenous Dosing (hours)
Adults	49	25
Children	43	22

Neonates

22

10

TABLE 43.6 SYNDROMES ASSOCIATED WITH FETAL/NEONATAL ANEMIA

Genetic Syndrome	Phenotypic Features	Genotypic Features
Adenosine deaminase deficiency	Autoimmune hemolytic anemia, reduced erythrocyte adenosine deaminase activity	AR, 20q13.11
Congenital dyserythropoietic anemias	Type I (rare): megaloblastoid erythroid hyperplasia and nuclear chromatin bridges between nuclei; type II (most common): "hereditary erythroblastic multinuclearity, positive acidified serum (HEMPAS) test, increased lysis to anti-i; type III: erythroblastic multinuclearity ("gigantoblasts), macrocytosis	Type I: 15q15.1-q15.3; type II: 20q11.2; type III: 15q21
Diamond-Blackfan syndrome	Steroid-responsive hypoplastic anemia, often macrocytic after 5 mo of age	AR; sporadic mutations and AD inheritance described; 19q13.2, 8p23.3-p22
Dyskeratosis congenita	Hypoproliferative anemia usually presenting between 5 and 15 yr of age	X-linked recessive, locus on Xq28; some cases with AD inheritance
Fanconi pancytopenia	Steroid-responsive hypoplastic anemia, reticulocytopenia, some macrocytic RBCs, shortened RBC lifespan. Cells are hypersensitive to DNA cross-linking agents	AR, multiple genes: complementation; group A: 16q24.3; B:: C: 9q22.3; D2: 3p25.3; E: 6p22-p21; F: 11p15; G: 9p13
Osler hemorrhagic telangiectasia syndrome	Hemorrhagic anemia	AD, 9q34.1
Osteopetrosis	Hypoplastic anemia from marrow compression; extramedullary erythropoiesis	AR: 16p13, 11q13.4-q13.5; AD: 1p21; lethal: reduced osteoclasts
Pearson syndrome	Hypoplastic sideroblastic anemia, marrow cell vacuolization	Pleioplasmatic rearrangement of mitochondrial DNA; X-linked or AR
Peutz-Jeghers syndrome	Iron-deficiency anemia from chronic blood loss	AD, 19p13.3
X-linked α -thalassemia/mental retardation (ATR-X and ATR-16) syndromes	ATR-X: hypochromic, microcytic anemia; mild form of hemoglobin H disease ATR-16: more significant hemoglobin H disease and anemia are present	ATR-X: X-linked recessive, Xq13.3; ATR-16: 16p13.3, deletions of α -globin locus

AD, autosomal dominant; AR, autosomal recessive; RBC, red blood cell.

Autosomal-recessive osteopetrosis is a rare disorder characterized by osteoclast dysfunction, resulting in a decreased bone marrow space.¹⁶³ Developmental delay, ocular involvement, and neurodegenerative findings occur in association with hypoplastic anemia. Patients are generally treated with hematopoietic stem cell transplantation, but they are particularly susceptible to posttransplantation complications after myeloablation, and reduced-intensity conditioning programs may be helpful.¹⁶⁴

Pearson syndrome is a congenital hypogenerative anemia that can progress to pancytopenia, and additionally affects the exocrine pancreas, liver, and kidneys.¹⁶⁵ Patients with this syndrome can present during the neonatal period, but typically do so later in infancy, often in the first year of life. Presenting features include failure to thrive, with anemia, neutropenia, and/or thrombocytopenia. The marrow examination typically shows characteristic vacuoles within erythroid and myeloid precursors, hemosiderosis, and ringed sideroblasts. The syndrome is caused by a loss of large segments of mitochondrial DNA.^{166, 167}

CONSIDERATIONS REGARDING ERYTHROCYTE TRANSFUSION IN THE NEONATAL PERIOD

Transfusion of banked donor erythrocytes can be life saving for small and ill neonates with severe anemia or hemorrhage. However, risks of transfusions exist and must be weighed against potential benefits each time a transfusion is considered. Two transfusion risks are highly unique to VLBW (<1,500 g) infants. The first is an association between RBC transfusions administered in the first few days after birth and the subsequent occurrence of a grade 3 or 4 IVH.^{156, 157, 167} The second is an association between RBC transfusions administered during the third to fourth week and the subsequent occurrence of NEC.^{155, 167, 168, 169, 170, 171, 172} Much remains to be discovered about the pathogenic links between transfusions and these adverse outcomes, and more work is needed to establish whether transfusions are causatively associated with these adverse outcomes or are co-variables.¹⁶⁸

P.1029

Means of avoiding transfusion among VLBW infants are listed in Table 43.7 and include: (1) Delay clamping of the umbilical cord, (2) strip or milk the cord, (3) draw all initial laboratory tests from fetal blood in the placenta and thereby draw no blood from the neonate, (4) reduce phlebotomy losses in the first days and weeks, (5) adopt written transfusion guidelines, (6) remove unnecessary indwelling catheters, (7) use an early dose(s) of erythropoietin or darbepoetin, and (8) optimize nutrition.

The idea of sterilely salvaging anticoagulated fetal blood from the umbilical cord and placenta at the time of birth, for a subsequent autologous transfusion for small or sick neonates has had limited study.^{173, 174, 175, 176, 177} Harvesting cord blood from term pregnancies for stem cell transplantation is successful and popular.¹⁷⁶ However, harvesting from extremely preterm deliveries has practical limitations that have prevented this from becoming routine practice.¹⁷⁷ A few reports have used a modification of this practice for transfusion immediately after birth, aimed at immediate volume expansion of ill and small neonates.^{178, 179, 180, 181} Most such reports describe processing and storing the fetal blood in case a transfusion is needed in the subsequent days or weeks. Reports from Japan¹⁸² and Germany¹⁸³ describe successful cord/placental blood transfusion for neonates with surgical problems. Earlier studies by Golden et al. demonstrated bacteriologic safety of this practice when the blood is used within 4 hours of delivery.^{174, 175} As better means are developed for harvesting, storing, and administering autologous fetal blood from extremely preterm deliveries, the benefits of using this blood, rather than donor blood, for early transfusions might outweigh the risks.^{184, 185, 186}

The recent use of bi- or multiprobe near infrared spectroscopic (NIRS) monitoring in the NICU has provided new evidence of a benefit of RBC transfusions in selected patients.¹⁸⁷ Tissue oxygenation is estimated by NIRS on the basis of different near infrared light absorbance by oxyhemoglobin versus deoxyhemoglobin. Unlike pulse oximetry, NIRS evaluates hemoglobin oxygen saturations deeper in the tissue, about 2 cm below the skin surface, thus reflecting values from mixed arteriolar, venous, and capillary sources. When oxygen delivery to tissues becomes limited by anemia, oxygen extraction increases and venous oxygen saturation falls.¹⁸⁷

Van Hoften et al. used NIRS monitoring to evaluate 33 preterm neonates before, during, and after a clinically ordered transfusion of 15 ml/kg RBC infused over a period of 3 hours.¹⁸⁸ They found that regional cerebral tissue oxygen saturation and the fractional tissue oxygen extraction correlated with the pretransfusion hemoglobin level, with lower hemoglobin levels predicting a lower cerebral oxygen tension. Their data supported the conclusion that a blood hemoglobin concentration <9.7 g/dl in a preterm infant corresponds with diminished cerebral oxygenation, and that erythrocyte transfusion improves this parameter. Dani et al. from Florence, Italy reported on 15 preterm infants using similar methodology, and came to a similar conclusion, that in neonates with a hemoglobin below about 6 g/dl, transfusion can often increase cerebral, splanchnic, and renal oxygenation.¹⁸⁹ Bailey et al. applied biprobe NIRS monitoring during a 20-minute period just before a clinically ordered RBC transfusion; 40 such measurements (each integrated over 30 seconds) were made.^{190, 191} One probe on the forehead was intended to assess cerebral and one on the abdomen to assess splanchnic changes. The measurements from each site were averaged into a ratio of oxygen saturations measured from the cerebral and splanchnic sites. The ratios were expressed as a SCOR (splanchnic-cerebral oxygenation ratio). Ratios

were correlated with independent means of judging whether the transfusion actually provided a benefit. A SCOR at or below 73% (meaning the average oxygenation in the splanchnic circulation was $\leq 73\%$ of the cerebral circulation) performed well in identifying the neonates who were likely to benefit from a transfusion.

TABLE 43.7 STRATEGIES FOR REDUCING ERYTHROCYTE TRANSFUSIONS AMONG VERY LOW BIRTH WEIGHT NEONATES

- Delay clamping of the umbilical cord by 45 to 60 sec after birth, with the neonate in a position lower than the placenta.
- Strip or milk the umbilical cord at birth, moving additional blood from the placenta and umbilical cord into the neonate, before the umbilical cord is clamped.
- Draw all initial laboratory blood tests (blood culture, CBC, etc.) using fetal blood in the umbilical cord/placenta, thereby initially drawing no blood from the neonate.
- Develop a consistent approach to minimizing phlebotomy losses in the first days and weeks.
- Adopt written transfusion guidelines.
- Remove indwelling catheters once they are not critically needed.
- Early dose(s) of recombinant erythropoietin or darbepoetin.
- Optimize nutrition.

With recent technological and other creative advances, it is becoming clear that NICU transfusions should not be ordered simply on the basis of the hemoglobin/hematocrit values. Better practice guidelines will likely consider NIRS and other measures of oxygen delivery to determine transfusion need.

REFERENCES

1. Christensen RD, Henry E, Jopling J, Wiedmeier SE. The CBC: reference ranges for neonates. *Semin Perinatol* 2009;33:3-11.
2. Christensen RD. Reference ranges in neonatal hematology. In: de Alarcon P, Werner E, Christensen RD, eds. *Neonatal hematology*, 2nd ed. New York, Cambridge University Press, 2012:383-406.
3. McPherson RJ, Juul SE. Erythropoietin for infants with hypoxic-ischemic encephalopathy. *Curr Opin Pediatr* 2010;22:139-145.
4. Shiou SR, Yu Y, Chen S, Ciancio MJ, Petrof EO, Sun J, Claud EC. Erythropoietin protects intestinal epithelial barrier function and lowers the incidence of experimental neonatal necrotizing enterocolitis. *J Biol Chem* 2011;286: 12123-12132.
5. Arsenault JE, Webb AL, Koulinska IN, Aboud S, Fawzi WW, Villamor E. Association between breast milk erythropoietin and reduced risk of mother-to-child transmission of HIV. *J Infect Dis* 2010;202:370-373.
6. Chateauvieux S, Grigorakaki C, Morceau F, Dicato M, Diederich M. Erythropoietin, erythropoiesis and beyond. *Biochem Pharmacol* 2011;82:1291-1303.
7. Kling PJ. Roles of erythropoietin in human milk. *Acta Paediatr Suppl* 2002;91(438):31-35.
8. Juul SE. Nonerythropoietic roles of erythropoietin in the fetus and neonate. *Clin Perinatol* 2000;27:527-541.
9. Juul SE, Yachnis AT, Christensen RD. Tissue distribution of erythropoietin and erythropoietin receptor in the developing human fetus. *Early Hum Dev* 1998;52:235-249.
10. Dame C, Juul SE, Christensen RD. The biology of erythropoietin in the central nervous system and its neurotrophic and neuroprotective potential. *Biol Neonate* 2001;79:228-235.
11. Juul SJ, Harcum J, Li Y, Christensen RD. Erythropoietin is present in the cerebrospinal fluid of neonates. *J Pediatr* 1997;130:428-430.
12. Juul SE, Stallings SA, Christensen RD. Erythropoietin in the cerebrospinal fluid of neonates who sustained CNS injury. *Pediatr Res* 1999;46:543-547.
13. Li Y, Juul SE, Morris-Winman JA, Calhoun DA, Christensen RD. Erythropoietin receptors are expressed in the central nervous system of mid-trimester human fetuses. *Pediatr Res* 1996;40:376-380.

14. Juul SJ, Anderson DK, Li Y, Christensen RD. Erythropoietin and erythropoietin receptor in the developing human central nervous system. *Pediatr Res* 1998;43:40-49.
 15. Juul SE, McPherson RJ, Farrell F Jolliffe L, Ness DJ, Gleason CA. Erythropoietin concentrations in cerebrospinal fluid of nonhuman primates and fetal sheep following high-dose recombinant erythropoietin. *Biol Neonate* 2004;85(2):138-144.
 16. Statler PA, McPherson RJ, Bauer LA, Kellert BA, Juul SE. Pharmacokinetics of high-dose recombinant erythropoietin in plasma and brain of neonatal rats. *Pediatr Res* 2007;61(6):671-675.
 17. McPherson RJ, Juul SE. Recent trends in erythropoietin-mediated neuroprotection. *Int J Dev Neurosci* 2008;26(1):103-111.
 18. Beirer R, Peceny MC, Hartenberger CH, Ohls RK. Erythropoietin concentrations and neurodevelopmental outcome in preterm infants. *Pediatrics* 2006;118:635-640.
 19. Ohls RK. Erythropoietin and hypoxia inducible factor-1 expression in the mid-trimester human fetus. *Acta Paediatr* 2002;91(SupplA38):27.
 20. Brown MS, Eichorst D, Lala-Black B, Gonzalez R. Higher cumulative doses of erythropoietin and developmental outcomes in preterm infants. *Pediatrics* 2009;124(4):e681-e687.
 21. Ohls RK. The use of erythropoietin in neonates. *Clin Perinatol* 2000;3: 681-696.
 22. Ohls RK, Roohi M, Peceny HM, Schrader R, Bierer R. A randomized, masked study of weekly erythropoietin dosing in preterm infants. *J Pediatr* 2012;160(5):790-795.
 23. Dijkstra F, Jozwiak M, De Matteo R, et al. Erythropoietin ameliorates damage to the placenta and fetal liver induced by exposure to lipopolysaccharide. *Placenta* 2010;31(4):282-288.
 24. Bhandari V, Buhimschi CS, Han CS, et al. Cord blood erythropoietin and interleukin-6 for prediction of intraventricular hemorrhage in the preterm neonate. *J Matern Fetal Neonatal Med* 2011;24(5):673-679.
 25. Loukovaara M, Teramo K, Alfthan H, Hämäläinen E, Stefanovic V, Andersson S. Amniotic fluid S100B protein and erythropoietin in pregnancies at risk for fetal hypoxia. *Eur J Obstet Gynecol Reprod Biol* 2009;142(2): 115-118.
 26. Teramo KA, Widness JA. Increased fetal plasma and amniotic fluid erythropoietin concentrations: markers of intrauterine hypoxia. *Neonatology* 2009;95(2):105-116.
 27. Gairdner D, Marks J, Roscoe JD. Blood formation in infancy. I. The normal bone marrow. II. Normal erythropoiesis. *Arch Dis Child* 1952;27:128-133.
 28. Gairdner D, Marks J, Roscoe JD. Blood formation in infancy. IV. The early anaemias of prematurity. *Arch Dis Child* 1955;30:203-211.
 29. Oettinger L, Mills WB. Simultaneous capillary and venous hemoglobin determinations in newborn infant. *J Pediatr* 1949;35:362-365.
 30. Jopling J, Henry E, Wiedmeier SE, Christensen RD. Reference ranges for hematocrit and blood hemoglobin concentration during the neonatal period: data from a multihospital health care system. *Pediatrics* 2009;123(2): e333-e337.
- P.1030
31. Linderkamp O, Versmold HT, Strohhacker I, Messow-Zahn K, Riegel KP, Betke K. Capillary-venous hematocrit differences in newborn infants. *Eur J Pediatr* 1977;127(1):9-14.
 32. Gaitti RA. Hematocrit values of capillary blood in the newborn. *J Pediatr* 1967;70:117-119.
 33. Christensen RD, Jopling J, Henry E, Wiedmeier SE. The erythrocyte indices of neonates, defined using data from over 12,000 patients in a multihospital health care system. *J Perinatol* 2008;28(1):24-28.
 34. Schmaier AH, Mauer HM. Alpha-thalassemia screening in neonates by mean corpuscular volume and mean corpuscular hemoglobin concentration. *J Pediatr* 1973;83:794.
 35. Christensen RD, Henry E. Hereditary spherocytosis in neonates with hyperbilirubinemia. *Pediatrics* 2010;125(1):120-125.

36. Sheffield MJ, Christensen RD. Evaluating neonatal hyperbilirubinemia in late preterm Hispanic twins led to the diagnosis of hereditary spherocytosis in them, and in their sibling and in their mother. *J Perinatol* 2011;31(9): 625-627.
37. Christensen RD, Henry E, Andres RL, Bennett ST. Reference ranges for blood concentrations of nucleated red blood cells in neonates. *Neonatology* 2011;99(4):289-294.
38. Christensen RD, Baer VL, Gordon PV, et al. Reference ranges for lymphocyte counts of neonates: associations between abnormal counts and outcomes. *Pediatrics* 2012;129(5):e1165-e1172.
39. Zipursky A, Brown E, Palko J, Brown EJ. The erythrocyte differential count in newborn infants. *Am J Pediatr Hematol Oncol* 1983;5:45-51.
40. Kurth D, Deiss A, Cartwright GE. Circulating siderocytes in human subjects. *Blood* 1969;34:754-764.
41. Komazawa M, Garcia AM, Oski FA. The relation of red cell size to fetal hemoglobin concentration in the term infant. *J Pediatr* 1974;85:114-116.
42. Stockman JA, Oski FA. RBC values in low-birth-weight infants during the first seven weeks of life. *Am J Dis Child* 1980;134:945-946.
43. Stockman JA, Garcia JF, Oski FA. The anemia of prematurity: factors governing the erythropoietin response. *N Engl J Med* 1977;296:647-650.
44. Mock DM, Bell EF, Lankford GL, Widness JA. Hematocrit correlates well with circulating red blood cell volume in very low birth weight infants. *Pediatr Res* 2001;50(4):525-531.
45. Pearson HA. Life-span of the fetal red blood cell. *J Pediatr* 1967;70:166-171.
46. Brace RA, Langendorfer C, Song TB, Mock DM. Red blood cell life span in the ovine fetus. *Am J Physiol Regul Integr Comp Physiol* 2000;279(4): R1196-R1204.
47. Bratteby LE, Garby L, Groth T, Schneider W, Wadman B. Studies on erythrokinetics in infancy. XII. Survival in adult recipients of cord blood red cells labeled in vitro with diisopropyl fluorophosphate (DF32P). *Acta Paediatr Scand* 1968;57:311-320.
48. Mollison PL. The survival of transfused erythrocytes in hemolytic disease of the newborn. *Arch Dis Child* 1943;18:161-172.
49. Ruth V, Widness JA, Clemons G, Raivio JO. Postnatal changes in serum immunoreactive erythropoietin in relation to hypoxia before and after birth. *J Pediatr* 1990;116(6):950-954.
50. Kling PJ, Schmidt RL, Roberts RA, Widness JA. Serum erythropoietin levels during infancy: associations with erythropoiesis. *J Pediatr* 1996;128(6): 791-796.
51. Saarinen UM, Siimes MA. Developmental changes in red blood cell counts and indices of infants after exclusion of iron deficiency by laboratory criteria and continuous iron supplementation. *J Pediatr* 1978;92:412-416.
52. Oh W, Lind J. Venous and capillary hematocrit in newborn infants and placental transfusion. *Acta Paediatr Scand* 1966;55:38-48.
53. Linderkamp O, Nelle M, Kraus M, Zilow EP. The effect of early and late cord-clamping on blood viscosity and other hemorheological parameters in full-term neonates. *Acta Paediatr* 1992;81:745-750.
54. Aladangady N, McHugh S, Aitchison TC, Wardrop CA, Holland BM. Infant's blood volume in a controlled trial of placental transfusion at preterm delivery. *Pediatrics* 2006;117(1):93-98.
55. Mercer JS, Vohr BR, McGrath MM, Padbury JF, Wallach M, Oh W. Delayed cord clamping in very preterm infants reduces the incidence of intraventricular hemorrhage and late-onset sepsis: a randomized, controlled trial. *Pediatrics* 2006;117(4):1235-1242.
56. Hosono S, Mugishima H, Fujita H, et al. Umbilical cord milking reduces the need for red cell transfusions and improves neonatal adaptation in infants born at less than 29 weeks gestation: a randomised controlled trial. *Arch Dis Child Fetal Neonatal Ed* 2008;93:F14-F19.
57. Hosono S, Mugishima H, Kitamura T, et al. Effect of hemoglobin on transfusion and neonatal adaptation in extremely low-birthweight infants. *Pediatric Int* 2008;50:306-311.

58. Rabe H, Jewison A, Alvarez RF, et al. Milking compared with delayed cord clamping to increase placental transfusion in preterm neonates: a randomized controlled trial. *Obstet Gynecol* 2011;117:205-211.
59. Glader B, Allen GA. Neonatal hemolysis. In: de Alarcon P, Werner E, Christensen RD, eds. *Neonatal Hematology*, 2nd ed. New York, Cambridge University Press, 2012:91-117.
60. Lawler J, Liu SC, Palek J, Prchal J. Molecular defect of spectrin in a subset of patients with hereditary elliptocytosis. Alterations in the subunit domain involved in spectrin self-association. *J Clin Invest* 1984;73:1688-1695.
61. Matovcik LM, Gröschel-Stewart U, Schrier SL. Myosin in adult and neonatal human erythrocyte membranes. *Blood* 1986;67:1668-1674.
62. Jain SK. The neonatal erythrocyte and its oxidative susceptibility. *Semin Hematol* 1989;26:286-300.
63. Neerhout RC. Erythrocyte lipids in infants with low birth weights. *Pediatr Res* 1971;5:101.
64. Fukuda M, Fukuda MN. Changes in cell surface glycoproteins and carbohydrate structures during development and differentiation of human erythroid cells. *J Supramol Struct Cell Biochem* 1981;17(4):313-324.
65. Linderkamp O, Nash GB, Wu PY, Meiselman HJ. Deformability and intrinsic material properties of neonatal red blood cells. *Blood* 1986;67:1244-1250.
66. Bautista ML, Altaf W, Lall R, Wapnir RA. Cord blood red cell osmotic fragility: a comparison between preterm and full-term newborn infants. *Early Hum Dev* 2003;72(1):37-46.
67. Konrad PN, Valentine WN, Paglia D. Enzymatic activities and glutathione content of erythrocytes in the newborn: comparison with red cells of older normal subjects and those with comparable reticulocytosis. *Acta Haematol* 1972;48:193-201.
68. Travis SF, Kumar SP, Paez PC, Delivoria-Papadopoulos M. Red cell metabolic alterations in postnatal life in term infants: glycolytic enzymes and glucose-6-phosphate dehydrogenase. *Pediatr Res* 1980;14:1349-1352.
69. Lachhein L, Grube E, Johnigk C, Matthies H. Der Verbrauch an glucose, galactose, ribose und inosin von erwachsenen- und nabelschnur-erythrocyten. *Klin Wochenschr* 1961;39:875.
70. Gahr M, Meves H, Schröter W. Fetal properties in red blood cells of newborn infants. *Pediatr Res* 1979;13:1231-1236.
71. Travis SF, Kumar SP, Delivoria-Papadopoulos M. Red cell metabolic alterations in intermediates and adenosine triphosphate. *Pediatr Res* 1981;15: 34-37.
72. Travis SF, Garvin JH. In vivo lability of red cell phosphofructokinase in term infants. The possible molecular basis of the relative PFK deficiency in neonatal red cells. *Pediatr Res* 1977;11:1159-1161.
73. Vora S, Poimelli S. Fetal isozyme of phosphofructokinase in newborn erythrocytes. *Pediatr Res* 1977;11:483.
74. Gahr M. Isoelectric focusing of hexokinase and glucose-6-phosphate dehydrogenase isoenzymes in erythrocytes of newborn infants and adults. *Br J Haematol* 1980;4:529.
75. Scopesi F, Canini S, Mazzella M, Arioni C, Lantieri P, Serra G. 2,3 diphosphoglycerate in preterm newborns. *Acta Biomed Ateneo Parmense* 2000;71(Suppl 1):621-626.
76. Barretto OC, Nonoyama K, Deutsch AD, Ramos JL. Physiological red cell, 2,3-diphosphoglycerate increase by the sixth hour after birth. *J Perinat Med* 1995;23(5):365-369.
77. Soubasi V, Kremenopoulos G, Tsantali C, Savopoulou P, Mussafir C, Dimitriou M. Use of erythropoietin and its effects on blood lactate and 2, 3-diphosphoglycerate in premature neonates. *Biol Neonate* 2000;78(4): 281-287.
78. Whaun JM, Oski FA. Relation of red cell glutathione peroxidase to neonatal jaundice. *J Pediatr* 1970;76:555-560.
79. Minnich V, Smith ME, Rajanasathit C, Majerus PW. Erythrocyte glutathione synthesis in the neonate. *Biol Neonate* 1974;24:128-133.
80. Glader BE, Conrad ME. Decreased glutathione peroxidase in neonatal erythrocytes. Lack of relation to hydrogen peroxide metabolism. *Pediatr Res* 1972;6:900-904.
81. Schroter W, Bodemann H. Experimentally induced cation leaks of the red cell membrane. *Biol Neonate* 1970;15:291-299.
82. Tillman W, Labitxke N, Schröter W. Favourable erythrocyte rheology in patients with glucose-6-phosphate dehydrogenase deficiency. *Klin Wochenschr* 1977;15;55(8):385-391.

83. Schroter W, Tillman W. Heinz body susceptibility of red cells and exchange transfusion. *Acta Haematol* 1973;49:74-79.
84. Stockman JA. The anemia of prematurity and the decision when to transfuse. *Adv Pediatr* 1983;30:191-219.
85. van Zoeren-Grobben D, Lindeman JH, Houdkamp E, Moison RM, Wijnen JT, Berger HM. Markers of oxidative stress and antioxidant activity in plasma and erythrocytes in neonatal respiratory distress syndrome. *Acta Paediatr* 1997;86(12):1356-1362.
86. Stevenson SS. Carbonic anhydrase in newborn infants. *J Clin Invest* 1943;22:403-409.
87. Colin FC, Schrier SL. Spontaneous endocytosis in human neonatal and adult red blood cells: comparison to drug-induced endocytosis and to receptor-mediated endocytosis. *J Hematol* 1991;37(1):34-40.
88. Kalan G, Derganc M, Primocic J. Phosphate metabolism in red blood cells of critically ill neonates. *Pflugers Arch* 2000;440(Suppl 5):R109-R111.
89. Jones PEH, McCance RA. Enzyme activities in the blood of infants and adults. *Biochem J* 1949;45:464-467.
90. Lagresle-Peyrou C, Six EM, Picard C, et al. Human adenylate kinase 2 deficiency causes a profound hematopoietic defect associated with sensorineural deafness. *Nat Genet* 2009;41(1):106-111.
91. Muller MM, Wagenbichler P. Activity of the salvage-pathway in erythrocytes of newborn infants, children, and adults. *Adv Exp Med Biol* 1977;76A:129.
92. Ross JD. Deficient activity of DPNH-dependent methemoglobin diaphorase in cord blood erythrocytes. *Blood* 1963;21:51.
93. Boyer SH, Noyes AN, Boyer ML. Enrichment of the erythrocytes of fetal origin from adult-fetal blood mixtures via selective hemolysis of adult blood cells: an aid to antenatal diagnosis of hemoglobinopathies. *Blood* 1976;47:883-897.
94. Choury D, Reghis A, Pichard AL, Kaplan JC. Endogenous proteolysis of membrane-bound red cell cytochrome-b5 reductase in adults and newborns: its possible relevance to the generation of soluble "methemoglobin reductase. *Blood* 1983;61:894-898.
95. Jensen M, Attenberger H, Schneider C, Walther JU. The developmental change in the G- γ - and A- γ -globin proportions in hemoglobin F. *Eur J Pediatr* 1982;138:311-314.
96. Cotter J, Prystowsky H. Fetal blood studies. XIX. Adult and fetal hemoglobin levels of human fetal blood in term pregnancy and in prolonged pregnancy. *Am J Obstet Gynecol* 1963;22:745-750.
97. Crowley MA, Mollan TL, Abdulmalik OY, et al. A hemoglobin variant associated with neonatal cyanosis and anemia. *N Engl J Med* 2011;364(19): 1837-1843.
98. Bauer C, Ludwig I, Ludwig M. Different effects of 2,3-diphosphoglycerate and adenosine triphosphate on oxygen affinity of adult and fetal human hemoglobin. *Life Sci* 1968;7:1339-1343.
99. Delivoria-Papadopoulos M, Roncevic NP, Oski FA. Postnatal changes in oxygen transport of term, premature, and sick infants: the role of red cell 2,3-diphosphoglycerate and adult hemoglobin. *Pediatr Res* 1971;5:235-45.
100. Kleihauer E, Braun H, Betke K. Demonstration of fetal hemoglobin in erythrocytes of a blood smear. *Klin Wochenschr* 1957;15;35(12):637-638.
101. Stevenson DK, Wong RJ, DeSandre GH, Vreman HJ. A primer on neonatal jaundice. *Adv Pediatr* 2004;51:263-288.
102. Bhutani VK, Donn SM, Johnson LH. Risk management of severe neonatal hyperbilirubinemia to prevent kernicterus. *Clin Perinatol* 2005;32(1): 125-139.
103. Toivanen B, Hirvonen T. Iso- and heteroagglutinins in human fetal and neonatal sera. *Scand J Haematol* 1969;6:42-48.
104. Geaghan SM. Diagnostic laboratory technologies for the fetus and neonate with isoimmunization. *Semin Perinatol* 2011;35:148-154.
105. Weiner CP, Widness JA. Decreased fetal erythropoiesis and hemolysis in Kell hemolytic anemia. *Am J Obstet Gynecol* 1996;174:547-551.
106. Kozlowski CL, Lee D, Shwe KH, Love EM. Quantification of anti-c in haemolytic disease of the newborn. *Transfus Med* 1995;5:37-42.
107. van Dijk BA, Dooren MC, Overbeeke MA. Red cell antibodies in pregnancy: there is no "critical titre. *Transfus Med* 1995;5:199-202.

108. May-Wewers J, Kaiser JR, Moore EK, Blackall, DP. Severe neonatal hemolysis due to a maternal antibody to the low-frequency Rh antigen C(w). *Am J Perinatol* 2006;23:213-217.
109. Kim YA, Makar RS. Detection of fetomaternal hemorrhage. *Am J Hematol* 2012;87:417-423.
110. Stroustrup A, Trasande L. Demographics, clinical characteristics and outcomes of neonates diagnosed with fetomaternal haemorrhage. *Arch Dis Child Fetal Neonatal Ed*. Epub 28/2/12.
111. Rustico MA, Lanna MM, Faiola S, et al. Fetal and maternal complications after selective fetoscopic laser surgery for twin-to-twin transfusion syndrome: a single-center experience. *Fetal Diagn Ther* 2012;31(3):170-178.
112. Quintero R, Kontopoulos EV, Barness E, Steffensen TS, Hilbelink D, Chmait R, Benirschke K. Twin-twin transfusion syndrome in a dichorionic-monozygotic twin pregnancy: the end of a paradigm? *Fetal Pediatr Pathol* 2010;29(2): 81-88.
113. Dennis LG, Winkler CL. Twin-to-twin transfusion syndrome: aggressive therapeutic amniocentesis. *Am J Obstet Gynecol* 1997;177(2):342-347.
114. Rossi AC, Vanderbilt D, Chmait RH. Neurodevelopmental outcomes after laser therapy for twin-twin transfusion syndrome: a systematic review and meta-analysis. *Obstet Gynecol* 2011;118:1145-1150.
115. Tchirikov M, Oshovskyy V, Steetskamp J, Thäle V. Neonatal outcome following long-distance air travel for fetoscopic laser coagulation treatment of twin-to-twin transfusion syndrome. *Int J Gynaecol Obstet* 2012;117(3):260-263.
116. Kowitt B, Tucker R, Watson-Smith D, et al. Long-term morbidity after fetal endoscopic surgery for severe twin-to-twin transfusion syndrome. *J Pediatr Surg* 2012;47(1):51-56.
117. Tchirikov M, Oshovskyy V, Steetskamp J, Falkert A, Huber G, Entezami M. Neonatal outcome using ultrathin fetoscope for laser coagulation in twin-to-twin-transfusion syndrome. *J Perinat Med* 2011;39(6):725-730.
118. Tikkanen M. Placental abruption: epidemiology, risk factors and consequences. *Acta Obstet Gynecol Scand* 2011;90(2):140-149.
119. Gargano JW, Holzman CB, Senagore PK, et al. Evidence of placental haemorrhage and preterm delivery. *BJOG* 2010;117(4):445-455.
120. Han CS, Schatz F, Lockwood CJ. Abruption-associated prematurity. *Clin Perinatol* 2011;38(3):407-421.
121. Matsuda Y, Hayashi K, Shiozaki A, Satoh S, Saito S. Comparison of risk factors for placental abruption and placenta previa: case-cohort study. *J Obstet Gynaecol Res* 2011;37(6):538-546.
122. Gurol-Urganci I, Cromwell DA, Edozien LC, et al. Risk of placenta previa in second birth after first birth cesarean section: a population-based study and meta-analysis. *BMC Pregnancy Childbirth* 2011;21:11-95.
123. Jang DG, Jo YS, Lee SJ, Lee GS. Risk factors of neonatal anemia in placenta previa. *Int J Med Sci* 2011;8(7):554-557.
124. Crane JM, van den Hof MC, Dodds L, Armson BA, Liston R. Neonatal outcomes with placenta previa. *Obstet Gynecol* 1999;93(4):541-544.
125. Gualandri G, Rivasi F, Santunione AL, Silingardi E. Spontaneous umbilical cord hematoma: an unusual cause of fetal mortality: a report of 3 cases and review of the literature. *Am J Forensic Med Pathol* 2008;29(2):185-190.
126. Valsky DV, Drai-Hasid R, Troim A, Haimov-Kochman R, Cohen SM, Yagel S. Millimeters from disaster: velamentous insertion with cord previa. *J Ultrasound Med* 2010;29(6):1015-1016.
127. Henry E, Andres RL, Christensen RD. Neonatal outcomes following a tight nuchal cord. *J Perinatol* 2012. doi:10.1038/jp.2012.79.
128. Christensen RD, Baer VL, Henry E. Neonatal subgaleal hemorrhage in a multihospital healthcare system: prevalence, associations, and outcomes. *J Neonat Res* 2011;1:4-11.
129. Davies MR. Iatrogenic hepatic rupture in the newborn and its management by pack tamponade. *J Pediatr Surg* 1997;32(10):1414-1419.
130. Emma F, Smith J, Moerman PH. Subcapsular hemorrhage of the liver and hemoperitoneum in premature infants: report of 4 cases. *Eur J Obstet Gynecol Reprod Biol* 1992 21;44(2):161-164.
131. Miele V, Galluzzo M, Patti G, Mazzoni G, Calisti A, Valenti M. Scrotal hematoma due to neonatal adrenal hemorrhage: the value of ultrasonography in avoiding unnecessary surgery. *Pediatr Radiol* 1997;27(8):672-674.

132. Al Inzi S, Mohiyiddeen G, Dalal N, Pratap C, Gilmour K. Spontaneous rupture of the spleen—a fatal complication of pregnancy. *J Obstet Gynaecol* 2009;29(6):555-556.
133. Abolmakarem H, Tharmaratnum S, Thilaganathan B. Fetal anemia as a consequence of hemorrhage into an ovarian cyst. *Ultrasound Obstet Gynecol* 2001;17:527-528.
134. Cleary TG, Lopez EL. The shiga-like toxin-producing *Escherichia coli* and hemolytic uremic syndrome. *Pediatr Infect Dis J* 1989;8:720-724.
135. de Jong EP, de Haan TR, Kroes AC. Parvovirus B19 infection in pregnancy. *J Clin Virol* 2006;36(1):1-7.
136. Matsuda H, Sakaguchi K, Shibasaki T, Takahashi H, Kawakami Y, Furuya K. Intrauterine therapy for parvovirus B19 infected symptomatic fetus using B19 IgG-rich IgG-rich high titer gammaglobulin. *J Perinat Med* 2005;33(6):561-563.
137. Runsewe-Abiodun IT, Ogunfowora OB, Fetuga BM. Neonatal malaria in Nigeria—a 2 year review. *BMC Pediatr* 2006;6:19.
138. Shah M, Li Y, Christensen RD. Effects of perinatal zidovudine on hematopoiesis: a comparison of effects on progenitors from human fetuses versus mothers. *AIDS* 1996;10(11):1239-1247.
139. Bishara N, Ohls RK. Current controversies in the management of anemia of prematurity. *Semin Perinatol*, 2009;33:29.
140. Widness JA. Pathophysiology of anemia during the neonatal period, including anemia of prematurity. *Neoreviews* 2008;9:e520
141. Ohls RK. Why, when, and how should we provide red cell transfusions and erythropoiesis-stimulating agents to support red cells mass in neonates? In *Hematology, Immunology and Infectious Disease*, Editors, Ohls RK and Maheshwari A, Second edition. Philadelphia, PA: Elsevier/Saunders, 2012:57-74.
142. Brown MS, Garcia JF, Phibbs RH, Dallman PR. Decreased response of plasma immunoreactive erythropoietin to “available oxygen in anemia of prematurity. *J Pediatr* 1984;105:793-798.
143. Shannon KM, Naylor GS, Torkildson JC, et al. Circulating erythroid progenitors in the anemia of prematurity. *N Engl J Med* 1987;31:728-733.
144. Rhondeau SM, Christensen RD, Ross MP, Rothstein G, Simmons MA. Responsiveness to recombinant human erythropoietin of marrow erythroid progenitors from infants with the “anemia of prematurity. *J Pediatr* 1988;112:935-940.
145. Ohls RK, Liechty KW, Turner MC, Kimura R, Christensen RD. Erythroid “burst promoting activity in the serum of patients with the anemia of prematurity. *J Pediatr* 1990;116:786-789.
146. Donato H. Erythropoietin: an update on the therapeutic use in newborn infants and children. *Expert Opin Pharmacother* 2005;6(5):723-734.
147. Ohls RK. Erythropoietin treatment in extremely low birth weight infants: blood in versus blood out. *J Pediatr* 2002;140:3-6.
148. Aher S, Ohlsson A. Late erythropoietin for preventing red blood cell transfusion in preterm and/or low birth weight infants. *Cochrane Database Syst Rev* 2006;3:CD004868.
149. Bierer R, Peceny MC, Hartenberger CH, Ohls RK. Erythropoietin concentrations and neurodevelopmental outcome in preterm infants. *Pediatrics* 2006;118(3):e635-e640.
150. Ohls RK, Ehrenkranz RA, Das A. Neurodevelopmental outcome and growth at 18 to 22 months corrected age in extremely low birth weight infants treated with early erythropoietin and iron. *Pediatrics* 2004;114(5):1287-1291.
151. Warwood TL, Ohls RD, Wiedmeier SE, et al. Single-dose darbepoetin administration to anemic preterm neonates *J Perinatol* 2005;25(11):725-730.
152. Warwood TL, Ohls RK, Lambert DK, et al. Intravenous administration of darbepoetin to NICU patients. *J Perinatol* 2006;26(5):296-300.
153. Warwood TL, Ohls RK, Lambert DK, Leve EA, Veng-Pedersen P, Christensen RD. Urinary excretion of darbepoetin after intravenous vs. subcutaneous administration to preterm neonates. *J Perinatol* 2006;26(10):636-639.

154. Warwood TL, Lambert DK, Henry E, Christensen RD. Very low birth weight infants qualifying for a "late erythrocyte transfusion: does giving darbepoetin along with the transfusion counteract the transfusion's erythropoietic suppression? *J Perinatol* 2011;31(Suppl 1):S17-S21.
155. Christensen RD. Association between red blood cell transfusions and necrotizing enterocolitis. *J Pediatr* 2011;158:349-350.
156. Baer VL, Lambert DK, Henry E, Snow GL, Butler A, Christensen RD. Among very-low-birth-weight neonates is red blood cell transfusion an independent risk factor for subsequently developing a severe intraventricular hemorrhage? *Transfusion* 2011;51:1170-1179.
157. Baer VL, Lambert DK, Henry E, Snow GL, Christensen RD. Red blood cell transfusion of preterm neonates with a Grade 1 intraventricular hemorrhage is associated with extension to a Grade 3 or 4 hemorrhage. *Transfusion* 2011;51(9):1933-1939.
158. Ball S. Diamond Blackfan anemia. *Hematology Am Soc Hematol Educ Program* 2011;2011:487-491.
159. Balci S. Limb anomalies and anemia: Aase-Smith syndrome. *Fetal Pediatr Pathol* 2008;27(6):292-293
160. Soulier J. Fanconi anemia. *Hematology Am Soc Hematol Educ Program* 2011;2011:492-749.
161. Tolar J, Becker PS, Clapp DW, et al. Gene therapy for fanconi anemia: one step closer to the clinic. *Hum Gene Ther* 2012 ;23(2):141-144
162. Landmann E, Bluettters-Sawatzki R, Schindler D, Gortner L. Fanconi anemia in a neonate with pancytopenia. *J Pediatr* 2004;145(1):125-127.
163. Charles JM, Key LL. Developmental spectrum of children with congenital osteopetrosis. *J Pediatr* 1998;132(2):371-374.
164. Pearson HA, Lobel JS, Kocoshis SA, et al. A new syndrome of refractory sideroblastic anemia with vacuolization of marrow precursors and exocrine pancreatic dysfunction. *J Pediatr* 1979;95(6):976-984.
165. Toth T, Bokay J, Szonyi L, Nagy B, Papp Z. Detection of mtDNA deletion in Pearson syndrome by two independent PCR assays from Guthrie card. *Clin Genet* 1998;53(3):210-213.
166. van den Ouweland JM, de Klerk JB, van de Corput MP, et al. Characterization of a novel mitochondrial DNA deletion in a patient with a variant of the Pearson marrow-pancreas syndrome. *Eur J Hum Genet* 2000;8(3):195-203.
167. Christensen RD, Ilstrup S. Recent advances toward defining the benefits and risks of erythrocyte transfusions in neonates. *Arch Dis Child Fetal Neonatal Ed*. Epub 29/6/12.
168. Christensen RD. Associations between "early red blood cell transfusion and severe intraventricular hemorrhage, and between "late red blood cell transfusion and necrotizing enterocolitis. *Semin Perinatol* 2012;36(4):283-289.
- P.1031
169. Blau J, Calo JM, Dozor D, Sutton M, Alpan G, La Gamma EF. Transfusion-related acute gut injury: necrotizing enterocolitis in very low birth weight neonates after packed red blood cell transfusion. *J Pediatr* 2011;158(3): 403-409.
170. Christensen RD, Lambert DK, Henry E, et al. Is "transfusion-associated necrotizing enterocolitis an authentic pathogenic entity? *Transfusion* 2010;50:1106-1112.
171. Josephson CD, Wesolowski A, Bao G, et al. Do red cell transfusions increase the risk of necrotizing enterocolitis in premature infants? *J Pediatr* 2010;157:972-978.e1-3.
172. El-Dib M, Narang S, Lee E, Massaro AN, Aly H. Red blood cell transfusion, feeding and necrotizing enterocolitis in preterm infants. *J Perinatol* 2011;31:183-187.
173. Paxon CL. Collection and use of autologous fetal blood. *Am J Obstet Gynecol* 1979;134:708-710.
174. Golden SM, O'Brien WF, Lissner C, et al. Hematologic and bacteriologic assessment of autologous cord blood for neonatal transfusions. *J Pediatr* 1980;97:810-812.
175. Golden SM, Petit N, Mapes T, Davis SE, Monaghan WP. Bacteriologic assessment of autologous cord blood for neonatal transfusion. *Am J Obstet Gynecol* 1984;149:907-908.

176. Rao M, Ahrlund-Richter L, Kaufman DS. Concise review: cord blood banking, transplantation and induced pluripotent stem cell: success and opportunities. *Stem Cells* 2012;30:55-60.
177. Strauss RG. Autologous transfusions for neonates using placental blood. A cautionary note. *Am J Dis Child* 1992;146:21-22.
178. Brune T, Garritsen H, Witteler R, et al. Autologous placental blood transfusion for the therapy of anaemic neonates. *Biol Neonate* 2002;81:236-243.
179. Khodabux CM, von Lindern JS, van Hilten JA, Scherjon S, Walther FJ, Brand A. A clinical study on the feasibility of autologous cord blood transfusion for anemia of prematurity. *Transfusion* 2008;48:1634-1643.
180. Strauss RG, Mock DM, Johnson KJ, et al. A randomized clinical trial comparing immediate versus delayed clamping of the umbilical cord in preterm infants: short-term clinical and laboratory endpoints. *Transfusion* 2008;48:658-665.
181. Jansen M, Brand A, von Lindern JS, Scherjon S, Walther FJ. Potential use of autologous umbilical cord blood red blood cells for early transfusion needs of premature infants. *Transfusion* 2006;46:1049-1056.
182. Taguchi T, Suita S, Nakamura M, et al. The efficacy of autologous cord-blood transfusions in neonatal surgical patients. *J Pediatr Surg* 2003;38:604-607.
183. Eichler H, Schaible T, Richter E, et al. Cord blood as a source of autologous RBCs for transfusion to preterm infants. *Transfusion* 2000 ;40:1111-1117.
184. Strauss RG, Widness JA. Is there a role for autologous/placental red blood cell transfusions in the anemia of prematurity? *Transfus Med Rev* 2010;24:125-129.
185. Khodabux CM, van Beckhoven JM, Scharenberg JG, El Barjiji F, Slot MC, Brand A. Processing cord blood from premature infants into autologous red-blood-cell products for transfusion. *Vox Sang* 2011;100:367-373.
186. Strauss RG, Widness JA. Autologous or allogeneic: cord blood red blood cells still are investigational. *Transfus Med Rev* 2012;26:91-92.
187. Christensen RD. Identifying neonates likely to benefit from a red blood cell transfusion. *Transfusion* 2012;52:217-218.
188. van Hoften JC, Verhagen EA, Keating P, ter Horst HJ, Bos AF. Cerebral tissue oxygen saturation and extraction in preterm infants before and after blood transfusion. *Arch Dis Child Fetal Neonatal Ed* 2010;95:F352-F358.
189. Dani C, Pratesi S, Fontanelli G, Barp J, Bertini G. Blood transfusions increase cerebral, splanchnic, and renal oxygenation in anemic preterm infants. *Transfusion* 2010;50:1220-1226.
190. Bailey SM, Hendricks-Muñoz KD, Wells JT, Mally P. Packed red blood cell transfusion increases regional cerebral and splanchnic tissue oxygen saturation in anemic symptomatic preterm infants. *Am J Perinatol* 2010;27:445-453.
191. Bailey SM, Hendricks-Muñoz KD, Mally P. Splanchnic-cerebral oxygenation ratio as a marker of preterm infant blood transfusion needs. *Transfusion* 2012;52:252-260.

Chapter 44 Erythrocytosis

> Table of Contents > Part IV - Disorders of Red Cells > Section 5 - Other Red Cell Disorders > Chapter 44 - Erythrocytosis

Chapter 44

Erythrocytosis

Robert T. Means, Jr.

DEFINITIONS AND TERMINOLOGY

The terms polycythemia and erythrocytosis are often used as if they are interchangeable; in fact, they describe related but distinct findings that usually, but not always, coexist. Polycythemia (“many cells”) describes an increase in the total quantity or volume (mass) of red blood cells in the body without any implication regarding leukocytes or platelets. An increase in the concentration of erythrocytes, however, whether measured as number of cells, hemoglobin (Hb), or packed cell volume (PCV, hematocrit), is more correctly designated erythrocytosis. Erythrocytosis may be the result of an increase in the red cell volume or mass (polycythemia; also called absolute erythrocytosis) or the result of a reduced plasma volume (called relative or spurious polycythemia or erythrocytosis), which produces an increase in red cell concentration that does not reflect an increase in the quantity of red cells in the body.

Despite the precision with which these terms are defined, opportunities for confusion abound. Polycythemia vera (also called polycythemia rubra vera) is a myeloproliferative disorder associated with trilineage marrow hyperplasia and characterized by an increased red cell mass, usually in association with leukocytosis and thrombocytosis. The outdated term erythremia refers to this disease (see Chapter 82). Some patients who do not have this myeloproliferative disease are described as having polycythemia vera simply because they have an elevated red cell mass (i.e., their polycythemia is “true” [“vera”]). Confusion on this point is frequently encountered in consultative hematology practice.

PATHOLOGIC PHYSIOLOGY

Red cell survival in polycythemic states is typically normal, implying that increased red cell mass reflects increased erythropoiesis. As the red cell mass rises, the total blood volume typically increases: the variability of changes in plasma volume means that the degree of increase is unpredictable.¹

The clinical manifestations of erythrocytosis are related in part to the disorder responsible for erythrocytosis (e.g., thrombosis in patients with polycythemia vera,² hypertension in relative polycythemia,³ etc.). In addition, the increased blood volume and increased blood viscosity that occur in association with polycythemia themselves produce certain symptoms and signs; these are related to the degree of the increase and the resulting effects on blood flow and oxygen transport.⁴ Thus, the “ruddy cyanosis” seen in patients with polycythemia vera is a consequence of dilatation of cutaneous vessels by expanded blood volume and sluggish local circulation caused by increased blood viscosity.^{5, 6, 7} Headache, dizziness, tinnitus, a full feeling in the head, and a bleeding tendency may develop in patients with erythrocytosis and expanded blood volume regardless of the basic cause.^{8, 9, 10, 11} These symptoms usually are relieved by normalization of the hematocrit.

Blood Viscosity and Oxygen Transport

Viscosity is an intrinsic characteristic of a liquid and represents the tendency of that liquid to resist changes in shape. The viscosity of blood is a result of the interaction of several factors, including the red cell concentration by volume, the physical characteristics (deformability, aggregability, and size) of red cells, the plasma volume, plasma proteins, platelet count, and leukocyte number and character.¹² In this chapter, the red cell concentration by volume is referred to as the hematocrit, reflecting common usage. Other authors, particularly those studying rheology and oxygen transport, refer to this parameter as the volume of packed red blood cells or PCV. As discussed below, the blood viscosity affects the oxygen content and delivery. This section focuses primarily on the contribution of red cell concentration to viscosity and oxygen transport; more complete discussions are available elsewhere.¹²

The rate of flow of a liquid through a tube of fixed length is directly related to the pressure gradient across that length of tube and to the radius raised to the fourth power (r^4) and inversely related to the viscosity of that liquid (Poiseuille's law).^{9, 10, 13, 14} Determinations of the effects of erythrocytosis on blood viscosity were largely made by determining the flow rate of venous blood through an 18-gauge needle under known pressure and thus calculating viscosity.¹⁴ The values thus determined are only an approximation of the in vivo situation. Poiseuille's law is strictly applicable only to fluids that maintain constant viscosity under differing flow rates; this is not the case with blood (Fig. 44.1).^{13, 14} As the velocity of flow (indicated by the shear rate) increases, the viscosity at any given hematocrit decreases.¹⁴ Other factors that interact with the hematocrit to contribute to viscosity are the mean erythrocyte corpuscular volume (MCV) and mean corpuscular hemoglobin (MCH).^{15, 16, 17} At any given hematocrit, decreased MCV or MCH (or both) is associated with increased viscosity, especially at low flow rates.^{16, 17} This is a clinically significant observation, because iron deficiency (low MCV) with a normal Hb

P.1033

or hematocrit is a common endpoint of the treatment of polycythemia by phlebotomy.

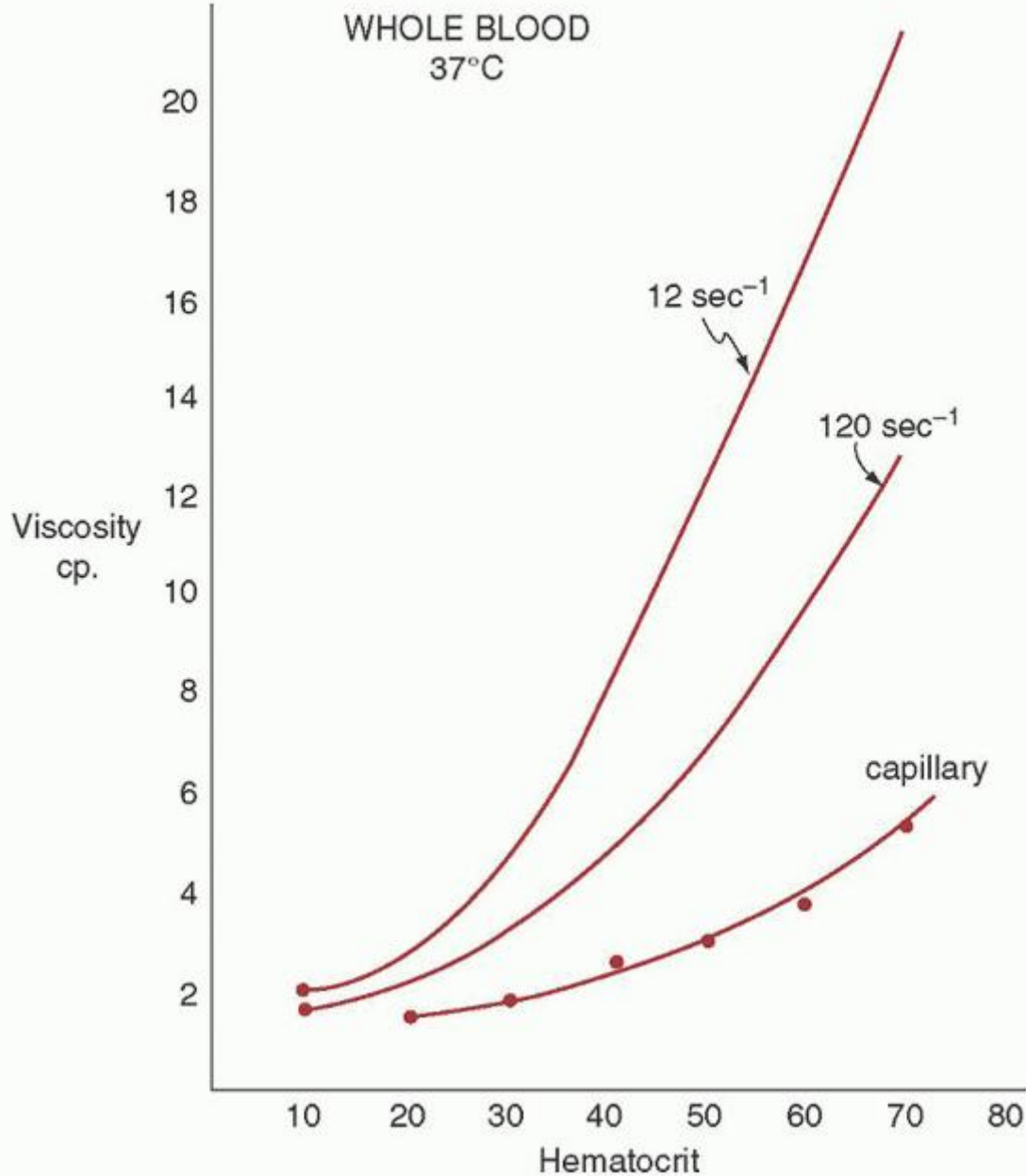

FIGURE 44.1. Relation of volume of packed red cells (hematocrit) to blood viscosity in centipoise (cp) as measured in a capillary viscosimeter compared with that calculated for shear rates of 120 sec^{-1} (ascending aorta) and 12 sec^{-1} (medium arteriole). (From Wells RE Jr, Merrill EW. The variability of blood viscosity. *Am J Med* 1961;31:505, with permission.)

It is noted above that the model for determining blood viscosity represents a somewhat artificial system: calculated values probably exceed those existing in vivo.¹³ However, studies of cerebral blood flow in patients with erythrocytosis of various etiologies have demonstrated the clinical effects of an elevated hematocrit on in vivo blood flow.^{18, 19, 20, 21} Cerebral blood flow in patients with erythrocytosis was significantly reduced compared to controls whether it was due to an elevated red cell mass,¹⁹ due to reduced plasma volume,^{20, 21} or of unknown etiology¹⁸ (Table 44.1). Hematocrit reduction, either by venesection^{18, 19, 20, 21} or by volume expansion,²¹ improved cerebral blood flow.

The determination of blood viscosity values at different hematocrits allows the estimation of blood flow rates under different conditions. As Poiseuille's law predicts (and the data in Table 44.1 imply), blood flow decreases linearly with increasing viscosity.²² The rate of oxygen transport can then be calculated from the blood flow rate and oxygen content. At a given vessel size and pressure gradient, the predicted relation of oxygen transport to hematocrit is expressed by an arch-shaped curve (Fig. 44.2A).^{14, 22, 23} At low hematocrits, the reduced Hb content of blood translates into reduced

oxygen content. At elevated hematocrits (>0.5 to 0.6), increased viscosity reduces oxygen transport despite increased blood oxygen content. Optimal oxygen transport would be predicted to occur in the normal hematocrit range.^{22, 23, 24, 25, 26} Experiments in normovolemic dogs (Fig. 44.2B, dashed line) support this prediction.²³

The differences in oxygen transport observed between normovolemic and hypervolemic dogs at different hematocrits (Fig. 44.2B) reflect the probable situation occurring in patients with erythrocytosis due to an expanded red cell mass (polycythemia). In polycythemia, the associated hypervolemia permits an oxygen transport curve that is similar to that of normovolemic patients but which is elevated and shifted to the right.^{23, 26} Therefore, in patients with tissue hypoxia, polycythemia is beneficial because it leads to hypervolemia and increases oxygen transport (compare oxygen transport at hematocrit 0.6 on the hypervolemic and normovolemic curves in Fig. 44.2B). In contrast, in patients who have a normal or decreased total blood volume (as in relative or spurious polycythemia), erythrocytosis has an adverse effect on oxygen transport.

Relation to Treatment of Polycythemia

The considerations noted above are of interest in understanding not only the pathophysiology of the different etiologies of erythrocytosis, but also their treatment. Patients with polycythemia vera have no need for increased tissue oxygen transport. In some areas where fixed vessel diameter (from arteriosclerosis) limits increased blood flow, however, the additional impeding effect of increased blood viscosity may limit oxygen transport and result in local tissue ischemia. Phlebotomy can bring about a significant clinical benefit (see Chapter 82). When treating by phlebotomy, however, blood volume should not be reduced too greatly at any one episode, especially in patients with known symptoms of cardiovascular disease (angina pectoris, transient ischemic attacks). This is particularly true early in the course of therapy, when hematocrit (and consequently viscosity) is highest.²⁷ Rather, time should be allowed for hemodilution to occur between phlebotomies; in emergencies, the blood volume should be maintained by infusing saline or some other plasma expander.⁶ A concern is that the patient not suddenly be shifted from the hypervolemic, erythrocytosis-beneficial curve to the normovolemic, erythrocytosis-adverse curve. Another concern is that a sudden fall in blood volume from any cause, such as dehydration or acute hemorrhage, may result in local ischemia because increased cardiac output cannot compensate immediately for the effects of high viscosity. In patients with congestive heart failure, the need for reduction of blood viscosity may be urgent, because the ability to increase cardiac output to compensate for the increased blood viscosity has been compromised. The oxygen-Hb dissociation curve is shifted to the right in such patients.²⁸

TABLE 44.1 EFFECT OF ERYTHROCYTOSIS ON CEREBRAL BLOOD FLOW

Etiology of Erythrocytosis (No. of Patients)	Reference	CBF (ml/100 g/min)	Percent Normal CBF
Polycythemia ¹⁶	19	37.9 ± 11.2	54.8 ± 16.2
Mixed ³⁹	18	41.4 ± 10.5	63.6 ± 16.2
Relative polycythemia	20		
High-normal red blood cell mass ²¹		45.8 ± 10.9	66.8 ± 15.9
Low plasma volume ¹⁸		48.8 ± 12.9	71.1 ± 18.8
Relative polycythemia ⁵	21	40.7 ± 5.4	59.9 ± 7.8

Note: Values expressed as mean ± standard deviation.

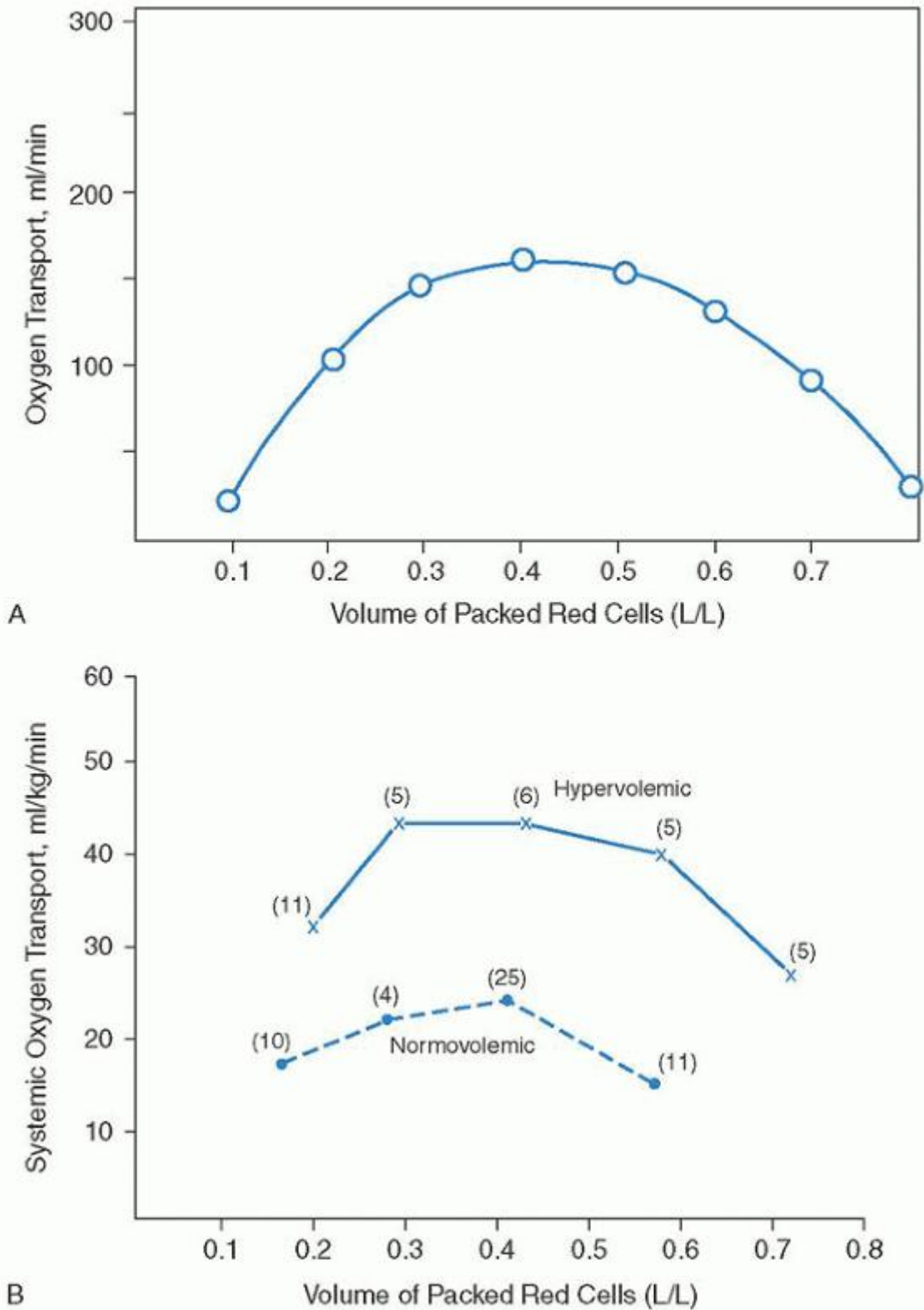

FIGURE 44.2. Arterial oxygen transport at different volumes of packed red cells and thus different viscosity values. A: Values in curve were calculated from blood viscosity values as measured by Pirofsky.⁹ B: Systemic oxygen transport as calculated from cardiac output measured in normovolemic and hypervolemic dogs. (From Murray JF, Gold P, Johnson BL Jr. The circulatory effects of hematocrit variations in normovolemic and hypovolemic dogs. *J Clin Invest* 1963;42:1150-1159, with permission.)

In contrast to polycythemia vera, patients with polycythemia due to tissue hypoxia may benefit from an increased hematocrit.

P.1034

Reduced arterial oxygen saturation means that blood oxygen transport is less efficient at particular Hb or hematocrit levels. Therefore, the curves for oxygen transport would be shifted closer to the origin than those noted in situations in which Hb oxygenation is normal (Fig. 44.2B). In the presence of decreased arterial oxygen saturation, tissue hypoxia may persist even when erythrocytosis is marked. The main advantage to decreasing blood viscosity and blood volume in hypoxic (secondary) polycythemia is to decrease the cardiac workload. One would predict that in such situations an increase in tissue oxygen transport and clinical improvement should result from phlebotomy; results show that this is the case.²⁹ Again, especially early in the course, phlebotomy with preservation of an expanded blood volume may be beneficial.^{6, 27} To achieve the best balance between increased cardiac work and decreased tissue hypoxia in patients with hypoxemic erythrocytosis, some authors suggest that the hematocrit be maintained between 0.50 and 0.55;^{6, 29} however, the subjective symptomatology of the patient is usually the best guide.²²

CLASSIFICATION AND APPROACH TO THE PATIENT WITH ERYTHROCYTOSIS

An increase in hematocrit (erythrocytosis) may result from decreased plasma volume or from polycythemia, which is an increase in the absolute quantity of red cells or red cell mass. The various forms of erythrocytosis are listed in Table 44.2. They are classified according to red cell mass (relative erythrocytosis or polycythemia vs. actual polycythemia). Polycythemia, in turn, is divided into primary polycythemia (polycythemia vera and familial primary polycythemia/primary proliferative polycythemia) and polycythemia driven by erythropoietin production (secondary polycythemia). The secondary polycythemic syndromes are divided into those that represent a response to tissue hypoxia (physiologically appropriate) and those driven by erythropoietin not produced in response to tissue hypoxia (physiologically inappropriate).

TABLE 44.2 CLASSIFICATION OF ERYTHROCYTOSIS

Relative Erythrocytosis or Polycythemia (Spurious Polycythemia)

Hemoconcentration

Spurious polycythemia (Gaisböck syndrome)

Polycythemia (Absolute Erythrocytosis)

Primary polycythemia

Polycythemia vera

Primary familial polycythemia

Secondary polycythemia

Secondary to decreased tissue oxygenation (physiologically appropriate polycythemia or hypoxic erythrocytosis)

High-altitude erythrocytosis (Monge disease)

Pulmonary disease

Chronic cor pulmonale

Ayerza syndrome

Cyanotic congenital heart disease

Hypoventilation syndromes

Primary alveolar hypoventilation

Pickwickian syndrome, Ondine curse

Positional desaturation

Sleep apnea

Abnormal hemoglobins

Inherited

Acquired: Drugs and chemicals, carboxyhemoglobin

Familial polycythemia

Secondary to aberrant erythropoietin production or response (physiologically inappropriate polycythemia)

Tumors, cysts, hemangiomas, and so forth

Androgen abuse

Erythropoietin abuse

Familial polycythemia

Idiopathic polycythemia

An approach to the evaluation of the patient with erythrocytosis is outlined in Figures 44.3 and 44.4. Although actual polycythemia can usually be differentiated from relative polycythemia on clinical grounds (as described below), an assessment of the red cell mass is the initial step in evaluation. Traditionally, this has been done by measurement of red cell mass and blood volume by isotope labeling. Normal values are presented in Table 44.3, but considerable variation exists from one subject to another in red cell, plasma, and total blood volume, even when expressed as milliliters per kilogram (ml/kg) body weight. This variation results, in part, from differences in body fat content^{31, 32, 33, 34}; blood volume is more closely related to lean body mass³³ than to weight or surface area. It has been proposed that a red cell mass of at least 125% of that predicted should be considered as indicating polycythemia.³⁵ It has been a common practice at many to measure either plasma volume or red cell volume and, from one of these determinations, to calculate total blood volume on the basis of the relative amounts as indicated by a hematocrit determination. In the view of most,^{36, 37, 38} but not all,¹⁵ investigators, this practice is associated with an increased chance of error; measuring red cell mass and plasma volume separately is preferable. It must be emphasized that blood volume measurements do not differentiate between secondary polycythemia and polycythemia vera; they are useful only in distinguishing absolute from relative erythrocytosis.

However, availability of actual red cell volume measurement has become limited to a small number of large medical centers with special expertise. Surrogate measures based on Hb or hematocrit are now the routine basis for distinguishing relative and actual polycythemia. In men with a hematocrit > 0.60 or women with a hematocrit > 0.55, there is reported to be >99% likelihood that the red cell mass is elevated.³⁹ In its 2007 criteria for the diagnosis of polycythemia vera, the World Health Organization (WHO) uses an Hb concentration of >18.5 g/dl in men or 16.5 g/dl in women to define an elevated red cell mass.⁴⁰ In a comparative study, the hematocrit 0.60/0.55 standard was reported to identify elevated red cell mass more accurately than the Hb concentration 18.5/16.5 g/dl standard.⁴¹ It should be noted that in certain circumstances of severe hemoconcentration (e.g., in the systemic capillary leak syndrome⁴²), Hb concentrations or hematocrits in this range may be observed in patients with a normal red cell mass. Such patients typically exhibit anasarca and other physical findings suggestive of severe intravascular volume depletion and redistribution of intravascular volume.

The goal of the approach outlined in Figures 44.3 and 44.4 is initially to distinguish spurious (relative) polycythemia from actual polycythemia, then to distinguish polycythemia vera from secondary polycythemia and primary proliferative polycythemia, to rule out other primary polycythemia, and finally to identify the etiology of secondary polycythemia. The characteristics of polycythemia vera are outlined in Chapter 82; the other polycythemic syndromes are discussed below. A certain number of patients are not readily classified as having either polycythemia vera or secondary polycythemia. These patients fall into a category called (for want of a more physiologic term) idiopathic polycythemia or idiopathic erythrocytosis and appear to represent a heterogeneous group of disorders (see below).

The diagnostic approach to polycythemia has been substantially altered by the observation that more than 95% of patients with polycythemia vera express a mutation in the JAK2 gene in which phenylalanine is substituted for valine at position 617.^{43, 44, 45} JAK2 V617F mutation-negative polycythemia vera patients have been reported to have mutations in other exons of JAK2.⁴⁶

P.1035

P.1036

It is tempting to regard the JAK2 mutation in polycythemia vera as conceptually analogous to the bcr/abl mutation in chronic myelogenous leukemia; however, the JAK2 V617F mutation is also found in other myeloproliferative disorders.⁴⁴ Its implications are discussed in more detail in Chapter 82, but in terms of differential diagnosis, it should be regarded as a marker of a myeloproliferative state. Polymerase chain reaction-based assays for JAK2 V617F versions of this test are widely available through reference laboratories in the United States and Europe at costs in the \$300 to \$500 range. As the role of JAK2 assessment in the approach to myeloproliferative disorders continues to expand, increasing numbers of medical centers are developing in-house tests for JAK2 V617F.

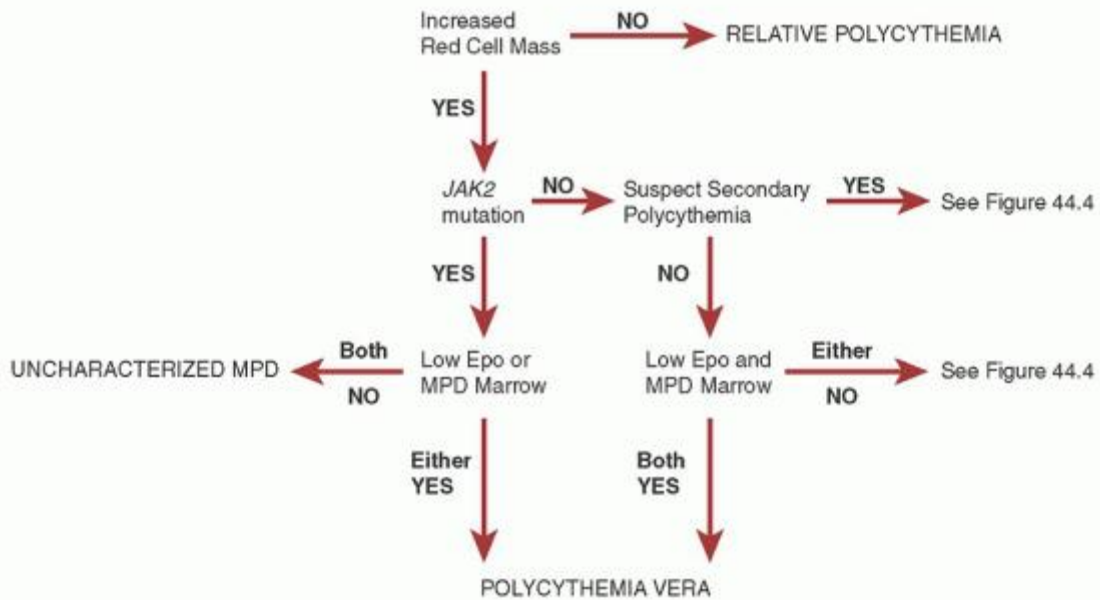

FIGURE 44.3. Approach to patients with erythrocytosis. EEC, endogenous erythroid colonies; EpoR, erythropoietin receptor; JAK2 mutation, testing for JAK2 V617F or other mutations associated with polycythemia vera; low Epo, serum or plasma erythropoietin concentration less than the lower limit of normal; MPD, myeloproliferative disorder; MPD marrow, bone marrow findings suggestive of a myeloproliferative disorder (see text); MPD, myeloproliferative disorder; VHL, von Hippel-Lindau protein.

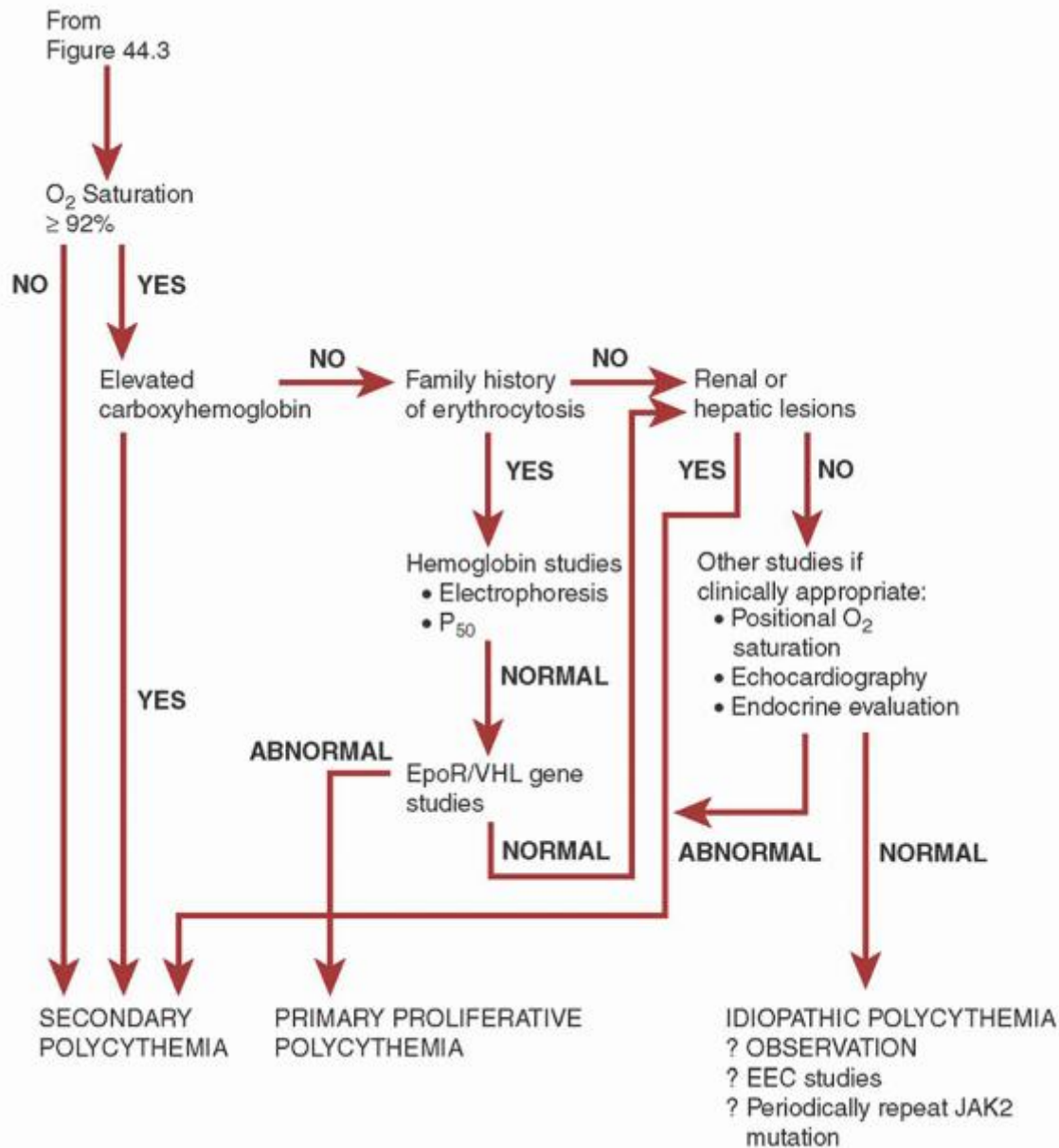

FIGURE 44.4. Approach to patients with erythrocytosis. JAK2 V617F-negative erythrocytosis. CNS, central nervous system; EEC, endogenous erythroid colonies; EpoR, erythropoietin receptor; MPD, myeloproliferative disorder; VHL, von Hippel-Lindau protein.

TABLE 44.3 NORMAL VALUES FOR RED BLOOD CELL, PLASMA, AND TOTAL BLOOD VOLUME (ML/KG ± 1 STANDARD DEVIATION^a)

	No.	Red Blood Cells	Plasma	Total Blood Volume
Women				
Sea level				
Wennesland et al. ³⁴	97	25.4 ± 2.6	36.8 ± 3.7	—
Huff and Feller ³¹	20	24.4 ± 2.6	34.8 ± 3.2	58.9 ± 4.9
Men				
Sea level				

Wennesland et al. ³⁴	199	28.3 ± 2.8	34.4 ± 4.0	—
Huff and Feller ³¹	42	28.3 ± 4.1	33.5 ± 5.2	61.5 ± 8.6
Weil et al. ³⁰ 1,600 m ^b	16	27.1 ± 3.7	33.0 ± 5.3	60.0 ± 8.6
Weil et al. ³⁰ 3,100 m ^b	19	26.8 ± 3.2	31.9 ± 3.6	58.7 ± 5.8
Weil et al. ³⁰	39	31.8 ± 6.7	35.2 ± 5.3	66.8 ± 8.5

^aRed blood cell volume measured by ⁵¹Cr method. Other values calculated without correction for trapped plasma.

^b Only values of which we are aware at altitudes significantly above sea level. They may be somewhat low for unknown reasons; the packed cell volumes at 1,600 m were the same as at sea level, a finding that contradicts an earlier author's own large experience.

The WHO criteria for the diagnosis of polycythemia vera requires evidence of an increased red cell mass, and a JAK2 or other functionally similar mutation and one minor criterion; or evidence of an increased red cell mass and all three minor criteria.⁴⁰ The minor criteria are a serum or plasma erythropoietin concentration below the range of normal for the laboratory; a bone marrow examination exhibiting the characteristic features of a myeloproliferative disorder (hypercellularity with trilineage hyperplasia, clustered pleomorphic megakaryocytes, and no features of inflammation) and the formation of erythroid colonies in vitro in the absence of added erythropoietin ("endogenous erythroid colonies"[EECs]).⁴⁰ Although these tests can be evaluated in any order desired, ease of test access would suggest that erythropoietin concentration be ordered first, followed by marrow evaluation if necessary. In a JAK2 mutation-positive patient, either a characteristic erythropoietin concentration or a characteristic marrow would permit the diagnosis of polycythemia vera. In a JAK2 mutation-negative patient, absence of both a characteristic erythropoietin concentration and a characteristic marrow would rule out the diagnosis. EEC assays, a hallmark of myeloproliferative disorders in general,^{47, 48} are not readily available outside of research laboratories, which limits their diagnostic practicality.

The roles of erythropoietin levels and EEC assays in the differential diagnosis of erythrocytosis are most strongly supported by their association with the WHO diagnostic criteria; as stand-alone tests in individual cases, utility is less clear.^{49, 50, 51} Although mean serum erythropoietin concentration in the subset of patients with polycythemia vera is significantly lower than that observed in secondary polycythemia, there is considerable overlap, making it less useful for individual cases. This would be expected physiologically. A patient with secondary polycythemia due to tissue hypoxia would have an elevated serum erythropoietin level until the hematocrit was sufficiently high to oxygenate tissue adequately; then the erythropoietin concentration would be expected to decrease. The intermittent nature of detection of an elevated serum erythropoietin concentration in secondary polycythemia has been described,⁵² as has the failure of serum erythropoietin concentrations to predict clinical course in idiopathic erythrocytosis.⁵³ Studies have been reported demonstrating that polycythemia vera and secondary polycythemia can be distinguished based on the serum erythropoietin response to phlebotomy: after phlebotomy, serum erythropoietin levels increase in secondary polycythemia but remain stable in polycythemia vera.⁴⁹ EECs corresponding to erythroid burst-forming units were observed in 12 of 17 polycythemia vera patients, 3 of 11 secondary polycythemics, 1 of 6 relative polycythemics, and 1 of 11 normal individuals in one series.⁵⁴

Soluble transferrin receptors are typically elevated in all forms of polycythemia and thus do not distinguish polycythemia vera and secondary polycythemia.⁵⁵

As a general approach to the evaluation of erythrocytosis, all patients with presumed polycythemia should undergo JAK2 V617F testing. If the clinical features are suggestive of a secondary etiology of polycythemia, patients who do not show a JAK2 mutation should follow the process outlined in Figure 44.4. Individuals without a documented JAK2 mutation but in whom suspicion of a myeloproliferative disorder is high, should be investigated for minor WHO criteria (Fig. 44.3).

RELATIVE POLYCYTHEMIA

Lowered fluid intake, marked loss of body fluids, or a combination of both causes a decrease in plasma volume and may produce a relative erythrocytosis. The decrease in plasma volume may result from any cause of intravascular fluid loss, insensible fluid loss, persistent vomiting, severe diarrhea, copious sweating, postoperative complications, or shift of fluid into the extravascular space ("third spacing")^{3, 37, 42, 56} or may be an effect of high altitude.⁵³ In severe burns, plasma loss leads to hemoconcentration.

Chronic relative polycythemia or erythrocytosis has been variously referred to as Gaisböck syndrome,⁵⁷ “stress” erythrocytosis,³ benign polycythemia,^{52, 56} benign erythrocytosis,⁵⁸ spurious polycythemia,^{59, 60} pseudopolycythemia,⁶¹ and apparent polycythemia.⁶² The last three terms are the most accurate: in the absence of an elevated red cell mass, there is no polycythemia. In one series of 215 patients referred with a diagnosis of polycythemia vera,⁶³ 18 (8.3%) were believed to have chronic relative erythrocytosis, possibly caused by “stress.”³ Patients with relative polycythemia or erythrocytosis are typically male; the mean age at diagnosis is less than is seen in patients with polycythemia vera.⁶² Obesity is typically described as an associated feature,³ although not all studies support this association.⁶⁴ Other features reported to be strongly associated with relative polycythemia are hypertension and smoking;^{62, 64, 65} associations with alcohol abuse and renal disease are occasionally reported.^{62, 63} It is probable that this syndrome is not a true clinical entity.⁶⁰ The red cell mass values generally accepted as normal at sea level, or at any given altitude, represent the mean ± 2 standard deviations. Thus, on the basis of the normal frequency distribution curve for this physiologic parameter, the values in 2.5% of the population are above this range. The individuals in this group should not be regarded as necessarily abnormal.⁶⁶

The optimal management of relative polycythemia is unknown. As noted previously, phlebotomy increases cerebral blood flow even in patients with relative polycythemia; whether it is of

P.1037

symptomatic benefit is less clear.^{20, 21} It should probably be avoided. Theoretic arguments can be made that contracting the blood volume further in these patients who already are normovolemic or slightly hypovolemic may impair tissue perfusion. Satisfactory control of hematocrit can be obtained in at least two thirds of patients by reduction of excess weight, improved hypertension control, avoidance of diuretics, and reduction if not cessation of smoking.⁶⁴ Potentially leukemogenic cytoreductive therapy, such as radioactive phosphorus or oral chemotherapeutic agents, is probably never indicated.

Some types of high-affinity Hbs (Heathrow,⁶⁷ Pierre-Benite,⁶⁸ Rahere⁶⁹) may show relative polycythemia.

POLYCYTHEMIA (ABSOLUTE ERYTHROCYTOSIS)

Primary Polycythemia

Polycythemia Vera

Polycythemia vera is discussed in Chapter 82.

Primary Familial Polycythemia (“Chuvash Polycythemia”)/Primary Proliferative

Polycythemia familial erythrocytosis or polycythemia is a term used to describe instances in which two or more members of a family have polycythemia, do not have polycythemia vera, and have no identifiable “secondary” causes.⁷⁰ This finding can result from a constellation of pathophysiologic mechanisms, including abnormalities of oxygen-Hb interaction, or idiopathic constitutive erythropoietin secretion. These syndromes are discussed under etiologies of secondary polycythemia, below.

Primary familial polycythemia is a term used to describe a syndrome observed in families with abnormalities of the erythropoietin receptor, resulting in hypersensitivity to erythropoietin and consequent erythrocytosis.^{71, 72, 73} This particular autosomal dominant trait does not necessarily confer an adverse prognosis early in life: the propositus of the first such family described was an Olympic gold medalist in cross-country skiing.⁷¹ However, these individuals are at increased risk for thrombotic and vascular mortality later on. A variant of this syndrome occurs with high frequency among the people of the Chuvashia region of the former Soviet Union.⁷⁴ These individuals appear to have a mutation in the oxygen-sensing pathway regulating erythropoietin production, typically involving von Hippel-Lindau protein, and also in the response of erythroid progenitors to erythropoietin.^{75, 76, 77, 78} This effect on erythropoietin signaling appears to be mediated by loss of JAK2 regulation of erythropoiesis.⁷⁹ As in other patients with familial erythrocytosis due to aberrant erythropoietin signaling, Chuvash polycythemia patients have increased risk for vascular disease.⁸⁰ Isolated cases with similar mechanisms are referred to as primary proliferative polycythemia.

Secondary Polycythemia (Physiologically Appropriate [Hypoxic])

Insufficient oxygen supply to the tissues may result from any of the following, alone or in combination: (a) decreased ambient oxygen pressure (e.g., high altitude); (b) pulmonary diffusion or mixing abnormalities; (c) right-to-left cardiopulmonary shunts, as in cyanotic congenital heart disease; (d) hypoventilation; or (e) altered oxygen-carrying

affinity of Hb. In all of these disorders, insufficient tissue oxygenation leads to increased erythropoietin production and a consequent increase in red cell mass (see Chapter 6).

High-altitude Erythrocytosis

In 1890, Viault showed that erythrocytosis develops during sojourn at high altitude.⁸¹ He found erythrocyte counts of 7.5 to 8.0×10^{12} cells/L not only in natives of the Peruvian Andes working in a mine at an altitude of 4,392 m above sea level, but also in himself and in a traveling companion, although his blood count in Lima (160 m above sea level) had been normal. On a Mt. Everest expedition, researchers demonstrated that red cell volume and values of total Hb rose progressively as higher altitudes were attained; at 19,000 feet (5,800 m), mean values were 49% above those at sea level. The increase in total blood volume was partially masked by reductions in plasma volume.^{82, 83} A sharp increase in erythropoietin production occurs within the first week of high-altitude exposure and is associated with mobilization of iron stores and evidence of iron-deficient erythropoiesis.⁸⁴ Mechanisms of adaptation to living at high altitude apparently are multiple and differ between ethnic groups.^{85, 86}

The rapid ascent to high altitude is accompanied by symptoms of fatigue, dizziness, pulsating headache, anorexia, nausea, vomiting, insomnia, and irritability, a syndrome well known to mountain climbers and residents of high altitudes and referred to as acute mountain sickness or acute altitude disease.^{87, 88, 89, 90} The symptoms first appear some 4 to 6 hours after reaching a high altitude but may be delayed for as many as 96 hours, suggesting that the pathogenesis represents more than simple hypoxia. The incidence is greatest in younger persons, in those flying to high altitude, or in those who climb fast and spend few nights acclimatizing. Gender, the weight of the load carried, and recent respiratory infection do not appear to affect the incidence.⁸⁸ Severity is greatest in the young and in less-experienced climbers and correlates with the speed of ascent and the altitude reached.⁹¹ Thus, all persons develop symptoms if they are suddenly transported from sea level to 15,000 feet (4,570 m) or higher, whereas a few develop symptoms at 8,000 to 10,000 feet (2,400 to 3,000 m).⁸³ After 4 to 8 days, acclimatization usually occurs, and symptoms remit spontaneously.^{88, 92} In some individuals, however, symptoms may progress to cerebral confusion, coma, and even death related to pulmonary edema unless the subject is returned to low altitude.^{87, 93}

The pathogenesis of acute mountain sickness may involve hypoxia and subsequent excessive secretion of antidiuretic hormone and adrenal steroids with resulting fluid retention, increased blood volume, and finally cerebral edema, pulmonary congestion, or both.^{94, 95, 96, 97, 98} The incidence and severity of symptoms can be considerably reduced or prevented by appropriate treatment.⁹⁹

The events associated with acclimatization after arrival at high altitude are not understood completely but probably include the following:

- An increase in erythrocyte 2,3-biphosphoglycerate (BPG) levels and a shift to the right in the oxygen-Hb dissociation curve, thus allowing better tissue delivery of oxygen despite decreased arterial oxygen saturation.^{86, 100, 101, 102} The increase in 2,3-BPG appears to compensate for the left shift in the curve that results from the initial hypocapnia and increase in arterial pH.^{100, 103}
- Increased erythropoietin production with subsequent increase in iron mobilization, reticulocytosis, and increase in red cell mass and blood volume.¹⁰⁴
- Correction of the initial excessive antidiuretic hormone and adrenal steroid secretion and return to the normal diurnal variation of plasma steroid levels.⁹⁸

The final result is a new equilibrium at decreased oxygen saturation and carbon dioxide tension with increases in alveolar ventilation, respiratory frequency, and red cell mass.⁹² These manifestations of acclimatization are quickly lost on descent to sea level, even after many years of residence at high altitude.

In some individuals, however, after a few or many years of good adaptation, excessive erythrocytosis develops, and arterial oxygen saturation may fall to as low as 60% (normal, 81%).

P.1038

An incapacitating illness characterized by alveolar hypoventilation develops. This entity is known as chronic mountain or altitude sickness or Monge disease.¹⁰⁵ Diminished mental acuity, headaches, dyspnea, fatigue, reduced physical fitness, nausea, vomiting, diminution of visual acuity, dizziness, tinnitus, vague or even excruciating pains in the extremities, paresthesias, and cough are characteristic symptoms. If the condition advances, symptoms include incessant dyspnea, aphonia, profound lethargy, and even coma. The face is bluish violet or almost black, the eyelids are edematous and

bluish, the sclerae are intensely colored by distended capillaries, the tongue is thick, the hands are enlarged and turgid, the fingers are clubbed, and dependent edema may be observed. The thorax is more barrel-shaped than in healthy inhabitants of the same region and altitude. Hypotension is often present. The spleen and the liver are infrequently enlarged, unless cardiac failure ensues.

Erythrocytosis is more marked than in normal residents of high altitudes, with hematocrits up to 0.84 L/L and Hb values as high as 28.0 g/dl. MCV is normal or slightly increased, and the mean corpuscular hemoglobin concentration (MCHC) is normal. Normal reticulocyte and leukocyte counts are usually observed. Hyperbilirubinemia owing to unconjugated bilirubin may be pronounced. Red cell turnover is greater in these individuals than in normal residents of high altitudes. Platelet counts usually are normal or high, yet epistaxis is common, and hemoptysis, bleeding of the gums, and purpura may occur. Red cell volume is greatly increased (88 to 95 ml/kg body weight). The results do not appear to be completely explainable by differences in erythropoietin production.^{105, 106, 107, 108, 109, 110}

Affected individuals usually are in the fourth to sixth decade of life. Remissions and relapses are described. Ascent to still higher altitudes aggravates symptoms, whereas descent to sea level relieves them. Cardiac impairment does not appear until late in the disease course, and death occurs more often from hemorrhage, pulmonary tuberculosis, or bronchopneumonia than from cardiac insufficiency.

At first, the disease was considered a distinct entity. It has been suggested that the disease is an exaggeration of the process of acclimatization and aging, because patients with chronic mountain sickness had Hb concentrations within the normally distributed values for large groups of native residents. Support for this suggestion comes from the observation that chronic lung disease increases the likelihood of chronic mountain sickness.¹¹¹ Chronic mountain sickness has not been reported to occur in natives of the Himalayas.¹¹² This may reflect in part occupational differences, namely mining, and a consequently high incidence of chronic lung disease in the Andes as compared with the pastoral occupation of the Sherpas. Investigation of selective gene expression in populations in whom chronic mountain sickness is prevalent, may further enhance understanding of this syndrome.^{113, 114, 115}

Differentiation of chronic mountain sickness from other causes of hypoxic polycythemia should not be difficult. Cases of congenital or acquired cyanotic heart disease can be distinguished by the cardiac findings. Polycythemia vera is not altered by increased ambient oxygen tension, whereas in Monge disease, descent to sea level produces complete relief of symptoms, together with a pronounced reduction in the blood volume and restoration of normal blood counts.¹¹⁶

Pulmonary Disease

A variety of diseases, such as chronic obstructive pulmonary disease, diffuse pulmonary infiltrates (fibrous or granulomatous), kyphoscoliosis, and multiple pulmonary emboli, leads to erythrocytosis as the result of inadequate oxygenation of the blood circulating through the lungs. Not all patients with lung disease and decreased arterial oxygen saturation, however, have elevated Hb or hematocrit levels,^{117, 118} and only in approximately 50% is an increase in red cell mass noted.¹¹⁹ The reason for this suboptimal response to hypoxia is not clear, but it does not appear to result from a decrease in erythropoietin production or the presence of chronic infection.^{117, 118, 120} When polycythemia occurs, it usually is associated with increased MCV, reduced MCHC,¹¹⁹ and normal MCH¹²⁰ values. The red cell morphology changes have been attributed to increased water uptake by the cell, which in turn may result from carbon dioxide retention.¹¹⁷ If polycythemia is present, it is corrected by chronic oxygen administration.¹²¹

Vascular malformations in the lung may also be associated with erythrocytosis.^{122, 123} Pulmonary arteriovenous fistulae should be suspected when a murmur is heard in a lung field in association with erythrocytosis.

Chronic Cor Pulmonale

The clinical picture of chronic cor pulmonale varies, but oxygen deficiency with arterial desaturation and elevated pulmonary artery pressure is of central importance.^{124, 125} Polycythemia with its associated increase in blood viscosity and volume appears to be the physiologic price of a compensatory mechanism progressively extended to the point at which it is more injurious than beneficial.¹²⁶ As in less severe pulmonary disease, the MCV of the red cells tends to be elevated, whereas the MCHC generally is decreased.¹²⁷

Cyanotic Heart Disease

Marked degrees of polycythemia may be seen in patients with a partial shunt of the blood from the pulmonary circuit. Hematocrit levels greater than 0.60 are not uncommon. The most frequent defects producing such polycythemia are pulmonary stenosis (usually with defective ventricular or atrial septum, patent foramen ovale, or patent ductus arteriosus), persistent truncus arteriosus, complete transposition of the great vessels, and the tetralogy of Fallot (pulmonary stenosis, defective ventricular septum, dextroposition of the aorta, right ventricular hypertrophy). Individuals

with such defects exhibit evidence of disturbed cardiorespiratory function, marked cyanosis, clubbing of the fingers and toes, and sometimes stunted growth.

The total plasma volume may be reduced to below normal levels, but the increase in the size of the red cell mass is so great that the total blood volume usually is higher than normal.¹²⁸ Erythroid hyperplasia is observed in the marrow.^{129, 130}

The general consensus is that low oxygen tension resulting from shunting of unoxygenated blood through or around the lungs with consequent desaturation of the arterial blood stimulates erythropoietin production. With successful operative intervention, this value may be significantly corrected, with resolution of polycythemia.

Acquired Heart Disease

In 1901, Abel Ayerza described a syndrome characterized clinically by slowly developing asthma, bronchitis, dyspnea, right-sided heart failure, and severe cyanosis with associated polycythemia.¹³¹ The striking degree of cyanosis led Ayerza to describe these patients as "black cardiacs." It was subsequently demonstrated that the unifying feature of these patients was not pulmonary disease but rather pulmonary arterial hyperplasia, leading to pulmonary hypertension and consequent right-sided heart failure.¹³² In all forms of acquired heart disease, any erythrocytosis that may develop is correlated to some extent with the degree of cardiopulmonary decompensation. It is typically minimal. Polycythemia is reportedly accompanied by evidence of intensified erythropoiesis in the bone marrow, an increase in red cell mass, and some macrocytosis.¹³¹

P.1039

Hypoventilation Syndromes

Polycythemia is found occasionally in patients who exhibit no evidence of pulmonary disease or cardiovascular shunts. The primary defect in at least some of these patients appears to be an inadequate ventilatory drive from the respiratory center in the brain.^{126, 133} A similar defect has been reported in patients with the Pickwickian syndrome, so called because of the description of Joe, the hypersomnolent fat boy, in Dickens's *The Pickwick Papers*.¹³⁴ In the setting of extreme obesity, these patients exhibit somnolence, cyanosis, and hypercapnia and may develop periodic respiration, ultimately with right ventricular failure. Voluntary hyperventilation alleviates the hypercapnia, and in many patients, loss of weight restores normal alveolar ventilation and reverses the syndrome.^{135, 136} Alveolar hypoventilation and erythrocytosis, however, do not develop in all obese individuals; it appears that only in the presence of an insensitive respiratory center does a massive panniculus limit respiratory function and result in alveolar hypoventilation, hypoxemia, and hypercapnia.¹³⁷ In some patients, the decreased ventilatory drive is of unknown cause or is a result of idiopathic disease of the medullary respiratory center (Ondine curse)^{133, 138}; other etiologies include bulbar poliomyelitis, vascular thrombosis, or previous encephalitis.^{126, 137} In any case, the consequent hypoxemia results in elevated levels of erythropoietin and erythrocytosis, with hematocrits reported as high as 0.75⁸.

Patients with polycythemia and positional arterial oxygen desaturation have also been reported.¹³⁹ Whether this results from alveolar hypoventilation while supine or from shunting through an arteriovenous malformation while upright is unclear.¹⁴⁰ Obstructive sleep apnea has been associated with polycythemia (presumably due to episodic erythropoietin secretion during apneic episodes) in some¹⁴¹ but not all¹⁴² reports.

Abnormal Hemoglobins

Inherited Abnormalities of Hemoglobin

Certain mutant Hbs are characterized by increased oxygen, and patients who carry such Hbs tend to develop erythrocytosis.^{143, 144, 145, 146} More than 200 high-affinity Hbs have been characterized, of which roughly half produce significant erythrocytosis.¹⁴⁷ Oxygen-Hb dissociation curves are shifted dramatically to the left in individuals carrying these abnormal Hbs. The degree of left shift can be quantified by determining the P₅₀ (i.e., the oxygen pressure at which Hb is half-saturated). The normal value in whole blood is 23 to 29 mm Hg at standard pH, temperature, CO₂ content, and barometric pressure. The whole-blood P₅₀ is almost invariably decreased in patients with a high-affinity Hb; most values fall between 9 and 21 mm Hg. In a few instances, the P₅₀ has been normal, or nearly so, in whole blood (e.g., HbG Norfolk¹⁴⁸), necessitating the measurement of the oxygen dissociation curve of the purified Hb to demonstrate the defect. The approach to the diagnosis of high-affinity Hb variants, the characteristics of patients with representative mutations, and the molecular pathology are discussed in Chapter 35.

The most important physiologic consequence of increased oxygen affinity is that release of oxygen is impaired at partial pressure of oxygen values normally found in tissues. Uptake of oxygen in the lungs is enhanced, but this effect is relatively unimportant, because normal Hb is nearly completely saturated in the lungs under the usual physiologic circumstances. As previously noted, however, the increased affinity may confer some advantages when environmental oxygen is low, such as at high altitudes.

Individuals with high-affinity Hbs are not at a disadvantage under hypoxic conditions. They tolerate ascent to high altitudes as well as or better than normal subjects and thus appear to be preadapted to hypoxic stresses. Under such conditions, the enhanced oxygen loading seems more important than the impaired delivery. Similarly, exercise tolerance appears unimpaired.¹⁴⁹ There is no evidence that oxygen delivery to the heart is defective in patients with high-affinity Hbs. Although myocardial infarctions and other findings of atherosclerotic cardiovascular disease are reported in these patients, it is unclear whether this is an actual association or simply reflects the high frequency of atherosclerosis in the general population.^{150, 151, 152}

High-affinity Hbs appear to exert no adverse effects on fetal development in utero. Theoretically, oxygen delivery to a developing noncarrier fetus might be impaired when the mother is a carrier, because the normal differential in oxygen affinity between fetal and adult Hb (which is in favor of the developing fetus) would be narrowed. However, only in the family with Hb Yakima was there a suggestion that spontaneous abortions occurred at an increased rate.^{153, 154} In contrast, normal pregnancy outcomes were recorded for mothers carrying the severe high-affinity variants Hb Bethesda, Hb Osler, and Hb Little Rock.¹⁵⁴ Evidently, maternal and fetal polycythemia and increased uterine and fetal blood flow compensate for the theoretic deficit in placental oxygen transport. There are no data addressing whether carrier fetuses have a developmental advantage over noncarriers born to these mothers; however, in dizygotic twins born to a mother with Hb Osler, the carrier twin developed more fully than the noncarrier as measured by the ponderal index (weight/length³).¹⁵⁴

It has been suggested that the homozygous state for high-affinity Hbs would be incompatible with life because of insufficient oxygen release to tissue. This may be true; however, at least four patients with abnormal Hb levels approximating those that would be observed in homozygotes have been described with no apparent ill effects (Hb Abruzzo,¹⁵⁵ Hb Crete,¹⁵⁶ and Hb Headlington¹⁵⁷). The unusually high proportion of abnormal Hb was clearly due to concurrent β -thalassemia in two cases¹⁵⁷ and probably in the others as well.

No treatment is indicated for most patients with high-affinity Hbs. Their erythrocytosis is a compensation for a physiologic state and should be regarded as "normal for them." In the rare patient with erythrocytosis and associated symptoms, phlebotomy may be used, but caution must be used to avoid lowering the hematocrit to a point at which oxygen delivery is impaired.¹⁵⁸ A reasonable approach is probably to phlebotomize the individual patient to the highest hematocrit at which he or she is no longer symptomatic rather than to a specific number.^{149, 158, 159} Certainly, reducing blood Hb concentrations to normal levels would be undesirable. Cyto-reductive agents should not be used for treatment.

Acquired Abnormalities of Hemoglobin

Moderate elevations of carboxyhemoglobin in erythrocytes shift the oxygen dissociation curve. In heavy smokers, carboxyhemoglobin concentration may reach sufficiently high levels (4.0% to 6.8%) to produce polycythemia.^{160, 161} In the older literature, polycythemia in association with phosphorus poisoning has been described, although it may have been merely relative erythrocytosis resulting from acute liver damage. Although certain drugs and chemicals (e.g., nitrites, nitrates, aniline dyes, sulfonamides, and nitrobenzene) produce toxic levels of methemoglobin, sulfhemoglobin, or both in the blood of even normal persons,^{162, 163, 164, 165, 166, 167} erythrocytosis apparently has not been described in patients with toxic methemoglobinemia.

Familial Polycythemia (Physiologically Appropriate)

Familial defects in 2,3-BPG metabolism (e.g., BPG mutase deficiency¹⁶⁸ or elevated erythrocyte adenosine triphosphate¹⁶⁹), which would have the effect of shifting the oxygen dissociation curve to the left, provide other physiologically appropriate (tissue hypoxia) reasons for polycythemia. A specific pyruvate kinase

P.1040

mutation resulting in higher than normal enzyme activity and decreased 2,3-BPG causing erythrocytosis has been described as well in association with erythrocytosis.¹⁷⁰

Secondary Polycythemia (Physiologically Inappropriate [Normoxic])

Unlike patients with physiologically appropriate secondary polycythemia, individuals with inappropriate polycythemia receive no benefit from the higher red cell concentrations. Treatment should be aimed at correcting the underlying disease; phlebotomy can be considered in the symptomatic.

Aberrant Erythropoietin Secretion

Erythrocytosis has been described in association with a variety of neoplasms, cysts, vascular abnormalities, and endocrinologic disorders. In the syndromes discussed in the preceding section, erythrocytosis was secondary (i.e., driven by increased erythropoietin); however, this erythropoietin secretion and the consequent erythrocytosis were physiologic responses to tissue hypoxia. In this section, disorders in which erythropoietin-driven erythrocytosis bears no relation to physiologic requirements are reviewed (Table 44.4).

Renal Disorders

Renal cell carcinoma (hypernephroma) is one of the disorders most frequently associated with erythrocytosis. Erythrocytosis is observed in 0.9% to 1.6% of patients with renal cell carcinoma (approximately one fourth as frequent a finding as anemia).¹⁷¹ Elevated serum erythropoietin levels, however, are observed in more than 60% of patients.¹⁷² Erythrocytosis also has been reported in patients with renal sarcoma, hemangioma, adenoma,¹⁷³ Wilms tumor,^{153, 174} renal cysts, hydronephrosis,^{175, 176, 177} horseshoe kidney,¹⁷⁵ and polycystic kidneys.¹⁷³ Renal artery stenosis has also been reported in association with erythrocytosis.¹⁷⁸

Erythrocytosis in renal cell carcinoma is attributed to constitutive erythropoietin production by the tumor. Erythropoietin messenger RNA can be demonstrated in renal carcinoma cells.¹⁷⁹ It is assumed that this is also the mechanism by which other parenchymal renal diseases produce erythrocytosis. Hydronephrosis and anatomic abnormalities probably produce erythrocytosis by increasing pressure on erythropoietin-producing cells in the renal parenchyma.¹⁸⁰ Significant and measurable concentrations of erythropoietin (sometimes >100 mU/ml) can be detected in fluid aspirated from renal cysts associated with polycythemia. Production of erythropoietin in renal cell carcinoma is said to predict a good response to therapy.¹⁸¹ Management of erythrocytosis in these patients should be directed at treatment of the responsible renal lesion with phlebotomy as an adjunct, when necessary.

Erythrocytosis is also observed in patients after renal transplantation.¹⁸² This phenomenon is associated with elevated serum erythropoietin; the source of erythropoietin is presumed to be the transplant recipient's native kidneys.^{183, 184} Effective therapeutic modalities include phlebotomy, angiotensin-converting enzyme inhibitors, and theophylline.^{185, 186, 187}

Liver Diseases

During fetal development, the liver contributes to erythropoietin production (Chapter 6); hepatic disease, like renal disease, may be associated with erythropoietin production and polycythemia. Erythrocytosis has been identified in persons with hepatocellular carcinoma with incidence 2.5% to 10.0%.^{188, 189} When measured, red cell mass has been shown to be increased,¹⁹⁰ and elevated serum erythropoietin levels have also been described.¹⁹¹ As with renal cell carcinoma, erythropoietin production by the tumor has been demonstrated.^{192, 193, 194} Remission of erythrocytosis may be observed after successful tumor treatment.^{193, 194}

TABLE 44.4 DISORDERS ASSOCIATED WITH NORMOXIC SECONDARY POLYCYTHEMIA

Renal Disease

Renal cell carcinoma

Renal sarcoma^a

Renal adenoma^a

Renal hemangioma^a

Wilms tumor^a

Solitary renal cysts

Polycystic kidney disease

Hydronephrosis

Horseshoe kidney^a

Renal artery stenosis^a

Postrenal transplantation

Hepatic Disease

Hepatocellular carcinoma

Hepatic hamartoma^a

Hepatic metastases^a

Hepatic angiosarcoma^a

Hepatic angioma^a

Viral hepatitis^a

Vascular cerebellar tumors

Other Neoplasms

Uterine leiomyomata

Uterine fibroid tumors^a

Cutaneous leiomyomata^a

Meningioma^a

Placental trophoblastic tumors^a

Chronic lymphocytic leukemia^a

Systemic amyloidosis^a

Atrial myxoma^a

Endocrine Disorders

Cushing syndrome

Primary aldosteronism

Virilizing ovarian tumors

Bartter syndrome^a

Pheochromocytoma^a

Other

Human immunodeficiency virus infection^a

^a Polycythemia infrequently reported.

Erythrocytosis has also been reported with hepatic hamartomas and tumors metastatic to liver,¹⁷³ as well as hepatic angiomas¹⁹⁵ and hemangiosarcomas.¹⁹⁶ Polycythemia has been reported in the early stages of viral hepatitis.^{197, 198} Cirrhosis is occasionally listed in texts as associated with erythrocytosis, but this apparently does not occur except in the setting of another disease, such as cirrhosis with hepatocellular carcinoma.

Cerebellar Vascular Tumors

The association of erythrocytosis with vascular tumors of the cerebellum is well established.^{173, 199} Elevated serum erythropoietin

P.1041

levels and tumor production of erythropoietin have been demonstrated,^{200, 201, 202} but abnormalities in Von Hippel-Lindau

protein are observed as well.^{203, 204, 205} Correction of erythrocytosis may be observed after effective therapy and erythrocytosis may return with recurrence of the tumor.¹⁷³

Leiomyoma and Fibroid Tumors of the Uterus

Several cases in which large leiomyomas and fibroid tumors of the uterus were associated with erythrocytosis have been reported.^{206, 207} Erythrocytosis tends to subside after effective therapy and is also associated with production of erythropoietin by tumor.^{207, 208} Cutaneous leiomyomata have also been associated with erythrocytosis.²⁰⁹

Other Neoplasms

Rare instances of erythrocytosis in association with a variety of other tumors have been reported, but some of these associations may be coincidental.¹⁷³ However, erythropoietin synthesis by tumor cells has been clearly demonstrated in a patient with meningioma.²¹⁰ Erythrocytosis has also been reported in rare patients with chronic lymphocytic leukemia,²¹¹ systemic amyloidosis,²¹² placental trophoblastic tumors,²¹³ and atrial myxomas.²¹⁴

Endocrinologic and Other Disorders

Erythrocytosis has been reported in association with a number of endocrinologic disorders, including Cushing syndrome, primary aldosteronism,²¹⁵ virilizing ovarian tumors,²¹⁶ Bartter syndrome,²¹⁷ and pheochromocytoma.^{218, 219} In the latter disorder, tumor erythropoietin production has been reported.²²⁰

There have been a number of reports describing small numbers of patients with human immunodeficiency virus infection and polycythemia.^{221, 222, 223, 224, 225, 226} It is unclear if there is an actual pathophysiologic association or if this is coincidental.

Drug-induced Erythrocytosis

Anabolic and androgenic steroids may be abused by both recreational and professional athletes for purposes of improving performance.²²⁷ A consequence of androgen administration, either medicinal or extralegal, may be erythrocytosis.^{228, 229, 230} In some cases, the degree of erythrocytosis may be severe.

Recombinant human erythropoietin has also been abused by athletes (particularly those in endurance sports) to increase the red cell mass and thus oxygen-carrying capacity.^{231, 232, 233} As indicated earlier in Figure 44.2, this may backfire if the athlete becomes hypovolemic as a result of exertion. Cases of surreptitious erythropoietin self-administration resulting in accelerated hypertension and unstable angina have been reported.²³⁴ A perceived advantage of erythropoietin over androgens for this purpose is the inability to distinguish endogenous from exogenous erythropoietin as well as the lack of hepatic toxicity. Newer approaches that allow discrimination between exogenous recombinant erythropoietin and endogenous erythropoietin may make this practice less frequent.^{235, 236, 237, 238}

Familial Polycythemia (Physiologically Inappropriate)

Kindreds that exhibit an autosomal recessive erythrocytosis associated with increased erythropoietin production have been described.²³⁹

Idiopathic Polycythemia

The term idiopathic polycythemia (or erythrocytosis) refers to patients who have an elevated red cell mass of unknown etiology after appropriate investigation. It would include most of the patients formerly categorized as "benign erythrocytosis." The existence of this group, which is estimated to contain 20% to 30% of patients evaluated for polycythemia,¹⁴¹ essentially represents a failure to categorize all polycythemic patients correctly.

Of 25 patients reported in one series, 12 were found to have elevated erythropoietin levels and were therefore assumed to represent patients with secondary polycythemia; these patients tended to be younger than the patients with normal erythropoietin levels.¹³⁹ Progenitor culture studies were not helpful in subcategorizing the group in this particular study.¹³⁹ Some studies have reported endogenous colony-formation studies to be useful and serum erythropoietin levels not helpful,⁵⁰ whereas others have reported the opposite.²⁴⁰

Kiladjian et al. treated 39 patients with idiopathic erythrocytosis with pipobroman and compared their clinical course to 140 concurrently treated polycythemia vera patients.²⁴¹ The risk of leukemia, thrombosis, and myelofibrosis was the same in the two groups. This study confirms that the idiopathic erythrocytosis group contains a certain number of polycythemia vera patients; however, it does not provide a way to identify individuals who do not have a myeloproliferative disorder and therefore should not be exposed to leukemogenic agents.²⁴¹

Because this category probably represents a mixed bag, including early polycythemia vera, mild secondary polycythemia, and normal individuals at the higher end of the bell-shaped curve for red cell mass,⁶⁴ a cautious approach is warranted. Observation may be the most reasonable intervention; this may be the patient subset in which otherwise low-yield studies, such as erythroid progenitor studies, are likely to be useful. Periodic retesting for the JAK2 V617F mutation or other JAK2 mutations may also be useful, although a study that addressed this question found that less than 2% of idiopathic erythrocytosis patients studied exhibited the mutation.²⁴²

REFERENCES

1. Huber H, Lewis SM, Szur L. The influence of anaemia, polycythaemia and splenomegaly on the relationship between venous haematocrit and red-cell volume. *Br J Haematol.* Oct 1964;10:567-575.
2. Schwarz TH, Hogan LA, Edean ED, Roitman IT, Kazmers A, Hyde GL. Thromboembolic complications of polycythemia: polycythemia vera versus smoker's polycythemia. *J Vasc Surg* 1993;17:518-522.
3. Lawrence JH, Berlin NI. Relative polycythemia; the polycythemia of stress. *The Yale journal of biology and medicine.* Jun 1952;24(6):498-505.
4. Finch CA, Lenfant C. Oxygen transport in man. *N Engl J Med.* Feb 24 1972;286(8):407-415.
5. Cobb LA, Kramer RJ, Finch CA. Circulatory effects of chronic hypervolemia in polycythemia vera. *J Clin Invest.* Nov 1960;39:1722-1728.
6. Harrison BD, Stokes TC. Secondary polycythaemia: its causes, effects and treatment. *British Journal of diseases of the chest.* Oct 1982;76(4):313-340.
7. Osler W. Chronic cyanosis with polycythemia and enlarged spleen; a new clinical entity. *American Journal of the Medical Sciences* 1903;126:187-201.
8. Fraser RS, Sproule BJ, Dvorkin J. Hypoventilation, cyanosis and polycythemia in a thin man. *Can Med Assoc J* Dec 7 1963;89:1178-1182.
9. Arregui A, Leon-Velarde F, Cabrera J, Paredes S, Vizcarra D, Umeres H. Migraine, polycythemia and chronic mountain sickness. *Cephalalgia an international journal of headache.* Oct 1994;14(5):339-341.
10. Ickenstein GW, Klotz JM, Langohr HD. Headache caused by polycythemia vera. Classification of a headache under the heading of metabolic disturbances. *Schmerz.* Aug 191999;13(4):279-282.
11. Stanzani Maserati M. Migraine attacks, aura, and polycythemia: a vasculoneural pathogenesis? *Journal of neural transmission.* Apr 2011;118(4): 545-547.
12. Chien S, Gallick S. Rheology in normal individuals and polycythemia vera. In: Wasserman LR, ed. *Polycythemia Vera and the Myeloproliferative Disorders.* Philadelphia, PA: WB Saunders; 1995:114-129.
13. Wells RE, Jr., Merrill EW. The variability of blood viscosity. *Am J Med.* Oct 1961;31:505-509.
14. Pirofsky B. The determination of blood viscosity in man by a method based on Poiseuille's law. *J Clin Invest.* Apr 1953;32(4):292-298.
15. Stone HO, Thompson HK, Jr., Schmidt-Nielsen K. Influence of erythrocytes on blood viscosity. *Am J Physiol.* Apr 1968;214(4):913-918.
16. Milligan DW, MacNamee R, Roberts BE, Davies JA. The influence of iron-deficient indices on whole blood viscosity in polycythaemia. *British Journal of Haematology* 1982;50:467-473.
17. Hutton RD. The effect of iron deficiency on whole blood viscosity in polycythaemic patients. *British Journal of Haematology* 1979;43:191-199.
18. Thomas DJ, Marshall J, Ross Russell RW, et al. Effect of haematocrit on cerebral blood-flow in man. *Lancet* 1977;2:941-943.
19. Thomas DJ, Marshall J, Ross Russell RW, et al. Cerebral blood-flow in polycythemia. *Lancet* 1977;2:161-163.
20. Humphrey PRD, Marshall J, Ross Russell RW, et al. Cerebral blood-flow and viscosity in relative polycythaemia. *Lancet* 1979;2:873-877.
21. Humphrey PRD, Michael J, Pearson TC. Management of relative polycythaemia: studies of cerebral blood flow and viscosity. *British Journal of Haematology* 1980;46:427-433.

22. Castle WB, Jandl JH. Blood viscosity and blood volume: Opposing influences upon oxygen transport in polycythemia. *Semin Hematol* 1966;3:193-198.
23. Murray JF, Gold P, Johnson BL, Jr. The circulatory effects of hematocrit variations in normovolemic and hypervolemic dogs. *J Clin Invest*. Jul 1963;42:1150-1159.
24. Anderson CB, Gray FD, Jr. The circulatory and ventilatory effects of normovolemic polycythemia. *The Yale journal biology and medicine* Dec 1962;35:233-240.
25. Richardson TQ, Guyton AC. Effects of polycythemia and anemia on cardiac output and other circulatory factors. *Am J Physiol* 1959;197:1167-1170.
26. Thorling EB, Erslev AJ. The "tissue" tension of oxygen and its relation to hematocrit and erythropoiesis. *Blood Mar* 1968;31(3):332-343.
27. Kiraly JF, Feldmann JE, Wheby MS. Hazards of phlebotomy in polycythemic patients with cardiovascular disease. *Journal of the American Medical Association* 1976;236:2080-2081.
28. Metcalfe J, Dhindsa DS, Edwards MJ, Mourdjinis A. Decreased affinity of blood for oxygen in patients with low-output heart failure. *Circ Res* Jul 1969;25(1):47-51.
29. Chetty KG, Brown SE, Light RW. Improved exercise tolerance of the polycythemic lung patient following phlebotomy. *Am J Med* Mar 1983;74(3): 415-420.
242. Weil JV, Jamieson G, Brown DW, Grover RF. The red cell mass—arterial oxygen relationship in normal man. Application to patients with chronic obstructive airway disease. *J Clin Invest* Jul 1968;47(7):1627-1639.
30. Huff RL, Feller DD. Relation of circulating red cell volume to body density and obesity. *J Clin Invest* Jan 1956;35(1):1-10.
31. Hyde RD, Jones NF. Red-cell volume and total body water. *Br J Haematol* Jul 1962;8:283-289.
32. Nathan DG. Comments on the interpretation of measurement of total red cell volume in the diagnosis of polycythemia vera. *Semin Hematol* 1966;3: 216-219.
33. Wennesland R, Brown E, Hopper J, Jr., et al. Red cell, plasma and blood volume in healthy men measured by radiochromium (Cr51) cell tagging and hematocrit: influence of age, somatotype and habits of physical activity on the variance after regression of volumes to height and weight combined. *J Clin Invest* Jul 1959;38(7):1065-1077.
34. Pearson TC, Messinezy M. The diagnostic criteria of polycythemia rubra vera. *Leukemia Lymphoma* 1996;22(Suppl 1):87-93.
35. Berson SA, Yalow RS. The use of K42 or P32 labeled erythrocytes and I131 tagged human serum albumin in simultaneous blood volume determinations. *J Clin Invest* Jun 1952;31(6):572-580.
36. Blum AS, Zbar MJ. Relative polycythemia: alterations of red cell distribution simulating hemoconcentration. *Arch Intern Med* Sep 1959;104:385-389.
37. Valentine WN. Polycythemia: erythrocytosis and erythremia. *Ann Intern Med* Sep 1968;69(3):587-606.
38. Djulbegovic B, Hadley T, Joseph G. A new algorithm for the diagnosis of polycythemia. *American Family Physician* 1991;44:113-120.
39. Tefferi A, Thiele J, Orazi A, et al. Proposals and rationale for revision of the World Health Organization diagnostic criteria for polycythemia vera, essential thrombocythemia, and primary myelofibrosis: recommendations from an ad hoc international expert panel. *Blood* 2007;110:1092-1097.
40. Johansson PL, Safai-Kutti S, Kutti J. An elevated venous haemoglobin concentration cannot be used as a surrogate marker for absolute erythrocytosis: a study of patients with polycythaemia vera and apparent polycythaemia. *Br J Haematol* Jun 2005;129(5):701-705.
41. Droder RM, Kyle RA, Griep PR. Control of systemic capillary leak syndrome with aminophylline and terbutaline. *American Journal of Medicine* 1992;92:523-526.
42. Kralovics R, Passamonti F, Buser AS, et al. A gain-of-function mutation of JAK2 in myeloproliferative disorders. *N Engl J Med* 2005;352(17): 1779-1790.
43. Jones AV, Kreil S, Zoi K, et al. Widespread occurrence of the JAK2 V617F mutation in chronic myeloproliferative disorders. *Blood* 2005;106(6): 2162-2168.

44. Means RT. JAK2 V617F mutation testing in polycythemia vera: use and impact in an academic practice. *Am J Med Sci* 2008;336(4):327-329.
45. Schnittger S, Bacher U, Haferlach C, et al. Detection of JAK2 exon 12 mutations in 15 patients with JAK2V617F negative polycythemia vera. *Haematologica*. Mar 2009;94(3):414-418.
46. Reid CDL. The significance of endogenous erythroid colonies in haematological disorders. *Blood Reviews* 1987;1:133-140.
47. Shih LY, Lee CT. Identification of masked polycythemia vera from patients with idiopathic marked thrombocytosis by endogenous erythroid colony assay. *Blood* 1994;83:744-748.
48. Birgegard G, Wide L. Serum erythropoietin in the diagnosis of polycythemia and after phlebotomy treatment. *British Journal of Haematology* 1992;81: 603-606.
49. Cotes PM, Dorie CJ, Yin JA, et al. Determination of serum immunoreactive erythropoietin in the investigation of erythrocytosis. *New England Journal of Medicine* 1986;315:283-287.
50. Koeffler HP, Goldwasswer E. Erythropoietin radioimmunoassay in evaluating patients with polycythemia. *Annals of Internal Medicine* 1981;94:44-47.
51. Remacha AF, Montserrat I, Santamaria A, Oliver A, Barcelo MJ, Parellada M. Serum erythropoietin in the diagnosis of polycythemia vera. A follow-up study. *Haematologica* Jul-Aug 1997;82(4):406-410.
52. Shih LY, Lee CT, Ou YC. Prediction of clinical course in patients with idiopathic erythrocytosis by endogenous erythroid colony assay but not by serum erythropoietin levels. *Experimental Hematology* 1997;25:288-292.
53. Westwood N, Dudley JM, Sawyer B, Messinezy M, Pearson TC. Primary polycythaemia: diagnosis by non-conventional positive criteria. *European Journal of Haematology* 1993;51:228-232.
54. Manteiga R, Remacha AF, Sarda MP, Ubeda J. Serum transferrin receptor in polycythemia. *Haematologica* 1998;83:958-959.
55. Russell RP, Conley CL. Benign polycythemia: Gaisboeck's syndrome. *Arch Intern Med* Dec 1964;114:734-740.
56. Stevens JE, Chabot OH. Intermediate polycythemia. The benign polycythemia of Gaisboeck. *Virginia medical monthly* Feb 1967;94(2):82-90.
57. Modan B, Modan M. Benign erythrocytosis. *Br J Haematol* 1968;14(4): 375-381.
58. Weinreb NJ, Shih CF. Spurious polycythemia. *Semin Hematol* Oct 1975;12(4):397-407.
59. Brown SM, Gilbert HS, Krauss S, Wasserman LR. Spurious (relative) polycythemia: a nonexistent disease. *Am J Med* Feb 1971;50(2):200-207.
60. Kaung DT, Peterson RE. "Relative polycythemia" or "pseudopolycythemia". *Arch Intern Med* Oct 1962;110:456-460.
61. Messinezy M, Pearson TC. Apparent polycythaemia: diagnosis, pathogenesis and management. *European Journal of Haematology* 1993;51:125-131.
62. Lawrence JH, Berlin NI, Huff RL. The nature and treatment of polycythemia; studies on 263 patients. *Medicine (Baltimore)* Sep 1953;32(3):323-388.
63. Messinezy M, Pearson TC. A retrospective study of spparent and relative polycythaemia: associated factors and early outcome. *Clinical and Laboratory Haematology* 1990;12:121-129.
64. Emery AC, Jr., Whitcomb WH, Frohlich ED. "Stress" polycythemia and hypertension. *JAMA*. Jul 8 1974;229(2):159-162.
65. Fessel WJ. Odd men out: individuals with extreme values. *Arch Intern Med* Jun 1965;115:736-737.
66. Beard ME, Hamer JW, Brennan SO, Jones JN, Sheat JM, Maclairin JS. Familial relative polycythaemia due to haemoglobin Heathrow. *Aust N Z J Med* Jun 1979;9(3):297-301.
67. Beard ME, Potter HC, Spearing RL, Brennan SO. Haemoglobin Pierre-Benite—a high affinity variant associated with relative polycythaemia. *Clin Lab Haematol* Dec 2001;23(6):407-409.
68. Lorkin PA, Stephens AD, Beard ME, Wrigley PF, Adams L, Lehmann H. Haemoglobin Rahere (beta Lys-Thr): A new high affinity haemoglobin associated with decreased 2, 3-diphosphoglycerate binding and relative polycythaemia. *Br Med J*. Oct 25 1975;4(5990):200-202.

69. Adamson JW. Familial polycythemia. *Semin Hematol* Oct 1975;12(4): 383-396.
70. Juvonen E, Ikkala E, Fyhrquist F, Ruutu T. Autosomal dominant erythrocytosis is caused by increased sensitivity to erythropoietin. *Blood* 1991;78: 3066-3069.
- P.1042
71. de la Chapelle A, Sistonen P, Lehaslaiho H, Ikkala E, Juvonen E. Familial erythrocytosis genetically linked to erythropoietin receptor gene. *Lancet* 1993;1:82-84.
72. de la Chapelle A, Traskelin AL, Juvonen E. Truncated erythropoietin receptor causes dominantly inherited benign human erythrocytosis. *Proceedings of the National Academy of Sciences of the United States of America* 1993;90: 4495-4499.
73. Sergeyeva A, Gordeuk VR, Tokarev YN, Sokol L, Prchal JF, Prchal JP. Congenital polycythemia in Chuvashia. *Blood* 1997;89:2148-2154.
74. Sokol L, Luhovy M, Guan Y, Prchal JF, Semenza GL, Prchal JT. Primary familial polycythemia: A frameshift mutation in the erythropoietin receptor gene and increased sensitivity of erythroid progenitors to erythropoietin. *Blood* 1995;86(1):15-22.
75. Watanabe D, Suzuma K, Matsui S, et al. Erythropoietin as a retinal angiogenic factor in proliferative diabetic retinopathy. *New England Journal of Medicine* 353:782-792.
76. Ang SO, Chen H, Hirota K, et al. Disruption of oxygen homeostasis underlies congenital Chuvash polycythemia. *Nat Genet* 2002;32(4):614-621.
77. Ang SO, Chen H, Gordeuk VR, et al. Endemic polycythemia in Russia: mutation in the VHL gene. *Blood Cells Mol Dis* 2002;28(1):57-62.
78. Russell RC, Sufan RI, Zhou B, et al. Loss of JAK2 regulation via a heterodimeric VHL-SOCS1 E3 ubiquitin ligase underlies Chuvash polycythemia. *Nat Med* Jul 2011;17(7):845-853.
79. Gordeuk VR, Prchal JT. Vascular complications in Chuvash polycythemia. *Semin Thromb Hemost* 2006;32(3):289-294.
80. Viault F. Sur l'augmentation considérable du nombre des globules rouge dans le sang chez les habitants des hauts plateaux de l'Amérique du Sud. *C R Hebd. Seances Acad. Sci* 1890;111:917.
81. Pugh LG. Haemoglobin levels on the British Himalayan Expeditions to Cho Oyu in 1952 and Everest in 1953. *The Journal of physiology*. Nov 29 1954;126(2):38-39P.
82. Pugh LG. Muscular exercise on Mount Everest. *The Journal of physiology*. Apr 30 1958;141(2):233-261.
83. Richalet JP, Souberbielle JC, Antezana AM, et al. Control of erythropoiesis in humans during prolonged exposure to the altitude of 6,542 m. *Am J Physiol* Mar 1994;266(3 Pt 2):R756-764.
84. Frisancho AR. Functional adaptation to high altitude hypoxia. *Science*. Jan 31 1975;187(4174):313-319.
85. Morpurgo G, Battaglia P, Bernini L, Paolucci AM, Modiano G. Higher Bohr effect in Indian natives of Peruvian Highlands as compared with Europeans. *Nature*. Jul 25 1970;227(5256):387-388.
86. Sutton J. Acute mountain sickness. An historical review, with some experiences from the Peruvian Andes. *The Medical Journal of Australia*. Jul 31 1971;2(5): 243-248.
87. Hackett PH, Rennie D, Levine HD. The incidence, importance, and prophylaxis of acute mountain sickness. *Lancet*. Nov 27 1976;2(7996): 1149-1155.
88. Droma Y, Hanaoka M, Basnyat B, et al. Symptoms of acute mountain sickness in Sherpas exposed to extremely high altitude. *High altitudemedicine & biology Winter* 2006;7(4):312-314.
89. Murdoch D. Altitude sickness. *Clinical Evidence* 2007 <http://clinicalevidence.bmj.com.easypass1.lib.cuhk.edu.hk>
90. Fayed N, Diaz L, Davila J, Medrano J. Hematological indices, mountain sickness and MRI brain abnormalities in professional and amateur mountain climbers after altitude exposure. *Neurologicalresearch* Mar 2010;32(2):144-147.
91. Hecht HH. A sea level view of altitude problems. *Am J Med* Jun 1971;50(6):703-708.

92. Fitch RF. Mountain sickness: a cerebral form. *Ann Intern Med* May 1964;60:871-876.
93. Milledge JS, Catley DM. Angiotensin converting enzyme response to hypoxia in man: its role in altitude acclimatization. *Clin Sci (Lond)* Oct 1984;67(4): 453-456.
94. Milledge JS, Beeley JM, McArthur S, Morice AH. Atrial natriuretic peptide, altitude and acute mountain sickness. *Clin Sci (Lond)* Nov 1989;77(5): 509-514.
95. Richalet JP, Rutgers V, Bouchet P, et al. Diurnal variations of acute mountain sickness, colour vision, and plasma cortisol and ACTH at high altitude. *Aviation,space, and environmentalmedicine* Feb 1989;60(2):105-111.
96. Panesar NS. High altitude sickness. Is acute cortisol deficiency involved in its pathophysiology? *Med Hypotheses* 2004;63(3):507-510.
97. Woods DR, Stacey M, Hill N, de Alwis N. Endocrine aspects of high altitude acclimatization and acute mountain sickness. *Journal of the Royal Army Medical Corps* Mar 2011;157(1):33-37.
98. Wright A, Brearey S, Imray C. High hopes at high altitudes: pharmacotherapy for acute mountain sickness and high-altitude cerebral and pulmonary oedema. *Expert opinion onpharmacotherapy* Jan 2008;9(1):119-127.
99. Lenfant C, Torrance J, English E, et al. Effect of altitude on oxygen binding by hemoglobin and on organic phosphate levels. *J Clin Invest* Dec 1968;47(12):2652-2656.
100. Lenfant C, Torrance JD, Woodson RD, Jacobs P, Finch CA. Role of organic phosphates in the adaptation of man to hypoxia. *Federation proceedings*. May-Jun 1970;29(3):1115-1117.
101. Torrance JD, Lenfant C, Cruz J, Marticorena E. Oxygen transport mechanisms in residents at high altitude. *Respir Physiol* 1970;11(1):1-15.
102. Shah MB, Braude D, Crandall CS, et al. Changes in metabolic and hematologic laboratory values with ascent to altitude and the development of acute mountain sickness in Nepalese pilgrims. *Wilderness&environmentalmedicine* Fall 2006;17(3):171-177.
103. Faura J, Ramos J, Reynafarje C, English E, Finne P, Finch CA. Effect of altitude on erythropoiesis. *Blood* May 1969;33(5):668-676.
104. Monge CC, Whittembury J. Chronic mountain sickness. *The Johns Hopkins medicaljournal* Dec 1976;139SUPPL:87-89.
105. Leon-Velarde F, Monge CC, Vidal A, Carcagno M, Criscuolo M, Bozzini CE. Serum immunoreactive erythropoietin in high altitude natives with and without excessive erythrocytosis. *Exp Hematol* May 1991;19(4):257-260.
106. Merino CF, Reynafarje C. Bone marrow studies in the polycythemia of high altitudes. *J Lab Clin Med* May 1949;34(5):637-647.
107. Merino CF. Studies on blood formation and destruction in the polycythemia of high altitude. *Blood* Jan 1950;5(1):1-31.
108. Sanchez C, Crosby E, Merino C. Bilirubinemia in the polycythemia of high altitude. *Proceedings of the Society for Experimental Biology and Medicine*. Society for Experimental Biology and Medicine Nov 1966;123(2):478-481.
109. Sanchez C, Merino C, Figallo M. Simultaneous measurement of plasma volume and cell mass in polycythemia of high altitude. *Journal ofappliedphysiology: respiratory,environmental andexercisephysiology* Jun 1970;28(6):775-778.
110. Leon-Velarde F, Arreugi A, Vargas M, Huicho L, Acosta R. Chronic mountain sickness and chronic lower respiratory tract disorders. *Chest* 1994;106: 151-155.
111. Eaton JW, Skelton TD, Berger E. Survival at extreme altitude: protective effect of increased hemoglobin-oxygen affinity. *Science*. Feb 22 1974;183(4126): 743-744.
112. Jiang C, Liu F, Luo Y, et al. Gene expression profiling of high altitude polycythemia in Han Chinese migrating to the Qinghai-Tibetan plateau. *Molecularmedicinereports* Jan 2012;5(1):287-293.
113. Buroker NE, Ning XH, Zhou ZN, et al. AKT3, ANGPTL4, eNOS3, and VEGFA associations with high altitude sickness in Han and Tibetan Chinese at the Qinghai-Tibetan Plateau. *Int J Hematol*. Jun 242012.
114. Buroker NE, Ning XH, Zhou ZN, et al. EPAS1 and EGLN1 associations with high altitude sickness in Han and Tibetan Chinese at the Qinghai-Tibetan Plateau. *Blood cells,molecules &diseases*. Aug 15 2012;49(2):67-73.

115. Ge RL, Helun G. Current concept of chronic mountain sickness: pulmonary hypertension-related high-altitude heart disease. *Wilderness&environmental medicine* Fall 2001;12(3):190-194.
116. Freedman BJ, Penington DG. Erythrocytosis in emphysema. *Br J Haematol* Oct 1963;9:425-430.
117. Gallo RC, Fraimow W, Cathcart RT, Erslev AJ. Erythropoietic response in chronic pulmonary disease. *Arch Intern Med* Apr 1964;113:559-568.
118. Rapin M, Lissac J, Pocard JJ, Corcket F. [The polyglobulia of chronic respiratory insufficiency]. *Nouvelle revue francaise d'hematologie* May-Jun 1961;1:479-492.
119. Murray JF. Classification of polycythemic disorders with comments on the diagnostic value of arterial blood oxygen analysis. *Annals of Internal Medicine* 1966;64(4):892-903.
120. Chamberlain DA, Millard FJ. The treatment of polycythaemia secondary to hypoxic lung disease by continuous oxygen administration. *The Quarterlyjournal ofmedicine* Oct 1963;32:341-350.
121. Pick A, Deschamps C, Stanson AW. Pulmonary arteriovenous fistula: presentation, diagnosis, and treatment. *World journal of surgery* Nov 1999;23(11): 1118-1122.
122. Hammelbo T, Rostad H. Pulmonary arteriovenous fistula. *Scandinavianjournal of thoracic andcardiovascularsurgery* 1982;16(2):161-163.
123. Kuwahira I, Iwamoto T. [Pulmonary hypertension and cor pulmonale in COPD]. *Nihon rinsho. Japanesejournal ofclinicalmedicine* Dec 2003;61(12): 2138-2143.
124. Lewis CS, Jr., Samuels AJ, Daines MC, Hecht HH. Chronic lung disease, polycythemia and congestive heart failure; cardiorespiratory, vascular and renal adjustments in cor pulmonale. *Circulation* Dec 1952;6(6):874-887.
125. Fishman AP. State of the art: chronic cor pulmonale. *The Americanreview ofrespiratorydisease* Oct 1976;114(4):775-794.
126. Grant JL, Macdonald A, Edwards JR, Stacey RR, Stueck GH, Jr. Red cell changes in chronic pulmonary insufficiency. *J Clin Invest* Aug 1958;37(8): 1166-1175.
127. Verel D. Blood volume changes in cyanotic congenital heart disease and polycythemia rubra vera. *Circulation* 1961;23:749-753.
128. Hedlund S. Studies on erythropoiesis and total red cell volume in congestive heart failure. *Acta medica Scandinavica. Supplementum* 1953;284:1-146.
129. Braun K. The bone marrow in secondary polycythemia associated with cor pulmonale. *Am J Clin Pathol* Feb 1951;21(2):149-152.
130. Mazzei JA, Mazzei ME. A tribute: Abel Ayerza and pulmonary hypertension. *European Respiratory Review. December 1, 2011* 2011;20(122):220-221.
131. Pinchin AJ. Variable heart block with cyanosis. ? Specific pulmonary arteritis (Ayerza syndrome) or congenital lesion? Case for diagnosis. *Proceedings of the Royal Society of Medicine* Jan 1930;23(3):275-277.
132. Wiesel S, Fox GS. Anaesthesia for a patient with central alveolar hypoventilation syndrome (Ondine's Curse). *Canadianjournal ofanaesthesia = Journal canadien d'anesthesie* Jan 1990;37(1):122-126.
133. Bickelmann AG, Burwell CS, Robin ED, Whaley RD. Extreme obesity associated with alveolar hypoventilation; a Pickwickian syndrome. *Am J Med* Nov 1956;21(5):811-818.
134. Reichel G. Lung volumes, mechanics of breathing and changes in arterial blood gases in obese patients and in Pickwickian syndrome. *Bulletin de physiopathologie respiratoire. Sep-Oct 1972*;8(5):1011-1020.
135. Littleton SW, Mokhlesi B. The pickwickian syndrome-obesity hypoventilation syndrome. *Clinics in chest medicine* Sep 2009;30(3):467-478, vii-viii.
136. Fishman AP, Goldring RM, Turino GM. General alveolar hypoventilation: a syndrome of respiratory and cardiac failure in patients with normal lungs. *The Quarterlyjournal ofmedicine* Apr 1966;35(138):261-275.
137. Mellins RB, Balfour HH, Jr., Turino GM, Winters RW. Failure of automatic control of ventilation (Ondine's curse). Report of an infant born with this syndrome and review of the literature. *Medicine (Baltimore)* Nov 1970;49(6):487-504.

138. Messinezy M, Sawyer B, Westwood NB, Pearson TC. Idiopathic erythrocytosis—additional new study techniques suggest a heterogenous group. *European Journal of Haematology* 1994;53:163-167.
139. Seward JB, Hayes DL, Smith HC, et al. Platypnea-orthodeoxia: clinical profile, diagnostic workup, management, and report of seven cases. *Mayo Clinic Proceedings* 1984;59:221-231.
140. Moore-Gillon JC, Treacher DF, Gaminara EJ, Pearson TC, Cameron IR. Intermittent hypoxia in patients with unexplained polycythemia. *British Medical Journal* 1986;293:588-590.
141. Hoffstein V, Herridge M, Mateika S, Redline S, Strohl KP. Hematocrit levels in sleep apnea. *Chest* 1994;106:787-791.
142. Wajcman H, Galacteros F. Abnormal hemoglobins with high oxygen affinity and erythrocytosis. *Hematology and cell therapy Aug* 1996;38(4):305-312.
143. Esparcieux A, Francina A, Vital-Durand D. [Abnormal hemoglobins with high oxygen affinity in the differential diagnosis of polycythemia]. *La Revue de medecine interne/fondee ... par la Societe nationale francaise de medecine interne Oct* 2011;32(10):e105-107.
144. Benjamin D, Tabak M, Avissar N, Spitzer SA, Pinkhas J. Oxygen affinity of hemoglobin in polycythemia of undetermined etiology. *Respiration* 1980;39(3):179-181.
145. Prchal JT, Sokol L. "Benign erythrocytosis" and other familial and congenital polycythemia. *Eur J Haematol Oct* 1996;57(4):263-268.
146. Wajcman H, Galacteros F. Hemoglobins with high oxygen affinity leading to erythrocytosis. New variants and new concepts. *Hemoglobin* 2005;29(2):91-106.
147. Cohen-Solal M, Manesse B, Thillet J, Rosa J. Haemoglobin G Norfolk alpha 85 (F6) Asp leads to Asn. Structural characterization by sequenator analysis and functional properties of a new variant with high oxygen affinity. *FEBS Lett. Feb 1* 1975;50(2):163-167.
148. Charache S, Achuff S, Winslow R, Adamson J, Chervenick P. Variability of the homeostatic response to altered p50. *Blood Dec* 1978;52(6):1156-1162.
149. Boyer SH, Charache S, Fairbanks VF, Maldonado JE, Noyes A, Gayle EE. Hemoglobin Malmo Beta-97 (FG-4) histidine—glutamine: a cause of polycythemia. *J Clin Invest Mar* 1972;51(3):666-676.
150. Lokich JJ, Moloney WC, Bunn HF, Bruckheimer SM, Ranney HM. Hemoglobin brigham (alpha2Abeta2100 Pro—Leu). Hemoglobin variant associated with familial erythrocytosis. *J Clin Invest Aug* 1973;52(8):2060-2067.
151. Wranne B, Berlin G, Jorfeldt L, Lund N. Tissue oxygenation and muscular substrate turnover in two subjects with high hemoglobin oxygen affinity. *J Clin Invest Oct* 1983;72(4):1376-1384.
152. Grace RJ, Gover PA, Treacher DF, Heard SE, Pearson TC. Venesection in haemoglobin Yakima, a high oxygen affinity haemoglobin. *Clin Lab Haematol* 1992;14(3):195-199.
153. Charache S, Catalano P, Burns S, et al. Pregnancy in carriers of high-affinity hemoglobins. *Blood Mar* 1985;65(3):713-718.
154. Tentori L, Carta SM, Buccella C. Hemoglobin Abruzzo: beta 143 (H 21) His leads to Arg. *Clinicachimicaacta; international journal of clinical chemistry Apr* 1972;38(1):258-262.
155. Papassotiriou I, Traeger-Synodinos J, Marden MC, et al. The homozygous state for Hb Crete [beta129 (H7) Ala—>Pro] is associated with a complex phenotype including erythrocytosis and functional anemia. *Blood cells, molecules & diseases May-Jun* 2005;34(3):229-234.
156. Rochette J, Barnetson R, Kiger L, et al. Association of a novel high oxygen affinity haemoglobin variant with delta beta thalassaemia. *Br J Haematol* 1994;86(1):118-124.
157. Winslow RM, Butler WM, Kark JA, Klein HG, Moo-Penn W. The effect of bloodletting on exercise performance in a subject with a high-affinity hemoglobin variant. *Blood Dec* 1983;62(6):1159-1164.
158. Giordano PC, Hartevelde CL, Brand A, et al. Hb Malmo [beta-97(FG-4) His—>Gln] leading to polycythemia in a Dutch family. *Ann Hematol Oct* 1996;73(4):183-188.
159. Moore-Gillon J. Smoking—a major cause of polycythemia. *Journal of the Royal Society of Medicine Jul* 1988;81(7):431.

160. Smith JR, Landaw SA. Smokers' polycythemia. *N Engl J Med*. Jan 5 1978;298(1):6-10.
161. Ackers GK. The energetics of ligand-linked subunit assembly in hemoglobin require a third allosteric structure. *Biophysicalchemistry*. Aug 31 1990;37(1-3):371-382.
162. Bogart L, Bonsignore J, Carvalho A. Massive hemolysis following inhalation of volatile nitrites. *Am J Hematol* Jul 1986;22(3):327-329.
163. Centers for Disease C, Prevention. Severe methemoglobinemia and hemolytic anemia from aniline purchased as 2C-E (4-ethyl-2,5-dimethoxyphenethylamine), a recreational drug, on the Internet—Oregon, 2011. *MMWR. Morbidity and mortality weekly report*. Feb 10 2012;61(5):85-88.
164. Hatlelid KM, Brailsford C, Carter DE. Reactions of arsine with hemoglobin. *J Toxicol Environ Health*. Feb 9 1996;47(2):145-157.
165. Schimelman MA, Soler JM, Muller HA. Methemoglobinemia: nitrobenzene ingestion. *Jacep* Nov 1978;7(11):406-408.
166. Millar J, Peloquin R, De Leeuw NK. Phenacetin-induced hemolytic anemia. *Can Med Assoc J*. Apr 8 1972;106(7):770-775.
167. Cartier P, Labie D, Leroux JP, Najman A, Demaugre F. [Familial diphosphoglycerate mutase deficiency: hematological and biochemical study]. *Nouvelle revue française d'hématologie* May-Jun 1972;12(3):269-287.
168. Zurcher C, Loos JA, Prins HK. Hereditary high ATP content of human erythrocytes. *Folia Haematologica Leipzig* 1965;83:366.
169. Rosa R, Max-Audit I, Izrael V, Beuzard Y, Thillet J, Rosa J. Hereditary pyruvate kinase abnormalities associated with erythrocytosis. *Am J Hematol* 1981;10(1):47-55.
170. Lasli ME, Vugrin D. Paraneoplastic syndromes in hypernephroma. *Seminars in Nephrology* 1987;7:123-130.
171. Sufrin G, Mirand EA, Moore RH. Hormones in renal cancer. *J Urol* 1977;117:433-438.
172. Thorling EB. Paraneoplastic erythrocytosis and inappropriate erythropoietin production. A review. *Scandinavian journal of haematology. Supplementum* 1972;17:1-166.
173. Souid AK, Dubansky AS, Richman P, Sadowitz PD. Polycythemia: a review article and case report of erythrocytosis secondary to Wilm's tumor. *Pediatric Hematology & Oncology* 1993;10:215-221.
174. Bailey RR, Shand BI, Walker RJ. Reversible erythrocytosis in a patient with a hydronephrotic horseshoe kidney. *Nephron* 1995;70:104-105.
175. Dhavan PS, Rajendra G, Handa S, Kamath MH, Desai HG. Unilateral hydronephrosis causing polycythemia and acute myocardial infarction. *The Journal of the Association of Physicians of India* Jan 1996;44(1):51-52.
176. Hirsch I, Leiter E. Hydronephrosis and polycythemia. *Urology* Apr 1983;21(4):345-350.
177. Maezawa M, Takaku F, Muto Y, Mizoguchi H, Miura Y. A case of intrarenal artery stenosis associated with erythrocytosis. *Scand J Haematol* Oct 1978;21(4): 278-282.
178. Shiramizu M, Katsuoka Y, Grodberg J, et al. Constitutive expression of erythropoietin by human renal adenocarcinoma cells in vivo and in vitro. *Experimental Cell Research* 1994;215:249-256.
179. Mitus WJ, Toyama K, Brauer MJ. Erythrocytosis, juxtaglomerular apparatus (JGA), and erythropoietin in the course of experimental unilateral hydronephrosis in rabbits. *Ann N Y Acad Sci*. Mar 29 1968;149(1):107-113.
180. Janik JE, Sznol M, Urba WJ, et al. Erythropoietin production. A potential marker for interleukin-2/interferon-responsive tumors. *Cancer* 1993;72: 2656-2659.
181. Wickre CG, Norman DJ, Bennison A, Barry JM, Bennett WM. Postrenal transplant erythrocytosis: a review of 53 patients. *Kidney Int* 1983;23(5):731-737.
182. Chan PC, Wei DC, Tam SC, Chan FL, Yeung WC, Cheng IK. Post-transplanterythrocytosis: role of erythropoietin and male sex hormones. *Nephrology, Dialysis, Transplantation* 1992;7:137-142.
183. Martino R, Oliver A, Ballarin JM, Remacha AF. Postrenal transplant erythrocytosis: further evidence implicating erythropoietin production by the native kidney. *Annals of Hematology* 1994;68:201-203.
184. Barenbrock M, Spieker C, Rahn KH, Zidek W. Therapeutic efficiency of phlebotomy in posttransplant hypertension associated with erythrocytosis. *Clin Nephrol* 1993;40(4):241-243.

185. Torregosa JV, Campistol JM, Montesinos M, Rogada AG, Oppenheimer F, Andreu J. Efficacy of captopril on posttransplant erythrocytosis. Long term followup. *Transplantation* 1994;58:311-314.
186. Ilan Y, Dranitzki-Elhallel M, Rubinger D, Silver J, Popovtzer MM. Erythrocytosis after renal transplantation. The response to theophylline treatment. *Transplantation* 1994;57:661-664.
187. Davidson CS. Hepatocellular carcinoma and erythrocytosis. *Semin Hematol* Apr 1976;13(2):115-119.
188. McFadzean AJ, Todd D, Tso SC. Erythrocytosis associated with hepatocellular carcinoma. *Blood* May 1967;29(5):808-811.
189. Brownstein MH, Ballard HS. Hepatoma associated with erythrocytosis. *Am J Med* Feb 1966;40(2):204-210.
190. Hwang SJ, Lee SD, Wu JC, et al. Clinical evaluation of erythrocytosis in patients with hepatocellular carcinoma. *Chung Hua i Hsueh Tsa Chih* 1994;53:262-269.
191. Okazaki N, Ozaki H, Arima M, Hattori N, Kimura K. Hepatocellular carcinoma associated with erythrocytosis. A nine year survival after successful chemotherapy and left lateral hepatectomy. *Acta Hepato-Gastroenterologica* 1979;36:248-252.
192. Muta H, Funakoshi A, Baba T, et al. Gene expression of erythropoietin in hepatocellular carcinoma. *Internal Medicine* 1994;33:427-431.
193. Sakisaka S, Watanabe M, Tateishi H, et al. Erythropoietin production in hepatocellular carcinoma cells associated with polycythemia: immunohistochemical evidence. *Hepatology* Dec 1993;18(6):1357-1362.
194. Taillan B, Sanderson F, Fuzibet JG, Vinti H, Pesce A, Dujardin P. Polycythemia secondary to hepatic hemangioma with abnormal secretion of erythropoietin. *Am J Med* Dec 1989;87(6):700.
195. Rothman SA, Savage RA, Paul P. Erythropoietin dependent erythrocytosis associated with hepatic angiosarcoma. *Journal of Surgical Oncology* 1982;20: 105-108.
196. Capron JP, Chivrac D, Lorriaux A. Erythrocytose moderee a la phase initiale de l'hepatite virale. *Nouvelle Presse Medicale* 1975;4:2951.
197. Bank H, Passwell J. Absolute erythrocytosis in early infectious hepatitis. *Medecine et Chirurgie Digestives* 1974;3:321-323.
198. So CC, Ho LC. Polycythemia secondary to cerebellar hemangioblastoma. *Am J Hematol* Dec 2002;71(4):346-347.
199. Lindstedt G, Lundberg PA, Norrby A, et al. Hormone conference at Sahlgren's University Hospital: polycythemia and inappropriately high serum erythropoietin concentration in a 62-year-old man. *Clin Chem* Nov 1994;40(11 Pt 1):2093-2098.
200. Tachibana O, Yamashita T, Yamashita J. Immunohistochemical study of erythropoietin in cerebellar hemangioblastomas associated with secondary polycythemia. *Neurosurgery* Jan 1991;28(1):24-26.
201. Trimble M, Caro J, Talalla A, Brain M. Secondary erythrocytosis due to a cerebellar hemangioblastoma: demonstration of erythropoietin mRNA in the tumor. *Blood*. Aug 1 1991;78(3):599-601.
202. Alaoui Mdaghri Y, Caidi A, Kabbaj S, Maazouzi W. [Hemostasis disorder in a patient with hemangioblastoma of the cerebellum and polycythemia]. *Annalesfrancaises d'anesthesie et dereanimation* Dec 2002;21(10):824-825.
203. Burns C, Levine PH, Reichman H, Stock JL. Adrenal hemangioblastoma in Von Hippel-Lindau disease as a cause of secondary erythrocytosis. *Am J Med Sci* Feb 1987;293(2):119-121.
204. S O, S R, C B, S G, P L-P. Germline mutation profile of the VHL gene in von Hippel-Lindau disease and in sporadic hemangioblastoma. *Hum. Mutat* 1998;12:424.
205. Wrigley PF, Malpas JS, Turnbull AL, Jenkins GC, McArt A. Secondary polycythaemia due to a uterine fibromyoma producing erythropoietin. *Br J Haematol* 1971;21(5):551-555.
206. Takkar D, Kumar A. Polycythemia associated with uterine fibroid. *Indian Journal of Medical Sciences* 1994;48:144-146.
207. Ossias AL, Zanjani ED, Zalusky R, Estren S, Wasserman LR. Case report: studies on the mechanism of erythrocytosis associated with a uterine fibromyoma. *Br J Haematol* 1973;25(2):179-185.

208. Venencie PY, Puissant A, Boffa GA, Sohier J, Duperrat B. Multiple cutaneous leiomyomata and erythrocytosis with demonstration of erythropoietic activity in the cutaneous leiomyomata. *The British Journal of Dermatology* Oct 1982;107(4):483-486.
209. Bruneval P, Sassy C, Mayeux P, et al. Erythropoietin synthesis by tumor cells in a case of meningioma associated with erythrocytosis. *Blood* 1993;81: 1593-1597.
210. Ballard HS, Kouri Y. The association of erythrocytosis and chronic lymphocytic leukemia. *Cancer* 1992;70:2431-2435.
211. Nagasawa T, Yanagisawa H, Hasegawa Y, Kanma H, Abe T. Polycythemia associated with primary systemic amyloidosis: elevated levels of hemopoietic factors and cytokines. *Am J Hematol* May 1993;43(1):57-60.
212. Brewer CA, Adelson MD, Elder RC. Erythrocytosis associated with a placental trophoblastic tumor. *Obstetrics and Gynecology* 1992;79:846-849.
213. Siggillino JJ, Crawley CJ, Clauss RH, Reed GE, Tice DA. Myxoma of the right atrium with polycythemia. *Arch Intern Med* Feb 1963;111:178-183.
214. Mann DL, Gallagher NI, Donati RM. Erythrocytosis and primary aldosteronism. *Ann Intern Med* Feb 1967;66(2):335-340.
215. Muechler EK. Testosterone-producing ovarian tumor associated with erythrocytosis, hyperuricemia, and recurrent deep vein thrombosis. *American Journal of Obstetrics and Gynecology* 1977;129:467-469.
216. Erkelens DW, Stadius van Eps LW. Bartter's syndrome and erythrocytosis. *Am J Med* Nov 1973;55(5):711-719.
217. Battle JD, Jr., Alfidi RJ, Straffon RA. Polycythemia secondary to pheochromocytoma. Report of a case. *Cleveland Clinic Quarterly* Jul 1971;38(3):121-124.
218. Rezkalla MA, Rizk SN, Ryan JJ. Pheochromocytoma associated with polycythemia: case report. *South Dakota Journal of Medicine* 1995;48:349-351.
219. Drenou B, Le Tulzo Y, Caulet-Maugendre S, et al. Pheochromocytoma and secondary erythrocytosis: role of tumour erythropoietin secretion. *Nouvelle Revue Francaise d'Hematologie* 1995;37:197-199.
220. Willocks L, Ludlam CA, Welsby PD. Polycythaemia and HIV infection. *Lancet* 1990;336:812-813.
221. Battan R, Ottaviano P, Porcelli M, Distenfeld A. Polycythaemia in patient with AIDS. *Lancet* 1990;335:1342-1343.
222. Edwards TB, Nelson RP, Ballesteros OP, Saba HI, Lockey RF. Polycythemia as a complication of human immunodeficiency virus infection. *Southern Medical Journal* 1993;86:686-688.
223. Barbone E, Girolami A, Randi ML. HIV infection and polycythemia vera: a relationship worth pursuing? *J Med* 1993;24(6):409-410.
224. Caminal Montero L, Trapiella Martinez L, Gonzalez Marroquin A, Fernandez Fernandez C, Sanz Rubiales A. Polycythemia in a patient with HIV. *Revista Clinica Espanola* 1997;197:383-384.
225. Koduri PR, Sherer R, Teter C. Polycythemia in patients infected with human immunodeficiency virus-1. *Am J Hematol* May 2000;64(1):80-81.
226. Wagner JC. The abuse of drugs to enhance athletic performance. *American Journal of Hospital Pharmacy* 1989;46:2059-2067.
227. Dickerman RD, Pertusi R, Zachariah NY, Schaller F. Androgen-induced erythrocytosis. *Am J Hematol* Nov 1998;59(3):263-264.
228. Shahani S, Braga-Basaria M, Maggio M, Basaria S. Androgens and erythropoiesis: past and present. *J Endocrinol Invest* 2009;32(8):704-716.
229. Ip FF, di Pierro I, Brown R, Cunningham I, Handelsman DJ, Liu PY. Trough serum testosterone predicts the development of polycythemia in hypogonadal men treated for up to 21 years with subcutaneous testosterone pellets. *European Journal of Endocrinology / European Federation of Endocrine Societies* Feb 2010;162(2):385-390.
230. Halmesmaki E, Teramo KA, Widness JA, Clemons G, Ylikorkala O. Maternal alcohol abuse is associated with elevated fetal erythropoietin levels. *Obstetrics and Gynecology* 1990;76:219-222.
231. Scott WC. The abuse of erythropoietin to enhance athletic performance (letter). *Journal of the American Medical Association* 1990;264:1660.

232. Garceau R, Audran M, Baynes RD, Flowers CHD, Senecal L, Brisson GR. Erythropoietin abuse in athletes (letter). *Nature* 1996;380:113.
233. Brown KR, Carter, Jr., Lombardi GE. Recombinant erythropoietin overdose. *American Journal of Emergency Medicine* 1993;11:619-621.
234. Garceau R, Gagnon MG, Thellend C, et al. Transferrin soluble receptor: a possible probe for detection of erythropoietin abuse by athletes. *Hormone & Metabolic Research* 1994;26:311-312.
235. Souillard A, Audran M, Bressolle F, Gareau R, Duvallet A, Chanal JL. Pharmacokinetics and pharmacodynamics of recombinant human erythropoietin in athletes. Blood sampling and doping control. *British Journal of Clinical Pharmacology* 1996;42(3):355-364.
236. Borrione P, Parisi A, Salvo RA, et al. A peculiar pattern of expression of the transferrin receptor (CD71) by reticulocytes in patients given recombinant human erythropoietin (rHuEPO): a novel marker for abuse in sport? *Journal of Biological Regulators and Homeostatic Agents* 2007;21(3-4):79-88.
237. Sharpe K, Ashenden MJ, Schumacher YO. A third generation approach to detect erythropoietin abuse in athletes. *Haematologica* Mar 2006;91(3): 356-363.
238. Adamson JW, Stamatoyannopoulos G, Kontras S, Lascari A, Detter J. Recessive familial erythrocytosis: aspects of marrow regulation in two families. *Blood* May 1973;41(5):641-652.
239. Shih LY, Lee CT, See LC, et al. In vitro culture growth of erythroid progenitors and serum erythropoietin assay in the differential diagnosis of polycythemia. *European Journal of Clinical Investigation* 1998;28:569-576.
240. Kiladjian JJ, Gardin C, Renoux M, Bruno F, Bernard JF. Long-term outcomes of polycythemia vera patients treated with pipobroman as initial therapy. *Hematol J* 2003;4(3):198-207.
241. Percy MJ, Jones FG, Green AR, Reilly JT, McMullin MF. The incidence of the JAK2 V617F mutation in patients with idiopathic erythrocytosis. *Haematologica* 2006;91(3):413-414.

Part V - Disorders of Hemostasis and Coagulation

Section 1 - Introduction

Chapter 45 Diagnostic Approach to the Bleeding Disorders

> Table of Contents > Part V - Disorders of Hemostasis and Coagulation > Section 1 - Introduction > Chapter 45 - Diagnostic Approach to the Bleeding Disorders

Chapter 45

Diagnostic Approach to the Bleeding Disorders

George M. Rodgers

Christopher M. Lehman

Except for that which occurs during menstruation, spontaneous bleeding is abnormal. Surprisingly, little blood is lost, even after large injuries, because of the efficiency with which vascular integrity is normally maintained and the rapidity with which it is restored after injury. In general, these phenomena reflect the functional effectiveness of normal hemostasis (see Chapters 17, 18, and 19). It must be recognized, however, that the adequacy of hemostasis is only relative, and despite the presence of normal vessels, platelets, and coagulation factors, bleeding can occur as the result of localized pathologic processes.

The 11 chapters in Part V deal with disorders that result from abnormalities of the hemostatic process. This chapter is a summary of the diagnostic approach to these disorders and includes a brief discussion of laboratory methods for their study. In subsequent chapters, individual disorders are considered in six categories: thrombocytopenia (Chapters 46, 47, 48, and 49), bleeding disorders caused by vascular abnormalities (Chapter 50), thrombocytosis (Chapter 51), disorders of

platelet function (Chapter 52), inherited coagulation disorders (Chapter 53), and acquired coagulation disorders (Chapter 54). The pathophysiology of thrombosis and the principles of antithrombotic therapy are summarized in Chapter 55.

CLINICAL EVALUATION OF THE BLEEDING PATIENT

A careful evaluation of the patient presenting with a bleeding disorder can often provide valuable clues as to whether the abnormality resides in the vessels, platelets, or the process of blood coagulation; a carefully obtained history can usually establish whether the disorder is inherited or acquired; and the physical examination may reveal findings such as the characteristic skin lesions of hereditary hemorrhagic telangiectasia, which alone may provide the diagnosis of a previously perplexing bleeding problem. Results of the clinical evaluation should lead to a rational and efficient laboratory investigation.

It is important to ask specific questions about bleeding because people with normal hemostasis may believe they bleed excessively.¹ Certain questions may discriminate between those with normal and abnormal hemostasis, including whether excessive bleeding occurs after tooth extraction or small cuts, whether spontaneous bruising or muscle bleeding occurs, or whether the patient has ever been transfused or treated with blood products.¹

MANIFESTATIONS OF DISORDERED HEMOSTASIS

Certain signs and symptoms are virtually diagnostic of disordered hemostasis. They can be divided arbitrarily into two groups: those seen more often in disorders of blood coagulation and those most commonly noted in disorders of the vessels and platelets. The latter group is often called purpuric disorders because cutaneous and mucosal bleeding usually are prominent. The clinical findings that are most valuable in distinguishing between these two broad categories are summarized in Table 45.1. Although these criteria are relative, they provide valuable clues to the probable diagnosis if they are applied to the predominant clinical features in a given patient.

TABLE 45.1 CLINICAL DISTINCTION BETWEEN DISORDERS OF VESSELS OR PLATELETS AND DISORDERS OF BLOOD COAGULATION

Finding	Disorders of Coagulation	Disorders of Platelets or Vessels
Petechiae	Rare	Characteristic
Deep dissecting hematomas	Characteristic	Rare
Superficial ecchymoses	Common; usually large and solitary	Characteristic; usually small and multiple
Hemarthrosis	Characteristic	Rare
Delayed bleeding	Common	Rare
Bleeding from superficial cuts and scratches	Minimal	Persistent; often profuse
Sex of patient	80%-90% of inherited forms occur only in male patients	Relatively more common in females
Positive family history	Common	Rare (except von Willebrand disease and hereditary hemorrhagic telangiectasia)

P.1044

Bleeding into Skin and Soft Tissues

Petechiae are characteristic of an abnormality of the vessels or the platelets, such as thrombocytopenia, and are exceedingly rare in the coagulation disorders. These lesions are small capillary hemorrhages ranging from the size of a pinhead to much larger (Fig. 45.1). They characteristically develop and regress in crops and are most conspicuous in areas of increased venous pressure, such as the dependent parts of the body and areas subjected to pressure or constriction from girdles or stockings. In patients with scurvy, petechiae may be distributed around hair follicles in the “saddle area” of

the thighs and buttocks (see Fig. 50.5). Petechiae must be distinguished from small telangiectasias and angiomas. Vascular structures such as telangiectasias or angiomas blanch with pressure, whereas petechiae do not.

In the purpuric disorders, petechiae commonly are associated with multiple superficial ecchymoses, which usually develop without perceptible trauma but seldom spread into deeper tissues. Small isolated ecchymoses are commonly noted in apparently normal women, especially on the legs, and in small children.

Although large superficial ecchymoses may be seen in association with the coagulation disorders, the most characteristic lesion is the large spreading hematoma (Fig. 45.2). Such hematomas may arise spontaneously or after trivial trauma and often spread to involve an entire limb by dissecting within muscles and deep fascial spaces, often with minimal discoloration of the overlying skin.

Hemarthrosis

Hemorrhage into synovial joints is virtually diagnostic of a severe inherited coagulation disorder, most commonly hemophilia A or hemophilia B, and is rare in disorders of the vessels and platelets or in acquired coagulation disorders. This disabling problem often develops with pain and swelling as chief symptoms but without discoloration or other external evidence of bleeding (see Fig. 53.3). Subperiosteal hemorrhages in children with scurvy and swollen painful joints that may develop in some patients with allergic purpura occasionally may be confused with hemarthrosis.



FIGURE 45.1. Diffuse petechial rash induced by a tourniquet in a patient with chronic idiopathic thrombocytopenic purpura (platelet count = $40 \times 10^9/L$).



FIGURE 45.2. Large dissecting hematoma of thigh in a patient with hemophilia. A. The lesion resulted from a slight bump to the inguinal area and spread to involve the entire thigh. (Courtesy of Dr. John Lukens.)

Traumatic Bleeding

The unavoidable traumas of daily life and even minor surgical procedures are a greater challenge to hemostasis than any test yet developed in the laboratory. In contrast to “spontaneous” bleeding manifestations, bleeding after trauma in a person with a hemorrhagic diathesis differs in a quantitative way from that which would normally be expected in terms of the amount, duration, and magnitude of the inciting trauma. Such variables are extremely difficult to assess accurately by taking the patient's history. The amount of blood lost may be exaggerated by the patient. The need for transfusions and the number administered may serve as a rough guide. The patient's statement concerning the duration of bleeding is

more reliable. Detailed inquiry as to past injuries and operations must be made because the patient is likely to forget procedures or injuries that were uncomplicated and to dwell on those in which bleeding was a problem. Whether reoperation was required for prolonged bleeding after tooth extraction or other minor surgical procedures may be helpful in identifying a patient with abnormal hemostasis.

In individuals with a coagulation disorder, the onset of bleeding after trauma often is delayed. For example, bleeding after a tooth extraction may stop completely, only to recur in a matter of hours and to persist despite the use of styptics, vasoconstrictors, and packing. The temporary hemostatic adequacy of the platelet plug despite defective blood coagulation may explain this phenomenon of delayed bleeding, as well as the fact that patients with coagulation disorders seldom bleed abnormally from small superficial cuts such as razor nicks. In contrast, posttraumatic or postoperative surgical bleeding in thrombocytopenic patients usually is immediate in onset, as a rule responds to local measures, and rarely is as rapid or voluminous as that encountered

P.1045

in patients with coagulation disorders. However, it may persist for hours or days after surprisingly small injuries.

Valuable information often is obtained from a careful review of dental procedures, because most patients have had one or more teeth extracted at some time during their lives. The amount of bleeding normally encountered varies greatly, but as a rough guide, uncomplicated extraction of a single molar tooth may result in brisk bleeding for up to 1 hour and slight oozing for up to 2 days in normal persons.² Typically, bleeding is more profuse from upper than from lower sockets and is more extensive after extraction of molar teeth, particularly impacted third molars, than after removal of other teeth. In patients with inherited coagulation disorders, the shedding of deciduous teeth often is uncomplicated.

The response to trauma is an excellent screening test for the presence of an inherited hemorrhagic disorder, and a history of surgical procedures or significant injury without abnormal bleeding is equally good evidence against the presence of such a disorder. The removal of molar teeth is a major challenge to hemostasis, as is a tonsillectomy, and it is a rare hemophiliac, however mildly affected, who can withstand these procedures without excessive bleeding.

Miscellaneous Bleeding Manifestations

Despite the fact that structural causes for bleeding (such as polyps, varices, and tumors) are commonly seen in patients with hematuria, hematemesis, and melena, bleeding from these sites may also be associated with both purpuric and coagulation disorders. Severe menorrhagia may be the sole symptom of women with von Willebrand disease (vWD), mild thrombocytopenia, or autosomally inherited coagulation disorders. Recurrent gastrointestinal bleeding or epistaxis in the absence of other bleeding manifestations is common in hereditary hemorrhagic telangiectasia. A coagulation disorder or a disorder of platelet function should be considered if protracted hematuria is the only symptom.

Bleeding into serous cavities and internal fascial spaces often occurs in patients with inherited coagulation disorders and may create serious diagnostic problems. In hemophilia, retroperitoneal hemorrhage or bleeding into the psoas sheath may mimic appendicitis, and hemorrhage into the bowel wall may be confused with intestinal obstruction. Signs and symptoms simulating a variety of acute intra-abdominal disorders also may be seen in association with allergic purpura. Bleeding into the central nervous system may complicate thrombocytopenia and may occur after minor trauma in patients with coagulation disorders. Multiple small retinal hemorrhages are common in patients with thrombocytopenia and other purpuric disorders but are uncommon in those with inherited coagulation disorders; large hematomas of the orbit may be seen in the latter group. The coexistence of bleeding and thromboembolic phenomena or bleeding from previously intact venipuncture sites is suggestive of diffuse intravascular coagulation (DIC). Protracted wound healing, wound dehiscence, and abnormal scar formation have been described in inherited afibrinogenemia, the dysfibrinogenemias, and in factor XIII deficiency.³ Hemoptysis rarely is associated with hemorrhagic disorders.

CLINICAL FEATURES OF INHERITED BLEEDING DISORDERS

An inherited bleeding disorder is suggested by the onset of bleeding symptoms in infancy and childhood, a positive family history (particularly if it reveals a consistent genetic pattern), and laboratory evidence of a single or isolated abnormality, most commonly the deficiency of a single coagulation factor.

Age at Onset: Bleeding in the Neonate

Birth and the neonatal period provide unique challenges to the hemostatic mechanism,⁴ and bleeding during the first month of life often is the first evidence of an inherited disorder of hemostasis. Small cephalohematomas and petechiae are common in the newborn as a result of the trauma of delivery. Large cephalohematomas that progressively increase in

size may result from hemophilia but are more common in association with acquired bleeding disorders such as hemorrhagic disease of the newborn (see Chapter 54). Bleeding from the umbilical stump and after circumcision is common in the acquired coagulation disorders, and it also occurs in the inherited coagulation disorders,⁵ with the exception of hypofibrinogenemia, dysfibrinogenemia, and factor XIII deficiency. The onset of bleeding from the umbilical cord may be delayed in these latter disorders. In the evaluation of bleeding in the neonate, the clinician should remember that hematochezia and hematemesis may originate from swallowed blood of maternal origin. Simple tests to distinguish such maternal blood from fetal blood have been described.⁵

Many infants with inherited coagulation disorders do not bleed significantly in the neonatal period. Less than one-third of patients with hemophilia A and B and only 10% of those with other inherited coagulation disorders have hemorrhagic symptoms during the first week of life. In such patients, the disorder may become clinically silent for a time. Hematomas may first be seen only when the child becomes active. Hemarthrosis commonly does not develop until a child is 3 or 4 years of age.

A mild inherited hemorrhagic disorder may be difficult to distinguish from the insidious onset of an acquired defect. Patients with mild inherited coagulation disorders may enter adult life before characteristic bleeding manifestations occur. These patients and those with some forms of inherited thrombocytopenia and disordered platelet function often describe a history of posttraumatic bruising and hematoma formation that they have come to accept as normal. In hereditary hemorrhagic telangiectasia, the lesions become more prominent with advancing age and may not be symptomatic until middle age. Similarly, in patients with Ehlers-Danlos syndrome, bleeding may not be a problem until adult life.

Family History

The family history is of great importance in the evaluation of bleeding disorders. In disorders inherited as autosomal dominant traits with characteristic symptoms and high penetrance, such as hereditary hemorrhagic telangiectasia, an accurate pedigree spanning several generations can often be obtained. The presence of typical bleeding manifestations in male siblings and maternal uncles is virtually diagnostic of X-linked recessive inheritance, which characterizes hemophilia A and hemophilia B. In such X-linked traits, the family history also may be helpful in a negative sense—that is, it may clearly exclude the disorder in certain offspring, such as the sons of a known hemophiliac. Details of the various genetic patterns that may be encountered are discussed in the chapters that deal with these conditions.

The limitations of the family history, however, are greater than is commonly realized. Hearsay history is difficult to evaluate, and it is often impossible to assess the significance of easy bruising or to differentiate between manifestations of a generalized bleeding disorder and more common localized lesions, such as peptic ulcer and uterine leiomyomas. A negative family history is of no value in excluding an inherited coagulation disorder in an individual patient. As many as 30% to 40% of patients with hemophilia A have a negative family history.⁶ The family history usually is negative in the autosomal recessive traits, and consanguinity, which is commonly present in these kindreds, is notoriously difficult to document or exclude.

P.1046

CLINICAL FEATURES OF ACQUIRED BLEEDING DISORDERS

Generalized bleeding may be a prominent feature of a wide variety of acquired disorders that encompass virtually the entire field of medicine. Bleeding manifestations usually are less severe than in the inherited forms, and the clinical picture often is dominated by evidence of the underlying disorder rather than by bleeding alone. In the neonate, for example, DIC usually is associated with significant complications such as sepsis, hypoxia, acidosis, or problems related to prematurity. The physician should suspect sepsis or occult thrombosis in any sick neonate with unexplained thrombocytopenia.⁵ Multiple hemostatic defects commonly are present in patients with acquired hemorrhagic diseases, which often include thrombocytopenia and significant coagulation abnormalities. In contrast, a single abnormality usually is found in patients with inherited hemorrhagic disorders.

In general, the emphasis of the study of the acquired bleeding disorders should be on the patient, not on the laboratory. A thorough history and the physical examination often reveal the cause of thrombocytopenia, such as a drug or acute leukemia. In most vascular disorders, including senile purpura, allergic purpura, scurvy, and amyloidosis, the history and physical examination are of primary diagnostic importance, and the laboratory has little to offer.

Drug History

The importance of exhaustive interrogation regarding drug use and chemical exposure cannot be overemphasized. The list of drugs associated with thrombocytopenia (see Table 47.6) or vascular purpura grows longer each year. Less common but more serious is drug-induced aplastic anemia, which may present initially with bleeding. Many commonly used drugs, notably aspirin, impair platelet function and produce abnormal findings on laboratory tests that often lead to expensive and unnecessary additional laboratory studies. The same drugs may provoke bleeding when administered to patients with pre-existing hemostatic defects such as hemophilia A. Drug ingestion also may produce coagulation abnormalities, and drugs that potentiate or antagonize the anticoagulant effects of coumarin derivatives may lead to bleeding or erratic laboratory control. The surreptitious ingestion of such agents is not uncommon.

TABLE 45.2 INTERPRETATION OF COMMON TESTS OF HEMOSTASIS AND BLOOD COAGULATION

Test	Normal Range ^a (±2 SD)	Common Causes of Abnormalities
Platelet count		
Phase microscopy	140,000-440,000/ μ l	Thrombocytopenia, thrombocytosis
Automated	177,000-406,000/ μ l	
Partial thromboplastin time (activated) ^b	26-36 sec ^{55, c}	Deficiencies or inhibitors of prekallikrein; high-molecular-weight kininogen; factors XII, XI, IX, VIII, X, and V; prothrombin or fibrinogen; lupus inhibitors; heparin; warfarin
Prothrombin time ^b	12.0-15.5 sec ^{66, c}	Deficiencies or inhibitors of factors VII, X, and V; prothrombin or fibrinogen; dysfibrinogenemia; lupus inhibitors; heparin; warfarin
Thrombin time ^b	14.7-19.5 sec	Afibrinogenemia, dysfibrinogenemia, hypofibrinogenemia, and hyperfibrinogenemia; inhibitors of thrombin (heparin) or fibrin polymerization (fibrin degradation products, paraproteins)
Fibrinogen assay ^b	150-430 mg/dl ⁷⁰	Afibrinogenemia, dysfibrinogenemia, and hypofibrinogenemia; inhibitors of thrombin or fibrin polymerization
Factor VIII assay ^b	50-150 U/dl	Hemophilia A and von Willebrand disease; acquired antibodies to factor VIII
Fibrin degradation product assay	0-5 μ g/ml ⁸⁰	Disseminated intravascular coagulation; fibrinolysis; thrombolytic drugs, liver disease; dysfibrinogenemia
D-dimer assay	0-0.4 μ g/ml	Disseminated intravascular coagulation; recent surgery; pregnancy; thromboembolism

^a Normal range in the University of Utah coagulation laboratory.

^b Tests affected by heparin.

^c Significant variations depending on reagents and technique.

Results of various coagulation tests may be abnormal in a surprisingly large percentage of hospitalized patients because of heparin that is administered therapeutically or is used in small amounts to maintain the patency of indwelling venous catheters, venous pressure lines, arteriovenous shunts, and various pumps and infusion machines. The partial thromboplastin time (PTT), in particular, may be greatly prolonged in patients who have received even a minute amount of this anticoagulant. Such coagulation abnormalities often are confused with DIC, inhibitors of factor VIII, and other serious coagulation disorders, and they commonly lead to repeated, and usually useless, coagulation studies. A thorough bedside inventory often is required to find out that heparin is indeed responsible. Prolongation of the thrombin time associated with a normal reptilase time or direct assay of heparin provides laboratory evidence of heparin contamination.

LABORATORY METHODS FOR STUDY OF HEMOSTASIS AND BLOOD COAGULATION

No single test is suitable for the laboratory evaluation of the overall process of hemostasis and blood coagulation, but methods of varying complexity and use are available for assessing various components and functions individually. The emphasis of the following discussion is on methods that are simple and widely available in most laboratories. The interpretation of the most commonly used tests and the range of values obtained in normal subjects with representative techniques are summarized in Table 45.2. Definitive coagulation methods usually require a specially equipped laboratory and trained personnel, and are discussed here from a general standpoint only. Additional comments concerning the use and limitations of the various methods are included in chapters dealing with individual disorders.

P.1047

Tests of Vascular and Platelet Phases

Bleeding Time

Hemostasis in a small superficial wound, such as that produced when measuring the bleeding time, depends on the rate at which a stable platelet plug is formed and, thus, provides a measure of the efficiency of the vascular and platelet phases. However, it does not discriminate between vascular defects, thrombocytopenia, and platelet dysfunction. The bleeding time leaves much to be desired in terms of reproducibility, because no two skin areas are exactly the same and it is impossible to produce a truly standard wound.⁷

Older studies using the bleeding time test supported the view that this test might be helpful in predicting bleeding in individual patients.⁸ More recent studies suggest that a bleeding time result is determined not only by platelet number and function, but also by hematocrit,⁹ certain components of the coagulation mechanism,^{10, 11} skin quality,¹² and technique.¹³ A careful analysis of this literature indicates that there is no correlation between a skin template bleeding time and certain visceral bleeding times,^{13, 14} and that no correlation exists between preoperative bleeding time results and surgical blood loss or transfusion requirements.¹⁵

A clinical outcomes study reported that discontinuation of the bleeding time in a major academic medical center had no detectable adverse clinical impact.¹⁶ A position paper of the College of American Pathologists and the American Society of Clinical Pathologists concluded that the bleeding time was not effective as a screening test, and that a normal bleeding time does not exclude a bleeding disorder.¹⁷ Patients thought to have a platelet-type bleeding disorder based on their personal or family history (or both) should be evaluated for vWD and the inherited qualitative platelet disorders, using assays discussed in the section Platelet Function Assays. Newer assays that may be useful in screening patients for platelet dysfunction are also discussed in the section New Assays of Platelet Function.

Platelet Enumeration

Platelets are considerably more difficult to count than erythrocytes or leukocytes. This difficulty is to be expected in view of the small size of these cells and their tendency to adhere to foreign surfaces and to aggregate when activated.

In general, techniques for platelet counting may be classified into two groups: hemacytometer or direct methods, in which whole blood is diluted and the platelets are counted in much the same way as leukocytes or erythrocytes, and fully automated electronic methods. Virtually identical values for the normal range of the platelet count have been obtained with modern methods, as summarized in Table 45.2.

An estimate of platelet numbers in a well-prepared blood smear by an experienced observer is a valuable check on the platelet count as determined by any method. In general, when a blood smear is examined at 100 × power, each platelet

counted/field represents approximately $10,000 \text{ platelets} \times 10^9/\text{L}$. Consequently, a normal blood smear should demonstrate, on average, at least 14 platelets/high-power field.

Instruments for totally automated platelet counting are widely used. Details of automated cell counters are discussed in Chapter 1. When automated methods are used, various nontechnical factors may produce falsely low platelet counts.¹⁸ These factors include platelet agglutinins,¹⁹ abnormal amounts of plasma proteins in various paraproteinemias, previous contact of platelets with foreign surfaces such as dialysis membranes,²⁰ large or giant platelets, platelet satellitism,²¹ lipemia,²² and ethylenediaminetetra-acetic acid (EDTA)-induced platelet clumping,²³ a phenomenon that may produce platelet clumps of sufficient size to artifactually increase the leukocyte count.²⁴ Spuriously high platelet counts may result from the presence of microspherocytes,²⁵ fragments of leukemic or red blood cells,²⁶ and Pappenheimer bodies.²⁷ Special technical modifications and the use of careful manual counting methods may be required to eliminate these artifacts and to obtain accurate platelet counts.

Platelet Volume Measurements

The widespread availability of particle counters in the clinical laboratory permits the accurate measurement of platelet volume on a routine basis. Mean platelet volume (MPV) is increased in disorders associated with accelerated platelet turnover as the result of large numbers of megathrombocytes²⁸ or in patients with Bernard-Soulier syndrome. Normal or decreased values for MPV usually are obtained in patients with disorders associated with deficient platelet production, in some patients with sepsis,²⁹ and in people with certain big-spleen syndromes.³⁰

Some authors suggest that increased MPV provides evidence of accelerated platelet production and may be interpreted in the same way as the reticulocyte count. The method is difficult to standardize, however, and when determined on routinely collected specimens by automated counters, it is affected by numerous variables pertaining to specimen collection, anticoagulant, temperature, and duration of storage.³¹ In view of these problems and the difficulty in interpreting platelet size heterogeneity under normal and abnormal conditions,³² these measurements should be interpreted with caution.

The presence of microcytic platelets in patients with some inherited thrombocytopenias such as Wiskott-Aldrich syndrome is reliably reflected by MPV measurements. On the other hand, giant platelets associated with Bernard-Soulier syndrome may be counted as leukocytes or erythrocytes and may not be reflected in the MPV.

Platelet Function Assays

Since the 1960s, platelet aggregation using platelet-rich plasma has been the standard method to assess platelet function. This method uses aggregometers, which are modified nephelometers that permit measurement of changes in optical density of a platelet suspension under conditions of constant temperature and continuous agitation (Fig. 45.3). Most instruments measure

P.1048

a combination of light scatter and absorption. Instruments have been developed that permit both nephelometric and photometric measurements and the simultaneous measurement of aggregation and nucleotide release.³³

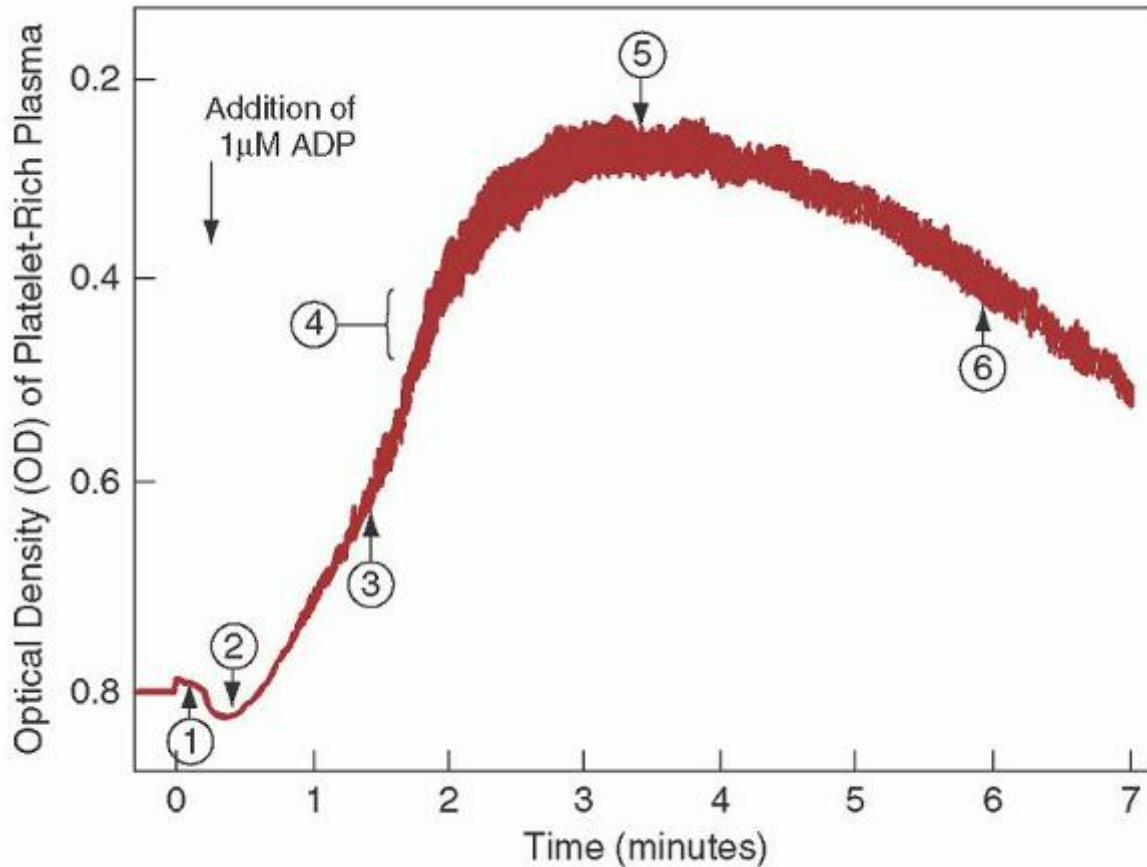

FIGURE 45.3. The interpretation of aggregometer tracings. Tracing of platelet aggregation produced by a low concentration of adenosine diphosphate (ADP), illustrating normal changes in optical density (OD)—that is, (1) a slight decrease caused by dilution with aggregating agent; (2) a transient increase caused by initial platelet swelling or shape change; (3) a rapid progressive decrease as platelet aggregates form, the size of which is roughly proportional to the amplitude of the oscillations in the tracing (4). The OD then reaches a nadir (5) from which maximal aggregation as a percentage of the initial OD may be calculated as follows: maximal aggregation (%) = $\text{OD at T}_0 - \text{minimum OD} / \text{OD at T}_0$. After this (6), a slow increase in OD caused by disaggregation occurs under some conditions.

Platelet aggregation usually is studied in suspensions of citrated platelet-rich plasma, in which the size and dimensions of the stirring bar, variations in plasma citrate concentration attributable to variations in hematocrit, the pH, and the nature of the buffers are important variables. Platelet suspensions usually are prepared by differential centrifugation, but methods that use albumin density gradient centrifugation and gel filtration have also been described.³⁴ Although harvesting platelets from the blood of thrombocytopenic patients is difficult, testing such platelets in the aggregometer is reproducible in suspensions containing as few as 50,000 platelets/ μl . Methods for the study of platelet aggregation in whole blood^{35, 36} also have been described. Interfaced computer systems have been developed for calculating and expressing platelet function data.³⁷

Adenosine diphosphate (ADP) in concentrations of 5 $\mu\text{mol/L}$ or higher produces platelet aggregation directly that is independent of the release of platelet-contained ADP.³⁸ Various other aggregating agents act mainly by inducing the release reaction, such as a suspension of connective tissue particles (collagen), epinephrine and norepinephrine, and thrombin. With epinephrine (5 $\mu\text{mol/L}$), a weak primary aggregating effect usually can be clearly distinguished from the subsequent release reaction, which produces a secondary wave of aggregation. Such primary and secondary waves of aggregation also may be seen with carefully titrated amounts of ADP (0.2 to 1.5 $\mu\text{mol/L}$).³⁸

Ristocetin is an antibiotic that induces platelet agglutination (platelet metabolic activity not required) in the presence of von Willebrand factor (vWF). Patients deficient in vWF (vWD) or in the receptor for vWF (Bernard-Soulier syndrome) have an abnormal ristocetin response. Ristocetin is tested in concentrations of 0.6 to 1.2 mg/ml; the lower concentrations are helpful in identifying specific variants of vWD, type 2B and platelet-type vWD (see Chapters 52 and 53).

The release reaction is measured only indirectly by routine aggregometry—that is, the aggregation associated with the release of ADP from the platelets (release-induced aggregation or secondary aggregation). Methods for the quantitation of various substances released from platelets have been described. For example, the amounts of ADP or serotonin released/unit of time serve as indices of dense body release³⁹; the amount of various hydrolytic enzymes or platelet factor 4 released is a measure of the extent of α -granule release.⁴⁰ Suggested guidelines for standardization of platelet aggregation methods have been proposed.^{41, 42}

Sensitive methods have been developed for the determination of platelet-derived substances in plasma that may serve as markers of intravascular platelet activation,⁴³ including platelet factor 4, β -thromboglobulin, stable prostaglandins (6-keto prostaglandin F₁ α and thromboxane A₂), and leukotrienes.⁴³ These measurements may have diagnostic value in thromboembolic disorders and syndromes characterized by intravascular platelet aggregation.

New Assays of Platelet Function

An appreciation of the limitations of the bleeding time test has led to the development of newer assays to evaluate platelet function.⁴⁴ Some of these are point-of-care tests. The clinical use and predictive value of these tests to identify patients with hemostatic disorders remain to be established. One assay, the platelet function analyzer (PFA-100), has been investigated for several years, and many published reports using this assay are available. In this method, citrated blood samples are exposed to high shear rates in a capillary flowing through an aperture within a membrane coated with collagen and either ADP or epinephrine.⁴⁵ The closure time to hemostatic plug formation within the aperture is the endpoint of the test. A large study using the PFA-100 found that prolonged closure times could be attributed to specific quantitative or qualitative abnormalities in platelet function or vWF (or both) in 93% of patients tested.⁴⁶ However, the International Society on Thrombosis and Haemostasis has taken the position that the PFA-100 is insufficiently sensitive and specific to be used as a screening device for platelet disorders.⁴⁷ It has been suggested that optimal use of the PFA-100 in evaluation of hemostasis would use an algorithmic approach, evaluating not only PFA-100 closure times, but also a complete blood count, blood smear, and assays for vWD and platelet aggregation to further evaluate abnormal closure times. A recent addition to the PFA repertoire is the INNOVANCE PFA P2Y test designed to assess P2Y₁₂-receptor blockade.

Several additional platelet function analyzers are available on the market, though they are not as well studied as the PFA-100.⁴⁸ The ICHOR II-Plateletworks system (Helena Laboratories, Beaumont, TX) compares impedance-derived platelet counts in samples with and without added platelet agonists to assess platelet function. This system has historically been used to evaluate cardiopulmonary bypass patients, but more recently has been applied to patients undergoing coronary stent placement. The Impact-R (Matis Medical, Beersel, Belgium) is an automated cone-and-plate research analyzer that assesses platelet adhesion and aggregation on a polystyrene surface under laminar flow conditions. The VerifyNow system analyzes platelet agonist-induced aggregation of fibrinogen-coated microparticles to assess platelet function. Agonist cartridges are designed to evaluate the effects of aspirin, clopidogrel, and GPIIb/IIIa platelet receptor inhibitor administration on platelet function. Platelet mapping, a modification of thromboelastography, measures the platelet contribution to clot strength in the presence of specific agonists.⁴⁹ To date, no platelet function analyzer assay has been sufficiently studied or validated to warrant routine clinical use.^{48, 50, 51}

Tests of Coagulation Phase

In general, meticulous performance of coagulation tests is more important than the exact technique chosen. Blood samples obtained by traumatic venipunctures or from indwelling catheters often are inadequate for coagulation studies.⁵² A poorly collected blood sample is a far more common cause of inaccurate results than is technical error.

With the exception of one assay for fibrin degradation products (FDPs), all coagulation tests are performed on citrated plasma, most commonly obtained using blue-top vacuum blood collection tubes that pull in nine parts of blood to one part citrate. The International Society for Thrombosis and Haemostasis recommends the routine use of 3.2% sodium citrate. A pool of freshly frozen citrated plasma from several normal donors is a suitable control for screening procedures in most laboratories. Lyophilized control plasma and borderline abnormal control plasmas are available commercially to standardize coagulation assays and to provide reference standards.

The citrate ion does not enter the erythrocyte. Consequently, the plasma citrate concentration is abnormally high when blood with a high hematocrit (>55%) is collected in usual concentrations of this anticoagulant. This may produce artifactual prolongation of one-stage screening tests of coagulation, such as the PTT.⁵³ To obtain interpretable data on such samples, tubes containing citrate concentrations appropriate for the hematocrit must be prepared by removing an aliquot of the citrate anticoagulant contained in standard blue-top tubes.

Activated Partial Thromboplastin Time

The activated partial thromboplastin time (PTT) is a simple test of the intrinsic and common pathways of coagulation. When a mixture of plasma and a phospholipid platelet substitute is recalcified,

P.1049

fibrin forms at a normal rate only if the factors involved in the intrinsic pathway (prekallikrein, high-molecular-weight kininogen, and factors XII, XI, IX, and VIII) and in the common pathway (factors X and V, prothrombin, and fibrinogen) are present in normal amounts (Fig. 45.4). Platelet substitutes of various kinds may be used, such as chloroform extract of brain⁵⁴ and other crude cephalin fractions as well as soybean phosphatides (inosithin). In the PTT, such platelet substitutes are provided in excess, and the test is unaffected by the number of platelets remaining in the plasma (unless the sample contains antiphospholipid antibodies). Platelet substitutes are only partial thromboplastins, however, and they are incapable of activating the extrinsic pathway, which requires complete tissue thromboplastin (tissue factor). Thus, the PTT bypasses the extrinsic pathway and is unaffected by a deficiency of factor VII. The PTT assay is used to detect factor deficiency, screen for the lupus anticoagulant, and monitor heparin anticoagulation.

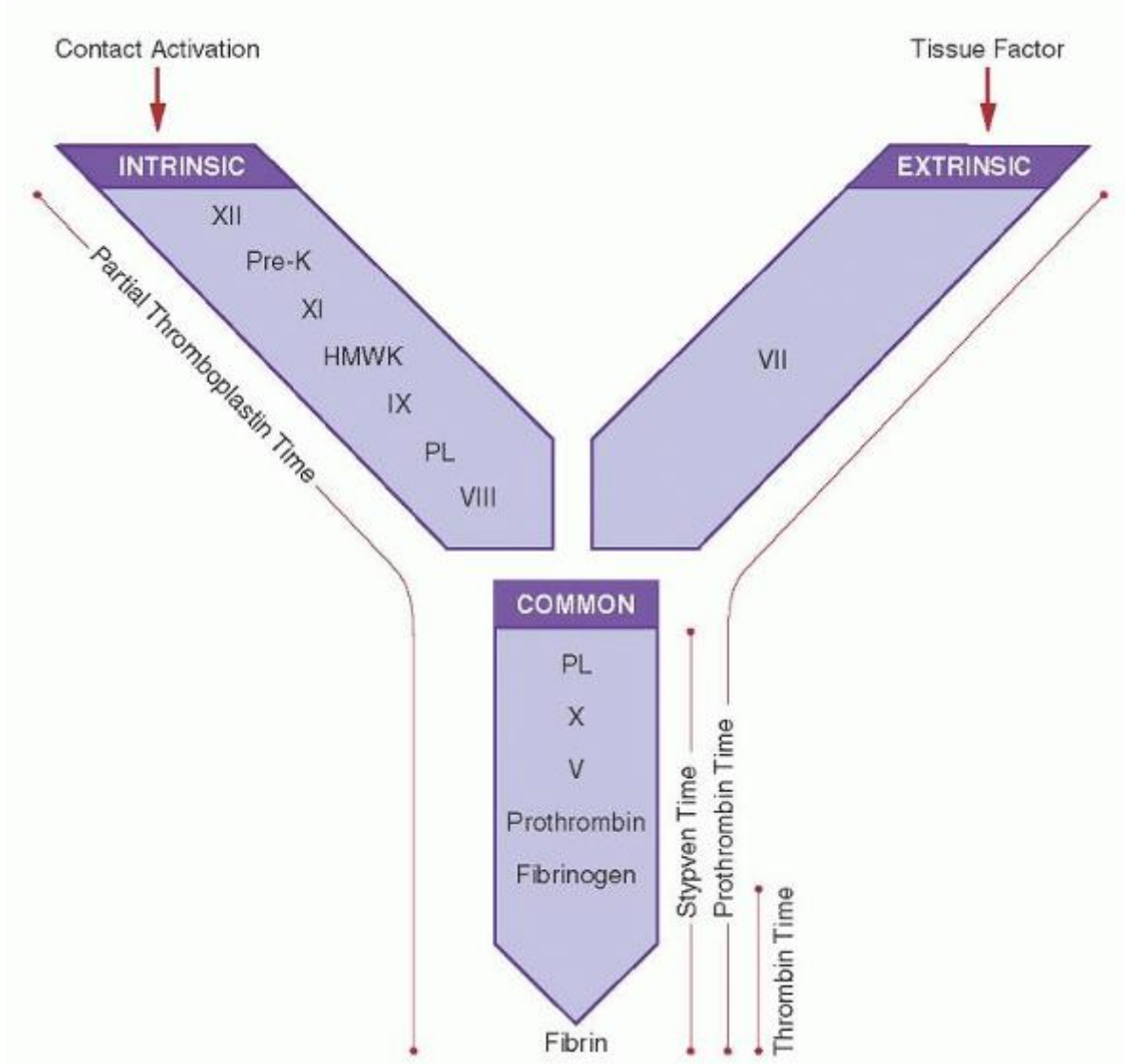

FIGURE 45.4. The interpretation of common screening tests of blood coagulation. Coagulation factors are indicated within arrow-shaped blocks, which represent the major pathways of coagulation. Screening tests are indicated at the side of these blocks in relation to pathways and coagulation factors measured by each. HMWK, high-molecular-weight kininogen; PL, phospholipid; Pre-K, prekallikrein.

The PTT is somewhat more sensitive to deficiencies of factors VIII and IX than to deficiencies of factors XI and XII or factors involved in the common pathway,^{55, 56} but with most techniques, the test usually yields abnormal results if the plasma level of any of the essential factors is <15% to 30% of the normal value. The PTT thus detects some mild coagulation disorders. However, the ability to detect mild factor deficiency is reagent-dependent, and certain PTT reagents may not detect factor deficiency as low as 5% to 10%.⁵⁷ As is the case with all one-stage tests, the PTT may be shortened by high levels of a single factor, most commonly factor VIII. Thus, a short PTT may signify any of the various hypercoagulable states (see Chapter 55),⁵⁸ and high levels of any of the factors involved in the intrinsic or common pathways of coagulation may mask deficiencies of other factors.⁵⁹

In the original method, contact activation was provided by the glass tube, but the addition of activators, such as ellagic acid, or particulate silicates, such as Celite or kaolin, provides more optimal and standardized contact activation and represents a significant improvement over the original nonactivated test.^{60, 61} The PTT is the routine assay currently used to evaluate intrinsic coagulation. The PTT of plasma deficient in prekallikrein (Fletcher factor) is abnormal when it is determined by standard methods using particulate activators such as Celite or kaolin.⁶² This abnormality is minimized or abolished by protracted contact activation (15 minutes⁶³), as compared with 2 to 3 minutes used in the standard technique. The PTT may yield normal results in prekallikrein deficiency when soluble activators such as ellagic acid are used.⁶³ A large recent pediatric reference interval study found no significant differences between adult PTT values and those of children ages 7 to 17 years.⁶⁴

Whereas increased PTT values may suggest a bleeding disorder, shortened PTT values have been found to be independent predictors of an increased risk of death, thrombosis, bleeding, and morbidity.^{58, 65} The use of the PTT in the control of heparin therapy and in detection of the lupus anticoagulant is discussed in Chapters 55 and 54, respectively.

Prothrombin Time

The production of fibrin by means of the extrinsic and common pathways (Fig. 45.4) requires tissue factor and factor VII, in addition to factors X and V, prothrombin, and fibrinogen. These pathways are measured by the prothrombin time (PT),⁶⁶ in which plasma is recalcified in the presence of excess tissue factor. This test does not require contact activation and bypasses the intrinsic pathway and the factors involved therein. Because tissue thrombo-plastins contain phospholipids that act as platelet substitutes, the test is unaffected by platelet numbers. Of the five coagulation factors measured by the PT (factors V, VII, and X, prothrombin, and fibrinogen), three (prothrombin and factors VII and X) are vitamin K-dependent and are decreased by coumarin-like drugs. As a result, the PT is the test used most widely for controlling oral anti-coagulant therapy. The PT usually is prolonged if the plasma levels of any of the requisite factors are <10% of normal, and it is more sensitive to deficiencies of factors VII and X than to deficiencies of fibrinogen and prothrombin. The PT also is prolonged by inhibitors of any of the essential factors and by heparin (unless heparin neutralizers are present in the PT reagent), but it is less sensitive to the anticoagulant action of heparin than is the PTT. A large pediatric reference interval study found that children ages 7 to 17 years have PT values ~1 second longer than normal adults.⁶⁴

Various modified techniques and thromboplastins,⁶⁷ including recombinant human thromboplastins,⁶⁸ have been developed to improve the use of the PT in the control of coumarin anticoagulant therapy (see Chapter 55). Use of the international normalized ratio in monitoring oral anticoagulation therapy is the recommended format (discussed in Chapter 55). The PT performed with bovine brain thromboplastin is abnormal in patients with certain genetic variants of factor IX deficiency but is normal in patients with the more common form of this disorder. The venom of the Russell viper contains an enzyme that initiates coagulation by the direct activation of factor X and does not require factor VII. The one-stage "prothrombin time" performed with this venom (the Stypven time) thus distinguishes between deficiency of factor VII and deficiency of factor X (Fig. 45.4).

Assay of Plasma Fibrinogen

Several accurate methods are available for the quantitative assay of plasma fibrinogen, a measurement of great clinical importance that should be available in all laboratories. Fibrinogen may be converted into fibrin, which is quantitated by gravimetric, nephelometric,⁶⁹ or chemical⁷⁰ methods. An immunologic⁷¹ method has also been described. Kinetic techniques based on the thrombin time, however, are simple to perform, and they have been widely adopted.⁷² Both gravimetric methods and those based on the thrombin time underestimate fibrinogen in the presence of high concentrations of FDPs; technical modifications designed to avoid these problems have been proposed.⁷³ Some nephelometric

P.1050

methods appear to be minimally affected by FDP. Modified methods that eliminate interference by heparin,⁷⁴ as well as

automated techniques, have been described. Marked differences in fibrinogen levels obtained by gravimetric and immunologic methods and those obtained by functional techniques are found in patients with the inherited dysfibrinogenemias. Reference values to identify patients with dysfibrinogenemia have been reported.⁷⁵

Thrombin Time and Related Techniques

When thrombin is added to plasma, the time required for clot formation is a measure of the rate at which fibrin forms (Fig. 45.4). This test (thrombin time) yields abnormal results when the fibrinogen level is <70 to 100 mg/dl, but it is unaffected by the levels of any of the other coagulation factors⁷⁶; it is greatly prolonged by heparin. The thrombin time may also be prolonged by a qualitatively abnormal fibrinogen (dysfibrinogen), elevated levels of fibrin (fibrinogen)-degradation products, certain paraproteins, and hyperfibrinogenemia. The thrombin time and modifications thereof are technically simple, can be performed quickly, and are valuable, particularly in the diagnosis of DIC. The reptilase clotting time is similar to the thrombin time in principle, but coagulation induced by this enzyme, which is prepared from snake venom, is unaffected by the presence of heparin.

Tests for Fibrin (Fibrinogen)-degradation Products and D-Dimer

Fibrin (fibrinogen)-degradation products (FDPs) are protein fragments of varying sizes that result from the proteolytic action of plasmin on fibrin or fibrinogen (see Chapter 18).⁷⁷ Plasma levels of these fragments are commonly increased in association with DIC and fibrinogenolysis, disorders in which their presence is of considerable diagnostic significance. Quantitative assays for FDP are based on several principles, such as the agglutination of latex particles coated with antifibrinogen antibody,⁷⁸ immunodiffusion,⁷⁹ and red cell hemagglutination inhibition.⁸⁰ Serum containing rheumatoid factor⁷⁸ or residual fibrinogen may yield false-positive results in some assays.⁸¹

None of the aforementioned methods distinguishes between fibrin degradation products and fibrinogen degradation products; to make this distinction, measurement of the DD-dimer or even more sophisticated methods are required.⁸² Extremely sensitive methods for the measurement of fibrinopeptides and specific FDP, such as the DD-dimer,⁸³ DDE-trimer, or B- β 15-42-related peptide, are useful as indices of DIC and as markers of subtle activation of coagulation in vivo (see Chapter 54).

Unpolymerized fibrin monomer is commonly present in the blood of patients with DIC. Various techniques (paracoagulation techniques) for demonstrating such monomers have been described; these range from the ethanol gelation test,⁸⁴ which is insensitive, to various protamine gelation techniques,⁸⁵ which are highly sensitive but nonspecific. Cryofibrinogen, which may be demonstrated in some cases of DIC, also may signify the presence of fibrin monomers. All of these assays to diagnose DIC have been supplanted by the D-dimer test.⁸³ The use of D-dimer tests to exclude venous thromboembolism is discussed in Chapter 55.

Tests for Factor XIII Activity

The principle of the factor XIII screening test is that clots crosslinked by factor XIII resist denaturation by high concentrations of urea or acid. Deficiency of factor XIII results in premature clot lysis.³ Patient plasma is recalcified to induce a clot; the clot is then suspended in 5 mol/L urea (or 1% monochloroacetic acid) for 24 hours. Clot stability is examined visually after 24 hours of incubation. Because this assay is a screening test, abnormal results should be repeated and confirmed using a quantitative factor XIII method, such as measuring factor XIII-dependent incorporation of labeled amines into substances such as fibrinogen or casein.⁸⁶

Tests for Fibrinolysis

The plasma euglobulin fraction contains plasminogen activators and fibrinogen. Most of the major antiplasmins are removed in the pseudoglobulin supernatant fluid. The rate of lysis of a fibrin clot prepared from the euglobulin fraction (the euglobulin clot lysis time) thus provides a measure of fibrinolysis in the absence of major inhibitors and is a measure of the activity of plasminogen activators.⁸⁷

Tests for fibrinogenolysis and assays for individual components of the fibrinolytic enzyme system, including plasminogen,⁸⁸ free plasmin,⁸⁹ and antiplasmins, are available. Routine coagulation assays for plasminogen activators and plasminogen activator inhibitors typically involve enzyme-linked immunosorbent assay (ELISA) methods.^{90, 91} Blood collection methods, timing, processing, and determination of assay-specific reference ranges are critically important in accurate evaluation of fibrinolysis parameters.^{90, 91}

Moderate concentrations of ϵ -aminocaproic acid (4×10^{-4} mol/L) inhibit plasminogen activators but not free plasmin. Thus, a shortened euglobulin lysis time in the presence of such concentrations of ϵ -aminocaproic acid indicates the

presence of free plasmin, as in association with fibrinolysis (see Chapter 54). Fibrinolysis in heated fibrin plates also measures free plasmin⁹² because plasminogen activators are thermolabile.

Bioassays for Coagulation Factors

Bioassays for coagulation factors are usually based on the familiar screening tests, such as the PT and PTT. In principle, the extent to which an unknown sample corrects the abnormality in plasma with a known deficiency is assumed to be proportional to the content of the deficient factor in the sample. The results of coagulation assays may be expressed in terms of units, which equal the amount of a given factor that is present in 1 ml of normal pooled or reference plasma. Alternatively, plasma levels of various factors may be expressed as a percentage of normal. Thus, plasma levels of various coagulation factors typically range from 50 to 150 U/dl, or 50% to 150% of normal.

One-stage methods for factors VIII and IX, which are based on the PTT and use substrate plasma from patients with severe inherited deficiencies (<1% of normal) of these factors, are somewhat simpler to perform than comparable two-stage methods. However, two-stage methods are more specific than one-stage methods, particularly in patients with intravascular coagulation and liver disease,⁹³ presumably because the two-stage methods are less affected by the presence of activated coagulation factors or traces of thrombin that increase the activity of factors V and VIII. One study found that for detecting low factor VIII levels, the clot-based assay was better than the chromogenic assay, while for elevated factor VIII levels, the chromogenic assay was preferred.⁹⁴ Plasmas deficient in specific factors are available commercially. Modifications that do not depend on natural substrates have been developed, including techniques for the assay of prothrombin⁹⁵; factors V,⁹⁶ VII, and X combined; and factors VIII,⁹⁷ IX,⁹⁸ X,⁹⁹ and XI.¹⁰⁰ Details of coagulation assay methodology have been summarized.¹⁰¹

Tests for Inhibitors of Coagulation

Abnormalities in any test of coagulation, if caused by deficiency of an essential factor, are corrected by the addition of small amounts of normal plasma. If the abnormality is caused by the presence of one of the various inhibitors of coagulation rather than a deficiency of an essential factor, the opposite is true: Small amounts of

P.1051

the patient's plasma impair coagulation in normal samples. These tests are called mixing studies or inhibitor screens. This phenomenon is the essence of all screening tests for inhibitors, most of which are based on one-stage coagulation techniques, such as the PT and PTT.¹⁰² The presence of heparin may be confirmed in various ways, including use of thrombin time and reptilase time assays, correction by protamine sulfate, or direct assays for activity of heparin or low-molecular-weight heparin.¹⁰¹

Tests for Physiologic Inhibitors of Coagulation

Several methods have been described for the assay of physiologic inhibitors of coagulation,¹⁰³ such as antithrombin,¹⁰⁴ heparin cofactor II, protein C,¹⁰³ ¹⁰⁵ and protein S.¹⁰⁶ ¹⁰⁷ Both immunologic and functional assays are available for many of these components.¹⁰³ Quantitative assays of such physiologic inhibitors may yield valuable information in patients with certain thromboembolic disorders (see Chapter 55).

Automated Coagulation Methods

Numerous instruments are available to detect automatically the endpoint of blood coagulation. These devices operate on a variety of principles: mechanical detection of the onset of fibrin formation, photometric recording of clot opacity, or the rate of fibrin polymerization. Such instruments are helpful in the performance of one-stage screening tests, such as the PT and PTT, especially if a large number of tests must be done daily.

Totally automated methods for performing coagulation tests are widely used. Automated instrument platforms have been developed to perform a large variety of coagulation methods with significant cost savings, permitting more laboratories to do comprehensive coagulation testing.¹⁰⁸ A College of American Pathologists Web site has summarized coagulation instrumentation (www.cap.org; see vendor surveys at the CAP Today link).

The thromboelastograph, an instrument that demonstrates changes occurring during blood coagulation and fibrinolysis, has been used by some investigators. Different coagulograms are described in association with various bleeding disorders and hypercoagulable states.¹⁰⁹ However, this is not a commonly used method to diagnose coagulation abnormalities in most laboratories. Its primary use is as a point-of-care instrument in the surgical setting.⁴⁴

The activated clotting time (ACT) is a whole blood clotting assay now used primarily as a point-of-care test. The ACT measures the clotting time for a whole blood sample after addition of particulate (contact) activators such as kaolin or

Celite; thus, this assay measures the intrinsic pathway of coagulation. The ACT is used mostly to monitor anticoagulation in the setting of cardiopulmonary bypass, cardiac catheterization, or dialysis. The ACT is preferable to the PTT in certain settings that require high-dose heparin, such as cardiopulmonary bypass.¹¹⁰

Other point-of-care coagulation instruments are being used in the setting of outpatient or home-based oral anticoagulation monitoring. Numerous studies have found that these instruments are at least as effective in providing safe and efficacious anticoagulation as is provided by physicians with standard laboratory anticoagulation testing.¹¹¹

Chromogenic and Fluorometric Techniques

Artificial peptides release chromogenic substances or fluorophores when they are enzymatically cleaved.^{112, 113} The hydrolysis of such peptides by activated coagulation factors provides a novel means for assessing various coagulation reactions.¹¹⁴ Such chromogenic and fluorometric techniques have been developed for the assay of prothrombin and factors VII, IX, and X¹¹⁵; antithrombin¹¹⁶; α_2 -antiplasmin; heparin; urokinase¹¹⁷; kallikrein¹¹⁸; plasmin; and other components of the fibrinolytic enzyme system.¹¹⁹ Assays also have been developed for coagulants that do not have enzymatic activity, such as cellulose sandwich fluoroimmunoassays for vWF antigen¹²⁰ and solid-phase front-surface fluorescence detection methods for factors VIIIc and IX.¹²¹ These methods appear to be intrinsically more precise and may be less time-consuming than traditional coagulation methods, and instruments designed specifically for their performance are available. Chromogenic and fluorometric assays are expensive, however, and at present are used mainly in research and in large reference coagulation laboratories.

INITIAL LABORATORY EVALUATION

Primary Screening Tests

The initial laboratory study of the bleeding patient should be guided by the information obtained from the clinical evaluation. In many cases, however, the routine use of a small battery of screening tests has merit because it usually saves time, and the results direct the course of further study. It is generally agreed that the most essential information usually can be obtained from the three tests summarized in Table 45.3, which, in view of their availability, simplicity, and low cost, are well suited to serve as primary screening tests. The platelet count provides the most reliable and reproducible test of primary hemostasis. The PTT measures all of the coagulation factors involved in the intrinsic and common pathways (Fig. 45.4) and generally is accepted as the best single screening test for disorders of blood coagulation. When supplemented with the PT, which assesses the extrinsic as well as the common pathway, the abnormality usually can be localized to one of the three pathways and the factors involved therein (Fig. 45.4 and Table 45.3). The results of these three tests thus provide a presumptive diagnosis, which can then be clarified further by the confirmatory methods summarized in the next section. The bleeding time test has been omitted from this evaluation because of its nonspecificity in the general clinical setting.^{13, 16} The definitive laboratory diagnosis of individual bleeding disorders is discussed in Chapters 46, 47, 48, 49, 50, 51, 52, 53 and 54.

It is important to realize that patients with mild bleeding disorders (factor VIII, IX, or XI deficiency) may have normal PTT values, because most PTT reagents do not detect mild deficiency states (factor levels of 20% to 30%).⁵⁷ Consequently, if the clinical suspicion is high, specific factor assays for these disorders should be performed, even if the initial evaluation suggested in Table 45.3 is not productive.

CONFIRMATORY TESTS

Thrombocytopenia

Thrombocytopenia, like anemia, is a symptom, not a diagnosis. It is the most common of the acquired bleeding disorders. Additional laboratory tests usually are not indicated merely to confirm the presence of thrombocytopenia (Table 45.3), but are helpful in establishing the mechanism for thrombocytopenia. It is useful, however, to examine the thrombocytopenic patient's blood smear to exclude pseudothrombocytopenia that may be seen in a small number of patients.^{18, 19} The differential diagnosis of thrombocytopenia is discussed at length in Chapters 46, 47, 48, and 49. One approach to evaluating thrombocytopenia is shown in Figure 45.5.

von Willebrand Disease

von Willebrand disease is the result of an abnormality in primary hemostasis combined with mild to moderate deficiency of

P.1052

factor VIIIc (see Chapter 53). In the classic case, the results of screening tests reveal a normal platelet count and a

prolonged PTT (Table 45.3). In many patients, however, the PTT will be normal. Furthermore, the results of all of the laboratory tests tend to fluctuate from time to time.¹²² If the clinical suspicion is high, initial laboratory studies directed at excluding vWD should be performed, because vWD is more common than the inherited disorders of platelet function (Fig. 45.6). Useful tests include bioassay of factor VIII (VIIIc), immunoassay of vWF antigen, and measurement of ristocetin cofactor activity. In many cases, the diagnosis of vWD requires repeated testing.

TABLE 45.3 PROFILES OF HEMOSTASIS SCREENING TESTS IN PATIENTS WITH BLEEDING DISORDERS

Prothrombin Time	Activated Partial Thromboplastin Time	Platelet Count	Differential Diagnosis
↑	—	—	Common Acquired factor VII deficiency (early liver disease; early vitamin K deficiency; early warfarin therapy) Rare Factor VII inhibitor; dysfibrinogenemia; some cases of DIC; inherited factor VII deficiency; certain factor X variants
—	↑	—	Common Deficiency or inhibitor of factors VIII, IX, or XI; vWD; heparin Rare Lupus inhibitor with qualitative platelet defect; certain factor X variants
↑	↑	—	Common Vitamin K deficiency; liver disease; warfarin; heparin; superwarfarin Rare Deficiency or inhibitor of factors X or V, prothrombin, or fibrinogen; lupus inhibitor with hypoprothrombinemia; DIC; dysfibrinogenemia; primary fibrinolysis
↑	↑	↓	Common DIC; liver disease Rare Heparin therapy with associated thrombocytopenia
—	—	↓	Common Increased platelet destruction; decreased platelet production; hypersplenism; hemodilution Rare Certain inherited platelet disorders (Wiskott-Aldrich syndrome, Bernard-Soulier syndrome)
—	—	↑	Myeloproliferative disorders

Common

Mild vWD; acquired qualitative platelet disorders (uremia, antiplatelet medications)

Rare

Inherited qualitative platelet disorders; vascular disorders; fibrinolytic disorders; factor XIII deficiency; autoerythrocyte sensitization; dysfibrinogenemia; mild factor deficiency (VIII, IX, XI); disorders of platelet procoagulant activity

↑, increased; ↓, decreased; —, normal; DIC, disseminated

intravascular coagulation; vWD, von Willebrand disease. *Note:* The differential diagnosis of bleeding disorders suggested by results of the prothrombin time, partial thromboplastin time, and platelet count is listed for each profile. This table includes the differential diagnosis of hemostasis screening test results in patients with a history of bleeding. Consideration of patients with abnormal coagulation tests and negative bleeding histories is not included in this table.

Modified from Rodgers GM. Common clinical bleeding disorders. In: Boldt DH, ed. Update on hemostasis. New York: Churchill Livingstone, 1990:75-120.

Another available test to evaluate patients for vWD is multimeric analysis of vWF. Patient plasma is separated by agarose electrophoresis, and vWF is identified by immunologic methods. The patient's multimeric pattern is compared to that of normal plasma. A more detailed description of this test is given in Chapter 53.

Qualitative Platelet Disorders

Symptoms of mucocutaneous bleeding in the presence of a normal number of platelets and normal results of coagulation tests (Table 45.3) are presumptive evidence of a disorder of platelet function (see Chapter 52). Inherited forms are uncommon, but bleeding caused by platelet dysfunction may be an important complication in patients with various acquired disorders, such as uremia. Commonly available confirmatory tests occasionally provide useful information regarding platelet dysfunction. Various morphologic abnormalities of the platelets may be seen on the blood smear. Strikingly large platelets are characteristic of certain inherited disorders, such as Bernard-Soulier syndrome. A markedly elevated platelet count is present in the myeloproliferative disorder, essential thrombocytosis.

Definitive methods for the study of platelet dysfunction are time-consuming and technically difficult. The absence of platelet aggregation by ADP, collagen, and epinephrine is characteristic of Glanzmann thrombasthenia. Deficient secondary wave aggregation is associated with various disorders of the release reaction, such as inherited deficiency of storage nucleotides, uremia, and aspirin ingestion. Abnormal responses to ristocetin indicate vWD or Bernard-Soulier syndrome.

P.1053

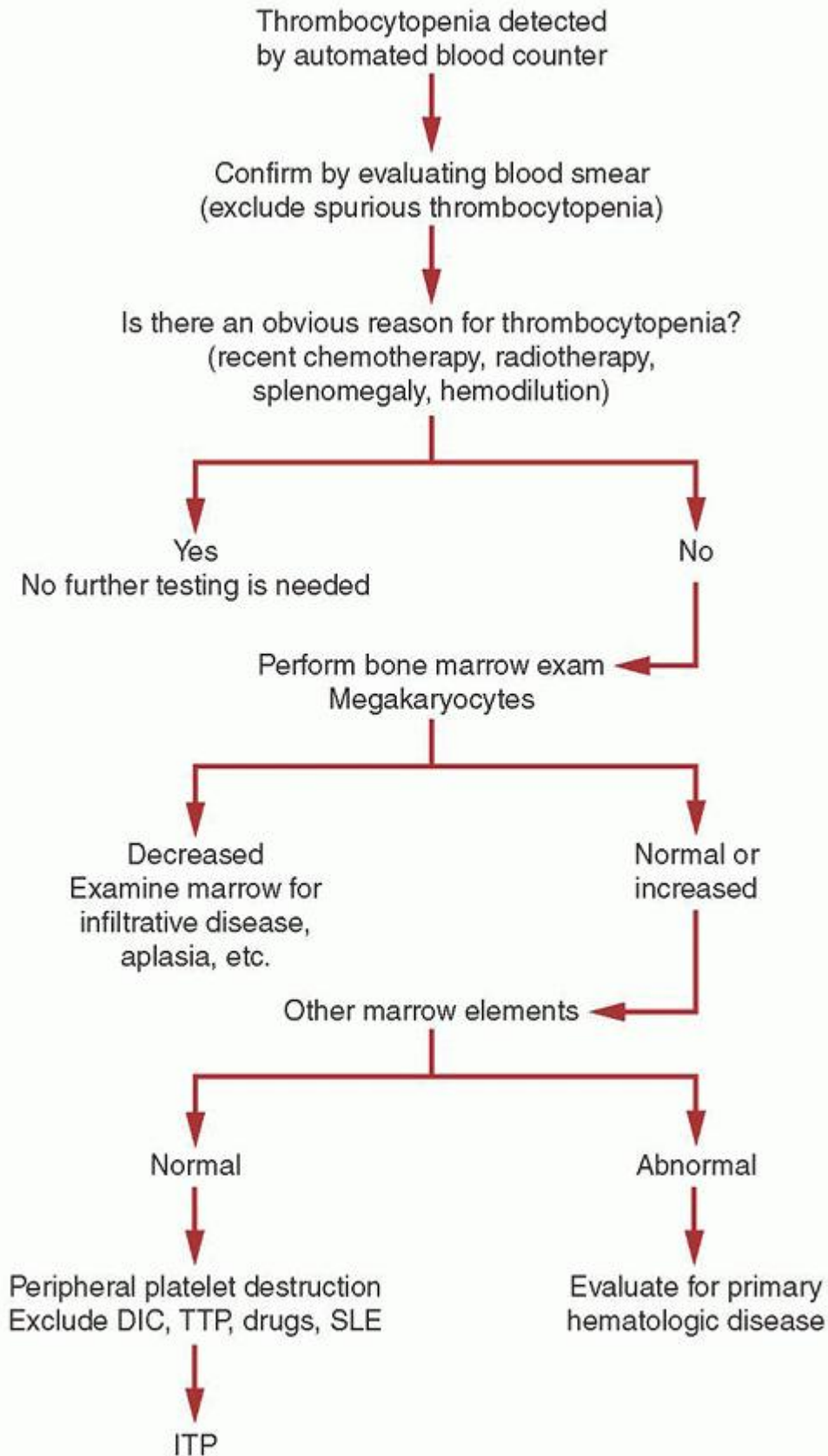

FIGURE 45.5. An approach for evaluation of thrombocytopenia. The necessity to do a bone marrow examination in the evaluation of idiopathic thrombocytopenic purpura (ITP) is controversial. ITP is a diagnosis of exclusion. DIC, disseminated

intravascular coagulation; SLE, systemic lupus erythematosus; TTP, thrombotic thrombocytopenic purpura. (Redrawn from Kjeldsberg C, ed. Practical diagnosis of hematologic disorders, 4th ed. Chicago: ASCP Press, 2006:319.)

Disorders of the Intrinsic Pathway of Coagulation

Disorders of the intrinsic pathway of coagulation are characterized by a prolonged PTT and a normal PT (Table 45.3). Inherited forms include deficiencies of factor VIII or IX (hemophilia A and B), prekallikrein, high-molecular-weight kininogen, factor XI, or factor XII (Fig. 45.7). Factor XII (Hageman factor) deficiency and deficiencies of prekallikrein or high-molecular-weight kininogen can be excluded readily, because they are not associated with excessive clinical bleeding. Distinguishing between deficiencies of factors VIII, IX, and XI is done by performing specific assays for these factors. Screens (mixing studies) should also be performed to exclude antibodies to the intrinsic factor under study. If a factor VIII inhibitor is identified, the titer should be quantitated (see Chapter 54). An algorithm approach for evaluating bleeding patients with an isolated, prolonged PTT is shown in Figure 45.8.

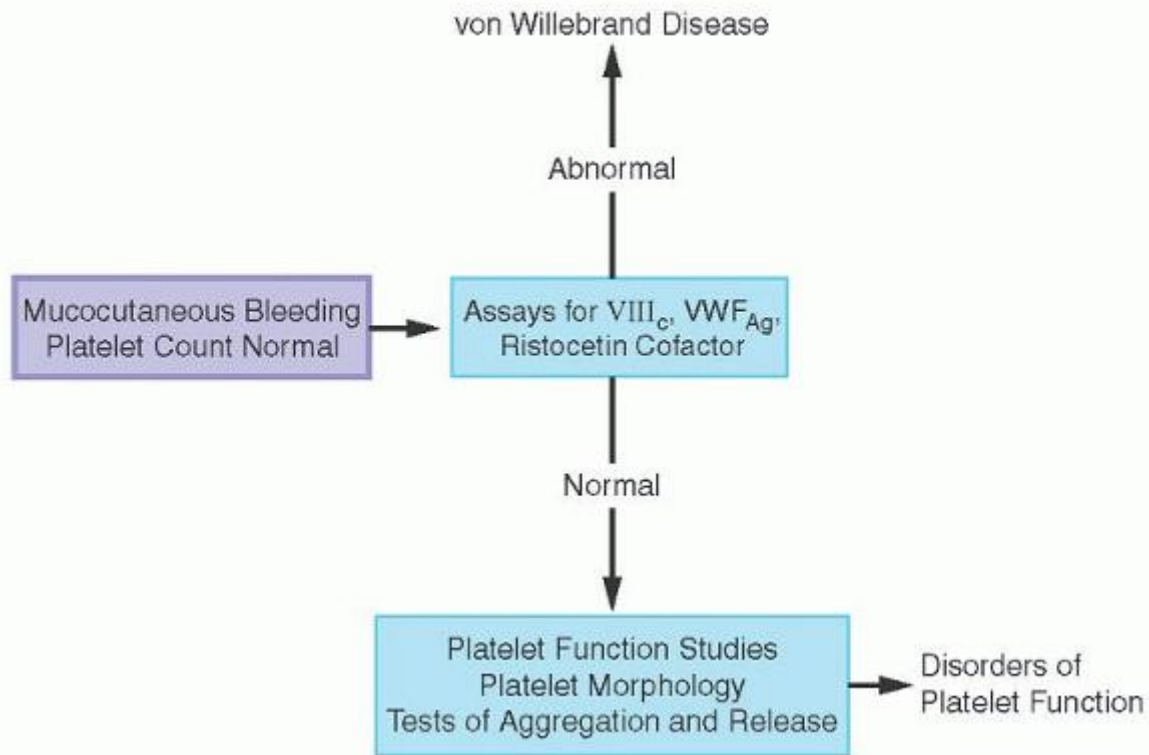

FIGURE 45.6. Laboratory diagnosis of von Willebrand disease (vWD) and platelet dysfunction. The initial evaluation reveals mucocutaneous bleeding symptoms in a patient with a normal platelet count (block on left). In vWD, the partial thromboplastin time also may be prolonged because of deficiency of factor VIIIc. Additional tests (blocks) and a suggested sequence for their performance are indicated as a flow diagram. Some patients with vWD may have normal assays for factor VIIIc, von Willebrand factor Ag (vWF_{Ag}), and ristocetin cofactor activity. These patients may be diagnosed by abnormal ristocetin-induced platelet agglutination when aggregation studies are performed or by multimeric analysis of vWF. For patients with normal studies for vWD and platelet dysfunction who are strongly suspected of having an inherited disorder, von Willebrand studies should be repeated.

Acquired coagulation disorders associated with a prolonged PTT and a normal PT include the lupus inhibitor and antibodies to factor VIII. Prolongation of the PTT is commonly the result of heparin administration or poorly collected blood samples.

Disorders of the Common Pathway of Coagulation

Prolongation of the PTT and PT in a patient with an inherited bleeding disorder indicates a deficiency of one of the factors in the common pathway—factor X, factor V, prothrombin, or fibrinogen, or a dysfibrinogen (Table 45.3 and Fig. 45.7). Such isolated deficiencies are exceedingly rare. On the other hand, deficiency of one or more of these factors is associated with additional abnormalities in the intrinsic and extrinsic pathways in many of the common acquired coagulation disorders, such as vitamin K deficiency, liver disease, and DIC. A prolonged PT usually suggests an acquired disorder

(excluding the rare cases of inherited factor VII deficiency) and usually is associated with a complex abnormality involving multiple pathways, such as DIC.

When confronted with this combination of findings, the first step should be to exclude or to identify an abnormality of fibrinogen. This may be accomplished by determination of the plasma fibrinogen level and tests for increased amounts of D-dimer or FDP. The most helpful ancillary procedures are the platelet count and examination of the blood smear for schistocytes. The laboratory findings characteristic of DIC are summarized in Chapter 54.

Inherited disorders associated with a low fibrinogen level include afibrinogenemia, hypofibrinogenemia, and dysfibrinogenemia (see Chapter 53). In certain dysfibrinogenemias, large amounts of unclotted fibrinogen remain in the serum and are detected by tests for FDP.

Inherited deficiencies of factor V, factor X, and prothrombin can be diagnosed by specific factor assays.

Disorders of the Extrinsic Pathway of Coagulation

A prolonged PT and a normal PTT (Table 45.3) suggest an isolated deficiency of factor VII, which is rare and may be the P.1054

result of an inherited or an acquired abnormality (Figs. 45.7 and 45.9). Less commonly, inhibitors of factor VII have been reported (see Chapter 54). Additionally, certain cases of DIC or dysfibrinogenemia may present with isolated prolonged PT values.¹²³ Because factor VII is essential only in the tissue factor-activated extrinsic pathway of coagulation, the Stypven time is normal in patients with factor VII deficiency.

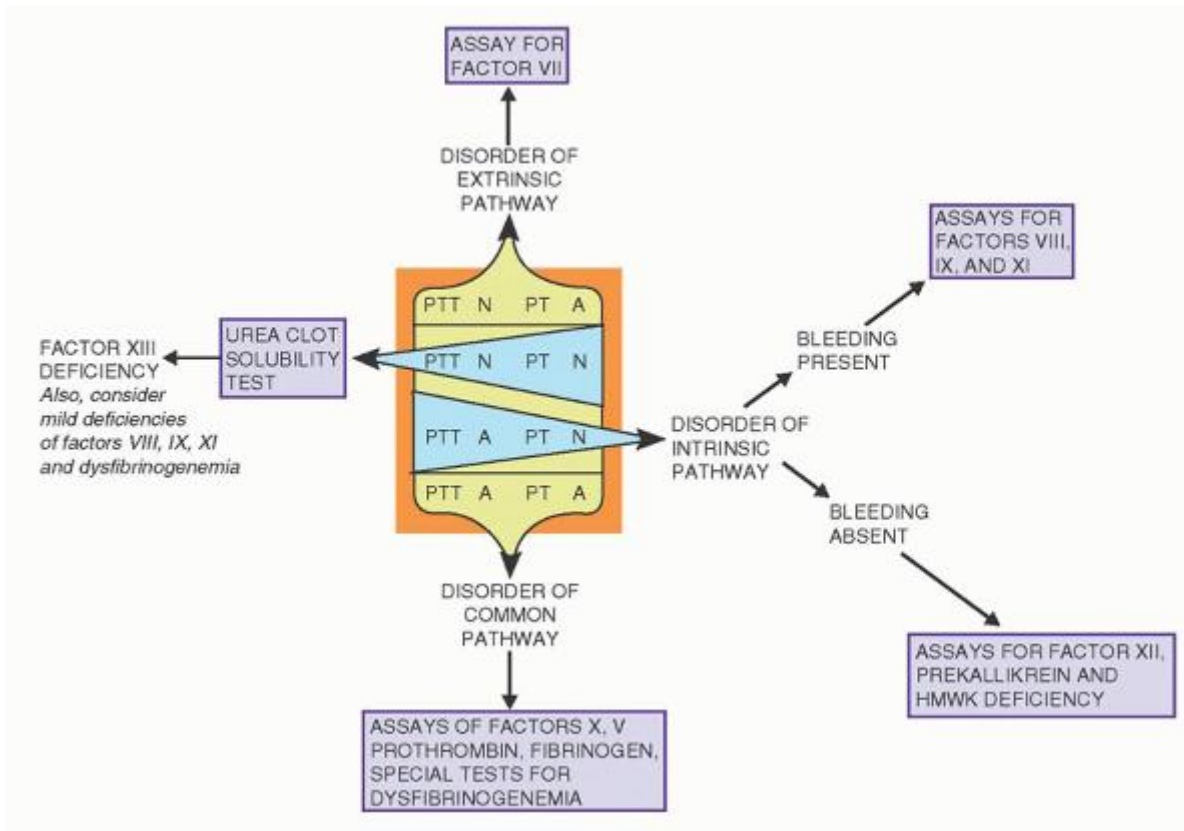

FIGURE 45.7. Laboratory diagnosis of inherited coagulation disorders. Results of primary screening tests of coagulation (activated partial thromboplastin time [PTT], prothrombin time [PT]) are summarized in the center block. Additional tests (blocks) and a suggested sequence for their performance are presented as a flow diagram. A more complete list of the differential diagnosis of bleeding disorders is presented in Table 45.3. A, abnormal; HMWK, high-molecular-weight kinogen; N, normal; PTT, partial thromboplastin time.

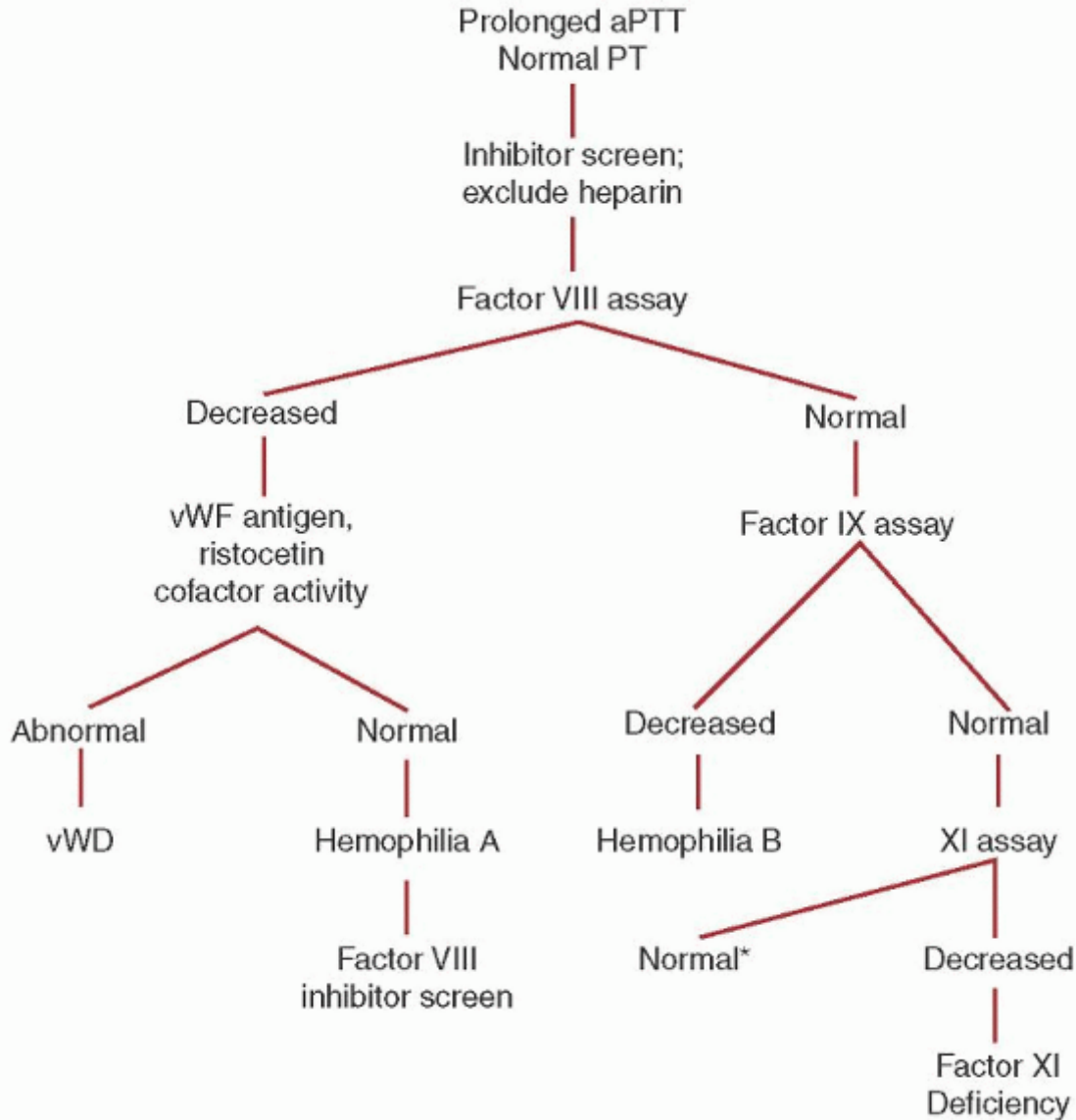

FIGURE 45.8. Evaluation of a patient with bleeding and an isolated, prolonged partial thromboplastin time (PTT). Asterisk indicates that patients with clinical bleeding but normal studies should be evaluated further for lupus anticoagulants associated with either platelet dysfunction or thrombocytopenia. PT, prothrombin time; PTT, activated partial thromboplastin time; vWD, von Willebrand disease; vWF, von Willebrand factor. (Redrawn from Kjeldsberg CR, Perkins SL, eds. Practical diagnosis of hematologic disorders, 5th ed. Chicago: ASCP Press, 2010:349.)

Disorders in Which Results of Primary Screening Tests Are Normal

Screening tests usually yield normal results in patients with bleeding disorders related to vascular abnormalities (Tables 45.3 and 45.4). The diagnosis is usually made from the associated clinical findings that are often characteristic, such as the skin lesions of

P.1055

hereditary hemorrhagic telangiectasia, allergic purpura, scurvy, and senile purpura. The results of screening tests also are normal in factor XIII (fibrin-stabilizing factor) deficiency, a disorder in which the diagnosis is made by the demonstration of characteristic clot solubility in urea or monochloroacetic acid.

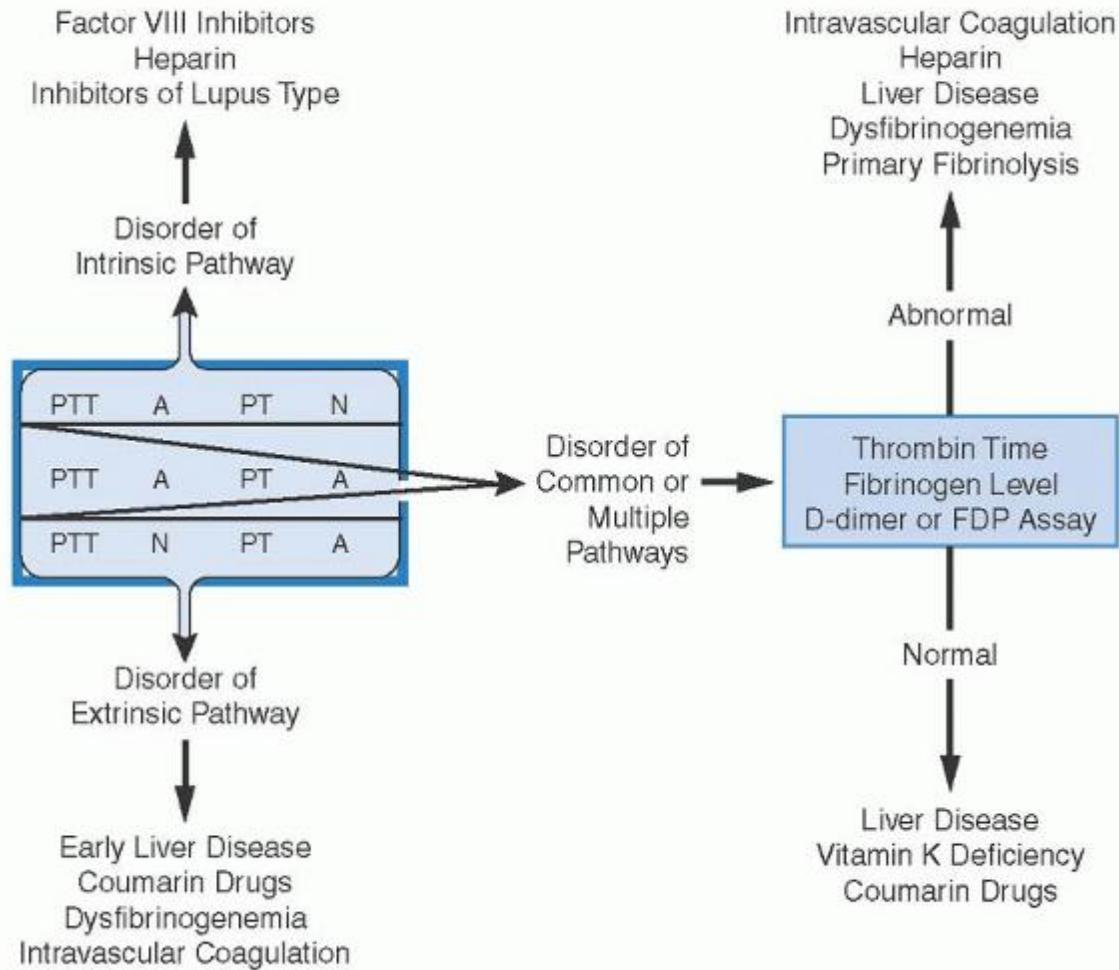

FIGURE 45.9. Laboratory diagnosis of acquired coagulation disorders. Results of primary screening tests of coagulation (partial thromboplastin time [PTT], prothrombin time [PT]) are summarized in the left-side block. Additional tests (right-side block) and a suggested sequence for their performance are presented as a flow diagram. Because of the complexity of acquired coagulation disorders and great variations in the results of laboratory tests that may be encountered in the various disorders and in individual patients, this diagram should be regarded as a general guide only. A more complete list of the differential diagnosis of bleeding disorders is presented in Table 45.3. A, abnormal; FDP, fibrin degradation products; N, normal.

TABLE 45.4 BLEEDING DISORDERS IN WHICH THE RESULTS OF PRIMARY SCREENING TESTS MAY BE NORMAL

- von Willebrand disease
- Mild inherited coagulation disorders, particularly factor XI deficiency
- Heterozygous carriers of inherited coagulation disorders
- Factor XIII (fibrin-stabilizing factor) deficiency
- Some forms of dysfibrinogenemia
- Disordered platelet function, particularly deficient release reaction; Scott syndrome
- Hereditary hemorrhagic telangiectasia
- Allergic and other vascular purpuras

α_2 -Plasmin inhibitor deficiency

Elevated levels of plasminogen activator

Although abnormal in the typical case, the results of screening tests may be normal or equivocal in patients with mild coagulation disorders (including heterozygous carriers), certain disorders of platelet function, mild forms of vWD, and dysfibrinogenemia or abnormal fibrinolysis.^{101, 124} More definitive tests are required to establish the diagnosis in these patients (Table 45.4). An increasing number of reports have indicated that many bleeding patients with normal screening studies have disorders of platelet procoagulant activity, such as Scott syndrome.¹²⁵

There are patients with a significant bleeding history in whom the results of detailed studies of hemostasis and blood coagulation are normal. Some have disorders of hemostasis that cannot be detected by methods currently available. The clinical management of these cases requires great care, and the fact that a clear-cut history of bleeding is always more significant than negative laboratory data cannot be overemphasized. Trauma may be denied in physically abused patients and may be self-inflicted in psychotic or neurotic patients.

PREOPERATIVE HEMOSTASIS EVALUATION

The value of obtaining routine screening tests before surgical procedures has been debated for years.¹²⁶ The screening tests for hemostasis are not totally satisfactory in detecting all mild hemostatic defects. Nevertheless, routine preoperative laboratory screening is of great value in certain high-risk patients who have disorders that predispose them to unexpected postsurgical bleeding, even from limited biopsy procedures. Important in this category are patients with liver disease, biliary obstruction, renal disease (particularly if complicated by azotemia), myelofibrosis, polycythemia vera, and other myeloproliferative disorders, particularly those associated with thrombocytosis and those with paraproteinemias. Included in this list should be all patients scheduled to undergo procedures involving the use of extracorporeal circulatory devices.

One approach to the question of preoperative hemostasis screening tests is to balance the financial costs of laboratory testing with the extent of surgery to be performed and with the amount of bleeding that can be safely tolerated. This approach makes the patient's hemostasis history particularly important. Patients scheduled for minor surgical procedures (dental, skin biopsy) do not need routine hemostasis screening tests if they have a negative history. In contrast, patients undergoing neurosurgery or other procedures that may induce a hemostatic defect (use of a bypass pump) or patients with a positive bleeding history need a hemostasis evaluation by the laboratory. Table 45.5 summarizes the recommendations of Rapaport in evaluating preoperative patients.¹²⁶

TABLE 45.5 GUIDELINES FOR PREOPERATIVE HEMOSTASIS EVALUATION

Bleeding Level	Bleeding History	Surgical Procedure	Recommended Hemostasis Evaluation
I	Negative	Minor	None
II	Negative	Major	Platelet count, PTT
III	Equivocal	Major, involving hemostatic impairment	PT, PTT, platelet count, factor XIII assay, euglobulin clot lysis time
IV	Positive	Major or minor	Level III tests; if negative, then factors VIII, IX, and XI assays, thrombin time, α_2 -antiplasmin assay; consider von Willebrand disease and platelet aggregation testing; consider specific tests for uncommon disorders listed in Table 45.3

PT, prothrombin time; PTT, activated partial thromboplastin time.

Note: Information in this table is a revision based on the suggested preoperative guidelines for hemostasis testing by Rapaport.¹²⁶ The bleeding time is omitted as a hemostasis test because of more recent appreciation of its weakness as a useful test. Comprehensive testing should be performed on level IV patients.

Modified from Rodgers GM. Preoperative hemostasis screening. In: Kjeldsberg CR, Perkins SL, eds.

Practical diagnosis of hematologic disorders, 5th ed. Chicago: ASCP Press, 2010:373.

EVALUATION OF THE NEONATE

Laboratory investigation of hemostasis and blood coagulation in the neonate and infant differs from that just outlined in several respects.¹²⁷ First, the quantity of blood that can be obtained is limited, and often, the venipuncture is difficult. Various microtechniques and modifications of standard coagulation techniques that involve the use of capillary blood have been developed to circumvent this problem.¹²⁸ Second, in terms of adult norms, the results of some tests are abnormal, even in healthy full-term infants (Table 45.6). Such physiologic abnormalities presumably are the result of deficiencies of the vitamin K-dependent factors and of additional abnormalities in the contact phase of coagulation and in the thrombin-fibrinogen reaction.^{4, 129}

The PT may be prolonged but often is normal if vitamin K is administered to the infant or mother.¹²⁹ Abnormalities of the thrombin time and the PTT are present in many normal neonates. These findings usually disappear within 2 to 6 months.⁴ These abnormalities and moderate deficiencies of the vitamin K-dependent factors (prothrombin; factors VII, IX, and X; and proteins C and S) are more pronounced in the premature than in the full-term infant, and they are inversely proportional to gestational age and birth weight. Levels of factors VIII and V as well as antithrombin may be low in extremely premature infants.¹³⁰ Factor VIII levels and the ratio of vWF_{Ag} to VIIIc are higher in term infants than in adults or older children.

Levels of factor V are normal in both neonates and thriving premature infants.^{129, 131} Levels of antithrombin and other physiologic inhibitors of coagulation and of factor XIII are below adult norms in term neonates.¹³² Significant abnormalities of platelet

P.1056

aggregation and of the results of other platelet function tests may be seen in normal neonates.¹³³ The newborn also is abnormally susceptible to drugs that impair platelet function, including those transferred placentally from the mother. The platelet count in term infants, as well as in thriving premature infants, is within the range found in adults and older children. Table 45.6 summarizes coagulation reference ranges in newborns, children, and adults.

TABLE 45.6 AGE-RELATED COAGULATION REFERENCE VALUES IN NEWBORNS, CHILDREN, AND ADULTS

Coagulation Tests	Age								
	3 Days ^a	1-12 Months ^a	1-5 Years ^a	7-9 Years ^{b, c}	10-11 Years ^{b, c}	12-13 Years ^{b, c}	14-15 Years ^{b, c}	16-17 Years ^{b, c}	Adult ^{b, c}
Fibrinogen (g/L)	2.83-4.01	0.82-3.83	1.62-4.01	1.98-4.13	1.97-4.10	2.15-3.78	2.04-3.92	2.08-4.38	2.11-4.41
Prothrombin (U/ml)	0.50-0.73	0.62-1.03	0.70-1.09	0.78-1.25	0.78-1.20	0.72-1.23	0.75-1.35	0.77-1.30	0.86-1.50
Factor V (U/ml)	0.92-1.54	0.94-1.41	0.67-1.27	0.69-1.32	0.66-1.36	0.66-1.35	0.61-1.29	0.65-1.31	0.62-1.40
Factor VII (U/ml)	0.67-1.07	0.83-1.60	0.72-1.50	0.67-1.45	0.71-1.63	0.78-1.60	0.74-1.80	0.63-1.63	0.80-1.81
Factor VIII (U/ml)	0.83-2.74	0.54-1.45	0.36-1.85	0.76-1.99	0.80-2.09	0.72-1.98	0.69-2.37	0.63-2.21	0.56-1.91
Factor IX (U/ml)	0.44-0.97	0.43-1.21	0.44-1.27	0.70-1.33	0.72-1.49	0.73-1.52	0.80-1.61	0.86-1.76	0.78-1.84
Factor X (U/ml)	0.46-0.75	0.77-1.22	0.72-1.25	0.74-1.30	0.70-1.34	0.69-1.33	0.63-1.46	0.74-1.46	0.81-1.57
Factor XI (U/ml)	0.24-0.79	0.62-1.25	0.65-1.62	0.70-1.38	0.66-1.37	0.68-1.38	0.57-1.29	0.65-1.59	0.56-1.53

vWFAg (U/ml)	—	—	—	0.62-1.80 ^d	0.63-1.89 ^d	0.60-1.89 ^d	0.57-1.99 ^d	0.50-2.05 ^d	0.52-2.14 ^d
R:Cof (U/ml)	—	—	—	0.52-1.76	0.60-1.95	0.50-1.84	0.50-2.03	0.49-2.04	0.51-2.15
Antithrombin (U/ml)	0.60-0.89	0.72-1.34	1.01-1.31	0.90-1.35	0.90-1.34	0.90-1.32	0.90-1.31	0.87-1.31	0.76-1.28
Protein C (U/ml)	0.24-0.51	0.28-1.24	0.50-1.34	0.70-1.42	0.68-1.43	0.66-1.62	0.69-1.70	0.70-1.71	0.83-1.68
Protein S ^e (U/ml)	0.33-0.67	0.29-1.62	0.67-1.36 M	0.66-1.40	0.65-1.39	0.72-1.39	0.68-1.45	0.77-1.67	0.66-1.43
				F 0.62-1.51	0.65-1.42	0.70-1.40	0.55-1.45	0.51-1.47	0.57-1.31
Plasminogen (U/ml)	—	—	—	0.76-1.16	0.74-1.17	0.66-1.14	0.71-1.24	0.75-1.32	0.71-1.44
α ₂ -antiplasmin (U/ml)	—	—	—	0.88-1.47	0.90-1.44	0.87-1.42	0.83-1.36	0.77-1.34	0.82-1.33

Note: Prothrombin time and partial thromboplastin time values are not shown because these values depend on reagent selection. Adult values represent those of the University of Utah Medical Center Hemostasis and Thrombosis Laboratory. There are no data for children 6 years of age.

^a Monagle P, Barnes C, Ignjatovic V, et al. Developmental haemostasis. Impact for clinical haemostasis laboratories. *Thromb Haemost* 2006;95:362-372.

^b Flanders MM, Crist RA, Roberts WL, Rodgers GM. Pediatric reference intervals for seven common coagulation assays. *Clin Chem* 2005;51:1738-1742.

^c Flanders MM, Phansalkar AR, Crist RA, et al. Pediatric reference intervals for uncommon bleeding and thrombotic disorders. *J Pediatr* 2006;149:275-277.

^d Results are of antigenic assays; all other results are of functional assays.

^e Gender-specific reference ranges are given for protein S for children ages 7-9 years and older.

REFERENCES

1. Wahlberg T, Blomback M, Hall P, Axelsson G. Application of indicators, predictors and diagnostic indices in coagulation disorders. *Methods Inf Med* 1980;19:194-200.
2. Wishart C. Oral surgery in the hemorrhagic states. *J Oral Surg* 1964;22: 178-183.
3. Lorand L, Losowsky MS, Miloszewski KJM. Human factor XIII: fibrin-stabilizing factor. *Prog Hemost Thromb* 1980;5:245-290.
4. Oski FA, Naiman JL. Hematologic problems in the newborn. Philadelphia, PA: WB Saunders, 1966.
5. Glader BE, Buchanan GR. The bleeding neonate. *Pediatrics* 1976;58: 548-555.
6. Biggs R, MacFarlane RG. Haemophilia and related conditions: a survey of 187 cases. *Br J Haematol* 1958;4:1-27.
7. Lind SE. Prolonged bleeding time. *Am J Med* 1984;77:305-312.
8. Day HJ, Rao AK. Evaluation of platelet function. *Semin Hematol* 1986;23: 89-101.
9. Livio M, Gotti E, Marchesi D. Uraemic bleeding: role of anaemia and beneficial effect of red cell transfusions. *Lancet* 1982;2:1013-1015.

10. Weiss HJ, Rogers J. Fibrinogen and platelets in the primary arrest of bleeding. Study in two patients with congenital afibrinogenemia. *N Engl J Med* 1971;285:369-374.
11. Breederveld K, van Royen EA, ten Cate JW. Severe factor V deficiency with prolonged bleeding time. *Thromb Diath Haemorrh* 1974;32:538-548.
12. Evensen SA, Myhre L, Stormorken H. Haemostatic studies in osteogenesis imperfecta. *Scand J Haematol* 1984;33:177-179.
13. Rodgers RPC, Levin J. A critical reappraisal of the bleeding time. *Semin Thromb Hemost* 1990;16:1-144.
14. O'Laughlin JC, Hoftiezer JW, Mahoney JP, Ivey KJ. Does aspirin prolong bleeding from gastric biopsies in man? *Gastrointest Endosc* 1981;27:1-5.
15. Lind SE. The bleeding time does not predict surgical bleeding. *Blood* 1991;77:2547-2552.
16. Lehman CM, Blaylock RC, Alexander DP, Rodgers GM. Discontinuation of the bleeding time test without detectable adverse clinical impact. *Clin Chem* 2001;47:1204-1211.
17. Peterson P, Hayes TE, Arkin CF, et al. The preoperative bleeding time test lacks clinical benefit. *Arch Surg* 1998;133:134-139.
18. Manthorpe R, Kofod B, Wiik A, et al. Pseudothrombocytopenia. In vitro studies on the underlying mechanism. *Scand J Haematol* 1981;26:385-392.
19. Onder O, Weinstein A, Hoyer LW. Pseudothrombocytopenia caused by platelet agglutinins that are reactive in blood anticoagulated with chelating agents. *Blood* 1980;56:177-182.
20. Lindsay RM, Koens F, Linton AL. An evaluation of the Coulter Thrombocounter in counting platelets before and after contact with foreign surfaces and its use in tests of platelet retention. *J Lab Clin Med* 1975;86:863-872.
21. Kjeldsberg CR, Hershgold EJ. Spurious thrombocytopenia. *JAMA* 1974;227:628-630.
22. Nicholls PD. Erroneous platelet counts on the Coulter Model S Plus counter after correction for hyperlipaemia. *Med Lab Sci* 1983;40:69-71.
23. Payne BA, Pierre RV. Pseudothrombocytopenia: a laboratory artifact with potentially serious consequences. *Mayo Clin Proc* 1984;59:123-125.
24. Savage RA. Pseudoleukocytosis due to EDTA-induced platelet clumping. *Am J Clin Pathol* 1984;81:317-322.
25. Akwari AM, Ross DW, Stass SA. Spuriously elevated platelet counts due to microspherocytosis. *Am J Clin Pathol* 1982;77:220-221.
26. Armitage JO, Goeken JA, Feagler JR. Spurious elevation of platelet count in acute leukemia. *JAMA* 1978;239:433-434.
27. Morton BD, Orringer EP, LaHart L, Stass SA. Pappenheimer bodies. An additional cause for a spurious platelet count. *Am J Clin Pathol* 1980;74:310-311.
28. Trowbridge EA, Martin JF. The platelet volume distribution: a signature of the prethrombotic state in coronary artery disease? *Thromb Haemost* 1987;58:714-717.
29. Bessman JD, Gardner FH. Platelet size in thrombocytopenia due to sepsis. *Surg Gynecol Obstet* 1983;156:177-180.
30. Karpatkin S, Freedman ML. Hypersplenic thrombocytopenia differentiated from increased peripheral destruction by platelet volume. *Ann Intern Med* 1978;89:200-203.
31. Milton JG, Yung W, Frojmovic MM. Dependence of platelet volume measurements on heterogeneity of platelet morphology. *Biophys J* 1981;35:257-261.
32. Roper-Drewinko PR, Drewinko B, Corrigan G, et al. Standardization of platelet function tests. *Am J Hematol* 1981;11:183-203.
33. Feinman RD, Lubowsky J, Charo I, Zabinski MP. The lumi-aggregometer: a new instrument for simultaneous measurement of secretion and aggregation by platelets. *J Lab Clin Med* 1977;90:125-129.
34. Walsh PN, Mills DCB, White JG. Metabolism and function of human platelets washed by albumin density gradient separation. *Br J Haematol* 1977;36: 281-296.

35. Challen A, Branch WJ, Cummings JH. Quantitation of platelet mass during aggregation in the electronic (Wellcome) whole-blood aggregometer. *J Pharmacol Methods* 1982;8:115-122.
36. Ingerman-Wojenski CM, Silver MJ. A quick method for screening platelet dysfunctions using the whole-blood lumi-aggregometer. *Thromb Haemost* 1984;51:154-156.
37. Miller JL. Platelet function testing: an improved approach utilizing lumi-aggregation and an interactive computer system. *Am J Clin Pathol* 1984;81:471-476.
38. Hardisty RM, Hutton RA, Montgomery D, et al. Secondary platelet aggregation: a quantitative study. *Br J Haematol* 1970;19:307-319.
39. Weiss HJ, Chervenick PA, Zalusky R, Factor A. A familial defect in platelet function associated with impaired release of adenosine diphosphate. *N Engl J Med* 1969;281:1264-1270.
40. Niewiarowski S, Lowery CT, Hawiger J, et al. Immunoassay of human platelet factor 4 (PF4, antiheparin factor) by radial immunodiffusion. *J Lab Clin Med* 1976;87:720-733.
41. Zhou L, Schmaier AH. Platelet aggregation testing in platelet-rich plasma. Description of procedures with the aim to develop standards in the field. *Am J Clin Pathol* 2005;123:172-183.
42. Hayward CP, Moffat KA, Raby A, et al. Development of North American consensus guidelines for medical laboratories that perform and interpret platelet function testing using light transmission aggregometry. *Am J Clin Pathol* 2010;134:955-963.
43. Fareed J, Bick RL, Squillaci G, et al. Molecular markers of hemostatic disorders: implications in the diagnosis and therapeutic management of thrombotic and bleeding disorders. *Clin Chem* 1983;29:1641-1658.
- P.1057
44. Harrison P. Progress in the assessment of platelet function. *Br J Haematol* 2000;111:733-744.
45. Kundu SK, Heilmann EJ, Sio R, et al. Description of an in vitro platelet function analyzer-PFA-100. *Semin Thromb Hemost* 1995;21:106-112.
46. Ortel TL, James AH, Thames EH, et al. Assessment of primary hemostasis by PFA-100 analysis in a tertiary care center. *Thromb Haemost* 2000;84:93-97.
47. Hayward CPM, Harrison P, Cattaneo M, et al. Platelet function analyzer (PFA)-100[®] closure time in the evaluation of platelet disorders and platelet function. *J Thromb Haemost* 2006;4:312-319.
48. Bennett ST, Lehman CM, Rodgers GM, eds. *Practical handbook of laboratory hemostasis for pathologists*. New York: Springer, 2007.
49. Kwak YL, Kim JC, Choi YS, Yoo KJ, Song Y, Shim JK. Clopidogrel responsiveness regardless of the discontinuation date predicts increased blood loss and transfusion requirement after off-pump coronary artery bypass graft surgery. *J Am Coll Cardiol* 2010;56:1994-2002.
50. Breet NL, van Werkum JW, Bouman HJ, et al. Comparison of platelet function tests in predicting clinical outcome in implantation. *JAMA* 2010;303:754-762
51. Gurbel PA, Mahla E, Tantry US. Peri-operative platelet function testing: the potential for reducing ischaemic and bleeding risks. *Thromb Haemost* 2011;106:248-252.
52. Jacobsson B, Nilsson IM. Catheter material and blood coagulation studies in vitro. *Scand J Haematol* 1969;6:386-394.
53. Koepke JA, Rodgers JL, Ollivier MJ. Pre-instrumental variables in coagulation testing. *Am J Clin Pathol* 1975;64:591-596.
54. Bell WN, Alton HG. A brain extract as a substitute for platelet suspensions in the thromboplastin generation test. *Nature* 1954;174:880-881.
55. Goulian M, Beck WS. The partial thromboplastin time test. *Am J Clin Pathol* 1965;44:97-103.
56. Nye SW, Graham JB, Brinkhous KM. The partial thromboplastin time as a screening test for the detection of latent bleeders. *Am J Med Sci* 1962;243:279-287.

57. Martin BA, Branch DW, Rodgers GM. The preparation of a sensitive partial thromboplastin reagent from bovine brain. *Blood Coagul Fibrinolysis* 1992;3:287-294.
58. Tripodi A, Chantarangkul V, Martinelli I, et al. A shortened activated partial thromboplastin time is associated with the risk of venous thromboembolism. *Blood* 2004;104:3631-3634.
59. Edson JR, Krivit W, White JG. Kaolin partial thromboplastin time: high levels of procoagulants producing short clotting times or masking deficiencies of other procoagulants or low concentrations of anticoagulants. *J Lab Clin Med* 1967;70:463-470.
60. Proctor RR, Rapaport SI. The partial thromboplastin time with kaolin. *Am J Clin Pathol* 1961;36:212-219.
61. Robbins JA, Rose SD. Partial thromboplastin time as a screening test. *Ann Intern Med* 1979;90:796-797.
62. Margolis J. Initiation of blood coagulation by glass and related surfaces. *J Physiol (Lond)* 1957;137:95-109.
63. Hattersley PG, Hayse D. The effect of increased contact activation time on the activated partial thromboplastin time. *Am J Clin Pathol* 1976;66:479-482.
64. Flanders MM, Crist RA, Roberts WL, Rodgers GM. Pediatric reference intervals for seven common coagulation assays. *Clin Chem* 2005;51: 1738-1742.
65. Reddy NM, Hall SW, MacKintosh FR. Partial thromboplastin time. Prediction of adverse events and poor prognosis by low abnormal values. *Arch Intern Med* 1999;159:2706-2710.
66. Quick AJ. Determination of prothrombin. *Am J Med Sci* 1935;190:501-511; *Proc Soc Exp Biol Med* 1939;42:788-789; *Am J Clin Pathol* 1945;15:560-566.
67. Boekhout-Mussert MJ, vander Kolk-Schaap PJ, Hermans J, Loeliger EA. Prospective double-blind clinical trial of bovine, human, and rabbit thromboplastins in monitoring long-term oral anticoagulation. *Am J Clin Pathol* 1981;75:297-303.
68. Tripodi A, Chantarangkul V, Braga M, et al. Results of a multicentre study assessing the status of a recombinant thromboplastin. *Thromb Haemost* 1994;72:261-267.
69. Ellis BC, Stransky A. A quick and accurate method for the determination of fibrinogen in plasma. *J Lab Clin Med* 1961;58:477-488.
70. Ratnoff OD, Menzie C. A new method for the determination of fibrinogen in small samples of plasma. *J Lab Clin Med* 1951;37:316-320.
71. Feinberg JG. A new quantitative method for antigen-antibody titration in gels. *Nature* 1956;177:530-531.
72. Koepke JA. Standardization of fibrinogen assays. *Scand J Haematol Suppl* 1980;37:130-138.
73. Alving BM, Bell WR. Methods for correcting inhibitory effects of fibrinogen degradation products in fibrinogen determinations. *Thromb Res* 1976;9:1-8.
74. Saleem A, Krieg AF, Fretz K. Improved micromethod for plasma fibrinogen unaffected by heparin therapy. *Am J Clin Pathol* 1975;63:426-433.
75. Rodgers, GM, Garr SB. Comparison of functional and antigenic fibrinogen values from a normal population. *Thromb Res* 1992;68:207-210.
76. Jim RTS. A study of the plasma thrombin time. *J Lab Clin Med* 1957;50: 45-60.
77. Marder VJ, Matchett MO, Sherry S. Detection of serum fibrinogen and fibrin degradation products. *Am J Med* 1971;51:71-82.
78. Marder VJ, Cruz GO, Schumer BR. Evaluation of a new anti-fibrinogen-coated latex particle agglutination test in the measurement of serum fibrin degradation products. *Thromb Haemost* 1977;37:183-191.
79. Thomas DP, Niewiarowski S, Myers AR, et al. A comparative study of four methods for detecting fibrinogen degradation products in patients with various diseases. *N Engl J Med* 1970;283:663-668.
80. Merskey C, Kleiner GJ, Johnson AJ. Quantitative estimation of split products of fibrinogen in human serum, relation to diagnosis and treatment. *Blood* 1966;28:1-18.
81. Rutstein JE, Holahan JR, Lyons RM, Pope RM. Rheumatoid factor interference with the latex agglutination test for fibrin degradation products. *J Lab Clin Med* 1978;92:529-535.

82. Edgington TS. Fibrinogen and fibrin degradation products: their differentiation. *Thromb Haemost* 1975;34:671-676.
83. Greenberg CS, Devine DV, McCrae KM. Measurement of plasma fibrin D-dimer levels with the use of a monoclonal antibody coupled to latex beads. *Am J Clin Pathol* 1987;87:94-100.
84. Breen FA, Tullis JL. Ethanol gelation: a rapid screening test for intravascular coagulation. *Ann Intern Med* 1968;69:1197-1206.
85. Gurewich V, Hutchinson E. Detection of intravascular coagulation by a serial-dilution protamine sulfate test. *Ann Intern Med* 1971;75:895-902.
86. Francis JL. The detection and measurement of factor XIII activity: a review. *Med Lab Sci* 1980;37:137-147.
87. Lowe ML, Cannon DC. Improved method for euglobulin clot lysis time. *Clin Biochem* 1975;8:206-212.
88. Wu KK, Jacobsen CD, Hoak JC. Highly sensitive method for the assay of plasminogen. *J Lab Clin Med* 1973;81:484-488.
89. Moroz LA, Gilmore NJ. A rapid and sensitive ¹²⁵I-fibrin solid-phase fibrinolytic assay for plasmin. *Blood* 1975;46:543-553.
90. Chandler WL, Schumer G, Stratton JR. Optimum conditions for the stabilization and measurement of tissue plasminogen activator in human plasma. *J Lab Clin Med* 1989;113:362-371.
91. Angleton P, Chandler WL, Schmer G. Diurnal variation of tissue-type plasminogen activator and its rapid inhibitor (PAI-1). *Circulation* 1989;79:101-106.
92. Astrup T, Mullertz S. The fibrin plate method for estimating fibrinolytic activity. *Arch Biochem Biophys* 1952;40:346-351.
93. Rogers JS, Eyster ME. Relationship of factor VIII-like antigen (VIII AGN) and clot promoting activity (VIII AHF) as measured by one- and two-stage assays in patients with liver disease. *Br J Haematol* 1976;34:655-661.
94. Chandler WL, Ferrell C, Lee J, Tun T, Kha H. Comparison of three methods for measuring factor VIII levels in plasma. *Am J Clin Pathol* 2003;120:34-39.
95. Ware AG, Seegers WH. Two-stage procedure for the quantitative determination of prothrombin concentration. *Am J Clin Pathol* 1949;19:471-482.
96. Johnson JF, Seegers WH. Estimation of Ac-globulin activity by the two-stage method. In: Tocantins LM, ed. *The coagulation of blood, methods of study*. New York: Grune & Stratton, 1955:127-140.
97. Essien EM, Ingram GIC. Diagnosis of haemophilia: use of an artificial factor VIII-deficient human plasma system. *J Clin Pathol* 1967;20:620-623.
98. Stapp WF. The assay of factor IX. *Scand J Clin Lab Invest* 1965;17(Suppl 84):109-118.
99. Denson KW. The specific assay of Prower-Stuart factor and factor VII. *Acta Haematol (Basel)* 1961;25:105-120.
100. Horowitz HI, Wilcox WP, Fujimoto MM. Assay of plasma thromboplastin antecedent (PTA) with artificially depleted normal plasma. *Blood* 1963;22:35-43.
101. Rodgers GM. Inherited coagulation disorders. In: Kjeldsberg CR, Perkins SL, eds. *Practical diagnosis of hematologic disorders*, 5th ed. Chicago: ASCP Press, 2010:345-356.
102. Schleider MA, Nachman RL, Jaffe EA, Coleman M. A clinical study of the lupus anticoagulant. *Blood* 1976;48:499-509.
103. Rodgers GM, Chandler WL. Laboratory and clinical aspects of inherited thrombotic disorders. *Am J Hematol* 1992;41:113-122.
104. Buller HR, ten Cate JW. Acquired antithrombin III deficiency: laboratory diagnosis, incidence, clinical implications, and treatment with antithrombin III concentrate. *Am J Med* 1989;87(Suppl 3B):44S-48S.
105. Marler RA, Adcock DM. Clinical evaluation of protein C: a comparative review of antigenic and functional assays. *Hum Pathol* 1989;20:1040-1047.
106. Comp PC. Measurement of the natural anticoagulant protein S: how and when. *Am J Clin Pathol* 1990;94:242-243.
107. Edson JR, Vogt JM, Huesman DA. Laboratory diagnosis of inherited protein S deficiency. *Am J Clin Pathol* 1990;94:176-186.

108. Flanders MM, Crist R, Safapour S, Rodgers GM. Evaluation and performance characteristics of the STA-R coagulation analyzer. *Clin Chem* 2002;48: 1622-1624.
109. Zuckerman L, Cohen E, Vagher JP, et al. Comparison of thromboelastography with common coagulation tests. *Thromb Haemost* 1981;46:752-756.
110. Olson JD, Arkin CF, Brandt JT, et al. Laboratory monitoring of unfractionated heparin therapy. *Arch Pathol Lab Med* 1998;122:782-798.
111. Tripodi A, Chantarangkul V, Mannucci PM. Near-patient testing devices to monitor oral anticoagulant therapy. *Br J Haematol* 2001;113:847-852.
112. Fareed J, Messmore HL, Bermes EW. New perspectives in coagulation testing. *Clin Chem* 1980;26:1380-1391.
113. Mattler LE, Bang NU. Serine protease specificity for peptide chromogenic substrates. *Thromb Haemost* 1977;38:776-792.
114. Huseby RM, Smith RE. Synthetic oligopeptide substrates: their diagnostic application in blood coagulation, fibrinolysis, and other pathologic states. *Semin Thromb Hemost* 1980;6:173-314.
115. Bergstrom K, Egberg N. Determination of vitamin K sensitive coagulation factors in plasma. *Thromb Res* 1978;12:531-547.
116. Kahle LH, Schipper HG, Jenkins CSP, ten Cate JW. Antithrombin III. I. Evaluation of an automated antithrombin III method. *Thromb Res* 1978;12:1003-1014.
117. Nieuwenhuizen W, Wijngaards G, Groeneveld E. Fluorogenic substrates for sensitive and differential estimation of urokinase and tissue plasminogen activator. *Haemostasis* 1978;7:146-149.
118. Kluft C. Determination of prekallikrein in human plasma: optimal conditions for activating prekallikrein. *J Lab Clin Med* 1978;91:83-95.
119. Friberger P, Knos M, Gustavsson S, et al. Methods for determination of plasmin, antiplasmin and plasminogen by means of substrate S-2251. *Haemostasis* 1978;7:138-145.
120. Fisher NC, Hinds-Aldrich N, Haddow JE, Hudson GA. A cellulose sandwich fluoroimmunoassay for factor VIII-related antigen. *Thromb Res* 1983;31: 145-154.
121. Mitchell GA, Abdullahad CM, Ruiz JA, et al. Fluorogenic substrate assays for factors VIII and IX: introduction of a new solid phase fluorescent detection method. *Thromb Res* 1981;21:573-584.
122. Abildgaard CF, Suzuki Z, Harrison J, et al. Serial studies in von Willebrand disease: variability versus "variants." *Blood* 1980;56:712-716.
123. Colman RW, Robboy SJ, Minna JD. Disseminated intravascular coagulation: a reappraisal. *Annu Rev Med* 1979;30:359-374.
124. Bachman F. Diagnostic approach to mild bleeding disorders. *Semin Hematol* 1980;17:292-305.
125. Solum NO. Procoagulant expression in platelets and defects leading to clinical disorders. *Arterioscler Thromb Vasc Biol* 1999;19:2841-2846.
126. Rapaport SI. Preoperative hemostatic evaluation: which tests, if any? *Blood* 1983;61:229-231.
127. Buchanan GR. Coagulation disorders in the neonate. *Pediatr Clin North Am* 1986;33:203-220.
128. Margolis J. Some experiences with a simplified micromethod for coagulation studies. *Br J Haematol* 1961;7:21-35.
129. Aballi AM, de Lamerens S. Coagulation changes in the neonatal period and in early infancy. *Pediatr Clin North Am* 1962;9:785-817.
130. Barnard DR, Simmons MA, Hathaway WE. Coagulation studies in extremely premature infants. *Pediatr Res* 1979;13:1330-1335.
131. Holmberg L, Henriksson P, Ekelund H, Astedt B. Coagulation in the human fetus. Comparison with term newborn infants. *J Pediatr* 1974;85:860-864.
132. Mahasandana C, Hathway WE. Circulating anticoagulants in the newborn: relation to hypercoagulability and the idiopathic respiratory distress syndrome. *Pediatr Res* 1973;7:670-673.

133. Mull MM, Hathaway WE. Altered platelet function in newborns. *Pediatr Res* 1970;4:229-237.

Section 2 - Thrombocytopenia

Chapter 46 Thrombocytopenia: Pathophysiology and Classification

> Table of Contents > Part V - Disorders of Hemostasis and Coagulation > Section 2 - Thrombocytopenia > Chapter 46 - Thrombocytopenia: Pathophysiology and Classification

Chapter 46

Thrombocytopenia: Pathophysiology and Classification

George M. Rodgers

PATHOPHYSIOLOGY

Thrombocytopenia may be defined as a subnormal number of platelets in the circulating blood. It is the most common cause of abnormal bleeding. Despite the number and diversity of disorders that may be associated etiologically, thrombocytopenia results from only four processes: artifactual thrombocytopenia, deficient platelet production, accelerated platelet destruction, and abnormal distribution or pooling of the platelets within the body (Fig. 46.1). The changes in the basic parameters of thrombopoiesis that are characteristic of each of these processes are summarized in Table 46.1.

Artifactual Thrombocytopenia

Artifactual thrombocytopenia, or falsely low platelet counts, occurs *ex vivo* when platelets are not counted accurately. This mechanism should be considered in patients who have thrombocytopenia but no petechiae or ecchymoses. Although inaccurate counting may occur in the presence of giant platelets¹ or with platelet satellitism,² the most common cause of artifactual thrombocytopenia is platelet clumping (pseudothrombocytopenia).³ Platelet clumping in pseudothrombocytopenia appears to be caused by anticoagulant-dependent platelet agglutinins that are immunoglobulins (Igs) of IgG, IgA, or IgM subtypes. Although clumping is most commonly seen when blood is collected into ethylenediaminetetraacetic acid anticoagulant, other anticoagulants may cause clumping, even hirudin or Phe-Pro-Arg chloromethyl ketone.⁴ Platelet clumping is also time-dependent and varies with the type of instrumentation used for automatic counting.⁴ There is evidence that the autoantibodies bind to glycoprotein IIb/IIIa,⁵ and in one study, there was over 80% concordance between the presence of anticardiolipin antibody and platelet agglutinins in individual patient plasmas.⁶ These autoantibodies have no known associations with disease or drugs and have been noted in some patients for over 10 years.⁷

Accelerated Platelet Destruction

Accelerated platelet destruction is the most common cause of thrombocytopenia. It leads to stimulation of thrombopoiesis and, consequently, to an increase in the number, size, and rate of maturation of the precursor megakaryocytes (Fig. 46.1).⁸ When the rate of platelet destruction exceeds this compensatory increase in platelet production, thrombocytopenia develops. "Compensated" platelet destruction without thrombocytopenia also may occur in patients with prosthetic heart valves and in patients with idiopathic thrombocytopenic purpura after splenectomy.^{9, 10, 11}

Platelet destruction may result from both intracorporeal defects and extracorporeal abnormalities. Intracorporeal defects are rare but have been demonstrated in certain forms of hereditary thrombocytopenia, such as Wiskott-Aldrich syndrome (see Chapter 49).¹² In such disorders, the survival of affected platelets is shortened in the circulation of both the patient and normal recipients. Platelets injured by either intracorporeal or extracorporeal processes usually are removed from the circulation by the spleen, liver, and reticuloendothelial system. Platelet destruction most often is the result of extracorporeal factors; various immunologic phenomena are the most common. Immunologic platelet destruction is discussed in Chapter 47.

Platelet consumption in intravascular thrombi or on damaged endothelial surfaces is another cause of thrombocytopenia. This occurs in disseminated intravascular coagulation (see Chapter 54) and in thrombotic thrombocytopenic purpura (see

Chapter 48) and other microangiopathic processes. Thrombocytopenia caused by other nonimmunologic platelet destruction is discussed in Chapter 49.

Deficient Platelet Production

Deficient platelet production may result from any of a number of processes. Those that depopulate the stem cell or megakaryocyte

P.1059

compartments are the most common, such as marrow injury by myelosuppressive drugs or irradiation and aplastic anemia. Deficient platelet production also may be the consequence of disordered proliferation within a precursor compartment of normal or even increased size. For example, in disorders characterized by megaloblastic hematopoiesis, hypertrophy of the precursor compartment occurs in response to thrombopoietic stimuli, but thrombopoiesis is ineffective and platelet production is insufficient. Rarely, abnormalities of the processes that normally regulate thrombopoiesis appear to underlie deficient platelet production, such as deficiency of thrombopoietin and cyclic thrombocytopenia.

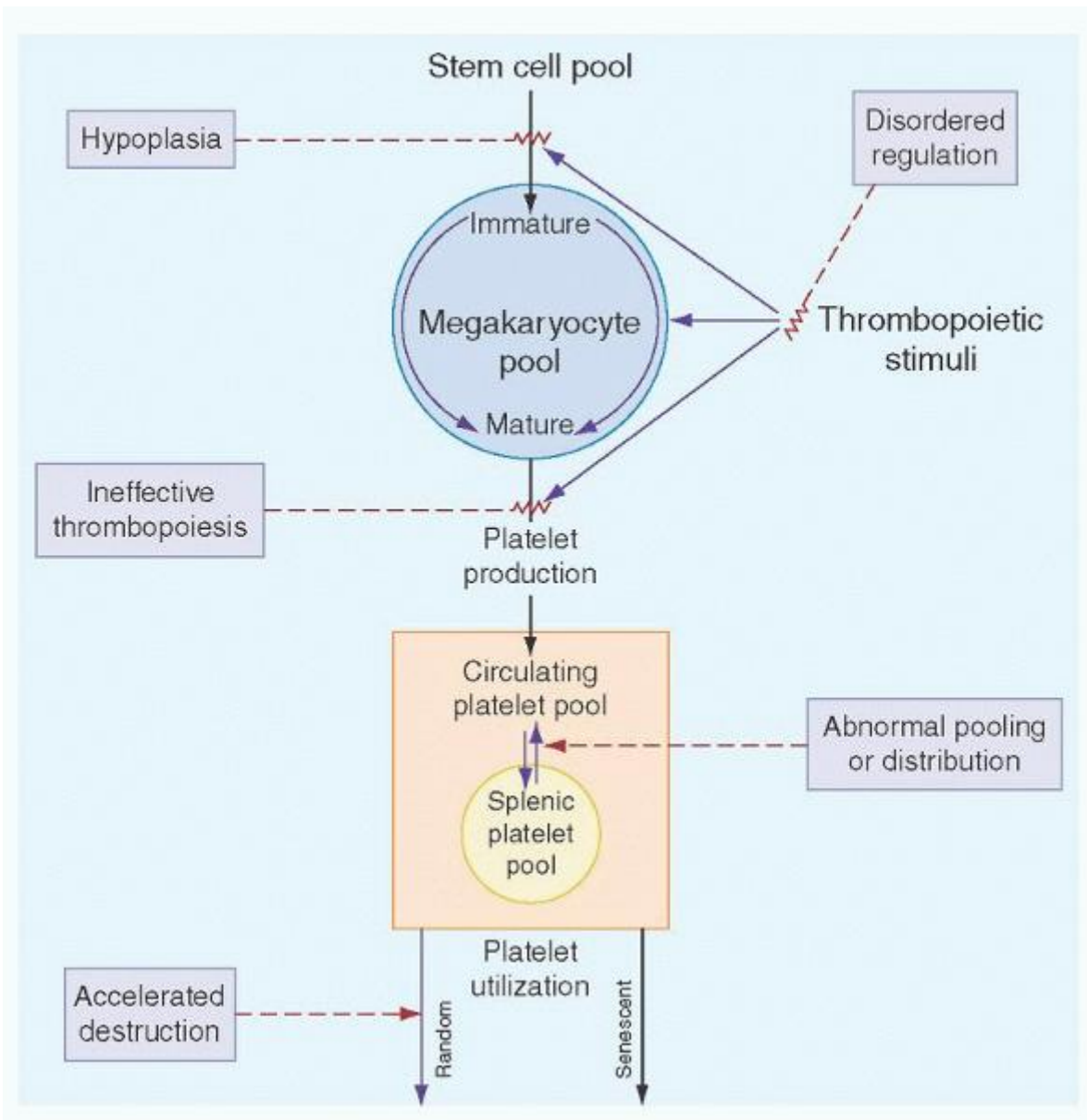

FIGURE 46.1. The pathophysiology of thrombocytopenia. A simplified diagram of the biodynamics of the megakaryocyte-platelet system (solid lines) and the mechanisms (dashed lines) by which pathologic processes (shaded blocks) produce

thrombocytopenia.

TABLE 46.1 THROMBOKINETIC PATTERNS IN VARIOUS FORMS OF THROMBOCYTOPENIA

Measurement	Decreased Production			
	Hypoproliferation or Hypoplasia ^a	Ineffective Thrombopoiesis ^b	Accelerated Destruction ^c	Abnormal Pooling
Total megakaryocyte mass ^d	Decreased	Increased	M increased	V increased
Megakaryocyte number	Decreased	M increased	Increased	V increased
Megakaryocyte volume	Increased	Normal or V decreased	Increased	V increased
Platelet turnover rate or production rate ^e	Decreased	Decreased	Increased	V increased
Total platelet mass	Decreased	Decreased	Decreased	? Normal
Splenic platelet pool	Decreased	Decreased	Decreased ^f	Increased
Platelet survival	Normal	V shortened	Shortened	V shortened

M, markedly; V, variably.

^a Includes myelophthistic processes.

^b Mainly in megaloblastic hematopoiesis; component of accelerated destruction present in some cases.

^c Minor component of ineffective thrombopoiesis present in some cases.

^d Equated to total thrombopoiesis.

^e Equated to effective thrombopoiesis.

^f Not representative of sequestered antibody-sensitized platelets.

Based on Harker LA. Megakaryocyte quantitation. *J Clin Invest* 1968;47:452-457; Harker LA. Thrombokinetics in idiopathic thrombocytopenic purpura. *Br J Haematol* 1970;19:95-104; and Harker LA, Finch CA. Thrombokinetics in man. *J Clin Invest* 1969;48:963-974.

Abnormal Pooling

Abnormal pooling or abnormal in vivo distribution of an essentially normal total platelet mass may produce thrombocytopenia. This type of thrombocytopenia is seen in the various disorders associated with splenomegaly (see Chapter 49), in which platelet production is normal or even increased, but most of the platelets are sequestered in the vastly enlarged extravascular splenic pool. Thrombocytopenia may also be caused by dilution of platelets when patients are massively transfused during blood loss. A discussion of various forms of thrombocytopenia attributable to deficient or ineffective thrombopoiesis or abnormal platelet pooling is included in Chapter 49.

CLASSIFICATION

A classification of thrombocytopenia based on pathophysiologic criteria is presented in Table 46.2. It should be recognized that multiple pathogenetic factors may simultaneously or sequentially play a role in the production of thrombocytopenia.

Methods for the measurement of serum thrombopoietin concentrations or reticulated platelets have been reported.

These techniques may both elucidate the pathophysiology of thrombocytopenia in various disease states and determine

the mechanism of thrombocytopenia in individual patients. Reticulated platelets can be identified with fluorescent dyes that bind to nucleic acids,

P.1060

especially RNA. Measurement of the percentage of reticulated platelets identifies platelets that have recently been released from the bone marrow. There is an increased percentage of reticulated platelets in patients with thrombocytopenia caused by increased destruction and a normal to reduced percentage of reticulated platelets in patients with deficient production.^{13, 14} The sensitivity and specificity of this method of distinguishing between these categories are reported to be more than 95%.¹⁵

TABLE 46.2 PATHOPHYSIOLOGIC CLASSIFICATION OF THROMBOCYTOPENIA

Artifactual thrombocytopenia

Platelet clumping caused by anticoagulant-dependent immunoglobulin (pseudothrombocytopenia)

Platelet satellitism

Giant platelets

Decreased platelet production (see Chapter 49)

Hypoplasia of megakaryocytes

Ineffective thrombopoiesis

Disorders of thrombopoietic control

Hereditary thrombocytopenias

Increased platelet destruction

Caused by immunologic processes (see Chapter 47)

Autoimmune

Idiopathic

Secondary: Infections, pregnancy, collagen vascular disorders, lymphoproliferative disorders, drugs, miscellaneous

Alloimmune

Neonatal thrombocytopenia

Posttransfusion purpura

Caused by nonimmunologic processes

Thrombotic microangiopathies

Disseminated intravascular coagulation (see Chapter 54)

Thrombotic thrombocytopenic purpura (see Chapter 48)

Hemolytic-uremic syndrome (see Chapter 48)

Platelet damage by abnormal vascular surfaces (see Chapter 49)

Miscellaneous (see Chapter 49)

Infection

Massive blood transfusions

Abnormal platelet distribution or pooling (see Chapter 49)

Disorders of the spleen (neoplastic, congestive, infiltrative, infectious, of unknown cause)

Hypothermia

Dilution of platelets with massive transfusions

REFERENCES

1. Kjeldsberg CR, Hershgold EJ. Spurious thrombocytopenia. *JAMA* 1974; 227:628-630.
2. Bizzaro N. Platelet satellitosis to polymorphonuclears: cytochemical, immunological, and ultrastructural characterization of eight cases. *Am J Hematol* 1991;36:235-242.
3. Gowland E, Kay HE, Spillman JC, et al. Agglutination of platelets by a serum factor in the presence of EDTA. *J Clin Pathol* 1969;22:460-464.
4. Schrezenmeier H, Müller H, Gunsilius E, et al. Anticoagulant-induced pseudothrombocytopenia and pseudoleukocytosis. *Thromb Haemost* 1995;73: 506-513.
5. Pegels JG, Bruynes EC, Engelfriet CP, et al. Pseudothrombocytopenia: an immunologic study on platelet antibodies dependent on ethylene diamine tetra-acetate. *Blood* 1982;59:157-161.
6. Bizzaro N, Brandalise M. EDTA-dependent pseudothrombocytopenia: association with antiplatelet and antiphospholipid antibodies. *Am J Clin Pathol* 1995;103:103-107.
7. Bizzaro N. EDTA-dependent pseudothrombocytopenia: a clinical and epidemiologic study of 112 cases, with 10-year follow-up. *Am J Hematol* 1995;50:103-109.
8. Harker LA. Megakaryocyte quantitation. *J Clin Invest* 1968;47:452-457.
9. Harker LA. Thrombokinetics in idiopathic thrombocytopenic purpura. *Br J Haematol* 1970;19:95-104.
10. Branehög I. Platelet kinetics in idiopathic thrombocytopenic purpura (ITP) before and at different times after splenectomy. *Br J Haematol* 1975;29: 413-426.
11. Hope AF, Heyns ADP, Lötter MG, et al. Kinetics and sites of sequestration of indium 111-labeled human platelets during cardiopulmonary bypass. *J Thorac Cardiovasc Surg* 1981;81:880-886.
12. Harker LA, Finch CA. Thrombokinetics in man. *J Clin Invest* 1969;48:963-974.
13. Rinder HM, Munz UJ, Ault KA, et al. Reticulated platelets in the evaluation of thrombocytopenic disorders. *Arch Pathol Lab Med* 1993;117:606-610.
14. Watanabe K, Takeuchi K, Kawai Y, et al. Automated measurement of reticulated platelets in estimating thrombopoiesis. *Eur J Haematol* 1995;54:163-171.
15. Richards EM, Baglin TP. Quantitation of reticulated platelets: methodology and clinical application. *Br J Haematol* 1995;91:445-451.

Chapter 47 Thrombocytopenia Caused by Immunologic Platelet Destruction

> Table of Contents > Part V - Disorders of Hemostasis and Coagulation > Section 2 - Thrombocytopenia > Chapter 47 - Thrombocytopenia Caused by Immunologic Platelet Destruction

Chapter 47

Thrombocytopenia Caused by Immunologic Platelet Destruction

Meghan S. Liel

Michael Recht

David C. Calverley

Immune thrombocytopenia (ITP) occurs when platelets undergo premature destruction as a result of autoantibody or immune complex deposition on their membranes. Although this disorder was previously known as idiopathic thrombocytopenic purpura, it is now correctly termed ITP because this nomenclature more clearly reflects the immune-

mediated mechanism of the disease.¹ In this chapter, both primary and secondary types of ITP are discussed (Table 47.1). Human immunodeficiencyvirus-related autoimmune thrombocytopenia, which is also in major part a result of the deposition of autoantibody or immune complexes, or both, on the platelet surface, is discussed in Chapter 64.

The diagnosis of ITP is primarily a diagnosis of exclusion, because currently available clinical assays for platelet-associated antibodies or serum antiplatelet antibodies/immune complexes are neither specific nor sensitive enough for routine clinical use. These disorders are characterized by peripheral thrombocytopenia (confirmed by examination of the peripheral smear), with a normal or increased number of megakaryocytes present on bone marrow examination, and absence of splenomegaly. Those patients who have no identifiable underlying cause, which might include infections, collagen vascular diseases, lymphoproliferative disorders (chronic lymphocytic leukemia or lymphoma), or drugs, are diagnosed as primary ITP. In some instances, ITP may be the presenting manifestation of an underlying disease, and additional manifestations appear weeks to months later.

PRIMARY IMMUNE THROMBOCYTOPENIA

Primary ITP refers to thrombocytopenia in which apparent exogenous etiologic factors are lacking and in which diseases known to be associated with secondary thrombocytopenia have been excluded. This syndrome has been recently reviewed.^{2, 3, 4, 5, 6}

Acute ITP and chronic ITP differ in incidence, prognosis, and therapy (Table 47.2). These differences illustrate the wide spectrum of disorders that by definition are included in the syndrome, but many clinicians have long believed that acute ITP and chronic ITP are fundamentally different disorders.

TABLE 47.1 IMMUNE THROMBOCYTOPENIA

Primary

Secondary

Infections

Collagen vascular diseases

Lymphoproliferative disorders

Solid tumors

Drugs

Miscellaneous

Incidence

The annual incidence of ITP in the United States is estimated to be 1.6/10,000.⁷ Acute ITP, defined as thrombocytopenia occurring for <6 months and usually resolving spontaneously, most often affects children and young adults. The incidence peaks in the winter and spring, following the incidence of viral infections.^{8, 9} Acute ITP is most common between 2 and 6 years of age. Approximately 7% to 28% of children with acute ITP develop the chronic variety.^{9, 10, 11} Chronic ITP, lasting >6 months and requiring therapy to improve the thrombocytopenia, occurs most commonly in adults. In chronic ITP in adults, the median age is usually 40 to 45 years,^{12, 13} although in one large series of patients, 74% of 934 cases were younger than age 40 (range, 16 to 87 years of age).¹⁴ The ratio of females to males is nearly 1:1 in acute ITP^{9, 10, 11, 15} and 2 to 3:1 in chronic ITP.^{13, 14}

Pathophysiology

The syndrome of ITP is caused by platelet-specific autoantibodies that bind to autologous platelets, which are then rapidly cleared from the circulation by the mononuclear phagocyte system via macrophage Fcγ receptors predominantly in the spleen and liver¹⁶ (Fig. 47.1). The ITP antibody does not fix complement in vitro when tested by the usual techniques, but activation of components of complement on the platelet surface may be demonstrated.^{17, 18}

A compensatory increase in platelet production takes place in most patients in response to the autoantibody-mediated platelet destruction described above. In others, however, platelet production appears to be impaired as a result of either intramedullary destruction of antibody-coated platelets by marrow macrophages or the inhibition of megakaryopoiesis. Autoantibodies from ITP patients have been shown to inhibit production of megakaryocytes in vitro, and megakaryocyte apoptosis has also been observed in this setting.^{19, 20, 21} Turnover studies have shown platelet production to be reduced or inappropriately normal in around two thirds of ITP patients.^{22, 23, 24} In one study, megakaryocytes were small in patients

with anti-gpIb/VI autoantibodies and increased in size and cytoplasmic area in patients with anti-gpIIb/IIIa autoantibodies,

P.1062

suggesting that the anti-gpIIb/IIIa autoantibody impairs platelet production.²⁵ Megakaryocyte colony formation (colony-forming unit megakaryocyte) is increased in acute ITP.^{26, 27} In chronic ITP, decreased megakaryocyte colony formation has been reported.²⁸

TABLE 47.2 FEATURES OF ACUTE AND CHRONIC IMMUNE THROMBOCYTOPENIA

Feature	Acute ITP	Chronic ITP
Peak age of incidence	Children, 2-6 y	Adults, 20-40 y
Sex predilection	None	3:1 female to male
Antecedent infection	Common 1-3 wk before	Unusual
Onset of bleeding	Abrupt	Insidious
Hemorrhagic bullae in mouth	Present in severe cases	Usually absent
Platelet count	<20,000/ μ l	30,000-80,000/ μ l
Eosinophilia and lymphocytosis	Common	Rare
Duration	2-6 wk; rarely longer	Months or years
Spontaneous remissions	Occur in 80% of cases	Uncommon

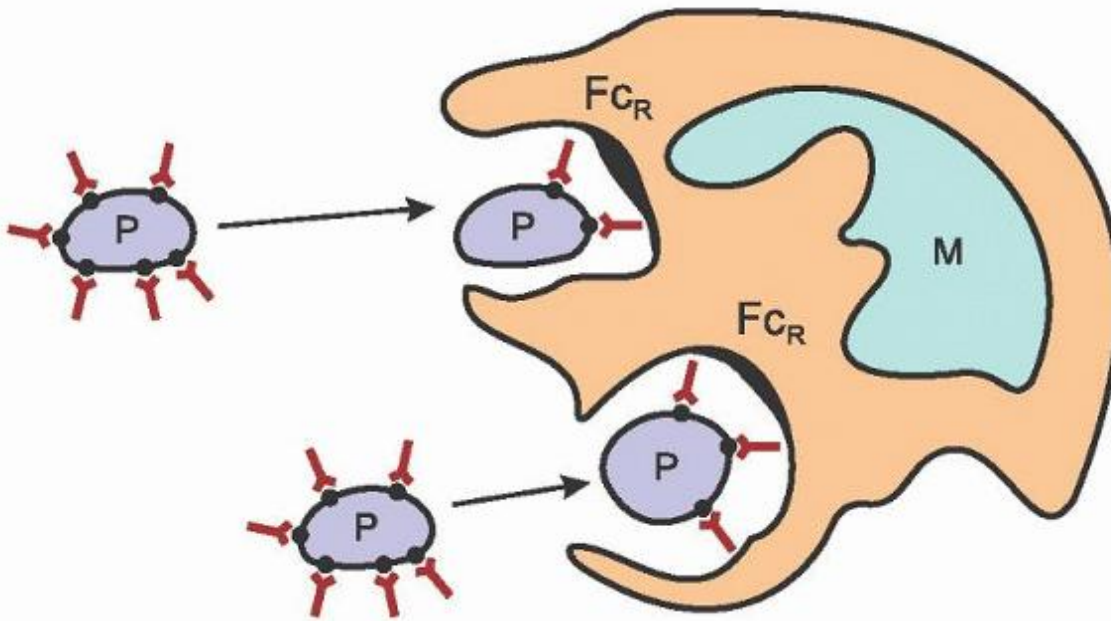

FIGURE 47.1. Antiplatelet antibody-induced destruction of platelets (P) in chronic immune thrombocytopenia. Immunoglobulin binds to platelet-associated antigen, resulting in phagocytosis by macrophages (M). Antiplatelet antibody-coated platelets bind to macrophages through macrophage Fc receptors (FcR). •, platelet membrane antigen; γ , platelet autoantibody.

Consistent with findings of inappropriately low platelet production in ITP, plasma levels of endogenous thrombopoietin have not been found to be elevated in ITP.^{29, 30} This differs from impaired platelet production settings such as following chemotherapy.^{29, 30, 31} This may be a result of clearance of thrombopoietin by the megakaryocyte and platelet mass.³²

Platelet Antibodies

In 1951, Harrington and colleagues first reported that the infusion of plasma from patients with ITP predictably induced thrombocytopenia in normal recipients.³³ Shulman and colleagues then demonstrated that the responsible factor was an immunoglobulin (Ig) of the IgG class that was species-specific and could be removed from serum by absorption to and elution from normal human platelets.³⁴ In addition, the platelet-depressing factor produced effects in vivo that were quantitatively and qualitatively similar to those produced by known platelet antibodies. In 1982, van Leeuwen first identified platelet membrane glycoprotein IIb/IIIa as a dominant antigen by demonstrating that the autoantibodies eluted from ITP platelets bound to normal platelets but not to platelets from patients with Glanzmann thrombasthenia.³⁵ Increased quantities of IgG have been demonstrated on the platelet surface in ITP, and the rate of platelet destruction is proportional to levels of such platelet-associated Ig.^{36, 37} Autoantibodies are readily found in plasma or platelet eluate in patients with active disease, but are infrequently found in patients in remission.^{38, 39} Disappearance of the antibodies correlates with the appearance of normal platelet counts.³⁸

The antiplatelet antibodies and platelet antigens involved in ITP have been extensively studied (Table 47.3). Antiplatelet autoantibodies bind to many of the major platelet membrane glycoproteins through the Fab portion of the molecule^{40, 41} (Fig. 47.2). Platelet gpIIb/IIIa was the first platelet antigen detected, and microtiter assays using platelet monoclonal antibodies to gpIb and gpIIb/IIIa later demonstrated that platelet autoantibodies bind to both major platelet membrane glycoproteins.^{42, 43, 44} Serum autoantibodies can react with IIb or IIIa or the intact IIb/IIIa complex.^{44, 45, 46, 47, 48, 49, 50, 51, 52, 53, 54, 55} Platelet autoantibody binding to gpIb α has been reported, but data indicate that the majority of Ib/V/IX autoantibodies are directed to the complex.^{56, 57} Some autoantibodies react with gpIV and $\alpha_2\beta_1$, although the plasma from these patients usually also contains autoantibodies reacting with one of the other two major platelet membrane antigens.⁵⁷ Serum antibodies to P-selectin (CD62P) and $\alpha_v\beta_3$ have been detected as well, but their clinical significance is unknown.^{58, 59}

TABLE 47.3 CHARACTERISTICS OF PLATELET AUTOANTIBODIES IN PRIMARY IMMUNE THROMBOCYTOPENIA

		Comments
Ig subtype	IgG, IgA, IgM ^a	IgG and IgA have equal frequency
Antigen specificity	gpIIb/IIIa, Ib/V/IX	Most common antigens
	gpIa/IIa, IV	Never only antigen if positive
	Granule membrane protein-140	One patient reported
	Glycosphingolipid	Rare; unclear pathogenetic importance
	Cardiolipin	Common; ?pathogenetic importance
Presence of antibody		
Plasma	85% of patients	
Platelet eluate	75% of patients	
Complement fixation by antibody	Rare	Unresolved importance
Circulating immune complexes	Rare	Unresolved importance

gp, glycoprotein; Ig, immunoglobulin.

^a IgM is never present as the only antiplatelet Ig in an individual patient.

Antibodies in ITP sera have also been demonstrated to bind to glycosphingolipids^{60, 61} and cardiolipin.^{62, 63, 64, 65} Although two studies identified antiphospholipid antibodies (lupus anticoagulant activity or anticardiolipin antibodies) in 46% and 38%, respectively, of ITP patients at diagnosis, there was little clinical evidence that they played a role in the pathogenesis of the disease or affected outcome.^{66, 67}

The presence of antibodies against multiple antigens is seen in most patients.⁶⁸ Once destruction of platelets within antigenpresenting cells occurs, this generates a series of neoantigens that in turn results in sufficient antibody to cause thrombocytopenia. This phenomenon is termed epitope spread.⁶⁹ Plasma autoantibodies and autoantibodies eluted from

platelets in the same patient may have slight differences in antigen specificities within a membrane glycoprotein complex.⁴⁹ There is evidence from two studies that the specific β_3 antigen epitope in any given patient to which anti-gpIIIa autoantibodies are directed may influence the clinical presentation and course of the disease.^{49, 70} Whether these findings can be generalized to other ITP autoantibody epitopes is unknown.

Autoantibodies bind to platelets and cause thrombocytopenia primarily by shortening platelet survival. However, rare autoantibodies have also been reported that bind to glycoproteins and activate platelets.^{71, 72, 73, 74, 75} Additionally, one patient with an anti-gpIIIa antibody was reported to have developed an antibody-related defect in aggregation and adhesion.⁷⁶

The incidence of serum autoantibodies to platelet gpIIb/IIIa is the same in the acute and chronic forms of childhood ITP (68% vs. 62%, respectively).⁷⁷ The presence of anti-gpIIb/IIIa, therefore, does not predict which children will develop the chronic form of the disease, and, in fact, these data provide evidence that the mechanism may be the same in both acute and chronic forms of ITP.

The role of cell-mediated immunity in ITP remains uncertain, although data from patients with ITP suggest that T lymphocytes

P.1063

demonstrate phenotypic and functional abnormalities. Platelet reactive T-cell clones can be identified from the peripheral blood of adults and peripheral blood and spleens of children with chronic ITP, suggesting that autoreactive peripheral T lymphocytes may mediate or participate in disease pathophysiology.^{53, 78, 79} Adults with ITP often have increased numbers of HLA-DR⁺ T cells, increased numbers of soluble interleukin-2 receptors, and a cytokine profile suggesting the activation of precursor and mature helper T-cells.⁷⁹ CD3⁺ T cells from ITP patients in one DNA microarray study had increased expression of genes involved in cell-mediated cytotoxicity and, in addition, cytotoxic cell-mediated lysis of autologous platelets was shown in active ITP.⁸⁰

AUTOANTIBODIES

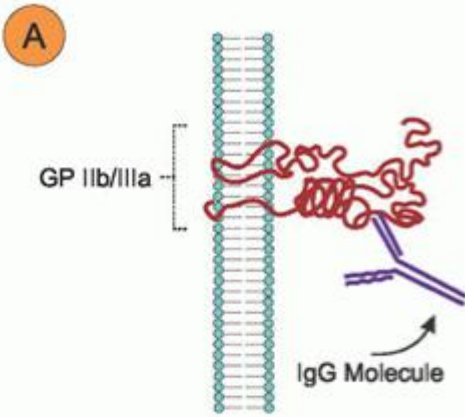

DRUG DEPENDENT ANTIBODIES

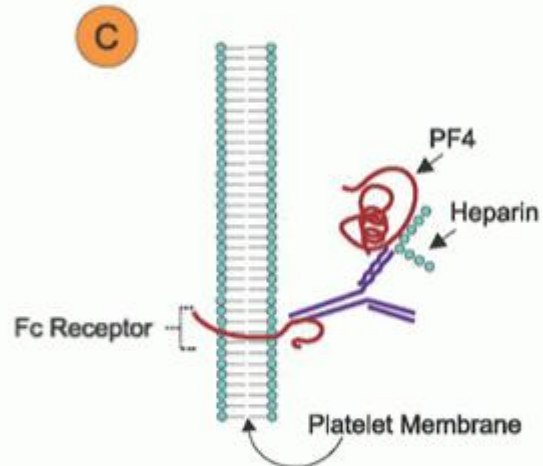
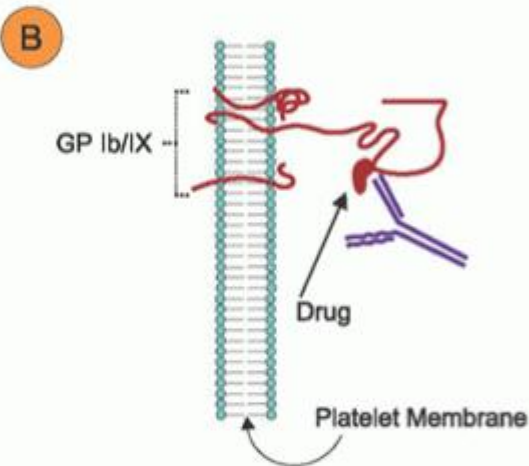

ALLOANTIBODIES

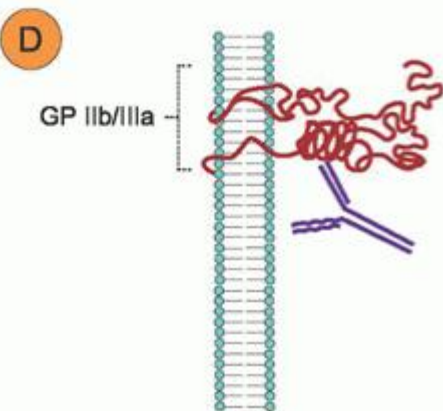

FIGURE 47.2. Types of antibody-mediated platelet destruction. A: Platelet autoantibodies bind to variable external and internal platelet epitopes. B: Quinine/quinidine-dependent antibodies. The antibody target is a complex of drug and glycoprotein (GP) (usually gIb/V/IX or gIIb/IIIa). C: Heparin-dependent antibodies. The antigen-antibody complex

(target: platelet factor 4 [PF4]/heparin) activates platelets by the binding of immunoglobulin G (IgG) to Fc γ RIIA on platelets. D: Platelet alloantibodies bind to platelet tertiary conformational epitopes on the platelet membrane. (Modified from Kelton, reference 40.)

Platelet Survival

Platelet survival, measured using ⁵¹chromium- or ¹¹¹indium-labeled platelets, is shortened in ITP, and the survival time can range from 2 to 3 days to a matter of minutes.^{22, 23, 24, 80, 81, 82, 83, 84, 85, 86, 87, 88, 89} Using ¹¹¹indium-labeled autologous platelets, some investigators found an inverse correlation between venous platelet count and platelet survival,⁸⁶ whereas others have not.⁸⁷ These study differences may relate to the types of patients included, as patients with mild to moderate thrombocytopenia have a longer measured platelet survival than patients with severe thrombocytopenia.

P.1064

Splenic sequestration and destruction account for the shortened survival in most patients,^{90, 91} but the liver and the reticuloendothelial cells of the bone marrow can play a major role in the sequestration of antibody-coated platelets, especially in patients with very low platelet counts or continued thrombocytopenia after splenectomy.^{22, 23, 86} Patients with severe thrombocytopenia have been found to have elevated levels of macrophage colony-stimulating factor⁹² and increased in vitro monocyte-platelet rosette formation.⁹³ The spleen has also been implicated as a site of antibody formation.^{94, 95} In a pathologic study of 83 spleens that had been removed after patients did not respond to steroid therapy, investigators found splenic weights of <300 g, prominent secondary lymphoid follicles (28%), foamy macrophages (67%), and megakaryocytic extramedullary hematopoiesis (60%).⁹⁶ These pathologic changes reflect the two major pathogenic roles of the spleen: Antiplatelet antibody production and macrophage-mediated platelet destruction.

Clinical Picture

Immune Thrombocytopenia in Children

In children with acute ITP, the onset of the disorder usually is sudden (Table 47.2). A history of infection preceding the onset of bleeding has been documented repeatedly.^{97, 98} In one series, such infections were noted within 3 weeks of the onset of ITP in 84% of cases.^{8, 9} Varicella zoster virus and Epstein-Barr virus are the most frequently identifiable viruses, although nonspecific unidentified viral infections predominate.⁹⁹ Acute ITP may also occur after vaccination.¹⁰⁰ Although it is most common between 2 and 5 years of age, ITP occurs in all pediatric age groups.¹⁰¹ The severity of ITP in infants is similar to that in older children, but compared to older children, a relatively small percentage of infants develop chronic ITP. A male preponderance was observed in the infant population in two studies.^{101, 102} Even though thrombocytopenia is likely to be severe, the bleeding manifestations of acute ITP in children usually are mild,¹⁰³ and intracranial hemorrhage occurs in <1% of patients. The rare adult with the acute form of the disorder, however, may suffer hemorrhage and a more fulminant course. Acute ITP in children usually is self-limited; spontaneous remissions occur in as many as 90% of patients.^{8, 9} The duration of the disease ranges from a few days to a few months, with an average of 4 to 6 weeks.¹⁰⁴ The favorable prognosis of ITP in children reflects the preponderance of the acute form of the disease in this age group. Children with thrombocytopenia of >6 months duration are classified as chronic ITP, although spontaneous remissions may still occur in an occasional child after 6 months.^{105, 106} Fever of mild degree has been reported, and the spleen tip may be palpable in up to 10% of patients, but this is believed to be the same incidence as is seen in normal children.¹⁰⁷ The spleen is usually of normal weight in those patients who proceed to splenectomy.⁹⁷

Immune Thrombocytopenia in Adults

In adults, the onset of the chronic form of the disorder usually is insidious (Table 47.2). A long history of hemorrhagic symptoms of mild to moderate severity is often described by the patient, but antecedent infections or fever are uncommon. Patients with chronic ITP usually have a fluctuating clinical course. Episodes of bleeding may last days or weeks and may be intermittent or even cyclic. Spontaneous remissions are very uncommon in adults, with an estimated occurrence of <5%.^{13, 14, 108, 109, 110} Most spontaneous remissions occur early; however, remissions have been described after 6 months in a small number of patients.¹³ Relapses in some cases are associated with vaccination.¹¹¹ Often the clinical course is surprisingly benign.

Bleeding Manifestations

The hemorrhagic manifestations of ITP are of the purpuric type. Patients with only ecchymoses and petechiae have "dry" purpura; those with mucous membrane bleeding in addition to skin manifestations have "wet" purpura.¹¹² Platelet counts

are usually lower and the complication rates higher in those with wet purpura. In a series of 712 patients reported by the Israeli ITP study group, 82% of all patients had bleeding limited to the skin, although 43% of adult women reported menometrorrhagia.⁹⁸

In general, the severity and frequency of hemorrhagic manifestations correlate with the platelet count (Fig. 47.3).¹¹³ Bleeding after trauma without spontaneous hemorrhage is usual in mildly affected patients with platelet counts $>50,000/\mu\text{l}$. Thrombocytopenia associated with counts between $10,000$ and $50,000/\mu\text{l}$ results in spontaneous hemorrhagic manifestations of varying severity, such as ecchymoses and petechiae. Patients with platelet counts $<10,000/\mu\text{l}$ are at risk for serious morbidity and mortality from bleeding, although the mortality rate is actually quite low.¹¹⁴ Patients who have an increased risk of bleeding include those with a history of bleeding, those with additional bleeding diatheses, and patients >60 years of age.^{12, 114} Older patients have also been reported to have an increased incidence of major, life-threatening bleeding.^{12, 115, 116}

Skin and Mucous Membranes

Spontaneous bleeding into the skin in the form of petechiae is characteristic. These lesions are minute, red to purple hemorrhages that range in size from that of a pinpoint to that of a pinhead (Fig. 47.4). They are flat, do not blanch with pressure, and appear and regress, often in crops, over a period of days. They are most conspicuous in areas of vascular stasis, such as the areas below tourniquet sites, the dependent portions of the body (especially around the ankles), and areas subjected to constriction from belts or stockings, as well as on skin surfaces over bony prominences. The presence of petechiae on the face and neck is unusual, except as the result of coughing.

Ecchymoses may develop on any skin surface. In ITP, they are seldom associated with subcutaneous hematomas and infrequently spread or dissect into deeper or adjacent structures. Large, purple, superficial ecchymoses may be seen, particularly on the back and thighs. Circular ecchymoses often surround even atraumatic venipuncture sites, but external bleeding from such sites is uncommon. Hemorrhagic vesicles or bullae may be seen inside the mouth and on other mucous surfaces. The bullae probably are the result of severe acute thrombocytopenia rather than a specific feature of any particular pathogenetic form.

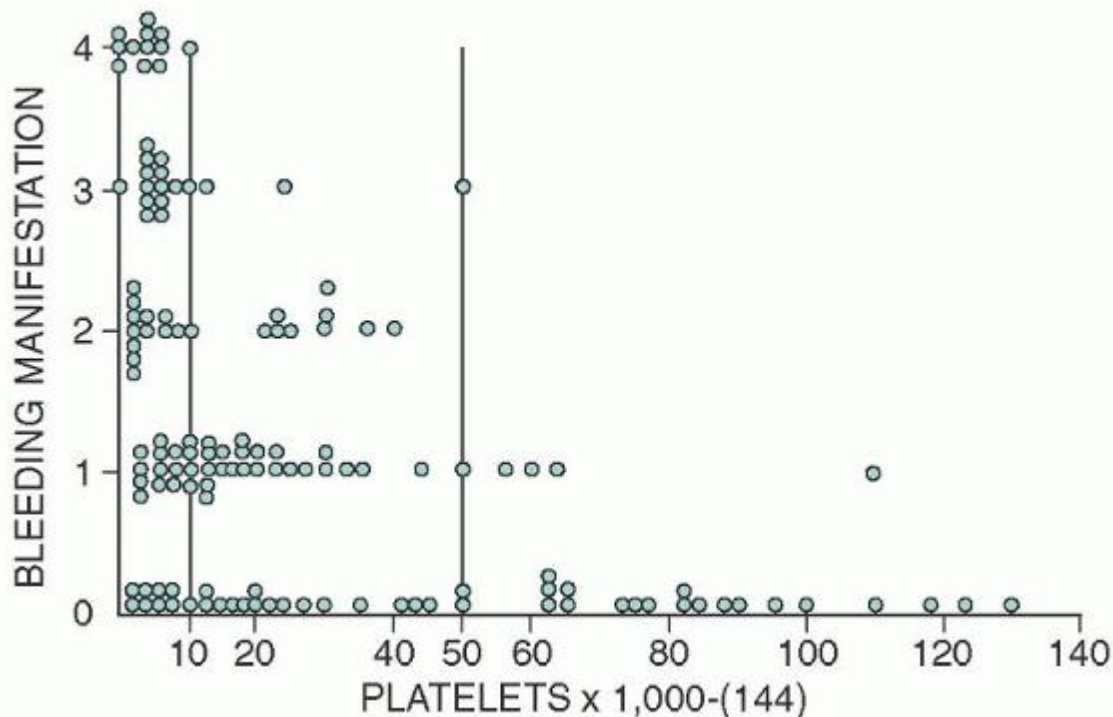

FIGURE 47.3. Bleeding manifestations in relation to platelet count in patients with primary immune thrombocytopenia. Bleeding manifestations (or duration) are graded from 0 to 4, as follows: 0, no bleeding; 1, minimal, resulting from trauma; 2, spontaneous, but self-limited; 3, spontaneous, requiring special attention (e.g., nasal packs); and 4, massive uncontrolled or poorly controlled. (From Lacey and Penner, reference 113.)



FIGURE 47.4. Petechiae. Pinpoint, nonblanching erythematous capillary bleeding sites are most common in dependent body areas or pressure points.

Gingival bleeding and epistaxis are common. The latter usually responds for a time to conservative measures, such as nasal packing or tamponade, often to recur intermittently. Epistaxis may originate from lesions resembling petechiae in the nasal mucosa. Such lesions also may be found in the mucous membranes of the throat and mouth, sometimes in the absence of cutaneous hemorrhage. In many patients, discrete bleeding points cannot be identified.

The genitourinary tract is a frequent site of bleeding. Menorrhagia may be the only symptom of ITP and may appear for the first time at puberty. Hematuria also is a common symptom, the blood coming from the kidneys, the bladder, or the urethra, although bleeding into the kidney parenchyma is rare. Gastrointestinal bleeding is usually manifested by melena or, less often, by hematemesis.

Central Nervous System

Intracranial hemorrhage is the most serious complication of ITP. Fortunately, it is rare, affecting 1% to 2% or less of patients with severe thrombocytopenia.^{9, 117} The hemorrhages usually are subarachnoid, often are multiple, and vary in size from petechiae to large extravasations of blood. Numerous small hemorrhages often are seen in the retina; subconjunctival hemorrhage may also occur.

Bleeding after Trauma

Excessive bleeding often follows tooth extractions, tonsillectomy, or other operations or injuries and may first suggest the diagnosis of ITP. In contrast to the hereditary coagulation disorders, such traumatic bleeding is seldom voluminous or rapid. Slow persistent oozing may occur after trivial cuts, razor nicks, and scratches. Delayed bleeding and spontaneous hemarthrosis, which are characteristic of the hereditary coagulation disorders, are extremely rare in ITP.

Laboratory Findings

Blood

The mean platelet count of patients at the time of diagnosis of ITP is 25 to 30,000 and severe thrombocytopenia (<10,000) is frequently seen.^{117, 118} Abnormalities in platelet size and morphologic appearance are common. The platelets often are

abnormally large (3 to 4 μm in diameter) and reveal more than normal variation in size and shape. Abnormally small platelets and platelet fragments ("microparticles") also are evident and may represent the equivalent of microspherocytes and schistocytes.^{119, 120, 121, 122} Although megakaryocyte fragments may be apparent in routine blood smears, quantitative studies reveal subnormal numbers of these fragments.¹²³

Estimates of mean platelet volume (MPV) and the extent of platelet size heterogeneity (platelet distribution width) by means of automated particle counters may, if present, provide useful information in the evaluation of patients with ITP.¹²⁴ The presence of numerous megathrombocytes results in high MPV values.¹²⁵ Platelet distribution width also is increased, presumably reflecting an abnormal degree of platelet anisocytosis.¹²⁶ The exact mechanism underlying such megathrombocytosis is still uncertain, but it may be the result of accelerated platelet production in response to platelet destruction. When MPV is increased in patients with ITP, it is typically inversely correlated in a nonlinear manner with the platelet count. In contrast, low MPV values have been reported in association with big spleen syndromes¹²⁶ and some myeloproliferative disorders, after chemotherapy with cytotoxic drugs, and in patients with septic thrombocytopenia.¹²⁷

Significant abnormalities in the other blood counts should prompt a thorough evaluation for other causes of thrombocytopenia as these findings are unusual in ITP. Anemia, if present, is proportional to the extent of blood loss and is usually normocytic. If bleeding has been severe and long-standing, iron deficiency anemia may occur. Occasionally, recent severe hemorrhage may produce reticulocytosis and moderate macrocytosis. Antiplatelet antibodies in patients with ITP do not usually cross-react with erythrocytes, although erythrocyte fragmentation, presumably the result of weak complement activation, may occur.¹²¹ Patients may also have a positive direct Coombs test and autoimmune hemolytic anemia; the combination is known as Evans syndrome.^{128, 129}

The total leukocyte count and the differential count usually are normal. Eosinophilia has been noted, particularly in children, but this finding is by no means consistent. Lymphocytosis with abnormal cells resembling those characteristic of infectious mononucleosis also has been reported.^{130, 131}

Tests of hemostasis and blood coagulation reveal only changes attributable to thrombocytopenia, such as a prolonged bleeding time. The results of tests of blood coagulation, including prothrombin time, partial thromboplastin time, and fibrinogen, are normal in patients with uncomplicated thrombocytopenia. Slight increases in the levels of fibrinogen degradation products have been demonstrated in the plasma of some patients with ITP.¹³² Plasma levels of glyocalicin, a portion of platelet membrane gplb, may be high in patients with ITP and other forms of platelet destruction. As noted previously, concentrations of thrombopoietin are not significantly increased in ITP.

Bone Marrow

ITP causes no characteristic bone marrow changes; therefore, bone marrow examination should not be routine. The American Society of Hematology (ASH) guidelines for management of ITP recommend against bone marrow biopsy in both children and adults with history, physical exam, CBC, and peripheral smear typical of ITP.⁵ However, bone marrow aspiration may be helpful in the differential diagnosis of ITP in patients who have atypical findings that may suggest some of these other etiologies.

In patients with ITP, alterations in the bone marrow are usually limited to the megakaryocytes, although normoblastic hyperplasia may develop as a result of blood loss. The leukocytes are essentially normal with the exception of occasional eosinophilia.¹³³

Megakaryocytes usually are increased in size¹³⁴ and are increased or normal in number,^{135, 136} the numbers correlating roughly with the MPV. Morphologic abnormalities of these giant cells are present in most patients with ITP. "Smooth" forms with single nuclei, scanty cytoplasm, and relatively few granules are common. Presumably, they represent the results of markedly

P.1066

accelerated platelet production and the presence of many young forms.^{137, 138} The changes just summarized are similar to those found in most forms of thrombocytopenia caused by accelerated platelet destruction and are not characteristic or diagnostic of ITP.

Antiplatelet Antibodies

Primary ITP is a diagnosis of exclusion and relies on clinical impression. A number of different types of antiplatelet antibody tests have been developed and reported through the years.^{36, 139, 140, 141, 142, 143, 144, 145, 146} Most of these tests were quite cumbersome and therefore never became available for routine testing. These tests measured different types

of Ig, including serum antiplatelet antibodies, platelet-associated surface Ig, or total platelet Ig and are now generally regarded as unreliable.¹⁴⁷ The platelet Ig is released, along with other α -granule proteins, such as platelet factor 4 and β -thromboglobulin, during platelet activation and secretion. It is presumed that some of these released proteins bind to the platelet surface. These observations make it difficult to use either the platelet-associated IgG assays or the total platelet Ig assays for the diagnosis of ITP.¹⁴⁸

In a more recent generation of antiplatelet antibody assays, monoclonal antibodies for the specific platelet membrane glycoproteins that are implicated in ITP are used in antigen-capture-type assays (also called glycoprotein immobilization assays).¹⁴⁹ Studies have identified a specificity of 78% to 93%.^{150, 151} However, the sensitivity (49% to 66%) is not high enough to exclude the presence of ITP if the test is negative.^{68, 151, 152} None of these tests is in routine clinical use, and experts disagree on their role in the diagnosis of ITP. Future direction might include the use of flow cytometry in the diagnosis and follow-up of autoimmune thrombocytopenia.¹⁵³

Differential Diagnosis

The initial step in the evaluation of a thrombocytopenic patient is inspection of the peripheral blood smear to confirm the decreased platelet count.¹⁵⁴ Thrombocytopenia may be produced artifactually by clumping of the platelets in the blood sample caused by ethylenediaminetetra-acetic acid-associated platelet agglutinins (pseudothrombocytopenia),^{155, 156} or the platelets may be unavailable for counting because they are bound in rosette formation to the surface of white blood cells in the venous blood sample ("platelet satellitism").^{157, 158}

The diagnosis of ITP is usually a diagnosis of exclusion based on a demonstration of peripheral thrombocytopenia, with a history, physical examination, and complete blood count that do not suggest another cause for the thrombocytopenia. Splenomegaly suggests that the thrombocytopenia may be a result of hypersplenism related to the presence of a separate underlying disease associated with splenic enlargement.

The initial manifestations of acute leukemia, myelodysplastic syndrome,^{159, 160} myelophthisic processes, and aplastic anemia may mimic ITP. These other types of underlying hematologic disorders are suggested by anemia out of proportion to blood loss and by changes in the leukocytes not attributable to either hemorrhage or complicating infection. Although not routinely recommended for the diagnosis of ITP, bone marrow aspiration may be helpful in the differential diagnosis of ITP in patients who have atypical findings that may suggest some of these other etiologies.

The presence of schistocytes in the blood smear suggests that thrombocytopenia may be associated with a microangiopathic process (see Chapter 48). In thrombotic thrombocytopenic purpura (TTP) or hemolytic-uremic syndrome (HUS), thrombocytopenia is associated with laboratory manifestations of hemolysis, including elevated levels of lactate dehydrogenase and indirect bilirubin.¹⁶¹ Patients may also have transient, multifocal neurologic signs or symptoms, renal insufficiency, and/or fever in TTP, or renal insufficiency alone in HUS. After a diagnosis of ITP, the next essential step is to distinguish between primary ITP purpura and secondary forms of ITP purpura, such as human immunodeficiency virus, hepatitis C, or *Helicobacter pylori* infections; collagen vascular diseases such as systemic lupus erythematosus (SLE); lymphoproliferative disorders such as chronic lymphocytic leukemia; and drug ingestion. The ASH guidelines recommend considering testing all adults with a new diagnosis of ITP for hepatitis C and HIV as treatment plans differ in these settings.⁵ The importance of careful inquiry regarding drug ingestion or exposure to toxic substances cannot be overemphasized, because thrombocytopenia attributable to drugs or toxins often is indistinguishable from ITP.¹⁶² The development of thrombocytopenia in an adult, in particular, should arouse suspicion of a pharmacologic etiology, because many of the drugs associated with thrombocytopenia are used more often by adults than by children. It is also essential to eliminate the possibility that the thrombocytopenia is secondary to heparin administration. ITP may be produced by heparin administered in any dose and by any route of administration, including heparin-bonded catheters.¹⁶³ Finally, the antiphospholipid antibody syndrome is a disorder that may be associated with thrombocytopenia. In the usual case, this presentation may be associated with thromboembolic manifestations, anticardiolipin antibodies, and coagulation inhibitors of the lupus type (see Chapter 54).

Treatment of Primary Immune Thrombocytopenia

Many of the treatment recommendations for ITP are based on expert opinion rather than high-level evidence from randomized controlled trials. The ASH has published a practice guideline on ITP.^{5, 164, 165} The reader is referred to this practice guideline for specific questions regarding the treatment of patients with ITP.

Children

Childhood ITP is usually benign and self-limited. Therefore, treatment is not required for most patients. Treatment is reserved for patients with severe thrombocytopenia ($<20,000/\mu\text{l}$) and bleeding, or patients who remain thrombocytopenic

for >6 months, that is, those with chronic ITP (Table 47.4).¹⁶⁶ Treatment guidelines recommend observation for all children with no or mild bleeding, regardless of platelet count.⁵ Although the greatest

P.1067

fear in the acute form is intracranial hemorrhage, several large studies show that even with low platelet counts (<30,000/ μ l) life-threatening bleeding and intracranial hemorrhage are rare (<0.5%).^{166, 167}

TABLE 47.4 RECOMMENDATIONS FOR INITIAL TREATMENT OF IMMUNE THROMBOCYTOPENIA (IVIG) PATIENTS WITH PLATELET COUNTS <20,000-30,000/ μ l^a

	Children	Adults
Asymptomatic	None	Steroids (preferred) or IVIG
Minor purpura	None	Steroids (preferred) or IVIG)
Mucosal membrane bleeding that may require clinical intervention	IVIG or steroids	IVIG and/or steroids
Severe, life-threatening bleeding	Steroids and IVIG	Steroids and IVIG
	Hospitalization	Hospitalization
	Consider platelet transfusion and other measures	Consider platelet transfusion and other measures

^aThe current ASH guidelines recommend treatment for adults with platelet counts of <30,000/ μ l.

Treatment guidelines for pediatric ITP recommend first-line treatment with either a single dose of intravenous immunoglobulin (IVIG) (0.8 to 1 g/kg) or a short course of steroids.⁵ Several multicenter randomized trials have been performed in high-risk patients with acute ITP to define whether treatment is associated with a prompt increase in platelet counts. These clinical trials demonstrated that treatment with either oral prednisone or IVIG was associated with a more rapid rise in platelet count to >20,000/ μ l than either no therapy or treatment with anti-D.^{168, 169} Only IVIG shortened the time to reach a platelet count >50,000/ μ l. More recently, children with platelet counts <10,000/ μ l or counts of 10,000 to 29,000/ μ l and mucosal bleeding were studied in a prospective randomized clinical trial, and IVIG raised platelet counts faster than three corticosteroid regimens.¹⁷⁰ Therefore, IVIG should be preferentially used if a rapid rise in platelet count is desired.

Treatment of children who develop persistent ITP or are unresponsive to initial treatment is evolving. Splenectomy remains a standard given high response rates; however, many experts recommend delaying splenectomy for at least 12 months given the frequency of spontaneous remission.⁵ Rituximab treatment has been used in children and adolescents in a small study comprised of 36 patients with chronic ITP.¹⁷¹ In contrast to observations in adults, the median time to response was 1 week (range 1 to 7 weeks), and the overall response rate was 31%. Outcome was not associated with age, prior pharmacologic response, prior splenectomy, duration of disease, screening platelet count, refractoriness, or IgM reduction. Therefore, rituximab may be considered as an alternative to splenectomy in children with chronic ITP or in patients with persistent bleeding despite first-line treatments.⁵ High-dose dexamethasone (0.6 mg/kg/day) may also be considered in patients who are unresponsive to initial therapy based on small studies showing a 25% response rate in refractory patients.¹⁷²

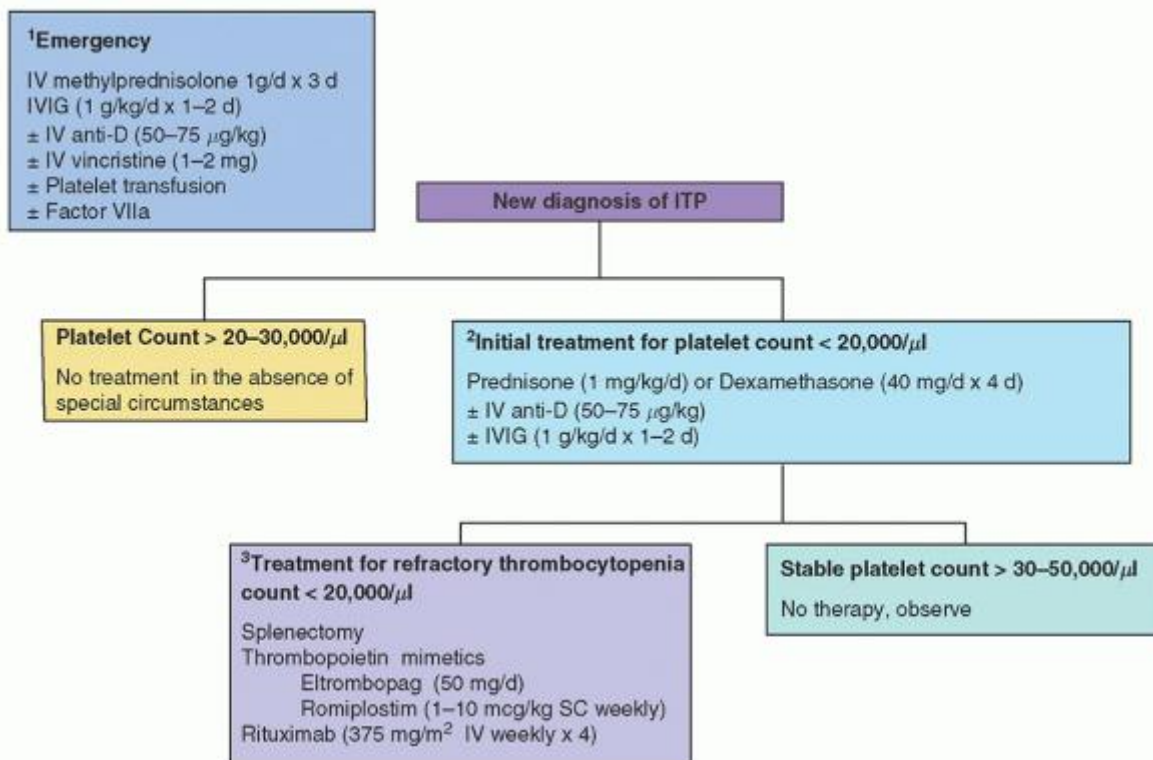

FIGURE 47.5. Therapy of adult immune thrombocytopenia (ITP). (1) Minimal emergency therapy includes intravenous (IV) methylprednisolone and intravenous immunoglobulin (IVIG). Intravenous anti-D and platelet transfusions may be given as needed. All three modalities given prior to transfusions may help preserve platelet longevity in the circulation and repeated or continuous platelet transfusions may be required in urgent situations. (2) Initial treatment of ITP typically consists of steroids (prednisone or dexamethasone) with the goal of attaining a platelet count of $>30,000/\mu\text{l}$ and cessation of bleeding. IVIG or anti-D may be used if steroids are contraindicated or the patient has persistent thrombocytopenia despite steroids. (3) Thrombocytopenia recurs in most adults as corticosteroids are tapered. Treatment options for refractory ITP include splenectomy, thrombopoietin mimetics, and rituximab. (Modified from Cines and Bussel, reference 459.)

Adults

Patients with chronic ITP may have mild thrombocytopenia that can be followed without treatment. The incidence of bleeding is correlated with the platelet count; therefore, patients with platelet counts $>50,000/\mu\text{l}$ rarely have spontaneous bleeding and may require treatment only if extensive operative procedures are planned. Patients with platelet counts $<20,000$ to $30,000/\mu\text{l}$ or significant mucosal membrane bleeding with platelet counts $<50,000/\mu\text{l}$ are usually treated⁵ (Table 47.4 and Fig. 47.5).

No prospective studies on long-term prognosis of ITP after treatment are reported. However, it has been reported that most adult patients have a good response to treatment (without necessarily returning to normal platelet counts) and have no excess mortality when compared to the general population.¹⁷³ A small group of patients who had severe thrombocytopenia after 2 years of primary and secondary therapies had a mortality risk of 4.2 (95% confidence interval, 1.7 to 10.0) resulting from both bleeding and infectious complications related to therapy.

ITP is uncommon in elderly patients; only 30% of patients in reported series are >45 years of age.^{133, 174} However, these patients may be more refractory to therapy¹¹⁵ and appear to have a higher incidence of hemorrhagic complications than younger patients.¹² Guthrie and colleagues reported a 52% incidence of life-threatening or fatal bleeding in their series of 40 patients

P.1068

older than age 45 years.¹¹⁵ This risk of fatal bleeding in patients with platelet counts that are chronically $<30,000/\mu\text{l}$ is estimated at 0.4% per year for patients <40 years of age and 13.0% per year for patients >60 years of age.¹⁷⁵

First-line Treatment

Initial treatment for adult patients with newly diagnosed ITP is typically steroids. Other options that increase the platelet count rapidly include IVIG and anti-D. The most recent ASH guideline recommends use of these alternative first-line therapies in patients with contraindications to steroids.⁵ Patients with life-threatening bleeding may require parenteral glucocorticoids and IVIG followed by platelet transfusions,¹⁷⁶ plasmapheresis,¹⁷⁷ or even emergency splenectomy as first-line treatment. Standard ITP treatments and their dosing schedules are shown in Table 47.5.

Steroids

Steroids are the conventional first-line therapy for adult ITP. Dameshek first reported his experience with prednisone therapy in 1958,¹⁷⁸ when 30 consecutive patients with acute (N = 11) or chronic (N = 19) ITP were treated with 20 to 150 mg/day of prednisone. Twenty-two of the patients demonstrated an increase in platelet count to normal after an average interval of 22 days and then were maintained on 2.5 to 15.0 mg/day of prednisone. In eight patients, prednisone was discontinued without relapse.

Numerous retrospective studies of steroid treatment in both children and adults with ITP have been reported.^{13, 14, 97, 98, 104, 108, 109, 110, 133, 174, 179, 180, 181, 182} The criteria for inclusion of patients in the individual studies and the criteria for response to treatment vary significantly among the reports; therefore, it is difficult to combine the data accurately. However, some useful observations can be made. Complete (CR) and partial (>50,000/ μ l) responses (PR) in patients treated with prednisone (usually, 1 mg/kg/day as starting dose) average 65% to 85%, but sustained responses after discontinuation of the drug occur in only 25% or less of patients.^{183, 184} Platelet counts usually increase within 1 week in responding patients and have usually reached peak values by 2 to 4 weeks. Patients who have not had any response by 4 weeks are unlikely to respond to prednisone and therefore should be considered for other forms of treatment. No pretreatment patient characteristics have predicted a patient's response to steroids.

TABLE 47.5 THERAPEUTIC AGENTS AND THEIR DOSING SCHEDULES

Agent	Dose and Schedule
Anti-D immunoglobulin	50-75 μ g/kg IV, repeated at 3-week intervals as indicated
Cyclophosphamide	150 mg daily for up to 8 wk
Colchicine	200 mg daily for up to 4 wk
Dexamethasone	40 mg daily for 4 d, repeated every 14 d for 4 cycles
Danazol	400 mg twice daily for 1 mo or longer
Eltrombopag	50 mg daily. Must be continued indefinitely.
IVIG	1 g/kg IV for 1-2 d, repeated every 2 to 4 wk as indicated
Prednisone	1 mg/kg daily for up to 28 d, then taper to lowest dose possible
Rituximab	375 mg/m ² IV weekly for 4 doses
Romiplostim	1-10 mcg/kg subcutaneous injection weekly. Start at 1 mcg/kg and titrate based on platelet count. Must be continued indefinitely.
Vincristine	2 mg at 5- to 7-day intervals for 2 or more doses
Vinblastin	7.5 mg at 5- to 7-day intervals for 3 or more doses

Modified from Narang et al.⁴⁶⁰

Several prospective randomized steroid treatment trials in patients with ITP have been reported. Bellucci and colleagues randomized patients between low (0.25 mg/kg/day) or high (1.0 mg/kg/day) prednisone for 3 weeks, with taper and discontinuation by the end of the fourth week.¹⁸⁵ If bleeding continued, patients could be increased from low dose to high dose, or a second 4-week course could be given. CR, defined as a platelet count >100,000/ μ l for at least 6 months, was seen in 74% of children and 41% of adults. CRs or PRs occurred in 83% of children and 59% of adults. No significant differences were seen between low- and high-dose regimens in either age group. Mazzucconi and colleagues randomized

patients between prednisone 0.5 mg/kg/day and 1.5 mg/kg/day.¹⁸⁶ The response rates in adults were not significantly different between patients treated with low- versus high-dose steroids: 30% and 34% CR, respectively. In children, however, the rates were 64% for low-dose versus 81% for high-dose prednisone. Therefore, there is evidence to support the use of lower doses of steroids in adults than have conventionally been used at the beginning of treatment. However, based on the opinion of an expert panel convened by the ASH, high-dose prednisone (1 mg/kg/day) is recommended as appropriate initial treatment in ITP patients with platelets <30,000/ μ l, including asymptomatic patients.^{5, 164, 165}

Another prospective randomized, controlled trial compared prednisone (1 mg/kg/day) to IVIG (400 mg/kg/day for 4 days), or to both in a small number of patients.¹⁸⁷ A platelet count >50,000/ μ l was achieved in 82%, 54%, and 92% of patients, respectively. The median times to peak platelet counts were 8.5, 7.0, and 7.0 days. These authors concluded that there was no advantage for IVIG over conventional corticosteroid treatment. In another recent randomized control trial, platelet counts >50,000/ μ l were achieved more quickly in patients receiving IVIG than in those receiving intravenous methylprednisolone, but long-term outcomes were the same.¹⁸⁸

There are also several studies that have evaluated the role of high-dose dexamethasone in the initial treatment of ITP. This protocol was initially developed because of concern regarding long-term side effects of daily prednisone use. Initial trials showed that using 40 mg of dexamethasone daily for 4 consecutive days results in an initial response in 85% of patients.^{189, 190} Additional work has shown that repeating dexamethasone bursts may provide long-term disease control in some patients. Mazzucconi and colleagues treated newly diagnosed patients with ITP with dexamethasone 40 mg daily for 4 days, repeating these cycles every 14 days for 4 cycles.¹⁹¹ A total of 85% of patients responded with 65% achieving a CR. Relapse-free survival at 15 months was 81% indicating that many of these patients may be long-term responders.

There are conflicting opinions regarding the choice of prednisone versus dexamethasone for first-line treatment of ITP. The writers of the 2011 ASH guidelines favor longer-term prednisone over dexamethasone⁵ but other experts in the field think that either is reasonable.¹⁹²

The mechanism of action of steroids in ITP involves both direct and indirect effects on thrombocytopenia. Steroids ameliorate thrombocytopenia directly by several mechanisms. Steroids may (a) decrease consumption of antibody-coated platelets by the spleen^{193, 194, 195} or bone marrow, (b) reduce antibody production by the spleen,^{94, 196} (c) decrease antibody production by the bone marrow,¹⁹⁷ and/or (d) increase marrow platelet production by undetermined mechanisms.¹⁹⁸

There is little doubt that corticosteroids in high doses ameliorate splenic sequestration of antibody-coated platelets. Corticosteroids decrease antibody-coated red blood cell sequestration in guinea

P.1069

pig spleens by decreasing Fc γ receptor proteins on macrophages,¹⁹⁹ and in vivo and in vitro data support a similar action of steroids in humans.^{90, 91, 194, 200, 201} Corticosteroids also decrease monocyte Fc receptors in autoimmune hemolytic anemia.²⁰² This down-regulation of monocyte/macrophage Fc receptors may account for the early effects of steroid treatment on platelet counts. Chronic corticosteroid treatment is associated with a decrease in antibody production, but this usually occurs after several weeks of high-dose steroids. Steroid treatment also results in increased platelet production in some ITP patients,¹⁹⁸ an effect that may be secondary to reduction of the antiplatelet Ig effect on thrombopoiesis, reduction in intramedullary destruction of antibody-coated platelets before their release into the circulation, or decreased antibody synthesis by bone marrow lymphocytes.

In addition to these direct effects on thrombocytopenia, steroids also act on endothelial cells to reduce bleeding. Experimental evidence indicates that thinning of the endothelium with development of endothelial fenestrations occurs in both animal models and humans with ITP, suggesting that platelets play a role in normal endothelial homeostasis.^{203, 204} Clinically, steroids are known to ameliorate the purpuric bleeding in ITP patients before the platelet count actually increases. Experimentally, investigators have demonstrated that 3 days after steroid therapy in rabbits and 4 days after steroid therapy in patients, the endothelial thinning reverts toward normal, providing a scientific explanation for this clinical observation.^{204, 205} This endothelial effect may in part be explained by the observation that when endothelial cells are cultured with steroids, cell morphology is altered, with greater confluence and increased protein synthesis and content.²⁰⁶

Intravenous Immunoglobulin

The intravenous administration of polyvalent Ig (IVIG), first used in 1981,²⁰⁷ may induce remissions in patients with life-threatening bleeding or in patients with refractory ITP. IVIG therapy has proved most effective in infants and small

children,^{208, 209} an age group in which the response is difficult to evaluate because of the frequency of spontaneous remissions. In adults this regimen has produced relatively less impressive long-term results,^{210, 211, 212, 213} although an occasional patient enters complete remission after the initial treatment and a series of booster doses.^{214, 215, 216, 217} In a review of 28 published reports of IVIG in 282 adults, 64% of patients had a peak platelet count $>100,000/\mu\text{l}$, and 83% had peak platelet counts $>50,000/\mu\text{l}$ ²¹⁸ after the initial infusion. Platelets may begin to rise after 2 days and usually reach peak levels by 1 week after treatment.

Regimens of 400 mg/kg/day for 5 days versus 1,000 mg/kg/day for either 1 or 2 days,^{219, 220} have been equally effective in randomized trials, and doses of 0.5 g/kg are as effective as 1.0 g/kg for maintenance therapy.²²¹ These doses produce significant increases in serum and platelet levels of IgG.^{209, 214, 216} In a randomized controlled trial, one dose of 1,000 mg/kg was superior to 500 mg/kg in raising platelet counts to $>80,000/\mu\text{l}$ by day 4.²²⁰ Most of these patients were being prepared for splenectomy or delivery.

Several mechanisms are thought to be involved in the beneficial effects of IVIG. They include Fc receptor blockade of reticuloendothelial cells,^{214, 216, 222, 223, 224, 225} effects on B cells and antibodies^{226, 227, 228, 229, 230, 231} and anti-inflammatory effects.^{232, 233} No evidence exists that reduction of antiplatelet antibodies accounts for the acute effects of therapy.²³²

Therapy with IVIG remains expensive. The rapid nature of the response to treatment makes it an ideal agent for treatment of patients for life-threatening bleeding or before surgery^{234, 235}; however, the role of IVIG in long-term therapy remains uncertain. The major side effect of treatment is headache, although some patients also develop fever, myalgias, and skin rashes.²³⁴ There are also reports of acute renal failure occurring in up to 7% of patients, especially older patients and those with diabetes, or baseline increases in creatinine (or both).^{236, 237} The patients may be oliguric, and most demonstrate peak creatinine levels by day 5 after the IVIG infusion. Hemodialysis may be required acutely, and several patients required chronic dialysis. The volume of fluid required for IVIG administration can also be a major problem in some older patients with co-morbidities such as congestive heart failure.

Anti-D

Intravenous Rho (D) immune globulin (anti-D) has been studied in children and adult ITP as an alternative to IVIG.^{238, 239, 240} The mechanism of action is unknown; however, it is believed that the antibody coats the red blood cells of Rh-positive patients and either blocks the reticuloendothelial clearance of platelets or modulates the immune system, resulting in an increase in the platelet count.^{240, 241} Although infusion of both IVIG and anti-D slow the Fc γ -receptor-mediated destruction of antibody-coated platelets, responses to anti-D appear to uniquely correlate with polymorphisms specific to the Fc γ RIIa and Fc γ RIIIa receptors.²⁴² This is characterized by increases in the plasma levels of IL-6, tumor necrosis factor- α , monocyte-chemoattractant protein-1, and IL-10 that are specific to IV anti-D infusions compared with IVIG.

Children respond better than adults, and nonsplenectomized patients respond better than splenectomized patients to anti-D.^{241, 243} The platelet count does not begin to increase for 48 to 72 hours, so it may not be as effective for the treatment of life-threatening bleeding compared with IVIG. The effect lasts for several weeks to a month, and patients respond well to retreatment. They may respond to intramuscular injections given weekly as maintenance.²⁴⁴ Occasionally, patients have a sustained remission.²⁴⁵ Most patients exhibit a modest decrease in hemoglobin, and most have subclinical signs of mild hemolysis,²⁴³ with decreased haptoglobin, increased lactate dehydrogenase, and increased indirect bilirubin. Red cell survival is only modestly reduced.²⁴⁶ No correlation has been found between the amount of hemolysis and the platelet response, leading some investigators to question the proposed effect on reticuloendothelial blockade.²⁴⁷

Reinfusion of autologous red blood cells that have been opsonized with anti-D has produced both complete and partial remissions in a small number of patients, even after splenectomy.²⁴⁸ With respect to anti-D dosing, early studies in adults receiving 25 to 50 $\mu\text{g}/\text{kg}/\text{day}$ showed an increase in platelet count of $>20,000/\mu\text{l}$ in 79% of patients. However, the platelet count did not increase for >72 hours, which made this treatment approach less efficient for bleeding patients.²⁴⁹ More recent studies have shown a more rapid increase of the platelet count within 24 hours and a longer duration of the increase when using a higher dose of 75 $\mu\text{g}/\text{kg}$ compared with 50 $\mu\text{g}/\text{kg}$.²⁵⁰ Anti-D therapy now carries a black box warning that requires observation of the patient for 8 hours after administration due to the risk of intravascular hemolysis and disseminated intravascular coagulation.²⁵¹

Treatment of Chronic Primary Immune Thrombocytopenia

Many adult patients with ITP, even if they initially respond to steroids, will develop chronic ITP. Chronic ITP is defined as ITP lasting longer than 12 months.¹ Patients who are asymptomatic and have platelet counts between 30,000 and 50,000/ μl may be managed with careful observation.^{164, 184} Symptomatic patients with platelet counts $<30,000/\mu\text{l}$ who had an initial response to steroids can be retreated with prednisone and then tapered to find the minimum dose that can

maintain the patient hemorrhage-free, even if the platelet count is not $>30,000/\mu\text{l}$. If patients can be maintained on 10 mg every other day, additional treatment may not be

P.1070

indicated. Some patients observed for years with platelet counts of $10,000/\mu\text{l}$ have had no significant bleeding other than ecchymoses or petechiae, even without steroid therapy.²⁵² Splenectomy has been the traditional therapy for refractory cases of ITP. There are more options now with accumulating evidence regarding the role of rituximab and thrombopoiesis-stimulating agents.

Splenectomy

Patients with severe thrombocytopenia ($<10,000/\mu\text{l}$) who do not respond to steroids (administered for up to 4 weeks) or who relapse during steroid tapering, and patients with platelet counts of $<30,000/\mu\text{l}$ for periods up to 3 months, should be considered for splenectomy.⁵ Most patients demonstrate a response to steroids within 2 to 4 weeks, but a late response is rarely seen. Therefore, the best time for splenectomy in a patient who does not respond to steroid therapy must be determined individually.

Sustained CRs to splenectomy (variously defined as platelet counts of $100,000$ to $150,000/\mu\text{l}$) have been reported in ~50% to 80% of patients, depending on the series.^{252, 253, 254, 255, 256, 257, 258, 259, 260, 261, 262, 263, 264, 265} After the operation, the platelet count may increase rapidly, often within 24 to 48 hours, and may reach levels as high as 1 million/ μl or even higher in approximately 10 days.⁹⁷ Operative mortality is $<1\%$, and perioperative bleeding is rare.^{13, 14, 98, 108, 109} Platelet transfusions are usually given only if the patient has bleeding after the spleen has been removed. Postsplenectomy infections are also rare, especially if patients have received immunization to encapsulated organisms (*Streptococcus pneumoniae*, *Haemophilus influenzae*, and *Neisseria meningitidis*) before splenectomy. Laparoscopic splenectomies in ITP patients are as successful as conventional splenectomies, although patients occasionally may require conversion to an open procedure.^{266, 267} Therapeutic responses are reported also when splenic ultrasound,²⁶⁷ splenic radiation,^{268, 269} or partial splenic embolization²⁷⁰ was used instead of splenectomy.

Patients who do not respond to splenectomy or who relapse after an initial response to splenectomy should be studied for the presence of accessory spleens.^{262, 271, 272, 273, 274, 275} The incidence of accessory spleens found at the time of the original splenectomy ranges from 15% to 20%.^{257, 262} The incidence of accessory spleens in patients who relapse after splenectomy may be as high as 50%,^{133, 263, 264} and surprisingly, the majority of these patients demonstrate postsplenectomy changes (i.e., Howell-Jolly bodies) on their peripheral blood smears. Relapse secondary to an accessory spleen may occur weeks to years after the initial splenectomy. Scanning methods have varying sensitivities; conventional ^{99m}Tc scans,^{99m}Tc scans using heatdenatured red blood cells, or computed tomography scans can be used. Accessory spleens as small as 0.5 cm have been found when ¹¹¹In scans were performed preoperatively and isotope detector probes were used intraoperatively to detect all accessory splenic tissue.²⁵⁷ A review of 56 published cases demonstrated a 73% excellent therapeutic response and a 27% moderate response to accessory splenectomy.²⁵⁷

The effectiveness of splenectomy in the therapy for ITP is attributed to removal of the organ that is primarily responsible for the destruction of antibody-sensitized platelets. The increase in platelet count correlates with an increase in platelet survival, whereas platelet production remains unchanged.¹⁹⁸ The removal of the spleen may also result in a reduction of antibody production, but this effect is probably of minimal significance in view of the immediate favorable responses to splenectomy. No factors have consistently predicted a response to splenectomy; age, concentration of platelet-associated IgG, the time between diagnosis and splenectomy, the patient's response to steroids, IVIG or intravenous anti-D, and the peak postoperative platelet count have all been studied.^{256, 276, 277, 278, 279, 280} The site of platelet sequestration, based on preoperative ⁵¹Cr- and ¹¹¹In-labeled platelet survival studies, may be predictive of response,^{260, 281} but these techniques are seldom used.

Rituximab

Rituximab, an anti-CD20 monoclonal antibody, has produced CRs or PRs in approximately 60% of patients.^{282, 283, 284, 285, 286} Rituximab causes selective B-cell lysis in vitro and B-cell depletion in vivo.²⁸⁷ Involved mechanisms of action include apoptosis, antibody-dependent cell-mediated cytotoxicity, and/or complement-dependent cytotoxicity. Recovery of B-cell counts usually occurs by 6 to 12 months after completion of treatment.

Most of the patients in the studies of rituximab in ITP had relapsed or refractory disease, and some had undergone splenectomy. The majority of studies have used the standard treatment dose of $375\text{ mg}/\text{m}^2$ weekly for four weekly doses;²⁸⁶ however, published reports have shown that lower doses are effective as well.²⁸⁸ The side effects were mild and

seen most commonly after the first infusion. The long-term safety profile of rituximab is felt to be favorable. Only one case of progressive multifocal leukoencephalopathy, a rare but fatal consequence of rituximab administration, has been reported in a patient with ITP.²⁸⁹ There are two different response patterns, early versus late.²⁹⁰ Patients with an early response to four weekly infusions had an increasing platelet count after the first or second infusion and peaked between weeks 6 and 10. Late responders had no rise of their platelet count during treatment but increased their platelet count between weeks 6 and 8, with the peak occurring shortly thereafter. In one study, the B-cell count in patients who responded was lower than in patients who did not have a response.²⁸⁵

A recent meta-analysis of studies employing rituximab in the treatment of refractory/relapsed patients consisted of 299 patients described in 15 reports.²⁹¹ The overall response rate was 55%, of which 38% of patients achieved a CR, which was defined as a platelet count of at least 100,000 to 150,000/ μ l. In addition, 17% of the patients achieved a PR, which was defined as a platelet count of >50,000 and <100,000/ μ l. The median duration of response was 74 weeks (24 to 120 weeks) and in PR patients was 55 weeks (12 to 160 weeks). CR in splenectomized patients (62%) was higher than in nonsplenectomized patients (available from five studies, n = 126).²⁷² Another recent meta-analysis showed similar results with 43.6% of patients achieving a CR (>150,000/ μ l) and 62.5% of patients achieving a PR (>50,000/ μ l).²⁸⁶

Longer-term studies have shown that prolonged disease responses are less common. Patel et al. reported that with 2.5 years of follow-up 1 in 6 patients remained in remission.²⁹² Most patients with relapse can be retreated with rituximab with success.²⁹³ The role of rituximab as part of first-line therapy for ITP is currently under investigation²⁹⁴ but is not considered a standard of care.

Thrombopoiesis-stimulating Agents

Thrombopoiesis-stimulating agents (thrombopoietin mimetics) are another, recently approved treatment option for management of refractory ITP. There are two currently available thrombopoiesis-stimulating agents, eltrombopag and romiplostim. They have both been the subject of randomized controlled trials in refractory ITP.

Eltrombopag, an oral agent, is a peptide that interacts with the transmembrane domain of the thrombopoietin receptor thereby stimulating differentiation and proliferation of megakaryocytes in the bone marrow. The most common side effects are mild elevation in liver enzymes and nausea/vomiting.²⁹⁵ In a study published in 2009, 114 patients with refractory ITP were randomized to eltrombopag versus placebo in a 2:1 randomization.²⁹⁵ After 6 weeks of follow-up, 59% of patients in the eltrombopag arm versus 16% in the placebo arm had achieved a platelet count >50,000 and less bleeding was observed in the eltrombopag arm.

P.1071

Platelet counts dropped again within 2 weeks of discontinuing therapy. A phase III study (RAISE) in patients with chronic ITP published in 2011 showed similar results.²⁹⁶ After two weeks of therapy, median platelet counts in the eltrombopag group were 53,000 to 73,500 versus 17,500 to 23,000 in the placebo arm. Patients in the eltrombopag arm had less bleeding and were more successfully tapered off their other ITP treatments.

Similar results have been seen with romiplostim. Romiplostim is an injectable thrombopoietin mimetic that is given once per week. It is a thrombopoietin mimetic peptide (peptibody) which binds to the thrombopoietin receptor. In a randomized study published in 2008, patients with ITP were randomized in a 2:1 fashion to romiplostim versus placebo.²⁹⁷ In splenectomized and nonsplenectomized patients, 79% and 88% of patients receiving romiplostim achieved a platelet count >50,000. Only a very low number of patients in the placebo arm achieved this threshold (14% of nonsplenectomized patients, 0% of splenectomized patients). This correlated with decreased use of other ITP therapies. The most common side effects are arthralgias, fatigue, and nausea.²⁹⁸ Serious adverse events are rare. Additional trials have shown that romiplostim is safe and effective for prolonged use²⁹⁹ and that decreased bleeding is observed in patients receiving romiplostim due to higher platelet counts.³⁰⁰ With prolonged use patients do still require regular platelet monitoring as the dose required may vary over time.²⁹⁹ As with eltrombopag, indefinite treatment is required as platelet counts fall quickly when treatment is discontinued.

There has been some concern regarding increased marrow fibrosis in patients receiving eltrombopag or romiplostim. Preclinical data showed increased fibrosis in the marrow of rats treated with romiplostim.³⁰¹ This appeared to be dose dependent and decreased after the treatment was discontinued. In the same paper, a retrospective review of clinical trials using romiplostim was performed.³⁰¹ Reticulin deposition was noted in 10 of 271 patients; however, most patients did not have bone marrow biopsies performed. In 5 patients who had pretreatment bone marrow biopsies, reticulin deposition increased in 4 patients. In all patients, reticulin staining decreased when romiplostim was discontinued. In 10 patients

followed prospectively with serial bone marrow biopsies, only 1 of 10 patients treated developed new reticulin fibrosis on treatment. Similar findings are seen with eltrombopag. The clinical significance of this finding is unclear.

Although the thrombopoietin mimetics are effective in both splenectomized and nonsplenectomized patients, expert panels recommend that they be reserved for patients with refractory ITP after splenectomy and patients with contraindications to splenectomy.⁵ This recommendation is based on concerns regarding the requirement for indefinite treatment which is accompanied by significant cost and risk of long-term toxicities that have not yet been identified.

Immunosuppressive Drugs

Immunosuppressive therapy for ITP has yet to be evaluated thoroughly; the overall effectiveness of these potent drugs is variable, and remissions achieved have been short-lived. Poor results were reported in children.³⁰² Favorable results are nevertheless noteworthy, because they were obtained in refractory patients who had not responded to splenectomy or steroids.³⁰³

Preliminary reports of successful treatment in refractory patients have been published using high-dose methylprednisolone^{234, 304} and cyclophosphamide-based combination chemotherapy.³⁰⁵ Cyclophosphamide alone, either daily oral or pulse intravenous therapy, induced remissions in 16% to 55% of patients.^{14, 303, 306, 307, 308} However, this drug must be administered for several weeks before the platelet count rises and often must be continued for an indefinite period to maintain the remission, and side effects such as leukopenia and alopecia often are significant. Azathioprine, cyclosporin A, mycophenolate mofetil, actinomycin, and other immunosuppressive agents, either alone or in combination with corticosteroids, have variable success.^{309, 310, 311, 312, 313, 314, 315} Vincristine and vinblastine, administered intravenously at weekly intervals, may be as effective as cyclophosphamide but act more rapidly, often increasing the platelet count within 7 days.^{316, 317, 318, 319, 320} In addition to their suppressive effects on cellular and humoral immune responses, these agents increase platelet production in both animals and normal human subjects.^{321, 322} In ITP, their mechanism of action has been postulated to be inhibition of microtubule-dependent events required for monocyte-macrophage function.³²³

Other Proposed Therapies

A number of other therapies have been reported to be successful in single case reports or in small series of patients. Danazol, an attenuated androgen, has been effective in increasing platelet counts in patients with ITP in doses ranging from 50 mg/day³²⁴ to 800 mg/day.^{325, 326, 327} The mechanism of action is postulated to be a danazol-induced reduction of Fc receptors on phagocytic cells.³²⁸ Long-term results indicate a final response rate of >40% at a median follow-up of 10 years with a reasonable safety profile.³²⁹ Recombinant α -interferon can increase platelet counts in up to 50% of patients when injected subcutaneously three times a week, and some responses were durable after stopping treatment.^{330, 331}

Supportive Measures

Physical activity should be restricted to minimize the hazards of trauma, particularly head injury. Drugs, such as nonsteroidal anti-inflammatory drugs, that impair platelet function should be avoided. Blood loss should be treated as indicated, and platelet concentrates should be administered in the presence of significant bleeding.³³² However, transfusions typically produce only a slight and transient increase in the platelet count, no doubt because of the rapidity with which they are destroyed *in vivo*.³³³ Platelet transfusions, nevertheless, may produce some increase in platelet numbers in many patients,³³⁴ often diminish bleeding for a time, and can be effective in the management of serious complications such as subarachnoid hemorrhage. They should be reserved for such life-threatening emergencies or for the immediate preoperative treatment of patients with serious hemorrhage before splenectomy. A single large dose of IVIG followed by a platelet transfusion can be effective in arresting hemorrhage in some critically ill patients.²³⁵ In most patients with platelet counts >50,000/ μ l, preoperative platelet transfusions are not indicated. Platelet transfusions should be avoided in patients with chronic ITP because of subsequent development of alloantibodies. Exchange plasmapheresis may be valuable in critically ill patients and may be particularly effective in children.^{335, 336, 337} Anovulatory hormones are useful when menorrhagia is a major complaint. Because of the risk of septicemia, polyvalent pneumococcal vaccine, Haemophilus influenzae B vaccine, and quadrivalent meningococcal polysaccharide vaccine should be administered at least 2 weeks before elective splenectomy in both adults and children.³³⁸

Immune Thrombocytopenia in Pregnancy

Both ITP and non-ITP may occur during pregnancy.^{339, 340} Thrombocytopenia was present in 7% of women when they were admitted to hospital for a full-term delivery in a prospective 7-year study of 15,741 mothers and 15,932 newborns.^{341, 342, 343} Most platelet counts were between 100,000 and 150,000/ μ l, and 1% of women had platelet counts <100,000/ μ l. Thrombocytopenia was detected incidentally in the majority of women, and only 0.01% of their infants had fetal platelet

counts $<50,000/\mu\text{l}$. None of the infants had hemostatic impairment, and most mothers had normal or near-normal platelet counts by discharge. If the

P.1072

mothers had an obstetric or medical complication, the incidence of thrombocytopenia ($<50,000/\mu\text{l}$) in the infants was 0.35%. It is unclear when the incidental thrombocytopenia (called gestational thrombocytopenia) developed during pregnancy, and the etiology of this mild abnormality is likewise unknown. Antiplatelet antibody testing was not sufficiently specific to differentiate patients with gestational thrombocytopenia from those with ITP.³⁴⁴ Among those with maternal thrombocytopenia, 74% have incidental thrombocytopenia, and only 4% have ITP.³⁴⁵ It is therefore recommended that healthy women who have a platelet count of 70,000 to 150,000/ μl at delivery require no specific treatment, and the mode of delivery should be determined only by obstetric indications.

A recent retrospective 11-year analysis of obstetric patients with ITP examined 92 women with ITP during 119 pregnancies.³⁴⁶ For most women, the pregnancy was uneventful, although women had moderate to severe bleeding in 25 pregnancies (21.5%). Women in 37 pregnancies received treatment to increase platelet counts. During delivery, 44 women received epidural analgesia without complications, with most having a platelet count between 50,000 and 149,000/ μl . Most deliveries were vaginal (82.4%). Bleeding was uncommon at delivery. In most settings epidural analgesia is held if platelets are less than 80 to 90,000/ μl .

Platelet autoantibodies in pregnant patients with ITP cross the placenta and can produce thrombocytopenia and clinical bleeding in the infant. During pregnancy, both maternal and infant health must be considered, and management of women with ITP diagnosed before or during the pregnancy is therefore more difficult and still controversial.^{345, 347} Women with severe thrombocytopenia should be treated with IVIG or the lowest dose of steroids needed to maintain a platelet count $>50,000$ to 60,000/ μl ; it must be noted, however, that when mothers have been treated during pregnancy, changes in their platelet counts do not correlate with the fetal platelet counts when these have been sampled before and after treatment.³⁴⁸ When betamethasone or placebo was given for 4 weeks before delivery in a randomized trial, no differences were seen in either the maternal or infant platelet counts or the incidence of bleeding at delivery.³⁴⁹ Splenectomy during pregnancy may have higher complication rates, but it is not contraindicated. IVIG can be used before delivery to increase the platelet count rapidly. The safety of other forms of therapy used in nonpregnant ITP patients is uncertain.

At the time of delivery, it must be decided whether to deliver the infant by cesarean section or by vaginal delivery. When 474 infants were analyzed from series reported over a 20-year period, 10% of infants had platelet counts between 50,000 and 100,000/ μl , and 15% had platelet counts $<50,000/\mu\text{l}$.³⁵⁰ Intracranial hemorrhage occurred in 3%, but no significant association existed between intracranial hemorrhage and mode of delivery. More recent data indicate that morbidity and mortality in infants with neonatal thrombocytopenia is lower than originally reported. Burrows and Kelton published a systematic review of pregnancy in patients with ITP, selecting only those series with more than 10 patients and those that included fetal platelet counts and infant outcome.³⁵¹ They reported 288 live births and an incidence of fetal thrombocytopenia of 10% with platelet counts $<50,000/\mu\text{l}$ and 4% with platelet counts $<20,000/\mu\text{l}$. There were no deaths and no cases of intracranial hemorrhage, and there was no difference in morbidity between cesarean sections and vaginal births. During the decade from 1990 to 2000, these cumulative totals from 13 prospective studies were 9% and 4%.³⁴⁵ Minor bleeding complications occurred in 3% of infants, and 2% had major bleeding complications.

Many studies have been done to determine maternal characteristics that may correlate with severe thrombocytopenia in the newborn³⁴⁵ and to help with decisions regarding method of delivery. To date, only the birth of a previously affected infant correlates with the incidence of neonatal thrombocytopenia. Other variables that were analyzed, such as the mother's platelet count or prior splenectomy, were predictive in some studies but not in others. Fetal platelet counts might be able to predict newborn risks of bleeding, but scalp-vein platelet counts can be artifactually low, and the incidence of complications associated with percutaneous umbilical blood sampling is higher than the incidence of postnatal major bleeding. In all these reports, it was also noted that the infant platelet count could fall for several days after delivery. It is therefore currently recommended that the mode of delivery should be determined solely by obstetric indications.⁵

SECONDARY AUTOIMMUNE THROMBOCYTOPENIC PURPURA

Autoimmune thrombocytopenia can be associated with drugs and with several common diseases (i.e., collagen vascular disease, infections, lymphoproliferative disorders, and Graves disease). Secondary ITPs are discussed separately because of their unique features and the issues of diagnosis and management. ITP associated with human immunodeficiency virus infection is discussed in Chapter 64.

Autoimmune Thrombocytopenic Purpura Secondary to Drugs

Numerous drugs have been associated with ITP. In some cases, the evidence associating a given drug to ITP is circumstantial. However, a systematic review is available in which specific criteria were established to determine the likelihood of drug-induced ITP due to specific drugs (Table 47.6).^{162, 352, 353, 354} The most common drugs with level 1 evidence are quinidine, quinine, rifampin, trimethoprim-sulfamethoxazole, danazol, methyldopa (Aldomet), acetaminophen, and digoxin. The most common drugs with level 2 evidence are gold, procainamide, carbamazepine, hydrochlorothiazide, ranitidine, and chlorpropamide. Heparin, which causes ITP in as many as 1% of patients, is discussed in Chapter 55.

Pathophysiology

Drug-induced platelet antibodies are the result of an idiosyncratic reaction that develops in only a small percentage of persons exposed to a drug. This ranges from an estimated 38 cases per 1 million exposures for trimethoprim-sulfamethoxazole to as many as 1 in 100 patients for gold salts, and 3 in 100 patients for true immune-mediated heparin-induced thrombocytopenia.^{355, 356, 357} It is not clear whether there are predisposing risk factors for most of the drugs that cause ITP, although evidence suggests that the risk of developing antibodies to gold salts depends on host HLA type, with the majority of patients studied expressing HLA-DR3 antigen.³⁵⁷

Drug-induced antibodies may be complement- or noncomplement-activating antibodies that react with platelets, in either the absence (autoantibodies) or presence of drugs. The most completely studied antibodies are those that develop in response to quinidine/quinine and heparin.⁴⁰ Most nonheparin drug-induced antibodies bind specifically to platelet membrane glycoproteins in the IIb/IIIa or the Ib/V/IX complex through the Fab portion of the antibody molecule (Fig. 47.2B). In contrast, antibodies to heparin bind to a heparin-platelet factor 4 complex, and the immune complex then binds to the platelet membrane via the Fc portion of the antibody molecule (Fig. 47.2C).

Most of the drug-induced antibodies are developed in response to the parent drug, and drug-dependent antibodies can be demonstrated in a variety of in vitro tests. In some cases, however, these tests are negative when the parent compound is present but positive if known metabolites are used instead of the

P.1073

parent compound. Antibodies against drug metabolites have been reported with acetaminophen, para-aminosalicylic acid, naproxen, and trimethoprim-sulfamethoxazole.

TABLE 47.6 DRUGS ASSOCIATED WITH IMMUNE THROMBOCYTOPENIA AND CRITERIA FOR THEIR CLASSIFICATION

	Level 1^a	Level 2^b
Acetaminophen	Iopanoic acid	Acetazolamide
Alprenolol	Isoniazid	Ampicillin
Aminoglutethimide	Levamisole	Captopril
Aminosalicylic acid	Linezolid	Carbamazepine
	Lithium	
Amiodarone	Meclofenamate	Chlorpropamide
		Filgastrim (G-CSF)
Amphotericin B	Mesalamine	Fluconazole
Amrinone	Methicillin	Glibenclamide
Atorvastatin	Methyldopa (Aldomet)	Gold
	Methylprednisolone	
Cephalothin	Minoxidil	Hydrochlorothiazide
Chlorothiazide	Nalidixic acid	Ibuprofen
Chlorpromazine	Naphazoline	Oxyphenbutazone

Cimetidine	Nitroglycerine	Oxytetracycline
Danazol	Novobiocin	Phenytoin
	Orofiban	
Deferoxamine	Oxprenolol	Procainamide
Diatrizoate meglumine/diatrizoate sodium	Pentoxifylline	Ranitidine
	Piperacillin	Sulindac
Diazepam	Quinidine	Ticlopidine
Diazoxide	Quinine	Trastuzumab
Diclofenac	Rifampin	
Diethylstilbestrol	Sulfasalazine	
Difluormethylornithine	Sulfasoxazole	
Digoxin	Tamoxifen	
Ethambutol	Thiothixene	
Haloperidol	Tolmetin	
Indinavir	Trimethoprim-sulfamethoxazole	
Interferon- α	Vancomycin	

Criteria^{a, b}

1. The candidate drug preceded thrombocytopenia, and recovery from thrombocytopenia was complete and sustained after the drug was discontinued.
2. The candidate drug was the only drug used before the onset of thrombocytopenia, or other drugs were continued or reintroduced after discontinuation of the candidate drug with a sustained normal platelet count.
3. Other etiologies for thrombocytopenia were excluded.
4. Re-exposure to the candidate drug resulted in recurrent thrombocytopenia.

^a Level 1 evidence met criteria 1-4.

^b Level 2 evidence met criteria 1-3.

Modified from publications by George et al. (references 162, 352-354).

Clinical Features

Drug-induced thrombocytopenia is associated with a heterogeneous clinical picture and varying degrees of bleeding. Thrombocytopenia and bleeding usually appear abruptly and may be severe. Mucosal membrane bleeding from all sites and oral hemorrhagic bullae may occur, and patients often develop fever, chills, nausea, vomiting, and fatigue as part of a prodrome to the bleeding.

Severe thrombocytopenia usually develops within hours in sensitized patients ingesting quinidine or quinine; however, a minimum of 6 to 7 days is required to initiate a primary immune response in individuals taking the drug for the first time. Some patients do not develop thrombocytopenia for months or years, a characteristic that seems to be more dependent on the host than the type of drug. The amount of drug that is required to cause thrombocytopenia is quite variable; however, even the amount of quinine present in a gin and tonic (15 mg) is sufficient to produce severe thrombocytopenia and bleeding in a patient who has been previously sensitized to quinine ("cocktail purpura").³⁵⁸ After the drug is stopped,

platelet counts return to normal within days and usually are normal by 1 week. Thrombocytopenia induced by gold salts resolves more slowly, usually over weeks or months, because gold remains in the tissues.

Diagnosis

It is often difficult to make a definite diagnosis of drug-associated ITP because either the patient has taken the medication intermittently or a hospitalized patient is receiving more than one drug that may cause thrombocytopenia. Although it may be possible to demonstrate drug-dependent antibodies against the parent drug or its metabolites, this type of testing is beyond the scope of hospital laboratories. The readministration of the suspected drug in an attempt to confirm an etiologic relationship is not recommended as a routine diagnostic measure. Most of the level 1 drugs listed in Table 47.6 were demonstrated to cause immune-mediated thrombocytopenia because of patient response to an inadvertent *in vivo* challenge.

A detailed history, including all prescribed drugs, over-the-counter medications, and any herbal supplements, is of great benefit. Complete data from all English-language articles describing patients with assumed drug-induced thrombocytopenia have been catalogued on the Internet (<http://www.ouhsc.edu/platelets/ditp.html>).

Treatment

Ordinarily, no therapy is needed, because withdrawal of the offending drug is followed by recovery. IVIG and plasmapheresis may be helpful if life-threatening bleeding occurs. Many patients are treated with corticosteroids, and a normal platelet count is usually restored within 1 week. The major exception is gold-induced thrombocytopenia, which may persist for weeks or even months. British anti-Lewisite (dimercaprol) may accelerate the excretion of gold and speed recovery.³⁵⁹

Autoimmune Thrombocytopenia in Systemic Lupus Erythematosus

Thrombocytopenia may complicate collagen vascular diseases and other disorders associated with disordered immunologic responses such as thymoma³⁶⁰ and myasthenia gravis.^{361, 362, 363} In most instances, the ITP in SLE appears to result from immunologic platelet injury and is identical to primary ITP in most respects.

From 5% to 15% of patients with ITP fulfill the criteria for diagnosis of SLE at the time of presentation.^{364, 365} Other patients have a positive antinuclear antibody test when they are first diagnosed with ITP, and a small number of them may develop SLE within several years. Patients with high-titer antinuclear antibody in a speckled pattern and antibodies against native DNA and other nuclear antigens are the patients most likely to develop SLE.^{366, 367, 368, 369} SLE is a chronic and debilitating disease, so it is important to identify such patients so therapy can be directed at all aspects of the autoimmune disease.

ITP in SLE patients may be the result of either specific platelet autoantibodies or immune complex deposition on platelets. Only

P.1074

a few studies have been reported in which the newest platelet antigen-capture autoantibody tests have been used, and in these patients, platelet autoantibodies to platelet membrane glycoproteins have been detected.^{370, 371, 372, 373} Thrombocytopenia correlates with SLE disease activity³⁷⁴ but not the presence of antiphospholipid antibodies.^{375, 376, 377} These antibodies, which may be present in SLE or in otherwise healthy patients, also bind to platelet membrane gpIIb/IIIa or Ib/IX/V.^{372, 373} It is unclear, however, whether they are specific to these glycoproteins or cross-reactive.

Patients with ITP and SLE should be treated the same as patients with primary ITP, even though there are conflicting reports on the success rate of splenectomy in this population.^{378, 379}

Immune Thrombocytopenia in Other Disorders

ITP has been reported in association with a number of other medical conditions, including infections, neoplasms, and thyroid disease, and it is unknown whether this increased platelet destruction involves antibody binding, immune complex deposition, and/or antibody-mediated complement activation.

ITP has been documented in patients with infectious mononucleosis, cytomegalovirus, varicella or zoster,^{380, 381, 382, 383} hepatitis C,^{384, 385} tuberculosis,³⁸⁶ and human immunodeficiency virus infections (discussed in Chapter 64). During the last several years, ITP was also reported in patients with *H. pylori*, particularly in Europe and Japan. Platelet counts may or may not normalize with treatment directed only at *Helicobacter*.^{387, 388, 389, 390, 391, 392, 393, 394, 395} The ASH guidelines

recommend that *H. pylori* infection be considered in all adults with ITP for whom eradication therapy would be undertaken if testing were positive.⁵

ITP is a well-known complication of chronic lymphocytic leukemia,³⁹⁶ although it is not as frequent as autoimmune hemolytic anemia in these patients. It has also been reported in patients with other lymphoproliferative disorders including Hodgkin disease.^{397, 398, 399, 400} Thrombocytopenia in patients with a variety of solid tumors has also been thought to most likely be immune-mediated.^{401, 402}

Thrombocytopenia may accompany Graves disease and Hashimoto thyroiditis,^{403, 404, 405, 406} but it is not certain that it is immunologically mediated. Platelet-associated IgG has been increased when studied,⁴⁰⁶ but there may also be an element of enhanced reticuloendothelial phagocytosis.

ALLOIMMUNE THROMBOCYTOPENIA

Platelets express membrane-associated epitopes as a result of polymorphisms in discrete regions of the platelet membrane surface glycoproteins.⁴⁰⁷ No natural antibodies to human platelet antigens are known. Acquired platelet alloantibodies are of clinical importance in three circumstances: (a) Neonatal alloimmune thrombocytopenia (NAIT), which is the result of the placental transfer of alloantibodies formed by the mother to incompatible fetal platelet antigens;⁴⁰⁸ (b) posttransfusion purpura (PTP), a rare disorder in which the transfusion of platelet-containing blood products provokes the formation of alloantibodies that act as autoantibodies;⁴⁰⁹ and (c) passive transfer of platelet alloantibodies after transfusion from a multiparous or multiply transfused donor.^{410, 411, 412, 413}

Neonatal Alloimmune Thrombocytopenia

Pathophysiology

Immunologic thrombocytopenia in the newborn may result from the placental transfer of platelet antibodies formed as the result of active immunization of the mother by fetal platelet antigens. Pathophysiologically, such NAIT is similar to erythroblastosis fetalis. Thus, as a consequence of the inheritance by the fetus of platelet antigens lacking in the mother, alloantibodies are formed in the maternal circulation and cross the placenta, producing thrombocytopenia in the fetus. Antibodies can be detected as early as the 19th week, and thrombocytopenia has been found in utero by 20 weeks' gestation.⁴¹⁴ Immunization to human platelet alloantigen (HPA)-1a (PL^A, Zw^A)^{415, 416, 417} or HPA-5b (Br^A, Zav, Hc)^{418, 419} is most common; however, other antigens have been detected and found to be responsible for occasional cases of NAIT (Fig. 47.2D).^{415, 416, 417, 418, 419, 420, 421, 422, 423, 424, 425, 426} One of the largest studies to date examined maternal sera for platelet-reactive antibodies in mothers of infants suspected of NAIT. Maternal HPA-1a (Pl^{A1}) alloimmunization accounted for 79% of confirmed NAIT cases.⁴²⁷ The overwhelming majority of platelet polymorphisms found to date are caused by a single base-pair mutation leading to a single amino acid substitution in the polypeptide chain of the specific glycoprotein.⁴²⁸ Rarely, HLA antibodies are responsible.^{415, 418}

Alloimmunization to platelet antigens commonly develops during the first pregnancy and then recurs in >80% of patients during subsequent pregnancies. However, not all mothers who are missing the antigens presented by the fetus develop antibodies, and not all fetuses and neonates develop thrombocytopenia in spite of antibody development.⁴¹⁸ HPA-1 mismatch is present in 1 in 50 births, yet NAIT occurs in only 1 in 1,000 to 2,000 births.^{414, 416, 417, 429} Maternal HLA Class II determinants appear to be important. A high incidence of maternal allotypes HLA-DR3 and HLA-DRw52a has been demonstrated in mothers isoimmunized to fetal alloantigen HPA-1,^{417, 430} and a high incidence of HLA-DR6 has been reported in mothers sensitized to PLA-5b.⁴¹⁸

Clinical Features

Infants with NAIT are born with signs of purpura and severe thrombocytopenia. Thrombocytopenia usually is present at birth, but the platelet count may fall further during the postpartum period. Intracranial hemorrhage occurs in 20% to 30%, with one half of the episodes occurring in utero.⁴³¹ An overall mortality rate of 6% to 14% has been reported.^{416, 419, 420} Thrombocytopenia usually resolves after 10 to 14 days. Platelet antibody titers during the second half of the pregnancy appear to correlate with the risk of thrombocytopenia or bleeding, or both, in NAIT.^{432, 433}

Laboratory Diagnosis

When infants are born with platelet counts <20,000 μ l, NAIT must be suspected. Maternal plasma should be studied with paternal or neonatal platelets as targets; maternal (antigen-negative) platelets and paternal plasma are appropriate negative controls. NAIT is diagnosed when platelet antigen incompatibility is found between the parents, maternal antipaternal platelet antibodies are present, and the antibody detected corresponds to the incompatibility of platelet antigens that have been noted.

Treatment

Severely thrombocytopenic children should be treated aggressively with IVIG and platelet transfusions of compatible irradiated platelets. Maternal platelets are usually obtained by pheresis, concentrated, irradiated, and transfused. Interestingly, a recent retrospective study reported that transfusion of platelet concentrates from random donors is an appropriate strategy in the management of unexpected severe NAIT predominantly in first pregnancies, pending the availability of compatible platelets.⁴³⁴

Prevention of NAIT In women with no personal or family history of NAIT, screening by platelet typing is currently not recommended.⁴³⁵ Maternal platelet antigen typing has been recommended for those with a sister whose pregnancy was complicated by NAIT or if personal or family history is suggestive of NAIT

P.1075

(e.g., neonatal thrombocytopenia of undetermined origin or fetal or neonatal intracranial hemorrhage of undetermined origin). In these cases, maternal and paternal platelet typing is performed simultaneously in order to look for incompatibility in the PHA-1 antigen system. Screening studies to detect neonatal thrombocytopenia during the first pregnancy have been limited to patients with known PL^{A1} incompatibility and an HLA allotype associated with an increased incidence of antibody formation.⁴¹⁷ However, after the birth of one child with NAIT, subsequent pregnancies should be evaluated antenatally.

When maternal and paternal platelet typing document a risk of NAIT, after the index case, over 85% of that couples' subsequent fetuses will be at risk for NAIT. In the absence of any intervention, thrombocytopenia in the second affected fetus is always as or more severe than in the previous fetus/infant.⁴³⁶ Because of the high risk of in utero bleeding, the majority of which include intracranial hemorrhage, initiating therapy antenatally, rather than waiting until birth, has become standard. Previously, it was recommended that fetal platelet typing^{402, 422, 423, 424, 425} and platelet counts should be obtained at 20 weeks' gestation.^{401, 426} If platelet incompatibility is noted and the infant is thrombocytopenic, in utero platelet transfusions or maternal treatment with IVIG should be instituted and maintained during the pregnancy.^{401, 427, 428} In the United States, the most common therapies include infusion of IVIG and/or oral prednisone.⁴³⁷ Combination therapy with IVIG plus steroids may lead to higher platelet counts in women with a previous child with intracranial hemorrhage or a current fetus with platelet counts <20,000/ μ l.⁴³¹ Fetal platelet transfusions have been advocated. However, because of the risk of fetal mortality, this has become a therapy of last resort, to be used only if IVIG or prednisone are ineffective.⁴³⁸ There is no consensus on whether fetuses affected by NAIT or at risk for NAIT should be delivered by cesarean section.⁴³⁹

Because the use of serial fetal blood sampling procedures is clearly associated with an increased risk of fetal morbidity and mortality, some practitioners prefer to avoid performing fetal blood sampling and choose to treat empirically. The precise role of this invasive procedure remains to be determined.^{440, 441} Studies of the cost-effectiveness of empiric treatment versus treatment directed by fetal blood sampling favored empiric treatment, decreasing perinatal deaths although increasing the number of infants with long-term neurologic deficits.⁴⁴¹ Follow-up studies of children after antenatal treatment for alloimmune thrombocytopenia show that general health and neurodevelopmental outcome is comparable to that of the general population. However, significantly more infections and hearing problems were observed in children who were not exposed to maternal IVIG treatment in comparison to children who were exposed to IVIG treatment or the normal population.⁴⁴²

Posttransfusion Purpura

Alloantibodies that develop as a result of transfusion of incompatible platelets are responsible for the destruction of the transfused platelets. This is a frequently encountered problem in patients who have received multiple platelet transfusions. Rarely, however, severe thrombocytopenia in the recipient—that is, destruction of host platelets—is produced by the transfusion of incompatible platelets, and this potentially fatal reaction is known as PTP.^{443, 444, 445} PTP is characterized by abrupt onset of thrombocytopenia and bleeding that occurs 1 week after the transfusion of packed red blood cells. PTP has also been described after the transfusion of other blood components, including plasma.⁴⁴⁶

The syndrome occurs most commonly in multiparous women who have been sensitized by pregnancy; however, previously transfused patients may also develop PTP. The antibody most commonly develops against PL^{A1} (HPA-1a) in PL^{A2} (HPA-1b) homozygous recipients, but the Bak (HPA-3a/HPA-3b), Pen (HPA-4a/HPA-4b), Br (HPA-5a/HPA-5b), and Nak^a polymorphisms have been implicated as well.^{409, 444, 445, 447, 448, 449, 450} (Table 47.7). The diagnosis of PTP is a clinical one, and physicians must therefore consider this diagnosis in any patient who develops thrombocytopenia within 3 to 14 days after transfusion of any blood product.

TABLE 47.7 PLATELET ALLOANTIGENS IMPLICATED IN THE DEVELOPMENT OF POSTTRANSFUSION PURPURA**Serologic Designation Alternative Designation Phenotype Frequency Antigen Location**

Serologic Designation	Alternative Designation	Phenotype	Frequency	Antigen Location
PL ^{A1} (HPA-1a)	Zw ^a		0.96-0.99	gpIIIa
PL ^{A2} (HPA-1b)	Zw ^b		0.27	gpIIIa
Bak ^a (HPA-3a)	Lek ^a		0.78-0.89	gpIIb
Bak ^b (HPA-3b)	Lek ^b		0.50-0.70	gpIIb
Pen ^a (HPA-4a)	Yuk ^b		0.99	gpIIIa ^a
Pen ^b (HPA-4b)	Yuk ^a		0.01	gpIIIa ^a
Br ^b (HPA-5a)	Zav ^b		0.99	gpIa
Br ^a (HPA-5b)	Zav ^a		0.18-0.20	gpIa

gp, glycoprotein; HPA, human platelet alloantigen.

^a Antigen appears to be distinct from PL^{A1} (HPA-1a).

Modified from McCrae and Herman.⁴⁰⁹

The pathophysiology of this rare but severe thrombocytopenia is still uncertain, but several hypotheses have been proposed: (a) Autologous platelets are destroyed because of binding of immune complexes to their surface; (b) recipient platelets acquire the phenotype of the donor's platelets because they bind soluble antigens from the transfused blood product, and the platelets are then destroyed by alloantibodies; and (c) exposure to foreign platelets in transfused products induces the formation of autoantibodies to the recipient's platelets.^{409, 451, 452}

PTP is self-limited, resolving within 1 to 3 weeks in most patients. Treatment with steroids, plasmapheresis, or IVIG may shorten the period of thrombocytopenia. Plasmapheresis is effective in 80% of patients,^{446, 453, 454, 455} but IVIG, in doses of 2 g/kg over 2 days, may be preferable because plasmapheresis requires central venous access with large-bore catheters and places the patient in danger of significant bleeding.^{456, 457, 458} Platelet transfusions should be reserved for life-threatening hemorrhage, because patients often develop a febrile reaction and an increase in platelet count is infrequent.

REFERENCES

- Rodeghiero F, Stasi R, Gernsheimer T, et al. Standardization of terminology, definitions and outcome criteria in immune thrombocytopenic purpura of adults and children: report from an international working group. *Blood* 2009;113:2386-2393.
- George JN. Management of immune thrombocytopenia- something old, something new. *N Engl J Med* 2010;363:1959-1961.
- Totl LJ, Arnold DM. Pathophysiology and management of chronic immune thrombocytopenia: focusing on what matters. *Br J Haematol* 2010;152: 52-60.
- Bussel JB. Traditional and new approaches to the management of immune thrombocytopenia: issues of when and who to treat. *Hematol Oncol Clin North Am* 2009;23:1329-1341.
- Neunert C, Lim W, Crowther M, et al. The American Society of Hematology 2011 evidence-based practice guideline for immune thrombocytopenia. *Blood* 2011;117:4190-4207.
- Provan D, Stasi R, Newland A, et al. International consensus report on the investigation and management of primary immune thrombocytopenia. *Blood* 2010;115:168-186.
- George J, Harake M, Aster R. Thrombocytopenia due to enhanced platelet destruction by immunologic mechanisms. In: Beutler E, Lichtman MA, Coller BS, Kipps TJ, eds. *Williams Hematology*, 5th ed. New York: McGraw-Hill, 1995:1315-1355.
- Lusher JM, Zuelzer WW. Idiopathic thrombocytopenic purpura in childhood. *J Pediatr* 1966;68:971-979.
- Lusher JM, Iyer R. Idiopathic thrombocytopenic purpura in children. *Semin Thromb Hemost* 1977;3:175-199.
- Choi SI, McClure PD. Idiopathic thrombocytopenic purpura in childhood. *Can Med Assoc J* 1967;97:562-568.

11. Komrower GM, Watson GH. Prognosis in idiopathic thrombocytopenic purpura of childhood. *Arch Dis Child* 1954;29:502.
 12. Cortelazzo S, Finazzi G, Buelli M, et al. High risk of severe bleeding in aged patients with chronic idiopathic thrombocytopenic purpura. *Blood* 1991;77:31-33.
 13. Stasi R, Stipa E, Masi M, et al. Long-term observation of 208 adults with chronic idiopathic thrombocytopenic purpura. *Am J Med* 1995;98:436-442.
 14. Pizzuto J, Ambriz R. Therapeutic experience on 934 adults with idiopathic thrombocytopenic purpura: multicentric trial of the Cooperative Latin American Group on Hemostasis and Thrombosis. *Blood* 1984;64:1179-1183.
 15. Hirsch EO, Dameshek W. "Idiopathic" thrombocytopenia. *Arch Intern Med* 1951;88:701-728.
 16. Kiefel V, Santoso S, Mueller-Eckhardt C. Serological, biochemical, and molecular aspects of platelet autoantigens. *Semin Hematol* 1992;29:26-33.
 17. Horstman L, Jy W, Schultz DR, et al. Complement-mediated fragmentation and lysis of opsonized platelets: gender differences in sensitivity. *J Lab Clin Med* 1994;123:515-525.
 18. Nomura S, Yanabu M, Soga T, et al. Analysis of idiopathic thrombocytopenic purpura patients with antiglycoprotein IIb/IIIa or Ib autoantibodies. *Acta Haematol* 1991;86:25-30.
 19. McMillan R, Wang L, Tomer A, Nichol J, Pistillo J. Suppression of in vitro megakaryocyte production by antiplatelet autoantibodies from adult patients with chronic ITP. *Blood* 2004;103:1364-1369.
 20. Chang M, Nakagawa PA, Williams SA, et al. Immune thrombocytopenic purpura (ITP) plasma and purified ITP monoclonal autoantibodies inhibit megakaryocytopoiesis in vitro. *Blood* 2003;102:887-895.
 21. Houwerzijl EJ, Blom NR, van der Want JJ, et al. Ultrastructural study shows morphologic features of apoptosis and para-apoptosis in megakaryocytes from patients with idiopathic thrombocytopenic purpura. *Blood* 2004;103:500-506.
 22. Heyns AD, Lotter MG, Badenhorst PN, et al. Kinetics and sites of destruction of ¹¹¹Indium-oxine-labeled platelets in idiopathic thrombocytopenic purpura: a quantitative study. *Am J Hematol* 1982;12:167-177.
 23. Heyns Adu P, Badenhorst PN, Lotter MG, et al. Platelet turnover and kinetics in immune thrombocytopenic purpura: results with autologous ¹¹¹In-labeled platelets and homologous ⁵¹Cr-labeled platelets differ. *Blood* 1986;67:86-92.
- P.1076
24. Ballem PJ, Segal GM, Stratton JR, et al. Mechanisms of thrombocytopenia in chronic autoimmune thrombocytopenic purpura: evidence of both impaired platelet production and increased platelet clearance. *J Clin Invest* 1987;80:33-40.
 25. Hasegawa Y, Nagasawa T, Kamoshita M, et al. Effects of anti-platelet glycoprotein Ib and/or IIb/IIIa autoantibodies on the size of megakaryocytes in patients with immune thrombocytopenia. *Eur J Haematol* 1995;55:152-157.
 26. de Alarcon PA, Mazur EM, Schmeider JA. In vitro megakaryocytopoiesis in children with acute idiopathic thrombocytopenic purpura. *Am J Pediatr Hematol Oncol* 1987;9:212-218.
 27. Podolak-Dawidziak M. Megakaryocyte progenitors in immune thrombocytopenic purpura/ITP. *Thromb Res* 1991;62:93-96.
 28. Abgrall JF, Berthou C, Sensebe L, et al. Decreased in vitro megakaryocyte colony formation in chronic idiopathic thrombocytopenic purpura. *Br J Haematol* 1993;85:803-804.
 29. Emmons RV, Reid DM, Cohen RL, et al. Human thrombopoietin levels are high when thrombocytopenia is due to megakaryocyte deficiency and low when due to increased platelet destruction. *Blood* 1996;87:4068-4071.
 30. Ichikawa N, Ishida F, Shimodaira S, et al. Regulation of serum thrombopoietin levels by platelets and megakaryocytes in patients with aplastic anaemia and idiopathic thrombocytopenic purpura. *Thromb Haemost* 1996;76:156-160.
 31. Nichol JL. Thrombopoietin levels after chemotherapy and in naturally occurring human diseases. *Curr Opin Hematol* 1998;5:203-208.
 32. Scheduling S, Bergmann M, Shimosaka A, et al. Human plasma thrombopoietin levels are regulated by binding to platelet thrombopoietin receptors in vivo. *Transfusion* 2002;42:321-327.

33. Harrington WJ, Minnich V, Hollingsworth JW, Moore CV. Demonstration of a thrombocytopenic factor in the blood of patients with thrombocytopenic purpura. *J Lab Clin Med* 1951;38:1-10.
34. Shulman NR, Marder VJ, Weinrach RS. Similarities between known anti-platelet antibodies and factor responsible for thrombocytopenia in idiopathic thrombocytopenic purpura. *Ann N Y Acad Sci* 1965;124:499.
35. Van Leeuwen EF, van der Ven JT, Engelfriet CP, von dem Borne AE. Specificity of autoantibodies in autoimmune thrombocytopenia. *Blood* 1982;59:23-26.
36. Dixon R, Rosse W, Ebbert L. Quantitative determination of antibody in idiopathic thrombocytopenic purpura: correlation of serum and platelet bound antibody with clinical response. *N Engl J Med* 1975;292:230-236.
37. Kernoff LM. Influence of the amount of platelet-bound IgG on platelet survival and the site of sequestration in autoimmune thrombocytopenia. *Blood* 1980;55:730-733.
38. Berchtold P, Wenger M. Autoantibodies against platelet glycoproteins in auto-immune thrombocytopenic purpura: their clinical significance and response to treatment. *Blood* 1993;81:1246-1250.
39. Hou M, Stockelberg D, Kutti J, Wadenvik H. Antibodies against platelet GPIb/IX, GPIIb/IIIa, and other platelet antigens in chronic idiopathic thrombocytopenic purpura. *Eur J Hematol* 1995;55:307-314.
40. Kelton JG. The serologic investigation of patients with autoimmune thrombocytopenia. *Thromb Haemost* 1995;74:228-233.
41. Hou M, Stockelberg D, Kutti J, Wadenvik H. Fab-mediated binding of glycoprotein Ib/IX and IIb/IIIa specific antibodies in chronic idiopathic thrombocytopenic purpura. *Br J Haematol* 1995;91:944-950.
42. Woods VL, Oh E, Mason D, McMillan R. Autoantibodies against the platelet glycoprotein IIb/IIIa complex in patients with chronic ITP. *Blood* 1984;63:368-375.
43. Woods VL, Kurata Y, Montgomery RR, et al. Autoantibodies against platelet glycoprotein Ib in patients with chronic immune thrombocytopenic purpura. *Blood* 1984;64:156-160.
44. Beardsley DS, Spiegel JE, Jacobs MM, et al. Platelet membrane glycoprotein IIIa contains target antigens that bind antiplatelet antibodies in immune thrombocytopenias. *J Clin Invest* 1984;74:1701-1707.
45. Tsubakio T, Tani P, Woods VL, McMillan R. Autoantibodies against platelet GPIIb/IIIa in chronic ITP react with different epitopes. *Br J Haematol* 1987;67:345-348.
46. Tomiyama Y, Kurata Y, Mizutani H, et al. Platelet glycoprotein IIb as a target antigen in two patients with chronic idiopathic thrombocytopenic purpura. *Br J Haematol* 1987;66:535-538.
47. Tomiyama Y, Kurata Y, Shibata Y, et al. Immunochemical characterization of an autoantigen on platelet glycoprotein IIb in chronic ITP: comparison with the Bak^a alloantigen. *Br J Haematol* 1989;71:77-83.
48. Fujisawa K, O'Toole TE, Tani P, et al. Autoantibodies to the presumptive cytoplasmic domain of platelet glycoprotein IIIa in patients with chronic immune thrombocytopenic purpura. *Blood* 1991;77:2207-2213.
49. Fujisawa K, Tani P, O'Toole TE, et al. Different specificities of platelet-associated and plasma autoantibodies to platelet GPIIb-IIIa in patients with chronic immune thrombocytopenic purpura. *Blood* 1992;79:1441-1446.
50. Fujisawa K, Tani P, McMillan R. Platelet-associated antibody to glycoprotein IIb/IIIa from chronic immune thrombocytopenic purpura patients often binds to divalent cation-dependent antigens. *Blood* 1993;81:1284-1289.
51. Bowditch RD, Tani P, McMillan R. Reactivity of autoantibodies from chronic ITP patients with recombinant glycoprotein IIIa peptides. *Br J Haematol* 1995;91:178-184.
52. Hou M, Stockelberg D, Kutti J, Wadenvik H. Glycoprotein IIb/IIIa autoantigenic repertoire in chronic idiopathic thrombocytopenic purpura. *Br J Haematol* 1995;91:971-975.
53. Kuwana M, Kaburaki J, Kitasato H, et al. Immunodominant epitopes on glycoprotein IIb-IIIa recognized by autoreactive T cells in patients with immune thrombocytopenic purpura. *Blood* 2001;98:130-139.
54. Kosugi S, Tomiyama Y, Honda S, et al. Platelet-associated anti-GPIIb-IIIa autoantibodies in chronic immune thrombocytopenic purpura recognizing epitopes close to the ligand-binding site of glycoprotein (GP) IIb. *Blood* 2001;98:1819-1827.

55. McMillan R, Lopez-Dee J, Loftus JC. Autoantibodies to $\alpha\text{IIb}\beta_3$ in patients with chronic immune thrombocytopenic purpura bind primarily to epitopes on $\alpha\text{IIb}\beta_3$. *Blood* 2001;97:2171-2172.
56. Kiefel V, Santoso S, Kaufmann E, Mueller-Eckhardt C. Autoantibodies against platelet glycoprotein Ib/IX: a frequent finding in autoimmune thrombocytopenic purpura. *Br J Haematol* 1991;79:256-262.
57. He R, Reid DM, Jones CE, Shulman NR. Extracellular epitopes of platelet glycoprotein Ib α reactive with serum antibodies from patients with chronic idiopathic thrombocytopenic purpura. *Blood* 1995;86:3789-3796.
58. Bierling P, Bettaieb A, Fromont P, et al. Anti-GMP 140 (CD62) autoantibody in a patient with autoimmune thrombocytopenic purpura. *Br J Haematol* 1994;87:631-633.
59. Kosugi S, Tomiyama Y, Honda S, et al. Anti- $\alpha_v\beta_3$ antibodies in chronic immune thrombocytopenia. *Thromb Haemost* 2001;85:36-41.
60. van Vliet HH, Kappers-Klune MC, van der Hel JW, Abels J. Antibodies against glycosphingolipids in sera of patients with idiopathic thrombocytopenic purpura. *Br J Haematol* 1987;67:103-108.
61. Koerner TAW, Weinfeld HM, Bullard LSB, Williams LCJ. Antibodies against platelet glycosphingolipids: detection in serum by quantitative HPTLC autoradiography and association with autoimmune and alloimmune processes. *Blood* 1989;74:274-284.
62. Harris EN, Asherson RA, Gharavi AE, et al. Thrombocytopenia in SLE and related autoimmune disorders: association with anticardiolipin antibody. *Br J Haematol* 1985;59:227-230.
63. Nomura S, Yanabu M, Fukuroi T, et al. Anti-phospholipid antibodies bind to platelet microparticles in idiopathic (autoimmune) thrombocytopenic purpura. *Ann Haematol* 1992;65:46-49.
64. Nomura S, Yanabu M, Miyake T, et al. Relationship of microparticles with β_2 -glycoprotein I and P-selectin positivity to anticardiolipin antibodies in immune thrombocytopenic purpura. *Ann Haematol* 1995;70:25-30.
65. Arfors L, Winiarski J, Lefvert AK. Prevalence of antibodies to cardiolipin in chronic ITP and reactivity with platelet membranes. *Eur J Haematol* 1996;56:230-234.
66. Stasi R, Stipa E, Masi M, et al. Prevalence and clinical significance of elevated antiphospholipid antibodies in patients with idiopathic thrombocytopenic purpura. *Blood* 1994;84:4203-4208.
67. Diz-Kucukkaya R, Hacıhanefioglu A, Yeneral M, et al. Antiphospholipid antibodies and antiphospholipid syndrome in patients presenting with immune thrombocytopenic purpura: a prospective cohort study. *Blood* 2001;98: 1760-1764.
68. He BR, Reid DM, Jones CE, Shulman NR. Spectrum of Ig classes, specificities, and titers of serum antiglycoproteins in chronic idiopathic thrombocytopenic purpura. *Blood* 1994;83:1024-1032.
69. Cines DB, Blanchette VS. Immune thrombocytopenic purpura. *N Engl J Med* 2002;346:995-1008.
70. Nardi MA, Liu LX, Karpatkin S. GPIIIa-(49-66) is a major pathophysiologically relevant antigenic determinant for anti-platelet GPIIIa of HIV-1 related immunologic thrombocytopenia. *Proc Natl Acad Sci U S A* 1997;94:7589-7594.
71. Sugiyama T, Okuma M, Ushikubi F, et al. A novel platelet-aggregating factor found in a patient with defective collagen-induced platelet aggregation and autoimmune thrombocytopenia. *Blood* 1987;69:1712-1720.
72. Yanabu M, Nomura S, Fukuroi T, et al. Synergistic action in platelet activation induced by an antiplatelet autoantibody in ITP. *Br J Haematol* 1991;78:87-93.
73. Yanabu M, Nomura S, Fukuroi T, et al. Platelet activation induced by an antiplatelet autoantibody against CD9 antigen and its inhibition by another autoantibody in immune thrombocytopenic purpura. *Br J Haematol* 1993;84:694-701.
74. Hashimoto Y, Tanabe J, Mohri H, Ohkubo T. Autoimmune antibody in a patient with idiopathic thrombocytopenic purpura reacted to the platelet low molecular weight glycoproteins and activated platelets. *Am J Clin Pathol* 1994;101:370-374.
75. Deckmyn H, DeReys S. Functional effects of human antiplatelet antibodies. *Semin Thromb Haemost* 1995;21:46-59.
76. Balduini CL, Bertolino G, Noris P, et al. Defect of platelet aggregation and adhesion induced by autoantibodies against platelet glycoprotein IIIa. *Thromb Haemost* 1992;68:208-213.
77. Taub JW, Warrier I, Holtkamp C, et al. Characterization of autoantibodies against the platelet glycoprotein antigens IIb/IIIa in childhood idiopathic thrombocytopenia purpura. *Am J Hematol* 1995;48:104-107.

78. Ware RE, Howard TA. Phenotypic and clonal analysis of T lymphocytes in childhood immune thrombocytopenic purpura. *Blood* 1993;82:2137-2142.
79. Semple JW, Milev Y, Cosgrove D, et al. Differences in serum cytokine levels in acute and chronic autoimmune thrombocytopenic purpura: relationship to platelet phenotype and antiplatelet T-cell reactivity. *Blood* 1996;87:4245-4254.
80. Olsson B, Andersson PO, Jernas M, et al. T-cell-mediated cytotoxicity toward platelets in chronic idiopathic thrombocytopenic purpura. *Nat Med* 2003;9:1123-1124.
81. Aster RH, Keene WR. Sites of platelet destruction in idiopathic thrombocytopenic purpura. *Br J Haematol* 1969;15:61-73.
82. Harker LA. Thrombokinetics in idiopathic thrombocytopenic purpura. *Br J Haematol* 1970;19:95-104.
83. Branehog I, Kutti J, Ridell B, et al. The relation of thrombokinetics to bone marrow megakaryocytes in idiopathic thrombocytopenic purpura (ITP). *Blood* 1975;45:551-562.
84. Ries CA, Price DC. [⁵¹Cr] platelet kinetics in thrombocytopenia: correlation between splenic sequestration of platelets and response to splenectomy. *Ann Intern Med* 1974;80:702-707.
85. Stoll D, Cines DB, Aster RH, Murphy S. Platelet kinetics in patients with idiopathic thrombocytopenic purpura and moderate thrombocytopenia. *Blood* 1985;65:584-588.
86. Stratton JR, Ballem PJ, Gernsheimer T, et al. Platelet destruction in autoimmune thrombocytopenic purpura: kinetics and clearance of indium-111-labeled autologous platelets. *J Nucl Med* 1989;30:629-637.
87. Tomer A, Hanson SR, Harker LA. Autologous platelet kinetics in patients with severe thrombocytopenia: discrimination between disorders of production and destruction. *J Lab Clin Med* 1991;118:546-554.
88. Siegel RS, Rae JL, Barth S, et al. Platelet survival and turnover: important factors in predicting response to splenectomy in immune thrombocytopenic purpura. *Am J Hematol* 1989;30:206-212.
89. Schmidt KG, Rasmussen JW. Kinetics and distribution in vivo of ¹¹¹In-labelled autologous platelets in idiopathic thrombocytopenic purpura. *Scand J Haematol* 1985;34:47-56.
90. Shulman NR, Weinrach RS, Libre EP, et al. The role of the reticuloendothelial system in the pathogenesis of idiopathic thrombocytopenic purpura. *Trans Assoc Am Physicians* 1965;78:374-390.
91. McMillan R, Longmire RL, Tavassoli M, et al. In vitro platelet phagocytosis by splenic leukocytes in idiopathic thrombocytopenic purpura. *N Engl J Med* 1974;290:249-251.
92. Ziegler ZR, Rosenfeld CS, Nemunaitis JJ, et al. Increased macrophage colony-stimulating factor levels in immune thrombocytopenic purpura. *Blood* 1993;81:1251-1254.
93. Saleh MN, Moore DL, Lee JY, LoBuglio AF. Monocyte-platelet interaction in immune and nonimmune thrombocytopenia. *Blood* 1989;74:1328-1331.
94. McMillan R, Longmire RL, Yelenosky R, et al. Immunoglobulin synthesis in vitro by splenic tissue in idiopathic thrombocytopenic purpura. *N Engl J Med* 1972;286:681-684.
95. Karparkin S, Strick N, Siskind GW. Detection of splenic anti-platelet antibody synthesis in idiopathic autoimmune thrombocytopenic purpura (ATP). *Br J Haematol* 1972;23:167-176.
96. Chang CS, Li CY, Cha SS. Chronic idiopathic thrombocytopenic purpura: splenic pathologic features and their clinical correlation. *Arch Pathol Lab Med* 1993;117:981-985.
97. Doan CA, Bouroncle BA, Wiseman BK. Idiopathic and secondary thrombocytopenic purpura: clinical study and evaluation of 381 cases over a period of 28 years. *Ann Intern Med* 1960;53:861-876.
98. Ben-Yehuda D, Gillis S, Eldor A, Israeli ITP Study Group. Clinical and therapeutic experience in 712 Israeli patients with idiopathic thrombocytopenic purpura. *Acta Haematol* 1994;91:1-6.
99. Buchanan GR. Overview of ITP treatment modalities in children. *Blut* 1989;59:96-104.
100. Meindersma TE, de Vries SI. Thrombocytopenic purpura after smallpox vaccination. *Br Med J* 1962;1:226-228.
101. Nugent DJ. Childhood immune thrombocytopenic purpura. *Blood Rev* 2002;16:27-29.
102. Kuhne T, Imbach P, Bolton-Maggs PH, et al. Newly diagnosed idiopathic thrombocytopenic purpura in childhood: an observational study. *Lancet* 2001;358:2122-2125.

103. Kurtzberg J, Stockman JA. Idiopathic thrombocytopenic purpura. *Adv Pediatr* 1994;41:111-134.
104. Meyers MC. Results of treatment in 71 patients with idiopathic thrombocytopenic purpura. *Am J Med Sci* 1961;242:295-302.
105. Reid MM. Chronic idiopathic thrombocytopenic purpura: incidence, treatment, and outcome. *Arch Dis Child* 1995;72:125-128.
106. Aronis S, Platokouki H, Mitsika A, et al. Seventeen years of experience with chronic idiopathic thrombocytopenic purpura in childhood. Is therapy always better? *Pediatr Hematol Oncol* 1994;11:487-498.
107. McWilliams NB, Mauer HM. Acute idiopathic thrombocytopenic purpura in children. *Am J Hematol* 1979;7:87-96.
108. Jacobs P, Wood L, Dent DM. Results of treatment in immune thrombocytopenia. *Q J Med* 1986;58:153-165.
109. den Ottolander JJ, Gratama JW, de Koning J, Brand A. Long-term follow-up study of 168 patients with immune thrombocytopenia: implications for therapy. *Scand J Haematol* 1984;32:101-110.
110. Ikkala E, Kivilaakso E, Kotilainen M, Hastbacka J. Treatment of idiopathic thrombocytopenic purpura in adults: long-term results in a series of 41 patients. *Ann Clin Res* 1978;10:83-86.
111. Kelton JG. Vaccination-associated relapse of immune thrombocytopenia. *JAMA* 1981;245:369-371.
112. Crosby WH. Wet purpura, dry purpura. *JAMA* 1975;232:744-745.
113. Lacey JV, Penner JA. Management of idiopathic thrombocytopenic purpura in the adult. *Semin Thromb Haemost* 1977;3:160-174.
114. Schattner E, Bussel J. Mortality in immune thrombocytopenic purpura: report of seven cases and consideration of prognostic indicators. *Am J Hematol* 1994;46:120-126.
115. Guthrie TH, Brannan DP, Prisant LM. Idiopathic thrombocytopenic purpura in the older adult patient. *Am J Med Sci* 1988;296:17-21.
116. Linares M, Cervero A, Colomina P, et al. Chronic idiopathic thrombocytopenic purpura in the elderly. *Acta Haematol* 1995;93:80-82.
117. Kuhne T, Berchtold W, Michaels LA, Wu R et al. Newly diagnosed immune thrombocytopenia in children and adults: a comparative prospective observational registry of the Intercontinental Cooperative Immune Thrombocytopenia Study Group. *Haematologica* 2011;96:1831-1837.
118. Wong GC, Lee LH. A study of idiopathic thrombocytopenic purpura (ITP) patients over a ten-year period. *Ann Acad Med Singapore* 1998;27:789-793.
119. Jy W, Horstman LL, Arce M, Ahn YS. Clinical significance of platelet microparticles in autoimmune thrombocytopenias. *J Lab Clin Med* 1992;119:334-345.
120. Khan I, Zucker-Franklin D, Karpatkin S. Microthrombocytosis and platelet fragmentation associated with idiopathic/autoimmune thrombocytopenic purpura. *Br J Haematol* 1975;31:449-460.
121. Zucker-Franklin D, Karpatkin S. Red-cell and platelet fragmentation in idiopathic thrombocytopenic purpura. *N Engl J Med* 1977;297:517-523.
122. Zucker-Franklin D. Clinical significance of platelet microparticles. *J Lab Clin Med* 1992;119:321-322.
123. Ikkala E, Suhonen O. Circulating megakaryocytes in immune thrombocytopenias. *Ann Clin Res* 1972;4:1-6.
124. Nelson RB, Kehl D. Electronically determined platelet indices in thrombocytopenic patients. *Cancer* 1981;48:954-956.
125. Garg SK, Lackner H, Karpatkin S. The increased percentage of megathrombocytes in various clinical disorders. *Ann Intern Med* 1972;77:361-369.
126. Karpatkin S, Freedman ML. Hypersplenic thrombocytopenia differentiated from increased platelet destruction by platelet volume. *Ann Intern Med* 1978;89:200-203.
127. Bessman JD, Gardner FH. Platelet size in thrombocytopenia due to sepsis. *Surg Gynecol Obstet* 1983;156:177-180.
128. Evans RS, Takahashi K, Duane RT, et al. Primary thrombocytopenic purpura and acquired hemolytic anemia. *Arch Intern Med* 1951;87:48-65.

129. Pegels JG, Helmerhorst FM, van Leeuwen EF, et al. The Evans syndrome: characterization of the responsible autoantibodies. *Br J Haematol* 1982;51:445-450.
130. Rosenberg A, Van Slyck EJ. A syndrome resembling infectious mononucleosis after splenectomy for idiopathic thrombocytopenic purpura. *Ann Intern Med* 1965;63:965-971.
131. Tager M, Klinghoffer KA. Acute thrombocytopenic purpura hemorrhagica with lymphocytosis; report of a case. *Ann Intern Med* 1943;18:96.
132. Nagasawa T, Kono I, Sakurai T, Kashiwagi H. Fibrinogen/fibrin degradation products in serum of patients with idiopathic thrombocytopenic purpura: elevated levels during severe thrombocytopenic phase of the disease. *Thromb Haemost* 1976;35:628-634.
133. DiFino SM, Lachant NA, Kirshner JJ, Gottlieb AJ. Adult idiopathic thrombocytopenic purpura: clinical findings and response to therapy. *Am J Med* 1980;69:430-442.
134. Harker LA. Megakaryocyte quantitation. *J Clin Invest* 1968;47:452-457.
135. Harker LA, Finch CA. Thrombokinetics in man. *J Clin Invest* 1969;48:963-974.
136. Louwes H, Lathori OAZ, Vellenga E, et al. Platelet kinetic studies in patients with idiopathic thrombocytopenic purpura. *Am J Med* 1999;106:430-434.
137. Pisciotta AV, Stefanini M, Dameshek W. Studies on platelets. X. Morphologic characteristics of megakaryocytes by phase contrast microscopy in normals and in patients with idiopathic thrombocytopenic purpura. *Blood* 1953;8:703-723.
138. Queisser U, Queisser W, Spiertz B. Polyploidization of megakaryocytes in normal humans, in patients with idiopathic thrombocytopenia and with pernicious anemia. *Br J Haematol* 1971;20:489-501.
139. Luiken GA, McMillan R, Lightsey AL, et al. Platelet-associated IgG in immune thrombocytopenic purpura. *Blood* 1977;50:317-325.
140. LoBuglio AF, Court WS, Vinocur L, et al. Use of a 125I-labeled antihuman IgG monoclonal antibody to quantify platelet-bound IgG. *N Engl J Med* 1983;309:459-463.
141. Sugiura K, Steiner M, Baldini MG. Platelet antibody in idiopathic thrombocytopenic purpura. *J Lab Clin Med* 1980;96:640-653.
142. Karpatkin M, Siskind GW, Karpatkin S. The platelet factor 3 immunoinjury technique re-evaluated. Development of a rapid test for antiplatelet antibody. Detection in various clinical disorders, including immunologic drug-induced and neonatal thrombocytopenias. *J Lab Clin Med* 1977;89:400-408.
143. Cines DB, Schreiber AD. Immune thrombocytopenia. Use of a Coombs antiglobulin test to detect IgG and C3 on platelets. *N Engl J Med* 1979;300:106-111.
144. Hirschman RJ, Shulman NR. The use of platelet serotonin release as a sensitive method for detecting anti-platelet antibodies and plasma anti-platelet factor in patients with idiopathic thrombocytopenic purpura. *Br J Haematol* 1973;24:793-802.
145. Mueller-Eckhardt C, Kayser W, Mersch-Baumert K, et al. The clinical significance of platelet-associated IgG: a study on 298 patients with various disorders. *Br J Haematol* 1980;46:123-131.
146. Hegde UM, Ball S, Zuiable A, Roter BLT. Platelet associated immunoglobulins (PAIgG and PAIgM) in autoimmune thrombocytopenia. *Br J Haematol* 1985;59:221-226.
147. Chong BH, Ho SJ. Autoimmune thrombocytopenia. *J Thromb Haemost* 2005;3:1763-1772.
148. George JN. Platelet immunoglobulin G: its significance for the evaluation of thrombocytopenia and for understanding the origin of α -granule proteins. *Blood* 1990;76:859-870.
149. McMillan R. Clinical role of antiplatelet antibody assays. *Semin Thromb Haemost* 1995;21:37-45.
150. McMillan R, Wang L, Tani P, et al. Prospective evaluation of the immunobead assay for the diagnosis of adult chronic immune thrombocytopenic purpura (ITP). *J Thromb Haemost* 2003;1:485-491.
151. Brighton TA, Evans S, Castaldi PA, et al. Prospective evaluation of the clinical usefulness of an antigen-specific assay (MAIPA) in idiopathic thrombocytopenic purpura and other immune thrombocytopenias. *Blood* 1996;88:194-201.

152. McMillan R, Tani P, Millard F, et al. Platelet-associated and plasma antiglycoprotein antibodies in chronic ITP. *Blood* 1987;70:1040-1045.
153. Tomer A. Flow cytometry for the diagnosis of autoimmune thrombocytopenia. *Curr Hematol Rep* 2006;5:64-69.
154. Nilsson T, Norberg B. Thrombocytopenia and pseudothrombocytopenia: a clinical and laboratory problem. *Scand J Haematol* 1986;37:341-346.
155. Casonato A, Bertomoro A, Pontara E, et al. EDTA dependent pseudothrombocytopenia caused by antibodies against the cytoadhesive receptor of platelet gpIIb-IIIa. *J Clin Pathol* 1994;47:625-630.
156. Bizzaro N. EDTA-dependent pseudothrombocytopenia: a clinical and epidemiological study of 112 cases, with 10-year follow-up. *Am J Hematol* 1995;50:103-109.
157. Bizzaro N. Platelet satellitosis to polymorphonuclears: cytochemical, immunological, and ultrastructural characterization of eight cases. *Am J Hematol* 1991;36:235-242.
158. Bizzaro N, Goldschmeding R, von dem Borne AE. Platelet satellitism is Fc gamma RIII (CD16) receptor-mediated. *Am J Clin Pathol* 1995;103:740-744.
159. Menke DM, Colon-Otero G, Cockerill KJ, et al. Refractory thrombocytopenia: a myelodysplastic syndrome that may mimic immune thrombocytopenic purpura. *Am J Clin Pathol* 1992;98:502-510.
160. Najean Y, Lecompte T. Chronic pure thrombocytopenia in elderly patients. *Cancer* 1989;64:2506-2510.
161. George JN. How I treat patients with thrombotic thrombocytopenic purpura: 2010. *Blood* 2010;116:4060-4069.
162. George JN, Raskob GE, Shah SR, et al. Drug-induced thrombocytopenia: a systematic review of published case reports. *Ann Intern Med* 1998;129:886-890.
163. Laster J, Silver D. Heparin-coated catheters and heparin-induced thrombocytopenia. *J Vasc Surg* 1988;7:667-672.
164. George JN, Woolf SH, Raskob GE, et al. Idiopathic thrombocytopenic purpura: a practice guideline developed by explicit methods for the American Society of Hematology. *Blood* 1996;88:3-40.
165. The American Society of Hematology ITP Practice Guideline Panel. Diagnosis and treatment of idiopathic thrombocytopenic purpura: recommendations of the American Society of Hematology. *Ann Intern Med* 1997;126:319-326.
166. Rosthoj S, Hedlund-Treutiger I, Rajantie J, et al. Duration and morbidity of newly diagnosed idiopathic thrombocytopenic purpura in children: a prospective Nordic study of an unselected cohort. *J Pediatr* 2003;143:302-307.
167. Kuhne T, Buchanan GR, Zimmerman S, et al. A prospective comparative study of 2540 infants and children with newly diagnosed idiopathic thrombocytopenic purpura (ITP) from the intercontinental childhood IP study group. *J Pediatr* 2003;143:605-608.
168. Blanchette VS, Luke B, Andrew M, et al. A prospective, randomized trial of high-dose intravenous immune globulin G therapy, oral prednisone therapy, and no therapy in childhood acute immune thrombocytopenic purpura. *J Pediatr* 1993;123:989-995.
169. Blanchette V, Imbach P, Andrew M, et al. Randomized trial of intravenous immunoglobulin G, intravenous anti-D, and oral prednisone in childhood acute immune thrombocytopenic purpura. *Lancet* 1994;344:703-707.
170. Fujisawa K, Iyori H, Ohkawa H, et al. A prospective randomized trial of conventional, dose-accelerated corticosteroids and intravenous immunoglobulin in children with newly diagnosed idiopathic thrombocytopenic purpura. *Int J Haematol* 2000;72:376-383.
171. Bennett CM, Rogers ZR, Kinnamon DD et al. Prospective phase 1/2 study of rituximab in childhood and adolescent chronic immune thrombocytopenic purpura. *Blood* 2006;107:2639-2642.
172. Hedlund-Treutiger I, Henter J-I, Elinder G. Randomized study of IVIg and high-dose dexamethasone therapy for children with chronic idiopathic thrombocytopenic purpura. *J Pediatr Hematol Oncol* 2003;25:139-144.
173. Portielje JEA, Westendorp RGJ, Kluin-Nelemans HC, et al. Morbidity and mortality in adults with idiopathic thrombocytopenic purpura. *Blood* 2001;97:2549-2554.
174. Jiji RM, Firozvi T, Spurling CL. Chronic idiopathic thrombocytopenic purpura: treatment with steroids and splenectomy. *Arch Intern Med* 1973;132:380-383.

175. Cohen YC, Djulbegovic B, Shamai-Lubovitz O, et al. The bleeding risk and natural history of idiopathic thrombocytopenic purpura in patients with persistent low platelet counts. *Arch Intern Med* 2000;160:1630-1638.
176. Baumann MA, Menitove JE, Aster RH, Anderson T. Urgent treatment of idiopathic thrombocytopenic purpura with single-dose gammaglobulin infusion followed by platelet transfusion. *Ann Intern Med* 1986;104:808-809.
177. Flick JT, Grush O, Morgan S, et al. Case report: the role of apheresis in the support of life-threatening ITP relapse. *Am J Med Sci* 1987;294:444-447.
178. Dameshek W, Rubio F, Mahoney JP, et al. Treatment of idiopathic thrombocytopenic purpura (ITP) with prednisone. *JAMA* 1958;166:1805-1815.
179. Thompson RL, Moore RA, Hess CE, et al. Idiopathic thrombocytopenic purpura: long-term results of treatment and the prognostic significance of response to corticosteroids. *Arch Intern Med* 1972;130:730-734.
180. Bunting WL, Kiely JM, Campbell DC. Idiopathic thrombocytopenic purpura: treatment in adults. *Arch Intern Med* 1961;108:733-738.
181. Carpenter AF, Wintrobe MW, Fuller EA, et al. Treatment of idiopathic thrombocytopenic purpura. *JAMA* 1959;171:1911-1916.
182. Shashaty GG, Rath CE. Idiopathic thrombocytopenic purpura in the elderly. *Am J Med Sci* 1978;276:263-267.
183. Berchtold P, McMillan R. Therapy of chronic idiopathic thrombocytopenic purpura in adults. *Blood* 1989;74:2309-2317.
184. George JN, El-Harake MA, Raskob GE. Chronic idiopathic thrombocytopenic purpura. *N Engl J Med* 1994;331:1207-1211.
185. Bellucci S, Charpak Y, Chastang C, Tobelem G, and the Cooperative Group on Immune Thrombocytopenic Purpura. Low doses v conventional doses of corticoids in immune thrombocytopenic purpura (ITP): results of a randomized clinical trial in 160 children, 223 adults. *Blood* 1988;71:1165-1169.
186. Mazzucconi GB, Francesconi M, Fidani P, et al. Treatment of idiopathic thrombocytopenic purpura (ITP): results of a multicentric protocol. *Haematologica* 1985;70:329-336.
187. Jacobs P, Wood L, Novitzky N. Intravenous gammaglobulin has no advantages over oral corticosteroids as primary therapy for adults with immune thrombocytopenia: a prospective randomized clinical trial. *Am J Med* 1994;97:55-59.
188. Godeau B, Chevret S, Varet B, et al. Intravenous immunoglobulin or high-dose methylprednisolone, with or without oral prednisone, for adults with untreated severe autoimmune thrombocytopenic purpura: a randomized, multicentre trial. *Lancet* 2002;359:23-29.
189. Cheng Y, Wong RS, Soo YO, et al. Initial treatment of immune thrombocytopenic purpura with high dose dexamethasone. *N Engl J Med* 2003;349:831-836.
190. Andersen JC. Response of resistant idiopathic thrombocytopenic purpura to pulsed high-dose dexamethasone therapy. *N Engl J Med* 1994;330:1560-1564.
191. Mazzucconi MG, Fazi P, Bernasconi S, et al. Therapy with high-dose dexamethasone (HD-DXM) in previously untreated patients affected by idiopathic thrombocytopenic purpura: a GIMEMA experience. *Blood* 2007;109:1401-1407.
192. George JN. Sequence of treatments for adults with primary immune thrombocytopenia. *Am J Hematol* 2012;87:S12-S15.
193. Handin RI, Stossel TP. Phagocytosis of antibody-coated platelets by human granulocytes. *N Engl J Med* 1974;290:989-993.
194. Handin RI, Stossel TP. Effect of corticosteroid therapy on the phagocytosis of antibody-coated platelets by human leukocytes. *Blood* 1978;51:771-779.
195. Verp M, Karpatkin S. Effect of plasma, steroids, or steroid products on the adhesion of human opsonized thrombocytes to human leukocytes. *J Lab Clin Med* 1975;85:478-486.
196. Fujisawa K, Tani P, Piro L, McMillan R. The effect of therapy on platelet-associated autoantibody in chronic immune thrombocytopenic purpura. *Blood* 1993;81:2872-2877.

197. McMillan R, Longmire R, Yelenosky R. The effect of corticosteroids on human IgG synthesis. *J Immunol* 1976;116:1592-1595.
198. Gernsheimer T, Stratton J, Ballem PJ, Slichter SJ. Mechanisms of response to treatment in autoimmune thrombocytopenic purpura. *N Engl J Med* 1989;230:974-980.
199. Atkinson JP, Frank MM. Complement-independent clearance of IgG-sensitized erythrocytes: inhibition by cortisone. *Blood* 1974;44:629-637.
200. Branehog I, Weinfeld A. Platelet survival and platelet production in idiopathic thrombocytopenic purpura (ITP) before and during treatment with corticosteroids. *Scand J Haematol* 1974;12:69-79.
201. Greendyke RM, Bradley EM, Swisher SN. Studies of the effects of administration of ACTH and adrenal corticosteroids on erythrophagocytosis. *J Clin Invest* 1965;44:746-753.
202. Fries LF, Brickman CM, Frank MM. Monocyte receptors for the Fc portion of IgG increase in number in autoimmune hemolytic anemia and other hemolytic states and are decreased by glucocorticoid therapy. *J Immunol* 1983;131:1240-1245.
203. Kitchens CS, Weiss L. Ultrastructural changes of endothelium associated with thrombocytopenia. *Blood* 1975;46:567-578.
204. Kitchens CS, Pendergast JF. Human thrombocytopenia is associated with structural abnormalities of the endothelium that are ameliorated by glucocortico-steroid administration. *Blood* 1986;67:203-206.
205. Kitchens CS. Amelioration of endothelial abnormalities by prednisone in experimental thrombocytopenia in the rabbit. *J Clin Invest* 1977;60:1129-1134.
206. Maca RD, Fry GL, Hoak JC. The effects of glucocorticoids on cultured human endothelial cells. *Br J Haematol* 1978;38:501-509.
207. Imbach P, Barandun S, d'Apuzzo V, et al. High-dose intravenous gamma-globulin for idiopathic purpura in childhood. *Lancet* 1981;1:1228-1231.
208. Warrier I, Lusher JM. Intravenous gamma globulin treatment for chronic idiopathic thrombocytopenic purpura in children. *Am J Med* 1984;76:193-198.
209. Warrier IA, Lusher JM. Intravenous gammaglobulin (Gamimune) for treatment of chronic idiopathic thrombocytopenic purpura (ITP): a two-year follow-up. *Am J Hematol* 1986;23:323-328.
210. Korninger C, Panzer S, Graninger W, et al. Treatment of severe chronic idiopathic thrombocytopenic purpura in adults with high-dose intravenous immunoglobulin. *Scand J Haematol* 1985;34:128-132.
211. Uchino H, Yasunaga K, Akatsuka JI. A cooperative clinical trial of high-dose immunoglobulin therapy in 177 cases of idiopathic thrombocytopenic purpura. *Thromb Haemost* 1984;51:182-185.
212. Oral A, Nusbacher J, Hill JB, Lewis JH. Intravenous gamma globulin in the treatment of chronic idiopathic thrombocytopenic purpura in adults. *Am J Med* 1984;76:187-192.
213. Godeau B, Lesage S, Divine M, et al. Treatment of adult chronic autoimmune thrombocytopenic purpura with repeated high-dose intravenous immunoglobulin. *Blood* 1993;82:1415-1421.
214. Bierling P, Divine M, Farcet JP, et al. Persistent remission of adult chronic autoimmune thrombocytopenic purpura after treatment with high-dose intravenous immunoglobulin. *Am J Hematol* 1987;25:271-275.
215. Bussel JB, Kimberly RP, Inman RD, et al. Intravenous immunoglobulin treatment of chronic idiopathic thrombocytopenic purpura. *Blood* 1983;62:480-486.
216. Bussel JB, Pham LC, Aledort L, Nachman R. Maintenance treatment of adults with chronic refractory immune thrombocytopenic purpura using repeated intravenous infusions of gammaglobulins. *Blood* 1988;72:121-127.
217. Bussel JB, Pham LC. Intravenous treatment with gammaglobulin in adults with immune thrombocytopenic purpura: a review of the literature. *Vox Sang* 1987;52:206-211.
218. Carroll RR, Noyes WD, Kitchens CS. High-dose intravenous immunoglobulin therapy in patients with immune thrombocytopenic purpura. *JAMA* 1983;249:1748-1750.

219. Kurlander R, Coleman RE, Moore J, et al. Comparison of the efficacy of a two-day and a five-day schedule for infusing intravenous gamma globulin in the treatment of immune thrombocytopenic purpura in adults. *Am J Med* 1987;83(Suppl 4A):17-24.
220. Godeau B, Caulier MT, Decuyper L, et al. Intravenous immunoglobulin for adults with autoimmune thrombocytopenic purpura: results of a randomized trial comparing 0.5 and 1 g/kg b.w. *Br J Haematol* 1999;107:716-719.
221. Bussel JB, Fitzgerald-Pedersen J, Feldman C. Alternation of two doses of intravenous gammaglobulin in the maintenance treatment of patients with immune thrombocytopenic purpura: more is not always better. *Am J Hematol* 1990;33:184-188.
222. Newland AC. Annotation: the use and mechanisms of action of intravenous immunoglobulin: an update. *Br J Haematol* 1989;72:301-305.
223. Fehr J, Hofmann V, Kappeler U. Transient reversal of thrombocytopenia in idiopathic thrombocytopenic purpura by high dose intravenous gamma globulin. *N Engl J Med* 1982;306:1254-1258.
224. Kimberly RP, Salmon JE, Bussel JB, et al. Modulation of mononuclear phagocyte function by intravenous γ -globulin. *J Immunol* 1984;132:745-750.
225. Saleh M, Court W, Huster W, et al. Effect of commercial immunoglobulin G preparation on human monocyte Fc-receptor dependent binding of antibody coated platelets. *Br J Haematol* 1988;68:47-51.
226. Dammacco F, Iodice G, Campobasso N. Treatment of adult patients with idiopathic thrombocytopenic purpura with intravenous immunoglobulin: effects on circulating T cell subsets and PWM-induced antibody synthesis in vitro. *Br J Haematol* 1986;62:125-135.
227. Winiarski J, Kreuger A, Ejderhamn J, Holm G. High dose intravenous IgG reduces platelet associated immunoglobulins and complement in idiopathic thrombocytopenic purpura. *Scand J Haematol* 1983;31:342-348.
228. Delfraissy JF, Tchernia G, Laurian Y, et al. Suppressor cell function after intravenous gammaglobulin treatment in adult chronic idiopathic thrombocytopenic purpura. *Br J Haematol* 1985;60:315-322.
229. Tsubakio T, Kurata Y, Katagiri S, et al. Alteration of T cell subsets and immunoglobulin synthesis in vitro during high dose γ -globulin therapy in patients with idiopathic thrombocytopenic purpura. *Clin Exp Immunol* 1983;53:697-702.
230. Berchtold P, Dale GL, Tani P, McMillan R. Inhibition of autoantibody binding to platelet glycoprotein IIb/IIIa by anti-idiotypic antibodies to intravenous immunoglobulin. *Blood* 1989;74:2414-2417.
231. Williams Y, Lynch S, McCann S, et al. Correlation of platelet Fc γ RIIA polymorphism in refractory idiopathic (immune) thrombocytopenic purpura. *Br J Haematol* 1998;101:779-782.
232. Barbano G, Saleh MN, Mori PG, et al. Effect of intravenous gammaglobulin on circulating and platelet bound antibody in immune thrombocytopenia. *Blood* 1989;73:662-665.
233. Samuelsson A, Towers TL, Ravetch JV. Anti-inflammatory activity of IVIG mediated through the inhibitory Fc receptor. *Science* 2001;291:484-486.
234. von dem Borne AE, Vos JJ, Pegels JG, et al. High dose intravenous methylprednisolone or high dose intravenous gammaglobulin for autoimmune thrombocytopenia. *Br Med J (Clin Res Ed)* 1988;296:249-250.
235. Spahr JE, Rodgers GM. Treatment of immune-mediated thrombocytopenia purpura with concurrent intravenous immunoglobulin and platelet transfusion: a retrospective review of 40 patient. *Am J Hematol* 2008;83:122-125.
236. Sati HIA, Ahya R, Watson HG. Incidence and associations of acute renal failure complicating high-dose intravenous immunoglobulin therapy. *Br J Haematol* 2001;113:556-557.
237. Gupta N, Ahmed I, Nissel-Horowitz S, et al. Intravenous immunoglobulin-associated acute renal failure. *Am J Hematol* 2001;66:151-152.
238. Salama A, Kiefel V, Amberg R, Mueller-Eckhardt C. Treatment of autoimmune thrombocytopenic purpura with rhesus antibodies [Anti-Rho (D)]. *Blut* 1984;49:29-35.
239. Salama A, Mueller-Eckhardt C. Use of Rh antibodies in the treatment of auto-immune thrombocytopenia. *Transfus Med Rev* 1992;6:17-25.
240. Andrew M, Blanchette VS, Adams M, et al. A multicenter study of the treatment of childhood chronic idiopathic thrombocytopenic purpura with anti-D. *J Pediatr* 1992;120:522-527.

241. Scaradavou A, Woo B, Woloski BMR, et al. Intravenous anti-D treatment of immune thrombocytopenic purpura: experience in 272 patients. *Blood* 1997;89:2689-2700.
242. Cooper N, Heddle NM, deHaas M, et al. Intravenous anti-D and IV immunoglobulin achieve acute platelet increases by different mechanism: modulation of cytokine and platelet responses to IV anti-D by FcγRIIIa and FcγRIIIa polymorphisms. *Br J Haematol* 2004;124:511-518.
243. Becker T, Kuenzlen E, Salama A, et al. Treatment of childhood idiopathic thrombocytopenic purpura with Rhesus antibodies (anti-D). *Eur J Pediatr* 1986;145:166-169.
244. Gringeri A, Cattaneo M, Santagostino E, Mannucci PM. Intramuscular anti-D immunoglobulins for home treatment of chronic immune thrombocytopenic purpura. *Br J Haematol* 1992;80:337-340.
245. Cooper N, Woloski BMR, Fodero EM, et al. Does treatment with intermittent infusions of intravenous anti-D allow a proportion of adults with recently diagnosed immune thrombocytopenic purpura to avoid splenectomy? *Blood* 2002;99:1922-1927.
246. Salama A, Kiefel V, Mueller-Eckhardt C. Effect of IgG anti-Rho (D) in adult patients with chronic autoimmune thrombocytopenia. *Am J Hematol* 1986;22:241-250.
247. Panzer S, Grumayer ER, Haas OA, et al. Efficacy of rhesus antibodies (anti-Rho [D]) in autoimmune thrombocytopenia: correlation with response to high dose IgG and the degree of hemolysis. *Blut* 1986;52:117-121.
248. Ruiz-Arguelles GJ, Apreza-Molina MG, Perez-Romano B, Ruiz-Arguelles A. The infusion of anti-RhO-(D) opsonized erythrocytes may be useful in the treatment of patients, splenectomized or not, with chronic, refractory auto-immune thrombocytopenic purpura—a prospective study. *Am J Hematol* 1993;43:72-73.
249. Bussell JB, Graziano JN, Kimberly JN, et al. Intravenous anti-D treatment of immune thrombocytopenic purpura: analysis of efficacy, toxicity and mechanism of effect. *Blood* 1991;77:1884-1893.
250. Newman GC, Novoa MV, Fodero EM, et al. A dose of 75 mg/kg/d of IV anti-D increases the platelet count more rapidly and for a longer period of time than does 50 mg/kg/d in adults with immune thrombocytopenic purpura (ITP). *Br J Haematol* 2001;112:1076-1078.
251. Gaines AR. Disseminated intravascular coagulation associated with acute hemoglobinemia or hemoglobinuria following Rho (D) immune globulin administration for immune thrombocytopenic purpura. *Blood* 2005;106:1532-1537.
252. Picozzi VJ, Roeske WR, Creger WP. Fate of therapy failures in adult idiopathic thrombocytopenic purpura. *Am J Med* 1980;69:690-694.
253. Brown DN, Elliott RHE. The results of splenectomy in thrombocytopenic purpura. *JAMA* 1936;107:1781-1788.
254. Eliason EL, Ferguson LK. Splenectomy in purpura hemorrhagica. *Ann Surg* 1932;96:801-829.
255. Wintrobe MM, Hanrahan EM, Thomas CB, et al. Purpura haemorrhagica with special reference to course and treatment. *JAMA* 1937;109:1170-1176.
256. Kernoff LM, Malan E. Platelet antibody levels do not correlate with response to therapy in idiopathic thrombocytopenic purpura. *Br J Haematol* 1983;53:559-562.
257. Akwari OE, Itani KMF, Coleman RE, Rosse WF. Splenectomy for primary and recurrent immune thrombocytopenic purpura. *Ann Surg* 1987;206:529-541.
258. Schwartz SI, Hoepf LM, Sachs S. Splenectomy for thrombocytopenia. *Surgery* 1980;88:497-506.
259. Mintz SJ, Petersen SR, Cheson B, et al. Splenectomy for immune thrombocytopenic purpura. *Arch Surg* 1981;116:645-650.
260. Gugliotta L, Isacchi G, Guarini A, et al. Chronic idiopathic thrombocytopenic purpura (ITP): site of platelet sequestration and results of splenectomy. *Scand J Haematol* 1981;26:407-412.
261. Brennan MF, Rapoport JM, Moloney WC, Wilson RE. Correlation between response to corticosteroids and splenectomy for adult idiopathic thrombocytopenic purpura. *Am J Surg* 1975;129:490-492.
262. Chirletti P, Cardi M, Barillari P, et al. Surgical treatment of immune thrombocytopenic purpura. *World J Surg* 1992;16:1001-1005.

263. Fabris F, Zanatta N, Casonata A, et al. Response to splenectomy in idiopathic thrombocytopenic purpura: prognostic value of the clinical and laboratory evaluation. *Acta Haematol* 1989;81:28-33.
264. Gibson J, May J, Rickard KA, et al. Management of splenectomy failures in chronic immune thrombocytopenic purpura: role of accessory splenectomy. *Aust N Z J Med* 1986;16:695-698.
265. Naouri A, Feghali B, Chabal J, et al. Results of splenectomy for idiopathic thrombocytopenic purpura. *Acta Haematol* 1993;89:200-203.
266. Szoid A, Schwartz J, Abu-Abeid S, et al. Laparoscopic splenectomies for idiopathic thrombocytopenic purpura: experience of 60 cases. *Am J Hematol* 2000;63:7-10.
267. Kathouda N, Grant SW, Mavor E, et al. Predictors of response after laparoscopic splenectomy for immune thrombocytopenic purpura. *Surg Endosc* 2001;15:484-488.
268. Calverley DC, Jones GW, Kelton JG. Splenic radiation for corticosteroidresistant immune thrombocytopenia. *Ann Intern Med* 1992;116:977-981.
269. Caulier MT, Darloy F, Rose C, et al. Splenic irradiation for chronic autoimmune thrombocytopenic purpura in patients with contra-indications to splenectomy. *Br J Haematol* 1995;91:208-211.
270. Miyazaki M, Itoh H, Kaiho T, et al. Partial splenic embolization for the treatment of chronic idiopathic thrombocytopenic purpura. *AJR Am J Roentgenol* 1994;163:123-126.
271. Wallace D, Fromm D, Thomas D. Accessory splenectomy for idiopathic thrombocytopenic purpura. *Surgery* 1982;91:134-136.
272. Ambriz P, Munoz R, Quintanar E, et al. Accessory spleen complicating response to splenectomy for idiopathic thrombocytopenic purpura. *Radiology* 1985;155:793-796.
273. Verheyden CN, Beart RW, Clifton MD, Phyliky RL. Accessory splenectomy in management of recurrent idiopathic thrombocytopenic purpura. *Mayo Clin Proc* 1978;53:442-446.
274. Massey MD, Stevens JS. Residual spleen found on denatured red blood cell scan following negative colloid scans. *J Nucl Med* 1991;32:2286-2287.
275. Facon T, Caulier MT, Fenaux P, et al. Accessory spleen in recurrent chronic immune thrombocytopenic purpura. *Am J Hematol* 1992;41:184-189.
276. Julia A, Araguas C, Rossello J, et al. Lack of useful clinical predictors of response to splenectomy in patients with chronic idiopathic thrombocytopenic purpura. *Br J Haematol* 1990;76:250-255.
277. Ruivard M, Caulier MT, Vantelon JM, et al. The response to high-dose intravenous immunoglobulin or steroids is not predictive of outcome after splenectomy in adults with autoimmune thrombocytopenic purpura. *Br J Haematol* 1999;105:1130-1132.
278. Choi CW, Kim BS, Seo JH, et al. Response to high-dose intravenous immune globulin as a valuable factor predicting the effect of splenectomy in chronic idiopathic thrombocytopenic purpura patients. *Am J Hematol* 2001;66:197-202.
279. Fabris F, Tassan T, Ramon R, et al. Age as the major predictive factor of longterm response to splenectomy in immune thrombocytopenic purpura. *Br J Haematol* 2001;112:637-640.
280. Bussel JB, Kaufman CP, Ware RE, Woloski BM. Do the acute platelet responses of patients with immune thrombocytopenic purpura (ITP) to IV anti-D and to IV gammaglobulin predict response to subsequent splenectomy? *Am J Hematol* 2001;67:27-33.
281. Najean Y, Dufour V, Rain JD, Toubert ME. The site of platelet destruction in thrombocytopenic purpura as a predictive index of the efficacy of splenectomy. *Br J Haematol* 1991;79:271-276.
282. Stasi R, Pagano A, Stipa E, et al. Rituximab chimeric anti-CD20 monoclonal antibody treatment for adults with chronic idiopathic thrombocytopenic purpura. *Blood* 2001;98:952-957.
283. Saleh MN, Moore M, Feinberg B, et al. A pilot study of anti-CD20 MOAB rituximab in patients with refractory immune thrombocytopenia. *Blood* 2001;98:521A.
284. Cooper N, Feuerstein M, Bussel JB. The use of rituximab, a chimeric anti-CD20 monoclonal antibody, in adults with refractory immune thrombocytopenic purpura. *Blood* 2001;98:521.

285. Grillo-Lopez AJ, Hendrick C, Rashford M, et al. Rituximab: ongoing and future clinical development. *Semin Oncol* 2002;29:105-112.
286. Arnold DM, Dentali F, Crowther MA, et al. Systemic review: efficacy and safety of rituximab for adults with idiopathic thrombocytopenic purpura. *Ann Intern Med* 2007;146:25-33.
287. Cooper N, Stasi R, Cunningham-Rundles S, et al. The efficacy and safety of B-cell depletion with anti-CD20 monoclonal antibody in adults with chronic immune thrombocytopenic purpura. *Br J Haematol* 2004;125:232-239.
288. Zaja F, Vianelli N, Volpetti S, Battista ML, et al. Low-dose rituximab in adult patients with primary immune thrombocytopenia. *Eur J Haematol* 2010;85:329-334.
289. Carson KR, Evens AM, Richey EA, Habermann TM, et al. Progressive multifocal leukoencephalopathy after rituximab therapy in HIV-negative patients: a report of 57 cases from the Research on Adverse Drug Events and Reports project. *Blood* 2009;113:4834-4840.
290. Stasi R, Stipa E, Forte V, et al. Variable patterns of response to rituximab treatments in adults with chronic idiopathic thrombocytopenic purpura. *Blood* 2002;99:3872-3873.
291. Ramanarayanan J, Brodzik F, Czuczman MS, et al. Efficacy and safety of rituximab in the treatment of refractory/relapsed idiopathic thrombocytopenic purpura (ITP): results of a meta-analysis of 299 patients. *Blood* 2006;108:a1076.
292. Patel V, Mihatov N, Cooper N, Stasi R, et al. Long term follow-up of patients with immune thrombocytopenic purpura (ITP) whose initial response to rituximab lasted a minimum of 1 yr. *Blood* 2006;108:479.
293. Hasan A, Michel M, Patel V, Stasi R, et al. Repeated courses of rituximab in chronic ITP: three different regimens. *Am J Hematol* 2009;84:661-665.
294. Zaja F, Baccarani M, Mazza P, et al. Dexamethasone plus rituximab yields higher sustained response rates than dexamethasone monotherapy in adults with primary immune thrombocytopenia. *Blood* 2010;115:2755-2762.
295. Bussel JB, Provan D, Shamsi T, et al. Effect of eltrombopag on platelet counts and bleeding during the treatment of chronic idiopathic thrombocytopenic purpura: a randomised, double-blind, placebo-controlled trial. *Lancet* 2009;373:641-648.
296. Chang G, Saleh MN, Marcher C, Vasey S, et al. Eltrombopag for management of chronic immune thrombocytopenia (RAISE): a 6-month, randomized, phase 3 study. *Lancet* 2011;377:393-402.
297. Kuter DJ, Bussel JB, Lyons RM, et al. Efficacy of romiplostim in patients with chronic immune thrombocytopenic purpura: a double-blind, randomised controlled trial. *Lancet* 2008;371:395-403.
298. Khellaf M, Michel M, Quittet P, Viallard JF, et al. Romiplostim safety and efficacy for immune thrombocytopenia in clinical practice: 2-year results of 72 adults in a romiplostim compassionate-use program. *Blood* 2011;118:4338-4345.
299. Bussel JB, Kuter DJ, Pullarkat V, et al. Safety and efficacy of long-term treatment with romiplostim in thrombocytopenic patients chronic ITP. *Blood* 2009;113:2161-2171.
300. Kuter DJ, Rummel M, Boccia R, Macik BG, et al. Romiplostim or standard of care in patients with immune thrombocytopenia. *N Engl J Med* 2010;363:1889-1899.
301. Kuter DJ, Mufti GJ, Bain BJ, et al. Evaluation of bone marrow reticulin formation in chronic immune thrombocytopenia patients treated with romiplostim. *Blood* 2009;114:3748-3756.
302. Joseph A, Evans DIK. Immunosuppressive treatment of idiopathic thrombocytopenic purpura in children. *Acta Paediatr Scand* 1982;71:467-469.
303. Finch SC, Castro O, Cooper M, et al. Immunosuppressive therapy of chronic thrombocytopenic purpura. *Am J Med* 1974;56:4-12.
304. Godeau B, Zini JM, Schaeffer A, Bierling P. High-dose methylprednisolone is an alternative treatment for adults with autoimmune thrombocytopenic purpura refractory to intravenous immunoglobulins and oral corticosteroids. *Am J Hematol* 1995;48:282-284.
305. Figueroa M, Gehlsen J, Hammond D, et al. Combination chemotherapy in refractory immune thrombocytopenic purpura. *N Engl J Med* 1993;328: 1226-1229.

306. Laros RK, Penner JA. "Refractory" thrombocytopenic purpura treated successfully with cyclophosphamide. *JAMA* 1971;215:445-449.
307. Verlin M, Laros RK, Penner JA. Treatment of refractory thrombocytopenic purpura with cyclophosphamide. *Am J Hematol* 1976;1:97-104.
308. Reiner A, Gernsheimer T, Slichter SJ. Pulse cyclophosphamide therapy for refractory autoimmune thrombocytopenic purpura. *Blood* 1995;85:351-358.
309. Bouroncle BA, Doan CA. Refractory idiopathic thrombocytopenic purpura treated with azathioprine. *N Engl J Med* 1966;275:630-635.
310. Bouroncle BA, Doan CA. Treatment of refractory idiopathic thrombocytopenic purpura. *JAMA* 1969;207:2049-2052.
311. Hilgartner MW, Lanzkowsky P, Smith CH. The use of azathioprine in refractory thrombocytopenic purpura in children. *Acta Paediatr Scand* 1970;59:409-415.
312. Quiquandon I, Fenaux P, Caulier MT, et al. Re-evaluation of the role of azathioprine in the treatment of adult chronic idiopathic thrombocytopenic purpura: a report on 53 cases. *Br J Haematol* 1990;74:223-228.
313. Kappers-Klunne MC, Van't Veer MB. Cyclosporin A for the treatment of patients with chronic idiopathic thrombocytopenic purpura refractory to corticosteroids or splenectomy. *Br J Haematol* 2001;114:121-125.
314. Ahn YS, Harrington WJ, Steelman RC, Eytel CS. Vincristine therapy of idiopathic and secondary thrombocytopenias. *N Engl J Med* 1974;291:376-380.
315. Colovic M, Suvajdzic N, Colovic N, Tomin D, et al. Mycophenolate mophetil therapy form chronic immune thrombocytopenic purpura resistant to steroids, immunosuppresants, and/or splenectomy in adults. *Platelets* 2011;22:153-156.
316. Manoharan A. Slow infusion of vincristine in the treatment of idiopathic thrombocytopenic purpura. *Am J Hematol* 1986;21:135-138.
317. Manoharan A. Targeted-immunosuppression with vincristine infusion in the treatment of immune thrombocytopenia. *Aust N Z J Med* 1991;21:405-407.
318. Sultan Y, Delobel J, Jeanneau C, Caen JP. Effect of periwinkle alkaloids in idiopathic thrombocytopenic purpura. *Lancet* 1971;1:496-497.
319. Aisenberg AC, Wilkes B. Studies on the suppression of immune response by the periwinkle alkaloids vincristine and vinblastine. *J Clin Invest* 1964;43:2394-2403.
320. Robertson JH, McCarthy GM. Periwinkle alkaloids and the platelet-count. *Lancet* 1969;2:353-355.
321. Hwang YF, Hamilton HE, Sheets RF. Vinblastine-induced thrombocytosis. *Lancet* 1969;2:1075-1076.
322. Owellen RJ, Owens AH, Donigian DW. The binding of vincristine, vinblastine and colchicine to tubulin. *Biochem Biophys Res Commun* 1972;47:685-691.
323. Paulson JC, McClure WO. Inhibition of axoplasmic transport by colchicine, podophyllotoxin, and vinblastine: an effect on microtubules. *Ann N Y Acad Sci* 1975;253:517-527.
324. Mylvaganam R, Ahn YS, Garcia RO, et al. Very low dose danazol in idiopathic thrombocytopenic purpura and its role as an immune modulator. *Am J Med Sci* 1989;298:215-220.
325. Ahn YS, Harrington WJ, Simon SR, et al. Danazol for the treatment of idiopathic thrombocytopenic purpura. *N Engl J Med* 1983;308:1396-1399.
326. Buelli M, Cortelazzo S, Viero P, et al. Danazol for the treatment of idiopathic thrombocytopenic purpura. *Acta Haematol* 1985;74:97-98.
327. Ahn YS, Mylvaganam R, Garcia RO, et al. Low-dose danazol therapy in idiopathic thrombocytopenic purpura. *Ann Intern Med* 1987;107:177-181.
328. Schreiber AD, Chien P, Tomaski A, Cines DB. Effect of danazol in immune thrombocytopenic purpura. *N Engl J Med* 1987;316:503-508.
329. Maloisel F, Andrès E, Zimmer J, et al. Danazol therapy in patients with chronic idiopathic thrombocytopenic purpura; long-term results. *Am J Med* 2004;116:590-594.

330. Donato H, Kohan R, Picon A, et al. Alpha-interferon therapy induces improvement of platelet count in children with chronic idiopathic thrombocytopenic purpura. *J Pediatr Hematol Oncol* 2001;23:598-603.
331. Proctor SJ. Alpha interferon therapy in the treatment of idiopathic thrombocytopenic purpura. *Eur J Cancer* 1991;27:S63-S68.
332. Kahn RA. Clinical evaluation of platelet transfusions in thrombocytopenic patients: methods and interpretation. *Vox Sang* 1981;40(Suppl 1):87-97.
333. Zucker MB, Lundberg A. Platelet transfusions. *Anesthesiology* 1966;27: 385-398.
334. Carr JM, Kruskall MS, Kaye JA, Robinson SH. Efficacy of platelet transfusions in immune thrombocytopenia. *Am J Med* 1986;80:1051-1054.
335. Branda RF, Tate DY, McCullough JJ, Jacob HS. Plasma exchange in the treatment of fulminant idiopathic (autoimmune) thrombocytopenic purpura. *Lancet* 1978;1:688-690.
336. Marder VJ, Nusbacher J, Anderson FW. One-year follow-up of plasma exchange therapy in 14 patients with idiopathic thrombocytopenic purpura. *Transfusion* 1981;21:291-298.
337. Novak R, Wilimas J. Plasmapheresis in catastrophic complications of idiopathic thrombocytopenic purpura. *J Pediatr* 1978;92:434-436.
338. Mourtzoukou EG, Pappas G, Peppas G, Falagas ME. Vaccination of asplenic or hyposplenic adults. *Br J Surg* 2008;95:273-280.
339. Kaplan C, Forestier F, Dreyfus M, et al. Maternal thrombocytopenia during pregnancy: diagnosis and etiology. *Semin Thromb Haemost* 1995;21:85-94.
340. McCrae KR, Samuels P, Schreiber AD. Pregnancy-associated thrombocytopenia: pathogenesis and management. *Blood* 1992;80:2697-2714.
341. Burrows RF, Kelton JG. Incidentally detected thrombocytopenia in healthy mothers and their infants. *N Engl J Med* 1988;319:142-145.
342. Burrows RF, Kelton JG. Thrombocytopenia at delivery: a prospective survey of 6715 deliveries. *Am J Obstet Gynecol* 1990;162:731-734.
343. Burrows RF, Kelton JG. Fetal thrombocytopenia and its relation to maternal thrombocytopenia. *N Engl J Med* 1993;329:1463-1466.
344. Lescale KB, Eddleman KA, Cines DB, et al. Antiplatelet antibody testing in thrombocytopenic pregnant women. *Am J Obstet Gynecol* 1996;174: 1014-1018.
345. Gill KK, Kelton JG. Management of idiopathic thrombocytopenic purpura in pregnancy. *Semin Hematol* 2000;37:275-289.
346. Webert KE, Mittal R, Sigouin C, et al. A retrospective 11-year analysis of obstetric patients with idiopathic thrombocytopenic purpura. *Blood* 2003;102:4306-4311.
347. Silver RM, Branch W, Scott JR. Maternal thrombocytopenia in pregnancy: time for a reassessment. *Am J Obstet Gynecol* 1995;173:479-482.
348. Kaplan C, Daffos F, Forestier F, et al. Fetal platelet counts in thrombocytopenic pregnancy. *Lancet* 1990;336:979-982.
349. Christiaens GC, Nieuwenhuis HK, von dem Borne AE, et al. Idiopathic thrombocytopenic purpura in pregnancy: a randomized trial on the effect of antenatal low dose corticosteroids on neonatal platelet count. *Br J Obstet Gynaecol* 1990;97:893-898.
350. Cook RL, Miller RC, Katz VL, Cefalo RC. Immune thrombocytopenic purpura in pregnancy: a reappraisal of management. *Obstet Gynecol* 1991;78: 578-583.
351. Burrows RF, Kelton JG. Pregnancy in patients with idiopathic thrombocytopenic purpura: assessing the risks for the infant at delivery. *Obstet Gynecol Surv* 1993;48:781-788.
352. Rizvi MA, Kojouri K, George JN. Drug-induced thrombocytopenia: an updated systematic review. *Ann Intern Med* 2001;134:346

353. Swisher KK, Li X, Vesely SK, George JN. Drug-induced thrombocytopenia: an updated systematic review, 2008. *Drug Saf* 2009;32:85-86.
354. Nguyen L, Reese J, George JN. Drug-induced thrombocytopenia: an updated systematic review, 2010. *Drug Saf* 2011;34:437-438.
355. Kaufman DW, Kelly JP, Johannes CB, et al. Acute thrombocytopenic purpura in relation to the use of drugs. *Blood* 1993;82:2714-2718.
356. Girolami B, Prandoni P, Stefani PM, et al. The incidence of heparin-induced thrombocytopenia in hospitalized medical patients treated with subcutaneous unfractionated heparin: a prospective cohort study. *Blood* 2003;101:2955-2999.
357. Wooley PH, Griffin J, Panayi GS, et al. HLA-DR antigens and toxic reaction to sodium aurothiomalate and D-penicillamine in patients with rheumatoid arthritis. *N Engl J Med* 1980;303:300-302.
358. Belkin GA. Cocktail purpura: an unusual case of quinine sensitivity. *Ann Intern Med* 1967;66:583-586.
359. Pedersen-Bjergaard U, Anderson M, Hansen PB. Drug-specific characteristics of thrombocytopenia caused by non-cytotoxic drugs. *Eur J Clin Pharmacol* 1998;54:701-706.
360. Kobayashi H, Kitano K, Ishida F, et al. Aplastic anemia and idiopathic thrombocytopenic purpura with antibody to platelet glycoprotein IIb/IIIa following resection of malignant thymoma. *Acta Haematol* 1993;90:42-45.
361. Bowen LM, Williams DM. Association of myasthenia gravis and idiopathic thrombocytopenic purpura. *South Med J* 1981;74:513-514.
362. Anderson MJ, Woods VL, Tani P, et al. Autoantibodies to platelet glycoprotein IIb/IIIa and to the acetylcholine receptor in a patient with chronic idiopathic thrombocytopenic purpura and myasthenia gravis. *Ann Intern Med* 1984;100:829-831.
363. Jansen PHP, Renier WO, deVaam G, et al. Effect of thymectomy on myasthenia gravis and autoimmune thrombocytopenic purpura in a 13-year-old girl. *Eur J Pediatr* 1987;146:587-589.
364. Panzer S, Penner E, Graninger W, et al. Antinuclear antibodies in patients with chronic idiopathic autoimmune thrombocytopenia followed 2-30 years. *Am J Hematol* 1989;32:100-103.
365. Nossent JC, Swaak AJG. Prevalence and significance of haematological abnormalities in patients with systemic lupus erythematosus. *Q J Med* 1991;291:605-612.
366. Anderson MJ, Peebles CL, McMillan R, Curd JG. Fluorescent antinuclear antibodies and anti-SS-A/Ro in patients with immune thrombocytopenia subsequently developing systemic lupus erythematosus. *Ann Intern Med* 1985;103:548-550.
367. Kurata Y, Miyagawa S, Kosugi S, et al. High-titer antinuclear antibodies, anti-SSA/Ro antibodies and antinuclear RNP antibodies in patients with idiopathic thrombocytopenic purpura. *Thromb Haemost* 1994;71:184-187.
368. Perez HD, Katler E, Embury S. Idiopathic thrombocytopenic purpura with high-titer, speckled pattern antinuclear antibodies: possible marker for systemic lupus erythematosus. *Arthritis Rheum* 1985;28:596-597.
369. Miescher PA, Tucci A, Beris P, Favre H. Autoimmune hemolytic anemia and/or thrombocytopenia associated with lupus parameters. *Semin Hematol* 1992;29:13-17.
370. Kurata Y, Hayashi S, Kosugi S, et al. Elevated platelet-associated IgG in SLE patients due to anti-platelet antibody: differentiation between autoantibodies and immune complexes by ether elution. *Br J Haematol* 1993;85:723-728.
371. Berchtold P, Harris JP, Tani P, et al. Autoantibodies to platelet glycoproteins in patients with disease-related immune thrombocytopenia. *Br J Haematol* 1989;73:365-368.
372. Macchi L, Rispoli P, Cloufent-Sanchez G, et al. Anti-platelet antibodies in patients with systemic lupus erythematosus and the primary antiphospholipid antibody syndrome: their relationship with the observed thrombocytopenia. *Br J Haematol* 1997;98:336-341.
373. Godeau B, Piette JC, Fromont P, et al. Specific antiplatelet glycoprotein auto-antibodies are associated with the thrombocytopenia of primary antiphospholipid syndrome. *Br J Haematol* 1997;98:873-879.
374. Pujol M, Ribera A, Vilardell M, et al. High prevalence of platelet autoantibodies in patients with systemic lupus erythematosus. *Br J Haematol* 1995;89:137-141.

375. Averbuch M, Koifman B, Levo Y. Lupus anticoagulant, thrombosis and thrombocytopenia in systemic lupus erythematosus. *Am J Med Sci* 1987;293:1-5.
376. Out HJ, deGroot PG, van Vliet M, et al. Antibodies to platelets in patients with anti-phospholipid antibodies. *Blood* 1991;77:2655-2659.
377. Fabris F, Steffan A, Cordiano I, et al. Specific antiplatelet antibodies in patients with antiphospholipid antibodies and thrombocytopenia. *Eur J Haematol* 1994;53:232-236.
378. Coon WW. Splenectomy for cytopenias associated with systemic lupus erythematosus. *Am J Surg* 1988;155:391-394.
379. Hall S, McCormick JL, Griep PR, et al. Splenectomy does not cure the thrombocytopenia of systemic lupus erythematosus. *Ann Intern Med* 1985;102:325-328.
380. Kappers-Klunne MC, van Vliet HHDM. IgM and IgG platelet antibodies in a case of infectious mononucleosis and severe thrombocytopenia. *Scand J Haematol* 1984;32:145-148.
381. Kahane S, Dvilansky A, Estok L, et al. Detection of anti-platelet antibodies in patients with idiopathic thrombocytopenic purpura (ITP) and in patients with rubella and herpes group viral infections. *Clin Exp Immunol* 1981;44:49-56.
382. Ellman L, Carvalho A, Jacobson BM, Colman RW. Platelet autoantibody in a case of infectious mononucleosis presenting as thrombocytopenic purpura. *Am J Med* 1973;55:723-726.
383. Krishnamurthy M, Lee CK, Dosik H. Case report: infectious mononucleosis and severe thrombocytopenia. *Am J Med Sci* 1976;272:221-224.
384. Pivetti S, Novarino A, Merico F, et al. High prevalence of autoimmune phenomena in hepatitis C virus antibody positive patients with lymphoproliferative and connective tissue disorders. *Br J Haematol* 1996;95:204-211.
385. Pawlotsky JM, Bouvier M, Fromont P, et al. Hepatitis C virus infection and autoimmune thrombocytopenic purpura. *J Hepatol* 1995;23:635-639.
386. Al-Majed SA, Al-Momen AK, Al-Kassimi FA, et al. Tuberculosis presenting as immune thrombocytopenic purpura. *Acta Haematol* 1995;94:135-138.
387. Gasbarrini A, Franceschi F, Tartaglione R, et al. Regression of autoimmune thrombocytopenia after eradication of *Helicobacter pylori*. *Lancet* 1998;352:878.
388. Grimaz S, Damiani D, Brosolo P, et al. Resolution of thrombocytopenia after treatment for *Helicobacter pylori*: a case report. *Haematologica* 1999;84:283-284.
389. Tohda S, Ohkusa T. Resolution of refractory idiopathic thrombocytopenic purpura after eradication of *Helicobacter pylori*. *Am J Hematol* 2000;65:329-330.
390. Emilia G, Longo G, Luppi M, et al. *Helicobacter pylori* eradication can induce platelet recovery in idiopathic thrombocytopenic purpura. *Blood* 2001;97:812-814.
391. Bussel JB. Novel approaches to management of immune thrombocytopenic purpura: results of recent trials. *American Society of Hematology Education Book*, 2001:282-293.
392. Jarque I, Andreu R, Llopis I, et al. Absence of platelet response after eradication of *Helicobacter pylori* infection in patients with chronic idiopathic purpura. *Br J Haematol* 2001;115:1002-1003.
393. Stasi R, Sarpawari A, Segal JB, et al. Effects of eradication of *Helicobacter pylori* infection in patients with immune thrombocytopenic purpura: a systemic review. *Blood* 2009;113:1231-1240.
394. Arnold DM, Bernotas A, Nazi I, et al. Platelet count response to *H. pylori* treatment in patients with immune thrombocytopenia with and without *H. pylori* infection: a systemic review. *Haematologica*. 2009;94:850-856.
395. Jackson Sc, Beck P, Buret AG, et al. Long term platelet responses to *Helicobacter pylori* eradication in Canadian patients with immune thrombocytopenic purpura. *Int J Hematol* 2008;88:212-218.
396. Ebbe S, Wittels B, Dameshek W. Autoimmune thrombocytopenic purpura ("ITP" type) with chronic lymphocytic leukemia. *Blood* 1962;19:23-37.
397. Hassidim K, McMillan R, Conjalka MS, Morrison J. Immune thrombocytopenic purpura in Hodgkin disease. *Am J Hematol* 1979;6:149-153.

398. Waddell CC, Cimo PL. Idiopathic thrombocytopenic purpura occurring in Hodgkin disease after splenectomy: report of two cases and review of the literature. *Am J Hematol* 1979;7:381-387.
399. Xiros N, Binder T, Anger B, et al. Idiopathic thrombocytopenic purpura and autoimmune hemolytic anemia in Hodgkin's disease. *Eur J Haematol* 1988;40:437-441.
400. Kaden BR, Rosse WF, Hauch TW. Immune thrombocytopenia in lymphoproliferative disorders. *Blood* 1979;53:545-551.
401. Schwartz KA, Slichter SJ, Harker LA. Immune-mediated platelet destruction and thrombocytopenia in patients with solid tumors. *Br J Haematol* 1982;51:17-24.
402. Kim HD, Boggs DR. A syndrome resembling idiopathic thrombocytopenic purpura in 10 patients with diverse forms of cancer. *Am J Med* 1979;67:371-377.
403. Valenta LJ, Treadwell T, Berry R, Elias AN. Idiopathic thrombocytopenic purpura and Graves disease. *Am J Hematol* 1982;12:69-72.
404. Adrouny A, Sandler RM, Carmel R. Variable presentation of thrombocytopenia in Grave's disease. *Arch Intern Med* 1982;142:1460-1464.
405. Hymes K, Blum M, Lackner H, Karpatkin S. Easy bruising, thrombocytopenia, and elevated platelet immunoglobulin G in Graves' disease and Hashimoto's thyroiditis. *Ann Intern Med* 1981;94:27-30.
406. Bizzaro N. Familial association of autoimmune thrombocytopenia and hyperthyroidism. *Am J Med* 1992;39:294-298.
407. Newman PJ. Nomenclature of human platelet alloantigens: a problem with the HPA system? *Blood* 1994;83:1447-1451.
408. Goldman M, Fillion M, Proulx C, et al. Neonatal alloimmune thrombocytopenia. *Transfus Med Rev* 1994;8:123-131.
409. McCrae KR, Herman JH. Posttransfusion purpura: two unusual cases and a literature review. *Am J Hematol* 1996;52:205-211.
410. Warkentin TE, Smith JW, Hayward CP, et al. Thrombocytopenia caused by passive transfusion of anti-glycoprotein Ia/IIa alloantibody (anti-HPA-5b). *Blood* 1992;79:2480-2484.
411. Ballem PJ, Buskard NA, Decary F, Doubroff P. Post-transfusion purpura secondary to passive transfer of anti-P1A1 by blood transfusion. *Br J Haematol* 1987;66:113-114.
412. Nijjar TS, Bonacosa IA, Israels LG. Severe acute thrombocytopenia following infusion of plasma containing anti P1A1. *Am J Hematol* 1987;25:219-221.
413. Scott EP, Moilan-Bergeland J, Dalmaso AP. Posttransfusion thrombocytopenia associated with passive transfusion of a platelet-specific antibody. *Transfusion* 1988;28:73-76.
414. Kaplan C, Daffos F, Forestier F, et al. Management of alloimmune thrombocytopenia: antenatal diagnosis and in utero transfusion of maternal platelets. *Blood* 1988;72:340-343.
415. von dem Borne AE, van Leeuwen EF, von Riesz LE, et al. Neonatal alloimmune thrombocytopenia: detection and characterization of the responsible antibodies by the platelet immunofluorescence test. *Blood* 1981;57:649-656.
416. Mueller-Eckhardt C, Kiefel V, Grubert A, et al. 348 cases of suspected neonatal alloimmune thrombocytopenia. *Lancet* 1989;1:363-366.
417. Blanchette VS, Chen L, de Friedberg ZS, et al. Alloimmunization to the PLA-1 antigen: results of a prospective study. *Br J Haematol* 1990;74:209-215.
418. Panzer S, Auerbach L, Cechova E, et al. Maternal alloimmunization against fetal platelet antigens: a prospective study. *Br J Haematol* 1995;90:655-660.
419. Kaplan C, Morel-Kopp MC, Kroll H, et al. HPA-5b (Br(a)) neonatal alloimmune thrombocytopenia: clinical and immunological analysis of 39 cases. *Br J Haematol* 1991;78:425-429.
420. Noris P, Simsek S, de Bruijne-Admiraal LG, et al. Max^a, a new low frequency platelet-specific antigen localized on glycoprotein IIb, is associated with neonatal alloimmune thrombocytopenia. *Blood* 1995;86:1019-1026.
421. Mueller-Eckhardt C, Becker T, Weisheit M, et al. Neonatal alloimmune thrombocytopenia due to fetomaternal Zwb incompatibility. *Vox Sang* 1986;50:94-96.

422. Mueller-Eckhardt C. Annotation: post-transfusion purpura. *Br J Haematol* 1986;64:419-424.
423. McFarland JG, Blanchette V, Collins J, et al. Neonatal alloimmune thrombocytopenia due to a new platelet-specific alloantibody. *Blood* 1993;81: 3318-3323.
424. McFarland JG, Aster RH, Bussel JB, et al. Prenatal diagnosis of neonatal alloimmune thrombocytopenia using allele-specific oligonucleotide probes. *Blood* 1991;78:2276-2282.
425. Glade-Bender J, McFarland JG, Kaplan C, et al. Anti-HPA-3A induces severe neonatal alloimmune thrombocytopenia. *J Pediatr* 2001;138:862-867.
426. Berry JE, Murphy CM, Smith GA, et al. Detection of Gov system antibodies by MAIPA reveals an immunogenicity similar to the HPA-5 alloantigens. *Br J Haematol* 2000;110:735-742.
427. Davoren A, Curtis BR, Aster RH, et al. Human platelet antigen-specific alloantibodies implicated in 1162 cases of neonatal alloimmune thrombocytopenia. *Transfusion* 2004;44:1220-1225.
428. Newman PJ, Derbes RS, Aster RH. The human platelet alloantigens, PIA1 and PIA2 are associated with a leucine33/proline33 amino acid polymorphism in membrane glycoprotein IIIa, and are distinguishable by DNA typing. *J Clin Invest* 1989;83:1778-1781.
429. Sainio S, Jarvenpaa AL, Renlund M, et al. Thrombocytopenia in term infants: a population-based study. *Obstet Gynecol* 2000;95:441-446.
430. Valentin N, Vergracht A, Bignon JD, et al. HLA-DRw52a is involved in alloimmunization against PL-A1 antigen. *Hum Immunol* 1990;27:73-79.
431. Doughty HA, Murphy MF, Metcalfe P, Waters AH. Antenatal screening for fetal alloimmune thrombocytopenia: the results of a pilot study. *Br J Haematol* 1995;90:321-325.
432. Williamson LM, Hackett G, Rennie J, et al. The natural history of fetomaternal alloimmunization to the platelet-specific antigen HPA-1a (Pl^{A1}, ZW^a) as determined by antenatal screening. *Blood* 1998;92:2280-2287.
433. Ohto H, Yamaguchi T, Takeuchi C, et al. Anti-HPA-5b induced neonatal alloimmune thrombocytopenia: antibody titre as a predictor. *Br J Haematol* 2000;110:223-227.
434. Kiefel V, Bassler D, Kroll H, et al. Antigen-positive platelet transfusion in neonatal alloimmune thrombocytopenia (NAIT). *Blood* 2006;107:3761-3763.
435. Tiller H, Killie MK, Skogen B, et al. Neonatal alloimmune thrombocytopenia in Norway: poor detection rate with nonscreening versus a general screening program. *BJOG* 2009;116:594-598.
436. Birchall JE, Murphy MF, Kaplan C, et al. European collaborative study of the antenatal management of fetomaternal alloimmune thrombocytopenia. *Br J Haematol* 2003;122:275-288.
437. Pacheco LD, Berkowitz RL, Moise KJ Jr, et al. Fetal and neonatal alloimmune thrombocytopenia: a management algorithm based on risk stratification. *Obstet Gynecol* 2011;118:1157-1163.
438. Overton TG, Duncan KR, Jolly M, et al. Serial aggressive platelet transfusion for fetal alloimmune thrombocytopenia: platelet dynamics and perinatal outcome. *Am J Obstet Gynecol* 2002;186:826-831.
439. van den Akker E, Oepkes D, Brand A, Kanhai HH. Vaginal delivery of fetuses at risk of alloimmune thrombocytopenia? *BJOG* 2006;113:781-783.
440. Berkowitz RL, Kolb EA, McFarland JG, et al. Parallel randomized trials of risk-based therapy for fetal alloimmune thrombocytopenia. *Obstet Gynecol* 2006;107:91-96.
441. Thung SF, Grobman WA. The cost effectiveness of empiric intravenous immunoglobulin for the antepartum treatment of fetal and neonatal alloimmune thrombocytopenia. *Am J Obstet Gynecol* 2005;193:1094-1099.
442. Radder CM, de Haan MJ, Brand A, et al. Follow up of children after antenatal treatment for alloimmune thrombocytopenia. *Early Hum Dev* 2004;80:65-76.
443. Shulman NR, Aster RH, Leitner A, Hiller MC. Immunoreactions involving platelets. V. Post-transfusion purpura due to complement-fixing antibody against a genetically controlled platelet antigen. A proposed mechanism for thrombocytopenia and its relevance in "autoimmunity." *J Clin Invest* 1961;40:1597-1620.

444. Vogelsang G, Kickler TS, Bell WR. Post-transfusion purpura: a report of five patients and a review of the pathogenesis and management. *Am J Hematol* 1986;21:259-267.
445. Chapman JF, Murphy MF, Berney SI, et al. Post-transfusion purpura associated with anti-Bak^a and anti-PL^{A2} platelet antibodies and delayed hemolytic transfusion reactions. *Vox Sang* 1987;52:313-317.
446. Cimo PL, Aster RH. Post-transfusion purpura: successful treatment by exchange transfusion. *N Engl J Med* 1972;287:290-292.
447. Keimowitz RM, Collins J, Davis K, Aster RH. Post-transfusion purpura associated with alloimmunization against the platelet-specific antigen, Baka. *Am J Hematol* 1986;21:79-88.
448. Kickler TS, Herman JH, Furihata K, et al. Identification of Baka, a new platelet-specific antigen associated with posttransfusion purpura. *Blood* 1988;71:894-898.
449. Christie DJ, Pulkrabek S, Putnam JL, et al. Post-transfusion purpura due to an alloantibody reactive with glycoprotein Ia/IIa (anti-HPA-5b). *Blood* 1991;77:2785-2789.
450. Bierling P, Godeau B, Fromont P, et al. Posttransfusion purpura-like syndrome associated with CD36 (Naka) isoimmunization. *Transfusion* 1995;35:777-782.
451. Taaning E, Tonnesen F. Pan-reactive platelet antibodies in post-transfusion purpura. *Vox Sang* 1999;76:120-123.
452. Lucas GF, Pittman SJ, Davies S, et al. Post-transfusion purpura (PTP) associated with anti-HPA-1a, anti-HPA-2b and anti-HPA-3a antibodies. *Transfusion Med* 1997;7:295-299.
453. Gerstner JB, Smith MJ, Davis KD, et al. Post-transfusion purpura: therapeutic failure of PL^{A1}-negative platelet transfusion. *Am J Hematol* 1979;6:71-75.
454. Laursen B, Morling N, Rosenkvist J, et al. Post-transfusion purpura treated with plasma exchange by Haemonetics Cell Separator. *Acta Med Scand* 1978;203:539-543.
455. Lau P, Sholtis CM, Aster RH. Post-transfusion purpura: an enigma of alloimmunization. *Am J Hematol* 1980;9:331-336.
456. Becker T, Panzer S, Maas D, et al. High-dose intravenous immunoglobulin for post-transfusion purpura. *Br J Haematol* 1985;61:149-155.
457. Berney SI, Metcalfe P, Wathen NC, Waters AH. Post-transfusion purpura responding to high dose intravenous IgG: further observations on pathogenesis. *Br J Haematol* 1985;61:627-632.
458. Glud TK, Rosthøj S, Jensen MK, et al. High-dose intravenous immunoglobulin for post-transfusion purpura. *Scand J Haematol* 1983;31:495-500.
459. Cines DB, Bussel JB. How I treat idiopathic thrombocytopenic purpura (ITP). *Blood* 2005;106:2244-2251.
460. Narang M, Penner JA, Williams D. Refractory autoimmune thrombocytopenic purpura: responses to treatment with a recombinant antibody to lymphocyte membrane antigen CD20 (rituximab). *Am J Hematol* 2003;74:263-267.

Chapter 48 Thrombotic Thrombocytopenic Purpura, Hemolytic-Uremic Syndrome, and Related Disorders

> Table of Contents > Part V - Disorders of Hemostasis and Coagulation > Section 2 - Thrombocytopenia > Chapter 48 - Thrombotic Thrombocytopenic Purpura, Hemolytic-Uremic Syndrome, and Related Disorders

Chapter 48

Thrombotic Thrombocytopenic Purpura, Hemolytic-Uremic Syndrome, and Related Disorders

Han-Mou Tsai

The various forms of thrombocytopenia discussed in this chapter share the common features of thrombocytopenia and hemolysis with characteristic schistocytes on blood smears (microangiopathic hemolytic anemia, MAHA) (Fig. 48.1). It is believed that thrombocytopenia results from consumption of platelets, whereas erythrocyte fragmentation and hemolysis are due to mechanical injury of the red blood cells by abnormal levels of shear stress.

Fragmentation of the red blood cells occurs in two types of clinical conditions: vascular devices such as prosthetic heart valves, ventricular assist devices, and extracorporeal oxygenator and microvascular stenosis.

In the absence of mechanical devices, fragmentation of the red blood cells signifies stenosis in the arteriolar microvasculature. This is because wall shear stress, determined by blood viscosity, flow rate, and the inverse of the luminal diameter to the third order, is at its highest in the arterioles and may be further increased to exceed the threshold level of red cell fragmentation when the lumen is narrowed. Furthermore, the red cells are likely to be entrapped in the presence of microvascular stenosis. The combination of abnormal shear stress and cell entrapment accounts for red cell fragmentation in patients with arteriolar stenosis. Due to their lower shear stress profile, it is unusual that stenosis in the venules, veins, or arteries is sufficient to cause red cell fragmentation.¹

Arteriolar stenosis may result from one of five different types of pathology (Fig. 48.1): (1) von Willebrand factor (vWF)-platelet thrombosis, as typically observed in patients with thrombotic thrombocytopenic purpura (TTP) due to severe ADAMTS13 (a disintegrin and metalloprotease with thrombospondin type 1 motif, member 13) deficiency; (2) platelet fibrin thrombosis, as exemplified in patients with disseminated intravascular coagulopathy (DIC) but also may occur in a variety of other conditions; (3) tumor cell invasion of the microvasculature in patients with metastatic neoplasm; (4) microvascular vasculitis, as occasionally observed in patients with systemic lupus erythematosus and related autoimmune disorders or certain types of infections such as Rocky Mountain spotted fever and anthrax; and (5) thrombotic microangiopathy (TMA), as observed in patients with the typical shiga toxin-associated hemolytic-uremic syndrome (stx-HUS) following *Escherichia coli* infection, pneumococcal HUS, or atypical hemolytic-uremic syndrome (aHUS) due to defective regulation of the alternative complement pathway.

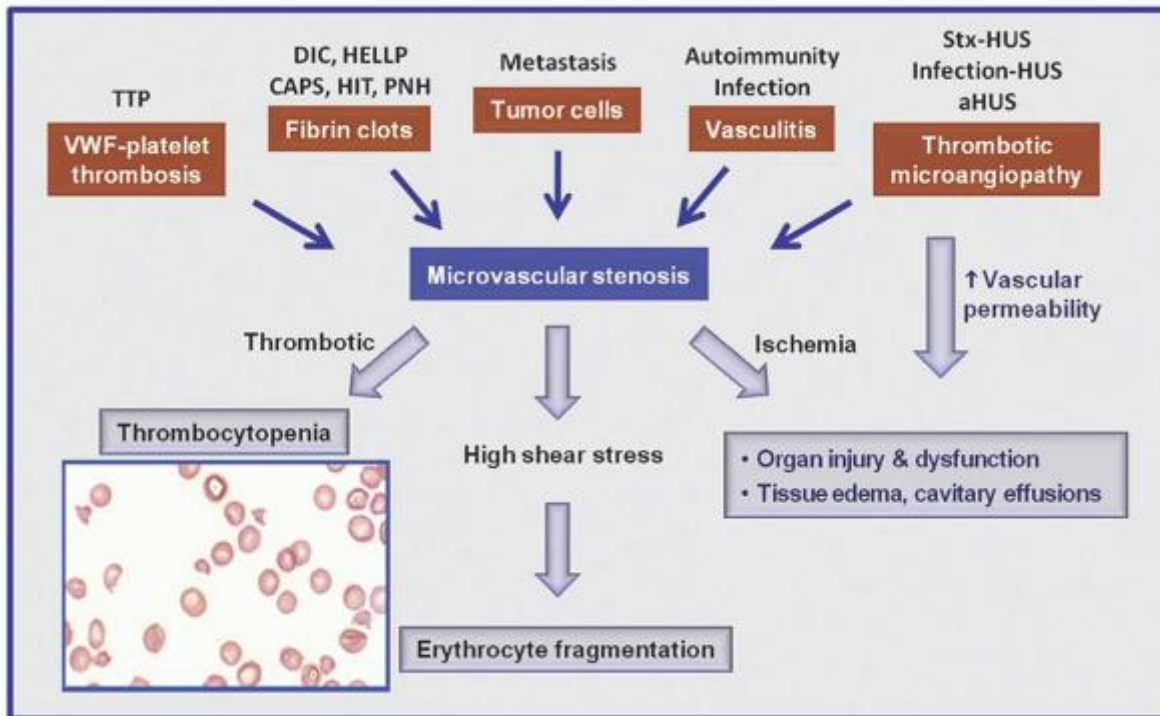

FIGURE 48.1. A scheme depicting how different types of pathology may lead to microvascular stenosis and the syndrome of thrombocytopenia and microangiopathic hemolysis (MAHA). Thrombotic microangiopathy may also lead to tissue edema and organ dysfunction by increasing vascular permeability. DIC, disseminated intravascular coagulopathy; CAPS, catastrophic antiphospholipid antibody syndrome; HELLP, hemolysis with elevated liver enzymes and low platelets; HIT, heparin-induced thrombocytopenia; HUS, hemolytic-uremic syndrome; PNH, paroxysmal nocturnal hemoglobinuria; Stx-HUS, shiga toxin-associated hemolytic-uremic syndrome; TTP, thrombotic thrombocytopenic purpura.

A comprehensive classification of microangiopathic disorders is listed in Table 48.1. This classification includes four groups: TTP, TMA due to defective complement regulation (aHUS), TMA due to other mechanisms, and MAHA due to other types of pathology. In TMA, organ dysfunction may result from thrombotic stenosis, which causes thrombocytopenia and MAHA; non-thrombotic stenosis, which causes MAHA but not thrombocytopenia; and/or abnormal vascular permeability, which causes tissue edema and cavitory effusions but not thrombocytopenia or MAHA. Due to multiple pathogenetic pathways, organ dysfunction or clinical disease severity in patients with aHUS or other types of TMA does not always closely correlate with thrombocytopenia or MAHA. TTP, stx-HUS, and aHUS are further discussed in this chapter.

TABLE 48.1 CLASSIFICATION OF MICROANGIOPATHIC DISORDERS**I. TTP: a disease with propensity to microvascular thrombosis due to ADAMTS13 deficiency**

- Acquired: autoimmune inhibitors of ADAMTS13
- Hereditary: mutations of ADAMTS13

II. aHUS: a disease with propensity to TMA due to defective complement regulation**A: Idiopathic aHUS**

- Mutations or genetic variants of CHF, MCP, CFI, CFB, C3, THBD, etc.
- Autoantibodies to CFH, with or without CFHR1 genomic deletion

B: Co-morbidity as a trigger of aHUS presentation in patients with the disease

- Pregnancy, IV contrast, pancreatitis, infection, inflammation, surgery, trauma, etc.

C: Co-morbidity causing defective complement regulation (e.g., CFH autoantibodies)

- Hematopoietic stem cell therapy
- Suspected, but not yet proven: HIV infection, systemic autoimmune diseases, drugs, etc.

III. TMA via other mechanisms

- Shiga toxin-associated HUS: Shiga toxin-producing *E. coli* or *Shigella dysenteriae*
- Microbial neuraminidases causing T-antigen activation (e.g., *Streptococcus pneumoniae* or *influenza virus*)
- Angiogenesis inhibitor: e.g., bevacizumab
- Undefined mechanisms: hematopoietic stem cell therapy, HIV infection, systemic autoimmune diseases, drugs (e.g., gemcitabine, mitomycin, quinine, calcineurin inhibitors*, cocaine, etc.), severe hypertension**

IV. Other types of pathology

- Microvascular thrombosis comprised of fibrin and platelets
- DIC, CAPS, HELLP syndrome, HIT, PNH, etc.
 - Vasculitis:
- Autoimmune diseases (e.g., systemic lupus erythematosus)
- Infectious diseases (e.g., Rocky Mountain spotted fever, anthrax)
 - Intravascular clusters of neoplastic cells
 - Intravascular devices:
- Ventricular assist device, extracorporeal membrane oxygenator, prosthetic heart valves, etc.

ADAMTS13, a disintegrin and metalloprotease with thrombospondin type 1 motif, member 13; aHUS, atypical hemolytic-uremic syndrome; CAPS, catastrophic antiphospholipid antibody syndrome; CFB, complement factor B; CFH, complement factor H; CFHR1, complement factor H-related protein 1; CFI, complement factor I; DIC, disseminated intravascular coagulopathy; HELLP, hemolysis with elevated liver enzymes and low platelet count; HUS, hemolytic-uremic syndrome; HIT, heparin-induced thrombocytopenia; MCP, membrane cofactor protein (CD46); PNH, paroxysmal nocturnal

hemoglobinuria; THBD, thrombomodulin; TMA, thrombotic microangiopathy; TTP, thrombotic thrombocytopenic purpura; vWF, von Willebrand factor.

* Some patients are found to have aHUS with defective complement regulation.

** Severe hypertension may be a consequence of aHUS rather than cause of thrombotic microangiopathy

ACQUIRED THROMBOTIC THROMBOCYTOPENIC PURPURA

The current definition of TTP is based on the demonstration of autoimmune inhibitor for acquired TTP and genetic mutation of the ADAMTS13 gene for hereditary TTP. By this definition, TTP is a disease that is prone to, but does not always have, microvascular thrombosis, thrombocytopenia, microangiopathic hemolysis, or organ dysfunction.

This definition is different from the conventional diagnosis of TTP as a clinical syndrome. It requires the demonstration of ADAMTS13 inhibitors or mutations and encompasses patients who are asymptomatic and patients who do not have thrombocytopenia or microangiopathic hemolysis.

The problem of conventional TTP diagnosis based solely on clinical features is most clearly illustrated by the vast difference in the prevalence of severe ADAMTS13 deficiency among the patients in the Canadian Apheresis Group trial on the efficacy of plasma therapy and the patients in the Oklahoma TTP registry. Severe ADAMTS13 deficiency was detectable in more than 76% of the patients in the Canadian Apheresis Group trial, yet in less than 15% of the patients in the Oklahoma registry.^{1, 2, 3} Indeed, many clinical series of 'TTP' or 'TTP/HUS' included patients with atypical HUS or other causes of microangiopathic hemolysis, resulting in confusion in the diagnosis and management of patients presenting with microangiopathic hemolysis and thrombocytopenia.

Pathology

The pathology of TTP, as first described by Moschcowitz in 1925⁴, is quite distinctive: widespread hyaline thrombi in the terminal arterioles and capillaries, accompanied by no or little endothelial injury or inflammation (i.e., microangiopathy) (Fig. 48.2A). The thrombi are present most extensively in the heart, pancreas, spleen, kidney, adrenal gland, and brain (mainly cerebral cortex) and are composed primarily of platelets and vWF (Fig. 48.2B).^{5, 6, 7} Small amounts of fibrin may be present surrounding or sometimes penetrating the amorphous or granular material. Glomerular microthrombi are usually spotty, and cortical necrosis of the kidney is uncommon in TTP. Fibrinoid necrosis and vascular or perivascular inflammatory cell infiltration are characteristically absent or minimal.

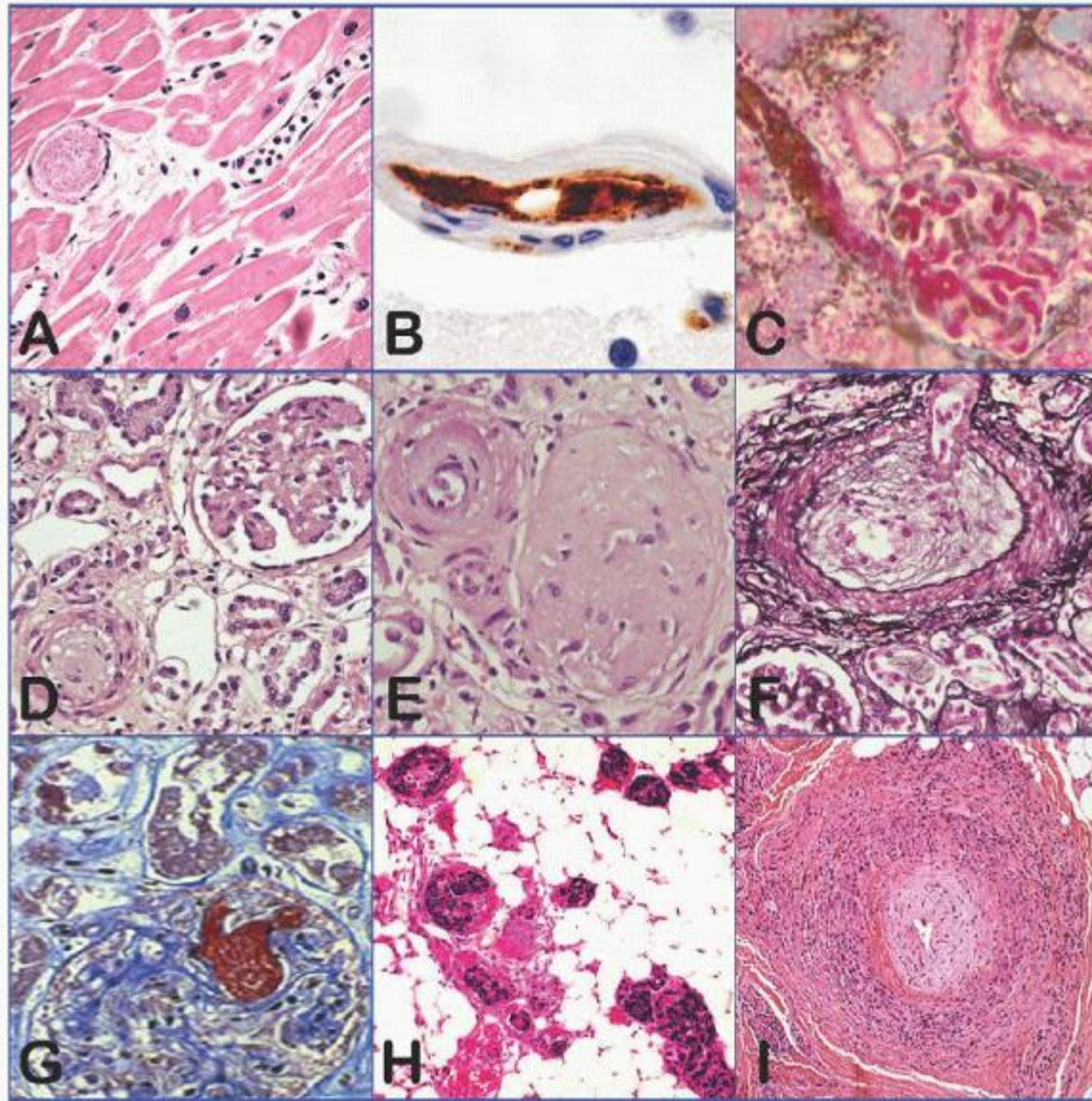

FIGURE 48.2. Histopathology and histochemistry of thrombotic thrombocytopenic purpura (TTP) and other microangiopathic disorders. A: TTP (heart); B: TTP (brain); C: shiga toxin-associated hemolytic-uremic syndrome (HUS) (kidney); D-F: atypical HUS (kidney); G: disseminated intravascular coagulopathy (DIC) (kidney); H: tumor cell invasion of microvasculature in metastatic neoplasm (soft tissue); I: proliferative vasculitis of lupus causing microvascular stenosis (soft tissue). The endothelial cells and the vessel wall are intact in TTP and DIC. All images are H&E stains except panel B (immunohistochemical stain for vWF, brown), panels C and G (fibrin stain of Carstairs), and panel F (Jones silver stain).

P.1079

In chronic cases, the thrombi may be infiltrated by fibroblasts or converted to subendothelial deposits by proliferating endothelial cell lesions. Pseudoaneurysmal dilatation may also be present upstream of the stenosis or occlusion.

In the literature, some investigators have suggested that endothelial cell injury is prominent in TTP. A review of the clinical features in those reports suggests that those patients likely had shiga toxin-associated or atypical HUS rather than TTP.

Pathophysiology

Historically two schemes have been proposed to account for the microvascular thrombosis in TTP: endothelial cell injury and uncontrolled platelet aggregation. The scheme of endothelial cell injury is not consistent with the absence or paucity

of microangiopathy in TTP patients. The predominance of vWF and platelets in the thrombi and the integrity of vascular endothelial cells suggest that thrombosis results from dysregulation of vWF-platelet interaction in TTP.

vWF, a plasma glycoprotein derived primarily from vascular endothelial cells, supports platelet adhesion and aggregation at sites of microvascular injury under high shear stress conditions. Deficiency in vWF causes defective microvascular hemostasis and a bleeding diathesis in patients with von Willebrand disease.

vWF is synthesized in vascular endothelial cells as a disulfide-bonded polymer that is converted to a series of multimers in the circulation (Fig. 48.3). This conversion is mediated by repetitive cleavage at the Tyr1605-Met1606 bond by ADAMTS13.

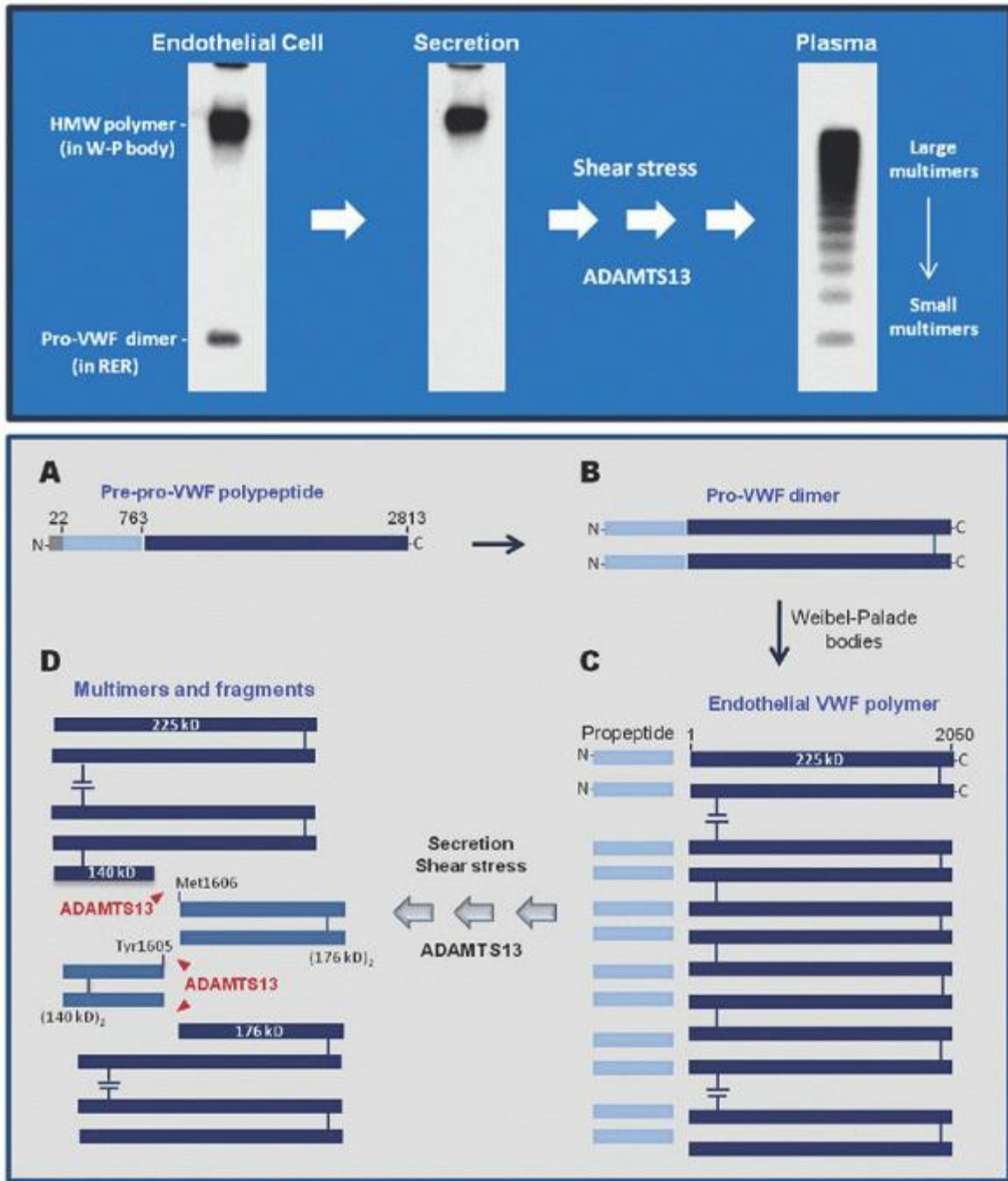

FIGURE 48.3. Gels and schemes depicting how vWF multimers are generated in the circulation. Upper panel: gels showing von Willebrand factor (vWF) polymer and multimers. In vascular endothelial cells vWF exists in two forms, a dimer of pro-vWF polypeptide in the rough endoplasmic reticulum (RER) and a polymer of mature vWF polypeptide in the Weibel-Palade bodies. Only the vWF polymer is secreted. Under the high shear stress conditions of the microcirculation, the vWF

polymer is cleaved by ADAMTS13. A repetition of this process converts a vWF polymer to a series of multimers in normal plasma. vWF is separated by SDS-agarose gel electrophoresis and visualized with a radio-labeled antibody to vWF. Lower panel: a scheme of vWF biosynthesis and proteolysis. A: Pre-pro-vWF with 2,813 amino acid residues. B: A dimer of pro-vWF with disulfide bonds near the C-terminus. C: In the Weibel-Palade bodies, a vWF polymer is formed through disulfide bonding near the N-terminus of vWF dimers and cleavage of the propeptide. D: Under the high shear stress conditions of the microcirculation, vWF is cleaved at the Tyr1605-Met1606 bond, generating dimers of the 140 kD and 176 kD fragments and a series of progressively smaller multimers.

vWF exists in a compact form with its cleavage sites and platelet binding sites cryptic. This explains why in a test tube vWF is not susceptible to cleavage by ADAMTS13 and is inactive in aggregating platelets. High levels of shear stress induce a conformational change of vWF, exposing its binding sites for platelet receptors (Fig. 48.4A). Due to its large molecular size and responsiveness to shear stress, vWF is uniquely capable of supporting platelet adhesion and aggregation under high shear stress conditions.

In the circulation, the activation of vWF by shear stress is prevented by ADAMTS13, which cleaves vWF whenever its cleavage sites are exposed by shear stress. The process of proteolysis is repeated during each cycle of circulation through the microvasculature, thereby converting vWF from a large polymer to a series of multimers while maintaining vWF in its compact inactive configuration (Fig. 48.4B).

A disruption in this proteolytic regulation of vWF occurs in TTP, in which ADAMTS13 deficiency, due to genetic mutation or autoimmune inhibitors, leads to incessant unfolding and activation of vWF by shear stress, resulting in vWF-platelet binding and microvascular thrombosis (Fig. 48.4C). This explains why a severe deficiency of ADAMTS13 can lead to microvascular thrombosis characteristic of TTP.

P.1080

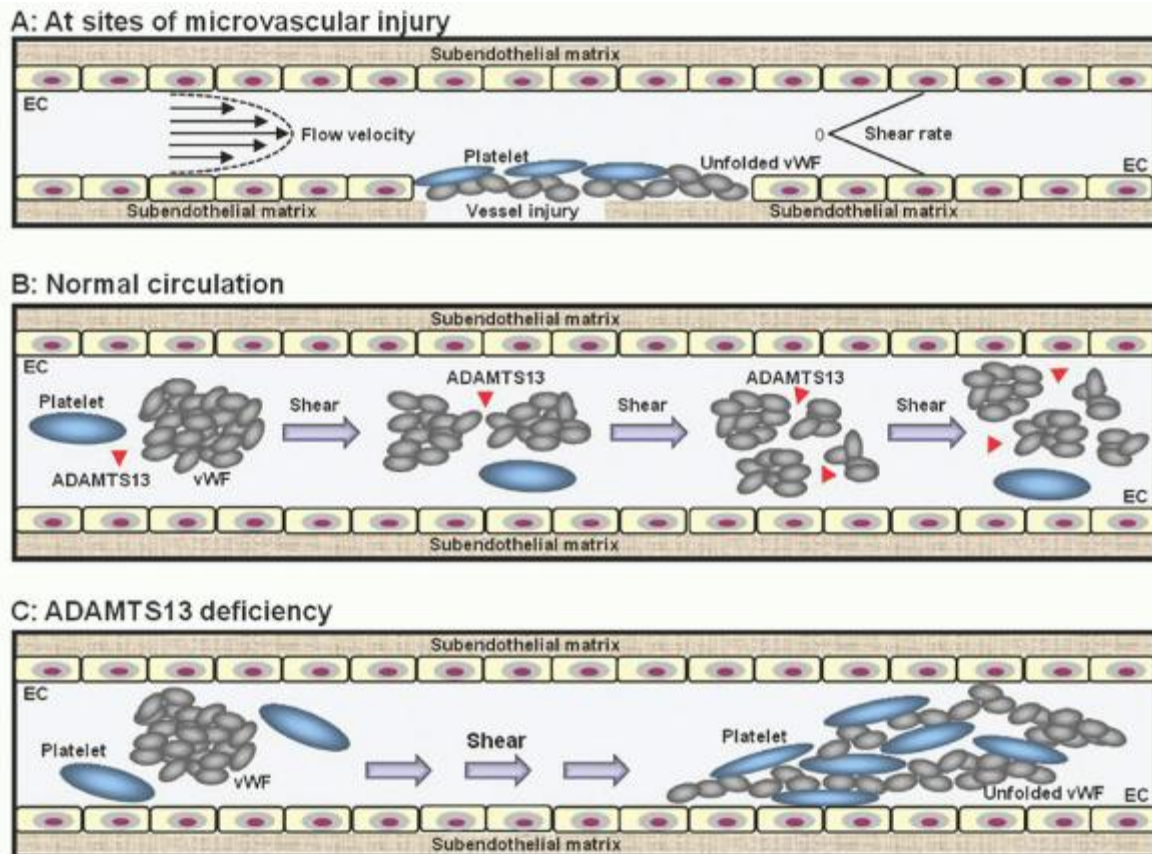

FIGURE 48.4. A scheme depicting how ADAMTS13 deficiency leads to von Willebrand factor (vWF)-platelet aggregation and microvascular thrombosis seen in thrombotic thrombocytopenic purpura (TTP). A. The responsiveness of vWF to shear stress allows it to be activated at sites of microvascular injury to support platelet adhesion and aggregation. B. In the

circulation, vWF-platelet aggregation is prevented by ADAMTS13, which cleaves vWF whenever its cleavage sites are exposed by shear stress. This process maintains vWF in its compact inactive configuration while its size becomes progressively smaller. C. In the absence of ADAMTS13, vWF is relentlessly activated by shear stress, leading to vWF-platelet aggregation and microvascular thrombosis of TTP. Thrombosis increases the shear stress in the microcirculation, leading to further cycles of vWF-platelet aggregation.

Observations in patients with TTP reveal that vWF-platelet aggregation and thrombosis does not occur when the plasma ADAMTS13 activity level is greater than 10% of normal. On the other hand, a patient with ADAMTS13 activity less than 10% may be asymptomatic and may have a normal platelet count. This is because other factors such as platelet number, vWF level, shear stress profile in the circulation, and modifiers of vWF response to shear stress such as thrombospondin⁸ may affect the propensity to vWF-platelet aggregation when ADAMTS13 is deficient.

Distinction between Thrombotic Thrombocytopenic Purpura Disease and Its Complications

A patient with autoimmune inhibitors or genetic mutations of ADAMTS13 may be completely asymptomatic and have normal blood counts. Such asymptomatic individuals are considered to have TTP, the disease, and are prone to the development of microvascular thrombosis causing clinical features such as thrombocytopenia, microangiopathic hemolysis, neurologic deficits, and injury of other organs.

Animal Models of ADAMTS13 Deficiency

Animal models of severe ADAMTS13 deficiency have been created in mice by inactivation of the ADAMTS13 gene and in baboons by infusion of an inhibitory ADAMTS13 antibody.^{9, 10, 11} In both models, thrombi comprising vWF and platelets ensue in the arterioles. The findings in these animal models support the role of ADAMTS13 deficiency in causing microvascular thrombosis of TTP. Nevertheless, some mouse strains are phenotypically free of thrombosis. The difference in phenotypic severity among the mouse strains highlights the principle of epistasis in which the composition of other genes modifies the expression of a molecularly defined disease.

Interactions between von Willebrand factor and ADAMTS13

The vWF polypeptide comprises a series of homologous domains. The cleavage site of vWF, Tyr1605-Met1606, is located in the A2 domain, sandwiched between the A1 domain, which contains epitopes interacting with the platelet glycoprotein Ib, and the A3 domain, where a collagen-binding epitope is located (Fig. 48.5). This topographic arrangement facilitates the regulation of platelet thrombus formation, as cleavage of vWF at the A2 domain disengages the platelet from the vessel wall.

Structural studies confirm that shear stress induces vWF cleavage by altering the conformation of vWF.^{12, 13} Narrow-angle neutron scattering studies of vWF in guanidine hydrochloride, which also promotes vWF cleavage by ADAMTS13,¹⁴ or after exposure to shear stress, shows that conformational change at the subdomain level is sufficient for proteolysis to occur.^{15, 16} Unfolding of vWF to extended configurations at the multimeric level is not necessary for proteolysis.

ADAMTS13, comprising 1,427 amino acid residues, is a member of the ADAMTS metalloprotease family, which shares a conserved domain structure of metalloprotease (MP)-disintegrin (Dis)-thrombospondin type 1 repeat (TSR)-cysteine rich region (Cys) and spacer (Spa) domains. ADAMTS13 contains 7 additional TSR downstream of the Spa domain, followed by two unique CUB (complement C1r/C1s, Uegf, Bmp1) domains (Fig. 48.5).

ADAMTS13 is synthesized primarily in the stellate cells of the liver.^{17, 18} ADAMTS13 may also be expressed, albeit at much P.1081

lower levels by at least one to two orders, in the spleen and other organs. The localization of its biosynthesis to the stellate cells instead of hepatocytes may be instrumental in maintaining the ADAMTS13 activity in patients with hepatic insufficiency, as the stellate cells react to liver injury by activation and proliferation. The expression of ADAMTS13 in hepatic stellate cells and endothelial cells may be down-regulated by cytokines such as IFN- γ , TNF- α , and IL-4.¹⁹

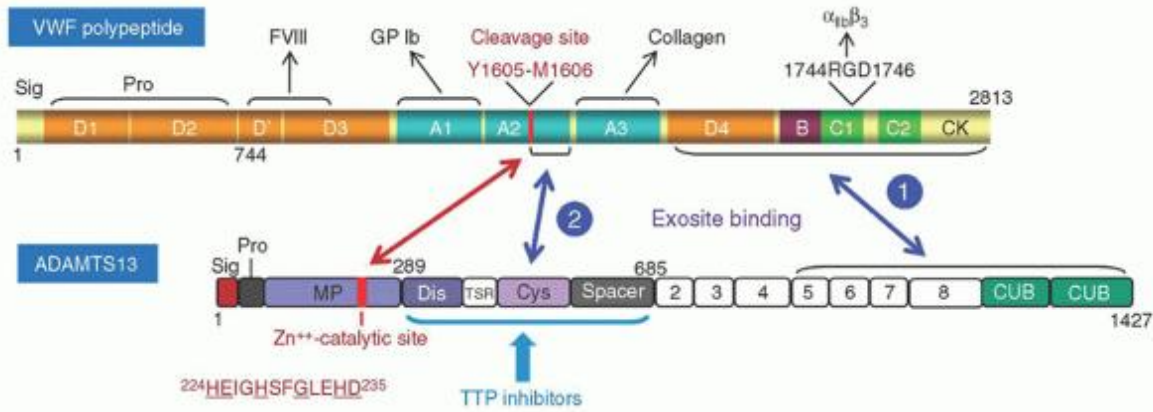

FIGURE 48.5. A scheme depicting the domain structures of von Willebrand factor (vWF) and ADAMTS13 and their interactions. The cleavage of vWF by ADAMTS13 involves exosite and catalytic interactions. It is believed that the exosite binding 1 occurs constitutively, whereas exosite binding 2 occurs only when the sequence in the A2 domain downstream of the scissile bond Tyr1605-Met1606 is exposed by shear stress. The exosite bindings orient the catalytic site of ADAMTS13 to attack the scissile bond of vWF (double-headed red line). The inhibitors of thrombotic thrombocytopenic purpura (TTP) patients target the exosites of ADAMTS13 downstream of the metalloprotease domain.

Expression of ADAMTS13 has been described in the renal glomerular podocytes and endothelial cells and vascular endothelial cells in culture.^{20, 21} The ADAMTS13 expressed in renal glomeruli may cleave vWF before it is neutralized by autoantibodies, accounting for the generally milder renal injury observed in acquired versus hereditary TTP.

The metalloprotease domain of ADAMTS13 contains a catalytic 224-HEIGHSFGL EHD-235 module characteristic of the ADAMTS proteases (conserved residues are underlined). Structural analysis has identified three surface exosites of ADAMTS13 in the Dis, Cys, and Spa domains that react with discrete epitopes of the vWF A2 sequence around and downstream of the Tyr1605-Met1606 scissile bond.^{22, 23}

The exosite bindings greatly enhance the efficiency of catalytic reaction between ADAMTS13 and vWF. The vWF scissile bond and the exosite binding sites of the vWF A2 domain are normally cryptic, only exposed by tensile force to initiate interaction with ADAMTS13. Another exosite in the TSR5-CUB region of ADAMTS13 may interact with a constitutively exposed epitope in the N-terminal D4-CK region of vWF. This C-terminal binding may facilitate the interaction of the exosites upstream.

Alteration of von Willebrand factor Multimers in Thrombotic Thrombocytopenic Purpura

The involvement of vWF in the pathophysiology of TTP was first suggested by the intriguing observation that large multimers disappear during acute crisis of chronic relapsing TTP and yet ultra-large multimers are present during remission.²⁴

The complexity of vWF multimers in TTP is due to two opposing processes acting upon plasma vWF in patients with ADAMTS13 deficiency: deficiency of ADAMTS13 leading to the presence of ultra-large multimers; and the activation of vWF by shear stress leading to the consumption and depletion of ultra-large and large multimers.

Three types of vWF multimer abnormalities are observed in TTP (Fig. 48.6). A shift of vWF to ultra-large forms occurs when ADAMTS13 activity is <20% to 30%; at this stage, no platelet thrombosis occurs (lane 1). The ultra-large and large multimers are partially depleted when ADAMTS13 is <10% and vWF-platelet aggregation begins to occur (lane 2). The ultra-large multimers are depleted and the large multimers are further decreased or depleted in patients presenting with extensive thrombosis and severe thrombocytopenia (lane 3).

The vWF changes in TTP are a dynamic process, as the multimers in a plasma sample represent a snapshot of the balance of the two changes acting in opposite directions. Transition from one multimer pattern to another occurs swiftly during the course of the disease, reflecting the changes in ADAMTS13 level and the process of vWF-platelet aggregation.

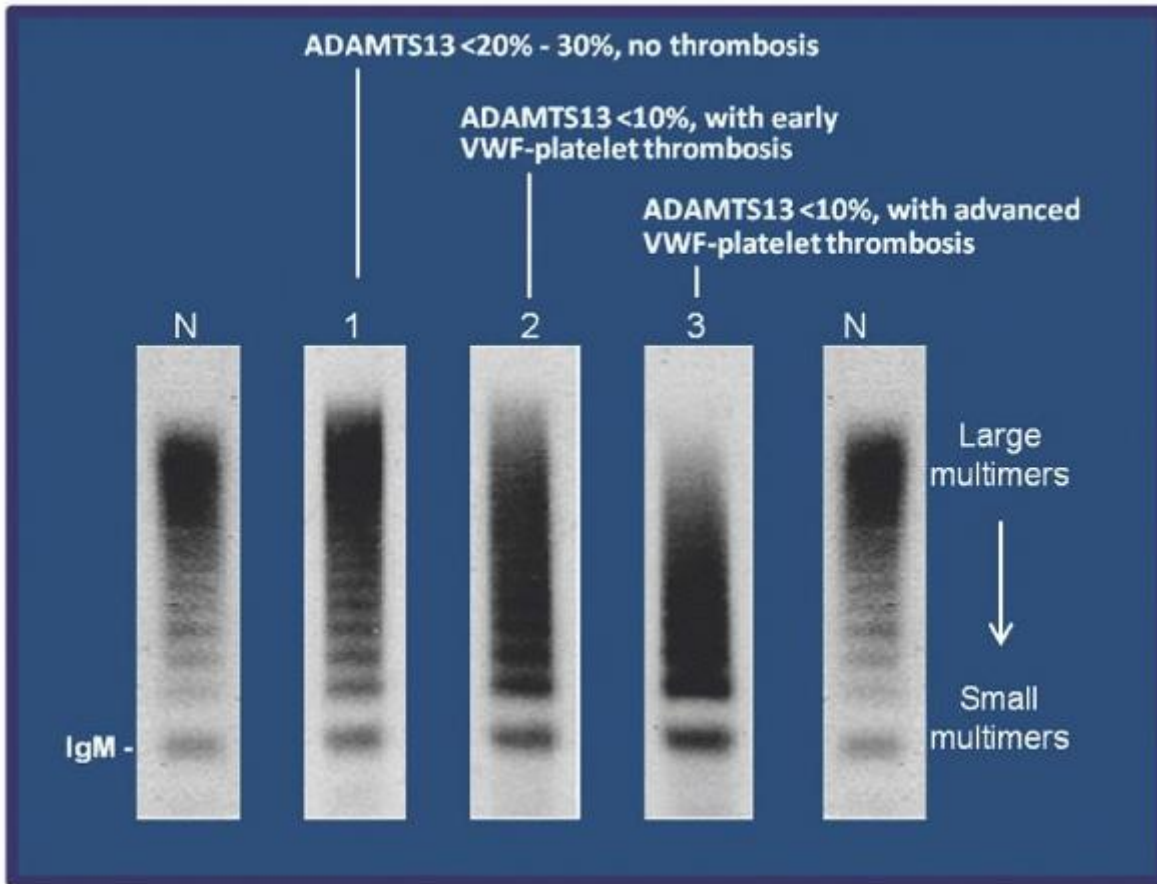

FIGURE 48.6. von Willebrand factor (vWF) abnormalities in thrombotic thrombocytopenic purpura (TTP) reflect the balance of underlying ADAMTS13 deficiency and vWF-platelet thrombosis. Three types of vWF abnormalities are detected in TTP during its course: Lane 1: A shift of vWF to ultra-large forms occurs when ADAMTS13 activity is <20%-30%. Lane 2: The ultra-large and large multimers are decreased when ADAMTS13 is <10%, and vWF-platelet aggregation begins to occur. Lane 3: The ultra-large multimers are depleted and the large multimers are further decreased in patients presenting with extensive thrombosis and severe thrombocytopenia.

P.1082

In other types of microangiopathic hemolysis such as shiga toxin-associated or atypical HUS, depletion of the large vWF multimers also occurs. In these conditions, the loss of large multimers is due to excessive cleavage of vWF by ADAMTS13 under abnormal shear stress conditions.⁷

Other Pathogenic Mechanisms in Thrombotic Thrombocytopenic Purpura

Various hypotheses have been proposed to explain the thrombosis of TTP, including defects in fibrinolytic activity²⁵ or prostacyclin homeostasis,²⁶ increased circulating thrombomodulin, abnormal tissue plasminogen activator or plasminogen activator inhibitor-1 levels,²⁷ antiendothelial cell antibodies,^{28, 29, 30} immune complexes,³¹ platelet aggregating proteins,³² anti-CD36 antibodies,³³ calcium-dependent cysteine proteases,³⁴ endothelial cell apoptotic factors,³⁵ and activation of the complement system.³⁶ These observations are preliminary, represent secondary changes, or are not specific for TTP.^{37, 38, 39, 40, 41} Immune complexes and activation of the complement system detected in patients with TTP may result from ADAMTS13 binding with its antibodies.

Causes of ADAMTS13 Deficiency

Severe ADAMTS13 deficiency results primarily from autoimmune inhibitors of the protease,⁴² although in a small number of patients the deficiency is the consequence of homozygous or, more commonly, compound heterozygous mutations of the ADAMTS13 gene.⁴³

The ADAMTS13 activity level is also decreased in various pathologic conditions such as sepsis, malarial infection, multiorgan failure, major surgery, DIC, metastatic neoplasm, and pregnancy.^{44, 45, 46, 47, 48, 49, 50, 51} In these conditions, the decrease in ADAMTS13 levels is mild to moderate, and generally not sufficient to cause platelet aggregation. Yet the decrease induced by infection, surgery, or pregnancy may be sufficient to precipitate vWF-platelet aggregation and thrombosis in patients with pre-existing ADAMTS13 mutations or inhibitors, giving rise to the suspicion that these conditions cause TTP.

The ADAMTS13 activity is also less stable in pathologic samples, yielding falsely low ADAMTS13 levels if the samples are not properly handled.

Autoimmune Inhibitors of ADAMTS13

In patients with acquired TTP, which accounts for >95% of TTP cases, deficiency of ADAMTS13 results from autoimmune inhibitors of the ADAMTS13 protease.⁵² In most cases of acquired TTP the causes of the autoimmunity are unknown. It is speculated that an otherwise innocuous infection may induce autoimmune reaction to ADAMTS13 in genetically susceptible individuals. Indeed 10% to 40% of TTP patients exhibit positive autoimmune reactions to other antigens, suggesting they have defective immune regulation. Deranged immune regulation is consistent with the finding that the HLADRB1*11 allele is overrepresented among patients with acquired TTP.⁵³

Ticlopidine therapy increases the risk of developing ADAMTS13 antibodies by 50- to 300-fold.^{54, 55} The antibodies occur between 2 to 8 weeks after institution of ticlopidine therapy, respond to plasma exchange and discontinuation of the culprit drug, and generally do not recur. Although another anti-platelet thienopyridine, clopidogrel, has also been implicated,⁵⁶ an association between clopidogrel and TTP has not been confirmed.

HIV infection has been associated with TTP.⁵⁷ It is estimated that the risk is increased by 35-fold among patients not being treated with antiretroviral therapy. This higher risk may be related to the predisposition of HIV-infected individuals to autoimmunity.

An ADAMTS13 polymorphism (R1060W) is reportedly more prevalent in acquired TTP patients than in the population, raising the speculation that certain ADAMTS13 polymorphisms may predispose the affected individuals to develop ADAMTS13 inhibitors.⁵⁸ The validity of this association remains to be confirmed.

ADAMTS13 Mutations

DNA sequence analysis reveals that hereditary TTP patients have compound heterozygous or, less commonly, homozygous mutations of the ADAMTS13 gene on chromosome 9q34.⁵⁹ More than 80 mutations, including nonsense, missense, frame-shifting insertion or deletion, and splicing mutations, have been detected in patients with hereditary TTP.

Only a few mutations have been detected in seemingly unrelated families. One mutation, 4143insA, has been detected in at least 15 patients in central-northern Europe, Turkey, and Australia that appear to share a common haplotype.⁶⁰

More than 25 polymorphisms have also been detected in the coding sequence of ADAMTS13. One polymorphism, P475S, common among Japanese (5%), Koreans (4%), and Chinese (1%), makes the ADAMTS13 variant more susceptible to inhibition by urea,^{61, 62, 63} which is used in some ADAMTS13 assays.⁶⁴ It yields falsely low ADAMTS13 activity levels if urea-based assays are used.⁶⁵ Certain cis-combinations of polymorphisms or mutation/polymorphism may result in severe ADAMTS13 deficiency.⁶⁶

Characteristics of the Inhibitors

In most patients the levels of the ADAMTS13 inhibitors are low (<10 U/ml), and often further decrease to undetectable levels after a few weeks or months. Occasionally the inhibitor level may surge to very high levels.

The ADAMTS13 inhibitors of TTP are primarily IgG, with IgA and IgM antibodies detectable infrequently.⁶⁷ The VH1-69 germline heavy chain gene appears to be used most frequently in producing the ADAMTS13 antibodies.⁶⁸ All four subclasses of IgG have been detected, although IgG4 appears to be the most prevalent, detectable in ≥90% of the patients according to one study.

Targets of the ADAMTS13 Inhibitors

The cysteine-rich region and spacer domain are an integral part of the epitopes of ADAMTS13 reacting with the inhibitors of TTP patients. ADAMTS13 variants truncated upstream of the cysteine-spacer domain, but not those truncated downstream, exhibit markedly decreased but detectable vWF cleaving activity that is not suppressible by the inhibitors of patients with TTP.⁶⁹ This decreased activity is consistent with the existence of critical exosites in the deleted domains.

Such nonsuppressible ADAMTS13 species may be exploited to overcome the therapeutic difficulty posed by ADAMTS13 inhibitors.

Further mapping studies show that residues R660, Y661, and Y665 in the spacer domain are critical for binding with vWF A2 domain sequences.⁷⁰ They are also the target of TTP inhibitors. Substitution of residues Arg660, Tyr661, or Tyr665 in ADAMTS13 with Ala abolishes the binding targets of ADAMTS13 inhibitors. Intriguingly, two vWF variants with substitutions of these three residues exhibit increased vWF cleaving activity by several fold. Such “super” variants of ADAMTS13 may be potential candidates as a replacement therapy for patients with TTP, although immune responses to these foreign proteins may be a concern.⁷¹

Some studies found that TTP antibodies may also target other epitopes downstream of the spacer domain. However, it remains unclear whether these antibodies contribute to ADAMTS13 deficiency in TTP patients.⁷²

Clinical Presentation

The incidence of TTP is estimated to be 2 to 15 cases per 1×10^6 person-years.^{3, 48, 49} The broad range of the observed incidence

P.1083

rates is likely due to differences in demographics, particularly the prevalence rate of HIV infection in the population.

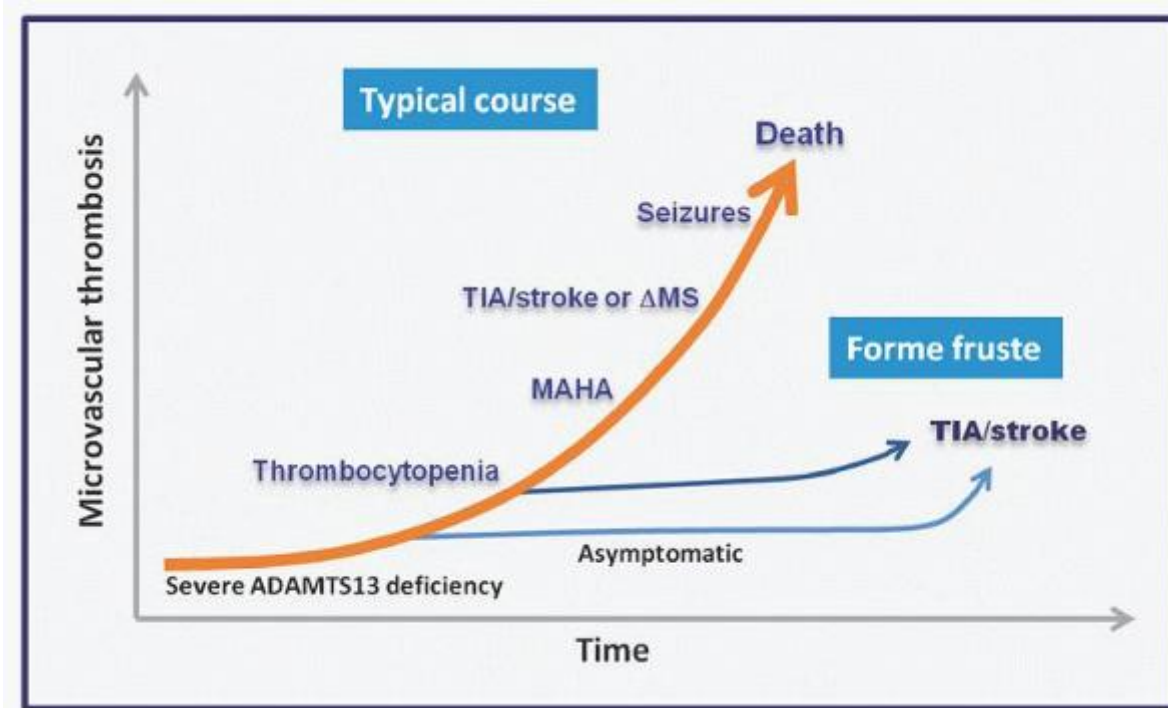

FIGURE 48.7. Progression of thrombotic complications in thrombotic thrombocytopenic purpura (TTP). When ADAMTS13 decreases below the threshold level, microvascular thrombosis begins to occur. In most patients, TTP evolves progressively from ADAMTS13 deficiency to thrombocytopenia, microangiopathic hemolytic anemia (MAHA), fleeting neurologic deficits (TIA), stroke, altered mental status, seizures, and death if it is not treated. Occasionally, a patient may be detected at the thrombocytopenia stage when a CBC is ordered for other reasons. TTP may also present in forme fruste, with microvascular thrombosis causing TIA or stroke before thrombocytopenia or MAHA occurs. Δ MS, altered mental status.

Acquired TTP primarily affects adolescents and adults, with median and mode ages between 30 and 40 years, although TTP may occasionally affect children <10 years of age. In most clinical series, the female-to-male ratio is 2 to 3:1.

Many patients present with the triad of thrombocytopenia, microangiopathic hemolytic anemia (MAHA), and neurologic deficits or the triad with fever and renal dysfunction (pentad); neither is invariably present or specific for the diagnosis of TTP. In a typical case, the course of TTP begins with the appearance of ADAMTS13 inhibitors, which progressively decrease

the plasma ADAMTS13 level, eventually leading to microvascular thrombosis, thrombocytopenia, microangiopathic hemolysis, and organ dysfunction (Fig. 48.7).

The duration of asymptomatic ADAMTS13 deficiency is quite variable, ranging from a few days to years. Serial monitoring of patients with a history of acquired TTP suggests that the plasma ADAMTS13 activity level may fluctuate for weeks to months before decreasing to less than 10% of normal and causing thrombosis.

Thrombocytopenia is detectable when platelet consumption exceeds compensatory platelet production. The stage of thrombocytopenia without overt hemolytic anemia may last for days to months, and the course of TTP at this stage is not invariably downhill; some patients may spontaneously revert to a normal platelet count. The patients at this stage may be given the incorrect diagnosis of immune thrombocytopenic purpura (ITP). On the other hand, infection, surgery, or pregnancy may worsen microvascular thrombosis in patients with subclinical ADAMTS13 deficiency, giving rise to the clinical impression that TTP is triggered by these events. Neurologic complications typically, albeit not invariably, present later, when thrombocytopenia is profound and microangiopathic hemolysis is evident.

Most of the patients have no other significant medical history and begin to notice ill-defined symptoms such as headache, dizziness, and fatigue that are often considered insignificant until more serious complications such as profound fatigue, focal neurologic deficits, syncope, mental status changes, or seizures ensue. Less frequently, a patient may present with abdominal pain, nausea, and vomiting, with or without pancreatitis, or chest pain due to myocardial infarction, or even sudden death.

Advanced renal failure causing oliguria, anuria, fluid retention, electrolyte abnormalities, or uremia is rare in acquired TTP. The creatinine generally increases only minimally. When advanced renal failure occurs in a patient with acquired TTP, it is likely due to other causes.

Thrombotic Thrombocytopenic Purpura without Microangiopathic Hemolysis or Thrombocytopenia

Thrombocytopenia and microangiopathic hemolysis are not invariably present at the time of acute presentation (Fig. 48.7). Relapse of TTP is also increasingly diagnosed before microangiopathic hemolysis ensues.

Until recently, TTP presenting with acute stroke or transient ischemic attack without overt microangiopathic hemolysis was diagnosed only in retrospect after the patients went on to develop thrombocytopenia and microangiopathic hemolysis. ADAMTS13 assays greatly facilitate the diagnosis of atypical TTP.

Hereditary Thrombotic Thrombocytopenic Purpura

Also known as Schulman-Upshaw syndrome or chronic relapsing TTP, hereditary TTP is rare, accounting for <5% of all TTP cases.^{73, 74} Because the diagnosis is not recognized in milder cases, the incidence is likely higher than presently appreciated.⁷⁵

Hereditary TTP typically has its initial manifestations during the neonatal period, but historically is often not recognized until later in life.^{76, 77} Some of these patients have siblings who died before birth presumably due to TTP complications. Milder cases may present with thrombotic complications or have their disease recognized later in their life.^{76, 77, 78}

In a typical case, the affected neonate is born with meconium stain or presents within a few hours after birth with neonatal distress, jaundice, and thrombocytopenia. Hemolysis may not be severe and schistocytes on blood smears may be overlooked. Occasionally, serious complications such as seizures and mental obtundation may occur.

The symptoms typically improve immediately after blood transfusion or exchange transfusion performed unknowingly for thrombocytopenia or hyperbilirubinemia. Consequently, the neonates may be discharged from the hospital without a correct diagnosis, only to present with complications of the disease weeks or years later.

Like most genetic disorders, hereditary TTP varies in its severity. Many patients with hereditary TTP invariably develop hematologic or other complications if not treated regularly with plasma infusion every 2 to 4 weeks. Others have no or only subtle symptoms and maintain normal or mildly subnormal platelet counts and develop more serious complications only intermittently. The severity may also vary during the lifetime of individual cases, with or without apparent exacerbating conditions such as pregnancy.

The thrombotic process may cause focal neurologic deficits, seizures, pancreatitis, or renal failure.^{79, 80} Of the patients not receiving regular plasma infusion, 10%-20% of the cases develop at least one episode of acute renal failure requiring dialysis during their course. The renal failure is reversible if the patients promptly receive plasma infusion. Chronic renal failure occurs in approximately 10% of the patients not being regularly treated with plasma infusion, likely a result of cumulative microinfarcts in the kidney.

The propensity to acute and chronic renal disease in hereditary TTP is quite different from its rarity in acquired TTP. It is speculated that local expression of ADAMTS13 in renal glomerular podocytes and endothelial cells²⁰ may provide protection against vWF-platelet aggregation before its activity is suppressed by the inhibitors. Such protection is not present in patients with genetic ADAMTS13 mutations. Rarely renal failure may occur because the patient also has concurrent atypical HUS.⁸¹

Laboratory Findings

In de novo TTP cases presenting at the emergency service, the diagnosis is typically raised by the laboratory findings of severe

P.1084

thrombocytopenia and hemolysis with the presence of schistocytes on blood smears. The haptoglobin level is decreased or undetectable. Other common laboratory tests for assessment of hemolysis, including reticulocyte count, LDH, and indirect bilirubin are often but not invariably abnormal. In chronic cases, hemolytic anemia may predominate, as active platelet consumption is masked by compensatory thrombopoiesis.

As mentioned above, a patient with TTP may have no symptoms or may present with acute focal neurologic deficits without thrombocytopenia and/or microangiopathic hemolysis. Therefore, absence of thrombocytopenia or microangiopathic hemolysis in laboratory tests does not exclude the diagnosis of TTP.

Hematuria and proteinuria reflect renal glomerular thrombosis. The increase in the creatinine level is minimal in most cases. This is consistent with the pathologic findings that the kidney is minimally affected and its architecture is well preserved in TTP patients at autopsy.

Overt renal failure causing hypertension, fluid retention, electrolyte derangement, oliguria, or anuria favors the diagnosis of typical or atypical HUS over autoimmune TTP, unless there is a concurrent renal disorder. As mentioned above, acute and chronic renal failure may occur in patients with hereditary TTP.

Imaging studies such as CT or MRI are often requested for neurologic dysfunction. In most cases, the studies yield negative results or reveal only subtle ischemic changes, although occasionally a TTP patient may present with macrovascular ischemic strokes detectable by conventional imaging studies. It is speculated that in such cases the macrovascular thrombosis may result from thrombotic injury of the vasa vasorum.

The literature includes reports of "TTP" case series with a high percentage showing abnormal CT or MRI findings. However, a review of cases in these reports reveals that most of these patients likely had typical or atypical HUS rather than TTP.

Abnormal electrocardiograms with nonspecific ST-T wave changes and elevated CPK or troponin levels are common. Occasionally thrombosis may affect large coronary arteries leading to myocardial infarction. Cardiac arrhythmia is uncommon. Electromechanical dissociation, heart failure, or pulmonary infiltrates or hemorrhage occur in advanced, pre-terminal cases.

The amylase and lipase levels may be elevated. Abnormal liver function is rare. Abdominal CT scans may detect focal pancreatitis, intestinal wall or mesenteric thickening, or stranding due to ischemia or infarction.

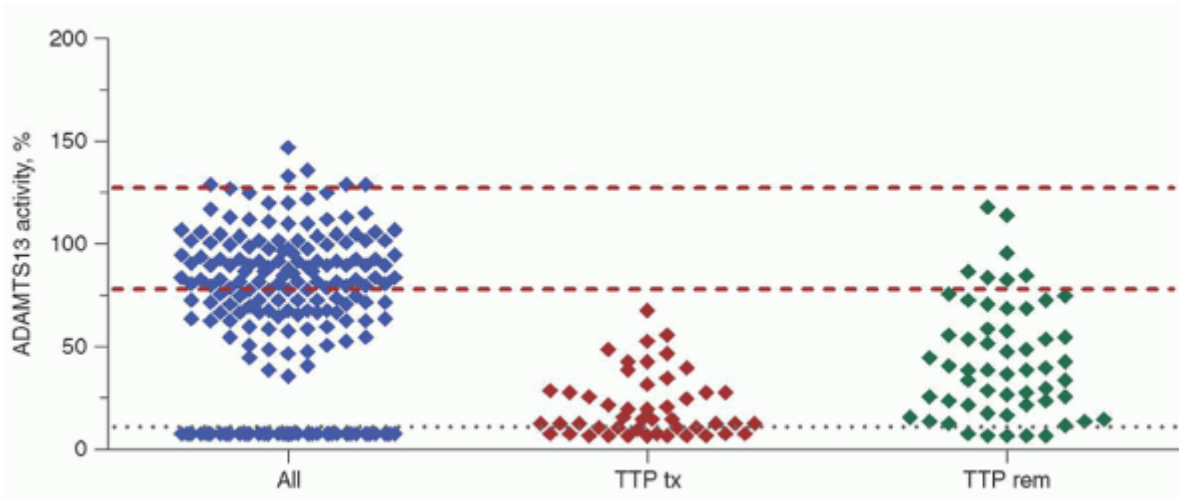

FIGURE 48.8. Plasma ADAMTS13 activity is undetectable in patients with thrombotic thrombocytopenic purpura (TTP). Patients (338 cases) presenting with thrombocytopenia and microangiopathic hemolysis segregate in two nonoverlapping groups based on their plasma ADAMTS13 activity levels. Severe ADAMTS13 deficiency defines the diagnosis of TTP in 219 patients (65%), of which 191 had autoimmune ADAMTS13 inhibitors and 28 had genetic mutation as the cause of the deficiency. ADAMTS13 activity is detectable in some patients after receiving plasma or blood transfusion (TTP tx). During remission, (TTP rem) most patients continue to have decreased ADAMTS13 activity levels, consistent with the chronic nature of their disease. The two upper dashed lines encompass the normal range of plasma ADAMTS13 activity. The lowest line marks the detection limit of the assay at 10%.

ADAMTS13 Activity Levels

Among patients presenting with thrombocytopenia and microangiopathic hemolysis, only TTP patients have severe ADAMTS13 deficiency (less than 10%), whereas patients with other disorders have detectable ADAMTS13 levels (Fig. 48.8). ADAMTS13 may be detectable if the assay is performed after the patients receive plasma or blood transfusions. The ADAMTS13 activity level remains decreased in most patients during their remission, suggesting that the autoimmunity is active. Severe ADAMTS13 deficiency provides the diagnosis of TTP in the patients with co-morbidities in whom the diagnosis would otherwise be difficult to make.

The assay used to obtain the data presented in Figure 48.8 uses purified vWF as the substrate and SDS-PAGE to detect the proteolytic products. This assay is technically demanding and not practical for use in clinical laboratories. Various assays using vWF peptides spanning the scissile bond have been developed for analysis of ADAMTS13 activity in clinical laboratories. The assays differ in their performance and reliability and may not provide a definitive diagnosis or exclusion of TTP.^{82 83 84 85 86 87 88}

Because some clinical assays may yield falsely high or low values of ADAMTS13, the diagnosis of TTP requires corroboration of the ADAMTS13 test results with clinical and other laboratory data.

ADAMTS13 Inhibitors

Inhibitors of ADAMTS13, measured by mixing patient and normal plasma samples, are detectable in 80% to 90% of the acquired TTP patients. A negative test for ADAMTS13 inhibitors does not exclude the presence of ADAMTS13 inhibitors. In such patients, the presence of inhibitors may be inferred if the increase of the ADAMTS13 activity level is less than expected after plasma therapy, or if the ADAMTS13 activity recovered to >10% during remission.

ADAMTS13 Antibody and Antigen Assays

Assays have been developed to measure ADAMTS13 antigen and antibody levels in enzyme-linked assay formats. These solid-phase microtiter plate-based assays have limited utility in practice. The antigenic assay detects free ADAMTS13 as well as ADAMTS13/inhibitor

P.1085

complex, yielding low ADAMTS13 antigen levels in <50% of TTP patients.⁸⁹ The ADAMTS13 antibody assay is highly

sensitive (>90%) for acquired TTP but may yield false-positive results in 5% to 10% of individuals without ADAMTS13 antibodies.^{90, 91}

ADAMTS13 Activity Levels during Plasma Therapy and Remission

ADAMTS13 activity assays are used not only for initial diagnosis of TTP, but are also used to assist management during plasma therapy and clinical remission.⁴³

In general, vWF-platelet aggregation does not occur when ADAMTS13 activity is >10% of normal. Thus, in a patient with persistent thrombocytopenia or declining platelet counts, an ADAMTS13 activity >10% of normal, either at initial presentation or during plasma therapy, precludes TTP as the cause of the low platelet count, and requires a search for other causes.

At the end of plasma therapy and during remission, persistently low (<10%) or steadily declining ADAMTS13 levels connote a high risk of immediate or impending relapse.

Hereditary Thrombotic Thrombocytopenic Purpura

The ADAMTS13 activity level should be ≤10% and the inhibitor and antibody tests should be negative in patients with hereditary TTP. Falsely-positive antibody results may cause confusion. Improvement of the ADAMTS13 level to greater than 10% during remission excludes the diagnosis of acquired TTP.

Familial studies may be performed to show that the parents have partial ADAMTS13 deficiency.⁵⁹ In practice, familial studies may be limited in the power to distinguish carriers from normal individuals.

Differential Diagnosis

Although the diagnosis of TTP depends on the demonstration of severe ADAMTS13 deficiency, it is essential to exclude other causes of microangiopathic hemolysis as listed in Table 48.1. On the other hand, the presence of a co-morbidity does not preclude the diagnosis of TTP.

A complete history and physical examination should be accompanied by appropriate laboratory tests such as ELISA or PCR tests for shiga toxins in the stool; blood or viral cultures or PCR analysis for pneumococcal or other bacterial or viral infections; autoimmune serology tests for lupus, scleroderma, and related autoimmune disorders; coagulation profile such as PT, PTT, fibrinogen, D-dimer assays, and additional clotting factor assays for disseminated intravascular coagulopathy; MRI for mental status changes; CT scan or other imaging studies and tissue biopsies for metastatic neoplasm; and flow cytometry for paroxysmal nocturnal hemoglobinuria.

Advanced renal failure, hypertension, and complications of abnormal vascular permeability such as brain edema, pleural or pericardial effusions, pulmonary edema, acute respiratory distress syndrome, ascites, and anasarca are rare in TTP. Any of these complications at presentation or during the course favors the diagnosis of thrombotic microangiopathy due to atypical HUS or other etiologies.

Management and Prognosis

Prompt plasma exchange is critical to prevent serious complications or death from TTP. The principles of management for patients with TTP are summarized in Table 48.2.

Plasma Therapy

Before plasma exchange or infusion was introduced in the 1970s,^{92, 93} more than 90% of patients died after presenting with symptomatic TTP. Plasma exchange and plasma infusion are the only therapies with proven efficacy for TTP presenting with thrombocytopenia and microangiopathic hemolysis.² With these treatments, a mortality rate of 10% to 20% and 40% to 50% is expected, respectively.

TABLE 48.2 PRINCIPLES OF MANAGEMENT FOR THROMBOTIC THROMBOCYTOPENIC PURPURA (TTP)

- High index of suspicion is essential for patients presenting with thrombocytopenia or TIA/stroke.

-Some patients may not have thrombocytopenia or microangiopathic hemolysis at presentation.

- Prompt treatment is critical to prevent serious complications and death.
- Daily plasma exchange is the therapy of choice for acquired TTP presenting with active thrombosis.

- Plasma infusion is used as an emergent substitute until plasma exchange is available.
- ADAMTS13 activity assay should be obtained before the patients receive any blood products.
- The diagnosis should be re-assessed during the course of therapy.
- Monitoring of ADAMTS13 during plasma therapy and remission may help clinical assessment.

-For patients with persistent thrombocytopenia, ADAMTS13 >10% should suggest other causes of thrombocytopenia.

-Monthly ADAMTS13 monitoring may detect impending relapses.

- Rituximab therapy should be considered for patients

-Unable to wean off plasma exchange due to persistent and severe ADAMTS13 deficiency.

-With persistent and severe ADAMTS13 deficiency during clinical remission.

-Exhibiting a trend of declining ADAMTS13 levels.

- Hereditary TTP

-Plasma infusion is effective for patients presenting with acute symptoms.

-Plasma exchange is used if the patient has renal failure or fluid overload.

-For most patients, plasma therapy every 2-3 wk prevents acute crisis, strokes, and renal failure.

Plasma exchange is typically performed daily at 1-1.5 total plasma volumes until the platelet count is normal, then gradually tapered to ensure the platelet count is stable before the therapy is discontinued. It is believed that plasma exchange therapy removes antibodies and replenishes the deficient ADAMTS13.

Serial analysis shows that the plasma ADAMTS13 activity level often fluctuates in the first several weeks before it gradually stabilizes to a steady-state level. This explains why the response to plasma therapy may be unsteady for weeks to months and why it is important to monitor the blood counts closely after plasma exchange therapy is tapered.

ADAMTS13 levels persistently less than 10% of normal at the end of plasma therapy indicate a high risk of early relapse. On the other hand, a measurable ADAMTS13 level at the end of plasma therapy does not preclude the possibility that levels will subsequently decrease and cause later relapse. Thus, serial ADAMTS13 analysis is more informative than single tests.

Plasma infusion has the advantage that it does not require a large venous catheter and special equipment. Its efficacy is limited by the risk of fluid overload. Plasma infusion is used primarily as an emergent substitute until plasma exchange is instituted.

Cryoprecipitate-depleted plasma has been advocated as a more effective alternative of fresh-frozen plasma because it lacks large vWF multimers.^{94, 95} However, two small randomized-controlled trials failed to demonstrate that the use of cryoprecipitate-depleted plasma is superior to fresh-frozen plasma as initial replacement therapy.^{96, 97}

P.1086

Acquired TTP is a chronic autoimmune disease punctuated with episodes of acute exacerbation. The ADAMTS13 level during clinical remission is quite variable, ranging from normal to undetectable. Normal ADAMTS13 activity levels during remission do not preclude the risk of future relapses. Serial monitoring may detect trends of declining ADAMTS13 levels before the patients develop symptomatic relapses, providing a window for immunosuppressive intervention before a relapse occurs.⁴³

Immunosuppressive Therapy

Plasma therapy does not address the underlying ADAMTS13 autoimmunity of TTP. Patients are able to achieve sustained remission primarily because the inhibitors spontaneously decrease, allowing the recovery of the ADAMTS13 activity above the threshold level. Nearly all patients will experience at least one relapse in their later lives. Some patients develop refractory disease after years of quiescent periods or several sporadic relapses.

For patients who cannot be weaned off plasma exchange due to persistent ADAMTS13 deficiency, suppression of B-cells with rituximab, a chimeric monoclonal antibody to CD20, induces clinical remission in approximately 70% to 90% of the patients.^{98, 99, 100, 101} Rituximab increases the ADAMTS13 level by suppressing, but not necessarily eliminating, the ADAMTS13 inhibitors. A small increase in the ADAMTS13 activity level to 10% or higher is sufficient to induce clinical remission, allowing the patient to be weaned off plasma therapy. Rituximab is less effective in patients with high ADAMTS13 inhibitor levels.

Rituximab may decrease the risk of immediate relapse in patients with severe ADAMTS13 deficiency entering or during remission.^{102, 103, 104, 105} It may also be used pre-emptively to avert relapses in patients exhibiting a trend of declining ADAMTS13 activity levels during remission.⁴³ The efficacy of rituximab lasts for several months to a few years, with a median remission duration ~1.5 years. Patients may be re-treated with rituximab when their plasma ADAMTS13 activity begins to show a steady decline. The major side effects of rituximab include allergic reaction and reactivation or exacerbation of viral infections such as hepatitis B and progressive multifocal leukoencephalopathy.

Cyclosporin may be efficacious, but the experience of using cyclosporine in TTP patients remains limited.¹⁰⁶ Splenectomy, which decreases the number of B-cells and immunocytes, has been recommended for patients unable to be weaned off plasma exchange or who experience frequent relapses.¹⁰⁷ With rituximab demonstrating high response rates, splenectomy is performed less frequently. Other immunosuppressive therapies that have been used in TTP include corticosteroids, vincristine, cyclophosphamide, and azathioprine. These therapies are generally less effective than rituximab and more likely to cause serious side effects.

Antiplatelet Agents

For most patients, adding antiplatelet drugs such as aspirin, dipyridamole, ticlopidine, or clopidogrel is unlikely to improve the response to plasma therapy. These drugs may prevent relapses in patients whose ADAMTS13 levels are low enough to cause platelet thrombosis. Nevertheless, the response to antiplatelet therapy is unreliable.

Hereditary Thrombotic Thrombocytopenic Purpura

Hereditary TTP responds to 7.5-10 ml fresh-frozen plasma per kilogram of body weight. Plasma exchange therapy is reserved for patients with renal failure. Inasmuch as thrombotic complications are unpredictable and may result in serious sequelae such as chronic renal failure or strokes, maintenance plasma therapy is recommended for most patients with hereditary TTP. The regimen should be tailored to prevent not only acute symptomatic crisis but also the development or progression of chronic organ injury. To achieve these goals, maintenance of normal platelet counts is recommended. Most patients require fresh-frozen plasma every 2 weeks to achieve and maintain normal platelet counts and prevent acute exacerbations. For patients not receiving maintenance therapy, serial monitoring of CBC, renal function, and urinalysis is recommended.

Special Considerations: Thrombotic Thrombocytopenic Purpura in Pregnancy

An association between pregnancy and TTP has been suspected, but never confirmed. Because TTP affects women in their reproductive years, it may occur co-incidentally during pregnancy. Patients presenting with TTP during pregnancy should be treated as other patients with plasma exchange, and with tapering of the treatment to be guided by serial ADAMTS13 levels.

A more difficult challenge is counseling and management of women with a history of TTP who desire pregnancy. Pregnancy progressively decreases ADAMTS13 levels by 30% at term, and by nearly 65% if the pregnancy is complicated with preeclampsia or the HELLP (hemolysis, elevated liver enzymes, and low platelet count) syndrome. Pregnancy also increases plasma vWF levels. Therefore, pregnancy may lead to exacerbation of TTP in patients with pre-existing ADAMTS13 deficiency. Microvascular thrombosis increases maternal and fetal morbidity and mortality, and therefore every effort should be made to prevent thrombosis and thrombocytopenia during pregnancy.

For women with a history of acquired TTP and low ADAMTS13 levels during their remission, pregnancy is not advised, as it involves real risks that cannot be reliably predicted or easily managed. ADAMTS13 levels may decrease to cause maternal TTP relapses. It may also cause fetal complications without overt maternal relapses.

If pregnancy is inevitable, rituximab may be an option to preemptively increase ADAMTS13 levels before pregnancy occurs. Rituximab is a class C drug for pregnancy, based on the adverse effect of lymphocytopenia observed in animal reproductive studies. In theory, its deleterious effects may last for 12 months. There are no adequate and well-controlled studies in humans. Rituximab use during pregnancy has been reported in a woman without causing adverse consequences. Thus, potential benefits may warrant use of the drug in pregnant women despite the theoretical risks.

Serial monitoring of ADAMTS13 levels is essential in pregnant patients. If ADAMTS13 exhibits a trend of decrease toward 10% of normal, pre-emptive plasma exchange or infusion therapy is used to prevent TTP relapses and fetal complications.

Patients with genetic ADAMTS13 mutations should receive adequate maintenance plasma therapy titrated to prevent thrombocytopenia and thrombosis. Some women with milder forms of hereditary TTP may become pregnant without knowing the diagnosis of the disease. These patients may develop thrombocytopenia that is often incorrectly attributed to immune thrombocytopenia or gestational thrombocytopenia, only to develop TTP exacerbation or fetal complications as the pregnancy progresses. A positive family history, a high index of suspicion, and liberal use of ADAMTS13 assays may help identify such patients for correct diagnosis and management.

Novel Therapeutic Modalities

Recombinant ADAMTS13 is under development for replacing deficient ADAMTS13 in patients with TTP. Truncated variants of ADAMTS13 or variants with substitutions at the residues critical for interaction with inhibitors may circumvent the difficulties posed by inhibitors. However, immunogenicity is a concern for variant ADAMTS13 molecules with substituted amino acid.

P.1087

N-acetylcysteine, presently used for acetaminophen liver toxicity and chronic lung disease, decreases the size of vWF by reducing the disulfide bonds of vWF multimers.¹⁰⁸ It may be an attractive therapy for TTP if its vWF-reducing activity is confirmed in human subjects.

Inhibitors of vWF-platelet aggregation such as the anti-vWF aptamer ARC1779¹⁰⁷ or nanobody ALX-0081¹⁰⁹ may prevent microvascular thrombosis in TTP patients. These drugs may best serve as a short-term measure to prevent serious complications or death before ADAMTS13 levels are raised by plasma replacement therapy or rituximab.

SHIGA TOXIN-ASSOCIATED HEMOLYTIC-UREMIC SYNDROME

First described by Gasser et al. in 1955,¹¹⁰ typical HUS refers to the constellation of renal failure, microangiopathic hemolysis, and thrombocytopenia following a bout of hemorrhagic diarrhea. This is a relatively uncommon disease but often draws public attention during outbreaks of food-borne illness.

Etiology

It is estimated that approximately 90% of North American and European children with HUS have infection with shiga toxin-producing *E. coli* (STEC) of the enterohemorrhagic serotype, typically serotype O157:H7. In the United States, approximately 4,000 cases of *E. coli* O157:H7 infections are diagnosed annually, with 15% of them developing the complication of HUS. STEC of non-O157 serotypes and even *Shigella dysenteriae* serotype I have also been implicated in causing HUS.

The offending organisms share the capacity of producing powerful shiga toxins, which are encoded by phage DNA and comprise several genotypes.¹¹¹ Most HUS cases are caused by shiga toxin genotype 2 or 1+2. With more laboratories conducting the shiga toxin assays, increasing numbers of non-O157 *E. coli* serotypes such as O26:H11, O103:H2, O111:H8, and O145:H28 are detected.

Enteropathogenic *E. coli* has a reservoir in bovine intestine and is transmitted by meat, milk, or water contaminated with ruminant feces. Most cases of shiga toxin-associated HUS result from ingestion of contaminated food such as beef, leafy vegetables, dairy, fruits, nuts, sprouts, poultry, or water. Other modes of transmission include direct animal contact and person-to-person contact during the acute diarrheal phase. Very low infectious doses (<100 organisms) are sufficient to cause clinical disease. Outbreaks account for only 20% of the cases. Approximately 50% of the cases occur during the summer months.

The outbreaks in Germany, France, and other countries in 2011 were due to contamination with *E. coli* O104:H4, which evolved from an unusual progenitor of enteroaggregative *E. coli* through acquisition of a *stx2*-encoding prophage and a plasmid encoding a CTX-M-15 extended-spectrum beta-lactamase (ESBL) gene.^{112, 113, 114, 115}

Many strains of STEC have not been associated with hemorrhagic diarrhea or HUS, indicating that other virulence factors of the organisms are also critical for pathogenesis. The expression of additional genes on a chromosomal locus of enterocyte effacement pathogenicity island, including intimin encoded by the *eae* gene for intimin attachment, has a strong association with the risk of HUS.¹¹⁶

STEC is one of the surveillance infections conducted by the Foodborne Disease Active Surveillance Network (FoodNet).

Pathology

The pathology of shiga toxin-associated HUS is quite different from that of TTP, as it is dominated by glomerular endothelial cell swelling or necrosis and subendothelial expansion in the kidney.^{117, 118} Fibrin-platelet thrombi are commonly present in glomerular loops and hila and may be seen extending into small and medium-sized arteries, including the interlobular arteries (Fig. 48.2C). Neutrophil infiltration may be present. Extensive thrombosis may result in renal cortical infarcts.

Other organs such as brain, heart, intestinal tract, and pancreas may also be affected, either with edema due to abnormal vascular permeability or with ischemic injury due to microvascular stenosis or thrombosis.

Pathophysiology

It is believed that injury of the kidney and other organs is a consequence of the cytotoxic effect of shiga toxins on vascular endothelial cells.^{119, 120, 121} A shiga toxin molecule comprises an A-subunit and a pentameric B-subunit. The shiga toxin molecule binds via its B-subunit to globotriaosylceramide (Gb3) expressed on the membrane lipid rafts of renal microvascular endothelial or other target cells. This binding is followed by internalization of the A-subunit via endocytosis. After proteolysis, a smaller fragment of the A-subunit is generated that is capable of disrupting the 60s ribosomes, blocking protein synthesis in the target cells. The sensitivity of endothelial cells may be enhanced by cytokines such as IL-1 and TNF- α released in response to endotoxins.

Additional studies suggest that shiga toxins may also alter the expression of vasoactive factors (e.g., endothelin and nitric oxide) and adhesive proteins (e.g., vWF, $\alpha_v\beta_3$, PCAM-1, and P-selectin), or activate the alternative complement pathway.^{122, 123, 124, 125} However, it is not clear whether the high concentrations of shiga toxins used in these studies are pathophysiologically relevant.

The cytotoxicity of shiga toxins leads to endothelial cell swelling, abnormal vascular permeability, and cell death. Endothelial cell disruption exposes the underlying thrombogenic glomerular basement membrane, triggering the activation of the coagulation cascade and subsequent thrombosis. Thrombosis leads to ischemic organ injury, thrombocytopenia, and abnormal shear stress causing red cell fragmentation. Vascular stenosis may also result from endothelial swelling and subendothelial expansion, causing tissue ischemia and red cell fragmentation without increasing platelet consumption. The microangiopathy may also increase vascular permeability, leading to brain edema, pleural or pericardial effusion, ascites, mesenteric or intestinal edema, and anasarca that do not correlate with thrombocytopenia or microangiopathic hemolysis.

Clinical Presentation

There is a spectrum of illness following ingestion of STEC, ranging from no symptoms to self-limited gastroenteritis, the HUS and death.

Symptomatic STEC infection leads to HUS in up to 15% of cases.^{111, 126} Diarrhea and other gastrointestinal symptoms develop between 2 and 12 days after ingestion of pathogenic *E. coli*. Bloody diarrhea develops 1 to 3 days later.

Symptoms and signs of HUS begin to manifest as the diarrhea begins to improve. Risk factors for HUS after infection with shiga toxin-producing *E. coli* include young or old age, long duration of diarrhea, elevated leukocyte count, antimicrobial or antidiarrheal drug use, and bloody diarrhea.¹²⁷

The onset of hemolysis and renal failure may be dramatic, with sudden pallor, abdominal pain, vomiting, and the appearance of dark-red or nearly black urine. These manifestations may quickly lead to oliguria or even anuria. On the other hand, mild or incomplete HUS with thrombocytopenia but no anemia or azotemia is almost as frequent as the complete form of HUS.

Extrarenal complications occur in approximately 50% of patients, and may include pancreatitis, glucose intolerance, P.1088

colonic necrosis and perforation, myocardial infarction, congestive heart failure, pericardial or pleural effusion, and acute respiratory distress syndrome.¹²⁸

Neurologic complications including irritability, confusion, transient paralysis, seizures, and coma are the most serious and often result from cerebral edema of thrombotic microangiopathy. Hemorrhagic or thrombotic stroke is quite infrequent.

Elderly individuals, especially frail nursing home residents, are more likely to experience cardiovascular and neurologic complications and death.¹²⁹

Laboratory Findings

Hematologic findings are similar to those of TTP, although the severity of thrombocytopenia is more variable and does not always reflect the severity of the clinical status. The anemia often is severe and may be accompanied by moderate polymorphonuclear leukocytosis. Hemoglobinemia may be marked. The prothrombin time and partial thromboplastin time usually are normal or minimally prolonged; fibrin degradation products or D-dimer tests are frequently elevated.¹³⁰ Serum haptoglobin levels are typically undetectable. The bilirubin level is usually elevated. The liver transaminases and amylase may also be elevated.¹³¹ The blood urea nitrogen and serum creatinine levels may be quite high. The urine usually contains hemoglobin and hemosiderin in addition to albumin. Microscopically, erythrocytes, leukocytes, and casts are seen.

CT and MRI studies of the brain in patients with neurologic complications may reveal various abnormalities including restricted water diffusion; edema or posterior reversible encephalopathy syndrome (PRES); contrast enhancement; or hemorrhage in the basal ganglia, thalamus, cerebellum, or brainstem.¹³² The lesions are most commonly due to abnormal vascular permeability and may resolve on follow-up examinations and are not necessarily associated with a poor long-term neurologic outcome. Similar lesions are also often detected in patients with atypical HUS.

With perhaps rare exception, patients with shiga toxin-associated HUS have normal or slightly decreased ADAMTS13 activity levels and no inhibitory antibodies.⁷ Large vWF multimers may be decreased as abnormal shear stress in the microcirculation augments proteolysis of vWF by ADAMTS13.⁷

Diagnosis, Management, and Prognosis

Conventionally, *E. coli* O157:H7 is detected by plating fresh feces on sorbitol-MacConkey agar. Direct detection of shiga toxins by ELISA or PCR analysis is more sensitive and also detects non-O157:H7 serotypes.¹³³

No specific treatment is available for shiga toxin-associated HUS. Early and careful management of acute renal failure and hypertension and the judicious use of packed red cell transfusions appear to constitute the safest and most effective approach to the management of HUS in children.

Plasma therapy is of no or little benefit in children.¹³⁴ Because of the excellent results achieved in the treatment of TTP and difficulty in distinguishing HUS from TTP, adult patients are often treated with plasma exchange, although evidence in support of this practice remains circumstantial.¹³⁵

Recently, based on laboratory observations of complement activation by shiga toxin and endothelial P-selectin,¹²² eculizumab, a humanized monoclonal antibody of C5 originally approved for patients with paroxysmal nocturnal hemoglobinuria and aHUS, was used in three patients with severe shiga toxin-associated HUS.¹³⁶ The patients promptly improved. This could represent a major therapeutic advance if its efficacy is reproduced in other trials.

Certain antibiotics such as ciprofloxacin may induce the expression of shiga toxins.^{126, 137, 138} Antibiotic usage increases the risk of HUS following *E. coli* O157:H7 infection.¹³⁹ Until future investigation shows otherwise, bactericidal antibiotics and antimotility drugs should be avoided in patients with shiga toxin-associated colitis.

Approximately 50% of patients with shiga toxin-associated HUS require dialysis. The usual indications for dialysis support include fluid overload unresponsive to diuretics, a rapidly rising creatinine value, anuria for more than 24 hours, severe electrolyte imbalance, and serious clinical signs of uremia.

Direct person-to-person transmission occurs during the acute diarrheal phase. In some cases, excretion of the microorganisms may persist for several months. Contact isolation and frequent hand washing are recommended to minimize the spread of infection.

The overall mortality in children with epidemic HUS is 12% (range 0 to 30%). The majority of patients recover without serious consequences. Long-term renal injury such as decreased glomerular filtration rate, proteinuria, hypertension, or renal failure may be present in as many as 1 of every 4 survivors.^{140, 141} However, this risk is quite variable. Some patients may develop irritable bowel syndrome.¹⁴² Young women may also be at higher risk of pregnancy-related hypertension, presumably due to subclinical kidney injury.¹⁴³ A few patients may require long-term dialysis or renal transplantation therapy. Shiga toxin-associated HUS is not expected to recur following renal graft transplantation.

ATYPICAL HEMOLYTIC-UREMIC SYNDROME

aHUS originally referred to the constellation of acute renal failure, microangiopathic hemolysis, and thrombocytopenia in children without a prodrome of hemorrhagic diarrhea or another apparent cause. It is now recognized that aHUS may present in adults as frequently as in children, although most of the adult patients have been given the diagnosis of TTP. Most patients with aHUS have defects in regulating the alternative complement pathway.¹⁴⁴ Defective complement regulation is also found in women with pregnancy-associated aHUS.¹⁴⁵ Preliminary evidence suggests that some of the patients with other co-morbidities such as bone marrow/hematopoietic stem cell transplantation also have defective regulation of the alternative complement pathway.¹⁴⁴ In such patients, aHUS is believed to be induced by the co-morbidity. In addition, severe hypertension may be a complication of aHUS instead of a cause of microangiopathic hemolysis as previously believed.

Because of overlapping clinical features, aHUS is not distinguished from TTP in many reports. In fact, most patients with the so-called "TTP without severe ADAMTS13 deficiency" really have aHUS instead of TTP. Interpretation of reports in the literature is difficult when the case definitions do not provide a clear distinction between TTP and aHUS. A comparison of the distinctive features of TTP and aHUS is summarized in Table 48.3.

Pathology

Although aHUS and TTP share the common features of thrombocytopenia and microangiopathic hemolysis, they are quite different pathologically.

In aHUS, the affected glomerular capillaries, arterioles, and interlobular small arteries typically exhibit endothelial cell swelling or death and subendothelial expansion due to edema and/or hypercellularity, often but not invariably accompanied by thrombosis.¹⁴⁶ The glomerular tufts may show mesangiolytic. Late changes may show double basement membranes, mesangial cell proliferation with expansion of the matrix and interstitial fibrosis. The lesions often include admixtures of acute and chronic changes (Fig. 48.2D-F). The prominence of chronic changes in

P.1089

patients at their first presentation suggests antecedent subclinical injury.

TABLE 48.3 COMPARISON OF THROMBOTIC THROMBOCYTOPENIC PURPURA (TTP) AND ATYPICAL HEMOLYTIC-UREMIC SYNDROME (aHUS)

Disorder	TTP		aHUS	
• Transmission	Acquired	Hereditary	Acquired	Hereditary
• Molecular defects	ADAMTS13 inhibitors	ADAMTS13 mutations	CFH Ab	Genetic defects of complement regulation
• Age	Teens-adults	Children-adults		Children-adults
• Gender (female vs. male)	2-3:1	~ 1:1		~ 1:1
• Pathology	Microvascular thrombosis		Thrombotic microangiopathy	
• Presentation	- General: fatigue, headache - Neuro: focal deficits, confusion - Others: abdominal or chest pain, nausea, vomiting		- General: fatigue, headache, dizziness - Cardiovascular: chest pain, dyspnea - GI: abdominal pain, diarrhea, nausea, vomiting - Neuro: somnolence, confusion, seizures, focal deficits	
• Thrombocytopenia	Precedes MAHA and organ injury		May not reflect disease severity	
• Advanced renal failure	Rare	Occasional		Common
• Hypertension	Rare	Occasional		Common

• ↑ Vascular permeability	Rare	Rare	Common
- Cerebral edema, PRES			
- Pulmonary edema			
- Effusions, ascites			
- Anasarca			
• Treatment of choice	Plasma exchange	Plasma infusion	Ecuzumab
• Mortality	10%-20%	Very low if promptly treated	- 10%-30% with plasma exchange - Expected to be very low with ecuzumab
• Long-term prognosis ^a	Relapse	Relapse, stroke, CRF	Relapse, ESRD

Complement regulators: complement factor H, membrane co-factor protein, complement factor I, C3, complement factor B, or thrombomodulin; CFH, complement factor H; CFHR1, complement factor H-related protein 1; CRF, chronic renal failure; ESRD, end-stage renal disease; MAHA, microangiopathic hemolytic anemia; ND, not detectable; PRES, posterior reversible encephalopathy syndrome.

^a If treated only for relapses.

The pathology of thrombotic microangiopathy may also be demonstrable, albeit less conspicuously, in other organs. More common is tissue edema in the brain, lung, gastrointestinal tract, mesentery and cutaneous soft tissues. Fluid accumulation may be present in the pericardial, alveolar, pleural, or peritoneal space. These changes result from abnormal vascular permeability and are uncommon in patients with TTP.

Molecular Pathogenesis

The complement system, an important part of the innate host defense against invading microorganisms, may be triggered by immune complexes or microbial lectins. The alternative pathway, via complement factors B, D, and P, amplifies complement activation by promoting the generation of alternative C3b and C5b convertases (Fig. 48.9). Complement factor H (CFH), factor I (CFI), membrane cofactor protein (MCP, or CD46), thrombomodulin (THBD), and possibly complement factor H-related proteins 1-5 (CFHR1-5) are involved in regulating self-perpetuating complement activation.

Genetic mutations of the alternative complement activators or regulators have been found in approximately 50% of aHUS patients, with a higher prevalence among patients with a family history (75%) than in patients without a family history (40%). The molecular defects include inactivating mutations of CFH (25%), MCP, CFI, and THBD (5% to 10% each); gain-of-function mutations of activators C3 (5% to 10%) and CFB (a few pedigrees).^{144, 147, 148} Additionally, antibodies to CFH are detected in 5% to 10% of the cases, often with concurrent homozygous or heterozygous genomic deletion of CFHR1.^{149, 150}

The genetics of aHUS are more complex than involvement of single genes. Compound mutations are present in 10% or more of the patients. Atypical HUS may only develop in patients with more than one variant of the activators or regulators.¹⁵¹ Analysis of single nucleotide polymorphisms (SNP) of complement activators and regulators demonstrates that the risk of aHUS is significantly increased or decreased with certain SNPs and haplotypes of CFH, CD46, CFHR2, CFHR4, and intergenic CR1-CD46.¹⁵² Laboratory studies have demonstrated that certain combinations of common variants (complotype) of the complement activators and regulators increase the risk of the disease.¹⁵³

Complement factor H-related proteins 1-5 (CFHR1-5) are the products of a series of genes located immediately downstream of the CFH gene, that are mapped to a region of chromosome 1q containing multiple retrotransposon sequences. Genomic deletion of CFHR1 and CFHR3 is detected in only 3% of the control population, but is present in 28% of aHUS patients.^{150, 154, 155} Further analysis intriguingly reveals that genomic CFHR1 deletions are present in 90% of patients with CFH autoantibodies and 20% of patients with CFI mutations, but not different from its background prevalence in patients with other or no mutations.¹⁵⁶ The presence of CFHR1 deletion markedly increases the severity of aHUS in patients with CFI mutations.¹⁵⁷ CFHR1 may block the binding between CFH and its antibodies in autoimmune aHUS patients.^{144, 158}

The genetic lesions of complement regulation affect the prognosis of aHUS. Long-term survival without advanced renal failure is approximately 80%-90% for patients with only mutations affecting MCP, and is 20%-30% for patients with mutations of CFH.

P.1090

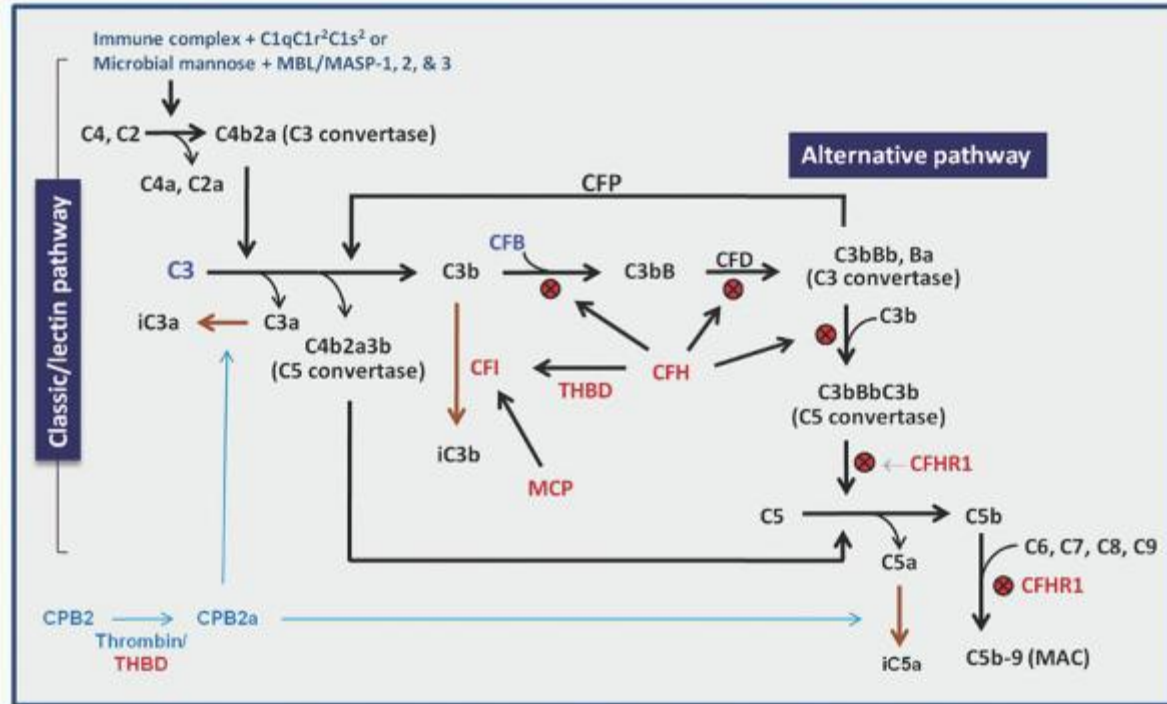

FIGURE 48.9. A scheme of the complement system highlighting the alternative pathway and its regulators (in red). Complement factor I is a plasma serine protease which, with the help of complement factor H (CFH) or membrane cofactor protein (MCP), cleaves C3b to its inactive form (iC3b). CFH also regulates other steps in the alternative pathway. Thrombomodulin (THBD) augments the cofactor activity of CFH and promotes the activation of carboxypeptidase B2 (CPB2) by thrombin, thereby accelerating the inactivation of C3a and C5a. CFB, complement factor B; CFHR1, complement factor H related protein 1; CPB2a, activated CPB2; iC3a, inactivated C3a; iC3b, inactivated C3b; iC5a, inactivated C5a; CFD, complement factor D; CFP, complement factor P; MBL, mannose binding lectin; MASP, mannose binding lectin associated protease.

More than 50% of patients with CFI mutation have concurrent mutations affecting other complement activator or regulatory proteins. Concurrency mutations increase the risk of serious aHUS complications.¹⁵⁷

As a consequence of the complexity in its genetics, atypical HUS due to complement mutations is transmitted as an autosomal dominant trait with incomplete and variable penetrance, which is greater than 50% with CFH and MCP mutations, but much lower with mutations of the other proteins.

Pathophysiology

The clinical features of aHUS are the consequence of microvascular stenosis, thrombosis, and abnormal vascular permeability resulting from uncontrolled activation of the complement system.

When the complement system is triggered by infection or other factors, defective regulation of the alternative pathway leads to unremitting generation of complement activation products, including C3a, C5a, and C5b-9 (membrane attack complex, MAC). It is believed that C5b-9 causes direct injury of vascular endothelial cells, whereas C3a and C5a may cause abnormal vascular permeability (Fig. 48.10).

Endothelial cell injury and disruption expose the prothrombotic components in the subendothelium, leading to the activation of the coagulation system, microvascular thrombosis, thrombocytopenia, and ischemic organ injury. Microvascular thrombosis also creates abnormal levels of shear stress, causing fragmentation of the red blood cells.

Endothelial injury causes cell swelling, subendothelial edema, and cellular proliferation. These changes may directly result in marked luminal stenosis (Fig. 48.2E,F) and ischemic organ injury. Vascular stenosis also increases the shear stress and causes microangiopathic hemolysis without concurrent thrombocytopenia. Abnormal vascular permeability may lead to tissue edema and organ dysfunction without concurrent thrombocytopenia or microangiopathic hemolysis. The combination of multiple pathophysiology pathways explains why microangiopathic hemolysis, thrombocytopenia, and organ dysfunction do not always closely correlate with each other in patients with aHUS.

Other Phenotypes of Complement Dysregulation

Excessive complement activation is also associated with the phenotype of mesangiocapillary or membranoproliferative glomerulonephropathy type 2 (dense-deposit disease).^{159, 160, 161, 162, 163} Occasionally, a patient may present with HUS, evolving to renal failure with histopathologic features of mesangiocapillary glomerulonephropathy later in life.¹⁶⁴

Complement dysregulation is also associated with age-related macular degeneration. The Y402H polymorphism in the short consensus repeat-7 (SCR-7) of CFH has been linked to age-related macular degeneration among European patients.^{165, 166, 167} More than 20 cases of CFI deficiency have been described from 19 pedigrees linked to increased risk of pyogenic infection.¹⁶⁸ Uncontrolled complement activation also underlies the mechanism of hemolysis in patients with paroxysmal nocturnal hemoglobinuria.¹⁶⁹

P.1091

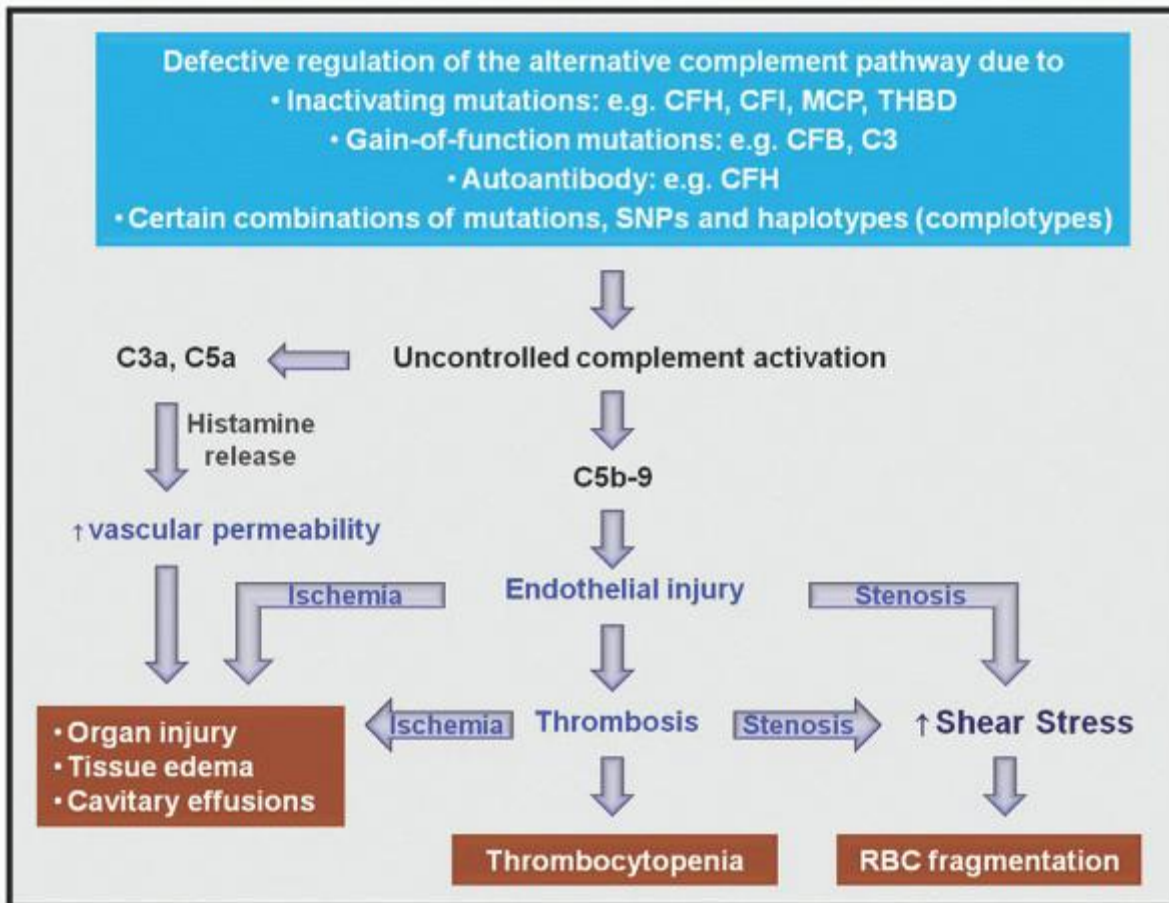

FIGURE 48.10. A scheme depicting how defective regulation of the alternative complement pathway may lead to atypical hemolytic-uremic syndrome (aHUS). Four types of molecular defects have been detected in patients with aHUS, in which organ dysfunction may result from ischemic injury or interstitial tissue edema. Consequently, it is not unusual that a patient with aHUS may continue to deteriorate neurologically due to brain edema while the platelet count is stable or increasing. CFB, complement factor B; CFH, complement factor H; CFI, complement factor I; MCP, membrane cofactor

protein; THBD, thrombomodulin.

Clinical Presentation

The prevalence of aHUS has been estimated at 3 per million children. Atypical HUS is likely to be as common as TTP in adults. Both males and females are equally affected.

The onset of an acute aHUS crisis may occur spontaneously or after trigger of stress conditions such as infection, surgery, trauma, inflammation, pancreatitis, intravenous contrast agents, or pregnancy. Although renal failure, microangiopathic hemolysis, and thrombocytopenia are its common features, aHUS is a systemic disease affecting multiple organs.

Gastrointestinal symptoms such as abdominal pain, bloody or nonbloody diarrhea, nausea, and vomiting are the most common acute presenting symptoms of aHUS. Some patients have recurrence of these symptoms for months to years before the diagnosis is recognized.

Laboratory tests may reveal elevated pancreatic enzymes such as amylase or lipase, diabetes mellitus, and/or abnormal liver function tests.

Imaging studies may reveal thickening, edema, and/or ischemic changes of the intestinal or bronchial wall, mesenteric edema, ascites and pancreatitis.

Headache and waxing and waning mental status changes are common. Impaired vision due to exudative or hemorrhagic retinopathy, seizures, and coma may ensue as the disease progresses. Focal neurologic deficits may occur although these are not as frequent as in patients with TTP.

The most common findings in brain imaging studies are cerebral edema or posterior reversible encephalopathy syndrome (PRES), a reflection of abnormal vascular permeability. Ischemic changes or overt infarction may be present, but are less common. Many of these changes may not be detectable with computerized tomography.

The severity of anemia and thrombocytopenia are quite variable in aHUS. Petechiae or other bleeding symptoms may occur but are uncommon. Rising platelet counts alone should not be taken as indication of disease improvement or remission.

Chest pain, dyspnea, respiratory failure, or congestive heart failure may result from pleurisy, pericarditis, airway edema, noncardiogenic pulmonary edema, or myocardial injury, which are detectable with chest radiograms, CT imaging, echocardiography, and EKG. Troponin and CPK levels may be elevated. Hypertension may be severe but often labile. Cardiac arrhythmias may lead to sudden death.

Proteinuria, hematuria, and renal function impairment are common. Hematuria is microscopic in most cases but may be gross occasionally. The severity of renal failure is variable. Some patients may present with very mild elevation of creatinine, and others present with anuric renal failure requiring dialysis support. Occasionally, a patient presents with aHUS only after receiving a renal graft for end-stage renal failure.

Diagnosis

No simple tests exist at this time for the diagnosis of defective alternative complement regulation. The C3 level is decreased in approximately 30%-50% of the patients. The C4 level is decreased in less than 10% of the cases. These changes are not specific for aHUS. In patients with mutations of CFH or CFI, the antigen levels of the affected proteins are decreased in approximately 30% of the cases.

Mutation analysis detects abnormalities in approximately 50% of the patients. Because compound mutations are common, all genes known to be involved in alternative complement regulation need to be analyzed. CFH antibodies are detected by ELISA in 5% to 10% of patients with aHUS. The genetics of aHUS also involve SNPs, haplotypes, and combinations of common or uncommon variants of complement activators or regulators. Due to its complexity and incomplete understanding of pathogenic mechanisms, genetic study is not required for the diagnosis of aHUS.

Presently the diagnosis of aHUS relies on a process of exclusion (Fig. 48.11). aHUS is suspected in patients presenting with the constellation of microangiopathic hemolysis, any degree of renal function impairment and thrombocytopenia, and the diagnosis is

P.1092

presumed after exclusion of TTP and groups III and IV disorders listed in Table 48.1.

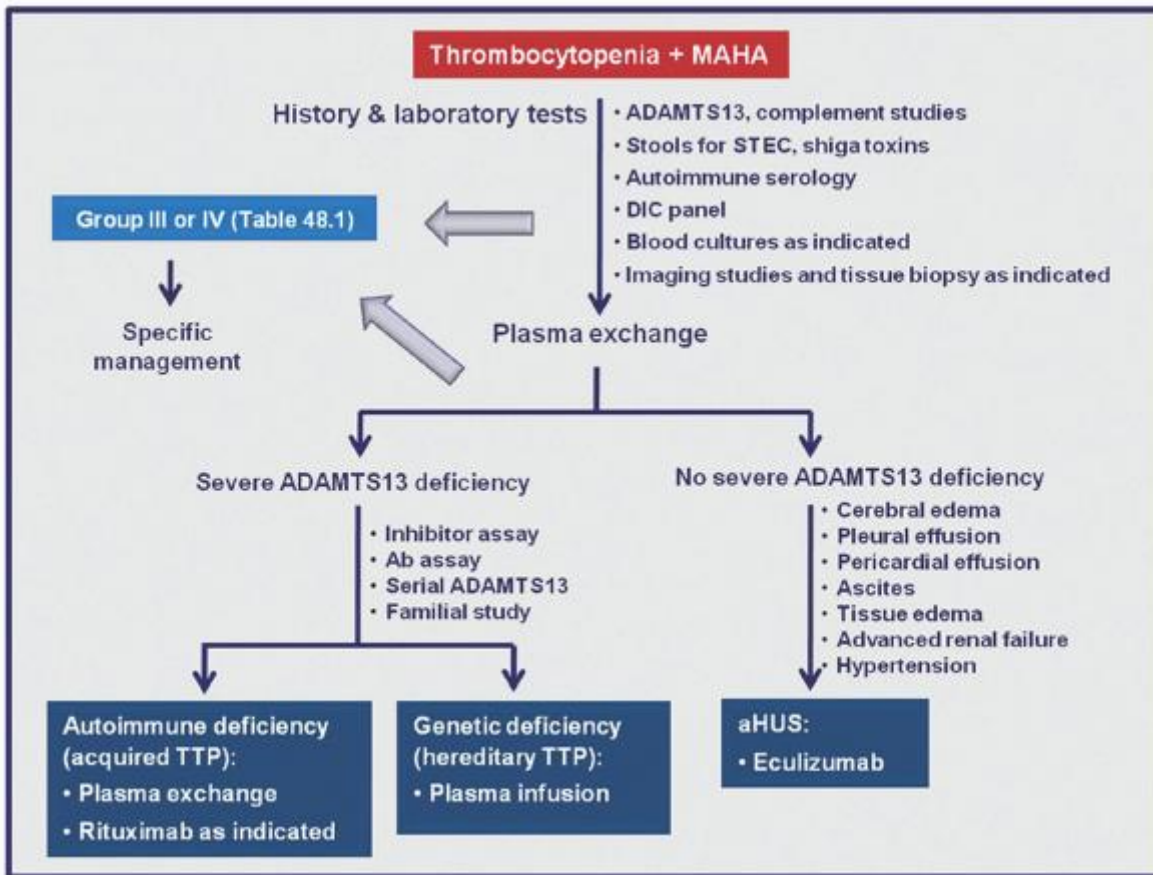

FIGURE 48.11. A scheme summarizing the current approach to patients presenting with thrombocytopenia and microangiopathic hemolytic anemia (MAHA). The patients should be empirically treated with plasma exchange unless history, physical examination, and laboratory tests strongly indicate otherwise. The indication of plasma exchange should be continually reassessed based on the evolution of clinical course and laboratory test results. Until ADAMTS13 assays are proven to be reliable, an ADAMTS13 level >10% should be correlated with clinical findings of advanced renal failure and/or abnormal vascular permeability for exclusion of thrombotic thrombocytopenic purpura (TTP). The role of eculizumab for treatment of shiga toxin-associated hemolytic-uremic syndrome (HUS) or other thrombotic microangiopathy of Group III disorders (Table 48.1) remains uncertain. DIC, disseminated intravascular coagulopathy.

aHUS needs to be distinguished from TMA via other mechanisms such as shiga toxins or microbial neuraminidases. Shiga toxin assays are indicated for patients presenting with diarrhea. Blood cultures or viral studies are indicated for patients with suspected systemic infections. There is insufficient knowledge to determine how frequent TMA occurs in patients with hematopoietic stem cell therapy, systemic autoimmune diseases, HIV infection, or various classes of drugs. Patients with autoimmune diseases may also develop MAHA due to vasculitis, which requires tissue biopsy for diagnosis. aHUS needs to be distinguished from hemolysis with elevated liver enzymes and low platelets (HELLP) syndrome and preeclampsia in women during pregnancy. Contrary to what is commonly believed, severe hypertension may be a consequence of aHUS rather than a cause of MAHA. The diagnosis of aHUS in patients without both MAHA and overt renal failure is more challenging and requires a high index of suspicion. The presence of hypertension, pleural or pericardial effusions, ascites, mesenteric or intestinal wall edema, anasarca, airway edema, acute respiratory distress syndrome, exudative retinopathy, brain edema, or posterior reversible encephalopathy syndrome (PRES) by CT or MRI strongly favors the diagnosis of aHUS over TTP.

Management

The principles of management for patients with aHUS are summarized in Table 48.4. Traditionally, aHUS patients were treated with plasma exchange. This practice was an extension of plasma exchange therapy for TTP, but its efficacy has never been rigorously investigated. It appears to be effective in a fraction of patients with aHUS.

Plasma Therapy

Many patients improve following the institution of plasma exchange therapy. Some patients deteriorate and even die after exhibiting an initial response. Others relapse after the therapy is discontinued, but do not respond to its reinstitution. Thus, the outcome with plasma therapy is uncertain for individual patients.

Knowledge of the molecular defects of aHUS may potentially predict which patients are likely to benefit from plasma exchange therapy. Plasma exchange or even plasma infusion is most likely

P.1093

to benefit patients with deficiency of plasma proteins such as CFH or CFI, but not patients with defective membrane-bound proteins such as MCP. Intensive plasma exchange may be effective for patients with gain-of-function C3 or CFH mutations, or CFH antibodies. For patients with multiple mutations or unknown mutations, it is impossible to predict whether they will respond to plasma therapy.

TABLE 48.4 PRINCIPLES OF MANAGEMENT OF ATYPICAL HEMOLYTIC-UREMIC SYNDROME (aHUS)

- Atypical HUS is a systemic disease
 - Gastrointestinal symptoms of nausea, vomiting, abdominal pain, diarrhea are common complaints.
 - Cardiopulmonary symptoms of chest pain and dyspnea may occur
 - Neurologic abnormalities such as headache, somnolence, confusion, seizures, or visual defects may occur.
 - Advanced renal failure, hypertension or complications of abnormal vascular permeability^a favors the diagnosis of aHUS over TTP.
 - Renal failure may be minimal or mild in some cases.
- Atypical HUS is a diagnosis of exclusion
 - TTP should be excluded with ADAMTS13 assays.
 - Stx-HUS should be excluded with stool shiga toxin assays for patients with diarrhea.
 - Other causes of MAHA should be excluded with history, coagulation tests, autoimmune serology, microbiology, and/or tissue biopsy as indicated.
 - Acute presentation of atypical HUS may be triggered by a co-morbidity (Table 48.1).
- Plasma exchange is the initial choice of therapy until TTP is excluded
- Eculizumab is the treatment of choice for aHUS
 - Improvement in thrombocytopenia and mental status change is evident after one or two doses of eculizumab.
 - Recovery of renal function may occur slowly over many months.
 - Vaccination is critical for prevention of meningococcal sepsis.
- Long-term therapy with eculizumab should be considered for patients who
 - have more than minimal renal dysfunction, or
 - are predisposed to relapse with serious complications.
- If eculizumab is discontinued, close monitoring is indicated for early detection of relapse or organ injury. Follow-up evaluation should include
 - Symptoms, physical findings, blood pressure.
 - CBC, renal function and hemolysis markers.

Stx-HUS, shiga toxin-associated hemolytic-uremic syndrome; TTP, thrombotic thrombocytopenic

purpura

^a As reflected by cerebral edema, posterior reversible encephalopathy syndrome, pleural or pericardial effusion, pulmonary edema, acute respiratory distress syndrome, ascites, or soft tissue swelling.

Some patients develop end-stage renal failure, months to years after plasma exchange is discontinued, without ever experiencing acute symptomatic relapses of aHUS. Thus, long-term maintenance plasma therapy is often needed for responsive patients to prevent relapses or progression of kidney injury. Long-term plasma therapy is technically demanding, poses a major stress on the patients, and its optimal regimen can only be determined empirically at best.

Eculizumab

A major advance in the treatment of aHUS is eculizumab, a humanized monoclonal antibody to C5 originally approved in 2007 for the treatment of paroxysmal nocturnal hemoglobinuria. Based on two prospective studies of 37 adult and adolescent patients, and a retrospective study of 19 pediatric patients,¹⁷⁰ the U.S. Food and Drug Administration and European Medicines Agency approved eculizumab in 2011 for the treatment of childhood and adult aHUS.

In the clinical trials, patients without identifiable mutations also responded to eculizumab, suggesting that defective regulation of the alternative complement pathway plays a pathogenetic role in most if not all patients of aHUS without identifiable molecular defects.

With eculizumab, clinical improvement in mental status, gastrointestinal symptoms, and increase in the platelet count are often apparent after one or two weekly administrations. Renal function improvement may be slow but continues for many months. Long-term eculizumab therapy may lead to gradual recovery of renal function, allowing some patients to come off dialysis therapy.

The aims of eculizumab therapy for aHUS include prevention of death, and avoidance of aHUS relapse. To achieve these aims, eculizumab should be instituted as soon as the diagnosis is reasonably established and TTP is excluded.

Atypical HUS is a chronic disease that often continues to cause subclinical injury of the kidney and other organs even in the absence of overt symptoms, thrombocytopenia, or microangiopathic hemolysis. Long-term eculizumab therapy should be considered for patients who are close to requiring renal replacement therapy and patients whose aHUS, if left untreated, may cause severe hypertension or other serious extra-renal complications. If eculizumab is discontinued, close monitoring of clinical status, blood pressure, blood counts, and renal function is indicated for early detection of aHUS relapse or progressive organ injury.

Eculizumab is well tolerated with minor adverse reactions. It is important to note that eculizumab therapy may predispose patients to fulminant *Neisseria meningitidis* infections. Patients should be given meningococcal vaccination and take prophylactic antibiotics until 2 weeks after the vaccination. Patients should also carry an identification card to facilitate emergency management of any infectious complications. Concern of serious infection has prompted some physicians to recommend long-term prophylactic antibiotic therapy.

The efficacy of eculizumab for patients with thrombotic microangiopathy in association with a co-morbidity such as those in Table 48.1 (group III), but no identifiable molecular defects in complement regulation has not been extensively investigated. Preliminary experience suggests that it is effective in some, if not all of such patients.

Eculizumab has been used in a small number of patients during pregnancy without causing adverse effects to the mother and fetus.^{171, 172}

Eculizumab versus Plasma Exchange Therapy

Compared to plasma exchange, eculizumab offers several advantages: the high efficacy of eculizumab is documented in clinical trials; it is expected to be effective for aHUS irrespective of the underlying molecular defects; and it is easier to administer, particularly for long-term maintenance therapy.

In contrast, the efficacy of plasma exchange has never been rigorously investigated in patients with aHUS; treatment failure is not uncommon; and plasma exchange requires a venous catheter that is inconvenient, uncomfortable, and carries the risk of infection or thrombosis.

Renal Transplantation

Due to high rates of disease recurrence, aHUS patients, except those with mutations of membrane proteins such as MCP, have a very high risk (>80% to 90%) of graft failure following kidney transplantation.

Previously, combined kidney and liver transplantation was performed based on the rationale that restoration of normal CFH in the circulation by the transplanted liver would prevent recurrence of aHUS and renal graft failure. However, because the complement system is triggered during major operations, the procedure was associated with a very high risk of morbidity and mortality. Pre-operative plasma exchange was advocated to prevent these complications.

Patients with mutations of membrane cofactor protein are expected to be cured, at least from the renal perspective, by a kidney allograft. Nevertheless, graft failure may occur if the donor is a family member who also carries the molecular trait, or if the patient carries other unidentified mutations. Due to the incomplete phenotypic expression of aHUS, family members of aHUS patients should not be organ donors. Extra-renal complications of aHUS may continue to occur after kidney transplantation. Maintenance eculizumab therapy is indicated for such patients.

If a patient with aHUS is to receive kidney transplantation, the patient should be treated with eculizumab prior to the operation.^{173, 174} Eculizumab should be continued post-operatively to prevent recurrence of the disease causing acute complications and graft failure. Because chronic eculizumab therapy is expected to be quite effective in preventing relapse of aHUS or organ injury, concurrent liver transplantation is no longer necessary.

Prognosis

Historically, approximately 10% to 30% of aHUS patients treated with plasma exchange died during their acute presentation. The overall risk of death or end-stage renal failure was ~60%. The risk was the highest (70% to 80%) for patients with CFH mutations, compound mutations, or CFI mutation with CFHR1 deletion, and the lowest mortality (10% to 20%) occurred in patients with MCP mutations.

Many of the patients never develop recurrence of overt thrombocytopenia or microangiopathic hemolysis while they progress to advanced renal failure. The absence of hematologic relapse leads to erroneous reports in the literature that "TTP" patients without severe ADAMTS13 are less likely to relapse and have a better long-term prognosis than those with severe ADAMTS13 deficiency. Eculizumab is expected to suppress systemic complications and prevent renal function, deterioration, and death.

PLATELET AND RED CELL DAMAGE BY ABNORMAL VASCULAR SURFACES

Platelets are subject to damage by interactions with "nonphysiologic" surfaces within the vascular system. Pathologic alterations of vessels that may produce such platelet damage include stenotic and roughened heart valves,¹⁷⁵ extensive atherosclerosis, metastatic cancer, and kidney disease associated with severe vascular changes in renal vessels.¹⁷⁶ An increasing number of surgical techniques involve the implantation of devices containing foreign material within the vascular system. Such circulatory prostheses include cardiac valves, vascular grafts of many types, indwelling catheters,¹⁷⁷ intra-aortic balloon pumps,¹⁷⁸ extracorporeal membrane oxygenators (ECMO),¹⁷⁹ and ventricular assist devices (VAD).¹⁸⁰ Extensive efforts have been made to render such materials nonthrombogenic, but most of these devices produce varying degrees of platelet destruction as well as hemolysis.¹⁸¹

Bleeding during cardiopulmonary bypass surgery appears to be multifactorial, including operative factors, dilution of clotting factors, inadequate neutralization of heparin, thrombocytopenia, platelet dysfunction,¹⁸⁰ and enhanced fibrinolysis. Hemodilution leads to a rapid reduction in platelet counts by as much as 50% shortly after cardiopulmonary bypass surgery begins. The platelet function defect is maximal during cardiopulmonary bypass surgery and usually disappears within 24 hours of surgery. The nature of the platelet defect is controversial. Investigators report partial platelet degranulation, circulating activated platelets by flow cytometry, and defects in platelet membrane glycoprotein Ib/IX and IIb/IIIa.^{182, 183} Efforts to minimize platelet and coagulation abnormalities in association with cardiac surgery include higher heparin doses to suppress thrombin generation,¹⁸⁴ heparin-coated circuit,¹⁸⁵ miniaturized closed circuit,¹⁸⁶ and offpump operations.¹⁸⁷ Avoidance of cardiotomy suction, perhaps in combination with a direct thrombin inhibitor such as bivalirudin as the anticoagulant, may substantially minimize activation of the coagulation system.¹⁸⁸ Bleeding is often reduced by infusion of normal platelets, 1-deamino-8-d-arginine vasopressin, epsilon aminocaproic acid, or aprotinin.^{189, 190, 191, 192} However, indiscriminate prophylactic platelet transfusion is ineffective and may increase the risk for adverse outcomes. A higher risk of end-organ damage has been observed with aprotinin, but not with tranexamic acid or aminocaproic acid.¹⁹³ Nitric oxide plus iloprost may reduce the deleterious effects of cardiopulmonary bypass on platelets and even reduce post-operative bleeding.¹⁹⁴

Red cell fragmentation and intravascular hemolysis are common in patients with left ventricular assist devices (LVAD), extracorporeal membrane oxygenator, or prosthetic heart valves. In such patients, monitoring of plasma hemoglobin

concentration is recommended, as an increase in plasma hemoglobin level may herald intradvice thrombosis or malfunction. Analysis of vWF may also demonstrate a decrease in the normal large multimers in patients with LVAD.^{195, 196, 197, 198, 199} Such vWF multimer changes, presumably due to excessive proteolysis induced by abnormal shear stress profiles, are more profound in patients with nonpulsatile than pulsatile devices. The vWF changes alone may not be sufficient to cause bleeding; yet they may contribute to the bleeding diathesis induced by anticoagulation or antiplatelet therapy, other hemostatic defects such as thrombocytopenia and platelet function defects, and acquired angiodysplasia of the gastrointestinal tract.²⁰⁰

MISCELLANEOUS FORMS OF NONIMMUNOLOGIC PLATELET DESTRUCTION

Extensive burns are associated with mild to moderate thrombocytopenia that results from nonimmunologic platelet destruction.²⁰¹ Thrombocytopenia may become severe and bleeding may develop when complications of sepsis or disseminated intravascular coagulation develop. Thrombocytopenia has been well described after hepatic cryotherapy²⁰² and in moderate hypothermia treatment.^{203, 204}

Certain drugs may produce thrombocytopenia by nonimmunologic phenomena. Ristocetin, an antituberculous agent no longer used clinically, promotes the attachment of vWF to its platelet receptor and initiates direct platelet-to-platelet interaction by means of an agglutination phenomenon. Studies of ristocetin-induced platelet aggregation have provided much information concerning von Willebrand disease.

Oxaliplatin may cause thrombocytopenia by causing liver injury and portal hypertension, leading to splenomegaly and hypersplenism.²⁰⁵ Protamine may produce reversible sequestration of platelets in the liver,²⁰⁶ but seldom is the cause of significant thrombocytopenia. Aggregation of platelets independent of immune mechanisms plays a role in type 1 heparin-induced thrombocytopenia. Thrombocytopenia is a common feature of post-decompression sickness in divers and has been attributed to intravascular platelet aggregation.²⁰⁷

P.1095

REFERENCES

1. Tsai HM, Li A, Rock G. Inhibitors of von Willebrand factor-cleaving protease in thrombotic thrombocytopenic purpura. *Clin Lab* 2001;47:387-392.
2. Rock GA, Shumak KH, Buskard NA, et al. Comparison of plasma exchange with plasma infusion in the treatment of thrombotic thrombocytopenic purpura. Canadian Apheresis Study Group. *N Engl J Med* 1991;325:393-397.
3. Terrell DR, Williams LA, Vesely SK, et al. The incidence of thrombotic thrombocytopenic purpura-hemolytic uremic syndrome: all patients, idiopathic patients, and patients with severe ADAMTS-13 deficiency. *J Thromb Haemost* 2005;3:1432-1436.
4. Moschowitz, E. An acute febrile pleiochromic anemia with hyaline thrombosis of the terminal arterioles and capillaries: an undescribed disease. *Proc N Y Pathol Soc* 1924;24: 21-24.
5. Asada Y, Sumiyoshi A, Hayashi T, Suzumiya J, Kaketani K. Immunohistochemistry of vascular lesions in thrombotic thrombocytopenic purpura, with special reference to factor VIII related antigen. *Thromb Res* 1985;38:469-479.
6. Hosler GA, Cusumano AM, Hutchins GM. Thrombotic thrombocytopenic purpura and hemolytic uremic syndrome are distinct pathologic entities. A review of 56 autopsy cases. *Arch Pathol Lab Med* 2003;127:834-839.
7. Tsai HM, Chandler WL, Sarode R, et al. von Willebrand factor and von Willebrand factor-cleaving metalloprotease activity in *Escherichia coli* O157:H7-associated hemolytic uremic syndrome. *Pediatr Res* 2001;49:653-659.
8. Bonnefoy A, Daenens K, Feys HB, et al. Thrombospondin-1 controls vascular platelet recruitment and thrombus adherence in mice by protecting (sub) endothelial VWF from cleavage by ADAMTS13. *Blood* 2006;107:955-964.
9. Banno F, Kokame K, Okuda T, et al. Complete deficiency in ADAMTS13 is prothrombotic, but it alone is not sufficient to cause thrombotic thrombocytopenic purpura. *Blood* 2006;107:3161-3166.
10. Feys HB, Roodt J, Vandeputte N, et al. Thrombotic thrombocytopenic purpura directly linked with ADAMTS13 inhibition in the baboon (*Papio ursinus*). *Blood* 2010;116:2005-2010.
11. Motto DG, Chauhan AK, Zhu G, et al. Shigatoxin triggers thrombotic thrombocytopenic purpura in genetically susceptible ADAMTS13-deficient mice. *J Clin Invest* 2005;115:2752-2761.

12. Schneider SW, Nuschele S, Wixforth A, et al. Shear-induced unfolding triggers adhesion of von Willebrand factor fibers. *Proc Natl Acad Sci U S A* 2007;104:7899-7903.
13. Siedlecki CA, Lestini BJ, Kottke-Marchant KK, et al. Shear-dependent changes in the three-dimensional structure of human von Willebrand factor. *Blood* 1996;88:2939-2950.
14. Tsai HM, Sussman II, Ginsburg D, et al. Proteolytic cleavage of recombinant type 2A von Willebrand factor mutants R834W and R834Q: inhibition by doxycycline and by monoclonal antibody VP-1. *Blood* 1997;89:1954-1962.
15. Singh I, Shankaran H, Beauharnois ME, et al. Solution structure of human von Willebrand factor studied using small angle neutron scattering. *J Biol Chem* 2006;281:38266-38275.
16. Singh I, Themistou E, Porcar L, Neelamegham S. Fluid shear induces conformation change in human blood protein von Willebrand factor in solution. *Biophys J* 2009;96:2313-2320.
17. Uemura M, Tatsumi K, Matsumoto M, et al. Localization of ADAMTS13 to the stellate cells of human liver. *Blood* 2005;106:922-924.
18. Zhou W, Inada M, Lee TP, et al. ADAMTS13 is expressed in hepatic stellate cells. *Lab Invest* 2005;85:780-788.
19. Cao WJ, Niiya M, Zheng XW, Shang DZ, Zheng XL. Inflammatory cytokines inhibit ADAMTS13 synthesis in hepatic stellate cells and endothelial cells. *J Thromb Haemost* 2008;6:1233-1235.
20. Manea M, Kristoffersson A, Schneppenheim R, et al. Podocytes express ADAMTS13 in normal renal cortex and in patients with thrombotic thrombocytopenic purpura. *Br J Haematol* 2007;138:651-662.
21. Turner N, Nolasco L, Tao Z, Dong JF, Moake J. Human endothelial cells synthesize and release ADAMTS-13. *J Thromb Haemost* 2006;4:1396-1404.
22. Akiyama M, Takeda S, Kokame K, Takagi J, Miyata T. Crystal structures of the noncatalytic domains of ADAMTS13 reveal multiple discontinuous exosites for von Willebrand factor. *Proc Natl Acad Sci U S A* 2009;106:19274-19279.
23. Crawley JT, de GR, Xiang Y, Luken BM, Lane DA. Unraveling the scissile bond: how ADAMTS13 recognizes and cleaves von Willebrand factor. *Blood* 2011;118:3212-3221.
24. Moake JL, Rudy CK, Troll JH, et al. Unusually large plasma factor VIII: von Willebrand factor multimers in chronic relapsing thrombotic thrombocytopenic purpura. *N Engl J Med* 1982;307:1432-1435.
25. Kwaan HC. The role of fibrinolysis in disease processes. *Semin Thromb Hemost* 1984;10:71-79.
26. Tsai AL, Manner CE, Rudersdorf T, Wu KK. Quantitation of serum prostacyclin-binding in thrombotic thrombocytopenic purpura. *Thromb Res* 1988;51:583-592.
27. Wada H, Kaneko T, Ohiwa M, et al. Increased levels of vascular endothelial cell markers in thrombotic thrombocytopenic purpura. *Am J Hematol* 1993;44:101-105.
28. Praprotnik S, Blank M, Levy Y, et al. Anti-endothelial cell antibodies from patients with thrombotic thrombocytopenic purpura specifically activate small vessel endothelial cells. *Int Immunol* 2001;13:203-210.
29. Leung DY, Moake JL, Havens PL, Kim M, Poher JS. Lytic anti-endothelial cell antibodies in haemolytic-uraemic syndrome. *Lancet* 1988;2:183-186.
30. Burns ER, Zucker-Franklin D. Pathologic effects of plasma from patients with thrombotic thrombocytopenic purpura on platelets and cultured vascular endothelial cells. *Blood* 1982;60:1030-1037.
31. Neame PB, Hirsh J. Circulating immune complexes in thrombotic thrombocytopenic purpura (TTP). *Blood* 1978;51:559-560.
32. Siddiqui FA, Lian EC. Characterization of platelet agglutinating protein p37 purified from the plasma of a patient with thrombotic thrombocytopenic purpura. *Biochem Mol Biol Int* 1993;30:385-395.
33. Tandon NN, Rock G, Jamieson GA. Anti-CD36 antibodies in thrombotic thrombocytopenic purpura. *Br J Haematol* 1994;88:816-825.
34. Kelton JG, Moore JC, Murphy WG. The platelet aggregating factor(s) of thrombotic thrombocytopenic purpura. *Prog Clin Biol Res* 1990;337:141-149.

35. Stefanescu R, Bassett D, Modarresi R, et al. Synergistic interactions between interferon-gamma and TRAIL modulate c-FLIP in endothelial cells, mediating their lineage-specific sensitivity to thrombotic thrombocytopenic purpura plasma-associated apoptosis. *Blood* 2008;112:340-349.
36. Reti M, Farkas P, Csuka D, et al. Complement activation in thrombotic thrombocytopenic purpura. *J Thromb Haemost* 2012;10:791-798.
37. Zeigler Z, Kelton J, Moore J, et al. Calpain activity in bone marrow transplant-associated thrombotic thrombocytopenic purpura. *Bone Marrow Transplant* 1999;24:641-645.
38. Schultz DR, Arnold PI, Jy W, et al. Anti-CD36 autoantibodies in thrombotic thrombocytopenic purpura and other thrombotic disorders: identification of an 85 kD form of CD36 as a target antigen. *Br J Haematol* 1998;103:849-857.
39. Rock G, Chauhan K, Jamieson GA, Tandon NN. Anti-CD36 antibodies in patients with lupus anticoagulant and thrombotic complications. *Br J Haematol* 1994;88:878-880.
40. Rock G, Clark W, Sternbach M, Kolajova M, McLaine P. Haemolytic uraemic syndrome is an immune-mediated disease: role of anti-CD36 antibodies. *Br J Haematol* 2005;131:247-252.
41. Hori Y, Wada H, Mori Y, et al. Plasma sFas and sFas ligand levels in patients with thrombotic thrombocytopenic purpura and in those with disseminated intravascular coagulation. *Am J Hematol* 1999;61:21-25.
42. Tsai HM, Lian EC. Antibodies to von Willebrand factor-cleaving protease in acute thrombotic thrombocytopenic purpura. *N Engl J Med* 1998;339: 1585-1594.
43. Tsai HM. Autoimmune thrombotic microangiopathy: advances in pathogenesis, diagnosis, and management. *Semin Thromb Hemost* 2012;38:469-482.
44. Uemura M, Matsuyama T, Ishikawa M, et al. Decreased activity of plasma ADAMTS13 may contribute to the development of liver disturbance and multiorgan failure in patients with alcoholic hepatitis. *Alcohol Clin Exp Res* 2005;29:264S-271S.
45. Park YD, Yoshioka A, Kawa K, et al. Impaired activity of plasma von Willebrand factor-cleaving protease may predict the occurrence of hepatic veno-occlusive disease after stem cell transplantation. *Bone Marrow Transplant* 2002;29:789-794.
46. Ono T, Mimuro J, Madoiwa S, et al. Severe secondary deficiency of von Willebrand factor-cleaving protease (ADAMTS13) in patients with sepsis-induced disseminated intravascular coagulation: its correlation with development of renal failure. *Blood* 2006;107:528-534.
47. Nguyen TC, Liu A, Liu L, et al. Acquired ADAMTS-13 deficiency in pediatric patients with severe sepsis. *Haematologica* 2007;92:121-124.
48. Mannucci PM, Canciani MT, Forza I, et al. Changes in health and disease of the metalloprotease that cleaves von Willebrand factor. *Blood* 2001;98: 2730-2735.
49. Lisman T, Bongers TN, Adelmeijer J, et al. Elevated levels of von Willebrand Factor in cirrhosis support platelet adhesion despite reduced functional capacity. *Hepatology* 2006;44:53-61.
50. Bianchi V, Robles R, Alberio L, Furlan M, Lammle B. Von Willebrand factor-cleaving protease (ADAMTS13) in thrombocytopenic disorders: a severely deficient activity is specific for thrombotic thrombocytopenic purpura. *Blood* 2002;100:710-713.
51. de MQ, Groot E, Asih PB, et al. ADAMTS13 deficiency with elevated levels of ultra-large and active von Willebrand factor in *P. falciparum* and *P. vivax* malaria. *Am J Trop Med Hyg* 2009;80:492-498.
52. Tsai HM. Pathophysiology of thrombotic thrombocytopenic purpura. *Int J Hematol* 2010;91:1-19.
53. Coppo P, Busson M, Veyradier A, et al. HLA-DRB1*11: a strong risk factor for acquired severe ADAMTS13 deficiency-related idiopathic thrombotic thrombocytopenic purpura in Caucasians. *J Thromb Haemost* 2010;8:856-859.
54. Bennett CL, Weinberg PD, Rozenberg-Ben-Dror K, et al. Thrombotic thrombocytopenic purpura associated with ticlopidine. A review of 60 cases. *Ann Intern Med* 1998;128:541-544.
55. Tsai HM, Rice L, Sarode R, Chow TW, Moake JL. Antibody inhibitors to von Willebrand factor metalloproteinase and increased binding of von Willebrand factor to platelets in ticlopidine-associated thrombotic thrombocytopenic purpura. *Ann Intern Med* 2000;132:794-799.

56. Bennett CL, Connors JM, Carwile JM, et al. Thrombotic thrombocytopenic purpura associated with clopidogrel. *N Engl J Med* 2000;342:1773-1777.
57. Hymes KB, Karpatkin S. Human immunodeficiency virus infection and thrombotic microangiopathy. *Semin Hematol* 1997;34:117-125.
58. Camilleri RS, Cohen H, MacKie IJ, et al. Prevalence of the ADAMTS-13 missense mutation R1060W in late onset adult thrombotic thrombocytopenic purpura. *J Thromb Haemost* 2008;6:331-338.
59. Levy GG, Nichols WC, Lian EC, et al. Mutations in a member of the ADAMTS gene family cause thrombotic thrombocytopenic purpura. *Nature* 2001;413:488-494.
60. Schneppenheim R, Kremer Hovinga JA, Becker T, et al. A common origin of the 4143insA ADAMTS13 mutation. *Thromb Haemost* 2006;96:3-6.
61. Akiyama M, Kokame K, Miyata T. ADAMTS13 P475S polymorphism causes a lowered enzymatic activity and urea lability in vitro. *J Thromb Haemost* 2008;6:1830-1832.
62. Jang MJ, Kim NK, Chong SY, et al. Frequency of Pro475Ser polymorphism of ADAMTS13 gene and its association with ADAMTS-13 activity in the Korean population. *Yonsei Med J* 2008;49:405-408.
63. Ruan C, Dai L, Su J, Wang Z, Ruan C. The frequency of P475S polymorphism in von Willebrand factor-cleaving protease in the Chinese population and its relevance to arterial thrombotic disorders. *Thromb Haemost* 2004;91: 1257-1258.
64. Furlan M, Robles R, Galbusera M, et al. von Willebrand factor-cleaving protease in thrombotic thrombocytopenic purpura and the hemolytic-uremic syndrome. *N Engl J Med* 1998;339:1578-1584.
65. Kokame K, Matsumoto M, Soejima K, et al. Mutations and common polymorphisms in ADAMTS13 gene responsible for von Willebrand factor-cleaving protease activity. *Proc Natl Acad Sci U S A* 2002;99:11902-11907.
66. Plaimauer B, Fuhrmann J, Mohr G, et al. Modulation of ADAMTS13 secretion and specific activity by a combination of common amino acid polymorphisms and a missense mutation. *Blood* 2006;107:118-125.
67. Ferrari S, Mudde GC, Rieger M, et al. IgG subclass distribution of anti-ADAMTS13 antibodies in patients with acquired thrombotic thrombocytopenic purpura. *J Thromb Haemost* 2009;7:1703-1710.
68. Pos W, Luken BM, Hovinga JA, et al. VH1-69 germline encoded antibodies directed towards ADAMTS13 in patients with acquired thrombotic thrombocytopenic purpura. *J Thromb Haemost* 2009;7:421-428.
69. Zhou W, Dong L, Ginsburg D, Bouhassira EE, Tsai HM. Enzymatically active ADAMTS13 variants are not inhibited by anti-ADAMTS13 autoantibodies: a novel therapeutic strategy? *J Biol Chem* 2005;280:39934-39941.
70. Pos W, Crawley JT, Fijnheer R, et al. An autoantibody epitope comprising residues R660, Y661, and Y665 in the ADAMTS13 spacer domain identifies a binding site for the A2 domain of VWF. *Blood* 2010;115:1640-1649.
71. Jian C, Xiao J, Gong L, et al. Gain-of-function ADAMTS13 variants that are resistant to autoantibodies against ADAMTS13 in patients with acquired thrombotic thrombocytopenic purpura. *Blood* 2012;119:3836-3843.
72. Zheng XL, Wu HM, Shang D, et al. Multiple domains of ADAMTS13 are targeted by autoantibodies against ADAMTS13 in patients with acquired idiopathic thrombotic thrombocytopenic purpura. *Haematologica* 2010;95:1555-1562.
73. Schulman I, Pierce M, Lukens A, Currimbhoy Z. Studies on thrombopoiesis. I. A factor in normal human plasma required for platelet production; Chronic thrombocytopenia due to its deficiency. *Blood* 1960;16:943-957.
74. Upshaw JD Jr. Congenital deficiency of a factor in normal plasma that reverses microangiopathic hemolysis and thrombocytopenia. *N Engl J Med* 1978;298:1350-1352.
75. Kokame K, Kokubo Y, Miyata T. Polymorphisms and mutations of ADAMTS13 in the Japanese population and estimation of the number of patients with Upshaw-Schulman syndrome. *J Thromb Haemost* 2011;9:1654-1656.
76. Jubinsky PT, Moraille R, Tsai HM. Thrombotic thrombocytopenic purpura in a newborn. *J Perinatol* 2003;23:85-87.
77. Schiff DE, Roberts WD, Willert J, Tsai HM. Thrombocytopenia and severe hyperbilirubinemia in the neonatal period secondary to congenital thrombotic thrombocytopenic purpura and ADAMTS13 deficiency. *J Pediatr Hematol Oncol* 2004;26:535-538.
78. Fujimura Y, Matsumoto M, Isonishi A, et al. Natural history of Upshaw-Schulman syndrome based on ADAMTS13 gene analysis in Japan. *J Thromb Haemost* 2011;9(Suppl 1):283-301.

79. Veyradier A, Obert B, Haddad E, et al. Severe deficiency of the specific von Willebrand factor-cleaving protease (ADAMTS 13) activity in a subgroup of children with atypical hemolytic uremic syndrome. *J Pediatr* 2003;142: 310-317.
80. Tsai HM. Mechanisms of microvascular thrombosis in thrombotic thrombocytopenic purpura. *Kidney Int Suppl* 2009;S11-S14.
81. Noris M, Bucchioni S, Galbusera M, et al. Complement factor H mutation in familial thrombotic thrombocytopenic purpura with ADAMTS13 deficiency and renal involvement. *J Am Soc Nephrol* 2005;16:1177-1183.
82. Savasan S, Lee SK, Ginsburg D, Tsai HM. ADAMTS13 gene mutation in congenital thrombotic thrombocytopenic purpura with previously reported normal VWF cleaving protease activity. *Blood* 2003;101:4449-4451.
83. Savasan S, Taub JW, Buck S, et al. Congenital microangiopathic hemolytic anemia and thrombocytopenia with unusually large von Willebrand factor multimers and von Willebrand factor-cleaving protease. *J Pediatr Hematol Oncol* 2001;23:364-367.
84. Hovinga JA, Vesely SK, Terrell DR, Lammler B, George JN. Survival and relapse in patients with thrombotic thrombocytopenic purpura. *Blood* 2010;115:1500-1511.
85. Kokame K, Matsumoto M, Fujimura Y, Miyata T. VWF73, a region from D1596 to R1668 of von Willebrand factor, provides a minimal substrate for ADAMTS-13. *Blood* 2004;103:607-612.
86. Zhou W, Tsai HM. An enzyme immunoassay of ADAMTS13 distinguishes patients with thrombotic thrombocytopenic purpura from normal individuals and carriers of ADAMTS13 mutations. *Thromb Haemost* 2004;91:806-811.
87. Kokame K, Nobe Y, Kokubo Y, Okayama A, Miyata T. FRET-VWF73, a first fluorogenic substrate for ADAMTS13 assay. *Br J Haematol* 2005;129:93-100.
88. Kato S, Matsumoto M, Matsuyama T, et al. Novel monoclonal antibody-based enzyme immunoassay for determining plasma levels of ADAMTS13 activity. *Transfusion* 2006;46:1444-1452.
89. Rieger M, Ferrari S, Kremer Hovinga JA, et al. Relation between ADAMTS13 activity and ADAMTS13 antigen levels in healthy donors and patients with thrombotic microangiopathies (TMA). *Thromb Haemost* 2006;95:212-220.
90. Tsai HM, Raoufi M, Zhou W, et al. ADAMTS13-binding IgG are present in patients with thrombotic thrombocytopenic purpura. *Thromb Haemost* 2006;95:886-892.
91. Rieger M, Mannucci PM, Kremer Hovinga JA, et al. ADAMTS13 autoantibodies in patients with thrombotic microangiopathies and other immunomediated diseases. *Blood* 2005;106:1262-1267.
92. Bukowski RM, King JW, Hewlett JS. Plasmapheresis in the treatment of thrombotic thrombocytopenic purpura. *Blood* 1977;50:413-417.
93. Byrnes JJ, Khurana M. Treatment of thrombotic thrombocytopenic purpura with plasma. *N Engl J Med* 1977;297:1386-1389.
94. Byrnes JJ, Moake JL, Klug P, Periman P. Effectiveness of the cryosupernatant fraction of plasma in the treatment of refractory thrombotic thrombocytopenic purpura. *Am J Hematol* 1990;34:169-174.
95. Moake JL, Byrnes JJ, Troll JH, et al. Effects of fresh-frozen plasma and its cryosupernatant fraction on von Willebrand factor multimeric forms in chronic relapsing thrombotic thrombocytopenic purpura. *Blood* 1985;65:1232-1236.
96. Rock G, Anderson D, Clark W, et al. Does cryosupernatant plasma improve outcome in thrombotic thrombocytopenic purpura? No answer yet. *Br J Haematol* 2005;129:79-86.
97. Zeigler ZR, Shadduck RK, Gryn JF, et al. Cryoprecipitate poor plasma does not improve early response in primary adult thrombotic thrombocytopenic purpura (TTP). *J Clin Apher* 2001;16:19-22.
98. Chemnitz J, Draube A, Scheid C, et al. Successful treatment of severe thrombotic thrombocytopenic purpura with the monoclonal antibody rituximab. *Am J Hematol* 2002;71:105-108.
99. Elliott MA, Heit JA, Pruthi RK, et al. Rituximab for refractory and or relapsing thrombotic thrombocytopenic purpura related to immune-mediated severe ADAMTS13-deficiency: a report of four cases and a systematic review of the literature. *Eur J Haematol* 2009; 83:365-372.
100. Gutterman LA, Kloster B, Tsai HM. Rituximab therapy for refractory thrombotic thrombocytopenic purpura. *Blood Cells Mol Dis* 2002;28:385-391.

101. Yomtovian R, Niklinski W, Silver B, Sarode R, Tsai HM. Rituximab for chronic recurring thrombotic thrombocytopenic purpura: a case report and review of the literature. *Br J Haematol* 2004;124:787-795.
102. Fakhouri F, Vernant JP, Veyradier A, et al. Efficiency of curative and prophylactic treatment with rituximab in ADAMTS13-deficient thrombotic thrombocytopenic purpura: a study of 11 cases. *Blood* 2005;106:1932-1937.
103. Galbusera M, Bresin E, Noris M, et al. Rituximab prevents recurrence of thrombotic thrombocytopenic purpura: a case report. *Blood* 2005;106: 925-928.
104. Scully M, McDonald V, Cavenagh J, et al. A phase 2 study of the safety and efficacy of rituximab with plasma exchange in acute acquired thrombotic thrombocytopenic purpura. *Blood* 2011;118:1746-1753.
105. Tsai HM, Shulman K. Rituximab induces remission of cerebral ischemia caused by thrombotic thrombocytopenic purpura. *Eur J Haematol* 2003;70:183-185.
106. Cataland SR, Jin M, Lin S, et al. Effect of prophylactic cyclosporine therapy on ADAMTS13 biomarkers in patients with idiopathic thrombotic thrombocytopenic purpura. *Am J Hematol* 2008;83:911-915.
107. Aquilino NA, Stein SH, Konkle BA, Abrams CS, Strobl FJ. Role of splenectomy in patients with refractory or relapsed thrombotic thrombocytopenic purpura. *J Clin Apheresis* 2003;18:51-54.
108. Chen J, Reheman A, Gushiken FC, et al. N-acetylcysteine reduces the size and activity of von Willebrand factor in human plasma and mice. *J Clin Invest* 2011;121:593-603.
109. Firbas C, Siller-Matula JM, Jilma B. Targeting von Willebrand factor and platelet glycoprotein Ib receptor. *Expert Rev Cardiovasc Ther* 2010;8: 1689-1701.
110. Gasser C, Gautier E, Steck A, et al. Hamolytisch-uramische syndrome: Bilaterale Nierenrindennekrosen bei akuten erworbenen hamolytischen anamien. *Schweiz Med Woch* 1955;85:905-909.
111. Tarr PI, Gordon CA, Chandler WL. Shiga-toxin-producing *Escherichia coli* and haemolytic uraemic syndrome. *Lancet* 2005;365:1073-1086.
112. Rasko DA, Webster DR, Sahl JW, et al. Origins of the *E. coli* strain causing an outbreak of hemolytic-uremic syndrome in Germany. *N Engl J Med* 2011;365:709-717.
113. Jourdan-da SN, Watrin M, Weill FX, et al. Outbreak of haemolytic uraemic syndrome due to Shiga toxin-producing *Escherichia coli* O104:H4 among French tourists returning from Turkey, September 2011. *Euro Surveill* 2012;17:pii=20065 P.1096

114. King LA, Nogareda F, Weill FX, et al. Outbreak of Shiga toxin-producing *Escherichia coli* O104:H4 associated with organic fenugreek sprouts, France, June 2011. *Clin Infect Dis* 2012;54:1588-1594.
115. Frank C, Werber D, Cramer JP, et al. Epidemic profile of Shiga-toxin-producing *Escherichia coli* O104:H4 outbreak in Germany. *N Engl J Med* 2011;365:1771-1780.
116. Karch H, Mellmann A, Bielaszewska M. Epidemiology and pathogenesis of enterohaemorrhagic *Escherichia coli*. *Berl Munch Tierarztl Wochenschr* 2009;122:417-424.
117. Habib R. Pathology of the hemolytic uremic syndrome. In: Kaplan B, Trompeter R, Moake J, eds. Hemolytic uremic syndrome and thrombotic thrombocytopenic purpura. New York: Marcel Dekker, 1992:315-353.
118. Inward CD, Howie AJ, Fitzpatrick MM, et al. Renal histopathology in fatal cases of diarrhoea-associated haemolytic uraemic syndrome. *British Association for Paediatric Nephrology. Pediatr Nephrol* 1997;11:556-559.
119. Obrig TG, Del Vecchio PJ, Brown JE, et al. Direct cytotoxic action of Shiga toxin on human vascular endothelial cells. *Infect Immun* 1988;56: 2373-2378.
120. Kaye SA, Louise CB, Boyd B, Lingwood CA, Obrig TG. Shiga toxin-associated hemolytic uremic syndrome: interleukin-1 beta enhancement of Shiga toxin cytotoxicity toward human vascular endothelial cells in vitro. *Infect Immun* 1993;61:3886-3891.

121. Louise CB, Obrig TG. Shiga toxin-associated hemolytic-uremic syndrome: combined cytotoxic effects of Shiga toxin, interleukin-1 beta, and tumor necrosis factor alpha on human vascular endothelial cells in vitro. *Infect Immun* 1991;59:4173-4179.
122. Morigi M, Galbusera M, Gastoldi S, et al. Alternative pathway activation of complement by Shiga toxin promotes exuberant C3a formation that triggers microvascular thrombosis. *J Immunol* 2011;187:172-180.
123. Morigi M, Galbusera M, Binda E, et al. Verotoxin-1-induced up-regulation of adhesive molecules renders microvascular endothelial cells thrombogenic at high shear stress. *Blood* 2001;98:1828-1835.
124. Zoja C, Buelli S, Morigi M. Shiga toxin-associated hemolytic uremic syndrome: pathophysiology of endothelial dysfunction. *Pediatr Nephrol* 2010;25:2231-2240.
125. Orth D, Khan AB, Naim A, et al. Shiga toxin activates complement and binds factor H: evidence for an active role of complement in hemolytic uremic syndrome. *J Immunol* 2009;182:6394-6400.
126. McGannon CM, Fuller CA, Weiss AA. Different classes of antibiotics differentially influence shiga toxin production. *Antimicrob Agents Chemother* 2010;54:3790-3798.
127. Tserenpuntsag B, Chang H-G, Smith PF, Morse DL. Hemolytic uremic syndrome risk and Escherichia coli O157:H7. *Emerg Infect Dis* 2005;11: 1955-1957.
128. Brandt JR, Fouser LS, Watkins SL, et al. Escherichia coli O 157:H7-associated hemolytic-uremic syndrome after ingestion of contaminated hamburgers. *J Pediatr* 1994;125:519-526.
129. Carter AO, Borczyk AA, Carlson JA, et al. A severe outbreak of Escherichia coli O157:H7—associated hemorrhagic colitis in a nursing home. *N Engl J Med* 1987;317:1496-1500.
130. Chandler WL, Jelacic S, Boster DR, et al. Prothrombotic coagulation abnormalities preceding the hemolytic-uremic syndrome. *N Engl J Med* 2002;346:23-32.
131. Tapper D, Tarr P, Avner E, Brandt J, Waldhausen J. Lessons learned in the management of hemolytic uremic syndrome in children. *J Pediatr Surg* 1995;30:158-163.
132. Steinborn M, Leiz S, Rudisser K, et al. CT and MRI in haemolytic uraemic syndrome with central nervous system involvement: distribution of lesions and prognostic value of imaging findings. *Pediatr Radiol* 2004;34:805-810.
133. Gould LH, Bopp C, Strockbine N, et al. Recommendations for diagnosis of shiga toxin—producing Escherichia coli infections by clinical laboratories. *MMWR Recomm Rep* 2009;58:1-14.
134. Loirat C, Sonsino E, Hinglais N, et al. Treatment of the childhood haemolytic uraemic syndrome with plasma. A multicentre randomized controlled trial. *The French Society of Paediatric Nephrology. Pediatr Nephrol* 1988;2: 279-285.
135. Dundas S, Murphy J, Soutar RL, et al. Effectiveness of therapeutic plasma exchange in the 1996 Lanarkshire Escherichia coli O157:H7 outbreak. *Lancet* 1999;354:1327-1330.
136. Lapeyraque AL, Malina M, Fremeaux-Bacchi V, et al. Eculizumab in severe Shiga-toxin-associated HUS. *N Engl J Med* 2011;364:2561-2563.
137. Bielaszewska M, Idelevich EA, Zhang W, et al. Effects of antibiotics on Shiga toxin 2 production and bacteriophage induction by epidemic Escherichia coli O104:H4 strain. *Antimicrob Agents Chemother* 2012;56:3277-3282.
138. Corogeanu D, Willmes R, Wolke M, et al. Therapeutic concentrations of antibiotics inhibit Shiga toxin release from enterohemorrhagic E. coli O104:H4 from the 2011 German outbreak. *BMC Microbiol* 2012;12:160.
139. Wong CS, Jelacic S, Habeeb RL, Watkins SL, Tarr PI. The risk of the hemolytic-uremic syndrome after antibiotic treatment of Escherichia coli O157:H7 infections. *N Engl J Med* 2000;342:1930-1936.
140. Garg AX, Suri RS, Barrowman N, et al. Long-term renal prognosis of diarrhea-associated hemolytic uremic syndrome: a systematic review, meta-analysis, and meta-regression. *JAMA* 2003;290:1360-1370.
141. Gagnadoux MF, Habib R, Gubler MC, Bacri JL, Broyer M. Long-term (15-25 years) outcome of childhood hemolytic-uremic syndrome. *Clin Nephrol* 1996;46:39-41.
142. Marshall JK. Post-infectious irritable bowel syndrome following water contamination. *Kidney Int Suppl* 2009;S42-S43.
143. Moist LM, Sontrop JM, Garg AX, et al. Risk of pregnancy-related hypertension within five years of exposure to bacteria-contaminated drinking water. *Kidney Int Suppl* 2009;S47-S49.

144. Noris M, Caprioli J, Bresin E, et al. Relative role of genetic complement abnormalities in sporadic and familial aHUS and their impact on clinical phenotype. *Clin J Am Soc Nephrol* 2010;5:1844-1859.
145. Fakhouri F, Roumenina L, Provot F, et al. Pregnancy-associated hemolytic uremic syndrome revisited in the era of complement gene mutations. *J Am Soc Nephrol* 2010;21:859-867.
146. Taylor CM, Chua C, Howie AJ, Risdon RA. Clinico-pathological findings in diarrhoea-negative haemolytic uraemic syndrome. *Pediatr Nephrol* 2004;19:419-425.
147. Le QM, Roumenina L, Noris M, Fremeaux-Bacchi V. Atypical hemolytic uremic syndrome associated with mutations in complement regulator genes. *Semin Thromb Hemost* 2010;36:641-652.
148. Maga TK, Nishimura CJ, Weaver AE, Frees KL, Smith RJ. Mutations in alternative pathway complement proteins in American patients with atypical hemolytic uremic syndrome. *Hum Mutat* 2010;31:E1445-E1460.
149. Dragon-Durey MA, Sethi SK, Bagga A, et al. Clinical features of anti-factor H autoantibody-associated hemolytic uremic syndrome. *J Am Soc Nephrol* 2010;21:2180-2187.
150. Moore I, Strain L, Pappworth I, et al. Association of factor H autoantibodies with deletions of CFHR1, CFHR3, CFHR4, and with mutations in CFH, CFI, CD46, and C3 in patients with atypical hemolytic uremic syndrome. *Blood* 2010;115:379-387.
151. Esparza-Gordillo J, Jorge EG, Garrido CA, et al. Insights into hemolytic uremic syndrome: segregation of three independent predisposition factors in a large, multiple affected pedigree. *Mol Immunol* 2006;43:1769-1775.
152. Ermini L, Goodship TH, Strain L, et al. Common genetic variants in complement genes other than CFH, CD46 and the CFHRs are not associated with aHUS. *Mol Immunol* 2012;49:640-648.
153. Heurich M, Martinez-Barricarte R, Francis NJ, et al. Common polymorphisms in C3, factor B, and factor H collaborate to determine systemic complement activity and disease risk. *Proc Natl Acad Sci U S A* 2011;108:8761-8766.
154. Zipfel PF, Edey M, Heinen S, et al. Deletion of complement factor H-related genes CFHR1 and CFHR3 is associated with atypical hemolytic uremic syndrome. *PLoS Genet* 2007;3:e41.
155. Jozsi M, Licht C, Strobel S, et al. Factor H autoantibodies in atypical hemolytic uremic syndrome correlate with CFHR1/CFHR3 deficiency. *Blood* 2008;111:1512-1514.
156. Dragon-Durey MA, Blanc C, Marliot F, et al. The high frequency of complement factor H related CFHR1 gene deletion is restricted to specific subgroups of patients with atypical haemolytic uraemic syndrome. *J Med Genet* 2009;46:447-450.
157. Bienaime F, Dragon-Durey MA, Regnier CH, et al. Mutations in components of complement influence the outcome of Factor I-associated atypical hemolytic uremic syndrome. *Kidney Int* 2010;77:339-349.
158. Strobel S, Abarrategui-Garrido C, Fariza-Requejo E, et al. Factor H-related protein 1 neutralizes anti-factor H autoantibodies in autoimmune hemolytic uremic syndrome. *Kidney Int* 2011;80:397-404.
159. Dragon-Durey MA, Fremeaux-Bacchi V, Loirat C, et al. Heterozygous and homozygous factor H deficiencies associated with hemolytic uremic syndrome or membranoproliferative glomerulonephritis: report and genetic analysis of 16 cases. *J Am Soc Nephrol* 2004;15:787-795.
160. Licht C, Heinen S, Jozsi M, et al. Deletion of Lys224 in regulatory domain 4 of Factor H reveals a novel pathomechanism for dense deposit disease (MPGN II). *Kidney Int* 2006;70:42-50.
161. Zhang Y, Meyer NC, Wang K, et al. Causes of alternative pathway dysregulation in dense deposit disease. *Clin J Am Soc Nephrol* 2012;7:265-274.
162. Sethi S, Nester CM, Smith RJ. Membranoproliferative glomerulonephritis and C3 glomerulopathy: resolving the confusion. *Kidney Int* 2012;81:434-441.
163. Smith RJ, Harris CL, Pickering MC. Dense deposit disease. *Mol Immunol* 2011;48:1604-1610.
164. Cooper M, McGraw ME, Unsworth DJ, Mathieson P. Familial mesangiocapillary glomerulonephritis with initial presentation as haemolytic uraemic syndrome. *Nephrol Dial Transplant* 2004;19:230-233.
165. Gorin MB. Genetic insights into age-related macular degeneration: controversies addressing risk, causality, and therapeutics. *Mol Aspects Med* 2012;33:467-486.

166. Sofat R, Casas JP, Webster AR, et al. Complement factor H genetic variant and age-related macular degeneration: effect size, modifiers and relationship to disease subtype. *Int J Epidemiol* 2012;41:250-262.
167. Martinez-Barricarte R, Recalde S, Fernandez-Robredo P, et al. Relevance of complement factor H-related 1 (CFHR1) genotypes in age-related macular degeneration. *Invest Ophthalmol Vis Sci* 2012;53:1087-1094.
168. Vyse TJ, Spath PJ, Davies KA, et al. Hereditary complement factor I deficiency. *QJM* 1994;87:385-401.
169. Richards SJ, Hill A, Hillmen P. Recent advances in the diagnosis, monitoring, and management of patients with paroxysmal nocturnal hemoglobinuria. *Cytometry B Clin Cytom* 2007;72:291-298.
170. Loirat C, Muus P, Legendre C, et al. A phase II study of eculizumab in patients with atypical hemolytic uremic syndrome receiving chronic plasma exchange/infusion. *Haematologica* 2011;96:S2-S0980.
171. Kelly R, Arnold L, Richards S, et al. The management of pregnancy in paroxysmal nocturnal haemoglobinuria on long term eculizumab. *Br J Haematol* 2010;149:446-450.
172. Marasca R, Coluccio V, Santachiara R, et al. Pregnancy in PNH: another eculizumab baby. *Br J Haematol* 2010;150:707-708.
173. Weitz M, Amon O, Bassler D, Koenigsrainer A, Nadalin S. Prophylactic eculizumab prior to kidney transplantation for atypical hemolytic uremic syndrome. *Pediatr Nephrol* 2011;26:1325-1329.
174. Nester C, Stewart Z, Myers D, et al. Pre-emptive eculizumab and plasmapheresis for renal transplant in atypical hemolytic uremic syndrome. *Clin J Am Soc Nephrol* 2011;6:1488-1494.
175. Jacobson RJ, Rath CE, Perloff JK. Intravascular haemolysis and thrombocytopenia in left ventricular outflow obstruction. *Br Heart J* 1973;35: 849-854.
176. Appel GB, Pirani CL, D'Agati V. Renal vascular complications of systemic lupus erythematosus. *J Am Soc Nephrol* 1994;4:1499-1515.
177. Kim YL, Richman KA, Marshall BE. Thrombocytopenia associated with Swan-Ganz catheterization in patients. *Anesthesiology* 1980;53:261-262.
178. Vonderheide RH, Thadhani R, Kuter DJ. Association of thrombocytopenia with the use of intra-aortic balloon pumps. *Am J Med* 1998;105:27-32.
179. Plotz FB, van OW, Bartlett RH, Wildevuur CR. Blood activation during neonatal extracorporeal life support. *J Thorac Cardiovasc Surg* 1993;105:823-832.
180. Velik-Salchner C, Maier S, Innerhofer P, et al. An assessment of cardiopulmonary bypass-induced changes in platelet function using whole blood and classical light transmission aggregometry: the results of a pilot study. *Anesth Analg* 2009;108:1747-1754.
181. Bick RL. Hemostasis defects associated with cardiac surgery, prosthetic devices, and other extracorporeal circuits. *Semin Thromb Hemost* 1985;11:249-280.
182. Rinder CS, Mathew JP, Rinder HM, et al. Modulation of platelet surface adhesion receptors during cardiopulmonary bypass. *Anesthesiology* 1991;75: 563-570.
183. Wenger RK, Lukasiewicz H, Mikuta BS, Niewiarowski S, Edmunds LH Jr. Loss of platelet fibrinogen receptors during clinical cardiopulmonary bypass. *J Thorac Cardiovasc Surg* 1989;97:235-239.
184. Despotis GJ, Joist JH. Anticoagulation and anticoagulation reversal with cardiac surgery involving cardiopulmonary bypass: an update. *J Cardiothorac Vasc Anesth* 1999;13:18-29.
185. Kutay V, Noyan T, Ozcan S, et al. Biocompatibility of heparin-coated cardiopulmonary bypass circuits in coronary patients with left ventricular dysfunction is superior to PMEA-coated circuits. *J Card Surg* 2006;21:572-577.
186. Castiglioni A, Verzini A, Pappalardo F, et al. Minimally invasive closed circuit versus standard extracorporeal circulation for aortic valve replacement. *Ann Thorac Surg* 2007;83:586-591.
187. Lo B, Nierich AP, Kalkman CJ, Fijnheer R. Relatively increased von Willebrand factor activity after off-pump coronary artery bypass graft surgery. *Thromb Haemost* 2007;97:21-26.
188. Koster A, Yeter R, Buz S, et al. Assessment of hemostatic activation during cardiopulmonary bypass for coronary artery bypass grafting with bivalirudin: results of a pilot study. *J Thorac Cardiovasc Surg* 2005;129: 1391-1394.

189. Despotis GJ, Levine V, Saleem R, Spitznagel E, Joist JH. Use of point-of-care test in identification of patients who can benefit from desmopressin during cardiac surgery: a randomised controlled trial. *Lancet* 1999;354:106-110.
190. Levi M, Cromheecke ME, de JE, et al. Pharmacological strategies to decrease excessive blood loss in cardiac surgery: a meta-analysis of clinically relevant endpoints. *Lancet* 1999;354:1940-1947.
191. Munoz JJ, Birkmeyer NJ, Birkmeyer JD, O'Connor GT, Dacey LJ. Is epsilonaminocaproic acid as effective as aprotinin in reducing bleeding with cardiac surgery?: a meta-analysis. *Circulation* 1999;99:81-89.
192. Ray MJ, O'Brien MF. Comparison of epsilon aminocaproic acid and low-dose aprotinin in cardiopulmonary bypass: efficiency, safety and cost. *Ann Thorac Surg* 2001;71:838-843.
193. Mangano DT, Tudor IC, Dietzel C. The risk associated with aprotinin in cardiac surgery. *N Engl J Med* 2006;354:353-365.
194. Chung A, Wildhirt SM, Wang S, Koshal A, Radomski MW. Combined administration of nitric oxide gas and iloprost during cardiopulmonary bypass reduces platelet dysfunction: a pilot clinical study. *J Thorac Cardiovasc Surg* 2005;129:782-790.
195. Tsai HM. von Willebrand factor, shear stress, and ADAMTS13 in hemostasis and thrombosis. *ASAIO J* 2012;58:163-169.
196. Budde U, Bergmann F, Michiels JJ. Acquired von Willebrand syndrome: experience from 2 years in a single laboratory compared with data from the literature and an international registry. *Semin Thromb Hemost* 2002;28:227-238.
197. Crow S, Milano C, Joyce L, et al. Comparative analysis of von Willebrand factor profiles in pulsatile and continuous left ventricular assist device recipients. *ASAIO J* 2010;56:441-445.
198. Uriel N, Pak SW, Jorde UP, et al. Acquired von Willebrand syndrome after continuous-flow mechanical device support contributes to a high prevalence of bleeding during long-term support and at the time of transplantation. *J Am Coll Cardiol* 2010;56:1207-1213.
199. Velik-Salchner C, Eschertzhuber S, Streif W, et al. Acquired von Willebrand syndrome in cardiac patients. *J Cardiothorac Vasc Anesth* 2008;22:719-724.
200. Crow S, John R, Boyle A, et al. Gastrointestinal bleeding rates in recipients of nonpulsatile and pulsatile left ventricular assist devices. *J Thorac Cardiovasc Surg* 2009;137:208-215.
201. Eurenium K, Mortensen RF, Meserol PM, Curreri PW. Platelet and megakaryocyte kinetics following thermal injury. *J Lab Clin Med* 1972;79:247-257.
202. Cozzi PJ, Stewart GJ, Morris DL. Thrombocytopenia after hepatic cryotherapy for colorectal metastases: correlates with hepatocellular injury. *World J Surg* 1994;18:774-776.
203. Straub A, Krajewski S, Hohmann JD, et al. Evidence of platelet activation at medically used hypothermia and mechanistic data indicating ADP as a key mediator and therapeutic target. *Arterioscler Thromb Vasc Biol* 2011;31:1607-1616.
204. Ranucci M, Carlucci C, Isgro G, et al. Hypothermic cardiopulmonary bypass as a determinant of late thrombocytopenia following cardiac operations in pediatric patients. *Acta Anaesthesiol Scand* 2009;53:1060-1067.
205. Jardim DL, Rodrigues CA, Novis YA, Rocha VG, Hoff PM. Oxaliplatin-related thrombocytopenia. *Ann Oncol* 2012;23:1937-1942.
206. Heyns AD, Lotter MG, Badenhorst PN, et al. Kinetics and in vivo redistribution of (111)Indium-labelled human platelets after intravenous protamine sulphate. *Thromb Haemost* 1980;44:65-68.
207. Slichter SJ, Stegall P, Smith K, Huang TW, Harker LA. Dysbaric osteonecrosis: a consequence of intravascular bubble formation, endothelial damage, and platelet thrombosis. *J Lab Clin Med* 1981;98:568-590.

Chapter 49 Miscellaneous Causes of Thrombocytopenia

> Table of Contents > Part V - Disorders of Hemostasis and Coagulation > Section 2 - Thrombocytopenia > Chapter 49 - Miscellaneous Causes of Thrombocytopenia

Chapter 49

Miscellaneous Causes of Thrombocytopenia

Archana M. Agarwal

George M. Rodgers

This chapter summarizes miscellaneous forms of congenital and acquired thrombocytopenia (Table 49.1), including thrombocytopenia attributable to deficient platelet production, associated with abnormal platelet pooling in the spleen, and resulting from dilution with massive transfusions.

CONGENITAL THROMBOCYTOPENIA

Hereditary thrombocytopenias have been well documented and may be inherited as an autosomal dominant trait, an autosomal recessive trait, or an X-linked recessive trait. Bleeding can be mild, and in some instances the affected family members are virtually asymptomatic, being identified only through incidental platelet counts or family studies after the identification of the proband. It is important to recognize these mild forms of familial thrombocytopenia because, although they may resemble autoimmune thrombocytopenic purpura, patients do not respond to steroid treatment or intravenous immunoglobulin, and this therapy may be harmful. These disorders can be classified according to platelet size (Table 49.2).

Autosomal Recessive Thrombocytopenias

Congenital Amegakaryocytic Thrombocytopenia

The presence of severe thrombocytopenia, absence of megakaryocytes in the bone marrow, and absence of any physical anomaly in an infant characterize congenital amegakaryocytic thrombocytopenia (CAMT).¹ Because of the recessive nature of the disease, family history is usually negative, with both parents having normal platelet counts and function. Patients with CAMT have markedly elevated serum levels of thrombopoietin (TPO)² and mutations in the *c-mpl* gene. Multiple mutations in the *c-mpl* gene have been reported, including deletions, nonsense mutations, and missense mutations. Many of the patients studied are compound heterozygotes with one mutation inherited from each parent.^{3, 4, 5} Because patients with CAMT develop progressive bone marrow aplasia during the course of the disease, it is likely that Mpl signaling is essential for the production of mature megakaryocytes as well as maintenance of the hematopoietic stem cell population.⁶

Further subgrouping of CAMT patients into two groups has been proposed based on their clinical course: Group CAMT I, with a more severe type of thrombocytopenia with constantly low platelet counts and an early onset of pancytopenia; and group CAMT II, which is characterized by a transient increase in platelet counts during the first year of life and a later or no development of pancytopenia.⁴ The type of *mpl* mutation determines the clinical course of CAMT; a total loss of the TPO receptor due to homozygous nonsense mutations, deletions, and frameshift mutations causes the more severe form of disease found in CAMT I patients. In contrast, the transient increase in platelet counts and the later development of pancytopenia in patients with homozygous or compound heterozygous missense mutations are the result of a residual function of the TPO receptor.⁷ Hematopoietic stem cell transplant is the only curative treatment for these patients, and matched sibling transplants have been successful.

Thrombocytopenia with Absent Radius Syndrome

The thrombocytopenia with absent radius (TAR) syndrome is a congenital malformation syndrome characterized by bilateral absence of the radii but with thumbs present, hypomegakaryocytic thrombocytopenia, and a number of additional features including skeletal and cardiac anomalies.^{8, 9} Among the skeletal anomalies, bilateral absence of the radii may be accompanied by ulnar or humeral anomalies, and the most severe cases exhibit phocomelia. Lower limb involvement is variable and includes dislocation of the patella and/or of the hips, absent tibiofibular joint, and lower limb phocomelia. Among the cardiac anomalies, tetralogy of Fallot and atrial septal defects are common.^{10, 11} Studies have noted a high incidence (62%) of cow's milk intolerance, which presents as persistent diarrhea and failure to thrive.

P.1098

An episode of thrombocytopenia may be precipitated by introduction of cow's milk and relieved by its exclusion from the diet.¹²

TABLE 49.1 MISCELLANEOUS CAUSES OF THROMBOCYTOPENIA

Congenital Thrombocytopenia

- Autosomal recessive thrombocytopenias
- Congenital amegakaryocytic thrombocytopenia
- Thrombocytopenia with absent radius (TAR) syndrome
- Bernard-Soulier syndrome
- Autosomal dominant thrombocytopenias
- MYH9-related disorder
- May-Hegglin anomaly
- Sebastian anomaly
- Fechtner anomaly
- Epstein anomaly
- Familial platelet disorder with predisposition to acute myelogenous leukemia
- Mediterranean macrothrombocytopenia
- Paris-Trousseau syndrome (in association with deletion of *FLII* gene)
- Autosomal dominant thrombocytopenia with linkage to human chromosome 10 (THC2)
- Gray platelet syndrome
- Amegakaryocytic thrombocytopenia with radial-ulnar synostosis (ATRUS) syndrome
- Variant von Willebrand disease (type 2b and platelet-type) (see Chapter 53)
- X-linked thrombocytopenia
- X-linked microthrombocytopenia (*WAS* gene mutation)
- X-linked macrothrombocytopenia with dyserythropoiesis (*GATA-1* mutation)
- Others
- 22q11 deletion syndrome (DiGeorge Syndrome)

Acquired Thrombocytopenia

- Thrombocytopenia caused by deficient platelet production
- Acquired pure amegakaryocytic thrombocytopenic purpura
- Chemical and physical agents that produce generalized bone marrow suppression
- Drugs that selectively suppress the megakaryocyte
- Drugs that cause ineffective thrombopoiesis
- Thrombocytopenia caused by abnormal platelet pooling
- Thrombocytopenia caused by hypothermia
- Thrombocytopenia associated with infections
- Thrombocytopenia associated with viral infections
- Thrombocytopenia associated with bacterial and protozoal infections
- Thrombocytopenia after massive blood transfusions

TABLE 49.2 CLASSIFICATION OF INHERITED THROMBOCYTOPENIA BY PLATELET SIZE (MPV)

Low MPV	Normal MPV	Increased MPV
---------	------------	---------------

Wiskott-Aldrich syndrome	ATRUS syndrome	MYH9-related disorders
	Thrombocytopenia with absent radius syndrome	Mediterranean macrothrombocytopenia
	Congenital amegakaryocytic thrombocytopenia	Bernard-Soulier syndrome
	Familial platelet disorder with predisposition to AML	GATA-1 mutation
	THC2	Gray platelet syndrome
	X-linked thrombocytopenia with GATA-1 mutation	Paris-Trousseau syndrome
		vWD type 2B Platelet type vWD 22q11 deletion syndrome

GATA-1 mutation platelets may have normal or increased MPV.

AML, acute myelocytic leukemia; ATRUS, amegakaryocytic thrombocytopenia with radial-ulnar synostosis; MPV, mean platelet volume; THC2, autosomal dominant thrombocytopenia with incomplete megakaryocyte differentiation and linkage to chromosome 10; vWD, von Willebrand disorder.

Adapted from Drachman JG, Inherited thrombocytopenia: when a low platelet count does not mean ITP. *Blood* 2004;103:390-398; Lambert MP. What to do when you suspect an inherited platelet disorder. *Hematology Am Soc Hematol Educ Program* 2011; 2011: 377-383.

These patients have elevated serum TPO levels and normal c-mpl and HOX genes. However, they have a profound defect in megakaryocyte differentiation and platelet production and no response of megakaryocytes to TPO.^{13, 14, 15} There may be a slight increase in platelet count in response to recombinant human erythropoietin.¹⁶ Although specific microdeletion of chromosome 1q21.1 has been reported in the majority of individuals with TAR syndrome, it is not the disease-causing mutation.¹⁷ Compound inheritance of a rare null mutation in exon-junction complex subunit RBM8A has been found to be the cause of TAR syndrome. RBM8A controls the production of the protein Y14, and its low level is responsible for the cause of low platelets.¹⁸

Diagnosis is rarely difficult because of obvious morphologic abnormalities in association with thrombocytopenia. Prenatal diagnosis has been described by ultrasonographic detection of morphologic abnormalities and detection of low fetal platelet counts.^{19, 20, 21} Congenital rubella and some variants of Fanconi syndrome should be excluded. Platelet counts gradually increase during the first 2 years of life. The degree of thrombocytopenia is usually greatest at the time of birth; platelet transfusions are frequently required and are effective. Thrombocytopenia becomes less severe during the first year of life, and most affected individuals with TAR do not require platelet transfusions after infancy.^{10, 22}

Bernard-Soulier Syndrome

Bernard-Soulier syndrome is an autosomal recessive bleeding disorder associated with deficiency of platelet membrane proteins GPIb, GPIX, and GPV. This results in abnormal platelet interaction with ligands of these receptor proteins, which include thrombin, von Willebrand factor (vWF), P-selectin, and leukocyte integrin $\alpha_M\beta_2$, in addition to causing thrombocytopenia. This topic is described in more detail in Chapter 52.

Autosomal Dominant Thrombocytopenia

A number of families have been described who have autosomal dominant inheritance of isolated mild thrombocytopenia characterized by normal platelet survival and a normal number of bone marrow megakaryocytes, a constellation of findings that suggests ineffective thrombopoiesis.^{23, 24, 25} Thrombocytopenia (platelet counts between 20,000 and 100,000/ μ l) or a history of increased bruising is apparent early in life, and examination of the peripheral blood smear

demonstrates platelet macrocytosis (mean platelet volume >10 μm³). Splenic size is always normal. Platelet aggregation abnormalities have been described in some families, but platelet membrane glycoproteins (GPs) have been normal when studied.²⁴

MYH9-related Disorders

A group of autosomal dominant macrothrombocytopenias caused by mutations in the MYH9 gene with variable penetrance and expression has been defined.^{26, 27, 28, 29} These include May-Hegglin anomaly, Sebastian syndrome, Epstein syndrome, and Fechtner syndrome. These disorders are defined by the presence of mutations involving the MYH9 gene located at chromosome 22q12.3-13.1 and include single nucleotide changes, in-frame deletions or duplications, and frameshift and nonsense mutations.³⁰ The MYH9 gene encodes nonmuscle myosin heavy chain IIA (NMMHC-IIA).³¹ NMMHC-IIA is part of the nonmuscle myosin IIA hexamer that is a component of the contractile cytoskeleton in megakaryocytes, platelets, and other tissues. Thrombocytopenia is usually mild and derives from complex defects of megakaryocyte maturation and platelet formation. More specifically, these mutations likely affect the platelet release from the mature megakaryocytes.³⁰ All of these MYH9 gene mutation-related disorders have macrothrombocytopenia, leukocyte inclusion bodies (Döhle body-like inclusions) and can have various combinations of hereditary nephritis, deafness, and cataracts (Table 49.3). Sometimes, the inclusions are rarely appreciated on conventional May-Grunwald-Giemsa staining, especially in patients with mutations at codon 702 because of their low RNA content. These cases can be diagnosed by the use of immunofluorescence assays.³² Thrombocytopenia is generally mild to moderate. Peripheral blood smears reveal enlarged platelets with frequent giant platelets.

Clinically, patients have a mild platelet-type bleeding disorder. May-Hegglin anomaly and Sebastian syndrome both have macrothrombocytopenia and granulocyte inclusions, but ultrastructural analysis of the Döhle-like inclusions demonstrates diagnostic differences between these two syndromes, and both types of inclusions can also be distinguished from Döhle bodies seen in acute infection. Patients with Fechtner syndrome and Epstein syndrome have hearing disability and nephritis. In Fechtner syndrome, cataracts are also present.³³ These two disorders result from allelic mutations at amino acid 702, which cause conformational changes to the myosin head.^{31, 34, 35, 36} Diagnosis is suggested by detection of macrothrombocytopenia and the presence of one or more of the above-mentioned clinical features. Döhle-like inclusion bodies within neutrophils on May-Grünwald-Giemsa-stained peripheral blood are highly suggestive of an MYH9-related disorder. Abnormal staining of neutrophil inclusions with anti-NMMHC-IIA may offer greater sensitivity. Definitive diagnosis requires the demonstration of a causative mutation within the MYH9 gene.³¹ Treatment options for bleeding include platelet transfusion, allogeneic stem cell transplantation, or use of a thrombopoietic drug (eltrombopag).³⁷

Platelet-type von Willebrand disease is another autosomal dominant disorder associated with hereditary thrombocytopenia, characterized by abnormal binding of large vWF multimers to platelets. This intrinsic platelet defect results in mild thrombocytopenia, increased ristocetin-induced platelet aggregation, and a selective

P.1099

loss of high-molecular-weight vWF multimers from the plasma. This disorder resembles type 2b von Willebrand disease (see Chapter 53).

TABLE 49.3 SYNDROMES CAUSED BY MYH9 GENE DEFECTS

Syndrome	Macrothrombocytopenia	Döhle-like Bodies	Nephritis	Deafness	Cataracts
May-Hegglin	Yes	Yes	No	No	No
Sebastian	Yes	Yes	No	No	No
Fechtner	Yes	Yes	Yes	Yes	Yes
Epstein	Yes	Yes	Yes	Yes	No

Familial Platelet Disorder with Predisposition to Acute Myelogenous Leukemia

Familial platelet disorder with predisposition to acute myelogenous leukemia (FPD/AML) is an autosomal dominant disorder characterized by moderate thrombocytopenia, a defect in platelet function, and predisposition to develop myeloid malignancy.³⁸ The defect in platelet function is manifested by prolonged bleeding times and abnormal platelet aggregation. Expansion of megakaryocyte progenitors in the bone marrow or peripheral blood cells reveals diminished megakaryocyte colony formation. Bone marrow from affected patients shows decreased megakaryopoiesis. Linkage analysis of several pedigrees affected by FPD/AML has led to identification of germline heterozygous mutations in the

hematopoietic transcription factor AML1, also known as RUNX1 and CBFA2. These mutations include missense, frameshift, and nonsense mutations and a large intragenic deletion.^{39, 40} CBFA2 is a transcription factor that trans-activates the expression of a spectrum of genes required for normal development of hematopoietic cells. Mutation of CBFA2 has been implicated in the pathogenesis of human leukemias resulting from somatically acquired chromosomal translocations.⁴¹ Normal megakaryopoiesis requires TPO binding to the Mpl receptor. In FPD/AML, CBFA2 mutation leads to diminished Mpl receptor expression, resulting in impaired TPO signaling leading to thrombocytopenia. Consequently, serum TPO levels are usually elevated in these patients.⁴²

Mediterranean Macrothrombocytopenia

A relatively common and mild form of macrothrombocytopenia has been described in a group of 145 apparently healthy subjects from Italy and the Balkan peninsula. Because this abnormality was not detected in control subjects from northern Europe, the condition was named Mediterranean macrothrombocytopenia.⁴³ Linkage analysis localized the gene mutation to the short arm of chromosome 17, in an interval containing the GPIIb gene. GPIIb, together with other proteins, constitutes the plasma vWF receptor, which is altered in Bernard-Soulier syndrome. Sequencing of the gene identified a mutation of GPIIb (Ala156Val) shared by 10 of 12 pedigrees studied.⁴⁴ These data demonstrate that for most families with Mediterranean thrombocytopenia, the genotype and phenotype are equivalent to that of a carrier of Bernard-Soulier syndrome. Clinically, patients have a mild bleeding diathesis, usually diagnosed after incidental discovery of thrombocytopenia. Peripheral blood shows platelets that are larger than normal.

Paris-Trousseau Syndrome (in Association with Deletion of the FLI1 Gene)

Paris-Trousseau syndrome (PTS) is an inherited disorder characterized by several congenital anomalies including dysmegakaryopoiesis with two morphologically distinct populations of megakaryocytes and giant α -granules in a low percentage of platelets. These features occur in association with deletion of the long arm of chromosome 11 at 11q23.3 (which includes the FLI1 gene), a region that is also deleted in Jacobsen syndrome (a variant form of PTS). Clinical features include a combination of mild to moderate psychomotor retardation, trigonocephaly, facial dysmorphism, cardiac defects, and thrombocytopenia.^{45, 46} Hematologic history, biologic data, ultrastructural, and molecular investigations were reported from a case series of 10 patients.⁴⁷ Thrombocytopenia is chronic, with mild clinical bleeding. Peripheral blood smears and electron microscopy show abnormal platelets with giant granules. Bone marrow findings consist of dysmegakaryopoiesis with many micromegakaryocytes. Abnormal α -granules are not seen in the bone marrow and cultured megakaryocytes. Platelets have a normal lifespan in the circulation. The number of megakaryocytes in the bone marrow is increased, accompanied by impaired maturation. Together these findings suggest that platelet release is substantially impaired. PTS occurs as a result of hemizygous loss of the FLI1 transcription factor gene, which has been shown to be critical for megakaryocyte differentiation and release of platelets. FLI1 shows monoallelic expression during a brief window in megakaryocyte differentiation. This monoallelic expression explains the dominant inheritance pattern of PTS despite the presence of one normal FLI1 allele.^{48, 49}

Autosomal Dominant Thrombocytopenia with Incomplete Megakaryocyte Differentiation and Linkage to Chromosome 10

The genetic defect for this autosomal dominant thrombocytopenia has been mapped to a region on the short arm of chromosome 10 (10p11-12).⁵⁰ This disorder is characterized by moderate thrombocytopenia, abnormal platelet size, and incomplete differentiation of megakaryocytes. Clinical features consist of mild to moderate bruising but absence of major bleeding even with minor surgery and childbirth, suggesting that the residual platelets have normal hemostatic function. However, platelets are deficient in GPIIb and α -granule content. Morphologically, the platelets appear normal. Bone marrow examination reveals impaired megakaryocyte maturation and small megakaryocytes. Colony assay on bone marrow and peripheral blood cells reveal expanded progenitors across all hematopoietic lineages, and tremendously increased expansion of immature megakaryocytes (CFU-Mk). Serum TPO level is only moderately elevated and is usually lower than expected for the degree of thrombocytopenia.⁵¹

Recently, mutations in ANKRD26 were identified in the original patients and in several additional families around the world; these mutations accounted for 10% of patients in an inherited thrombocytopenia database.⁵² The term "thrombocytopenia 2" (THC2) has been applied to this disorder.

P.1100

Gray Platelet Syndrome

The gray platelet syndrome for which both autosomal recessive and autosomal dominant inheritance have been described is characterized by macrothrombocytopenia with bleeding tendency, myelofibrosis, and classical abnormal platelet morphology.⁵³ The α -granules are absent or greatly reduced, giving the platelets a gray color on Wright-Giemsa stain. The α -granules are the principal storage site for hemostatic proteins such as fibrinogen, vWF, thrombospondin, and factor V and for growth factors such as platelet-derived growth factor and transforming growth factor- β .⁵⁴ One result of absence of α -granules is a continued leakage of growth factors and cytokines into the marrow, causing myelofibrosis.

Amegakaryocytic Thrombocytopenia with Radial-Ulnar Synostosis Syndrome in Association with HOXA11 Mutation

Homeobox genes encode regulatory proteins that are critical to bone morphogenesis as well as hematopoietic differentiation and proliferation.⁵⁵ This defect is the first reported germline HOX gene mutation associated with a human nonneoplastic hematologic disorder, and only the third HOX gene implicated in a human disorder.⁵⁶ HOXA11 is suggested to be endogenously expressed in very early hematopoietic precursor cells and involved in regulation of megakaryocytic differentiation.⁵⁷ Clinical features consist of CAMT, aplastic anemia, proximal radial-ulnar synostosis, clinodactyly, syndactyly, hip dysplasia, and sensorineural hearing loss.⁵⁸ Platelet transfusions are effective as initial symptomatic management. The only definitive treatment is hematopoietic stem cell transplantation.⁵⁹

X-linked Thrombocytopenia

X-linked Microthrombocytopenia (WAS Gene Mutation)

Wiskott-Aldrich syndrome (WAS), originally described in 1937, is now known as an X-linked hereditary disorder associated with combined immunodeficiency, thrombocytopenia, small platelets, eczema, and an increased risk of autoimmune disorders and cancers. It has a broad range of phenotypes.⁶⁰ At one end of the clinical spectrum, patients exhibit platelet abnormalities only, and at the other end, patients manifest thrombocytopenia, eczema, and immune abnormalities with progressive T-cell lymphopenia, and increased susceptibility to infection. The severe form of WAS and its milder manifestations—X-linked thrombocytopenia and X-linked neutropenia—are caused by mutations in the gene for the WAS, located at Xp11.22-p11.23 and cloned in 1994.^{61, 62, 63, 64} The WAS gene is composed of 12 exons and encodes a polypeptide of 502 amino acids. Most mutations consist of single-nucleotide substitutions, small insertions and deletions, and splice-site mutations, and these are distributed throughout the coding region and the intron-exon junctions.⁶⁵ Even within families, the same genotype can be associated with varying phenotypes. Measurement of the WAS protein (WASP) is now possible, making diagnosis less difficult.⁶⁶ The mature WASP contains numerous protein-interacting domains and appears to provide a critical link between the cellular cytoskeleton and signal transduction pathways. WASP is a key regulator of actin polymerization in hematopoietic cells. It has five well-defined domains that are involved in signaling, cell locomotion, and immune synapse formation. WASP facilitates the nuclear translocation of nuclear factor κ B and has been shown to play an important role in lymphoid development and in the maturation and function of myeloid monocytic cells.⁶⁷

Megakaryocyte mass is normal or increased in WAS. Platelet differentiation and production are normal, and platelets produced *in vitro* are normal in size. These observations suggest that increased destruction in the spleen is responsible for both the thrombocytopenia and decreased platelet size. Management of patients with WAS is challenging; however, early diagnosis is very important for prophylaxis and treatment.⁶⁸ Splenectomy definitely improves platelet counts in these patients, which frequently return to normal, suggesting a role of the reticuloendothelial system in platelet removal. Notably, antiplatelet antibodies are not present.⁶⁹ The only curative therapy remains hematopoietic stem cell transplantation, which corrects both thrombocytopenia and immunodeficiency. The administration of WAS gene corrected autologous hematopoietic stem cells may represent an alternative treatment option.⁶⁰

X-linked Macrothrombocytopenia with Dyserythropoiesis (GATA-1 Mutation)

The X-linked gene GATA-1 regulates the expression of a large number of genes in multiple cell types.^{70, 71} GATA-1 transcription factor contains both DNA binding and transactivation activity within three functional domains: Two zinc fingers (known as the N finger and the C-finger) and an N-terminal activation domain. The C-finger is responsible for binding of GATA-1 to typical GATA-binding sites (WGATAR consensus). The N terminus of GATA-1 constitutes an activation domain, as defined by the ability of this region to confer transcriptional activation in reporter assays in fibroblasts.⁷² Taken together, these domains act in a manner similar to a multitude of transcription factors that bind DNA and activate transcription of target genes. In addition to binding DNA, the N finger has a second essential function, recruitment of the co-factor Friend of GATA-1 (FOG-1).⁷³ FOG-1, as is GATA-1, is primarily expressed in hematopoietic cells, and is absolutely essential for the development of red blood cells and megakaryocytes. Five germline mutations of GATA-1 that cause X-linked disorders have been described, and all cluster in the N-terminal zinc finger.

GATA-1 mutation-associated thrombocytopenia is clinically distinguished from WAS by the presence of large or normal-sized platelets and the absence of immunodeficiency, eczema, and lymphomas.⁷⁴ Thrombocytopenia is more severe (10,000 to 40,000/ μ l). Clinically, bleeding and bruising in affected individuals are severe, and platelet aggregation studies have shown that platelet function is also diminished.⁷⁵ The bone marrow is hypercellular, with dysplastic features in the erythroid and megakaryocytic lineages.⁷⁶

Others

22q11.2 Deletion Syndrome (DiGeorge Syndrome)

This relatively common genetic disorder occurs in 1:4,000 live births, and in addition to thrombocytopenia, is associated with cardiac abnormalities, velofacial anomalies, hypocalcemia, immune defects, and a variety of other features.⁷⁷ One particular gene in the region of 22q11-TBX1 is likely responsible for cardiac defects.⁷⁷ The macrothrombocytopenia seen in this disorder is mild.⁷⁴

ACQUIRED THROMBOCYTOPENIA

Deficient Platelet Production

Deficient platelet production may result from three mechanisms: Hypoplasia or suppression of the precursor megakaryocytes; ineffective thrombopoiesis despite a normal precursor mass; or, rarely, deficiency or aberration of thrombopoietic control mechanisms.

P.1101

Acquired Amegakaryocytic Thrombocytopenic Purpura

Acquired amegakaryocytic thrombocytopenic purpura (AATP) is a rare cause of thrombocytopenia associated with decreased or absent megakaryocytes in otherwise normal bone marrow. The prevalence is possibly higher than reported, as many cases are underdiagnosed or misdiagnosed as immune thrombocytopenia.

The differential diagnosis of patients with severe thrombocytopenia and isolated amegakaryocytosis includes a misdiagnosis of immune thrombocytopenic purpura, as mentioned above; ethanol use or drug ingestion; immune suppression associated with diseases such as systemic lupus erythematosus; and prodromal manifestations of acquired aplastic anemia, myelodysplastic disorders, or acute leukemia.^{78, 79} Thrombocytopenia and amegakaryocytosis caused by chemotherapy or postradiation therapy should be apparent.

The pathogenesis of AATP is uncertain. AATP can occur individually or as a component of aplastic anemia secondary to exposure to environmental agents such as viruses (cytomegalovirus [CMV], parvovirus B19), and certain toxins such as benzene.^{78, 80} Both cell-mediated suppression of megakaryopoiesis and the role of humoral immunity in AATP have been proposed, but the exact role of either remains unclear. A marked increase of T-activated suppressor cells (CD8⁺/DR⁺) in association with AATP has been reported.⁸¹ AATP has also been associated with high levels of anti-TPO IgG antibodies.⁸² No cytogenetic abnormality has been shown to be consistently associated with AATP.⁸³ A defect in cytokine-mediated regulation of megakaryopoiesis is another proposed mechanism leading to AATP, but conclusive data are lacking.

Patients with AATP do not have a palpable spleen. The platelets are usually small or normal in size. An increased mean red cell volume is a common finding. In most patients, an etiology cannot be determined, and empirical therapy is necessary. Platelet transfusions should be used to treat bleeding and may be required prophylactically in some patients. Although there are occasional spontaneous remissions, most sustained remissions have occurred in patients receiving immunosuppressive therapy. Treatment with intravenous immunoglobulin, prednisone, cyclophosphamide, and vincristine has not been efficacious in AATP. Myeloablative chemotherapy (busulfan and cyclophosphamide) followed by allogeneic bone marrow transplant from a fully HLA-matched sibling is effective.⁸⁴ Danazol has been reported to be effective in two cases of AATP.⁸⁵ Antithymocyte globulin (ATG) alone,⁸⁶ rituximab,⁸⁷ azathioprine,⁸⁸ and cyclosporine alone or in combination with ATG, have been shown to be very effective in treatment of AATP.^{83, 89, 90} The role of recombinant interleukin-11 (IL-11, a thrombopoietic growth factor) in AATP is uncertain. The availability of thrombopoietic drugs,⁹¹ may offer another treatment option for AATP patients.

Chemical and Physical Agents That Produce Generalized Bone Marrow Suppression

Ionizing radiation, alkylating agents, antimetabolites, and cytotoxic drugs may produce thrombocytopenia as the result of predictable suppression of the marrow. The mechanisms by which these agents act are well defined, and

thrombocytopenia is a common complication when they are used in immunosuppression and cancer chemotherapy. In addition, many drugs, such as chloramphenicol, produce marrow hypoplasia as a result of idiosyncratic reactions. The pathophysiology in these cases is poorly understood.

Agents that produce thrombocytopenia may damage other bone marrow precursors as well as megakaryocytes, and the usual picture is one of diffuse bone marrow hypoplasia and pancytopenia. Rarely, only thrombocytopenia may be present. Platelets often are the last cell type to return to normal after recovery from bone marrow hypoplasia; in some patients, thrombocytopenia may persist indefinitely.

Drugs That Selectively Suppress the Megakaryocyte

Chlorothiazides. Chlorothiazides and various congeners may produce thrombocytopenia by one of at least two mechanisms: by the formation of platelet antibodies or by a poorly understood suppression of thrombopoiesis.⁹² The latter action is by far the most common. Evidence of marrow suppression is largely indirect.⁷⁹ Serologic tests for platelet antibodies usually yield negative results. Diminution in the number of megakaryocytes has been observed in infants born of mothers who were taking these drugs, but few instances of megakaryocytic hypoplasia have been documented in adults. Mild asymptomatic thrombocytopenia may occur in as many as 25% of patients taking these agents, an observation that implies that thrombocytopenia may be a pharmacologic rather than an idiosyncratic effect. Recovery from thrombocytopenia associated with the use of thiazide drugs is slow, and thrombocytopenia usually can be reproduced only by readministration of the drug for a protracted period.

Estrogens. Estrogenic hormones appear to affect platelet kinetics in animals both by facilitating reticuloendothelial phagocytosis and by impairing thrombopoiesis. Neither effect has been convincingly demonstrated in humans, but several instances of "amgakaryocytic" thrombocytopenia have been reported after the administration of diethylstilbestrol. In one patient, thrombocytopenia recurred when the hormone was readministered.⁹³

Ethanol. Ethanol can suppress platelet production, a phenomenon that may be a common cause of mild thrombocytopenia in the alcoholic patient. In most reported cases, nutritional factors, folate deficiency, and splenomegaly were excluded, but patients did have evidence of impaired hepatic function. Platelet counts $<100,000/\mu\text{l}$ occur in as many as 26% of acutely ill alcoholics.^{94, 95} The experimental administration of ethanol produces thrombocytopenia with decreased platelet survival and platelet turnover.⁹⁶ Bleeding is rare, and when ethanol is withdrawn, the platelet count begins to increase in 2 to 3 days and returns to normal or supranormal levels in 2 to 3 weeks.⁹⁵ Several patients developed venous thromboembolic disease when platelet counts reached values $>500,000/\mu\text{l}$.⁹⁷

Pathophysiologic studies in alcohol-induced thrombocytopenia reveal accelerated platelet destruction and a subnormal compensatory increase in thrombopoiesis. Platelet function abnormalities have also been described. The bone marrow usually reveals normal numbers of megakaryocytes. Studies using mice and guinea pig megakaryocytes demonstrate that the effect of ethanol is primarily on the maturing megakaryocytes, a finding consistent with ineffective thrombopoiesis.⁹⁸ Several cases of bone marrow hypoplasia secondary to consumption of excessive alcohol have also been described. Colony-forming unit (CFU) granulocytemacrophage-derived colony formation in one of these patients was inhibited by much lower concentrations of ethanol than that of normal volunteers.⁹⁹

Drugs That Cause Ineffective Thrombopoiesis

Ineffective thrombopoiesis may play a role in several different types of thrombocytopenia. Thrombocytopenia is a consistent feature of megaloblastic hematopoiesis that results from deficiency of vitamin B₁₂ or folic acid. Although seldom severe and rarely of clinical significance, this form of thrombocytopenia results from a distinctive abnormality of platelet production called ineffective thrombopoiesis. This abnormality was first demonstrated in thrombokinetic studies and is characterized by diminished platelet production despite the presence of an increased megakaryocyte mass. Thus, it is analogous to ineffective erythropoiesis,

P.1102

which is also characteristic of the megaloblastic anemias. Platelet production, whether calculated per megakaryocyte or per nuclear unit, is diminished. Although the number of megakaryocytes increases in response to thrombopoietic stimuli, the normal concomitant increase in their volume does not occur. This phenomenon presumably results from impaired DNA synthesis and the consequent limitation in nuclear endoreduplication. In stained smears, the megakaryocytes often appear hyperlobulated, and circulating platelets are abnormally large.¹⁰⁰ Moderate shortening of platelet survival and, rarely, hypoplasia of the megakaryocytes may be important contributory factors in the production of thrombocytopenia in some cases.

Thrombocytopenia Caused by Abnormal Platelet Pooling

The splenic pool normally contains approximately one third of the total platelet mass, and this pool may increase in size as a result of disorders that are associated with splenomegaly, such as cirrhosis with portal hypertension, sarcoidosis and other granulomatous infections, Gaucher and other lipid-storage diseases, leukemias and lymphomas, and Felty syndrome.^{101, 102, 103} This shift of platelets into the spleen may result in thrombocytopenia in the circulating blood despite a normal or even increased total platelet mass. The clinical picture in hypersplenic thrombocytopenia is usually dominated by the underlying disease, and numerous other hematologic abnormalities, such as neutropenia, anemia, and coagulation defects, may also be present.

The pathophysiology of thrombocytopenia in disorders associated with splenomegaly is not completely understood. Rat spleens demonstrate large numbers of platelets adherent to reticuloendothelial cells.¹⁰⁴ It is also hypothesized that the splenic pool increase may occur because of very slow passage of platelets through the tortuous splenic vasculature. The platelets in the splenic pool are in equilibrium with the circulating pool and can be mobilized with an infusion of epinephrine or during plateletpheresis.^{105, 106, 107} This is in contrast to the irreversible thrombocytopenia caused by splenic removal of damaged or antibody-coated platelets in disorders such as autoimmune thrombocytopenic purpura. There is some evidence for accelerated platelet destruction in many instances of thrombocytopenia associated with disorders of the spleen.^{108, 109} Survival of isotopically labeled platelets is shortened in some patients with cirrhosis and portal hypertension, even though the major mechanism of thrombocytopenia in these patients appears to be splenic pooling.

The usual laboratory findings are pancytopenia with mild thrombocytopenia and a normal or moderately increased number of megakaryocytes in the bone marrow. Platelet counts in cirrhotic patients have been as low as 20,000/ μ l, although thrombocytopenia of this severity is uncommon. Patients with hypersplenism have smaller platelets than those with autoimmune thrombocytopenia, so platelet sizing may provide a means of differentiating between thrombocytopenia related primarily to immunologic platelet destruction and that related to big-spleen syndromes. In general, the severity of the thrombocytopenia correlates poorly with the size of the spleen, but it is nonetheless difficult to entertain a diagnosis of thrombocytopenia caused by abnormal splenic platelet pooling in the absence of significant splenic enlargement.¹¹⁰

Therapy is seldom indicated for thrombocytopenia alone, but splenectomy, embolic occlusion of the splenic vasculature, and splenic damage secondary to infusion of radiolabeled particles can improve the thrombocytopenia and sometimes alleviate the pancytopenia completely.^{108, 111, 112, 113, 114, 115, 116} Patients with thrombocytopenia secondary to cirrhosis with portal hypertension may benefit from portocaval shunts or transjugular intrahepatic portosystemic shunts.^{117, 118}

Thrombocytopenia Caused by Hypothermia

In humans, mild reversible thrombocytopenia is a predictable consequence of surgical hypothermia below 25°C.^{119, 120} Thrombocytopenia has also been noted after hypothermia caused by environmental exposure.¹²¹ Finally, thrombocytopenia occurs in almost all patients undergoing one- or two-cycle cryotherapy for hepatic metastases from colorectal adenocarcinoma.¹²²

Adhesion of platelets to subendothelium is mediated through an interaction of the platelet GP Ib-IX-V complex and subendothelial vWF. The GP Ib-IX-V complex comprises four transmembrane polypeptide chains, GPIb α , GPIb β , GPiX, and GPV. Lipid rafts (also known as glycolipid-enriched membranes) are dynamic assemblies of cholesterol and sphingolipids that are more ordered in structure than the rest of the plasma membrane.¹²³ Receptor clustering is an essential feature of signaling through lipid rafts and occurs in platelet membrane at lower temperatures.¹²⁴ A subset of the GP Ib-IX-V complex is constitutively associated with lipid rafts in unstimulated platelets.¹²⁵ Upon exposure to cold, the cooled platelets irreversibly reorganize vWF receptors (the [GPIb α IX]₂V complex) into clusters on the platelet surface. The hepatic macrophage integrin receptor Mac-1 (CD11b/CD18) recognizes clustered GPIb α , leading to phagocytosis of cooled platelets. Cooling, however, does not grossly impair the interaction between GPIb and activated vWF, implying that the hemostatic and clearance functions of GPIb are distinct.^{126, 127}

Thrombocytopenia Associated with Infections

Purpura was recognized as a manifestation of pestilential fevers 2,000 years ago. Several factors are now known to cause bleeding in association with infections, of which thrombocytopenia is the most common.

Thrombocytopenia Associated with Viral Infections

Viruses may produce thrombocytopenia by several different mechanisms: Impaired platelet production as a result of invasion of megakaryocytes by the virus, impaired platelet production caused by toxic effects of viral proteins on

progenitor cells, viral-induced hemophagocytosis, destruction of circulating platelets by the virus, and increased platelet destruction caused by binding of viral-induced autoantibodies or viral antigen-antibody complexes.

The administration of live measles vaccine produced significant yet subclinical thrombocytopenia in most normal children.¹²⁸ Degenerating vacuolated megakaryocytes were evident 3 days after administration of the vaccine. The nadir of the platelet count occurred 7 days after vaccination. There are now several reports of thrombocytopenia occurring after immunization with measles-mumps-rubella vaccine, monovalent measles vaccine, and measles-mumps vaccine.¹²⁹ Thrombocytopenia has been severe (<20,000/ μ l), and some patients have had significant hemorrhagic complications. The majority of the patients have been <2 years of age, but the age range was 1 to 40 years.¹³⁰ Thrombocytopenia after vaccination for hepatitis A and B and varicella has also been noted.^{131, 132, 133} Children with neonatal infections with mumps and rubella are often thrombocytopenic,^{134, 135} and hepatomegaly and splenomegaly may also be present. CMV infection is usually asymptomatic in immunocompetent adults. However, there are reports of severe thrombocytopenia and even thrombocytopenia with hemolysis.^{136, 137} It is unclear whether the thrombocytopenia is caused by a direct cytopathologic effect of the virus on megakaryocytes, viral-induced hemophagocytosis, or immunologic destruction.

Parvovirus B19 is the etiologic agent responsible for erythema infectiosum. It is also cytotoxic to erythroid progenitors and can cause aplastic crises in patients with hemolytic anemia and chronic bone marrow failure in immunocompromised hosts. Thrombocytopenia may occur in some of these patients,

P.1103

and recent studies demonstrate cytotoxic effects of viral nonstructural-1 proteins on megakaryocytes.^{138, 139, 140}

Thrombocytopenia has been reported following the administration of adenoviral gene transfer vectors.^{138, 141} The interaction between adenovirus and platelets leads to platelet activation and rapid exposure of P-selectin on the platelet surface. P-selectin interacts with major P-selectin ligand on leukocytes, leading to the formation of platelet-leukocyte aggregates.¹⁴² Adenovirus also activates endothelial cells either directly or indirectly through activated platelets. It is followed by increases in total amounts of vWF and of ultralarge vWF multimers in plasma as well as an increase in the number of circulating endothelial cell-derived microparticles. Endothelial cell activation and the associated up-regulation of adhesion molecules (VCAM-1) contribute to leukocyte and/or platelet leukocyte aggregate rolling and transendothelial migration, a critical process for tissue macrophage influx. This is followed by removal of activated platelets by tissue macrophages.

Thrombocytopenia Associated with Bacterial and Protozoal Infections

Thrombocytopenia commonly is associated with septicemia resulting from both Gram-negative and Gram-positive bacteria. This complication is particularly common in infants and children, and the presence of unexplained thrombocytopenia, particularly in this age group, should always alert the physician to the possibility of septicemia. The etiology of thrombocytopenia may be multifactorial. Thrombocytopenia may be caused by disseminated intravascular coagulation (DIC), and the diagnosis of DIC may be apparent when coagulation studies are performed. Thrombocytopenia has also been described in patients with Gram-negative or Gram-positive septicemia, and 46% of these patients had elevated platelet-associated immunoglobulin G without evidence of DIC. These studies were interpreted as demonstrating the presence of platelet destruction caused by splenic destruction of immune complex-coated platelets. These data must be reinterpreted with third-generation immune complex capture assays that can better define platelet autoantibodies and immune complexes.

Platelet adherence to damaged vascular surfaces may also account for thrombocytopenia in certain bacterial infections, such as meningococcemia. Endotoxins, exotoxins, or platelet-activating factor may damage platelets, resulting in increased clearance. Patients with sepsis syndrome may develop hemophagocytic histiocytosis with phagocytosis of platelets, white cells, and platelets in bone marrow histiocytes.¹⁴³

Thrombocytopenia may also be caused by direct platelet toxicity caused by the microorganism. Thrombocytopenia occurs in >80% of patients with malaria, and platelets from malaria patients have been demonstrated to contain plasmodia.¹⁴⁴ Significant ultrastructural changes in platelets of patients with malaria are present, and the extent of abnormal findings correlates with the level of parasitemia.¹⁴⁵

The pathophysiology of thrombocytopenia in malaria has recently been studied in a mouse model of experimental malaria induced by *Plasmodium berghei*. Signaling through multipotent immunomodulator CD40L and its receptor CD40, expressed on activated platelets, initiates the caspase cascade, resulting in apoptosis of the platelet and the formation of platelet microparticles.¹⁴⁶ Early depletion of platelets leads to an altered immune response with significantly decreased

levels of proinflammatory cytokines, such as interferon- γ and interleukin-2 (IL-2), as well as increased levels of IL-10, indicating a role for platelets in the regulation of pathogenic cytokines and cell-mediated immune responses.¹⁴⁷ Cell-mediated rather than the humoral immune response has been shown to play a major role in development of thrombocytopenia.¹⁴⁸

Theoretically, any bacterial or protozoal infection can be associated with thrombocytopenia that is caused by one of the mechanisms hypothesized in this chapter. There are reports of thrombocytopenia in Lyme disease and *Mycoplasma pneumoniae* infections, a manifestation of these infections that appears to be uncommon.^{149, 150}

Patients with thrombocytopenia associated with infection should be tested for the presence of DIC. At this time, no other clinically available tests can be used to define the precise etiology in patients without evidence of DIC. The most important therapy for infection-related thrombocytopenia is that directed at the underlying infection. Platelet transfusions, with or without intravenous IgG, can be used to control bleeding until antimicrobial therapy is effective.

Thrombocytopenia after Massive Blood Transfusion

Massive blood transfusion is defined as complete replacement of a patient's blood volume within 24 hours, usually 10 units of packed red blood cells for an average-sized adult. Because packed red blood cells do not contain a significant number of functional platelets and do not replace labile clotting factors, there has been concern about the incidence of developing hemostatic abnormalities and clinical bleeding in patients given only packed red blood cells.

Some studies demonstrate a correlation between the number of units of packed red blood cells transfused and both reduction in platelet counts ("dilutional thrombocytopenia") and increases in prothrombin and partial thromboplastin times. However, significant changes (platelets, 50,000 to 100,000/ μ l) are not apparent until patients have received >15 units of blood.^{148, 149} Severe thrombocytopenia, defined as a platelet count <50,000/ μ l, is most common in patients receiving >20 units of blood.^{151, 152} Microvascular bleeding occurs in 20% to 60% of patients who are massively transfused, but neither the platelet count nor changes in coagulation studies can be used to predict which patients will bleed.¹⁵³ Although bleeding appears to be more dependent on thrombocytopenia than on coagulation abnormalities, prophylactic administration of platelets was no more effective than equivalent volumes of prophylactic fresh-frozen plasma infusions in preventing bleeding.¹⁵⁴ Therefore, it is recommended that platelet and plasma replacement during massive transfusions be guided by serial monitoring of platelet counts, prothrombin time, and partial thromboplastin time, and that platelet counts be kept >75,000/ μ l and prothrombin time and partial thromboplastin time <1.5 times normal.¹⁵² The coagulopathy associated with massive blood transfusion is discussed further in Chapter 54.

REFERENCES

1. Freedman MH, Estrov Z. Congenital amegakaryocytic thrombocytopenia: an intrinsic hematopoietic stem cell defect. *Am J Pediatr Hematol Oncol* 1990;12:225-230.
2. Muraoka K, Ishii E, Tsuji K, et al. Defective response to thrombopoietin and impaired expression of c-mpl mRNA of bone marrow cells in congenital amegakaryocytic thrombocytopenia. *Br J Haematol* 1997;96:287-292.
3. Ihara K, Ishii E, Eguchi M, et al. Identification of mutations in the c-mpl gene in congenital amegakaryocytic thrombocytopenia. *Proc Natl Acad Sci U S A* 1999;96:3132-3136.
4. Ballmaier M, Germeshausen M, Schulze H, et al. c-mpl mutations are the cause of congenital amegakaryocytic thrombocytopenia. *Blood* 2001;97:139-146.
5. Gandhi MJ, Pendergrass TW, Cummings CC, et al. Congenital amegakaryocytic thrombocytopenia in three siblings: molecular analysis of atypical clinical presentation. *Exp Hematol* 2005;33:1215-1221.
6. Drachman JG. Role of thrombopoietin in hematopoietic stem cell and progenitor regulation. *Curr Opin Hematol* 2000;7:183-190.
7. Germeshausen M, Ballmaier M, Welte K. MPL mutations in 23 patients suffering from congenital amegakaryocytic thrombocytopenia: the type of mutation predicts the course of the disease. *Hum Mutat* 2006;27:296.
8. Hall JG, Levin J, Kuhn JP, et al. Thrombocytopenia with absent radius (TAR). *Medicine (Baltimore)* 1969;48:411-439.
9. Shaw S, Oliver RA. Congenital hypoplastic thrombocytopenia with skeletal deformities in siblings. *Blood* 1959;14:374-377.
10. Hedberg VA, Lipton JM. Thrombocytopenia with absent radii. A review of 100 cases. *Am J Pediatr Hematol Oncol* 1988;10:51-64.

11. Greenhalgh KL, Howell RT, Bottani A, et al. Thrombocytopenia-absent radius syndrome: a clinical genetic study. *J Med Genet* 2002;39:876-881.

P.1104

12. Whitfield MF, Barr DG. Cows' milk allergy in the syndrome of thrombocytopenia with absent radius. *Arch Dis Child* 1976;51:337-343.

13. Letestu R, Vitrat N, Masse A, et al. Existence of a differentiation blockage at the stage of a megakaryocyte precursor in the thrombocytopenia and absent radii (TAR) syndrome. *Blood* 2000;95:1633-1641.

14. Strippoli P, Savoia A, Iolascon A, et al. Mutational screening of thrombopoietin receptor gene (c-mpl) in patients with congenital thrombocytopenia and absent radii (TAR). *Br J Haematol* 1998;103:311-314.

15. Ballmaier M, Schulze H, Strauss G, et al. Thrombopoietin in patients with congenital thrombocytopenia and absent radii: elevated serum levels, normal receptor expression, but defective reactivity to thrombopoietin. *Blood* 1997;90:612-619.

16. Dempfle CE, Burck C, Grutzmacher T, et al. Increase in platelet count in response to rHuEpo in a patient with thrombocytopenia and absent radii syndrome. *Blood* 2001;97:2189-2190.

17. Klopocki E, Schulze H, Strauss G, et al. Complex inheritance pattern resembling autosomal recessive inheritance involving a microdeletion in thrombocytopenia-absent radius syndrome. *Am J Hum Genet* 2007;80:232-240.

18. Albers CA, Paul DS, Schulze H, et al. Compound inheritance of a low-frequency regulatory SNP and a rare null mutation in exon-junction complex subunit RBM8A causes TAR syndrome. *Nat Genet* 2012;44:435-439.

19. Weinblatt M, Petrikovsky B, Bialer M, et al. Prenatal evaluation and in utero platelet transfusion for thrombocytopenia absent radii syndrome. *Prenat Diagn* 1994;14:892-896.

20. Donnenfeld AE, Wiseman B, Lavi E, Weiner S. Prenatal diagnosis of thrombocytopenia absent radius syndrome by ultrasound and cordocentesis. *Prenat Diagn* 1990;10:29-35.

21. Boute O, Depret-Mosser S, Vinatier D, et al. Prenatal diagnosis of thrombocytopenia-absent radius syndrome. *Fetal Diagn Ther* 1996;11:224-230.

22. Gounder DS, Pullon HW, Ockelford PA, Nicol RO. Clinical manifestations of the thrombocytopenia and absent radii (TAR) syndrome. *Aust N Z J Med* 1989;19:479-482.

23. Najean Y, Lecompte T. Genetic thrombocytopenia with autosomal dominant transmission: a review of 54 cases. *Br J Haematol* 1990;74:203-208.

24. Greaves M, Pickering C, Martin J, et al. A new familial "giant platelet syndrome" with structural, metabolic and functional abnormalities of platelets due to a primary megakaryocyte defect. *Br J Haematol* 1987;65:429-435.

25. Downton SB, Beardsley D, Jamison D, et al. Studies of a familial platelet disorder. *Blood* 1985;65:557-563.

26. D'Apolito M, Guarnieri V, Boncristiano M, et al. Cloning of the murine non-muscle myosin heavy chain IIA gene ortholog of human MYH9 responsible for May-Hegglin, Sebastian, Fechtner, and Epstein syndromes. *Gene* 2002;286:215-222.

27. Seri M, Cusano R, Gangarossa S, et al. Mutations in MYH9 result in the May-Hegglin anomaly, and Fechtner and Sebastian syndromes. The May-Hegglin/Fechtner Syndrome Consortium. *Nat Genet* 2000;26:103-105.

28. Kelley MJ, Jawien W, Lin A, et al. Autosomal dominant macrothrombocytopenia with leukocyte inclusions (May-Hegglin anomaly) is linked to chromosome 22q12-13. *Hum Genet* 2000;106:557-564.

29. Kelley MJ, Jawien W, Ortel TL, Korczak JF. Mutation of MYH9, encoding non-muscle myosin heavy chain A, in May-Hegglin anomaly. *Nat Genet* 2000;26:106-108.

30. Balduini CL, Pecci A, Savoia A. Recent advances in the understanding and management of MYH9-related inherited thrombocytopenias. *Br J Haematol* 2011;154:161-174.

31. Seri M, Pecci A, Di Bari F, et al. MYH9-related disease: May-Hegglin anomaly, Sebastian syndrome, Fechtner syndrome, and Epstein syndrome are not distinct entities but represent a variable expression of a single illness. *Medicine (Baltimore)* 2003;82:203-215.
32. Savoia A, De Rocco D, Panza E, et al. Heavy chain myosin 9-related disease (MYH9 -RD): neutrophil inclusions of myosin-9 as a pathognomonic sign of the disorder. *Thromb Haemost* 2010;103:826-832.
33. Saito H, Kunishima S. Historical hematology: May-Hegglin anomaly. *Am J Hematol* 2008;83:304-306.
34. Pecci A, Panza E, Pujol-Moix N, et al. Position of nonmuscle myosin heavy chain IIA (NMMHC-IIA) mutations predicts the natural history of MYH9-related disease. *Hum Mutat* 2008;29:409-417.
35. Dong F, Li S, Pujol-Moix N, et al. Genotype-phenotype correlation in MYH9-related thrombocytopenia. *Br J Haematol* 2005;130:620-627.
36. Heath KE, Campos-Barros A, Toren A, et al. Nonmuscle myosin heavy chain IIA mutations define a spectrum of autosomal dominant macrothrombocytopenias: May-Hegglin anomaly and Fechtner, Sebastian, Epstein, and Alportlike syndromes. *Am J Hum Genet* 2001;69:1033-1045.
37. Pecci A, Gresele P, Klersy C, et al. Eltrombopag for the treatment of the inherited thrombocytopenia deriving from MYH9 mutations. *Blood* 2010;116:5832-5837.
38. Ho CY, Otterud B, Legare RD, et al. Linkage of a familial platelet disorder with a propensity to develop myeloid malignancies to human chromosome 21q22.1-22.2. *Blood* 1996;87:5218-5224.
39. Song WJ, Sullivan MG, Legare RD, et al. Haploinsufficiency of CBFA2 causes familial thrombocytopenia with propensity to develop acute myelogenous leukaemia. *Nat Genet* 1999;23:166-175.
40. Jongmans MC, Kuiper RP, Carmichael CL, et al. Novel RUNX1 mutations in familial platelet disorder with enhanced risk for acute myeloid leukemia: clues for improved identification of the FPD/AML syndrome. *Leukemia* 2010;24:242-246.
41. Speck NA, Stacy T, Wang Q, et al. Core-binding factor: a central player in hematopoiesis and leukemia. *Cancer Res* 1999;59:1789s-1793s.
42. Heller PG, Glembotsky AC, Gandhi MJ, et al. Low Mpl receptor expression in a pedigree with familial platelet disorder with predisposition to acute myelogenous leukemia and a novel AML1 mutation. *Blood* 2005;105:4664-4670.
43. Behrens WE. Mediterranean macrothrombocytopenia. *Blood* 1975;46: 199-208.
44. Savoia A, Balduini CL, Savino M, et al. Autosomal dominant macrothrombocytopenia in Italy is most frequently a type of heterozygous Bernard-Soulier syndrome. *Blood* 2001;97:1330-1335.
45. Penny LA, Dell'Aquila M, Jones MC, et al. Clinical and molecular characterization of patients with distal 11q deletions. *Am J Hum Genet* 1995;56:676-683.
46. Grossfeld PD, Mattina T, Lai Z, et al. The 11q terminal deletion disorder: a prospective study of 110 cases. *Am J Med Genet A* 2004;129A:51-61.
47. Favier R, Jondeau K, Boutard P, et al. Paris-Trousseau syndrome: clinical, hematological, molecular data of ten new cases. *Thromb Haemost* 2003;90:893-897.
48. Raslova H, Komura E, Le Couedic JP, et al. FLI1 monoallelic expression combined with its hemizygous loss underlies Paris-Trousseau/Jacobsen thrombopenia. *J Clin Invest* 2004;114:77-84.
49. Shivdasani RA. Lonely in Paris: when one gene copy isn't enough. *J Clin Invest* 2004;114:17-19.
50. Savoia A, Del Vecchio M, Totaro A, et al. An autosomal dominant thrombocytopenia gene maps to chromosomal region 10p. *Am J Hum Genet* 1999;65:1401-1405.
51. Drachman JG, Jarvik GP, Mehaffey MG. Autosomal dominant thrombocytopenia: incomplete megakaryocyte differentiation and linkage to human chromosome 10. *Blood* 2000;96:118-125.
52. Noris P, Perrotta S, Seri M, et al. Mutations in ANKRD26 are responsible for a frequent form of inherited thrombocytopenia: analysis of 78 patients from 21 families. *Blood* 2011;117:6673-6680.
53. Nurden AT, Nurden P. The gray platelet syndrome: clinical spectrum of the disease. *Blood Rev* 2007;21:21-36.
54. Harrison P, Cramer EM. Platelet alpha-granules. *Blood Rev* 1993;7:52-62.
55. Mark M, Rijli FM, Chambon P. Homeobox genes in embryogenesis and pathogenesis. *Pediatr Res* 1997;42:421-429.

56. Thompson AA, Nguyen LT. Amegakaryocytic thrombocytopenia and radio-ulnar synostosis are associated with HOXA11 mutation. *Nat Genet* 2000;26:397-398.
57. Horvat-Switzer RD, Thompson AA. HOXA11 mutation in amegakaryocytic thrombocytopenia with radio-ulnar synostosis syndrome inhibits megakaryocytic differentiation in vitro. *Blood Cells Mol Dis* 2006;37:55-63.
58. Thompson AA, Woodruff K, Feig SA, et al. Congenital thrombocytopenia and radio-ulnar synostosis: a new familial syndrome. *Br J Haematol* 2001;113:866-870.
59. Bolton-Maggs PH, Chalmers EA, Collins PW, et al. A review of inherited platelet disorders with guidelines for their management on behalf of the UKHCDO. *Br J Haematol* 2006;135:603-633.
60. Bosticardo M, Marangoni F, Aiuti A, et al. Recent advances in understanding the pathophysiology of Wiskott-Aldrich syndrome. *Blood* 2009;113: 6288-6295.
61. Derry JM, Kerns JA, Weinberg KI, et al. WASP gene mutations in Wiskott-Aldrich syndrome and X-linked thrombocytopenia. *Hum Mol Genet* 1995;4:1127-1135.
62. Derry JM, Ochs HD, Francke U. Isolation of a novel gene mutated in Wiskott-Aldrich syndrome. *Cell* 1994;78:635-644.
63. Devriendt K, Kim AS, Mathijs G, et al. Constitutively activating mutation in WASP causes X-linked severe congenital neutropenia. *Nat Genet* 2001;27:313-317.
64. Ancliff P, Blundell MP, Gale RE, et al. Activating mutations in the Wiskott-Aldrich syndrome protein may define a subgroup of severe congenital neutropenia (SCN) with specific and unusual laboratory features. *Blood* 2001;98:493.
65. Jin Y, Mazza C, Christie JR, et al. Mutations of the Wiskott-Aldrich Syndrome Protein (WASP): hotspots, effect on transcription, and translation and phenotype/genotype correlation. *Blood* 2004;104:4010-4019.
66. Qasim W, Gilmour KC, Heath S, et al. Protein assays for diagnosis of Wiskott-Aldrich syndrome and X-linked thrombocytopenia. *Br J Haematol* 2001;113:861-865.
67. Ochs HD, Thrasher AJ. The Wiskott-Aldrich syndrome. *J Allergy Clin Immunol* 2006;117:725-738; quiz 739.
68. Thrasher AJ. New insights into the biology of Wiskott-Aldrich syndrome (WAS). *Hematology Am Soc Hematol Educ Program* 2009;132-138.
69. Ho LL, Ayling J, Prosser I, et al. Missense C168T in the Wiskott-Aldrich Syndrome protein gene is a common mutation in X-linked thrombocytopenia. *Br J Haematol* 2001;112:76-80.
70. Wall L, deBoer E, Grosveld F. The human beta-globin gene 3' enhancer contains multiple binding sites for an erythroid-specific protein. *Genes Dev* 1988;2:1089-1100.
71. Tsai SF, Martin DI, Zon LI, et al. Cloning of cDNA for the major DNA-binding protein of the erythroid lineage through expression in mammalian cells. *Nature* 1989;339:446-451.
72. Martin DI, Orkin SH. Transcriptional activation and DNA binding by the erythroid factor GF-1/NF-E1/Eryf 1. *Genes Dev* 1990;4:1886-1898.
73. Tsang AP, Visvader JE, Turner CA, et al. FOG, a multitype zinc finger protein, acts as a cofactor for transcription factor GATA-1 in erythroid and megakaryocytic differentiation. *Cell* 1997;90:109-119.
74. Drachman JG. Inherited thrombocytopenia: when a low platelet count does not mean ITP. *Blood* 2004;103:390-398.
75. Freson K, Devriendt K, Matthijs G, et al. Platelet characteristics in patients with X-linked macrothrombocytopenia because of a novel GATA1 mutation. *Blood* 2001;98:85-92.
76. Mehaffey MG, Newton AL, Gandhi MJ, et al. X-linked thrombocytopenia caused by a novel mutation of GATA-1. *Blood* 2001;98:2681-2688.
77. McDonald-McGinn DM, Sullivan KE. Chromosome 22q11.2 deletion syndrome (DiGeorge syndrome/velocardiofacial syndrome). *Medicine (Baltimore)* 2011;90:1-18.
78. Hoffman R. Acquired pure amegakaryocytic thrombocytopenic purpura. *Semin Hematol* 1991;28:303-312.
79. Griner PF, Hoyer LW. Amegakaryocytic thrombocytopenia in systemic lupus erythematosus. *Arch Intern Med* 1970;125:328-332.
80. Bhattacharyya J, Kumar R, Tyagi S, et al. Human parvovirus B19-induced acquired pure amegakaryocytic thrombocytopenia. *Br J Haematol* 2005;128:128-129.

81. Benedetti F, de Sabata D, Perona G. T suppressor activated lymphocytes (CD8+/DR+) inhibit megakaryocyte progenitor cell differentiation in a case of acquired amegakaryocytic thrombocytopenic purpura. *Stem Cells* 1994;12:205-213.
82. Shiozaki H, Miyawaki S, Kuwaki T, et al. Autoantibodies neutralizing thrombopoietin in a patient with amegakaryocytic thrombocytopenic purpura. *Blood* 2000;95:2187-2188.
83. Agarwal N, Spahr JE, Werner TL, et al. Acquired amegakaryocytic thrombocytopenic purpura. *Am J Hematol* 2006;81:132-135.
84. Lonial S, Bilodeau PA, Langston AA, et al. Acquired amegakaryocytic thrombocytopenia treated with allogeneic BMT: a case report and review of the literature. *Bone Marrow Transplant* 1999;24:1337-1341.
85. Kashyap R, Choudhry VP, Pati HP. Danazol therapy in cyclic acquired amegakaryocytic thrombocytopenic purpura: a case report. *Am J Hematol* 1999;60:225-228.
86. Trimble MS, Glynn MF, Brain MC. Amegakaryocytic thrombocytopenia of 4 years duration: successful treatment with antithymocyte globulin. *Am J Hematol* 1991;37:126-127.
87. Deeren D, Dorpe JV. Effective use of rituximab for acquired amegakaryocytic thrombocytopenia. *Am J Hematol* 2010;85:977-978.
88. Chang H, Tang TC. Successful treatment of amegakaryocytic thrombocytopenia with azathioprine. *Acta Haematol* 2011;126:135-137.
89. Quintas-Cardama A. Acquired amegakaryocytic thrombocytopenic purpura successfully treated with limited cyclosporin A therapy. *Eur J Haematol* 2002;69:185-186.
90. Azuno Y, Yaga K. Successful cyclosporin A therapy for acquired amegakaryocytic thrombocytopenic purpura. *Am J Hematol* 2002;69:298-299.
91. Bussel JB, Kuter DJ, George JN, et al. AMG 531, a thrombopoiesis-stimulating protein, for chronic ITP. *N Engl J Med* 2006;355:1672-1681.
92. Kutti J, Weinfeld A. The frequency of thrombocytopenia in patients with heart disease treated with oral diuretics. *Acta Med Scand* 1968;183:245-250.
93. Cooper BA, Bigelow FS. Thrombocytopenia associated with the administration of diethylstilbestrol in man. *Ann Intern Med* 1960;52:907-909.
94. Cowan DH. Effect of alcoholism on hemostasis. *Semin Hematol* 1980;17: 137-147.
95. Cowan DH, Hines JD. Thrombocytopenia of severe alcoholism. *Ann Intern Med* 1971;74:37-43.
96. Cowan DH. Thrombokinetic studies in alcohol-related thrombocytopenia. *J Lab Clin Med* 1973;81:64-76.
97. Haselager EM, Vreeken J. Rebound thrombocytosis after alcohol abuse: a possible factor in the pathogenesis of thromboembolic disease. *Lancet* 1977;1:774-775.
98. Levine RF, Spivak JL, Meagher RC, Sieber F. Effect of ethanol on thrombopoiesis. *Br J Haematol* 1986;62:345-354.
99. Nakao S, Harada M, Kondo K, et al. Reversible bone marrow hypoplasia induced by alcohol. *Am J Hematol* 1991;37:120-123.
100. Queisser U, Queisser W, Spiertz B. Polyploidization of megakaryocytes in normal humans, in patients with idiopathic thrombocytopenia and with pernicious anaemia. *Br J Haematol* 1971;20:489-501.
101. Aster RH. Pooling of platelets in the spleen: role in the pathogenesis of "hypersplenic" thrombocytopenia. *J Clin Invest* 1966;45:645-657.
102. Heyns AD, Lotter MG, Badenhorst PN, et al. Kinetics and fate of (111) Indium-oxine labelled blood platelets in asplenic subjects. *Thromb Haemost* 1980;44:100-104.
103. Peters AM, Klonizakis I, Lavender JP, Lewis SM. Use of 111Indium-labeled platelets to measure spleen function. *Br J Haematol* 1980;46:587-593.
104. Weiss L. A scanning electron microscopic study of the spleen. *Blood* 1974;43:665-691.
105. Wadenvik H, Kutti J. The effect of an adrenaline infusion on the splenic blood flow and intrasplenic platelet kinetics. *Br J Haematol* 1987;67:187-192.

106. Heyns AD, Badenhorst PN, Lotter MG, et al. Kinetics and mobilization from the spleen of indium-111-labeled platelets during platelet apheresis. *Transfusion* 1985;25:215-218.
107. Lee EJ, Schiffer CA. Evidence for rapid mobilization of platelets from the spleen during intensive plateletpheresis. *Am J Hematol* 1985;19:161-165.
108. Noguchi H, Hirai K, Aoki Y, et al. Changes in platelet kinetics after a partial splenic arterial embolization in cirrhotic patients with hypersplenism. *Hepatology* 1995;22:1682-1688.
109. Cooney DP, Smith BA. The pathophysiology of hypersplenic thrombocytopenia. *Arch Intern Med* 1968;121:332-337.
110. Kutti J, Weinfeld A, Westin J. The relationship between splenic platelet pool and spleen size. *Scand J Haematol* 1972;9:351-354.
111. McAllister E, Goode S, Cordista AG, Rosemurgy A. Partial portal decompression alleviates thrombocytopenia of portal hypertension. *Am Surg* 1995;61:129-131.
112. Becker CD, Rosler H, Biasiutti FD, Baer HU. Congestive hypersplenism: treatment by means of radioembolization of the spleen with Y-90. *Radiology* 1995;195:183-186.
113. Sangro B, Bilbao I, Herrero I, et al. Partial splenic embolization for the treatment of hypersplenism in cirrhosis. *Hepatology* 1993;18:309-314.
114. Israel DM, Hassall E, Culham JA, Phillips RR. Partial splenic embolization in children with hypersplenism. *J Pediatr* 1994;124:95-100.

P.1105

115. Pinca A, Di Palma A, Soriani S, et al. Effectiveness of partial splenic embolization as treatment for hypersplenism in thalassaemia major: a 7-year follow up. *Eur J Haematol* 1992;49:49-52.
116. Coon WW. Splenectomy for thrombocytopenia due to secondary hypersplenism. *Arch Surg* 1988;123:369-371.
117. Alvarez OA, Lopera GA, Patel V, et al. Improvement of thrombocytopenia due to hypersplenism after transjugular intrahepatic portosystemic shunt placement in cirrhotic patients. *Am J Gastroenterol* 1996;91:134-137.
118. Pursnani KG, Sillin LF, Kaplan DS. Effect of transjugular intrahepatic portosystemic shunt on secondary hypersplenism. *Am J Surg* 1997;173:169-173.
119. Pina-Cabral JM AI, Pinto MM, et al. Hepatic and splenic platelet sequestration during deep hypothermia in the dog. *Haemostasis* 1973/74;2:235-244.
120. Villalobos TJ, Adelson E, Riley PA, Jr., Crosby WH. A cause of the thrombocytopenia and leukopenia that occur in dogs during deep hypothermia. *J Clin Invest* 1958;37:1-7.
121. Chan KM, Beard K. A patient with recurrent hypothermia associated with thrombocytopenia. *Postgrad Med J* 1993;69:227-229.
122. Cozzi PJ, Stewart GJ, Morris DL. Thrombocytopenia after hepatic cryotherapy for colorectal metastases: correlates with hepatocellular injury. *World J Surg* 1994;18:774-776; discussion 777.
123. Simons K, Ikonen E. Functional rafts in cell membranes. *Nature* 1997;387:569-572.
124. Tablin F, Wolkers WF, Walker NJ, et al. Membrane reorganization during chilling: implications for long-term stabilization of platelets. *Cryobiology* 2001;43:114-123.
125. Shrimpton CN, Borthakur G, Larrucea S, et al. Localization of the adhesion receptor glycoprotein Ib-IX-V complex to lipid rafts is required for platelet adhesion and activation. *J Exp Med* 2002;196:1057-1066.
126. Hoffmeister KM, Felbinger TW, Falet H, et al. The clearance mechanism of chilled blood platelets. *Cell* 2003;112:87-97.
127. Josefsson EC, Gebhard HH, Stossel TP, et al. The macrophage alphaMbeta2 integrin alphaM lectin domain mediates the phagocytosis of chilled platelets. *J Biol Chem* 2005;280:18025-18032.
128. Oski FA, Naiman JL. Effect of live measles vaccine on the platelet count. *N Engl J Med* 1966;275:352-356.

129. Nieminen U, Peltola H, Syrjala MT, et al. Acute thrombocytopenic purpura following measles, mumps and rubella vaccination. A report on 23 patients. *Acta Paediatr* 1993;82:267-270.
130. Beeler J, Varricchio F, Wise R. Thrombocytopenia after immunization with measles vaccines: review of the vaccine adverse events reporting system (1990 to 1994). *Pediatr Infect Dis J* 1996;15:88-90.
131. Poullin P, Gabriel B. Thrombocytopenic purpura after recombinant hepatitis B vaccine. *Lancet* 1994;344:1293.
132. Meyboom RH, Fucik H, Edwards IR. Thrombocytopenia reported in association with hepatitis B and A vaccines. *Lancet* 1995;345:1638.
133. Myllyla G, Vaheri A, Vesikari T, Penttinen K. Interaction between human blood platelets, viruses and antibodies. IV. Post-Rubella thrombocytopenic purpura and platelet aggregation by Rubella antigen-antibody interaction. *Clin Exp Immunol* 1969;4:323-332.
134. Berge T, Brunnhage F, Nilsson LR. Congenital hypoplastic thrombocytopenia in rubella embryopathy. *Acta Paediatr* 1963;52:349-352.
135. Cooper LZ, Green RH, Krugman S, et al. Neonatal thrombocytopenic purpura and other manifestations of rubella contracted in utero. *Am J Dis Child* 1965;110:416-427.
136. van Spronsen DJ, Breed WP. Cytomegalovirus-induced thrombocytopenia and haemolysis in an immunocompetent adult. *Br J Haematol* 1996;92:218-220.
137. Eisenberg MJ, Kaplan B. Cytomegalovirus-induced thrombocytopenia in an immunocompetent adult. *West J Med* 1993;158:525-526.
138. Nagai K, Morohoshi T, Kudoh T, et al. Transient erythroblastopenia of childhood with megakaryocytopenia associated with human parvovirus B19 infection. *Br J Haematol* 1992;80:131-132.
139. Yoto Y, Kudoh T, Suzuki N, et al. Thrombocytopenia induced by human parvovirus B19 infections. *Eur J Haematol* 1993;50:255-257.
140. Murray JC, Morad AB, Pierce MA, Mihm S. Thrombocytopenia accompanying early postnatal infection by human parvovirus B19. *Am J Hematol* 1995;49:360.
141. Varnavski AN, Calcedo R, Bove M, et al. Evaluation of toxicity from high-dose systemic administration of recombinant adenovirus vector in vector-naive and pre-immunized mice. *Gene Ther* 2005;12:427-436.
142. Othman M, Labelle A, Mazzetti I, et al. Adenovirus-induced thrombocytopenia: the role of von Willebrand factor and P-selectin in mediating accelerated platelet clearance. *Blood* 2007;109:2832-2839.
143. Stephan F, Thiolier B, Verdy E, Tulliez M. Role of hemophagocytic histiocytosis in the etiology of thrombocytopenia in patients with sepsis syndrome or septic shock. *Clin Infect Dis* 1997;25:1159-1164.
144. Fajardo LF TC. Malarian parasites withing human platelets. *JAMA* 1974;229:1205.
145. el-Shoura S. Falciparum malaria in naturally infected humans. III. Platelet ultrastructural alterations during thrombocytopenia. *Virchows Arch B Cell Pathol Incl Mol Pathol* 1993;63:257-262.
146. Piguet PF, Kan CD, Vesin C. Thrombocytopenia in an animal model of malaria is associated with an increased caspase-mediated death of thrombocytes. *Apoptosis* 2002;7:91-98.
147. van der Heyde HC, Gramaglia I, Sun G, Woods C. Platelet depletion by anti-CD41 (alphaIIb) mAb injection early but not late in the course of disease protects against *Plasmodium berghei* pathogenesis by altering the levels of pathogenic cytokines. *Blood* 2005;105:1956-1963.
148. Gramaglia I, Sahlin H, Nolan JP, et al. Cell- rather than antibody-mediated immunity leads to the development of profound thrombocytopenia during experimental *Plasmodium berghei* malaria. *J Immunol* 2005;175:7699-7707.
149. Ballard HS, Bottino G, Bottino J. The association of thrombocytopaenia and Lyme disease. *Postgrad Med J* 1994;70:285-287.
150. Pugliese A, Levchuck S, Cunha BA. *Mycoplasma pneumoniae* induced thrombocytopenia. *Heart Lung* 1993;22:373-375.
151. Leslie SD, Toy PT. Laboratory hemostatic abnormalities in massively transfused patients given red blood cells and crystalloid. *Am J Clin Pathol* 1991;96:770-773.

152. Harvey MP, Greenfield TP, Sugrue ME, Rosenfeld D. Massive blood transfusion in a tertiary referral hospital. Clinical outcomes and haemostatic complications. *Med J Aust* 1995;163:356-359.

153. Harrigan C, Lucas CE, Ledgerwood AM, et al. Serial changes in primary hemostasis after massive transfusion. *Surgery* 1985;98:836-844.

154. Reed RL 2nd, Ciavarella D, Heimbach DM, et al. Prophylactic platelet administration during massive transfusion. A prospective, randomized, double-blind clinical study. *Ann Surg* 1986;203:40-48.

Chapter 50 Bleeding Disorders Caused by Vascular Abnormalities

> Table of Contents > Part V - Disorders of Hemostasis and Coagulation > Section 2 - Thrombocytopenia > Chapter 50 - Bleeding Disorders Caused by Vascular Abnormalities

Chapter 50

Bleeding Disorders Caused by Vascular Abnormalities

George M. Rodgers

Matthew M. Rees

This chapter discusses causes of bleeding that are not the result of thrombocytopenia, coagulation factor deficiency, or qualitative platelet defects. Bleeding disorders caused by these various “vascular” abnormalities represent a heterogeneous group of diseases, and in considering the differential diagnosis, it is convenient to consider cutaneous causes, connective tissue abnormalities, vascular lesions, and intravascular causes.

CLINICAL APPROACH TO THE PATIENT

The initial approach to the bleeding patient is discussed in Chapter 45. When considering “vascular” causes of bleeding, the appearance of the lesions (petechiae vs. more extensive ecchymosis, size, shape, color), location and pattern of involvement, associated features (fever, ulcers, scars, livedo reticularis), and the clinical setting are helpful clues. Table 50.1 lists some common physical finding patterns helpful in considering the differential diagnosis of vascular disorders.

Purpura is the term used to describe the skin lesions that develop when red blood cells extravasate from capillaries. Purpura refers to either pinpoint lesions called petechiae or more widespread lesions known as ecchymoses. Purpura can be differentiated from other erythematous lesions by the use of diascopy, which is the application of a glass slide to the border of the lesions. True purpura does not blanch with pressure.¹

MECHANICAL PURPURA

External pressure such as blunt trauma results in ecchymoses when the force is sufficient to disrupt vascular integrity and allow extravasation of red blood cells. The size of the resulting lesion is dependent on the durability of the tissue traumatized, the vascularity of the region, the density of the surrounding tissue, and the time elapsed.^{2, 3} The extent of bruising can increase over time, and tracking through tissue planes can occur, resulting in bruises in areas remote from the area of trauma.⁴ The color of the lesion is in part dependent on the location of the red cells—lesions near the surface have a more reddish color, and deeper lesions appear bluish. This finding is due to optical scattering in the dermis, and the fact that blue wavelengths scatter and reflect more than red.⁵

Bruises change color with time, and the color of bruise has been used to determine the age of lesions. However, evidence suggests that there is more variability in color changes than previously recognized.^{4, 6}

Mechanical purpura can be seen on occasion with minor trauma such as blood pressure cuff monitoring in anticoagulated patients³ or even vigorous scratching. Young adults playing active sports such as basketball can develop calcaneal petechiae resulting from relatively minor, but repetitive, heel trauma.⁷ Periorbital, face, or neck purpura can occur after a sudden increase in intravascular pressure with a Valsalva maneuver⁸ and has been described after bungee jumping.⁹

Suction purpura occurs when negative pressure is applied to the skin in sufficient force to result in extravasation of erythrocytes. Young healthy people develop petechiae with 350 to 400 mm Hg negative pressure, but the required amount of pressure to induce purpura decreases with age to as low as 100 mm Hg.¹⁰ The application of rubber suction devices to the forehead can result in circumscribed purpura. This seems to occur mostly when new parents apply children's suction toys to their foreheads and has been termed cyclops purpura.¹¹ A similar, relatively common cause of

suction purpura is seen in adolescents who place a drinking glass over their chin and suck out the air to form a vacuum, ultimately causing chin or perioral purpura.¹² Adolescents are also prone to develop small purpuric lesions in the neck region from “hickeys” or “love bites,” another form of suction purpura.

Large areas of contusions develop with blunt force injuries. Certain patterns of contusion can help identify the type of device causing the injury. Skin bruises corresponding to the sites of seat belts are known as “seat belt mark” signs. It is important to recognize these, as the presence of this sign should alert physicians to the higher likelihood of internal injuries.¹³ A direct blow from a linear or cylindrical object causes parallel lines (“tram-line” appearance) with central clearing, as the blood beneath the site of highest impact is displaced laterally. Similarly, a bruise in the shape of a circle with central clearing may occur as a result of a blow from the circular edge of a pipe or spherical objects.¹⁴ Caution, however, should be used in interpreting these types of bruises, as simple bruises can sometimes occur with “ring resolution.”¹⁵ Circular contusions 1 to 1.5 cm in diameter may be due to fingertip pressure and grab marks or bite marks, and they show semicircular arch contusions, but are highly variable.¹⁴ Certain bruising patterns can suggest child or elder abuse, but results should be interpreted carefully.^{16, 17}

Larger ecchymotic areas also may demonstrate other patterns that can be a clue to underlying pathology. The well-known Cullen sign refers to bluish discoloration around the umbilicus, and Grey-Turner sign is flank ecchymosis. Both may indicate hemorrhagic pancreatitis or a rectus sheath hematoma.¹⁸ Scrotal ecchymosis may be a clue to intraperitoneal hemorrhage, and perianal ecchymosis has been described as a manifestation of aneurysmal rupture into the sigmoid mesocolon.^{19, 20} “Raccoon eyes” and mastoid ecchymosis (Battle sign) may indicate a basilar skull fracture after head trauma.²¹ Ecchymosis occurring in patients with swollen calves suggests a ruptured popliteal cyst with gravitational spread of the bruise down to the ankle and occasional linear appearance (“tide mark” appearance) with sparing of the foot and lower ankle due to the pressure of footwear.²²

STRUCTURAL MALFORMATIONS OF VESSELS

Hereditary Hemorrhagic Telangiectasia

Hereditary hemorrhagic telangiectasia (HHT) was first described in 1864 by Sutton²³ and later recognized and reported by Rendu,²⁴ Osler,²⁵ and Weber,²⁶ and it is thus also known as Osler-Weber-Rendu syndrome. It is an autosomal dominant disorder characterized by multiple telangiectatic lesions involving the skin and mucous membranes associated with epistaxis and other bleeding complications. HHT has an estimated prevalence of 1 in 8,000,²⁷ with complete penetrance by 40 years of age.²⁸

Genetic studies have identified several mutations responsible for the vascular malformations. Mutations in the endoglin gene on chromosome 9 (HHT1) or in the activin receptor-like kinase

P.1107

(ALK1) gene on chromosome 12 (HHT2) account for ~85% of the cases. Currently more than 500 mutations in the ALK1 or endoglin genes have been identified, and each family studied appears to have a unique mutation.²⁷ Endoglin is an integral membrane glycoprotein expressed on endothelial cells in arterioles, venules, and capillaries. This glycoprotein and ALK1 serve as a binding protein for transforming growth factor-β (TGF-β).

TGF-β regulates many transcriptional targets and plays a crucial role in vascular development and homeostasis. Recently identified mutations in the MADH4 gene abnormalities are associated with juvenile polyposis and HHT,²⁹ and linkage studies suggest additional mutations exist on other chromosomes.^{30, 31} An HHT mutation database is available at <http://www.hhtmuation.org>.

TABLE 50.1 COMMON PHYSICAL FINDINGS AND ASSOCIATIONS OF VASCULAR DISORDERS

Pattern and Usual Location	Etiology	Associated Features
Subconjunctival and axillary petechiae	Fat emboli	Dyspnea
Periorbital, facial, and neck petechiae	Valsalva maneuvers	
Periorbital ecchymosis (“black eye”)	Trauma; in penetrating globe injuries without periorbital trauma, suggests posterior rupture	
“Raccoon eyes”	Basilar skull fracture	

“Battle sign” (mastoid ecchymosis)	Basilar skull fracture	
Palatal petechiae	Viral upper respiratory infection	
Ecchymosis of limbs and face of infant	AIHE	Inflammatory edema
Eyelid and periorbital edema and purpura, often after dependency; purpura in other areas with minimal trauma	Amyloid	
Glove and stocking petechiae with areas of confluence and sharp line of demarcation between normal and abnormal areas	PPGSS	
Palm and sole petechiae	Rat bite fever and other infections	
Purpuric lesions on the forearm in elderly patients	Solar or steroid purpura	
Bluish discoloration of the umbilicus (Cullen sign)	Hemorrhagic pancreatitis or rectus sheath hematoma	
Flank ecchymosis (Grey-Turner sign)	Hemorrhagic pancreatitis	
Periumbilical purpura with “thumbprint” signing	<i>Strongyloides</i> infection	
Scrotal/perineal ecchymosis	Intraperitoneal hemorrhage or iliac aneurysmal rupture (rupture into sigmoid mesocolon)	
Telangiectatic lesions along the face, lips, nares, tongue, and nail beds	HHT	
Lower extremity palpable, nonblanching purpura	Vasculitis	
Perifollicular lower extremity, with areas of confluence	Scurvy	Gingival, intramuscular bleeds
Urticarial lesions followed by purpura	Urticarial vasculitis	
Proximal thigh involvements often with a “kissing” or symmetric lesion	Calciphylaxis	
Mucosal oozing and easy bruising	EDS	Skin hyperextensibility, joint immobility
Hemorrhagic bulla	Bacterial infections (<i>Clostridium</i> , <i>Vibrio</i> , <i>Aeromonas</i>); hypersensitivity to insect bites, snakebites; pemphigus	
“Tram lines”	Blunt force with cylindrical or linear object	
“Ring” bruises	Blunt force with circular end or sphere; may also be seen in normal bruise resolution	

AIHE, acute infantile hemorrhagic edema; EDS, Ehlers-Danlos syndrome; HHT, hereditary

hemorrhagic telangiectasia; PPGSS, papular-purpuric gloves and socks syndrome.

The mechanisms by which these genetic defects result in telangiectatic lesions have not been identified. Ultrastructural analysis of cutaneous HHT lesions suggests that postcapillary venule dilation is the earliest identifiable morphologic abnormality.^{32, 33} As the venules enlarge, they become convoluted and interconnect with arterioles through capillary segments. The capillary segments eventually disappear, and direct arteriolar-venular communications are established (Fig. 50.1). An infiltrate of mononuclear cells appears in the perivascular region of the HHT lesions.

The bleeding manifestations are thought to occur because of mechanical fragility of these vessels. Common abnormalities in the hemostatic system do not seem to represent a major factor in the underlying bleeding tendency. HHT patients manifest a variety of other complications including shunting, emboli, and thrombosis.

Clinical Manifestations

The cutaneous lesions usually appear in affected persons by 40 years of age, and they increase in number with age. The lesions measure 1 to 3 mm in diameter and are sharply demarcated in appearance (Fig. 50.2). They blanch with pressure, but the blanching may be incomplete as a result of "strangulation" of coiled loops of vessels.^{34, 35} The telangiectatic lesions are most commonly found on the face, lips, nares, tongue, nail beds, and hands. Some patients have only a few lesions, necessitating a thorough search in anyone suspected of having HHT. Bleeding from these cutaneous telangiectasias is uncommon and rarely of clinical importance. One report suggests that capillaroscopy of the dorsal hands can detect morphologic changes in the skin microcirculation, including microscopic telangiectatic lesions, but the clinical utility of this is undefined.³⁶

P.1108

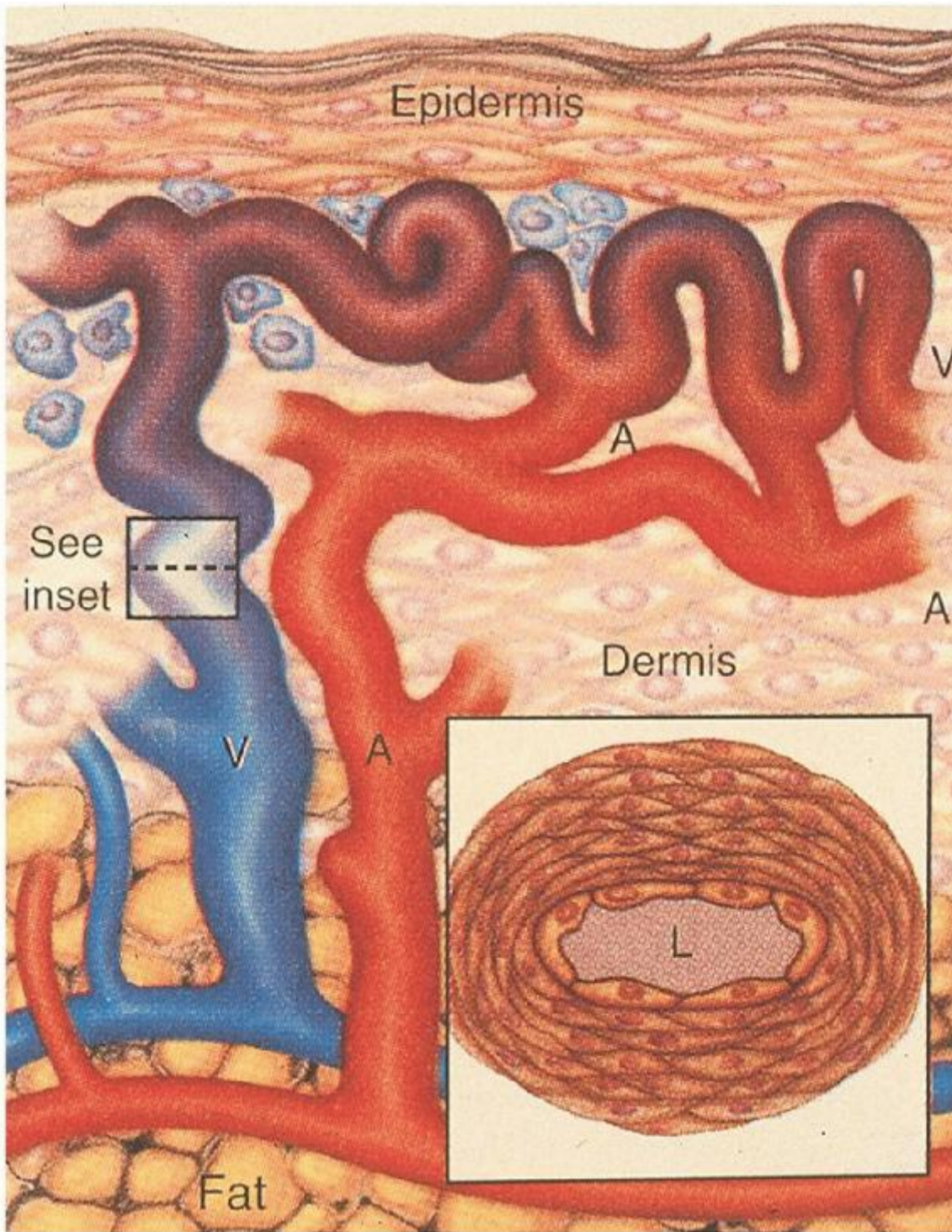

FIGURE 50.1. Arteriovenous malformations in hereditary hemorrhagic telangiectasia. In a fully developed cutaneous telangiectasia, the venule (V) and its branches have become dilated and convoluted throughout the dermis. The connecting arterioles (A) have also become dilated and communicate directly with the venules without intervening capillaries. A perivascular infiltrate is present. The thickened wall of a dilated postcapillary venule is also shown. L, lumen of the vessel. (From Guttmacher AE, Marchuk DA, White RI. Hereditary hemorrhagic telangiectasia. *N Engl J Med* 1995;333:918-924, with permission.)

Epistaxis is the presenting complaint in up to 90% of patients with HHT. This symptom results from bleeding telangiectatic lesions over the inferior turbinates and nasal septum. Symptoms usually occur before 35 years of age and are highly variable. Approximately one-third of patients have mild symptoms requiring no treatment, and another third have

moderate symptoms requiring only outpatient treatment. The remaining third have severe symptoms often requiring inpatient treatment, transfusions or chronic iron replacement therapy, and surgery.³⁵ The nosebleeds may become more difficult to control as the patient ages.



FIGURE 50.2. Telangiectasias of the tongue and lower lip in a patient with hereditary hemorrhagic telangiectasia. (From Guttmacher AE, Marchuk DA, White RI. Hereditary hemorrhagic telangiectasia. *N Engl J Med* 1995;333:918-924, with permission.)

Pulmonary arteriovenous malformations (PAVMs) occur in 30% of patients with HHT, and 85% to 90% of people with PAVM are found to have HHT.^{32, 34, 35, 37} Genetic linkage studies have found that patients with endoglin mutations have significantly higher rates of PAVMs (40%) than HHT patients with other mutations (14%).^{38, 39} The PAVMs are primarily located in the lower lung lobes and are multiple. These PAVMs may result in a significant right-to-left shunt, and patients may develop dyspnea, cyanosis, clubbing, fatigue, decreased exercise tolerance, migraine headaches, and polycythemia. Paradoxical emboli can occur and result in brain abscesses, transient ischemic attacks, and strokes. The prevalence of cortical infarcts has been reported to be as high as 14% in patients with a single PAVM and increases to 27% in patients with multiple PAVMs.⁴⁰ These lesions may also bleed and result in hemoptysis or hemothorax; pregnant women with PAVMs appear to be at increased risk.⁴¹

The detection of PAVMs may be difficult in patients with few or no symptoms. Physical examination may uncover an end-inspiratory bruit.³⁴ A chest radiograph may detect a coin lesion but often misses smaller lesions. Gravitational shifts in blood flow to the lung bases result in increased right-to-left shunting in the sitting or standing position. Physiologic tests such as measuring O₂ saturation in the supine and standing position (on room air and 100% O₂) can detect the positional change in shunting and can be used to screen patients for PAVMs. However, the best screening test for PAVM appears to be contrast echocardiography.⁴² Patients with a positive screening test should undergo an unenhanced spiral computed tomography (CT) to confirm and further characterize the PAVM.⁴³ Pulmonary angiography is a less sensitive study but is necessary in treatment planning.

Approximately 20% of patients with HHT develop significant upper and lower gastrointestinal (GI) tract hemorrhage. Bleeding is rare before the fifth decade of life. Approximately 40% of the bleeding episodes occur from upper GI tract lesions, whereas only 10% occur in the colon, and a full one-half are indeterminate after evaluation.³⁵ Spontaneous regression of GI bleeding is rare, and steady progression or chronic intermittent bleeding is the norm.

Hepatic involvement occurs in 70% of patients, but symptoms and complications are rare.⁴⁴ Patients may have hepatomegaly, a hepatic bruit or thrill, or elevated liver function studies.⁴⁵ Types of intrahepatic shunting include hepatic artery to hepatic vein (arteriovenous), hepatic artery to portal vein (arterioportal), and portal vein to hepatic vein (portovenous). These shunts can lead to clinical complications of high-output heart failure, portal hypertension, encephalopathy, biliary ischemia, and nodular regenerative hyperplasia. The dominant type of shunt identified on multiphasic CT does not correlate strongly with the clinical syndrome.⁴⁶ Nodular regenerative hyperplasia is found with a 100-fold increased prevalence compared to the general population, and along with portal hypertension can lead to a misdiagnosis of cirrhosis (pseudocirrhosis).⁴⁴ It is important to consider this diagnosis in the setting of a liver mass, as biopsy should generally be avoided when suspected. Additionally, if patients with known focal nodular hyperplasia are being treated with estrogen or progesterone therapy, close monitoring is indicated with discontinuation of hormones in the case of symptomatic tumor enlargement.⁴⁴ Hepatic AVMs can be detected by dynamic CT,⁴⁵ color Doppler ultrasound, magnetic resonance imaging/magnetic resonance angiography (MRI/MRA), or celiac angiography. CT evidence for AVMs includes both the characteristic heterogenous enhancement of the entire liver as well as a dilated common hepatic artery.⁴⁶

The neurologic manifestations of HHT result from PAVM in up to two-thirds of cases.³² The remainder of the neurologic symptoms are the result of cerebrovascular telangiectasias, AVMs, aneurysms, and cavernous hemangiomas. Ten to twenty percent of patients with HHT have cerebral AVM, but only 10% of people who have cerebral AVM are found to have HHT.⁴⁷ The cerebral

P.1109

AVMs are often multiple.⁴⁷ The annual risk of bleeding from cerebral AVM is low, reported as 0.41% to 0.72%/year (compared to 2% to 4% risk for sporadic, non-HHT AVM).^{47, 48} MRI is recommended for detecting these lesions.⁴¹

TABLE 50.2 CURACAO CRITERIA FOR THE DIAGNOSIS OF HEREDITARY HEMORRHAGIC TELANGIECTASIA (HHT)

1. Epistaxis—spontaneous and recurrent
2. Telangiectasias—multiple, at characteristic sites (lips, oral cavity, fingers, nose)
3. Visceral lesions—with or without bleeding (gastrointestinal, pulmonary, cerebral, hepatic)
4. Positive family history—a first-degree relative with HHT

The presence of three of the above criteria indicate definite HHT; the presence of two criteria are suspicious for HHT.

From Shovlin CL, Guttmacher AE, Buscarini E, et al. Diagnostic criteria for hereditary hemorrhagic telangiectasia (Rendu-Osler-Weber Syndrome). *Am J Med Genet* 2000;91:66-67.

The clinical diagnostic criteria (Curacao criteria) are listed in Table 50.2.⁴⁹ Genetic testing is now available, but requires sequencing the entire coding regions of ALK1 and endoglin, and is complex and expensive.²⁷ Consultation with a medical geneticist is recommended.

Management

Asymptomatic patients with HHT should be screened with a thorough history, careful physical exam, complete blood count (CBC), and stool guaiac studies. A brain MRI to screen for cerebral AVMs is recommended, and contrast echocardiography to screen for PAVMs should be performed in all patients at least once after the age of 10. Children younger than 10 should be screened with oxygen saturations in the sitting and supine position every 1 to 2 years, with further testing for saturations <97%.⁴¹ Hepatic AVM screening is controversial, but if considered, an ultrasound is the preferred study.⁴⁴

Recurrent epistaxis can be a perplexing problem, and few trials exist that compare various treatment modalities. Recent efforts to classify the nasal vasculature pattern⁵⁰ and develop an epistaxis severity scoring system should pave the way for randomized trials of the various approaches. Prophylactic measures include humidification and saline nose drops. Nasal trauma from vigorous nose blowing, straining, and finger manipulation should be avoided. Antihistamines should also be avoided to prevent drying of the nasal mucosa. Mild bleeding can be treated with absorptive packing and direct pressure. Cautery is commonly used to stop persistent bleeding, but repeated cauterizations can result in necrosis and septal perforation, and should be avoided.⁵¹ Fibrin glue spray was of benefit in a small study.⁵² The neodymium:yttrium-

aluminum-garnet (Nd:YAG) laser system has been shown to be effective treatment for epistaxis, and analysis of the vascular pattern appears to correlate with the success rates of laser therapies.⁵⁰ Argon plasma coagulation also appears promising, and application of topical estrogens may be useful.⁵³ Arterial embolization or ligation is effective in some patients. Septal dermoplasty is a technique of removing diseased nasal mucosa and the subepithelial telangiectasias and replacing abnormal tissue with an enduring barrier. In refractory cases, rhinotomy with forehead flap reconstruction may be required.⁵⁴ The use of estrogen and e-aminocaproic acid is discussed in the following section.

PAVMs are treated with transcatheter embolotherapy^{55, 56} to diminish the risk of paradoxical emboli and other complications. PAVMs with feeder artery diameters >3 mm should be treated. This procedure is effective at decreasing the right-to-left shunt and improving oxygen saturation, and it has a low complication rate. In cases in which embolotherapy is technically difficult, surgical resection should be used. After embolotherapy or surgery, small AVMs may enlarge and become clinically significant. For this reason, patients should undergo screening helical CT scans every 5 years.³² Because brain abscesses and septic emboli occur in 1% to 20% of patients with HHT and PAVM, these patients should receive prophylactic antibiotic therapy before dental or surgical procedures.⁵⁷

Bleeding GI vascular malformations can be treated with endoscopic thermal devices including bipolar electrocautery and laser techniques. The mucosa coagulates and sloughs, leaving a small ulcer in the place of the vascular lesion.⁵⁸ The ulcer re-epithelializes over the next few days. These treatments are rarely effective for the long term, however, because new lesions continue to develop and small intestinal lesions are not accessible. Estrogen and progesterone have been effective in decreasing the bleeding episodes.

Cerebral AVMs have been treated with surgery, stereotactic radiosurgery, and embolotherapy. A follow-up angiogram should be repeated at 1 year, followed by periodic MRI. Hepatic malformations resulting in high-output heart failure, portal hypertension, or cholangitis should be treated with intensive medical management. Refractory cases have been treated with transcatheter embolization, but the complication rate is significant.⁵⁹ The mortality rate of this procedure in HHT has been calculated to be as high as 25% to 40%.⁵⁸ Consensus recommendations suggest that the procedure be used only "as a last resort in patients who are not candidates for liver transplant," and should be absolutely avoided in patients with biliary signs or symptoms.⁴⁴ Other treatments that have been successfully used include hepatic artery ligation for localized vascular malformations⁵⁹ and liver transplant in patients with extensive lesions.⁶⁰

Medical Therapy

Observations in the 1950s that epistaxis decreased during pregnancy and increased after menopause led to the use of estrogens as therapy for HHT. Estrogens in large doses result in metaplasia of the nasal mucosa, resulting in thick layers of squamous epithelium, and electron microscopy studies indicated that estrogen reestablished endothelial cell continuity.⁶¹ A small randomized trial of 3 months' duration showed no benefit in reducing the number of bleeding episodes with estradiol valerate.⁶² However, another author reported 100% success in an uncontrolled series of 67 consecutively treated patients who continued with high-dose estrogen therapy.⁶¹ Several case reports and one small randomized controlled trial evaluated the use of low-dose estrogen-progesterone combination therapy in patients with severe GI bleeding. The bleeding episodes and transfusion requirements significantly diminished in treated patients.⁶³ Patients on tamoxifen have also been noted in case reports to have decreased episodes of bleeding. Recent reports suggest that either oral or intranasal tranexamic acid may be useful.^{64, 65, 66}

Several intriguing case reports describe regression of telangiectatic lesions and decreased bleeding in patients treated for unrelated reasons with interferon, sirolimus, and bevacizumab,^{67, 68, 69} suggesting a possible role for angiogenic inhibitors in managing HHT.

Virtually all patients with HHT have iron deficiency anemia. The treatment of iron deficiency anemia in this setting usually requires more than oral iron replacement. Patients with significant blood loss and anemia who do not respond or do not tolerate maximal doses of oral iron should be given intravenous iron therapy. Three products are recommended for parenteral iron therapy: low-molecular-weight iron dextran, iron gluconate, and iron sucrose.⁷⁰ Patients who have toxicity with iron dextran should receive one of the other products. With the currently available options for iron replacement in anemic HHT patients, red cell transfusion should rarely be necessary.

P.1110

Genetic counseling should be part of the treatment, and referral to a designated HHT center should be considered in most cases. Seventeen U.S. and Canadian HHT centers currently exist and are listed on the HHT Foundation International, Inc.

Web site (www.hht.org). Additional centers exist in Europe, South America, Israel, and Asia. A recent review summarizes all aspects of HHT diagnosis and management.⁷¹

Vascular Malformations

Vascular malformations result from localized errors of angiogenic development. The underlying molecular genetics of angiogenesis are complex (see Chapter 19). Mutations in angiogenic pathways can result in a variety of malformations, including capillary or venous angiomas, cerebral cavernous malformations (CCMs), and AVMs, either as isolated or multifocal lesions. Bleeding problems occur from rupture or leakage from these vascular anomalies, and the clinical sequelae depend on their location.

Skin lesions are the most common vascular malformation and include a variety of birthmarks. Hemoptysis can result from pulmonary vascular anomalies including AVM and a rare disease known as pulmonary capillary hemangiomatosis. Hematuria may rarely be due to genitourinary AVMs or hemangiomas.

GI bleeding may be due to vascular malformations such as the blue rubber nevus syndrome, gastric antral vascular ectasia, telangiectasias, and AVM. GI angiodysplastic lesions deserve special attention, given their frequency. They appear to be due to degenerative dysplasia and are the most frequent cause of obscure GI bleeding. The cause is thought to be intermittent obstruction of the submucosal veins where they penetrate the muscular layers of the colon, ultimately leading to dilated, tortuous submucosal veins and venules.⁷² Small intestinal angiodysplastic lesions can be particularly hard to detect, but wireless capsule endoscopy can facilitate this diagnosis. Endoscopic-based therapy or surgery may be required for treatment. This disorder is frequently associated with aortic stenosis, and there are reports of cessation of bleeding after aortic valve repair. Continuous estrogen-progestin treatment is not useful in the prevention of rebleeding from GI angiodysplasia.⁷³

Central nervous system vascular lesions include AVMs, berry aneurysms, and cavernomas. Bleeding from these lesions may account for 30% of spontaneous intraparenchymal lobar bleeds.⁷⁴ Autopsy studies show the presence of intracranial aneurysms in 1% to 5% of the adult population, and 20% to 50% of these aneurysms rupture. They are sporadically acquired, but patients with autosomal dominant polycystic kidney disease may have up to a 40% incidence. Screening is recommended for families with two immediate relatives with intracranial aneurysms and all patients with autosomal dominant polycystic kidney disease. Histologically, there is a decrease in the tunica media causing structural defects, leading to aneurysmal dilatation at branch points at the base of the brain. Rupture leads to subarachnoid hemorrhage with symptoms ranging from headache and nuchal rigidity to drowsiness, stupor, and coma.⁷⁵

CCMs are vascular lesions characterized by abnormally enlarged capillary cavities without intervening brain parenchyma. The most common presentation is with seizures and cerebral hemorrhage. Sporadic and familial forms exist, with the familial form showing autosomal dominant inheritance with incomplete penetrance. The familial forms usually have multiple CCM lesions. Three CCM loci have been identified, and the clinical and neuroradiologic features compared.⁷⁶ CCM3 carriers have an earlier age of onset of cerebral hemorrhage. CCMs are not usually visible on angiography, but T1- and T2-weighted images on MRI show characteristic findings.

Patients with brain AVMs present between the ages of 10 and 40. The risk of bleeding in patients with untreated AVMs is 2.8% per year, but varies between 1% in low-risk patients to 30% in high-risk patients.⁷⁷ Genetic abnormalities have been identified in CCMs; these defects result in abnormal blood vessel architecture, and interestingly, may be reversible by statin therapy (reviewed in Ref. 78).

Other Vasculopathies

Amyloidosis

Patients with multiple myeloma or systemic amyloidosis may have light chain deposits in the cutaneous blood vessels. These vessels are particularly fragile, and purpura can occur as a result of minor trauma ("pinch purpura"). The eyelids and periorbital regions are particularly prone to developing purpura (Fig. 50.3), and a classic sign is postproctoscopic periorbital purpura occurring after proctoscopies (for diagnostic rectal biopsies done in the past) or after Valsalva maneuvers. Purpura also commonly develops in other flexural skin areas such as the nasolabial folds, neck, axillae, and umbilicus.⁷⁹ Biopsies of the cutaneous vascular lesions demonstrate amyloid deposits in the dermis and subcutaneous tissues, and inflammatory cells are scarce. The diagnosis and treatment of these disorders are discussed in detail in Chapter 99.

Moyamoya Disease

Moyamoya disease is a chronic cerebral vasculopathy initially described in Japan. The disease is characterized by occlusion of the terminal portion of the internal carotid arteries, or the proximal aspects of the middle or anterior cerebral arteries. An abnormal vascular network of collaterals develops in the regional area of occlusion. Cerebral infarcts are common in children, but adults have a higher propensity for intracranial hemorrhage. The risk of bleeding appears to be highest in adult Asians. Features of moyamoya phenomenon differ in U.S. patients, with women aged 30 to 50 most commonly affected, predominantly with ischemic symptoms.⁸⁰ The etiology is unknown, and diagnosis rests on characteristic angiographic findings.

Cerebral Small Vessel Disease

Cerebral small vessel disease usually refers to arterioles <100 μm in size consisting of an internal elastic membrane and a tunica media one to two layers thick, or small arteries measuring 100 to 400 μm in size with tunica media composed of smooth muscle cells three to four layers thick. These vessels are usually end arteries. A constellation of syndromes is now recognized as causing cerebral small vessel disease, and these are mostly characterized

P.1111

by recurrent ischemic strokes with progressive cognitive impairment. Bleeding, however, is a recognized complication of most of these disorders, and it is important to recognize that many disorders have a substantially increased risk of bleeding with anticoagulants.



FIGURE 50.3. Periorbital purpura in a 58-year-old woman with immunoglobulin A κ plasma cell dyscrasia associated with secondary amyloidosis. (This photograph was kindly provided by Drs. Theresa Scholz and Pamela Nemzer, Department of Dermatology, University of Utah Health Sciences Center.)

Degenerative cerebral microangiopathy is characterized by lipohyalinosis of small vessels associated with aging and increasing in severity with vascular risk factors such as hypertension, diabetes, and hyperhomocystinemia. The vessel walls thicken due to sclerosis, hyalinosis, and lipid deposition. Most of the bleeding appears to occur at or near the bifurcation of affected arteries where prominent degeneration of the media and smooth muscles is most appreciated. Occlusion leads to lacunar infarcts, and rupture can lead to cerebral microbleeds and lobar intracranial hemorrhages.

Cerebral amyloid angiopathy typically presents with lobar hemorrhages in patients older than 70 years, and is due to several types of mutations that lead to the accumulation of b-amyloid material in the media and adventitia of small cortical and leptomeningeal vessels. This leads to a “vessel in vessel” appearance on pathology studies. Because of the higher risk of bleeding, strict avoidance of anticoagulation and antiplatelet agents are recommended.

Cerebral autosomal dominant arteriopathy with stroke and ischemic leukoencephalopathy (CADASIL) is a cerebral vasculopathy occurring in patients usually between the ages of 40 and 60. Patients present with subcortical strokes and a slowly progressive dementia and may have mood disorders, migraine headaches, and in the later stages, pseudobulbar palsy. The diagnosis is suggested by a characteristic finding of widespread leukoencephalopathy on MRI. White matter lesions located in the temporal poles of the brain are considered pathognomonic for CADASIL syndrome.⁸¹ Recent studies suggest that cerebral microbleeds are found in 31% to 69% of patients with CADASIL syndrome and intracranial hemorrhaging occurs in 25% of patients.⁸² The vascular defect lies in the smooth muscle cells, with electron microscopy showing exocytosis of granular osmophilic material from the vascular smooth muscle cells and pericytes.

Type 4 collagen is a component of the vascular basement membrane in the brain, and recent mouse studies indicate that mutations can lead to microvascular fragility and result in intracranial hemorrhage. Some familial forms of intracerebral hemorrhage also appear to be due to mutations in the COL4A1 gene.⁸³

BLEEDING DUE TO DISORDERS OF PERIVASCULAR TISSUE

Ehlers-Danlos Disease

The Ehlers-Danlos syndromes (EDSs) are a group of rare connective tissue disorders caused by abnormalities of collagen synthesis or processing. The prevalence is estimated to be 1 in between 10,000 and 20,000 births. A simplified classification system has identified six major types of EDS and their genetic defects.^{84, 85} The clinical features include hyperextensible, fragile skin associated with joint hypermobility. The majority of patients with EDS also report a history of excessive bruising and bleeding.⁸⁶ Other bleeding manifestations may include subcutaneous nodular hematomas, mucosal oozing after dental procedures, hemoptysis, and GI bleeding. In most patients, screening tests show no hemostatic abnormalities, and the bleeding is thought to result from abnormalities in the perivascular collagen leading to fragility of the subcutaneous vessels. However, several authors have noted abnormal bleeding times and platelet function studies, as well as factor deficiencies in individual patients.^{86, 87}

Certain types of EDS have an increased risk of major bleeding. In particular, vascular EDS (type IV) has unique clinical features of interest to hematologists. This disorder is due to quantitative or qualitative defects in type 3 collagen, which is particularly abundant in the arterial wall^{88, 89} and intestine. Patients with this disorder are prone to develop arterial aneurysms and dissections, significant bleeding from spontaneous rupture of medium-sized abdominal arteries, and intestinal rupture.



FIGURE 50.4. “Papyrus” scarring and thin skin with petechiae in a patient with Ehlers-Danlos syndrome. (From Anstey A, Mayne K, Winter M, et al. Platelet and coagulation studies in Ehlers-Danlos syndrome. *Br J Dermatol* 1991;125:155-163, with permission.)

Carotid-cavernous fistula is another well-documented complication, and clinical diagnosis is based on the findings of pulsatile exophthalmia, tinnitus, thrill, and headache. In addition to vascular abnormalities, patients with vascular EDS have characteristic facial features (prominent eyes, thin nose, small lips, and lobeless ears)⁹⁰ and thin translucent skin with a conspicuous venous network. Papyrus scarring (Fig. 50.4) may be present, but patients usually have minimal joint hypermobility (often limited to the hands) or skin hyperextensibility. Median life expectancy is 48 years with one-fourth of the patients developing complications by age 20, and 80% developing complications by age 40.⁹¹ The diagnosis can be confirmed by skin fibroblast cultures with biochemical analysis of type 3 collagen with or without screening for COL3A1 mutations. If vascular EDS is suspected but the above tests are negative, patients should be screened for TGF- β receptor gene mutations, as clinical features overlap with the newly described Loays-Dietz syndrome (see below).

Patients with EDS, particularly vascular EDS, should generally avoid contact sports and isometric exercise and are advised to avoid medications with antiplatelet properties.⁸⁸ Arterial rupture should be considered in the differential diagnosis when these patients present with new-onset symptoms such as abdominal pain. Diagnostic procedures that involve arterial puncture are relatively contraindicated because of a high incidence of complications.^{88, 92} If surgery is mandatory, extreme care should be used in the manipulation of vascular tissues. Postpartum hemorrhage is a major risk for pregnant patients with EDS, and the management of pregnancy has been reviewed in case reports.^{93, 94} Patients with vascular EDS can develop uterine or vessel rupture in the peripartum period, and should be followed in high-risk centers.⁹¹ Genetic counseling and referral to the Ehlers-Danlos National Foundation (www.ednf.org) should be considered.

Marfan Syndrome

Marfan syndrome is a genetic disorder with characteristic ocular, skeletal, and cardiovascular abnormalities, affecting 1 in 5,000 individuals. Easy bruisability has been reported but does not seem to be a major feature of the Marfan syndrome.⁹⁵ However, the risk of postpartum hemorrhage is reported to be increased.⁹⁶

The basic defect is due to a mutated fibrillin gene on chromosome 15.⁹⁷ Fibrillin is a component of extracellular microfibrils

P.1112

associated with elastin, and is necessary for connecting and anchoring tissue. Fibrillin was recently found to be important as a TGF- β receptor binding protein, holding TGF- β in an inactive complex. Dietz's group discovered that blocking TGF- β in affected mice prevents some of the developmental abnormalities (including aneurysms), suggesting that certain clinical manifestations are due to excess levels of TGF- β .⁹⁸ Further studies, in fact, showed that some families diagnosed with Marfan syndrome and familial thoracic aneurysms have a missense mutation in the TGF- β receptor 2, and this syndrome is now known as the Loeys-Dietz syndrome.^{98, 99}

Loeys-Dietz Syndrome

The pathogenesis of Loeys-Dietz syndrome has been described.¹⁰⁰ Patients with Loeys-Dietz syndrome have a phenotype characterized by hypertelorism, bifid uvula or cleft palate, and arterial tortuosity with vascular aneurysms, resulting in dissections and arterial rupture. The severity of the craniofacial abnormalities appears to correlate with the outcome.⁹⁸ The natural history of Loeys-Dietz varies from Marfan syndrome and EDS, with median survival of 37 years (vs. 48 and 70 years, respectively), but with a much lower complication rate after vascular surgery. It is of note that childhood aortic dissections occurred in patients with aortic diameters <5 cm, and it is recommended that repair occur when the maximum dimension of the ascending aorta exceeds the 99th percentile in children.

Osteogenesis Imperfecta

Osteogenesis imperfecta (OI) is an autosomal dominant disease characterized by brittle bones with pathologic fractures as a result of a deficiency in bone matrix. Approximately 95% of cases are caused by mutations in the genes COLA1 and COLA2, which code for the pro- α 1(1) and pro- α 2(2) peptides of type 1 collagen.¹⁰¹

There are two α ₁-chains and one α ₂-chain in each type 1 collagen, and many different mutations in the genes coding for these subunits have been characterized. Eight clinical types of OI are currently recognized.¹⁰¹ Approximately 25% of patients have been noted to bruise easily; this tendency appears to vary with the clinical type.¹⁰² Skin contains predominantly type 1 collagen, and bruising is thought to be the result of defective supporting structures. The ecchymoses are generally mild and insignificant compared to the broader clinical picture. Recent reports describe patients with extradural hematomas, subdural hematomas, and retinal bleeds after minor trauma in patients with OI, occasionally being misinterpreted as child abuse.^{103, 104} Excessive bleeding from wound sites after surgery has also been described.¹⁰⁵ Recombinant factor VIIa and desmopressin have been reported to be useful in postoperative bleeding in case reports.^{106, 107} The Osteogenesis Imperfecta Foundation can be accessed at <http://www.oif.org>.

Pseudoxanthoma Elasticum

Pseudoxanthoma elasticum is an inherited connective tissue disorder that results in calcification of elastic fibers,¹⁰⁸ especially in the internal elastic lamina of medium-sized arteries. The basic genetic defect is now known to be a variety of loss of function mutations in the gene encoding the transmembrane transporter protein ABC-C6.¹⁰⁹ This protein is in the multiple drug resistance family of proteins and may function as an efflux pump, but it is not yet known what the substance transported is or how the mutation causes the disease. It is possible that this defect could result in accumulation of compounds that could lead to the calcification of the elastin fibers.¹⁰⁹

Patients with pseudoxanthoma elasticum have skin that becomes grooved and thickened over time and has been described as resembling Moroccan leather.¹¹⁰ Other cutaneous features include the development of yellow cutaneous plaques usually in the neck or axillary region or in other flexural sites. Cardiovascular disease results from calcification of the arterial internal elastic lamina. Criteria for the diagnosis of pseudoxanthoma elasticum have been published.¹⁰⁸ Bleeding can result when the calcified vessels rupture. The manifestations include bruising, epistaxis, and bleeding from the uterus, bladder, and joints. GI bleeding occurs in 13% of patients, usually between 20 and 30 years of age, and is usually of gastric origin. Treatment should include the avoidance of gastric irritants and careful control of hypertension and hypercholesterolemia. Regular ophthalmology evaluations are also recommended, as is the avoidance of antiplatelet agents and trauma. First-degree relatives should be screened. The National Association for Pseudoxanthoma Elasticum can be contacted at <http://www.pxenape.org/>.

Scurvy

Humans require vitamin C in the diet to promote the peptidyl hydroxylation of procollagen. In the absence of vitamin C, collagen strands are weakened as a result of abnormal triple helical structures. The abnormal collagen results in defective perivascular supportive tissues, which predispose to capillary fragility and delayed wound healing.^{111, 112}

The clinical manifestations of scurvy depend on the severity of vitamin C deficiency. Patients classically develop perifollicular petechiae (Fig. 50.5).¹¹¹ The petechiae can coalesce and form purpura, particularly in a "saddle" distribution,

and patients may develop gingival or intramuscular hemorrhage. Up to 75% of patients have a multifactorial normochromic, normocytic anemia. Other manifestations include peripheral edema and fatigue.

Patients at risk for scurvy include elderly edentulous patients who cook for themselves, alcoholics, mentally ill patients, and people on unusual diets. The treatment is replacement of ascorbic acid in doses of 200 mg/day.^{111, 113}

Steroid-induced Purpura

Patients on chronic steroids develop thinning of the connective tissues, and minor trauma can result in extensive purpura, especially in older patients. Avoidance of trauma is the best prophylaxis for bleeding in these patients.

Solar Purpura

Senile purpura or solar purpura is a common phenomenon first described in 1817 by Bateman. The lesions are typically located

P.1113

on the extensor surfaces of the forearms and dorsum of the hands and occur without recognized preceding trauma (Fig. 50.6).¹¹⁴ The prevalence in hospitalized patients older than 65 years of age is approximately 5% but increases exponentially with age to include up to 30% of men 90 years of age or older.¹¹⁵ The skin in elderly people is thin as a result of loss of subcutaneous fat and changes in both the amount and quality of collagen. Skin lesions are thought to develop by incidental lateral displacement of slack skin with resulting capillary shearing. The lesions tend to last longer than other purpuric lesions and do not generally undergo the changes in hue that other ecchymotic lesions do.¹¹⁴ Hemostasis tests are normal, and no treatment other than reassurance is indicated.

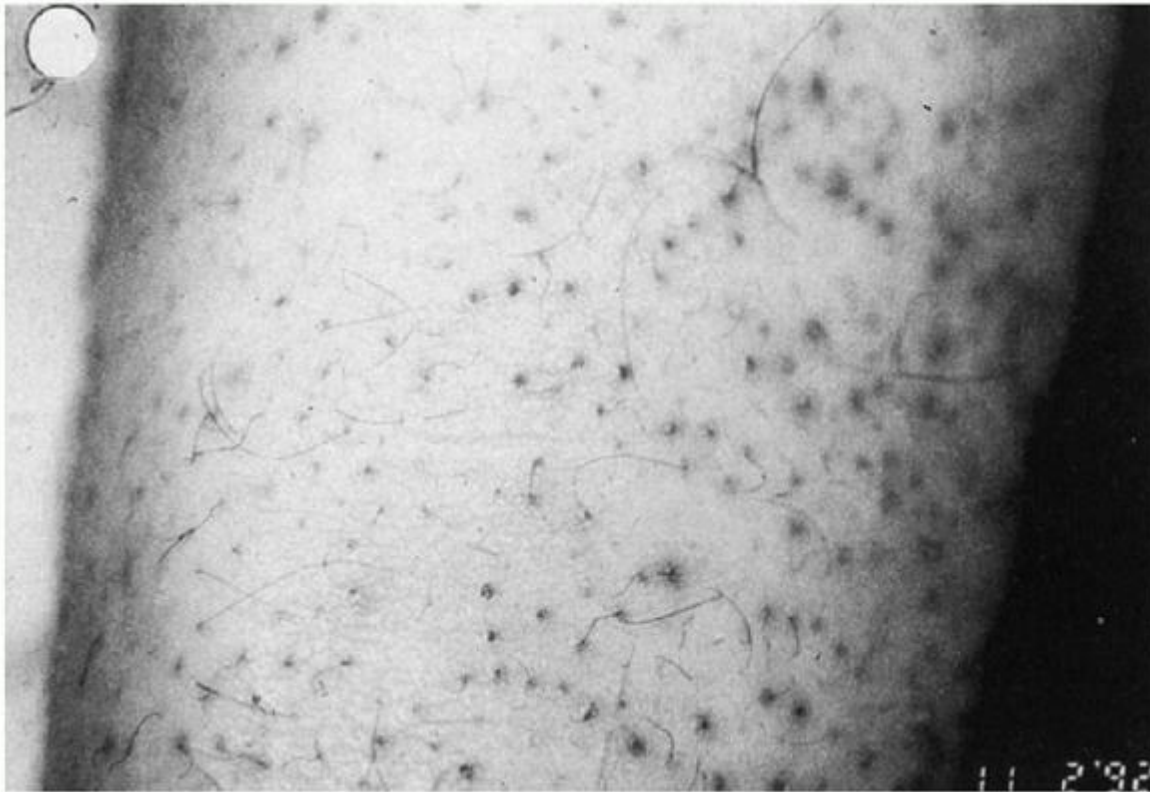

FIGURE 50.5. Perifollicular hemorrhages and corkscrew hairs in a patient with scurvy. (From Ghorbani AJ, Eichler C. Scurvy. *J Am Acad Dermatol* 1994;30:881-883, with permission.)



FIGURE 50.6. Senile purpura (also known as Bateman purpura) in a 70-year-old man. (This photograph was kindly provided by Dr. Kappa Meadows, Department of Dermatology, University of Utah Health Sciences Center.)

VASCULITIS

The nomenclature of the vasculitides is quite confusing, but an international consensus conference has developed a system based on vessel size. This classification system recommends abandoning the term hypersensitivity vasculitis in favor of microscopic polyangiitis for small vessel vasculitides with few or no immune complexes and cutaneous leukocytoclastic vasculitis for small vessel vasculitis with isolated skin involvement.¹¹⁶

Cutaneous Leukocytoclastic Vasculitis

Leukocytoclastic vasculitis is characterized by immune complex deposition in postcapillary venules resulting in an inflammatory infiltrate, red cell extravasation, fibrinoid necrosis of the vessel wall, and fragmentation of nuclei (leukocytoclasia). The lesions typically develop 7 to 10 days after exposure to the offending antigen.

Palpable purpura is the classic clinical finding associated with cutaneous small vessel vasculitis. The lesions are the result of extravasation of erythrocytes into the inflamed dermis; therefore, the lesions do not blanch with pressure. The lesions range in size from pinpoint to several centimeters in diameter and are most prominent on the lower legs. The diagnosis should be confirmed by skin biopsy. Evaluation for the etiologic agent can be challenging and requires a detailed history to identify causative agents (Table 50.3).^{117, 118} Helpful laboratory studies include CBC, blood cultures, serum protein electrophoresis, cryoglobulins, hepatitis screen, rheumatoid factor, antinuclear antibody, antineutrophil cytoplasmic antibodies (ANCA), and complement. Systemic involvement should be determined by the history and physical as well as urinalysis, chest radiography, and electrocardiography.

TABLE 50.3 ETIOLOGIES OF LEUKOCYTOCLASTIC VASCULITIS

Underlying disorders

Malignancy (leukemia, lymphoma, myeloma, cryoglobulinemia)

Autoimmune disease (systemic lupus, ulcerative colitis, periarteritis nodosa, Sjögren syndrome, viral hepatitis, primary biliary cirrhosis, etc.)

Infections (viral, bacterial, mycobacterial, fungal)

Drugs/chemicals

Penicillin, aspirin, phenothiazines, tetracycline, retinoids, colony-stimulating factors, contrast dye, insecticides, herbicides

Idiopathic

Antineutrophil Cytoplasmic Antibody-Positive Vasculitis

A major advance in understanding and classifying the vasculitides has been the recognition of ANCA in specific vasculitic syndromes. Patients with ANCA-associated small vessel vasculitis include three major categories, which are histologically identical. Speed in the diagnosis of ANCA-associated small vessel vasculitis is critical, as early treatment with immunosuppressive drugs can prevent life-threatening organ damage.¹¹⁷

Wegener granulomatosis is distinguished by necrotizing granulomatous inflammation and pulmonary, upper respiratory, and renal involvement. Vascular inflammation in these areas can cause epistaxis, hemoptysis, and hematuria. Churg-Strauss disease is defined by the presence of necrotizing granulomas with asthma and eosinophilia. Vasculitis affects the nerves, GI tract, and skin primarily. Microscopic polyangiitis is recognized by the characteristic histology with the absence of asthma and granulomas. This vasculitis typically occurs in males older than 50 years of age. Prodromal symptoms include fever, myalgias, and arthralgias. Microhematuria, proteinuria, and oliguric renal failure may develop, and 30% to 40% of patients develop cutaneous lesions (splinter hemorrhages, palpable purpura). Pulmonary involvement occurs in one-third of patients.

Cryoglobulinemia

Essential cryoglobulinemic vasculitis is a vasculitis with cryoglobulin immune deposits. Cryoglobulins are immunoglobulins (Igs) that form a precipitate in cooled serum. They were first described by Wintrobe and Buell in 1933.¹¹⁹ The cryoglobulins can precipitate in dermal vessels and result in leukocytoclastic vasculitis¹²⁰ and palpable purpura. When the cryocrit is significantly elevated (e.g., in lymphoproliferative diseases), hyaline thrombi can form and result in vasculopathy without associated vasculitis.¹²⁰

Clinically, patients develop crops of purpuric macules, papules, and patches most prominently over the lower extremities that are occasionally associated with burning or pruritus. Cutaneous infarcts and petechiae are also occasionally present. Only rarely are these symptoms precipitated by exposure to cold; more commonly, prolonged standing or exercise is the inciting event. Systemic manifestations of cryoglobulinemia include arthralgias, asthenia, neuropathy, and renal disease.¹²⁰ Cryoglobulinemia is further discussed in Chapter 101.

Hypergammaglobulinemic Purpura

Hypergammaglobulinemic purpura (HP) is a syndrome first described by Waldenström in 1943; this disorder is characterized by polyclonal hypergammaglobulinemia associated with recurrent

P.1114

attacks of palpable or nonpalpable purpura.¹²¹ The syndrome has a marked predilection for women. The onset is often in the third and fourth decades of life, but young children and octogenarians have also been reported to develop this syndrome.¹²² The attacks of purpura are often sudden in onset and sometimes occur after prolonged standing, exercise, dancing, wearing tight-fitting clothes (e.g., jeans), and alcohol ingestion.^{122, 123} Some patients have premonitory symptoms such as stinging, itching, or mild pain before the development of purpura. The purpura typically involves the lower extremities and is palpable in approximately 75% of cases.¹²⁴ Associated systemic symptoms include arthralgias (particularly adjacent to the purpura), low-grade fever, and lower extremity edema. The purpura usually resolves over 2 to 10 days. Recurrences are common but highly variable. Some patients have up to four attacks per week; others have only rare recurrences.¹²⁴

HP can be divided into primary and secondary forms. Primary HP occurs with no underlying disease process; secondary HP is identified when the typical symptoms of HP develop in patients with underlying diseases such as Sjögren syndrome, systemic lupus erythematosus, or other autoimmune, inflammatory, or neoplastic diseases.^{123, 124} The purpuric lesions can occur years before or after the diagnosis of autoimmune disease.

The laboratory features of HP include hypergammaglobulinemia, elevated erythrocyte sedimentation rate, mild anemia, and mild leukopenia. Both primary and secondary HP have a high prevalence of positive rheumatoid factor (88% to 100%).^{123, 124} Anti-Ro antibodies are similarly elevated in both primary HP and HP associated with Sjögren syndrome¹²² and

in up to 100% of HP associated with systemic lupus.¹²⁴ Histopathologically, the lesions show inflammation of the superficial dermal vessels with an early neutrophil infiltrate followed by a mononuclear cell infiltrate and varying degrees of leukocytoclasia. Skin biopsies are often positive under direct immunofluorescence for IgM and IgG. Circulating immune complexes have also been identified.^{121, 124}

Treatment in the past has been described as unsatisfactory.¹²³ However, a recent prospective, nonrandomized trial of 17 patients suggests that milder cases respond to indomethacin or hydroxychloroquine (200 mg twice daily) and more severe cases respond to prednisone at doses more than 20 mg/day.¹²⁴ Plasmapheresis results in only temporary relief of symptoms.¹²⁵

A relative deficiency of IgG₂ has been reported in some patients despite the hypergammaglobulinemia. IgG subclass determination should be considered in HP patients with recurrent infections.¹²⁶

Urticarial Vasculitis

Patients who present with purpura after resolution of urticaria may have urticarial vasculitis. Typically, the urticarial lesions burn, sting, or itch and last longer than 24 hours. The trunk and proximal extremities are affected more than the distal extremities. Residual hyperpigmentation may be present after resolution of the skin lesions. The pathogenesis appears to be due to immune complexes that activate complement and lead to mast cell degranulation. Patients with normal complement levels usually have minimal, if any, systemic involvement, whereas patients with depressed complement levels may have more severe disease.¹²⁷ Hypocomplementemic urticarial vasculitis is due to anti-C1q precipitins.

Acute Infantile Hemorrhagic Edema

Acute infantile hemorrhagic edema is a leukocytoclastic vasculitis confined to the skin in infants 4 to 24 months of age. Patients present with the dramatic onset of ecchymotic purpura involving the limbs and face with inflammatory edema in an otherwise healthy child. Spontaneous and complete resolution occurs in 1 to 3 weeks. Pathology shows leukocytoclastic vasculitis. Perivascular IgA deposits are often identified, and some authors consider this disorder to be a variant of Henoch-Schönlein purpura (HSP).¹²⁸

Henoch-Schönlein Purpura

HSP is an acute vasculitic syndrome with features of colicky abdominal pain, nephritis, arthritis, and palpable purpura. The manifestations of the syndrome were initially described by Schönlein in 1837 and further developed by Henoch in 1874.^{129, 130} The disease occurs primarily in children, with a peak incidence occurring between 4 and 11 years of age. There appears to be a seasonal variation, with most reported cases occurring from fall to spring and a paucity of cases in the summer.^{129, 131} Many of the cases occur after upper respiratory infections. Epidemiologic studies generally suggest that HSP occurs as sporadic cases, but clustering does occasionally occur. In 1987, a series of 20 cases occurred in Connecticut in a 5-month span and were found to be clustered in one ethnic group.¹³² This space-time clustering suggests a possible role for an infectious agent in precipitating the disease. Other infections, medications, insect bites, and malignancy have also been described as potential precipitating factors.

Biopsies of the superficial dermis and bowel in HSP show an acute vasculitis of precapillary arterioles and postcapillary venules. Immunofluorescent staining commonly shows IgA deposits in the walls of the arterioles of both the involved and noninvolved skin.¹³³ In patients with renal involvement, a proliferative and necrotizing vasculitis is described, and IgA deposits are found in the glomerular mesangium.¹³⁴ Circulating immune complexes containing IgA are detected in approximately 70% of patients shortly after the onset of purpura, followed by the appearance of complement and IgA, IgM, and IgG immune complexes later in the disease course.¹³⁵ A variety of genetic polymorphisms that may predispose patients to developing HSP have been investigated.¹³⁶

The onset of symptoms is usually acute, with fever and palpable purpura involving the extremities and buttocks.^{129, 130} The purpuric lesions appear in symmetric crops with a predilection for extensor surfaces of the extremities (Fig. 50.7). They are most abundant around the knees, ankles, and elbows.¹³⁰ A transient oligoarticular arthritis involving the large joints occurs in approximately 40% of cases, and the pain is often out of proportion to the physical findings. Renal involvement is manifest as proteinuria or hematuria. The renal abnormalities are almost always transient in younger children, but up to 20% to 25% of older children and adults have progressive renal disease.^{129, 137} Poor prognostic factors for renal disease include nephrotic syndrome and >50% glomerular crescent formation on renal biopsy.¹³⁸



FIGURE 50.7. Lower extremity palpable purpura in a patient with Henoch-Schönlein purpura. (From Van Hale HM, Gibson LE, Schroeter AL. Henoch-Schönlein vasculitis: direct immunofluorescence study of uninvolved skin. *J Am Acad Dermatol* 1986;15:665-670, with permission.)

P.1115

Diffuse, crampy abdominal pain occurs in more than one-third of the cases and may occur before the characteristic purpura. The abdominal pain can be severe enough to mimic a surgical abdomen, and appears to be due to submucosal bleeding, edema, and ulcerations. Because abdominal pain is common, it is important to be aware that rare complications requiring surgery do occur, and include intussusception, perforation, and bowel necrosis.¹³⁹ An abdominal ultrasound should be considered in the evaluation of abdominal pain, as other studies may miss ileoileal intussusception. GI bleeding presenting as melena or hematochezia can occur and is occasionally severe. Scrotal involvement is not uncommon, affecting up to 20% males, and can mimic testicular torsion.¹⁴⁰

Criteria for the classification of HSP have been published.¹²⁹ The presence of two of the following four criteria can usually accurately differentiate HSP from other forms of vasculitis: Palpable purpura, age of onset 20 years or younger, acute abdominal pain, and biopsy showing granulocytes in the walls of arterioles or venules. A biopsy is not required in children with the classic presentation of HSP. The prognosis depends in part on the age at presentation. Children usually recover completely from HSP, but relapses may occur over a 3- to 6-week period before complete resolution of symptoms.¹²⁹ Adults have more severe disease at presentation, with a worse renal prognosis.¹⁴¹

Supportive care alone is used to treat mild cases. Steroids may be useful to alleviate symptoms in severe cases, but do not prevent renal complications from developing.¹⁴² Nonsteroidal anti-inflammatory drugs are beneficial for symptom relief in some patients, and plasmapheresis is of reported use with renal involvement.¹⁴³ Patients with crescentic nephritis are treated with methylprednisolone, immunosuppressive drugs, plasmapheresis, and renal transplant.

Serum Sickness

Serum sickness is a specific clinical syndrome with systemic features and immune complex-induced vasculitis. The clinical syndrome typically occurs 7 to 12 days after administration of heterologous serum. The features include fever, urticaria, palpable purpura or other rash, and lymphadenopathy.¹⁴⁴ The purpura is caused by immune complex deposition, and skin

biopsies show a necrotizing angitis. Drugs such as cefaclor, penicillin, hydralazine, sulfonamides, and thiazide diuretics have been associated with serum sickness-like reactions.

PURPURA ASSOCIATED WITH INFECTION

Infectious agents can cause petechiae, purpura, and diffuse bleeding manifestations through a variety of mechanisms including disseminated intravascular coagulation, vasculitis, septic emboli, vascular toxins, and direct vascular or endothelial invasion.¹⁴⁵ Certain clinical syndromes in the latter two categories are considered here. Septic emboli are briefly discussed under the section on vascular obstruction.

Acute Febrile Illness with Petechiae

Petechiae are often associated with acute febrile illnesses in children and immediately raise the concern for possible meningococemia. Although a florid meningococcal infection may be instantly recognizable, children who present with small skin hemorrhages and fever, but who are not acutely ill, can be a diagnostic challenge. Petechiae that are present only above the nipple line in the distribution of the superior vena cava are often due to the coughing or vomiting that accompanies the acute infection. Bacterial agents such as streptococcal infections, pneumococcus, and *Haemophilus influenzae* may cause fever and petechiae. Viral illnesses due to enterovirus and adenovirus are well-known causes of fever and petechiae as well. To help clinicians distinguish between the agents responsible (and to avoid missing an early meningococcal infection), algorithms have been developed.^{146, 147}

Papular-purpuric Gloves and Socks Syndrome

Patients with sharply demarcated purpura involving the hands and feet may have a syndrome known as papular-purpuric "gloves and socks" syndrome as shown in Figure 50.8. This syndrome was initially described in 1990¹⁴⁸ and has been confirmed in several other reports.¹⁴⁹ Patients are usually adolescents or young adults that present in the spring or summer with pruritic edema and erythema of the hands and feet. Petechiae and confluent purpura follow, with a relatively sharp demarcation at the wrists and ankles. Oral mucosal involvement is common, and patients may have other systemic signs or symptoms including lymphadenopathy, fever, elevated liver function studies, and cytopenias. Rare presentations may include a perioral petechial rash or more generalized petechial eruption.¹⁵⁰ The syndrome is self-limited and usually resolves within 1 to 2 weeks. The etiologic agent is usually parvovirus B19, but cytomegalovirus, hepatitis B, measles, rubella, and human herpesvirus 6 have also been implicated. Immunohistochemical studies show viral invasion of endothelial and epidermal cells.¹⁵¹

Rickettsial Diseases

Rickettsiae infection results in damage to the endothelial cell with a characteristic multifocal lymphohistiocytic immune response causing increased vascular permeability, decreased perfusion, and activation of coagulation.

Rocky Mountain spotted fever is transmitted by the bite of ixodid ticks and, therefore, has a peak incidence in the United States in May, June, and July. The incubation period is 2 to 14 days (mean, 7 days), and symptoms usually include the sudden onset of fever, chills, headache, and myalgia. A pink macular rash develops on the wrists, hands, and ankles and spreads to cover most of the body. After 2 to 7 days, the lesions become petechial, and hemorrhagic areas may coalesce to form large areas of ecchymosis. The major complications are a result of vascular injury, and multiple organs may become involved. Diagnosis is based on serologic studies showing a rise in antibody titers or biopsy of the skin lesions with immunofluorescent identification of the organisms. Treatment is with a tetracycline or chloramphenicol.

Other rickettsial diseases such as Mediterranean spotted fever, Asian tick typhus, and Queensland tick typhus are generally milder and have an eschar (tache noire) at the site of the primary tick bite. The treatment is the same as for Rocky Mountain spotted fever.¹⁵²

Brazilian Purpuric Fever

Brazilian purpuric fever is a disease of pediatric patients that usually begins with purulent conjunctivitis followed 7 to 16 days later by acute onset of fever, bacteremia, petechiae purpura, and vascular collapse. The etiologic agent is *H. influenzae* biogroup *aegyptius*. The purpuric tendency appears to be due to direct invasion of endothelial cells with subsequent vascular damage.¹⁵³

Rat Bite Fever

Rat bite fever is an acute illness caused by rodent bite or exposure due to organisms that are part of their normal oral flora. Over 200 cases have been reported in the United States.¹⁵⁴ Most U.S. cases are caused by *Streptobacillus moniliformis*, whereas cases in Asia are due to *Spirillum minus*. The onset of symptoms

P.1116

is usually within 1 week of the bite but can occur several weeks after the wound has healed. Initial symptoms include abrupt onset of fever, chills, headache, malaise, and cough followed in 75% by morbilliform or petechial rash involving the palms and soles. Hemorrhagic vesicles on the peripheral extremities may be particularly suggestive of the diagnosis.¹⁵⁴ Migratory polyarthritides develops in 50% of patients with the *Streptobacillus* type. The case mortality rate if untreated is 10%. Treatment is with procaine penicillin, tetracycline, or streptomycin.



A



B

FIGURE 50.8. Skin lesions of hands and feet associated with papular-purpuric gloves (A) and socks syndrome (B). (From Harms M, Feldmann R, Saurat J-H. Papular-purpuric "gloves and socks" syndrome. *J Am Acad Dermatol* 1990;23:850-854,

with permission.)

Strongyloides

Strongyloides stercoralis is endemic to parts of South America, Central Africa, South East Asia, and the Southern United States (particularly Kentucky and Tennessee).¹⁵⁵ Disseminated strongyloidiasis can occur in patients receiving chemotherapy or steroids, and in otherwise immunocompromised patients. Periumbilical purpura that resembles “multiple thumbprints” has been described,¹⁵⁶ and it appears to be associated with a poor prognosis. More diffuse purpura may develop as well. Biopsy of the skin lesions frequently reveals larva.¹⁵⁷ Other bleeding manifestations include alveolar hemorrhage and GI bleeding.

Vibrio vulnificus

An increasing number of infections caused by *Vibrio vulnificus* are being reported in the United States, particularly in Gulf coastal communities. The consumption of raw oysters is one of the primary mechanisms of infection along with localized wound infections due to exposure to infected salt water. Almost all patients are immunocompromised because of liver disease, diabetes, hemochromatosis, or steroid use.¹⁵⁸ Patients present with abrupt onset of fever, chills, hypotension, and the development of hemorrhagic bullae. These bullae can develop into necrotic ulcers. The hemorrhagic complications appear to be due to a secreted metalloprotease, which has prothrombin-activating and fibrinolytic activities.¹⁵⁹

Hemorrhagic Fever Viruses

The hemorrhagic fever viruses are a diverse group of small RNA viruses with a lipid envelope. The clinical presentations vary, but symptoms usually begin with fever, headache, and myalgias progressing to generalized malaise. These symptoms last 3 to 4 days and are followed by petechiae, mucosal bleeding, and GI tract hemorrhage. However, infection of the endothelium may be common to all,¹⁶⁰ and direct disruption of endothelial cells may occur. Some of the viruses have almost no cytopathologic effect; however, others are highly destructive to the endothelial cells. Activation of immune cells with the release of cytokines and chemokines that target endothelial cells is another suggested mechanism of damage.¹⁶¹ Release of tissue factor from damaged cells can trigger coagulation abnormalities,¹⁶² and varying degrees of thrombocytopenia and disseminated intravascular coagulation are present and contribute to the bleeding diathesis.

The major etiologic agents and the distinctive clinical features are outlined in Table 50.4.¹⁶³ A high index of suspicion is required to diagnose hemorrhagic fever virus. Risk factors for naturally occurring cases include foreign travel, handling of animal carcasses, contact with sick animals or people, and arthropod bites within 21 days of the onset of symptoms. Lack of identifiable risk factors should raise the suspicion of a bioterrorist attack.

Rapid diagnosis is currently available only by sending clinical specimens to the Centers for Disease Control and Prevention or the U.S. Army Medical Research Institute of Infectious Disease in Frederick, Maryland. Suspected cases should be reported immediately to the health department. Protective measures from nosocomial spread should be followed.

PURPURA ASSOCIATED WITH VASCULAR OBSTRUCTION

Although oversimplified, it is often convenient to think of some disorders as causing purpura by intravascular obstruction with subsequent hemorrhage due to necrosis, vasculitic injury, or consumptive coagulopathy. Table 50.5 lists disorders that can be grouped together as causing abruptly decreased blood flow with

P.1117

subsequent bleeding. Note that cold agglutinins are not included because necrosis and bleeding are not expected complications.

TABLE 50.4 HEMORRHAGIC FEVER (HF) VIRUSES

Viral HF	Cytopathic Effect	Endothelial Cell Infection	Cytokine Activation	Disseminated Intravascular Coagulation
South American HF	±	++	++++	No
Lassa fever	±	++	+++	No
Rift Valley fever	++++	?	?	Yes
Crimean Congo HF	+	+	?	Yes

Hantavirus pulmonary syndrome	O	++++	++++	No
Filovirus HF	+++	+++	+++	Yes
Yellow fever	++	?	?	No

O, no effect; ±, negligible effect; +, through; +++++, minimal to major effect; ? = unknown.

TABLE 50.5 CLASSIFICATION OF BLEEDING DISORDERS ASSOCIATED WITH VASCULAR OBSTRUCTION

Vascular Obstruction

Component	Disease Examples
Thrombus	Warfarin-induced skin necrosis, disseminated intravascular coagulation
Emboli	
Thromboemboli	Atrial fibrillation
Septic emboli	Endocarditis
Marantic emboli	Sterile endocarditis
Cholesterol emboli	Invasive vascular procedures, warfarin blue-toe syndrome
Immunoglobulins	Waldenström macroglobulinemia, myeloma
Plasma proteins	Cryoglobulinemia
Fibrin	Cryofibrinogenemia
Red cells	Polycythemia
Platelets	Thrombocytosis, heparin-induced skin necrosis
Fat	Fat emboli syndrome

Cryofibrinogenemia

Cryofibrinogens are cold-precipitable plasma proteins that dissolve as plasma is rewarmed. The proteins are distinct from cryoglobulins, which precipitate on cooling of serum (after the plasma proteins have been removed). Approximately 3% to 13% of hospitalized patients have detectable cryofibrinogens when appropriate assays are used.^{164, 165} Cryofibrinogens can be associated with underlying malignancies or inflammatory processes (secondary cryofibrinogenemia) or be present as an isolated finding (essential cryofibrinogenemia).

Although patients with cryofibrinogenemia are often asymptomatic, they may present with symptoms of lower extremity or acral ulcers, cold intolerance, cutaneous purpura, livedo reticularis, gangrene, or Raynaud phenomenon.¹⁶⁶ Paradoxical bleeding may occur and appears to be proportional to the cryocrit.¹⁶⁵ Many patients have an elevated total fibrinogen level.¹⁶⁴ It is hypothesized that the abnormal cryofibrinogen is due to high levels of α_1 -antitrypsin and α_2 -macroglobulin that inhibit plasmin, resulting in decreased fibrinolysis.¹⁶⁵ The cutaneous lesions develop as a result of fibrin thrombi obstructing the small and medium-sized dermal vessels.¹⁶⁶ Biopsies from the edge of ulcers show eosinophilic thrombi with sparse lymphocytic infiltrate.¹⁶⁷ Leukocytoclastic vasculitis has also been described.¹⁶⁸ To measure cryofibrinogens, blood should be anticoagulated with ethylenediaminetetraacetic acid, citrate, or oxalate. The sample should be maintained at 37°C until centrifuged, and the separated plasma should be chilled at 4°C for 72 hours. Chilling the sample in this way increases the sensitivity for detection. The cryocrit is expressed as a percentage of the plasma sample volume.

Cryofibrinogenemia may be asymptomatic and require no treatment. Mild cases can be treated with avoidance of cold, and procedures that include cooling. Patients with more severe symptoms are usually treated with streptokinase, other fibrinolytic agents, or plasmapheresis. A small clinical trial and case reports have suggested that stanozolol, an androgenic steroid with fibrinolytic activity, can produce excellent results.^{166, 169} Immunosuppressant agents have been reported to be effective in some patients.¹⁶⁷ Heparin use is discouraged.¹⁶⁵

Cholesterol Embolization Syndrome

Cholesterol embolization syndrome is an increasingly recognized disorder caused by dislodged cholesterol crystals from atherosclerotic plaques. This occurs after vascular procedures or can be due to warfarin (blue-toe syndrome) and results in renal insufficiency, peripheral emboli, and possibly GI or central nervous system involvement. Livedo reticularis is the most common skin finding and can be best appreciated with the patient in the upright position. Cyanosis, purpura, ulcers, and gangrene can all occur.¹⁷⁰ Biopsies of the cutaneous lesions, including livedo reticularis, demonstrate thrombi with cholesterol "clefs," since the cholesterol is dissolved during fixation.

Fat Emboli Syndrome

Fat emboli syndrome is poorly understood. It is characterized by hypoxemia, tachypnea, petechiae, and changes in mental status occurring after long bone and pelvic fractures or intramedullary fixation. It may result from release of fat from bone marrow resulting in diffuse microvascular fat emboli. Although embolization of fat is common after trauma, only a few patients develop the fat emboli syndrome. Pulmonary dysfunction typically occurs 12 to 24 hours after fracture or operative fixation and is

P.1118

manifested as hypoxemia and tachypnea. The delay in symptoms suggests the role of a biochemical reaction leading to lung toxicity. Forty percent of patients develop petechiae, particularly in the axilla and subconjunctiva 24 to 48 hours after the event. Up to 70% of patients develop mental status changes.¹⁷¹ Fat droplets can be identified on bronchoalveolar lavage, and fat globules have been identified in pulmonary capillary blood obtained through a wedged pulmonary artery catheter.

Silicone Embolism Syndrome

Liquid silicone is an inert material used in illegal subcutaneous injections for breast augmentation and other cosmetic procedures. A recent review of the literature showed many similarities with the fat emboli syndrome in 33 patients. The most common symptoms are respiratory distress and hypoxemia occurring within 72 hours of the procedure with fever, alveolar hemorrhage (64%), and petechiae (18%). Six patients presented with neurologic symptoms occurring during or several hours after the injections and all patients deteriorated rapidly. Transbronchial biopsies show vacuolated globular deposits of silicone in the interstitial capillaries.¹⁷²

Septic Emboli

Calciophylaxis

Calciophylaxis is a small vessel vasculopathy characterized by calcifications of the tunica media of small to medium-sized cutaneous and subcutaneous vessels. The vasculopathy leads to development of tissue ischemia, necrosis of the skin and subcutaneous fat, and sometimes deeper tissues. Patients typically have end-stage renal disease and are on hemodialysis, but the disorder has now been described in a variety of other conditions. Clinically, painful dusky, purple-hued subcutaneous nodules and induration occur on the trunk, buttocks, or proximal extremity, and can progress to necrotic ulcers with eschars. In retrospective review, obesity, liver disease, steroid use, calcium phosphate product of >70 mg²/dl, and an aluminum >25 ng/ml were identified as risk factors. The diagnosis is usually made by biopsy of one of the lesions showing calcification of the tunica media with intimal proliferation and microthrombosis. Treatment involves lowering the calcium phosphate product when elevated by using sevelamer hydrochloride as a substitute for calcium phosphate binders, and decreasing the phosphate intake and calcium in the dialysate bath. Elevated parathyroid levels can be managed with calcimimetic agents or parathyroidectomy. Wound management is of key importance, as sepsis is the leading cause of death.¹⁷³

Livedoid Vasculopathy

Livedoid vasculopathy is a cause of lower extremity purpura progressing to shallow ulcerations that heal with atrophic hypopigmented scarlike plaques (atrophie blanche). Biopsy of the lesions shows hyaline vascular changes with intraluminal thrombosis. It is associated with multiple coagulation abnormalities.¹⁷⁴

PURPURA ASSOCIATED WITH SKIN DISEASES

Pigmented Purpuric Dermatitis

Pigmented purpuric eruptions encompass a group of related skin diseases that have in common the clinical appearance of red-brown skin pigmentation (caused by hemosiderin deposits) associated with purpura or petechiae. These lesions tend to develop on the lower extremities of middle-aged people and are usually chronic. Histologically, there is a mononuclear upper dermal infiltrate without evidence of leukocytoclasia. Extravasated red blood cells are present around the

capillaries, and hemosiderin deposits are found in older lesions. Six skin diseases are commonly classified as pigmented purpura. In Schamberg progressive pigmentary dermatosis, the lesions appear as orange-brown patches of skin with "cayenne pepper spots" at the borders or within the lesion (Fig. 50.9). Majocchi purpura annularis is distinguished by an annular 0.5- to 2.0-cm patch of reddish-brown macules. Eczematoidlike purpura has a seasonal pattern and appears as pinpoint lesions that spread rapidly over 2 to 4 weeks and develop a slight scale. The lesion in pigmented purpura lichenoid dermatitis (Gougerot-Blum purpura) is a reddish-brown macule with telangiectasias. These lesions tend to coalesce and form plaques. Itching purpura presents with an acute onset of pigmented macules associated with severe pruritus. Lastly, lichen aureus is described as "grouped copper-orange to purple lichenoid papules forming an irregular, usually singular, plaque."¹⁷⁵ The etiology of pigmented purpura is unknown, but some degree of venous stasis is apparent in many patients and may be a factor in its development. The importance of these lesions is to differentiate them from other causes of chronic purpura with hemosiderin deposits such as purpura associated with abnormal proteins. The lesions may clear in up to two-thirds of patients with long-term follow-up.¹⁷⁶ Some patients with longstanding pigmented and purpuric dermatitis develop mycoses fungoides, and the differentiation between mycoses fungoides and pigmented purpuric lesions can sometimes be difficult.¹⁷⁷



FIGURE 50.9. Skin lesions associated with Schamberg progressive pigmentary dermatosis. Note the irregular patches of punctate hemorrhagic lesions with yellow-brown discoloration of hemosiderin deposits. (From Sherertz EF. Pigmented purpuric eruptions. *Semin Thromb Hemost* 1984;10:190-195, with permission.)

Pigmented purpuric eruptions have been described in children¹⁷⁸ (Fig. 50.10), and may be familial. Treatment in the past has been with fluorinated steroids, but recently, psoralen

P.1119

plus ultraviolet light of A wavelength has been found to be effective in some cases.¹⁷⁹



FIGURE 50.10. Pigmented purpura in a child. (This photograph was kindly provided by Drs Payem Tristani-Firouzi and Sheryll Vanderhooft, Department of Dermatology, University of Utah Health Sciences Center.)

Purpuric Contact Dermatitis

Purpura can be a presenting sign of allergic contact dermatitis and is often due to textile dyes in clothing. This diagnosis should be considered in patients who develop purpura only in areas of skin contact with clothing. Several allergens in textile dyes have been identified.¹⁸⁰ Other reported antigens include benzoyl peroxide, epoxy resin, and agave sap.¹⁸¹

Drug Reactions

Drug reactions can cause nonthrombocytopenic purpura by a number of different mechanisms, including leukocytoclastic vasculitis, serum sickness, and, occasionally, a pigmented purpura. Some of the drugs associated with pigmented purpuric dermatosis include acetaminophen, aspirin, glipizide, hydralazine, meprobamate, dipyridamole, creatine, thiamine, interferon, injected medroxyprogesterone acetate, and infliximab.¹⁸² A fixed drug reaction can occur, with an isolated purpuricappearing lesion occurring in a location without preceding trauma (Fig. 50.11).



FIGURE 50.11. A fixed drug eruption lesion. This 30-year-old woman developed this thigh lesion after taking ibuprofen. (This photograph was kindly provided by Dr. Pamela Nemzer, Department of Dermatology, University of Utah Health Sciences Center.)

PSYCHOGENIC PURPURA

Autoerythrocyte Sensitization

Autoerythrocyte sensitization is a rare disorder characterized by recurrent spontaneous ecchymotic lesions in patients with otherwise normal hemostasis. The syndrome was first described in 1955 by Gardner and Diamond after their discovery that intradermal injections of autologous red blood cells reproduced the skin lesion.¹⁸³ Since the original description, more than 200 cases have been described, with the largest series collected by Ratnoff.¹⁸⁴

The cutaneous lesions are usually preceded by localized symptoms, including pain and a burning or stinging sensation in the involved area. The area then becomes erythematous, raised, and warm, and within hours, ecchymoses occur in the inflamed area. The ecchymoses can range in size from 1 to 2 cm to extensive involvement of the trunk or an extremity. The erythema and swelling usually subside within 48 hours of the development of ecchymoses. The lesions can recur weeks to years later. The ecchymotic lesions are usually only one symptom among many. Patients commonly have systemic symptoms including headaches, paresthesias, syncopal episodes, abdominal pain, nausea, vomiting, chest pain, dyspnea, dysuria, and arthralgia.

Autoerythrocyte sensitization typically affects adolescent to middle-aged females who have significant underlying emotional problems. Patients are commonly found to suffer from depression, anxiety, and inability to handle hostile feelings, as well as hysterical and masochistic character traits. They have often sustained significant physical and emotional trauma in the past, and up to two-thirds of the patients describe significant emotional stress present at the time the initial purpuric lesions develop.

The skin lesions can classically be reproduced in most patients with the intradermal injection of 0.1 ml autologous whole blood, packed red blood cells, or red cell stroma. However, this test has limited sensitivity, and some authorities recommend using clinical criteria to diagnose this disorder.¹⁸⁵ No specific therapy is of proven value in psychogenic purpura. Psychotherapy appears to be beneficial in some younger patients but is less effective in the older population.¹⁸⁶

Autosensitivity to DNA

A similar syndrome of recurrent ecchymoses after a prodrome of localized itching was described in 1961 by Levin and Pinkus.¹⁸⁷ This patient developed the typical skin lesions described above after the intradermal injection of frozen and thawed buffy coat leukocytes or purified calf thymus DNA. There are few data concerning the emotional background of these patients. Since the initial description, a few other cases have been reported, but some of these also had a positive reaction to intradermal injection of blood or washed red cells. Chloroquine can induce remissions, and cyproheptadine was useful in one patient.^{188, 189, 190}

Factitious Purpura

Self-inflicted ecchymoses can be difficult to diagnose. This disorder should be considered when there is a clear secondary gain present, when the lesions only occur in accessible areas, or when ecchymotic lesions assume unusual shapes. Circular, wellcircumscribed lesions around the upper limbs and breasts may be a result of sucking of the skin.

Religious Stigmata

Purpuric religious stigmata are bruises that allegedly occur spontaneously and resemble the wounds of the crucified body of Christ. The phenomenon usually occurs in women, and many have belonged to a religious order. The etiology is unknown.¹⁸⁴

P.1120

REFERENCES

1. Fitzpatrick TB, Bernhard JD. The structure of skin lesions and fundamentals of diagnosis. In: Fitzpatrick TB, Eisen AZ, Wolff K, et al., eds. *Dermatology in general medicine*, 4th ed. New York: McGraw-Hill, 1993:27-55.
2. Simpson K, Knight B. Types of injury and wounds. In: *Forensic medicine*. London: Edward Arnold, 1985:48-70.
3. Pedley CF, Bloomfield RL, Colflesh MJ, et al. Blood pressure monitor-induced petechiae and ecchymosis. *Am J Hypertens* 1994;7:1031-1032.
4. Stephenson T, Bialas Y. Estimation of the age of bruising. *Arch Dis Child* 1996;74:53-55.
5. Bohnert M, Baumgartner R, Pollak S. Spectrophotometric evaluation of the color of intra- and subcutaneous bruises. *Int J Legal Med* 2000;113:343-348.
6. Mosqueda L, Burnight K, Liao S. The life cycle of bruises in older adults. *J Am Geriatr Soc* 2005;53:1339-1343.
7. Casas JG, Woscoff A. Calcaneal petechiae. *Arch Dermatol* 1977;109:571.
8. Pierson JC, Suh PS. Powerlifter's purpura: a Valsalva-associated phenomenon. *Cutis* 2002;70:93-94.
9. Amgwerd MG. Acute venous stasis in the area of the head after bungeejumping. A report of two cases. *Unfallchirurg* 1995;98:447-448.
10. Gough KR. Capillary resistance to suction in hypertension. *BMJ* 1962;1:21-24.
11. Fisher AA. Suction purpura: Part 1. "Sucker daddy" or "cyclops purpura." *Cutis* 1992;49:393-394.
12. Metzker A, Merlob P. Suction purpura. *Arch Dermatol* 1992;128:822-824.
13. Velmahos GC, Tatevossian R, Demetriades D. The "seatbelt mark" sign: a call for increased vigilance among physicians treating victims of motor vehicle accidents. *Am Surg* 1999;65:181-185.
14. Smock WS. Forensic emergency medicine. In: Marx JA, ed. *Rosen's emergency medicine: concepts and clinical practice*, 5th ed. St. Louis, MO: Mosby, 2001:828-841.
15. Hunt AC. Ring resolution of bruises—a little recognized phenomenon. *J Clin Forensic Med* 2007;14:85-86.
16. Dunstan FD, Guildea ZE, Kontos K, et al. A scoring system for bruise patterns: a tool for identifying abuse. *Arch Dis Child* 2002;86:330-333.
17. Maguire S, Mann MK, Sibert J, et al. Are there patterns of bruising in children which are diagnostic or suggestive of abuse? A systematic review. *Arch Dis Child* 2005;90:182-186.
18. Guthrie CM, Stanfey HA. Rectus sheath haematoma presenting with Cullen's sign and Grey-Turner's sign. *Scott Med J* 1996;41:54-55.

19. Ratzan RM, Donaldson MC, Foster JH. The blue scrotum sign of Bryant: a diagnostic clue to ruptured abdominal aortic aneurysm. *J Emerg Med* 1987;5:323-329.
20. Amoury RA, Barth GW, Hall RT, et al. Scrotal ecchymosis: sign of intraperitoneal hemorrhage in the newborn. *South Med J* 1982;75:1471-1475, 1478.
21. Herbella FA, Mudo M, Delminti C, et al. "Raccoon eyes" (periorbital hematoma) as a sign of skull base fracture. *Injury* 2001;32:745-747.
22. Davidson C, Smik EE. Bruising: a useful physical sign in ruptured knee joint. *Clin Rheumatol* 1985;4:452-454.
23. Sutton HG. Epistaxis as an indication of impaired nutrition and of degeneration of the vascular system. *Med Mirror* 1864;1:786.
24. Rendu M. Epistaxis repetees chez un sujet porteur de petis angiomes cutanes et muquenx. *Bull Soc Med Hop Paris* 1896;13:731-733.
25. Osler W. On a family form of recurring epistaxis associated with multiple telangiectasias of the skin and mucous membranes. *Bull Johns Hopkins Hosp* 1901;12:333-337.
26. Weber FP. Multiple hereditary developmental angiomas (telangiectases) of the skin and mucous membranes associated with recurring haemorrhages. *Lancet* 1907;2:160-162.
27. Giordano P, Nigro A, Lenato GM, et al. Screening for children of families with Rendu-Osler-Weber disease: from geneticist to clinician. *J Thromb Haemost* 2006;4:1237-1245.
28. Plauchu H, deChadarevian JP, Bidean A, et al. Age-related clinical profile of hereditary hemorrhagic telangiectasia in an epidemiologically recruited population. *Am J Med Genet* 1989;32:291-297.
29. Gallione CJ, Repetto GM, Legius E, et al. A combined syndrome of juvenile polyposis and hereditary haemorrhagic telangiectasia associated with mutations in MADH4(SMAD4). *Lancet* 2004;363:852-859.
30. Cole SG, Begbie ME, Wallace GM, et al. A new locus for hereditary haemorrhagic telangiectasia (HHT3) maps to chromosome 5. *J Med Genet* 2005;42:557-582.
31. Bayrak-Toydemir P, McDonald J, Akarsu N, et al. A fourth locus for hereditary hemorrhagic telangiectasia maps to chromosome 7. *Am J Med Genet A* 2006;140:2155-2162.
32. Guttmacher AE, Marchuk DA, White RI. Hereditary hemorrhagic telangiectasia. *N Engl J Med* 1995;333:918-924.
33. Braverman IM, Keh A, Jacobsen BS. Ultrastructure and three-dimensional organization of the telangiectasias of hereditary hemorrhagic telangiectasia. *J Invest Dermatol* 1990;95:422-427.
34. Porteous MEM, Burn J, Proctor SJ. Hereditary haemorrhagic telangiectasia: a clinical analysis. *J Med Genet* 1992;29:527-530.
35. Reilly PJ, Nostrant TT. Clinical manifestations of hereditary hemorrhagic telangiectasia. *Am J Gastroenterol* 1984;79:363-367.
36. Pasculli G, Quaranta D, Lenato GM, et al. Capillaroscopy of the dorsal skin of the hands in hereditary hemorrhagic telangiectasia. *QJM* 2005;98:757-763.
37. Kjeldsen AD, Oxhoj H, Andersen PE, et al. Prevalence of pulmonary arteriovenous malformations (PAVMS) and occurrence of neurologic symptoms in patients with hereditary hemorrhagic telangiectasia (HHT). *J Int Med* 2000; 248:255-262.
38. Haitjema T, Westermann CJJ, Overtoom TTC. Hereditary hemorrhagic telangiectasia (Osler-Weber-Rendu disease): new insights in pathogenesis, complications and treatment. *Arch Intern Med* 1996;156:714-719.
39. McAllister K, Lennon F, Bowles-Biesecker B, et al. Genetic heterogeneity in hereditary hemorrhagic telangiectasia: possible correlation with clinical phenotype. *J Med Genet* 1994;31:927-932.
40. Moussouttas M, Fayad P, Rosenblatt M, et al. Pulmonary arteriovenous malformations. Cerebral ischemia and neurologic manifestations. *Neurology* 2000;55:959-964.
41. Bayrak-Toydemir P, Mao R, Lewin S, et al. Hereditary hemorrhagic telangiectasia: an overview of diagnosis and management in the molecular era for clinicians. *Genet Med* 2004;6:175-191.

42. Nanthakumar K, Graham AT, Robinson TI, et al. Contrast echocardiography for detection of pulmonary arteriovenous malformations. *Am Heart J* 2001;141:243-246.
43. Remy J, Remy-Jardin M, Giraud F, Wattinne L. Angioarchitecture of pulmonary arteriovenous malformations: clinical utility of three dimensional helical CT. *Radiology* 1994;191:657-664.
44. Buscarini E, Plauchu H, Garcia-Tsao, et al. Liver involvement in hereditary hemorrhagic telangiectasia: consensus recommendations. *Liver Int* 2006;26:1040-1046.
45. Bernard G, Mion F, Henry L, et al. Hepatic involvement in hereditary hemorrhagic telangiectasia: clinical, radiological and hemodynamic studies of 11 cases. *Gastroenterology* 1993;105:482-487.
46. Wu JS, Saluja S, Garcia-Tsao, et al. Liver involvement in hereditary hemorrhagic telangiectasia; CT and clinical findings do not correlate in symptomatic patients. *AJR Am J Roentgenol* 2006;187:W399-W405.
47. Willemse RB, Johannes JM, Westerman CJJ, et al. Bleeding risk of cerebrovascular malformations in hereditary hemorrhagic telangiectasia (HHT). *J Neurosurg* 2000;92:779-784.
48. Maher CO, Piepgras DG, Brown RD, et al. Cerebrovascular manifestations in 321 cases of hereditary hemorrhagic telangiectasia. *Stroke* 2001;32: 877-882.
49. Shovlin CL, Guttmacher AE, Buscarini E, et al. Diagnostic criteria for hereditary hemorrhagic telangiectasia (Rendu-Osler-Weber Syndrome). *Am J Med Genet* 2000;91:66-67.
50. Mahoney EJ, Shapshay SM. New classification of nasal vasculature patterns in hereditary hemorrhagic telangiectasia. *Am J Rhinol* 2006;20:87-90.
51. Rebeiz EE, Bryan DJ, Ehrlichman RJ, et al. Surgical management of life-threatening epistaxis due to Osler-Weber-Rendu disease. *Ann Plast Surg* 1995;35:208-213.
52. Vaiman M, Marthovich V, Eviatan E. Fibrin glue in the initial treatment of epistaxis in hereditary hemorrhagic telangiectasia (Rendu-Osler-Weber Syndrome). *Blood Coagul Fibrinolysis* 2004;15:359-363.
53. Bergler W, Sadick H, Gotte K, et al. Topical estrogens combined with argon plasma coagulation in the management of epistaxis in hereditary hemorrhagic telangiectasia. *Ann Otol Rhinol Laryngol* 2002;111(3 Pt 1):222-228.
54. Shah RK, Dhingra JK, Shapshay SM. Hereditary hemorrhagic telangiectasia: a review of 76 cases. *Laryngoscope* 2002;112:767-773.
55. Dutton JAE, Jackson JE, Hughes JMB, et al. Pulmonary arteriovenous malformations: results of treatment with coil embolization in 53 patients. *AJR Am J Roentgenol* 1995;165:1119-1125.
56. Lee DW, White RI, Eggin TK, et al. Embolotherapy of large pulmonary arteriovenous malformations: long-term results. *Ann Thorax Surg* 1997;64: 930-940.
57. Mohler ER, Monahan B, Canty MD, et al. Cerebral abscess associated with dental procedure in hereditary hemorrhagic telangiectasia. *Lancet* 1991;338:508-509.
58. Buchi KN. Vascular malformations of the gastrointestinal tract. *Surg Clin North Am* 1992;72:559-570.
59. Whiting JH, Morton KA, Datz FL, et al. Embolization of hepatic arteriovenous malformations using radiolabeled and non-radiolabeled polyvinyl alcohol sponge in a patient with hereditary hemorrhagic telangiectasia: case report. *J Nucl Med* 1992;33:260-262.
60. Bauer T, Britton P, Lomas D, et al. Liver transplantation for hepatic arteriovenous malformation in hereditary hemorrhagic telangiectasia. *J Hepatol* 1995;22:586-590.
61. Harrison DFN. Use of estrogen in treatment of familial hemorrhagic telangiectasia. *Laryngoscope* 1982;92:314-320.
62. Vase P. Estrogen treatment of hereditary hemorrhagic telangiectasia. A double-blind controlled clinical trial. *Acta Med Scand* 1981;209:393-396.
63. van Cutsem E, Rutgeerts P, Vantrappen G. Treatment of bleeding gastrointestinal malformations with oestrogen-progesterone. *Lancet* 1990;335:953-955.
64. Saba HI, Morelli GA, Logrono LA. Treatment of bleeding in hereditary hemorrhagic telangiectasia with aminocaproic acid. *N Engl J Med* 1994;330: 1789-1790.

65. Fernandez-L A, Garrido-Martin EM, Sanz-Rodriguez F, et al. Therapeutic action of tranexamic acid in hereditary haemorrhagic telangiectasia (HHT): regulation of ALK-1/endothelin pathway in endothelial cells. *Thromb Haemost* 2007;97:254-262.
66. Klepfish A, Berrebi A, Schattner A. Intranasal tranexamic acid treatment for severe epistaxis in hereditary hemorrhagic telangiectasia. *Arch Intern Med* 2001;161:767.
67. Wheatley-Price D, Shovlin C, Chao D. Interferon for metastatic renal cell cancer causing regression of hereditary hemorrhagic telangiectasia. *J Clin Gastroenterol* 2005;39:344-345.
68. McAlister V. Regression of cutaneous and gastrointestinal telangiectasia with sirolimus and aspirin in a patient with hereditary hemorrhagic telangiectasia. *Ann Int Med* 2006;144:226-227.
69. Brinkerhoff BT, Poetker DM, Choong NW. Long-term therapy with bevacizumab in hereditary hemorrhagic telangiectasia. *N Engl J Med* 2011;364: 688-689.
70. Silverstein SB, Rodgers GM. Parenteral iron therapy options. *Am J Hematol* 2004;76:74-78.
71. McDonald J, Bayrak-Toydemir P, Pyeritz RE. Hereditary hemorrhagic telangiectasia: an overview of diagnosis, management, and pathogenesis. *Genet Med* 2011;13:607-616.
72. Sharma R, Gorbien MJ. Angiodysplasia and lower gastrointestinal tract bleeding in elderly patients. *Arch Intern Med* 1995;155:807-812.
73. Junquera F, Feu F, Papo M. A multicenter, randomized clinical trial of hormonal therapy in the prevention of rebleeding from gastrointestinal angiodysplasia. *Gastroenterology* 2001;121:1073-1079.
74. Barnes B, Cawley CM, Barrow DL. Intracerebral hemorrhage secondary to vascular lesions. *Neurosurg Clin North Am* 2002;13:289-297.
75. Brisman JL, Sony JD, Newell DW. Cerebral aneurysms. *N Engl J Med* 2006;335:928-939.
76. Denier C, Labauge P, Bergametti F, et al. Genotype-phenotype correlations in cerebral cavernous malformation patients. *Ann Neurol* 2006;60:550-556.
77. Friedlander RM. Arteriovenous malformation of the brain. *N Engl J Med* 2007;356:2204-2712.
78. Patterson C. Torturing a blood vessel. *Nat Med* 2009;15:137-138.
79. Williams JT, Arrington J, Gruber HM. Purpura as the presenting sign of an internal disease. Multiple myeloma. *Arch Dermatol* 1993;129:775-776.
80. Hallemeier CL, Rich KM, Grubb RL, et al. Clinical features and outcomes in North American adults with Moyamoya phenomenon. *Stroke* 2006;37: 1490-1496.
81. Ringelstein EB, Nabari DG. Cerebral small vessel disease: cerebral microangiopathies. *Curr Opin Neurol* 2005;18:179-188.
82. Choi JC, Kang SY, Kang JH, et al. Intracerebral hemorrhages in CADASIL. *Neurology* 2006;67:2042-2044.
83. Gould DB, Phalan FC, Van Mill SE, et al. Rule of COL4A1 in small vessel disease and hemorrhagic stroke. *N Engl J Med* 2006;354:1489-1496.
84. Beighton P, De Paepe A, Steinmann B, et al. Ehlers-Danlos syndromes: revised nosology, Villefranche, 1997. Ehlers-Danlos National Foundation (USA) and Ehlers-Danlos Support Group (UK). *Am J Med Genet* 1998;77:31-37.
85. Malfait F, De Paepe A. Molecular genetics in classic Ehlers-Danlos syndrome. *Am J Med Genet C Semin Med Genet* 2005;139C:17-23.
86. Anstey A, Mayne K, Winter M, et al. Platelet and coagulation studies in Ehlers-Danlos syndrome. *Br J Dermatol* 1991;125:155-163.
87. Nuss R, Manco-Johnson M. Hemostasis in Ehlers-Danlos syndrome: patient report and literature review. *Clin Ped* 1995;34:552-555.
88. De Paepe A. Ehlers-Danlos syndrome type IV. Clinical and molecular aspects and guidelines for diagnosis and management. *Dermatology* 1995;189 (Suppl 2):21-25.
89. Lum YW, Brooke BS, Black JH 3rd. Contemporary management of vascular Ehlers-Danlos syndrome. *Curr Opin Cardiol* 2011;26:494-501.

90. De Paepe A, Malfait F. Bleeding and bruising in patients with Ehlers-Danlos Syndrome and other collagen vascular disorders. *Br J Haematol* 2004;127:491-500.
91. Pepin M, Schwarze U, Superti-Furga A., et al. Clinical and genetic features of Ehlers-Danlos syndrome type IV, the vascular type. *N Engl J Med* 2000;342:673-680.
92. Mattar SG, Kumar SG, Lumsden AB. Vascular complication in Ehlers-Danlos syndrome. *Am Surg* 1994;60:827-831.
93. Weinbaum PJ, Cassidy SB, Campbell WA, et al. Pregnancy management and successful outcome of Ehlers-Danlos syndrome type IV. *Am J Perinatol* 1987;4:134-137.
94. Attala A, Page I. Ehlers-Danlos syndrome type III in pregnancy. *Obstet Gynecol* 1988;71:508-509.
95. Pyeritz RE, McKusick VA. The Marfan syndrome: diagnosis and management. *N Engl J Med* 1979;300:772-777.
96. Irons DW, Pollard KP. Post-partum haemorrhage secondary to Marfan's disease of the uterine vasculature. *Br J Obstet Gynecol* 1993;100:279-281.
97. Cañadas V, Vilacosta I, Bruna I, Fuster V. Marfan syndrome. Part 1: pathophysiology and diagnosis. *Nat Rev Cardiol* 2010;7:256-265.
98. Loeys BL, Schwarze U, Holm T, et al. Aneurysm syndromes caused by mutations in the TGF- β receptor. *N Engl J Med* 2006;355:788-798.
99. Gelb BD. Marfan's syndrome and related disorders—more tightly connected than we thought. *N Engl J Med* 2006;355:841-842.
100. Van Hemelrijk C, Renard M, Loeys B. The Loeys-Dietz syndrome: an update for the clinician. *Curr Opin Cardiol* 2010;25:546-551.
101. Van Dijk FS, Pals G, Van Rijn RR, et al. Classification of osteogenesis imperfecta revisited. *Eur J Med Genet* 2010;53:1-5.
102. Falvo KA, Root L, Bullough PG. Osteogenesis imperfecta: clinical evaluation and management. *J Bone Joint Surg Am* 1974;56:783-793.
103. Groninger A, Schaper J, Messing-Juenger M, et al. Subdural hematoma as clinical presentation of osteogenesis imperfecta. *Pediatr Neurol* 2005;32: 140-142.
104. Ganesh A, Jenny C, Geyer J, et al. Retinal hemorrhages in type 1 osteogenesis imperfecta after minor trauma. *Ophthalmology* 2004;111:1428-1431.
105. Edge G, Okafor B, Fennelly ME. An unusual manifestation of bleeding diathesis in a patient with osteogenesis imperfecta. *Eur J Anaesth* 1997;14: 215-219.
106. Kastrup M, von Heymann C, Hotz H, et al. Recombinant factor VIIa after aortic valve replacement in a patient with osteogenesis imperfecta. *Ann Thorac Surg* 2002;74:910-912.
107. Keegan M, Whatcott BD, Harrison BA. Osteogenesis imperfecta, perioperative bleeding and desmopressin. *Anesthesiology* 2002;97:1011-1013.
108. Uitto J, Bercovitch L, Terry SF, Terry PF. Pseudoxanthoma elasticum: progress in diagnostics and research towards treatment: summary of the 2010 PXE International Research Meeting. *Am J Med Genet A* 2011;155A: 1517-1526.
109. Le Saux O, Beck K, Sachsinger C, et al. A spectrum of ABCC6 mutations is responsible for pseudoxanthoma elasticum. *Am J Hum Genet* 2001;69: 749-764.
110. Luft FC. Pseudoxanthoma elasticum revisited. *J Mol Med* 2000;78:237-238.
111. Ghorbani AJ, Eichler C. Scurvy. *J Am Acad Dermatol* 1994;30:881-883.
112. Levine M. New concepts in the biology and biochemistry of ascorbic acid. *N Engl J Med* 1986;314:892-902.
113. Léger D. Scurvy: reemergence of nutritional deficiencies. *Can Fam Physician* 2008;54:1403-1406.
114. Schuster S, Scarbrough H. Senile purpura. *Q J Med* 1961;30:33-40.
115. Wong HY. Hypothesis: senile purpura is a prognostic feature in elderly patients. *Age Ageing* 1988;6:422-424.
116. Jennette JC, Falk RJ, Andrassy K, et al. Nomenclature of systemic vasculitides. Proposal of an international consensus conference. *Arthritis Rheum* 1994;37:187-192.

117. Koutkia P, Mylonakis E, Rounds S, et al. Leukocytoclastic vasculitis: an update for the clinician. *Scand J Rheumatol* 2001;30:315-322.
118. Stevens GL, Adelman HM, Wallach PM. Palpable purpura: an algorithmic approach. *Am Fam Physician* 1995;52:1355-1362.
119. Wintrobe MM, Buell MV. Hyperproteinemia associated with multiple myeloma: with report of a case in which an extraordinary hyperproteinemia was associated with thrombosis of the retinal veins and symptoms suggesting Raynaud's disease. *Bull Johns Hopkins Hosp* 1933;52:156-165.
120. Cohen SJ, Pittelkow MR, Su WPD. Cutaneous manifestations of cryoglobulinemia: clinical and histopathologic study of seventy-two patients. *J Am Acad Dermatol* 1991;25:21-27.
121. Waldenström J. Clinical methods for determination of hyperproteinemia and their practical value for diagnosis. *Nord Med* 1943;20:2228-2295.
122. Ferreiro JE, Pasarin G, Quesada R, et al. Benign hypergammaglobulinemic purpura of Waldenstrom associated with Sjögren's syndrome. Case report and review of immunologic aspects. *Am J Med* 1986;81:734-740.
123. Kyle RA, Gleich GJ, Bayrd ED, et al. Benign hypergammaglobulinemic purpura of Waldenström. *Medicine* 1971;50:113-123.
124. Senecal JL, Chartier S, Rothfield N. Hypergammaglobulinemic purpura in systemic autoimmune rheumatic diseases: predictive value of anti-Ro (SSA) and anti-La (SSB) antibodies and treatment with indomethacin and hydroxychloroquine. *J Rheumatol* 1995;22:868-875.
125. Hewitt P, Davies S, Cohen H, et al. Therapy of Waldenström's benign hypergammaglobulinemia by regular plasmapheresis. *Acta Haematol* 1984;71:345-349.
126. Al-Mayout SM, Ghonaïm A, Bahabri S. Hypergammaglobulinemic purpura associated with IgG subclass imbalance and recurrent infection. *Clin Rheumatol* 2000;19:499-501.
127. Venzor J, Lee WL, Huston PP. Urticarial vasculitis. *Clin Rev Allergy Immunol* 2002;23:201-216.
128. Caksen H, Odabas D, Kosen M, et al. Report of eight infants with acute infantile hemorrhagic edema and review of the literature. *J Dermatol* 2002;29:290-295.
129. Mills JA, Michel BA, Bloch DA, et al. The American College of Rheumatology 1990 criteria for the classification of Henoch-Schönlein purpura. *Arthritis Rheum* 1990;33:1114-1121.
130. Patrignelli R, Sheikh SH, Shaw-Stiffel TA. Henoch-Schönlein purpura. A multisystem disease also seen in adults. *Postgrad Med* 1995;97:123-134.
131. Saulsbury FT. Epidemiology of Henoch-Schönlein purpura. *Cleve Clin J Med* 2002;69(Suppl II):87-89.
132. Nielsen HE. Clusters or clustering of Henoch-Schönlein purpura [Letter]. *Am J Dis Child* 1990;144:620.
133. Van Hale HM, Gibson LE, Schroeter AL. Henoch-Schönlein vasculitis: direct immunofluorescence study of uninvolved skin. *J Am Acad Dermatol* 1986;15:665-670.
134. Levy M, Broyer M, Arsan A, et al. Anaphylactoid purpura nephritis in childhood: natural history and immunopathology. *Adv Nephrol Necker Hosp* 1976;6:183-228.
135. Kaufmann RH, Herrmann WA, Meyer CJ, et al. Circulating IgA-immune complexes in Henoch-Schönlein purpura. A longitudinal study of their relationship to disease activity and vascular deposition of IgA. *Am J Med* 1980;69:859-866.
136. Rueda B, Perez-Armengol C, Lopez-Lopez S, et al. Association between functional haplotypes of vascular endothelial growth factor and renal complications in Henoch-Schönlein purpura. *J Rheumatol* 2006;33:69-73.
137. Pillebout E, Thervet E, Hill G, et al. Henoch-Schönlein purpura in adults: outcome and prognostic factors. *J Am Soc Nephrol* 2002;13:1271-1278.
138. Counahan R, Winterborn MH, White RHR, et al. Prognosis of Henoch-Schönlein nephritis in children. *BMJ* 1977;2:11-14.
139. Katz S, Borst M, Seekri I, et al. Surgical evaluation of Henoch-Schönlein purpura: experience with 110 children. *Arch Surg* 1991;126:849-854.
140. Ha TS, Lee JS. Scrotal involvement in childhood Henoch-Schönlein purpura. *Acta Paediatr* 2007;96:552-555.

P.1121

141. Uppal SS, Hussain MA, A1-Raqum HA, et al. Henoch-Schönlein purpura in adults versus children/adolescents: a comparative study. *Clin Exp Rheumatol* 2006;24(2 Suppl 41):526-530.
142. Bayrakei US, Topaloglu R, Soylemezoglu O, et al. Effect of early corticosteroid therapy on development of Henoch-Schönlein nephritis. *J Nephrol* 2007;20:406-409.
143. Shenoy M, Ognjanovic MV, Coulthard MG. Treating severe Henoch-Schönlein purpura and IgA nephritis with plasmapheresis alone. *Pediatr Nephrol* 2007;22:1167-1171.
144. Gigli I, Rosen FS. Angioedema associated with complement abnormalities. In: Fitzpatrick TB, Eisen AZ, Wolff K, et al., eds. *Dermatology in general medicine*, 4th ed. New York: McGraw-Hill, 1993:1494-1500.
145. Kingston ME, Mackey D. Skin clues in the diagnosis of life-threatening infections. *Rev Infect Dis* 1986;8:1-11.
146. Brogan PA, Raffles A. The management of fever and petechiae: making sense of rash decisions. *Arch Dis Child* 2000;83:506-507.
147. Nielsen HE, Andersen EA, Anderson J, et al. Diagnostic assessment of haemorrhagic rash and fever. *Arch Dis Child* 2001;85:160-165.
148. Harms M, Feldmann R, Saurat JH. Papular-purpuric "gloves and socks" syndrome. *J Am Acad Dermatol* 1990;23:850-854.
149. Guibal F, Buffet P, Mouly F, et al. Papular-purpuric gloves and socks syndrome with hepatitis B infection. *Lancet* 1996;347:473.
150. McNeely M, Friedman J, Pope E. Generalized petechial eruption induced by parvovirus B19 infection. *J Am Acad Dermatol* 2005;52:S109-S133.
151. Aractingi S, Bakhos D, Flageul B, et al. Immunohistochemical and virological study of skin in the papular-purpura gloves and socks syndrome. *Br J Dermatol* 1996;135:599-602.
152. Gentile GA, Lang JE. Tick-borne diseases. In: Auerbach PS, ed. *Wilderness medicine*, 4th ed. St. Louis: Mosby, 2001:769-806.
153. Brazilian purpuric fever—Mato Grosso, Brazil. *MMWR Morb Mortal Wkly Rep* 1990;39:903-905.
154. Elliott SP. Rat bite fever and *Streptobacillus moniliformis*. *Clin Microbiol Rev* 2007;20:13-22.
155. Elkston DM, Czarnik K, Brackett R, et al. What's eating you? *Strongyloides stercoralis*. *Cutis* 2003;71:22-24.
156. Bank DE, Grossman ME, Kohn SR, et al. The thumbprint sign: rapid diagnosis of disseminated strongyloides. *J Am Acad Dermatol* 1990;23:324-326.
157. Chaudhary K, Smith RJ, Himelright IM, et al. Case report: purpura in disseminated strongyloidiasis. *Am J Med Sci* 1994;308:186-191.
158. Liu J-W, Lee I-K, Tang H-J, et al. Prognostic factors and antibiotics in vibrio vulnificus septicemia. *Arch Int Med* 2006;166:2117-2123.
159. Chang AK, Kim HY, Park JE, et al. *Vibrio vulnificus* secretes a broad specificity metalloprotease capable of interfering with blood hemostasis through prothrombin activation and fibrinolysis. *J Bacteriol* 2005;187:6909-6916.
160. Peters CJ, Zaki SR. Role of endothelium in viral hemorrhagic fevers. *Crit Care Med* 2002;30(Suppl):S268-S273.
161. Schittler H-J, Feldman H. Viral hemorrhagic fever—a vascular disease? *Thromb Haemost* 2003;89:967-972.
162. Bray M. Pathogenesis of viral hemorrhagic fever. *Current Opin Immunol* 2005;17:399-400.
163. Borio L, Inglesby T, Peters CJ. Hemorrhagic fever viruses as biologic weapons. Medical and public health management. *JAMA* 2002;287:2391-2405.
164. Smith SB, Arkin C. Cryofibrinogenemia: incidence, clinical correlations and a review of the literature. *Am J Clin Pathol* 1972;58:524-530.

165. Amdo TD, Welker JA. An approach to the diagnosis and treatment of cryofibrinogenemia. *Am J Med* 2003;116:332-337.
166. Klein AD, Kerdel FA. Purpura and recurrent ulcers on the lower extremities. *Arch Dermatol* 1991;127:113.
167. Beightler E, Diven DG, Sanchez RL, et al. Thrombotic vasculopathy associated with cryofibrinogenemia. *J Am Acad Dermatol* 1991;24:342-345.
168. Jantunen E, Soppi E, Neittaanmaki H, et al. Essential cryofibrinogenemia, leukocytoclastic vasculitis and chronic purpura. *J Intern Med* 1991;234: 331-333.
169. Falanga V, Kirsner RS, Eaglstein WH, et al. Stanozolol in the treatment of leg ulcers due to cryofibrinogenemia. *Lancet* 1991;338:347-348.
170. Falanga V, Fine MJ, Kapora WN. The cutaneous manifestations of cholesterol crystal embolization. *Arch Dermatol* 1986;122:1194-1198.
171. Fabian TC. Unraveling the fat emboli syndrome. *N Engl J Med* 1993;329: 961-963.
172. Schmid A, Tzur A, Leshko L, et al. Silicone embolism syndrome: a case report, review of the literature, and comparison with fat embolism syndrome. *Chest* 2005;127:2276-2281.
173. Weenig RH, Sewell LD, Davis MD, et al. Calciphylaxis: natural history, risk factor analysis and outcome. *J Am Acad Dermatol* 2007;56:569-579.
174. Hairston BR, Davis MD, Pittelkow MR, et al. Livedoid vasculopathy. Further evidence for procoagulant pathogenesis. *Arch Dermatol* 2006;142: 1413-1418.
175. Sherertz EF. Pigmented purpuric eruptions. *Semin Thromb Hemost* 1984;10:190-195.
176. Ratnam KV, Su WPD, Peters MS. Purpura simplex (inflammatory purpura without vasculitis): a clinicopathologic study of 174 cases. *J Am Acad Dermatol* 1991;25:642-647.
177. Hanna S, Walsh N, D'Initino Y, et al. Mycoses fungoides presenting as pigmented purpuric dermatitis. *Pediatr Dermatol* 2006;23:350-354.
178. Tristani-Firouzi P, Meadows KP, Vanderhooft S. Pigmented purpuric eruptions of childhood: a series of cases and review of the literature. *Pediatr Dermatol* 2001;18:299-304.
179. Krizsa J, Hunyadi J, Dobozy A. PUVA treatment of pigmented purpuric lichenoid dermatitis (Gougerot-Blum). *J Am Acad Dermatol* 1992;27:778-780.
180. Lazarov A, Cordoba M. Purpuric contact dermatitis in patients with allergic reactions to textile dyes and resins. *J Eur Acad Dermatol Venerol* 2000;14:101-105.
181. Ricks MR, Vogel PS, Elston DM. Purpuric agave dermatitis. *J Am Acad Dermatol* 1999;40(2 Pt 2):356-358.
182. Sardana K, Sarkar R, Sehgal VN. Pigmented purpuric dermatoses: an overview. *Int J Dermatol* 2004;43:482-488.
183. Gardner FH, Diamond LK. Autoerythrocyte sensitization. A form of purpura producing painful bruises following autosensitization to red blood cells in certain women. *Blood* 1955;10:675-690.
184. Ratnoff OD. The psychogenic purpuras: a review of autoerythrocyte sensitization, autosensitivity to DNA, "hysterical" and factitial bleeding and the religious stigmata. *Semin Hematol* 1980;17:192-213.
185. Ratnoff OD. Psychogenic purpura (autoerythrocyte sensitization): an unsolved dilemma. *Am J Med* 1989;87(Suppl 3N):16N-21N.
186. Silny W, Marciniak A, Czarnecka-Operacz M, et al. Gardner-Diamond syndrome. *Int J Dermatol* 2010;49:1178-1181.
187. Levin MB, Pinkus H. Autosensitivity to desoxyribonucleic acid (DNA). Report of a case with inflammatory skin lesions controlled by chloroquine. *N Engl J Med* 1961;264:533-537.
188. Little AS, Bell HE. Painful subcutaneous hemorrhages of the extremities with unusual reaction to injected deoxyribonucleic acid. *Ann Intern Med* 1964;60:886-891.
189. Pinnaas JL, Tan EM, Teplitz RL, et al. Autosensitization to DNA: evidence for an immunologic basis. *J Invest Dermatol* 1979;72:157-160.

190. Schwartz RS, Lewis FB, Dameshek W. Hemorrhagic cutaneous anaphylaxis due to autosensitization to deoxyribonucleic acid. *N Engl J Med* 1962;267:1105-1111.

Chapter 51 Thrombocytosis and Essential Thrombocythemia

> Table of Contents > Part V - Disorders of Hemostasis and Coagulation > Section 2 - Thrombocytopenia > Chapter 51 - Thrombocytosis and Essential Thrombocythemia

Chapter 51

Thrombocytosis and Essential Thrombocythemia

George M. Rodgers

Robert T. Means, Jr.

The normal reference interval for platelet counts in adults approximates 150,000 to 450,000/ μ l; patients with platelet counts higher than the upper limit of normal have thrombocytosis, which can be broadly classified as reactive (secondary), essential (clonal or primary), or inherited (Table 51.1). Routine screening of healthy individuals has identified persons with asymptomatic thrombocytosis; some of these people will have essential thrombocythemia (ET).¹ In contrast, hospitalized patients with elevated platelet counts usually have reactive thrombocytosis (RT).² At least 90% of all patients with thrombocytosis have RT due to an underlying clinical disorder.³ It is important to distinguish ET from RT or inherited thrombocytosis because patients with the former disorder may be at risk of ischemic or bleeding complications, or evolution to myelofibrosis or acute leukemia, whereas patients with the latter disorders usually require only treatment of their underlying medical condition, with minimal or no treatment in the case of inherited thrombocytosis.

REACTIVE (SECONDARY) THROMBOCYTOSIS

Epidemiology and Pathophysiology

A retrospective Turkish survey of the incidence and etiology of thrombocytosis over a 5-year period demonstrated that of 124,340 patients who had platelet counts determined, 2,000 patients (1.6%) had at least one platelet count \geq 500,000/ml.⁴ RT was identified in 96.7% of these 2,000 patients, with infection being the most common cause of RT.⁴ Another survey found that tissue injury (surgery) was the most common cause of RT.⁵

Increased thrombopoiesis seen in infectious, inflammatory, or malignant disorders results from cytokines and other acute-phase response mediators active in these circumstances. Mediators that have been linked to RT include interleukin (IL)-6⁶ and thrombopoietin (TPO).^{6, 7} TPO may act as an acute-phase protein in some, but not all circumstances.⁷ Both thrombocytosis⁸ and thrombocytopenia⁹ have been reported in iron-deficiency anemia. Patients with solid tumors (e.g., lung, ovarian cancers) have a 30% to 40% incidence of thrombocytosis.^{3, 6} Extreme thrombocytosis may occur after splenectomy³ or in patients with hyposplenism or asplenia.¹⁰

TABLE 51.1 CLASSIFICATION OF THROMBOCYTOSIS

Reactive (Secondary)	Clonal (Primary)	Inherited
Infection	Essential thrombocytosis	<i>THPO</i> mutations
Inflammation	Other myeloproliferative neoplasms:	<i>MPL</i> mutations
Malignancy	Polycythemia vera	
Iron deficiency	Chronic myeloid leukemia	
Hemolytic anemia	Myelofibrosis	
Post-splenectomy	Myelodysplasia	
Recovery from thrombocytopenia		
Tissue injury:		
Surgery		

Burns

MPL, thrombopoietin receptor gene; *THPO*, thrombopoietin gene.

Treatment

Although no trials have formally addressed the need for treating RT, the general recommendation is not to treat the elevated platelet count, either with antiplatelet or with myelosuppressive therapy.³ However, there are case reports describing thrombotic events in RT patients¹¹ and studies identifying a thrombosis risk in hospitalized patients or cancer patients with RT.¹² In general, these patients have well-established cardiovascular risk factors, such as smoking,¹¹ diabetes, older age, and the like, or they have venous thromboembolism risk factors such as cancer,¹² or as seen in a hospitalized population. One approach may be that when RT is encountered in such patients with cardiovascular risk factors, antiplatelet therapy can be considered. Hospitalized patients with RT should receive venous thromboembolism prophylaxis, and primary therapy for all RT patients should focus on treating the underlying disorder.

Inherited Thrombocytosis

Inherited thrombocytosis is suspected in patients with a lifelong history of asymptomatic thrombocytosis, especially if other family members are also affected. The genetic mutations in inherited thrombocytosis are heterogeneous and may or may not involve mutations in the thrombopoietin gene (*THPO*) or its receptor (*MPL*).³ At least four different mutations in *THPO* associated with increased TPO production and inherited thrombocytosis have been described in European and Japanese kindreds.¹³ Thrombocytosis was inherited in an autosomal dominant manner in all four families. The TPO molecule in these patients is normal, and increased translation appears to explain elevated levels of TPO in these patients.¹³ At least three different *MPL* mutations have been linked to inherited thrombocytosis; affected kindreds are of European, African-American, Arabic, and Japanese ancestry.¹³ Approximately 7% of African-Americans are heterozygous for the *MPL*-Baltimore mutation.¹⁴ Thrombocytosis in patients with *MPL* mutations appears to result from either constitutive receptor activation or reduced receptor binding affinity for TPO.¹³

Clinical findings in patients with inherited thrombocytosis can be classified by whether the patients have *THPO* or *MPL* mutations. In general, those with *THPO* mutations have elevated TPO levels and mild splenomegaly, but a low incidence of vascular complications and low risk of evolution to acute leukemia and myelofibrosis,¹³ although development of bone marrow disease was described in two family members with inherited thrombocytosis due to *THPO* mutations.¹⁵ Some patients with *MPL* mutations and inherited thrombocytosis have been reported to experience thrombosis, splenomegaly, and myelofibrosis, but these complications have not been reported in African-American patients with *MPL*-Baltimore.¹³

P.1123

Clonal Thrombocytosis Other Than Essential Thrombocytosis

Clonal or primary thrombocytosis includes not only ET (discussed later) but also a prominent feature of the other myeloproliferative neoplasms and certain myelodysplastic syndromes. Between 35% and 50% of patients with chronic myeloid leukemia (CML), polycythemia vera, or myelofibrosis may have elevated platelet counts.^{5, 16} The diagnosis, clinical aspects, and management of these disorders are discussed in Chapters 81, 82 and 83.

Clonal thrombocytosis is also seen in myelodysplastic syndromes associated with certain cytogenetic features (trisomy 8,¹⁷ 5q- syndrome,¹⁸ and chromosome 3 abnormalities¹⁹), as well as the presence of ringed sideroblasts.²⁰ However, the frequency of thrombocytosis in myelodysplasia is lower than in the myeloproliferative neoplasms. Myelodysplastic syndromes are discussed in Chapter 79.

DIFFERENTIAL DIAGNOSIS AND CLINICAL APPROACH TO THROMBOCYTOSIS

When evaluating a patient with thrombocytosis, the key consideration is to exclude ET and CML²¹ from reactive or inherited thrombocytosis and other disorders. Thrombocytosis may be a presenting feature of CML.²¹ Inasmuch as CML patients are at risk of conversion to acute leukemia, and there is targeted therapy for CML, BCR-ABL, and cytogenetic testing is important in patients with thrombocytosis who do not have inherited or reactive etiologies. Patients with RT usually will have major symptoms of an underlying inflammatory, infectious, or malignant disorder. However, patients with occult malignancy may initially present without obvious cancer symptoms. Post-splenectomy thrombocytosis will usually be obvious, but patients with asplenia or hyposplenia will be identified by observing Howell-Jolly bodies on the blood smear and by abdominal imaging showing a vestigial spleen or no splenic tissue. The World Health Organization (WHO) criteria for ET are discussed in the next section, and focus on distinguishing essential thrombocytosis from the

other myeloproliferative neoplasms. These criteria provide no direct definitions of RT. Thus, the physician is left with practical clinical criteria to suggest an RT if a patient does not have an obvious underlying disorder. Such criteria might include the presence of fever, an elevated C-reactive protein or erythrocyte sedimentation rate, a blood smear showing reactive or toxic changes in the leukocytes, the presence of iron deficiency, or the post-splenectomy state.^{3, 5}

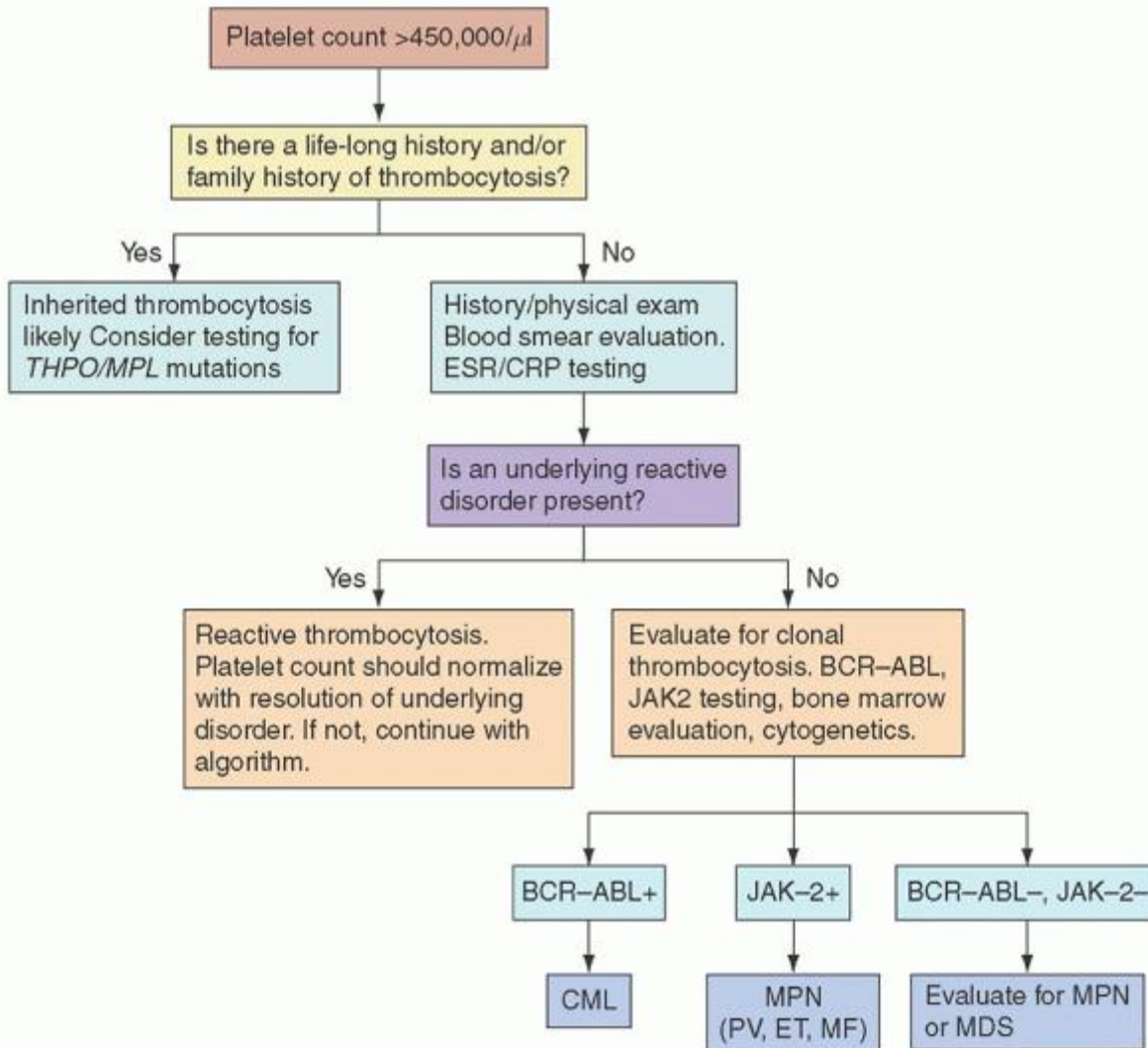

FIGURE 51.1. An approach to evaluating thrombocytosis. A life-long personal history and family history of thrombocytosis would suggest a diagnosis of inherited thrombocytosis. If that diagnosis is excluded, reactive etiologies should next be considered. If an underlying cause is identified and is treatable, thrombocytosis should resolve with appropriate therapy. If neither inherited nor reactive thrombocytosis is likely, testing for clonal thrombocytosis should be performed; this should include BCR-ABL and JAK2 testing. The appropriate tests include bone marrow evaluation and cytogenetics for myeloproliferative neoplasms and myelodysplasia. CML, chronic myeloid leukemia; CRP, C-reactive protein; ESR, erythrocyte sedimentation rate; MF, myelofibrosis; ET, essential thrombocytosis; MDS, myelodysplasia; MPL, thrombopoietin receptor gene; MPN, myeloproliferative neoplasms; PV, polycythemia vera; THPO, thrombopoietin gene.

One approach to the evaluation of thrombocytosis is shown in Figure 51.1. Inherited thrombocytosis can be rapidly excluded if there is no life-long history of thrombocytosis and the family history is negative. Patients who may possibly have inherited thrombocytosis can be further evaluated with testing for THPO and MPL mutations. Because >90% of patients with thrombocytosis will have a reactive etiology,^{3, 4, 5} significant effort should be made in excluding secondary thrombocytosis before considering testing for myeloproliferative neoplasms, including ET.

ESSENTIAL THROMBOCYTHEMIA

Definition

ET is a clonal myeloproliferative disorder characterized by excessive production of platelets that is independent of usual drivers of thrombocytosis. This thrombocytosis is in many ways analogous to the erythrocytosis characteristic of the related disorder, polycythemia vera. This “family resemblance” between what we now

P.1124

recognize as BCR/ABL-negative myeloproliferative disorders was initially pointed out by William Dameshek more than 60 years ago.²²

Epidemiology

Evolving diagnostic criteria (discussed below) make it difficult to characterize the incidence and prevalence of ET. In studies published between 2001 and 2008, an incidence of 1.5/100,000 was reported.^{23, 24} Prevalence based on insurance claims data in the northeastern United States has been reported to be 24 cases/100,000 population.²⁵ However, these reports antedate the 2008 revision of the WHO diagnostic criteria for ET, which includes a lower platelet threshold and could potentially alter the reported prevalence and incidence.

The median age at diagnosis is in the mid-50s in large reported series, and females represent 60% to 70% of cases.^{26, 27} Cases have been reported in children but are uncommon.^{28, 29, 30} First-degree relatives of ET patients have an increased risk of ET.³¹

Risk for developing ET appears to be associated with environmental factors linked to other myeloid neoplasms, such as radon and gamma irradiation.^{32, 33} Hairdressers, electricians, and farmers appear to be at increased risk to develop ET compared to other occupations, although it should be remembered that these risks are still quite low.^{32, 33}

Diagnostic Criteria

For many years, the diagnosis of ET was based on the demonstration of significant sustained thrombocytosis (typically greater than $600 \times 10^9/L$) in the absence of a reactive etiology.³⁴ However, the observation that a specific gain-of-function mutation in Janusassociated kinase 2 (JAK2V617F) is found in virtually all cases of polycythemia vera and in most cases of ET,^{35, 36} provided an additional positive criteria for the diagnosis of ET.

The 2008 revision of the WHO criteria for the diagnosis of ET is shown in Table 51.2.³⁴ The first criterion represents a reduction in the threshold for thrombocytosis from $600 \times 10^9/L$ to what is in essence the upper limit of the normal platelet count and addresses concerns that the higher threshold prevented the detection of early disease.^{37, 38, 39} The second criterion requires demonstration of the characteristic bone marrow morphology of ET.⁴⁰

As discussed earlier in this chapter, a number of other myeloid neoplasms may be associated with thrombocytosis. This is particular true when employing the lower platelet threshold of the 2008 criteria. Polycythemia vera is excluded by the absence of an elevated hematocrit or hemoglobin concentration with adequate iron stores demonstrated on a Prussian blue-stained marrow specimen or a normal serum ferritin: if iron stores are absent, a trial of iron replacement that does not elevate the hematocrit or hemoglobin above normal is required.³⁴ Primary myelofibrosis is excluded by the absence of excessive reticulin deposition on the marrow biopsy. Chronic myelogenous leukemia is excluded by the absence of the BCR/ABL mutation. Myelodysplastic syndromes and other myeloid neoplasms are excluded by absence of characteristic marrow abnormalities, such as ringed sideroblasts.⁴¹

TABLE 51.2 WORLD HEALTH ORGANIZATION DIAGNOSTIC CRITERIA FOR ESSENTIAL THROMBOCYTHEMIA

Diagnosis requires meeting all four criteria

1. Sustained platelet count $\geq 450 \times 10^9/L$
2. Bone marrow biopsy specimen showing proliferation mainly of enlarged mature megakaryocytes; no significant increase or left shift of neutrophil granulopoiesis or erythropoiesis
3. Not meeting criteria for polycythemia vera, primary myelofibrosis, chronic myelogenous leukemia, myelodysplastic syndrome, or other myeloid neoplasm (details discussed in text)
4. Demonstration of JAK2V617F or other clonal marker; or, in the absence of a clonal marker, no evidence for reactive thrombocytosis. However, the presence of a condition associated with reactive thrombocytosis does not exclude essential thrombocytosis if first three criteria are met

Modified from Tefferi et al., Proposals and rationale for revision of the World Health Organization diagnostic criteria for polycythemia vera, essential thrombocythemia, and primary myelofibrosis: recommendations from an ad hoc international expert panel. *Blood* 2007;110:1092-1097.

In the absence of the JAK2V617F mutation, exclusion of nonclonal reactive processes remains a key element of the diagnosis of ET. Etiologies of RT specifically cited in the criteria that should be excluded by history or laboratory studies include iron deficiency, previous splenectomy, recent surgery, active inflammation, connective tissue disorders, metastatic cancer, and lymphoproliferative diseases.³⁴ In polycythemia vera, mutations of JAK2 in exons other than the site of the V617F mutation have been found in a significant number of JAK2V617F-negative cases.⁴² Similar findings have not been reported for ET.

The 2008 revised criteria have generally performed well in validation studies,^{43, 44} although at least one study suggests that they function poorly in distinguishing ET from early stage primary myelofibrosis.⁴⁵ They also may be of less utility in children with ET, who are often polyclonal and JAK2V617F-negative.^{46, 47}

Pathophysiology

In polycythemia vera, in vitro studies of erythroid progenitors have shown hypersensitivity to erythropoietin or erythropoietin independence,⁴⁸ as well as hypersensitivity to other growth factors such as IL-3 or granulocyte-macrophage colony stimulating factor (GM-CSF).^{49, 50} In an analogous manner, megakaryocyte progenitors from ET patients have been reported to show a similar response pattern to IL-3, GM-CSF, and/or IL-6 in vitro.^{51, 52} Such studies provide some rationale for a proposed hypothesis that inflammation may be a driver of clonal evolution in ET.⁵³

However, the primary focus of pathophysiologic investigation in ET is on specific mutations found in myeloproliferative disorders and their contributions to its pathogenesis. The involved or potentially involved genes include JAK2, ASXL1 (additional sex combs-like 1), CBL (Casitas B-lineage lymphoma), DNMT3A (DNA methyl transferase 3α), EZH2 (enhancer of zeste homolog 2), IDH1 (isocitrate dehydrogenase 1) and IDH2, LNK (lymphocyte specific adaptor protein), the TPO receptor/ligand MPL (myeloproliferative leukemia virus), SF3B1 (splicing factor gene B1), NF1 (nuclear factor 1), SUZ12 (suppressor of zeste 2 homolog), and TET2 (ten-eleven translocation oncogene family member 2).^{54, 55, 56} Brecqueville and colleagues studied several of these genes in 53 ET patients. A total of 70% of patients had mutations in one or more of the genes studied (Table 51.3).⁵⁴

JAK2V617F is the most common mutation found in ET, and is detected in 50% to 75% of patients.^{54, 57, 58} As Table 51.3 indicates, it may occur alone or with other mutations. As noted earlier, JAK2V617F is a gain-of-function mutation resulting in constitutive activation of signaling through the JAK/STAT pathway.³⁶

Expression of JAK2V617F in hematopoietic progenitors in vitro or in whole animals leads to a myeloproliferative disorder phenotype resembling polycythemia vera.^{59, 60, 61} It has been proposed that the extent of the JAK2V617F allele burden distinguishes ET from polycythemia vera.⁶² However, JAK2 mutations do not appear to be universally present in ET, and data from other myeloproliferative disorders suggest it is a late pathogenetic event.⁶³ The precise mechanistic contributions of JAK2 mutations to ET pathogenesis, their interactions with other genes and significant hematopoietic

P.1125

proteins such as ASXL1,⁵⁵ TET2,⁶⁴ and Mpl,⁶⁵ remain to be clarified.

TABLE 51.3 FREQUENCY OF SPECIFIC GENE MUTATIONS IN 53 ESSENTIAL THROMBOCYTHEMIA PATIENTS

Gene	Percent
<i>JAK2</i> V617F	65
Isolated mutation	55
Concurrent with <i>ASXL1</i>	2
Concurrent with <i>TET2</i>	8
<i>ASXL1</i>	4
Isolated mutation	2
Concurrent with <i>JAK2</i> V617F	2

<i>CBL</i>	2
<i>SF3B1</i>	2
<i>TET2</i>	8
Concurrent with <i>JAK2V617F</i>	8

DNMT3A, *IDH1*, *IDH2*, *MPL*, *NF1*, and *SUZ12* mutations were not found in ET patients, although *MPL* and *SUZ12* mutations were detected in post-ET myelofibrosis patients.

Abbreviations per text.

Data from Brecqueville et al., Mutation analysis of *ASXL1*, *CBL*, *DNMT3A*, *IDH1*, *IDH2*, *JAK2*, *MPL*, *NF1*, *SF3B1*, *SUZ12*, and *TET2* in myeloproliferative neoplasms. *Genes Chromosomes Cancer* 2012;51:743-755.

Clinical and Laboratory Features

Most ET patients are asymptomatic at time of presentation,⁴⁴ although some may be diagnosed after a thrombotic event or in the course of evaluation of vasomotor symptoms such as dizziness and headache, which may reflect vascular occlusion.^{66, 67} Erythromelalgia (burning dysesthesia in the fingers or toes relieved almost instantly by aspirin) is a characteristic symptom of myeloproliferative thrombocytosis, whether from ET or polycythemia vera.⁶⁸ Distal ischemia ("blue toes syndrome"⁶⁹) and cutaneous changes such as livedo reticularis or ulceration⁷⁰ are occasionally found; frank limb gangrene is fortunately rare.^{71, 72}

Presenting blood counts and physical examination results from three series are shown in Table 51.4.^{27, 44, 66} Although hemoglobin concentration and white blood cell counts are typically normal, anemia and/or leukocytosis $> 15 \times 10^9/L$ may be found in 15% to 20% of patients.²⁷ The white blood cell differential is usually normal but may show the basophilia, eosinophilia, or left-shift characteristic of myeloproliferative disorders. Splenomegaly, whether palpable or radiographic, is found in fewer than 25% of cases without transformation to myelofibrosis.^{27, 44, 66}

The characteristic bone marrow feature is proliferation of large, mature-appearing megakaryocytes (Fig. 51.2). Marrow cellularity is increased in approximately a third of cases,⁴⁴ but is otherwise normal. The presence of significant reticulin deposition, dyserythropoiesis, or dysmyelopoiesis should raise suspicion for other diagnoses.

Patients with ET exhibit evidence of aspirin-reversible increased platelet activation in vivo (increased circulating levels of beta thromboglobulin, platelet factor 4, and thrombomodulin and increased urinary thromboxane B2 excretion), whereas paradoxically exhibiting defective platelet function in vitro, both by classic platelet aggregation or platelet function analyzer (PFA)-100 studies.^{73, 74, 75} Some ET patients with platelet counts $> 1,000 \times 10^9/L$ develop a bleeding diathesis due to an acquired type 2 von Willebrand syndrome which is reversed by platelet reduction.⁷³

TABLE 51.4 CLINICAL AND LABORATORY FEATURES OF ESSENTIAL THROMBOCYTHEMIA PATIENTS FROM THREE SERIES

	USA ²⁷	Spain ⁴⁴	Japan ⁶⁶
<i>N</i>	585 ^a	92	381
Age, years	57	51	58
Female/male, %	66/34	65/35	55/45
White blood count, $\times 10^9/L$	8.6	9.6	11.3
Hemoglobin, g/dl	13.9	14.4	13.6
Platelet Count, $\times 10^9/L$	1,000	711	1,066
Splenomegaly present, %	23	18	11

Median values from the USA and Spanish series; mean values from Japanese series.

^a Patients with leukemic transformation excluded.

Natural History and Prognosis

The median overall survival of ET patients appears to exceed 22 years and does not significantly differ from that of the age-adjusted general population (Fig. 51.3).²⁶ A plurality (40%) of deaths is unrelated to ET; the next greatest contributor is thrombosis (26%). Solid tumors (14%) are the next most common cause of death, followed by leukemia, either de novo or post-myelofibrotic (8%) and myelofibrosis (4%).²⁶ Compared to polycythemia vera patients, the 15-year cumulative risks of thrombosis (27% vs. 17%), leukemia (7% vs. 2%) and myelofibrosis (6% vs. 4%) are lower in ET patients.²⁶

Reported risk factors for overall survival include age >60 years, history of thrombosis, anemia, and leukocytosis $>15 \times 10^9/L$; age, anemia, and platelet count $>1,000 \times 10^9/L$, are reported risk factors for leukemic transformation.²⁷ Studies have reported that JAK2V617F-negative ET patients have a lower arterial thrombotic risk than JAK2V617F-positive ET patients.⁷⁶ In contrast, the JAK2V617F allele burden itself may or may not predict a greater thrombotic diathesis.^{76, 77} Among JAK2V617F-negative ET patients, the presence of other markers of clonality such as mutations in human androgen receptor (HUMARA), TET2, ASXL1, or MPL, predicts an increased thrombotic risk.⁷⁸

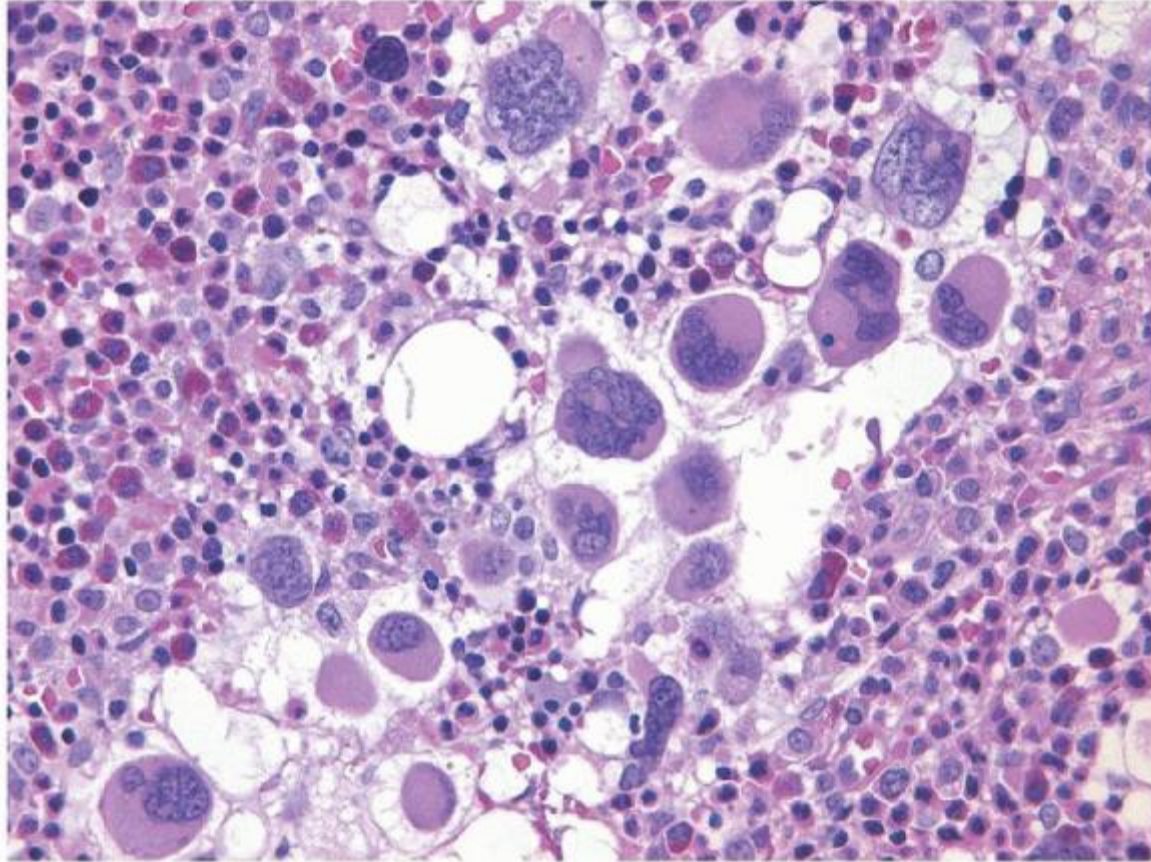

FIGURE 51.2. Characteristic megakaryocyte proliferation in a marrow specimen from an essential thrombocythemia (ET) patient.

P.1126

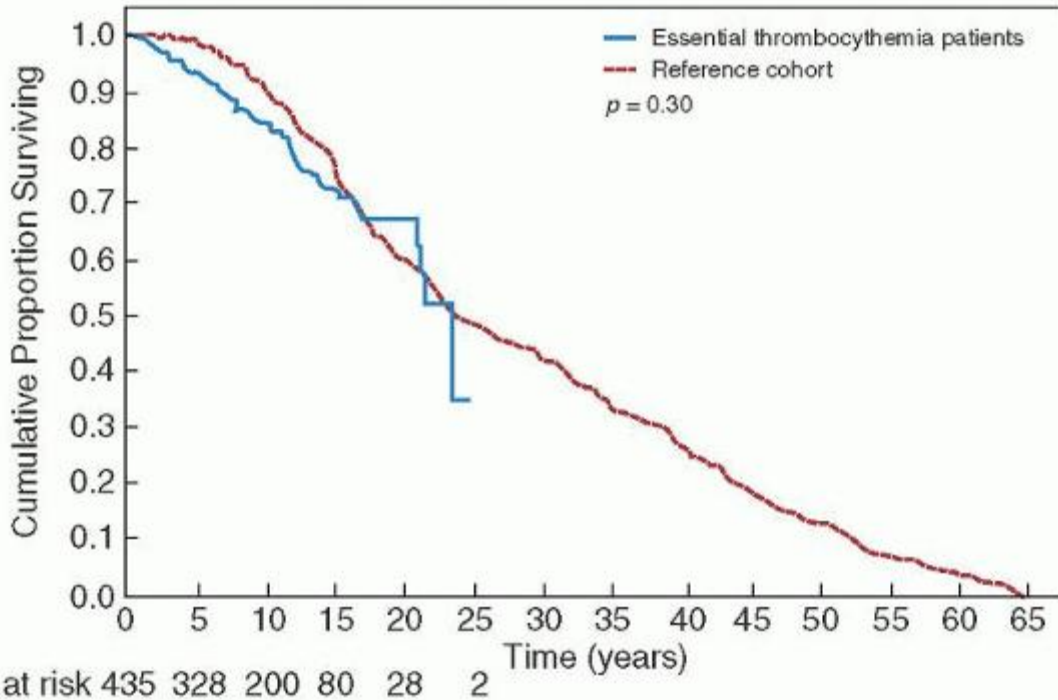

FIGURE 51.3. Survival curves of 435 patients with essential thrombocythemia, compared with life expectancy of the general population. From Passamonti et al., Life expectancy and prognostic factors for survival in patients with polycythemia vera and essential thrombocythemia. *Am J Med* 2004;117:755-761, with permission.

The standard model for thrombotic risk in ET has two components: age >60 years and history of thrombosis. The absence of both denotes low risk, and the presence of either denotes a high risk of thrombosis.⁷⁹ A model proposed more recently, the International Prognostic Score for ET-thrombosis (IPSET-thrombosis), incorporates the two elements of the standard model as well as the presence of cardiovascular risk factors and JAK2V617F mutation status.⁸⁰ The IPSET-thrombosis model defines low, intermediate, and high risk categories. Approximately half the patients in the low risk category from the standard model are relocated to the intermediate category in the IPSET-thrombosis model, whereas the standard model high risk patients are distributed essentially evenly between the three IPSET-thrombosis categories.⁸⁰ The two models are outlined in Table 51.5.

TREATMENT

The goal of treatment in ET is the prevention of thrombotic events, the primary cause of morbidity and mortality.²⁶ Therefore, treatment strategy is based on thrombotic risk stratification.^{79, 81, 82} At present, only the standard risk stratification model has been validated as a guide to therapy. Low risk patients can be managed with low dose aspirin or, under some circumstances, observation only. Cytoreduction of the platelet count is recommended for high risk patients.^{81, 82}

TABLE 51.5 PROGNOSTIC MODELS FOR THROMBOTIC RISK IN ESSENTIAL THROMBOCYTHEMIA

Standard Model⁷⁹

Age > 60 years

History of thrombosis

Low risk: Neither factor

High risk: One or both factors

IPSET-Thrombosis Model⁸⁰

Age > 60 years

1 point

Cardiovascular risk factors^a

1 point

History of thrombosis	2 points
<i>JAK2V617F</i> mutation present	2 points
Low risk: 0 or 1 point	
Intermediate risk: 2 points	
High risk: ≥ 3 points	

^a Cardiovascular risk factors include diabetes, hypertension, and/or tobacco use.

The IPSET-thrombosis model has not been prospectively validated as a guide to therapy, but the developers of the model have suggested that cytoreductive therapy be considered in any patient with a history of thrombosis and in older patients with cardiovascular risk factors and/or *JAK2V617F* mutation. Aspirin therapy is recommended for younger patients without a thrombosis history but with either cardiovascular risk factors and/or *JAK2V617F* mutation.⁸⁰

The bleeding associated with acquired von Willebrand syndrome in ET can be resolved by reduction of the platelet count to a value approximating normal.⁸³

Aspirin

Aspirin therapy, usually at 100 mg/day or less, is generally well tolerated in ET patients, with a low risk of bleeding.⁸⁴ Antiplatelet agents such as aspirin reduce the risk of venous thrombosis in ET patients with the *JAK2V617F* mutation, and the risk of arterial thrombosis in patients with cardiovascular risk factors. Its benefits in other low risk patients are unclear.⁸⁵ Aspirin and antiplatelet agents should be avoided in patients with a history of bleeding. Although markedly elevated platelet counts are not a risk factor per se for aspirin-induced bleeding,⁸⁵ acquired von Willebrand syndrome may be unmasked by aspirin in patients with platelet counts greater than $1,000 \times 10^9/L$.⁷³ Many physicians regard it as prudent to assess von Willebrand factor activity prior to initiating aspirin in such patients.⁸³

Cytoreductive Therapy

Hydroxyurea

Hydroxyurea is considered the first-line cytoreductive agent in ET.^{81, 82, 86, 87} Some of the beneficial effects of hydroxyurea in ET and other myeloproliferative disorders may reflect reduction of leukocytosis and leukocyte-platelet interaction.⁸⁸ The extent to which hydroxyurea reduces *JAK2V617F* expression in ET patients is disputed.^{89, 90, 91, 92}

Anagrelide

The platelet-reducing drug anagrelide is a reasonable second choice for patients intolerant of, or unresponsive to, hydroxyurea.^{93, 94} As a first-line agent in ET, anagrelide has been reported to be non-inferior to hydroxyurea.⁹⁵ Unlike hydroxyurea, it does not affect leukocytosis.

Interferon

Administration of recombinant interferon can also be considered in patients refractory to hydroxyurea or to both hydroxyurea and anagrelide.^{96, 97, 98} The systemic side effects and need for subcutaneous injection limit its acceptability to some patients.⁹⁹ High risk pregnant females with ET can be successfully managed with interferon.¹⁰⁰

Other Agents/Modalities

Busulphan is an agent of established efficacy in myeloproliferative disorders such as ET,^{82, 101} however, its risk profile as an alkylating agent makes it less attractive than hydroxyurea, anagrelide, or interferon. Apheresis can be utilized to obtain rapid reduction in the platelet count in emergencies associated with severe thrombocytosis such as bleeding with acquired von Willebrand syndrome or limb gangrene or in preparation for surgery, but should be

P.1127

accompanied by cytoreductive drugs.⁸³ *JAK2* inhibitors currently available appear to be of primary benefit in post-ET myelofibrosis rather than in ET itself.

Post-essential Thrombocythemia Myelofibrosis

Myelofibrosis may be a late complication of ET, with an incidence of approximately 1.6 per thousand person-years of follow-up and is the cause of death in approximately 4% of ET patients.²⁶ Patients may develop transfusion-dependent anemia and/or thrombocytopenia, and symptomatic splenomegaly. *JAK2* inhibitors appear to have benefit in the

management of cytopenias and splenomegaly in myelofibrosis.^{102, 103, 104} In general, management follows the pattern outlined for primary myelofibrosis in Chapter 83.

REFERENCES

1. Jensen MK, de Nully Brown P, Nielsen OJ, Hasselbalch HC. Incidence, clinical features and outcome of essential thrombocythaemia in a well defined geographical area. *Eur J Haematol* 2000;65(2):132-139.
2. Buss DH, Cashell AW, O'Connor ML, Richards F 2nd, Case LD. Occurrence, etiology, and clinical significance of extreme thrombocytosis: a study of 280 cases. *Am J Med* 1994;96:247-253.
3. Vannucchi AM, Barbui T. Thrombocytosis and thrombosis. Hematology/the education program of the American society of hematology. *Am Soc Hematol. Educ Program* 2007;363-370.
4. Aydogan T, Kanbay M, Alici O, Kosar A. Incidence and etiology of thrombocytosis in an adult Turkish population. *Platelets* 2006;17(5):328-331.
5. Griesshammer M, Bangerter M, Sauer T, Wennauer R, Bergmann L, Heimpel H. Aetiology and clinical significance of thrombocytosis: analysis of 732 patients with an elevated platelet count. *J Intern Med* 1999;245(3):295-300.
6. Stone RL, Nick AM, McNeish IA, et al. Paraneoplastic thrombocytosis in ovarian cancer. *N Engl J Med* 2012;366(7):610-618.
7. Ceresa IF, Noris P, Ambaglio C, Pecci A, Balduini CL. Thrombopoietin is not uniquely responsible for thrombocytosis in inflammatory disorders. *Platelets* 2007;18(8):579-582.
8. Kulnigg-Dabsch S, Evstatiev R, Dejaco C, Gasche C. Effect of iron therapy on platelet counts in patients with inflammatory bowel disease-associated anemia. *PloS one* 2012;7(4):e34520.
9. Ibrahim R, Khan A, Raza S, et al. Triad of iron deficiency anemia, severe thrombocytopenia and menorrhagia-a case report and literature review. *Clin Med Insights. Case Rep* 2012;5:23-27.
10. Imashuku S, Kudo N, Kubo K, Takahashi N, Tohyama K. Persistent thrombocytosis in elderly patients with rare hyposplenias that mimic essential thrombocythemia. *Int J Hematol* 2012;95(6):702-705.
11. Ghaffari S, Pourafkari L. Acute myocardial infarction in a patient with postsplenectomy thrombocytosis: a case report and review of literature. *Cardiol J* 2010;17(1):79-82.
12. Zecchina G, Ghio P, Bosio S, Cravino M, Camaschella C, Scagliotti GV. Reactive thrombocytosis might contribute to chemotherapy-related thrombophilia in patients with lung cancer. *Clin Lung Cancer* 2007;8(4):264-267.
13. Teofili L, Larocca LM. Advances in understanding the pathogenesis of familial thrombocythaemia. *Br J Haematol* 2011;152(6):701-712.
14. Moliterno AR, Williams DM, Gutierrez-Alamillo LI, Salvatori R, Ingersoll RG, Spivak JL. Mpl Baltimore: a thrombopoietin receptor polymorphism associated with thrombocytosis. *Proc Natl Acad Sci U S A* 2004;101(31): 11444-11447.
15. Posthuma HL, Skoda RC, Jacob FA, van der Maas AP, Valk PJ, Posthuma EF. Hereditary thrombocytosis not as innocent as thought? Development into acute leukemia and myelofibrosis. *Blood* 2010;116(17):3375-3376.
16. Tefferi A. Essential thrombocythemia and thrombocytosis. In: Greer JP, Foerster J, Rodgers GM, et al., eds. *Wintrobe's clinical hematology*, 12 ed. Philadelphia: Lippincott Williams & Wilkins, 2009:1352-1360.
17. Patel K, Kelsey P. Primary acquired sideroblastic anemia, thrombocytosis, and trisomy 8. *Ann Hematol* 1997;74(4):199-201.
18. Brusamolino E, Orlandi E, Morra E, et al. Hematologic and clinical features of patients with chromosome 5 monosomy or deletion (5q). *Med Pediatr Oncol* 1988;16(2):88-94.
19. Jenkins RB, Tefferi A, Solberg LA Jr, Dewald GW. Acute leukemia with abnormal thrombopoiesis and inversions of chromosome 3. *Cancer Genet Cytogenet* 1989;39(2):167-179.
20. Cabello AI, Collado R, Ruiz MA, et al. A retrospective analysis of myelodysplastic syndromes with thrombocytosis: reclassification of the cases by WHO proposals. *Leuk Res* 2005;29(4):365-370.
21. Rice L, Popat U. Every case of essential thrombocythemia should be tested for the Philadelphia chromosome. *Am J Hematol* 2005;78(1):71-73.
22. Dameshek W. Editorial: some speculations on the myeloproliferative syndromes. *Blood* 1951;6(4):372-375.

23. Kutti J, Ridell B. Epidemiology of the myeloproliferative disorders: essential thrombocythaemia, polycythaemia vera and idiopathic myelofibrosis. *Pathol Biol (Paris)* 2001;49(2):164-166.
24. Johansson P. Epidemiology of the myeloproliferative disorders polycythemia vera and essential thrombocythemia. *Semin Thromb Hemost* 2006;32(3): 171-173.
25. Ma X, Vanasse G, Cartmel B, Wang Y, Selinger HA. Prevalence of polycythemia vera and essential thrombocythemia. *Am J Hematol* 2008;83(5): 359-362.
26. Passamonti F, Rumi E, Pungolino E, et al. Life expectancy and prognostic factors for survival in patients with polycythemia vera and essential thrombocythemia. *Am J Med* 2004;117(10):755-761.
27. Gangat N, Wolanskyj AP, McClure RF, et al. Risk stratification for survival and leukemic transformation in essential thrombocythemia: a single institutional study of 605 patients. *Leukemia* 2007;21(2):270-276.
28. Randi ML, Putti MC, Fabris F, Sainati L, Zanesco L, Girolami A. Features of essential thrombocythaemia in childhood: a study of five children. *Br J Haematol* 2000;108(1):86-89.
29. Dame C, Sutor AH. Primary and secondary thrombocytosis in childhood. *Br J Haematol* 2005;129(2):165-177.
30. Giona F, Teofili L, Moleti ML, et al. Thrombocythemia and polycythemia in patients younger than 20 years at diagnosis: clinical and biologic features, treatment, and long-term outcome. *Blood* 2012;119(10):2219-2227.
31. Landgren O, Goldin LR, Kristinsson SY, Helgadóttir EA, Samuelsson J, Björkholm M. Increased risks of polycythemia vera, essential thrombocythemia, and myelofibrosis among 24 577 first-degree relatives of 11 039 patients with myeloproliferative neoplasms in Sweden. *Blood* 2008;112(6):2199-2204.
32. Falcetta R, Sacerdote C, Bazzan M, et al. Occupational and environmental risk factors for essential thrombocythemia: a case-control study. *Giornale italiano di medicina del lavoro ed ergonomia* 2003;25(Suppl 3):9-12.
33. Mele A, Visani G, Pulsoni A, et al. Risk factors for essential thrombocythemia: a case-control study. Italian Leukemia Study Group. *Cancer* 1996;77(10):2157-2161.
34. Tefferi A, Thiele J, Orazi A, et al. Proposals and rationale for revision of the World Health Organization diagnostic criteria for polycythemia vera, essential thrombocythemia, and primary myelofibrosis: recommendations from an ad hoc international expert panel. *Blood* 2007;110:1092-1097.
35. Levine RL, Wadleigh M, Cools J, et al. Activating mutation in the tyrosine kinase JAK2 in polycythemia vera, essential thrombocythemia, and myeloid metaplasia with myelofibrosis. *Cancer Cell* 2005;7(4):387-397.
36. Kralovics R, Passamonti F, Buser AS, et al. A gain-of-function mutation of JAK2 in myeloproliferative disorders. *N Engl J Med* 2005;352(17): 1779-1790.
37. Thiele J, Kvasnicka HM. A critical reappraisal of the WHO classification of the chronic myeloproliferative disorders. *Leuk Lymphoma* 2006;47(3): 381-396.
38. Ruggeri M, Tosetto A, Frezzato M, Rodeghiero F. The rate of progression to polycythemia vera or essential thrombocythemia in patients with erythrocytosis or thrombocytosis. *Ann Intern Med* 2003;139:470-475.
39. Lengfelder E, Hochhaus A, Kronawitter U, et al. Should a platelet limit of $600 \times 10^9/l$ be used as a diagnostic criterion in essential thrombocythaemia? An analysis of the natural course including early stages. *Br J Haematol* 1998;100(1):15-23.
40. Thiele J, Zankovich R, Schneider G, Kremer B, Fischer R, Diehl V. Primary (essential) thrombocythemia versus polycythemia vera rubra. A histomorphometric analysis of bone marrow features in trephine biopsies. *Anal Quant Cytol Histol* 1988;10(5):375-382.
41. Cheng DS, Kushner JP, Wintrobe MM. Idiopathic refractory sideroblastic anemia: incidence and risk factors for leukemic transformation. *Cancer* 1979;44(2):724-731.
42. Pardanani A, Lasho TL, Finke C, Hanson CA, Tefferi A. Prevalence and clinicopathologic correlates of JAK2 exon 12 mutations in JAK2V617F-negative polycythemia vera. *Leukemia* 2007;21:1960-1963.
43. Kondo T, Okuno N, Naruse H, et al. Validation of the revised 2008 WHO diagnostic criteria in 75 suspected cases of myeloproliferative neoplasm. *Leuk Lymphoma* 2008;49(9):1784-1791.
44. Kwon M, Osorio S, Munoz C, Sanchez JM, Buno I, Diez-Martin JL. Essential thrombocythemia in patients with platelet counts below $600 \times 10^9/l$: applicability of the 2008 World Health Organization diagnostic criteria revision proposal. *Am J Hematol* 2009;84(7):452-454.

45. Buhr T, Hebeda K, Kaloutsi V, Porwit A, Van der Walt J, Kreipe H. European bone marrow working group trial on reproducibility of World Health Organization criteria to discriminate essential thrombocythemia from prefibrotic primary myelofibrosis. *Haematologica* 2012;97(3):360-365.
46. Randi ML, Putti MC, Scapin M, et al. Pediatric patients with essential thrombocythemia are mostly polyclonal and V617F/JAK2 negative. *Blood* 2006;108(10):3600-3602.
47. Teofili L, Giona F, Martini M, et al. The revised WHO diagnostic criteria for Ph-negative myeloproliferative diseases are not appropriate for the diagnostic screening of childhood polycythemia vera and essential thrombocythemia. *Blood* 2007;110(9):3384-3386.
48. Cashman J, Henkelmann D, Humphries K, Eaves C, Eaves A. Individual BFU-E in polycythemia vera produce both erythropoietin dependent and independent progeny. *Blood* 1983;61:876-884.
49. Dai CH, Krantz SB, Means RT Jr, Horn ST, Gilbert HS. Increased sensitivity of polycythemia vera burst-forming units-erythroid to interleukin-3. *Trans Assoc Am Phys* 1990;103:249-257.
50. Dai CH, Krantz SB, Dessypris EN, Means RT Jr, Horn ST, Gilbert HS. Polycythemia vera. II. Hypersensitivity of bone marrow erythroid, granulocyte-macrophage, and megakaryocyte progenitor cells to interleukin-3 and granulocyte-macrophage colony-stimulating factor. *Blood* 1992;80(4):891-899.
51. Li Y, Hetet G, Maurer AM, Chait Y, Dhermy D, Briere J. Spontaneous megakaryocyte colony formation in myeloproliferative disorders is not neutralizable by antibodies against IL3, IL6 and GM-CSF. *Br J Haematol* 1994;87(3):471-476.
52. Kobayashi S, Teramura M, Hoshino S, Motoji T, Oshimi K, Mizoguchi H. Circulating megakaryocyte progenitors in myeloproliferative disorders are hypersensitive to interleukin-3. *Br J Haematol* 1993;83(4):539-544.
53. Hasselbalch HC. Perspectives on chronic inflammation in essential thrombocythemia, polycythemia vera, and myelofibrosis: is chronic inflammation a trigger and driver of clonal evolution and development of accelerated atherosclerosis and second cancer? *Blood* 2012;119(14):3219-3225.
54. Brecqueville M, Rey J, Bertucci F, et al. Mutation analysis of ASXL1, CBL, DNMT3A, IDH1, IDH2, JAK2, MPL, NF1, SF3B1, SUZ12, and TET2 in myeloproliferative neoplasms. *Genes Chromosomes Cancer* 2012;51(8):743-755.
55. Stein BL, Williams DM, O'Keefe C, et al. Disruption of the ASXL1 gene is frequent in primary, post-essential thrombocytosis and post-polycythemia vera myelofibrosis, but not essential thrombocytosis or polycythemia vera: analysis of molecular genetics and clinical phenotypes. *Haematologica* 2011;96(10):1462-1469.
56. Pardanani A, Lasho TL, Finke CM, Tefferi A. Infrequent occurrence of MPL exon 10 mutations in polycythemia vera and post-polycythemia vera myelofibrosis. *Am J Hematol* 2011;86(8):701-702.
57. Schafer AI. Molecular basis of the diagnosis and treatment of polycythemia vera and essential thrombocythemia. *Blood* 2006;107(11):4214-4222.
58. Lippert E, Boissinot M, Kralovics R, et al. The JAK2-V617F mutation is frequently present at diagnosis in patients with essential thrombocythemia and polycythemia vera. *Blood* 2006;108(6):1865-1867.
59. Lacout C, Pisani DF, Tulliez M, Gachelin FM, Vainchenker W, Villeval JL. JAK2V617F expression in murine hematopoietic cells leads to MPD mimicking human PV with secondary myelofibrosis. *Blood* 2006;108(5): 1652-1660.
60. Bumm TG, Elsea C, Corbin AS, et al. Characterization of murine JAK2V617F-positive myeloproliferative disease. *Cancer Res* 2006;66(23): 11156-11165.
61. Zaleskas VM, Krause DS, Lazarides K, et al. Molecular pathogenesis and therapy of polycythemia induced in mice by JAK2 V617F. *PLoS One* 2006;1:e18.
62. Larsen TS, Pallisgaard N, Moller MB, Hasselbalch HC. The JAK2 V617F allele burden in essential thrombocythemia, polycythemia vera and primary myelofibrosis—impact on disease phenotype. *Eur J Haematol* 2007;79(6):508-515.
63. Kralovics R, Teo SS, Li S, et al. Acquisition of the V617F mutation of JAK2 is a late genetic event in a subset of patients with myeloproliferative disorders. *Blood* 2006;108(4):1377-1380.
64. Tefferi A, Pardanani A, Lim KH, et al. TET2 mutations and their clinical correlates in polycythemia vera, essential thrombocythemia and myelofibrosis. *Leukemia* 2009;23:905-1011.

65. Moliterno AR, Williams DM, Rogers O, Spivak JL. Molecular mimicry in the chronic myeloproliferative disorders: reciprocity between quantitative JAK2 V617F and Mpl expression. *Blood* 2006;108(12):3913-3915.
66. Dan K, Yamada T, Kimura Y, et al. Clinical features of polycythemia vera and essential thrombocythemia in Japan: retrospective analysis of a nationwide survey by the Japanese elderly leukemia and lymphoma study group. *Int J Hematol* 2006;83(5):443-449.
67. Smalberg JH, Arends LR, Valla DC, Kiladjian JJ, Janssen HL, Leebeek FW. Myeloproliferative neoplasms in Budd-Chiari syndrome and portal vein thrombosis: a meta-analysis. *Blood* 2012;120(25):4921-4928.
68. Michiels JJ, Berneman Z, Schroyens W, et al. Platelet-mediated erythromelalgic, cerebral, ocular and coronary microvascular ischemic and thrombotic manifestations in patients with essential thrombocythemia and polycythemia vera: a distinct aspirin-responsive and coumadin-resistant arterial thrombophilia. *Platelets* 2006;17(8):528-544.
69. Gerry JL Jr, Persich D, Gumbart CH, Schramel RJ. Primary thrombocythemia: another cause of the "blue toe syndrome". *J La State Med Soc* 1986;138(4):38-40.
70. Itin PH, Winkelmann RK. Cutaneous manifestations in patients with essential thrombocythemia. *J Am Acad Dermatol* 1991;24(1):59-63.
71. Preston FE, Emmanuel IG, Winfield DA, Malia RG. Essential thrombocythaemia and peripheral gangrene. *Br Med J* 1974;3(5930):548-552.
72. Fernando EA, Senanayake B, Sivakumaran S. Essential thrombocythemia: an uncommon cause of digital gangrene. *Ceylon Med J* 1998;43(1):34-35.
73. Michiels JJ, Berneman ZN, Schroyens W, Van Vliet HH. Pathophysiology and treatment of platelet-mediated microvascular disturbances, major thrombosis and bleeding complications in essential thrombocythaemia and polycythaemia vera. *Platelets* 2004;15(2):67-84.
74. Cesar JM, de Miguel D, Garcia Avello A, Burgaleta C. Platelet dysfunction in primary thrombocythemia using the platelet function analyzer, PFA-100. *Am J Clin Pathol* 2005;123(5):772-777.
75. Tsantes AE, Dimoula A, Bonovas S, et al. The role of the Platelet Function Analyzer (PFA)-100 and platelet aggregometry in the differentiation of essential thrombocythemia from reactive thrombocytosis. *Thromb Res* 2010;125(2):142-146.
76. Larsen TS, Pallisgaard N, Moller MB, Hasselbalch HC. High prevalence of arterial thrombosis in JAK2 mutated essential thrombocythaemia: independence of the V617F allele burden. *Hematology* 2008;13(2):71-76.
77. Zhang S, Qiu H, Fischer BS, et al. JAK2 V617F patients with essential thrombocythemia present with clinical features of polycythemia vera. *Leuk Lymphoma* 2008;49(4):696-699.
78. Martinez-Aviles L, Alvarez-Larran A, Besses C, et al. Clinical significance of clonality assessment in JAK2V617F-negative essential thrombocythemia. *Ann Hematol* 2012;91:1-8.
79. Passamonti F. Prognostic factors and models in polycythemia vera, essential thrombocythemia, and primary myelofibrosis. *Clin Lymphoma, Myeloma Leuk* 2011;11(Suppl 1):S25-S27.
80. Barbui T, Finazzi G, Carobbio A, et al. Development and validation of an International Prognostic Score of thrombosis in World Health Organization-essential thrombocythemia (IPSET-thrombosis). *Blood* 2012;120(26): 5128-5133.
81. Tefferi A. Polycythemia vera and essential thrombocythemia: 2012 update on diagnosis, risk stratification, and management. *Am J Hematol* 2012;87(3):285-293.
82. Barbui T, Finazzi MC, Finazzi G. Front-line therapy in polycythemia vera and essential thrombocythemia. *Blood Rev* 2012;26:205-211.
83. Elliott MA, Tefferi A. Pathogenesis and management of bleeding in essential thrombocythemia and polycythemia vera. *Curr Hematol Rep* 2004;3(5): 344-351.
84. Finazzi G, Carobbio A, Thiele J, et al. Incidence and risk factors for bleeding in 1104 patients with essential thrombocythemia or prefibrotic myelofibrosis diagnosed according to the 2008 WHO criteria. *Leukemia* 2012;26(4): 716-719.
85. Alvarez-Larran A, Cervantes F, Pereira A, et al. Observation versus anti-platelet therapy as primary prophylaxis for thrombosis in low-risk essential thrombocythemia. *Blood* 2010;116(8):1205-1210, quiz 1387.

86. Carobbio A, Finazzi G, Antonioli E, et al. Hydroxyurea in essential thrombocythemia: rate and clinical relevance of responses by European LeukemiaNet criteria. *Blood* 2010;116:1051.
87. Dingli D, Tefferi A. Hydroxyurea: the drug of choice for polycythemia vera and essential thrombocythemia. *Curr Hematol Malignancy Rep* 2006;1(2):69-74.
88. Trelinski J, Tybura M, Smolewski P, Robak T, Chojnowski K. The influence of low-dose aspirin and hydroxyurea on platelet-leukocyte interactions in patients with essential thrombocythemia. *Blood Coagul Fibrinolysis* 2009;20(8):646-651.
89. Latagliata R, Rago A, Spadea A, et al. Decisional flow with a scoring system to start platelet-lowering treatment in patients with essential thrombocythemia: long-term results. *Int J Hematol* 2009;90(4):486-491.
90. Antonioli E, Carobbio A, Pieri L, et al. Hydroxyurea does not appreciably reduce JAK2 V617F allele burden in patients with polycythemia vera or essential thrombocythemia. *Haematologica* 2010;95(8):1435-1438.
91. Zalcberg IR, Ayres-Silva J, de Azevedo AM, Solza C, Daumas A, Bonamino M. Hydroxyurea dose impacts hematologic parameters in polycythemia vera and essential thrombocythemia but does not appreciably affect JAK2-V617F allele burden. *Haematologica* 2011;96(3):e18-e20.
92. Besses C, Alvarez-Larran A, Martinez-Aviles L, et al. Modulation of JAK2 V617F allele burden dynamics by hydroxycarbamide in polycythaemia vera and essential thrombocythaemia patients. *Br J Haematol* 2011;152(4): 413-419.
93. Petitt RM, Silverstein MN, Petrone ME. Anagrelide for control of thrombocythemia in polycythemia and other myeloproliferative disorders. *Semin Hematol* 1997;34(1):51-54.
94. Finazzi G, Barbui T. Evidence and expertise in the management of polycythemia vera and essential thrombocythemia. *Leukemia* 2008;22(8):1494-1502.
95. Gisslinger H, Gotic M, Holowiecki J, et al. Anagrelide compared with hydroxyurea in WHO-classified essential thrombocythemia: the ANAHYDRET Study, a randomized controlled trial. *Blood* 2013;121:1720-1728.
96. Giles FJ. Maintenance therapy in the myeloproliferative disorders: the current options. *Br J Haematol* 1991;79(Suppl 1):92-95.
97. Silver RT. Long-term effects of the treatment of polycythemia vera with recombinant interferon-alpha. *Cancer* 2006;107(3):451-458.
98. Quintas-Cardama A, Kantarjian H, Manshour T, et al. Pegylated interferon alfa-2a yields high rates of hematologic and molecular response in patients with advanced essential thrombocythemia and polycythemia vera. *J Clin Oncol* 2009;27(32):5418-5424.
99. Merup M, Aberg W, Lofvenberg E, et al. Symptoms, symptom distress and health-related quality of life in patients with polycythaemia vera or essential thrombocythaemia during treatment with interferon-alpha. *Acta Oncol* 2002;41(1):50-55.
100. Elliott MA, Tefferi A. Interferon-alpha therapy in polycythemia vera and essential thrombocythemia. *Semin Thromb Hemost* 1997;23:463-472.
101. Epstein IS. The treatment of Polycythemia vera and thrombocythemia with myleran (busulphan). *Isr J Med Sci* 1965;1(4):797-799.
102. Mesa RA. How I treat symptomatic splenomegaly in patients with myelofibrosis. *Blood* 2009;113(22):5394-5400.
103. Verstovsek S, Kantarjian H, Mesa RA, et al. Safety and efficacy of INCB018424, a JAK1 and JAK2 inhibitor, in myelofibrosis. *N Engl J Med* 2010;363(12):1117-1127.
104. Santos FP, Kantarjian HM, Jain N, et al. Phase 2 study of CEP-701, an orally available JAK2 inhibitor, in patients with primary or post-polycythemia vera/essential thrombocythemia myelofibrosis. *Blood* 2010;115(6):1131-1136.

Chapter 52 Qualitative Disorders of Platelet Function

> Table of Contents > Part V - Disorders of Hemostasis and Coagulation > Section 2 - Thrombocytopenia > Chapter 52 - Qualitative Disorders of Platelet Function

Chapter 52

Qualitative Disorders of Platelet Function

Thomas J. Kunicki

Diane J. Nugent

Much of our current understanding of normal platelet structure-function relationships has been derived from the study of patients with congenital platelet disorders. These syndromes are the subject of excellent recent reviews.^{1, 2, 3, 4, 5}

NORMAL PLATELET FUNCTION: A SUMMARY

When a blood vessel is damaged, circulating platelets interact with components of the extracellular matrix, particularly collagen, and a complex series of receptor-ligand interactions ensue that ultimately lead to the formation of a stable platelet plug or thrombus (Fig. 52.1). This process is a continuum of at least three phases that we can describe as initiation, extension, and consolidation, each of which entails the cooperation of a different group of receptors.

In the initiation phase (Fig. 52.2), plasma von Willebrand factor (VWF) binds to collagen via its A3 domain and becomes structurally altered such that its A1 domain then binds to the platelet membrane receptor glycoprotein Ib-IX-V complex (GPIb complex). This association is a requisite step in the adhesion of platelets to exposed thrombogenic surfaces at sites of vessel wall injury or in regions of atherosclerotic plaque rupture. Concurrently, a more stable platelet monolayer is formed on the collagen surface mediated predominantly by the platelet-specific receptor GP VI (GPVI) and platelet integrin $\alpha_2\beta_1$.

The engagement of these receptors enhances platelet activation leading to the extension phase (Fig. 52.3), mediated largely by the conversion of prothrombin to thrombin at the activated platelet surface and the secretion of active compounds from platelet granules (α -granules and δ -granules) that can further stimulate platelets. One of these, adenosine diphosphate (ADP), plays a particularly important role in the platelet response, binding to its cognate platelet receptors to augment platelet activation. The activated platelet also produces and/or releases additional agonists, including the agonist thromboxane A2 (TXA₂). Most of the receptors involved in the events of the extension phase are members of the G protein-coupled receptor family.

In the consolidation phase (Fig. 52.4), platelet-platelet cohesion (aggregation), mediated by the binding of fibrinogen and/or VWF to the activated platelet integrin $\alpha_{IIb}\beta_3$ (GPIIb-IIIa), together with the assembly of a fibrin network, results in the generation of platelet-rich aggregates or thrombi. Further complexity is inherent in this final phase of platelet plug formation, and current research indicates an essential role for outside-in signaling through integrins and via receptor tyrosine kinases, including members of the Eph kinase family.

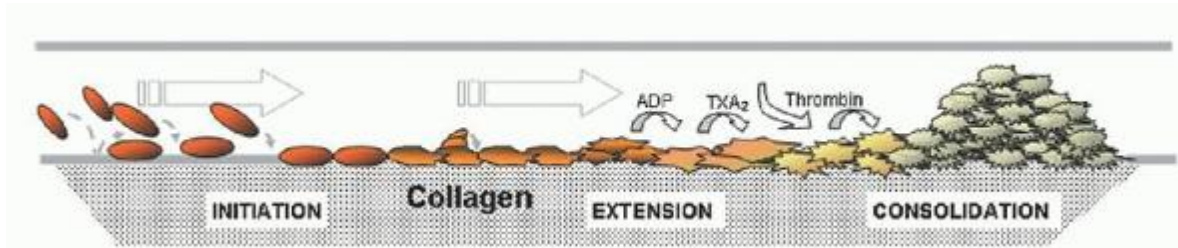

FIGURE 52.1. Platelet thrombus formation. The formation of a platelet thrombus can be envisaged as occurring in three distinct phases. The initiation phase entails the transient tethering of the platelet followed by a firmer adhesion to components of the matrix, leading to platelet activation. In the extension phase, the activated platelets synthesize and/or release from granule stores potent agonists, such as adenosine diphosphate (ADP) or thromboxane A2 (TXA₂). These augment platelet activation. At the same time, the procoagulant platelet surface facilitates the formation of thrombin, which is itself a potent platelet agonist. In the consolidation phase, platelet-platelet cohesion (platelet aggregation) mediates the formation of the stable platelet plug.

Inherited or acquired defects that affect any phase of this complex process can result in excessive thrombosis or bleeding. Hereditary disorders can be divided into groups (Table 52.1), based on whether they predominantly influence the initiation, extension, or consolidation phases of platelet-dependent hemostasis. Platelet dysfunction can also be a manifestation of many acquired disorders, and these are also discussed in this chapter.

DIAGNOSIS AND CLASSIFICATION OF PLATELET DYSFUNCTION: AN ALGORITHM

The preliminary diagnosis of platelet dysfunction must be made on the basis of patient history, and the diagnosis then confirmed by specific laboratory tests of platelet function. A practical algorithm for this purpose, depicted in Figure 52.5, is reproduced with permission from the excellent review by Bolton-Maggs et al.⁵

Bedside Exam and Patient History

An accurate and detailed patient and family history is a key element in the assessment of platelet disorders. One should bear in mind that bleeding histories are subjective and that bleeding can be variable, often evolving or decreasing throughout a person's lifetime. In particular, children may not have yet had enough hemostatic challenges to develop a strong clinical. The subjectivity of the oral history is reflected in a recent statistic that at least one quarter of persons who complain of serious bleeding do not have a bleeding disorder, whereas at least one third of persons who

P.1129

have no bleeding can be shown to have von Willebrand disease (vWD) or a platelet disorder.⁶

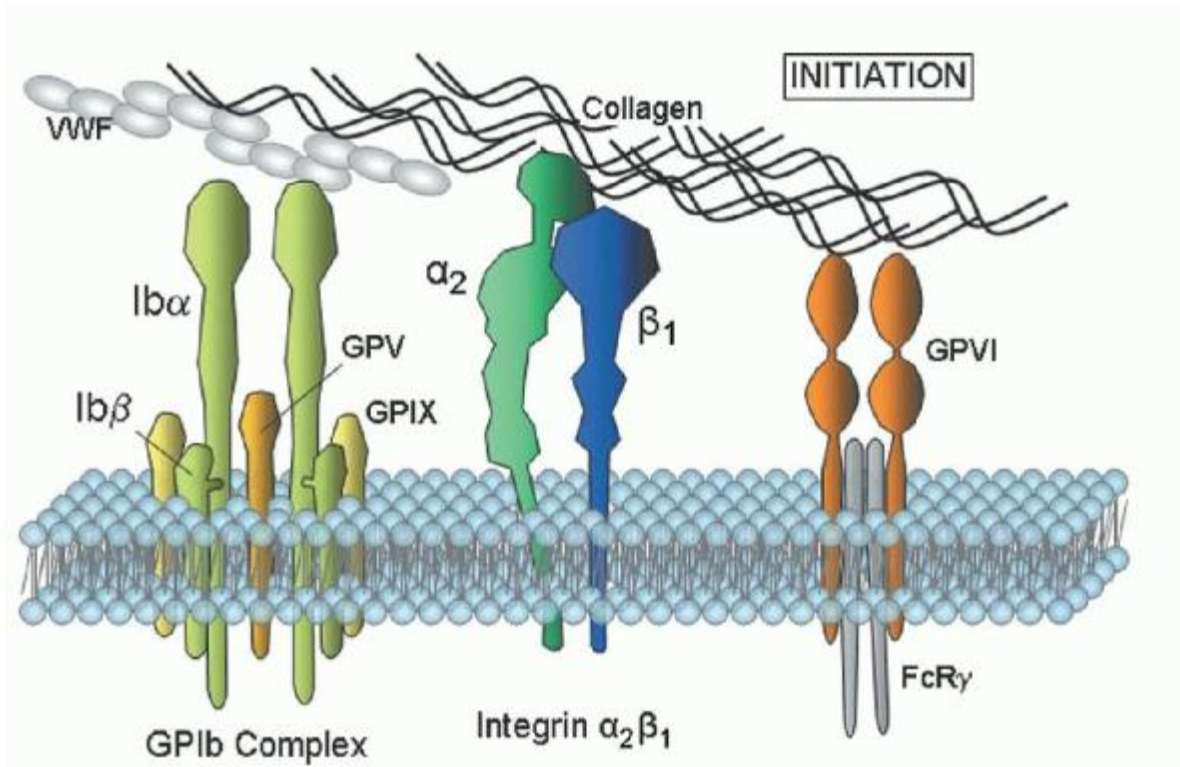

FIGURE 52.2. Initiation of platelet adhesion by matrix components, particularly collagen. Platelets employ a number of collagen receptors. These include VWF-mediated binding of collagen to the glycoprotein Ib (GPIb) complex (a heptamer composed of GPIb α , GPIb β , GPV, and GPIX), the direct engagement of collagen by the integrin $\alpha_2\beta_1$ and GPVI/FcR γ . Engagement and clustering of GPVI initiates tyrosine phosphorylation of FcR γ by a Src family kinase (SFK). The tyrosine kinase Syk then binds and is activated, in turn activating phospholipase C γ , which then initiates phosphoinositide hydrolysis, secretion of ADP, and the production of TXA₂. ADP and TXA₂ augment platelet activation by binding to their respective platelet receptors.

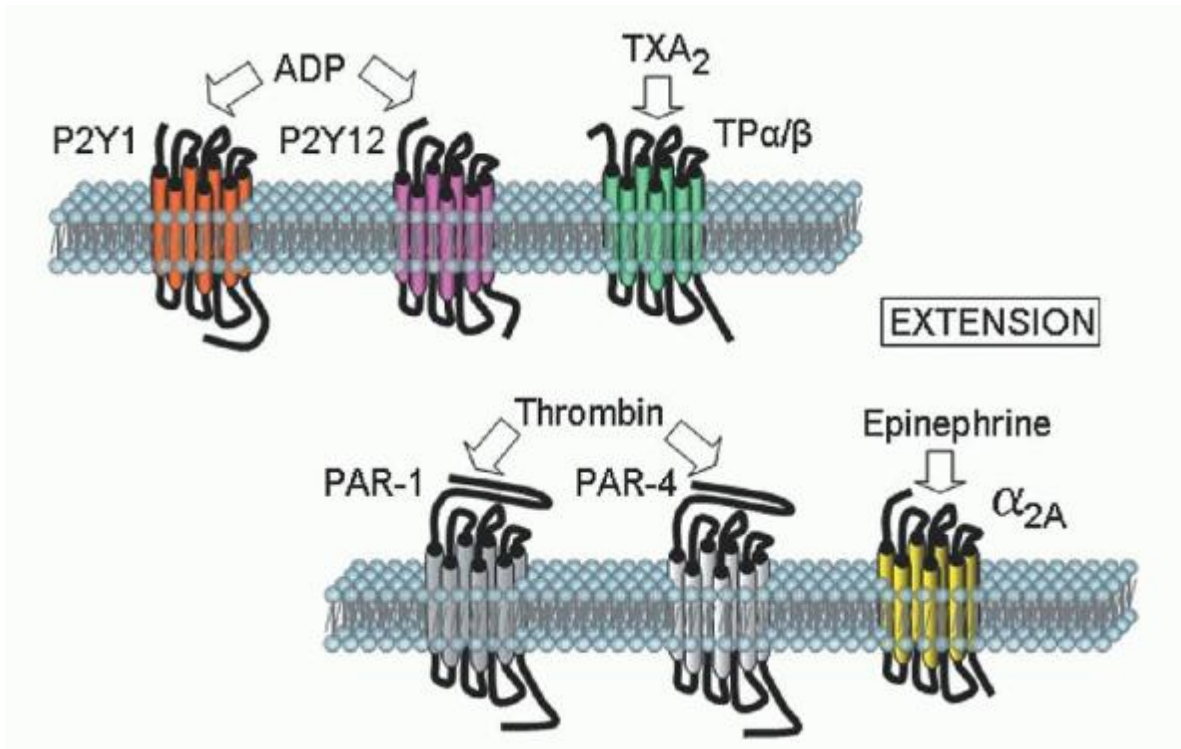

FIGURE 52.3. The extension phase of platelet plug formation accelerates and augments the activation of the platelet and is mediated largely by G protein-coupled receptors, including: the purinogenic receptors P2Y1 and P2Y12, which are bound by ADP; the α and β isoforms of the thromboxane A₂ (TXA₂) receptor TP; the protease-activated receptor (PAR) family members PAR1 and PAR4, that are recognized by thrombin; and the α _{2A}-adrenergic receptor that is specific for epinephrine.

To overcome the subjectivity of a history for superficial mucocutaneous bleeding, the International Society on Thrombosis and Hemostasis (ISTH) suggests that bleeding should be considered clinically significant when there are two or more distinct bleeding sites such as the skin, nose, gums, vagina, gastrointestinal tract, or genitourinary tract. This includes either spontaneous bleeding or provoked bleeding, such as that which might result from dental work, parturition, trauma, or surgery. In addition, a bleeding history involving only a single site should be considered significant when it is so severe as to warrant blood transfusions. Finally, a single bleeding symptom that recurs on three or more unrelated and separate occasions should also be considered significant.^{7, 8}

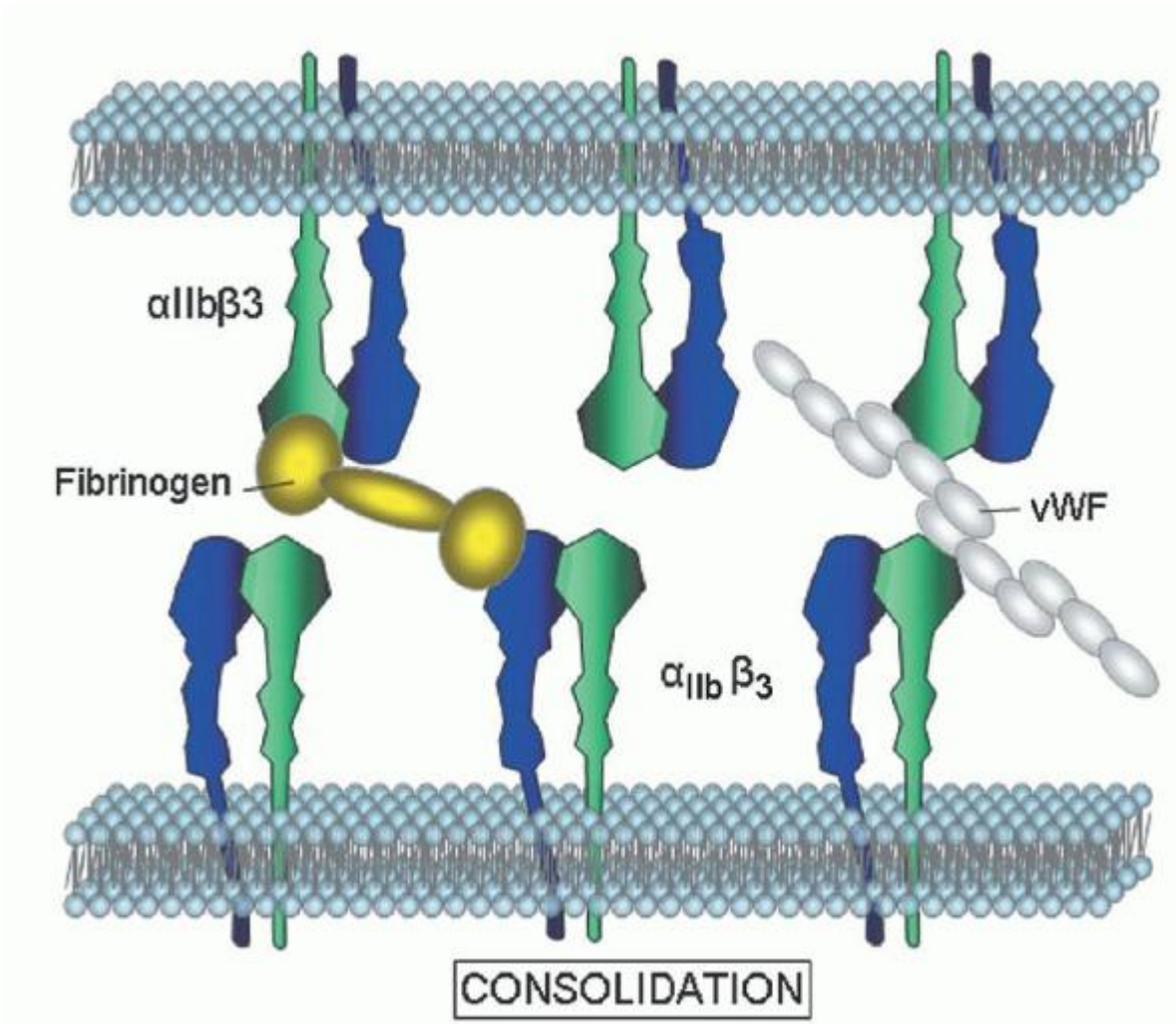

FIGURE 52.4. The consolidation phase of platelet thrombus formation occurs through the bridging of adjacent integrin $\alpha_{IIb}\beta_3$ complexes by fibrinogen or VWF, as well as other adhesive proteins.

TABLE 52.1 DISORDERS OF PLATELET FUNCTION

Hereditary platelet dysfunction

Initiation phase

Bernard-Soulier syndrome

GPVI deficiency

Extension phase

Secretion disorders/granule deficiencies

α -Granule abnormalities (gray platelet syndrome)

δ -Granule (dense body) abnormalities

Hermansky-Pudlak syndrome

Chediak-Higashi syndrome

Wiskott-Aldrich syndrome

α/δ -Granule deficiency

Defects of signal transduction and secretion

Impaired liberation of arachidonic acid
Cyclooxygenase deficiency
Thromboxane synthetase deficiency
Thromboxane A₂ receptor abnormalities
Defects in calcium mobilization
Defects of platelet procoagulant activity

Consolidation phase

Glanzmann thrombasthenia

Miscellaneous

Hereditary macrothrombopathy/sensorineural hearing loss

Acquired disorders of platelet function

Drug-induced platelet dysfunction

Analgesics
Antibiotics
Cardiovascular drugs
Psychotropic drugs

Secondary platelet dysfunction

Uremia
Paraproteinemia
Myeloproliferative disorders

A number of quantitative approaches to assess the relative severity of patient bleeding have been proposed, some including a normalization based on patient age.^{9, 10} However, such approaches work best for a comparison of cohorts of related individuals with comparable bleeding disorders, such as families of patients with vWD.

The distinction between normal individuals and those with bleeding disorders is not always clear cut. Care should be taken in all patients to note the use of medicines, either “over the counter,” herbal, or prescription, that are known to influence platelet function. This is particularly true of medications such as aspirin, other nonsteroidal anti-inflammatory drugs (NSAIDs), ticlopidine or clopidogrel, integrin α IIb β 3 antagonists (e.g., Abciximab, tirofiban, and eptifibatide), epoprostenol, statins, cilostazol, sildenafil, fluoxetine, and large doses of various β -lactam antibiotics (penicillins > cephalosporins).⁷

Bleeding manifestations typical of platelet dysfunction include: (1) Unexplained or extensive bruising; (2) epistaxis, particularly if lasting more than 30 minutes, causing anemia or admission to hospital; (3) menorrhagia, particularly if this has been present since the menarche; (4) oral cavity bleeding; (5) bleeding during

P.1130

childbirth; (6) bleeding following invasive procedures; and (7) bleeding following dental extraction.

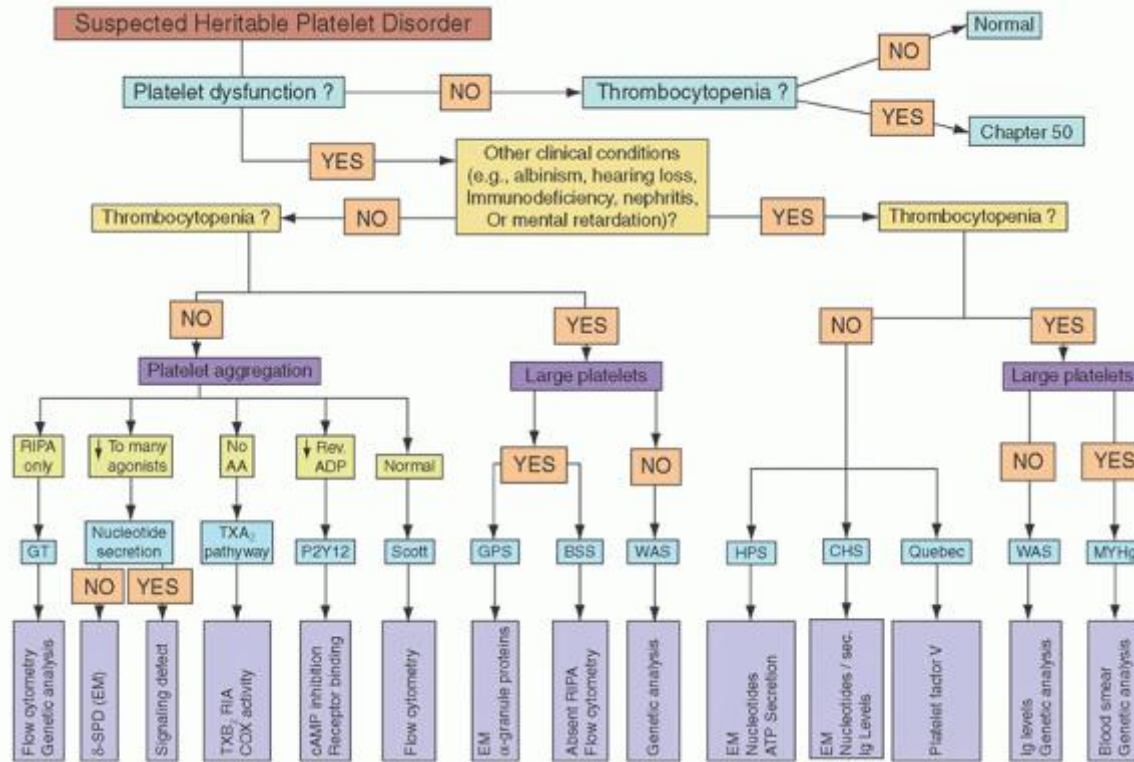

FIGURE 52.5. A scheme for the analysis of patients with suspected hereditary platelet dysfunction. In order to establish a precise diagnosis, specific laboratory tests are needed to establish a defect in platelet number or function. Generally, an automated full blood count, blood film, platelet aggregometry, and quantification of platelet nucleotides are necessary. The purpose of this algorithm is to assist the investigator in the systematic interpretation of laboratory results. To complete a diagnosis, specialty analyses may be necessary, and these are included for the specific disorder. Such assays might include flow cytometry to measure expression of surface glycoproteins, such as α IIb or β 3 (GT), GPIb or GPIIb/IIIa (BSS). In addition, quantitation of annexin V binding (Scott syndrome) and genetic analyses to identify specific gene mutations might be needed: α IIb or β 3 (GT), WAS (WAS and XLA) and MYH9. Certain disorders can be caused by mutations in more than one gene (e.g., HPS and BSS), so genetic analysis has not been considered as a definitive test in all cases. The algorithm includes the most frequent or best characterized heritable platelet disorders. Symbols and abbreviations: \downarrow , reduced aggregation; AA, arachidonic acid; BSS, Bernard-Soulier Syndrome; CHS, Chediak-Higashi syndrome; COX, cyclooxygenase; δ -SPD, dense-granule disorder; EM, electron microscopy; GPS, gray platelet syndrome; GT, Glanzmann thrombasthenia; HPS, Hermansky-Pudlak syndrome; MYH9, MYH-9-related disorder; P2Y12, deficiency of P2Y12 ADP receptor; QBS, Quebec platelet syndrome; Rev., reversible aggregation; RIA, radioimmunoassay; RIPA, ristocetin-induced platelet aggregation; Sec., secretion; TXA2, thromboxane A2; WAS, Wiskott-Aldrich syndrome. From Bolton-Maggs PH, Chalmers EA, Collins PW, et al. A review of inherited platelet disorders with guidelines for their management on behalf of the UKHCDO. *Br J Haematol* 2006;603-633.

Severe platelet dysfunction is present from early childhood onward. Following delivery of an affected infant one may find intracranial and/or subdural hemorrhage, excessive bleeding from the umbilical stump or after circumcision, or easy bruising after handling. As the infant becomes more mobile, easy or extensive bruising following relatively mild trauma can be indicative of platelet dysfunction. Prolonged epistaxis is a common finding throughout childhood and can even become life threatening. In adults, menorrhagia and bleeding during childbirth are common and potentially serious, whereas bleeding following any invasive procedure should be anticipated.⁵

Mild platelet dysfunction is more likely to manifest itself at any age most commonly following a definable hemostatic challenge, such as surgery or dental extractions. Easy bruising is a very nonspecific symptom, and many cases are difficult to distinguish from what would otherwise be considered a normal response.

Consanguinity increases the likelihood of an autosomal recessive platelet disorder, and a family history is invaluable in establishing the diagnosis of inherited platelet dysfunction.

Laboratory Assessment

A number of laboratory-based evaluations are critical for an accurate diagnosis of platelet dysfunction.

Whole Blood Platelet Count

A key element in assessing platelet dysfunction is an accurate whole blood platelet count. Automated counts should be viewed as provisional. Inasmuch as macrothrombocytes or platelet aggregates created inadvertently during blood processing will not be counted, the whole blood platelet count should be confirmed by an optical method.

Global Coagulation Tests

To rule out abnormalities in clotting factors, all patients should have a prothrombin time, activated partial thromboplastin time, and thrombin time performed. Laboratories should determine their own age-related normal range. It is also critical to investigate all patients for VWD, which is far more common than platelet function disorders and creates a similar bleeding phenotype.

Bleeding Time

The bleeding time is historically a common measure of platelet function. However, because the test is poorly reproducible, time consuming, and insensitive, the bleeding time has gradually fallen out of favor as a clinically useful test.¹¹ In cases of mild platelet dysfunction, the bleeding time is often normal or minimally prolonged;¹¹ in severe cases, it will usually be prolonged.

P.1131

Unfortunately, the bleeding time does not correlate well with the *in vivo* bleeding tendency within individual patients, and an accurate bleeding history is considered by many to be a more valuable screening test. Nonetheless, a prolonged bleeding time should be considered sufficient grounds to perform additional tests of platelet function.

Platelet Function Analyzer-100

The platelet function analyzer-100 (PFA-100) measures the rate of thrombus formation under high shear in citrated whole blood that is perfused through a membrane aperture coated with collagen/epinephrine or collagen/ADP. The closure time (CT) will be significantly prolonged in Glanzmann thrombasthenia (GT) and Bernard-Soulier syndrome (BSS) using either ADP/collagen or epinephrine/collagen membrane cartridges.^{12, 13} Consequently, the PFA-100 can be used to screen patients to exclude these diagnoses.

The PFA-100 may be sensitive to platelet storage pool disease (SPD), primary secretion defects, the Hermansky-Pudlak syndrome (HPS), and the Quebec syndrome. However, because falsenegative results occur in patients with all of these disorders, there are those who question its usefulness as a screening tool.^{12, 14} The PFA-100 is affected by platelet count and hematocrit, and is dependent on normal VWF levels and naturally occurring (genetic) differences in platelet membrane GPVI or $\alpha 2\beta 1$ expression.^{13, 14, 15}

Platelet Aggregation

Platelet aggregation in platelet-rich plasma remains an important test in the analysis of platelet function. The typical agonists that are used to induce platelet aggregation are ADP, epinephrine, collagen, arachidonic acid (AA), ristocetin, the TX receptor agonist U46619, thrombin or the thrombin receptor-activating peptide. Because the level and/or activity of each of the receptors for the agonists can vary among normal subjects, it is recommended that dose-response curves to each agonist be obtained from the patient under study and compared to a reference range obtained from multiple normal subjects.¹⁶ When thrombin is the agonist, an inhibitor of fibrin polymerization, such as glycine-proline-arginine-proline peptide, must be added to the PRP, or alternatively, plasma-depleted washed platelets must be used.

Platelet aggregation is sensitive to platelet count, and at counts $\leq 120,000/\mu\text{l}$, the response to some agonists will be impaired. In thrombocytopenic samples, the best options are to adjust a control sample to the same count as the patient or to perform studies on washed platelets where the platelet number can be normalized. Consideration should also be given to more specialized tests, such as a measure of P-selectin expression or integrin $\alpha\text{IIb}\beta 3$ activation by flow cytometry. The expected aggregation responses associated with specific diagnoses are covered in the appropriate sections.

Adenine Nucleotide Content and Release

Measurement of platelet adenosine nucleotide (ADP and adenosine triphosphate [ATP]) content and release can be used in the diagnosis of storage pool and release defects.¹⁷ A finding of normal platelet aggregation does not exclude the diagnosis of SPD. It is recommended that patients suspected of having platelet dysfunction should have both platelet aggregation and adenine nucleotide release performed, unless it is certain that the laboratory performing the platelet

aggregation assays can demonstrate that their assay conditions are sensitive to defects in platelet nucleotide amount or release.

Platelet nucleotide content and release varies with age. Ideally, age-related normal ranges should be established for total and released levels of ATP and ADP and their ratios. Platelet aggregation, nucleotide content, and nucleotide release in children over 12 months of age do not differ significantly from adult values, whereas collagen-induced platelet nucleotide release has been shown to be reduced in neonates compared with children older than 1 year. Agonist-induced secretion of platelet granule contents has been shown to be reduced in both term and premature babies due to immature signal transduction pathways.^{18, 19}

Flow Cytometry

Flow cytometry is routinely used to measure platelet surface receptor density, platelet activation, α -granule release, procoagulant phospholipid expression, and microvesicle production.^{20, 21} A common application of flow cytometry is the assessment of GPIb complex and integrin α IIb β 3 expression in the diagnosis of BSS and GT. Individuals who are heterozygous for these disorders are also readily distinguished. An important benefit of flow cytometry is the small quantities of blood required, an attractive feature in young children or thrombocytopenic individuals.

Electron Microscopy

Transmission electron microscopy (TEM) of fixed/embedded platelet thin sections can be performed by a limited number of specialized personnel, but is critical in the assessment of platelet granule defects and changes in platelet ultrastructure (e.g., in the evaluation of patients with MYH-9 defects). Whole-mount EM can be used to quantitate δ -granule content because this is readily identified in unstained preparations.²²

Additional Assays

Several additional assays are available in specialized laboratories that can provide further information relevant to the diagnosis of the particular platelet disorder, including analysis of receptor expression, specific molecular or genetic defects, protein phosphorylation, formation of signal transduction intermediates, or a characterization of the platelet proteome. The utility of these tests in clinical diagnoses is currently under intense investigation.

Overview of Treatment Options for Platelet Disorders

Although the number of clearly identifiable platelet dysfunction syndromes is growing, our choice of treatment options remains limited. Minor membrane bleeding may be controlled with topical agents in the nasal or oral cavities with antifibrinolytic agents. Epsilon-aminocaproic or tranexamic acids will decrease blood loss associated with epistaxis or menorrhagia. Some patients may benefit from Stimate as documented by DiMichele and Hathaway,²³ whereas others actually bleed more with this agent due to the fibrinolysis induced by this medication. For this reason many centers recommend the use of Stimate in conjunction with Amicar or Cyklokapron.

In the case of menorrhagia, hormonal suppression is the mainstay for women who do not wish to undergo endometrial ablation for hysterectomies. In combination with antifibrinolytics and Stimate, even severe bleeding may be controlled; however, more aggressive therapy including platelet infusion may be required to control bleeding before these agents take effect.

Platelet transfusion may pose a dilemma to those physicians wishing to avoid alloimmunization in patients who may require multiple transfusions throughout their lifetimes to control hemorrhage. This is particularly true for those patients who are lacking membrane GPs, such as α IIb β 3 or GPIb. In this setting patients are at risk of developing isoimmunization, making antibodies against the "foreign" proteins that they lack and thus becoming refractory to all subsequent platelet transfusions.

P.1132

Although rare, this creates a significant challenge in patients who require frequent platelet infusions to control life-threatening bleeding. Patients with GT have not only developed antibodies to α IIb and/or β 3 but also demonstrated anti-idiotypic antibodies that bind to fibrinogen, thus creating a hemorrhagic disorder far worse than the underlying platelet dysfunction. In general, physicians avoid platelet transfusion apart from cases of severe hemorrhage. Isoimmunization appears to be rare in Glanzmann but the risk of alloimmunization is still a major concern, therefore leukocyte depletion of transfused platelets is recommended to decrease the frequency of sensitization.

Activated recombinant Factor VII (rFVIIa) has been used to slow or arrest bleeding associated with platelet dysfunction.²⁴ Dosages have varied widely but many patients have responded to this regimen when others have failed. Used in combination with antifibrinolytics, minor bleeding can be controlled in certain patients. This treatment is often used prior to platelet transfusion in order to avoid blood product exposure and isoimmunization.

For those patients who present with recurrent life-threatening bleeds, bone marrow transplant or stem cell infusion following immune ablation is recommended before the patients have extensive blood product exposure.²⁵ Successful transplantation with normal stem cells represents long-term cure for these patients. Although complications related to stem cell transplantation cannot be overlooked, successful engraftment essentially eliminates the significant risk of mortality related to hemorrhage in patients with severe disorders.

Patients with rare platelet dysfunction syndromes are now included in many of the rare bleeding disorder international and regional registries that will aid physicians in understanding the natural course, optimal therapy, and life expectancy for each of the syndromes listed below, as well as the numerous platelet disorders that have yet to be defined. Definitive molecular and biochemical diagnoses will dictate appropriate therapy in these patients. With improvement in platelet function measurement and proteomic approaches one should see significant improvement in early diagnosis and medical management.

HEREDITARY DISORDERS OF PLATELET FUNCTION

Defects in the Initiation Phase: Bernard-Soulier Syndrome

BSS is a rare disorder first described in 1948 as “dystrophie thrombocytaire hemorrhagipare congenitale” caused by abnormal expression or activity of the platelet GPIb complex.²⁶

Etiology

BSS platelets have a quantitative or qualitative abnormality of the membrane GPIb complex, a heptamer composed of four leucine-rich GP that are the products of distinct genes (Fig. 52.2). The prominent member of the complex, GPIb, is a heterodimer composed of disulfide-bonded GPIb α and GPIb β subunits. GPIb then forms a noncovalent complex with GPIIX, and two GPIb-IX trimers then associate noncovalently with one molecule of GPV. The amino-terminal type A domain of GPIb α binds directly to VWF, mediating normal platelet adhesion during the initial phases of primary hemostasis, whereas BSS platelets do not adhere to the extracellular matrix when perfused at a high shear rate.²⁷ The defect in the GPIb complex also explains the failure of affected platelets to agglutinate in the presence of ristocetin, even in the presence of normal plasma or VWF.

Mutations in the gene for GPIb α , GPIb β , or GPIIX, but not GPV, have been shown to result in decreased expression of the GPIb complex and the BSS. Defects range from virtually absent GPIb to variant forms in which patients retain measurable amounts of apparently dysfunctional GPs.¹

BSS is usually inherited as an autosomal-recessive disorder, and consanguinity is common in reported kindreds. Heterozygotes typically have “giant” platelets and reduced levels of the GPIb complex and may or may not be symptomatic.

Clinical Features

Bleeding symptoms are usually evident shortly after birth or in early childhood. The clinical manifestations include purpura, epistaxis, gingival bleeding and menorrhagia, and more rarely gastrointestinal bleeding, major hematomas, or hematuria. Severe bleeding episodes can result from trauma and surgical procedures, such as tonsillectomy, appendectomy, splenectomy, oral surgery, and menses. However, individual bleeding can vary substantially in severity and frequency.

Laboratory Findings

The typical laboratory findings include an increased bleeding time, mild thrombocytopenia, giant platelets on blood smear, and defective adhesion to collagens *in vitro*. Platelet morphologic abnormalities are a hallmark of BSS, featured by large platelets with a diameter as high as 10 μm . A defective platelet agglutination in response to ristocetin, as measured by aggregometry *in vitro*, is a unique characteristic of BSS that differentiates this syndrome from other rare inherited disorders that are also associated with macrothrombocytopenia, such as the MHY9-related disorders.¹ A firm diagnosis requires the combined findings of increased bleeding times, macrothrombocytopenia, defective ristocetin-induced agglutination, and low or absent levels of platelet GPIb-V-IX (CD42a-d) by flow cytometry.

In bone marrow aspirates, megakaryocytes are normal or increased in number, but they reveal no characteristic morphologic abnormalities when viewed by light microscopy. Electron microscopic studies have revealed abnormalities of the dense tubular system and vacuolization of the demarcation membrane system.²⁸

Management

Therapeutic approaches include both general and specific treatment of bleeding. Patients should be warned to avoid trauma and antiplatelet medication, such as aspirin, and to maintain proper dental hygiene. Females may benefit from contraceptive therapy once they reach puberty. Treatment of bleeding or prophylaxis during surgical procedures usually requires blood or platelet transfusion with the associated risk of developing antiplatelet alloantibodies. Desmopressin and rFVIIa administration have been shown to shorten the bleeding time in some patients. In rare cases of life-threatening bleeding, a bone marrow or umbilical cord hematopoietic stem cell transplantation may be considered.²⁹ Responses to antifibrinolytic agents are more variable, and the administration of adrenal corticosteroids and splenectomy are usually ineffective.

Platelet-reactive isoantibodies have been generated by BSS who have received multiple blood or platelet transfusions.³⁰ These antibodies produce a particularly severe clinical complication because they will bind to and may neutralize the function of GPIb on transfused platelets. This results in impaired adhesion of the transfused platelets. The presence of such antibodies can be established by a finding of impaired in vitro aggregation of normal platelets induced by ristocetin and bovine VWF in the presence of patient plasma. Alloimmunization is also a common side effect of multiple platelet transfusions, and this may necessitate the subsequent use of HLA-matched platelets.

P.1133

Variation in the Initiation Phase: Collagen Receptor Polymorphisms

A lifelong bleeding disorder and the unique absence of in vitro platelet aggregation to collagen have been associated with a deficiency of either of the collagen receptors, integrin $\alpha_2\beta_1$ or GPVI,¹ yet specific gene defects have not been identified. Careful evaluation is needed to establish a specific molecular defect in either receptor.

The Integrin $\alpha_2\beta_1$

Among normal individuals, platelet $\alpha_2\beta_1$ levels can vary up to tenfold and correlate with differences in adhesiveness to type-I or type-III collagens and genetic variants of the α_2 subunit gene ITGA2. We identified several single nucleotide polymorphisms (SNPs) within the coding sequence of the α_2 gene ITGA2 that correlate with platelet $\alpha_2\beta_1$ density³¹ and define six major ITGA2 haplotypes.

Clinical Relevance of α_2 Polymorphisms

In VWD, platelet adhesive functions are impaired due to the decrease in functional VWF multimers in plasma and platelets. Inheritance of the ITGA2 haplotypes associated with lower $\alpha_2\beta_1$ density will increase the risk of bleeding in patients with either type I and type 2 VWD.^{9, 10}

The association of ITGA2 haplotypes with risk for arterial thrombosis has been studied in acute coronary syndromes, diabetic nephropathy, and stroke. Although several studies have found that the inheritance of high-density ITGA2 haplotypes correlates with increased thrombosis, this association is not a consistent observation.³²

Platelet Glycoprotein VI

GPVI is a major platelet GP (60 to 65 kDa) that has been confirmed as an important receptor for collagen since the initial identification of a patient with a mild bleeding disorder whose platelets lacked GPVI and exhibited defective collagen-induced responses.³³ Autoantibodies against GPVI can cause substantial shedding of this receptor through metalloproteinase cleavage.^{34, 35}

Glycoprotein VI Polymorphism

Aside from isolated cases of GPVI defects, it is important to note that there is variation in platelet GPVI content among normal healthy subjects,³⁶ which is directly proportional to normal variation in mean platelet volume.³⁷ This variation is manifested in a significant difference in prothrombinase activity induced by GPVI-specific agonists such as the snake venom protein convulxin or collagen-related peptide (CRP).³⁶ The direct association between platelet $\alpha_2\beta_1$ density and GPVI content is also attributable to variation in mean platelet volume, which has a proportional effect on levels of other

receptors, including $\alpha\text{IIb}\beta\text{3}$.³⁷ Variation in GPVI content represents yet another genetically controlled risk factor predisposing individuals to hemorrhagic or thromboembolic disorders.

Defects in the Extension Phase

Secretion Defects: Storage Pool Disease

SPD is a heterogeneous group of congenital disorders that have in common a deficiency of granules or their constituents that results in a defect in ADP release from activated platelets and abnormal secretion-dependent platelet aggregation.¹ Defective platelet secretion can result from the absence of or defects in one or both of the dominant types of platelet granules: The α -granule or the δ -granule (dense body). Thus, three subgroups of SPD are now distinguished. The isolated deficiency of α -granules (α -SPD) has been studied for several years and is more commonly known as the Gray platelet syndrome (GPS)³⁸; the exclusive abnormality of dense-granules (δ -SPD) can be congenital or acquired, as in myeloproliferative syndromes or rheumatologic disorders;¹⁷ and abnormalities of both α - and δ -granules are classified as $\alpha\delta$ -SPD.¹⁷

α -Granule Storage Pool Disease: Gray Platelet Syndrome

GPS is a very rare disorder with less than 100 cases reported worldwide and is characterized by a selective deficiency in the number and content of α -granules.^{17, 38} The formation of α -granules in immature megakaryocytes proceeds normally, but the granule number then decreases during maturation, and the mature megakaryocytes are left with only small abnormal granules that are few in number. Some of the normal protein constituents of α -granule membranes, such as GPIV, integrin $\alpha\text{IIb}\beta\text{3}$, and P-Selectin remain in the abnormal granules and will be normally redistributed during platelet activation. The defect is limited to megakaryocytes and platelets. Recent evidence suggests that GPS is associated with mutations in NBEAL2 (neurobeachin-like 2 gene), which encodes a protein containing a BEACH domain that is predicted to be involved in vesicular trafficking and may be critical for the development of platelet α -granules.^{39, 40, 41}

Several proteins are synthesized but not stored properly in the abnormal α -granules. These include platelet factor 4, β -thromboglobulin, fibrinogen, fibronectin, vWF, platelet-derived growth factor, and thrombospondin. Other organelles, such as lysosomal granules, mitochondria, and δ -granules (dense bodies) are present in normal numbers, and δ -granules contain normal amounts of adenine nucleotides and serotonin.

Clinical Features

GPS is inherited as an autosomal trait and is associated with mild to moderate thrombocytopenia (20,000 to 150,000/ μl) and moderately enlarged platelets.^{17, 38} The bleeding time is usually prolonged, and platelet survival may be shortened, but splenomegaly is not common. As in other platelet function defects, a history of mild bleeding is the norm, and treatment is seldom required. The bone marrow exhibits normal megakaryocyte numbers and increased reticulin, occasionally around clusters of megakaryocytes, but myelofibrosis is not a feature of this disorder. In Wright-stained blood smears, the platelets appear large, misshapen, agranular, and gray. In electron photomicrographs, an almost total lack of α -granules is evident in platelets and in megakaryocytes.

When analyzed by EM, it is the only disorder that is characterized by the selective absence of platelet α -granules. Megakaryocytes show defective α -granule biogenesis, with impaired uptake and storage of endogenously synthesized proteins, such as platelet factor 4, β -thromboglobulin, or vWF, and defective sequestration of exogenous proteins, such as fibrinogen, albumin, or factor V. On the other hand, in the platelet, the α -granule marker P-selectin is retained and is redistributed to the surface upon activation. Both autosomal recessive and autosomal dominant inheritance have been reported, implicating more than one gene in the etiology of the disease. Myelofibrosis of bone marrow is an additional feature that is attributed to the spontaneous release of platelet-derived growth factor and transforming growth factor- β1 from megakaryocytes.

Laboratory Findings

Gray platelets have a normal aggregation and release in response to AA or ionophore and generate TX normally. Platelet aggregation induced by ADP, epinephrine, thrombin, or collagen is variably affected. Release from dense bodies usually is subnormal,

P.1134

particularly when induced by thrombin. Abnormal calcium influx and mobilization from intracellular stores have also been reported. The platelet count is often reduced and can be as low as 50,000 per μl . By EM, the platelets have reduced numbers or a complete absence of α -granules.

Management

Because of the rare nature of α -granule disorders, there is not a very extensive clinical database upon which to make generalizations about effective treatment of the bleeding problem. However, these patients should be managed in the same manner as other patients with mild bleeding disorders. In the case of major bleeding or surgical challenge, they may require platelet transfusion.

Isolated δ -Storage Pool Disease

δ -SPD is characterized by easy bruising, mucocutaneous bleeding, and excessive post-operative and post-partum hemorrhage.¹⁷

Clinical Features

The symptoms can become more severe if the patient ingests aspirin or other antiplatelet agents, and patients with SPD should be advised to avoid such drugs. Platelet counts are typically normal, and the bleeding time is usually prolonged. The platelets are morphologically normal on Wright-stained smears, but they are deficient in dense bodies by EM. The diagnosis of δ -SPD must be made by the finding of a decrease in dense granule constituents and/or EM to demonstrate the absence of dense granule-limiting membranes and contents. The most consistent finding is that adenine nucleotides are reduced with an increased ratio of ATP to ADP and normal levels of lysosomal enzymes.

The platelet content of serotonin, however, can be variably reduced. Whole-mount EM recognizes calcium, but it cannot differentiate the absence of a dense granule from the absence of its calcium. Dense granules can also be quantitated by fluorescent microscopy because, whether full and empty, δ -granules take up the fluorescent dye quinacrine (mepacrine).⁴²

Laboratory Findings

Because of the defect in δ -granules and the decreased level of ADP, primary aggregation responses in vitro are normal, but secondary aggregation may be diminished. Typically, there is an impaired response to collagen and a deficient secondary wave with ADP, epinephrine, and low concentrations of thrombin, but ristocetin aggregation is normal. Although this functional defect is often encountered in this disorder, it cannot be relied upon as a diagnostic criterion. The platelets are also deficient in serotonin, calcium, and pyrophosphate, which are stored in the δ -granules.¹⁷

The bleeding time is increased, with normal platelet counts and morphology. Subsets of patients have been identified who have a prolonged bleeding time, decreased dense bodies, and ADP release but normal platelet aggregation. The diagnosis of δ -granule SPD can best be made following a combination of studies, including bleeding time, platelet aggregation, an assessment of storage pool adenine nucleotides, thrombin-induced radioactive serotonin uptake and release, and TEM.

There is suggestive evidence that δ -SPD is inherited as an autosomal dominant characteristic, but neither the causative gene nor the molecular nature of the basic defect have yet been determined.

Management

To treat the symptoms of SPD, desmopressin (DDAVP) can normalize the bleeding time in some patients, often within 1 hour after infusion.²³ This treatment is particularly effective in improving hemostasis after procedures.

Combined $\alpha\delta$ -Storage Pool Disease

In $\alpha\delta$ -SPD, which is much less common than isolated δ -SPD, δ -granules and/or their contents are uniformly decreased, and the deficiency of α -granules and/or their constituents can vary.¹⁷ Platelets in these patients form significantly smaller thrombi in flowing blood than is seen with platelets from patients with δ -SPD. The defects are also not uniformly among the platelet population, such that α -granules and δ -granules may be completely absent in one portion of the population yet present in nearly normal levels in another.⁴³

The mode of inheritance appears to be autosomal dominant, but a basic molecular defect and a genetic basis have not yet been determined.

Animal Models and Etiology

The comparative study of granule deficiencies in the mouse or rat can provide clues to understanding the etiology of SPD. For example, the gunmetal mouse⁴⁴ and the fawn-hooded hypertensive rat⁴⁵ are characterized by reduced platelet α - and δ -granules, a disorganization of megakaryocyte internal membranes, and impaired α -granule protein retention. Mutations in RabggtA result in defective geranylgeranyl transferase, which catalyzes the attachment of lipid geranylgeranyl groups to Rab proteins.⁴⁴ Rab proteins are small guanosine triphosphatases (GTPases), which split GTP to provide energy for

membrane fusion events and for attachment to cytoskeletons. By analogy, it is possible that mutations in the human gene RABGGTA are also responsible for human $\alpha\delta$ -SPD, but this remains to be proven.

Clinical Features

Bleeding in this disorder is clinically similar to bleeding in δ -SPD and GPS, and is manifested by a prolonged bleeding time with normal platelet counts.¹⁷ Except for their bleeding tendency, patients with $\alpha\delta$ -SPD appear otherwise healthy.

Laboratory Findings

Defects in secondary platelet aggregation are typical, and defects in primary aggregation are even more extreme than seen in δ -SPD. Because of variability, in vitro platelet aggregation in $\alpha\delta$ -SPD is not an appropriate diagnostic criterion, and an accurate diagnosis requires measurement of δ - and α -granule constituents and/or EM of platelet organelles. The lysosomal enzyme content of $\alpha\delta$ -SPD platelets is normal.

Management

Because of the few numbers of patients with combined $\alpha\delta$ -SPD, there is little clinical information upon which to develop a treatment scheme. However, this disorder can likely be managed in the same manner as the isolated δ -SPD (see above).

Quebec Platelet Syndrome (Factor V Quebec)

The Quebec platelet syndrome is an extremely rare, autosomal dominant disorder that was originally identified by the finding of low levels of platelet α -granule factor V but normal plasma factor V.^{1, 17} It is characterized by protease-related degradation of many platelet α -granule proteins, including P-selectin. The α -granule ultrastructure is normal. Increased expression of α -granule urokinase-type plasminogen activator is thought to lead to spontaneous intracellular activation of the fibrinolytic pathway resulting in the generation of plasmin, which cleaves multimerin that would otherwise stabilize factor V.⁴⁶

Clinical Features and Laboratory Findings

Many cases may go undiagnosed because there are no characteristic morphologic features or platelet aggregation abnormalities. The main laboratory finding is defective procoagulant activity,

P.1135

reflected by a failure to assemble the prothrombinase complex. A related defect, platelet Factor V New York, is also characterized by decreased levels of platelet Factor V, although there is no indication of Factor V proteolysis, as in Factor V Quebec.⁴⁷

Management

The Quebec platelet syndrome is unresponsive to platelet transfusions. It is the current opinion that fibrinolytic inhibitors are the most effective means to control bleeding.⁴⁸ Otherwise, treatment should be similar to that given to patients with bleeding disorders.

Hermansky-Pudlak and Chediak-Higashi Syndromes

The HPS and Chediak-Higashi syndrome (CHS) are rare autosomal recessive disorders that have in common platelet dense granule deficiency, albinism, and lysosomal granule defects.⁴⁹

Hermansky-Pudlak Syndrome

HPS is as an autosomal-recessive trait that has a worldwide distribution but is most prevalent in Puerto Rico.

Etiology

The genetic causes of HPS are diverse. Mutations in at least seven genes have been linked to this disease, and the absence of platelet dense bodies is thought to result from a defect in organelle development.⁵⁰

Clinical Features and Laboratory Findings

A diagnosis of HPS is based on the presence of oculocutaneous albinism and absent platelet dense bodies on whole-mount EM.⁵¹ Typical findings are a lifelong history of easy bruising; minor bleeding episodes, such as mucus membrane bleeding; epistaxis, and metromenorrhagia. Many patients will require whole blood or platelet transfusions when bleeding symptoms become more severe. Pulmonary fibrosis and inflammatory bowel disease, associated with infiltration of ceroid-pigmented reticuloendothelial cells in the lung and colon, have been reported in several cases of this syndrome.⁵²

In platelet aggregation assays, there is an absence of the secondary wave in response to ADP and epinephrine, and the response to collagen is also abnormal. Usually, the template bleeding time will also be longer than normal.

Management

Localized and limited treatment of the bleeding symptoms is the norm in HPS.^{49, 53} The albinism necessitates skin and eye protection, and the bleeding can be controlled topically with thrombin and Gelfoam. Prophylactic use of intravenous 1-desamino-8-D-arginine vasopressin or Stimate is recommended for procedures such as tooth extractions or biopsies. Menstrual bleeding can be regulated by birth control pills. In the event of major surgeries or severe bleeding episodes, platelet or red blood cell transfusions may be required.

Chediak-Higashi Syndrome

SPD also may be associated with the CHS.^{1, 54} In addition to defective platelet dense granules and oculocutaneous albinism, CHS is also characterized by immune deficiency and progressive neurologic dysfunction. In CHS patients, the granule abnormalities are not restricted to the megakaryocyte lineage, and numerous cell types exhibit giant cytoplasmic inclusions that are enlarged vesicles.

Etiology

Numerous cases of CHS have been reported to result from mutations in the lysosomal trafficking regulator gene (LYST) located on chromosome 1q42.1-42.2. Mutations in the LYST protein can be associated with defective natural killer cell function.⁵⁵ However, LYST mutations cannot be identified in all CHS patients, suggesting the existence of causative defects in other genes.⁵⁶ Several proteins are known to interact with LYST, including the SNARE complex protein HRS, signaling protein 14-3-3, and casein kinase II.⁵⁷ It has been proposed that LYST may be an adaptor protein that brings into close proximity proteins that mediate intracellular membrane fusion reactions. Along this vein, LYST contains several consensus motifs that play distinct roles in vesicle transport and fusion.

Clinical Features and Laboratory Findings

Platelet counts are normal prior to development of the accelerated phase. The dense granule defect results in mucocutaneous bleeding and a prolonged bleeding time. The secondary wave of platelet aggregation is impaired, there is an increased ATP-to-ADP ratio, decreased platelet serotonin, and decreased platelet calcium. Some patients have a normal number and shape of dense bodies, but most often there is an absence of or marked reduction in dense bodies.

Management

Prior to the accelerated phase, hemostatic problems can be treated as in the case of other mild platelet disorders. With time, infections and a lymphoproliferative accelerated phase are serious developments that can result in death within the first decade.^{1, 54} Although experience is still limited, hematopoietic cell transplantation is a potentially effective therapy for correcting and preventing hematologic and immunologic complications of CHS.⁵⁸

Griscelli Syndrome

Mutations in RAB27A, a gene for a small GTPase involved in vesicular transport and organelle dynamics, are considered to be the cause of GS.⁵⁹ The ashken mouse with mutated RAB27A is a model of GS and exhibits a reduction in the number of platelet dense granules. However, the hemostatic phenotype of these mice is affected by the genetic background, and it is likely that additional modifier gene polymorphisms have an important influence on the hemostatic phenotype.

Clinical Features and Laboratory Findings

GS is a rare autosomal recessive disorder in which patients present with abnormal pigmentation, immunodeficiency, and development of the accelerated phase.⁶⁰ GS patients have no obvious bleeding prior to the accelerated phase, and it has not been firmly established that there is a characteristic platelet dense granule defect. Hypopigmented hair with a silvery-gray sheen and pigment clumps is a characteristic of GS, but these are larger and less homogeneously distributed than one sees with CHS patients. The giant cytoplasmic granules typical of CHS cells are not seen in GS cells.

Management

Like CHS, the disease is usually fatal by the first decade of life. The same management as observed with CHS will likely be effective in patients with Griscelli syndrome.^{1, 54}

Paris-Trousseau (Jacobsen) Syndrome

The Paris-Trousseau (Jacobsen) syndrome is an autosomal dominant disorder characterized by thrombocytopenia, a history of relatively mild bleeding, the presence of giant α -granules in a minor proportion of platelets, and two

morphologically distinct populations of megakaryocytes in the bone marrow, some of which exhibit signs of abnormal maturation. Additional congenital abnormalities include mental retardation, cardiac abnormalities, and cranio-facial abnormalities. This is an extremely rare disorder, and only 10 childhood cases have been reported.⁶¹

P.1136

These patients have deletions of the long arm of chromosome 11q that include the gene *FLI1*, which encodes a transcription factor that plays a critical role in normal megakaryocytopoiesis. Thus, the hemizygous deletion of *FLI1* generates a subpopulation of megakaryocyte progenitors that fail to differentiate normally, forming small immature megakaryocytes that undergo massive lysis.⁶² Those platelets with giant α -granules fail to release their contents normally upon stimulation.

Arthrogryposis-Renal Dysfunction-Cholestasis Syndrome

The gene *VPS33B* encodes a protein that is involved in protein trafficking. A mutation of the gene is the cause of ARC syndrome.⁶³ ARC is an autosomal recessive disorder with multiple systemic abnormalities, one of which is platelet dysfunction caused by a deficiency in platelet α -granules.⁶⁴ This disorder is diagnosed by severe distinguishing features other than the platelet dysfunction, and affected individuals usually do not survive their first year.

Inherited Disorders of Primary Membrane Receptors

Congenital Defects of P2Y₁₂

The adenine nucleotides ADP and ATP are both released from platelet δ -granules during activation induced by a variety of agonists, and both can augment or modulate the platelet functional response through autocrine and paracrine mechanisms by binding to platelet purinergic receptors.⁶⁵

Two platelet purinergic receptors are specific for ADP, the G_q-protein-coupled receptor P2Y₁ and the G_i-protein-coupled receptor P2Y₁₂. One receptor, the P2X₁ ion channel, is bound by ATP. The P2Y and P2X receptors operate in a temporally distinct manner and selectively trigger distinct intracellular signaling pathways. Recent advances in our understanding of P2Y receptor physiology suggest that these receptors are a potentially relevant target of antithrombotic therapy. P2Y₁ mediates ADP-induced intracellular calcium ion mobilization and shape change, and P2Y₁₂ is coupled to adenylyl cyclase inhibition and is responsible for ADP-induced macroscopic platelet aggregation.⁶⁶

At the same time, we have only a perfunctory understanding of the function of P2X₁ in platelet activation. It is known, however, that P2X₁ function is linked to calcium ion influx.⁶⁶

Etiology

P2Y₁₂ defects are inherited as autosomal recessive traits,⁶⁷ and heterozygous individuals display a mild abnormality in platelet function similar to that observed in patients with SPD. In two cases, different homozygous frameshift mutations cause premature termination of translation. In another case, one allele presented a reading frameshift caused by the deletion of two nucleotides, whereas the other case had a normal coding sequence but a reduced expression, possibly resulting from another mutation in a regulatory region of the gene.⁶⁸

Clinical Features and Laboratory Findings

A limited number of patients have been described with congenital abnormalities of P2Y₁₂ resulting in bleeding diatheses and abnormalities of platelet function.⁴ The common clinical findings in these patients are a lifelong history of mucosal bleeding, easy bruising and/or excessive post-operative bleeding, and mildly to severely prolonged bleeding times. Laboratory findings were a weak and rapidly reversible primary wave of aggregation induced by ADP and abnormal aggregation induced by collagen, arachidonate, and TXA₂ analogs. Aggregation induced by high concentrations of thrombin was normal. ADP-induced shape change is normal, but ADP fails to inhibit the expected normal rise in cAMP levels seen after stimulation with prostaglandin E₁.

Management

Inasmuch as there are generally no serious side effects, DDAVP is recommended for prophylaxis and treatment in these patients.²³

Thromboxane A₂ Receptor

Defective TXA₂ receptor function is characterized by impaired platelet aggregation in response to the TXA₂ analog U46619, a variable response to other agonists comprising a reduced primary wave and absent secondary wave, and defective secretion.⁶⁹

Epinephrine Receptor

A selective absence of an aggregation in response to adrenaline has been reported as a heritable trait in association with easy bruising and reduced expression of platelet α_2 -adrenoceptors.^{70, 71} However, the aggregation response to adrenaline among normal individuals is itself quite variable, and a relative decrease in the aggregation response to adrenaline may represent the lower segment of a common asymptomatic population variant.⁷²

Inherited Defects in Signal Transduction Pathways

Cyclooxygenase Defects

Defects in platelet cyclooxygenase (COX) or TX synthase⁷³ give the same laboratory findings as seen in TXA₂ receptor defects (see above), but can be distinguished from the latter by the preservation of platelet aggregation in response to prostaglandin-H₂ or the TXA₂ analog U46619.

Scott Syndrome

Scott syndrome is a rare autosomal recessive disorder characterized by a defect in calcium-induced phospholipid scrambling and prothrombin conversion on platelets and other blood cells.⁷⁴

When Scott platelets are activated, phosphatidylserine is not transported from the inner to the outer phospholipid leaflet of the membrane. The binding of factor Va-Xa and factor VIIIa-IXa complexes is impaired, resulting in decreased thrombin generation and impaired platelet-dependent fibrin formation on subendothelium. It has been reported that Scott syndrome may be explained, at least in part, by mutations in an ATP-binding cassette transporter A1 implicated in the exofacial translocation of phosphatidylserine.⁷⁵

Additional Defects

Patients have been described with: A lineage-specific G α_q subunit deficiency and impaired α IIb β 3 activation; reduced G α_i 1 expression and signaling; defective calcium ion mobilization and an abnormal response to ionophore A23187; a reduced production of inositol 1,4,5-triphosphate and phosphatidic acid, diminished plekstrin phosphorylation and defective phospholipase C activation; and a specific defect in phospholipase C β 2 expression.⁷⁶ Pseudohypoparathyroidism type 1b, which is associated with a mild bleeding disorder, is caused by a defect in the heterotrimeric G protein subunit G α_s , which regulates adenylyl cyclase.⁷⁷

Defect in the Consolidation Phase: Glanzmann Thrombasthenia

GT is an autosomal-recessive disorder characterized by defective in vitro platelet aggregation and a lifelong bleeding tendency due

P.1137

to quantitative or qualitative abnormalities of the platelet GPIIb-IIIa,² also known as the integrin α IIb β 3.

Etiology

A qualitative or quantitative defect of either GPIIb or GPIIIa is the basic biochemical basis for GT. GPIIb-IIIa is a calcium-dependent heterodimer that binds preferentially to fibrinogen or vWF, but also to fibronectin or vitronectin. The genes for GPIIb and GPIIIa are distinct but are physically located within 1 Mb of each other on the long arm of chromosome 17 (17q21-22). A genetic defect in either GPIIb or GPIIIa can inhibit synthesis of that subunit and/or prevent normal assembly and processing of the functional receptor. This results in the lack of a fibrinogen receptor and defective fibrinogen binding after platelet activation. Platelet aggregation, which requires this protein, is therefore deficient or completely absent.

A continually maintained database is accessible on the Internet (<https://haemgen.haem.cam.ac.uk/thrombogenomics/>) which contains a list of over 100 mutations that give rise to GT. The α IIb and β 3 genes (ITGA2B and ITGB3, respectively) are both affected, and although post-translational defects predominate, reduced mRNA stability can also be a cause. Integrin synthesis occurs in the megakaryocytes with α IIb β 3 complex formation in the endoplasmic reticulum. Noncomplexed or incorrectly folded gene products fail to undergo processing in the Golgi apparatus and are rapidly degraded intracellularly.⁷⁸

In GT, isoantibodies specific for the deleted GPs have been demonstrated in the blood of multiply transfused patients,² and these can reproduce the thrombasthenic defect in normal transfused platelets.

Clinical Features

Thrombasthenia is inherited as an autosomal-recessive trait, and consanguinity is common within affected kindreds, resulting in geographic clusters of patients.² Hemorrhagic symptoms occur only in patients homozygous for GT mutations, whereas the heterozygous condition is mostly asymptomatic, even though platelets from heterozygotes have only one half the normal level of $\alpha\text{IIb}\beta\text{3}$. The sites of bleeding in GT are clearly defined: Purpura, epistaxis, gingival hemorrhage, and menorrhagia are nearly constant features; gastrointestinal bleeding and hematuria are less common but can cause serious complications. Bleeding at menarche is severe enough to require transfusions in most patients. Deep visceral hematomas, a characteristic of coagulation disorders such as hemophilia, are not usually seen in GT. Bleeding symptoms normally manifest rapidly after birth, even if most patients are diagnosed before the age of five. Epistaxis is a common cause of severe bleeding, and is typically more severe in childhood. In general, the bleeding tendency in GT decreases with age. Post-traumatic and post-operative hemorrhage can be serious, and pregnancy and delivery represent a severe hemorrhagic risk, because bleeding may not always be preventable by platelet transfusions. Although GT can be a severe hemorrhagic disease, the prognosis is excellent with careful supportive care. Death from hemorrhage in diagnosed patients is rare unless associated with trauma, other disease (e.g., cancer), or chronic isoimmunization.

Laboratory Findings

A prolonged bleeding time, deficient clot retraction, and deficient platelet aggregation with ADP, collagen, epinephrine, or thrombin are typical findings. Ristocetin-induced aggregation, on the other hand, and coagulation tests are normal. Thrombasthenic platelets are present in normal numbers and are morphologically normal when viewed by light microscopy.

Management

With GT patients, it is important to anticipate bleeding risks before performing procedures, and because the risk for bleeding is so unpredictable, it is prudent to administer prophylactic platelet transfusions even in the absence of a prior history of bleeding.

Localized bleeding can be treated by limited measures, such as fibrin sealants or topical thrombin and antifibrinolytic agents (ϵ -aminocaproic acid, tranexamic acid). Epistaxis and gingival bleeding can be controlled by nasal packing or the application of gel foam soaked in topical thrombin. The risk of gingival bleeding can be minimized by regular, proper dental care. When tooth extractions must be performed or when hemorrhage accompanies the loss of deciduous teeth, bleeding can be significantly reduced by the application of individually prepared plastic splints that provide physical support for hemostasis.

Severe menorrhagia is common and can be effectively treated with high doses of progesterone, followed by maintenance treatment with birth control pills. Severe gastrointestinal bleeding is an isolated but severe problem. Iron deficiency anemia can develop insidiously with gingival oozing or minor menorrhagia. Confronted with a severe bleeding episode or as prophylaxis for invasive procedures, most GT patients receive blood transfusions, regardless of bleeding history.⁷⁹ Transfusions should be continued until wound healing is complete. However, a significant number of transfused patients can develop HLA-specific alloantibodies or GPIIb-IIIa-specific isoantibodies, which seriously complicate transfusion therapy and limit future treatment. Isoantibodies can block normal transfused platelet aggregation and/or lead to the rapid removal of transfused platelets by immune mechanisms. It is not yet possible to predict the propensity of individual GT patients to develop such antibodies. Antibodies may be successfully removed prior to surgery by immunoadsorption on Protein A Sepharose, but this is a complex procedure restricted to specialized centers.⁸⁰

Pregnancy and delivery represent a severe hemorrhagic risk. Platelet transfusions are required not only prior to delivery, but afterward as well. Successful delivery by cesarean section, with platelet transfusions, has been reported.

The use of rFVIIa (NovoSeven[®]; NovoNordisk A/S, Malov, Denmark) is an alternative approach for early cessation of bleeding in GT, especially in the case of patients who have developed antibodies and/or have a history of transfusion refractoriness.⁸¹ It seems that rFVIIa enhances deposition of $\alpha\text{IIb}\beta\text{3}$ -deficient platelets on the subendothelial matrix through an interaction with fibrin formed by the increased thrombin generation⁸² leading to increased clot stability.⁸³ However, some question the efficacy of rFVIIa in children with GT.⁸⁴

In a few GT patients, the bleeding symptoms have been considered sufficiently serious to warrant allogeneic bone-marrow transplantation.⁸⁵

Additional Hereditary Defects of Platelet Function (with Thrombocytopenia)

MYH-9-related Thrombocytopenia Syndromes

MYH-9-related disorder encompasses autosomal dominant macrothrombocytopenia syndromes previously classified as May-Hegglin anomaly, Sebastian, Fechtner, and Epstein syndromes and certain inherited thrombocytopenias that have in common mutations within MYH9, the gene for nonmuscle myosin heavy chain II-A (NMMHC-IIA).⁸⁶

Etiology

NMMHC-IIA is part of the nonmuscle myosin IIA hexamer that is a component of the contractile cytoskeleton in megakaryocytes, platelets, and other many other cell types. Mutations of MYH9

P.1138

that give rise to MYH-9-related disorder disrupt the stability of the nonmuscle myosin IIA hexamer or its association with regulatory proteins. This results in defective megakaryocytopoiesis that leads to thrombocytopenia. Additional platelet function defects arise from abnormal shape change or impaired expression of the GPIb complex.⁸⁷ As in many other inherited hematologic disorders, incomplete penetrance accounts for a poor correlation between the MYH9 genotype and clinical phenotype as well as variability in phenotype among individuals with identical mutations.⁸⁶

Clinical Features

Patients with MYH-9-related disorder present with bleeding, sensorineural hearing loss, glomerulonephritis, and/or eye abnormalities. The severity of the bleeding symptoms is out of proportion to the moderately decreased platelet count, suggesting the concurrence of a platelet function defect. Life-threatening bleeding has been reported, but is the exception. The combination of macrothrombocytopenia and one or more of the recognized clinical features of MYH-9-related disorder is strong evidence for this diagnosis.

Laboratory Findings

Platelet counts are normally from 20,000 to 130,000/ μ l, and are associated with an increased mean platelet volume and a conspicuous population of very large platelets. The presence of Dohle-like bodies within neutrophils on stained peripheral blood smears is highly suggestive of MYH-9-related disorder. An abnormal staining of neutrophil inclusions with antibodies specific for NMMHC-IIA is a more sensitive index of the syndrome, but a definitive diagnosis must be based on the identification of a causative mutation within MYH9.

Management

The symptoms of MYH-9-related disorders are highly variable, and therefore treatment of individual patients should be guided as much as possible by personal and family history.⁵ In general, management would be the same as for other mild platelet disorders.

Wiskott-Aldrich Syndrome

Wiskott-Aldrich syndrome (WAS) is an X-linked recessive disease characterized by microthrombocytopenia, eczema, and immunodeficiency.¹ The WAS gene encodes the WAS protein (WASP), and mutations in WAS result in decreased or absent expression of WASP, a key regulator of actin polymerization in hematopoietic cells playing a role as an adapter protein. The reduction in or absence of WASP results in premature proplatelet formation in the bone marrow and the microthrombocytopenia characteristic of WAS.

Etiology

WAS arises from mutations in WAS, the gene for the protein WASP that is expressed in all hematopoietic cell lineages. Isolated X-linked thrombocytopenia (XLT) is also caused by mutations in WAS and is a variant of the same disease but generally lacks severe immune deficiency.⁸⁸

Clinical Features

Infants with WAS often present with bruising and purpura in the neonatal period with an increased risk of intracranial hemorrhage. Gastrointestinal bleeding or prolonged bleeding after circumcision may be a presenting feature. Eczema develops during the first year of childhood and can vary in severity, from widespread and debilitating in children with "classic" WAS to mild or absent in those with the XLT. Infections begin in the first 6 months of life. Bacterial infections occur more often, particularly otitis media and respiratory tract infections, whereas severe viral infections and opportunistic infections occur less frequently. In the XLT phenotype, eczema and infection do not occur. With increasing

age, hemolytic anemia and vasculitis become the most frequent manifestations of the autoimmune component of this disease.⁸⁹ Another life-threatening complication of WAS is malignancy, usually but not exclusively lymphoreticular in origin.

Laboratory Findings

Thrombocytopenia (ranging from 5,000 to 50,000/ μ l) with small platelets is evident at birth. Despite normal bone marrow megakaryocyte numbers and morphology, there may be ineffective thrombocytopoiesis with reduced platelet survival.

Management

The management of WAS should address bleeding manifestations, recurrent infections, eczema, autoimmune disorders, and the risk of malignancy. When available, bone marrow or stem cell transplant is the treatment of choice as early as possible. Proper management is benefited by a multidisciplinary approach, which should include an immunologist. When transfusion is necessary, HLA-compatible and irradiated platelets should be used in order to avoid sensitization. Because of the immune deficiency, platelets to be transfused should always be irradiated and certified free of cytomegalovirus. Splenectomy can result in an increase both in platelet number and size, but the risk of sepsis is increased post splenectomy, and a risk-benefit analysis of this operation must be considered for individual patients. Splenectomy does not influence the development of malignancy or autoimmune disorders, and it may thus be more successful in the milder phenotype of XLT.

ACQUIRED DISORDERS OF PLATELET FUNCTION

Drug-induced Platelet Dysfunction

An adult patient that presents with a normal platelet count, mucocutaneous bleeding, and a negative family history, defined as no bleeding among first degree relatives, should be evaluated for an acquired disorder. Although inherited platelet disorders are rare, acquired disorders of platelet function are encountered frequently.

A diverse variety of medications, from ionophores to ADP analogs, certain systemic diseases, and various procedures can induce platelet dysfunction (Table 52.2). Even common dietary substances, such as garlic or fish oil, can impair platelet function.⁹⁰ This chapter focuses on commonly used drugs that can impair platelet function at therapeutic doses. Other drugs that are used to treat thromboembolic disorders are discussed in detail in Chapter 62.

The extent of platelet dysfunction produced by drugs in healthy individuals is usually not clinically significant. On the other hand, patients with coagulation disorders, uremia, thrombocytopenia, and patients receiving heparin or Coumadin as anticoagulant

P.1139

therapy, can exhibit serious bleeding when they receive a drug that attenuates platelet function. In addition, the inherent variation in platelet reactivity among normal individuals⁹¹ can greatly influence the susceptibility of an individual to the antiplatelet effects of dietary supplements or drugs.

TABLE 52.2 DRUGS AFFECTING PLATELET FUNCTION

Analgesics

Aspirin

Nonsteroidal anti-inflammatory drugs

Acetaminophen

Antibiotics

β -Lactams: Penicillins, cephalosporins

Cardiovascular drugs

Aspirin

Aspirin inhibits platelet function via irreversible acetylation of platelet COX-1 and the resulting inhibition of TXA₂ synthesis. A single high dose of aspirin (e.g., 325 mg or more) or consecutive smaller doses (e.g., 81 mg) taken for 3 or more days will produce essentially complete inhibition of TXA₂ production. The hemostatic risk following aspirin is

predictable, with a 5% to 10% incidence of minor bleeding and a 1% to 2% incidence of major bleeding, i.e., requiring hospitalization or red cell transfusion.⁹²

In *ex vivo* whole blood perfusion assays, aspirin-treated platelets will adhere normally to denuded arterial segments or collagen-coated surfaces, but they fail to form thrombi due to inhibition of aggregate formation. By EM, one notes an inhibition of organelle centralization that normally follows platelet stimulation by collagen. In platelet aggregation assays, aspirin-treated platelets exhibit decreased responses to collagen and an absence of the secondary wave of aggregation that is normally induced by epinephrine and low concentrations of ADP, which is reflected in a marked reduction in the release of δ -granule ADP, ATP, and serotonin.

Individual differences in platelet responsiveness to aspirin have been noted. In some normal individuals, aspirin ingestion can modestly elevate the bleeding time and have a small impact on platelet aggregation *in vivo*, more so in men than in women, but in certain patients with otherwise minor platelet dysfunction, the bleeding time can be markedly prolonged and platelet aggregation severely impaired after aspirin ingestion. The search for a genetic basis for this difference in aspirin sensitivity is a hotly contested area of investigation.

Other Nonsteroidal Anti-inflammatory Drugs

NSAIDs reversibly inhibit platelet COX-1, and normal platelet function is gradually restored when these drugs are stopped. For example, ibuprofen (600 mg daily) will prolong PFA-100 CTs, but these will conform to baseline within 24 hours after drug in-take is ceased.⁹³ It is uncommon to see clinical bleeding in normal individuals as a result of an NSAID, but gastrointestinal bleeding due to gastric ulceration is not uncommon. Paradoxically, ibuprofen can also exhibit a prothrombotic effect if it is ingested within 2 hours of taking aspirin, inasmuch as it can transiently block acetylation of the COX-1 target site.

Cyclooxygenase-2 Inhibitors

COX-2 inhibitors provide the anti-inflammatory effects of COX blockade without affecting platelet function. COX-2 is expressed in endothelial cells, fibroblasts, and monocytes and is up-regulated in response to growth factors, cytokines, endotoxin, and hormones. Even though COX-2 inhibitors have no direct effect on platelets, they increase the risk for thrombosis and cardiovascular disease because they inhibit vascular (endothelial) cell synthesis of prostacyclin, a natural inhibitor of platelet activation and thrombosis.⁹⁴

P2Y₁₂ Antagonists

Platelet responses to natural agonists are normally enhanced by the binding of released ADP to platelet purinogenic receptors. The thienopyridines clopidogrel and ticlopidine bind irreversibly to the platelet purinogenic receptor P2Y₁₂ and thereby inhibit platelet responses induced by both exogenous ADP and ADP released from platelet δ -granules. However, clopidogrel has replaced ticlopidine as the preferred medication because the latter is associated with potentially life-threatening hematologic side effects (thrombotic thrombocytopenic purpura, agranulocytosis, and aplastic anemia). Steady-state inhibition of platelet function occurs after 3 to 5 daily doses of 75 mg clopidogrel, but it can be achieved sooner with a 300-mg loading dose. Even though clopidogrel has a greater effect than aspirin on the bleeding time,⁹⁵ there is no greater risk of bleeding *in vivo*. The combination of clopidogrel and aspirin is currently used to prevent or treat arterial thrombosis.⁹⁶ The effect of clopidogrel on platelet function is irreversible, such that after cessation of clopidogrel, platelet function returns to roughly 50% of normal levels by 72 hours, and its effect is completely reversed by 7 days.⁹⁷

Antibiotics

Large doses of various β -lactam antibiotics (penicillins more often than cephalosporins) can cause clinical bleeding, abnormal platelet function *in vitro*, and increased bleeding times, because of a nonspecific effect on ligand-receptor interactions.⁹⁸ The effect on platelet function can be manifested by a dose-dependent reduction in platelet aggregation *in vitro* to ADP, epinephrine, and collagen. The clinical effect is exaggerated in hypoalbuminemic patients because the level of free drug is increased and thus more interact with the platelet surface. β -Lactam compounds influence clinical bleeding when there is co-existing hemostatic defect, such as in uremia, thrombocytopenia, or vitamin K deficiency.

β -Lactams appear to modify the platelet membrane and decrease agonist binding. The effect can become event after several days of treatment and will not resolve until 7 to 10 days after discontinuation. Moxalactam and cefotetan can produce clinical bleeding as a result of both platelet dysfunction and the N-methylthiotetrazole side-chain effect on vitamin K-dependent clotting factor synthesis.^{99, 100}

Integrin α IIb β ₃ Antagonists

Specific inhibitors of integrin $\alpha\text{IIb}\beta\text{3}$ are potent inhibitors of platelet function, and three are currently approved by the FDA: Abciximab is a chimeric human-mouse monoclonal Fab fragment; tirofiban is an arginine-glycine-aspartate-based peptidomimetic; and eptifibatid (integrelin) is a synthetic cyclic heptapeptide based on the lysine-glycine-aspartate motif of the snake venom disintegrin barbourin.

These antagonists, which inhibit platelet aggregation effectively because they prevent fibrinogen and VWF binding to $\alpha\text{IIb}\beta\text{3}$, are used commonly in patients undergoing percutaneous coronary intervention (PCI), concurrently with heparin and other antiplatelet therapy such as aspirin. Bleeding is a common side effect of these antagonists and occurs in ~10% of recipients, but intracranial bleeding (<0.5%) and death due to bleeding (<0.1%) are rare. The duration of the antiplatelet effect of these drugs varies: Although unbound abciximab is cleared rapidly, elimination of bound drug is significantly slower and some residual receptor blockade (~25%) can be detected for up to 7 days; the inhibitory effects of the other two small molecules are directly proportional to their elimination half-life and usually disappear within hours of drug removal.¹⁰¹

Uremia

Patients with uremia are at risk for bleeding complications because of a number of factors that include minor coagulation abnormalities, platelet dysfunction, thrombocytopenia, or the widespread use of medications that compromise hemostasis.¹⁰² Defects in all stages of platelet hemostasis including adhesion, secretion, and aggregation have been noted in studies of platelet function in uremic patients.

P.1140

Factors That Influence Hemostasis

Nitric oxide is a potent modulator of vascular tone that limits platelet adhesion to the endothelium and platelet-platelet interaction by increasing the formation of cGMP,¹⁰³ and enhanced nitric oxide synthesis has been demonstrated in uremic patients. The inhibition of nitric oxide formation in a rat model of uremia completely normalized the bleeding tendency in rats.¹⁰⁴

Additional platelet changes have been noted. Deficient platelet stores of ADP and serotonin have been described in uremic platelets, suggesting that these platelets have an acquired storage pool deficiency. Elevated cAMP levels may be responsible for an acquired defect of COX activity with reduced ability to synthesize TXA₂. Alterations in intraplatelet calcium mobilization have also been reported and theorized to be associated with uremic bleeding.¹⁰⁵

In uremic patients, integrin $\alpha\text{IIb}\beta\text{3}$ has a reduced ability to bind both VWF and fibrinogen,¹⁰⁶ most likely due to a conformational change in this integrin. Hemodialysis improved fibrinogen binding, leading to the hypothesis that a dialyzable toxic substance is responsible in part for altered platelet function. Uremic substances that inhibit platelet function in concentrations detectable in uremic plasma include: Urea, guanidine-succinate, parathyroid hormone, phenol, and tryptophan products.¹⁰⁷ Small peptides containing the RGD that could potentially inhibit $\alpha\text{IIb}\beta\text{3}$ function accumulate in uremic patients due to reduced clearance.¹⁰⁸

The Effects of Anemia

Anemia predisposes uremic patients to bleeding complications.^{109, 110} When the hematocrit is reduced, platelets travel closer to the center of the vascular lumen and are thus less likely to interact with the subendothelium. In addition, red blood cells release ADP and TXA₂ which enhances platelet aggregation.¹¹¹ Hemoglobin also scavenges nitric oxide and therefore a reduced hematocrit would be associated with enhanced nitric oxide activity and promoting platelet inhibition and vasodilatation. Finally, significant anemia in current vintage dialysis populations often co-occurs with other major problems such as iron deficiency, malnutrition, and inflammation in the sickest patients. This may further confound observational studies of bleeding risk in current dialysis patients.

Secondary Effects of Medications

The bleeding risk in uremic patients is increased by exposure to antiplatelet agents and anticoagulants, including aspirin, $\alpha\text{IIb}\beta\text{3}$ antagonists, heparin, and warfarin.¹¹²

Clinical Features

The bleeding sites in the uremic patient are gastrointestinal and intracranial. Through gastrointestinal bleeding, chronic renal failure patients may lose 4 to 6 times as much blood per day as normal individuals through peptic ulcer disease,

gastric bleeding, telangiectasias in the stomach, duodenum, jejunum, and colon, and duodenitis and esophagitis.¹¹³ In a long-term follow study of 1,609 chronic hemodialysis patients, there was a tenfold higher incidence of intracerebral hemorrhage compared to the general population.¹⁰⁷

Laboratory Findings

Platelet aggregation to exogenous agents is often but not always defective, such that the sensitivity to aggregating concentrations of collagen, ADP, and epinephrine is decreased, and TXB₂ generation and δ -granule ADP content are reduced relative to control platelets.¹⁰⁴

Management

The most effective treatment of uremic bleeding includes hemodialysis and peritoneal dialysis,¹¹⁴ although a transient worsening of platelet function may be encountered immediately following.¹¹⁵ When platelet function was prospectively evaluated after renal transplantation, platelet aggregation, F-actin, and platelet cytoskeletal abnormalities were completely normal by 8 weeks after renal transplant.

Red blood cell transfusions and/or administration of erythropoietin (rHUEPO) have been observed to decrease bleeding, shorten the bleeding time, and increase platelet adhesiveness when given to hemodialyzed patients.¹¹⁶ However, some patients may become hypercoagulable.

Administration of DDAVP can shorten the bleeding time and is effective for short-term control of bleeding in some uremic patients as a result of changes in vWF activity.¹¹⁷

Cardiovascular disease is common in patients with chronic renal insufficiency and end-stage renal disease. Antiplatelet medications are associated with an increased risk of bleeding, compared to the risk associated with their use in patients who do not have end-stage renal disease. Among patients undergoing PCI and treated with abciximab, those with renal insufficiency had a greater tendency of major bleeding.¹¹⁸

Paraproteinemias

Bleeding is a common complication of paraproteinemias associated with multiple myeloma, Waldenstrom macroglobulinemia, monoclonal gammopathies, and even polyclonal hypergammaglobulinemia.^{119, 120} The etiology is complex, but various mechanisms have been proposed, such as thrombocytopenia or platelet dysfunction, inhibitors of specific coagulation factors, circulating monoclonal proteins that bind to and promote clearance of coagulation factors, and hyperviscosity syndrome.

Clinical Features and Laboratory Findings

Hematologic findings that are limited to purpura and mucocutaneous bleeding are most often encountered in patients with IgA myeloma and macroglobulinemia. Platelet dysfunction likely results from nonspecific binding of immunoglobulins to the platelet surface.¹²¹

Myeloproliferative Disorders

Chronic myeloproliferative disorder (MPD) defines a group of Philadelphia chromosome-negative disorders that includes essential thrombocythemia (ET), polycythemia vera (PV), and agnogenic myeloid metaplasia and chronic idiopathic myelofibrosis.¹²² Various platelet defects have been reported in patients with MPD, including defective platelet aggregation and secretion, subnormal uptake of serotonin, abnormal expression of Fc receptors, specific defects in integrin α IIb β 3 expression or activity, and an acquired SPD.

Etiology

Vainchenker et al. showed that acquired JAK2 V617F mutation in hematopoietic precursors causes PV.¹²³ The V617F mutation results in the loss of inhibitory activity of the JH2 pseudokinase segment of JAK2 leading to enhanced activity of the JH1 kinase of JAK2, which renders hematopoietic precursors hypersensitive to thrombopoietin, erythropoietin (EPO), insulin growth factor 1, stem cell factor, and granulocyte colony-stimulating factor. The result is a trilinear myeloproliferation that explains the common proliferative features of ET, PV, and MF.^{124, 125}

P.1141

Clinical Features and Laboratory Findings

Microvascular disturbances in ET and PV, including erythromelalgia, and atypical and typical transient cerebral, ocular, and coronary ischemic attacks, are caused by platelet-mediated transient and occlusive thrombosis in the end-arterial circulation.¹²² An inconsistent pattern of laboratory abnormalities has been encountered, with poor correlation between lab results and bleeding severity. As in MDS and acute leukemia, platelet dysfunction appears to result from defective megakaryocyte maturation and/or thrombopoiesis.

The endogenous synthesis of TXA2 by platelets, reflected by the stable urine metabolite TXB2, is increased in ET and PV patients.¹²⁶ This increased biosynthesis of TXA2 is a reflection of spontaneous platelet activation in vivo.^{126, 127}

Management

Correction of hematocrit to normal by phlebotomy will reduce the major arterial and venous thrombotic complications, but fail to prevent the platelet-mediated microvascular circulation disturbances in PV patients because thrombocytopenia persists. Complete relief and prevention of microvascular and major thrombosis in ET and PV patients, in addition to phlebotomy, are obtained by treatment with aspirin but not with warfarin.¹²²

REFERENCES

1. Nurden A, Nurden P. Advances in our understanding of the molecular basis of disorders of platelet function. *J Thromb Haemost* 2011;9(Suppl 1):76-91.
2. Nurden AT, Fiore M, Nurden P, et al. Glanzmann thrombasthenia: a review of ITGA2B and ITGB3 defects with emphasis on variants, phenotypic variability, and mouse models. *Blood* 2011;118:5996-6005.
3. Hayward CPM, Rao AK, Cattaneo M. Congenital platelet disorders: overview of their mechanisms, diagnostic evaluation and treatment. *Haemophilia* 2006;12(Suppl 3):128-136.
4. Cattaneo M. Bleeding manifestations of congenital and drug-induced defects of the platelet P2Y12 receptor for adenosine diphosphate. *Thromb Haemost* 2011;105(Suppl 1):S67-S74.
5. Bolton-Maggs PH, Chalmers EA, Collins PW, et al. A review of inherited platelet disorders with guidelines for their management on behalf of the UKHCDO. *Br J Haematol* 2006;603-633.
6. Coller BS, Schneiderman PI. Clinical evaluation of hemorrhagic disorders: the bleeding history and differential diagnosis of purpura. In: Hoffman R, Benz EJ Jr, Shattil SJ, et al., eds. *Hematology (Basic Principles and Practice)*. Churchill Livingstone/Elsevier. Philadelphia, PA. 2005:1975-2000.
7. Hassan AA, Kroll MH. Acquired disorders of platelet function. *Hematology Am Soc Hematol Educ Program* 2005:403-408.
8. Sadler JE, Rodeghiero F. Provisional criteria for the diagnosis of VWD type 1. *J Thromb Haemost* 2005;3:775-777.
9. Kunicki TJ, Baronciani L, Canciani MT, et al. An association of candidate gene haplotypes and bleeding severity in von Willebrand Disease (VWD) type 2A, 2B, and 2M pedigrees. *J Thromb Haemost* 2006;4:137-147.
10. Kunicki TJ, Federici AB, Salomon DR, et al. An association of candidate gene haplotypes and bleeding severity in Von Willebrand Disease (VWD) type 1 pedigrees. *Blood* 2004;104:2359-2367.
11. Lind SE. The bleeding time. *Platelets* 2002;283-289.
12. Harrison P, Robinson M, Liesner R, et al. The PFA-100: a potential rapid screening tool for the assessment of platelet dysfunction. *Clin Lab Haematol* 2002;24:225-232.
13. Jilma B. Platelet function analyzer (PFA-100): a tool to quantify congenital or acquired platelet dysfunction. *J Lab Clin Med* 2001;138:152-163.
14. Favaloro EJ. Utility of the PFA-100 for assessing bleeding disorders and monitoring therapy: a review of analytical variables, benefits and limitations. *Haemophilia* 2001;7:170-179.
15. Di Paola J, Federici AB, Mannucci PM, et al. Low platelet alpha2beta1 levels in type I von Willebrand disease correlate with impaired platelet function in a high shear stress system. *Blood* 1999;93:3578-3582.
16. Cattaneo M, Hayward CPM, Moffat KA, et al. Results of a worldwide survey on the assessment of platelet function by light transmission aggregometry: a report from the platelet physiology subcommittee of the SSC of the ISTH. *J Thromb Haemost* 2009;7:1029.
17. Sandrock K, Zieger B. Current strategies in diagnosis of inherited storage pool defects. *Transfus Med Hemother* 2010;37:248-258.

18. Simon D, Kunicki T, Nugent D. Platelet function defects. *Haemophilia* 2008;14:1240-1249.
19. O'Brien SH. An update on pediatric bleeding disorders: bleeding scores, benign joint hypermobility, and platelet function testing in the evaluation of the child with bleeding symptoms. *Am J Hematol* 2012;87(Suppl 1):S40-S44.
20. Harrison P. Assessment of platelet function in the laboratory. *Hämostaseologie* 2009;29:25-31.
21. Lacroix R, Robert S, Poncelet P, et al. Standardization of platelet-derived microparticle enumeration by flow cytometry with calibrated beads: results of the International Society on Thrombosis and Haemostasis SSC Collaborative workshop. *J Thromb Haemost* 2010;8:2571-2574.
22. Clauser S, Cramer-Bordé E. Role of platelet electron microscopy in the diagnosis of platelet disorders. *Semin Thromb Hemost* 2009;35:213-223.
23. DiMichele DM, Hathaway WE. Use of DDAVP in inherited and acquired platelet dysfunction. *Am J Hematol* 1990;33:39-45.
24. Poon MC. The evidence for the use of recombinant human activated factor vii in the treatment of bleeding patients with quantitative and qualitative platelet disorders. *Transfus Med Rev* 2007:223-236.
25. Wiegering V, Winkler B, Langhammer F, et al. Allogeneic hematopoietic stem cell transplantation in Glanzmann thrombasthenia complicated by platelet alloimmunization. *Klin Padiatr* 2011;223:173-175.
26. Nurden AT, Dupuis D, Kunicki TJ, et al. Analysis of the glycoprotein and protein composition of Bernard-Soulier platelets by single and two-dimensional sodium dodecyl sulfate-polyacrylamide gel electrophoresis. *J Clin Invest* 1981;67:1431-1440.
27. Ruggeri ZM. Von Willebrand factor: looking back and looking forward. *Thromb Haemost* 2007;98:55-62.
28. Hourdille P, Pico M, Jandrot-Perrus M, et al. Studies on the megakaryocytes of a patient with the Bernard-Soulier syndrome. *Br J Haematol* 1990;76:521-530.
29. Locatelli F, Rossi G, Balduini C. Hematopoietic stem-cell transplantation for the Bernard-Soulier syndrome. *Ann Intern Med* 2003;138:79.
30. Levy-Toledano S, Tobelem G, Legrand C, et al. Acquired IgG antibody occurring in a thrombasthenic patient: its effect on human platelet function. *Blood* 1978;51:1065-1071.
31. Kunicki TJ, Nugent DJ. The genetics of normal platelet reactivity. *Blood* 2010;116:2627-2634.
32. Kunicki TJ, Nugent DJ. Platelet glycoprotein polymorphisms and relationship to function and immunogenicity. In: Marder VJ, Aird WC, Bennett JS, et al., eds. *Hemostasis and thrombosis*. Philadelphia, PA: Lippincott Williams & Wilkins, 2013:393-399. In Press.
33. Moroi M, Okuma M, Jung SM. Platelet adhesion to collagen-coated wells: analysis of this complex process and a comparison with the adhesion to matrigel-coated wells. *Biochim Biophys Acta Mol Cell Res* 1992;1137:1-9.
34. Boylan B, Chen H, Rathore V, et al. Anti-GPVI-associated ITP: an acquired platelet disorder caused by autoantibody-mediated clearance of the GPVI/FcRgamma-chain complex from the human platelet surface. *Blood* 2004;104:1350-1355.
35. Gardiner EE, Karunakaran D, Shen Y, et al. Controlled shedding of platelet glycoprotein (GP)VI and GPIb-IX-V by ADAM family metalloproteinases. *J Thromb Haemost* 2007;5:1530-1537.
36. Furihata K, Clemetson KJ, Deguchi H, et al. Variation in human platelet glycoprotein VI content modulates glycoprotein VI-specific prothrombinase activity. *Arterioscler Thromb Vasc Biol* 2001;21:1857-1863.
37. Kunicki TJ, Williams SA, Nugent DJ, et al. Mean Platelet Volume and Integrin Alleles Correlate With Levels of Integrins α IIb β 3 and α 2 β 1 in Acute Coronary Syndrome Patients and Normal Subjects. *Arterioscler Thromb Vasc Biol* 2011;32:147-152.
38. Nurden AT, Nurden P. The gray platelet syndrome: clinical spectrum of the disease. *Blood Rev* 2007;21:21-36.
39. Gunay-Aygun M, Falik-Zaccai TC, Vilboux T, et al. NBEAL2 is mutated in gray platelet syndrome and is required for biogenesis of platelet α -granules. *Nat Genet* 2011:1-3.
40. Albers CA, Cvejic A, Favier R, et al. Exome sequencing identifies NBEAL2 as the causative gene for gray platelet syndrome. *Nat Genet* 2011:1-3.

41. Kahr WH, Hinckley J, Li L, et al. Mutations in NBEAL2, encoding a BEACH protein, cause gray platelet syndrome. *Nature Genetics* 2012;1-3.
42. Wall JE, Buijs-Wilts M, Arnold JT, et al. A flow cytometric assay using mepacrine for study of uptake and release of platelet dense granule contents. *Br J Haematol* 1995;89:380-385.
43. Biddle DA, Neto TG, Nguyen AN. Platelet storage pool deficiency of alpha and delta granules. *Arch Pathol Lab Med* 2001;125:1125-1126.
44. Detter JC, Zhang Q, Mules EH, et al. Rab geranylgeranyl transferase alpha mutation in the gunmetal mouse reduces Rab prenylation and platelet synthesis. *Proc Natl Acad Sci U S A* 2000;97:4144-4149.
45. Ninkovic I, White JG, Rangel-Filho A, et al. The role of Rab38 in platelet dense granule defects. *J Thromb Haemost* 2008;6:2143-2151.
46. Sheth PM, Kahr WHA, Haq A, et al. Intracellular activation of the fibrinolytic cascade in the Quebec Platelet Disorder. *Thromb Haemost* 2003;90:293-298.
47. Weiss HJ, Lages B, Zheng S, et al. Platelet factor V New York: a defect in factor V distinct from that in factor V Quebec resulting in impaired prothrombinase generation. *Am J Hematol* 2001;66:130-139.
48. Hayward CP, Eikelboom J. Platelet function testing: quality assurance. *Semin Thromb Hemost* 2007;33:273-282.
49. Huizing M, Anikster Y, Gahl WA. Hermansky-Pudlak syndrome and Chediak-Higashi syndrome: disorders of vesicle formation and trafficking. *Thromb Haemost* 2001;86:233-245.
50. Huizing M, Anikster Y, Fitzpatrick DL, et al. Hermansky-Pudlak syndrome type 3 in Ashkenazi Jews and other non-Puerto Rican patients with hypopigmentation and platelet storage-pool deficiency. *Am J Hum Genet* 2001;69:1022-1032.
51. Huizing M, Anikster Y, Gahl WA. Hermansky-Pudlak syndrome and related disorders of organelle formation. *Traffic* 2000;1:823-835.
52. Falik-Zaccai TC, Anikster Y, Rivera CE, et al. A new genetic isolate of gray platelet syndrome (GPS): clinical, cellular, and hematologic characteristics. *Mol Genet Metab* 2001;74:303-313.
53. Gahl WA, Brantly M, Kaiser-Kupfer MI, et al. Genetic defects and clinical characteristics of patients with a form of oculocutaneous albinism (Hermansky-Pudlak syndrome). *N Engl J Med* 1998;338:1258-1264.
54. Fantinato GT, Cestari SdCP, Afonso JPJM, et al. Do you know this syndrome? Chediak-Higashi syndrome. *An Bras Dermatol* 2011;86:1029.
55. Kaya Z, Ehl S, Albayrak M, et al. A novel single point mutation of the LYST gene in two siblings with different phenotypic features of Chediak Higashi syndrome. *Pediatr Blood Cancer* 2011;56:1136-1139.
56. Karim MA, Suzuki K, Fukai K, et al. Apparent genotype-phenotype correlation in childhood, adolescent, and adult Chediak-Higashi syndrome. *Am J Med Genet* 2002;108:16-22.
57. Tchernev VT, Mansfield TA, Giot L, et al. The Chediak-Higashi protein interacts with SNARE complex and signal transduction proteins. *Mol Med* 2002;8:56-64.
58. Eapen M, DeLaat CA, Baker KS, et al. Hematopoietic cell transplantation for Chediak-Higashi syndrome. *Bone Marrow Transplant* 2007;39:411-415.
59. Menasche G, Pastural E, Feldmann J, et al. Mutations in RAB27A cause Griscelli syndrome associated with haemophagocytic syndrome. *Nat Genet* 2000;25:173-176.
60. Sanal O, Ersoy F, Tezcan I, et al. Griscelli disease: genotype-phenotype correlation in an array of clinical heterogeneity. *J Clin Immunol* 2002;22:237-243.
61. Favier R, Jondeau K, Boutard P, et al. Paris-Trousseau syndrome : clinical, hematological, molecular data of ten new cases. *Thromb Haemost* 2003;90:893-897.
62. Raslova H, Komura E, Le Couedic JP, et al. FLI1 monoallelic expression combined with its hemizygous loss underlies Paris-Trousseau/Jacobsen thrombopenia. *J Clin Invest* 2004;114:77-84.
63. Lo B, Li L, Gissen P, et al. Requirement of VPS33B, a member of the Sec1/Munc18 protein family, in megakaryocyte and platelet alpha-granule biogenesis. *Blood* 2005;106:4159-4166.

64. Gissen P, Johnson CA, Morgan NV, et al. Mutations in VPS33B, encoding a regulator of SNARE-dependent membrane fusion, cause arthrogyposis-renal dysfunction-cholestasis (ARC) syndrome. *Nat Genet* 2004;36:400-404.
65. Oury C, Toth-Zsomboki E, Vermylen J, et al. The platelet ATP and ADP receptors. *Curr Pharm Des* 2006;12:859-875.
66. Gachet C, Hechler B. The platelet P2 receptors in thrombosis. *Semin Thromb Hemost* 2005;31:162-167.
67. Cattaneo M. The platelet P2Y₁₂ receptor for adenosine diphosphate: congenital and drug-induced defects. *Blood* 2011;117:2102-2112.
68. Hollopeter G, Jantzen HM, Vincent D, et al. Identification of the platelet ADP receptor targeted by antithrombotic drugs. *Nature* 2001;409:202-207.
69. Kamae T, Kiyomizu K, Nakazawa T, et al. Bleeding tendency and impaired platelet function in a patient carrying a heterozygous mutation in the thromboxane A2 receptor. *J Thromb Haemost* 2011;9:1040-1048.
70. Tamponi G, Pannocchia A, Arduino C, et al. Congenital deficiency of alpha-2-adrenoceptors on human platelets: description of two cases. *Thromb Haemost* 1987;58:1012-1016.
71. Rao AK, Willis J, Kowalska MA, et al. Differential requirements for platelet aggregation and inhibition of adenylate cyclase by epinephrine. Studies of a familial platelet alpha 2-adrenergic receptor defect. *Blood* 1988;71:494-501.
72. Johnson AD, Yanek LR, Chen M-H, et al. Genome-wide meta-analyses identifies seven loci associated with platelet aggregation in response to agonists. *Nat Genet* 2010;42:608-613.
73. Reiter RA, Peskar BA, Sinzinger H. Defects in the prostaglandin system—what is known? *Prostaglandins Leukot Essent Fatty Acids* 2004;71:347-350.
74. Zwaal RF, Comfurius P, Bevers EM. Scott syndrome, a bleeding disorder caused by defective scrambling of membrane phospholipids. *Biochim Biophys Acta* 2004;1636:119-128.
75. Albrecht C, McVey JH, Elliott JJ, et al. A novel missense mutation in ABCA1 results in altered protein trafficking and reduced phosphatidylserine translocation in a patient with Scott syndrome. *Blood* 2005;106:542-549.
76. Rao AK. Inherited defects in platelet signaling mechanisms. *J Thromb Haemost* 2003;1:671-681.
- P.1142
77. Freson K, Devriendt K, Matthijs G, et al. Platelet characteristics in patients with X-linked macrothrombocytopenia because of a novel GATA1 mutation. *Blood* 2001;98:85-92.
78. Rosenberg N, Yatuv R, Sobolev V, et al. Major mutations in calf-1 and calf-2 domains of glycoprotein IIb in patients with Glanzmann thrombasthenia enable GPIIb/IIIa complex formation, but impair its transport from the endoplasmic reticulum to the Golgi apparatus. *Blood* 2003;101:4808-4815.
79. Bellucci S, Caen J. Molecular basis of Glanzmann's Thrombasthenia and current strategies in treatment. *Blood* 2002;100:193-202.
80. Martin I, Kriaa F, Proulle V, et al. Protein A Sepharose immunoabsorption can restore the efficacy of platelet concentrates in patients with Glanzmann's thrombasthenia and anti-glycoprotein IIb-IIIa antibodies. *Br J Haematol* 2002;119:991-997.
81. Poon MC, Zotz R, Di Minno G, et al. Glanzmann's thrombasthenia treatment: a prospective observational registry on the use of recombinant human activated factor VII and other hemostatic agents. *Semin Hematol* 2006;43:S33-S36.
82. Lisman T, Moschatsis S, Adelmeijer J, et al. Recombinant factor VIIa enhances deposition of platelets with congenital or acquired alpha IIb beta 3 deficiency to endothelial cell matrix and collagen under conditions of flow via tissue factor-independent thrombin generation. *Blood* 2003;101(5):1864-1870.
83. He S, Ekman GJ, Hedner U. The effect of platelets on fibrin gel structure formed in the presence of recombinant factor VIIa in hemophilia plasma and in plasma from a patient with Glanzmann thrombasthenia. *J Thromb Haemost* 2005;3:272-279.
84. Almeida AM, Khair K, Hann I, et al. The use of recombinant factor VIIa in children with inherited platelet function disorders. *Br J Haematol* 2003;121:477-481.

85. Nurden P, Nurden AT. Congenital disorders associated with platelet dysfunctions. *Thromb Haemost* 2008;99:253-263.
86. Seri M, Pecci A, Di BF, et al. MYH9-related disease: May-Hegglin anomaly, Sebastian syndrome, Fechtner syndrome, and Epstein syndrome are not distinct entities but represent a variable expression of a single illness. *Medicine (Baltimore)* 2003;82:203-215.
87. Di Pumpo MF, Noris PF, Pecci AF, et al. Defective expression of GPIb/IX/V complex in platelets from patients with May-Hegglin anomaly and Sebastian syndrome. *Haematologica* 2002;94:943-947.
88. Gulácsy V, Freiberger T, Shcherbina A, et al. Genetic characteristics of eighty-seven patients with the Wiskott-Aldrich syndrome. *Mol Immunol* 2011;48:788-792.
89. Sullivan KE, Mullen CA, Blaese RM, et al. A multiinstitutional survey of the Wiskott-Aldrich syndrome. *J Pediatr* 1994;125:876-885.
90. Stanger MJ, Thompson LA, Young AJ, et al. Anticoagulant activity of select dietary supplements. *Nutr Rev* 2012;70:107-117.
91. Kunicki TJ, Williams SA, Nugent DJ. Genetic variants that affect platelet function. *Curr Opin Hematol* 2012.
92. Cattaneo M. Resistance to antiplatelet drugs: molecular mechanisms and laboratory detection. *J Thromb Haemost* 2007;5(Suppl 1):230-237.
93. Goldenberg NA, Jacobson L, Manco-Johnson MJ. Brief communication: duration of platelet dysfunction after a 7-day course of Ibuprofen. *Ann Intern Med* 2005;142:506-509.
94. Nussmeier NA, Whelton AA, Brown MT, et al. Complications of the COX-2 inhibitors parecoxib and valdecoxib after cardiac surgery. *N Engl J Med* 2005;352:1081-1091.
95. Wilhite DB, Comerota AJ, Schmieder FA, et al. Managing PAD with multiple platelet inhibitors: the effect of combination therapy on bleeding time. *J Vasc Surg* 2003;38:710-713.
96. Savi P, Herbert JM. Clopidogrel and ticlopidine: P2Y₁₂ adenosine diphosphate-receptor antagonists for the prevention of atherothrombosis. *Semin Thromb Hemost* 2005;31:174-183.
97. Schleinitz MD, Heidenreich PA. A cost-effectiveness analysis of combination antiplatelet therapy for high-risk acute coronary syndromes: clopidogrel plus aspirin versus aspirin alone. *Ann Intern Med* 2005;142:251-259.
98. Schulz C, von Beckerath O, Okrojek R, et al. Platelet dysfunction and inhibition of multiple electrode platelet aggregometry caused by penicillin. *Thromb J* 2010;8:13.
99. Ingalls CS, Freimer EH. Detection of antibiotic-induced platelet dysfunction in whole blood using flow cytometry. *J Antimicrob Chemother* 1992;29:313-321.
100. Thompson JW, Jacobs RF. Adverse effects of newer cephalosporins. An update. *Drug Saf* 1993;9:132-142.
101. Harder S, Klinkhardt U, Alvarez JM. Avoidance of bleeding during surgery in patients receiving anticoagulant and/or antiplatelet therapy: pharmacokinetic and pharmacodynamic considerations. *Clin Pharmacokinet* 2004;43:963-981.
102. Sohal AS, Gangji AS, Crowther MA, et al. Uremic bleeding: pathophysiology and clinical risk factors. *Thromb Res* 2006;118:417-422.
103. Noris M, Remuzzi G. Uremic bleeding: closing the circle after 30 years of controversies? *Blood* 1999;94:2569-2574.
104. Remuzzi G, Perico N, Zoja C, et al. Role of endothelium-derived nitric oxide in the bleeding tendency of uremia. *J Clin Invest* 1990;86:1768-1771.
105. Ware JA, Clark BA, Smith M, et al. Abnormalities of cytoplasmic Ca²⁺ in platelets from patients with uremia. *Blood* 1989;73:172-176.
106. Benigni A, Boccardo P, Galbusera M, et al. Reversible activation defect of the platelet glycoprotein IIb-IIIa complex in patients with uremia. *Am J Kidney Dis* 1993;22:668-676.
107. Iseki K, Kinjo K, Kimura Y, et al. Evidence for high risk of cerebral hemorrhage in chronic dialysis patients. *Kidney Int* 1993;44:1086-1090.
108. Zwaginga JJ, Ijsseldijk MJW, De Groot PG, et al. Defects in platelet adhesion and aggregate formation in uremic bleeding disorder can be attributed to factors in plasma. *Arterioscler Thromb* 1991;11:733-744.
109. Weigert AL, Schafer AI. Uremic bleeding: pathogenesis and therapy. *Am J Med Sci* 1998;316:94-104.

110. Sloand JA. Long-term therapy for uremic bleeding. *IntJArtifOrgans* 1996;19:439-440.
111. Valles J, Santos MT, Aznar J, et al. Erythrocytes metabolically enhance collagen-induced platelet responsiveness via increased thromboxane production, adenosine diphosphate release, and recruitment. *Blood* 1991;78:154-162.
112. McMahan DA, Smith DM, Carey MA, et al. Risk of major hemorrhage for outpatients treated with warfarin. *J Gen Intern Med* 1998;13:311-316.
113. Janssen MJ, van der MJ. The bleeding risk in chronic haemodialysis: preventive strategies in high-risk patients. *Neth J Med* 1996;48:198-207.
114. Ribeiro AC, Brunini TM, Ellory JC, et al. Abnormalities in L-arginine transport and nitric oxide biosynthesis in chronic renal and heart failure. *Cardiovasc Res* 2001;49:697-712.
115. Reverter JC, Escolar G, Sanz C, et al. Platelet activation during hemodialysis measured through exposure of p-selectin: analysis by flow cytometric and ultrastructural techniques. *J Lab Clin Med* 1994;124:79-85.
116. Cases A, Escolar G, Reverter JC, et al. Recombinant human erythropoietin treatment improves platelet function in uremic patients. *Kidney Int* 1992;42:668-672.
117. Franchini M. The use of desmopressin as a hemostatic agent: a concise review. *Am J Hematol* 2007;82:731-735.
118. Best PJ, Lennon R, Gersh BJ, et al. Safety of abciximab in patients with chronic renal insufficiency who are undergoing percutaneous coronary interventions. *Am Heart J* 2003;146:345-350.
119. Zangari M, Elice F, Fink L, et al. Hemostatic dysfunction in paraproteinemias and amyloidosis. *Semin Thromb Hemost* 2007;33:339-349.
120. Treon SP, Gertz MA, Dimopoulos M, et al. Update on treatment recommendations from the Third International Workshop on Waldenström's macroglobulinemia. *Blood* 2006;107:3442-3446.
121. Merchionne F, Procaccio P, Dammacco F. Waldenström's macroglobulinemia. An overview of its clinical, biochemical, immunological and therapeutic features and our series of 121 patients collected in a single center. *Crit Rev Oncol Hematol* 2011;80:87-99.
122. Michiels JJ, Berneman Z, Van BD, et al. Clinical and laboratory features, pathobiology of platelet-mediated thrombosis and bleeding complications, and the molecular etiology of essential thrombocythemia and polycythemia vera: therapeutic implications. *Semin Thromb Hemost* 2006;32:174-207.
123. James C, Ugo V, Casadevall N, et al. A JAK2 mutation in myeloproliferative disorders: pathogenesis and therapeutic and scientific prospects. *Trends MolMed* 2005;11:546-554.
124. Kaushansky K. On the molecular origins of the chronic myeloproliferative disorders: it all makes sense. *Blood* 2005;105:4187-4190.
125. Goldman JM. A unifying mutation in chronic myeloproliferative disorders. *N Engl J Med* 2005;352:1744-1746.
126. Michiels J, Zijlstra FJ. Prostaglandin cyclooxygenase products but not thromboxane A2 are involved in the pathogenesis of erythromelalgia in thrombocythemia. *Mediators Inflamm* 1993;2:385-389.
127. Rocca B, Ciabattini G, Tartaglione R, et al. Increased thromboxane biosynthesis in essential thrombocythemia. *Thromb Haemost* 1995;74:1225-1230.

Section 3 - Coagulation Disorders

Chapter 53 Inherited Coagulation Disorders

> Table of Contents > Part V - Disorders of Hemostasis and Coagulation > Section 4 - Coagulation Disorders > Chapter 53 - Inherited Coagulation Disorders

Chapter 53

Inherited Coagulation Disorders

Jerry S. Powell

George M. Rodgers

Inherited disorders of coagulation result from the deficiency or functional abnormality of one of the plasma proteins involved in providing normal coagulation.¹ There are other proteins that regulate the kinetics of coagulation, and abnormalities in one of these proteins usually result in increased risk of thrombosis; these proteins will not be covered in this chapter. If von Willebrand disease (vWD) is included, the inherited coagulation abnormalities (Table 53.1) are common; for example, vWD may affect up to 1% of the population. The other inherited coagulation disorders occur less often.

Since the purpose of the coagulation cascade is to rapidly produce fibrin to form a clot, the clinical manifestation of any deficiency or functional abnormality in any coagulation protein will be similar, i.e., clinical bleeding, with greater bleeding associated with more severe deficiency. Therefore, the manifestations and complications of clinical bleeding will be described in this chapter in the section on hemophilia A. A recent review of treatment of hemophilia A has been published with proposed algorithms for therapy.²

TABLE 53.1 INHERITED DISORDERS OF COAGULATION

X-linked recessive traits

Hemophilia A

Hemophilia B (i.e., CRM⁺ and CRM⁻ variants; hemophilia B_m, B Leyden, etc.)

Autosomal recessive traits

Factor XI deficiency

Prothrombin deficiency

Factor V deficiency

Factor VII deficiency

Factor X deficiency (i.e., Prower variant, Stuart variant, Friuli variant, others)

Afibrinogenemia

Hypofibrinogenemia

Factor XII deficiency

Factor XIII deficiency

Autosomal dominant traits

von Willebrand disease

Dysfibrinogenemias

Combined abnormalities

Associated with factor VIII deficiency (i.e., factor V deficiency, hemophilia B, factor XI deficiency, factor VII deficiency, von Willebrand disease, dysfibrinogenemias, platelet dysfunction)

Involving vitamin K-dependent factors (i.e., factors II, VII, IX, and X; factors IX and XII; others)

Miscellaneous

Prekallikrein deficiency

High-molecular-weight kininogen deficiency

Deficiency of physiologic inhibitors (i.e., α_2 -antiplasmin, abnormal α_1 -antitrypsin [antithrombin Pittsburgh])

CRM, cross-reacting material.

NOMENCLATURE

Historically, the best known inherited coagulation disorder is hemophilia, which dramatically manifested itself in the royal families of Europe in the 20th century, following a spontaneous mutation that apparently arose in Queen Victoria in

England. The international Roman numeral designations for these disorders are summarized in Table 18.1. Like abnormal hemoglobins, qualitatively abnormal fibrinogens are designated by the name of the city in which they were first discovered, as in fibrinogen Paris.

PRINCIPLES OF PATHOPHYSIOLOGY

With the exception of fibrinogen and prothrombin, the coagulation factors are trace proteins. Clinical laboratory measurements of their activity depend on bioassays, which detect both quantitative absence of a specific factor and a qualitative functional abnormality in a factor that is present in normal amounts. Further laboratory testing is required to determine the actual concentration of the protein, usually by enzyme-linked immunoabsorbent assay (ELISA) methodology. Thus, for example, in hemophilia A, the bioassay measures factor VIII coagulant activity (factor VIIIc) and refers to the functional property of the factor VIII molecule that corrects the coagulation defect of patients with hemophilia A. The amount of protein measures the amount of antigen by ELISA and is referred to as factor VIII_{Ag} (Table 53.2). Many hemophilia treatment centers currently proceed to determine the genotype for individual persons with inherited coagulation disorders; such analysis is helpful to predict the severity of the clinical phenotype, to predict the risk of inhibitor development, and to aid in family counseling.

Most qualitative abnormalities in coagulation factors result in loss of function of the protein in the coagulation cascade. However, some mutations produce qualitative abnormalities that result in “gain of function.” Such factors are called abnormal or aberrant factors to distinguish them. The most clearly defined disorders of this type are the dysfibrinogenemias, in which the abnormal fibrinogen typically is not completely nonfunctional, but may also inhibit the function of normal fibrinogen. Other disorders characterized by aberrant coagulation factors include the B_m variant of hemophilia B and some of the variants of prothrombin deficiency. Aberrant procoagulant proteins also may be synthesized in acquired deficiencies of the vitamin K-dependent factors (see Chapter 54). An example of a “gain of function” mutation for factor IX was described recently, factor IX Padua, in which a leucine was substituted for arginine at position 338 (R338L) and, despite a normal concentration of factor IX protein in plasma, the factor IX clotting activity was eight times normal, resulting in clinically significant thrombosis.³

P.1144

TABLE 53.2 NOMENCLATURE FOR FACTOR VIII AND VON WILLEBRAND FACTOR

Definition	International Nomenclature
Protein lacking or aberrant in hemophilia A	Factor VIII
Functional property of factor VIII that is deficient in hemophilia A and measured using coagulation assays	Factor VIIIc
Antigenic property of factor VIII that is measured by immunoassays in which homologous antibodies are used	Factor VIII _{Ag}
Protein required for normal platelet adhesion that is aberrant or deficient in von Willebrand disease	von Willebrand factor (vWF)
Antigenic property of vWF that is measured by immunoassays in which heterologous antibodies are used	vWF antigen (vWF _{Ag})
Property of vWF required for platelet agglutination by ristocetin	Ristocetin cofactor activity (vWF:RC _o)

Note: This table is based on recommendations of the International Committee on Thrombosis and Haemostasis.

From Marder VJ, Mannucci PM, Firkin BG, et al. Standard nomenclature for factor VIII and von Willebrand factor: a recommendation by the International Committee on Thrombosis and Haemostasis. *Thromb Haemost* 1985;54:871-872; and Mazurier C, Rodeghiero F. Recommended abbreviations for von Willebrand factor and its activities. *Thromb Haemost* 2001;86:712.

HEMOPHILIA A

Hemophilia A refers to the inherited coagulation disorder characterized by deficiency of function of the coagulation protein called factor VIII. Except for vWD, it is the most common inherited coagulation disorder, and is X-linked. As the most common bleeding disorder, historians assume that it is the severe and often fatal hemorrhagic diathesis that affected the male children of certain families and that was well recognized in antiquity, as noted in the writings of Rabbi Simon ben Gamaliel (2nd century A.D.) in the Talmud, and those of Maimonides, the Hebrew physician and philosopher, and Albucasis, the Arab (twelfth century).⁴ Complete monographs have reviewed the early literature.⁵ However, the bleeding disorder that occurred in males throughout the royal families of Europe due to a mutation that arose with Queen Victoria, long assumed to be the more common hemophilia A, turned out, after extensive medical forensic investigation, to be hemophilia B.⁶

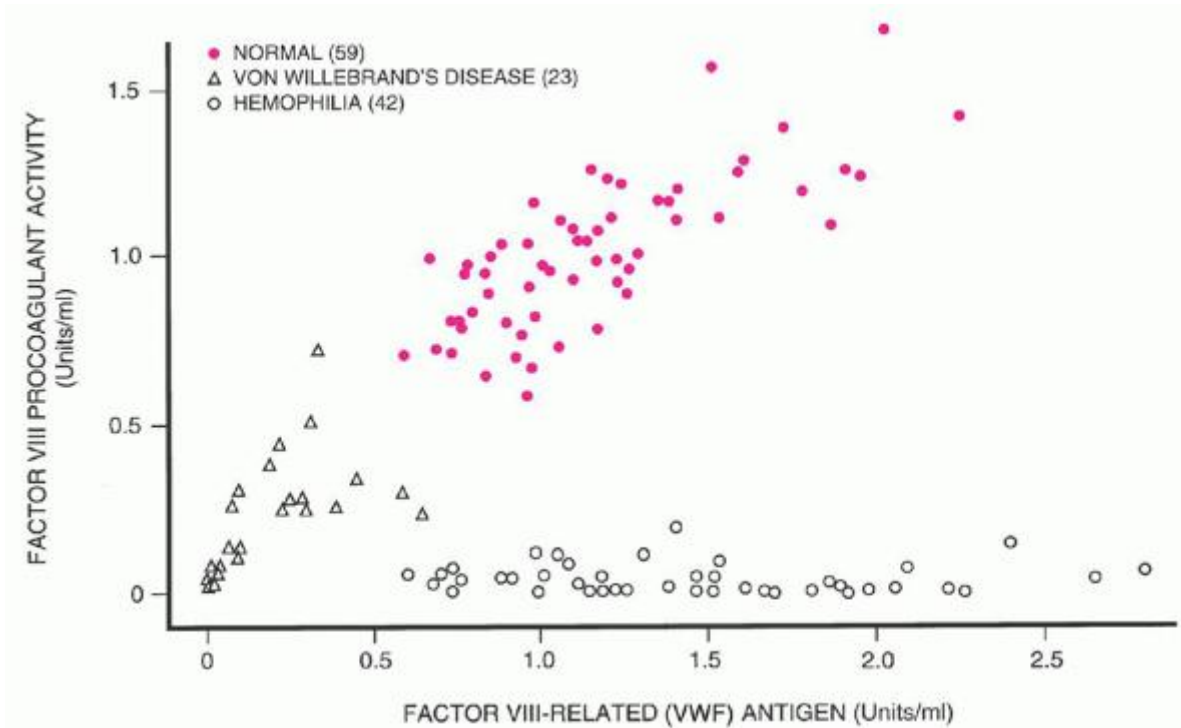

FIGURE 53.1. The relationship of factor VIII procoagulant activity and factor VIII-related antigen (von Willebrand factor [vWF]) in the plasma of normal subjects and patients with hemophilia or von Willebrand disease. (From Hoyer LW. The factor VIII complex: structure and function. *Blood* 1981;58:1-13, with permission.)

Pathophysiology

The hemostatic abnormality in hemophilia A (factor VIII deficiency, classic hemophilia) is a deficiency or functional abnormality of the plasma protein factor VIII. It normally circulates in the plasma bound to a much larger molecule, vWF. The half-life of factor VIII in the absence of vWF is much shorter, as seen in individuals with the vWF Normandy mutation, resulting in loss of the protein sequences for the binding interaction site between factor VIII and vWF, and causing low levels of factor VIII and clinical bleeding that appears similar to the bleeding seen in patients with hemophilia A. The production of vWF is coded by an autosomal gene, and this protein is qualitatively normal and is present in normal or increased amounts in patients with hemophilia A (Fig. 53.1).^{7, 8} The function of the coagulation protein factor VIII is to serve (when activated) as a cofactor for the serine protease enzyme factor IX, and accelerate the reaction as part of the coagulation cascade. No other function for factor VIII has been clearly characterized.

Incidence

Hemophilia A has been recognized in all areas of the world and in all ethnic groups. Estimates of its incidence approximate 1 in 5,000 males, or 1 in 10,000 persons.^{9, 10} A population-based study of the southeastern United States by the Centers for Disease Control and Prevention found that 11 cases per 100,000 persons had hemophilia A and that the prevalence was similar among different racial groups.¹¹ This same survey estimated that in 1994, there were 13,320 cases of hemophilia A in the United States.¹¹

Genetics

Hemophilia A is a classic example of an X-linked recessive trait. In such a disorder, the defective gene is located on the X chromosome¹²; the factor VIII gene maps to Xq28, on the distal end of the long arm of the X chromosome. In males who lack a normal allele, the defect is manifested by clinical hemophilia (Fig. 53.2; generation I, number 1). The affected male does not transmit the disorder to his sons (generation II, numbers 4 and 5) because

P.1145

his Y chromosome is normal. However, all of his daughters are obligate carriers of the trait because they inherit his X chromosome (generation II, numbers 2 and 3). Most of these women are unaffected clinically because of the presence of a normal allele from the mother. The female carrier transmits the disorder to half of her sons (generation III, numbers 6 and 7) and the carrier state to half of her daughters (generation III, numbers 8 and 9). Due to Lyonization of the X chromosome, if the normal factor VIII allele is inactivated more often by chance, then some of the carrier females may have clinical bleeding. The severity of their bleeding depends on their factor VIII activity level; and, rarely, a woman can have very low factor VIII activity and present with symptoms of moderate or even severe hemophilia.

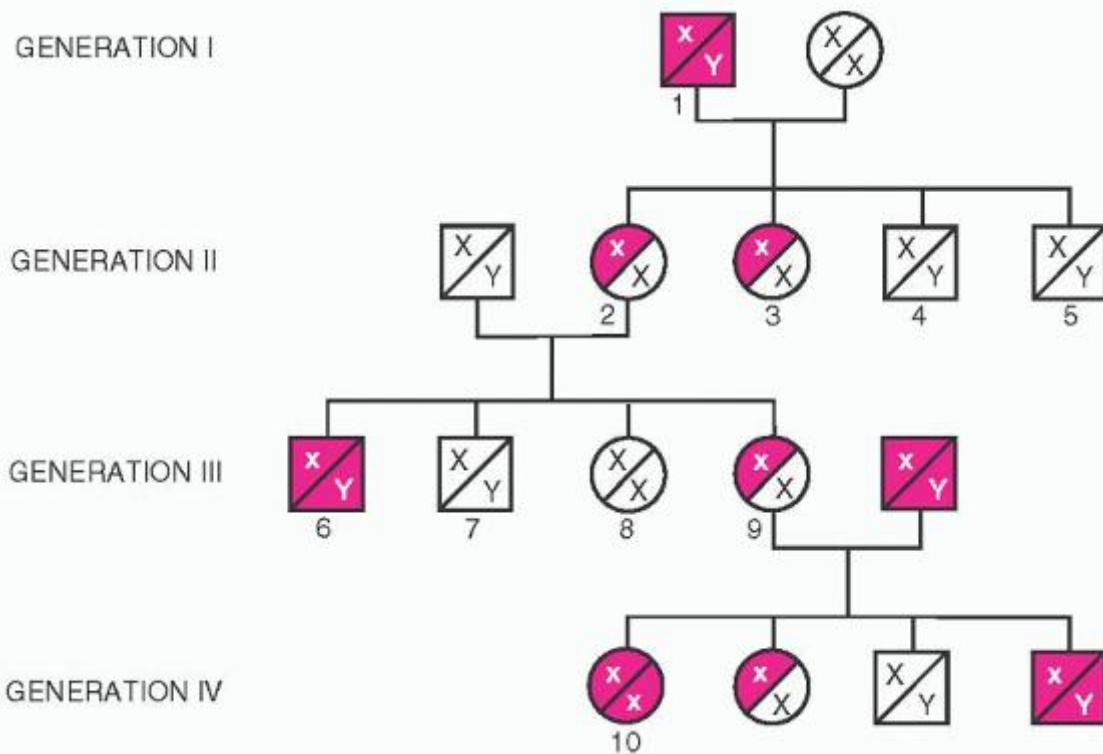

FIGURE 53.2. The inheritance of hemophilia A and hemophilia B. The pedigree is hypothetical. Squares indicate male; circles indicate female; fully shaded squares or circles indicate affected members; half-shaded circles indicate carriers. X, normal X chromosome; x, abnormal X chromosome.

The severity of bleeding varies in different kindreds, and closely depends on the particular genetic defect. Since the same gene defect is present in the kindred, each of the affected males will have very similar clinical phenotypes.¹³ As expected, hemophilia A has been observed several times in twins.¹⁴ Occasionally, however, the coinheritance of other genetic defects can influence the clinical symptoms of hemophilia A patients. An example is the coinheritance of the factor V Leiden mutation (discussed in Chapter 55) with hemophilia A. These patients have a milder clinical phenotype than expected for the same molecular defect in factor VIII.¹⁵ The coinheritance of the factor V Leiden mutation or other prothrombotic risk factors in children with severe hemophilia A may delay the first symptomatic bleeding event.¹⁶

Intriguing, and yet to be fully explained, is the fact that in over a third of families with hemophilia A, there is no evidence or history of abnormal bleeding in other members of the family.^{17, 18} This percentage is consistent with the Haldane hypothesis, which predicted that maintenance of a consistent frequency of a genetic disorder in the population would require that approximately onethird of cases result from spontaneous mutation. In other instances, neonatal deaths or

the passage of the trait through a succession of female carriers may explain the negative family history. For practical purposes, therefore, a negative family history is of little value in excluding the possibility of hemophilia A. Mutations that cause hemophilia A originate in males at least threefold more often than in females.¹⁹ The large size of the factor VIII gene (186 kb), the presence of hot spots (e.g., CpG dinucleotides), and the fact that the X chromosome is unpaired in males may predispose for the factor VIII gene to undergo spontaneous mutation.^{20, 21, 22, 23}

Nearly 3,000 individuals with hemophilia have had their factor VIII genes analyzed; this genetic information is collected in the Hemophilia A Mutation Database (HADB, formerly the Hemophilia A Mutation, Structure, Test and Resource Site [HAMSTeRS] database).²¹ The genetic defects of hemophilia A encompass deletions, insertions, and mutations throughout the factor VIII gene.²⁴ Point mutations involving CpG dinucleotides are especially common. Approximately 5% of patients with hemophilia A have large (>50 nucleotides) deletions in the factor VIII gene.²⁵

Approximately 45% of severe hemophilia A cases result from a major inversion of a section of the tip of the long arm of the X chromosome, one breakpoint of which is situated within intron 22 of the factor VIII gene.²⁶ This common inversion is associated with severe hemophilia A, and a higher incidence of inhibitor formation. It is presumed that in the absence of homologous X chromosome pairing during male meiosis, an intrachromosomal recombination event occurs on the single X chromosome, resulting in this inversion. This event typically occurs in the father of the mother of a child with severe hemophilia A, and often leads to relief of guilt feelings in the mother, as the genetic mutation is not "her fault." Another common inversion (intron 1) accounts for 5% of patients with severe factor VIII deficiency.²⁷ Thus, two inversions of the factor VIII gene are seen in nearly one-half of all severely affected patients with hemophilia A. In contrast, point mutations are most likely found in patients with mild to moderate hemophilia A.²⁸ The first case of hemophilia A caused by unequal homologous Alu/Alu recombination has been reported.²⁹ Because there are ~50 Alu repeats in the factor VIII gene, it is possible that many cases of hemophilia may result from this mechanism.²⁹ More than 95% of hemophilia A patients have mutations detected.^{22, 30, 31} Approximately 2% of hemophilia A patients have no detectable mutations in the coding region of the factor VIII gene.³² These results indicate that a substantial number of families with severe hemophilia A can undergo accurate gene tracking and carrier analysis. The intron 1 and 22 inversions responsible for 50% of severe hemophilia A cases can be sought using long and inverse polymerase chain reaction (PCR) techniques. Various algorithmic approaches to rapid laboratory genetic testing have been described,^{30, 33, 34} and a recent method of performing linkage analysis of hemophilia A in families in whom mutations could not be identified has been reported.³⁵

There is a strong association between genetic mutations that lead to absence of large portions of the factor VIII protein and the development of antibodies to therapeutic factor VIII infusions. These antibodies generally develop within the first 50 infusions of factor VIII, as expected when the immune system detects a protein to which it has not been exposed previously.

Variants

Hemophilia A with autosomal dominant transmission has been reported; however, it is important to distinguish these "variant hemophilia A patients" with negative X-linked transmission from patients with variant vWD (type 2N, vWD Normandy), an autosomal vWD subtype caused by defective factor VIII binding to vWF and with a clinical picture similar to hemophilia A.³⁶

Carrier Detection

Despite the high rate of spontaneous de novo mutations in hemophilia A, detection of females who are carriers is important. When the family history of a patient suggests risk for being a carrier, then coagulation-based assays are performed, followed by DNA testing. The daughter of a man with hemophilia is an obligate carrier, whether she has symptomatic bleeding or not. Similarly, if a female has two sons with hemophilia, then she is likely a carrier; if she has one son with hemophilia and a family history of hemophilia, then she is likely a carrier; but if she has one son with hemophilia and a negative family history, then the odds are approximately 67% that she is a carrier. A number of specialized laboratories perform molecular testing for the factor VIII gene. It is most efficient and less expensive if the DNA of the relative with hemophilia is available to identify the specific genetic mutation in that kindred; then only that specific mutation is evaluated in the potential carrier.³⁷

P.1146

Coagulation-based Assays

Coagulation-based assays may be useful in confirming or excluding the carrier state, although they have limitations. The regularity with which the abnormal factor VIII gene is suppressed by the normal allele in female carriers of hemophilia varies because of the phenomenon of random X chromosome inactivation (the Lyon hypothesis). Thus, although the mean concentration of factor VIIIc in the plasma of heterozygous female carriers is ~50% of that in normal women,^{13, 38} observed values scatter widely around this mean and often overlap with those found in the normal population. This is a result, in part, of the large error of assay methods and the wide range of factor VIIIc levels in normal subjects.

Although the demonstration of low levels of factor VIIIc by means of the usual assay methods strongly suggests the presence of the carrier state, the converse statement cannot be made with equal certainty—that is, the presence of normal levels of factor VIIIc does not reliably exclude the carrier state.³⁹ Furthermore, pregnancy and hormonal medications may increase the levels of factor VIIIc in female carriers.⁴⁰ Normal women and carriers with blood types A, B, or AB have higher levels of factor VIIIc and vWF_{Ag} than those with blood type O.⁴¹

The use of immunoassays for vWF has improved carrier detection in hemophilia A.⁴² These methods allow measurement of levels of vWF, which are normal⁴³ or increased in carriers of the disorder, despite mild but variable deficiencies of factor VIIIc. Results obtained when a bioassay and an immunoassay are performed on the same sample, and the ratio of VIIIc to vWF is computed, differentiate between the carrier population and the normal population with minimal overlap.⁴⁴ This ratio normally ranges from 0.74 to 2.20 and was found to be from 0.18 to 0.90 in obligatory carriers. The overall detection rate ranged from 72% to 94% in such obligatory carriers⁴⁶ and from 48% to 51% in women without hemophilic sons or fathers.⁴² In the latter group (possible carriers), 50% would be predicted to be carriers. Abnormally low ratios of VIIIc:vWF (false positives) have been encountered in an occasional normal subject,^{43, 45} which may be attributable to nonspecific variables such as stress.⁴⁶ Pregnancy and the use of oral contraceptives, blood type,⁴¹ or contamination of plasma samples with thrombin⁴⁶ or other proteolytic enzymes may produce falsely high ratios (false negatives) in documented obligatory carriers. Linear discriminant analysis⁴⁷ has been recommended for the expression and analysis of such laboratory data. The carrier detection rates using standardized assays with discriminant analysis exceed 90%.⁴⁸

DNA-based Assays

Molecular analyses of the factor VIII gene identify mutations in 97% of hemophilia A patients. Based on the frequency of the intron 22 inversion, severe hemophilia A patients should be initially screened for this defect. Inversion-negative patients and those with mild or moderate hemophilia A should have systematic sequencing of the factor VIII promoter, exons, and splice junctions performed. Such an approach has been reported to identify mutations in 97% of hemophilia A patients.³⁰

DNA-based assays have been adapted for prenatal diagnosis,⁴⁹ and for pre-implantation genetic diagnosis in association with in vitro fertilization. One commonly used method is to obtain chorionic villi samples during the eleventh to twelfth gestational week and perform direct genotype testing.⁵⁰ Alternatively, genetic linkage analysis of polymorphisms can be performed. The subject of genetic counseling in hemophilia has been reviewed.⁵¹

Hemophilia in the Female

Hemophilia has been well documented in human females.^{44, 52} The most common form is that seen in a minority of heterozygous carriers, discussed previously, in whom X chromosome inactivation may occur at an unusually early stage of embryogenesis, resulting in unusually low levels of factor VIII.

A second cause of female hemophilia is a mating between an affected male and a carrier female (Fig. 53.2; generation IV, number 10).⁵³ One-half of the female offspring of such a match would inherit two abnormal X chromosomes, one from the father and one from the mother. Such homozygous female hemophilia was once thought to be lethal and to inhibit the development of the embryo. That this is not true was first suggested by the successful experimental production of hemophilia in female dogs. Homozygous hemophilia is now well authenticated in several women^{53, 54} and resembles the disorder seen in affected males in all respects.

Clinical Manifestations of Hemophilia

Prior to effective replacement therapy, the life expectancy for a child born with severe hemophilia was less than 20 years. These boys would die from exsanguinating hemorrhage after a trivial traumatic injury, from spontaneous internal bleeding or from spontaneous intracranial hemorrhage. It is dramatic that a boy born today with severe hemophilia A can expect to have a normal life expectancy.

However, the most characteristic bleeding manifestations in hemophilia are spontaneous bleeding in weight-bearing joints, leading to severe hemarthrosis. The frequency and severity of these joint bleeds are related to the functional activity level of factor VIII in plasma^{8, 55} (Table 53.3). Three categories of severity have been defined by a consensus

committee on the basis of FVIII activity levels (Table 53.3).⁵⁶ Severe hemophilia (factor VIII level <1 IU/dl) is manifested clinically by repeated and severe hemarthroses, resulting almost invariably in crippling arthropathy in the absence of replacement therapy; such severe cases often are called classic hemophilia. Moderate hemophilia (factor VIII level of 1 to 5 IU/dl) is associated with less frequent and less severe hemarthroses and seldom results in serious orthopedic disability. In mild hemophilia (factor VIII level of 6 to 40 IU/dl), hemarthroses and other spontaneous bleeding manifestations may be absent altogether, although serious bleeding may follow surgical procedures or traumatic injury.⁵⁷ As indicated in Table 53.3, most patients with hemophilia A have severe disease. However, one epidemiologic survey reported variable differences in the incidence of severity between individual states within the United States; for example, 13% of hemophilia cases were of moderate

P.1147

severity in Massachusetts, whereas 35% of cases in Georgia were classified as moderate severity.¹¹

TABLE 53.3 PREVALENCE AND SEVERITY OF HEMOPHILIA A AND HEMOPHILIA B IN THE UNITED STATES

Factor VIII or IX Level (IU/dl)	Clinical Picture ^a	Incidence (%) ^b	
		Hemophilia A	Hemophilia B
<1	Severe, spontaneous bleeding	70	50
1-5	Moderate bleeding with minimal trauma or surgery	15	30
6-40	Mild bleeding with major trauma or surgery	15	20

^a The criteria for classifying hemophilia severity are taken from White GC, Rosendaal F, Aledort M, et al. Definitions in hemophilia. *Thromb Haemost* 2001;85:560.

^b Incidence figures are for the United States in 1989 and were provided by the National Hemophilia Foundation (Courtesy of Kathleen F. Cortes, PhD).

From Rodgers GM. Common clinical bleeding disorders. In: Boldt DH, ed. *Update on hemostasis: contemporary management in internal medicine*. New York: Churchill Livingstone, 1990:75-120, with permission.

Hemarthrosis

Hemarthrosis is the most common manifestation of the inherited coagulation disorders (Fig. 53.3). Joint bleeding and the consequent damage to weight-bearing joints remain the most common debilitating symptom in severe hemophilia.

Pathophysiology

Bleeding presumably originates from the synovial vessels and develops spontaneously or as the result of imperceptible or trivial trauma. Spontaneous joint bleeding in the absence of identifiable mild trauma is unusual in patients with moderate hemophilia and very rare in patients with mild hemophilia. Hemorrhage occurs into the joint cavity or into the diaphysis or epiphysis of the bone. In the acute stage, the synovial space is distended with blood. Muscular spasm further increases the intrasynovial pressure. Hemorrhage into the periarticular structures is a common complicating feature that occurs most often around small joints. The inflammatory response to joint bleeding is highly variable and not well studied. However, in many patients permanent joint damage, detectable by MRI, appears to occur after only one or two minor bleeds into a single joint.⁵⁸

The joint may regain normal function after the first few episodes of hemarthrosis. More often, however, the absorption of intraarticular blood is incomplete, and the acute bleeding leads to chronic inflammation of the synovial membrane with the development of long-term damage to the joint. Sometimes, the joint remains swollen, tender, and painful for months, and in this setting may often suffer episodes of rebleeding. Such a joint is often termed a "target joint," and should be treated aggressively with physical therapy and appropriate factor replacement to interrupt the vicious cycle of

inflammation, swollen synovium, and recurrent bleeding. Release of inflammatory cell proteolytic enzymes initiates destruction of cartilage and bone.⁵⁹

Acute hemarthroses almost invariably recur from time to time. With each recurrence, the synovium becomes progressively more thickened and vascular; folds and villi, which predispose to synovial injury during even minimal activity, may form. Proliferating synovium often fills and distends the joint, which remains swollen and enlarged in the absence of bleeding or pain (chronic proliferative synovitis).⁶⁰ Together with the weakening of the periarticular supporting structures, this process predisposes the joint to recurrent episodes of bleeding. Repeated episodes of hemarthrosis, with the associated subchondral and synovial ischemia, result in progressive loss of hyaline cartilage, particularly at the margins of the joint. Large punched-out areas of destruction are sometimes produced by subchondral hemorrhages and, in the cancellous structure of the bone, cavitation may be caused by intraosseous hemorrhage. Through disuse, diffuse demineralization of the involved bones also may occur. Subperiosteal hemorrhages are not common.

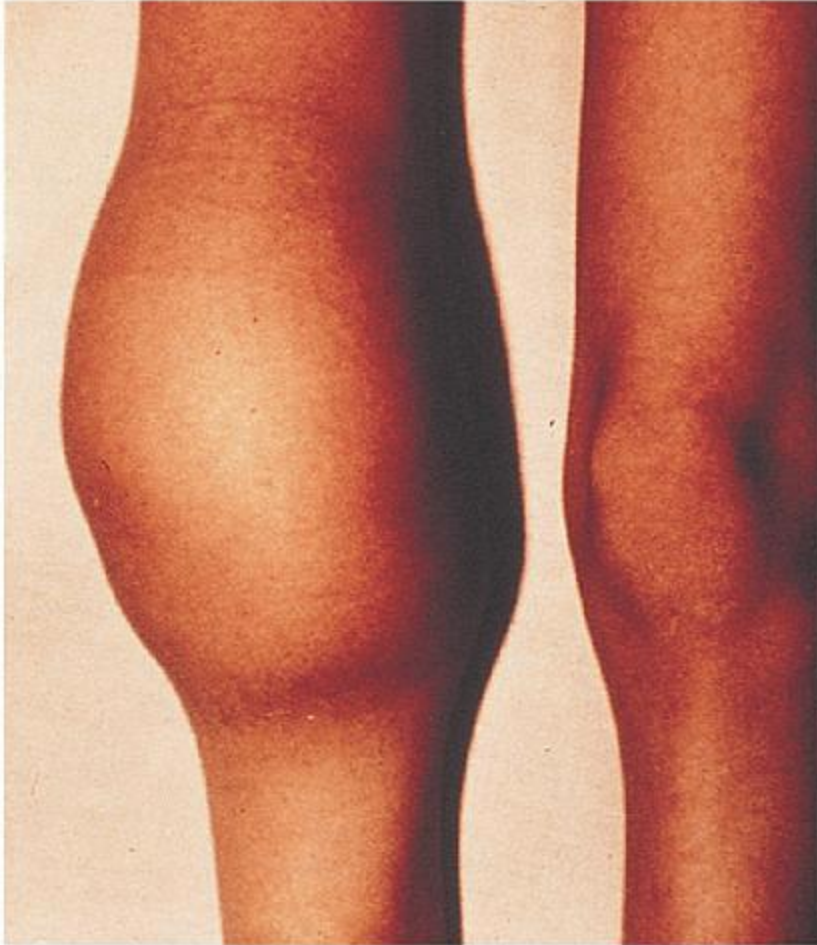

FIGURE 53.3. Hemophilic arthropathy. This figure illustrates the sequelae of recurrent joint bleeding.

The terminal stage of hemarthrosis is called chronic hemophilic arthropathy.⁶¹ It is manifested by fibrous or bony ankylosis of larger joints; complete destruction may take place in the smaller articulations because of the weaker joint structure and the thinner cortices of the smaller bones. Other permanent sequelae of hemarthrosis include atrophy and proliferation of bone, roughening of the articular surfaces with lipping and osteophyte formation, bone necrosis and cyst formation, stunted growth as the result of interference with the nutrition of the bone, and accelerated development and overgrowth of the epiphyses caused by excessive blood flow (Figs. 53.3 and 53.4). Chronic hemophilic arthropathy is less common now because of widespread use of prophylactic replacement therapy and improved availability of factor replacement therapy. Magnetic resonance imaging is superior to standard radiography for assessment of early arthropathy.⁶² A scoring system for magnetic resonance joint evaluation has been reported⁶² (Table 53.4).

It should be emphasized that with modern prophylactic therapy of regular factor infusions to maintain the plasma factor concentration above 1% of normal, boys are now reaching adolescence and young adulthood with essentially normally functioning joints. However, such a program of regular infusions with currently available factor therapies requires intensive medical and family support.

Clinical Presentation

Most persons with severe hemophilia report a characteristic warm, tingling sensation before the onset of symptoms of joint bleeding and hemarthrosis; this is called the aura. The earliest definite symptom is pain, which in the acute form may be excruciating. Physical examination reveals muscle spasm and limited motion of the affected joint. If therapy is not initiated immediately, typically within approximately 30 minutes, then the joint may progress so that it is warm and grossly distended and discolored,

P.1148

but external evidence of bleeding may be minimal or absent in chronically damaged large joints because of thickening of the articular capsule. Generally, only one joint is involved at a time, although bleeding may develop simultaneously in two or more joints. The weight-bearing joints are most commonly affected and the knees are the joints most often severely affected. However, because of the success of total knee and total hip replacement surgeries, the ankles are the most commonly affected joints that lead to chronic problems that interfere with quality of life for persons with severe hemophilia.

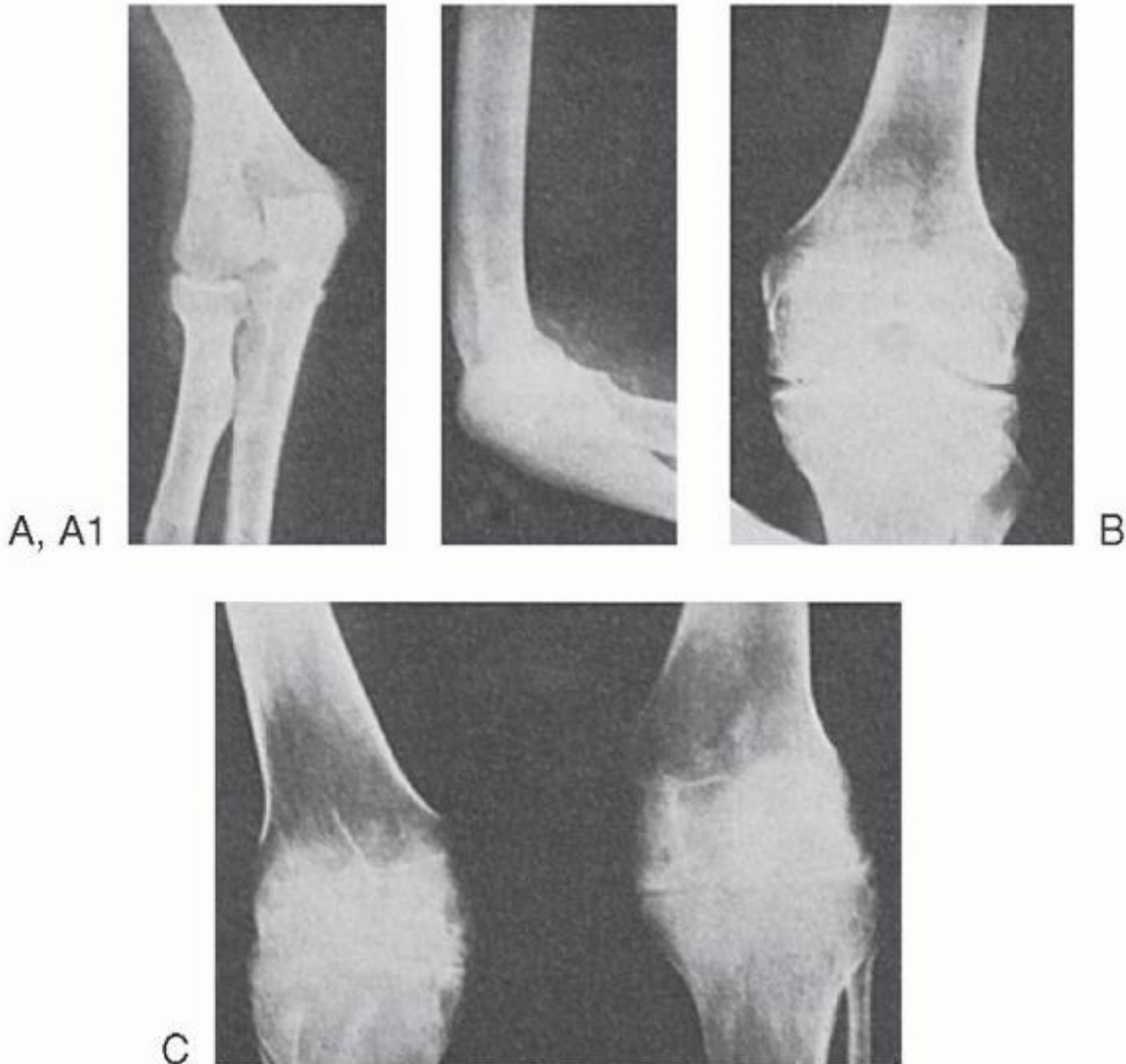

FIGURE 53.4. Elbow and knee joints in a patient with hemophilia A. Thickening of synovium with deposition of calcium is shown in (A) and (A1); increased intercondylar notch is shown in (B); increased density and decreased interarticular space are shown in (A), (B), and (C); and lipping along the borders of the joint surfaces is shown in (C).

TABLE 53.4 SCORING SYSTEM FOR HEMOPHILIC ARTHROPATHY USING MAGNETIC RESONANCE IMAGING

Score Abnormalities on Imaging

- O None
- I Minimal hemosiderin
- II Large amount of hemosiderin and cartilaginous erosion
- III Cartilage destruction, bone erosion, subchondral cysts
- IV Osteoarthritis with or without ankylosis

Subcutaneous and Intramuscular Hematomas

Large ecchymoses and subcutaneous and intramuscular hematomas were common in hemophilia A prior to the use of regular infusion therapy, reflecting the substantial amounts of time patients had factor levels less than 1% of normal. With modern treatment protocols designed to keep plasma levels above 1% of normal, and immediate home infusion when a bleeding episode occurs, the frequency of large soft tissue bleeds has decreased dramatically. Such hemorrhages, when not treated promptly, characteristically spread within fascial spaces and dissect deeper structures (see Fig. 45.2). Subcutaneous bleeding may be extensive. When not treated promptly with factor infusion, the bleeding continues; and at the site of origin, the tissue is hard, indurated, raised, and purplish black. From this center, the hemorrhage extends in all directions, with each successive concentric extension less deeply colored. The point of origin of the hemorrhage may be absorbed entirely while the margin is still progressing. Intramuscular and subcutaneous hematomas may produce leukocytosis, fever, and severe pain in the absence of significant discoloration of the overlying skin.

Hematomas may produce serious consequences from the compression of vital structures. Bleeding into the tongue, throat, or neck may develop spontaneously and is especially dangerous because it may compromise the airway with surprising rapidity.⁶³ Gangrene may result from pressure on arteries; and the development of compartment syndrome and, if not promptly treated, ischemic contractures are common sequelae of hemorrhage into the calves or forearms. Peripheral nerve lesions of varying severity are common complications of untreated hemorrhage into joints or muscles. Hemophilic cysts are discussed in the section Special Aspects of Treatment.

Psoas and Retroperitoneal Hematomas

Spontaneous hemorrhage into internal fascial spaces and muscles of the abdomen is common in severe hemophilia A,⁶⁴ reflecting plasma factor levels less than 1% of normal. Bleeding into or around the iliopsoas muscle produces pain of progressively increasing severity and tenderness; when it occurs on the right side, it may closely simulate acute appendicitis. Femoral nerve involvement may be partial or complete, with the development of pain on the anterior surface of the thigh. The psoas sign is positive, and the hip is held in partial flexion. Paresthesias, partial or complete anesthesia, and, ultimately, weakness or paralysis of the thigh extensors with eventual muscular atrophy may ensue. Retroperitoneal hemorrhage and intraperitoneal hemorrhage also are common. Computed tomography may be helpful in the diagnosis of these hematomas.⁶⁴ Prompt factor infusion is critical to normalize coagulation and should be continued until the hematoma has resolved completely, as any residual hematoma is at higher risk for rebleeding and pseudocyst formation.

Gastrointestinal and Genitourinary Bleeding

Hemorrhage from the mouth, gums, lips, frenulum, and tongue is common and often serious. The eruption and shedding of deciduous teeth usually occur without abnormal bleeding, but may occasionally be accompanied by hemorrhage that lasts for days or weeks if not treated. Epistaxis occurs in many patients and may be of exsanguinating proportions.

Hematemesis, melena, or both are not uncommon. The source of the bleeding is usually the upper gastrointestinal tract. In most patients in whom bleeding is persistent or recurrent, it originates from a structural lesion, most commonly a peptic ulcer or gastritis. Hemorrhage may be accompanied by abdominal pain, distention, increased peristalsis, fever, and leukocytosis. Intramural bleeding into the intestinal wall may result in intussusception or obstruction.

Hematuria is more common than gastrointestinal bleeding, but it is less often the result of a demonstrable pathologic condition in the genitourinary tract. The bleeding may arise in the bladder or in one or both kidneys and may persist for

days or weeks.⁶⁵ When clots form, ureteral colic may develop. Typically, the hematuria resolves after factor infusion, but if persistent, then a short course of prednisone may prove helpful to shorten the course of hematuria.⁶⁶

Traumatic Bleeding

Patients with coagulation disorders seldom bleed abnormally from small cuts such as razor nicks, reflecting the normal function of platelets, as measured by platelet function tests. All laboratory assays of platelet function are normal in patients with severe hemophilia A. After larger injuries, however, hemorrhage out of proportion to the extent of the injury is characteristic. The bleeding reflects both increased acute bleeding rates beyond what is expected after the trauma, and persistent bleeding as slow continuous oozing occurs for days, weeks, or months. Such traumatic bleeding may be massive and life-threatening unless coagulation replacement therapy is provided by immediate factor infusion.

Delayed bleeding is common. Thus, although hemostasis after an injury or a minor surgical procedure may appear to be adequate, hemorrhage, often of sudden onset and serious proportions, may develop several hours or even days later. This phenomenon apparently occurs because the processes of primary hemostasis are only temporarily effective. Delayed bleeding may occur in patients with mild hemophilia and is a significant hazard after minor surgical procedures, particularly those performed on an outpatient basis, such as tooth extraction and tonsillectomy.

Venipuncture, if skillfully performed, is without danger for the person with severe hemophilia, primarily because of the elasticity of the venous walls. If venipuncture is traumatic, digital pressure on the puncture site or a pressure dressing may prevent further complications. Subcutaneous, intracutaneous, and small intramuscular injections seldom produce hematomas if firm finger pressure is maintained for at least 5 minutes. Large intramuscular injections should be avoided. Vaccination using intramuscular injections is acceptable with minimal increase in bleeding risks.

Other Clinical Aspects

Infants usually are asymptomatic because they are insulated from trauma.⁶⁷ However, trauma during birth or afterwards may trigger

P.1149

life-threatening bleeding. Infants of women who are known carriers may be at risk during delivery, and instrumentation during vaginal delivery should be avoided. Currently, the usual standard of care is to avoid testing the infant in utero due to the risks inherent in current techniques available to test the fetus, and to allow normal vaginal delivery with back-up Caesarean section available if any difficulties arise during birth. Typically, hematomas are seen first when children become active, and hemarthroses seldom develop until they begin to walk. Occasionally, evidence of the disorder is not seen until patients reach teenage years or young adult life. Spontaneous hemorrhage may be cyclic in nature. Petechiae, which are characteristic of disorders of platelets and blood vessels, are rare in patients with hemophilia but have been noted in severely affected patients during an exacerbation of bleeding. Hemorrhage from the umbilical cord or stump is unusual, but prolonged bleeding after circumcision is common and brought hemophilia to the attention of the ancient Hebrews. Pulmonary and pleural bleeding are uncommon, although mediastinal and pleural shadows have been noted radiographically and presumably originate from fresh or old hematomas. Intraocular hemorrhage is uncommon, but bleeding into the orbit and conjunctiva occurs often. Spontaneous rupture of the spleen has been reported. Intracranial bleeding is discussed in the section Special Aspects of Treatment. The website for the National Hemophilia Foundation is www.hemophilia.org and contains useful information and links to more detailed information on this bleeding disorder.

Course and Prognosis

In recent years, the prognosis in severe hemophilia has improved dramatically. With modern therapy using regular factor infusions to maintain adequate plasma factor concentrations to prevent nearly all spontaneous bleeding episodes, a person born with severe hemophilia A can expect to live an essentially normal lifespan. No other genetic disease has made such dramatic progress in the past 50 years. It is not yet clear whether hemophilia protects older hemophilia patients from thromboembolic disorders,⁶⁸ atherosclerosis,⁶⁹ or cardiovascular diseases. Despite the lack of stringent prospective clinical studies for this emerging problem of aging patients with severe hemophilia and other medical problems, reviews of current practice and expert opinion on how to treat aging patients with severe hemophilia have been published.^{70, 71, 72, 73}

TABLE 53.5 LABORATORY FINDINGS IN COMMON INHERITED COAGULATION DISORDERS

Disorder	Partial Thromboplastin	Prothrombin Time	Thrombin Time	Ancillary Tests
-----------------	-----------------------------------	-----------------------------	--------------------------	------------------------

	Time (PTT)			
	A	N	N	
Hemophilia A	A	N	N	vWF antigen and activities are normal or increased, ratio VIIIc:vWF is low.
Hemophilia B ^a	A	N ^a	N	—
von Willebrand disease ^{a, b}	A or N	N	N	vWF antigen and VIIIc are usually low, ratio VIIIc:vWF is variable; ristocetin-induced platelet aggregation and ristocetin cofactor activity are usually diminished.
Afibrinogenemia	A	A	A	Platelet function may be abnormal.
Dysfibrinogenemia ^a	vA	vA	A ^{c, d}	Hypofibrinogenemia, ^e reptilase time is prolonged, ^a fibrin(ogen) degradation products levels are increased. ^a
Hypoprothrombinemia ^a	A	A	N	Two-stage assay is abnormal. ^f
Factor V deficiency	A	A	N	—
Factor VII deficiency ^a	N	A	N	Stypven (Russell viper venom) time is normal.
Factor X deficiency ^a	A	A	N	Stypven time is abnormal.
Factor XI deficiency	A	N	N	—
Factor XII deficiency	A	N	N	—
Factor XIII deficiency	N	N	N	Clot solubility tests are abnormal.

A, abnormal; N, normal; v, variable; vWF, von Willebrand factor.

Certain PTT reagents may not detect mild deficiency of factors VIII, IX, and XI.

^a Findings are significantly different in some variants.

^b Coagulation abnormalities are caused by deficiency of factor VIIIc.

^c Patient's plasma may inhibit normal coagulation.

^d Abnormality may be corrected by increasing calcium concentration and may be magnified by diluting the thrombin solution.

^e Abnormality varies depending on technique.

^fResults of one-stage techniques may be uninterpretable.

Laboratory Diagnosis

The activity of the various coagulation factors is expressed in terms of units, defined as the activity present in 1 ml of fresh plasma from normal donors. The concentration of all coagulation factors in normal pooled plasma is thus 1 IU/ml or 100 IU/dl, or 100% activity. It should be noted that the activity levels in blood bank plasma are somewhat lower, approximately 80 IU/dl because of the dilution with anticoagulant.

Routine clinical laboratory tests (noncoagulation) are normal in patients with hemophilia A. The presence or absence of anemia or of signs of blood regeneration depends on the severity and frequency of bleeding, as in any individual patient. Neutrophilia may accompany severe hemorrhage, and the destruction of red blood cells in the hematoma may be reflected in elevated LDH, AST, or bilirubin. As in other instances of posthemorrhagic anemia, the bone marrow reflects the response to blood loss.

Screening Tests of Hemostasis and Coagulation

The partial thromboplastin time (PTT) usually is prolonged in patients with hemophilia A (Table 53.5). The biochemical conditions for most laboratory assays of PTT are set so that the PTT is abnormal if the factor VIII level is <25% of normal; however, some PTT reagents are insensitive to mild factor VIII deficiency.⁷⁴ Therefore, in most situations the abnormality of the PTT can be

P.1150

normalized by mixing the patient's plasma with normal plasma in a ratio of 1:1; and this test, called a mixing study, is routinely used to detect whether neutralizing factor VIII antibodies are present. The platelet count usually is normal, but may be elevated in the stress reaction to hemorrhage.

Factor VIIIc Assays

Assay of factor VIII is a simple technique, but requires trained and experienced technicians, as the results are sensitive to errors in laboratory technique, or to errors in proper handling of the blood specimen. In clinical practice, if the laboratory results do not seem to fit the clinical picture, then most clinicians will repeat the laboratory test, and/or discuss the results with the laboratory personnel. Two-stage methods,⁷⁵ one-stage methods,⁷⁶ and micromethods⁷⁷ are suitable for diagnosis. The one-stage techniques are used most widely because they are simple to perform. They require either a supply of plasma from a known individual with severe hemophilia, which is available commercially, or artificial substrate plasma. Two-stage assays detect approximately 20% more factor VIII than do one-stage methods,⁷⁸ and they are less subject to variables⁷⁹ such as fluctuations attributable to contaminating traces of thrombin or other proteolytic enzymes.

The World Health Organization makes international standards, but many laboratories purchase commercial secondary standards that are calibrated to the international standard. Under most circumstances, a pool of citrated plasma carefully collected from normal subjects and frozen in individual laboratories also serves as an acceptable standard.

The factor VIII assay has a large potential for error, even in expert hands. Therefore, when borderline values are obtained, the assay should always be repeated. Extensive studies of the many variables of the factor VIII assay have been reported.^{80, 81, 82, 83}

In the clinical setting of delivery of a boy with a question of hemophilia A, assays for both factor VIII and vWF may be carried out with reasonable accuracy on material obtained by fetoscopy—that is, mixtures of blood and amniotic fluid⁸⁴ or unmixed fetal blood.⁸⁵

The availability of a new recombinant form of factor VIII (B domain-deleted factor VIII, Xyntha) raised concerns about accurate laboratory monitoring of patients receiving this product.⁸⁶ Chromogenic substrate assays or typical one-stage PTT assays using physiologic phospholipids are needed to quantitate factor VIII levels accurately in patients receiving B domain-deleted factor VIII.⁸⁷ Alternatively, a standard one-stage PTT assay using B domain-deleted factor VIII as the assay

standard would be appropriate. The use of concentrate standards (rather than plasma standards) diluted in factor VIII-deficient plasma has been proposed as a solution to resolve discordant results using different assay methods.⁸⁸

Analysis of appropriate methods for laboratory assays of factor VIII activity levels after therapeutic infusions of the newer factor VIII products with extended half-life will be an important part of the small phase III clinical trials initiated in 2012.⁸⁹ The Scientific Subcommittee on Standards of the International Society of Thrombosis and Haemostasis is involved in defining appropriate standards for these new products.

Factor VIII Ag (cAg) Assays

Highly specific but complicated assays using immunoradiometric methods and ELISA techniques⁹⁰ are available to measure factor VIII Ag (VIII Ag). The latter methods use liquid- and solid-phase principles and both natural factor VIII antibodies and monoclonal antibodies. The results of both of these techniques demonstrate the absence of factor VIII Ag in most severely affected hemophiliacs and correlate well with factor VIIIc measurements in most cases. Results are more variable when mild hemophiliacs are tested. In most series, ~10% of patients have detectable levels of factor VIII Ag and a low VIIIc-to-VIII Ag ratio (the CRM-positive variant). Immunoassays for vWF are discussed in the section Laboratory Diagnosis.

Differential Diagnosis

The diagnosis of hemophilia A is seldom difficult, especially in the severely affected patient with repeated and often serious hemorrhagic manifestations, including such characteristic signs as hemarthrosis. Typically the PTT is abnormal and leads to specific assays for clotting factor activity and mixing studies to rule out neutralizing inhibitors of coagulation activity. Hemarthrosis with significant orthopedic disability is rare in patients with coagulation disorders other than hemophilia A or B.

In patients with mild forms of the disorder, however, failure to recognize the existence of the disease or to make the correct diagnosis is more likely. Such patients rarely have a history of spontaneous bleeding, and the family history tends to be vague or negative. A history of abnormal bleeding after minor trauma may be difficult to establish due to variability in bleeding. Occasionally, mild hemophilia A may present with a normal PTT when the factor VIII activity assay result is greater than 25%; thus a normal PTT may be misleading. It must be emphasized that individuals with mild hemophilia are still at risk for hazardous hemorrhage after trauma or during surgical procedures.^{91, 92} A survey of hemophilia carriers found that mild reduction in factor VIII or IX levels (41 to 60 IU/dl) was associated with excessive bleeding.⁹³ A normal PTT value, therefore, cannot be relied on to exclude the possibility of hemophilia. In the mildly affected patient, specific factor assays must be performed to confirm or exclude the diagnosis of hemophilia.

The results of screening tests (Table 53.5) usually are sufficient to exclude the possibility of acquired hemorrhagic disorders associated with serious bleeding. Such disorders are seldom associated with a prolonged PTT and a normal prothrombin time (PT), a combination that strongly suggests an inherited disorder or an inhibitor. Among the inherited disorders characterized by this combination of findings (hemophilia A, hemophilia B, and deficiencies of factors XI, XII, prekallikrein, and high-molecularweight kininogen [HMWK]), deficiency of the latter three factors can be readily excluded because their deficiency is not associated with excessive clinical bleeding. Factor XI deficiency in males may mimic mild hemophilia, and hemophilia B is clinically identical to hemophilia A. Both factor XI deficiency and hemophilia B must be distinguished from hemophilia A in the laboratory using specific factor activity assays. The best way to accomplish this goal in evaluating patients with an isolated prolonged PTT is by performing specific assays of these three factors in the order of their statistical frequency—that is, VIII, IX, and XI. A PTT mixing study should also be performed to exclude an inhibitor. A definitive diagnosis is of great importance because specific products are used to treat each of these disorders.

Severe vWD in males may be indistinguishable from mild hemophilia A. Confirmatory tests for vWD are needed to make this distinction. Patients with the uncommon type 2N vWD may also be clinically indistinguishable from patients with hemophilia A. This diagnosis is important to establish, because therapeutic infusions of recombinant factor VIII (r-FVIII) would be ineffective due to the shortened half-life of factor VIII resulting from the absence of effective binding to von Willebrand protein. An X-linked family history of bleeding supports a diagnosis of hemophilia A in these patients, and an autosomal recessive family history of bleeding supports a diagnosis of type 2N vWD. Statistically, one would expect a rare family that might carry both genetic disorders; clearly that situation may be problematic to resolve without additional genetic testing.

Bleeding manifestations in hemophilia may simulate a variety of conditions. However, serious confusion results only when the

correct diagnosis has not been considered and appropriate laboratory studies have not been ordered. Thus, a deep hematoma may be mistaken for a suppurative condition, and surgical drainage may be attempted. Bleeding into a small joint may produce a clinical and radiologic picture suggestive of sarcoma; when larger joints are involved, findings simulate tuberculosis, arthritis, or Perthes disease. Bleeding elsewhere may suggest local causes such as kidney tumor, pulmonary disease, or peptic ulcer. For example, blood clots due to hemophilia bleeding in the renal collection system might appear as masses on a CT scan and be confused with cancer, leading potentially to inappropriate invasive procedures to obtain tissue for cancer diagnosis.

Intra-abdominal bleeding raises particularly serious diagnostic and therapeutic problems in the patient with hemophilia, even when the hemophilia condition has been accurately diagnosed. Thus, hemorrhage into the psoas, when on the right side, may simulate acute appendicitis so closely that, in the opinion of many experienced clinicians, there is no reliable clinical means to differentiate between the two diagnoses. A retroperitoneal hematoma may be mistaken for an appendiceal abscess. Intraperitoneal hemorrhage and bleeding into and around other viscera may simulate perforating peptic ulcer, bowel obstruction, or virtually any acute intra-abdominal condition. Computed tomography scanning and sonography may be particularly helpful in differentiating between intra-abdominal conditions that require surgical intervention and retroperitoneal and psoas hemorrhages. In any case, early therapeutic infusion of factor VIII will prevent further bleeding and carries no additional risk for the individual with hemophilia. Therefore, when there is a question and further diagnostic tests are planned, factor VIII should be administered first and promptly before the diagnostic tests are performed.

HEMOPHILIA B

Hemophilia B was recognized as a separate disorder from hemophilia A in 1947.⁹⁴ Hemophilia B (Christmas disease, factor IX deficiency) was established as different from hemophilia A by Aggeler et al. in 1952.^{95, 96} Hemophilia A is approximately 5 times more common than hemophilia B.¹⁸ A 1994 survey estimated that there were 3,640 cases of hemophilia B in the United States.¹¹ As expected, it appears that the severity of hemophilia B is a consequence of the plasma factor IX concentration, and that for any particular plasma concentration, the clinical severity is similar for hemophilia A and B. However, in contrast with hemophilia A, most of the genetic causes of hemophilia B are not large deletions or inversions; therefore in many patients there is some antigenic protein, and often some low level of function of the mutated protein. Consequently, the clinical phenotype is often less severe. As with hemophilia A, hemophilia B is classified as severe, moderate, or mild based on the percentage of functional factor IX in coagulation activity assays. In addition, because of the presence of low levels of factor IX protein in more patients with hemophilia B, there are fewer persons with hemophilia B that develop neutralizing inhibitors (approximately 3% versus more than 25% in hemophilia A).

Historically, when plasma from patients with hemophilia B was tested against autologous antibodies, three distinct groups were defined: A cross-reactive material (CRM)-positive variant, the most common form; a CRM-negative variant; and a third form of the disorder in which antibody neutralization was variable in extent and was approximately proportional to coagulant factor IX activity (the CRM-reduced variant).⁹⁷ These distinctions are only of historical interest now.

In a disorder called hemophilia B Leyden,⁹⁸ the clinical manifestations tend to diminish during puberty in association with a rise in the factor IX level from as low as 1 IU/dl in childhood to levels of 20 IU/dl or more in adult life. The Leyden variant is characterized as CRM-negative at birth but becomes CRM-positive or CRM-reduced with advancing age.⁹⁸ The genetic basis for factor IX Leyden is that mutations occur in the factor IX gene promoter region; this region contains an androgen response element that, with age, stimulates factor IX gene transcription and protein synthesis.⁹⁹

In another variant of hemophilia B, the PT is prolonged when performed with ox brain thromboplastin.¹⁰⁰ This disorder has been called hemophilia B_m and is characterized by the presence in the plasma of CRM that neutralizes both autologous and heterologous antibodies to factor IX.¹⁰¹ The degree of abnormality of the ox brain PT is proportional to the plasma level of CRM in both affected males and carrier females. This variant results from mutations in the carboxy terminus of the factor IX molecule, resulting in a factor IX molecule that interacts abnormally with ox brain thromboplastin.

Numerous factor IX mutations have been recognized.^{22, 102} Factor IX purified from the plasma of affected members of one kindred did not fragment normally when activated in vitro (hemophilia B Chapel Hill).¹⁰¹ The molecular defect was found to be a substitution of histidine for arginine at position 145, a defect that inhibits cleavage by factor XIa.¹⁰³ Studies of factor IX obtained from another family¹⁰⁴ revealed biochemical abnormalities identical to those characteristic of the descarboxy analog of this factor that is found in vitamin K deficiency or produced by coumarin drugs. Such molecules lack Ca²⁺-binding sites and do not undergo conformational changes induced by Ca²⁺. Another report concerns a unique variant with deficient Ca²⁺ binding and an abnormally high-molecular-weight (factor IX Zutphen).¹⁰⁵

Genetics

Hemophilia B is inherited as an X-linked recessive trait, but the locus on the X chromosome of the gene controlling factor IX production is remote from that involved with factor VIII biosynthesis.¹⁰⁶ Factor IX levels <10% have been documented in a few women, including some with chromosomal abnormalities.^{107, 108, 109} Ten useful polymorphisms have been described that are associated with the factor IX gene.⁴⁹ An updated listing of mutations is available at www.kcl.ac.uk/ip/petergreen/haemBdatabase.html. Unlike hemophilia A, the spontaneous mutation rate is low,¹⁷ and most patients with hemophilia B have positive family histories.

Factor IX defects may be severe, moderate, or mild. Severe defects result from large gene deletions, nonsense mutations, and inversions; these defects are associated with absence of factor IX protein. Milder gene defects such as splice-site or missense mutations result in a dysfunctional protein with some residual activity. Missense mutations account for ~80% of mutations in severe hemophilia B patients.^{22, 110, 111, 112}

Detection of Carriers

Detection of heterozygous carriers of hemophilia B involves the same principles and limitations as described for hemophilia A. Carrier detection based on coagulation assay alone usually is more reliable than is the case with hemophilia A.¹¹³ Thus, in one series of 45 obligatory carriers, the mean factor IX level in the plasma was 33 IU/dl; 40 from the group had levels <50 IU/dl, and 10 had levels <25 IU/dl. As a consequence of these low levels of factor IX, abnormal hemorrhage is not uncommon in carriers of hemophilia B.

Results of immunoassays of factor IX and the ratio of factor IX-related antigen to coagulant factor IX levels in the carrier population overlap with the normal population to a considerable degree, particularly in the CRM-positive variants.^{114, 115} Such studies provide a lower overall detection rate among obligatory carriers of hemophilia B than is the case with hemophilia A.^{114, 115} Levels of factor IX-related antigen obtained by immunoassay

P.1152

are significantly increased by the use of oral contraceptives. The use of DNA probes¹¹⁶ and monoclonal immunoassays¹¹⁷ provide highly accurate methods for determining carrier status. Rapid carrier testing using allele-specific microarray methods has been described. This method permits detection of a majority of common factor IX mutations in a single assay.¹¹⁸ Prenatal diagnosis of hemophilia B has been successful in the CRM-negative variants.¹¹⁹ Modern methods for prenatal diagnosis use genetic testing and are quite reliable.^{120, 121} Determination of carrier status is based on several factors, including pedigree analysis, factor IX assay results, and genotype.¹²²

Clinical Features

Severely affected patients (those with factor IX activity levels <1 IU/dl) are less common than in hemophilia A (Table 53.3), but the clinical manifestations of the two disorders are identical for the same activity levels of the coagulation factors. Specific factor assays are necessary to distinguish between hemophilia A and hemophilia B. Mild factor IX deficiency should always be considered in the differential diagnosis of patients with coagulation-type bleeding and normal routine coagulation test results (PT, PTT).¹²³ Many PTT reagents do not detect mild factor IX deficiency (factor IX levels of 20% to 30%).⁷⁴

Laboratory Diagnosis

The laboratory diagnosis of hemophilia B involves the same approach and methods as those described for the recognition of hemophilia A (Table 53.5). The screening tests reveal similar abnormalities in the two disorders, except that the PT is abnormal in the B_m variant when either ox brain or Thrombotest is used as the thromboplastin.

Hemophilia A may be easily distinguished from hemophilia B by a specific factor assay. One-stage and two-stage assays for factor IX use the same principles as those discussed for factor VIIIc. Sensitive immunoassay methods for factor IX have been developed.¹²⁴

VON WILLEBRAND DISEASE

The historical confusion that has surrounded the pathogenesis of vWD is apparent from the many names that have been applied to this disorder. These designations include angiohemophilia, vascular hemophilia, pseudohemophilia, constitutional thrombopathy, and idiopathic prolonged bleeding time. von Willebrand first recognized the disorder in a 1926 study of the inhabitants of the Åland Islands.¹²⁵ Three cardinal manifestations of this bleeding disorder are mucocutaneous hemorrhage rather than hemarthrosis and deep-muscle bleeds; autosomal dominant inheritance, rather than sex-linked as seen in hemophilia A; and prolonged bleeding time. Evaluation of one large kindred revealed variable

severity of bleeding symptoms, with some obligate heterozygote carriers being asymptomatic. von Willebrand thought that the hemostatic defect resulted from combined defects in platelet function and vascular endothelium. The discovery that plasma from normal volunteers or patients with hemophilia A corrected the hemostatic defect of vWD suggested that a plasma protein distinct from factor VIII caused vWD. In 1972, von Willebrand factor (vWF) was purified. Genetic variants were correlated with various vWF structural abnormalities, and demonstration of the heterogeneous nature of vWD was furthered by development of vWF multimer analysis by gel electrophoresis.¹²⁶ In its most common form (type 1), the disorder is characterized by mild mucocutaneous hemorrhage, which is attributable to deficiency of both vWF and factor VIIIc. The disorder is not homogeneous, however, in part because of the multiple physiologic functions played by vWF. The recognition of a number of variants, together with the demonstration of multiple genetic patterns, suggested that vWD is very heterogeneous. However, all forms of vWD can be traced to insufficient amounts of vWF or defective function of this protein. Recent reviews of this area have been published,^{127, 128} and a consensus document on vWD sponsored by the National Institutes of Health reviewed all aspects of the disorder.^{129, 130}

Incidence

Epidemiologic studies indicate that vWD is the most common bleeding disorder, affecting about 1% of the population.¹³¹ The high incidence of the disease is not limited to certain ethnic groups^{131, 132}; however, only a fraction of people come to medical attention because of bleeding symptoms. This may be because of either the relatively mild nature of the disease in many affected individuals, or a lack of recognition by patients of excessive bleeding in response to either physiologic challenge (e.g., heavy menstrual bleeding) or trauma.

Nomenclature

The identification of numerous variants of vWD has led to attempts to simplify classification of this disorder. An updated classification system has been proposed (Table 53.6).¹²⁸ Quantitative defects are divided into partial deficiency (type 1) and severe deficiency with virtually complete absence of vWF (type 3). The qualitative defects (type 2) are divided into four categories according to the nature of the defect of vWF function. Type 2A refers to variants with impaired interaction between vWF and platelets, resulting from a deficiency of intermediate- and high-molecular-weight multimers of vWF. Type 2B refers to variants in which vWF exhibits increased affinity for its receptor, platelet GPIIb. Paradoxically, bleeding in these patients develops as a result of clearance of larger vWF multimers and platelets from the circulation. Type 2M refers to variants with defective interaction between vWF and the platelet GPIIb receptor that is not due to deficiency of high-molecular-weight multimers of vWF from plasma, but rather results from defects within the GPIIb-binding domain of vWF. Finally, variants of vWD in which decreased affinity of vWF for factor VIII results in depressed plasma factor VIII levels are classified as type 2N.¹²⁸ Thus, six major categories of vWD are defined, each having distinct pathophysiology.

TABLE 53.6 REVISED CLASSIFICATION OF VON WILLEBRAND DISEASE

Revised Type	Features
1	Partial deficiency of vWF
2	Qualitative vWF defects
2A	vWF variants with loss of high-molecular-weight multimers and decreased vWF-dependent platelet adhesion
2B	vWF variants with loss of high-molecular-weight multimers caused by increased affinity for platelet glycoprotein IIb
2M	vWF variants with decreased vWF-dependent platelet adhesion not associated with the loss of high-molecular-weight multimers
2N	vWF variants with decreased binding affinity for factor VIII
3	Severe deficiency of vWF

vWF, von Willebrand factor.

Data from Sadler JE, Budde U, Eikenboom JC, et al. Update on the pathophysiology and classification of von Willebrand disease: a report of the Subcommittee on von Willebrand Factor. *J Thromb Haemost* 2006;4:2103-2114.

P.1153

Genetics

A gene on chromosome 12 codes for the synthesis of the vWF macromolecule. The genetic message is composed of 52 exons covering a span of 158 kb.^{132, 133} The vWF gene encodes for a protein with multiple copies of homologous motifs, including three "A," three "B," two "C," and four "D" motifs (see Fig. 53.5). These motifs in turn encode protein domains that subserve the various functions of vWF. The A1 domain contains binding sites for platelet GPIb, ristocetin, and collagen,^{134, 135} the A2 domain contains a protease-sensitive domain that may have a role in regulating vWF function,¹³⁶ the A3 domain contains a second collagen-binding domain,¹³⁵ the C1 domain has an RGD sequence capable of interacting with platelet glycoprotein IIb/IIIa, and the D' and D3 domains contain a factor VIII-binding sequence.¹³⁵

vWD appears to be inherited by multiple genetic mechanisms (Table 53.7). The most common form of the disorder (type 1 vWD) accounts for ~70% of all cases of vWD. Diagnostic criteria for type 1 vWD have been proposed,¹²⁸ including a history of bleeding symptoms, a positive family history of bleeding symptoms, and bleeding that is attributable to quantitatively low vWF levels. Population screening suggests that the prevalence of vWD may be as high as 1% of the population, but only a minority of these patients subsequently present with clinically significant bleeding.¹³⁷ vWD is inherited as an incompletely dominant autosomal trait with variable penetrance, even among members within a single kindred. Because of variable penetrance and expression of vWD, only ~33% of children may be affected. Figure 53.6 illustrates one of the original pedigrees described by von Willebrand.

Twin studies demonstrated that ~60% of the variation in vWF level and ~50% of the variation in factor VIII level is attributable to genetic factors.¹³⁸ Genetic loci outside of the vWF gene contribute to variation of vWF level. Individuals with blood group O have vWF levels that are on average 30% lower than those of people with blood group A, B, or AB,¹³⁹ and it is likely that carbohydrate groups attached to vWF play a subtle role in clearance of vWF from plasma.^{140, 141} In addition, variation in expression of levels of other hemostatically active proteins, such as variation in the level of platelet adhesion receptors, may modulate the severity of symptoms conferred by vWF deficiency.¹⁴² vWF levels are under hormonal and other controls, which further complicates disease expression. Variation in levels of as much as 20% has been reported with menstrual cycle, with levels lowest in the early follicular phase (before day 7 of the cycle); and levels increase with age, rising ~15% for each decade increase in age.¹⁴³ As will be discussed later, the criteria for diagnosing quantitative vWD deficiency, and the specificity of historic bleeding, have introduced controversy in what constitutes type 1 vWD and have led to the potential for the new diagnostic entity of "low vWF".^{137, 144}

Mild to moderate quantitative deficiency of vWF characterizes patients with type 1 vWD, whereas virtual absence of vWF characterizes type 3 disease. Two large studies of families with a diagnosis of type 1 vWD and genetic evaluation of patients with type 3 disease have begun to shed light on the genetics of quantitative vWF deficiency.

Very low vWF levels in the range of 5 to 20 IU/dl tend to be highly inheritable and are frequently associated with "dominant negative"-acting mutations. Mutations in these patients with type 1 vWD appear to be different than those with type 3 disease, such that type 1 disease is not simply explained by being heterozygous for a type 3 allele. Genetic defects associated with these more severe type 1 phenotypes encode amino acid changes that in turn lead to defects in protein expression. Mechanisms responsible for decreased plasma vWF level include reduced secretion related to impaired intracellular transport of vWF subunits, increased clearance from the circulation, or accelerated catabolism as a result of increased susceptibility to degradation by ADAMTS13. Changes that were most likely to cause a "dominant negative" mechanism

P.1154

are often missense mutations that change the number of cysteine residues in the vWF protein. Although such changes probably affect vWF synthesis and trafficking in the cell, at least one common mutation (Tyr1584Cys) also results in enhanced degradation by ADAMTS13.^{145, 146} One non-cysteine-related mutation is seen in vWD Vicenza. In these patients, a mutation encoding for Arg1205His results in accelerated clearance of plasma vWF, with levels of vWF in the range of 15 IU/dl. With DDAVP stimulation, timed plasma sampling revealed that the released vWF had a circulation half-life that was approximately one-sixth of normal.¹⁴⁷ Several other similar mutations have recently also been described.¹⁴⁸

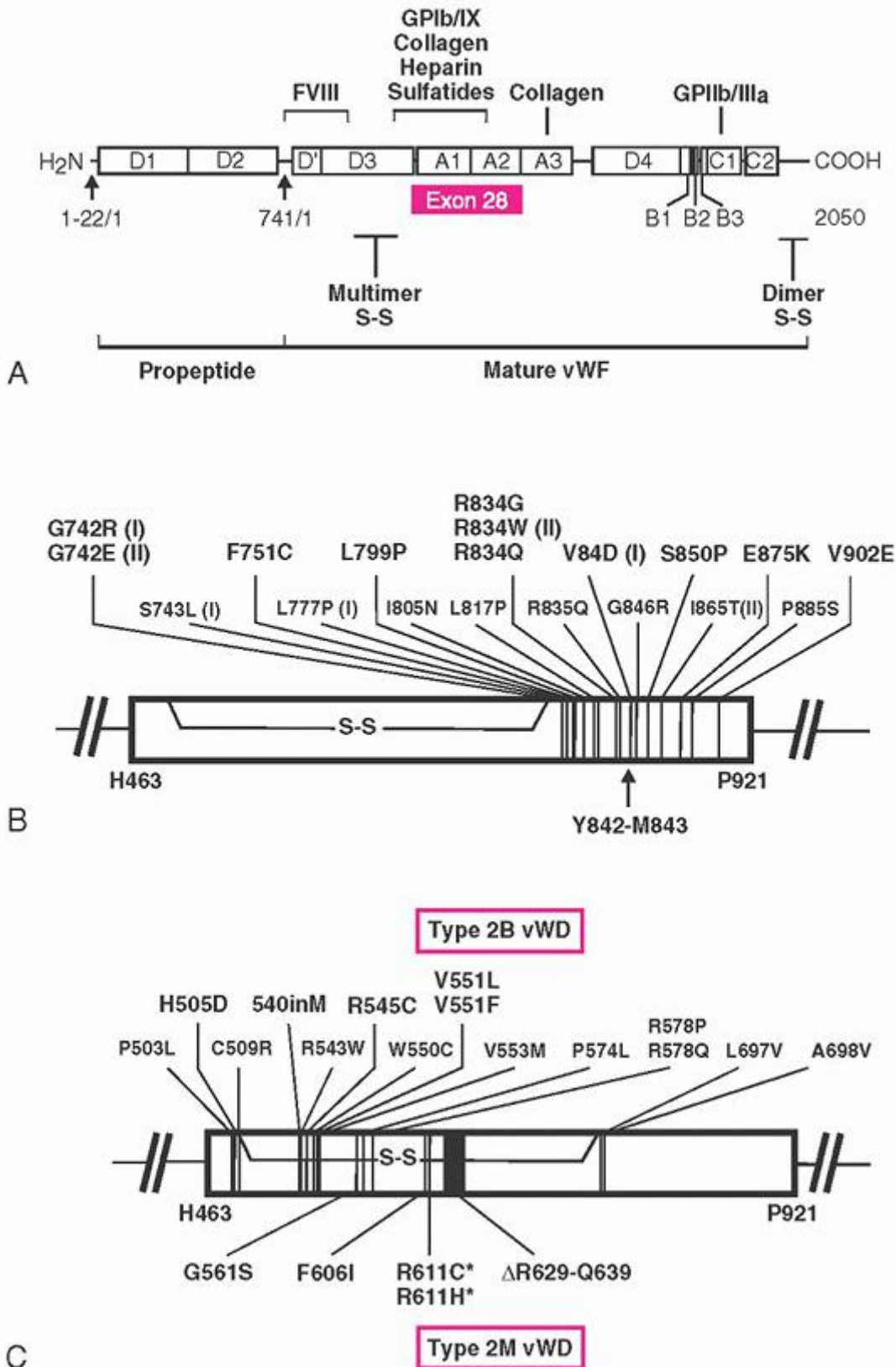

FIGURE 53.5. A: Structure and functional domains of von Willebrand factor (vWF). The open rectangles indicate domains of pre-pro-vWF. The first 22 amino acids of pre-pro-vWF are the signal sequence. The left arrow identifies the site of

cleavage of the signal peptide, resulting in pre-vWF monomers. Pro-vWF monomers form dimers, and the vWF propeptide (vWAgII) is cleaved from mature vWF (right arrow indicates cleavage site). Dimer S-S and multimer S-S indicate locations of disulfide bonds that covalently link monomeric vWF into dimers and dimeric vWF into multimers, respectively. The red rectangle identifies exon 28, which encodes the A1 and A2 domains of mature vWF. Functional domains are identified above the open rectangles. The factor VIII binding site is located in the D' and D3 domains in the amino-terminal 272 amino acids of mature vWF. The A domains of vWF contain the binding site for the platelet glycoprotein (gp) Ib/IX complex, as well as binding sites for heparin, collagen, and sulfatides. The gpIIb/IIIa complex binding site of activated platelets is located at the carboxy-terminal portion of the C1 domain and contains the Arg-Gly-Asp sequence. The numbers below the open rectangles indicate amino acid numbers: Signal peptide, 22 amino acids; propeptide (vWA-gII), 741 amino acids; mature vWF, 2,050 amino acids. B: Mutations associated with type 2A von Willebrand disease (vWD). The open rectangle represents vWF exon 28 encoding domains A1 and A2. The arrow indicates the site of proteolysis seen in type 2A vWD. Mutations are identified using the single-letter code for amino acids. I and II identify group I and group II missense mutations that result in impaired synthesis of vWF or increased sensitivity to proteolysis in plasma, respectively. The disulfide bridge shown represents the boundary of the Cys 509-Cys 695 loop in the A1 domain. Type 2A vWD mutations associated with defective vWF multimerization are not shown in this figure; these latter mutations occur in the propeptide (vWAgII) D1 and D2 domains. C: Mutations associated with types 2B and 2M vWD. The large open rectangle represents exon 28, which encodes domains A1 and A2 of vWF. The mutations responsible for type 2B vWD are shown above the rectangle. Most type 2B mutations lie between residues 540 and 578 of mature vWF. The mutations responsible for type 2M vWD are shown below the rectangle. Asterisks identify mutations that reduce the platelet-dependent function of vWF and vWF multimeric size. δ indicates deletion of an amino acid sequence. [Modified from the Symposium Proceedings of the National Hemophilia Foundation's 1995 Annual Meeting. Diagnosis and management of severe von Willebrand disease (types 2 and 3). Kroner PA, Montgomery RR. The molecular basis of von Willebrand disease, 1996:15-25. Published with permission of Advanstar Communications.]

TABLE 53.7 FEATURES OF COMMON VARIANTS OF VON WILLEBRAND DISEASE

Features	Type 1	Type 2A	Type 2B	Type 3	Platelet Type
Inheritance	Autosomal dominant	Autosomal dominant	Autosomal dominant	Autosomal recessive	Autosomal dominant
Factor VIIIc in plasma	Normal or reduced	Normal or reduced	Normal or reduced	Markedly reduced	Normal or reduced
vWF antigen	Normal or reduced	Normal or reduced	Normal or reduced; increased affinity for platelets	Markedly reduced	Normal or reduced; increased affinity for platelets
Ristocetin cofactor activity	Normal or reduced	Reduced	Normal or reduced	Markedly reduced	Reduced or normal
vWF multimeric analysis	Normal (plasma and platelets)	Absence of large and intermediate-sized multimers in plasma	Absence of large multimers from plasma; normal in platelets	Small or absent multimers in plasma and platelets	Reduction in large multimers caused by "consumption" by platelets
Ristocetin-induced platelet aggregation	Normal or diminished	Diminished	Increased aggregation at low ristocetin concentrations	Markedly diminished	Hyperaggregation with patient's platelets, normal plasma, and low concentration of ristocetin

vWF in platelets	Normal or reduced	Normal or absence of large and intermediatesized multimers	Normal	Absent	Normal
Ancillary findings	DDAVP usually produces significant increase in plasma VIIIc and vWF	DDAVP produces rise in factor VIIIc but functional vWF increase is variable and may be of short duration	Variable response to DDAVP, with intravascular platelet aggregation and thrombocytopenia in some cases; ristocetin-induced platelet aggregation enhanced in presence of patient's plasma; cryoprecipitate does not aggregate platelets in vitro unless ristocetin is added	Response to DDAVP lacking; endothelial vWF absent and	Transfusion of vWF or DDAVP may produce intravascular platelet aggregation and thrombocytopenia; cryoprecipitate produces in vitro platelet aggregation

DDAVP, 1-deamino-8-d-arginine vasopressin; vWF, von Willebrand factor.

At higher levels of vWF, linkage of the vWF level to the vWF gene is found less often. The recent European type 1 vWF cohort study demonstrated this observation. Almost all families with vWF levels <30 IU/dl showed linkage to the vWF gene, but the proportion fell to only 51% with vWF levels >30 IU/dl.⁹⁸ These data were corroborated in the Canadian study.¹⁴⁶

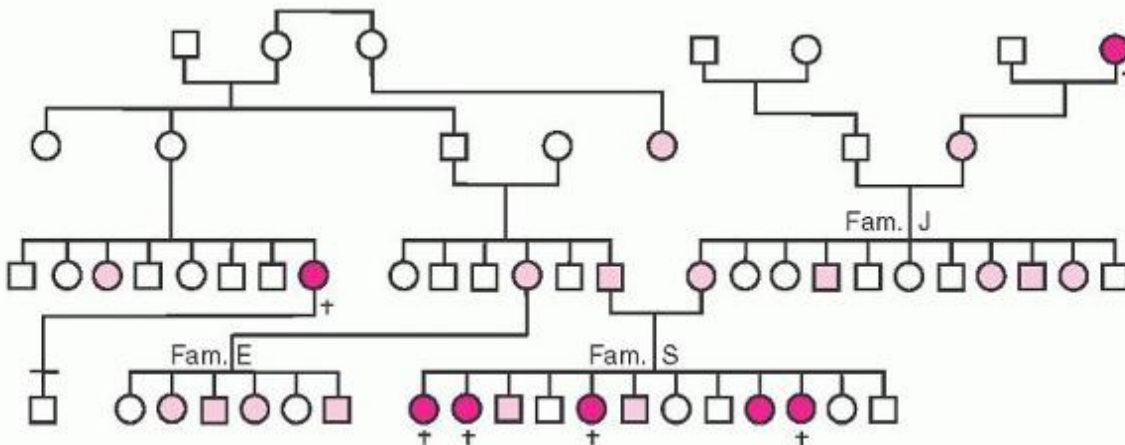

FIGURE 53.6. Pedigree of patients described by von Willebrand. Three families are emphasized: S, E, and J. Clinical details of bleeding events in these families have been reported. Open circles indicate female nonbleeders, open squares indicate male nonbleeders. Shaded circles and squares indicate female and male bleeders, respectively. Solid symbols indicate family members who experienced severe bleeding, and crosses indicate family members who experienced hemorrhagic deaths. (Modified from von Willebrand EA. Über hereditäre pseudohämophilie. Acta Med Scand 1931;76:521-550, with permission of the publisher.)

Complete absence of vWF is responsible for the most extreme form of vWD, and this is classified as type 3 vWD.¹²⁸ As one might predict, a large variety of genetic abnormalities scattered throughout the vWF gene have been reported in families with type 3 vWD. These have included large gene deletions, small gene deletions, frame-shift mutations, splice-site mutations, nonsense mutations, and point mutations.¹⁴⁹

Type 2 vWD is characterized by production of a qualitatively defective protein, and the genetics of these variant forms is more straightforward than that of type 1 vWD. In families affected by types 2B and 2M, as well as in the majority of families with type 2A vWD, inheritance is autosomal dominant. Rare cases of type 2A disease are transmitted in an autosomal recessive fashion, as are most cases of type 2N disease. vWF gene sequencing studies combined with vWF

mutation-expression analysis has revealed that single missense point mutations underlie the majority of type 2 disorders.¹²⁸ Type 3 vWD is also inherited as a recessive trait and occurs when both copies of the vWF gene are defective. In type 3 disease, gene abnormalities include large or partial gene deletions, disruption of orderly messenger RNA transcription (frame-shift mutation, splice site, or nonsense mutation), and missense mutation. For patients with recessively inherited vWD phenotypes (type 2N, type 3, or some rare type 2A), genetic analysis may reveal either homozygous or compound heterozygous gene abnormalities. Members of the International Society of Thrombosis and Hemostasis maintain a database of vWD mutations (www.vwf.group.shef.ac.uk).

Pathophysiology

The basic defect in vWD is a deficiency or abnormality of vWF function. vWF is synthesized in endothelial cells and P.1155

megakaryocytes.¹³⁴ The primary transcription product is 2,813 amino acids in length and undergoes extensive further processing, including dimerization and polymerization, to form very-large-molecular-weight “multimers”.¹³⁴ Multimerization and intracellular trafficking of vWF through the endoplasmic reticulum and Golgi apparatus and into storage granules is directed by the vWF propeptide (vWFpp). vWFpp is cleaved off the “mature subunit” after multimer assembly. Large vWF multimers, which may exceed 20 million daltons in size, are stored in endothelial cells in Weibel-Palade bodies and in platelet α -granules.

The majority of circulating vWF is present in plasma, with a concentration of ~ 10 $\mu\text{g/ml}$. The circulating half-life of plasma vWF is ~ 8 to 12 hours. Approximately 15% of circulating vWF is present intracellularly within platelets. Ultralarge multimers released from endothelial cells into the plasma are further degraded to smaller multimers through the activity of a “vWF cleaving protease”.¹³⁶ The cDNA sequence identified this protein to be the thirteenth member of the ADAMTS family (a disintegrinlike and metalloproteinase with thrombospondin type 1 motifs, ADAMTS13).^{150, 151} vWF is cleaved between tyrosine 1605 and methionine 1606 located in the A2 domain.¹⁵² High shear stress and tethering of vWF by platelets most likely enhance exposure of the cleavage site.¹⁵³ The physiologic importance of enzymatic degradation of vWF after release is demonstrated clinically by the association of an inherited form of thrombotic microangiopathy (Schulman-Upshaw syndrome) with congenital absence of the protein due to defects of the ADAMTS13 gene,¹⁵⁰ and the observation of plasma deficiency of the protein with presence of autoantibody in most patients with sporadic thrombotic thrombocytopenic purpura.¹⁵⁴ Endothelial cell stores of vWF can be released therapeutically with administration of desmopressin.¹⁵⁵

vWF is required for normal platelet adhesion (see Chapter 17), and also acts as a carrier of factor VIII in the plasma. When vWF is deficient or aberrant, both factor VIII deficiency and abnormalities in the early steps of primary hemostasis result. vWD is thus manifested as a multifaceted hemostatic defect. Both abnormalities— factor VIII deficiency and abnormal primary hemostasis—give rise to characteristic and distinct laboratory abnormalities, and both defects contribute to the bleeding tendency.

Abnormalities of Primary Hemostasis

Convincing evidence exists that the platelets, although intrinsically normal, do not adhere to subendothelium normally in the setting of deficient or defective vWF.¹⁵⁶ This abnormality is well demonstrated by methods that measure platelet adhesion to subendothelial surfaces under flow conditions (the Baumgartner technique). The physiologic stimulus for interaction of vWF with platelets is not completely defined, but tethering of vWF on exposed subendothelial cell matrix or shear stress may cause vWF to undergo conformational change. Results of experimental studies suggest that in the absence of vWF, platelet adhesion to collagen in a flowing stream of blood may be particularly deficient at high rates of shear, when only a short time is available for formation of a platelet-collagen bond.¹⁵⁷ Deficient platelet plug formation has been observed directly in experimental wounds.¹⁵⁸ In vitro, the interaction of vWF with the platelet GPIb receptor can be induced by addition of the antibiotic ristocetin, by the snake venom protein botrocetin, or by subjecting platelets to high shear stress in the presence of vWF. For the effective support of platelet adhesion, vWF is multimerized into long chains (strings), which can exceed 2 μm in length. Plasma vWF demonstrates a spectrum of sizes; however, the longest vWF multimers are the most efficient at supporting platelet adhesion.¹³⁴

Abnormalities of Secondary Hemostasis

A second function of vWF is as a molecular chaperone for factor VIII, increasing the plasma half-life of factor VIII approximately fivefold.¹⁵⁹ This effect may occur through protection of factor VIII from activated protein C-mediated degradation.¹⁶⁰ Furthermore, the binding of vWF to subendothelium at sites of vascular injury could serve to co-localize

factor VIII, where it can participate in its role in the regulation of hemostasis on the activated platelet membrane.¹³⁴ It is generally thought that whereas vWF is synthesized in endothelial cells and megakaryocytes, factor VIII is synthesized by hepatocytes. When the drug desmopressin (DDAVP, 1-deamino-8-D-arginine vasopressin) is administered to normal subjects or individuals with mild quantitative deficiency of vWF or factor VIII, levels of both molecules rise. Studies of hemophilia patients and patients with type 3 vWD on replacement therapies suggest that both vWF and factor VIII must be endogenously synthesized in order for there to be coordinated release after DDAVP. The cell responsible for that coordinated synthesis remains controversial.

Response to Transfusion

When blood products containing the vWF-factor VIII complex are infused into patients with hemophilia A, peak levels of factor VIIIc are present immediately after the infusion; this activity then declines rapidly, with an overall half-life of 8 to 10 hours (Fig. 53.7). Twenty-four hours later, factor VIIIc activity is minimal. This response is highly predictable and is discussed in a later section concerning replacement therapy for hemophilia A. In most patients with vWD, the infusion of normal vWF-factor VIII complex produces an initial rise in factor VIIIc that is predicted from the preinfusion level and the amount of factor infused. This is followed by a sustained but variable rise in factor VIIIc activity that reaches a plateau about 24 hours later and may persist for 48 to 72 hours. This phenomenon is highly variable and irregular; in some patients, a rapid initial fall of factor VIIIc is followed by a secondary rise in activity. This disproportionate response to transfused factor VIII has been called the secondary transfusion response, a feature that is apparently unique to vWD. Various hypotheses have been advanced to explain the disproportionate response to transfusion described above. The leading hypothesis is that the infused vWF results in stimulation of increased factor VIII release into the plasma with the attachment of the newly released factor VIII onto infused vWF.¹⁶¹

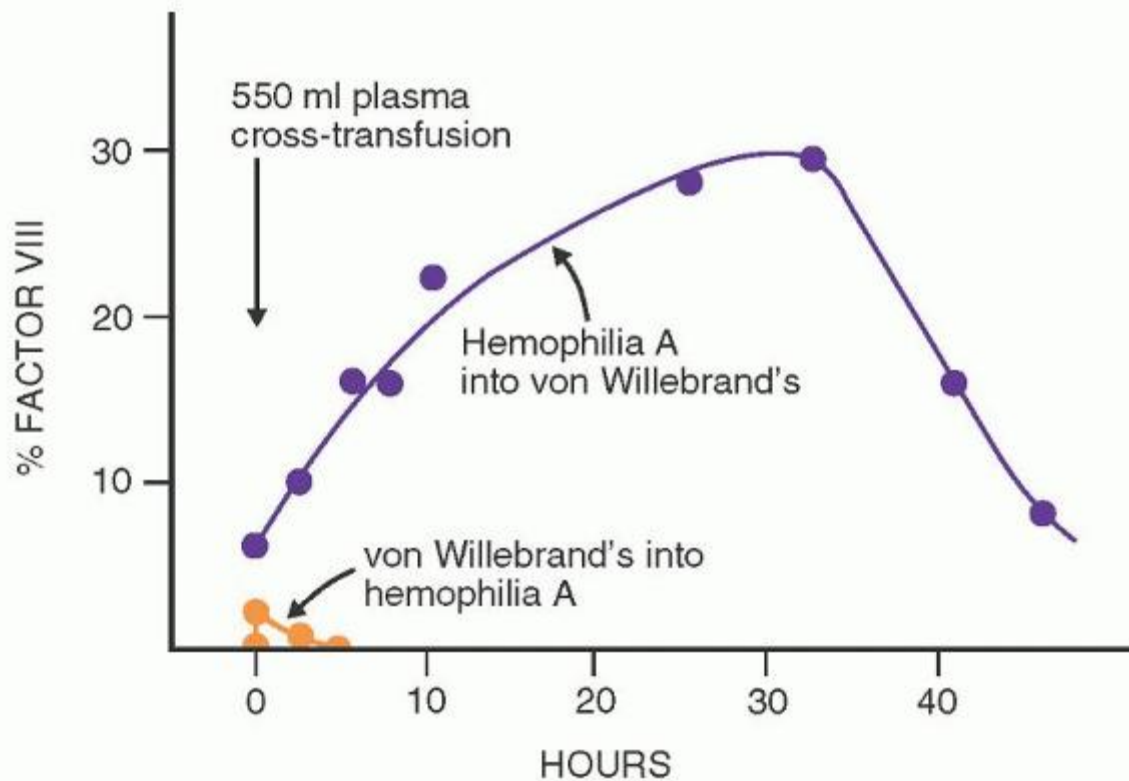

FIGURE 53.7. The phenomenon of new factor VIII synthesis in patients with von Willebrand disease (vWD) who receive plasma transfusion. Open circles indicate changes in the plasma factor VIII levels of a patient with vWD after infusion of plasma from a patient with severe hemophilia A. A significant and sustained increase in the factor VIII levels of the recipient was observed even though no active factor VIII was present in the infused plasma. Solid circles indicate effects of infusing plasma from a patient with vWD into a patient with severe hemophilia A. The factor VIII level in the infused plasma was 15% of normal. Note the slight and transitory effects. (From Shulman NR, Cowan DH, Libre EP, et al. The physiologic basis for therapy of classic hemophilia (factor VIII deficiency) and related disorders. *Ann Intern Med*

1967;67:856-882, with permission.)

P.1156

Transfusions of blood products containing vWF shorten the bleeding time to a variable degree in patients with vWD. This corrective effect seldom persists for more than a few hours, even after massive transfusions that raise vWF to high levels. The correction of the bleeding time apparently requires the large molecular forms of vWF that are present in cryoprecipitate and select intermediate-purity factor VIII concentrates,¹⁶² but that are completely absent from monoclonally purified or recombinant concentrates of factor VIII.¹⁶³ Failure of the skin template bleeding time of patients with vWD to show sustained correction with appropriate replacement therapy has been noted, and does not necessarily predict defective surgical hemostasis. This apparent paradox may be a result of sensitivity of the bleeding time test to platelet α -granule vWF, which is not replenished during vWF replacement therapies.¹⁶⁴

Clinical Manifestations

The bleeding manifestations in vWD are heterogeneous but consistent with the dual roles of vWF in supporting both primary and secondary hemostasis. Thus, in the mild forms of vWD, the clinical picture is dominated by cutaneous and mucosal bleeding, which appears to be mainly the result of disordered primary hemostasis. In the most severe forms of the disorder, in which factor VIII levels are low, hemarthroses and dissecting intramuscular hematomas may develop. As in mild classic hemophilia, serious hemorrhage resulting from traumatic injuries or after surgical procedures is a significant hazard in severe vWD. Petechiae are rare, but hematoma formation and the extent of bruising are excessive compared with the inciting trauma.

The bleeding manifestations in the usual patient with type 1 vWD are mild, however, and many patients are virtually asymptomatic. The disorder may be symptomatic at any age, but it is not always recognized. Easy bruising is common in vWD, but it is not specific. Mucosal bleeding is particularly common. Childhood epistaxis, a life-long history of easy bruising, bleeding with dental extraction, heavy menstrual bleeding or anemia attributed to excessive menstrual blood losses, or postpartum hemorrhage are all included in the spectrum of vWD symptomatology. Systemic bleeding disorders are often not considered in women with menorrhagia,¹⁶⁵ but clinical studies reveal that the prevalence of vWD is significant in individuals who present with this complaint.¹⁶⁶ Angiodysplasia of various vascular beds, particularly those in the gut, has been demonstrated in some patients with vWD and may be an important contributory factor in chronic gastrointestinal bleeding.¹⁶⁷ In type 1 vWD, symptoms usually become milder during pregnancy or with estrogen therapy, when the vWF and factor VIIIc levels rise significantly.⁴⁰ The disorder may also decrease in severity with advancing age. Bleeding manifestations tend to be more prominent in patients with more severe quantitative deficiency and in patients with qualitative (type 2) defects.

While eliciting the history of bleeding, one should bear in mind that women are often inaccurate assessors of whether their menstrual flow is normal or excessive. Supplemental questioning regarding the frequency of changes of menstrual protection, and questions regarding a history of iron deficiency anemia and transfusion, may be informative. Retrospective studies of women with vWD show that abnormal bleeding can often be traced to menarche.¹⁶⁸ Family history also may provide important clues to a diagnosis. The physician should specifically seek a history of the response to hemostatic challenge, such as dental extraction, tonsillectomy, surgical procedures, menstruation, peripartum hemorrhage, and transfusion. A model questionnaire with a scoring system has been published.¹⁶⁹ Coexistent conditions or drug effects can strongly influence the severity of bleeding symptoms. Risk of hemorrhage may increase in patients with concomitant liver disease, uremia, gastrointestinal ulcer, or angiodysplasia. Excessive bleeding in response to challenge with aspirin may also point toward a bleeding disorder, but this history is not specific for vWD. Valproic acid use can result in lower vWF activity levels, as may hypothyroidism and valvular heart disease. Conversely, oral contraception frequently ameliorates menorrhagia.¹²⁷

Laboratory Diagnosis

Criteria for the laboratory diagnosis of vWD are imperfect. One goal of applying a series of laboratory evaluations is to exclude other causes of bleeding. When specifically considering vWD, the laboratory evaluation may be complicated. Even with the more elaborate confirmatory tests now available, the diagnosis of this disorder may be difficult and may require repeated observations over a period of time. Both vWF and factor VIII are "acute-phase reactants," increasing with stress, trauma, estrogen therapy, or pregnancy, such that levels may fluctuate from time to time. Evaluation of a patient at a time remote from acute infection, pregnancy, or strenuous activity is preferable. However, pregnancy and acute-phase reaction are unlikely to obscure diagnosis in patients with more severe quantitative deficiency or qualitative defects.

Diagnosis of vWD is complicated, because of both the breadth of vWF functions and the spectrum of disorders that constitutes vWD. Consequently, a battery of studies should be considered to evaluate a patient conclusively for vWD.¹³⁴ Screening tests such as bleeding time, Platelet Function Analyzer-100 (PFA-100), and PTT lack sensitivity; specific tests such as those for vWF antigen, vWF activity, and factor VIII level are preferred. Correlating the values of these various quantitative assays with each other, or obtaining qualitative tests such as vWF multimer analysis or lowdose ristocetin-induced platelet aggregation, may provide important clues toward a diagnosis of type 2 vWD (Table 53.7).

Bleeding Time and Platelet Function Analyzer-100

The template bleeding time, the Ivy bleeding time, or technical modifications thereof may be useful in detecting the abnormality characteristic of vWD. However, the bleeding time may be normal in many patients with vWD.¹⁷⁰ Consequently, the bleeding time adds to the diagnosis of vWD if it is prolonged, but otherwise may have little clinical utility in the diagnosis and management of patients with vWD. The bleeding time may not improve following replacement therapy with vWF, and monitoring is generally not recommended,¹⁷¹ because surgical bleeding can generally be prevented by replacement of plasma vWF.

Standardization issues, inconvenience, and residual scarring of patients are some of the issues that have fostered development of in vitro tests to replace the bleeding time. The PFA-100 evaluates platelet adhesion and aggregation to collagen in a whole-blood assay under high shear conditions.¹⁷² Citrate-anticoagulated whole blood is aspirated through an aperture in a collagen-coated membrane, and the device measures the time from first flow until flow ceases as the "closure time." PFA-100 closure times are sensitive to multiple factors, including vWF function, platelet count, platelet function, and hematocrit. Initial studies using the PFA-100 in patients with diagnosed vWD indicated that the assay was sensitive to most forms of vWD. However, when the closure time test was applied in clinical settings where patients were referred for evaluation of bleeding symptoms, the sensitivity of the PFA-100 for diagnosis of vWD ranged from 62% to 80%, with specificity ranging from 84% to 89%.^{173, 174} In addition, the closure time may remain normal in acquired vWD despite a very reduced plasma vWF level, because the platelet vWF level may remain normal. The PFA-100 closure time may also be normal in patients with type 2N vWD, in which the major defect is low factor VIII levels. As with the bleeding time, correction of plasma vWF level in the absence of concomitant correction of the platelet vWF may be insufficient to correct the closure time, so this test may not be very helpful for perioperative monitoring of patients on replacement therapy.^{175, 176}

P.1157

Partial Thromboplastin Time and Factor VIIIc Assay

Among the simple screening tests (Table 53.5), the PTT may be abnormal, reflecting reduced levels of factor VIIIc. Plasma levels of factor VIIIc vary greatly in this disorder and range from as low as 3 IU/dl in patients with type 3 vWD to normal levels in patients with mild type 1 vWD. Because factor VIIIc deficiency is often mild in patients with vWD, a diagnosis of vWD may be missed by the routine screening PTT. Consequently, a specific assay is required to reliably detect factor VIIIc deficiency in patients with vWD.

von Willebrand Factor Immunoassay

The immunoassay of vWF is a quantitative measure of vWF protein that is one of the most sensitive methods available for the diagnosis of vWD.¹⁷⁷ A variety of methods have been used, all of which depend on antibodies specific to vWF. The electroimmunodiffusion method of Laurell was initially widely used because it was simple to perform, but ELISA or automated assays using related methodologies have now largely replaced this technique. Average levels of vWF antigen (vWF:Ag) obtained by different laboratories will vary, but a level of ~45 to 50 IU/dl is the lower limit of normal reported by many laboratories. The ratio of factor VIII to vWF also varies by laboratory but normally ranges from ~0.7 to 2.2 (Fig. 53.1). Plasma levels of vWF:Ag are regulated to some extent by carbohydrate residues attached to the protein; ~25% lower vWF antigenic levels have been noted in patients with blood type O compared to patients with other blood types.¹³⁹ The contribution of blood group O is more marked in patients with mild quantitative vWF deficiency, where the low vWF level is less likely to be related to abnormalities of the vWF gene.^{145, 146} Whether these patients actually have vWD type I is subject to debate, and the role of blood group in the diagnosis of vWF deficiency remains to be resolved.¹²⁸ Patients with type 2 vWD may have normal vWF:Ag levels, emphasizing the need to use more than just a vWF antigen assay to evaluate a patient for vWD.

von Willebrand Factor Functional Assays

vWF has multiple functions, and assays have been devised to specifically evaluate many of these. The function most often clinically assessed is its ability to interact with platelets. An assay that evaluates the ability of vWF to interact with collagen has also been proposed as a functional assay. The relevance of collagen-binding activity analysis is questioned for routine screening, and collagen-binding activity assay has not gained widespread acceptance in the United States.¹⁷⁸ Finally, vWF binding of factor VIII can be assessed in special circumstances when questioning whether mild factor VIII deficiency is due to failure of vWF chaperone function. vWF functional assay generally correlates well with vWF:Ag in patients with quantitative disorders of vWF. Observing a discrepancy between vWF function and vWF:Ag provides a useful clue for qualitative defects, provided that the testing laboratory uses the same control plasma for determining both assays.¹⁷⁹

Ristocetin Cofactor Activity and Ristocetin-induced Platelet Aggregation

The assay for ristocetin cofactor activity (vWF:RCo) is a quantitative technique for estimating the ability of vWF in patient plasma to bind target platelets that are specially prepared or preserved for use in the assay.¹⁸⁰ Ristocetin induces an activated conformation of vWF such that it will then bind platelets via the platelet GPIb receptor, mimicking the in vivo sequence of events that allows interaction between subendothelial tissue-bound vWF and platelets. Quantitation of vWF:RCo is held to be the single most sensitive and specific assay for vWD by multiple authorities.^{181, 182, 183} vWF:RCo activity is adversely affected by loss of the larger-molecular-weight vWF multimers. The discrepancy between vWF:RCo and vWF:Ag that is observed in qualitative defects characterized by loss of both the intermediate- and higher-molecular-weight multimers (such as type 2A vWD) is thought to result from this. Ristocetin cofactor activity is also generally utilized to follow a vWD patient's response to therapeutic interventions. However, obtaining typical ristocetin cofactor activity is a time-consuming procedure, and assay standardization remains somewhat problematic. Automation of the vWF:RCo assay has resulted in a clinically more available, but less sensitive technique, which requires modification to detect levels below ~10 to 20 IU/dl. Simpler ELISA-based methods using monoclonal antibody to the GPIb-binding domain of vWF have been explored for estimating vWF activity.¹⁸⁴ Unfortunately, commercial functional epitope assays have not performed sufficiently well to allow them to replace vWF:RCo assay,^{185, 186} and these assays do not measure the increased functionality of the larger vWF multimers directly.

Ristocetin-induced platelet aggregation (RIPA) is a distinct test from ristocetin cofactor activity. RIPA is a qualitative test that involves evaluating the rate or extent of agglutination of patient-derived platelet-rich plasma in response to the addition of the antibiotic ristocetin. The concentration of vWF and platelets present in the test plasma, as well as the amount of ristocetin added, affect RIPA. The assay is relatively insensitive to mild deficiency of vWF, but decreased aggregation response is observed in both more severe deficiency and in patients with Bernard-Soulier syndrome (in which platelets are missing the GPIb receptor). Titrating down the amount of ristocetin added in the assay may be of specific interest in defining variants of vWD in which there are "gain of function" mutations (type 2B and platelet-type [pseudo] vWD). These two conditions are characterized by increased sensitivity of patient vWF or platelets to the effect of ristocetin.¹²⁸ However, insensitivity of patient samples to low-dose ristocetin aggregation is seen in occasional patients with type 2B vWD in whom there is marked reduction in the amount of high- and intermediate-molecular-weight multimers, and genetic analysis may be required to distinguish some cases of type 2B from type 2A vWD. In addition, low-dose ristocetin aggregation of patient-derived platelet-rich plasma cannot differentiate type 2B vWD from the rarer platelet-type (pseudo) vWD, and mixing studies using patient plasma and donor platelets have been devised to help make that distinction at the phenotypic level.¹⁸⁷

von Willebrand Collagen-binding Activity

vWF contains collagen-binding sites in both the A1 and A3 domains of the vWF protein, and collagen-binding activity (vWF:CB) may be an important function that allows vWF to adhere to platelets at sites of vascular injury. Like ristocetin cofactor activity, vWF:CB is dependent on multimer size, with the larger multimers binding collagen more avidly. The assay is generally done in an ELISA format, in which type I and/or type III collagen is plated into microtiter wells, and the amount of vWF captured is assayed.¹⁸⁸ vWF:CB correlates well with vWF:Ag in normal individuals and those with quantitative deficiency of vWF, and discrepant results are indicative of vWD subtypes that are characterized by deficiency of larger vWF multimers. A single case of vWD characterized by mutation of the vWF A3 domain with isolated loss of collagen-binding function despite the presence of a normal multimer distribution has been described.¹⁸⁹ Although some studies suggest that vWF:CB testing complements assays of vWF:Ag and vWF:RCo in distinguishing type 1 vWD from type 2A and 2B variants, the role of vWF:CB testing in routine clinical practice remains to be determined.^{127, 178, 190}

Assay of von Willebrand Factor's Ability to Bind Factor VIII

Factor VIII binding by vWF (vWF:FVIII) can be measured in a few reference coagulation laboratories, and is indicated for the evaluation of patients suspected of having factor VIII deficiency on the basis of defective vWF chaperone function (type 2N vWD).¹⁹¹ In this ELISA format assay, ELISA plate wells are coated with antibody to vWF in order to capture vWF from patient plasma. After washing patient-derived factor VIII from the well, the ability of patient-derived vWF to capture r-FVIII is assessed using a chromogenic or immunoassay for factor VIII, and the quantity of patient-derived vWF:Ag in the well is quantified by standard ELISA technique. The calculated ratio of captured r-FVIII to vWF:Ag is expected to be in the normal range when testing plasma from a patient with hemophilia A, whereas it will be abnormally low in the rare cases of type 2N vWD.¹⁹²

Multimeric Analysis of von Willebrand Factor

Normal vWF in plasma consists of a complex series of multimers, ranging in size from about 500 to 20,000 kDa. vWD initially diagnosed by abnormal assays for factor VIIIc, vWF antigen, or ristocetin cofactor activity should be further characterized by multimeric analysis. In this test, the spectrum of vWF molecular sizes of the patient's vWF is assessed by size-based separation of vWF multimers via agarose gel electrophoresis, and vWF multimers are imaged by immunologic methods coupled to autoradiography or other detection methods.¹⁹³ Multimer analysis is characterized as either "low-resolution" (which differentiates the largest multimer forms from the intermediate and smaller forms), or "high-resolution" (which resolves each multimer band into three to five satellite bands), which inform on the activity of ADAMTS13 on plasma vWF. Multimer analysis will confirm the presence of the entire spectrum of vWF multimers in normal individuals and those with type 1 vWD, and allows identification of the loss of intermediate- or high-molecular-weight multimers of vWF as is characteristic of the type 2A and type 2B qualitative defects.¹⁹³ Unfortunately, the distinction between type 2A and type 2B vWD is not always possible using multimer analysis alone, necessitating further testing. Multimeric analysis is a very labor-intensive test and is usually performed only in coagulation reference laboratories. The multimeric composition of plasma from normal subjects and patients with vWD is shown in Figure 53.8. This methodology has been reviewed.¹⁹⁴

Genetic Testing in von Willebrand Disease

Direct mutational analysis by vWF gene sequencing, allele-specific PCR, or restriction enzyme analysis is useful in confirming a diagnosis of type 2 variant vWD.¹⁹⁵ The functional domain structure of the vWF gene results in clustering of the various type 2 vWD defects in limited areas of the vWF sequence.¹²⁸ vWF exon 28 encodes for the A1 loop of vWF responsible for the interaction of vWF with platelet GPIb, and vWD variants characterized by defects of this interaction (types 2B and 2M) are encoded by genetic mutations clustered in this exon.¹⁹⁶ Exon 28 also encodes the A2 domain, which contains the ADAMTS13-sensitive bond tyrosine1605-methionine 1606. Mutations that increase the susceptibility of this bond to cleavage by ADAMTS13 underlie a high fraction of type 2A vWD (previously classified as 2A, subtype 2). Less commonly, type 2A vWD results from a defect of the multimerization process. The carboxy terminus of the vWF peptide (encoded by exons 51 to 52) is involved in initial vWF dimer formation in the rough endoplasmic reticulum. The vWFpp (encoded by exons 3 to 17) directs further multimerization via cross-linkage of the amino-terminal D' and D3 of the mature vWF protein (encoded by exons 18 to 28). As one might expect, type 2A vWD on the basis of failure of multimerization (previously classified as 2A, subtype 1) has been attributed to genetic abnormalities in each of these regions of the genome. Mutations responsible for defective interaction of vWF with factor VIII (type 2N vWD) are predominantly clustered in exons 18 to 20, which encode for the factor VIII-binding domain of vWF; however, rare cases have been attributed to mutations in exons 24 and 25. An online database of defects found in vWD patients can be accessed at www.vwf.group.shef.ac.uk. Figure 53.5 shows the location of these various genetic abnormalities schematically. Rapid, complete vWF gene sequencing has been reported.¹⁹⁷

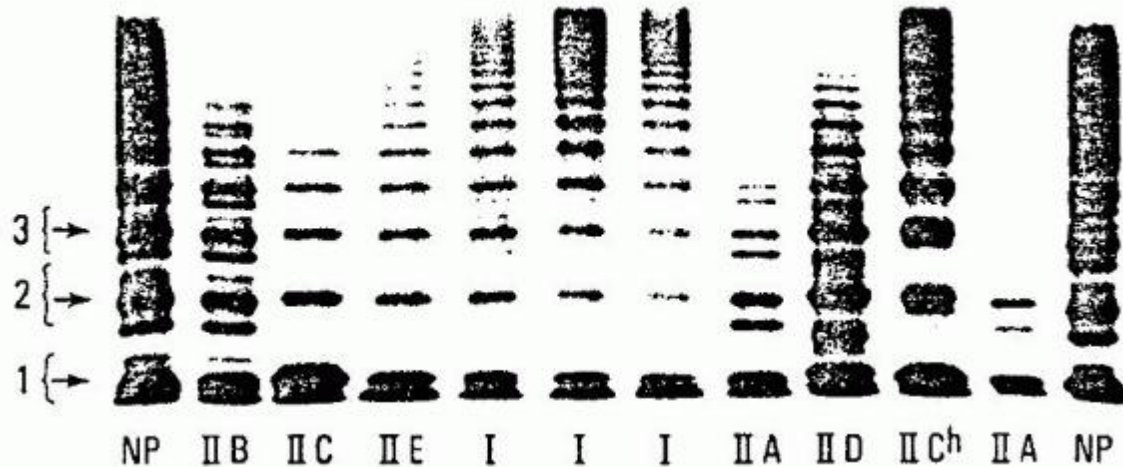

FIGURE 53.8. Multimeric composition of von Willebrand factor from normal plasma and that from types I, IIA, IIB, IIC, IID, and IIE von Willebrand disease (vWD), as well as from a type IIC heterozygote (IIC^h). Using the revised classification scheme, these types would correspond to 1, 2A, 2B, 2A, 2A, and 2A, respectively. The three brackets include the smallest normal oligomers, with arrows pointing to the central predominant band in each. In type 1 vWD, the relative concentration of large multimers varies. (From Zimmerman TS, Ruggeri ZM. von Willebrand disease. *Hum Pathol* 1987;18:140-152, with permission.)

Genetics of Type 1 and Type 3 vWD

Mild to moderate quantitative deficiency of vWF characterizes patients with type 1 vWD, whereas virtual absence of vWF characterizes type 3 disease. Genetic analysis is not generally required to make these diagnoses, but may provide useful additional information concerning pathogenesis of a patient's condition, responsiveness to DDAVP, or risk for alloantibody formation. In distinction from type 2 vWD, genetic defects underlying quantitative vWF deficiency are distributed throughout the vWF gene, complicating evaluation. In addition, for families with patients who demonstrate normal multimer structure and higher vWF levels, the chances of finding linkage to the vWF gene are reduced,^{145, 146} and family members are usually asymptomatic.¹³⁷ Type 3 patients with large gene deletions are particularly prone to develop anti-vWF alloantibodies after treatment with vWF-containing concentrates.

Type 1 von Willebrand Disease and "Low von Willebrand Factor"

Patients with bleeding attributed to decreased production of qualitatively normal vWF are classified as having type 1 vWD. Most patients with vWD (70% to 80%) fall into this category.¹³⁴ The majority of patients have a mildly symptomatic disorder, but bleeding may increase with physical trauma, surgery, or during menstruation. vWF levels are low, with concordant reduction of vWF:Ag and vWF:RCo (and vWF:CB, if that is measured). Factor VIII levels are generally equal to or higher than vWF levels, and all vWF multimers should be present if that analysis is performed as part of the patient evaluation. The diagnosis of type 1 vWD may be simpler in an individual with mucosal bleeding symptoms, a strong family history of similar symptoms, and quantitative vWF level (vWF:Ag and/or vWF:RCo) <30 IU/dl. Although not required for a diagnosis of type 1 vWD, the probability of finding linkage of the phenotype to the vWF gene in such an individual would be high, such that both therapeutic choices and genetic counseling would be straightforward.

P.1159

Unfortunately, many factors make the diagnosis of type 1 vWD difficult.¹⁴⁴ Mild bleeding symptoms are common in hemostatically normal people (see Chapter 45). In addition, the relative risk of bleeding for individuals with only modest reductions in vWF level appears to be minimal. Finally, because of the strong influence of blood group on vWF levels, there is a high prevalence of blood group O among individuals with mildly depressed vWF levels. These observations have led to the recent proposal of the concept of "low vWF".^{137, 144} The term "low vWF" could be applied to patients with vWF levels below the normal reference range but above some lower limit. A recently convened "expert group" brought together by the National Heart, Lung and Blood Institute is considering this proposal.¹²⁹ Studies of families of patients with a diagnosis of type 1 vWD suggest that linkage to the vWF gene is less often seen when the vWF level rises above 30 IU/dl,

suggesting that this might be a candidate for the lower limit of the "low vWF" category.^{145, 198} Empiric therapy to raise vWF levels in patients with "low vWF" at times of hemostatic challenge would be reasonable for patients with a history of bleeding, but the genetic counseling issues would clearly be different.¹⁴⁴

On the other hand, two population-based studies have shown that "low vWF" causes increased bleeding.^{199, 200} These latter studies would suggest that abnormally low ristocetin cofactor activity, and not the presence of a mutation, should primarily be used to identify bleeders.

Type 3 von Willebrand Disease

Type 3 vWD is the most severe form of vWD, because it results from complete failure of vWF synthesis. This bleeding disorder is generally diagnosed during infancy. Hematoma formation is common, epistaxis may be life-threatening, and hemarthrosis may occur as a result of the low factor VIII levels that are seen in this condition. Plasma from patients with type 3 vWD contains virtually no detectable vWF, and vWF is not present in either platelets or endothelial cells. Factor VIII level is generally in the range of 1 to 10 IU/dl, similar to that seen in moderate to mild hemophilia A. Multimeric analysis of the little vWF present yields variable results, in some cases revealing only small multimers.¹⁹³ Type 3 vWD is rare, with an estimated frequency of 1 in a million people.²⁰¹ Genetic analysis reveals either homozygous or compound (double) heterozygous defects of the vWF gene, with gene deletions, frame-shift mutations, missense mutations, or nonsense mutations. Careful laboratory evaluation of the parents of patients with type 3 disease may reveal mild quantitative deficiency of vWF. In a review of 117 obligate heterozygotes, the mean plasma vWF level was 45 IU/dl, with a range from 5 to 130 IU/dl.¹⁴⁴ Parents are frequently asymptomatic, consistent with the impression that type 3 disease is inherited as a recessive trait. Consanguinity is common in kindreds with this variant. In some patients with type 3 vWD, large gene deletions have been identified on one or both vWF alleles.^{128, 202} Such patients are at increased risk of developing inhibitory alloantibodies to vWF after transfusion therapy.²⁰²

Because these patients lack vWF in their endothelial cells and platelets, there is no rise in vWF level in response to DDAVP. For replacement therapy, these patients require vWF-containing concentrates. This is usually provided in the form of specific intermediate-purity factor VIII concentrates that have been documented to contain intact vWF.¹⁵⁵ Because these patients possess a normal factor VIII gene but are missing the vWF chaperone, posttransfusion factor VIII recovery and survival may be longer in a patient with type 3 vWD than in a patient with hemophilia A, owing to endogenous factor VIII production. Although life-threatening bleeds require immediate replacement of both vWF and factor VIII, replacement with vWF alone may be sufficient if therapy is begun 12 to 24 hours before elective surgery.²⁰³

Qualitative Defects of von Willebrand Factor

Several subsets of patients with vWD differ substantially from those with the common quantitative deficiency states (Table 53.6).¹²⁸ Classified as type 2 variants, these qualitative defects of vWF are less common, but they may represent up to 20% to 25% of cases of vWD. Type 2 forms of vWD are suspected when the severity of the patient's symptoms seems in excess of the observed vWF and factor VIII levels, when there is discordant reduction between vWF antigen and vWF functional activity or factor VIII assay, or when there is concomitant vWF deficiency and thrombocytopenia. Discrimination between qualitatively normal and abnormal vWF can be difficult; however, when the ratio of vWF:RCo to vWF:Ag or vWF:CB to vWF:Ag is found to be <0.6, dysfunctional vWF should be considered. The sensitivity and specificity of such ratio screening depends to a large extent on the expertise and precision of the laboratory performing the assays, but the predictive value of ratios decreases when the level of vWF antigen is <20 IU/dl. Examining the structure of patient vWF may provide further definition of the nature of the qualitative defect. This can be demonstrated by vWF multimer analysis. If required, further information is provided by supplemental studies of vWF function, or via genetic analysis of the vWF gene (Fig. 53.5).^{126, 128, 193} Type 2 defects were initially classified using a Roman numeral system, but further understanding of the genetics of vWD led to the consolidation and reclassification into types 2A, 2B, 2M, and 2N,¹²⁸ based on the nature of the vWF functional defect. In addition to the well-defined variants described in this chapter, other forms of vWD continue to be described.

Type 2A von Willebrand Disease

vWD with defective interaction of vWF with platelets due to deficiency of intermediate- and high-molecular-weight forms of vWF is classified as type 2A vWD.¹²⁸ This form of the disorder is generally inherited as an autosomal dominant trait,²⁰⁴ and it accounts for the majority of patients with type 2 defects. Levels of factor VIIIc and vWF:Ag in the plasma may be normal or reduced. The vWF activity as assayed by either vWF:RCo or vWF:CB is significantly lower than vWF:Ag because of the absence of the larger multimers (which are more potent in their ability to interact with platelet GPIb and collagen). Analysis of vWF multimers reveals a relative reduction in intermediate- and high-molecularweight species.¹²⁷ Protein studies followed by genetic analysis of the basis of type 2A vWD revealed multiple mechanisms for the generation of this

disorder.^{205, 206, 207} In some patients, there is failure to synthesize full-length multimers (type 2A, subgroup 1). Mutations associated with impaired vWF multimerization have been localized to the vWFpp (formerly called type IIC), the region of the mature vWF protein associated with the amino terminus area of multimer formation (formerly called type IIE), and the carboxy terminus region that is involved in initial dimer formation (formerly called type IID). Subtle abnormalities uncovered by high-resolution multimer analysis or genetic evaluation can be used to distinguish these subtypes of type 2A vWD. The spectrum of multimers released into plasma after DDAVP administration would not be expected to improve significantly in these patients whose defects prevent normal multimer assembly.

A second group of type 2A patients has been described in whom there is excessive catabolism of fully multimerized vWF after vWF is released into the plasma. These patients demonstrate mutations in exon 28, encoding the A1 and A2 regions of vWF. These mutations allow increased proteolysis of multimerized vWF by ADAMTS13. Again, high-resolution multimer gel studies may be informative by demonstrating increased "satellite" band intensity, which accumulates as a result of excessive ADAMTS13 activity. Because intracellular vWF is protected from cleavage by ADAMTS13, these patients may demonstrate very transient

P.1160

improvement in both vWF:RCo and multimer spectrum after DDAVP administration.

Inheritance of type 2A vWD is generally autosomal dominant, with the majority of cases caused by mutations clustered in the region of exon 28, which encodes the vWF A2 homologous repeat (Fig. 53.5).¹²⁸ Rare recessive forms of type 2A vWD have been reported with some multimerization defects (formerly called types IIC and IID).

Because of the underlying structural abnormality of the vWF produced in these patients, neither stress nor pregnancy significantly increases the functional amount of vWF protein in the plasma. As noted above, the administration of DDAVP does not result in a significant rise in vWF:RCo in patients with type 2A vWD, in which the underlying mechanism is defective multimerization or transport, but a very short-lived correction may be observed in patients with mutations associated with increased vWF cleavage by ADAMTS13.

Type 2B von Willebrand Disease

Type 2B vWD is a paradoxical bleeding disorder, characterized by increased interaction of patient vWF with platelets which is demonstrated in vitro in the presence of low doses of ristocetin. Increased in vivo interaction of the larger multimers of type 2B vWF with platelets is thought to result from mutations that either allow increased access of platelets to the A1 loop of vWF or that stabilize that interaction.¹²⁷ This may in turn allow increased generation of vWF-platelet complexes, which are subsequently cleared from circulation, resulting in thrombocytopenia.

This bleeding disorder is characterized by deficient vWF function attributable to mild reduction of vWF:Ag, a somewhat more marked deficiency of vWF:RCo activity (and vWF:CB, if measured). Multimeric analysis reveals a deficiency of the highest-molecular-weight vWF multimers. Measurements of factor VIIIc are variable. Many patients with the type 2B variant have mild persistent thrombocytopenia.²⁰⁸ The platelet count may fall further during physiologic stresses, pregnancy, in association with surgical procedures, or after the administration of DDAVP.²⁰⁹

Additional laboratory evaluation is required to support a diagnosis of type 2B vWD. In most cases, multimeric analysis reveals absence of higher-molecular-weight forms of plasma vWF, but distinction of type 2B from type 2A vWD is not possible by multimeric analysis alone. To show the distinct "gain in function" in type 2B disease, RIPA studies are done to reveal enhanced interaction of patient vWF and platelets with low doses of the drug. Finally, to differentiate the more common type 2B vWD from the rare platelet-type (pseudo) vWD, one should prove that the defect resides in vWF. This is done either through performing mixing studies of patient plasma with donor platelets¹⁸⁷ or by analysis of the patient's vWF gene.

Type 2B vWD is inherited as an autosomal dominant trait. A small cluster of mutations within the portion of vWF exon 28 that encodes the vWF A1 domain that interacts with platelet GPIb accounts for all the cases of type 2B vWD that have been reported (Fig. 53.5).¹²⁸

Recent studies evaluating a large number of patients with type 2B vWD mutations revealed diversity in laboratory findings.²¹⁰ Not all patients had reduced vWF:RCo activity or abnormal multimeric analysis, and not all patients had thrombocytopenia.²¹⁰ Type 2B patients with normal multimers did not develop thrombocytopenia.

Type 2M von Willebrand Disease

The type 2M vWD variant is defined by diminished platelet-dependent vWF function that is not attributed to deficiency of vWF multimers.¹²⁸ Thus, these patients have an initial laboratory profile that in many ways is similar to that of patients with type 2A vWD, revealing variable deficiency of vWF:Ag but disproportionately decreased interaction of vWF with platelets in the presence of ristocetin as measured by vWF:RCO assay. Factor VIII level is proportionate to the vWF:Ag, and the platelet counts are normal. What differentiates type 2M vWD from the type 2A patients is that the vWF multimeric analysis is normal (and, if measured, the vWF:CB is usually similar to the vWF:Ag). Type 2M vWD is inherited as an autosomal dominant trait, and, when investigated, mutations have been found in the region of exon 28 that encodes the A1 domain of vWF. Unlike the type 2B mutations, 2M mutations cause impairment of the binding of vWF to the GP1b receptor and have been shown to be localized to an alternative area in the A1 domain (Fig. 53.5).¹⁹⁶

One case classified as a type 2M defect was described in which the vWF interaction with collagen was defective. In that case, a mutation in the A3 domain that contributes to the interaction of vWF with collagen was found.¹⁸⁹

Type 2N von Willebrand Disease

Mutations affecting the association of vWF with factor VIII can result in “autosomal hemophilia” in which factor VIII levels are significantly reduced relative to vWF.¹²⁸ Affected patients have factor VIII levels in the range of 5 to 30 IU/dl, attributed to mutations at the factor VIII-binding site near the amino terminus of the vWF subunit.²¹¹ Indeed, genetic studies indicate that the majority of mutations underlying type 2N vWD involve vWF exons 18, 19, and 20, which encode the bulk of the factor VIII-binding domain of vWF. The other functions of vWF in patients with type 2N vWD are qualitatively normal, and thus vWF laboratory parameters (vWF:Ag, ristocetin cofactor activity, etc.) are usually normal (unless there is coinheritance of type 1 vWD). This variant was originally named vWD Normandy but has been renamed type 2N vWD in the revised classification.¹²⁸ The factor VIII-binding defect in these patients is inherited in an autosomal recessive manner, and thus affected patients must inherit 2N alleles from each of their two parents, or inherit type 1 vWD from one parent while inheriting a 2N allele from the other. Patients with factor VIII deficiency and a bleeding disorder that is not clearly transmitted as an X-linked disorder or who demonstrate an unexpectedly short in vivo survival of infused factor VIII should be evaluated for type 2N vWD.²¹² Diagnosis requires performance of an assay that assesses the interaction of factor VIII with vWF,^{191, 192} or genetic studies of the vWF gene. A survey of almost 400 unrelated patients with either hemophilia A or type 1 vWD indicated a prevalence of type 2N vWD in these patient populations of 3% and 1.5%, respectively.²¹³ Consideration of this diagnosis is important because both therapy and genetic counseling are distinct from that of mild hemophilia A.

Platelet-type (Pseudo) von Willebrand Disease

Platelet-type (pseudo) vWD resembles type 2B vWD in most respects, except that the basis for platelet-type vWD is a structural defect in platelet GP1b²¹⁴ rather than a defect of vWF (thus platelet-type [pseudo] vWD is a form of platelet dysfunction). However, as with type 2B vWD, a genetic defect results in increased interaction between GP1b and vWF. Phenotypically, platelet-type (pseudo) vWD is manifested by mild thrombocytopenia, a prolonged bleeding time, and variable deficiency of plasma vWF and factor VIIIc. The reductions in plasma vWF and factor VIIIc may be a result of the attachment of these proteins to platelets that are subsequently removed from the circulation. This “consumption” of vWF and platelets results in preferential loss of high-molecular-weight multimers from patient plasma.²¹⁴ In vitro platelet aggregation studies reveal platelet agglutination at unusually low concentrations of ristocetin. Spontaneous intravascular platelet clumping may also occur. Platelet-type (pseudo) vWF is inherited as an autosomal dominant trait in most families.^{214, 215}

P.1161

Distinction of platelet-type vWD from type 2B vWD is based on showing that the enhanced interaction of platelets with vWF is either platelet-based or resides in the plasma phase (type 2B vWD).²¹⁶ This can sometimes be demonstrated through low-dose ristocetin-based agglutination assays using mixtures of normal donor and patient samples, or genetic analysis can be used. To date, all cases of platelet-type vWD have been traced to genetic variations of platelet GPIb α .²¹⁷ These include missense mutations that alter the amino acid sequence from Gly233 to Met 239. This region of the protein adopts a β -sheet conformation after interaction with vWF, and these mutations may function to stabilize this conformation.²¹⁸ In addition, a 27-bp gene deletion that encodes for deletion of proline 421 through serine 429 has been shown to underlie platelet-type vWD in one kindred. Thus, genetic analysis of the GPIb α gene could confirm a diagnosis of platelet-type vWD in cases in which phenotypic studies were unsuccessful.

CLINICAL DISORDERS OF THE FIBRINOGEN MOLECULE

The clinical disorders of fibrinogen are complex, and depending on the types of mutation may present with bleeding or with thrombotic symptoms, or both. These disorders can be divided based on whether the defect is predominantly a quantitative or qualitative abnormality of the fibrinogen molecule.^{219, 220} Quantitative abnormalities are disorders associated with the complete absence of fibrinogen (afibrinogenemia) or with low levels of fibrinogen (hypofibrinogenemia). Qualitative abnormalities are disorders resulting from synthesis of an abnormal fibrinogen molecule (dysfibrinogenemia) with altered functional properties.^{219, 220, 221, 222} Dysfibrinogenemia may be asymptomatic and identified only through laboratory studies, or it may be associated with either hemorrhagic or thrombotic consequences.

Fibrinogen is a 340-kDa plasma protein that circulates at a concentration of 1.5 to 3.5 mg/ml. It is a symmetric disulfidelinked dimer with a central E domain linked via "coiled coil" peptide chains to outer D domains.²²³ Each half-molecule consists of a set of three different peptide chains, termed A α , B β , and γ , which are linked at their amino termini by disulfide bonds to form the E domain. The D domains are formed by disulfide linkages near the carboxy termini of the peptides. Fibrinogen is synthesized in hepatocytes²²⁴ by coordinated expression of three separate genes on chromosome 4.²²⁵ The rate-limiting step in fibrinogen synthesis is transcription of the B β gene. Fibrinogen is an acute-phase reactant, and levels may rise considerably with inflammation. The circulation half-life of plasma fibrinogen is ~4 days. Fibrinogen participates in multiple physiologic processes, including fibrin clot formation mediated by the enzymatic activities of thrombin and factor XIIIa, and cohesion of activated platelets through interaction with the GP IIb/IIIa receptor. Fibrinogen also acts as a plasma carrier for factor XIII. Fibrinogen physiology has been reviewed.²²³

The congenital disorders of fibrinogen associated with afibrinogenemia and hypofibrinogenemia are reviewed in the next section, followed by a discussion of the dysfibrinogenemias. Afibrinogenemia is a very uncommon condition. The first case was described in 1920 (reviewed in Ref. 226), and ~300 cases have been reported since then (see database at isth.org). Congenital hypofibrinogenemia was first reported in 1935 (reviewed in Ref. 227), and at least 40 cases have been reported in the literature. However, it is likely that many of the cases of hypofibrinogenemia were actually cases of dysfibrinogenemia with a reduced level of circulating clottable fibrinogen. Congenital disorders of fibrinogen are rare, and, in practice, most commonly observed disorders are acquired as a result of liver disease or consumptive processes.

Pathogenesis of Quantitative Fibrinogen Disorders

In congenital afibrinogenemia and hypofibrinogenemia, defects in synthesis, secretion, or intracellular processing of the final gene product result in deficiency of plasma fibrinogen.²²⁸ When newly synthesized fibrinogen is not secreted, the protein may accumulate in the rough endoplasmic reticulum of hepatocytes or other cells, resulting in amyloid-like accumulations.²²⁹ In both afibrinogenemia and hypofibrinogenemia, the fibrinolytic system and other coagulation pathways are completely normal. Similarly, there is no evidence of blood coagulation activation, which could cause consumption, or degradation of the fibrinogen molecule. The fibrinogen gene locus is located on chromosome 4; it contains three distinct genes that encode for the A α , B β , and γ peptide chains that compose the fibrinogen molecule.²³⁰ The inheritance pattern of afibrinogenemia is autosomal recessive in nature,²²⁷ and many reported cases are the result of consanguineous relationships between asymptomatic parents with symptomatic homozygote offspring. The molecular basis for quantitative fibrinogen disorders has been reviewed.²³¹ Genetic defects are scattered throughout the three fibrinogen genes that code for the three polypeptide chains—A α , B β , and γ . Multiple genetic defects have been reported, including deletions, point mutations, missense mutations, and uniparental isodisomy.²³¹ Deletion of an 11-kb region of the fibrinogen α gene appears to be a recurrent finding in unrelated families from both Europe and the United States.²³² A database of genetic defects that have been identified in patients with congenital fibrinogen abnormalities is accessible at www.geht.org/databaseang/fibrinogen. An unexpectedly large number of individuals with congenital fibrinogen disorders have been described in southern Iran.²³³

Afibrinogenemia

Inherited afibrinogenemia is a rare autosomal recessive disorder, with an estimated frequency of 1 in a million individuals.²³² It is somewhat of an anomaly that patients who are afibrinogenemic have little hemorrhage, despite the fact that their blood cannot clot normally. This may in part be due to the presence of functional vWF, which allows platelet adhesion and aggregation, with the formation of loose thrombi even in the absence of fibrinogen.²³⁴ A similar phenotype was recently described for afibrinogenemic mice created by gene-targeted knockout.²³⁵ In patients with afibrinogenemia, life-threatening hemorrhages do occur, but in many situations the bleeding is not as severe as is seen in hemophilia. The diagnosis is often made early in infancy, when prolonged umbilical stump bleeding occurs.²³⁶ A major cause of death is intracranial hemorrhage during infancy or childhood.²³⁷ The clinical manifestations include mucosal membrane bleeding, such as epistaxis, menorrhagia, or gastrointestinal hemorrhage. A review of the cases entered into

the North American Rare Bleeding Disorder Registry indicated that most bleeding events were triggered by trauma, with only 20% to 30% occurring spontaneously.²³⁸

Increased incidence of first-trimester abortion, placental abruption, and postpartum hemorrhage have been observed in patients with afibrinogenemia.²³⁹ Fetuses of female afibrinogenemic patients rarely reach full term unless replacement therapy is given.²⁴⁰ Although 20% of afibrinogenemic patients are affected with hemarthrosis, the severity is generally less than that seen in patients with hemophilia. Replacement therapy for patients with afibrinogenemia is available,^{241, 242} although there may be some concern with increased risk of thrombosis during therapy. Transgenic afibrinogenemic mice demonstrate abundant thrombus formation in a vascular injury model.²³⁴ The basis for this is not well understood, but may be in part related to the fact that fibrinogen has non-substrate-binding sites for thrombin that

P.1162

could potentially modulate thrombin availability to activate platelets.²⁴³ Patients with congenital hypofibrinogenemia do not typically have any spontaneous bleeding unless the fibrinogen level is <50 mg/dl. These patients may actually have hypodysfibrinogenemia, which is discussed in a later section of this chapter.

Laboratory Diagnosis

Screening coagulation tests from afibrinogenemic and hypofibrinogenemic patients typically show a marked prolongation of all tests where the endpoint is the appearance of fibrin clot, as severe fibrinogen deficiency renders plasma nonclottable. These tests include the PT, PTT, thrombin clotting time, and reptilase time. These test abnormalities, when due to functional deficiency of clottable fibrinogen, are usually corrected when patient plasma is mixed with normal plasma.²⁴⁴ A diagnosis of afibrinogenemia depends on the specific finding of undetectable fibrinogen antigen in the plasma of these patients. Platelet fibrinogen is also absent. Mild thrombocytopenia has been reported in some afibrinogenemic patients, but typically the platelet count is usually not lower than 100,000/ μ l.²⁴⁵ The bleeding time is prolonged in approximately one-third of patients with afibrinogenemia, presumably caused by the failure of platelets to aggregate in the absence of plasma or platelet fibrinogen. These abnormalities are correctable by infusion of plasma,²⁴⁶ or more recently therapeutic concentrates of fibrinogen.^{241, 242} Furthermore, afibrinogenemic patients who undergo hypersensitivity reaction skin testing do not typically show an induration response to allergens. They show only erythema because the later phases of the hypersensitivity reaction depend on the deposition of subcutaneous fibrin.²⁴⁷

Differential Diagnosis and Therapy of Afibrinogenemia

Congenital quantitative defects in fibrinogen must be carefully distinguished from acquired quantitative defects in the fibrinogen molecule, which are often seen in the setting of liver disease or disseminated intravascular coagulation. Acquired hypofibrinogenemia has been reported after therapy with L-asparaginase, which impairs hepatic synthesis of fibrinogen,²⁴⁸ and in patients with aplastic anemia treated with antithymocyte globulin and corticosteroids.²⁴⁹ In the absence of purified fibrinogen concentrates, cryoprecipitate administration is used for replacement therapy for patients with severe afibrinogenemia. Prophylactic therapy is recommended only for pregnant patients, or patients with a history of central nervous system (CNS) hemorrhage.²³⁶ Replacement therapy is indicated for any episode of acute active bleeding, preoperatively, and in pregnant patients. Fibrinogen levels between 50 and 100 mg/dl are usually adequate for normal hemostasis.²³⁶ Levels >100 mg/dl are recommended for maintenance during pregnancy, based on empiric clinical observations.²³⁶ Weekly infusions are recommended, but one should be aware that fibrinogen requirements may rise significantly around the time of parturition, and that levels as high as 150 mg/ml may be helpful to avert abruption.²⁵⁰ Each bag of cryoprecipitate contains ~250 mg of fibrinogen, and one bag of cryoprecipitate typically raises plasma fibrinogen levels of an adult by ~10 mg/dl; thus 5 to 10 bags of cryoprecipitate are usually sufficient in the average adult patient. Because the fractional catabolic rate of fibrinogen is 25% per day, acute-care patients should receive one-third of their loading dose daily for as long as fibrinogen support is desired.^{241, 242, 251} There are plasma concentrates of fibrinogen now available that may provide advantages over the use of cryoprecipitate.^{252, 253} Measurement of plasma fibrinogen levels after infusion is recommended to confirm that a patient has obtained the desired therapeutic effect. The complications of replacement therapy in afibrinogenemia include allergic reactions, development of antifibrinogen antibodies, and anaphylaxis.²⁵⁴ Thromboembolic complications following cryoprecipitate infusions include deep venous thrombosis and pulmonary emboli; the risk of these complications may be increased when an inhibitor of fibrinolysis or oral contraceptive therapy is also administered.^{255, 256} Low-molecular-weight heparin in combination with fibrinogen replacement has been used to avoid these thromboembolic complications.²⁵⁷ Antifibrinolytics alone may be sufficient to prevent bleeding from mucosal sites, but caution should be exercised in patients with a personal or family history of thrombosis.

Dysfibrinogenemia

The first reported case of dysfibrinogenemia mediated by a qualitatively abnormal fibrinogen molecule occurred in 1965, and since that time >300 families have been reported with this disorder.^{220, 221, 222} The molecular genetic basis of fibrinogen dysfunction has been fairly well established in many families that have been studied. However, uncertainty persists concerning the linkage of genetic defects of fibrinogen and the disease phenotype expressed by patients, as environmental factors and other concomitant genetic abnormalities may be influencing disease manifestations.²⁵⁸ There is an intriguing report of an increased association of dysfibrinogenemia with chronic thromboembolic pulmonary hypertension.²⁵⁹ A database containing an updated list of the genetic defects associated with dysfibrinogenemia is accessible at http://site.geht.org/site/Pratiques-Professionnelles/Base-de-donnees-Fibrinogene/Database-English-Version/Fibrinogen-variants-Database-_79_.html.

Molecular Basis of Dysfibrinogenemia

The reported abnormalities in the fibrinogen molecule include defects in each of the major steps of fibrin formation and stabilization. The conversion of fibrinogen to an insoluble fibrin clot requires that the molecule first be cleaved by thrombin between arginine 16 and glycine 17 of the A α chain to release fibrinopeptide A, and between arginine 14 and valine 15 of the B β chain to release fibrinopeptide B. This produces a fibrin monomer capable of undergoing the second step, fibrin polymerization. Once these molecules polymerize, they are stabilized by the action of factor XIIIa. Fibrinogen also supports the hemostatic process through interaction with platelets during platelet cohesion (aggregation). Finally, during the process of wound healing and tissue remodeling, the fibrin clot undergoes fibrinolysis by concerted activities of plasminogen and plasminogen activators. Fibrinogen dysfunction may affect any of these various steps of fibrin clot formation, platelet interaction, or lysis. It is therefore expected that the dysfibrinogenemias can be associated with abnormal clinical bleeding, thrombotic tendency, disorders of wound healing, or no clinically apparent disease. Domain location of a mutation does not necessarily predict the associated disease phenotype. Defects of fibrinopeptide release have been associated with both hemorrhagic and thrombotic complications. Similarly, disruption of D-D interactions have been associated with both bleeding and thrombosis. Patients who have heterozygous dysfibrinogenemia typically have ~50% of normal fibrinogen levels, which should be adequate for hemostasis. Clottable fibrinogen protein measurements may not be a reliable indicator of plasma fibrinogen concentration, because functionally abnormal molecules are not always incorporated into the clot. An abnormal fibrinogen may inhibit the conversion of normal fibrinogen to fibrin, so the tendency for many of these patients to bleed is higher than one would suspect. Hypodysfibrinogenemia occurs when an abnormality of the fibrinogen molecule results in decreased secretion or increased clearance of the protein. More than 20 families have been reported with hypodysfibrinogenemia. Autosomal amyloidosis has been attributed to genetic disorders of fibrinogen, as well as to genetic disorders of several other proteins (including transthyretin, gelsolin, apolipoprotein A, and lysozyme).

P.1163

Hereditary renal amyloid disease has been associated with genetic defects of the A α chain, and renal amyloid has recurred in renal transplants. Hepatic amyloid disease has also been attributed to abnormalities of fibrinogen.^{230, 260}

Dysfibrinogenemia is typically inherited as an autosomal dominant trait with high levels of penetrance. Most of these patients are heterozygotes, but a few homozygotes and some rare compound heterozygotes have been reported in the literature. Approximately 40% of dysfibrinogenemic patients are asymptomatic, and 45% to 50% have a bleeding disorder.²⁶¹ The remaining 10% to 15% have either a thrombotic disorder (venous or arterial) or both bleeding and thrombotic tendencies. The bleeding associated with dysfibrinogenemia is generally mild and includes soft tissue hemorrhage, easy bruising, and menorrhagia. Although intraoperative and postoperative bleeding have been reported, most bleeding is not life-threatening.

There are only a few families in which a thrombotic tendency can be unambiguously associated with dysfibrinogenemia, and criteria for making this association have been proposed. These criteria include a demonstrated molecular defect, thrombosis at an early age or in multiple family members, presence of no other predisposing factor for thrombosis, strong association between the fibrinogen defect and thrombus complications within a family, and association of the same molecular defect with thrombosis in another, unrelated kindred.²⁶² The true prevalence of thrombosis among patients with dysfibrinogenemia is unknown. Studies indicate a distinct thrombotic tendency in individuals with dysfibrinogenemia related to defects in the α -C domain of the A α chain of fibrinogen, especially if new cysteine residues are encoded that can become disulfide-linked to albumin. In contrast, dysfibrinogenemic patients with defective cross-linking experience primarily defective wound healing.

Laboratory Diagnosis of Dysfibrinogenemia

The thrombin clotting time remains a sensitive screening test for dysfibrinogenemias,²⁴⁴ and the PT appears to be more sensitive than the PTT to the effects of dysfibrinogenemia. In some cases, clot formation may be absent. Reptilase is a snake venom enzyme that differs from thrombin in that it cleaves only fibrinopeptide A of fibrinogen. The reptilase time is often more prolonged than the thrombin clotting time, especially in patients who have defective fibrinopeptide A release. Some dysfibrinogenemias exhibit a very short thrombin clotting time, and these patients may have thrombotic complications. The fibrinogen concentration can be either low or normal in these patients. Most patients with dysfibrinogenemia have a significant discrepancy between the level of clottable fibrinogen and that detected by immunologic methods. Criteria for diagnosing dysfibrinogenemias using ratios of immunologic and functional fibrinogen assays have been reported,²⁶³ but the sensitivity and specificity of these criteria are not well characterized. The euglobulin clot lysis time is a crude measure of fibrinolytic potential, and may be helpful in detecting abnormal fibrinogens that show increased susceptibility to fibrinolysis. For example, with fibrinogen St. Louis,²⁶⁴ the euglobulin clot lysis time is shortened, and fibrinogen degradation products are elevated in the plasma. Laboratory testing for fibrinogen abnormalities has been reviewed.²⁶⁵

The diagnosis of inherited dysfibrinogenemia must be distinguished from hypofibrinogenemia, which is either acquired or congenital in nature. Acquired dysfibrinogenemia occurs typically in the setting of severe liver disease,²⁶⁶ and the suspicion can be readily investigated by evaluation of liver function tests. Acquired dysfibrinogenemias are also associated with malignancies that produce an abnormal fibrinogen molecule, such as some hepatomas (see Chapter 54), multiple myeloma,²⁶⁷ and renal cell carcinoma,²⁶⁸ as well as autoimmune disorders. An algorithm has been proposed for the orderly evaluation of patients in whom dysfibrinogenemia is a consideration.²⁴⁴

Acquired inhibitors to fibrin formation that interfere with fibrinogen-to-fibrin conversion may also be confused with dysfibrinogenemia. These acquired inhibitors include heparin-like molecules, elevated levels of fibrin split products, and antibodies at concentrations such as may occur in macroglobulinemia, multiple myeloma, or other disorders that interfere with fibrin polymerization.²⁶⁹ Acquired antibodies against the fibrinogen molecule are quite rare but have been reported in association with a variety of diseases.^{270 271}

Therapy

The majority of patients with dysfibrinogenemia do not require any specific therapy. Any bleeding complications that develop can be managed with transfusion of either plasma or cryoprecipitate. The role of the newer fibrinogen concentrates in treating patients with dysfibrinogenemia has not been clarified through appropriate clinical trials yet. Antifibrinolytic drugs have been used in some patients but should be especially avoided in patients who have thrombotic tendencies. Patients who have repeated venous thrombotic episodes may actually require long-term antithrombotic therapy. A patient with life-threatening thrombophilic manifestations was successfully managed with plasma exchange prior to surgery,²⁷² but one wonders whether simple anticoagulation therapy would have been sufficient to provide a satisfactory outcome. In women with dysfibrinogenemia, recurrent miscarriages may be prevented using prophylactic cryoprecipitate, and successful pregnancy outcomes in such cases have been reported.²³⁶

FACTOR XIII DEFICIENCY

The initial hemostatic plug is not sufficient to prevent blood loss unless it is stabilized by the action of plasma factor XIII (fibrin stabilizing factor). A complex set of reactions among thrombin, fibrin, and plasma factor XIII is necessary for clot stabilization (see Chapter 18). When fibrin begins to polymerize after thrombin cleaves the fibrinopeptides, a complex forms between thrombin and fibrin, which promotes the conversion of factor XIII to factor XIIIa. Fibrin is the main catalytic substrate for factor XIIIa.²⁷³ Factor XIIIa transforms the unstable, noncovalently associated fibrin clot to a stable covalently cross-linked set of fibrin fibers that are mechanically stronger, more rigid, and more elastic. A cross-linked fibrin clot is more resistant to mechanical as well as enzymatic degradation by plasmin than uncross-linked fibrin because α_2 -plasmin inhibitor is also cross-linked to fibrin to inhibit plasmin activity. Factor XIIIa is a transglutaminase that catalyzes the formation of intermolecular γ -glutamyl- ϵ -lysyl covalent (isopeptide) bonds between the γ chains and α chains of fibrin strands within the clot. Cross-linkage of γ -chain Gln 398 and Lys 406 residues appears to occur earlier, with α -chain linkages between Gln 328 and 366 with Lys 508, 556, and 562 occurring more slowly.²⁷³ In addition, several other plasma and extracellular matrix proteins are linked to the fibrin clot through the action of factor XIII. Cross-linking of thrombin-activatable fibrinolysis inhibitor into fibrin clots further increases the resistance of the clot to plasmin degradation.²⁷³ Cross-linkage of fibrin to adhesive proteins such as vWF, fibronectin, thrombospondin, and vitronectin may improve adhesion to vessel walls and may play a role in cell migration during wound healing. In fact, fibronectin is the second most abundant material in the fibrin clot, accounting for 4% of the total protein.²⁷⁴

The importance of factor XIII function in normal health is emphasized by the clinical scenarios characteristic of inherited and acquired deficiency of factor XIII. In the following section, the pathogenesis, molecular genetics, clinical laboratory, diagnostic, and therapeutic elements of the diagnosis and treatment of factor XIII deficiency are discussed.

P.1164

Pathogenesis

In 1944, Robbins postulated that a deficiency of fibrin-stabilizing factor, which later became known as factor XIII, would produce a serious bleeding disorder.²⁷⁵ However, it was not until the first case of factor XIII deficiency was described in 1960 that the severe nature of this bleeding disorder was recognized.²⁷⁶ During the last five decades, >200 cases of congenital factor XIII deficiency have been reported in the literature.²⁷⁷ It is estimated that ~1 person in every 1 million to 5 million people has factor XIII deficiency. The disorder is inherited as an autosomal recessive trait.^{236, 277}

The factor XIII molecule is present in both plasma and in blood platelets and monocytes. The plasma concentration of factor XIII is 14 to 28 µg/ml. Approximately half that concentration circulates within blood platelets. Tissue-based factor XIII resides in monocyte/macrophages. Structurally, platelet and monocyte factor XIII consists of only A dimers, present within the cytoplasm of both platelets and megakaryocytes. The plasma factor XIII molecular complex is a heterotetramer, containing two of each of the A and B subunits. The A subunit mediates factor XIII function, containing an activation peptide, calcium-binding site, and enzymatic domain with an active site sulfhydryl residue that is characteristic of this class of enzymes.²⁷⁸ The three-dimensional structure for the A subunit has been determined by x-ray crystallography.²⁷³ The majority of the A subunit in circulation is derived from cells of marrow origin.²⁷⁹ The B subunit of plasma factor XIII is synthesized in the liver and probably associates with the A subunit in the plasma phase after release from the hepatocyte. The B subunit appears to promote stabilization of the A subunit in plasma and may play an important role in regulating both the localization of the A subunit to the fibrin clot and thrombin-dependent activation of the protein. Two distinct forms of factor XIII deficiency have been described, based on whether the A and B subunits are absent or present.²⁷³ In type I deficiency there is absence of the B subunit, with resultant decreased concentration of the A subunit in plasma, but platelet A subunit content is maintained. In type II deficiency, the A subunit is absent and the B subunit is present.

Molecular Genetics

Since the protein was initially described in human serum in 1944, both the A and B subunits have been purified, and cDNA sequence and gene structure have been established.²⁷³ The A subunit is encoded on chromosome 6, containing 15 exons and spanning a region of 160 kb. A common genetic polymorphism of the A subunit has been described that results in Val34 replacement by Leu just three amino acid residues from the site of cleavage of the activation peptide. This polymorphism may influence factor XIII activation and has been investigated in reference to risk for myocardial infarction.²⁸⁰ The B subunit is encoded by chromosome 1.²⁸¹ Because the mode of inheritance of factor XIII deficiency is autosomal recessive in nature, only homozygotes or compound heterozygotes are clinically symptomatic. The homozygotes reported in the literature are often children of consanguineous marriages.²⁸²

In the cases reported to date, factor XIII deficiency is more frequently attributed to mutation of the gene encoding the A subunit, confirming the functional importance of this subunit. To date, over 70 mutations have been described.²⁷⁷ The majority of defects observed are "point mutations" resulting in stop codons, missense errors, or frame-shifts and small deletions. Inherited deficiency of the factor XIII A chain is not restricted to any specific ethnic group.²⁸³

Factor XIII B chain deficiency is a very rare autosomal recessive disorder, with very few reported cases in the literature.²⁸⁴ One unique patient displayed a complete absence of the B chain and a shortened half-life of the A chain. Interestingly, this B chain-deficient patient had many of the same symptoms as an A chain-deficient patient. The ability of the B chain to promote A chain binding to the fibrinogen molecule may account for this clinical finding.²⁸⁵ Only ~5 mutations have been reported in the B chain gene.²⁷⁷

Clinical Aspects

Clinically affected factor XIII-deficient patients typically have plasma levels that are <1% of normal,²⁷³ with bleeding attributed to accelerated fibrin clot degradation. The bleeding phenotype in patients with inherited factor XIII deficiency is unusually severe. Abnormal bleeding manifests shortly after birth, when bleeding from the healthy umbilical cord remnant occurs.²⁸⁶ This has been a prominent feature, reported in up to 80% of cases,²⁸² but this complication was observed in only 22% of the 34 cases reported to the North American Rare Bleeding Disorders Registry.²³⁸ Umbilical stump bleeding is an uncommon presentation for other congenital bleeding disorders. Rebleeding at circumcision is also

common. Other bleeding manifestations in these patients include soft tissue hemorrhage, hemarthrosis, hematomas, and the development of large pseudocysts.²⁸⁶ The most life-threatening complication of factor XIII deficiency is spontaneous intracranial hemorrhage. Intracranial hemorrhage is more prevalent in factor XIII deficiency than in other inherited bleeding disorders. Approximately 25% of factor XIII-deficient patients experience intracranial hemorrhage.²⁸⁷ Bleeding is usually spontaneous, and prevention of intracranial hemorrhage forms the basis for the recommendation of prophylactic therapy of factor XIII-deficient patients. Surgery in these patients is often complicated by abnormal wound healing and excessive postoperative bleeding, which can occur either immediately or later. Delayed bleeding may occur several days after surgery or tissue injury, and patients may experience cycles of repetitive bleeding that span weeks to months. Poor wound healing is reported in ~20% of patients with factor XIII deficiency. The affected males in some families also have oligospermia, resulting in infertility. Furthermore, infertility in affected females results from spontaneous abortions. Females with this deficiency cannot carry a pregnancy to term unless plasma factor XIII levels are maintained at levels that prevent bleeding.²⁸⁸ The manifestations of factor XIII deficiency vary greatly among patients and may not necessarily present as bleeding symptoms. It has been hypothesized that heterogeneity of genetic defects underlying the deficient state accounts for the clinical variability in disease expression.²⁸⁹ Factor XIII-deficient mice display a similar phenotype to the human condition.²⁹⁰

Differential Diagnosis

Congenital or acquired factor XIII deficiency must be considered when a patient has a major bleeding disorder and all of the initial screening laboratory tests are normal, including PT, PTT, and platelet count. Bleeding can occur spontaneously or after major surgery. It remains imperative in the adult to exclude both inherited and acquired factor XIII deficiency, because patients can develop antibodies to factor XIII that interfere with fibrin stabilization. Specific antibodies to factor XIII were reported in patients taking isoniazid, phenytoin, procainamide, penicillin, and valproic acid.²⁷³ Factor XIII antibodies also occur in association with autoimmune disease, in patients with monoclonal gammopathy, or as an idiopathic occurrence. Acquired factor XIII deficiency has been reported in Henoch-Schönlein purpura, liver disease, Crohn disease, and ulcerative colitis.²⁷³

Laboratory Diagnosis

The PT and PTT assays are normal (Table 53.5). The solubility of a fibrin clot in 5M urea or 1% monochloroacetic acid (clot stability assay) is the most useful screening test for factor XIII deficiency.

P.1165

In these conditions, clots formed in the absence of factor XIII activity dissolve within 60 minutes.²⁷³ In contrast, normal clots covalently modified by factor XIIIa remain insoluble for at least 24 hours. This is a qualitative assay, and as little as 5% of the normal factor XIII activity level can render a clot insoluble in urea. Unfortunately, clot stability testing is not well standardized. If clot solubility is found, a mixing study with normal plasma is recommended to exclude factor XIII inhibitor. Deficiency of α_2 -antiplasmin may also cause a bleeding disorder with normal coagulation screening studies and increased urea clot solubility; a specific assay for α_2 -antiplasmin should be considered, to exclude this possibility.²⁹¹ Quantitative measurements of factor XIII activity can also be done, and these tests are useful to confirm factor XIII deficiency that is suspected based on an abnormal qualitative clot solubility assay. Specialized laboratories may measure either ammonia production (an end product of the factor XIIIa reaction)²⁹² or the incorporation of fluorescent or radioactive amines (such as dansylcadaverine) into proteins such as casein.²⁹³ However, the most sensitive and specific measurement of factor XIIIa activity remains the functional assay measuring the stability of a covalently cross-linked fibrin clot.²⁹⁴ Finally, immunologic based assays that detect factor XIII antigen are available, such as ELISAs specific for either the A or B subunits of factor XIII.²⁷³ Results of immunologic assays correlate with factor XIII activity assays, but immunologic assays are not widely available.

PROTHROMBIN DEFICIENCY

Inherited prothrombin deficiency is an exceedingly rare, autosomal recessive bleeding disorder, with a frequency of <1 in 1 million.²⁹⁵ To date, <40 mutations have been identified from <100 reported cases (Ref. 296, isth.org database). As with some of the other factor deficiencies, the frequency of prothrombin deficiency is greater in countries where consanguineous marriages occur. Phenotypically, prothrombin deficiency is classified as either hypoprothrombinemia (type I), distinguished by reduced prothrombin activity and reduced prothrombin antigen, or dysprothrombinemia (type II), distinguished by reduced prothrombin activity but normal prothrombin antigen.

Pathophysiology

Similar to deficiencies of the other vitamin K-dependent coagulation factors, prothrombin deficiencies result from mutant prothrombins that are either CRM-negative (hypoprothrombinemia) or CRM-positive (dysprothrombinemia). The CRM-negative form may be more common, is a product of missense, nonsense, insertion, or deletion mutations, and is characterized by a true deficiency of prothrombin, with a strong correlation between functional assays and immunoassays. The CRM-positive form is a product of missense mutations and is characterized by antigenically competent prothrombin, usually in quantities much greater than the associated functional activity.

By convention, these mutant prothrombins have been named according to the proband's origin, e.g., prothrombin Cardeza.²⁹⁷ The prevalence of prothrombin deficiency in Puerto Ricans led to the recent description of several unrelated families of Puerto Rican ancestry having a common mutation, prothrombin Puerto Rico I, with characteristics of both hypoprothrombinemia and dysprothrombinemia.²⁹⁸ Dysprothrombins with amino acid substitutions at or near the factor Xa cleavage sites inhibit activation to thrombin.^{299, 300} Amino acid substitutions elsewhere in prothrombin can affect the function determined by that region, including the catalytic domain (Quick II,³⁰¹ Molise, Perijé³⁰²), and fibrinogen-binding (Quick I³⁰³). Figure 53.9 summarizes some of these mutant prothrombins and their concomitant functional abnormalities.

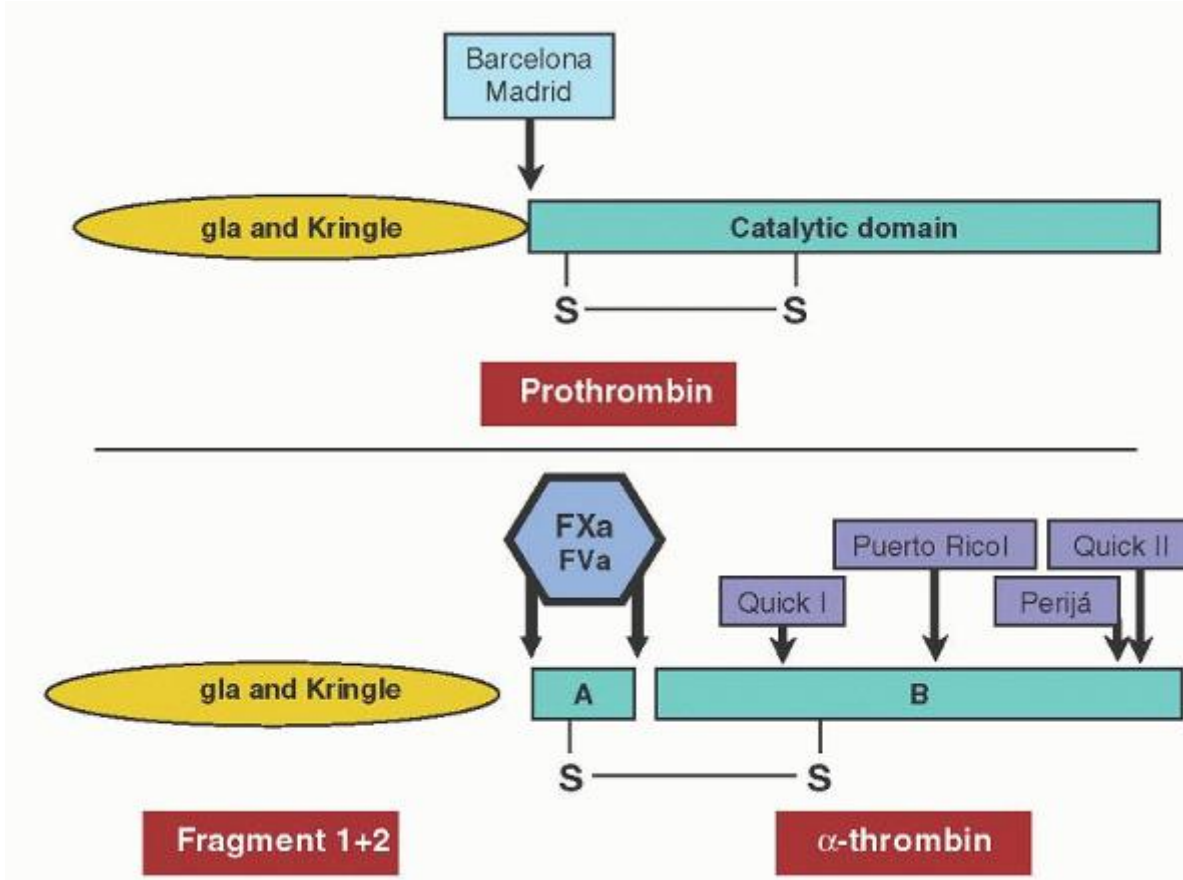

FIGURE 53.9. Schematic representation of prothrombin activation by prothrombinase (i.e., factors Xa, Va, and a negatively charged phospholipid surface) and sites of certain prothrombin mutations leading to inherited prothrombin deficiency. The fragment 1 + 2 domain contains γ -carboxyglutamic acid (gla) residues responsible for Ca^{2+} -dependent binding of prothrombin to cellular membranes. Prothrombins Barcelona and Madrid have a mutation at the factor Xa cleavage site (Arg271Cys), preventing activation to thrombin. The remaining depicted mutations are within the catalytic site/regulatory elements of α -thrombin. Prothrombin Quick I results in decreased proteolytic activity toward fibrinogen, as well as reduced abilities to release fibrinopeptide A, aggregate platelets, and stimulate the release of prostacyclin from human endothelial cells; prothrombins Perijé and Quick II result in decreased proteolytic activity due to alterations within the primary binding pocket; and prothrombin Puerto Rico I results in decreased activation to thrombin, possibly due to the removal of a salt bridge linking the A and B chains of thrombin.

Clinical Features

Epistaxis, menorrhagia, and posttraumatic bleeding are the most common complaints. Hemarthroses and muscle hematomas have also been reported.²⁹⁵ The extent of prothrombin deficiency does not necessarily correlate with clinical

bleeding. Although hemostasis can be maintained by prothrombin levels >25% of normal, significant bleeding is usually seen when prothrombin levels are <2% of normal.³⁰⁴ Of the severe prothrombin deficiency patients reported to the Rare Bleeding Disorders Registry, 20% experienced intracranial bleeding.²³⁸ Prothrombin-deficient heterozygotes have 40% to 60% of normal prothrombin activity; compound heterozygotes and homozygotes usually have <10% of normal prothrombin activity.³⁰⁵ As of yet, no human cases of total prothrombin deficiency have been reported. Based on studies with knockout mice, such a complete deficiency is thought to be incompatible with life, leading to a loss of vascular integrity, arrested development, and tissue necrosis, ultimately resulting in embryonic or neonatal lethality.³⁰⁶ This effect is thought to result from a developmental activity of thrombin on yolk sac vasculature. The genetic elimination of prothrombin in an adult mouse model was also not compatible with survival.³⁰⁷

Laboratory Diagnosis

A summary of laboratory findings in prothrombin deficiency is included in Table 53.5. Prothrombin deficiency is associated with normal thrombin times but prolonged PT and aPTT, which can be corrected in mixing studies. Specific factor assays for prothrombin are used in diagnosis. Acquired prothrombin deficiency, caused by either vitamin K deficiency or an antiprothrombin antibody associated with antiphospholipid antibodies, should be considered before making the diagnosis of inherited prothrombin deficiency. Fresh-frozen plasma (FFP) and prothrombin complex concentrates (PCCs) are used to treat prothrombin deficiency, as outlined later, in Table 53.8.

P.1166

TABLE 53.8 REPLACEMENT THERAPY IN OTHER INHERITED COAGULATION DISORDERS

Disorder	Therapeutic Product	Loading Dose	Maintenance Dose
von Willebrand disease	Humate-P ^a	40-60 IU/kg	40-50 IU/kg every 12-24 h for up to 7 d
	Cryoprecipitate ^b	Not required	1 bag/10 kg daily
Fibrinogen deficiency	Cryoprecipitate	1-2 bags/10 kg	1 bag/10 kg every other d
	Purified fibrinogen ^c	50-100 mg/kg	20 mg/kg every other d
Prothrombin deficiency	Fresh-frozen plasma ^d	15 ml/kg	5-10 ml/kg daily
Dysprothrombinemia	Purified prothrombin complex ^e	20 IU/kg	10 IU/kg daily
Factor V deficiency	Fresh-frozen plasma	20 ml/kg	10 ml/kg every 12-24 h
Factor VII deficiency	Fresh-frozen plasma ^d	20 ml/kg	5 ml/kg every 6-24 h
	Purified prothrombin complex ^e	30 IU/kg	10-20 IU/kg every 6-24 h
Factor X deficiency	Fresh-frozen plasma ^d	15-20 ml/kg	5-10 ml/kg daily
	Purified prothrombin complex ^e	15 IU/kg	10 IU/kg daily
Factor XI deficiency	Fresh-frozen plasma ^d	15-20 ml/kg	5 ml/kg every 12-24 h
Factor XIII deficiency	Fresh-frozen plasma ^f	5 ml/kg every 1-	Not usually required
		2 wk	

Note: The replacement therapy regimens suggested in this table are for major bleeding or surgical prophylaxis. Patients with minor bleeding may require lower dosages of these replacement products. Confirmation of hemostatic levels of the appropriate coagulation factor being replaced should be done, with dosage adjustments performed as needed.

^a Labeled in ristocetin cofactor units. Alphanate and Wilate can also be used to treat von Willebrand

disease.

^b Recommended only if purified factor replacement therapy is not available.

^c Not routinely available in the United States.

^d Plasma after removal of cryoprecipitate is satisfactory.

^e Prothrombin complex concentrates are thrombogenic and should be used only for major bleeding or major surgery. Antifibrinolytic drugs (ϵ -aminocaproic acid, tranexamic acid) should not be used in conjunction with prothrombin complex concentrates.

^f A factor XIII concentrate is now available in the United States. See text for details.

FACTOR V DEFICIENCY

Inherited factor V deficiency, also known as labile factor deficiency, proaccelerin deficiency, and parahemophilia, is a rare autosomal recessive bleeding disorder first described by Owren,³⁰⁸ with an estimated frequency of 1 in 1 million.²⁹⁵ To date, >100 mutations have been identified from >200 reported cases,^{309, 310, 311} and a database at isth.org lists >120 factor V mutations. As with some of the other factor deficiencies, the frequency of factor V deficiency is greater in countries where consanguineous marriages occur.²⁹⁵ Phenotypically, factor V deficiency is classified as either type I, distinguished by reduced factor V activity and reduced factor V antigen, or type II, distinguished by reduced factor V activity but normal factor V antigen.

Pathophysiology

The majority of factor V deficiencies result from a failure to either synthesize or secrete factor V. The mutants responsible for these deficiencies are CRM-negative (type I); CRM-positive factor V mutations (type II) have also been detected.³¹² The CRM-negative form is a product of missense, nonsense, insertion, or deletion mutations and is characterized by a true deficiency of factor V, with a strong correlation between functional assays and immunoassays. Factor V New Brunswick, a CRM-positive form, is caused by a missense mutation and is characterized by antigenically competent factor V with reduced activity, most likely due to reduced stability of factor Va.^{313, 314}

By convention, many of these mutant factor Vs have been named according to the proband's origin, e.g., factor V Stanford³¹⁵ and factor V Ogden.³¹⁶ Factor V Quebec is associated with a moderate reduction in plasma factor V levels and a severe reduction in platelet factor V, but also other α -granule proteins, including multimerin (a factor V carrier molecule within platelets), and is thus more properly considered a platelet disorder.³¹⁷ Approximately 20% of the circulating pool of factor V is contained within platelets. This platelet pool of factor V and low levels of tissue factor pathway inhibitor seen in factor V deficient patients may explain the milder bleeding phenotype in this bleeding disorder.³¹⁰

Clinical Features

Epistaxis, menorrhagia, and posttraumatic bleeding are the most common complaints. Trauma-induced hemarthroses and muscle hematomas have also been reported.²⁹⁵ Gastrointestinal or CNS bleeding is observed very rarely. Although neonatal bleeding has seldom been observed, factor V deficiency has been associated with other congenital abnormalities.³¹⁸ Hemostasis can be maintained by factor V levels >10% to 20% of normal, but moderately severe bleeding

is usually seen when factor V levels are <10% of normal. Factor V-deficient heterozygotes have 40% to 60% of normal factor V activity; compound heterozygotes and homozygotes usually have <10% of normal factor V activity. Bleeding symptoms may correlate better with platelet factor V content rather than the plasma factor V level.³¹⁷

A genetic model of factor V deficiency utilizing factor V-knockout mice underscores the importance of factor V in not only hemostasis but development, as fetal loss in utero is markedly increased.³¹⁹ Based on these knockout-mouse studies, complete factor V deficiency is apparently incompatible with life, but <0.1% of normal factor V activity is sufficient to rescue completely deficient mice.³²⁰ As of yet, no human cases of total factor V deficiency have been reported, and even patients with a homozygous or compound heterozygous factor V deficiency usually have some residual factor V activity.

Laboratory Diagnosis

A summary of laboratory findings in factor V deficiency is included in Table 53.5. Factor V deficiency is associated with P.1167

normal thrombin times but prolonged PT and aPTT, which can be corrected in mixing studies. A PT-based factor V assay or an ELISA can be used to verify quantitative reductions in factor V. Good results have been obtained using aged oxalated or ethylenediaminetetraacetic acid plasma as a factor V-deficient substrate,³²¹ as well as artificially depleted substrate plasmas. Acquired factor V deficiency, caused by liver disease, disseminated intravascular coagulation, or antibodies to factor V, should be excluded before making the diagnosis of inherited factor V deficiency. Upon confirmation of factor V deficiency, however, a specific assay for factor VIII should also be performed to rule out the rare combined factor V/factor VIII deficiency,³²² treatment of which entails a different replacement therapy. Currently, FFP is used to treat factor V deficiency, as outlined later, in Table 53.8.

FACTOR VII DEFICIENCY

Factor VII deficiency was first described in 1951 by Alexander et al. under the name serum prothrombin conversion accelerator (SPCA) deficiency. Approximately 200 cases of true factor VII deficiency have been reported, and the population prevalence is estimated to be 1 in 500,000,²⁹⁵ making it the most common of the “rare bleeding disorders.” Also known as stable factor or proconvertin deficiency, the condition is inherited as an autosomal recessive trait that produces severe deficiency in the homozygote and mild deficiency, usually without clinical manifestations, in the heterozygote. As in other rare bleeding disorders, it is more common in cultures where consanguineous marriage is practiced.

Pathophysiology

Factor VII is secreted as a single-chain proenzyme glycoprotein of ~50 kDa by hepatocytes. Factor VII has the shortest plasma half-life of all coagulation factors (~5 hours), and its plasma concentration is very low, ~500 ng/ml.³²³ Factor VIIa is detectable in trace amounts in normal plasma,³²⁴ and sensitive assays indicate that ~1% of circulating factor VII is in the activated form.³²⁴ The circulating half-life of activated factor VIIa is approximately 2.5 hours.³²⁵ Tissue factor increases the rate of activation of factor VII significantly,³²⁴ and current theory is that coagulation is initiated in the presence of tissue factor that is exposed at sites of vascular injury or contributed by blood monocytes.³²⁶

The factor VII gene includes nine exons and spans 128 kb on chromosome 13.³²⁷ It is located just upstream of the factor X gene. In a mouse knockout model in which factor VII is completely lacking, fatal hemorrhage occurs perinatally.³²⁸ In humans, factor VII deficiency occurs as a recessive trait resulting from homozygous or compound heterozygous mutations. Many mutations of the factor VII gene have been reported, with >200 mutations listed in 2012 in a database at isth.org. Most reported genetic defects are single-base substitutions, including missense, splice-site, and nonsense mutations. Most mutations affect only a few patients, but one mutation (Ala242Val) was detected in 23 “apparently” unrelated Jews in Israel.³²⁹ More extended haplotype testing suggests a “founder effect”.³²⁹ Although Dubin-Johnson syndrome is associated with factor VII deficiency,³³⁰ the genetic defect underlying that syndrome is located on chromosome 10, and the association of Dubin-Johnson syndrome and factor VII deficiency may simply reflect a high consanguinity rate in one population.²⁹¹ Combined deficiency of factor VII along with the other vitamin K-dependent coagulation proteins or as a deficiency with a single other coagulation protein has been reported in rare families (see below).

Clinical Features

Only severe factor VII deficiency is associated with hemorrhagic symptoms, and heterozygous carriers are asymptomatic. Factor VII levels do not completely correlate with the severity of symptoms, and this may in part reflect heterogeneity in the molecular basis of factor VII deficiency or the tissue factor-containing reagents used to quantify the factor VII activity

level in patients.³³¹ However, patients with levels of >10 to 15 IU/dl rarely manifest bleeding.³³² Patients with levels between 5 and 10 IU/dl tend to have milder symptoms, such as epistaxis, gingival bleeding, or genitourinary and gastrointestinal bleeding. Patients with levels <1 IU/dl may have symptoms similar to patients with hemophilia A or hemophilia B, with spontaneous joint and deepmuscle bleeding, but some patients with factor VII levels of <1 IU/dl have been asymptomatic. Bleeding into the CNS is particularly common, being observed in 15% to 60% of patients with factor VII levels <2 IU/dl.³³³ CNS bleeds often present during the neonatal period, and the risk of recurrence is high enough that prophylaxis with factor replacement therapy should be considered in patients who present with this complication.³³⁴ The severity of bleeding after trauma or surgical procedures varies to a surprising degree in this disorder, with oral and urogenital cavity procedures being particularly troublesome, possibly reflecting the high local fibrinolytic activity in these regions of the body. Prior clinical bleeding symptoms are an important prognostic factor predicting surgical bleeding complications in patients with factor VII deficiency.

Some reports indicate that patients with factor VII deficiency may also be more prone to various thromboembolic manifestations.³³⁵ The explanation for this phenomenon is unknown, but thrombophilic markers have been observed in most of these cases.³³⁶

Laboratory Diagnosis

In factor VII deficiency, normal results are obtained with coagulation tests that bypass the extrinsic pathway of coagulation and factor VII (Table 53.5), that is, the PTT, thrombin time, and, if tested, the Stypven (Russell viper venom) time. Thus, a diagnosis of factor VII deficiency is suspected in a patient with a life-long history of bleeding when there is an isolated prolonged PT and normal PTT. The PT will correct on 1:1 mixing of patient plasma with normal plasma, but a diagnosis of factor VII deficiency requires a specific factor VII assay for confirmation. Use of human thromboplastin in the PT assay is recommended. A factor VII mutation (factor VII Padua) has been described in African-American patients who are asymptomatic; this defect results in low factor VII activity levels when rabbit brain thromboplastin is used, but normal factor VII activity when human thromboplastin is used.³³⁷ Confirmation of low factor VII antigen level can be obtained by ELISA assay. Levels of factor VII in heterozygous carriers overlap the normal range. Before making a diagnosis of factor VII deficiency, one should exclude causes for acquired abnormalities such as vitamin K deficiency, liver disease, or warfarin therapy. Also, rare conditions such as combined deficiency of all vitamin K-dependent factors, and combined factor VII and factor X deficiency should be considered. Autoantibody directed to factor VII occurs, but few case reports have been published.

Phenotypically, patients have been characterized by evaluating plasma levels of factor VII antigen (or CRM). CRM-negative patients have low factor VII antigen as a result of the lack of synthesis or increased factor clearance, whereas CRM-positive patients produce factor VII that is detected antigenically but is structurally abnormal and with deficient function. CRM-reduced individuals presumably represent a combination of these two entities. Further complexity of the factor VII-deficient phenotype is introduced because of insensitivity of some factor VII activity assays to low levels of factor VII or from variability in assays that is introduced by the use of varying animal sources of tissue thromboplastin.

Treatment of factor VII deficiency with recombinant human factor VIIa, plasma, or PCCs is discussed later in this chapter. Although the necessity for correcting factor VII deficiency has

P.1168

been questioned,³³⁸ patients who have factor VII deficiency and a history of excessive clinical bleeding should be given replacement therapy before surgery. Numerous clinical reviews confirm that the patient's clinical bleeding history is the best predictive parameter of bleeding risk.³³⁹ It has been reported that patients with factor VII deficiency who have factor VII levels >10% when assayed using human thromboplastin reagents have minimal bleeding symptoms.

FACTOR X DEFICIENCY

Inherited factor X deficiency, first described in the Prower³⁴⁰ and Stuart³⁴¹ kindreds, is a rare autosomal recessive bleeding disorder with an estimated frequency of 1 in 1 million.²⁹⁵ Factor X deficiency represents ~10% of all rare bleeding disorders. To date, >100 mutations have been identified,^{342, 343, 344} with the majority being missense mutations.³⁴⁵ As with some of the other factor deficiencies, the frequency of factor X deficiency is greater in countries where consanguineous marriages occur.²⁹⁵ Phenotypically, factor X deficiency is classified as either type I, distinguished by reduced factor X activity and reduced factor X antigen, or type II, distinguished by reduced factor X activity but normal factor X antigen.

Pathophysiology

The CRM-negative form is a product of missense, insertion, or deletion mutations, and is characterized by a true deficiency of factor X, with a strong correlation between functional assays and immunoassays. The CRM-reduced and -positive forms are products of missense mutations and are characterized by low to normal levels of antigenically competent factor X but with disproportionately reduced factor X activity. Deletion mutations result in premature termination and thus the loss of the factor X catalytic domain, whereas missense mutations may affect not only the catalytic domain, but phospholipid binding, activation, secretion, or even synthesis of factor X. By convention, these mutant factor Xs have been named according to the proband's origin, e.g., factor X San Antonio I,³⁴⁶ factor X Friuli,³⁴⁷ and factor X St. Louis II.³⁴⁸

Clinical Features

The symptoms of factor X deficiency tend to be the most severe of the inherited coagulation deficiencies. Epistaxis, menorrhagia, and posttraumatic bleeding are common complaints, and hemarthroses and hematomas have been reported in two-thirds of factor X-deficient patients.²⁹⁵ Umbilical stump, gastrointestinal, and CNS bleeding are also frequently observed. Heterozygotes generally appear asymptomatic, as hemostasis can be maintained by factor X levels >10% of normal. On the other hand, compound heterozygotes and homozygotes with factor X levels <1% of normal suffer from severe bleeding. Experiments utilizing factor X-knockout mice resulted in either neonatal death or postnatal death, caused by intraabdominal or intracranial bleeding.³⁴⁹

Laboratory Diagnosis

A summary of laboratory findings in factor X deficiency is included in Table 53.5. Factor X deficiency is associated with normal thrombin times but prolonged PT, aPTT, and often Stypven (Russell viper venom) time, particularly among the CRM-negative variants. Unfortunately, factor X-deficiency variants have been described with isolated prolonged PT or aPTT values.^{350, 351} Upon ruling out other inherited bleeding disorders, a factor X-specific assay can be used to verify factor X deficiency. Acquired factor X deficiency, caused by liver disease, warfarin therapy, amyloidosis,³⁵² or antibodies to factor X, should be excluded before making the diagnosis of inherited factor X deficiency. Currently, FFP or PCCs are used to treat factor X deficiency, as outlined in Table 53.8.

FACTOR XI DEFICIENCY

Factor XI deficiency (plasma thromboplastin antecedent deficiency) was first recognized by Rosenthal et al. in 1953³⁵³ and was called hemophilia C. Factor XI deficiency is transmitted as an incompletely recessive autosomal trait manifested either as a major defect in homozygous patients with factor XI levels <20 IU/dl or as a minor defect in heterozygous patients with levels ranging from 30 to 65 IU/dl.³⁵⁴ The incidence of this disorder varies widely, with estimates of frequency in the general population being 1 in 1 million persons. A particularly high frequency of the disorder exists in people of Jewish extraction,^{354, 355, 356} with an estimated gene frequency of 5% to 11% in Ashkenazi Jews.³⁵⁷ Up to 0.3% of this population is homozygous for factor XI deficiency.³⁵⁷

Factor XI deficiency has been reported to result from three major types of mutations: Type I mutations result in disruption of splicing; type II mutations result in a stop codon and nonfunctional molecule; and type III mutations result in amino acid substitutions and a dysfunctional molecule.³⁵⁸ Patients with type II mutations have the greatest bleeding tendency.³⁵⁹ Type II and III mutations are most common in Ashkenazi Jews. The type II mutation is also common in Iraqi Jews,³⁶⁰ who may represent the ancient gene pool of Jews.³⁶¹

A more recent classification scheme for factor XI-deficiency cases that are CRM-negative includes three mechanistic categories: (a) Mutations that reduce or prevent polypeptide synthesis, (b) mutations resulting in polypeptides that fail to form intracellular dimers, and (c) mutations resulting in polypeptides that form dimers that are not secreted.³⁶² Mechanism (c) may account for some kindreds with apparent autosomal dominant factor XI deficiency.³⁶³ In general, most factor XI mutations result in decreased factor XI protein proportionate to factor XI clotting activity. Over 100 factor XI mutations have been reported^{364, 365} (database at isth.org).

Clinical Features

The clinical manifestations of factor XI deficiency are extremely variable and generally milder than those of hemophilia A or B.^{355, 364, 366} As a rule, spontaneous bleeding is rare, and hemorrhage usually occurs only after trauma or a surgical procedure. The extent of factor XI deficiency may not correlate with bleeding.^{355, 364, 366} Hemarthrosis is uncommon, but delayed bleeding is a particularly treacherous feature in some patients,^{353, 367, 368} especially for surgical procedures involving tissues rich in fibrinolytic activity.²³⁶ Mild factor XI deficiency may be associated with Noonan syndrome³⁶⁹ and Gaucher disease.³⁷⁰ Hemorrhagic manifestations may be absent in certain patients,³⁷¹ especially in those with type I mutations. Approximately onehalf of heterozygous factor XI-deficient patients have a bleeding tendency.³⁷² Factor XI

deficiency should be considered in female patients with menorrhagia.³⁷³ In one study of women with menorrhagia, the prevalence of factor XI deficiency was 4%.¹⁶⁸

Laboratory Diagnosis

In the homozygous form of factor XI deficiency,³⁷⁴ the PTT is prolonged. In most of these patients, factor XI levels in the plasma are in the range of 3 to 15 IU/dl. In people with the mild form of the disorder, the PTT often is normal because most PTT reagents are insensitive to mild factor XI deficiency.^{74, 236} Abnormalities in the plasma of such mildly affected patients may be removed by freezing. Specific factor assays are used to diagnose

P.1169

factor XI deficiency. The bleeding time and thrombin time are normal. Factor XI deficiency has also been reported in combination with inherited factor IX deficiency (type VI familial multiple factor deficiency).³⁷⁶ Treatment of factor XI deficiency is discussed later in this chapter in the section "Plasma".

FACTOR XII DEFICIENCY

Factor XII deficiency was discovered by Ratnoff and Colopy during routine preoperative coagulation studies on John Hageman, an adult who had no evidence or history of abnormal bleeding.^{376, 377, 378} The disorder, subsequently named Hageman factor deficiency, is inherited as an autosomal recessive trait. Factor XII deficiency has been identified in 1.5% to 3.0% of a healthy blood donor population.³⁷⁹

Pathophysiology

The plasma of most patients with factor XII deficiency does not contain material that reacts with antibodies to this factor. Radioimmunoassays with heterologous antibodies have demonstrated antigenic material identical to normal factor XII in only 2 of 42³⁸⁰ and 2 of 31³⁸¹ separate kindreds. One large study of 31 factor XII-deficient kindreds identified most mutations in the serine protease domain.³⁸¹

Clinical Features

Factor XII deficiency usually is not associated with hemorrhagic manifestations.^{376, 382} It is noteworthy that myocardial infarction and thrombophlebitis have been observed in patients with severe factor XII deficiency,³⁸³ and that Hageman died of thromboembolic complications.³⁸⁴ It was originally thought that factor XII deficiency might actually predispose to thrombosis, possibly as the result of deficient activation of fibrinolysis.³⁸⁵ However, more recent surveys indicate that factor XII deficiency is not associated with an excessive risk of thrombosis^{68, 386, 387}; thrombotic events in factor XII-deficient patients may be explained by the presence of other prothrombotic gene defects in these patients.³⁸⁸

In vitro experiments suggest that factor XII has a central role in the initiation of the intrinsic pathway of coagulation and mediates a variety of other processes such as fibrinolysis, complement activation, inflammation, and chemotaxis.^{382, 389} The physiologic importance of these factor XII-mediated phenomena remains obscure, because patients with even severe deficiency of this proenzyme reveal no evidence of deficiency or aberrance of host defenses.

The discrepancy between in vitro evidence of grossly abnormal blood coagulation and the absence of hemorrhagic manifestations in factor XII deficiency poses a fundamental question regarding the role of the intrinsic coagulation pathway in hemostasis and the significance of laboratory measurements of coagulation. Alternative mechanisms for initiation of coagulation are discussed in Chapter 18.

Results of an animal model of arterial thrombosis have again raised the question of whether factor XII has a role in thrombosis.³⁹⁰ When factor XII-deficient mice were exposed to arterial vascular injury, defective platelet-rich thrombosis was observed, a defect that was corrected by administration of exogenous factor XII.³⁹⁰ Results from a mouse stroke model indicate that factor XII deficiency protects affected mice from ischemic brain injury.³⁹¹ Although a large body of clinical evidence suggests that factor XII is not important for hemostasis, the animal model data suggest that factor XII is important for pathologic (arterial) thrombosis, perhaps by factor XII_a-mediated factor XI activation.³⁹²

Laboratory Diagnosis

Factor XII-deficient patients typically present with a negative history of clinical bleeding and an isolated, prolonged PTT that corrects with mixing with normal plasma. The coagulant effects of contact activation are diminished or absent in plasma from subjects with factor XII deficiency.³⁹³ Normal levels of factor XII range from 50 to 150 IU/dl. As with factor XI, accurate assays of factor XII depend on a source of deficient substrate plasma. Laboratory demonstration of the heterozygous state is difficult. The mean level of factor XII in the plasma of carriers is ~50% of normal, but observed values

are distributed in a bimodal manner, an observation interpreted as suggesting the presence of multiple abnormal alleles.³⁹⁴

PREKALLIKREIN DEFICIENCY

An additional abnormality of the intrinsic pathway of coagulation was defined and named Fletcher factor deficiency by Hathaway in 1965.³⁹⁵ In 1972, Wuepper et al. established that Fletcher factor was identical to plasma prekallikrein, a protein that had been studied for many years in terms of its role in inflammation.³⁹⁶ The convergence of these two avenues of research demonstrated that prekallikrein, in addition to its role in inflammation and chemotaxis, is essential for the optimal activation and fragmentation of factor XII in the early steps of coagulation.³⁸⁹

Pathophysiology

Prekallikrein deficiency apparently is inherited as an autosomal recessive trait,³⁹⁵ although genetic information is scanty. ~80 cases have been reported.³⁹⁷ Heterozygotes with ~50% of normal plasma levels of prekallikrein can be identified. The disorder is associated with the absence of antigenically competent prekallikrein in most cases.³⁹⁸

Clinical Features

Prekallikrein deficiency, like factor XII deficiency, is not associated with abnormal bleeding. Studies of affected patients revealed variable deficiencies in stress-induced fibrinolysis, chemotaxis, immediate and delayed inflammatory responses, and responses to preformed permeability-enhancing activity.³⁹⁹ These abnormalities are not associated with any apparent deleterious effects. Most patients with prekallikrein deficiency are of African ancestry.⁴⁰⁰ Prekallikrein deficiency is not associated with an excessive risk of thrombosis.⁶⁸

Laboratory Diagnosis

Prekallikrein deficiency is associated with a moderate prolongation of the PTT. The PT and thrombin time are normal. The time required for release of vascular plasminogen activators in vivo after venous occlusion is prolonged.⁴⁰¹ The disorder is characterized by abnormally slow contact activation. Thus, the PTT may be normalized by prolonged incubation (10 to 15 minutes) of plasma with particulate activators.^{395, 402} This phenomenon appears to result from autoactivation of factor XII.⁴⁰³ Specific assays for prekallikrein are based on traditional coagulation techniques and chromogenic substrate assays.⁴⁰⁴

HIGH-MOLECULAR-WEIGHT KININOGEN DEFICIENCY

A unique inherited coagulation abnormality associated with deficiencies of kinin formation and fibrinolysis was described in three unrelated kindreds in 1975. The disorder received the names

P.1170

of the affected families (Fitzgerald trait,⁴⁰⁵ Williams trait,⁴⁰⁶ Flaujeac trait, and Fujiwara trait⁴⁰⁷) and has subsequently been found to be the result of deficiency of HMWK. Patients with this disorder are asymptomatic. The data suggest that HMWK functions in its nonactivated form as a cofactor, binding prekallikrein and factor XI to anionic surfaces, accelerating their activation by surface-bound factor XIIIa (see Chapter 18).

Pathophysiology

Deficiency of HMWK appears to be inherited as an autosomal recessive trait.³⁶⁶ Mildly affected heterozygotes have been identified in some families. Detailed biochemical studies of five kindreds revealed considerable heterogeneity.^{406, 408} Thus, HMWK levels in the plasma ranged from nil⁴⁰⁶ to 50 IU/dl.⁴⁰⁵ With the exception of the Fitzgerald kindred, associated deficiencies in low-molecular-weight kininogen have been demonstrated in all families. Variable deficiency of prekallikrein also was present in the Williams, Fitzgerald, and Fujiwara kindreds; prekallikrein levels were normal in the Flaujeac kindred. Immunologic studies revealed the absence of kininogen antigen in the homozygotes and 50% of normal levels in the heterozygotes.⁴⁰⁹ The associated prekallikrein deficiency also apparently is of the CRM-negative type.⁴⁰⁹ The absence of the stabilizing effects of HMWK may lead to accelerated degradation and deficiency of prekallikrein in this disorder.⁴⁰⁹ HMWK deficiency is not associated with excessive clinical bleeding or thrombosis. There is limited information on the genetic basis for HMWK deficiency.^{410, 411, 412}

Laboratory Diagnosis

Deficiency of HMWK is manifested by an isolated, prolonged PTT. The PTT assay results are abnormal whether particulate or soluble contact activators are used, and values are not normalized by prolonged incubation of the plasma with particulate activators.

MISCELLANEOUS INHERITED COAGULATION DISORDERS

Combined Defects

Of unusual interest are reports concerning the presence of combined deficiencies of two or more coagulation factors. Deficiency of factors V and VIII, and combined deficiency of various vitamin K-dependent factors appear to be the most common combined deficiency disorders.⁴¹³ Several other combined coagulation defects have been described (Table 53.1).

Deficiency of Factors V and VIII

Combined deficiency of factors V and VIII, reported in <200 patients, is inherited as an autosomal recessive trait.⁴¹⁴ This combined defect manifests clinically with mild mucosal and cutaneous bleeding. Severe posttraumatic and postsurgical bleeding is common (e.g., after tooth extractions).⁴¹⁴ Hemarthrosis is rare. Laboratory findings in homozygous patients include a prolonged PTT and PT and levels of factor VIIIc and Vc that average 15 IU/dl. Levels of factor VIIIa (VIIIa) and VAg are low and are proportional to those obtained by coagulation measurements.⁴¹⁵

Linkage analysis of combined factor V and VIII deficiency to chromosome 18q excluded all known hemostasis proteins, suggesting that the basis for the disease is a defect affecting a process common to the biosynthesis of factors V and VIII. Indeed, subsequent studies by two groups identified the genetic basis for most patients with the disorder as mutations in the endoplasmic reticulum-Golgi intermediate compartment protein 53 (also known as lectin mannose-binding type 1 [LMAN1]). Other patients with this combined defect have mutations in another protein termed multiple coagulation factor deficiency-2 (MCFD2).^{416, 417, 418} LMAN1 and MCFD2 form a complex that acts as a receptor (chaperone) or cargo receptor for transport of several secreted proteins, including factors V and VIII.^{417, 419} Still other patients with combined factors V and VIII deficiency have been identified⁴¹⁷ who appear to have unique mutations.

Combined Deficiency of Factors II, VII, IX, and X

Combined deficiency of factors II, VII, IX, and X is an autosomal recessive coagulation disorder that has been identified in only a small number of patients.^{238, 413, 420, 421} In addition to affecting levels of the vitamin K-dependent factors, skeletal abnormalities may also be seen, resulting from effects on bone Gla proteins.⁴²² Levels of the vitamin K-dependent proteins range from <12% to 50% of normal; thus, clinical bleeding manifestations may vary widely. Both the PT and PTT are prolonged. Measurement of serum warfarin levels may be necessary to exclude surreptitious anticoagulant use. Mutations in the γ -glutamyl carboxylase gene have been identified in a few patients with this disorder,^{423, 424, 425} and another group has identified a second gene locus (vitamin K epoxide reductase complex, subunit 1 [VKORC1]) causing this defect.⁴²⁶ Some patients have clinical improvement and correction of the coagulopathy with vitamin K therapy.^{420, 424}

ABNORMALITIES OF PROTEASE INHIBITORS

Rare abnormalities of three plasma antiproteases, which are associated with bleeding, are described in this section. Other, more numerous abnormalities of the components of the antiprotease system and the fibrinolytic enzyme system that may be associated with thrombosis are discussed in Chapter 55.

 α_2 -Antiplasmin Deficiency

Severe bleeding, including hemarthrosis, was associated with deficiency of α_2 -antiplasmin in several kindreds.^{427, 428, 429, 430, 431} This disorder appears to be inherited as an autosomal recessive trait, in which heterozygotes have detectable deficiencies of this antiprotease but only mild bleeding. CRM-positive and CRM-negative forms have been identified.⁴³⁰ A report published in 2008 identified 15 cases; seven cases had genetic abnormalities defined.⁴³²

Most cases had mutations in exon 10, which is the location of the active site, and the plasminogen-binding site.^{431, 432} Bleeding presumably is the result of premature lysis of hemostatically important fibrin plugs caused by unregulated plasmin activity. The laboratory findings are variable. Hypofibrinogenemia and increased clot solubility in urea have been reported. Fibrinogen degradation product levels and platelet counts were normal in most cases.⁴³⁰ When assayed qualitatively by fluorometric or photochromogenic techniques, α_2 -antiplasmin levels usually are <10 IU/dl. Treatment of bleeding episodes with tranexamic acid and other antifibrinolytic agents may be helpful.

Plasminogen Activator Inhibitor-1 Deficiency

Deficiency of plasminogen activator inhibitor (PAI)-1 is associated with a moderate bleeding disorder.⁴³³ Only ~10 to 20 families have been reported.⁴³⁴ One study investigated a large kindred with multiple family members who were homozygous for this disorder.⁴³⁵ Homozygous patients, but not heterozygous patients, exhibited clinical bleeding.⁴³⁵ The null gene mutation responsible for PAI-1 deficiency was identified in this kindred.⁴³⁵ Other cases have been described.⁴³⁶ The basis of the bleeding is similar to that described for α_2 -antiplasmin deficiency: Excessive plasmin activity, caused in this case by excessive activation of plasminogen.

P.1171

Laboratory screening studies are typically normal, but the euglobulin clot lysis time is shortened. It is recommended that measurement of PAI-1 antigen and activity in both serum and plasma be done to screen for PAI-1 deficiency.⁴³⁵ The in vitro activities and clinical relevance of PAI-1 have been reviewed.⁴³⁷

α_1 -Antitrypsin Pittsburgh

A life-long hemorrhagic diathesis in a 14-year-old boy was associated with a unique qualitatively abnormal form of α_1 -antitrypsin (antithrombin III Pittsburgh).^{438, 439} This disorder is the result of the substitution of a single amino acid (arginine for methionine at position 358 in the α_1 -antitrypsin molecule).⁴³⁹ This site corresponds to the P1 residue or "bait" amino acid of the molecule, and the substitution produced a mutation of α_1 -antitrypsin, a weak antiprotease with little affinity for thrombin, into a potent antithrombin that impaired blood coagulation to a significant degree. The mutant molecule also is a potent inhibitor of factor XIa, factor XIIa, and kallikrein, a property lacking in the normal molecule.⁴⁴⁰ The plasma concentration of the abnormal molecule increased after trauma, possibly as the result of an acute-phase response. The patient ultimately died of bleeding. A second family was reported with the disorder; it is inherited in an autosomal dominant manner.⁴⁴¹ Other amino acid substitutions at position 358 have been produced artificially by genetic engineering.⁴⁴²

TREATMENT OF INHERITED COAGULATION DISORDERS

The principal treatment for the inherited coagulation disorders is replacement therapy—that is, the intravenous administration of the required factor in the form of blood products derived from normal people or animals, or recombinant coagulation proteins.⁴⁴³ Estrogens may be useful in treating female patients with vWD.⁴⁴⁴ Topical hemostatics (thrombin) may be temporarily effective in small injuries or nose bleeds, and certain other treatments such as DDAVP and inhibitors of fibrinolysis are useful adjunctive therapy under specific circumstances such as dental surgery.⁴⁴⁵

Replacement Therapy

The objective of replacement therapy is to obtain a concentration of the required factor at the bleeding site such that coagulation may become hemostatically effective. The pharmacokinetic (PK) properties of the various coagulation factors (Table 53.9) and clinical assessment of the severity of the hemorrhagic risk are important considerations in determining appropriate doses and duration for therapy. Replacement products are dosed on the basis of actual body weight (Tables 53.8 and 53.10) or plasma volume. This latter method may be more precise in patients who do not have a normal plasma volume because of bleeding. In one such method, blood volume is considered to be 7% of body weight; plasma volume is then calculated using the patient's hematocrit. Next, the therapeutic objective is assessed (e.g., the desired incremental increase in factor VIII level). For example, if a patient with severe hemophilia A (<1% factor VIII) has a plasma volume of 3,000 ml and requires major surgery, the target factor VIII level should be 100% of normal. Infusion of 3,000 IU of factor VIII would result in a calculated peak factor VIII level of 1 IU/ml (100% of normal). Peak factor levels should be monitored to determine whether the expected response was achieved, and then further dosage adjustments can be calculated if necessary. Subsequent doses are scheduled according to the predicted half-life of the factor, with laboratory tests to verify actual levels when appropriate. Case reports and clinical experience detailing management of hemophilia A during surgery have been published.^{446, 447, 448, 449, 450}

TABLE 53.9 BIODYNAMIC PROPERTIES OF COAGULATION FACTORS OF CONCERN IN REPLACEMENT THERAPY

Disorder	Hemostatic Level (IU/dl) ^a		Biologic Half-life (h)
	*	+	
Hemophilia A (factor VIII deficiency)	25-30		12
Hemophilia B (factor IX deficiency)	20-60		20-24
Fibrinogen deficiency	100 mg/dl	>100 mg/dl	77-106
Prothrombin deficiency	40-50		72-96
Factor V deficiency	10-30	12	15-36
Factor VII deficiency	10-20	25	4-7
Factor X deficiency	10-40	56	32-48

Factor XI deficiency	20-30	26	40-80
Factor XIII deficiency	10	31	280
von Willebrand disease	20-50		20-40

^aPatients undergoing major surgery or experiencing major bleeding should receive dosages to achieve higher factor levels; for example, patients with hemophilia A should have replacement such that factor VIII levels approach 100% of normal. For patients with factor XIII deficiency and major trauma, plasma factor XIII levels of at least 25% should be achieved.

*Data in this table are taken from Teruya J, Ramsey G. Blood components for hemostasis. Lab Med 2001;32:31-35.

[†]Data taken from Peyvandi F, Palla R, Menegatti M, et al. Coagulation factor activity and clinical bleeding severity in rare bleeding disorders: results from the European Network of Rare Bleeding Disorders. J Thromb Haemost 2012;10:615-621.

Hemostatic Levels

The hemostatic level may be defined as the lowest plasma concentration of a given coagulation factor that is required for normal hemostasis (Table 53.9). This value was determined by purely empiric means—that is, by measurement of the blood levels of the deficient factor at which bleeding appeared to stop in patients with one of the inherited coagulation disorders during the course of replacement therapy. Such estimates obviously may be inaccurate. In patients with hemophilia A, the hemostatic level of factor VIIIc is ~25 to 30 IU/dl; in those with hemophilia B, values range from 20 to 60 IU/dl. However, for patients with major trauma or those undergoing surgery, higher plasma levels of these coagulation proteins should be achieved (i.e., 100% for factors VIII or IX; 25% to 50% for factor XIII).

In Vivo Recovery and Survival of Infused Coagulation Factors

When a coagulation factor is infused intravenously into a recipient who is deficient in that factor, the levels present in the circulation after intravascular mixing usually are significantly lower than those that would be expected from mere dilution in the recipient's plasma. That this initial in vivo recovery of infused coagulation factors (Table 53.9) is <100% presumably is the result of loss of these proteins from the intravascular space. The adsorption of coagulation factors by platelets and various cell and vascular surfaces may also be involved. The initial recovery of infused coagulation factors is difficult to quantify and ranges from nearly 100% for factor XI to as low as 30% for factor IX. Typically, because the range of in vivo recovery in a population is so variable, clinicians will determine the in vivo recovery for each individual by laboratory testing of blood samples drawn 10 to 20 (peak level) minutes after the therapeutic infusion.

P.1172

TABLE 53.10 REPLACEMENT THERAPY IN HEMOPHILIA A AND HEMOPHILIA B

Disorder	Therapeutic Product	Minor Bleeding (i.e., Uncomplicated Hemarthroses; Hematomas in Noncritical Areas; Hematuria; Dressing Changes; ^a Arthrocentesis; ^a Removal of Sutures and Drains ^a)		Major Bleeding (Hematomas in Critical Locations; Traumatic Injuries; Multiple Tooth Extractions; Major Surgical Procedures)	
		Loading Dose	Maintenance Dose	Loading Dose	Maintenance Dose
Hemophilia A (factor VIII deficiency)	Cryoprecipitate ^b	Not required	1.25-1.75 bags/10 kg every 12 h for 1-3 d	3.5 bags/10 kg	1.75 bags/10 kg every 8 h for 1-2 d; every 12 h thereafter
	Purified factor	Not	10-15 IU/kg every 12 h	30-40	30-40 IU/kg every 12

	VIII ^c	required	for 2-4 d	IU/kg	h
Hemophilia B (factor IX deficiency)	Prothrombin complex ^{b, c}	20-30 IU/kg	15 IU/kg every 24 h for 2-4 d	40-60 IU/kg	20-25 IU/kg every 24 h
	Purified factor IX ^{c, d}	20-30 IU/kg	15 IU/kg every 24 h for 2-4 d	60-70 IU/kg	20-40 IU/kg every 24 h

Note: Because weight-based calculations may not correctly predict plasma volumes in bleeding patients, confirmation of the hemostatic level of the coagulation factor being replaced should always be performed for patients with major bleeding indications, with appropriate dosage adjustments performed based on these results.

^a Single dose of 15 IU/kg or equivalent amounts of concentrated product usually are sufficient.

^b Recommended only if purified factor replacement therapy is not available. Antifibrinolytic therapy should not be used with prothrombin complex concentrates.

^c Initial in vivo recovery of active factor varies somewhat depending on preparation.

^d Recombinant factor IX may require higher doses.

After in vivo mixing is complete, the activity of most coagulation factors in the plasma declines in a biphasic manner—that is, an initial rapid loss of activity is followed by a more gradual decline (Fig. 53.10).⁴⁵¹ The first or rapid phase presumably is the result of diffusion into extravascular pools. This diffusion half-life ranges from minutes for factor VII to several hours for factor VIII. In general, it is the rapidity of this first phase, together with the initial in vivo recovery of the particular factor, that determines the necessity for and the size of the preliminary or loading dose of therapeutic product.

The second or slow phase of the survival curve presumably is the result of degradation and reflects the true biologic half-life of the infused factor (Table 53.9; Fig. 53.10). This parameter, together with the hemostatic level for the factor of concern, is the main determinant of the frequency of administration and the size of the maintenance dose of therapeutic product. For example, ~80% of factor VIII infused is initially recovered in the circulation; its initial (diffusion) and subsequent (biologic) half-lives are ~6 and 12 hours, respectively.⁴⁵² Thus, in the treatment of patients with hemophilia A, doses are administered every 8 to 12 hours. In patients with hemophilia B, the initial recovery of factor IX is 50% or less; its initial and subsequent half-lives are ~3 and 24 hours, respectively.⁴⁵³ Hence, larger doses are required initially, but dosing is usually once a day to maintain adequate hemostasis. After a large loading dose or after several courses of therapeutic product have been administered, the survival curves of infused coagulation factors become nearly monophasic, presumably because extravascular spaces and the other mechanisms that remove infused coagulation factors from the circulation are saturated. New factor VIII and factor IX products currently in small phase III clinical trials have extended half-lives, so it will be important during these clinical trials to determine the appropriate initial dosing and dosing intervals for each of the new products.^{89, 454, 455}

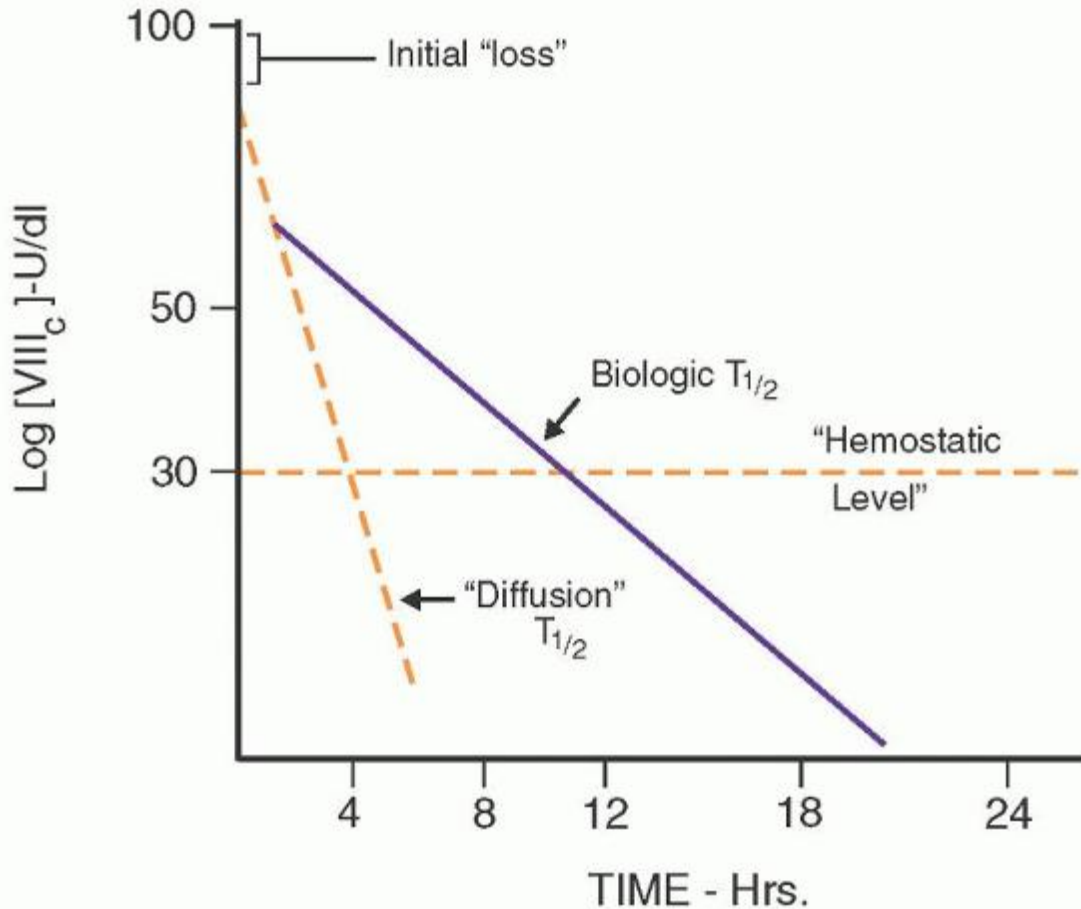

FIGURE 53.10. Biodynamics of factor VIII. A hypothetical survival curve obtained in a patient with severe hemophilia A after transfusion of sufficient factor VIII to increase the plasma factor VIIIc level to 100 IU/dl is shown. $T_{1/2}$, half-life.

Products

Before 1960, plasma was the only agent generally available for the treatment of the inherited coagulation disorders. Tremendous progress has been made in treating congenital coagulation disorders, primarily through development of effective therapeutic products. It should be noted that the life expectancy of a boy born in 1960 with severe hemophilia A was approximately 20 years, and now the life expectancy is essentially normal with modern therapeutic products and the comprehensive care of hemophilia treatment centers.⁴⁵⁶ Tables 53.11, Tables 53.12, Tables 53.13, Tables 53.14, Tables 53.15 and 53.16 summarize therapeutic choices available to treat certain inherited bleeding disorders.

Plasma

Although most current replacement therapies of coagulation factor deficiencies involve sterile purified concentrates or recombinant proteins, plasma therapy is still important in treating some deficient states such as factor XI deficiency. FFP is usually preferred for therapeutic purposes. For factor VIII and fibrinogen deficiencies, and vWD, the appropriate coagulation factors are concentrated in cryoprecipitate. Both the rate of administration and the total dose of plasma administered are limited by the possibility of acute or chronic circulatory overload. The volume expansion

P.1173

P.1174

resulting from even moderate doses of plasma also limits the blood levels of the missing coagulation factor that can be attained. As a consequence, therapy with plasma alone can be expected to increase the levels of a deficient factor no

more than 20 IU/dl above baseline values. When plasma is the only therapeutic agent available, plasmapheresis may be of adjunctive value.⁴⁵⁷ A sterile solvent-detergent-treated plasma preparation is available,⁴⁵⁸ but activity of certain coagulation proteases and inhibitors in this product is not equivalent to that of FFP.^{459, 460} Better preparations of solvent-detergent-treated plasma are available in Europe and are in clinical trials for the U.S. A British guideline for the use of FFP and cryoprecipitate has been published.⁴⁶¹

TABLE 53.11 COMPARISON OF ANTIHEMOPHILIC FACTOR (FACTOR VIII) PRODUCTS DERIVED FROM HUMAN PLASMA

Agent	Manufacturer Site	Method of Viral Depletion or Inactivation	Mean Half-life (h)	Labeled Uses	AWP per Unit	Miscellaneous
Hemofil M	Baxter Healthcare Corporation USA	<ul style="list-style-type: none"> • Immunoaffinity chromatography • Solvent-detergent treatment 	14.8 ± 3	<ul style="list-style-type: none"> • Prevention and control of bleeding in patients with hemophilia A 	\$1.38	<ul style="list-style-type: none"> • Contains mouse proteins • Contains human albumin • May be ineffective in patients with Factor VIII inhibitors
Koate-DVI	Talecris Biotherapeutics, Inc. USA	<ul style="list-style-type: none"> • Solvent-detergent treatment • Heat-treated at 80°C 	16.12	<ul style="list-style-type: none"> • Treatment of hemophilia A in patients with deficiency of factor VIII activity 	\$1.37	<ul style="list-style-type: none"> • Contains naturally occurring vWF, but is not labeled for treatment of vWD • Contains anti-A and anti-B blood group isoagglutinins • Contains human albumin • May be ineffective in patients with Factor VIII

Monoclate-P CSL Behring, LLC USA	<ul style="list-style-type: none"> • Pasteurization at 17.5 60°C for 10 hours • Immunoaffinity chromatography 	<ul style="list-style-type: none"> • Treatment of hemophilia A, including prevention of surgical bleeding 	inhibitors <ul style="list-style-type: none"> • Contains mouse proteins • Contains human albumin
-------------------------------------	---	--	---

AWP, average wholesale price; vWD, von Willebrand disease, vWF, von Willebrand Factor.

References

1. Baxter Healthcare Corporation. Hemofil M (antihemophilic factor, human) [prescribing information]. Westlake Village, CA: Baxter Healthcare Corporation, 2010.
2. Talecris Biotherapeutics, Inc. (antihemophilic factor, human) [prescribing information]. Research Triangle Park, NC: Talecris Biotherapeutics, Inc, 2011.
3. CSL Behring, LLC. Monoclate-P (antihemophilic factor, human) [prescribing information]. Kankakee, IL, 2011.
4. Anon, ed. Red Book Online. via Drugdex System [internet database]. Greenwood Village, CO: Thomson Healthcare, 2011.

TABLE 53.12 COMPARISON OF ANTIHEMOPHILIC FACTOR (FACTOR VIII)/VON WILLEBRAND FACTOR COMPLEX PRODUCTS DERIVED FROM HUMAN PLASMA

Agent	Manufacturer/ Site	Method of Viral Depletion or Inactivation	Mean Half-life (h)	Labeled Uses	AWP per Unit	Miscellaneous
Alphatec	Grifols Biologicals Inc. USA	<ul style="list-style-type: none"> • 3.5% PEG precipitation • Solvent-detergent treatment • Column chromatography • Lyophilization • Dry heat treatment at 80°C for 72 h 	Factor VIII 17.9 ± 9.6 vWF:RCo 7.67 ± 3.32	<ul style="list-style-type: none"> • Prevention and control of bleeding patients with hemophilia A • Prevention of surgical bleeding in patients with vWD who do not tolerate or do not respond to desmopressin 	\$1.32	<ul style="list-style-type: none"> • Not indicated for patients with severe vWD (Type 3) undergoing major surgery • Contains human albumin • Contains anti-A and anti-B blood group isoagglutinins

Humate- P	CSL Behring, GmbH Germany	<ul style="list-style-type: none"> • Cryoprecipitation Factor VIII • Aluminum hydroxide adsorption 12.2 (8.4-17.4) • Glycine precipitation vWF: RCo • Sodium chloride precipitation 10.5^a (2.8-33.6) • Pasteurization at 60°C for 10 h 	<ul style="list-style-type: none"> • Treatment and prevention of bleeding events in patients with hemophilia A • Treatment of spontaneous or traumatic bleeding events in patients with vWD • Prevention of surgical bleeding in patients with vWD 	\$1.2 0	<ul style="list-style-type: none"> • Not indicated for routine prophylaxis in vWD • Contains human albumin • Contains anti-A and anti-B blood group isoagglutinins
Wilate	Octopharma Austria	<ul style="list-style-type: none"> • Solvent-detergent treatment Factor VIII • Terminal dry heat treatment at +100°C for 120 minutes 19.6 (10.9-34.7) vWF: RCo • Ion exchange chromatography 15.8 (5.7-48.5) 	<ul style="list-style-type: none"> • Treatment of traumatic or spontaneous bleeding in patients with severe vWD • Treatment of traumatic or spontaneous bleeding in patients with mild-moderate vWD who cannot tolerate or do not respond to desmopress 	\$1.3 8	<ul style="list-style-type: none"> • Not indicated for prevention of surgical bleeding or routine prophylaxis in vWD • Not indicated for hemophilia A • Patients with vWF inhibitors will have inadequate response • Albumin-free

in

AWP, average wholesale price; PEG, polyethylene glycol; vWD, von Willebrand Disease; vWF, Von Willebrand Factor; vWF: Rco, von Willebrands Factor: Ristocetin cofactor activity.

^a Median half-life.

References

1. Grifols Biologicals, Inc. Alphanate (Antihemophilic Factor/von Willebrand Complex, human) [prescribing information]. Los Angeles, CA: Grifols Biologicals, Inc, 2010.
2. CSL Behring, GmbH. Humate-P (Antihemophilic Factor/von Willebrand Complex, human) [prescribing information]. Marburg, Germany: CSL Behring, GmbH, 2010.
3. Octapharma. Wilate (Antihemophilic Factor/von Willebrand Complex, human) [prescribing information]. Vienna, Austria: Octapharma, 2010.
4. Anon, ed. Red Book Online. via Drugdex System [internet database]. Greenwood Village, CO: Thomson Healthcare; 2011.

TABLE 53.13 COMPARISON OF RECOMBINANT ANTIHEMOPHILIC FACTOR (FACTOR VIII) PRODUCTS

Agent	Manufacturer/Site	Method of Depletion or Inactivation	Viral Proteins in Culture Media	Stabilizers	Median Half-life (h)	Labeled Uses	AWP per Unit	Miscellaneous
Advate	Baxter Healthcare Corporation USA	<ul style="list-style-type: none"> • Immunoaffinity chromatography • Solvent-detergent treatment 	None	<ul style="list-style-type: none"> • Mannitol • Trehalose • Sodium Citrate • Histidine • Tris • Calcium • Polysorbate-80 • Glutathione 	Adults ± 4.1 Children 11.1 (1.6-3.7)	<ul style="list-style-type: none"> • Prevention and control of bleeding in patients with hemophilia A • Perioperative management of patients with hemophilia A 	\$1.68	<ul style="list-style-type: none"> • Contains mouse and hamster proteins • Albumin-free • Patients with inhibitor titers >10 Bethesda Units may not achieve

								adequate response
								• Contains <2 ng vWF per unit
Helixate FS	Bayer HealthCare, LLC USA	• Solvent detergent treatment	• Human plasma Protein solution	• Sucrose	Adults 13.7 ± 1.8	• Perioperative management and prevention and control of bleeding in patients with hemophilia A	\$1.44	• Contains mouse and hamster proteins
Kogenate FS	(Distributed by CSL Behring, LLC) Bayer HealthCare, LLC USA	• Ion exchange chromatography	• Insulin	• Glycine	Children 10.7 (7.8-15.3)	• Routine prophylaxis to reduce bleeding events and the risk of joint damage in children with hemophilia A who do not have pre-existing joint	8	• Albumin-free
		• Immunoaffinity chromatography						• Patients with inhibitor titers >10 Bethesda Units may not achieve adequate response

Recombinate	Baxter Healthcare Corporation USA	<ul style="list-style-type: none"> • Immunoaffinity chromatography 	Bovine serum albumin	<ul style="list-style-type: none"> • Human albumin 14.6 ± 4.9 • Calcium • Polyethylene glycol • Sodium • Histidine • Polysorbate-80 	<p>damage</p> <ul style="list-style-type: none"> • Perioperative management and prevention and control of bleeding in patients with hemophilia A 	<ul style="list-style-type: none"> • Contains bovine, mouse, and hamster proteins • Patients with inhibitor titers >10 Bethesda Units may not achieve adequate hemostasis • Contains $<2\text{ng}$ vWF per unit
Xyntha	Wyeth/Pfizer Sweden	<ul style="list-style-type: none"> • Immunoaffinity chromatography • Solvent detergent treatment • Nanofiltration 	Insulin	<ul style="list-style-type: none"> • Sodium chloride 11.2 ± 5 • Sucrose Children 8 ± 2.4 • Calcium (3.5-10.6) 	<ul style="list-style-type: none"> • Surgical prophylaxis in patients with hemophilia A • Prevention and control 	<ul style="list-style-type: none"> • Contains hamster proteins • Albumin-free • Does not

e of conta
 • Polysorbate-80 bleeding in vWF
 patients with hemophilia A

AWP, average wholesale price; vWD, von Willebrand disease; vWF, von Willebrand Factor.

References

1. Baxter Healthcare Corporation. Advate (Antihemophilic Factor, Recombinant) [prescribing information]. Westlake Village, CA: Baxter Healthcare Corporation, 2010.
2. CSL Behring, LLC. Helixate FS (Antihemophilic Factor, Recombinant) [prescribing information]. Kankakee, IL: CSL Behring, LLC, 2009.
3. Bayer Healthcare, LLC. Kogenate FS (Antihemophilic Factor, Recombinant) [prescribing information]. Tarrytown, NY: Bayer Healthcare, 2009
4. Baxter Healthcare Corporation. Recombinate (Antihemophilic Factor, Recombinant) [prescribing information]. Westlake Village, CA: Baxter Healthcare Corporation, 2010.
5. Wyeth Pharmaceuticals, Inc. Xyntha (Antihemophilic Factor, Recombinant) [prescribing information]. Philadelphia, PA: Wyeth Pharmaceuticals Inc, 2010.
6. Anon, ed. Red Book Online. via Drugdex System [internet database]. Greenwood Village, CO: Thomson Healthcare, 2011.

P.1175

TABLE 53.14 COMPARISON OF FACTOR IX PRODUCTS

Agent	Manufacturer/Site	Method of Viral Depletion or Inactivation	Proteins in Culture Media	Uses	AWP per Unit	Miscellaneous
AlphaNine SD (plasma-derived)	Grifols USA	<ul style="list-style-type: none"> • Column chromatography • Solvent-detergent treatment • Nanofiltration 	None	Control and prevention of bleeding in patients with hemophilia B	\$1.42	<ul style="list-style-type: none"> • Contains nontherapeutic levels of Factor II, Factor VII, and Factor X
Benefix (recombinant)	Wyeth/Pfizer USA	<ul style="list-style-type: none"> • Nanofiltration 	None	Control and prevention of bleeding and perioperative management of patients	\$1.25	<ul style="list-style-type: none"> • Does not contain any additional coagulation factors • Contains hamster

Mononine (plasma-derived)	CSL Behring LLC USA	<ul style="list-style-type: none"> Immunoaffinity chromatography Ultrafiltration 	None	Control and prevention of bleeding in patients with hemophilia B	\$1.20	<ul style="list-style-type: none"> Contains nondetectable levels of Factor II, Factor VII, and Factor X Contains mouse proteins
---------------------------	---------------------	--	------	--	--------	---

AWP, average wholesale price.

References

1. Grifols Biologicals, Inc. AlphaNine SD (coagulation factor IX, human) [prescribing information]. Los Angeles, CA: Grifols Biologicals, Inc, 2010.
2. Wyeth Pharmaceuticals Inc. Benefix (Coagulation Factor IX, Recombinant) [prescribing information]. Philadelphia, PA: Wyeth Pharmaceuticals Inc, 2011.
3. CSL Behring, LLC. Mononine (coagulation factor IX, human) [prescribing information]. Kankakee, IL: CSL Behring, LLC, 2010.
4. Anon, ed. Red Book Online. via Drugdex System [internet database]. Greenwood Village, CO: Thomson Healthcare, 2011.

TABLE 53.15 COMPARISON OF PROTHROMBIN COMPLEX PRODUCTS DERIVED FROM HUMAN PLASMA

Agent	Manufacturer/Site	Method of Viral Depletion or Inactivation	Proteins in Culture Media	Labeled Uses	AWP per Unit	Miscellaneous
Bebulin	Baxter Healthcare Corporation USA	<ul style="list-style-type: none"> Nanofiltration Vapor heat treatment DEAE-Sephadex adsorption 	Heparin added	Control and prevention of bleeding in patients with hemophilia B	\$1.09	Contains Factor II, Factor X, and low amounts of Factor VII
Profilnine SD	Grifols Biologicals Inc. USA	<ul style="list-style-type: none"> DEAE cellulose adsorption Solvent-detergent treatment 	No heparin added	Control and prevention of bleeding in patients with hemophilia B	\$0.90	Contains ≤ 150 units Factor II, ≤ 35 units Factor VII, and ≤ 100 units Factor X per 100 units Factor IX

AWP, average wholesale price.

References

1. Baxter Healthcare Corporation. Bebulin (coagulation factor IX, human) [prescribing information]. Westlake Village, CA: Baxter Healthcare Corporation, 2011.
2. Grifols Biologicals, Inc. Profilnine SD (Factor IX Complex) [prescribing information]. Los Angeles, CA: Grifols Biologicals, Inc, 2010.
3. Anon, ed. Red Book Online. via Drugdex System [internet database]. Greenwood Village, CO: Thomson Healthcare, 2011.

Purified or Concentrated Coagulation Factors

Cryoprecipitate

A major advance in the therapy of hemophilia A was the demonstration by Pool et al. that cold insoluble material obtained from plasma contains high concentrations of factor VIII and fibrinogen.⁴⁶² Cryoprecipitate, which for many years was discarded during clarification of plasma, is prepared by slowly thawing rapidly frozen plasma at 2-4°C, then harvesting the precipitate by centrifugation. Cryoprecipitate prepared from 200 ml of fresh plasma (1 unit) contains 50 to 120 units of factor VIII, ~250 mg of fibrinogen, and therapeutically useful amounts of factor XIII and vWF that are rich in high-molecular-weight multimers. Cryoprecipitation provides 7- to 20-fold purification of factor VIII with respect to plasma and can be carried out by means of a closed double-bag system, even in small blood banks without special equipment. With the widespread availability of modern therapeutic products to treat hemophilia A and vWD, cryoprecipitate is now used primarily to treat hypofibrinogenemia.

Purified Factor VIII

Among the many methods developed to purify factor VIII, several are suitable for the large-scale production of concentrates of the human protein for therapeutic use, and sufficiently robust to attain in vivo factor VIIIc levels as high as 100 IU/dl in hemophilic patients without significant expansion of the plasma volume. Most plasma-derived factor VIII concentrates contain vWF but lack the high-molecularweight vWF multimers found in cryoprecipitate or plasma.

Nearly all individuals with severe or moderate hemophilia require frequent therapeutic intravenous infusions and therefore,

P.1176

as the concentrated factor products became available in the late 1970s most patients learned how to administer these infusions themselves at home.

TABLE 53.16 COMPARISON OF MISCELLANEOUS ANTIHEMOPHILIC AGENTS

Agent	Manufacturer/Site	Method of Viral Depletion or Inactivation	Labeled Uses	AWP per Unit	Miscellaneous
Factor VIIa, Recombinant (Novoseven RT, Recombinant)	Novo Nordisk A/S Denmark	• Chromatographic purification	• Surgical prophylaxis and treatment of bleeding in patients with hemophilia A with inhibitors to Factor	\$1.67	• Contains mouse, hamster, and bovine proteins • Contains sodium chloride, calcium chloride dihydrate, glycylglycine

<p>Factor XIII, human (Corifact, human plasma-derived)</p>	<p>CSL Behring, GmbH Germany</p>	<ul style="list-style-type: none"> • Aluminum hydroxide adsorption • Vitacel defibrination • Ion exchange chromatography • Heat treatment at 60°C for 10 h 	<p>VIII</p> <ul style="list-style-type: none"> • Surgical prophylaxis and treatment of bleeding in patients with hemophilia B with inhibitors to Factor IX • Surgical prophylaxis and treatment of bleeding in patients with acquired hemophilia a • Surgical prophylaxis and treatment of bleeding in patients with congenital Factor VII deficiency <p>Routine prophylaxis in patients with congenital Factor XIII deficiency \$9.36</p>	<ul style="list-style-type: none"> • e, polysorbate-80, mannitol, sucrose, and methionine • RT formulation is stable at room temperature • Contains human albumin, glucose, and sodium chloride • Maintain trough Factor XIII activity levels
--	----------------------------------	--	---	---

Anti-inhibitor Coagulant Complex (Feiba NF, human plasma-derived)	Baxter Healthcare Corporation, USA	<ul style="list-style-type: none"> • Nanofiltration • Vapor heat treatment • DEAE-Sephadex adsorption 	<ul style="list-style-type: none"> • Surgical prophylaxis and treatment of bleeding in patients with hemophilia A and hemophilia B with inhibitors to Factor VIII or Factor IX 	<p>between 5% and 20%</p> <ul style="list-style-type: none"> • Contains Factor II, IX, and X (mainly inactivated), Factor VII (mainly activated), trisodium citrate, and sodium chloride • Generally used in patients with Inhibitor titers >5 Bethesda Units
---	------------------------------------	--	---	--

AWP, average wholesale price.

References

1. Novo Nordisk A/S. NovoSeven RT (Coagulation Factor VIIa, Recombinant) [prescribing information]. Bagsvaerd, Denmark: Novo Nordisk A/S, 2010.
2. CSL Behring GmbH. Corifact (Factor XIII Concentrate, human) [prescribing information]. Marburg, Germany: CSL Behring, GmbH, 2011.
3. Baxter Healthcare Corporation. Feiba (Anti-inhibitor Coagulant Complex) [prescribing information]. Westlake Village, CA: Baxter Healthcare Corporation, 2011.
4. Anon, ed. Red Book Online. via Drugdex System [internet database]. Greenwood Village, CO: Thomson Healthcare, 2011.

Unfortunately, before the mid-1980s, the risk of viral transmission accompanied the use of these concentrated preparations, because they were prepared from large plasma pools and specific virucidal treatment was not used. The risk of virus transmission has been greatly diminished by serologic testing of the plasma for viruses and by sterilization of the concentrate by solvent-detergent treatment and/or heat sterilization.⁴⁶³ High-potency preparations of factor VIII can be obtained by affinity chromatography using monoclonal antibodies. Therapeutic products of r-FVIII, activated factor VII, and factor IX are available for clinical use.⁴⁶⁴ The initial (first-generation) r-FVIII products contain human albumin. Second-generation products eliminated albumin, but human and/or animal protein components are utilized in the manufacturing process. Third-generation products have removed all exogenous human and animal proteins from the manufacturing process. Other recombinant factor products are in development or in clinical trials in 2013, including products with extended half-life for factors VIII, IX, and VII.

Although modern production methods have reduced the risk of transmitting lipid-enveloped viruses (e.g., human immunodeficiency virus [HIV] and hepatitis B and C), transmission of non-lipid-enveloped viruses, such as hepatitis A and parvovirus B19, has been reported with sterilized plasma-derived products.^{465, 466, 467} Tables 53.11, 53.13, and 53.14 summarize information on currently available products used to treat hemophilia A and hemophilia B.

Prothrombin Complex Concentrates, Factor IX, and Factor VII (VIIa)

The vitamin K-dependent factors (prothrombin; factors VII, IX, and X; and proteins C and S) are avidly absorbed by aluminum hydroxide or barium sulfate and can be readily concentrated by elution therefrom. This simple procedure is the starting point for several methods of preparing therapeutically useful concentrates of these proteins⁴⁶⁸ (Table 53.15).

Concentrates of vitamin K-dependent coagulation factors contain small but significant amounts of activated coagulation factors that may be thrombogenic when administered in large doses or for extended periods of time. The thrombogenicity of such concentrates varies from preparation to preparation and from lot to lot and has been variously attributed to thrombin, factor VIIa,³²⁷ factor Xa,⁴⁶⁹ factor IXa,⁴⁷⁰ and coagulant phospholipids.⁴⁷¹ Attention has been directed to the serious and even fatal thromboembolic complications of these products, including disseminated intravascular coagulation.^{469, 472} Such complications are particularly common in infants and in patients with liver disease,⁴⁷³ as discussed in Chapter 54. The availability of monoclonally purified and recombinant factor IX products has led to decreased use of PCCs in the treatment of hemophilia B.^{474, 475, 476} PCCs are now used primarily to treat patients with inhibitors to factor VIII, a condition in which the presence of thrombogenic proteins is clinically useful.^{477, 478, 479} PCCs are also useful in treating deficiencies of prothrombin and factors VII and X. PCCs also are used for reversal of the anticoagulation effects of warfarin or the new oral anticoagulants when bleeding occurs, although their usefulness with the latter is controversial.^{480, 481}

P.1177

When treating hemophilia B with replacement factor IX products, it should be noted that factor IX distributes to both intravascular and extravascular compartments. Consequently, loading doses required to achieve 100% of the normal plasma factor IX level are usually 1.5 to 2.0 times greater than those calculated from the patient's plasma volume. Thus, when purified factor IX products are used, twice the calculated amount of factor IX should be given for the initial dose. On the other hand, PCCs are thrombogenic, and when these products are used to treat patients with hemophilia B, the dosage should be reduced below that given when the purified products are used.

Recombinant factor VIIa is being used primarily for treatment of bleeding episodes in patients with hemophilia with inhibitors,⁴⁸² but also in patients with bleeding due to refractory thrombocytopenia, platelet dysfunction, factor VII deficiency (discussed in the section Factor VII Deficiency), or severe liver disease (discussed in Chapter 54).

Detailed summaries of prior and current coagulation factor products have been published recently.^{2, 483, 484} A summary of the biologic properties of the new factor products in clinical trials in 2013 has also been published.⁴⁸⁵

Adjunctive Therapies

A congener of vasopressin, DDAVP, was originally developed for the treatment of diabetes insipidus. Its extrarenal actions stimulate vascular endothelial cells to release several proteins, including vWF in amounts sufficient to raise the plasma levels of this protein and associated factor VIII two to five times (Fig. 53.11).⁴⁸⁶ This effect is therapeutically useful in most patients with type 1 vWD⁴⁸⁷ and in some patients with mild hemophilia A,⁴⁸⁸ and it is particularly useful because the biohazards of blood products are avoided. Excellent responses were obtained in the prevention of bleeding after minor surgical procedures, such as tooth extractions, and in some major surgical procedures.^{489, 490} It has been noted that young boys with mild to moderate hemophilia A have a lower response rate to DDAVP; the response rate of these patients improves later in life, and nonresponder children are candidates for retesting when they are older.⁴⁹¹

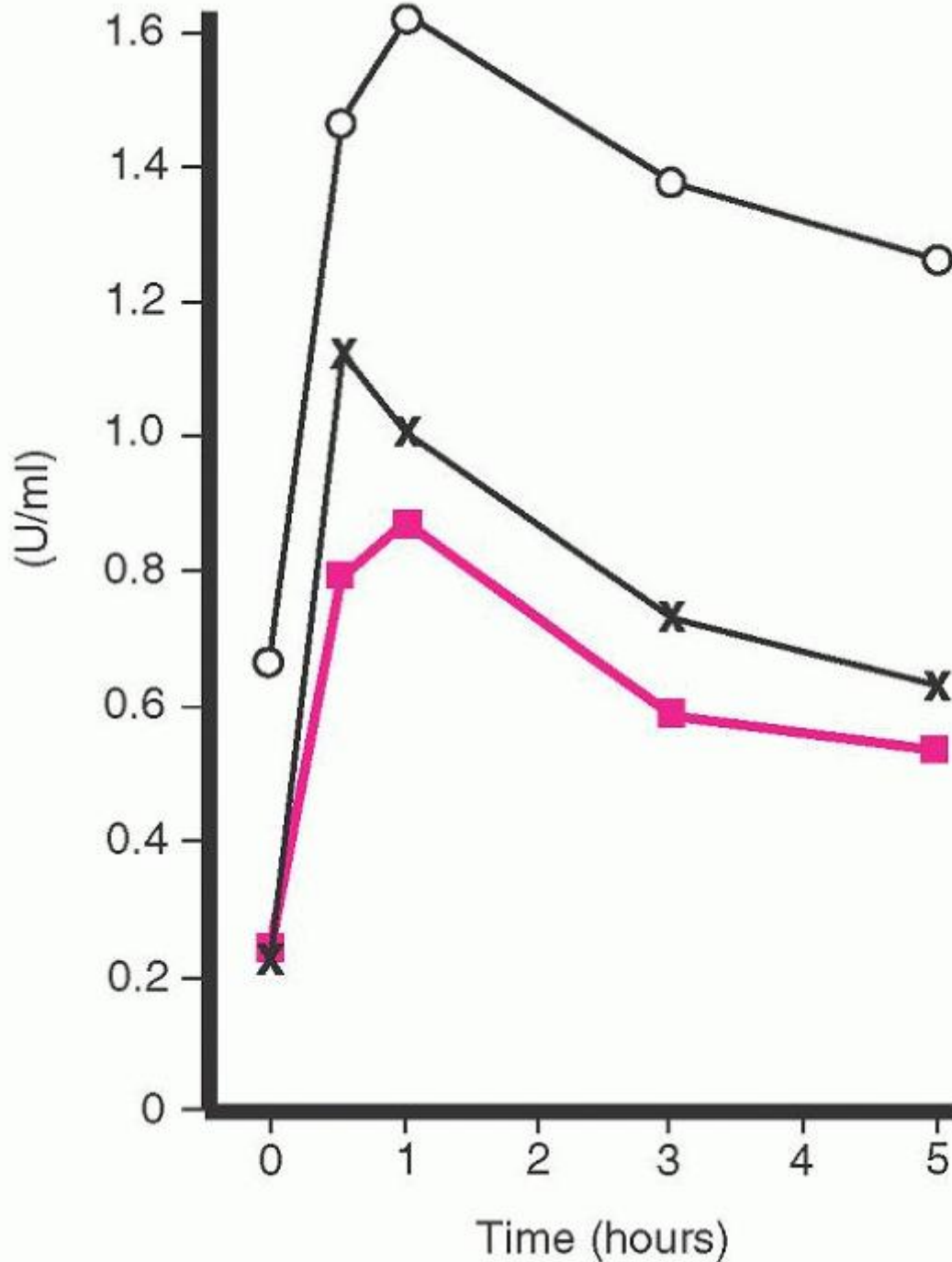

FIGURE 53.11. The response to desmopressin infusion ($0.3 \mu\text{g}/\text{kg}$ body weight) in a hemophilic patient. Open circles indicate von Willebrand factor antigen, solid boxes indicate factor VIIIc activity, and crosses indicate factor VIIIc antigen. (From de la Fuente B, Kasper CK, Rickles FR, et al. Response of patients with mild and moderate hemophilia A and von Willebrand disease to treatment with desmopressin. *Ann Intern Med* 1985;103:6-14, with permission.)

The vWF released in response to DDAVP is rich in high-molecular-weight multimers⁴⁹² that increase adhesion and spreading of platelets at injury sites. This effect may explain the therapeutic efficacy of the drug in several disorders of platelet function, including uremia.⁴⁹³

DDAVP has also been reported to be clinically useful in patients with hemophilia B.⁴⁹⁴ Although factor IX levels are minimally increased by DDAVP, the improved PTT values in hemophilia B patients given DDAVP associated with increases

in factor VIII and vWF activity probably account for drug efficacy. Another group found DDAVP useful in hemophilia B patients when combined with antifibrinolytic therapy.⁴⁹⁵

DDAVP also induces the release of endothelial cell-derived plasminogen activators and has produced exaggerated fibrinolytic phenomena in several rare cases. For this reason, it is sometimes given with ϵ -aminocaproic acid (EACA) or other fibrinolytic enzyme inhibitors. Compared to vasopressin, DDAVP is markedly less potent as a pressor agent, but does retain significant antidiuretic activity. Neither effect has proved to be a major problem in its therapeutic use, but most experienced clinicians use caution when treating patients with hypertension or congestive heart failure. Reports of hyponatremia and seizures in children less than 2 years of age have led to cautious use of DDAVP in this population. Serum sodium should be monitored in adults who receive more than 3 or 4 sequential doses of DDAVP because of the side effect of hyponatremia, and in these patients water restriction is advised. DDAVP should not be administered more than once a day, and repeated doses of DDAVP may produce progressively diminishing amounts of vWF (tachyphylaxis), presumably because of exhaustion of stored vWF. DDAVP is available in a formulation for parenteral use or by the nasal spray Stimate.^{490, 496} DDAVP can be given parenterally (0.3 μ g/kg, up to a maximal dose of 20 to 24 μ g).⁴⁹⁷ Physicians should be aware that two DDAVP nasal sprays are available, and that only the nasal spray with the higher DDAVP concentration (Stimate, 1.5 mg/ml) is effective in treating vWD. DDAVP should be used cautiously in older patients with vascular disease because of the potential risk of drug-induced thrombosis.^{497, 498, 499}

Increasing use of DDAVP has revealed certain limitations of this hemostatic drug. One report in adult patients indicated that ~20% of patients experienced toxicity with DDAVP, including nausea and headache, and symptomatic hyponatremia was seen in ~5% of patients.⁴⁹⁶ These side effects may be minimized with water restriction. Limitations of DDAVP in the pediatric population have been summarized.⁵⁰⁰

Inhibitors of fibrinolysis, such as EACA or tranexamic acid, may diminish bleeding from mucosal membranes where the concentrations of fibrinolytic enzymes are high, in patients with inherited coagulation disorders: For example, with bleeding in the mouth, tongue, tonsils, and pharynx, and with bleeding associated with operative dental procedures.⁵⁰¹ These drugs act to protect labile hemostatic plugs from fibrinolytic degradation. The use of EACA alone has been effective in the treatment of patients with mild hemophilia A (plasma levels of factor VIII >5 IU/dl)⁵⁰² and those with other mild inherited coagulation disorders such as vWD or factor XI deficiency. Some clinicians have used EACA as an adjunct to single-dose⁵⁰³ or various other factor replacement regimens. EACA should be administered in oral doses (pills or syrup) of 6 g every 6 hours to adults and 100 mg/kg every 6 hours to children, for 3 to 4 days after tooth extraction. Doses of as little as 1 g every 6 hours may be as effective in most adult patients. The drug can be given intravenously (1 g/hour) for patients who cannot swallow. Hematuria or abnormal renal function is a contraindication to the use of this drug because of the hazard of intrarenal or ureteral obstruction by blood clots.⁵⁰⁴ EACA also should not be given to patients with disseminated intravascular coagulation or active hepatitis, or to patients receiving PCCs, although an EACA mouthwash can be used with these latter drugs.^{501, 505}

P.1178

Tranexamic acid is now available; the recommended adult dosage is two 650 mg tablets orally three times daily. These drugs may be teratogenic and should be used with caution in pregnant women.

MAJOR AND MINOR BLEEDING

General treatment guidelines for patients, including newborns with hemophilia and other bleeding disorders, have been published.^{73, 505, 506} Additional detailed guidelines are available on the National Hemophilia Foundation's website, www.hemophilia.org, under Medical and Scientific Advisory Council (MASAC) recommendations.

For purposes of replacement therapy, the various bleeding manifestations commonly encountered in the inherited coagulation disorders are often divided subjectively into major and minor bleeding. Manifestations falling into the minor category include bleeding associated with uncomplicated hemarthrosis, symptomatic hematomas in noncritical areas, and minor traumatic injuries, as well as such therapeutic procedures as minor dental procedures, arthrocentesis, and dressing changes. Small cuts and scratches, removal of stitches or drains, superficial ecchymoses, and small hematomas may require no replacement therapy.

Major bleeding is by definition life-threatening and includes hematomas in critical locations and bleeding resulting from traumatic injuries, particularly those in which external blood loss is significant. Major bleeding occurs in surgical procedures, including tonsillectomy and the extraction of molar teeth. In the treatment of major bleeding, general guidelines recommend that the in vivo levels of the missing factor should be maintained above 60% to 80% to provide effective hemostasis until bleeding has stopped and appropriate healing has occurred so that there is no risk of

rebleeding. In bleeding of a particularly critical nature, such as intracranial hemorrhage, or for the prevention of excessive bleeding during neurosurgery, factor levels should be maintained at 100% of normal.

Hemophilia A Minor Bleeding

DDAVP is effective in the treatment of minor bleeding manifestations in individuals with hemophilia A with baseline factor VIIIc levels >5 IU/dl, if patients have been previously demonstrated to respond to DDAVP with therapeutic levels of factor VIIIc after administration of DDAVP.^{489, 490} Side effects are more prominent if the total dose exceeds 24 µg. Both parenteral and intranasal administration produce significant increases in factor VIIIc and vWF.⁵⁰⁷ Repeated doses of DDAVP at approximately daily intervals may produce useful increments of factor VIII in many patients. At least 24 hours should elapse before repeat administration of the drug in order for the endothelial cell stores of vWF to be replenished. Patients should be tested before surgery for their response to DDAVP by documenting adequate hemostatic levels of factor VIII levels 30 to 60 minutes after treatment, to ensure that the drug will be effective in appropriate responders. Only small amounts of factor VIII are produced by DDAVP in persons with severe hemophilia, and the use of this drug in patients with factor VIII levels <5 IU/dl is seldom useful and therefore is not recommended, even for minor bleeding manifestations. EACA (6 g orally every 6 hours) or tranexamic acid (25 mg/kg orally every 6 to 8 hours) has been administered together with DDAVP in an attempt to minimize fibrinolysis.⁵⁰¹ For maximal effectiveness, antifibrinolytic drugs should be started 24 hours prior to surgical procedures.

Although effective in minor bleeding, plasma or cryoprecipitate is not currently recommended for use in the treatment of patients with hemophilia A. Factor VIII concentrates are widely available and are the most useful therapeutic products. The regimens summarized in Table 53.10 illustrate one approach to treating hemophilia A. For some minor bleeding manifestations, treatment for a minimum of 3 days is required, but in most cases, a single dose of 10 to 15 IU/kg of factor VIII is usually sufficient.⁵⁰⁸ In the treatment of minor bleeding, loading doses are not required, and laboratory monitoring of in vivo factor VIII levels is unnecessary. The minor bleeding treatment regimens summarized in Table 53.10 typically result in peak factor VIII levels of ~30%. Occasionally, if the minor bleeding episode is not treated promptly and bleeding is prolonged, then a hematoma may form, and often additional doses of factor products at higher doses are needed to prevent continued bleeding around the hematoma and potential pseudocyst formation. It is generally recommended in such cases of delayed treatment that full (100%) doses be administered to maintain adequate hemostatic levels until the hematoma is completely resolved.

Hemophilia A Major Bleeding

To treat major bleeding in patients with hemophilia A, sufficient factor VIII must be given often enough to ensure that the blood level does not fall to <30 to 50 IU/dl for any length of time. Most experienced clinicians target trough levels of more than 50% IU/dl until bleeding has stopped and substantial healing has taken place. Maintenance doses usually are administered every 8 to 12 hours. Regimens of continuous infusion of factor VIII are being used with increasing frequency during hospitalization, and have been shown to save total factor use by as much as 30%.^{509, 510, 511, 512, 513} The administration of 2 IU/kg/hour of factor VIII produces a mean factor VIIIc level in the plasma of ~50 IU/dl and appears to be more cost-effective than twice-daily intravenous bolus treatments.⁵¹⁴ Continuous infusion also has the advantage of maintaining a consistent, therapeutic factor level. It is important to note that the treatment of postsurgical or major traumatic hemorrhage in patients with mild hemophilia A requires nearly as much therapeutic product as is needed for the severely affected patient. Many authors recommend treatment for 10 to 14 days after major surgical procedures, whereas others administer the full doses indicated in Table 53.10 for 10 days and continue half-doses for longer periods as healing continues and the patient is undergoing increasingly active physical therapy, especially after major orthopedic surgeries.

Determination in the laboratory of the in vivo levels of factor VIIIc is recommended during the treatment of patients with major hemorrhage. Incidents of unexpected subtherapeutic responses to infused factor VIII have been reported.⁵¹⁵ The use of the PTT to guide factor VIII replacement therapy is not recommended, because the results of these tests may be normal at levels of factor VIII that do not provide adequate hemostasis.⁷⁴

von Willebrand Disease

In a disease as heterogeneous as vWD, decisions about treatment begin with accurate diagnosis (including vWD subtype) and complete evaluation. Fortunately, in many patients with vWD, bleeding manifestations are mild, and replacement therapy is seldom required. Unlike the situation in hemophilia, in which there is a close correlation between factor levels and clinical outcome, treatment decisions are more complicated in vWD because it is unclear which measurement (vWF, factor VIII, or platelet function) correlates best with the severity of bleeding or clinical outcome.¹²⁷ Many experts recommend following vWF:RCo and factor VIII levels,⁵¹⁶ but little information exists about the level of vWF:RCo that is

critical for control of mucosal bleeding or the prevention of surgical bleeding. Bleeding times may not normalize, but a normal bleeding time is not required for a satisfactory response, and monitoring of bleeding time is not recommended.¹⁵⁵ Therapeutic goals include resolution of active bleeding and prevention of excessive bleeding in response to invasive procedures or trauma.

P.1179

Unlike the situation with hemophilia A or B, chronic prophylaxis therapy is rarely required, but should be considered in patients with type 3 vWD who have recurrent gastrointestinal or joint hemorrhage.

The spectrum of therapeutic interventions in vWD includes desmopressin (DDAVP), concentrate infusion, and adjunctive therapy with medications that modulate bleeding symptoms by affecting either menstrual pattern or fibrinolysis. Dosing recommendations in vWD are empiric. In the case of a patient with major surgery or trauma, one recommendation is that clinicians attempt to bring the vWF (and factor VIII) level to near 100 IU/dl, and maintain it >40 to 50 IU/dl for the first 3 to 5 days, after which one recommended goal is to maintain the factor VIII level at >40 IU/dl for a total of 7 to 10 days or until healing is completed.¹⁵⁵ In surgical settings, monitoring of factor levels seems prudent, but monitoring of the bleeding time is discouraged, as surgeries have been done successfully in patients with type 3 vWD in the face of only partial correction of bleeding time.¹⁵⁵

DDAVP is the mainstay of treatment for patients with mild forms of type 1 vWD.¹⁵⁵ The dosage, route of administration, and contraindications described under the discussion of hemophilia A also apply to the use of the drug in vWD. vWF and factor VIII levels generally increase by two- to fourfold over baseline. Because responsiveness to therapy between patients is variable, a test dose given at the time of diagnosis or before elective surgery is advised. Obtaining both vWF:RCo and factor VIII levels 1 hour after DDAVP administration is recommended in order to confirm a patient's responsiveness. It may also be informative to obtain a second sample between 2 and 4 hours after DDAVP to confirm that vWF has the expected 8- to 10-hour half-life after release.¹⁴⁷ Concerns regarding tachyphylaxis, hyponatremia, and rare thrombotic complications are similar to those when treating patients with hemophilia A. Note that whereas patients with type 1 vWD are likely to have a satisfactory response, patients with non-type 1 vWD respond poorly or unpredictably to DDAVP. Type 3 patients have essentially no endogenous vWF synthesis, and are DDAVP-nonresponsive. In one large series of patients with type 2B vWD, the platelet count fell from an average of 86,000 to 60,000/ μ l after administration of this drug.²¹⁰ Because thrombocytopenia may worsen after administration of DDAVP to patients with type 2B vWD and the platelet-type form of the disorder, patients with these variants should not be treated routinely with DDAVP.¹⁵⁵ However, some authors report good-responder type 2B vWD patients who received DDAVP.⁵¹⁷ Response in type 2A vWD is variable and may be of shorter duration than in type 1 patients, because of increased vWF proteolysis. Similarly, factor VIII levels may rise in response to DDAVP in patients with type 2N vWD, but because of the deficient factor VIII-stabilizing activity of vWF in this variant, levels of factor VIII then fall at an accelerated rate.⁵¹⁸ Because of interindividual variability, a documented therapeutic response to DDAVP should be obtained before surgical prophylaxis with the drug, to ensure adequate hemostasis postoperatively. It is recommended that this DDAVP trial be performed at the time of diagnosis of vWD.

Transfusion therapy with plasma-derived products is the therapy of choice in DDAVP-unresponsive patients who require factor support. In order to treat both the factor VIII deficiency and the defect in primary hemostasis seen in patients with severe vWD, it is generally necessary to give a product with factor VIII activity that also contains high-molecular-weight multimers of vWF. The concentrations of vWF and factor VIII in FFP are insufficient for appropriate therapy. Cryoprecipitate contains ~80 to 100 units/bag, 5 to 10 times the concentration of these factors compared to plasma. Cryoprecipitate has a small residual risk of viral transmission and is not currently suited for virus-inactivation therapy; consequently, pathogen-inactivated, intermediate-purity factor VIII concentrates with demonstrated preservation of vWF multimers are the preferred replacement product. At the time of this writing, three commercial plasma-derived products were licensed in the United States for this indication (Humate-P, manufactured by CSL Behring and known as Haemate-P in Europe; Wilate, manufactured by Octapharma; and Alphanate SD/HT, manufactured by Grifols) (Table 53.12). Several other commercial products have been developed and are currently licensed in other countries. A Canadian multicenter study confirmed "excellent" or "good" outcomes in 97% of patients treated with Humate-P, with a median recovery of 1.23 IU/kg per IU/kg infused.⁵¹⁹ Similarly, Alphanate was shown to ultimately control all bleeding episodes in one large multicenter trial.⁵²⁰ Alphanate is currently not licensed for treatment of vWD; it is labeled only in factor VIII units, but vWF:RCo has been reported to be ~50% lower than the labeled factor VIII content.⁵²⁰ A PK clinical trial compared Wilate vs Humate-P and found similar PK parameters for the two products; however, Wilate achieved a 1:1 ratio for vWF:factor VIII, suggesting simpler dosing of Wilate.⁵²¹ A chromatographically purified vWF concentrate with minimal factor VIII (Wifactin) has been evaluated in type 3 vWD. After infusion, factor VIII levels rise slowly and peak ~6 to 8 hours later. These data

imply that if type 3 patients are to be pretreated for surgery with a pure vWF-containing concentrate, either concomitant factor VIII will need to be administered, or the surgery should be scheduled for 6 to 8 hours after the vWF administration.^{155, 203} Very-high-purity plasma-derived factor VIII concentrates and r-FVIII concentrates are essentially devoid of vWF, and they should not be used to treat vWD.

Suggested doses and target factor levels for treatment of vWD patients have been published.^{129, 522} Recommended doses in ristocetin cofactor units are similar to factor VIII doses, because both have similar in vivo recovery (~2 IU/dl rise in plasma concentration for each IU/kg of factor administered). Monitoring response to therapy with both factor VIII and vWF:RCo is appropriate. Although vWF levels can be expected to fall between doses of vWF-containing concentrate, which has a half-life of 8 to 10 hours, factor VIII levels may continue to rise in response to the patient's endogenous factor VIII production. Avoidance of unusually high factor VIII levels is suggested in order to minimize venous thrombotic risk.⁵²³

Platelets are estimated to contain ~15% of the total body vWF. Some authors suggest using platelet transfusion in patients with severe vWD who exhibit bleeding despite plasma factor VIII concentrate therapy.¹⁵⁵ Thrombocytopenia may be exacerbated by the administration of normal exogenous vWF in platelet-type (pseudo) vWD,⁵²⁴ but not in type 2B vWD. Patients with platelet-type vWD should receive platelet transfusions for significant bleeding or surgery.

Adjunctive therapy for vWD patients with menorrhagia usually takes the form of oral contraception or other hormonal intervention.¹⁵⁵ Antifibrinolytic therapy and DDAVP have also found a role in control of menorrhagia^{501, 525} and oral bleeding. Doses of intranasal DDAVP administered every 12 to 24 hours for up to 3 days, or ϵ -aminocaproic acid up to 5 g three times per day, or tranexamic acid, have been reported to be useful in control of menorrhagia,¹²⁷ but toxicity profiles should also be considered. Failure of medical therapy may lead to surgical approaches, such as endometrial resection or even hysterectomy.

Pregnancy is a special situation for patients with vWD. vWF levels generally improve in patients with type 1 vWD as pregnancy proceeds, but improvement is less likely in type 2A vWD, and thrombocytopenia may actually worsen in patients with type 2B and platelet-type (pseudo) vWD variants. Current information indicates that the patient's factor VIIIc at delivery predicts the risk of bleeding, with a factor VIII level <50% of normal at term being associated with excessive bleeding.⁵²⁶ If sufficient factor VIII levels are achieved, aggressive surgical hemostasis and efficient uterine contraction should prevent peripartum bleeding. Thus, factor levels should be determined before delivery. If sufficient

P.1180

factor VIII levels are not achieved before delivery and the patient is known to respond to DDAVP, this drug can be given to the mother immediately postpartum. If the patient does not respond to DDAVP, then vWF/factor VIII concentrate should be administered peripartum. Although endogenous vWF levels rise during pregnancy in patients with type 1 vWD, the vWF levels fall quickly after parturition, and patients should be advised to report late bleeding. DDAVP or replacement therapy may be useful to prevent late bleeding in patients with vWD. Finally, unlike type 1 vasopressin agonists, DDAVP has little or no oxytocic activity, and some authorities have advocated prophylactic use before invasive diagnostic or surgical interventions in pregnant vWD patients.¹⁵⁵

Alloantibodies to vWF develop in a minority of patients with type 3 vWD after replacement therapy. The risk appears to be highest in patients with large gene deletions. Administration of vWF-containing concentrates to these allosensitized patients has been associated with anaphylactic reactions. Alternative therapies that have been successful include high-dose r-FVIII administered by continuous infusion at doses of 700 to 900 IU/kg/day,¹²⁷ or recombinant factor VIIa. Patients with acquired vWD (see Chapter 54) have broader therapeutic options, because DDAVP and replacement therapy may have some efficacy, as would treatment of the underlying disease process.

Hemophilia B Treatment

Most of the guidelines for replacement therapy of patients with hemophilia A apply to the treatment of those with hemophilia B (Table 53.10). Because of the low initial in vivo recovery and the rapid initial disappearance of factor IX from the circulation, higher initial doses are recommended, even for the treatment of minor bleeding. In patients with hemophilia B, purified factor IX concentrates or recombinant factor IX products are recommended for the treatment of major or minor hemorrhage because of the thrombotic potential of PCCs^{469, 472} (Table 53.14). One disadvantage of recombinant factor IX compared to plasma-derived factor IX is a lower in vivo recovery of recombinant factor IX (~30% lower than predicted), perhaps related to different posttranslational modifications of the recombinant protein.⁵²⁷ Higher doses of recombinant factor IX need to be given routinely to achieve similar therapeutic levels, and monitoring factor IX levels with this product should be done routinely,⁵²⁸ especially in young children.⁵²⁹ These concerns about in vivo recovery do not seem to apply to the new extended half-life factor IX products in clinical trials in 2013.^{454, 455, 530}

An unusual complication of hemophilia B therapy is anaphylaxis. These patients typically have severe factor IX deficiency with complete gene deletions.^{531, 532} The anaphylaxis typically occurs with the first or second administration of factor IX, and essentially never with subsequent infusions if the initial doses are tolerated well. These patients rarely respond to immunetolerance induction, and should be treated with either PCCs or recombinant factor VIIa (see Chapter 54).

Gene Therapy for Hemophilia

Gene therapy for the inherited bleeding disorders is now promising, after many years of frustrating failures.^{533, 534, 535} A major success was recently published involving patients with severe factor IX deficiency.⁵³⁶ Six of six subjects with severe hemophilia B were treated with adeno-associated viral vector carrying a normal factor IX gene, and have had factor IX levels of 2% to 4% for many months. While this is encouraging, there need to be additional studies with more subjects to evaluate safety and efficacy of gene therapy in hemophilia.⁵³⁷ Work with the factor VIII gene for viral delivery is more complex because of its much larger size. Viral and nonviral constructs containing genes for factor VIII or factor IX have been used, as well as modified retrovirus, adenovirus, or adeno-associated virus vectors. Sustained partial correction of factor VIII or factor IX deficiency has been seen with gene transfer in animal models, and it is expected that with additional work, these encouraging results will be seen in patients also. A major focus of gene therapy research is to develop a gene delivery system that is efficient, safe, nonimmunogenic, and provides longterm gene expression.^{538, 539} The promise for gene therapy lies in the fact that if gene therapy could increase endogenous factor VIII or factor IX levels only from <1% to 1 to 2 IU/dl, this incremental change would dramatically alter the clinical course and treatment of patients with severe hemophilia. Significant questions about potential risks associated with gene therapy, including inflammatory responses, inhibitor development, oncogenesis, and germline mutations will need to be addressed as further clinical trials are undertaken.⁵⁴⁰

Factor VII Deficiency

Unlike in patients with severe hemophilia A or B, bleeding in a patient with factor VII deficiency undergoing surgery is variable, so multiple issues should be considered in the perioperative care of factor VII-deficient patients,^{541, 542, 543} including the individual patient's prior experiences and symptomatology: Patients with a history of hemarthrosis or CNS hemorrhage are at a higher risk for bleeding complications. The oral and urogenital tracts are areas of high local fibrinolytic activity. The minimum factor VII level required for surgical hemostasis is not known; patients with levels <3 IU/dl are at high risk for bleeding, whereas patients with levels of 15 to 25 IU/dl are less likely to develop bleeding complications associated with surgery. Finally, one should consider the logistics of therapy, because factor VII has a short half-life, possibly as short as 3.5 hours. Volume overload is likely, as plasma is commonly used as a source for factor replacement, and the safety profile of the various factor VII-containing products varies.

Traditionally, FFP, PCCs, or plasma-derived factor VII concentrate has been used for factor VII replacement therapy, and more recently, recombinant human activated factor VIIa (rFVIIa) has been the recommended product.^{544, 545, 546, 547, 548, 549, 550} In general, doses of between 15 and 30 µg/kg of rFVIIa were administered at intervals of 4 to 6 hours. The half-life of recombinant factor VIIa is between 2.5 and 3 hours, and the roles of continuous factor infusion and laboratory monitoring remain to be defined in treating factor VII-deficient patients.⁵⁵¹ Antibody to factor VII has developed in response to therapy in some individuals with congenital factor VII deficiency.⁵⁵¹ Although serious thrombotic events have been reported when rFVIIa has been used in an attempt to control bleeding in the setting of acquired coagulopathy,⁵⁵² only three reports of serious thrombotic complications were collected in a recent review of rFVIIa use to treat congenital factor VII deficiency. Furthermore, at least two of those three cases were managed using higher doses of rFVIIa than are recommended here. The risk of thrombosis should be considered when rFVIIa is being used, especially when treating a condition that itself is associated with thrombosis, such as orthopedic surgery.⁵⁵³

Although the half-life of factor VII is short, both factor VII and, more recently, rFVIIa infusions have been successful in chronic infusion prophylaxis programs to prevent spontaneous CNS and joint bleeding. Factor VIIa was administered every other day or twice weekly, suggesting that an additional mechanism of action independent of the short plasma half-life was operative in these cases.

Although it is no longer the "product of choice," plasma can be used for replacement therapy for factor VII in emergency situations when other products are not available. Plasma has the disadvantage of posing a large volume load and has potential for viral transmission. For patients treated with plasma, a loading dose of 15 to 20 ml/kg, followed by 4 to 6 ml/kg every 6 hours for 7 to 10 days has been recommended. Plasma exchange therapy has been used in some patients to avoid volume overload.⁵⁵⁴ PCCs

have been used, but they too are not the product of choice. PCCs carry some thrombotic risk, which may be associated with the generation of unnecessarily high levels of other activated vitamin K-dependent coagulation proteins.⁵⁵⁵ This is especially a problem with extended PCC use or use of PCCs in the setting of liver disease. Those products are not generally labeled with their factor IX content, but the factor VII content is usually available from the manufacturer. Recovery studies indicate that an administered factor VII dose of 1 IU/kg will raise the patient's plasma factor level by ~2 IU/dl. If it is available, the use of purified factor VII concentrate might decrease the thrombotic risk associated with the use of less-specific PCCs. A heat-treated intermediate-purity factor VII concentrate (manufactured by Immuno A.G.) had been used for treatment of acute bleeds, perioperative prophylaxis, and for prevention of recurrent CNS hemorrhage. Factor VII levels rose ~2.33 IU/dl for each IU/kg infused, and the factor VII half-life was ~6 hours. Despite the short half-life of factor VII, infusions as infrequent as once per week were successful in preventing recurrent intracranial bleeding.³³⁶ For replacement therapy in a surgical setting, factor-level monitoring is recommended, to ensure that perioperative factor levels are >25 IU/dl.

Factor XIII Deficiency Treatment

Therapy for congenital factor XIII deficiency is based on the principle that only a small quantity of factor XIII must be present in human plasma to promote normal hemostasis.⁵⁵⁶ The long half-life of factor XIII (estimated as being between 9 and 19 days in the literature⁵⁵⁷) makes prophylactic therapy both practical and highly advisable given the high frequency of intracranial hemorrhage.²⁸⁴ This long half-life may not be present in some situations in newborn infants with severe FXIII deficiency.⁵⁸⁸ FFP and factor concentrates have been used successfully to prevent factor XIII-associated bleeding, and these remain the treatment of choice. Pasteurized factor XIII concentrate that contained only the A subunit prepared from human placenta has been replaced by plasma-derived preparations that contain both A and B subunits.⁵⁵⁹ A plasma-derived factor XIII preparation is available (Corifact, CSL Behring, Table 53.16) to treat congenital factor XIII deficiency. Recommended dosing is 40 IU/kg every 4 weeks with dose adjustments based on achieving a trough level of 5% to 20%. Two other preparations that have been used therapeutically are Fibrogammin-P, which is licensed in several countries (but not the United States or Canada), and a factor XIII preparation from Bio Products Laboratory that has been used in the United Kingdom. Kinetic studies with Fibrogammin-P indicate a mean recovery of 65% and a plasma half-life of ~5 to 11 days.^{560, 561} A recombinant factor XIII concentrate composed of the A subunit has been developed and is currently undergoing clinical investigation.⁵⁶² Recommended dosing for factor XIII concentrate is 10 to 20 IU/kg body weight every 4 to 6 weeks for prophylaxis against unprovoked bleeding. It is strongly recommended that all patients with severe factor XIII deficiency be placed on life-long prophylaxis in order to prevent the devastating complication of intracranial hemorrhage. Prophylactic therapy of affected patients undergoing surgery may actually require more intensive replacement therapy. If concentrates are unavailable, patients can be given either FFP or cryoprecipitate.⁵⁶³ A typical plasma dose is 10 to 20 ml/kg body weight, every 4 to 6 weeks. Cryoprecipitate at a dose of 1 bag per 10 to 20 kg of body weight every 3 to 4 weeks is an alternative therapy that has the advantage of requiring transfusion of a smaller volume. It is recommended that factor XIII levels be kept between 25% and 50% of normal to achieve normal hemostasis following major trauma in these patients; doses of concentrate recommended are 35 IU/kg preoperatively, followed by 10 IU/kg/day for 5 more days. Affected patients with a history of spontaneous abortions can complete a normal pregnancy when they are managed with prophylactic FFP or factor XIII concentrates. Factor XIII levels fall during pregnancy, and replacement therapy is recommended every 21 days.⁵⁶⁴ Monitoring of factor XIII trough levels may also be helpful. Formation of antibody inhibitors to factor XIII after replacement therapy appears to be rare.

In acquired factor XIII deficiency, >50% of patients need aggressive therapy. The most useful therapy for patients who have acquired inhibitors to factor XIII remains plasma exchange with or without immunosuppression with cytotoxic drugs. In addition, infusions of platelets can be given with occasional success, because platelets contain large amounts of factor XIII. Alternatively, replacement therapy with a factor XIII concentrate can be considered.

Treatment Considerations for Miscellaneous Disorders

Therapeutic regimens recommended for the treatment of patients with any of the less common inherited coagulation disorders are summarized in Table 53.8.

The management of major bleeding caused by deficiencies of prothrombin and factor X has been facilitated by the availability of PCCs (Table 53.15). The majority of these plasma-derived products contain three factors (prothrombin, factor IX, and factor X), but four-factor concentrates are also available.⁴⁸¹ Factor IX content has generally been used to label the potency of these concentrates, but factor content of the other vitamin K-dependent factors relative to the factor IX content is often available, either in published reports⁴⁸¹ or from the manufacturer. The currently available PCC products are subjected to virus-attenuation steps to inactivate hepatitis B, hepatitis C, and HIV. However, the thrombogenicity of

these products remains a concern,^{469, 472} and concomitant use of antifibrinolytics may increase that risk. In the absence of a specific factor concentrate, plasma transfusion may also be used to replace vitamin K-dependent coagulation factors.

There are few data on which to base recommendations on treating the rare bleeding disorders. It is estimated that 1 IU/kg of infused PCC will raise the prothrombin level by 1 IU/dl. Relatively low levels of prothrombin are required for normal hemostasis, and target values of 40 to 50 IU/dl are recommended for surgery. The half-life of prothrombin is ~72 hours, so infrequent postoperative infusions, every 2 to 3 days, is reasonable.⁵⁶⁵ Guidelines for the treatment of factor X deficiency vary. The biologic half-life of factor X is 20 to 40 hours. Calculation of the factor X dose is based on the empiric observation that for each 1 IU/kg infused, factor X levels rise ~1.5 IU/kg. Factor X levels varying from 5 IU/dl to as high as 40 IU/dl have been recommended for surgery; however, levels >20 IU/dl were suggested by the United Kingdom Haemophilia Centre Doctors' Organisation.²³⁶ Monitoring of the factor level achieved is prudent.

There are currently no factor V concentrates, so patients with factor V deficiency who require replacement therapy are treated with transfusions of plasma. Target levels of factor V recommended before surgery vary. The United Kingdom Haemophilia Centre Doctors' Organisation recommend target levels >15 IU/dl, whereas others have suggested levels of 25 to 30 IU/dl.²³⁶ The half-life of plasma factor V is reported to be 12 to 36 hours. In the United States, some blood collection organizations are moving away from production of FFP, toward production of plasma that is separated and frozen within 24 hours after collection (FP-24). Although factor V has been called "labile factor," levels of factor V in FP-24 are only modestly reduced compared to those in FFP.⁵⁶⁶ In addition, factor V appears to be relatively stable in "thawed plasma" held up to 5 days in transfusion service refrigerators at 0-4°C.⁵⁶⁷ Loading plasma doses of 20 ml/kg are often given, followed by maintenance infusions of 3 to 6 ml/kg every 12 hours. Cryoprecipitate does not contain sufficient factor V to be used as an alternative to plasma. If adequate factor V levels cannot be achieved by simple transfusion, exchange transfusion may be

P.1182

tried. Finally, in the setting of acquired factor V autoantibody, platelet transfusion has been used successfully. Similarly, platelet transfusion might hold some promise in treatment of a patient with congenital factor V with alloantibody.²³⁶

Patients with factor XI deficiency usually respond well to FFP. A solvent-detergent plasma preparation has been developed⁵⁶⁸ and may be the desired therapy not only for factor XI deficiency, but for other factor deficiencies for which sterile concentrates are not available. Unfortunately, some of the factor XI concentrates were shown to be thrombogenic in early clinical studies,²³⁶ and their clinical utility may be limited by this toxicity.

Cryoprecipitate is used in replacement therapy for afibrinogenemia, hypofibrinogenemia, and dysfibrinogenemia. When a sterile, nonthrombogenic fibrinogen concentrate becomes routinely available, it should replace cryoprecipitate for treating these latter disorders. Such a product is in clinical trial.²⁴¹ Fibrinogen replacement therapy has been reviewed.²⁴¹

SPECIAL ASPECTS OF TREATMENT

Hemarthrosis

All patients with hemarthrosis should receive adequate replacement therapy in order to prevent the development of permanent disability due to repeated bleeding into a joint. Pain usually is relieved promptly and is a reliable index of the therapeutic response. Supportive therapy follows the acronym of RICE: Rest through immobilization, ice to cool the inflammation and reduce the swelling, compression to reduce the swelling and bleeding, and elevation to reduce the swelling. The administration of analgesics that do not interfere with platelet function is appropriate to relieve the pain of bleeding into the joint.

Arthrocentesis usually is unnecessary if therapeutic infusion is accomplished early, but it may be of significant benefit when the joint is severely distended or when resolution of the hemarthrosis is delayed despite adequate replacement therapy.⁵⁶⁹ Large volumes of blood seldom can be aspirated, but even a small volume may relieve symptoms. If arthrocentesis is performed, it should be done immediately after the administration of a therapeutic dose of factor.

Early physiotherapy aimed at restoring the full range of motion of the affected joint should be instituted as soon as the acute stage of hemarthrosis has resolved. More energetic physiotherapeutic techniques should be carried out only in conjunction with an adequate course of replacement therapy. Various orthopedic devices (orthotics), such as braces and removable bivalve plaster casts, which provide additional support for chronically injured joints, have proved useful in reducing the frequency of recurrent hemarthrosis, particularly in the knee and ankle joints.⁵⁷⁰ For pain management of hemophilic arthropathy, nonsteroidal antiinflammatory agents may be helpful.⁵⁷¹ In particular, salsalate (Disalcid) or

choline magnesium trisalicylate (Trilisate) or the newer cyclo-oxygenase-2 inhibitors (Celebrex) may be useful in patients with bleeding disorders, because these drugs have antiinflammatory activity but do not impair platelet function.^{572, 573}

Regular infusions of factor concentrates may prevent or significantly delay progression of hemophilic arthropathy. A randomized clinical trial in boys demonstrated the markedly better results of a prophylaxis program versus episodic treatment on long-term joint function.⁵⁸ This study demonstrated a significant reduction in joint damage and other bleeding episodes in the prophylaxis group. Similar results would be expected in adult patients also, but have not yet been demonstrated in a rigorous clinical trial.

Prophylaxis therapy is regarded as optimal treatment for patients with severe hemophilia. One report compared two prophylaxis regimens for hemophilia A—standard prophylaxis (20 to 40 IU/kg every other day) vs. PK-tailored prophylaxis (20 to 80 IU/kg every third day). Annualized bleeding rates, factor consumption, and adverse events were similar.⁵⁷⁴

Reconstructive surgical procedures are available to improve the function of chronically damaged joints.^{61, 575, 576} Favorable results have been reported with total knee arthroplasty in several series.⁵⁷⁶ Long-term follow-up (>5 years) indicates adequately functioning prostheses and persistent pain relief in most patients. Synovectomy is effective in reducing the frequency of hemarthrosis that cannot be controlled by replacement therapy.⁵⁷⁷ Radioisotopic synovectomy is also effective therapy for hemophilic arthropathy.⁵⁷⁸ A review of the literature on radioisotopic synovectomy indicates that ~80% of patients benefit from the procedure,⁵⁷⁹ but an updated safety review identified two patients who subsequently developed acute lymphocytic leukemia.⁵⁸⁰ While not statistically significant, this report raises a safety question, and until more data and long-term follow-up is obtained, radioisotopic synovectomy should be considered carefully in the context of each patient's needs.

Hemophilic Cysts

Hemophilic cysts are very rare with modern treatment, but once were a serious complication that developed in patients with severe hemophilia A or B that had recurrent bleeding with inadequate treatment. Also known as hemophilic pseudotumors, such cysts are gradually expanding blood-filled loculations that apparently originate from hemorrhages into confined subperiosteal, tendinous, or fascial spaces. The osmotic pressure created by breakdown products of blood in such confined spaces may produce further influx of fluid; this, together with recurrent bleeding, explains the progressive increase in the size of the cyst and its ability to erode contiguous structures. Such cysts most commonly develop in the thigh and may destroy bone as well as the soft tissues as they increase in size. Hemophilic cysts are readily prevented, but difficult to treat. Although long-term replacement therapy combined with x-ray treatment has been successful in a few cases,⁵⁸¹ hemophilic pseudocysts may require radical surgical procedures such as extensive resections or amputations. Even with optimal supportive therapy, these procedures often are unsuccessful and may be complicated by infection. Surgical and nonsurgical approaches to manage pseudotumors have been reviewed.^{582, 583} The modern use of home prophylaxis has made pseudotumors an unusual complication of hemophilia, although they still occur in parts of the world that do not have access to prophylaxis treatment of hemophilia.

Intracranial Bleeding

Despite the widespread use of prophylaxis programs, hemorrhage, including intracranial hemorrhage, remains a leading cause of death among persons with hemophilia.⁵⁸⁴ After the neonatal period, intracranial hemorrhage affects 3% to 10% of hemophilia patients not receiving prophylaxis.⁵⁸⁵ An estimate of the incidence of intracranial hemorrhage placed the risk at 1 in 200 per year, proportional to the time spent with factor levels below 1 IU/dl.⁵⁸⁵ A mortality survey for hemophilia A for the years 1995 to 1998 found that hemorrhage was the listed cause of death for 22% of hemophilia A patients who died during that time period.¹¹ Approximately 50% of cases are associated with head injury⁵⁸⁶; the etiology is not apparent in 38% of cases (spontaneous cases).⁵⁸⁷ Bleeding may be subdural, epidural, or intracerebral. Subarachnoid bleeding occurs least commonly, but it carries the best prognosis. Hemorrhage also may develop in the spinal cord or spinal meninges. In cases associated with head trauma, the presence of a lucid interval and the absence of localizing neurologic signs at the time of presentation are commonly seen.⁵⁸⁷

Significant head injury must be treated early and intensively in patients with inherited coagulation disorders. Those with

P.1183

hemophilia A and B should immediately receive sufficient factor product to raise the plasma level of deficient factor to 100 IU/dl. Samples for essential coagulation studies should be drawn before administration of replacement therapy, but treatment should not be delayed while waiting for results of these studies. Radiologic procedures, such as computed tomography scanning, should be performed after the therapeutic product is administered. If it is performed expertly,

lumbar puncture usually can be carried out without serious risk, but many clinicians prefer to wait until replacement therapy has been given. In one series, replacement therapy given within 6 hours of head injury prevented any intracranial bleeding.⁵⁸⁸

In cases involving major cranial trauma, if neurologic signs or symptoms develop, or if intracranial bleeding is confirmed radiologically or otherwise, the administration of factor VIII or factor IX concentrates should continue on a schedule in doses sufficient to keep the nadir levels of the deficient factor >30 IU/dl. Treatment should be maintained for 10 to 14 days.⁵⁸⁷ Before the widespread use of factor VIII concentrates, the mortality rate after intracranial bleeding was greater than 70%.⁵⁸⁶ For treatment of patients who have suffered from an episode of spontaneous intracranial hemorrhage, most experts recommend prophylaxis therapy so that the factor level rarely is below 1 IU/dl, as the risk of recurrence is significantly higher in such patients. It is expected that the morbidity and mortality of intracranial bleeding will be reduced further with the increased use of the extended half-life factor products currently in phase 3 clinical trials.

Viral Transmission from Past Factor Concentrates: HIV and Hepatitis C

Acquired immunodeficiency syndrome (AIDS) was first recognized in 1978 and was found to be transmitted in blood products in the early 1980s,⁵⁸⁹ infecting approximately 70% of persons with severe hemophilia using factor concentrates prior to 1984. HIV transmission through factor concentrate was reduced to zero after 1985, through the development of factor concentrates including virucidal steps in the manufacturing process, the institution of stringent donor testing, and the availability of recombinant products. Improvements in therapy for HIV have allowed many persons with hemophilia to become long-term survivors, although there remain many seropositive patients who have not progressed to AIDS.

In the United States mortality survey of hemophilia A patients between 1995 and 1998, liver disease was listed as a cause of death in 15% of patients.⁵⁹⁰ It is estimated that approximately 90% of persons with severe hemophilia who used factor concentrates prior to 1984 were infected by the hepatitis C virus transmitted in the factor concentrate.⁵⁹¹ Nearly 20% of these individuals were able to eradicate the virus, thus becoming hepatitis C antibody positive, but hepatitis C virus negative. However, for other patients, the hepatitis C virus has progressed inexorably with many dying from chronic liver disease. Liver biopsies confirmed the presence of chronic active hepatitis in many patients.⁵⁹² The disorder is usually the result of persistent infection with the hepatitis C virus, but may be complicated in some individuals by coinfection with hepatitis B.^{593, 594} A prospective study of U.S. hemophilia patients found that 66% of the hepatitis C-infected hemophilia patients also had HIV infection,⁵⁹¹ and that coinfection was associated with a five- to sixfold increase in endstage liver disease. Modern manufacturing methods render factor concentrates free of hepatitis C virus and other lipid-enveloped viruses. No hepatitis C viral transmission has been connected with factor concentrates since 1986. Patients who are seronegative for the hepatitis A and B viruses should receive immunizations for these viruses. However, standard solvent-detergent-inactivated products may still transmit non-lipid-enveloped viruses such as parvovirus,⁵⁹⁵ hepatitis A,⁵⁹⁶ and other viruses.⁵⁹⁷ An unresolved issue is the transmission potential of the agent that causes Creutzfeldt-Jakob disease, but the manufacturers of plasmaderived factor concentrates have taken steps to reduce the risk of transmitting this agent also.^{598, 599, 600}

Antibodies to Coagulation Factors

A major problem with current therapeutic products in hemophilia A is the development of neutralizing antibodies (inhibitors) to factor VIII. This complication is less common in patients with hemophilia B and other inherited coagulation disorders. Such antibodies may seriously complicate the treatment of these patients (see Chapter 54).

Home Treatment Programs

In general, current recommended therapy of hemophilia is replacement therapy or prophylaxis treatment to prevent any spontaneous bleeding episodes, rather than treating bleeding episodes after they occur, termed "on demand." A prospective randomized clinical trial has demonstrated that joint damage is minimized if treatment is begun immediately after the onset of symptoms.⁵⁸ The availability of factor VIII concentrates that are stable in home refrigerators led to the development of various early home-care programs.⁶⁰¹ Parents and patients are trained to administer the product at the first sign of bleeding. Such programs have resulted in decreased bleeding episodes and improved preservation of joint function.^{602, 603} Typical prophylactic regimens are 25 to 40 IU/kg of factor VIII three times per week for hemophilia A, and 25 to 40 IU/kg of factor IX twice per week for hemophilia B. Such therapy usually maintains the trough factor level at or above 1% of normal. In older hemophilia patients with significant joint arthropathy, higher doses often are needed, while in younger patients with essentially normal joints, the lower factor doses are sufficient. A 30-year follow-up report confirmed the efficacy of prophylaxis.⁶⁰⁴ An economic analysis of prophylaxis found that although higher costs were associated with prophylaxis programs, the approach was justified on medical grounds.⁶⁰⁵ It is recommended that patients begin prophylaxis soon after the first joint bleed.⁶⁰⁶

In 2013 there were at least 3 new factor VIII products and 3 factor IX products with extended half-lives in clinical trials. There have been no safety issues demonstrated so far in this clinical trial experience. These new products should dramatically improve the treatment of patients with hemophilia by simplifying prophylaxis regimens.

Dental Care

Special attention should be given to preventive dental care in patients with coagulation disorders, so as to minimize the complications, expense, and hazards of operative dental procedures. The extraction of even a single tooth usually requires replacement therapy. Most authorities recommend that dental procedures in patients with inherited coagulation disorders be carried out under cover of replacement therapy and antifibrinolytic therapy.⁵⁰²

THE FUTURE IN HEMOPHILIA TREATMENT

After the devastating epidemics in the hemophilia community caused by HIV and hepatitis C, it was a major step forward to have available recombinant products for treatment of hemophilia in the early 1990s. Now, 20 years later, several new products are in clinical trials that promise major advances in hemophilia treatment. Factor VIII and factor IX have been available as recombinant proteins for nearly 20 years, but due to their relatively short

P.1184

half-lives, still require frequent intravenous infusions in order to maintain clotting factor concentrations in plasma to avoid the risk of spontaneous bleeding. The longer half-life factor VIII and factor IX products will change treatment paradigms. In addition, there are efforts to provide other coagulation proteins as recombinant therapeutic products. Finally, there are renewed efforts in gene therapy for hemophilia, with better and safer viral vectors.

REFERENCES

1. Ratnoff OD. The molecular basis of hereditary clotting disorders. *Prog Hemost Thromb* 1972;1:39-74.
2. Berntorp E, Shapiro AD. Modern haemophilia care. *Lancet* 2012;379:1447-1456.
3. Simioni P, Tormene D, Tognin G, et al. X-linked thrombophilia with a mutant factor IX (factor IX Padua). *N Engl J Med* 2009;361:1671-1675.
4. Rosner F. Hemophilia in the Talmud and rabbinic writings. *Ann Intern Med* 1969;70:833-837.
5. Ingram GI. The history of haemophilia. *J Clin Pathol* 1976;29:469-479.
6. Rogaev EI, Grigorenko AP, Faskhutdinova G, et al. Genotype analysis identifies the cause of the "royal disease". *Science* 2009;326:817.
7. Hoyer LW. Immunologic properties of antihemophilic factor. *Prog Hematol* 1973;8:191-221.
8. Hoyer, LW. Hemophilia A. *N Engl J Med* 1994;330:38-47.
9. Stonebraker JS, Bolton-Maggs PH, Michael Soucie J, et al. A study of variations in the reported haemophilia B prevalence around the world. *Haemophilia* 2012;18:e91-e94.
10. Stonebraker JS, Brooker M, Amand RE, et al. A study of reported factor VIII use around the world. *Haemophilia* 2010;16:33-46.
11. Soucie JM, Evatt B, Jackson D. Occurrence of hemophilia in the United States. The Hemophilia Surveillance System Project Investigators. *Am J Hematol* 1998;59:288-294.
12. Graham JB. Genetic control of factor VIII. *Lancet* 1980;1:340-342.
13. Pitney WR, Arnold BJ. Plasma antihemophilic factor (AHF) concentrations in families of patients with hemorrhagic states. *Br J Haematol* 1959;5:184-193.
14. Quick AJ, Conway JP. Hemophilia in twins. *Am J Med* 1949;7:841-843.
15. Nichols WC, Amano K, Cacheris PM, et al. Moderation of hemophilia A phenotype by the factor V R506Q mutation. *Blood* 1996;88:1183-1187.
16. Escuriola Ettingshausen C, Halimeh S, Kurnik K, et al. Symptomatic onset of severe hemophilia A in childhood is dependent on the presence of prothrombotic risk factors. *Thromb Haemost* 2001;85:218-220.
17. Barrai I, Cann HM, Cavalli-Sforza LL, De Nicola P. The effect of parental age on rates of mutation for hemophilia and evidence for differing mutation rates for hemophilia A and B. *Am J Hum Genet* 1968;20:175-196.

18. Biggs R, Macfarlane RG. Haemophilia and related conditions: a survey of 187 cases. *Br J Haematol* 1958;4:1-27.
19. Oldenburg J, Ananyeva NM, Saenko EL. Molecular basis of haemophilia A. *Haemophilia* 2004;10(Suppl 4):133-139.
20. Lawn RM. The molecular genetics of hemophilia: blood clotting factors VIII and IX. *Cell* 1985;42:405-406.
21. Gouw SC, van den Berg HM, Oldenburg J, et al. F8 gene mutation type and inhibitor development in patients with severe hemophilia A: systematic review and meta-analysis. *Blood* 2012;119:2922-2934.
22. Miller CH, Benson J, Ellingsen D, et al. F8 and F9 mutations in US haemophilia patients: correlation with history of inhibitor and race/ethnicity. *Haemophilia* 2012;18:375-382.
23. Rossetti LC, Radic CP, Abelleyro MM, et al. Eighteen years of molecular genotyping the hemophilia inversion hotspot: from Southern blot to inverse shifting-PCR. *Int J Mol Sci* 2011;12:7271-7285.
24. Antonarakis SE, Kazazian HH, Tuddenham EG. Molecular etiology of factor VIII deficiency in hemophilia A. *Hum Mutat* 1995;5:1-22.
25. Antonarakis SE, Kazazian HH, Gitschier J, et al. Molecular etiology of factor VIII deficiency in hemophilia A. *Adv Exp Med Biol* 1995;386:19-34.
26. Antonarakis SE, Rossiter JP, Young M, et al. Factor VIII gene inversions in severe hemophilia A: results of an international consortium study. *Blood* 1995;86:2206-2212.
27. Bagnall RD, Waseem N, Green PM, Giannelli F. Recurrent inversion breaking intron 1 of the factor VIII gene is a frequent cause of severe hemophilia A. *Blood* 2002;99:168-174.
28. Amano K, Sarkar R, Pemberton S, et al. The molecular basis for cross-reacting material-positive hemophilia A due to missense mutations within the A2-domain of factor VIII. *Blood* 1998;91:538-548.
29. Vidal F, Farssac E, Tusell J, et al. First molecular characterization of an unequal homologous alu-mediated recombination event responsible for hemophilia. *Thromb Haemost* 2002;88:12-16.
30. Vidal F, Farssac E, Altisent C, et al. Rapid hemophilia A molecular diagnosis by a simple DNA sequencing procedure: identification of 14 novel mutations. *Thromb Haemost* 2001;85:580-583.
31. Oldenburg J. Mutation profiling in haemophilia A. *Thromb Haemost* 2001;85:577-579.
32. Klopp N, Oldenburg J, Uen C, et al. 11 hemophilia A patients without mutations in the factor VIII encoding gene. *Thromb Haemost* 2002;88:357-360.
33. Goodeve A. Molecular genetic testing of hemophilia A. *Semin Thromb Hemost* 2008;34:491-501.
34. Jayandharan GR, Srivastava A. Role of molecular genetics in hemophilia: from diagnosis to therapy. *Semin Thromb Hemost* 2012;38:64-78.
35. Harraway JR, Smith MP, George PM. A highly informative, multiplexed assay for the indirect detection of hemophilia A using five-linked microsatellites. *J Thromb Haemost* 2006;4:587-590.
36. Nishino M, Girma JP, Rothschild C, et al. New variant of von Willebrand disease with defective binding to factor VIII. *Blood* 1989;74:1591-1599.
37. Balak DM, Gouw SC, Plug I, et al. Prenatal diagnosis for haemophilia: a nationwide survey among female carriers in the Netherlands. *Haemophilia* 2012;18:584-592.
38. Mulder E, Mochtar IA, Van Creveld, Cardozo EB. Factor-8 activity in carriers of haemophilia A. *Br J Haematol* 1965;11:206-209.
39. Rapaport SI, Patch MJ, Casey JE. The antihemophilic globulin in plasma; content of freshly frozen single-donor plasma units prepared by the Los Angeles Red Cross Blood Center. *Calif Med* 1960;93:208-210.
40. Bennett B, Ratnoff OD. Changes in antihemophilic factor (AHF, factor 8) procoagulant activity and AHF-like antigen in normal pregnancy, and following exercise and pneumoencephalography. *J Lab Clin Med* 1972;80:256-263.
41. Blann AD, Daly RJ, Amiral J. The influence of age, gender and ABO blood group on soluble endothelial cell markers and adhesion molecules. *Br J Haematol* 1996;92:498-500.
42. Ratnoff OD, Jones PK. The laboratory diagnosis of the carrier state for classic hemophilia. *Ann Intern Med* 1977;86:521-528.

43. Seligsohn U, Zivelin A, Perez C, Modan M. Detection of haemophilia A carriers by replicate factor VIII activity and factor VIII antigenicity determinations. *Br J Haematol* 1979;42:433-439.
44. de la Chapelle, Ikkala E, Nevanlinna HR. Haemophilia A in a girl. A probable exception from sex-linked recessive inheritance. *Lancet* 1961;2:578-580.
45. Klein HG, Aledort LM, Bouma BN, et al. A co-operative study for the detection of the carrier state of classic hemophilia. *N Engl J Med* 1977;296:959-962.
46. Göbel U, von Kries R, Jürgens H, von Voss H. Problems in the detection of carriers of hemophilia A: the influence of stress and thrombin. *Blut* 1978;37:37-41.
47. Green PP, Mannucci PM, Briët E, et al. Carrier detection in hemophilia A: a cooperative international study. II. The efficacy of a universal discriminant. *Blood* 1986;67:1560-1567.
48. Ratnoff OD, Jones PK. Diagnosis of the carrier state in hemophilia. *Am J Hematol* 1988;28:132.
49. Peake I. Molecular genetics and counselling in haemophilia. *Thromb Haemost* 1995;74:40-44.
50. Ljung RC. Prenatal diagnosis of haemophilia. *Haemophilia* 1999;5:84-87.
51. Miller R. Counselling about diagnosis and inheritance of genetic bleeding disorders: haemophilia A and B. *Haemophilia* 1999;5:77-83.
52. Gilchrist, GS, Hammond D, Melnyk J. Hemophilia A in a phenotypically normal female with XX-XO mosaicism. *N Engl J Med* 1965;273:1402-1406.
53. Merskey C. The occurrence of haemophilia in the human female. *Q J Med* 1951;20:299-312.
54. Joist JH, Bouhasin JD, Roodman S. Classic hemophilia A in a female. *Acta Haematol* 1977;58:94-102.
55. Mannucci PM, Tuddenham EG. The hemophilias—from royal genes to gene therapy. *N Engl J Med* 2001;344:1773-1779.
56. White GC 2nd, Rosendaal F, Aledort LM, et al. Definitions in hemophilia. Recommendation of the scientific subcommittee on factor VIII and factor IX of the scientific and standardization committee of the International Society on Thrombosis and Haemostasis. *Thromb Haemost* 2001;85:560.
57. Graham JB, McLendon WW, Brinkhous KM. Mild hemophilia; allelic form of the disease. *Am J Med Sci* 1953;225:46-53.
58. Manco-Johnson MJ, Abshire TC, Shapiro AD, et al. Prophylaxis versus episodic treatment to prevent joint disease in boys with severe hemophilia. *N Engl J Med* 2007;357:535-454.
59. Rosendaal G, Vianen ME, Wenting MJ, et al. Iron deposits and catabolic properties of synovial tissue from patients with haemophilia. *J Bone Joint Surg Br* 1998;80:540-545.
60. Gilbert MS. Musculoskeletal manifestations of hemophilia. *Mt Sinai J Med* 1977;44:339-358.
61. Arnold WD, Hilgartner MW. Hemophilic arthropathy. Current concepts of pathogenesis and management. *J Bone Joint Surg Am* 1977;59:287-305.
62. Soler R, López-Fernández F, Rodríguez E, Marini M. Hemophilic arthropathy. A scoring system for magnetic resonance imaging. *Eur Radiol* 2002;12:836-843.
63. Leatherdale RA. Respiratory obstruction in haemophilic patients. *Br Med J* 1960;1:1316-1320.
64. Jones JJ, Kitchens CS. Spontaneous intra-abdominal hemorrhage in hemophilia. *Arch Intern Med* 1984;144:297-300.
65. Prentice CR, Lindsay RM, Barr RD, et al. Renal complications in haemophilia and Christmas disease. *Q J Med* 1971;40:47-61.
66. Abildgaard CF, Simone JV, Schulman I. Steroid treatment of hemophilic hematuria. *J Pediatr* 1965;66:117-119.
67. Baehner RL, Strauss HS. Hemophilia in the first year of life. *N Engl J Med* 1966;275:524-528.
68. Goodnough LT, Saito H, Ratnoff OD. Thrombosis or myocardial infarction in congenital clotting factor abnormalities and chronic thrombocytopenias: a report of 21 patients and a review of 50 previously reported cases. *Medicine (Baltimore)* 1983;62:248-255.
69. Srámek A, Reiber JH, Gerrits WB, Rosendaal FR. Decreased coagulability has no clinically relevant effect on atherogenesis: observations in individuals with a hereditary bleeding tendency. *Circulation* 2001;104:762-767.

70. Quon DV, Konkle BA. How we treat: haematuria in adults with haemophilia. *Haemophilia* 2010;16:683-685.
71. Konkle BA, Kessler C, Aledort L, et al. Emerging clinical concerns in the ageing haemophilia patient. *Haemophilia* 2009;15:1197-1209.
72. Fogarty PF, Olin JW, Kessler CM, et al. An algorithmic approach to peripheral artery disease in hemophilia: extrapolation of management principles from noncoagulopathic patients. *Blood Coagul Fibrinolysis* 2012;23:23-29.
73. Dolan G, Cruz JA, Steinhagen-Thiessen E, et al. Advances in hemophilia care: report of two symposia at the Hemophilia 2010 World Congress. *Adv Ther* 2012;29(Suppl 1):1-16.
74. Martin BA, Branch DW, Rodgers GM. The preparation of a sensitive partial thromboplastin reagent from bovine brain. *Blood Coagul Fibrinolysis* 1992;3:287-294.
75. Kekwick RA, Walton PL. An assay for antihaemophilic factor (factor VIII) with some considerations affecting the establishment of a standard reference preparation. *Br J Haematol* 1964;10:299-313.
76. Margolis J. An improved procedure for accurate assays of factor VIII. *Pathology* 1979;11:149-159.
77. Vermylen C, Verstraete M. A simple method for the assay of factor 8, using 20 microlitres of capillary blood. *Br J Haematol* 1968;14:241-245.
78. Kirkwood TB, Barrowcliffe TW. Discrepancy between one-stage and two-stage assay of factor VIII:C. *Br J Haematol* 1978;40:333-338.
79. Blombäck M, Kjellman H, Allain JP, et al. On the unreliability of one-stage factor VIII:C clotting assays after infusion of factor VIII concentrates. *Scand J Clin Lab Invest* 1987;47:561-566.
80. Barrowcliffe TW, Kirkwood TB. An international collaborative assay of factor VIII clotting activity. *Thromb Haemost* 1978;40:260-271.
81. Kocoshis TA, Triplett DA. Cap survey results for factor VIII assays (1977-1978). *Am J Clin Pathol* 1979;72(Suppl 2): 346-351.
82. Raut S, Sands D, Heath AB, Barrowcliffe TW. Variability in factor VIII concentrate measurement: results from SSC field collaborative studies. *J Thromb Haemost* 2003;1:1927-1934.
83. Viuff D, Barrowcliffe T, Saugstrup T, et al. International comparative field study of N8 evaluating factor VIII assay performance. *Haemophilia* 2011;17:695-702.
84. Firshein SI, Hoyer LW, Lazarchick J, et al. Prenatal diagnosis of classic hemophilia. *N Engl J Med* 1979;300:937-941.
85. Mibashan RS, Rodeck CH, Thumpston JK, et al. Plasma assay of fetal factors VIIC and IX for prenatal diagnosis of haemophilia. *Lancet* 1979;1:1309-1311.
86. Morfini M, Cinotti S, Bellatreccia A, et al. A multicenter pharmacokinetic study of the B-domain deleted recombinant factor VIII concentrate using different assays and standards. *J Thromb Haemost* 2003;1:2283-2289.
87. Mikaelsson M, Oswaldsson U, Sandberg H. Influence of phospholipids on the assessment of factor VIII activity. *Haemophilia* 1998;4:646-650.
88. Barrowcliffe TW, Raut S, Sands D, Hubbard AR. Coagulation and chromogenic assays of factor VIII activity: general aspects, standardization, and recommendations. *Semin Thromb Hemost* 2002;28:247-256.
89. Powell JS, Josephson NC, Quon D, et al. Safety and prolonged activity of recombinant factor VIII Fc fusion protein in hemophilia A patients. *Blood* 2012;119:3031-3037.
90. Hellstern P, Miyashita C, Köhler M, et al. Measurement of factor VIII procoagulant antigen in normal subjects and in hemophilia A patients by an immunoradiometric assay and by an enzyme-linked immunosorbent assay. *Haemostasis* 1987;17:173-181.
91. Pappas AM, Barr JS, Salzman EW, et al. The problem of unrecognized "mild hemophilia". Survival of a patient after disarticulation of the hip. *JAMA* 1964;187:772-774.
92. Richards M, Lavigne Lissalde G, Combescure C, et al. Neonatal bleeding in haemophilia: a European cohort study. *Br J Haematol* 2012;156:374-382.
93. Plug I, Mauser-Bunschoten EP, Bröcker-Vriends AH, et al. Bleeding in carriers of hemophilia. *Blood* 2006;108:52-56.
94. Pavlovsky A. Contribution to the pathogenesis of hemophilia. *Blood* 1947;2:185-191.

95. Aggeler PM, White SG, Glendening MB, et al. Plasma thromboplastin component (PTC) deficiency; a new disease resembling hemophilia. *Proc Soc Exp Biol Med* 1952;79:692-694.
96. Aggeler PM, Spaet TH, Emery BB. Purification of plasma thromboplastin factor B (plasma thromboplastin component) and its identification as a beta2 globulin. *Science* 1954;119:806.
97. Neal WR, Tayloe DT Jr, Cederbaum AI, Roberts HR. Detection of genetic variants of haemophilia B with an immunosorbent technique. *Br J Haematol.* 1973;25:63-68.
98. Veltkamp JJ, Meilof J, Rimmelts HG, et al. Another genetic variant of haemophilia B: haemophilia B Leyden. *Scand J Haematol* 1970;7:82-90.
99. Crossley M, Ludwig M, Stowell KM, et al. Recovery from hemophilia B Leyden: an androgen-responsive element in the factor IX promoter. *Science* 1992;257:377-379.
100. Meyer D, Larrieu MJ, Obert B. Factor VIII and IX variants. Relationship between haemophilia B M and haemophilia B+. *Eur J Clin Invest* 1971;1:425-431.
101. Griffith MJ, Breitzkreutz L, Trapp H, et al. Characterization of the clotting activities of structurally different forms of activated factor IX. Enzymatic properties of normal human factor IXa alpha, factor IXa beta, and activated factor IX Chapel Hill. *J Clin Invest* 1985;75:4-10.
102. Payne A, Bean C, Hooper W, Miller C. Utility of multiplex ligation-dependent probe amplification (MLPA) for hemophilia mutation screening. *J Thromb Haemost* 2012;10(9):1951-1954.
103. Noyes CM, Griffith MJ, Roberts HR, Lundblad RL. Identification of the molecular defect in factor IX Chapel Hill: substitution of histidine for arginine at position 145. *Proc Natl Acad Sci U S A* 1983;80:4200-4202.
104. Bertina RM, Veltkamp JJ. A genetic variant of factor IX with decreased capacity for Ca²⁺ binding. *Br J Haematol* 1979;42:623-635.
105. Bertina RM, Van Der Linden IK. Factor IX Zutphen. A genetic variant of blood coagulation factor IX with an abnormally high molecular weight. *J Lab Clin Med* 1982;100:695-704.
106. Davies SH, Gavin J, Goldsmith KL, et al. The linkage relations of hemophilia A and hemophilia B (Christmas disease) to the Xg blood group system. *Am J Hum Genet* 1963;15:481-492.
107. Bithell TC, Pizarro A, MacDiarmid WD. Variant of factor IX deficiency in female with 45, X Turner's syndrome. *Blood* 1970;36:169-79.
108. Neuschatz J, Necheles TF. Hemophilia B in a phenotypically normal girl with XX (ring) XO mosaicism. *Acta Haematol* 1973;49:108-113.
109. Nisen P, Stamberg J, Ehrenpreis R, et al. The molecular basis of severe hemophilia B in a girl. *N Engl J Med* 1986 30;315:1139-1142.
110. Oldenburg J, Schröder J, Brackmann HH, et al. Environmental and genetic factors influencing inhibitor development. *Semin Hematol* 2004;41(1 Suppl 1):82-88.
111. Hamasaki-Katagiri N, Salari R, Simhadri VL, et al. Analysis of F9 point mutations and their correlation to severity of haemophilia B disease. *Haemophilia* 2012;(6):933-940.
112. Pinotti M, Caruso P, Canella A, et al. Ribosome readthrough accounts for secreted full-length factor IX in hemophilia B patients with nonsense mutations. *Hum Mutat* 2012;33:1373-1376.
113. Didisheim P, Vandervoort RL. Detection of carriers for factor IX (PTC) deficiency. *Blood* 1962;20:150-155.
114. Orstavik KH, Veltkamp JJ, Bertina RM, Hermans J. Detection of carriers of haemophilia B. *Br J Haematol* 1979;42:293-301.
115. Pechet L, Tiarks CY, Stevens J, et al. Relationship of factor IX antigen and coagulant in hemophilia B patients and carriers. *Thromb Haemost* 1979;40:465-477.
116. Poon MC, Chui DH, Patterson M, et al. Hemophilia B (Christmas disease) variants and carrier detection analyzed by DNA probes. *J Clin Invest* 1987;79:1204-1209.
117. Smith KJ, Thompson AR, McMullen BA, et al. Carrier testing in hemophilia B with an immunoassay that distinguishes a prevalent factor IX dimorphism. *Blood* 1987;70:1006-1013.

118. Chan K, Sasanakul W, Mellars G, et al. Detection of known haemophilia B mutations and carrier testing by microarray. *Thromb Haemost* 2005;94: 872-878.
119. Holmberg L, Gustavii B, Cordesius E, et al. Prenatal diagnosis of hemophilia B by an immunoradiometric assay of factor IX. *Blood* 1980;56:397-401.
120. Tagariello G, Belvini D, Salviato R, et al. The Italian haemophilia B mutation database: a tool for genetic counselling, carrier detection and prenatal diagnosis. *Blood Transfus* 2007;5:158-163.
121. Peyvandi F, Jayandharan G, Chandy M, et al. Genetic diagnosis of haemophilia and other inherited bleeding disorders. *Haemophilia* 2006;12(Suppl 3):82-89.
122. Ljung R, Tedgard U. Genetic counseling of hemophilia carriers. *Semin Thromb Hemost* 2003;29:31-36.
123. Aggeler PM, Hoag MS, Wallerstein RO, Whissell D. The mild hemophilias. Occult deficiencies of AHF, PTC and PTA frequently responsible for unexpected surgical bleeding. *Am J Med* 1961;30:84-94.
124. Thompson AR. Factor IX antigen by radioimmunoassay. Abnormal factor IX protein in patients on warfarin therapy and with hemophilia B. *J Clin Invest* 1977;59:900-910.
125. Nyman D, Eriksson AW, Blomback M, et al. Recent investigations of the first bleeder family in Åland (Finland) described by von Willebrand. *Thromb Haemost* 1981;45:73-76.
126. Federici AB, Mannucci PM. Advances in the genetics and treatment of von Willebrand disease. *Curr Opin Pediatr* 2002;14:23-33.
127. Sadler JE, Blinder M. Von Willebrand disease: diagnosis, classification and treatment. In: Colman RW, Marder VJ, Clowes AW, et al., eds. *Hemostasis and thrombosis: basic principles and clinical practice*. Philadelphia, PA: Lippincott Williams & Wilkins, 2006:905-921.
128. Sadler JE, Budde U, Eikenboom JCJ, et al. Update on the pathophysiology and classification of von Willebrand disease: a report of the Subcommittee on von Willebrand Factor. *J Thromb Haemost* 2006;4:2103-2114.
129. Nichols WL, Hultin MB, James AH, et al. The diagnosis, evaluation and management of von Willebrand disease. <http://www.nhlbi.nih.gov/easyaccess1.lib.cuhk.edu.hk/guidelines/vwd/>. Accessed Feb 12, 2013.
130. Nichols WL, Rick ME, Ortel TL, et al. Clinical and laboratory diagnosis of von Willebrand disease: a synopsis of the 2008 NHLBI/NIH guidelines. *Am J Hematol* 2009;84:366-370.
131. Werner EJ, Broxson EH, Tucker EL, et al. Prevalence of von Willebrand disease in children: a multiethnic study. *J Pediatr* 1993;123:893-898.
132. Ginsberg D, Handin RI, Bonthron DT, et al. Human von Willebrand factor (vWF): isolation of complementary DNA (cDNA) clones and chromosomal localization. *Science* 1985;228:1401-1406.
133. Sadler JE, Shelton-Inloes BB, Sorace JM, et al. Cloning and characterization of two cDNAs coding for human von Willebrand factor. *Proc Natl Acad Sci U S A* 1985;82:6394-6398.
134. Montgomery RR. Structure and function of von Willebrand factor. In: Colman RW, Hirsh J, Marder VJ, et al., eds. *Hemostasis and thrombosis: basic principles and clinical practice*. Philadelphia, PA: Lippincott Williams & Wilkins, 2001:249-274.
135. Jenkins PV, Pasi KJ, Perkins SJ. Molecular modeling of the ligand and mutation sites of the type A domains of human von Willebrand factor and their relevance to von Willebrand disease. *Blood* 1998;91:2032-2044.
136. Furlan M, Robles R, Lammle B. Partial purification and characterization of a protease from human plasma cleaving von Willebrand factor to fragments produced by in vivo proteolysis. *Blood* 1996;87:4223-4234.
137. Sadler JE. New concepts in von Willebrand disease. *Annu Rev Med* 2005;56:173-191.
138. Orstavik KH, Magnus P, Reisner H, et al. Factor VIII and factor IX in a twin population. Evidence for a major effect of ABO locus on factor VIII level. *Am J Hum Genet* 1985;37:89-101.
139. Gill JC, Endres-Brooks J, Bauer PJ, et al. The effect of ABO blood group on the diagnosis of von Willebrand disease. *Blood* 1987;69:1691-1695.
140. Ginsberg D. Molecular genetics of von Willebrand disease. *Thromb Haemost* 1999;82:585-589.

141. Gallinaro L, Cattini MG, Sztukowska M, et al. A shorter von Willebrand factor survival in O blood group subjects explains how ABO determinants influence plasma von Willebrand factor. *Blood* 2008;111:3540-3545.
142. Di Paola J, Federici AB, Mannucci PM, et al. Low platelet $\alpha_2\beta_1$ levels in type I von Willebrand disease correlate with impaired platelet function in a high shear stress system. *Blood* 1999;93:3578-3582.
143. Kadir R, Economides DL, Sabin CA, et al. Variations in coagulation factors in women: effects of age, ethnicity, menstrual cycle and combined oral contraceptive. *Thromb Haemost* 1999;82:1456-1461.
144. Sadler JE. Von Willebrand disease type 1: a diagnosis in search of a disease. *Blood* 2003;101:2089-2093.
145. Goodeve A, Eikenboom J, Castaman G, et al. Phenotype and genotype of a cohort of families historically diagnosed with type 1 von Willebrand disease in the European study, Molecular and Clinical Markers for the Diagnosis and Management of Type I von Willebrand Disease (MCMDM-1VWD). *Blood* 2007;109:112-121.
146. James PD, Notley C, Hegadorn C, et al. The mutational spectrum of type 1 von Willebrand disease: results from a Canadian cohort study. *Blood* 2007;109:145-154.
147. Casonato A, Pontara E, Sartorello F, et al. Reduced von Willebrand factor survival in type Vicenza von Willebrand disease. *Blood* 2002;99:180-184.
148. Haberichter SL, Balistreri M, Christopherson P, et al. Assay of the von Willebrand factor (VWF) propeptide to identify patients with type 1 von Willebrand disease with decreased survival. *Blood* 2006;108:3344-3351.
149. Baronciani L, Cozzi G, Canciani MT, et al. Molecular characterization of a multiethnic group of 21 patients with type 3 von Willebrand disease. *Thromb Haemost* 2000;84:536-540.
150. Levy GG, Nichols WC, Lian EC, et al. Mutations in a member of the ADAMTS gene family cause thrombotic thrombocytopenic purpura. *Nature* 2001;413:488-494.
151. Zheng X, Chung D, Takayama TK, et al. Structure of von Willebrand factor-cleaving protease (ADAMTS13), a metalloprotease involved in thrombotic thrombocytopenic purpura. *J Biol Chem* 2002;276:41059-41063.
152. Tsai H-M. Physiologic cleavage of von Willebrand factor by a plasma protease is dependent on its conformation and requires calcium ion. *Blood* 1996;87:4235-4244.
153. Dong J-F, Moake JL, Nolasco L, et al. ADAMTS13 metalloprotease rapidly cleaves newly secreted ultralarge von Willebrand factor multimers on the endothelial surface under flowing conditions. *Blood* 2002;100:4033-4039.
154. Lammler B, Kremer Hovinga JA, Alberio L. Thrombotic thrombocytopenic purpura. *J Thromb Haemost* 2005;3:1663-1675.
155. Mannucci PM. Treatment of von Willebrand's disease. *N Engl J Med* 2004;351:683-694.
156. Hellem AJ. Platelet adhesiveness in von Willebrand disease: a study with a new modification of the glass bead filter method. *Scand J Haematol* 1970;7:374-382.
157. Baumgartner HR, Tschopp TB, Meyer D. Shear rate dependent inhibition of platelet adhesion and aggregation on collagenous surfaces by antibodies to human factor VIII/von Willebrand factor. *Br J Haematol* 1980;44:127-139.
158. Hovig T, Stormorken H. Ultrastructural studies on the platelet plug formation in bleeding time wounds from normal individuals and patients with von Willebrand disease. *Acta Pathol Microbiol Scand* 1974;248(Suppl):105-122.
159. Brinkhouse KM, Sandberg H, Garris JB, et al. Purified human factor VIII procoagulant protein: comparative hemostatic response after infusion into hemophilic and von Willebrand disease dogs. *Proc Natl Acad Sci U S A* 1985;82:8752-8756.
160. Koedam JA, Meijers JC, Sixma JJ, Bouma BN. Inactivation of human factor VIII by activated protein C. Cofactor activity of protein S and protective effect of von Willebrand factor. *J Clin Invest* 1988;82:1236-1243.
161. Weiss HJ, Sussman II, Hoyer LW. Stabilization of factor VIII in plasma by the von Willebrand factor: studies on posttransfusion and dissociated factor VIII and in patients with von Willebrand disease. *J Clin Invest* 1977;60:390-404.
162. Agrawal YP, Dzik W. The vWF content of factor VIII concentrates. *Transfusion* 2001;41:153-154.
163. Weinstein M, Deykin D. Comparison of factor VIII-related von Willebrand factor proteins prepared from human cryoprecipitate and factor VIII concentrate. *Blood* 1979;53:1095-1105.
164. Castillo R, Escolar G, Monteagudo J, et al. Hemostasis in patients with severe von Willebrand disease improves after normal platelet transfusion and normalizes with further correction of the plasma defect. *Transfusion* 1987;37:785-790.

165. Dilley A, Drews C, Lally C, et al. A survey of gynecologists concerning menorrhagia: perceptions of bleeding disorders as a possible cause. *J Womens Health Gender Based Med* 2002;11:39-44.
166. Kadir RA, Economides DL, Sabin CA, et al. Frequency of inherited bleeding disorders in women with menorrhagia. *Lancet* 1998;351:485-489.
167. Duray PH, Marcal JM, LiVolsi VA, et al. Gastrointestinal angiodysplasia: a possible component of von Willebrand disease. *Hum Pathol* 1984;15:539-544.
168. Ragni MV, Bontempo FA, Hassett AC. von Willebrand disease and bleeding in women. *Haemophilia* 1999;5:313-317.
169. Rodeghiero F, Castaman G, Tosetto A, et al. The discriminant power of bleeding history for the diagnosis of type 1 von Willebrand disease: an international multicenter study. *J Thromb Haemost* 2005;3:2619-2626.
170. Fressinaud E, Veyradier A, Truchard F, et al. Screening for von Willebrand disease with a new analyzer using high shear stress: a study of 60 cases. *Blood* 1998;91:1325-1331.
171. Borchgrevink CF, Egeberg O, Godal HC, Hjort PF. The effect of plasma and Cohn's fraction I on the Duke and Ivy bleeding times in von Willebrand disease. *Acta Med Scand* 1963;173:235-242.
172. Kundu SK, Heilmann EJ, Sio R, et al. Description of an in-vitro platelet function analyzer—PFA-100. *Semin Thromb Hemost* 1995;21(Suppl 2):106-112.
173. Posan E, McBane RD, Grill DE, et al. Comparison of PFA-100 testing and bleeding time for detecting platelet hypofunction and von Willebrand disease in clinical practice. *Thromb Haemost* 2003;90:483-490.
174. Quiroga T, Goycoolea M, Munoz B, et al. Template bleeding time and PFA-100 have low sensitivity to screen patients with hereditary mucocutaneous hemorrhages: comparative study in 148 patients. *J Thromb Haemost* 2004;2:892-898.
175. Favaloro EJ, Facey D, Henniker A, et al. Use of a novel platelet function analyzer (PFA-100) with high sensitivity to disturbances in von Willebrand factor to screen for von Willebrand's disease and other disorders. *Am J Hematol* 1999;62:165-174.
176. Cattaneo M, Federici AB, Lecchi A, et al. Evaluation of the PFA-100 system in the diagnosis and therapeutic monitoring of patients with von Willebrand disease. *Thromb Haemost* 2002;82:35-39.
177. Sultan Y, Simeon J, Maisonneuve P, Caen JP. Immunologic studies in von Willebrand disease. *Thromb Haemost* 1976;35:110-119.
178. Favaloro EJ. Evaluation of commercial von Willebrand factor collagen binding assays to assist the discrimination of types 1 and 2 von Willebrand disease. *Thromb Haemost* 2010;104:1009-1021.
179. Federici AB, Canciani MT, Forza I, Cozzi G. Ristocetin cofactor and collagen binding activities normalized to antigen levels for a rapid diagnosis of type 2 von Willebrand disease: single center comparison of four different assays. *Thromb Haemost* 2000;84:1127-1128.
180. Brinkhous KM, Read MS. Preservation of platelet receptors for platelet aggregating factor/von Willebrand factor by air drying, freezing, or lyophilization: a new stable platelet preparation for von Willebrand factor assays. *Thromb Res* 1978;13:591-597.
181. Rodeghiero F, Castaman G, Tosetto A. von Willebrand factor antigen is less sensitive than ristocetin-cofactor for the diagnosis of type I von Willebrand disease: results based on an epidemiological investigation. *Thromb Haemost* 1990;64:349-352.
182. Werner EJ, Abshire TC, Giroux DS, et al. Relative value of diagnostic studies for von Willebrand disease. *J Pediatr* 1992;121:34-38.
183. Favaloro EJ, Smith J, Petinos P, et al. Laboratory testing for von Willebrand disease: an assessment of current diagnostic practice and efficacy by means of a multi-laboratory survey. RCPA Quality Assurance Program (QAP) in Haematology Haemostasis Scientific Advisory Panel. *Thromb Haemost* 1999;82:1276-1282.
184. Goodall AH, Jarvis J, Chand S, et al. An immunoradiometric assay for human factor VIII/von Willebrand factor (VIII:VWF) using a monoclonal antibody that defines a functional epitope. *Br J Haematol* 1985;59:565-577.
185. Preston FE. Assays for von Willebrand factor functional activity: a UK NEQAS survey. *Thromb Haemost* 1998;80:863.
186. Favaloro EJ. Detection of von Willebrand disorder and identification of quantitative von Willebrand factor defects: direct comparison of commercial ELISA-based von Willebrand factor activity options. *Am J Clin Pathol* 2000;114:608-618.

187. Scott JP, Montgomery RR. The rapid differentiation of type IIb von Willebrand disease from platelet-type (pseudo-) von Willebrand disease by the "neutral" monoclonal antibody binding assay. *Am J Clin Pathol* 1991;96:723-728.
188. Favalaro EJ. Collagen binding assay for von Willebrand factor (VWF:CBA): detection of von Willebrand disease and discrimination of von Willebrand disease subtypes, depends on collagen source. *Thromb Haemost* 2000;83:127-135.
189. Ribba A-S, Loisel I, Lavergne J-M, et al. Ser968Thr within the A3 domain of von Willebrand factor (VWF) in two related patients leads to a defective binding of VWF to collagen. *Thromb Haemost* 2001;86:848-854.
190. Favalaro EJ, Henniker A, Facey D, Hertzberg M. Discrimination of von Willebrand's disease (VWD) subtypes: direct comparison of von Willebrand factor:collagen binding assay (VWF:CBA) with monoclonal antibody (MAB) based VWF-capture systems. *Thromb Haemost* 2000;84:541-547.
191. Casonato A, Pontara E, Zerbinati P, et al. The evaluation of factor VIII binding activity of von Willebrand factor by means of an ELISA method: significance and practical implications. *Am J Clin Pathol* 1997;109:347-352.
192. Kroner PA, Foster PA, Fahs SA, Montgomery RR. The defective interaction between von Willebrand factor and factor VIII in a patient with type 1 von Willebrand disease is caused by substitution of Arg19 and His54 in mature von Willebrand factor. *Blood* 1996;87:1013-1021.
193. Zimmerman TS, Ruggeri ZM. von Willebrand disease. *Hum Pathol* 1987;18:140-152.
194. Ledford-Kraemer MR. Analysis of von Willebrand factor structure by multimer analysis. *Am J Hematol* 2010;85:510-514.
195. Hambleton J. Diagnosis and incidence of inherited von Willebrand disease. *Curr Opin Hematol* 2001;8:306-311.
196. Hillery CA, Mancuso DJ, Sadler JE, et al. Type 2M von Willebrand disease: F606I and I662F mutations in the glycoprotein Ib binding domain selectively impair ristocetin- but not botrocetin-mediated binding of von Willebrand factor to platelets. *Blood* 1998;91:1572-1581.
197. Corrales I, Ramírez L, Altisent C, Parra R, Vidal F. Rapid molecular diagnosis of von Willebrand disease by direct sequencing. Detection of 12 novel putative mutations in VWF gene. *Thromb Haemost* 2009;101:570-576.
198. James PD, Paterson AD, Notley C, et al. Genetic linkage and association analysis in type 1 von Willebrand disease: results from the Canadian type 1 VWD study. *J Thromb Haemost* 2006;4:783-792.
199. Gudmundsdottir BR, Marder VJ, Onundarson PT. Risk of excessive bleeding associated with marginally low von Willebrand factor and mild platelet dysfunction. *J Thromb Haemost* 2007;5:274-281.
200. Lethagen S, Hillarp A, Ekholm C, et al. Distribution of von Willebrand factor levels in young women with and without bleeding symptoms: influence of ABO blood group and promoter haplotypes. *Thromb Haemost* 2008;99:1013-1018.
201. Mannucci PM, Bloom AL, Larrieu MJ, et al. Atherosclerosis and von Willebrand factor. I. Prevalence of severe von Willebrand disease in Western Europe and Israel. *Br J Haematol* 1984;57:163-169.
202. Mancuso DJ, Tuley EA, Castillo R, et al. Characterization of partial gene deletions in type III von Willebrand disease with alloantibody inhibitors. *Thromb Haemost* 1994;72:180-185.
203. Borel-Derlon A, Federici AB, Roussel-Robert V, et al. Treatment of severe von Willebrand disease with a high-purity von Willebrand factor concentrate (Wilfactin): a prospective study of 50 patients. *J Thromb Haemost* 2007;5:1115-1124.
204. Hill FGH, Enayat MS, George AJ. Investigation including VIIIIR: AG multimeric analysis of a large kindred with type IIa von Willebrand disease showing a dominant inheritance and similar gene expression in four generations. *Thromb Haemost* 1983;50:735-739.
205. Berkowitz SD, Dent J, Roberts J, et al. Epitope mapping of the von Willebrand factor subunit distinguishes fragments present in normal and type IIA von Willebrand disease from those generated by plasmin. *J Clin Invest* 1987;79 524-531.
206. Gralnick HR, Williams SB, McKeown LP, et al. In vitro correction of abnormal multimeric structure of von Willebrand factor in type IIa von Willebrand disease. *Proc Natl Acad Sci U S A* 1985;82:5968-5972.
207. Lyons SE, Bruck ME, Bowie EJW, Ginsburg D. Impaired intracellular transport produced by a subset of type II A von Willebrand disease mutations. *J Biol Chem* 1992;67:4424-4430.
208. Kyrle PA, Niessner H, Dent J, et al. IIB von Willebrand disease: pathogenetic and therapeutic studies. *Br J Haematol* 1988;69:55-59.

209. Holmberg L, Nilsson IM, Borge L, et al. Platelet aggregation induced by 1-desamino-8-D-arginine vasopressin (DDAVP) in type IIB von Willebrand disease. *N Engl J Med* 1983;309:816-821.
210. Federici AB, Mannucci PM, Castaman G, et al. Clinical and molecular predictors of thrombocytopenia and risk of bleeding in patients with von Willebrand disease type 2B: a cohort study of 67 patients. *Blood* 2009;113:526-534.
211. Foster PA, Fulcher CA, Marti T, et al. A major factor VIII binding domain resides within the amino-terminal 272 amino acid residues of von Willebrand factor. *J Biol Chem* 1987;262:8443-8446.
212. Mazurier C. von Willebrand disease masquerading as hemophilia A. *Thromb Haemost* 1992;67:391-396.
213. Schneppenheim R, Budde U, Krey S, et al. Results of a screening for von Willebrand disease type 2N in patients with suspected haemophilia A or von Willebrand disease type 1. *Thromb Haemost* 1996;76:598-602.
214. Miller JL, Castella A. Platelet-type von Willebrand disease: characterization of a new bleeding disorder. *Blood* 1982;60:790-794.
215. Bryckaert MC, Pietu G, Ruan C, et al. Abnormality of glycoprotein Ib in two cases of "pseudo"-von Willebrand disease. *J Lab Clin Med* 1985;106:393-400.
216. Favalaro EJ, Patterson D, Denholm A, et al. Differential identification of a rare form of platelet-type (pseudo-) von Willebrand disease (VWD) from Type 2B VWD using a simplified ristocetin-induced-platelet-agglutination mixing assay and confirmed by genetic analysis. *Br J Haematol* 2007;139:623-626.
217. Nurden AT, George JN. Inherited abnormalities of the platelet membrane: Glanzmann thrombasthenia, Bernard-Soulier syndrome, and other disorders. In: Colman RW, Marder VJ, Clowes AW, et al., eds. *Hemostasis and thrombosis: basic principles and clinical practice*. Philadelphia, PA: Lippincott Williams & Wilkins, 2006:987-1010.
218. Huizinga EG, Tsuji S, Romijn RAP, et al. Structures of glycoprotein Ib α and its complex with von Willebrand factor A1 domain. *Science* 2002;297:1176-1179.
219. Acharya SS, Dimichele DM. Rare inherited disorders of fibrinogen. *Haemophilia* 2008;14:1151-1158.
220. Moen JL, Lord ST., Afibrinogenemias and dysfibrinogenemias. In: Colman RW, Marder VJ, Clowes AW, George JN, Goldhaber SZ, eds. *Hemostasis and thrombosis: basic principles and clinical practice*, 5th ed. Philadelphia, PA: Lippincott Williams & Wilkins, 2006:939.
221. Neerman-Arbez M, de Moerloose P, Bridel C, et al. Mutations in the fibrinogen A alpha gene account for the majority of cases of congenital afibrinogenemia. *Blood* 2000;96:149-152.
222. Miesbach W, Scharer I, Henschen A, et al. Inherited dysfibrinogenemia: clinical phenotypes associated with five different fibrinogen structure defects. *Blood Coagul Fibrinolysis* 2010;21:35-40.
223. Mosesson MW. Fibrinogen and fibrin structure and functions. *J Thromb Haemost* 2005;3:1894-1904.
224. Fuller GM, Nickerson JM, Adams MA. Translational and cotranslational events in fibrinogen synthesis. *Ann N Y Acad Sci* 1983;408:440-448.
225. Chung DW, Rixon MW, Que BG, Davie EW. Cloning of fibrinogen genes and their cDNA. *Ann N Y Acad Sci* 1983;408:449-456.
226. De Silva CC, Thanabalasundaram RS. Congenital afibrinogenemia. *Br Med J* 1951;2:86-88.
227. de Moerloose P, Neerman-Arbez M. Congenital fibrinogen disorders. *Semin Thromb Hemost* 2009;35:356-366.
228. Uzan G, Courtois G, Besmond C, et al. Analysis of fibrinogen genes in patients with congenital afibrinogenemia. *Biochem Biophys Res Commun* 1984;120:376-383.
229. Callea F, Tortura O, Kojima T, et al. Hypofibrinogenemia and fibrinogen storage disease. In: Mosesson MW, Amrani DL, Siebenlist KR, DiOrio JP, eds. *Fibrinogen 3: biochemistry, biological functions, gene regulation, and expression*. New York: Elsevier Science Pub. Co., 1988:247-250.
230. Kant JA, Fornace AJ Jr, Saxe D, et al. Evolution and organization of the fibrinogen locus on chromosome 4: gene duplication accompanied by transposition and inversion. *Proc Natl Acad Sci U S A* 1985;82:2344-2348.
231. Asselta R, Duga S, Tenchini ML. The molecular basis of quantitative fibrinogen disorders. *J Thromb Haemost* 2006;4:2115-2129.
232. Neerman-Arbez M. The molecular basis of inherited afibrinogenemia. *Thromb Haemost* 2001;86:154-163.

233. Karimi M, Yarmohammadi H, Ardeshiri R. Inherited coagulation disorders in southern Iran. *Haemophilia* 2002;8:740-744.
234. Ni H, Denis CV, Subbarao S, et al. Persistence of platelet thrombus formation in arterioles of mice lacking both von Willebrand factor and fibrinogen. *J Clin Invest* 2000;106:385-392.
235. Suh TT, Holmbäck K, Jensen NJ, et al. Resolution of spontaneous bleeding events but failure of pregnancy in fibrinogen-deficient mice. *Genes Dev* 1995;9:2020-2033.
236. Bolton-Maggs PH, Perry DJ, Chalmers EA, et al. The rare coagulation disorders —review with guidelines for management from the United Kingdom Haemophilia Centre Doctors' Organisation. *Haemophilia* 2004;10:593-628.
237. Fried K, Kaufman S. Congenital afibrinogenemia in 10 offspring of uncle-niece marriages. *Clin Genet* 1980;17:223-227.
238. Acharya SS, Coughlin A, Dimichele DM. Rare Bleeding Disorder Registry: deficiencies of factors II, V, VII, X, XIII, fibrinogen and dysfibrinogenemias. *J Thromb Haemost* 2004;2:248-256.
239. Goodwin TM. Congenital hypofibrinogenemia in pregnancy. *Obstet Gynecol Surv* 1989;44:157-161.
240. Mensah PK, Oppenheimer C, Watson C, Pavord S. Congenital afibrinogenemia in pregnancy. *Haemophilia* 2011;17:167-168.
241. Bornikova L, Peyvandi F, Allen G, et al. Fibrinogen replacement therapy for congenital fibrinogen deficiency. *J Thromb Haemost* 2011;9:1687-1704.
242. Sorensen B, Bevan D. A critical evaluation of cryoprecipitate for replacement of fibrinogen. *Br J Haematol* 2010;149:834-843.
243. Meh DA, Siebenlist KR, Mosesson MW. Identification and characterization of the thrombin binding sites on fibrin. *J Biol Chem* 1996;271:23121-23125.
244. Cunningham MT, Brandt JT, Laposata M, Olson JD. Laboratory diagnosis of dysfibrinogenemia. *Arch Pathol Lab Med* 2002;126:499-505.
245. Yamagata S, Mori K, Kayaba T, et al. A case of congenital afibrinogenemia and review of reported cases in Japan. *Tohoku J Exp Med* 1968;96:15-35.
246. Cattaneo M, Bettega D, Lombardi R, et al. Sustained correction of the bleeding time in an afibrinogenemic patient after infusion of fresh frozen plasma. *Br J Haematol* 1992;82:388-390.
247. Colvin RB, Mosesson MW, Dvorak HF. Delayed-type hypersensitivity skin reactions in congenital afibrinogenemia lack fibrin deposition and induration. *J Clin Invest* 1979;63:1302-1306.
248. Ramsay NK, Coccia PF, Krivit W, et al. The effect of L-asparaginase of plasma coagulation factors in acute lymphoblastic leukemia. *Cancer* 1977;40: 1398-1401.
249. Fischer M, Lechner K, Hinterberger W, et al. Deficiency of fibrinogen and factor VII following treatment of severe aplastic anaemia with anti-thymocyte globulin and high-dose methylprednisolone. *Scand J Haematol* 1985;34:312-316.
250. Frenkel E, Duksin C, Herman A, Sherman DJ. Congenital hypofibrinogenemia in pregnancy: report of two cases and review of the literature. *Obstet Gynecol Surv* 2004;59:775-779.
251. Theodoulou A, Berryman J, Nathwani A, Scully M. Comparison of cryoprecipitate with fibrinogen concentrate for acquired hypofibrinogenemia. *Transfus Apher Sci* 2012;46:159-162.
252. Manco-Johnson MJ, Dimichele D, Castaman G, et al. Pharmacokinetics and safety of fibrinogen concentrate. *J Thromb Haemost* 2009;7:2064-2069.
253. Bevan DH. Cryoprecipitate: no longer the best therapeutic choice in congenital fibrinogen disorders? *Thromb Res* 2009;124(Suppl 2):S12-S16.
254. De Vries A, Rosenberg T, Kochwa S, Boss JH. Precipitating antifibrinogen antibody appearing after fibrinogen infusions in a patient with congenital afibrinogenemia. *Am J Med* 1961;30:486-494.
255. MacKinnon HH, Fekete JF. Congenital afibrinogenemia. Vascular changes and multiple thromboses induced by fibrinogen infusions and contraceptive medication. *Can Med Assoc J* 1971;104:597-599.
256. Ruiz-Saez A. Thrombosis in rare bleeding disorders. *Hematology* 2012;17(Suppl 1):S156-S158.

257. Calenda E, Borg JY, Peillon C, et al. Perioperative management of a patient with congenital hypofibrinogenemia. *Anesthesiology* 1989;71:622-623.
258. Falvo MR, Gorkun OV, Lord ST. The molecular origins of the mechanical properties of fibrin. *Biophys Chem* 2010;152:15-20.
259. Morris TA, Marsh JJ, Chiles PG, et al. High prevalence of dysfibrinogenemia among patients with chronic thromboembolic pulmonary hypertension. *Blood* 2009;114:1929-1936.
260. Benson MD. Amyloidosis. In: Scriver CR, Beaudet AL, Sly WS, Valle D, eds. *The metabolic basis of inherited disease*, 7th ed. New York: McGraw-Hill, 1995:4159-4191.
261. Francis RB Jr. Clinical disorders of fibrinolysis: a critical review. *Blut* 1989;59:1-14.
262. Mosesson MW. Dysfibrinogenemia and thrombosis. *Semin Thromb Hemost* 1999;25:311-319.
263. Rodgers GM, Garr SB. Comparison of functional and antigenic fibrinogen values from a normal population. *Thromb Res* 1992;68:207-210.
264. Sherman LA, Gaston LW, Kaplan ME, Spivack AR. Fibrinogen St. Louis: a new inherited fibrinogen variant, coincidentally associated with hemophilia A. *J Clin Invest* 1972;51:590-597.
265. Verhovsek M, Moffat KA, Hayward CP. Laboratory testing for fibrinogen abnormalities. *Am J Hematol* 2008;83:928-931.
266. Pluta A, Gutkowski K, Hartleb M. Coagulopathy in liver diseases. *Adv Med Sci* 2010;55:16-21.
267. Post GR, James L, Alapat D, et al. A case of acquired dysfibrinogenemia in multiple myeloma treated with therapeutic plasma exchange. *Transfus Apher Sci* 2012. Epub 27/7/12.
268. Dawson NA, Barr CF, Alving BM. Acquired dysfibrinogenemia. Paraneoplastic syndrome in renal cell carcinoma. *Am J Med* 1985;78:682-686.
269. Galanakis DK, Ginzler EM, Fikrig SM. Monoclonal IgG anticoagulants delaying fibrin aggregation in two patients with systemic lupus erythematosus (SLE). *Blood* 1978;52:1037-1046.
270. Hoots WK, Carrell NA, Wagner RH, et al. A naturally occurring antibody that inhibits fibrin polymerization. *N Engl J Med* 1981;304:857-861.
271. Marciniak E, Greenwood MF. Acquired coagulation inhibitor delaying fibrinopeptide release. *Blood* 1979;53:81-92.
272. Siebenlist KR, Mosesson MW, Meh DA, et al. Coexisting dysfibrinogenemia (gammaR275C) and factor V Leiden deficiency associated with thromboembolic disease (fibrinogen Cedar Rapids). *Blood Coagul Fibrinolysis* 2000;11:293-304.
273. Greenberg CS, Sane DC, Lai T-S. Factor XIII and fibrin stabilization. In: Colman RW, Marder VJ, Clowes AW, et al., eds. *Hemostasis and thrombosis: basic principles and clinical practice*. Philadelphia, PA: Lippincott Williams & Wilkins, 2006:317-334.
274. Mosher DF. Cross-linking of plasma and cellular fibronectin by plasma transglutaminase. *Ann N Y Acad Sci* 1978;312:38-42.
275. Robbins KC. A study on the conversion of fibrinogen to fibrin. *Am J Physiol* 1944;142:581-588.
276. Duckert F, Jung E, Shmerling DH. A hitherto undescribed congenital haemorrhagic diathesis probably due to fibrin stabilizing factor deficiency. *Thromb Diath Haemorrh* 1960;5:179-186.
277. Kohler HP, Ichinose A, Seitz R, et al. Diagnosis and classification of factor XIII deficiencies. *J Thromb Haemost* 2011;9:1404-1406.
278. Takagi T, Doolittle RF. Amino acid sequence studies on factor XIII and the peptide released during its activation by thrombin. *Biochemistry* 1974;13:750-756.
279. Poon MC, Russel JA, Low S, et al. Hematopoietic origin of factor XIII subunits in platelets, monocytes and plasma. Evidence from bone marrow transplantation studies. *J Clin Invest* 2002;84:787-792.
280. Kohler HP, Strickland MH, Ossei-Gerning N, et al. Association of a common polymorphism in the factor XIII gene with myocardial infarction. *Thromb Haemost* 1998;79:8-13.
281. Webb GC, Coggan M, Ichinose A, Board PG. Localization of the coagulation factor XIII B subunit gene (F13B) to chromosome bands 1q31-32.1 and restriction fragment length polymorphism at the locus. *Hum Genet* 1989;81:157-160.

282. Kitchens CS, Newcomb TF. Factor XIII. *Medicine (Balt)* 1979;58:413-429.
283. Miloszewski KJM, Losowsky MS. Fibrin stabilization and factor XIII deficiency. In: Francis JL, ed. *Fibrinogen, fibrin stabilisation, and fibrinolysis: clinical, biochemical and laboratory aspects*. Chichester: Ellis Horwood, 1988:175-202.
284. Greenberg DL, Davie EW. Blood coagulation factors: their complementary DNAs, genes, and expression. In: Colman RW, Hirsh J, Marder VJ, et al., eds. *Hemostasis and thrombosis: basic principles and clinical practice*, 4th ed. Philadelphia, PA: Lippincott Williams & Wilkins, 2001:21-57.
285. Santiago MA, Santiago RJ, Achyuthan KE, et al. Factor XIII B-chains enhance the binding of A-chains to fibrin(ogen): role of the C-terminus of the A-chains. *Blood* 1994;84:391a.
286. Britten AFH. Congenital deficiency of factor XIII (fibrin-stabilizing factor): report of a case and review of the literature. *Am J Med* 1967;43:751-761.
287. Duckert F. Documentation of the plasma factor XIII deficiency in man. *Ann N Y Acad Sci* 1972;202:190-199.
288. Ikkala E. Transfusion therapy in congenital deficiencies of plasma factor XIII. *Ann N Y Acad Sci* 1972;202:200-203.
289. Nugent DJ. Prophylaxis in rare coagulation disorders—Factor XIII deficiency. *Thromb Res* 2006;118(Suppl 1):s23-s28.
290. Lauer P, Metzner HJ, Zettlmeissl G, et al. Targeted inactivation of the mouse locus encoding coagulation factor XIII-A: hemostatic abnormalities in mutant mice and characterization of the coagulation deficit. *Thromb Haemost* 2002;88:967-974.
291. Seligsohn U, White JG. Inherited deficiencies of coagulation factors II, V, VII, XI, and XIII, and the combined deficiencies of factors V and VIII and of the vitamin K-dependent factors. In: Beutler E, Lichtman MA, Coller BS, et al., eds. *Williams hematology*, 6th ed. New York: McGraw-Hill, 2002:1617-1638.
292. Henriksson P, Stenberg P, Nilsson IM, et al. A specific, fluorescent activity staining procedure applied to plasma and red blood cells in congenital factor XIII deficiency. *Br J Haematol* 1980;44:141-147.
293. Lorand L, Urayama T, De Kiewiet JWC, Nossel HL. Diagnostic and genetic studies on fibrin-stabilizing factor with a new assay based on amine incorporation. *J Clin Invest* 1969;48:1054-1064.
294. Dempfle CE, Harenberg J, Hochreuter K, Heene DL. Microtiter assay for measurement of factor XIII activity in plasma. *J Lab Clin Med* 1992;119:522-528.
295. Peyvandi F, Mannuci PM. Rare coagulation disorders. *Thromb Haemost* 1999;82:1207-1214.
296. Stenson PD, Ball EV, Mort M, et al. The Human Gene Mutation Database (HGMD®): 2003 update. *Hum Mutat* 2003;21:577-581.
297. Shapiro SS, Martinez J, Holburn RR. Congenital dysprothrombinemia: an inherited structural disorder of human prothrombin. *J Clin Invest* 1969;48:2251-2259.
298. Lefkowitz JB, Weller A, Nuss R, et al. A common mutation, Arg457→Gln, links prothrombin deficiencies in the Puerto Rican population. *J Thromb Haemost* 2003;1:2381-2388.
299. Bezeaud A, Guillin MC, Olmeda F, et al. Prothrombin Madrid: a new familial abnormality of prothrombin. *Thromb Res* 1979;16:47-58.
300. Rabiet MJ, Furie BC, Furie B. Molecular defect of prothrombin Barcelona. Substitution of cysteine for arginine at residue 273. *J Biol Chem* 1986;261: 15045-15048.
301. Henriksen RA, Mann KG. Substitution of valine for glycine-558 in the congenital dysthrombin thrombin Quick II alters primary substrate specificity. *Biochemistry* 1989;28:2078-2082.
302. Sekine O, Sugo T, Ebisawa K, et al. Substitution of Gly-548 to Ala in the substrate binding pocket of prothrombin Perijé leads to the loss of thrombin proteolytic activity. *Thromb Haemost* 2002;87:282-287.
303. Henriksen RA, Mann KG. Identification of the primary structural defect in the dysthrombin thrombin Quick I: substitution of cysteine for arginine-382. *Biochemistry* 1988;27:9160-9165.
304. Shapiro SS, McCord S. Prothrombin. *Prog Hemost Thromb* 1978;4:177-209.
305. Girolami A, Scarano L, Saggiorato G, et al. Congenital deficiencies and abnormalities of prothrombin. *Blood Coagul Fibrinolysis* 1998;9:557-569.

306. Xue J, Wu Q, Westfield LA, et al. Incomplete embryonic lethality and fatal neonatal hemorrhage caused by prothrombin deficiency in mice. *Proc Natl Acad Sci U S A* 1998;95:7603-7607.
307. Mullins ES, Kombrinck KW, Talmage KE, et al. Genetic elimination of prothrombin in adult mice is not compatible with survival and results in spontaneous hemorrhagic events in both heart and brain. *Blood* 2009;113: 696-704.
308. Owren PA. The coagulation of blood: investigations on a new clotting factor. *Acta Med Scand* 1947;194(Suppl):1-327.
309. Vos HL. An online database of mutations and polymorphisms in and around the coagulation factor V gene. *J Thromb Haemost* 2007;5:185-188.
310. Duckers C, Simioni P, Rosing J, Castoldi E. Advances in understanding the bleeding diathesis in factor V deficiency. *Br J Haematol* 2009;146:17-26.
311. Asselta R, Tenchini ML, Duga S. Inherited defects of coagulation factor V: the hemorrhagic side. *J Thromb Haemost* 2006;4:26-34.
312. Chiu HC, Whitaker E, Colman RW. Heterogeneity of human factor V deficiency: evidence for the existence of antigen-positive variants. *J Clin Invest* 1983;72:493-503.
313. Murray JM, Rand MD, Egan JO, et al. Factor V New Brunswick: Ala221-to-Val substitution results in reduced cofactor activity. *Blood* 1995;86:1820-1827.
314. Steen M, Miteva M, Villoutreix BO, et al. Factor V New Brunswick: Ala221Val associated with FV deficiency reproduced in vitro and functionally characterized. *Blood* 2003;102:1316-1322.
315. Zehnder JL, Hiraki DD, Jones CD, et al. Familial coagulation factor V deficiency caused by a novel 4 base pair insertion in the factor V gene: factor V Stanford. *Thromb Haemost* 1999;82:1097-1099.
316. Kling SJ, Griffiee M, Flanders MM, Rodgers GM. Factor V deficiency caused by a novel missense mutation, Ile417Thr, in the A2 domain. *J Thromb Haemost* 2006;4:481-483.
317. Tracy PB, Giles AR, Mann KG, et al. Factor V (Quebec): a bleeding diathesis associated with a qualitative platelet factor V deficiency. *J Clin Invest* 1984;74:1221-1228.
318. Seeler RA. Parahemophilia: factor V deficiency. *Med Clin North Am* 1972;56:119-125.
319. Cui J, O'Shea KS, Purkayastha A, et al. Fatal haemorrhage and incomplete block to embryogenesis in mice lacking coagulation factor V. *Nature* 1996;384:66-68.
320. Yang TL, Cui J, Taylor JM, et al. Rescue of fatal neonatal hemorrhage in factor V deficient mice by low level transgene expression. *Thromb Haemost* 2000;53:70-77.
321. Bloom JW, Nesheim ME, Mann KG. A rapid technique for the preparation of factor V deficient plasma. *Thromb Res* 1979;15:595-599.
322. Fischer RR, Giddings JC, Roisenberg I. Hereditary combined deficiency of clotting factors V and VIII with involvement of von Willebrand factor. *Clin Lab Haematol* 1988;10:53-62.
323. Fair DS. Quantitation of factor VII in the plasma of normal and warfarin-treated individuals by radioimmunoassay. *Blood* 1983;62:784-791.
324. Morrissey JH, Macik BG, Neuenschwander PF, Comp PC. Quantitation of activated factor VII levels in plasma using a tissue factor mutant selectively deficient in promoting factor VII activation. *Blood* 1993;81: 734-744.
325. Seligsohn U, Kasper CK, Osterud B, Rapaport SI. Activated factor VII: presence in factor IX concentrates and persistence in the circulation after transfusion. *Blood* 1979;53:828-837.
326. Edgington TS, Dickinson CD, Ruf W, et al. The structural basis of function of the TF-FVIIa complex in the cellular initiation of coagulation. *Thromb Haemost* 1997;78:401-405.
327. O'Hara PJ, Grant FJ, Haldeman BA, et al. Nucleotide sequence of the gene coding for human factor VII, a vitamin K-dependent protein participating in blood coagulation. *Proc Natl Acad Sci U S A* 1987;84:5158-5162.
328. Rosen ED, Chan JC, Idusogie E, et al. Mice lacking factor VII develop normally but suffer fatal perinatal bleeding. *Nature* 1997;390:290-294.
329. Tamary H, Fromovich Y, Shalmon L, et al. Ala244Val is a common, probably ancient mutation causing factor VII deficiency in Moroccan and Iranian Jews. *Thromb Haemost* 1996;76:283-291.

330. Marder VJ, Shulman NR. Clinical aspects of congenital factor VII deficiency. *Am J Med* 1964;37:182-194.
331. Roberts HR, Escobar MA. Inherited disorders of prothrombin conversion. In: Colman RW, Marder VJ, Clowes AW, et al., eds. *Hemostasis and thrombosis: basic principles and clinical practice*. Philadelphia, PA: Lippincott Williams & Wilkins, 2006:923-937.
332. Triplett DA, Brandt JT, Batard MGM, et al. Hereditary factor VII deficiency: heterogeneity defined by combined functional and immunochemical analysis. *Blood* 1985;66:1284-1287.
333. Ragni MV, Lewis JH, Spero JA, Hasiba U. Factor VII deficiency. *Am J Hematol* 1981;10:79-88.
334. Cohen LJ, McWilliams NB, Neuberger R, et al. Prophylaxis and therapy with factor VII concentrate (human) immuno, vapor heated in patients with congenital factor VII deficiency: a summary of case reports. *Am J Hematol* 1995;50:269-276.
335. Perry DJ. Factor VII deficiency. *Br J Haematol* 2002;118:689-700.
336. Girolami A, Tezza F, Scandellari R, et al. Associated prothrombotic conditions are probably responsible for the occurrence of thrombosis in almost all patients with congenital FVII deficiency. Critical review of the literature. *J Thromb Thrombolysis* 2010;30:172-178.
337. Pollak ES, Russell TT, Ptashkin B, et al. Asymptomatic factor VII deficiency in African Americans. *Am J Clin Pathol* 2006;126:128-132.
338. Yorke AJ, Mant MJ. Factor VII deficiency and surgery: is preoperative replacement therapy necessary? *JAMA* 1977;238:424-425.
339. Giansily-Blaizot M, Schved JF. Potential predictors of bleeding risk in inherited factor VII deficiency. Clinical, biological and molecular criteria. *Thromb Haemost* 2005;94:901-906.
340. Telfer TP, Denson KW, Wright DR. A "new" coagulation defect. *Br J Haematol* 1956;2:308-316.
341. Hougie C, Barrow EM, Graham JB. Stuart clotting defect. I. Segregation of an hereditary hemorrhagic state from the heterogeneous group heretofore called stable factor (SPCA, proconvertin, factor VII) deficiency. *J Clin Invest* 1957;36:485-496.
342. Uprichard J, Perry DJ. Factor X deficiency. *Blood Rev* 2002;16:97-110.
343. Peyvandi F, Menegatti M, Santagostino E, et al. Gene mutations and three-dimensional structural analysis in 13 families with severe factor X deficiency. *Br J Haematol* 2002;117:685-692.
344. Jayandharan G, Viswabandya A, Baidya S, et al. Six novel mutations including triple heterozygosity for Phe31Ser, 514delT and 516T→G factor X gene mutations are responsible for congenital factor X deficiency in patients of Nepali and Indian origin. *J Thromb Haemost* 2005;3:1482-1487.
345. Menegatti M, Peyvandi F. Factor X deficiency. *Semin Thromb Hemost* 2009;35:407-415.
346. Reddy SV, Zhou ZQ, Rao KJ, et al. Molecular characterization of human factor X_{San Antonio}. *Blood* 1989;74:1486-1490.
347. James HL, Girolami A, Fair DS. Molecular defect in coagulation factor X_{Friuli} results from a substitution of serine for proline at position 343. *Blood* 1991;77:317-323.
348. Rudolph AE, Mullane MP, Porche-Sorbet R, et al. Factor X_{St. Louis II}. Identification of a glycine substitution at residue 7 and characterization of the recombinant protein. *J Biol Chem* 1996;271:28601-28606.
349. Dewerchin M, Liang Z, Moons L, et al. Blood coagulation factor X deficiency causes partial embryonic lethality and fatal neonatal bleeding in mice. *Thromb Haemost* 2000;83:185-190.
350. Bertina RM, Alderkamp GJH, DeNooy E. A variant of factor X that is defective only in extrinsic coagulation. *Thromb Haemost* 1981;46:88 [abstr].
351. Parkin JD, Madaras F, Sweet B, Castaldi PA. A further inherited variant of coagulation factor X. *Aust N Z J Med* 1974;4:561-564.
352. Greipp PR, Kyle RA, Bowie EJ. Factor-X deficiency in amyloidosis: a critical review. *Am J Hematol* 1981;11:443-450.
353. Rosenthal RL, Dreskin OH, Rosenthal N. New hemophilia-like disease caused by deficiency of a third plasma thromboplastin factor. *Proc Soc Exp Biol Med* 1953;82:171-174.
354. Rapaport SI, Proctor RR, Patch MJ, Yetta M. The mode of inheritance of PTA deficiency: evidence for the existence of major PTA deficiency and minor PTA deficiency. *Blood* 1961;18:149-165.

355. Gomez K, Bolton-Maggs P. Factor XI deficiency. *Haemophilia* 2008;14:1183-1189.
356. Seligsohn U, Modan M. Definition of the population at risk of bleeding due to factor XI deficiency in Ashkenazi Jews and the value of activated partial thromboplastin time in its detection. *Isr J Med Sci* 1981;17:413-415.
357. Seligsohn U. High gene frequency of factor XI (PTA) deficiency in Ashkenazi Jews. *Blood* 1978;51:1223-1228.
358. Asakai R, Chung DW, Ratnoff OD, Davie EW. Factor XI (plasma thromboplastin antecedent) deficiency in Ashkenazi Jews is a bleeding disorder that can result from three types of point mutations. *Proc Natl Acad Sci U S A* 1989;86:7667-7671.
359. Asakai R, Chung DW, Davie EW, Seligsohn U. Factor XI deficiency in Ashkenazi Jews in Israel. *N Engl J Med* 1991;325:153-158.
360. Shpilberg O, Peretz H, Zivelin A, et al. One of the two common mutations causing factor XI deficiency in Ashkenazi Jews (type II) is also prevalent in Iraqi Jews, who represent the ancient gene pool of Jews. *Blood* 1995;85:429-432.
361. Peretz H, Mulai A, Usher S, et al. The two common mutations causing factor XI deficiency in Jews stem from distinct founders: one of ancient Middle Eastern origin and another of more recent European origin. *Blood* 1997;90:2654-2659.
362. Kravtsov DV, Monahan PE, Gailani D. A classification system for cross-reactive material-negative factor XI deficiency. *Blood* 2005;105:4671-4673.
363. Kravtsov DV, Wu W, Meijers JC, et al. Dominant factor XI deficiency caused by mutations in the factor XI catalytic domain. *Blood* 2004;104:128-134.
364. Bolton-Maggs PHB. Factor XI deficiency and its management. *Haemophilia* 2000;6(Suppl 1):100-109.
365. Quelin F, Trossaert M, Sigaud M, et al. Molecular basis of severe factor XI deficiency in seven families from the west of France. Seven novel mutations, including an ancient Q88X mutation. *J Thromb Haemost* 2004;2:71-76.
366. Seligsohn U. Factor XI deficiency. *Thromb Haemost* 1993;70:68-71.
367. Rosenthal RL, Dreskin OH, Rosenthal N. Plasma thromboplastin antecedent (PTA) deficiency: clinical, coagulation, therapeutic and hereditary aspects of a new hemophilia-like disease. *Blood* 1955;10:120-131.
368. Phillips LL, Hyman GA, Rosenthal RL. Prolonged postoperative bleeding in a patient with factor XI (PTA) deficiency. *Ann Surg* 1965;162:37-42.
369. Kitchens CS, Alexander JA. Partial deficiency of coagulation factor XI as a newly recognized feature of Noonan syndrome. *J Pediatr* 1983;102:224-227.
370. Berrebi A, Malnick SDH, Vorst EJ, Stein D. High incidence of factor XI deficiency in Gaucher's disease. *Am J Hematol* 1992;40:153.
371. Edson JR, White JG, Krivit W. The enigma of severe factor XI deficiency without hemorrhagic symptoms. *Thromb Diath Haemorrh* 1967;18:342-348.
372. Bolton-Maggs PHB, Patterson DA, Wensley RT, Tuddenham EGD. Definition of the bleeding tendency in factor XI-deficient kindreds: a clinical and laboratory study. *Thromb Haemost* 1995;73:194-202.
373. Kadir RA, Economides DL, Lee CA. Factor XI deficiency in women. *Am J Hematol* 1999;60:48-54.
374. DeVries SI, Braat-van Straaten MAJ. Haemorrhagic diathesis as the result of severe deficiency of plasma thromboplastin antecedent (PTA, factor XI). *Thromb Haemost* 1964;11:167-186.
375. Soff GA, Levin J, Bell WR. Familial multiple coagulation factor deficiencies. II. Combined factor VIII, IX, and XI deficiency and combined factor IX and XI deficiency: two previously uncharacterized familial multiple factor deficiency syndromes. *Semin Thromb Hemost* 1981;7:149-169.
376. Ratnoff OD, Colopy JE. A familial hemorrhagic trait associated with a deficiency of a clot-promoting fraction of plasma. *J Clin Invest* 1955;34: 602-613.
377. Ratnoff OD, Rosenblum JM. Role of Hageman factor in the initiation of clotting by glass. *Am J Med* 1958;25:160-168.
378. Ratnoff OD, Steinberg AG. Further studies on the inheritance of Hageman trait. *J Lab Clin Med* 1962;59:980-985.
379. Halbmayr WM, Haushofer A, Schon R, et al. The prevalence of moderate and severe FXII (Hageman factor) deficiency among the normal population: evaluation of the incidence of FXII deficiency among 300 healthy blood donors. *Thromb Haemost* 1994;71:68-72.

380. Saito H, Scott JG, Movat HZ, Scialla SJ. Molecular heterogeneity of Hageman trait (factor XII deficiency). *J Lab Clin Med* 1979;94:256-265.
381. Schloesser M, Zeerleder S, Lutze G, et al. Mutations in the human factor XII gene. *Blood* 1997;90:3967-3977.
382. Wachtfogel YT, De La Cadena RA, Colman RW. Structural biology, cellular interactions and pathophysiology of the contact system. *Thromb Res* 1993;72:1-21.
383. Glueck HI, Roehill W. Myocardial infarction in a patient with a Hageman (factor XII) defect. *Ann Intern Med* 1966;64:390-396.
384. Ratnoff OD, Busse RJ, Sheon RP. The demise of John Hageman. *N Engl J Med* 1968;279:760-761.
385. Lodi S, Isa L, Pollini E, et al. Defective intrinsic fibrinolytic activity in a patient with severe factor XII-deficiency and myocardial infarction. *Scand J Haematol* 1984;33:80-82.
386. Koster T, Rosendaal FR, Briet E, Vandenbroucke JP. John Hageman's factor and deep-vein thrombosis: Leiden thrombophilia study. *Br J Haematol* 1994;87:422-424.
387. Zeerleder S, Schloesser M, Rendondo M, et al. Reevaluation of the incidence of thromboembolic complications in congenital factor XII deficiency. *Thromb Haemost* 1999;82:1240-1246.
388. Girolami A, Randi ML, Gavasso S, et al. The occasional venous thromboses seen in patients with severe (homozygous) FXII deficiency are probably due to associated risk factors: a study of prevalence in 21 patients and review of the literature. *J Thromb Thrombolysis* 2004;17:139-143.
389. Colman RW, Schmaier AH. Contact system: a vascular biology modulator with anticoagulant, profibrinolytic, antiadhesive, and proinflammatory attributes. *Blood* 1997;90:3819-3843.
390. Renne T, Pozgajova M, Gruner S, et al. Defective thrombus formation in mice lacking coagulation factor XII. *J Exp Med* 2005;202:271-281.
391. Kleinschnitz C, Stoll G, Bendszus M, et al. Targeting coagulation factor XII provides protection from pathological thrombosis in cerebral ischemia without interfering with hemostasis. *J Exp Med* 2006;203:513-518.
392. Cheng Q, Tucker EI, Pine MS, et al. A role for factor XIIa-mediated factor XI activation in thrombus formation in vivo. *Blood* 2010;116:3981-3989.
393. Nossel HL. The contact phase of blood coagulation. Oxford: Blackwell Science, 1964.
394. Kasper CK, Buechy DY, Aggeler PM. Hageman factor (factor XII) in an affected kindred and in normal adults. *Br J Haematol* 1968;14:543-551.
395. Hathaway WE, Belhasen LP, Hathaway HS. Evidence for a new plasma thromboplastin factor. I. Case report, coagulation studies and physicochemical properties. *Blood* 1965;26:521-532.
396. Wuepper KD. Prekallikrein deficiency in man. *J Exp Med* 1973;138:1345-1355.
397. Girolami A, Scarparo P, Candeo N, Lombardi AM. Congenital prekallikrein deficiency. *Expert Rev Hematol* 2010;3:685-695.
398. Saito H, Ratnoff OD, Donaldson VH. Defective activation of clotting, fibrinolytic and permeability-enhancing systems in human Fletcher trait plasma. *Circ Res* 1974;34:641-651.
399. Weiss AS, Gallin JI, Kaplan AP. Fletcher factor deficiency: a diminished rate of Hageman factor activation caused by absence of prekallikrein with abnormalities of coagulation, fibrinolysis, chemotactic activity, and kinin generation. *J Clin Invest* 1974;53:622-633.
400. Sollo DG, Saleem A. Prekallikrein (Fletcher factor) deficiency. *Ann Clin Lab Sci* 1985;15:279-285.
401. Estelles A, Aznar J, Espana F. The absence of release of the plasminogen activator after venous occlusion in a Fletcher trait patient. *Thromb Haemost* 1983;49:66.
402. Abildgaard DF, Harrison J. Fletcher factor deficiency: family study and detection. *Blood* 1974;43:641-644.
403. Asmis LM, Sulzer I, Furlan M, Lammler B. Prekallikrein deficiency. The characteristic normalization of the severely prolonged aPTT following increased preincubation time is due to autoactivation of factor XII. *Thromb Res* 2002;105:463-470.

404. Soulier JP, Gozin D. Assay of Fletcher factor (plasma prekallikrein) using an artificial clotting reagent and a modified chromogenic assay. *Thromb Haemost* 1979;42:538-547.
405. Saito H, Ratnoff OD, Waldman R, Abraham JP. Fitzgerald trait. *J Clin Invest* 1975;55:1082-1089.
406. Colman RW, Bagdasarian A, Talamo RC, et al. Williams trait. *J Clin Invest* 1975;56:1650-1662.
407. Oh-Ishi S, Uemo A, Uchida Y, et al. Abnormalities in the contact activation through factor-XII in Fujiwara trait: a deficiency in both high and low-molecular-weight kininogens with low-level of prekallikrein. *Tohoku J Exp Med* 1981;133:67-80.
408. Wuepper KD, Miller DR, Lacombe MJ. Flaujeac trait: deficiency of human plasma kininogen. *J Clin Invest* 1975;56:1663-1672.
409. Donaldson VH, Kleniewski J, Saito H, Sayed JK. Prekallikrein deficiency in a kindred with kininogen deficiency and Fitzgerald trait clotting defect: evidence that high-molecular-weight kininogen and prekallikrein exist as a complex in normal human plasma. *J Clin Invest* 1977;60:571-583.
410. Hayashi H, Ishimaru F, Fugita T, et al. Molecular genetic survey of five Japanese families with high-molecular-weight kininogen deficiency. *Blood* 1990;75:1296-1304.
411. Cheung PP, Kunapuhi SP, Scott CF, et al. Genetic basis of total kininogen deficiency in Williams' trait. *J Biol Chem* 1993;268:23361-23365.
412. Krijanovski Y, Proulle V, Mahdi F, et al. Characterization of molecular defects of Fitzgerald trait and another novel high-molecular-weight kininogen-deficient patient: insights into structural requirements for kininogen expression. *Blood* 2003;101:4430-4436.
413. Zhang B, Ginsburg D. Familial multiple coagulation factor deficiencies: new biologic insight from rare genetic bleeding disorders. *J Thromb Haemost* 2004;2:1564-1572.
414. Peyvandi F, Tuddenham EG, Akhtari AM, et al. Bleeding symptoms in 27 Iranian patients with the combined deficiency of factor V and factor VIII. *Br J Haematol* 1998;150:773-776.
415. Seligsohn U, Zivelin A, Zwang E. Combined factor V and factor VIII deficiency among non-Ashkenazi Jews. *N Engl J Med* 1982;307:1191-1195.
416. Nichols WC, Seligsohn U, Zivelin A, et al. Mutations in the ER-Golgi intermediate compartment protein ERGIC-53 cause combined deficiency of coagulation factors V and VIII. *Cell* 1998;93:61-70.
417. Zhang B, McGee B, Yamaoka JS, et al. Combined deficiency of factor V and factor VIII is due to mutations in either LMAN1 or MCFD2. *Blood* 2006;107:1903-1907.
418. Mohanty D, Ghosh K, Shetty S, et al. Mutations in the MCFD2 gene and a novel mutation in the LMAN1 gene in Indian families with combined deficiency of factor V and VIII. *Am J Hematol* 2005;79:262-266.
419. Zheng C, Liu HH, Yuan S, et al. Molecular basis of LMAN1 in coordinating LMAN1-MCFD2 cargo receptor formation and ER-to-Golgi transport of FV/FVIII. *Blood* 2010;116:5698-5706.
420. Brenner B. Hereditary deficiency of vitamin K-dependent coagulation factors. *Thromb Haemost* 2000;84:935-936.
421. Napolitano M, Mariani G, Lapecorella M. Hereditary combined deficiency of the vitamin K-dependent clotting factors. *Orphanet J Rare Dis* 2010;5:21.
422. Goldsmith GH, Pence RE, Ratnoff OD, et al. Studies on a family with combined functional deficiencies of vitamin K-dependent coagulation factors. *J Clin Invest* 1982;69:1253-1260.
423. Brenner B, Sanchez-Vega B, Wu SM, et al. A missense mutation in γ -glutamyl carboxylase gene causes combined deficiency of all vitamin K-dependent blood coagulation factors. *Blood* 1998;92:4554-4559.
424. Spronk HMH, Farah RA, Buchanan GR, et al. Novel mutation in the γ -glutamyl carboxylase gene resulting in congenital combined deficiency of all vitamin K-dependent blood coagulation factors. *Blood* 2000;96:3650-3652.
425. Darghouth D, Hallgren KW, Shtofman RL, et al. Compound heterozygosity of novel missense mutations in the gamma-glutamyl-carboxylase gene causes hereditary combined vitamin K-dependent coagulation factor deficiency. *Blood* 2006;108:1925-1931.

426. Rost S, Fregin A, Ivaskevicius V, et al. Mutations in VKORC1 cause warfarin resistance and multiple coagulation factor deficiency type 2. *Nature* 2004;427:537-541.
427. Aoki N, Saito H, Kamiya T, et al. Congenital deficiency of α_2 -plasmin inhibitor associated with severe hemorrhagic tendency. *J Clin Invest* 1979;63:877-884.
428. Aoki N, Sakata Y, Matsuda M, Tateno K. Fibrinolytic states in a patient with congenital deficiency of α_2 -plasmin inhibitor. *Blood* 1980;55:483-488.
429. Collen D. α_2 -Antiplasmin inhibitor deficiency. *Lancet* 1979;1:1039-1040.
430. Saito H. α_2 -Plasmin inhibitor and its deficiency states. *J Lab Clin Med* 1988;112:671-678.
431. Favier R, Aoki N, de Moerloose P. Congenital α_2 -plasmin inhibitor deficiencies: a review. *Br J Haematol* 2001;114:4-10.
432. Maino A, Garagiola I, Artoni A, et al. A novel mutation of alpha2-plasmin inhibitor gene causes an inherited deficiency and a bleeding tendency. *Haemophilia* 2008;14:166.
433. Lee MH, Vosburgh E, Anderson K, McDonagh J. Deficiency of plasma plasminogen activator inhibitor 1 results in hyperfibrinolytic bleeding. *Blood* 1993;81:2357-2362.
434. Minowa H, Takahashi Y, Tanaka T, et al. Four cases of bleeding diathesis in children due to congenital plasminogen activator inhibitor-1 deficiency. *Haemostasis* 1999;29:286-291.
435. Fay WP, Parker AC, Condrey LR, Shapiro AD. Human plasminogen activator inhibitor-1 (PAI-1) deficiency: characterization of a large kindred with a null mutation in the PAI-1 gene. *Blood* 1997;90:204-208.
436. Mehta R, Shapiro AD. Plasminogen activator inhibitor type 1 deficiency. *Haemophilia* 2008;14:1255-1260.
437. Horrevoets AJ. Plasminogen activator inhibitor 1 (PAI-1): in vitro activities and clinical relevance. *Br J Haematol* 2004;125:12-23.
438. Lewis JH, Iammarino RM, Spero JA, Hasiba U. Antithrombin Pittsburgh: an α_1 -antitrypsin variant causing hemorrhagic disease. *Blood* 1978;51:129-137.
439. Owen MC, Brennan SO, Lewis JH, Carrell RW. Mutation of antitrypsin to antithrombin: α_1 -antitrypsin Pittsburgh (358 Met Arg), a fatal bleeding disorder. *N Engl J Med* 1983;309:694-698.
440. Scott CF, Carrell RW, Glaser CB, et al. Alpha-1-antitrypsin Pittsburgh: a potent inhibitor of plasma factor XI_a, kallikrein, and factor XII_f. *J Clin Invest* 1986;77:631-634.
441. Hua B, Fan L, Liang Y, et al. Alpha1-antitrypsin Pittsburgh in a family with bleeding tendency. *Haematologica* 2009;94:881-884.
442. Courtney M, Jallat S, Tessier LH, et al. Synthesis in *E. coli* of α_1 -antitrypsin variants of therapeutic potential for emphysema and thrombosis. *Nature* 1985;313:149-151.
443. Lusher JM, Arkin S, Abildgaard CF, Schwartz RS. Recombinant factor VIII for the treatment of previously untreated patients with hemophilia A. Safety, efficacy, and development of inhibitors. Kogenate Previously Untreated Patient Study Group. *N Engl J Med* 1993;328:453-459.
444. Alperin JB. Estrogens and surgery in women with von Willebrand's disease. *Am J Med* 1982;73:367-371.
445. Green D, Smith NJ. Hemophilia. Current concepts in management. *Med Clin North Am* 1972;56:105-117.
446. Zatorska K, Orłowska-Baranowska E, Abramczuk E, et al. Short and long-term management of haemophilia A patient requiring heart valve surgery. *Haemophilia* 2012;18:e352-354.
447. Fogarty PF, Kouides P. How we manage prostate biopsy and prostate cancer therapy in men with haemophilia. *Haemophilia* 2012;18:e88-90.
448. Ljung RC, Knobe K. How to manage invasive procedures in children with haemophilia. *Br J Haematol* 2012;157:519-528.
449. Négrier C, Shapiro A, Berntorp E, et al. Surgical evaluation of a recombinant factor VIII prepared using a plasma/albumin-free method: efficacy and safety of Advate in previously treated patients. *Thromb Haemost* 2008;100:217-223.

450. Aryal KR, Wiseman D, Siriwardena AK, et al. General surgery in patients with a bleeding diathesis: how we do it. *World J Surg* 2011;35:2603-2610.
451. Bowie EJ, Thompson JH Jr, Didisheim P, Owen CA Jr. Disappearance rates of coagulation factors: transfusion studies in factor-deficient patients. *Transfusion* 1967;7:174-184.
452. Abildgaard CF, Cornet JA, Fort E, Schulman I. The in vivo longevity of anti-haemophilic factor (factor VIII). *Br J Haematol* 1964;10:225-237.
453. Smith KJ, Thompson AR. Labeled factor IX kinetics in patients with hemophilia-B. *Blood* 1981;58:625-629.
454. Shapiro AD, Ragni MV, Valentino LA, et al. Recombinant factor IX-Fc fusion protein (rFIXFc) demonstrates safety and prolonged activity in a phase 1/2a study in hemophilia B patients. *Blood* 2012;119:666-672.
455. Santagostino E, Negrier C, Klamroth R, et al. Safety and pharmacokinetics of a novel recombinant fusion protein linking coagulation factor IX with albumin (rIX-FP) in hemophilia B patients. *Blood* 2012;120(12):2405-2411.
456. Soucie JM, Nuss R, Evatt B, et al. Mortality among males with hemophilia: relations with source of medical care. The Hemophilia Surveillance System Project Investigators. *Blood* 2000;96:437-442.
457. Perkins HA. Plasmapheresis of the patient as a method for achieving effective levels of plasma coagulation factors using fresh frozen plasma. *Transfusion* 1966;6:293-301.
458. Klein HG, Dodd RY, Dzik WH, et al. Current status of solvent/detergent-treated frozen plasma. *Transfusion* 1998;38:102-107.
459. Mast AE, Stadanlick JE, Lockett JM, Dietzen DJ. Solvent/detergent-treated plasma has decreased antitrypsin activity and absent antiplasmin activity. *Blood* 1999;94:3922-3927.
460. Leebeek FW, Schipperus MR, van Vliet HH. Coagulation factor levels in solvent/detergent-treated plasma. *Transfusion* 1999;39:1150-1151.
461. O'Shaughnessy DF, Atterbury C, Bolton-Maggs P, et al. Guidelines for the use of fresh-frozen plasma, cryoprecipitate and cryosupernatant. *Br J Haematol* 2004;126:11-28.
462. Pool JG, Shannon AE. Production of high-potency concentrates of antihemophilic globulin in a closed-bag system. *N Engl J Med* 1965;273:1443-1447.
463. Brettler DB, Levine PH. Factor concentrates for treatment of hemophilia: which one to choose? *Blood* 1989;73:2067-2073.
464. Schwartz RS, Abildgaard CF, Aledort LM, et al. Human recombinant DNA-derived antihemophilic factor (factor VIII) in the treatment of hemophilia A. Recombinant Factor VIII Study Group. *N Engl J Med* 1990;323:1800-1805.
465. Ragni MV, Koch WC, Jordan JA. Parvovirus B19 infection in patients with hemophilia. *Transfusion* 1996;36:238-241.
466. Gaboulaud V, Parquet A, Tahiri C, et al. Prevalence of IgG antibodies to human parvovirus B19 in haemophilia children treated with recombinant factor (F) VIII only or with at least one plasma-derived FVIII or FIX concentrate: results from the French haemophilia cohort. *Br J Haematol* 2002;116:383-389.
467. Geng Y, Wu CG, Bhattacharyya SP, et al. Parvovirus B19 DNA in Factor VIII concentrates: effects of manufacturing procedures and B19 screening by nucleic acid testing. *Transfusion* 2007;47:883-889.
468. Zauber NP, Levin J. Factor IX levels in patients with hemophilia B (Christmas disease) following transfusion with concentrates of factor IX or fresh frozen plasma (FFP). *Medicine (Baltimore)* 1977;56:213-224.
469. White GC 2nd, Roberts HR, Kingdon HS, Lundblad RL. Prothrombin complex concentrates: potentially thrombogenic materials and clues to the mechanism of thrombosis in vivo. *Blood* 1977;49:159-170.
470. Hultin MB. Activated clotting factors in factor IX concentrates. *Blood* 1979;54:1028-1038.
471. Giles AR, Nesheim ME, Hoogendoorn H, et al. The coagulant-active phospholipid content is a major determinant of in vivo thrombogenicity of prothrombin complex (Factor IX) concentrates in rabbits. *Blood* 1982;59:401-407.
472. Campbell EW, Neff S, Bowdler AJ. Therapy with factor IX concentrate resulting in DIC and thromboembolic phenomena. *Transfusion* 1978;18:94-97.
473. Blatt PM, Lundblad RL, Kingdon HS, et al. Thrombogenic materials in prothrombin complex concentrates. *Ann Intern Med* 1974;81:766-770.

474. Shapiro AD, Ragni MV, Lusher JM, et al. Safety and efficacy of monoclonal antibody purified factor IX concentrate in previously untreated patients with hemophilia B. *Thromb Haemost* 1996;75:30-35.
475. Mannucci PM, Bauer KA, Gringeri A, et al. Thrombin generation is not increased in the blood of hemophilia B patients after the infusion of a purified factor IX concentrate. *Blood* 1990;76:2540-2545.
476. Brinkhous KM, Sigman JL, Read MS, et al. Recombinant human factor IX: replacement therapy, prophylaxis, and pharmacokinetics in canine hemophilia B. *Blood* 1996;88:2603-2610.
477. Lusher JM, Shapiro SS, Palascak JE, et al. Efficacy of prothrombin-complex concentrates in hemophiliacs with antibodies to factor VIII: a multicenter therapeutic trial. *N Engl J Med* 1980;303:421-425.

P.1185

478. Teitel J, Berntorp E, Dolan G, et al. A consensus statement on clinical trials of bypassing agent prophylaxis in inhibitor patients. *Haemophilia* 2011;17:516-521.
479. Leissinger C, Gringeri A, Antmen B, et al. Anti-inhibitor coagulant complex prophylaxis in hemophilia with inhibitors. *N Engl J Med* 2011;365: 1684-1692.
480. Levi M. Reverse engineering for new oral anticoagulants: non-specific reversal agents and the anticoagulant activity of dabigatran and rivaroxaban. *Thromb Haemost* 2012;108:201-202.
481. Rodgers GM. Prothrombin complex concentrates in emergency bleeding disorders. *Am J Hematol* 2012;87:898-902.
482. Glazer S, Hedner U, Falch JF. Clinical update on the use of recombinant factor VII. *Adv Exp Med Biol* 1995;386:163-174.
483. Key NS, Negrier C. Coagulation factor concentrates: past, present, and future. *Lancet* 2007;370:439-448.
484. Mannucci PM, Mancuso ME, Santagostino E. How we choose factor VIII to treat hemophilia. *Blood* 2012;119:4108-4114.
485. Fogarty PF. Biological rationale for new drugs in the bleeding disorders pipeline. *Hematology Am Soc Hematol Educ Program* 2011;2011:397-404.
486. Cash JD, Gader AM, da Costa J. Proceedings: the release of plasminogen activator and factor VIII to lysine vasopressin, arginine vasopressin, l-desamino-8-d-arginine vasopressin, angiotensin and oxytocin in man. *Br J Haematol* 1974;27:363-364.
487. Theiss W, Schmidt G. DDAVP in von Willebrand's disease: repeated administration and the behaviour of the bleeding time. *Thromb Res* 1978;13:1119-1123.
488. Mannucci PM. Desmopressin (DDAVP) in the treatment of bleeding disorders: the first 20 years. *Blood* 1997;90:2515-2521.
489. Warrier AI, Lusher JM. DDAVP: a useful alternative to blood components in moderate hemophilia A and von Willebrand disease. *J Pediatr* 1983;102:228-233.
490. de la Fuente B, Kasper CK, Rickles FR, Hoyer LW. Response of patients with mild and moderate hemophilia A and von Willebrand's disease to treatment with desmopressin. *Ann Intern Med* 1985;103:6-14.
491. Revel-Vilk S, Blanchette VS, Sparling C, et al. DDAVP challenge tests in boys with mild/moderate haemophilia A. *Br J Haematol* 2002;117:947-951.
492. Ruggeri ZM, Mannucci PM, Lombardi R, et al. Multimeric composition of factor VIII/von Willebrand factor following administration of DDAVP: implications for pathophysiology and therapy of von Willebrand's disease subtypes. *Blood* 1982;59:1272-1278.
493. Kobrinsky NL, Israels ED, Gerrard JM, et al. Shortening of bleeding time by 1-deamino-8-D-arginine vasopressin in various bleeding disorders. *Lancet* 1984;1:1145-1148.
494. Ehl S, Severin T, Sutor AH. DDAVP (desmopressin; 1-deamino-cys-8-D-argininevasopressin) treatment in children with haemophilia B. *Br J Haematol* 2000;111:1260-1262.

495. Kavakli K, Aydinok Y, Karapinar D, Balkan C. DDAVP treatment in children with haemophilia B. *Br J Haematol* 2001;114:733-734.
496. Dunn AL, Powers JR, Ribeiro MJ, et al. Adverse events during use of intranasal desmopressin acetate for haemophilia A and von Willebrand disease: a case report and review of 40 patients. *Haemophilia* 2000;6:11-14.
497. Mannucci PM. Desmopressin: a nontransfusional form of treatment for congenital and acquired bleeding disorders. *Blood* 1988;72:1449-1455.
498. Bond L, Bevan D. Myocardial infarction in a patient with hemophilia treated with DDAVP. *N Engl J Med* 1988;318:121.
499. Miesbach W, Berntorp E. When von Willebrand disease comes into age—a matter of change? *Eur J Haematol* 2011;86:496-501.
500. Sutor AH. DDAVP is not a panacea for children with bleeding disorders. *Br J Haematol* 2000;108:217-227.
501. Mannucci PM. Hemostatic drugs. *N Engl J Med* 1998;339:245-253.
502. Kasper CK, Dietrich SL. Comprehensive management of haemophilia. *Clin Haematol* 1985;14:489-512.
503. Evans BE, Aledort LM. Hemophilia and dental treatment. *J Am Dent Assoc* 1978;96:827-834.
504. Stark SN, White JG, Lange RL Jr, Krivit W. Epsilon amino caproic acid therapy as a cause of intrarenal obstruction in haematuria of haemophiliacs. *Scand J Haematol* 1965;2:99-107.
505. Kasper CK. Hereditary plasma clotting factor disorders and their management. *Haemophilia* 2000;6(Suppl 1):13-27.
506. Kulkarni R, Lusher J. Perinatal management of newborns with haemophilia. *Br J Haematol* 2001;112:264-274.
507. Köhler M, Hellstern P, Miyashita C, et al. Comparative study of intranasal, subcutaneous and intravenous administration of desamino-D-arginine vasopressin (DDAVP). *Thromb Haemost* 1986;55:108-111.
508. Ashenhurst JB, Langehannig PL, Seeler RA. Early treatment of bleeding episodes with 10 U/kg of factor VIII. *Blood* 1977;50:181-182.
509. Bona RD, Weinstein RA, Weisman SJ, et al. The use of continuous infusion of factor concentrates in the treatment of hemophilia. *Am J Hematol* 1989; 32:8-13.
510. Batorova A, Martinowitz U. Intermittent injections vs. continuous infusion of factor VIII in haemophilia patients undergoing major surgery. *Br J Haematol* 2000;110:715-720.
511. Batorova A, Martinowitz U. Continuous infusion of coagulation factors. *Haemophilia* 2002;8:170-177.
512. Takedani H. Continuous infusion during total joint arthroplasty in Japanese haemophilia A patients: comparison study among two recombinants and one plasma-derived factor VIII. *Haemophilia* 2010;16:740-746.
513. Ménart C, Petit PY, Attali O, et al. Efficacy and safety of continuous infusion of Mononine during five surgical procedures in three hemophilic patients. *Am J Hematol* 1998;58:110-116.
514. Hathaway WE, Christian MJ, Clarke SL, Hasiba U. Comparison of continuous and intermittent Factor VIII concentrate therapy in hemophilia A. *Am J Hematol* 1984;17:85-88.
515. Rodgers GM, Ford MH. Lack of response to commercial factor VIII concentrate in hemophilia A. *Am J Hematol* 1991;37:288.
516. Lusher JM. Clinical guideline for treating von Willebrand disease patients who are not candidates for DDAVP—a survey of European physicians. *Haemophilia* 1998;4(Suppl 3):11-14.
517. Fowler WE, Berkowitz LR, Roberts HR. DDAVP for type IIB von Willebrand disease. *Blood* 1989;74:1859-1860.
518. Mazurier C, Gaucher C, Jorieux S, et al. Biological effect of desmopressin in eight patients with type 2N (“Normandy”) von Willebrand disease. *Br J Haematol* 1994;88:849-854.
519. Lillicrap D, Poon MC, Walker I, et al. Efficacy and safety of the factor VIII/von Willebrand factor concentrate, Haemate-P/Humate-P: ristocetin cofactor unit dosing in patients with von Willebrand disease. *Thromb Haemost* 2002;87:224-230.
520. Mannucci PM, Chediak J, Hanna W, et al. Treatment of von Willebrand disease with a high-purity factor VIII/von Willebrand factor concentrate: a prospective, multicenter study. *Blood* 2002;99:450-456.

521. Kessler CM, Friedman K, Schwartz BA, et al. The pharmacokinetic diversity of two von Willebrand factor (VWF)/factor VIII (FVIII) concentrates in subjects with congenital von Willebrand disease. Results from a prospective, randomised crossover study. *Thromb Haemost* 2011;106:279-288.
522. Thompson AR, Gill JC, Ewenstein BM, et al. Successful treatment for patients with von Willebrand disease undergoing urgent surgery using factor VIII/VWF concentrate (Humate-P). *Haemophilia* 2004;10:42-51.
523. Makris M, Colvin B, Gupta V, et al. Venous thrombosis following the use of intermediate purity FVIII concentrate to treat patients with von Willebrand disease. *Thromb Haemost* 2002;88:387-388.
524. Miller JL, Kupinski JM, Castella A, Ruggeri ZM. von Willebrand factor binds to platelets and induces aggregation in platelet-type but not type IIB von Willebrand disease. *J Clin Invest* 1983;72:1532-1542.
525. Kouides PA. Current understanding of von Willebrand's disease in women—some answers, more questions. *Haemophilia* 2006;12(Suppl 3):143-151.
526. Conti M, Mari D, Conti E, et al. Pregnancy in women with different types of von Willebrand disease. *Obstet Gynecol* 1986;68:282-285.
527. Roth DA, Kessler CM, Pasi KJ, et al. Human recombinant factor IX: safety and efficacy studies in hemophilia B patients previously treated with plasma-derived factor IX concentrates. *Blood* 2001;98:3600-3606.
528. Gioia KP, Bouhasin JD. Call for post-licensing human pharmacokinetic studies of administration of recombinant factor IX. *Haemophilia* 1998;4:67.
529. Poon MC, Lillicrap D, Hensman C, et al. Recombinant factor IX recovery and inhibitor safety: a Canadian post-licensure surveillance study. *Thromb Haemost* 2002;87:431-435.
530. Berntorp E, Shapiro AD, Waters J, et al. The international factor IX treatment network survey. *Haemophilia* 2012;18:e60-e62.
531. Thorland EC, Drost JB, Lusher JM, et al. Anaphylactic response to factor IX replacement therapy in haemophilia B patients: complete gene deletions confer the highest risk. *Haemophilia* 1999;5:101-105.
532. Jadhav M, Warriar I. Anaphylaxis in patients with hemophilia. *Semin Thromb Hemost* 2000;26:205-208.
533. Powell JS, Ragni MV, White GC 2nd, et al. Phase 1 trial of FVIII gene transfer for severe hemophilia A using a retroviral construct administered by peripheral intravenous infusion. *Blood* 2003;102:2038-2045.
534. Roth DA, Tawa NE Jr, O'Brien JM, et al. Nonviral transfer of the gene encoding coagulation factor VIII in patients with severe hemophilia A. *N Engl J Med* 2001;344:1735-1742.
535. Arruda VR, Schuettrumpf J, Herzog RW, et al. Safety and efficacy of factor IX gene transfer to skeletal muscle in murine and canine hemophilia B models by adeno-associated viral vector serotype 1. *Blood* 2004;103:85-92.
536. Nathwani AC, Tuddenham EG, Rangarajan S, et al. Adenovirus-associated virus vector-mediated gene transfer in hemophilia B. *N Engl J Med* 2011;365:2357-2365.
537. High KA. The gene therapy journey for hemophilia: are we there yet? *Blood* 2012;120(23):4482-4487.
538. Buchlis G, Podsakoff GM, Radu A, Hawk SM, et al. Factor IX expression in skeletal muscle of a severe hemophilia B patient 10 years after AAV-mediated gene transfer. *Blood* 2012;119:3038-3041.
539. Pierce GF, Lillicrap D, Pipe SW, Vandendriessche T. Gene therapy, bioengineered clotting factors and novel technologies for hemophilia treatment. *J Thromb Haemost* 2007;5:901-906.
540. Giangrande PL. Gene therapy for hemophilia? No. *J Thromb Haemost* 2004;2:1236-1237.
541. Livnat T, Shenkman B, Spectre G, et al. Recombinant factor VIIa treatment for asymptomatic factor VII deficient patients going through major surgery. *Blood Coagul Fibrinolysis* 2012;23:379-387.
542. Benlakhhal F, Mura T, Schved JF, et al. A retrospective analysis of 157 surgical procedures performed without replacement therapy in 83 unrelated factor VII-deficient patients. *J Thromb Haemost* 2011;9:1149-1156.
543. Giansily-Blazot M, Biron-Andreani C, Aguilar-Martinez P, et al. Inherited factor VII deficiency and surgery: clinical data are the best criteria to predict the risk of bleeding. *Br J Haematol* 2002;117:172-175.
544. Mariani G, Konkle BA, Ingerslev J. Congenital factor VII deficiency: therapy with recombinant activated factor VII — a critical appraisal. *Haemophilia* 2006;12:19-27.

545. Ingerslev J, Kristensen HL. Clinical picture and treatment strategies in factor VII deficiency. *Haemophilia* 1998;4:689-696.
546. Mariani G, Herrmann FH, Bernardi F, et al. Clinical manifestations, management, and molecular genetics in congenital factor VII deficiency: the International Registry on Congenital Factor VII Deficiency (IRF7). *Blood* 2000;96:374.
547. Mariani G, Herrmann FH, Dolce A, et al. Clinical phenotypes and factor VII genotype in congenital factor VII deficiency. *Thromb Haemost* 2005;93:481-487.
548. Giangrande PL, Wilde JT, Madan B, et al. Consensus protocol for the use of recombinant activated factor VII [eptacog alfa (activated); NovoSeven] in elective orthopaedic surgery in haemophilic patients with inhibitors. *Haemophilia* 2009;15:501-508.
549. Mariani G, Dolce A, Batorova A, et al. Recombinant, activated factor VII for surgery in factor VII deficiency: a prospective evaluation—the surgical STER. *Br J Haematol* 2011;152:340-346.
550. Mariani G, Dolce A, Napolitano M, et al. Invasive procedures and minor surgery in factor VII deficiency. *Haemophilia* 2012;18:e63-e65.
551. Ingerslev J, Christiansen K, Sorensen B. Inhibitor to factor VII in severe factor VII deficiency: detection and course of the inhibitory response. *J Thromb Haemost* 2005;3:799-800.
552. O'Connell KA, Wood JJ, Wise RP, et al. Thromboembolic adverse events after use of recombinant human coagulation factor VIIa. *JAMA* 2006;295:293-298.
553. Mariani G, Testa MG, Di Paolantonio T, et al. Use of recombinant, activated factor VII in the treatment of congenital factor VII deficiencies. *Vox Sang* 1999;77:131-136.
554. Briet E, Onvlee G. Hip surgery in a patient with severe factor VII deficiency. *Haemostasis* 1987;17:273-277.
555. Wilde JT. Evidence for the use of activated prothrombin complex concentrates (aPCCs) in the treatment of patients with haemophilia and inhibitors. *Pathophysiol Haemost Thromb* 2002;32(Suppl 1):9-12.
556. Ichinose A. Factor XIII is a key molecule at the intersection of coagulation and fibrinolysis as well as inflammation and infection control. *Int J Hematol* 2012;95:362-370.
557. Lovejoy AE, Reynolds TC, Visich JE, et al. Safety and pharmacokinetics of recombinant factor XIII-A2 administration in patients with congenital factor XIII deficiency. *Blood* 2006;108:57-62.
558. Fujii N, Souri M, Ichinose A. A short half-life of the administered factor XIII (FXIII) concentrates after the first replacement therapy in a newborn with severe congenital FXIII deficiency. *Thromb Haemost* 2012;107:592-594.
559. Gootenberg JE. Factor concentrates for the treatment of factor XIII deficiency. *Curr Opin Hematol* 1998;5:372-375.
560. Dreyfus M, Barrois D, Borg JY, et al. Successful long-term replacement therapy with FXIII concentrate (Fibrogammin[®]) P for severe congenital factor XIII deficiency: a prospective multicentre study. *J Thromb Haemost* 2011;9:1264-1266.
561. Nugent DJ. Prophylaxis in rare coagulation disorders—factor XIII deficiency. *Thromb Res* 2006;118(Suppl 1):S23-S28.
562. Inbal A, Oldenburg J, Carcao M, et al. Recombinant factor XIII: a safe and novel treatment for congenital factor XIII deficiency. *Blood* 2012;119:5111-5117.
563. Greenberg LH, Schiffman S, Wong YS. Factor XIII deficiency. Treatment with monthly plasma infusions. *JAMA* 1969;209:264-265.
564. Rodeghiero F, Castaman GC, Di Bona E, et al. Successful pregnancy in a woman with congenital factor XIII deficiency treated with substitutive therapy. Report of a second case. *Blut* 1987;55:45-48.
565. Meeks SL, Abshire TC. Abnormalities of prothrombin: a review of the pathophysiology, diagnosis, and treatment. *Haemophilia* 2008;14:1159-1163.
566. Cardigan R, Lawrie AS, Mackie IJ, Williamson LM. The quality of fresh-frozen plasma produced from whole blood stored at 4 degrees C overnight. *Transfusion* 2005;45:1342-1348.
567. Downes KA, Wilson E, Yomtovian R, Sarode R. Serial measurement of clotting factors in thawed plasma stored for 5 days. *Transfusion* 2001;41:570.

568. Horowitz B, Bonomo R, Prince AM, et al. Solvent/detergent-treated plasma: a virus-inactivated substitute for fresh frozen plasma. *Blood* 1992;79:826-831.
569. Ingram GI, Mathews JA, Bennett AE. A controlled trial of joint aspiration in acute haemophilic haemarthrosis. *Br J Haematol* 1972;23:649-654.
570. Querol F, Aznar JA, Haya S, Cid A. Orthoses in haemophilia. *Haemophilia* 2002;8:407-412.
571. Inwood MJ, Killackey B, Startup SJ. The use and safety of ibuprofen in the hemophiliac. *Blood* 1983;61:709-711.
572. Hoffman M, Pradhan S, Monroe DM. Celecoxib does not delay cutaneous wound healing in haemophilia B mice. *Haemophilia* 2009;15:615-616.
573. Rattray B, Nugent DJ, Young G. Celecoxib in the treatment of haemophilic synovitis, target joints, and pain in adults and children with haemophilia. *Haemophilia* 2006;12:514-517.
574. Valentino LA, Mamonov V, Hellmann A, et al. A randomized comparison of two prophylaxis regimens and a paired comparison of on-demand and prophylaxis treatments in hemophilia A management. *J Thromb Haemost* 2012;10:359-367.
575. Rana NA, Shapiro GR, Green D. Long-term follow-up of prosthetic joint replacement in hemophilia. *Am J Hematol* 1986;23:329-337.
576. Wang K, Street A, Dowrick A, Liew S. Clinical outcomes and patient satisfaction following total joint replacement in haemophilia—23-year experience in knees, hips and elbows. *Haemophilia* 2012;18:86-93.
577. McCollough NC 3rd, Enis JE, Lovitt J, et al. Synovectomy or total replacement of the knee in hemophilia. *J Bone Joint Surg Am* 1979;61:69-75.
578. Molho P, Verrier P, Stieltjes N, et al. A retrospective study on chemical and radioactive synovectomy in severe haemophilia patients with recurrent haemarthrosis. *Haemophilia* 1999;5:115-123.
579. Dunn AL, Busch MT, Wylly JB, Abshire TC. Radionuclide synovectomy for hemophilic arthropathy: a comprehensive review of safety and efficacy and recommendation for a standardized treatment protocol. *Thromb Haemost* 2002;87:383-393.
580. Dunn AL, Manco-Johnson M, Busch MT, et al. Leukemia and P32 radionuclide synovectomy for hemophilic arthropathy. *J Thromb Haemost* 2005;3:1541-1542.
581. Hilgartner MW, Arnold WD. Hemophilic pseudotumor treated with replacement therapy and radiation. Report of a case. *J Bone Joint Surg Am* 1975;57:1145-1146.
582. Rodriguez-Merchan EC. Haemophilic cysts (pseudotumours). *Haemophilia* 2002;8:393-401.
583. Valentino LA, Martinowitz U, Doolas A, Murali P. Surgical excision of a giant pelvic pseudotumour in a patient with haemophilia A. *Haemophilia* 2006;12:541-544.
584. Blattner RJ. Recent developments in the management of hemophilia with particular reference to intracranial bleeding. *J Pediatr* 1967;70:449-452.
585. Ljung RC. Intracranial haemorrhage in haemophilia A and B. *Br J Haematol* 2008;140:378-384.
586. Silverstein A. Intracranial bleeding in hemophilia. *Arch Neurol* 1960;3:141-157.
587. Eyster ME, Gill FM, Blatt PM, et al. Central nervous system bleeding in hemophiliacs. *Blood* 1978;51:1179-1188.
588. Andes WA, Wulff K, Smith WB. Head trauma in hemophilia. A prospective study. *Arch Intern Med* 1984;144:1981-1983.
589. Curran JW, Lawrence DN, Jaffe H, et al. Acquired immunodeficiency syndrome (AIDS) associated with transfusions. *N Engl J Med* 1984;310:69-75.
590. Chorba TL, Holman RC, Clarke MJ, Evatt BL. Effects of HIV infection on age and cause of death for persons with hemophilia A in the United States. *Am J Hematol* 2001;66:229-240.
591. Goedert JJ, Eyster ME, Lederman MM, et al. End-stage liver disease in persons with hemophilia and transfusion-associated infections. *Blood* 2002;100:1584-1589.
592. White GC 2nd, Zeitler KD, Lesesne HR, et al. Chronic hepatitis in patients with hemophilia A: histologic studies in patients with intermittently abnormal liver function tests. *Blood* 1982;60:1259-1262.

593. Fletcher ML, Trowell JM, Craske J, et al. Non-A non-B hepatitis after transfusion of factor VIII in infrequently treated patients. *Br Med J (Clin Res Ed)* 1983;287:1754-1757.
594. Gerety RJ, Eyster ME, Tabor E, et al. Hepatitis B virus, hepatitis A virus and persistently elevated aminotransferases in hemophiliacs. *J Med Virol* 1980;6:111-118.
595. Lefrere JJ, Mariotti M, Thauvin M. B19 parvovirus DNA in solvent/detergent-treated anti-haemophilia concentrates. *Lancet* 1994;343:211-212.
596. Mannucci PM, Gdovin S, Gringeri A, et al. Transmission of hepatitis A to patients with hemophilia by factor VIII concentrates treated with organic solvent and detergent to inactivate viruses. The Italian Collaborative Group. *Ann Intern Med* 1994;120:1-7.
597. Giangrande PL. Hepatitis in haemophilia. *Br J Haematol* 1998;103:1-9.
598. Peden A, McCardle L, Head MW, et al. Variant CJD infection in the spleen of a neurologically asymptomatic UK adult patient with haemophilia. *Haemophilia* 2010;16:296-304.
599. Chtourou S, Porte P, Nogr e M, et al. A solvent/detergent-treated and 15-nm filtered factor VIII: a new safety standard for plasma-derived coagulation factor concentrates. *Vox Sang* 2007;92:327-337.
600. Cardone F, Simoneau S, Arzel A, et al. Comparison of nanofiltration efficacy in reducing infectivity of centrifuged versus ultracentrifuged 263K scrapie-infected brain homogenates in "spiked" albumin solutions. *Transfusion* 2012;52:953-962.
601. Smith PS, Keyes NC, Forman EN. Socioeconomic evaluation of a state-funded comprehensive hemophilia-care program. *N Engl J Med* 1982;306: 575-579.
602. Helske T, Ikkala E, Myllyl a G, et al. Joint involvement in patients with severe haemophilia A in 1957-59 and 1978-79. *Br J Haematol* 1982;51:643-647.
603. Nilsson IM, Berntorp E, L ofqvist T, Pettersson H. Twenty-five years' experience of prophylactic treatment in severe haemophilia A and B. *J Intern Med* 1992;232:25-32.
604. L ofqvist T, Nilsson IM, Berntorp E, Pettersson H. Haemophilia prophylaxis in young patients—a long-term follow-up. *J Intern Med* 1997;241:395-400.
605. Bohn RL, Avorn J, Glynn RJ, et al. Prophylactic use of factor VIII: an economic evaluation. *Thromb Haemost* 1998;79:932-937.
606. Fischer K, van der Bom JG, Mauser-Bunschoten EP, et al. The effects of postponing prophylactic treatment on long-term outcome in patients with severe hemophilia. *Blood* 2002;99:2337-2341.

Chapter 54 Acquired Coagulation Disorders

> Table of Contents > Part V - Disorders of Hemostasis and Coagulation > Section 4 - Coagulation Disorders > Chapter 54 - Acquired Coagulation Disorders

Chapter 54

Acquired Coagulation Disorders

George M. Rodgers

Abnormalities in blood coagulation may complicate a large number of disorders (Table 54.1). In contrast to inherited disorders in which deficiency or abnormality of a single factor is characteristic, the acquired forms usually are associated with multiple coagulation abnormalities, and the disorder often is complicated by thrombocytopenia, deficient platelet function, and abnormal inhibitors of coagulation. Because of the compound nature of the hemostatic defect, the severity of bleeding often correlates poorly with the results of laboratory tests in patients with acquired coagulation disorders, and replacement therapy may be ineffective. With some notable exceptions, however, bleeding usually is less severe than in the inherited forms, and the clinical picture often is complicated by signs and symptoms of the underlying disease.

DEFICIENCIES OF VITAMIN K-DEPENDENT FACTORS

Prothrombin; factors VII, IX, and X; and proteins C and S are synthesized by the liver by a process that depends on vitamin K (see Chapter 18 and Fig. 54.1).^{1, 2} When stores of this vitamin are deficient or abnormal, hypofunctional analogs of these factors are synthesized, which inhibit normal coagulation. These descarboxy analogs of the vitamin K-dependent factors

do not bind to cellular phospholipid surfaces and, therefore, do not participate in cell-associated coagulation reactions. This may occur in disorders in which intake or absorption of vitamin K is deficient and in disorders that impair the biosynthetic capacity of the liver (Fig. 54.1). A similar coagulation abnormality may be produced by anticoagulant drugs such as coumarin and indanediones, which antagonize the action of vitamin K (see Chapter 55).

Vitamin K Deficiency Bleeding (Hemorrhagic Disease of the Newborn)

Hemorrhagic disease of the newborn is the result of vitamin K deficiency in the neonate; this phrase was first used more than 100 years ago.³ The preferred term is vitamin K deficiency bleeding (VKDB) in infancy as proposed by a consensus committee.⁴ Formerly a major cause of bleeding, this disorder is now uncommon because of the routine administration of vitamin K at birth⁵; however, it is still encountered in economically deprived populations.

Pathophysiology

The normal newborn has a moderate deficiency of the vitamin K-dependent coagulation factors. The plasma levels of these factors normally fall even further during the first 2 to 5 days of life, rise again when the infant is 7 to 14 days old, and attain normal adult levels later in life (see also Table 45.6). The deficiency of the vitamin K-dependent coagulation factors that is present at birth, as well as the slow rate at which adult levels are attained, presumably is the result of intrinsic "liver immaturity;" neither of these physiologic phenomena is affected by vitamin K administration.⁶ On the other hand, the diminution in levels of these factors that occurs at age 2 to 5 days is prevented by vitamin K administration because it is the result of a transitory physiologic deficiency of this vitamin. Factors that further diminish the amount of vitamin K available at this juncture and those that further impair the synthetic capacity of the liver predispose neonates to hemorrhagic disease of the newborn. These factors are (a) prematurity, (b) inadequate dietary intake, (c) delayed gut colonization by bacteria, (d) various obstetric and perinatal complications, and, possibly, (e) maternal deficiency of vitamin K.

Prematurity often has been associated with VKDB.⁷ Levels of the vitamin K-dependent factors at birth are approximately proportional to gestational age and birth weight.⁸ In premature infants, the physiologic immaturity of the liver is marked, and the response to vitamin K that is present is subnormal.

Most factors associated with deficient intake of vitamin K also delay the colonization of the gut by bacteria. These factors include delayed feeding, breast-feeding, vomiting, severe diarrhea, and antibiotics, including those present in maternal milk. Human milk and colostrum are poor sources of vitamin K,⁶ and reliance on breast milk as the sole source of nutrients in the neonatal period is an important factor in many cases of VKDB.⁵

Coumarin and indanedione drugs cross the placenta and may produce hemorrhagic disease in the newborn.⁹ Infants born of mothers who were taking diphenylhydantoin or other anticonvulsants, including barbiturates, or salicylates have developed a syndrome similar to VKDB.¹⁰ Treatment of the mother with vitamin K during the last trimester may prevent this complication.

Clinical Features and Laboratory Diagnosis

VKDB etiology is considered idiopathic (no cause other than breast-feeding) or secondary (malabsorption of vitamin K, liver

P.1187

disease, drugs).⁴ VKDB can also be classified in terms of age of onset: Early (onset <24 hours of age), classic (onset usually between 3 and 5 days), and late (onset on or after 8 days). Early VKDB is uncommon and usually results from placental transfer of maternal drugs that antagonize vitamin K in the newborn. Late VKDB occurs almost exclusively in breast-fed infants who may also have hepatobiliary disease.⁴

TABLE 54.1 ACQUIRED COAGULATION DISORDERS

Deficiencies of vitamin K-dependent coagulation factors

Hemorrhagic disease of the newborn (vitamin K deficiency bleeding)

Biliary obstruction (gallstone, strictures, fistulas)

Malabsorption of vitamin K (sprue, idiopathic steatorrhea, celiac disease, ulcerative colitis, regional enteritis, gastrocolic fistulas, *Ascaris* infestation)

Nutritional deficiency

Drugs

1. Pharmacologic antagonists of vitamin K (coumarins, indandiones, others)
2. Those that alter gut flora (broad-spectrum antibiotics, sulfonamides)
3. Miscellaneous (cholestyramine)

Liver disease (see Table 54.3)

Accelerated destruction of coagulation factors

Disseminated intravascular coagulation (see Table 54.4)

Fibrinolysis (liver disease, thrombolytic agents, tumors, after surgery)

Inhibitors of coagulation

Specific inhibitors (antibodies) (see Table 54.6)

Antiphospholipid-protein antibodies (see Table 54.7)

Miscellaneous (antithrombins, paraproteinemias)

Miscellaneous

After massive transfusion

After extracorporeal circulation

Drugs (antibiotics, antineoplastic agents, others)

Other disorders (polycythemia vera, congenital heart disease, amyloidosis, nephrotic syndrome, Sheehan syndrome, Gaucher disease, leukemia, others)

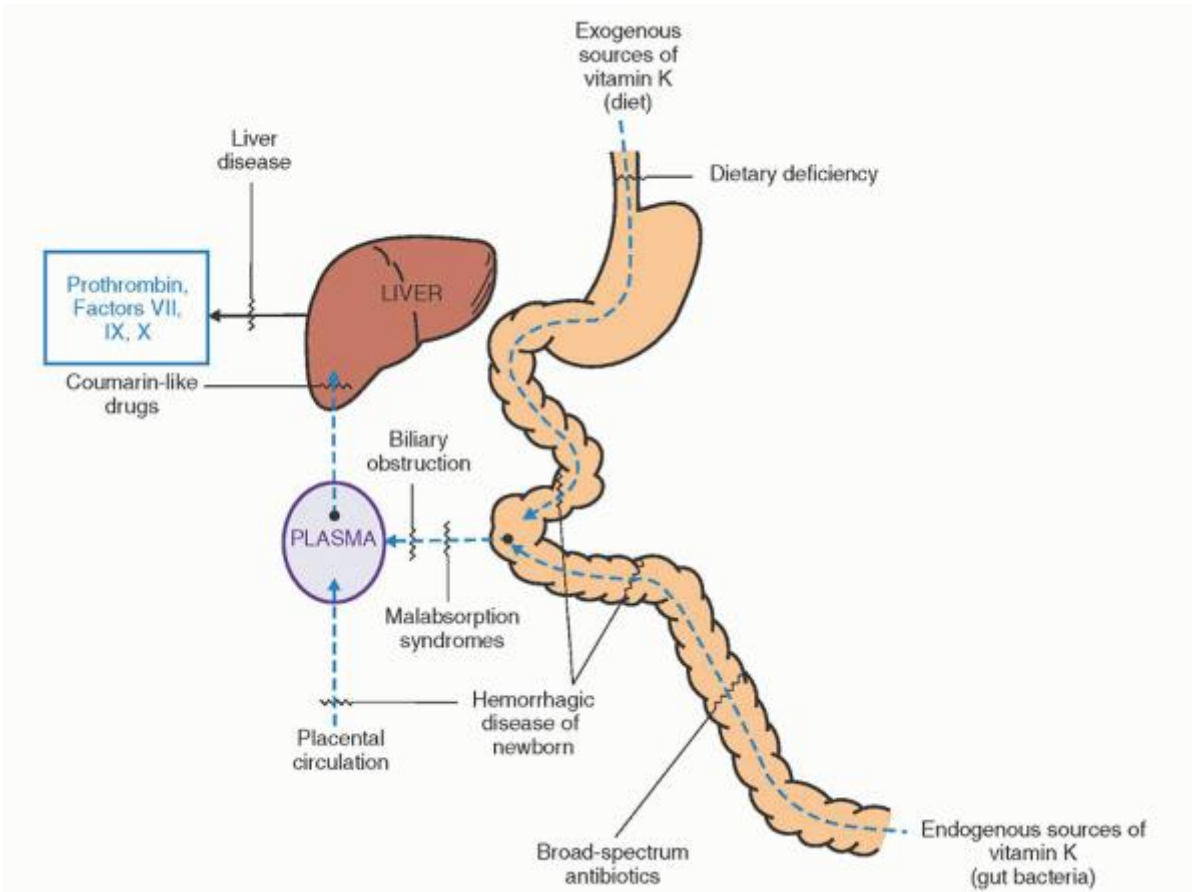

FIGURE 54.1. Etiologies of vitamin K deficiency. Sources of vitamin K include the diet and gut bacterial synthesis. Processes leading to vitamin K deficiency are indicated with a solid line ending in a squiggle.

Bleeding in classic VKDB is severe.³ The most common manifestations are melena, large cephalohematomas, and bleeding from the umbilical stump and after circumcision. Generalized ecchymoses, often without petechiae, intracranial bleeding, and large intramuscular hemorrhages also may develop.^{3, 6}

Laboratory diagnosis is relatively simple (Table 54.2), but physiologic differences in the results of various coagulation tests in normal neonates must be kept in mind (see Table 45.6). In infants with VKDB, the prothrombin time (PT) always is prolonged. The partial thromboplastin time (PTT) is also prolonged. Specific factor assays reveal deficiencies of prothrombin; factors VII, IX, and X; and proteins C and S. The presence of normal antigenic levels of the vitamin K-dependent factors may be demonstrated by immunoassays.¹¹ Factors V and VIII, as well as fibrinogen, are present in normal amounts. The consensus committee recommends diagnosing VKDB with a prolonged PT value, a normal fibrinogen level, and a normal platelet count.⁴

The clinician should not assume that bleeding in the neonate is invariably the result of vitamin K deficiency.⁴ In the differential diagnosis of VKDB, virtually all causes of bleeding, particularly thrombocytopenia (see Chapter 46) and disseminated intravascular coagulation (DIC) must be considered.¹² The inherited coagulation disorders (see Chapter 53) also may produce serious hemorrhage in the neonatal period, but significant prolongation of the PT is not found in the most common forms, for example, hemophilia A and hemophilia B. Umbilical bleeding and hemorrhage after circumcision are relatively less common in the inherited coagulation disorders than in VKDB.

Treatment

Vitamin K₁ (0.5 to 1.0 mg given intramuscularly) is dramatically effective in the treatment of VKDB¹³; the 0.5-mg dose appears to be more than adequate.¹⁴ Shortening of the PT may be expected within 6 hours, and normal neonatal levels of the vitamin K-dependent factors usually are attained within 24 hours of administration. An American Academy of Pediatrics consensus report has summarized recommendations of vitamin K therapy for prevention of early and late VKDB.¹⁵ Larger (2 mg) or repeated (every 4 to 8 hours) doses of vitamin K₁ may be required to counteract the effects of coumarin drugs in infants.⁶ The response in premature infants to vitamin K₁ usually is incomplete. The administration of

large doses of vitamin K may produce hemolysis, hyperbilirubinemia, and even kernicterus in the neonate. These complications appear to be associated more commonly with the synthetic derivatives than with vitamin K₁, but even the latter may be dangerous in large doses.⁶

In severe cases of VKDB, the transfusion of plasma may be helpful.⁶ Concentrates of vitamin K-dependent coagulation factors are effective but have led to thrombosis and intravascular coagulation in some infants, particularly in premature infants. This result has been attributed to immaturity of the hepatic clearance functions and physiologic deficiency of antithrombin.

Because VKDB is primarily a disease of breast-fed infants,¹⁶ VKDB can be prevented by the administration of vitamin K to the mother before delivery. Most authorities, however, recommend administering vitamin K₁ to the infant. This procedure is now routine in most nurseries. Many pediatricians also recommend the

P.1188

prophylactic administration of vitamin K₁ to infants 1 to 5 months of age, especially those who are breast-fed or who have a disorder that may impair vitamin K absorption.¹⁷ The usual dosage in such older infants is 50 to 100 µg daily or 1 mg monthly.

TABLE 54.2 LABORATORY FINDINGS IN ACQUIRED COAGULATION DISORDERS

	Hemorrhagic Disease of the Newborn	Severe Liver Disease	Disseminated Intravascular Coagulation	Primary Fibrinolysis	Antibodies to Factor VIII	Inhibitors of Lupus Type
Screening Tests						
Platelet count ^a	N	vD	D	uN	N	V ^a
Prothrombin time ^b	I	I	I	vI	N	V ^a
Partial thromboplastin time ^b	I	I	V	vI	I	I
Thrombin time ^b	vI	uI	I	I	N	N
Erythrocyte morphology ^a	Macrocytes	Target cells and macrocytes	Schistocytes and microspherocytes	uN	uN ^a	uN ^a
Specific Assays						
Fibrinogen	N	vD	D	vD	N	N
Prothrombin ^b	D	D	V	uN	N	vD ^c
Factor V	N	uD	uD	vD	N	N ^c
Factor VII ^b	D	D	V	uN	N	N ^c
Factor VIIIc	N	uI	uD ^c	vD	D	N ^c
von Willebrand factor	N	uI	vI	V	N	N
Factor IX ^b	D	D	V ^c	uN	N	N ^c
Factor X ^b	D	D	vD	uN	N	N ^c
Factor XI ^b	vD	vD	uN	uN ^c	N	N ^c

Factor XIII ^d	uN	vD	uD	vD	N	N
Tests for Fibrinolysis and FDP						
FDP	uN	uI	I	I	N	N ^e
Plasminogen ^b	vD	vD	D	D	N	N
α^2 -Antiplasmin	uN	vD	V	vD	N	N
Plasmin	N	vI	uI	uI	N	N
D-Dimer	uN	uN	I	uN	N	N ^e
Miscellaneous Tests						
Antithrombin	N	vD	vD	uN	N	N
Protein C	D	D	V	uN	N	uN
Protein S	D	D	V	uN	N	V

D, decreased; FDP, fibrin(ogen) degradation products; I, increased; N, normal; u, usually; v, variably; V, variable.

^a May reveal effects of acute bleeding or abnormality characteristic of underlying disease.

^b Results may differ from adult norms in normal neonates.

^c One-stage assays may yield aberrant results.

^d Hypofibrinogenemia may alter results.

^e The presence of immunoglobulin M rheumatoid factors in certain patients may lead to a false-positive result in latex-agglutination assays.

Most pediatricians would attribute the decrease in incidence of VKDB in recent years to the prophylactic administration of vitamin K. There is widespread consensus on continuing vitamin K prophylaxis to newborns.^{3, 15} A prospective population study in the United Kingdom found that with prophylaxis, VKDB in newborns is rare,¹⁸ whereas in developing countries, prophylaxis is not frequently used, and VKDB is common.

Other Causes of Vitamin K Deficiency

Obstruction of the biliary tract, either intrahepatic or extrahepatic, produces vitamin K deficiency because of the absence of bile salts in the gut. Complete obstruction may lead to severe coagulation abnormalities and bleeding within 2 to 4 weeks. This was a major obstacle to surgical procedures on the biliary tract before the discovery of vitamin K.

Most malabsorption syndromes and various other chronic gastrointestinal disorders also may give rise to vitamin K deficiency. Such disorders include celiac disease, sprue, gastrocolic fistulas, ulcerative colitis, regional enteritis, extensive gut resections, protracted diarrhea of any cause, *Ascaris* infestations, and cystic fibrosis. The last named disorder often is complicated by liver disease.¹¹ Severe abnormalities of coagulation and bleeding are less common in association with these disorders than with biliary obstruction, presumably because absorption of vitamin K is seldom completely deficient.

Because vitamin K normally is available from two independent sources (Fig. 54.1), neither nutritional deficiency nor gut sterilization alone produces deficiency of a degree that results in significant coagulation abnormalities. In normal adults, the daily oral intake of vitamin K must be reduced to 20 µg or less for several weeks to produce significant hypoprothrombinemia.¹ However, vitamin K deficiency is more common than is usually realized in hospitalized patients with poor or negligible oral food intake, especially if they are also taking antibiotics.^{19, 20} Significant coagulation abnormalities may arise with surprising rapidity

P.1189

in such patients, and when unsuspected, they may be confused with DIC or may first be revealed by serious, unexpected postoperative hemorrhage. Antimicrobial agents presumably impair vitamin K production by inhibiting the synthesis of menadiones by gut bacteria, but they may also directly affect carboxylation reactions.^{21, 22} Vitamin K deficiency also may result from use of drugs other than antimicrobial agents, such as cholestyramine,²³ which acts by binding bile salts, or mineral oil and other cathartics when used for protracted periods. Vitamin E may antagonize the metabolic action of vitamin K and potentiate the action of coumarins.⁶ When taken in large doses, this vitamin may prolong the PT.²⁴ Antibiotic therapy, poor diet, or any of the aforementioned disorders may predispose patients to coumarin toxicity (see Chapter 55).²⁵ Large doses of aspirin, as given to treat rheumatic disorders or in amounts associated with overdosage of the drug, may also induce vitamin K deficiency.²⁶

Treatment

In adults, the parenteral administration of 10 mg of vitamin K₁ abolishes coagulation abnormalities within 12 to 24 hours if they are the consequence of a deficiency of this vitamin. Failure of vitamin K to normalize the PT is evidence for the presence of a complicating process, such as liver disease or DIC, or super-warfarin ingestion.²⁷ The synthetic vitamin K₃ (menadiones) may be absorbed in the absence of bile salts and in various malabsorption syndromes. However, these congeners of vitamin K have a more transient effect than the natural forms of this vitamin and offer minimal therapeutic advantage in the usual case. Replacement therapy with fresh frozen plasma or prothrombin complex concentrates (PCCs) is effective in the treatment of emergent vitamin K deficiency.

Intravenous administration of vitamin K may produce hemolytic anemia in patients with inherited deficiencies of various red cell enzymes, and may be associated with a risk of anaphylaxis.²⁸ Malnourished patients receiving broad-spectrum antibiotic therapy should receive vitamin K prophylactically, 5 mg twice weekly, orally or subcutaneously.²⁹

Commercially available rodenticides (super-warfarins) that exhibit long-acting vitamin K antagonism have been associated with significant bleeding disorders when these compounds have been ingested by humans.²⁷ These drugs are chemically distinct from warfarin, are 100 times more potent than warfarin, and can induce vitamin K deficiency lasting for months. In 1995 alone, more than 13,000 people were exposed to these agents and treated.³⁰ Initial treatment of these patients may require up to 100 mg of vitamin K daily to normalize vitamin K metabolism.³⁰

LIVER DISEASE

Virtually every hemostatic function may be impaired in patients with severe hepatic disease (Table 54.3)^{31, 32, 33} as the result of failure of both the biosynthetic and clearance functions of the liver. The pathophysiology of some of these abnormalities is tied to thrombocytopenia (see Chapter 46), platelet dysfunction (see Chapter 52), intravascular coagulation and fibrinolysis, and the effects of products of fibrinogen catabolism on hemostasis (see below).

Pathophysiology

Thrombocytopenia

Patients with significant liver disease have portal hypertension, splenomegaly, and splenic sequestration of platelets, contributing to thrombocytopenia. The liver is also the major site of production of thrombopoietin, the principal humoral factor involved in megakaryocyte maturation and platelet formation (see Chapter 15). Recent studies have evaluated whether deficient levels of thrombopoietin occur in liver disease. Results indicate that thrombocytopenia in liver disease is not explained by deficient hepatic production of thrombopoietin.^{34, 35} However, there is a correlation between the extent of liver disease and platelet expression of the thrombopoietin receptor, c-Mpl,³⁵ and this reduced expression may contribute to thrombocytopenia. Additionally, increased thrombopoietin degradation by platelets sequestered in the spleen may also contribute to thrombocytopenia in these patients.³⁶

TABLE 54.3 ABNORMALITIES OF HEMOSTASIS AND COAGULATION IN LIVER DISEASE

Deficient biosynthesis

Of fibrinogen; prothrombin; coagulation factors V,³⁹ VII, IX, X, XI, XII, XIII; prekallikrein; high-molecular-weight kininogen

Of antiplasmins,⁵⁸ antithrombin,⁵⁷ proteins C and S

Aberrant biosynthesis

Of abnormal fibrinogen,⁴¹, ⁴⁵ factor V

Of abnormal inhibitory analogs of prothrombin, factors VII, IX, and X⁴⁶

Deficient clearance

Of hemostatic “products” (e.g., fibrin monomers, fibrin[ogen] degradation products, platelet factor-3)

Of activated coagulation factors (IXa, Xa¹⁵⁸, XIa)

Of plasminogen activators⁴⁹

Accelerated destruction of coagulation factors

Disseminated intravascular coagulation⁶⁴, ⁶⁵, ⁶⁶

Abnormal fibrinolysis⁵⁰

Thrombocytopenia

Hypersplenism (portal hypertension)

Folic acid deficiency

Chronic ethanol intoxication

Disseminated intravascular coagulation

Platelet dysfunction

Acute and chronic ethanol intoxication

Effects of products of fibrinogen degradation⁵¹

Uremia

Miscellaneous

Inhibition of coagulation by products of fibrinogen degradation⁵³, ⁵⁴

Loss or consumption of coagulation factors in ascitic fluid⁶⁸

Deficient or Aberrant Synthesis of Coagulation Factors

In patients with liver disease, all coagulation factors except factor VIII may be deficient as a consequence of synthetic failure of the hepatic cells. Failure of biosynthesis of coagulation factors often correlates with the severity of hypoalbuminemia, but exceptions to this rule are common. Deficiencies of prothrombin; factors VII, IX, and X; and proteins C and S result mainly from synthetic incompetence. For example, factor VII expression in liver biopsies from patients with liver disease decreases as the severity of hepatic dysfunction increases.³⁷ Impaired carboxylation of precursors may contribute to the defect.¹¹ Superimposed vitamin K deficiency may result from a poor diet or malabsorption caused by insufficient production of bile salts or by exocrine pancreatic insufficiency.³⁸ The failure of these coagulation abnormalities to respond to vitamin K administration provides good evidence of hepatic cell dysfunction.

P.1190

Factors V, XI, and XIII are synthesized by the liver but are not vitamin K-dependent³⁹; all of these factors may be deficient in patients with severe liver disease. Plasma levels of factor XII, prekallikrein (Fletcher factor), and high-molecular-weight

kininogen (Fitzgerald factor) also may be low in association with liver disease. Deficiencies of these latter three factors do not contribute to a bleeding diathesis.

Hypofibrinogenemia rarely may result from deficient hepatic biosynthesis^{39, 40} or may be the consequence of fibrinogenolysis or DIC, as discussed subsequently. In many patients with liver disease, prolongation of the thrombin time can be significant in the absence of hypofibrinogenemia or increased levels of fibrin(ogen) degradation products (FDPs).⁴¹ This apparently is the result of a qualitatively abnormal fibrinogen that is synthesized by the diseased hepatic cell. Such acquired dysfibrinogenemia has been reported in most forms of liver disease, ranging from mild acute hepatitis to acute hepatic necrosis and cirrhosis.⁴² Fibrin monomer polymerization is delayed,⁴³ and the abnormal fibrinogen molecule acts as an antithrombin.⁴¹ Additionally, this hepatic disease dysfibrinogen may have an abnormally high content of sialic acids⁴⁴ and may produce a structurally defective fibrin clot.⁴⁵ Acquired dysfibrinogenemia, abnormal inhibitors of fibrinolysis, and the presence within the plasma of descarboxy analogs of prothrombin⁴⁶ have been reported in patients with hepatomas.⁴⁷ Hepatoma-associated dysfibrinogens have also been noted to have an increased carbohydrate content.

Plasma levels of factor VIIIc usually are elevated in both parenchymal and cholestatic liver disease.⁴⁸ Studies in patients with cirrhosis indicate that elevated plasma factor VIII levels are not due to increased transcriptional activity of factor VIII in the liver, but instead likely result from increased liver synthesis of von Willebrand factor (vWF) and decreased levels of lipoprotein receptor-related protein. Both of these latter proteins regulate plasma factor VIII levels.⁴⁸

Fibrinogenolysis and Fibrinolysis

Endogenous plasminogen activators normally are removed from the circulation by the liver. In patients with severe liver disease, however, they may circulate for an abnormally long time and lead to the chronic or intermittent activation of the fibrinolytic enzyme system.^{49, 50} This process may be a contributory factor in the pathogenesis of hypofibrinogenemia in patients with liver disease. It also leads to the production of large amounts of FDP, which persist in the circulation for abnormally long periods because of deficient hepatic clearance, and may impair blood coagulation and platelet function.⁵¹ Such proteolytic activity also may produce a shift in the mean molecular weight of circulating fibrinogen from the normal species to a less reactive species of lower molecular weight,⁵² thereby contributing to the "antithrombins of liver disease."^{53, 54}

The incidence of hyperfibrinolysis was surveyed in patients with cirrhotic and noncirrhotic liver disorders.⁵⁵ Hyperfibrinolysis, as measured by a shortened euglobulin clot lysis time, was present in approximately 30% of cirrhotic patients but not present in noncirrhotic patients.⁵⁵ The role of thrombin-activatable fibrinolysis inhibitor deficiency in liver disease in contributing to hyperfibrinolysis has been studied; thrombin-activatable fibrinolysis inhibitor levels are reduced in liver disease, with lower levels seen in more severe liver disease.⁵⁶ However, there was no association of low thrombin-activatable fibrinolysis inhibitor levels with hyperfibrinolysis, even in cirrhotic patients. These studies suggest that hyperfibrinolysis is not common in liver disease, even in cirrhosis.^{55, 56}

Plasma levels of antithrombin,⁵⁷ antiplasmin,⁵⁸ and plasminogen⁵⁹ are subnormal in patients with liver disease. These abnormalities are of uncertain clinical importance.

Intravascular Coagulation

Severe liver disease theoretically predisposes individuals to the development of DIC because DIC is associated with deficient hepatic clearance of activated coagulation factors and other coagulant substances. The in vivo turnover rates of prothrombin,⁶⁰ fibrinogen,⁶¹ plasminogen,⁶⁰ and antithrombin⁵⁷ often are accelerated in patients with cirrhosis. Plasma levels of fibrinopeptide A are elevated in most patients with cirrhosis.⁶² All of these abnormalities may be normalized in some cases by the administration of heparin.⁶³ It has been hypothesized that accelerated catabolism of coagulation factors in these disorders is the result of DIC. The nature of the initiating process is unclear, but one suggestion is that DIC is activated by hypoperfusion of the congested portal bed.⁴⁰ Indirect evidence suggests that in severe liver disease, activators of coagulation, possibly endotoxin, may originate in the gut.

Low-grade DIC or localized intravascular coagulation indeed may occur in association with severe liver disease, but overt DIC is responsible only rarely for bleeding in the absence of other etiologic factors that trigger this process, for instance, sepsis, shock, and cancer.^{64, 65} This conclusion is supported by findings in patients with stable cirrhosis that demonstrated no increased levels of markers of activation of coagulation, such as prothrombin fragment 1+2, thrombin-antithrombin complex, and so forth.⁶⁶

Evidence for accelerated fibrinogen turnover in ascitic fluid suggests that the loss or consumption of coagulation factors in peritoneal fluid may be a contributory factor in the coagulopathy of chronic liver failure. Shunting of ascitic fluid into the venous circulation by means of LeVeen shunts consistently produces coagulation abnormalities consistent with DIC in

cirrhotic patients.⁶⁷ Although this phenomenon usually is attributed to intravascular coagulation, evidence shows that it may result in part from the presence of plasminogen activators and active plasmin⁶⁸ or collagen⁶⁹ in peritoneal fluid.

A transitory coagulation disorder that resembles intravascular coagulation with active fibrinolysis has been documented during liver transplantation procedures. Coagulation abnormalities disappear promptly if the graft is successful.⁷⁰ The complex coagulopathy seen with liver transplantation has been reviewed.⁷¹

Clinical Manifestations

In view of the numerous hemostatic abnormalities associated with severe liver disease, it is surprising that many patients do not bleed abnormally. Gastrointestinal hemorrhage is the most common bleeding manifestation, but it almost always originates from a local lesion, such as esophageal varices, peptic ulcer, or gastritis. The degree to which coagulation abnormalities contribute to such bleeding is uncertain. In one large series, gastrointestinal bleeding was not significantly more severe or protracted in patients with coagulation abnormalities than in those without them.⁷² In another study, serious hemorrhage occurred only in patients with prolonged PTs and significant factor IX deficiency.⁷³ Moderate generalized bleeding manifestations, such as recurrent ecchymoses and epistaxis, are not uncommon, and severe generalized bleeding may complicate surgical procedures, including biopsies, tooth extractions, and other minor procedures.

The above-mentioned paradox of the lack of bleeding in many patients with severe liver disease despite multiple hemostatic abnormalities has been explored.⁷⁴ An emerging concept is that coagulation in liver disease patients is "rebalanced" due to parallel reductions in both procoagulant and anticoagulant factors. Standard coagulation tests (such as the PT) do not measure major *in vivo* regulators of coagulation such as thrombomodulin and may not adequately reflect hemostasis in these patients.^{32, 74} This new paradigm has implications for managing the coagulopathy of liver disease.

P.1191

Laboratory Diagnosis

The laboratory findings in liver disease vary with the cause and severity of the underlying disorder and range from a slight prolongation of the PT in anicteric hepatitis to the findings summarized in Table 54.2, which are seen in severe decompensated cirrhosis. In cirrhosis, coagulation abnormalities correlate with the presence of portal hypertension and may be minimal in inactive cirrhosis; thrombocytopenia alone is common in association with portal hypertension. Acute fibrinogenolysis is significantly more common in patients with cirrhosis⁵⁵ than in those with acute hepatocellular disease, such as hepatitis, although elevations of FDP are consistently found in people with chronic aggressive hepatitis.⁴² Coagulation abnormalities are seldom marked in biliary cirrhosis, and some patients with this disorder have abnormally high levels of prothrombin and factors VII and X. Hemostatic abnormalities of any sort are rare in metastatic liver disease. In acute liver failure, the PT value has prognostic value and is indicative of the need for liver transplantation.⁷⁵ The spectrum of coagulation abnormalities in liver disease has been reviewed.³¹

Although screening tests of coagulation are almost invariably performed before liver biopsy, they apparently are of little value in predicting hemorrhage after this and other minor surgical procedures.^{32, 74, 76, 78} Similarly, the bleeding time test is of little clinical use in predicting bleeding.⁷⁹ Many physicians use the international normalized ratio (INR) as a substitute coagulation test for the PT.⁸⁰ When measured with a sensitive thromboplastin, the INR can quantitate vitamin K deficiency due to liver disease, but it should not be interpreted as in patients receiving warfarin.⁸⁰

Treatment

Not all patients with the coagulopathy of liver disease require hemostatic correction before procedures such as liver biopsy. A retrospective study looked at the PT ratio (patient PT/mean of reference range PT) and degree of thrombocytopenia to determine the necessity of plasma and platelet transfusion.⁸¹ In patients with platelet counts of 50,000/ μ l or greater, there was no increased bleeding with liver biopsy compared with patients with normal platelet counts. With regard to elevated PT values, if the PT ratio was <1.5, no increased bleeding was observed.⁸¹ Therefore, patients with moderate thrombocytopenia and mild liver disease coagulopathy do not need routine hemostatic correction with blood products. One exception to this recommendation is patients with a diagnosis of malignancy, who may have a higher bleeding risk, possibly due to chronic DIC and elevated FDP levels.⁸¹ On the other hand, a British guidelines committee on the use of plasma products suggests that "patients with liver disease and a PT more than 4 seconds longer than control are unlikely to benefit from FFP."⁸² This recommendation is based on expert opinion.

Elevated FDP levels may be a significant hemostasis risk factor in liver disease. High levels of FDP may impair platelet function and fibrin monomer polymerization. The thrombin time can screen for the latter defect. A prolonged thrombin time in a patient with a normal functional fibrinogen level and high FDP levels, who is not receiving heparin, may constitute a significant bleeding risk, especially in the setting of moderate thrombocytopenia.

Vitamin K₁, in a dose of 10 mg, produces some improvement in the coagulation abnormalities in approximately 30% of patients with liver disease,⁷³ but the PT often becomes prolonged again after an initially favorable response. Patients with severe liver disease have minimal or no response to vitamin K therapy.

Replacement therapy with fresh frozen plasma is indicated only in the presence of serious bleeding or before surgical procedures, and its effect is often disappointing in patients with liver disease.⁷³ Reasons for this may include the short in vivo half-life of factor VII, hypervolemia, the loss of transfused factors into ascitic fluid, and the fact that the in vivo recovery of transfused factor IX is significantly lower than that of other factors, even in the absence of liver disease. Concentrates of vitamin K-dependent coagulation factors (PCC) have been used in the replacement therapy of bleeding in patients with liver disease with variable success but, in several cases, have led to thromboembolic complications and DIC.⁸³ Thrombosis presumably develops because such concentrates contain trace amounts of activated coagulation factors, particularly factors IXa and Xa,^{83, 84} that normally are not cleared from the circulation by the diseased liver and because of antithrombin deficiency, which is commonly present. Newer PCCs are becoming available; these also contain proteins C and S in addition to the procoagulant vitamin K-dependent factors. These products have not been well studied in liver disease coagulopathy, but appear to be effective in reversing warfarin coagulopathy.⁸⁵ Fresh frozen plasma is the preferable treatment option, but the effects of even maximum doses (20 to 30 ml/kg of body weight) often are transitory. Cryoprecipitate is useful to maintain fibrinogen levels over 100 mg/dl. A controlled trial found that 1-desamino-8-darginine vasopressin (DDAVP) is not helpful in management of variceal bleeding in cirrhotic patients.⁸⁶

Recombinant factor VIIa (rVIIa) is a potential therapy for liver disease patients with significant coagulopathy. However, the drug is not indicated for use in variceal bleeding, partial hepatectomy, or liver transplantation.⁸⁷ Disadvantages of rVIIa include its high cost and risk of DIC and thromboembolic complications.

Even though heparin administration may normalize fibrinogen catabolism, little evidence is cited that it decreases the duration or severity of bleeding in patients with low-grade DIC and severe liver disease. However, heparin may be useful in conjunction with PCC therapy. In this setting, the addition of small amounts of normal plasma and heparin to vials of these thrombogenic concentrates inactivates activated proteases and minimizes the thrombotic risks of these concentrates.⁸⁸

Correction of thrombocytopenia may be difficult in patients with severe liver disease. One promising intervention is the use of synthetic thrombopoietins and thrombopoietin mimetic agents. Eltrombopag is approved to treat thrombocytopenia in chronic hepatitis C patients who receive interferon therapy.

For patients requiring liver biopsy who are deemed "high risk" from the hemostasis perspective, the transjugular approach should be considered.

DISSEMINATED INTRAVASCULAR COAGULATION

The syndrome of DIC (defibrination syndrome, consumption coagulopathy) has been one of the most intensively studied subjects in hematology. This large body of information has been summarized in many detailed reviews and monographs.^{89, 90, 91} A consensus definition of DIC has been proposed: "DIC is an acquired syndrome characterized by the intravascular activation of coagulation with loss of localization arising from different causes. It can originate from and cause damage to the microvasculature, which if sufficiently severe, can produce organ dysfunction."⁹⁰

Etiology and Incidence

DIC has been well documented in association with the disorders summarized in Table 54.4. Several retrospective studies suggest that DIC remains a relatively uncommon entity, but in one large general hospital, its overall incidence was 1 in 1,000 admissions.⁹² The most prevalent etiologic factor was infection,⁹² but in another study, more than 50% of cases were obstetric patients.⁹³ A Japanese study found that in a hospital population, 45% of DIC cases were associated with malignancy.⁹⁴ In many of the disorders listed in Table 54.4, DIC develops only in an occasional case. Thus, it is rare in heatstroke,⁹⁵ autoimmune disorders,⁹⁶ and hemolytic anemias.⁹⁷ DIC is present in most cases of venomous

P.1192

snakebite, which is probably one of the most common causes of the disorder worldwide.

TABLE 54.4 ETIOLOGIES OF DISSEMINATED INTRAVASCULAR COAGULATION**Obstetric complications**

Abruptio placentae,¹⁸⁸ septic abortion and chorioamnionitis, amniotic fluid embolism, intrauterine fetal death, miscellaneous (degenerating hydatidiform moles and leiomyomas, postpartum hemolytic-uremic syndrome, abdominal pregnancy, tetracycline-induced hepatorenal failure, fetomaternal blood passage, saline-¹⁹⁴ and urea-induced¹⁹⁵ abortions)

Infections

Viral (herpes, rubella, smallpox, acute hepatitis, Reye syndrome, cytomegalic inclusion disease, various epidemic hemorrhagic fevers, others)

Rickettsial (Rocky Mountain spotted fever, others)

Bacterial (meningococemia, septicemia, particularly that due to Gram-negative organisms, many others)

Mycotic (histoplasmosis, aspergillosis)

Protozoal (malaria, kala-azar, trypanosomiasis)

Neoplasms

Carcinomas⁹⁸ (prostate, pancreas, breast, lung, ovary, many others)

Miscellaneous (metastatic carcinoid, rhabdomyosarcoma, neuroblastoma, others)

Disorders of the hematopoietic system

Acute leukemia (promyelocytic²¹⁹, other types)

Intravascular hemolysis (transfusion of incompatible blood, paroxysmal nocturnal hemoglobinuria⁶⁰⁷, fresh-water submersion⁶⁰⁸)

Histiocytic medullary reticulosis

Vascular disorders

Malformation (giant hemangiomas [Kasabach-Merritt syndrome]²²⁵, aneurysms, coarctations of the aorta and other large vessels, Takayasu aortitis, large prosthetic arterial grafts,⁶⁰⁹ cyanotic congenital cardiac lesions)

Collagen-vascular disorders⁶¹⁰

Hypoxia and hypoperfusion, myocardial infarction, cardiac arrest,⁶¹¹ various forms of shock, hypothermia

Massive tissue injury

Large traumatic injuries and burns, extensive surgical intervention,⁶¹² extracorporeal circulation, fat embolism⁶¹³

Miscellaneous

Acute iron toxicity, head trauma,⁶¹⁴ snakebite,²³¹ anaphylaxis, concentrates of vitamin K-dependent coagulation factors,⁸³ heatstroke,⁹⁵ allograft rejection, graft versus host disease, severe respiratory distress syndrome, diabetic acidosis,⁶¹⁵ status epilepticus,⁶¹⁶ acute pancreatitis,⁶¹⁷ homozygous deficiency of protein C⁶¹⁸

Pathophysiology

Mechanisms by Which Disseminated Intravascular Coagulation Is Initiated

The pathophysiology of DIC is complex. The mechanisms that activate or “trigger” DIC act on processes that are involved in normal hemostasis, namely, the processes of platelet adhesion and aggregation and contact-activated (intrinsic) and tissue factor-activated (extrinsic) pathways of coagulation (Fig. 54.2). These mechanisms have in common the capacity, in terms of either the magnitude or the duration of the activating stimulus, to exceed normal compensatory processes. Thrombin is persistently generated, and fibrin is formed in the circulating blood. Fibrinogen, various other coagulation factors, and platelets are consumed. The fibrinolytic mechanism is activated, and large amounts of FDP are produced, which further impair hemostatic function. Bleeding, shock, and vascular occlusion commonly supervene and produce profound alterations in the function of various organ systems. Normal compensatory processes may become impaired, creating a self-perpetuating “vicious cycle.” The ultimate outcome is determined by a dynamic interplay between the various pathologic processes and compensatory mechanisms, in other words, fibrin deposition versus fibrinolysis; depletion versus repletion of coagulation factors and platelets; and production versus clearance of fibrin, FDPs, and other products of coagulation (Fig. 54.3). In most forms of DIC, the initiating factors are multiple and interrelated. For example, in meningococemia, endothelial cell injury may lead to expression of tissue factor and to collagen exposure; the latter then initiates platelet adhesion, aggregation, and thrombosis.

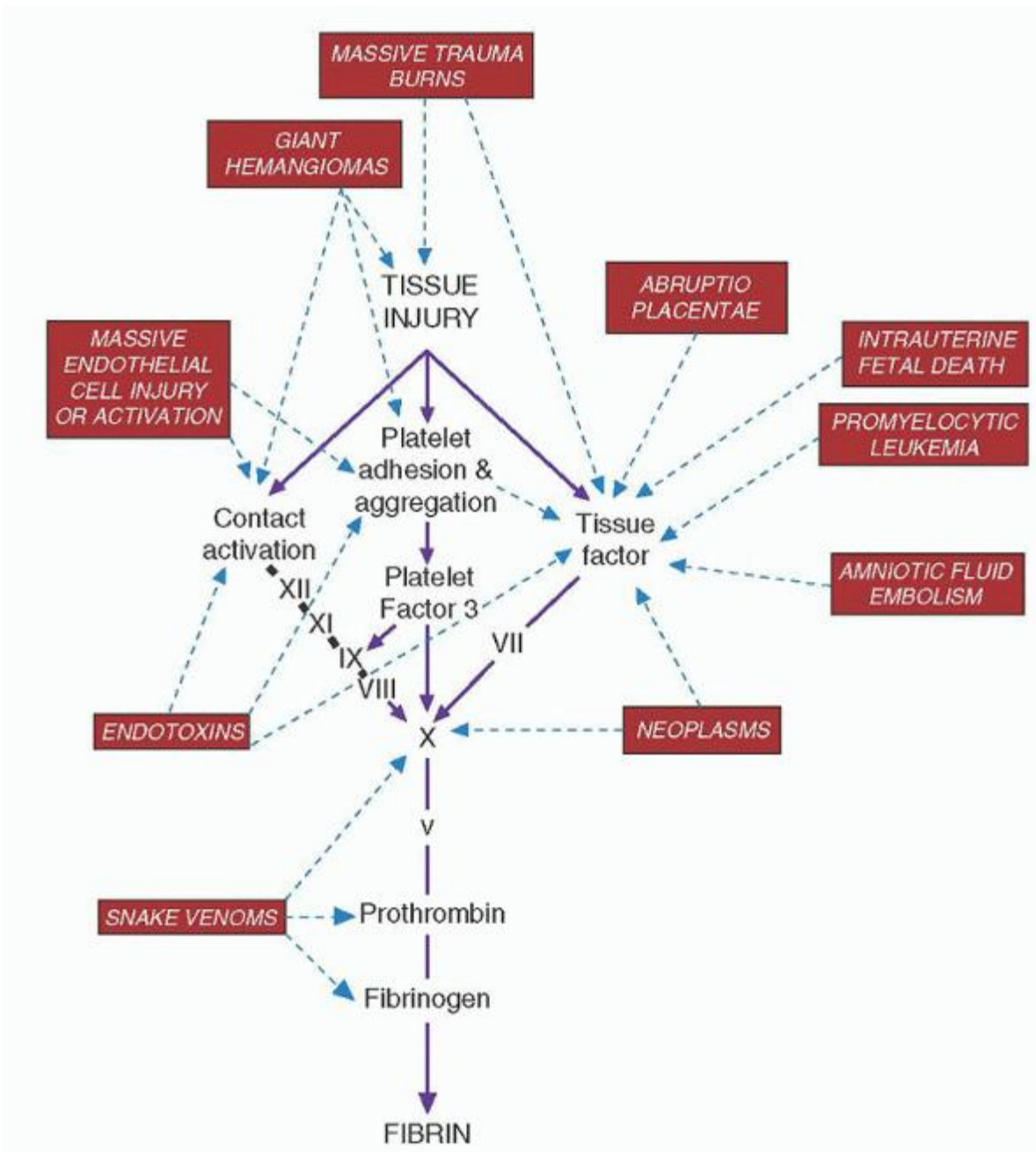

FIGURE 54.2. Initiating mechanisms of disseminated intravascular coagulation (DIC). The solid arrows indicate normal hemostatic pathways, and dotted arrows indicate pathways by which certain disorders associated with DIC initiate or promote the coagulopathy of DIC. Initiation of coagulation by expression of tissue factor activity is probably the most important mechanism triggering DIC.

Tissue Factor

The exposure of procoagulant tissue extracts to blood is a major contributory factor in most forms of DIC and is of major pathogenetic importance in cases associated with abruptio placentae, intrauterine fetal death, acute promyelocytic leukemia, amniotic fluid embolism, massive trauma, and various neoplasms.⁹⁸ The active component of such extracts is tissue factor (thromboplastin); that is, tissue factor interacts with factor VIIa to activate the extrinsic pathway of coagulation.

In abruptio placentae⁹⁹ decidual fragments, serum-containing activated coagulation factors, and other substances from the placental site enter the intervillous “maternal lake” and, hence, the venous circulation. This process is initiated by rupture of the basal decidual plate.

In amniotic fluid embolism, relatively weak thromboplastins that increase in potency with gestational age¹⁰⁰ and large P.1193

amounts of particulate matter enter the circulation suddenly. In intrauterine fetal death, thromboplastic substances from the dead fetus are slowly but continuously absorbed, producing a picture of chronic but progressive DIC.

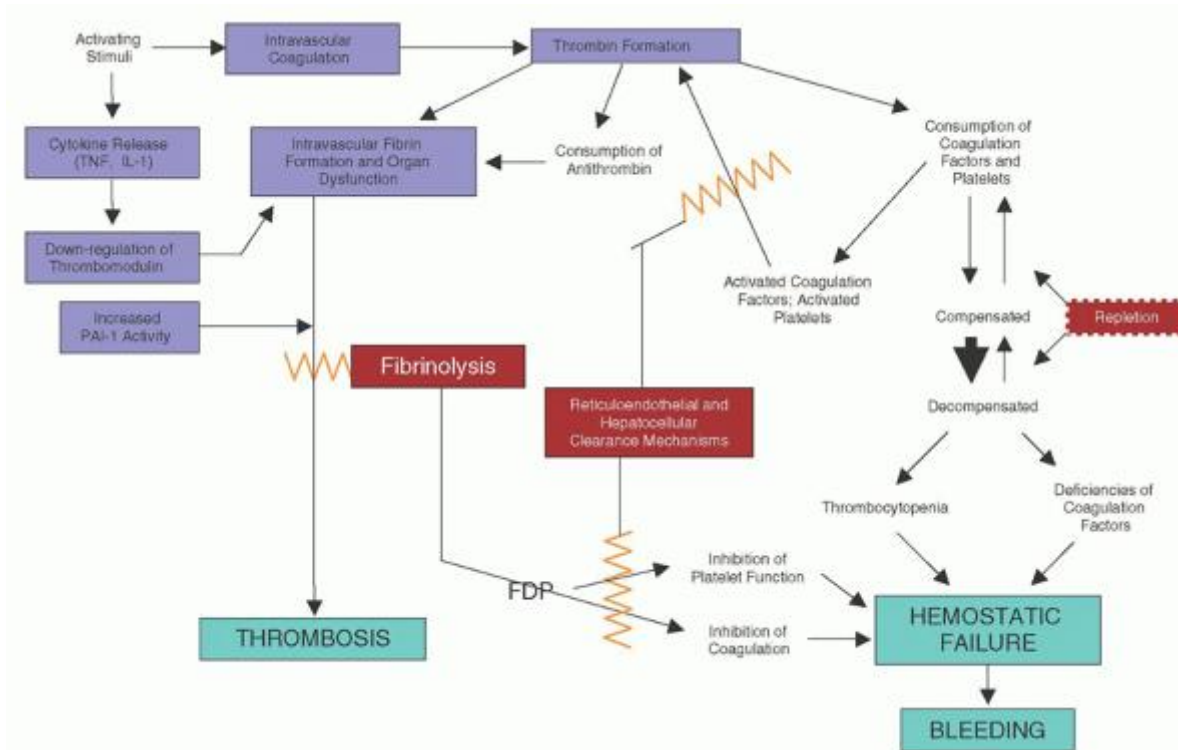

FIGURE 54.3. Pathophysiology of disseminated intravascular coagulation (DIC). The critical event in DIC is the generation of thrombin in an unregulated fashion. The clinical consequences of thrombin production depend on the rate of thrombin formation as well as underlying host factors (marrow reserve of platelet production, liver function). Patients with adequate compensatory responses (ability to enhance platelet or coagulation factor production, fibrinolysis, intact clearance mechanisms) may have minimal symptoms, whereas other patients with defective compensatory responses may bleed, thrombose, or both. Increased levels of cytokines occur (TNF, IL-1) that contribute to the proinflammatory state by down-regulating thrombomodulin activity; this leads to enhancement of intravascular fibrin formation and organ dysfunction. Major compensatory factors that influence clinical events are indicated in colored blocks. The zig-zag line indicates interruption of an adverse clinical event by a compensatory factor. FDP, fibrin(ogen) degradation product; IL-1, interleukin-1; PAI-1, plasminogen activator inhibitor-1; TNF, tumor necrosis factor.

In neoplasms, tumor microemboli and tumor “vesicles”¹⁰¹ are thought to enter the circulation and act as thromboplastins.^{98, 102} Tumor cell surface expression of tissue factor has been demonstrated.¹⁰³ Some neoplasms may secrete a factor X activator.¹⁰⁴

DIC in association with acute leukemia presumably results from the formation or release of tissue factor by leukemic cells.¹⁰⁵ Additional leukocyte enzymes such as elastase may contribute to DIC and fibrin(ogen)olysis by proteolysis of coagulation zymogens and fibrinogen.¹⁰⁶ Malignant promyelocytes, as seen in promyelocytic leukemia, express high levels of annexin II, a phospholipid-binding protein and receptor for plasminogen and tissue plasminogen activator.¹⁰⁷ This overexpression of annexin II results in enhanced plasmin production and increased fibrinolytic activity.¹⁰⁷ The granules of various “blast” forms contain tissue factor, with the promyelocyte containing particularly high concentrations.¹⁰⁵

In DIC associated with massive trauma,¹⁰⁸ major surgical procedures, or large burns, damaged tissue expressing tissue factor activity presumably is a major initiating factor. In such cases, additional abnormalities and complications are important contributory factors, such as “hypercoagulability,” azotemia, shock, intravascular hemolysis, massive transfusions of stored blood, septicemia, and hypoxia. Cerebral trauma of sufficient magnitude to produce significant brain destruction induces a brief episode of DIC, which, although transitory, may be significant in that it may perpetuate cerebral bleeding.¹⁰⁹

Monocyte-associated Procoagulants

It has been known for many years that monocytes and tissue macrophages may, when suitably activated, express substances capable of initiating blood coagulation.¹¹⁰ This phenomenon is thought to be of importance in inflammation and in tissue localization of infectious agents and tumors. It has become apparent that “recognition-coupled” responses of the monocyte-macrophage system¹¹¹ may be important in triggering DIC in association with meningococcemia¹¹² and other forms of septicemia, certain forms of leukemia, major transfusion reactions, and anaphylaxis. The best defined model of this process is the induction of tissue factor by monocytes exposed to endotoxin¹¹³ or immune complexes.¹¹⁴ Other substances that may induce monocyte procoagulant activity include anaphylatoxins¹¹⁵ and cytokines.¹¹⁶ Most of these substances induce the formation of monocyte coagulants only in the presence of T lymphocytes¹¹⁷ and the complement system.¹¹⁵ A prothrombinase-like activity¹¹⁸ and a specific activator of factor X¹¹⁹ also are formed by appropriately conditioned monocytes.

Vascular Endothelium

In addition to monocytes or macrophages, vascular endothelium can be induced to express tissue factor activity in the setting of experimental DIC.¹²⁰ Endothelium can also be down-regulated in

P.1194

terms of anticoagulant properties (e.g., thrombomodulin activity, fibrinolysis) by stimuli relevant in the pathogenesis of DIC (see Chapter 19). This altered endothelium is referred to as activated; properties of activated endothelium include conversion of the normally anticoagulant phenotype to a procoagulant phenotype, expression of adhesion molecules, production of inflammatory mediators, and production of vasoactive agents.¹²¹ Many of these pathologic events are amplified by endothelial cell protease-activated receptors (PARs) (see Chapter 19). Vascular endothelium may also promote coagulation by formation of thrombogenic microparticles, which express anionic phospholipid.¹²² Microparticles in DIC may also originate from platelets or granulocytes.¹²³ Thrombin generation caused by activation of factor XII in DIC appears to be less important than that initiated by tissue factor.¹²⁴ Contact activation, instead, appears critical in mediating DIC-associated hypotension.¹²⁵

Role of Cytokines

Although there are numerous etiologies for DIC (Table 54.4), a common pathway for activation of coagulation by these disorders is cytokine release.⁸⁹ Important mediators include endotoxin, interleukin-1 (IL-1), IL-6, IL-8, platelet activating factor, and tumor necrosis factor (TNF). TNF and IL-1 both increase monocyte and endothelial cell tissue factor activity and inhibit protein C activation. Elevated levels of IL-8 correlate with sepsis mortality and DIC.¹²⁶

Infections

DIC often accompanies septicemia as a result of bacteria that possess potent endotoxins. This correlation has led to the intensive study of the effects of endotoxin on the hemostatic mechanism. Purified endotoxin produces several effects that may lead to DIC, namely, activation of factor XII,¹²⁷ platelet aggregation, inhibition of fibrinolysis, leukocyte aggregation, direct endothelial injury,¹²⁸ cellular induction of tissue factor activity,¹²⁹ and impairment of compensatory clearance

functions. Many of these phenomena may be mediated by the interaction between endotoxin and monocytes, as discussed earlier.

Shock, Hypoperfusion, and Hypoxemia

Shock may favor the development of DIC by potentiating various activating stimuli that ordinarily would not exceed the capacity of compensatory processes and may perpetuate DIC after a transient activating stimulus has been dissipated. Hypoperfusion, even of normal vessels, acidosis, and hypoxemia produce hypercoagulability and favor intravascular platelet aggregation. Furthermore, splanchnic hypoperfusion impairs reticuloendothelial and hepatic clearance functions and is present in virtually all forms of shock. Shock also may impair hepatic synthesis of coagulation factors and thus contribute to the coagulation defect in DIC. Activated neutrophils may generate oxygen radicals and proteases to alter vascular permeability. Vascular injury may also occur with ischemia/reperfusion that elicits inflammatory responses.

DIC in association with giant hemangiomas (Kasabach-Merritt syndrome)¹³⁰ or with aneurysms of the aorta or other large vessels¹³¹ has been attributed to hypoperfusion and stasis in local vascular beds. In Kasabach-Merritt syndrome, large gaps in the endothelium that expose subendothelial collagen and other fibers, together with the induction of thromboplastic substances by poorly supported, recurrently injured vessels within the tumor, also may be important factors leading to the initiation of DIC.

Miscellaneous Activating Stimuli

Snake venoms contain enzymes that may trigger coagulation in unique ways. Such venoms may produce defibrination without affecting other coagulation factors, such as ancrod, an enzyme purified from the venom of the Malayan pit viper (*Agkistrodon rhodostoma*). Other venoms contain thrombinlike enzymes or substances that specifically activate factor X or prothrombin.¹³² Crude venoms also contain substances that act as thromboplastins and produce intravascular red cell hemolysis and massive vascular damage.¹³³ An inventory of the biochemical properties of snake venoms and their constituent enzymes has been summarized elsewhere.^{134, 135}

Consumption of Coagulation Factors and Impaired Anticoagulant Pathways

DIC constitutes a model of accelerated turnover of various coagulation factors, the levels of which at any time are determined by the size of the plasma pool and the differences between the rates at which they are being destroyed and replenished. Results of quantitative studies have demonstrated accelerated turnover rates for platelets, fibrinogen,¹³⁶ and prothrombin. Numerous factors complicate a simple kinetic approach. For example, the depletion of plasma fibrinogen induces a compensatory release of large amounts of fibrinogen into the circulation, possibly from the hepatic-lymphatic system, and also increases the rate of fibrinogen synthesis. Other complexities include impaired hepatic synthesis of coagulation factors and the phenomenon of postdepletion “rebound” and “overshoot.”¹³⁷

Generalizations based on the consumption of coagulation factors during *in vitro* coagulation are not always consistent with laboratory findings in patients with DIC. Plasma levels of factors that are normally consumed, such as fibrinogen, prothrombin, and factors V and XIII, often are reduced in severe DIC, but factors that normally are not consumed also may be deficient, such as factors VII, IX, and X. Prothrombin, which is consumed completely during coagulation *in vitro*, often is at a normal level in patients with DIC. Significant hypoprothrombinemia must reflect either massive and protracted activation of coagulation or complicating factors, because in animals, severe depletion of platelets, fibrinogen, and factors V and VIII results from activation of only 10% of plasma prothrombin.¹³⁸

Proteins other than coagulation factors may be depleted as a result of DIC; those of potential importance include antithrombin,¹³⁹ α_2 -antiplasmin,¹⁴⁰ and plasminogen.¹⁴¹ Plasminogen has great avidity for fibrin and may co-precipitate in fibrin thrombi. In experimental animals, depletion of tissue plasminogen activator, as well as plasminogen, can be produced by the protracted infusion of tissue factor.

Antithrombin is the principal inhibitor of thrombin activity; low levels of antithrombin in DIC result from consumption due to persistent neutralization of thrombin, degradation by elastase released from activated neutrophils, and decreased hepatic synthesis. Other natural anticoagulant pathways—the protein C pathway and tissue factor pathway inhibitor—are also diminished in DIC.¹⁴² Proinflammatory cytokines (TNF, IL-1) down-regulate endothelial cell thrombomodulin activity, resulting in decreased levels of activated protein C (APC). Low levels of APC not only fail to inhibit activation of coagulation (by inactivating factors V_a and VIII_a), but also contribute to failure to down-regulate inflammation. Thus, impairment of the protein C pathway in DIC contributes to the procoagulant and inflammatory phenotype seen in the disorder.

The numerous and diverse defense processes that are mediated by factor XIIa are activated in DIC, including the complement system and the kallikrein system. It has been suggested that the hypotensive effects of bradykinin may

explain the conspicuous presence of hypotension in patients with DIC triggered by activation of factor XII,¹⁴³ for example, that associated with endotoxemia.

Consumption of Platelets

In DIC, the platelet count often is depressed out of proportion to the severity of coagulation abnormalities. Thrombocytopenia may result from processes other than the consumption of platelets in

P.1195

thrombotic lesions. These processes include adhesion to denuded or damaged endothelial cell surfaces and intravascular aggregation with subsequent sequestration, which may be caused by endotoxin, antigen-antibody complexes, thrombin, particulate matter, and, possibly, fibrin-FDP complexes.

All of these agents initiate the platelet release reaction, which may produce a population of partially activated platelets that are depleted of storage nucleotides (acquired storage pool disease). Partially activated platelets may contribute to impairment of clearance functions. Epinephrine and serotonin are released from the platelets and may reach extremely high concentrations in hypoperfused vascular beds. This process may produce sustained constriction of the afferent renal arteriole and may predispose to cortical necrosis. Serotonin also may produce pulmonary and cerebral hypoperfusion.

A mouse model of DIC investigated the role of PARs in mediating the endothelial cell and platelet response to activation of coagulation. In this model of endotoxemia, activation of coagulation occurred, but knockout of PARs failed to improve survival or thrombocytopenia. Although this model may not be extrapolated to human DIC, the possibility is suggested that PARs may not mediate the DIC response, and that thrombocytopenia in DIC may result from mechanisms other than thrombin activation.¹⁴⁴

Intravascular Fibrin Formation

The formation of fibrin, in the form of small strands and "microclots", is the immediate result of DIC; the ultimate consequence of this process is determined by a balance between the rate of fibrin formation and the rate of its clearance from the circulation or lysis by the fibrinolytic enzyme system.

Erythrocytes are injured mechanically during passage through fibrin networks in the microcirculation. Such microangiopathic hemolysis leads to the production of schistocytes and microspherocytes. Erythrocyte damage in metastatic carcinoma appears to be caused mainly by fibrin strands that form around tumor cell emboli as a result of low-grade DIC.¹⁴⁵ It should be noted that red cell fragmentation is not seen in all patients with DIC.¹⁴⁶

Fibrinolysis

Fibrinolysis is present in virtually every patient with DIC, but it generally plays a homeostatic rather than a pathologic role. In the setting of DIC, this "secondary fibrinolysis" is an appropriate response to persistent thrombin generation. Fibrinolysis may be activated by several mechanisms. The major endogenous source of plasminogen activators is in the vascular endothelium of the microcirculation, and in DIC, such activators, especially tissue plasminogen activator, are apparently released as a result of thrombin formation and fibrin deposition on endothelial surfaces, endothelial injury, or hypoxia. Many of the thromboplastic substances that initiate DIC, such as tumor tissues and extracts of leukemic cells, also contain plasminogen activators. The release of plasminogen activators from platelets and leukocytes also may be significant. Finally, factor XIIa activates plasminogen by interacting with normal proactivators and the kinin system.¹⁴⁷

Fibrinolysis must be distinguished clearly from the process of fibrinogenolysis, in which fibrinogen and other coagulation factors are proteolytically destroyed in the circulation. Fibrinogenolysis may be an inappropriate response in DIC associated with amniotic fluid embolism,¹⁴⁸ heatstroke,⁹⁵ and, rarely, carcinoma. It is uncommon in other forms of DIC; when present, it is usually transitory and overshadowed by marked fibrinolysis. Disorders in which fibrinogenolysis arises in the absence of DIC (primary fibrinolysis) are discussed elsewhere in this chapter.

Following the initial enhanced fibrinolytic response to DIC, suppression of fibrinolysis occurs due to elevated levels of plasminogen activator inhibitor-1; this inhibition of fibrinolysis was associated with a poorer clinical outcome.¹⁴⁹

Fibrin(ogen) Degradation Products

The stepwise process by which fibrin is degraded proteolytically and the biologic effects of the various products of the process (FDPs) are discussed in Chapter 18. These protein fragments act as antithrombins,^{53, 54} inhibit fibrin polymerization, produce a structurally defective fibrin polymer,¹⁵⁰ and may impair platelet⁵¹ and reticuloendothelial

clearance functions. The presence of large amounts of FDP in the circulation is a major factor in the production of hemorrhage in many patients with DIC.

The infusion of large amounts of FDP (fragment D) into rabbits produces changes that resemble the posttraumatic respiratory distress syndrome in humans.¹⁵¹ This observation suggests that large amounts of FDP may directly damage the pulmonary vasculature, leading to respiratory distress syndrome, which has been reported in association with DIC and the use of thrombolytic agents.¹⁵² The smallest FDPs are peptides of 3,000 to 4,000 molecular weight that inhibit smooth muscle contractility, an effect that may explain the frequency of uterine inertia in abruptio placentae.¹⁵³

In DIC, a large amount of fibrin remains in a soluble state as a consequence of the formation of complexes between fibrin monomers, various FDPs, and fibrinogen. This solubility has been regarded as a final defense against vascular occlusion. In vitro, the complexes dissociate in the presence of alcohol or protamine sulfate to form gels or precipitates of various types (paracoagulation).

Impairment of Clearance Mechanisms

The numerous processes that normally remove procoagulant material from the circulation are of the utmost importance in DIC because of the presence of massive amounts of both activators and products of coagulation. Most of the products of intravascular coagulation (prothrombinase, platelet factor-3 activity, various types of FDPs and complexes thereof^{154, 155}), as well as various initiators of the process (tissue fragments, endotoxin, antigenantibody complexes, tissue factor, and red cell stroma), are removed from the circulation by the reticuloendothelial system¹⁵⁶ (Fig. 54.3). The Kupffer cells of the liver¹⁵⁷ and splenic macrophages are of particular importance. In certain forms of DIC, large amounts of relatively inert particulate matter (e.g., amniotic fluid embolism) place an additional burden on the reticuloendothelial system. The hepatic cells are of primary importance in the clearance of activated coagulation factors (IXa, Xa,¹⁵⁸ and XIa).

Investigators have suggested that various substances saturate and produce an "autoblockade" of reticuloendothelial and hepatic clearance functions in DIC in a manner comparable to that produced experimentally in the Schwartzman reaction.^{156, 159} This blockade may be an important pathophysiologic factor, particularly in perpetuating DIC after a transient activating stimulus. Shock and endotoxemia, both of which produce significant hepatic hypoperfusion, may contribute indirectly to autoblockade of clearance functions.

Chronic or "Compensated" Disseminated Intravascular Coagulation

Certain forms of DIC result from a weak or intermittent activating stimulus. In such patients, destruction and production of coagulation factors and platelets are balanced (Fig. 54.3). The pathophysiology of such chronic, subacute, or "compensated" DIC is fundamentally the same as that in the acute case. Nevertheless, the distinction is valuable because the clinical picture and laboratory findings in the chronic form are quite variable and may be diagnostically confusing.

Chronic DIC has been described in many patients with intrauterine fetal death or giant hemangiomas (Kasabach-Merritt syndrome) and in many cases of adenocarcinoma.⁹⁸ Other etiologic factors that may produce chronic DIC include various forms of vasculitis, acute leukemia, aneurysms, hemangiomatous transformation of the spleen, and renal allograft rejection.

In cancer patients, a virtually continuous spectrum of clinical and laboratory features has been described; these range

P.1196

from recurrent venous thrombosis or arterial embolism⁹⁸ with high levels of platelets and coagulation factors to acute DIC with severe hemorrhage.⁹⁸ The clinical and experimental evidence is incontrovertible that pregnancy, the best studied form of hypercoagulability, is associated with an increased propensity for the development of DIC.^{160, 161} Indeed, even normal pregnancy has been suggested as a form of low-grade "physiologic" DIC,¹⁶⁰ which, at term, becomes overt for a short time. Thus, transitory but significant elevations of FDP and corresponding diminution in fibrinogen levels are observed regularly during the first 4 hours after delivery.¹⁶⁰ This may be triggered, in part, by the release of tissue factor into the circulation.

Clinical Features

The major clinical features of DIC are bleeding, often of serious magnitude and abrupt onset; a variable element of shock that is often out of proportion to apparent blood loss; and symptoms of hypoperfusion of various vascular beds. Acute renal failure is common, and thromboembolic manifestations often are noted.¹⁶² Any of these features or signs and symptoms of the underlying disorder may predominate in a given case.

Evidence of major organ dysfunction is a common finding in patients with DIC, most often including signs, symptoms, and laboratory evidence of abnormal pulmonary, renal, hepatic, and central nervous system function. Although virtually all of these manifestations have been attributed to the underlying DIC, the clinical manifestations that have been described usually were the result of the underlying disorder. For example, one study observed that patients with DIC due to aortic aneurysm had laboratory features of DIC but minimal clinical manifestations. Patients with DIC due to obstetric disorders all had bleeding, but only 20% had organ dysfunction. In contrast, of patients with DIC due to sepsis, only 15% had bleeding, but 76% had organ failure.⁹⁴ These results suggest that marked heterogeneity exists in clinical manifestations of DIC, and that the etiology of DIC is a major predictor of clinical events.⁹⁴

In this section, the clinical manifestations and diagnosis of DIC are discussed in general terms. Various specific clinical features and details regarding treatment of the most common forms follow in a separate section.

Acute Disseminated Intravascular Coagulation

Bleeding manifestations of virtually every kind have been described, and they may evolve rapidly in the patient with acute DIC. Generalized ecchymoses, petechiae, and bleeding from previously intact venipuncture sites or around indwelling intravenous needles or catheters are noted in many patients. Large, spreading, hemorrhagic skin lesions often are superimposed on familiar exanths in patients with rickettsial and viral infections. "Geographic" acral cyanosis is a prominent feature in some patients. Large, sharply demarcated ecchymotic areas may result from thrombotic occlusion of dermal vessels and may progress to skin infarction. Such infarcts are particularly common in patients with purpura fulminans (Fig. 54.4) and are seen also in coumarin-induced skin necrosis and inherited homozygous deficiency of protein C (see Chapter 55). In patients with meningococcemia, cutaneous hemorrhage may be striking. Bleeding from apparently normal gingivae, epistaxis, gastrointestinal bleeding, pulmonary hemorrhage, and hematuria are common. In patients who develop DIC after surgical procedures, alarming hemorrhage may develop around drains and tracheostomies, and accumulations of blood may be concealed in serous cavities.

Chronic Disseminated Intravascular Coagulation

Superficial but extensive ecchymoses of the extremities, often without petechiae, may develop intermittently or may persist. Recurrent episodes of epistaxis or more serious internal mucosal bleeding may punctuate the course. Trousseau sign (recurrent migratory thrombophlebitis in association with cancer) in most instances is a manifestation of chronic DIC. More serious hemorrhagic manifestations may develop as the underlying disease progresses or may arise with dramatic suddenness after surgical procedures such as a prostatectomy. Acute DIC may be heralded by further thrombophlebitis or pulmonary emboli. In some patients, evidence of vascular obstruction (e.g., impairment of renal function, confusion, transitory neurologic syndromes, or repeated episodes of cerebral thrombosis) may develop with minimal bleeding.



FIGURE 54.4. Purpura fulminans in infection-associated disseminated intravascular coagulation. Early lesions (A) are circumscribed; progressive lesions (B) may become necrotic. (From Dudgeon DL, Kellogg DR, Gilchrist GS, et al. Purpura fulminans. *Arch Surg* 1971;103: 351-358; copyright 1971, American Medical Association.)

Laboratory Diagnosis

The laboratory findings in DIC are summarized in Table 54.2. Contrary to what is commonly assumed, they may be quite variable. The plasma fibrinogen level, PTT, PT, platelet count, and estimates of FDP or D-dimer are the cornerstones on which the diagnosis of DIC is based. These simple tests should always be performed first. Additional information may

confirm, but seldom refutes, the diagnosis of DIC if typical abnormalities are demonstrated by these tests. Laboratory data may change with remarkable rapidity in DIC, based on disease progression or therapy.

Laboratory data must be interpreted with caution. Levels of platelets and various coagulation factors, fibrinogen, and factor VIII, in particular, may be elevated in many of the conditions associated with DIC, including pregnancy. Thus, a fibrinogen level of 200 mg/dl, although within the normal range determined in

P.1197

healthy subjects, may represent a significant decrease in a patient whose baseline level was 800 mg/dl due to acute-phase changes.

The best test for diagnosing DIC is the D-dimer assay. The semiquantitative method is sensitive,¹⁶³ and D-dimer values >2,000 ng/ml have been reported to be consistent with DIC.¹⁶⁴ More sensitive, quantitative D-dimer assays are now available; one study reported that a sensitive D-dimer assay result <8.2 µg/ml optimized sensitivity and negative predictive value in patients with DIC.¹⁶⁵

A new test, measurement of the biphasic waveform in the PTT assay, has been reported to precede development of DIC and to predict DIC better than the D-dimer assay.¹⁶⁶ The biphasic waveform results from the formation of a precipitate on plasma recalcification; the precipitate contains very-low-density lipoprotein complexed with C-reactive protein. If confirmed in clinical outcome studies, this assay may be a useful addition to laboratory tests for DIC.

Basic Blood Examinations

In patients with DIC, routine hematologic tests may reveal evidence of acute bleeding, accelerated red cell destruction, or signs of the underlying disease. Examination of the blood smear reveals schistocytes in approximately 50% of cases,^{93, 146} but the degree of schistocytosis bears no necessary correlation with other facets of the disorder. More subtle evidence of intravascular hemolysis often is found, such as increased serum levels of lactic acid dehydrogenase and diminished haptoglobin levels. Rarely, massive intravascular hemolysis with hemoglobinemia and hemoglobinuria is noted.¹⁴⁴

Thrombocytopenia is an early and consistent sign of acute DIC, and the consideration of this diagnosis in the presence of a persistently normal platelet count is difficult. Platelet counts in the range of 50,000 to 100,000/µl are the usual finding, but thrombocytopenia may be severe.

Coagulation Defect

The PTT, PT, and thrombin time are prolonged in most patients with acute DIC. Early in the course of the disorder and in chronic DIC, the PTT may be normal or even shorter than normal, which may be the result of the procoagulant effects of activated coagulation factors or elevated factor VIII levels.

Occasionally, one can follow the process of DIC from its inception, and specific assays for various coagulation factors obtained at the time of diagnosis reveal a variable and rapidly changing picture. The plasma levels of fibrinogen and of factors V and XIII usually are significantly depressed; fibrinogen and factor V are the most consistently affected.¹⁶⁷ The level of factor X may be lower than that of other "stable" factors (factors VII, IX, and XI), which usually are present in normal amounts.¹⁶⁷ In many patients, particularly those with abruptio placentae, normal prothrombin levels are maintained,^{99, 167} but marked hypoprothrombinemia often is present in those with septic DIC.¹⁶⁸

The levels of factors VIII, IX, and XI as determined by onestage assays may fluctuate widely as the result of the presence of activated factors¹⁶⁹ such as thrombin and factor Xa.¹⁶² This problem is minimized in two-stage assays.¹⁶⁷ Levels of factor VIIIc often are normal or increased, particularly when assayed by twostage techniques.¹⁷⁰ In many patients, the levels of coagulation factors tend to "overshoot" after repletion. As a consequence of the inhibitory effects of FDPs, the thrombin time may be prolonged out of proportion to the reduction in the fibrinogen level.

Tests for Fibrinolysis: Fibrin Monomers, Fibrin(ogen) Degradation Products, and D-Dimer

In most patients with DIC, FDP levels as determined by quantitative methods, such as red cell hemagglutination inhibition or latex agglutination, are 25-µg fibrinogen "equivalents"/ml or higher.¹⁶⁷ All methods are most sensitive to large or "early" FDPs. These fragments, particularly fragment X, retain thrombin-binding sites or may form a complex with fibrinogen and consequently be removed during the preparation of serum for FDP tests. This phenomenon or the presence of only small FDPs may explain the normal levels of FDPs in some patients with otherwise typical DIC.

Fibrinopeptide A and certain fibrinogen fragments that are formed by the lysis of cross-linked fibrin, such as the DD-dimer and the DD-dimer-E complex, can be demonstrated by using special techniques. These latter FDPs provide direct evidence

of the action of thrombin on fibrinogen and provide a means of differentiating fibrin degradation products from fibrinogen degradation products.^{171, 172}

The simplicity, specificity, and sensitivity of the D-dimer test have led many laboratories to replace less sensitive or less convenient tests for DIC with the D-dimer test. Because false-positive results may be seen with FDP latex agglutination tests in patients with dysfibrinogenemia, the D-dimer test may be more specific in diagnosing DIC, especially in distinguishing the coagulopathy of liver disease from DIC.^{65, 163, 173} False-positive D-dimer latex agglutination tests may occur in patients with elevated levels of immunoglobulin M (IgM) (rheumatoid factor).

“Paracoagulation” techniques are simple to perform, but they are less specific than tests for FDPs. The results of the ethanol gelation test, in particular, often are negative in DIC. To the contrary, results of protamine gelation tests usually are positive,¹⁷⁴ but abnormal results are obtained in numerous other disorders, including many that commonly are associated with DIC.

Other Laboratory Findings

Plasma levels of fibrinopeptide A¹⁷⁵ and the rate of incorporation of ¹⁴C-labeled glycine ethyl ester into soluble “circulating fibrin”¹⁷⁶ are exceptionally sensitive indicators of DIC and may be abnormal even in patients with normal levels of FDP. Levels of antithrombin,¹⁷⁷ α_2 -antiplasmin, and proteins C and S may be diminished in some cases.

Other parameters of activation of coagulation and fibrinolysis have been studied in DIC, especially in sepsis. Thrombin-antithrombin III (TAT) complexes and plasmin- α_2 -antiplasmin (PAP) complexes are often elevated in sepsis-associated DIC. Assays such as TAT and PAP complexes may have prognostic significance in DIC, as may other coagulation parameters, including plasminogen activator inhibitor type-1, vWF antigen, and α_2 -antiplasmin.¹⁷⁸ In a primate model of Gram-negative sepsis, a number of molecular markers of coagulation were investigated for their use in monitoring DIC.¹⁷⁹ Markers such as soluble thrombomodulin and soluble fibrin monomer are useful in assessing the status of microvascular injury.

The clinical role of these assays in diagnosing or managing DIC patients at this time is uncertain. The best test for diagnosis and monitoring DIC appears to be a sensitive D-dimer assay; the PTT waveform analysis may also prove to be a useful test. The International Society on Thrombosis and Haemostasis (ISTH) has proposed clinical and laboratory criteria to better define the spectrum of DIC cases.^{90, 180}

Differential Diagnosis

The syndrome of DIC is seldom difficult to recognize. Problems arise when the diagnosis simply is not considered or in chronic forms, when the underlying coagulation disorder may be masked by features of the basic disease or by thromboembolic complications.¹⁸¹

Two disorders, however, produce laboratory abnormalities that resemble DIC: Severe liver disease, which is common, and primary fibrinogenolysis or “pathologic” fibrinolysis, which is rare (Table 54.2).

In patients with primary fibrinogenolysis, the following conditions may be evident: Hypofibrinogenemia; increased levels

P.1198

of FDP; abnormalities of the PTT, PT, and thrombin time; and deficiencies of factors V and VIIIc. The euglobulin lysis time is significantly and persistently shortened, often in association with plasminemia. However, the platelet count usually is normal, the D-dimer level should be normal or only minimally elevated, and protamine sulfate tests should be negative. Hypoprothrombinemia and deficiencies of stable coagulation factors VII, IX, X, and XI are rare. Thus, routine coagulation tests should be able to distinguish DIC from primary fibrinogenolysis.

In patients with liver disease, coagulation abnormalities and thrombocytopenia may originate from many pathologic processes (Table 54.3). Chronic or intermittent fibrinogenolysis with high levels of FDP is common, particularly in patients with cirrhosis. In such patients, the exclusion of the diagnosis of DIC may be difficult. Factor VIIIc levels usually are elevated when liver disease is severe, and the levels of factors VII and IX typically are low. A helpful test in discriminating between the coagulopathy of liver disease and DIC is the D-dimer test, the results of which should be abnormal in DIC but normal in liver disease (unless additional disorders coexist^{65, 173}).

DIC, particularly that associated with carcinoma, may be confused with various microangiopathic hemolytic anemias, such as thrombotic thrombocytopenic purpura and hemolytic-uremic syndrome; in these disorders, the clinical picture may resemble that of DIC in many respects. High levels of FDP may be encountered in patients with microangiopathic hemolytic anemias, but significant coagulation abnormalities are not commonly present. Many other disorders may produce slight to moderate elevations of FDP: For example, pulmonary embolism and chronic renal disease with uremia.

Moderate thrombocytopenia is a common consequence of the use of extracorporeal circulatory devices, and coagulation abnormalities often are noted immediately after their use because of the presence of residual heparin. Heparin levels also may rise several hours later (the rebound phenomenon). In such patients, the presence of thrombocytopenia together with the effects of heparin may be confused with DIC; similar difficulties may arise after hemodialysis. Even the small amounts of heparin required to irrigate indwelling catheters, or to contaminate Hickman catheters, are a common cause of "pseudo-DIC."

Treatment

DIC always is the end result of a serious underlying disorder. Although the patient may benefit greatly from the replacement of depleted coagulation factors and platelets, correction of the syndrome depends on prompt and energetic treatment of the primary disorder. This—not the therapeutic measures described in this section—remains the cornerstone of therapy.

Anticoagulants

Heparin is a specific activator of the physiologic antithrombin system and thereby inhibits a number of proteolytic enzymes, including factors IXa and Xa and thrombin (see Chapter 55). The therapeutic efficacy of heparin is unquestionable in some animal models of DIC, but assessment of its effectiveness in humans has proved more difficult. In view of the complexity of DIC, inhibition of coagulation alters only one facet, albeit a fundamental one, of the pathophysiologic cycle. Recent appreciation of the role of anticoagulation and inflammatory pathways has led to consideration of novel therapies, including replacement of anticoagulant proteins such as antithrombin and APC.¹⁴²

In patients with chronic DIC, the results of heparin therapy usually are favorable and may be dramatic. In most patients, heparin would not be expected to alter ultimate mortality because of the nature of the underlying diseases; however, this drug typically does reduce the severity of bleeding and thromboembolic manifestations and produces parallel improvement in the abnormalities of laboratory test values. Elevated levels of D-dimer and FDPs drop rapidly, and accelerated fibrinolysis, if present, disappears after the administration of heparin, often before the coagulation defect has been alleviated. The response of the platelet count to heparin therapy for DIC is slow and often erratic.

In patients with acute DIC, particularly that associated with sepsis, the results of heparin therapy have been less encouraging.¹⁸² Most clinicians are reluctant to use heparin in patients with acute DIC. Because baseline PTT values are usually prolonged in acute DIC, heparin levels may be required to monitor therapy (see Chapter 55).

Replacement Therapy with Platelets and Coagulation Factors

Many patients with DIC ultimately receive large amounts of blood products, even though evidence is only anecdotal that they are necessary or therapeutically effective.¹⁸³ The major aim of replacement therapy with blood products in DIC is to replenish fibrinogen. This goal is best accomplished by the administration of cryoprecipitate, each unit of which contains approximately 250 mg of fibrinogen.¹⁸⁴ The amount of cryoprecipitate given should be sufficient to elevate the plasma fibrinogen level to at least 100 to 150 mg/dl. As a general guide, 3 g of fibrinogen can be expected to raise the plasma level of an adult patient approximately 100 mg/dl. Fibrinogen administration probably should be restricted to the occasional patient with hypofibrinogenemia and significant bleeding, in whom DIC is self-limited or has been controlled by heparin therapy (e.g., in intrauterine fetal death before surgical intervention). Sterile fibrinogen concentrates are not yet available for routine therapeutic use in the United States.

Patients with DIC, bleeding, and platelet counts $<50,000/\mu\text{l}$ should be considered for platelet transfusion. Due to the acquired storage pool defect seen with DIC, as well as FDP inhibition of platelet function, DIC patients may require a higher platelet count for adequate hemostasis than patients with thrombocytopenia in the absence of platelet dysfunction.

The availability of purified, sterile antithrombin concentrates has led to its investigation in treating DIC. As seen in most studies,¹⁸⁵ although antithrombin concentrates can normalize plasma levels of this protein in patients with DIC and improve hemostasis parameters, consistent clinical benefit in terms of survival is not evident. A large clinical trial demonstrated that high-dose antithrombin therapy in patients with sepsis had no effect on mortality.¹⁸⁶ A post hoc analysis of this clinical trial indicated that high-dose antithrombin therapy may be effective in improving survival in the subset of patients with severe sepsis and high risk of death, especially if concomitant heparin treatment is avoided.¹⁸⁷ Prospective studies will be important to confirm this subgroup analysis.

Other Therapeutic Measures

Treatment of shock should be immediate and vigorous in all patients with DIC. Packed erythrocytes should be given promptly if indicated. The indiscriminate use of ϵ -aminocaproic acid (EACA) and other antifibrinolytic drugs should be discouraged. Because of the potential risks, fibrinolytic enzyme inhibitors should be administered only to carefully selected patients, that is, those in whom DIC has resulted from a transitory stimulus or has been arrested by heparin administration and in whom fibrinogenolysis or inappropriate fibrinolysis, hypofibrinogenemia, and adequate renal function have been clearly documented. The therapeutic use of EACA in fibrinogenolysis and appropriate dosage schedules are discussed elsewhere in this chapter.

P.1199

Specific Features of Various Forms of Disseminated Intravascular Coagulation

Obstetric Disorders

Abruptio Placentae

DIC complicates abruptio placentae in approximately 10% of cases¹⁸⁸ in which fetal compromise occurs. Shock develops rapidly, but vaginal bleeding may be minimal or absent for a time and bears little relationship to the extent of abruption. Brisk external hemorrhage may originate from episiotomies and lacerations, and large amounts of blood may be concealed behind the placenta and within the wall of the uterus. Severe placental abruption associated with fetal death is often linked with DIC.¹⁸⁹

Hemorrhage is the major factor leading to shock and renal complications in abruptio placentae, and the most essential therapeutic measures are the vigorous treatment of blood loss and the prompt evacuation of the uterus. Extensive replacement therapy seldom is required. Often, fibrinogen replacement is given if immediate surgical treatment is necessary. Fibrinogen replacement may be most useful in patients with fetal death requiring cesarean delivery. If the coagulation defect and thrombocytopenia are severe or persist for an unusually long time, the administration of platelets, fibrinogen in the form of cryoprecipitate, and fresh frozen plasma¹⁹⁰ may reduce hemorrhage. Most obstetricians do not administer heparin because it may increase bleeding and because rapid spontaneous remission of DIC is usual when the uterus is evacuated.

Intrauterine Fetal Death

In the event of intrauterine fetal death, definite laboratory abnormalities are not seen until the dead fetus has been retained for ≥ 5 weeks¹⁸⁸; plasma levels of FDPs then begin to rise, and the platelet count and fibrinogen level gradually decline. Bleeding may be inconspicuous, but a progressive loss of renal function is not uncommon. In most women in whom delivery of the dead fetus is induced promptly according to usual obstetric practice, bleeding is not serious, even in the presence of low-grade DIC. Operative intervention is dangerous when hypofibrinogenemia is severe, and such patients should receive heparin until safe fibrinogen levels are restored.¹⁹¹ If immediate surgery is imperative, heparin administration should be followed by platelet replacement and enough fibrinogen, in the form of cryoprecipitate, to produce plasma fibrinogen levels of 150 mg/dl or greater.¹⁹²

Amniotic Fluid Embolism

In women who survive amniotic fluid embolism (mortality rate of up to 80% in early studies), DIC with severe hemorrhage may develop within 1 to 2 hours.^{162, 193} More recent surveys indicate a mortality rate of 20% to 30%¹⁹⁴; 50% of patients with amniotic fluid embolism had DIC.¹⁸⁸ Often, the syndrome is complicated by significant fibrinolysis and even fibrinogenolysis.¹⁴⁸ Hypoxia and other sequelae of pulmonary vascular obstruction dominate the clinical picture and usually determine the outcome. The release of serotonin and other vasoactive substances from platelets may contribute to the profound pulmonary vasoconstriction.

Miscellaneous Obstetric Disorders

Intravascular coagulation has been documented after abortions induced by intra-amniotic injection of hypertonic saline solutions¹⁹⁴ and hypertonic urea,¹⁹⁵ but it apparently does not complicate abortions performed by suction curettage or those induced by prostaglandin F₂ α .

Disseminated Intravascular Coagulation in Neonates and Infants

Several disorders unique to the neonate and infant may be associated with DIC (Table 54.2).¹⁹⁶ The transplacental passage of thromboplastins or other procoagulant substances has been the apparent cause of DIC in neonates born of mothers

affected with DIC owing to abruptio placentae, eclampsia, or septicemia. Asphyxia may be a common precipitating factor for DIC in these disorders.¹⁹⁷ Bacterial infection and generalized viral infections (e.g., herpes simplex, cytomegalic inclusion disease, and rubella), acidosis, and hypoxia are more common causes of DIC in infants than in adults.¹⁹⁸ DIC secondary to giant hemangiomas and purpura fulminans has been reported in neonates.

Management of septic DIC in the neonate should emphasize treatment of underlying infection. A controlled study that compared treatment with heparin, extensive replacement therapy with blood products, and supportive care only revealed no significant differences in outcome for the three groups.¹⁹⁹ A more recent study confirms that clinical trials in neonatal sepsis have not identified a beneficial therapy.²⁰⁰

The diagnosis seldom is difficult, but DIC must be distinguished from septic shock, endotoxin shock, or simple thrombocytopenia, all of which may develop independently of DIC in severe infections.²⁰¹

In many patients, no additional measures other than treating infection and shock (if present) are required. No evidence has been cited that heparin has diminished mortality.¹⁶⁸ In one series, the alleviation of septic shock appeared to be more important in the ultimate prognosis than did correction of the coagulation abnormalities.¹⁶⁸ Recombinant APC (r-APC) was demonstrated in one study to reduce mortality in adult patients with sepsis²⁰²; however, a Cochrane database review of the effects of r-APC in neonates with sepsis concluded that there were insufficient data to support the use of the drug in the pediatric setting.²⁰³ Subsequent studies in adult patients demonstrating no clinical benefit of r-APC in sepsis led to withdrawal of this drug.

Purpura Fulminans

The hemorrhagic manifestations of purpura fulminans develop several days after an acute infection; these are most commonly scarlet fever or various viral respiratory diseases. Purpura fulminans is most common in children but is also well documented in adults. The most common manifestations are symmetric ecchymoses of the lower extremities and buttocks, sharply circumscribed infarcts of the skin and genitalia, and gangrene of the extremities that often involves the digits symmetrically.²⁰⁴ These ecchymotic lesions often become necrotic, ultimately forming blood-filled bullae (Fig. 54.4). Petechiae are rare. Fever and prostration are seen, but visceral lesions, including renal involvement, are relatively uncommon.

The mortality rate associated with purpura fulminans ranges from 18%²⁰⁵ to 40% to 70%.²⁰⁶ Heparin in therapeutic doses has often proved therapeutically effective, and it has been suggested that poor results obtained previously with this anticoagulant reflect late treatment of moribund patients. In patients with purpura fulminans, relapses are particularly common after cessation of heparin therapy,²⁰⁵ and the administration of this anticoagulant, possibly in reduced doses, should always be continued for 2 to 3 weeks. The subject of purpura fulminans diagnosis and treatment has been recently reviewed.²⁰⁷ Evidence that purpura fulminans may be a manifestation of homozygous protein C deficiency is discussed in Chapter 55. The efficacy of protein C in patients with sepsis and purpura fulminans is discussed below.

Neoplastic Disorders

Carcinoma

In patients with DIC associated with carcinoma, the clinical picture is quite variable and often consists of a combination of bleeding and thromboembolic phenomena, including arterial embolism.^{98, 102, 103} The association of chronic DIC,

P.1200

thromboembolism, and cancer is often called Trousseau syndrome.⁹⁸ Laboratory findings are variable. Evidence of chronic DIC, hypercoagulability, or acute DIC may be found. In a study of more than 1,000 patients with solid tumors, 7% were diagnosed with DIC using standard coagulation tests (platelet count, fibrinogen, D-dimer, FDPs).²⁰⁸ Risk factors associated with the occurrence of DIC included older age, male gender, advanced disease, breast cancer, and necrosis of the tumor specimen.²⁰⁸

One reason for the variability in cancer patients having venous thromboembolism relates to the histology of the malignancy. Analysis of a very large database of Medicare patients with cancer identified tissue-specific differences in thrombotic risks among cancers.²⁰⁹ Those cancers with a high risk of thrombosis included uterine, brain, leukemia, ovary, and pancreas (twofold or greater risk), whereas prostate, liver, head or neck, bladder, and breast cancer had less than a onefold risk (compared to noncancer patients).²⁰⁹

DIC in association with carcinoma resolves with effective treatment of the underlying tumor. Heparin or low-molecular-weight heparin (LMWH) in therapeutic doses has proved effective in controlling the hemorrhagic and thromboembolic

symptoms.^{98, 102, 210} There is a suggestion in the literature that the use of LMWH therapy is associated with improved mortality in cancer patients. A large European study of patients with noncurable solid tumors evaluated the survival effects of a LMWH (nadroparin) given in therapeutic dose for 2 weeks followed by half-dose for 4 weeks.²¹¹ There was significant improvement in survival in the LMWH group with minimal toxicity.²¹¹ The basis for this antitumor activity of LMWH may not relate to anticoagulant activity.²¹² A recent Cochrane literature review of the effects of anticoagulation on cancer patient survival found improved survival after 24 months, but not 12 months.²¹³

A significant minority of patients with cancer and thrombosis will experience recurrent thrombosis with oral anticoagulation⁹⁸ and will benefit from long-term heparin or LMWH.²¹⁴ Based on these data, optimal anticoagulant therapy for cancer patients with thrombosis is LMWH. In the case of DIC associated with prostate cancer, adjunctive therapy with ketoconazole²¹⁵ or antiandrogens²¹⁶ may be useful.

An animal model of cancer has provided evidence that tumors may activate coagulation through overexpression of the MET oncogene.²¹⁷ When MET-induced carcinogenesis was established in mice, a hypercoagulable state resulted. Inhibition of the activated MET oncogene may be a potential therapeutic target in patients with cancer and DIC. The spectrum of mechanisms of thrombosis in Trousseau syndrome has been reviewed.²¹⁸

Acute Promyelocytic Leukemia

DIC has been reported in association with all forms of acute leukemia, but it is most common in the “hypergranular” promyelocytic variety,²¹⁹ in which it may occur in 60% to 100% of cases. The cause of the coagulopathy is multifactorial: Tissue factor is present in the granules of the abnormal promyelocytes¹⁰⁵ as well as leukocyte proteases, including elastase.²²⁰ Enhanced fibrinolysis also results from increased promyelocyte expression of annexin II, a receptor for plasminogen and tissue plasminogen activator.¹⁰⁷ Additionally, the malignant promyelocytes contain plasminogen activators.²²¹ The clinical picture usually is one of chronic progressive DIC with a significant fibrinolytic component that may antedate the other manifestations of the disease. Acute fulminant DIC may develop spontaneously or may be triggered by the administration of chemotherapeutic agents, which cause the release of thromboplastic contents of the promyelocytes.

In some patients with acute leukemia, accelerated fibrinolysis is a conspicuous finding. In one study, depletion of α_2 -antiplasmin developed during induction of chemotherapy, a finding that was more predictive of bleeding complications than traditional indices of DIC, such as levels of fibrinogen, antithrombin, and plasminogen.²²² This study suggests that “unregulated” fibrinolysis, by destroying functional hemostatic plugs and depleting fibrinogen, may be more important than DIC in some cases.

In the past, heparin has produced clear-cut remissions in patients with chronic forms of DIC associated with acute leukemia. An earlier approach²²⁰ recommended fibrinogen replacement therapy for fibrinogen levels <100 mg/dl and platelet transfusion for platelet counts <20,000/ μ l. Fresh frozen plasma is given to patients with prolonged PT and PTT values who are bleeding. If the fibrinogen level is difficult to maintain over 100 mg/dl, or if FDP levels are rising, heparin is infused at 500 U/hour.²²⁰ When α_2 -antiplasmin levels are below 30% of normal, EACA or another antifibrinolytic agent should be added to this regimen,²²² and α_2 -antiplasmin levels should be monitored during induction of chemotherapy.

A newer approach that has virtually replaced the need for heparin and antifibrinolytic agents in the treatment of acute promyelocytic leukemia is the early administration of all-trans retinoic acid.²²³ However, these patients still may require replacement therapy for hypofibrinogenemia and thrombocytopenia.²²³ Current protocols for acute promyelocytic leukemia combine all-trans retinoic acid and combination chemotherapy (or arsenic trioxide) to ameliorate the coagulopathy; all-trans retinoic acid is more effective than chemotherapy alone in improving the coagulopathy.²²⁴

Kasabach-Merritt Syndrome (Giant Hemangiomas)

The severity and incidence of DIC tends to parallel the size of the vascular tumors in the Kasabach-Merritt syndrome.²²⁵ Platelet consumption, activation of coagulation, and microangiopathic red cell destruction take place mainly within the hemangioma (“sequestered” or localized intravascular coagulation), but laboratory evidence of DIC in the general circulation usually is clearcut.^{130, 225} Recurrent bleeding from the surface of the tumor is the major hemorrhagic manifestation; in the presence of DIC, this bleeding may be intractable. Periodic swelling of the lesions often is observed. This phenomenon may be a consequence of intermittent obstruction of blood outflow from the hemangioma and may provoke serious hemorrhage. Irradiation and corticosteroids have produced favorable results in a few cases, but surgical removal of the tumors has ultimately been required in most patients.²²⁵ Interferon- α has been successful in large numbers of patients; this cytokine probably acts as an antiproliferative/antiangiogenic agent.²²⁵ Antifibrinolytic therapy has been reported to be useful in controlling the coagulopathy.^{226, 227} Other useful therapies include cryoprecipitate and platelets for replacement therapy to correct a severe coagulopathy. The use of heparin therapy is uncertain.²²⁵

For patients with aneurysms associated with DIC, LMWH has been reported to be useful in resolving the coagulopathy.²²⁸

Shock and Massive Trauma

Heparin therapy may be hazardous for patients with massive injuries. Even in the face of DIC, intensive supportive care and replacement therapy with plasma and platelets are the mainstays of treatment.²²⁹

Hemolytic Transfusion Reactions

DIC is present in many patients with hemolytic transfusion reactions. Severe, acute hemolytic transfusion events are triggered by antigen-antibody reactions that initiate complement activation and activation of coagulation. These reactions are usually a result of ABO incompatibility. These patients may experience not only DIC, but also shock and renal failure. Primary therapy is directed to control of hypotension and restoration of renal blood flow. Fluid, diuretics, and dopamine may be useful therapies. Heparin therapy for DIC in hemolytic transfusion reactions is controversial.²³⁰

P.1201

Snakebite

DIC associated with snakebite differs from the usual form of the syndrome in several respects. Hemorrhage may be relatively inconspicuous,²³¹ even in the presence of incoagulable blood. When present, it is mainly the result of a vascular toxin. Platelets often are spared, although the venom of the timber rattlesnake (*Crotalus horridus horridus*) contains a unique serine protease that acts as a potent platelet activator.²³² In some cases, a disorder manifested mainly by brisk fibrinolysis in the absence of evidence of DIC has been described.²³³ The specific coagulopathy seen in individual patients in large part depends on venom constituents present in the particular snake species. Detailed lists of venom constituents affecting hemostasis have been published.^{132, 134, 135}

The treatment of snakebite involves the administration of specific antivenom and intensive supportive care. Heparin therapy has proved marginally effective at best.^{231, 234} In general, it is not indicated when specific antivenom is available. Cryoprecipitate should be given to maintain the fibrinogen level over 100 mg/dl.

Pathology

The fatality rate associated with DIC is up to 60%.²³⁵ In many cases, death is attributed to bleeding or thrombosis. Mortality increases with age, underlying co-morbidities, the number of clinical manifestations, and the severity of laboratory abnormalities.

The deposition of fibrin in small vessels represents the ultimate result of DIC. In many patients, fibrin can be formed and lysed without significant vascular occlusion. Indeed, at autopsy, fibrin thrombi in some subjects were absent or were demonstrated only with special stains or by electron microscopy. This may result from postmortem lysis or from deposition of thin films of fibrin on the vast endothelial surface and on the erythrocytes. The localization of fibrin thrombi varies somewhat with the cause of DIC. The kidney is the single most common site of fibrin thrombi. Renal lesions range from patchy tubular necrosis to massive bilateral cortical necrosis and have been attributed to a sieving effect of the renal microvasculature. Nonthrombotic endocarditis and pulmonary hyaline membranes have been found in many patients,^{98, 236} especially those with cancer.

Emerging Therapies for Disseminated Intravascular Coagulation

The recognition of pathogenic mechanisms critical in initiation or progression of DIC has led to investigation of new therapeutic agents in animal models of DIC and clinical trials in humans. For example, protease inhibitors such as aprotinin²³⁷ or gabexate²³⁸ have been studied. However, survival advantages have not been shown with these agents. Similarly, high-dose antithrombin replacement therapy had no effect on mortality in patients with severe sepsis.¹⁸⁶

The key role of tissue factor in triggering DIC²³⁹ has led to studies in which neutralizing antibodies to this procoagulant were found to prevent lethal septic shock in animal models.^{240, 241} Two published clinical trials in sepsis patients used tissue factor pathway inhibitor as therapy; there was no significant benefit observed.²⁴²

The role of protein C in ameliorating the mortality of sepsis has also been demonstrated; neutralization of protein C activity in an animal model exacerbated the lethal response,²⁴³ and infusion of protein C²⁴⁴ or APC²⁴³ prevented the lethal response in humans with meningococemia or in a primate model, respectively. APC had previously been demonstrated to improve survival in sepsis²⁰²; subsequent studies demonstrated no clinical benefit of the drug, and it is no longer available.

PRIMARY FIBRINOLYSIS (FIBRINOGENOLYSIS)

Fibrinolysis is an appropriate response to thrombosis and necessary in the re-establishment of blood flow. This localized response, termed physiologic fibrinolysis, is discussed in Chapter 18. The term pathologic fibrinolysis has been used indiscriminately to refer to any situation in which *in vitro* evidence of fibrinolysis was associated with bleeding. In retrospect, it seems probable that fibrinolysis in many cases was secondary to DIC and that in others it represented an essentially physiologic response to anoxia, shock, or stress. In fibrinogenolysis, on the other hand, the proteolytic destruction of fibrinogen and other proteins occurs in the general circulation, and severe bleeding may develop. The pathophysiology of fibrinogenolysis may represent a disproportionate or "inappropriate" response to underlying DIC or may result from a defective fibrinolytic mechanism that may be inherited or acquired.

Etiology

Fibrinogenolysis may complicate various disorders, among which severe liver disease⁴⁹ is the most common. Fibrinogenolysis is a predominant laboratory feature in several patients with disseminated neoplasms,^{245, 246, 247} especially urogenital neoplasms.²⁴⁸ The mechanism for enhanced fibrinolysis in these patients is probably increased tumor cell secretion of plasminogen activators such as urokinase.²⁴⁶ Fibrinogenolysis and marked fibrinolysis rarely complicate the immediate puerperium,^{192, 193} and they have been reported in association with acute promyelocytic leukemia.^{220, 221} Enhanced fibrinolysis has also been associated with cardiac bypass surgery²⁴⁹ and aortic clamping during vascular surgery.²⁵⁰ Inherited deficiency of plasminogen activator inhibitor type-1²⁵¹ or α_2 -plasmin inhibitor²⁵² also results in hyperfibrinolysis and a bleeding tendency.

Pathophysiology

Fibrinogenolysis is a consequence of the generation of plasmin within the general circulation (plasminemia). Potent plasmin inhibitors (antiplasmins) normally neutralize free plasmin rapidly (see Chapter 18); the result is that the proteolytic effects of this enzyme normally are restricted to fibrin. Fibrinogenolysis occurs only when the neutralizing capacity of the antiplasmins is exceeded.

The proteolytic action of plasmin is nonspecific. In addition to fibrin and fibrinogen, this enzyme may degrade factor VIIIc, factor XIII, other coagulation factors, and a wide variety of other plasma proteins, such as complement and various hormones. Free plasmin also may activate bradykinin, a phenomenon that may underlie the marked hypotension present in some patients with fibrinogenolysis. Thus, pathologic proteolysis is an appropriate synonym for fibrinogenolysis.

Fibrinogenolysis is activated by mechanisms that are remarkably similar to those that initiate DIC. Therefore, tumor tissue contains plasminogen activators in addition to tissue factor.²⁴⁶ The secretion of these activators into the circulation may rapidly activate most of the circulating plasminogen.

Hypoxia and hypoperfusion may lead to plasminogen activation and, occasionally, to fibrinogenolysis. However, in many of these patients, bleeding is minimal; when present, it cannot be clearly related to the presence of fibrinogenolysis. In these patients, fibrinogenolysis probably is a nonspecific, essentially physiologic response. Fibrinogenolysis may also result from therapy with thrombolytic agents, as discussed in Chapter 55.

Clinical Features and Laboratory Diagnosis

The clinical picture in most reported cases of fibrinogenolysis is similar to that of DIC. The usual laboratory findings are

summarized in Table 54.2 and are discussed in an earlier section of this chapter. Hypofibrinogenemia may be seen. The PTT, PT, and thrombin time may be prolonged because of the anticoagulant effects of FDPs. Moderate concentrations of EACA (4×10^{-4} mol/L) inhibit plasminogen activators but not free plasmin. Thus, the euglobulin lysis time, which invariably is shortened in patients with fibrinogenolysis, is unaffected by the addition of EACA if free plasmin is present. Among the coagulation factors, factors V and VIIIc are the most sensitive to the proteolytic action of plasmin; factor XIII also is deficient in some patients. The plasma levels of other factors (e.g., factors VII and IX), including some that are degraded by plasmin *in vitro*, usually are normal in patients with fibrinogenolysis. Depletion of plasminogen and α_2 -antiplasmin and the presence of α_2 -antiplasmin-plasmin complexes in the plasma also may be demonstrated in many patients with fibrinogenolysis and in those with DIC and active fibrinolysis.²⁵³

The standard FDP test does not discriminate between fibrinogen degradation products and fibrin degradation products. Measurements of fibrinopeptide A and the D-dimer, which is a specific indication of degraded cross-linked fibrin, yield normal results in fibrinogenolysis. Thus, patients with hypofibrinogenemia, prolonged PT and PTT values, elevated FDP

levels, and a normal D-dimer may have primary fibrinogenolysis. In the absence of intravascular coagulation, paracoagulable complexes containing fibrin monomers do not form in plasma; thus, plasma protamine gelation tests are negative in fibrinogenolysis. Assays for plasminogen and for the various inhibitors of the fibrinolytic enzyme system may reveal a pattern of depletion. In addition to normal results for D-dimer, patients with fibrinogenolysis have normal platelet counts or mild thrombocytopenia with bleeding out of proportion to the reduction in platelet count.²⁴⁶

Treatment

Antifibrinolytic agents would seem therapeutically desirable in the treatment of fibrinogenolysis; however, these drugs are hazardous in the presence of DIC. EACA and tranexamic acid are specific and potent inhibitors of fibrinolysis and fibrinogenolysis.²⁵⁴ In low concentrations (10^{-4} mol/L), EACA inhibits plasminogen activation competitively; in high concentrations (0.06 M), it inhibits plasmin directly in a noncompetitive manner. The clinical effectiveness of this drug is dramatic in carefully selected patients.²⁵⁵ For severe bleeding, EACA should be administered intravenously (0.1 g/kg every 6 hours, up to 24 g/day), or intravenous doses of 1 g/hour, after a 5-g loading dose. The drug can also be given orally. The total dosage should not exceed 24 g in a 24-hour period. Tranexamic acid is a newer antifibrinolytic agent that, like EACA, possesses the ability to bind to the lysine-binding sites of plasminogen, thereby preventing plasmin that is generated from binding to fibrin. The oral dosage of tranexamic acid is 25 mg/kg, three or four times daily. The intravenous dosage is 10 mg/kg given three or four times daily.

Because antifibrinolytic agents are potentially dangerous drugs in the presence of DIC,²⁵⁶ the diagnosis of DIC should be excluded in these patients using a specific test, such as D-dimer, before administering these agents. Patients with DIC and a substantial secondary fibrinolytic component should be considered for heparin therapy before administration of antifibrinolytics.²⁴⁸

Patients with hormone-refractory prostate cancer and fibrinogenolysis have been reported to benefit from docetaxel, with resolution of bleeding symptoms and laboratory evidence of hyperfibrinolysis.²⁵⁷

Pathologic Inhibitors of Coagulation

Circulating anticoagulants are pathologic endogenous inhibitors that can act at any stage in the process of coagulation. Most are antibodies that act as specific inhibitors, inactivating a single coagulation protein. The clinical and laboratory manifestations resemble the corresponding inherited coagulation disorders in many respects. Antibody disorders with wider effects on the coagulation system are sometimes seen, especially in the antiphospholipid-protein antibody (APA) disorders. Other inhibitors of coagulation often have heparinlike activities and are much less common.

Antibodies to Factor VIII

Factor VIII is the most common target of monospecific acquired anticoagulant antibodies. Conditions that are associated with monospecific factor VIII antibodies are outlined in Table 54.5. Factor VIII inhibitors are termed alloantibodies when they appear in treated hemophilia patients and autoantibodies when they appear in nonhemophilia patients.

Alloantibodies in Hemophilia A

Frequency of Inhibitors

Prospective studies suggest a higher incidence of inhibitors than that historically appreciated^{258, 259, 260} (up to 45%), even in patients treated with traditional factor VIII concentrates. However, many patients have only transient inhibitors, and perhaps only 5% to 10% of hemophiliacs have persistent inhibitors.²⁶¹ As a consequence, initial concerns based on historical prevalence controls suggesting that newer factor VIII concentrates, such as those purified by monoclonal antibody affinity chromatography or produced by recombinant technology, might be inducing an increased percentage of inhibitors appear to be allayed. In fact, continued longitudinal surveillance of patients receiving such products indicates a similar or perhaps lower incidence of clinically significant persistent inhibitor induction.^{262, 263} Those at high risk of development of inhibitors include patients with severe hemophilia A whose factor VIII mutation prevents factor VIII synthesis (nonsense mutation or intron 22 inversion), or patients with mild or moderate hemophilia A whose factor VIII mutation in the A2 domain or near the junction of the C1-C2 domains results in an abnormal factor VIII molecule.²⁶¹ This latter mutation results in a factor VIII molecule identified by the patient's immune system as abnormal. Other factors affecting the risk of inhibitor development include the patient's human leukocyte antigen (HLA) class II haplotype, the type of factor VIII therapy used,²⁶¹ African-American

P.1203

ancestry,^{264, 265} periods of intensive therapy,²⁶⁶ and early use of factor VIII at the time of a major bleed or surgery.²⁶⁷

Additional reports have confirmed these conclusions in patients with mild to moderate hemophilia.^{268, 269} A more recent literature metaanalysis observed that use of recombinant factor VIII products was associated with an almost twofold increase in inhibitor development compared to plasma-derived factor VIII products,²⁷⁰ and an initial study identifies an increased risk of inhibitor development with second-generation full-length recombinant products.^{270a} A provocative study reported that patient age at initiation of therapy was an independent risk factor for inhibitor development.²⁷¹ Patients beginning therapy before 6 months of age had three times the rate of inhibitors than patients beginning therapy after 1 year of age.²⁷¹ If these data are confirmed, exposure of hemophilia A patients to factor VIII should be delayed, and patients should be treated with other products during the first year of life (such as rVIIa). A United Kingdom epidemiology study reported that there is a bimodal distribution of factor VIII antibodies in hemophilia A patients, with peaks in early childhood and >60 years of age.²⁷² The genetic and immunologic aspects of induction of antifactor VIII alloantibodies have been reviewed.^{267, 273}

TABLE 54.5 CONDITIONS ASSOCIATED WITH MONOSPECIFIC FACTOR VI ANTIBODIES

Alloantibodies in hemophilia A

Autoantibodies in nonhemophilic patients

Autoimmune disease

Systemic lupus erythematosus

Rheumatoid arthritis

Inflammatory bowel disease

Dermatologic conditions

Psoriasis

Pemphigus vulgaris

Pregnancy (peripartum)

Malignancy

Lymphoproliferative disorders

Plasma cell dyscrasias

Medications: penicillin, sulfa antibiotics, chloramphenicol, phenytoin

Idiopathic

Induced Antibody Titer

It is recognized, particularly in patients with mild hemophilia, that 50% to 75% of inhibitors are subclinical, occur relatively early (median of 10 days) after product exposure, are of low titer, are transient, and often resolve even with continuing product exposure.^{260, 262} Hemophiliacs with inhibitors can be categorized as either strong or weak responders to administered factor VIII. Once an antibody has developed in a hemophiliac, further administered factor VIII may act as an inducing antigen. Additionally, it has been appreciated that certain factor VIII products, depending on the manufacturing process, may be immunogenic in hemophilia A patients.^{261, 270, 270a}

Autoantibodies to Factor VIII in the Nonhemophilic Patient

It is estimated that acquired factor VIII autoantibodies are seen in 1 to 2 persons per million population annually.²⁷⁴ Monospecific antibodies to factor VIII can arise spontaneously in association with various autoimmune and chronic inflammatory diseases, such as systemic lupus erythematosus (SLE), rheumatoid arthritis, and ulcerative colitis.^{275, 276} Antibodies to factor VIII can develop in the puerperium,²⁷⁷ usually appearing at term or within several months after parturition in association with a first pregnancy. The antibody may disappear spontaneously in postpartum patients after 12 to 18 months. Reappearance during subsequent pregnancy seems to be very unusual, and in those patients who have persistent antibodies, remission can occur during a subsequent pregnancy.²⁷⁸ Acquired hemophilia may also be seen in association with hematologic malignancies and solid tumors,^{279, 280, 281} certain medications such as penicillin,²⁸² sulfa antibiotics, chlorpromazine, and phenytoin²⁸³; and dermatologic conditions such as psoriasis and pemphigus vulgaris.²⁸⁴

Most often, acquired factor VIII antibodies are idiopathic, particularly in older persons without apparent underlying disease.^{276, 284}

Pathophysiology of Development of Antibodies to Factor VIII

The immunologic mechanism that underlies inhibitor induction in a select minority of patients with hemophilia A and the corresponding presumed lack of immunologic tolerance is unclear. Although inhibitor induction is more common in more severely affected patients, inhibitors are also seen in mild hemophilic patients.^{268, 285} In patients with severe hemophilia, major deletions, the intron 22 inversion, nonsense mutations, and early initiation of replacement therapy are risk factors for antibody development.^{261, 264, 276} Underlying genetic susceptibility factors have been suggested by studies of brother pairs with a significant predisposition to the development of inhibitors.²⁸⁶ Specific associations between factor VIII genotype and HLA class II phenotype have been made,²⁸⁷ but the associations are weak. Genetic influences on inhibitor development are postulated to be additive and polygenic.²⁸⁷ Mutations resulting in a major loss of factor VIII gene coding information and a lack of circulating factor VIII antigen are associated with a high incidence of inhibitor formation.²⁸⁸ For example, a high frequency (70%) of inhibitor development is seen in patients with either large, multidomain deletions or nonsense mutations in the factor VIII A3 domain.²⁸⁹ Fewer patients with other gene defects (missense point mutation) form inhibitors. However, the presence of inhibitors is not consistent, even in a given family with similar factor VIII mutations, suggesting that other factors contribute to induction of factor VIII antibodies.²⁶¹ A clinical prediction score to identify the risk of untreated hemophilia A patients to develop an inhibitor has been reported.²⁹⁰

Another hypothesis as to how inhibitors to factor VIII might occur is that these antibodies arise from the expansion of preexisting natural factor VIII clones that possess neutralizing properties²⁹¹; such antibodies have been identified from the IgG fraction of plasma from normal people.²⁹¹ Clonal expansion of antifactor VIII antibodies may be modulated by the presence of anti-idiotypic antibodies.²⁹²

Characteristics of Factor VIII Inhibitory Antibodies

The majority of antibodies to factor VIII are IgG immunoglobulins that appear to be specific for the coagulant subunit of the factor VIII complex (VIIIc).^{293, 294} Common epitopes for allo- and autoantibodies include those in the A2 domain, the C2 domain, or both.²⁹⁵ Typically, hemophilic alloantibodies recognize both domains,²⁹⁶ whereas autoantibodies recognize the C2 domain more frequently than the A2 domain.²⁹⁵ Circulating factor VIII immune complexes have been identified in plasma from patients with acquired hemophilia A with autoantibodies.²⁹⁷ IgA or IgM inhibitors are rare, as are antibodies that inhibit both VIIIc and vWF. The factor VIII inhibitory antibody subunits in hemophilia A show limited heterogeneity²⁹⁸ but are not truly monoclonal. In nonhemophiliacs, antibodies to factor VIII more often reveal normal heterogeneity of their subunits. Antibodies to factor VIII are disproportionately often of the IgG₄ subclass and do not fix complement.

Antibodies inactivate factor VIII in a time- and temperature-dependent process,²⁹⁹ the kinetics and stoichiometry of which are variable. Two types of antibody inhibition are described³⁰⁰: Type I inhibitors completely inhibit factor VIII activity following second-order kinetics (linear time course of inactivation); these antibodies are seen in hemophilia patients.³⁰¹ Type II inhibitors have complex kinetics and do not completely inhibit factor VIII activity; these are autoantibodies seen in nonhemophilic patients.³⁰² The type II inhibition phenomenon may produce aberrations in the assay system and may explain certain puzzling laboratory features in atypical cases, such as detectable factor VIII clotting activity in a patient with a high-titer inhibitor.³⁰³ A report on alloantibody inhibition of factor VIII activity indicated that certain alloantibodies possess catalytic activity that can proteolyze factor VIII.³⁰⁴

Laboratory Evaluation

Simple mixing techniques based on the PTT usually suggest the presence of an inhibitor. Factor VIII levels usually are undetectable in severely affected patients but may be detectable in patients with autoantibodies. Specific tests for antibodies involve the demonstration of progressive and time-dependent inactivation of factor VIII in vitro by the plasma or serum of the patient. Methods

P.1204

for detecting low-titer inhibitors and for quantifying the levels of antibody have been devised,³⁰⁵ and standardized inhibitor units (the Bethesda unit in the United States³⁰⁶ and the Oxford unit in Britain³⁰⁷) have been defined. In the Bethesda assay, in vitro tests are performed at 37°C using 2-hour incubation mixtures of various dilutions of patient plasma with normal plasma. The inhibitor titer is the reciprocal of the dilution of inhibitor plasma that neutralizes 50% of normal factor VIII activity. Because the Bethesda assay may underestimate the inhibitor titer in acquired hemophilia, it is recommended that the titer should be calculated from the lowest dilution that results in 50% residual factor VIII activity

after the incubation period.³⁰⁸ The New Oxford method measures residual activity at 37°C after a 4-hour incubation. A Bethesda unit is generally equivalent to 1.21 Oxford units. The standard Bethesda assay does not control pH, permitting variable low-level inactivation of factor VIII by nonimmunologic mechanisms. The Nijmegen modification controls pH, thus improving classification of positive and negative samples.³⁰⁶ The Nijmegen modification of the Bethesda assay has been endorsed by the ISTH.³⁰⁹ Additional improvements in this assay have been described.³¹⁰ Although an inhibitor unit does not imply that any specific number of factor VIII units infused into the patient will neutralize any specific number of inhibitor units, the titer provides a general estimate of the initial likelihood of response to infusion of factor VIII products.

Clinical Manifestations

The bleeding manifestations resulting from antibodies to factor VIII are often similar to those seen in hemophilia A.^{275, 284} Prolonged or unexpectedly severe hemorrhage may occur after comparatively trivial trauma, postoperatively, or postpartum. Soft tissue or muscle hematomas, hematuria, and spontaneous and intractable epistaxis seem relatively common. For unknown reasons, hemarthrosis is relatively less common in acquired hemophilia than in congenital hemophilia A. Figure 54.5 illustrates soft tissue hematomas occurring in a nonhemophilic patient with an acquired inhibitor to factor VIII. When antibodies arise in patients with mild hemophilia A, bleeding typical of severe deficiency may develop; more significantly, the bleeding may be refractory to replacement therapy. This condition may have serious consequences, and fatal events are seen in 10% to 20% of clinically symptomatic patients.^{275, 311} Antibodies to factor VIII arising during pregnancy may cross the placenta.

Treatment

The treatment of bleeding in patients with antibodies to factor VIII presents several challenges.^{312, 313} No adequate randomized trials have been conducted to evaluate different forms of therapy or to investigate the timing and sequence of their application; therefore, practical treatment decisions are somewhat arbitrarily based on estimates of benefits and risks deduced from retrospective literature review and consideration of each patient's circumstances and co-morbidities. A consensus group from the United Kingdom and an international panel have published guidelines on treatment of inhibitors in patients with hemophilia,^{314, 314a, 315} and a literature review of acquired hemophilia therapy options has summarized treatment recommendations.³¹⁶ An algorithm that has some general applicability is shown in Figure 54.6. As a first step, basic clinical information should be obtained, including whether the inhibitor arose in the setting of hemophilia or is acquired; the severity of bleeding; anticipated surgical procedures; inhibitor titer and persistence; prior inhibitor response and relation in time to previous factor infusions; possible triggering events such as recent medication exposure or pregnancy; and the presence of other diseases. For example, the mere presence of an inhibitor may in itself not warrant immediate therapy because many inhibitors are present in low titer and are often transient. Spontaneous remissions may occur in a significant number of patients, particularly if the inhibitor develops during the puerperium.²⁷⁶ At the other end of the spectrum, an unfortunate clinical scenario might involve significant spontaneous clinical hemorrhage, a persistent high-titer inhibitor, and incidental co-morbidities such as cardiac, hepatic, or renal insufficiency. Principles of management include stopping bleeding using bypass therapy, eradication of the inhibitor with immunosuppression, and recognizing and treating any underlying disorder that may have triggered autoantibodies to factor VIII.



FIGURE 54.5. Soft tissue hemorrhage in a 76-year-old man with a high-titer factor VIII inhibitor. This patient has a history of ischemic cardiomyopathy and diabetes and developed spontaneous extremity bruising as shown. The antihuman factor VIII antibody titer was 10 Bethesda units. (Courtesy of Alan Grosset.)

In patients with low-titer inhibitors who do not have any clinical bleeding and for whom no surgical procedures are foreseen, the most reasonable approach may be to monitor the abnormal laboratory finding. Steroids and cytotoxic therapy (usually cyclophosphamide) are usually ineffective when inhibitors arise in patients with congenital hemophilia A, but they are effective in the setting of nonhemophilic patients.^{275, 316} Cyclosporin has also been used to treat acquired antibodies to factor VIII.³¹⁷ Procedures or medications (antiplatelet drugs) that would increase hemostatic risks should be avoided, and ancillary local therapeutic measures to control minor bleeding are recommended and may in themselves be sufficient. For patients with minor bleeding who have residual factor VIII activity >5% of normal, DDAVP therapy may be helpful (0.3 µg/kg, up to 24 µg maximal dose).^{273, 318} Antifibrinolytic therapy, such as the administration of EACA or tranexamic acid, may be helpful, especially for oral or nasal bleeding; however, this therapy should be used cautiously in muscle bleeds because it appears to be less effective, and it should not be used in conjunction with PCCs, activated PCCs (APCCs), or rVIIa.

The inhibitor titer and its prior response to factor VIII infusion may be of particular use in guiding therapeutic decisions (Fig. 54.6). As a rule, replacement therapy with factor VIII in the usual doses is ineffective. If clinical bleeding mandates active therapy, patients with a low Bethesda titer (<5 U/ml), particularly if they are known to be low responders, usually respond to high-purity or recombinant human factor VIII³¹⁴ given as a large initial 150 U/kg bolus followed by a continuous infusion of 1,000 U/hour. The therapeutic response to human factor VIII should be clinically assessed; factor VIII levels and repeat assays of inhibitor titer response may be helpful. Therapy with human factor VIII is seldom successful in patients with high-titer antibodies (>5 Bethesda U/ml), high-affinity antibodies, and infinite coagulation times. As an alternative, particularly in patients with high-titer inhibitors or a history of an anamnestic response, or routinely in medical centers that prefer to reduce the uncertain risk of inducing an increased inhibitor titer, the use of inhibitor-bypassing products may be useful. These include the PCCs, APCCs, and rVIIa. The best-studied treatment options are FEIBA (factor VIII inhibitor bypassing activity) and rVIIa.³¹⁶ There is no consensus as to the best therapeutic approach between these options.³¹⁹

A literature review of efficacy and safety of FEIBA and rVIIa in treating bleeding events in acquired hemophilia indicates “indistinguishable” efficacy between the two products³¹⁶; if one agent is not successful in stopping bleeding, the other agent should be used. A typical dose for FEIBA in this indication is 75 U/kg every 8 to 12 hours. Both therapies (FEIBA, rVIIa) are associated with thrombosis.³¹⁶

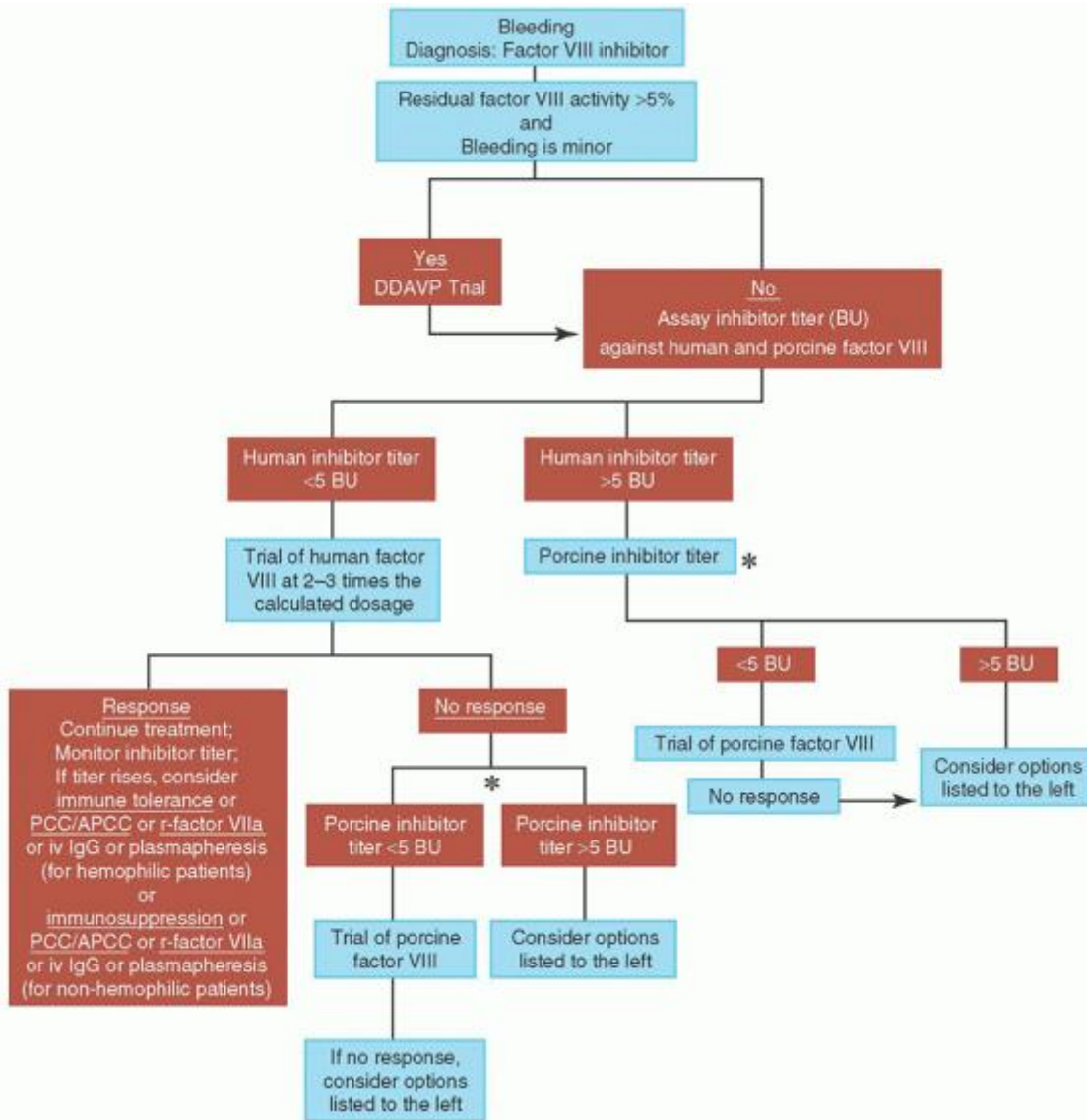

FIGURE 54.6. A strategy for management of factor VIII inhibitors in hemophilic and nonhemophilic patients. Key decisions are based on antihuman and antiporcine factor VIII inhibitor titers. Multiple options for patients not responding to human or porcine factor VIII are available. BU, Bethesda units; DDAVP, 1-desamino-8-D-arginine vasopressin; PCC/APCC, prothrombin complex concentrate/activated prothrombin complex concentrate. The underlined options are preferred. Immunosuppression options include rituximab, steroids, and cytotoxic drugs. *As of early 2013, porcine factor VIII was not routinely available, so testing porcine inhibitor titers should not be done. If a recombinant porcine product becomes available, then these tests will be relevant. (Information in this figure is from the literature, including Morrison AE, Ludlam CA. Acquired haemophilia and its management. *Br J Haematol* 1995;89:231-236.)

rVIIa is a treatment option for inhibitor patients.^{320, 321} This drug was originally thought to exert activity by binding to tissue factor at sites of vascular injury to initiate coagulation. More recent data indicate that at the pharmacologic concentrations of factor VIIa achieved during rVIIa therapy, there may be platelet-dependent, tissue factor-independent mechanisms to mediate hemostasis.³²² The standard dose of rVIIa is 90 µg/kg every 2 hours for serious bleeding³²³ or 90 µg/kg every 3 hours for mild to moderate bleeding in home treatment.³²⁴ Recent trial data indicate that a single rVIIa dose of 270 µg/kg is effective home treatment for hemarthroses.³²⁵ Continuous infusion of rVIIa is also effective, targeting

factor VII levels to 30 to 40 U/ml.³²⁶ rVIIa, like FEIBA therapy, is associated with potential thrombotic complications; a comparative evaluation of the thrombotic event rate of rVIIa versus FEIBA revealed that rVIIa was associated with approximately threefold more thrombotic events than APCC.³²⁷ FEIBA has been successfully used as a prophylaxis therapy for hemophilia patients with inhibitors.³²⁸

There are few studies directly comparing the efficacy of rVIIa versus FEIBA or other activated PCCs in inhibitor patients with serious bleeding. These products have similar efficacies,^{316, 329, 330} and consensus recommendations generally include multiple treatment options.^{314, 331, 332} For patients refractory to both drugs used as single agents, sequential therapy with FEIBA and rVIIa has been reported.³³³

P.1206

Another potentially useful product in inhibitor patients is porcine factor VIII. Obtaining an antiporcine antibody titer is useful, but as a rule of thumb, the initial antiporcine titer is often 5% to 10% of the antihuman titer. However, the antiporcine titer may rapidly rise after administration of porcine factor VIII. For these reasons, porcine factor VIII is usually reserved for one-time use.³³² Some investigators consider porcine factor VIII to be the therapy of choice for patients with factor VIII antibodies in which the antibody has minimal cross-reactivity to porcine factor VIII,³³⁴ and consensus groups consider porcine factor VIII an appropriate treatment option.^{314, 331} Porcine factor VIII is currently unavailable in the United States; however, a recombinant B-domain-deleted porcine factor VIII product is in clinical trials.

Long-term eradication of antibodies to factor VIII requires immunosuppressive therapy. Numerous treatment options exist.³¹⁶ A literature review³³⁵ of the efficacy of intravenous Ig in the treatment of acquired factor VIII antibodies found a cumulative response rate of only 12%, suggesting that other modalities should be attempted first for these patients.

Standard immunosuppression should be reserved for patients with autoantibodies because this therapy is rarely beneficial in the alloimmune setting. Corticosteroids (e.g., prednisone in doses of 1.0 to 1.5 mg/kg/day) produced improvement in approximately 50% of patients when administered on a long-term basis,²⁷⁵ with the best results obtained with nonhemophilic patients. Similar therapeutic responses have been reported when immunosuppressive drugs, such as cyclophosphamide (2 to 3 mg/kg/day), were administered alone or with prednisone.^{316, 336} Remission of bleeding and reduction of antibody titer have been well documented, but total suppression of the antibody is rare.

Rituximab, a monoclonal antibody to the CD20 antigen on B cells, has been reported to be effective in case series of patients with acquired factor VIII antibodies,^{316, 337, 338} and a United Kingdom practice guideline recommends rituximab as second-line therapy if patients have not responded to steroids and cyclophosphamide.³¹⁴

One aggressive treatment regimen for acquired hemophilia combined protein A immunosorption, factor VIII, intravenous IgG, and immunosuppression; this regimen resulted in abolition of antibody levels within 3 days and a complete response rate of 88%.³³⁹ This aggressive regimen should be considered for patients with severe, life-threatening bleeding.³¹⁶ Cyclosporin A has been reported to be useful in patients failing first-line eradication therapy.³¹⁶

In many patients with hemophilia A who have developed alloantibodies to factor VIII, infused factor VIII provokes a rapid increase in the antibody titer. However, in many of these patients, the administration of large doses of factor VIII for periods of months to years may produce immune tolerance (IT) to factor VIII. An international registry of patients treated with this approach reported that approximately 70% of patients achieved long-lasting tolerance.³⁴⁰ A 1997 update of this registry indicated that 52% of patients were successfully treated with IT.³⁴¹ Several IT regimens have been summarized.³⁴² The registry data suggest that success of inducing tolerance is greatest in patients given more than 100 U/kg/day factor VIII who had an initial inhibitor titer of <10 Bethesda U before starting IT.^{340, 341} Data from the North American Immune Tolerance Registry have been reported; the overall success rate was 70%.³⁴³ The cost effectiveness of IT therapy has been demonstrated.³⁴⁴

The International Immune Tolerance Study compared high-dose (200 U/kg daily) versus low-dose (50 U/kg daily) factor VIII. Both dosage regimens were equivalent in terms of inducing tolerance; however, the low-dose regimen was associated with more bleeding.³⁴⁵ The use of factor VIII products that contain vWF may be more effective in IT induction.³⁴⁶ The topic of IT induction in hemophilia A and B patients has been recently reviewed.³⁴⁷

Monospecific Antibodies to Other Coagulation Factors

Table 54.6 summarizes certain conditions associated with antibodies to other coagulation factors.

Factor IX

Inhibitors of factor IX have been demonstrated in approximately 5% of patients with hemophilia B^{348, 349} and rarely in previously normal persons (acquired hemophilia).³⁵⁰ Hemophilia B patients who acquire antibodies to factor IX often have gross

P.1207

gene deletions.³⁵¹ In contrast to antibodies to factor VIII, factor IX antibodies act instantaneously. One series of eight hemophilia B inhibitor patients found that antibodies typically were IgG₁ and IgG₄, and that the antibodies targeted the Gla domain and protease domain epitopes of factor IX.³⁵² rVIIa³⁵³ or IT therapy³⁴³ has been used to treat these patients, although IT for hemophilia B inhibitor patients may be less effective than for hemophilia A inhibitor patients.³⁵⁴ PCCs are also a treatment option.³⁵⁵ Patients with antibodies to factor IX may experience anaphylaxis when treated with factor IX-containing products³⁵⁴; rVIIa may be the appropriate therapy for this patient group. A British consensus group has published guidelines on treating factor IX inhibitor patients,^{314, 314a} and an ISTH registry of factor IX inhibitor patients has been established.³⁵⁶

TABLE 54.6 ACQUIRED DISORDERS ASSOCIATED WITH DEFICIENCY OF A SINGLE COAGULATION FACTOR

Deficient Factor	Specific Inhibitors^a	Other Disorders
Fibrinogen	Hereditary afibrinogenemia ³⁸⁶ ; lupus erythematosus; liver disease	—
Prothrombin	Previously normal persons ³⁸⁷	Lupus inhibitors ³⁸⁹
Factor V	Previously normal persons; ³⁵⁷ often associated with streptomycin; ³⁵⁷ rarely in inherited factor V deficiency; postoperative patients who received bovine thrombin ^{361, 362, 363, 364, 365, 366}	Chronic myelocytic leukemia ⁶²⁰
Factor VII	Bronchogenic carcinoma, ³⁹⁸ acquired immunodeficiency syndrome ³⁹⁹	Aplastic anemia, ⁵⁹³ liposarcoma ⁵⁹⁴
Factor VIII (VIIIc)	Hemophilia A; ^{258, 259} puerperium; ²⁷⁷ inflammatory disorders; drug reactions; in absence of underlying disease ²⁷⁵	—
von Willebrand factor	Previously normal persons; lymphoproliferative disorders; ^{372, 373, 374, 375, 376, 377, 378} rarely in von Willebrand disease; thrombocytosis	Wilms tumor ⁶¹⁹
Factor IX	Hemophilia B; ^{348, 349} rarely in previously normal persons ³⁵⁰	Nephrotic syndrome; ⁵⁸⁷ Sheehan syndrome ⁵⁹¹ ; Gaucher disease ⁵⁹² Factor X — Amyloidosis; ^{577, 578, 579, 580, 581, 582, 583} upper respiratory infection; ³⁹⁴ other associations ⁵⁸⁴
Factor XI	Lupus erythematosus; rarely in inherited factor XI deficiency and chronic lymphocytic leukemia; previously normal persons ³⁹²	—
Factor XII	Lupus erythematosus, rarely	Nephrotic syndrome; chronic myelocytic leukemia
Factor XIII	Previously normal persons, often associated with isoniazid; ³⁸¹ rarely in inherited factor XIII deficiency; ³⁸⁰ other associations ⁵⁹⁷	Acute and chronic leukemia; ⁵⁹⁵ Crohn disease ⁵⁹⁶

^a Evidence suggests these inhibitors are antibodies. In patients with inherited deficiencies of the various factors, their development usually is related to transfusion of blood or blood products.

Factor V

Inhibitors of factor V³⁵⁷ have developed spontaneously in previously normal older persons after administration of streptomycin,³⁵⁸ gentamicin, or penicillin and after surgical procedures. More rarely, factor V inhibitors have been associated with tuberculosis, femoral fracture, and bullous pemphigoid. These antibodies are usually of IgG isotype. An Australian survey estimated the annual incidence of factor V inhibitors at 0.29 cases per million population,³⁵⁹ and a Singapore incidence rate was 0.09 cases per million person years.³⁶⁰ Alloantibodies to factor V may occur in factor V-deficient patients who receive blood products.³⁶¹

Over the past 30 years, an iatrogenic coagulopathy has been identified: The occurrence of antibodies to thrombin and factor V in patients treated with bovine thrombin during surgery.^{361, 362, 363} The antithrombin antibody neutralizes bovine thrombin and therefore can prolong the thrombin time when bovine thrombin is used for this test.^{364, 365} However, no clinically significant hemostatic defect appears to result from this single laboratory abnormality. Some patients acquire additional antibodies to human factor V, which may result in significant factor V deficiency and bleeding.^{364, 365} In a large surgical series of patients exposed to bovine thrombin, more than 95% of patients developed antibodies to bovine thrombin or factor V, and 50% of these patients had antibodies cross-reacting to human coagulation proteins.³⁶⁶ These latter patients have a bleeding risk.³⁶⁶

In contrast to most other specific inhibitors, antibodies to factor V seldom produce serious hemorrhage.^{361, 367} Patients with alloantibodies to factor V typically have significant bleeding.³⁶⁶ Patients with antibody recognition of the C2 domain of factor V have also been reported to have a significant bleeding risk. A literature review identified a bleeding mortality rate of 12% in patients with factor V antibodies not due to exposure to bovine factor V or noninherited acquired factor V antibodies.³⁶⁰ In several patients with severe hemorrhage, platelet transfusions were therapeutically more effective than plasma.^{360, 363, 368} This clinical benefit of platelet transfusions likely relates to platelet α -granule content of factor V which is released at sites of bleeding to improve local hemostasis. Plasmapheresis,³⁶⁹ immunosuppression, and intravenous IgG³⁷⁰ have been reported to be effective in resolving antibodies to factor V. In some cases, these antibodies resolve spontaneously.³⁶⁶

A small number of patients have been described with thrombosis symptoms associated with factor V antibodies. These patients may³⁵⁷ or may not^{361, 371} have coexisting antiphospholipid antibodies.

von Willebrand Factor

Acquired von Willebrand disease (vWD) has been reported in association with a variety of disorders, primarily including patients with lymphoproliferative disorders, myeloproliferative disorders, solid tumors, autoimmune disease, aortic stenosis, and artificial heart devices. An international registry identified lymphoproliferative and myeloproliferative disease as accounting for more than 60% of acquired vWD.³⁷² A literature review concluded that most cases of acquired vWD result from an antibody that recognizes high-molecular-weight multimers of vWF and mediates subsequent antigen-antibody clearance.³⁷³ Another mechanism for the development of this disorder includes adsorption of vWF by tumor cells³⁷⁴ or platelets. Acquired vWD has also been reported in patients with aortic stenosis³⁷⁵ and in patients with ventricular-assist devices and artificial hearts.³⁷⁶ In these cardiac conditions, vWF is subjected to shear stress and proteolysis.^{375, 376} Ristocetin co-factor activity is usually decreased, whereas factor VIII activity may be normal.³⁷³ In most patients, the hemostatic abnormalities disappear when the underlying disorder is treated.³⁷⁷ For patients with acquired vWD resulting from a lymphoproliferative disorder or monoclonal gammopathy, intravenous Ig may be effective.³⁷⁸ The consensus group recommends a trial of DDAVP as initial therapy³⁷⁹; DDAVP failures are then treated with vWF concentrates (e.g., Humate-P or Wilate).³⁷² Intravenous Ig is reserved for those patients having no success with DDAVP and vWF concentrates.³⁷² For patients with acquired vWD associated with monoclonal gammopathy of uncertain significance, a trial comparing DDAVP and vWF concentrates versus intravenous Ig found that the latter treatment provided a sustained response compared to DDAVP/vWF concentrates.³⁷⁹

Factor XIII

Inhibitors of factor XIII have been described after transfusions in patients with inherited deficiency of this proenzyme and in previously normal persons.³⁸⁰ Many of the latter group had received isoniazid,³⁸¹ and it was suggested that this drug may alter factor XIII in such a manner that it becomes antigenic.³⁸² These inhibitors may recognize the zymogen, impair the activation of factor XIII by thrombin, or be directed against the cross-linking sites of fibrin, or to the B-subunit.^{383, 384} Therapeutic options include factor XIII replacement therapy (plasma, cryoprecipitate), rVIIa, as well as inhibitor

eradication options (steroids, cyclophosphamide, rituximab, etc.).³⁸⁴ A factor XIII concentrate, Fibrogammin, if available, may also be useful.³⁸⁴ A survey of hemophilia treatment centers reported that ~38% of inherited factor XIII-deficient patients developed antibodies as a treatment complication³⁸⁵; these patients may require bypassing agents to treat bleeding.

Fibrinogen and Prothrombin

A precipitating antibody to fibrinogen has been demonstrated after transfusions in patients with hereditary afibrinogenemia.³⁸⁶ Acquired hypofibrinogenemia is usually seen in acute DIC. Dysfibrinogenemia may occur in patients with liver disease or hepatoma, or in plasma cell disorders (discussed in the section "Deficient or Aberrant Synthesis of Coagulation Factors"). Antibodies to prothrombin have also been reported.³⁸⁷ An unusual case of an autoantibody to prothrombin was described; the antibody induced protease activity from the zymogen, leading to neutralization by antithrombin.³⁸⁸ Acquired hypoprothrombinemia usually occurs in the setting of the lupus anticoagulant (LA) when patients have antibodies to prothrombin that clear prothrombin activity from blood.³⁸⁹

Factor XI

A survey of prevalence of acquired inhibitors to factor XI in patients with inherited factor XI deficiency found that ~5% of patients with severe deficiency developed antibodies after plasma therapy.³⁹⁰ Of those factor XI-deficient patients homozygous for a null allele, one third developed antibodies.³⁹⁰ A combination of

P.1208

low-dose rVIIa and tranexamic acid was reported to be safe and effective for such patients requiring surgery.³⁹¹ Specific inhibitors of factor XI have been described primarily in association with autoimmune disease.^{392, 393}

Factor X

Antibodies to factor X are very uncommon and may be associated with upper respiratory tract infections,³⁹⁴ either viral or mycoplasma; however, in these cases, inhibitors to factor X have been directly proved infrequently. Bleeding has been controlled using PCCs,³⁹⁵ or ivIgG and steroids.³⁹⁶ Acquired factor X deficiency has been frequently reported in amyloidosis (discussed below).

Factor VII

Antibodies to factor VII are rare, with fewer than 20 cases reported in the English literature.³⁹⁷ They have been reported in lung cancer³⁹⁸ and human immunodeficiency virus infection,³⁹⁹ and with no apparent disorder.⁴⁰⁰ Immunosuppression has been used successfully in anecdotal case reports of autoantibodies to factor VII.⁴⁰¹

Tissue Factor

Antibodies to tissue factor are very uncommon, with one group reporting two patients who developed antitissue factor antibodies after liver surgery.⁴⁰² Similar to patients who acquire antithrombin and antifactor V antibodies after use of topical bovine thrombin,^{361, 362, 363, 364} the patients who developed antitissue factor antibodies were both treated with a topical hemostatic agent prepared from bovine tissue that contained tissue factor. The antibodies to bovine tissue factor did not cause clinical bleeding but did prolong PT values.⁴⁰²

Antiphospholipid-Protein Antibodies: Lupus Anticoagulants and Anticardiolipin Antibodies

Historical Considerations and Nomenclature

The two best-known clinical types of APAs are traditionally called LA and anticardiolipin (aCL) antibodies. These antibodies are associated in some patients, but not in others, with clinical illness^{403, 404} of varying severity. Individual patients may manifest arterial or venous thromboembolic disease, recurrent pregnancy loss, thrombocytopenia or other cytopenias, and neurologic and skin abnormalities. The clinical importance, particularly of the LA or higher-titer aCL antibodies, has been increasingly recognized; these antibodies or their functional consequences are found in approximately 10% of patients with venous thromboembolic events.^{405, 406} Bleeding is quite uncommon, and when present, it is usually the result of severe thrombocytopenia, platelet dysfunction, hypoprothrombinemia, or the effects of an underlying disease. On the other hand, thrombosis and its many manifestations are common.

Synonyms for LA and aCL antibodies include antiphospholipid (aPL) antibodies, APAs, and autoantibodies to phospholipid-binding plasma proteins.⁴⁰⁷ The associated clinical manifestations including thrombosis are variously called the LA syndrome, antiphospholipid syndrome (APS), or antiphospholipid-protein syndrome. APS without a known well-

defined autoimmune disease is termed primary APS (PAPS). A few patients with APA develop an acute, severe, multiple-organ APS illness. These patients are designated as having catastrophic APS (CAPS).

The existence of these antibodies was first detected more than 50 years ago when it became apparent that approximately 15% of patients with active SLE have a false-positive Venereal Disease Research Laboratory (VDRL) test.⁴⁰⁸ The VDRL test assesses antibody reactivity to “reagin” (antigen), an acidic-phospholipid complex that is chemically extracted from bovine heart tissue. Reagin consists of a mixture of lecithin, cholesterol, and cardiolipin. A nonspecific antibody reaction to reagin is also seen less often in other autoimmune disorders and in some apparently healthy patients. Other laboratory assays discussed in this section identified a family of antibodies that were initially thought to have direct specificity to various phospholipids, although it is now known that the antibodies recognize phospholipid-protein complexes. The proteins often serve a critical cofactor role,⁴⁰⁹ and the antibodies collectively are thus most accurately called APAs.⁴¹⁰

Coagulation assays are sensitive to some of these antibodies. Plasma samples from some patients with SLE, often those with the abnormal VDRL tests, show an *in vitro* inhibitor effect in several coagulation assays. This association gave rise to the term LA.⁴¹¹ Most often, a prolonged PTT result that is not corrected on mixing with normal plasma is observed; other phospholipid-dependent assays, including the modified Stypven time (dilute Russell viper venom time [DRVVT]), are also affected.³⁶⁷ Despite persistent clinical use, it is now known that most patients with an LA phenomenon do not have SLE. Moreover, clinical thrombosis is much more often seen than is bleeding with APS antibodies. Patients with SLE occasionally have inhibitors to other hemostatic factors,⁴¹² but these inhibitors are not considered LAs.

In addition to the biologically false-positive VDRL results and the paradoxical *in vitro* lupus-anticoagulant effect, laboratory studies found a third phenomenon, initially detected by radioimmunoassay: Antibodies to cardiolipin.⁴¹³ In aCL-antibody assay systems, serum Igs bind to various anionic phospholipid-protein complexes, most commonly to cardiolipin in a coated microwell enzyme-linked immunosorbent assay (ELISA). The sensitivity and specificity of this assay are substantially higher than those of the VDRL. A phospholipid-binding protein, β_2 -glycoprotein I (β_2 gpl), has been identified,⁴¹⁴ and antibodies to this antigen can also be demonstrated in patients with APS.⁴¹⁵ Thus, the most useful assays to evaluate patients for antiphospholipid antibodies include the LA, aCL antibodies, and antibodies to β_2 gpl.

Epitope Specificity

In these disorders, the antibodies were initially thought to react with anionic phospholipids directly, but the presence of specific plasma proteins associated with phospholipids is now known to be of great importance.⁴¹⁶ In the case of LAs, the seemingly paradoxical discordance between laboratory screening test results and clinical symptoms is frequently the consequence of antibodies that bind to a complex of phospholipid-bound prothrombin.^{389, 417} This antibody binding impairs the function of the standard prothrombin-binding synthetic anionic phospholipids⁴¹⁸ that are used routinely in the laboratory to replace platelets in phospholipid-dependent coagulation assays, such as the PTT. Other more natural phospholipids, or platelets themselves, are less affected by this phenomenon and are used in some assays as correction factors in mixing studies.

In the case of aCL antibodies, especially in autoimmune and drug-induced aCL, β_2 gpl⁴¹⁹ serves as a mandatory protein cofactor.⁴¹⁴ Patient-derived antibodies directed against β_2 gpl that have LA activity have also been reported.⁴²⁰ β_2 gpl is a 57-kD plasma protein with an uncertain physiologic role, but it is often considered a noncomplement member of the complement-control family of proteins, with structural similarity to complement factor H. A recent study reported that β_2 gpl inhibited complement activation at the level of C3.⁴²¹ β_2 gpl has a number of anticoagulant activities,^{422, 423} but inherited deficiency of β_2 gpl has no thrombophilic association.⁴²⁴ The antibodies in these settings are often of the IgG isotype, are relatively persistent and high in titer, are associated with an LA phenomenon in approximately 60% of patients, and are clearly associated with the clinical syndromes

P.1209

discussed subsequently. IgM and IgA antibodies occur less often. aCL antibodies are not directed primarily against cardiolipin itself, but against epitopes formed after β_2 gpl binds to anionic phospholipid membranes or anionic synthetic surfaces. One study observed that pathogenic antibodies targeted an epitope in domain 1 of β_2 gpl, and that these antibodies had LA activity.⁴²⁵ β_2 gpl may also mediate aCL binding to endothelial cell membranes.⁴²⁶ Other proteins have been occasionally implicated as possible obligatory cofactors, including annexin A5,⁴²⁷ annexin A2,⁴²⁸ factor Xa, protein C, protein S, and vimentin.⁴²⁹ Anti- β_2 gpl antibodies have been reported to induce acquired resistance to APC.⁴³⁰

It was previously thought that APA recognized neoepitopes of the above phospholipid-binding proteins expressed on cell surface binding. Another hypothesis is that the true antibody target is an appropriate density (“clustering”) of proteins bound to phospholipid surfaces, which is necessary for antibody recognition.⁴³¹ For example, based on *in vitro* data, it has

been proposed that β_2 gpl acts as an antigen in vivo only when the antigen (β_2 gpl) clusters on membrane surfaces such as endothelium. When clustering occurs, this increased antigenic density allows antibody recognition to occur, leading to antibody binding and endothelial cell activation and potentially triggering cellular events resulting in thrombosis.⁴³² Figure 54.7 illustrates how this phenomenon might occur. Additional studies found that β_2 gpl undergoes a conformational change (circular to “fishhook”) upon cell binding to anionic phospholipids, leading to clustering⁴³³ and antibody binding.⁴³⁴ Involvement of the MyD88 signal transduction pathway in antibody-mediated endothelial cell activation has been described,⁴³⁵ and others have reported involvement of the p38 mitogen-activated protein kinase pathway.⁴³⁶ Receptors that have been described that could possibly mediate the APA response include a toll-like receptor on endothelium,⁴³⁵ annexin A2, and apoER2'. The latter receptor has been demonstrated to promote leukocyte-endothelial cell adhesion and thrombosis by inhibition of endothelial cell nitric oxide synthase activity.⁴³⁷ Other investigators have identified cell signaling through the toll-like receptor 4 mediated by a multiprotein complex as a pathway for endothelial cell activation by APS antibodies.⁴³⁸

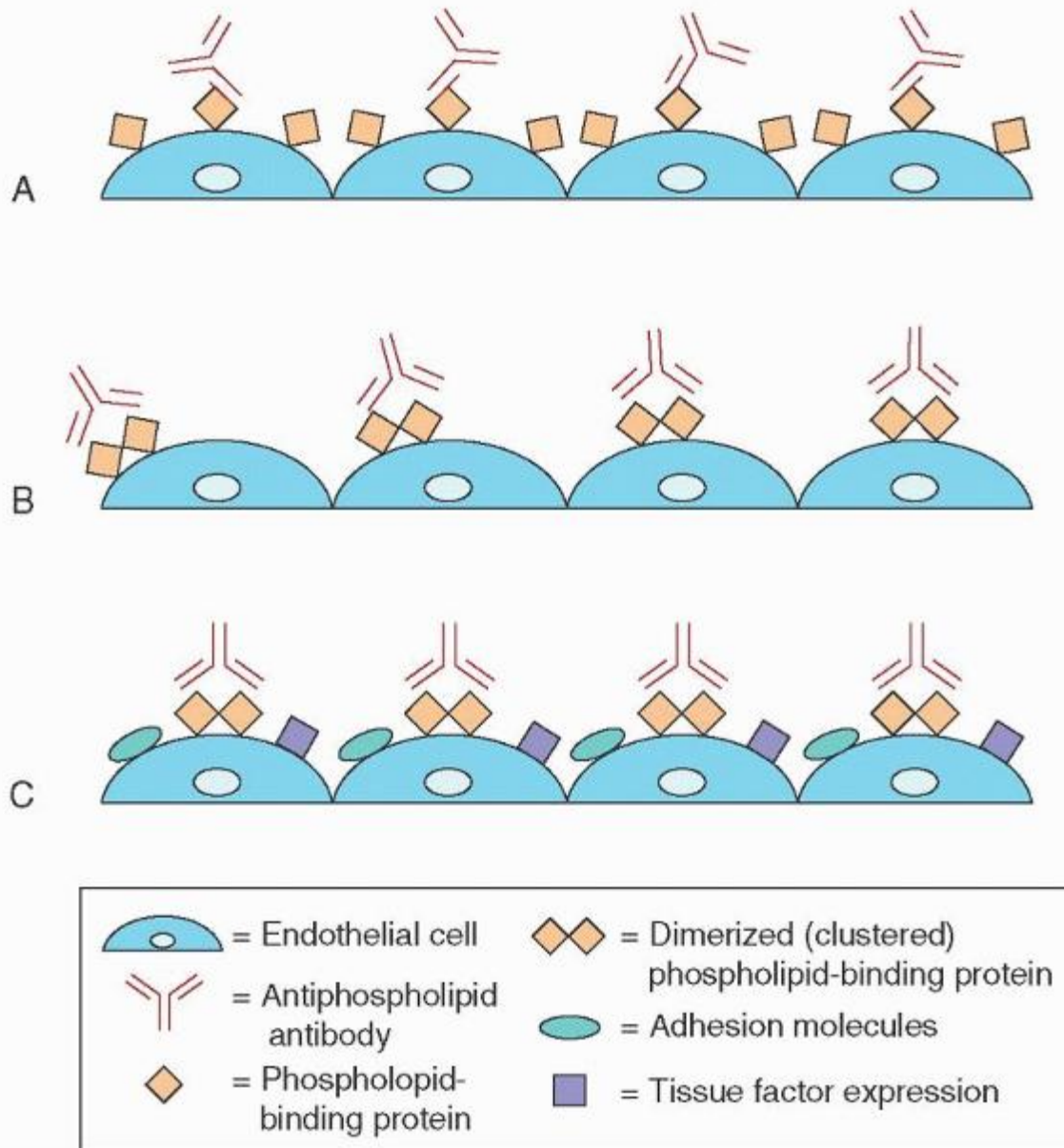

FIGURE 54.7. A proposed mechanism by which antiphospholipid antibodies induce endothelial cell activation and thrombosis. A: Endothelial cells express a phospholipid-binding protein (e.g., β_2 gpl). In the absence of high antigenic density (“clustering”), antibody binding is inefficient. B: Endothelial cells display dimerized (“clustered”) antigen, which

allows for efficient antibody binding, resulting in endothelial cell activation and promotion of thrombosis (C).

In other settings, particularly those related to infection, the aCL antibodies are often of IgM isotype, are often of low titer and relatively transitory, and have no identified co-factor protein.⁴⁰⁹ Although β_2 gpl is an absolute protein co-factor requirement for aCL activity in autoimmune settings, it may, in contrast, be inhibitory in the infection-related circumstance.⁴⁰⁹ The clinical association of IgM antibodies with thrombophilia is less strong,⁴³⁹ particularly thrombosis occurring after drug administration,⁴⁴⁰ although exceptions to this generalization have been noted.⁴⁴¹ The detection of subgroups of aPLs has been reviewed.⁴⁰³

Another key question related to the pathogenesis of APS is, how are antiphospholipid antibodies generated? One report found that only β_2 gpl bound to phospholipids could be successfully presented to T lymphocytes to elicit a pathogenic immune response.⁴⁴² Oxidation of β_2 gpl increases its immunogenicity, and patients with APS have increased amounts of oxidized β_2 gpl.⁴⁴³

Mechanism of Thrombosis

Potential mechanisms to explain how aPL induces thrombosis⁴⁰⁵ include (a) endothelial cell activation, (b) oxidant-mediated vascular injury, (c) interference with the function of phospholipid-binding proteins in regulating coagulation, and (d) complement activation.⁴⁰⁴ In the first hypothesis, aPL antibodies directly bind to endothelium to up-regulate expression of adhesion molecules and cytokine secretion.⁴⁰³ In the second hypothesis, autoantibodies to oxidized low-density lipoprotein occur with aCL antibodies, and aCL antibodies recognize oxidized phospholipids and phospholipid-binding proteins.⁴⁴⁴ In the third hypothesis, aPL antibodies may interfere with the anticoagulant functions of protein C or annexin V or enhance procoagulant activity.^{403, 427, 428} In the fourth hypothesis, complement activation by aPL antibodies leads to neutrophil expression of tissue factor.⁴⁴⁵

Immunologic studies lend strong support for a direct pathophysiologic role of these antibodies in the clinically observed thrombotic syndromes.⁴⁴⁶ In animal models using standardized vessel injury to induce thrombosis, either passively conferred APA⁴⁴⁷ or active induction of antibody with either APA or β_2 gpl⁴⁴⁸ resulted in thrombosis; this suggested that APAs are not merely epiphenomena of thrombi arising for other reasons but, in some cases, play a direct role in initiation, propagation, or maintenance of thrombosis. Immunization of mice or rabbits with β_2 gpl produces two populations of antibodies: One with specificity for β_2 gpl alone without binding to phospholipids and the other with specificities for both cardiolipin and β_2 gpl.⁴⁴⁹ This dual specificity of antibodies is also seen with those aPLs that are present in patients with autoimmune diseases.

The concept of hexagonal phase configuration has been popularized. This configuration is thought to arise in vivo in response to membrane damage.^{450, 451} Normally, polar heads of phospholipids exist on the external surface, whereas in the hexagonal phase, lipid cylinders exist with internal aqueous channels formed by polar head groups.⁴⁵² LA and aCL may represent antibodies generated in response to these neoantigens. APAs have been generated in mice immunized with hexagonal phase phospholipid⁴⁵³; these antibodies reacted with cardiolipin and possessed functional LA activity.

The precise cause of thrombosis in APS is uncertain, and is likely multifactorial. Presumably, APAs act by interfering with coagulation,⁴⁰⁴ possibly involving dysfunction or apoptosis⁴⁵⁴ of endothelial cells, platelets, and coagulation proteins, and affect pregnancy outcome by interfering with embryo implantation and fetal development.⁴⁰³

P.1210

Specific mechanisms of thrombosis that have been implicated include inhibition of APC,⁴⁰⁴ acquired free protein S deficiency, platelet activation, and abnormalities in the antigenic levels or activity of endothelium-derived hemostatic factors, including inhibition of prostacyclin secretion, fibrinolysis, nitric oxide synthesis, or disruption of annexins A5 or A2.^{404, 427, 428, 437} The thrombogenicity of APAs may also result from their interference with endothelial cell phospholipids required for antithrombin and proteins C and S anticoagulant activity, and increased endothelial cell expression of the following procoagulants: Tissue factor, vWF, platelet-activating factor, and plasminogen activator inhibitor type-1.^{403, 404, 455, 456} Tissue factor was identified as a mediator of complement-induced APS fetal loss in a mouse model.^{445, 457}

Epidemiology and Clinical Associations

Young, apparently healthy control subjects are reported to have a prevalence of 1% to 5% of aPL antibodies.⁴⁵⁸ In patients with systemic lupus, aPL occurs in 12% to 34%. After prolonged followup, APS may develop in more than 50% of patients with systemic lupus.⁴⁰³

LA and aCL antibodies have been reported in a variety of clinical disorders, including SLE and other autoimmune and connective tissue diseases, and in disorders that are unrelated to SLE (Table 54.7). The presence of phospholipid-binding antibodies could in some cases be an epiphenomenon. In other cases, APAs may be of profound direct etiologic relevance. In general terms, although there are individual patient exceptions, clinical symptoms are seen less often with aCL than with LA, particularly when APAs are associated with infection or medication, are of low titer, and are of IgM isotype.

Interpretation of estimates of APA frequency must consider the sensitivity of the diverse assay systems that have been used by investigators. Different LA assay systems have been tested with plasma samples from a rigorously defined group of patients with the antiphospholipid-protein syndrome, confirming the importance of variables such as the concentration and composition of phospholipids used in the assay,⁴⁵⁹ phospholipid reagent conformation,⁴⁵² and so forth.

TABLE 54.7 CLINICAL DIAGNOSES ASSOCIATED WITH ANTIPHOSPHOLIPID-PROTEIN ANTIBODIES

Primary antiphospholipid-protein antibody syndrome

Autoimmune disorder with no apparent cause

Secondary autoimmune disorders

Systemic lupus erythematosus; other autoimmune and connective tissue diseases; drug induced: procainamide, hydralazine, quinidine, phenothiazines, penicillin

Malignancies

Leukemia, lymphoproliferative and plasmacytic disorders, solid tumors, essential thrombocytosis

Infections

Viral, bacterial, protozoal, fungal

Neurologic disorders

Liver disease

Valvular heart disease

Peripheral arterial disease

Chronic renal failure

Sickle cell disease

Ethylenediaminetetraacetic acid-dependent pseudothrombocytopenia

In a large series of internal medicine patients, 7% were APA positive, and 2% fulfilled the criteria of antiphospholipid antibody syndrome.⁴⁶⁰ The most commonly associated diseases were cancer and chronic or acute alcoholic intoxication. In another study, elevations of APA were found in approximately 20% of an unselected autopsy population, 10% of age- and sex-matched controls, and 2% of healthy normal subjects.⁴⁶¹

Inhibitors of the lupus type originally were recognized in association with SLE.³⁶⁷ The prevalence of LA in patients with SLE strongly depends on the type of LA assay system used; three standard PTT reagents detected LA in only 10% of SLE patients.⁴⁶² A modified PTT with a reduced concentration of phospholipid detected LA activity in approximately 50% of SLE patients.^{462, 463} The kaolin clotting time, a test similar to the PTT, detected LA in 70% of patients with SLE.⁴⁶⁴ LA activity was associated with higher mortality in SLE patients.⁴⁶⁵ APAs have been seen in other connective tissue disorders, including rheumatoid arthritis and Behçet syndrome.

APAs are present in many patients with malignancy.⁴⁶⁶ APAs have been associated with monoclonal gammopathy of undetermined significance and Waldenström macroglobulinemia. APAs have been identified in liver disease, the prevalence increasing significantly as the liver disease progresses; APA positivity was as high as 80% in patients with alcoholic hepatitis or cirrhosis.⁴⁶⁷ The antibodies have been found in many infections, including hepatitis C,⁴⁶⁸ infection with human immunodeficiency virus,^{469, 470} human T-cell lymphotropic virus-1-associated tropical spastic paraparesis, Q fever, and malaria.⁴⁷¹ Children with viral infections often acquire a transient LA effect.⁴⁶² Perhaps as a result of the structural changes in the red cell membrane with increased hexagonal-phase content, APAs are common in sickle cell disease.⁴⁷² Patients with transient ischemic attacks and cardiac valve lesions had a high incidence of APAs.⁴⁶¹ APAs have

been seen in a variety of unrelated neurologic disorders.⁴⁷³ Patients with essential thrombocytosis have an increased prevalence of APA and increased risk of thrombosis.⁴⁷⁴

Several medications are associated with APA, most often, phenothiazines such as chlorpromazine,⁴⁴⁰ procainamide,⁴⁷⁵ quinine and quinidine,⁴⁷⁶ hydralazine, and penicillin.⁴⁷⁷ APAs were common in patients with ethylenediaminetetraacetic acid-dependent pseudothrombocytopenia.⁴⁷⁸ aCL antibodies can occur in both active and quiescent Crohn disease, usually without concomitant LA expression,⁴⁷⁹ but their role in the thrombotic complications that can occur in the active phase of this disease is uncertain.

APA positivity is a common finding in patients with idiopathic thrombocytopenic purpura,⁴⁸⁰ with either LA or elevated aCL antibodies in almost one half of patients. Moreover, APA levels were not influenced by immunosuppressive therapy with steroids and are not related to the activity of idiopathic thrombocytopenic purpura.

aCL antibodies and, less often, LA are seen in apparently healthy people,^{458, 481} especially in the elderly.⁴⁸² In studies of normal blood donors, 5% to 10% have aCL antibodies, often present transiently and in relatively low titer without a concomitant LA effect; these donors do not have an increased risk of developing thrombosis.⁴⁸³ An inherited predisposition to the development of lupus inhibitors was suggested by their presence in two pairs of siblings⁴⁸⁴ and in familial studies.⁴⁸⁵ Further investigations have suggested associations with certain HLA types.^{486, 487}

Clinical Manifestations

Although LAs are immunologically distinct from aCL antibodies, clinical manifestations associated with each antibody appear to be similar. Clinical experience suggests that venous thrombosis is more likely associated with the LA, and arterial thrombosis is more likely associated with high-titer aCL antibodies. However,

P.1211

a literature meta-analysis found that the LA was a stronger risk factor for all thrombosis.⁴⁸⁸

The antiphospholipid-antibody syndrome is characterized by the clinical events of pregnancy morbidity or thromboembolic disease (arterial, venous, or small vessel), or both (Table 54.8).⁴⁸⁹ These clinical features are most highly associated with aPL antibodies in prospective studies.⁴⁸⁹ Older definitions included immune thrombocytopenia as a clinical event, but the newer classification omits thrombocytopenia.⁴⁸⁹ A wide variety of clinical features may be seen with APA.^{404, 489, 490, 491, 492} However, many patients with APA are asymptomatic. A proportion of asymptomatic patients develop SLE⁴⁹³ or other disorders.⁴⁹⁴ The diverse clinical manifestations of APA are listed in Table 54.9.

Arterial and Venous Thromboembolic Disease

The most common clinical presentation of patients with LA or aCL antibodies, or both, is arterial or venous thromboembolism,^{404, 495, 496} affecting up to 70% of patients in some series but averaging approximately 30% to 40% of patients in most studies.^{463, 496, 497} The most common site is extremity deep vein thrombosis, but occasionally, unusual sites are involved, such as the axillary, retinal, and hepatic veins and cerebral venous sinus thrombosis.⁴⁹⁸ Cerebral thrombosis, often heralded by repeated transient ischemic attacks, is a common arterial lesion.^{404, 499} Mesenteric artery occlusion, adrenal infarction, gastrointestinal ischemia or ulceration, and subclavian thrombosis with “pulseless” disease also have been described. Multiple cerebral infarcts with dementia in addition to coronary occlusions have occurred in unusually young age groups.⁵⁰⁰ A paradoxical syndrome of cerebral infarction with concurrent severe thrombocytopenia and bleeding has been reported in several cases.⁴⁹⁹ Antibodies to β_2 gpl are highly associated with venous thrombosis,⁵⁰¹ and in other studies, assays for the LA correlated best with thrombosis, compared with assays for other APAs.^{488, 502} Another unusual ischemic syndrome associated with APA is avascular osteonecrosis.⁵⁰³

TABLE 54.8 CRITERIA FOR DIAGNOSIS OF THE ANTIPHOSPHOLIPID-ANTIBODY SYNDROME (APS)

Clinical Event	Laboratory Abnormality
Venous thrombosis	Positive lupus anticoagulant test (according to guideline in Table 54.11)
<i>or</i>	<i>or</i>
Arterial thrombosis	Positive anticardiolipin antibody test (moderate titer or high-titer IgG or IgM antibodies)

or

Small-vessel thrombosis

or

Complications of pregnancy

One or more unexplained deaths of normal fetuses at or after 10 wk of gestation with normal fetal morphology

One or more premature births of normal neonates before 34 wk of gestation

Three or more unexplained consecutive spontaneous abortions before 10 wk of gestation, excluding anatomic, hormonal, and chromosomal abnormalities

Note: A diagnosis of definite APS requires the presence of at least one clinical event and at least one laboratory abnormality.

Ig, immunoglobulin.

Criteria from Miyakis S, Lockshin MD, Atsumi T, et al. International consensus statement on an update of the classification criteria for definite antiphospholipid syndrome (APS). *J Thromb Haemost* 2006;4:295-306.

or

Positive β_2 gpI antibody test (titer >99th percentile, IgG or IgM antibodies)

and

Laboratory abnormality should persist for two or more occasions at least 12 wk apart

TABLE 54.9 CLINICAL MANIFESTATIONS OF ANTIPHOSPHOLIPID ANTIBODIES

Asymptomatic

Arterial and venous thromboembolism

Avascular osteonecrosis

Hematologic

Cytopenias: thrombocytopenia, autoimmune hemolytic anemia, leukopenia

Coagulopathy: platelet dysfunction, prothrombin deficiency, lupus anticoagulant

Neurologic

Acute ischemia (cerebrovascular accident, transient ischemic attack, encephalopathy); severe migraine; multiple infarct dementia; cognitive dysfunction; seizures

Dermatologic

Livedo reticularis; acrocyanosis (distal cutaneous ischemia, ulceration, gangrene); widespread cutaneous necrosis; pyoderma gangrenosum-like skin lesions; anetoderma

Cardiopulmonary

Marantic endocarditis; myocardial ischemia and infarction; intracardiac thrombotic mass; peripheral arterial disease; thromboembolic and nonthrombotic pulmonary hypertension

Obstetric

Recurrent spontaneous abortion; intrauterine growth restriction; preeclampsia; chorea gravidarum; low

Apgar scores; prematurity

Catastrophic antiphospholipid syndrome

Thrombocytopenia

Moderate immune thrombocytopenia is noted in approximately 50% of patients with lupus inhibitors, but in many cases, it apparently is the result of the underlying disorder.⁵⁰⁴ Immune thrombocytopenia is no longer considered a clinical criterion for diagnosis of APS.⁴⁸⁹ When bleeding occurs in patients with aPLs,⁵⁰⁵ this is generally attributed to co-existent thrombocytopenia, platelet dysfunction,⁵⁰⁶ prothrombin deficiency,⁵⁰⁷ or other underlying coagulopathies. Other cytopenias may be associated with APA, including autoimmune hemolytic anemia and leukopenia.

Neurologic Syndromes

Various neurologic disorders have been linked with APA, including dementia, migraines, chorea, seizures, transverse myelopathy, Guillain-Barré syndrome, mononeuritis multiplex, transient global amnesia, and myasthenia gravis. Many of these disorders are not associated with ischemia or thrombosis, and the pathologic relationship of these disorders with APA is uncertain. A consensus statement on stroke and APS proposed criteria to determine the likelihood that APA is associated with ischemic stroke.⁵⁰⁸ A literature survey determined that the presence of APA in patients with ischemic stroke did not predict recurrence of stroke or differential response to treatment, and that routine screening for APA in these patients was not warranted.⁵⁰⁹

Dermatologic Disorders

A variety of ischemic-dermatologic syndromes have been associated with aCL antibodies, including livedo reticularis, P.1212

acrocyanosis (distal cutaneous ischemia, ulceration, gangrene), widespread cutaneous necrosis, and pyoderma gangrenosum-like skin lesions.^{489, 510} Livedo reticularis is more prevalent among APS patients with systemic lupus, and in females.⁴⁸⁹

Cardiac Disorders

A high incidence of APA is seen in patients with peripheral arterial disease who experience an associated increased risk of early graft thrombosis.⁵¹¹ This may justify routine testing for APA before reconstructive vascular surgery, with consideration of perioperative antiplatelet agents or anticoagulation. Some reports have noted the presence of APA in survivors of myocardial infarction.⁵¹² A variety of valvular heart lesions is associated with APS.⁴⁸⁹ The consensus group recommends that patients with biopsy-proven myocardial small-vessel thrombosis or those with intracardiac thrombi be considered for meeting criteria for APS. Coronary artery disease also fulfills the APS thrombosis criterion.⁴⁸⁹

Pulmonary Disorders

Ischemic and thrombotic pulmonary disease is linked to APA, including pulmonary embolism, pulmonary hypertension, intraalveolar pulmonary hemorrhage, and adult respiratory distress syndrome.^{513, 514} The latter syndrome has been reported in patients with CAPS.⁵¹⁴

Obstetric Aspects

APAs are associated with obstetric complications,^{403, 489, 515, 516, 517} including intrauterine growth restriction, preeclampsia, chorea gravidarum, and, primarily, recurrent spontaneous fetal loss (RSFL). Pregnancy losses in women with aPLs are often caused by fetal death despite normal fetal karyotypes. Spontaneous fetal loss is perhaps most common in the first trimester, but paradoxically, early first-trimester pregnancy losses are relatively less common than in other patients with recurrent fetal loss.⁵¹⁸ The international consensus statement listed obstetric criteria for diagnosis of APA: (a) One or more unexplained deaths of a morphologically normal fetus at or beyond the 10th week of gestation (with normal fetal morphology); (b) one or more premature births of a morphologically normal neonate before the 34th week of gestation because of preeclampsia, eclampsia, or placental insufficiency; or (c) three or more unexplained consecutive spontaneous abortions before the 10th week of pregnancy (with maternal anatomic or hormonal abnormalities, and paternal and maternal chromosomal causes excluded).⁴⁸⁹

There is a significantly increased incidence of elevated APA in women with a history of two or more miscarriages in the first trimester of pregnancy.⁵¹⁹ Women with a history of RSFL should be tested for both LA and aCL antibodies.⁵²⁰ Repeat testing is important because only 66% of LA-positive, 37% of IgG aCL-positive, and 36% of IgM aCL-positive women had a

positive test result on repeat evaluation. Laboratory screening for LA is confounded in pregnancy because altered coagulation factor concentrations in normal pregnancy may change the observed normal range of coagulation tests, including the PTT. In two studies, the DRVVT was the most frequently positive test for the LA in this population. Rigorous adherence to diagnostic criteria is particularly appropriate in pregnancy because treatment may require potentially hazardous antithrombotic therapy. Elevated maternal serum levels of α -fetoprotein⁵²¹ or human chorionic gonadotrophin⁵²² are common in women with aPLs and are significantly associated with fetal loss. Maternal APA testing may be appropriate if prenatal screening reveals an elevated human chorionic gonadotrophin level and ultrasonography demonstrates an otherwise normal singleton gestation.

It is generally considered not appropriate to screen for APA in asymptomatic pregnancies without a history of RSFL.⁵²³ APAs were identified at the first pre-natal visit in almost 25% of healthy pregnant women.⁵²⁴ LA appears to be much rarer than aCL antibodies in pregnancy.⁵²⁵ It appears that women with isolated IgM aCL or with low levels of IgG aCL are a distinct group that is not at risk for APA-related complications beyond the risk conferred by their medical histories.⁵²⁶

Although the mechanism by which APA causes recurrent pregnancy loss has not been fully explained, these antibodies may induce intervillous thrombosis and intravillous infarctions, resulting in poor placental perfusion, and have been shown to affect cytotrophoblast tissue in vitro. The thrombotic phenomenon may be mediated by aPL antibodies interfering with trophoblastic annexin V.^{404, 527}

The role of inflammation and the complement pathway in APS-associated pregnancy complications was reported.⁵²⁸ Anticoagulants that prevented complement activation (unfractionated or LMWH) were successful in preventing pregnancy loss in an animal model of APS; anticoagulants that did not inhibit complement activation (fondaparinux, hirudin) did not prevent pregnancy loss. These data suggest that the beneficial effects of anticoagulants in APS-associated pregnancy loss result from inhibition of complement activation.⁵²⁸

Catastrophic Antiphospholipid-antibody Syndrome

Some patients with APA develop an acute, severe, multiorgan illness^{403, 514, 529} characterized by diffuse small vessel ischemia and occlusion with extensive tissue damage, including myocardial infarction, limb ischemia, DIC, and a high mortality rate of 50%.⁵³⁰ The patients present with a dramatic illness, often without an obvious precipitating event, that prompts consideration of a wide differential diagnosis including severe lupus vasculitis, thrombotic thrombocytopenic purpura, or severe DIC. The syndrome is defined by clinical involvement of at least three different organ systems with histologic evidence of thrombosis.^{529, 530} Typically, small vessel thrombotic lesions occur, with common sites of involvement including the kidney, lung, central nervous system, heart, and skin.^{529, 530} In a larger series of CAPS patients, nearly one half of the cases had systemic lupus, and 40% had PAPS.⁵³¹ Precipitating factors for development of CAPS included infections, trauma/procedures, cancer, and subtherapeutic anticoagulation.⁵³¹ LA activity and, particularly, high aCL antibody titers are usually present. Central nervous system symptoms and hypertension are common, and leukocytosis and a significantly elevated sedimentation rate are often also present. The clinical manifestations of this syndrome can include all the symptoms and signs indicated in Table 54.9. Preliminary criteria for the classification and diagnosis of CAPS have been published.⁵²⁹ Effective therapies include therapeutic anticoagulation, steroids, ivIgG, plasma exchange, and cyclophosphamide.⁵²⁹ A literature review of rituximab use in CAPS found encouraging results.⁵³² A summary of CAPS registry cases reported that anticoagulation with steroids \pm plasma exchange/ivIgG was associated with at least a 70% success rate.⁵³³

Laboratory Diagnosis of Antiphospholipid-Protein Antibodies

LA and high-titer aCL antibodies have similar clinical implications, although studies suggest a higher thrombotic risk in patients with the LA.^{488, 502} In patients with SLE, the LA is the best predictor for both venous and arterial thrombosis. The laboratory should perform both fibrin-based coagulation assays to detect LA and solid-phase ELISA assays for aCL and β_2 gpl antibodies in patients suspected of having APA.

A considerable array of phospholipid-responsive laboratory tests, such as the PTT, dilute PTT, kaolin clotting time, and DRVVT, may serve to screen for the LA.⁴⁰⁹ LA may be defined as an immunoglobulin (IgG, IgM, IgA, or a mixture) that interferes with one or more of these in vitro, phospholipid-dependent coagulation tests. A more recent definition of the LA would be antibodies to β_2 gpl or to prothrombin that prolong phospholipid-dependent coagulation

P.1213

assays. Coagulation tests that are phospholipid independent are not affected by LA. Unless concurrent additional factor deficiencies are present, the standard PT is usually normal because of the large amount of phospholipids in this reagent.

No individual test seems to have a universal detection rate; this observation may reflect LA subtypes with distinct activities or the requirement of various co-factors. Consequently, it is recommended to perform at least two independent assays for the LA.^{489, 534} A simplified algorithm approach for diagnosis of the LA has been described that uses two assays, the DRVVT and a hexagonal phase assay.⁵³⁵ Comparative studies suggest that activated PTT reagents with reduced levels or different types of phospholipids are more sensitive than routine PTT reagents.^{409, 536} Platelet-poor plasma should be used in these screening assays, particularly if frozen plasma samples are to be tested.⁵³⁷ A recent update of LA guidelines has reviewed these issues.⁵³⁸ Table 54.10 indicates some of the clinical and laboratory differences between specific anticoagulant antibodies to particular factors, such as factor VIII and LA. Other nonspecific anticoagulants are uncommon but include the heparinlike anticoagulants discussed in the section "Other Acquired Coagulation Disorders." Confirmatory tests for LA based on activated PTT or DRVVT include abnormal mixing studies with normal plasma and correction with mixing using phospholipids, such as lysed washed platelets (platelet neutralization procedure), or with added hexagonal-phase phospholipids.⁵³⁹ A high concentration of liposomes prepared from rabbit brain extracts may achieve the most efficient correction of the defect,⁵⁴⁰ but this method is not widely used. The College of American Pathologists has published detailed recommendations for LA testing,⁵⁴¹ and testing issues affecting the LA have been reviewed.⁵⁴²

Several clinical points are worth stating. The search for LA or aCL antibodies should not be abandoned even if normal plasma in a mixing study corrects the test patient plasma, particularly in a human immunodeficiency virus-positive population.⁵⁴³ It is sometimes important for the clinician to discern the possible effect that heparin in the test patient plasma can have on the confirmatory laboratory assay; satisfactory correction procedures should be resistant to heparin, and many commercial LA reagents have heparin neutralizers. The ideal test to identify the LA is controversial; some investigators have reported the kaolin clotting time to be the most sensitive test.^{536, 544} On the other hand, some DRVVT assays are more able to identify LA associated with thrombosis.⁵⁴⁵ A subgroup of patients with unexplained thrombosis with antibodies to phosphatidylethanolamine as the only abnormal APA test has been identified.⁵⁴⁶ Optimal detection of the LA requires more than one of the phospholipid-dependent assays described earlier.^{489, 538, 547} This latter suggestion is supported by reports that different phospholipid-dependent coagulation tests detect different populations of LA antibodies.⁵⁴⁸ Table 54.11 summarizes the recommendations of an ISTH consensus group on laboratory diagnosis of LA.⁴⁸⁹

TABLE 54.10 COMPARISON OF FACTOR VIII ANTIBODIES AND ANTIPHOSPHOLIPID-PROTEIN ANTIBODIES

Clinical Event or Laboratory Test	Factor VIII Antibodies	Antiphospholipid-Protein Antibodies
Bleeding	Often severe	Uncommon
Thrombosis	Rare	Common
Obstetric complications (abortion and intrauterine fetal death)	Rare	Common
Prothrombin time	Normal	May be prolonged
Thrombin time	Normal	Occasionally prolonged
Thrombocytopenia	Rare	Common
Inhibitory effect in plasma mixtures	Usually time dependent	Often is instantaneous; occasionally, mixing studies show time-dependent inhibition
Prothrombin level	Normal	Occasionally deficient
Factor VIII level	Deficient; one-stage assay curve is aberrant with low-affinity antibodies	Normal when assayed in a dilute system; all one-stage assay curves are aberrant
Anticardiolipin and β_2 gpI antibodies	Rare	Common
Phospholipid or platelet correction of abnormal assay	No	Usually

result

Ig, immunoglobulin.

aPLs may also be detected by ELISA⁴⁸⁹ or by radioimmunoassay. Commercial ELISA systems are reasonably well standardized. The aCL-antibody assay used to improve sensitivity and specificity has undergone several modifications. Using anti- β_2 gpl-dependent assay systems is useful to discriminate between transiently positive aCL antibodies that are associated with infection, which characteristically do not have a β_2 gpl cofactor requirement, and those aCL antibodies associated with an increased risk of thrombosis.⁵⁴⁹ IgA aCL antibodies should not be considered a laboratory criterion for diagnosis of APS.⁴⁸⁹

Definitional standardization of the criteria for clinical and laboratory APA has been published.^{403, 489} For the diagnosis of APS, in addition to a clinical event (e.g., at least one venous, arterial, or small-vessel thrombosis, pregnancy morbidity/mortality), positive laboratory tests for LA, aCL, or β_2 gpl antibodies (in medium or high titer) should be found on two occasions at least 12 weeks apart (Table 54.8). It is recommended that aCL antibodies be measured by a standardized ELISA for β_2 gpl-dependent antibodies.^{403, 489} Although consensus criteria require persistence of the laboratory abnormality for at least 12 weeks, in clinical practice, a functional definition taking into account the number of clinical manifestations and the titer of aCL antibodies or positivity for the LA on even a single occasion may help categorize patients as having definite, probable, or doubtful APS and may direct immediate treatment options. A "triple positive"

P.1214

profile (positive results for all three assays: LA, aCL antibodies, and β_2 gpl antibodies) has been identified as a strong independent risk factor for thrombosis.⁵⁵⁰

TABLE 54.11 LABORATORY DIAGNOSIS OF LUPUS ANTICOAGULANT: INTERNATIONAL SOCIETY ON THROMBOSIS AND HAEMOSTASIS CRITERIA

- Prolongation of at least two phospholipid-dependent coagulation tests with the use of platelet-poor plasma (e.g., the activated partial thromboplastin time, dilute prothrombin time, dilute Russell viper venom time, kaolin clotting time). The DRVVT should be the first test considered.
- Failure to correct the prolonged coagulation time by mixing patient and normal plasma.
- Confirmation of lupus anticoagulant by demonstrating correction of the prolonged coagulation time by addition of excess phospholipids or freeze-thawed platelets.
- Exclusion of alternative coagulopathies using specific assays (e.g., factor VIII antibodies).

Diagnostic criteria from Levine JS, Branch DW, Rauch J. The antiphospholipid syndrome. *N Engl J Med* 2002;346:752-763; and Brandt JT, Triplett DA, Alving B, et al. Criteria for the diagnosis of lupus anticoagulants: an update. On behalf of the Subcommittee on Lupus Anticoagulant/Antiphospholipid Antibody of the Scientific and Standardisation Committee of the ISTH. *Thromb Haemost* 1995;74:1185-1190. Additional laboratory details and patient selection criteria are discussed in Pengo V, Tripodi A, Reber G, et al. Update of the guidelines for lupus anticoagulant detection. *J Thromb Haemost* 2009;7:1737-1740.

Even if the patient is asymptomatic, lupus inhibitors should always be identified correctly when discovered, even though costly and time-consuming laboratory study is required. If the cause for a prolonged PTT is not identified, the necessity for definitive laboratory evaluation almost invariably arises again, often in the context of an emergency. This may result in the unnecessary use of blood products and a delay of required surgical procedures.

Treatment of Antiphospholipid-Protein Antibody Syndrome

The optimal treatment of patients with APA syndrome is undefined, although randomized treatment trials are providing useful therapy recommendations. Depending on the clinical symptoms, patients with APA may need no treatment or may need anticoagulant or immunosuppressive therapy. Although spontaneous remissions are uncommon and aCL antibodies and LA can be associated with life-threatening thromboembolic events, only 10% to 15% of asymptomatic patients with APA develop these complications. Based on the uncertainty of predicting when thrombotic events might occur, as well as

the risks of anticoagulation, most investigators do not treat asymptomatic patients prophylactically, with the possible exception of short-term intervention when additional thrombophilic hazards such as immobilization or surgery are anticipated.

Patients with significant thrombotic events (e.g., deep vein thrombosis, arterial ischemia, or fetal loss) are appropriate candidates for antithrombotic therapy. Two randomized trials investigated the optimal intensity of warfarin therapy in APS patients.^{551, 552} Both studies found that high-intensity warfarin (INR 3.1 to 4.0 or 4.5) was not superior to standard intensity warfarin (INR 2.0 to 3.0).^{551, 552} Long-term treatment with oral anticoagulation therapy is advised because of the high rate of recurrence even if the venous or arterial occlusion occurred many years previously.^{553, 554} Patients receiving oral anticoagulants had no recurrence over 8 years, whereas patients in whom anticoagulant drugs had been discontinued had a 50% probability of a recurrent venous thromboembolic episode after 2 years and an almost 80% probability of recurrence after 8 years.⁵⁵⁵ This strategy is supported by a study that found that APS patients with thrombosis benefited from prolonged oral anticoagulation because persistent elevation of aCL levels predicted an increased risk of thrombosis recurrence and death.⁵⁵⁶ Many investigators follow this approach,⁴⁰⁴ unless all laboratory evidence of LA and aCL in patients in whom high titers were initially detected or in whom a thrombotic risk was attributed to APA has been continually absent for at least 6 months; no other thrombophilic risk is present; and close surveillance is feasible. An emerging treatment strategy in APS patients is to consider single-positivity test results for β_2 gpl or aCL antibodies as a lesser risk for recurrent thrombosis, and perhaps less-intense or shorter duration treatment periods.⁴⁰⁴

A literature review of treatment for APS patients with ischemic stroke concluded that treatment with either aspirin or low-intensity warfarin (INR 2.0 to 3.0) is effective.⁵⁵⁷ For noncerebral arterial thrombosis, combined therapy with low-intensity warfarin (INR 2.0 to 3.0) plus aspirin (81 mg) was recommended.⁵⁵⁷

A relatively new therapy for APS is hydroxychloroquine, an immunosuppressive agent used to treat patients with SLE. Hydroxychloroquine therapy decreases thrombosis risk in SLE patients,⁵⁵⁸ perhaps by interfering with aPL antibody binding to phospholipid.⁵⁵⁹

Patients with the uncommon LA hypoprothrombinemia syndrome who either have bleeding or need surgery may benefit from steroid therapy or intravenous IgG.⁵⁶⁰

Patients with the LA and acute thrombosis pose difficulty in terms of monitoring heparin anticoagulation. The usually prolonged PTT value seen with the LA renders this test unreliable. These patients can be monitored using heparin assays, which are available by automated methodology (see Chapter 55). Alternatively, patients can be treated using a LMWH, without the necessity for laboratory monitoring (see Chapter 55).

In those patients with an LA and hypoprothrombinemia, or an LA that affects the PT, the use of the INR to monitor anticoagulation has been questioned. These patients may require monitoring with a test that is insensitive to the LA, such as a prothrombin-proconvertin assay or a chromogenic factor X assay.⁵⁶¹

Corticosteroid use often diminishes or abolishes the coagulation abnormalities and immune thrombocytopenia of APA syndrome within a short time. However, for most patients, the role of steroids, other immunosuppressive agents, or aspirin is uncertain. Although immunosuppression with cyclophosphamide in pulse form is effective in reducing elevated antibody levels, there is often a rapid rebound to pre-treatment levels shortly after discontinuation of the therapy. Consequently, additional therapies with aspirin or steroids or more aggressive immunosuppression are not used unless recurrent thrombotic or ischemic events are seen despite optimal warfarin therapy. High-dose corticosteroid therapy has equivocal efficacy and considerable toxicity and is reserved for treatment of underlying co-morbid conditions such as active lupus and not for the laboratory phenomena of the antiphospholipid antibody syndrome itself.

In patients with CAPS who experience multisystem involvement, intensive treatment with corticosteroids, immunosuppression, intravenous IgG, or plasmapheresis may be useful.^{530, 532, 533} In one literature analysis of CAPS therapy, the highest response to therapy occurred in patients treated with anticoagulation and steroids (64%).⁵³¹ Immune thrombocytopenia and autoimmune hemolytic anemia in patients with APA are treated similarly as in patients without APA.

Obstetric Treatment

Because the risk of pregnancy loss in women with APS and prior pregnancy loss may exceed 60%, a history of recurrent fetal loss is an indication for treatment during pregnancy. Antiplatelet agents such as aspirin 80 mg/day,⁵⁶² low-dose immunosuppressive agents such as prednisolone 10 mg/day,⁵⁶³ or anticoagulants (heparin or LMWH) have all been used in an attempt to improve pregnancy outcome.^{403, 404} Several randomized studies have provided information about useful treatment strategies in pregnancy-associated APS (reviewed in References 403 and 564). Intravenous IgG is of no benefit

in these patients, and heparin may be more effective than aspirin. A meta-analysis recommends that a combination of unfractionated heparin (5,000 U s.c. twice daily) and low-dose aspirin be used,⁵⁶⁴ and a recent consensus guideline recommends “prophylactic or intermediate-dose unfractionated heparin or prophylactic LMWH combined with low-dose aspirin (75 to 100 mg/day)”.⁵⁶⁵

Transfusion-associated Coagulation Abnormalities

The administration of blood products in a volume >1.5 times the patient's estimated blood volume or replacement of total blood volume in <24 hours constitutes massive blood transfusion.⁵⁶⁶ Traditional resuscitation efforts were initiated with large volumes of crystalloid and packed red cell transfusions; a new paradigm is termed “damage control resuscitation” which includes administration of tranexamic acid for cases of uncontrolled hemorrhage, use of a massive transfusion protocol with fixed blood product

P.1215

ratios, avoidance of large-volume crystalloid use, and usage of permissive hypotension.^{567, 568}

The importance of core body temperature on hemostasis parameters has been demonstrated; at a temperature of 33°C, platelet function is impaired. Below 33°C, both coagulation factor activity and platelet function are reduced.⁵⁶⁹

Bleeding Associated with Extracorporeal Circulation

Defective hemostasis with cardiopulmonary bypass is associated with multiple contributory causes, including hemodilution of coagulation factors, inadequate neutralization of heparin, acquired platelet dysfunction, and thrombocytopenia. These latter two defects are further discussed in Chapter 52. In general, extracorporeal-circulation-induced hemostatic defects may be ascribed to activation of platelets and coagulation proteins by artificial surfaces.

Platelet dysfunction (acquired storage pool defect) is considered the major hemostatic insult induced by bypass.⁵⁷⁰ Although DDAVP was shown to reduce bleeding and transfusion requirements in these patients in earlier studies, subsequent trials indicated no benefit from DDAVP,⁵⁷¹ and routine DDAVP therapy may be hazardous in older patients with significant vascular disease.⁵⁷² Aprotinin should not be used in this setting.⁵⁷³

Drug-induced Coagulation Abnormalities

Broad-spectrum antibiotics, such as the β -lactam antibiotics, may induce a coagulopathy by inhibition of vitamin K synthesis by gut bacteria and direct inhibition of essential carboxylation reactions.²² A number of antibiotics may also inhibit platelet function (see Chapter 52).

L-Asparaginase produces hypofibrinogenemia and deficiency of other coagulation factors.⁵⁷⁴ Hematin produces a complex coagulopathy.⁵⁷⁵ Valproic acid therapy has been associated with acquired vWD.⁵⁷⁶

Acquired Deficiencies of Single Coagulation Factors

An uncommon phenomenon is the development of deficiency of a single coagulation factor during the course of an acquired disorder (Table 54.6). Isolated deficiency of factor X is well documented in patients with primary amyloidosis and amyloidosis associated with multiple myeloma.⁵⁷⁷ Factor X levels in these patients do not rise even after massive replacement therapy, and studies using ¹³¹I-labeled factor X suggest that this proenzyme is bound to subendothelial amyloid fibrils in blood vessels.⁵⁷⁸ A combined deficiency of factors IX and X in amyloidosis also has been reported.⁵⁷⁹ In many patients, the hemostatic defect is complicated by other abnormalities, such as vascular infiltration, liver disease, high levels of antithrombins, and azotemia with platelet dysfunction.⁵⁸⁰ Splenectomy abolished the factor X deficiency and produced complete remission of bleeding in several cases,⁵⁸¹ presumably because of extensive amyloid infiltration in the splenic vasculature. Chemotherapy with melphalan and prednisone may also resolve factor X deficiency in amyloidosis.⁵⁸² High-dose chemotherapy with stem cell transplantation is also effective therapy.⁵⁸³ Factor X deficiency has also been associated with upper respiratory tract infections.³⁹⁴ A detailed literature review of acquired factor X deficiency has been published.⁵⁸⁴

Hypoprothrombinemia has been reported as an isolated finding,⁵⁸⁵ most commonly in association with LAs, as discussed previously. Deficiencies of prothrombin, factors IX and XII, plasminogen, and antithrombin have been reported in some patients with the nephrotic syndrome,^{586, 587, 588, 589, 590} presumably as the result of massive protein loss in the urine. In one patient with Sheehan syndrome, a selective deficiency of factor IX responded to treatment with corticosteroids and thyroid replacement.⁵⁹¹ Isolated deficiency of factor IX in several patients with Gaucher disease also has been documented.⁵⁹² Acquired factor VII deficiency has been reported with aplastic anemia⁵⁹³ and liposarcoma.⁵⁹⁴

Factor XIII deficiency has been associated with chronic myelocytic leukemia and with various forms of acute leukemia.⁵⁹⁵ Factor XIII deficiency has also been associated with inflammatory bowel disease,⁵⁹⁶ and isoniazid-induced antibodies to factor XIII have been reported.^{381, 382, 597} Factor XII deficiency has been described in association with chronic myelocytic leukemia⁵⁹⁸ and antiphospholipid antibodies.⁵⁹⁹ Factor XI deficiency has been linked to Gaucher disease⁶⁰⁰ and Ehlers-Danlos syndrome.⁶⁰¹ Factor V deficiency has been reported in chronic myeloid leukemia and in celiac disease. Acquired vWD was discussed earlier in the section on vWF.

Other Acquired Coagulation Disorders

Heparinlike anticoagulants have been reported in patients with hematologic malignancies (e.g., plasma cell dyscrasias⁶⁰² or leukemias^{603, 604} or solid tumors⁶⁰⁵). A prolonged thrombin time and normal reptilase clotting time are typically seen in these patients. Significant clinical bleeding may occur with heparinlike anticoagulants; a titrated protamine sulfate infusion may be helpful in these patients.

Malignancy may also be associated with other inhibitors of coagulation, including FDPs and paraproteins, dysfibrinogenemias, and specific antibodies to coagulation factors (discussed earlier). A monoclonal antithrombin antibody associated with bleeding has been reported in a patient with myeloma.⁶⁰⁶

REFERENCES

1. Olson RE. The function and metabolism of vitamin K. *Annu Rev Nutr* 1984;4:281-337.
2. Furie B, Furie BC. Molecular basis of vitamin K-dependent gamma-carboxylation. *Blood* 1990;75:1753-1762.
3. Townsend CW. The haemorrhagic disease of the newborn. *Arch Paediatr* 1894;11:559-565.
4. Sutor AH, von Kries R, Cornelissen EA, et al. Vitamin K deficiency bleeding (VKDB) in infancy. ISTH Pediatric/Perinatal Subcommittee. International Society on Thrombosis and Haemostasis. *Thromb Haemost* 1999;81:456-461.
5. Suntherland JM, Glueck HI, Gleser G. Hemorrhagic disease of the newborn. *Am J Dis Child* 1967;113:524-533.
6. Oski FA, Naiman JL. Hematology in the newborn, 2nd ed. Philadelphia, PA: WB Saunders, 1972.
7. Aballi AJ, DeLamerens S. Coagulation changes in the neonatal period and early infancy. *Pediatr Clin North Am* 1962;9:785-817.
8. Cade JF, Hirsh J, Martin M. Placental barrier to coagulation factors: its relevance to the coagulation defect at birth and to haemorrhage in the newborn. *BMJ* 1969;2:281-283.
9. Fillmore SJ, McDevitt E. Effects of coumarin compounds on the fetus. *Ann Intern Med* 1970;73:731-735.
10. Mountain KR, Hirsh J, Gallus AS. Neonatal coagulation defect due to anticonvulsant drug treatment in pregnancy. *Lancet* 1970;1:265-268.
11. Corrigan JJ Jr, Taussig LM, Beckerman R, Wagener JS. Factor II (prothrombin) coagulant activity in immunoreactive protein: detection of vitamin K deficiency and liver disease in patients with cystic fibrosis. *J Pediatr* 1981;99:254-257.
12. Hathaway WE. The bleeding newborn. *Semin Hematol* 1975;12:175-188.
13. Zipursky A. Prevention of vitamin K deficiency bleeding in newborns. *Br J Haematol* 1999;104:430-437.
14. Costakos DT, Greer FR, Love LA, et al. Vitamin K prophylaxis for premature infants: 1 mg versus 0.5 mg. *Am J Perinatol* 2003;20:485-490.
15. American Academy of Pediatrics Committee on fetus and newborn controversies concerning vitamin K and the newborn. *Pediatrics* 2003;112 (1 Part 1):191-192.
16. Greer FR. Are breast-fed infants vitamin K deficient? *Adv Exp Med Biol* 2001;501:391-395.
17. Lukens JN. Vitamin K and the older infant. *Am J Dis Child* 1972;124: 639-640.
18. McNinch A. Vitamin K deficiency bleeding: early history and recent trends in the United Kingdom. *Early Hum Dev* 2010;86(Suppl 1):63-65.
19. Ansell JE, Kumar R, Deykin D. The spectrum of vitamin K deficiency. *JAMA* 1977;238:40-42.
20. Mercer KW, Macik G, Williams ME. Hematologic disorders in critically ill patients. *Semin Respir Crit Care Med* 2006;27:286-296.

21. Allison PM, Mummah-Schendel LL, Kindberg CG, et al. Effects of a vitamin K-deficient diet and antibiotics in normal human volunteers. *J Lab Clin Med* 1987;110:180-188.
22. Brown RB, Klar J, Lemeshow S, et al. Enhanced bleeding with cefoxitin or moxalactam. Statistical analysis within a defined population of 1493 patients. *Arch Intern Med* 1986;146:2159-2164.
23. Gross L, Brotman M. Hypoprothrombinemia and hemorrhage associated with cholestyramine therapy. *Ann Intern Med* 1970;72:95-96.
24. Corrigan JJ Jr, Marcus FI. Coagulopathy associated with vitamin E ingestion. *JAMA* 1974;230:1300-1301.
25. Holbrook AM, Pereira JA, Labiris R, et al. Systematic overview of warfarin and its drug and food interactions. *Arch Intern Med* 2005;165:1095-1106.
26. Goldsweig HG, Kapusta M, Schwartz J. Bleeding, salicylates, and prolonged prothrombin time: three case reports and a review of the literature. *J Rheumatol* 1976;3:37-42.
27. Spahr JE, Maul JS, Rodgers GM. Superwarfarin poisoning: a report of two cases and review of the literature. *Am J Hematol* 2007;82:656-660.
28. de la Rubia J, Grau E, Montserrat I, et al. Anaphylactic shock and vitamin K1. *Ann Intern Med* 1989;110:943.
29. Alperin JB. Coagulopathy caused by vitamin K deficiency in critically ill, hospitalized patients. *JAMA* 1987;258:1916-1619.
30. Chua JD, Friedenberg WR. Superwarfarin poisoning. *Arch Intern Med* 1998;158:1929-1932.
31. Amitrano L, Guardascione MA, Brancaccio V, et al. Coagulation disorders in liver disease. *Semin Liver Dis* 2002;22:83-96.
32. Tripodi A, Mannucci PM. The coagulopathy of chronic liver disease. *N Engl J Med* 2011;365:147-156.
33. Mammen EF. Coagulation defects in liver disease. *Med Clin North Am* 1994;78:545-554.
34. Schoffski P, Tacke F, Trautwein C, et al. Thrombopoietin serum levels are elevated in patients with hepatitis B/C infection compared to other causes of chronic liver disease. *Liver* 2002;22:114-120.
35. Ishikawa T, Ichida T, Sugahara S, et al. Thrombopoietin receptor (c-Mpl) is constitutively expressed on platelets of patients with liver cirrhosis, and correlates with its disease progression. *Hepatol Res* 2002;23:115-121.
36. Rios R, Sangro B, Herrero I, et al. The role of thrombopoietin in the thrombocytopenia of patients with liver cirrhosis. *Am J Gastroenterol* 2005;100:1311-1316.
37. Rodriguez-Inigo E, Bartolome J, Quiroga JA, et al. Expression of factor VII in the liver of patients with liver disease: correlations with the disease severity and impairment in the hemostasis. *Blood Coagul Fibrinolysis* 2001;12: 193-199.
38. Yanofsky RA, Jackson VG, Lilly JR, et al. The multiple coagulopathies of biliary atresia. *Am J Hematol* 1984;16:171-180.
39. Losowsky MS, Simmons AV, Miloszewski K. Coagulation abnormalities in liver disease. *Postgrad Med* 1973;53:147-152.
40. Ratnoff OD. Hemostatic defects in liver and biliary tract diseases. In: Ratnoff OD, Forbes CD, eds. *Disorders of hemostasis*. New York: Grune & Stratton, 1984:1.
41. Palascak JE, Martinez J. Dysfibrinogenemia associated with liver disease. *J Clin Invest* 1977;60:89-95.
42. Ruggiero G, De Biasi R, Attanasio S, et al. Hemostatic abnormalities in chronic aggressive hepatitis and liver cirrhosis. *Acta Hepatogastroenterol (Stuttg)* 1975;22:221-228.
43. Lane DA, Scully MF, Thomas DP, et al. Acquired dysfibrinogenaemia in acute and chronic liver disease. *Br J Haematol* 1977;35:301-308.
44. Martinez J, Palascak JE, Kwasniak D. Abnormal sialic acid content of the dysfibrinogenemia associated with liver disease. *J Clin Invest* 1978;61:535-538.
45. Soria J, Soria C, Ryckewaert JJ, et al. Study of acquired dysfibrinogenaemia in liver disease. *Thromb Res* 1980;19:29-41.

46. Blanchard RA, Furie BC, Jorgensen M, et al. Acquired vitamin K-dependent carboxylation deficiency in liver disease. *N Engl J Med* 1981;305:242-248.
47. Liebman HA, Furie BC, Tong MJ, et al. Des-gamma-carboxy (abnormal) prothrombin as a serum marker of primary hepatocellular carcinoma. *N Engl J Med* 1984;310:1427-1431.
48. Hollestelle MJ, Geerteen HGM, Straatsburg IH, et al. Factor VIII expression in liver disease. *Thromb Haemost* 2004;91:267-275.
49. Booth NA, Anderson JA, Bennett B. Plasminogen activators in alcoholic cirrhosis: demonstration of increased tissue type and urokinase type activator. *J Clin Pathol* 1984;37:772-777.
50. Fletcher AP, Biederman O, Moore D. Abnormal plasminogen-plasmin system activity (fibrinolysis) in patients with hepatic cirrhosis. *J Clin Invest* 1964;43:681-695.
51. Ballard HS, Marcus AJ. Platelet aggregation in portal cirrhosis. *Arch Intern Med* 1976;136:316-319.
52. Lipinski B, Lipinska I, Nowak A, et al. Abnormal fibrinogen heterogeneity and fibrinolytic activity in advanced liver disease. *J Lab Clin Med* 1977;90: 187-194.
53. Fletcher AP, Alkjaersig N, Sherry S. Pathogenesis of the coagulation defect developing during pathological plasma proteolytic ("fibrinolytic") states. I. The significance of fibrinogen proteolysis and circulating fibrinogen breakdown products. *J Clin Invest* 1962;41:896-916.
54. Fletcher AP, Alkjaersig N, Fisher S, et al. The proteolysis of fibrinogen by plasmin: the identification of thrombin-clottable fibrinogen derivatives which polymerize abnormally. *J Lab Clin Med* 1962;68:780-802.
55. Hu KQ, Yu AS, Tiyyagura L, et al. Hyperfibrinolytic activity in hospitalized cirrhotic patients in a referral liver unit. *Am J Gastroenterol* 2001;96: 1581-1586.
56. Lisman T, Leebeek FW, Mosnier LO, et al. Thrombin-activatable fibrinolysis inhibitor deficiency in cirrhosis is not associated with increased plasma fibrinolysis. *Gastroenterology* 2001;121:131-139.
57. Knot E, Ten Cate JW, Drijfhout HR, et al. Antithrombin III metabolism in patients with liver disease. *J Clin Pathol* 1984;37:523-530.
58. Tytgat G, Collen D, De Vreker R, et al. Investigations on the fibrinolytic system in liver cirrhosis. *Acta Haematol* 1968;40:265-274.
59. Gallus AS, Lucas CR, Hirsh J. Coagulation studies in patients with acute infectious hepatitis. *Br J Haematol* 1972;22:761-771.
60. Collen D, Rouvier J, Chamone DA, et al. Turnover of radiolabeled plasminogen and prothrombin in cirrhosis of the liver. *Eur J Clin Invest* 1978;8:185-188.
61. Tytgat GN, Collen D, Verstraete M. Metabolism of fibrinogen in cirrhosis of the liver. *J Clin Invest* 1971;50:169-701.
62. Coccheri S, Mannucci PM, Palareti G, et al. Significance of plasma fibrinopeptide A and high molecular weight fibrinogen in patients with liver cirrhosis. *Br J Haematol* 1982;52:503-509.
63. Cordova C, Musca A, Violi F, et al. Improvement of some blood coagulation factors in cirrhotic patients treated with low doses of heparin. *Scand J Haematol* 1982;29:235-240.
64. Bloom AL. Intravascular coagulation and the liver. *Br J Haematol* 1975;30:1-7.
65. vanDeWater L, Carr JM, Aronson D, et al. Analysis of elevated fibrin(ogen) degradation product levels in patients with liver disease. *Blood* 1986;67: 1468-1473.
66. Ben-Ari Z, Osman E, Hutton RA, et al. Disseminated intravascular coagulation in liver cirrhosis: fact or fiction? *Am J Gastroenterol* 1999;94:2977-2982.
67. Stein SF, Fulenwider JT, Ansley JD, et al. Accelerated fibrinogen and platelet destruction after peritoneovenous shunting. *Arch Intern Med* 1981;141:1149-1151.
68. Henderson JM, Stein SF, Kutner M, et al. Analysis of twenty-three plasma proteins in ascites. The depletion of fibrinogen and plasminogen. *Ann Surg* 1980;192:738-742.
69. Salem HH, Dudley FJ, Merrett A, et al. Coagulopathy of peritoneovenous shunts: studies on the pathogenic role of ascitic fluid collagen and value of antiplatelet therapy. *Gut* 1983;24:412-417.

70. Bohmig HJ. The coagulation disorder of orthotopic hepatic transplantation. *Semin Thromb Hemost* 1977;4:57-82.
71. Ozier Y, Steib A, Ickx B, et al. Haemostatic disorders during liver transplantation. *Eur J Anaesthesiol* 2001;18:208-218.
72. Chalmers TC, Bigelow FS, Desforges JF. The effects of massive gastrointestinal hemorrhage on hemostasis. II. Coagulation factors. *J Lab Clin Med* 1954;43:511-517.
73. Spector I, Corn M. Laboratory tests of hemostasis. The relation to hemorrhage in liver disease. *Arch Intern Med* 1967;119:577-582.
74. Lisman T, Porte RJ. Rebalanced hemostasis in patients with liver disease: evidence and clinical consequences. *Blood* 2010;116:878-885.
75. O'Grady JG, Alexander GJ, Hayllar KM, et al. Early indicators of prognosis in fulminant hepatic failure. *Gastroenterology* 1989;97:439-445.
76. Ewe K. Bleeding after liver biopsy does not correlate with indices of peripheral coagulation. *Dig Dis Sci* 1981;26:388-393.
77. McGill DB. Predicting hemorrhage after liver biopsy. *Dig Dis Sci* 1981;26: 385-387.
78. Mannucci PM. Abnormal hemostasis tests and bleeding in chronic liver disease: are they related? No. *J Thromb Haemost* 2006;4:721-723.
79. Lehman CM, Blaylock RC, Alexander DP, et al. Discontinuation of the bleeding time test without detectable adverse clinical impact. *Clin Chem* 2001;47:1204-1211.
80. Deitcher SR. Interpretation of the international normalised ratio in patients with liver disease. *Lancet* 2002;359:47-48.
81. McVay PA, Toy PT. Lack of increased bleeding after liver biopsy in patients with mild hemostatic abnormalities. *Am J Clin Pathol* 1990;94:747-753.
82. O'Shaughnessy DF, Atterbury C, Bolton Maggs P, et al.; British Committee for Standards in Haematology, Blood Transfusion Task Force. Guidelines for the use of fresh-frozen plasma, cryoprecipitate and cryosupernatant. *Brit J Haematol* 2004;126:11-28.
83. Blatt PM, Lundblad RL, Kingdon HS, et al. Thrombogenic materials in prothrombin complex concentrates. *Ann Intern Med* 1974;81:766-770.
84. White GC II, Roberts HR, Kingdon HS, et al. Prothrombin complex concentrates: potentially thrombogenic materials and clues to the mechanism of thrombosis in vivo. *Blood* 1977;49:159-170.
85. Scott LJ. Prothrombin complex concentrate (Beriplex P/N). *Drugs* 2009;69:1977-1984.
86. de Franchis R, Arcidiacono PG, Carpinelli L, et al. Randomized controlled trial of desmopressin plus terlipressin vs. terlipressin alone for the treatment of acute variceal hemorrhage in cirrhotic patients: a multicenter, double-blind study. *New Italian Endoscopic Club. Hepatology* 1993;18:1102-1107.
87. Lisman T, Porte RJ. Recombinant factor VIIa to treat severe bleeding in patients with liver disease: pitfalls and possibilities. *J Hepatol* 2011;55: 950-951.
88. Kasper CK, Dietrich SL. Comprehensive management of haemophilia. *Clin Haematol* 1985;14:489-512.
89. Carey MJ, Rodgers GM. Disseminated intravascular coagulation: clinical and laboratory aspects. *Am J Hematol* 1998;59:65-73.
90. Taylor FB, Toh CH, Hoots K, et al. Towards a definition, clinical and laboratory criteria and a scoring system for disseminated intravascular coagulation. *Thromb Haemost* 2000;86:1327-1330.
91. Levi M, Toh CH, Thachil J, Watson HG. Guidelines for the diagnosis and management of disseminated intravascular coagulation. British Committee for Standards in Haematology. *Br J Haematol* 2009;145:24-33.
92. Siegal T, Seligsohn U, Aghai E, et al. Clinical and laboratory aspects of disseminated intravascular coagulation (DIC): a study of 118 cases. *Thromb Haemost* 1978;39:122-134.
93. Jacobson RJ, Jackson DP. Erythrocyte fragmentation in defibrination syndromes. *Ann Intern Med* 1974;81:207-209.
94. Okajima K, Sakamoto Y, Uchiba M. Heterogeneity in the incidence and clinical manifestations of disseminated intravascular coagulation: a study of 204 cases. *Am J Hematol* 2000;65:215-222.

95. Shibolet S, Coll R, Gilat T, et al. Heatstroke: its clinical picture and mechanism in 36 cases. *QJM* 1967;36:525-548.
96. Corrigan JJ Jr. Studies on the coagulation and fibrinolytic systems in "autoimmune" disease. *Am J Dis Child* 1970;120:324-328.
97. Amris CJ, Hansen NE. Coagulation and fibrinolytic studies in paroxysmal nocturnal haemoglobinuria. *Acta Med Scand* 1968;184:551-559.
98. Sack GH Jr, Levin J, Bell WR. Trousseau's syndrome and other manifestations of chronic disseminated coagulopathy in patients with neoplasms: clinical, pathophysiologic, and therapeutic features. *Medicine (Baltimore)* 1977;56:1-37.
99. Sutton DM, Hauser R, Kulapongs P, et al. Intravascular coagulation in abruptio placentae. *Am J Obstet Gynecol* 1971;109:604-614.
100. Yaffe H, Hay-Am E, Sadovsky E. Thromboplastic activity of amniotic fluid in term and ostmature gestations. *Obstet Gynecol* 1981;57:490-492.
101. Dvorak HF, Van DeWater L, Bitzer AM, et al. Procoagulant activity associated with plasma membrane vesicles shed by cultured tumor cells. *Cancer Res* 1983;43:4434-4442.
102. Rickles FR, Edwards RL. Activation of blood coagulation in cancer: Trousseau's syndrome revisited. *Blood* 1983;62:14-31.
103. Callander N, Rapaport SI. Trousseau's syndrome. *West J Med* 1993;158: 364-371.
104. Gordon SG, Cross BA. A factor X-activating cysteine protease from malignant tissue. *J Clin Invest* 1981;67:1665-1671.
105. Gralnick HR, Abrell E. Studies of the procoagulant and fibrinolytic activity of promyelocytes in acute promyelocytic leukaemia. *Br J Haematol* 1973;24: 89-99.
106. Plow EF. Leukocyte elastase release during blood coagulation. A potential mechanism for activation of the alternative fibrinolytic pathway. *J Clin Invest* 1982;69:564-572.
107. Menell JS, Cesarman GM, Jacovina AT, et al. Annexin II and bleeding in acute promyelocytic leukemia. *N Engl J Med* 1999;340:994-1004.
108. McKay DG. Trauma and disseminated intravascular coagulation. *J Trauma* 1969;9:646-660.
109. Goodnight SH, Kenoyer G, Rapaport SI, et al. Defibrination after brain-tissue destruction: a serious complication of head injury. *N Engl J Med* 1974;290:1043-1047.
110. van Ginkel CJ, van Aken WG, Oh JI, et al. Stimulation of monocyte procoagulant activity by adherence to different surfaces. *Br J Haematol* 1977;37: 35-45.
111. Edgington TS. Recognition coupled responses of the monocyte: activation of coagulation pathways. *Nouv Rev Fr Hematol* 1983;25:1-6.
112. Osterud B, Flaegstad T. Increased tissue thromboplastin activity in monocytes of patients with meningococcal infection: related to an unfavourable prognosis. *Thromb Haemost* 1983;49:5-7.
113. Edwards RL, Rickles FR. Macrophage procoagulants. *Prog Hemost Thromb* 1984;7:183-209.
114. Lyberg T, Prydz H. Thromboplastin (factor III) activity in human monocytes induced by immune complexes. *Eur J Clin Invest* 1982;12:229-234.
115. Muhlfelder TW, Niemetz J, Kreutzer D, et al. C5 chemotactic fragment induces leukocyte production of tissue factor activity: a link between complement and coagulation. *J Clin Invest* 1979;63:147-150.
116. Zuckerman SH, Suprenant YM. Induction of endothelial cell/macrophage procoagulant activity: synergistic stimulation by gamma interferon and granulocyte-macrophage colony stimulating factor. *Thromb Haemost* 1989;61: 178-182.
117. Schwartz BS, Edgington TS. Lymphocyte collaboration is required for induction of murine monocyte procoagulant activity by immune complexes. *J Immunol* 1981;127:438-443.
118. Rothberger H, McGee MP. Generation of coagulation factor V activity by cultured rabbit alveolar macrophages. *J Exp Med* 1984;160:1880-1890.
119. Shands JW Jr. The endotoxin-induced procoagulant of mouse exudate macrophages: a factor-X activator. *Blood* 1983;62:333-340.

120. Drake TA, Cheng J, Chang A, et al. Expression of tissue factor, thrombomodulin, and E-selectin in baboons with lethal *Escherichia coli* sepsis. *Am J Pathol* 1993;142:1458-1470.
121. Hack CE, Zeerleder S. The endothelium in sepsis: source of and a target for inflammation. *Crit Care Med* 2001;29:S21-S27.
122. Combes V, Simon AC, Grau GE, et al. In vitro generation of endothelial microparticles and possible prothrombotic activity in patients with lupus anticoagulant. *J Clin Invest* 1999;104:93-102.
123. Nieuwland R, Berckmans RJ, McGregor S, et al. Cellular origin and procoagulant properties of microparticles in meningococcal sepsis. *Blood* 2000;95:930-935.
124. Pixley RA, De La Cadena R, Page JD, et al. The contact system contributes to hypotension but not disseminated intravascular coagulation in lethal bacteremia. In vivo use of a monoclonal anti-factor XII antibody to block contact activation in baboons. *J Clin Invest* 1993;91:61-68.
125. Schapira M, Ramus MA, Waeber B, et al. Protection by recombinant α 1-antitrypsin Ala357 Arg358 against arterial hypotension induced by factor XII fragment. *J Clin Invest* 1987;80:582-585.
126. Damas P, Canivet JL, de Groot D, et al. Sepsis and serum cytokine concentrations. *Crit Care Med* 1997;25:405-412.
127. Mason JW, Colman RW. The role of Hageman factor in disseminated intravascular coagulation induced by septicemia, neoplasia, or liver disease. *Thromb Diath Haemorrh* 1971;26:325-331.
128. McGrath JM, Stewart GJ. The effects of endotoxin on vascular endothelium. *J Exp Med* 1969;129:833-848.
129. Colucci M, Balconi G, Lorenzet R, et al. Cultured human endothelial cells generate tissue factor in response to endotoxin. *J Clin Invest* 1983;71: 1893-1896.
130. Hillman RS, Phillips LL. Clotting-fibrinolysis in a cavernous hemangioma. *Am J Dis Child* 1967;113:649-653.
131. Bieger R, Vreeken J, Stibbe J, et al. Arterial aneurysm as a cause of consumption coagulopathy. *N Engl J Med* 1971;285:152-154.
132. Kornalik F, Blomback B. Prothrombin activation induced by Ecarin-a prothrombin converting enzyme from *Echis carinatus* venom. *Thromb Res* 1975;6:57-63.
133. Gold BS, Dart RC, Barish RA. Bites of venomous snakes. *N Engl J Med* 2002;347:347-356.
134. Markland FS Jr. Snake venom fibrinogenolytic and fibrinolytic enzymes: an updated inventory. Registry of Exogenous Hemostatic Factors of the Scientific and Standardization Committee of the International Society on Thrombosis and Haemostasis. *Thromb Haemost* 1998;79:668-674.
135. Manjunatha Kini R, Morita T, Rosing J. Classification and nomenclature of prothrombin activators isolated from snake venoms. *Thromb Haemost* 2001;86:710-711.
136. Harker LA, Slichter SJ. Platelet and fibrinogen consumption in man. *N Engl J Med* 1972;287:999-1005.
137. Cooper HA, Bowie EJ, Didisheim P, et al. Paradoxical changes in platelets and fibrinogen in chronically induced intravascular coagulation. *Mayo Clin Proc* 1971;46:521-523.
138. Rapaport SI, Hjort PF, Patch MJ, et al. Consumption of serum factors and prothrombin during intravascular clotting in rabbits. *Scand J Haematol* 1966;3:59-75.
139. Braunstein KM, Eurenium K. Minimal heparin cofactor activity in disseminated intravascular coagulation and cirrhosis. *Am J Clin Pathol* 1976;66: 488-494.
140. Aoki N, Moroi M, Matsuda M, et al. The behavior of α 2-plasmin inhibitor in fibrinolytic states. *J Clin Invest* 1977;60:361-369.
141. Velasco F, Torres A, Andres P, et al. Functional activities and concentrations of plasmin inhibitors in normal subjects and D.I.C. patients. *Thromb Haemost* 1982;47:275-277.
142. Levi M. Disseminated intravascular coagulation. *Crit Care Med* 2007;35: 2191-2195.
143. Mason JW, Kleeberg U, Dolan P, et al. Plasma kallikrein and Hageman factor in gram-negative bacteremia. *Ann Intern Med* 1970;73:545-551.
144. Camerer E, Cornelissen I, Kataoka H, et al. Roles of protease-activated receptors in a mouse model of endotoxemia. *Blood* 2006;107:3912-3921.

145. Lohrmann HP, Adam W, Heymer B, et al. Microangiopathic hemolytic anemia in metastatic carcinoma. Report of eight cases. *Ann Intern Med* 1973;79: 368-375.
146. Visudhiphan S, Piankijagum A, Sathayapraser P, et al. Erythrocyte fragmentation in disseminated intravascular coagulation and other diseases. *N Engl J Med* 1983;309:113.
147. Ogston D, Ogston CM, Ratnoff OD, et al. Studies on a complex mechanism for the activation of plasminogen by kaolin and by chloroform: the participation of Hageman factor and additional cofactors. *J Clin Invest* 1969;48: 1786-1801.
148. Beller FK, Douglas GW, Debrovner CH, et al. The fibrinolytic system in amniotic fluid embolism. *Am J Obstet Gynecol* 1963;87:48-55.
149. Mesters RM, Florke N, Ostermann H, et al. Increase of plasminogen activator inhibitor levels predicts outcome of leukocytopenic patients with sepsis. *Thromb Haemost* 1996;75:902-907.
150. Bang NU, Fletcher AP, Alkjaersig N, et al. Pathogenesis of the coagulation defect developing during pathological plasma proteolytic ("fibrinolytic") states. III. Demonstration of abnormal clot structure by electron microscopy. *J Clin Invest* 1962;41:935-948.
151. Rinaldo JE, Rogers RM. Adult respiratory-distress syndrome: changing concepts of lung injury and repair. *N Engl J Med* 1982;306:900-909.
152. Martin TR, Sandblom RL, Johnson RJ. Adult respiratory distress syndrome following thrombolytic therapy for pulmonary embolism. *Chest* 1983;83: 151-153.
153. Kumar-Basu H. Fibrinolysis and abruptio placentae. *J Obstet Gynaecol Br Commonw* 1969;76:481-496.
154. Gans H, Lowman JT. The uptake of fibrin and fibrin-degradation products by the isolated perfused rat liver. *Blood* 1967;29:526-539.
155. Sherman LA, Lee J, Jacobson A. Quantitation of the reticuloendothelial system clearance of soluble fibrin. *Br J Haematol* 1977;37:231-238.
156. Lee L. Reticuloendothelial clearance of circulating fibrin in the pathogenesis of the generalized Schwartzman reaction. *J Exp Med* 1962;115: 1065-1082.
157. Oka K, Shimamura K, Nakazawa M, et al. The role of Kupffer's cells in disseminated intravascular coagulation. A morphologic study in thrombin-infused rabbits. *Arch Pathol Lab Med* 1983;107:570-576.
158. Deykin D, Cochios F, DeCamp G, et al. Hepatic removal of activated factor X by the perfused rabbit liver. *Am J Physiol* 1968;214:414-419.
159. Ahlgren T, Berghem L, Lagergren H, et al. Phagocytic and catabolic function of the reticuloendothelial system in dogs subjected to defibrinogenation. *Thromb Res* 1976;8:819-828.
160. Kleiner GJ, Merskey C, Johnson AJ, et al. Defibrination in normal and abnormal parturition. *Br J Haematol* 1970;19:159-178.
161. Letsky EA. Disseminated intravascular coagulation. *Best Pract Res Clin Obstet Gynaecol* 2001;15:623-644.
162. Deykin D. The clinical challenge of disseminated intravascular coagulation. *N Engl J Med* 1970;283:636-644.
163. Greenberg CS, Devine DV, McCrae KM. Measurement of plasma fibrin D-dimer levels with the use of a monoclonal antibody coupled to latex beads. *Am J Clin Pathol* 1987;87:94-100.
164. Calverley DC, Liebman HA. Disseminated intravascular coagulation. In: Hoffman R, Benz EJ, Shattil SJ, eds. *Hematology: basic principles and practice*, 3rd ed. New York: Churchill Livingstone, 2000:1983-1995.
165. Lehman CM, Wilson LW, Rodgers GM. Analytic validation and clinical evaluation of the STA LIATEST immunoturbidimetric D-dimer assay for the diagnosis of disseminated intravascular coagulation. *Am J Clin Pathol* 2004;122:178-184.
166. Toh CH, Samis J, Downey C, et al. Biphasic transmittance waveform in the APTT coagulation assay is due to the formation of a Ca(++)-dependent complex of C-reactive protein with very-low-density lipoprotein and is a novel marker of impending disseminated intravascular coagulation. *Blood* 2002;100:2522-2529.
167. Merskey C, Johnson AJ, Kleiner GJ, et al. The defibrination syndrome: clinical features and laboratory diagnosis. *Br J Haematol* 1967;13:528-549.

168. Corrigan JJ Jr, Jordan CM. Heparin therapy in septicemia with disseminated intravascular coagulation. *N Engl J Med* 1970;283:778-782.
169. Niemetz J, Nossel HL. Activated coagulation factors: in-vivo and in-vitro studies. *Br J Haematol* 1969;16:337-351.
170. Giles AR, Nesheim ME, Mann KG. Studies of factors V and VIII:C in an animal model of disseminated intravascular coagulation. *J Clin Invest* 1984;74:2219-2225.
171. Marder VJ, Budzynski AZ. Degradation products of fibrinogen and cross-linked fibrin-projected clinical applications. *Thromb Diath Haemorrh* 1974;32:49-56.
172. Whitaker AN, Rowe EA, Masci PP, et al. Identification of D dimer-E complex in disseminated intravascular coagulation. *Thromb Res* 1980;18:453-459.
173. Carr JM, McKinney M, McDonagh J. Diagnosis of disseminated intravascular coagulation. Role of d-dimer. *Am J Clin Pathol* 1989;91:280-287.
174. Niewiarowski S, Gurewich V. Laboratory identification of intravascular coagulation. The serial dilution protamine sulfate test for the detection of fibrin monomer and fibrin degradation products. *J Lab Clin Med* 1971;77: 665-676.
175. Nossel HL. Radioimmunoassay of fibrinopeptides in relation to intravascular coagulation and thrombosis. *N Engl J Med* 1976;295:428-432.
176. Kisker CT, Rush R. Detection of intravascular coagulation. *J Clin Invest* 1971;50:2235-2241.
177. Tanaka H, Kobayashi N, Maekawa T. Studies on production of antithrombin III with special reference to endotoxin-induced DIC in dogs. *Thromb Haemost* 1986;56:137-143.
178. Thijs LG, de Boer JP, de Groot MC, et al. Coagulation disorders in septic shock. *Intensive Care Med* 1993;19(Suppl 1):S8-S15.
179. Wada H, Yamamuro M, Inoue A, et al. Comparison of the responses of global tests of coagulation with molecular markers of neutrophil, endothelial, and hemostatic system perturbation in the baboon model of E. coli sepsis-toward a distinction between uncompensated overt DIC and compensated non-overt DIC. *Thromb Haemost* 2001;86:1489-1494.
180. Toh CH, Hoots WK; SSC on Disseminated Intravascular Coagulation of the ISTH. The scoring system of the Scientific and Standardisation Committee on Disseminated Intravascular Coagulation of the International Society on Thrombosis and Haemostasis: a 5-year overview. *J Thromb Haemost* 2007;5:604-606.
181. Kim HS, Suzuki M, Lie JT, et al. Clinically unsuspected disseminated intravascular coagulation (DIC): an autopsy survey. *Am J Clin Pathol* 1976;66:31-39.
182. Feinstein DI. Diagnosis and management of disseminated intravascular coagulation: the role of heparin therapy. *Blood* 1982;60:284-287.
183. Bick RL, Schmalhorst WR, Fekete L. Disseminated intravascular coagulation and blood component therapy. *Transfusion* 1976;16:361-365.
184. Ness PM, Perkins HA. Cryoprecipitate as a reliable source of fibrinogen replacement. *JAMA* 1979;241:1690-1691.
185. Lechner K, Kyrle PA. Antithrombin III concentrates-are they clinically useful? *Thromb Haemost* 1995;73:340-348.
186. Warren BL, Eid A, Singer P, et al. Caring for the critically ill patient. High-dose antithrombin III in severe sepsis: a randomized controlled trial. *JAMA* 2001;286:1869-1878.
187. Wiedermann CJ, Hoffmann JN, Juers M, et al. High-dose antithrombin III in the treatment of severe sepsis in patients with a high risk of death: efficacy and safety. *Crit Care Med* 2006;34:285-292.
188. Montagnana M, Franchi M, Danese E, Gotsch F, Guidi GC. Disseminated intravascular coagulation in obstetric and gynecologic disorders. *Semin Thromb Hemost* 2010;36:404-418.
189. Sher G, Statland BE. Abruptio placentae with coagulopathy: a rational basis for management. *Clin Obstet Gynecol* 1985;28:15-23.
190. Barbara C, Hirsh J. Severe post-partum bleeding in abruptio placentae: failure to respond to fibrinogen infusion. *Med J Aust* 1968;2:1182-1184.
191. Strauss JH, Ballard JO, Chamlian D. Consumption coagulopathy associated with intrauterine fetal death: the role of heparin therapy. *Int J Gynaecol Obstet* 1978;16:225-227.

192. Beller FK, Uszynski M. Disseminated intravascular coagulation in pregnancy. *Clin Obstet Gynecol* 1974;17:250-278.
193. Bonnar J. Blood coagulation and fibrinolysis in obstetrics. *Clin Haematol* 1973;2:213-233.
194. Laros RK Jr, Penner JA. Pathophysiology of disseminated intravascular coagulation in saline-induced abortion. *Obstet Gynecol* 1976;48:353-356.
195. Burkman RT, Bell WR, Atienza MF, et al. Coagulopathy with midtrimester induced abortion: association with hyperosmolar urea administration. *Am J Obstet Gynecol* 1977;127:533-536.
196. Whaun JM, Oski FA, Urmson J. Experience with disseminated intravascular coagulation in a children's hospital. *Can Med Assoc J* 1972;107:963-967.
197. Suzuki S, Morishita S. Hypercoagulability and DIC in high-risk infants. *Semin Thromb Hemost* 1998;24:463-466.
198. Hathaway WE, Mull MM, Pechet GS. Disseminated intravascular coagulation in the newborn. *Pediatrics* 1969;43:233-240.
199. Gross SJ, Filston HC, Anderson JC. Controlled study of treatment for disseminated intravascular coagulation in the neonate. *J Pediatr* 1982;100:445-448.
200. Kreuz W, Veldmann A, Fischer D, et al. Neonatal sepsis: a challenge in hemostaseology. *Semin Thromb Hemost* 1999;25:531-535.
201. Neame PB, Kelton JG, Walker IR, et al. Thrombocytopenia in septicemia: the role of disseminated intravascular coagulation. *Blood* 1980;56:88-92.
202. Bernard GR, Vincent JL, Laterre PF, et al. Efficacy and safety of recombinant human activated protein C for severe sepsis. *N Engl J Med* 2001;344: 699-709.
203. Kylat RI, Ohlsson A. Recombinant human activated protein C for severe sepsis in neonates. *Cochrane Database Syst Rev* 2006;2:CD005385.
204. Dudgeon DL, Kellogg DR, Gilchrist GS, et al. Purpura fulminans. *Arch Surg* 1971;103:351-358.
205. Spicer TE, Rau JM. Purpura fulminans. *Am J Med* 1976;61:566-571.
206. Gamper G, Oschatz E, Herkner H, et al. Sepsis-associated purpura fulminans in adults. *Wien Klin Wochenschr* 2001;113:107-112.
207. Chalmers E, Cooper P, Forman K, Grimley C, Khair K, et al. Purpura fulminans: recognition, diagnosis and management. *Arch Dis Child* 2011;96: 1066-1071.
208. Sallah S, Wan JY, Nguyen NP, et al. Disseminated intravascular coagulation in solid tumors: clinical and pathologic study. *Thromb Haemost* 2001;86: 828-833.
209. Thodiyil PA, Kakkar AK. Variation in relative risk of venous thromboembolism in different cancers. *Thromb Haemost* 2002;87:1076-1077.
210. Walsh-McMonagle D, Green D. Low-molecular-weight heparin in the management of Trousseau's syndrome. *Cancer* 1997;80:649-655.
211. Klerk CP, Smorenburg SM, Otten HM, et al. The effect of low molecular weight heparin on survival in patients with advanced malignancy. *J Clin Oncol* 2005;23:2130-2135.
212. Wahrenbrock M., Borsig L, Le D, et al. Selectin-mucin interactions as a probable molecular explanation for the association of Trousseau syndrome with mucinous adenocarcinomas. *J Clin Invest* 2003;112:853-862.
213. Akl EA, van Doormaal FF, Barba M, et al. Parenteral anticoagulation for prolonging survival in patients with cancer who have no other indication for anticoagulation. *Cochrane Database Syst Rev* 2011;1:CD006652.
214. Lee AY, Levine MN, Baker RI, et al. Low-molecular-weight heparin versus a coumarin for the prevention of recurrent venous thromboembolism in patients with cancer. *N Engl J Med* 2003;349:146-153.
215. Litt MR, Bell WR, Lepor HA. Disseminated intravascular coagulation in prostatic carcinoma reversed by ketoconazole. *JAMA* 1987;258:1361-1362.
216. Martinez JF, Taberero Redondo MD, Alberca Silva I, et al. Disseminated intravascular coagulation in prostatic carcinoma reversed by antiandrogenic therapy. *JAMA* 1988;260:2507.

217. Boccaccio C, Sabatino G, Medico E, et al. The MET oncogene drives a genetic programme linking cancer to haemostasis. *Nature* 2005;434:396-400.
218. Varki A. Trousseau's syndrome: multiple definitions and multiple mechanisms. *Blood* 2007;110:1723-1729.
219. Sultan C, Heilmann-Gouault M, Tulliez M. Relationship between blast-cell morphology and occurrence of a syndrome of disseminated intravascular coagulation. *Br J Haematol* 1973;24:255-259.
220. Tallman MS, Kwaan HC. Reassessing the hemostatic disorder associated with acute promyelocytic leukemia. *Blood* 1992;79:543-553.
221. Kaplan R, De La Cadena RA. Mechanism of the coagulopathy associated with acute promyelocytic leukemia-clinical conference. *Am J Hematol* 1998;59:234-237.
222. Schwartz BS, Williams EC, Conlan MG, et al. Epsilon-aminocaproic acid in the treatment of patients with acute promyelocytic leukemia and acquired α -2-plasmin inhibitor deficiency. *Ann Intern Med* 1986;105:873-877.
223. Warrell RP Jr, Frankel SR, Miller WH Jr, et al. Differentiation therapy of acute promyelocytic leukemia with tretinoin (all-trans-retinoic acid). *N Engl J Med* 1991;324:1385-1393.
224. Tallman MS, Lafebvre P, Baine RM, et al. Effects of all-trans retinoic acid or chemotherapy on the molecular regulation of systemic blood coagulation and fibrinolysis in patients with acute promyelocytic leukemia. *J Thromb Haemost* 2004;2:1341-1350.
225. Hall GW. Kasabach-Merritt syndrome: pathogenesis and management. *Br J Haematol* 2001;112:851-862.
226. Warrell RP Jr, Kempin SJ. Treatment of severe coagulopathy in the Kasabach-Merritt syndrome with aminocaproic acid and cryoprecipitate. *N Engl J Med* 1985;313:309-312.
227. Ortel TL, Onorato JJ, Bedrosian CL, et al. Antifibrinolytic therapy in the management of the Kasabach Merritt syndrome. *Am J Hematol* 1988;29:44-48.
228. Cummins D, Segal H, Hunt BJ, et al. Chronic disseminated intravascular coagulation after surgery for abdominal aortic aneurysm: clinical and haemostatic response to dalteparin. *Br J Haematol* 2001;113:658-660.
229. Hehne HJ, Nyman D, Burri H, et al. Management of bleeding disorders in traumatic-haemorrhagic shock states with deep frozen fresh plasma. *Eur J Intensive Care Med* 1976;2:157-161.
230. Rock RC, Bove JR, Nemerson Y. Heparin treatment of intravascular coagulation accompanying hemolytic transfusion reactions. *Transfusion* 1969;9: 57-61.
231. Hasiba U, Rosenbach LM, Rockwell D, et al. DIC-like syndrome after envenomation by the snake, *Crotalus horridus horridus*. *N Engl J Med* 1975;292:505-507.
232. Schmaier AH, Claypool W, Colman RW. Crotalocytin: recognition and purification of a timber rattlesnake platelet aggregating protein. *Blood* 1980;56:1013-1019.
233. Budzynski AZ, Pandya BV, Rubin RN, et al. Fibrinogenolytic afibrinogenemia after envenomation by western diamondback rattlesnake (*Crotalus atrox*). *Blood* 1984;63:1-14.
234. Warrell DA, Pope HM, Prentice CR. Disseminated intravascular coagulation caused by the carpet viper (*Echis carinatus*): trial of heparin. *Br J Haematol* 1976;33:335-342.
235. Spero JA, Lewis JH, Hasiba U. Disseminated intravascular coagulation. Findings in 346 patients. *Thromb Haemost* 1980;43:28-33.
236. Kim HS, Suzuki M, Lie JT, et al. Nonbacterial thrombotic endocarditis (NBTE) and disseminated intravascular coagulation (DIC): autopsy study of 36 patients. *Arch Pathol Lab Med* 1977;101:65-68.
237. Svartholm E, Haglund U, Ljungberg J, et al. Influence of aprotinin, a protease inhibitor, on porcine *E. coli* shock. Studies on coagulation, fibrinolytic and hemodynamic response. *Acta Chir Scand* 1989;155:7-13.
238. Umeki S, Adachi M, Watanabe M, et al. Gabexate as a therapy for disseminated intravascular coagulation. *Arch Intern Med* 1988;148:1409-1412.
239. Key NS, Bach RR. Tissue factor as a therapeutic target. *Thromb Haemost* 2001;85:375-376.
240. Levi M, ten Cate H, Bauer KA, et al. Inhibition of endotoxin-induced activation of coagulation and fibrinolysis by pentoxifylline or by a monoclonal anti-tissue factor antibody in chimpanzees. *J Clin Invest* 1994;93:114-120.

241. Taylor FB Jr, Chang A, Ruf W, et al. Lethal *E. coli* septic shock is prevented by blocking tissue factor with monoclonal antibody. *Circ Shock* 1991;33:127-134.
242. Minneci PC, Deans KJ, Cui X, et al. Antithrombotic therapies for sepsis: a need for more studies. *Crit Care Med* 2006;34:538-541.
243. Taylor FB Jr, Chang A, Esmon CT, et al. Protein C prevents the coagulopathic and lethal effects of *Escherichia coli* infusion in the baboon. *J Clin Invest* 1987;79:918-925.
244. White B, Livingstone W, Murphy C, et al. An open-label study of the role of adjuvant hemostatic support with protein C replacement therapy in purpura fulminans-associated meningococemia. *Blood* 2000;96:3719-3724.
245. Zacharski LR, Memoli VA, Ornstein DL, et al. Tumor cell procoagulant and urokinase expression in carcinoma of the ovary. *J Natl Cancer Inst* 1993;85:1225-1230.
246. Bennett B, Croll AM, Robbie LA, et al. Tumour cell u-PA as a cause of fibrinolytic bleeding in metastatic disease. *Br J Haematol* 1997;99:570-574.
247. Bell WR. The fibrinolytic system in neoplasia. *Semin Thromb Hemost* 1996;22:459-478.
248. Taylor RN, Lacey CG, Shuman MA. Adenocarcinoma of Skene's duct associated with a systemic coagulopathy. *Gynecol Oncol* 1985;22:250-256.
249. Kevy SV, Glickman RM, Bernhard WF, et al. The pathogenesis and control of the hemorrhagic defect in open heart surgery. *Surg Gynecol Obstet* 1966;123:313-318.
250. Illig KA, Green RM, Ouriel K, et al. Primary fibrinolysis during supraceliac aortic clamping. *J Vasc Surg* 1997;25:244-251; discussion 252-254.
251. Lee MH, Vosburgh E, Anderson K, et al. Deficiency of plasma plasminogen activator inhibitor 1 results in hyperfibrinolytic bleeding. *Blood* 1993;81:2357-2362.
252. Aoki N, Saito H, Kamiya T, et al. Congenital deficiency of α 2-plasmin inhibitor associated with severe hemorrhagic tendency. *J Clin Invest* 1979;63: 877-884.
253. Booth NA, Bennett B. Plasmin- α 2-antiplasmin complexes in bleeding disorders characterized by primary or secondary fibrinolysis. *Br J Haematol* 1984;56:545-556.
254. Bachmann F. Disorders of fibrinolysis and use of antifibrinolytic agents. In: Beutler E, Lichtman MA, Coller BS, et al., eds. *Williams hematology*, 6th ed. New York: McGraw-Hill, 2001:1829-1840.
255. Nilsson IM, Andersson L, Bjorkman SE. Epsilon-aminocaproic acid (E-ACA) as a therapeutic agent based on 5 years' clinical experience. *Acta Med Scand Suppl* 1966;448:1-46.
256. Naeye RL. Thrombotic state after a hemorrhagic diathesis, a possible complication of therapy with epsilon-aminocaproic acid. *Blood* 1962;19:694-701.
257. Sallah S, Gagnon GA. Reversion of primary hyperfibrinogenolysis in patients with hormone-refractory prostate cancer using docetaxel. *Cancer Invest* 2000;18:191-196.
258. McMillan CW, Shapiro SS, Whitehurst D, et al. The natural history of factor VIII:C inhibitors in patients with hemophilia A: a national cooperative study. II. Observations on the initial development of factor VIII:C inhibitors. *Blood* 1988;71:344-348.
259. Rasi V, Ikkala E. Haemophiliacs with factor VIII inhibitors in Finland: prevalence, incidence and outcome. *Br J Haematol* 1990;76:369-371.
260. Ehrenforth S, Kreuz W, Scharrer I, et al. Incidence of development of factor VIII and factor IX inhibitors in haemophiliacs. *Lancet* 1992;339:594-598.
261. Hay CR. Why do inhibitors arise in patients with haemophilia A? *Br J Haematol* 1999;105:584-590.
262. Lusher JM, Salzman PM. Viral safety and inhibitor development associated with factor VIII:C ultra-purified from plasma in hemophiliacs previously unexposed to factor VIII:C concentrates. The Monoclate Study Group. *Semin Hematol* 1990;27:1-7.

263. Lusher JM, Arkin S, Abildgaard CF, et al. Recombinant factor VIII for the treatment of previously untreated patients with hemophilia A. Safety, efficacy, and development of inhibitors. Kogenate Previously Untreated Patient Study Group. *N Engl J Med* 1993;328:453-459.
264. Aledort LM. Inhibitors in hemophilia patients: current status and management. *Am J Hematol* 1994;47:208-217.
265. Viel KR, Ameri A, Abshire TC, et al. Inhibitors of factor VIII in black patients with hemophilia. *N Engl J Med* 2009;360:1618-1627.
266. Gouw SC, van den Berg HM, le Cessis S, van der Bom JG. Treatment characteristics and the risk of inhibitor development: a multicenter cohort study among previously untreated patients with severe hemophilia A. *J Thromb Haemost* 2007;5:1383-1390.
267. Ragni MV. FVIII, CD4, and liaisons dangereuses. *Blood* 2011;117:6060-6061.
268. Hay CR, Ludlam CA, Colvin BT, et al. Factor VIII inhibitors in mild and moderate-severity haemophilia A. UK Haemophilia Centre Directors Organisation. *Thromb Haemost* 1998;79:762-766.
269. Goodeve AC, Williams I, Bray GL, et al. Relationship between factor VIII mutation type and inhibitor development in a cohort of previously untreated patients treated with recombinant factor VIII (Recombinate). Recombinate PUP Study Group. *Thromb Haemost* 2000;83:844-848.
270. Iorio A, Halimeh S, Holzhauser S, et al. Rate of inhibitor development in previously untreated hemophilia A patients treated with plasma-derived or recombinant factor VIII concentrates: a systematic review. *J Thromb Haemost* 2010;8:1256-1265.
- 270a. Gouw SC, van der Bom JG, Ljung R, et al. Factor VIII products and inhibitor development in severe hemophilia A. *N Engl J Med* 2013;368:231-239.
271. Lorenzo JJ, Lopez A, Altisent C, et al. Incidence of factor VIII inhibitors in severe haemophilia: the importance of patient age. *Br J Haematol* 2001;113:600-603.
272. Hay CR, Palmer B, Chalmers E, et al.; United Kingdom Haemophilia Centre Doctors' Organisation (UKHCDO). Incidence of factor VIII inhibitors throughout life in severe hemophilia A in the United Kingdom. *Blood* 2011;117: 6367-6370.
273. Lavigne-Lissalde G, Schved J-F, Granier C, et al. Anti-factor VIII antibodies. A 2005 update. *Thromb Haemost* 2005;94:760-769.
274. Collins PW, Percy CL. Advances in the understanding of acquired haemophilia A: implications for clinical practice. *Br J Haematol* 2010;148:183-194.
275. Green D, Lechner K. A survey of 215 non-hemophilic patients with inhibitors to factor VIII. *Thromb Haemost* 1981;45:200-203.
276. Francini M, Gandini G, DiPaolantano T, et al. Acquired hemophilia A: a concise review. *Am J Hematol* 2005;80:55-63.
277. Solymoss S. Postpartum acquired factor VIII inhibitors: results of a survey. *Am J Hematol* 1998;59:1-4.
278. Hauser I, Schneider B, Lechner K. Post-partum factor VIII inhibitors. A review of the literature with special reference to the value of steroid and immunosuppressive treatment. *Thromb Haemost* 1995;73:1-5.
279. Hultin MB. Acquired inhibitors in malignant and nonmalignant disease states. *Am J Med* 1991;91:9S-13S.
280. Hauser I, Lechner K. Solid tumors and factor VIII antibodies. *Thromb Haemost* 1999;82:1005-1007.
281. Sallah S, Nguyen NP, Abdallah JM, et al. Acquired hemophilia in patients with hematologic malignancies. *Arch Pathol Lab Med* 2000;124:730-734.
282. Moraca RJ, Ragni MV. Acquired anti-FVIII inhibitors in children. *Haemophilia* 2002;8:28-32.
283. Poon MC, Saito H, Ratnoff OD, et al. Techniques for demonstration of the specificity of circulating anticoagulants against antihemophilic factor (factor VIII), with studies of two cases possibly related to diphenylhydantoin therapy. *Blood* 1977;49:477-482.
284. Bossi P, Cabane J, Ninet J, et al. Acquired hemophilia due to factor VIII inhibitors in 34 patients. *Am J Med* 1998;105:400-408.
285. Franchini M, Salvagno GL, Lippi G. Inhibitors in mild/moderate haemophilia: an update. *Thromb Haemost* 2006;96:113-118.

286. Frommel D, Allain JP. Genetic predisposition to develop factor VIII antibody in classic hemophilia. *Clin Immunol Immunopathol* 1977;8:34-38.
287. Hay CR, Ollier W, Pepper L, et al. HLA class II profile: a weak determinant of factor VIII inhibitor development in severe haemophilia A. UKHCDO Inhibitor Working Party. *Thromb Haemost* 1997;77:234-237.
288. Tuddenham EG, McVey JH. The genetic basis of inhibitor development in haemophilia A. *Haemophilia* 1998;4:543-545.
289. Hoyer LW. Why do so many haemophilia A patients develop an inhibitor? *Br J Haematol* 1995;90:498-501.
290. ter Avest PC, Fischer K, Mancuso ME, et al.; CANAL Study Group. Risk stratification for inhibitor development at first treatment for severe hemophilia A: a tool for clinical practice. *J Thromb Haemost* 2008;6:2048-2054.
291. Moreau A, Lacroix-Desmazes S, Stieltjes N, et al. Antibodies to the FVIII light chain that neutralize FVIII procoagulant activity are present in plasma of nonresponder patients with severe hemophilia A and in normal polyclonal human IgG. *Blood* 2000;95:3435-3441.
292. Sultan Y, Kazatchkine MD, Maisonneuve P, et al. Anti-idiotypic suppression of autoantibodies to factor VIII (antihaemophilic factor) by high-dose intravenous gammaglobulin. *Lancet* 1984;2:765-768.
293. Allain JP, Gaillandre A, Frommel D. Acquired haemophilia: functional study of antibodies to factor VIII. *Thromb Haemost* 1981;45:285-289.
294. Allain JP, Croissant MP, Lerolle D, et al. In vivo interactions of autoantibodies to factor VIII with the factor VIII complex. *Thromb Haemost* 1982;48: 142-145.
295. Prescott R, Nakai H, Saenko EL, et al. The inhibitor antibody response is more complex in hemophilia A patients than in most nonhemophiliacs with factor VIII autoantibodies. Recombinate and Kogenate Study Groups. *Blood* 1997;89:3663-3671.
296. Scandella D, DeGraaf Mahoney S, Mattingly M, et al. Epitope mapping of human factor VIII inhibitor antibodies by deletion analysis of factor VIII fragments expressed in *Escherichia coli*. *Proc Natl Acad Sci U S A* 1988;85: 6152-6156.
297. Nogami K, Shima M, Giddings JC, et al. Circulating factor VIII immune complexes in patients with type 2 acquired hemophilia A and protection from activated protein C-mediated proteolysis. *Blood* 2001;97:669-677.
298. Allain JP, Gaillandre A, Lee H. Immunochemical characterization of antibodies to factor VIII in hemophilic and nonhemophilic patients. *J Lab Clin Med* 1981;97:791-800.
299. Pool JG, Miller RG. Assay of the immune inhibitor in classic haemophilia: application of virus-antibody reaction kinetics. *Br J Haematol* 1972;22:517-528.
300. Gawryl MS, Hoyer LW. Inactivation of factor VIII coagulant activity by two different types of human antibodies. *Blood* 1982;60:1103-1109.
301. Biggs R, Austen DE, Denson KW, et al. The mode of action of antibodies which destroy factor VIII. I. Antibodies which have second-order concentration graphs. *Br J Haematol* 1972;23:125-135.
302. Biggs R, Austen DE, Denson KW, et al. The mode of action of antibodies which destroy factor VIII. II. Antibodies which give complex concentration graphs. *Br J Haematol* 1972;23:137-155.
303. Ewing NP, Kasper CK. In vitro detection of mild inhibitors to factor VIII in hemophilia. *Am J Clin Pathol* 1982;77:749-752.
304. Lacroix-Desmazes S, Moreau A, Sooryanarayana, et al. Catalytic activity of antibodies against factor VIII in patients with hemophilia A. *Nat Med* 1999;5:1044-1047.
305. Kasper CK, Aledort LM, Counts RB. A more uniform measurement of factor VIII inhibitors. *Thromb Diath Haemorrh* 1975;34:869-872.
306. Verbruggen B, Novakova I, Wessels H, et al. The Nijmegen modification of the Bethesda assay for factor VIII:C inhibitors: improved specificity and reliability. *Thromb Haemost* 1995;73:247-251.
307. Rizza CR, Biggs R. The treatment of patients who have factor-VIII antibodies. *Br J Haematol* 1973;24:65-82.
308. Kasper CK. Laboratory tests for factor VIII inhibitors, their variation, significance and interpretation. *Blood Coagul Fibrinolysis* 1991;2:7-10.

309. Giles AR, Verbruggen B, Rivard GE, et al. A detailed comparison of the performance of the standard versus the Nijmegen modification of the Bethesda assay in detecting factor VIII:C inhibitors in the haemophilia A population of Canada. Association of Hemophilia Centre Directors of Canada. Factor VIII/IX Subcommittee of Scientific and Standardization Committee of International Society on Thrombosis and Haemostasis. *Thromb Haemost* 1998;79: 872-875.
310. Verbruggen B, Giles A, Samis J, et al. The type of factor VIII deficient plasma used influences the performance of the Nijmegen modification of the Bethesda assay for factor VIII inhibitors. *Thromb Haemost* 2001;86: 1435-1439.
311. Lottenberg R, Kentro TB, Kitchens CS. Acquired hemophilia. A natural history study of 16 patients with factor VIII inhibitors receiving little or no therapy. *Arch Intern Med* 1987;147:1077-1081.
312. Aledort L. Inhibitors in hemophilia patients: current status and management. *Am J Hematol* 1994;47:208-217.
313. Aledort LM, White GC. Challenges in the treatment of haemophilia with inhibitors. *Haemophilia* 1999;5(Suppl 3):1-51.
314. Hay CRM, Brown S, Collins PW, et al. The diagnosis and management of factor VIII and IX inhibitors: a guideline from the United Kingdom Haemophilia Centre Doctors' Organization. *Br J Haematol* 2006;133:591-605.
- 314a. Collins PW, Chalmers E, Hart DP, et al. Diagnosis and treatment of factor VIII and IX inhibitors in congenital haemophilia: (4th edition). *Br J Haematol* 2013;160:153-170.
315. Teitel J, Berntorp E, Collins P, et al. A systematic approach to controlling problem bleeds in patients with severe congenital haemophilia A and high-titre inhibitors. *Haemophilia* 2007;13:256-263.
316. Collins PW. Management of acquired haemophilia A. *J Thromb Haemost* 2011;9(Suppl 1):226-235.
317. Brox AG, Laryea H, Pelletier M. Successful treatment of acquired factor VIII inhibitors with cyclosporin. *Am J Hematol* 1998;57:87-88.
318. Mudad R, Kane WH. DDAVP in acquired hemophilia A: case report and review of the literature. *Am J Hematol* 1993;43:295-299.
319. Grunewald M, Beneke H, Guthner C, et al. Acquired haemophilia: experiences with a standardized approach. *Haemophilia* 2001;7:164-169.
320. Hay CR, Negrier C, Ludlam CA. The treatment of bleeding in acquired haemophilia with recombinant factor VIIa: a multicentre study. *Thromb Haemost* 1997;78:1463-1467.
321. Kessler CM. New products for managing inhibitors to coagulation factors: a focus on recombinant factor VIIa concentrate. *Curr Opin Hematol* 2000;7:408-413.
322. Monroe DM, Hoffman M, Oliver JA, et al. A possible mechanism of action of activated factor VII independent of tissue factor. *Blood Coagul Fibrinolysis* 1998;9(Suppl 1):S15-S20.
323. Shapiro AD, Gilchrist GS, Hoots WK, et al. Prospective, randomised trial of two doses of rFVIIa (NovoSeven) in haemophilia patients with inhibitors undergoing surgery. *Thromb Haemost* 1998;80:773-778.
324. Key NS, Aledort LM, Beardsley D, et al. Home treatment of mild to moderate bleeding episodes using recombinant factor VIIa (Novoseven) in haemophiliacs with inhibitors. *Thromb Haemost* 1998;80:912-918.
325. Santagostino E, Mancuso ME, Rocino A, et al. A prospective randomized trial of high and standard dosages of recombinant factor VII_a for treatment of hemarthroses in hemophiliacs with inhibitors. *J Thromb Haemost* 2006;4:367-371.
326. Ewenstein BM. Continuous infusion of recombinant factor VIIa: continue or not? *Thromb Haemost* 2001;86:942-944.
327. Aledort LM. Comparative thrombotic event incidence after infusion of recombinant factor VII_a versus factor VIII inhibitor bypass activity. *J Thromb Haemost* 2004;2:1700-1708.
328. Leissinger C, Gringeri A, Antmen B, et al. Anti-inhibitor coagulant complex prophylaxis in hemophilia with inhibitors. *N Engl J Med* 2011;365: 1684-1692.
329. Astermark J, Donfield SM, DiMichele DM, et al. A randomized comparison of bypassing agents in hemophilia complicated by an inhibitor: the FEIBA NovoSeven Comparative (FENOC) study. *Blood* 2007;109:546-551.
330. Zhou ZY, Hay JW. Efficacy of bypassing agents in patients with hemophilia and inhibitors: a systematic review and meta-analysis. *Clin Ther* 2012;34:434-445.

331. Monahan PE, Aledort L, for the ad hoc Hemophilia Inhibitor Study Group. Factors affecting choice of hemostatic agent for the hemophilia patient with an inhibitor antibody. *Am J Hematol* 2004;77:346-350.
332. Allen G, Aledort L. Therapeutic decision-making in inhibitor patients. *Am J Hematol* 2006;81:71-72.
333. Ingerslev J, Sørensen B. Parallel use of by-passing agents in haemophilia with inhibitors: a critical review. *Br J Haematol* 2011;155:256-262.
334. Morrison AE, Ludlam CA, Kessler C. Use of porcine factor VIII in the treatment of patients with acquired hemophilia. *Blood* 1993;81:1513-1520.
335. Crenier L, Ducobu J, des Grottes JM, et al. Low response to high-dose intravenous immunoglobulin in the treatment of acquired factor VIII inhibitor. *Br J Haematol* 1996;95:750-753.
336. Herbst KD, Rapaport SI, Kenoyer DG, et al. Syndrome of an acquired inhibitor of factor VIII responsive to cyclophosphamide and prednisone. *Ann Intern Med* 1981;95:575-578.
337. Wiestner A, Cho HJ, Asch AS, et al. Rituximab in the treatment of acquired factor VIII inhibitors. *Blood* 2002;100:3426-3428.
338. Onitilo AA, Skorupa A, Lal A, et al. Rituximab in the treatment of acquired factor VIII inhibitors. *Thromb Haemost* 2006;96:84-87.
339. Zeitler H, Ulrich-Merzenich G, Hess L, et al. Treatment of acquired hemophilia by the Bonn-Malmö protocol: documentation of an in vivo immunomodulating concept. *Blood* 2005;105:2287-2293.
340. Mariani G, Ghirardini A, Bellocco R. Immune tolerance in hemophilia-principal results from the International Registry. Report of the factor VIII and IX Subcommittee. *Thromb Haemost* 1994;72:155-158.
341. Mariani G, Kroner B. International immune tolerance registry, 1997 update. *Vox Sang* 1999;77(Suppl 1):25-27.
342. Nilsson IM, Berntorp E, Zettervall O. Induction of immune tolerance in patients with hemophilia and antibodies to factor VIII by combined treatment with intravenous IgG, cyclophosphamide, and factor VIII. *N Engl J Med* 1988;318:947-950.
343. DiMichele DM, Kroner BL. The North American Immune Tolerance Registry: practices, outcomes, outcome predictors. *Thromb Haemost* 2002;87:52-57.
344. Colowick AB, Bohn RL, Avorn J, et al. Immune tolerance induction in hemophilia patients with inhibitors: costly can be cheaper. *Blood* 2000;96: 1698-1702.
345. Hay CR, DiMichele DM; International Immune Tolerance Study. The principal results of the International Immune Tolerance Study: a randomized dose comparison. *Blood* 2012;119:1335-1344.
346. Ettingshausen CE, Kreuz W. Role of von Willebrand factor in immune tolerance induction. *Blood Coagul Fibrinolysis* 2005;16(Suppl 1):S27-S31.
347. DiMichele DM. Immune tolerance in haemophilia: the long journey to the fork in the road. *Br J Haematol* 2012;159:123-134.
348. Giannelli F, Choo KH, Rees DJ, et al. Gene deletions in patients with haemophilia B and anti-factor IX antibodies. *Nature* 1983;303:181-182.
349. Ljung RC. Gene mutations and inhibitor formation in patients with hemophilia B. *Acta Haematol* 1995;94(Suppl 1):49-52.
350. Largo R, Sigg P, von Felten A, et al. Acquired factor-IX inhibitor in a non-haemophilic patient with autoimmune disease. *Br J Haematol* 1974;26: 129-140.
351. Ljung R, Petrini P, Tengborn L, et al. Haemophilia B mutations in Sweden: a population-based study of mutational heterogeneity. *Br J Haematol* 2001;113:81-86.
352. Christophe OD, Lenting PJ, Cherel G, et al. Functional mapping of anti-factor IX inhibitors developed in patients with severe hemophilia B. *Blood* 2001;98:1416-1423.
353. Ekert H, Brewin T, Boey W, et al. Cost-utility analysis of recombinant factor VIIa (NovoSeven) in six children with long-standing inhibitors to factor VIII or IX. *Haemophilia* 2001;7:279-285.
354. Lusher JM. Inhibitor antibodies to factor VIII and factor IX: management. *Semin Thromb Hemost* 2000;26:179-188.

355. Barthels M. Clinical efficacy of prothrombin complex concentrates and recombinant factor VIIa in the treatment of bleeding episodes in patients with factor VII and IX inhibitors. *Thromb Res* 1999;95:S31-S38.
356. Chitlur M, Warriar I, Rajpurkar M, Lusher JM. Inhibitors in factor IX deficiency a report of the ISTH-SSC international FIX inhibitor registry (1997-2006). *Haemophilia* 2009;15:1027-1031.
357. Feinstein DI. Acquired inhibitors of factor V. *Thromb Haemost* 1978;39: 663-674.
358. Coots MC, Muhleman AF, Glueck HI. Hemorrhagic death associated with a high titer factor V inhibitor. *Am J Hematol* 1978;4:193-206.
359. Favaloro EJ, Posen J, Ramakrishna R, et al. Factor V inhibitors: rare or not so uncommon? A multi-laboratory investigation. *Blood Coagul Fibrinolysis* 2004;15:637-647.
360. Ang AL, Kuperan P, Ng CH, Ng HJ. Acquired factor V inhibitor. A problem-based systematic review. *Thromb Haemost* 2009;101:852-859.
361. Ortel TL. Clinical and laboratory manifestations of anti-factor V antibodies. *J Lab Clin Med* 1999;133:326-334.
362. Streiff MB, Ness PM. Acquired FV inhibitors: a needless iatrogenic complication of bovine thrombin exposure. *Transfusion* 2002;42:18-26.
363. Ness P, Creer M, Rodgers GM, et al.; Recognition, Evaluation and Treatment of Acquired Coagulopathy Consensus (RETACC) Panel. Building an immune-mediated coagulopathy consensus: early recognition and evaluation to enhance post-surgical patient safety. *Patient Saf Surg* 2009;3:8.
364. Stricker RB, Lane PK, Leffert JD, et al. Development of antithrombin antibodies following surgery in patients with prosthetic cardiac valves. *Blood* 1988;72:1375-1380.
365. Zehnder JL, Leung LL. Development of antibodies to thrombin and factor V with recurrent bleeding in a patient exposed to topical bovine thrombin. *Blood* 1990;76:2011-2016.
366. Ortel TL, Mercer MC, Thames EH, et al. Immunologic impact and clinical outcomes after surgical exposure to bovine thrombin. *Ann Surg* 2001;233: 88-96.
367. Feinstein DI, Rapaport SI. Acquired inhibitors of blood coagulation. *Prog Hemost Thromb* 1972;1:75-95.
368. Chediak J, Ashenhurst JB, Garlick I, et al. Successful management of bleeding in a patient with factor V inhibitor by platelet transfusions. *Blood* 1980;56:835-841.
369. Grace CS, Wolf P. Proceedings: a high titre circulating inhibitor of human factor V: clinical, biochemical and immunological features and its treatment by plasmapheresis. *Thromb Diath Haemorrh* 1975;34:322.
370. DeRaucourt E, Barbier C, Sinda P, et al. High-dose intravenous immunoglobulin treatment in two patients with acquired factor V inhibitors. *Am J Hematol* 2003;74:187-190.
371. Kalafatis M, Simioni P, Tormene D, et al. Isolation and characterization of an antifactor V antibody causing activated protein C resistance from a patient with severe thrombotic manifestations. *Blood* 2002;99:3985-3992.
372. Federici AB, Rand JH, Bucciarelli P, et al. Acquired von Willebrand syndrome: data from an international registry. *Thromb Haemost* 2000;84:345-349.
373. Rinder MR, Richard RE, Rinder HM. Acquired von Willebrand's disease: a concise review. *Am J Hematol* 1997;54:139-145.
374. Veyradier A, Jenkins CS, Fressinaud E, et al. Acquired von Willebrand syndrome: from pathophysiology to management. *Thromb Haemost* 2000;84:175-182.
375. Vincentelli A, Susen S, Le Tourneau T, et al. Acquired von Willebrand syndrome in aortic stenosis. *N Engl J Med* 2003;349:343-349.
376. Heilmann C, Geisen U, Beyersdorf F, et al. Acquired von Willebrand syndrome in patients with ventricular assist device or total artificial heart. *Thromb Haemost* 2010;103:962-967.
377. Tiede A, Rand JH, Budde U, Ganser A, Federici AB. How I treat the acquired von Willebrand syndrome. *Blood* 2011;117:6777-6785.
378. Tefferi A, Nichols WL. Acquired von Willebrand disease: concise review of occurrence, diagnosis, pathogenesis, and treatment. *Am J Med* 1997;103: 536-540.

379. Federici AB, Stabile F, Castaman G, et al. Treatment of acquired von Willebrand syndrome in patients with monoclonal gammopathy of uncertain significance: comparison of three different therapeutic approaches. *Blood* 1998;92:2707-2711.
380. Lorand L, Jacobsen A, Bruner-Lorand J. A pathological inhibitor of fibrin cross-linking. *J Clin Invest* 1968;47:268-273.
381. Lewis JH, Szeto ILF, Ellis LD, et al. An acquired inhibitor to coagulation factor XIII. *Johns Hopkins Med J* 1967;120:401-407.
382. Lorand L, Maldonado N, Fradera J, et al. Haemorrhagic syndrome of autoimmune origin with a specific inhibitor against fibrin stabilizing factor (factor XIII). *Br J Haematol* 1972;23:17-27.
383. Ajzner E, Schlamadinger A, Kerényi A, et al. Severe bleeding complications caused by an autoantibody against the B subunit of plasma factor XIII: a novel form of acquired factor XIII deficiency. *Blood* 2009;113:723-725.
384. Luo YY, Zhang GS. Acquired factor XIII inhibitor: clinical features, treatment, fibrin structure and epitope determination. *Haemophilia* 2011;17:393-398.
385. Acharya SS, Coughlin A, DiMichele DM. Rare Bleeding Disorder Registry: deficiencies of factors II, V, VII, X, XIII, fibrinogen and dysfibrinogenemias. *J Thromb Haemost* 2003;2:248-256.
386. DeVries A, Rosenberg T, Kochwa S, et al. Precipitating antifibrinogen antibody appearing after fibrinogen infusions in a patient with congenital afibrinogenemia. *Am J Med* 1961;30:486-494.
387. Scully MF, Ellis V, Kakkar VV, et al. An acquired coagulation inhibitor to factor II. *Br J Haematol* 1982;50:655-664.
388. Madoiwa S, Nakamura Y, Mimuro J, et al. Autoantibody against prothrombin aberrantly alters the proenzyme to facilitate formation of a complex with its physiological inhibitor antithrombin III without thrombin conversion. *Blood* 2001;97:3783-3789.
389. Bajaj SP, Rapaport SI, Fierer DS, et al. A mechanism for the hypoprothrombinemia of the acquired hypoprothrombinemia-lupus anticoagulant syndrome. *Blood* 1983;61:684-692.
390. Salomon O, Zivelin A, Livnat T, et al. Prevalence, causes, and characterization of factor XI inhibitors in patients with inherited factor XI deficiency. *Blood* 2003;101:4783-4788.
391. Livnat T, Tamarin I, Mor Y, et al. Recombinant activated factor VII and tranexamic acid are haemostatically effective during major surgery in factor XI-deficient patients with inhibitor antibodies. *Thromb Haemost* 2009;102:487-492.
392. Reece EA, Clyne LP, Romero R, et al. Spontaneous factor XI inhibitors. Seven additional cases and a review of the literature. *Arch Intern Med* 1984;144:525-529.
393. Bortoli R, Monticelo OA, Chakr RM, et al. Acquired factor XI inhibitor in systemic lupus erythematosus—case report and literature review. *Semin Arthritis Rheum* 2009;39:61-65.
394. Mulhare PE, Tracy PB, Golden EA, et al. A case of acquired factor X deficiency with in vivo and in vitro evidence of inhibitor activity directed against factor X. *Am J Clin Pathol* 1991;96:196-200.
395. Henson K, Files JC, Morrison FS. Transient acquired factor X deficiency: report of the use of activated clotting concentrate to control a life-threatening hemorrhage. *Am J Med* 1989;87:583-585.
396. Hsia CC, Keeney M, Bosco AA, Xenocostas A. Treatment of acquired factor X inhibitor by plasma exchange with concomitant intravenous immunoglobulin and corticosteroids. *Am J Hematol* 2008;83:318-320.
397. Aguilar C, Lucia JF, Hernandez P. A case of an inhibitor autoantibody to coagulation factor VII. *Haemophilia* 2003;9:119-120.
398. Campbell E, Sanal S, Mattson J, et al. Factor VII inhibitor. *Am J Med* 1980;68:962-964.
399. Ndimbie OK, Raman BK, Saeed SM. Lupus anticoagulant associated with specific inhibition of factor VII in a patient with AIDS. *Am J Clin Pathol* 1989;91:491-493.
400. Delmer A, Horellou MH, Andreu G, et al. Life-threatening intracranial bleeding associated with the presence of an antifactor VII autoantibody. *Blood* 1989;74:229-232.
401. Okajima K, Ishii M. Life-threatening bleeding in a case of autoantibody-induced factor VII deficiency. *Int J Hematol* 1999;69:129-132.

402. Tsuda H, Higashi S, Iwanaga S, et al. Development of antitissue factor antibodies in patients after liver surgery. *Blood* 1993;82:96-102.
403. Levine JS, Branch DW, Rauch J. The antiphospholipid syndrome. *N Engl J Med* 2002;346:752-763.
404. Ruiz-Irastorza G, Crowther M, Branch W, Khamashta MA. Antiphospholipid syndrome. *Lancet* 2010;376:1498-1509.
405. Doig RG, O'Malley CJ, Dauer R, et al. An evaluation of 200 consecutive patients with spontaneous or recurrent thrombosis for primary hypercoagulable states. *Am J Clin Pathol* 1994;102:797-801.
406. Ginsberg JS, Wells PS, Brill-Edwards P, et al. Antiphospholipid antibodies and venous thromboembolism. *Blood* 1995;86:3685-3691.
407. Roubey RA. Autoantibodies to phospholipid-binding plasma proteins: a new view of lupus anticoagulants and other "antiphospholipid" autoantibodies. *Blood* 1994;84:2854-2867.
408. Moore JE, Lutz WB. The natural history of systemic erythematosus: an approach to its study through chronic biologic false-positive reactors. *J Chronic Dis* 1955;1:297-316.
409. Triplett DA. Antiphospholipid-protein antibodies: laboratory detection and clinical relevance. *Thromb Res* 1995;78:1-31.
410. Vermeylen J, Arnout J. Is the antiphospholipid syndrome caused by antibodies directed against physiologically relevant phospholipid-protein complexes? *J Lab Clin Med* 1992;120:10-12.
411. Mueller JF, Ratnoff O, Heinle RW. Observations on the characteristics of an unusual circulating anticoagulant. *J Lab Clin Med* 1951;38:254-261.
412. Simone JV, Cornet JA, Abildgaard CF. Acquired von Willebrand's syndrome in systemic lupus erythematosus. *Blood* 1968;31:806-812.
413. Harris EN, Gharavi AE, Boey ML, et al. Anticardiolipin antibodies: detection by radioimmunoassay and association with thrombosis in systemic lupus erythematosus. *Lancet* 1983;2:1211-1214.
414. McNeil HP, Simpson RJ, Chesterman CN, et al. Anti-phospholipid antibodies are directed against a complex antigen that includes a lipid-binding inhibitor of coagulation: beta 2-glycoprotein I (apolipoprotein H). *Proc Natl Acad Sci U S A* 1990;87:4120-4124.
415. Gomez-Pacheco L, Villa AR, Drenkard C, et al. Serum anti-beta2-glycoprotein-I and anticardiolipin antibodies during thrombosis in systemic lupus erythematosus patients. *Am J Med* 1999;106:417-423.
416. Roubey RA. Antigenic specificities of "antiphospholipid" autoantibodies. *Springer Semin Immunopathol* 1994;16:211-222.
417. Bevers EM, Galli M, Barbui T, et al. Lupus anticoagulant IgG's (LA) are not directed to phospholipids only, but to a complex of lipid-bound human prothrombin. *Thromb Haemost* 1991;66:629-632.
418. Simmelink MJ, Horbach DA, Derksen RH, et al. Complexes of anti-prothrombin antibodies and prothrombin cause lupus anticoagulant activity by competing with the binding of clotting factors for catalytic phospholipid surfaces. *Br J Haematol* 2001;113:621-629.
419. Kandiah DA, Krilis SA. Beta 2-glycoprotein I. *Lupus* 1994;3:207-212.
420. Dienava-Verdoold I, Boon-Spijker MG, de Groot PG, et al. Patient-derived monoclonal antibodies directed towards beta2 glycoprotein-1 display lupus anticoagulant activity. *J Thromb Haemost* 2011;9:738-747.
421. Gropp K, Weber N, Reuter M, et al. β_2 -glycoprotein I, the major target in antiphospholipid syndrome, is a special human complement regulator. *Blood* 2011;118:2774-2783.
422. Nimpf J, Wurm H, Kostner GM. Beta 2-glycoprotein-I (apo-H) inhibits the release reaction of human platelets during ADP-induced aggregation. *Atherosclerosis* 1987;63:109-114.
423. Nimpf J, Bevers EM, Bomans PH, et al. Prothrombinase activity of human platelets is inhibited by beta 2-glycoprotein-I. *Biochim Biophys Acta* 1986;884:142-149.
424. Haupt H, Schwick HG, Storiko K. [On a hereditary beta-2-glycoprotein I deficiency]. *Humangenetik* 1968;5:291-293.
425. deLaat HB, Derksen RHWM, Urbanus RT, et al. β_2 -GPI dependent lupus anticoagulant highly correlates with thrombosis in the antiphospholipid syndrome. *Blood* 2004;104:3598-3602.

426. Le Tonqueze M, Salozhin K, Dueymes M, et al. Role of beta 2-glycoprotein I in the antiphospholipid antibody binding to endothelial cells. *Lupus* 1995;4:179-186.
427. Rand JH, Wa X-X, Lapinski R, et al. Detection of antibody-mediated reduction of annexin A5 anticoagulant activity in plasmas of patients with the antiphospholipid syndrome. *Blood* 2004;104:2783-2790.
428. Cesarman-Maus G, Rios-Luna NP, Deora AB, et al. Autoantibodies against the fibrinolytic receptor, annexin 2, in antiphospholipid syndrome. *Blood* 2006;107:4375-4382.
429. Ortona E, Capozzi A, Colasanti T, et al. Vimentin/cardiolipin complex as a new antigenic target of the antiphospholipid syndrome. *Blood* 2010;116: 2960-2967.
430. Galli M, Ruggeri L, Barbui T. Differential effects of anti-beta 2-glycoprotein I and antiprothrombin antibodies on the anticoagulant activity of activated protein C. *Blood* 1998;91:1999-2004.
431. Sheng Y, Kandiah DA, Krilis SA. Anti-beta 2-glycoprotein I autoantibodies from patients with the "antiphospholipid" syndrome bind to beta 2-glycoprotein I with low affinity: dimerization of beta 2-glycoprotein I induces a significant increase in anti-beta 2-glycoprotein I antibody affinity. *J Immunol* 1998;161:2038-2043.
432. Triplett DA, Asherson RA. Pathophysiology of the catastrophic antiphospholipid syndrome (CAPS). *Am J Hematol* 2000;65:154-159.
433. Gamsjaeger R, Johs A, Gries A, et al. Membrane binding of beta2-glycoprotein I can be described by a two-state reaction model: an atomic force microscopy and surface plasmon resonance study. *Biochem J* 2005;389:665-673.
434. Agar C, van Os GM, Mörgelin M, et al. Beta2-glycoprotein I can exist in 2 conformations: implications for our understanding of the antiphospholipid syndrome. *Blood* 2010;116:1336-1343.
435. Raschi E, Testoni C, Bosisio D, et al. Role of the MyD88 transduction signaling pathway in endothelial activation by antiphospholipid antibodies. *Blood* 2003;101:3495-3500.
436. Vega-Ostertag M, Casper K, Swerlick R, et al. Involvement of p38 MAPK in the up-regulation of tissue factor on endothelial cells by antiphospholipid antibodies. *Arthritis Rheum* 2005;52:1545-1554.
437. Ramesh S, Morrell CN, Tarango C, et al. Antiphospholipid antibodies promote leukocyte-endothelial cell adhesion and thrombosis in mice by antagonizing eNOS via β 2GPI and apoER2. *J Clin Invest* 2011;121:120-131.
438. Allen KL, Fonseca FV, Betapudi V, Willard B, Zhang J, McCrae KR. A novel pathway for human endothelial cell activation by antiphospholipid/anti- β ₂ glycoprotein I antibodies. *Blood* 2012;119:884-893.
439. Pierangeli SS, Goldsmith GH, Krnic S, et al. Differences in functional activity of anticardiolipin antibodies from patients with syphilis and those with antiphospholipid syndrome. *Infect Immun* 1994;62:4081-4084.
440. Canoso RT, Sise HS. Chlorpromazine-induced lupus anticoagulant and associated immunologic abnormalities. *Am J Hematol* 1982;13:121-129.
441. Triplett DA, Brandt JT, Musgrave KA, et al. The relationship between lupus anticoagulants and antibodies to phospholipid. *JAMA* 1988;259:550-554.
442. Kuwana M, Matsuura E, Kobayashi K, et al. Binding of β ₂-glycoprotein I to anionic phospholipids facilitates processing and presentation of a cryptic epitope that activates pathogenic autoreactive T cells. *Blood* 2005;105: 1552-1557.
443. Passam FH, Giannakopoulos B, Mirarabshahi P, Krilis SA. Molecular pathophysiology of the antiphospholipid syndrome: the role of oxidative post-translational modification of beta 2 glycoprotein I. *J Thromb Haemost* 2011;9(Suppl 1):275-282.
444. Horkko S, Miller E, Dudl E, et al. Antiphospholipid antibodies are directed against epitopes of oxidized phospholipids. Recognition of cardiolipin by monoclonal antibodies to epitopes of oxidized low density lipoprotein. *J Clin Invest* 1996;98:815-825.
445. Redecha P, Tilley R, Tencati M, et al. Tissue factor: a link between C5a and neutrophil activation in antiphospholipid antibody induced fetal injury. *Blood* 2007;110:2423-2431.
446. Pierangeli SS, Barker JH, Stikovac D, et al. Effect of human IgG antiphospholipid antibodies on an in vivo thrombosis model in mice. *Thromb Haemost* 1994;71:670-674.
447. Pierangeli SS, Liu XW, Barker JH, et al. Induction of thrombosis in a mouse model by IgG, IgM and IgA immunoglobulins from patients with the antiphospholipid syndrome. *Thromb Haemost* 1995;74:1361-1367.

448. Yodfat O, Blank M, Krause I, et al. The pathogenic role of anti-phosphatidylserine antibodies: active immunization with the antibodies leads to the induction of antiphospholipid syndrome. *Clin Immunol Immunopathol* 1996;78:14-20.
449. Gharavi AE, Sammaritano LR, Bovastro JL Jr, et al. Specificities and characteristics of beta 2 glycoprotein I-induced antiphospholipid antibodies. *J Lab Clin Med* 1995;125:775-778.
450. Rote NS, Ng AK, Dostal-Johnson DA, et al. Immunologic detection of phosphatidylserine externalization during thrombin-induced platelet activation. *Clin Immunol Immunopathol* 1993;66:193-200.
451. Casciola-Rosen L, Rosen A, Petri M, et al. Surface blebs on apoptotic cells are sites of enhanced procoagulant activity: implications for coagulation events and antigenic spread in systemic lupus erythematosus. *Proc Natl Acad Sci U S A* 1996;93:1624-1629.
452. Rauch J, Tannenbaum M, Tannenbaum H, et al. Human hybridoma lupus anticoagulants distinguish between lamellar and hexagonal phase lipid systems. *J Biol Chem* 1986;261:9672-9677.
453. Rauch J, Janoff AS. Phospholipid in the hexagonal II phase is immunogenic: evidence for immunorecognition of nonbilayer lipid phases in vivo. *Proc Natl Acad Sci U S A* 1990;87:4112-4114.
454. Bordron A, Dueymes M, Levy Y, et al. The binding of some human antiendothelial cell antibodies induces endothelial cell apoptosis. *J Clin Invest* 1998;101:2029-2035.
455. Esmon NL, Smirnov MD, Esmon CT. Thrombogenic mechanisms of antiphospholipid antibodies. *Thromb Haemost* 1997;78:79-82.
456. Lopez-Pedraza C, Buendia P, Aguirre MA, et al. Antiphospholipid syndrome and tissue factor: a thrombotic couple. *Lupus* 2006;15:161-166.
457. Redecha P, Franzke CW, Ruf W, Mackman N, Girardi G. Neutrophil activation by the tissue factor/Factor VIIa/PAR2 axis mediates fetal death in a mouse model of antiphospholipid syndrome. *J Clin Invest* 2008;118:3453-3461.
458. Petri M. Epidemiology of the antiphospholipid antibody syndrome. *J Autoimmun* 2000;15:145-151.
459. Kelsey PR, Stevenson KJ, Poller L. The diagnosis of lupus anticoagulants by the activated partial thromboplastin time—the central role of phosphatidyl serine. *Thromb Haemost* 1984;52:172-175.
460. Schved JF, Dupuy-Fons C, Biron C, et al. A prospective epidemiological study on the occurrence of antiphospholipid antibody: the Montpellier Antiphospholipid (MAP) Study. *Haemostasis* 1994;24:175-182.
461. Ford SE, Kennedy L, Ford PM. Clinicopathologic correlations of antiphospholipid antibodies. An autopsy study. *Arch Pathol Lab Med* 1994;118: 491-495.
462. Feinstein DI, Francis RB. The lupus anticoagulant and anticardiolipin antibodies. In: Wallace DJ, Hahn BH, eds. *Dubois' lupus erythematosus*, 4th ed. Philadelphia, PA: Lea & Febiger, 1993:246-253.
463. Boey ML, Colaco CB, Gharavi AE, et al. Thrombosis in systemic lupus erythematosus: striking association with the presence of circulating lupus anticoagulant. *Br Med J (Clin Res Ed)* 1983;287:1021-1023.
464. Exner T, Rickard KA, Kronenberg H. A sensitive test demonstrating lupus anticoagulant and its behavioural patterns. *Br J Haematol* 1978;40:143-151.
465. Jouhikainen T, Stephansson E, Leirisalo-Repo M. Lupus anticoagulant as a prognostic marker in systemic lupus erythematosus. *Br J Rheumatol* 1993;32:568-573.
466. Stasi R, Stipa E, Masi M, et al. Antiphospholipid antibodies: prevalence, clinical significance and correlation to cytokine levels in acute myeloid leukemia and non-Hodgkin's lymphoma. *Thromb Haemost* 1993;70:568-572.
467. Chedid A, Chadalawada KR, Morgan TR, et al. Phospholipid antibodies in alcoholic liver disease. *Hepatology* 1994;20:1465-1471.
468. Prieto J, Yuste JR, Beloqui O, et al. Anticardiolipin antibodies in chronic hepatitis C: implication of hepatitis C virus as the cause of the antiphospholipid syndrome. *Hepatology* 1996;23:199-204.
469. Bloom EJ, Abrams DI, Rodgers G. Lupus anticoagulant in the acquired immunodeficiency syndrome. *JAMA* 1986;256:491-493.
470. Gotoh M, Matsuda J. Human immunodeficiency virus rather than hepatitis C virus infection is relevant to the development of an anti-cardiolipin antibody. *Am J Hematol* 1995;50:220-222.

471. Facer CA, Agiostratidou G. High levels of anti-phospholipid antibodies in uncomplicated and severe Plasmodium falciparum and in P. vivax malaria. Clin Exp Immunol 1994;95:304-309.
472. Kucuk O, Gilman-Sachs A, Beaman K, et al. Antiphospholipid antibodies in sickle cell disease. Am J Hematol 1993;42:380-383.
473. Levine SR, Welch KM. The spectrum of neurologic disease associated with antiphospholipid antibodies. Lupus anticoagulants and anticardiolipin antibodies. Arch Neurol 1987;44:876-883.
474. Harrison CN, Donohoe S, Carr P, et al. Patients with essential thrombocythaemia have an increased prevalence of antiphospholipid antibodies which may be associated with thrombosis. Thromb Haemost 2002;87:802-807.
475. Bell WR, Boss GR, Wolfson JS. Circulating anticoagulant in the procainamide-induced lupus syndrome. Arch Intern Med 1977;137:1471-1473.
476. Bird MR, O'Neill AI, Buchanan RR, et al. Lupus anticoagulant in the elderly may be associated with both quinine and quinidine usage. Pathology 1995;27:136-139.
477. Orris DJ, Lewis JH, Spero JA, et al. Blocking coagulation inhibitors in children taking penicillin. J Pediatr 1980;97:426-429.
478. Bizzaro N, Brandalise M. EDTA-dependent pseud thrombocytopenia. Association with antiplatelet and antiphospholipid antibodies. Am J Clin Pathol 1995;103:103-107.
479. Chamouard P, Grunebaum L, Wiesel ML, et al. Prevalence and significance of anticardiolipin antibodies in Crohn's disease. Dig Dis Sci 1994;39: 1501-1504.
480. Stasi R, Stipa E, Masi M, et al. Prevalence and clinical significance of elevated antiphospholipid antibodies in patients with idiopathic thrombocytopenic purpura. Blood 1994;84:4203-4208.
481. Shi W, Krilis SA, Chong BH, et al. Prevalence of lupus anticoagulant and anticardiolipin antibodies in a healthy population. Aust N Z J Med 1990;20: 231-236.
482. Manoussakis MN, Tzioufas AG, Silis MP, et al. High prevalence of anti-cardiolipin and other autoantibodies in a healthy elderly population. Clin Exp Immunol 1987;69:557-565.
483. Vila P, Hernandez MC, Lopez-Fernandez MF, et al. Prevalence, follow-up and clinical significance of the anticardiolipin antibodies in normal subjects. Thromb Haemost 1994;72:209-213.
484. Exner T, Barber S, Kronenberg H, et al. Familial association of the lupus anticoagulant. Br J Haematol 1980;45:89-96.
485. Goldberg SN, Conti-Kelly AM, Greco TP. A family study of anticardiolipin antibodies and associated clinical conditions. Am J Med 1995;99:473-479.
486. Camps MT, Cuadrado MJ, Ocon P, et al. Association between HLA class II antigens and primary antiphospholipid syndrome from the south of Spain. Lupus 1995;4:51-55.
487. Colucci AT, Di Lorenzo G, Ingrassia A, et al. Blood antiphospholipid antibody levels are influenced by age, sex and HLA-B8,DR3 phenotype. Exp Clin Immunogenet 1992;9:72-79.
488. Galli M, Luciani D, Bertolini G, et al. Lupus anticoagulants are stronger risk factors for thrombosis than anticardiolipin antibodies in the antiphospholipid syndrome: a systematic review of the literature. Blood 2003;101:1827-1832.
489. Miyakis S, Lockshin MD, Atsumi T, et al. International consensus statement on an update of the classification criteria for definite antiphospholipid syndrome (APS). J Thromb Haemost 2006;4:295-306.
490. Morgan M, Downs K, Chesterman CN, et al. Clinical analysis of 125 patients with the lupus anticoagulant. Aust N Z J Med 1993;23:151-156.
491. Cervera R, Asherson RA, Lie JT. Clinicopathologic correlations of the antiphospholipid syndrome. Semin Arthritis Rheum 1995;24:262-272.
492. Triplett DA. Protean clinical presentation of antiphospholipid-protein antibodies (APA). Thromb Haemost 1995;74:329-337.
493. Derksen RH, Gmelig-Meijling FH, de Groot PG. Primary antiphospholipid syndrome evolving into systemic lupus erythematosus. Lupus 1996;5:77-80.

494. Silver RM, Draper ML, Scott JR, et al. Clinical consequences of antiphospholipid antibodies: an historic cohort study. *Obstet Gynecol* 1994;83:372-377.
495. Bowie EWJ, Thompson JH Jr, Pascuzzi CA, et al. Thrombosis in systemic lupus erythematosus despite circulating anticoagulants. *J Lab Clin Med* 1963;62:416-430.
496. Gastineau DA, Kazmier FJ, Nichols WL, et al. Lupus anticoagulant: an analysis of the clinical and laboratory features of 219 cases. *Am J Hematol* 1985;19:265-275.
497. Mueh JR, Herbst KD, Rapaport SI. Thrombosis in patients with the lupus anticoagulant. *Ann Intern Med* 1980;92:156-159.
498. Boggild MD, Sedhev RV, Fraser D, et al. Cerebral venous sinus thrombosis and antiphospholipid antibodies. *Postgrad Med J* 1995;71:487-489.
499. Coull BM, Levine SR, Brey RL. The role of antiphospholipid antibodies in stroke. *Neurol Clin* 1992;10:125-143.
500. Levine SR, Brey RL, Sawaya KL, et al. Recurrent stroke and thrombo-occlusive events in the antiphospholipid syndrome. *Ann Neurol* 1995;38:119-124.
501. Sanmarco M, Soler C, Christides C, et al. Prevalence and clinical significance of IgG isotype anti-beta 2-glycoprotein I antibodies in antiphospholipid syndrome: a comparative study with anticardiolipin antibodies. *J Lab Clin Med* 1997;129:499-506.
502. Horbach DA, van Oort E, Donders RC, et al. Lupus anticoagulant is the strongest risk factor for both venous and arterial thrombosis in patients with systemic lupus erythematosus. Comparison between different assays for the detection of antiphospholipid antibodies. *Thromb Haemost* 1996;76: 916-924.
503. Asherson RA, Liote F, Page B, et al. Avascular necrosis of bone and antiphospholipid antibodies in systemic lupus erythematosus. *J Rheumatol* 1993;20:284-288.
504. Galli M, Finazzi G, Barbui T. Thrombocytopenia in the antiphospholipid syndrome. *Br J Haematol* 1996;93:1-5.
505. Ordi J, Vilardel M, Oristrell J, et al. Bleeding in patients with lupus anticoagulant. *Lancet* 1984;2:868-869.
506. Dorsch CA, Meyerhoff J. Mechanisms of abnormal platelet aggregation in systemic lupus erythematosus. *Arthritis Rheum* 1982;25:966-973.
507. Natelson EA, Cyprus GS, Hettig RA. Absent factor II in systemic lupus erythematosus. Immunologic studies and response to corticosteroid therapy. *Arthritis Rheum* 1976;19:79-82.
508. Brey RL, Chapman J, Levine SR, et al. Stroke and the antiphospholipid syndrome: consensus meeting Taormina 2002. *Lupus* 2003;12:508-513.
509. Levine SR, Brey RL, Tilley BC, et al. Antiphospholipid antibodies and subsequent thrombo-occlusive events in patients with ischemic stroke. *JAMA* 2004;291:576-584.
510. Alegre VA, Gastineau DA, Winkelmann RK. Skin lesions associated with circulating lupus anticoagulant. *Br J Dermatol* 1989;120:419-429.
511. Fligelstone LJ, Cachia PG, Ralis H, et al. Lupus anticoagulant in patients with peripheral vascular disease: a prospective study. *Eur J Vasc Endovasc Surg* 1995;9:277-283.
512. Hamsten A, Norberg R, Bjorkholm M, et al. Antibodies to cardiolipin in young survivors of myocardial infarction: an association with recurrent cardiovascular events. *Lancet* 1986;1:113-116.
513. Asherson RA, Mackworth-Young CG, Boey ML, et al. Pulmonary hypertension in systemic lupus erythematosus. *Br Med J (Clin Res Ed)* 1983;287:1024-1025.
514. Asherson RA. The catastrophic antiphospholipid syndrome. *J Rheumatol* 1992;19:508-512.
515. Branch DW, Scott JR, Kochenour NK, et al. Obstetric complications associated with the lupus anticoagulant. *N Engl J Med* 1985;313:1322-1326.
516. Harris EN, Chan JK, Asherson RA, et al. Thrombosis, recurrent fetal loss, and thrombocytopenia. Predictive value of the anticardiolipin antibody test. *Arch Intern Med* 1986;146:2153-2156.
517. Shapiro GA. Antiphospholipid syndrome in obstetrics and gynecology. *Semin Thromb Hemost* 1994;20:64-70.
518. Oshiro BT, Silver RM, Scott JR, et al. Antiphospholipid antibodies and fetal death. *Obstet Gynecol* 1996;87:489-493.

519. MacLean MA, Cumming GP, McCall F, et al. The prevalence of lupus anticoagulant and anticardiolipin antibodies in women with a history of first trimester miscarriages. *Br J Obstet Gynaecol* 1994;101:103-106.
520. Rai RS, Regan L, Clifford K, et al. Antiphospholipid antibodies and beta 2-glycoprotein-I in 500 women with recurrent miscarriage: results of a comprehensive screening approach. *Hum Reprod* 1995;10:2001-2005.
521. Silver RM, Draper ML, Byrne JL, et al. Unexplained elevations of maternal serum alpha-fetoprotein in women with antiphospholipid antibodies: a harbinger of fetal death. *Obstet Gynecol* 1994;83:150-155.
522. Clark F, Dickinson JE, Walters BN, et al. Elevated mid-trimester hCG and maternal lupus anticoagulant. *Prenat Diagn* 1995;15:1035-1039.
523. Harris EN, Spinnato JA. Should anticardiolipin tests be performed in otherwise healthy pregnant women? *Am J Obstet Gynecol* 1991;165:1272-1277.
524. Lynch A, Marlar R, Murphy J, et al. Antiphospholipid antibodies in predicting adverse pregnancy outcome. A prospective study. *Ann Intern Med* 1994;120:470-475.
525. Rix P, Stentoft J, Aunsholt NA, et al. Lupus anticoagulant and anticardiolipin antibodies in an obstetric population. *Acta Obstet Gynecol Scand* 1992;71:605-609.
526. Silver RM, Porter TF, van Leeuwen I, et al. Anticardiolipin antibodies: clinical consequences of "low titers." *Obstet Gynecol* 1996;87:494-500.
527. Rand JH, Wu XX, Andree HA, et al. Pregnancy loss in the antiphospholipid-antibody syndrome—a possible thrombogenic mechanism. *N Engl J Med* 1997;337:154-160.
528. Girardi G, Redecha P, Salmon JE. Heparin prevents antiphospholipid antibody-induced fetal loss by inhibiting complement activation. *Nat Med* 2004;10:1222-1226.
529. Erkan D, Cervera R, Asherson RA. Catastrophic antiphospholipid antibody syndrome. Where do we stand? *Arthritis Rheum* 2003;48:3320-3327.
530. Asherson RA, Cervera R, Piette JC, et al. Catastrophic antiphospholipid syndrome. Clinical and laboratory features of 50 patients. *Medicine (Baltimore)* 1998;77:195-207.
531. Asherson RA, Cervera R, Piette JC, et al. Catastrophic antiphospholipid syndrome: clues to the pathogenesis from a series of 80 patients. *Medicine (Baltimore)* 2001;80:355-377.
- P.1217
532. Erre GL, Pardini S, Faedda R, Passiu G. Effect of rituximab on clinical and laboratory features of antiphospholipid syndrome: a case report and a review of literature. *Lupus* 2008;17:50-55.
533. Cervera R; CAPS Registry Project Group. Catastrophic antiphospholipid syndrome (CAPS): update from the "CAPS Registry". *Lupus* 2010;19:412-418.
534. Wisloff F, Jacobsen EM, Liestol S. Laboratory diagnosis of the antiphospholipid syndrome. *Thromb Res* 2003;108:263-271.
535. Zhang L, Whitis JG, Embry MB, et al. A simplified algorithm for the laboratory detection of lupus anticoagulants. *Am J Clin Pathol* 2005;124:894-901.
536. Martin BA, Branch DW, Rodgers GM. Sensitivity of the activated partial thromboplastin time, the dilute Russell's viper venom time, and the kaolin clotting time for the detection of the lupus anticoagulant: a direct comparison using plasma dilutions. *Blood Coagul Fibrinolysis* 1996;7:31-38.
537. Brien WF, Schaus MR, Cooper KE, et al. Lupus anticoagulant testing: effect of the platelet count on the activated partial thromboplastin time. *Br J Biomed Sci* 1993;50:114-116.
538. Pengo V, Tripodi A, Reber G, et al.; Subcommittee on Lupus Anticoagulant/Antiphospholipid Antibody of the Scientific and Standardisation Committee of the International Society on Thrombosis and Haemostasis. Update of the guidelines for lupus anticoagulant detection. *J Thromb Haemost* 2009;7:1737-1740.

539. Rauch J, Tannenbaum M, Janoff AS. Distinguishing plasma lupus anticoagulants from anti-factor antibodies using hexagonal (II) phase phospholipids. *Thromb Haemost* 1989;62:892-896.
540. Stevenson KJ, Seddon JM. The role of lipids in the detection of lupus anticoagulant by the dilute Russell viper venom test: are platelets or reagents containing hexagonal HII phases necessary? *Br J Haematol* 1994;86:583-589.
541. Triplett DA. Antiphospholipid antibodies. *Arch Pathol Lab Med* 2002;126:1424-1429.
542. Tripodi A. Laboratory testing for lupus anticoagulants: a review of issues affecting results. *Clin Chem* 2007;53:1629-1635.
543. Clyne LP, Yen Y, Kriz NS, et al. The lupus anticoagulant. High incidence of "negative" mixing studies in a human immunodeficiency virus-positive population. *Arch Pathol Lab Med* 1993;117:595-601.
544. Lo SC, Oldmeadow MJ, Howard MA, et al. Comparison of laboratory tests used for identification of the lupus anticoagulant. *Am J Hematol* 1989;30:213-220.
545. Galli M, Dlott J, Norbis F, et al. Lupus anticoagulants and thrombosis: clinical association of different coagulation and immunologic tests. *Thromb Haemost* 2000;84:1012-1016.
546. Sanmarco M, Alessi MC, Harle JR, et al. Antibodies to phosphatidyl-ethanolamine as the only antiphospholipid antibodies found in patients with unexplained thromboses. *Thromb Haemost* 2001;85:800-805.
547. Brandt JT, Triplett DA, Alving B, et al. Criteria for the diagnosis of lupus anticoagulants: an update. On behalf of the Subcommittee on Lupus Anticoagulant/Antiphospholipid Antibody of the Scientific and Standardisation Committee of the ISTH. *Thromb Haemost* 1995;74:1185-1190.
548. Kandiah DA, Krillis SA. Heterogeneity of lupus anticoagulant (LA) antibodies: LA activity in dilute Russell's Viper Venom Time and dilute Kaolin Clotting Time detect different populations of antibodies in patients with the "antiphospholipid" syndrome. *Thromb Haemost* 1998;80:250-257.
549. McNally T, Purdy G, Mackie IJ, et al. The use of an anti-beta 2-glycoprotein-I assay for discrimination between anticardiolipin antibodies associated with infection and increased risk of thrombosis. *Br J Haematol* 1995;91: 471-473.
550. Pengo V, Biasiolo A, Pegoraro C, et al. Antibody profiles for the diagnosis of antiphospholipid syndrome. *Thromb Haemost* 2005;93:1147-1152.
551. Crowther MA, Ginsberg JS, Julian J, et al. A comparison of two intensities of warfarin for the prevention of recurrent thrombosis in patients with the antiphospholipid antibody syndrome. *N Engl J Med* 2003;349:1133-1138.
552. Finazzi G, Marchioli R, Brancaccio V, et al. A randomized clinical trial of high-intensity warfarin vs conventional antithrombotic therapy for the prevention of recurrent thrombosis in patients with the antiphospholipid syndrome (WAPS). *J Thromb Haemost* 2005;3:848-853.
553. Ordi-Ros J, Perez-Peman P, Monasterio J. Clinical and therapeutic aspects associated to phospholipid binding antibodies (lupus anticoagulant and anticardiolipin antibodies). *Haemostasis* 1994;24:165-174.
554. Khamashta MA, Hughes GR. Antiphospholipid antibodies and antiphospholipid syndrome. *Curr Opin Rheumatol* 1995;7:389-394.
555. Derksen RH, de Groot PG, Kater L, Nieuwenhuis HK. Patients with antiphospholipid antibodies and venous thrombosis should receive long term anticoagulant treatment. *Ann Rheum Dis* 1993;52:689-692.
556. Schulman S, Svenungsson E, Granqvist S. Anticardiolipin antibodies predict early recurrence of thromboembolism and death among patients with venous thromboembolism following anticoagulant therapy. Duration of Anticoagulation Study Group. *Am J Med* 1998;104:332-338.
557. Crowther MA, Wisloff F. Evidence based treatment of the antiphospholipid syndrome II. Optimal anticoagulant therapy for thrombosis. *Thromb Res* 2005;115:3-8.
558. Petri M. Thrombosis and systemic lupus erythematosus: the Hopkins Lupus Cohort perspective. *Scand J Rheumatol* 1996;25:191-193.
559. Rand JH, Wu XX, Quinn AS, Chen PP, Hathcock JJ, Taatjes DJ. Hydroxychloroquine directly reduces the binding of antiphospholipid antibody- β 2-glycoprotein I complexes to phospholipid bilayers. *Blood* 2008;112:1687-1695.
560. Pernod G, Arvieux J, Carpentier PH, et al. Successful treatment of lupus anticoagulant-hypoprothrombinemia syndrome using intravenous immunoglobulins. *Thromb Haemost* 1997;78:969-970.

561. Moll S, Ortel TL. Monitoring warfarin therapy in patients with lupus anticoagulants. *Ann Intern Med* 1997;127:177-185.
562. Balasch J, Carmona F, Lopez-Soto A, et al. Low-dose aspirin for prevention of pregnancy losses in women with primary antiphospholipid syndrome. *Hum Reprod* 1993;8:2234-2239.
563. Bramham K, Thomas M, Nelson-Piercy C, Khamashta M, Hunt BJ. First-trimester low-dose prednisolone in refractory antiphospholipid antibody-related pregnancy loss. *Blood* 2011;117:6948-6951.
564. Empson M, Lassere M, Craig J, Scott J. Prevention of recurrent miscarriage for women with antiphospholipid antibody or lupus anticoagulant. *Cochrane Database Syst Rev* 2005;2:CD002859.
565. Bates SM, Greer IA, Middeldorp S, Veenstra DL, Prabulos AM, Vandvik PO; American College of Chest Physicians. VTE, thrombophilia, antithrombotic therapy, and pregnancy: antithrombotic therapy and prevention of thrombosis, 9th ed: American College of Chest Physicians Evidence-Based Clinical Practice Guidelines. *Chest* 2012;141(Suppl 2):e691S-e736S.
566. Donaldson MD, Seaman MJ, Park GR. Massive blood transfusion. *Br J Anaesth* 1992;69:621-630.
567. Young PP, Cotton BA, Goodnough LT. Massive transfusion protocols for patients with substantial hemorrhage. *Transfus Med Rev* 2011;25:293-303.
568. Cherkas D. Traumatic hemorrhagic shock: advances in fluid management. *Emerg Med Pract* 2011;13:1-19.
569. Wolberg AS, Meng ZH, Monroe DM, et al. A systematic evaluation of the effect of temperature on coagulation enzyme activity and platelet function. *J Trauma* 2004;56:1221-1228.
570. Woodman RC, Harker LA. Bleeding complications associated with cardiopulmonary bypass. *Blood* 1990;76:1680-1697.
571. de Prost O, Barbier-Boehm G, Hazebroucq J, et al. Desmopressin has no beneficial effect on excessive postoperative bleeding or blood product requirements associated with cardiopulmonary bypass. *Thromb Haemost* 1992;68:106-110.
572. Bond L, Bevan D. Myocardial infarction in a patient with hemophilia treated with DDAVP. *N Engl J Med* 1988;318:121.
573. Schneeweiss S, Seeger JD, Landon J, et al. Aprotinin during coronary-artery bypass grafting and risk of death. *N Engl J Med* 2008;358:771-783.
574. Ramsay NK, Coccia PF, Krivit W, et al. The effect of l-asparaginase on plasma coagulation factors in acute lymphoblastic leukemia. *Cancer* 1977;40: 1398-1401.
575. Glueck R, Green D, Cohen I, et al. Hematin: unique effects of hemostasis. *Blood* 1983;61:243-249.
576. Kreuz W, Linde R, Funk M, et al. Valproate therapy induces von Willebrand disease type I. *Epilepsia* 1992;33:178-184.
577. Thompson CA, Kyle R, Gertz M, Heit J, Pruthi R, Pardanani A. Systemic AL amyloidosis with acquired factor X deficiency: a study of perioperative bleeding risk and treatment outcomes in 60 patients. *Am J Hematol* 2010;85: 171-173.
578. Furie B, Voo L, McAdam KP, et al. Mechanism of factor X deficiency in systemic amyloidosis. *N Engl J Med* 1981;304:827-830.
579. McPherson RA, Onstad JW, Ugoretz RJ, et al. Coagulopathy in amyloidosis: combined deficiency of factors IX and X. *Am J Hematol* 1977;3:225-235.
580. Yood RA, Skinner M, Rubinow A, et al. Bleeding manifestations in 100 patients with amyloidosis. *JAMA* 1983;249:1322-1324.
581. Rosenstein ED, Itzkowitz SH, Penziner AS, et al. Resolution of factor X deficiency in primary amyloidosis following splenectomy. *Arch Intern Med* 1983;143:597-599.
582. Camoriano JK, Greipp PR, Bayer GK, et al. Resolution of acquired factor X deficiency and amyloidosis with melphalan and prednisone therapy. *N Engl J Med* 1987;316:1133-1135.
583. Choufani EB, Sanchorawala V, Ernst T, et al. Acquired factor X deficiency in patients with amyloid light-chain amyloidosis: incidence, bleeding manifestations, and response to high-dose chemotherapy. *Blood* 2001;97: 1885-1887.
584. Uprichard J, Perry DJ. Factor X deficiency. *Blood Rev* 2002;16:97-110.
585. Karpatkin S, Ingram GIC, Graham JB. Severe isolated prothrombin deficiency: an acquired state with complete recovery. *Thromb Diath Haemorrh* 1962;8:221-234.

586. Vaziri ND, Toohey J, Paule P, et al. Urinary excretion and deficiency of prothrombin in nephrotic syndrome. *Am J Med* 1984;77:433-436.
587. Natelson EA, Lynch EC, Hettig RA, et al. Acquired factor IX deficiency in the nephrotic syndrome. *Ann Intern Med* 1970;73:373-378.
588. Thompson AR. Factor XII and other hemostatic protein abnormalities in nephrotic syndrome patients. *Thromb Haemost* 1982;48:27-32.
589. Kauffmann RH, Veltkamp JJ, Van Tilburg NH, et al. Acquired antithrombin III deficiency and thrombosis in the nephrotic syndrome. *Am J Med* 1978;65:607-613.
590. Panicucci F, Sagripanti A, Vispi M, et al. Comprehensive study of haemostasis in nephrotic syndrome. *Nephron* 1983;33:9-13.
591. Brown CH III, Kvols LK, Hsu TH, et al. Factor IX deficiency and bleeding in a patient with Sheehan's syndrome. *Blood* 1972;39:650-657.
592. Boklan BF, Sawitsky A. Factor IX deficiency in Gaucher disease. An in vitro phenomenon. *Arch Intern Med* 1976;136:489-492.
593. Weisdorf D, Hasegawa D, Fair DS. Acquired factor VII deficiency associated with aplastic anaemia: correction with bone marrow transplantation. *Br J Haematol* 1989;71:409-413.
594. de Raucourt E, Dumont MD, Tourani JM, et al. Acquired factor VII deficiency associated with pleural liposarcoma. *Blood Coagul Fibrinolysis* 1994;5: 833-836.
595. Rasche H, Dietrich M, Gaus W, et al. Factor XIII-activity and fibrin subunit structure in acute leukemia. *Biomedicine* 1974;21:61-66.
596. Oshitani N, Kitano A, Hara J, et al. Deficiency of blood coagulation factor XIII in Crohn's disease. *Am J Gastroenterol* 1995;90:1116-1118.
597. Nijenhuis AVM, van Bergeijk L, Huijgens PC, et al. Acquired factor XIII deficiency due to an inhibitor: a case report and review of the literature. *Haematologica* 2004;89:ECR14.
598. McGrath K, Koutts J. A case of Hageman factor deficiency with myeloid leukaemia. *Aust N Z J Med* 1975;5:155-157.
599. D'Uva M, Strina I, Mollo A, et al. Acquired factor XII deficiency in a woman with recurrent pregnancy loss. *J Transl Med* 2005;3:43.
600. Berrebi A, Malnick SD, Vorst EJ, et al. High incidence of factor XI deficiency in Gaucher's disease. *Am J Hematol* 1992;40:153.
601. Anstey A, Mayne K, Winter M, et al. Platelet and coagulation studies in Ehlers-Danlos syndrome. *Br J Dermatol* 1991;125:155-163.
602. Khoory MS, Nesheim ME, Bowie EJ, et al. Circulating heparan sulfate proteoglycan anticoagulant from a patient with a plasma cell disorder. *J Clin Invest* 1980;65:666-674.
603. Bussel JB, Steiner PG, Miller DR, et al. A heparin-like anticoagulant in an 8-month-old boy with acute monoblastic leukemia. *Am J Hematol* 1984;16:83-90.
604. Llamas P, Outeirino J, Espinoza J, et al. Report of three cases of circulating heparin-like anticoagulants. *Am J Hematol* 2001;67:256-258.
605. Rodgers GM, Corash L. Acquired heparinlike anticoagulant in a patient with metastatic breast carcinoma. *West J Med* 1985;143:672-675.
606. Colwell NS, Tollefsen DM, Blinder MA. Identification of a monoclonal thrombin inhibitor associated with multiple myeloma and a severe bleeding disorder. *Br J Haematol* 1997;97:219-226.
607. Steinberg D, Carvalho AC, Chesney CM, et al. Platelet hypersensitivity and intravascular coagulation in paroxysmal nocturnal hemoglobinuria. *Am J Med* 1975;59:845-850.
608. Ports TA, Deuel TF. Intravascular coagulation in fresh-water submersion: report of three cases. *Ann Intern Med* 1977;87:60-61.

609. Myers TJ, Hild DH. Consumption coagulopathy and microangiopathic hemolytic anemia with an axillo-femoral graft. *Circulation* 1977;56:891-893.
610. Whitaker AN, Emmerson BT. Acute disseminated intravascular coagulation in systemic lupus erythematosus. *Aust N Z J Med* 1972;2:182-187.
611. Mehta B, Briggs DK, Sommers SC, et al. Disseminated intravascular coagulation following cardiac arrest: a study of 15 patients. *Am J Med Sci* 1972;264:353-363.
612. Cafferata HT, Aggeler PM, Robinson AJ, et al. Intravascular coagulation in the surgical patient: its significance and diagnosis. *Am J Surg* 1969;118:281-291.
613. Bradford DS, Foster RR, Nossel HL. Coagulation alterations, hypoxemia, and fat embolism in fracture patients. *J Trauma* 1970;10:307-321.
614. Drayer BP, Poser CM. Disseminated intravascular coagulation and head trauma. Two case studies. *JAMA* 1975;231:174-175.
615. Kwaan HC, Colwell JA, Suwanwela N. Disseminated intravascular coagulation in diabetes mellitus, with reference to the role of increased platelet aggregation. *Diabetes* 1972;21:108-113.
616. Fischer SP, Lee J, Zatuchni J, et al. Disseminated intravascular coagulation in status epilepticus. *Thromb Haemost* 1977;38:909-913.
617. Ranson JH, Lackner H, Berman IR, et al. The relationship of coagulation factors to clinical complications of acute pancreatitis. *Surgery* 1977;81: 502-511.
618. Marlar RA, Montgomery RR, Broekmans AW. Report on the diagnosis and treatment of homozygous protein C deficiency. Report of the Working Party on Homozygous Protein C Deficiency of the ICTH-Subcommittee on Protein C and Protein S. *Thromb Haemost* 1989;61:529-531.
619. Scott JP, Montgomery RR, Tubergen DG, et al. Acquired von Willebrand's disease in association with Wilm's tumor: regression following treatment. *Blood* 1981;58:665-669.
620. Hasegawa DK, Bennett AJ, Coccia PF, et al. Factor V deficiency in Philadelphia-positive chronic myelogenous leukemia. *Blood* 1980;56:585-595.

Section 4 - Thrombosis

Chapter 55 Thrombosis and Antithrombotic Therapy

> Table of Contents > Part V - Disorders of Hemostasis and Coagulation > Section 5 - Thrombosis > Chapter 55 - Thrombosis and Antithrombotic Therapy

Chapter 55

Thrombosis and Antithrombotic Therapy

Robert C. Pendleton

George M. Rodgers

The term thrombosis refers to the formation, from constituents of the blood, of a mass within the venous or arterial vasculature of a living animal. Hemostatic thromboses, namely, self-limited and localized thromboses that prevent excessive blood loss, represent the body's natural and desired response to acute vascular injury. Pathologic thromboses such as deep venous thrombosis (DVT), pulmonary embolism (PE), coronary arterial thrombosis leading to myocardial infarction (MI), and cerebrovascular thrombotic occlusion represent the body's undesired response to acute and chronic perturbations of the vasculature, blood, or both. The terms coagulated blood and clot are not synonymous with thrombosis and refer to the formation of a solid mass of blood components outside of the vascular tree. Examples of clots include soft tissue, body cavity (e.g., peritoneal), and visceral hematomas. Coagulated blood best describes clots formed *ex vivo*.

Thrombosis of the veins and arteries, together with complicating embolic phenomena, is perhaps the most important cause of sickness and death in the developed countries of the world at the present time. Deaths from MI and thrombotic stroke consistently represent the major causes of death in the United States, numbering >700,000 people annually

(almost 30% of all deaths) in a recent report.¹ Venous thromboembolic disease is the third most common cardiovascular disease, after atherosclerotic heart disease and stroke. It has been estimated that between 500,000 and 2 million venous thromboembolic events (VTE) including calf vein thrombosis, proximal DVT (e.g., lower extremity and pelvic veins), and PE occur annually in the United States alone.² The incidence of pathologic thrombosis, prevalence of disorders that predispose to thrombosis, and morbidity and mortality associated with thrombotic events all reflect the magnitude of the importance of the study of thrombotic mechanisms and development of effective antithrombotic and thrombolytic therapies.

In this chapter, the pathophysiology of arterial and venous thrombosis and mechanisms of action of antithrombotic pharmacologic agents including antiplatelet drugs, anticoagulants, and fibrinolytic agents are summarized and discussed. Inherited conditions that predispose an individual to thrombosis, also termed hypercoagulable states, and the management of venous thromboembolic disease are covered. The management of arterial thrombotic events is beyond the scope of this chapter, and the reader is referred to several excellent recent review articles.^{3, 4, 5}

PHYSIOLOGY AND PATHOPHYSIOLOGY OF THROMBOSIS

The human hemostatic system consists of multiple independent, yet integrally related, cellular and protein components that function to maintain blood fluidity under normal conditions and promote localized, temporary thrombus (hemostatic thrombus) formation at sites of vascular injury. A normal hemostatic system is the human physiologic defense against exsanguination. An abnormal hemostatic system can result in pathologic bleeding, vascular thrombosis, or both.

The hemostatic system is comprised of six major components: Platelets, vascular endothelium, procoagulant plasma protein "factors," natural anticoagulant proteins, fibrinolytic proteins, and antifibrinolytic proteins. Each of these six hemostatic components must be present in fully functional form, in adequate quantity, and at the proper location to prevent excessive blood loss after vascular trauma and, at the same time, to prevent pathologic thrombosis. The hemostatic system is highly regulated and maintains a delicate balance between a prohemorrhagic state and a prothrombotic state. Any significant acquired or congenital imbalance in the hemostatic "scales" can lead to a pathologic outcome.

Normal hemostasis in response to vascular injury can be divided into two major processes of equal importance, known as primary and secondary hemostasis. Primary hemostasis comprises the reactions needed to form a platelet plug at a site of vascular damage, whereas secondary hemostasis comprises a series of reactions (coagulation cascade) needed to generate cross-linked fibrin required to stabilize the platelet plug and form a durable thrombus. Natural anticoagulants (antithrombin [AT] and activated protein C [APC]) function to confine thrombus formation to the sites of vascular injury and limit thrombus size to prevent vessel occlusion and flow interruption in the affected vessel. The activity of AT is greatly enhanced by endothelial cell heparan sulfate and pharmacologic heparins. The function of APC is enhanced by its cofactor, protein S. Physiologic fibrinolysis is initiated by endothelial-cell-derived tissue-type plasminogen activator (t-PA), which converts plasminogen to plasmin. Plasmin can degrade cross-linked fibrin, limit thrombus size, and help dissolve a thrombus once the vascular injury has been repaired. The fibrinolytic system is regulated and localized by antiplasmin and PA inhibitor (PAI)-1. Details of the hemostatic mechanisms and endothelial cell regulation of hemostasis are given in Chapters 18 and 19.

Specific alterations in the quantitative and qualitative status of any hemostatic cellular or protein element can lead to pathologic thrombosis. A marked increase in the platelet count (thrombocytosis) and accentuated platelet aggregation ("sticky platelet syndrome") are associated with thromboembolic events. Elevated levels of procoagulant factors such as fibrinogen, factors VIII, IX, XI, and VII, as well as resistance to inactivation of factor Va by APC, are recognized risk factors for vascular disease and thrombosis. Deficiency of a natural anticoagulant protein such as protein C, protein S, or AT is associated with venous thromboembolic disease. Deficiency of a fibrinolytic cascade component, such as t-PA or plasminogen, and excess plasma levels of the fibrinolytic inhibitor PAI-1 have been linked to hypercoagulability and thrombosis. It is the net balance between the participating and, at times, opposing groups of proteins and not the level of any individual factor that is most critical to hemostatic regulation.

VIRCHOW TRIAD

In the mid-19th century (1854), German pathologist Rudolph Virchow postulated that vascular obstruction was precipitated by, and thrombosis resulted from, three interrelated factors:

P.1219

(a) "Decreased blood flow" (stasis of blood flow), (b) "inflammation of or near the blood vessels" (vascular endothelial

injury), and (c) "intrinsic alterations in the nature of the blood itself" (hypercoagulability).⁶ Many students of coagulation medicine, though, do not realize that Virchow actually recognized his "triad" as being the result of vascular occlusion, not necessarily as the original precipitant of vascular thrombosis. Nonetheless, the vascular, rheologic, and hematologic aspects of thrombosis known as the Virchow triad remain relevant and instructive today (Fig. 55.1).

Abnormalities of Blood Flow

Arterial thrombosis initially occurs under conditions of rapid blood flow (high shear stress), a condition in which von Willebrand factor (vWF) is critical for platelet adhesion.⁷ Arterial thrombi usually are composed of tightly coherent masses of platelets, which contain small amounts of fibrin and a few erythrocytes and leukocytes. These thrombi are the classic "white thrombi," which resemble, in many respects, normal hemostatic plugs. As arterial thrombi enlarge, progressive or intermittent deposition of new layers of platelets and fibrin produces the characteristic lines of Zahn; partial or complete obstruction of blood flow may produce a "tail" of "red thrombus." The most serious consequences of arterial thrombosis are vascular occlusion with resultant ischemia and infarction of tissue and distal thrombus embolization.

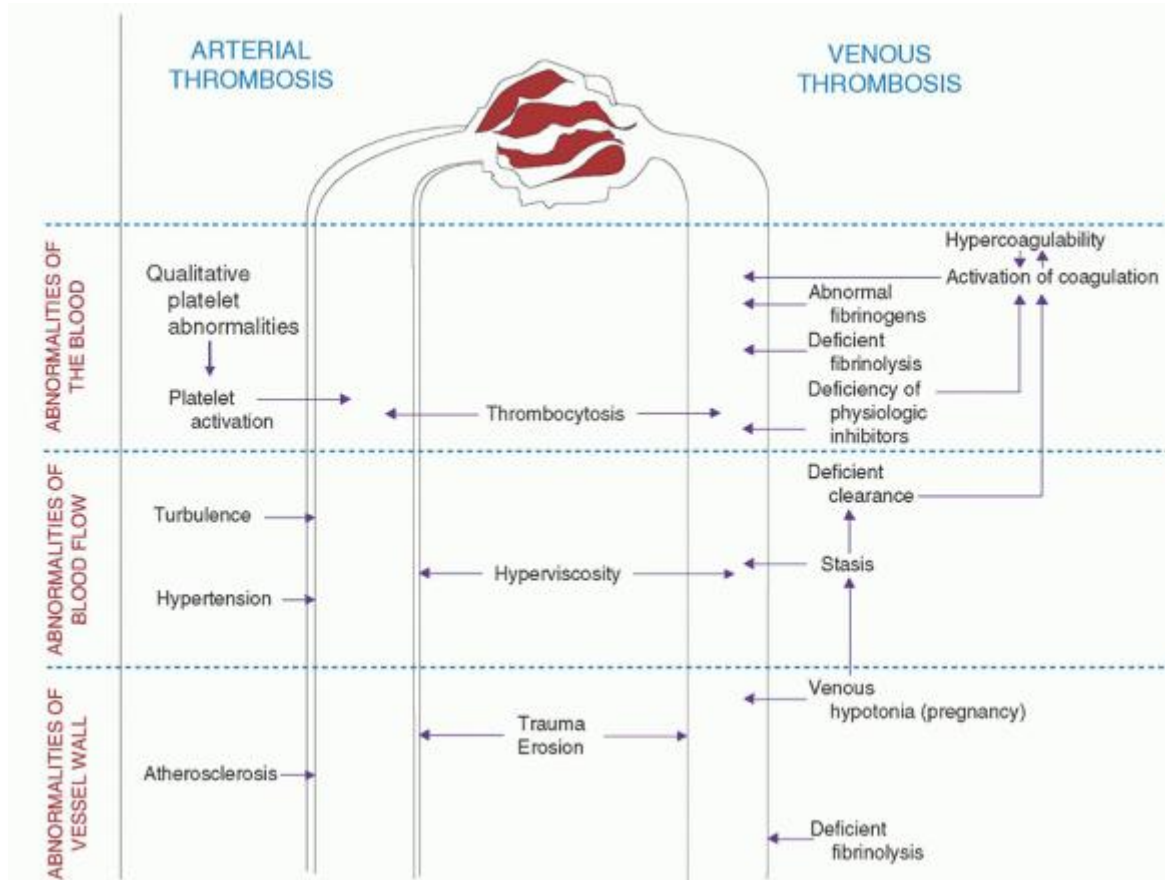

FIGURE 55.1. Pathophysiology of thrombosis. Factors implicated in the pathogenesis of arterial thrombosis (left) and venous thrombosis (right) are depicted. Examples of disorders leading to platelet activation and arterial thrombosis include atherosclerosis, the myeloproliferative disorders, heparin-associated thrombocytopenia/thrombosis syndrome, thrombotic thrombocytopenic purpura, and certain platelet polymorphisms. Examples of disorders leading to venous thrombosis in the category of deficiency of physiologic inhibitors include the inherited disorders, factor V Leiden, proteins C and S deficiencies, and AT deficiency. Many patients with thrombosis may have more than one of the risk factors listed. Estrogen therapy is a risk factor for venous thrombosis; its use is associated with activation of coagulation.

Hypertension, turbulent blood flow at arterial branch points and at sites of focal atherosclerosis, and hyperviscosity may be contributory factors in certain forms of arterial thrombosis. Causes of plasma hyperviscosity that can precipitate thrombosis and exacerbate ischemia include acute myeloid leukemia, myeloproliferative syndromes such as polycythemia rubra vera, cryoglobulinemia, and the plasma cell dyscrasias, including multiple myeloma and Waldenström macroglobulinemia. Immunoglobulin (Ig) paraproteins produced by plasma cell dyscrasias can increase viscosity, and promote red blood cell agglutination.

Venous thrombosis typically develops under conditions of slow blood flow (low shear stress) and is augmented by further retardation and stagnation of flow caused by the developing thrombus itself. Right-sided heart failure, pre-existent venous thrombosis, extrinsic vascular compression by tumor, and chronic venous insufficiency all promote venous stasis, blood pooling, and a concentration of procoagulant factors.⁸ The anatomic structure of venous valves results in retrograde eddy currents, which produce pockets of stasis even in normal veins.⁹ The venous arcades in the soleus muscles of the calves may represent another site of physiologic venous stasis. These structures may enlarge and lose vascular tone with aging.^{10, 11} These facts may partially explain why DVT most commonly occurs in the valve cusps and veins of the pelvis and lower extremities, and why older age is an important risk factor for venous thrombosis.¹²

P.1220

Venous thrombi are composed of large amounts of fibrin containing numerous erythrocytes. In these loose, friable masses (the red thrombus), the platelets and leukocytes are enmeshed in random fashion. Venous thrombi resemble blood clots formed *in vitro*, and they usually produce significant obstruction to blood flow from the outset, but their most serious consequence is embolization. Blood flow obstruction secondary to venous thrombosis itself promotes the further formation of thrombus. Results of studies of clots formed in a thromboviscometer at varying rates of shear suggest that the differences in the structure of venous and arterial thrombi may be mainly the result of the velocity of blood flow. The many and complicated rheologic factors that may be involved in thrombosis have been reviewed.¹³ Although traditional teaching holds that risk factors for arterial and venous thrombotic disease are distinct, new epidemiologic data suggest that common risk factors exist for both disorders, and that appropriate management of thrombosis patients should address secondary prevention of both arterial and venous thrombosis.¹⁴ The pathogenesis of venous and arterial thrombosis has been recently reviewed.¹⁵

Vascular Injury

Permanent and transient vascular injuries play major roles in the development of arterial thrombosis. Intraluminal vascular endothelial cell injury, atherosclerotic plaque rupture, hyperhomocysteinemia, arterial outflow obstruction, aneurysm formation, and vessel dissection are among the recognized risk factors for arterial thrombosis.¹⁶ Arterial thrombosis usually begins with platelet adhesion to an abnormal vascular endothelial surface or exposed subendothelial constituent such as collagen. The adherent platelets become activated, leading to the release of α - and dense granule contents.¹⁵ Platelet-dense granules (dense bodies) release adenosine diphosphate (ADP), adenosine triphosphate (ATP), calcium, and serotonin into the surrounding milieu, resulting in the recruitment and activation of additional platelets.¹⁶ This release reaction and platelet synthesis of thromboxane A₂ (TxA₂) and other agonists induce the aggregation of more platelets and enlargement of the temporary platelet plug. In addition to the recruitment of additional platelets, the original nidus of adherent platelets provides a phospholipid surface rich in phosphatidylserine to support and concentrate the generation of thrombin and fibrin necessary to reinforce and stabilize the platelet plug.

New insights into arterial thrombus formation have been gleaned from experiments using confocal and wide-field microscopy to image real-time thrombus formation in live-mouse cremaster muscle arterioles.¹⁷ Thrombosis is precipitated by laser-induced endothelial injury. These experiments demonstrated that the initiation of blood coagulation *in vivo* involves the initial accumulation of tissue factor (TF) on the upstream and thrombus-vessel wall interface of the developing thrombus. The TF is biologically active and is associated with intrathrombus fibrin generation. TF density is highest at the thrombus-vessel wall interface and is eventually observed throughout the thrombus. Leukocyte rolling is noted approximately 2 minutes after endothelial cell injury and correlates with P-selectin expression on the outer aspect of the thrombus. Minimal TF and fibrin are detected in platelet thrombi formed in mice lacking P-selectin or the P-selectin glycoprotein ligand, PSGL-1.

In venous thrombosis, the luminal surface of the vessel wall is usually histologically normal, and factors extrinsic to the vessel appear to have a major pathophysiologic role. Exceptions to this generalization are direct venous trauma, extrinsic venous compression, and vascular endothelial cell injury resulting from the toxic effect of cancer chemotherapy and excess levels of homocysteine. A limited quantity of activated platelets likely serves as a phospholipid surface to support local thrombin and fibrin formation. A generalized reduction in venous tone may be an important pathophysiologic factor in venous thrombosis in pregnant women and in women taking oral contraceptives.¹⁸ vWF-mediated platelet adhesion was shown to be essential for venous thrombosis in an animal model.¹⁹ Additional mechanisms may contribute to a prothrombotic state, including up-regulation of stress-response genes, endothelial cell activation, formation of neutrophil extracellular traps, and activation of the intrinsic coagulation pathway.²⁰

Studies indicate that human platelets express TF pre-mRNA, and when activated, splice this message into mature mRNA which is expressed.²¹ These results suggest that both platelets and the vessel wall may contribute to initiation of thrombosis.

Abnormalities of the Blood: Hypercoagulability

The term hypercoagulable state and its synonym thrombophilia refer to any inherited or acquired abnormality of the hemostatic system that places an individual at increased risk for venous or arterial thrombosis (or both). Blood from patients with active thrombosis or with a hypercoagulable state may clot at an abnormally rapid rate in vitro.²² The concept of hypercoagulability has gained widespread acceptance, and it is generally appreciated that these hemostatic changes are important in the pathogenesis of thrombosis; however, whether testing for these disorders may be helpful in patient management is uncertain.^{23, 24, 25}

Platelet Abnormalities

Although platelets may be incorporated into virtually any thrombus, they appear to be pathogenetically most important in arterial thrombosis. Increased platelet turnover (shortened platelet survival, compensated platelet destruction) occurs in vascular disease and thrombosis, including arterial and venous thrombosis, coronary artery disease, vasculitis, hyperhomocysteinemia, and valvular heart disease.^{26, 27, 28, 29} Increased platelet turnover can also be seen in patients with risk factors for vascular disease, including those who use tobacco and those with hyperlipidemia.^{30, 31} Increased platelet turnover and activation can reflect thromboembolic disease and also probably contribute to an exacerbation of thrombotic events.

As a consequence of platelet-vessel wall interactions in patients with vascular disease, platelet adhesion, activation, and aggregation occur, resulting in acquired storage pool disease and the presence in the blood of platelet-granule-derived proteins such as platelet factor-4 (PF4) and β -thromboglobulin.^{32, 33} Although elevated blood levels of these proteins indicate increased platelet turnover, improper blood collection technique may artifactually result in abnormal levels, and the clinical value of such testing is uncertain.

Vascular endothelium possesses multiple antiplatelet properties that may be important in preventing platelet adhesion, promoting vasodilation, and inhibiting platelet aggregation.^{34, 35, 36, 37} However, interruption of endothelial cell prostacyclin synthesis by aspirin does not result in a net thrombotic tendency. The potential role of hyperactive platelets in patients with thrombosis, as well as the use of platelet function testing in this setting, is somewhat controversial.

Because of the importance of vWF in mediating platelet adhesion to subendothelium, the role of vWF in human vascular disease has been a topic of investigation. An association between elevated plasma vWF levels and recurrent MI has been demonstrated, and vWF antigen is an independent predictor of coronary artery disease.³⁸

Platelet polymorphisms have been evaluated as risk factors for arterial thrombosis. These include polymorphisms for glycoprotein (gp) IIIa (PI^{A2}), gpl α (807 T allele), and gpl β .³⁹ The PI^{A2} polymorphism is linked with coronary artery disease; PI^{A2}-positive platelets exhibit a lower threshold for activation and also have variable aspirin sensitivity.³⁹

P.1221

Coagulation Abnormalities

Coagulation disorders that can contribute to hypercoagulability can be divided into three risk-factor categories: Transient, inherited, and acquired.⁴⁰ Transient risk factors represent well-defined, temporary clinical circumstances that are associated with increased thrombosis risk both while they are present and for a short period after they have resolved. Examples include surgery, prolonged immobilization, oral contraceptive pill (OCP) use, hormone replacement therapy (HRT), pregnancy, cancer chemotherapy, and heparin-induced thrombocytopenia (HIT). Inherited risk factors represent genetic mutations and polymorphisms that result in deficiency of a natural anticoagulant (e.g., protein C, protein S, or AT), procoagulant factor accumulation (e.g., prothrombin G20210A), or coagulation factor resistance to inactivation by a natural anticoagulant (i.e., factor V G1691A, also known as factor V Leiden). These conditions are characterized by a disruption in the normally highly regulated coagulation mechanism, resulting in greater thrombin generation and an increased risk of clinical thrombosis. Acquired risk factors result either from medical conditions or from nonfamilial hematologic abnormalities that interfere with normal hemostasis or blood rheology. Examples include cancer, inflammatory bowel disease, nephrotic syndrome, vasculitis, antiphospholipid antibodies, myeloproliferative syndromes, paroxysmal nocturnal hemoglobinuria, and hyperviscosity syndromes. These acquired risk factors are distinct from

transient risk factors by the fact that they represent alterations in hemostatic homeostasis as a result of disease or, for the most part, nonreversible processes. In contrast, transient risk factors result from either a therapeutic intervention or an adverse reaction to such an intervention. Hyperhomocysteinemia and increased factor VIII functional activity are examples of thrombosis risk factors that can be acquired in nature or have a genetic predisposition.^{41, 42} Age defies categorization but remains the single most predictable risk factor for thrombosis. The estimated baseline annual age-associated risk of VTE is 1 in 10,000 people <40 years of age, increasing to 1 in 100 people >75 years of age.^{43, 44, 45}

Recent reports have focused on elevated levels of various coagulation factors, particularly fibrinogen and factors V, VII, VIII, X, and XI, that have been documented in patients with thrombosis and prethrombotic disorders, including pregnancy and use of estrogen-containing contraceptives.⁴⁶ Fibrinogen and factors V and VIII are acute-phase reactants, and their plasma levels may rise in patients with virtually any disorder associated with tissue damage or inflammation, including most thrombotic processes. Whether increased because of a genetic factor or an acute-phase reaction, excess procoagulant factor concentrations may tilt the hemostatic scales in favor of hypercoagulability and may be associated with an increased risk of thrombosis. Epidemiologic studies have identified dose-dependent elevations in plasma levels of vWF, fibrinogen, factor VII, factor IX, and factor XI as independent risk factors for cardiovascular disease.^{47, 48, 49, 50}

Fibrinolytic Abnormalities

Abnormal fibrinolysis has also been linked to vascular disease. Low fibrinolytic activity (measured by dilute clot lysis) was a significant determinant of coronary artery disease in the Northwick Park Heart Study, and elevated PAI-1 activity was associated with major ischemic events in other studies.^{51, 52} In the European Concerted Action on Thrombosis and Disabilities study, an increased incidence of vascular events was associated with higher baseline PAI-1 antigen concentrations ($p = .02$) and PAI-1 activity ($p = .001$).⁵³ Defects in endogenous fibrinolytic capacity have also been found in young patients with severe limb ischemia or unexplained arterial thromboembolism. Deficient t-PA release was found in 45% of such patients, and elevated levels of PAI-1 were found in 59%.⁵⁴ Excess PAI-1 resulting in impaired endogenous fibrinolysis has also been associated with venous thrombosis in select cases.⁵⁵

ACTIVATION OF COAGULATION

Mechanisms leading to activation of coagulation in patients with thrombosis have been proposed. TF is thought to be the primary initiator of *in vivo* coagulation.^{56, 57} In the absence of TF expression, endothelial cells actively maintain thromboresistance. TF may be expressed in trace amounts during various physiologic processes, such as during normal parturition and after even minimal trauma, including minor head injuries. Immunologic injury of endothelium may lead to the exposure of TF.⁵⁸ Antibodies formed to exogenous heparin may bind to heparan sulfate on the endothelium, resulting in cell injury, the expression of TF, and the initiation of coagulation.⁵⁹ In a similar manner, endothelial cells may be induced to express TF by interleukin-1, homocysteine, tumor necrosis factor, and endotoxin.^{60, 61, 62, 63} TF antigen expression by endothelium has been demonstrated in pathologic primate and human tissues.^{64, 65, 66} Activation of coagulation may also occur on monocytes, and platelets can be activated to mediate factor-Xa-catalyzed prothrombin conversion to thrombin.^{67, 68} Deficient hepatic clearance of activated coagulation factors may represent an important thrombogenic factor in premature infants and in patients with liver disease, especially after administration of prothrombin complex concentrates that contain trace amounts of activated vitamin-K-dependent coagulation factors.

Various other mechanisms may be responsible for low-grade *in vivo* coagulation under certain conditions. Certain tumor cells can promote thrombin generation directly, by producing TF, expressing the coagulation factor X activator known as cancer procoagulant, or displaying surface sialic acid residues that can support nonenzymatic factor X activation.^{69, 70} Tumor cells can also promote thrombin generation indirectly, by eliciting TF expression by monocytes and endothelial cells. Tumor-associated coagulation cascade activation can result in the generation of thrombin that can promote angiogenesis by signaling through protease-activated receptors PAR-1, PAR-3, and PAR-4. In addition to its normal role in coagulation, evidence is mounting that TF plays a direct role in growth, invasion, dissemination, and angiogenesis of tumors.^{71, 72} Clotting-independent signaling through the TF cytoplasmic tail can lead to vascular endothelial growth factor (VEGF) up-regulation. Because VEGF can promote TF up-regulation, the potential for a self-perpetuating proangiogenic amplification loop exists. The TF:factor VIIa complex can also activate PAR-2 directly in a manner that results in gene expression related to angiogenesis and cell migration.⁷² Selected tumors may mediate an accentuation of platelet activation and accumulation, whereas other tumor cells may express surface phospholipid species such as phosphatidylserine, which can support prothrombin and factor X activation.⁷³

A laboratory picture similar to that described in the hypercoagulable state may also be seen in patients with nonovert (compensated or chronic) disseminated intravascular coagulation (DIC).⁷⁴ In such patients, the prothrombin time (PT) and the activated partial thromboplastin time (aPTT) may be shortened because of the presence of traces of thrombin or other

activated coagulation factors. These activated factors affect one-stage, but not two-stage, clot endpoint coagulation assays. High levels of factor V and factor VIII activity may reflect the presence of thrombin-activated forms of these factors in the circulation. Pregnancy, which can be regarded as a hypercoagulable state, has also been described as a physiologic form of nonovert DIC by some clinicians.⁷⁵ Pregnancy increases the risk of venous thromboembolism (VTE) approximately fivefold among the general population, and female patients who have experienced prior venous thrombosis have a threefold risk of venous thrombosis during pregnancy.⁷⁶ The use of estrogen-containing oral contraceptives and estrogen HRT is clearly associated with an increased risk of VTE.^{77, 78, 79} A prospective study of these patients indicates that estrogens induce activation of coagulation as well as reduction in levels of natural anticoagulants

P.1222

such as AT and protein S.⁸⁰ However, many patients who experience VTE while taking oral contraceptives have a common inherited thrombotic disorder, APC resistance (APC-R), or prothrombin G20210A.⁸¹ Another report indicated that oral contraceptives induced "acquired APC-R" in women.⁸² The relative risk of VTE in postmenopausal women using estrogen replacement is 2.14, and the risk is highest during the first year of use.⁸³ The thrombotic risk imparted by pharmacologic estrogens appears to dissipate following medication discontinuation.⁸⁴ One study found that transdermal estrogen products were safer than oral estrogens in women receiving HRT.⁸⁵ One literature review of hormonal therapy and venous thrombosis concluded that all oral estrogen-containing products used for contraception or HRT, as well as therapeutic doses of progesterone-only products increased thrombosis risk.⁷⁹ The risk of venous thrombosis is not clearly increased for the levonorgestrel-containing intrauterine device, transdermal estrogen, and tibolone.⁷⁹ Regarding the risk of thrombotic stroke and MI, a very large Danish study found that use of ethinyl estradiol increased risk by 0.9 to 2.3, depending on drug concentration in the contraceptive pill.⁸⁶ Table 55.1 summarizes acquired etiologies that predispose to thrombosis.

INHERITED THROMBOTIC DISORDERS

Several monographs and reviews have covered the topic of inherited thrombotic disorders in detail.^{40, 46, 86, 87, 88} Table 55.2 summarizes the prevalence of selected inherited and acquired hypercoagulable states in different populations, whereas Table 55.3 summarizes the clinical presentations of venous thrombosis that may be suggestive of particular hypercoagulable states. Many patients who experience thrombosis are found to have a combination of defects, for example, APC-R plus use of oral contraceptive agents,⁸¹ or a combination of inherited defects.⁴⁰ Although people with inherited hypercoagulable states are at a greater risk for developing a thrombotic event than those without such disorders, not all people with a well-defined hypercoagulable state develop an overt thrombosis, and not all people with thrombosis have an identifiable hypercoagulable state. Testing for an inherited hypercoagulable state is likely to uncover an abnormality in >60% of patients presenting with idiopathic (i.e., spontaneous or unprovoked) venous thrombosis.⁸⁹ Although the remaining

P.1223

30% to 40% have unremarkable test results, this does not imply a true absence of a hypercoagulable state. Some of these individuals may have an acquired condition such as cancer or antiphospholipid antibodies, whereas others may have a disorder or genetic defect that has not yet been discovered or characterized.

TABLE 55.1 ACQUIRED DISORDERS PREDISPOSING TO THROMBOSIS

Vascular disorders

Atherosclerosis

Diabetes

Vasculitis

Prosthetic materials (grafts, valves, indwelling vascular catheters)

Abnormal rheology

Stasis (immobilization, surgery, congestive heart failure)

Hyperviscosity (polycythemia vera, Waldenström macroglobulinemia, acute leukemia, sickle cell disease)

Other disorders associated with hypercoagulability

- Cancer (Trousseau syndrome)
- Cancer chemotherapeutic agents, thalidomide, bevacizumab
- Oral contraceptives, estrogen therapy, selective estrogen-receptor modulators
- Pregnancy
- Infusion of prothrombin complex concentrates and recombinant factor VIIa
- Nephrotic syndrome
- Myeloproliferative disorders
- Paroxysmal nocturnal hemoglobinuria
- Inflammatory bowel disease
- Thrombotic thrombocytopenic purpura
- Disseminated intravascular coagulation
- Antiphospholipid antibody syndrome
- Heparin-induced thrombocytopenia/thrombosis
- Human immunodeficiency virus infection

TABLE 55.2 PREVALENCE OF SELECTED INHERITED AND ACQUIRED HYPERCOAGULABLE STATES IN DIFFERENT PATIENT POPULATIONS

Hypercoagulable State	General Population (%)	Patients with First Venous Thromboembolism (%)	Thrombophilic Families (%)
Factor V Leiden	3-7 ^a	20	50
Prothrombin G20210A	1-3	6	18
Protein C deficiency	0.2-0.4	3	6-8
Protein S deficiency	N/A	1-2	3-13
Antithrombin deficiency	0.02	1	4-8
Mild hyperhomocysteinemia	5-10	10-25	N/A
Elevated factor VIII	11	25	N/A
Lupus anticoagulant	0-3	5-15	N/A
Elevated anticardiolipin antibodies	2-7	14	N/A

N/A, not available or unknown.

^a Prevalence as high as 15% in northern Europe.

TABLE 55.3 CLINICAL PRESENTATIONS OF VENOUS THROMBOEMBOLISM THAT MAY SUGGEST CERTAIN HYPERCOAGULABLE STATES

Venous Thromboembolism Presentation	Hypercoagulable State
Cerebral vein thrombosis in women using oral contraceptives	Prothrombin G20210A mutation
Cerebral vein thrombosis in general	Paroxysmal nocturnal hemoglobinuria, essential

	thrombocytopenia, antiphospholipid antibodies, antithrombin deficiency, PT G20210A mutation
Intra-abdominal vein thrombosis (inferior vena cava, renal vein, portal vein, mesenteric and hepatic veins)	Antiphospholipid antibodies, paroxysmal nocturnal hemoglobinuria, myeloproliferative syndromes, cancer, antithrombin deficiency
Warfarin skin necrosis	Protein C, protein S deficiencies
Unexplained recurrent fetal loss	Antiphospholipid antibodies; factor V Leiden
Recurrent superficial thrombophlebitis	Factor V Leiden, polycythemia vera, protein C, protein S, or antithrombin deficiency
Migratory superficial thrombophlebitis (Trousseau syndrome)	Adenocarcinoma (particularly of the gastrointestinal tract)
Neonatal purpura fulminans	Homozygous protein C or protein S deficiency

PT, prothrombin.

Antithrombin Deficiency

AT, formally known as AT-III, deficiency was first described by Egeberg in 1965.⁹⁰ AT, a serine protease inhibitor, regulates coagulation by inactivating thrombin and other procoagulant enzymes, including factors Xa, IXa, XIa, and XIIa. As are most inherited thrombotic disorders, AT deficiency is inherited as an autosomal dominant disorder.^{91, 92} A blood bank survey reported that 1 in 600 people has AT deficiency.⁹³ The interactions of unfractionated and low-molecular-weight heparin (LMWH) with AT are discussed in the section "Heparin."

Pathophysiology and Genetics

Patients with AT deficiency may have either type I (quantitative deficiency) or type II (qualitative abnormality) disease. Type I AT-deficient patients usually have concordant reductions in AT measured by both immunologic and functional assays. Type II patients have reduced functional AT activity associated with normal amounts of AT protein. Plasma concentrations of the thrombin activation peptide, prothrombin fragment 1+2, are elevated in patients with AT deficiency, indicating persistent activation of coagulation as a result of deficient neutralization of factor Xa in these patients.⁹⁴

The genetic basis for type I AT deficiency is either deletion of a gene segment or the occurrence of point mutations or deletions, resulting in a nonsense mutation and an incomplete protein. The genetic basis for type II AT deficiency is the occurrence of point mutations that do not impair synthesis of the protein, but that result in a dysfunctional protease inhibitor. A summary of AT mutations (>100) has been reported.⁹⁵ A database of AT mutations is located at: <http://www1.imperial.ac.uk/departmentofmedicine/divisions/experimentalmedicine/haematology/coag/AT/>. In general, mutant AT molecules exhibit deficient heparin binding, deficient protease inhibition, or both.

Clinical Aspects

AT deficiency is manifested primarily by recurrent VTE.^{91, 92} Almost every vein site has been reported to be involved with thrombosis in AT-deficient patients, including unusual sites such as mesenteric vessels.⁹⁶ Thrombosis may occur in the absence of precipitating factors or may result from events such as pregnancy, estrogen use, trauma, or surgery. AT deficiency can result in heparin resistance manifesting as a normal to minimally increased aPTT in patients receiving large doses of heparin.⁹⁷ However, most patients with AT deficiency do not exhibit heparin resistance, and most cases of heparin resistance are not due to AT deficiency. In family studies, venous thrombosis occurred in 85% of AT-deficient relatives before 55 years of age.⁹⁷ The estimated increased lifetime relative risk of venous thrombosis has been reported to be up to 40-fold.^{98, 99} An annual absolute risk of venous thrombosis of 27.5% has been reported in female carriers of AT deficiency who also use OCPs.¹⁰⁰ Early studies reported pregnancy-related venous thrombosis rates as high as 70% for AT-deficient women.^{101, 102} Most AT-deficient patients are heterozygotes and possess ~50% of normal activity levels. Although homozygotes have been reported in consanguineous kindreds, in general, homozygous type I AT deficiency is believed to be fatal in utero.¹⁰³

Laboratory Diagnosis

Results of the PT and aPTT are normal in AT-deficient patients. A variety of commercial assays is available to measure AT levels, including functional and immunologic assays. Functional assays are preferable because they detect both type I and

type II patients. One report found that 2% of patients with AT deficiency had type II disease.¹⁰⁴ Functional assays for AT measure heparin cofactor activity using a chromogenic substrate method to quantitate thrombin or factor Xa neutralization.¹⁰⁵ A potential disadvantage of functional AT assays is that plasma AT levels may be overestimated because of the presence of heparin cofactor II (HCII) in the sample. The use of bovine thrombin and a low heparin concentration (3 U/ml) in the assay system can minimize this problem.¹⁰⁶

Immunologic assays for AT use Laurell rocket immunoelectrophoresis, microlatex-particle immunoassay, radial immunodiffusion, or enzyme-linked immunosorbent assay (ELISA) methods.¹⁰⁷ Ideally, patients should be evaluated for AT deficiency at a time when they are not receiving therapeutic heparin or oral anticoagulants, because heparin depresses AT levels, whereas long-term warfarin therapy increases plasma AT levels in some patients.^{92, 108} Laboratory tests for AT deficiency have been summarized.¹⁰⁹

Treatment

Some AT-deficient patients may experience heparin resistance, requiring the administration of AT by using virally inactivated, plasma-derived, or transgenic AT concentrates, or fresh-frozen plasma. Supplemental AT may make it easier to achieve therapeutic anticoagulation with heparin in these patients.¹¹⁰ Patients with recurrent thrombosis should receive long-term warfarin therapy at a dosage to maintain an international normalized ratio (INR) value of 2.0 to 3.0 (discussed in the section "Warfarin"). Patients with a single thrombotic event should receive at least 3 to 6 months of warfarin therapy and, because of an increased recurrence rate, should be considered for long-term therapy beyond 6 months. Patients with massive venous thrombosis or PE may be candidates for thrombolytic therapy. AT-deficient patients who become pregnant or who will undergo general surgery should be considered for anticoagulant prophylaxis, including AT concentrate administration.^{110, 111} Most asymptomatic patients should not be treated. The avoidance of estrogens should be considered in AT-deficient patients, who are not therapeutically anticoagulated.

Acquired Antithrombin Deficiency

AT deficiency is also associated with numerous disorders, including DIC, liver disease, nephrotic syndrome, and preeclampsia, and is seen in patients taking oral contraceptive agents and during pregnancy.^{112, 113, 114, 115} Although logic suggests that correction of AT deficiency might be clinically useful in disorders such as DIC or liver disease, there are no conclusive data supporting AT replacement therapy outside the setting of prophylaxis of high-risk patients, such as pregnant, AT-deficient patients.¹¹⁶

Heparin Cofactor II Deficiency

HCII is another heparin-dependent thrombin inhibitor, differing from AT in that a glycosaminoglycan other than heparin, dermatan sulfate, catalyzes this inhibitor of coagulation.¹¹⁷ HCII deficiency is inherited as an autosomal dominant trait. Although there have been anecdotal studies of thrombosis associated with HCII-deficient kindreds, a larger study has concluded that HCII deficiency by itself may not be an inherited risk factor for thrombosis.^{118, 119, 120} Commercial assays to measure HCII levels are available, but the clinical utility of such assays in routine evaluation of patients for inherited thrombosis is uncertain.

Protein C Deficiency

Protein C is a vitamin-K-dependent plasma protein that, when activated by the thrombin-thrombomodulin complex to APC,

P.1224

inactivates factors Va and VIIIa to inhibit coagulation.¹²¹ APC also possesses profibrinolytic activity that results from neutralization of PAI-3 activity.¹²² Inherited deficiency of protein C and its association with thrombosis were first described by Griffin and coworkers in 1981.¹²³ Protein C deficiency was believed to be inherited in an autosomal dominant pattern with incomplete penetrance. More recent studies have suggested that protein C deficiency may be an autosomal recessive disorder and that coinheritance of another defect (particularly factor V Leiden) results in a high degree of penetrance that appears as the dominant inheritance in double-heterozygous carriers.^{124, 125}

Pathophysiology and Genetics

As with AT deficiency, patients with protein C deficiency may have type I (quantitative deficiency) or type II (qualitative abnormality) disease. Most patients are heterozygotes with ~50% of normal protein C levels. A hypercoagulable state can be demonstrated in nonanticoagulated protein-C-deficient patients using activation peptide (fragment 1+2) assays.¹²⁶

In type I protein C deficiency, more than half of the gene mutations identified are missense mutations. Point mutations affecting protein function appear to be common in patients with type II protein C deficiency. At least 195 different gene abnormalities have been associated with both types of protein C deficiency.¹²⁷ Despite the clear association of protein C deficiency with thrombosis in large epidemiologic studies, there are also definitive data indicating that many protein-C-deficient patients are asymptomatic.¹²⁸ For example, one report found that heterozygous protein C deficiency occurred in approximately 1:250 subjects, whereas a large Scottish study estimated the prevalence to be approximately 1:500.^{124, 129} No patient in either study had a history of symptomatic venous thrombosis. These findings indicate that additional risk factors—acquired, genetic, or both—are necessary to provoke thrombosis in heterozygous protein-C-deficient patients. Indeed, in one study, up to 20% of symptomatic protein-C-deficient patients also had APC-R, supporting the concept that many patients with recurrent thrombosis have more than one risk factor.¹²⁵

Clinical Aspects

Three clinical syndromes are associated with protein C deficiency: VTE in heterozygous adults, neonatal purpura fulminans in homozygous newborns, and warfarin-induced skin necrosis in certain heterozygous adults. The predominant clinical symptom of protein-C-deficient patients is recurrent VTE, although arterial thrombotic events, including stroke, have been reported.^{130, 131} As mentioned above, many patients are found to have risk factors other than inherited protein C deficiency on investigation, such as APC-R, use of oral contraceptive agents, and pregnancy. Protein C deficiency has also been linked to fetal loss.¹³²

Neonatal purpura fulminans is seen in homozygous newborns of heterozygous parents. These children develop DIC at birth, associated with extensive venous or arterial thrombosis (or both) and very low levels of protein C (<5% of normal).¹³³ Warfarin-induced skin necrosis is an unusual syndrome seen in certain patients with heterozygote protein C deficiency.¹³⁴ Most patients who develop this syndrome have received large doses of warfarin in the absence of concomitant overlapping therapeutic parenteral anticoagulation. The basis for this syndrome is that warfarin therapy, especially in large loading doses, reduces protein C levels more rapidly than the vitamin-K-dependent procoagulant factors, leading to exacerbation of the basal hypercoagulable state and thrombosis.

In family studies, venous thrombosis occurred in 50% of protein-C-deficient relatives of affected probands before 40 years of age.¹³⁵ The estimated increased lifetime relative risk of venous thrombosis has been reported to be up to 31-fold.⁹⁸ As stated above, other studies did not detect an increased thrombosis risk in carriers of protein C deficiency. Differences in risk between family- and population-based studies can be in part explained by greater difficulty in obtaining reliable population-based estimates because of the overall low prevalence of this and other natural anticoagulant deficiencies. In studies of unselected patients with venous thrombosis, the odds ratio (OR) of having protein C deficiency is increased six- to ninefold compared to controls.^{40, 135, 136, 137} An annual absolute risk of venous thrombosis of 4.3% has been reported in women carriers of a natural anticoagulant deficiency such as protein C deficiency who also use OCPs.^{100, 138}

Laboratory Diagnosis

Patients with heterozygous protein C deficiency have normal PT and aPTT values, whereas patients with homozygous protein C deficiency have abnormal coagulation tests consistent with DIC. Because both type I and type II disorders may occur, functional assays are suggested to optimize identification of affected patients. Some investigators prefer the clot endpoint-based assay, because it measures complete function of the protein C molecule, including those patients with abnormal protein C molecules that possess normal activity by a chromogenic substrate assay. However, therapeutic heparin levels affect the clot-based assay. A College of American Pathologists' consensus conference on thrombophilia recommends use of the chromogenic substrate assay.¹³⁹ One report indicated that measurement of the ratio of protein C to protein S antigen was useful in identifying carriers of protein C deficiency.¹⁴⁰

Protein C levels can also be measured by immunologic methods, including Laurell rocket immunoelectrophoresis and ELISA. However, immunologic assays may not detect type II patients and may overestimate protein C levels in warfarin-treated patients. Immunologic assays may be more useful in evaluating patients with homozygous deficiency and DIC.

Age-related changes occur with protein C levels.¹⁴¹ Consequently, it is important to consider this when testing younger patients (<30 years); otherwise, normal subjects may be misclassified as protein C deficient.

A common problem faced by laboratories is measuring protein C levels in patients taking oral anticoagulants. Many clinicians forget that protein C is a vitamin-K-dependent molecule, and that otherwise hemostatically normal people taking warfarin may have low protein C levels. Griffin and coworkers suggested that protein C data be normalized against the level of another vitamin-K-dependent protein to distinguish inherited protein-C-deficient patients from normal subjects taking warfarin.¹²³ One author reported that using a ratio between protein C and prothrombin optimally categorized patients.¹⁴² However, for this method to be useful, patients must be stably anticoagulated for at least 2

weeks, and the laboratory must obtain plasma samples and reference ranges from patients taking warfarin for reasons other than recurrent thrombosis. The consensus conference did not recommend assaying protein C levels in patients on oral anticoagulants.¹³⁹ Laboratory tests for protein C deficiency have been reviewed.¹⁴³

Treatment

Many patients with protein C deficiency are asymptomatic, especially those identified in screening studies. Asymptomatic patients should not be treated but should be considered for prophylaxis when they experience high-risk procedures, such as surgery. Symptomatic protein-C-deficient patients should be anticoagulated with heparin and then considered for long-term secondary prophylaxis with warfarin at an INR of 2.0 to 3.0. Those patients with a single thrombotic event should receive at least 3 to 6 months of warfarin. Patients with more than one thrombotic event, patients with a single life-threatening thromboembolic event, and those with a significant family history of thrombosis should be

P.1225

considered for long-term anticoagulation. Patients with massive thrombosis or PE may be candidates for thrombolytic therapy.

Infants with neonatal purpura fulminans should be treated with protein C replacement therapy. Protocols using a purified protein C concentrate or prothrombin complex concentrates have been described.^{144, 145} Use of the purified concentrate normalizes activation of coagulation in these homozygous patients.¹⁴⁶

Acquired Protein C Deficiency

Because protein C is a vitamin-K-dependent protein, any disorder associated with vitamin K deficiency may result in protein C deficiency, including warfarin use, liver disease, and malnutrition.¹⁴⁷ Protein C levels are also reduced in DIC, presumably reflecting thrombin activation of the zymogen and consumption of APC.¹⁴⁸ Protein C levels may also be reduced in renal disease, especially the nephrotic syndrome.¹⁴⁹

Protein S Deficiency

Protein S is a vitamin-K-dependent plasma protein that facilitates the anticoagulant activity of APC. Protein S deficiency in association with inherited thrombotic disease was first described by two groups in 1984.^{150, 151} As with AT and protein C deficiencies, protein S deficiency is inherited as an autosomal dominant trait. Many patients with a previous diagnosis of protein S deficiency actually have APC-R.^{152, 153} This diagnostic error results from interference in the functional protein S assay of patients with the inherited disorder, APC-R, and misclassification of patients. These patients have a "pseudo" protein S deficiency, often display a type II deficiency pattern, and have protein S activity levels that correlate with the APC ratio. Based on these reports and the high incidence of APC-R in the general population, the true importance of protein S deficiency in inherited thrombosis is uncertain.^{152, 153, 154}

Pathophysiology and Genetics

As described for AT and protein C deficiencies, patients with protein S deficiency may have quantitative or qualitative disorders. Under normal circumstances, protein S exists in plasma in two forms: Bound to C4b-binding protein (60% of total protein S) and free (40% of total). Because only free protein S has APC co-factor activity, a revised classification system has been proposed for protein S deficiency.¹⁵⁵ Type I protein S deficiency is a quantitative disorder in which protein S functional activity, total antigen, and free antigen levels are equally reduced to ~50% of normal. Type IIa protein S deficiency is a deficiency of free protein S with preserved normal levels of total protein S. In type IIb protein S deficiency, the levels of both total and free protein S antigen are normal. Apparent type IIb protein S deficiency has been described in patients with APC-R.¹⁵⁴ An acquired type IIa protein S deficiency may result from excess levels of C4b-binding protein or the presence of free protein S inhibitory and clearing autoantibodies.¹⁵⁶ Almost 200 different mutations have been identified in the gene that codes for protein S.^{95, 157} A full listing of protein S gene mutations and polymorphisms can be found at www.ISTH.org.

As with protein C deficiency, many patients with protein S deficiency and thrombosis have additional risk factors. In one study, among patients with protein S deficiency, ~40% also had APC-R; of family members with thrombosis, 72% had both defects, whereas <20% of patients with single defects experienced thrombosis.¹⁵⁸

Clinical Aspects

Like AT and protein-C-deficient patients, most patients with protein S deficiency and thrombosis have experienced VTE.^{150, 151} However, unlike most other inherited thrombotic disorders, up to 25% of patients with protein S deficiency may experience arterial thrombosis, including stroke.^{131, 159} As mentioned previously, many patients with protein S deficiency

and thrombosis have other risk factors, including APC-R, estrogen use, or pregnancy.¹⁵⁸ Neonatal purpura fulminans, fetal loss, and warfarin-induced skin necrosis have also been associated with protein S deficiency.^{132, 160} In family studies, venous thrombosis occurred in 100% of protein-S-deficient relatives of affected probands by 70 years of age.¹⁶¹ The estimated lifetime increased relative risk of thrombosis has been reported to be as high as 36-fold for protein S deficiency.⁹⁸

Laboratory Diagnosis

Patients with heterozygous protein S deficiency have normal PT and aPTT values. The laboratory diagnosis of protein S deficiency is complicated by four factors: The levels of C4b-binding protein, the coexistence of APC-R in certain patients, elevated factor VIII activity levels, and warfarin therapy. C4b-binding protein is an acute-phase-reactant protein-S-binding protein, often elevated in thromboembolism, resulting in reduced free protein S levels from the patient's true baseline. Consequently, measurement of protein S levels in patients with acute thrombosis may yield misleading results. Similarly, false-positive results may be seen when functional protein S assays are performed on patients who have APC-R or factor VIII activity levels $\geq 250\%$.¹⁵⁵ Patients should not be assumed to have protein S deficiency (diagnosed by functional assay) until APC-R has been excluded. Lastly, because protein S is a vitamin-K-dependent protein, warfarin therapy and vitamin K deficiency pose the same difficulty as described for patients evaluated for protein C deficiency. Protein S levels may also be decreased in the setting of pregnancy but are not necessarily associated with thrombotic events.

Both functional and immunologic assays are commercially available to quantitate plasma protein S levels. Functional assays may be PT- or aPTT-based, measuring inhibition of factor Va by APC.¹⁶² These assays have the advantage of measuring free protein S activity. Immunologic assays to measure either total (free plus C4b-binding-protein bound) or free protein S levels are available.^{163, 164} Immunologic assays may be useful in evaluating patients who have co-existing APC-R. Total protein S levels are measured by Laurell rocket immunoelectrophoresis or ELISA. In the interpretation of immunologic assays, one should consider the report that the mean plasma level of protein S antigen in males is higher than it is in females.¹⁶⁴

Treatment

Asymptomatic patients should not be treated but should be considered for prophylaxis when they experience high-risk procedures such as surgery. Symptomatic protein-S-deficient patients should be anticoagulated as described for protein-C-deficient patients.

Protein Z Deficiency

Protein Z is a vitamin-K-dependent plasma protein that serves as a co-factor for activated factor X inhibition by the protein-Z-dependent protease inhibitor.¹⁶⁵ Reduced circulating levels of protein Z have been implicated in thrombosis.^{166, 167} Protein Z deficiency has also been linked to early and late fetal demise and intrauterine growth restriction.¹⁶⁷ Protein Z deficiency has also been found in the setting of acute coronary syndromes, whereas a deficiency state and the presence of a series of protein Z variants that modulate protein Z plasma levels have been associated with stroke.^{167, 168, 169, 170} Further data are required before routine protein Z testing can be recommended.

Activated Protein C Resistance (Factor V Leiden)

Before 1993, most patients with idiopathic venous thrombosis evaluated for inherited thrombosis were not given a diagnosis,

P.1226

because AT, protein C, and protein S deficiencies together were found in <20% of patients. In 1993, Dahlback and colleagues in Sweden postulated that certain patients with recurrent thrombosis might have additional abnormalities of the protein C pathway, resulting in a hypercoagulable state.¹⁷¹ They found that addition of APC to plasma obtained from patients with recurrent thrombosis did not prolong the aPTT to the same degree as that seen when APC was added to normal plasma.¹⁷¹ These patients did not have any previously recognized inherited thrombotic disorder. The term APC resistance was used for these patients. Other investigators then used the aPTT-based APC screening test to examine other populations for this phenotype. APC-R was found in 20% to 60% of patients with recurrent thrombosis.^{172, 173, 174} Like other inherited thrombotic disorders, APC-R was inherited in an autosomal dominant manner.

Pathophysiology and Genetics

APC inactivates factor Va in an orderly and sequential series of cleavages, first at Arg506, and then at Arg306 and Arg679.^{175, 176, 177} Although the affected factor V cleavage site in APC-R is not directly responsible for complete

inactivation of factor Va, APC cleavage at this site is necessary for subsequent proteolytic events. This “partial resistance” is explained by the fact that cleavage of factor Va by APC at Arg306 continues to occur, albeit at a slower rate.¹⁷⁸ In fact, factor V Arg506Gln (factor V Leiden) is inactivated 10 times more slowly than normal factor Va. This provides a pathophysiologic explanation for why factor V Leiden, although common, is a relatively weak risk factor for VTE. Because factor Va functions as a cofactor in the conversion of prothrombin to thrombin, the mutation results in greater amounts of factor Va being available for coagulation reactions, “shifting” the hemostatic balance toward greater thrombin generation.⁹⁵

APC-R due to factor V Leiden is the most common inherited predisposition to hypercoagulability in Caucasian populations of northern European background.⁹⁵ Factor V Leiden follows a geographic and an ethnic distribution: The mutation occurs most frequently in northern and western Europe (the highest prevalences, 10% to 15%, have been reported in Cyprus, Sweden, and Turkey) but is rare in the Asian and African continents as well as in ethnic groups of Asian descent, such as Inuit Eskimos, Amerindians, Australian Aborigines, and Polynesians.¹⁷⁹ In the United States, factor V Leiden is most commonly seen in Caucasians (6.0%), with lower prevalences in Hispanics (2.2%), African and Native Americans (1.2%), and Asian Americans (0.45%).¹⁸⁰

Factor V Leiden accounts for 92% of cases of APC-R, with the remaining 8% of cases resulting from pregnancy, oral contraceptive use, cancer, selected antiphospholipid antibodies, plasma glucosylceramide deficiency,^{181, 182, 183} and other factor V point mutations. Therefore, the terms factor V Leiden and APC-R should not be considered synonymous; in fact, APC-R is an independent risk factor for VTE even in the absence of factor V Leiden.¹⁸⁴ It is estimated that the mutation arose in a single Caucasian ancestor some 21,000 to 34,000 years ago, well after the evolutionary separation of non-Africans from Africans (~100,000 years ago) and of Caucasoid (white Caucasians) from Mongoloid (Asians) subpopulations (~60,000 years ago).¹⁸⁵

Clinical Aspects

Heterozygous carriers of factor V Leiden have a 2- to 10-fold increased lifetime relative risk of developing VTE.^{98, 138, 172, 186, 187, 188, 189, 190} This risk is further increased in combination with pregnancy (9-fold), OCP use (36-fold), and HRT (13- to 16-fold).^{191, 192, 193, 194} VTE is the most common clinical symptom of APC-R in patients who experience thrombosis. In general, there is a notable lack of association of APC-R with arterial thrombosis (exceptions discussed below).¹⁸⁸ Another clinical association with APC-R is recurrent miscarriage, with one study reporting that 20% of patients with second-trimester pregnancy loss have APC-R.^{132, 195} Factor V Leiden does not appear to be a cause of recurrent pregnancy loss occurring late in the first trimester.^{195, 196} Neonatal purpura fulminans has been reported in a patient with factor V Leiden who did not have protein C or S deficiency.¹⁹⁷ APC-R is also a common inherited risk factor for cerebral venous thrombosis.¹⁹⁸ The factor V Leiden mutation has also been identified in children who experience thrombosis.¹⁹⁹ However, this mutation does not appear to play a major role in the hypercoagulability of cancer.²⁰⁰ An intriguing report has demonstrated that the factor V Leiden mutation is a risk factor for MI in young women; the combination of factor V Leiden with smoking increased the risk of MI more than 30-fold.²⁰¹ Factor V Leiden has also been associated with MI in individuals with coronary artery thrombosis in the absence of evidence of underlying fixed atherosclerotic lesions.²⁰²

There are conflicting data on the role of factor V Leiden heterozygosity as an independent risk factor for VTE recurrence.^{203, 204} Two studies (“positive studies”) have found an increased risk of VTE recurrence compared to control subjects, with relative risk of 4.1 and 2.4, respectively. Six other studies (“negative studies”) have found no such association.^{205, 206, 207, 208, 209, 210} The positive studies by Ridker et al. and Simioni et al. were prospective but included a small number of patients with factor V Leiden heterozygosity (14 and 41, respectively).^{203, 204} The Physicians' Health Study (by Ridker et al.) included only men.²⁰³ Among the negative studies, four were prospective and two were retrospective.^{205, 206, 207, 208, 209, 210} Three of the prospective studies and the large retrospective cohort study by De Stefano et al. each included 80 to 112 patients with factor V Leiden heterozygosity.^{205, 206, 208, 210} A recent re-evaluation of the study by Simioni et al. did confirm the original study findings of increased relative risk of recurrent VTE in heterozygous carriers of factor V Leiden.²¹¹ The PREVENT trial later demonstrated equivalent rates of recurrent VTE in patients with and without factor V Leiden.²¹²

Homozygous carriers of the factor V Leiden mutation are estimated to have an 80-fold increased lifetime relative risk of VTE.¹⁸⁸ A more recent estimate, derived from a pooled analysis of a larger population, has confirmed an increased risk of VTE but of lower magnitude (10-fold).¹⁹¹ The discrepancy is likely due to the very low prevalence of factor V Leiden homozygosity found in the healthy controls from the general population. Most homozygous carriers present with VTE before 40 years of age, but some can live thrombosis-free until the sixth or seventh decade of life or even remain asymptomatic for life.^{213, 214} The majority of VTE is situational, and women appear more likely to develop VTE than men, suggesting an important role of OCP use and pregnancy in triggering thrombosis.^{213, 214, 215} Based on data from the first

prospective Duration of Anticoagulation trial, the risk of VTE recurrence is significantly increased in homozygous factor V Leiden carriers (36.4% at 48 months) when compared to heterozygous carriers (16.1%) and controls (12.4%).²⁰⁶

Laboratory Diagnosis

The intense interest in this common inherited thrombotic disorder has focused substantial attention on laboratory methods for its diagnosis. Laboratory aspects of its discovery have been reviewed by Dahlback.²¹⁶ The disorder can be evaluated by coagulation assays that have as their basis inhibition of factor Va by APC and prolongation of the clotting time. Typically, APC is added to patient plasma, and a clotting assay is performed (usually the PTT), with results expressed as a ratio:

$$\frac{\text{Patient PTT} + \text{APC}}{\text{Patient PTT}}$$

Reference ranges are established for normal patients with and without addition of APC. Affected patients with mutant factor V have clotting times prolonged to a lesser extent (lower ratio) than

P.1227

normals. Alternatively, a DNA test can be done to look specifically for the Arg506Gln mutation; this highly conserved point mutation is present in most patients with APC-R.

With properly collected plasma samples, the APC-R clotting test can correctly classify nearly 100% of patients, when normalized to a control plasma pool.²¹⁷ Predilution of the patient sample with factor-V-deficient plasma has improved the performance characteristics of most currently available commercial assays.²¹⁸ Samples from patients with baseline abnormal coagulation studies (e.g., anticoagulant therapy, lupus anticoagulants, liver disease) yield uninterpretable results. A TF-dependent factor V assay has been described that is useful in patients taking oral anticoagulants or with the lupus anticoagulant.²¹⁹ The polymerase chain reaction test for factor V Leiden uses the restriction enzyme MnlI to digest a 267-base pair amplified fragment of patient DNA.¹⁷⁶ Consensus recommendations on methodologies to assay for factor V Leiden and APC-R have been presented.^{220, 221}

Treatment

Therapy of VTE in patients with APC-R is similar to that described for patients without an identified hypercoagulable state. Long-term secondary prophylaxis is not necessary for heterozygotes unless they experience more than one thrombotic event or experience life-threatening thromboembolism. Asymptomatic patients with APC-R should not be treated, but female patients with this disorder should be informed about the additional thrombotic risk associated with oral contraceptive use, pregnancy, and HRT.^{82, 222} Prophylaxis for high-risk situations, such as surgery, should be given. Homozygotes who experience VTE should be considered for long-term anticoagulation.

Prothrombin Mutations

The prothrombin G20210A mutation is the second most common inherited predisposition to hypercoagulability. Heterozygous prothrombin G20210A has been found in 18% of probands of thrombophilic families, 6% of unselected patients with deep vein thrombosis (DVT), and 2% of normal Caucasian individuals.^{40, 223}

More recently, a novel single-point mutation of the prothrombin gene at position 20209 has been reported in four unrelated patients, two of whom had a history of VTE and one of whom had a history of stroke.²²⁴ Although the clinical significance of the prothrombin C20209T mutation is unknown, it may be underrecognized because it is not detected by the polymerase chain reaction/digestion assay commonly used for prothrombin gene mutation testing. Interestingly, all four reported individuals with prothrombin C20209T were African-Americans.

Pathophysiology and Genetics

Prothrombin G20210A is a single-point mutation (G-to-A substitution at nucleotide 20210) in the 3' untranslated region of the prothrombin gene.²²³ This autosomal dominant mutation results in elevated concentrations of plasma prothrombin.²²³ In fact, the VTE risk increases as the plasma prothrombin level increases, with levels >115 IU/dl leading to a 2.1-fold increased relative risk of VTE.²²³ The G20210A mutation leads to a "gain of function" of the prothrombin gene, perhaps by

resulting in an altered polyadenylation pattern in mutant prothrombin mRNA.²²⁵ An in vitro study of thrombin generation found that increasing prothrombin levels to 150% of normal resulted in enhanced thrombin activity.²²⁶

The mutation appears to follow a geographic and ethnic distribution, with the highest prevalence occurring, unlike factor V Leiden, in Caucasians from southern Europe (3%).²²⁷ This prevalence is nearly twice that observed in northern Europe (1.7%).²²⁷ Similar to factor V Leiden, the prothrombin G20210A mutation is also found in the Middle East and Indian regions, but it is virtually absent in individuals of Asian and African backgrounds.²²⁷ These distributions provide support to the estimate that both mutations (factor V Leiden and prothrombin G20210A) originated relatively recently in the European founding population, after the evolutionary divergences of subpopulations. An evaluation of patients in northeast Ohio who underwent hypercoagulability evaluations revealed an equivalent prevalence of prothrombin gene mutations in whites and blacks.²²⁴

Clinical Aspects

Heterozygous prothrombin G20210A is associated with a two- to sixfold increased lifetime relative risk of VTE.^{40, 214, 223, 228} The risk appears to be further increased in combination with pregnancy (15-fold) and OCP use (16-fold).^{191, 229} The relative risk of cerebral vein thrombosis is increased 10-fold in women with this mutation who are not on OCPs, as opposed to 150-fold in OCP users.²³⁰ Homozygosity for prothrombin G20210A has an estimated population prevalence of 0.014%, and homozygous carriers appear to have greater predisposition to develop early (before 40 years of age) idiopathic recurrent VTE than heterozygotes.^{223, 231, 232}

The role of prothrombin G20210A as a risk factor for VTE recurrence is less controversial than it is for factor V Leiden, but data are also somewhat conflicting. Simioni et al., re-evaluating a prospective study from 1997, retrospectively determined patients' prothrombin G20210A mutation status and found that the hazard ratio of VTE recurrence was 2.4.²¹¹ However, three prospective studies, which each included 28 to 52 patients, found no increased risk of recurrent VTE in heterozygous prothrombin G20210A carriers.^{206, 233, 234}

A fourfold increased risk of MI has been demonstrated, particularly in young women carriers of this mutation. A large case-control study of >14,000 men, though, revealed no increased risk of stroke or MI associated with this abnormal prothrombin gene. The reasons for this apparent male/female disparity are unknown.^{201, 235}

Laboratory Diagnosis

The prothrombin G20210A and C20209T mutations can only be reliably and routinely identified using molecular biologic techniques. Measurements of functional prothrombin activity do not sufficiently differentiate between carriers and noncarriers of this gene mutation. Testing can be performed accurately despite concomitant treatment with any form of anticoagulation.

Treatment

Treatment paradigms for patients with prothrombin G20210A heterozygosity parallel those for patients with heterozygous factor V Leiden. Patients with concomitant prothrombin G20210A heterozygosity and factor V Leiden heterozygosity should be considered for long-term anticoagulation following a first thrombotic event.

Hyperhomocysteinemia

Homocysteine is a sulfhydryl amino acid formed during the conversion of methionine to cysteine. Hyperhomocysteinemia results when homocysteine metabolism is abnormal. Hyperhomocysteinemia has been identified as an independent risk factor for stroke, MI, peripheral arterial disease, and venous thrombotic disease.^{236, 237, 238} Even mild to moderate hyperhomocysteinemia is a significant risk factor for vascular disease. However, lowering homocysteine levels with vitamin therapy has not resulted in improved outcomes in vascular disease and thrombosis.^{239, 240}

Pathophysiology and Genetics

The amino acid homocysteine is normally metabolized via the transsulfuration pathway by the enzyme cystathionine- β -synthase (CBS), which requires vitamin B₆ as co-factor, and via the

P.1228

remethylation pathway by the enzymes methylenetetrahydrofolate reductase (MTHFR), which is folate dependent, and methionine synthase, which requires vitamin B₁₂ as co-factor.^{241, 242} Inherited severe hyperhomocysteinemia (plasma level >100 μ mol/L), as seen in classic homocystinuria, may result from homozygous MTHFR and CBS deficiencies and, more rarely, from inherited errors of cobalamin metabolism.^{241, 242} Inherited mild to moderate hyperhomocysteinemia (plasma

level >15 to 100 $\mu\text{mol/L}$) may result from heterozygous MTHFR and CBS deficiencies, but most commonly results from the thermolabile variant of MTHFR (tMTHFR) that is encoded by the C677T gene polymorphism.^{241, 242}

Acquired hyperhomocysteinemia may be caused by folate deficiency, vitamin B₆ or B₁₂ deficiency, renal insufficiency, hypothyroidism, type II diabetes mellitus, pernicious anemia, inflammatory bowel disease, advanced age, climacteric state, carcinoma (particularly involving breast, ovaries, or pancreas), and acute lymphoblastic leukemia, as well as methotrexate, theophylline, and phenytoin therapy.^{241, 242}

The precise mechanisms underlying the thrombogenicity of homocysteine remain unclear. Several diverse mechanisms have been proposed, including endothelial cell desquamation, low-density lipoprotein (LDL) oxidation, promotion of monocyte adhesion to endothelium, and factor V activation and promotion of thrombin generation.^{241, 242, 243} Homocysteine also enhances platelet aggregation and adhesiveness as well as turnover, presumably as a result of endothelial cell injury.²⁴⁴ One study found that moderate hyperhomocysteinemia does not impair the activation of protein C by thrombin and does not impair the inactivation of factor Va by APC.²⁴⁵

Severe homocysteinemia usually results from homozygous CBS deficiency. The incidence of this disorder is ~1 in 335,000 live births. Classic symptoms for homozygous patients include premature vascular disease and thrombosis, mental retardation, ectopic lens, and skeletal abnormalities.²⁴⁶ Heterozygous homocysteinemia has been recognized as a disease entity; this disorder may affect 0.3% to 1.0% of the general population.²⁴⁶

Clinical Aspects

Heterozygous carriers of the tMTHFR mutation have normal plasma homocysteine levels unless folate levels are reduced.²⁴⁷ More important, the majority of case-control studies have not demonstrated an increased VTE risk in homozygous carriers of the tMTHFR, and the majority of individuals with hyperhomocysteinemia do not have the tMTHFR polymorphism. Thus, characterization of the tMTHFR polymorphism is not useful to determine an individual's VTE risk. VTE risk is most closely related to elevated fasting plasma homocysteine levels, regardless of etiology. Hyperhomocysteinemia (plasma level >18.5 $\mu\text{mol/L}$) has been associated with a two- to fourfold increased VTE risk.^{248, 249} It is interesting that, in the Physicians' Health Study, hyperhomocysteinemia (plasma level above the 95th percentile; 17.2 $\mu\text{mol/L}$) did increase the risk of idiopathic VTE (relative risk, 3.4) but not the risk of all (transient and idiopathic) VTE.¹⁸⁹

The majority of reports linking hyperhomocysteinemia to thrombosis have focused on venous thromboembolic disease. Kottke-Marchant et al. compared 23 patients with documented arterial peripheral thrombosis to age- and sex-matched controls.²⁵⁰ Elevated homocysteine levels (>13 $\mu\text{mol/L}$) conferred an OR of 7.8 for thrombosis. Elevated homocysteine levels were found in 73% of cases versus 28% of controls. Only smoking and homocysteine level were independent risk factors for arterial thrombosis. Currie et al. evaluated homocysteine and cardiovascular risk factors in 66 adult patients with vascular disease. Hyperhomocysteinemia was identified in 29% of patients and was an independent risk factor for the failure of vascular procedures ($p = 0.006$).²⁵¹

Laboratory Diagnosis

The initial step in the evaluation of the patient with suspected hyperhomocysteinemia involves measurement of fasting total plasma homocysteine (the sum of nonprotein-bound and proteinbound).²⁴¹ Many laboratories report homocysteine values in reference to published "normal" ranges such as 5 to 15 $\mu\text{mol/L}$, but, ideally, a local, laboratory-specific normal range should always be established. A normal value in the nonfasting setting does not normally require repeating. Testing 2 to 8 hours after an oral methionine load (100 mg/kg) increases the sensitivity of detecting occult vitamin B₆ deficiency and obligate heterozygotes for CBS deficiency,²⁵² but methionine loading is not routinely recommended.²⁵³ Vitamin B₁₂ and folate deficiency do not affect post-methionine loading homocysteine values. In patients found to have elevated levels of homocysteine, testing for vitamin B₁₂ deficiency is advocated to avoid missing subclinical deficiency before beginning oral folic acid therapy. Methodologies to measure homocysteine levels have been reviewed.²⁵⁴

Treatment

Folic acid supplementation is the mainstay of effective hyperhomocysteinemia therapy.²⁴¹ A recent meta-analysis of 1,114 patients enrolled in 12 randomized studies of vitamin supplementation to lower homocysteine levels demonstrated a 25% reduction in homocysteine levels, with similar effects across a dosage range from 0.5 to 5.0 mg daily.²⁵⁵ The usual recommended dose is 0.4 to 1.0 mg daily. Whether patients who are not responsive to one dose benefit from an escalation in dose is unclear. Because patients with subclinical vitamin B₁₂ deficiency may be prone to developing peripheral neuropathy if they receive folic acid supplementation alone, additional treatment with 0.5 mg/day of oral vitamin B₁₂ has been advocated. In the same meta-analysis, an additional 7% reduction of homocysteine levels was noted with vitamin B₁₂ supplementation.²⁵⁵ Vitamin B₁₂ administration results in normalization of homocysteine levels in B₁₂-

deficient individuals. In these patients, a monthly intramuscular injection of 200 to 1,000 µg of vitamin B₁₂ is considered adequate replacement. Vitamin B₆ supplementation did not appear to have any effect on homocysteine levels. Betaine, a nutritional supplement derived from beets, functions as an alternative methyl donor in the remethylation of homocysteine to methionine. Betaine has been used in individuals with homocystinuria and may facilitate homocysteine reduction in individuals who are not responsive to folate and vitamin B₆.²⁵⁶

Thrombotic events in hyperhomocysteinemic patients should be treated as described for other inherited disorders. An additional treatment strategy is to lower plasma homocysteine levels, with the hope of alleviating a risk factor for recurrent thrombosis. However, results of the Heart Outcomes Prevention Evaluation (HOPE)-2 trial and Norwegian Vitamin (NORVIT) trial do not support the utility of homocysteine lowering in patients with arterial disease.^{257, 258} In patients with a history of coronary artery, cerebrovascular, or peripheral artery disease, or diabetes with at least one risk factor for atherosclerosis, lowering plasma homocysteine levels with folic acid and B vitamins did not reduce risk for the composite endpoint of MI, stroke, or death from cardiovascular causes more than placebo despite a 22% reduction in plasma homocysteine.²⁵⁷ In NORVIT, folic acid and vitamin B₁₂, with or without vitamin B₆, did not reduce risk for the composite endpoint of MI, stroke, or death from coronary artery disease in patients with an index MI.²⁵⁸ Other clinical trials have also failed to show a cardiovascular benefit of lowering homocysteine levels.^{239, 240} Secondary analysis of the HOPE-2 trial regarding effects of vitamin therapy on VTE risk found that there was no significant risk reduction in VTE with vitamin therapy.²⁵⁹ These trials yielding negative results with vitamin therapy raise questions about the utility of testing and treating homocysteinemia.

P.1229

Increased Factor VIII Activity

It is now appreciated that elevated levels of procoagulant coagulation factors, in addition to deficiencies of natural anticoagulant proteins, are risk factors for VTE. Factor VIII levels >1.5 IU/ml (150%) are associated with a threefold and a sixfold greater relative risk of VTE when compared to levels <1.5 IU/ml (150%) and <1.0 IU/ml (100%), respectively.²⁶⁰ VTE risk is increased 11-fold with levels >200%, but it does not appear to be accentuated by concomitant OCP use.^{261, 262}

Elevated activity levels of factor VIII associated with VTE risk seem to be persistent and not solely attributable to acute-phase response.²⁶³ Transiently elevated factor VIII levels associated with acute-phase protein release, though, may in part explain the hypercoagulability associated with inflammatory disorders such as inflammatory bowel disease and cancer. Individuals with plasma factor VIII activity >234% (above the 90th percentile cutoff point for the study population) have a 6.7-fold increased relative risk of recurrent VTE compared to those with activity levels of <120%.⁴²

Because factor VIII is indeed an acute-phase reactant and its levels can be affected by many factors, including blood type and vWF concentration, determination of the true meaning of an elevated factor VIII level in an individual patient with VTE is challenging. In the study by Koster et al., in which blood samples for factor VIII activity were obtained a minimum of 6 months after the VTE, it was impossible to distinguish completely between inherited elevation and postthrombotic, transient elevation of factor VIII.²⁶⁰ Nonetheless, the fact that an increased factor VIII level is prevalent in persons with VTE may, in fact, imply that elevated factor VIII is not only frequent, but also an important risk factor for VTE.²¹⁴ More recent studies support the concept that elevated factor VIII levels are a significant risk factor in asymptomatic individuals for both arterial and venous thrombosis.^{264, 264a} The College of American Pathologists' consensus conference recommendations are not to routinely measure factor VIII levels in patients with venous or arterial thrombosis.²⁶⁵

Increased Levels of Factors IX, X, XI, and XIII

The Longitudinal Investigation of Thromboembolism Etiology study investigated the possible role of elevated factors IX, X, XI, and XIII in VTE risk²⁶⁶ and found that of these coagulation proteins, only elevated factor XI levels were associated with VTE risk. Elevated factor XI levels have also been linked to stroke²⁶⁷ and coronary disease.²⁶⁸ This effect of elevated factor XI levels may be mediated by increased fibrin formation and decreased fibrinolysis.²⁶⁹

Impaired Endogenous Fibrinolysis

The endogenous fibrinolytic system is comprised of plasminogen, PAs, and antifibrinolytic regulatory proteins. Intravascular plasminogen is converted to the active fibrinolytic enzyme plasmin primarily by t-PA derived from vascular endothelial cells and by urokinase-type PA (u-PA) from leukocytes. The principal physiologic inhibitor of t-PA is PAI-1, whereas plasmin itself is inactivated by circulating and thrombus-bound α₂-antiplasmin, and to a lesser extent, α₂-macroglobulin. Decreased endogenous fibrinolytic activity as a result of qualitative and quantitative abnormalities of

plasminogen, an inadequate release of t-PA in response to vascular injury, and excessive production of PAI-1, such as is found in inflammatory and malignant diseases, can result in impaired endogenous fibrinolysis and accumulation of pathologic thrombus.²⁷⁰

Abnormal fibrinolysis was previously thought to account for a large proportion of patients with inherited thrombosis. However, the discovery of APC-R as a common inherited disorder and a literature review that concluded that a causal relationship between abnormal fibrinolysis and inherited thrombosis had not been clearly demonstrated diminished enthusiasm for routinely evaluating patients with recurrent thrombosis for abnormal fibrinolysis.²⁷¹ However, newer data from the Leiden Thrombophilia Study indicate that reduced plasma fibrinolytic potential is a risk factor for venous thrombosis,²⁷² and another group identified an elevated level of thrombin-activatable fibrinolysis inhibitor (TAFI) as a risk factor for recurrent venous thrombosis.²⁷³ Additionally, elevated levels of α_2 -antiplasmin are linked to increased risk of MI,²⁷⁴ and elevated levels of PAI-1 are associated with venous thrombosis.²⁷⁵

Plasminogen Deficiency

Quantitative and qualitative abnormalities of plasminogen have been reported in patients with recurrent venous thrombosis.^{276, 277} Quantitative deficiency is inherited as an autosomal dominant disorder, whereas qualitative plasminogen defects (dysplasminogenemia) are usually inherited as autosomal recessive disorders. Dysplasminogenemia is more common in Japanese subjects, and a single mutation accounts for >90% of cases in this population.²⁷⁸ Two reports have suggested that quantitative plasminogen deficiency²⁷⁹ and dysplasminogenemia²⁸⁰ may not be risk factors for thrombosis, and a recent large series of 50 patients with quantitative plasminogen deficiency found the major clinical manifestation to be ligneous conjunctivitis; venous thrombosis was not observed.²⁸¹ The College of American Pathologists Consensus Conference on Thrombophilia does not recommend routine assay for plasminogen deficiency in thrombophilia patients.²⁸²

Tissue Plasminogen Activator Deficiency

Defective synthesis or release of t-PA from the vessel wall represents a potential mechanism for thrombosis. Plasma t-PA activity is unstable, and for accurate assays, citrated plasma samples must be immediately acidified and red blood cells removed.^{283, 284} Addition of a platelet activation inhibitor to the blood collection tube may help reduce the release of platelet-derived PAI-1, which can interfere with t-PA activity quantification. A plasminogenchromogenic substrate assay is used to measure t-PA activity; t-PA antigen can be measured by ELISA using citrated plasma. The CAP Consensus Conference on Thrombophilia does not recommend routine assay for t-PA deficiency in thrombophilia patients.²⁸²

Increased Plasminogen Activator Inhibitor-1 Levels

Increased levels of PAI-1 have been associated with venous or arterial thrombosis. Plasma PAI-1 activity is measured in citrated plasma using a back-titration method with single-chain t-PA.²⁸⁵ Because blood fibrinolytic activity exhibits a diurnal rhythm (decreased fibrinolysis in the morning as a result of peak PAI-1 levels; increased fibrinolysis in the evening as a result of low PAI-1 levels), plasma samples should be obtained at standardized times, such as between 8:00 and 9:00 a.m..²⁸⁶ In addition, because fibrinolytic component levels can be affected by acute-phase changes, patients should not be evaluated for abnormal fibrinolysis until 2 to 3 months after an acute thrombotic event.

In the European Concerted Action on Thrombosis and Disabilities study, an increased incidence of vascular events was associated with higher baseline PAI-1 antigen concentrations ($p = .02$) and PAI-1 activity ($p = .001$).⁵³ Elevated levels of PAI-1 may effectively reduce t-PA activity levels, thereby blocking the activation of plasminogen to plasmin and inducing impaired fibrinolysis that may ultimately lead to thrombosis. Theoretically, markedly elevated levels of PAI-1 might also impair attempts at pharmacologic thrombolysis in the setting of acute arterial and venous thrombosis.²⁸⁷ Defects in endogenous fibrinolytic capacity have also been found in young patients with unexplained arterial thromboembolism. Deficient t-PA release was found in 45% of such patients, and elevated levels of PAI-1 were found in 59%.⁵⁴

P.1230

Similar defects have been detected in individuals with recurrent venous thrombosis.²⁷⁵ It has been noted that patients who have undergone major surgical procedures might experience a transient "fibrinolytic shutdown" as a result of elevated PAI-1 levels as part of an acute-phase response.²⁸⁸

Avoidance of obesity and associated insulin resistance, correction of hypertriglyceridemia, cessation of smoking, and exercise may improve the innate fibrinolytic status.^{53, 289, 290} Treatment of hypertension with angiotensin-converting enzyme inhibitors or angiotensin II receptor antagonists has been associated with significantly reduced PAI-1 production.^{291, 292} The lipid-lowering agent gemfibrozil has also been shown to decrease the PAI-1 synthesis rate.²⁹³

Modest alcohol consumption and hormone replacement treatment in postmenopausal women also seem to be beneficial.^{294, 295}

Dysfibrinogenemia

The clinical and biochemical aspects of dysfibrinogens are reviewed in Chapter 53. In general, dysfibrinogens associated with thrombosis have as their molecular defect generation of an abnormal fibrin that is resistant to fibrinolysis. An updated summary of dysfibrinogen molecular abnormalities is presented at www.ISTH.org. Dysfibrinogenemia as a cause of inherited thrombosis is uncommon.

Certain patients with dysfibrinogenemia may have a prolonged PT; more typically, these patients are detected by prolonged thrombin and reptilase times, suggesting a defect in the conversion of fibrinogen to fibrin.²⁹⁶ Confirmation of a dysfibrinogen can be done by simultaneous measurement of functional and immunologic fibrinogen levels. Typically, immunologic levels are found to be higher than levels measured by functional assay. Published data for the healthy population indicate that for fresh plasma samples, the ratio of immunologic to functional fibrinogen ranges from 1.12 to 1.65; ratios >1.65 are suggestive of dysfibrinogenemia.²⁹⁷

Another potentially useful test to evaluate patients for dysfibrinogenemia is the fibrinogen lysis time. This test requires partial purification of the patient's fibrinogen, followed by clotting and lysis in a standardized assay.²⁹⁸ Dysfibrinogens may also result in a false positive test for fibrin(ogen)-degradation products (FDPs) as assayed by latex agglutination, because residual fibrinogen remains in serum after clotting and is detected by the antibody-coated latex beads. An algorithm for the laboratory diagnosis of dysfibrinogenemia has been reported.²⁹⁹

Thrombomodulin Deficiency

Thrombomodulin complexed with thrombin is required to activate protein C. In theory, thrombomodulin deficiency should result in hypercoagulability. A number of mutations in the thrombomodulin gene have been identified in patients with venous thrombosis and their families.³⁰⁰ Routine laboratory testing for this disorder is not yet available, but an Italian study of thrombosis patients indicated that thrombomodulin deficiency is not a common cause of thrombosis.³⁰¹ Thrombomodulin gene mutations have been linked to MI.³⁰² In the prospective Atherosclerosis Risk in Communities study, soluble thrombomodulin levels had a graded inverse association with, and were a good predictor of, coronary artery disease.³⁰³ The levels correlated in their extreme quartiles with the coagulation activation marker prothrombin fragment 1+2.³⁰³

Lipoprotein(a)

Lipoprotein(a) (Lp[a]) is a lipoprotein moiety similar to LDL cholesterol in core lipid composition, and it has apolipoprotein (apo) B-100 as a surface apolipoprotein. In addition, Lp(a) has a unique glycoprotein, apo(a), which is bound to apoB-100. Apo(a) is structurally similar to plasminogen but lacks fibrinolytic activity.³⁰⁴ Lp(a) has both atherogenic and thrombogenic properties. Its thrombogenic effect is derived from stimulation of PAI-1 synthesis, promotion of intercellular adhesion molecule-1 expression by vascular endothelium, inhibition of both plasminogen and t-PA binding to fibrin, inhibition of plasminogen activation by t-PA, and competition with plasminogen for binding sites on endothelial cells and fibrin.³⁰⁵ The cumulative effect is impaired activation of plasminogen to plasmin at the vessel wall, inhibition of fibrinolysis, and increased risk for thrombosis.

The exact mechanisms that control Lp(a) levels are unknown, but genetic factors that regulate hepatic synthesis of apo(a) are likely important. One's plasma Lp(a) level is stabilized during infancy and maintained throughout life.³⁰⁶ Plasma concentrations >20 mg/dl seem to increase the risk of coronary artery disease, peripheral arterial occlusive disease (PAOD), and stroke.³⁰⁵ Lippi et al. evaluated Lp(a) in 68 patients subjected to vascular and endovascular surgery.³⁰⁷ Significant restenosis or reocclusion occurred in 23 (34%) patients. Lp(a) concentrations were significantly higher in those with restenosis and reocclusion compared with those in the no-restenosis group. Occlusive complications were unlikely to occur in patients with Lp(a) concentrations <5 mg/dl.³⁰⁷ Different isoforms of the apo(a) component of Lp(a) have different atherogenic potential and possibly different thrombogenic potential.

Measurement of Lp(a) should be considered mainly in individuals with atherosclerosis in the absence of classic risk factors, rapidly progressive atherosclerotic lesions despite aggressive risk factor modification, and individuals with acute arterial thrombosis.^{306, 308} Because it is an acute-phase reactant, an elevated Lp(a) level must be carefully interpreted if drawn shortly after surgery, acute thrombosis, or acute coronary syndromes.³⁰⁹

Patients with elevated Lp(a) benefit most from aggressive LDL cholesterol lowering. Although hepatic 3-methylglutaryl coenzyme A reductase inhibitors ("statins") may be the ideal agents for LDL lowering and atherosclerotic plaque stabilization, this class of drug does not appreciably lower Lp(a) levels themselves.³¹⁰ Nicotinic acid (niacin), usually in high

doses, is the first-line pharmacologic therapy to lower Lp(a) levels. Reductions up to 38% have been reported.³¹¹ Because nicotinic acid therapy may be poorly tolerated, a gradual escalation in dose and pretreatment with aspirin are recommended. In women, estrogen replacement therapy can lower Lp(a) levels by as much as 50%.³⁰⁸

Tissue Factor Pathway Inhibitor

Tissue factor pathway inhibitor (TFPI) is a major anticoagulant, present in plasma, and associated with vascular endothelium. TFPI binds to and neutralizes the TF/factor VIIa complex to inhibit activation of factor X. Low levels of TFPI are a weak risk factor for a first venous thrombosis, as well as recurrent VTE events.^{312, 313} Recent studies have also linked TFPI deficiency to arterial thrombosis.³¹⁴

Combined Defects

Compound heterozygosity for two different natural anticoagulant deficiencies is extremely rare, because of the low prevalence of each individual defect. The phenotypic presentation of such compound heterozygotes does not appear to be as severe as it is for the homozygous forms of each deficiency, with the rarely reported patient presenting with VTE of early onset (in the teenage years).^{98, 214} Because factor V Leiden is the most common inherited thrombophilia, double heterozygosity for factor V Leiden and a natural anticoagulant deficiency has been described in some families.^{125, 315} In families with both factor V Leiden and protein C deficiency, 73% of compound heterozygotes reported a history of VTE, compared with 31% and 13% of relatives with

P.1231

protein C deficiency only and factor V Leiden only, respectively.¹²⁵ In families with factor V Leiden and AT deficiency, 92% of double-heterozygous carriers had a history of VTE, as opposed to 57% and 20% of individuals with AT deficiency only and factor V Leiden only, respectively.³¹⁵

Combined heterozygosity for both the factor V Leiden and prothrombin G20210A mutations, which is estimated to occur in 1 in 1,000 persons, does appear to be associated with an increased relative risk of both first and recurrent VTE.^{190, 210, 316} In a pooled analysis of eight case-control studies including more than 2,000 patients with VTE, a 2.2% prevalence for the combined mutations was found in patients.¹⁹⁰ Double heterozygosity was associated with a 20-fold increased relative risk of VTE.¹⁹⁰ The risk of recurrent VTE for heterozygous carriers of both factor V Leiden and PT G20210A also appears to be increased (2.6-fold).²¹⁰

The prevalence of factor V Leiden carriership in combination with acquired hypercoagulable states has also been studied. Factor V Leiden appears to increase the risk of VTE in patients with antiphospholipid antibodies but is not a prerequisite for the development of VTE in those patients.³¹⁷ The interaction between factor V Leiden and hyperhomocysteinemia has been a matter of interest since the observation, not corroborated by further studies, that factor V Leiden appeared to be a prerequisite for VTE in individuals from families with classic homocystinuria.³¹⁸ Nonetheless, two studies on the interaction between mild to moderate hyperhomocysteinemia and factor V Leiden have yielded somewhat different findings. Den Heijer et al. found that the risk of VTE associated with the combination of conditions (2-fold) did not exceed the risk associated with each condition alone (9.5-fold for factor V Leiden, 2.2-fold for hyperhomocysteinemia).²⁴⁸ However, in the large Physicians' Health Study, the concomitant presence of both conditions did appear to be synergistic.¹⁸⁹

Inherited Risk Factors in Childhood Venous Thrombosis

Many of the common inherited thrombotic disorders described in adult patients have been linked to pediatric thrombosis. A prospective European study identified a single genetic risk factor in 54% of pediatric thrombosis patients.³¹⁹ Common defects identified were factor V Leiden (32%), protein C deficiency (9%), protein S deficiency (6%), prothrombin gene mutation (4%), and AT deficiency (3%).³¹⁹ In most patients, thrombosis is precipitated by superimposed nongenetic risk factors that included central venous catheters, cancer, sepsis, immobility, surgery, trauma, or use of oral contraceptives.³²⁰ For neonatal patients with thrombosis, the most significant factor associated with thrombosis is the presence of a central venous catheter.³²¹ In children with recurrent thrombosis, the factor V Leiden mutation is present in most patients.³²² Homozygous deficiencies of protein C or protein S are causal in neonatal purpura fulminans.^{133, 160} When pediatric patients are evaluated for protein C, protein S, or AT deficiency, pediatric reference ranges are mandatory, because age-related changes occur in the levels of these proteins.^{322a}

A consensus panel of the International Society on Thrombosis and Haemostasis has recommended that pediatric patients with thrombosis be routinely tested for inherited and acquired disorders in a comprehensive fashion.³²³ However, many of the suggested tests are not recommended by the College of American Pathologists' consensus panel, and there are no

data to indicate that patients with a genetic predisposition to thrombosis—children or adults—should be treated differently^{324, 325} from those without risk factors (discussed in the following section).

Perspective on Laboratory Testing for Inherited Thrombotic Disorders

Increased availability of hypercoagulable-state test “panels” and enhanced ability to identify an abnormality in tested patients have prompted widespread testing of thrombosis patients. Testing for acquired and inherited hypercoagulable states uncovers an abnormality in >50% of patients presenting with an initial VTE but may have minimal actual impact on management in most of these patients.^{24, 98, 326, 327} Such laboratory screening should be reserved for patients for whom the results of individual tests significantly affect the choice of anticoagulant agent, intensity of anticoagulant therapy, therapeutic monitoring, family screening, family planning, prognosis determination, and, most of all, duration of antithrombotic therapy. Testing “just to know” is neither cost-effective nor clinically appropriate. Table 55.4 lists situations in which hypercoagulable-state testing should be considered, but not necessarily performed, unless an a priori use of the test results has been determined. Table 55.5 lists potential elements of an initial battery of tests to detect a defined hypercoagulable state.

Patients should be considered for evaluation of these disorders if they are young (<45 years of age) with recurrent thrombosis, or if they have had a single idiopathic thrombotic event and have a positive family history.⁸⁹ This recommendation is based on the fact that, with the exception of hyperhomocysteinemia and qualitative abnormalities of plasminogen, inherited thrombotic disorders, especially the five most common (APC-R, prothrombin G20210A, protein C deficiency, protein S deficiency, and AT deficiency), are autosomal dominant disorders, and most patients with these disorders (but not all³²⁸) have supportive family histories. Patients without a family history of thrombosis should be evaluated for common acquired etiologies for thrombosis, including malignancy, myeloproliferative disorders, PNH, and antiphospholipid antibodies.⁸⁹ Because thrombosis may induce an acute-phase response that may affect functional coagulation assays, testing is ideally done when the patient has fully recovered from the acute event and is not receiving anticoagulants. Functional assays are preferred over immunologic assays, so that both type I and type II disorders can be detected. An important exception to this recommendation is APC-R, which can be screened for using a DNA test that is not affected by acute-phase responses or anticoagulant therapy. Diagnosis of protein C or S deficiency in patients already anticoagulated with warfarin can be facilitated by parental testing, testing symptomatic family members who are not receiving anticoagulation, referral to a reference laboratory that has standardized assays for these natural anticoagulants in anticoagulated patients, or temporary cessation of warfarin therapy (minimum of 3 to 4 weeks).⁸⁹ Patients with arterial thrombosis should be considered for testing for hyperhomocysteinemia, Lp(a), and, possibly, protein S deficiency and antiphospholipid antibodies.³

TABLE 55.4 CLINICAL CIRCUMSTANCES IN WHICH SELECTED HYPERCOAGULABLE STATE TESTING MAY BE CONSIDERED

Idiopathic VTE

VTE in unusual sites

Heparin resistance

Recurrent VTE (especially if idiopathic)

VTE at young age (<45 y)

VTE in the setting of a strong family history of VTE

Unexplained recurrent (≥ 3 in first trimester) pregnancy loss

Family members of VTE patients with known inherited hypercoagulable states

VTE, venous thromboembolism.

P.1232

TABLE 55.5 SCREENING LABORATORY EVALUATION FOR PATIENTS SUSPECTED OF HAVING A HYPERCOAGULABLE STATE

Activated protein C resistance (diluting patient plasma with factor V-deficient plasma)

Prothrombin G20210A mutation testing by polymerase chain reaction

Activity assays for antithrombin, protein C, and protein S^a

Activated partial thromboplastin time, mixing studies, and dilute Russell viper venom time^{a, b}

Fasting total plasma homocysteine level

Anticardiolipin and β_2 -glycoprotein 1 antibody testing by enzyme-linked immunosorbent assays

Factor VIII activity^a

^a Assays should not be done at the time of acute thrombosis or while the patient is anticoagulated.

^b aPTT and dRVVT mixing studies that do not correct should be further evaluated for the lupus anticoagulant with phospholipid correction tests.

In addition to a positive family history of thrombosis, other clinical features may suggest inherited thrombosis, including recurrent spontaneous thromboses, thrombosis in unusual sites (mesenteric vein), thrombosis at an early age, heparin resistance (suggestive of AT deficiency), warfarin-induced skin necrosis and neonatal purpura fulminans (suggestive of protein C or protein S deficiency), and thrombosis occurring with estrogen therapy or pregnancy (suggestive of APC-R or prothrombin G20210A). The presence of these clinical events may justify laboratory evaluation of these patients. Even in situations in which the relative risk of thrombosis and recurrent thrombosis is increased, the absolute risk for a particular patient may not warrant the risks of chronic anticoagulation. Thus, one should always assess the pretest use of hypercoagulable-state testing before embarking on an expensive investigation.

A more fundamental question is whether routine laboratory testing for inherited thrombotic disorders will change treatment (intensity or duration of anticoagulation). This is a controversial subject because the available data do not support the contention that patients with an inherited thrombotic disorder should be managed differently from patients without such a disorder.^{24, 327} Several prospective trials performed to address this question found that positive inherited thrombophilia testing results did not affect the rate of recurrent VTE (reviewed in Reference 24). Another study found that thrombophilia testing at a major urban medical center was overutilized, and that a majority of tests were ordered at suboptimal times.³²⁹

There are three thrombotic risk factors that may influence treatment strategy: The presence of antiphospholipid antibodies (discussed in Chapter 54), AT deficiency, and (perhaps) hyperhomocysteinemia. Patients with antiphospholipid antibodies may require a longer duration of oral anticoagulation, and some patients with hyperhomocysteinemia may respond to vitamin therapy to resolve this thrombosis risk factor (although clinical trial data have not demonstrated a benefit of lowering homocysteine levels^{257, 258, 259}). Patients identified as having AT deficiency may benefit from this diagnosis because availability of AT concentrates may optimize their management. Table 55.6 summarizes the clinical laboratory testing recommendations of the College of American Pathologists' Consensus Conference on Thrombophilia.

Laboratory Testing for the Prethrombotic State

Levels of fibrin degradation products, including cross-linked fibrin degradation products (D-dimer), are usually increased in the presence of acute VTE. Absence of an elevated level of D-dimer in patients undergoing an evaluation for acute DVT or PE has an excellent negative predictive value for thrombosis.³³⁰ D-dimer measured 3 months after oral anticoagulation for DVT treatment was discontinued has been shown to have a negative predictive value of 95.6% for VTE recurrence.³³¹ It has also been shown that baseline elevations of D-dimer are strongly and positively related to the occurrence of future venous thrombosis.³³² Plasma levels of fibrinopeptide A can be increased in venous thrombosis patients, but this assay has the disadvantage of requiring rigorous attention to specimen collection to avoid an activated plasma sample. The activation peptide generated when prothrombin is cleaved to form thrombin, prothrombin fragment 1+2, is a sensitive measure of thrombin formation.³³³ Other markers of activation of coagulation include thrombin-AT complex and plasmin-antiplasmin complex.

One active area of investigation is optimizing the combination of a sensitive D-dimer assay with clinical criteria to exclude VTE^{334, 335} or risk of recurrent VTE.^{336, 337} Figure 55.2 depicts one strategy algorithm to incorporate D-dimer testing in thrombosis evaluation.

ANTITHROMBOTIC THERAPY

Arterial and venous thrombotic events combined, including acute coronary syndromes, stroke, peripheral arterial thrombosis, DVT, and PE, are likely responsible for more morbidity and mortality than any other condition in the developed world.

Cardiovascular disease was reported to be the underlying cause of death in ~30% of all deaths in the United States in 2010.¹ Every year 750,000 new strokes occur in the United States, of which 85% are ischemic in nature.³³⁸ Because approximately one third of these patients die as a direct or indirect result of their cerebrovascular-thrombosis-related occlusion, stroke is the third leading cause of death in this country. In addition, stroke is the leading cause of serious long-term disability in the United States, with roughly 4.7 million total stroke survivors.³³⁸ Acute limb ischemia secondary to peripheral arterial thrombosis and thromboembolism involving native and prosthetic vessels is a relatively uncommon but ominous form of vascular accident. National databases suggest a rate of 16 events annually per 100,000 population.³³⁹ In a fashion similar to coronary artery thrombosis, acute peripheral arterial thrombosis typically develops at sites of pre-existing peripheral atherosclerotic occlusive disease (PAOD). PAOD has been diagnosed in as many as 17% of men and 20% of women >55 years of age and is highly predictive for the coexistence of coronary and cerebral vascular disease. It has been estimated that PAOD progresses to critical limb ischemia in 15% to 20% of patients.^{340, 341}

Acute VTE, including DVT and PE, is a common, potentially life-threatening, often preventable vascular condition associated with trauma, major surgery, advanced congestive heart failure, pregnancy, HRT, malignancy, and inherited hypercoagulability. Proximal lower-extremity DVT can result in venous limb gangrene (phlegmasia cerulea dolens), chronic stasis changes related to the postthrombotic syndrome (PTS), and symptomatic PE. PE in its most severe presentation can result in pulmonary hypertension, right-sided heart failure, cardiopulmonary collapse, and death.

A common feature of the management of all thromboembolic vascular diseases is the use of antithrombotic agents. Antithrombotic agents, including antiplatelet drugs, anticoagulants, and thrombolytic agents, are used to prevent thrombotic events, prevent or mitigate the complications of thrombotic events, and restore vascular patency to prevent loss of tissue, organ, and limb function, as well as life. Based on the pathologic basis of thrombosis involving different vascular beds, drugs that inhibit platelet activation and aggregation play a primary role in arterial disease management, whereas drugs that inhibit thrombin and fibrin generation play a primary role in venous disease

P.1233

management. The following sections describe the pharmacodynamics, pharmacokinetics, and clinical uses of select antithrombotic agents.

TABLE 55.6 SUMMARY OF THE COLLEGE OF AMERICAN PATHOLOGISTS™ RECOMMENDATIONS ON LABORATORY TESTING FOR INHERITED THROMBOSIS

Thrombotic Disorder	Who Should Be Tested?	Test Method(s)	Comments
FVL	First VTE at age <50 y Recurrent VTE First unprovoked VTE First VTE, unusual site First VTE, positive family history First VTE related to pregnancy or hormonal therapy Unexplained second- or third-trimester pregnancy loss	APC-R assay using factor V-deficient plasma <i>or</i> DNA-based assay	Patients with relatives who are known to have FVL should be tested directly with DNA-based assays. Patients with positive APC-R assays should have confirmatory DNA tests.
Prothrombin gene	As above	DNA-based assay	Prothrombin activity assays should not be

mutation			used.
Homocysteinemia	Arterial vascular disease; controversial for VTE	High-performance liquid chromatography or immunoassays	Genotyping for methylenetetrahydrofolate reductase mutations is not recommended. Fasting may not be necessary. Proper sample processing is necessary. Testing in VTE patients may be appropriate to identify and treat affected patients with vitamins.
PC deficiency	Infants with neonatal purpura fulminans; VTE patient from a family with known PC deficiency Asymptomatic female from a known PC-deficient family before hormonal therapy	Chromogenic substrate assays preferred Functional assays are useful Immunologic assays are discouraged	Avoid testing during acute thrombosis or anticoagulant therapy. Exclude causes of acquired PC deficiency. Consider age-dependent reference ranges.
PS deficiency	Patient with VTE from a family with known PS deficiency	Functional assay <i>or</i> immunoassay for free PS Total PS antigen assays not recommended	Abnormal functional assay results should be confirmed with an immunoassay for free PS. Exclude acquired causes of PS deficiency. Avoid testing during acute thrombosis, anticoagulant therapy, and pregnancy. Consider age- and gender-dependent reference ranges.
AT deficiency	Patient with VTE from a family with known AT deficiency Asymptomatic female from a known AT-deficient family before hormonal therapy	Chromogenic substrate assays preferred AT antigen assays not recommended	Exclude acquired causes of AT deficiency. Avoid testing during acute thrombosis or anticoagulant therapy.
Elevated factor VIII levels	Controversial	Factor VIII activity assay	Test 6 mo after thrombosis. Avoid anticoagulant therapy.
Dysfibrinogenemia	Not recommended		
Heparin cofactor II	Not recommended		
Factor XIII polymorphisms	Not recommended		
Plasminogen	Not recommended		

activator inhibitor-1

Plasminogen deficiency Test in non-DVT patients with ligneous conjunctivitis

APC, activated protein C; AT, antithrombin; FVL, factor V Leiden; PC, protein C; PS, protein S; VTE, venous thromboembolism.

From the College of American Pathologists' Consensus Conference on Thrombophilia. Arch Pathol Lab Med 2001;126:1277-1433, with permission.

Antiplatelet Drugs

Given the important role of platelets in mediating arterial thrombosis and the significant morbidity and mortality of arterial thrombotic disorders, the safety and efficacy of antiplatelet drugs have been evaluated in numerous primary and secondary prevention trials. A 1988 meta-analysis indicated that antiplatelet treatment reduced overall mortality from vascular disease by 15% and that nonfatal vascular events were reduced by 30%.³⁴² A 2002 update on this subject supports the original observation of the efficacy of antiplatelet therapy.³⁴³ The American College of Chest Physicians' consensus conference has summarized the status of clinical trials with aspirin and other antiplatelet drugs.³⁴⁴

Numerous potential targets exist for antiplatelet therapy (Fig. 55.3). Platelet cyclo-oxygenase (COX) is the target of acetylation and irreversible inactivation by aspirin.^{345, 346} ADP-induced platelet aggregation can be selectively inhibited by the thienopyridines, ticlopidine, clopidogrel, prasugrel, and by ticagrelor, a member of the cyclopentyltriazolopyrimidine class of drugs.^{345, 346} Dipyridamole alters platelet function, in part, by inhibition of cyclic nucleotide phosphodiesterase to increase platelet cyclic AMP levels.³⁴⁶ Other potential targets for antiplatelet therapy include the platelet membrane receptor, gpIb, mediator of platelet adhesion, and inhibitors to thrombin, the most potent stimulus to platelet activation.^{345, 346} Interference with fibrinogen-mediated platelet aggregation by anti-gpIIb-IIIa antibodies and peptides is well established.³⁴⁴

P.1234

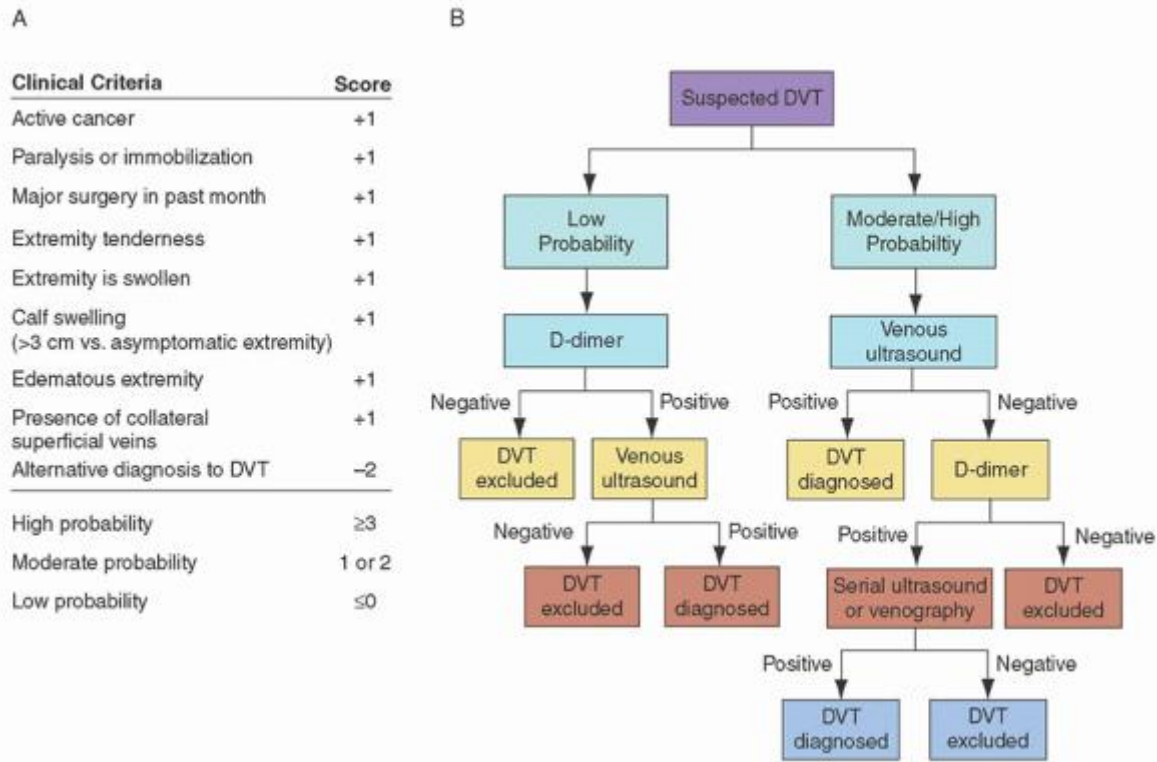

FIGURE 55.2. Algorithm for excluding deep vein thrombosis (DVT) using clinical criteria, D-dimer testing, and venous ultrasound. Clinical criteria are based on those of Wells PS, Anderson DR, Bormanis J, et al. Value of assessment of pretest probability of deep-vein thrombosis in clinical management. *Lancet* 1997;350:1795-1798. D-dimer methods are similar to those described by Hirsh J, Lee AY. How we diagnose and treat deep vein thrombosis. *Blood* 2002;99: 3102-3110. A: Based on clinical criteria fulfilled by the patient, the cumulative score is tallied. High probability is a score ≥3, moderate probability is 1 or 2, low probability is ≤0. B: The probability score is used with D-dimer assay and ultrasound to determine which patients may be excluded from DVT testing.

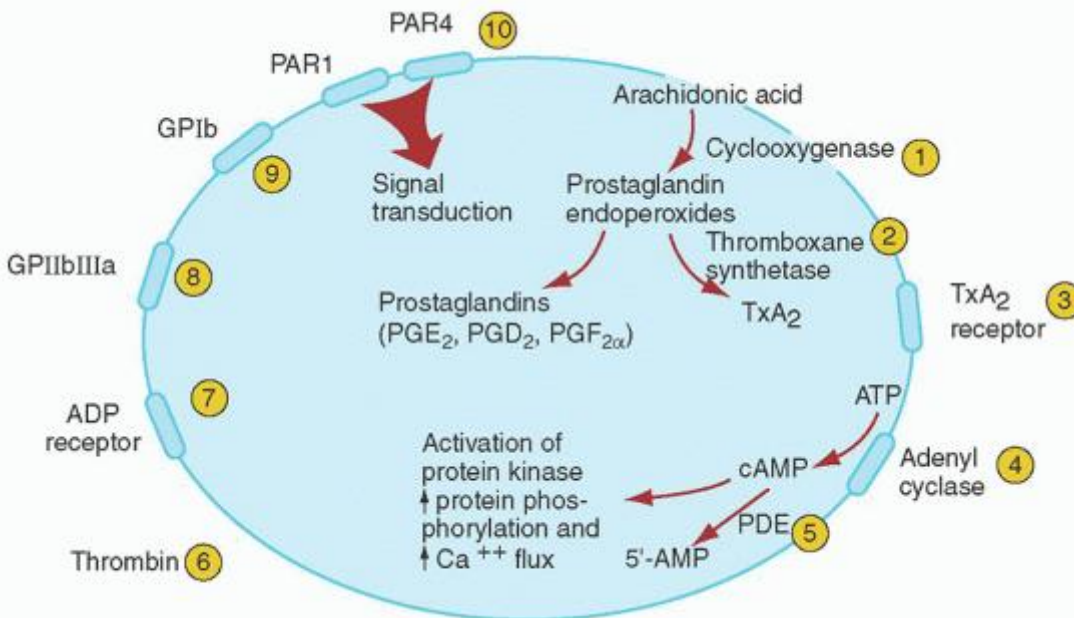

FIGURE 55.3. Targets for antiplatelet agents. This diagram summarizes certain aspects of platelet function relevant to antiplatelet therapy. Platelet metabolic pathways, membrane receptors, and enzymes are depicted with specific therapeutic targets enumerated. Four target categories for antiplatelet drugs are the arachidonic acid pathway, which

regulates production of prostaglandins (PGs) and thromboxanes; the cyclic adenosine monophosphate (cAMP) mechanism, which modulates important metabolic events; platelet membrane glycoproteins (GPs), which act as receptors for platelet agonists; and thrombin, a key stimulus to platelet activation. Specific targets for antiplatelet therapies include the following: (1) COX is the target of acetylation and irreversible inactivation by aspirin, as well as reversible inactivation by the nonsteroidal anti-inflammatory agents; (2) inhibitors to thromboxane synthetase prevent generation of thromboxane A₂ (TxA₂); (3) an example of a TxA₂ receptor antagonist is BM 531; (4) infusion of PGE₁ or stable analogs of prostacyclin (Iloprost) increases platelet concentrations of cAMP via stimulation of adenylate cyclase; (5) dipyridamole increases platelet cAMP concentrations by inhibition of cyclic nucleotide phosphodiesterase (PDE), and cilostazol inhibits PDE3 to increase platelet cGMP concentrations; (6) because thrombin is the most potent stimulus to platelet activation, inhibitors of thrombin (heparin, argatroban, and bivalirudin) are important agents in preventing platelet-dependent thrombosis; (7) ticlopidine, clopidogrel, prasugrel, and ticagrelor inhibit platelet activation by inhibition of adenosine-diphosphate (ADP)-induced aggregation; (8) monoclonal antibodies or peptides directed against the GPIIb-IIIa complex inhibit fibrinogen binding to platelets and subsequent platelet aggregation; (9) inhibitors to the von Willebrand factor receptor (GPIb) are being developed to prevent platelet adhesion; and (10) inhibitors to protease-activated receptors 1 and 4 (PAR 1 and 4) such as vorapaxar antagonize thrombin activation of platelets. ATP, adenosine triphosphate. Reproduced and modified from Greenberg PL, Negrin R, Rodgers GM. Hematologic disorders. In: Melmon KL, Morrelli HF, Hoffman BB, et al., eds. Clinical pharmacology: basic principles in therapeutics, 3rd ed. McGraw-Hill, 1992:524-599.

P.1235

Aspirin

Aspirin (acetylsalicylic acid) is the prototypical antiplatelet drug, exerting its antithrombotic action by irreversibly inactivating (by acetylation) the COX activity of platelet prostaglandin H synthase-1 (COX-1) and prostaglandin H synthase-2 (COX-2).³⁴⁷ This COX inhibition leads to the prevention of TxA₂ synthesis and impairment of platelet secretion and aggregation.³⁴⁸ A variety of nonsteroidal anti-inflammatory drugs can inhibit TxA₂-dependent platelet function via competitive reversible inhibition of COX-1. A lesser degree of COX-1 inhibition may explain why long-term use of nonaspirin nonsteroidal anti-inflammatory drugs is not protective against first MIs in postmenopausal women.³⁴⁹ Aspirin is the least expensive, most widely studied, and most widely used antiplatelet drug.

Aspirin (when not enteric-coated) is rapidly absorbed from the upper gastrointestinal tract; plasma salicylate concentrations peak within 1 hour of ingestion. The effects of aspirin on platelet function occur within 1 hour and last for the duration of the affected platelets' lifespan (~1 week). The toxicity of aspirin is dose-related, explaining why clinical studies have focused on finding the lowest effective antithrombotic dose of the drug. Toxicities include gastrointestinal discomfort and blood loss, and the risk of systemic bleeding. Clinical trials suggest that aspirin doses as low as 75 mg/day or 30 mg/day are antithrombotic.^{343, 344}

In addition to reducing aspirin toxicity, lower aspirin doses also inhibit vascular endothelial cell prostacyclin production to a lesser extent, because inhibition of endothelial cell COX is of shorter duration and requires higher aspirin doses than does platelet COX inhibition.³⁵⁰ The inhibitory effects of chronic low-dose aspirin administration are cumulative.³⁵¹ However, even when taken chronically in large doses, aspirin is not believed to be thrombogenic.³⁵²

The 2012 consensus conference statement on antiplatelet therapy indicates that aspirin has been convincingly demonstrated to be effective in treatment of the following thrombotic disorders: Stable and unstable angina, acute MI, transient ischemic attack and incomplete stroke, stroke after carotid artery surgery, atrial fibrillation (low risk), and prosthetic heart valves (in combination with warfarin).³⁴⁴ The minimum effective aspirin dose for these indications is 75 to 325 mg/day. Aspirin has also been shown to reduce mortality post-coronary-artery bypass surgery and to be effective for primary prevention of cardiovascular events,^{353, 354} although more recent meta-analysis data of aspirin use for primary prophylaxis show less-certain benefits.³⁵⁵

Data from the Clopidogrel for High Atherothrombotic Risk and Ischemic Stabilization, Management, and Avoidance (CHARISMA) trial highlight aspirin's pre-eminent antiplatelet role in cardioprevention.³⁵⁶ CHARISMA assessed whether adding clopidogrel (75 mg/day) to aspirin therapy (75 to 162 mg/day) provided any benefit over aspirin monotherapy in preventing MI, stroke, or death from cardiovascular disease. The study involved 15,603 patients aged 45 years or older who were at high risk for these events. The study showed that the addition of clopidogrel to aspirin did not result in a significant lowering of risk of the primary composite endpoint. In addition, the rate of severe bleeding was 1.7% and 1.3% for the clopidogrel-plus-aspirin and aspirin-only groups, respectively. Clopidogrel in addition to aspirin did reduce the

relative risk of a recurrent MI, stroke, or cardiovascular death by 12.5% in the subgroup of patients with established atherothrombotic disease. The subgroup of patients with multiple risk factors but no clearly established vascular disease did not benefit from the addition of clopidogrel and actually had nonstatistically significant increases in cardiovascular events and bleeding. Clopidogrel plus aspirin remains an approved and standard therapy in conjunction with coronary artery stenting.

Aspirin may modify the natural history of intermittent claudication from lower-extremity arteriosclerosis. Because these patients are at high risk for future cardiovascular and cerebrovascular atherothrombotic events, life-long aspirin therapy is recommended.³⁵⁷ Similar therapy is advisable after peripheral arterial bypass surgery and carotid endarterectomy.

The Pulmonary Embolism Prevention trial was a large-scale, double-blind, multicenter study of 13,356 patients undergoing surgery for hip fracture and an additional 4,088 patients undergoing elective knee or hip arthroplasty.³⁵⁸ Patients were assigned to a regimen of 160 mg of aspirin or placebo once daily for 5 weeks, with the first dose given before surgery. Other forms of prophylaxis were allowed, and 40% of patients received unfractionated heparin (UFH) or LMWH in addition to the aspirin. The study demonstrated that aspirin reduced the incidence of fatal PE (58% risk reduction) and symptomatic nonfatal DVT or PE (36% risk reduction) in patients with hip fracture.³⁵⁸ Although beneficial when compared to placebo, aspirin cannot be recommended as first-line VTE prophylaxis in hip fracture patients, because the benefit of aspirin is less than with anticoagulants.³⁵⁹ The potential role of aspirin in treating VTE has been resurrected by the results of a VTE treatment trial that demonstrated that aspirin therapy, begun after 6 to 18 months of oral anticoagulant treatment, reduced VTE recurrence by ~40% compared to placebo.³⁶⁰ Aspirin, used as prophylaxis for VTE recurrence, would have the advantage of being an active drug to also prevent arterial thrombosis.^{360a}

The concept of "aspirin resistance" has been popularized. This term refers to persistent platelet activation that occurs in patients treated with aspirin who experience treatment failure. There are numerous reasons for aspirin resistance;³⁶¹ current recommendations are to not test routinely for aspirin resistance and to not change therapy based on such test results.³⁶² One literature review concluded that the most common cause for aspirin resistance was noncompliance.³⁶³ Routine laboratory monitoring for aspirin resistance is not recommended.³⁶⁴

Thienopyridines

Ticlopidine and clopidogrel are structurally related compounds that selectively inhibit ADP-induced platelet aggregation and likely ADP-mediated amplification of the platelet response to other agonists.³⁶⁵ A lack of in vitro platelet aggregation inhibition suggests that in vivo hepatic transformation to an active metabolite is necessary for an antiplatelet effect. Both agents were initially used as aspirin substitutes in aspirin-intolerant patients. Enthusiasm for ticlopidine has been dampened by associated hematologic complications. Ticlopidine has been associated with neutropenia, thrombocytopenia, aplastic anemia, and thrombotic thrombocytopenic purpura.^{366, 367, 368, 369}

Clopidogrel, an irreversible inhibitor of the P2Y₁₂ ADP receptor, is rapidly absorbed and extensively metabolized. The plasma half-life of the main systemic metabolite, SR 26334, is roughly 8 hours.³⁷⁰ Platelet function returns to normal approximately 7 days after the last dose of clopidogrel. The Clopidogrel Versus Aspirin in Patients at Risk of Ischemic Events trial compared clopidogrel to aspirin in patients who had experienced a recent stroke or a recent MI and in those presenting with symptomatic peripheral arterial disease.³⁷¹ A modest difference in efficacy was observed. The annual ischemic event rate for aspirin was 5.83% compared to 5.32% for clopidogrel. The majority of the difference in efficacy occurred in the patients who entered the trial because of symptomatic peripheral arterial disease, with a 23.8% relative risk reduction.³⁷¹ The Clopidogrel in Unstable Angina to Prevent Recurrent Events trial has demonstrated an advantage of clopidogrel plus aspirin over aspirin alone in patients with acute coronary syndromes.³⁷² Clopidogrel, like ticlopidine, can rarely precipitate thrombotic thrombocytopenic purpura.³⁷³

Despite the current standard antiplatelet regimen of aspirin and clopidogrel (with or without glycoprotein IIb/IIIa inhibitors) in percutaneous coronary intervention (PCI) patients, peri-procedural and postprocedural ischemic events continue to occur. Prasugrel, a newer potent thienopyridine P2Y₁₂ receptor antagonist, can

P.1236

achieve more rapid and higher levels of inhibition of ADP-induced platelet aggregation than clopidogrel.³⁷⁴ However, although a major clinical trial with prasugrel found that it did not reduce overall mortality, it did increase major bleeding (reviewed in Reference 344).

Ticagrelor, a new antiplatelet agent of the cyclopentyltriazolopyrimidine class, reversibly inhibits the P2Y₁₂ ADP receptor in platelets.³⁴⁶ An international trial that compared clopidogrel versus ticagrelor in patients with an acute coronary

syndrome found that although the overall trial results demonstrated that ticagrelor was the superior drug, the results for United States' patients showed the opposite, with clopidogrel associated with better outcomes. Major bleeding rates between the two drugs were similar.³⁴⁶ Perioperative management of patients on antiplatelet therapy has been reviewed.^{374a}

Integrin $\alpha_{IIb}\beta_3$ (Glycoprotein IIb/IIIa) Receptor Antagonists

Because of the multitude of pathways that lead to platelet aggregation, it is not surprising that the clinical efficacy of the antiplatelet agents described above is only partial. Even combination therapy with clopidogrel and aspirin, resulting in partial inhibition of TxA_2 - and ADP-mediated platelet aggregation, leaves platelets susceptible to agonists such as thrombin and collagen.³⁴¹ Because expression of functionally active gPIIb/IIIa on platelet surfaces is the final common pathway of platelet aggregation regardless of initial stimulus, it is logical to target this glycoprotein receptor with antiplatelet agents for maximal platelet inhibition.

gPIIb/IIIa is a member of the integrin family of receptors. These receptors recognize the amino acid sequence arginine-glycine-aspartate (Arg-Gly-Asp [RGD]), which represents the cell attachment regulation sequence present in certain adhesive proteins such as fibrinogen.³⁷⁵ Inhibitors of fibrinogen binding to gPIIb/IIIa , called the disintegrins, include a chimeric monoclonal antibody against the receptor, naturally occurring RGD sequence-containing peptides from snake (pit viper) venoms, synthetic RGD peptides, synthetic Lys-Gly-Asp (KGD) peptides, peptidomimetics, and nonpeptide RGD mimetics.^{344, 376, 377, 378}

Three parenteral gPIIb/IIIa inhibitors have been extensively studied, primarily in the settings of PCI, unstable angina, and non-Q-wave MI. These are abciximab, eptifibatide, and tirofiban.^{344, 346} Abciximab (c7E3 Fab) is a chimeric Fab fragment of human and murine protein that binds to gPIIb/IIIa . Abciximab is unique among the gPIIb/IIIa antagonists because it also blocks the $\alpha_v\beta_3$ receptor.³⁷⁹ Eptifibatide is a synthetic cyclic heptapeptide with a KGD sequence that is more specific for gPIIb/IIIa than the RGD sequence.^{344, 376} Tirofiban is a synthetic peptidomimetic based on the RGD sequence.³⁸⁰ Oral gPIIb/IIIa inhibitors have been generally unsuccessful. Current and emerging antiplatelet therapies have been reviewed.³⁴⁶

Anticoagulant Drugs

Anticoagulant drugs are ubiquitous in medical and surgical practice. Anticoagulants are used to prevent and treat thrombosis. Traditionally, short-term anticoagulation is provided in the form of an intravenous infusion or subcutaneous injection whereas more chronic anticoagulation is facilitated by the use of oral agents. However, narrow-spectrum (single-protein-target) oral anticoagulants (e.g., dabigatran, rivaroxaban, and apixaban) are beginning to supplant more broad-spectrum anticoagulants (e.g., heparin and warfarin) and this trend will likely continue. The 2012 version of the American College of Chest Physicians Clinical Practice Guidelines has been published.³⁸¹

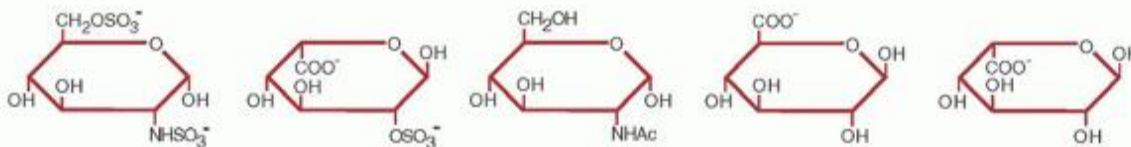

FIGURE 55.4. Structure of the common active saccharide moieties found in commercial unfractionated heparin. These polymeric structures are termed glycosaminoglycans. From left to right, the saccharide structures are 2-deoxy-2-sulfamino- α -D-glucose-6-sulfate; α -L-iduronic acid-2-sulfate; 2-acetamido-2-deoxy- α -D-glucose; β -D-glucuronic acid; and α -L-iduronic acid. Reproduced from Greenberg PL, Negrin R, Rodgers GM. Hematologic disorders. In: Melmon KL, Morrelli HF, Hoffman BB, et al., eds. Clinical pharmacology: basic principles in therapeutics, 3rd ed. McGraw-Hill, 1992:524-599, with permission.

Heparin

Heparin is a naturally occurring, highly sulfated glycosaminoglycan that is normally present in human tissues (Fig. 55.4). McLean first isolated heparin from ox liver and identified its anticoagulant properties.³⁸² Commercial UFH is obtained from either bovine lung or porcine intestinal mucosa and consists of a heterogeneous mixture of polysaccharides (glycosaminoglycans) with molecular weights ranging from 4,000 to 30,000 D, with a mean molecular weight of approximately 15,000 D (approximately 45 saccharide units). UFH molecules possessing anticoagulant activity constitute approximately one third by weight of commercial heparin products.³⁸³ Sodium and calcium salts of heparin are available, and most commercial heparin preparations have specific activities of ~ 150 U/mg. Heparin structure consists of alternating residues of uronic acid and glucosamine that are variably sulfated.³⁸⁴ Sulfation of residues in heparin is a major

determinant of the anticoagulant activity of a given heparin preparation; the heparin molecules with anticoagulant activity exhibit high-affinity binding to AT.

UFH molecules contain a randomly distributed unique pentasaccharide sequence that binds to AT. Once bound to UFH, the natural anticoagulant effect of AT is potentiated, resulting in the accelerated binding and inactivation of serine proteases in general, and factor Xa and thrombin in particular.^{385, 386} The inhibition of these factors affects the common pathway of coagulation, resulting in decreased formation of thrombin and fibrin.

Heparin's interaction with AT is thought to occur as follows and is depicted in Figure 55.5. A ternary complex with heparin, thrombin, and AT first occurs; this association permits inactivation of thrombin by the active site inhibitor domain of AT. Lastly, heparin dissociates from the AT-thrombin complex to subsequently catalyze additional AT-mediated reactions.³⁸⁷ A pentasaccharide series interacts only with the AT-binding sequence and promotes factor Xa inhibition substantially but has minimal effect on thrombin inhibition.³⁸⁸ In this case, only the conformational change induced by the pentasaccharide is necessary for factor Xa inhibition to occur. Oligosaccharides of greater length (at least 18 residues) are necessary for enhancement of thrombin inhibition by AT. It is likely that in this latter case, a ternary complex of ATIII, thrombin, and heparin forms to mediate protease inhibition.³⁸⁹ In vitro experiments suggest that UFH exerts its major anticoagulant effect by promoting AT suppression of thrombin-dependent amplification reactions.³⁹⁰

In addition to its anticoagulant activity, heparin possesses other, unrelated biologic effects.³⁹¹ Heparin hydrolyzes triglycerides

P.1237

from chylomicrons and very-low-density lipoproteins by release of endothelial cell lipoprotein lipase into the blood.³⁹² Heparin can also activate platelets, suppress cell-mediated immunity, and affect metabolism of aldosterone and thyroxine. Heparin is active when given parenterally, either intravenously or subcutaneously. Because of its highly charged nature and inability to cross biologic membranes alone, oral use of heparin has historically been viewed as impossible. Recently, delivery systems have been developed that make oral heparin a possibility and when sufficient amounts of heparin are administered orally, a prophylactic intensity of anticoagulation can be achieved.³⁹³

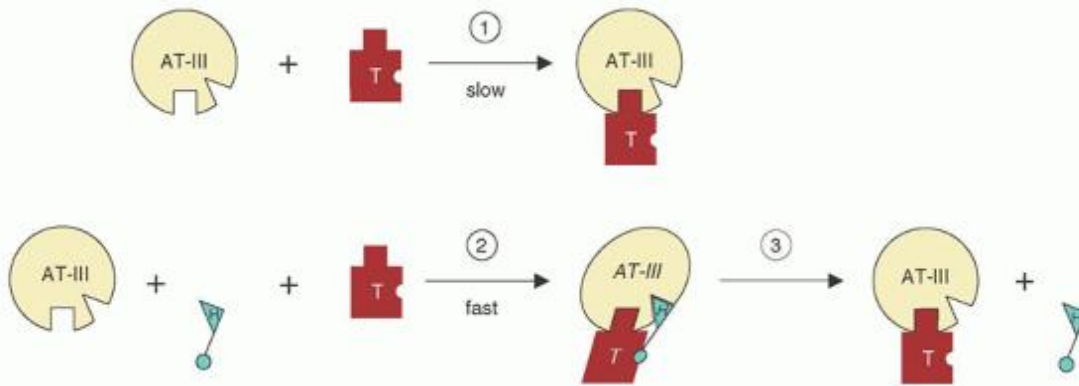

FIGURE 55.5. Inhibition of thrombin activity by the heparin (H)-antithrombin (AT) mechanism. Reaction 1 indicates that in the absence of heparin catalysis, AT can irreversibly inactivate thrombin (T), albeit in an inefficient manner. In the presence of H, a conformation change occurs in the AT molecule, and heparin also acts as a template to bind both AT and T, promoting rapid inactivation of coagulation (reaction 2). In reaction 3, heparin is released from the AT-T complex and is available to catalyze subsequent reactions. Inhibition of factor Xa by AT-H does not require binding of heparin to the factor Xa molecule.

The half-life of heparin varies with the dosage given, with the half-life increasing with increasing dosage.³⁹⁴ A 100-U/kg intravenous dose is cleared with a half-life of ~1 hour. The clearance of heparin is also affected by the extent of thromboembolism, with extensive thrombosis decreasing heparin half-life.³⁹⁵ Heparin is cleared by the reticuloendothelial system and metabolized by the liver, and metabolic products are excreted in the urine. The anticoagulant effect of heparin is also altered by its nonspecific binding to plasma proteins and cells.³⁹⁶ Given these numerous variables affecting the plasma half-life of heparin, therapeutic use of this drug generally requires close laboratory monitoring to ensure attainment of a therapeutic effect and regulation of heparin levels within a targeted range to optimize safety and efficacy. When using intravenous heparin, the use of established nomogram-guided therapy is preferred.³⁹⁷ Table 55.7 illustrates an example of a weight-based nomogram for using UFH. This assumes that the hospital laboratory has calibrated the aPTT

values such that an aPTT range from 1.5 to 2.5 times the mean laboratory control aPTT is equivalent to plasma heparin levels of 0.3 to 0.7 U/ml, as measured by anti-factor Xa activity.³⁹⁷

Pharmacologic reversal of UFH anticoagulant activity can be achieved with protamine sulfate. Protamine is a positively charged moiety derived from salmon sperm that can interact with the negatively charged UFH to form a stable complex that lacks anticoagulant activity. One milligram of protamine can inactivate ~100 U of UFH. Protamine, in excess, can promote an anticoagulant state. Because of a clinically meaningful risk of anaphylaxis, protamine should be administered with caution and is normally reserved for use in case of life-threatening bleeding or UFH overdose and reversal of anticoagulation following cardiopulmonary bypass.

An additional challenge to the use of heparin to prevent and treat thrombosis is heparin resistance. "True" heparin resistance manifests as inadequate anticoagulant and antithrombotic responses from what would otherwise be perceived as an adequate, and probably weight-based, dose of heparin. Some have deemed a requirement of >35,000 U of heparin per 24-hour period, regardless of patient weight, to reflect this form of heparin resistance.³⁹⁸ With true heparin resistance, both a measurement of anticoagulant activity such as the aPTT and a measurement of antithrombotic activity such as the anti-factor Xa activity assay demonstrate inadequate degrees of heparin activity. True heparin resistance most likely results from the nonspecific binding of heparin to mononuclear white cells, vascular endothelial cells, and acute-phase proteins such as histidine-rich glycoprotein, vitronectin, and PF4, resulting in an inadequate quantity of free or AT-bound heparin.³⁹⁶ Another potential cause of heparin resistance is acquired AT deficiency such as can be seen in cancer patients.

Patients can also manifest an "apparent" heparin resistance characterized by dissociation between the aPTT and heparin assays.³⁹⁸ In these patients, the aPTT may be normal or near normal, whereas the anti-factor Xa activity assay reveals an appropriate target heparin activity level between 0.3 and 0.7 U/ml. Simply escalating the dose of heparin to achieve the desired aPTT without checking a heparin assay may result in a pronounced bleeding risk. Dissociation between the aPTT and

P.1238

heparin concentration likely reflects elevated levels of factor VIII that can shorten the in vitro aPTT without affecting the antithrombotic actions of the drug.

TABLE 55.7 WEIGHT-BASED NOMOGRAM OF UNFRACTIONATED HEPARIN (UFH) IN TREATMENT OF VENOUS THROMBOEMBOLISM

Initial UFH Bolus	80 U/kg
Initial UFH infusion rate	18 U/kg/h
Check aPTT after 6 h of IV infusion; modify infusion rate as follows:	
If aPTT < 1.2 × control, repeat bolus (80 U/kg) and increase infusion rate by	4 U/kg/h
If aPTT is 1.2-1.5 × control, repeat bolus (40 U/kg) and increase infusion rate by	2 U/kg/h
If aPTT is 1.5-2.3 × control, no change	—
If aPTT is 2.3-3.0 × control, decrease infusion rate by	2 U/kg/h
If aPTT > 3 × control, hold infusion for 1 h, then decrease infusion by	3 U/kg/h

aPTT, activated partial thromboplastin time.

Data from Raschke RA, Reilly BM, Guidry JR, et al. The weight-based heparin dosing nomogram compared with a "standard care" nomogram. *Ann Intern Med* 1993; 119:874-881.

Low-molecular-weight Heparins

LMWH is derived from the enzymatic or chemical cleavage of UFH to produce a mixture of low-molecular-weight glycosaminoglycan molecules with a mean molecular weight of ~5,000 D (~15 saccharide units).³⁹⁶ For example, enoxaparin sodium is produced by benzoylation followed by alkaline hydrolysis, dalteparin sodium is produced by controlled nitrous acid depolymerization, and tinzaparin sodium is produced by enzymatic digestion with heparinase. LMWH binds AT via the same pentasaccharide sequence as UFH.³⁹⁶ However, because of the predominance of molecules <18 saccharide units in length, LMWH has limited anti-thrombin (IIa) activity compared to its anti-factor Xa activity.

Whereas UFH has an anti-factor Xa to anti-IIa activity ratio of 1:1, LMWHs have reported ratios of 1.9:1 to 4.1:1.³⁹⁶ Because of limited thrombin inhibition, LMWH therapy cannot be monitored using the aPTT. Other differences between LMWH preparations include the degree of TF pathway inhibitor release, degree of sulfation, and degree of stimulated vWF release.^{399, 400, 401} These differences form the basis for many medical organizations' stating that LMWHs are unique drugs and not therapeutically interchangeable.^{402, 403, 404}

At low doses, subcutaneous LMWH has 90% bioavailability, compared to 30% for UFH. LMWHs have limited nonspecific binding to plasma proteins and platelets, endothelial cells, and macrophages compared to UFH, as well as a predictable clearance and a longer half-life that facilitates once- or twice-daily administration.^{396, 405} Unlike UFH, the half-life of LMWH is not dose-dependent.³⁹⁶ These characteristics make LMWH preferred in settings that may normally result in heparin resistance. These advantages of LMWH allow these drugs to be given subcutaneously, once or twice daily and without the need for laboratory monitoring.³⁹⁶ Similar to UFH, absolute contraindications for LMWH include active bleeding, HIT, or a history of HIT, and known sensitivity to LMWH, UFH, or pork products.

LMWHs have substantial renal clearance; therefore, multi-day therapeutic use of LMWH in patients with significant renal insufficiency (creatinine clearance <30 ml/minute) should be avoided.⁴⁰⁶ In the setting of less severe renal insufficiency, LMWH should be used with caution and with a reduced dosing frequency. Only ~60% of LMWH anticoagulant activity can be reversed after the administration of protamine sulfate.⁴⁰⁷ Table 55.8 summarizes the LMWH products available in the United States and their properties and U.S. Food and Drug Administration (FDA)-approved indications.

Heparinoids

Heparinoids are low-molecular-weight glycosaminoglycans that are not derived from heparin. Heparinoids include dermatan sulfate and danaparoid sodium. Dermatan sulfate and low-molecular-weight dermatan sulfate act as anticoagulants by activating HCII.^{408, 409} Danaparoid sodium is a glycosaminoglycan mixture derived from porcine intestinal mucosa and composed of heparan sulfate (84%), dermatan sulfate (12%), and chondroitin sulfate (4%).⁴¹⁰ Danaparoid has an anti-factor Xa activity to anti-IIa activity ratio of greater than 22:1 (compared to a 1:1 ratio for heparin), which explains why it is minimally neutralized by protamine sulfate.⁴¹⁰

The largest collection of clinical experience with danaparoid is in the setting of HIT. Danaparoid may cross-react with 10% to 50% of HIT sera, but in vivo cross-reactivity, although reported, has not been commonly observed.^{411, 412} Danaparoid has a relatively long half-life of ~24 hours, which may make its use less desirable in patients at high risk for developing bleeding or those likely to need surgery. Significant experience exists with the administration of danaparoid by both intravenous and subcutaneous routes. Danaparoid anticoagulation is monitored using an anti-factor Xa activity chromogenic assay calibrated with danaparoid standards. The drug is approved for deep vein thromboprophylaxis after orthopedic surgery at a dose of 750 U anti-Xa twice daily by subcutaneous injection. A common dose for the treatment of active thrombosis in patients with normal renal function is 1,500 U as an intravenous bolus followed by 1,500 U subcutaneously twice daily. The target therapeutic anti-factor Xa activity is 0.5 to 0.8 U/ml. Danaparoid's potential for cross-reactivity and the longer half-life make it less desirable than a direct thrombin inhibitor (DTI) for the treatment of patients with HIT.³⁹⁶ The manufacturer of the drug has discontinued availability of danaparoid in the United States.

Pentasaccharides

Because factor Xa is situated at the start of the common pathway of coagulation and upstream of thrombin in the cascade, it is an attractive target for new anticoagulants. By not directly inhibiting thrombin activity, factor Xa inhibitors might allow small amounts of thrombin to be generated, facilitating hemostasis and theoretically leading to a more favorable bleeding-risk profile. Fondaparinux is an FDA-approved synthetic pentasaccharide (molecular weight, 1,728 D) that causes selective indirect (i.e., AT-mediated) inhibition of factor Xa.⁴¹³ Fondaparinux is administered subcutaneously, has a half-life of ~17 hours, and does not require therapeutic monitoring. Fondaparinux elimination is prolonged in patients with renal impairment. The reduction in clearance increases as the creatinine clearance decreases. Elimination is also prolonged in patients >75 years of age and in those weighing <50 kg. Fondaparinux has been used with success to treat HIT.⁴¹⁴ Fondaparinux is approved for the prevention and treatment of VTE.

A long-acting, hypermethylated pentasaccharide, idraparinix, and a similar compound with a biotin moiety at the reducing end unit allowing for neutralization with avidin, idrabiotaparinix, have a half-life of up to 130 hours, which may facilitate anticoagulation with once-weekly subcutaneous dosing.⁴¹⁵ However, Phase III trials to date have been disappointing. In the VTE treatment studies, idraparinix was less effective than comparators, and in a large atrial fibrillation trial, idraparinix was equally effective as vitamin K antagonists, but caused more bleeding.^{416, 417}

Parenteral Direct Thrombin Inhibitors

The parenteral DTIs have been studied for use in patients with acute coronary events, but are most widely utilized in patients with HIT. In these patients, elimination of all heparin exposure is the most essential element in the treatment. This includes discontinuing heparin intravenous catheter flushes, prophylactic subcutaneous heparin or LMWH, and heparin-coated indwelling catheters. Yet, despite heparin discontinuation and platelet count recovery, patients with isolated, serologically confirmed HIT have up to a 50% risk of developing a confirmed thrombotic event during the 30-day period after heparin cessation.⁴¹⁸ The persistent prothrombotic tendency associated with HIT and the patient's original indication for heparin therapy warrant use of an alternative anticoagulant agent such as the DTIs after heparin cessation (Table 55.9).

Hirudins

Hirudin, a polypeptide originally isolated from the salivary glands of the medicinal leech, directly inhibits thrombin. Two recombinant forms of hirudin, lepirudin, and desirudin, are available for clinical use. Lepirudin is a recombinant hirudin analog that received FDA approval in 1998 for anticoagulant treatment in patients with HIT in the setting of thromboembolic disease to

P.1239

P.1240

prevent further thrombosis.⁴¹⁹ Lepirudin differs from native hirudin in that it lacks sulfation on the tyrosine at position 63 and has a leucine at position 1 rather than isoleucine.⁴²⁰ Lepirudin is a potent DTI that lacks any structural homology with heparin, does not cross-react with heparin, has a short half-life, is able to inactivate clot-bound thrombin, and can be monitored using the ubiquitous aPTT assay or the less readily available ecarin clotting time.⁴²¹

TABLE 55.8 LOW-MOLECULAR-WEIGHT HEPARIN AND POLYSACCHARIDE PRODUCTS AVAILABLE IN THE UNITED STATES

Low-Molecular-Weight Heparin

Low-Molecular-Weight Heparin	Approved Indications	FDA-Approved Dosage Regimen
Dalteparin (Fragmin®)	DVT/PE prophylaxis for abdominal surgery	2,500 U SC daily, starting 1-2 h before surgery and continued 5-10 d postoperatively.
	DVT/PE prophylaxis for hip replacement surgery	High-risk patients (e.g., malignancy): 5,000 U SC daily, starting the evening before surgery and continued for 5-10 d postoperatively. Or, give 2,500 U SC 1-2 h before surgery, then give 2,500 U SC 12 h later, and 5,000 U SC daily for 5-10 d postoperatively.
		Preoperative start, evening before surgery: 5,000 U SC daily, starting 10-14 h before surgery. The usual duration is 5-10 d postoperatively, although 14 d has been studied. Allow 24 h between doses.
Preoperative start, day of surgery: 2,500 U SC within 2 h before surgery, then 2,500 U SC 4-8 h after surgery, then 5,000 U SC daily postoperatively. The usual duration is 5-10 d postoperatively, although 14 d has been studied. Allow at least 6 h between the first postoperative dose and the next postoperative dose.		
Postoperative start: 2,500 U SC 4-8 h after surgery, then 5,000 U SC daily. The usual duration is 5-10 d postoperatively, although 14 d has been studied. Allow at		

		least 6 h between the first postoperative dose and the next postoperative dose.
	DVT/PE prophylaxis in medical patients with severely restricted mobility due to acute illness	5,000 U SC daily for 12-14 d.
	Prophylaxis of ischemic complications of non-Q-wave myocardial infarction in patients on concurrent aspirin therapy	120 U/kg SC every 12 h for 5-8 d, given concurrently with aspirin 75-165 mg/d PO. Do not exceed 10,000 U/dose. Continue until patient is clinically stabilized.
	Prophylaxis of ischemic complications of unstable angina in patients on concurrent aspirin therapy	120 U/kg SC every 12 h for 5-8 d, given concurrently with aspirin 75-165 mg/d PO. Do not exceed 10,000 U/dose. Continue until patient is clinically stabilized.
	Extended treatment of DVT/PE in cancer patients	200 U/kg SC daily (max. 18,000 U) for 1 mo, then 150 U/kg SC daily (max. 18,000 U) for 5 mo
Enoxaparin (Lovenox [®])	DVT/PE prophylaxis for abdominal surgery	40 mg SC daily, starting 2 h before surgery. The usual duration is 7-10 d postoperatively, although 12 d has been studied.
	DVT/PE prophylaxis for hip replacement surgery	30 mg SC every 12 h, starting 12-24 h after surgery. The usual duration is 7-10 d postoperatively, although 14 d has been studied. An alternative regimen is 40 mg SC daily, starting 9-15 h before surgery and continued for 3 wk.
	DVT/PE prophylaxis for knee replacement surgery	30 mg SC every 12 h, starting 12-24 h after surgery. The usual duration is 7-10 d postoperatively, although 14 d has been studied.
	DVT/PE prophylaxis in medical patients with severely restricted mobility due to acute illness	40 mg SC daily. The usual duration is 6-11 d, although 14 d has been studied.
	Treatment of DVT with or without PE (inpatient therapy) in patients starting on warfarin sodium	1 mg/kg SC every 12 h, or 1.5 mg/kg SC daily (at the same time each day). Start warfarin when appropriate (usually within 72 h of starting enoxaparin). Continue enoxaparin for at least 5 d, until INR is therapeutic; usually an additional 7 d is needed, although up to 17 d may be required.
	Treatment of DVT without PE (outpatient therapy) in patients starting on warfarin sodium	1 mg/kg SC every 12 h. Start warfarin when appropriate (usually within 72 hr of starting enoxaparin). Continue enoxaparin for at least 5 d, until INR is therapeutic; usually an additional 7 d is needed, although up to 17 d may be required.
	Prophylaxis of ischemic	1 mg/kg SC every 12 h given concurrently with aspirin

	complications of non-Q-wave myocardial infarction in patients on concurrent aspirin therapy	100-325 mg/d PO. The usual duration is 2-8 d, although up to 12.5 d has been studied.
	Prophylaxis of ischemic complications of unstable angina in patients on concurrent aspirin therapy	1 mg/kg SC every 12 h given concurrently with aspirin 100-325 mg/d PO. The usual duration is 2-8 d, although up to 12.5 d has been studied.
Fondaparinux (Arixtra®)	DVT/PE prophylaxis following abdominal surgery	2.5 mg SC daily, starting 6-8 h after surgery. The usual duration is 5-9 d, although up to 10 d has been studied.
	DVT/PE prophylaxis following hip replacement surgery	2.5 mg SC daily, starting 6-8 h after surgery. The usual duration is 5-9 d, although up to 11 d has been studied.
	DVT/PE prophylaxis following hip fracture surgery	2.5 mg SC daily, starting 6-8 h after surgery. The usual duration is 5-9 d, although up to 11 d has been studied.
	DVT/PE prophylaxis following knee replacement surgery	2.5 mg SC daily, starting 6-8 h after surgery. The usual duration is 5-9 d, although up to 11 d has been studied.
	Treatment of DVT and PE in patients starting on warfarin sodium	5 mg SC daily for patients <50 kg, 7.5 mg SC daily for patients 50-100 kg, or 10 mg SC daily for patients >100 kg. Start warfarin when appropriate (usually within 72 h of starting fondaparinux). Continue fondaparinux for at least 5 d, until INR is therapeutic; The usual duration is 5-9 d, although up to 26 d has been studied.

DVT, deep vein thrombosis; INR, international normalized ratio; IV, intravenous; PE, pulmonary embolism; PO, orally; SC, subcutaneously.

Data from Arixtra (fondaparinux sodium) Injection package insert. Research Triangle Park, NC: GlaxoSmithKline; 2005; Lovenox (enoxaparin sodium injection) package insert. Bridgewater, NJ: Sanofi-Aventis U.S. LLC; 2006; Fragmin (dalteparin sodium injection) package insert. New York, NY: Pfizer Inc; 2008 website.

TABLE 55.9 COMPARISON OF DIRECT THROMBIN INHIBITORS

Drug Profile	Lepirudin (Refludan)*	Argatroban (Argatroban)	Bivalirudin (Angiomax)
Derivative	Recombinant hirudin	L-Arginine derivative	Synthetic hirudin-based peptide
Action	Direct thrombin inhibitor	Direct thrombin inhibitor	Direct thrombin inhibitor
Clearance	Renal	Hepatic	Renal
Administration	IV (or SC)	IV	IV or SC
Half-life	1.5 hr	40 min	25 min
Monitoring	aPTT	aPTT	aPTT or ACT

Heparin cross-reactivity	None	None	None
Effect on international normalized ratio	Yes	Yes	Yes
Approved for heparin-induced thrombocytopenia	Yes	Yes	Yes
Immunogenic	Yes	No	Unknown

ACT, activated clotting time; aPTT, activated partial thromboplastin time; IV, intravenous; SC, subcutaneous.

* No longer available in the U.S.

In composite, when compared to historical controls in patients with HIT with associated thrombosis, lepirudin (n = 389 patients, 3 cohorts) demonstrates a relative risk of 0.70 (95% confidence intervals [CIs], 0.27 to 1.8), 0.28 (0.15 to 0.52), and 2.31 (0.94 to 5.71) for limb amputation, new thrombosis, and major bleeding, respectively.⁴²²

Current lepirudin dosing recommendations are an infusion of 0.15 mg/kg/hour (up to 110 kg) with or without an initial bolus of 0.4mg/kg.³⁹⁷ The target aPTT is 1.5 to 2.5 times the median value for the normal range. Monitoring during bypass requires performance of the less readily available ecarin clotting time with a target plasma lepirudin concentration of 2.0 µg/ml.⁴²³ The activated clotting time (ACT) and point-of-care aPTT assays do not appear to be suitable for lepirudin therapeutic monitoring.⁴²⁴ Outpatient subcutaneous lepirudin has been used to treat patients with HIT and thrombosis and patients who are refractory to other anticoagulant therapy.⁴²⁵

The major challenges of lepirudin treatment are the lack of an antidote, the extreme care needed when treating patients with even mild renal insufficiency, and immunogenicity. In the event of lepirudin overdose or lepirudin-induced bleeding, infusions of prothrombin complex concentrates or recombinant factor VIIa may help promote hemostasis.⁴¹⁹ High-flux capillary hemodialysis membranes may facilitate the hemofiltration of lepirudin in some cases.⁴²⁶ Partial-exchange transfusions, plasmapheresis, and immobilized thrombin affinity columns have also been tried to neutralize the effects of lepirudin.⁴¹⁹ Marked bolus and infusion rate reductions are necessary in patients with a creatinine clearance of <60 ml/minute (serum creatinine >1.6 mg/dl). Lepirudin is to be avoided completely or administered with extreme care in the settings of hemodialysis and acute renal failure and in patients undergoing continuous venovenous hemodialysis, even in the setting of a normal serum creatinine. Careful monitoring of both the aPTT and serum creatinine is indicated during lepirudin therapy. Approximately 40% of HIT patients treated with lepirudin develop antihirudin antibodies of the IgG class.⁴²⁷ The antibodies seem to be capable of decreasing renal elimination of the drug rather than exerting any in vivo neutralizing effect. This paradoxical enhancement of the anticoagulant effect of lepirudin often warrants a significant reduction of infusion rate. Lepirudin is no longer available in the United States.

Desirudin is another recombinant form of hirudin that is approved in the United States for VTE prevention after elective hip replacement surgery. When used for thromboprophylaxis, desirudin is given subcutaneously at a dose of 15 mg twice daily.³⁹⁷ More recently, a small open-label study comparing desirudin, dosed at 30 mg twice daily, to argatroban in patients with HITT has been reported.⁴²⁸

Argatroban

Argatroban is a synthetic, small-molecule, L-arginine derivative that received FDA approval in June 2000 for prophylaxis and treatment of thrombosis in patients with HIT. Argatroban is a rapid and reversible DTI, in contrast to lepirudin, which is an irreversible thrombin inhibitor. Argatroban is capable of inhibiting both free and fibrin-associated thrombin. Argatroban exerts its antithrombotic effects by inhibiting thrombin-mediated reactions including fibrin formation; activation of coagulation factors V, VIII, and XIII; activation of the natural anticoagulant protein C; and platelet activation.⁴²⁹ Like lepirudin, argatroban does not cross-react with heparin. Argatroban is metabolized by the liver with biliary excretion and has a half-life of only 40 minutes. Renal excretion has also been documented; however, renal impairment has been shown to have little adverse effect on drug clearance and half-life. Unlike lepirudin, argatroban does not require dose adjustment in the setting of renal insufficiency. Dose reduction is required in patients with significant hepatic disease.⁴²⁹

In two cohorts (n = 419) of patients with HITT treated with argatroban and compared to historical controls who were followed for 37 days, the relative risk for death due to thrombosis, limb amputation, new thrombosis, and major bleeding

was 0.12 (95% CI, 0.05 to 0.34), 1.26 (95% [CI]; 0.53 to 2.99), 0.45 (95% [CI]; 0.28 to 0.71), and 3.70 (95% [CI]; 0.52 to 26.5), respectively.⁴²²

Argatroban is dosed based on patient weight. The recommended starting intravenous infusion rate is 2 µg/kg/minute with a target aPTT of 1.5 to 3.0 times the baseline value. Therapy may also be monitored by whole-blood ACT and the ecarin clotting time. Like lepirudin, argatroban prolongs the PT as well as the aPTT. This PT prolongation makes determination of an accurate INR during conversion to oral warfarin therapy a challenge. Holding the infusion of either DTI for several hours before INR determination is prudent. Argatroban has been shown to provide adequate anticoagulation with minimal bleeding risk while enabling procedural success in HIT patients undergoing PCI.⁴³⁰ Patients were given a 350-µg/kg bolus of argatroban followed by 25 µg/kg/minute infusion titrated to achieve an ACT of 300 to 450 seconds. This dosing regimen may provide satisfactory anticoagulation during cardiopulmonary bypass and allow intraoperative dose adjustments based on the readily available ACT.

Bivalirudin

Bivalirudin is a semisynthetic, bivalent DTI consisting of a dodecapeptide analog of the carboxy-terminus of hirudin.⁴³¹ Bivalirudin has four glycine residues that connect the thrombin exosite 1 and thrombin active-site moieties. After binding to bivalirudin, thrombin cleaves a Pro-Arg bond at the amino-terminus of the molecule, making it a reversible thrombin inhibitor. The short half-life of bivalirudin (~25 minutes) may enhance its safety profile. Bivalirudin is used primarily during PCIs, in which it has been

P.1241

shown to be at least as effective as heparin with gpIIb/IIIa inhibition, but with an improved safety profile.^{432, 433} Bivalirudin has also been evaluated in patients presenting with acute coronary syndromes as an alternate to heparin.⁴³⁴ In patients with moderate- or high-risk acute coronary syndromes who were undergoing invasive treatment including gpIIb/IIIa inhibition, bivalirudin was associated with rates of ischemia and bleeding similar to those in heparin-treated subjects. However, bivalirudin alone was associated with similar rates of ischemia and significantly lower rates of bleeding compared to heparin plus gpIIb/IIIa blockade.⁴³⁴ Bivalirudin has also been evaluated for the management of patients with HIT, especially those requiring cardiac surgery. The currently recommended dose of bivalirudin is a bolus of 0.75 mg/kg followed by an infusion of 1.75 mg/kg/h for the duration of the procedure.³⁹⁷ Bivalirudin is also recommended for anticoagulation in managing hemodialysis patients with HIT.⁴²²

Warfarin

In the 1920s, cattle developed a bleeding disorder when they were fed spoiled sweet clover. Campbell and Link later identified the active agent as bishydroxycoumarin (dicoumarol).⁴³⁵ Drugs that inhibit the biosynthesis of the vitamin-K-dependent coagulation proteins are derived either from 4-hydroxycoumarin or 1,3-indanedione. Although the indanediones are used in Europe, a coumarin derivative, warfarin, is the major formulation used in the United States. Warfarin inhibits γ-carboxylation of select glutamic acid residues in the N-terminus of prothrombin and factors VII, IX, and X, as well as the vitamin-K-dependent natural anticoagulants, protein C and protein S.⁴³⁶ Warfarin inhibits the two enzymes critical for the generation of reduced vitamin K, namely, vitamin K epoxide reductase and vitamin K reductase.^{437, 438} Reduced vitamin K is necessary for catalyzing γ-carboxylation of glutamic acid residues. Inhibition of γ-carboxylation by warfarin leads to synthesis of incomplete, hypofunctional coagulation proteins that are unable to bind to cellular surfaces to mediate coagulation reactions. The effect of warfarin on vitamin-K-dependent procoagulant protein production is depicted in Figure 55.6. Details of vitamin K metabolism are presented in Chapter 18.

Commercially available warfarin is a racemic mixture of levorotatory and dextrorotatory forms of the drug. The half-life of warfarin in blood is ~36 hours.⁴³⁹ Laboratory monitoring of warfarin therapy is best done using functional coagulation tests, such as the PT. Plasma warfarin levels are most useful in evaluating the unusual patient who does not respond to standard warfarin dosages or in whom malabsorption, noncompliance, or inherited drug resistance is an issue.^{438, 440}

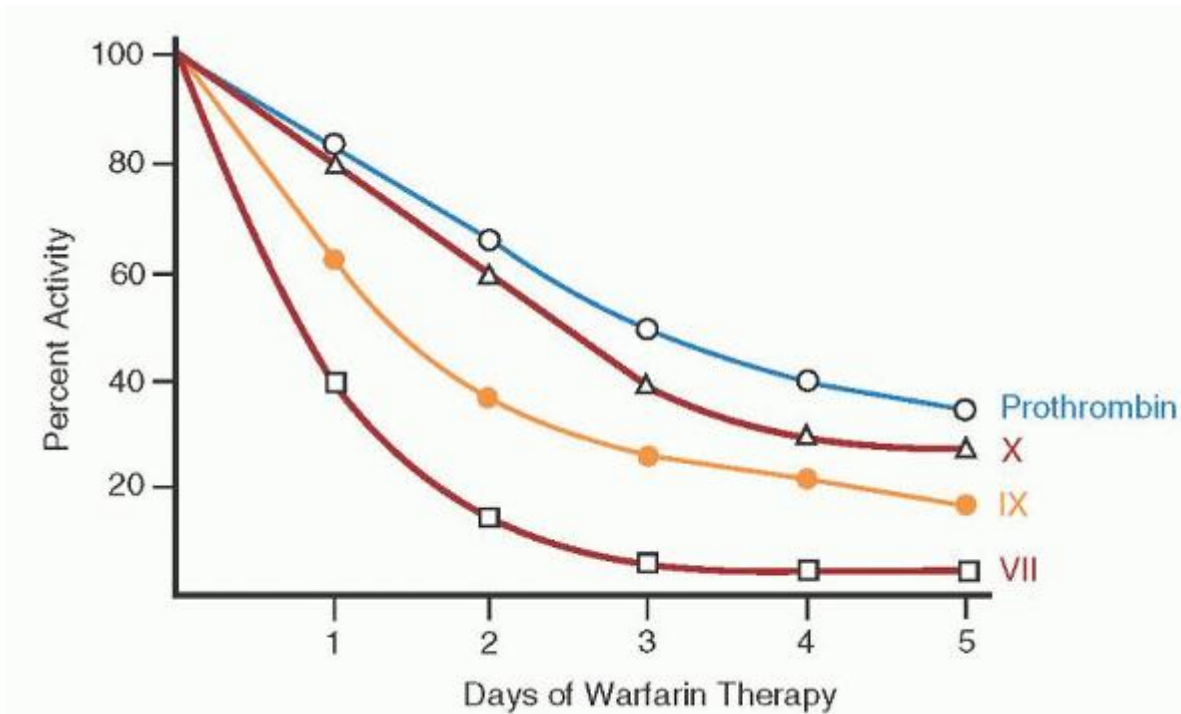

FIGURE 55.6. Effects of standard warfarin therapy on the plasma vitamin-K-dependent procoagulant coagulation proteins. Administration of 5 to 10 mg daily of warfarin results in inhibition of synthesis of functional vitamin-K-dependent proteins. The coagulant activity of these proteins in plasma declines as a function of their half-life. Half-lives of factors VII, IX, and X and prothrombin are 6, 24, and 40 and 60 hours, respectively. Although 1 to 2 days of warfarin prolongs the PT assay (because of the rapid decrease in factor VII concentration), therapeutic anticoagulation requires at least 4 to 5 days. Data from O'Reilly RA. The pharmacodynamics of the oral anticoagulant drugs. *Prog Hemost Thromb* 1974;2:175-213; reproduced from Greenberg PL, Negrin R, Rodgers GM. Hematologic disorders. In: Melmon KL, Morrelli HF, Hoffman BB, et al., eds. *Clinical pharmacology: basic principles in therapeutics*, 3rd ed. McGraw-Hill, 1992:524-599, with permission.

Because factor X and prothrombin have half-lives >2 days, reduction of all vitamin-K-dependent coagulation proteins into the therapeutic range (~20% of normal) requires 4 to 5 days of therapy.⁴⁴¹ This is the basis for the “parenteral anticoagulant overlap” period of 4 to 5 days during which patients receive therapeutic parenteral anticoagulant while waiting to achieve the therapeutic effects of warfarin.⁴⁴² An animal study indicated that depression of both factor X and prothrombin levels by warfarin was important in the prevention of hypercoagulability.⁴⁴¹

Warfarin dosage is influenced by numerous variables, including the patient's age, body mass, dietary stores of vitamin K, liver function, co-existing medical disorders, concurrent medications,⁴⁴³ and presence or absence of cytochrome P-450 complex (CYP2C9) and vitamin K epoxide reductase complex subunit 1 (VKORC1) single-nucleotide polymorphisms that affect coumarin metabolism or sensitivity.^{444, 445, 446} Patients with liver disease, malnutrition, or other factors associated with sensitivity to warfarin should receive lower warfarin dosages. The most common adverse interaction of warfarin use occurs in a patient with marginal dietary vitamin K intake (postoperative state) who is given a broad-spectrum antibiotic, reducing enteric bacterial synthesis of vitamin K, resulting in increased sensitivity to warfarin.⁴³⁸ Starting warfarin therapy early after heparin therapy (day 1 or 2) has many advantages, including earlier hospital discharge on adequate oral anticoagulation and potential reduction in the incidence of HIT.⁴⁴⁷ The metabolism of warfarin may be affected by other drugs metabolized by the cytochrome P-450 enzyme complex, drugs that displace albumin-bound warfarin into the circulation, drugs that impair gastrointestinal absorption, and many antibiotics that alter the natural flora of the colon (an endogenous source of vitamin K)^{438, 443} (Table 55.10).

Certain genotypes for CYP2C9 and VKORC1 have a significant effect on the pharmacokinetic and pharmacodynamic response to warfarin dosing, respectively. Although there is a clear gene-dose relationship, it is uncertain if the routine use of genotype-guided warfarin dosing improves clinical outcomes.⁴⁴⁶ Yet, as clinical dosing algorithms are increasingly refined, the prospects for warfarin pharmacogenetics increase.⁴⁴⁸ Clinical outcome trials are underway to determine definitively the role of genetic testing in routine warfarin therapy.

Certain patients may require very large doses of warfarin (>50 mg/day) to achieve therapeutic anticoagulation; the term warfarin resistance has been applied.⁴⁴⁰ Patients who are difficult to anticoagulate with warfarin, either because they exhibit warfarin resistance or because they are very sensitive to the drug and cannot be safely regulated, may be candidates for long-term parenteral anticoagulants, or a novel oral anticoagulant.

Laboratory Monitoring of Warfarin Therapy

The PT assay is useful to monitor warfarin therapy, because this assay measures three vitamin-K-dependent coagulation proteins: Factors VII, X, and prothrombin. The PT is particularly sensitive to factor VII deficiency; with a half-life of 4 to 6 hours, the factor VII level may drop rapidly after only 1 day of warfarin therapy and prolong the PT value. However, because the other vitamin-K-dependent proteins have longer half-lives, therapeutic anticoagulation takes 4 to 5 days. There is no advantage to giving larger loading doses of warfarin (e.g., >10 mg); this regimen only results in a more rapid drop in factor VII levels, delay in attainment of a stable PT, a precipitous fall in protein C levels, and predisposition to warfarin-induced skin necrosis.^{439, 449, 450}

To understand current recommendations for monitoring warfarin therapy, it is important to appreciate the concept of the INR,

P.1242

a method that standardizes PT assays.^{438, 451} An international reference thromboplastin preparation has been adopted by the World Health Organization (WHO). Each new commercial thromboplastin is calibrated against the primary WHO reference preparation. These results are used to calculate the relative sensitivity of the unknown preparation compared with the WHO standard (international sensitivity index [ISI]). The method to determine the ISI for a particular thromboplastin is depicted in Figure 55.7. By adjusting for the ISI of a particular thromboplastin, an INR, defined as the PT ratio that would have been obtained if the WHO standard thromboplastin had been used, can be determined. The INR is calculated using the following formula: $INR = (PT\ ratio)^{ISI}$ (Fig. 55.8).

TABLE 55.10 DRUGS AND MEDICAL CONDITIONS AFFECTING WARFARIN POTENCY

Potentiators	Antagonists
Drugs	Drugs
Acetaminophen	Adrenal corticosteroids
Anabolic steroids	Barbiturates
Broad-spectrum antibiotics	Carbamazepine
Chloral hydrate	Chlordiazepoxide
Cimetidine	Cholestyramine
Clofibrate	Efavirenz
Disulfiram	Griseofulvin
Fluconazole	Nafcillin
Indomethacin	Rifampin
Influenza vaccine	Sucralfate
Lovastatin	Trazodone
Metronidazole	Medical Conditions
Omeprazole	Excess dietary vitamin K
Phenylbutazone	Inherited resistance to warfarin
Phenytoin	Hypothyroidism
Propranolol	Nephrotic syndrome

Protease inhibitors (except ritonavir)

Quinine/quinidine

Salicylates

Tamoxifen

Thyroid drugs

Trimethoprim/sulfamethoxazole

Medical Conditions

Older age

Liver disease

Biliary disease

Malabsorption

Congestive heart failure

Fever

Hyperthyroidism

Malnutrition

Vitamin K deficiency

Cancer

Data from the 2003 Physicians' Desk Reference. Montvale, NJ: Thomson Healthcare; Hirsh J, Dalen JE, Anderson DR, et al. Oral anticoagulants: mechanism of action, clinical effectiveness, and optimal therapeutic range. *Chest* 2001;119(Suppl):108S-121S.

The American College of Chest Physicians' consensus panel recommends low-intensity warfarin therapy (INR, 2.0 to 3.0) for all indications except prosthetic mechanical heart valves and prophylaxis of recurrent MI, for which higher-intensity warfarin therapy (INR, 2.5 to 3.5) is suggested.⁴³⁸

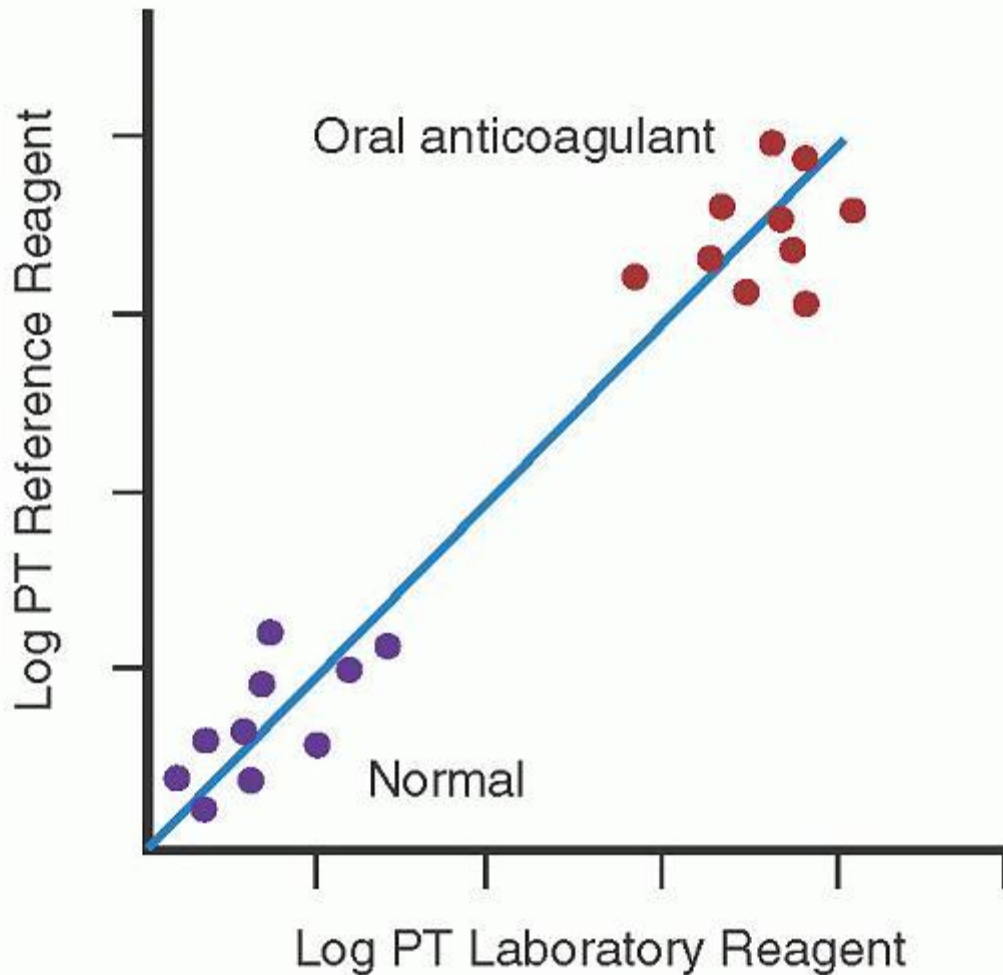

FIGURE 55.7. Method for determination of an international sensitivity index (ISI) value for a laboratory's thromboplastin preparation. Log prothrombin time (PT) values are determined using a reference thromboplastin reagent and the commercial laboratory thromboplastin reagent on patients receiving stable (2 weeks) oral anticoagulant therapy and a group of normal, untreated volunteers. The best-fit line is determined, and the slope of this line multiplied by the ISI of the reference thromboplastin reagent is the ISI value for the commercial thromboplastin reagent. From Rodgers GM. Laboratory monitoring of anticoagulant and fibrinolytic therapy. In: Kjeldsberg C, McKenna R, Perkins S, et al., eds. Practical diagnosis of hematologic disorders, 2nd ed. Chicago, IL: ASCP Press, 1995:745-755, with permission.

Adverse Effects of Warfarin Therapy

Bleeding. A direct relationship exists between the risk of bleeding and the intensity of anticoagulation, with patients receiving higher-intensity (INR > 3.0) therapy having a fivefold greater risk of bleeding.⁴⁵² Other major factors contributing to bleeding include co-existing conditions such as structural gastrointestinal lesions, hypertension, renal disease, and cerebrovascular disease.^{453, 454} Investigation of patients who experience visceral bleeding while on warfarin therapy often results in identification of structural disease.⁴⁵⁵ Highest bleeding rates occur early in the course of warfarin therapy and in patients with cerebrovascular disease.^{456, 453} For patients given low-intensity warfarin therapy for prophylaxis of VTE, the risk of major bleeding is <1%. Antiplatelet medications or other drugs

P.1243

that potentiate warfarin activity are important contributors to bleeding (Table 55.10).

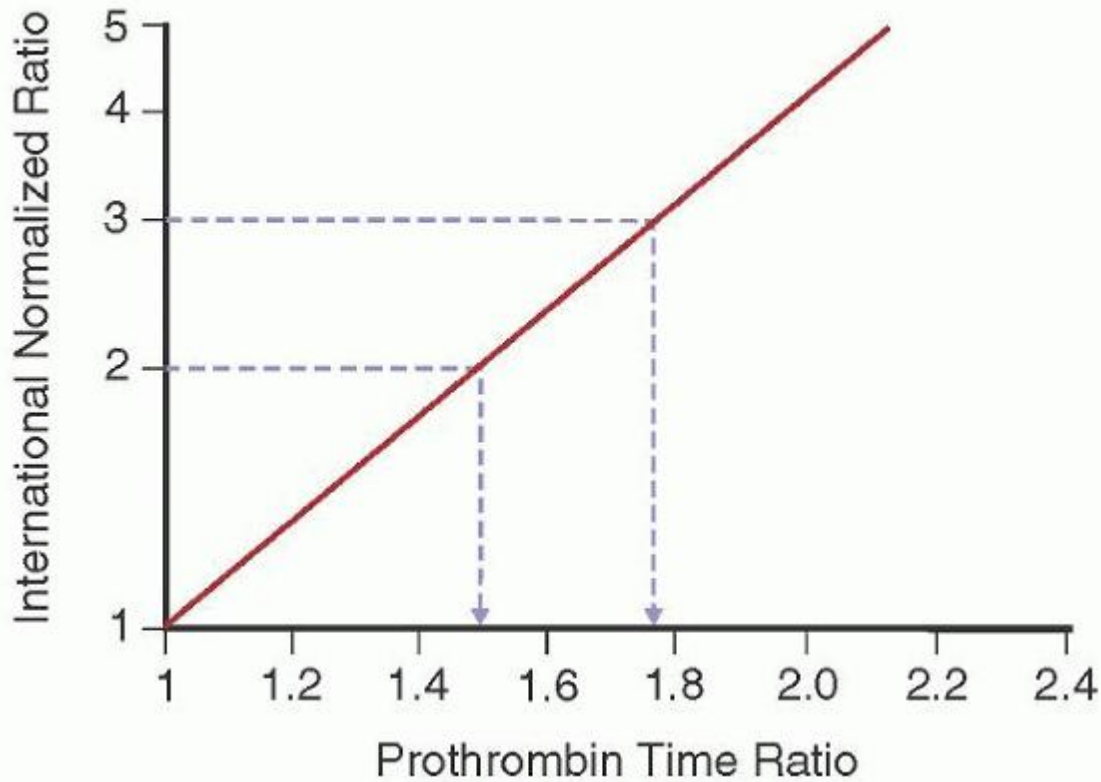

FIGURE 55.8. Relationship between a patient's prothrombin time (PT) ratio on warfarin therapy and the corresponding international normalized ratio (INR) value. The slope of the line represents the international sensitivity index (ISI) value of the particular thromboplastin preparation used in the laboratory's PT assay. In this example, for low-intensity warfarin therapy (INR 2.0 to 3.0), a PT ratio between 1.50 and 1.75 would be required. Thromboplastins with higher ISI values would have slopes greater than that shown and would be less sensitive reagents for the PT assay, whereas thromboplastins with lower ISI values would have slopes less than that shown (more sensitive reagents). From Greenberg PL, Negrin R, Rodgers GM. Hematologic disorders. In: Melmon KL, Morrelli HF, Hoffman BB, et al., eds. Clinical pharmacology: basic principles in therapeutics, 3rd ed. McGraw-Hill, 1992:524-599, with permission.

Treatment strategy of bleeding in patients receiving warfarin depends on several factors: The duration of expected warfarin therapy, the severity of bleeding, and the extent of INR elevation. Patients with minor bleeding (bruising, microscopic hematuria) and an INR of <6.0 can have warfarin withheld until the INR approaches the desired INR target. Warfarin can then be resumed at a lower maintenance dosage. If patients have visceral bleeding that is not immediately life threatening, their coagulopathy can be reversed with vitamin K, 2.5 to 10 mg, IV or PO. Patients with significant emergent bleeding should be reversed with freshfrozen plasma (4 to 5 U) or prothrombin complex concentrates in addition to parenterally administered vitamin K. If the INR <10 and no clinical bleeding exists, several warfarin doses should be held and the INR reassessed; the routine administration of vitamin K in these patients does not lead to improved outcomes and is not recommended.^{438, 457} For an INR >10 in patients without bleeding, oral vitamin K can be given (2 to 10 mg) and repeated at 12- to 24-hour intervals, depending on posttreatment INR values and the patient's clinical condition. Failure of vitamin K to correct the coagulopathy suggests that another process is present, such as liver disease or DIC. The management of warfarin overdosage and reversal has been reviewed.⁴³⁸

Patients who ingest rodenticides that contain long-acting vitamin K antagonists ("superwarfarins") may require massive daily doses (≥ 100 mg) of vitamin K to correct the coagulopathy, for periods of weeks to months (see Chapter 54).

For patients on long-term warfarin therapy who require temporary interruption for procedures or elective surgery, an individualized risk-benefit assessment should be performed to determine the need for bridging therapy with a parenteral anticoagulant during the period of interruption (i.e., when warfarin is discontinued 4 to 5 days before surgery; Table 55.11). Postoperatively, heparin or LMWH can be used to achieve anticoagulation overlap until re-initiation of therapeutic warfarin has been achieved; however, in most cases after a major surgical procedure, the use of therapeutic-dosed

parenteral anticoagulants should be avoided in the first 48 to 72 hours postoperatively due to a high risk of bleeding.⁴⁵⁸,
^{459, 460, 461}

Nonhemorrhagic adverse effects of warfarin therapy include alopecia, gastrointestinal discomfort, rash, and liver dysfunction.⁴⁵³ A warfarin embryopathy can occur when pregnant mothers receive warfarin during the first trimester. A bone matrix protein, osteocalcin, is vitamin-K-dependent, and in the presence of vitamin K deficiency induced by warfarin, osteocalcin is synthesized in a nonfunctional manner, resulting in fetal bone malformations.⁴⁶² Additional fetal abnormalities have been noted when warfarin is used during pregnancy. Because of these fetal risks, most practitioners avoid warfarin during pregnancy.⁴⁶³

TABLE 55.11 GENERAL APPROACH TO PERI-PROCEDURAL ANTICOAGULATION FOR PATIENTS ON LONG-TERM WARFARIN THERAPY

Thromboembolic Risk Group	Indication for Warfarin		
	Mechanical Valve	Atrial Fibrillation	Venous Thromboembolism (VTE)
High	Mitral	CHADS ₂ ^a Score = 5-6	VTE past 3 mo
Management strategy:	Older generation	Stroke past 3 mo	Severe thrombophilia
Bridge(caution in postoperative dosing)	Recent stroke	Rheumatic valve disease	
Intermediate	Bileaflet aortic valve + stroke risk factors	CHADS ₂ Score = 3-4	VTE past 3-12 mo
Management strategy:			Thrombophilia
Bridge (caution in postoperative dosing)			Recurrent VTE
			Active cancer
Low	Bileaflet Aortic valve	CHADS ₂ Score = 0-2	VTE past > 12 mo and no other risk factors
Management strategy:	No stroke risk factors	(and no prior stroke)	
No Bridge			

^aCHADS₂ stroke score is calculated by adding one point for each of: congestive heart failure, hypertension, Age > 75 years old, diabetes and 2 points for prior stroke. Adapted from Douketis JD, Spyropoulos AC, Spencer FA, et al. Perioperative management of antithrombotic therapy: antithrombotic therapy and prevention of thrombosis, 9th ed: American college of chest physicians evidence-based clinical practice guidelines. Chest 2012;141(2):e326S-e350S.

Warfarin-induced Skin Necrosis. Skin necrosis is an unusual but devastating complication of warfarin therapy, occurring within the first week of initiating therapy. Affected patients have usually received large loading doses of warfarin, perhaps in the absence of therapeutic heparin anticoagulation. The basis for this complication is thought to be a warfarin-induced rapid reduction in protein C levels in patients with a pre-existing inherited protein C deficiency that results in a hypercoagulable state and thrombosis. Not all heterozygous protein-C-deficient patients receiving warfarin experience this complication, and not all patients with this complication have protein C deficiency.

Clinically, the skin lesions begin on certain subcutaneous areas of the body (breasts, abdomen, thighs) as erythematous patches.⁴⁶⁴ Lesions progress to blebs followed by demarcated skin necrosis. Skin biopsy reveals generalized thrombosis of skin vessels. This complication may require amputation, plastic reconstructive surgery, or both. The use of standard maintenance doses of warfarin (5 to 10 mg/day) beginning after patients are therapeutically anticoagulated with heparin may avoid this complication. Patients who experience warfarin-induced skin necrosis should be heparinized, warfarin should be discontinued, and vitamin K should be administered promptly. Patients experiencing this complication should be screened for protein C deficiency. A few cases of warfarin-induced skin necrosis have been reported in protein-S-deficient patients.⁴⁶⁵ A literature review of warfarin-induced skin necrosis found that warfarin therapy could be reinstated in affected patients; smaller initial doses of warfarin were recommended.⁴⁶⁶

The “purple toe syndrome” is an uncommon disorder that has been described in patients with underlying atherosclerotic vascular disease who are receiving anticoagulants including warfarin therapy.^{467, 468, 469} These patients present with atheroembolic symptoms including ischemic toes (purple toes), livedo reticularis, gangrene, abdominal pain, or symptoms of renal infarction. Involved visceral organs include the kidneys, pancreas, spleen,

P.1244

and liver. This complication may be difficult to distinguish from warfarin-induced skin necrosis, except that on biopsy, cholesterol emboli are present in the purple toe syndrome, and widespread vascular thromboses are seen in skin necrosis. Treatment involves prompt recognition of the syndrome and discontinuation of warfarin therapy.⁴⁷⁰

Novel Oral Anticoagulants. Warfarin has substantial limitations including inter- and inpatient dosing variability, drug-drug and drug-diet interactions, and a narrow therapeutic index. These limitations necessitate routine laboratory monitoring and dose adjustment that can be cumbersome for some patients. An oral anticoagulant that is safe and effective, has predictable pharmacology, has few drug-drug and drug-dietary interactions, and does not require laboratory monitoring has the potential to revolutionize the chronic management of patients with atrial fibrillation, prosthetic heart valves, and recurrent venous thrombosis as well as facilitate better compliance with out-of-hospital thromboprophylaxis regimens. Over the past 5 years, there has been a rapid emergence of such novel oral anticoagulants (NOACs) into the clinical landscape. At the forefront are the oral DTI dabigatran etexilate and the oral factor Xa inhibitors (e.g., rivaroxaban, apixaban, and edoxaban). Tables 55.12 and 55.13 summarize the properties of the NOACs that are currently available for clinical use and the comparative results of large-scale studies in patients with atrial fibrillation, respectively.⁴⁷¹ It is important to note that numerous additional agents are also currently under investigation.⁴⁷¹

Dabigatran Etexilate

Dabigatran etexilate is an oral prodrug that is rapidly converted by serum esterases to dabigatran, a potent univalent DTI. Oral bioavailability is ~6% to 7%, and uptake is reduced by proton pump inhibitors and delayed with food; however, these kinetic alterations are not thought to be clinically significant and do not require dose adjustments. Peak dabigatran serum levels occur ~2 hours after an oral dose; dabigatran is primarily eliminated by renal clearance, and has a half-life of ~14 to 17 hours.⁴⁷¹ Although a reduced dose has been approved for use in the United States by the FDA for patients with a creatinine clearance of less than 30 ml/minute, this recommendation is solely based upon drug kinetic modeling, and the drug is contraindicated in patients with a clearance <15 ml/minute.⁴⁷² A reduced dose should also be considered for frail elderly patients with a reduced creatinine clearance; however, no dose reduction is needed at any age for patients with normal renal function. Strong p-glycoprotein inhibitors (e.g., quinidine, ketoconazole) and inducers (e.g., rifampin, St John's Wort) affect serum levels. Because of the predictability in dose-response, laboratory monitoring is unnecessary. If, however, laboratory assessment is required (e.g., need for urgent surgery or management of bleeding) a normal aPTT, thrombin time, or ecarin clotting time suggest little drug activity is present. Conversely, the INR is insensitive to the presence of dabigatran and is not a useful test for drug presence.⁴⁷³ Table 55.14 suggests a management approach to patients requiring temporary interruption of anticoagulation for an invasive procedure. As with all anticoagulants, the primary adverse effect of dabigatran is an increase in bleeding risk. In addition, dabigatran is associated with an increased risk of dyspepsia, and in some clinical trials has been associated with higher gastrointestinal bleeding rates and myocardial ischemia events as compared to warfarin.⁴⁷³ In cases of overdose, the rapid administration of charcoal may decrease absorption, and hemodialysis can remove 60% of plasma drug levels.⁴⁷⁴ Management of bleeding is problematic as there is no known reversal agent. Patients who have bleeding on dabigatran should be managed with aggressive conservative measures including active control of bleeding site. In cases of life-threatening bleeding, the administration of recombinant factor VIIa or activated prothrombin complex concentrates can be tried, although their utility is unproven.⁴⁷³

TABLE 55.12 PHARMACOLOGY OF NOVEL ORAL ANTICOAGULANTS

	Dabigatran (Pradaxa®)	Rivaroxaban (Xarelto®)	Apixaban (Eliquis®)
Target	Thrombin (Binds Reversibly)	Factor Xa (Binds Reversibly)	Factor Xa (Binds Reversibly)
Dosage Form	Capsule	Tablet	Tablet
Bioavailability	6%	60-80%	50-85%

Time to Peak	1-2 h	2-4 h	1-3 h
Metabolism	Conjugation; No CYP involvement	Oxidation (via CYP3A4 + CYP2J2) + hydrolysis	Oxidation (via CYP3A4) + conjugation
Drug-Interactions	Strong p-gp inducers and inhibitors	Strong p-gp and CYP3A4 inducers and inhibitors	Strong p-gp and CYP3A4 inducers and inhibitors
Renal Excretion	80%	66%	25%
Half-life	14-17 h	9-13 h	9-14 h
Dosing Frequency, Major Trials	BID	QD	BID

BID, twice daily; CYP, cytochrome p 450; p-gp, p-glycoprotein; QD, daily.

To date, dabigatran etexilate has undergone extensive clinical investigation in the RE-VOLUTION program, a large clinical trials program assessing the efficacy and safety of dabigatran across a variety of indications. For a recent and thorough survey of clinical trial results, we refer the reader to a recent review.⁴⁷³ Based upon the results of the RE-LY trial, dabigatran etexilate is currently approved in the United States for the prevention of stroke and systemic embolism in patients with atrial fibrillation.⁴⁷⁵ In RE-LY, 18,113 patients with nonvalvular atrial fibrillation and at least one additional stroke risk factor were randomized to receive warfarin or dabigatran dosed either 110 mg or 150 mg twice daily. Dabigatran dosed at 110 mg twice daily was demonstrated to be noninferior to warfarin (RR, 0.91; 95% [CI], 0.74 to 1.11; $p < 0.001$), and dabigatran dosed at 150 mg twice daily was demonstrated to be superior to warfarin (RR, 0.66; 95% [CI], 0.53 to 0.82; $p < 0.001$) in preventing the primary outcome of stroke or systemic embolism. As compared to warfarin, major bleeding, the primary safety outcome, was less common in the 110-mg twice-daily dabigatran group (RR, 0.80; 95% [CI], 0.69 to 0.93; $p = 0.003$), but was similar when compared to the 150-mg twice-daily dose (RR, 0.93; 95% [CI], 0.81 to 1.07; $p = 0.31$), but hemorrhagic stroke was lower for both dabigatran doses.⁴⁷⁵ Using a composite of adverse clinical events (stroke, systemic embolism, MI, death, PE, and major bleeding), dabigatran was clearly superior for those patients on warfarin who have a time in TTR of less than 57.1% whereas benefit was less certain in those with a TTR of >72.6% with hazard ratios of 0.67 (95% CI, 0.56 to 0.80) and 1.11 (95% CI, 0.91 to 1.35), respectively.⁴⁷⁶

Oral Factor Xa Inhibitors

Because of the demonstrated efficacy and safety of factor Xa inhibition with fondaparinux, oral factor Xa inhibitors have entered the clinical landscape. Oral factor Xa inhibitors that are available for clinical use or are in development include rivaroxaban (Bayer Healthcare), apixaban (Bristol Myers Squibb/Pfizer),

P.1245

edoxaban (Daiichi), betrixaban (Portola), and TAK-442 (Takeda).⁴⁷¹ Currently, rivaroxaban and apixaban are the most advanced in their clinical trials programs and are approved for use in the European Union, Canada, or the United States.

TABLE 55.13 NOVEL ORAL ANTICOAGULANT ATRIAL FIBRILLATION CLINICAL TRIAL OVERVIEW

Trial	RE-LY	ROCKET-AF	ARISTOTLE	AVERROES
Drug and dose	Dabigatran etexilate 150 mg and 110 mg BID ^a	Rivaroxaban 20 mg QD ^a	Apixaban 5 mg BID ^a	Apixaban 5 mg BID ^a
Adjusted dose?	No	Yes: 15 mg QD if CrCl 30-49 ml	Yes: 2.5 mg BID if 2 of: age >80, weight <60 kg, Cr >1.5	Yes: 2.5 mg BID if 2 of: age >80, weight <60 kg, Cr >1.5
Design	Randomized open label ($n = 18,113$)	Randomized double blind ($n = 14,000$)	Randomized double blind ($n = 18,201$)	Randomized double blind ($n = 5,599$)
Mean age (y)	71.5	73	70	70

Prior stroke/TIA	20%	55%	19%	13.5%
Mean CHADS2	2.1	3.5	2.1	2.1
Warfarin naïve (%)	50.4	37.5	43	60.5
Comparator	Warfarin: INR 2-3 67% TTR	Warfarin: INR 2-3 57.8% TTR	Warfarin: INR 2-3 TTR	66% Aspirin 81-324 mg

^a BID, twice daily; Cr, creatinine; CrCl, creatinine clearance; INR, international normalized ratio; QD, daily; TIA, transient ischemic attack; TTR, time in therapeutic range; wt, weight.

Data from references 475, 479, 480, 481.

Rivaroxaban is a reversible small molecule direct factor Xa inhibitor that binds to and inactivates both fluid-phase factor Xa as well as factor Xa associated with the prothrombinase complex. Rivaroxaban has an oral bioavailability of ~60% to 80%, with peak levels achieved 2 to 3 hours after an oral dose. The drug is metabolized in part by both CYP3A4-dependent and CYP3A4-independent pathways, and has an elimination half-life of ~7 to 11 hours.⁴⁷¹ The kidneys eliminate approximately 35% of active drug as well as inactive metabolites. Potent combined P-gp and CYP3A4 inhibitors (e.g., ketoconazole, itraconazole, lopinavir/ritonavir, ritonavir, indinavir/ritonavir, and conivaptan) and inducers (e.g., carbamazepine, phenytoin, rifampin, St John's Wort) should be avoided in patients on rivaroxaban because they can significantly increase or decrease plasma drug concentrations, respectively.⁴⁷⁷

Rivaroxaban is currently approved for the prevention of VTE in patients undergoing elective joint replacement surgery, the prevention of stroke and systemic embolism in patients with nonvalvular atrial fibrillation, and the treatment of VTE.⁴⁷⁷ In the RECORD trials, rivaroxaban (10 mg daily) was compared to enoxaparin for thromboprophylaxis in patients undergoing elective joint replacement surgery. In a pooled analysis, the combined endpoint of symptomatic VTE and mortality occurred less often in patients receiving rivaroxaban (1.3% vs. 0.6%, $p < 0.001$), whereas clinically relevant bleeding was more frequent (2.6% vs. 3.3%, $p = 0.026$).⁴⁷⁸ The ROCKET-AF trial was a large ($n = 14,000$) double-blind, noninferiority, randomized trial comparing rivaroxaban (20 mg daily in patients with normal renal function and 15 mg daily in patients with a creatinine clearance of 30 to 49 ml/min) to adjusted-dose warfarin (target INR 2 to 3) in patients with atrial fibrillation who were at an increased risk of stroke or systemic embolism.⁴⁷⁹ Rivaroxaban met the prespecified endpoint of stroke/systemic embolism occurrence with a HR of 0.88 (95% CI 0.74 to 1.03, $p < 0.001$ for noninferiority), had similar rates of major bleeding (HR 1.04, 95% CI 0.9 to 1.2, $p = 0.58$), and less intracranial hemorrhage (HR 0.67, 95% CI 0.47 to 0.93, $p = 0.02$).⁴⁷⁹

TABLE 55.14 NOVEL ANTICOAGULANT AGENTS: PERI-PROCEDURAL MANAGEMENT

Preprocedure	Half-life (Range) Hours	Low Bleeding Risk Procedures (Average of 2-3 Drug Half-lives Separate Last Dose and Surgery)	Moderate to High Bleeding Risk (Average of 5 Drug Half-lives Separate Last Dose and Surgery)
DABIGATRAN			
CrCl >50	14 (11-24)	Skip 2 doses (1 d)	Skip 4 doses (2 d)
CrCl 30-50	18 (13-23)	Skip 4 doses (2 d)	Skip 6-8 doses (3-4 d)
CrCl <30	27 (22-35)	Skip 4-10 doses (2-5 d)	Skip >10 doses (>5 d)
RIVAROXABAN			
CrCl >50	8 h	Skip 1 dose (1 d)	Skip 2 doses (2 d)
CrCl <50	9-10 h	Skip 2 doses (2 d)	Skip 3-4 doses (3-4 d)
APIXABAN			
	9 h	Skip 1 dose (1 d)	Skip 2 doses (2 d)

Postprocedure Delay re-initiation until hemostasis is certain (24-72 h) and no epidural catheter is present

CrCl, creatinine clearance (ml/min).

Apixaban is a reversible, small molecule, direct factor Xa inhibitor that, as does rivaroxaban, binds to and inactivates both fluid-phase as well as clot-bound factor Xa. Apixaban has an oral bioavailability of >45%, achieves peak levels ~3 hours after an oral dose, has an elimination half-life of ~8 to 14 hours, and

P.1246

is eliminated via multiple mechanisms. Similar to rivaroxaban, potent inhibitors of CYP3A4 (e.g., ketoconazole, itraconazole, lopinavir/ritonavir, ritonavir, indinavir/ritonavir, and conivaptan) and inducers (e.g., carbamazepine, phenytoin, rifampin, St John's Wort) should be avoided.⁴⁷¹

Apixaban has also been studied for thromboprophylaxis, stroke prevention in atrial fibrillation, and VTE treatment. Apixaban is currently approved for use in the European Union, Canada, and approved in the United States for the treatment of non-valvular atrial fibrillation. The AVERROES trial was a large (n = 5,599) double-blind, randomized trial comparing apixaban (5 mg twice daily) to aspirin (81 to 324 mg) in patients with atrial fibrillation who were unsuitable candidates for warfarin therapy. Compared to aspirin, apixaban was more effective and equally safe with a HR of 0.45 (95% CI 0.32 to 0.62, p < 0.001) for stroke/systemic embolism occurrence, HR 1.13 (95% CI 0.74 to 1.75, p = 0.57) for major bleeding, and a HR 0.85 (95% CI 0.38 to 1.9, p = 0.69) for intracranial bleeding.⁴⁸⁰ The ARISTOTLE trial was a large (n = 18,201) double-blind, double dummy, randomized trial comparing apixaban (5 mg twice daily) to adjusted dose warfarin (INR 2 to 3) in patients with atrial fibrillation. Compared to warfarin, apixaban was more effective and safer with a HR of 0.79 (95% CI 0.66 to 0.95, p = 0.01) for stroke/systemic embolism occurrence, HR 0.69 (95% CI 0.6 to 0.8, p < 0.001) for major bleeding, and a HR 0.42 (95% CI 0.3 to 0.58, p < 0.001) for intracranial bleeding.⁴⁸¹

Because of the predictability in dose-response, laboratory monitoring of the oral factor-Xa inhibitors is unnecessary. If, however, lab assessment is required (e.g., need for urgent surgery or management of bleeding), a normal aPTT and a normal INR suggest little anticoagulant presence, although clinical judgment is required.^{274a, 482} Table 55.14 suggests a management approach to patients requiring temporary interruption of anticoagulation for an invasive procedure. Like all anticoagulants, the primary adverse effect of the factor Xa inhibitors is an increase in bleeding risk. Both rivaroxaban and apixaban have significant protein binding and so are not anticipated to be dialyzable. Management of bleeding in patients on these agents is problematic as there is no known reversal agent. Patients who have bleeding on rivaroxaban or apixaban should be managed with aggressive conservative measures including active control of bleeding site.⁴⁷⁴ In cases of life-threatening bleeding, the administration of activated prothrombin complex concentrates may be effective in reversing the effect.⁴⁸³

Thrombolytic Drugs

The major reaction of the fibrinolytic (plasminogen) system involves the conversion by PAs of the inactive proenzyme, plasminogen, into the active enzyme, plasmin. Plasmin can degrade fibrinogen, fibrin monomers, and cross-linked fibrin (as found in thrombi) into FDPs. These plasmin-mediated reactions generate many species of FDPs including unique species of FDP such as fragment X from fibrinogenolysis and cross-linked FDPs such as (DD)E- and D-dimer from cross-linked fibrin.^{484, 485} Knowledge of these reactions is necessary to appreciate the mechanisms of action and limitations of commercial PAs.

A common feature of the management of all thromboembolic diseases is the desire to restore vascular patency in a timely fashion to prevent loss of tissue, organ, and limb function, as well as life. Acute arterial thrombosis warrants an attempt at immediate thrombolysis, whereas venous thrombosis only warrants such intervention in extreme cases. Recognition of the importance of the endogenous fibrinolytic system in limiting the size of hemostatic thrombi, clearing hemostatic thrombi after vascular repair, and preventing pathologic thrombosis has resulted in the development of pharmacologic fibrinolytic (thrombolytic) agents to facilitate rapid restoration of vascular patency. Most thrombolytic agents are recombinant forms of physiologic PAs. The commercially available PAs differ with regard to plasma half-life, fibrin selectivity, primary clinical usage, primary infusion strategy, and immunogenicity. Currently available and investigational PAs and their key characteristics are summarized in Table 55.15.

Most thrombolytic agents are fashioned after endogenous t-PA or urokinase. Traditional thrombolytic drugs include bacteriaderived streptokinase (SK), anisoylated plasminogen SK activator complex, urokinase (two-chain u-PA), and recombinant t-PA (rt-PA). Newer molecules have been and are being developed in an attempt to improve on the

traditional agents. Major goals of new thrombolytic agent development include increasing fibrin specificity, theoretically to reduce bleeding complications, prolonging initial plasma half-life to facilitate single- or double-bolus administration, reducing sensitivity to inactivation by PAI-1, and improving production efficiency. New thrombolytic agents include mutants of PAs, chimeric PAs, conjugates of PAs with monoclonal antibodies, and novel PAs from animal or bacterial origin. Non-PA thrombolytic agents that can degrade fibrin and/or fibrinogen directly (e.g., microplasmin, alfineprase, and ancred) are also under investigation.

TABLE 55.15 PROPERTIES OF CURRENTLY AVAILABLE AND INVESTIGATIONAL THROMBOLYTIC AGENTS

Thrombolytic Agent	Molecular Weight (Daltons)	Plasma Half-life (Minutes)	Key Properties
Streptokinase	47,000	20 (drug); 90 (lytic effect)	Complexes with plasminogen to achieve activity
Anisoylated plasminogen streptokinase activator complex	131,000	40-90	Streptokinase and plasminogen complex
Urokinase	34,000/54,000	15	Direct plasminogen activator derived from fetal kidney cells
Recombinant urokinase	54,000	7	Recombinant high-molecular-weight urokinase
Recombinant prourokinase	49,000	7	Active after conversion to urokinase
Alteplase	65,000	4-8	A recombinant t-PA
Reteplase (recombinant plasminogen activator)	39,000	15	Truncated t-PA with an extended half-life
Tenecteplase	65,000	20 (initial); 90-130 (terminal)	A modified t-PA with an extended half-life, enhanced plasminogen activator inhibitor-1 resistance, and greater fibrin specificity
Desmoteplase (rDSPA α 1)	52,000	2.8 h	Highly fibrin specific and lacking in neurotoxic effects of alteplase
Plasmin	85,000	—	Catheter-directed therapy

t-PA, tissue-type plasminogen activator.

P.1247

Streptokinase

SK is obtained from cultures of β -hemolytic streptococci. By itself, SK has no PA activity, but after combining with plasminogen, a complex is formed that is capable of activating other plasminogen molecules to plasmin.⁴⁸⁶ Purified SK has a molecular weight of 47,000 D. SK was the first clinically used thrombolytic agent. It is not fibrin-selective in that its therapeutic use results in systemic fibrin(ogen)olysis and what is termed the lytic state from proteolysis of fibrinogen, factors V and VIII, and other plasma proteins.⁴⁸⁶ Platelet function may also be perturbed, because plasmin can proteolyze key platelet membrane receptors.⁴⁸⁷ Generation of FDPs also contributes to the significant hemostatic defect of thrombolytic therapy. Although the lytic state predisposes patients to bleeding, the benefit of decreased blood viscosity that results from the lytic state may be clinically important. The half-life of SK is ~20 minutes. Because SK is a bacterial protein, it is antigenic, and allergic reactions occur in ~6% of patients. Anaphylaxis during SK use occurs in ~0.1% of patients.⁴⁸⁸ Patients previously exposed to SK or those with previous streptococcal infections may acquire

antistreptococcal antibody levels sufficient to neutralize the activity of SK. Therefore, all patients receiving SK should be monitored to ensure attainment of the lytic state. This can be done with the thrombin time assay. SK has been used primarily to treat VTE and MI, as well as to treat central venous access-device-associated thrombosis.

Urokinase-type Plasminogen Activator

In the past, u-PA was obtained from human fetal kidney cell cultures. It is currently produced using nonhuman mammalian tissue cultures. Its molecular weight is 34,000 D. u-PA is not fibrin-selective, and this drug also produces a lytic state. The half-life of u-PA is ~15 minutes. u-PA is used to treat VTE, MI, and thrombolysis of clotted catheters.

Tissue-type Plasminogen Activator

Currently, t-PA is produced by recombinant technology as a two-chain species, with a molecular weight of ~65,000 D.⁴⁸⁹,⁴⁹⁰ In vitro, t-PA is fibrin-specific, because of its high affinity for fibrin with which it forms a ternary complex with plasminogen. However, with t-PA dosage regimens currently being used, the lytic state is produced in vivo.⁴⁹¹ Consequently, bleeding complications with t-PA are similar to those with SK or u-PA.⁴⁹² The half-life of t-PA is much shorter than that of SK or u-PA, ~5 minutes. t-PA is used to treat VTE and acute MI^{492, 493, 494, 495, 496} and has also been approved for use in acute ischemic stroke (within 3 hours of stroke onset) and venous catheter withdrawal occlusion.⁴⁹⁷ Laboratory monitoring of t-PA therapy is usually not recommended.

Tissue-type Plasminogen Activator Variants

Recombinant PA (r-PA; reteplase) is a nonglycosylated deletion mutant of wild-type human t-PA comprised of only the kringle 2 and the protease domains of the parent molecule. Lack of the finger domain imparts lower fibrin-binding affinity.⁴⁹⁸ Lack of glycosylation, a finger domain, and an epidermal growth factor domain impart an extended half-life (15 minutes vs. 5 minutes). The longer half-life allows for double-bolus administration. The longer half-lives of r-PA and TNK-r-PA compared with t-PA facilitate bolus administration primarily for acute coronary thrombosis.

Other Plasminogen Activators

Recombinant glycosylated prourokinase (single-chain u-PA) has a greater stability than recombinant nonglycosylated prourokinase and has been evaluated for catheter-directed, intra-arterial treatment of stroke.⁴⁹⁹ Staphylokinase is produced by *Staphylococcus aureus*. It appears to have substantial thrombolytic activity, but it may also be immunogenic.⁵⁰⁰ Vampire bat (*Desmodus rotundus*) salivary PA (rDSPA α 1, desmoteplase) possesses >72% primary structure homology to human t-PA but lacks a kringle 2 domain⁵⁰¹ which may impart greater fibrin specificity. Finally, although not a PA, plasmin therapy has been investigated in arterial vascular disease.⁴⁷¹

Thrombolytic Therapy-Associated Bleeding

Bleeding is the most common complication associated with thrombolytic therapy, regardless of the agent. The bleeding stems from plasmin's inability to distinguish between hemostatic and pathologic thrombi. This complication can range from minor bleeding at an intravenous infusion site to life-threatening hemorrhage.⁵⁰² Intracranial hemorrhage is a relatively uncommon but serious complication of thrombolysis in patients being treated for acute MI.

The factors that increase the risk for bleeding during thrombolytic therapy are not fully understood. However, Gurwitz and associates used the National Registry for MI to determine risk factors for this adverse event in individuals treated with t-PA.⁵⁰³ Their analysis of 673 patients with intracranial hemorrhage indicated that older age, female sex, black ethnicity, systolic blood pressure \geq 140 mm Hg, diastolic blood pressure \geq 100 mm Hg, history of stroke, t-PA dose \geq 1.5 mg/kg, and lower body weight were all significantly associated with an increased risk for intracranial hemorrhage. It is also possible that the properties of the agent used for thrombolysis may contribute to the risk for bleeding complications.

Thrombolytic Fibrin Specificity and Hemorrhagic Risk

Thrombolytic agents can be characterized along a variety of dimensions, but one that is often mentioned is fibrin specificity.⁵⁰⁴ The ability of a thrombolytic agent (PA) to distinguish between plasminogen in the general circulation and plasminogen bound to fibrin surfaces dictates its fibrin specificity. Activation of fibrin-bound plasminogen results in the generation of fibrin-bound plasmin that is protected from inactivation by α_2 -antiplasmin. Bound plasmin generates soluble fibrin degradation products; circulating plasmin degrades fibrinogen into FDPs. Fibrin specificity differs from fibrin affinity, which is a measure of how avidly a given agent binds to fibrin, but not its specificity for this molecule.⁵⁰⁴ At present, there is little evidence to support the view that differences in fibrin affinity among PAs are significantly correlated with either the efficacy or safety of these preparations.⁵⁰⁵ High fibrin specificity is thought to be associated with lower risk for hemorrhagic complications in patients undergoing thrombolytic therapy because of the belief that plasmin generated on

the fibrin surface of a thrombus restricts its activity only to that surface. This view is not universally supported by available data from large-scale clinical trials.

A relationship between high fibrin specificity and reduced bleeding risk has been demonstrated.⁵⁰⁶ The results of the Assessment of the Safety and Efficacy of a New Thrombolytic (ASSENT)-2 trial, which included 16,949 patients with acute MI, showed that the use of the highly fibrin-specific thrombolytic agent TNK-tPA, compared with rt-PA, was associated with a significantly lower risk for major noncerebral bleeding.⁵⁰⁶ This lower rate of bleeding complications was correlated with a significant reduction in the need for blood transfusions. The ASSENT-2 investigators also reported that TNK-tPA was associated with a significantly lower risk for noncerebral bleeding than the less-specific agent alteplase.⁵⁰⁷ Intracranial bleeding rates were comparable with the two agents.

Results from other large-scale studies support the opposing view that high fibrin specificity may actually be associated with increased risk for intracranial bleeding in patients undergoing

P.1248

thrombolytic therapy for acute MI. For example, the Global Utilization of Streptokinase and Tissue Plasminogen Activator for Occluded Coronary Arteries (GUSTO) trial showed that the risk of intracranial bleeding was slightly higher in 41,021 patients with MIs who received treatment with rt-PA as compared with SK.⁵⁰⁸ These findings are consistent with those from another very large-scale comparison of SK with rt-PA in 20,768 patients with MI (Gruppo Italiano per lo Studio della Streptochinasi nell'Infarto Miocardico 2 [GISSI-2]), which showed a significantly higher risk of stroke in patients who received the latter, more fibrin-specific agent.⁵⁰⁹ Similarly, the Third International Study of Infarct Survival (ISIS-3) showed that treatment of patients with anisoylated plasminogen SK activator complex was associated with increased risk for intracranial bleeding compared with SK in a large cohort of 41,299 patients who received thrombolytic therapy for suspected MI.⁵¹⁰

There are a number of potential explanations for the association between high fibrin specificity and increased intracranial bleeding observed in the patients treated in the GUSTO, GISSI-2, and ISIS-3 trials. These include the inability of fibrin-specific agents to distinguish between pathologic thrombi and hemostatic thrombi, and the possibility that treatment with fibrin-specific agents resulted in greater degradation of hemostatic fibrinogen and other circulating coagulation factors than SK. Finally, it may be that fibrin-specific therapy resulted in increased production and accumulation of fragment X, and that this enhanced the bleeding risk.⁵¹¹

VENOUS THROMBOEMBOLIC DISEASE

VTE, encompassing both DVT and PE is a common disease that carries a substantial risk of morbidity and mortality, is associated with high healthcare costs, and for many patients can be prevented. It has been estimated that between 500,000 and 2 million VTE cases, including calf vein thrombosis, proximal DVT, and PE, occur annually in the United States alone. It is estimated that up to 50% of DVT and PE are asymptomatic or undetected.⁵¹²

The major clinical consequences of extremity DVT include the PTS (chronic swelling, stasis dermatitis, stasis ulceration, and venous claudication: All secondary to venous insufficiency) and PE. The major clinical consequences of PE include acute lung infarction, chronic dyspnea, chronic pulmonary hypertension, and death. DVT restricted to the calf veins uncommonly results in clinically important PE and is rarely associated with a fatal outcome. In contrast, inadequately treated DVT involving the popliteal or more proximal leg veins is associated with a 20% to 50% risk of clinically relevant recurrence and is strongly associated with both symptomatic and fatal PE.^{513, 514} In untreated patients, death from PE occurs most frequently within 24 to 48 hours of initial presentation. All-cause mortality rates in treated patients with PE is as high as 11% at 2 weeks and 17% at 3 months.⁵¹² Even small PE in patients with emphysema, cardiac disease, or lung involvement with malignancy may result in death. Any VTE in a patient with a contraindication to anticoagulation presents a therapeutic challenge and greater likelihood of adverse outcome.

Management of Venous Thromboembolism

For a majority of patients with VTE, treatment is traditionally straightforward and includes an initial treatment phase (first 5 to 7 days) wherein there is an immediate initiation of a therapeutically dosed parenteral anticoagulant (e.g., heparin or low-molecular-weight heparin) and simultaneous initiation of long-term therapy (e.g., vitamin K antagonist), followed by a long-term treatment phase (from 5 to 7 days to 3 months) where the parenteral anticoagulant is discontinued, and VKA therapy is continued, and then an extended treatment phase (3 months to indefinite) where there is a decision to continue treatment or not.^{515, 516, 517} The emergence of the NOACs will greatly simplify this approach for a majority of patients.

Initial Treatment of Venous Thromboembolism

The mainstay of pharmacologic therapy for VTE is anticoagulation. A delay in achieving therapeutic anticoagulant intensity may have a negative effect on a patient's long-term VTE recurrence rate.^{518, 519} VKA have a delayed onset of action and the necessity of instituting a rapid-onset parenteral anticoagulant (e.g., heparin) in patients with acute VTE during VKA initiation has been highlighted.⁵²⁰ As long as warfarin is dosed to a therapeutic level, overlap therapy with heparins can be minimized to 5 days.^{517, 521, 522}

UFH remains the preferred initial parenteral anticoagulant for certain patients with acute VTE such as those with end-stage renal disease. When heparin is used, weight-based dosing (80-U/kg bolus followed by 18 U/kg/hour) with subsequent dose adjustments based on a standardized nomogram (Table 55.7) facilitates achieving a target aPTT.⁵²³ Use of any published nomogram helps facilitate the rapid achievement of target intensity anticoagulation. Adjusted-dose subcutaneous UFH, intermittent intravenous UFH boluses, and fixed dose subcutaneous heparin have also been used effectively in the treatment of VTE.^{513, 524, 525} The therapeutic intensity of UFH is monitored using the aPTT. An aPTT therapeutic range that correlates with an anti-FXa activity level of 0.3 to 0.7 U/ml is preferred.³⁹⁷ The aPTT should be checked every 4 to 6 hours until the aPTT surpasses the minimum of the therapeutic range.

As compared to heparin, weight-based subcutaneous LMWH is a preferred treatment option for most patients with acute VTE.⁵¹⁷ In 1992 two separate groups of investigators demonstrated that fixed-dose LMWH therapy was at least as safe and effective as adjusted-dose intravenous heparin in patients with proximal vein thrombosis.^{526, 527} Subsequently, numerous other comparative trials have been performed, and in a meta-analysis of 13 comparative trials Dolovich et al.⁵²⁸ demonstrated the LMWHs to be comparable to heparin for the initial treatment of VTE with regard to recurrence, major bleeding, and total mortality.⁵²⁸ Similarly, in a meta-analysis of 2,110 patients who presented with acute symptomatic PE, LMWH were found to be at least as effective (OR for recurrence, 0.68, 95% CI, 0.42 to 1.09) and safe (OR for major bleeding, 0.67, 95% CI, 0.36 to 1.27) as heparin.⁵²⁹ Enoxaparin sodium is dosed at 1.0 mg/kg body weight every 12 hours or 1.5 mg/kg once daily.⁵³⁰ Tinzaparin is dosed at 175 U/kg once daily.⁵¹⁷ Dalteparin is dosed at 200 U/kg (up to 18,000 U) once daily. The Matisse trials also support the use of fondaparinux in patients with VTE with efficacy and safety at least as good as LMWH.^{517, 531}

Efficient initial dosing of VKA therapy in patients with VTE minimizes excessive duration (i.e., beyond 5 to 7 days) of potentially costly parenteral anticoagulants and may allow for shorter hospitalization. The use of standardized warfarin initiation dosing nomograms has been shown to be efficient and safe.^{450, 532, 533} In two separate studies of predominantly inpatients, dosing nomograms using a 5-mg initial dose was compared to 10 mg and shown to be effective in achieving a therapeutic INR within 5 days with less risk of excessive anticoagulation.^{450, 532} More recently a 10-mg initial VKA dose nomogram in outpatients being treated for VTE had a greater percentage of patients achieving a therapeutic INR by day 5 of therapy with no difference in excessive anticoagulation or adverse events as compared to a lower initial dose.⁵³³ Lower initial doses (e.g., 5 mg or less) may be most appropriate for those patients who are elderly, have low body weight, are on interacting medications, or have poor nutrition, whereas a higher dose (e.g., 10 mg) may be acceptable for others.

The initial treatment of VTE used to be confined to the inpatient setting; however, two clinical trials demonstrated that

P.1249

outpatient LMWH treatment for carefully selected patients with acute DVT is safe and effective and can lead to substantial cost savings.^{534, 535, 536} Assuming an appropriate care-delivery system is in place, outpatient DVT treatment has become appropriate for a majority of DVT patients except perhaps, those with massive iliofemoral DVT, a high bleeding risk, or substantial co-morbid illness that otherwise necessitates hospitalization.⁵³⁷ Appropriate initial site-of-care for patients who present with acute PE is more controversial. Unlike patients with acute DVT, patients with acute PE represent a very heterogeneous risk-group with 3-month mortality rates ranging from 1.4% to 17.4%.^{512, 538} Standardized clinical assessments, biomarkers, and right ventricular size on imaging can all help to identify patients with a favorable prognosis. For carefully selected, low-risk patients with acute PE, a predominantly outpatient management approach has been shown to be safe and effective.⁵³⁹

Anticoagulation Considerations in Special Populations with Venous Thromboembolism

In occasional patients with thrombosis, the aPTT assay may not be reliable in monitoring UFH therapy, for example, patients with the lupus anticoagulant and a prolonged baseline aPTT. For these patients, one option would be to use UFH levels that can be obtained by an automated assay using an anti-factor Xa method. In this instance, the targeted therapeutic range would be 0.35 to 0.7 U/ml. Alternatively, these patients could be given LMWH or fondaparinux, with

the dosage determined solely by body weight and no necessity for laboratory monitoring. Patients with marked elevation in factor VIII levels may also be more reliably anticoagulated using LMWH.⁴⁰⁰

Obese patients are underrepresented in VTE treatment trials, and that has led to uncertainty about optimal LMWH dosing in these patients.^{540, 541} Studies evaluating drug (e.g., dalteparin, enoxaparin, tinzaparin) activity with the use of anti-Xa activity levels, suggest the pharmacodynamics of LMWHs in obese patients (weighing up to 190 kg) are similar to nonobese patients.^{542, 543, 544} Consequently, weight-based dosing (using total body weight) in obese patients without dose-capping and without anti-Xa monitoring appears appropriate.^{397, 540} However, due to limited published experience, anti-Xa monitoring with subsequent dose adjustment should be considered in patients at extreme weights, i.e., those patients weighing over 190 kg in whom LMWH are used.⁵⁴⁰

The concomitant presence of renal insufficiency (creatinine clearance [CrCl] <30 ml/minute) is associated with worse outcomes, including fatal bleeding, in patients with VTE.⁵⁴⁵ Although inconsistent, the LMWHs have a significant degree of renal clearance with anti-Xa activity levels strongly correlating with CrCl and drug accumulation occurring in those patients with a CrCl less than 30 ml/minute.³⁹⁷ Clinically, unadjusted LMWH therapy is associated with greater bleeding complications (OR 2.25, 95% CI 1.19 to 4.27) in patients with CrCl <30 ml/min compared to those without renal impairment.⁵⁴⁶ Because of potentially worse outcomes with LMWHs in patients with significant renal impairment, weight-based adjusted-dose UFH is recommended over LMWH for VTE treatment.^{397, 540, 541}

Extended Treatment of Venous Thromboembolism

The optimal duration of anticoagulation should be determined for each individual patient. Patients with DVT secondary to a time-limited (transient) risk factor such as recent surgery, immobilization, trauma, or pregnancy may be anticoagulated for a short duration of 3 months, as long as the risk factor has resolved. Patients with recurrent unprovoked VTE (two or more events) or ongoing major risk factors, such as malignancy or antiphospholipid antibody syndrome, require indefinite therapy. Patients with a first unprovoked VTE should be anticoagulated for a minimum of 3 months and consideration should be given to longer duration of therapy.⁵¹⁷ In general, patients with an unprovoked VTE have a risk of recurrence of ~5% to 7%/year after 3 months of therapy if anticoagulation is discontinued.⁵¹⁷ Continuation of anticoagulation beyond 3 months (e.g., 6 or 12 months) reduces this risk as long as the patient remains on anticoagulation, but the heightened long-term recurrence risk remains unchanged once anticoagulation is discontinued. Unfortunately, residual thrombus on repeat imaging and the presence of the most common thrombophilias (e.g., heterozygote factor V Leiden mutation, prothrombin gene mutation, etc.) are only weak predictors of recurrence risk and so their utility in helping to decide whether to continue or stop anticoagulation after the initial 3 months in patients with unprovoked VTE is controversial.^{547, 548, 550} For these reasons, current guidelines suggest extended duration of therapy for patients with unprovoked VTE as long as the predicted long-term bleeding risk is estimated to be low.⁵¹⁷ The use of posttreatment D-dimer to guide the decision to continue or stop anticoagulation after 3 months has potential utility.⁵⁵¹ It is probable that with additional data, D-dimer testing will continue to have an emerging role in helping with duration of therapy decisions in some patients with unprovoked VTE. Guidelines for the duration of anticoagulant therapy are suggested in Table 55.16.

For those patients assigned to extended (e.g., beyond initial 3 months) duration therapy, the intensity of oral anticoagulation has been a subject of controversy. A consensus group concluded that low-intensity oral anticoagulation (INR 1.5 to 2.0) was less effective and no safer than standard-intensity therapy (INR 2.0 to 3.0).⁵⁵²

All patients anticoagulated with warfarin should be educated regarding maintaining a stable diet. Patients should be encouraged to consume a constant intake of dietary vitamin K and avoid large variations or fluctuations in their diet. Because of the number of pharmacologic interactions that exist between warfarin and other drugs (Table 55.10), patients should be instructed to inform their physician of the addition or withdrawal of any medication during warfarin therapy. In addition, patients should be encouraged to avoid over-the-counter multivitamin supplements or herbal preparations that contain vitamin K or vitamin K analogs and those known to have an effect on warfarin anticoagulation (e.g., ginkgo biloba). The risk of bleeding during therapy should be explained to all patients. It is strongly recommended that patients avoid high-risk activities, including contact sports. Patients should be instructed to seek medical attention for severe bleeding or bleeding that is not controlled after 10 to 15 minutes of continuous compression. The appropriate use of protective gear, such as bicycle helmets, should be emphasized. Patients should be instructed to carry a wallet card that identifies their use of an anticoagulant. In addition, they should be encouraged to wear a medical identification bracelet or necklace.

P.1250

Patient instruction is best provided by anticoagulation clinics that focus specifically on anticoagulation monitoring and education. Studies suggest that anticoagulation services offer better control of anticoagulation (time in therapeutic range,

TTR).⁵⁵³ Point-of-care instruments that can reliably monitor a patient's INR values in the hospital or home setting are being increasingly used.⁵⁵⁴ Patient self-testing and self-management of oral anticoagulation therapy have been demonstrated to be effective, but overall impact on clinical outcomes, cost-effectiveness, and patient selection remain incompletely defined.^{555, 556, 557}

TABLE 55.16 DURATION OF ANTICOAGULATION IN VENOUS THROMBOEMBOLIC DISEASE

Disease	Duration
Situational DVT or PE (transient risk factors)	3 mo
Unprovoked DVT or PE	3 mo (minimum)/indefinite
Recurrent unprovoked DVT or PE	Indefinite
DVT with ongoing risk factors ^a	Long-term/indefinite
Massive PE	Long-term/indefinite
Calf vein DVT	3 mo
DVT, deep venous thrombosis; PE, pulmonary embolism.	

^aFor example, malignancy, antiphospholipid antibody syndrome, or natural anticoagulant deficiency.

In select cases, LMWH may be used in lieu of oral warfarin for chronic-phase anticoagulation. Because of its teratogenic effects, warfarin therapy is contraindicated in pregnancy, so long-term heparin or LMWH is prudent for pregnant patients; LMWH may be preferred in pregnancy, because osteopenia occurs less often with LMWH than with UFH.⁵⁵⁸

In addition, patients with variable oral intake, episodic vomiting, malabsorption, and difficult to regulate INR values on warfarin may be better served by chronic subcutaneous LMWH administration.

The management, efficacy, and safety of VKA are particularly problematic in cancer patients with VTE.⁵⁵⁹ Both recurrent VTE and major bleeding events are significantly more common in patients with cancer compared to those without in the first month of therapy and are not explained by anticoagulant intensity outside the target range.⁵⁶⁰ Due to the limitations of VKA in this population, long-term LMWH therapy has been evaluated as an alternative to LMWH followed by VKA in cancer patients with VTE. In the pivotal 2003 CLOT trial, Lee et al. randomized 672 patients with acute proximal DVT, PE, or both to either 6 months of dalteparin (200 IU per kilogram of body weight once daily for 1 month followed by 150 IU per kilogram once daily for 5 months) to 5 to 7 days of dalteparin followed by 6 months of VKA with a target INR of 2.5. During the 6-month study period, recurrent VTE was significantly less common in the long-term LMWH group (hazard ratio 0.48, 95% CI 0.30 to 0.77) without a difference in bleeding events or mortality.⁵⁶¹ In a separate randomized open-label clinical trial comparing usual care to long-term tinzaparin in patients with a proximal DVT in the setting of cancer (n = 200), Hull et al.⁵⁶² demonstrated long-term tinzaparin to be associated with fewer recurrent VTE events, 16% versus 7% (absolute risk difference -9%, 95% CI -21.7% to -0.7%).⁵⁶² Most recently, a Cochrane meta-analysis of six randomized trials showed that long-term LMWH, compared to usual therapy provided a reduction in VTE (HR 0.47, 95% CI 0.32 to 0.71) with no statistically significant survival benefit (HR 0.96, 95% CI 0.81 to 1.14) or difference in bleeding outcomes (RR 0.91, 95% CI 0.64 to 1.31).⁵⁶³ From a patient perspective, long-term LMWH therapy is deemed acceptable and is preferable to VKA.⁵⁶⁴ Based upon favorable outcomes, long-term LMWH therapy in cancer patients is currently endorsed by numerous practice guidelines as the preferred therapeutic approach in these patients.^{517, 565, 566, 567}

Novel Oral Anticoagulants for the Treatment of Venous Thromboembolism

Rivaroxaban has recently been approved for VTE treatment, and the continued emergence of the NOACs will likely change the treatment approach for many patients with VTE. Noninferiority trials have compared a single drug treatment approach (e.g., rivaroxaban) or treatment after an initial course of LMWH (e.g., dabigatran etexilate) to standard therapy in patients with acute VTE. Other similar trials evaluating apixaban and edoxaban are near completion. In the EINSTEIN-DVT trial (n = 3449), oral rivaroxaban, 15 mg twice daily for 3 weeks and then 20 mg once daily, was compared to standard therapy in patients with acute DVT.⁵⁶⁸ Rivaroxaban was demonstrated to have both similar efficacy (hazard ratio for the primary endpoint of symptomatic recurrence was 0.68, 95% CI 0.44 to 1.04) and safety.⁵⁶⁸ In a companion study of patients with acute PE, the EINSTEIN-PE trial (n = 4,832), as compared to usual therapy, rivaroxaban was similarly effective and safe, HR 1.12 (95% CI 0.75 to 1.68) and 0.49 (95% CI .031 to 0.79), respectively.⁵⁶⁹ In the RE-COVER trial (n = 2,539), patients with acute VTE received either VKA or dabigatran, 150 mg twice daily, after an initial period of parenteral

anticoagulation with LMWH. After 6 months of therapy recurrence, HR 1.10, 95% CI 0.65 to 1.84, and major bleeding, HR 0.82, 95% CI 0.45 to 1.48, were similar.⁵⁷⁰

Calf Deep Venous Thrombosis

Many perceive that calf DVT is of limited clinical significance. This misunderstanding and underappreciation of the potential morbidity and mortality associated with calf DVT have resulted in a lack of clear consensus on the optimal management strategy for this condition. Isolated calf DVT may account for as few as 6.2% of all symptomatic acute DVT and as many as 43.0% of all acute VTE.⁵⁷¹ Studies have also demonstrated that although calf DVT and proximal DVT may be considered separate diseases at their outset, 15% to 25% of calf DVT propagate into the proximal veins within 2 to 3 weeks wherein a risk of embolism ensues.^{572, 573, 574, 575} Such “proximal conversion” renders what was initially a calf DVT just as dangerous as any proximal DVT.

Whereas the primary goals of proximal DVT treatment include the prevention of DVT recurrence and PE, the most essential goals of calf DVT treatment should be to treat severe symptoms and to prevent early proximal conversion. Current treatment approaches for isolated calf DVT are either to implement the same intensity and duration of anticoagulant therapy as is used for proximal DVT or to implement serial duplex ultrasound surveillance, with therapy begun only in the event of proximal conversion or significant extension. Surveillance consists of serial imaging (e.g., twice weekly) for 2 weeks, the usual period for proximal conversion. The limitations of serial surveillance include cost, compliance, and convenience whereas anticoagulant therapy has limitations of cost, inconvenience, and risk of bleeding. Anticoagulation is preferable for those patients with a low bleeding risk who have severe symptoms or risk factors for extension (thrombus >5 cm, involves multiple calf veins, proximal extent near the calf trifurcation, ongoing underlying risk factors such as immobility or cancer, prior history of VTE, or occurrence without provocation).⁵¹⁷

Whereas 6 months of anticoagulation has been shown to be superior to 6 weeks' duration of therapy in patients with proximal DVT, the shorter course of therapy has not been shown to be inferior in patients with initial distal thrombosis.⁵⁷¹ In general, calf vein DVT should be treated for 3 months.⁵¹⁷ However, patients with situational calf DVT (DVT with a clear precipitant such as major surgery or hospitalization) can be considered for only 6 weeks of treatment, assuming the precipitating illness or event has resolved. Inferior vena cava (IVC) filter placement is not recommended for calf DVT in most circumstances.

Advanced Therapies for Venous Thromboembolism

Vena Caval Filter

Patients with acute VTE and active bleeding require placement of an IVC filter, as do patients with acute VTE who have failed therapeutic anticoagulation. Relative contraindications to anticoagulation are listed in Table 55.17. It is important to note that active bleeding may be a treatable and transient contraindication to anticoagulation. An IVC filter should not be viewed as an equivalent substitute to anticoagulation in the setting of acute VTE and is certainly not an “insurance policy” against subsequent PE. The use of IVC filters has been associated with an increased

P.1251

risk of recurrent DVT, reduced PE, and no difference in overall mortality.^{576, 577} In patients with filters placed because of bleeding, appropriate anticoagulation should begin as soon as the bleeding source has been properly and completely treated. Because of the significant risk of rebleeding, such a patient should have his or her anticoagulation begun in the hospital. Placement and subsequent removal of a temporary (or retrievable) IVC filter once the contraindication to anticoagulation has passed seems ideal. Placement of an IVC filter because of a “free-floating” DVT may not be necessary in all patients.⁵⁷⁸ Guidelines on using IVC filters have been published.^{517, 579}

TABLE 55.17 RELATIVE CONTRAINDICATIONS TO ANTICOAGULATION THERAPY

Bacterial endocarditis

Recent organ biopsy or noncompressible arterial intervention site

Recent gastrointestinal or genitourinary bleeding (<10 d)

Thrombocytopenia or marked anemia

History of a bleeding disorder

History of intracranial, spinal, or ocular bleeding

Recent (<2 wk) history of major surgery, stroke, or trauma

Hepatic insufficiency

Catheter-directed Thrombolysis of Deep Venous Thrombosis

Catheter-directed thrombolytic therapy is usually reserved for patients with extensive DVT involving the IVC or iliac veins and for patients who have signs and symptoms of actual or impending phlegmasia cerulea dolens.^{580, 581, 582, 583, 584, 585} An initial venogram is performed via a distal vessel, usually a popliteal or foot vein, to delineate fully the extent of the DVT. Access for the vascular access sheath is best accomplished via the popliteal vein, typically using ultrasound guidance to assure nontraumatic, single-puncture catheter placement. A multiple-side-hole catheter is advanced and embedded within the thrombus. Thrombolytic agent is infused through this catheter. At a minimum, low-dose heparin (500 U/hour) should be infused through the sheath to prevent sheath thrombosis. Periodic surveillance with venography should be performed to assess resolution of the DVT. As lysis is achieved, the infusion catheter may require repositioning to maintain infusion within the thrombus.⁵⁸¹

Lytic therapy for DVT carries the same contraindications as for lysis of PE. Active bleeding is an absolute contraindication to the procedure; relative contraindications include those for any anticoagulant. In addition, a history of contrast allergy or renal insufficiency is a relative contraindication to the procedure. Complications are similar to the complications for PE lysis. The major complication associated with the use of lytic agents is bleeding. Access-site bleeding is the most common complication. Bleeding in the popliteal space may be particularly significant because the popliteal vein is poorly compressible. Additional complications such as intracranial bleeding are also seen with lytic infusion for DVT lysis. PE, potentially fatal, has been reported in patients undergoing DVT lytic therapy.

Only SK has an approved indication for use in lytic treatment of DVT. Urokinase, rt-PA, r-PA, and TNK-t-PA are not approved for DVT lysis. After the completion of thrombolytic therapy, patients should be anticoagulated with an appropriate parenteral agent (UFH, LMWH, or DTI) and converted to warfarin in the usual fashion. Patients who have a contraindication to lysis may be able to derive some benefit from mechanical thrombectomy performed at the time of venography/intervention. However, mechanical thrombectomy should not be attempted in patients with a contraindication to anticoagulation, because any benefit from suction thrombectomy would likely be lost without maintenance of therapeutic anticoagulation.

Benefits of DVT thrombolysis include the ability subsequently to diagnose and treat any underlying venous stenosis, venous compression (as in May-Thurner syndrome), or venous webs that may be discovered after thrombolysis.^{582, 583} The use of angioplasty, stent placement, or both may improve outcomes in these patients.⁵⁸⁴ Most recently, the combined use of localized pharmacomechanical intervention has been demonstrated to reduce subsequent PTS occurrence but increase overall bleeding.^{586, 587} These more recent findings are important as the primary goal of catheter-based interventions for the management of DVT is to reduce the subsequent occurrence of PTS. PTS develops in up to 50% of patients with symptomatic DVT.⁵⁸⁸ Pain, swelling, edema, pigmentation changes, and skin ulcers may occur. PTS results from damage to venous valves by clot, leading to valvular incompetence and venous reflux.⁵⁸⁸ Management of PTS involves use of graduated elastic compression stockings⁵⁸⁹ and, as discussed, consideration of use of invasive catheter-directed approaches to treat DVT (and prevent PTS); however, consensus opinion currently recommends against the routine use of thrombolytic therapy, and large randomized trials are in progress.⁵¹⁷

Thrombolysis for Pulmonary Embolism

Most patients with symptomatic PE should be treated solely with anticoagulation. Some patients with PE may derive benefit from thrombolytic therapy to actively degrade the thrombus obstructing the pulmonary vasculature. Clear indications for PE thrombolysis are debatable.^{590, 591} Thrombolysis has been demonstrated to improve survival in patients with massive PE plus shock and is probably indicated in these patients. When compared to anticoagulation alone, thrombolytic therapy results in more rapid thrombus lysis, an early improvement in pulmonary blood flow, and improvement of right ventricular function.⁵⁹² However, these improvements in cardiopulmonary function alone have not resulted in decreased mortality in stable patients without significant hemodynamic compromise. Even in patients with submassive PE, initial thrombolysis with intravenous alteplase did not reduce mortality.⁵⁹³ It remains unclear whether patients with PE and evidence of right ventricular dysfunction or elevated cardiac troponin levels (or both) benefit from thrombolysis.

Currently approved drug regimens for PE lysis include the following: SK, 250,000-U intravenous bolus over 30 minutes followed by 100,000-U/hour intravenous infusion for 24 hours; rt-PA, 100-mg intravenous infusion over 2 hours; and urokinase, 4,400-U/kg bolus over 10 minutes followed by intravenous infusion of 4,400 U/kg/hour for 12 hours. Reteplase

is not FDA-approved for PE management, but when administered as two 10-U boluses separated by 30 minutes, it has been shown to improve pulmonary vascular resistance and blood flow more rapidly than standard-dose rt-PA.⁵⁹⁴ Lytic therapy is contraindicated in patients with an increased risk of bleeding. Active bleeding is an absolute contraindication to therapy. In addition, recent organ biopsy or arterial puncture in a noncompressible site and recent cardiopulmonary resuscitation, uncontrolled hypertension, and pregnancy or recent delivery are relative contraindications. For all patients, the potential benefits of lysis must be weighed heavily against the potential risks of bleeding.⁵⁹⁵

Major hemorrhage rates have varied between 4% and 22% in studies at the currently recommended doses. Extrapolation from acute MI thrombolysis trials supports intracranial hemorrhage rates between 1% and 3%, approximately one half of which are

P.1252

fatal. There is no benefit to lytic infusion via a centrally placed catheter when compared to peripheral infusion in patients with PE. Many believe that heparin should not be administered concomitantly with the lytic agent. An aPTT should be determined at the completion of the lysis; if the aPTT is ≤ 2.5 times the control, then heparin infusion should be started/resumed. If the aPTT is > 2.5 times the control, the aPTT should be repeated every 4 hours; once it decreases into an acceptable range, the heparin infusion may be initiated. If a complication of therapy occurs, the lytic agent and any other anticoagulants should be held. Freshfrozen plasma and cryoprecipitate may be used to replete fibrinogen and clotting factors. Consideration should be given to the use of antifibrinolytic agents to reverse excessive fibrinolysis.^{590, 591}

PREVENTION OF VENOUS THROMBOEMBOLIC DISEASE

If physicians focused more on VTE prophylaxis, much less time would be needed to emphasize methods for VTE diagnosis and treatment. Fatal PE is considered to be the most common preventable cause of hospital death.⁵⁹⁶ Because the clinical diagnosis of VTE is unreliable and serial surveillance of all high-risk patients is expensive, widespread use of anticoagulants (or other prophylactic measures) has been recommended and is the subject of recent comprehensive practice guidelines by the American College of Chest Physicians.^{359, 597, 598, 599}

Optimal delivery of thromboprophylaxis requires an assessment of risk versus benefit, and this is particularly relevant to medically-ill patients wherein the absolute risk of clinically relevant VTE may be less than in patients undergoing major surgical procedures. There is an abundance of literature supporting the benefits of thromboprophylaxis in surgical patients, but the absolute clinical impact in nonsurgical patients is less certain. In a recent meta-analysis by Lederle and colleagues, medically-ill patients who received pharmacologic prophylaxis had reduced incidence of symptomatic PE (number needed to treat 306), but increased bleeding events (number needed to harm 296 for major bleeding), and no reduction in total mortality.⁶⁰⁰ Risk assessment, however, is imperfect and can be viewed as group risk (e.g., all orthopedic patients) or individualized risk (e.g., based upon individual patient characteristics). Figure 55.9 illustrates several VTE risk assessment models that have been validated.^{601, 602, 603} It is important to note that not all patients at risk develop a thrombosis, and not all thromboses result in symptoms, morbidity, or death. The benefit of pharmacologic thromboprophylaxis must always be weighed against the bleeding risk. Patients at high risk for bleeding should still receive prophylaxis in the form of an intermittent pneumatic compression device, thromboembolism-deterrence stockings, or both. Furthermore, prophylaxis strategies must take into account whether a patient has a history of HIT. Figure 55.10 illustrates a general approach to thromboprophylaxis, and Table 55.17 lists relative contraindications to anticoagulant therapy.

All Hospitalized*		Medical†		Non-orthopedic Surgical Patients‡	
Risk Factor	Points	Risk Factor	Points		
Cancer	3	Prior VTE	3	5 points each: Joint replacement surgery, hip/pelvic/leg fracture, stroke, multiple trauma, SCI	
Prior VTE	3	Thrombophilia	2	3 points each: Age >75, history of VTE, family history of thrombosis, HIT, thrombophilia	
Thrombophilia	3	LE paralysis	2	2 points each: Age 60–74, cancer, major surgery, laparoscopic or arthroscopic surgery, CVC, bed rest >72h, immobilizing cast	
Major Surgery	2	Cancer	2	1 point each: Age 41–60, minor surgery, IBD, edema, BMI > 25, sepsis, serious lung disease, medical patient on bed rest, CHF, AMI, varicose veins, OCP/ERT, pregnant/postpartum	
Age >75 years	1	Immobility 7+ days	1	High Risk = 8+ points	
Obesity	1	ICU/CCU	1	Low Risk = 0–1+ points	
Bed Rest	1	Age >60 years	1		
Hormones	1				
High Risk = 4+ points		High Risk = 4+ points			

- High Risk = >4% Symptomatic VTE Rate
- Greater # RF = Greater RAM Sensitivity

FIGURE 55.9. Individualized venous thromboembolism risk assessment models (RAMs). Individualized risk assessment for venous thromboembolism using validated risk assessment models may optimize patient selection and subsequent net benefit of thromboprophylaxis for acutely ill hospitalized patients or those undergoing major surgical intervention. In general, RAMs have a good positive predictive value in identifying high-risk patients, but may be relatively less useful in identifying lower-risk patients. AMI, acute myocardial infarction; BMI, body mass index; CHF, congestive heart failure; CVC, central venous catheter; HIT, heparin-induced thrombocytopenia; IBD, inflammatory bowel disease; ICU/CCU, intensive care unit or critical care unit; LE, lower extremity; OCP/ERT, oral contraceptives/estrogen replacement therapy; SCI, spinal cord injury; VTE, venous thromboembolism. Adapted from Kucher N, Koo S, Quiroz R, et al. Electronic alerts to prevent venous thromboembolism among hospitalized patients. *N Engl J Med* 2005;352:969-977. †Spyropoulos AC, Anderson FA, Fitzgerald G, et al. Predictive and associative models to identify hospitalized medical patients at risk for VTE. *Chest* 2011;140:706-714. ‡Bahl V, Hu HM, Henke PK, et al. A validation study of a retrospective venous thromboembolism scoring method. *Ann Surg* 2010;251:344-350.

Duration of thromboprophylaxis has also received attention. In general, extended prophylaxis (i.e., up to 4 weeks) has been suggested for patients undergoing elective hip arthroplasty, hip fracture repair, and high-risk abdominal-pelvic cancer surgery. Extending prophylaxis in medical patients, however, has not been shown to be effective and is associated with increased bleeding.^{604, 605}

HEPARIN-INDUCED THROMBOCYTOPENIA

Although bleeding is the most common adverse event associated with heparin and LMWH therapy, HIT, also known as the white clot syndrome, is increasingly recognized as a potentially severe, albeit paradoxical, immune-mediated complication of heparin therapy.^{606, 607} HIT is a “clinical-pathologic” syndrome, meaning that the diagnosis is optimally based on compatible clinical features as well as laboratory assay results positive for heparin-dependent antibodies. Platelet activation occurs in vivo in normal people. This results in release of PF4, a tetrameric platelet α-granule constituent into blood where it may also bind to the external platelet surface. Heparin is a polyanion, i.e., a chain of negatively

P.1253

charged oligosaccharides, that can bind to positively charged PF4 tetramers, resulting in heparin-PF4 complex formation that is immunogenic under certain circumstances.⁶⁰⁸ Binding of IgG to the heparin-PF4 complex forms an immune complex that triggers cross-linking of the platelet FcγIIa receptor, an event that leads to platelet activation and formation of thrombogenic microparticles.⁶⁰⁹ The end result is development of thrombocytopenia in the setting of a profound hypercoagulable state.

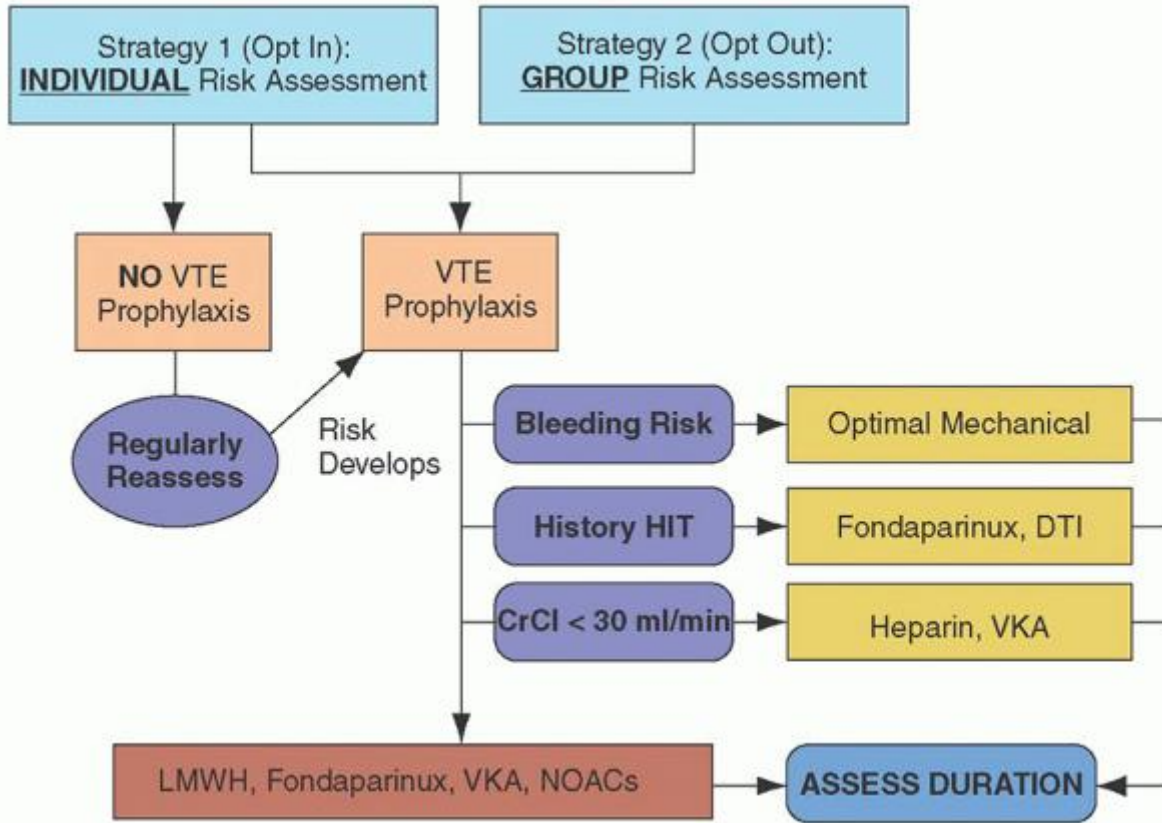

FIGURE 55.10. General approach to venous thromboembolism (VTE) prophylaxis in hospitalized patients. Some form of venous thromboembolism risk assessment should be performed in patients admitted to the hospital to identify those patients who are most likely to benefit from thromboprophylaxis. Risk assessment can be either individualized or considering at-risk patient groups (e.g., orthopedic surgery patients). Once risk has been identified, the choice of prophylactic strategy should be based upon the patient's bleeding risk, history of heparin-induced thrombocytopenia, renal function, duration of therapy, and cost. CrCl, creatinine clearance; DTI, direct thrombin inhibitor; HIT, heparin-induced thrombocytopenia; LMWH, low-molecular-weight heparin; ml/min, milliliters per minute; NOACs, novel oral anticoagulants; VKA, vitamin-K-antagonists.

HIT typically develops between 5 and 14 days after the commencement of heparin therapy and produces a variable but often moderate degree of thrombocytopenia wherein nadir platelet counts are typically in the range of 60,000/ μ l and the development of severe thrombocytopenia (<20,000/ μ l) is unusual.^{610, 611, 612} A platelet count fall that begins before day 5 of heparin is unlikely to represent HIT except in patients with a recent (within 3 months) heparin exposure.⁶⁰⁶ These patients may experience an abrupt onset of thrombocytopenia on re-exposure to heparin as a result of acute platelet activation due to preformed, circulating HIT-associated antibodies. In contrast, delayed-onset HIT represents a clinical challenge as patients may develop thrombocytopenia with or without thrombosis days to weeks after heparin cessation.⁶¹³

Although the exact incidence of HIT has not been well established, HIT has been noted to develop in up to 3% to 5% of patients exposed to unfractionated porcine-intestine-derived heparin.⁶¹⁰ Patients exposed to bovine-lung-derived UFH have been reported to have a greater likelihood of developing HIT than those exposed to porcine-intestine-derived UFH, and UFH induces pathogenic HIT antibodies to a greater extent than LMWH (~5% vs. ~1%, respectively, in orthopedic patients).^{614, 615} Warkentin et al. evaluated the incidence of HIT in 665 patients randomized to receive subcutaneous UFH or LMWH for venous thromboprophylaxis after elective hip surgery. HIT was diagnosed in 2.7% (9/332) of patients given UFH versus 0% (0/333) of those given LMWH. HIT with thrombosis developed in 88.9% (8/9) of the patients who developed HIT, compared with a thrombosis rate of 17.8% (117/656) in patients without HIT.⁶⁰⁶ The clinical setting also influences the frequency of HIT; patients undergoing cardiac surgery who receive UFH have a higher incidence of pathogenic HIT antibodies (2.5%) compared to medical (<1%) or obstetric (<0.1%) patients, and HIT may develop more commonly in women.^{614, 616}

The most feared complication of HIT is thrombosis. Thirty-six to fifty percent of patients with HIT have been noted to develop life- or limb-threatening thromboses.⁶¹⁰ The thrombotic tendency associated with HIT can last for at least 30 days, and HIT with thrombosis can develop well after the discontinuation of heparin and platelet-count recovery. Venous thrombosis is more common than arterial thrombosis in HIT patients, especially in those who receive UFH for postoperative DVT prevention.^{612, 617} Extremity DVT is the most frequently encountered venous thrombotic complication in HIT patients, followed in frequency by PE and cerebral sinus thrombosis.⁶¹⁰ Most HIT-associated arterial thromboses involve the extremities, but stroke, MI, and renal artery thrombosis related to heparin infusions have been described. HIT with thrombosis after coronary artery bypass grafting may present as bypass-graft occlusion, left atrial thrombus formation, valvular thrombosis, or PE.⁶¹⁸ Acute graft occlusion secondary to HIT has been described in vascular surgery patients even after platelet-count normalization. It is reasonable to assume that patients with pre-existing vascular lesions, intravascular catheters, sepsis, or postoperative venous stasis are particularly susceptible to the thrombotic complications of HIT.

Other clinical presentations of HIT include heparin-induced skin lesions, heparin “resistance,” and adrenal vein thrombosis leading to hemorrhagic infarction.^{619, 620} Heparin-induced skin lesions have been observed in ~10% to 20% of patients who generate HIT-IgG in response to subcutaneous UFH injections. The skin lesions develop at heparin injection sites and can range from painful red plaques to overt skin necrosis reminiscent of warfarin-induced skin necrosis. Thrombocytopenia may not develop in the majority of patients with heparin-induced skin lesions, but those who develop skin lesions and thrombocytopenia appear to be at extremely high risk for arterial thrombosis. The thrombocytopenia that develops in HIT is not normally associated with hemorrhagic events, and platelet transfusion may exacerbate the HIT-induced prothrombotic tendency.⁶¹⁰

HIT is primarily a clinical diagnosis. HIT should be strongly suspected in any patient who develops thrombocytopenia while receiving heparin in any dose or by any route of administration. Whereas HIT is usually associated with a platelet count below the lower limits of normal (150,000/μl in most laboratories), the extent of thrombocytopenia is quite variable, and the diagnosis should be strongly considered in any patient in whom the platelet count falls below 50% of the baseline value (even if still within the normal range) after the fifth day of heparin treatment.⁶¹⁰ Similarly, a 30% fall in baseline platelet count combined with any form of thrombosis in a patient receiving heparin should be

P.1254

considered due to HIT until proven otherwise. Thrombotic events occurring or progressing during therapeutic-intensity heparin therapy, even if the platelet count is normal, may also constitute a HIT variant.^{621, 622, 623}

Limitations of laboratory assays for HIT (discussed below) have led to development of a clinical scoring system to determine the pretest probability of HIT, in an attempt to identify patients with the likely diagnosis more rapidly. The “4T’s” scoring system (Table 55.18) uses easily available clinical information (nadir platelet count, timing of thrombocytopenia, presence or absence of thrombosis, and alternative explanations for thrombocytopenia) to classify patients into high (score of 6 to 8), intermediate (score of 4 to 5), or low (score of ≤3) probability of HIT.⁶²⁴ Study results indicate that this scoring system has a high negative predictive value. Consequently, a low pretest score may be useful in ruling out an HIT diagnosis.⁶²⁴ A meta-analysis of clinical trials using the 4T’s scoring system found that the negative predictive value of a low probability score was 99.8%.^{624a}

The currently available in vitro diagnostic assays for HIT are either immunoassays or functional assays.⁶²⁵ Immunoassays detect the presence of heparin-PF4 antibodies using ELISA methodology.⁶²⁶ HIT ELISAs have high sensitivity, but poor specificity for the diagnosis.⁶²⁷ Most will detect IgG, IgM, and IgA antibodies, but only IgG antibodies are thought to be pathogenic in the disorder. In addition, not all antibodies to the heparin-PF4 complex will induce platelet activation.⁶²⁷ Recent data indicate that the optimal immunoassay uses ELISA methodology to detect only IgG antibodies.⁶²⁸ The reliability of an IgG ELISA in diagnosing HIT can be further improved by considering the “positivity” of the result. ELISA optical density results near the upper limit of the normal range (usually ~0.4 O.D. units) are less likely to be associated with clinical HIT than a much higher positive result (≥1.0 O.D. units).⁶²⁹

TABLE 55.18 THE 4T'S CLINICAL PREDICTION SCORE FOR THE DIAGNOSIS OF HEPARIN-INDUCED THROMBOCYTOPENIA

4T's	Score = 2 points	Score = 1 point	Score = 0 points
<i>Thrombocytopenia</i>	Platelet count fall >50% and platelet count nadir ≥20,000 and no surgery	Platelet count fall 30-50% or platelet count nadir 10-19,000	Platelet count fall <30% <i>or</i>

	within preceding 3 d	<i>or</i>	Platelet count nadir <10,000
			Platelet count fall >50% but surgery within preceding 3 d
<i>Timing of platelet count fall</i>	Onset of fall 5-10 d after heparin start	Uncertain as to time course but likely platelet count fall 5-10 d after heparin start	Platelet count fall <4 d after heparin start and no recent heparin exposure
	<i>or</i>		
	Platelet count fall \leq 1 d after heparin start with prior heparin exposure within 30 d	<i>or</i>	
		Platelet count fall after day 10 of heparin start	
		<i>or</i>	
		Platelet count fall within 1 d after heparin start with prior heparin exposure in past 31-100 d	
<i>Thrombosis (or other clinical events)</i>	Confirmed new thrombosis	Recurrent VTE in a patient receiving therapeutic anticoagulation	—
	<i>or</i>		
	Skin necrosis at injection site	<i>or</i>	
		Suspected thrombosis	
	<i>or</i>	<i>or</i>	
	Acute systemic reaction to IV UFH	Erythematous skin lesions at heparin injection sites	
	<i>or</i>		
	Adrenal hemorrhage		
<i>Other cause for thrombocytopenia</i>	None obvious	Possible	Probable/definite (DIC, sepsis, drug-induced, etc.)

Each 4T's parameter is evaluated and scored; patients with scores \leq 3 points are at low risk for HIT. Those with scores of 4-5 points are at intermediate risk, and patients with scores of 6-8 points are at high risk of HIT.

DIC, disseminated intravascular coagulation; UFH, unfractionated heparin; VTE, venous thromboembolism.

Data from references 422, 624.

Functional assays detect platelet aggregation or platelet activation after exposure to suspected HIT serum and heparin. Functional assays include the platelet aggregation test, the heparin-induced platelet aggregation test, heparin-induced platelet release of ATP detected by lumi-aggregometry, the ^{14}C -serotonin release assay (^{14}C -SRA), heparin-induced platelet microparticle formation detected by flow cytometry, and enzyme immunoassay detection of platelet serotonin release. Traditionally, the ^{14}C -SRA has been considered the "gold standard" for HIT diagnostic confirmation. However, most studies evaluating the diagnostic use of the available functional assays and immunoassays, including studies of ^{14}C -SRA, used a clinical diagnosis of HIT as the true "gold standard." Also, the SRA is tedious to perform, has a lengthy turnaround time, and is offered by few laboratories. Patients should be assessed clinically (Table 55.18) using the 4T's pretest likelihood scoring system to determine their likelihood of having HIT while awaiting immunoassay results. Those patients with a low pretest likelihood for HIT probably need no further testing or alternative anticoagulation, and an alternate explanation for thrombocytopenia should be pursued. Conversely, patients with a high pretest probability for HIT should receive

alternative anticoagulation, and for any positive immunoassay result, no further testing is indicated. Patients with a high pretest probability, but who have negative immunoassay results should be tested with the SRA to confirm or refute a diagnosis of HIT. Patients with an intermediate likelihood of HIT should receive an alternative anticoagulant while awaiting immunoassay results. If the result is strongly positive (e.g., >1 O.D. units), no further testing may be necessary. If the result is negative or only weakly positive, the SRA should be performed to diagnose or exclude HIT definitively. Alternative anticoagulation should be continued while awaiting the SRA results. Figure 55.11 suggests an initial diagnostic and management approach to HIT.

P.1255

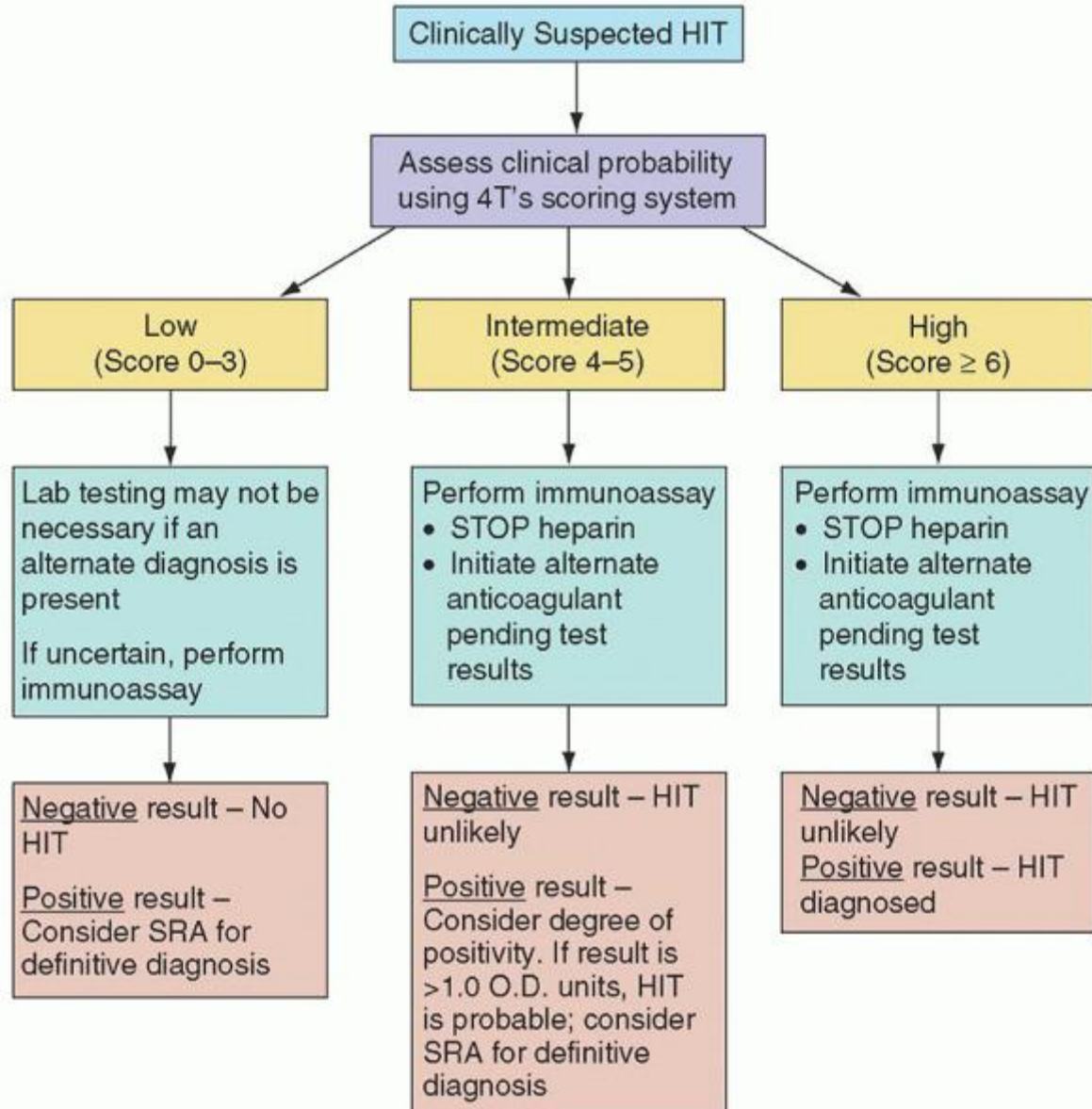

FIGURE 55.11. Initial management of patients with suspected heparin-induced thrombocytopenia (HIT). Patients with suspected HIT should be approached in a rapid and evidence-based fashion, wherein a pretest probability assessment is completed (e.g., using the 4T's scoring system, Table 55.18) and application of an immunoassay test, in particular to those patients at intermediate to high pretest probability. While awaiting immunoassay test results, implementation of an

alternative anticoagulant (e.g., direct thrombin inhibitor) is recommended. Patients with discordant clinical probability assessment and immunoassay results or those with intermediate findings should undergo additional testing with a functional platelet activation assay, such as the serotonin release assay (SRA). HIT, heparin-induced thrombocytopenia; O.D., optical density.

The initial treatment of HIT with or without thrombosis is to discontinue all exposure to heparin or LMWHs (including heparin-coated catheters) and immediately begin an alternative anticoagulant, usually a DTI, such as argatroban, lepirudin, or bivalirudin.⁴²² DTI therapy is continued as monotherapy until normalization of the platelet count, at which time bridging therapy with warfarin is started. Warfarin anticoagulation may be desired for long-term therapy, but should never be used as the sole alternative anticoagulant in patients with HIT. Warfarin treatment is the major factor contributing to limb amputation caused by progression of otherwise unremarkable deep vein thromboses to phlegmasia cerulea dolens in patients with HIT.^{630, 631} The combination of HIT-associated hypercoagulability and warfarin-induced protein C deficiency most likely produces a profound procoagulant state that causes venous limb gangrene. After both platelet count normalization and subsequent initiation of warfarin, both warfarin and DTI are continued for at least 5 days, or until a therapeutic INR (2.0 to 3.0) is achieved on warfarin alone. For isolated HIT without and with thrombosis, respectively, warfarin therapy duration of 4 weeks and 12 weeks is recommended.⁴²² Fondaparinux has also been used to treat HIT in small case series, but is not approved to treat HIT.⁶³² Patients should be informed that they should never be exposed to heparin again, although protocols are available in which short-term exposure to heparin can be safely done in patients who require heparin therapy.⁶³³

Considering the complexity of HIT diagnosis and treatment, HIT prevention must be emphasized. Patients receiving UFH should have platelet-count monitoring at baseline and at least every third day between day 5 and day 14 of heparin exposure. Platelet count monitoring recommendations in patients receiving heparin have been published in the recent ACCP guidelines.⁴²² Appropriate medical record documentation and patient education should help avert heparin re-exposure in patients with a history of HIT. Re-exposure to heparin in patients with past HIT should be delayed at least 3 months, kept to a minimum duration to provide succinct anamnesis, and avoided whenever possible. LMWH and fondaparinux may be preferable to UFH for both the treatment and prevention of thromboembolic disease because of the greatly reduced likelihood of initiating HIT.⁶³⁴ For those patients with acute or subacute HIT who require urgent cardiac surgery or PCI, the use of bivalirudin is recommended.⁴²²

REFERENCES

1. Murphy SL, Xu J, Kochanek KD. Deaths: Preliminary Data for 2010. National Vital Statistics Reports. 2012;60, number 4. <http://www.cdc.gov/nchs/fastats/lcod.htm>. Accessed May 10, 2012.
2. Goldhaber S, Visani L, De Rosa M. Acute pulmonary embolism: clinical outcomes in the International Cooperative Pulmonary Embolism Registry (ICOPER). *Lancet* 2002;52:23-47.
3. Alonso-Coello P, Bellmunt S, McGorrian C, et al. American College of Chest Physicians. Antithrombotic therapy in peripheral artery disease: antithrombotic therapy and prevention of thrombosis, 9th ed: American College of Chest Physicians Evidence-Based Clinical Practice Guidelines. *Chest* 2012;141(Suppl 2):e669S-e690S.
4. Lansberg MG, O'Donnell MJ, Khatri P, et al. American College of Chest Physicians. Antithrombotic and thrombolytic therapy for ischemic stroke: antithrombotic therapy and prevention of thrombosis, 9th ed: American College of Chest Physicians Evidence-Based Clinical Practice Guidelines. *Chest* 2012;141(Suppl 2):e601S-e636S.
5. Kushner FG, Hand M, Smith SC Jr, et al. 2009 focused updates: ACC/AHA guidelines for the management of patients with ST-elevation myocardial infarction (updating the 2004 guideline and 2007 focused update) and ACC/AHA/SCAI guidelines on percutaneous coronary intervention (updating the 2005 guideline and 2007 focused update) a report of the American College of Cardiology Foundation/American Heart Association Task Force on Practice Guidelines. *J Am Coll Cardiol* 2009;54:2205-2241.
6. Virchow R. *Gesammelte Abhandlungen zur Wissenschaftlichen Medicin*. [Thrombosis and Emboli; translated by AC Matzdorff and WR Bell. 1998.]. Canton, MA: Science History Publications/USA, 1856:220-380 (original text).
7. Badimon L, Badimon JJ, Galvez A, et al. Influence of arterial wall damage and wall shear rate on platelet deposition: ex-vivo study in a swine model. *Arteriosclerosis* 1986;6:312-320.
8. Thomas DP. Overview of venous thrombogenesis. *Semin Thromb Hemost* 1988;14:1-8.
9. Strandness DE, Ward K, Krugmire R. The present status of acute deep-venous thrombosis. *Surg Gynecol Obstet* 1977;145:433-445.

10. Nicolaides AN, Kakkar VV, Renney JTG. The soleal sinuses: origin of deep-vein thrombosis. *Br J Surg* 1970;57:860.
11. Nicolaides AN, Kakkar VV, Renney JTG. Soleal sinuses and stasis. *Br J Surg* 1971;58:307.
12. van Langevelde K, Srámek A, Rosendaal FR. The effect of aging on venous valves. *Arterioscler Thromb Vasc Biol* 2010;30:2075-2080.
13. Goldsmith HL. The flow of model particles and blood cells and its relation to thrombogenesis. *Prog Hemost Thromb* 1972;1:97-139.
14. Lowe GD. Common risk factors for both arterial and venous thrombosis. *Br J Haematol* 2008;140:488-495.
15. Turpie AG, Esmon C. Venous and arterial thrombosis—pathogenesis and the rationale for anticoagulation. *Thromb Haemost* 2011;105:586-596.
16. Ross R. The pathogenesis of atherosclerosis: a perspective for the 1990s. *Nature* 1993;362:801-809.
17. Falati S, Gross P, Merrill-Skoloff G, et al. Real-time in vivo imaging of platelets, tissue factor and fibrin during arterial thrombus formation in the mouse. *Nat Med* 2002;8:1175-1181.
18. Goodrich SM, Wood JE. Peripheral venous distensibility and velocity of venous blood flow during pregnancy or during oral contraceptive therapy. *Am J Obstet Gynecol* 1964;90:740-744.
19. Brill A, Fuchs TA, Chauhan AK, et al. von Willebrand factor-mediated platelet adhesion is critical for deep vein thrombosis in mouse models. *Blood* 2011;117:1400-1407.
20. Reitsma PH, Versteeg HH, Middeldorp S. Mechanistic view of risk factors for venous thromboembolism. *Arterioscler Thromb Vasc Biol* 2012;32:563-568.
21. Schwertz H, Tolley ND, Foulks JM, et al. Signal-dependent splicing of tissue factor pre-mRNA modulates the thrombogenicity of human platelets. *J Exp Med* 2006;203:2433-2440.
22. Hirsh J. Hypercoagulability. *Semin Hematol* 1977;14:409-425.
23. Martinelli I. Risk factors in venous thromboembolism. *Thromb Haemost* 2001;86:395-403.
24. Rondina MT, Pendleton RC, Wheeler M, Rodgers GM. The treatment of venous thromboembolism in special populations. *Thromb Res* 2007;119:391-402.
25. Coppens M, Reijnders JH, Middeldorp S, Doggen CJ, Rosendaal FR. Testing for inherited thrombophilia does not reduce the recurrence of venous thrombosis. *J Thromb Haemost* 2008;6:1474-1477.
26. Harker LA, Slichter SJ. Arterial and venous thromboembolism: kinetic characterization and evaluation of therapy. *Thromb Diath Haemorrh* 1974;31:188-203.
27. Abrahamsen AF, Eika C, Godal HC, Lorentsen E. Effect of acetylsalicylic acid and dipyridamole on platelet survival and aggregation in patients with atherosclerosis obliterans. *Scand J Haematol* 1974;13:241-245.
28. Steele P, Weily HS, Davies H, Genton E. Platelet survival in patients with rheumatic heart disease. *N Engl J Med* 1974;290:537-539.
29. Steele P, Weily H, Davies H, et al. Platelet survival time following aortic valve replacement. *Circulation* 1975;51:358-362.
30. Miller GJ, Bauer KA, Cooper JA, Rosenberg RD. Activation of the coagulant pathway in cigarette smokers. *Thromb Haemost* 1998;79:549-553.
31. Harker LA, Hazzard W. Platelet kinetic studies in patients with hyperlipoproteinemia: effects of clofibrate therapy. *Circulation* 1979;60:492-496.
32. Nichols AB, Owen J, Kaplan KL, et al. Fibrinopeptide A, platelet factor 4, and β -thromboglobulin levels in coronary heart disease. *Blood* 1982;60:650-654.
33. Sobel M, Salzman EW, Davies GC, et al. Circulating platelet products in unstable angina pectoris. *Circulation* 1981;63:300-306.
34. Moncada S. Prostacyclin and arterial wall biology. *Arteriosclerosis* 1982;2:193-207.
35. Radomski MW, Palmer RMJ, Moncada S. Endogenous nitric oxide inhibits human platelet adhesion to vascular endothelium. *Lancet* 1987;2:1057-1058.

36. Pearson JD, Gordon JL. Nucleotide metabolism by endothelium. *Annu Rev Physiol* 1985;47:617-627.
37. Marcus AJ, Broekman MJ, Drosopoulos JHF, et al. The endothelial cell ecto-ADPase responsible for inhibition of platelet function is CD39. *J Clin Invest* 1997;99:1351-1360.
38. Thompson SG, Kienast J, Pyke SDM, et al. Hemostatic factors and the risk of myocardial infarction or sudden death in patients with angina pectoris. *N Engl J Med* 1995;332:635-641.
- P.1256
39. Williams MS, Bray PF. Genetics of arterial prothrombotic risk states. *Exp Biol Med* 2001;226:409-419.
40. Rosendaal FR. Venous thrombosis: a multicausal disease. *Lancet* 1999;353:1167-1173.
41. Welch GN, Loscalzo J. Homocysteine and atherothrombosis. *N Engl J Med* 1998;338:1042-1050.
42. Kyrle PA, Minar E, Hirschl M, et al. High plasma levels of factor VIII and the risk of recurrent venous thromboembolism. *N Engl J Med* 2000;343:457-462.
43. Anderson FA, Wheeler HB, Goldberg RJ, et al. A population-based perspective of the hospital incidence and case-fatality rates of deep vein thrombosis and pulmonary embolism. The Worcester DVT Study. *Arch Intern Med* 1991;151:933-938.
44. Nordström M, Lindblad B, Bergqvist D, Kjellström T. A prospective study of the incidence of deep-vein thrombosis within a defined urban population. *J Intern Med* 1992;232:155-160.
45. Oger E, Baron N, Bressollette L, et al. Incidence of venous thromboembolism: a community-based study in Western France. *Thromb Haemost* 2000;83:657-660.
46. Crowther MA, Kelton JG. Congenital thrombophilic states associated with venous thrombosis: a qualitative overview and proposed classification system. *Ann Intern Med* 2003;138:128-134.
47. Kannel WB, Wolf PA, Castelli WP, D'Agostino RB. Fibrinogen and risk of cardiovascular disease: the Framingham Study. *JAMA* 1987;258:1183-1186.
48. Ernst E, Resch KL. Fibrinogen as a cardiovascular risk factor: a meta-analysis and review of the literature. *Ann Intern Med* 1993;118:956-963.
49. Meade TW, Mellows S, Brozovic M, et al. Haemostatic function and ischaemic heart disease: principal results of the Northwick Park Heart Study. *Lancet* 1986;2:533-537.
50. Doggen CJM, Rosendaal FR, Meijers JCM. Levels of intrinsic coagulation factors and the risk of myocardial infarction among men: opposite and synergistic effects of factor XI and XII. *Blood* 2006;108:4045-4051.
51. Meade TW, Rudduck V, Stirling Y, et al. Fibrinolytic activity, clotting factors, and long-term incidence of ischaemic heart disease in the Northwick Park Heart Study. *Lancet* 1993;342:1076-1079.
52. Cortellaro M, Cofrancesco E, Boschetti C, et al. Increased fibrin turnover and high PAI-1 activity as predictors of ischaemic events in atherosclerotic patients: a case-control study. *Arterioscler Thromb* 1993;13:1412-1417.
53. Juhan-Vague I, Pyke SD, Alessi MC, et al. Fibrinolytic factors and the risk of myocardial infarction or sudden death in patients with angina pectoris. ECAT Study Group. *Circulation* 1996;94:2057-2063.
54. Valentine RJ, Kaplan HS, Green R, et al. Lipoprotein (a), homocysteine, and hypercoagulable states in young men with premature peripheral atherosclerosis: a prospective, controlled analysis. *J Vasc Surg* 1996;23:53-63.
55. Juhan-Vague I, Valadier J, Alessi MC, et al. Deficient t-PA release and elevated PA inhibitor levels in patients with spontaneous or recurrent deep venous thrombosis. *Thromb Haemost* 1987;57:67-72.
56. Nemerson Y. Tissue factor and hemostasis. *Blood* 1988;71:1-8.
57. Steffel J, Luscher TF, Tanner FC. Tissue factor in cardiovascular disease: molecular mechanisms and clinical implications. *Circulation* 2006;113:722-731.
58. Vermynen J, Blockmans D, Spitz B, Deckmyn H. Thrombosis and immune disorders. *Clin Haematol* 1986;15:393-412.

59. Visentin GP, Ford SE, Scott JP, Aster RH. Antibodies from patients with heparin-induced thrombocytopenia/thrombosis are specific for platelet factor 4 complexed with heparin or bound to endothelial cells. *J Clin Invest* 1994;93:81-88.
60. Bevilacqua MP, Pober JS, Majeau GR, et al. Interleukin 1 (IL-1) induces biosynthesis and cell surface expression of procoagulant activity in human vascular endothelial cells. *J Exp Med* 1984;160:618-623.
61. Fryer RH, Wilson BD, Gubler DB, et al. Homocysteine, a risk factor for premature vascular disease and thrombosis, induces tissue factor activity in endothelial cells. *Arterioscler Thromb* 1993;13:1327-1333.
62. Nawroth PP, Stern DM. Modulation of endothelial cell hemostatic properties by tumor necrosis factor. *J Exp Med* 1986;163:740-745.
63. Colucci M, Balconi G, Lorenzet R, et al. Cultured human endothelial cells generate tissue factor in response to endotoxin. *J Clin Invest* 1983;71:1893-1896.
64. Courtney MA, Haidaris PJ, Marder VJ, Sporn LA. Tissue factor mRNA expression in the endothelium of an intact umbilical vein. *Blood* 1996;87:174-179.
65. Drake TA, Cheng J, Chang A, Taylor FB. Expression of tissue factor, thrombomodulin, and E-selectin in baboons with lethal *Escherichia coli* sepsis. *Am J Pathol* 1993;142:1458-1470.
66. Speiser W, Kapiotis S, Kopp CW, et al. Effect of intradermal tumor necrosis factor- α -induced inflammation on coagulation factors in dermal vessel endothelium: an in vitro study of human skin biopsies. *Thromb Haemost* 2001;85:362-367.
67. Edwards RL, Rickles FR, Bobrove AM. Mononuclear cell tissue factor: cell of origin and requirement for activation. *Blood* 1979;54:359-370.
68. Miletich JP, Jackson CM, Majerus PW. Properties of the factor Xa binding site on human platelets. *J Biol Chem* 1978;253:6908-6916.
69. Callander N, Rapaport SI. Trousseau's syndrome. *West J Med* 1993;158:364-371.
70. Gordon SG, Cross BA. A factor X-activating cysteine protease from malignant tissue. *J Clin Invest* 1981;67:1665-1671.
71. Fernandez PM, Rickles FR. Tissue factor and angiogenesis in cancer. *Curr Opin Hematol* 2002;9:401-406.
72. Versteeg HH, Spek CA, Peppelenbosch M, Richel DJ. Tissue factor and cancer metastasis: the role of intracellular and extracellular signaling pathways. *Mol Med* 2004;10:6-11.
73. Deitcher SR. Cancer-related deep venous thrombosis: clinical importance, treatment challenges, and management strategies. *Semin Thromb Hemost* 2003;29:247-258.
74. Taylor FB, Kinasewitz GT. The diagnosis and management of disseminated intravascular coagulation. *Curr Heme Reports* 2002;1:34-40.
75. Weiner CP, Kwaan H, Hauck WW, et al. Fibrin generation in normal pregnancy. *Obstet Gynecol* 1984;64:46-48.
76. Pabinger I, Grafenhofer H, Kyrle A, et al. Temporary increase in the risk for recurrence during pregnancy in women with a history of venous thromboembolism. *Blood* 2002;100:1060-1062.
77. Grodstein F, Stampfer MJ, Goldhaber SZ, et al. Prospective study of exogenous hormones and risk of pulmonary embolism in women. *Lancet* 1996;348:983-987.
78. Gomes MP, Deitcher SR. Risk of venous thromboembolic disease associated with hormonal contraceptives and hormone replacement therapy: a clinical review. *Arch Intern Med* 2004;164:1965-1976.
79. van Hylckama Vlieg A, Middeldorp S. Hormone therapies and venous thromboembolism: where are we now? *J Thromb Haemost* 2011;9:257-266.
80. Quehenberger P, Loner U, Kapiotis S, et al. Increased levels of activated factor VII and decreased plasma protein S activity and circulating thrombomodulin during use of oral contraceptives. *Thromb Haemost* 1996;76:729-734.
81. Vandenbroucke JP, Koster T, Briet E, et al. Increased risk of venous thrombosis in oral-contraceptive users who are carriers of Factor V Leiden mutation. *Lancet* 1994;344:1453-1457.
82. Rosing J, Tans G, Nicolaes AF, et al. Oral contraceptives and venous thrombosis: different sensitivities to activated protein C in women using second- and third-generation oral contraceptives. *Br J Haematol* 1997;97:233-238.

83. Miller J, Chan BKS, Nelson HD. Postmenopausal estrogen replacement and risk for venous thromboembolism: a systematic review and meta-analysis for the U.S. Preventive Services Task Force. *Ann Intern Med* 2002;136:680-690.
84. Cushman M, Glynn RJ, Goldhaber SZ, et al. Hormonal factors and risk of recurrent venous thrombosis: the Prevention of Recurrent Venous Thromboembolism Trial. *J Thromb Haemost* 2006;4:2199-2203.
85. Canonico M, Oger E, Plu-Bureau G, et al. Hormone therapy and venous thromboembolism among postmenopausal women: impact of the route of estrogen administration and progestogens: the ESTHER study. *Circulation* 2007;115:840-845.
86. Lidegaard Ø, Løkkegaard E, Jensen A, Skovlund CW, Keiding N. Thrombotic stroke and myocardial infarction with hormonal contraception. *N Engl J Med* 2012;366:2257-2266.
87. Varga EA, Kujovich JL. Management of inherited thrombophilia: guide for genetics professionals. *Clin Genet* 2012;81:7-17.
88. Khor B, Van Cott EM. Laboratory evaluation of hypercoagulability. *Clin Lab Med* 2009;29:339-366.
89. Robetorye RS, Rodgers GM. Update on selected venous thrombotic disorders. *Am J Hematol* 2001;68:256-268.
90. Egeberg O. Inherited antithrombin deficiency causing thrombophilia. *Thromb Diath Haemorrh* 1965;13:516-530.
91. Cosgriff TM, Bishop DT, Hershgold EJ, et al. Familial antithrombin III deficiency: its natural history, genetics, diagnosis and treatment. *Medicine* 1983; 62:209-220.
92. Marciniak E, Farley CH, DeSimone PA. Familial thrombosis due to antithrombin III deficiency. *Blood* 1974;43:219-231.
93. Tait RC, Walker ID, Perry DJ, et al. Prevalence of antithrombin deficiency in the healthy population. *Br J Haematol* 1994;87:106-112.
94. Bauer KA, Rosenberg RD. The pathophysiology of the prethrombotic state in humans: insights gained from studies using markers of hemostatic system activation. *Blood* 1987;70:343-350.
95. Seligsohn U, Lubetsky A. Genetic susceptibility to venous thrombosis. *N Engl J Med* 2001;344:1222-1231.
96. Gruenberg JC, Smallridge RC, Rosenberg RD. Inherited antithrombin-III deficiency causing mesenteric venous infarction: a new clinical entity. *Ann Surg* 1975;181:791-794.
97. Hirsh J. Congenital antithrombin III deficiency. Incidence and clinical features. *Am J Med* 1989;87(suppl 3B):34S-38S.
98. Martinelli I, Mannucci PM, De Stefano V, et al. Different risks of thrombosis in four coagulation defects associated with inherited thrombophilia: a study of 150 families. *Blood* 1998;92:2353-2358.
99. Patnaik MM, Moll S. Inherited antithrombin deficiency: a review. *Haemophilia* 2008;14:1229-1239.
100. Pabinger I, Schneider B, and the GTH Study Group on Natural Inhibitors. Thrombotic risk of women with hereditary antithrombin III-, protein C- and protein S-deficiency taking oral contraceptive medication. *Thromb Haemost* 1994;71:548-552.
101. Toglia MR, Weg JG. Venous thromboembolism during pregnancy. *N Engl J Med* 1996;335:108-114.
102. Friederich PW, Sanson BJ, Simioni P, et al. Frequency of pregnancy-related venous thromboembolism in anticoagulant factor-deficient women: implications for prophylaxis. *Ann Intern Med* 1996;125:955-960.
103. Boyer C, Wolf M, Vedrenne J, et al. Homozygous variant of antithrombin III: AT III Fontainebleau. *Thromb Haemost* 1986;56:18-22.
104. Harper PL, Luddington RJ, Daly M, et al. The incidence of dysfunctional antithrombin variants: four cases in 210 patients with thromboembolic disease. *Br J Haematol* 1991;77:360-364.
105. Holmes EW, Fareed J, Bermes EW. Automation of plasma antithrombin III assays. *Clin Chem* 1981;27:816-818.
106. Tollefsen DM. Laboratory diagnosis of antithrombin and heparin cofactor II deficiency. *Semin Thromb Haemost* 1990;16:162-168.
107. Buller HR, ten Cate JW. Acquired antithrombin III deficiency: laboratory diagnosis, incidence, clinical implications, and treatment with antithrombin III concentrate. *Am J Med* 1989;87(Suppl 3B):44S-48S.
108. Marciniak E, Gockerman JP. Heparin-induced decrease in circulating antithrombin III. *Lancet* 1997;2:581-584.
109. Khor B, Van Cott EM. Laboratory tests for antithrombin deficiency. *Am J Hematol* 2010;85:947-950.

110. Rodgers GM. Role of antithrombin concentrate in treatment of hereditary antithrombin deficiency. An update. *Thromb Haemost* 2009;101:806-812.
111. Brandt P. Observations during the treatment of antithrombin-III deficient women with heparin and antithrombin concentrate during pregnancy, parturition, and abortion. *Thromb Res* 1981;22:15-24.
112. Damus PS, Wallace GA. Immunologic measurement of antithrombin III-heparin cofactor and alpha 2-macroglobulin in disseminated intravascular coagulation and hepatic failure coagulopathy. *Thromb Res* 1975;6:22-38.
113. Kauffmann RH, Veltkamp JJ, van Tilburg NH, van Es LA. Acquired antithrombin III deficiency and thrombosis in the nephrotic syndrome. *Am J Med* 1978;65:607-613.
114. Friedman KD, Borok Z, Owen J. Heparin cofactor activity and antithrombin III antigen levels in preeclampsia. *Thromb Res* 1986;43:409-416.
115. Ball AP, McKee PA. Fibrin formation and dissolution in women receiving oral contraceptive drugs. *J Lab Clin Med* 1977;89:751-762.
116. Lechner K, Kyrle PA. Antithrombin III concentrates—are they clinically useful? *Thromb Haemost* 1995;73:340-348.
117. Tollefsen DM, Pestka CA, Monafu WJ. Activation of heparin cofactor II by dermatan sulfate. *J Biol Chem* 1983;258:6713-6716.
118. Tran TH, Marbet GA, Duckert F. Association of hereditary heparin cofactor II deficiency with thrombosis. *Lancet* 1985;2:413-414.
119. Sie P, Dupouy D, Pichon J, Boneu B. Constitutional heparin co-factor II deficiency associated with recurrent thrombosis. *Lancet* 1985;2:414-416.
120. Bertina RM, van der Linden IK, Engesser L, et al. Hereditary heparin cofactor II deficiency and the risk of development of thrombosis. *Thromb Haemost* 1987;57:196-200.
121. Esmon CT. The roles of protein C and thrombomodulin in the regulation of blood coagulation. *J Biol Chem* 1989;264:4743-4746.
122. Esmon CT. The regulation of natural anticoagulant pathways. *Science* 1987;235:1348-1352.
123. Griffin JH, Evatt B, Zimmerman TS, et al. Deficiency of protein C in congenital thrombotic disease. *J Clin Invest* 1981;68:1370-1373.
124. Miletich J, Dherman L, Broze G. Absence of thrombosis in subjects with heterozygous protein C deficiency. *N Engl J Med* 1987;317:991-996.
125. Koeleman BPC, Reitsma PH, Allart CF, Bertina RM. Activated protein C resistance as an additional risk factor for thrombosis in protein C-deficient families. *Blood* 1994;84:1031-1035.
126. Bauer KA, Broekmans AW, Bertina RM, et al. Hemostatic enzyme generation in the blood of patients with hereditary protein C deficiency. *Blood* 1988;71:1418-1426.
127. D'Ursi P, Marino F, Caprera A, Milanese L, Faioni EM, Rovida E. ProCMD: a database and 3D web resource for protein C mutants. *BMC Bioinformatics* 2007;8(Suppl 1):S11.
128. Koster T, Rosendaal FR, Briet E, et al. Protein C deficiency in a controlled series of unselected outpatients: an infrequent but clear risk factor for venous thrombosis (Leiden Thrombophilia Study). *Blood* 1995;85:2756-2761.
129. Tait RC, Walker ID, Reitsma PH, et al. Prevalence of protein C deficiency in the healthy population. *Thromb Haemost* 1995;73:87-93.
130. Bovill EG, Bauer KA, Dickerman JD, et al. The clinical spectrum of heterozygous protein C deficiency in a large New England kindred. *Blood* 1989;73:712-717.
131. Mahmoodi BK, Brouwer JL, Veeger NJ, van der Meer J. Hereditary deficiency of protein C or protein S confers increased risk of arterial thromboembolic events at a young age: results from a large family cohort study. *Circulation* 2008;118:1659-1667.
132. Preston FE, Rosendaal FR, Walker ID, et al. Increased fetal loss in women with heritable thrombophilia. *Lancet* 1996;348:913-916.

133. Marlar RA, Montgomery RR, Broekmans AW. Report on the diagnosis and treatment of homozygous protein C deficiency. *Thromb Haemost* 1989;61:529-531.
134. McGehee WG, Klotz TA, Epstein DJ, Rapaport SI. Coumarin necrosis associated with hereditary protein C deficiency. *Ann Intern Med* 1984;100:59-60.
135. Alaart CF, Poort SR, Rosendaal FR, et al. Increased risk of venous thrombosis in carriers of hereditary protein C deficiency defect. *Lancet* 1993;341:134-138.
136. Van der Meer FJM, Koster T, Vandenbroucke JP, et al. The Leiden Thrombophilia Study (LETS). *Thromb Haemost* 1997;78:631-635.
137. Koster T, Rosendaal FR, Briët E, et al. Protein C deficiency in a controlled series of unselected outpatients: an infrequent but clear risk factor for venous thrombosis (Leiden Thrombophilia Study). *Blood* 1995;85:2756-2761.
138. Simioni P, Sanson BJ, Prandoni P, et al. Incidence of venous thromboembolism in families with inherited thrombophilia. *Thromb Haemost* 1999;81:198-202.
139. Kottke-Marchant K, Comp P. Laboratory issues in diagnosing abnormalities of protein C, thrombomodulin, and endothelial cell protein C receptor. *Arch Pathol Lab Med* 2002;126:1337-1348.
140. Libourel EJ, Meinardi JR, deKam PJ, et al. Protein C/S ratio, an accurate and simple test to identify carriers of a protein C gene mutation. *Br J Haematol* 2002;118:615-618.
141. Tait RC, Walker ID, Islam SIA, et al. Age related changes in protein C activity in healthy adult males. *Thromb Haemost* 1991;65:326-327.
142. Pabinger I, Kyrle PA, Speiser W, et al. Diagnosis of protein C deficiency in patients on oral anticoagulant treatment: comparison of three different protein C assays. *Thromb Haemost* 1990;63:407-412.
143. Khor B, Van Cott EM. Laboratory tests for protein C deficiency. *Am J Hematol* 2010;85:440-442.
144. Dreyfus M, Magny JF, Bridey F, et al. Treatment of homozygous protein C deficiency and neonatal purpura fulminans with a purified protein C concentrate. *N Engl J Med* 1991;325:1565-1568.
145. Marlar RA, Sills RH, Groner PK, et al. Protein C survival during replacement therapy in homozygous protein C deficiency. *Am J Hematol* 1992;41:24-31.
146. Conard J, Bauer KA, Gruber A, et al. Normalization of markers of coagulation activation with a purified protein C concentrate in adults with homozygous protein C deficiency. *Blood* 1993;82:1159-1164.
147. D'Angelo SV, Comp PC, Esmon CT, D'Angelo A. Relationship between protein C antigen and anticoagulant activity during oral anticoagulation and in selected disease states. *J Clin Invest* 1986;77:416-425.
148. Griffin JH, Mosher DF, Zimmerman TS, Kleiss AJ. Protein C, an antithrombotic protein, is reduced in hospitalized patients with intravascular coagulation. *Blood* 1982;60:261-264.
149. Sorensen PJ, Knudsen F, Nielsen AH, Dyerberg J. Protein C activity in renal disease. *Thromb Res* 1985;38:243-249.
150. Comp PC, Esmon CT. Recurrent venous thromboembolism in patients with a partial deficiency of protein S. *N Engl J Med* 1984;311:1525-1528.
151. Schwartz HP, Fischer M, Hopmeier P, et al. Plasma protein S deficiency in familial thrombotic disease. *Blood* 1984;64:1297-1300.
152. Faioni EM, Franchi F, Asti D, et al. Resistance to activated protein C in nine thrombophilic families: interference in a protein S functional assay. *Thromb Haemost* 1993;70:1067-1071.
153. Cooper PC, Hampton KK, Makris M, et al. Further evidence that activated protein C resistance can be misdiagnosed as inherited functional protein S deficiency. *Br J Haematol* 1994;88:201-203.
154. Deitcher SR, Kottke-Marchant K. Pseudo-protein S deficiency due to activated protein C resistance. *Thromb Res* 2003;112:349-353.
155. Comp PC. Measurement of the natural anticoagulant protein S: how and when. *Am J Clin Pathol* 1990;94:242-243.
156. Deitcher SR, Erban JK, Limentani SA. Acquired free protein S deficiency associated with multiple myeloma: a case report. *Am J Hematol* 1996;51:319-323.

157. García de Frutos P, Fuentes-Prior P, Hurtado B, et al. Molecular basis of protein S deficiency. *Thromb Haemost* 2007;98:543-556.
158. Zoller B, Berntsdotter A, de Frutos GP, Dahlback B. Resistance to activated protein C as an additional genetic risk factor in hereditary deficiency of protein S. *Blood* 1995;85:3518-3523.
159. Sie P, Boneu B, Bierme R, et al. Arterial thrombosis and protein S deficiency. *Thromb Haemost* 1989;62:1040.
160. Mahasandana C, Suvatte V, Chuansumrit A, et al. Homozygous protein S deficiency in an infant with purpura fulminans. *J Pediatr* 1990;117:750-753.
161. Simmonds RE, Ireland H, Lane DA, et al. Clarification of the risk for venous thrombosis associated with hereditary protein S deficiency by investigation of a large kindred with a characterized gene defect. *Ann Intern Med* 1998;128:8-14.
162. Boyer-Neumann C, Bertina RM, Tripodi A, et al. Comparison of functional assays for protein S: European collaborative study of patients with congenital and acquired deficiency. *Thromb Haemost* 1993;70:946-950.
163. Hubbard AR, Wong MY. A collaborative study in the measurement of protein S antigen in plasma. *Thromb Haemost* 1992;68:115-118.
164. Edson JR, Vogt JM, Huesman DA. Laboratory diagnosis of inherited protein S deficiency. *Am J Clin Pathol* 1990;94:176-186.
165. Broze GJ Jr. Protein Z dependent regulation of coagulation. *Thromb Haemost* 2001;86:8-13.
166. Yin ZF, Huang ZF, Cui J, et al. Prothrombotic phenotype of protein Z deficiency. *Proc Natl Acad Sci U S A* 2000;97:6734-6738.
167. Sofi F, Cesari F, Abbate R, Gensini GF, Broze G Jr, Fedi S. A meta-analysis of potential risks of low levels of protein Z for diseases related to vascular thrombosis. *Thromb Haemost* 2010;103:749-756.
168. Fedi S, Sofi F, Brogi D, et al. Low protein Z plasma levels are independently associated with acute coronary syndromes. *Thromb Haemost* 2003;90:1173-1178.
169. Vasse M, Guegan-Massardier E, Borg JY, et al. Frequency of protein Z deficiency in patients with ischemic stroke. *Lancet* 2001;357:933-934.
170. Lichy C, Kropp S, Dong-Si T, et al. A common polymorphism of the protein Z gene is associated with protein Z plasma levels and with risk of cerebral ischemia in the young. *Stroke* 2004;35:40-45.
171. Dahlback B, Carlsson M, Svensson PJ. Familial thrombophilia due to a previously unrecognized mechanism characterized by poor anticoagulant response to activated protein C: prediction of a cofactor to activated protein C. *Proc Natl Acad Sci U S A* 1993;90:1004-1008.
172. Koster T, Rosendaal FR, de Ronde, et al. Venous thrombosis due to poor anticoagulant response to activated protein C: Leiden Thrombophilia Study. *Lancet* 1993;342:1503-1506.
173. Svensson PJ, Dahlback B. Resistance to activated protein C as a basis for venous thrombosis. *N Engl J Med* 1994;330:517-522.
174. Griffin JH, Evatt B, Wideman C, Fernandez JA. Anticoagulant protein C pathway defective in majority of thrombophilic patients. *Blood* 1993;82:1989-1993.
175. Lane DA, Mannucci PM, Bauer KA, et al. Inherited thrombophilia: part 1. *Thromb Haemost* 1996;76:651-662.
176. Bertina RM, Koeleman BPC, Koster T, et al. Mutation in blood coagulation factor V associated with resistance to activated protein C. *Nature* 1994;369:64-67.
177. Kalafatis M, Haley PE, Lu D, et al. Proteolytic events that regulate factor V activity in whole plasma from normal and activated protein C (APC)-resistant individuals during clotting: an insight into the APC resistance assay. *Blood* 1996;87:4695-4707.
178. Heeb MJ, Kojima Y, Greengard JS, Griffin JH. Activated protein C resistance: molecular mechanisms based on studies using purified Gln506-factor V. *Blood* 1995;85:3405-3411.
179. De Stefano V, Chiusolo P, Paciaroni K, Leone G. Epidemiology of factor V Leiden. *Semin Thromb Hemost* 1998;24:367-379.

180. Ridker PM, Miletich JP, Hennekens CH, Buring JE. Ethnic distribution of factor V Leiden in 4047 men and women: implications for venous thromboembolism screening. *JAMA* 1997;277:1305-1307.
181. Deguchi H, Fernández JA, Pabinger I, et al. Plasma glucosylceramide deficiency as potential risk factor for venous thrombosis and modulator of anticoagulant protein C pathway. *Blood* 2001;97:1907-1914.
182. Galli M, Ruggeri L, Barbui T. Differential effects of anti- β 2-glycoprotein I and antiprothrombin antibodies on the anticoagulant activity of activated protein C. *Blood* 1998;91:1999-2004.
183. Castoldi E, Rosing J. APC resistance: biological basis and acquired influences. *J Thromb Haemost* 2010;8:445-453.
184. Rodeghiero F, Tosetto A. Activated protein C resistance and factor V Leiden mutation are independent risk factors for venous thromboembolism. *Ann Intern Med* 1999;130:643-650.
185. Zivelin A, Griffin JH, Xu X, et al. A single genetic origin for a common Caucasian risk factor for venous thrombosis. *Blood* 1997;89:397-402.
186. Middeldorp S, Henkens CMA, Koopman MMW, et al. The incidence of venous thromboembolism in family members of patients with factor V Leiden mutation and venous thrombosis. *Ann Intern Med* 1998;128:15-20.
187. Rosendaal FR, Koster T, Vandenbroucke JP, Reitsma PH. High risk of thrombosis in patients homozygous for factor V Leiden (activated protein C resistance). *Blood* 1995;85:1504-1508.
188. Ridker PM, Hennekens CH, Lindpaintner K, et al. Mutation in the gene coding for coagulation factors V and the risk of myocardial infarction, stroke, and venous thrombosis in apparently healthy men. *N Engl J Med* 1995;332:912-917.
189. Ridker PM, Hennekens CH, Selhub J, et al. Interrelation of hyperhomocyst (e)inemia factor V Leiden, and risk of future venous thromboembolism. *Circulation* 1997;95:1777-1782.
190. Emmerich J, Rosendaal FR, Cattaneo M, et al. Combined effect of factor V Leiden and prothrombin 20210A on the risk of venous thromboembolism: pooled analysis of 8 case-control studies including 2310 cases and 3204 controls. *Thromb Haemost* 2001;86:809-816.
191. Gerhardt A, Scharf RE, Beckmann MW, et al. Prothrombin and factor V mutations in women with a history of thrombosis during pregnancy and the puerperium. *N Engl J Med* 2000;342:374-380.
192. Rosendaal FR, Vessey M, Rumley A, et al. Hormonal replacement therapy, prothrombotic mutations and the risk of venous thrombosis. *Br J Haematol* 2002;116:851-854.
193. Herrington DM, Vittinghoff E, Howard TD, et al. Factor V Leiden, hormone replacement therapy, and the risk of venous thromboembolic events in women with coronary disease. *Arterioscler Thromb Vasc Biol* 2002;22:1012-1017.
194. Lowe G, Woodward M, Vessey M, et al. Thrombotic variables and risk of idiopathic venous thromboembolism in women aged 45-64 years. *Thromb Haemost* 2000;83:530-535.
195. Kutteh WH, Park VM, Deitcher SR. Hypercoagulable state mutation analysis in white patients with early first-trimester recurrent pregnancy loss. *Fertil Steril* 1999;71:1048-1053.
196. Rai R, Regan L, Hadley E, et al. Second trimester pregnancy loss is associated with activated protein C resistance. *Br J Haematol* 1996;92:489-490.
197. Pipe SW, Schmaier AH, Nichols WC, et al. Neonatal purpura fulminans in association with factor V R506Q mutation. *J Pediatr* 1996;128:706-709.
198. Martinelli I, Landi G, Merati G, et al. Factor V gene mutation is a risk factor for cerebral venous thrombosis. *Thromb Haemost* 1996;75:393-394.
199. Gurgey A, Mesci L, Renda Y, et al. Factor V Q506 mutation in children with thrombosis. *Am J Hematol* 1996;53:37-39.
200. Otterson GA, Monahan BP, Harold N, et al. Clinical significance of the FV: Q⁵⁰⁶ mutation in unselected oncology patients. *Am J Med* 1996;101:406-412.
201. Rosendaal FR, Siscovick DS, Schwartz SM, et al. Factor V Leiden (resistance to activated protein C) increases the risk of myocardial infarction in young women. *Blood* 1997;89:2817-2821.
202. Mansourati J, Da Costa A, Munier S, et al. Prevalence of factor V Leiden in patients with myocardial infarction and normal coronary angiography. *Thromb Haemost* 2000;79:822-825.

203. Ridker PM, Miletich JP, Stampfer MJ, et al. Factor V Leiden and risks of recurrent idiopathic venous thromboembolism. *Circulation* 1995;92:2800-2802.
204. Simioni P, Prandoni P, Lensing AWA, et al. The risk of recurrent venous thromboembolism in patients with an Arg⁵⁰⁶→Gln mutation in the gene for factor V (factor V Leiden). *N Engl J Med* 1997;336:399-403.
205. Eichinger S, Pabinger I, St1/4mpflen A, et al. The risk of recurrent venous thromboembolism in patients with and without factor V Leiden. *Thromb Haemost* 1997;77:624-628.
206. Lindmarker P, Schulman S, Sten-Linder M, et al., and the DURAC Trial Study Group. The risk of recurrent venous thromboembolism in carriers and non-carriers of the G1691A allele in the coagulation factor V gene and the G20210A allele in the prothrombin gene. *Thromb Haemost* 1999;81:684-689.
207. Kearon C, Gent M, Hirsh J, et al. A comparison of three months of anticoagulation with extended anticoagulation for a first episode of idiopathic venous thromboembolism. *N Engl J Med* 1999;340:901-907.
208. Eichinger S, Weltermann A, Mannhalter C, et al. The risk of recurrent venous thromboembolism in heterozygous carriers of factor V Leiden and a first spontaneous venous thromboembolism. *Arch Intern Med* 2002;162:2357-2360.
209. Rintelen C, Pabinger I, Knöbl P, et al. Probability of recurrence of thrombosis in patients with and without factor V Leiden. *Thromb Haemost* 1996;75:229-232.
210. De Stefano V, Martinelli I, Mannucci PM, et al. The risk of recurrent deep venous thrombosis among heterozygous carriers of both factor V Leiden and the G20210A prothrombin mutation. *N Engl J Med* 1999;341:801-806.
211. Simioni P, Prandoni P, Lensing AWA, et al. Risk of subsequent venous thromboembolic complications in carriers of the prothrombin or the factor V Leiden gene mutation with a first episode of deep-vein thrombosis. *Blood* 2000;96:3329-3333.
212. Ridker PM, Goldhaber SZ, Danielson E, et al. Long-term, low-intensity warfarin therapy for the prevention of recurrent venous thromboembolism. *N Engl J Med* 2003;348:1425-1434.
213. Emmerich J, Alhenc-Gelas M, Aillaud MF, et al. Clinical features in 36 patients homozygous for the ARG 506 →GLN factor V mutation. *Thromb Haemost* 1997;77:620-623.
214. Rosendaal FR. Risk factors for venous thrombosis: prevalence, risk, and interaction. *Semin Hematol* 1997;34:171-187.
215. Rintelen C, Mannhalter C, Ireland H, et al. Oral contraceptives enhance the risk of clinical manifestation of venous thrombosis at a young age in females homozygous for Factor V Leiden. *Br J Haematol* 1996;93:487-490.
216. Dahlback B. The discovery of activated protein C resistance. *J Thromb Haemost* 2003;1:3-9.
217. de Ronde H, Bertina RM. Laboratory diagnosis of APC resistance: a critical evaluation of the test and the development of diagnostic criteria. *Thromb Haemost* 1994;72:880-886.
218. Jorquera JI, Montoro JM, Fernandez MA, et al. Modified test for activated protein C resistance. *Lancet* 1994;344:1162-1163.
219. Le DT, Griffin JH, Greengard JS, et al. Use of a generally applicable tissue factor-dependent factor V assay to detect activated protein C resistant factor Va in patients receiving warfarin and in patients with a lupus anticoagulant. *Blood* 1995;85:1704-1711.
220. Press RD, Bauer KA, Kujovich JL, Heit JA. Clinical utility of factor V Leiden (R506Q) testing for the diagnosis and management of thromboembolic disorders. *Arch Pathol Lab Med* 2002;126:1304-1318.
221. Johnson NV, Khor B, Van Cott EM. Advances in laboratory testing for thrombophilia. *Am J Hematol* 2012;87(Suppl 1):S108-S112.
222. Bokarewa MI, Bremme K, Blomback M. Arg 506 Gln mutation in factor V and risk of thrombosis during pregnancy. *Br J Haematol* 1996;92:473-478.
223. Poort SR, Rosendaal FR, Reitsma PH, Bertina RM. A common genetic variation in the 3' untranslated region of the prothrombin gene is associated with elevated plasma prothrombin levels and an increase in venous thrombosis. *Blood* 1996;88:3698-3703.
224. Warshawsky I, Hren C, Sercia L, et al. Detection of a novel point mutation of the prothrombin gene at position 20209. *Diagn Mol Pathol* 2002;11:152-156.

225. Pollak ES, Lam HS, Russell JE. The G20210 A mutation does not affect the stability of prothrombin mRNA in vivo. *Blood* 2002;100:359-362.
226. Butenas S, van't Veer C, Mann KG. "Normal" thrombin generation. *Blood* 1999;94:2169-2178.
227. Rosendaal FR, Doggen CJM, Zivelin A, et al. Geographic distribution of the 20210A G to A prothrombin variant. *Thromb Haemost* 1998;79:706-708.
228. Margaglione M, Brancaccio V, Giuliani N, et al. Increased risk for venous thrombosis in carriers of the prothrombin G →A²⁰²¹⁰ gene variant. *Ann Intern Med* 1998;129:89-93.
229. Martinelli I, Taioli E, Bucciarelli P, et al. Interaction between G20210A mutation of the prothrombin gene and oral contraceptive use in deep vein thrombosis. *Arterioscler Thromb Vasc Biol* 1999;19:700-703.
230. Martinelli I, Sacchi E, Landi G, et al. High risk of cerebral vein thrombosis in carriers of a prothrombin-gene mutation and in users of oral contraceptives. *N Engl J Med* 1998;338:1793-1797.
231. Zawadzki C, Gaveriaux V, Trillot N, et al. Homozygous G20210A transition in the prothrombin gene associated with severe thrombotic disease: two cases in a French family. *Thromb Haemost* 1998;80:1027-1028.
232. Kyrle PA, Mannhalter C, Beguin S, et al. Clinical studies and thrombin generation in patients homozygous and heterozygous for the G20210A mutation in the prothrombin gene. *Arterioscler Thromb Vasc Biol* 1998;18:1287-1291.
233. De Stefano V, Martinelli I, Mannucci PM, et al. The risk of recurrent venous thromboembolism among heterozygous carriers of the G20210A prothrombin gene mutation. *Br J Haematol* 2001;113:630-635.
234. Eichinger S, Minar E, Hirschl M, et al. The risk of early recurrent venous thromboembolism after oral anticoagulant therapy in patients with the G20210A transition in the prothrombin gene. *Thromb Haemost* 1999;81:14-17.
235. Ridker PM, Hennekens CH, Miletich JP, et al. G20210A mutation in prothrombin gene and risk of myocardial infarction, stroke, and venous thrombosis in a large cohort of US men. *Circulation* 1999;99:999-1004.
236. Clarke R, Daly L, Robinson K, et al. Hyperhomocysteinemia: an independent risk factor for vascular disease. *N Engl J Med* 1991;324:1149-1155.
237. Stampfer MJ, Malinow MR, Willett WC, et al. A prospective study of plasma homocyst(e)ine and risk of myocardial infarction in U.S. physicians. *JAMA* 1992;268:877-881.
238. Molgaard J, Malinow MR, Lassvik C, et al. Hyperhomocyst(e)inemia: an independent risk factor for intermittent claudication. *J Intern Med* 1992;231:273-279.
239. Albert CM, Cook NR, Gaziano JM, et al. Effect of folic acid and B vitamins on risk of cardiovascular events and total mortality among women at high risk for cardiovascular disease: a randomized trial. *JAMA* 2008;299:2027-2036.
240. Armitage JM, Bowman L, Clarke RJ, et al. Effects of homocysteine-lowering with folic acid plus vitamin B12 vs placebo on mortality and major morbidity in myocardial infarction survivors: a randomized trial. *JAMA* 2010;303:2486-2494.
241. Welch GN, Loscalzo J. Homocysteine and atherothrombosis. *N Engl J Med* 1998;338:1042-1050.
242. Guba SC, Fonseca V, Fink LM. Hyperhomocystinemia and thrombosis. *Semin Thromb Hemost* 1999;25:291-309.
243. Rees MM, Rodgers GM. Homocysteinemia: association of a metabolic disorder with vascular disease and thrombosis. *Thromb Res* 1993;71:337-359.
244. Harker LA, Slichter SJ, Scott CR, Ross R. Homocystinemia: vascular injury and arterial thrombosis. *N Engl J Med* 1974;291:537-543.
245. Lentz SR, Piegors DJ, Fernandez JA, et al. Effect of hyperhomocystinemia on protein C activation and activity. *Blood* 2002;100:2108-2112.
246. Mudd SH, Levy HL, Skovby F. Disorders of transsulfuration. In: Scriver CR, Beaudet AL, Sly WS, Valle D, eds. *The metabolic basis of inherited disease*, 6th ed. New York: McGraw-Hill, 1989:693-734.
247. Hanson NQ, Aras O, Yang F, Tsai MY. C677T and A1298C polymorphisms of the methylenetetrahydrofolate reductase gene: incidence and effect of combined genotypes on plasma fasting and post-methionine load homocysteine in vascular disease. *Clin Chem* 2001;47:661-666.
248. Den Heijer M, Koster T, Blom HJ, et al. Hyperhomocystinemia as a risk factor for deep-vein thrombosis. *N Engl J Med* 1996;334:759-762.

249. Simioni P, Prandoni P, Burlina A, et al. Hyperhomocystinemia and deep-vein thrombosis: a case-control study. *Thromb Haemost* 1996;76:883-886.
250. Kottke-Marchant K, Green R, Jacobsen DW, et al. High plasma homocysteine: a risk factor for arterial and venous thrombosis in patients with normal coagulation profiles. *Clin Appl Thromb Hemost* 1997;34:239-244.
251. Currie JC, Wilson YG, Scott J, et al. Homocysteine: an independent risk factor for the failure of vascular intervention. *Br J Surg* 1996;83:1238-1241.
252. Van Cott EM, Laposata M. Laboratory evaluation of hypercoagulable states. *Hematol Oncol Clin North Am* 1998;12:1141-1166.
253. Key NS, McGlennen RC. Hyperhomocyst(e)inemia and thrombophilia. *Arch Pathol Lab Med* 2002;126:1367-1375.
254. Ueland PM, Refsum H, Stabler SP, et al. Total homocysteine in plasma or serum: methods and clinical applications. *Clin Chem* 1993;39:1764-1779.
255. Homocysteine Lowering Trialists' Collaboration. Lowering blood homocysteine with folic acid based supplements: meta-analysis of randomized trials. *Br Med J* 1998;316:894-898.
256. Wilcken DE, Wilcken B, Dudman NP, et al. Homocysteine—the effects of betaine in the treatment of patients not responsive to pyridoxine. *N Engl J Med* 1983;309:448-453.
257. Lonn E, Yusuf S, Arnold MJ, et al. Homocysteine lowering with folic acid and B vitamins in vascular disease. *N Engl J Med* 2006;354:1567-1577.
258. Bønaa KH, Njølstad I, Ueland PM, et al. Homocysteine lowering and cardiovascular events after acute myocardial infarction. *N Engl J Med* 2006;354:1578-1588.
259. Ray JG, Kearon C, Yi Q, et al. Homocysteine-lowering therapy and risk for venous thromboembolism: a randomized trial. *Ann Intern Med* 2007;146:761-767.
260. Koster T, Blann AD, Briët E, et al. Role of clotting factor VIII in effect of von Willebrand factor on occurrence of deep-vein thrombosis. *Lancet* 1995;345:152-155.
261. Kraaijenhagen RA, Pieternella S, Anker PS, et al. High plasma concentration of factor VIIIc is a major risk factor for venous thromboembolism. *Thromb Haemost* 2000;83:5-9.
262. Bloemenkamp KWM, Helmerhorst FM, Rosendaal FR, Vandenbroucke JP. Venous thrombosis, oral contraceptives and high factor VIII levels. *Thromb Haemost* 1999;82:1024-1027.
263. O'Donnell J, Mumford AD, Manning RA, Laffan M. Elevation of factor VIII:C in venous thromboembolism is persistent and independent of the acute phase response. *Thromb Haemost* 2000;83:10-13.
264. Bank I, van de Poel MH, Coppens M, et al. Absolute annual incidences of first events of venous thrombolism and arterial vascular events in individuals with elevated FVIII:c. A prospective family cohort study. *Thromb Haemost* 2007;98:1040-1044.
- 264a. Jenkins PV, Rawley O, Smith OP, O'Donnell JS. Elevated factor VIII levels and risk of venous thrombosis. *Br J Haematol* 2012;157:653-663.
265. Chandler WL, Rodgers GM, Sprouse JT, Thompson AR. Elevated hemostatic factor levels as potential risk factors for thrombosis. *Arch Pathol Lab Med* 2002;126:1405-1414.
266. Cushman M, O'Meara ES, Folsom AR, Heckbert SR. Coagulation factors IX through XIII and the risk of future venous thrombosis: the Longitudinal Investigation of Thromboembolism Etiology. *Blood* 2009;114:2878-2883.
267. Yang DT, Flanders MM, Kim H, Rodgers GM. Elevated factor XI activity levels are associated with an increased odds ratio for cerebrovascular events. *Am J Clin Pathol* 2006;126:411-415.
268. Berliner JJ, Rybicki AC, Kaplan RC, et al. Elevated levels of Factor XI are associated with cardiovascular disease in women. *Thromb Res* 2002;107:55-60.
269. von dem Borne PA, Cox LM, Bouma BN. Factor XI enhances fibrin generation and inhibits fibrinolysis in a coagulation model initiated by surface-coated tissue factor. *Blood Coagul Fibrinolysis* 2006;17:251-257.
270. Hong JJ, Kwaan HC. Hereditary defects in fibrinolysis associated with thrombosis. *Semin Thromb Hemost* 1999;25:321-331.

271. Prins MH, Hirsh J. A critical review of the evidence supporting a relationship between impaired fibrinolytic activity and venous thromboembolism. *Arch Intern Med* 1991;151:1721-1731.
272. Lisman T, de Groot PG, Meijers JC, Rosendaal FR. Reduced plasma fibrinolytic potential is a risk factor for venous thrombosis. *Blood* 2005;105:1102-1105.
273. Eichinger S, Schonauer V, Weltermann A, et al. Thrombin-activatable fibrinolysis inhibitor and the risk for recurrent venous thromboembolism. *Blood* 2004;103:3773-3776.
274. Meltzer ME, Doggen CJ, de Groot PG, et al. Plasma levels of fibrinolytic proteins and the risk of myocardial infarction in men. *Blood* 2010;116:529-536.
275. Meltzer ME, Lisman T, de Groot PG, et al. Venous thrombosis risk associated with plasma hypofibrinolysis is explained by elevated plasma levels of TAFI and PAI-1. *Blood* 2010;116:113-121.
276. Aoki N, Moroi M, Sakata Y, et al. Abnormal plasminogen: a hereditary molecular abnormality found in a patient with recurrent thrombosis. *J Clin Invest* 1978;61:1186-1195.
277. Dolan G, Greaves M, Cooper P, Preston FE. Thrombovascular disease and familial plasminogen: a report of three kindreds. *Br J Haematol* 1988;70:417-421.
278. Tsutsumi S, Saito T, Sakata T, et al. Genetic diagnosis of dysplasminogenemia: detection of an Ala⁶⁰¹-Thr mutation in 118 out of 125 families and identification of a new Asp⁶⁷⁶-Asn mutation. *Thromb Haemost* 1996;76:135-138.
279. Shigekiyo T, Uno Y, Tomonari A, et al. Type I congenital plasminogen deficiency is not a risk factor for thrombosis. *Thromb Haemost* 1992;67:189-192.
280. Schuster V, H1/4gle B, Tefs K. Plasminogen deficiency. *J Thromb Haemost* 2007;5:2315-2322.
281. Tefs K, Gueorguieva M, Klammt J, et al. Molecular and clinical spectrum of type I plasminogen deficiency: a series of 50 patients. *Blood* 2006;108:3021-3026.
282. Brandt JT. Plasminogen and tissue-type plasminogen activator deficiency as risk factors for thromboembolic disease. *Arch Pathol Lab Med* 2002;126:1376-1381.
283. Chandler WL, Trimble SL, Loo SC, et al. Effect of PAI-1 levels on the molar concentrations of active tissue plasminogen activator (t-PA) and t-PA/PAI-1 complex in plasma. *Blood* 1990;76:930-937.
284. Chandler WL, Schmer G, Stratton JR. Optimum conditions for the stabilization and measurement of tissue plasminogen activator activity in human plasma. *J Lab Clin Med* 1989;113:362-371.
285. Chandler WL, Loo SC, Nguyen SV, et al. Standardization of methods for measuring plasminogen activator inhibitor in human plasma. *Clin Chem* 1989;35:787-793.
286. Angleton P, Chandler WL, Schmer G. Diurnal variation of tissue-type plasminogen activator and its rapid inhibitor (PAI-1). *Circulation* 1989;79:101-106.
287. Stringer HA, van Swieten P, Heijnen HF, et al. Plasminogen activator inhibitor-1 release from activated platelets plays a key role in thrombolysis resistance. Studies with thrombi generated in the Chandler loop. *Arterioscler Thromb* 1994;14:1452-1458.
288. D'Angelo A, Kluff C, Verheijen JH, et al. Fibrinolytic shut down after surgery: impairment of the balance between tissue-type plasminogen activator and its specific inhibitor. *Eur J Clin Invest* 1985;15:308-312.
289. Hamsten A, Wiman B, de Faire U, et al. Increased plasma levels of a rapid inhibitor of plasminogen activator in young survivors of myocardial infarction. *N Engl J Med* 1985;313:1557-1563.
290. Meade TW, Chakrabarti R, Haines AP, et al. Characteristics affecting fibrinolytic activity and plasma fibrinogen concentrations. *Br Med J* 1979;1:153-156.
291. Vaughan DE, Rouleau JL, Ridker PM, et al. Effects of ramipril on plasma fibrinolytic balance in patients with acute anterior myocardial infarction. HEART Study Investigators. *Circulation* 1997;96:442-447.
292. Pahor M, Franse LV, Deitcher SR, et al. Fosinopril versus amlodipine comparative treatments study: a randomized trial to assess effects on plasminogen activator inhibitor-1. *Circulation* 2002;105:457-461.
293. Fujii S, Sobel BE. Direct effects of gemfibrozil on the fibrinolytic system: diminution of synthesis of plasminogen activator inhibitor type I. *Circulation* 1992;85:1888-1893.

294. Gebara OC, Mittleman MA, Sutherland P, et al. Association between increased estrogen status and increased fibrinolytic potential in the Framingham Offspring Study. *Circulation* 1995;91:1952-1958.
295. Ridker PM, Vaughan DE, Stampfer MJ, et al. Association of moderate alcohol consumption and plasma concentration of endogenous tissue-type plasminogen activator. *JAMA* 1994;272:929-933.
296. Bithell TC. Hereditary dysfibrinogenemia. *Clin Chem* 1985;31:509-516.
297. Rodgers GM, Garr SB. Comparison of functional and antigenic fibrinogen values from a normal population. *Thromb Res* 1992;68:207-210.
298. Carrell N, Gabriel DA, Blatt PM, et al. Hereditary dysfibrinogenemia in a patient with thrombotic disease. *Blood* 1983;62:439-447.
299. Cunningham MT, Brandt JT, Laposata M, Olson JD. Laboratory diagnosis of dysfibrinogenemia. *Arch Pathol Lab Med* 2002;126:499-505.
300. Kunz G, öhlin AK, Adami A, et al. Naturally occurring mutations in the thrombomodulin gene leading to impaired expression and function. *Blood* 2002;99:3646-3653.
301. Faioni EM, Franchi F, Castaman G, et al. Mutations in the thrombomodulin gene are rare in patients with severe thrombophilia. *Br J Haematol* 2002;118:595-599.
302. Ireland H, Kunz G, Kyriakoulis K, et al. Thrombomodulin gene mutations associated with myocardial infarction. *Circulation* 1997;96:15-18.
303. Salomaa V, Matei C, Aleksic N, et al. Soluble thrombomodulin as a predictor of incident coronary heart disease and symptomless carotid artery atherosclerosis in the Atherosclerosis Risk in Communities (ARIC) Study: a case-cohort study. *Lancet* 1999;353:1729-1734.
304. Scanu AM. Structural and functional polymorphism of lipoprotein (a): biological and clinical implications. *Clin Chem* 1995;41:170-172.
305. Kullo Ij, Gau GT, Tajik AJ. Novel risk factors for atherosclerosis. *Mayo Clin Proc* 2000;75:369-380.
306. Miles LA, Plow EF. Lp(a): an interloper into the fibrinolytic system? *Thromb Haemost* 1990;63:331-335.
307. Lippi G, Veraldi GF, Dorucci V, et al. Usefulness of lipids, lipoprotein(a) and fibrinogen measurements in identifying subjects at risk of occlusive complications following vascular and endovascular surgery. *Scand J Clin Lab Invest* 1998;58:497-504.
308. Scanu AM. Lipoprotein (a). A genetic risk factor for premature coronary heart disease. *JAMA* 1992;267:3326-3329.
309. Maeda S, Abe A, Seishima M, et al. Transient changes of serum lipoprotein(a) as an acute phase protein. *Atherosclerosis* 1989;78:145-150.
310. Maher VM, Brown BG, Marcovina SM, et al. Effects of lowering elevated LDL cholesterol on the cardiovascular risk of lipoprotein(a). *JAMA* 1995;274:1771-1774.
311. Carlson LA, Hamsten A, Asplund A. Pronounced lowering of serum levels of lipoprotein Lp(a) in hyperlipidemic subjects treated with nicotinic acid. *J Intern Med* 1989;226:271-276.
312. Dahm A, Van Hylckama Vlieg A, Bendz B, et al. Low levels of tissue factor pathway inhibitor (TFPI) increase the risk of venous thrombosis. *Blood* 2003;101:4387-4392.
313. Hoke M, Kyrle PA, Minar E, et al. Tissue factor pathway inhibitor and the risk of recurrent venous thromboembolism. *Thromb Haemost* 2005;94:787-790.
314. Winckers K, Siegerink B, Duckers C, et al. Increased tissue factor pathway inhibitor activity is associated with myocardial infarction in young women: results from the RATIO study. *J Thromb Haemost* 2011;9:2243-2250.
315. Van Boven HH, Reitsma PH, Rosendaal FR, et al. Factor V Leiden (FV R506Q) in families with inherited antithrombin deficiency. *Thromb Haemost* 1996;75:417-421.
316. Margaglione M, D'Andrea G, Colaizzo D, et al. Coexistence of factor V Leiden and factor II A20210 mutations and recurrent venous thromboembolism. *Thromb Haemost* 1999;82:1583-1587.
317. Dizon-Townson D, Hutchison C, Silver R, et al. The factor V Leiden mutation which predisposes to thrombosis is not common in patients with antiphospholipid syndrome. *Thromb Haemost* 1995;74:1029-1031.

318. Mandel H, Brenner B, Berant M, et al. Coexistence of hereditary homocystinuria and factor V Leiden. Effect on thrombosis. *N Engl J Med* 1996;334:763-768.
319. Junker R, Koch HG, Auberger K, et al. Prothrombin G20210A gene mutation and further prothrombotic risk factors in childhood thrombophilia. *Arterioscler Thromb Vasc Biol* 1999;19:1568-1572.
320. Sifontes MT, Nuss R, Hunger SP, et al. Activated protein C resistance and the factor V Leiden mutation in children with thrombosis. *Am J Hematol* 1998;57:29-32.
321. Chalmers EA. Neonatal thrombosis. *J Clin Pathol* 2000;53:419-423.
322. Nowak-Gottl U, Junker R, Kreuz W, et al. Risk of recurrent venous thrombosis in children with combined prothrombotic risk factors. *Blood* 2001;97:858-862.
- 322a. Flanders MM, Phansalkar AR, Crist RA, Roberts WL, Rodgers GM. Pediatric reference intervals for uncommon bleeding and thrombotic disorders. *J Pediatr* 2006;149:275-277.
323. Manco-Johnson MJ, Grabowski EF, Hellgreen M, et al. Laboratory testing for thrombophilia in pediatric patients. *Thromb Haemost* 2002;88:155-156.
324. Tormene D, Simioni P, Prandoni P, et al. The incidence of venous thromboembolism in thrombophilic children: a prospective cohort study. *Blood* 2002;100:2403-2405.
325. Raffini L, Thornburg C. Testing children for inherited thrombophilia: more questions than answers. *Br J Haematol* 2009;147:277-288.
326. Schafer AI. Hypercoagulable states: molecular genetics to clinical practice. *Lancet* 1994;344:1739-1742.
327. Bauer KA. The thrombophilias: well-defined risk factors with uncertain therapeutic implications. *Ann Intern Med* 2001;135:367-373.
328. van Sluis GL, Sohne M, El Kheir DY, et al. Family history and inherited thrombophilia. *J Thromb Haemost* 2006;4:2182-2187.
329. Somma J, Sussman II, Rand JH. An evaluation of thrombophilia screening in an urban tertiary care medical center: a "real world" experience. *Am J Clin Pathol* 2006;126:120-127.
330. Turkstra F, van Beek EJR, ten Cate JW, Buller HR. Reliable rapid blood test for the exclusion of venous thromboembolism in symptomatic outpatients. *Thromb Haemost* 1996;76:9-11.
331. Palareti G, Legnani C, Cosmi B, et al. Risk of venous thromboembolism recurrence: high negative predictive value of D-dimer performed after oral anticoagulation is stopped. *Thromb Haemost* 2002;87:7-12.
332. Cushman M, Folsom AR, Wang L, et al. Fibrin fragment D-dimer and the risk of future venous thrombosis. *Blood* 2003;101:1243-1248.
333. Teitel JM, Bauer KA, Lau HK, Rosenberg RD. Studies of prothrombin activation pathway utilizing radioimmunoassays for the F₂/F₁₊₂ fragment and thrombin-antithrombin complex. *Blood* 1982;59:1086-1097.
334. Kearon C, Ginsberg JS, Douketis J, et al. Management of suspected deep vein thrombosis in outpatients by using clinical assessment and D-dimer testing. *Ann Intern Med* 2001;135:108-111.
335. Douma RA, Tan M, Schutgens R, et al. Age-dependent D-dimer cut-off value increases the number of older patients in whom deep vein thrombosis can be safely excluded. *Haematologica* 2012; in press.
336. Palareti G, Cosmi B, Legnani C, et al. D-dimer testing to determine the duration of anticoagulation therapy. *N Engl J Med* 2006;355:1780-1789.
337. Ageno W, Cosmi B, Ghirarduzzi A, et al. The negative predictive value of D-dimer on the risk of recurrent venous thromboembolism in patients with multiple previous events: a prospective cohort study (the PROLONG PLUS study). *Am J Hematol* 2012;87:713-715.
338. Furlan AJ, Fischer M. Devices, drugs, and the Food and Drug Administration. Increasing implications for ischemic stroke. *Stroke* 2005;36:398-399.
339. Davies B, Braithwaite BD, Birch PA, et al. Acute leg ischaemia in Gloucestershire. *Br J Surg* 1997;84:504-508.
340. Ouriel K. Peripheral arterial disease. *Lancet* 2001;358:1257-1264.

341. Weitz JI, Byrne J, Clagett P, et al. Diagnosis and treatment of chronic arterial insufficiency of the lower extremities: a critical review. *Circulation* 1996;94:3026-3049.
342. Antiplatelet Trialists' Collaboration. Secondary prevention of vascular disease by prolonged antiplatelet treatment. *Br Med J* 1988;296:320-331.
343. Antithrombotic Trialists' Collaboration. Collaborative meta-analysis of randomised trials of antiplatelet therapy for prevention of death, myocardial infarction, and stroke in high risk patients. *BMJ* 2002;324:71-86.
344. Eikelboom JW, Hirsh J, Spencer FA, et al. Antiplatelet drugs: antithrombotic therapy and prevention of thrombosis, 9th ed: American College of Chest Physicians Evidence-Based Clinical Practice Guidelines. *Chest* 2012;141(Suppl 2):e89S-e119S.
345. De Meyer SF, Vanhoorelbeke K, Broos K, et al. Antiplatelet drugs. *Br J Haematol* 2008;142:515-528.
346. Michelson AD. Advances in antiplatelet therapy. *Hematology Am Soc Hematol Educ Program* 2011;2011:62-69.
347. Roth GJ, Majerus PW. The mechanism of the effect of aspirin on human platelets. I. Acetylation of a particulate fraction protein. *J Clin Invest* 1975;56:624-632.
348. Catella-Lawson F, Reilly MP, Kapoor SC. Cyclooxygenase inhibitors and anti-platelet effects of aspirin. *N Engl J Med* 2001;345:1809-1817.
349. Garcia Rodriguez LA, Varas C, Patrono C. Differential effects of aspirin and non-aspirin nonsteroidal anti-inflammatory drugs in the primary prevention of myocardial infarction in postmenopausal women. *Epidemiology* 2000;11:382-387.
350. Masotti G, Galanti G, Poggesi L, et al. Differential inhibition of prostacyclin production and platelet aggregation by aspirin. *Lancet* 1979;2:1213-1216.
351. Patrignani P, Filabozzi P, Patrono C. Selective cumulative inhibition of platelet thromboxane production by low-dose aspirin in healthy subjects. *J Clin Invest* 1982;69:1366-1372.
352. Hirsh J. The optimal antithrombotic dose of aspirin. *Arch Intern Med* 1985;145:1582-1583.
353. Mangano DT. Aspirin and mortality from coronary bypass surgery. *N Engl J Med* 2002;347:1309-1317.
354. Hayden M, Pignone M, Phillips C, et al. Aspirin for the primary prevention of cardiovascular events: a summary of the evidence for the U.S. Preventive Services Task Force. *Ann Intern Med* 2002;136:161-172.
355. Antithrombotic Trialists' (ATT) Collaboration. Aspirin in the primary and secondary prevention of vascular disease: collaborative meta-analysis of individual participant data from randomised trials. *Lancet* 2009;373: 1849-1860.
356. Bhatt DL, Fox KA, Hacke W, et al. Clopidogrel and aspirin versus aspirin alone for the prevention of atherothrombotic events. *N Engl J Med* 2006;354:1706-1717.
357. Alonso-Coello P, Bellmunt S, McGorrian C, et al. Antithrombotic therapy in peripheral artery disease: antithrombotic therapy and prevention of thrombosis, 9th ed: American College of Chest Physicians Evidence-Based Clinical Practice Guidelines. *Chest* 2012;141(Suppl 2):e669S-e690S.
358. Pulmonary Embolism Prevention (PEP) Trial Collaborative Group. Prevention of pulmonary embolism and deep vein thrombosis with low dose aspirin: Pulmonary Embolism Prevention (PEP) trial. *Lancet* 2000;355:1295-1302.
359. Falck-Ytter Y, Francis CW, Johanson NA, et al. Prevention of VTE in orthopedic surgery patients: antithrombotic therapy and prevention of thrombosis, 9th ed: American College of Chest Physicians Evidence-Based Clinical Practice Guidelines. *Chest* 2012;141(Suppl 2):e278S-e325S.
360. Becattini C, Agnelli G, Schenone A, et al. Aspirin for preventing the recurrence of venous thromboembolism. *N Engl J Med* 2012;366:1959-1967.
- 360a. Warkentin TE. Aspirin for dual prevention of venous and arterial thrombosis. *N Engl J Med* 2012;367:2039-2041.
361. Sanderson S, Emery J, Baglin T, Kinmonth AL. Narrative review: aspirin resistance and its clinical implications. *Ann Intern Med* 2005;142:370-380.
362. Michelson AD, Cattaneo M, Eikelboom JW, et al. Aspirin resistance: position paper of the Working Group on Aspirin Resistance. *J Thromb Haemost* 2005;3:1309-1311.
363. Dalen JE. Aspirin resistance: is it real? Is it clinically significant? *Am J Med* 2007;120:1-4.
364. Smock KJ, Rodgers GM. Laboratory evaluation of aspirin responsiveness. *Am J Hematol* 2010;85:358-360.

365. Quinn MJ, Fitzgerald DJ. Ticlopidine and clopidogrel. *Circulation* 1999;100:1667-1672.
366. Sharis PJ, Cannon CP, Loscalzo J. The antiplatelet effects of ticlopidine and clopidogrel. *Ann Intern Med* 1998;129:394-405.
367. Gent M, Blakely JA, Easton JD, et al. The Canadian American Ticlopidine Study (CATS) in thromboembolic stroke. *Lancet* 1989;1:1215-1220.
368. Chen DK, Kim JS, Sutton DM. Thrombotic thrombocytopenic purpura associated with ticlopidine: a report of 3 cases and review of the literature. *Arch Intern Med* 1999;159:311-314.
369. FitzGerald GA. Ticlopidine in unstable angina: a more expensive aspirin? *Circulation* 1990;82:296-298.
370. Herbert JM, Frehel D, Vallee E, et al. Clopidogrel, a novel antiplatelet and antithrombotic agent. *Cardiovasc Drug Rev* 1993;11:180-198.
371. CAPRIE Steering Committee. A randomized, blinded, trial of clopidogrel versus aspirin in patients at risk of ischaemic events (CAPRIE). *Lancet* 1996;348:1329-1339.
372. Mehta SR, Yusuf S, Peters RJ, et al. Effects of pretreatment with clopidogrel and aspirin followed by long-term therapy in patients undergoing percutaneous coronary intervention: the PCI-CURE study. *Lancet* 2001;358:527-533.
373. Bennett CL, Connors JM, Carwile JM, et al. Thrombotic thrombocytopenic purpura associated with clopidogrel. *N Engl J Med* 2000;342:1773-1777.
374. Wiviott SD, Antman EM, Winters KJ, et al. Randomized comparison of prasugrel (CS-747, LY640315), a novel thienopyridine P2Y₁₂ antagonist, with clopidogrel in percutaneous coronary intervention: results of the Joint Utilization of Medications to Block Platelets Optimally (JUMBO)-TIMI 26 trial. *Circulation* 2005;111:3366-3373.
- 374a. Ortel TL. Perioperative management of patients on chronic antithrombotic therapy. *Blood* 2012;120:4699-4705.
375. Hynes RO. Integrins: versatility, modulation, and signaling in cell adhesion. *Cell* 1992;69:11-25.
376. Dennis MS, Henzel WJ, Pitti RM, et al. Platelet glycoprotein IIb/IIIa protein antagonists from snake venoms: evidence for a family of platelet aggregation inhibitors. *Proc Natl Acad Sci U S A* 1989;87:2471-2475.
377. Topol EJ, Byzova TV, Plow EF. Platelet GPIIb/IIIa blockers. *Lancet* 1999;353:227-231.
378. Scarborough RM, Kleiman NS, Phillips DR. Platelet glycoprotein IIb/IIIa antagonists: what are the relevant issues concerning their pharmacology and clinical use? *Circulation* 1999;100:437-444.
379. Coller BS. Binding of abciximab to alpha V beta 3 and activated alpha M beta 2 receptors: with a review of platelet-leukocyte interactions. *Thromb Haemost* 1999;82:326-336.
380. Barrett JS, Murphy G, Peerlinck K, et al. Pharmacokinetics and pharmacodynamics of MK-383, a selective non-peptide platelet glycoprotein-IIb/IIIa receptor antagonist, in healthy men. *Clin Pharmacol Ther* 1994;56:377-388.
381. Guyatt G, Akl EI, Crowther M, et al. Executive summary: antithrombotic therapy and prevention of thrombosis, 9th ed: American College of Chest Physician evidence-based clinical practice guidelines. *Chest* 2012;141:7S-47S.
382. McLean J. The thromboplastic action of cephalin. *Am J Physiol* 1916;41:250-257.
383. Lam LH, Silbert JE, Rosenberg RD. The separation of active and inactive forms of heparin. *Biochem Biophys Res Commun* 1976;69:570-577.
384. Rosenberg RD, Edelberg JM, Zhang L. The heparin/antithrombin system: a natural anticoagulant mechanism. In: Colman RW, Hirsh J, Marder VJ, et al., eds. *Hemostasis and thrombosis: basic principles and clinical practice*, 4th ed. Philadelphia, PA: JB Lippincott, 2001:711-732.
385. Bjork I, Jackson CM, Jornvall H, et al. The active site of antithrombin: release of the same proteolytically cleaved form of the inhibitor from complexes with factor IXa, factor Xa, and thrombin. *J Biol Chem* 1982;257:2406-2411.
386. Choay J, Petitou M, Lormeau JC, et al. Structure-activity relationship in heparin: a synthetic pentasaccharide with high affinity for antithrombin III and eliciting high anti-factor Xa activity. *Biochem Biophys Res Commun* 1983;116:492-499.
387. Olson ST, Bjork I. Predominant contribution of surface approximation to the mechanism of heparin acceleration of the antithrombin-thrombin reaction: elucidation from salt concentration effects. *J Biol Chem* 1991;266:6353-6364.

388. Olson ST, Bjork I, Sheffer R, et al. Role of the antithrombin-binding pentasaccharide in heparin acceleration of antithrombin-proteinase reactions: resolution of the antithrombin conformational change contribution to heparin rate enhancement. *J Biol Chem* 1992;267:12528-12538.
389. Danielsson A, Raub E, Lindahl U, Bjork I. Role of ternary complexes, in which heparin binds both antithrombin and proteinase, in the acceleration of the reactions between antithrombin and thrombin or factor Xa. *J Biol Chem* 1986;261:15467-15473.
390. Ofosu FA, Hirsh J, Esmon CT, et al. Unfractionated heparin inhibits thrombin-catalyzed amplification reactions of coagulation more efficiently than those catalyzed by factor Xa. *Biochem J* 1989;257:143-150.
391. Jaques LB. Heparin. A unique misunderstood drug. *Trends Pharmacol Sci* 1982;3:289-291.
392. Bengtsson-Olivecrona G, Olivecrona T. Binding of active and inactive forms of lipoprotein lipase to heparin: effects of pH. *Biochem J* 1985;226:409-413.
393. Paliwal R, Paliwal SR, Agrawal GP, Vyas SP. Recent advances in search of oral heparin therapeutics. *Med Res Rev* 2012;32(2):388-409.
394. Nyman D, Thurnherr N, Duckert F. Heparin dosage in extracorporeal circulation and its neutralization. *Thromb Diath Haemorrh* 1974;33:102-104.
395. Hirsh J, van Aken WG, Gallus AS, et al. Heparin kinetics in venous thrombosis and pulmonary embolism. *Circulation* 1976;53:691-695.
396. Hirsh J, Warkentin TE, Shaughnessy SG, et al. Heparin and low-molecular-weight heparin: mechanisms of action, pharmacokinetics, dosing, monitoring, efficacy, and safety. *Chest* 2001;119(Suppl):64S-94S.
397. Garcia DA, Baglin TP, Weitz JI, and Samama M. Parenteral anticoagulants: antithrombotic therapy and prevention of thrombosis, 9th ed: American College of Chest Physicians Evidence-based clinical practice guidelines. *Chest* 2012;114:e24S-e43S.
398. Levine MN, Hirsh J, Gent M, et al. A randomized trial comparing activated thromboplastin time with heparin assay in patients with acute venous thromboembolism requiring large daily doses of heparin. *Arch Intern Med* 1994;154:49-56.
399. Nader HB, Walenga JM, Berkowitz SD, et al. Preclinical differentiation of low molecular weight heparins. *Semin Thromb Hemost* 1999;25:63-72.
400. Casu B, Torri G. Structural characterization of low molecular weight heparins. *Semin Thromb Hemost* 1999;25:17-25.
401. Montalescot G, Collet JP, Lison L, et al. Effects of various anticoagulant treatments on von Willebrand factor release in unstable angina. *J Am Coll Cardiol* 2000;36:110-114.
402. Garcia-Arieta A, Blazquez A. Regulatory considerations for generic or biosimilar low molecular weight heparins. *Curr Drug Discov Technol* 2012;9(2):137-42.
403. Ryan TJ, Antman EM, Brooks NH, et al. 1999 update: ACC/AHA guidelines for the management of patients with acute myocardial infarction. A report of the American College of Cardiology/American Heart Association Task Force on Practice Guidelines. *J Am Coll Cardiol* 1999;34:890-911.
404. Antman EM, Fox KM. Guidelines for the diagnosis and management of unstable angina and non-Q-wave myocardial infarction: proposed revisions. *International Cardiology Forum. Am Heart J* 2000;139:461-475.
405. Palm M, Mattsson CH. Pharmacokinetics of heparin and low molecular weight heparin fragment (Fragmin) in rabbits with impaired renal or metabolic clearance. *Thromb Haemost* 1987;58:932-935.
406. Rondina M, Pendleton R, Wheeler M and Rodgers G. VTE Treatment in Special Patient Populations. *Thromb Res* 2007;119:391-402.
407. Woltz M, Weltermann A, Nieszpaar-Los M, et al. Studies on the neutralizing effects of protamine on unfractionated and low molecular weight heparin (Fragmin) at the site of activation of the coagulation system in man. *Thromb Haemost* 1995;73:439-443.
408. Tollefsen DM. Insights into the mechanism of action of heparin cofactor II. *Thromb Haemost* 1995;74:1209-1214.
409. Miglioli M, Pironi L, Ruggeri E, et al. Bioavailability of desmin, a low molecular weight dermatan sulphate, after subcutaneous administration to healthy volunteers. *Int J Clin Lab Res* 1997;27:195-198.

410. Chong BH. Danaparoid for the treatment of heparin-induced thrombocytopenia. In: Warkentin TE, Greinacher A, eds. Heparin-induced thrombocytopenia. New York: Marcel Dekker, 2000:291-311.
411. Greinacher A, Amiral J, Dummel V, et al. Laboratory diagnosis of heparin-associated thrombocytopenia and comparison of platelet aggregation test, heparin-induced platelet activation test, and platelet factor 4/heparin enzyme-linked immunosorbent assay. *Transfusion* 1994;34:381-385.
412. Tardy B, Tardy-Poncet B, Viallon A, et al. Fatal danaparoid-sodium induced thrombocytopenia and arterial thromboses. *Thromb Haemost* 1998;80:530.
413. Herbert JM, Herault JP, Bernat A, et al. Biochemical and pharmacologic properties of SANORG 340006, a potent and long-acting synthetic pentasaccharide. *Blood* 1998;91:4197-4205.
414. Warkentin TE. How I diagnose and manage HIT. *Hematology Am Soc Hematol Educ Program* 2011;2011:143-149.
415. Persist Investigators. A novel long-acting synthetic factor Xa inhibitor (SanOrg34006) to replace warfarin for secondary prevention in deep vein thrombosis. A Phase II evaluation. *J Thromb Haemost* 2004;21:47-53.
416. Van Gogh Investigators. Idraparinux versus standard therapy for venous thromboembolic disease. *N Engl J Med* 2007;357:1094-1104.
417. Amadeus Investigators. Comparison of idraparinux with vitamin K antagonists for prevention of thromboembolism in patients with atrial fibrillation: a randomized, open-label, non-inferiority trial. *Lancet* 2008;371:315-321.
418. Warkentin TE, Kelton JG. A 14-year study of heparin-induced thrombocytopenia. *Am J Med* 1996;101:502-507.
419. Markwardt F. The development of hirudin as an antithrombotic drug. *Thromb Res* 1994;74:1-23.
420. Schiele F, Vuilleminot A, Kramarz P, et al. Use of recombinant hirudin as antithrombotic treatment in patients with heparin-induced thrombocytopenia. *Am J Hematol* 1995;50:20-25.
421. Warkentin TE, Chong BH, Greinacher A. Heparin-induced thrombocytopenia: towards consensus. *Thromb Haemost* 1998;79:1-7.
422. Linkins LA, Dans AL, Moores LK, et al. Treatment and prevention of heparin-induced thrombocytopenia: antithrombotic therapy and prevention of thrombosis, 9th ed: American College of Chest Physicians Evidence-based clinical practice guidelines. *Chest* 2012;114:495S-530S.
423. Pötzsch B, Madlener K, Seelig C, et al. Monitoring of r-hirudin anticoagulation during cardiopulmonary bypass: assessment of the whole blood ecarin clotting time. *Thromb Haemost* 1997;77:920-925.
424. Topoulos AP, Bartholomew JR, Mee R, et al. Refludan™ (lepirudan) in pediatrics: safe use for heparin-induced thrombocytopenia (HIT) and extracorporeal membrane oxygenation (ECMO). *Thromb Haemost* 1999;394(Suppl):1250.
425. Begelman SM, Deitcher SR. Outpatient management of venous thromboembolic disease with subcutaneous lepirudin: a case report. *J Thromb Thrombol* 2002;13:183-185.
426. Frank RD, Farber H, Stefanidis I, et al. Hirudin elimination by hemofiltration: a comparative in vitro study of different membranes. *Kidney Int* 1999;58(Suppl 72):S41-S45.
427. Eichler P, Friesen HJ, Lubenow N, et al. Antihirudin antibodies in patients with heparin-induced thrombocytopenia treated with lepirudin: incidence, effects on aPTT, and clinical relevance. *Blood* 2000;96:2373-2378.
428. Boyce SW, Bandyk DF, Bartholomew JR, et al. A randomized, open-label pilot study comparing desirudin and argatroban in patients with suspected heparin-induced thrombocytopenia with or without thrombosis: PREVENT-HIT Study. *Am J Ther* 2011;181:14-22.
429. Hursting MJ, Alford KL, Becker JC, et al. Novastan(r) (brand of argatroban): a small-molecule, direct thrombin inhibitor. *Semin Thromb Hemost* 1997;23:503-516.
430. Lewis BE, Matthai WH Jr, Cohen M, et al. Argatroban anticoagulation during percutaneous coronary intervention in patients with heparin-induced thrombocytopenia. *Catheterization Cardiovasc Interv* 2002;57:177-184.
431. Maraganore JM, Bourdon P, Jablonski J, et al. Design and characterization of hirulogs: a novel class of bivalent peptide inhibitors of thrombin. *Biochemistry* 1990;29:7095-7101.

432. Lincoff AM, Bittl JA, Kleiman NS, et al. Comparison of bivalirudin versus heparin during percutaneous coronary intervention (the Randomized Evaluation of PCI Linking Angiomax to Reduced Clinical Events [REPLACE-1] trial). *Am J Cardiol* 2004;93:1092-1096.
433. Lincoff AM, Bittl JA, Harrington RA, et al. for the REPLACE-2 Investigators. Bivalirudin and provisional glycoprotein IIb/IIIa blockade compared with heparin and planned glycoprotein IIb/IIIa blockade during percutaneous coronary intervention: REPLACE-2 randomized trial. *JAMA* 2003;289:853-863. Erratum, *JAMA* 2003;289:1638.
434. Stone GW, McLaurin BT, Cox DA, et al. Bivalirudin for patients with acute coronary syndromes. *N Engl J Med* 2006;355:2203-2216.
435. Campbell HA, Link KP. Studies on the hemorrhagic sweet clover disease: IV. The isolation and crystallization of the hemorrhagic agent. *J Biol Chem* 1941;138:21-33.
436. Furie B, Furie BC. Molecular basis of vitamin K-dependent γ -carboxylation. *Blood* 1990;75:1753-1762.
437. Fasco MJ, Principe LM, Walsh WA, Friedman PA. Warfarin inhibition of vitamin K 2,3-epoxide reductase in rat liver microsomes. *Biochemistry* 1983;22:5655-5660.
438. Ageno W, Gallus AS, Wittkowsky A, et al. Oral anticoagulant therapy: antithrombotic therapy and prevention of thrombosis, 9th ed: American college of chest physicians evidence-based clinical practice guidelines. *Chest* 2012;141(Suppl 2): e44S-e88S.
439. O'Reilly RA. The pharmacodynamics of the oral anticoagulant drugs. *Prog Hemost Thromb* 1974;2:175-213.
440. O'Reilly RA, Aggeler PM, Hoag MS, et al. Hereditary transmission of exceptional resistance to coumarin anticoagulant drugs. The first reported kindred. *N Engl J Med* 1964;271:809-815.
441. Zivelin A, Rao LVM, Rapaport SI. Mechanism of the anticoagulant effect of warfarin as evaluated in rabbits by selective depression of individual procoagulant vitamin K-dependent clotting factors. *J Clin Invest* 1993;92:2131-2140.
442. Choueiri T, Deitcher SR. Why shouldn't we solely use warfarin to treat acute venous thrombosis? *Cleve Clin J Med* 2002;69:546-548.
443. Holbrook AM, Pereira JA, Labiris R, et al. Systematic overview of warfarin and its drug and food interactions. *Arch Intern Med* 2005;165: 1095-1106.
444. Wells PS, Holbrook AM, Crowther NR, Hirsh J. Interactions of warfarin with drugs and food. *Ann Intern Med* 1994;121:676-683.
445. Deitcher SR. Interpretation of the international normalized ratio (INR) in patients with liver disease. *Lancet* 2002;359:47-48.
446. International Warfarin pharmacogenetics consortium. Estimation of the warfarin dose with clinical and pharmacogenetic data. *N Engl J Med* 2009;360:753-764.
447. Deitcher SR. Heparin induced thrombocytopenia: pathogenesis, management, and prevention. *Formulary* 2001;36:26-41.
448. Anderson JL, Horne BD, Stevens SM, et al. A randomized and clinical effectiveness trial comparing two pharmacogenetic algorithms and standard care for individualizing warfarin dosing (CoumaGen-II). *Circulation* 2012;125:1997-2005.
449. Hirsh J. Oral anticoagulant drugs. *N Engl J Med* 1991;324:1865-1875.
450. Harrison L, Johnston M, Massicotte MP, et al. Comparison of 5-mg and 10-mg loading doses in initiation of warfarin therapy. *Ann Intern Med* 1997;126:133-136.
451. Hirsh J, Poller L. The international normalized ratio: a guide to understanding and correcting its problems. *Arch Intern Med* 1994;154:282-288.
452. Hull R, Hirsh J, Jay R, et al. Different intensities of oral anticoagulant therapy in the treatment of proximal-vein thrombosis. *N Engl J Med* 1982;307:1676-1681.
453. Levine MN, Raskob G, Beyth RJ, et al. Hemorrhagic complications of anticoagulant treatment. *Chest* 2004;126(Suppl):287S-310S.

454. Beyth RJ, Quinn LM, Landefeld CS. Prospective evaluation of an index for predicting the risk of major bleeding in outpatients treated with warfarin. *Am J Med* 1998;105:91-99.
455. Landefeld CS, Rosenblatt MW, Goldman L. Bleeding in outpatients treated with warfarin: relation to the prothrombin time and important remediable lesions. *Am J Med* 1989;87:153-159.
456. Fang MC, Go AS, Hylek EM, et al. Age and the risk of warfarin-associated hemorrhage: the anticoagulation and risk factors in atrial fibrillation study. *J Am Geri Soc* 2006;54:1231-1236.
457. Crowther MA, Ageno W, Garcia D, et al. Oral vitamin K versus placebo to correct excessive anticoagulation in patients receiving warfarin. *Ann Intern Med*. 2009;150:293-300.
458. Johnson J, Turpie AGG. Temporary discontinuation of oral anticoagulants: role of low molecular weight heparin. *Thromb Haemost* 1999;82(Suppl):62-63.
459. Dunn AS, Spyropoulos AC, Turpie AG. Bridging therapy in patients on long-term oral anticoagulants who require surgery: the Prosperative Peri-operative Enoxaparin Cohort Trial (PEOSPECT). *J Thromb Haemost* 2007;5:2211-2218.
460. Vinik R, Wanner N, and Pendleton RC. Peri-procedural anti-thrombotic management: a review of the literature and practical approach for the hospitalist physician. *J Hosp Med* 2009;4:551-559.
461. Douketis JD, Spyropoulos AC, Spencer FA, et al. Perioperative management of antithrombotic therapy: antithrombotic therapy and prevention of thrombosis, 9th ed: American college of chest physicians evidence-based clinical practice guidelines. *Chest* 2012;141(Suppl 2):e326S-e350S.
462. Hall JAG, Pauli RM, Wilson KM. Maternal and fetal sequelae of anticoagulation during pregnancy. *Am J Med* 1980;68:122-140.
463. Ginsberg JS, Hirsh J, Turner DC, et al. Risks to the fetus of anticoagulant therapy during pregnancy. *Thromb Haemost* 1989;61:197-203.
464. Faraci PA, Deterling RA, Stein AM, et al. Warfarin induced necrosis of the skin. *Surg Gynecol Obstet* 1978;146:695-700.
465. Grimaudo V, Gueissaz F, Hauert J, et al. Necrosis of skin induced by coumarin in a patient deficient in protein S. *Br Med J* 1989;298:233-234.
466. Jillella AP, Lutcher CL. Reinstating warfarin in patients who develop warfarin skin necrosis. *Am J Hematol* 1996;52:117-119.
467. Feder W, Auerbach R. "Purple toes": an uncommon sequela of oral coumarin drug therapy. *Ann Intern Med* 1961;55:911-917.
468. Moldvee-Geronimus M, Merriam JC. Cholesterol embolization: from pathological curiosity to clinical entity. *Circulation* 1967;35:946-953.
469. Sallah S, Thomas DP, Roberts HR. Warfarin and heparin-induced skin necrosis and the purple toe syndrome: infrequent complications of anticoagulant treatment. *Thromb Haemost* 1997;78:785-790.
470. Bruns FJ, Segel DP, Adler S. Control of cholesterol embolization by discontinuation of anticoagulant therapy. *Am J Med Sci* 1978;275:105-108.
471. Weitz JI, Eikelboom JW, and Samama MM. New antithrombotic drugs: antithrombotic therapy and prevention of thrombosis, 9th ed: American college of chest physicians evidence-based clinical practice guidelines. *Chest* 2012;141(Suppl 2):e120S-e151S.
472. Pradaxa (dabigatran etexilate) prescribing information. Boehringer Ingelheim pharmaceuticals, Ridgefield CT. May 2012.
473. Iyer V, Singh HS, Reiffel JA. Dabigatran: comparison to warfarin, pathway to approval, and practical guidelines for use. *J Cardiovasc Pharmacol Ther* 2012;17(3):237-247.
474. Crowther MA, Warkentin TE. Managing bleeding in anticoagulated patients with a focus on novel therapeutic agents. *J Thromb Haemost* 2009;7(Suppl 1):107-110.
475. Connolly SJ, Ezekowitz MD, Yusuf S, et al. Dabigatran versus warfarin in patients with atrial fibrillation. *N Engl J Med* 2009;361:1139-1151.

476. Wallentin, Lars, Yusuf, Salim, Ezekowitz, Michael D, et al. Efficacy and safety of dabigatran compared with warfarin at different levels of international normalized ratio control for stroke prevention in atrial fibrillation: an analysis of the RE-LY trial. *Lancet* 2012;376:975-983.
477. Xarelto (Rivaroxaban) prescribing information. Janssen pharmaceuticals, December 2011.
478. Gomez-Outes A, Suarez-Gea ML, Blazquez-Perez A, et al. Will oral rivaroxaban improve clinically relevant outcomes and thromboprophylaxis management in the orthopedic patient? *J Thromb Haemost* 2009;7:2149-2151.
479. Patel MR, Mahaffey KW, Garg J, et al. Rivaroxaban versus warfarin in nonvalvular atrial fibrillation. *N Engl J Med* 2011;365:883-891.
480. Connolly SJ, Eikelboom J, Joyner C, et al. Apixaban in patients with atrial fibrillation. *N Engl J Med* 2011;364:806-817.
481. Granger CB, Alexander JH, McMurray J, et al. Apixaban versus warfarin in patients with atrial fibrillation. *N Engl J Med* 2011;365:981-992.
- P.1257
482. Castellone, Donna D, Van Cott, Elizabeth M. Laboratory Monitoring of new anticoagulations. *Am J Hematol* 2010;85:185-187.
483. Erenberg ES, Kamphuisen PW, Sijpkens MK, et al. Reversal of rivaroxaban and dabigatran by prothrombin complex concentrate: a randomized, placebo-controlled, crossover study in healthy subjects. *Circulation* 2011;124: 1573-1579.
484. Collen D, Lijnen HR. Molecular basis of fibrinolysis, as relevant for thrombolytic therapy. *Thromb Haemost* 1995;74:167-171.
485. Eisenberg PR, Sobel BE, Jaffe AS. Characterization in vivo of the fibrin specificity of activators of the fibrinolytic system. *Circulation* 1988;78:592-597.
486. Marder VJ, Bell WR. Fibrinolytic therapy. In: Colman RW, Hirsh J, Marder VJ, Salzman EW, eds. *Hemostasis and thrombosis: basic principles and clinical practice*, 2nd ed. Philadelphia, PA: JB Lippincott, 1987:1393-1437.
487. Stricker RB, Wong D, Shiu DT, et al. Activation of plasminogen by tissue plasminogen activator on normal and thrombasthenic platelets: effects on surface proteins and platelet aggregation. *Blood* 1986;68:275-280.
488. Sharma GVRK, Cella G, Parisi AF, Sasahara AA. Thrombolytic therapy. *N Engl J Med* 1982;306:1268-1276.
489. Bell W. Therapeutic agents-pharmacokinetics and pharmacodynamics. *Rev Cardiovasc Med* 2002;3(suppl 2):S34-S44.
490. Pennica D, Holmes WE, Kohr WJ, et al. Cloning and expression of human tissue-type plasminogen activator cDNA in *E. coli*. *Nature* 1983;301:214-221.
491. Collen D, Bounameaux H, De Cock F, et al. Analysis of coagulation and fibrinolysis during intravenous infusion of recombinant human tissue-type plasminogen activator in patients with acute myocardial infarction. *Circulation* 1986;73:511-517.
492. Goldhaber SZ, Vaughn DE, Markis JE, et al. Acute pulmonary embolism treated with tissue plasminogen activator. *Lancet* 1986;2:886-889.
493. Rapaport E. Thrombolytic agents in acute myocardial infarction. *N Engl J Med* 1989;320:861-864.
494. Neuhaus KL, Feuerer W, Jeep-Tebbe S, et al. Improved thrombolysis with a modified dose regimen of recombinant tissue-type plasminogen activator. *J Am Coll Cardiol* 1989;14:1566-1569.
495. The National Institute of Neurological Disorders and Stroke rt-PA Stroke Study Group. TPA for acute ischemic stroke. *N Engl J Med* 1995;333:1581-1587.
496. Adams HP, Brott TG, Furlan AJ, et al. Guidelines for thrombolytic therapy for acute stroke: a supplement to the guidelines for the management of patients with acute ischemic stroke. *Circulation* 1996;94:1167-1174.
497. Deitcher SR, Fesen MR, Kiproff PM, et al. Safety and efficacy of alteplase for restoring function in occluded central venous catheters: results of the Cardiovascular Thrombolytic to Open Occluded Lines trial. *J Clin Oncol* 2002;20:317-324.
498. Kohnert U, Rudolph R, Verheijen JH, et al. Biochemical properties of the kringle 2 and protease domains are maintained in the refolded t-PA deletion variant BM 06.022. *Protein Eng* 1992;5:93-100.

499. Furlan AJ, Higashida R, Wechsler L, et al. Intra-arterial prourokinase for acute ischemic stroke. The PROACT II study: a randomized controlled trial. *JAMA* 1999;282:2003-2011.
500. Verstraete M. Third-generation thrombolytic drugs. *Am J Med* 2000;109:52-58.
501. Liberatore GT, Samson A, Bladin C, et al. Vampire bat salivary plasminogen activator (desmoteplase): a unique fibrinolytic enzyme that does not promote neurodegeneration. *Stroke* 2003;34:537-543.
502. Berkowitz SD, Granger CB, Pieper KS, et al. Incidence and predictors of bleeding after contemporary thrombolytic therapy for myocardial infarction. *Circulation* 1997;95:2508-2516.
503. Gurwitz JH, Gore JM, Goldberg RJ, et al. Risk for intracranial hemorrhage after plasminogen activator treatment for acute myocardial infarction. Participants in the National Registry of Myocardial Infarction 2. *Ann Intern Med* 1998;129:597-604.
504. Ouriel K. Safety and efficacy of the various thrombolytic agents. *Rev Cardiovasc Med* 2002;3(suppl 2):S17-S24.
505. Lijnen HR, Collen D. Remaining perspectives of mutant and chimeric plasminogen activators. *Ann N Y Acad Sci* 1992;667:357-364.
506. Assessment of the Safety and Efficacy of a New Thrombolytic Investigators. Single-bolus tenecteplase compared with front-loaded alteplase in acute myocardial infarction: the ASSENT-2 double-blind randomized trial. *Lancet* 1999;354:716-722.
507. Van de Werf F, Barron HV, Armstrong PW, et al. Incidence and predictors of bleeding events after fibrinolytic therapy with fibrin-specific agents: a comparison of TNK-tPA and rt-PA. *Eur Heart J* 2001;22:2253-2261.
508. Gore JM, Granger CB, Simons ML, et al. Stroke after thrombolysis: mortality and functional outcomes in the GUSTO-I trial. *Circulation* 1995;92:2811-2818.
509. Maggioni AP, Franzosi MG, Santoro E, et al. The risk of stroke in patients with acute myocardial infarction after thrombolytic and antithrombotic treatment. Gruppo Italiano per lo Studio della Sopravvivenza nell'Infarto Miocardico II (GISSI-2), and the International Study Group. *N Engl J Med* 1992;327:1-6.
510. Third International Study of Infarct Survival Collaborative Group. ISIS-3: a randomised comparison of streptokinase vs tissue plasminogen activator vs anistreplase and of aspirin plus heparin vs aspirin alone among 41,299 cases of suspected acute myocardial infarction. *Lancet* 1992;339:753-770.
511. Deitcher SR, Jaff MR. Pharmacologic and clinical characteristics of thrombolytic agents. *Rev Cardiovasc Med* 2002;3(Suppl):S25-S33.
512. Goldhaber S, Visani L, De Rosa M. Acute pulmonary embolism: clinical outcomes in the International Cooperative Pulmonary Embolism Registry (ICOPER). *Lancet* 1999;353:1386.
513. Hull RD, Raskob GE, Hirsh J, et al. Continuous intravenous heparin compared with intermittent subcutaneous heparin in the initial treatment of proximal-vein thrombosis. *N Engl J Med* 1986;315:1109-1114.
514. Prandoni P, Lensing AWA, Cogo A, et al. The long-term clinical course of acute deep venous thrombosis. *Ann Intern Med* 1996;125:1-7.
515. Prevention and treatment of venous thromboembolism. International Consensus Statement (guidelines according to scientific evidence). *Int Angiol* 2006;25:101-161.
516. Snow V, Qaseem A, Barry P, et al. Management of venous thromboembolism: a clinical practice guideline from the American College of Physicians and the American Academy of Family Physicians. *Ann Intern Med* 2007;146:204-210.
517. Kearon C, Akl EA, Comerota AJ, et al. Antithrombotic therapy for VTE disease: antithrombotic therapy and prevention of thrombosis, 9th ed: American college of chest physicians evidence-based clinical practice guidelines. *Chest* 2012;141(Suppl 2):e419S-e494S.
518. Anand SS, Bates S, Ginsberg JS, et al. Recurrent venous thrombosis and heparin therapy; an evaluation of the importance of early activated partial thromboplastin times. *Arch Intern Med* 1999;159:2029-2032.
519. Hull RD, Raskob GE, Brant RF, et al. Relation between the time to achieve the lower limit of the APTT therapeutic range and recurrent venous thromboembolism during heparin treatment for deep vein thrombosis. *Arch Intern Med* 1997;157:2562-2568.

520. Brandjes DP, Heijboer H, Buller HR, et al. Acenocoumarol and heparin compared with acenocoumarol alone in the initial treatment of proximal-vein thrombosis. *N Engl J Med* 1992;327:1485-1489.
521. Gallus A, Jackaman J, Tillett J, et al. Safety and efficacy of warfarin started early after submassive venous thrombosis or pulmonary embolism. *Lancet* 1986;2:1293-1296.
522. Hull RD, Raskob GE, Rosenbloom D, et al. Heparin for 5 days as compared with 10 days in the initial treatment of proximal venous thrombosis. *N Engl J Med* 1990;322:1260-1264.
523. Raschke RA, Reilly BM, Guidry JR, et al. The weight-based heparin dosing nomogram compared with a standard care nomogram: a randomized, controlled trial. *Ann Intern Med* 1993;119:874-881.
524. Prandoni P, Carnovali M, Marchiori A. Subcutaneous adjusted-dose unfractionated heparin vs fixed-dose low-molecular-weight heparin in the initial treatment of venous thromboembolism. *Arch Intern Med* 2004;164:1077-1083.
525. Kearon C, Ginsberg JS, Julian JA, et al. Comparison of fixed-dose weight-adjusted unfractionated heparin for acute treatment of venous thromboembolism. *JAMA* 2006; 296:935-942.
526. Hull RD, Raskob GE, Pineo GF, et al. Subcutaneous low-molecular-weight heparin compared with continuous intravenous heparin in the treatment of proximal-vein thrombosis. *N Engl J Med* 1992;326:975-982.
527. Prandoni P, Lensing AW, Buller HR, et al. Comparison of subcutaneous low-molecular-weight heparin with intravenous standard heparin in proximal deep-vein thrombosis. *Lancet* 1992;339:441-445.
528. Dolovich LR, Ginsberg JS, Douketis JD, et al. A meta-analysis comparing low-molecular-weight heparins with unfractionated heparin in the treatment of venous thromboembolism: examining some unanswered questions regarding location of treatment, product type, and dosing frequency. *Arch Intern Med* 2000;160:181-188.
529. Quinlan DJ, McQuillan A, Eikelboom JW. Low-molecular-weight heparin compared with intravenous unfractionated heparin for treatment of pulmonary embolism: a meta-analysis of randomized, controlled trials. *Ann Intern Med* 2004;140:175-183.
530. Merli G, Spiro TE, Olsson CG, et al. Subcutaneous enoxaparin once or twice daily compared with intravenous unfractionated heparin for treatment of venous thromboembolic disease. *Ann Intern Med* 2001;134:191-202.
531. Buller HR, Davidson BL, Decousus H, et al. Fondaparinux or enoxaparin in the initial treatment of symptomatic deep vein thrombosis: a randomized trial. *Ann Intern Med* 2004;140:867-873.
532. Crowther MA, Ginsberg JB, Kearon C, et al. A randomized trial comparing 5-mg and 10-mg warfarin loading doses. *Arch Intern Med* 1999;159: 46-48.
533. Kovacs MJ, Rodger M, Anderson DR, et al. Comparison of 10-mg and 5-mg warfarin initiation nomograms together with low-molecular-weight heparin for outpatient treatment of acute venous thromboembolism. A randomized, double-blind, controlled trial. *Ann Intern Med* 2003;138:714-719.
534. Koopman MM, Prandoni P, Piovella F, et al. Treatment of venous thrombosis with intravenous unfractionated heparin administered in the hospital as compared with subcutaneous low-molecular-weight heparin administered at home. The Tasman Study Group. *N Engl J Med* 1996;334: 682-687.
535. Levine M, Gent M, Hirsh J, et al. A comparison of low-molecular-weight heparin administered primarily at home with unfractionated heparin administered in the hospital for proximal deep-vein thrombosis. *N Engl J Med* 1996;334:677-681.
536. O'Brien B, Levine M, Willan A, et al. Economic evaluation of outpatient treatment with low-molecular-weight heparin for proximal vein thrombosis. *Arch Intern Med* 1999;159:2298-2304.
537. Douketis JD: treatment of deep vein thrombosis: what factors determine appropriate treatment? *Can Fam Physician* 2005;51:217-223.
538. Douketis JD, Kearon C, Bates S, et al. Risk of fatal pulmonary embolism in patients with treated venous thromboembolism. *JAMA* 1998;279:458-462.
539. Aujesky D, Roy PM, Verschuren F, et al. Outpatient versus inpatient treatment for patients with acute pulmonary embolism: an international, op-label, randomized, non-inferiority trial. *Lancet* 2011;378:41-8.
540. Nutescu EA, Spinler SA, Wittkowsky A, et al. Low-molecular-weight heparins in renal impairment and obesity: available evidence and clinical practice recommendations across medical and surgical settings. *Ann Pharmacother* 2009;43:1064-1083.

541. Rondina MT, Pendleton RC, Wheeler M, et al. The treatment of venous thromboembolism in special populations. *Thromb Res* 2007;119:391-402.
542. Bazinet A, Almanric K, Brunet C, et al. Dosage of enoxaparin among obese and renal impairment patients. *Thromb Res* 2005;116:41-50.
543. Hainer JW, Barrett JS, Assaid CA, et al. Dosing in heavy-weight/obese patients with the LMWH, tinzaparin: a pharmacodynamic study. *Thromb Haemost* 2002;87:817-823.
544. Wilson SJ, Wilbur K, Burton E, et al. Effect of patient weight on the anticoagulant response to adjusted therapeutic dosage of low-molecular-weight heparin for the treatment of venous thromboembolism. *Haemostasis* 2001;31:42-48.
545. Falga C, Capdevila JA, Soler S, et al. Clinical outcome of patients with venous thromboembolism and renal insufficiency. Findings from the RIETE registry. *Thromb Haemost* 2007;98:771-776.
546. Lim W, Dentali F, Eikelboom JW, et al. Meta-analysis: low-molecular-weight heparin and bleeding in patients with severe renal insufficiency. *Ann Intern Med* 2006;144:673-684.
547. Ho WK, Hankey GJ, Quinlan DJ, Eikelboom JW. Risk of recurrent venous thromboembolism in patients with common thrombophilia: a systematic review. *Arch Intern Med* 2006;166:729-736.
548. Baglin T, Luddington R, Brown K, Baglin C. Incidence of recurrent venous thromboembolism in relation to clinical and thrombophilic risk factors: prospective cohort study. *Lancet* 2003;362:523-526.
549. Cosmi B, Legnani C, Cini M, Guazzaloca G, Palareti G. D-dimer levels in combination with residual venous obstruction and the risk of recurrence after anticoagulation withdrawal for a first idiopathic deep vein thrombosis. *Thromb Haemost* 2005;94:969-974.
550. Carrier M, Rodgers MA, Welle PS, et al. Residual vein obstruction to predict the risk of recurrent venous thromboembolism in patients with deep vein thrombosis: a systematic review and meta-analysis. *J Thromb Haemost* 2011;9:119-125.
551. Verhovsek M, Douketis JD, Yi Q, et al. Systematic review: D-dimer to predict recurrent disease after stopping anticoagulant therapy for unprovoked venous thromboembolism. *Ann Intern Med* 2008;149:481-490.
552. Kearon C. Indefinite anticoagulation after a first episode of unprovoked venous thromboembolism: yes. *J Thromb Haem* 2007;5:2330-2335.
553. van Walraven C, Jennings A, Oake N, et al. Effect of study setting on anticoagulation control: a systematic review and metaregression. *Chest* 2006;129:1155-1166.
554. Fitzmaurice DA, Gardiner C, Kitchen S, et al. An evidence-based review and guidelines for patient self-testing and management of oral anticoagulation. *Br J Haematol* 2005;131:156-165.
555. Gardiner C, Williams K, Longair I, et al. A randomised control trial of patient self-management of oral anticoagulation compared with patient self-testing. *Br J Haematol* 2006;132:598-603.
556. Matchar DB, Jacobson A, Dolor R, et al. Effect of home testing of international normalized ratio on clinical events. *N Engl J Med* 2010;363:1608-1620.
557. Bloomfield HE, Krause A, Greer N et al. Meta-analysis: effect of patient self-testing and self-management of long-term anticoagulation on major clinical outcomes. *Ann Intern Med*. 2011;154:472-482.
558. Ginsberg JS, Kowalchuk G, Hirsh J, et al. Heparin effect on bone density. *Thromb Haemost* 1990;64:286-289.
559. Lee AY. Cancer and venous thromboembolism: prevention, treatment and survival. *J Thromb Thrombolysis* 2008;25:33-36.
560. Prandoni P, Lensing AW, Piccioli A, et al. Recurrent venous thromboembolism and bleeding complications during anticoagulant treatment in patients with cancer and venous thrombosis. *Blood* 2002;100:3484-3488.
561. Lee AY, Levine MN, Baker RI, et al. Low-molecular-weight heparin versus a coumarin for the prevention of recurrent venous thromboembolism in patients with cancer. *N Engl J Med* 2003;349:146-153.
562. Hull RD, Pineo GF, Brant RF, et al. Long-term low-molecular-weight heparin versus usual care in proximal-vein thrombosis patients with cancer. *Am J Med* 2006;119:1062-1072.

563. Akl EA, Barba M, Rohilla S, et al. Anticoagulation for the long term treatment of venous thromboembolism in patients with cancer. *Cochrane Database Syst Rev* 2008;(2):CD006650.
564. Noble SI, Finlay IG. Is long-term low-molecular-weight heparin acceptable to palliative care patients in the treatment of cancer related venous thromboembolism? A qualitative study. *Palliat Med* 2005;19:197-201.
565. National Comprehensive Cancer Network. NCCN Clinical Practice Guidelines in Oncology. Venous thromboembolic disease, V.2.2009. www.nccn.org. Accessed January 25, 2010.
566. Lyman GH, Khorana AA, Falanga A, et al. American Society of Clinical Oncology guideline: recommendations for venous thromboembolism prophylaxis and treatment in patients with cancer. *J Clin Oncol* 2007;25:5490-5505.
567. Mandala M, Falanga A, Roila F. Management of venous thromboembolism in cancer patients: ESMO clinical recommendations. *Ann Oncol* 2009;20(Suppl 4):182-184.
568. The EINSTEIN Investigators. Oral rivaroxaban for symptomatic venous thromboembolism. *N Engl J Med* 2010;363:2499-2510.
569. The EINSTEIN-PE Investigators. Oral rivaroxaban for the treatment of symptomatic pulmonary embolism. *N Engl J Med* 2012;366:1287-1297.
570. Schulman S, Kearon C, Kakkar AK, et al. Dabigatran versus warfarin in the treatment of acute venous thromboembolism. *N Engl J Med* 2009;361:2342-2352.
571. Schulman S, Rhedin AS, Lindmaker P, et al. A comparison of six weeks with six months of oral anticoagulant therapy after a first episode of venous thromboembolism. *N Engl J Med* 1995;332:1661-1665.
572. Philbrick JT, Becker DM. Calf deep venous thrombosis. A wolf in sheep's clothing? *Arch Intern Med* 1988;148:2131-2138.
573. Lohr JM, Lutter KS, Cranley RD, et al. Lower extremity calf thrombosis: to treat or not to treat? *J Vasc Surg* 1991;14:618-623.
574. Kelly J, et al. The natural history of untreated subclinical below knee deep vein thrombosis (DVT) following acute ischemic stroke. *Blood* 2002;100(Suppl 1):abstr 106.
575. Deitcher SR, Clark T, Carman TL. Clinical course of patients with calf vein thrombosis followed by serial duplex ultrasound. *The American Venous Forum* 2003;(abstract):8.
576. Decousus H, Leizorovicz A, Parent F, et al. A clinical trial of vena caval filters in the prevention of pulmonary embolism in patients with proximal deep-vein thrombosis. *N Engl J Med* 1998;338:409-415.
577. The PREPIC Study Group. Eight- Year follow-up of patients with permanent vena Cava filters in the prevention of pulmonary embolism. *Circulation* 2005;112:416-422.
578. Pacouret G, Alison D, Pottier JM, et al. Free-floating thrombus and embolic risk in patients with angiographically confirmed proximal deep venous thrombosis: a prospective study. *Arch Intern Med* 1997;157:305-308.
579. Baglin TP, Brush J, Streiff M. Guidelines on use of vena cava filters. *Br J Haematol* 2006;134:590-595.
580. Mewissen MW, Seabrook GR, Meissner MH, et al. Catheter-directed thrombolysis for lower extremity deep venous thrombosis: report of a national multicenter registry. *Radiology* 1999;211:39-49.
581. Patel NH, Stookey KR, Ketcham DB, et al. Endovascular management of acute extensive iliofemoral deep venous thrombosis caused by May-Thurner syndrome. *J Vasc Interv Radiol* 2000;11:1297-1302.
582. O'Sullivan GJ, Semba CP, Sittner CA, et al. Endovascular management of iliac vein compression (May-Thurner) syndrome. *J Vasc Interv Radiol* 2000;11:823-836.
583. AbuRahma A, Perkins SE, Wulu JT, et al. Iliofemoral deep vein thrombosis: conventional therapy versus lysis and percutaneous transluminal angioplasty and stenting. *Ann Surg* 2001;233:752-760.
584. Schweizer J, Kirch W, Koch R, et al. Short- and long-term results after thrombolytic treatment of deep venous thrombosis. *J Am Coll Cardiol* 2000;36:1336-1343.
585. Comerota AJ, Thom RC, Mathias SD, et al. Catheter-directed thrombolysis for iliofemoral deep venous thrombosis improves health-related quality of life. *J Vasc Surg* 2000;32:130-137.

586. Enden T, Haig Y, Klow NE, Slagsvold CE, et al. Long-term outcome after additional catheter-directed thrombolysis versus standard treatment for acute iliofemoral deep vein thrombosis (the CaVenT study): a randomized controlled trial. *Lancet* 2012;379:31-38.
587. Sharifi M, Bay C, Mehdipour M, Sharifi J; TORPEDO Investigators. Thrombus Obliteration by Rapid Percutaneous Endovenous intervention in Deep venous Occlusion (TORPEDO) trial: midterm results. *J Endovasc Ther* 2012;19:273-280.
588. Kahn SR. The post-thrombotic syndrome: progress and pitfalls. *Br J Haematol* 2006;134:357-365.
589. Kakkos SK, Daskalopoulou SS, Daskalopoulos ME, et al. Review on the value of graduated elastic compression stockings after deep vein thrombosis. *Thromb Haemost* 2006;96:441-445.
590. Goldhaber SZ. Thrombolysis in pulmonary embolism: a debatable indication. *Thromb Haemost* 2001;86:444-451.
591. Arcasoy SM, Kreit JW. Thrombolytic therapy of pulmonary embolism: a comprehensive review of current evidence. *Chest* 1999;115:1695-1707.
592. Konstantinides S, Tiede N, Geibel A, et al. Comparison of alteplase versus heparin for resolution of major pulmonary embolism. *Am J Cardiol* 1998;82:966-970.
593. Konstantinides S, Geibel A, Heusel G, et al. Heparin and alteplase compared with heparin alone in patients with submassive pulmonary embolism. *N Engl J Med* 2002;347:1143-1150.
594. Tebbe U, Graf A, Kamke W, et al. Hemodynamic effects of double bolus reteplase versus alteplase infusion in massive pulmonary embolism. *Am Heart J* 1999;138:39-44.
595. Kanter DS, Mikkola KM, Patel SR, et al. Thrombolytic therapy for pulmonary embolism: frequency of intracranial hemorrhage and associated risk factors. *Chest* 1997;111:1241-1245.
596. Morrell MT, Dunnill MS. The post-mortem incidence of pulmonary embolism in a hospital population. *Br J Surg* 1965;55:347-352.
597. Guyatt GH, Eikelboom JW, Gould MK, et al. Approach to outcome measurement in the prevention of thrombosis in surgical and medical patients: antithrombotic therapy and prevention of thrombosis, 9th ed: American College of Chest physicians evidence-based clinical practice guidelines. *Chest* 2012;141(Suppl 2):e185s-e194s.
598. Kahn SR, Lim W, Dunn AS, et al. Prevention of VTE in nonsurgical patients: antithrombotic therapy and prevention of thrombosis, 9th ed: American College of Chest physicians evidence-based clinical practice guidelines. *Chest* 2012;141(Suppl 2):e195s-e226s.
599. Gould MK, Garcia DA, Wren SM, et al. Prevention of VTE in non-orthopedic surgical patients: antithrombotic therapy and prevention of thrombosis, 9th ed: American College of Chest physicians evidence-based clinical practice guidelines. *Chest* 2012;141(Suppl 2):e227s-e277s.
600. Lederle FA, Zylla D, et al. Venous thromboembolism prophylaxis in hospitalized medical patients and those with stroke: a background review for an American College of Physicians clinical practice guideline. *Ann Intern Med* 2011;155:602-615.
601. Kucher N, Koo S, Quiroz R, et al. Electronic alerts to prevent venous thromboembolism among hospitalized patients. *N Engl J Med* 2005;352: 969-977.
602. Spyropoulos AC, Anderson FA, Fitzgerald G, et al. Predictive and associative models to identify hospitalized medical patients at risk for VTE. *Chest* 2011;140:706-714.
603. Bahl V, Hu HM, Henke PK, et al. A validation study of a retrospective venous thromboembolism scoring method. *Ann Surg* 2010;251:344-350.
604. Hull RD, Schellong SM, Tapson VF, et al. Extended-duration venous thromboembolism prophylaxis in acutely ill medical patients with recently reduced mobility: a randomized trial. *Ann Intern Med* 2010;153:8-18.
605. Goldhaber SZ, Leizorovicz A, Kakkar AK, et al. Apixaban versus enoxaparin for thromboprophylaxis in medically ill patients. *N Engl J Med* 2011;365:2167-2177.
606. Warkentin TE, Levine MN, Hirsh J, et al. Heparin-induced thrombocytopenia in patients treated with low-molecular-weight heparin or unfractionated heparin. *N Engl J Med* 1995;332:1330-1335.
607. Chong BH. Heparin-induced thrombocytopenia. *Br J Haematol* 1995;89:431-439.

608. Amiral J, Bridey F, Dreyfus M, et al. Platelet factor 4 complexed to heparin is the target for antibodies generated in heparin-induced thrombocytopenia. *Thromb Haemost* 1992;68:95-96.
609. Warkentin TE, Hayward CPM, Boshkov LD, et al. Sera from patients with heparin-induced thrombocytopenia generate platelet-derived microparticles with procoagulant activity; an explanation for the thrombotic complications of heparin-induced thrombocytopenia. *Blood* 1994;84:3691-3699.
610. Warkentin TE. Clinical picture of heparin-induced thrombocytopenia. In: Warkentin TE, Greinacher A, eds. *Heparin-induced thrombocytopenia*, 4th ed. New York: Informa Healthcare USA, Inc.;2008:21-66.
611. King DJ, Kelton JG. Heparin-associated thrombocytopenia. *Ann Intern Med* 1984;100:535-540.
612. Warkentin TE, Kelton JG. Heparin-induced thrombocytopenia. *Prog Hemost Thromb* 1991;10:1-34.
613. Warkentin TE and Kelton JG. Delayed-onset heparin-induced thrombocytopenia and thrombosis. *Annals Intern Med* 2001;135:502-506.
614. Lee DH, Warkentin TE. Frequency of heparin-induced thrombocytopenia. In: Warkentin TE, Greinacher A, eds. *Heparin-induced thrombocytopenia*, 4th ed. New York: Informa Healthcare USA, Inc.;2008:67-116.
615. Bell WR, Royall RM. Heparin-associated thrombocytopenia: a comparison of three heparin preparations. *N Engl J Med* 1980;303:902-907.
616. Warkentin TE, Sheppard JA, Sigouin CS, et al. Gender imbalance and risk factor interactions in heparin-induced thrombocytopenia. *Blood* 2006;108:2937-2941.
617. Hunter JB, Lonsdale RJ, Wenham PW, et al. Heparin-induced thrombosis: an important complication of heparin prophylaxis for thromboembolic disease in surgery. *Br Med J* 1993;307:53-55.
618. Singer RL, Mannion JD, Bauer TL, et al. Complications from heparin-induced thrombocytopenia in patients undergoing cardiopulmonary bypass. *Chest* 1993;104:1436-1440.
619. Warkentin TE. Heparin-induced skin lesions. *Br J Haematol* 1996;92:494-497.
620. Ansell J, Deykin D. Heparin-induced thrombocytopenia and recurrent thromboembolism. *Am J Hematol* 1980;8:325-332.
621. Klement D, Rammos S, Van Kries R, et al. Heparin as a cause of thrombus progression. Heparin-associated thrombocytopenia is an important differential diagnosis in pediatric patients even with normal platelet counts. *Eur J Pediatr* 1996;155:11-14.
622. Hach-Wunderle V, Kainer K, Salzmann G, et al. Heparin-related thrombosis despite normal platelet counts in vascular surgery. *Am J Surg* 1997;173:117-119.
623. Calaites JG, Liem TK, Spadone D, et al. The role of heparin-associated antiplatelet antibodies in the outcome of arterial reconstruction. *J Vasc Surg* 1999;29:779-785.
624. Lo GK, Juhl D, Warkentin TE, et al. Evaluation of pretest clinical score (4 T's) for the diagnosis of heparin-induced thrombocytopenia in two clinical settings. *J Thromb Haemost* 2006;4:759-765.
- 624a. Cuker A, Gimotty PA, Crowther MA, Warkentin TE. Predictive value of the 4Ts scoring system for heparin-induced thrombocytopenia: a systematic review and meta-analysis. *Blood* 2012;120:4160-4167.
625. Chong BH, Eisbacher M. Pathophysiology and laboratory testing of heparin-induced thrombocytopenia. *Semin Hematol* 1998;35(4 Suppl 5):3-8; discussion 35-36.
626. Warkentin TE. Platelet count monitoring and laboratory testing for heparin-induced thrombocytopenia. Recommendations of the College of American Pathologists. *Arch Pathol Lab Med* 2002;126:1415-1423.
627. Warkentin TE. Laboratory testing for heparin-induced thrombocytopenia. In: Warkentin TE, Greinacher A, eds. *Heparin-induced Thrombocytopenia*, 4th ed. New York: Informa Healthcare USA, Inc.;2008:227-260.
628. Bakchoul T, Giptner A, Najaoui A, et al. Prospective evaluation of PF4/heparin immunoassays for the diagnosis of heparin-induced thrombocytopenia. *J Thromb Haemost* 2009;7:1260-1265.
629. Zwicker JJ, Uhl L, Huang WY, et al. Thrombosis and ELISA optical density values in hospitalized patients with heparin-induced thrombocytopenia. *J Thromb Haemost* 2004;2:2133-2137.

630. Warkentin TE, Russett JI, Johnston M, et al. Warfarin treatment of deep vein thrombosis complicating heparin-induced thrombocytopenia (HIT) is a risk factor for initiation of venous limb gangrene: report of nine patients implicating the interacting procoagulant effects of two anticoagulant agents. *Thromb Haemost* 1995;73:1110.
631. Warkentin TE. Heparin-induced thrombocytopenia: IgG-mediated platelet activation, platelet microparticle generation, and altered procoagulant/anticoagulant balance in the pathogenesis of thrombosis and venous limb gangrene complicating heparin-induced thrombocytopenia. *Transfus Med Rev* 1996;10:249-258.
632. Warkentin TE, Sheppard JL, Schulman S, et al. Fondaparinux treatment of acute heparin-induced thrombocytopenia confirmed by the serotonin release assay: a 30 month, 16 patient case series. *J Thromb Haemost* 2011;9:2389-2396.
633. Warkentin TE, Kelton JG. Temporal aspects of heparin-induced thrombocytopenia. *N Engl J Med* 2001;344:1286-1292.
634. Warkentin TE. Heparin-induced thrombocytopenia: pathogenesis and management. *Br J Haematol* 2003;121:535-555.

Part VI - Benign Disorders of Leukocytes, The Spleen, and/or Immunoglobins

Chapter 56 Diagnostic Approach to Malignant and Nonmalignant Disorders of the Phagocytic and Immune Systems

> Table of Contents > Part VI - Benign Disorders of Leukocytes, The Spleen, and/or Immunoglobins > Chapter 56 - Diagnostic Approach to Malignant and Nonmalignant Disorders of the Phagocytic and Immune Systems

Chapter 56

Diagnostic Approach to Malignant and Nonmalignant Disorders of the Phagocytic and Immune Systems

Daniel A. Arber

Thomas L. McCurley

John P. Greer

Cost-effective, efficient evaluation of patients with hematologic diseases is often based on the quality of collaboration between clinicians and pathologists. This has become even more important as the number and complexity of diagnostic tests has exploded. Flow cytometry, cytogenetic, fluorescence in situ hybridization (FISH), and molecular genetic testing present opportunities for improving diagnostic precision but are expensive, and each has its limitations and shortcomings. The goal of this chapter is to guide selection of testing to minimize the cost and time involved in making diagnoses in common clinical problems in hematology.

This chapter introduces an approach to disorders that produce abnormalities of circulating blood cells, constitutional symptoms, or enlargement of lymph nodes or the spleen. The emphasis is on distinguishing benign from malignant disease. The disorders may take the form of (a) immune reactions, particularly infection resulting in changes in blood leukocytes, lymphadenopathy, and/or organomegaly; (b) neoplastic diseases (leukemias, lymphomas, and plasmacytic neoplasms and related diseases); and (c) inherited or acquired diseases that result in immunodeficiency.

APPROACH TO DIAGNOSIS

Patients with disorders of the immune system (innate and adaptive) usually come to medical attention with symptoms and signs suggestive of infection. Many patients with hematopoietic lymphoid neoplasms may also present with fever or other nonlocalizing constitutional signs and symptoms such as fatigue, generalized lymphadenopathy, abnormal bleeding, weight loss, bone pain, arthralgias, and pruritus. Suspicion of an underlying immune disorder, benign or malignant, may be raised during the course of a routine examination or during the evaluation of unrelated disorders by the detection of

skin lesions, lymphadenopathy, splenomegaly, or hilar or mediastinal masses. In other instances, routine blood examination may disclose abnormalities in the numbers or morphology of circulating red cells, white cells, or platelets.

A detailed history should be obtained, and a thorough physical examination should be performed. Age of the patient, immunocompetence (focusing on types and number of infections), family history, travel history, animal exposure, history of prior therapy, and drug ingestion are particularly important areas to address. Complete blood cell count (CBC) and blood examination (including morphologic assessment of red cells, white cells, and platelets) may be diagnostic or help determine the next step in diagnosis. Chest x-ray and computed tomography (CT) may assist in identifying possible biopsy sites. Electrophoresis to characterize serum or urine immunoglobulins, marrow examination, lymph node aspiration or biopsy, liver biopsy, and splenectomy with flow cytometry immunophenotyping of blood, marrow, or tissue, may be necessary. In addition, evaluation of delayed type hypersensitivity and tests of neutrophil and/or lymphocyte function may be required. Finally, cytogenetic and molecular genetic testing may be necessary for a complete assessment. Clearly, not all or even most of these tests and surgical procedures are indicated for each patient who has the symptoms or signs described. Rather, a logical sequence is undertaken for each patient, tailored to the particular findings. A diagrammatic summary of a sequential approach is shown in Figure 56.1.

The examination of stained tissues by light microscopy remains the principal means of establishing a diagnosis in most of the benign and malignant conditions considered in Parts VI (Nonmalignant Disorders of Leukocytes, the Spleen, and/or Immunoglobulins) and VII (Hematologic Malignancies). Other studies, however, including immunophenotypic studies, cytogenetics, and molecular genetics, are increasingly valuable in making, confirming, and “fine-tuning” diagnoses as well as in defining clinically important subcategories of disease.^{1, 2}

Flow cytometry has become a primary immunophenotyping method in the diagnosis, classification, and detection of residual disease in patients with hematologic malignancies, and is covered in more detail in Chapter 2. For example, flow cytometry is helpful in the differential diagnosis of reactive and neoplastic lymphoid proliferations, but requires specimens that are submitted fresh or in saline. Figure 56.2 demonstrates the difference between immunoglobulin light chain distribution in a patient with follicular hyperplasia (with polytypic light chain expression) versus a patient with a diffuse large B-cell lymphoma (with monotypic light chain expression). In T-cell neoplasms, the detection of a population of lymphocytes with aberrant phenotypes (e.g., lost or diminished expression of pan T-cell markers) as illustrated in Figure 56.3, is very helpful in detecting abnormal T-cell populations. Flow cytometry is essential for classification of acute leukemia, in part because most diagnostic studies can be completed in less than 2 hours. Additionally, flow cytometry immunophenotyping detects myeloid antigen expression in cases that are myeloperoxidase or Sudan black B negative by cytochemical studies. Finally, flow cytometry can detect aberrant blast cell immunophenotypes, which are useful for the detection of minimal residual disease in post-therapy specimens. The level of detection of minimal residual disease by flow cytometry is well

P.1260

below what can be identified by morphologic assessment of aspirate smears. However, flow cytometry does have limitations. It requires fresh or viable tissue and is of less value in the diagnosis of Hodgkin lymphoma (HL), T-cell-rich B-cell lymphomas, and subclassification of reactive processes (see Table 56.1), and may miss some T-cell neoplasms that do not demonstrate aberrant immunophenotypes. Most laboratories do not use methods that are effective in detecting the rare tumor cells of HL, but some studies have used this method effectively and this application of flow cytometry may emerge in the future.³ Additional applications in morphologically difficult areas such as myelodysplastic syndromes are evolving.

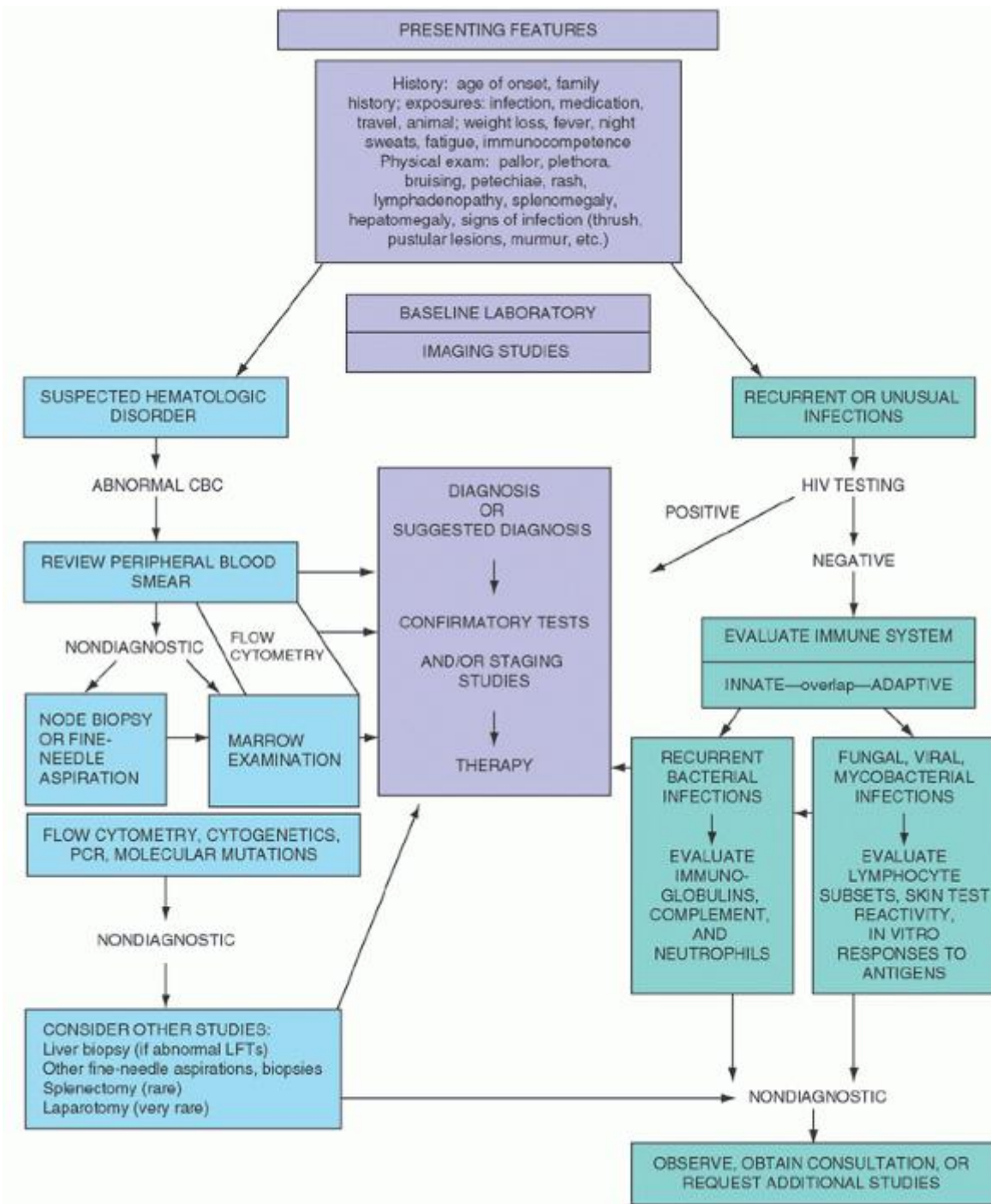

FIGURE 56.1. Diagnostic steps in diseases of the hematopoietic lymphoid system. CBC, complete blood cell count; HIV, human immunodeficiency virus.

P.1261

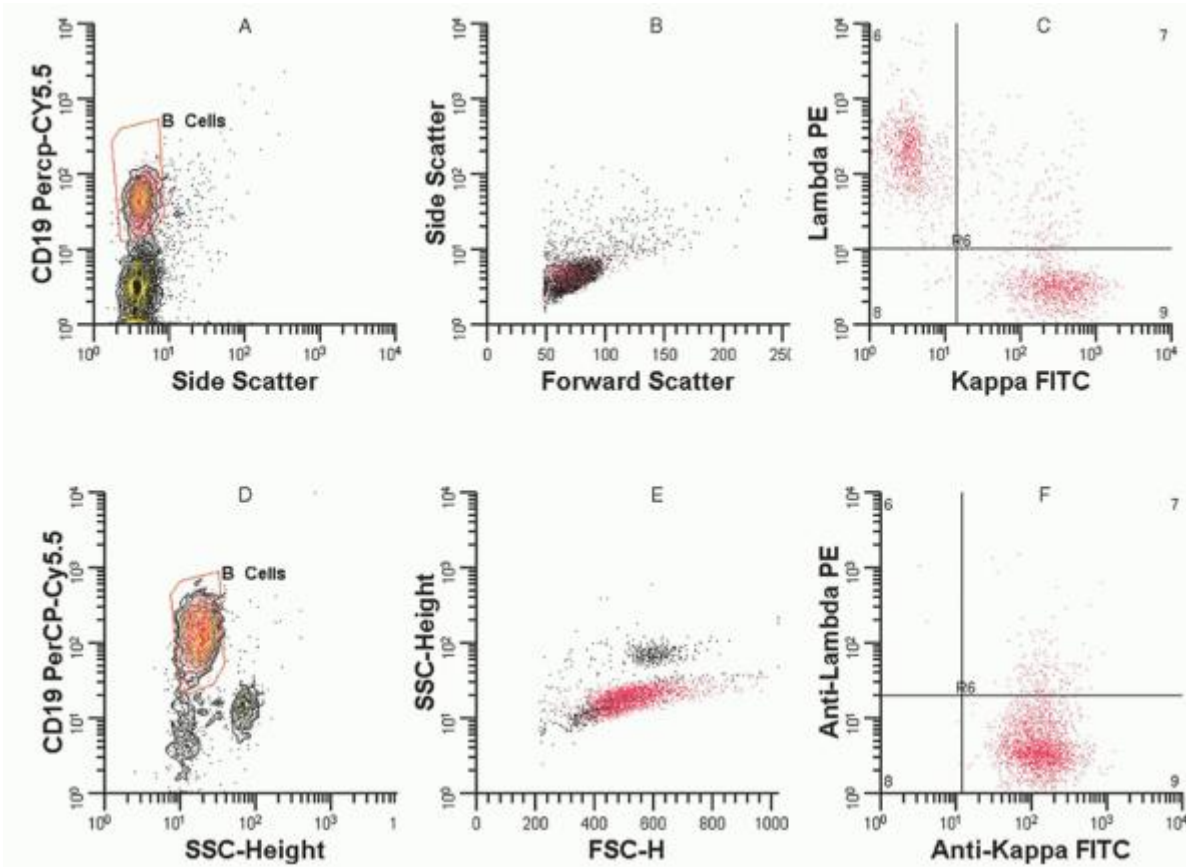

FIGURE 56.2. Flow cytometry of reactive B cells and monoclonal B cells. A: Histogram (picture) of pan B-cell anti-CD19 antibody expression versus this log side scatter signal (related to cellular complexity), which is used to define and identify the B-cell lymphocytes. B: Histogram shows lymphocytes based on forward scatter signal (size) versus log side scatter signal. The red population shows that the CD19⁺ B cells and predominantly T-cell CD19⁻ population (black dots) are of similar small size. (1) C: A two-parameter histogram gating on CD19⁺ B cells with anti-Kappa fluorescein isothiocyanate (FITC) versus anti-lambda phycoerythrin. This pattern, which shows a mix of kappa and lambda, is consistent with a reactive polyclonal B-cell population. D: Histogram (picture) of anti-CD19 antibody expression versus log side scatter in a second patient. E: Histogram shows lymphocytes based on forward scatter signal versus log side scatter signal. The red population which represents the CD19⁺ B cells is larger in size than the smaller CD19⁻ population (black dots). F: A two-parameter histogram of anti-kappa fluorescein isothiocyanate (FITC) versus anti-lambda phycoerythrin. Red dots are the CD19⁺ B cells from histogram and show a dominant kappa expressing B-cell population consistent with a large B-cell lymphoma. (Diagrams courtesy of Bruce Grieg, MT, Vanderbilt University.)

Cytogenetic studies have made enormous contributions to our understanding of the genetic pathogenesis of hematologic malignancies, and the field has established itself as a primary player in the diagnosis of prognostically important subsets of leukemia and lymphoma (e.g., Burkitt lymphoma, mantle cell lymphoma, and acute promyelocytic leukemia) (see Chapter 3). FISH has an expanding role in diagnosis (Table 56.2), and has several key advantages over routine cytogenetics: (1) it can be performed on interphase nuclei in fixed tissues (including paraffin-embedded), (2) results are available in 24 to 48 hours, and (3) it shows enhanced sensitivity over routine cytogenetics for critical translocations. Figure 56.4 illustrates FISH studies showing a MYC break apart probe in a patient with an 8;14 translocation in Burkitt lymphoma.

Molecular genetic studies, primarily polymerase chain reaction (PCR) techniques, are the most sensitive for detecting small critical genetic mutations or translocations in samples which may contain very few (less than one in a million) tumor cells (see Chapter 4). PCR has also replaced Southern blot analysis as the standard for the demonstration of T-cell and B-cell clonality and is ideal for detecting minimal residual disease in patients with lymphoma as well as in patients with chronic myelogenous leukemia (CML) (Table 56.3). Many of these applications work in fixed tissues. These studies are of limited or no value in patients with HL, myelodysplasia (MDS), or translocations that have widely spaced, variable breakpoints, as in mantle cell lymphoma.

Hematologic neoplasms are clonal tumors, and methods that can prove clonality of a cell population are extremely useful when the differential diagnosis is between a benign and neoplastic proliferation. The demonstration that an expanded B-cell population is clonal by immunoglobulin light chain restriction, karyotype analysis, or gene rearrangement studies facilitates the distinction between benign and malignant proliferations. However, clonality does not always indicate malignancy, and small clonal populations and pseudoclonal populations may exist in non-neoplastic conditions.^{1, 2, 4, 5} Clinicians have recognized for years that the vast majority of patients with monoclonal gammopathies do not have an underlying B-cell neoplasm. Similarly, sensitive molecular genetic techniques frequently identify oligoclonal and monoclonal T- and B-cell populations in “benign” disorders,

P.1262

including lymphomatoid papulosis, autoimmune disorders (e.g., Sjögren syndrome and Hashimoto thyroiditis) in association with viral infections, celiac disease, and other lymphoid hyperplasias (particularly those in extranodal sites)^{5, 6, 7} (Table 56.4). Although these disorders may evolve into frank malignancy, they can remain clinically benign, remit spontaneously, or regress in the setting of antibiotics and removal of an antigen (*Helicobacter pylori* in gastric marginal zone lymphoma). Thus, although new techniques to identify clonality have astonishing sensitivity, the clinical, laboratory, and histopathologic data must be correlated to distinguish benign from malignant disorders. A major pitfall in diagnosis is failure to recognize that very sensitive studies for clonality by flow cytometry, protein electrophoresis, or molecular techniques are accompanied by a corresponding loss of specificity for the diagnosis of frank neoplasia.

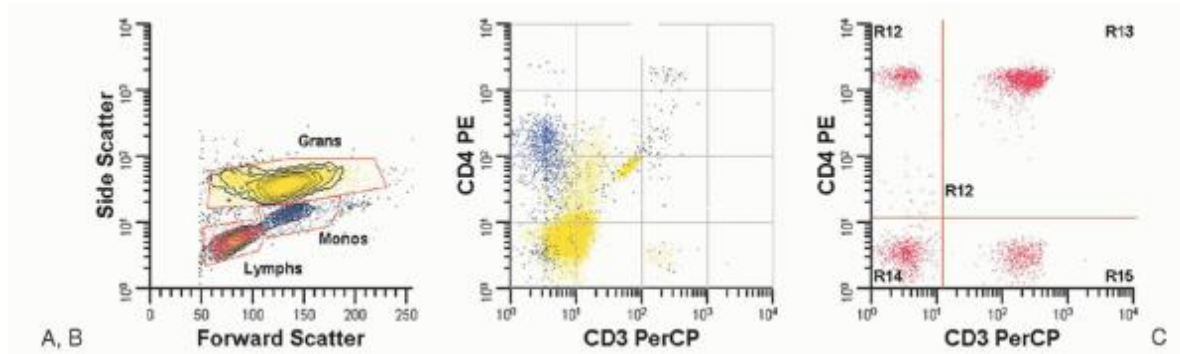

FIGURE 56.3. Histograms demonstrating a phenotypically aberrant T-cell population in a patient with peripheral blood involvement by a T-cell lymphoproliferative disorder. In A, a side scatter versus forward histogram, the lymphocytes (low forward scatter, low side scatter) are painted red. The granulocytes with high side scatter and high forward scatter are painted yellow and the monocytes with forward scatter similar to granulocytes but with intermediate side scatter are painted blue. B displays the granulocytes and monocytes stained with anti-CD3 and anti-CD4, both of which do not stain with the pan T-cell marker anti-CD3 but the monocytes express intermediate levels of CD4. In C which displays CD3 and CD4 expression on the lymphocytes (painted red), normal T helper cells express CD4 and CD3 while the neoplastic T-cell population (upper left) expresses bright CD4 but have lost CD3. (Histograms courtesy Bruce Grieg, MT, Vanderbilt University.)

In the next sections, the examination of the blood, marrow, nodes, and spleen are reviewed in the context of making a diagnosis, introducing the subsequent chapters, and outlining overviews on the evaluation of fever of unknown origin (FUO) and patients with recurrent infection.

TABLE 56.1 MAJOR CLINICAL APPLICATIONS OF FLOW CYTOMETRY

Established	Evolving	Limited Value or Superseded by Other Techniques
<ul style="list-style-type: none"> Acute leukemia (diagnosis and detection of residual disease) Chronic lymphoid leukemias 	Myelodysplastic syndromes	
Suspected non-Hodgkin lymphoma ^a	Multiple myeloma ^b	Hodgkin lymphoma
Paroxysmal nocturnal hemoglobinuria		Myeloproliferative disease (except

blast crisis)

Major disadvantage of this technique: Requires viable cells. False negatives occur with necrotic or sclerotic tissues, partial tissue involvement and in tumors where neoplastic cells are in a minority (e.g., T-cell-rich B-cell lymphoma).

Major advantages of this technique: Can be applied to any tissue or body fluid. Rapid turnaround times.

^a Flow cytometry should be performed on all fine-needle aspirations and tissue biopsies in which a hematopoietic lymphoid process is suggested by clinical history or touch preps/frozen sections.

^b Flow cytometry using cytoplasmic immunoglobulin light chain markers is effective in establishing clonality of plasma cells in multiple myeloma, but not useful in accurately enumerating plasma cells.

TABLE 56.2 COMMON CLINICAL APPLICATIONS OF CYTOGENETICS INCLUDING FLUORESCENCE IN SITU HYBRIDIZATION

Acute Leukemia with prognostically important translocations

APL with t(15;17)(q24.1;21.1) (*PML/RARA*) and *RARA* variants

AML with t(8;21)(q22;q22) (*RUNX1-RUNX1T1*)

AML with inv(16)(p13.1q22) or t(16;16)(p13.1;q22) (*CBFB/MYH11*)

AML with t(9;11)(p22;q23); *MLLT3-MLL* and other *MLL* translocations

ALL with t(12;21)(p13;q22) (*ETV6-RUNX1*)

ALL with t(4;11)(q21.3;q23) (*AFF4-MLL*) and other *MLL* translocations

ALL with t(9;22)(q34;q11.2) (*BCR-ABL1*)

Non-Hodgkin lymphoma with diagnostically critical translocations

Burkitt lymphoma: t(8;14)(q24;q32.33) (*MYC-IGH@*) and other *MYC* variants

Mantle cell lymphoma: t(11;14)(q13;q32.33) (*CCND1-IGH@*)

Follicular lymphoma: t(14;18)(q32.33;q21.3) (*IGH@-BCL2*)

Diffuse large B-cell lymphoma: 8q24 (*MYC*), 18q21.2 (*BCL2*) and 3q27 (*BCL6*) translocations

Anaplastic large cell lymphoma: t(2;5)(p23;5q35.1) (*ALK-NPM1*) and other *ALK* variants

Myelodysplasia

5q31 deletion

Gains and loss of chromosomes 5 and 7

Myeloproliferative neoplasms

Chronic myelogenous leukemia: t(9;22)(q34;q11.2) (*BCR-ABL1*)

Myeloid (and lymphoid) neoplasm with *PDGFRA*, *PDGFRB* and *FGFR1* abnormalities

Chronic lymphocytic leukemia

13q deletion

11q deletion

17q deletion

Trisomy 12

Plasma cell myeloma

13q deletion

17q deletion

t(11;14)(q13;q32.33) (*CCND1-IGH@*)

t(14;16)(q32.33;q22-q23)(*IGH@-MAF*)

t(4;14)(p16.3;q32.33)(*FGFR3-IGH@* or *WHSC1-IGH@*)

t(6;14)(p21;q32.33)(*CCND3-IGH@*)

t(14;20)(q32.33;q11.1-q13.1)(*IGH@-MAFB*)

ALL, acute lymphoblastic leukemia; AML, acute myeloid leukemia; APL, acute promyelocytic leukemia.

P.1263

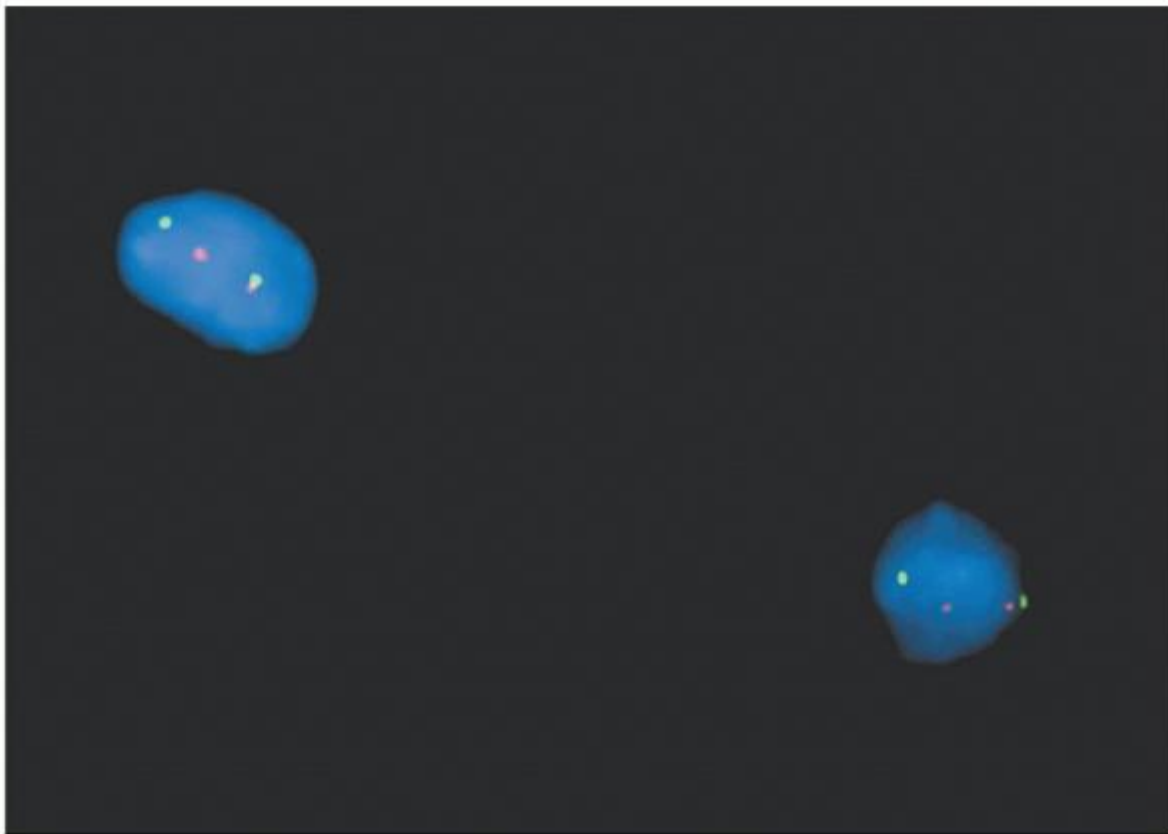

FIGURE 56.4. FISH studies demonstrating a MYC translocation in Burkitt lymphoma using a dual color MYC break apart probe with the red labeled probe binding the 5 prime end of MYC and the green labeled probe binding the 3 prime end of MYC. In the chromosomes with unarranged MYC, the green and red signals are together but the colors separate when MYC is part of a translocation with the *IGH@* gene on chromosome 14.

EXAMINATION OF THE BLOOD

Physicians are too busy to examine peripheral blood smears in all of their patients. They usually do so in one of these circumstances: (a) patients with constitutional symptoms, particularly fever (see section on “Fever of Unknown Origin”) or weight loss, without an obvious underlying cause; (b) an abnormality in blood counts, either cytosis or cytopenia; or (c) as a part of the evaluation of a patient with clinical features of immunodeficiency.

The blood counts and peripheral smear are frequently abnormal in patients with constitutional symptoms, immunodeficiency, hematologic neoplasms, or a variety of other syndromes associated with lymphadenopathy or splenomegaly. Anemia, when present, usually is normochromic and normocytic. Many patients with chronic disease, MDS,

plasma cell myeloma, and, rarely, acute leukemias have anemia but no other abnormalities. In patients with anemia of unknown origin, the evaluation begins with examination of the blood smear, red cell indices, and reticulocyte count. The evaluation proceeds based on the results of these simple tests as outlined in Chapter 22.

TABLE 56.3 COMMON APPLICATIONS OF NON-FLUORESCENCE IN SITU HYBRIDIZATION MOLECULAR GENETIC TECHNIQUES

Established	Of Little or Limited Value
	Myelodysplastic syndromes ^a
B-cell lymphoma	Hodgkin lymphoma
B-cell clonality	
<i>IGH@</i> PCR	
<i>IGK@</i> PCR	
<i>IGH@/BCL2</i> PCR	
T-cell lymphoma	Non-Hodgkin lymphoma with translocations with widely spaced breakpoints (e.g., mantle cell lymphoma)
T-cell clonality	
<i>TRG@</i> PCR	
<i>TRB@</i> PCR	
Acute leukemia	
<ul style="list-style-type: none"> • Balanced translocation PCR (similar to those listed in Table 56.2 for FISH) • <i>NPM1</i>, <i>FLT3</i>, <i>KIT</i>, <i>CEBPA</i>, <i>DNMT3A</i> mutations 	
Myeloproliferative neoplasms	
<i>BCR/ABL1</i> PCR	
<i>JAK2</i> mutations	
Post-transplant engraftment	

^aEmerging mutations may become prognostically significant in myelodysplastic syndromes.

TABLE 56.4 EXAMPLES OF CLONAL PROCESSES WHICH MAY BE CLINICALLY IRRELEVANT

B-Cell Clonality

Monoclonal gammopathies on protein electrophoresis with immunofixation

Small circulating monotypic B-cell populations in healthy adults by flow cytometry

Transient clonal *IGH@* rearrangements by PCR in(1) salivary glands in Sjögren syndrome, (2) in thyroid tissues in Hashimoto thyroiditis, (3) in bone marrow following solid organ or bone marrow transplantation, (4) small biopsies (i.e., skin, gastric)

Clonal *IGH@-BCL2* rearrangements detected in low quantity in normal children and adults in blood and tonsil by ultrasensitive PCR methods

T-Cell Clonality

Transient clonal T-cell receptor rearrangements by PCR in blood of healthy elderly patient

Clonal T-cell receptor rearrangement by PCR in skin of patients with reactive dermatitis

Clonal T-cell receptor rearrangement by PCR in celiac disease

PCR, polymerase chain reaction.

Abnormal Platelet Counts

Thrombocytopenia

The major differential diagnosis of patients with thrombocytopenia includes (a) thrombocytopenia secondary to autoantibody-mediated platelet destruction (idiopathic thrombocytopenic purpura [ITP], systemic lupus erythematosus [SLE], drug-related thrombocytopenia, and perhaps human immunodeficiency virus [HIV]); (b) primary marrow disease, particularly MDS or acute leukemia; and (c) peripheral consumption secondary to intravascular activation of clotting (e.g., disseminated intravascular coagulation, thrombotic thrombocytopenic purpura, or hemolytic uremic syndrome). Although thrombocytopenia can be secondary to a nutritional deficiency (e.g., folate, vitamin B₁₂), usually the macrocytic anemia is the dominant clinical feature.

In ITP and drug-related thrombocytopenias, the peripheral smear red cell and white cell morphology should be normal and rare giant platelets (megathrombocytes) are present. Thrombocytopenic patients with SLE may also be neutropenic and lymphopenic. Thrombocytopenia is present in up to 50% of patients with antiphospholipid antibody syndrome.⁸ Thrombocytopenia is the first sign of HIV infection in 10% of patients who may also be lymphopenic.⁹ Thrombocytopenia occurs in up to 45% of patients with hepatitis C viral infection. MDS and leukemia rarely present with isolated thrombocytopenia. Most MDS patients are anemic and have white blood cell (WBC) abnormalities (e.g., blasts or hyposegmented or hypogranulated polymorphonuclear neutrophils [PMNs]) that indicate primary marrow disease. Schistocytes and polychromatophilic red cells in patients with disseminated intravascular coagulation, thrombotic thrombocytopenic purpura, and hemolytic uremic syndrome are helpful in pointing away from marrow disease or an autoimmune thrombocytopenia. In rare patients, platelets will satellite around PMNs or clump in blood collected in ethylenediaminetetraacetic acid. This artifact, readily apparent on examination of stained blood smears, disappears

P.1264

when blood is anticoagulated in heparin.¹⁰ Similarly, when blood is collected for platelet counts on heel sticks, clumping (also seen on smears) may produce spurious thrombocytopenia.

Congenital thrombocytopenias are rare, but can be misdiagnosed as ITP, and size of platelets may guide further evaluation.¹¹ Small platelets in a male suggest X-linked Wiskott Aldrich syndrome (WAS). Large platelets are found in von Willebrand 2B, May-Hegglin anomaly, Bernard-Soulier syndrome, and the gray platelet syndrome. Normal-sized platelets are found in amegakaryocytic thrombocytopenia, thrombocytopenia with absent radii, and familial platelet disorders with a predisposition to acute myeloid leukemia (AML).

Drug-induced thrombocytopenia (DITP) may be misdiagnosed as ITP and overlooked if patients are not asked about over-the-counter medicines, food, beverages, and/or herbal supplements.¹¹ DITP can be due to immune-mediated or non-immune processes. In a large series of patients initially diagnosed as ITP, 8% were found to have DITP with quinine (including tonic water) as the most common cause.¹² Hematologists are frequently consulted about heparin-induced thrombocytopenia (HIT) which is due to antibodies against platelet factor 4 heparin complexes and leads to an increased risk of thrombosis.¹³

Bone marrow examination with cytogenetic studies is essential only in the cases of thrombocytopenia in patients with suspected MDS or acute leukemia or in those for whom the diagnosis of autoimmune or consumptive thrombocytopenia is in doubt. In most children or young adults with otherwise normal counts and a normal blood smear, a bone marrow is probably not needed.¹⁴ Amegakaryocytic thrombocytopenias secondary to genetic or autoimmune disease are exceedingly rare.

Thrombocytosis

Thrombocytosis with platelet counts of greater than $600 \times 10^9/L$ are commonly seen transiently during a variety of infections, after splenectomy, after acute blood loss, or during recovery from marrow injury or nutritional deficiency. The concern in persistent thrombocytosis is the presence of an underlying myeloproliferative neoplasm or occult malignancy. The presence of a myeloproliferative neoplasm is almost always suggested by the peripheral blood counts and smear (e.g., polycythemia in polycythemia vera [PV], leukoerythroblastic changes in primary myelofibrosis [PMF or agnogenic myeloid metaplasia], and leukocytosis with immature myeloid precursors in CML). The one myeloproliferative neoplasm in which thrombocytosis is often an isolated finding is essential thrombocythemia (ET), a diagnosis that is supported by the

demonstration of megakaryocytic dysplasia on bone marrow examination or the demonstration of JAK2 mutations on molecular genetic studies of peripheral blood.^{15, 16} The JAK2 V617F mutation is estimated to occur in 60% of ET and myelofibrosis and 95% of PV.¹⁷ Congenital thrombocytosis is rare and results from mutations in either thrombopoietin (THPO) or its receptor (MPL).¹⁸

Morphologic Changes in Leukocytes

Morphologic changes in WBC are often diagnostic of certain rare diseases such as Alder-Reilly or Pelger-Huët anomaly, some of which are associated with infection (Chediak-Higashi syndrome) (Chapter 58).

Changes in the blood of patients with acute leukemia strongly suggest the diagnosis in virtually all patients.⁷ In approximately 60% of these individuals, the smear confirms the diagnosis by the presence of a large proportion of immature cells, whether or not the leukocyte count is increased. Blasts are easily demonstrable in blood smears of more than 90% of patients, and, even in patients whose blood smears have few blasts, anemia, thrombocytopenia, neutropenia, or combinations of these changes are suggestive of acute leukemia. For almost all such patients, bone marrow aspiration proves diagnostic and should be supplemented by flow cytometry immunophenotyping and karyotype analysis.

Lymphocytosis of Small Mature Lymphocytes

More than 5.0×10^9 small lymphocytes/L of blood in adults over 50 years of age is usually indicative of chronic lymphocytic leukemia (CLL). Many patients are asymptomatic and one-fourth are diagnosed while undergoing blood work for another problem. Flow cytometry demonstrating small B lymphocytes with weak CD20 and weak, monotypic light chain expression and coexpression of CD5 and CD23 is characteristic. Proceeding with other examinations in such patients, such as lymph node biopsy or bone marrow examination, is usually unnecessary, but immunophenotyping is required to exclude other B-cell lymphomas in the blood, such as mantle cell lymphoma, that may mimic CLL. In children, pertussis is associated with lymphocytosis of small CD4 T cells¹⁹ that may be worrisome for a lymphoid leukemia on review of the blood smear. Chronic polyclonal B-cell lymphocytosis is well described in young to middle-aged asymptomatic women who usually smoke.²⁰ These women typically present with a lymphocyte count that is less than 5×10^9 /L, the number required for a diagnosis of CLL, and the B cells are polytypic by immunoglobulin light chain studies and by PCR studies of the immunoglobulin heavy chain. Monotypic B-cell proliferations that present with less than 5×10^9 /L B cells are now classified as monoclonal B lymphocytosis rather than as overt CLL.²¹

Lymphocytosis of "Atypical Lymphocytes"

Atypical or abnormal lymphocytes are a classic feature of Epstein-Barr virus (EBV) infectious mononucleosis but also occur in other acute viral infections including cytomegalovirus (CMV), hantavirus, hepatitis, HIV, and less commonly in lymphomas with a leukemic phase (e.g., human T-lymphotropic virus -1, hepatosplenic T-cell lymphoma, etc.). Thrombocytopenia, an elevated hematocrit, neutrophilia, and circulating lymphoblasts in a patient from the desert Southwest strongly suggest hantavirus infection.²² Usually the clinical features and other routine laboratory tests such as serologic studies for viral infection make the diagnosis straightforward. When distinguishing reactive lymphocytes from leukemic blasts or the leukemic phase of a lymphoma is difficult, flow cytometry can provide invaluable help in defining the phenotype and clonality of circulating cells.

Neutrophilic Leukocytosis

The presence of CML is strongly considered in a patient with neutrophilic leukocytosis, particularly when the WBC count is greater than 50.0×10^9 /L and is accompanied by an increase in circulating immature myeloid cells and basophilia. Additional findings suggesting the diagnosis of CML include (a) symptoms of fatigue, bone pain, left upper quadrant pain, or fullness; (b) sternal tenderness and splenomegaly on physical examination; and (c) thrombocytosis. A leukemoid reaction must also be considered and can be caused by either benign, particularly infectious, or malignant conditions. Interphase FISH studies on peripheral blood for the BCR/ABL1 translocation can establish the diagnosis of CML, obviating the need for bone marrow examination; but many recommend an initial bone marrow to screen for other cytogenetic abnormalities that could affect prognosis.

Chronic idiopathic neutrophilia is defined by leukocytosis of 11.0 to 40.0×10^9 /L and is associated with smoking and obesity.²³ Familial neutrophilia (WBC $> 20.0 \times 10^9$ /L) is a rare autosomal dominant disorder which is caused by a mutation in the granulocyte colony-stimulating factor (G-CSF) receptor.²⁴ A transient myeloproliferative disorder is seen in up to 10% of children

with Down syndrome.²⁵ Neonates with persistent leukocytosis, delayed separation of the umbilical stump, and recurrent infections should be screened for leukocyte adhesion deficiency (LAD) (see section "Recurrent Infections").

Monocytosis

Monocytosis ($> 1.0 \times 10^9/L$) is commonly caused by infections, including granulomatous disease (tuberculosis [TB], fungal disease), brucellosis, infectious mononucleosis, syphilis, protozoal infections (kala-azar, malaria) and rickettsial infections. Monocytosis may be prominent in chronic myelomonocytic leukemia (CMML), juvenile myelomonocytic leukemia, or AMLs with a monocytic component.²⁶ These neoplastic monocytic proliferations cannot be distinguished on peripheral blood evaluation alone and a bone marrow examination is necessary to separate CMML from AML. Autoimmune disease, inflammatory bowel disease, and sarcoidosis may be associated with monocytosis. Monocytosis has been associated with carcinomas (lung, colorectal, renal) and has been caused by secretion of interleukin (IL)-6 by the neoplastic cells.²⁷

Eosinophilia

Unexpected eosinophilia is most commonly seen in patients with atopy or reactions to drugs or environmental allergens.²⁸ Autochthonous parasitic disease as a cause of eosinophilia is rare in the United States, but visceral larva migrans caused by *Toxocara canis* or *cati* can be seen. In international travelers and immigrants, evaluations for tissue invasive parasites is warranted. In patients who are immunosuppressed (particularly organ transplant recipients and patients on high-dose steroids for autoimmune diseases) strongyloides should be excluded.

Persistently high eosinophilia ($> 1.5 \times 10^9/L$ for > 6 months) carries significant risk for end organ damage and requires thorough investigation. A minority of these patients have elevated IL-5 levels with circulating clonal T-cell populations with aberrant phenotypes by flow cytometry.²⁹ Several neoplastic eosinophil proliferations are now recognized (see Chapter 84), including a group with a cryptic translocation involving FIP1LI-PDGFR α .^{30, 31} The latter patients can respond to imatinib therapy, while other genetic subtypes do not.

Increased Circulating Plasma Cells

Patients with plasma cell (multiple) myeloma usually have a few plasma cells in the blood, although occasionally large numbers are noted (plasma cell leukemia). Such patients almost invariably have other symptoms and signs of myeloma. A few plasma cells may also be observed in blood smears of patients with infectious mononucleosis or other viral infections. Plasma cells also are seen in the blood of persons recovering from bacterial infections or having allergic reactions, especially serum sickness. The first step when the diagnosis of myeloma is considered is to perform studies of serum and urine immunoglobulins. The technique of immunoelectrophoresis has been replaced by electrophoresis with immunofixation. This sensitive and specific technique identifies a monoclonal serum Ig and/or light chain in urine in more than 5% of patients with myeloma. The diagnosis is confirmed on bone marrow examination.

Neutropenia

Neutropenia may be mild ($ANC < 1.5$ but $> 1.0 \times 10^9/L$), moderate ($ANC < 1.0$ but $> 0.5 \times 10^9/L$), or severe ($ANC < 0.5 \times 10^9/L$).³² There can be ethnic variation, as exemplified by a prevalence of neutropenia of 4.5% among African-Americans in the United States compared to 0.79% and 0.38% in whites and Mexican-Americans, respectively.³³ While infections and drugs are the leading causes of neutropenia, nutritional deficiencies (B_{12} , folate, copper) should be ruled out early because of their responsiveness to replacement therapy. Alcohol abuse may present with isolated neutropenia, but is usually accompanied by other features of alcohol or nutritional marrow injury (macrocytosis, ringed sideroblasts). Immune-mediated neutropenia can be primary without an etiology or secondary to drugs, particularly β -lactam antibiotics and antithyroid medications; and autoimmune disease, including SLE, rheumatoid arthritis, and Graves' disease.^{34, 35, 36} Late-onset neutropenia following rituximab therapy has been reported in 5% to 27% of lymphoma patients.³⁷

Chronic idiopathic neutropenia (CIN) is a diagnosis of exclusion, rarely has increased infections, and is due to increased inflammatory changes within the bone marrow microenvironment. CIN is associated with activated T cells and increased levels of interferon γ (IFN- γ), tumor necrosis factor α , Fas-ligand, and transforming growth factor $\beta 1$, which suppresses IL-10, an antiinflammatory cytokine, and promotes apoptosis of neutrophil progenitor cells.³⁸

Hematologists should be familiar with congenital neutropenias, particularly cyclic neutropenia and severe congenital neutropenia (Kostmann syndrome), because the former can be mild and not be recognized until adulthood and the latter, which is supported by G-CSF, can evolve into leukemia in one-fifth of patients.³⁹ Mutations in the neutrophil elastase gene (ELA2) account for 60% of cases of severe congenital neutropenia, either in autosomal dominant or sporadic forms, while mutations in the HS-1-associated protein X (HAX1) gene are found in 30% of cases and are autosomal recessive.⁴⁰

Bone marrow aspiration and biopsy are usually reserved for neutropenia patients where there is an index of suspicion of malignancy usually due to immature cells in the differential; physical clues, such as adenopathy or splenomegaly; and/or other hematologic and laboratory abnormalities. MDS rarely presents as an isolated neutropenia and usually will have accompanying dysplastic abnormalities in more than one cell line. Patients with two indolent leukemias, hairy cell leukemia and large granular lymphocyte (LGL) leukemia, often present with bacterial infections secondary to neutropenia. Circulating hairy cell cases may be few in number, but a bone marrow examination with flow cytometry is usually diagnostic. LGL leukemia can be either T-cell (85% to 90%) or NK-cell (10% to 15%) in origin, is suspected when there are LGLs in the peripheral blood smear, and can be diagnosed by flow cytometry.⁴¹ Molecular genetic studies of the T-cell receptor gene can be confirmatory of clonality in T-LGL.⁴²

Lymphopenia

Lymphopenia is defined as an absolute lymphocyte count $< 1.5 \times 10^9/L$ in adults and $< 2.0 \times 10^9/L$ in children. Since 70% to 80% of circulating lymphocytes are T cells (most of which are CD4 T cells), severe lymphopenia implies T-cell deficiency and warrants serologic investigation for HIV infection. In infants with infection, the possibility of severe combined immunodeficiency (SCID) or DiGeorge syndrome is suggested. Lymphopenia is common in systemic autoimmune diseases like lupus and sarcoidosis and in serious illness/infections associated with hypercortisolism.

A variety of viral infections including influenza and measles may produce transient lymphopenia in association with loss of skin test reactivity and transient susceptibility to reactivation of TB.⁴³ One rare but noteworthy population with persistent lymphopenia is HIV-negative patients with CD4 T-cell counts less than $0.3 \times 10^9/L$. These patients fall into two categories, those susceptible to infection (who usually have low CD4/CD8 ratios) and those who have no increased susceptibility for infection with normal CD4/CD8 ratios.⁴⁴

P.1266

Peripheral Blood Findings in Infection

Blood leukocyte changes that are secondary to a variety of diseases usually consist of neutrophilia, eosinophilia, monocytosis, or abnormal-appearing lymphocytes. Changes in the distribution or appearance of circulating WBCs may provide important clues to the presence and type of an underlying infection. Eosinophilia is common in atopic individuals but can be seen in many parasitic infections. Atypical lymphocytosis is a helpful diagnostic clue in viral infections, particularly EBV infection. In many parasitic diseases, such as malaria, acute Chagas disease, and filariasis, the infectious agent may be demonstrated on peripheral blood smears. However, these three parasitic diseases are rarely autochthonous in North America, and the diagnosis is suggested by the nationality as well as the recent travel history of the patient.^{45, 46, 47}

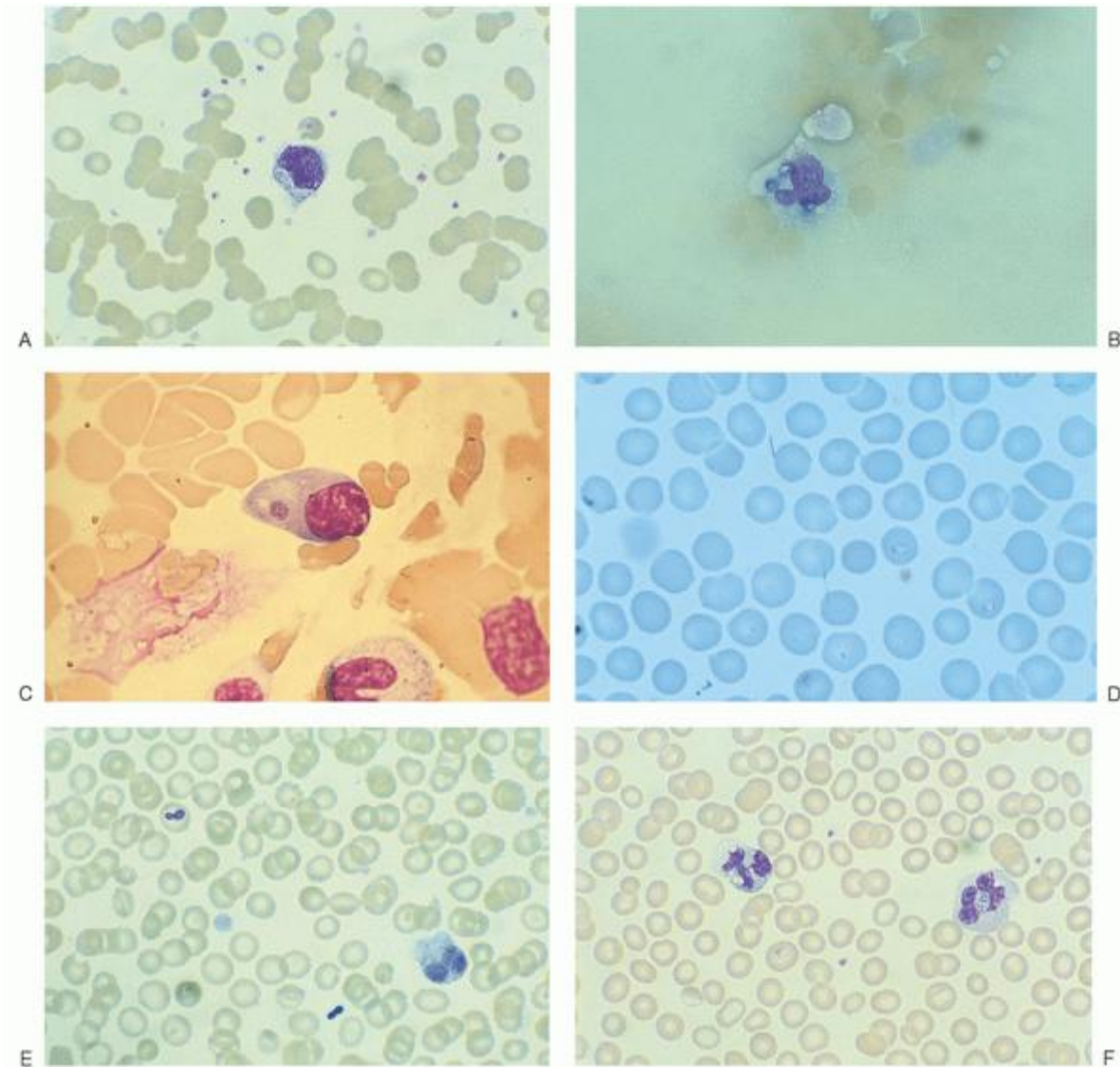

FIGURE 56.5. Wright-stained peripheral blood smears demonstrating (A) *Mycobacteria avium-intracellulare* as negative staining rods in a monocyte from patient with human immunodeficiency virus infection, (B) *Histoplasma capsulatum* with three intracellular yeast forms in a monocyte at the feather edge of smear in patient with acquired immunodeficiency syndrome, (C) *Ehrlichia chaffeensis* as a single basophilic cytoplasmic inclusion (photomicrograph courtesy of Dr. Charles Coleman, University of Missouri), (D) *Babesia* as single intracellular ring forms in two erythrocytes, (E) *Malassezia furfur* as extracellular budding yeasts (one of which is overlying an erythrocyte) in an infant on total parenteral alimentation, and (F) intracellular bacteria in a neutrophil with an adjacent vacuolated neutrophil in a patient with septicemia.

Although in most infections the causative agents are not demonstrable in peripheral blood, there are certain notable exceptions. In acquired immunodeficiency syndrome (AIDS) patients or in other severely immunocompromised patients, mycobacteria (Fig. 56.5A), fungi, such as histoplasmosis (Fig. 56.5B), or *Candida* may occasionally be identified on the peripheral blood smear. Residents of the central United States (particularly Arkansas and Missouri) and the Southeast may acquire ehrlichiosis through tick vectors. Anaplasmosis, formerly called human granulocytic

P.1267

ehrlichiosis, is a closely related tickborne disease found more often in the Northeast and upper Midwest. The typical inclusions in mononuclear cells (*Ehrlichia chaffeensis*) (Fig. 56.5C) or in neutrophils (*Anaplasma phagocytophilum*) are present in up to one-third of these patients, who often present with unexplained fever with accompanying leukopenia and elevated transaminases. The diagnosis of ehrlichiosis/anaplasmosis may be confirmed either serologically or by PCR methods.⁴⁸ Babesiosis, first recognized in the 1890s as the cause of Texas cattle fever, has now been identified in febrile

patients in the Northeast (Nantucket, Martha's Vineyard, Connecticut), Wisconsin, and on the West Coast. Infections can be life threatening in splenectomized patients. The diagnosis is suggested by finding single ring forms (1.0 to 3.5 μm in diameter) in red blood cells (Fig. 56.5D) (characteristic tetrads are usually seen only in infected animals).⁴⁹ In nonimmunocompromised patients with indwelling venous catheters, *Malassezia furfur* (Fig. 56.5E), *Candida*, and *Torulopsis* (*C. glabrata*) may be identified in the peripheral blood.^{50, 51} In bacterial sepsis, visible circulating bacteria are rare, but the presence of cytoplasmic neutrophilic vacuoles in a fresh finger stick blood smear is a specific clue to the diagnosis of septicemia⁵² (Fig. 56.5F). Toxic granulation (also seen in patients with sepsis) is often quite prominent in uninfected patients receiving granulocyte or granulocyte/macrophage colony-stimulating factor.

EXAMINATION OF THE BONE MARROW

If a diagnosis is not established by examining the blood, bone marrow examination may be helpful (Table 56.5). Needle biopsy is usually performed in addition to aspiration, particularly if lymphoma, carcinoma, granulomatous conditions, or myelofibrosis are under consideration. To adequately triage marrow, the stained aspirate smear is reviewed along with the clinical information and any previous studies shortly after the procedure. This allows rapid decisions about cytogenetics (including FISH), molecular genetics, and flow cytometry to be made when viable cells are still available and also limits inappropriate studies (Table 56.6). In the case of inaspirable marrows, touch preparations should be made for morphologic assessment, and sufficient cells for flow cytometry may be obtained by maintaining negative pressure on withdrawal of the biopsy or aspirate needle and then rinsing the needle in nutrient media or buffered saline. In some cases, a second, fresh core biopsy can be minced and processed for flow cytometry and cytogenetic studies.

In cases of acute leukemia, the first question is whether it is lymphoid or nonlymphoid. Identification of Auer rods on Wright-stained aspirate smears is specific for a myeloid leukemia; however, Auer rods are found only in a minority of cases. Morphology is very important in the early identification of myeloid leukemias with promyelocytic differentiation, which can be sent for confirmatory FISH studies for the 15;17 translocation and can be completed in less than 24 hours. Flow cytometry is now a standard part of the diagnosis of many hematologic diseases, including all acute leukemias (Table 56.1), and for detecting minimal residual disease post therapy.^{53, 54, 55, 56, 57} Most cases (> 95%) can be classified as to lineage in less than 2 hours during the normal working hours of the laboratory. Flow cytometry is helpful in suggesting possible promyelocytic differentiation (DR^- , $\text{CD}2^+$, bright myeloperoxidase), megakaryoblastic differentiation ($\text{CD}61^+$, $\text{CD}41^+$, myeloperoxidase $^-$), or the t(8;21)(q22;q22) ($\text{CD}19^+$, $\text{CD}34^+$, myeloid antigen $^+$), but is not as useful in identifying other subsets in the French-American-British Cooperative Group (FAB) or World Health Organization classification. Cytochemical stains which were essential for FAB classification are now being performed infrequently and are now used most commonly when flow cytometry findings are ambiguous, especially in the case of possible mixed phenotype acute leukemia. Immunohistochemistry on the bone marrow core biopsy is helpful for lesions that may not be present in aspirated material, such as fibrosed areas of lymphoma or metastatic tumors. In some cases, both flow cytometry immunophenotyping and immunohistochemistry are required due to sampling differences between the aspirate and biopsy. Some cytoplasmic markers, such as BCL2 and cyclin D1, are only available by immunohistochemistry in most laboratories.

TABLE 56.5 INDICATIONS FOR BONE MARROW EXAMINATION

Unexplained cytopenia
Evaluation of leukemia
Confirmation of myeloproliferative neoplasm
Unexplained lymphadenopathy
Splenomegaly without a diagnosis
Diagnosis or staging of lymphoid neoplasms
Constitutional symptoms (fever, weight loss) without a diagnosis
Bone pain with abnormal laboratory work (e.g., complete blood cell count, \uparrow protein, \uparrow lactate dehydrogenase, and \uparrow uric acid)

TABLE 56.6 SUSPECTED DIAGNOSIS ON MARROW SMEAR

Suspected Diagnosis	Flow Cytometry Cytogenetics/FISH
---------------------	----------------------------------

Acute leukemia		+	+
Suspected myelodysplasia		<i>a</i>	+
Myeloproliferative neoplasm (particularly chronic myelogenous leukemia)		<i>b</i>	+
Lymphocytosis (predominantly small cells)	Child	No	No
	Adult	+	<i>c</i>
Suspected non-Hodgkin lymphoma with large cells		+	+
Plasma cell myeloma	<i>d</i>	+	

FISH, fluorescence in situ hybridization.

^a Evolving application but not well established in many centers

^b Helpful only in blast crisis

^c If flow cytometry shows an aberrant T-cell or monotypic B-cell population

^d Flow cytometry underestimates the percentage of plasma cells in bone marrow which is better assessed by immunohistochemistry on tissue sections

FISH and cytogenetics are playing an expanded role in the classification of hematologic neoplasia and the identification of prognostically favorable and unfavorable subsets of disease.^{54, 58, 59, 60, 61} Favorable cytogenetics in AML include t(15;17)(q24.1;q21.1) (PML/RARA) of APL, t(8;21)(q22;q22) (RUNX1-RUNX1T1), and inv(16) (p13.1q22) or t(16;16)(p13.1;q22) (CBFB/MYH11); these identify patients who are predominantly treated with either all-transretinoic acid plus chemotherapy (APL) or chemotherapy alone without early transplantation. Hyperdiploidy (more than 50 chromosomes per leukemia cell) and t(12;21)(p13;q22) (ETV6-RUNX1) are found in approximately 50% of childhood acute lymphoblastic leukemia (ALL) and confer a favorable prognosis.⁶² Hypodiploidy (less than 45 chromosomes per leukemia cell), t(4;11)(q21.3;q23) (AFF4-MLL), and t(9;22)(q34;q11.2) (BCR-ABL1) are associated with a poor prognosis in ALL.

In suspected MDS, FISH and cytogenetic studies are helpful when morphologic abnormalities in hematopoietic cells are P.1268

relatively subtle.^{63, 64} Identifying 5q31 deletion in MDS is important because the patients may respond to lenalidomide.⁶⁵ Patients with abnormalities of chromosome 7 and/or complex cytogenetics are more likely to evolve to AML and should be considered for early allogeneic transplantation. Flow cytometric evaluation of MDS is an evolving application which holds great promise, although it is not well standardized in this application and thus not available at many institutions.⁶⁶ Flow cytometry is of no help in the evaluation of myeloproliferative neoplasms except when the presence of increased blasts on marrow smear point to an evolving acute leukemia/blast transformation.⁵³

Molecular genetics can identify clonality in lymphoid neoplasms, confirm diagnoses in CML and subtypes of acute leukemia, and monitor minimal residual disease when a molecular marker is present (Table 56.3). NPM1 and CEBPA mutations, when present alone, are favorable mutations in AML while FLT3 and DNMT3 mutations are usually unfavorable. In the core binding factor leukemias (AML with t[8;21][q22;q22][RUNX1-RUNX1T1] and AML with inv[16][p13.1q22] or t[16;16][p13.1;q22][CBFB/MYH11]), mutations of KIT are usually unfavorable. JAK2 mutations are present in most patients with PV and over one-half of patients with PMF and ET.^{15, 17} Genomic profiles are being evaluated in hematopoietic neoplasms and can discriminate prognostic subgroups. Restriction fragment length polymorphisms and chimerism studies identifying percentage of donor myeloid and lymphoid cells are employed to monitor engraftments in allogeneic transplantation.

Lymphocytosis on a marrow smear is common in very young children. Phenotypically, the lymphocytes are usually B cells in all stages of differentiation (so-called hematogones). In such cases, the numbers and morphology of the myeloid, megakaryocytic, and erythroid cell lines are usually normal, which is helpful in differentiating these non-neoplastic

precursor B cells from the blasts of the pre-B ALL.⁶⁷ Lymphocytosis on marrow smear in an older adult should always have phenotypic studies by flow cytometry. Further cytogenetic/FISH studies are helpful in small B-cell lymphomas with ambiguous phenotypes or in confirmation of the diagnosis of mantle cell lymphoma (by FISH).⁶⁸ In unusual proliferations, cells from the bone marrow aspiration should be frozen for possible future studies.

Bone marrow examination should also be considered in patients who complain of bone pain whether or not bone lesions have been demonstrated radiographically and particularly if there is an abnormal CBC or abnormal chemistries, such as an elevated lactate dehydrogenase (LDH), total protein, or uric acid. Some processes, including myeloma, lymphoma, carcinoma, neuroblastoma, and granulomatous infections, may be quite focal and missed on marrow examination. Occasionally, radionuclide scans with gallium-67 or indium,¹¹¹ CT, magnetic resonance imaging (MRI), and/or positron emission tomography (PET) scans may be helpful in localizing various types of tumors and identifying specific marrow sites for biopsy.^{69, 70, 71, 72, 73} Again, serum and urine electrophoresis, with immunofixation (which allows detection of monoclonal immunoglobulins hiding in the beta region) should be performed on adults with bone pain. Screening tests for neuroblastoma, including urine catecholamines, should be performed in children with bone pain and a nondiagnostic marrow examination.

EXAMINATION OF LYMPH NODES AND TISSUES

This section is concerned with the evaluation of the patient with palpable or visible enlargement of cervical, supraclavicular, axillary, inguinal, mediastinal, or hilar lymph nodes or tonsils. If the blood and marrow (when indicated, as discussed in the previous sections) fail to provide a diagnosis, the clinician should consider a fine-needle aspiration (FNA) or biopsy of enlarged lymphoid tissue. The presence of a variety of signs and symptoms may modify and shorten the diagnostic evaluation. For example, if the patient is ill with B symptoms or the clinical picture is fairly typical of a lymphoma, lymph node biopsy or aspiration should be performed immediately.

The causes of enlargement of lymph nodes are extremely varied. Table 56.7 outlines the major categories of disease leading to lymphadenopathy. This table is in no sense exhaustive. The approach to lymphadenopathy is similar to that of FUO, with the most common broad diagnoses being infection, cancer, and immune disorders. The first step is determining whether adenopathy is localized or generalized, and this differentiation points to a local disease versus systemic illness.

The most common cause of lymphoid enlargement is lymphocyte proliferation in response to antigenic stimulation.

P.1269

The frequency of trichophyton infection of toes and trauma to feet and legs is reflected in the frequency of palpable inguinal nodes (usually smaller than 1 cm in diameter). If the patient's occupation or hobby leads to frequent trauma of hands and arms, small palpable epitrochlear and axillary nodes are expected. Thus, the assessment of the lymphoid system in a laborer differs somewhat from that of an educator (unless the latter's hobby is gardening or hunting).

TABLE 56.7 CONDITIONS LEADING TO LYMPH NODE ENLARGEMENT

Lymphadenopathy Primarily Related to Immune Response from Infections

Viral infections

Local or generalized lymphadenopathy with systemic infections (e.g., infectious mononucleosis (cervical), rubella (occipital), infectious hepatitis, and acquired immunodeficiency syndrome)

Pyogenic infections

Local enlargement of nodes draining areas of local infection (e.g., furuncles caused by staphylococci and oral infection)

Local enlargement of nodes draining the portal of entry of infections such as cat scratch fever, cryptococcosis, lymphogranuloma venereum, primary chancre of syphilis, and tularemia

Generalized lymphadenopathy from (e.g., *Salmonella* septicemia bacterial endocarditis, secondary syphilis, and toxoplasmosis)

Lymphadenopathy primarily from infection of the node by organisms

Pyogenic infection: the classic example is the bubo of *Pasteurella pestis*; more commonly, abscess

formation by staphylococcal invasion

Granuloma formation: the entrance of tubercle bacilli or fungi, such as *Histoplasma capsulatum*, into nodes often results in granuloma formation as well as hypertrophy; identifiable organisms can be present within the granuloma.

Neoplasia

Primary neoplastic diseases of nodes: non-Hodgkin and Hodgkin lymphomas

Metastatic neoplastic processes occurring in nodes

Lymphoid leukemias: acute lymphoblastic leukemia and chronic lymphocytic leukemia

Myeloid leukemias: acute myeloid leukemia (granulocytic sarcoma) and chronic myelogenous leukemia

Primary myelofibrosis with extramedullary hematopoiesis, producing lymph node enlargement

Metastases from carcinoma, producing lymph node enlargement

Autoimmune Diseases (e.g., systemic lupus erythematosus, rheumatoid arthritis, Sjögren syndrome, and Hashimoto thyroiditis)

Reaction to Drugs, such as the Hydantoins

Dermatopathic Related to Skin Diseases

Miscellaneous Diseases

Granuloma formation as seen with sarcoid or in patients exposed to beryllium

Reactive hyperplasia, as seen in hyperthyroidism

Progressive transformation of germinal centers

Kikuchi-Fujimoto disease (histiocytic necrotizing lymphadenitis)

Kawasaki disease

Castleman disease

Histiocytic disorders

Langerhans cell histiocytosis

Erdheim Chester disease

Rosai Dorfman disease

Children and adolescents commonly have more palpable nodes than do adults.⁷⁴ This difference is presumed to reflect their more frequent exposure to new antigens and a larger total lymphoid mass in relation to body weight as compared to adults. Thus, significant generalized adenopathy has a more liberal definition in the young than in adults. Prominently visible tonsils, protruding into the oropharynx, are expected in preschool children but are uncommon in adults.

Retroperitoneal lymphadenopathy must be extreme before an abdominal mass becomes palpable. CT scan and lymphangiography (LG) provide complementary information concerning the status of retroperitoneal lymph nodes, although LG is no longer used.⁷⁵ Abdominal CT scan provides images of nodal areas that usually are not visualized with LG, such as pararectal, omental, and superior retroperitoneal areas, and the hilus of the spleen and liver. Other imaging techniques, such as PET scan, gallium scan, and radiolabeled monoclonal antibody scans, may further delineate worrisome lymph nodes.

Improvements in imaging and clinical dependence upon imaging has led to its increased use and contributed to the rising cost of health care.⁷⁶ Additionally, imaging techniques are so sensitive that incidental findings of uncertain clinical significance such as chest, adrenal, or renal masses may require additional evaluation, which further contributes to the expense.⁷⁷ In conjunction with CT scans, PET scans are used to assess extent of disease and response to therapy in HL and many types of non-Hodgkin lymphoma (NHL).⁷⁸

Experience with many patients is the best guide in the selection and timing of lymph node biopsies or FNA. If doubt exists as to whether enlargement is significant, the choice between immediate biopsy or periodic observation to discover whether the nodes will enlarge or shrink should be made on the basis of ancillary findings. If other signs and/or symptoms are suggestive of lymphoma, biopsy of small, questionably enlarged nodes may yield a diagnosis. Biopsy should be performed after no more than 1 or 2 months of observation if the physician is still suspicious that the nodes are abnormal. Again, however, the physician's suspicion must be tempered by experience. Persistently enlarged lymph nodes considered abnormal in an adult may be well within the limits of normal in a child or adolescent patient.

There is no absolute size which can be used to determine the presence of pathology. Age of the patient, history, location, and physical evaluation assist in making a decision about biopsy. A size of 1.5 cm was used as a discrimination measurement in a study of 220 lymph node biopsies.⁷⁹ Others have suggested that a persistent lymph node of 10 mm or more except in the inguinal region is a reasonable guideline. A multifactorial, retrospective analysis involving 22 clinical findings was made of 123 patients, ages 9 to 25 years, in whom results of lymph node biopsies were known.⁸⁰ Only three variables proved to have significant discriminatory function; nodes larger than 2 cm in diameter on physical examination and abnormal findings on chest radiographs favored the diagnosis of a disorder necessitating treatment, whereas a history of recent symptoms related to otolaryngologic disease in the presence of enlarged cervical nodes was strong evidence against the presence of a disease requiring therapy.

Certain physical characteristics of nodes aid in the diagnosis of the cause of lymphadenopathy. Infected nodes usually are tender, and the overlying skin often is inflamed. Such nodes may be matted together. In certain types of infection, such as TB, aspergillosis, or actinomycosis, sinus tract formation is common. Infected nodes may be fluctuant. Nodes undergoing an immune response to infection also may be tender, but other signs of inflammation usually are absent. Tenderness may be related to other conditions, but this is uncommon. Carcinomatous nodes usually are hard and may be bound to one another and to surrounding tissue. Lymphomatous nodes are more often firm, rubbery, discrete, and freely movable; occasionally, anaplastic large cell lymphoma has a significant inflammatory component.

The location of the nodes may be helpful in diagnosis, and, again, the age and immunocompetence of the patient are critical factors in determining the approach. Axillary and inguinal adenopathy are often enlarged because of trauma or infection distally. Cervical lymphadenopathy is often due to localized infection but also can represent metastatic disease from the head and neck. Posterior occipital lymphadenopathy is classically seen in rubella (also toxoplasmosis) usually in conjunction with a maculopapular rash. Supraclavicular lymphadenopathy more often represents distant metastases or contiguous spread from the mediastinum. Isolated mediastinal adenopathy in a young person is usually HL. Large, bilateral hilar nodes without other detectable adenopathy are unusual in lymphomas and are more suggestive of sarcoidosis.

Infections may be either localized or generalized as the cause of lymphadenopathy. The most common forms of localized infections with cervical lymphadenopathy are pharyngitis and tonsillitis due to viral, mycoplasmal, and pyogenic infections (*Streptococcus*, *Staphylococcus aureus*, and *S. epidermidis*).⁸¹ Although the above usually cause bilateral adenopathy, unilateral adenopathy occurs with tonsillar abscesses, salivary adenitis, and dental abscesses.⁸² Systemic infections that may present with localized adenopathy include cat scratch disease, Lyme disease, tularemia, toxoplasmosis, and bubonic plague, but these patients usually have constitutional symptoms and may give a history of animal or tick exposure, or have a characteristic rash (e.g., Lyme disease). TB involving the cervical lymph nodes (scrofula) is one of the more common presentations of extrapulmonary TB.⁸³ Adenopathy in HIV patients tends to be generalized and painless and can be due to HIV alone or other infections (e.g., atypical mycobacteria, toxoplasmosis, syphilis) or lymphoma.

Immunologic disorders may present with adenopathy as a prominent clinical feature. Kikuchi-Fujimoto disease (histiocytic necrotizing lymphadenitis) is a self-limiting illness characterized by cervical adenopathy and systemic symptoms; excisional biopsy is often performed to rule out neoplasia.^{84, 85} Kawasaki disease is a multisystem vasculitis of infants and children usually with mucocutaneous lesions and cervical adenopathy; therapy with intravenous gammaglobulin and aspirin can prevent or ameliorate coronary artery abnormalities.^{86, 87} Patients with SLE and rheumatoid arthritis may develop adenopathy but usually have characteristic clinical features and serology. Early lymph node biopsy should be considered in patients at increased risk for developing lymphoma such as those with an underlying autoimmune disorder (e.g., Sjögren syndrome and rheumatoid arthritis treated with methotrexate) or immunodeficiency (e.g., HIV infection and posttransplant). Drugs, such as phenytoin, allopurinol, and cephalosporins, can be associated with diffuse adenopathy that may regress with discontinuation of the drug.

In the event of a strong presumption of malignancy (particularly metastatic carcinoma or in patients with a previous diagnosis of lymphoma), or in lymphadenopathy in areas difficult to biopsy (retroperitoneum), needle biopsy or aspiration is becoming the primary procedure for diagnosis^{88, 89} (Table 56.8). The procedure for lymph node aspiration is simple and can produce diagnostic information in the time it takes to stain and examine the smears. In addition the use of cultures,

flow cytometry, and cytogenetic studies on aspirated material greatly amplify the quality of diagnostic information and its availability.⁹⁰ This approach requires a two-step triage: 1) rapid examination of the smear to determine

P.1270

if flow cytometry is warranted; 2) if flow shows evidence for a neoplasm, deciding whether or which cytogenetic/FISH/molecular genetic studies are indicated. However, the frequency of indeterminate or incorrect diagnosis is higher with needle biopsy aspiration than with excisional biopsy, as the histologic diagnosis often depends on changes in the overall architecture of the lymph node in addition to the cytology of individual cells.⁹¹ Excisional biopsy yields more tissue for diagnostic studies, facilitating preparation of multiple histologic sections for routine and special stains as well as providing more adequate material for cultures and immunophenotypic and genetic studies. Therefore, when appropriate, excisional lymph node biopsy is preferred over FNA or core biopsy for complete diagnostic evaluation.

TABLE 56.8 APPLICATION OF FINE-NEEDLE ASPIRATION OF LYMPH NODES AND EXTRANODAL MASSES

Established^a	Limitations
Diagnosis of relapse in lymphoma	Primary diagnosis of lymphoma ^a
Diagnosis of nonhematologic malignancies	Specific diagnoses of reactive processes
Presumptive diagnosis of reactive processes	
Primary diagnosis of many nonhematologic malignancies and metastases	

^aMost of these require flow cytometry as an adjunct. In processes which are focally neoplastic or tumor cells are in minority (Hodgkin and T-cell-rich B-cell lymphoma), a missed diagnosis is possible.

For excisional biopsy or FNA, the largest palpable node available is given preference. More than one node should be removed, if possible, avoiding irradiated areas. When other considerations are equal, biopsy of cervical or supraclavicular nodes is preferable to biopsy of axillary nodes, and biopsy of nodes from any of these regions is preferable to that of inguinal nodes. As previously mentioned, inguinal nodes frequently are enlarged from chronic foot infection, in which case the architecture often is distorted. Axillary nodes, unless enlarged, may be difficult to find during surgical procedures because of the complex and changed anatomy during exposure of this area.

TABLE 56.9 GUIDELINES FOR EVALUATION OF LYMPH NODE BIOPSIES/FINE-NEEDLE ASPIRATION

Tests to Consider	Touch Prep Cytology				
	Small Lymphocytes	Small Lymphocytes and Large Lymphocytes (No Atypical Large Cells)	Mixed Small Lymphocytes and Large Lymphocytes	Mixed Small and Large Lymphocytes (A Few Large Atypical Cells)	Frequent Large Lymphocytes or Blasts
Age of patient	Child or young adult	Adult	Child or young adult	Adult	Child or adult
Flow cytometry	No	Yes ^a		Yes ^b	Yes
Cytogenetics/molecular genetics/FISH	No	^c	^d	^d	^d Yes

FISH, fluorescence in situ hybridization.

^aIf clinical features are highly suggestive of non-Hodgkin lymphoma or tissue is from a site difficult to sample (e.g., mediastinum or retroperitoneum) a limited panel for B-cell clonality and T-cell

distribution may be helpful.

^b If clinical features and gross appearance are typical for Hodgkin lymphoma, flow cytometry and genetic studies are unlikely to be helpful.

^c If flow cytometry suggests a neoplastic process.

^d Usually not helpful except if screening flow cytometric studies demonstrate an abnormal B- or T-cell population.

In the “good old days” when most diagnoses of disease involving marrow or lymph nodes were made (or not made) based solely on the morphology of smears and tissue sections, coordination of the efforts of the clinician, surgeon, and pathologist was less important and much less complex. Today, with a bewildering array of morphologic, cytochemical, immunologic, molecular genetic, and cytogenetic techniques available (and essential for many diagnoses), the clinician, surgeon, and pathologist must work closely together to optimize the diagnostic information of any biopsy while, at the same time, limiting expense. The major pitfall in these efforts is improper specimen handling, precluding the use of important techniques available only in fresh tissue (i.e., cultures for pathogens, cytogenetics, and flow cytometry for surface markers).

The process of evaluation begins before the procedure. The studies that are done are guided by clinical information and a review of previous biopsy material. At the time of biopsy or needle aspiration, the studies available within minutes of the procedure (i.e., the Wright-stained marrow aspirate smear of bone marrow or the hematoxylin- and eosin-stained smear of a lymph node biopsy touch prep) are used to decide which diagnostic techniques will be applied to any given case. If the suspicion of infection is high, material for cultures is best obtained in the sterile environment of the operating room before sending it to pathology.

Table 56.9 includes guidelines for the diagnostic evaluation of tissue biopsies and aspirations based on clinical information and the aspirate smear/touch prep appearance. The most important clinical information is the likelihood that a process is (a) NHL, (b) HL, (c) a carcinoma, or (d) a reactive process. The clinical information, including the age of the patient along with the touch prep or smear appearance, often helps in determining whether flow cytometry or cytogenetics is needed (as in many cases of NHL or leukemia).

NHL would be uncommon in a child or young adult with a predominance of small lymphocytes on touch preps (Fig. 56.6A), but would more likely occur in an elderly patient. In a child or teenager, the major differential diagnosis would be between a reactive node or lymphocyte-predominant HL. In neither diagnosis would flow cytometry or cytogenetics be of much benefit. On the other hand, in an older patient in whom a small B-cell NHL is more likely, immunophenotyping is of great help in proving clonality and in identifying immunophenotypic patterns characteristic of subsets of NHL of therapeutic and prognostic significance (e.g., hairy cell leukemia and mantle cell lymphoma). The role of FISH

P.1271

and cytogenetic studies is assuming increasing importance in the diagnosis of small B-cell lymphomas, particularly follicular (t[14;18]) and mantle cell (t[11;14]) lymphoma, and is prognostically important in subsets of extranodal marginal zone lymphoma (e.g., t[11;18]).^{92, 93, 94, 95}

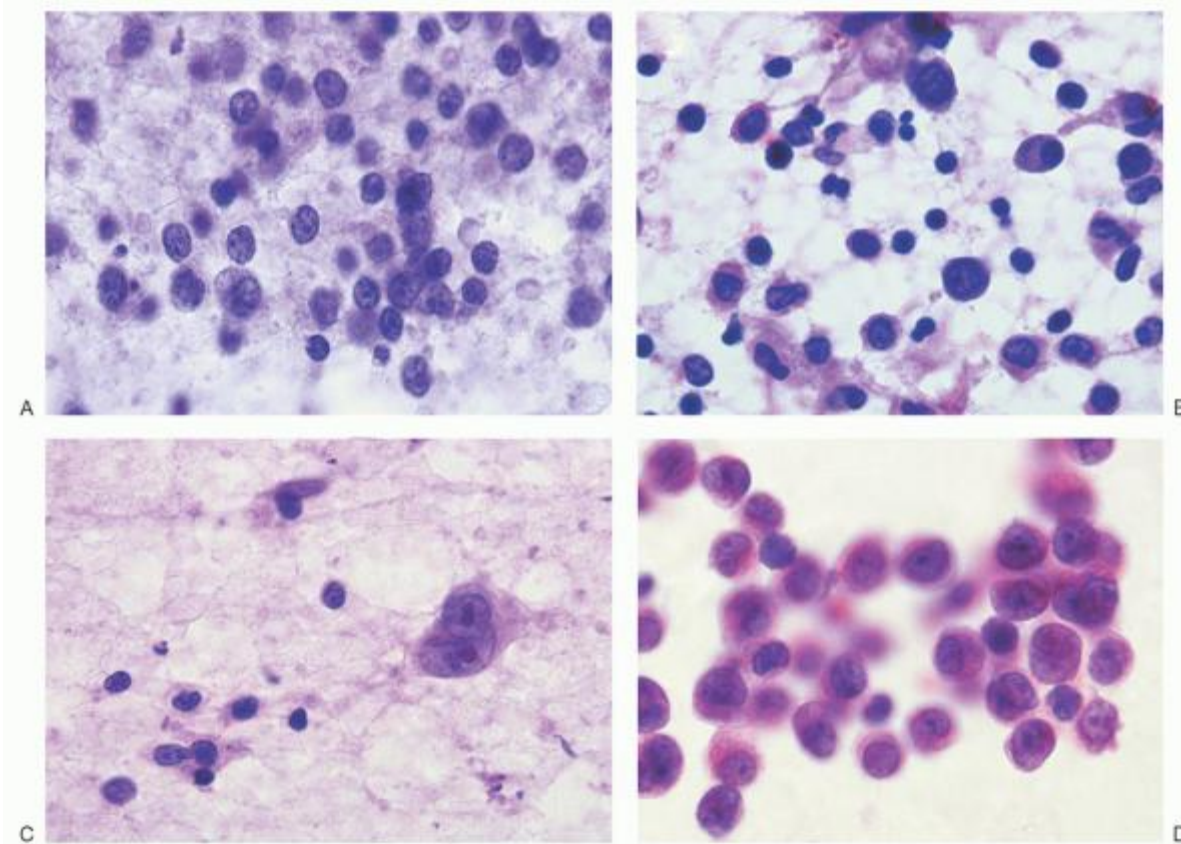

FIGURE 56.6. High power of hematoxylin eosin-stained touch preps of lymph node biopsies demonstrating (A) predominance of small lymphocytes in an adult with small lymphocytic lymphoma/chronic lymphocytic leukemia; (B) mixed pattern of small and large lymphocytes, macrophages, plasma cells, and neutrophils in a child with reactive adenitis; (C) mixed population of small and large lymphocytes with occasional large atypical cells in a patient with classical Hodgkin lymphoma; and (D) predominance of large lymphocytes (many with polylobate nuclei) in a patient with large B-cell lymphoma of the mediastinum.

In children and young adults with a touch prep showing a polymorphous mix of small and large lymphocytes and inflammatory cells (Fig. 56.6B), flow cytometry is not routinely performed. Most patients with this mixed pattern on touch preps will have a reactive process or HL (Fig. 56.6C); however, a few B-cell NHL and peripheral T-cell lymphomas may show such patterns. If the clinical likelihood of NHL is high, or in those patients with occasional large atypical cells who do not have clinical features of HL, a limited and inexpensive panel for B-cell clonality and T-cell antigen loss can be performed. If these studies demonstrate an abnormality either in the small or large cell population, then more expanded panels can be run. If the case is not typed and on permanent tissue sections appears to be NHL, immunophenotyping can be performed on paraffin sections and information about clonality (T and B) can be retrieved from frozen tissue or the paraffin-embedded tissue as needed.^{96, 97}

In patients with numerous large cells or blasts on a touch prep (Fig. 56.6D) typing studies (and in many, cytogenetics) are essential in identifying prognostically significant patient subgroups. For example, in patients with blast cells on touch prep, the differential diagnosis would be lymphoblastic lymphoma (both B and T), blastic transformation of mantle cell lymphoma, and extramedullary acute leukemia. Flow cytometry is quite useful in the differential diagnosis and can provide an answer in hours (well in advance of other cytogenetic or immunohistologic techniques) (Figs. 56.2 and 56.3). Tissue should also be placed in glutaraldehyde for electron microscopy in these cases, because poorly differentiated tumors, such as neuroblastoma or rhabdomyosarcoma, may mimic hematopoietic neoplasms on touch prep.

A histologic appearance of reactive hyperplasia or of nonspecific granulomatous changes does not rule out the possibility of HL or NHL at another site. For example, not all enlarged nodes from patients known to have HL show evidence of the disease⁹⁸; it is not surprising that the first biopsy may give negative findings in a patient in whom a second biopsy is diagnostic.^{99, 100} Similarly, analysis of surface antigens on cells from an initial biopsy that may not contain the tumor may indicate that the B-cell population is polyclonal when later specimens containing the tumor show a monoclonal

proliferation.¹⁰¹ Molecular studies may identify monoclonal lymphoid populations earlier than flow cytometry or routine immunoperoxidase stains in selected cases. In equivocal or difficult cases, particularly those in which there are discrepancies between the histologic diagnosis, the clinical picture, and the results of ancillary studies, consideration should be given to obtaining consultation in hematopathology.¹⁰² If more than one node is removed initially, the likelihood of positive findings is enhanced. In nondiagnostic biopsies, the decision to obtain more

P.1272

tissue for further study must be individualized. If no other nodes are enlarged and the patient has few or no symptoms, observation may be advisable. Prompt diagnosis and proper therapy are important in bacterial and fungal infections, HL, aggressive NHL, and acute leukemias, but are less important for the eventual outcome of the other conditions listed in Table 56.7.

EXAMINATION OF THE SPLEEN

Many of the conditions that lead to lymphadenopathy also produce a palpably enlarged spleen. Consequently, the preceding discussion regarding evaluation of the patient with lymphadenopathy is equally applicable to the patient with splenomegaly. When splenomegaly is associated with systemic infection (acute splenic tumor), the spleen usually is barely palpable, soft to firm, but not hard, and splenomegaly disappears shortly after recovery from the infection. A palpable spleen usually indicates disease, but a soft spleen tip can be palpated by an experienced physician in approximately 1% to 2% of apparently healthy persons.¹⁰³

Splenic puncture may be helpful in the evaluation of patients with certain conditions (e.g., leishmaniasis and kala-azar), but is rarely used in North America.^{104, 105} Diagnostic splenectomy is required in some patients, especially those in whom the only palpably enlarged tissue is the spleen. Before this procedure is considered, however, numerous other studies should be considered and may include CT scan, liver/spleen scan, and other imaging studies to outline splenic vein patency, as well as hepatic blood flow and any associated adenopathy. In many cases, results of these studies indicate the diagnosis. For instance, splenic hypertrophy owing to increased red cell destruction, such as occurs in hereditary spherocytosis and thalassemia, should be detected by means of appropriate blood and other examinations. Biopsy of enlarged nodes should always be carried out before splenectomy is undertaken. Examination of the marrow should also be considered. Liver function tests (LFTs) and needle biopsy of the liver also are warranted to exclude, among other considerations, the possibility that the splenomegaly results from hepatic disease, producing increased portal pressure.

Indications for splenectomy are discussed in Chapter 65 and elsewhere in relation to the various diseases associated with splenomegaly. If no explanation is found for splenomegaly, splenectomy should be considered to make or to exclude a diagnosis of lymphoma.

FEVER OF UNKNOWN ORIGIN

The classic definition of FUO proposed by Petersdorf and Beeson in 1961 is a temperature elevation of 38.3°C (101°F) or higher persisting over 3 weeks in duration and without a diagnosis after 1 week of intensive in-hospital investigation.¹⁰⁶ The definition of FUO has been modified due to the changing medical environment which required a shift to an initial outpatient evaluation. Durack and Street proposed the duration of evaluation for FUO be changed to only 3 days of hospitalization or at least 3 outpatient visits or 1 week of ambulatory investigation.¹⁰⁷ Because of changing medical practices and different types of patients with prolonged fever, FUO is currently subdivided according to four categories: (a) classic FUO, (b) nosocomial FUO, (c) immune-deficient FUO, and (d) HIV-related FUO. Host factors (e.g., age of the patient and immunocompetence) and environment (e.g., socioeconomic status and geographic location) are factors in the evaluation of FUO. Arnow and Flaherty have proposed a minimum number of tests to be performed prior to labeling a patient with FUO.¹⁰⁸

The “big three” categories of FUO remain infections, autoimmune or non-infectious inflammatory disease (NIID), and malignancies (Table 56.10), although the incidence of cancer has

P.1273

declined due to improved diagnostic techniques.¹⁰⁹ Miscellaneous diseases and undiagnosed conditions round out the main five categories of FUO. There are over 200 different causes of FUO, but most patients have common illnesses presenting with unusual manifestations.¹⁰⁶ In a systematic review of the literature for 1995 to 2004 which identified 1,488 cases of FUO, 74% of the patients were accurately diagnosed, with 37% due to infections, 16% due to NIID, 11% due to neoplasms and 10% due to miscellaneous diseases.¹¹⁰ In developing countries, infections, particularly TB, often represent

more than one-half the cases of FUO, whereas developed countries have a higher incidence of NIID and neoplasms.¹¹¹ Undiagnosed conditions and infections are more common in younger patients, whereas NIID, including temporal arteritis and polymyalgia rheumatica, and malignancies are more common in the elderly. Despite improved imaging and better culture techniques, the percentage of undiagnosed conditions has increased to the 25% to 50% range in recent series and is higher in children.^{112, 113}

TABLE 56.10 DISEASES CAUSING FEVER OF UNKNOWN ORIGIN

Malignancy

Common

Hodgkin lymphoma

Non-Hodgkin lymphoma

Hypernephroma

Metastatic carcinoma: liver, central nervous system

Uncommon/rare

Hepatomas

Pancreatic carcinoma

Acute leukemia/myelodysplastic syndrome

Atrial myxoma

Neuroblastoma

Central nervous system tumor

Infection

Common

Tuberculosis: extrapulmonary— renal, meningitis, miliary

Abscesses

Intraabdominal

Subdiaphragmatic (periappendiceal, pericolic, hepatic)

Pelvic

Uncommon

Abscesses: splenic, perinephric, dental, brain

Subacute bacterial endocarditis (if culture-negative, suspect rightsided endocarditis, intravenous drug abuse)

Cytomegalovirus

Toxoplasmosis

Salmonella enteric fevers

Rare

Localized, culture-negative infections: sinusitis, osteomyelitis, chronic meningitis, cholecystitis, urinary tract infection, mastoiditis

Viruses: Epstein-Barr, hepatitis (all types), human immunodeficiency virus, parvovirus, other

Cat scratch disease

Brucellosis

Listeriosis

Spirochetal infections

Relapsing fever

Lyme disease

Leptospirosis

Rat bite fever

Rickettsial infections: Rocky Mountain spotted fever, endemic typhus,

Q fever, ehrlichiosis, trench fever, bacillary angiomatosis

Parasitic disease: malaria, babesiosis, toxoplasmosis, trypanosomiasis, leishmaniasis, trichinosis, amebic liver abscess

Fungal infections: blastomycosis, histoplasmosis, coccidioidomycosis, cryptococcosis, candidiasis

Yersinia infections

Chlamydial infections: psittacosis, lymphogranuloma venereum

Foreign object-related infections: vascular grafts, indwelling catheters, prosthetic devices

Vascular infections: aortic aneurysm, jugular phlebitis

Autoimmune Disease

Common

Still disease

Giant cell (temporal) arteritis

Uncommon

Periarteritis nodosa

Rheumatoid arthritis

Wegener granulomatosis

Rare

Systemic lupus erythematosus

Vasculitis (Takayasu arteritis, hypersensitivity vasculitis)

Felty syndrome

Acute rheumatic fever

Pseudogout

Sjögren syndrome

Behçet disease

Familial Mediterranean fever

Polymyositis

Tumor necrosis factor receptor-associated periodic syndrome

Miscellaneous

Common

Drug fever

Cirrhosis

Alcoholic hepatitis

Uncommon: granulomatous hepatitis

Rare

Gastrointestinal: regional enteritis,

Whipple disease

Endocrine: hyperthyroidism, hyperparathyroidism, pheochromocytoma, Addison disease, subacute thyroiditis, hypothalamic dysfunction

Granulomatous disease: sarcoidosis

Vascular related: pulmonary emboli, subacute dissecting aneurysm, giant hepatic hemangioma, occult hematomas

Immune-related: hyper-immunoglobulin D syndrome, pseudolymphoma

Factitious fever

Habitual hyperthermia

Cyclic neutropenia

Other: Fabry disease, Kikuchi-Fujimoto disease, Weber-Christian disease, mesenteric fibromatosis, malakoplakia, Castleman disease, hemophagocytic syndromes

Undiagnosed Conditions

Adapted from Cunha BA. Fever of unknown origin. In Gorbach SL, Bartlett JB, Blacklow NR, eds. *Infectious diseases*, 3rd ed. Philadelphia, PA: Lippincott, Williams and Wilkins, 2004: 1569-1578.

Nosocomial FUO is a particular problem for the patient in an intensive care unit and is related to the type of instrumentation (indwelling vascular lines, Foley catheters, and endotracheal tubes),¹¹⁴ the specific spectrum of microorganisms and their antimicrobial sensitivity, and the degree of immunodeficiency. Common conditions causing nosocomial FUO include septic thrombophlebitis, pulmonary embolism, *Clostridium difficile* enterocolitis, and drug fever.¹¹⁵ More than 60% of FUO in the immunodeficient host is due to infections; the type and severity of infection correlate with the severity and length of neutropenia.¹¹⁶ Occult fungal infections, including hepatosplenic candidiasis, aspergillosis, and mucormycosis should be considered in the immunodeficient host with prolonged neutropenia.¹¹⁵

The initial exposure to HIV may cause FUO, and the HIV may go undetected due to lack of seroconversion.^{117, 118} FUO in HIV patients is due to an opportunistic infection in over 70% of patients.¹¹⁹ Atypical and typical mycobacteria are the most common infections in HIV patients; other infections causing FUO in AIDS include CMV, *Pneumocystis jiroveci*, toxoplasmosis, histoplasmosis, leishmaniasis, and cryptococcosis. In Asia, *Penicillium marneffei* is a common cause of FUO in HIV patients; papular skin lesions with central necrosis are seen in 70% of HIV patients.¹²⁰ Lymphoma, both aggressive B-cell NHL and HL, multicentric Castleman, and drug reactions may also be a cause of FUO in HIV patients. Long-lasting fever in HIV without a diagnosis is seen in patients with advanced HIV and low CD4⁺ T lymphocytes.¹¹⁸ The use of highly active antiretroviral therapy (HAART) in AIDS has led to a decline in FUO.^{118, 121} After the start of HAART, an immune reconstitution inflammatory syndrome is seen in 25% to 35% of HIV-positive patients and usually occurs within 2 months. The patient can deteriorate due to worsening of an opportunistic infection, particularly *Mycobacterium tuberculosis*, *M. avium* complex, or *Cryptococcus neoformans*.¹²²

The pattern of fever has been extensively evaluated, but rarely is so specific as to be diagnostic of a disease. Possible exceptions include a Pel-Ebstein pattern of recurrent high fever with intermittent afebrile, asymptomatic periods in HL; the tertian and quartan patterns of malaria; the pulse-temperature dissociation of typhoid fever; the reversal of the normal diurnal pattern observed in disseminated TB; and a cyclical pattern (every 3 to 4 weeks) with cyclic neutropenia.¹²³

A continuous fever is more likely to be diagnosed than a periodic fever.^{124, 125} The prognosis of a patient with undiagnosed FUO is favorable, with mortality less than 5%.¹²⁶

In the evaluation of a patient with FUO, history and physical examinations often need to be repeated.^{119, 127, 128} Host factors (e.g., HIV, sickle cell disease, prior malignancy, organ transplant, cardiac valve disease, diabetes, and prior surgery) and external factors (e.g., occupation; travel; and exposures to infections, animals, and drugs) may point to the types of studies warranted to diagnose the etiology of FUO. The goal of the history and physical examination is to identify potentially diagnostic clues. The physical examination should pay particular attention to the skin (e.g., rashes, subcutaneous nodules, aphthous ulcers, and nail beds), eyes (e.g., uveitis and Roth spots and infections on fundoscopic examination), sinuses, lymph nodes, heart (e.g., rubs and murmurs), lungs, organomegaly, and perirectal area. Bone, joint, and musculoskeletal examinations are important when symptoms of pain, limping, or weakness are associated with FUO.

The laboratory evaluation of FUO involves a minimal set of tests which may further direct the investigation: CBC, sedimentation rate, C-reactive protein; comprehensive metabolic profile, including lactose dehydrogenase; urinalysis, antinuclear antibodies, rheumatoid factor; viral screens, particularly CMV, EBV, and HIV; tuberculin skin test, and chest x-ray and/or CT scans of specific areas as determined by history and/or physical exam. Three sets of routine blood cultures have been added to the initial battery of tests.¹⁰⁸ If a patient has two of the three laboratory abnormalities: elevated C-reactive protein, elevated ferritin but < 500 µg/L, or eosinopenia, infection is more likely than non-infection.¹²⁹

Table 56.11 outlines possible etiologies as suggested by the findings on CBC and sedimentation rate or C-reactive protein. Anemia, an abnormal white cell count, elevated LFTs, and elevated LDH were independent predictors of having a serious illness, commonly neoplasia, and a poor prognosis for patients with FUO.¹³⁰ Examination of the blood smear for abnormal cells or pathogens may be warranted according to history, such as travel or tick exposure; or physical exam, particularly petechia, adenopathy, or organomegaly. Flow cytometry can be confirmatory in specifying the type of malignant cell. Ehrlichiosis, malaria, leishmaniasis, histoplasmosis, TB, and babesiosis are among the diseases in which organisms may be seen in the peripheral blood.

NIID that have remained a cause of FUO are those that are not readily diagnosed by serologic testing, such as temporal arteritis and Still disease.¹³¹ Giant cell, or temporal, arteritis (GCA) represented 17% of cases of FUO in the elderly and is suggested by jaw or tongue claudication, localized headaches, visual disturbances, and temporal artery abnormalities (e.g., decreased pulse, tenderness, or nodularity). The diagnosis is suggested by an elevated sedimentation rate (> 50 mm/hour) and formerly was confirmed by an abnormal temporal artery biopsy. Color Doppler ultrasonography and high resolution MRI can diagnose GCA in most patients so that biopsy may be reserved for patients with

P.1274

negative imaging.¹³² Adult onset Still disease can present as an FUO in a younger patient with or without a characteristic rash. Four variables associated with Still disease are arthritis, pharyngitis, splenomegaly, and neutrophilia.¹³³ The highest elevations in serum ferritin are seen in Still disease and hemophagocytic lymphohistiocytosis (HLH).

TABLE 56.11 COMPLETE BLOOD CELL COUNT CLUES TO FEVER OF UNKNOWN ORIGIN

Monocytosis	Eosinophilia	Elevated Erythrocyte Sedimentation Rate (> 100 mm/h)
Tuberculosis	Trichinosis	Adult Still disease
Brucellosis	Lymphomas	Temporal arteritis
Subacute bacterial endocarditis	Drug fever	Hypernephroma
Polyarteritis nodosa	Addison disease	Subacute bacterial endocarditis
Temporal arteritis	Polyarteritis nodosa	Drug fever
Cytomegalovirus	Hypersensitivity vasculitis	Carcinomas
Sarcoidosis	Hypernephroma	Lymphomas
Systemic lupus erythematosus	Myeloproliferative neoplasms	Myeloproliferative neoplasms

Lymphomas	Thrombocytopenia	Abscesses
Carcinomas	Acute leukemias	Subacute osteomyelitis
Regional enteritis	Lymphomas	Polymyositis
Myeloproliferative neoplasms	Myeloproliferative neoplasms	Hyperimmunoglobulin D syndrome
Myelodysplastic syndrome		
Atypical Lymphocytosis	Relapsing fever	Basophilia
Epstein-Barr virus	Epstein-Barr virus	Carcinomas
Cytomegalovirus	Drug fever	Lymphomas
Brucellosis	Systemic lupus erythematosus	Myeloproliferative neoplasms
Toxoplasmosis	Human immunodeficiency virus	Lymphocytosis
Drug fever	Leukopenia	Tuberculosis
Thrombocytosis	Miliary tuberculosis	Epstein-Barr virus
Myeloproliferative neoplasms	Brucellosis	Cytomegalovirus
Tuberculosis	Systemic lupus erythematosus	Toxoplasmosis
Carcinomas	Lymphomas	Non-Hodgkin lymphoma
Lymphomas	Acute leukemia	Lymphocytopenia
	Myelodysplastic syndrome	
Sarcoidosis	Typhoid fever	Human immunodeficiency virus
Vasculitis	Kikuchi disease	Hodgkin lymphoma
Temporal arteritis		Whipple disease
Subacute osteomyelitis		Tuberculosis
Hypernephroma		Systemic lupus erythematosus
		Sarcoidosis

Adapted from Cunha BA. Fever of unknown origin. In Gorbach SL, Bartlett JB, Blacklow NR, eds. Infectious diseases, 3rd ed. Philadelphia, PA: Lippincott, Williams and Wilkins, 2004:1569-1578.

HLH may be familial, with 70% to 80% occurring in children under the age of 1 year, or sporadic secondary to infections, malignancies, particularly peripheral T/NK lymphomas, or autoimmune diseases. The most common features of HLH are FOU, hepatosplenomegaly, and cytopenias; and a diagnosis can be made by confirmation of an underlying genetic defect (in 80% of familial cases), or by having five of eight clinical criteria, including ferritin $\geq 500 \mu\text{g/L}$, soluble CD25 (IL-2 receptor) $\geq 2,400 \text{ U/ml}$, and decreased natural killer cell activity.^{134, 135, 136} Early diagnosis of HLH is critical because of a high early mortality, varying from 20% to 70%, and the availability of effective therapy.^{134, 137} After the syndrome is controlled by immunotherapy with a combination of dexamethasone, etoposide, and cyclosporine, familial forms of HLH which have mutations in genes regulating the granule-dependent exocytosis pathway, and genetic immune deficiencies, such as X-linked lymphoproliferative (XLP), Chediak-Higashi, and Hermansky-Pudlak, should undergo allogeneic stem cell transplant.^{134, 136, 138}

Rare, hereditary disorders characterized by recurrent episodes of fever and autoimmune features include familial Mediterranean fever, tumor necrosis factor receptor-associated periodic syndrome, and the hyperimmunoglobulinemia D syndrome.¹³⁹ Familial Mediterranean fever is an autosomal recessive disorder and is caused by mutations in the pyrin-marenostrin gene MEFV, which provides inhibitory signals to inflammatory cells.¹⁴⁰ Tumor necrosis factor receptor-associated periodic syndrome is an autosomal dominant condition caused by missense mutations in the gene encoding type I tumor necrosis factor receptor (TNFRSF1A), which results in an exaggerated response to tumor necrosis factor.¹⁴¹ Hyperimmunoglobulin D syndrome is due to mutations in the gene mevalonate kinase (MVK), but the mechanism producing fever and autoimmune features is unknown.¹⁴²

Two diseases that can be overlooked are factitious fever and Whipple disease.¹⁴³ Patients presenting with factitious fever tend to be young adults who are often in the medical field and have a relative bradycardia. Intravenous injections of organisms or a

P.1275

febrile child with a Munchausen by proxy parent are other indications of factitious fever. Whipple disease should be suspected in patients with FUO, arthritis, mental status changes, and malabsorption. Diagnosis is made by demonstration of PAS-positive macrophages on small bowel biopsy and can be confirmed by detecting *Tropheryma whipplei* by PCR.

Imaging tests (e.g., CT, MRI, PET/CT, transesophageal echocardiography, and radioisotope scans) have altered the distribution but not the type of illnesses causing FUO.^{144, 145} Endocarditis and abscesses, as well as neoplasia, have decreased with improved imaging and cultures.¹⁴⁶ The ability to diagnose an etiology of FUO has paradoxically decreased and led to a higher incidence of unclassifiable causes in some recent series.¹⁴⁶ [18F]-fluorodeoxyglucose (FDG-PET) in conjunction with fusion CT is emerging as an effective modality in the diagnostic work-up of FUO.^{147, 148} Advantages of PET/CT over gallium scintigraphy include completion of the exam within a short period of time and improved resolution, while disadvantages include a relatively high cost and limited availability in most of the world.¹⁴⁸ A meta-analysis of FUO studies indicated that 32% of FDG-PET scans and 62% of FDG-PET/CT scans contributed to a final diagnosis.¹⁴⁹ Indium 111 granulocyte scintigraphy may be more helpful than PET scans in diagnosing infections.¹⁵⁰

Invasive tests have a variable yield and depend upon the type of host, the initial evaluation of FUO, physical exam findings, and laboratory abnormalities. Bone marrow aspiration with biopsy was diagnostic in nearly a fifth of patients with FUO and was particularly helpful in the presence of anemia or thrombocytopenia.¹⁵¹ Bone marrow exam with cultures is more rewarding in immunocompromised than in immunocompetent hosts. Percutaneous liver biopsy is similarly helpful in HIV-infected patients with FUO, organomegaly, and increased LFTs.¹⁵² Lymph node biopsy is useful in diagnosing lymphomas for which an excisional or core needle biopsy is preferable over a FNA for the initial diagnosis. Necrotizing lymphadenopathy may be present in lymphomas or in reactive processes, including infections (toxoplasmosis, lymphogranuloma venereum, *Yersinia pseudotuberculosis*, cat scratch, tularemia), rheumatologic disorders, Kawasaki, and Kikuchi-Fujimoto disease. The latter is usually seen in middle-aged women of Asian descent who present with fever, cervical adenopathy, and leukopenia and have a self-limited course over 1 to 4 months.¹⁵³ Granulomas in lymph node biopsies are nonspecific and may be seen in sarcoidosis, infections, both HL and NHL, and carcinoma. Laparotomy is rarely performed unless there is adenopathy that is not easily approached by less invasive procedures, including FNA, mediastinoscopy, thoracoscopy, and laparoscopy. The goal is to identify treatable disease as expediently as possible.

Empirical antibiotic trials are rarely warranted except in the immunocompromised patient with neutropenia and fever.^{154, 155} Empirical antifungal therapy was established as an effective strategy in the 1980s for acute leukemia patients with prolonged neutropenia following chemotherapy and for patients undergoing stem cell transplantation (SCT).^{155, 156} Prophylaxis against infections and pre-emptive antiviral strategies are routinely used in SCT.¹⁵⁷ Occasionally, antibiotics are given in culture-negative endocarditis; and antituberculosis therapy is used in the elderly with suspected miliary TB.^{158, 159} High-dose steroids with or without alkylating agents can be considered in cases of vasculitis which have diagnostic images or proven biopsies.¹⁵⁸ Naprosyn has been advocated as a means to distinguish fever of malignancy from infection but should not prevent the search for infection.¹⁶⁰ Treatment for malignancy should almost never be instituted without a tissue diagnosis.

RECURRENT INFECTIONS

The most common clinical presentation of immunodeficiency (either congenital or acquired) is infection (Table 56.12). More than one infection requiring hospitalization, infection with unusual pathogens, or an inappropriately delayed response to optimal therapy should all be tip-offs to possible underlying immunodeficiency.¹⁶¹ Chronic sinusitis, recurrent otitis, persistent thrush, chronic diarrhea, or skin rashes may be an early manifestation of immunodeficiency. Delayed

umbilical cord stump separation is indicative of neutrophil defects, including LAD and interleukin-1 receptor (ILR-1)-associated complex deficiency.^{162, 163} Eczema or pustular rash, skin abscesses, and sinopulmonary infections within the first few weeks of life suggest hyper-IgE (HIES or Job) syndrome.¹⁶⁴ Patients may present with sequelae of immunodeficiency (e.g., delayed growth or failure to thrive in children or unexplained chronic obstructive pulmonary disease). Cytopenias, including lymphopenia or thrombocytopenia, or splenomegaly, may be an early finding.¹⁶⁵ In some patients, particularly those with HIV infection, lymphoma or a nonhematologic malignancy may be the presenting manifestation. In congenital immunodeficiency diseases, such as IgA deficiency, or deficiency of classic pathway complement components, features of autoimmunity may dominate the clinical picture.¹⁶⁶

TABLE 56.12 CLINICAL APPROACH TO IMMUNODEFICIENCY

Red Flags for Immunodeficiency

More than one hospitalization for infection
 Infection with organisms not usually pathogenic
 Recurrent otitis, sinusitis or pneumonia
 Persistent thrush
 Deep skin or organ abscesses
 Growth failure in children
 Delayed or absent response of infection on appropriate therapy

Initial Evaluation

History
 Family history of primary immunodeficiency
 Age of onset of infection
 Type of infection
 Physical examination

Initial Investigation for:

Bacterial infection (implies B-cell, phagocyte, or complement deficiency)
 Infection with intracellular organisms (implies deficient T-cell/cellular immunity)
 CBC and differential for neutrophil count and morphology, quantitative immunoglobulins, CH50
 Human immunodeficiency virus serology, CBC and differential for lymphocyte count, T-subset analysis, skin testing in adults
 CBC, complete blood count.

Age of onset of infection, family history, including parental consanguinity, and clinical findings provide clues to diagnosis, but laboratory tests identifying abnormal component(s) of the immune system are essential. Testing is directed at different parts of the immune system: T cells and cell-mediated immunity, B cells and humoral immunity, phagocytes, and complement. Congenital defects in T-cell-mediated immunity may appear in the neonatal period and usually effect antibody production which is dependent on intact T-cell function, whereas antibody deficiencies appear at the 6 to 9 months stage after the waning of maternal antibodies. Immunoglobulin levels, flow cytometry, and complement levels detect deficiencies of the immune system, but immune function studies, such as lymphocyte response to mitogens, specific antibody response to vaccine antigens, skin testing, and assays of neutrophil function may be more important in diagnosis. Skin testing is of little value in children younger than 1 year because they are unlikely to have previously been exposed to antigen used in testing. In older children and adults, the presence of reactive skin tests to recall antigens virtually excludes a significant defect in cell-mediated immune response. In utero or neonatal screening

for immune deficiencies can be critical in identifying congenital disorders, many of which are optimally treated with early SCT.¹⁶⁷ T-cell receptor excision circles and kappa-deleting recombination circles can detect T- and B-cell lymphopenia and suggest a diagnosis of SCID and X-linked agammaglobulinemia, respectively.¹⁶⁸ Detecting a molecular mutation in a gene and/or protein controlling part of the immune system is the ideal diagnosis.

Primary immunodeficiency disorders (PIDs) refer to a heterogeneous group of diseases characterized by defects in one of more parts of the immune system (Chapter 63). PIDs are usually inherited and are rare, with an estimated prevalence of 1 in 1,200 live births.¹⁶⁹ IgA deficiency is the most common; it occurs in 1 in 300 to 500 births, but only one-third have significant infections.¹⁷⁰ Although PID may present as life-threatening infections in childhood, more than 40% may not be diagnosed until adulthood. Time until diagnosis of any PID has decreased with better awareness and improved diagnostic tests.¹⁶⁸ Antibody deficiency syndromes comprise approximately 50% to 65% of PID, followed by 30% to 40% combined immune deficiencies, 10% to 18% phagocyte dysfunctions, and 1% to 2% complement deficiencies.^{167, 171}

An early test in any patient of any age with suspected immunodeficiency is HIV serology. In the HIV-negative patient, the age of the patient, geographic location, and type of infection or problem should dictate the tests ordered.¹⁷² Congenital immunodeficiencies predisposing to sepsis can be subdivided into those affecting innate immunity and those affecting the adaptive immune system. The subdivision is somewhat arbitrary and there can be clinical overlap, as some molecular lesions will affect both types of immunity. The former involves the immediate response of the immune system to a pathogen and includes defects in complement proteins and mannose-binding lectin (MBL), nuclear factor kappa B (NF- κ B) activation, phagocyte quantity and quality, and the type-1 cytokine axis.¹⁷² *Neisseria* bacteremia and meningitis are seen in complement deficiencies. Neutrophil defects result in periodontal disease, oral ulceration, or cutaneous and visceral abscesses; and they have a narrow spectrum of infections: *Staphylococcus aureus*, *Burkholderia cepacia*, *Serratia marcescens* spp., or *Aspergillus* spp.¹⁷³ In the absence of immune suppression, invasive aspergillosis is seen only in chronic granulomatous disease (CGD), and disseminated nontuberculous mycobacterial infection is seen in patients with defects of the IFN- γ /IL-12 axis. An overwhelming EBV infection may be the initial presentation of XLP syndrome. XLP1 results from defects in signaling lymphocytic activation molecule-associated protein, which is required for the activation of NK and cytotoxic lymphocytes. The adaptive immune system requires time after the initial exposure and representative defects include the different types of SCID, ataxia telangiectasia, and WAS.

In a patient with recurrent bacterial infection, the three major screening tests are a CBC with differential and peripheral blood smear, quantitative immunoglobulins, and a CH50.¹⁷⁴ Giant granules in neutrophils in a patient with oculocutaneous albinism indicates Chédiak-Higashi syndrome. Neutropenia in a neonate suggests Kostmann syndrome (congenital agranulocytosis). Thrombocytopenia with small platelets in a patient with eczema and abnormal gamma globulin levels is consistent with WAS. Interpretation of quantitative immunoglobulins depends on an awareness of the variation in the normal ranges with age. IgG, IgA, and IgM are markedly decreased in children with physiologic hypogammaglobulinemia of infancy, common variable immunodeficiency (CVID), and X-linked agammaglobulinemia. In the first two conditions, patients have circulating B cells by flow cytometry, whereas in X-linked agammaglobulinemia B cells are absent.^{175, 176, 177} Thymoma is another circumstance with decreased immunoglobulins and decreased or absent B cells.¹⁷⁸ In hyper-IgM syndrome, the presence of markedly elevated IgM with depressed IgG and IgA is virtually diagnostic.¹⁷⁹ Patients with WAS who respond poorly to encapsulated bacteria often have an isolated decrease in IgM or may also have increases in IgE and IgA. Marked elevations of IgE (HIES or Job syndrome) are seen in patients with chemotactic defects, recurrent staphylococcal skin disease, cyst-forming pneumonia, and musculoskeletal abnormalities.^{164, 180} An autosomal dominant form involving a mutation in signal transducer and activator of transcription 3 (STAT3) and an autosomal recessive form resulting from mutation of the dedicator of cytokinesis 8 protein (DOCK8) have been described.¹⁸¹ In occasional patients with recurrent bacterial infection, measurement of IgG subclasses or responses to individual antigens (e.g., tetanus and diphtheria) may be helpful in making a diagnosis.¹⁸²

In adults with low IgG, the three major considerations are CVID, CLL, and multiple myeloma. Patients with CVID not only have recurrent infections but also may develop ITP, autoimmune hemolytic anemia, sarcoid-like granulomatous disease, inflammatory bowel disease, hepatitis, and NHL.^{183, 184} Patients with CLL have hypogammaglobulinemia, lymphocytosis, and immunophenotypic studies demonstrating a monotypic CD5⁺, CD23⁺ B-cell population.¹¹¹ In myeloma patients with a decreased IgA, IgM, or IgG, electrophoresis of serum identifies a paraprotein in more than 80% of patients, although immunofixation may be required to uncover IgA monoclonal protein hiding in the beta region. Some myeloma patients have a negative serum electrophoresis with immunofixation. Most of these patients have a monoclonal light chain on urine electrophoresis. Serum light chain assays can identify and quantify the kappa and lambda light chains.

The complement system is a part of innate immunity and can be activated by three pathways.¹⁸⁵ The classical pathway (C1, C4, C2) is activated by binding C1q to immunoglobulins on microbes or by direct binding to cells undergoing apoptosis. Patients with deficiency in the early classic complement pathway often have autoimmune disease (e.g., SLE and rheumatoid arthritis), which in part may be related to the physiologic role of the classic pathway in clearing immune complexes from the circulation.¹⁸⁶ The alternative pathway can be directly activated by microbes; and the lectin pathway is activated by carbohydrate moieties present on microbes. Hemolytic assays to assess the classical and alternative pathways have been available for years, but a complement kit can now assess all three pathways.¹⁸⁷

Congenital complement deficiencies are rare autosomal recessive diseases except for properdin deficiency which is X-linked. All patients with deficiency of C1, C2, C3, C4, C5, C6, C7, or C8 have a zero CH50 (also seen with improperly handled specimens and occasionally in patients with severe immune complex disease).¹⁸⁶ Deficiency of C3, the central component of all three pathways is associated with SLE, glomerulonephritis, and bacterial infections. Deficiencies of properdin and factor D, components of the alternative pathway, and deficiencies of the late components C5, 6, 7, 8, and 9 often present with fulminant infection due to *Neisseria* species. Deficiency of MBL, an initiator of the lectin pathway, is due to point mutations of the MBL2 gene and is associated with an increased risk to a variety of infections.^{186, 187}

If quantitative immunoglobulins, CH50, the absolute neutrophil count, and neutrophil morphology are normal in a patient with recurrent bacterial infections, WBC functional studies for CGD or other enzyme deficiencies are indicated (Chapter 58). The nitroblue tetrazolium test is abnormal in many, but not all, of these defects.¹⁷³ CGD is due to deficient function of the reduced nicotinamide adenine dinucleotide phosphate oxidase, which is responsible for the respiratory burst in phagocytes.¹⁷¹ The diagnosis of CGD is now made by assays that rely on superoxide production. There are four genetic subtypes of CGD, with two-thirds X-linked due to mutations of the cytochrome b-245, beta polypeptide (CYBB) gene, and one-third autosomal recessive with the most common due to mutation of the neutrophil cytosolic factor 1 (NCF1) gene on chromosome 7q11.23.¹⁷¹

Flow cytometry for the CD11b/CD18 complex is diagnostic of patients with LAD type I.^{188, 189} LAD1 is an autosomal recessive

P.1277

disorder due to mutations in the gene ITGB2, which encodes the common beta 2 subunit of the integrin (CD18) on chromosome 21q22.3.^{162, 188} There is diminished CD18 on leukocytes, which affects the third phase of the adhesion cascade, the firm adhesion of leukocytes to the endothelium. The severe type of LAD1 is caused by less than 1% expression of CD18 and presents early in life often with delayed umbilical stump separation; while moderate types have 1% to 30% expression, have fewer severe infections, and are diagnosed later in life.¹⁹⁰ LAD2 is due to mutations in the guanosine diphosphate fucose transporter which lead to a lack of sialyl Lewis X (CD153) and a defect in the first phase, the rolling phase. LAD3 is caused by mutations in FERMT3 (KINDLIN-3), encoding a molecule responsible for integrin activation, the second phase.^{162, 173}

Defects affecting phagocyte signaling via the Toll-like receptor canonical pathway include mutations of the myeloid differentiation primary response gene 88 (MYD88) and ILR-1-associated kinase 4 (IRAK4) which lead to invasive bacterial infections, primarily caused by *Streptococcus pneumoniae*, *Staphylococcus aureus*, and *Pseudomonas aeruginosa*.¹⁶³ Mutations in IKBKG, encoding the NF- κ B essential modulator (NEMO), result in a susceptibility to a wider variety of infections and frequently have ectodermal dysplasia.^{163, 191} Mutations in the alternative pathway lead primarily to herpes simplex encephalitis.

WHIM (warts, hypogammaglobulinemia, infections, and myelokathexis) syndrome is due to heterozygous mutations of the intracellular c-terminus of the chemokine receptor 4 (CXCR4).¹⁹² Hyperfunction of CXCR4 delays egress of neutrophils leading to neutropenia, and reduces circulating CD27⁺ memory B cells resulting in B-cell lymphopenia and hypogammaglobulinemia.

In HIV-negative children with infections suggesting defective cell-mediated immunity (viral, fungal, or mycobacterial), the evaluation begins with the absolute lymphocyte count (Chapter 63). Because 75% of circulating lymphocytes are T cells, moderate lymphopenia implies T-cell lymphopenia. Distinct forms of SCID are characterized by different combinations of T/B/NK counts: T⁺B⁻NK⁻, T⁺B⁺NK⁻, T⁻B⁻NK⁺, T⁻B⁺NK⁺. There are over 20 different gene mutations associated with SCID.¹⁹³ Most newborns with SCID appear normal at birth, and the median age at diagnosis is 4 to 7 months.¹⁹³ X-linked SCID, the most common type, has absent T and NK cells with normal or elevated B cells, which can mask T-cell lymphopenia and is due to mutation of the IL2RG gene, localized at Xq13.1 and encoding the γ chain of the ILR-2. In adenosine deaminase

deficiency, the second most common type of SCID, purine nucleoside phosphorylase deficiency, and reticular dysgenesis, all lymphocytes are absent ($T^-B^-NK^-$).

$T^-B^-NK^+$ SCID can be due to mutations in recombination activating genes RAG1 and RAG2, which lead to defects of the first step of antigen receptor V(D)J recombination for both T and B lymphocytes.¹⁹⁴ Defects of the second step of recombination affect nonhomologous end-joining proteins and result not only in immunodeficiency, but also in defects in DNA repair, which predispose to neoplasia and toxicity to conditioning regimens.¹⁹⁵ In DiGeorge syndrome (suggested by hypocalcemia and congenital heart disease), T-cell numbers are decreased, whereas B cells are normal or elevated (sometimes masking T-cell lymphopenia).^{166, 196} In the bare lymphocyte syndrome in which either class I or class II HLA antigens are observed, the CD8 T-cell subset is decreased in defects involving class I HLA, and CD4 T cells are decreased in defects involving class II.¹⁹⁷ T^+ SCID can be due to engraftment of transplacentally derived maternal T lymphocytes or to Omenn syndrome, characterized by erythroderma, hepatosplenomegaly, and eosinophilia, and caused by hypomorphic mutations ("leaky SCID") of RAG 1/2 and other genes whose null mutations cause typical SCID.^{193, 198}

In HIV-negative adults, acquired defects in cell-mediated immunity with unusual susceptibility to viral, fungal, or mycobacterial infection are most commonly secondary to immunosuppressive therapy, chemotherapy (particularly nucleoside analogs), or malnutrition. Patients with sarcoidosis and neoplasms, such as HL, may be anergic on skin testing but usually do not develop infection before immunosuppressive therapy.^{199, 200} In 1992, idiopathic CD4 lymphocytopenia (ICL) was defined in HIV-negative patients who had low CD4 T lymphocytes ($0.3 \times 10^9/L$ or $< 20\%$ of total T cells) on a minimum of two separate points at least 6 weeks apart. Patients with a profound decrease in CD4 T-cell numbers and low CD4/CD8 ratios present with opportunistic infections similar to those seen in AIDS.^{201, 202} Hypomorphic gene mutations, which control T-cell receptor recombination or signaling, have been identified in a few patients with ICL.^{203, 204} Rarely, ICL patients have normal CD4/CD8 ratios and do not have increased susceptibility to infection.^{44, 202}

SUMMARY

This chapter is a brief overview and introduction to the subsequent chapters in Part VI on nonmalignant disorders of the phagocytic and immune system. A primary objective is to separate benign from malignant disorders. Identifying a specific defect in the immune system begins with a history and physical examination followed by tests to identify the defect. A single gene mutation may account for a congenital immune deficiency, and prenatal diagnosis may be possible by sex determination in utero if X-linked or by fetal blood sampling if the defective gene is known or if characteristic abnormalities in the peripheral blood can be identified. Some of the congenital immune deficiencies, such as SCID and its variants, represent medical emergencies. Acquired immune abnormalities, particularly functional asplenia, severe hypogammaglobulinemia, and iatrogenic neutropenia or T-cell deficiency, can also be life threatening. Knowledge of the site of the defect in a host's immune system—whether in the neutrophils, humoral, cell-mediated, or complement arms or a combination thereof—is critical in predicting types of infections that can occur and instituting appropriate therapy.

REFERENCES

1. Craig FE, Foon KA. Flow cytometric immunophenotyping for hematologic neoplasms. *Blood* 2008;111(8):3941-3967.
2. Hummel M, Stein H. Clonality and malignancy. PCR assays for the diagnosis of clonal B- and T-cell proliferations: potentials and pitfalls. *Verh Dtsch Ges Pathol* 2003;87:102-108.
3. Fromm JR, Thomas A, Wood BL. Flow cytometry can diagnose classical Hodgkin lymphoma in lymph nodes with high sensitivity and specificity. *Am J Clin Pathol* 2009;131(3):322-332.
4. Davey MP, Waldmann TA. Clonality and lymphoproliferative lesions. *N Engl J Med* 1986;315(8):509-511.
5. Collins RD. Is clonality equivalent to malignancy: specifically, is immunoglobulin gene rearrangement diagnostic of malignant lymphoma? *Hum Pathol* 1997;28(7):757-759.
6. Chamberlain WD, Falta MT, Kotzin BL. Functional subsets within clonally expanded CD8(+) memory T cells in elderly humans. *Clin Immunol* 2000;94(3):160-172.
7. Lust JA, Donovan KA. Biology of the transition of monoclonal gammopathy of undetermined significance (MGUS) to multiple myeloma. *Cancer Control* 1998;5(3):209-217.
8. Krause I, Blank M, Fraser A, et al. The association of thrombocytopenia with systemic manifestations in the antiphospholipid syndrome. *Immunobiology* 2005;210(10):749-754.
9. Vannappagari V, Nkhoma ET, Atashili J, Laurent SS, Zhao H. Prevalence, severity, and duration of thrombocytopenia among HIV patients in the era of highly active antiretroviral therapy. *Platelets* 2011;22(8):611-618.

10. Kjeldsberg CR, Swanson J. Platelet satellitism. *Blood* 1974;43(6):831-836.
11. Wong EY, Rose MG. Why does my patient have thrombocytopenia? *Hematol Oncol Clin North Am* 2012;26(2):231-252, vii.
12. Neylon AJ, Saunders PW, Howard MR, Proctor SJ, Taylor PR. Clinically significant newly presenting autoimmune thrombocytopenic purpura in adults: a prospective study of a population-based cohort of 245 patients. *Br J Haematol* 2003;122(6):966-974.
13. Cuker A, Cines DB. How I treat heparin-induced thrombocytopenia. *Blood* 2012;119(10):2209-2218.
14. Neunert C, Lim W, Crowther M, Cohen A, Solberg L Jr, Crowther MA. The American Society of Hematology 2011 evidence-based practice guideline for immune thrombocytopenia. *Blood* 2011;117(16):4190-4207.
15. Kralovics R, Passamonti F, Buser AS, et al. A gain-of-function mutation of JAK2 in myeloproliferative disorders. *N Engl J Med* 2005;352(17):1779-1790.
16. Levine RL, Wadleigh M, Cools J, et al. Activating mutation in the tyrosine kinase JAK2 in polycythemia vera, essential thrombocythemia, and myeloid metaplasia with myelofibrosis. *Cancer Cell* 2005;7(4):387-397.
17. Vannucchi AM, Guglielmelli P, Tefferi A. Advances in understanding and management of myeloproliferative neoplasms. *CA Cancer J Clin* 2009;59(3):171-191.
18. Wiestner A, Padosch SA, Ghilardi N, et al. Hereditary thrombocythaemia is a genetically heterogeneous disorder: exclusion of TPO and MPL in two families with hereditary thrombocythaemia. *Br J Haematol* 2000;110(1):104-109.
19. Kubic VL, Kubic PT, Brunning RD. The morphologic and immunophenotypic assessment of the lymphocytosis accompanying Bordetella pertussis infection. *Am J Clin Pathol* 1991;95(6):809-815.
20. Troussard X, Cornet E, Lesesve JF, Kourel C, Mossafa H. Polyclonal B-cell lymphocytosis with binucleated lymphocytes (PPBL). *Onco Targets Ther* 2008;1:59-66.
21. Hallek M, Cheson BD, Catovsky D, et al. Guidelines for the diagnosis and treatment of chronic lymphocytic leukemia: a report from the International Workshop on Chronic Lymphocytic Leukemia updating the National Cancer Institute-Working Group 1996 guidelines. *Blood* 2008;111(12):5446-5456.
22. Zaki SR, Greer PW, Coffield LM, et al. Hantavirus pulmonary syndrome. Pathogenesis of an emerging infectious disease. *Am J Pathol* 1995;146(3):552-579.
23. Weir AB, Lewis JB Jr, Arteta-Bulos R. Chronic idiopathic neutrophilia: experience and recommendations. *South Med J* 2011;104(7):499-504.
24. Plo I, Zhang Y, Le Couedic JP, et al. An activating mutation in the CSF3R gene induces a hereditary chronic neutrophilia. *J Exp Med* 2009;206(8):1701-1707.
25. Mundschau G, Gurbuxani S, Gamis AS, Greene ME, Arceci RJ, Crispino JD. Mutagenesis of GATA1 is an initiating event in Down syndrome leukemogenesis. *Blood* 2003;101(11):4298-4300.
26. Dunphy CH. Bone marrow evaluation of monocytosis. *Diagn Histopathol* 2009;15(3):116-124.
27. Blay JY, Rossi JF, Wijdenes J, et al. Role of interleukin-6 in the paraneoplastic inflammatory syndrome associated with renal-cell carcinoma. *Int J Cancer* 1997;72(3):424-430.
28. Sims KL. Peripheral eosinophilia and diagnosis of hypereosinophilic syndrome. *Lab Medicine* 2006;37:440-553.
29. Simon HU, Plotz SG, Dummer R, Blaser K. Abnormal clones of T cells producing interleukin-5 in idiopathic eosinophilia. *N Engl J Med* 1999;341(15):1112-1120.
30. Gotlib J. Molecular classification and pathogenesis of eosinophilic disorders: 2005 update. *Acta Haematol* 2005;114(1):7-25.
31. Gotlib J, Cools J, Malone JM 3rd, Schrier SL, Gilliland DG, Coutre SE. The FIP1L1-PDGFRalpha fusion tyrosine kinase in hypereosinophilic syndrome and chronic eosinophilic leukemia: implications for diagnosis, classification, and management. *Blood* 2004;103(8):2879-2891.
32. Reagan JL, Castillo JJ. Why is my patient neutropenic? *Hematol Oncol Clin North Am* 2012;26(2):253-266, vii.
33. Hsieh MM, Everhart JE, Byrd-Holt DD, Tisdale JF, Rodgers GP. Prevalence of neutropenia in the U.S. population: age, sex, smoking status, and ethnic differences. *Ann Intern Med* 2007;146(7):486-492.

34. Dias AM, Do Couto MC, Duarte CC, Ines LP, Malcata AB. White blood cell count abnormalities and infections in one-year follow-up of 124 patients with SLE. *Ann N Y Acad Sci* 2009;1173:103-107.
 35. Starkebaum G, Loughran TP Jr, Gaur LK, Davis P, Nepom BS. Immunogenetic similarities between patients with Felty's syndrome and those with clonal expansions of large granular lymphocytes in rheumatoid arthritis. *Arthritis Rheum* 1997;40(4):624-626.
 36. Weitzman SA, Stossel TP, Harmon DC, Daniels G, Maloof F, Ridgway EC. Antineutrophil autoantibodies in Graves' disease. Implications of thyrotropin binding to neutrophils. *J Clin Invest* 1985;75(1):119-123.
 37. Tesfa D, Palmblad J. Late-onset neutropenia following rituximab therapy: incidence, clinical features and possible mechanisms. *Expert Rev Hematol* 2011;4(6):619-625.
 38. Pyrovolaki K, Mavroudi I, Papadantonakis N, et al. Transforming growth factor-beta1 affects interleukin-10 production in the bone marrow of patients with chronic idiopathic neutropenia. *Eur J Haematol* 2007;79(6):531-538.
 39. Rosenberg PS, Alter BP, Bolyard AA, et al. The incidence of leukemia and mortality from sepsis in patients with severe congenital neutropenia receiving long-term G-CSF therapy. *Blood* 2006;107(12):4628-4635.
 40. Palmblad J, Papadaki HA. Chronic idiopathic neutropenias and severe congenital neutropenia. *Curr Opin Hematol* 2008;15(1):8-14.
 41. Bateau B, Rey J, Hamidou M, et al. Analysis of a French cohort of patients with large granular lymphocyte leukemia: a report on 229 cases. *Haematologica* 2010;95(9):1534-1541.
 42. Lamy T, Loughran TP Jr. Clinical features of large granular lymphocyte leukemia. *Semin Hematol* 2003;40(3):185-195.
 43. Lewis DE, Gilbert BE, Knight V. Influenza virus infection induces functional alterations in peripheral blood lymphocytes. *J Immunol* 1986;137(12):3777-3781.
 44. Laurence J. T-cell subsets in health, infectious disease, and idiopathic CD4+ T lymphocytopenia. *Ann Intern Med* 1993;119(1):55-62.
 45. Dabrow MB. Malaria in New Jersey. *N Engl J Med* 1994;331(21):1454; author reply 1454-1455.
 46. Ochs DE, Hnilica VS, Moser DR, Smith JH, Kirchhoff LV. Postmortem diagnosis of autochthonous acute chagasic myocarditis by polymerase chain reaction amplification of a species-specific DNA sequence of *Trypanosoma cruzi*. *Am J Trop Med Hyg* 1996;54(5):526-529.
 47. Ottesen EA. Filariasis now. *Am J Trop Med Hyg* 1989;41(Suppl 3):9-17.
 48. Caldwell CW, Everett ED, McDonald G, Yesus YW, Roland WE. Lymphocytosis of gamma/delta T cells in human ehrlichiosis. *Am J Clin Pathol* 1995;103(6):761-766.
 49. Dao AH. Human babesiosis. *Compr Ther* 1996;22(11):713-718.
 50. Dankner WM, Spector SA, Fierer J, Davis CE. *Malassezia* fungemia in neonates and adults: complication of hyperalimentation. *Rev Infect Dis* 1987;9(4):743-753.
 51. Portnoy J, Wolf PL, Webb M, Remington JS. *Candida* blastospores and pseudohyphae in blood smears. *N Engl J Med* 1971;285(18):1010-1011.
 52. Zieve PD, Haghshenass M, Blanks M, Krevans JR. Vacuolization of the neutrophil. An aid in the diagnosis of septicemia. *Arch Intern Med* 1966;118(4):356-357.
- P.1278
53. Dunphy CH. Applications of flow cytometry and immunohistochemistry to diagnostic hematopathology. *Arch Pathol Lab Med* 2004;128(9):1004-1022.
 54. Venditti A, Del Poeta G, Buccisano F, et al. Minimally differentiated acute myeloid leukemia (AML-M0): comparison of 25 cases with other French-American-British subtypes. *Blood* 1997;89(2):621-629.
 55. Larson RS, Mccurley TL 3rd. CD4 predicts nonlymphocytic lineage in acute leukemia. Insights from analysis of 125 cases using two-color flow cytometry. *Am J Clin Pathol* 1995;104(2):204-211.

56. Hurwitz CA, Loken MR, Graham ML, et al. Asynchronous antigen expression in B lineage acute lymphoblastic leukemia. *Blood* 1988;72(1):299-307.
57. Dinardo CD, Luger SM. Beyond morphology: minimal residual disease detection in acute myeloid leukemia. *Curr Opin Hematol* 2012;19(2):82-88.
58. Kern W, Schoch C, Haferlach T, Schnittger S. Monitoring of minimal residual disease in acute myeloid leukemia. *Crit Rev Oncol Hematol* 2005;56(2):283-309.
59. Pui CH, Evans WE. Treatment of acute lymphoblastic leukemia. *N Engl J Med* 2006;354(2):166-178.
60. Mrozek K, Heerema NA, Bloomfield CD. Cytogenetics in acute leukemia. *Blood Rev* 2004;18(2):115-136.
61. Sanz MA, Tallman MS, Lo-Coco F. Practice points, consensus, and controversial issues in the management of patients with newly diagnosed acute promyelocytic leukemia. *Oncologist* 2005;10(10):806-814.
62. Pui CH, Carroll WL, Meshinchi S, Arceci RJ. Biology, risk stratification, and therapy of pediatric acute leukemias: an update. *J Clin Oncol* 2011;29(5):551-565.
63. Steensma DP, List AF. Genetic testing in the myelodysplastic syndromes: molecular insights into hematologic diversity. *Mayo Clin Proc* 2005;80(5):681-698.
64. Shali W, Helias C, Fohrer C, et al. Cytogenetic studies of a series of 43 consecutive secondary myelodysplastic syndromes/acute myeloid leukemias: conventional cytogenetics, FISH, and multiplex FISH. *Cancer Genet Cytogenet* 2006;168(2):133-145.
65. List A, Dewald G, Bennett J, et al. Lenalidomide in the myelodysplastic syndrome with chromosome 5q deletion. *N Engl J Med* 2006;355(14):1456-1465.
66. Kussick SJ, Fromm JR, Rossini A, et al. Four-color flow cytometry shows strong concordance with bone marrow morphology and cytogenetics in the evaluation for myelodysplasia. *Am J Clin Pathol* 2005;124(2):170-181.
67. Caldwell CW, Poje E, Helikson MA. B-cell precursors in normal pediatric bone marrow. *Am J Clin Pathol* 1991;95(6):816-823.
68. Ventura RA, Martin-Subero JI, Jones M, et al. FISH analysis for the detection of lymphoma-associated chromosomal abnormalities in routine paraffin-embedded tissue. *J Mol Diagn* 2006;8(2):141-151.
69. McCaffrey JA, Rudders RA, Kahn PC, Harvey HA, Delellis RA. Clinical usefulness of ⁶⁷gallium scanning in the malignant lymphomas. *Am J Med* 1976;60(4):523-530.
70. Gilbert EH, Earle JD, Glatstein E, Goris ML, Kaplan HS, Kriss JP. Indium bone marrow scintigraphy as an aid in selecting marrow biopsy sites for the evaluation of marrow elements in patients with lymphoma. *Cancer* 1976;38(4):1560-1567.
71. Lapela M, Leskinen S, Minn HR, et al. Increased glucose metabolism in untreated non-Hodgkin's lymphoma: a study with positron emission tomography and fluorine-18-fluorodeoxyglucose. *Blood* 1995;86(9):3522-3527.
72. Hughes DK. Nuclear medicine and infection detection: the relative effectiveness of imaging with ¹¹¹In-oxine-, ^{99m}Tc-HMPAO-, and ^{99m}Tc-stannous fluoride colloid-labeled leukocytes and with ⁶⁷Ga-citrate. *J Nucl Med Technol* 2003;31(4):196-201; quiz 203-194.
73. Vos FJ, Bleeker-Rovers CP, Corstens FH, Kullberg BJ, Oyen WJ. FDG-PET for imaging of non-osseous infection and inflammation. *Q J Nucl Med Mol Imaging* 2006;50(2):121-130.
74. Knight PJ, Mulne AF, Vassy LE. When is lymph node biopsy indicated in children with enlarged peripheral nodes? *Pediatrics* 1982;69(4):391-396.
75. Wittenberg J. Computed tomography of the body (first of two parts). *N Engl J Med* 1983;309(19):1160-1165.
76. Iglehart JK. The new era of medical imaging—progress and pitfalls. *New England Journal of Medicine* 2006;354(26):2822-2828.
77. Stone JH. Incidentalomas—clinical correlation and translational science required. *N Engl J Med* 2006;354(26):2748-2749.
78. Cheson BD, Pfistner B, Juweid ME, et al. Revised response criteria for malignant lymphoma. *J Clin Oncol* 2007;25(5):579-586.

79. Pangalis GA, Vassilakopoulos TP, Boussiotis VA, Fessas P. Clinical approach to lymphadenopathy. *Semin Oncol* 1993;20(6):570-582.
80. Slap GB, Brooks JS, Schwartz JS. When to perform biopsies of enlarged peripheral lymph nodes in young patients. *JAMA* 1984;252(10):1321-1326.
81. Raanani P, Ben-Bassat I. Detection of minimal residual disease in acute myelogenous leukemia. *Acta Haematol* 2004;112(1-2):40-54.
82. Case records of the Massachusetts General Hospital. Weekly clinicopathological exercises. Case 5-1997. A 24-year-old woman with cervical lymphadenopathy, fever, and leukopenia. *N Engl J Med* 1997;336(7):492-499.
83. Shriner KA, Mathisen GE, Goetz MB. Comparison of mycobacterial lymphadenitis among persons infected with human immunodeficiency virus and seronegative controls. *Clin Infect Dis* 1992;15(4):601-605.
84. Kikuchi M, Yoshizumi T, Nakamura H. Necrotizing lymphadenitis: possible acute toxoplasmic infection. *Virchows Arch A Pathol Anat Histol* 1977;376(3):247-253.
85. Nieman RB. Diagnosis of Kikuchi's disease. *Lancet* 1990;335(8684):295.
86. Kawasaki T, Kosaki F, Okawa S, Shigematsu I, Yanagawa H. A new infantile acute febrile mucocutaneous lymph node syndrome (MLNS) prevailing in Japan. *Pediatrics* 1974;54(3):271-276.
87. Falcini F. Kawasaki disease. *Curr Opin Rheumatol* 2006;18(1):33-38.
88. Pugh JL, Jhala NC, Eloubeidi MA, et al. Diagnosis of deep-seated lymphoma and leukemia by endoscopic ultrasound-guided fine-needle aspiration biopsy. *Am J Clin Pathol* 2006;125(5):703-709.
89. Mayall F, Darlington A, Harrison B. Fine needle aspiration cytology in the diagnosis of uncommon types of lymphoma. *J Clin Pathol* 2003;56(11):821-825.
90. Jorgensen JL. State of the Art Symposium: flow cytometry in the diagnosis of lymphoproliferative disorders by fine-needle aspiration. *Cancer* 2005;105(6):443-451.
91. Kline TS, Kannan V, Kline IK. Lymphadenopathy and aspiration biopsy cytology. Review of 376 superficial nodes. *Cancer* 1984;54(6):1076-1081.
92. Nowakowski GS, Dewald GW, Hoyer JD, et al. Interphase fluorescence in situ hybridization with an IGH probe is important in the evaluation of patients with a clinical diagnosis of chronic lymphocytic leukaemia. *Br J Haematol* 2005;130(1):36-42.
93. Johnson PW, Price CG, Smith T, et al. Detection of cells bearing the t(14;18) translocation following myeloablative treatment and autologous bone marrow transplantation for follicular lymphoma. *J Clin Oncol* 1994;12(4):798-805.
94. Williams ME, Zukerberg LR, Harris NL, et al. Mantle cell/centrocytic lymphoma: molecular and phenotypic analysis including analysis of the bcl-1 major translocation cluster by PCR. *Curr Top Microbiol Immunol* 1995;194:341-346.
95. Liu H, Ye H, Ruskone-Fourmesttraux A, et al. T(11;18) is a marker for all stage gastric MALT lymphomas that will not respond to H. pylori eradication. *Gastroenterology* 2002;122(5):1286-1294.
96. Sukpanichnant S, Vnencak-Jones CL, Mccurley TL. Determination of B-cell clonality in paraffin-embedded endoscopic biopsy specimens of abnormal lymphocytic infiltrates and gastrointestinal lymphoma by polymerase chain reaction. *Am J Clin Pathol* 1994;102(3):299-305.
97. Aisenberg AC. Utility of gene rearrangements in lymphoid malignancies. *Annu Rev Med* 1993;44:75-84.
98. Glatstein E, Guernsey JM, Rosenberg SA, Kaplan HS. The value of laparotomy and splenectomy in the staging of Hodgkin's disease. *Cancer* 1969;24(4):709-718.
99. Hyland CH, Murad TM, Dismukes WE. Evolution of reactive lymphadenopathy into lymphoma over a nine-year period. A clinicopathologic study. *Am J Clin Pathol* 1977;68(5):606-610.
100. Kissane JM, Gephardt GN. Lymphadenopathy in childhood: long term follow-up in patients with nondiagnostic lymph node biopsies. *Hum Pathol* 1974;5(4):431-439.
101. Evans HL. Extranodal small lymphocytic proliferation: a clinicopathologic and immunocytochemical study. *Cancer* 1982;49(1):84-96.
102. Dorfman RF, Warnke R. Lymphadenopathy simulating the malignant lymphomas. *Hum Pathol* 1974;5(5):519-550.

103. McIntyre OR, Ebaugh FG Jr. Palpable spleens in college freshmen. *Ann Intern Med* 1967;66(2):301-306.
104. Moeschlen S. Spleen puncture. London: Heinemann, 1951.
105. Shields JW, Hargraves MM. An evaluation of splenic puncture. *Proc Staff Meet Mayo Clin* 1956;31(16):440-453.
106. Petersdorf RG, Beeson PB. Fever of unexplained origin: report on 100 cases. *Medicine (Baltimore)* 1961;40:1-30.
107. Durack DT, Street AC. Fever of unknown origin—reexamined and redefined. *Curr Clin Top Infect Dis* 1991;11:35-51.
108. Arnow PM, Flaherty JP. Fever of unknown origin. *Lancet* 1997;350(9077):575-580.
109. De Kleijn EM, Vandenbroucke JP, Van Der Meer JW. Fever of unknown origin (FUO). I A. prospective multicenter study of 167 patients with FUO, using fixed epidemiologic entry criteria. The Netherlands FUO Study Group. *Medicine (Baltimore)* 1997;76(6):392-400.
110. Gaeta GB, Fusco FM, Nardiello S. Fever of unknown origin: a systematic review of the literature for 1995-2004. *Nucl Med Commun* 2006;27(3):205-211.
111. Kejarawal D, Sarkar N, Chakraborti SK, Agarwal V, Roy S. Pyrexia of unknown origin: a prospective study of 100 cases. *J Postgrad Med* 2001;47(2):104-107.
112. Bleeker-Rovers CP, Van Der Meer JW, Oyen WJ. Fever of unknown origin. *Semin Nucl Med* 2009;39(2):81-87.
113. Chow A, Robinson JL. Fever of unknown origin in children: a systematic review. *World J Pediatr* 2011;7(1):5-10.
114. Manthous CA. Toward a more thoughtful approach to fever in critically ill patients. *Chest* 2000;117(3):627-628.
115. Roth AR, Basello GM. Approach to the adult patient with fever of unknown origin. *Am Fam Physician* 2003;68(11):2223-2228.
116. Hughes WT, Armstrong D, Bodey GP, et al. 2002 guidelines for the use of antimicrobial agents in neutropenic patients with cancer. *Clin Infect Dis* 2002;34(6):730-751.
117. Bissuel F, Lepout C, Perronne C, Longuet P, Vilde JL. Fever of unknown origin in HIV-infected patients: a critical analysis of a retrospective series of 57 cases. *J Intern Med* 1994;236(5):529-535.
118. Hot A, Schmulewitz L, Viard JP, Lortholary O. Fever of unknown origin in HIV/AIDS patients. *Infect Dis Clin North Am* 2007;21(4):1013-1032, ix.
119. Cunha BA. Fever of unknown origin. In: Gorbach SL, Bartlett JG, Blacklow NR, eds. *Infectious diseases*, 3rd ed. Philadelphia, PA: Lippincott, Williams & Wilkins, 2004.
120. Duong TA. Infection due to *Penicillium marneffe*, an emerging pathogen: review of 155 reported cases. *Clin Infect Dis* 1996;23(1):125-130.
121. Lozano F, Torre-Cisneros J, Santos J, et al. Impact of highly active antiretroviral therapy on fever of unknown origin in HIV-infected patients. *Eur J Clin Microbiol Infect Dis* 2002;21(2):137-139.
122. Shelburne SA, Visnegarwala F, Darcourt J, et al. Incidence and risk factors for immune reconstitution inflammatory syndrome during highly active antiretroviral therapy. *AIDS* 2005;19(4):399-406.
123. Cunha BA, Nausheen S. Fever of unknown origin (FUO) due to cyclic neutropenia with relative bradycardia. *Heart Lung* 2009;38(4):350-353.
124. Bleeker-Rovers CP, Vos FJ, De Kleijn EM, et al. A prospective multicenter study on fever of unknown origin: the yield of a structured diagnostic protocol. *Medicine (Baltimore)* 2007;86(1):26-38.
125. Vanderschueren S, Knockaert D, Adriaenssens T, et al. From prolonged febrile illness to fever of unknown origin: the challenge continues. *Arch Intern Med* 2003;163(9):1033-1041.
126. Knockaert DC, Dujardin KS, Bobbaers HJ. Long-term follow-up of patients with undiagnosed fever of unknown origin. *Arch Intern Med* 1996 Mar 25;156(6):618-620.
127. Williams J, Bellamy R. Fever of unknown origin. *Clin Med* 2008;8(5):526-530.
128. Mourad O, Palda V, Detsky AS. A comprehensive evidence-based approach to fever of unknown origin. *Arch Intern Med* 2003 Mar 10;163(5):545-551.
129. Efstathiou SP, Pefanis AV, Tsiakou AG, et al. Fever of unknown origin: discrimination between infectious and non-infectious causes. *Eur J Intern Med* 2010;21(2):137-143.

130. Baicus C, Bolosiu HD, Tanasescu C, Baicus A. Fever of unknown origin-predictors of outcome. A prospective multicenter study on 164 patients. *Eur J Intern Med* 2003;14(4):249-254.
131. Efthimiou P, Paik PK, Bielory L. Diagnosis and management of adult onset Still's disease. *Ann Rheum Dis* 2006;65(5):564-572.
132. Borchers AT, Gershwin ME. Giant cell arteritis: a review of classification, pathophysiology, geoeconomics and treatment. *Autoimmun Rev* 2012 Jan 21.
133. Crispin JC, Martinez-Banos D, Alcocer-Varela J. Adult-onset Still disease as the cause of fever of unknown origin. *Medicine (Baltimore)* 2005;84(6):331-337.
134. Jordan MB, Allen CE, Weitzman S, Filipovich AH, McClain KL. How I treat hemophagocytic lymphohistiocytosis. *Blood* 2011;118(15):4041-4052.
135. Janka GE. Familial and acquired hemophagocytic lymphohistiocytosis. *Annu Rev Med* 2012;63:233-246.
136. Sieni E, Cetica V, Mastrodicasa E, et al. Familial hemophagocytic lymphohistiocytosis: a model for understanding the human machinery of cellular cytotoxicity. *Cell Mol Life Sci* 2012;69(1):29-40.
137. Park HS, Kim DY, Lee JH, et al. Clinical features of adult patients with secondary hemophagocytic lymphohistiocytosis from causes other than lymphoma: an analysis of treatment outcome and prognostic factors. *Ann Hematol* 2012;91(6):897-904.
138. Risma K, Jordan MB. Hemophagocytic lymphohistiocytosis: updates and evolving concepts. *Curr Opin Pediatr* 2012;24(1):9-15.
139. Arkwright PD, Abinun M, Cant AJ. Autoimmunity in human primary immunodeficiency diseases. *Blood* 2002;99(8):2694-2702.
140. Centola M, Wood G, Frucht DM, et al. The gene for familial Mediterranean fever, MEFV, is expressed in early leukocyte development and is regulated in response to inflammatory mediators. *Blood* 2000;95(10):3223-3231.
141. Galon J, Aksentijevich I, McDermott MF, O'Shea JJ, Kastner DL. TNFRSF1A mutations and autoinflammatory syndromes. *Curr Opin Immunol* 2000;12(4):479-486.
142. Drenth JP, Cuisset L, Grateau G, Vasseur C, et al. Mutations in the gene encoding mevalonate kinase cause hyper-IgD and periodic fever syndrome. International Hyper-IgD Study Group. *Nat Genet* 1999;22(2):178-181.
143. Cunha BA. Fever of unknown origin: focused diagnostic approach based on clinical clues from the history, physical examination, and laboratory tests. *Infect Dis Clin North Am* 2007;21(4):1137-1187, xi.
144. Mackowiak PA, Durack DT. Fever of unknown origin. In: Mandell GL, Bennett JE, Dolin R, eds. *Principles and practice of infectious diseases*, 7th ed. Philadelphia, PA: Churchill Livingstone, 2010.
145. Cunha BA. Fever of unknown origin (FUO): diagnostic importance of serum ferritin levels. *Scand J Infect Dis* 2007;39(6-7):651-652.
146. Varghese GM, Trowbridge P, Doherty T. Investigating and managing pyrexia of unknown origin in adults. *BMJ* 2010;341:C5470.
147. Blockmans D, Knockaert D, Maes A, et al. Clinical value of [(18)F]fluoro-deoxyglucose positron emission tomography for patients with fever of unknown origin. *Clin Infect Dis* 2001;32(2):191-196.
148. Basu S, Chryssikos T, Moghadam-Kia S, Zhuang H, Torigian DA, Alavi A. Positron emission tomography as a diagnostic tool in infection: present role and future possibilities. *Semin Nucl Med* 2009;39(1):36-51.
149. Dong MJ, Zhao K, Liu ZF, Wang GL, Yang SY, Zhou GJ. A meta-analysis of the value of fluorodeoxyglucose-PET/PET-CT in the evaluation of fever of unknown origin. *Eur J Radiol* 2011;80(3):834-844.
150. Kjaer A, Lebech AM, Eigtved A, Hojgaard L. Fever of unknown origin: prospective comparison of diagnostic value of 18F-FDG PET and 111In-granulocyte scintigraphy. *Eur J Nucl Med Mol Imaging* 2004;31(5):622-626.
151. Hot A, Jaisson I, Girard C, et al. Yield of bone marrow examination in diagnosing the source of fever of unknown origin. *Arch Intern Med* 2009;169(21):2018-2023.
152. Garcia-Ordonez MA, Colmenero JD, Jimenez-Onate F, Martos F, Martinez J, Juarez C. Diagnostic usefulness of percutaneous liver biopsy in HIV-infected patients with fever of unknown origin. *J Infect* 1999;38(2):94-98.

153. Cunha BA, Mickail N, Durie N, Pherez FM, Strollo S. Fever of unknown origin (FUO) caused by Kikuchi's disease mimicking lymphoma. *Heart Lung* 2009;38(5):450-456.
154. Donowitz GR. Fever in the compromised host. *Infect Dis Clin North Am* 1996;10(1):129-148.
155. Martino R, Viscoli C. Empirical antifungal therapy in patients with neutropenia and persistent or recurrent fever of unknown origin. *Br J Haematol* 2006;132(2):138-154.
156. Leather HL, Wingard JR. New strategies of antifungal therapy in hematopoietic stem cell transplant recipients and patients with hematological malignancies. *Blood Rev* 2006;20(5):267-287.
157. Boeckh M. Complications, diagnosis, management, and prevention of CMV infections: current and future. *Hematology Am Soc Hematol Educ Program* 2011;2011:305-309.
158. Cunha BA. Fever of unknown origin. *Infect Dis Clin North Am* 1996;10(1):111-127.
159. Cunha BA, Bouyarden M, Hamid NS. Fever of unknown origin (FUO) caused by multiple myeloma: the diagnostic value of the Naprosyn test. *Heart Lung* 2006;35(5):358-362.
160. Tal S, Guller V, Gurevich A, Levi S. Fever of unknown origin in the elderly. *J Intern Med* 2002;252(4):295-304.
161. Holland SM, Gallin JI. Evaluation of the patient with suspected immunodeficiency. In: Mandell GL, Bennett JE, Dolin R, eds. *Principles and practice of infectious diseases*. Philadelphia, PA: Elsevier Churchill Livingstone, 2010.
162. Hanna S, Etzioni A. Leukocyte adhesion deficiencies. *Ann N Y Acad Sci* 2012;1250:50-55.
163. Picard C, Casanova JL, Puel A. Infectious diseases in patients with IRAK-4, MyD88, NEMO, or I κ B α deficiency. *Clin Microbiol Rev* 2011;24(3):490-497.
164. Sowerwine KJ, Holland SM, Freeman AF. Hyper-IgE syndrome update. *Ann N Y Acad Sci* 2012;1250:25-32.
165. Yarmohammadi H, Estrella L, Doucette J, Cunningham-Rundles C. Recognizing primary immune deficiency in clinical practice. *Clin Vaccine Immunol* 2006;13(3):329-332.
166. Buckley RH. Pulmonary complications of primary immunodeficiencies. *Paediatr Respir Rev* 2004;5 Suppl A:S225-233.
167. Savides C, Shaker M. More than just infections: an update on primary immune deficiencies. *Curr Opin Pediatr* 2010;22(5):647-654.
168. Borte S, Wang N, Oskarsdottir S, Von Döbeln U, Hammarström L. Newborn screening for primary immunodeficiencies: beyond SCID and XLA. *Ann N Y Acad Sci* 2011;1246:118-130.
169. Mccusker C, Warrington R. Primary immunodeficiency. *Allergy Asthma Clin Immunol* 2011;7 Suppl 1:S11.
170. Boyle JM, Buckley RH. Population prevalence of diagnosed primary immunodeficiency diseases in the United States. *J Clin Immunol* 2007;27(5):497-502.
171. Song E, Jaishankar GB, Saleh H, Jithpratuck W, Sahni R, Krishnaswamy G. Chronic granulomatous disease: a review of the infectious and inflammatory complications. *Clin Mol Allergy* 2011;9(1):10.
172. Orange JS. Congenital immunodeficiencies and sepsis. *Pediatr Crit Care Med* 2005;6(3 Suppl):S99-S107.
173. Rosenzweig SD, Holland SM. Phagocyte immunodeficiencies and their infections. *J Allergy Clin Immunol* 2004;113(4):620-626.
174. Shearer WT, Paul ME, Smith CW, Huston DP. Laboratory assessment of immune deficiency disorders. *Immunol Allergy Clin North Am* 1994;14:265-299.
175. Siegel RL, Issekutz T, Schwaber J, Rosen FS, Geha RS. Deficiency of T helper cells in transient hypogammaglobulinemia of infancy. *N Engl J Med* 1981;305(22):1307-1313.
176. Winkelstein JA, Marino MC, Lederman HM, et al. X-linked agammaglobulinemia: report on a United States registry of 201 patients. *Medicine (Baltimore)* 2006;85(4):193-202.
177. Castigli E, Geha RS. Molecular basis of common variable immunodeficiency. *J Allergy Clin Immunol* 2006;117(4):740-746; quiz 747.
178. Pearl ER, Vogler LB, Okos AJ, Crist WM, Lawton AR 3rd, Cooper MD. B lymphocyte precursors in human bone marrow: an analysis of normal individuals and patients with antibody-deficiency states. *J Immunol* 1978;120(4):1169-1175.

179. Lougaris V, Badolato R, Ferrari S, Plebani A. Hyper immunoglobulin M syndrome due to CD40 deficiency: clinical, molecular, and immunological features. *Immunol Rev* 2005;203:48-66.
180. Grimbacher B, Holland SM, Puck JM. Hyper-IgE syndromes. *Immunol Rev* 2005;203:244-250.
181. Holland SM, Deleo FR, Elloumi HZ, et al. STAT3 mutations in the hyper-IgE syndrome. *N Engl J Med* 2007;357(16):1608-1619.
182. Heiner DC. Significance of immunoglobulin G subclasses. *Am J Med* 1984;76(3A):1-6.
183. Knight AK, Cunningham-Rundles C. Inflammatory and autoimmune complications of common variable immune deficiency. *Autoimmun Rev* 2006;5(2):156-159.
184. Resnick ES, Moshier EL, Godbold JH, Cunningham-Rundles C. Morbidity and mortality in common variable immune deficiency over 4 decades. *Blood* 2012;119(7):1650-1657.
185. Skattum L, Van Deuren M, Van Der Poll T, Truedsson L. Complement deficiency states and associated infections. *Mol Immunol* 2011;48(14):1643-1655.
186. Sjöholm AG, Jonsson G, Braconier JH, Sturfelt G, Truedsson L. Complement deficiency and disease: an update. *Mol Immunol* 2006;43(1-2):78-85.
187. Seelen MA, Roos A, Wieslander J, et al. Functional analysis of the classical, alternative, and MBL pathways of the complement system: standardization and validation of a simple ELISA. *J Immunol Methods* 2005;296(1-2):187-198.
188. Etzioni A, Doerschuk CM, Harlan JM. Of man and mouse: leukocyte and endothelial adhesion molecule deficiencies. *Blood* 1999;94(10):3281-3288.
189. Hibbs ML, Wardlaw AJ, Stacker SA, et al. Transfection of cells from patients with leukocyte adhesion deficiency with an integrin beta subunit (CD18) restores lymphocyte function-associated antigen-1 expression and function. *J Clin Invest* 1990;85(3):674-681.
190. Rosenzweig SD, Holland SM. Recent insights into the pathobiology of innate immune deficiencies. *Curr Allergy Asthma Rep* 2011;11(5):369-377.
191. Van De Vosse E, Van Dissel JT, Ottenhoff TH. Genetic deficiencies of innate immune signalling in human infectious disease. *Lancet Infect Dis* 2009;9(11):688-698.
192. Kawai T, Malech HL. WHIM syndrome: congenital immune deficiency disease. *Curr Opin Hematol* 2009;16(1):20-26.
193. Cossu F. Genetics of SCID. *Ital J Pediatr* 2010;36:76.
194. De Villartay JP. V(D)J recombination deficiencies. *Adv Exp Med Biol* 2009;650:46-58.
195. Ochi T, Sibanda BL, Wu Q, Chirgadze DY, Bolanos-Garcia VM, Blundell TL. Structural biology of DNA repair: spatial organisation of the multicomponent complexes of nonhomologous end joining. *J Nucleic Acids* 2010;2010:Article ID 621695.
196. Driscoll DA, Salvin J, Sellinger B, et al. Prevalence of 22q11 microdeletions in DiGeorge and velocardiofacial syndromes: implications for genetic counselling and prenatal diagnosis. *J Med Genet* 1993;30(10):813-817.
197. Lisowska-Grospierre B, Charron DJ, De Preval C, Durandy A, Griscelli C, Mach B. A defect in the regulation of major histocompatibility complex class II gene expression in human HLA-DR negative lymphocytes from patients with combined immunodeficiency syndrome. *J Clin Invest* 1985;76(1):381-385.
198. Marrella V, Maina V, Villa A. Omenn syndrome does not live by V(D)J recombination alone. *Curr Opin Allergy Clin Immunol* 2011;11(6):525-531.
199. Thomas PD, Hunninghake GW. Current concepts of the pathogenesis of sarcoidosis. *Am Rev Respir Dis* 1987;135(3):747-760.
200. Twomey JJ, Laughter AH, Rice L, Ford R. Spectrum of immunodeficiencies with Hodgkin's disease. *J Clin Invest* 1980;66(4):629-637.
201. Smith DK, Neal JJ, Holmberg SD. Unexplained opportunistic infections and CD4+ T-lymphocytopenia without HIV infection. An investigation of cases in the United States. The Centers for Disease Control Idiopathic CD4+ T-lymphocytopenia Task Force. *N Engl J Med* 1993;328(6):373-379.
202. Walker UA, Warnatz K. Idiopathic CD4 lymphocytopenia. *Curr Opin Rheumatol* 2006;18(4):389-395.

203. Kuijpers TW, Ijspeert H, Van Leeuwen EM, et al. Idiopathic CD4+ T lymphopenia without autoimmunity or granulomatous disease in the slipstream of RAG mutations. *Blood* 2011;117(22):5892-5896.

204. Gorska MM, Alam R. A mutation in the human uncoordinated 119 gene impairs TCR signaling and is associated with CD4 lymphopenia. *Blood* 2012;119(6):1399-1406.

Chapter 57 Neutropenia

> Table of Contents > Part VI - Benign Disorders of Leukocytes, The Spleen, and/or Immunoglobins > Chapter 57 - Neutropenia

Chapter 57

Neutropenia

Caron A. Jacobson

Nancy Berliner

INTRODUCTION

The normal range for the peripheral white blood count (WBC) is between $4.5 \times 10^9/L$ and $10.0 \times 10^9/L$, with a mean of $7.5 \times 10^9/L$. The total WBC includes neutrophils and lymphocytes, as well as smaller numbers of monocytes, basophils, and eosinophils. Leukopenia, a depressed WBC, may reflect either neutropenia or lymphopenia. Neutrophils constitute about 60% of the peripheral WBC, and therefore, reduction of WBC number most commonly reflects a decreased absolute neutrophil count (ANC). Neutropenia can occur as a secondary manifestation of an underlying disease or exposure or may reflect primary hematologic disease. This chapter focuses on the primary and secondary causes of neutropenia.

NORMAL NEUTROPHIL KINETICS

The circulating neutrophil pool represents only approximately 5% of the body's total neutrophil number. It is therefore a fairly distant reflection of the dynamics of neutrophil maturation within the bone marrow.¹ Neutrophils arise in the bone marrow from a multipotent progenitor cell that also gives rise to all other formed elements of the blood. Maturation of neutrophil precursors occurs over 6 to 10 days. The majority of mature neutrophils constitute a storage pool that remains in the bone marrow poised for release as needed. The proliferating pool and storage pool together make up about 95% of the total granulocyte mass. Of the remaining 5% of neutrophils that enter the peripheral circulation, about 60% are a "marginating pool" that adheres to the vascular endothelium. These marginated neutrophils are easily mobilized into the circulation in response to stress. Circulating neutrophils survive for only 6 to 12 hours; when mobilized to sites of infection or inflammation, they can migrate into tissues where they survive for 1 to 4 days. Neutropenia can occur upon disruption of any of these processes: it may reflect decreased marrow production, increased margination (especially in the setting of splenomegaly and sequestration by the spleen), or peripheral immune destruction of mature cells.

DEFINITION AND CLASSIFICATION OF NEUTROPENIA

Neutropenia is defined by a decreased ANC, calculated by multiplying the total WBC by the percentage of neutrophils and bands noted on the differential cell count. What constitutes a low ANC differs by age, sex, race, and other factors; the normal range for the ANC for a given population, then, is defined as the mean ANC for that population +/- two standard deviations.^{2, 3} In general, however, an ANC less than $1.5 \times 10^9/L$ is considered neutropenic in most patient populations. Neutropenia can be further classified as mild, moderate, or severe based on the degree of ANC depression: an ANC of 1.0 to $1.5 \times 10^9/L$ is considered mild, 0.5 to $1.0 \times 10^9/L$ is considered moderate, and less than $0.5 \times 10^9/L$ is considered severe. Although this classification is useful in predicting the risk of severe bacterial infection, other features may modify the risk. The risk of infection may be modified by the neutrophil storage pool.⁴ Risk may also be modified by the cause of neutropenia. For instance, chemotherapy-induced neutropenia is associated with a much greater risk of serious infection than chronic immune or nonimmune neutropenia. The risk of infection is also a function of both the degree and duration of neutropenia.⁵

DIFFERENTIAL DIAGNOSIS

The differential diagnosis of neutropenia includes pseudoneutropenia, primary or congenital neutropenias (Table 57.1), and acquired neutropenias (Table 57.2). Global marrow defects such as aplastic anemia, leukemia, myelodysplasia, or myeloproliferative disorders can also cause neutropenia and are discussed in other chapters. Here we outline and discuss the causes of isolated neutropenia.

Pseudoneutropenia

Neutropenia may be the result of laboratory or clerical error, an artifact due to prolonged processing time of a peripheral blood specimen, the consequence of neutrophil clumping due to the presence of a paraprotein or certain anticoagulants, or as a result of marginalization of the circulating neutrophil pool.^{6, 7} In each of these situations, the ANC is not actually low and these patients are not at increased risk of infection. Manual examination of the peripheral blood smear and repeated measurements can help to differentiate these causes of pseudoneutropenia from true neutropenia.

Primary Causes of Neutropenia

Ethnic and Benign Familial Neutropenia

A number of racial and ethnic groups have neutrophil counts that fall below the published normal range, which is largely based on Caucasian populations. These include African Americans, Yemenite Jews, Falasha Jews, and African Bedouins.^{8, 9, 10, 11} The occurrence of ethnic neutropenia has been linked to single nucleotide polymorphisms in the gene encoding the Duffy antigen receptor for chemokine (DARC), which is also the receptor for the malarial parasite. Loss of expression of the Duffy blood group is prevalent in the areas where malaria is endemic, which are also areas where ethnic neutropenia has been described.¹² There is also an autosomal dominantly inherited condition called benign familial neutropenia characterized by neutrophil counts in the 800 to 1,400/ μ l range, for which the responsible gene is not known.

Ethnic and benign familial neutropenias are not associated with an increased risk of infection.^{13, 14} Bone marrow biopsies have normal cellularity but a reduction in mature granulocytes and neutrophil kinetic studies reveal a reduced myeloid precursor pool in the marrow, reduced mitotic pool size, and reduced concentration of colony-forming unit culture (CFU-C) consistent with the faulty release of mature neutrophils from the bone marrow.^{15, 16}

Nonfamilial Chronic Benign and Idiopathic Chronic Severe Neutropenia

Nonfamilial chronic benign neutropenia is a condition defined by neutropenia in the absence of a familial pattern and without an increased risk of infection. There is often a compensatory monocytosis and eosinophilia and bone marrow biopsies show hypercellularity and myeloid hyperplasia with maturation arrest at the band stage of myeloid ontogeny. Neutrophil counts do

P.1280

rise, however, under conditions of stress such as infection or exogenous epinephrine or corticosteroid administration, perhaps explaining the absence of risk for infection.¹⁷ Some cases are associated with the presence of autoantibodies pointing toward an immune mechanism in the pathophysiology of this condition.^{18, 19} Other cases seem to be the result of abnormal phagocytosis of normal marrow neutrophils by macrophages or the result of T-cell and cytokine-mediated suppression of granulopoiesis in the bone marrow.^{20, 21} Included in this diagnosis is chronic benign granulocytopenia of infancy and childhood which typically resolves spontaneously around age 4 years.¹⁷ Although neutrophil counts do rise in response to G-CSF administration, G-CSF therapy is not recommended given the relatively benign clinical course associated with this condition.^{22, 23}

TABLE 57.1 DIFFERENTIAL DIAGNOSIS AND FEATURES OF CONGENITAL NEUTROPENIA

Syndrome	Inheritance Pattern	Gene (Frequency)	Clinical Features
Ethnic neutropenia	?	<i>DARC</i> SNPs (?%)	African American, Yemenite and Falasha Jews, African Bedouins; Mild and clinically insignificant neutropenia
Benign familial neutropenia	AD	?	Mild and clinically insignificant neutropenia
Severe congenital neutropenia	AR	Unknown (~40%)	Severe (ANC <500), chronic neutropenia; increased risk of severe infection and MDS/AML; responsive to G-CSF
	AD	<i>HAX1</i> (~0-2%) <i>G6PC3</i>	
	X-linked	(~4%)	

			<i>ELANE</i> (~55%) <i>WASP</i> (~2%)	
Cyclic neutropenia	AD		<i>ELANE</i> (100%)	Severe (ANC <200) neutropenia for 3-5 d every 21 d; increased risk of infection during nadir; responsive to G-CSF; no increased risk of MDS/AML; sporadic forms a/w diseases such as LGL
Shwachman-Diamond syndrome	AR		<i>SBDS</i> (100%)	ANC 200-800 at infancy; progresses to marrow failure; pancreatic dysfunction, skeletal abnormalities, and developmental retardation; increased risk of MDS/AML; responsive to G-CSF and SCT
Fanconi anemia	AR X-linked		<i>FANCA</i> ^a - <i>SLX4</i>	Marrow failure; short stature with upper limb abnormalities; <i>café-au-lait</i> spots; increased risk of malignancies; neutropenia is responsive to G-CSF and RIC SCT
Dyskeratosis congenita	X-linked AD		<i>DKC1</i> (~80%) <i>TERC</i> (0-20%) <i>TERT</i> (0-20%)	Marrow failure; nail dystrophy; leukoplakia; skin pigmentation abnormalities; pulmonary and liver fibrosis; osteoporosis; premature graying of the hair; increased risk of MDS/AML and other malignancies
	AR		Misc (0-20%)	
Glycogen storage disease Ib	AR		<i>SLC37A4</i> (100%)	Hepatomegaly; metabolic crises; neutropenia
Myelokathexis	AD		<i>CXCR4</i> (100%)	Neutropenia due to marrow retention; can be part of the WHIM syndrome; responsive to G-CSF and the CXCR4 antagonist plerixafor
Chediak-Higashi syndrome	AR		<i>LYST</i> (100%)	Oculocutaneous albinism; platelet dysfunction; neurologic disease; neutropenia; risk of HLH
Griscelli syndrome II	AR		<i>RAB27A</i> (100%)	Oculocutaneous albinism; neutropenia
Hermansky-Pudlak syndrome II	AR		<i>AP3B1</i> (100%)	Oculocutaneous albinism; platelet dysfunction; pulmonary fibrosis; neutropenia
Cartilage-hair hypoplasia	AR		<i>RMRP</i> (100%)	Moderate-severe neutropenia; short-limb dwarfism; fine hair; defects in cellular immunity

AD, autosomal dominant; ANC, absolute neutrophil count; AR, autosomal recessive; G-CSF, granulocyte colony stimulating factor; HLH, hemophagocytic lymphohistiocytosis; LGL, large granular lymphocytosis; MDS/AML, myelodysplastic syndrome/acute myelogenous leukemia; Misc, miscellaneous; RIC, reduced intensity conditioning; SCT, stem cell transplantation; SNPs, single nucleotide polymorphisms; WHIM syndrome, warts, hypogammaglobulinemia, immunodeficiency, myelokathexis syndrome.

^a Indicates the most commonly mutated complementation group in Fanconi anemia.

Idiopathic chronic severe neutropenia is distinguished from this benign condition in that it typically affects patients in their late childhood or as adults and has a more severe clinical course with increased risk and number of infections.²⁴ There is evidence of myeloid hypoplasia, maturation arrest, or abnormal myeloid morphology on bone marrow biopsy; the form

associated with severe myeloid hypoplasia is called chronic hypoplastic neutropenia.^{25, 26} To diagnose patients with idiopathic chronic severe neutropenia, other causes of neutropenia must be ruled out, including autoimmune etiologies. The pathogenesis of this form of severe neutropenia is completely unknown. Despite ANC's that may be in the 100 to 250 cells/ μ l range, these patients have a remarkably benign course, although some have recurrent infections requiring chronic cytokine support with G-CSF.

A large body of literature has focused on chronic neutropenia in Greece. The incidence of neutropenia on the island of Crete is quite high. This should be distinguished from chronic severe neutropenia, in that nearly all these patients have an ANC in the 0.8 to $1.4 \times 10^9/L$ range, and an ANC of $<0.5 \times 10^9/L$ rarely if ever occurs. There is evidence that these patients may have a cytokine-mediated, inflammatory component to their illness.²¹ It is unknown whether these patients have an increased prevalence of the DARC polymorphism associated with neutropenia.

Severe Congenital Neutropenia

Severe congenital neutropenia (SCN) is a disorder of severe neutropenia first described in 1956 by Rolf Kostmann. He postulated that this was the first described congenital disorder of neutrophil number, presenting as an autosomal recessive disorder in neonates and infants with neutrophil counts <500 cells/ μ l associated with recurrent bacterial infections, most commonly due to *Staphylococcus aureus*, *Escherichia coli*, and *Pseudomonas aeruginosa*.^{27, 28} His original report described this syndrome in nine families from a remote region in northern Sweden where consanguinity was common, explaining the increased incidence

P.1281

of this rare autosomal recessive syndrome.²⁷ The syndrome was named infantile genetic agranulocytosis, which later was renamed SCN or Kostmann syndrome. Afflicted children suffer from infections that can occur as early as the first months of life and often include omphalitis and perirectal abscesses; otitis media, pneumonia, gingivitis, and urinary tract infections are also common. The diagnosis is usually apparent within the first 3 months of life. Death may occur as a result of septicemia, peritonitis, and enteritis, with fatal infections common in infancy and early childhood. All patients have severe neutropenia with an ANC $<0.5 \times 10^9/L$, but often $<0.2 \times 10^9/L$, and there is often an increase in other myeloid cell lines including monocytes and eosinophils. SCN was previously hypothesized to be a result of a deficiency in G-CSF or its receptor but further studies have demonstrated that G-CSF production is not impaired in patients with SCN, G-CSF receptor number and function are normal in patients with SCN, and the administration of G-CSF results in correction of neutropenia and improved clinical outcomes.^{29, 30, 31, 32, 33} Kostmann's early studies suggested that intramedullary apoptosis of myeloid precursors was a prominent feature of SCN, and more recent studies have confirmed that accelerated apoptosis is a central defect of this disorder, suggesting that G-CSF functions to correct the phenotype in part through its activity as an antiapoptotic agent.^{34, 35, 36, 37}

TABLE 57.2 DIFFERENTIAL DIAGNOSIS AND FEATURES OF ACQUIRED NEUTROPENIAS

Cause	Mechanism	Management
<i>Infection</i>		
Viral	Redistribution; decreased production; immune destruction	Supportive care; treatment of the underlying infection; G-CSF or WBC transfusions reserved for protracted or severe cases; IVIg may be useful for immune or complement mediated neutrophil destruction
Atypical organisms	Redistribution; decreased production; immune and complement mediated destruction; direct marrow suppression	
Sepsis	Consumption of the marrow neutrophil reserve; increased margination	
<i>Drug-induced</i>		
Penicillin, PTU, gold	Immune-mediated destruction via hapten-induced antibody formation and complement	Supportive care; removal of the offending agent; G-CSF reserved for protracted or severe cases

	fixation or the formation of circulating immune complexes	
Valproic acid, Carbamazepine, β -lactams	Dose-dependent inhibition of CFU-GM resulting in marrow suppression	
<i>Immune-mediated</i>		
Systemic/autoimmune disease	Pan-reactive antibodies against neutrophils and neutrophil precursors	Supportive care; treatment of the underlying condition; G-CSF as needed
LGL/Felty's syndrome	Antineutrophil antibodies and immune complex mediated neutrophil destruction; increased neutrophil adhesion to the endothelium; FAS mediated apoptosis of neutrophils; impaired myelopoiesis; splenic destruction	Supportive care; immunosuppression with methotrexate, cyclosporine, cyclophosphamide, and/or rituximab; G-CSF as needed
Neonatal alloimmune neutropenia	Maternal IgG antibodies to paternally inherited neutrophil antigens	Self-limited; supportive care with antibiotics as needed; plasma exchange, IVIg, maternal neutrophils for life-threatening infections
Autoimmune neutropenia of infancy and childhood;	Antibody mediated neutrophil destruction, usually against a specific neutrophil antigen	Supportive care; G-CSF therapy to prevent recurrent or severe infection
Primary autoimmune neutropenia of adults		
Pure white cell aplasia	Cellular and humoral immune mediated; associated with thymoma	Thymectomy; adjuvant cyclophosphamide, steroids, cyclosporine, IVIg, and/or SCT
<i>Neutrophil margination/hypersplenism</i>	C5a and complement activation leading to increased adhesion and aggregation within pulmonary vessels; splenic sequestration	
<i>Nutritional deficiency (B12, folate, copper)</i>	Ineffective myelopoiesis and maturation arrest	Vitamin and mineral replacement

Abbreviations: G-CSF - granulocyte colony stimulating factor; WBC - white blood cell; IVIg - intravenous immunoglobulin; PTU - propylthiouracil; CFU-GM - colony forming unit granulocyte macrophages; LGL - large granular lymphocytosis; IgG - immunoglobulin class G; SCT - stem cell transplantation.

Since the initial description in 1956, SCN has come to be recognized as a syndrome resulting from a heterogeneous mix of genetic mutations with different patterns of inheritance. SCN can follow autosomal dominant, autosomal recessive, and X-linked patterns of inheritance and has been shown to be associated with mutations in a variety of genes including those for neutrophil elastase, HAX-1, WAS (WASP), GF11, SBDS, and G6PC3.^{38, 39, 40, 41, 42} Neutrophil elastase (ELANE) is a serine protease that is synthesized predominantly at the promyelocyte stage of neutrophil maturation and stored in primary granules. It has been hypothesized that ELANE mutations lead to cytoplasmic accumulation of defective protein, subsequently triggering apoptosis. Evidence supports activation of the unfolded protein response as the driver of

apoptosis in ELANE-associated SCN.^{43, 44} SCN due to ELANE mutations is inherited in an autosomal dominant fashion. It was the first SCN gene to be identified and is responsible for the majority of cases of SCN. It is not the mutation found in the original Swedish cohort described by Kostmann, however, which is an autosomal recessive disorder that results from mutations in HAX-1.⁴⁵ "Kostmann's syndrome" now refers only to SCN with mutant HAX-1.⁴¹ HAX-1 is a mitochondrial protein with weak homology to BCL-2 and its absence results in mitochondrial-dependent apoptosis. WASP regulates actin polymerization in hematopoietic cells. Absolute deficiency in this protein resulting from gene-inactivating mutations results in the Wiskott-Aldrich syndrome, characterized by thrombocytopenia, small platelets, sinopulmonary infections, and eczema. WASP mutations resulting in hypomorphic alleles, however, may lead to X-linked thrombocytopenia and neutropenia.^{40, 42} GFI1 encodes a transcription factor, growth factor independent-1, that regulates the expression of genes involved in granulopoiesis, Shwachman-Bodian-Diamond syndrome gene (SBDS) encodes a gene involved in ribosomal RNA regulation and is responsible for Shwachman-Diamond syndrome (SDS) (which is discussed in a later section), and G6PC3 encodes the catalytic subunit 3 of glucose-6-phosphatase. Mutations in each of these three genes have been associated with SCN.^{46, 47, 48}

P.1282

The gene(s) responsible for approximately 40% of SCN, however, remains unknown.⁴⁰

Although G-CSF receptor signaling is intact in the vast majority of patients with SCN, rare patients have been described in which SCN arises from a congenital abnormality in the G-CSF receptor. Not surprisingly, these patients are marked by resistance to therapy with G-CSF.^{49, 50, 51, 52} The most important observation to emerge from the studies of the G-CSF receptor in SCN, however, is the finding of frequent somatic mutations in the G-CSF receptor arising in patients with SCN on cytokine therapy. When searching for potential constitutional mutations in the G-CSF receptor that might cause SCN, investigators identified a somatic missense mutation that appeared to be associated with transformation to myelodysplastic syndrome (MDS) and acute myelogenous leukemia (AML).⁴⁹ This mutation introduces a stop codon leading to truncation of the distal intracellular domain of the receptor. The distal portion of the receptor is known to be the site of JAK-STAT activation and maturation signaling.⁴⁹ Some investigators have postulated that the mutation causes proliferation at the expense of maturation, explaining why patients with this mutation have a higher risk of MDS/AML.⁵³ It has clearly been demonstrated that the mutation shifts the dose-response curve for G-CSF, rendering the cells hyperproliferative, and permitting clonal dominance of the mutant clone in the setting of G-CSF therapy. Whether the mutation actually blocks differentiation or merely predisposes to further genetic events by virtue of increasing cell proliferation remains controversial. Regardless, these G-CSF receptor mutations have been found to confer resistance to apoptosis and enhance cell survival in patients with SCN.⁵⁴

In general, patients with SCN have an increased risk of developing MDS and AML at a rate of approximately 2% to 8% per year.^{55, 56, 57} In patients who do develop MDS and/or AML, there appears to be a sequential gain of mutations that were not present in the subpopulation of progenitor cells in the early SCN phase such that over two thirds of patients with SCN that develop MDS or leukemia have a G-CSF receptor mutation (CSF3R).⁵⁸ Increasing mutations in the G-CSF receptor gene point toward a role for aberrant G-CSF receptor signaling in leukemogenesis.^{58, 59} The role of G-CSF in causing or promoting these mutations remains unknown and a subject of considerable controversy.

G-CSF has revolutionized the treatment and management of SCN. Prior to the development of G-CSF as a clinical agent, SCN was almost uniformly fatal, with death from infection occurring in infancy or early childhood. Patients were treated with corticosteroids, testosterone, splenectomy, vitamin B6, and lithium, all of which were largely ineffective.^{60, 61, 62, 63} The use of G-CSF for this disease began in the 1980s, and has prevented infection in the vast majority of patients (80% to 90%), although some patients require higher doses.^{57, 64} The resultant increased life expectancy of these patients has coincided with an increased incidence of MDS and AML. This has led some to posit that G-CSF therapy facilitates the transformation to these malignant diseases, whereas others contend that prolonged survival allows for the emergence of a predisposition to MDS/AML as part of the natural history of this disease. The potential role of G-CSF in the development of MDS/AML in SCN is discussed later in this chapter. Chronic G-CSF therapy in this disease has led to other complications, including osteoporosis, vasculitis, splenomegaly, hepatomegaly, and glomerulonephritis.^{57, 64}

Cyclic Neutropenia

Cyclic neutropenia (CN) is a periodic disorder characterized by neutropenia ($ANC \leq 0.2 \times 10^9/L$) occurring at approximately 21-day intervals, although one quarter of patients may have cycles as short as 12 days or as long as 36 days.^{65, 66, 67} Nadirs of the ANC last 3 to 5 days and may be associated with recurrent fevers, aphthous ulcers, and infections of the skin, upper respiratory tract, and ears. The severity of infection reflects the severity and duration of neutropenia.⁶⁸ Fatal infections

are uncommon, however, owing to the relatively brief period of neutropenia that is the hallmark of this disease, and as a result patients enjoy favorable overall survivals. With time, the cyclic nature of the disorder becomes less prominent, however, and patients can look more like patients with chronic neutropenia.⁶⁹ It was first described in 1910 in an infant with recurrent episodes of fever, stomatitis, skin infections, and neutropenia.⁷⁰ Diagnosis of CN can be demonstrated by documenting intermittent neutropenia via blood counts every 2 to 3 weeks over a course of 6 weeks, but can now be confirmed by the detection of a pathogenic mutation in the setting of a suggestive pattern of WBC fluctuation. CN is inherited as an autosomal dominant disorder, although it may arise sporadically. CN can also be acquired in association with systemic diseases such as large granular lymphocytosis.^{71, 72} Virtually 100% of patients with congenital CN also have point mutations in the gene for neutrophil elastase (ELANE).⁷³ These mutations are largely distinct from those that are associated with SCN, although both syndromes have been seen arising from the same mutation within the same pedigree.^{74, 75}

Serial measurements of other hematopoietic cells in patients with CN reveal a periodicity to the numbers of platelets, reticulocytes, monocytes, and eosinophils as well, and the condition is sometimes referred to as cyclic hematopoiesis.⁷⁶ As opposed to the depression seen in the neutrophil count, these other cells are often increased in number on or around periods of neutropenia.⁷⁷ Bone marrow biopsies done during times of neutropenia and times of normal neutrophil counts reveal an absence of neutrophils and neutrophil precursors immediately preceding the period of neutropenia, whereas neutrophil precursors increase in number before recovery of peripheral neutrophil counts.⁷⁸ The periodicity of the cell counts is thought to be the result of variations in the rate of release of mature cells from the marrow. Although knock-in mice fail to reproduce the phenotype of either SCN or CN, a dog model of CN has provided insight into its pathogenesis.⁷⁹ In grey collie dogs, the disease can be transmitted to unaffected animals following bone marrow transplantation from an affected animal and can be cured following transplantation from an unaffected animal.⁸⁰ In humans, a patient with acute lymphoblastic leukemia treated with a donor stem cell transplantation from a sibling with this disorder developed the disease.⁸¹ These observations and experiments support the notion that this disease is the result of an intrinsic stem cell regulatory defect, possibly related to accelerated apoptosis.⁸² A comparison of bone marrow biopsies from patients with CN and SCN, and normal subjects revealed that there were no differences in the frequency of CD34, KIT, and G-CSFR expression on marrow precursor cells between CN patients and normal subjects.⁸³ Differences emerged, however, in response to hematopoietic growth factors with impaired granulopoiesis in both CD34⁺/KIT⁺/G-CSFR⁺ and CD34⁺/KIT⁺/G-CSFR⁻ cells in patients with CN; in SCN impaired granulopoiesis was only observed in the former.

Despite the impairment of granulopoiesis observed in response to hematopoietic growth factors, this disease is successfully treated with G-CSF and is not associated with an increased risk of leukemic transformation.^{57, 69, 84} G-CSF therapy does not prevent the cyclical depressions in neutrophil counts but does decrease the duration of neutropenia. GM-CSF therapy, on the other hand, has been noted to prevent the cycles but not to increase the neutrophil numbers to the same extent as seen with G-CSF.⁸⁵ G-CSF remains the treatment of choice for this disease when therapy is required. Lower doses of G-CSF are needed for the treatment of CN than SCN, with a median dose of 2.5 µg/kg/day in one cohort.⁶⁵ G-CSF is safe and well tolerated, although patients may develop a gradual asymptomatic splenic enlargement.⁶⁹ The acquired, adult-onset forms of CN that are associated with systemic diseases are treated differently and are often successfully managed with immunosuppression including daily or alternatedaily corticosteroids or cyclosporine.^{86, 87} These therapies are not successful in the congenital forms of this disease.^{65, 68}

P.1283

Congenital Immune Defects with Associated Neutropenia

Patients with inherited immunodeficiencies of humoral and/or cellular immunity are at risk of developing neutropenia. The infectious consequences in such patients are magnified due to the co-existing immune defects. Diseases involving immunoglobulin production, including X-linked agammaglobulinemia, hyper-IgM syndrome, dysgammaglobulinemia type I, isolated IgA deficiency, and familial forms of hypogammaglobulinemia have all been associated with periodic neutropenia and in some are thought to be related to the production of autoantibodies.^{88, 89, 90, 91, 92} These patients should be treated with intravenous immunoglobulin, which may correct both immune defects, with growth factors reserved for patients who do not respond to immunoglobulin replacement.⁹³ Likewise, neutropenia has been associated with defects in cellular immunity; one familial syndrome was described in 1976 in which patients manifested severe neutropenia coincident with decreased antibody production in response to tetanus and poliomyelitis vaccines with resultant infectious complications.⁹⁴ Finally, reticular dysgenesis is a rare immunodeficiency marked by severe neutropenia, lymphopenia, agammaglobulinemia and absent cellular immunity believed to be due to an inherent defect in

hematopoietic stem cells committed to myeloid and lymphoid development.^{95, 96} It is not responsive to G-CSF but can be cured with stem cell transplantation.^{97, 98, 99}

Other Congenital Syndromes with Associated Neutropenia

Neutropenia is an important feature of several other congenital disorders. (see also Chapter 37.) These include SDS, Fanconi anemia (FA), dyskeratosis congenita (DKC), glycogen storage disease Ib, myelokathexis, Chediak-Higashi syndrome (CHS), Griscelli syndrome type II (GS2), Hermansky-Pudlak syndrome II (HPSII), and cartilage-hair hypoplasia.

SDS usually presents with neutropenia in infancy and subsequently progresses to marrow failure. It is also associated with pancreatic dysfunction and skeletal abnormalities.¹⁰⁰ It was initially described in 1964 and is also associated with anemia, thrombocytopenia, developmental and mental retardation, diarrhea, weight loss, failure to thrive, eczema, recurrent otitis media and pneumonia, and neutrophil motility defects.^{101, 102, 103} SDS is an autosomal recessive disease caused by mutations in the SBDS on chromosome 7q, which is involved in the regulation of ribosomal RNA processing.⁴⁷

Neutropenia, in the range of 0.2 to $0.8 \times 10^9/L$, appears to be the result of myeloid hypoplasia.¹⁰⁴ The mechanism of neutropenia is unknown, but neutrophils from affected patients appear to have increased ubiquitin-proteasome-rich cytoplasmic structures.¹⁰⁵ SDS patients are predisposed to the development of MDS/AML, with myelodysplasia or clonal cytogenetic abnormalities (usually monosomy 7) present in up to one third of patients. The risk of severe hematologic complications is greatest in patients with cytopenias and symptoms before 3 months of age.^{106, 107} Before the use of G-CSF for this disease mortality reached 25% and was the result of infection, marrow failure, and/or malignancy.¹⁰⁸ The use of G-CSF, at an average dose of $4.3 \mu\text{g/kg/day}$, corrects the neutropenia and decreases the risk and mortality from infection.¹⁰⁹ As seen in SCN, however, the use of G-CSF and improvements in survival have also been associated with increased risk of MDS and AML and it is unclear if this is due to G-CSF or the natural history of the disease; the risk of MDS/AML is similar to that seen in SCN in the International Registry but was slightly lower than this in the French Registry.¹¹⁰ Stem cell transplantation can be curative but is associated with increased transplant-related morbidity and mortality and thus requires careful consideration and consultation with experienced transplant centers.^{111, 112, 113, 114} The successful use of reduced intensity conditioning transplantation for this disease may make transplant a more widely available option for these patients.¹¹⁵

FA is the most common cause of congenital aplastic anemia. It can be inherited in an autosomal recessive or X-linked manner and is due to mutations in genes involved in DNA repair. Marrow failure develops somewhat later than in other congenital marrow syndromes (median age 7 years), presumably because marrow failure occurs secondary to acquired mutations in the setting of defective DNA repair.^{116, 117, 118} Multiple genes have been found to be mutated in FA and 15 complementation groups have been identified (FANCA-SLX4 I [FA-P]), with FANCA being the most common.¹¹⁹ In addition to marrow dysfunction, up to two thirds of patients with FA have a constellation of other abnormalities, including short stature with upper limb anomalies, and hyperpigmented, café-au-lait spots. FA patients are at increased risk for malignancies, especially MDS/AML and squamous cell carcinomas.¹²⁰ The diagnosis of FA is established by demonstrating chromosomal fragility following exposure to diepoxybutane or mitomycin C; subsequent gene analysis can then identify mutations in one of the genes involved in the DNA repair complex.¹²¹ Stem cell transplantation can treat the hematologic manifestations of the disease but carries a high risk of morbidity and mortality due to the effects of conditioning on these patients with impaired DNA repair; consequently, reduced intensity conditioning regimens are necessary.^{122, 123, 124, 125, 126} Other therapies for the hematologic manifestations of this disease include androgens, which may be effective in half of FA patients, and growth factors such as G-CSF at doses starting at $5 \mu\text{g/kg/d}$.^{127, 128}

DKC is a rare multiorgan syndrome associated with neutropenia and/or aplastic anemia; patients may also have other abnormalities, including nail dystrophy, leukoplakia, and abnormal skin pigmentation.^{129, 130, 131} Additional clinical manifestations include premature graying of the hair, idiopathic pulmonary fibrosis, cancer predisposition (including AML and solid tumors including squamous cell carcinomas), osteoporosis, and cirrhosis.¹³² The majority of cases involve mutations in the DKC1 gene on chromosome Xq28 but DKC can also be due to genetic mutations that are inherited in an autosomal dominant or recessive manner such as mutations in TERT and TERC.^{133, 134} The DKC1 gene encodes dyskerin, a protein that is involved in RNA function and telomere maintenance. TERT and TERC are the genes for the reverse transcriptase portion of telomerase and the telomerase RNA component, respectively, and as is DKC1, are crucial for maintenance of telomere length. Clinical manifestations reflect progressive telomere shortening, and are therefore not present at birth; clinical symptoms typically do not present until the second decade of life. The severity and penetrance of some variants of DKC is unpredictable. However, inasmuch as offspring of affected individuals will inherit shortened telomeres, this is a syndrome that can manifest anticipation, with earlier and more severe symptoms occurring in consecutive generations. Telomere length in three different lymphocyte subsets can be measured to screen for this disease; patients with DKC have telomere lengths less than the first percentile for age in all three cell lines.¹³⁵ Genetic

testing for known mutations can be helpful but does not rule out the disease as a subset of patients lack identifiable mutations. G-CSF or GM-CSF is effective in improving neutrophil counts in patients with DKC, and allogeneic stem cell transplantation, with reduced intensity conditioning given the sensitivity to genotoxic agents, is effective in treating the hematologic manifestations of this disease.^{131, 136, 137, 138} DKC affects other organ systems, however, which will not improve following stem cell transplantation, and pulmonary disease and solid tumors remain a major source of morbidity and mortality following stem cell transplantation.

Glycogen storage disease Ib is an autosomal recessive disorder caused by mutations in the gene for glucose-6-phosphatase translocase. This leads to hepatomegaly and a metabolic disorder related to intracellular accumulation of polysaccharide. It is also

P.1284

associated with defects in the neutrophil respiratory burst that increase apoptosis of circulating neutrophils and lead to neutropenia.^{139, 140} Patients typically present at 6 months of age with hepatomegaly, hypoglycemia, and lactic acidosis.¹⁴¹ Neutropenia presents within the first year of life in the majority of patients and although it is usually intermittent, it has no faithful periodicity or cycle.¹⁴² Diagnosis is made by looking for the most common genetic mutations but if none are identified, liver biopsy to confirm excess glycogen stores and steatosis without prominent fibrosis is recommended. A strict carbohydrate-restricted diet is necessary to control the disease and G-CSF can be used to treat the neutropenia.^{143, 144} Liver transplantation has been used to correct many complications of this disease but neutropenia persists.¹⁴⁵ Neutropenia has also been reported in other metabolic disorders, including propionic academia, methylmalonic academia, and isovaleric academia.^{146, 147, 148}

Myelokathexis is a rare syndrome in which mature neutrophils are retained in the bone marrow, leading to a decreased peripheral ANC.¹⁴⁹ Retained neutrophils display an abnormal morphology with cytoplasmic vacuolization, pyknotic nuclei, nuclear hypersegmentation, and thin nuclear strands connecting nuclear lobes.¹⁵⁰ There is also evidence that neutrophils undergo accelerated apoptosis in affected patients, resulting in a shortened peripheral lifespan. Evidence suggests that this is a cell-intrinsic defect, as neutrophil survival is also reduced following injection into unaffected volunteers.^{150, 151} Accelerated apoptosis may be due to decreased expression of Bcl-x, an inhibitor of apoptosis. The storage pool of mature neutrophils is not reduced, and neutrophil counts rise in response to infection in patients with myelokathexis, making the risk of overwhelming infectious complications low. There is a female predominance in this disease and most patients are diagnosed in infancy.¹⁵² The combination of myelokathexis with hypogammaglobulinemia and warts is termed WHIM syndrome (warts, hypogammaglobulinemia, immunodeficiency, myelokathexis),¹⁵³ which is caused by heterozygous mutations in the gene for the chemokine receptor CXCR4.¹⁵⁴ These mutations cause hyperreactivity of CXCR4, leading to retention of neutrophils in the marrow. These patients respond to growth factor therapy with G-CSF or GM-CSF, which down-regulate the expression of CXCR4.^{155, 156} The CXCR4 antagonist, plerixafor, has been given to nine patients with the WHIM syndrome with resultant transient normalization of WBC counts.^{157, 158}

Congenital disorders of vesicular trafficking are also associated with neutropenia. These include CHS, GS2, and HPSII.¹⁵⁹ These diseases are also associated with disorders of other granulated cells, leading to oculocutaneous albinism (from disrupted melanin granules), bleeding (from abnormal platelet secretory granules), and neurologic disease (from abnormal trafficking and release of neuronal granules). All of these diseases can enter a terminal phase of hemophagocytic syndrome, often in the setting of Epstein-Barr virus (EBV) infection. In all cases, this is postulated to occur because of abnormal secretion of perforin-containing granules into the immunologic synapse, impairing natural killer-cell-mediated killing. CHS is an autosomal recessive disorder caused by mutations in the LYST gene (lysosomal trafficking regulatory gene) and is associated with characteristic neutrophils containing giant granules.^{159, 160, 161} Three quarters of patients with CHS develop moderate to severe neutropenia, thought to be the result of increased destruction of peripheral neutrophils and decreased marrow release of neutrophils.^{160, 162} Infectious risk is increased above that expected for the ANC due to concomitant humoral and cellular immune defects in this disease.^{163, 164} GS2 is also an autosomal recessive disorder, due to mutations in a small GTPase RAB27A, which is part of the protein complex necessary for granule release.^{165, 166} HPSII is due to defects in AP3B1 which encodes a part of a protein transport complex that mediates sorting of lysosomal proteins.¹⁶⁷ Defects in AP3B1 lead to widespread functional impairment of cells carrying secretory granules. As for many of the syndromes and diseases noted above, stem cell transplantation can cure the hematologic manifestations of these diseases and may be necessary to control the hemophagocytosis associated with CHS and GS2, but does not treat the other systemic findings.^{168, 169} Otherwise, growth factor support and antibiotics provide supportive care and steroids, splenectomy, intravenous immunoglobulin, and chemotherapy have been used to manage the accelerated phase of CHS.^{170, 171}

Lastly, cartilage-hair hypoplasia is a rare syndrome associated with moderate to severe neutropenia, as well as short-limb dwarfism, fine hair, and defects in cellular immunity.¹⁷² It is inherited in an autosomal recessive manner and has increased prevalence in the Amish and Finnish populations.^{173, 174} It is caused by mutations in the RMRP gene on chromosome 9 which has an unknown function but is a noncoding RNA essential for early murine development.^{175, 176} As in other syndromes with combined neutropenia and cellular immune defects, infectious risk is additive. G-CSF is effective and stem cell transplantation can cure the hematologic and immunologic manifestations of this disease.^{177, 178}

Secondary Causes of Neutropenia

Post-infectious Neutropenia

Several viral infections have been shown to cause a transient neutropenia, including varicella, measles, rubella, hepatitis A and B, Epstein-Barr, influenza, parvovirus, and cytomegalovirus. Neutropenia typically corresponds to the period of peak viremia during the first 1 to 2 days of clinical symptoms. Neutropenia usually resolves within 3 to 7 days. Neutropenia results from a combination of decreased production and immune destruction of neutrophils; in addition, some viral infections increase neutrophil adherence to the vasculature, causing increased margination.^{179, 180} Because neutropenia is short lived, it rarely results in bacterial superinfection regardless of its severity. However, the neutropenia associated with hepatitis B and EBV infections can be more prolonged and thus more dangerous. Human immunodeficiency virus (HIV) infection is commonly associated with neutropenia that arises from a combination of decreased marrow production of neutrophils and peripheral immune destruction.¹⁸¹ As with EBV and hepatitis B infection, this neutropenia may be protracted as a result of direct viral infection of hematopoietic precursor cells or as a result of antineutrophil antibodies. Moderate neutropenia can also be seen in association with atypical bacterial infections, including those caused by *Mycobacterium tuberculosis*, ehrlichiosis, rickettsia, tularemia, and brucellosis. This may be related to by direct bone marrow suppression of myelopoiesis by toxins released by the pathogenic organisms, decreased neutrophil production as a result of infection-mediated decrease in growth factor production, and complement mediated peripheral neutrophil destruction. Neutropenia is fairly common in the setting of overwhelming sepsis, and reflects consumption of marrow reserves of neutrophils. This is usually seen at the extremes of life, in infants and elderly patients, in which patients typically have decreased marrow reserves.¹⁸² Management of patients with infection-related neutropenia requires good supportive care with treatment of the underlying infection. G-CSF or white blood cell transfusions are reserved for protracted and severe cases.^{183, 184} Intravenous immunoglobulin may be effective for neutropenia that results from autoimmune or complement-mediated destruction as a result of the underlying infection.¹⁸⁵

Drug-induced Neutropenia and Neutropenia due to Marrow Injury

Although accurate estimates of the incidence of drug-induced neutropenia are not readily available, a 10-year Swedish experience, a 5-year Dutch experience, a 22-year Spanish experience, and the

P.1285

International Aplastic Anemia and Agranulocytosis Study demonstrate an annual incidence of severe drug-induced neutropenia of 1.0 to 3.4 cases per million population per year.^{186, 187, 188} Multiple drugs have been implicated in neutropenia and agranulocytosis, both in predictable and idiosyncratic patterns. Antineoplastic, antiviral, and immunosuppressive agents all cause an expected dose-dependent decrease in neutrophils, often accompanied by general marrow suppression. Common drugs known to cause neutropenia that is more idiosyncratic include clozapine, the thionamides, and sulfasalazine. Most drugs cause direct dosedependent marrow suppression and others incite immune-mediated destruction; these mechanisms may not be mutually exclusive.^{189, 190, 191, 192} Immune-mediated destruction may occur by one of two mechanisms: the drug may act as a hapten and induce antibody formation and complement fixation, or the drug can cause the formation of circulating immune complexes that bind to neutrophils. The former is the mechanism associated with penicillin, propylthiouracil, and gold and the latter is associated with quinine administration. Marrow suppression, on the other hand, is the result of dose-dependent inhibition of colony-forming unit granulocyte macrophages and can be seen with valproic acid, carbamazepine, and β -lactam antibiotics. Finally, drugs can cause damage to the marrow microenvironment and myeloid precursors; certain patients with specific genetic polymorphisms or other medical problems may be at increased risk for drug-induced neutropenia by this mechanism.^{193, 194, 195}

Drug-induced neutropenia typically occurs after 1 to 2 weeks of exposure to the drug, although it may occur after a longer period of exposure. Recovery usually begins within days of stopping the drug, but this pattern is highly variable depending on the mechanism of neutropenia. For example, immune-mediated neutropenia may be immediate, occurring within hours of administration of the drug especially if there has been a previous exposure and prior antibody production, whereas drugs that cause direct marrow suppression or toxicity follow the paradigm above.¹⁹⁶ Some patients may present

with agranulocytosis, fever, and possible sepsis; in these patients mortality may be significant. Neutrophil recovery is often preceded by the appearance of monocytes and immature neutrophil forms. Although marrow examination is rarely necessary, one can roughly predict the duration of neutropenia from the cellularity of the marrow, as patients with hypercellular marrows or marrows with abundant metamyelocytes and later forms tend to have more rapid reconstitution following discontinuation of the offending medication. Management is similar to that for post-infectious neutropenia with supportive care and removal of the offending agent, although growth factor support is recommended for patients presenting with agranulocytosis.¹⁹⁷

Radiation can also result in acute or chronic marrow failure. Exposure to radiation is also a risk factor for AML/MDS. These diseases are discussed in greater detail in Chapters 75 and 79, respectively. Likewise, metastatic carcinoma to the bone can also cause marrow failure as the marrow becomes increasingly occupied by the metastatic cells.

Immune Neutropenia

As previously discussed, infection and drugs can cause immune-mediated neutrophil destruction. However, primary immune neutropenia can occur in the absence of other inciting events, or can also arise in association with an underlying systemic autoimmune disease. Antineutrophil antibodies are implicated in mediating neutrophil destruction either by destruction in the spleen or by intravascular complement mediated neutrophil lysis. A number of neutrophil-specific antigens have been identified in patients with a history of autoimmune neutropenia, including human neutrophil antigen (HNA)-1, an isoform of the Fcγ IIIb receptor, and HNA-4 and HNA-5, which are CD11b and CD11a, respectively.^{198, 199} The clinical presentation is variable, and depends on whether the antineutrophil antibodies react primarily with mature neutrophils or with myeloid progenitor cells, whether the antibodies are primary or secondary to an underlying condition, and whether the antibody is of restricted or nonrestricted clonality.^{200, 201} Some patients may have an absence of only mature neutrophils, whereas others may be missing all or some myeloid forms. In primary immune neutropenia, antibodies are more likely to be directed against a specific neutrophil-specific antigen whereas secondary conditions are commonly associated with pan-reactive antibodies. Similarly, antibodies that are produced as a result of an exposure to a foreign antigen are more likely to be polyclonal and short lived, whereas those due to the loss of suppression of a clone of cells producing an autoantibody are associated with a more protracted and severe course of neutropenia. Bone marrow biopsy findings will depend on the stage in neutrophil maturation against which the antibodies are directed, but in most cases, the marrow is hyper- or normocellular with a “maturation arrest” that reflects destruction of later stage cells.

Hyperthyroidism, Wegener granulomatosis, rheumatoid arthritis, systemic lupus erythematosus (SLE), chronic hepatitis and other systemic infections, and malignancy are autoimmune and systemic disorders associated with antineutrophil antibodies. In many of these diseases, especially SLE, neutropenia is often mild and reflects the activity of the underlying disease. It rarely requires treatment outside of treatment of the underlying disease.²⁰²

Felty syndrome and large granular lymphocytic (LGL) leukemia can also cause immune-mediated neutrophil destruction, and may be associated with profound neutropenia and increased infections. LGL is a syndrome of autoimmune neutropenia in association with marrow infiltration by clonal large granular lymphocytes.²⁰³ These lymphocytes are cytotoxic T-cells with the following immunophenotype: CD3⁺, CD8⁺, CD16⁺, and CD57⁺. LGL can occur sporadically or in association with systemic autoimmune diseases, especially rheumatoid arthritis.²⁰⁴ LGL is closely related to Felty syndrome, a syndrome associated with splenomegaly and neutropenia in the setting of rheumatoid arthritis.²⁰⁵ Ninety percent of patients with Felty syndrome and LGL associated with RA are HLA-DR4+, leading many investigators to postulate that the two syndromes are in a spectrum of the same disease.²⁰⁶ The pathophysiology of neutropenia is complex, including both antibody-mediated and cell-mediated destruction, immune complexes, and increased FAS mediated apoptosis.^{207, 208, 209, 210, 211} The neutropenia is responsive to G-CSF, which is usually utilized until the primary disease can be treated.²¹² Treatment options for LGL and Felty syndrome include immunosuppressive therapies including methotrexate, cyclosporine, cyclophosphamide, and, most recently, rituximab for Felty syndrome.^{213, 214, 215, 216, 217}

Neonatal neutropenia, or neonatal alloimmune neutropenia, is caused by transplacental passage of maternal IgG antibodies against paternal neutrophil antigens, resulting in neutropenia in a similar manner to anemia in Rh hemolytic disease. During gestation, the mother is sensitized to unique fetal neutrophil antigens and produces IgG antibodies against these antigens that can cross the placenta. These antigens will be shared with the father and so will be reactive against the father's neutrophils, thus facilitating the diagnosis. Neutropenia typically resolves within 2 months, and appropriate antibiotics will usually be sufficient to support the patient. In the event of severe or life-threatening infection, plasma exchange, intravenous immunoglobulin, and transfusion of maternal neutrophils have all been used.²¹⁸

Autoimmune neutropenia of infancy and childhood, termed “primary immune neutropenia,” occurs in children ages 6 months to 10 years and is the most frequent primary immune neutropenia.²¹⁹ Infections tend to be mild and include otitis

media, gastroenteritis, and/or cellulitis. Resolution of neutropenia occurs in over 95% of patients by age 2.²²⁰ Primary autoimmune neutropenia in adults is rare, and tends to be more chronic. However, even adults tend to have a mild clinical course.

P.1286

Lastly, pure white cell aplasia is a rare disease associated with severe pyogenic infections, and associated with a thymoma in over two thirds of cases.²²¹ It has also occurred following ibuprofen therapy.²²² There is a complete absence of myeloid precursors on bone marrow examination. It is immune-mediated but removal of the thymoma in thymoma-associated cases may not be sufficient for remission. Adjuvant therapy with cytoxan, steroids, cyclosporine, IVIg, and even stem cell transplantation may be needed.^{223, 224, 225}

Neutropenia Due to Increased Margination and Hypersplenism

Complement activation increases margination of neutrophils and can suppress the peripheral ANC.²²⁶ This has been seen in patients suffering from burns and transfusion reactions as well as a result of exposure to artificial membranes used in dialysis, cardiopulmonary bypass, apheresis, and extracorporeal membrane oxygenation.^{227, 228, 229} Neutropenia in the setting of transfusion is due to an anamnestic response to foreign antigens on neutrophils in a prior transfused blood product. Complement activation may also lead to direct neutrophil destruction, as in the case of paroxysmal nocturnal hemoglobinuria. Splenomegaly with hypersplenism can also reduce the neutrophil count.²³⁰

Neutropenia Due to Nutritional Deficiency

Neutropenia is part of the clinical spectrum of megaloblastic anemia arising from deficiency of vitamin B12, folate, and copper.^{231, 232} These diseases typically cause pancytopenia because of disordered maturation of all cell lines.

CLINICAL PRESENTATION AND DIAGNOSTIC APPROACH TO NEUTROPENIA

One of the first definitions of the syndrome of neutropenia and infection was in 1922 by Werner Schultz who described the findings of sore throat, prostration, and neutropenia in a cohort of middle-aged women and called this entity agranulocytosis.²³³ This fulminant form of neutropenia has sometimes been referred to as Schultz disease.²³⁴ The description highlights that the first evidence of neutropenia is often the development of infection, and that severe neutropenia is associated with a risk for spontaneous infection. Although the lower level of the normal ANC is 1,500 cells/ μ l, patients rarely develop infectious complications of neutropenia until their ANC falls below 500 cells/ μ l, and in fact, patients with chronic neutropenia rarely develop fever unless their ANC is below 200 cells/ μ l. Common sites of infection include the oral cavity and mucous membranes including mouth ulcers, pharyngeal inflammation, and periodontitis, the skin with rashes, cellulitis, abscesses, and poor wound healing, the perirectal and anal areas, and the respiratory tract. Endogenous flora are the primary pathogens. It should be remembered that most of the signs and symptoms of infection are generated by neutrophils. Consequently, patients with neutropenia may have minimal signs and symptoms of infection, with minimal inflammatory infiltrates. Fever is the most informative sign in neutropenia patients, and should be evaluated emergently, because in the setting of profound neutropenia, patients may rapidly develop fatal sepsis. A presentation of neutropenia should prompt a careful evaluation for signs and symptoms of infection with cultures and antibiotic administration when indicated.

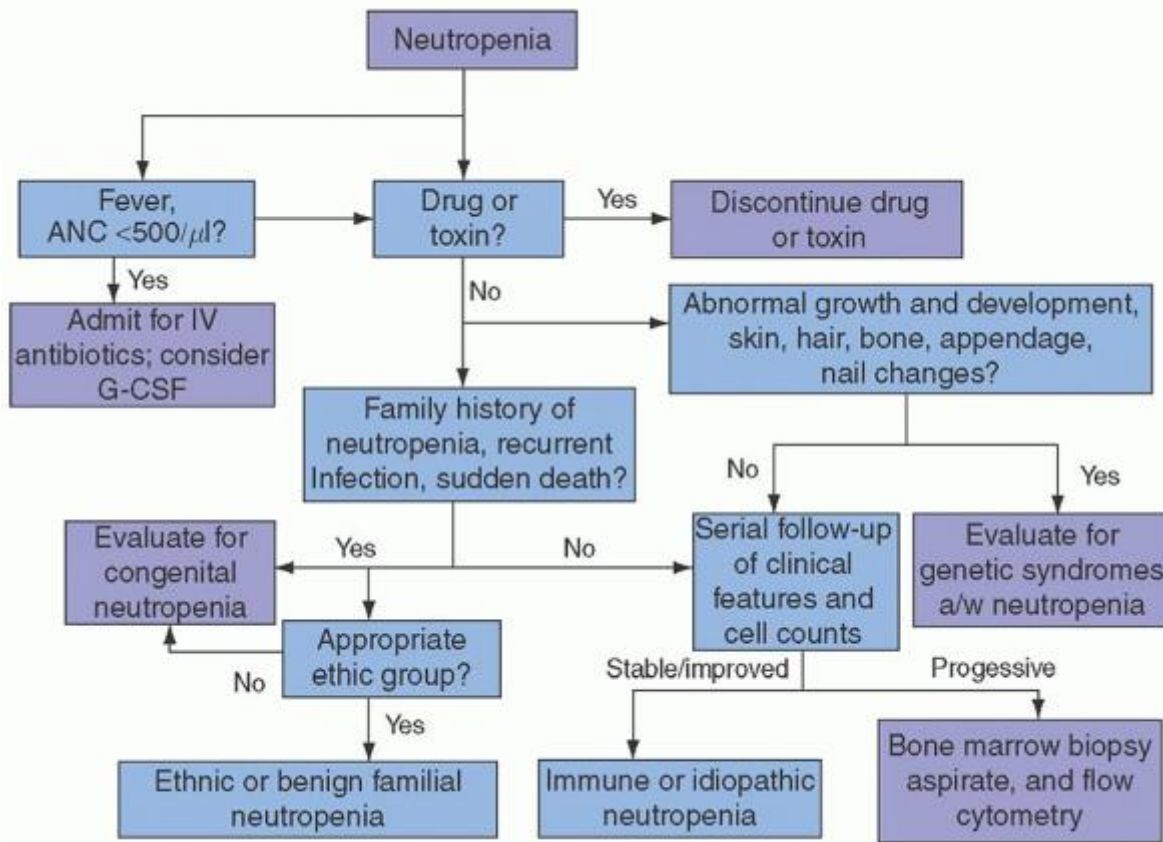

FIGURE 57.1. Diagnostic approach to neutropenia in the infant. ANC, absolute neutrophil count; a/w, associated with; G-CSF, granulocyte colony stimulating factor; IV, intravenous.

In children presenting for the first time with neutropenia, growth and development should be documented (Fig. 57.1). Attention should be paid to the skin, bones/appendages, and nails as abnormalities in these may point toward one of the congenital neutropenia syndromes. Family history of recurrent infections and sudden death may be helpful in this regard. If congenital neutropenia is suspected, appropriate genetic testing should be obtained. In adults previously known to have a normal ANC who present with profound neutropenia (agranulocytosis) and an otherwise normal CBC, the diagnosis is almost invariably drug-induced neutropenia. These patients usually present with an acute febrile episode. A thorough history of drug and toxin exposure should be obtained and all potential offending agents discontinued. For patients of all ages, the perineum and perirectal area should be examined, in addition to a complete physical exam. The peripheral blood smear should be examined and tests for vitamin B12 and folate levels obtained. Older tests included hydrocortisone stimulation tests (for marrow myeloid reserve), the epinephrine challenge test (for estimation of the size of the marginated neutrophil pool), and the Rebutck skin window (which evaluates neutrophil margination into tissues) but these are rarely

P.1287

used today.^{235, 236, 237} Bone marrow examination is not required unless there are other features to suggest an alternative diagnosis.

In patients presenting with unexplained neutropenia in the absence of a well-documented normal ANC in the past, evaluation depends on the severity of the neutropenia (Fig. 57.2). There is little information to be gained from an extensive evaluation of healthy patients with no history of infections and ANC of 1,200 to 1,500 cells/ μ l that has been present for many years. In appropriate ethnic groups the diagnosis of constitutional neutropenia obviates the need for further evaluation. Even in patients who do not have clear ethnic or familial neutropenia, studies to rule out marrow pathology in the absence of clinical sequelae or evidence of continued decrease in the blood counts are unlikely to be informative.

In patients with severe neutropenia of indeterminate duration, the pace and extent of diagnosis should be determined by the clinical presentation. In patients in whom cycling is suspected, genetic testing for ELANE mutations and peripheral blood flow cytometry and T-cell receptor rearrangement studies to assess for LGL should be obtained. In the cases of a selective severe chronic neutropenia, even in the absence of a history of infection or drug/toxin exposure or an evident B12 or folate deficiency, a single bone marrow examination is recommended to assess for myelodysplasia. If marrow morphology is unremarkable and cytogenetics are normal, repeated bone marrow examination is not recommended unless there is a significant change in the peripheral blood counts that suggests a new intervening diagnosis. Bone marrow biopsy should be performed in all patients with bi- or tricytopenias to evaluate the adequacy of hematopoietic marrow pools, the relative maturation of these pools, and the morphology of these pools for clues as to the etiology of the cytopenias.

MANAGEMENT OF NEUTROPENIA

Decisions regarding the treatment of neutropenia depend primarily on the presence or absence of fever. Neutropenia with fever should be treated as a medical emergency, with the goal of evaluating patients and initiating antibiotics within 30 to 60 minutes. The administration of empiric broad-spectrum antibiotics to patients with febrile neutropenia has been demonstrated to improve survival.^{238, 239} Third- or fourth-generation cephalosporins as single agents have become the standard initial empiric therapy, replacing previous combinations that emphasized double coverage for pseudomonal species.²⁴⁰ In patients with indwelling lines, the addition of vancomycin may be considered, and patients at increased risk for fungal infection or who remain febrile despite 3 to 5 days of antibiotics should receive antifungal agents.²⁴¹

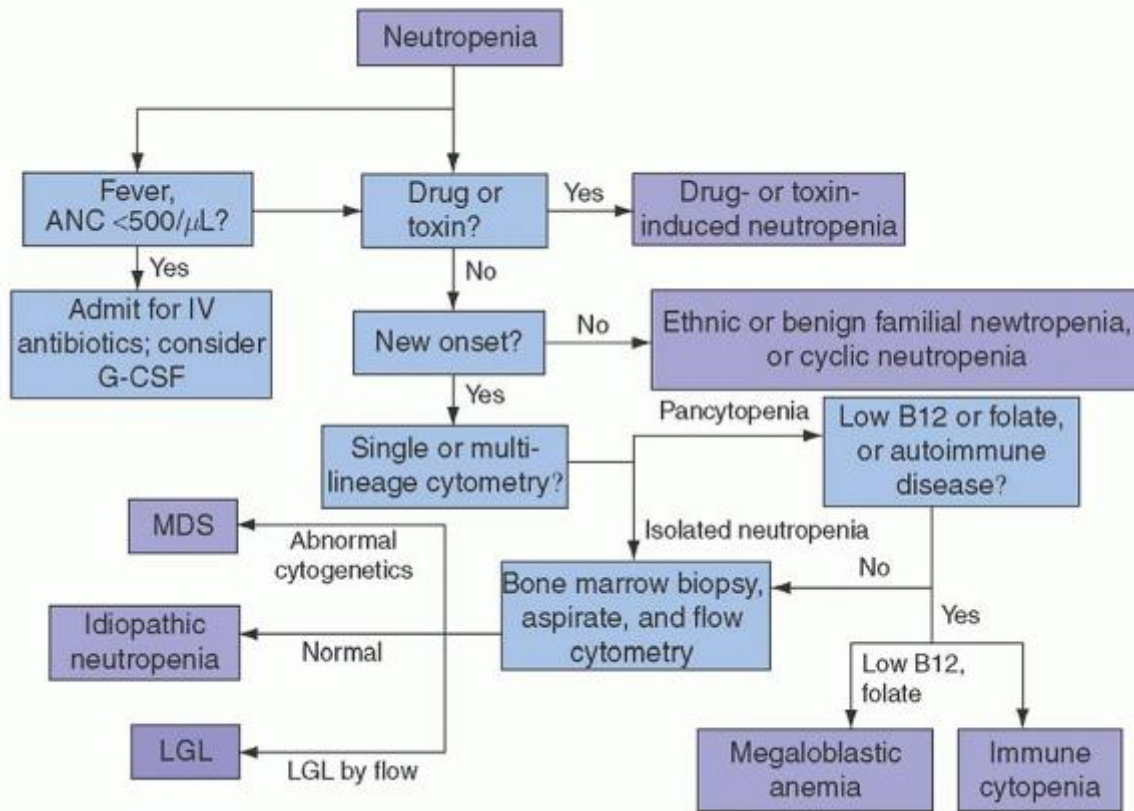

FIGURE 57.2. Diagnostic approach to neutropenia in the adult. ANC, absolute neutrophil count; G-CSF, granulocyte colony stimulating factor; IV, intravenous; LGL, large granular lymphocytosis; MDS, myelodysplastic syndrome.

For patients with mild neutropenia and infections, outpatient antibiotic therapy may be warranted and is based on the clinical judgment of the treating physician. The cause of neutropenia is important in determining further therapies: transient neutropenia due to a drug, infection, or chemotherapy administration may require no further therapy, although G-CSF can be used for high-risk patients with pneumonia, hypotension, and/or fungemia whereas neutropenia due to autoantibodies, an underlying systemic disease, or a congenital syndrome may require preventative approaches including immunologic therapies such as corticosteroids, intravenous immunoglobulin, and/or plasmapheresis, treatment of the

underlying disease, G-CSF therapy, or possibly a hematopoietic stem cell transplant. For cases of severe life-threatening infection that is unresponsive to antibiotics, granulocyte transfusion may be warranted.²⁴²

In patients with neutropenia who have not had a history of infection, treatment is rarely necessary. Patients should be educated to simple approaches to preventing infection, including skin and mouth care, good oral and dental hygiene, avoidance of rectal trauma by rectal thermometers and prevention of constipation with stool softeners, proper cleaning and topical antibiotic application to all skin abrasions. For patients with profound neutropenia not on G-CSF, they should be instructed to notify a physician as soon as they develop a fever. It is advisable that they also be supplied with prophylactic antibiotics such as trimethoprim-sulfamethoxazole or ciprofloxacin to take in the event there is a delay in seeking medical attention; it should be emphasized, however, that use of these agents is for emergencies only and should not be used in place of seeking appropriate medical evaluation and care.

Patients with SCN require lifelong G-CSF therapy. The use of G-CSF has extended the life expectancy for these patients from 2 to 3 years to adulthood.⁵⁷ Some patients with CN also require G-CSF, but can often restrict treatment to low daily doses of G-CSF or cyclical administration during the period around the nadir of the ANC. Dose requirements vary depending on G-CSF response.^{57, 69, 84} As previously mentioned, with improved survival of patients with SCN, a significant risk of MDS/AML has emerged.^{55, 56, 57} The risk of MDS/AML appears to be associated

P.1288

with higher doses of G-CSF, but whether this is a reflection of the underlying disease phenotype or whether transformation is enhanced or accelerated by G-CSF itself is unknown.^{53, 54, 58, 59}

Other congenital syndromes associated with neutropenia, such as SDS, FA, and DKC, respond to doses of G-CSF similar to those used in SCN and these patients are also at increased risk of MDS and/or AML, but again it is not clear if this is due to the G-CSF or the underlying disease.^{109, 128, 131} Patients with idiopathic and CN, as well as neutropenia associated with glycogen storage Ib, and myelokathexis, however, do not develop MDS or AML, despite therapy with G-CSF.^{69, 84, 144, 155} One could argue, though, that this may be a dose-dependent phenomenon as patients with SCN, SDS, FA, and DKC require higher doses of G-CSF than do those with idiopathic and CN. Long-term use of G-CSF or GM-CSF has been associated with osteoporosis and organomegaly.

Severe drug-induced neutropenia/agranulocytosis requires the permanent discontinuation of the causative agent. However, agents that cause dose-related marrow suppression and mild neutropenia can be continued if necessary, provided the neutropenia is not progressive or severe. Patients with agranulocytosis frequently present with life-threatening infections. They should be admitted to the hospital for broad-spectrum antibiotics. G-CSF speeds the recovery of the ANC and, given the morbidity and mortality associated with this syndrome, is recommended.

Immune neutropenia related to SLE or other systemic autoimmune disease rarely needs direct treatment, and ANC usually responds to decreased disease activity with therapy directed at the underlying rheumatologic disorder. Patients with LGL respond well to low-dose immunosuppression with cyclophosphamide or methotrexate.

Finally, stem cell transplantation can be useful to reverse the hematologic effects and neutropenia associated with a number of the congenital neutropenia and bone marrow failure syndromes such as SDS, FA, DKC, and cartilage-hair hypoplasia. The risk of transplant in many of these patients is greater than that seen in transplantation for hematologic malignancies due to the nature of the underlying genetic disorder. Furthermore, many of these disorders are associated with disease of other organs, including pulmonary fibrosis, or a risk of solid tumors. Transplantation does nothing to prevent these manifestations of the underlying disease and should be considered before undertaking the procedure.

REFERENCES

1. von Vietinghoff S, Ley K. Homeostatic regulation of blood neutrophil counts. *J Immunol* 2008;181(8):5183-5188.
2. Weetman RM, Boxer LA. Childhood neutropenia. *Pediatr Clin North Am* 1980;27(2):361-376.
3. Reed WW, Diehl LF. Leukopenia, neutropenia, and reduced hemoglobin levels in healthy American blacks. *Arch Intern Med* 1991;151(3):501-505.
4. Bodey GP, Buckley M, Sathe YS, et al. Quantitative relationships between circulating leukocytes and infection in patients with leukemia. *Ann Intern Med* 1966;64:328-340.
5. Alario AJ, O'Shea JS. Risk of infectious complications in well-appearing children with transient neutropenia. *Am J Dis Child* 1989;143(8):973-976.

6. Galifi M, Schinella M, Nicoli M, Lippi G. Instrumental reports and effect of anticoagulants in a case of neutrophil agglutination in vitro. *Haematologica* 1993;78(6):364-370.
7. Joyce RA, Boggs DR, Hasiba U, Srodes CH. Marginal neutrophil pool size in normal subjects and neutropenic patients as measured by epinephrine infusion. *J Lab Clin Med* 1976;88(4):614-620.
8. Djaldetti M, et al. Familial leukopenia-neutropenia in Yemenite Jews. *Bull Res Council Isr* 1961;9E:24-28.
9. Shaper AG, Lewis P. Genetic neutropenia in people of African origin. *Lancet* 1971;2(7732):1021-1023.
10. Jacobs P. Letter: Familial benign chronic neutropenia. *S Afr Med J* 1975;49(17):692.
11. Denic S, Showqi S, Klein C, Takala M, Nagelkerke N, Agarwal MM. Prevalence, phenotype and inheritance of benign neutropenia in Arabs. *BMC Blood Disord* 2009;9:3.
12. Reich D, Nalls MA, Kao WH, et al. Reduced neutrophil count in people of African descent is due to a regulatory variant in the Duffy antigen receptor for chemokines gene. *PLoS Genet* 2009;5(1):e1000360.
13. Stabholz A, Soskolne V, Machtei E, Or R, Soskolne WA. Effect of benign familial neutropenia on the periodontium of Yemenite Jews. *J Periodontol* 1990;61(1):51-54.
14. Shoenfeld Y, Alkan ML, Asaly A, Carmeli Y, Katz M. Benign familial leukopenia and neutropenia in different ethnic groups. *Eur J Haematol* 1988;41(3): 273-277.
15. Mintz U, Sachs L. Normal granulocyte colony-forming cells in the bone marrow of Yemenite Jews with genetic neutropenia. *Blood* 1973;41(6):745-751.
16. Joyce RA, Boggs DR, Chervenick PA. Neutrophil kinetics in hereditary and congenital neutropenias. *N Engl J Med* 1976;295(25):1385-1390.
17. Jonsson OG, Buchanan GR. Chronic neutropenia during childhood. A 13-year experience in a single institution. *Am J Dis Child* 1991;145(2):232-235.
18. Komiyama A, Ishiguro A, Kubo T, et al. Increases in neutrophil counts by purified human urinary colony-stimulating factor in chronic neutropenia of childhood. *Blood* 1988;71(1):41-45.
19. Sabbe LJ, Claas FH, Langerak J, et al. Group-specific auto-immune antibodies directed to granulocytes as a cause of chronic benign neutropenia in infants. *Acta Haematol* 1982;68(1):20-27.
20. Parmley RT, Crist WM, Ragab AH, Boxer LA, Malluh A, Findley H. Phagocytosis of neutrophils by marrow macrophages in childhood chronic benign neutropenia. *J Pediatr* 1981;98(2):207-212.
21. Papadaki HA, Pontikoglou C. Pathophysiologic mechanisms, clinical features and treatment of idiopathic neutropenia. *Expert Rev Hematol* 2008;1(2): 217-229.
22. Jakubowski AA, Souza L, Kelly F, et al. Effects of human granulocyte colony-stimulating factor in a patient with idiopathic neutropenia. *N Engl J Med* 1989;320(1):38-42.
23. Sonoda Y, Yashige H, Fujii H, Maekawa T, Abe T. Treatment of idiopathic neutropenia in the elderly with recombinant human granulocyte colony-stimulating factor. *Acta Haematol* 1991;85(3):146-152.
24. Kyle RA. Natural history of chronic idiopathic neutropenia. *N Engl J Med* 1980;302(16):908-909.
25. Lipton A. Chronic idiopathic neutropenia. Treatment with corticosteroids and mercaptopurine. *Arch Intern Med* 1969;123(6):694-700.
26. Spaet TH, Dameshek W. Chronic hypoplastic neutropenia. *Am J Med* 1952;13(1):35-45.
27. Kostman R. Infantile genetic agranulocytosis. A review with presentation of ten new cases. *Acta Paediatr Scand* 1975;64(2):362-368.
28. Kostmann R. Infantile genetic agranulocytosis. *Acta Paediatr Scand* 1956;45(Suppl 105):1-78.
29. Pietsch T, Buhner C, Mempel K, et al. Blood mononuclear cells from patients with severe congenital neutropenia are capable of producing granulocyte colony-stimulating factor. *Blood* 1991;77(6):1234-1237.
30. Kyas U, Pietsch T, Welte K. Expression of receptors for granulocyte colony-stimulating factor on neutrophils from patients with severe congenital neutropenia and cyclic neutropenia. *Blood* 1992;79(5):1144-1147.

31. Guba SC, Sartor CA, Hutchinson R, Boxer LA, Emerson SG. Granulocyte colony-stimulating factor (G-CSF) production and G-CSF receptor structure in patients with congenital neutropenia. *Blood* 1994;83(6):1486-1492.
32. Welte K, Zeidler C, Reiter A, et al. Differential effects of granulocyte-macrophage colony-stimulating factor and granulocyte colony-stimulating factor in children with severe congenital neutropenia. *Blood* 1990;75(5):1056-1063.
33. Mempel K, Pietsch T, Menzel T, Zeidler C, Welte K. Increased serum levels of granulocyte colony-stimulating factor in patients with severe congenital neutropenia. *Blood* 1991;77(9):1919-1922.
34. Dale DC, Liles WC, Garwicz D, Aprikyan AG. Clinical implications of mutations of neutrophil elastase in congenital and cyclic neutropenia. *J Pediatr Hematol Oncol* 2001;23(4):208-210.
35. Carlsson G, Aprikyan AA, Tehranchi R, et al. Kostmann syndrome: severe congenital neutropenia associated with defective expression of Bcl-2, constitutive mitochondrial release of cytochrome c, and excessive apoptosis of myeloid progenitor cells. *Blood* 2004;103(9):3355-3361.
36. Nakamura K, Kobayashi M, Konishi N, et al. Abnormalities of primitive myeloid progenitor cells expressing granulocyte colony-stimulating factor receptor in patients with severe congenital neutropenia. *Blood* 2000;96(13):4366-4369.
37. Konishi N, Kobayashi M, Miyagawa S, Sato T, Katoh O, Ueda K. Defective proliferation of primitive myeloid progenitor cells in patients with severe congenital neutropenia. *Blood* 1999;94(12):4077-4083.
38. Welte K, Zeidler C, Dale DC. Severe congenital neutropenia. *Semin Hematol* 2006;43(3):189-195.
39. Dale DC, Person RE, Bolyard AA, et al. Mutations in the gene encoding neutrophil elastase in congenital and cyclic neutropenia. *Blood* 2000;96(7): 2317-2322.
40. Xia J, Bolyard AA, Rodger E, et al. Prevalence of mutations in ELANE, GFI1, HAX1, SBDS, WAS and G6PC3 in patients with severe congenital neutropenia. *Br J Haematol* 2009;147(4):535-542.
41. Klein C, Grudzien M, Appaswamy G, et al. HAX1 deficiency causes autosomal recessive severe congenital neutropenia (Kostmann disease). *Nat Genet* 2007;39(1):86-92.
42. Ancliff PJ, Blundell MP, Cory GO, et al. Two novel activating mutations in the Wiskott-Aldrich syndrome protein result in congenital neutropenia. *Blood* 2006;108(7):2182-2189.
43. Kollner I, Sodeik B, Schreek S, et al. Mutations in neutrophil elastase causing congenital neutropenia lead to cytoplasmic protein accumulation and induction of the unfolded protein response. *Blood* 2006;108(2):493-500.
44. Grenda DS, Murakami M, Ghatak J, et al. Mutations of the ELA2 gene found in patients with severe congenital neutropenia induce the unfolded protein response and cellular apoptosis. *Blood* 2007;110(13):4179-4187.
45. Carlsson G, Aprikyan AA, Ericson KG, et al. Neutrophil elastase and granulocyte colony-stimulating factor receptor mutation analyses and leukemia evolution in severe congenital neutropenia patients belonging to the original Kostmann family in northern Sweden. *Haematologica* 2006;91(5): 589-595.
46. Zarebski A, Velu CS, Baktula AM, et al. Mutations in growth factor independent-1 associated with human neutropenia block murine granulopoiesis through colony stimulating factor-1. *Immunity* 2008;28(3):370-380.
47. Boocock GR, Morrison JA, Popovic M, et al. Mutations in SBDS are associated with Shwachman-Diamond syndrome. *Nat Genet* 2003;33(1):97-101.
48. Boztug K, Appaswamy G, Ashikov A, et al. A syndrome with congenital neutropenia and mutations in G6PC3. *N Engl J Med* 2009;360(1):32-43.
49. Dong F, Hoefsloot LH, Schelen AM, et al. Identification of a nonsense mutation in the granulocyte-colony-stimulating factor receptor in severe congenital neutropenia. *Proc Natl Acad Sci U S A* 1994;91(10):4480-4484.
50. Ward AC, van Aesch YM, Gits J, et al. Novel point mutation in the extracellular domain of the granulocyte colony-stimulating factor (G-CSF) receptor in a case of severe congenital neutropenia hyporesponsive to G-CSF treatment. *J Exp Med* 1999;190(4):497-507.
51. Sinha S, Zhu QS, Romero G, Corey SJ. Deletional mutation of the external domain of the human granulocyte colony-stimulating factor receptor in a patient with severe chronic neutropenia refractory to granulocyte colony-stimulating factor. *J Pediatr Hematol Oncol* 2003;25(10):791-796.
52. Druhan LJ, Ai J, Massullo P, Kindwall-Keller T, Ranalli MA, Avalos BR. Novel mechanism of G-CSF refractoriness in patients with severe congenital neutropenia. *Blood* 2005;105(2):584-591.

53. Dong F, Brynes RK, Tidow N, Welte K, Lowenberg B, Touw IP. Mutations in the gene for the granulocyte colony-stimulating-factor receptor in patients with acute myeloid leukemia preceded by severe congenital neutropenia. *N Engl J Med* 1995;333(8):487-493.
54. Hunter MG, Avalos BR. Granulocyte colony-stimulating factor receptor mutations in severe congenital neutropenia transforming to acute myelogenous leukemia confer resistance to apoptosis and enhance cell survival. *Blood* 2000;95(6):2132-2137.
55. Freedman MH, Alter BP. Risk of myelodysplastic syndrome and acute myeloid leukemia in congenital neutropenias. *Semin Hematol* 2002;39(2):128-133.
56. Dale DC, Cottle TE, Fier CJ, et al. Severe chronic neutropenia: treatment and follow-up of patients in the Severe Chronic Neutropenia International Registry. *Am J Hematol* 2003;72(2):82-93.
57. Rosenberg PS, Alter BP, Bolyard AA, et al. The incidence of leukemia and mortality from sepsis in patients with severe congenital neutropenia receiving long-term G-CSF therapy. *Blood* 2006;107(12):4628-4635.
58. Beekman R, Valkhorf MG, Sanders MA, et al. Sequential gain of mutations in severe congenital neutropenia progressing to acute myeloid leukemia. *Blood*. Epub 2012.
59. Tschan CA, Pilz C, Zeidler C, Welte K, Germeshausen M. Time course of increasing numbers of mutations in the granulocyte colony-stimulating factor receptor gene in a patient with congenital neutropenia who developed leukemia. *Blood* 2001;97(6):1882-1884.
60. Gilman PA, Jackson DP, Guild HG. Congenital agranulocytosis: prolonged survival and terminal acute leukemia. *Blood* 1970;36(5):576-585.
61. Lang JE, Cutting HO. Infantile Genetic Agranulocytosis. *Pediatrics* 1965;35:596-600.
62. Beard ME, Newmark P, Smith ME, Franklin AW. Infantile genetic agranulocytosis associated with changes in serum vitamin B 12 binding proteins. *Acta Paediatr Scand* 1972;61(5):526-532.
63. Wriedt K, Kauder E, Mauer AM. Defective myelopoiesis in congenital neutropenia. *N Engl J Med* 1970;283(20):1072-1077.
64. Dale DC, Bolyard AA, Schwinger BG, et al. The severe chronic neutropenia international registry: 10-year follow-up report. *Support Cancer Ther* 2006;3(4):220-231.
65. Dale DC, Bolyard AA, Aprikyan A. Cyclic neutropenia. *Semin Hematol* 2002;39(2):89-94.
66. Haurie C, Dale DC, Mackey MC. Cyclical neutropenia and other periodic hematological disorders: a review of mechanisms and mathematical models. *Blood* 1998;92(8):2629-2640.
67. Lange RD. Cyclic hematopoiesis: human cyclic neutropenia. *Exp Hematol* 1983;11(6):435-451.
68. Wright DG, Dale DC, Fauci AS, Wolff SM. Human cyclic neutropenia: clinical review and long-term follow-up of patients. *Medicine (Baltimore)* 1981;60(1):1-13.
69. Dale DC, Bolyard AA, Hammond WP. Cyclic neutropenia: natural history and effects of long-term treatment with recombinant human granulocyte colony-stimulating factor. *Cancer Invest* 1993;11(2):219-223.
70. Leale M. Recurrent furunculosis in an infant showing an unusual blood picture. *JAMA* 1910;54:1854-1855.
71. Morley AA, Carew JP, Baikie AG. Familial cyclical neutropenia. *Br J Haematol* 1967;13(5):719-738.
72. Loughran TP Jr, Clark EA, Price TH, Hammond WP. Adult-onset cyclic neutropenia is associated with increased large granular lymphocytes. *Blood* 1986;68(5):1082-1087.
73. Horwitz M, Benson KF, Person RE, Aprikyan AG, Dale DC. Mutations in ELA2, encoding neutrophil elastase, define a 21-day biological clock in cyclic haematopoiesis. *Nat Genet* 1999;23(4):433-436.
74. Berliner N, Horwitz M, Loughran TP Jr. Congenital and acquired neutropenia. *Hematol Am Soc Hematol Educ Program* 2004;15:63-79.
75. Newburger PE, Pindyck TN, Zhu Z, et al. Cyclic neutropenia and severe congenital neutropenia in patients with a shared ELANE mutation and paternal haplotype: evidence for phenotype determination by modifying genes. *Pediatr Blood Cancer* 2010;55(2):314-317.

76. Guerry DT, Dale DC, Omine M, Perry S, Wolff SM. Periodic hematopoiesis in human cyclic neutropenia. *J Clin Invest* 1973;52(12):3220-3230.
77. Engelhard D, Landreth KS, Kapoor N, et al. Cycling of peripheral blood and marrow lymphocytes in cyclic neutropenia. *Proc Natl Acad Sci U S A* 1983;80(18):5734-5738.
78. Quesenberry PJ. Cyclic hematopoiesis: disorders of primitive hematopoietic stem cells. *Exp Hematol* 1983;11(8):687-700.
79. Lund JE, Padgett GA, Ott RL. Cyclic neutropenia in grey collie dogs. *Blood* 1967;29(4):452-461.
80. Dale DC, Graw RG Jr. Transplantation of allogenic bone marrow in canine cyclic neutropenia. *Science* 1974;183(4120):83-84.
81. Krance RA, Spruce WE, Forman SJ, et al. Human cyclic neutropenia transferred by allogeneic bone marrow grafting. *Blood* 1982;60(6):1263-1266.
82. Aprikyan AA, Liles WC, Rodger E, Jonas M, Chi EY, Dale DC. Impaired survival of bone marrow hematopoietic progenitor cells in cyclic neutropenia. *Blood* 2001;97(1):147-153.
- P.1289
83. Sera Y, Kawaguchi H, Nakamura K, et al. A comparison of the defective granulopoiesis in childhood cyclic neutropenia and in severe congenital neutropenia. *Haematologica* 2005;90(8):1032-1041.
84. Hammond WPt, Price TH, Souza LM, Dale DC. Treatment of cyclic neutropenia with granulocyte colony-stimulating factor. *N Engl J Med* 1989;320(20): 1306-1311.
85. Wright DG, Kenney RF, Oette DH, LaRussa VF, Boxer LA, Malech HL. Contrasting effects of recombinant human granulocyte-macrophage colony-stimulating factor (CSF) and granulocyte CSF treatment on the cycling of blood elements in childhood-onset cyclic neutropenia. *Blood* 1994;84(4):1257-1267.
86. Wright DG, Fauci AS, Dale DC, Wolff SM. Correction of human cyclic neutropenia with prednisolone. *N Engl J Med* 1978;298(6):295-300.
87. Selleri C, Catalano L, Alfinito F, De Rosa G, Vaglio S, Rotoli B. Cyclosporin A in adult-onset cyclic neutropenia. *Br J Haematol* 1988;68(1):137-138.
88. Winkelstein JA, Marino MC, Lederman HM, et al. X-linked agammaglobulinemia: report on a United States registry of 201 patients. *Medicine (Baltimore)* 2006;85(4):193-202.
89. Rosen FS, Janeway CA. Diagnosis and treatment of antibody deficiency syndromes. *Postgrad Med* 1968;43(5):188-194.
90. Kozlowski C, Evans DI. Neutropenia associated with X-linked agammaglobulinaemia. *J Clin Pathol* 1991;44(5):388-390.
91. Ng RP, Prankerd TA. IgA deficiency and neutropenia. *Br Med J* 1976;1(6009): 563.
92. Lonsdale D, Deodhar SD, Mercer RD. Familial granulocytopenia and associated immunoglobulin abnormality. Report of three cases in young brothers. *J Pediatr* 1967;71(6):790-801.
93. Rieger CH, Moehr JW, Rothberg RM. Correction of neutropenia associated with dysgammaglobulinemia. *Pediatrics* 1974;54(4):508-511.
94. Bjorksten B, Lundmark KM. Recurrent bacterial infections in four siblings with neutropenia, eosinophilia, hyperimmunoglobulinemia A, and defective neutrophil chemotaxis. *J Infect Dis* 1976;133(1):63-71.
95. de VO, Seynhaeve V. Reticular dysgenesis. *Lancet* 1959;2(7112):1123-1125.
96. Roper M, Parmley RT, Crist WM, Kelly DR, Cooper MD. Severe congenital leukopenia (reticular dysgenesis). Immunologic and morphologic characterizations of leukocytes. *Am J Dis Child* 1985;139(8):832-835.
97. Levinsky RJ, Tiedeman K. Successful bone-marrow transplantation for reticular dysgenesis. *Lancet* 1983;1(8326 Pt 1):671-672.
98. Bertrand Y, Muller SM, Casanova JL, Morgan G, Fischer A, Friedrich W. Reticular dysgenesis: HLA non-identical bone marrow transplants in a series of 10 patients. *Bone Marrow Transplant* 2002;29(9):759-762.

99. Bujan W, Ferster A, Azzi N, Devalck C, Leriche A, Sariban E. Use of recombinant human granulocyte colony stimulating factor in reticular dysgenesis. *Br J Haematol* 1992;81(1):128-130.
100. Shwachman H, Diamond LK, Oski FA, Khaw KT. The Syndrome of Pancreatic Insufficiency and Bone Marrow Dysfunction. *J Pediatr* 1964;65:645-663.
101. Shimamura A. Shwachman-Diamond syndrome. *Semin Hematol* 2006;43(3):178-188.
102. Hall GW, Dale P, Dodge JA. Shwachman-Diamond syndrome: UK perspective. *Arch Dis Child* 2006;91(6):521-524.
103. Aggett PJ, Harries JT, Harvey BA, Soothill JF. An inherited defect of neutrophil mobility in Shwachman syndrome. *J Pediatr* 1979;94(3):391-394.
104. Saunders EF, Gall G, Freedman MH. Granulopoiesis in Shwachman's syndrome (pancreatic insufficiency and bone marrow dysfunction). *Pediatrics* 1979;64(4):515-519.
105. Necchi V, Minelli A, Sommi P, et al. Ubiquitin-proteasome-rich cytoplasmic structures in neutrophils of patients with Shwachman-Diamond syndrome. *Haematologica* Epub 2012.
106. Ginzberg H, Shin J, Ellis L, et al. Shwachman syndrome: phenotypic manifestations of sibling sets and isolated cases in a large patient cohort are similar. *J Pediatr* 1999;135(1):81-88.
107. Donadieu J, Fenneteau O, Beaupain B, et al. Classification and risk factors of hematological complications in a French national cohort of 102 patients with Shwachman-Diamond syndrome. *Haematologica* Epub 2012.
108. Woods WG, Roloff JS, Lukens JN, Krivit W. The occurrence of leukemia in patients with the Shwachman syndrome. *J Pediatr* 1981;99(3):425-428.
109. Ventura A, Dragovich D, Luxardo P, Zanazzo G. Human granulocyte colony-stimulating factor (rHuG-CSF) for treatment of neutropenia in Shwachman syndrome. *Haematologica* 1995;80(3):227-229.
110. Donadieu J, Leblanc T, Bader Meunier B, et al. Analysis of risk factors for myelodysplasias, leukemias and death from infection among patients with congenital neutropenia. Experience of the French severe chronic neutropenia study group. *Haematologica* 2005;90(1):45-53.
111. Donadieu J, Michel G, Merlin E, et al. Hematopoietic stem cell transplantation for Shwachman-Diamond syndrome: experience of the French neutropenia registry. *Bone Marrow Transplant* 2005;36(9):787-792.
112. Cesaro S, Oneto R, Messina C, et al. Haematopoietic stem cell transplantation for Shwachman-Diamond disease: a study from the European Group for blood and marrow transplantation. *Br J Haematol* 2005;131(2):231-236.
113. Okcu F, Roberts WM, Chan KW. Bone marrow transplantation in Shwachman-Diamond syndrome: report of two cases and review of the literature. *Bone Marrow Transplant* 1998;21(8):849-851.
114. Hsu JW, Vogelsang G, Jones RJ, Brodsky RA. Bone marrow transplantation in Shwachman-Diamond syndrome. *Bone Marrow Transplant* 2002;30(4): 255-258.
115. Bhatla D, Davies SM, Shenoy S, et al. Reduced-intensity conditioning is effective and safe for transplantation of patients with Shwachman-Diamond syndrome. *Bone Marrow Transplant* 2008;42(3):159-165.
116. Taniguchi T, D'Andrea AD. Molecular pathogenesis of Fanconi anemia: recent progress. *Blood* 2006;107(11):4223-4233.
117. Wang W. Emergence of a DNA-damage response network consisting of Fanconi anaemia and BRCA proteins. *Nat Rev Genet* 2007;8(10):735-748.
118. Giampietro PF, Adler-Brecher B, Verlander PC, Pavlakis SG, Davis JG, Auerbach AD. The need for more accurate and timely diagnosis in Fanconi anemia: a report from the International Fanconi Anemia Registry. *Pediatrics* 1993;91(6):1116-1120.
119. Positional cloning of the Fanconi anaemia group A gene. *Nat Genet* 1996;14(3):324-328.
120. Kutler DI, Singh B, Satagopan J, et al. A 20-year perspective on the International Fanconi Anemia Registry (IFAR). *Blood* 2003;101(4):1249-1256.
121. Seyschab H, Friedl R, Sun Y, et al. Comparative evaluation of diepoxybutane sensitivity and cell cycle blockage in the diagnosis of Fanconi anemia. *Blood* 1995;85(8):2233-2237.

122. Gluckman E, Auerbach AD, Horowitz MM, et al. Bone marrow transplantation for Fanconi anemia. *Blood* 1995;86(7):2856-2862.
123. Socie G, Devergie A, Girinski T, et al. Transplantation for Fanconi's anaemia: long-term follow-up of fifty patients transplanted from a sibling donor after low-dose cyclophosphamide and thoraco-abdominal irradiation for conditioning. *Br J Haematol* 1998;103(1):249-255.
124. Guardiola P, Pasquini R, Dokal I, et al. Outcome of 69 allogeneic stem cell transplantations for Fanconi anemia using HLA-matched unrelated donors: a study on behalf of the European Group for Blood and Marrow Transplantation. *Blood* 2000;95(2):422-429.
125. Pasquini R, Carreras J, Pasquini MC, et al. HLA-matched sibling hematopoietic stem cell transplantation for Fanconi anemia: comparison of irradiation and nonirradiation containing conditioning regimens. *Biol Blood Marrow Transplant* 2008;14(10):1141-1147.
126. Torjemane L, Ladeb S, Ben Othman T, Abdelkefi A, Lakhali A, Ben Abdeladhim A. Bone marrow transplantation from matched related donors for patients with Fanconi anemia using low-dose busulfan and cyclophosphamide as conditioning. *Pediatr Blood Cancer* 2006;46(4):496-500.
127. Shahidi NT, Diamond LK. Testosterone-induced remission in aplastic anemia of both acquired and congenital types. Further observations in 24 cases. *N Engl J Med* 1961;264:953-967.
128. Rackoff WR, Orazi A, Robinson CA, et al. Prolonged administration of granulocyte colony-stimulating factor (filgrastim) to patients with Fanconi anemia: a pilot study. *Blood* 1996;88(5):1588-1593.
129. Trowbridge AA, Sirinavin C, Linman JW. Dyskeratosis congenita: hematologic evaluation of a sibship and review of the literature. *Am J Hematol* 1977;3:143-152.
130. Sirinavin C, Trowbridge AA. Dyskeratosis congenita: clinical features and genetic aspects. Report of a family and review of the literature. *J Med Genet* 1975;12(4):339-354.
131. Putterman C, Safadi R, Zlotogora J, Banura R, Eldor A. Treatment of the hematological manifestations of dyskeratosis congenita. *Ann Hematol* 1993;66(4):209-212.
132. Armanios MY, Chen JJ, Cogan JD, et al. Telomerase mutations in families with idiopathic pulmonary fibrosis. *N Engl J Med* 2007;356(13):1317-1326.
133. Mitchell JR, Wood E, Collins K. A telomerase component is defective in the human disease dyskeratosis congenita. *Nature* 1999;402(6761):551-555.
134. Yamaguchi H, Calado RT, Ly H, et al. Mutations in TERT, the gene for telomerase reverse transcriptase, in aplastic anemia. *N Engl J Med* 2005;352(14):1413-1424.
135. Alter BP, Baerlocher GM, Savage SA, et al. Very short telomere length by flow fluorescence in situ hybridization identifies patients with dyskeratosis congenita. *Blood* 2007;110(5):1439-1447.
136. Russo CL, Glader BE, Israel RJ, Galasso F. Treatment of neutropenia associated with dyskeratosis congenita with granulocyte-macrophage colony-stimulating factor. *Lancet* 1990;336(8717):751-752.
137. Mahmoud HK, Schaefer UW, Schmidt CG, Becher R, Gotz GF, Richter HJ. Marrow transplantation for pancytopenia in dyskeratosis congenita. *Blut* 1985;51(1):57-60.
138. Langston AA, Sanders JE, Deeg HJ, et al. Allogeneic marrow transplantation for aplastic anaemia associated with dyskeratosis congenita. *Br J Haematol* 1996;92(3):758-765.
139. Melis D, Fulceri R, Parenti G, et al. Genotype/phenotype correlation in glycogen storage disease type 1b: a multicentre study and review of the literature. *Eur J Pediatr* 2005;164(8):501-508.
140. Gerin I, Veiga-da-Cunha M, Achouri Y, Collet JF, Van Schaftingen E. Sequence of a putative glucose 6-phosphate translocase, mutated in glycogen storage disease type 1b. *FEBS Lett* 1997;419(2-3):235-238.
141. Rake JP, Visser G, Labrune P, Leonard JV, Ullrich K, Smit GP. Glycogen storage disease type I: diagnosis, management, clinical course and outcome. Results of the European Study on Glycogen Storage Disease Type I (ESGSD I). *Eur J Pediatr* 2002;161(Suppl 1):S20-S34.

142. Visser G, Rake JP, Fernandes J, et al. Neutropenia, neutrophil dysfunction, and inflammatory bowel disease in glycogen storage disease type Ib: results of the European Study on Glycogen Storage Disease type I. *J Pediatr* 2000;137(2):187-191.
143. Visser G, Rake JP, Labrune P, et al. Consensus guidelines for management of glycogen storage disease type 1b—European Study on Glycogen Storage Disease Type 1. *Eur J Pediatr* 2002;161(Suppl 1):S120-S123.
144. Schroten H, Roesler J, Breidenbach T, et al. Granulocyte and granulocyte-macrophage colony-stimulating factors for treatment of neutropenia in glycogen storage disease type Ib. *J Pediatr* 1991;119(5):748-754.
145. Matern D, Starzl TE, Arnaout W, et al. Liver transplantation for glycogen storage disease types I, III, and IV. *Eur J Pediatr* 1999;158(Suppl 2):S43-S48.
146. Childs B, Nyhan WL. Further observations of a patient with hyperglycinemia. *Pediatrics* 1964;33:403-412.
147. Matsui SM, Mahoney MJ, Rosenberg LE. The natural history of the inherited methylmalonic acidemias. *N Engl J Med* 1983;308(15):857-861.
148. Sidbury JB Jr, Smith EK, Harlan W. An inborn error of short-chain fatty acid metabolism. The odor-of-sweaty-feet syndrome. *J Pediatr* 1967;70(1):8-15.
149. Mamlok RJ, Juneja HS, Elder FF, Haggard ME, Schmalstieg FC, Goldman AS. Neutropenia and defective chemotaxis associated with binuclear, tetraploid myeloid-monocytic leukocytes. *J Pediatr* 1987;111(4):555-558.
150. Zuelzer WW. "Myelokathexis"—a new form of chronic granulocytopenia. Report of a case. *N Engl J Med* 1964;270:699-704.
151. Aprikyan AA, Liles WC, Park JR, Jonas M, Chi EY, Dale DC. Myelokathexis, a congenital disorder of severe neutropenia characterized by accelerated apoptosis and defective expression of bcl-x in neutrophil precursors. *Blood* 2000;95(1):320-327.
152. Hord JD, Whitlock JA, Gay JC, Lukens JN. Clinical features of myelokathexis and treatment with hematopoietic cytokines: a case report of two patients and review of the literature. *J Pediatr Hematol Oncol* 1997;19(5):443-448.
153. Gorlin RJ, Gelb B, Diaz GA, Lofsness KG, Pittelkow MR, Fenyk JR Jr. WHIM syndrome, an autosomal dominant disorder: clinical, hematological, and molecular studies. *Am J Med Genet* 2000;91(5):368-376.
154. Hernandez PA, Gorlin RJ, Lukens JN, et al. Mutations in the chemokine receptor gene CXCR4 are associated with WHIM syndrome, a combined immunodeficiency disease. *Nat Genet* 2003;34(1):70-74.
155. Weston B, Axtell RA, Todd RF, 3rd, et al. Clinical and biologic effects of granulocyte colony stimulating factor in the treatment of myelokathexis. *J Pediatr* 1991;118(2):229-234.
156. Wetzler M, Talpaz M, Kellagher MJ, Gutterman JU, Kurzrock R. Myelokathexis: normalization of neutrophil counts and morphology by GM-CSF. *JAMA* 1992;267(16):2179-2180.
157. McDermott DH, Liu Q, Ulrick J, et al. The CXCR4 antagonist plerixafor corrects panleukopenia in patients with WHIM syndrome. *Blood* 2011;118(18):4957-4962.
158. Dale DC, Bolyard AA, Kelley ML, et al. The CXCR4 antagonist plerixafor is a potential therapy for myelokathexis, WHIM syndrome. *Blood* 2011;118(18):4963-4966.
159. Huizing M, Anikster Y, Gahl WA. Hermansky-Pudlak syndrome and Chediak-Higashi syndrome: disorders of vesicle formation and trafficking. *Thromb Haemost* 2001;86(1):233-245.
160. Blume RS, Wolff SM. The Chediak-Higashi syndrome: studies in four patients and a review of the literature. *Medicine (Baltimore)* 1972;51(4):247-280.
161. Certain S, Barrat F, Pastural E, et al. Protein truncation test of LYST reveals heterogenous mutations in patients with Chediak-Higashi syndrome. *Blood* 2000;95(3):979-983.
162. Blume RS, Bennett JM, Yankee RA, Wolff SM. Defective granulocyte regulation in the Chediak-Higashi syndrome. *N Engl J Med* 1968;279(19):1009-1015.
163. Root RK, Rosenthal AS, Balestra DJ. Abnormal bactericidal, metabolic, and lysosomal functions of Chediak-Higashi Syndrome leukocytes. *J Clin Invest* 1972;51(3):649-665.

164. Merino F, Amesty C, Henle W, Layrisse Z, Bianco N, Ramirez-Duque P. Chediak-Higashi syndrome: immunological responses to Epstein-Barr virus studies in gene heterozygotes. *J Clin Immunol* 1986;6(3):242-248.
165. Menasche G, Pastural E, Feldmann J, et al. Mutations in RAB27A cause Griscelli syndrome associated with haemophagocytic syndrome. *Nat Genet* 2000;25(2):173-176.
166. Kurowska M, Goudin N, Nehme NT, et al. Terminal transport of lytic granules to the immune synapse is mediated by the kinesin-1/Slp3/Rab27a complex. *Blood* 2012;119(17):3879-3889.
167. Di Pietro SM, Dell'Angelica EC. The cell biology of Hermansky-Pudlak syndrome: recent advances. *Traffic* 2005;6(7):525-533.
168. Eapen M, DeLaat CA, Baker KS, et al. Hematopoietic cell transplantation for Chediak-Higashi syndrome. *Bone Marrow Transplant* 2007;39(7): 411-415.
169. Pachlopnik Schmid J, Moshous D, Boddaert N, et al. Hematopoietic stem cell transplantation in Griscelli syndrome type 2: a single-center report on 10 patients. *Blood* 2009;114(1):211-218.
170. Aslan Y, Erduran E, Gedik Y, Mocan H, Yildiran A. The role of high dose methylprednisolone and splenectomy in the accelerated phase of Chediak-Higashi syndrome. *Acta Haematol* 1996;96(2):105-107.
171. Ayas M, Al-Ghoniaim A. In patients with Chediak-Higashi syndrome under-going allogeneic SCT, does adding etoposide to the conditioning regimen improve the outcome? *Bone Marrow Transplant* 2007;40(6):603.
172. Lux SE, Johnston RB Jr, August CS, et al. Chronic neutropenia and abnormal cellular immunity in cartilage-hair hypoplasia. *N Engl J Med* 1970;282(5):231-236.
173. McKusick VA, Eldridge R, Hostetler JA, Ruangwit U, Egeland JA. Dwarfism in the Amish. II. Cartilage-Hair Hypoplasia. *Bull Johns Hopkins Hosp* 1965;116:285-326.
174. Makitie O, Kaitila I. Cartilage-hair hypoplasia—clinical manifestations in 108 Finnish patients. *Eur J Pediatr* 1993;152(3):211-217.
175. Hermanns P, Tran A, Munivez E, et al. RMRP mutations in cartilage-hair hypoplasia. *Am J Med Genet A* 2006;140(19):2121-2130.
176. Rosenbluh J, Nijhawan D, Chen Z, Wong KK, Masutomi K, Hahn WC. RMRP is a non-coding RNA essential for early murine development. *PLoS One* 2011;6(10):e26270.
177. O'Reilly RJ, Brochstein J, Dinsmore R, Kirkpatrick D. Marrow transplantation for congenital disorders. *Semin Hematol* 1984;21(3):188-221.
178. Ammann RA, Duppenhaler A, Bux J, Aebi C. Granulocyte colony-stimulating factor-responsive chronic neutropenia in cartilage-hair hypoplasia. *J Pediatr Hematol Oncol* 2004;26(6):379-381.
179. MacGregor RR, Friedman HM, Macarak EJ, Kefalides NA. Virus infection of endothelial cells increases granulocyte adherence. *J Clin Invest* 1980;65(6):1469-1477.
180. Schooley RT, Densen P, Harmon D, et al. Antineutrophil antibodies in infectious mononucleosis. *Am J Med* 1984;76(1):85-90.
181. Zon LI, Groopman JE. Hematologic manifestations of the human immune deficiency virus (HIV). *Semin Hematol* 1988;25(3):208-218.
182. Christensen RD, Rothstein G. Exhaustion of mature marrow neutrophils in neonates with sepsis. *J Pediatr* 1980;96(2):316-318.
183. Cairo MS. Review of G-CSF and GM-CSF. Effects on neonatal neutrophil kinetics. *Am J Pediatr Hematol Oncol* 1989;11(2):238-244.
184. Cairo MS. Granulocyte transfusions in neonates with presumed sepsis. *Pediatrics* 1987;80(5):738-740.
185. Cairo MS, Worcester CC, Rucker RW, et al. Randomized trial of granulocyte transfusions versus intravenous immune globulin therapy for neonatal neutropenia and sepsis. *J Pediatr* 1992;120(2 Pt 1):281-285.
186. Bottiger LE, Furhoff AK, Holmberg L. Drug-induced blood dyscrasias. A ten-year material from the Swedish Adverse Drug Reaction Committee. *Acta Med Scand* 1979;205(6):457-461.

187. van der Klauw MM, Goudsmit R, Halie MR, et al. A population-based case-cohort study of drug-associated agranulocytosis. *Arch Intern Med* 1999;159(4):369-374.
188. Ibanez L, Vidal X, Ballarin E, Laporte JR. Population-based drug-induced agranulocytosis. *Arch Intern Med* 2005;165(8):869-874.
189. Salama A, Schutz B, Kiefel V, Breithaupt H, Mueller-Eckhardt C. Immune-mediated agranulocytosis related to drugs and their metabolites: mode of sensitization and heterogeneity of antibodies. *Br J Haematol* 1989;72(2): 127-132.
190. Eisner EV, Carr RM, MacKinney AR. Quinidine-induced agranulocytosis. *JAMA* 1977;238(8):884-886.
191. Neftel KA, Hauser SP, Muller MR. Inhibition of granulopoiesis in vivo and in vitro by beta-lactam antibiotics. *J Infect Dis* 1985;152(1):90-98.
192. Irvine AE, French A, Daly A, Ranaghan L, Morris TC. Drug-induced neutropenia due to direct effects on CFU-C—ten years of culture experience. *Eur J Haematol* 1994;52(1):21-27.
193. Hodinka L, Geher P, Meretey K, Gyodi EK, Petranyi GG, Bozsoky S. Levamisole-induced neutropenia and agranulocytosis: association with HLA B27 leukocyte agglutinating and lymphocytotoxic antibodies. *Int Arch Allergy Appl Immunol* 1981;65(4):460-464.
194. Duchin KL, Singhvi SM, Willard DA, Migdalof BH, McKinstry DN. Captopril kinetics. *Clin Pharmacol Ther* 1982;31(4):452-458.
195. Pisciotta AV, Kaldahl J. Studies on agranulocytosis. IV. Effects of chlorpromazine on nucleic acid synthesis of bone marrow cells in vitro. *Blood* 1962;20:364-376.
196. Pisciotta AV. Immune and toxic mechanisms in drug-induced agranulocytosis. *Semin Hematol* 1973;10(4):279-310.
197. Muroi K, Ito M, Sasaki R, Suda T, Sakamoto S, Miura Y. Treatment of drug-induced agranulocytosis with granulocyte-colony stimulating factor. *Lancet* 1989;2(8653):55.
198. Stroncek D, Bux J. Is it time to standardize granulocyte alloantigen nomenclature? *Transfusion* 2002;42(4):393-395.
199. Lalezari P, Jiang AF, Yegen L, Santorineou M. Chronic autoimmune neutropenia due to anti-NA2 antibody. *N Engl J Med* 1975;293(15):744-747.
200. Harmon DC, Weitzman SA, Stossel TP. The severity of immune neutropenia correlates with the maturational specificity of antineutrophil antibodies. *Br J Haematol* 1984;58(2):209-215.
201. Bruin MC, von dem Borne AE, Tamminga RY, Kleijer M, Buddelmeijer L, de Haas M. Neutrophil antibody specificity in different types of childhood auto-immune neutropenia. *Blood* 1999;94(5):1797-1802.
202. Starkebaum G. Chronic neutropenia associated with autoimmune disease. *Semin Hematol* 2002;39(2):121-127.
203. Loughran TP Jr, Kadin ME, Starkebaum G, et al. Leukemia of large granular lymphocytes: association with clonal chromosomal abnormalities and auto-immune neutropenia, thrombocytopenia, and hemolytic anemia. *Ann Intern Med* 1985;102(2):169-175.
204. Saway PA, Prasthofer EF, Barton JC. Prevalence of granular lymphocyte proliferation in patients with rheumatoid arthritis and neutropenia. *Am J Med* 1989;86(3):303-307.
205. Felty AR. Chronic arthritis in the adult, associated with splenomegaly and neutropenia. *Johns Hopkins Med J* 1924;35:16.
206. Sokol L, Loughran TP Jr. Large granular lymphocyte leukemia. *Curr Hematol Malig Rep* 2007;2(4):278-282.
207. Campion G, Maddison PJ, Goulding N, et al. The Felty syndrome: a case-matched study of clinical manifestations and outcome, serologic features, and immunogenetic associations. *Medicine (Baltimore)* 1990;69(2):69-80.
208. Breedveld FC, Lafeber GJ, de Vries E, van Krieken JH, Cats A. Immune complexes and the pathogenesis of neutropenia in Felty's syndrome. *Ann Rheum Dis* 1986;45(8):696-702.
209. Liu JH, Wei S, Lamy T, et al. Chronic neutropenia mediated by fas ligand. *Blood* 2000;95(10):3219-3222.
210. Papadaki HA, Eliopoulos AG, Kosteas T, et al. Impaired granulocytogenesis in patients with chronic idiopathic neutropenia is associated with increased apoptosis of bone marrow myeloid progenitor cells. *Blood* 2003;101(7): 2591-2600.

211. Vincent PC, Levi JA, Macqueen A. The mechanism of neutropenia in Felty's syndrome. *Br J Haematol* 1974;27(3):463-475.
212. Choi MF, Mant MJ, Turner AR, Akabutu JJ, Aaron SL. Successful reversal of neutropenia in Felty's syndrome with recombinant granulocyte colony stimulating factor. *Br J Haematol* 1994;86(3):663-664.
213. Loughran TP Jr, Kidd PG, Starkebaum G. Treatment of large granular lymphocyte leukemia with oral low-dose methotrexate. *Blood* 1994;84(7):2164-2170.
214. Rashba EJ, Rowe JM, Packman CH. Treatment of the neutropenia of Felty syndrome. *Blood Rev* 1996;10(3):177-184.
215. Burks EJ, Loughran TP Jr. Perspectives in the treatment of LGL leukemia. *Leuk Res* 2005;29(2):123-125.
216. Narvaez J, Domingo-Domenech E, Gomez-Vaquero C, et al. Biological agents in the management of Felty's syndrome: a systematic review. *Semin Arthritis Rheum* 2012;41(5):658-668.
217. Lamy T, Loughran TP Jr. How I treat LGL leukemia. *Blood* 2011;117(10): 2764-2774.
218. Lalezari P, Nussbaum M, Gelman S, Spaet TH. Neonatal neutropenia due to maternal isoimmunization. *Blood* 1960;15:236-243.
219. Bux J, Behrens G, Jaeger G, Welte K. Diagnosis and clinical course of auto-immune neutropenia in infancy: analysis of 240 cases. *Blood* 1998;91(1): 181-186.
220. Bruin M, Dassen A, Pajkrt D, Buddelmeyer L, Kuijpers T, de Haas M. Primary autoimmune neutropenia in children: a study of neutrophil antibodies and clinical course. *Vox Sang* 2005;88(1):52-59.
221. Levitt LJ, Ries CA, Greenberg PL. Pure white-cell aplasia. Antibody-mediated autoimmune inhibition of granulopoiesis. *N Engl J Med* 1983;308(19): 1141-1146.
222. Mamus SW, Burton JD, Groat JD, Schulte DA, Lobell M, Zanjani ED. Ibuprofen-associated pure white-cell aplasia. *N Engl J Med* 1986;314(10):624-625.
223. Barbui T, Bassan R, Viero P, Minetti B, Comotti B, Buelli M. Pure white cell aplasia treated by high dose intravenous immunoglobulin. *Br J Haematol* 1984;58(3):554-555.
224. Chakupurakal G, Murrin RJ, Neilson JR. Prolonged remission of pure white cell aplasia (PWCA), in a patient with CLL, induced by rituximab and maintained by continuous oral cyclosporin. *Eur J Haematol* 2007;79(3):271-273.
225. Passweg JR, Rabusin M, Musso M, et al. Haematopoietic stem cell transplantation for refractory autoimmune cytopenia. *Br J Haematol* 2004;125(6):749-755.
226. Sacks T, Moldow CF, Craddock PR, Bowers TK, Jacob HS. Oxygen radicals mediate endothelial cell damage by complement-stimulated granulocytes. An in vitro model of immune vascular damage. *J Clin Invest* 1978;61(5):1161-1167.
227. Craddock PR, Fehr J, Dalmasso AP, Brighan KL, Jacob HS. Hemodialysis leukopenia. Pulmonary vascular leukostasis resulting from complement activation by dialyzer cellophane membranes. *J Clin Invest* 1977;59(5):879-888.
228. Boogaerts MA, Roelant C, Goossens W, Verwilghen RL. Complement activation and adult respiratory distress syndrome during intermittent flow apheresis procedures. *Transfusion* 1986;26(1):82-87.
229. Sirchia G, Rebulli P, Mascaretti L, et al. The clinical importance of leukocyte depletion in regular erythrocyte transfusions. *Vox Sang* 1986;51(Suppl 1): 2-8.
230. Amorosi EL. Hypersplenism. *Semin Hematol* 1965;2:249-285.
231. Dunlap WM, James GW 3rd, Hume DM. Anemia and neutropenia caused by copper deficiency. *Ann Intern Med* 1974;80(4):470-476.
232. Drenick EJ, Alvarez LC. Neutropenia in prolonged fasting. *Am J Clin Nutr* 1971;24(7):859-863.
233. Schultz W. Uber eigenartige Halserkrankungen. *Dtsch Med Wochenschr* 1922;48:1495.
234. Hartl W. Drug allergic agranulocytosis (Schultz's disease). *Semin Hematol* 1965;2(4):313-337.
235. Senn H, Holland JF, Banerjee T. Kinetic and comparative studies on localized leukocyte mobilization in normal man. *J Lab Clin Med* 1969;74(5):742-756.
236. Athens JW, Haab OP, Raab SO, et al. Leukokinetic studies. IV. The total blood, circulating and marginal granulocyte pools and the granulocyte turnover rate in normal subjects. *J Clin Invest* 1961;40:989-995.

237. Rebeck JW, Crowley JH. A method of studying leukocytic functions in vivo. *Ann N Y Acad Sci* 1955;59(5):757-805.
238. Schimpff S, Satterlee W, Young VM, Serpick A. Empiric therapy with carbenicillin and gentamicin for febrile patients with cancer and granulocytopenia. *N Engl J Med* 1971;284(19):1061-1065.
239. Ceftazidime combined with a short or long course of amikacin for empirical therapy of Gram-negative bacteremia in cancer patients with granulocytopenia. The EORTC international antimicrobial therapy cooperative group. *N Engl J Med* 1987;317(27):1692-1698.
240. Pizzo PA, Hathorn JW, Hiemenz J, et al. A randomized trial comparing ceftazidime alone with combination antibiotic therapy in cancer patients with fever and neutropenia. *N Engl J Med* 1986;315(9):552-558.
241. Vancomycin added to empirical combination antibiotic therapy for fever in granulocytopenic cancer patients. European Organization for Research and Treatment of Cancer (EORTC) international antimicrobial therapy cooperative group and the national cancer institute of Canada-Clinical trials group. *J Infect Dis* 1991;163(5):951-958.
242. Bishton M, Chopra R. The role of granulocyte transfusions in neutropenic patients. *Br J Haematol* 2004;127(5):501-508.

Chapter 58 Qualitative Disorders of Leukocytes

> Table of Contents > Part VI - Benign Disorders of Leukocytes, The Spleen, and/or Immunoglobins > Chapter 58 - Qualitative Disorders of Leukocytes

Chapter 58

Qualitative Disorders of Leukocytes

Ashish Kumar

Keith M. Skubitz

DISORDERS OF PHAGOCYtic LEUKOCYTES CHARACTERIZED BY MORPHOLOGIC CHANGES

For the most part, the disorders considered here are rare, are usually familial, and often reflect a general metabolic defect, the major manifestation of which may be more serious in tissues than in leukocytes. Nevertheless, the leukocytic morphologic abnormalities may come to the attention of the hematologist, and familiarity with them and the associated diseases may facilitate diagnosis.

Pelger-Huët Anomaly

Pelger-Huët anomaly is a benign anomaly of leukocytes and is inherited as a non-sex-linked, dominant trait. It is characterized by distinctive shapes of the nuclei of leukocytes, a reduced number of nuclear segments (best seen in the neutrophils), and coarseness of the chromatin of the nuclei of neutrophils, lymphocytes, and monocytes. The nuclei appear rod-like, dumbbell-shaped, peanut-shaped, and spectacle-like (“pince-nez”) with smooth, round, or oval individual lobes, contrasted with the irregular lobes seen in normal neutrophils.¹ The incidence of this disorder in different studies has ranged from as high as 1 in 1,000 persons^{2, 3} to 1 in 4,000,^{4, 5} 6,000,⁶ or even 10,000.⁷ Originally observed mainly in Holland, Germany, and Switzerland, the anomaly has now been described in other parts of the world, including individuals of Asian⁸ and African descent and whites. The practical importance of identifying the Pelger-Huët anomaly lies in distinguishing this defect from the shift to the left that occurs in association with infection.

The discovery of this anomaly in rabbits led to breeding experiments and the production of homozygotes.^{2, 5} These studies demonstrated that in the heterozygote, bilobed, rod-shaped, and spectacle forms predominate, whereas in the homozygote, round nuclei with no evidence of segmentation are predominant. In rabbits, the homozygous form was often lethal, with most animals dying in utero; some survivors suffered skeletal malformations.

TABLE 58.1 DISTRIBUTION OF NUCLEAR LOBES IN NEUTROPHILS OF NORMAL PERSONS AND IN THOSE WITH PELGER-HUËT ANOMALY

	Cases Examined	Number of Lobes ^a				
		1	2	3	4	5
Normals ^b	50	2.8	22.0	54.3	18.1	2.8

		±2.8	±6.3		±5.3	±6.9	±2.1
Pelger-Huët heterozygotes ^b	34	31.3	63.8		4.9	0.3	0
		±9.2	±9.5		±3.7	—	—
Pelger-Huët homozygotes ^{2, 9}	2	100.0	—		—	—	

^a Mean and variance.

^b Modified from Davidson WM, Lawler SD, Ackerly AG. The Pelger-Huët anomaly: Investigation of family "A." *Ann Hum Genet* 1954;19:1.

Two human homozygotes have been reported.^{2, 9} In them, the cytoplasm of the neutrophils appeared mature, but the nuclei were round or oval in all the neutrophils, in contrast to the fewer than 40% single-lobed neutrophils present in heterozygotes (Table 58.1).^{2, 6, 9} In the homozygotes, the eosinophils, basophils, and megakaryocytes also were characterized by dense nuclear chromatin and rounded nuclear lobes; these individuals had fewer nuclear lobes than normal subjects.² Examination of the bone marrow revealed normal morphologic features in myeloid precursors through the myelocyte stage, and electron microscopy revealed persistence of nucleoli in the otherwise mature neutrophils that contained single oval nuclei.⁹ This finding was interpreted as indicating some retardation of nuclear maturation, because no cytochemical defects were noted in the cytoplasm. This syndrome is now known to be due to mutations in the lamin B receptor (LBR) gene, a gene important in maintaining nuclear structure.^{10, 11, 12}

Pelger-Huët cells appear to be normal functionally,^{9, 13, 14} are able to phagocytize and kill microorganisms,⁵ and survive normally in the circulation in both humans¹⁵ and dogs.^{16, 17}

The Pelger-Huët heterozygote is recognized by finding (a) 69% to 93% of the neutrophils to be of the bilobed, pince-nez type; (b) few cells with three lobes (usually <10%); and (c) rare or no cells with four lobes (Table 58.1).^{4, 5, 6} In normal blood smears, no more than 27% of the cells are bilobed, and significant numbers of cells have three or more lobes.⁵ The presence of similar abnormalities in the blood smear in other family members also is helpful in establishing the diagnosis. In heterozygotes, mature neutrophils with round or oval nuclei of the type that is characteristic of the homozygous state may increase after stress, such as the injection of colchicine^{18, 3} A shift toward increased numbers of neutrophil lobes was described in a patient with the anomaly who developed pernicious anemia.¹⁹

Pseudo- or Acquired Pelger-Huët Anomaly

Cells with morphologic changes, such as those just described, have been observed occasionally in association with myxedema, acute enteritis, agranulocytosis, multiple myeloma, malaria,

P.1291

leukemoid reactions secondary to metastases to the bone marrow,²⁰ drug sensitivity,²¹ or chronic lymphocytic leukemia.³ More commonly, pseudo-Pelger-Huët cells (Fig. 58.1)²² are seen in patients with myeloid leukemia of either the acute or chronic type or in those with myeloid metaplasia.^{23, 24} In these subjects, the pseudo-Pelger-Huët cells tend to appear late in the disease, often after considerable chemotherapy has been administered. In addition, most of the nuclei are of the single oval type characteristic of the homozygous state.²³

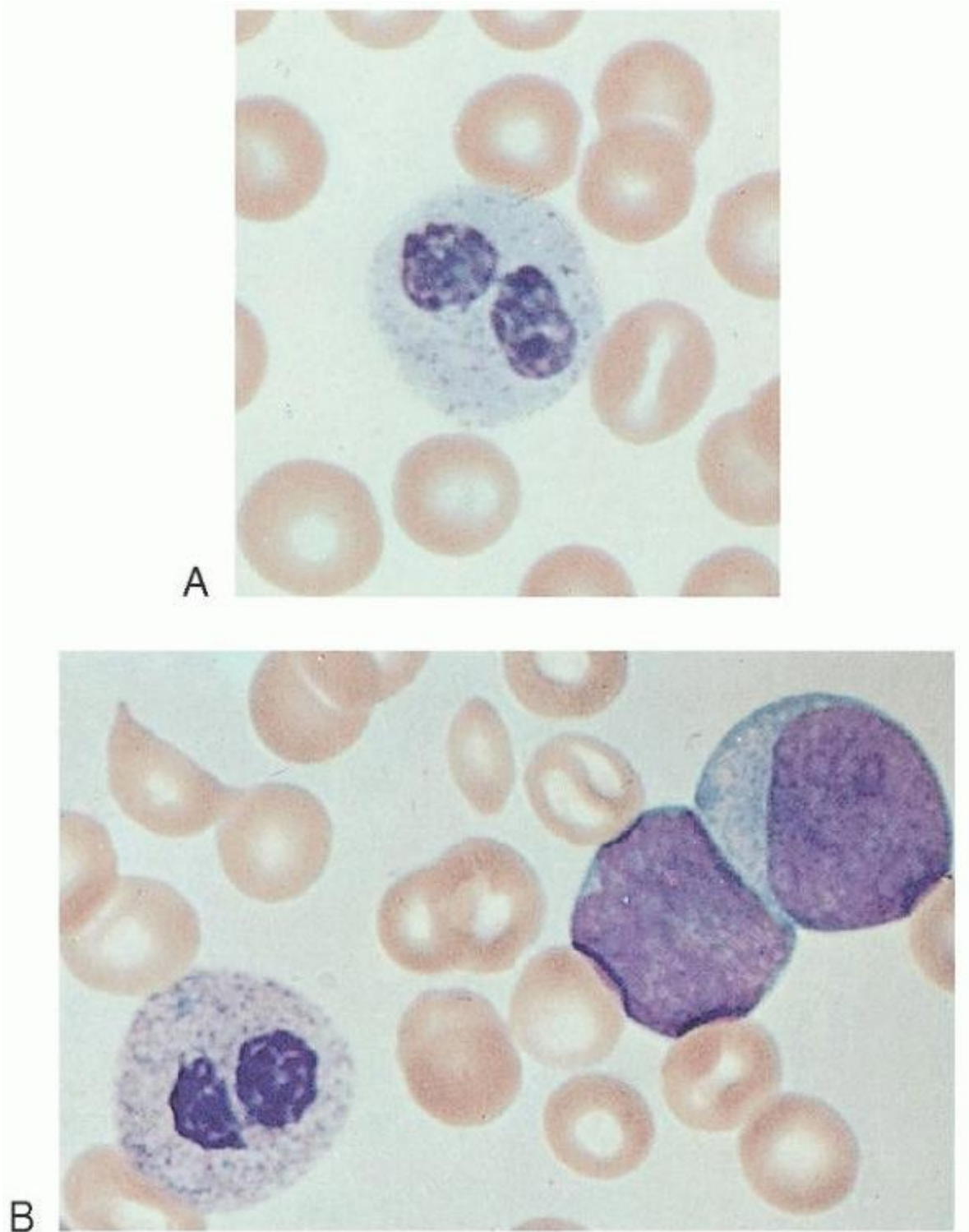

FIGURE 58.1. A: Pseudo-Pelger-Huët cells. B: From a patient with acute myeloblastic leukemia.

Alder-Reilly Anomaly

Alder-Reilly anomaly, inherited as a recessive trait,²⁵ apparently does not interfere with leukocyte function.²⁶ It is characterized by the presence of larger-than-normal azurophil and basophil granules (Alder-Reilly bodies), which may be easily confused with granulations due to toxic states (Fig. 58.2). These granules stain dark lilac with Wright-Giemsa stains and are seen in patients with various types of bone and cartilage abnormalities.^{27, 28} They are most common, however, in association with Hurler syndrome, Hunter syndrome, and Maroteaux-Lamy polydystrophic dwarfism.²⁹

Similar inclusions may be seen in blood lymphocytes (Gasser cells) and monocytes.^{30, 31} The lymphocyte inclusions stain dark red or purple with May-Grünwald-Giemsa stain and metachromatically with toluidine blue; normal azurophilic granules do not stain at all.^{31, 32} Such lymphocyte granules are found in all types of mucopolysaccharidoses except Morquio syndrome, but they are most common in the Hurler, Hunter, Sanfilippo, and Maroteaux-Lamy syndromes.^{29, 31, 32} They tend to occur in clusters rather than diffusely throughout the cytoplasm, are surrounded by vacuoles, and are shaped like a dot or comma. In one series of 19 patients, 8% to 50% of the lymphocytes contained the inclusions, and their presence was thought to be of diagnostic significance.³²

These inclusions are seen inconsistently in the blood but are more common in the bone marrow. For example, in a series of 18 patients with Hurler form of mucopolysaccharidosis, Alder-Reilly bodies were present in the blood of <10% of them. Careful examination of the bone marrow, however, revealed mucopolysaccharide granules in large mononuclear cells (Buhot cells) in 17 of 18 patients.^{33, 34, 35}

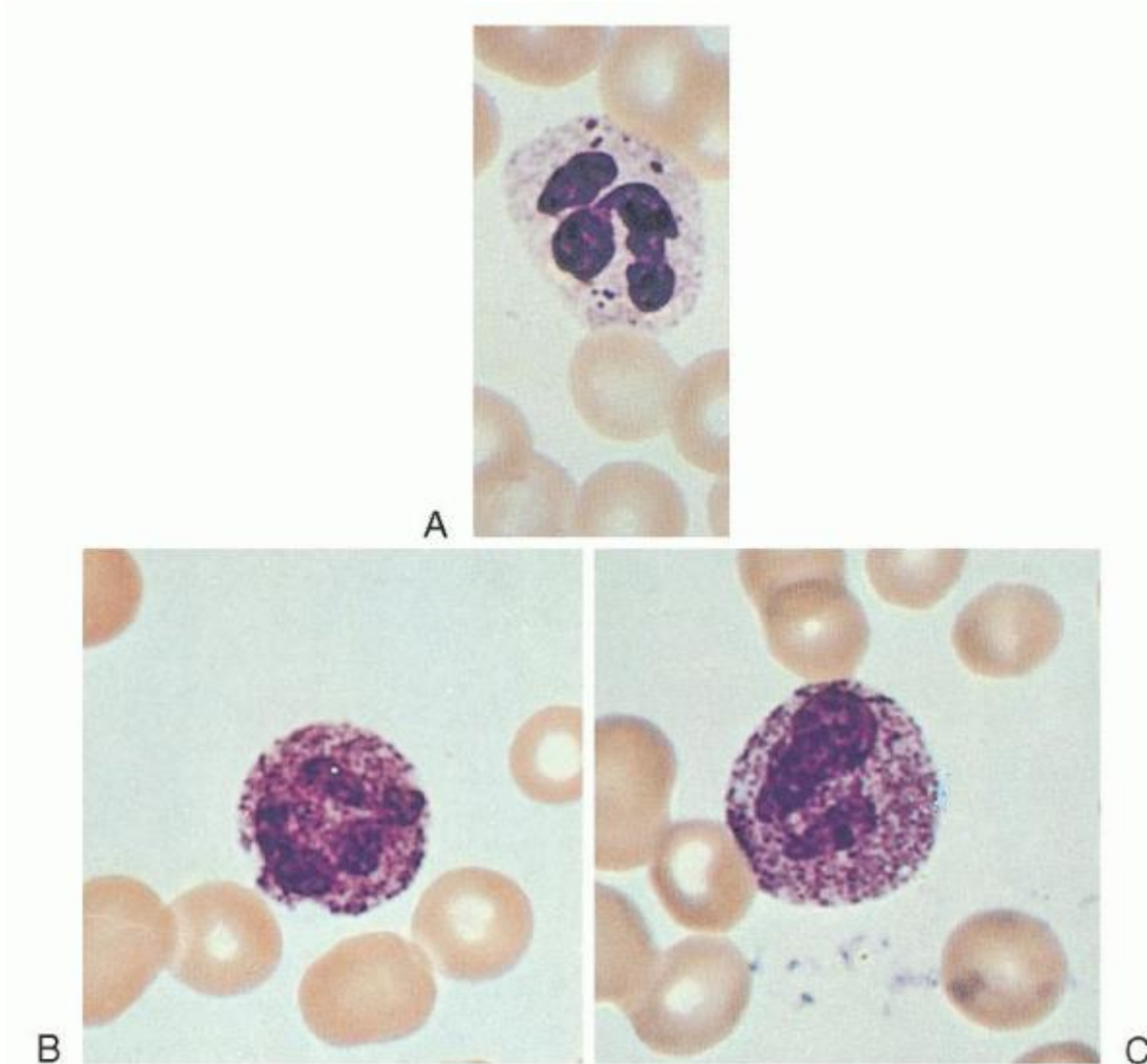

FIGURE 58.2. Neutrophils with Alder-Reilly bodies (A) compared with neutrophils exhibiting toxic granulation (B,C).

The type of inclusion seen is not diagnostic of a particular type of mucopolysaccharidosis, and the frequency of the inclusions is not correlated with clinical severity.³⁶ The basic defect in this group of diseases lies in the incomplete degradation of the protein-carbohydrate complexes known as mucopolysaccharides, and the different forms of mucopolysaccharidosis involve different enzymatic deficiencies.²⁹ The accumulation of partially degraded mucopolysaccharides within lysosomes has been demonstrated by electron microscopy²⁹; the degradation of the protein core of the mucopolysaccharide appears to proceed normally, but catabolism of the carbohydrate side chains is impaired.

May-Hegglin Anomaly

The May-Hegglin anomaly is a rare, dominantly inherited disorder characterized by large (2 to 5 μm), well-defined, basophilic, and pyroninophilic inclusions in granulocytes (neutrophils, eosinophils, basophils, monocytes), and accompanied by variable thrombocytopenia and giant platelets containing few granules.³⁷ For the most part, affected family members have not been ill, but occasionally abnormal bleeding has occurred.^{38, 39, 40, 41} Clot retraction time is prolonged, and the reaction to the tourniquet test may be positive. Platelet survival was short (half-life = 3 days, as compared with the normal, which is 6.9 ± 1.5 [1 standard deviation] days).⁴² Platelet aggregation and retraction were normal, but spreading and serotonin uptake were increased.⁴³ Enzyme and substrate content per platelet were increased, but this value was decreased as related to platelet volume.⁴³ The granulocyte inclusions are similar to Döhle bodies in appearance, but they often are larger, are more round and discrete, and may be present in a large percentage of the cells.^{40, 41, 44} It is claimed that these inclusions differ from the Döhle bodies of infection in morphologic appearance in that they are present in granulocytes other than neutrophils.⁴⁴ Like Döhle bodies,^{40, 44} the inclusions were felt to consist mainly of RNA and may exhibit differing ultrastructure.^{41, 45, 46, 47} More recently, mutations in MYH9, the gene encoding NMMHC-A,

P.1292

have been found in this syndrome.^{48, 49, 50} NMMHC-A is a nonmuscle myosin heavy chain that is part of a family of genes coding for proteins that form part of the actin-myosin force-generating complexes.⁵¹ In the bone marrow, clumping of the megakaryocyte cytoplasm has also been reported.³⁹

Mutations in MYH9 are inherited in an autosomal dominant fashion, but depending on the mutation generate a spectrum of clinical findings manifest as several syndromes due to variable expressivity of the clinical features.^{52, 53, 54, 55, 56, 57, 58} These clinical syndromes include May-Hegglin anomaly, Sebastian syndrome, Fechtner syndrome, and Epstein syndrome and are characterized by giant platelets, leukocyte inclusions, and variable thrombocytopenia, in addition to problems with hearing, vision, or renal function.^{52, 53, 54, 55, 56, 57}

Chédiak-Steinbrinck-Higashi Anomaly (Congenital Gigantism of Peroxidase Granules)

Chédiak-Steinbrinck-Higashi anomaly, an autosomal recessive disorder, has been reported in humans,^{59, 60, 61, 62} mice,⁶³ mink,⁶⁴ cattle,⁶⁴ cats,⁶⁵ rats,⁶⁶ and a killer whale.⁶⁷ It is characterized by partial ocular and cutaneous albinism, increased susceptibility to pyogenic infections, the presence of large lysosome-like organelles in most granule-containing cells, and a bleeding tendency.⁶⁸ The abnormal granules are most readily seen in blood and marrow leukocytes, especially granulocytes (Fig. 58.3), and in melanocytes.

In the first families that were reported with this anomaly, the mothers noted that some of their children exhibited pale hair (Fig. 58.4) and photophobia.^{59, 60} Because these children often had infections and adenopathy and died at an early age, the children born subsequently who were similarly affected were brought to medical attention in the hope of avoiding a fatal outcome.⁶⁰ It was then that the large, peroxidase-positive granules were noted in their blood and marrow granulocytes.^{59, 60, 61} Nevertheless, without definitive treatment (bone marrow transplantation, described later) most patients die in infancy or early childhood; only a few survive into early adult life.^{69, 70, 71}

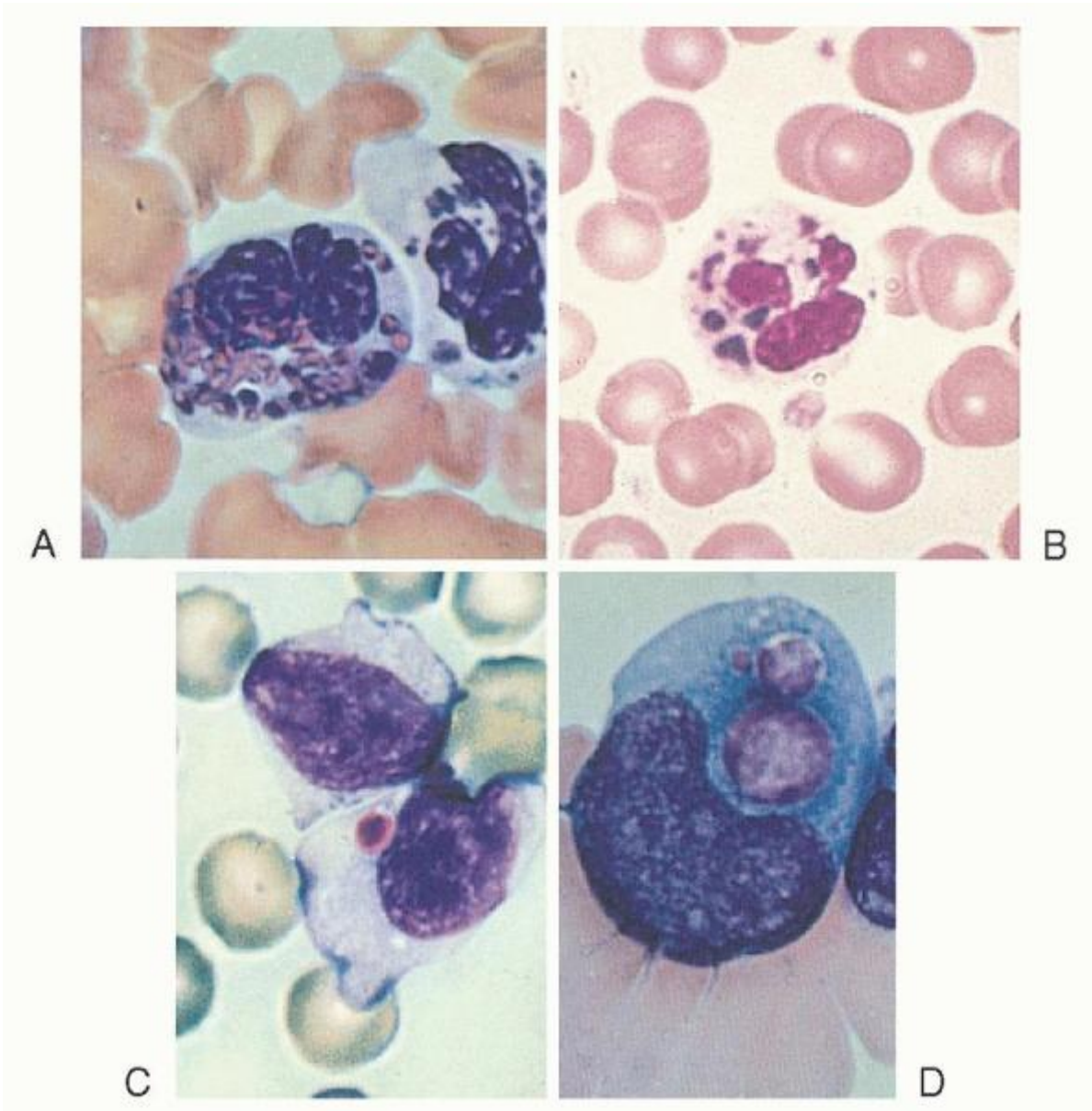

FIGURE 58.3. Inclusion bodies in Chédiak-Steinbrinck-Higashi anomaly. A, B: Neutrophils. C: A lymphocyte. D: A monocytoic cell.



FIGURE 58.4. The characteristic silver-gray hair of a child (left) with Chédiak-Steinbrinck-Higashi anomaly contrasted with that of her mother. (Courtesy of Dr. Dorothy Windhorst, National Institutes of Health.)

During the 30 years after the first description of Chédiak-Higashi syndrome (CHS)⁷² 59 cases were reported.⁶⁹ The similar disorder in animals is of use in investigations of the pathogenic defect and is of significant economic impact in mink, in that affected animals, inbred for their unusual color, seldom survive more than a year and exhibit increased susceptibility to a slow viral infection that produces hepatitis and a myeloma-like illness (Aleutian mink disease).⁶⁴

Etiology and Pathogenesis

The manifestations of this disorder appear to result from abnormal intracellular protein transport, resulting in abnormal granule fusion with larger, fewer-than-normal, and perhaps defective granules being formed in most granule-containing cells throughout the body.^{73, 74, 75, 76, 77} The resulting abnormalities can be found in the hematopoietic tissues, hair, ocular pigment, skin, adrenal glands, pituitary gland, gastrointestinal organs, peripheral nerves, and elsewhere.⁷⁴

In neutrophils, the anomalously large, peroxidase-positive granules seen by light microscopy^{59, 60} have been shown by electron microscopy to be abnormal primary (azurophilic) granules, the contents of which remain pleomorphic, the normal granule crystalloid structure not being formed.^{73, 78} Characterization of the abnormal granules by means of immunofluorescence microscopy demonstrated that they were formed by the progressive aggregation and fusion of azurophilic granules.^{79, 80}

In a subsequent electron microscopic study, investigators demonstrated the presence of two types of giant, peroxidase-positive granules in CHS neutrophils: large, round, or oval granules with homogeneous internal structure similar to normal azurophilic granules; and irregular granules much larger than those of the first type. Because basophils and eosinophils from CHS patients do not contain type 2 granules, and because type 2 granules are less common in promyelocytes, myelocytes, and young neutrophils in the bone marrow than in blood neutrophils, the authors suggested that normal primary (azurophil) granules are formed, but progressive granule fusion occurs during maturation, especially in the blood. In this process, granules and bits of cytoplasm are trapped within the fused granules.⁸¹ An abnormal calcium uptake pump in CHS lysosomes may be part of the underlying defect.^{82, 83} Also noted is an increased tendency to autophagic vacuole formation in Chédiak-Higashi neutrophils, perhaps because of increased permeability and leakage of injurious materials from the massive granules.⁸⁴ A secretory defect appears to prevent granule release in CHS T cells.⁸⁵ Abnormal granules have been observed less often in erythroid cells, whereas in megakaryocytes and platelets, the granules appear normal by light microscopy.⁷³ By electron microscopy, however, a decrease in dense bodies was seen,⁷³ and decreased serotonin, adenosine triphosphate, and adenosine diphosphate levels were noted.⁶⁸

P.1293

Similar large granules containing a glycolipid have been observed in the Schwann cells of peripheral nerves, in neurons in the central nervous system,^{84, 86} in renal tubular cells,⁸⁶ and in the vascular endothelium and fibroblasts.^{69, 87} In addition, giant pigment granules have been demonstrated in melanosomes⁸⁶ and in hair strands.^{69, 86} In the several different tissues affected, the consistent feature is that the histochemical reactions of the large abnormal granules are those usually seen in normal granules of that cell line⁸⁶; no qualitative alteration in granule enzyme content is noted, but some decrease in granule enzymes and an increase in cytoplasmic enzyme content have been described.⁸⁸ The effects of the abnormality in different tissues depend on granule function in that tissue. Thus, the large but fewer melanin granules produce pigment dilution, which explains the peculiar hair color, partial albinism, photophobia, and nystagmus.⁸⁶

The abnormal large granules in neutrophils lead to increased susceptibility to infection. Infection occurs despite an above-normal rate of phagocytosis and a normal postphagocytic metabolic burst (H_2O_2 production).⁸⁹ Apparently, the intracellular destruction of some bacteria by Chédiak-Higashi leukocytes is delayed because the postphagocytic delivery of lysosomal enzymes into phagosomes is inefficient and incomplete.⁹⁰ A similar defect in granule extrusion has been noted in the renal tubule.⁹¹

Chédiak-Higashi neutrophils from humans lack cathepsin G and elastase⁹² and have reduced C3bi receptor expression.⁹³ Because measurements of elastase and cathepsin G were normal in the bone marrow of beige mice, the primary lesion is thought not to be a gene defect but rather is likely a disorder of protein processing, protein synthesis, or granule assembly.⁹² In addition, a defect in cellular response to chemotactic stimuli both in *in vitro* and in *in vivo* skin windows has been demonstrated in humans, mice, and mink,^{94, 95} and a neutrophil membrane abnormality consisting of spontaneous cap formation has been described.⁹⁶ Recent studies show that lysosomes function as calcium-regulated secretory compartments and may play an important role in membrane resealing. Lysosomal exocytosis triggered by membrane wounding is defective in human CHS and beige mouse fibroblasts, and this defect may be central to the CHS phenotype.⁸²

Inheritance

In 1972, in families with 127 children, 59 were reported to be affected.⁶⁹ This statistic and animal studies⁶⁴ indicate that this disorder is inherited as an autosomal recessive trait. Male and female subjects are affected at a ratio of 0.87:1.00. A high proportion of marriages producing affected children have been consanguineous. Some heterozygotes may be identifiable by the presence of granulation in some of their lymphocytes.^{97, 98}

Clinical Features and Course

The partial albinism (more properly, pigment dilutional defect),⁸⁶ silvery hair (Fig. 58.4), and photophobia are usually noted early in infancy. The poor resistance to respiratory and cutaneous infection, especially by *Staphylococcus* and other Gram-positive organisms, soon becomes evident. Four patients studied for more than 1 year experienced 29 episodes of fever and pyogenic infection.⁷¹ Increased bleeding with abnormal platelet function has also been recognized.⁹⁹ Many of the afflicted children develop potentially fatal infections during infancy or early childhood. In others, the disease remains quiescent. Eventually, in more than 85% of patients, it changes to an accelerated phase that is characterized by lymphadenopathy, hepatosplenomegaly, neuropathy, anemia, neutropenia, and, less often, thrombocytopenia.¹⁰⁰ During this phase, infiltration of the tissues by mononuclear cells is widespread and the accelerated phase is now considered akin to the disorder hemophagocytic lymphohistiocytosis.¹⁰¹ During the accelerated phase, neurologic manifestations (peripheral neuropathy) may become prominent, and hemorrhage may occur.

Laboratory Findings

The characteristic microscopic findings are the large, often multiple, peroxidase-positive lysosomal granules in the granulocytes of the blood and bone marrow, and the large melanosomes in the hair. Less common are granules in the lymphocytes. Abnormal platelet aggregation can be demonstrated regularly.⁶⁸ During the early phases of the disease, blood counts yield normal values, but as the disease progresses, anemia, neutropenia, and thrombocytopenia often develop. Immunoglobulin (Ig) and complement levels are normal, as are cellular immune reactions. In the accelerated phase, erythrocyte and granulocyte survival may be shortened.⁶⁹

Gene Defect

The origin of CHS in mice has been found to be a mutation in the CHS/LYST gene on chromosome 1 in humans, which codes for a lysosomal trafficking regulatory protein.^{102, 103} The human homologue CHS1 has since been cloned, and mutations of this gene have been found in patients with CHS.^{76, 77, 102, 104, 105, 106, 107, 108, 109, 110}

Management

Some believe that the prophylactic administration of antibiotics may be beneficial.⁷¹ The administration of ascorbic acid corrected the defective leukocyte function *in vitro* and *in vivo* in several patients,^{111, 112} and the administration of cholinergic agonists was effective in mice.^{96, 113} The increased susceptibility to infection has been corrected in mice by the transplantation of normal bone marrow, and the hematopoietic defects can be transmitted to normal mice by transplanting marrow from an animal with CHS.¹¹⁴ In the accelerated phase, splenectomy has been only temporarily helpful⁶⁹; a few patients have been treated with a combination of vincristine and prednisone. Bone marrow transplantation appears to be a logical treatment, if possible,^{115, 116, 117} but does not alter the neurologic deterioration.^{109, 117}

Familial Vacuolization of Leukocytes (Jordan Anomaly)

Jordan anomaly is characterized by the presence of vacuoles in the cytoplasm of granulocytes, monocytes, and occasionally lymphocytes and plasma cells. In members of one family, all of the blood neutrophils and more than 70% of the monocytes contained three to ten vacuoles ranging in size from 2 to 5 μm ; fewer and smaller vacuoles were seen in eosinophils, basophils, and lymphocytes.¹¹⁸ By means of histochemical and fluorescence microscopic analysis, the vacuoles were shown to contain lipids. These lipids were seen in promyelocytes, myelocytes, metamyelocytes, and occasionally plasma cells in the bone marrow, but they were not present in myeloblasts, erythroblasts, or megakaryocytes.¹¹⁸ This type of vacuolization must be distinguished from that characterized by fat-staining vacuoles occurring in people with serious infections, toxic hepatitis, or diabetic ketoacidosis.¹¹⁹

The disorder appears to be familial. Two members were affected in each of two unrelated families.^{118, 119} None of the four patients had acute disease, but in members of one family, progressive muscular dystrophy was present,¹¹⁸ whereas in members of the other, ichthyosis was associated.¹¹⁹

Other Inclusions in Leukocytes

In an infant with congenital bile duct atresia, amorphous, round-to-oval bodies stained green or gray-green with Romanovsky stains in 3% to 13% of the blood neutrophils and in 1% to 5% of the monocytes.¹²⁰ Similar inclusions were present in all stages of myeloid cells in the bone marrow but not in lymphocytes or plasma cells. Electron microscopic analysis showed that the inclusions were not enclosed in a phagocytic vesicle.

P.1294

In the blood monocytes of patients with the Hermansky-Pudlak syndrome,¹²¹ a rare familial disorder characterized by albinism, mild bleeding related to platelet dysfunction, accumulation of ceroidlike pigment in marrow macrophages, and deficiency of the tetraspan protein CD63 in platelets,¹²² lipopigment bodies as well as another type of inclusion were demonstrated.

Abnormal Specific (Secondary) Granule Formation

A syndrome of recurrent staphylococcal skin and sinus infections associated with abnormal chemotaxis, impaired staphylococcal killing, and morphologic abnormalities in the neutrophils was described in a 14-year-old boy.¹²³ No other family members were affected. The patient's polymorphonuclear neutrophils exhibited bilobed nuclei with unevenly distributed chromatin, drumsticklike nuclear projections, and nearly absent cytoplasmic granules that stained with peroxidase but not with alkaline phosphatase. Electron microscopy revealed primary granules, but specific granules were small and reduced in number. These neutrophils were capable of phagocytosis, generated H_2O_2 , reduced nitroblue tetrazolium (NBT) dye, and killed *Candida*, but staphylococcal killing was impaired.

Since the original report, at least five cases of specific granule deficiency (SGD) have been identified with both sexes affected, leading to the assumption that the disorder is an autosomal recessive disease.^{124, 125} SGD neutrophils exhibit decreased chemotaxis and bacterial killing *in vitro* and decreased migration into skin windows *in vivo*, and they fail to upregulate CD11/CD18, laminin, or f-met-leu-phe (FMLP) receptors after activation,¹²⁴ although oxygen radical generation is apparently normal. Myeloperoxidase (MPO)-positive primary granules are present, but the specific secondary granules appeared to be absent in Wright-stained blood smears and were decreased in number and small when viewed with

electron microscopy.¹²³ These structures do not stain with alkaline phosphatase. The specific granule constituents lactoferrin and B₁₂ binding protein are reduced or absent.

Lactoferrin deficiency in patients with SGD is tissue specific (i.e., confined to myeloid cells, whereas lactoferrin is secreted normally in nasal secretions) and is secondary to a deficiency of RNA transcripts.¹²⁶ Because morphologic changes have been described in the primary granule¹²⁷ and because other granule proteins, such as primary granule defensin⁹² and "tertiary" granule gelatinase, are also deficient in SGD neutrophils, it was suggested that the basic defect in SGD is one of regulation of production of these proteins.¹²⁶ Thus, this disorder may be one of incomplete granule synthesis rather than a true SGD.¹²⁷

C/EBPE is an important regulator of neutrophil secondary granule genes,¹²⁸ and mutations in the C/EBPE gene have been found in two patients with SGD.^{129, 130, 131} Neutrophils from Cebp-deficient mice have functional defects very similar to those of patients with SGD,^{129, 132} and these mice have defects in eosinophil and macrophage function as well.^{133, 134} Monocyte/macrophage abnormalities have also been noted in an SGD patient.¹³⁵ One case of SGD has been reported with no mutation in the C/EBPE gene.¹³⁶

Hereditary Giant Neutrophilia

Neutrophils with a diameter of approximately 17 μm (as compared with a normal diameter of about 13 μm) are rare in blood smears from normal people (1 in 20,000 neutrophils or less). They may be seen with greater frequency in patients who are ill, but even then the number rarely exceeds 0.2% unless a disease involving leukocyte production is present or a reaction to a cytotoxic drug occurs.¹³⁷ A family with giant neutrophils in healthy members of three generations has been reported.¹³⁷ Over several years, the proband had an average of 1.6% giant neutrophils in the blood. The large neutrophils appeared to be nearly double the normal cell volume and contained from six to ten nuclear lobes. Therefore, it was suggested that the cells may have been tetraploid. This anomaly appeared to be transmitted as an autosomal dominant trait.

Hereditary Hypersegmentation of Neutrophil Nuclei

Several families have been described whose members had a hereditary (autosomal dominant) increase in the number of neutrophil nuclear segments (Fig. 58.5).¹³⁸ The proportion of neutrophils containing five lobes or more exceeded 10% in most heterozygotes and was >14% in several suspected homozygotes, as compared with no more than 10% in normal controls.¹³⁸ The bone marrow findings suggested a tendency toward nuclear indentation in early myeloid forms (eosinophils and basophils as well as neutrophils).¹³⁸ The normal size of these neutrophils was thought to provide evidence against tetraploidy, but in one study of five female family members, the mean number of nuclear drumsticks appeared to be increased above normal.¹³⁹ The chief significance of this anomaly is in its differentiation from other causes of hypersegmentation such as folate or vitamin B₁₂ deficiency.

Hypersegmentation of Eosinophils and Negative Staining for Peroxidase and Phospholipids

Hypersegmentation of eosinophils can be inherited as an autosomal recessive trait, and the abnormality is characterized by a lack of sudanophilia and peroxidase activity in all of the eosinophils, whereas these histochemical reactions remain positive in the neutrophils and monocytes.^{140, 141} In addition, the number of eosinophilic granules per cell appears to be reduced, and some hypersegmentation of the eosinophil nucleus may occur. No disease accompanies the disorder. This has been most commonly reported in people of Jewish (predominantly Yemenite) extraction, although members of other races have not been studied adequately.

FUNCTIONAL DISORDERS OF LEUKOCYTES NOT CHARACTERIZED BY MORPHOLOGIC CHANGES

The topic of neutrophil dysfunction is under active study. Several reviews summarize this topic^{142, 143, 144, 145}; the reader is also referred to the current literature.

Chronic Granulomatous Disease of Childhood

Chronic granulomatous disease (CGD) is a rare clinical syndrome that results from genetically heterogeneous inherited defects of

P.1295

leukocyte function, that result from mutations in one of four genes coding for subunits of the neutrophil NADPH oxidase.^{146, 147, 148, 149, 150, 151, 152, 153}

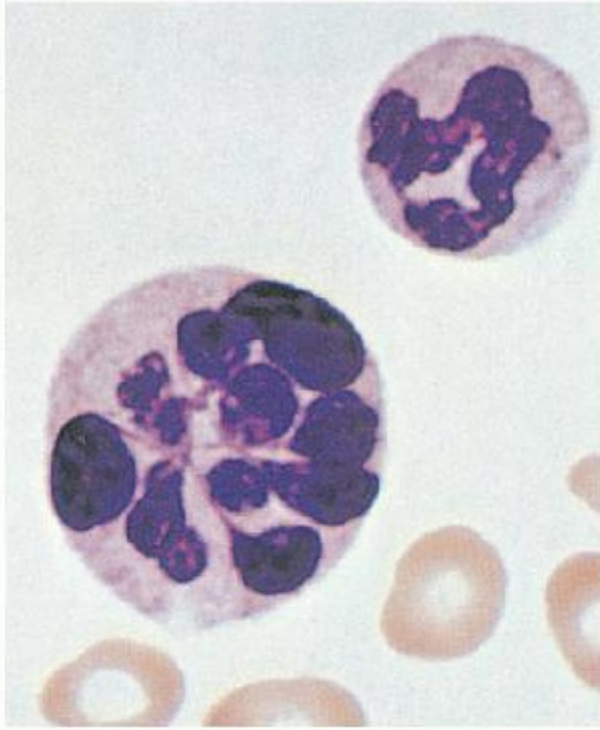

FIGURE 58.5. Hypersegmented neutrophil.

Activation of the nicotinamide adenine dinucleotide phosphate (NADPH) oxidase requires protein kinases, lipid-mobilizing enzymes, and factors that activate the Rac GTPase, and thus the CGD phenotype could be due to a variety of other mutations as well. Recent reviews have been published.^{145, 150, 151, 154, 155, 156, 157, 158, 159, 160, 161, 162, 163}

CGD neutrophils are characterized by a defective respiratory burst during phagocytosis and an inability to generate superoxide. The impaired superoxide production usually occurs transiently in each phagosome with phagocytosis and leads to recurrent bacterial and fungal infections, most commonly at epithelial surfaces. CGD is characterized by recurrent infections with catalase-positive bacteria. CGD neutrophils can use H_2O_2 produced by ingested bacteria to generate hypochlorous acid (HOCl) via MPO and aid in killing the bacteria. Catalase-positive bacteria generate H_2O_2 levels in the phagocytic vacuole that are too low for generation of sufficient HOCl to contribute to significant bacterial killing via this mechanism.¹⁵⁵ This syndrome can be the result of different genetic defects in the superoxide generating system. Variable inheritance patterns have been observed with approximately two-thirds of the pedigrees being X-linked and one-third autosomal recessive. Multiple molecular defects have been identified that result in the CGD phenotype.^{144, 145, 155, 157, 158, 161, 164, 165} Potential treatments include prophylactic antibiotics, interferon- γ , and bone marrow transplantation. Knowledge in this field is changing rapidly.¹⁵¹

CGD neutrophils, eosinophils, monocytes, and macrophages fail to generate superoxide, hydrogen peroxide, and other oxygen radicals after particle phagocytosis (or other stimulation), and thus have decreased microbicidal activity. CGD is associated with no leukocyte morphologic abnormalities and was first noted in male children with a history, beginning in early childhood, of recurrent suppurative infections caused by organisms of low-grade pathogenicity, including fungi, or by staphylococci. The eczematoid, granulomatous, and sometimes purulent skin infections recur repeatedly and clear slowly. Associated adenopathy develops and may persist. Pulmonary and other infections (e.g., osteomyelitis) also are common, and progressive granulomatous disease of the lungs, liver, and other sites develops. Hepatosplenomegaly is common, and biopsy reveals necrotizing granulomas, often with associated purulent inflammation. The disorder often progresses to death in early childhood,^{166, 167} but some patients survive longer.^{152, 168} Although rare, CGD has assumed great importance as a prototype of defects in leukocyte bactericidal capacity.

History and Mode of Inheritance

CGD was first described from 1954 to 1957^{166, 167} as affecting only males. By 1970, more than 90 cases were reported.^{148, 168} X-linked inheritance was established, and female heterozygotes were identifiable by the presence of defective leukocyte bactericidal capacity intermediate in degree between that of affected patients and that of normal individuals.¹⁶⁹

Measurements of postphagocytic release of $^{14}\text{CO}_2$ from glucose-1- ^{14}C or reduction of NBT dye were used to detect the defect. By means of the NBT dye test, female carriers were found to have a mixed population of neutrophils, approximately one-half being NBT negative and one-half being NBT positive. The defect is transmitted on an X chromosome, and the degree of deficit in female subjects varies according to random X chromosome inactivation. Consequently, one may expect to find an occasional female carrier with clinical disease as severe as that in male patients.^{169, 170}

Because of the clinical and pathologic picture of chronic recurrent infection caused by low-grade pathogens and the resultant granuloma formation, it was suggested that a defect in inflammatory response results in lesions comparable to those that normal people develop after infection with tubercle bacilli or brucella.¹⁴⁷ No abnormality in antibody response to diphtheria, tetanus, or poliovirus was demonstrated in these patients, and their delayed hypersensitivity response also was normal.¹⁴⁷ In addition, leukocyte migration and surface phagocytosis were normal.¹⁴⁷ Nevertheless, when leukocytes of CGD patients were incubated with bacteria, such as staphylococci, serratia, or other organisms causing infection in these patients, decreased bacterial killing and prolonged bacterial survival in the phagocytic vacuoles were observed.^{171, 172} Decreased killing of fungi and incomplete inactivation of vaccinia and herpes virus also was reported,^{147, 173} but streptococci were killed normally by CGD leukocytes.^{172, 174}

Although the mechanisms of bacterial killing by normal leukocytes are still incompletely understood, it is clear that phagocytosis is followed by fusion of lysosomes with the phagocytic vacuole, discharge of lysosomal enzymes into the phagosome, and a burst of postphagocytic metabolic activity. These events are usually accompanied by bacterial death and digestion (see Chapters 7 and 10). Early studies of CGD reported that a deficiency of NADPH oxidase or an abnormality in its activation is the underlying cause of this syndrome.¹⁷⁵ The finding that iodination of bacteria in the phagosome appears to be one mode of bacterial killing, and that this process is defective in CGD leukocytes and can be partially repaired by the insertion of an oxidase into the phagosome, either carried on oxidase-coated polystyrene particles^{176, 177} or as part of the ingested bacteria,¹⁴⁹ provided strong evidence incriminating defective generation of H_2O_2 , superoxide,¹⁷⁸ or related ions¹⁷⁹ as the pathogenic defect in this disorder.^{176, 180} Although most studies have focused on neutrophils, it was recognized in the earliest reports that lipid-laden macrophages were present in the granulomatous lesions,¹⁸¹ and a defect in the mononuclear phagocytes¹⁸² and in eosinophils¹⁸³ also has since been demonstrated. The platelets appear normal.¹⁸⁴

In the late 1960s and 1970s, an autosomal recessive form of CGD was described.^{148, 149} It is clinically identical to the X-linked forms, with the exception that the parents of affected children usually have normal neutrophil function, and the clinical course may be milder.¹⁴⁶

Molecular Pathology

In 1978, a unique cytochrome β , termed β_{558} (named for its absorption spectrum) or β_{245} (named for its midpoint potential), present only in phagocytic cells, was described and suggested to be a primary component of the oxidase that normally generates superoxide but, when defective, results in CGD.¹⁸⁵ This cytochrome was absent from X-linked CGD phagocytes (thus termed X⁻) but was present in phagocytes from patients with autosomal recessive inheritance patterns (A⁺).¹⁸⁵

In 1985, a family with CGD and an autosomal recessive inheritance pattern but with absence of cytochrome β was reported, thus identifying a third type of CGD (A⁻).¹⁸⁶ In these studies, a somatic cell hybridization technique was used to demonstrate that fusing monocytes from any two of these three types of CGD (X⁻, A⁺, or A⁻) restored their ability to oxidize NBT, thus defining three distinct molecular defects.¹⁸⁶ Also in 1985, several groups demonstrated that both membrane and cytosolic components are necessary for superoxide generation, and deficiencies in either can result in CGD.¹⁴⁶

In 1987, cytochrome β was purified and shown to be a heterodimer composed of two polypeptides, a heavily glycosylated, 91,000-dalton heavy chain (approximately 50,000 of the molecular weight is peptide) and a 22,000-dalton light chain.¹⁸⁷ Antibodies to these two polypeptides showed them both to be absent from the phagocytes of two types of CGD (X⁻ and A⁻). The defective gene in X-linked, cytochrome-negative CGD has since been cloned and shown to encode for the polypeptide portion of the 91,000-dalton subunit of cytochrome β now known as gp91phox.^{187, 188} Because postphagocytic activation of the

P.1296

respiratory burst with generation of superoxide and peroxide, as well as bacterial killing, involves complex reactions and multiple enzymes (e.g., phospholipases, protein kinases, NADPH oxidase, glucose-6-phosphate dehydrogenase [G6PD],

glutathione peroxidase),¹⁴⁶ one might expect that defects other than those described in NADPH oxidase would result in a disorder phenotypically like that described in the section Variants.

Clinical and Laboratory Features

The clinical picture of CGD includes the development of recurrent infections, especially of the skin and lungs, with septic lymphadenitis, development of hepatosplenomegaly and granulomas, and ultimately death from infection.^{147, 152, 166}

The blood neutrophil count is not reduced, and it increases appropriately with infection or after endotoxin injection; monocytosis is sometimes observed.¹⁴⁷ Because chronic infection is common, the Ig levels often are elevated, and plasma cells may be present in increased numbers in the bone marrow. Ig deficiencies have not been encountered, and antibody titers (both IgM and IgG) increase normally after antigenic stimulation. Reticuloendothelial clearance of colloidal gold also is normal. Peroxidase staining of blood cells demonstrates more intense dye uptake in CGD neutrophils than in normal cells.¹⁸³ The classical method for detecting the defect is the postphagocytic, intraphagosomal reduction of almost colorless NBT dye to blue-black formazan.^{183, 189} When tests are properly standardized with respect to time of incubation of leukocytes with the dye-tagged zymosan particles, affected patients and most carriers are readily recognized. When the reaction to this test is negative in suspected carriers, the reaction to the quantitative dye reduction test usually is positive.¹⁸³ Nowadays, the preferred diagnostic test is flow cytometry-based detection of the conversion of the nonfluorescent dye dihydrorhodamine to its oxidized form that emits green fluorescence.¹⁹⁰ The sensitivity and quantitative nature of this method make it more reliable and also allow for detection of residual oxidase activity that can be important in prognosis.¹⁹¹

An alteration in the B-cell compartment in patients with CGD has been reported.¹⁹² It appears that CGD is associated with a reduction in the peripheral blood memory B-cell compartment, suggesting a role for NADPH in memory B-cell formation.¹⁹²

Course and Prognosis

There is considerable heterogeneity in the severity of the clinical course of patients with CGD. Without treatment, this disease usually runs a progressive downhill course because of repeated infections and granuloma formation. The average life expectancy was reported to be 5 to 7 years in 1968.¹⁴⁷ One-half of patients are projected to survive into the fourth decade in 2008.¹⁵⁰ Recent studies suggest that the clinical course may be predictable by the specific mutation and those individuals with higher residual ability to produce reactive oxygen intermediates might fare better.¹⁹¹

Treatment

Treatment of infections with appropriate antibiotics and surgical procedures remains the cornerstone of management.^{149, 156, 193, 194} Prophylactic use of antibiotics, including trimethoprim-sulfamethoxazole and itraconazole with interferon- γ , is generally recommended.^{150, 151, 155, 156, 158, 194, 195} Trimethoprim-sulfamethoxazole alone or in combination with dicloxacillin can prolong the infection-free interval in many CGD patients.¹⁹³

In some patients with CGD, the administration of interferon- γ has induced partial correction of cytochrome β content and restored phagocyte bactericidal capacity toward normal, and reports have suggested that interferon- γ increases the ability of CGD neutrophils to kill *Aspergillus* and decreases the number of serious infections in patients with CGD.^{194, 195, 196, 197} The exact mechanism by which interferon- γ exerts its beneficial effect in CGD is unclear and may include other effects in addition to augmentation of the respiratory burst. Bone marrow transplantation and gene therapy are potential experimental approaches.^{115, 193, 198, 199, 200}

Variants

Because the clinical picture of CGD results from delayed killing of catalase-positive bacteria, enzymatic defects in the bactericidal system other than decreased NADPH oxidase may produce an almost identical picture. Results of several studies demonstrate clearly that such biochemical variants exist. For example, in a brother and sister with the clinical picture of CGD, after phagocytosis of latex particles by their neutrophils, all oxidative metabolic reactions were absent. If the latex particles were opsonized with Ig, however, postphagocytic oxidative changes were stimulated dramatically.¹⁸⁶ Another patient was reported in whom no oxidative changes (measured by chemiluminescence) occurred after phagocytosis of a variety of opsonized particles (latex, bacteria, or zymosan), but normal chemiluminescent responses occurred when the neutrophils were stimulated with soluble agents (concanavalin A and phorbol myristate acetate).²⁰¹ These patients appear to have a defect in signal transduction and activation of the oxidase system rather than in the oxidase enzyme(s). Another patient with clinically mild, X-linked CGD exhibited normal membrane depolarization (and therefore presumably normal activation), but NADPH oxidase apparently had a low affinity for NADPH and thus produced low but measurable amounts of superoxide.²⁰²

Neutrophil dysfunction also occurs in a variety of immunodeficiency states. Deficiency in any of the steps of oxidase assembly and activation could result in decreased superoxide production. In the primary immunodeficiency state interleukin-1 receptor-associated kinase 4 deficiency, there was decreased phosphorylation of p47phox, and decreased translocation to the membrane of p47phox, p67phos, and other oxidase components with associated decreased oxidase activity.²⁰³ In NF-kappaB essential modulator (NEMO) deficiency, NEMO-deficient cells had similar but less prominent changes, although p47phox translocation was normal.²⁰³ With Bruton tyrosine kinase (Btk) deficiency (also known as X-linked agammaglobulinemia), the picture is less clear. In patients with X-linked agammaglobulinemia there is both a deficiency of the kinase Btk and neutropenia.²⁰⁴ Studies suggest that in humans Btk-deficient neutrophils produce excessive NADPH oxidase activity after various stimuli, and that this was associated with increased apoptosis.²⁰⁴ It appears that the NADPH oxidase complex is partially assembled in resting Btk-deficient human neutrophils, making them ready for activation; that is, human Btk-deficient neutrophils are in a primed state. This is in contrast to studies of BTK-deficient mouse neutrophils where impaired NADPH oxidase activity was found. The model is that in humans BTK functions as a cytosolic component that inhibits translocation of NADPH oxidase components to the membrane and subsequent interactions with other NADPH components.

Lipochrome Histiocytosis

A clinical variant lipochrome histiocytosis was described in three sisters with rheumatoid arthritis, hyperglobulinemia, splenomegaly, pulmonary infiltrates, and increased susceptibility to infection.^{205, 206} No granulomas were found in tissue biopsies, but lipochrome pigmentation in large macrophages was present throughout the tissues. Studies of blood leukocyte function in two of the sisters revealed impaired postphagocytic respiration, NBT reduction, and hexose monophosphate shunt activity identical to that seen in patients with CGD.

P.1297

Glucose-6-Phosphate Dehydrogenase Deficiency

NADPH is the major substrate for the respiratory burst oxidase. A bactericidal defect similar to CGD has been described in a patient with a complete deficiency of G6PD, an enzyme important in the generation of NADPH.^{207, 208} Apparently, almost complete absence of G6PD activity is necessary to interfere with bacterial killing, because no difference from normal could be detected in cells with 25% activity or greater.²⁰⁹

Glutathione Peroxidase Deficiency

Two unrelated 9- and 13-year-old girls presented a clinical picture similar to that of CGD and with decreased bactericidal capacity.²¹⁰ The findings in these girls differed from those in males with CGD only in that no heterozygotes were detected in their families and their clinical course was somewhat milder. These patients were reported before the nature of the NADPH oxidase was known, and it was suggested that the CGD phenotype was due to glutathione peroxidase deficiency, resulting in inhibition of the oxidase by accumulated peroxides. A subsequent study, however, suggested that glutathione peroxidase activity was normal in these patients and that both had mutations in the NADPH oxidase.²¹¹ Thus, there is no firm evidence that glutathione peroxidase deficiency is a cause of the CGD phenotype.

Glutathione Synthetase or Reductase Deficiency

Reduced glutathione plays an important role in protecting neutrophils (including the NADPH oxidase system) from reactive metabolites, including H₂O₂. Because glutathione levels are generated by both direct synthesis via glutathione synthetase and the reduction of oxidized glutathione by glutathione reductase, deficiencies of these enzymes might be expected to result in defective neutrophil function. The neutrophils of a normally growing infant with a relatively benign history of recurrent otitis and repeated episodes of neutropenia were found to have 5% of normal glutathione synthetase activity and 10% to 20% of normal glutathione content. The cells ingested particles and metabolized 1-¹⁴C glucose normally, but after phagocytosis, excess peroxide accumulated and impaired iodination and killing of bacteria were demonstrable. Electron microscopic examination showed damage to the microtubules and membranes of the neutrophils.^{212, 213} Neutrophil dysfunction resulting from a deficiency of glutathione reductase has also been reported.²¹⁴ Patients with glutathione reductase deficiency or glutathione synthetase deficiency generally pursue a fairly benign clinical course. Vitamin E may be useful in patients with severe glutathione synthetase deficiency.²¹²

Catalase Deficiency

The neutrophil is protected from products of the NADPH oxidase not only by glutathione but also by superoxide dismutase, which generates H_2O_2 from superoxide, and by catalase, which converts H_2O_2 to H_2O and O_2 . A deficiency in neutrophil catalase has been reported in which the surface of the neutrophil was more susceptible to damage by H_2O_2 than normal.²¹⁵ These patients do not appear to have severe complications with infections.²¹⁵

Job Syndrome

Job syndrome (also known as hyperimmunoglobulinemia E syndrome) was reported as occurring in two unrelated girls with red hair and fair skin who suffered from repeated staphylococcal cold abscesses, sinusitis, eczema, and pulmonary disease, a syndrome not unlike the affliction of Job.²¹⁶ The leukocytes of these patients were capable of normal phagocytosis, bacterial killing, NBT reduction, and iodine fixation,^{216, 217} unlike those of patients with CGD. Subsequently, hyperimmunoglobulinemia E and defective chemotaxis were demonstrated.^{218, 219} It is now clear that this disorder is not limited to red-haired women, in that it is seen in both sexes and in patients of varied racial backgrounds and hair colors.²²⁰ The common features are increased susceptibility to infection (usually evident in the first 6 weeks of life), chronic dermatitis, and hyperimmunoglobulinemia E.

Job syndrome is now recognized as a multisystem disease, characterized by not only recurrent infections, elevated IgE, and dermatitis, but also retained primary dentition, unusual facial phenotype, bone fragility, and hyperextensible joints.^{221, 222} While typically sporadic, autosomal dominant transmission in kindreds has been reported.²²⁰ Most cases of Job syndrome have been associated with mutations of STAT3, though others with the syndrome do not have this finding and mutations in other genes have been reported.^{223, 224, 225} Less frequent autosomal recessive transmission is now also recognized, with the gene defect being localized to DOCK8.²²⁶

Job syndrome is rare but with the advent of genetic diagnosis, more patients are being identified and the complete clinical repertoire of the disease is now being realized.²²⁷ Fungal, viral, and bacterial infections are common. Survivors with DOCK8 mutations have developed T-cell lymphomas and squamous cell carcinoma of the skin in early adulthood.²²⁸ Blood eosinophilia and elevated IgE levels are the most common laboratory findings. Prophylactic treatment with dicloxacillin or trimethoprim-sulfamethoxazole may be helpful in managing afflicted patients. The role of interferon- γ is unclear.²²⁹

Myeloperoxidase Deficiency

An inherited deficiency of MPO was described in 1969.²³⁰ The 49-year-old male proband, one of his two sisters, and all four sons exhibited decreased MPO activity; no increased frequency of infections accompanied this defect. In two other families, apparently similarly affected, infection was also not a problem.²³⁰

Until the late 1970s, this disorder was described in only rare cases (some familial, others apparently sporadic and acquired).^{231, 232, 233} This frequency seemed consistent with the apparently pivotal role of MPO in the oxygen-dependent killing of microorganisms.^{230, 232} With the development of flow cytometry and automated differential cell-counting techniques, however, MPO deficiency was often detected (approximately 1 in 2,000 subjects) during routine hematologic evaluation of patients admitted to the hospital.^{231, 233, 234} From these studies, MPO deficiency clearly is the most common disorder of neutrophil function.²³³ This disorder is now known to be autosomal recessive with mutations localized in the MPO gene on chromosome 17q23.²³⁵

Most studies of MPO-deficient neutrophils reveal that bacteria and fungi are phagocytized normally, and ingestion is followed by a vigorous respiratory burst. Bactericidal killing, however, is somewhat delayed, reaching normal levels only after 1 to 3 hours.²³² The findings of these studies and the rarity of clinical infections in MPO-deficient individuals support the concept of MPO-independent microbicidal mechanisms.^{230, 232} In contrast, although ingested normally, several *Candida* species and *Aspergillus* are killed poorly, if at all; and several MPO-deficient patients, including one of the first reported cases, suffered from disseminated fungal infection.^{230, 232} MPO-deficient mice also have impaired defense against *Candida*,^{237, 238} and have also been noted to have increased atherogenesis.^{236, 237}

The respiratory burst in MPO-deficient cells is actually prolonged and supernormal, and evidence exists that MPO normally acts to modulate and terminate the inflammatory response; for example, MPO oxidizes the methionine group in FMLP, thus modulating chemotaxis, and it also modulates NADPH oxidase activity.²³²

Results of studies of the structure of MPO have shown it to be a tetramer (150,000 D) composed of two heavy and two light

P.1298

chains ($\alpha_2\beta_2$) of 55,000 to 60,000 and 10,000 to 15,000 daltons, respectively.^{238, 239} MPO is encoded by a single gene

generating an 80-kD product that is modified and glycosylated generating a 90-kD enzymatically inactive apopro-MPO that is further modified to the active 90-kD pro-MPO, which is further modified and dimerizes before entering the primary granule.^{240, 241} In one study, completely MPO-deficient neutrophils lacked all of these subunits but contained the precursor protein, whereas partially MPO-deficient neutrophils contained decreased amounts of the precursor protein and the subunits derived from it. In some cases, specific mutations in the MPO gene in MPO deficiency have been described. In spite of these abnormalities, a majority of the patients are asymptomatic and a small percentage suffer from Candida infections.^{239, 240, 241}

MPO deficiency also occurs as an acquired defect in a variety of situations (e.g., pregnancy, lead intoxication, Hodgkin lymphoma, and activated coagulation),²³² but it is encountered most commonly in association with acute myeloblastic leukemia (up to 48% of patients), myeloproliferative states (20% to 60% in chronic myelogenous leukemia, 32% in myelofibrosis), and myelodysplastic syndromes (25%).²³² In many of these conditions, only some of the circulating myeloid cells are deficient, presumably those produced by the abnormal clone.²³²

Other Enzymatic Defects

Two siblings with negative peroxidase, oxidase, and lipid reactions in the neutrophils and monocytes also have been reported.²⁴²

Cystic Fibrosis

As described above, an important mechanism of bacterial killing by neutrophils involves the production of HOCl from H₂O₂ and chloride. Cystic fibrosis (CF) is caused by mutations in the gene encoding the CF transmembrane conductance regulator (CFTR), a cyclic adenosine monophosphate-regulated chloride channel. CFTR is present in neutrophil secretory vesicles and phagolysosomes.²⁴³ Although CF neutrophils produce extracellular HOCl normally, they have impaired chlorination and killing of phagocytosed bacteria due to defective HOCl production in phagolysosomes.²⁴³

Leukocyte Adhesion Defects

As described in Chapter 7, cell-cell adhesion plays an important role in neutrophil function. Three types of leukocyte adhesion deficiency (LAD) have been described.^{151, 244}

Leukocyte Adhesion Deficiency-1 (CD11/CD18 Deficiency)

CD11/CD18 deficiency is a rare, inherited disorder of leukocyte function first reported in 1974. It usually is detected in infancy or early childhood as a result of frequent bacterial (and sometimes viral) infections or delayed umbilical cord separation, and high neutrophil counts.²⁴⁵ The infections are recurrent, often life threatening or fatal, and usually involve the skin and subcutaneous tissues, middle ear, and oropharynx. Neutrophils are present in the blood in increased numbers (even between infections) and appear normal, but fail to migrate into Rebeck skin windows or sites of infection in normal numbers. When studied in vitro, they exhibit defects in motility, phagocytosis, granule secretion, and particle-stimulated respiratory burst activity. Humoral (immunoglobulins and complement) and cellular immunity (skin tests and lymphocyte stimulation tests) otherwise appeared normal, and no specific enzyme deficiencies were detectable.²⁴⁶

The pathogenesis of this disorder was first suggested in 1980 when a patient's neutrophils were found to lack a high-molecular-weight glycoprotein.²⁴⁷ Subsequent work revealed the absence of CD11/CD18. As described in Chapter 7, the CD11/CD18 family consists of three heterodimeric proteins each composed of a noncovalently associated α (α_L , α_M , or α_X) and β (β_2) chain (Table 58.2). Translocation of α - and β -chains to the cell surface requires assembly of the $\alpha\beta$ heterodimer. Mutations in the β_2 -chain (ITGB2) prevent normal assembly of the $\alpha\beta$ heterodimer and subsequent translocation to the surface. CD11/CD18-deficient neutrophils roll normally on endothelial cells but do not adhere or migrate with chemotactic stimulation²⁴⁸ (Table 58.2). Studies involving eight patients revealed two distinct phenotypes: patients with severe deficiency (<0.3%) and patients with moderate deficiency (2.5% to 31.0%) of CD11a/CD18 glycoproteins on the neutrophil surface. The severity of clinical manifestations correlated directly with the degree of glycoprotein deficiency.²⁴⁹ Results of other studies further expand the heterogeneity of defects causing this disorder in which mutations in CD18 have been identified.^{245, 250, 251, 252, 253, 254, 255, 256, 257, 258, 259, 260, 261, 262, 263} The disease has also been reported in cattle.^{264, 265, 266} Hematopoietic cell transplantation is curative for this disease and recommended.²⁶⁷

Leukocyte Adhesion Deficiency-2

A second form of LAD has also been described in which the patients have severe mental retardation, short stature, a distinctive facial appearance, the Bombay (hh) blood phenotype, and recurrent bacterial infections, including pneumonia, otitis media, periodontitis, and localized cellulitis without the accumulation of pus, in association with an elevated white count.^{248, 268, 269, 270, 271, 272, 273} Phagocytosis was normal, but motility and homotypic aggregation were defective. Surface

CD18 expression was normal. As described in Chapter 7, cell surface selectins, including CD62E (E-selectin), CD62P (P-selectin), and CD62L (L-selectin), and their ligands (carbohydrates whose structures appear to be related to sialyl-Le^x [CD15s]), play an important role in neutrophil adhesion. The critical structure of CD15s is (NeuAc α2 → 3 Gal β1 → 4, [Fuc α1 → 3] GlcNAc) and the Bombay phenotype is a deficiency of Fuc α1 → 2 Gal linkages, which serve as the core of the A, B, and O blood groups.²⁷⁴ LAD-2 neutrophils were found to lack CD15s expression and did not bind interleukin-1β-stimulated endothelial cells (which express E-selectin). Because these patients had deficiencies of several fucosylated carbohydrates, the syntheses of which depend on different fucosyltransferase genes, a general defect in fucose metabolism was postulated.²⁶⁸ This syndrome has since been termed congenital disorder of glycosylation, type IIc, and is a member of a group of disorders characterized by defects in processing protein-bound glycans. In some of these patients mutations in SLC35C1, a GDP-fucose transporter, have been described.^{272, 273} LAD-2 neutrophils do not roll well on endothelial cells and do not adhere under shear stress.²⁴⁸ However, under

P.1299

static conditions, LAD-2 neutrophils can adhere and migrate.²⁴⁸ Few patients have been described, and these cases may represent different biochemical defects.^{275, 276, 277, 278, 279, 280} Oral fucose supplementation may be useful in some patients.^{276, 279} Bone marrow transplantation might be considered in some cases.

TABLE 58.2 LEUKOCYTE β₂ INTEGRINS

Neutrophil Integrin	Expression	Ligand
α ₁ β ₂ LFA-1, CD11a/CD18	All leukocytes	ICAM-1 (CD54) ICAM-2 (CD102) ICAM-3 (CD50)
α _M β ₂ HMac-1, CD11b/CD18	Monocytes, neutrophils, some natural killer cells	ICAM-1, iC3b, fibrinogen, factor X
α _X β ₂ p150,95, CD11c/CD18	Monocytes, neutrophils	iC3b, fibrinogen

Leukocyte Adhesion Deficiency-3

A third form of LAD was described in four patients, which appeared to be due to a defect in integrin activation following stimulation of G-protein-coupled chemokine receptors.²⁸¹ LAD-3 follows an autosomal recessive pattern, and is associated with recurrent infections and leukocytosis, with a bleeding tendency like Glanzmann thrombasthenia. LAD-3 has been associated with mutations of FERMT3, formerly known as KIND3, which codes for a protein that associates with β-integrins.^{282, 283} These mutations interfere with β-integrin activation.

Rac2 GTPase Mutation

A defect of neutrophil adhesion, oxidase activation, degranulation, and chemotaxis in response to chemoattractants has been reported in one patient who had a double negative mutation in Rac2 GTPase.^{284, 285} This patient had leukocytosis with a deficiency of pus at sites of infection, exhibiting a similar phenotype as that of Rac2 knockout mice.^{286, 287}

FcγRIII Deficiency

Several patients who lack the IgG receptor FcγRIII (CD16) have been reported.^{288, 289, 290, 291, 292} Two homologues of FcγRIII (FcγRIIIA and FcγRIIIB) have been identified. FcγRIIIB is glycosyl-phosphatidyl inositol-linked and expressed on neutrophils. Because FcγRIII bears the NA1 and NA2 polymorphic neutrophil-specific antigens, these cells are NA1 and NA2 negative. The clinical expression of this deficiency ranges from a normal state to one characterized by multiple infections.^{288, 289, 290, 291, 292}

Actin Dysfunction

A genetic disorder of neutrophil actin function, characterized by recurrent bacterial infections and defects in chemotaxis, adhesion, and phagocytosis, due to neutrophil actin dysfunction (NAD) also has been described.^{293, 294, 295, 296} These cells appeared to have actin that does not polymerize well and had lower levels of F-actin in both the resting state and after stimulation. Subsequent studies after the death of the index case found that one, but not both, parent was heterozygous for LAD-1. Most patients with LAD-1 do not have abnormal actin polymerization. Patients with this syndrome and

overexpression of 47- and 89-kD proteins (NAD 47/89) were also described.²⁹⁴ A more recent patient was described with overexpression of leufactin—an F-actin-binding protein that regulates microfilaments—and NAD with serious infections.^{297, 298} Leufactin was shown to be the 47-kD protein overexpressed in NAD 47/89. Overexpression of leufactin, also known as lymphocyte-specific protein 1, can create the morphologic and motility abnormalities seen in leufactin-overexpressing neutrophils.²⁹⁹

Localized Juvenile Periodontitis

Localized juvenile periodontitis is an adolescent disease characterized by alveolar bone loss, most prominently of the incisors and first molars.^{300, 301} Interestingly, these patients do not have demonstrable problems with extra-oral infections. Abnormal neutrophil chemotaxis to FMLP and C5a in these patients has been reported,^{300, 301} and a similar chemotactic defect was also observed in siblings of patients before developing clinical disease. Neutrophils from patients with localized juvenile periodontitis have been reported to express CR2 (the C3d receptor) on the cell surface, in contrast to control cells, which do not.³⁰² CR2 is present on normal immature neutrophils but is lost during maturation before release from the marrow. The mechanism of this abnormality has not been defined.

Desensitization

After previous exposure to a stimulus, neutrophils react less to subsequent stimulation by the same stimulus.^{303, 304, 305} This phenomenon has been termed desensitization. In some cases, the desensitization appears specific to the original stimulus, but in other cases desensitization to different stimuli is also observed (cross-desensitization).^{303, 304, 305}

Such desensitization has been observed in patients undergoing hemodialysis, in which exposure of blood to a cuprophane dialyzer membrane results in the generation of C5a, which causes a transient neutropenia due to pulmonary leukostasis, as described in Chapter 7.^{306, 307} Although C5a generation persists throughout dialysis, the neutropenia is transient.³⁰⁸ In contrast to neutrophils obtained at the start of dialysis, neutrophils obtained after 2 hours of dialysis (after the leukostasis has resolved) do not aggregate in response to plasma leaving the dialyzer membrane, demonstrating desensitization in vivo.³⁰⁸ A patient with cytomegalovirus infection and serum-induced granulocyte aggregation (presumably due to C5a) did not experience neutropenia during dialysis; and his neutrophils did not aggregate in response to serum leaving the dialyzer, in contrast to control cells, also demonstrating in vivo desensitization.³⁰⁸ Similar desensitization was demonstrated in rabbits using the chemotactic peptide FMLP, wherein continuous intravenous infusion of FMLP reproduced a transient neutropenia due to pulmonary sequestration.³⁰⁹ It is likely that neutrophil desensitization may also occur in other pathologic states, including infection, trauma, and multiorgan failure syndrome, and may contribute to neutrophil dysfunction, although the clinical significance of this phenomenon is unclear.

The phenomenon of desensitization has also been implicated as part of the mechanism by which glucocorticoids inhibit neutrophil function. It appears that the glucocorticoid-regulated protein annexin 1 (lipocortin 1) can bind a formyl-peptide receptor, induce calcium transients, and desensitize neutrophils to subsequent stimulation by other agents.³¹⁰ Two formyl-peptide receptors are expressed in neutrophils, the classic FPR and the related receptor FPRL-1/AXL. Annexin 1 appears to bind to FRPL-1/AXL, while some peptides derived from annexin 1 may bind both receptors.³¹¹

Viral Infection

Neutrophil dysfunction has been reported to occur in response to influenza A exposure. Both influenza A virus and its purified hemagglutinin activate neutrophils, and neutrophil responses to other stimuli are depressed after preexposure to influenza A and parainfluenza.^{312, 313, 314, 315, 316, 317, 318, 319} Neutrophils from patients with human immunodeficiency virus (HIV) infection also may exhibit abnormal function. In one study, neutrophils from patients with early HIV infection had enhanced superoxide production in response to bacterial products.³²⁰ Another study found evidence for neutrophil activation in patients with HIV infection as manifested by increased CD11b expression, decreased CD62L expression, increased H₂O₂ production, and increased actin polymerization.³²¹ Interestingly, H₂O₂ production, in response to FMLP after tumor necrosis factor and interleukin-8 priming, was decreased, and CD62L downregulation in response to FMLP was less complete; these abnormalities correlated with the clinical stage of disease. Whether these abnormalities are a direct effect of the HIV virus, a manifestation of desensitization as described in the previous section, or the result of another mechanism is unclear. These observations suggest that neutrophil dysfunction

P.1300

may occur in response to other viral infections as well, although the clinical significance of such a phenomenon is unclear.

Hyperalimentation Hypophosphatemia

In the past, the use of hyperalimentation without adequate phosphate occasionally resulted in hypophosphatemia that was associated with neutrophil dysfunction, including impaired chemotaxis.³²² The exact mechanism of this defect is unclear, and this syndrome is now rarely encountered, although evidence suggests that the impairment of phagocytosis seen in phosphate depletion may result from an increase in intracellular calcium.³²³

Hyperglycemia

Abnormalities have been observed in several neutrophil functions in patients with poorly controlled diabetes, including phagocytosis, chemotaxis, adhesion, and the oxidative burst.^{324, 325, 326, 327, 328, 329, 330} Improvement in glucose control is associated with an improvement in neutrophil function.³³⁰ Improvement in neutrophil function can occur after incubation with insulin for as little as 15 minutes.³³⁰ In patients with non-insulin-dependent diabetes, neutrophil dysfunction is associated with an increased intracellular calcium that returns to normal in association with normalization of phagocytic function when glucose control is improved.³²⁴

Miscellaneous

Other apparently unique neutrophil disorders have been reported. One patient with leukocytosis, severe bacterial infections, and impaired wound healing had neutrophils that appeared to have a defect in signal transduction.³³¹ These cells had a severe defect in chemotaxis, activation of the respiratory burst, and azurophil granule release in response to a variety of chemotaxis. In contrast, FMLP induced a normal increase in intracellular free calcium and specific granule release. Actin polymerization was defective in response to FMLP but normal in response to some other stimuli. Phagocytosis of opsonized bacteria was normal. Presumably, these cells have a defect in the intracellular signal transduction pathway.

Neutrophil Dysregulation in the Systemic Inflammatory Response Syndrome

Although this chapter has primarily addressed disorders resulting in decreased neutrophil function, neutrophil activity may also be increased. For example, one study reported increased neutrophil functional activity in patients with severe acute pancreatitis.³³² The clinical significance of this phenomenon is unclear.

FREQUENCY OF IDENTIFIABLE QUALITATIVE NEUTROPHIL DISORDERS

Most patients suspected of having a defect in neutrophil function do not have a well-defined abnormality. In one study of 100 patients referred for evaluation of a suspected neutrophil abnormality, only four were identified as a described syndrome.³³³ Some degree of impaired chemotaxis or superoxide production was found in 53 of 100 patients, but no abnormality was found in 41 of 100.

WEB SITES

www.jmfworld.com/

www.niaid.nih.gov/topics/immuneDeficiency/Pages/default.aspx

<http://primaryimmune.org/>

REFERENCES

1. Klein A, Hussar AE, Bornstein S. Pelger-Huet anomaly of the leukocytes. *N Engl J Med* 1955;253(24):1057-1062.
2. Haverkamp Begemann N, Van Lookeren Campagne A. Homozygous form of Pelger-Huet's nuclear anomaly in man. *Acta Haematol* 1952;7(5):295-303.
3. Heinivaara O, Kaipainen WJ. Pelger-Huet anomaly in lymphocytic leukaemia. *Acta Haematol* 1961;25(13906076):375-380.
4. Ebbing HC. Contributions to the genetics of the Pelger anomaly. *Schweiz Med Wochenschr* 1959;89:1082-1085.
5. Skendzel LP, Hoffman GC. The Pelger anomaly of leukocytes: forty-one cases in seven families. *Am J Clin Pathol* 1962;37(13913617):294-301.
6. Davidson WM, Lawler SD, Ackerley AG. The Pelger-Huet anomaly: investigation of family A. *Ann Hum Genet* 1954;19(1):1-9.
7. Ludden TE, Harvey M. Pelger-Huet anomaly of leukocytes. Report of a case and survey of incidence. *Am J Clin Pathol* 1962;37(14467172):302-304.
8. Yamasowa Y, Fujii T, Tsuchitori K. The Pelger-Huet familial anomaly of leukocytes. *Blood* 1953;8(13032207):370-374.

9. Stobbe H, Jorke D. Findings in homozygous carriers of Pelger's anomaly. *Schweiz Med Wochenschr* 1965;95(44):1524-1529.
10. Best S, Salvati F, Kallo J, et al. Lamin B-receptor mutations in Pelger-Huet anomaly. *Br J Haematol* 2003;123(3):542-544.
11. Cohen TV, Klarmann KD, Sakchaisri K, et al. The lamin B receptor under transcriptional control of C/EBP epsilon is required for morphological but not functional maturation of neutrophils. *Hum Mol Genet* 2008;17(19): 2921-2933.
12. Hoffmann K, Dreger CK, Olins AL, et al. Mutations in the gene encoding the lamin B receptor produce an altered nuclear morphology in granulocytes (Pelger-Huet anomaly). *Nat Genet* 2002;31(4):410-414.
13. Johnson CA, Bass DA, Trillo AA, et al. Functional and metabolic studies of polymorphonuclear leukocytes in the congenital Pelger-Huet anomaly. *Blood* 1980;55(6244014):466-469.
14. Matsumoto T, Harada Y, Yamaguchi K, et al. Cytogenetic and functional studies of leukocytes with Pelger-Huet anomaly. *Acta Haematol* 1984;72(6438994):264-273.
15. Rosse WF, Gurney CW. The Pelger-Huet anomaly in three families and its use in determining the disappearance of transfused neutrophils from the peripheral blood. *Blood* 1959;14(13618374):170-186.
16. Carper HA, Hoffman PL. The intravascular survival of transfused canine Pelger-Huet neutrophils and eosinophils. *Blood* 1966;27(5936828):739-743.
17. Latimer KS, Kircher IM, Lindl PA, et al. Leukocyte function in Pelger-Huet anomaly of dogs. *J Leukoc Biol* 1989;45(2649629):301-310.
18. Harm H. Effect of colchicine on the white blood picture of Pelger and non-Pelger rabbits. *Acta Haematol* 1953;10(2):96-105.
19. Ardeman S, Chanarin I, Frankland AW. The Pelger-Huet anomaly and megaloblastic anemia. *Blood* 1963;22(14072576):472-476.
20. Shanbrom E, Tanaka KR. Acquired Pelger-Huet granulocytes in severe myxedema. *Acta Haematol* 1962;27(13911204):289-293.
21. Kaplan JM, Barrett O. Reversible pseudo-Pelger anomaly related to sulfisoxazole therapy. *N Engl J Med* 1967;277(4378299):421-422.
22. Kaur J, Catovsky D, Valdimarsson H, et al. Familial acute myeloid leukaemia with acquired Pelger-Huet anomaly and aneuploidy of C group. *Br Med J* 1972;4(4508672):327-331.
23. Dorr AD, Moloney WC. Acquired pseudo-Pelger anomaly of granulocytic leukocytes. *N Engl J Med* 1959;261(13817713):742-746.
24. Shanbrom E, Collins Z, Miller S. "Acquired" Pelger-Huet cells in blood dyscrasias. *Am J Med Sci* 1960;240:732-738.
25. Alder A. über konstitutionell bedingte Granulations-veränderungen der Leukozyten. *Dtsch Arch Klin Med* 1939;183.
26. Jordans GH. Hereditary granulation anomaly of the leucocytes (Alder). *Acta Med Scand* 1947;129(4):348-351.
27. Fricker-Alder H. Alder's granulation anomaly; follow-up studies on the first described case & review of current knowledge of the problem. *Schweiz Med Wochenschr* 1958;88(41):989-991.
28. Mauri C, Soldati M. Cytochemical characteristics of Alder's cell granulations; definition of multiple endochondrol dysostosis in terms of disorders of polysaccharide metabolism. *Schweiz Med Wochenschr* 1958;88(41):992-994.
29. Groover RV, Burke EC, Gordon H, et al. The genetic mucopolysaccharidoses. *Semin Hematol* 1972;9(4263636):371-402.
30. Grgic Z, Kalafatic Z. Three cases of incomplete Alder's granulation anomaly. *Schweiz Med Wochenschr* 1958;88(41):994-995.
31. Mittwoch U. Inclusions of mucopolysaccharide in the lymphocytes of patients with gargoylism. *Nature* 1961;191:1315-1316.
32. Mittwoch U. Abnormal lymphocytes in gargoylism. *Br J Haematol* 1959;5: 365-368.
33. Griffiths SB, Findlay M. Gargoylism: clinical, radiological and haematological features in two siblings. *Arch Dis Child* 1958;33(13545874):229-234.

34. Pearson HA, Lorincz AE. A characteristic bone marrow finding in the Hurler syndrome. *Pediatrics* 1964;34(14211092):280-282.
35. Peterson L, Parkin J, Nelson A. Mucopolysaccharidosis type VII. A morphologic, cytochemical, and ultrastructural study of the blood and bone marrow. *Am J Clin Pathol* 1982;78(6814236):544-548.
36. Matsaniotis N, Kattamis C, Lehmann H, et al. Urinary excretion of acid mucopolysaccharide in sibs with Morquio's syndrome and Reilly's granules in leucocytes. *Arch Dis Child* 1967;42(4965318):652-653.
37. Buchanan JG, Pearce L, Wetherley-Mein G. The May-Hegglin anomaly; a family report and chromosome study. *Br J Haematol* 1964;10(14218453):508-512.
38. Hamilton RW, Shaikh BS, Ottie JN, et al. Platelet function, ultrastructure, and survival in the May-Hegglin anomaly. *Am J Clin Pathol* 1980;74(7446470): 663-668.
39. Hegglin R, Gross R, Loehr GW. Hegglin-May anomaly (Polyphyletic maturation disorder). *Schweiz Med Wochenschr* 1964;94:1357-1364.
40. Lusher JM, Schneider J, Mizukami I, et al. The May-Hegglin anomaly: platelet function, ultrastructure and chromosome studies. *Blood* 1968;32(5726230):950-961.
41. Wassmuth DR, Hamilton HE, Sheets RF. May-Hegglin anomaly. Hereditary affection of granulocytes and platelets. *JAMA* 1963;183:737-740.
42. Davis JW, Wilson SJ. Platelet survival in the May-Hegglin anomaly. *Br J Haematol* 1966;12(1):61-65.
43. Lechner K, Breddin K, Moser K, et al. May-Hegglin's anomaly. Description of a new family and studies on the function, biochemistry and ultrastructure of thrombocytes. *Acta Haematol* 1969;42(5):303-320.
44. Cawley JC, Hayhoe FG. The inclusions of the May-Hegglin anomaly and Dohle bodies of infection: an ultrastructural comparison. *Br J Haematol* 1972;22(4112846):491-496.
45. Jordan SW, Larsen WE. Ultrastructural studies of the May-Hegglin anomaly. *Blood* 1965;25(14294769):921-932.
46. Kunishima S, Matsushita T, Kojima T, et al. Immunofluorescence analysis of neutrophil nonmuscle myosin heavy chain-A in MYH9 disorders: association of subcellular localization with MYH9 mutations. *Lab Invest* 2003;83(12533692):115-122.
47. Pujol-Moix N, Kelley MJ, Hernandez A, et al. Ultrastructural analysis of granulocyte inclusions in genetically confirmed MYH9-related disorders. *Haematologica* 2004;89(15020273):330-337.
48. Kelley MJ, Jawien W, Ortel TL, et al. Mutation of MYH9, encoding non-muscle myosin heavy chain A, in May-Hegglin anomaly. *Nat Genet* 2000;26(10973260):106-108.
49. Kunishima S, Kojima T, Matsushita T, et al. Mutations in the NMMHC-A gene cause autosomal dominant macrothrombocytopenia with leukocyte inclusions (May-Hegglin anomaly/Sebastian syndrome). *Blood* 2001;97(11159552):1147-1149.
50. Seri M, Cusano R, Gangarossa S, et al. Mutations in MYH9 result in the May-Hegglin anomaly, and Fechtner and Sebastian syndromes. The May-Hegglin/Fechtner syndrome consortium. *Nat Genet* 2000;26(1):103-105.
51. Weiss A, Schiaffino S, Leinwand LA. Comparative sequence analysis of the complete human sarcomeric myosin heavy chain family: implications for functional diversity. *J Mol Biol* 1999;290(1):61-75.
52. Seri M, Pecci A, Di Bari F, et al. MYH9-related disease: May-Hegglin anomaly, Sebastian syndrome, Fechtner syndrome, and Epstein syndrome are not distinct entities but represent a variable expression of a single illness. *Medicine (Baltimore)* 2003;82(12792306):203-215.
53. Dong F, Li S, Pujol-Moix N, et al. Genotype-phenotype correlation in MYH9-related thrombocytopenia. *Br J Haematol* 2005;130(16098078):620-627.
54. Kunishima S, Matsushita T, Yoshihara T, et al. First description of somatic mosaicism in MYH9 disorders. *Br J Haematol* 2005;128(15667538):360-365.
55. Otsubo K, Kanegane H, Nomura K, et al. Identification of a novel MYH9 mutation in a patient with May-Hegglin anomaly. *Pediatr Blood Cancer* 2006;47(16642488):968-969.

56. D'Apolito M, Guarnieri V, Boncristiano M, et al. Cloning of the murine non-muscle myosin heavy chain IIA gene ortholog of human MYH9 responsible for May-Hegglin, Sebastian, Fechtner, and Epstein syndromes. *Gene* 2002;286(11943476):215-222.
57. Heath KE, Campos-Barros A, Toren A, et al. Nonmuscle myosin heavy chain IIA mutations define a spectrum of autosomal dominant macrothrombocytopenias: May-Hegglin anomaly and Fechtner, Sebastian, Epstein, and Alportlike syndromes. *Am J Hum Genet* 2001;69(11590545):1033-1045.
58. Saito H, Kunishima S. Historical hematology: May-Hegglin anomaly. *Am J Hematol* 2008;83(4):304-306.
59. Chediak MM. New leukocyte anomaly of constitutional and familial character. *Rev Hematol* 1952;7(3):362-367.
60. Higashi O. Peroxidase response of erythron in anemia. *Tohoku J Exp Med* 1953;58(13136174):327-343.
61. Sato A. Chediak and Higashi's disease: probable identity of a new leucocytal anomaly (Chediak) and congenital gigantism of peroxidase granules (Higashi). *Tohoku J Exp Med* 1955;61(2-3):201-210.
62. Steinbrinck W. Über eine neue Granulations anomalie der Leukocyten (A new granulation anomaly of the leukocytes). *Dtsch Arch Klin Med* 1948;193: 577-581.
63. Lutzner MA, Lowrie CT, Jordan HW. Giant granules in leukocytes of the beige mouse. *J Hered* 1967;58(5590154):299-300.
64. Padgett GA, Leader RW, Gorham JR, et al. The familial occurrence of the Chediak-Higashi syndrome in mink and cattle. *Genetics* 1964;49(14135410): 505-512.
65. Kramer JW, Davis WC, Prieur DJ, et al. An inherited disorder of Persian cats with intracytoplasmic inclusions in neutrophils. *J Am Vet Med Assoc* 1975;166(11):1103-1104.
66. Nishimura M, Inoue M, Nakano T, et al. Beige rat: a new animal model of Chediak-Higashi syndrome. *Blood* 1989;74(2752114):270-273.
67. Taylor RF, Farrell RK. Light and electron microscopy of peripheral blood neutrophils in a killer whale affected with Chediak-Higashi syndrome. *Fed Proc* 1973;32(822):3403.
68. Bell TG, Meyers KM, Prieur DJ, et al. Decreased nucleotide and serotonin storage associated with defective function in Chediak-Higashi syndrome cattle and human platelets. *Blood* 1976;48(949545):175-184.
69. Blume RS, Wolff SM. The Chediak-Higashi syndrome: studies in four patients and a review of the literature. *Medicine (Baltimore)* 1972;51(5064229): 247-280.
70. Kritzler RA, Turner JY, Lindenbaum J, et al. Chediak-Higashi syndrome. Cytologic and serum lipid observations in a case and family. *Am J Med* 1964;36(14142411):583-594.
71. Wolff SM. The Chediak-Higashi syndrome: studies of host defenses. *Ann Intern Med* 1972;76(2):293-306.
72. Béguez César A. Neutropenia crónica maligna familiar con granulaciones atípicas de los leucocitos. *Bo Soc Cubana Pediat* 1943;15:900-922.
73. Davis WC, Douglas SD. Defective granule formation and function in the Chediak-Higashi syndrome in man and animals. *Semin Hematol* 1972;9(5082360):431-450.
74. Essner E, Oliver C. Lysosome formation in hepatocytes of mice with Chediak-Higashi syndrome. *Lab Invest* 1974;30(4133090):597-607.
75. Kaplan J, De Domenico I, Ward DM. Chediak-Higashi syndrome. *Curr Opin Hematol* 2008;15(1):22-29.
76. Westbroek W, Adams D, Huizing M, et al. Cellular defects in Chediak-Higashi syndrome correlate with the molecular genotype and clinical phenotype. *J Invest Dermatol* 2007;127(11):2674-2677.
77. Lazarchick J, McRae B. Chediak-Higashi syndrome. *Blood* 2005;105(11):4162.
78. Efrati P, Danon D. Electron-microscopical study of bone marrow cells in a case of Chediak-Higashi-Steinbrinck syndrome. *Br J Haematol* 1968;15(4877512):173-176.
79. Kjeldsen L, Calafat J, Borregaard N. Giant granules of neutrophils in Chediak-Higashi syndrome are derived from azurophil granules but not from specific and gelatinase granules. *J Leukoc Biol* 1998;64(1):72-77.
80. Rausch PG, Pryzwansky KB, Spitznagel JK. Immunocytochemical identification of azurophilic and specific granule markers in the giant granules of Chediak-Higashi neutrophils. *N Engl J Med* 1978;298(75504):693-698.

81. White JG, Krumwiede M. Normal-sized primary lysosomes are present in Chediak-Higashi syndrome neutrophils. *Pediatr Res* 1987;22(2821473): 208-215.
82. Huynh C, Roth D, Ward DM, et al. Defective lysosomal exocytosis and plasma membrane repair in Chediak-Higashi/beige cells. *Proc Natl Acad Sci U S A* 2004;101(48):16795-16800.
83. Styrts B, Pollack CR, Klempner MS. An abnormal calcium uptake pump in Chediak-Higashi neutrophil lysosomes. *J Leukoc Biol* 1988;44(2):130-135.
84. White JG. The Chediak-Higashi syndrome: cytoplasmic sequestration in circulating leukocytes. *Blood* 1967;29(4):435-451.
85. Baetz K, Isaaz S, Griffiths GM. Loss of cytotoxic T lymphocyte function in Chediak-Higashi syndrome arises from a secretory defect that prevents lytic granule exocytosis. *J Immunol* 1995;154(7751653):6122-6131.
86. Windhorst DB, Zelickson AS, Good RA. Chediak-Higashi syndrome: hereditary gigantism of cytoplasmic organelles. *Science* 1966;151(5908967):81-83.
87. Burkhardt JK, Wiebel FA, Hester S, et al. The giant organelles in beige and Chediak-Higashi fibroblasts are derived from late endosomes and mature lysosomes. *J Exp Med* 1993;178(7902407):1845-1856.
88. Kimball HR, Ford GH, Wolff SM. Lysosomal enzymes in normal and Chediak-Higashi blood leukocytes. *J Lab Clin Med* 1975;86(170348):616-630.
89. Root RK, Rosenthal AS, Balestra DJ. Abnormal bactericidal, metabolic, and lysosomal functions of Chediak-Higashi syndrome leukocytes. *J Clin Invest* 1972;51(4400956):649-665.
90. Stossel TP, Root RK, Vaughan M. Phagocytosis in chronic granulomatous disease and the Chediak-Higashi syndrome. *N Engl J Med* 1972;286(5007151): 120-123.
91. Brandt EJ, Elliott RW, Swank RT. Defective lysosomal enzyme secretion in kidneys of Chediak-Higashi (beige) mice. *J Cell Biol* 1975;67(408):774-788.
92. Ganz T, Metcalf JA, Gallin JI, et al. Microbicidal/cytotoxic proteins of neutrophils are deficient in two disorders: Chediak-Higashi syndrome and "specific" granule deficiency. *J Clin Invest* 1988;82(2841356):552-556.
93. Cairo MS, Vandeven C, Toy C, et al. Fluorescent cytometric analysis of polymorphonuclear leukocytes in Chediak-Higashi syndrome: diminished C3b_i receptor expression (OKM1) with normal granular cell density. *Pediatr Res* 1988;24(2974532):673-676.
94. Clark RA, Kimball HR. Defective granulocyte chemotaxis in the Chediak-Higashi syndrome. *J Clin Invest* 1971;50(4942966):2645-2652.
95. Clark RA, Kimball HR, Padgett GA. Granulocyte chemotaxis in the Chediak-Higashi syndrome of mink. *Blood* 1972;39(4553941):644-649.
96. Oliver JM, Zurier RB. Correction of characteristic abnormalities of microtubule function and granule morphology in Chediak-Higashi syndrome with cholinergic agonists. *J Clin Invest* 1976;57(1262469):1239-1247.
97. Douglas SD, Blume RS, Wolff SM. Fine structural studies of leukocytes from patients and heterozygotes with the Chediak-Higashi syndrome. *Blood* 1969;33(5776200):527-540.
98. Moran TJ, Estevez JM. Chediak-Higashi disease. Morphologic studies of a patient and her family. *Arch Pathol* 1969;88(4):329-339.
99. Costa JL, Fauci AS, Wolff SM. A platelet abnormality in the Chediak-Higashi syndrome of man. *Blood* 1976;48(963292):517-520.
100. Blume RS, Bennett JM, Yankee RA, et al. Defective granulocyte regulation in the Chediak-Higashi syndrome. *N Engl J Med* 1968;279(5681251):1009-1015.
101. Rubin CM, Burke BA, McKenna RW, et al. The accelerated phase of Chediak-Higashi syndrome. An expression of the virus-associated hemophagocytic syndrome? *Cancer* 1985;56(3):524-530.
102. Barbosa MD, Nguyen QA, Tchernev VT, et al. Identification of the homologous beige and Chediak-Higashi syndrome genes. *Nature* 1996;382(8717042): 262-265.

103. Perou CM, Moore KJ, Nagle DL, et al. Identification of the murine beige gene by YAC complementation and positional cloning. *Nat Genet* 1996;13(8673129): 303-308.
104. Nagle DL, Karim MA, Woolf EA, et al. Identification and mutation analysis of the complete gene for Chediak-Higashi syndrome. *Nat Genet* 1996;14(3): 307-311.
105. Perou CM, Leslie JD, Green W, et al. The Beige/Chediak-Higashi syndrome gene encodes a widely expressed cytosolic protein. *J Biol Chem* 1997;272(9368050):29790-29794.
106. Barbosa MD, Barrat FJ, Tchernev VT, et al. Identification of mutations in two major mRNA isoforms of the Chediak-Higashi syndrome gene in human and mouse. *Hum Mol Genet* 1997;6(9215680):1091-1098.
107. Karim MA, Nagle DL, Kandil HH, et al. Mutations in the Chediak-Higashi syndrome gene (CHS1) indicate requirement for the complete 3801 amino acid CHS protein. *Hum Mol Genet* 1997;6(7):1087-1089.
108. Shiflett SL, Kaplan J, Ward DM. Chediak-Higashi syndrome: a rare disorder of lysosomes and lysosome related organelles. *Pigment Cell Res* 2002;15(12100490):251-257.
109. Ward DM, Shiflett SL, Kaplan J. Chediak-Higashi syndrome: a clinical and molecular view of a rare lysosomal storage disorder. *Curr Mol Med* 2002;2(12125812):469-477.
110. Zarzour W, Kleta R, Frangoul H, et al. Two novel CHS1 (LYST) mutations: clinical correlations in an infant with Chediak-Higashi syndrome. *Mol Genet Metab* 2005;85(15896657):125-132.
111. Baehner RL, Boxer LA. Disorders of polymorphonuclear leukocyte function related to alterations in the integrated reactions of cytoplasmic constituents with the plasma membrane. *Semin Hematol* 1979;16(384521):148-162.
112. Boxer LA, Watanabe AM, Rister M, et al. Correction of leukocyte function in Chediak-Higashi syndrome by ascorbate. *N Engl J Med* 1976;295(184391): 1041-1045.
113. Oliver JM. Impaired microtubule function correctable by cyclic GMP and cholinergic agonists in the Chediak-Higashi syndrome. *Am J Pathol* 1976;85(187062):395-418.
114. Kazmierowski JA, Elin RJ, Reynolds HY, et al. Chediak-Higashi syndrome: reversal of increased susceptibility to infection by bone marrow transplantation. *Blood* 1976;47(4):555-559.
115. Eapen M, DeLaat CA, Baker KS, et al. Hematopoietic cell transplantation for Chediak-Higashi syndrome. *Bone Marrow Transplant* 2007;39(17293882): 411-415.
116. Fischer A, Griscelli C, Friedrich W, et al. Bone-marrow transplantation for immunodeficiencies and osteopetrosis: European survey, 1968-1985. *Lancet* 1986;2(8515):1080-1084.
117. Tardieu M, Lacroix C, Neven B, et al. Progressive neurologic dysfunctions 20 years after allogeneic bone marrow transplantation for Chediak-Higashi syndrome. *Blood* 2005;106(15790783):40-42.
118. Rozenszajn L, Klajman A, Yaffe D, et al. Jordans' anomaly in white blood cells. Report of case. *Blood* 1966;28(5330405):258-265.
119. Jordans GH. The familial occurrence of fat containing vacuoles in the leukocytes diagnosed in two brothers suffering from dystrophia musculorum progressiva (ERB). *Acta Med Scand* 1953;145(13079655):419-423.
120. Smith H. Unidentified inclusions in haemopoietic cells, congenital atresia of the bile ducts and livedo reticularis in an infant: a new syndrome. *Br J Haematol* 1967;13(5):695-705.
121. White JG, Witkop CJ, Gerritsen SM. The Hermansky-Pudlak syndrome: inclusions in circulating leucocytes. *Br J Haematol* 1973;24(4351906):761-765.
122. Nishibori M, Cham B, McNicol A, et al. The protein CD63 is in platelet dense granules, is deficient in a patient with Hermansky-Pudlak syndrome, and appears identical to granulophysin. *J Clin Invest* 1993;91(7682577): 1775-1782.
123. Strauss RG, Bove KE, Jones JF, et al. An anomaly of neutrophil morphology with impaired function. *N Engl J Med* 1974;290(4129798):478-484.
124. Boxer LA, Smolen JE. Neutrophil granule constituents and their release in health and disease. *Hematol Oncol Clin North Am* 1988;2(2831184):101-134.
125. Gallin JI. Neutrophil specific granule deficiency. *Annu Rev Med* 1985;36: 263-274.

126. Lomax KJ, Gallin JI, Rotrosen D, et al. Selective defect in myeloid cell lactoferrin gene expression in neutrophil specific granule deficiency. *J Clin Invest* 1989;83(2):514-519.
127. Parmley RT, Gilbert CS, Boxer LA. Abnormal peroxidase-positive granules in "specific granule" deficiency. *Blood* 1989;73(2917198):838-844.
128. Gombart AF, Kwok SH, Anderson KL, et al. Regulation of neutrophil and eosinophil secondary granule gene expression by transcription factors C/EBP epsilon and PU.1. *Blood* 2003;101(12515729):3265-3273.
129. Gombart AF, Koeffler HP. Neutrophil specific granule deficiency and mutations in the gene encoding transcription factor C/EBP(epsilon). *Curr Opin Hematol* 2002;9(11753076):36-42.
130. Gombart AF, Shiohara M, Kwok SH, et al. Neutrophil-specific granule deficiency: homozygous recessive inheritance of a frameshift mutation in the gene encoding transcription factor CCAAT/enhancer binding protein-epsilon. *Blood* 2001;97(11313242):2561-2567.
131. Lekstrom-Himes JA, Dorman SE, Kopar P, et al. Neutrophil-specific granule deficiency results from a novel mutation with loss of function of the transcription factor CCAAT/enhancer binding protein epsilon. *J Exp Med* 1999;189(10359588):1847-1852.
132. Yamanaka R, Barlow C, Lekstrom-Himes J, et al. Impaired granulopoiesis, myelodysplasia, and early lethality in CCAAT/enhancer binding protein epsilon-deficient mice. *Proc Natl Acad Sci U S A* 1997;94(9371821):13187-13192.
133. Gombart AF, Krug U, O'Kelly J, et al. Aberrant expression of neutrophil and macrophage-related genes in a murine model for human neutrophil-specific granule deficiency. *J Leukoc Biol* 2005;78(16204633):1153-1165.
134. Shiohara M, Gombart AF, Sekiguchi Y, et al. Phenotypic and functional alterations of peripheral blood monocytes in neutrophil-specific granule deficiency. *J Leukoc Biol* 2004;75(14576362):190-197.
135. Chumakov AM, Grillier I, Chumakova E, et al. Cloning of the novel human myeloid-cell-specific C/EBP-epsilon transcription factor. *Mol Cell Biol* 1997;17(9032264):1375-1386.
136. Wynn RF, Sood M, Theilgaard-Monch K, et al. Intractable diarrhoea of infancy caused by neutrophil specific granule deficiency and cured by stem cell transplantation. *Gut* 2006;55(16407388):292-293.
137. Davidson WM, Milner RDG, Lawler SD, et al. Giant neutrophil leucocytes: an inherited anomaly. *Br J Haematol* 1960;6(4):339-343.
138. Undritz E. A new family with hereditary-constitutional hypersegmentation of neutrophil nuclei. *Schweiz Med Wochenschr* 1958;88(41):1000-1001.
139. Lueers T. The numerical count of sex-specific nuclear drumsticks in hereditary-constitutional hypersegmentation of neutrophil nucleus of Undritz. *Schweiz Med Wochenschr* 1960;90:246-248.
140. Joshua H, Spitzer A, Presentey B. The incidence of peroxidase and phospholipid deficiency in eosinophilic granulocytes among various Jewish groups in Israel. *Am J Hum Genet* 1970;22(5516238):574-578.
141. Presentey BZ. A new anomaly of eosinophilic granulocytes. *Tech Bull Regist Med Technol* 1968;38(4174581):131-134.
142. Boxer LA, Blackwood RA. Leukocyte disorders: quantitative and qualitative disorders of the neutrophil, Part 1. *Pediatr Rev* 1996;17(1):19-28.
143. Holland SM, Gallin JI. Evaluation of the patient with recurrent bacterial infections. *Annu Rev Med* 1998;49(9509258):185-199.
144. Malech HL. The role of neutrophils in the immune system: an overview. *Methods Mol Biol* 2007;412:3-11.
145. Matzner Y. Acquired neutrophil dysfunction and diseases with an inflammatory component. *Semin Hematol* 1997;34(9347579):291-302.
146. Curnutte JT, Babior BM. Chronic granulomatous disease. *Adv Hum Genet* 1987;16:229-297.
147. Good RA, Quie PG, Windhorst DB, et al. Fatal (chronic) granulomatous disease of childhood: a hereditary defect of leukocyte function. *Semin Hematol* 1968;5(5662845):215-254.
148. Johnston RB, Baehner RL. Chronic granulomatous disease: correlation between pathogenesis and clinical findings. *Pediatrics* 1971;48(5121235):730-739.

149. Klebanoff SJ, White LR. Iodination defect in the leukocytes of a patient with chronic granulomatous disease of childhood. *N Engl J Med* 1969;280(4974160):460-466.
150. Martire B, Rondelli R, Soresina A, et al. Clinical features, long-term follow-up and outcome of a large cohort of patients with chronic granulomatous disease: an Italian multicenter study. *Clin Immunol* 2008;126(18037347): 155-164.
151. Malech HL, Hickstein DD. Genetics, biology and clinical management of myeloid cell primary immune deficiencies: chronic granulomatous disease and leukocyte adhesion deficiency. *Curr Opin Hematol* 2007;14(17133097): 29-36.
152. Carson MJ, Chadwick DL, Brubaker CA, et al. Thirteen boys with progressive septic granulomatosis. *Pediatrics* 1965;35(14258653):405-412.
153. Matute JD, Arias AA, Wright NA, et al. A new genetic subgroup of chronic granulomatous disease with autosomal recessive mutations in p40 phox and selective defects in neutrophil NADPH oxidase activity. *Blood* 2009;114(15): 3309-3315.
154. Assari T. Chronic granulomatous disease; fundamental stages in our understanding of CGD. *Med Immunol* 2006;5:4.
155. Curnutte JT. Chronic granulomatous disease: the solving of a clinical riddle at the molecular level. *Clin Immunol Immunopathol* 1993;67(3 Pt 2):S2-S15.
156. Dinauer MC. Chronic granulomatous disease and other disorders of phagocyte function. *Hematology Am Soc Hematol Educ Program* 2005:89-95.
157. Heyworth PG, Curnutte JT, Noack D, et al. Hematologically important mutations: X-linked chronic granulomatous disease—an update. *Blood Cells Mol Dis* 1997;23(9454688):443-450.
158. Maly F, Schurer-Maly C. How and why cells make superoxide: the “Phagocytic” NADPH oxidase. *Physiology* 1995;10(5):233-238.
159. Roos D, de Boer M, Kuribayashi F, et al. Mutations in the X-linked and autosomal recessive forms of chronic granulomatous disease. *Blood* 1996;87(8634410):1663-1681.
160. Winkelstein JA, Marino MC, Johnston RB, et al. Chronic granulomatous disease. Report on a national registry of 368 patients. *Medicine (Baltimore)* 2000;79(10844935):155-169.
161. Roos D. X-CGD base: a database of X-CGD-causing mutations. *Immunol Today* 1996;17(11):517-21.
162. Heyworth PG, Cross AR, Curnutte JT. Chronic granulomatous disease. *Curr Opin Immunol* 2003;15(5):578-584.
163. Jones LB, McGrogan P, Flood TJ, et al. Special article: chronic granulomatous disease in the United Kingdom and Ireland: a comprehensive national patient-based registry. *Clin Exp Immunol* 2008;152(2):211-218.
164. Roos D, de Boer M, Koker MY, et al. Chronic granulomatous disease caused by mutations other than the common GT deletion in NCF1, the gene encoding the p47phox component of the phagocyte NADPH oxidase. *Hum Mutat* 2006;27(16972229):1218-1229.
165. Thelen M, Dewald B, Baggiolini M. Neutrophil signal transduction and activation of the respiratory burst. *Physiol Rev* 1993;73(8415926):797-821.
166. Berendes H, Bridges RA, Good RA. A fatal granulomatosis of childhood: the clinical study of a new syndrome. *Minn Med* 1957;40(13430573):309-312.
167. Janeway CA, Craig J, Davidson M. Hypergammaglobulinemia associated with severe recurrent and chronic non-specific infection. *Am J Dis Child* 1954;88:388-392.
168. Mandell GL, Hook EW. Leukocyte function in chronic granulomatous disease of childhood. Studies on a seventeen-year-old boy. *Am J Med* 1969;47(4390136):473-486.
169. Windhorst DB, Page AR, Holmes B, et al. The pattern of genetic transmission of the leukocyte defect in fatal granulomatous disease of childhood. *J Clin Invest* 1968;47(5645849):1026-1034.
170. Dupree E, Smith CW, MacDougall NL, et al. Undetected carrier state in chronic granulomatous disease. *J Pediatr* 1972;81(4403778):770-774.
171. Kauder E, Kahle LL, Moreno H, et al. Leukocyte degranulation and vacuole formation in patients with chronic granulomatous disease of childhood. *J Clin Invest* 1968;47(5666110):1753-1762.

172. Quie PG, White JG, Holmes B, et al. In vitro bactericidal capacity of human polymorphonuclear leukocytes: diminished activity in chronic granulomatous disease of childhood. *J Clin Invest* 1967;46(6021213):668-679.
173. Macfarlane PS, Speirs AL, Sommerville RG. Fatal granulomatous disease of childhood and benign lymphocytic infiltration of the skin (congenital dysphagocytosis). *Lancet* 1967;1(4163887):408-410.
174. Kaplan EL, Laxdal T, Quie PG. Studies of polymorphonuclear leukocytes from patients with chronic granulomatous disease of childhood: bactericidal capacity for streptococci. *Pediatrics* 1968;41(3):591-599.
175. Hohn DC, Lehrer RI. NADPH oxidase deficiency in X-linked chronic granulomatous disease. *J Clin Invest* 1975;55(235560):707-713.
176. Baehner RL, Nathan DG, Karnovsky ML. Correction of metabolic deficiencies in the leukocytes of patients with chronic granulomatous disease. *J Clin Invest* 1970;49(5441540):865-870.
177. Johnston RB, Baehner RL. Improvement of leukocyte bactericidal activity in chronic granulomatous disease. *Blood* 1970;35(4908653):350-355.
178. Curnutte JT, Whitten DM, Babior BM. Defective superoxide production by granulocytes from patients with chronic granulomatous disease. *N Engl J Med* 1974;290(4359964):593-597.
179. Fridovich I. Editorial: superoxide radical and the bactericidal action of phagocytes. *N Engl J Med* 1974;290(4591067):624-625.
180. Baehner RL, Karnovsky ML. Deficiency of reduced nicotinamide-adenine dinucleotide oxidase in chronic granulomatous disease. *Science* 1968;162(4387010):1277-1279.
181. Landing BH, Shirkey HS. A syndrome of recurrent infection and infiltration of viscera by pigmented lipid histiocytes. *Pediatrics* 1957;20(13465232): 431-438.
182. Davis WC, Huber H, Douglas SD, et al. A defect in circulating mononuclear phagocytes in chronic granulomatous disease of childhood. *J Immunol* 1968;101(5696651):1093-1095.
183. Nathan DG, Baehner RL, Weaver DK. Failure of nitro blue tetrazolium reduction in the phagocytic vacuoles of leukocytes in chronic granulomatous disease. *J Clin Invest* 1969;48(10):1895-1904.
184. Dejesus M, Fikrig S, Detwiler T. Phagocytosis-stimulated nitroblue tetrazolium reduction by platelets. *J Lab Clin Med* 1972;80(5033892):117-124.
185. Segal AW. Absence of both cytochrome b-245 subunits from neutrophils in X-linked chronic granulomatous disease. *Nature* 1987;326(3821877):88-91.
186. Weening RS, Roos D, Weemaes CM, et al. Defective initiation of the metabolic stimulation in phagocytizing granulocytes: a new congenital defect. *J Lab Clin Med* 1976;88(185306):757-768.
187. Parkos CA, Allen RA, Cochrane CG, et al. The quaternary structure of the plasma membrane b-type cytochrome of human granulocytes. *Biochim Biophys Acta* 1988;932(3337799):71-83.
188. Parkos CA, Dinauer MC, Jesaitis AJ, et al. Absence of both the 91kD and 22kD subunits of human neutrophil cytochrome b in two genetic forms of chronic granulomatous disease. *Blood* 1989;73(6):1416-1420.
189. Baehner RL, Nathan DG. Leukocyte oxidase: defective activity in chronic granulomatous disease. *Science* 1967;155(6018195):835-836.
190. Vowells SJ, Sekhsaria S, Malech HL, et al. Flow cytometric analysis of the granulocyte respiratory burst: a comparison study of fluorescent probes. *J Immunol Methods* 1995;178(1):89-97.
191. Kuhns DB, Alvord WG, Heller T, et al. Residual NADPH oxidase and survival in chronic granulomatous disease. *N Engl J Med* 2010;363(27):2600-2610.
192. Bleesing JJ, Souto-Carneiro MM, Savage WJ, et al. Patients with chronic granulomatous disease have a reduced peripheral blood memory B cell compartment. *J Immunol* 2006;176(11):7096-7103.
193. Gallin JI, Buescher ES, Seligmann BE, et al. NIH conference. Recent advances in chronic granulomatous disease. *Ann Intern Med* 1983;99(6227266):657-674.
194. Gallin JI, Farber JM, Holland SM, et al. Interferon-gamma in the management of infectious diseases. *Ann Intern Med* 1995;123(3):216-224.

195. Gallin JI, Alling DW, Malech HL, et al. Itraconazole to prevent fungal infections in chronic granulomatous disease. *N Engl J Med* 2003;348(12802027): 2416-2422.
196. Rex JH, Bennett JE, Gallin JI, et al. In vivo interferon-gamma therapy augments the in vitro ability of chronic granulomatous disease neutrophils to damage *Aspergillus* hyphae. *J Infect Dis* 1991;163(1901332):849-852.
197. Woodman RC, Erickson RW, Rae J, et al. Prolonged recombinant interferon-gamma therapy in chronic granulomatous disease: evidence against enhanced neutrophil oxidase activity. *Blood* 1992;79(1312372):1558-1562.
198. Gungor T, Halter J, Klink A, et al. Successful low toxicity hematopoietic stem cell transplantation for high-risk adult chronic granulomatous disease patients. *Transplantation* 2005;79(15940051):1596-1606.
199. Ott MG, Schmidt M, Schwarzwaelder K, et al. Correction of X-linked chronic granulomatous disease by gene therapy, augmented by insertional activation of MDS1-EVI1, PRDM16 or SETBP1. *Nat Med* 2006;12(16582916):401-409.
200. Soncini E, Slatter MA, Jones LB, et al. Unrelated donor and HLA-identical sibling haematopoietic stem cell transplantation cure chronic granulomatous disease with good long-term outcome and growth. *Br J Haematol* 2009;145(1):73-83.
201. Harvath L, Andersen BR. Defective initiation of oxidative metabolism in polymorphonuclear leukocytes. *N Engl J Med* 1979;300(219339):1130-1135.
202. Lew PD, Southwick FS, Stossel TP, et al. A variant of chronic granulomatous disease: deficient oxidative metabolism due to a low-affinity NADPH oxidase. *N Engl J Med* 1981;305(6270561):1329-1333.
203. Singh A, Zarembler KA, Kuhns DB, et al. Impaired priming and activation of the neutrophil NADPH oxidase in patients with IRAK4 or NEMO deficiency. *J Immunol* 2009;182(10):6410-6417.
204. Honda F, Kano H, Kanegane H, et al. The kinase Btk negatively regulates the production of reactive oxygen species and stimulation-induced apoptosis in human neutrophils. *Nat Immunol* 2012;13(4):369-378.
205. Ford DK, Price GE, Culling CF, et al. Familial lipochrome pigmentation of histiocytes with hyperglobulinemia, pulmonary infiltration, splenomegaly, arthritis and susceptibility to infection. *Am J Med* 1962;33(13958700): 478-489.
206. Rodey GE, Park BH, Ford DK, et al. Defective bactericidal activity of peripheral blood leukocytes in lipochrome histiocytosis. *Am J Med* 1970;49(5455564): 322-327.
207. Cooper MR, DeChatelet LR, McCall CE, et al. Complete deficiency of leukocyte glucose-6-phosphate dehydrogenase with defective bactericidal activity. *J Clin Invest* 1972;51(4):769-778.
208. Cooper MR, DeChatelet LR, McCall CE, et al. Leucocyte G.-6-P.D. deficiency. *Lancet* 1970;1(7663):110.
209. Rodey GE, Jacob HS, Holmes B, et al. Leucocyte G.-6-P.D. levels and bactericidal activity. *Lancet* 1970;1(4189605):355-356.
210. Holmes B, Park BH, Malawista SE, et al. Chronic granulomatous disease in females. *N Engl J Med* 1970;283(4393202):217-221.
211. Newburger PE, Malawista SE, Dinauer MC, et al. Chronic granulomatous disease and glutathione peroxidase deficiency, revisited. *Blood* 1994;84(11):3861-3869.
212. Boxer LA, Oliver JM, Spielberg SP, et al. Protection of granulocytes by vitamin E in glutathione synthetase deficiency. *N Engl J Med* 1979;301(481537): 901-905.
213. Spielberg SP, Boxer LA, Oliver JM, et al. Oxidative damage to neutrophils in glutathione synthetase deficiency. *Br J Haematol* 1979;42(465367):215-223.
214. Roos D, Weening RS, Voetman AA, et al. Protection of phagocytic leukocytes by endogenous glutathione: studies in a family with glutathione reductase deficiency. *Blood* 1979;53(435643):851-866.
215. Roos D, Weening RS, Wyss SR, et al. Protection of human neutrophils by endogenous catalase: studies with cells from catalase-deficient individuals. *J Clin Invest* 1980;65(7410555):1515-1522.
216. Davis SD, Schaller J, Wedgwood RJ. Job's syndrome. Recurrent, "cold," staphylococcal abscesses. *Lancet* 1966;1(4161105):1013-1015.
217. White LR, Iannetta A, Kaplan EL, et al. Leucocytes in Job's syndrome. *Lancet* 1969;1(4180157):630-630.

218. Leung DY, Geha RS. Clinical and immunologic aspects of the hyperimmunoglobulin E syndrome. *Hematol Oncol Clin North Am* 1988;2(3279022): 81-8100.
219. Schopfer K, Baerlocher K, Price P, et al. Staphylococcal IgE antibodies, hyperimmunoglobulinemia E and Staphylococcus aureus infections. *N Engl J Med* 1979;300(423920):835-838.
220. Grimbacher B, Holland SM, Puck JM. Hyper-IgE syndromes. *Immunol Rev* 2005;203(1):244-250.
221. Grimbacher B, Schaffer AA, Holland SM, et al. Genetic linkage of hyper-IgE syndrome to chromosome 4. *Am J Hum Genet* 1999;65(10441580):735-744.
222. Sillaber C, Valent P. New insights into the pathogenesis of the hyperimmunoglobulinaemia E syndrome. *Eur J Clin Invest* 2005;35(16269015):667-668.
223. Minegishi Y, Saito M, Tsuchiya S, et al. Dominant-negative mutations in the DNA-binding domain of STAT3 cause hyper-IgE syndrome. *Nature* 2007;448(7157):1058-1062.
224. Holland SM, DeLeo FR, Elloumi HZ, et al. STAT3 mutations in the hyper-IgE syndrome. *N Engl J Med* 2007;357(16):1608-1619.
225. Minegishi Y, Karasuyama H. Hyperimmunoglobulin E syndrome and tyrosine kinase 2 deficiency. *Curr Opin Allergy Clin Immunol* 2007;7(6):506-509.
226. Zhang Q, Davis JC, Lamborn IT, et al. Combined immunodeficiency associated with DOCK8 mutations. *N Engl J Med* 2009;361(21):2046-2055.
227. Sowerwine KJ, Holland SM, Freeman AF. Hyper-IgE syndrome update. *Ann N Y Acad Sci* 2012;1250(1):25-32.
228. Su HC, Jing H, Zhang Q. DOCK8 deficiency. *Ann N Y Acad Sci* 2011;1246(1): 26-33.
229. Jeppson JD, Jaffe HS, Hill HR. Use of recombinant human interferon gamma to enhance neutrophil chemotactic responses in Job syndrome of hyperimmunoglobulinemia E and recurrent infections. *J Pediatr* 1991;118(3):383-387.
230. Lehrer RI, Cline MJ. Leukocyte myeloperoxidase deficiency and disseminated candidiasis: the role of myeloperoxidase in resistance to Candida infection. *J Clin Invest* 1969;48(5796360):1478-1488.
231. Kitahara M, Simonian Y, Eyre HJ. Neutrophil myeloperoxidase: a simple, reproducible technique to determine activity. *J Lab Clin Med* 1979;93(219116): 232-237.
232. Nauseef WM. Myeloperoxidase deficiency. *Hematol Oncol Clin North Am* 1988;2(1):135-158.
233. Parry MF, Root RK, Metcalf JA, et al. Myeloperoxidase deficiency: prevalence and clinical significance. *Ann Intern Med* 1981;95(3):293-301.
234. Kitahara M, Eyre HJ, Simonian Y, et al. Hereditary myeloperoxidase deficiency. *Blood* 1981;57(6260268):888-893.
235. Nauseef WM, Brigham S, Cogley M. Hereditary myeloperoxidase deficiency due to a missense mutation of arginine 569 to tryptophan. *J Biol Chem* 1994;269(2):1212-1216.
236. Brennan ML, Anderson MM, Shih DM, et al. Increased atherosclerosis in myeloperoxidase-deficient mice. *J Clin Invest* 2001;107(11181641):419-430.
237. Suzuki K, Muso E, Nauseef WM. Contribution of peroxidases in host-defense, diseases and cellular functions. *Jpn J Infect Dis* 2004;57(5):S1-S2.
238. Nauseef WM. Aberrant restriction endonuclease digests of DNA from subjects with hereditary myeloperoxidase deficiency. *Blood* 1989;73(2462938): 290-295.
239. Tobler A, Selsted ME, Miller CW, et al. Evidence for a pretranslational defect in hereditary and acquired myeloperoxidase deficiency. *Blood* 1989;73(7):1980-1986.
240. Hansson M, Olsson I, Nauseef WM. Biosynthesis, processing, and sorting of human myeloperoxidase. *Arch Biochem Biophys* 2006;445(16183032):214-224.
241. Nauseef WM. Lessons from MPO deficiency about functionally important structural features. *Jpn J Infect Dis* 2004;57(5):S4-S5.
242. Grignaschi VJ, Sperperato AM, Etcheverry MJ, et al. Un nuevo cuadro citoquimico: negatividad espontanea de las reacciones de peroxidadas, oxidasas y lipido en la progenie neutrofila y en los monocitos de dos hermanos. *Rev Asoc Med Argent* 1963;77.

243. Painter RG, Valentine VG, Lanson NA, et al. CFTR Expression in human neutrophils and the phagolysosomal chlorination defect in cystic fibrosis. *Biochemistry* 2006;45(16922501):10260-10269.
244. Hanna S, Etzioni A. Leukocyte adhesion deficiencies. *Ann N Y Acad Sci* 2012;1250(1):50-55.
245. Todd RF3rd, Freyer DR. The CD11/CD18 leukocyte glycoprotein deficiency. *Hematol Oncol Clin North Am* 1988;2(1):13-31.
246. Etzioni A. Leukocyte adhesion deficiencies: molecular basis, clinical findings, and therapeutic options immune-mediated diseases. In: Shurin MR, Smolkin YS, eds. New York, NY: Springer, 2007:51-60.
247. Crowley CA, Curnutte JT, Rosin RE, et al. An inherited abnormality of neutrophil adhesion. Its genetic transmission and its association with a missing protein. *N Engl J Med* 1980;302(7366657):1163-1168.
248. Von Andrian UH, Berger EM, Ramezani L, et al. In vivo behavior of neutrophils from two patients with distinct inherited leukocyte adhesion deficiency syndromes. *J Clin Invest* 1993;91(7685776):2893-2897.
249. Anderson DC, Schmalsteig FC, Finegold MJ, et al. The severe and moderate phenotypes of heritable Mac-1, LFA-1 deficiency: their quantitative definition and relation to leukocyte dysfunction and clinical features. *J Infect Dis* 1985;152(4):668-689.
250. Anderson DC, Smith CW, Springer TA. Leukocyte adhesion deficiency and other disorders of leukocyte motility, in the metabolic basis of inherited disease. In: Scriver CR, Beaudet AL, Sly WS, et al., eds. New York, NY: McGraw-Hill, 1989:2751-2777.
251. Arnaout MA, Dana N, Gupta SK, et al. Point mutations impairing cell surface expression of the common beta subunit (CD18) in a patient with leukocyte adhesion molecule (Leu-CAM) deficiency. *J Clin Invest* 1990;85(1968911): 977-981.
252. Back AL, Kerkering M, Baker D, et al. A point mutation associated with leukocyte adhesion deficiency type 1 of moderate severity. *Biochem Biophys Res Commun* 1993;193(7686755):912-918.
253. Corbi AL, Vara A, Ursa A, et al. Molecular basis for a severe case of leukocyte adhesion deficiency. *Eur J Immunol* 1992;22(7):1877-1881.
254. Dana N, Clayton LK, Tennen DG, et al. Leukocytes from four patients with complete or partial Leu-CAM deficiency contain the common beta-subunit precursor and beta-subunit messenger RNA. *J Clin Invest* 1987;79(2880869):1010-1015.
255. Dimanche MT, Le Deist F, Fischer A, et al. LFA-1 beta-chain synthesis and degradation in patients with leukocyte-adhesive proteins deficiency. *Eur J Immunol* 1987;17(3):417-419.
256. Harlan JM. Leukocyte adhesion deficiency syndrome: insights into the molecular basis of leukocyte emigration. *Clin Immunol Immunopathol* 1993;67(3 Pt 2): S16-S24.
257. Kishimoto TK, Hollander N, Roberts TM, et al. Heterogeneous mutations in the beta subunit common to the LFA-1, Mac-1, and p150,95 glycoproteins cause leukocyte adhesion deficiency. *Cell* 1987;50(3594570):193-202.
258. Kobayashi K, Fujita K, Okino F, et al. An abnormality of neutrophil adhesion: autosomal recessive inheritance associated with missing neutrophil glycoproteins. *Pediatrics* 1984;73(6718115):606-610.
259. Lopez Rodriguez C, Nueda A, Gros-pierre B, et al. Characterization of two new CD18 alleles causing severe leukocyte adhesion deficiency. *Eur J Immunol* 1993;23(7901025):2792-2798.
260. Matsuura S, Kishi F, Tsukahara M, et al. Leukocyte adhesion deficiency: identification of novel mutations in two Japanese patients with a severe form. *Biochem Biophys Res Commun* 1992;184(3):1460-1467.
261. Sligh JE, Hurwitz MY, Zhu CM, et al. An initiation codon mutation in CD18 in association with the moderate phenotype of leukocyte adhesion deficiency. *J Biol Chem* 1992;267(1346132):714-718.
262. Wardlaw AJ, Hibbs ML, Stacker SA, et al. Distinct mutations in two patients with leukocyte adhesion deficiency and their functional correlates. *J Exp Med* 1990;172(1694220):335-345.
263. Wright AH, Douglass WA, Taylor GM, et al. Molecular characterization of leukocyte adhesion deficiency in six patients. *Eur J Immunol* 1995;25(7705401): 717-722.
264. Muller KE, Bernadina WE, Kalsbeek HC, et al. Bovine leukocyte adhesion deficiency—clinical course and laboratory findings in eight affected animals. *Vet Q* 1994;16(2):65-71.

265. Nagahata H, Nochi H, Tamoto K, et al. Characterization of functions of neutrophils from bone marrow of cattle with leukocyte adhesion deficiency. *Am J Vet Res* 1995;56(7717579):167-171.
266. Ryncarz RE, Dietz AB, Kehrl ME Jr, Recognition of leukochimerism during genotyping for bovine leukocyte adhesion deficiency (BLAD) by polymerasechain-reaction-amplified DNA extracted from blood. *J Vet Diagn Invest* 1995;7(4):569-572.
267. Qasim W, Cavazzana-Calvo M, Davies EG, et al. Allogeneic hematopoietic stem-cell transplantation for leukocyte adhesion deficiency. *Pediatrics* 2009;123(3):836-840.
- P.1301
268. Etzioni A, Frydman M, Pollack S, et al. Brief report: recurrent severe infections caused by a novel leukocyte adhesion deficiency. *N Engl J Med* 1992;327(1279426):1789-1792.
269. Etzioni A, Phillips LM, Paulson JC, et al. Leukocyte adhesion deficiency (LAD) II. *Ciba Found Symp* 1995;189(7587637):51-58.
270. Frydman M, Etzioni A, Eidlitz-Markus T, et al. Rambam-Hasharon syndrome of psychomotor retardation, short stature, defective neutrophil motility, and Bombay phenotype. *Am J Med Genet* 1992;44(1488976):297-302.
271. Price TH, Ochs HD, Gershoni-Baruch R, et al. In vivo neutrophil and lymphocyte function studies in a patient with leukocyte adhesion deficiency type II. *Blood* 1994;84(8068953):1635-1639.
272. Lubke T, Marquardt T, von Figura K, et al. A new type of carbohydrate-deficient glycoprotein syndrome due to a decreased import of GDP-fucose into the golgi. *J Biol Chem* 1999;274(37):25986-25989.
273. Luhn K, Wild MK, Eckhardt M, et al. The gene defective in leukocyte adhesion deficiency II encodes a putative GDP-fucose transporter. *Nat Genet* 2001;28(1):69-72.
274. Le Pendu J, Cartron JP, Lemieux RU, et al. The presence of at least two different H-blood-group-related beta-D-gal alpha-2-L-fucosyltransferases in human serum and the genetics of blood group H substances. *Am J Hum Genet* 1985;37(9556663):749-760.
275. Marquardt T, Lühn K, Srikrishna G, et al. Correction of leukocyte adhesion deficiency type II with oral fucose. *Blood* 1999;94(12):3976-3985.
276. Etzioni A, Tonetti M. Fucose supplementation in leukocyte adhesion deficiency type II. *Blood* 2000;95(11):3641-3643.
277. Karsan A, Cornejo CJ, Winn RK, et al. Leukocyte adhesion deficiency type II is a generalized defect of de novo GDP-fucose biosynthesis. Endothelial cell fucosylation is not required for neutrophil rolling on human nonlymphoid endothelium. *J Clin Invest* 1998;101(9616215):2438-2445.
278. Lubke T, Marquardt T, von Figura K, et al. A new type of carbohydrate-deficient glycoprotein syndrome due to a decreased import of GDP-fucose into the golgi. *J Biol Chem* 1999;274(10473542):25986-25989.
279. Marquardt T, Brune T, Luhn K, et al. Leukocyte adhesion deficiency II syndrome, a generalized defect in fucose metabolism. *J Pediatr* 1999;134(10356134):681-688.
280. Sturla L, Etzioni A, Bisso A, et al. Defective intracellular activity of GDP-Dmannose-4,6-dehydratase in leukocyte adhesion deficiency type II syndrome. *FEBS Lett* 1998;429(9662431):274-278.
281. Etzioni A, Alon R. Leukocyte adhesion deficiency III: a group of integrin activation defects in hematopoietic lineage cells. *Curr Opin Allergy Clin Immunol* 2004;4(15640688):485-490.
282. Zimmerman GA. LAD syndromes: FERMT3 kindles the signal. *Blood* 2009;113(19):4485-4486.
283. Svensson L, Howarth K, McDowall A, et al. Leukocyte adhesion deficiency-III is caused by mutations in KINDLIN3 affecting integrin activation. *Nat Med* 2009;15(3):306-312.
284. Ambruso DR, Knall C, Abell AN, et al. Human neutrophil immunodeficiency syndrome is associated with an inhibitory Rac2 mutation. *Proc Natl Acad Sci U S A* 2000;97(10758162):4654-4659.
285. Williams DA, Tao W, Yang F, et al. Dominant negative mutation of the hematopoietic-specific Rho GTPase, Rac2, is associated with a human phagocyte immunodeficiency. *Blood* 2000;96(10961859):1646-1654.

286. Kim C, Dinauer MC. Rac2 is an essential regulator of neutrophil nicotinamide adenine dinucleotide phosphate oxidase activation in response to specific signaling pathways. *J Immunol* 2001;166(11145705):1223-1232.
287. Roberts AW, Kim C, Zhen L, et al. Deficiency of the hematopoietic cell-specific Rho family GTPase Rac2 is characterized by abnormalities in neutrophil function and host defense. *Immunity* 1999;10(10072071):183-196.
288. Clark MR, Liu L, Clarkson SB, et al. An abnormality of the gene that encodes neutrophil Fc receptor III in a patient with systemic lupus erythematosus. *J Clin Invest* 1990;86(1694867):341-346.
289. de Haas M, Kleijer M, van Zwieten R, et al. Neutrophil Fc gamma RIIIb deficiency, nature, and clinical consequences: a study of 21 individuals from 14 families. *Blood* 1995;86(7662988):2403-2413.
290. Fromont P, Bettaieb A, Skouri H, et al. Frequency of the polymorphonuclear neutrophil Fc gamma receptor III deficiency in the French population and its involvement in the development of neonatal alloimmune neutropenia. *Blood* 1992;79(1532916):2131-2134.
291. Huizinga TW, Kuijpers RW, Kleijer M, et al. Maternal genomic neutrophil FcRIII deficiency leading to neonatal isoimmune neutropenia. *Blood* 1990;76(10):1927-1932.
292. Stroncek DF, Skubitz KM, Plachta LB, et al. Alloimmune neonatal neutropenia due to an antibody to the neutrophil Fc-gamma receptor III with maternal deficiency of CD16 antigen. *Blood* 1991;77(1826224):1572-1580.
293. Boxer LA, Hedley-Whyte ET, Stossel TP. Neutrophil action dysfunction and abnormal neutrophil behavior. *N Engl J Med* 1974;291(4609060):1093-1099.
294. Coates TD, Torkildson JC, Torres M, et al. An inherited defect of neutrophil motility and microfilamentous cytoskeleton associated with abnormalities in 47-Kd and 89-Kd proteins. *Blood* 1991;78(1878595):1338-1346.
295. Southwick FS, Dabiri GA, Stossel TP. Neutrophil actin dysfunction is a genetic disorder associated with partial impairment of neutrophil actin assembly in three family members. *J Clin Invest* 1988;82(3183050):1525-1531.
296. Southwick FS, Howard TH, Holbrook T, et al. The relationship between CR3 deficiency and neutrophil actin assembly. *Blood* 1989;73(7):1973-1979.
297. Howard T, Li Y, Torres M, et al. The 47-kD protein increased in neutrophil actin dysfunction with 47- and 89-kD protein abnormalities is lymphocyte-specific protein. *Blood* 1994;83(1):231-241.
298. Li Y, Guerrero A, Howard TH. The actin-binding protein, lymphocyte-specific protein 1, is expressed in human leukocytes and human myeloid and lymphoid cell lines. *J Immunol* 1995;155(7561054):3563-3569.
299. Howard TH, Hartwig J, Cunningham C. Lymphocyte-specific protein 1 expression in eukaryotic cells reproduces the morphologic and motile abnormality of NAD 47/89 neutrophils. *Blood* 1998;91(9616178):4786-4795.
300. Van Dyke TE, Levine MJ, Tabak LA, et al. Reduced chemotactic peptide binding in juvenile periodontitis: a model for neutrophil function. *Biochem Biophys Res Commun* 1981;100(6268085):1278-1284.
301. Van Dyke TE, Levine MJ, Genco RJ. Neutrophil function and oral disease. *J Oral Pathol* 1985;14(3920369):95-9120.
302. Genco RJ, Van Dyke TE, Levine MJ, et al. 1985 Kreshover lecture. Molecular factors influencing neutrophil defects in periodontal disease. *J Dent Res* 1986;65(12):1379-1391.
303. O'Flaherty JT, Kreutzer DL, Showell HJ, et al. Selective neutrophil desensitization to chemotactic factors. *J Cell Biol* 1979;80(3):564-572.
304. Ward PA, Becker EL. The deactivation of rabbit neutrophils by chemotactic factor and the nature of the activatable esterase. *J Exp Med* 1968;127(5642465): 693-709.
305. Webster RO, Hong SR, Johnston RB, et al. Biological effects of the human complement fragments C5a and C5ades Arg on neutrophil function. *Immunopharmacology* 1980;2(6254906):201-219.
306. Craddock PR, Fehr J, Dalmaso AP, et al. Hemodialysis leukopenia. Pulmonary vascular leukostasis resulting from complement activation by dialyzer cellophane membranes. *J Clin Invest* 1977;59(856872):879-888.
307. Craddock PR, Hammerschmidt D, White JG, et al. Complement (C5-a)-induced granulocyte aggregation in vitro. A possible mechanism of complement-mediated leukostasis and leukopenia. *J Clin Invest* 1977;60(1):260-264.

308. Skubitz KM, Craddock PR. Reversal of hemodialysis granulocytopenia and pulmonary leukostasis: a clinical manifestation of selective down-regulation of granulocyte responses to C5adesarg. *J Clin Invest* 1981;67(7229031):1383-1391.
309. Skubitz KM, Craddock PR, Hammerschmidt DE, et al. Corticosteroids block binding of chemotactic peptide to its receptor on granulocytes and cause disaggregation of granulocyte aggregates in vitro. *J Clin Invest* 1981;68(7251857):13-20.
310. Walther A, Riehemann K, Gerke V. A novel ligand of the formyl peptide receptor: annexin I regulates neutrophil extravasation by interacting with the FPR. *Mol Cell* 2000;5(10882119):831-840.
311. Hayhoe RPG, Kamal AM, Solito E, et al. Annexin 1 and its bioactive peptide inhibit neutrophil-endothelium interactions under flow: indication of distinct receptor involvement. *Blood* 2006;107(16278303):2123-2130.
312. Abramson JS, Mills EL. Depression of neutrophil function induced by viruses and its role in secondary microbial infections. *Rev Infect Dis* 1988;10(2): 326-341.
313. Abramson JS, Mills EL, Giebink GS, et al. Depression of monocyte and polymorphonuclear leukocyte oxidative metabolism and bactericidal capacity by influenza A virus. *Infect Immun* 1982;35(7054126):350-355.
314. Cassidy LF, Lyles DS, Abramson JS. Depression of polymorphonuclear leukocyte functions by purified influenza virus hemagglutinin and sialic acid-binding lectins. *J Immunol* 1989;142(2723434):4401-4406.
315. Ruutu P, Vaheri A, Kosunen TU. Depression of human neutrophil motility by influenza virus in vitro. *Scand J Immunol* 1977;6(905779):897-906.
316. Abramson JS, Hudnor HR. Role of the sialoprotein (CD43) receptor in mediating influenza A virus-induced polymorphonuclear leukocyte dysfunction. *Blood* 1995;85(7888680):1615-1619.
317. Abramson JS, Lyles DS, Heller KA, et al. Influenza A virus-induced polymorphonuclear leukocyte dysfunction. *Infect Immun* 1982;37(2):794-799.
318. Larson HE, Blades R. Impairment of human polymorphonuclear leukocyte function by influenza virus. *Lancet* 1976;1(55591):283-283.
319. Larson HE, Parry RP, Tyrrell DA. Impaired polymorphonuclear leukocyte chemotaxis after influenza virus infection. *Br J Dis Chest* 1980;74(7356914):56-62.
320. Bandres JC, Trial J, Musher DM, et al. Increased phagocytosis and generation of reactive oxygen products by neutrophils and monocytes of men with stage 1 human immunodeficiency virus infection. *J Infect Dis* 1993;168(8515135):75-83.
321. Elbim C, Prevot MH, Bouscarat F, et al. Polymorphonuclear neutrophils from human immunodeficiency virus-infected patients show enhanced activation, diminished fMLP-induced L-selectin shedding, and an impaired oxidative burst after cytokine priming. *Blood* 1994;84(7522641):2759-2766.
322. Craddock PR, Yawata Y, VanSanten L, et al. Acquired phagocyte dysfunction. A complication of the hypophosphatemia of parenteral hyperalimentation. *N Engl J Med* 1974;290(4208370):1403-1407.
323. Kiersztein M, Chervu I, Smogorzewski M, et al. On the mechanisms of impaired phagocytosis in phosphate depletion. *J Am Soc Nephrol* 1992;2(1600119):1484-1489.
324. Alexiewicz JM, Kumar D, Smogorzewski M, et al. Polymorphonuclear leukocytes in non-insulin-dependent diabetes mellitus: abnormalities in metabolism and function. *Ann Intern Med* 1995;123(7486486):919-924.
325. Andersen B, Goldsmith GH, Spagnuolo PJ. Neutrophil adhesive dysfunction in diabetes mellitus; the role of cellular and plasma factors. *J Lab Clin Med* 1988;111(3343542):275-285.
326. Bagdade JD, Root RK, Bulger RJ. Impaired leukocyte function in patients with poorly controlled diabetes. *Diabetes* 1974;23(4809622):9-15.
327. Bagdade JD, Stewart M, Walters E. Impaired granulocyte adherence. A reversible defect in host defense in patients with poorly controlled diabetes. *Diabetes* 1978;27(658613):677-681.
328. Brayton RG, Stokes PE, Schwartz MS, et al. Effect of alcohol and various diseases on leukocyte mobilization, phagocytosis and intracellular bacterial killing. *N Engl J Med* 1970;282(4982606):123-128.

329. Marhoffer W, Stein M, Maeser E, et al. Impairment of polymorphonuclear leukocyte function and metabolic control of diabetes. *Diabetes Care* 1992;15(1547682):256-260.
330. Repine JE, Clawson CC, Goetz FC. Bactericidal function of neutrophils from patients with acute bacterial infections and from diabetics. *J Infect Dis* 1980;142(7007524):869-875.
331. Roos D, Kuijpers TW, Mascart-Lemone F, et al. A novel syndrome of severe neutrophil dysfunction: unresponsiveness confined to chemotaxin-induced functions. *Blood* 1993;81(10):2735-2743.
332. Simms HH, D'Amico R. Polymorphonuclear leukocyte dysregulation during the systemic inflammatory response syndrome. *Blood* 1994;83(8118041):1398-1407.
333. Ottonello L, Dapino P, Pastorino G, et al. Neutrophil dysfunction and increased susceptibility to infection. *Eur J Clin Invest* 1995;25(9): 687-692.

Chapter 59 Lysosomal Abnormalities of the Monocyte-Macrophage System: Gaucher and Niemann-Pick Diseases

> Table of Contents > Part VI - Benign Disorders of Leukocytes, The Spleen, and/or Immunoglobins > Chapter 59 - Lysosomal Abnormalities of the Monocyte-Macrophage System: Gaucher and Niemann-Pick Diseases

Chapter 59

Lysosomal Abnormalities of the Monocyte-Macrophage System: Gaucher and Niemann-Pick Diseases

Margaret M. McGovern

Robert J. Desnick

Abnormalities of the monocyte-macrophage system include certain of the inherited lysosomal storage diseases that result from specific defects in lysosomal function. Most of these disorders are caused by the deficiency of a particular hydrolytic enzyme, but others are due to impaired receptors, transporters, or deficiencies of crucial cofactors or protective proteins. Prevalent among these disorders are the sphingolipidoses, which are a unique family of diverse diseases related by their molecular pathology. Here, the clinical, biochemical, and genetic features of two of these disorders are presented: Niemann-Pick types A and B disease, caused by defects in the acid sphingomyelinase (SMPD1) gene, and Gaucher disease, caused by defects in the acid α -glucosidase (GBA) gene. In each of these autosomal recessive disorders, mutations in the gene that encodes the lysosomal enzyme result in a defective gene product (i.e., a noncatalytic enzyme) that is unable to perform its normal function as a hydrolase. The deficiency of these lysosomal hydrolases results in abnormal metabolism of the enzyme's specific sphingolipid substrate, and the substrate accumulates in the cells of the monocyte-macrophage system, causing the clinical manifestations. For example, in Gaucher disease and Niemann-Pick types A and B diseases, anemia, thrombocytopenia, leukopenia, and/or hepatosplenomegaly can be the presenting symptoms. Thus, these disorders are frequently diagnosed by the hematologist and must be included in the differential diagnosis for patients with monocyte-macrophage involvement.

PATHOPHYSIOLOGY OF THE LYSOSOMAL STORAGE DISEASES

The underlying defect in the inherited lipidoses is the accumulation of metabolites, including glycolipids and sphingomyelin. The glycosphingolipids, which are present in the membranes of many cell types, are formed by the addition of various carbohydrates to a ceramide backbone (Fig. 59.1). The fatty acid portion of ceramide consists primarily of stearic acid (C₁₈) in the brain, whereas in non-neural tissues it is somewhat longer (C₂₀ to C₂₄). Each sphingolipid is characterized by the nature of the compound that is esterified to the first carbon of the ceramide molecule. For example, the addition of hexoses and N-acetylneuraminic acid to ceramide forms the gangliosides, which are found in brain, whereas the neutral glycolipids are found more ubiquitously in cell membranes. The blood group antigens are also glycosphingolipids. In the lysosomal storage diseases, these lipid compounds vary in amount in different cell types, so their rate and amount of accumulation because of a specific lysosomal enzyme defect will vary, leading to their cell-related manifestations (Fig. 59.2). Tables 59.1 and 59.2 outline the biochemical and phenotypic characteristics and the molecular basis of the lysosomal storage diseases, respectively.

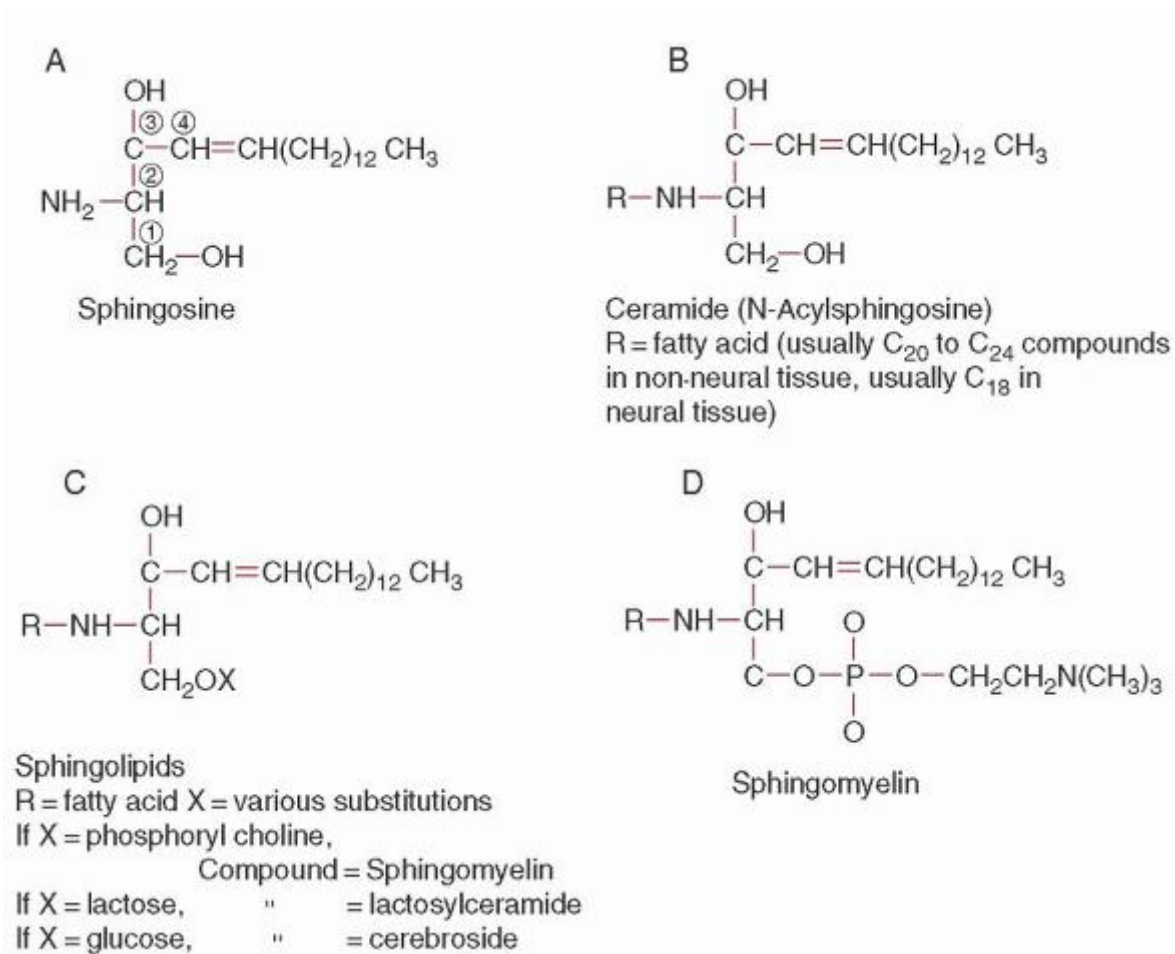

FIGURE 59.1. Formulas of some of the sphingolipids.

GAUCHER DISEASE

Definition and History

Gaucher disease is a lipid storage disease characterized by the deposition of glucocerebroside in cells of the macrophage-monocyte system. It was first described by Gaucher in 1882, and the storage of glucocerebroside was first recognized by Epstein in 1924. The metabolic defect, which is the deficiency of the lysosomal hydrolase acid β-glucosidase, or β-glucocerebrosidease, was identified by Brady et al.¹ There are three clinical subtypes, which are delineated by the absence or presence and progression of neurologic involvement: type 1 or the non-neuronopathic form; type 2, the infantile-onset, acute neuronopathic form; and type 3, the juvenile-onset neuronopathic form.² All three subtypes are inherited as autosomal recessive traits. Type 1 disease is the most common lysosomal

P.1303

storage disease and one of the most prevalent genetic disorders among Ashkenazi Jewish individuals, with an incidence of about 1 in 1,000 and a carrier frequency of about 1 in 15.³

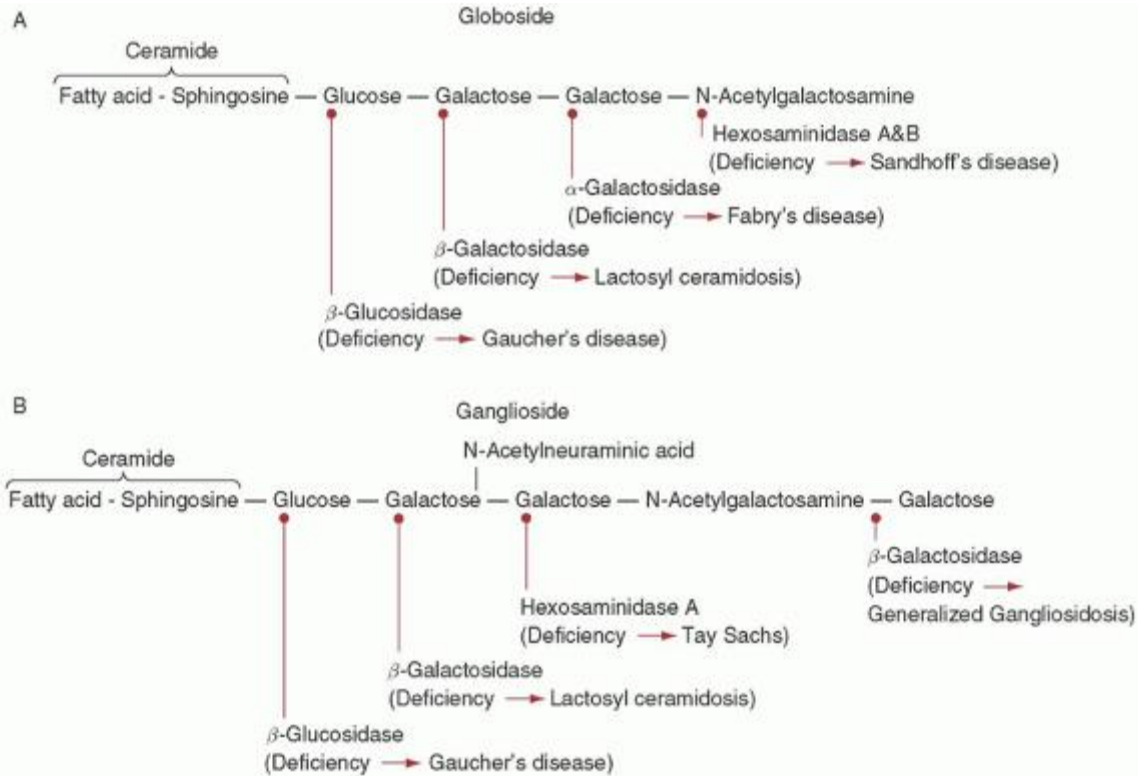

FIGURE 59.2. Schematic structure of globoside (A) and ganglioside (B) to show site of action of the several catabolic enzymes, which result in one of the storage diseases when defective.

Etiology and Pathogenesis

All three subtypes of Gaucher disease result from the deficient activity of the lysosomal hydrolase, acid β -glucosidase (Table 59.1). The major acid β -glucosidase gene mutations that cause Gaucher disease among Ashkenazi Jewish patients have been identified (Table 59.2). Genotype/phenotype correlations have been made for the different subtypes and provide insight into the molecular basis for the remarkable clinical variation in Gaucher disease. Presumably, the amount of residual enzymatic activity determines disease subtype and severity. For example, the mutations that cause the severe type 2 (infantile) disease express little, if any, enzymatic activity in vitro, whereas type 1 patients who are homozygous for the milder N370S mutation tend to have a later

P.1304

onset and a milder course than patients with one N370S allele and another mutant allele. However, the wide variability in clinical presentation among Gaucher disease patients cannot be fully explained by the underlying acid β -glucosidase mutations, and presumably other “modifier” genes can influence disease severity.

TABLE 59.1 BIOCHEMICAL AND PHENOTYPIC CHARACTERISTICS OF GAUCHER AND NIEMANN-PICK DISEASES

Disease	Enzyme Deficiency	Substance Accumulated	Site	Complications
Gaucher Disease				
Type 1	Acid β -glucosidase	Primarily glucosylceramide	Macrophage-monocyte system	Infiltration of bone marrow, progressive hepatosplenomegaly, skeletal complications
Type 2	Acid β -glucosidase	Primarily glucosylceramide	Macrophage-monocyte system, CNS	Infiltration of bone marrow, progressive hepatosplenomegaly, skeletal complications,

Type 3	Acid β -glucosidase	Primarily glucosylceramide	Macrophage-monocyte system, CNS	neurodegeneration Progressive neurodegeneration
Niemann-Pick Disease				
Type A	Acid sphingomyelinase	Sphingomyelin	Monocyte-macrophage system, CNS	Hepatosplenomegaly, progressive neurodegeneration
Type B	Acid sphingomyelinase	Sphingomyelin	Monocyte-macrophage system	Progressive hepatosplenomegaly, infiltrative lung disease
Type C	Abnormal cholesterol transport	Primarily cholesterol	Most cells, especially liver, CNS	Hepatosplenomegaly, progressive neurodegeneration

CNS, central nervous system.

TABLE 59.2 MOLECULAR BASIS OF GAUCHER AND NIEMANN-PICK DISEASES

Disease	Chromosome Assignment	Molecular Characteristics	Comments
Gaucher disease	1q21	cDNA, functional and pseudogenomic sequences, >200 mutant alleles known	Four mutations (N370S, L444P, 84insG, IVS2 ⁺ 1) account for 90 to >95% of mutant alleles in Ashkenazi Jewish patients
Niemann-Pick disease			
Types A and B	11p15.1 to p15.4	cDNA, entire genomic sequence, >70 mutant alleles known	Four mutations account for >95% of mutant alleles in Ashkenazi Jewish patients with type A disease
Type C	18q11-q12 region	cDNA, entire genomic sequence, >100 mutant alleles known	More than 100 mutations in NPC1 gene

Pathology

The pathologic hallmark in Gaucher disease is the presence of Gaucher cells in the macrophage-monocyte system, particularly in the bone marrow. These cells, which are 20 to 100 μ m in diameter, have a characteristic wrinkled-paper appearance resulting from intracytoplasmic substrate deposition. These cells stain strongly positive with periodic acid-Schiff reagent, and their presence in bone marrow and/or other tissues suggests the diagnosis (Fig. 59.3). The accumulated glycosphingolipid, glucosylceramide, is derived primarily from the phagocytosis and degradation of senescent leukocytes and, to a lesser extent, erythrocyte membranes. Glucosylceramide storage results in organomegaly and pulmonary infiltration. Neuronal cell loss in patients with types 2 and 3 disease presumably results from the neural accumulation of the cytotoxic glycosphingolipid, glucosylsphingosine, due to the severe deficiency of acid β -glucosidase activity. Glucosylceramide accumulation in the bone marrow, liver, spleen, lungs, and kidney leads to pancytopenia, massive hepatosplenomegaly, diffuse infiltrative pulmonary disease, and nephropathy or glomerulonephritis. The progressive infiltration of Gaucher cells in the bone marrow causes thinning of the cortex, pathologic fractures, bone pain,

bony infarcts, and osteopenia, particularly in type 1 disease. Central nervous system (CNS) involvement occurs only in patients with types 2 and 3 disease.

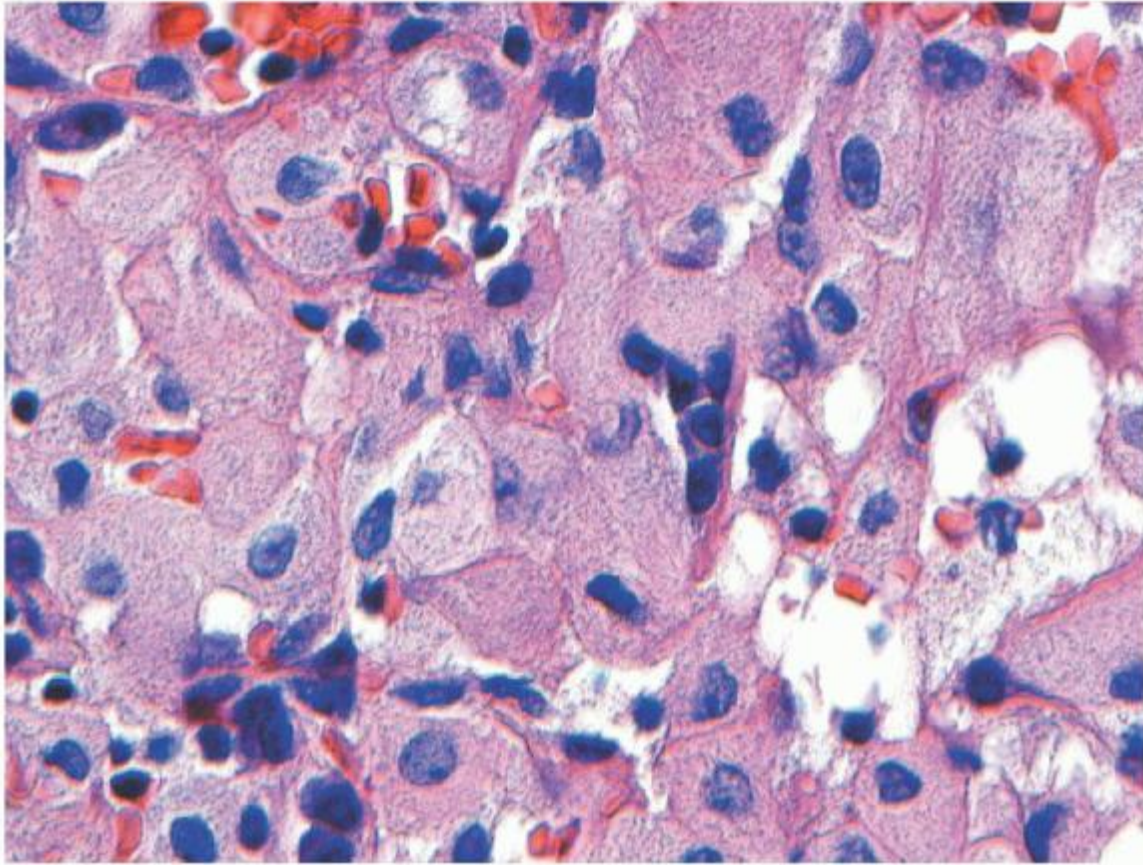

FIGURE 59.3. Splenic histopathology in Gaucher disease. There are sheets of histiocytes with bland nuclei and abundant pink cytoplasm with a fine “tissue paper” appearance.

Clinical Manifestations

Type 1 Disease

There is a broad spectrum of clinical expression among type 1 disease patients, in part because of the combination of different mutant alleles. Onset of clinical manifestations occurs from early childhood to late adulthood, with more symptomatic patients presenting in childhood or adolescence. At presentation, patients may have easy bruisability resulting from thrombocytopenia, chronic fatigue secondary to anemia, hepatomegaly with or without elevated liver function tests, splenomegaly, and bone pain or pathologic fractures. Occasional patients present with pulmonary involvement. Patients who are diagnosed in the first 5 years of life are frequently non-Jewish and typically have a more malignant disease course. Milder patients are discovered later in life during evaluations for hematologic or skeletal problems, or are found to have splenomegaly on routine examinations. In symptomatic patients, splenomegaly is progressive and can become massive. Clinically apparent bony involvement can present as bone pain or pathologic fractures. Most patients have radiologic evidence of skeletal involvement, including an “Erlenmeyer flask” deformity of the distal femur, which is an early skeletal change. In patients with symptomatic bone disease, lytic lesions can develop in the long bones, ribs, and pelvis, and osteosclerosis may be evident at an early age. Bone crises with severe pain and swelling can occur. Bleeding secondary to thrombocytopenia may manifest as epistaxis and bruising and is frequently overlooked until other symptoms become apparent. Children with massive splenomegaly are short of stature because of the energy expenditure required by the enlarged organ.

Type 2 Disease

Infants with the rare and panethnic type 2 subtype have a rapid neurodegenerative course with extensive visceral involvement and death within the first 2 years of life. The disease presents in infants with increased tone, strabismus, and

organomegaly. Failure to thrive and stridor resulting from laryngospasm are typical. The progressive psychomotor degeneration leads to death, usually due to respiratory compromise.

Type 3 Disease

Patients with type 3 Gaucher disease typically present in infancy or childhood. In addition to the organomegaly and bony involvement, neurologic involvement is present. There is a high frequency of type 3 disease in Sweden (1 in 50,000), which has been

P.1305

traced to a common founder in the 17th century. Type 3 has been further classified as type 3a or 3b based on the extent of neurologic involvement and whether there is progressive myotonia and dementia (type 3a) or isolated supranuclear gaze palsy (type 3b).

Diagnosis

Gaucher disease should be considered in the differential diagnosis of patients who present with unexplained organomegaly, easy bruisability, and/or bone pain.⁴ In the past, bone marrow examination revealing the presence of Gaucher cells was used for diagnosis. Today, all suspect diagnoses should be confirmed by demonstrating deficient acid β -glucosidase activity in isolated leukocytes or cultured fibroblasts. For genotype/phenotype correlations, the specific acid β -glucosidase gene mutation should be determined, particularly in Ashkenazi Jewish patients. Carrier identification can be achieved by enzymatic assay, although in the Ashkenazi this can be achieved by detection of the common mutations. Testing should be offered to all family members, keeping in mind that heterogeneity even among members of the same kindred can be significant and that asymptomatic affected individuals may be diagnosed during such testing. Prenatal diagnosis is available by determining the enzymatic activity and/or the parent's specific mutations in chorionic villi or cultured amniotic fluid cells.

Treatment

Enzyme replacement with recombinant acid β -glucosidase (imiglucerase [Cerezyme, Genzyme Corporation, Cambridge, MA] or velaglucerase alfa [VPRIV, Shire HGT, Lexington, MA]) is the standard of care for the treatment of patients with type 1 disease. Clinical trials have demonstrated that most extra-skeletal symptoms are reversed within 12 to 36 months by an initial debulking dose of enzyme (60 units/kg) administered by intravenous infusion every other week. Initial higher doses may be indicated in patients with severe disease (type 3) at the time of diagnosis and in those with rapid progression or significant comorbidities.⁵ Early treatment may be efficacious in normalizing linear growth and bone morphology in affected children. Experience during the last 20 years has proven enzyme replacement therapy to be safe and effective in preventing the complications of type 1 disease. However, enzyme replacement does not alter the neurologic progression of patients with Gaucher disease types 2 and 3. It has been used in these patients as a palliative measure, particularly in type 3 patients with severe visceral involvement. Alternative treatments being evaluated include therapies targeted to reducing the synthesis of glucosylceramide by chemical inhibition of glucosylceramide synthase, as well as pharmacologic chaperone monotherapy to increase the residual activity of missense mutations, and pharmacologic chaperone coadministration with the recombinant enzyme to stabilize it in the circulation and to increase its delivery to other tissues.

NIEMANN-PICK DISEASE

Definition

Niemann-Pick disease (NPD) types A and B are lipid storage disorders that result from the deficiency of the lysosomal enzyme, acid sphingomyelinase, and the subsequent accumulation of its substrate, sphingomyelin.⁶ The original description of NPD referred to what is now known as type A NPD, which is a fatal neurodegenerative disorder of infancy characterized by failure to thrive, hepatosplenomegaly, and a rapidly progressive neurodegenerative course that leads to death by the age of 2 or 3 years. Type B NPD has a wide phenotypic spectrum that can include neurologic manifestations, but typically does not.^{6, 7, 8} Type C NPD is a neurodegenerative disorder that results from defective intracellular cholesterol transport and accumulation of unesterified cholesterol in lysosomes.^{7, 8} Previously, a type D disease was identified in patients from Nova Scotia; however, these patients actually have type C disease. All the subtypes are inherited as autosomal recessive traits and display variable clinical features.

Etiology and Pathogenesis

Types A and B NPD result from the deficient activity of the lysosomal hydrolase, acid sphingomyelinase (Table 59.1). In type C NPD, the genetic defect involves the defective transport of cholesterol from the lysosome to the cytosol. Two different genes causing the altered cholesterol transport in type C disease have been identified (NPC1 and NPC2), permitting more precise diagnosis, carrier detection, and prenatal diagnosis in affected families. Only types A and B are discussed here; for type C, see Refs. 7 and 8.

Pathology

Types A and B Niemann-Pick Disease

The pathologic hallmark in types A and B NPD is the histochemically characteristic lipid-laden foam cell, often referred to as the "Niemann-Pick cell." These cells, which can be readily distinguished from Gaucher cells by their histologic and histochemical characteristics, are not pathognomonic for NPD, because histologically similar cells are found in patients with Wolman disease, cholesterol ester storage disease, lipoprotein lipase deficiency, and in some patients with GM1 gangliosidosis, type 2 (Fig. 59.4). Sphingomyelin is the major lipid that accumulates in the cells and tissues of patients with types A and B NPD. In most normal tissues, sphingomyelin constitutes from 5% to 20% of the total cellular phospholipid content; however, in patients with types A and B NPD, the sphingomyelin levels may be elevated up to 50-fold, constituting ~70% of the total phospholipid fraction. Lysosomal sphingomyelin accumulation in liver, kidney, and lungs has been documented with organs from types A and B NPD patients containing about the same amount of sphingomyelin, with the notable finding of significant sphingomyelin and psychosphingosine in the CNS of type A NPD patients. In general, patients with type A disease have <5% of normal acid sphingomyelinase activity when assayed in cultured fibroblasts and/or lymphocytes, whereas cells from type B patients typically have >5% of normal activity,

P.1306

which presumably prevents the development of the neurologic symptoms.

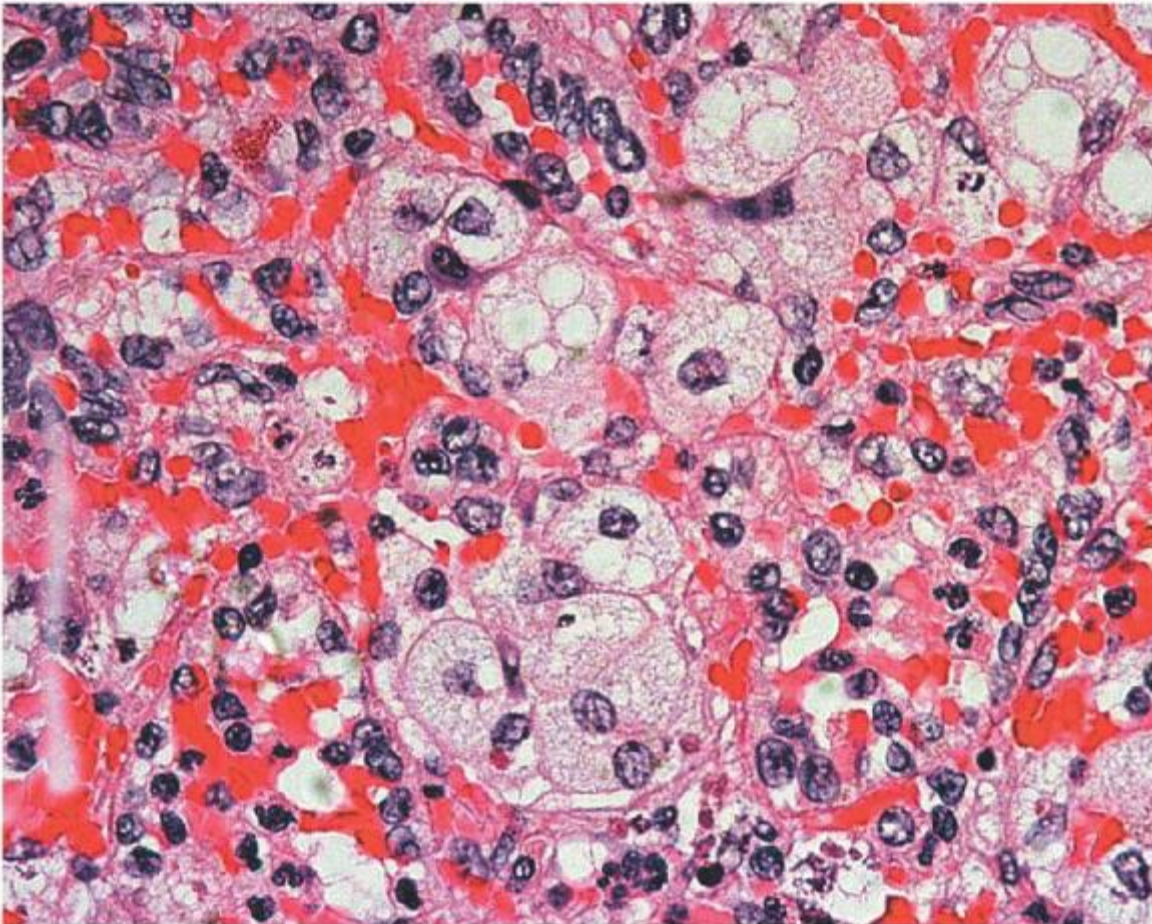

FIGURE 59.4. Splenic histology in Niemann-Pick disease type B. Aggregates of histiocytes are present with distinct

vacuoles. Although some large vacuoles are seen, most are small. (Image provided by Professor Attilio Orazi, Department of Pathology, Indiana University.)

Clinical Manifestations

Types A and B Niemann-Pick Disease

The clinical presentation and course of type A NPD is relatively uniform and is characterized by a normal appearance at birth. Hepatosplenomegaly and psychomotor retardation are evident by 6 months of life, followed by rapid neurodegeneration and death by 3 years. The loss of motor function and the deterioration of intellectual capabilities are progressive. In later stages, spasticity and rigidity are evident, with affected infants experiencing complete loss of contact with their environment.

In contrast to the stereotyped type A phenotype, the clinical presentation and course of patients with type B disease are more variable. Most patients are diagnosed in infancy or childhood, when enlargement of the liver and/or spleen is detected during a routine physical examination. At diagnosis, type B patients also have evidence of mild pulmonary involvement, usually detected as a diffuse reticular or finely nodular infiltration on chest roentgenogram. In most patients, hepatosplenomegaly is particularly prominent in childhood, but with increasing linear growth the abdominal protuberance decreases and becomes less conspicuous. In mildly affected patients, the splenomegaly may not be noted until adulthood, and there may be minimal disease manifestations. In most type B patients, decreased pulmonary diffusion resulting from alveolar infiltration becomes evident in childhood and progresses with age. Severely affected individuals may experience significant pulmonary compromise by age 15 to 20 years. Such patients have low pO_2 values and dyspnea on exertion. Lifethreatening bronchopneumonias may occur, and cor pulmonale has been described. Severely affected patients also may have liver involvement leading to life-threatening cirrhosis, portal hypertension, and ascites. Clinically significant pancytopenia resulting from secondary hypersplenism may necessitate partial or total splenectomy, although removal of the spleen can exacerbate the pulmonary disease.

Cholesterol abnormalities characterized by low high-density lipoprotein cholesterol and increased total cholesterol are found in most patients and can be associated with early atherosclerotic changes. Some type B patients have neurologic involvement, which can include cerebellar signs and nystagmus, extrapyramidal involvement, mental retardation, and psychiatric disorders. As in other lysosomal storage diseases, it is evident that neurologic manifestations in acid sphingomyelinase deficiency may occur along a continuum among patients. Nevertheless, there is a distinctive, fatal neurodegenerative form (NPD-A), characterized by a brief period of normal development followed by a severe neurodegenerative course and death in early childhood.

Patients with NPD type C disease often have prolonged neonatal jaundice, appear normal for 1 to 2 years, and then experience a slowly progressive and variable neurodegenerative course. Their hepatosplenomegaly is less severe than that in patients with type A or B disease, and they may survive into adulthood.

Diagnosis

Type A NPD patients are diagnosed in the first year of life with failure to thrive, organomegaly, and severe psychomotor retardation. In type B NPD patients, splenomegaly is usually noted early in childhood; however, in very mildly affected patients, the enlargement may be subtle and detection may be delayed until adolescence or adulthood. The presence of the characteristic Niemann-Pick cells in the bone marrow supports the diagnosis. However, patients with type C disease also have extensive infiltration of these cells in the bone marrow. Thus, all suspect cases should be evaluated enzymatically to confirm the clinical diagnosis by measuring the acid sphingomyelinase activity in peripheral leukocytes, or cultured fibroblasts and/or lymphoblasts. Patients with type A or B disease will have markedly decreased levels of enzymatic activity (1% to 10% of normal), whereas patients with type C disease may have slightly decreased sphingomyelinase activities (50% to 75% of normal), and patients with Gaucher disease and other storage disorders presenting with hepatosplenomegaly and/or neurologic involvement will have normal or near-normal acid sphingomyelinase levels. Type C NPD can be documented biochemically by demonstrating the cholesterol transport defect in cultured fibroblasts or by determining the specific mutations in the NPC1 or NPC2 genes.

The enzymatic identification of type A and B carriers is problematic. However, in families in which the specific molecular lesion has been identified, family members can be accurately tested for heterozygote status by DNA analysis. Prenatal diagnosis of types A and B disease may be made reliably by measuring the acid sphingomyelinase activity in cultured amniocytes or chorionic villi. In families in which the specific gene mutations are known, the prenatal diagnosis can be made by DNA analysis of fetal cells. In type C disease, the cholesterol defect can be demonstrated by filipin staining, but DNA diagnosis using fetal cells is most accurate.

Treatment

Orthotopic liver transplantation in an infant with type A disease and amniotic cell transplantation in several type B patients have been attempted, with little or no success. Bone marrow transplantation of type B patients has reduced the spleen and liver volumes, the sphingomyelin content of the liver, the number of Niemann-Pick cells in the marrow, and the radiologic infiltration of the lungs. However, no long-term information is available, as these patients often lose their engraftment or have significant morbidity and mortality in the post-transplant period. To date, lung transplantation has not been reported in any severely compromised type B patient. Clinical trials of enzyme replacement therapy have begun for NPD type B. Treatment of types A and C disease is limited by the severe neurologic involvement.

WEB SITES

www.gaucherdisease.com

www.nnpdf.org

www.ninds.nih.gov/health_and_medical/disorders/niemann.doc.htm

REFERENCES

1. Brady RO, Kanfer JN, Bradley RM, Shapiro D. Demonstration of a deficiency of glucocerebrosidase in Gaucher's disease. *J Clin Invest* 1966;45(7):1112-1115.
2. Grabowski GA, Petsko GA, Kolodny EH. Gaucher disease. In: Valle D, Beaudet AL, Vogelstein B, et al., eds. The online metabolic and molecular bases of inherited disease-OMMBID. www.ommbid.com. New York: McGraw-Hill. 2010, Chapter 186.
3. Scott SA, Edelmann L, Liu L, Luo M, Desnick RJ, Kornreich R. Experience with carrier screening and prenatal diagnosis for 16 Ashkenazi Jewish genetic diseases. *Hum Mutat* 2010;31(11):1240-1250.
4. Charrow J, Esplin JA, Gribble TJ, et al. Gaucher disease: recommendations on diagnosis, evaluation, and monitoring. *Arch Intern Med* 1998;158(16): 1754-1760.
5. Mistry PK, Cappellini MD, Lukina E, et al. A reappraisal of Gaucher disease-diagnosis and disease management algorithms. *Am J Hematol* 2011;86(1):110-115.
6. Schuchman EH, Desnick RJ. Niemann-Pick disease types A and B: Acid sphingomyelinase deficiencies. In: Valle D, Beaudet AL, Vogelstein B, et al., eds. The online metabolic and molecular bases of inherited disease-OMMBID. www.ommbid.com. New York: McGraw-Hill. 2010, Chapter 144.
7. Patterson M, Vanier MT, Suzuki K, et al. Niemann-Pick disease type C: A lipid trafficking disorder. In: Valle D, Beaudet AL, Vogelstein B, et al., eds. The online metabolic and molecular bases of inherited disease-OMMBID. www.ommbid.com. New York: McGraw-Hill. 2010, Chapter 145.
8. Vanier MT. Niemann-Pick disease type C. *Orphanet J Rare Dis*. 2010;5:16.

Chapter 60 Langerhans Cell Histiocytosis

> Table of Contents > Part VI - Benign Disorders of Leukocytes, The Spleen, and/or Immunoglobulins > Chapter 60 - Langerhans Cell Histiocytosis

Chapter 60

Langerhans Cell Histiocytosis

Suman Malempati

H. Stacy Nicholson

Langerhans cell histiocytosis (LCH) is a disorder characterized by clonal proliferation of cells in the mononuclear phagocyte system. Since the first case was described more than a century ago,¹ LCH has often been a source of confusion, perhaps best demonstrated by the several labels given to the disorder during the past 100 years. Since 1985, Langerhans cell histiocytosis has been the preferred term,^{2, 3} replacing histiocytosis X, coined in 1953.⁴ The X demonstrated the lack of knowledge about the etiology and pathophysiology of LCH, and about how the different clinical syndromes were related. The term histiocytosis X did serve to bind the syndromes, which included Hand-Schuller-Christian syndrome, Letterer-Siwe disease, eosinophilic granuloma, Hashimoto-Pritzker syndrome,⁵ self-healing histiocytosis,⁶ and pure cutaneous

histiocytosis,⁷ into one clinical entity. The term Langerhans cell histiocytosis reflects the central role of the Langerhans cell in these diseases. LCH also distinguishes these disorders from other histiocytic syndromes, which include primary and secondary hemophagocytic lymphohistiocytosis, Rosai-Dorfman disease, and neoplastic disorders such as acute monocytic leukemia, malignant histiocytosis, and true histiocytic lymphoma.³ This chapter focuses on LCH.

HISTORY

The clinical triad of defects in membranous bone, exophthalmos, and polyuria in children, which became known as Hand-Schuller-Christian disease,⁸ was described in 1921 in a review by Hand.⁹ Hand described the first six reported cases, including those of Christian, Schuller, and his own first case reported in 1893.¹ All six patients had hepatosplenomegaly, lymphadenopathy, and bone lesions. However, not all had exophthalmos and polyuria. Attempts to link the disorder to xanthoma tuberosum, lipid storage disease, and the xanthomatoses proved unsuccessful, and to this day, no evidence exists that a specific biochemical defect is responsible for the condition. However, the foamy or xanthoma cell came to be regarded as a pathognomonic feature of the syndrome.¹⁰

A different syndrome, consisting of fever, bilateral otitis media, hepatosplenomegaly, and adenopathy in a young infant who died, was described by Letterer in 1924.¹¹ In 1933, Siwe described a 16-month-old girl who died after a 3-month illness characterized by fever, hepatosplenomegaly, lymphadenopathy, neutrophilia, and a destructive lesion in her fibula.¹² At autopsy, massive infiltrates of large cells resembling histiocytes were found. Siwe reviewed five other cases from the literature (including that of Letterer) and concluded that they constituted a single clinical entity.¹²

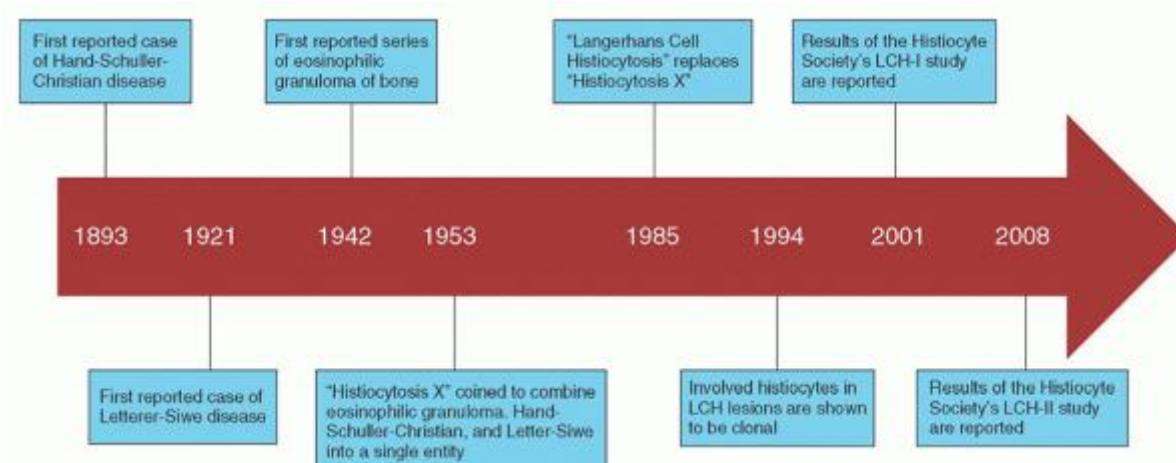

FIGURE 60.1. Historical timeline demonstrating the major discoveries regarding the pathogenesis and treatment of Langerhans cell histiocytosis (LCH).

In 1940, two groups of investigators described a syndrome in which a characteristic feature was infiltration of bone by eosinophilic granulomas.^{13, 14} In 1942, Green and Farber described a series of patients with eosinophilic granulomas of bone, which usually healed promptly after irradiation or curettage.¹⁵ They noted that these cases shared pathologic features similar to those of the Letterer-Siwe and Hand-Schuller-Christian syndromes. In 1953, because of the similarity of the histiocytes observed in these three disorders, Lichtenstein combined them into a single entity called histiocytosis X to indicate their unknown cause.⁴ The recognition that these three disorders were related was an important contribution. The term Langerhans cell histiocytosis, proposed in 1985, reflects an improved understanding of these disorders.³

Despite our understanding of the central role played by the Langerhans cells in LCH, little is known about the etiology of LCH. Although clinical features of LCH were first recognized over a century ago, the pathogenesis remains uncertain. In 1994, two separate groups detected clonality of the involved histiocytes from LCH lesions.^{16, 17} Clonality was demonstrated in LCH cells from unifocal lesions as well as disseminated disease. However, debate continues as to whether LCH represents a neoplastic disorder or a reactive proliferation of histiocytes (Fig. 60.1).

EPIDEMIOLOGY

Although estimates vary by region and time period, the annual childhood incidence of LCH has been estimated to be approximately 4 to 9 cases per million.^{18, 19, 25} The discrepancy between epidemiologic studies is likely due to variation in reporting and data collection. Across studies, there is consistently a slight

predominance of cases in males.^{18, 19, 20} LCH occurs less frequently in adults with an incidence of 1 to 2 cases per million per year.²¹ The disease is more common and tends to be more severe in younger children. For children under 1 year of age, the annual incidence is 9.9 cases per million.²² Almost all cases of multisystem LCH occur before 5 years of age.^{23, 24, 25} In an exploratory case-control study comparing 177 children with LCH to children with cancer and community controls,²⁰ LCH was associated with a family history of benign tumors and less strongly with feeding problems during infancy. Other factors associated with LCH in this study were maternal urinary tract infections during pregnancy and blood transfusions during infancy. Factors not associated with LCH were the typical childhood viral infections and medication use. In a case-control study of 459 children with LCH, which compared risk factors in children with LCH to those in both community and cancer controls,²⁶ LCH was associated with neonatal infections, solvent exposure, and thyroid disease in the proband or the family. Childhood immunizations appeared to be protective. Reports of seasonal variation in incidence are conflicting.^{18, 25} Familial clustering of LCH has been observed, suggesting that a genetic predisposition may exist.²⁷ The concordance rates between dizygotic and monozygotic twins are 33% and 80%, respectively. In addition, patients with LCH may have a predisposition to cancer and vice versa. Links with both solid tumors and leukemia have been documented.²⁸ Several cases of LCH developing in patients with acute lymphoblastic and acute myelogenous leukemia have been reported.^{29, 30, 31, 32} Patients with LCH have genetic instability and increased chromosomal breakage, which also suggests a genetic predisposition to malignancy.^{33, 34, 35}

PATHOLOGY AND PATHOPHYSIOLOGY

The basic histologic lesion in LCH is granulomatous, with lesions containing histiocytes, mature eosinophils, and lymphocytes.³⁶ Other cells present may include giant cells, neutrophils, and plasma cells. Initially, lesions are proliferative and dominated by histiocytes, some of which are Langerhans cells. Although mitotic figures may occasionally be identified, the histiocytes are not neoplastic by histologic criteria. As lesions progress, necrosis may develop, and the number of eosinophils and phagocytic cells containing cellular debris increases. Ultimately, xanthomatous changes and fibrosis may occur, and late in the course of disease, Langerhans cells may no longer be demonstrable. Multinucleated giant cells occasionally are prominent, especially in bone and lymph nodes. The histologic findings do not correlate with the extent or aggressiveness of disease.³⁷

The Langerhans cell is the sine qua non of the diagnostic lesion. Langerhans cells are dendritic antigen-presenting cells that are normally found in skin and other organs. Langerhans cells are classified as dendritic cells because of their capacity to form long cytoplasmic extensions through which they establish intimate contact with other cells. The presence of fascin, a highly selective marker of dendritic cells, on the surface of Langerhans cells confirms their derivation from dendritic cells.³⁸ Langerhans cells are found primarily in normal epidermis, but also are evident in lymph nodes and spleen. A hematopoietic progenitor of Langerhans cells has been identified in normal bone marrow.³⁹ In the skin, Langerhans cells form a trap for external contact antigens and are involved in delayed hypersensitivity. Despite low phagocytic activity, they fix antigens for presentation to other cells, especially T lymphocytes.⁴⁰

Although its demonstration is essential for diagnosis, the Langerhans cell may constitute no more than a small proportion of histiocytes within lesions. Viewed by light microscopy, these cells appear as large mononuclear cells with few cytoplasmic vacuoles and little or no phagocytic material.⁴¹ The nuclei are irregularly shaped and contain a fine chromatin pattern. Electron microscopic or immunohistochemical studies may be required to identify Langerhans cells with confidence. The former demonstrate structures known as Birbeck granules (Langerhans bodies, X granules),⁴² rod-shaped organelles with a central striation and occasional terminal vesicular dilation, giving them a tennis racket appearance (Fig. 60.2). Birbeck granules are thought to be produced by invagination of the cell membrane, and their function is not known. The other feature that conclusively establishes the diagnosis of LCH is the demonstration of either CD1a antigen or CD207 (Langerin) on the surface of LCH cells by immunohistochemical staining.^{36, 43} Langerin is a cell-surface receptor that induces the formation of Birbeck granules.⁴⁴ Langerin expression has recently been recognized as a sensitive and relatively specific marker in establishing the diagnosis of LCH. Other distinctive features of Langerhans cells that can be demonstrated with immunohistochemical techniques include the expression of S-100 protein,⁴¹ Ia-like antigen,⁴⁵ and CD101.⁴⁶

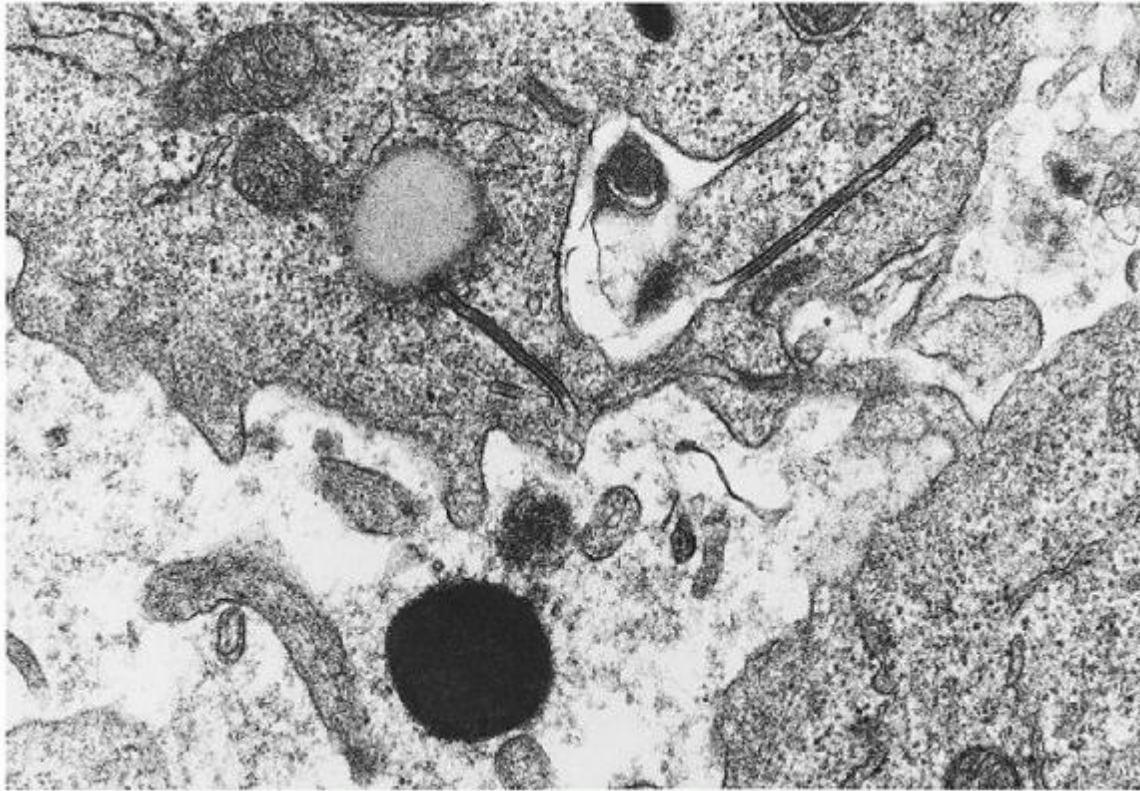

FIGURE 60.2. Electron micrograph of Langerhans cells from a bone lesion demonstrating characteristic Birbeck granules with a trilaminar structure. (Magnification $\times 45,000$; courtesy of Roma Chandra.)

The intralesional histiocytes of LCH were previously thought to be similar to normal Langerhans cells found in skin. However, it is now recognized that pathologic Langerhans cells or LCH cells are a less differentiated and more activated type of dendritic cell.⁴⁷ CD1a-positive LCH cells from bone lesions express CD14 and CD68, monocyte antigens that are not expressed or are expressed at low levels in normal skin Langerhans cells.⁴⁸ A recent study demonstrated a gene expression profile of intralesional LCH cells that was distinct from that of normal skin Langerhans cells.⁴⁹ LCH cells also express the immature dendritic cell marker CCR6 in the absence of CCR7, which is expressed on mature dendritic cells.⁵⁰ LCH cells exhibit a degree of migration capability, which is absent in mature dendritic cells. LCH cells can be induced to differentiate in the presence of CD40 ligand *in vitro*.⁴⁸ However, as CD40 ligand is abundant in LCH lesions, the reason for maturational arrest is unclear.⁵¹ Abnormal cellular adhesion molecules in LCH cells, suggested by the presence of CD2, CD11a, CD11b, and CD11d, may contribute to the migration of Langerhans cells into LCH lesions, as well as their abnormal persistence and proliferation.⁵² Compared to normal Langerhans cells, LCH cells are defective in their alloantigen-presenting activity.⁵³

The focal accumulation of Langerhans cells, macrophages, lymphocytes, and eosinophils suggests that LCH is immunologically mediated. This reasoning is supported by both histologic abnormalities of the thymus and disturbances of immunoregulation in patients with active disease.⁵⁴ Thymic abnormalities were noted by Letterer in his initial description of the disorder, later known as Letterer-Siwe disease.¹¹ Abnormalities noted on pre-therapy biopsy samples and postmortem materials include dysmorphic

P.1309

changes, dysplasia, and nonspecific involution.^{55, 56, 57} In patients with LCH, the number of normal thymocytes (expressing CD6) and late differentiating suppressor lymphocytes (expressing CD8) is decreased.⁵⁸ These abnormalities are noted even when the disease is limited in its distribution.

Recognition of the possible pathogenic significance of thymic abnormalities prompted several studies of T lymphocytes in blood. The demonstration of decreased numbers of H2 receptors on blood lymphocytes suggested loss of T-suppressor cells.⁵⁹ This loss was confirmed by quantitation of T-cell subsets in patients with active disease. Both the relative and absolute numbers of suppressor T lymphocytes (CD8⁺ cells) are decreased, resulting in an increase in the T4-to-T8 ratio.

Suppressor cell activity as measured by the concanavalin A and indomethacin stimulation assays also is poor.⁵⁹ That T-suppressor cell deficiency may be causally related to a functionally abnormal thymus is suggested by the normalization of T4-to-T8 ratios with thymic extract.⁵⁷ Moreover, the apparent ability of crude thymic extract to reverse disease activity in some patients suggests that the T-cell abnormalities may be of primary pathogenic significance.⁵⁷

Although less consistent, other abnormalities in immune regulation also have been described, including hypergammaglobulinemia,⁶⁰ deficiency in antibody-dependent monocyte-mediated cytotoxicity,⁶¹ and abnormal in vitro response to mitogens and antigens.⁵⁵ However, most investigators note normal mitogeninduced responses and normal delayed hypersensitivity.⁶² Also, several cytokines are increased in LCH.^{63, 64} Cytokines serve as mediators of inflammation, regulators of lymphocyte growth and differentiation, and activators of specialized effector cells. In tissue culture, Langerhans cells purified from bony LCH lesions secrete interleukin-1 (IL-1) and prostaglandin E2, both of which induce bone resorption in vitro.⁶⁵ These lesions also secrete angiotensinconverting enzyme, transforming growth factor-β1 and IL-2.⁶⁶ These mediators are probably responsible for the osteolytic lesions that are a prominent clinical feature of LCH. Other cytokines that have been demonstrated to be increased in the serum of LCH patients include granulocyte-macrophage colony-stimulating factor (GM-CSF), IL-3, IL-8, IL-10, and tumor necrosis factor-α.⁶⁷ These cytokines are related to local activation of T lymphocytes and other inflammatory leukocytes. In addition, GM-CSF receptors are expressed by Langerhans cells.⁶⁸ GM-CSF induces Langerhans cell proliferation and activation in vitro, and serum levels of GM-CSF have been correlated with the extent of disease.⁶⁸

The link between proliferation of Langerhans cells and immune dysfunction has not been worked out entirely. One suggestion is that the disorder results from a physiologically appropriate response of the Langerhans cell to an external antigen or neoantigen, possibly infectious in origin. However, the lack of seasonal variation or geographic clustering argues against an infectious basis. In addition, no direct evidence for a viral etiology (viral particles or nuclear material) in LCH lesions has been demonstrated.^{69, 70} Alternatively, LCH may result from an appropriate response of the Langerhans cell to abnormal signals from other cells in the immune system, perhaps from T lymphocytes. In either event, deficiency of T-suppressor cells may disrupt the mechanism for termination of immune responses. Failure of this homeostatic mechanism could result in unrestrained macrophage proliferation. Patients with interferon-γ deficiency present with findings that mimic LCH.⁷¹

TABLE 60.1 SYSTEMS AFFECTED ON DIAGNOSIS OF LANGERHANS CELL HISTIOCYTOSIS BY AGE

Age Group	Number	Multisystem Disease (%)	Percentage of Cases with Each System Affected on Diagnosis							
			Bone	Skin	Soft Tissue	Lymph Nodes	Liver/Spleen	Lung	Ear	Other
<1	25	64	32	76	24	24	28	16	36	8
1-4	52	71	69	35	27	21	17	31	13	4
5-14	24	17	100	0	8	8	0	0	4	0
0-14	101	56	67	37	22	19	16	20	17	4
<i>p</i> Value ^a		<0.001	<0.001	<0.001	0.19	0.32	0.02	0.003	0.01	0.54

^a*p* Value for proportion of cases with involvement of each system varying by age group.

From Alston RD, Tatevossian RG, McNally RJ, et al. Incidence and survival of childhood Langerhans cell histiocytosis in Northwest England from 1954 to 1998. *Pediatr Blood Cancer* 2007;48:555-560, with permission.

Whether LCH is primarily a reactive or neoplastic process has long been debated. The predominant theory has been that LCH is a reactive process to an unknown stimulus.⁷² However, in 1994 two groups showed that the lesional cells are clonal^{16, 17}; clonality occurred in patients with all forms of LCH, including acute disseminated LCH and unifocal LCH, and in those with intermediate forms of the disease. T-cells within LCH lesions were polyclonal.¹⁶ Interestingly, LCH occurs in some individuals with malignant disorders.²⁸ Most cases of malignancy occur after treatment for LCH, although acute lymphoblastic leukemia, in particular, may precede the diagnosis of LCH.^{31, 32} The presence of chromosomal instability and mutational events reported in a few studies support a neoplastic process.^{34, 35} However, at least some cases of pulmonary LCH are not clonal.⁷³ Moreover, the immature phenotype of LCH cells appears dependent on the microenvironment,

suggesting a reactive process. Therefore, although the clonality of LCH cells has fueled the argument that LCH may be a neoplastic disorder, the debate continues.

CLINICAL FEATURES

LCH can present along a continuum of illness, ranging from indolent to explosive disease. In some patients, pathologic lesions are solitary, whereas in others they are widely disseminated. Moreover, the distribution of lesions in a given patient may vary considerably over time. Although LCH can occur at any age, it occurs with greatest frequency in infants and children. The median age at diagnosis for all disease variants is 3 to 6 years.^{18, 19} The acute disseminated form of the disease characteristically occurs in younger children and almost all cases occur before the age of 5 years.²⁵ Children younger than 1 year old, in particular, often present with multiple organ involvement.^{22, 74} The more indolent forms of LCH occur primarily in older children and young adults.⁷⁵ Approximately 70% of cases of LCH in children involve a single organ system, with bone being the most common site.^{18, 19, 22, 25} Table 60.1 shows the distribution of involved sites

P.1310

by age at diagnosis of LCH. The most commonly involved organ in adults is bone, often accompanied by an adjacent soft tissue mass.^{76, 77} Other organs that are involved less often in adults include the lungs and pituitary gland.⁷⁶ In adults, multisystem disease, including liver, lymph node, and bone marrow involvement, is extremely rare.

The traditional classification of clinical variants was based on patterns of organ involvement.⁸ Eosinophilic granuloma was used to describe a syndrome characterized by single or multiple bone lesions in the absence of visceral involvement.¹³ When granulomas involved the liver, spleen, lymph nodes, skin, central nervous system (CNS), or bone marrow as well as bones, the disorder was called Letterer-Siwe disease.^{11, 12} The triad of multiple bone lesions, exophthalmos (resulting from retro-orbital granulomas), and diabetes insipidus (DI; the result of hypothalamic or pituitary involvement) constituted Hand-Schuller-Christian disease (Figs. 60.3 and 60.4).⁹ The separation of eosinophilic granuloma of bone from syndromes characterized by visceral dissemination proved to be useful prognostically. However, the distinction between Letterer-Siwe disease and Hand-Schuller-Christian disease was often subtle and clinically irrelevant. The current classification is based on the number of organ systems involved and the number of sites involved within an organ system.^{23, 78} The main classifications of disease are unifocal eosinophilic granuloma (i.e., single-system, single-site disease, usually in bone), multifocal eosinophilic granuloma (i.e., single-system, multiplesite disease, usually in bone), and acute disseminated histiocytosis (i.e., multisystem disease). The presence and degree of organ dysfunction are important distinctions in those with multisystem disease.⁷⁸

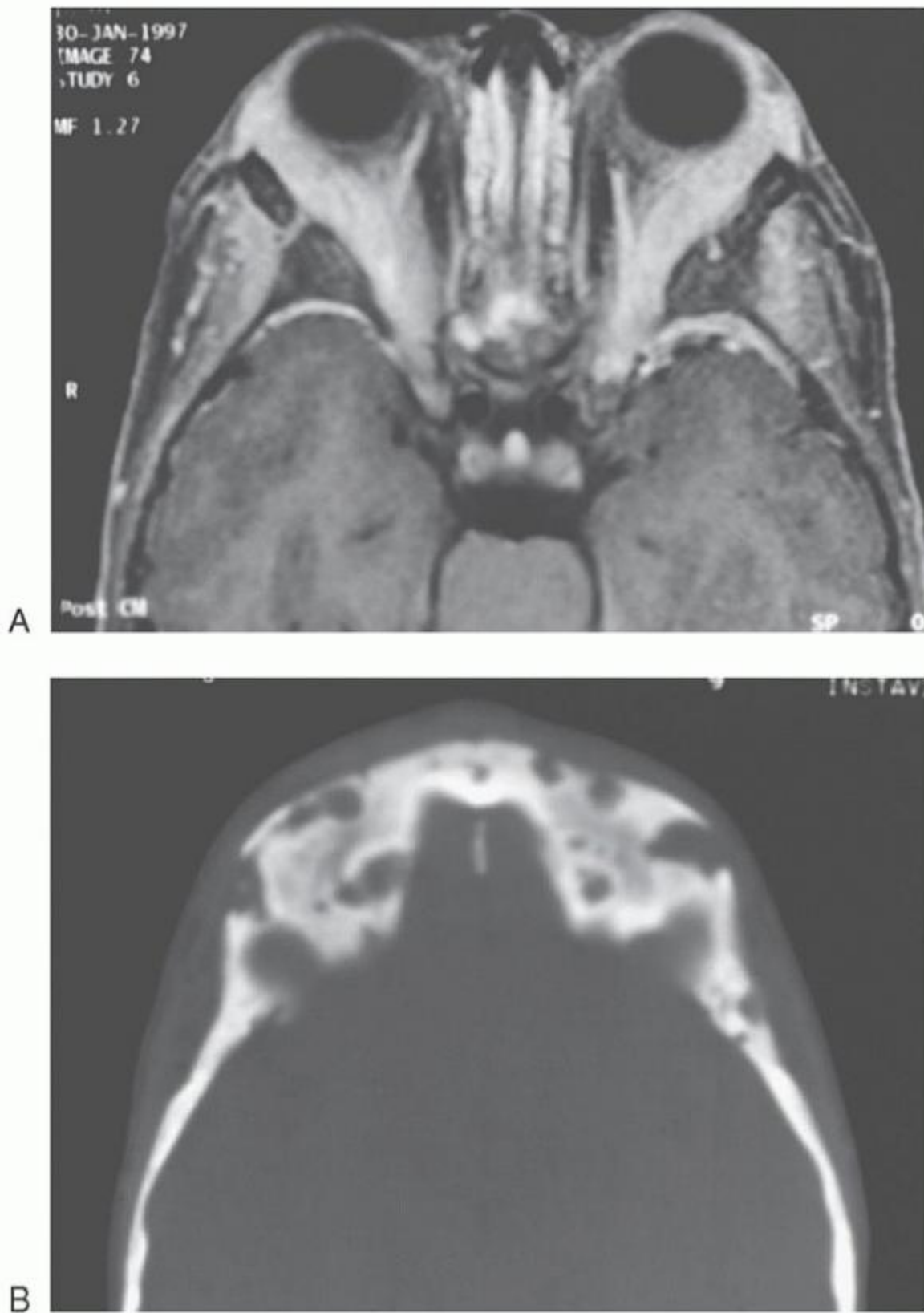

FIGURE 60.3. A: Axial magnetic resonance image of the orbits in a 4-year-old boy with recurrent disseminated Langerhans cell histiocytosis and marked proptosis. There are large orbital soft tissue masses bilaterally. B: Computed tomography scan of the same patient showing marked bony erosion of skull and orbit.

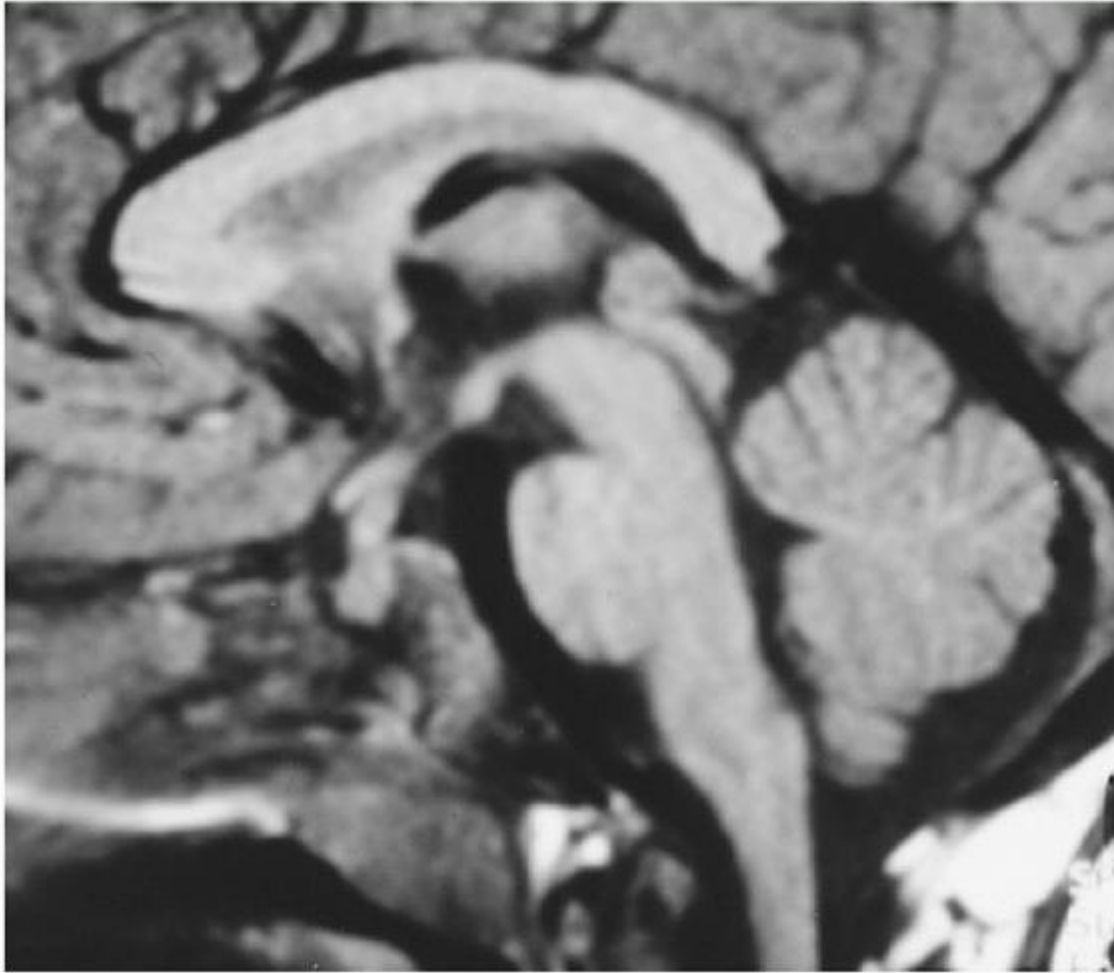

FIGURE 60.4. Sagittal magnetic resonance imaging scan showing thickened pituitary stalk in the same patient shown in Figure 60.3. He had a long-standing history of diabetes insipidus.

Bone is the most commonly involved organ, with the skull being the most commonly involved site in both children and adults.^{79, 80} Unifocal eosinophilic granuloma of bone is the most common form of the disease.^{10, 81} Multifocal bone involvement may or may not be associated with visceral disease. Characteristically, patients note mild discomfort at the site of bone involvement. However, skull lesions are often painless and are found only because of a soft tissue mass over the bony defect. In young children, multifocal lesions of the skull are often associated with other head and neck manifestations. Gingival swelling and inflammation, usually associated with cervical adenopathy, may be the first manifestations of disease. Premature eruption or loss of teeth and breakdown of the lower alveolar ridge result from involvement of the mandible.⁸² Mandibular lesions may be palpable and painful, giving rise to facial swelling.⁸³ The maxilla and upper gingival ridge are involved less often. Involvement of the Petrous ridge of the temporal bone and mastoid is common, predisposing to chronic otitis media. Vertebral lesions pose special problems because of the risk of injury to the spinal cord. Vertebral collapse gives rise to vertebral plana (Fig. 60.5). Extension of granulomas into the spinal space may compress the cord, causing permanent neurologic damage. Recurrent bony lesions in children, particularly those involving the craniofacial region, are often associated with DI.^{84, 85}

Radiographically, skeletal lesions are characterized by sharply demarcated rarefactions of the medullary portions of bone, producing a “punched out” appearance (Fig. 60.6).^{79, 81} Reactive sclerosis in surrounding uninvolved bone is unusual at diagnosis, but when present, signifies that healing has begun. As healing occurs, the sharp endosteal margins become less distinct, and sclerosis is often seen. Both tables of the skull characteristically are involved, the outer more so than the inner. Erosion of mandibular bone around unerupted teeth gives them the appearance of floating in space. Skeletal lesions are well delineated with conventional radiography, computed tomography, and magnetic resonance imaging.⁸⁶ The relative benefit of radionuclide bone scintigraphy, on the other hand, is controversial.^{87, 88, 89} Radionuclide bone scans

often are falsely negative for skull lesions, but may be more sensitive in identifying lesions in the ribs, spine, and pelvis.^{90, 91}

P.1311

Positron emission tomography (PET) may have greater specificity in identifying active osseous lesions, but its clinical utility in LCH requires further study.^{92, 93}



FIGURE 60.5. Sagittal magnetic resonance image of the thoracic spine showing collapse of the T8 vertebral body, more prominent in the anterior aspect, in a patient with reactivation of Langerhans cell histiocytosis.

Skin involvement occurs in about one third of patients overall.^{22, 25} Although skin manifestations are seen in only 10% of patients with single-system disease, it is a much more common feature of acute disseminated histiocytosis.^{81, 94} Even in

those with skin-only disease, the rate of progression to multisystem disease is 30% to 40%.⁹⁵ The skin lesions are typically vesiculopustular and may have a hemorrhagic crust. They are similar in appearance to those of seborrheic dermatitis. LCH is often suspected after a seborrheic rash fails to respond to treatment. The rash has a predilection for the scalp, postauricular areas, and diaper area (Fig. 60.7). The back, axillae, and intertriginous areas also may be involved.⁹⁴ With advanced stages of the disease, the entire integument may be affected. Breakdown of severely affected areas is common, and concurrent thrombocytopenia imparts a hemorrhagic component to the rash.



FIGURE 60.6. Skull radiograph showing active osteolytic lesions in a patient with disseminated Langerhans cell histiocytosis. Note absence of reactive sclerosis.

A rash indistinguishable from that seen in acute disseminated histiocytosis may occur as a congenital, self-limited phenomenon not associated with skeletal or visceral disease. This form of histiocytosis has been called congenital self-healing histiocytosis or Hashimoto-Pritzker syndrome.^{5, 96} The lesions are present at birth or appear within the first 2 or 3 weeks of life. They are most numerous over the scalp and face, but also may extend over the trunk and proximal extremities. Mucous membranes are spared. Langerhans cells present in biopsy material have the same immunophenotypic characteristics as those in the other variants of histiocytosis, although they contain fewer Birbeck granules.⁹⁶ The lesions typically undergo spontaneous regression, with complete healing by the time the patient is 3 to 4 months of age. The prognosis is generally excellent without therapy, although occasionally isolated cutaneous LCH in infants can progress to multisystem disease.⁹⁷

Increasingly appreciated as a problem in LCH, CNS involvement^{98, 99} occurs by contiguous spread of skull lesions into brain substance or by granulomatous infiltration of deep structures. The disease demonstrates a predilection for the hypothalamic nuclei¹⁰⁰ and cerebellum,^{101, 102} although focal lesions may occur in the temporal lobe, occipital lobe, and spinal cord. Rarely, CNS

P.1312

lesions are found in patients who have no other evidence of histiocytosis. Neurologic signs and symptoms include ataxia, nystagmus, dysmetria, seizures, dysphagia, cranial nerve deficits, and spastic paraparesis.¹⁰³ DI resulting from infiltration of the hypothalamus or pituitary stalk is common.¹⁰⁴ Whereas mass lesions are satisfactorily visualized by computed tomography or magnetic resonance imaging, infiltrative lesions within the hypothalamus and elsewhere often are of similar density to adjacent brain tissue and produce little or no mass effect. Some of these lesions may be seen with magnetic resonance imaging.⁹⁸ CNS involvement may leave survivors with permanent sequelae.^{98, 84}



FIGURE 60.7. Erythematous maculopapular rash in a boy with disseminated Langerhans cell histiocytosis. (From Esterly NB, Maurer HS, Gonzalez-Crussi F. Histiocytosis X: A seven year experience at a children's hospital. *J Am Acad Dermatol* 1985;13:481-496, with permission.)

Of the endocrinopathies associated with LCH, DI is the most common.¹⁰⁵ LCH is a common cause of DI in both adults and children.¹⁰⁶ DI is caused by infiltration of the hypothalamus, pituitary stalk, or posterior pituitary by Langerhans cells. The

prevalence of DI in large series of patients ranges from 10% to 50%.^{84, 85, 105, 106, 107, 108, 109} In a study of 1,741 children with LCH, the cumulative risk of DI was 20% at 15 years from diagnosis.⁸⁵ DI is more common in patients with multisystem disease and in those with proptosis.¹⁰⁹ Patients with multiple craniofacial bone lesions are also at increased risk.⁸⁵ DI is not typically a complication of unifocal bone disease not involving the skull. Characteristically, the onset of DI is after the diagnosis of LCH is made. Symptoms of DI occur at or preceding the diagnosis of LCH in only about one third of patients.⁸⁴ However, LCH should be considered in the differential diagnosis in patients who present with central DI.¹⁰⁶ In such cases a thickened pituitary stalk seen on MRI may be the only radiographic manifestation (Fig. 60.4).¹¹⁰ For most children, symptoms occur within 2 years of diagnosis and rarely, if ever, after 4 to 5 years.^{109, 111} Although most affected patients have complete absence of antidiuretic hormone, partial deficiency may occur. Progression from partial to complete DI may occur, and once complete DI has developed, it cannot be reversed. Whether systemic chemotherapy for LCH may prevent the development of DI is unclear. However, more rapid response to therapy and shorter disease duration corresponds to a decreased incidence of DI.⁸⁵ Reactivation of disease after complete resolution is associated with an increased risk of DI.⁸⁵

Neurodegenerative disease is the next most common CNS consequence of LCH after DI.¹¹² The typical MRI findings are diffuse, symmetrical signal changes of variable intensity in the basal ganglia or cerebellum (Fig. 60.8).^{113, 114} Patients with LCH-associated neurodegenerative disease demonstrate variable manifestations of disease. Some patients have no neurologic signs or symptoms, whereas others may have significant neurologic effects. Clinical signs may include tremor, ataxia, spasticity, dysarthria, and behavioral or psychiatric problems. The time course of disease progression is also variable, but neurologic deterioration may be severe and devastating. Histologic evaluation of neurodegenerative lesions show a T-cell mediated inflammatory process with tissue degeneration, and most importantly, absence of CD1a-positive cells.¹¹⁵

Growth retardation resulting from growth hormone (GH) deficiency is another complication of LCH.^{105, 108} GH deficiency occurs in approximately 10% of patients with LCH overall and up to 60% of patients with LCH-associated DI.^{84, 116} Loss of GH, along with deficiency of other anterior pituitary hormones, is usually due to involvement of the hypothalamus or anterior pituitary by Langerhans cells.¹¹⁶ GH replacement has been shown to be safe and effective in children with LCH and GH deficiency.¹¹⁷

Thyroid involvement by histiocytosis gives rise to goiter and may lead to hypothyroidism.¹⁰⁸ Obstruction of the upper airway by diffuse enlargement of the thyroid gland has been described.¹¹⁸ Most children with thyroid involvement have DI and other evidence of disseminated disease.¹⁰⁵

Enlargement of the liver, often associated with abnormal liver function, is observed in many children with the disseminated form of LCH.^{119, 120, 121} In some patients, liver involvement leads to portal cirrhosis or intrahepatic cholestasis.¹²¹ Tissue from liver biopsies obtained from children with hepatomegaly infrequently shows the infiltrates of Langerhans cells, eosinophils, and lymphocytes that are hallmarks of the disease in other organs. Instead, subtle changes in the portal triads are observed, including triaditis, bile duct proliferation, and fibrosis.¹²² Patients with triaditis alone at diagnosis are less likely to have abnormal liver function or progressive liver disease than those with fibrohistiocytic or cirrhotic changes. Persistent abnormality of liver function is a wellrecognized adverse prognostic indicator.¹²³

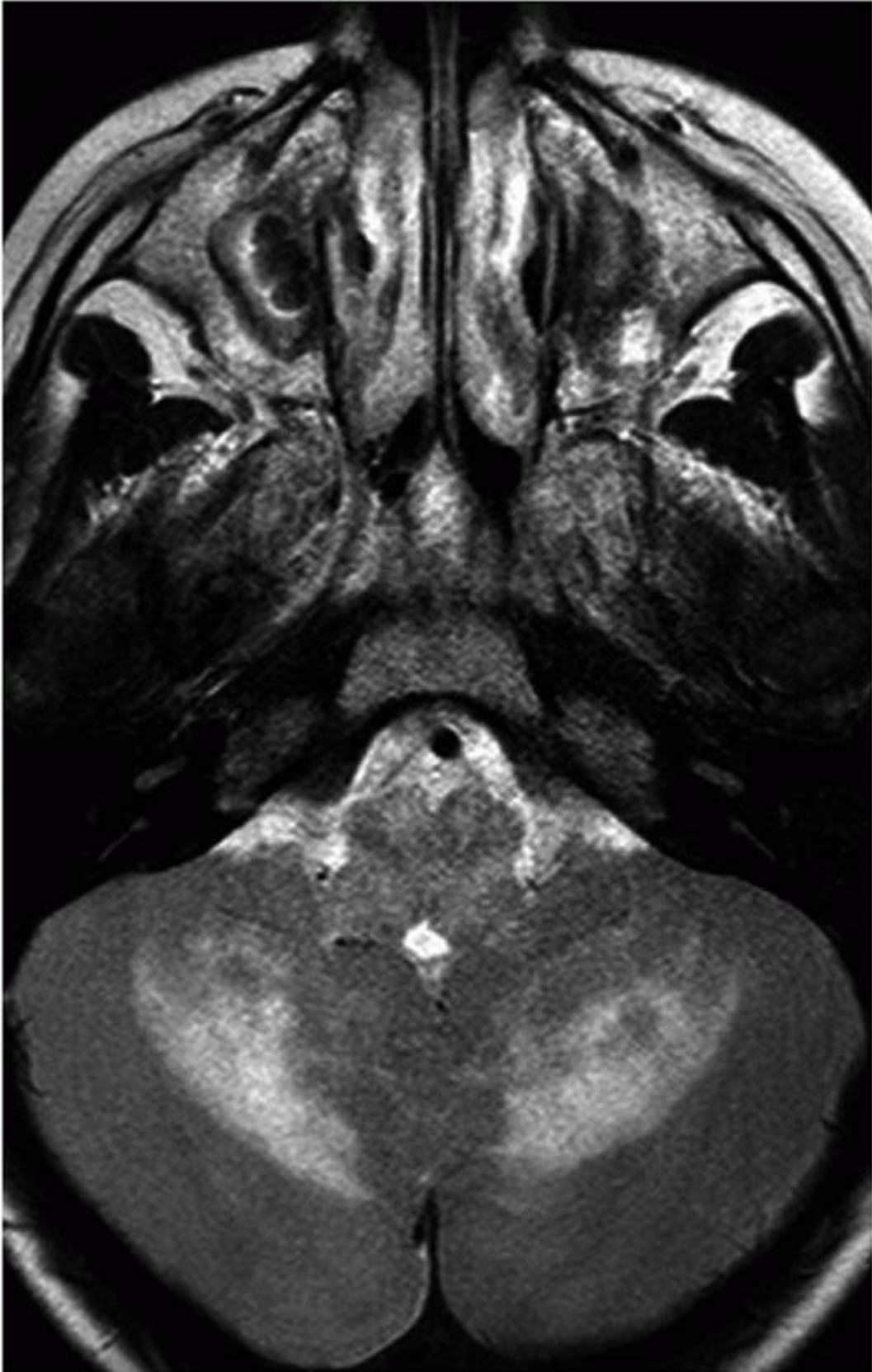

FIGURE 60.8. Axial magnetic resonance imaging scan showing diffuse bilateral signal abnormality in the cerebellum in a patient with neurodegenerative Langerhans cell histiocytosis.

Involvement of lymph nodes and spleen is often a feature of disseminated disease.²³ Lymph nodes may be involved because of contiguous bone or skin disease or as a result of widespread histiocytic dissemination. Splenomegaly is caused by portal hypertension or involvement of the spleen by large numbers of histiocytes. Curiously, Birbeck granules are rarely seen in otherwise characteristic Langerhans cells in the spleen and liver.^{41, 42}

Although not common, the lungs may be involved with disseminated histiocytosis.¹²⁴ As with other forms of disseminated disease, lung involvement occurs primarily in infants and young children. In contrast, primary pulmonary histiocytosis is principally a disease of young and middle-aged adults,^{125, 126, 127, 128, 129} although it does occur in children.^{130, 131} Smoking is often associated with pulmonary LCH.^{132, 133} Affected patients are without

P.1313

apparent multisystem disease at diagnosis; with further evaluation, however, some patients have asymptomatic bone lesions,¹³⁰ and as many as 10% subsequently develop DI.¹³⁴ Signs and symptoms of pulmonary involvement may be subtle or may include growth failure or weight loss, dyspnea, tachypnea, and hemoptysis. Recurrent pneumothoraces occur in as many as 20 to 25% of cases.¹³⁵ Lung involvement is characterized radiographically by diffuse micronodular densities with cyst formation, sometimes giving rise to a picture of "honeycomb lung." Lesions are usually prominent in the perihilar regions and the upper lung fields. Costophrenic angles are usually spared, and enlargement of hilar nodes is unusual. Permanent pulmonary sequelae often occur,¹³⁶ and reactivation in the lungs may be associated with smoking.¹³³

Bone marrow involvement by Langerhans cells has been described most often in infants with disseminated disease.^{23, 24, 137} It is characterized by anemia, neutropenia, and thrombocytopenia, occurring singly or together. Erythrophagocytosis may rarely be a factor in the pathogenesis of anemia.¹³⁸ Because bone marrow and splenic involvement often occur together, splenic sequestration of blood cells may further exaggerate the cytopenias of bone marrow involvement.

DIAGNOSIS

The clinical and radiographic features of LCH are distinctive enough to suggest the diagnosis in most patients. However, the diagnosis must be made pathologically, and for a definitive diagnosis, the presence of Birbeck granules or the presence of Langerin and/or CD1a on the surface of LCH cells must be demonstrated.¹³⁹

Assessment of the extent of disease is critical. To help standardize the workup and management of LCH patients, the Histiocyte Society has published guidelines on how to evaluate and follow patients.¹⁴⁰ A thorough physical examination is necessary to evaluate for hepatomegaly or splenomegaly, lymphadenopathy, and any bone or soft tissue masses. Bony lesions may be diagnosed by either bone scan or skeletal survey. Each modality has been shown to discover lesions missed by the other. However, radionuclide bone scan may miss osteolytic lesions that do not have any osteoblastic characteristics. This is particularly true for skull lesions.^{90, 91} Other studies required include a chest radiograph, complete blood count, assessment of liver function, and determination of renal concentrating ability. A bone marrow examination is required if cytopenias exist, and a high-resolution chest CT scan may be necessary if signs and symptoms suggest pulmonary involvement.¹³¹ Although not required to evaluate disease, some authors have recommended studies of T- and B-cell numbers, T-cell subsets, and lymphocyte function. New imaging modalities, including PET and octreotide scans, may be useful in LCH, but they require additional study.^{93, 141, 142}

TABLE 60.2 OUTCOME DATA

Group	No Reactivation or Progression	Progression	Reactivation	4-Year Event Free Survival Death (%)	
Single bone (n = 48)	46	0	2	0	89.7
Multiple organ All (n = 34)	10	7	17	7	24
Age < 1 y (n = 19)	5	6	8	7	22
					Multiple bone (n = 261) 130 58.1 40)

From Jubran RF, Marachelian A, Dorey F, et al. Predictors of outcome in children with Langerhans cell histiocytosis. *Pediatr Blood Cancer* 2005;45:37-42, with permission.

Several staging or scoring systems have been proposed as having prognostic and therapeutic relevance. Most cite age (age younger than 2 years being a liability), extent of disease, and the function of involved organs as the important prognostic variables.^{23, 24, 143} An important distinction made by the Histiocyte Society and proven to be highly prognostic is whether "risk" organs are involved. "Risk" organs are the hematopoietic system defined as at least two cytopenias (with or without documented bone marrow involvement), spleen, liver, and lungs. The presence of "CNS-risk lesions" results in a higher risk of developing DI. CNS-risk lesions are those involving the craniofacial bones, particularly those around the eyes, ears, and oral cavity.⁸⁵ The Histiocyte Society also recognizes "Special Sites" as being bone lesions that are located in critical anatomic sites in which lesions may cause immediate morbidity. Examples include the odontoid peg and vertebral lesions with intraspinal soft tissue extension. Stratification for treatment is defined based on these parameters. Patients are divided into those with single-system LCH or multisystem disease. Patients with multisystem disease with or without risk organ involvement and those with single-system disease and either CNS-risk, multifocal bone lesion, or special site lesions are candidates for systemic therapy.

PROGNOSIS

For most patients with LCH, the prognosis is excellent. Although LCH may wax and wane over many years, most patients improve over time. However, patients with multisystem disease may experience organ failure, which can be fatal. Outcome by single bone, multiple bone, and multiple organ involvement are shown in Table 60.2.

Most patients with unifocal bone disease experience complete resolution of lesions with or without treatment. Progression of bone erosion and recurrences at new sites are the exception rather than the rule.¹⁴⁴ In a study of 48 patients with single bone involvement, the recurrence rate was 8% and no deaths were reported.⁷⁴ In contrast, disease that is multifocal at the time of diagnosis is often characterized by one or more recurrences after disease control.^{74, 80} Patients with multiple bone lesions, particularly those with skull involvement, have a much higher incidence of disease reactivation than those with single bone lesions.⁷⁴ In addition, most patients with multiple organ involvement will experience disease recurrence. In one large series, 72% of patients with multisystem disease who initially responded to treatment experienced recurrent LCH from 2 months to more than 5 years after cessation of therapy, and most recurrences were in previously uninvolved sites.⁷⁵ Young children, especially those younger than 2 years of age at diagnosis, are at particular risk for multiple relapses. However, in most patients the disease appears to eventually burn out.^{145, 146}

P.1314

Despite the favorable prognosis for most patients, mortality from disease progression can occur. Approximately one third of adults with pulmonary LCH die from the disease.¹²⁸ The highest incidence of mortality, however, is seen in children with involvement of the liver, lungs, hematopoietic system, or spleen at diagnosis ("risk" organs as defined by the Histiocyte Society).¹⁴⁰ A 5-year survival rate of only 25% has been reported in children with liver or spleen involvement at diagnosis.⁷⁵ In a series of 18 patients with "risk" organ involvement, 7 died after either disease progression or recurrence.⁷⁴ In contrast, in two separate studies, all patients 2 years of age or older without "risk" organ involvement survived.^{78, 146} After disease resolution, LCH survivors may be left with permanent complications, including DI, pulmonary difficulties, neurologic complications, orthopedic abnormalities, neuropsychological impairment, dental problems, chronic otitis, or hearing impairment.^{72, 84, 145} Patients with one or more reactivations after initial therapy are more likely to have long-term sequelae from LCH.¹⁴⁷

MANAGEMENT AND TREATMENT

Management is dictated by the likely natural history of the disease based on the location and extent of lesions and by the presence of specific organ involvement and/or dysfunction. Given that LCH tends to improve with time, most patients do not require treatment aimed at ablating the disease. In most patients, disease manifestations are reversed with therapy that is far less intensive than that used for neoplastic disease. As noted previously, multiple courses of treatment may be required for recurrences. DI is not ameliorated by chemotherapy. Although some authors describe reversal of DI with radiotherapy directed to the hypothalamus-pituitary region soon after the onset of symptoms,¹⁴⁸ the consensus is that radiotherapy, like chemotherapy, is without benefit in this situation.^{108, 149}

Treatment decisions should be based on the number of systems involved and on whether a particular lesion is likely to result in disability. Children with single-system disease, particularly if they have a solitary lesion of bone (e.g., eosinophilic granuloma of bone), may require no therapy other than curettage.¹⁴⁴ However, some patients have aggressive disease, warranting treatment with multiagent chemotherapy.¹²³ In addition, multiple courses of treatment may be required for recurrences. However, in contrast to neoplastic disease, patients with LCH recurrence can often be successfully re-treated with a previously received regimen. Sometimes, recurrence can be ameliorated with less intensive therapy than originally received. Rarely are aggressive approaches, such as bone marrow or liver transplantation, justified.

Because unifocal bone disease is associated with a uniformly excellent prognosis, therapy with potential late effects should be avoided. The surgical procedure required for diagnostic purposes often is definitively therapeutic as well. Lesions other than those for which curettage is performed for diagnostic purposes often heal spontaneously.¹⁵⁰ Lesions that progress or recur; those that threaten an important function, such as sight or hearing; and those that pose a risk of pathologic fracture or future disability may be treated effectively with low-dose radiotherapy. Doses of 600 to 1,000 cGy in three to five fractions effect local control in most patients.^{148, 149, 151} Lesions in weight-bearing sites, such as the neck of the femur, may require curettage and autologous bone grafting. Direct steroid injection into the lesion has been used¹⁵²; however, the benefit of this treatment has never been proven in a randomized fashion. Isolated histiocytosis of the skin in infants usually regresses spontaneously and does not require systemic therapy.^{5, 96, 153} Skin lesions in older children or adults may respond at least temporarily to radiation with ultraviolet light.¹⁵⁴

Systemic therapy is required for multisystem disease and for single-system disease in which multiple bones or CNS-risk bones are involved. Approximately 50% of patients requiring systemic therapy respond to corticosteroids alone.¹⁵⁵ Because of the toxicity of corticosteroids when used for more than brief periods, however, other chemotherapeutic agents are now the mainstay of management. Vinblastine, vincristine, 6-mercaptopurine, methotrexate, alkylating agents, anthracyclines, and etoposide, singly or in combinations, are effective in controlling LCH.¹⁴³ Patients with liver, lung, or bone marrow dysfunction as well as those at high risk for adverse CNS outcome are best treated with combination chemotherapy. In a clinical trial in which patients were stratified by risk, treatment included induction chemotherapy with vinblastine, etoposide, and prednisone followed by maintenance chemotherapy with etoposide, vinblastine, prednisone, 6-mercaptopurine, and methotrexate.¹²³ Two thirds of those patients with organ dysfunction achieved a complete remission, as did approximately 90% of those with either multisite bony disease or soft tissue disease without organ dysfunction.

The Histiocyte Society has conducted multinational randomized clinical trials in LCH.^{78, 156} In the first international trial (LCH I),⁷⁸ 143 patients were randomized to receive 24 weeks of vinblastine (6 mg/m² intravenously weekly) or etoposide (150 mg/m²/day intravenously for 3 days, every 3 weeks); all patients received a single dose of steroids. Both of those monotherapies were equivalent. Due to the risk of secondary leukemias with etoposide, subsequent studies have been built from the vinblastine arm. One robust finding in this study was that the response at 6 weeks was strongly prognostic, regardless of initial treatment. However, LCH I did not produce superior results compared to studies from the German/Austrian Group, DAK-HX 83 and DAL-HX 90.¹⁵⁷ Overall survival was similar, but a lower reactivation rate, longer reaction free interval, and fewer permanent disabilities were seen in the DAL studies compared to LCH I.

The Histiocyte Society's LCH II trial demonstrated that intensified treatment increased early response in patients younger than 2 years with multisystem disease and risk organ involvement.¹⁵⁶ The study showed that the addition of etoposide to a regimen of vinblastine, prednisone, and daily 6-mercaptopurine reduced the risk of mortality for these patients. The most recent LCH III trial evaluated the effect of adding methotrexate to the combination of vinblastine and prednisone for patients with "risk" organ involvement. Although data from that trial are pending, the current recommendation is that patients with multisystem disease should receive a 6-week course of therapy with weekly vinblastine and daily prednisone, followed by 12 months of maintenance therapy with vinblastine and prednisone pulses every 3 weeks with daily oral 6-mercaptopurine. Treatment should be similar for patients with multifocal bone and CNS-risk lesions, except that there is no proven benefit to 6-mercaptopurine.

Newer agents that have been evaluated for LCH that are refractory to standard therapy include cladribine (2-chlorodexoyadenosine). The early promise of cladribine reported in several small studies prompted further evaluation by the Histiocyte Society.^{158, 159, 161} In a Phase 2 study, cladribine showed benefit to patients with reactivation of disease in nonrisk organs.¹⁶² However, cladribine proved no more beneficial than standard therapy for patients with multisystem disease and risk organ involvement. The combination of cladribine with other agents such as cytarabine or etoposide may be more effective, but carries the risk of more pronounced bone marrow suppression and hematologic toxicity.¹⁶³ Other agents that have shown promise in small series include clofarabine, bisphosphonates, and etanercept.^{164, 165, 166, 167}

Etanercept inhibits TNF- α , which is highly expressed in Langerhans cells, lymphocytes, and macrophages of LCH lesions and promotes proliferation of Langerhans cells.^{168, 169}

Several patients with recurrent progressive LCH refractory to conventional therapy have benefited from allogeneic hematopoietic

P.1315

stem cell transplantation (HSCT).^{170, 171, 172, 173, 174, 175, 176} However, toxicity from HSCT in these patients has been an issue with high rates of transplant-related mortality. A few patients have undergone HSCT with reduced-intensity conditioning with less transplant-related morbidity and mortality.¹⁷⁷ The most effective conditioning regimens and appropriate timing of HSCT are yet to be determined.

REFERENCES

1. Hand A. General tuberculosis. *Trans Pathol Soc Phila* 1893;16:282.
2. Chu A, Favara BE, Ladisch S, Nezelof C, Prichard J. Report and recommendations of the workshop on the childhood histiocytosis. *Med Pediatr Oncol* 1986;14:116.
3. Writing Group of the Histiocyte Society. Histiocytosis syndromes in children. *Lancet* 1987;1:208-209.
4. Lichtenstein L. Histiocytosis X: integration of eosinophilic granuloma of bone, Letterer-Siwe disease and Schuller-Christian disease as related manifestations of a single nosologic entity. *Arch Pathol Lab Med* 1953;56:84-102.
5. Hashimoto K, Pritzker MS. Electron microscopic study of reticulohistiocytoma. An usual case of congenital, self-healing reticulohistiocytosis. *Arch Dermatol* 1973;107:263-267.
6. Hashimoto K, Griffin D, Kohsubi M. Self-healing reticulohistiocytosis. *Cancer* 1982;49:331-337.
7. Wolfson SL, Botero F, Hurwitz S, et al. Pure cutaneous histiocytosis X. *Cancer* 1981;48:2236-2238.
8. Komp DM. Historical perspectives of Langerhans cell histiocytosis. *Hematol Oncol Clin North Am* 1987;1:9-21.
9. Hand A. Defects of membranous bones, exophthalmos and polyuria in childhood. *Am J Med Sci* 1921;162:509.
10. Lieberman PH, Jones CR, Dargeon HW, et al. A reappraisal of eosinophilic granuloma of bone, Hand-Schuller-Christian syndrome and Letterer-Siwe syndrome. *Medicine* 1969;48:375-400.
11. Letterer E. Aleukamische Retikulose (ein Beitrag zu den proliferativen Erkrankungen des Retikuloendothelialapparates). *Frankfurt Z Pathol* 1924;30:377.
12. Siwe SA. Die Reticuloendotheliose: Ein neues Krankheitsbild unter den Hepatosplenomegalien. *Z Kinderheilkd* 1933;55:212.
13. Lichtenstein L, Jaffe HL. Eosinophilic granuloma of bone. *Am J Pathol* 1940;16:595.
14. Otani S, Ehrlich JC. Solitary granuloma. *Am J Pathol* 1940;16:479.
15. Green WT, Farber S. "Eosinophilic or solitary granuloma" of bone. *J Bone Joint Surg* 1942;24:499.
16. Willman CL, Busque L, Griffith BB, et al. Langerhans'-cell histiocytosis (Histiocytosis X): a clonal proliferative disease. *N Engl J Med* 1994;331:154-160.
17. Yu RC, Chu C, Buluwela L, et al. Clonal proliferation of Langerhans cells in Langerhans cell histiocytosis. *Lancet* 1994;343:767-768.
18. Salotti JA, Nanduri V, Pearce MS, et al. Incidence and clinical features of Langerhans cell histiocytosis in the UK and Ireland. *Arch Dis Child* 2009;94:376-380.
19. Stalemark H, Laurencikas E, Karis J, et al. Incidence of Langerhans cell histiocytosis in children: a population-based study. *Pediatr Blood Cancer* 2008;51:76-81.
20. Hamre M, Hedberg J, Buckley J, et al. Langerhans cell histiocytosis: an exploratory epidemiologic study of 177 cases. *Med Pediatr Oncol* 1997;28:92-97.
21. Baumgartner I, von Hochstetter A, Baumart B, et al. Langerhans'-cell histiocytosis in adults. *Med Pediatr Oncol* 1997;28:9-14.

22. Alston RD, Tatevossian RG, McNally RJ, et al. Incidence and survival of childhood Langerhans cell histiocytosis in Northwest England from 1954 to 1998. *Pediatr Blood Cancer* 2007;48:555-560.
23. Komp DM, Herson J, Starling KA, et al. A staging system for histiocytosis X. *Cancer* 1981;47:798-800.
24. Nezelof C, Rileux-Herbert F, Cronier-Sachot J. Disseminated histiocytosis X. *Cancer* 1979;44:1824-1838.
25. Guyot-Goubin A, Donadieu J, Barkaoui M, et al. Descriptive epidemiology of childhood Langerhans cell histiocytosis in France, 2000-2004. *Pediatr Blood Cancer* 2008;51:71-75.
26. Bhatia S, Nesbit ME, Egeler RM, et al. Epidemiologic study of Langerhans cell histiocytosis in children. *J Pediatr* 1977;130:774-784.
27. Arico M, Nichols K, Whitlock J, et al. Familial clustering of Langerhans cell histiocytosis. *Br J Haematol* 1999;107:883-888.
28. Egeler RM, Neglia JP, Arico M, et al. The relation of Langerhans cell histiocytosis to acute leukemia, lymphomas, and other solid tumors. The LCHMalignancy Study Group of the Histiocyte Society. *Hematol Oncol Clin North Am* 1998;12:369-378.
29. Chiles LR, Christian MM, McCoy DK, et al. Langerhans cell histiocytosis in a child while in remission for acute lymphocytic leukemia. *J Am Acad Dermatol* 2001;45:S233-S234.
30. Kager L, Heise A, Minkov M, et al. Occurrence of acute nonlymphoblastic leukemia in two girls after treatment of recurrent, disseminated Langerhans cell histiocytosis. *Pediatr Hematol Oncol* 1999;16:251-256.
31. Raj A, Bendon R, Moriarty T, et al. Langerhans cell histiocytosis following childhood acute lymphoblastic leukemia. *Am J Hematol* 2001;68:284-286.
32. Trebo MM, Attarbaschi A, Mann G, et al. Histiocytosis following T-acute lymphoblastic leukemia: a BFM study. *Leuk Lymphoma* 2005;46:1735-1741.
33. Scappaticci S, Danesino C, Rossi E, et al. Cytogenetic abnormalities in PHA-stimulated lymphocytes from patients with Langerhans cell histiocytosis. IEOP-Istiocitosi Group. *Br J Haematol* 2000;111:258-262.
34. Betts DR, Leibundgut KE, Feldges A, et al. Cytogenetic abnormalities in Langerhans cell histiocytosis. *Br J Cancer* 1998;77:552-555.
35. Murakami I, Gogusev J, Fournet JC, et al. Detection of molecular cytogenetic aberrations in Langerhans cell histiocytosis of bone. *Hum Pathol* 2002;33:555-560.
36. Favara BE, Jaffe R. The histopathology of Langerhans cell histiocytosis. *Br J Cancer* 1994;70(Suppl 23):S17-S23.
37. Risdall RJ, Dehner LP, Duray, et al. Histiocytosis X (Langerhans' cell histiocytosis). Prognostic role of histopathology. *Arch Pathol Lab Med* 1983;107:59-63.
38. Pinkus GS, Lones MA, Matsumura F, et al. Langerhans cell histiocytosis immunohistochemical expression of fascin, a dendritic cell marker. *Am J Clin Pathol* 2002;118:335-343.
39. Reid CDL, Fryer PR, Clifford C, et al. Identification of hematopoietic progenitors of macrophages and dendritic Langerhans cells (DL-CFU) in human bone marrow and peripheral blood. *Blood* 1990;76:1139-1149.
40. Choi KL, Saunder DN. The role of Langerhans cells and keratinocytes in epidermal immunity. *J Leukocyte Biol* 1986;39:343-358.
41. Favara BE, McCarthy RC, Mierau GW. Histiocytosis X. *Hum Pathol* 1983;14:663-676.
42. Mierau GW, Favara BE, Brenman JM. Electron microscopy in histiocytosis X. *Ultrastruct Pathol* 1982;3:137-142.
43. Lau SK, Chu PG, Weiss LM. Immunohistochemical expression of langerin in Langerhans cell histiocytosis and non-Langerhans cell histiocytic disorders. *Am J Surg Pathol* 2008;32:615-619.
44. Valladeau J, Ravel O, Dezutter-Dambuyant C, et al. Langerin, a novel c-type lectin specific to Langerhans cells, is an endocytic receptor that induces the formation of Birbeck granules. *Immunity* 2000;12:71-81.
45. Rowden G. Expression of Ia antigens on Langerhans cells in mice, guinea pigs, and man. *J Invest Dermatol* 1980;75:22-31.
46. Bouloc A, Boulland ML, Geissmann F, et al. CD101 expression by Langerhans cell histiocytosis cells. *Histopathology* 2000;36:229-232.

47. Chu T, Jaffe R. The normal Langerhans cell and the LCH cell. *Br J Cancer* 1994;70(Suppl 23):S4-S10.
48. Geissmann F, Lepelletier Y, Fraitag S, et al. Differentiation of Langerhans cells in Langerhans cell histiocytosis. *Blood*. 2001;97:1241-1248.
49. Allen CE, Li L, Peters TL, et al. Cell-specific gene expression in Langerhans cell histiocytosis lesions reveals a distinct profile compared with epidermal Langerhans cells. *J Immunol* 2010;184:4557-4567.
50. Annels NE, Da Costa CE, Prins FA, et al. Aberrant chemokine receptor expression and chemokine production by Langerhans cells underlies the pathogenesis of Langerhans cell histiocytosis. *J Exp Med* 2003;197:1385-1390.
51. Egeler RM, Favara BE, Laman JD, et al. Abundant expression of CD40 and CD40-ligand (CD154) in paediatric Langerhans cell histiocytosis lesions. *Eur J Cancer* 2000;36:2105-2110.
52. de Graff JH, Tamminga RYJ, Kamps WA, et al. Expression of cellular adhesion molecules in Langerhans cell histiocytosis and normal Langerhans cells. *Am J Pathol* 1995;147:1161-1171.
53. Yu RC, Alaibac M, Chu AC. Functional defect in cells involved in Langerhans cell histiocytosis. *Arch Dermatol Res* 1995;287:627-631.
54. Leikin SL. Immunobiology of histiocytosis-X. *Hematol Oncol Clin North Am* 1987;1:49-61.
55. Nesbit ME, O'Leary M, Dehner LP, et al. The immune system and the histiocytosis syndromes. *Am J Pediatr Hematol Oncol* 1981;3:141-149.
56. Newton WA Jr, Hamoudi AB, Shannon BT. Role of the thymus in histiocytosis X. *Hematol Oncol Clin North Am* 1987;1:63-74.
57. Osband ME, Lipton JM, Lavin P, et al. Histiocytosis X. Demonstration of abnormal immunity, T-cell histamine-H2-receptor deficiency, and successful treatment with thymic extract. *N Engl J Med* 1981;304:146-153.
58. Bove KE, Hurtubise P, Wong KY. Thymus in untreated systemic histiocytosis-X. *Pediatr Pathol* 1985;4:99-115.
59. Shannon BT, Newton WA. Suppressor cell dysfunction in children with histiocytosis-X. *J Clin Immunol* 1986;6:510-518.
60. Lahey ME, Heyn R, Ladisch S, et al. Hypergammaglobulinemia in histiocytosis X. *J Pediatr* 1985;107:572-574.
61. Kragballe K, Zachariae H, Herlin T, et al. Histiocytosis X: an immune deficiency disease? Studies on antibody-dependent monocyte-mediated cytotoxicity. *Br J Dermatol* 1981;105:13-18.
62. Leikin SL. Immunologic parameters in histiocytosis-X. *Cancer* 1973;32:796.
63. Kannourakis G, Abbas A. The role of cytokines in the pathogenesis of Langerhans cell histiocytosis. *Br J Cancer* 1994;70(Suppl 23):S37-S40.
64. Ishii R, Morimoto A, Ikushima S, et al. High serum values of soluble CD154, IL-2 receptor, RANKL and osteoprotegerin in Langerhans cell histiocytosis. *Pediatr Blood Cancer* 2006;47:194-199.
65. Arenzana-Seisdedos F, Barbey S, Virelizier JL, et al. Histiocytosis X. Purified (T6 +) cells from bone granuloma produce interleukin 1 and prostaglandin E2 in culture. *J Clin Invest* 1986;77:326-329.
66. Brown RE. Angiotensin-converting enzyme, transforming growth factor beta (1), and interleukin 11 in the osteolytic lesions of Langerhans cell histiocytosis. *Arch Pathol Lab Med* 2000;124:1287-1290.
67. Andersson By U, Tani E, Andersson U, et al. Tumor necrosis factor, interleukin 11, and leukemia inhibitory factor produced by Langerhans cells in Langerhans cell histiocytosis. *J Pediatr Hematol Oncol* 2004;26:706-711.
68. Emile JF, Fraitag S, Andry P, et al. Expression of GM-CSF receptor by Langerhans' cell histiocytosis cells. *Virchows Arch* 1995;427:125-129.
69. Mierau GW, Wills EJ, Steele PO. Ultrastructural studies in Langerhans cell histiocytosis: a search for evidence of viral etiology. *Pediatr Pathol* 1994;14: 895-904.
70. McClain K, Jin H, Gresik V, et al. Langerhans cell histiocytosis: lack of a viral etiology. *Am J Hematol* 1994;47:16-20.
71. Edgar JD, Smyth AE, Pritchard J, et al. Interferon gamma receptor deficiency mimicking Langerhans' cell histiocytosis. *J Pediatr* 2001;139:600-603.
72. Komp DL. Langerhans cell histiocytosis. *N Engl J Med* 1987;316:747-748.

73. Yousem SA, Colby TV, Chen YY, et al. Pulmonary Langerhans' cell histiocytosis: molecular analysis of clonality. *Am J Surg Pathol* 2001;25:630-636.
74. Jubran RF, Marachelian A, Dorey F, et al. Predictors of outcome in children with Langerhans cell histiocytosis. *Pediatr Blood Cancer* 2005;45:37-42.
75. Matus-Ridley M, Raney RB, Jr., Thawerani H, et al. Histiocytosis X in children: patterns of disease and results of treatment. *Med Pediatr Oncol* 1983;11: 99-105.
76. Baumgartner I, von Hochstetter A, Baumert B, et al. Langerhans' cell histiocytosis in adults. *Med Pediatr Oncol* 1997;28:9-14.
77. Islinger RB, Kuklo TR, Owens BD, et al. Langerhans' cell histiocytosis in patients older than 21 years. *Clin Orthop* 2000;379:231-235.
78. Gadner H, Grois N, Arico M, et al. A randomized trial of treatment for multisystem Langerhans' cell histiocytosis. *J Pediatr* 2001;138:728-734.
79. Kilpatrick SE, Wenger DE, Gilchrist GS, et al. Langerhans' cell histiocytosis (histiocytosis X) of bone. *Cancer* 1995;76:2471-2484.
80. Howarth DM, Gilchrist GS, Mullan BP, et al. Langerhans cell histiocytosis: diagnosis, natural history, management, and outcome. *Cancer* 1999;85: 2278-2290.
81. Titgemeyer C, Grois N, Minkov M, et al. Pattern and course of single-system disease in Langerhans cell histiocytosis data from the DAL-HX 83- and 90-study. *Med Pediatr Oncol* 2001;34:108-114.
82. Hartman KS. Histiocytosis X: a review of 114 cases with oral involvement. *Oral Surg Oral Med Oral Pathol* 1980;49:38-54.
83. Smith RJH, Evans JNG. Head and neck manifestations of histiocytosis X. *Laryngoscope* 1984;94:395-399.
84. Haupt R, Nanduri V, Calevo MG, et al. Permanent consequences in Langerhans cell histiocytosis patients: a pilot study from the histiocyte society-late effects study group. *Pediatr Blood Cancer* 2004;42:438-444.
85. Grois N, Potschger U, Prosch H, et al. Risk factors for diabetes insipidus in Langerhans cell histiocytosis. *Pediatr Blood Cancer* 2006;46:228-233.
86. Moore JB, Kulkarni R, Crutcher DC, et al. The MRI in multifocal eosinophilic granuloma. Staging disease and monitoring response to therapy. *Am J Pediatr Hematol Oncol* 1989;11:174-177.
87. Crone-Munzebrock W, Brassow F. A comparison of radiographic and bone scan findings in histiocytosis X. *Skeletal Radiol* 1983;9:170-173.
88. Parker BR, Pinckney L, Etcubanas E, et al. Relative efficacy of radiographic and radionuclide bone surveys in the detection of skeletal lesions of histiocytosis X. *Radiology* 1980;134:377-380.
89. Siddiqui AR, Tashjian JH, Lazarus K, et al. Nuclear medicine studies in evaluation of skeletal lesions in children with histiocytosis X. *Radiology* 1981;140:787-789.
90. Van Nieuwenhuyse JP, Clapuyt P, Malghem J, et al. Radiographic skeletal survey and radionuclide bone scan in Langerhans cell histiocytosis of bone. *Pediatr Radiol* 1996;26:734-738.
91. Dogan AS, Conway JJ, Miller JH, et al. Detection of bone lesions in Langerhans cell histiocytosis: complementary roles of scintigraphy and conventional radiography. *J Pediatr Hematol Oncol* 1996;18:51-58.
92. Binkovitz LA, Olshefski RS, Adler BH. Coincidence FDG-PET in the evaluation of Langerhans' cell histiocytosis: preliminary findings. *Pediatr Radiol* 2003;33:598-602.
93. Phillips M, Allen C, Gerson P, et al. Comparison of FDG-PET scans to conventional radiography and bone scans in management of Langerhans cell histiocytosis. *Pediatr Blood Cancer* 2009;52:97-101.
94. Winkelmann RK. The skin in histiocytosis X. *Mayo Clin Proc* 1969;44: 535-548.
95. Lau L, Krafchik B, Trebo MM, et al. Cutaneous Langerhans cell histiocytosis in children under one year. *Pediatr Blood Cancer* 2006;46:66-71.
96. Kanitakis J, Zambruno G, Schmitt D, et al. Congenital self-healing histiocytosis (Hashimoto-Pritzker syndrome). *Cancer* 1988;61:508-516.

97. Kapur P, Erickson C, Rakheja D, et al. Congenital self-healing reticulohistiocytosis (Hashimoto-Pritzker disease): ten-year experience at Dallas Children's Medical Center. *J Am Acad Dermatol* 2007;56:290-294.
98. Barthez MA, Araujo E, Donadieu J. Langerhans cell histiocytosis and the central nervous system in childhood: evolution and prognostic factors. Results of a collaborative study. *J Child Neurol* 2000;15:150-156.
99. Grois N, Fahrner B, Arceci RJ, et al. Central nervous system disease in Langerhans cell histiocytosis. *J Pediatr* 2010;156:873-881, 881 e871.
100. Rothman JG, Snyder PG, Utiger RD. Hypothalamic endocrinopathy in Hand-Schuller-Christian disease. *Ann Intern Med* 1978;88:512-513.
101. Grois N, Barkovich J, Rosenau W, et al. Central nervous system disease associated with Langerhans' cell histiocytosis. *Am J Pediatr Hematol Oncol* 1993;15:245-254.
102. Shuper A, Start B, Yaniv Y, et al. Cerebellar involvement in Langerhans' cell histiocytosis: a progressive neuropsychiatric disease. *J Child Neurol* 2000;15:824-826.
103. Whitsett SF, Kneppers K, Coppes MJ, et al. Neuropsychologic deficits in children with Langerhans cell histiocytosis. *Med Pediatr Oncol* 1999;33:486-492.
104. Mittheisz E, Seidl R, Prayer D, et al. Central nervous system-related permanent consequences in patients with Langerhans cell histiocytosis. *Pediatr Blood Cancer* 2007;48:50-56.
105. Nanduri VR, Bareille P, Pritchard J, et al. Growth and endocrine disorders in multisystem Langerhans' cell histiocytosis. *Clin Endocrinol* 2000;53:509-515.
106. Maghnie M, Cosi G, Genovese E, et al. Central diabetes insipidus in children and young adults. *N Engl J Med* 2000;343:998-1007.
107. Grois N, Flucher-Wolfram B, Heitger A, et al. Diabetes insipidus in Langerhans cell histiocytosis: results from the DAL-HX 83 study. *Med Pediatr Oncol* 1995;24:248-256.
108. Braunstein GD, Kohler PO. Endocrine manifestations of histiocytosis. *Am J Pediatr Hematol Oncol* 1981;3:67-75.
109. Dunger DB, Broadbent V, Yeoman E, et al. The frequency and natural history of diabetes insipidus in children with Langerhans-cell histiocytosis. *N Engl J Med* 1989;321:1157-1162.
110. Czernichow P, Garel C, Leger J. Thickened pituitary stalk on magnetic resonance imaging in children with central diabetes insipidus. *Horm Res* 2000;53(Suppl 3):61-64.
111. Helbock J, Krivit W, Nesbit ME Jr. Patterns of anti-diuretic function in diabetes insipidus caused by histiocytosis X. *J Lab Clin Med* 1971;78:194-202.
112. Wnorowski M, Prosch H, Prayer D, et al. Pattern and course of neurodegeneration in Langerhans cell histiocytosis. *J Pediatr* 2008;153:127-132.
113. Martin-Duverneuil N, Idbaih A, Hoang-Xuan K, et al. MRI features of neurodegenerative Langerhans cell histiocytosis. *Eur Radiol* 2006;16:2074-2082.
114. Prayer D, Grois N, Prosch H, et al. MR imaging presentation of intracranial disease associated with Langerhans cell histiocytosis. *AJNR Am J Neuroradiol* 2004;25:880-891.
115. Grois N, Prayer D, Prosch H, et al. Neuropathology of CNS disease in Langerhans cell histiocytosis. *Brain* 2005;128:829-838.
116. Dean HJ, Bishop A, Winter JS. Growth hormone deficiency in patients with histiocytosis X. *J Pediatr* 1986;615-618.
117. Howell SJ, Wilton P, Shalet SM. Growth hormone replacement in patients with Langerhans cell histiocytosis. *Arch Dis Child* 1998;78:469-473.
118. Lahey ME, Rallison ML, Hilding DA, et al. Involvement of the thyroid in histiocytosis X. *Am J Pediatr Hematol Oncol* 1986;8:257-259.
119. Leblanc A, Hadchouel M, Jehan P, et al. Obstructive jaundice in children with histiocytosis X. *Gastroenterology* 1981;80:134-139.
120. Thompson HH, Pitt HA, Lewin KJ, et al. Sclerosing cholangitis and histiocytosis X. *Gut* 1984;25:526-530.

121. Braier J, Ciocca M, Latella A, et al. Cholestasis, sclerosing cholangitis and liver transplantation in Langerhans cell histiocytosis. *Med Pediatr Oncol* 2002;38:178-182.
122. Heyn RM, Hamoudi A, Newton WA Jr. Pretreatment liver biopsy in 20 children with histiocytosis X: a clinicopathologic correlation. *Med Pediatr Oncol* 1990;18:110-118.
123. Gadner H, Heitger A, Grois N, et al. Treatment strategy for disseminated Langerhans cell histiocytosis. *Med Pediatr Oncol* 1994;23:72-80.
124. Carlson RA, Hattery RR, O'Connell EJ, et al. Pulmonary involvement by histiocytosis X in the pediatric age group. *Mayo Clin Proc* 1976;51:542-547.
125. Basset F, Corrin B, Spencer H, et al. Pulmonary histiocytosis X. *Am Rev Respir Dis* 1978;118:811-820.
126. Friedman PJ, Liebow AA, Sokoloff J. Eosinophilic granuloma of lung: clinical aspects of primary pulmonary histiocytosis in the adult. *Medicine* 1981;60:385-396.
127. Marcy TW, Reynolds HY. Pulmonary histiocytosis X. *Lung* 1985;163:129-150.
128. Vassallo R, Ryu JH, Schroeder DR, et al. Clinical outcomes of pulmonary Langerhans' cell histiocytosis in adults. *N Engl J Med* 2002;346:484-490.
129. Arico M, Girschikofsky M, Genereau T, et al. Langerhans cell histiocytosis in adults. Report from the International Registry of the Histiocyte Society. *Eur J Cancer* 2003;39:2341-2348.
130. Nondahl SR, Finlay JL, Farrell PM, et al. A case report and literature review of "primary" pulmonary histiocytosis X of childhood. *Med Pediatr Oncol* 1986;14:57-62.
131. Al-Trabolsi HA, Alshehri M, Al-Shomrani A, et al. "Primary" pulmonary Langerhans cell histiocytosis in a two-year-old child: case report and literature review. *J Pediatr Hematol Oncol* 2006;28:79-81.
132. Watanabe R, Tatsumi K, Hashimoto S, et al. The respiratory failure research group of Japan. Clinico-epidemiological features of pulmonary histiocytosis X. *Intern Med* 2001;40:988-1003.
133. Bernstrand C, Cederlund K, Asahrom L, et al. Smoking preceded pulmonary involvement in adults with Langerhans' cell histiocytosis diagnosed in childhood. *Acta Paediatr* 2000;89:1389-1392.
134. Lewis JG. Eosinophilic granuloma and its variants with special reference to lung involvement. *Q J Med* 1964;33:337-359.
135. Roland AS, Merdinger WF, Froeb HF. Recurrent spontaneous pneumothorax: a clue to the diagnosis of histiocytosis X. *N Engl J Med* 1942;270:73.
136. Bernstrand C, Cederlund K, Sandstedt B, et al. Pulmonary abnormalities at long-term follow-up of patients with Langerhans cell histiocytosis. *Med Pediatr Oncol* 2001;36:459-468.
137. Berry DH, Gresik MV, Humphrey GB, et al. Natural history of histiocytosis X: a Pediatric Oncology Group study. *Med Pediatr Oncol* 1986;14:1-5.
138. Favara BE, Jaffe R, Egeler RM. Macrophage activation and hemophagocytic syndrome in Langerhans cell histiocytosis: report of 30 cases. *Pediatr Dev Pathol* 2002;5:130-140.
- P.1316
139. Jaffe R, Weiss LM, Facchetti F. Tumors derived from Langerhans cells. In: Swerdlow SH, Campo E, Harris NL, et al., eds. *WHO classification of tumors of hematopoietic and lymphoid tissues*. Lyon: IARC Press, 2008:358-360.
140. Broadbent V, Gadner H, Komp DM, et al. Histiocytosis syndromes in children: II. Approach to the clinical and laboratory evaluation of children with Langerhans cell histiocytosis. *Med Pediatr Oncol* 1989;17:492-495.
141. Calming U, Bernstrand C, Mosskin M, et al. Brain 18-FDG PET scan in central nervous system Langerhans cell histiocytosis. *J Pediatr* 2002;141:435-440.
142. Lastoria S, Montella L, Catalano L, et al. Functional imaging of Langerhans cell histiocytosis by (111) In-DTPA-D-Phe(1)-octreotide scintigraphy. *Cancer* 2002;94:633-640.

143. Minkov M. Multisystem Langerhans cell histiocytosis in children: current treatment and future directions. *Paediatr Drugs* 2011;13:75-86.
144. Berry DH, Gresik M, Maybee D, et al. Histiocytosis X in bone only. *Med Pediatr Oncol* 1990;18:292-294.
145. Willis B, Ablin A, Weinberg V, et al. Disease course and late sequelae of Langerhans' cell histiocytosis: 25-year experience at the University of California, San Francisco. *J Clin Oncol* 1996;14:2073-2082.
146. Bernstrand C, Sandstedt B, Ahstrom L, et al. Long-term follow-up of Langerhans cell histiocytosis: 39 years' experience at a single centre. *Acta Paediatr* 2005;94:1073-1084.
147. Pollono D, Rey G, Latella A, et al. Reactivation and risk of sequelae in langerhans cell histiocytosis. *Pediatr Blood Cancer* 2007;48:696-699.
148. Cassady JR. Current role of radiation therapy in the management of histiocytosis X. *Hematol Oncol Clin North Am* 1987;1:123-129.
149. Selch MT, Parker RG. Radiation therapy in the management of Langerhans cell histiocytosis. *Med Pediatr Oncol* 1990;18:97-102.
150. Womer RB, Raney RB Jr, D'Angio GJ. Healing rates of treated and untreated bone lesions in histiocytosis X. *Pediatrics* 1985;76:286-288.
151. Smith DG, Nesbit ME Jr, D'Angio GJ, et al. Histiocytosis X: role of radiation therapy with special reference to dose levels employed. *Radiology* 1973;106:419-422.
152. Cohen M, Zornoza J, Cangir A, et al. Direct injection of methylprednisolone in the treatment of solitary eosinophilic granuloma of bone. *Radiology* 1980;136:289-293.
153. Larralde M, Rositto A, Giardelli M, et al. Congenital self-healing histiocytosis (Hashimoto-Pritzker). *Int J Dermatol* 1999;38:693-696.
154. Iwatsuki K, Tsugiki M, Yoshizawa N, et al. The effect of phototherapies on cutaneous lesions of histiocytosis X in the elderly. *Cancer* 1986;57:1931-1936.
155. Lahey ME. Histiocytosis X: comparison of three treatment regimens. *J Pediatr* 1975;87:179-183.
156. Gadner H, Grois N, Potschger U, et al. Improved outcome in multisystem langerhans cell histiocytosis is associated with therapy intensification. *Blood* 2008;111:2556-2562.
157. Minkov M, Grois N, Heitger A, et al. Treatment of multisystem Langerhans cell histiocytosis. Results of the DAL-HX 83 and DAL-HX 90 studies. DAL-HX Study Group. *Klinische Padiatrie* 2000;212:139-144.
158. Rodriguez-Galindo C, Kelly P, Jeng M, et al. Treatment of children with Langerhans cell histiocytosis with 2-chlorodeoxyadenosine. *Am J Hematol* 2002;69:179-184.
159. Grau J, Ribera JM, Tormo M, et al. Results of treatment with 2-chlorodeoxyadenosine in refractory or relapsed Langerhans cell histiocytosis. Study of 9 patients. *Med Clin (Barc)* 2001;116:339-342.
160. Watts J, Files B. Langerhans cell histiocytosis: central nervous system involvement treated successfully with 2-chlorodeoxyadenosine. *Pediatr Hematol Oncol* 2001;18:119-204.
161. Weitzman S, Wayne AS, Arceci R, et al. Nucleoside analogues in the therapy of Langerhans cell histiocytosis: a survey of members of the histiocyte society and review of the literature. *Med Pediatr Oncol* 1999;33:476-481.
162. Stine KC, Saylor RL, Williams LL, et al. 2-Chlorodeoxyadenosine (2-CDA) for the treatment of refractory or recurrent Langerhans cell histiocytosis (LCH) in pediatric patients. *Med Pediatr Oncol* 1997;29:288-292.
163. Bernard F, Thomas C, Bertrand Y, et al. Multi-centre pilot study of 2-chlorodeoxyadenosine and cytosine arabinoside combined chemotherapy in refractory Langerhans cell histiocytosis with haematological dysfunction. *Eur J Cancer* 2005;41:2682-2689.
164. Rodriguez-Galindo C, Jeng M, Khoo P, et al. Clofarabine in refractory langerhans cell histiocytosis. *Pediatr Blood Cancer* 2008;51:703-706.
165. Farran RP, Zaretski E, Egeler RM. Treatment of langerhans cell histiocytosis with pamidronate. *J Pediatr Hematol Oncol* 2001;23:54-56.

166. Arzoo K, Sadeghi S, Pullarkat V. Pamidronate for bone pain from osteolytic lesions in langerhans'-cell histiocytosis. *N Engl J Med* 2001;345:225.
167. Henter JI, Karlen J, Calming U, et al. Successful treatment of Langerhans'-cell histiocytosis with etanercept. *N Engl J Med* 2001;345:1577-1578.
168. Geissmann F, Lepelletier Y, Fraitag S, et al. Differentiation of Langerhans cells in Langerhans cell histiocytosis. *Blood* 2001;97:1241-1248.
169. Egeler RM, Favara BE, van Meurs M, et al. Differential In situ cytokine profiles of Langerhans-like cells and T cells in Langerhans cell histiocytosis: abundant expression of cytokines relevant to disease and treatment. *Blood* 1999;94:4195-4201.
170. Stool M, Freund M, Schmid H, et al. Allogeneic bone marrow transplantation for Langerhans cell histiocytosis. *Cancer* 1990;66:284-288.
171. Greinix HT, Storb R, Sanders JE, et al. Marrow transplantation for treatment of multisystem progressive Langerhans cell histiocytosis. *Bone Marrow Transplant* 1992;10:39-44.
172. Suminoe A, Matsuzaki A, Hattori H, et al. Unrelated cord blood transplantation for an infant with chemotherapy-resistant progressive Langerhans cell histiocytosis. *J Pediatr Hematol Oncol* 2001;23:633-639.
173. Nagarajan R, Neglia J, Ramsay N, et al. Successful treatment of refractory Langerhans cell histiocytosis with unrelated cord blood transplantation. *J Pediatr Hematol Oncol* 2001;23:629-632.
174. Kimugawa N, Imashuki S, Hirota Y, et al. Hematopoietic stem cell transplantation (HSCT) for Langerhans cell histiocytosis (LCH) in Japan. *Bone Marrow Transplant* 1999;24:935-938.
175. Akkari V, Donadieu J, Pigué C, et al. Hematopoietic stem cell transplantation in patients with severe Langerhans cell histiocytosis and hematological dysfunction: experience of the French Langerhans Cell Study Group. *Bone Marrow Transplant* 2003;31:1097-1103.
176. Hale GA, Bowman LC, Woodard JP, et al. Allogeneic bone marrow transplantation for children with histiocytic disorders: use of TBI and omission of etoposide in the conditioning regimen. *Bone Marrow Transplant* 2003;31: 981-986.
177. Steiner M, Matthes-Martin S, Attarbaschi A, et al. Improved outcome of treatment-resistant high-risk Langerhans cell histiocytosis after allogeneic stem cell transplantation with reduced-intensity conditioning. *Bone Marrow Transplant* 2005;36:215-225.

Chapter 61 Pathology of Langerhans Cell Histiocytosis and Other Histiocytic Proliferations

> Table of Contents > Part VI - Benign Disorders of Leukocytes, The Spleen, and/or Immunoglobins > Chapter 61 - Pathology of Langerhans Cell Histiocytosis and Other Histiocytic Proliferations

Chapter 61

Pathology of Langerhans Cell Histiocytosis and Other Histiocytic Proliferations

Karen L. Chang

Lawrence M. Weiss

Langerhans cell histiocytosis and other dendritic and histiocytic neoplasms and related proliferations are uncommon diseases.¹ Dendritic cells, also known as classical dendritic cells, arise from the myeloid-derived common dendritic cell precursor and are divided by function and structure to include Langerhans cells, interdigitating dendritic cells, and follicular dendritic cells. Langerhans cells and interdigitating dendritic cells both show strong expression of S-100 protein and HLA-DR, with Langerhans cells positive for CD1a and langerin, and interdigitating dendritic cells negative for CD1a and langerin. Normal Langerhans cells reside primarily in the skin and migrate via lymphatics (as veiled cells) to the lymph nodes as they differentiate into interdigitating dendritic cells, which reside in the paracortical region of the lymph nodes. Langerhans cells are efficient antigen-processing presentation machines, whereas interdigitating dendritic cells interact closely with T-cells, leading to the initiation of strong cellular immunity. Follicular dendritic cells express CD21, CD35, and/or CD23, and not CD1a, langerin or S-100 protein. They are fixed cells that reside in lymphoid follicles, interacting

with follicular B cells in the formation and organization of the follicles. In addition, they trap and store antigen-antibody complexes and they are important in memory cell formation and affinity maturation of follicular B-cells. Plasmacytoid dendritic cells also arise from the common dendritic cell precursor and are the main source of α -interferon upon viral infection or CD154 stimulation. Plasmacytoid dendritic cells also play an important role in immune tolerance through immune regulation and/or depletion via the uptake of self-peptides captured by the uptake of apoptotic classic dendritic cells. They express CD123 and not S100, CD1a, or langerin. A subset of plasmacytoid dendritic cells has immunoglobulin rearrangements.

Histiocytes are noncirculating cells derived from a bone marrow stem cell known as monocyte/macrophage and dendritic cell precursor, which is the same stem cell that gives rise to the common dendritic cell precursor. Histiocytes are the tissue-based equivalent of monocytes and are normally resident in a variety of organs, including the spleen, lymph nodes, and bone marrow; liver (Kupffer cells); lung (alveolar macrophages); lamina propria of the gut; and brain (microglia). They express CD163 and CD68 (an antigenic marker of lysosomes). They play an important role in resistance to intracellular microorganisms and tumors through nonimmunologic mechanisms and in the recognition and clearance of apoptotic cells.

Each of these major dendritic and histiocytic cells has corresponding tumors, as summarized in Table 61.1 and discussed in further detail below.

LANGERHANS CELL HISTIOCYTOSIS

Langerhans cell histiocytosis is a neoplastic proliferation of Langerhans cells, albeit at perhaps a more immature state of maturation.² Langerhans cells are dendritic cells that are normally resident in the basal layer of the epidermis and are characterized by immunohistochemical expression of CD1a, S-100 protein, and langerin and the presence of Birbeck granules by ultrastructural examination. Three major syndromes of involvement are recognized.^{3, 4, 5} In the most common type, unifocal disease (formerly solitary eosinophilic granuloma), involvement of a single site, usually bone, is seen. This syndrome is seen primarily in adolescents and young adults. In multifocal unisystem disease (formerly many cases of Hand-Schuller-Christian disease), there is involvement of several sites within one organ system, almost always bone. This syndrome is seen primarily in children. In the least common multifocal multisystem disease (formerly many cases of Letterer-Siwe disease), multiple organs are involved, usually including the bones, skin, liver and spleen, and lymph nodes, often in a lymphoma-like distribution. These latter cases are usually seen in infants.

Langerhans cell histiocytosis represents a monoclonal proliferation, as revealed by molecular studies of the X-linked androgen receptor gene.⁶ There is no association with known viruses.⁷ Cytogenetic and other studies have shown abnormalities involving chromosomes 1p and 7.⁸ Recurrent mutations of the oncogene BRAF have been found in a large number of LCH cases, including the allegedly polyclonal pulmonary variant of LCH.⁹ Some investigators have theorized that immune dysfunction plays a role in the pathogenesis, although direct evidence is lacking. Neoplastic Langerhans cells may aberrantly express chemokines of immature dendritic cells, and abnormal reactions between Langerhans cells and macrophages may contribute to production of a cytokine "storm."^{10, 11}

Biopsy is essential to the diagnosis of Langerhans cell histiocytosis. The key to the diagnosis is the identification of neoplastic Langerhans cells. Langerhans cells are dendritic cells with characteristic grooved, folded, or indented nuclei, inconspicuous nucleoli, a relative bland chromatin pattern, and thin nuclear membranes¹² (Fig. 61.1). The degree of nuclear atypia or the mitotic rate in general does not correlate with outcome, with the exception that cases with frankly sarcomatous features probably represent rare cases of Langerhans cell sarcoma (see the section "Langerhans Cell Sarcoma"). The cytoplasm is usually moderately abundant and pale to intensely eosinophilic. Langerhans cells may be the only cell type, particularly as seen in cases of multifocal, multisystem disease, but most often they are found admixed in a characteristic cellular milieu that usually includes variable

P.1318

numbers of eosinophils, histiocytes, and neutrophils. Occasionally, eosinophilic microabscesses are seen. More mature lesions have greater numbers of histiocytes, which may be nonstimulated, epithelioid, or multinucleated and simulating osteoclasts. Late lesions tend to have variable numbers of foamy macrophages and plasma cells and are often associated with a significant degree of fibrosis. Ultrastructurally, neoplastic Langerhans cells have Birbeck granules, numerous lysosomes, small vesicles, and multivesicular bodies, and irregular cell membranes with an absence of cell junctions. Birbeck granules are specific to Langerhans cells and are usually "tennis racket"-shaped intracytoplasmic membranous bodies, with an osmiophilic core and a double outer sheath. The langerin antibody is an endocytic receptor associated

with the formation of Birbeck granules and thus is highly specific and sensitive and has in large part supplanted the need for electron microscopy studies.¹³

TABLE 61.1 MAJOR DENDRITIC AND HISTIOCYTIC CELLS AND THEIR TUMORS

Cell	Tumor	Major Phenotype
Langerhans cell	Langerhans cell histiocytosis/sarcoma	CD1a ⁺ , S-100 protein ⁺ , Langerin ⁺
Follicular dendritic cell	Follicular dendritic cell sarcoma	CD21 ⁺ , CD35 ⁺ , CD23 ⁺
Interdigitating dendritic cell	Interdigitating dendritic cell sarcoma	S-100 protein ⁺ , CD1a-
Plasmacytoid dendritic cell	Blastic plasmacytoid dendritic cell neoplasm	CD4 ⁺ , CD56 ⁺ , CD123 ⁺
Histiocyte	Histiocytic sarcoma	CD163 ⁺ , CD68 ⁺
Subset of sinusoidal histiocyte	Rosai-Dorfman disease	S-100 protein ⁺ , CD163 ⁺ , CD68 ⁺
Activated histiocyte	Hemophagocytic lymphohistiocytosis	CD163 ⁺ , CD68 ⁺

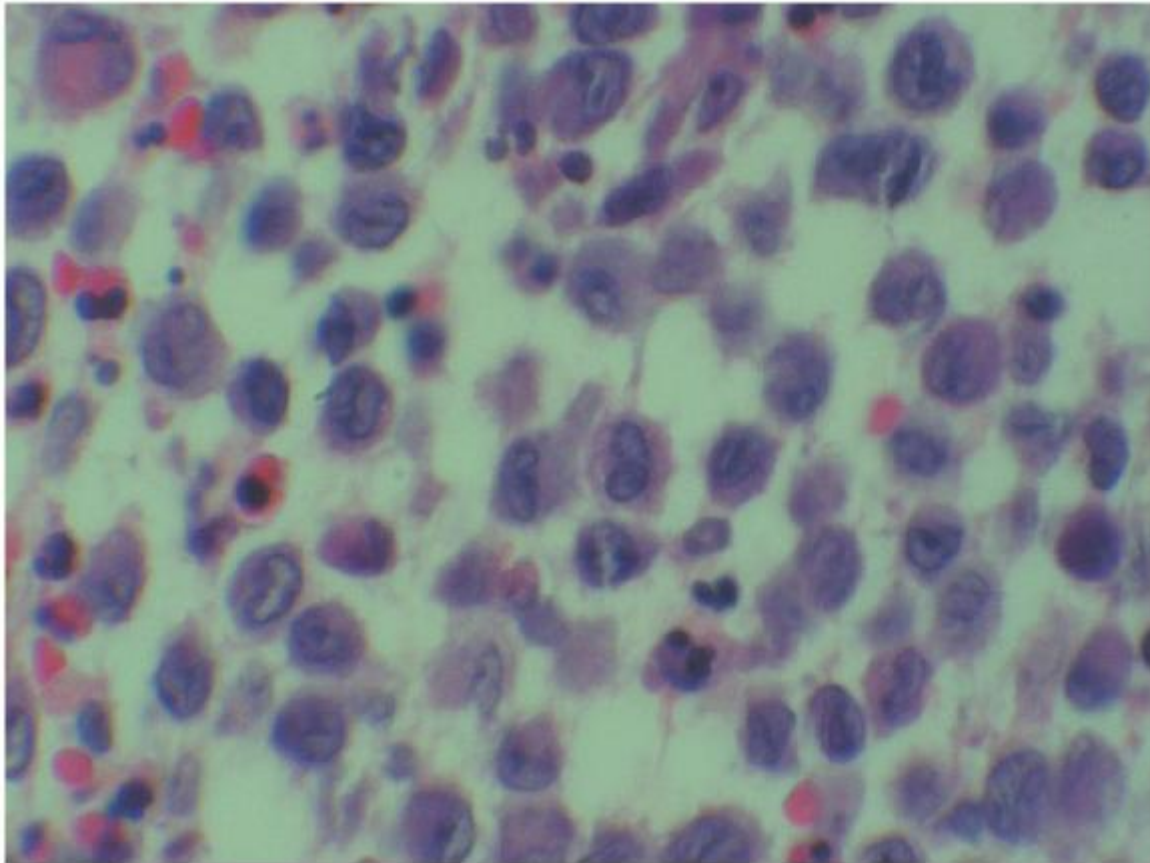

FIGURE 61.1. Langerhans cell histiocytosis. Histiocytic cells with frequent nuclear clefts are seen. Scattered eosinophils are present in the background.

Neoplastic Langerhans cells tend to have a similar (but not identical) phenotype as normal Langerhans cells, and are usually identified by expression of CD1a, langerin, and S-100 protein¹⁴ (Fig. 61.2). In addition, Langerhans cell histiocytosis expresses vimentin, HLA-DR, placental alkaline phosphatase (in contrast to normal Langerhans cells), and peanut agglutinin lectin. The tumor has been reported to be variably positive for CD45, CD68, CD163, CD4, and lysozyme; however, expression of these antigens probably represents positivity of the intimately admixed histiocytes. The Ki-67

index is usually low (<25%). Neoplastic and normal Langerhans cells are consistently negative for B- and T-lineage markers, CD30, CD34, and follicular dendritic cell markers CD21 and CD35. By enzyme histochemistry, normal and neoplastic Langerhans cells are positive for adenosine triphosphatase, α -D-mannosidase, α -naphthyl acetate esterase, α -naphthyl butyrate esterase, and acid phosphatase.¹⁵ There is no evidence of antigen-receptor gene rearrangements.

The differential diagnosis includes reactive proliferations of Langerhans cells, including dermatopathic lymphadenitis, so-called pulmonary Langerhans cell histiocytosis, and Langerhans cell histiocytosis-like proliferations associated with malignancy lymphoma. In dermatopathic lymphadenitis, the reactive Langerhans cells occur in the paracortex, in contrast to the sinusoidal or patchy pattern of lymph node involvement by Langerhans cell histiocytosis, and the proliferating Langerhans cells are accompanied by melanin-containing histiocytes and numerous interdigitating dendritic cells. So-called pulmonary Langerhans cell histiocytosis and Langerhans cell histiocytosis-like proliferations associated with malignant lymphoma are morphologically indistinguishable from Langerhans cell histiocytosis. Langerhans cell histiocytosis can be distinguished from most other histiocytic and dendritic disorders by their characteristic expression of CD1a, S-100 protein, and langerin.

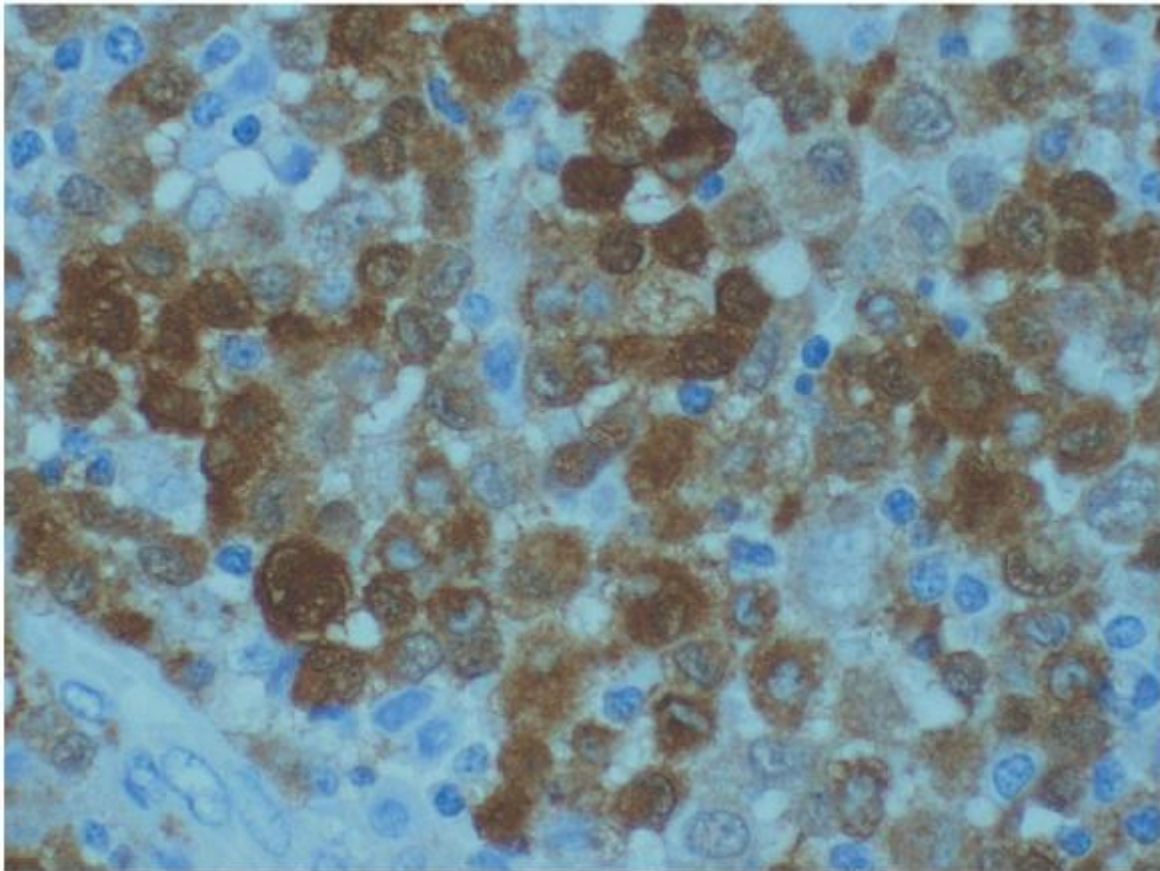

FIGURE 61.2. Langerhans cell histiocytosis, S-100 protein stain (same case as Fig. 61.1). Nuclear staining of the Langerhans cells is seen.

LANGERHANS CELL SARCOMA

Langerhans cell sarcoma is an extremely rare neoplasm defined as a neoplastic proliferation of Langerhans cells that have overtly malignant cytologic features.^{16, 17, 18} It usually presents de novo but may also represent progression from typical Langerhans cell histiocytosis. There is a wide age range affected, and there may be a female predominance. Typically, multifocal multisystem disease is present. An aggressive behavior is seen, with an overall survival of ~50%.

Histologically, a proliferation of cytologically malignant histiocyte-like cells is seen (Fig. 61.3). The presence of occasional nuclear features characteristic of Langerhans cells may suggest the diagnosis. The mitotic rate is high, and the characteristic cellular milieu of Langerhans cell histiocytosis is not usually seen. Given this histologic picture, the diagnosis is usually established with the identification of the CD1a (which may be focal; (Fig. 61.4) and S-100 protein, reactivities that are characteristic of Langerhans cells. The identification of Birbeck granules on ultrastructural examination is also

helpful in confirming the diagnosis. None of the cases reported to date have included langerin study. The Ki-67 index is usually much higher than that seen in typical Langerhans cell histiocytosis.

FOLLICULAR DENDRITIC CELL SARCOMA

Follicular dendritic cell sarcoma is a neoplasm of cells differentiating toward follicular dendritic cells. Normal follicular dendritic cells are the antigen-processing cells of the germinal center. Follicular dendritic cell sarcoma is a very rare neoplasm, occurring in a wide age range and even gender distribution.^{17, 19, 20, 21, 22} A subset of cases may occur in association with Castleman disease, and there may also be an association with schizophrenia.^{17, 22, 23} Most cases are not associated with known viruses, although a subset of cases, particularly those arising in liver or spleen, may be associated with Epstein-Barr virus (EBV).^{24, 25, 26} It most often presents in

P.1319

lymph nodes, but may also present in a variety of extranodal sites. Patients usually present with a slow-growing mass. Treatment usually consists of complete surgical excision, with or without adjuvant radiotherapy and/or chemotherapy. The tumor usually behaves in an indolent fashion, although local recurrence may occur in about one half of cases, and metastasis may occur in one fourth of cases.²⁷

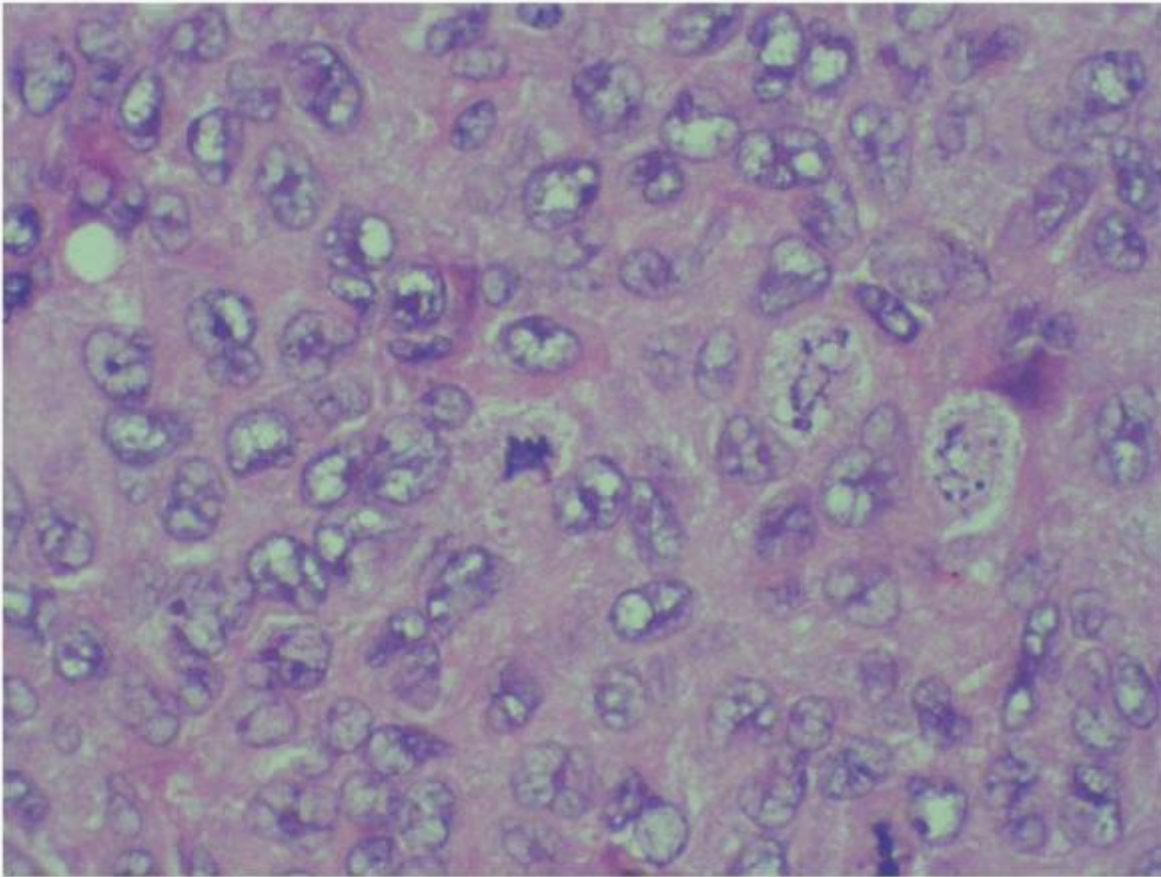

FIGURE 61.3. Langerhans cell sarcoma. Although some of the nuclei have features of Langerhans cells, the nuclear atypia is striking. Note the presence of several mitotic figures, including atypical forms.

Histologically, one sees a spindle cell neoplasm, which may resemble a low-grade sarcoma (Fig. 61.5). The spindled cells may form fascicles and whorls, and there is characteristically an admixture of small mature lymphocytes, both amid the spindled cells or architecturally segregated into a second component, which may include secondary lymphoid follicles. The individual cells usually have bland spindled nuclei, although significant atypia may be seen in a minority of cases. The chromatin may vary from vesicular to granular and generally have small nucleoli. Occasional multinucleated cells may be seen. Ultrastructural studies show complex interdigitating cell processes with scattered mature desmosomes, typical of normal follicular dendritic cells, and an absence of Birbeck granules.

Immunohistochemical studies show the presence of phenotypic markers characteristic of normal follicular dendritic cells: expression of CD21, CD35, and/or CD23.¹⁷ They are also usually positive for vimentin, desmoplakin, and HLA-DR, variably positive for S-100 protein and CD68, and negative for keratin, CD45, langerin, and specific markers of B- and T-cell differentiation (although CD20 may occasionally be aberrantly expressed). A germline configuration of the antigen-receptor genes is found.

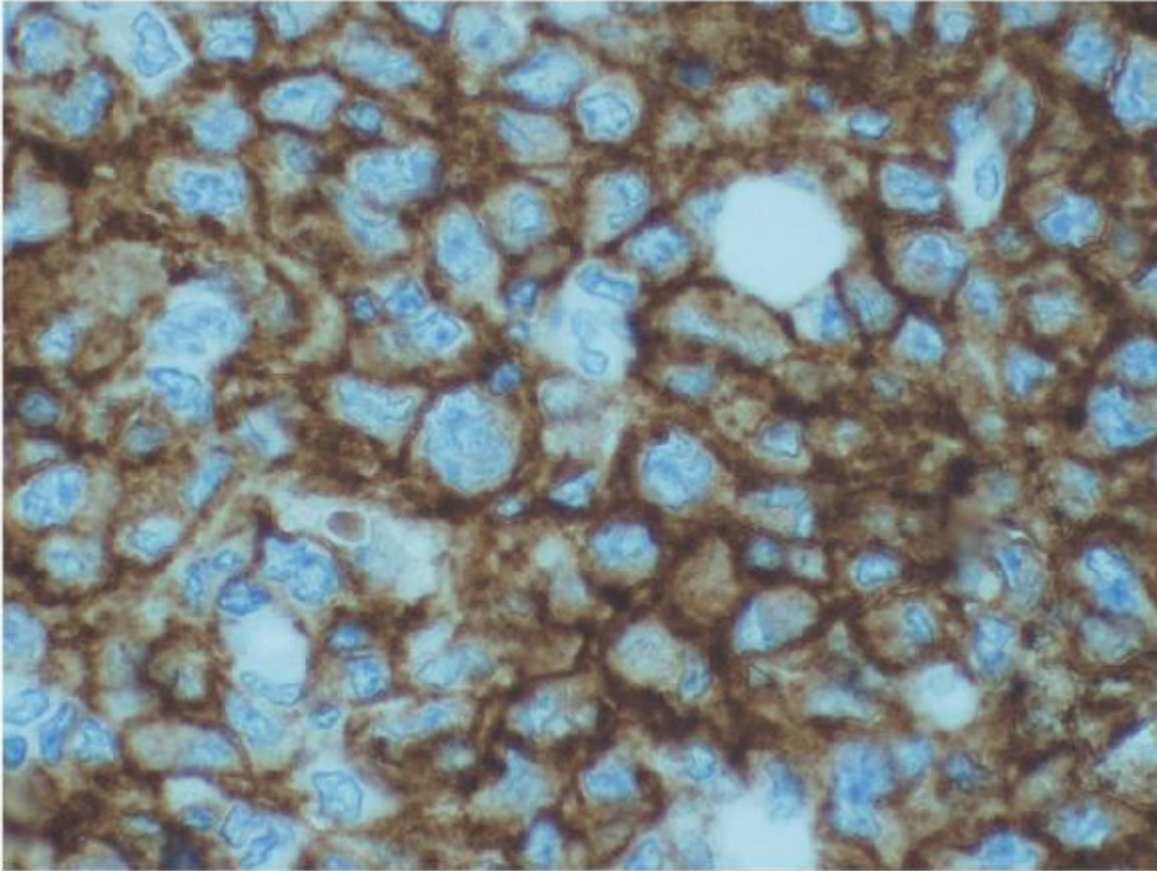

FIGURE 61.4. Langerhans cell sarcoma, CD1a (same case as Fig. 61.3). Membrane staining with CD1a is seen, characteristic of Langerhans cells.

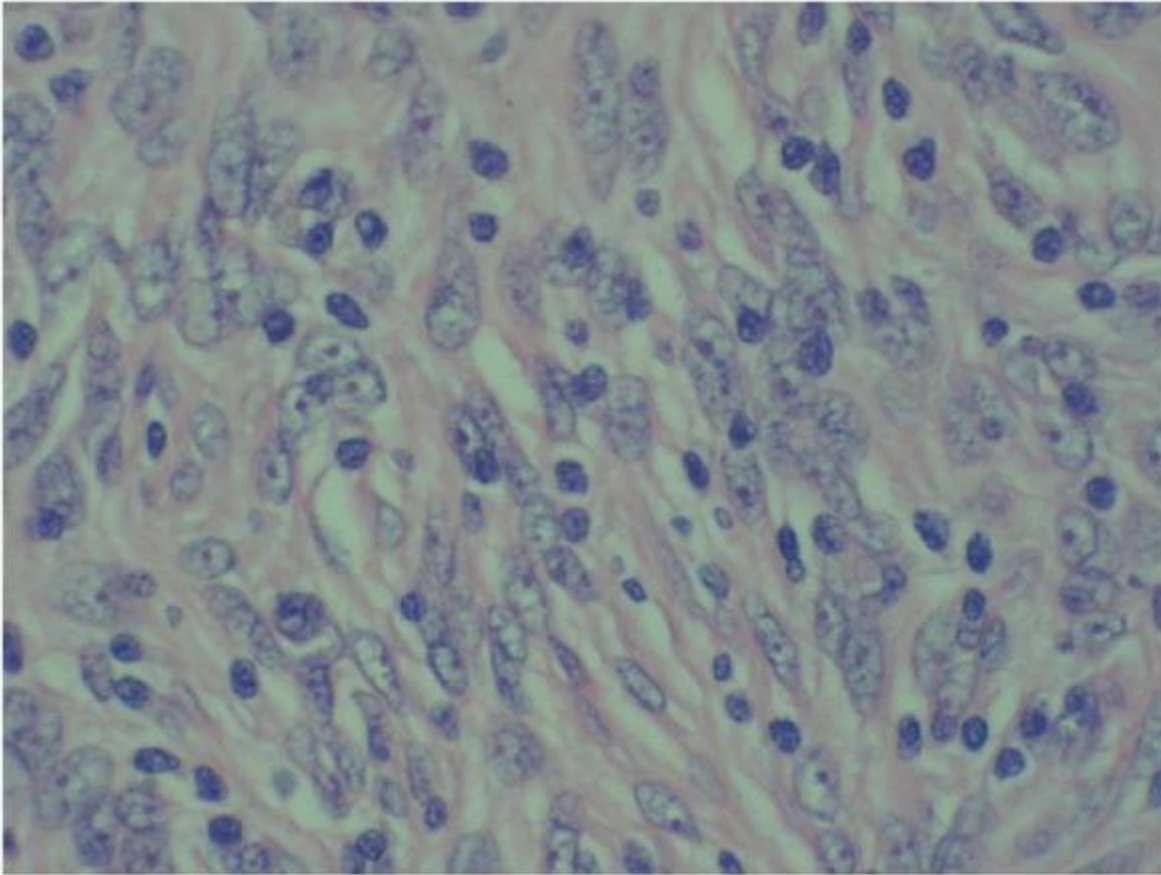

FIGURE 61.5. Follicular dendritic cell sarcoma. A bland spindle cell proliferation is seen, with scattered mature lymphocytes.

The differential diagnosis includes other dendritic tumors as well as other sarcomas, carcinoma, and malignant melanoma. Other sarcomas and dendritic tumors lack CD21, CD35, and/or CD23, whereas carcinoma is keratin-positive and malignant melanoma expresses specific markers of melanocytic differentiation.

INTERDIGITATING DENDRITIC CELL SARCOMA

Interdigitating cell sarcoma is a tumor differentiating toward normal interdigitating dendritic cells.^{17, 22, 28, 29} Normal interdigitating dendritic cells are major antigen-processing cells, usually located in the lymph node paracortical region. Interdigitating dendritic cell tumor is a very rare neoplasm usually occurring in adults, equally in men and women. Tumors may present either primarily in lymph nodes or at extranodal sites. Patients usually present with a solitary mass, although systemic symptoms may be present. The clinical course varies from benign to rapidly progressive lethal disease. Some cases may be associated with B-cell lymphoma; in such occurrences, both entities have been shown to be clonally related.^{30, 31}

Interdigitating dendritic cell sarcoma usually shows a paracortical pattern of distribution, with residual follicles (Fig. 61.6). It may be comprised of spindled cells and has a close resemblance to follicular dendritic cell sarcoma, although the cells may be more rounded and occasionally simulate a diffuse large-cell lymphoma. Nuclear atypia may vary widely, as does the mitotic rate. Immunohistochemical studies usually show strong expression of S-100 protein, in the absence of specific markers of follicular dendritic cells (CD21, CD35, and/or CD23), the Langerhans cell markers CD1a and langerin, or B- and T-cell markers. CD45, CD163, and CD68 may be variably positive. There is a germline configuration of the antigen-receptor genes. Ultrastructural studies show an absence of Birbeck granules or well-formed desmosomes, although complex interdigitating cell processes are seen.

Immunohistochemical studies are necessary to distinguish interdigitating dendritic cell sarcoma from follicular dendritic

cell sarcoma (CD21-, CD35-, and/or CD23-positive), Langerhans cell histiocytosis (CD1a-positive and langerin-positive), malignant lymphoma (B-, T-, and/or CD30-positive), spindled carcinoma (keratin-positive), or malignant melanoma (which expresses HMB-45, MELAN-A, and/or melanoma-associated transcription factor).

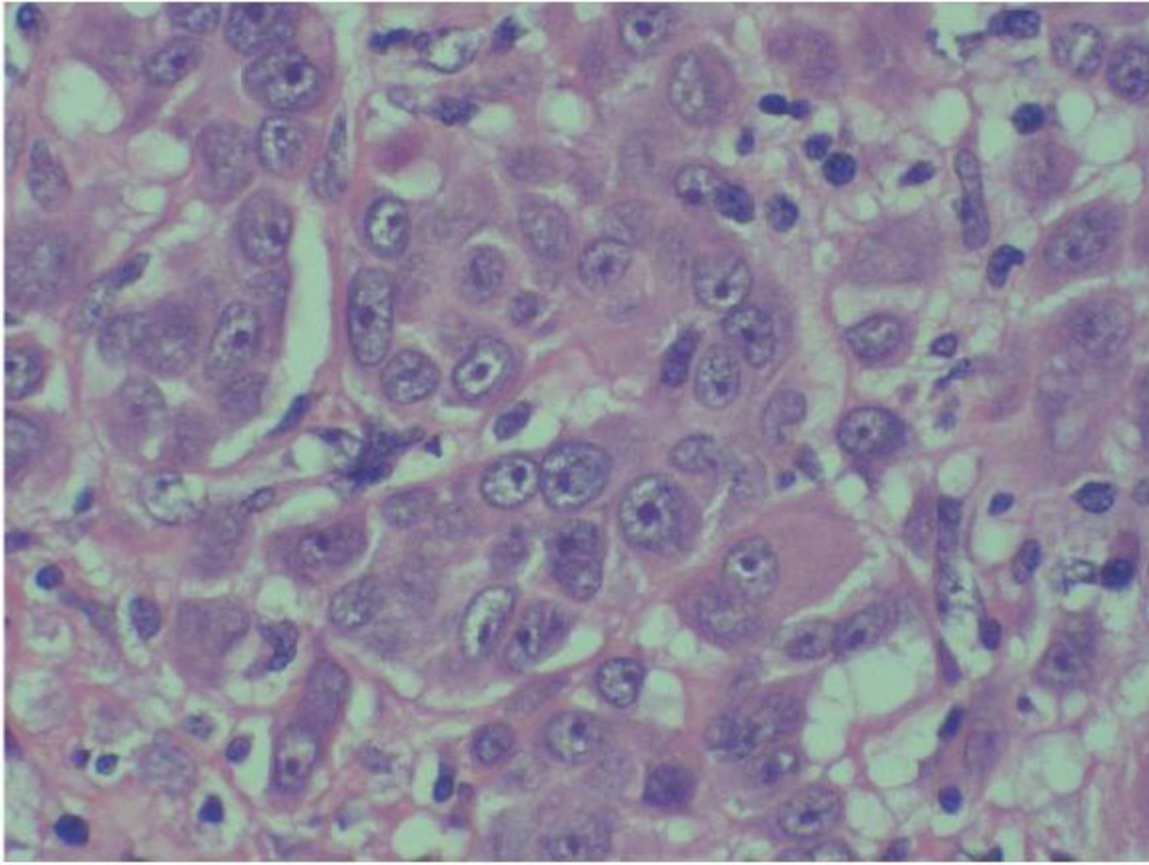

FIGURE 61.6. Interdigitating dendritic cell sarcoma. The cells are epithelioid. This case showed strong nuclear staining for S-100 protein, yet was negative for CD1a.

OTHER RARE DENDRITIC CELL SARCOMAS

Other rare dendritic cell sarcomas described in the World Health Organization Classification of Hematopoietic and Lymphoid Tissues includes indeterminate cell tumor and fibroblastic reticular cell neoplasm. Indeterminate cell tumor is a CD1a-negative, S-100 protein-positive skin-based spindled cell tumor, which lacks Birbeck granules.^{19, 32, 33} The tumor comprises bland spindled cells, some of which show irregular grooves and clefts (Fig. 61.7). Ultrastructural studies do not show Birbeck granules, suggesting a transitional neoplasm between Langerhans cell histiocytosis and interdigitating dendritic cell sarcoma. Obviously, such hard-to-classify cases are extraordinarily rare, and not yet well characterized. Fibroblastic reticular cell neoplasms are also extremely rare.^{19, 34} They generally occur in the lymph node paracortex and have a spindled to histiocytic appearance, and express vimentin, actin, and smooth muscle actin (in a heterogeneous pattern), and not S-100, CD1a, langerin, CD45, or markers of lymphoid or follicular dendritic cells.

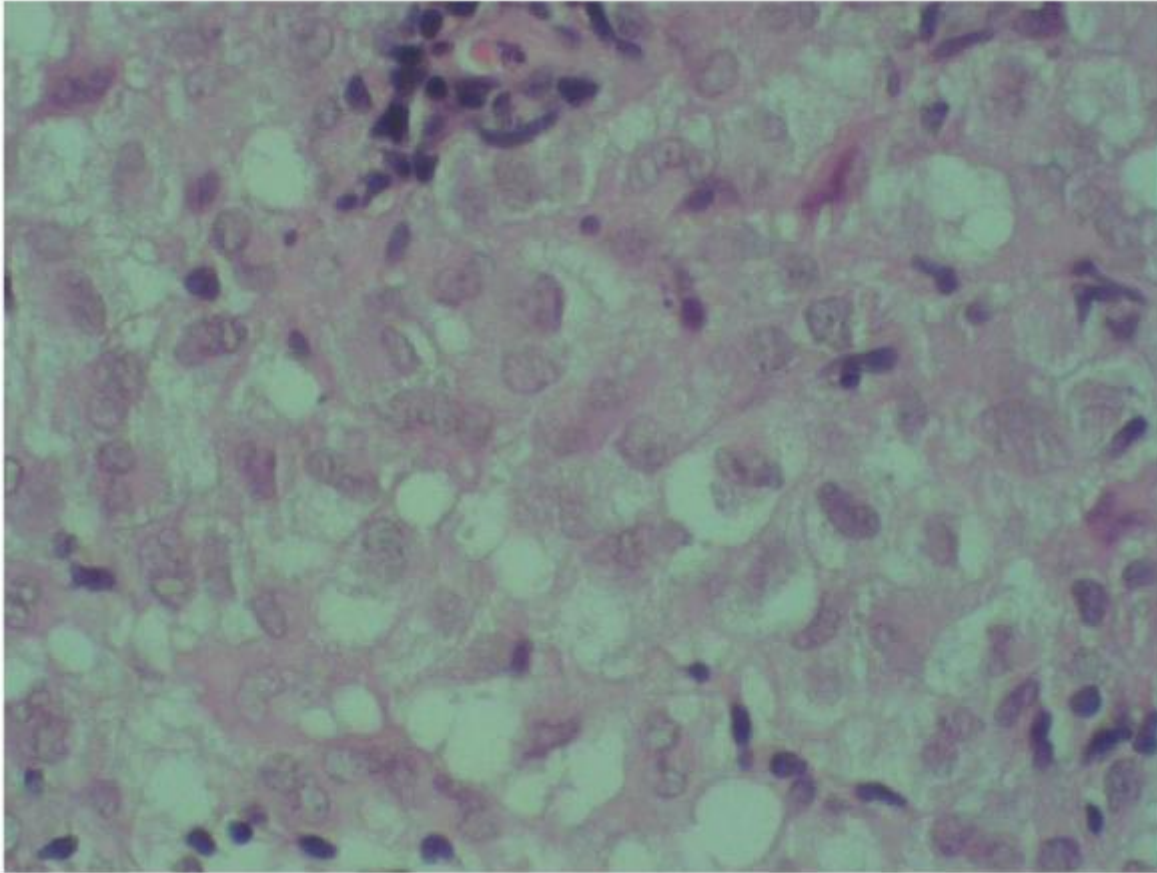

FIGURE 61.7. Indeterminate cell tumor. This cutaneous case showed positivity for CD1a and S-100 protein, yet Birbeck granules were not present on ultrastructural study.

BLASTIC PLASMACYTOID DENDRITIC CELL NEOPLASM

Blastic plasmacytoid dendritic cell neoplasm (formerly, $CD4^+CD56^+$ hematodermic neoplasm or blastic NK-cell lymphoma) is a rare aggressive neoplasm that probably shows differentiation toward plasmacytoid dendritic cells (formerly known as plasmacytoid monocytes). Normal plasmacytoid dendritic cells are predendritic cells of the lymph node paracortex and are a major source of α -interferon in viral infection or CD154 stimulation.³⁵ The neoplasm consistently expresses CD123 (the interleukin-3 receptor), CD68, and CD4, and a subset of cells expresses CD56 (the neural cell adhesion molecule NCAM). There is no association with known viruses, including EBV.³⁶ Most patients with $CD4^+CD56^+$ hematodermic neoplasm are elderly and present with skin lesions.³⁷ Bone marrow, peripheral blood, and lymph nodes are commonly simultaneously involved. The disease is usually rapidly progressive, with the development of disseminated disease in most patients, although some cases localized to skin may have a good prognosis.

Histologically, one sees a diffuse monotonous infiltrate of medium-sized cells with fine, blastic-appearing chromatin, closely resembling a lymphoblastic neoplasm (Fig. 61.8). Immunohistochemical studies show a phenotype resembling normal plasmacytoid dendritic cells, with positivity for CD4, CD56, CD123, and CD68.³⁸ In addition, there is also consistent positivity for CD45, CD43, HLA-DR, CD62L, and CXCR3, and some cases show positivity for terminal deoxyribonucleotide transferase or CD34. Antigen-receptor genes are germline. The differential diagnosis includes lymphoblastic lymphoma and acute myeloid leukemia, both of which lack the characteristic $CD4^-$, $CD56^-$, $CD123^-$ phenotype of $CD4^+CD56^+$ hematodermic neoplasm.

HISTIOCYTIC SARCOMA

Histiocytic sarcoma is a neoplastic proliferation of cells showing histologic, immunohistochemical, and molecular features of histiocytes.^{1, 17} By definition, there is the presence of one or more

specific histiocytic markers and absence of specific B- and T-cell markers. The neoplasms are tissue-based, and neoplasms associated with monocytic leukemias are excluded.

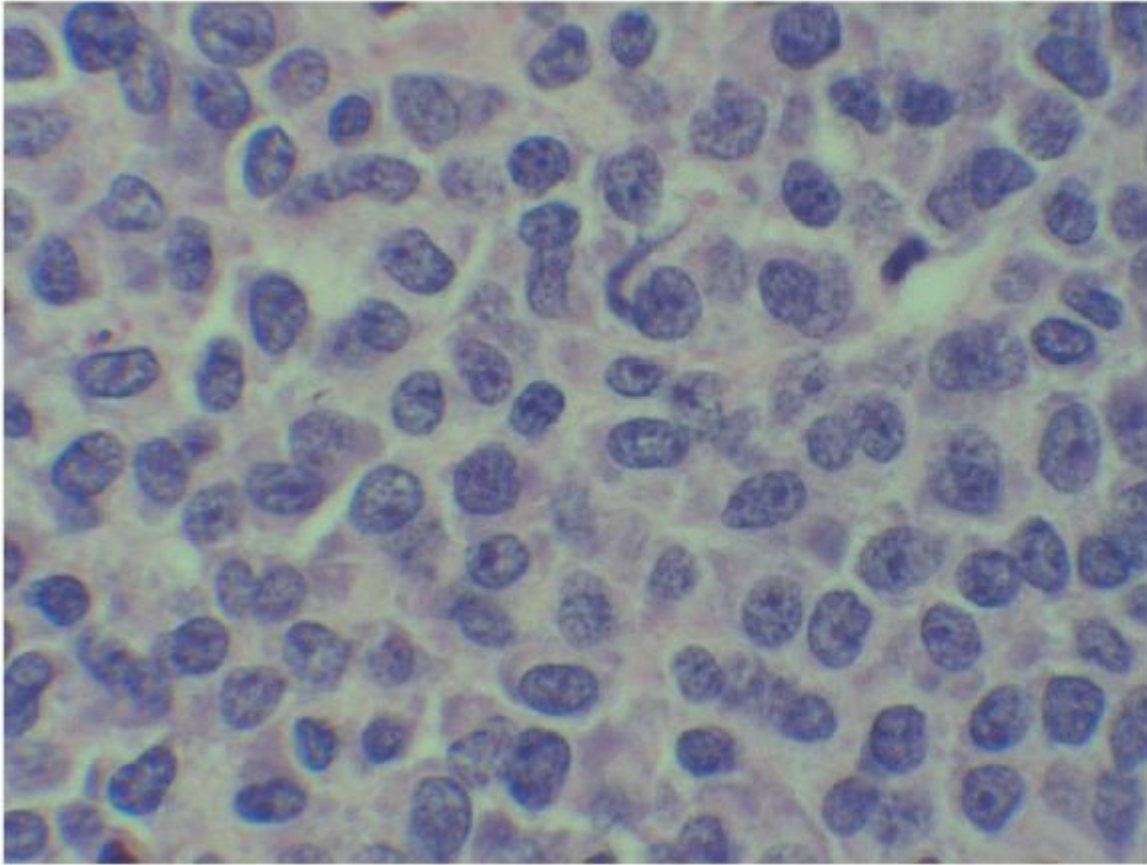

FIGURE 61.8. Blastic plasmacytoid dendritic cell neoplasm. Note the uniform proliferation of cells with a blastic chromatin pattern.

Histiocytic sarcoma is a rare neoplasm, mostly commonly occurring in adults, although it has been reported in all ages.^{17, 39, 40, 41, 42} A subset of cases may be associated with mediastinal germ cell tumor, usually malignant teratoma, with or without yolk sac tumor.⁴³ Lymph nodes and skin are most commonly involved, although virtually any site may be affected, including liver, spleen, bone, and intestinal tract. The bone may show lytic lesions or diffuse marrow involvement, with the latter occasionally causing pancytopenia. Some patients may show a “systemic” pattern of spread, recalling the old term, “malignant histiocytosis.” Most patients present a high clinical stage. Histiocytic sarcoma is an aggressive neoplasm, generally with a poor response to therapy, with most patients dying of progressive disease.

Histologically, one usually sees a patternless diffuse infiltrate of large cells, with a close resemblance to diffuse large-cell lymphoma (Fig. 61.9). Occasionally, one sees a preferential or exclusively sinusoidal pattern of infiltration. The proliferating cells generally have irregularly shaped nuclei, sometimes eccentrically placed, often with multilobulation and occasionally with multinucleation. Nuclear atypia ranges from mild to severe. The chromatin pattern is usually vesicular, and nucleoli may vary from small to large. Cytoplasm is usually moderate to abundant and eosinophilic, and may show some spindling. There may be some cells with foamy cytoplasm. Cytophagocytosis, usually hemophagocytosis, may be present, but is not considered to be a defining feature.

Phenotyping studies are essential to distinguish histiocytic sarcoma from other malignancies. Histiocytic sarcoma shows expression of at least one specific histiocytic marker in the absence of specific B- and T-cell markers. Positive markers of histiocytic differentiation may include CD163, CD68, CD4, CD11c, CD14, and lysozyme (Fig. 61.10). Additional, albeit nonspecific, antigens expressed by the neoplastic cells of histiocytic sarcoma may include CD45 and HLA-DR. The myeloid markers CD34 and myeloperoxidase are negative, although CD33 is usually positive.⁴⁴ There may also be expression of S-100 protein, but CD1a, CD21, CD35, and langerin are negative. Antigen-receptor gene rearrangement studies show a germ

line configuration, with the exception of those with an association with B cell lymphoma, and there is no association with known viruses.

The most important differential diagnostic consideration is with malignant lymphoma. Histiocytic sarcoma is ~0.1% as frequent as malignant lymphoma, which can be identified by the presence of specific B- and T-cell markers and/or CD30. The malignancy most frequently confused with histiocytic sarcoma is anaplastic large-cell lymphoma, which often has a focal or preferential sinusoidal pattern of involvement and may be comprised of highly pleomorphic cells. In fact, most cases previously diagnosed as malignancy histiocytosis on histologic grounds alone probably represent anaplastic large-cell lymphoma, which may be distinguished from histiocytic sarcoma by the former's constant expression of CD30, with or without ALK staining.⁴⁵ Rarely, carcinomas and malignant melanoma may be confused with histiocytic sarcoma. Use of keratin and specific markers of melanocytic differentiation other than S-100 protein (such as HMB-45, melanocytic-associated transcription factor, and Melan-A) should identify these cases.

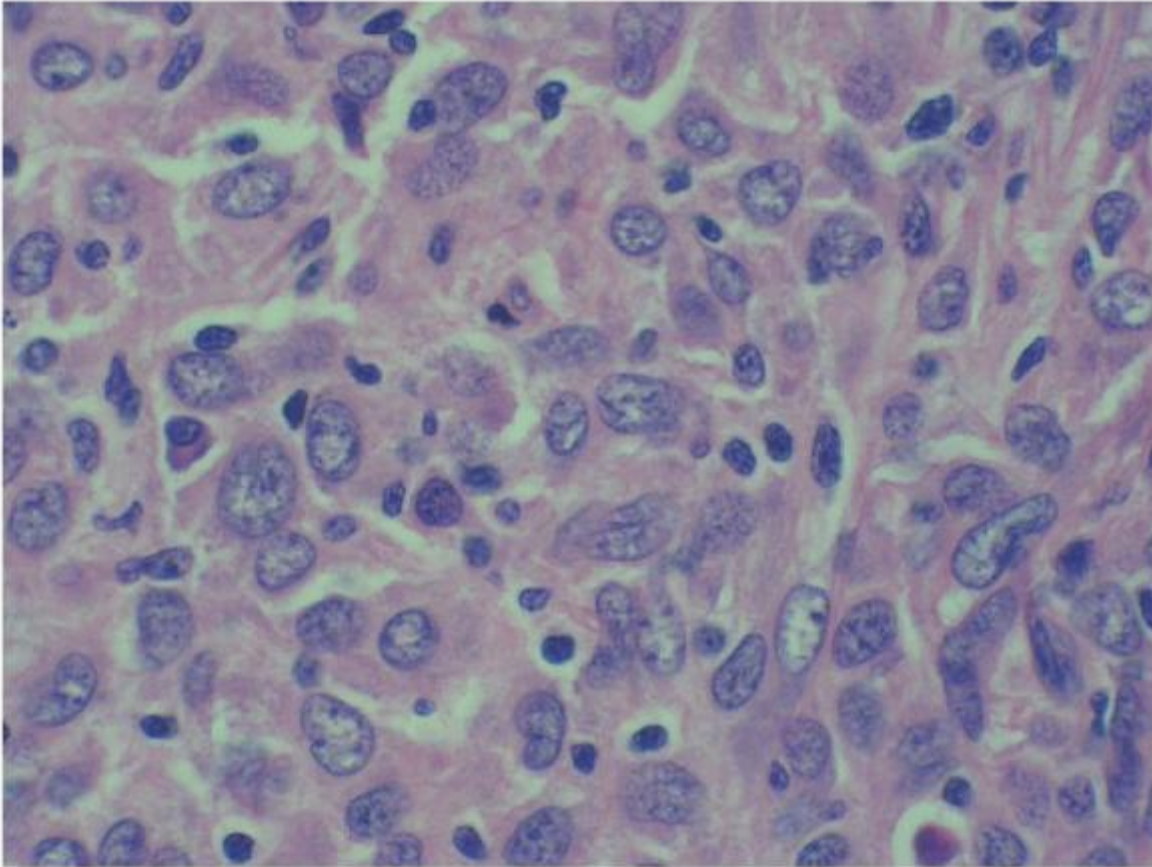

FIGURE 61.9. Histiocytic sarcoma. The nuclei appear lymphoid-like and closely resemble a diffuse large cell lymphoma.

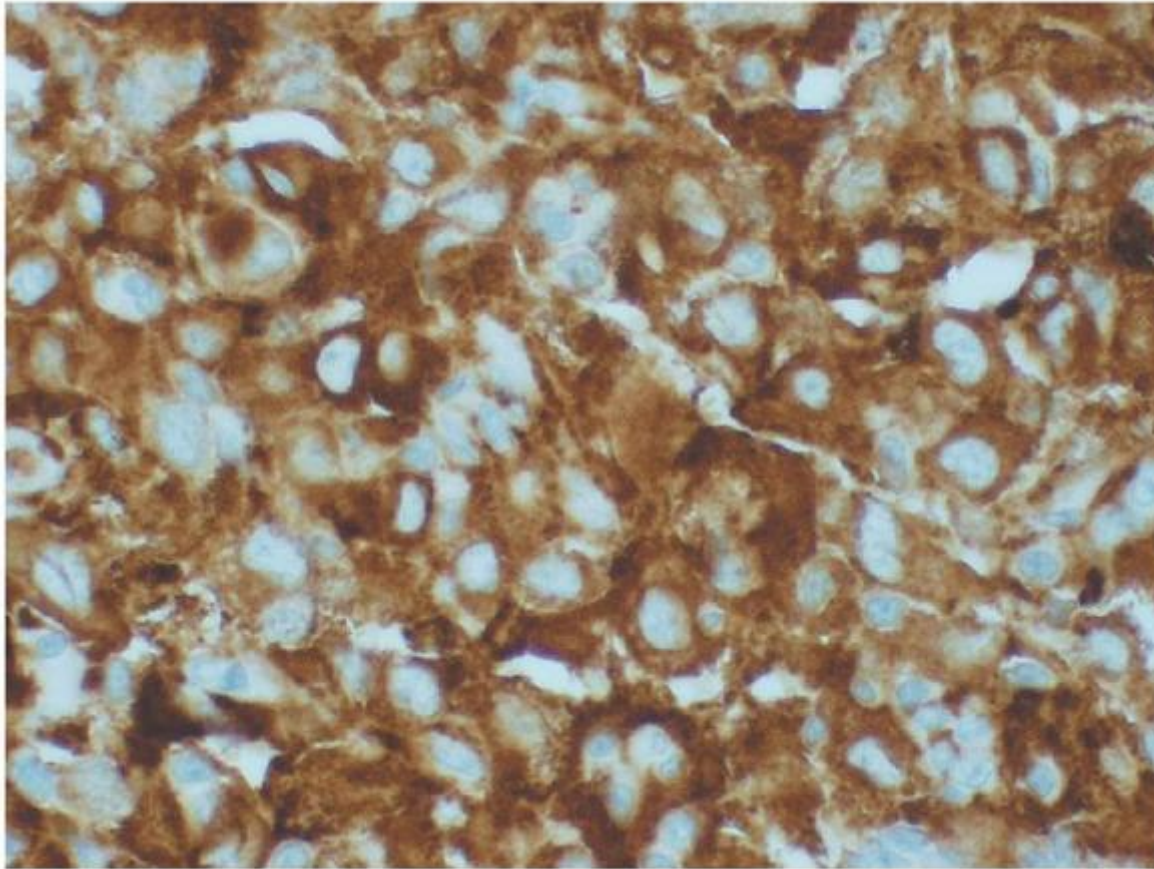

FIGURE 61.10. Histiocytic sarcoma (same case as Fig. 61.9). CD163: strong positivity for CD163 is seen, consistent with a histiocytic lineage.

DISSEMINATED JUVENILE XANTHOGRANULOMA

Juvenile xanthogranulomata are protuberant cutaneous nodules that usually present in the head and neck of children.^{46, 47, 48} The lesions may measure up to 1 cm in diameter and may occasionally occur in the soft tissues or internal organs. An aggressive systemic form, known as disseminated juvenile xanthogranuloma, accounts for <5% of cases. This variant also most commonly affects children, although rarely adults are affected (Erdheim-Chester disease). The etiology of disseminated juvenile xanthogranuloma is unknown, but rare patients also have neurofibromatosis-1 and/or juvenile myelomonocytic leukemia. Of note, NF-1 and JMML are also associated with usual type juvenile xanthogranuloma.^{49, 50, 51} Pathologically, the lesions of disseminated juvenile xanthogranuloma are cellular, with a mixture of histiocytic, spindled, and giant cells.⁴⁷ Nuclear pleomorphism is not prominent. The tumor cells express factor XIIIa, fascin, CD163, and CD68, and do not express S-100 protein.

ROSAI-DORFMAN DISEASE

Rosai-Dorfman disease (sinus histiocytosis with massive lymphadenopathy) is a probably reactive disorder of as yet unknown etiology and whose proliferating cells may derive from a surfeit of sinusoidal macrophages.^{52, 53} Patients usually present with

P.1322

markedly enlarged, often bilateral, painless cervical lymph nodes. However, a wider variety of extranodal sites are involved in about one-half of cases, including skin, upper respiratory tract, bone, soft tissue, including orbit, and these extranodal sites may be the presenting or only site of disease.⁵⁴ Patients are generally young, presenting at a median age of 20 years, with no sex predilection, but a marked propensity for African Americans. There are usually a wide variety of laboratory abnormalities; including leukocytosis (neutrophilia), polyclonal hypergammaglobulinemia, and elevated

sedimentation rate. The clinical course is usually benign, although there may be persistence or recurrence of disease, and a small subset may be associated with immune dysfunction and have a poor outcome.⁵⁵

Involved lymph nodes are usually markedly enlarged and have a fibrotic lymph node capsule with massive dilation of the lymph node sinuses (Fig. 61.11). The sinuses show characteristic histiocytes, usually admixed with numerous plasma cells and the adjacent medullary cords also show numerous plasma cells. Extranodal sites usually show strikingly identical features, with dilated lymphatic sinuses, although surrounding fibrosis is usually more prominent. The characteristic histiocytes are very large with round nuclei that have a vesicular chromatin pattern, a delicate nuclear membrane, and one to several distinct nucleoli. Cytoplasm is abundant, amphiphilic to eosinophilic, and occasionally foamy. A distinctive feature is that the cytoplasm often contains numerous lymphocytes (lymphophagocytosis) or other cells (including neutrophils or erythrocytes).

Immunohistochemical studies show that the distinctive histiocytes are strongly positive for S-100 protein, CD163, CD68, CD11c, and CD14.^{56, 57, 58} They may also be focally positive for CD30 or, and more rarely, positive for CD1a. They are consistently negative for the follicular dendritic cell markers CD21 and CD35. Molecular studies show a germline configuration of the antigen-receptor genes, and the cells have been shown to be polyclonal by analyses of the X-linked androgen-receptor gene. There is no convincing evidence of an association with any known viruses.

The differential diagnosis includes sinus histiocytosis, Langerhans cell histiocytosis, hemophagocytic lymphohistiocytosis, and histiocytic sarcoma. The key to the diagnosis of Rosai-Dorfman disease is the recognition of the peculiar proliferating histiocytes, which contain a distinctive nucleus, and prominent lymphophagocytosis. Sinus histiocytosis lacks these peculiar cells, although it may show focal lymphophagocytosis.

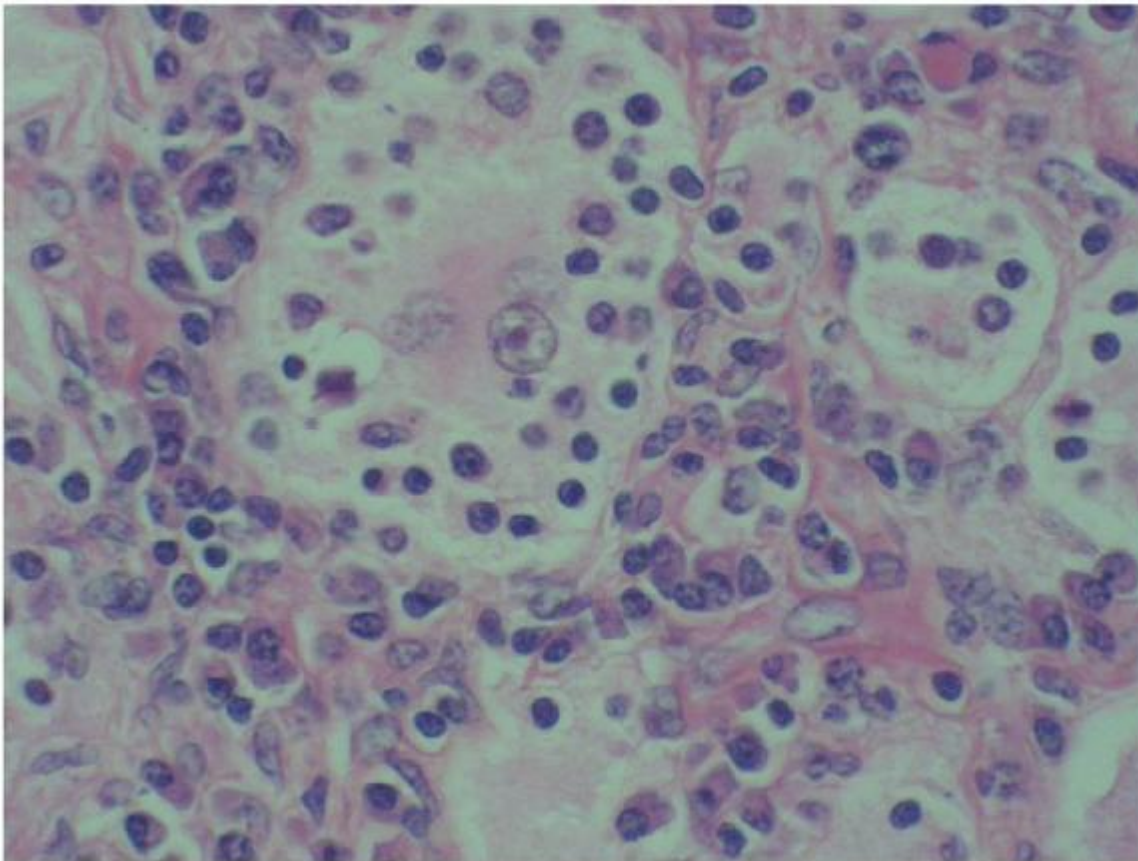

FIGURE 61.11. Rosai-Dorfman disease. Note the peculiar histiocytes with abundant lymphophagocytosis, along with the accompanying infiltrate of mature plasma cells.

HEMOPHAGOCYtic LYMPHOHISTIOCYTOSIS

Hemophagocytic lymphohistiocytosis is a clinicopathologic syndrome characterized by uncontrolled hyperinflammation caused by a variety of inherited or acquired immune deficiencies.⁵⁹ Most of the genetic defects involve defects in granulocyte-mediated cytotoxicity and NK-cell function.⁶⁰ Familial hemophagocytic lymphohistiocytosis usually presents within the first

year of life, with a symptom-free interval after birth typically seen.^{59, 61} EBV is the triggering agent in ~75% of cases of infection-associated hemophagocytic lymphohistiocytosis.⁶² The terminal stages of any malignancy, including malignant lymphoma, may be associated with hemophagocytic lymphohistiocytosis. However, EBV-associated T/NK neoplasms are particularly common, and the accompanying hemophagocytic syndromes may occur at an early stage and may even be the presenting symptom of the lymphoma.^{63, 64} Patients with hemophagocytic lymphohistiocytosis usually present with fever, hepatosplenomegaly, and cytopenias, and central nervous system symptoms are also common. Laboratory abnormalities include cytopenias of two or more cell lines, hypertriglyceridemia and/or hyperfibrinogenemia, and an increase in serum ferritin and soluble CD25. The prognosis is poor, with the immediate aim of therapy being to suppress the increased inflammatory response by immunosuppressive/immunomodulatory agents and cytotoxic drugs. Hematopoietic cell transplant has been curative in a selected group of patients with primary hemophagocytic lymphohistiocytosis.⁶⁵

Early in the disease course, biopsied lymph nodes may show a marked immunoblastic proliferation in the paracortex, with only minor hyperplasia of histiocytes noted in the sinuses. Later on, however, there is a massive infiltrating of the sinusoid by benign-appearing histiocytes. They show a normal histiocytic phenotype, with CD163 and CD68 positivity, and often show prominent hemo- and platelet phagocytosis (Fig. 61.12). There are also usually scattered to abundant plasma cells. The cortical and paracortical regions become comparatively diminished in size and stimulation. Finally, the lymph node may show lymphocyte depletion, with marked histiocytic hyperplasia with abundant phagocytosis in sinusoids. The hemophagocytic lymphohistiocytosis syndrome is usually established on clinical criteria, with lymph node biopsy performed to rule out coexisting malignant lymphoma.

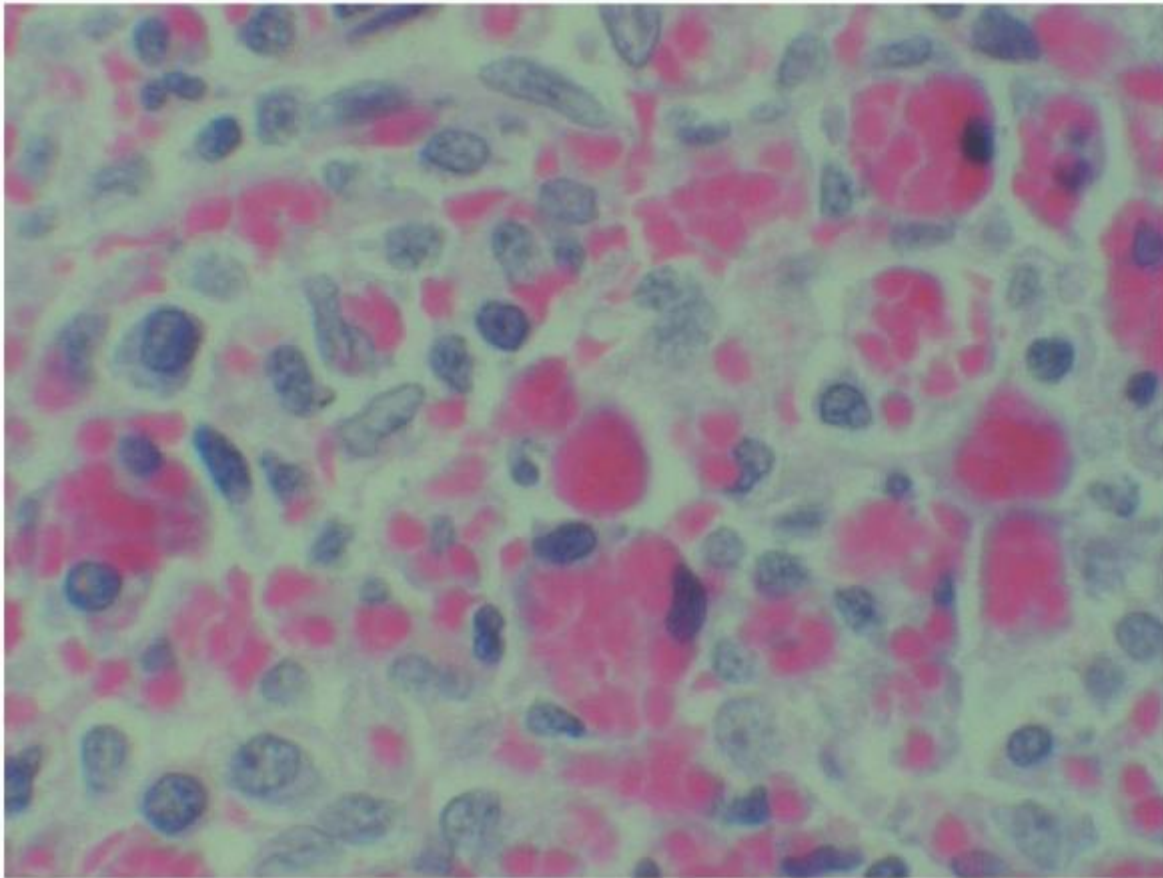

FIGURE 61.12. Lymphohistiocytic hemophagocytosis, spleen. Note the prominent hemophagocytosis. This case was associated with Epstein-Barr infection.

P.1323

REFERENCES

1. Swerdlow SH, Campo E, Harris NL, et al. eds. World Health Organization classification of tumours of haematopoietic and lymphoid tissues. Lyon: IARC Press, 2008.
2. Geissmann F, Lepelletier Y, Fraitag S, et al. Differentiation of Langerhans cells in Langerhans cell histiocytosis. *Blood* 2001;97:1241-1248.
3. Coppes-Zantinga A, Egeler RM. The Langerhans cell histiocytosis X files revealed. *Br J Haematol* 2002;116:3-9.
4. Lieberman PH, Jones CR, Steinman RM, et al. Langerhans cell (eosinophilic) granulomatosis: a clinicopathologic study encompassing 50 years. *Am J Surg Pathol* 1996;20:519-552.
5. Guyot-Goubin A DJ, Barkaoui M, Bellec S, Thomas C, Clavel J. Descriptive epidemiology of childhood Langerhans cell histiocytosis in France, 2000-2004. *Pediatr Blood Cancer* 2008;51:71-75.
6. Willman CL, Busque L, Griffith BB, et al. Langerhans'-cell histiocytosis (Histiocytosis X)—a clonal proliferative disease. *N Engl J Med* 1994;331: 154-160.
7. McClain K, Jin H, Gresik V, et al. Langerhans cell histiocytosis: lack of a viral etiology. *Am J Hematol* 1994;47:16-20.
8. Murakami I, Gogusev J, Fournet JC, et al. Detection of molecular cytogenetic aberrations in Langerhans cell histiocytosis of bone. *Hum Pathol* 2002;33:555-560.
9. Badalian-Very G VJ, Degar BA, MacConaill LE, et al. Recurrent BRAF mutations in Langerhans cell histiocytosis. *Blood* 2010;116:1919-1923.
10. Annels NE, Da Costa CE, Prins FA, et al. Aberrant chemokine receptor expression and chemokine production by Langerhans cells underlies the pathogenesis of Langerhans cell histiocytosis. *J Exp Med* 2003;197:1385-1390.
11. Egeler RM, Favara BE, van Meurs M, et al. Differential in situ cytokine profiles of Langerhans-like cells and T cells in Langerhans cell histiocytosis: abundant expression of cytokines relevant to disease and treatment. *Blood* 1999;94:4195-4201.
12. Favara BE, Jaffe R. Pathology of Langerhans cell histiocytosis. *Hematol Oncol Clin North Am* 1987;1:75-97.
13. Valladeau J, Dezutter-Dambuyant C, Saeland S. Langerin/CD207 sheds light on formation of Birbeck granules and their possible function in Langerhans cells. *Immunol Res* 2003;28:93-107.
14. Hage C, Willman CL, Favara BE, et al. Langerhans' cell histiocytosis (histiocytosis X): immunophenotype and growth fraction. *Hum Pathol* 1993;24: 840-845.
15. Turner RR, Wood GS, Beckstead JH, et al. Histiocytic malignancies. Morphologic, immunologic, and enzymatic heterogeneity. *Am J Surg Pathol* 1984;8:485-500.
16. Ben-Ezra J, Bailey A, Azumi N, et al. Malignant histiocytosis X. A distinct clinicopathologic entity. *Cancer* 1991;68:1050-1060.
17. Pileri SA, Grogan TM, Banks P, et al. Tumours of histiocytes and accessory dendritic cells: an immunohistochemical approach to classification from the International Lymphoma Study Group based on 61 cases. *Histopathology* 2002;41:1-29.
18. Wood C, Wood GS, Deneau DG, et al. Malignant histiocytosis X. Report of rapidly fatal case in an elderly man. *Cancer* 1984;54:347-352.
19. Andriko JW, Kaldjian EP, Tsokos M, et al. Reticulum cell neoplasms of lymph nodes: a clinicopathologic study of 11 cases with recognition of a new subtype derived from fibroblastic reticular cells. *Am J Surg Pathol* 1998;22:1048-1058.
20. Perez-Ordóñez B, Rosai J. Follicular dendritic cell tumor: review of the entity. *Semin Diagn Pathol* 1998;15:144-154.
21. Monda L, Warnke R, Rosai J. A primary lymph node malignancy with features suggestive of dendritic reticulum cell differentiation. A report of 4 cases. *Am J Pathol* 1986;122:562-572.
22. Weiss LM, Berry GJ, Dorfman RF, et al. Spindle cell neoplasms of lymph nodes of probable reticulum cell lineage. True reticulum cell sarcoma? *Am J Surg Pathol* 1990;14:405-414.
23. Sun X, Chang KC, Abruzzo LV, et al. Epidermal growth factor receptor expression in follicular dendritic cells: a shared feature of follicular dendritic cell sarcoma and Castleman's disease. *Hum Pathol* 2003;34:835-840.
24. Arber DA, Weiss LM, Chang KL. Detection of Epstein-Barr virus in inflammatory pseudotumor. *Semin Diagn Pathol* 1998;15:155-160.

25. Nayler SJ, Taylor L, Cooper K. HHV-8 is not associated with follicular dendritic cell tumours. *Mol Pathol* 1998;51:168-170.
26. Cheuk W, Chan JK, Shek TW, et al. Inflammatory pseudotumor-like follicular dendritic cell tumor: a distinctive low-grade malignant intra-abdominal neoplasm with consistent Epstein-Barr virus association. *Am J Surg Pathol* 2001;25:721-731.
27. Chan JK, Fletcher CD, Nayler SJ, et al. Follicular dendritic cell sarcoma. Clinicopathologic analysis of 17 cases suggesting a malignant potential higher than currently recognized. *Cancer* 1997;79:294-313.
28. Fonseca R, Yamakawa M, Nakamura S, et al. Follicular dendritic cell sarcoma and interdigitating reticulum cell sarcoma: a review. *Am J Hematol* 1998;59:161-167.
29. Pillay K, Solomon R, Daubenton JD, et al. Interdigitating dendritic cell sarcoma: a report of four paediatric cases and review of the literature. *Histopathology* 2004;44:283-291.
30. Feldman AL, Arber DA, Pittaluga S, et al. Clonally related follicular lymphomas and histiocytic/dendritic cell sarcomas: evidence for transdifferentiation of the follicular lymphoma clone. *Blood* 2008;111:5433-5439.
31. Shao H SL, Raffeld M, Feldman AL, et al. Clonally related Histiocytic/dendritic cell sarcoma and chronic lymphocytic leukemia/small lymphocytic lymphoma: a study of 7 cases. *Mod Pathol* 2011;24:1421-1432.
32. Berti E, Gianotti R, Alessi E. Unusual cutaneous histiocytosis expressing an intermediate immunophenotype between Langerhans' cells and dermal macrophages. *Arch Dermatol* 1988;124:1250-1253.
33. Rezk SA, Spagnolo DV, Brynes RK, et al. Indeterminate cell tumor: a rare dendritic neoplasm. *Am J Surg Pathol* 2008;32:1868-1676.
34. Martel M, Sarli D, Colecchia M, et al. Fibroblastic reticular cell tumor of the spleen: report of a case and review of the entity. *Am J Surg Pathol* 2003;16:175-183.
35. Geissmann F MM, Jung S, Sieweke MH, Merad M, Ley K. Development of monocytes, macrophages and dendritic cells. *Science* 2010;327:656-661.
36. Matano S, Nakamura S, Annen Y, et al. Monomorphic agranular natural killer cell lymphoma/leukemia with no Epstein-Barr virus association. *Acta Haematol* 1999;101:206-208.
37. Magro CM PP, Schaefer J, Erter JW, Furman RR, Shitabata PK, Crowson AN. Cutaneous CD4+ CD56+ hematologic malignancies. Cutaneous CD4+CD56+ hematologic malignancies. *J Am Acad Dermatol* 2010;63:292-308.
38. Petrella T, Comeau MR, Maynadie M, et al. "Agranular CD4+ CD56+ hematodermic neoplasm" (blastic NK-cell lymphoma) originates from a population of CD56+ precursor cells related to plasmacytoid monocytes. *Am J Surg Pathol* 2002;26:852-862.
39. Kamel OW, Gocke CD, Kell DL, et al. True histiocytic lymphoma: a study of 12 cases based on current definition. *Leuk Lymphoma* 1995;18:81-86.
40. Copie-Bergman C, Wotherspoon AC, Norton AJ, et al. True histiocytic lymphoma. A morphologic, immunohistochemical and molecular genetic study of 13 cases. *Am J Surg Pathol* 1998;22:1386-1392.
41. Hanson CA, Jaszcz W, Kersey JH, et al. True histiocytic lymphoma: histopathologic, immunophenotypic and genotypic analysis. *Br J Haematol* 1989;73:187-198.
42. Ralfkiaer E, Delsol G, O'Connor NTJ, et al. Malignant lymphomas of true histiocytic origin. A clinical, histological, immunophenotypic and genotypic study. *J Pathol* 1990;160:9-17.
43. Nichols CR, Roth BJ, Heerema N, et al. Hematologic neoplasia associated with primary mediastinal germ-cell tumors. *N Engl J Med* 1990;322: 1425-1429.
44. Soria C, Orradre JL, Garcia-Almagro D, et al. True histiocytic lymphoma (monocytic sarcoma). *Am J Dermatopathol* 1992;14:511-517.
45. Wilson MS, Weiss LM, Gatter KC, et al. Malignant histiocytosis: a reassessment of cases previously reported in 1975 based upon paraffin section immunophenotyping studies. *Cancer* 1990;66:530-536.
46. Weitzman S, Jaffe R. Uncommon histiocytic disorders: the non-Langerhans cell histiocytoses. *Pediatr Blood Cancer* 2005;45:256-264.

47. Zelger B, Cerio R, Orchard G, et al. Juvenile and adult xanthogranuloma. A histological and immunohistochemical comparison. *Am J Surg Pathol* 1994;18:126-135.
48. Dehner LP. Juvenile xanthogranulomas in the first two decades of life: a clinicopathologic study of 174 cases with cutaneous and extracutaneous manifestations. *Am J Surg Pathol* 2003;27:579-593.
49. Cambiaghi S, Restano L, Caputo R. Juvenile xanthogranuloma associated with neurofibromatosis 1: 14 patients without evidence of hematologic malignancies. *Pediatr Dermatol* 2004;21:97-101.
50. Burgdorf WHC, Zelger B. JXG, NF1, and JMML: alphabet soup or a clinical issue? *Pediatr Dermatol* 2004;21:174-176.
51. Zvulunov A, Barak Y, Metzker A. Juvenile xanthogranuloma, neurofibromatosis, and juvenile chronic myelogenous leukemia. World statistical analysis. *Arch Dermatol* 1995;131:904-908.
52. Rosai J, Dorfman RF. Sinus histiocytosis with massive lymphadenopathy: a pseudolymphomatous benign disorder. Analysis of 34 cases. *Cancer* 1972;1174-1188.
53. Foucar E, Rosai J, Dorfman RF. Sinus histiocytosis with massive lymphadenopathy (Rosai-Dorfman disease). Review of the entity. *Semin Diagn Pathol* 1990;7:19-73.
54. Montgomery EA, Meis JM, Frizzera G. Rosai-Dorfman disease of soft tissue. *Am J Surg Pathol* 1992;16:122-129.
55. Foucar E, Rosai J, Dorfman RF. Sinus histiocytosis with massive lymphadenopathy. An analysis of 14 deaths occurring in a patient registry. *Cancer* 1984;54:1834-1840.
56. Bonetti F, Chilosi M, Menestrina F, et al. Immunohistological analysis of Rosai-Dorfman histiocytosis. A disease of S-100 + CD1-histiocytes. *Virchows Archiv. A, Pathological anatomy and histopathology* 1987;411:129-135.
57. Eisen RN, Buckley PJ, Rosai J. Immunophenotypic characterization of sinus histiocytosis with massive lymphadenopathy (Rosai-Dorfman disease). *Semin Diagn Pathol* 1990;7:74-82.
58. Paulli M, Rosso R, Kindl S, et al. Immunophenotypic characterization of the cell infiltrate in five cases of sinus histiocytosis with massive lymphadenopathy. *Hum Pathol* 1992;6:647-654.
59. Weitzman S. Approach to hemophagocytic syndromes. *Hematology Am Soc Hematol Educ Program* 2011;2011:178-183.
60. Stepp SE, Dufourcq-Lagelouse R, Le Deist F, et al. Perforin gene defects in familial hemophagocytic lymphohistiocytosis. *Science* 1999;286:1957-1959.
61. Arico M, Janka G, Fischer A, et al. Hemophagocytic lymphohistiocytosis. Report of 122 children from the International Registry. FHL Study Group of the Histiocyte Society. *Leukemia* 1996;10:197-203.
62. Risdall RJ, McKenna RW, Nesbitt ME, et al. Virus associated hemophagocytic syndrome. A benign histiocytic proliferation distinct from malignant histiocytosis. *Cancer* 1979;44:993-1002.
63. Falini B, Pileri S, De Solas I, et al. Peripheral T-cell lymphoma associated with hemophagocytic syndrome. *Blood* 1990;75:434-444.
64. Jaffe ES, Costa J, Fauci AS, et al. Malignant lymphoma and erythrophagocytosis simulating malignant histiocytosis. *Am J Med* 1983;75:741-749.
65. Marsh RA JM, Filipovich AH. Reduced-intensity conditioning haematopoietic cell transplantation for haemophagocytic lymphohistiocytosis: an important step forward. *Br J Haematol* 2011;154:556-563.

Chapter 62 Infectious Mononucleosis and Other Epstein-Barr Virus-Related Disorders

> Table of Contents > Part VI - Benign Disorders of Leukocytes, The Spleen, and/or Immunoglobins > Chapter 62 - Infectious Mononucleosis and Other Epstein-Barr Virus-Related Disorders

Chapter 62

Infectious Mononucleosis and Other Epstein-Barr Virus-Related Disorders

Thomas G. Gross

Epstein-Barr virus (EBV) infects the majority of human individuals but usually results in subclinical infections. EBV has been etiologically linked to a wide spectrum of human disease, but it has been shown to be the etiologic agent in relatively few. Although EBV has been identified as the etiologic agent for infectious mononucleosis (IM), the diagnosis is predicated on the presence of a well-described constellation of clinical and laboratory features. EBV has been associated with Burkitt lymphoma (BL) and nasopharyngeal carcinoma (NPC), as well as many other human malignancies, such as non-Hodgkin lymphoma (NHL; B-cell, T-cell, and natural killer [NK]-cell phenotype), Hodgkin lymphoma (HL), leiomyosarcoma, gastric carcinoma, even hepatocellular carcinoma, and breast cancer. EBV has been associated with premalignant conditions or diseases with features of malignancy, such as oral hairy leukoplakia in human immunodeficiency virus (HIV)/acquired immunodeficiency syndrome (AIDS) and lymphoproliferative disorders (LPDs) in patients with primary or secondary immunodeficiencies. EBV has been associated with several other nonmalignant disorders as well, such as hemophagocytic lymphohistiocytosis (HLH) and chronic active EBV infection (CAEBV), and even has been implicated in diseases such as multiple sclerosis and chronic fatigue syndrome. The role of EBV in the pathogenesis of these disorders remains to be fully understood. This chapter reviews the biology of EBV and IM in detail. The other diseases that have been associated with EBV infection are discussed, focusing on data pertaining to the role EBV may play in their pathogenesis.

HISTORICAL BACKGROUND

In the first decade of the 20th century, several cases of glandular enlargement, sore throat, and increased numbers of mononuclear cells on the blood smear were described by Turk,¹ Cabot, Marchant, and others.² These cases were sometimes reported as acute leukemia that apparently resulted in spontaneous remission and cure. In the 1920s, Sprunt and Evans³ classified these cases and six of their own as infectious mononucleosis (IM), emphasizing the peculiar blastlike cells present in the blood. In 1923, Downey et al. published a detailed morphologic description of these cells.⁴

In 1958, Denis Burkitt described an unusual, rapidly growing lymphoma in children of central Africa.⁵ In 1961, Dr. Burkitt gave a lecture at the Middlesex Hospital Medical School in London about the epidemiology of this lymphoma that now bears his name.⁶ A young doctor named Anthony Epstein was in attendance at this lecture and upon hearing the predilection of this tumor occurring in endemic malaria areas, he hypothesized a viral etiology for this tumor. For 3 years, Dr. Epstein and his colleagues were unsuccessful in finding viruses in the tumor tissue provided by Dr. Burkitt. However, in 1964, Dr. Epstein reported, along with Achong and Barr, the presence of viral particles in lymphoblasts cultured from tumor biopsies.⁷

The discovery of EBV as the etiologic cause of IM was the result of a very astute observation made in 1967.⁸ The Henles noted that blood taken from a laboratory technician who had recently contracted IM led to the spontaneous establishment of a lymphoid cell line containing characteristic EBV particles, whereas previous attempts to establish cell lines from this individual's blood had been unsuccessful. They also observed that sera obtained before the onset of IM were negative for an anti-EBV or heterophile titers, whereas after the onset of clinical IM, the anti-EBV and heterophile titers appeared and rose for a period of time. The Henles and associates studied the sera of a number of students from Yale University, where a prospective study of IM had been in progress for many years. In all instances of clinical IM, the anti-EBV and heterophile titers rose together from a negative baseline. Of even greater interest was the observation that the anti-EBV titer remained persistently elevated, in contrast to the transient nature of the heterophile response. Confirmation of EBV as the etiologic agent in the majority of cases of IM soon followed.^{9, 10, 11}

PATHOPHYSIOLOGY OF EPSTEIN-BARR VIRUS INFECTION

EBV is one of eight known human herpes viruses (HHVs) and is subgrouped into the γ -herpes virus subfamily. Immature virus particles that measure 75 to 80 nm can be found in both the nucleus and the cytoplasm of infected cells. Mature, fully infectious particles, with a diameter of 150 to 200 nm, are found only in the cytoplasm.¹² The infectious virus particle has three components: a nucleoid, a capsid, and an envelope. The doughnutshaped central core, or nucleoid, contains the viral DNA in linear form. Surrounding the nucleoid is the capsid, which is icosahedral and is made up of hollow, tubular protein subunits called capsomeres. Finally, the nucleocapsid (the capsid and the contained viral DNA) is enclosed in a protective envelope that is derived either from the nuclear membrane or from the outer membrane of the host cell. The envelope contains a number of viral antigens that are manufactured and inserted into the host cell membrane before the assembly of mature virus particles. The EBV genome (Fig. 62.1) is a double-stranded DNA molecule of approximately 173,000 base pairs (bp) organized into a series of unique coding regions (U1 to U5), divided by interval repeat regions (IR1 to IR4)

P.1325

and terminal repeat domains. The genome encodes approximately 100 proteins.^{13, 14} Figures 62.1 and 62.2 illustrate viral

genes encoded by the genome and are discussed in detail in the section, "Epstein-Barr Virus Infection." When EBV infects a cell, its linear genome circularizes to form an episome, an extrachromosomal element in the nucleus of the cell.^{13, 15, 16, 17}

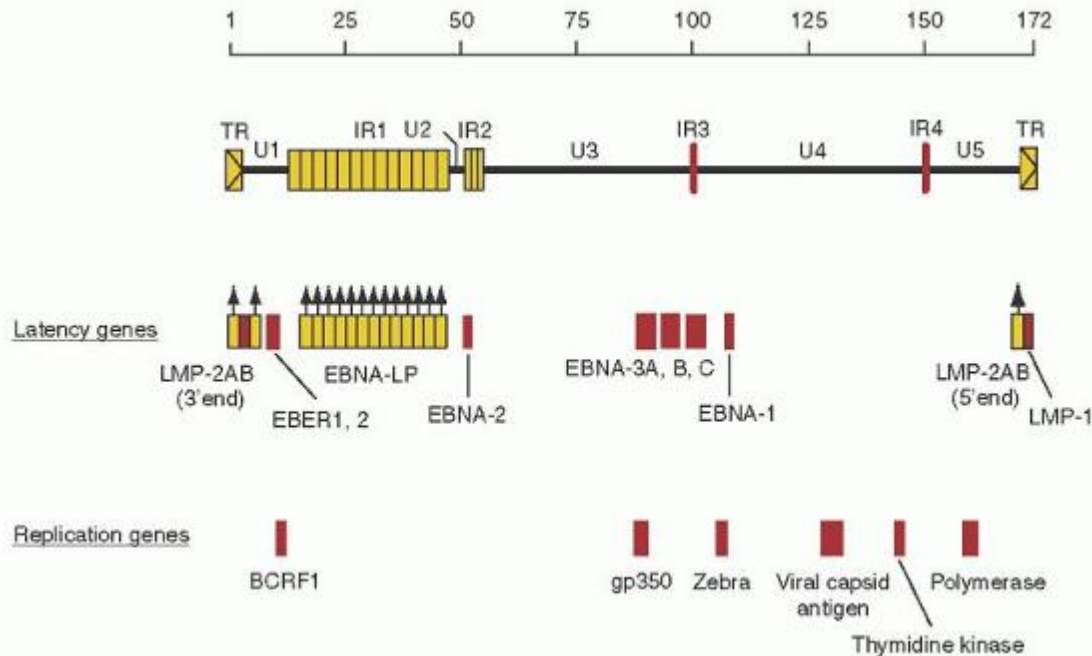

FIGURE 62.1 Epstein-Barr virus (EBV) genome and its organization. Schematic representation of linear EBV DNA showing the general organization in a series of unique (U1 to U5), internal repeat (IR1 to IR4), and terminal repeat (TR) domains. The location of several EBV genes expressed during viral latency and replication is shown. EBER, EBV-encoded RNA; EBNA, EBV-determined nuclear antigen; gp, glycoprotein; LMP, latent membrane protein; ZEBRA, Z EBV replication activator. (From Tosato G, Tata K, Angiolillo AL, et al. Epstein-Barr virus as an agent of hematological disease. *Baillere Clin Hematol* 1995;8(1):165-199, with permission.)

Many variants have been reported, although the relevance to human disease pathogenesis is unclear. Two variants EBV-1 (A type) and EBV-2 (B type) exist, which are differentiated mainly by their differences in the EBV-determined nuclear antigens (EBNAs) 2, 3A, and 3C.^{13, 15, 18} Both types of EBV are found in most populations. The relationship between these different strains and specific diseases remains to be determined. Additional EBV variants with differences in EBNA-1 have been reported to be associated with specific EBV-affiliated diseases, such as BL, but the incidence of these variants has been shown to be similar in the general population of a particular geographic region.¹⁹ Furthermore, mutations (so-called 30-bp or 69-bp deletions) of latent membrane protein (LMP-1) have been reported to be highly associated with the development of HL, certain forms of T- and B-cell lymphoma, and NPC.^{20, 21, 22, 23} But again, when compared with EBV variants found in the geographic regions, there exists no difference between healthy individuals and those associated with tumors.^{23, 24} Therefore, caution must be exercised when attributing specific EBV viral strains to particular diseases in the absence of geographically matched control isolates.

Epstein-Barr Virus Infection

The only host that the virus infects naturally is the human, although lymphocytes from other species, namely New World primates (i.e., cottontop marmosets, owl monkeys, and tamarins), are infectible.^{25, 26} EBV has been found in a variety of human tissue types associated with disease (i.e., T lymphocytes, NK cells, HL, leiomyosarcoma, gastric carcinoma, hepatocellular carcinoma, and breast cancer).^{27, 28, 29, 30, 31, 32, 33} The mechanism of EBV infection in these tumors remains to be fully elucidated.

Infection of B lymphocytes begins with attachment of the virus envelope glycoprotein (gp) 350/220 to the complement receptor C3d, also known as CR2 or CD21.³⁴ For entry into B lymphocytes, a complex of three viral proteins (gH-gL-gp42) is required, and human leukocyte antigen (HLA) class II molecules serve as a coreceptor for gp42.³⁵ Epithelium of the oropharynx is a source of viral replication,³⁶ but it has been difficult to determine the mechanism of infection, inasmuch as these cells do not express CD21 or HLA class II molecules. Recent studies have demonstrated that during primary

infection, the majority of virions are not internalized after binding to B lymphocytes of the oropharyngeal tissue. And these B lymphocytes can form cellular conjugates with epithelial cells that allow for transfer of EBV virions into the epithelial cells.³⁷ The mechanism for EBV entry into other cell types (e.g., T cells, gastric mucosa, smooth muscle cells, etc.) may also be via direct contact with B cells that have bound virions with subsequent virion internalization. Infection of epithelium leads to the replication of the virus with the release of large quantities of viral particles containing three-part complexes (gH-gL-gp42) that favor infection of HLA class II and CD21-expressing cells (i.e., B lymphocytes located in the oropharyngeal lymphoid tissues of the Waldeyer ring).³⁵ These B lymphocytes may remain latently infected in the oropharynx, but if viral reactivation and replication occur, cellular lysis and death result, and the virus can be shed into the saliva. Virus contained in infectious saliva is produced by B lymphocytes of the oropharynx.^{38, 39} Salivary virus may then be transmitted to another host.

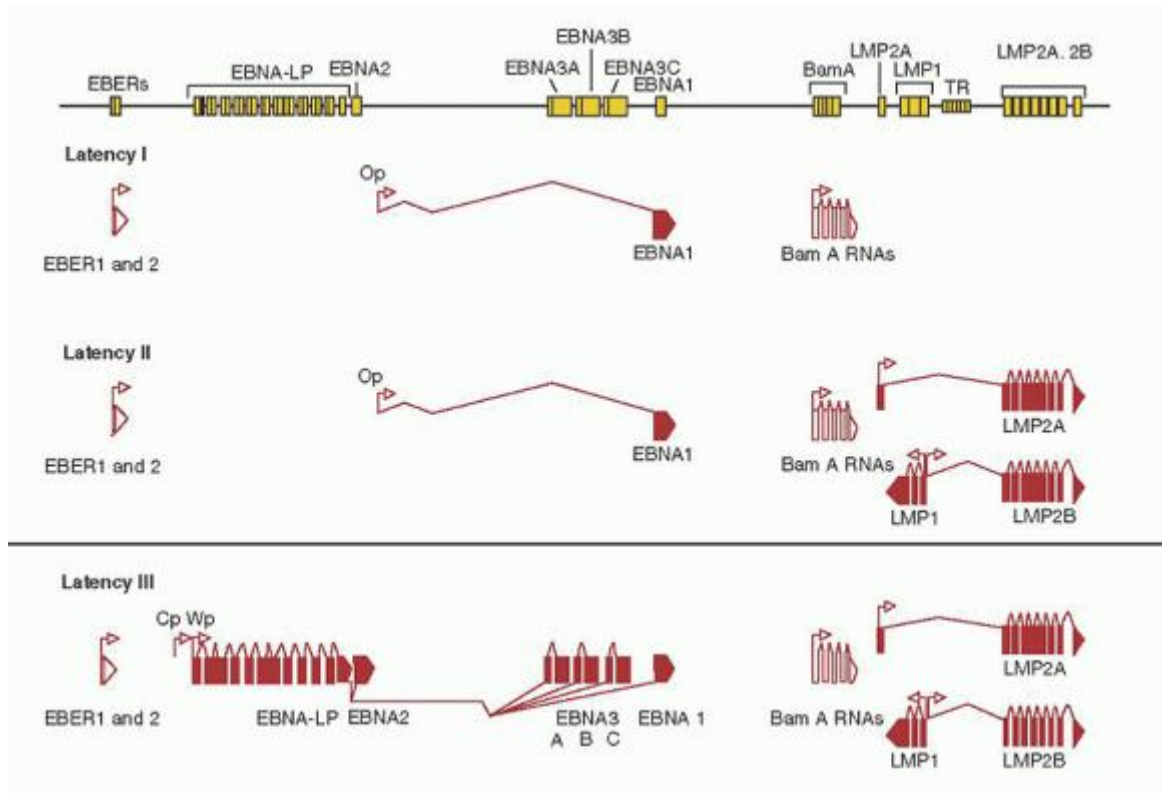

FIGURE 62.2 Epstein-Barr virus (EBV) gene transcription in the three forms of latency. The top panel shows the position of the exons on a linear map of the genome. The lower panel shows the direction of transcription from each promoter (arrows) and the splicing structure between the exons. Coding exons are shown in black and noncoding exons in white. EBER, EBV-encoded small RNA; EBNA, EBV-encoded nuclear antigen; LP, leader protein; LMP, latent membrane protein; TR, terminal repeat. (From Young LS, Dawson CW, Eliopoulos AG. The expression and function of Epstein-Barr virus encoded latent genes. *J Clin Pathol Mol Pathol* 2000;53:238-247.)

The mechanisms underlying viral replication are not completely understood as there exist no *in vitro* models that recapitulate viral replication in humans. Viral replication is initiated through oriLyt.⁴⁰ Two key early immediate genes are first transcribed, BRLF1 and BZLF-1, encoding Z EBV replication activator (ZEBRA) protein.^{13, 15, 41} These proteins then up-regulate the expression of early gene products essential for viral replication, including viral DNA polymerase and viral thymidine kinase. Late gene products follow, including viral capsid antigen (VCA), the major envelope glycoprotein (gp350), and the viral protein BCRF-1, which contains 70% homology to interleukin (IL)-10.^{13, 15, 42, 43} Complete viral replication results in the lysis and death of the host cell. Recently, it has been shown that viral proteins associated with type III latency (see below) are associated with viral replication.⁴⁴ What role this plays in B-cell transformation and immortalization remains to be determined.

Alternatively, infected B lymphocytes appear to undergo normal B-cell differentiation and disseminate throughout the body into secondary lymphatic organs (i.e., lymph nodes, spleen, and bone marrow).^{44, 45, 46, 47} Studies have demonstrated that the reservoir for latent EBV infection is a small percentage of postgerminal center, antigen-selected

resting memory B lymphocytes.⁴⁷ The number of latently infected B cells is approximately 10^{-5} to 10^{-6} of all B cells and remains stable for the majority of the life of the infected individual.^{46, 48}

P.1326

Latent infection is characterized by the expression of nine virally encoded proteins. Figures 62.1 and 62.2 illustrate the transcriptions of the nine latent proteins of EBV (EBNA-1, EBNA-2, EBNA-3A, EBNA-3B, EBNA-3C, EBNA leader protein [LP], LMP-1, LMP-2A, and LMP-2B).^{13, 15, 49} Two EBV-encoded RNAs (EBER-1 and EBER-2) are expressed abundantly in all EBV-infected cells and are valuable for making the diagnosis of EBV disease, but do not code for proteins and their function remains to be determined.¹³ In addition, the Bam HI-A rightward transcript (BART) is generally found in infected cells, but its function also remains to be fully delineated.⁵⁰

The state of latent infection is maintained by EBNA-1. The function of EBNA-1 is to bind to a nucleotide sequence called ori-P, part of the DNA origin of EBV replication, thereby allowing the viral genome to be maintained in the nucleus of the latently infected B cell.^{51, 52} By this mechanism, the EBV DNA is assured of being maintained in B cells that undergo replication.

EBNA-2 and LMP-1 appear to be required for B-cell immortalization.¹³ EBNA-2 transactivates the expression of LMP-1 and LMP-2.^{13, 53} EBNA-LP augments the ability of EBNA-2 to up-regulate LMP-1. LMP-1 and LMP-2 are associated with a cellular tyrosine kinase. The function of LMP-1 is similar to that of other members of the tumor necrosis factor (TNF) receptor family and is similar—but not identical—to that of CD40. LMP-1 interacts with TNF-receptor-associated factors and the TNF-receptor-associated death domain in infected cells and activates nuclear factor- κ B and c-Jun N-terminal kinase pathways, resulting in B-cell activation and proliferation.^{49, 54, 55, 56, 57} Additionally, LMP-1 expression also induces bcl-2 expression and can prevent apoptosis in B cells.⁵⁷ LMP-2 prevents viral reactivation by blocking tyrosine phosphorylation and promotes B-cell survival.⁵⁸ The EBNA-3 proteins regulate expression of certain cellular genes, including specific cellular receptors such as CD28, CD19, CD21, CD23, and CD30; T-cell co-stimulatory molecules CD80/CD86; adhesion molecules such as intercellular adhesion molecule-1, leukocyte factor antigen-1, and leukocyte factor antigen-3, and a member of the src oncogene family, c-fgr.^{15, 59}

Expression of EBV genes varies along the spectrum of EBV-associated diseases and often differs from in vitro immortalized B cells or normal human resting B cells infected by EBV.^{49, 53} The viral gene expression of viral latency is illustrated in Figure 62.2. Briefly, in type I latency- EBNA-1, EBER-1, and EBER-2 and BART are expressed. Type I latency is observed in BL and a portion of EBV-positive gastric carcinoma. Type II latency is characterized by the expression of EBNA-1, LMP-1, LMP-2A and B, EBER-1, and EBER-2 and is observed in NPC, and other EBV-positive lymphomas, such as T- or NK-cell NHL, and the Reed-Sternberg (RS) cells of HL. EBV-infected cells of LPD observed in immunodeficient patients resemble in vitro immortalized B cells and generally express all nine of the EBV-related latent proteins (type III latency). The site of EBV latency in seropositive healthy individuals, the resting memory B cells does not appear to express EBNA-1 but only LMP-2, EBER-1, and EBER-2 together with BART (type IV latency).⁶⁰

Immune Response to Epstein-Barr Virus Infection

Understanding the immune response to EBV infection is essential to comprehend the pathogenesis of EBV-related disease. EBV is a very potent immune stimulus. The immune system controls lymphoproliferation in the normal host and maintains a host/virus symbiosis. Figure 62.3 illustrates the delicate balance between the host T-cell immune response and control of B-cell proliferation of latently infected B cells. In a healthy individual, although only 10^{-5} to 10^{-6} B cells are latently infected with EBV, approximately 1% to 5% of all circulating CD8⁺ T cells are capable of reacting against EBV.^{48, 61, 62, 63} Initially, there is B-cell proliferation, producing both EBV-specific and -nonspecific antibodies. The number of these virus-containing B cells rises during the acute phase of the infection but never exceeds 0.03% to 0.1% of the circulating mononuclear cells.^{64, 65} A cellular immune response follows, which is composed primarily of an expansion of cytotoxic T lymphocytes (CTLs), with the vast majority being EBV-specific, although some are not EBV-specific.^{66, 67} Figure 62.4 illustrates the pathologic consequences of an abnormal CTL response to EBV infection. A deficient CTL response, either quantitative or qualitative, results in an EBV-driven B-cell proliferative process. The lack of an appropriate CTL response can also result in an aggressive, predominantly T-cell and histiocytic reaction that is not EBV-specific. This reaction is characterized by extensive infiltration of lymphoid and parenchymal organs with hemophagocytosis, and tissue destruction is often observed. If unchecked, this reaction can be rapidly fatal.^{68, 69}

EBV-Infected B Cells
1/10,000 – 1/100,000

EBV-CTL
1 – 5/100

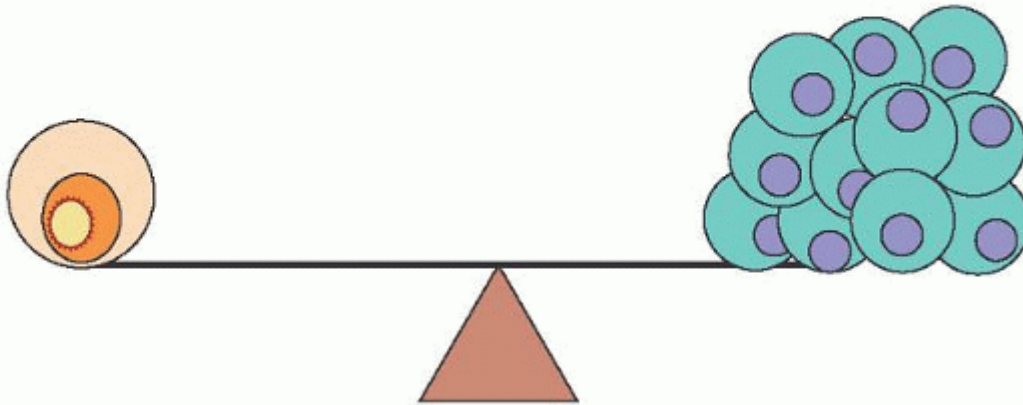

FIGURE 62.3 Balance of immune control in Epstein-Barr virus (EBV) infections. CTL, cytotoxic T lymphocyte.

The humoral response to EBV is well characterized (Fig. 62.5).^{70, 71, 72, 73} VCA antibodies are the earliest to appear: first immunoglobulin M (IgM) and, later, IgG. IgM antibodies probably arise during the incubation period, peak with symptoms, and then decline rapidly.⁷³ IgA anti-VCA antibodies are seen in some patients and, like IgM anti-VCA antibodies, are gone within several weeks.^{74, 75} IgG anti-VCA antibodies reach a peak 2 to 3 weeks after their IgM predecessors and persist for life.^{74, 75} The majority of patients also have a transient response to the EBV early antigen (EA), peaking usually within a month of infection.⁷² Antibodies to EBNA may appear several weeks after the onset of the illness in some patients but, in general, take several months to appear, and titers rise slowly over 1 to 2 years and persist for life. The majority of normal individuals have detectable IgG to EBNA by 6 months after EBV infections, although it may take years to develop detectable anti-EBNA titers.⁷⁶ In young children, the anti-VCA and anti-EA responses may be much less intense, and anti-EBNA may take much longer to be seen.⁷⁷

An EBV-nonspecific humoral response also occurs with EBV infection. Paul et al.⁷⁸ first described this phenomenon in 1932 when they reported that the sera of patients with IM contained heterophil antibodies against sheep erythrocytes in concentrations far above normal. The use of heterophil antibodies in the diagnosis of IM is discussed in detail in the section, "Infectious Mononucleosis: Diagnosis." Many of these EBV-nonspecific antibodies function as autoantibodies and include cold reactive anti-i antibodies, Donath-Landsteiner cold hemolysins, and antibodies against smooth muscle, thyroid, and stomach.^{79, 80, 81, 82} In addition, antinuclear antibodies have been found in the sera of some patients,^{83, 84} as well as rheumatoid factors,⁸⁵ including anti-Gm antibodies,⁸⁶ anticardiolipin antibodies, and antiactin and anticytoskeletal antibodies.⁸⁷ The serum of some persons with IM may contain cryoglobulins.⁸⁸ Some of these autoantibodies have been reported to be monoclonal.⁸⁴

Although neutralizing antibodies produced after primary infection may play a role in thwarting the spread to additional B cells, EBV-specific antibodies are most useful for diagnosis,

P.1327

whereas the cellular response is the most important for control of EBV infections. NK cells and CD4⁺ T cells have been shown to play a role, but CD8⁺ memory cytotoxic T cells (EBV-CTLs) are the primary defense in controlling EBV infections.^{66, 67, 89, 90} The absolute number of NK cells may initially be increased, but a decrease in NK function is usually observed, returning to normal gradually over several weeks.⁹¹ Initially, these EBV-CTLs account for the majority of cells causing the lymphocytosis and the large, pleomorphic, atypical lymphocytes, or "Downey cells," characteristic of IM.^{66, 67, 90, 92} Of note, it has been shown that the amount of these T cells in the peripheral blood correlates with symptoms seen in IM, not the number of EBV-infected B cells or the viral load.⁹³ Not surprisingly, at first the majority of EBV-CTLs are reactive against lytic viral antigens. During lytic infection three EBV proteins, BNLF2A, BILF1, and BGLF5, function to lower HLA I surface expression, which in effect helps EBV-infected cells evade the immune system.⁹⁴ However, over time the number of EBV-CTLs reactive against latent viral antigens predominates.^{66, 67}

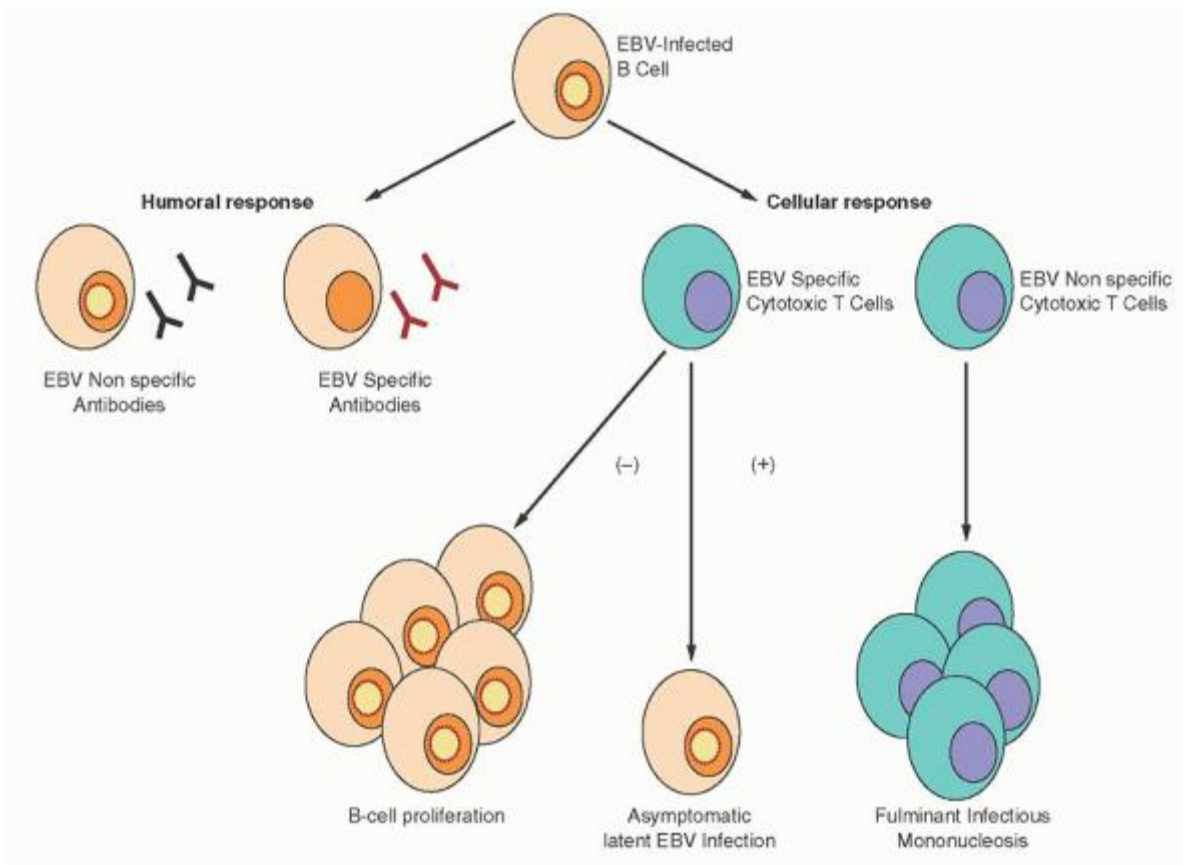

FIGURE 62.4 Immune response to Epstein-Barr virus (EBV) infection.

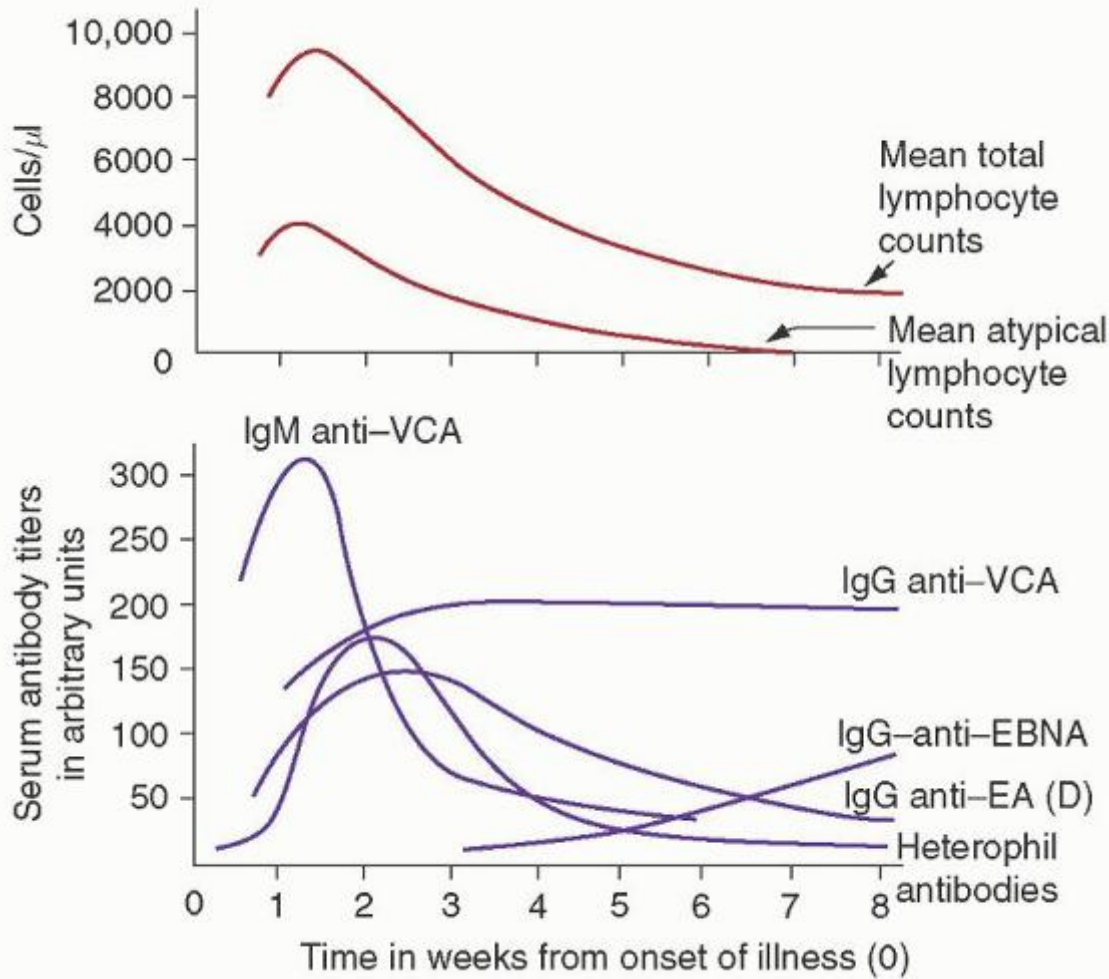

FIGURE 62.5 Laboratory tests I. Time course relationship between heterophil antibodies, various anti-Epstein-Barr virus antibodies, and the mean total and atypical lymphocyte counts. EA, early antigen; EBNA, Epstein-Barr nuclear antigen; D, diffuse component; Ig, immunoglobulin; VCA, viral capsid antigen.

This symbiosis of EBV and the infected host is maintained by interactions between viral gene expression in latently infected B cells and host EBV-CTL surveillance. The reservoir of viral latency is found among the resting memory B cells.^{46, 47} These resting memory B cells do not express high levels of adhesion molecules or T-cell co-stimulatory molecules, making them poor antigen-presenting cells. When these cells divide, EBNA-1 is expressed to ensure passage of viral DNA to progeny cells.⁵² Although CD4⁺ T-cell responses against EBNA-1 have been documented,⁹⁵ EBNA-1-specific cytotoxic T cells are not readily generated.^{96, 97} Thus, the reservoir of latent EBV infection is not recognized readily by the immune system.

Activated EBV-infected B cells express major histocompatibility complex class I antigens; various adhesion molecules make these proliferating EBV-infected B cells good antigen-presenting cells. Proliferating, latently infected B cells express all latent proteins, including EBNA-2, EBNA-3A, EBNA-3C, LMP-1, and LMP-2 (type III latency). These proliferating EBV-infected B cells are highly susceptible to cellular lysis by EBV-CTL and are eliminated during convalescence, whereas memory EBV-CTL provide lifetime immunosurveillance against EBV-driven B-cell proliferation. The immunodominant epitope of the EBV-CTL response is highly restricted by the HLA type of the individual.⁹⁸ For months after the expansion of EBV-infected B cells is controlled, virus is shed at high titers in the saliva,⁹⁹ indicating ongoing viral replication in infected B cells of the oropharynx.⁴⁶ Recent studies have demonstrated that EBV-CTL against latent viral antigens home more efficiently to lymphoid tissue of the oropharynx than EBV-CTL against lytic viral antigens.¹⁰⁰ This observation helps explain that the greatest risk of acquiring primary infection is salivary exposure from a recently infected person or a person in early convalescence, although infective virions can be found in the saliva of persons with a long latent infection.

INFECTIOUS MONONUCLEOSIS

Epidemiology

The typical clinical syndrome associated with IM occurs most commonly in young adults, the peak incidence being in persons between 17 and 25 years of age (Fig. 62.6).^{70, 101} Children often acquire immunity to EBV without developing the typical clinical manifestations of IM, for reasons still not understood.^{101, 102, 103} Because symptoms of EBV correlate with the CTL response,⁹³ this would suggest that young children generally respond with a less exuberant cellular response. The yearly conversion rate to EBV seropositivity among children in the United States is not known. Past studies suggest earlier conversion with lower socioeconomic status, i.e., 51% of Yale University freshmen and 86% of Marine recruits, had antibodies to EBV.^{12, 104} Authors of a British study concluded that 30% to 40% of children had been infected by their fifth year.¹⁰⁵ Generally speaking, the rate of seroconversion is high in developing countries, where standards of hygiene are relatively low compared to higher socioeconomic countries.^{10, 70} Under these circumstances, primary infection occurs in almost all children before 10 years of age, leaving few young adults susceptible to develop IM, and the observed incidence of IM in such countries is very low.^{10, 70} IM is sufficiently uncommon in individuals older than 30 years of age and is so rare in those older than 40 years of age that special care is needed when making the diagnosis in persons in their middle or late years. Nevertheless, well-documented cases of this illness in patients older than 40 years of age have been reported.^{105, 106, 107, 108} Complications such as protracted fever, jaundice, pleural effusion, and Guillain-Barré syndrome often dominate the clinical picture in these patients, detracting from the evidence that would allow the clinician to make the correct diagnosis.¹⁰⁷

IM is not as contagious as is commonly believed. It is rare for members of a patient's family, roommates of the same sex, and other close associates to develop symptoms of IM.^{109, 110} "Kissing disease," the colloquial term for IM, underscores the association of intimate kissing with IM.^{70, 99, 102, 111} Although oral shedding occurs throughout the life of a carrier, it peaks shortly after infection but often is readily detectable for 18 months or longer.^{99, 112, 113} Other modes of acquiring EBV infection include transplantation of organs or hematopoietic cells in which transmission to the transplant recipient is common.^{114, 115, 116, 117} Although it is not thought to occur frequently, there are anecdotal reports of transmission from blood transfusions,^{118, 119} in utero, or perinatally.^{120, 121} Although there are anecdotal reports of virus detected in cervical epithelium and semen, sexual transmission has never been demonstrated.¹²²

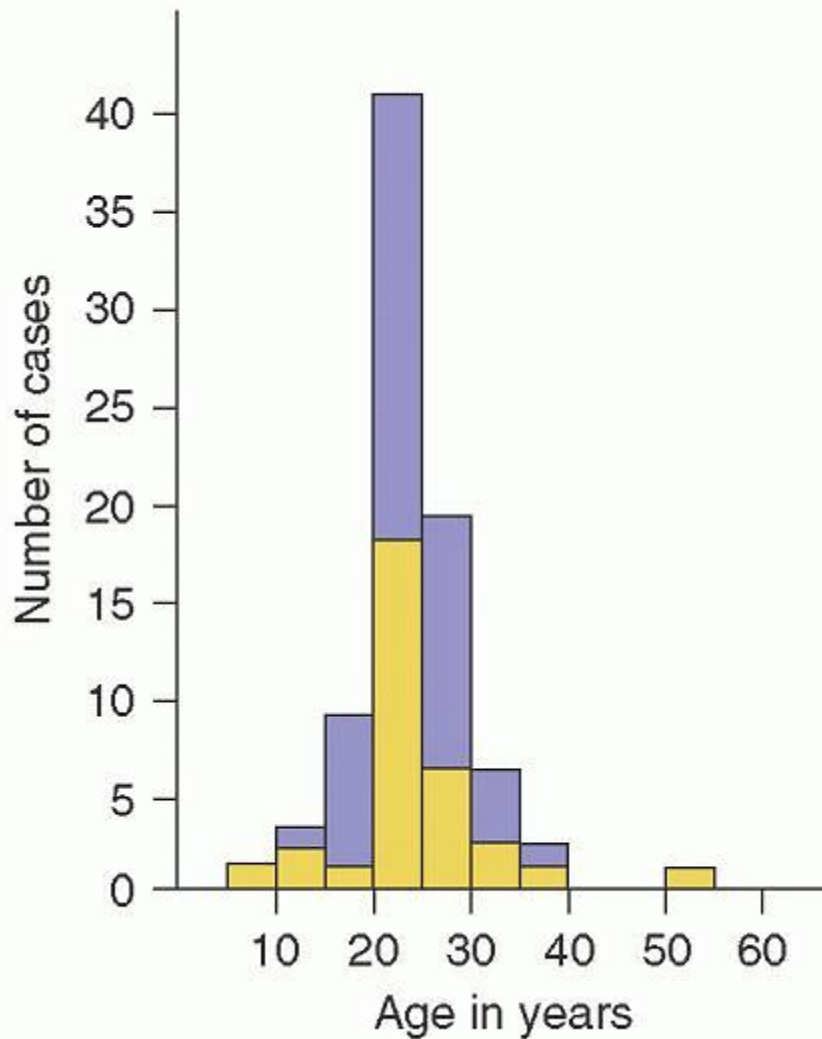

FIGURE 62.6 Age incidence. Age and sex of 82 patients with infectious mononucleosis at Johns Hopkins Hospital. Shaded columns, males; open columns, females.

Clinical Features

Many individuals have held that the manifestations of IM are protean and that many disorders may be simulated by this condition. IM is traditionally characterized by the clinical triad of fever, pharyngitis, and generalized adenopathy, with demonstration of an atypical lymphocytosis, defined as an absolute lymphocytosis with more than 50% lymphocytes and 10% or more atypical forms in the differential count, and the presence of heterophil antibodies.¹⁰² Usually, IM occurs only once in the lifetime of a host, although recurrences have been reported, and exacerbations of unresolved infection or transition to a chronic course may also occur. (See the section, “Chronic Active Epstein-Barr Virus Infections.”)

The signs and symptoms of IM are summarized in Table 62.1. The clinical course based on physical signs and symptoms is illustrated in Figures 62.7 and 62.8. In most young adults, the symptoms are fairly abrupt in onset, although close questioning frequently elicits vague complaints of lassitude and ill-being for several days before the onset of more pronounced symptoms. Most of the early symptoms are nonspecific. Myalgias do occur, but they are usually mild and are often confined to the neck and upper back. Excessive fatigue and general malaise may be accompanied by fever, sweating, and chills. Severe rigors rarely occur, and the patterns of fever are generally moderate and nonspecific. The fever is of no characteristic type. It may be transient and slight in degree, but in as many as one third of patients, it reaches a peak of 40°C. A secondary rise in temperature may occur after an initial drop to normal and may accompany the onset of glandular swelling or sore throat.

Anorexia is a common early symptom. Its intensity and duration are often linked to the severity of sore throat and dysphagia. The anorexia often persists for several weeks. Nausea is equally common and may be one of the earliest symptoms of IM, but

P.1329

vomiting is rare. Sore throat and dysphagia are among the most important manifestations of IM and may be the only symptoms in some patients. These symptoms usually develop gradually and subside in 1 to 2 weeks. For most patients, the symptoms of pharyngitis are mild, but occasionally, even taking sips of water may be painful.

TABLE 62.1 SYMPTOMS AND SIGNS OF INFECTIOUS MONONUCLEOSIS

Symptoms	%	Signs	%
Malaise and fatigue	90-100	Adenopathy	100
Sweats	80-95	Fever	80-95
Sore throat, dysphagia	80-85	Pharyngitis	65-85
Anorexia	50-80	Splenomegaly	50-60
Nausea	50-70	Bradycardia	35-50
Headache	40-70	Periorbital edema	25-40
Chills	40-60	Palatal exanthem	25-35
Cough (mild)	30-50	Liver or splenic tenderness	15-30
Myalgia	12-30	Hepatomegaly	15-25
Ocular muscle pain	10-20	Rhinitis	10-25
Chest pain	5-20	Jaundice	5-10
Arthralgia	5-10	Skin rash	3-6
Diarrhea or soft stools	5-10	Conjunctivitis	5
Photophobia	5-10	Pneumonitis	3
Abdominal pain	5		
Epistaxis	3		

From Finch SC. Clinical symptoms and signs of infectious mononucleosis. In: Carter RL, Penman HG, eds. Infectious mononucleosis. Oxford: Blackwell Scientific, 1969.

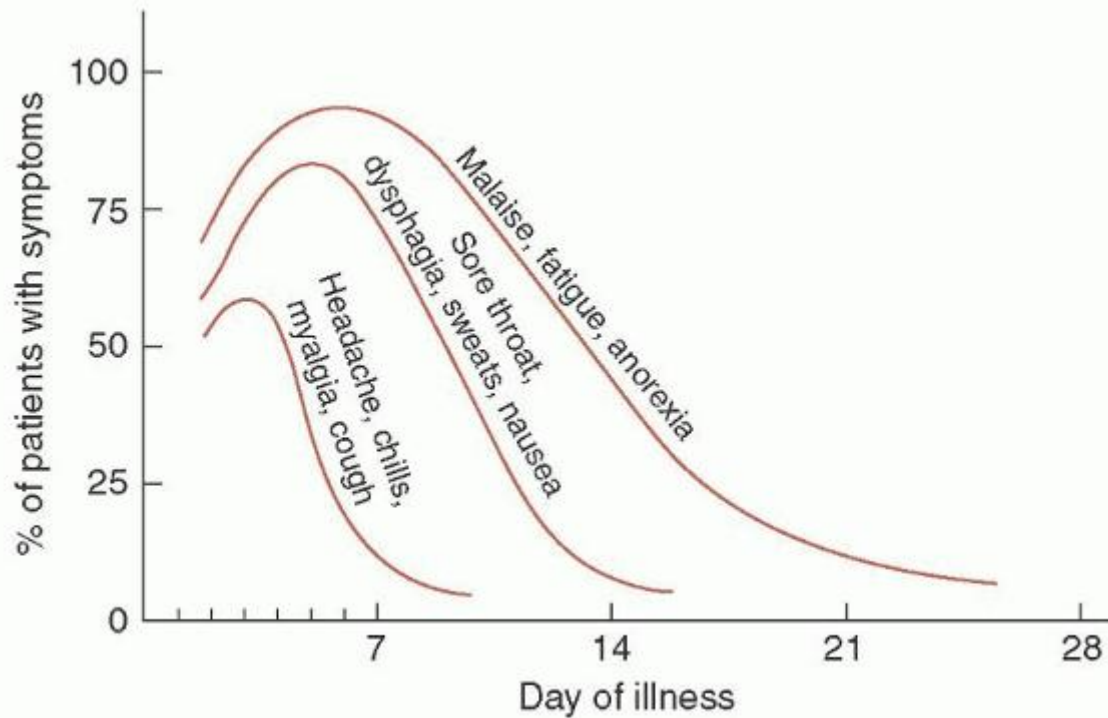

FIGURE 62.7 Major symptoms. Usual frequency and duration of major symptoms in young adults with infectious mononucleosis. (From Finch SC. Clinical symptoms and signs of infectious mononucleosis. In: Carter RL, Penman HG, eds. Infectious mononucleosis. Oxford: Blackwell Scientific, 1969.)

Lymph node enlargement is invariably present at some time.^{123, 124, 125} Adenopathy usually appears during the first week of illness and slowly resolves thereafter. Anterior and posterior cervical node enlargement is almost always present, and palpable axillary and inguinal nodes are common. Radiographically detectable hilar adenopathy is rare (<1%).¹²⁶ Although splenomegaly is expected, the spleen is palpable in only one half to three fourths of all patients, and massive splenomegaly is rare.¹²⁷ Hepatomegaly is detected in 15% to 25% of patients and is usually accompanied by percussion tenderness over the liver and discomfort on palpation. The course of hepatomegaly closely follows that of adenopathy and splenomegaly.¹²⁷ Pharyngeal inflammation usually appears in the first week and then subsides rapidly. In approximately 25% of patients, pharyngitis first occurs after the initial week of illness, and there are no pathognomonic features. It varies in intensity, but rarely, massive tonsillar and pharyngeal edema may cause virtually complete pharyngeal obstruction.¹²⁵ Severe cough is relatively rare, although mild cough is common.

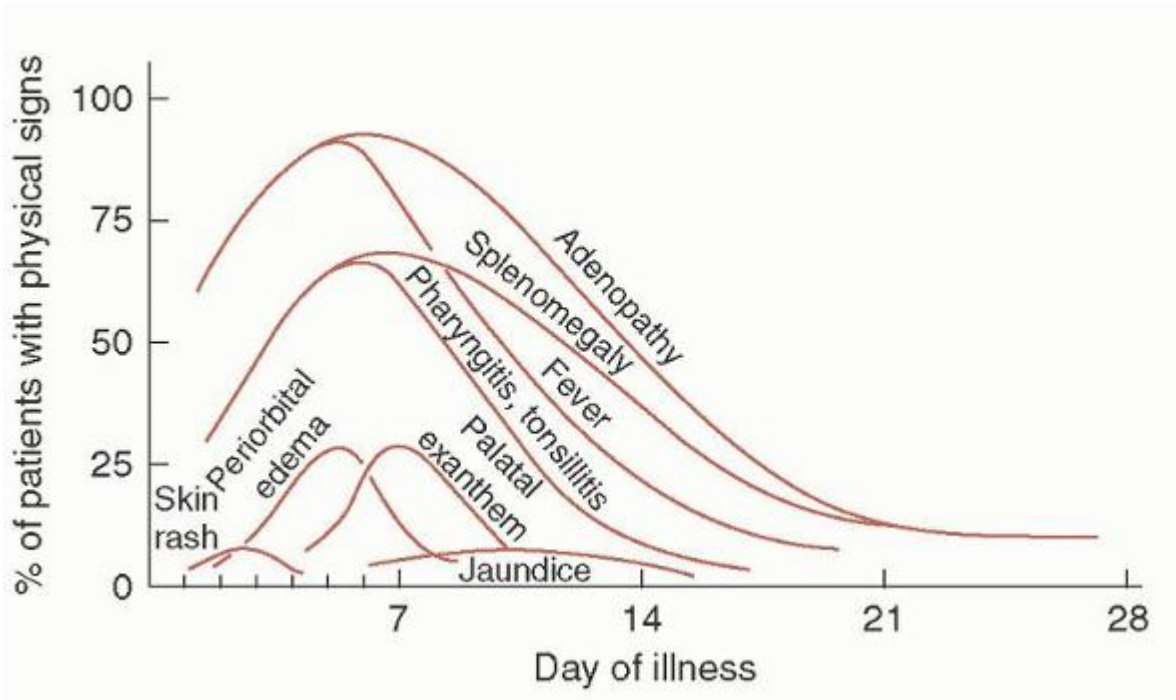

FIGURE 62.8 Physical signs. Usual frequency and duration of major physical signs in young adults with infectious mononucleosis. (From Finch SC. Clinical symptoms and signs of infectious mononucleosis. In: Carter RL, Penman HG, eds. Infectious mononucleosis. Oxford: Blackwell Scientific, 1969.)

Headaches occur early, as well as photophobia, and ocular muscle pain can occur. Ocular manifestations occur in approximately one third of patients and include eyelid edema, conjunctivitis, dry eyes, keratitis, uveitis, choroiditis, retinitis, papillitis, and ophthalmoplegia.¹²⁸ Rashes are also common with primary EBV infection and may be the only symptom in young children.^{129, 130} Several observers have noted that patients experiencing IM are peculiarly prone to rashes when treated with ampicillin, which appear to be the result of vasculitis caused by circulating ampicillin-antibody complexes.^{131, 132, 133}

Laboratory Findings

Hematologic abnormalities in IM are observed in virtually all patients. The hematologic changes persist for a minimum of 2 weeks and usually persist for 1 to 2 months. One of the classic features of IM is the atypical lymphocytosis. The pleomorphism of the mononuclear cells found in the blood is usually striking. In addition to normal lymphocytes and monocytes, large mononuclear cells, or atypical lymphocytes, are observed in the blood (Fig. 62.9). Although nonspecific⁴ because they may be found in the blood of patients with a variety of conditions, including other viral infections,¹³⁴ they are a prominent feature of IM. The abnormal cells vary greatly in size and shape. They possess a nucleus that may be oval, kidney-shaped, or slightly lobulated and cytoplasm that most often is nongranular and vacuolated or foamy. The nuclear chromatin forms a coarse network of strands and masses and is not clearly differentiated from the parachromatin. The identity of these cells has been shown to be CD8⁺ T lymphocytes, as discussed previously (see the section, "Immune Response to Epstein-Barr Virus Infection"). The rapid proliferation of these activated T cells is responsible for the large numbers of atypical cells seen in the peripheral blood, whereas the proliferating B cells are primarily responsible for the generalized lymphadenopathy, hepatosplenomegaly, tonsillar and adenoidal changes, and the cellular infiltration seen in many parenchymal organs; this is discussed in detail in the section, "Infectious Mononucleosis: Histologic Findings."

Most patients with IM have slightly or moderately increased total white blood cell counts in the range of 10.0 to 20.0×10^9 cells/L, with approximately 15% of patients reaching levels in excess of 20.0×10^9 /L.^{111, 135, 136} The absolute lymphocyte count most often exceeds 5.0×10^9 cells/L; with atypical lymphocytes usually $>20\%$.¹¹¹ Lymphocytosis begins toward the end of the first week of illness and reaches a peak corresponding to symptoms, as does the total leukocyte count (Fig. 62.10). Leukopenia has also been observed and can be manifested as lymphopenia or granulocytopenia.¹³⁶ Most patients with IM have normal hemoglobin levels, and severe thrombocytopenia is rare, although mild depressions of platelet counts may be found in perhaps one half of patients.¹³⁷ Severe neutropenia and thrombocytopenia may be very ominous signs, as they are frequently seen in the hemophagocytic reactions (VAHS or EBV-HLH).

Nonhematologic abnormalities are also commonly observed in patients with IM. Many patients show mild to moderate abnormal liver function tests.¹³⁶ The reported incidence varies from 40% to 100%, depending on the severity of the disease, the time of testing, and the diligence with which the changes were sought. Reported enzyme changes include elevations of lactate dehydrogenase, alkaline phosphatase, glutamic pyruvate transaminase, phosphohexose isomerase, and aldolase, in roughly that order of frequency. Perhaps one third of patients have mild to moderate elevations of serum bilirubin values; levels above 8 mg/dl (135 μ mol/L) are exceedingly rare but have been reported.^{136, 138} Occasionally, proteinuria or hematuria is present, but renal function is usually unimpaired. When the patient is jaundiced, bile and increased concentrations of urobilinogen may be found. When

P.1330

lumbar puncture has been performed to evaluate patients with severe headaches, the cerebrospinal fluid (CSF) pressure may be elevated, and pleocytosis and increased levels of protein are often noted. The sugar content is normal. In a few patients, heterophil antibodies have even been demonstrated in the CSF.¹³⁹

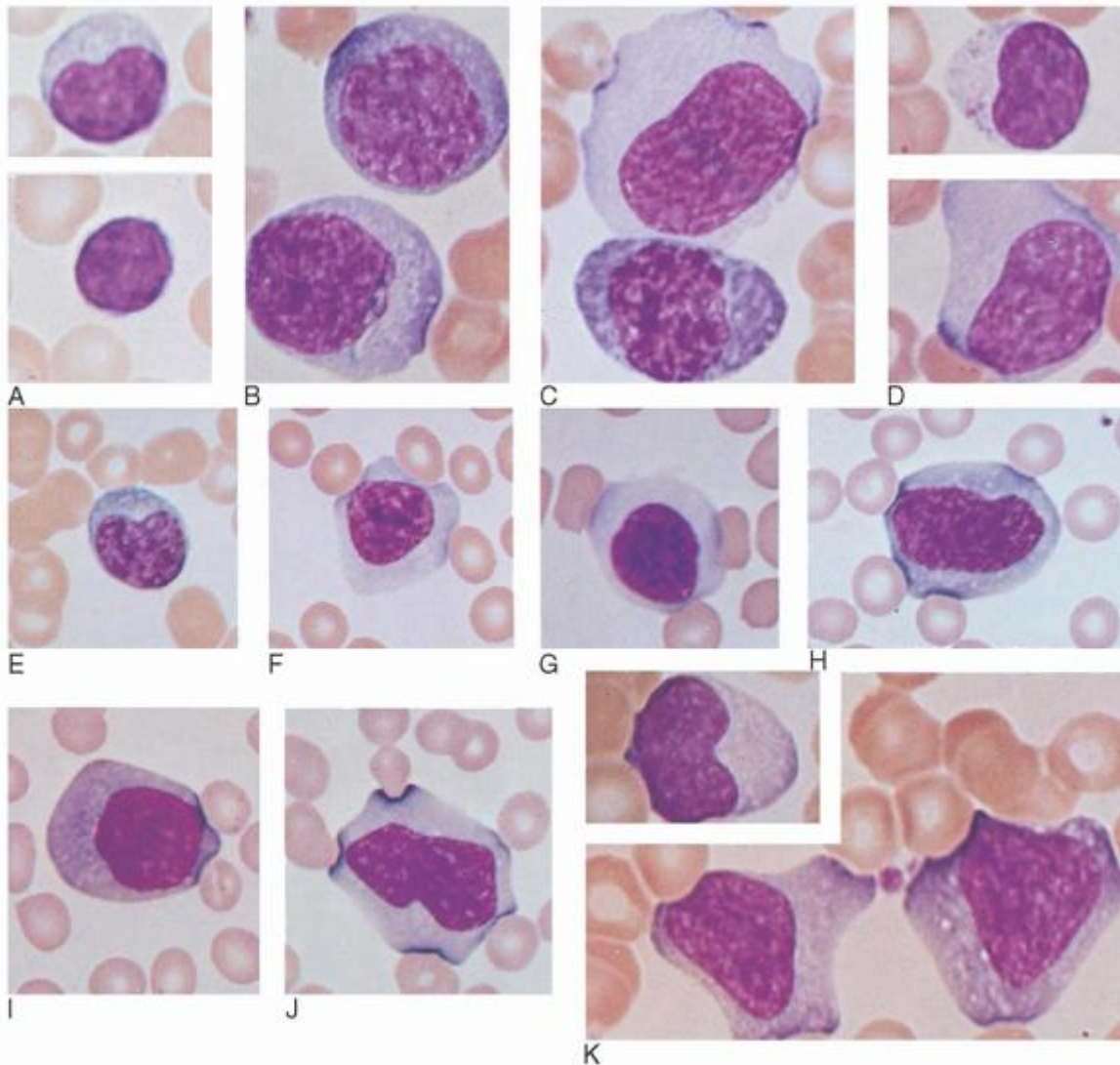

FIGURE 62.9 Lymphocytes and cells of infectious mononucleosis. A: Large and small lymphocytes from the blood of normal subjects. B: Lymphocytes resembling plasma cells (“plasmacytoid” cells) in the blood of a patient with viral pneumonia. C: Somewhat atypical lymphocyte and plasmacytoid lymphocytes in blood. D: Lymphocytes from the blood of a patient with viral infection; azurophilic granules are clearly seen in one of the cells. E-J: Infectious mononucleosis; lymphocytes showing increasing levels of atypia. E: Downey type I. F,G: Downey type II. H-J: Downey type III. K: Lymphocytes from blood of patient with infectious mononucleosis.

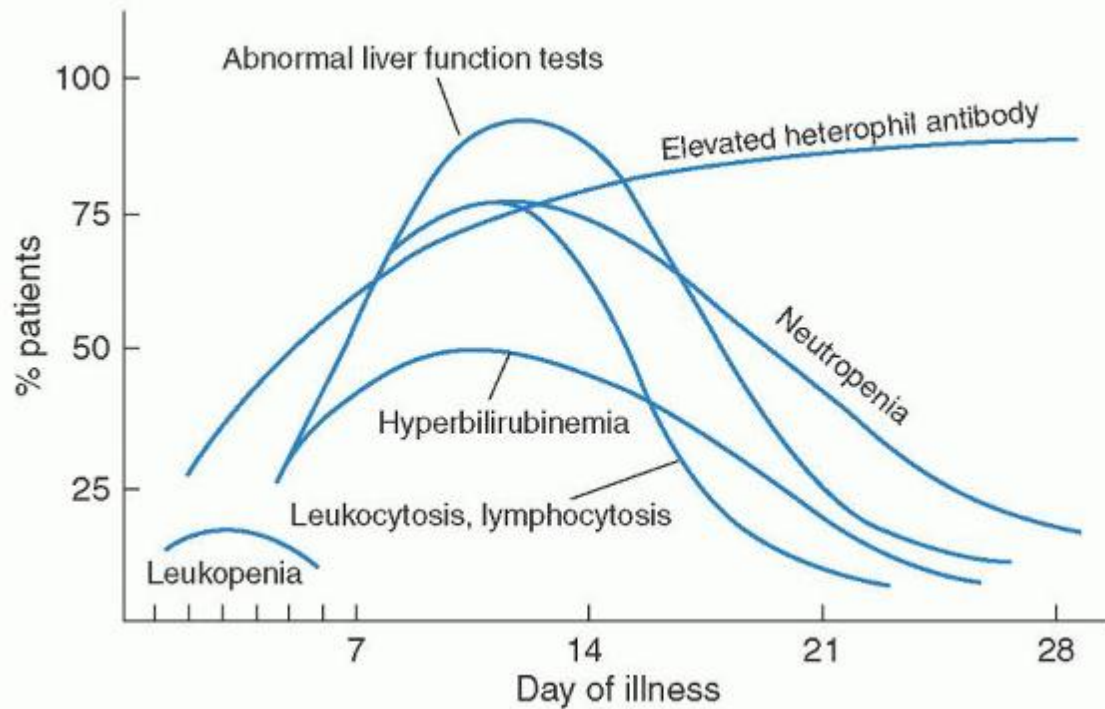

FIGURE 62.10 Laboratory tests II. Major laboratory findings in adults with infectious mononucleosis. (From Finch SC. Clinical symptoms and signs of infectious mononucleosis. In: Carter RL, Penman HG, eds. Infectious mononucleosis. Oxford: Blackwell Scientific, 1969.)

Histologic Findings

The main pathologic feature of IM is a notable proliferative response within the reticuloendothelial system, especially by the lymph nodes and the spleen. It can be difficult to distinguish between malignant lymphoma and nonmalignant disease associated with EBV infection, especially in the immunodeficient patient population.⁶⁹ In summary, the histologic diagnosis of IM is one of suspicion rather than certainty.^{69, 140}

The lymph node architecture is generally intact^{141, 142} but may be distorted.^{140, 141, 142, 143} Other morphologic features mimicking lymphoma include extensive immunoblastic proliferation in sheets and nodules and significant cellular atypia.¹⁴¹ Clonality studies are often necessary to differentiate IM from malignant disease. The germinal centers are usually identifiable, but follicular prominence is diminished, probably because of the irregular and vaguely defined borders that result from the lymphocytic and reticuloendothelial hyperplasia of paracortical structures and, to a lesser extent, the medullary cords. This intense proliferative activity within the paracortical areas is in keeping with the characterization of atypical lymphocytes as T cells.¹⁴³ In addition, focal proliferations of macrophages are noted, as is, most characteristically, the presence of "typical" IM cells throughout the pulp, on the edges of germinal centers, and in the sinuses.¹⁴² RS-like cells^{140, 141, 143} are often observed in association with areas of necrosis.⁶⁹ Because the presence of EBV has been demonstrated in approximately 50% of HL specimens,^{144, 145, 146} the identification of

P.1331

the virus or EBV-determined antigens is not particularly helpful in the differential diagnosis of these two disorders.

The spleen is striking for infiltration of its fibromuscular structures by mononuclear cells.¹⁴⁷ Both the capsule and trabeculae are often thin and invaded by proliferating lymphocytes. This may explain the occurrence of splenic rupture in this disease. In vitro hybridization studies can be used to track the distribution pattern of cells carrying the viral genome.^{140, 148} Most labeled cells are found in the hyperplastic T-cell zones, the paracortical or interfollicular areas^{140, 148}; smaller numbers are found within the epithelioid venules, the lymph node sinuses, and, occasionally, the germinal centers and the mantle zone.¹⁴⁸ In the spleen, labeled cells are found mainly within pulp cords.¹⁴⁸ Most of the labeled cells are small lymphocytes, but occasional labeled blasts, dendritic cells, and macrophages can be identified.¹⁴⁸

The bone marrow may be cellular with generalized hyperplasia of erythroid, myeloid, and megakaryocytic elements.¹⁴⁹ With special techniques, sarcoidlike granulomas may also be demonstrated.^{149, 150, 151} In most instances, however, routine marrow aspiration reveals no abnormalities of note.

Diagnosis

The diagnosis of IM rests primarily on documentation of a primary EBV infection. Because EBV cannot be cultured, the humoral response to EBV infection, which has been discussed in the section, "Immune Response to Epstein-Barr Virus Infection," is the usual method to discern infection. In summary, a recent, primary EBV infection is characterized serologically by (a) a positive heterophil antibody titer; (b) high titers of anti-VCA antibodies, both IgM and IgG; (c) high titers of anti-EA antibodies; and (d) the absence of anti-EBNA-1 antibodies (Fig. 62.5). Convalescent sera demonstrate the disappearance of IgM anti-VCA antibodies and the appearance of anti-EBNA-1 antibodies.^{72, 73} At present, the diagnosis of IM is made by the presence of anti-IgM to EBV VCA. Rapid test systems using recombinant EBV antigens and enzymelinked immunosorbent or other assay technologies have been developed for use in clinical laboratories,^{152, 153} but false-positive tests, especially for anti-EBV IgM antibodies, can occur.¹⁵⁴

Because so many antibodies have been linked to the development of IM, elevation of Ig levels in association with this disease is not surprising.^{155, 156} Although this change is especially true for IgM, lesser elevations have also been seen in IgG and IgA. A general increase in titers of IgG antibodies and production of IgM antibodies against heterophile antigens and other infectious agents is common during the primary EBV infection^{157, 158} and must be taken into account when performing a diagnostic workup. Antibodies with recognized antigenic specificities make up only a small proportion of the total γ -globulins of the serum,^{155, 159} and the antigenic specificity of most of the increased γ -globulins remains undefined.

A serologic diagnostic test for IM has been available since Paul et al.⁷⁸ discovered that the sera of patients with IM contain agglutinins against sheep red cells. They called the antibody heterophil because it reacted with a heterologous antigen that obviously had not elicited its production. Historically, the heterophil antibody test was felt to be a sine qua non in the diagnosis of IM in adults. Investigators soon learned that the antibody reacted not only with sheep red cells, but also with beef and horse erythrocytes.^{157, 160, 161} The heterophil antibody is an IgM globulin,^{162, 163, 164} which, in some studies,¹⁶⁴ was shown to have λ light chains only. The Paul Bunnell (PB) antigen with which the heterophil antibody interacts is thermostable,^{160, 162} in contrast to the Forssman antigen. Its immunologically reactive sites appear to be carbohydrate in nature.¹⁶⁵ The carbohydrate nature of the antigen probably explains the observation that the antibody response is almost exclusively IgM. PB antigens are found also on cells other than heterologous erythrocytes.¹⁶² Of particular interest is the demonstration of PB-like antigens on murine T lymphocytes, Thy-1-positive murine lymphoma cells, and murine neutrophilic granulocytes.¹⁶² In addition, PB antigens have been demonstrated in various tissues of IM patients during the early stages of the disease,¹⁶² in cultures of some lymphoid cell lines,¹⁶⁶ in fresh BL tissues,¹⁶⁷ and in the spleens of some patients experiencing lymphoma or leukemia.¹⁶² The formation of PB antibodies by cultures of lymphocytes from IM patients also has been demonstrated.¹⁶⁸

Heterophil antibodies in titers of up to 1:28 are present in most normal persons and, occasionally, in titers of 1:56.¹⁶⁹ A study of more than 3,000 IM patients showed the following age distribution of PB antibodies: 5 to 9 years of age, 4%; 10 to 14 years of age, 8%; 15 to 24 years of age, 80%; 25 to 29 years of age, 3%; and older than 30 years of age, 5%.¹⁷⁰ For these reasons, the test for heterophil antibodies has been called "presumptive,"¹⁷¹ but in the presence of clinical and hematologic findings suggestive of IM and a titer of 1:256 or higher, the diagnosis of IM is likely. In patients with IM, positive heterophil reactions almost always appear during the first 2 weeks of the illness (Fig. 62.5). Highest titers usually are found during the second and third weeks. As a rule, positive reactions last 4 to 8 weeks, but they have been observed to persist for as short as 7 to 9 days or as long as 18 weeks.¹⁶⁹ The titer bears no relation to the severity of the disease or to the leukocyte changes. Although elevated heterophil antibody titers are quite common in EBV infection, occasionally patients with other disorders produce elevated levels.¹⁷²

Molecular diagnostic techniques are useful for the demonstration of EBV in tissues and body fluids. In situ hybridization techniques^{140, 148, 173} and the polymerase chain reaction (PCR)^{174, 175} are most commonly used. The use of quantitative EBV PCR has been evaluated for diagnostic and prognostic value in EBV-related diseases.^{176, 177} The detection of EBV DNA in peripheral blood or serum by PCR provides good evidence that the patient has been infected by EBV. However, interpretation of quantitative EBV DNA PCR or "viral load" results can be problematic, especially in the immunodeficient patient. Immunocompromised patients tend to have higher amounts of EBV DNA than normal healthy individuals with latent EBV infections. Also, different laboratories use different methods of detection, different specimens (blood vs. serum vs. mononuclear cells), and different measurements (copies per micrograms DNA vs. cells vs. ml of serum/blood).¹⁷⁷ It appears that the amount of EBV DNA detectable in the blood of a patient with EBV-related disease may be useful in

monitoring response to therapy in some diseases, but its value for diagnosis or prognosis still remains to be determined. The best method to diagnose EBV as an etiologic agent is tissue biopsy and in situ hybridization.

Differential Diagnosis

The diagnosis of IM usually is not difficult. In most instances, a young adult complains of malaise, fatigue, anorexia, and a sore throat and is found to have fever, adenopathy, pharyngitis, and splenomegaly. Appropriate changes in EBV titers will confirm the diagnosis. Much has been written about complications that can be devastating or even fatal, but serious complications in IM are rare, occurring in <1% of all diagnosed patients.¹²⁵ Therefore, signs of significant respiratory, cardiovascular, intestinal, urinary, or joint disease make considerations of other diagnoses mandatory.

The fever and general malaise can be seen in many infectious diseases including salmonella infections, listeriosis, brucellosis, subacute bacterial endocarditis, the lymphadenopathic form of toxoplasmosis, and malaria.⁶⁹ Generalized lymph node enlargement, including the postauricular and occipital nodes, is also characteristic of rubella.⁶⁹ The pharyngitis of IM must be differentiated from acute streptococcal pharyngitis, diphtheria, and acute viral pharyngitis of other types. β -Hemolytic streptococci are isolated relatively often from patients with classic IM.¹²³ Thus, a

P.1332

positive throat culture for streptococci does not make a search for an EBV infection unnecessary. In addition, a palatine exanthem may be present in patients with rubella, and atypical lymphocytes have been described in this condition. Drug fever and serum sicknesslike reactions may also suggest IM, because they often are characterized by fever, jaundice, lymph node enlargement, and atypical lymphocytes.⁶⁹ Lymphocytosis, absolute or relative, may be encountered in association with diseases other than IM. These disorders include tuberculosis, tularemia, pertussis, dengue, mumps, chickenpox, German measles, typhoid fever, infectious hepatitis, serum sickness, and various other allergic states. In association with some of these conditions, abnormal lymphocytes resembling those of IM have been observed, as mentioned previously. Leukocytosis due to small lymphocytes of normal appearance and not associated with splenomegaly, lymphadenopathy, or a positive heterophil titer is suggestive of some other acute infectious process.

The hematologist may be called on to differentiate IM from other more serious hematologic diseases, such as acute leukemia or lymphoma. Although many leukocytes of patients with IM appear abnormal, few contain nucleoli, and thrombocytopenia and anemia are rare in these patients. EBV serologies confirming primary infection can be very helpful. Bone marrow examination is rarely necessary to differentiate IM from acute leukemia. Nodal biopsy can be difficult at times to differentiate IM from a malignant process. (See the section, "Histologic Findings.") Patients who have had IM do not have a higher incidence of leukemia, but a few cases of concurrent IM and leukemia have been reported.^{178, 179, 180, 181}

A number of self-limiting diseases are associated with a peripheral blood picture that satisfies all of the morphologic criteria established for the diagnosis of IM; failure to recognize these illnesses can result in unnecessary lymph node or liver biopsies, bone marrow aspiration, or other irrelevant diagnostic tests. The most common causes include cytomegalovirus (CMV), rubella, hepatitis and adenoviruses, *Toxoplasma gondii*, trichinosis, HIV, and HHV6, as well as a number of bacterial infections, with CMV being the most common.^{182, 183, 184, 185, 186, 187, 188, 189}

When CMV-mononucleosis occurs, the illness can clinically be identical to IM with similar laboratory findings.¹⁸² The diagnosis is confirmed by demonstrating the presence of IgM antibodies to CMV in virtually all cases.^{123, 182} A few patients have been reported to present with evidence of simultaneous CMV and EBV infection.¹⁸¹

Complications

Unusual clinical patterns and serious complications are probably seen in no more than 1% of all patients.¹³⁸ Misconceptions about a higher incidence stem from the fact that most of the medical literature concerning IM deals with complications and from impressions of subspecialists who usually do not see patients with uncomplicated disease. The most frequently reported complications are listed in Tables 62.2 and 62.3.^{190, 191, 192, 193, 194, 195, 196, 197, 198, 199, 200, 201, 202, 203, 204, 205, 206, 207, 208, 209, 210, 211, 212, 213, 214, 215}

TABLE 62.2 HEMATOLOGIC COMPLICATIONS OF INFECTIOUS MONONUCLEOSIS^a

- Immune hemolytic anemia
- Immune thrombocytopenia
- Granulocytopenia

Marrow aplasia

Virus-associated hemophagocytic syndrome

Acquired immune deficiencies

^aSee text for references.

TABLE 62.3 NONHEMATOLOGIC COMPLICATIONS OF INFECTIOUS MONONUCLEOSIS

Splenic Rupture^{190, 191, 192}

Neurologic complications

Guillain-Barré syndrome^{193, 194, 195}

Encephalitis^{196, 197, 198, 199}

Reye syndrome²⁰⁰

Meningitis/meningoencephalitis^{242, 200, 201, 429}

Cranial nerve palsies^{202, 203, 204}

Optic neuritis¹²⁸

Peripheral neuropathy^{205, 206, 207, 208, 209}

Cerebellar ataxia^{210, 211}

Transverse myelitis^{212, 213}

Cardiac complications

Electrocardiography changes^{129, 243}

Pericarditis^{214, 215}

Myocarditis⁸⁰

Respiratory complications

Acute airway obstruction^{244, 245}

Pleural effusion^{247, 248, 249}

Parenchymal changes^{246, 247, 249}

Liver failure^{239, 250, 251, 252}

Pancreatitis^{253, 254}

Renal failure²⁵⁵

Hematologic complications are the most common. The incidence of hemolytic anemia may be as high as 3%.^{216, 217} Hemolysis usually is mild; in approximately 70% of the patients with hemolytic anemia, the reaction to the antiglobulin test (or Coombs test) is positive, and in approximately the same number, the titers of cold agglutinins are increased,²¹⁷ usually with anti-i specificity.²¹⁸ Occasionally, hemolysis has been attributed to Donath-Landsteiner cold hemolysins.^{219, 220} In summary, anti-i antibodies are extremely common, but hemolytic anemia is rare.^{218, 221, 222} Sometimes, however, no antibody of any kind is detectable. IM has been associated with accelerated hemolysis in patients with underlying hereditary spherocytosis,^{223, 224} elliptocytosis,²²⁵ or thalassemia,²²⁶ and in one patient, the onset of paroxysmal nocturnal hemoglobinuria coincided with the development of IM.²²⁷

Hematologic cytopenias are common. Although mild depression of the platelet count (100 to 140 $10^9/L$) may be found in perhaps one half of patients with IM,¹³⁷ thrombocytopenic purpura is a rare complication that is seen primarily in younger children.^{228, 229, 230} Thrombocytopenia occurring in acute IM has been attributed to increased destruction by an enlarged spleen or the production of platelet autoantibodies.^{231, 232} Immune thrombocytopenia preceding the development of severe aplastic anemia has been reported.²³³ Mild granulocytopenia is a common finding in patients with IM,²³³ but severe granulocytopenia is rare.^{233, 234, 235} When marrow examination has been performed, myeloid hyperplasia has been noted

with increased numbers of promyelocytes, but with depletion of more mature neutrophilic cells.^{234, 235} This picture is compatible with a proliferative response to an earlier marrow injury or peripheral destruction or increased use of granulocytes. Serious suppression of the entire marrow is rare.^{217, 236, 237} Fatal aplastic anemia has been noted after what appeared to be typical IM^{219, 238} but is more often related to hemophagocytic reactions (VAHS or EBV-HLH).²³⁹

P.1333

One of the most common reported complications is splenic rupture, which has led to death in several cases^{190, 191} but has been reported to occur with an incidence of 0.1% to 0.2% in North America. Of the 107 cases reported in the world literature up to 1978, only 18 were considered "spontaneous" by one reviewer.¹⁹² The diagnosis of a ruptured spleen should be entertained whenever a patient with IM has severe or even moderate pain below the left costal margin, especially if the pain is accompanied by radiation to the left shoulder and supraclavicular area, or has evidence of impending peripheral vascular collapse. Other signs include those characteristic of peritoneal irritation, abdominal tenderness, and shifting dullness if massive intra-abdominal bleeding has occurred. Frank rupture may be preceded by one or more episodes of subcapsular hemorrhage or minor capsular tears, which may be difficult to differentiate from rupture. Because potentially fatal bleeding may occur at any time, it is recommended that surgical intervention be pursued whenever the typical pain pattern is accompanied by signs of hemodynamic instability.^{190, 191} Delayed surgical intervention often is attributable to the misconception that abdominal pain is a common feature of the uncomplicated disease. Preservation of splenic function by surgical repair of the capsular tear (splenorrhaphy) or partial splenectomy has been recommended by some but is not generally recommended, as the altered splenic architecture in IM makes it unlikely that such interventions will be successful.^{190, 191}

Complications of almost all organ systems have been described in association with IM²⁴⁰ and are listed in Table 62.3. Neurologic manifestations are not infrequent in IM and may occur in 1% to 2% of patients.^{193, 194, 241} When serious neurologic complications occur, the mortality rate may be as high as 8% to 11%,²⁴² and, in addition, the incidence of serious residual damage may be as high as 12%.²⁴² Cardiac complications are rare, although electrocardiographic abnormalities may occur in approximately 10% of patients,^{129, 243} and fatal myocarditis has been reported in association with IM.⁸⁰ The most serious respiratory complication is acute airway obstruction, which usually is the result of extreme hyperplasia of the tonsils and other pharyngeal lymphatic tissue.^{244, 245} Pleural effusion and pulmonary parenchymal changes are exceedingly rare,^{246, 247, 248, 249} but occasional cases are characterized by extensive interstitial infiltrates (lymphoid interstitial pneumonitis), and severe respiratory insufficiency has been reported.²⁴⁷ Evidence for some degree of hepatic involvement is found in most patients but is usually mild; the necrosis and inflammatory exudate seen in association with infectious hepatitis are encountered only rarely.^{239, 250, 251, 252} Liver failure is rare^{239, 250} but can be a prominent feature in fatal cases of IM [fulminant infectious mononucleosis (FIM) or EBV-HLH],²⁵⁰ including those associated with subtle forms of immune deficiency.²⁵⁰ Acute pancreatitis has been associated with IM.^{253, 254} An association between IM and irreversible renal failure was postulated in one patient.²⁵⁵

Treatment

Most patients experiencing uncomplicated acute IM require only symptomatic therapy. Bed rest is recommended for patients with fever, malaise, and myalgias. Strenuous exercises, especially contact sports, should be avoided for at least 1 month or until resolution of splenomegaly. Nonsteroidal anti-inflammatory drugs, such as acetaminophen or ibuprofen, should be used to control pain, although in patients with severe hepatitis, these agents should be used judiciously. It has been suggested that aspirin may prolong convalescence.²⁵⁶ Aspirin also interferes with platelet function, potentially increasing the risk of bleeding in thrombocytopenic patients, and Reye syndrome has been reported in association with IM, albeit rarely.²⁰⁰ Antibiotics are of no value in uncomplicated IM, but many patients show culture or serologic evidence of a recent streptococcal infection,¹²³ and these should be treated with appropriate antibiotics. Ampicillin and amoxicillin should be avoided because they often cause a severe rash.^{123, 130, 132}

Corticosteroids have been used in cases of life-threatening complications such as airway obstruction, carditis, lymphoid interstitial pneumonitis, pleural effusions, or cerebral edema. Their efficacy is largely anecdotal and is presumably due to their anti-inflammatory and lympholytic properties. The cumulative results of several small, controlled clinical trials suggest that corticosteroids hasten the resolution of fever and tonsillopharyngeal symptoms but do not provide significant benefits in the therapy of lymphadenopathy or hepatosplenomegaly.^{15, 257, 258, 259, 260} Therefore, caution should be exercised when using corticosteroids.²⁶⁰ There are reports of encephalitis or myocarditis in association with steroid use in

IM,^{261, 263} and secondary bacterial and fungal infections can occur. However, in the face of severe complications, the use of steroids may well be indicated and necessary.

Several antiviral agents such as acyclovir, ganciclovir, zidovudine, foscarnet, and the interferons (IFNs) have been shown to inhibit the replication of EBV in vitro.²⁶² Only the linear form of the genome, not the latent circular form, is susceptible to inhibition. The efficacy of acyclovir in the therapy of uncomplicated IM has been assessed in several controlled trials.^{263, 264, 265, 266} In general, acyclovir reduces viral shedding during the time of therapy, but viral shedding resumed when therapy was discontinued.¹⁵ Clinical trials have documented few clinical benefits as measured by duration of illness and sore throat, weight loss, or absence from school or work, even when acyclovir was given in combination with steroids.^{259, 266} IFN- α has been used in a few patients experiencing persistent EBV infection with severe complications of interstitial pneumonitis, encephalitis, or genital ulcers, apparently with some success.²⁶⁷ Patients with IM-associated immune thrombocytopenia have responded to therapy with large doses of intravenously administered γ -globulin.²³² A viral protein vaccine has been developed that protects marmosets from developing LPD^{268, 269} but not from infection. Several groups are working on the development of EBV vaccines^{270, 271} Although these vaccines can induce a neutralizing antibody response they do not protect against primary infection or reduce the risk of developing clinical disease, i.e., IM.

Prognosis

Complete recovery occurs within 2 months in the majority of patients. Recurrences of IM are so rare that one must question whether the initial diagnosis or the diagnosis of recurrence is accurate. It is estimated that IM is fatal in as many as 1 in 3,000 cases, or approximately 50 cases annually in the United States.^{76, 272} Penman,²³⁹ in reviewing the world literature on IM, catalogued 87 fatalities attributed to the disease or its complications. Only 20 of these reports, however, contained adequate evidence for an unequivocal diagnosis. Of these 20 cases, 9 fatalities were related to be due to neurologic complications, 4 were related to respiratory failure from peripheral neuropathy of the Guillain-Barré type, and 5 were related to central respiratory paralysis; 3 were related to splenic rupture; and 3 were related to secondary infection. Other fatal complications included hepatic failure (two cases) and myocarditis (one case). In two cases, the cause of death was unrelated to IM. The majority of deaths associated with IM occur in patients who develop VAHS or EBV-HLH.^{76, 272}

A recent study has demonstrated that the severity and duration of the illness does not correlate with either control of viremia or rapidity of the antiviral humoral or cellular responses.²⁷³ Therefore, in the nearly 100 years since the first description of IM and the etiologic agent (i.e., Epstein-Barr virus) countless reports of describing the spectrum of potential complications have been published. But despite enormous numbers of studies to define the pathogenesis, it remains a mystery how and why EBV causes the symptoms of IM, and a therapy that reproducibly improves symptoms remains elusive.

P.1334

OTHER EPSTEIN-BARR VIRUS-RELATED DISEASES

Recently, methods for detecting infectious agents in human disease have become highly developed. Consequently, many ubiquitous infectious agents have been etiologically linked to certain human diseases (e.g., EBV infection has been associated with a wide spectrum of human diseases). Classically, EBV is associated with the development of human malignancies such as BL and NPC. EBV infection has also been associated with other human malignancies, such as NHL (B-cell, T-cell, and NK-cell phenotype), HL, gastric carcinoma, leiomyosarcoma, hepatocellular carcinoma, breast cancer, and LPDs associated with immunodeficiency. In addition, EBV infection has been associated with several nonmalignant, but potentially life-threatening human diseases, such as VAHS or EBV-HLH, and CAEBV, in which development of malignant lymphoma can occur. Also, some have linked EBV infection to chronic illnesses, such as chronic fatigue syndrome and most recently multiple sclerosis. Although association has been demonstrated, it remains controversial whether EBV is causative in these disorders (Table 62.4). The following discussion focuses on diagnosis of and evidence for the role of EBV in the pathogenesis of these diseases.

Chronic Active Epstein-Barr Virus Infection

EBV rarely causes recurrent or persistent symptomatic infections in apparently immunocompetent hosts. Diagnostic criteria for CAEBV have been proposed²⁷⁴ and consist of (a) evidence of severe, progressive EBV illness beginning as a primary EBV infection and lasting more than 6 months with anti-EBV titers of IgG anti-VCA 1:5120, anti-EA 1:640, or anti-EBNA<1:2, or all three; (b) histologic evidence of major organ involvement; and (c) increased amounts of EBV in peripheral

blood or affected tissues, or both. CAEBV is characterized by persistent or recurrent IM-like symptoms, such as recurrent fever, lymphadenopathy, and hepatosplenomegaly, and unusual anti-EBV antibody patterns.²⁷⁴ CAEBV occurs most commonly in patients who develop IM as older children or young adults.^{274, 275, 276} This entity may be more prevalent in Asia, as most of the published literature is from Japan. A cohort of 30 patients in Japan diagnosed with CAEBV presented with the following clinical manifestations: Fever (100%), liver dysfunction (90%), splenomegaly (90%), lymphadenopathy (50%), thrombocytopenia (50%), anemia (50%), hypersensitivity to mosquito bites (43%), calcification in the basal ganglia (18%), and oral ulcer (18%).²⁷⁵ CAEBV can be lethal, with 30 to 50% mortality within 5 years of diagnosis.^{28, 276} Life-threatening complications include the hemophagocytic syndrome (21%), coronary artery aneurysm (21%), hepatic failure (18%), malignant lymphoma (16%), and interstitial pneumonia (12%).²⁷⁶ The majority of deaths are due to hemophagocytic syndromes or hematologic malignancies, which may be of T-cell, B-cell, or NK-cell phenotype.^{28, 274, 276}

TABLE 62.4 DISEASES THAT HAVE BEEN ASSOCIATED WITH EPSTEIN-BARR VIRUS

Definite Etiologic Role	Strong Association	Etiologic Role Unclear	Controversial Association
Infectious mononucleosis	Burkitt lymphoma		Chronic fatigue syndrome
CAEBV	Nasopharyngeal carcinoma		Multiple sclerosis
EBV-HLH	Lymphoproliferative disease of immunodeficiency		Breast carcinoma
	Leiomyosarcoma of immunodeficiency		
	X-linked lymphoproliferative disease		
	Hodgkin disease		
	Nasal NK-/T-cell lymphoma		
	Gastric carcinoma		

CAEBV, chronic active Epstein-Barr virus infection; EBV, Epstein-Barr virus; HLH, hemophagocytic lymphohistiocytosis; NK, natural killer.

It is believed that cellular immunologic abnormalities are responsible for the development of CAEBV. In the peripheral blood of patients with CAEBV, high levels of EBV DNA have been found in CD4⁺ T cells and NK cells, but not in B cells.²⁷⁷ The significance of this finding in the pathogenesis of CAEBV and the mechanism of infection of these cells remain to be elucidated. This entity may overlap with severe or fulminant IM (FIM or EBV-HLH).^{68, 274, 277} Further studies are needed to differentiate between these enigmatic disorders and to determine the role of EBV infection in their pathogenesis.

A standard treatment approach to CAEBV has not been established. Most reports are anecdotal but include antiviral agents (acyclovir, ganciclovir, and vidarabine) and/or immunomodulating agents (IFN- α or IL-2).^{274, 275, 276, 277, 278, 279} Because immunochemotherapy (e.g., etoposide, corticosteroids, and cyclosporin A) has been effective in treating the EBV-hemophagocytic syndrome,^{280, 281} it has been used to control symptoms and treat hemophagocytic complications.²⁷⁴ Hematologic malignancies have been treated with standard NHL therapy,²⁷⁶ but curative therapy for the severely affected patient appears to require the replacement of the patient's immune system with a normally functioning immune system to control the EBV infection, for instance, by an allogeneic stem cell or marrow transplant^{275, 282} or by allogeneic adoptive T-cell therapy.²⁸³

CAEBV infections should be differentiated from the so-called chronic mononucleosis, or chronic fatigue syndrome. Due to the similar symptoms and reports of elevated anti-VCA and anti-EA titers, EBV has been suggested to be the etiologic agent in the chronic fatigue syndrome.²⁸⁴ In controlled studies, no specific EBV serologies have been found that differentiate chronic fatigue syndrome patients from controls.²⁸⁵ In a randomized, placebocontrolled trial of acyclovir, clinical improvement was seen as frequently with the placebo.²⁸⁶ Chronic fatigue syndrome has been associated with other infections (viral and bacterial) and, therefore, should not be considered a disease caused by EBV.^{285, 287}

Fulminant Infectious Mononucleosis or Epstein-Barr Virus-Associated Hemophagocytic Lymphohistiocytosis

The self-limited course of IM contrasts with the atypical responses that can occur in FIM, also called VAHS or EBV-associated HLH.⁶⁸ Death occurs in approximately 1 in 3,000 IM cases, or approximately 50 cases annually in the United States.^{76, 272} The median age at presentation of FIM/EBV-HLH is similar to that of uncomplicated IM (i.e., 13 years of age). Whereas FIM/EBV-HLH is the most common manifestation in males affected with X-linked lymphoproliferative disease

(XLP), it often occurs outside the context of XLP.^{68, 69, 272, 288, 289, 290} Outside the context of XLP, the male-to-female ratio is approximately 1:1.²⁷² VAHS has been associated with CMV, herpes simplex virus, and adenovirus, but EBV is the most common.^{68, 280} Clinically, FIM/EBV-HLH is indistinguishable from other types of VAHS, familial HLH, and the accelerated phase of Chédiak-Higashi disease or X-linked inhibitor of apoptosis (XIAP) or sometimes referred to as XLP2.^{68, 69, 280, 291} Because FIM/EBV-HLH is rare, a search for a heritable immune deficiency in family members is mandatory.

P.1335

Patients who progress to FIM/EBV-HLH initially present with the usual signs and symptoms of IM, but these symptoms usually rapidly progress in severity.²⁷² The EBV antibody responses vary considerably from completely lacking to unusually high; therefore, it may be difficult to differentiate FIM/EBV-HLH from other hemophagocytic syndromes, CAEBV, acute leukemia, other malignancies, or even overwhelming sepsis.^{68, 272} The course and progression of the disease are variable, ranging from multiorgan failure developing over hours to persistent or recurring symptoms of IM lasting for months. An atypical lymphocytosis usually is present at early stages of the disease, but patients subsequently develop severe persistent pancytopenia and/or hepatic dysfunction resulting in fulminant hepatitis and varying degrees of multiorgan failure.^{69, 272, 288, 289} The development of hepatic dysfunction, often with coagulation abnormalities secondary to liver failure or disseminated intravascular coagulation, and pancytopenia are ominous signs, as are other signs of hemophagocytic syndromes, such as hypofibrinogenemia and elevated triglyceride levels.^{68, 69, 280, 289, 292}

As discussed previously, EBV is a potent stimulus to the immune system, resulting in a massive EBV-specific and -nonspecific response of both the humoral and cellular immune systems (Fig. 62.4). In FIM/EBV-HLH, the EBV-nonspecific response, primarily the cellular immune response, is uncontrolled. FIM/EBV-HLH is characterized by extensive infiltration of parenchymal organs by lymphoid cells, primarily CD8⁺ cells in varying degrees of transformation and histiocytes with surprisingly few B cells.^{69, 292} The cells infected by EBV in FIM/EBV-HLH are usually T cells^{68, 277, 292} and are generally CD8⁺, as opposed to the CD4⁺ or NK cells observed in CAEBV.^{277, 292}

If this aggressive immune reaction proceeds unabated, all organs ultimately sustain extensive and irreparable damage.^{68, 69, 288, 290, 292} Early in the course of the disease, the bone marrow may be hypercellular with few infiltrating histiocytes; erythrophagocytosis is seen best in smears of marrow aspirates. The marrow later becomes hypocellular with varying numbers of infiltrating histiocytes.^{288, 290} Lymph nodes initially show an intense lymphoblastic proliferative response, again primarily T cells, but later, lymphoid depletion supervenes.^{69, 288, 290} Liver biopsies reveal active portal infiltration with lymphocytes and histiocytes, with occasional erythrophagocytosis in liver sinusoids.²⁵⁰ In the spleen, extensive necrosis of white pulp develops. Perivascular mononuclear cell infiltrates of the brain, mononuclear cell myocarditis, and interstitial nephritis also are observed.^{69, 272, 288, 289, 290, 293, 294} The thymus shows thymocyte depletion and necrosis of thymic epithelia.²⁹⁵ Increased serum levels of IL-2, IFN- γ , L-6, TNF- α , and soluble IL-2 receptors have been demonstrated.⁶⁸ The T cells that are activated in response to EBV are believed to be stimulated to produce proinflammatory cytokines (e.g., IL-2, IFN- γ , etc.), and it is believed this activates macrophages, which produce more proinflammatory cytokines, such as IL-6 and TNF- α , culminating in the phagocytosis, tissue destruction, and cellular depletion seen in FIM/EBV-HLH; death usually follows shortly thereafter due to multisystem organ failure.⁶⁸

Once FIM/EBV-HLH develops, therapy is difficult and often unsuccessful, with a median survival time of approximately 4 weeks.²⁹⁰ Antiviral drugs, Ig supplementation, IL-2, IFN- α , IFN- γ , plasmapheresis, corticosteroids, and most cytotoxic drugs have been ineffective.^{68, 76} The only therapy that has demonstrated consistent success in the treatment of FIM/EBV-HLH is with the early use of etoposide, which reduces the activity of stimulated macrophages *in vitro*.^{281, 296} The best results appear to be obtained with a combination of etoposide and concomitant immunosuppression with corticosteroids and cyclosporin A or tacrolimus (FK506).^{281, 297} Others have reported using rituximab (anti-CD20 monoclonal antibody) in combination with chemotherapy and immunotherapy.²⁹⁸ The rationale for this approach is that the reduction of EBV (+) B cells decreases immunogenic stimulus for the abnormal T-cell response. Therapy may have to be continued for 6 to 12 months. These patients are profoundly immunocompromised from their disease and the therapy. Therefore, a successful outcome is dependent on control of FIM/EBV-HLH symptoms as well as the prevention and successful treatment of life-threatening infectious complications. Even with remission of symptoms, recurrences are common and carry a poor prognosis. Curative therapy usually involves replacement of the patient's immune system with a normal immune system by allogeneic stem cell or marrow transplantation.^{289, 299, 300} With the advent of therapy with etoposide and immunomodulation therapy to "quiet" the disease and early intervention with allogeneic stem cell transplantation, the outcome has gone from <5% 1-year survival to approximately 50% 3- to 5-year survival.³⁰⁰

Epstein-Barr Virus-Associated Disorders in Immunodeficiency

In the mid-1970s, Purtilo et al. described XLP, in which affected males were thought to have a specific immunodeficiency to EBV, resulting in FIM, malignant lymphoma, hypogammaglobulinemia or agammaglobulinemia, or aplastic anemia.³⁰¹ Later, it was noted that patients with ataxia telangiectasia had high antibody titer responses against EBV-replicating antigens, and EBV genome positive malignant lymphomas were observed.^{302, 303} Similar antibody patterns and EBV-associated B-cell LPD (EBV-LPD) were also reported in patients with Wiskott-Aldrich syndrome.³⁰⁴ With more efficacious immunosuppression, EBV-LPD was also observed more frequently in recipients of organ and marrow transplants, whereas stopping or decreasing the dose of immunosuppressants sometimes resulted in the regression of EBV-LPD, suggesting that a deficiency of immunosurveillance is responsible for the development of EBV-LPD in such patients.³⁰⁵ In the late 1980s, an increased incidence of EBV-LPD, including BL, was reported in association with a growing number of patients with AIDS.³⁰⁶ In recent years, advances in the treatment of patients with immune disorders have resulted in longer survival, and the number of patients at risk of EBV-associated diseases has increased.

In LPD of immunodeficiency, EBV has been identified predominantly in the B-cell phenotypes, but EBV (+) T-cell LPD and HL can also be observed. However, not all LPD of immunodeficiency is EBV-associated. Even in XLP, where affected boys have a very aberrant immune response to EBV infection, many of the NHLs have been found to be EBV-negative.^{307, 308}

Primary Immunodeficiencies

As mentioned previously, the main immune defense against EBV-driven B-cell proliferation are EBV-CTL. Patients with primary immunodeficiencies often lack T-cell functions, which may manifest as insufficient EBV-CTL activity. Immunodeficiencies primarily affecting B cells or neutrophil function are not at increased risk of EBV-associated disease unless treated with T-cell immunosuppression.^{309, 310} There are numerous reports of the occurrence of EBV-LPD in patients with a primary immunodeficiency disease (e.g., ataxia telangiectasia, Wiskott-Aldrich syndrome, Chédiak-Higashi syndrome, severe combined immunodeficiency, and common variable immunodeficiency).³⁰⁷ Type III EBV latency is predominantly seen in these lymphomas,^{27, 307} suggesting a lack of appropriate EBV-CTL immunosurveillance (see the section, "Immune Response to Epstein-Barr Virus Infection"). In addition, relapses are common but may not represent failure to eradicate the original clone, instead indicating a new clonal proliferation.³¹¹ These data underscore the role of immunosurveillance in the pathogenesis of these malignancies.

The treatment is often difficult because of the underlying serious immunodeficiency and/or genetic susceptibility to

P.1336

chemotherapeutic agents. Antiviral therapy has had little effect in the treatment of EBV-LPD associated with immunodeficiency.^{309, 310, 312} Although complete remissions can be achieved with chemotherapy, immunodeficient patients with NHL have a far inferior outcome compared to those expected for immunocompetent children with NHL receiving similar therapy.^{310, 313, 314} These poor results are due to increased toxicity of chemotherapy, especially in defects of DNA repair such as ataxia telangiectasia patients, but infection-related deaths are also greatly increased compared to immunocompetent patients. Because recurrences can be of different clonal origin, successful treatment depends on controlling B-cell proliferation by developing appropriate EBV-CTL immunity. In the majority of cases, the only way to achieve this is allogeneic bone marrow transplantation (BMT).^{300, 309, 310, 315}

X-Linked Lymphoproliferative Disease

In 1974, there were two reports of maternally related boys dying of IM.^{316, 317} In 1975, Purtilo et al. described a kindred in which 6 of 18 boys died of an LPD associated with EBV infection.³¹⁷ XLP has also been called Duncan disease, after the original kindred, or Purtilo disease. XLP is a rare disorder, affecting an estimated 1 out of a million male individuals.²⁸⁹ Initially, three phenotypes were described in XLP patients, and these continue to characterize the majority of patients: FIM (or EBV-HLH), malignant lymphoma (LPD), and dysgammaglobulinemia.³¹⁷ Less commonly reported manifestations include disorders such as vasculitis, pulmonary lymphomatoid granulomatosis, and hematologic cytopenias, including aplastic anemia and pure red cell aplasia.^{289, 308} The "disease state" is capricious, as it may feature a single phenotype or two or more phenotypes, which may develop sequentially in susceptible individuals.^{289, 308}

Reflecting on the ubiquitous nature of EBV infection, FIM is the most common XLP phenotype, affecting approximately 50% of patients.^{289, 308} FIM is decidedly the most lethal of the XLP phenotypes; historically, most of the boys died within 1 month and historically only 7% of FIM patients survived.³⁰⁸ Treatment should be the same as for FIM or EBV-HLH as discussed previously. The median age of onset for XLP-associated FIM is 5 years of age, but the condition has occurred up to 40 years of age. The pathology and clinical findings of FIM associated with XLP are identical to those seen in patients

with EBV-HLH but without XLP, and have been discussed previously. It is interesting that over a third of XLP patients with evidence of current or prior EBV infection never develop FIM.³⁰⁸

Dysgammaglobulinemia is the second most common XLP phenotype, affecting approximately one fourth of boys.^{289, 308} Most boys manifesting this phenotype demonstrate global decreases of serum Ig levels. However, some have featured increased levels of IgM or IgA, or both, as well as variable deficiencies in IgG1 and IgG3 subclasses.³¹⁸ Although hypogammaglobulinemia often occurs after EBV infection, some XLP patients develop hypogammaglobulinemia without prior evidence of EBV infection.³⁰⁸ Mice with the XLP gene “knockout” can manifest progressive hypogammaglobulinemia and abnormalities in Ig switching.³¹⁹ The pathogenesis of dysgammaglobulinemia in XLP has not been delineated, but appears to be due to a defect in T-cell help and affects B-cell memory.

An LPD develops in approximately one fourth of XLP patients.^{289, 308} Most lymphomas are of B-cell phenotype and are characterized by Burkitt or diffuse large-cell histology.^{69, 320} Karyotypic analysis has not been extensively performed; however, the t(8;14) associated with classic BL is rare.^{321, 322} Approximately 10% of LPD are not of B-cell phenotype, including a small number of patients with HL or T-cell LPD.⁶⁹ As in other immunodeficiencies, the role of EBV in the LPD of XLP is unclear, inasmuch as approximately one half of the boys with LPD have had no evidence of prior EBV infection, and EBV is detectable in only 25% of tumor specimens.³⁰⁸

Distinct from the marrow depletion seen with FIM, a limited number (4%) of boys have developed isolated hematologic cytopenias.^{289, 308} Most manifest with suppression of two or more hematologic cell lines, although aplastic anemia and pure red cell aplasia have been observed.

Initially, it was thought that males affected with XLP only manifested symptoms after primary EBV infection. Although IM is, by definition, caused by EBV, other XLP phenotypes develop in EBV-seronegative patients.³⁰⁸ About 10% of affected boys will manifest symptoms of XLP before exposure to EBV.^{289, 308} There is no difference in the age of onset of clinical symptoms between males who have or have not been previously exposed to EBV.³⁰⁸ Therefore, prevention of EBV infection in boys with XLP does not avert clinical manifestations. In addition, whereas approximately 60% of the boys develop FIM after primary infection with EBV, others develop LPD, dysgammaglobulinemia, and hematologic cytopenias, and a few have no symptoms at all.³⁰⁸ These data suggest that the genetic defect in XLP is more global and not EBV-specific as once thought. There must be other genetic and/or environmental factors that influence the host susceptibility to EBV and are important in determining the clinical phenotype of XLP.

Now, the diagnosis can be made easily by identifying a mutated SH2D1A gene^{308, 323, 324, 325} or lack of the corresponding SLAM-associated protein (SAP) protein expression.³²⁶ Female carriers on average express SAP on only 50% of their lymphocytes, due to random X-chromosome inactivation,³²⁷ but do not develop overt clinical manifestations of XLP. Molecular analysis should be pursued in females at risk of being a carrier to provide accurate genetic counseling. Spontaneous mutations in SH2D1A in affected males where mothers do not have mutations have been reported.³²⁸

One might predict that mutations that delete the XLP gene or truncate the protein would be more likely to be associated with a severe phenotype, whereas missense mutations would occur preferentially in mildly affected patients. Attempts to correlate mutations of the SH2D1A gene and the clinical manifestations of XLP found that it was not uncommon to observe different phenotypes and severities with identical mutations, even within the same family.³⁰⁸ No significant differences were observed in the phenotypes or severity of disease based on the type (missense, nonsense, truncating) or localization of SH2D1A mutations. The age of onset of clinical manifestations of XLP varied considerably, from younger than 1 to 40 years of age, as did survival, but there was no correlation with the type of mutation. Therefore, genetic analysis does not predict the phenotype or severity of disease.³⁰⁸

The SH2D1A gene codes for a protein of 128 amino acid residues that consists of an SH2 domain and a 25-amino acid C-terminal tail.^{323, 324} SH2D1A is expressed throughout thymocyte development, as well as in CD4⁺ and CD8⁺ peripheral T cells, NK and NKT cells, but not on B cells.^{291, 325} SAP appears to function in the regulation of immune response by interacting with several proteins, including SLAM (signaling lymphocyte activating protein; CD150), also called SAP.³²⁴ SAP also has been demonstrated to interact with members of the CD2 superfamily of molecules, including CD2, CD48, CD583, CD84, Ly-9, and 2B4, and with a new family of RasGAP adapter proteins such as p62Dok (Dok [downstream of kinases]-1), p56Dok (Dok-2), and Dok-3.^{329, 330, 331, 332} The immunologic effects of SAP interactions with these proteins are under investigation but appear to be very important in NKT cell development and terminal B-cell differentiation.²⁹¹

Mice genetically deficient in Sh2d1 α (the murine homolog) expression have been generated.³³³ Consistent with human XLP, mutant animals are viable and fertile, transmit the gene defect in an X-linked Mendelian fashion, and display no significant defects in the number and phenotype of developing thymocytes or circulating T, B, or NK cells. After infection with lymphocytic

P.1337

choriomeningitis virus, Sh2d1 α -deficient mice recapitulate important aspects of the human disease. For example, these mice exhibit abnormal lymphocyte responses to a virus resulting in a large CD8⁺ cytotoxic T-cell response that is fatal to the mice.³³³ As mentioned previously, these mice also have defects in humoral responses and develop hypogammaglobulinemia over time.^{322, 333}

XLP is highly lethal, with historically 75% of patients dying by 10 years of age, although the oldest known survivor with XLP is over 50 years of age and has not required allogeneic transplantation.^{289, 308} Antiviral therapies, including acyclovir, ganciclovir, intravenous Ig, and IFN- α , have been used to treat primary EBV infection; none has been particularly effective.^{309, 334} The only therapy that has been consistently beneficial for males with FIM is etoposide and immunosuppression, as discussed previously.^{68, 297, 308} Several affected males have been treated successfully with anti-CD20 (rituximab) following primary infection with EBV but before they develop all the clinical signs and symptoms of FIM or EBV-HLH.²⁸⁸ With FIM or EBV-HLH, even with remissions, relapses are invariable. Therefore, an allogeneic BMT is recommended once the patient's condition is stabilized and a suitable donor has been identified.^{309, 310, 311, 315} As with EBV-HLH not associated with XLP, the outcome has improved from a <10% 1-year survival to perhaps half of the boys with FIM surviving with the early initiation of etoposide, immunosuppression, and allogeneic stem cell transplantation.^{300, 315} Patients with hypogammaglobulinemia require regular Ig supplementation to prevent bacterial and viral infections. However, Ig infusions do not offer the guarantee of protection from primary EBV infection in an EBV-seronegative patient.³⁰⁸ For patients with lymphoma or hematologic cytopenias, standard therapeutic protocols suffice. Although treatment can induce disease remissions, relapses and other XLP phenotypes invariably occur, and allogeneic BMT is recommended.^{309, 310, 311, 312, 313, 314, 315} With definitive diagnosis by genetic mutational analysis, BMT now can be performed before the appearance of clinical manifestations of the disease^{315, 335} and is recommended to prevent the life-threatening complications of the disease.

In 2006, another X-linked disorder that was characterized by EBV-HLH was described to be caused by deficiency in the BIRC4 gene.^{336, 337} Of note, BIRC4 resides in close proximity to the SH2D1A gene. Further studies demonstrated that these patients have defects in their antiapoptotic functions and the disorder has been named deficiency of the XIAP. Because XIAP patients frequently have problems with EBV-HLH, XIAP has also been called XLP2. However, unlike SAP which is limited to T, NK and NKT cells, XIAP is widely expressed on human tissue.²⁹¹ As the name suggests, the XIAP function is to inhibit apoptosis; therefore deficiency leads to increased sensitivity to apoptosis and hypogammaglobulinemia is observed in XIAP patients.²⁹¹ The immune mechanism for susceptibility to complications of EBV infection, including EBV-HLH is unclear, but XIAP patients do not have an increased incidence of lymphoma.²⁹¹ Therefore, it is best to differentiate XLP and XIAP as distinct clinical entities.

Secondary Immunodeficiencies

It is well recognized that patients infected with HIV, as well as transplant recipients, are at increased risk of developing LPD that are often associated with EBV. Rarely, elderly patients, malnourished patients, and those with cancer develop EBV-associated atypical lymphoproliferation.^{69, 312} Indeed, the World Health Organization (WHO) now recognizes a EBV-positive diffuse large B-cell lymphoma as a distinct entity.³³⁸ EBV-induced LPD have been reported in patients without severe immunodeficiency (e.g., individuals who received methotrexate as treatment for rheumatoid arthritis).³³⁹ Therefore, a high index of suspicion is warranted in any patient who may be immunosuppressed.

Human Immunodeficiency Virus/Acquired Immunodeficiency Syndrome

EBV has been found in several diseases associated with HIV infection, including oral hairy leukoplakia,^{340, 341} leiomyosarcoma,³³ and NHL.³⁴² Oral hairy leukoplakia is characterized by white raised plaques on the lateral surfaces of the tongue. EBV has been found in the lesions of oral hairy leukoplakia in HIV patients,^{342, 343} and these lesions have been reported to respond well to therapy with acyclovir.³⁴³ The EBV-associated leiomyomas and leiomyosarcomas account for 3% to 15% of all cancers in HIV-infected children.^{344, 345} For reasons that are not clear, leiomyomas and leiomyosarcomas do not appear to be increased in HIV-infected adults. Tumors can be found in the lung, brain, adrenal glands, and spleen.^{33, 346, 347, 348, 349, 350} How EBV gains access to smooth muscle cells and its pathogenic role in tumorigenesis remains unclear. The clinical course is highly variable, but aggressive treatment with highly active antiretroviral therapy (HAART) and primary excision of tumors, if feasible, are recommended in all patients, but chemotherapy and/or radiation are often required.

The clinical spectrum of HIV-related NHL typically includes systemic NHL, primary central nervous system (CNS) NHL, and pleural effusion lymphoma (PEL). Although EBV is detected in essentially all the primary CNS NHL³⁴⁹ and most PEL,³⁵⁰ only

approximately 50% to 60% of systemic HIV-related NHL have detectable EBV.³⁵¹ PEL is not typically associated with solid masses and is associated with HHV8, but most also have EBV present in tumor cells.³⁵⁰ The relative contribution of HHV8 and EBV in the pathogenesis of PEL is unclear. Following the introduction of HAART into clinical practice in the 1990s, there has been a dramatic effect on the incidence of AIDS-defining diseases. In the HAART era, there has been a decrease in primary CNS NHL and systemic diffuse large B-cell lymphoma; however, the incidence of BL has appeared to be unchanged.^{352, 353, 354} The outcome for patients with HIV and NHL has improved dramatically. There are some overlapping toxicities from HAART and cytotoxic agents; however, with the concurrent use of HAART and aggressive supportive care, HIV patients can now tolerate standard therapies for NHL with similar outcomes.³⁵⁵

Post-transplant Lymphoproliferative Disease

Figures 62.3 and 62.4 illustrate the importance of a qualitatively and quantitatively appropriate T-cell response in maintaining homeostasis and preventing EBV-driven B-cell proliferation. Therefore, with chronic immunosuppressive therapy following the transfer of EBV-infected B cells via blood, marrow, or organ grafts, complications due to EBV are frequently seen in transplant patients.

Post-transplant lymphoproliferative disease (PTLD) represents a spectrum of clinical and morphologic heterogeneous lymphoid proliferations.^{69, 309, 356, 357, 358, 359, 360} EBV LPD post-transplant may manifest as isolated hepatitis, lymphoid interstitial pneumonitis, or meningoencephalitis, or as an IM-like syndrome with peripheral adenopathy, fever, or hepatitis, or all three. Frequently, the definition of PTLD is limited to lymphomatous lesions (localized or diffuse) that are often extranodal (often in the allograft). Although less frequent, the most fulminant presentation of PTLD is a disseminated systemic disease that clinically resembles septic shock and histologically resembles FIM.

Histologically, EBV disease is quite heterogeneous as well. There have been several histologic classifications for PTLD over the years,^{356, 357, 358, 360} but the WHO has now proposed a classification, which includes (a) early lesions not considered PTLD and that are polymorphic hyperplasia, without disruption of the normal tissue architecture and often accompanied by more classic clinical signs and symptoms of IM; (b) polymorphic PTLD, where T-cell infiltration and disruption of normal tissue architecture are observed; and (c) monomorphic PTLD, which resembles

P.1338

intermediate- to high-grade NHL and tissue necrosis is more frequent.³³⁸ Distinguishing between a polyclonal and a monoclonal PTLD can be difficult as up to 50% of PTLDs do not express surface Ig.^{69, 338} Cytogenetic abnormalities are rare in PTLD, even with Burkitt histology, and abnormalities in genes observed in NHL (i.e., c-myc; N-, H-, and K-ras; p53; and bcl-2, etc.) are rare in PTLD.^{338, 358, 361}

The diagnosis of PTLD should be made by biopsy and evaluated by in situ hybridization with EBER probes or immunohistochemical staining for LMP-1, although LMP-1 staining is not as sensitive as EBER staining.³⁶² PTLD must be distinguished from the increased background number of EBV-positive cells in lymphoid tissue in the post-transplant patient, where up to 10 EBER-positive cells per high powered field (hpf) can be observed without PTLD compared to the nontransplant patient where 0 to 1 cell/hpf is normal.³⁶³ Perhaps the greatest difficulty in making the diagnosis of PTLD occurs in the proliferations that do not produce a mass lesion but have disseminated or infiltrative disease in solid organs. The diagnosis can sometimes be suspected upon examination of the peripheral blood, bone marrow, CSF, or other body fluids for the presence of plasmacytoid cells or large B cells. This type of PTLD is often first discovered at autopsy, with pre-mortem diagnosis being sepsis or graft-versus-host disease (GVHD).^{364, 365}

The majority of PTLD is CD20+,^{70, 369} but not all PTLD is of B-cell phenotype and not all are EBV positive. T-cell PTLD tends to occur late, often more than 10 years after transplantation.³⁶⁶ PTLD with HL phenotype can also occur but tends to occur later (i.e., >4 years post-transplant) and is generally EBV positive.³⁶⁷ The validity of the Hodgkin phenotype of PTLD has been questioned and it has been suggested that it may be a variant of polymorphic B-cell PTLD.³⁶⁸ The diagnosis of HL in the posttransplant patient should be reserved for disease where the RS cells are CD45(-) and/or CD15(+).³⁶⁸ The reason for the long latency in non-B-cell PTLD is unknown, but probably reflects a lesser role for EBV and/or deficient immunosurveillance in the pathogenesis.

More than 90% of early (<1 year post-transplant) PTLD is EBV positive, when EBV-CTL immunity is lowest,^{365, 369, 370} whereas late (>2 years post-transplant) PTLD are frequently EBV negative, can be of T-cell origin, and may have a poorer prognosis.^{366, 371, 372, 373, 374} The etiology of EBV-negative PTLD is not known, and no other virus has been identified as an etiologic agent. These late PTLD may be a different disease and appear more akin to LPD observed in other immunodeficient states (e.g., AIDS and primary immunodeficiencies), in which B-cell origin and EBV association are not universal.³⁷²

The risk factors for PTLD are well described and in general include anything that favors B-cell proliferation and/or suppresses T-cell activity. The reported incidence of PTLD ranges from 1% to 5% in low-risk procedures (e.g., renal, heart, liver, and non-T-cell-depleted bone marrow transplants) to >10% in the high-risk procedures (e.g., lung, small bowel, and T-cell-depleted bone marrow transplants).^{365, 369, 374} In children receiving a solid organ transplant, the effect of the type of allograft appears to be much less. This is likely due to the fact that age and EBV-seronegativity at the time of transplant are very strong risk factors.^{375, 376}

Successful treatment of PTLD necessitates controlling the B-cell proliferation and facilitating the development of an appropriate memory cytotoxic T-cell (EBV-CTL) response to maintain an asymptomatic state of viral latency (Figs. 62.3 and 62.4). Additional factors that contribute to the difficulty of treating these patients include increased toxicity from therapy, secondary infections, and the increased risk of organ rejection or GVHD due to the enhancement of alloreactive T-cell immunity. Surgery, radiotherapy, or both are effective in curing localized disease, but this benefits only a small percentage of patients.^{309, 312} The use of antiviral agents such as acyclovir or ganciclovir and/or intravenous Ig may reduce viral replication and thereby limit the number of infected B cells and may be useful in prophylaxis or preemptive therapy.^{312, 374, 375, 376, 377, 378} The efficacy of antiviral drugs in treating PTLD is controversial because they are seldom used without other interventions (e.g., reduction of immunosuppression); in addition, if viral replication, which is lytic to the infected B cells, is suppressed, B-cell proliferation could theoretically be enhanced.

The approach most widely used as initial therapy for PTLD is reduction of immunosuppression.^{312, 374} In some cases, this is sufficient for controlling the disease, especially in localized polymorphic cases or cases that present like IM. As opposed to PTLD after solid organ transplantation, reduction of immune suppression is rarely successful following BMT, because the major immunosuppression after BMT is from delayed EBV-CTL recovery, not suppression of EBV-CTL function. Patients who do not tolerate reduction of immunosuppression because of graft rejection or GVHD, or who do not respond to immunosuppression reduction, require more aggressive therapy and have a much poorer prognosis.^{309, 312, 374}

Anti-B-cell monoclonal antibodies have been used successfully, including anti-CD21 and anti-CD23³⁷⁹ and, more recently, anti-CD20.^{380, 381} Chemotherapy has also been used successfully for PTLD.^{382, 383} Chemotherapy is attractive because it kills proliferating B cells and is immunosuppressive enough to treat or prevent GVHD or organ rejection.^{382, 384} However, at conventional doses used in the treatment of NHL, post-transplant patients have more end-organ toxicity and susceptibility to infection, with as many as 35% of patients dying of toxicity caused by the therapy.³⁸³ A low-dose chemotherapy approach has been shown to be at least as effective in treating PTLD in children following organ transplant with little toxicity.³⁸⁴

Because the problem in most cases of PTLD is an inadequate number of EBV-CTL,^{370, 385} replacement of EBV-CTL is a logical therapeutic intervention. Infusion of donor lymphocytes has been demonstrated to be successful in the treatment of PTLD post-BMT.³⁸⁶ To avoid the GVHD and other associated toxicities with infusion of donor lymphocytes, ex vivo-generated EBV-specific CTL have been shown to be effective in treating and preventing PTLD post-BMT.³⁸⁷ The ex vivo generation of EBV-specific CTL takes several weeks^{387, 388, 389} and requires a high level of technology and cost. Therefore, due to the cost and regulatory oversight necessary to generate and administer the in vitro-generated EBV-CTL, this approach is not feasible for most centers. The use of adoptive T-cell therapy in an organ transplant recipient is more complex. First, cadaver organs are most widely used; therefore, donor lymphocytes are often not available. Second, as opposed to BMT, after organ transplant, the PTLD cells are usually of recipient origin, so the immunologic recognition, specificity, and efficacy of donor lymphocytes are uncertain. Third, the use of closely matched relatives' lymphocytes runs the risk of both rejection and GVHD. It has been shown that in organ transplant patients EBV-specific CTL can be given safely, and when given prophylactically no PTLD developed.³⁸⁹ However, despite detection of an increased number of EBV-specific CTL, EBV DNA levels in the peripheral blood decreased very little and the infused cells persisted only 2 to 6 months.³⁸⁹ EBV-specific CTL have been used to treat PTLD successfully following organ transplant, but again multiple infusions were required as the adoptively transferred EBV-specific CTL did not last.³⁸⁸ Although a logical and exciting therapeutic strategy, at present adoptive cellular therapy is not available for the majority of patients with PTLD.

Epstein-Barr Virus-Associated Malignancies

Burkitt Lymphoma

The neoplastic cells in BL have a mature germinal center B-cell phenotype as demonstrated by the expression of B-cell-associated

P.1339

antigens (CD19, 20, and 21) and the presence of surface Ig.⁹ Approximately 95% of endemic African BL are EBV positive, as

compared with 20% of sporadic BL occurring mainly in Europe and North America.^{9, 20, 390} Regardless of EBV status, BL is characterized by specific chromosomal translocations that involve chromosomes 8 and 14 (t[8;14]) in 70% of cases, or 8 and 22 (t[8;22]) and 8 and 2 (t[8;2]) in the remaining cases.^{390, 391, 392, 393} As a result, the MYC oncogene becomes juxtaposed to one of the Ig gene loci (i.e., chromosome 14 [heavy chain], chromosome 22 [λ-light chain], or chromosome 2 [κ-light chain]) and is constitutively expressed.^{391, 392, 393}

The role of EBV in the pathogenesis of BL remains to be fully defined. It has been hypothesized that chronic B-cell stimulation by EBV, HIV, and/or malaria^{6, 390, 393} plays a key role by enhancing the chances of a MYC translocation.^{6, 390, 393} The very restricted EBV viral gene expression of type I latency EBV gene expression (i.e., EBNA-1 and the EBERs only) seen in EBV-positive BL makes it difficult to explain the role of EBV in transformation of BL.^{13, 53, 394, 395} In vitro systems have demonstrated that latency III viral gene expression is incompatible with high c-myc expression and maintenance of BL cells,³⁹⁶ and that EBV gene expression, although not promoting cellular proliferation, inhibits apoptosis in MYC-expressing BL cells.³⁹⁷

Nasopharyngeal Carcinoma

NPC is another important EBV-associated malignant disorder. This tumor is mainly observed in Southeast Asia, Southern China, and a few other limited regions of the world.⁹ In these areas, NPC is one of the most frequent malignancies observed. A genetic predisposition appears to be a major factor in the development of this epithelial malignancy. The first generation of southern Chinese immigrants to the United States has an incidence of NPC that is approximately one half that of native Chinese, suggesting that both genetic and environmental factors contribute to the development of NPC.³⁹⁸ The evidence linking EBV to NPC is more compelling than with BL, with essentially all cases being EBV positive.³⁹⁹ The etiologic link between NPC and EBV was first suggested by serologic evidence, especially with anti-IgA antibodies directed against EA, present in high titers in NPC patients as compared with matched controls, IM patients, and BL patients.^{9, 400, 401} In fact, prospective screening for these IgA antibodies or quantitative PCR of EBV DNA in the serum has been useful in detecting preclinical NPC and in anticipating recurrences after therapy.^{402, 403}

Despite the universal association of EBV with NPC, the role EBV plays in the pathogenesis is unclear. The finding of monoclonal EBV found in precancerous lesions of NPC is noteworthy, as it suggests EBV infection takes place early in the pathogenesis and is essential in the development of NPC.^{404, 406} However, all attempts to transform nasopharyngeal epithelium with EBV in vitro have failed. As stated before, NPC tumor cells demonstrate type II viral latency gene expression (i.e., EBERs, EBNA-1, LMP-1 and LMP-2, and BARF1).³⁹⁹ It is hypothesized that because LMP-1 and BARF1 have effects on expression of cellular genes associated with proliferation, they are important in the pathogenesis of NPC.^{399, 405, 406} Other studies have identified genetic defects with presumed inactivation of tumor suppressor genes on chromosomes 3p, 9p, and 14q.⁴⁰⁷ For some time, environmental factors such as exposure to toxins contained in traditional Chinese medicines, including Euphorbia plant extracts, which induce EBV replication, and the ingestion of nitrosamines or other oncogenic substances in salted fish, have also been felt to play an important role in the development of NPC.⁹

Hodgkin Lymphoma

A pathologic link between EBV and HL has been suspected for some time on the basis of serologic studies that demonstrated unusually high titers of antibodies to VCA and EA, as well as the observation that individuals with high antibody titers to EBV have an increased risk of developing HL.^{408, 409, 410} The presence of EBV has been demonstrated conclusively within the RS cells and their mononuclear variants in 40% to 50% of HL specimens.^{28, 144, 145, 146} The virus appears to be monoclonal in any given individual, suggesting that infection occurred before the clonal expansion of RS cells.^{144, 411} EBV positivity is most frequent in mixed cellularity histology, followed by nodular sclerosing, whereas lymphocyte-predominant and lymphocyte-depleted types are usually negative.⁴¹² Again, as in NPC, the viral gene expression is latency type II.^{53, 145, 413}

What role EBV plays in HL also remains undetermined. A large epidemiologic study demonstrated that individuals who developed signs and symptoms of IM following primary infection had a 1 in a 1,000 chance of developing HL. This risk is small, but it was found to be statistically significant compared to the general population and to individuals who did not develop IM following primary infection.⁴¹⁴ In addition, the increased risk was only for developing EBV-positive HL.⁴¹⁴ It has recently been shown that in individuals who develop IM following primary EBV, a persistent deficit in their T cells to respond to IL-15 in vitro is prevalent, although this deficit was not found in individuals who did not develop IM following primary EBV infection.⁴¹⁵ LMP expression in RS cells occurs at very high levels,⁴¹⁶ which usually are immunogenic. It is hypothesized that individuals with IM have a lessened ability in immunosurveillance for EBV-induced lymphoproliferation, and this explains the increased incidence of EBV-positive HL in IM patients.⁴¹⁵ Inasmuch as only 1 in 1,000 individuals with IM ever develops HL, there must be other co-factors important in the pathogenesis.

T-cell Lymphoma

EBV genome-positive T-cell lymphoma was first described unexpectedly in three patients who had extraordinarily high IgG antibody titers to EBV-VCA and EBV-EA.⁴¹⁷ After this report, EBV genome-positive peripheral T-cell lymphoma had been increasingly reported mainly in Asian populations.⁴²⁶ Type II latency is predominantly shown in these malignancies.⁵³ The mechanism of EBV infection into human T cells still remains to be elucidated. CD21 expression has been reported on some T-cell lines^{418, 419}; however, in vitro experiments have failed to demonstrate continuous presence of EBV in such T-cell lines. Variable clinical manifestations are observed in patients with T-cell lymphoma. This may be in part due to cytokine production and cytotoxic functions that can be observed in these tumor cells. It is interesting that this type of lymphoma is often associated with severe CAEBV.^{274, 276} These malignancies are highly resistant to the standard therapies and the outcome is very poor despite aggressive therapy including transplantation.

Natural Killer-Cell Lymphoma/Leukemia

Patients with EBV genome-positive, CD3- NK-cell proliferations were initially reported by Japanese investigators.⁴²⁰ Type II latency is predominant in these malignancies as well.²³ NK-cell lymphoma/leukemia has often been associated with mosquito bite sensitivity⁴²¹ and CAEBV (see discussion in the section, "Chronic Active Epstein-Barr Virus Infection"). Midline granuloma, which is predominantly of T-/NK-cell origin, was first reported in Asia,⁴²² but now cases in North America and Europe have been shown to be EBV genome positive, with monoclonal viral episomes detected in virtually all tumor cells. In general, these malignancies have the same poor prognosis as EBV-positive T-cell malignancies.

Gastric Carcinoma

Gastric carcinoma is a leading cause of death due to cancer in Japan. Shibata and Weiss initially reported the presence of the EBV genome by in situ hybridization.²⁹ The incidence

P.1340

of the EBV genome in gastric carcinoma is 2% to 16% worldwide.^{29, 423, 424, 425} The viral gene expression pattern is unique. All EBV-positive gastric carcinomas express EBERs, EBNA-1, and BARF1 (BART) consistent with type I latency. However, some tumors express LMP-2A and/or lytic genes such as BZLF1 (ZEBRA protein).⁴²⁶

Miscellaneous Epstein-Barr Virus-Associated Human Disease

There are anecdotal reports of numerous human diseases that have been associated with EBV or that EBV DNA has been detected in pathologic tissues. The association of EBV to leiomyoma/leiomyosarcomas in immunodeficient children is strong, but the role in their pathogenesis is far from being understood.^{32, 33} Reports of EBV being detected in other malignancies include hepatocellular carcinoma,³⁰ lymphoepithelial carcinomas of the salivary glands, tonsillar carcinoma, parotid gland carcinoma, and thymoma (reviewed in Ref. 76). EBV has been found in breast carcinoma,³¹ but epidemiology studies have failed to demonstrate an association.⁴²⁷ One of the more intriguing associations is with multiple sclerosis (MS). There have been several epidemiology studies attempting to determine whether there is a link between the development of IM followed by MS. Published results are conflicting, but a recent meta-analysis suggested that an association does exist.⁴²⁸ Because EBV is so ubiquitous in the human population, associations of disease with EBV must be interpreted with caution.

REFERENCES

1. Turk W. Septische Erkrankungen bei Verkuerung des Granulozytensystems. *Wien Klin Wochenschr* 1907;20:157.
2. Wintrobe MM. *Clinical hematology*, 6th ed. Philadelphia, PA: Lea & Febiger, 1967.
3. Sprunt TP, Evans FA. Mononuclear leukocytosis in reaction to acute infection ("infectious mononucleosis"). *Bull Johns Hopkins Hosp* 1920;31:410.
4. Downey H, McKinlay CA. Acute lymphadenosis compared with acute lymphatic leukemia. *Arch Intern Med* 1923;32:82.
5. Burkitt D. A sarcoma involving the jaws in African children. *Br J Surg* 1958; 46:218-223.
6. Burkitt D. Discovering Burkitt's lymphoma: a special address to the Second International Symposium on the Epstein-Barr virus and associated diseases. In: Levine PH, Ablashi DV, Nonoyama M, et al., eds. *Epstein-Barr virus and human disease*. Clifton, NJ: Humana Press, 1987:1.
7. Epstein MA, Achong BG, Barr YM. Virus particles in cultured lymphoblasts from Burkitt's lymphoma. *Lancet* 1964;1:702.

8. Henle G, Henle W, Diehl V. Relation of Burkitt's tumor associated herpes-type virus to IM. *Proc Natl Acad Sci U S A* 1968;39:94.
9. De-Th G. Epidemiology of Epstein-Barr virus and associated diseases in man. In: Roizman B, ed. *The herpes virus*, vol. 1. New York: Plenum Press, 1982:25.
10. Evans AS, Niederman JC, McCollum RW. Seroepidemiologic studies of IM and EBV. *N Engl J Med* 1968;279:1121.
11. Sawyer RN, Evans AS, Niederman JC, et al. Prospective studies of a group of Yale University freshman. I. Occurrence of infectious mononucleosis. *J Infect Dis* 1971;123:263.
12. Epstein MA, Achong BG. Morphology of the virus and of virus-induced cytopathologic changes. In: Epstein MA, Achong BG, eds. *The Epstein-Barr virus*. New York: Springer, 1979:23-37.
13. Kieff E. Epstein-Barr virus and its replication. In: Fields BN, Knipe DM, Howley PM, eds. *Fields virology*, 3rd ed., vol. 2. Philadelphia, PA: Lippincott-Raven, 1996:2343-2396.
14. Baer R, Bankier AT, Biggin MD, et al. DNA sequence and expression of the B95-8 Epstein-Barr virus genome. *Nature* 1984;310:207-211.
15. Straus SE, Cohen JI, Tosato G, et al. Epstein-Barr virus infections: biology, pathogenesis, and management. *Ann Intern Med* 1993;118(1):45-58.
16. Thorley-Lawson D, Mann K. Early events in EB viral infection provide a model for B cell activation. *J Exp Med* 1985;162:45-59.
17. Knutson J, Sugden B. immortalization of B lymphocytes by Epstein-Barr virus: what does the virus contribute to the cell? In: Klein G, ed. *Advances in viral oncology*. New York: Raven Press, 1989:151.
18. Rowe M, Young L, Cadwallader K, et al. Distinction between Epstein-Barr virus type A (EBNA 2A) and type B (EBNA 2B) isolates extends to the EBNA 3 family of nuclear proteins. *J Virol* 1989;63:1031-1039.
19. Habeshaw G, Yao QY, Bell AI, et al. Epstein-Barr virus nuclear antigen 1 sequences in endemic and sporadic Burkitt's lymphoma reflect virus strains prevalent in different geographic areas. *J Virol* 1999;73:965-975.
20. Hu L-F, Chen F, Zheng X, et al. Isolation and sequencing of the Epstein-Barr virus BNF-1 gene (LMP1) from Chinese nasopharyngeal carcinoma. *J Gen Virol* 1991;72:2399-2409.
21. Knecht H, Bachmann E, Brousset P, et al. Deletions within the LMP1 oncogene of Epstein-Barr virus are clustered in Hodgkin's disease and identical to those observed in nasopharyngeal carcinoma. *Blood* 1993;82:2937-2942.
22. Knecht H, Martius F, Bachmann E, et al. A deletion mutant of the LMP1 oncogene of Epstein-Barr virus is associated with evolution of angioimmunoblastic lymphadenopathy into B immunoblastic lymphoma. *Leukemia* 1995;9:458-465.
23. Chang YS, Su IJ, Chung PJ, et al. Detection of an Epstein-Barr virus variant in T-cell lymphoma tissues identical to the distinct strain observed in nasopharyngeal carcinoma in Taiwanese population. *Int J Cancer* 1995;62:673-677.
24. Jenkins PJ, Farrell PJ. Are particular Epstein-Barr virus strains linked to disease? *Semin Cancer Biol* 1996;7:209-215.
25. Shope T, Dechairo D, Miller G. Malignant lymphoma in cottontop marmosets after inoculation with Epstein-Barr virus. *Proc Natl Acad Sci U S A* 1973;70:2487.
26. Cleary ML, Epstein MA, Finerty S, et al. Individual tumors of multifocal EBV virus-induced malignant lymphomas in tamarins arise from different B-cell clones. *Science* 1985;228:772.
27. Okano M, Gross TG. From Burkitt's lymphoma to chronic active Epstein-Barr virus (EBV) infection: an expanding spectrum of EBV associated diseases. *Pediatr Hematol Oncol* 2001;18:427-442.
28. Weiss LM, Strickler JG, Warnke RA, et al. Epstein-Barr virus DNA in tissues of Hodgkin's disease. *Am J Pathol* 1987;129:86-91.
29. Shibata D, Weiss LM. Epstein-Barr virus-associated gastric adenocarcinoma. *Am J Pathol* 1992;140:769-774.
30. Sugawara Y, Mizuzaki Y, Uchida T, et al. Detection of Epstein-Barr virus (EBV) in hepatocellular carcinoma tissue: a novel EBV latency characterized by the absence of EBV-encoded small RNA expression. *Virology* 1999;256:196-202.
31. Bennet M, Guinebretiere JM, Kremmer E, et al. Detection of Epstein-Barr virus in invasive breast cancers. *J Natl Cancer Inst* 1999;91:1376-1381.

32. McClain KL, Leach CT, Jenson HB, et al. Association of Epstein-Barr virus with leiomyosarcomas in young people with AIDS. *N Engl J Med* 1995;332: 12-18.
33. Lee ES, Locker J, Nalesnik M, et al. The association of Epstein-Barr virus with smooth-muscle tumors occurring after organ transplantation. *N Engl J Med* 1995;332:19-25.
34. Fingerroth JD, Weiss JJ, Tedder TF, et al. Epstein-Barr virus receptor of human B lymphocytes is the C3d receptor CR2. *Proc Natl Acad Sci U S A* 1984;81:4510-4514.
35. Borza CM, Hutt-Fletcher LM. Alternate replication in B cells and epithelial cells switches tropism of Epstein-Barr virus. *Nat Med* 2002;8:594-599.
36. Sixbey JW, Nedrud JG, Raab-Traub N, et al. Epstein-Barr virus in replication in oropharyngeal epithelial cells. *N Engl J Med* 1984;310:1225-1230.
37. Shannon-Lowe CD, Neuhierl B, Baldwin G, et al. Resting B cells as a transfer vehicle for Epstein-Barr virus infection of epithelial cells. *Proc Natl Acad Sci U S A* 2006;103:7065-7070.
38. Anagnostopoulos I, Hummel M, Kreschel C, et al. Morphology, immunophenotype, and distribution of latently and/or productively Epstein-Barr virus-infected cells in acute mononucleosis: implications for the interindividual infection route of Epstein-Barr virus. *Blood* 1995;85:744-750.
39. Niedobitek G, Agathangelou A, Herbst H, et al. Epstein-Barr virus (EBV) infection in infectious mononucleosis: viral latency, replication and phenotype of EBV-infected cells. *J Pathol* 1997;278:151-159.
40. Hammerschmidt W, Sugden B. Identification and characterization of oriLyt, a lytic origin of DNA replication of Epstein-Barr virus. *Cell* 1988;55:427-433.
41. Miller G. The switch between latency and replication of Epstein-Barr virus. *J Infect Dis* 1990;161:833-844.
42. Tsurumi T, Fujita M, Kudoh A. Latent and lytic Epstein-Barr virus replication strategies. *Rev Med Virol* 2005;15:3-15.
43. Hsu DH, de Waal Malefyt R, Fiorentino DF, et al. Expression of interleukin-10 activity by Epstein-Barr virus protein BCRF1. *Science* 1990;250:830-832.
44. Yuan J, Cahir-McFarland E, Zhao B, et al. Virus and cell RNAs expressed during Epstein-Barr virus replication. *J Virol* 2006;80:2548-2565.
45. Masucci MG, Ernberg I. Epstein-Barr virus: adaptation to a life within the immune system. *Trends Microbiol* 1994;2(4):125-130.
46. Babcock GJ, Decker LL, Volk M, et al. EBV persistence in memory B cells in vivo. *Immunity* 1998;9:395-404.
47. Souza TA, Stollar BD, Sullivan JL, et al. Peripheral B cells latently infected with Epstein-Barr virus display molecular hallmarks of classical antigen-selected memory B cells. *Proc Natl Acad Sci U S A* 2005;102:18093-18098.
48. Yang J, Tao Q, Flinn IW, et al. Characterization of Epstein-Barr virus-infected B cells in patients with posttransplantation lymphoproliferative disease: disappearance after rituximab therapy does not predict clinical response. *Blood* 2000;96:4055-4063.
49. Young LS, Dawson CW, Eliopoulos AG. The expression and function of Epstein-Barr virus encoded latent genes. *J Clin Pathol Mol Pathol* 2000;53:238-247.
50. Brooks LA, Lean AC, Young LS, et al. Transcription from the Epstein-Barr virus BamHI A fragment are detectable in all three forms of virus latency. *J Virol* 1993;67:3182-3190.
51. Rawlins D, Milman G, Hayward S, et al. Sequence specific DNA binding of the Epstein-Barr virus nuclear antigen (EBNA-1) to clustered sites in the plasmid maintenance region. *Cell* 1985;42:859.
52. Yates JL, Warren N, Sugden B. Stable replication of plasmids derived from Epstein-Barr virus in various mammalian cells. *Nature* 1985;313:812-815.
53. Cohen JI. Epstein-Barr virus infection. *N Engl J Med* 2000;343:481-492.
54. Izumi KM, Kieff ED. The Epstein-Barr virus oncogene product latent membrane protein 1 engages the tumor necrosis factor-associated death domain protein to mediate B lymphocyte growth transformation and activate NF- κ B. *Proc Natl Acad Sci U S A* 1996;94:12592-12597.

55. Eliopoulos AG, Young LS. Activation of the cjun N-terminal kinase (JNK) pathway by the Epstein-Barr virus-encoded latent membrane protein 1 (LMP1). *Oncogene* 1998;16:1731-1742.
56. Liebowitz D. Epstein-Barr virus and a cellular signaling pathway in lymphomas from immunosuppressed patients. *N Engl J Med* 1998;338:1413-1421.
57. Henderson S, Rowe M, Gregory C, et al. Induction of bcl-2 expression by Epstein-Barr virus latent membrane protein 1 protects infected B cells from programmed cell death. *Cell* 1991;65:1107-1115.
58. Caldwell RG, Wilson JB, Anderson SJ, et al. Epstein-Barr virus LMP2A drives B cell development and survival in the absence of normal B cell receptor signals. *Immunity* 1998;9:405-411.
59. Gregory CD, Murray RJ, Edwards CF, et al. Downregulation of cell adhesion molecules LFA-3 and ICAM-1 in Epstein-Barr virus-positive Burkitt's lymphoma underlies tumor cell escape from virus-specific T cell surveillance. *J Exp Med* 1988;167:1811-1824.
60. Chen H, Smith P, Ambinder PF, et al. Expression of Epstein-Barr virus BamHI-A rightward transcripts in latency infected B cells from peripheral blood. *Blood* 1999;93:3026-3032.
61. Yang J, Lemas VM, Flinn IW, et al. Application of the ELISPOT assay to the characterization of CD8⁺ responses to Epstein-Barr virus antigens. *Blood* 2000;95:241-248.
62. Kuzushima K, Hoshino Y, Fujii K, et al. Rapid determination of Epstein-Barr virus-specific CD8⁺ T-cell frequencies by flow cytometry. *Blood* 1999;94: 3094-3100.
63. Tan LC, Gudgeon N, Annels NE, et al. A re-evaluation of the frequency of CD8⁺ T cells specific for EBV in healthy carriers. *J Immunol* 1999;162: 1827-1835.
64. Thorley-Lawson DA. Basic virological aspects of Epstein-Barr virus infection. *Semin Hematol* 1988;25:247.
65. Tosato G, Magrath I, Koski I, et al. Activation of suppressor T cells during Epstein-Barr virus-induced infectious mononucleosis. *N Engl J Med* 1979;301:1133.
66. Callan MFC, Tan L, Annels N, et al. Direct visualization of antigen-specific CD8⁺ T cells during the primary immune response to Epstein-Barr virus in vivo. *J Exp Med* 1998;187:1395-1402.
67. Hislop AD, Annels NE, Gudgeon NH, et al. Epitope-specific evolution of human CD8⁺ T cell responses from primary to persistent phases of Epstein-Barr virus infection. *J Exp Med* 2002;195:893-905.
68. Okano M, Gross TG. Epstein-Barr virus-associated hemophagocytic syndrome and fatal infectious mononucleosis. *Am J Hematol* 1996;53:111-115.
69. Greiner TC, Gross TG. Atypical immune lymphoproliferations. In: Hoffman R, Benz E, Shattil S, et al., eds. *Hematology: basic principles and practice*, 4th ed. Philadelphia, PA: Churchill-Livingstone, 2004:1449.
70. Epstein MA, Achong BG. Pathogenesis of infectious mononucleosis. *Lancet* 1977;2:1270.
71. Norwitz CA, Henle W, Henle G, et al. Long-term serological follow-up of patients for Epstein-Barr virus after recovery from infectious mononucleosis. *J Infect Dis* 1985;151:1150-1153.
72. Henle W, Henle GE, Horwitz CA. The Epstein-Barr virus-specific diagnostic tests in infectious mononucleosis. *Hum Pathol* 1974;5:551.
73. Evans AS, Niederman JC, Cenabre LC, et al. A prospective evaluation of heterophile and Epstein-Barr virus-specific IgM antibody tests in clinical and subclinical infectious mononucleosis: specificity and sensitivity of the tests and persistence of antibody. *J Infect Dis* 1975;132:546-554.
74. Nikoskelainen J, Neel EU, Stevens DA. Epstein-Barr virus-specific serum immunoglobulin A as an acute phase antibody in infectious mononucleosis. *J Clin Microbiol* 1979;10:75.
75. Hewetson JF, Rocchi G, Henle W, et al. Neutralizing antibodies to Epstein-Barr virus in healthy populations and patients with infectious mononucleosis. *J Infect Dis* 1973;128:283.
76. Okano M, Thiele GM, Davis JR, et al. Epstein-Barr virus and human diseases: recent advances in diagnosis. *Clin Microbiol Rev* 1988;1:300-312.
77. Durbin WA, Sullivan JL. Epstein-Barr virus infection. *Pediatr Rev* 1994;15: 63-68.
78. Paul JR, Bunnell WW. The presence of heterophile antibodies in infectious mononucleosis. *Am J Med Sci* 1932;183:90.

79. Ritter K, Brestrich H, Thomssen R, et al. IgM autoantibodies against two cellular antigens always appear in acute Epstein-Barr virus infection. *Scand J Infect Dis* 1990;22:135.
80. Frishman W, Kraus ME, Zabkar J, et al. Infectious mononucleosis and fatal myocarditis. *Chest* 1977;72:535.
81. Garzelli C, Pacciardi A, Basolo F, et al. Mechanisms other than polyclonal B cell activation possibly involved in Epstein-Barr virus-induced autoimmunity. *Clin Exp Immunol* 1989;76:412.
82. Garzelli C, Taub FE, Scharff JE, et al. EBV-transformed lymphocytes produce monoclonal autoantibodies that react with antigens in multiple organs. *J Virol* 1984;52:722.
83. Kaplan ME, Pan EM. Antinuclear antibodies in infectious mononucleosis. *Lancet* 1968;1:561.
84. Elling P, Faber V. Antinuclear antibodies in infectious mononucleosis. *Lancet* 1968;1:918.
85. Capra JD, Winchester RJ, Kunkel HG. Cold-reactive rheumatoid factors in infectious mononucleosis and other diseases. *Arthritis Rheum* 1969;12:67.
86. Grubb R. The Gm system. Anti-Gm's: characteristics in rheumatoid arthritis: experimental induction without resort to allotype; frequent occurrence in mononucleosis. *Scand J Rheumatol* 1988;75(Suppl):227.
87. Misra R, Venables PJ, Plater-Zyberk C, et al. Anti-cardiolipin antibodies in infectious mononucleosis react with the membrane of activated lymphocytes. *Clin Exp Immunol* 1989;75:35.
88. Kaplan ME. Cryoglobulinemia in infectious mononucleosis: quantitation and characterization of the cryoproteins. *J Lab Clin Med* 1968;71:745.
89. Appay V, Dunbar PR, Callan M, et al. Memory CD8+ T cells vary in differentiation phenotype in different persistent virus infections. *Nat Med* 2002;8: 379-385.
90. Tomkinson BE, Wagner DK, Nelson DL, et al. Activated lymphocytes during acute Epstein-Barr virus infection. *J Immunol* 1987;139:3802.
91. Williams ML, Loughran TP Jr, Kidd PG, et al. Polyclonal proliferation of activated suppressor/cytotoxic T cells with transient depression of natural killer cell function in acute infectious mononucleosis. *Clin Exp Immunol* 1989;77:71-76.
92. McKenna RW, Parkin J, Gajl-Peczalska KJ, et al. Ultrastructural, cytochemical, and membrane surface marker characteristics of the atypical lymphocytes in infectious mononucleosis. *Blood* 1977;50:505.
93. Silins SL, Sherritt MA, Silleri JM, et al. Asymptomatic primary Epstein-Barr virus infection occurs in the absence of blood T-cell repertoire perturbations despite high levels of systemic viral load. *Blood* 2001;98:3739-3744.
94. Rensing ME, Horst D, Griffin BD, et al. Epstein-Barr virus evasion of CD8 (+) and CD4 (+) T cell immunity via concerted actions of multiple gene products. *Semin Cancer Biol* 2008;18:397-408.
95. Munz C, Bickham KL, Sublewe M, et al. Human CD4(+) T lymphocytes consistently respond to the latent Epstein-Barr virus nuclear antigen EBNA1. *J Exp Med* 2000;191:1649-1660.
96. Apcher S, Daskalogianni C, Manoury B, Fahraeus R. Epstein-Barr virus-encoded EBNA1 interference with MHC class I antigen presentation reveals a close correlation between mRNA and translation initiation and antigen presentation. *Plos Pathog* 2010;6:e1001151.
97. Levitskaya J, Shapiro A, Leonchiks A, et al. Inhibition of ubiquitin/proteasome-dependent protein degradation by the Gly-Ala repeat of the Epstein-Barr virus nuclear antigen 1. *Proc Natl Acad Sci U S A* 1997;94:12616-12621.
98. Khanna R, Burrows SR, Moss DJ. Immune regulation in Epstein-Barr virus-associated diseases. *Microbiol Rev* 1995;387-405.
99. Miller G, Niederman JC, Andrews LL. Prolonged oropharyngeal excretion of Epstein-Barr virus after infectious mononucleosis. *N Engl J Med* 1973; 288:229.
100. Hislop A, Kuo M, Drake-Lee AB, et al. Tonsillar homing of Epstein-Barr virus-specific CD8+ T cells and the virus-host balance. *J Clin Invest* 2005;115:2546-2555.
101. Karzow DT. Infectious mononucleosis. *Adv Pediatr* 1976;22:231.
102. Rapp C, Hewetson J. Infectious mononucleosis and the Epstein-Barr virus. *Am J Dis Child* 1978;132:78-86.
103. Shurin SB. Infectious mononucleosis. *Pediatr Clin North Am* 1979;26:315.

104. Lehane DE. A seroepidemiologic study of infectious mononucleosis. *JAMA* 1970;212:2240.
105. Young LS, Rowe M. Epstein-Barr virus, lymphomas and Hodgkin's disease. *Semin Cancer Biol* 1992;3:273-284.
106. Carter JW, Edson RS, Kennedy CC. Infectious mononucleosis in the older patient. *Mayo Clin Proc* 1978;53:146.
107. Horwitz CA, Henle W, Henle G. Infectious mononucleosis in patients aged 40 to 72 years. *Medicine* 1983;62:256.
108. Schmader KE, van der Horst CM, Klotman ME. Epstein-Barr virus and the elderly host. *Rev Infect Dis* 1989;11:64.
109. Bender CE. Clinical epidemiology of mononucleosis at a State University. *Northwest Med* 1959;58:697.
110. Nye FJ, Lambert HP. Epstein-Barr virus antibody in cases and contacts of infectious mononucleosis; a family study. *J Hyg (Lond)* 1973;71:151.
111. Straus S, Fleisher LG. Infectious mononucleosis epidemiology and pathogenesis. In: Schlossberg D, ed. *Infectious mononucleosis*. New York: Springer, 1989:8-28.
112. Mygand N. The Epstein-Barr virus carrier state in infectious mononucleosis. *N Engl J Med* 1973;289:867.
113. Niederman JC, Miller G, Pearson HA, et al. Infectious mononucleosis. Epstein-Barr virus shedding in saliva and oropharynx. *N Engl J Med* 1976;294: 1355.
114. Gratama JW, Oosterveer MA, Lepoutre J, et al. Persistence and transfer of Epstein-Barr virus after allogeneic bone marrow transplantation. *Transplant Proc* 1989;21:3097-3098.
115. Shapiro RS, McClain K, Frizzera G, et al. Epstein-Barr virus associated B cell lymphoproliferative disorders following bone marrow transplantation. *Blood* 1988;71:1234-1243.
116. Gross TG, Hinrichs SH, Davis JR, et al. Effect of counterflow elutriation (CE) on Epstein-Barr virus (EBV) infected cells in donor bone marrow. *Exp Hematol* 1998;26:395-399.
117. Cen H, Breinig MC, Atchinson RW, et al. Epstein-Barr virus transmission via donor organs in solid organ transplantation polymerase chain reaction and restriction fragment length polymorphism analysis of IR2, IR3 and IR4. *J Virol* 1991;65:976-980.
118. Alfieri C, Tanner J, Carpentier L, et al. Epstein-Barr virus transmission from a blood donor to an organ transplant recipient with recovery of the same virus strain from the recipient's blood and oropharynx. *Blood* 1996;87:812-817.
119. Gerber P, Walsh JH, Rosenblum EN, et al. Association of EB-virus infection with the post-perfusion syndrome. *Lancet* 1969;1:593-595.
120. Goldberg GN, Fulginiti VA, Ray G, et al. In utero Epstein-Barr virus (infectious mononucleosis) infection. *JAMA* 1981;246:1579-1581.
121. Joncas JH, Wills A, McLaughlin B. Congenital infection with cytomegalovirus and Epstein-Barr virus. *Can Med J* 1977;117:1417-1418.
122. Sixbey JW, Lemon SM, Pagano JS. A second site for Epstein-Barr virus shedding: the uterine cervix. *Lancet* 1986;2:1122-1124.
123. Cheeseman SH. Infectious mononucleosis. *Semin Hematol* 1988;25:261.
124. Contratto AW. Infectious mononucleosis. *Arch Intern Med* 1944;73:449.
125. Finch SC. Clinical symptoms and signs of infectious mononucleosis. In: Carter RL, Penman HG, eds. *Infectious mononucleosis*. Oxford: Blackwell Science, 1969:47-52.
126. Rosenthal T, Hertz M. Mediastinal lymphadenopathy in infectious mononucleosis. *JAMA* 1975;233:1300.
127. Kilpatrick ZM. Structural and functional abnormalities of liver infectious mononucleosis. *Arch Intern Med* 1966;117:47.
128. Matoba AY. Ocular disease associated with Epstein-Barr virus infection. *Surv Ophthalmol* 1990;35:145-150.
129. Dunnet WN. Infectious mononucleosis. *BMJ* 1963;1:1187.
130. Brown GL, Kanwar GS. Drug rashes in glandular fever. *Lancet* 1967;2:1418.
131. Pullen H, Wright N, Murdoch JM. Hypersensitivity reactions to antibacterial drugs in infectious mononucleosis. *Lancet* 1967;2:1176.

132. Weary PE, Cole JW 3rd, Hickam LH. Eruptions from ampicillin in patients with infectious mononucleosis. *Arch Dermatol* 1970;101:86.
133. Mckenzie H, Parratt D, White RG. IgM and IgG antibody levels to ampicillin in patients with infectious mononucleosis. *Clin Exp Immunol* 1976;26:214.
134. Wood TA, Frenkel EP. The atypical lymphocyte. *Am J Med* 1967;43:923.
135. Pearson G. Infectious mononucleosis: the humoral response. In: Schlossberg D, ed. *Infectious mononucleosis*. New York: Springer, 1989:89-99.
136. Finch SC. Laboratory findings in infectious mononucleosis. In: Carter RL, Penman HG, eds. *Infectious mononucleosis*. Oxford: Blackwell Science, 1969:47-62.
137. Carter RL. Platelet levels in infectious mononucleosis. *Blood* 1965;25:817.
138. Fuhrman SA, Gill R, Horwitz CA, et al. Marked hyperbilirubinemia in infectious mononucleosis. *Arch Intern Med* 1987;147:850.
139. Freedman MJ, Odland LT, Cleve EA. Infectious mononucleosis with diffuse involvement of nervous system. *Arch Neurol* 1953;69:49.
140. Strickler JG, Fedeli F, Horwitz CA, et al. Infectious mononucleosis in lymphoid tissue. Histopathology, in situ hybridization, and differential diagnosis. *Arch Pathol Lab Med* 1993;117:269-278.
141. Childs CC, Parham DM, Berard CW. Infectious mononucleosis. The spectrum of morphologic changes simulating lymphoma in lymph nodes and tonsils. *Am J Surg Pathol* 1987;11:122-132.
142. Gall EA, Stout HA. The pathology of lymph nodes of infectious mononucleosis. *Am J Pathol* 1940;16:433.
143. Gowing NFC. Infectious mononucleosis: histopathologic aspects. *Pathol Annu* 1975;10:1.
144. Anagnostopoulos I, Herbst H, Niedobitek G, et al. Demonstration of monoclonal EBV genomes in Hodgkin's disease and Ki-1 positive anaplastic large cell lymphoma by combined Southern blot and in situ hybridization. *Blood* 1989;74:810-816.
145. Pallesen G, Sandvej K, Hamilton-Dutoit SJ, et al. Expression of Epstein-Barr virus latent gene products in tumor cells of Hodgkin's disease. *Lancet* 1991;337:320-322.
146. Herbst H, Dallenbach F, Hummel M, et al. Epstein-Barr virus latent membrane protein expression in Hodgkin and Reed-Sternberg cells. *Proc Natl Acad Sci U S A* 1991;88:4766-4770.
147. Custer RP, Smith EB. The pathology of infectious mononucleosis. *Blood* 1948;3:830.
148. Prang E, Trautmann JC, Kreipe H, et al. Detection of Epstein-Barr virus in lymphoid tissues of patients with infectious mononucleosis by in situ hybridization. *J Pathol* 1992;166:113-119.
149. Boyd JF, Reid D. Bone marrow in nine cases of clinical glandular fever and a review of the literature. *J Clin Pathol* 1968;21:683.
150. Martin MFR. Atypical infectious mononucleosis with bone marrow granulomas and pancytopenia. *BMJ* 1977;2:200.
151. Schleicher EM. Reticulum hyperplasia and proliferation of lymphoid cells in the bone marrow in infectious mononucleosis. *Acta Haematol (Basel)* 1949;2:242.
152. Gorgievski-Hrisoho M, Hinderer W, Nebel-Schickel H, et al. Serodiagnosis of infectious mononucleosis by using recombinant Epstein-Barr virus antigens and enzyme-linked immunosorbent assay technology. *J Clin Microbiol* 1990;28:2305.
153. Matheson BA, Chisholm SM, Ho-Yen DO. Assessment of rapid ELISA test for detection of Epstein-Barr virus infection. *J Clin Pathol* 1990;43:691.
154. Levine D, Tilton RC, Parry MF, et al. False positive EBNA IgM and IgG antibody tests for infectious mononucleosis in children. *Pediatrics* 1994;94:892-894.
155. Wollheim FA, Williams RC Jr. Polyclonal immunoglobulin class M (IgM) increase in infectious mononucleosis. *N Engl J Med* 1966;274:64.
156. Allansmith M, Bergstresser P. Sequence of immunoglobulin changes resulting from an attack of infectious mononucleosis. *Am J Med* 1968;44:124.

157. Lee CL, Davidson I, Staby R. Horse agglutinins in infectious mononucleosis. I. Am J Clin Pathol 1968;49:3; II. The spot test. Am J Clin Pathol 1968;49:12; III. Criterion for differential diagnosis. J Clin Pathol 1968;21:631.
158. Haukenes G, Viggan B, Boye B, et al. Viral antibodies in infectious mononucleosis. FEMS Immunol Med Microbiol 1994;8:219-224.
159. Leikola J. Quantitative aspects of mononucleosis antibodies. Int Arch Allergy 1968;33:105.
160. Bailey GH, Raffel S. Hemolytic antibodies for sheep and ox erythrocytes in infectious mononucleosis. J Clin Invest 1935;14:228.
161. Beer P. The heterophil antibodies in infectious mononucleosis and after the injection of serum. J Clin Invest 1936;15:541.
162. Kanok MF. Heterophil antigens and antibodies in medicine. Curr Top Microbiol Immunol 1977;77:43.
163. Wilkinson PC, Carmichael DS. Immunochemical characterization and serologic behavior of antibodies against red cells in infectious mononucleosis. J Lab Clin Med 1964;64:529.
164. Yoshida K, Nahmias A. Further characterization of specific heterophil antibody from infectious mononucleosis serum. Proc Soc Exp Biol Med 1967;126:872.
165. Springer GF, Rapaport MJ. Specific release of heterogenic "mononucleosis receptor" by influenza viruses, receptor destroying enzyme and plant proteases. Proc Soc Exp Biol Med 1957;96:103.
166. Malave I, Milgram F. Reactions of infectious mononucleosis sera with lymphoid cell cultures. Fed Proc 1972;31:762; Int Arch Allergy 1973;44:601.
167. Lowenthal RM, McLauchlan SL, Tyrrell DA. Human antigen for Paul-Bunnell antibody. Nature 1973;244:109.
168. Mori T, Kano K, Milgrom F. Formation of Paul-Bunnell antibodies by cultures of lymphocytes from infectious mononucleosis. Cell Immunol 1977;34:289.
169. Davidsohn I, Stern K, Kashiwagi C. The differential test for infectious mononucleosis. Am J Clin Pathol 1951;21:1101; J Lab Clin Med 1955; 45:561; Med Clin North Am 1962;46:225; J Immunol 1963;91:783.
170. McCort JJ. Infectious mononucleosis. AJR Am J Roentgenol 1949;62:645.
171. Davidsohn I, Lee CL. Serologic diagnosis of infectious mononucleosis. A comparative study of five tests. Am J Clin Pathol 1964;41:115.
172. Schultz LE. Heterophile antibody titer in diseases other than infectious mononucleosis. Arch Intern Med 1948;81:328-333.
173. Chang KL, Chen YY, Shibata D, et al. Description of an in situ hybridization methodology for detection of Epstein-Barr virus RNA in paraffin embedded tissues. Diagn Mol Pathol 1992;1:246.
174. Shibata D, Weiss L, Nathwaini B, et al. Epstein-Barr virus in benign lymph node biopsies from individuals infected with the human immunodeficiency virus is associated with concurrent or subsequent development of non-Hodgkin's lymphoma. Blood 1991;177:1527-1533.
175. Rooney CM, Loftin SK, Holladay HS, et al. Early identification of Epstein-Barr virus-associated post transplantation lymphoproliferative disease. Br J Hematol 1995;89:98-103.
176. Wagner HJ, Bein G, Bitsch A, et al. Detection and quantification of latently infected B lymphocytes in Epstein-Barr virus-seropositive, healthy individuals by polymerase chain reaction. J Clin Microbiol 1992;30:2826-2829.
177. Rowe DT, Qu L, Reyes J, et al. Use of quantitative competitive PCR to measure Epstein-Barr virus genome load in the peripheral blood of pediatric transplant patients with lymphoproliferative disorders. J Clin Microbiol 1997;35:1612-1615.
178. Deardorff WL, Gerber P, Vogler WR. Infectious mononucleosis in acute leukemia with rising Epstein-Barr virus antibody titers. Ann Intern Med 1970;72:235.
179. Freedman MH, Gilchrist GS, Hammond GD. Concurrent infectious mononucleosis and acute leukemia. JAMA 1970;214:1677.
180. Stevens DA, Levine PH, Lee SK, et al. Concurrent infectious mononucleosis and acute leukemia. Am J Med 1971;50:208.
181. Fraumeni JK. Infectious mononucleosis and acute leukemia. JAMA 1971;215:1159.

182. Horwitz CA, Henle W, Henle G, et al. Clinical and laboratory evaluation of cytomegalovirus-induced mononucleosis in previously healthy individuals. *Medicine* 1986;65:124.
183. Beverley JKA, Beattie CP. Glandular toxoplasmosis. A survey of 30 cases. *Lancet* 1958;2:379.
184. Cooper DA, Gold J, MacLean P, et al. Acute AIDS virus infection. *Lancet* 1985;1:537.
185. Gaines H, von Sydow M, Pehrson PO, et al. Clinical picture of primary HIV infection presenting as a glandular-fever-like illness. *BMJ* 1988;297:1363.
186. Horwitz CA, Henle W, Henle G. Heterophile-negative infectious mononucleosis and mononucleosis-like illnesses. *Am J Med* 1977;63:947.
187. Steeper TA, Horwitz CA, Ablashi DV, et al. The spectrum of clinical and laboratory findings resulting from human herpesvirus-6 (HHV-6) in patients with mononucleosis-like illnesses not resulting from Epstein-Barr virus or cytomegalovirus. *Am J Clin Pathol* 1990;93:776.
188. Cohen JI, Corey GR. Cytomegalovirus infection in the normal host. *Medicine* 1985;64:100.
189. Klemola E, Von Essen R, Henle G, et al. Infectious mononucleosis-like disease with negative heterophil agglutination test; clinical features in relation to EB virus and cytomegalovirus antibodies. *J Infect Dis* 1970;121:608.
190. Farley DR, Zietlow SP, Bannon MP, et al. Spontaneous rupture of the spleen due to infectious mononucleosis. *Mayo Clin Proc* 1992;67:846-853.
191. Aldrete JS. Spontaneous rupture of the spleen in patients with infectious mononucleosis. *Mayo Clin Proc* 1992;67:910-912.
192. Rutkow IM. Rupture of the spleen in infectious mononucleosis. *Arch Surg* 1978;113:718.
193. Grose C, Henle W, Henle G, et al. Primary Epstein-Barr virus infections in acute neurologic diseases. *N Engl J Med* 1975;292:392.
194. Connelly KP, DeWitt D. Neurologic complications of infectious mononucleosis. *Pediatr Neurol* 1994;10(3):181-184.
195. Ricker W, Blumberg A, Peters C, et al. The association of the Guillain-Barre syndrome with infectious mononucleosis. *Blood* 1947;2:217-226.
196. Kennard C, Swash M. Acute viral encephalitis. Its diagnosis and outcome. *Brain* 1981;104:129-148.
197. Lange BJ, Berman PH, Bender J, et al. Encephalitis in infectious mononucleosis. Diagnostic considerations. *Pediatrics* 1976;58:877.
198. Demey HE, Martin JJ, Leus RM, et al. Coma as a presenting sign of Epstein-Barr encephalitis. *Arch Intern Med* 1988;148:1459.
199. Copperman SM. "Alice in Wonderland" syndrome as a presenting symptom of infectious mononucleosis in children. *Clin Pediatr* 1977;16:143-146.
200. Fleisher G, Schwartz J, Lennette E. Brief clinical and laboratory observations. Primary Epstein-Barr virus infection in association with Reye syndrome. *J Pediatr* 1980;97:935-937.
201. Graman PS. Mollaret's meningitis associated with acute EBV mononucleosis. *Arch Neurol* 1987;44:1204.
202. Sibert JR. Hypoglossal nerve palsy complicating a case in infectious mononucleosis. *Postgrad Med J* 1972;48:691-692.
203. Williams LL, Lowery HW, Glaser P. Sudden hearing loss following infectious mononucleosis: possible effect of altered immunoregulation. *Pediatrics* 1985;75:1020-1027.
204. Grose LC, Feorino PM, Dye LA, et al. Bell's palsy and infectious mononucleosis. *Lancet* 1973;2:231-232.
205. Watson P, Ashby P. Brachial plexus neuropathy associated with infectious mononucleosis. *Can Med Assoc J* 1976;114:758-767.
206. Dussalix E, Ietouze P, Tardieu M. Neuropathy of the brachial plexus complicating infectious mononucleosis in an 18 month old child. *Arch Fr Pediatr* 1986;43:129-130.
207. Yahr M, Frontera A. Acute autonomic neuropathy. *Arch Neurol* 1975;32:132-133.
208. Estanol-Vidal B, Perez-Ortega R, Vargas-Lugo B, et al. Acute autonomic neuropathy. *Arch Invest Med* 1979;10:53-64.

209. Vassallo M, Camilleri M, Caron BL, et al. Gastrointestinal motor dysfunction in acquired selective cholinergic dysautonomia associated with infectious mononucleosis. *Gastroenterology* 1991;100:252.
210. Cleary TG, Henle W, Pickering LK. Acute cerebellar ataxia associated with Epstein-Barr virus infection. *JAMA* 1980;243:148.
211. Erzurum S, Kalausky SM, Watanakunakorn C. Acute cerebellar ataxia and hearing loss as initial symptoms of infectious mononucleosis. *Arch Neurol* 1983;40:760-762.
212. Cotton PB, Webb-Peploe MM. Acute transverse myelitis as a complication of glandular fever. *BMJ* 1966;1:654-655.
213. Junker AK, Roland EH, Hahn G. Transverse myelitis with Epstein-Barr virus infection with delayed antibody response. *Neurology* 1991;41:1523-1524.
214. Roseman DM, Barry RM. Acute pericarditis as the first manifestation of infectious mononucleosis. *Ann Intern Med* 1957;47:351.
215. Shugoll GI. Pericarditis associated with infectious mononucleosis. *Arch Intern Med* 1957;100:630.
216. Deaton JG, Skaggs H Jr, Levin WC. Acute hemolytic anemia complicating infectious mononucleosis: the mechanisms of hemolysis. *Tex Rep Biol Med* 1967;25:309.
217. Mahoney D, Fernbach D. The hematologic response. In: Schlossberg D, ed. *Infectious mononucleosis*. New York: Springer, 1989:80-88.
218. Hossaini AA. Anti-i in infectious mononucleosis. *Am J Clin Pathol* 1970;53:198.
219. Wishart MM, Davey MG. Infectious mononucleosis complicated by acute haemolytic anemia with a positive D-L reaction. *J Clin Pathol* 1973;26:332.
220. Uzokwe CO, Gwynn AM, Gorst DW, Adamson AR. Infectious mononucleosis complicated by haemolytic anaemia due to the Donath Landsteiner antibody and by severe neutropenia. *Clin Lab Haematol* 1993;15:137-140.
221. Calvo R, Stein W, Kochwa S, et al. Acute hemolytic anemia due to anti-i. *J Clin Invest* 1965;44:1033.
222. Jenkins WJ, Koster HG, Marsh WL, et al. Infectious mononucleosis: an unsuspected source of anti-i. *Br J Haematol* 1965;11:480.
223. Denardo GL, Ray JP. Hereditary spherocytosis and infectious mononucleosis with acquired hemolytic anemia. *Am J Clin Pathol* 1963;39:284.
224. Godal HC, Skaga E. Aggravation of congenital spherocytosis during infectious mononucleosis. *Scand J Haematol* 1969;6:33.
225. Ho-Yen DO. Autoimmune hemolytic anemia complicating infectious mononucleosis in a patient with hereditary elliptocytosis. *Acta Haematol (Basel)* 1978;59:45.
226. Thurm RH, Bassen F. Infectious mononucleosis and acute hemolytic anemia. *Blood* 1955;10:841.
227. Vogel SJ, Reinhard EH. Paroxysmal nocturnal hemoglobinuria associated with infectious mononucleosis. *Blood* 1979;54:351.
228. Clarke BF, Davies SH. Severe thrombocytopenia in infectious mononucleosis. *Am J Med Sci* 1964;248:703.
229. Weinblatt ME. Immune thrombocytopenic purpura evolving into aplastic anemia in association with Epstein-Barr virus infection. *Am J Pediatr Hematol Oncol* 1991;13(4):465-469.
230. Sumaya C, Ench Y. Epstein-Barr virus infectious mononucleosis in children. I. Clinical and general laboratory findings. *Pediatrics* 1985;75:1003-1010.
231. Wong S, Bennett B. Natural history of severe thrombocytopenia in infectious mononucleosis. *Postgrad Med J* 1982;58:249-251.
232. Cyran EM, Rowe JM, Bloom RE. Intravenous gammaglobulin treatment for immune thrombocytopenia associated with infectious mononucleosis. *Am J Hematol* 1991;38:124-129.
233. Levy M, Kelly JP, Kaufman DW, et al. Risk of agranulocytosis and aplastic anemia in relation to history of infectious mononucleosis: a report from the international agranulocytosis and aplastic anemia study. *Ann Hematol* 1993;67:187-190.
234. Fisher BD. Neutropenia in infectious mononucleosis. *N Engl J Med* 1973;288:633.

235. Stevens DL, Everett ED, Boxer LA, et al. Infectious mononucleosis with severe neutropenia and opsonic antineutrophil activity. *South Med J* 1979;72:519.
236. Lazarus KH, Baehner RL. Aplastic anemia complicating infectious mononucleosis: a case report and review of the literature. *Pediatrics* 1981; 67:907.
237. Shadduck RK, Winkelstein A, Zeigler Z, et al. Aplastic anemia following infectious mononucleosis. Possible immune etiology. *Exp Hematol* 1979;7:264.
238. Baranski B, Armstrong G, Truman JT, et al. Epstein-Barr virus in the bone marrow of patients with aplastic anemia. *Ann Intern Med* 1988;109:695-704.
239. Penman HG. Fatal infectious mononucleosis: a critical review. *J Clin Pathol* 1970;23:765-771.
240. Evans AS. Complications of infectious mononucleosis. *Hosp Med* 1967;3:24.
241. Feasby TE. Inflammatory-demyelinating polyneuropathies. *Neurol Clin* 1992; 10:651-670.
242. Heinze EG, Quinn L. Aseptic meningitis in siblings with infectious mononucleosis. *Henry Ford Hosp Med Bull* 1966;14:229.
243. Hoagland RJ. Mononucleosis and heart disease. *Am J Med Sci* 1964;248:1.
244. Maddern BR, Werkhaven J, Wessell H, et al. Infectious mononucleosis with airway obstruction and multiple cranial nerve paresis. *Otolaryngol Head Neck Surg* 1991;104:529-532.
245. Snyderman NL. Otolaryngologic presentation of infectious mononucleosis. *Pediatr Clin North Am* 1981;29:1011.
246. Fermaglich DR. Pulmonary involvement in infectious mononucleosis. *J Pediatr* 1975;86:93.
247. Haller A, von Segesser L, Baumann PC, et al. Severe respiratory insufficiency complicating Epstein-Barr virus infection: case report and review. *Clin Infect Dis* 1995;21:206-209.
248. Eaton OM, Little PF, Silver HM. Infectious mononucleosis with pleural effusion. *Arch Intern Med* 1965;115:87.
249. Offit PA, Fleisher GR, Koven NL, et al. Severe Epstein-Barr virus pulmonary involvement. *J Adolesc Health Care* 1981;2:121-125.
250. Markin RS, Linder J, Zuerlein K, et al. Hepatitis in fatal infectious mononucleosis. *Gastroenterology* 1987;93:1210.
251. Pelletier LL, Borel DM, Romig DA, et al. Disseminated intravascular coagulation and hepatic necrosis. *JAMA* 1976;235:1144.
252. Tazawa Y, Nishinomiya F, Noguchi H, et al. A case of fatal infectious mononucleosis presenting with fulminant hepatic failure associated with an extensive CD8-positive lymphocyte infiltration in the liver. *Hum Pathol* 1993;24:1135-1139.
253. Everett ED, Volpe JA, Bergin JJ. Pancreatitis in infectious mononucleosis. *South Med J* 1969;62:359.
254. Wislocki LG. Acute pancreatitis in infectious mononucleosis. *N Engl J Med* 1966;275:322.
255. Lowery TA, Rutsky EA, Hartley MW, et al. Renal failure in infectious mononucleosis. *South Med J* 1976;69:1212.
256. Schumacher HR, Jacobson WA, Bemiller CR. Treatment of infectious mononucleosis. *Ann Intern Med* 1963;58:217.
257. Prout C, Dalrymple W. A double-blind study of eighty-two cases of infectious mononucleosis treated with corticosteroids. *J Am Coll Health Assoc* 1966;15:62-66.
258. Klein EM, Cochran JF, Buck RL. The effects of short-term corticosteroid therapy on the symptoms of infectious mononucleosis pharyngotonsillitis: a double-blind study. *J Am Coll Health Assoc* 1969;17:446-450.
259. Andersson J, Ernberg I. Management of Epstein-Barr virus infections. *Am J Med* 1988;85:107-115.
260. McGowan JE Jr, Chesney PJ, Crossley KB, et al. Guidelines for the use of systemic glucocorticosteroids in the management of selected infections. Working Group on Steroid Use, Antimicrobial Agents Committee, Infectious Diseases Society of America. *J Infect Dis* 1992;165:1-13.
261. Waldo RT. Neurologic complications on infectious mononucleosis after steroid therapy. *South Med J* 1981;74:1159-1160.
262. Straus SE. Epstein-Barr virus and human herpesvirus type 6. In: Galasso GJ, Whitely RJ, Merigan TC, eds. *Antiviral agents and viral diseases of man*, 3rd ed. New York: Raven Press, 1990:647-668.

263. Andersson J, Britton S, Ernberg I, et al. Effect of acyclovir on infectious mononucleosis: a double-blind, placebo-controlled study. *J Infect Dis* 1986;153:283-290.
264. Andersson J, Skildenberg B, Henle W, et al. Acyclovir treatment in infectious mononucleosis: a clinical and virological study. *Infection* 1987;15:14-20.
265. Van der Horst C, Joncas J, Ahronhein G, et al. Lack of effect of peroral acyclovir for the treatment of infectious mononucleosis. *J Infect Dis* 1991;164: 788-792.
266. Tynell E, Aurelius E, Brandell A, et al. Acyclovir and prednisolone treatment of acute infectious mononucleosis: a multicenter, double-blind, placebo-controlled study. *J Infect Dis* 1996;174:324-331.
267. Andersson J. EBV, everybody's virus: the management of Epstein-Barr virus infections. *Herpes* 1996;3(2):55-62.
268. Morgan AJ. Control of viral disease: the development of Epstein-Barr virus vaccine. *Springer Semin Immunopathol* 1991;13:249-262.
269. Cox C, Naylor BA, Mackett M, et al. Immunization of common marmosets with Epstein-Barr virus (EBV) envelope glycoprotein gp340: effect on viral shedding following EBV challenge. *J Med Virol* 1998;55:255-261.
270. Moutschen M, Leonard P, Sokal EM, et al. Phase I/II studies to evaluate safety and immunogenicity of a recombinant gp350 Epstein-Barr virus vaccine in healthy adults. *Vaccine* 2007;25:4697-4705.
271. Sokal EM, Hoppenbrouwers K, Vandermeulen C, et al. Recombinant gp350 vaccine for infectious mononucleosis: a phase 2, randomized, double-blinded, placebo controlled trial to evaluate the safety, immunogenicity, and efficacy of an Epstein-Barr virus vaccine in healthy young adults. *J Infect Dis* 2007;196:1749-1753.
272. Weisenburger DD, Purtilo DT. Failure in immunological control of virus infection: fatal infectious mononucleosis. In: Epstein MA, Achong BG, eds. *The Epstein-Barr virus: recent advances*. London: Heinemann, 1986:127-161.
273. Cameron B, Bharadwaj M, Burrows J, et al. Prolonged illness after infectious mononucleosis is associated with altered immunity but not with increased viral load. *J Infect Dis* 2006;193:664-671.
274. Okano M, Kawa K, Kimura H, et al. Proposed guidelines for diagnosing chronic active Epstein-Barr virus infection. *Am J Hematol* 2005; 80:64-69.
275. Straus SE. Acute progressive Epstein-Barr virus infection. *Annu Rev Med* 1992; 43:437-449.
276. Kimura H, Kanegane H, Tsuge I, et al. Clinical and virologic characteristics of chronic active Epstein-Barr virus infection. *Blood* 2001;98:280-286.
277. Kasahara Y, Yachie A, Takei K, et al. Differential cellular targets of Epstein-Barr virus (EBV) infection between acute EBV-associated hemophagocytic lymphohistiocytosis and chronic active EBV infection. *Blood* 2001;98:1882-1888.
278. Kawa-Ha K, Franco E, Doi S, et al. Successful treatment of chronic active Epstein-Barr virus infection with recombinant interleukin-2. *Lancet* 1987;1:154.
279. Sakai Y, Ohga S, Tonegawa Y, et al. Interferon-alpha therapy for chronic active Epstein-Barr virus infection: potential effect on the development of T-cell lymphoproliferative disease. *J Pediatr Hematol Oncol* 1998;20:342-346.
280. Henter JI, Elinder G, Ost A. Diagnostic guidelines for hemophagocytic lymphohistiocytosis. *Semin Oncol* 1991;18:29.
281. Imashuku S, Kuriyama K, Teramura T, et al. Requirement for etoposide in the treatment of Epstein-Barr virus associated hemophagocytic lymphohistiocytosis. *J Clin Oncol* 2001;19:2665-2673.
282. Okamura T, Hatsukawa Y, Arai H, et al. Blood stem cell transplantation for chronic active Epstein-Barr virus with lymphoproliferation. *Lancet* 2000;358:223-224.
283. Kuzushima K, Yamamoto M, Kimura H, et al. Establishment of an anti-Epstein-Barr virus (EBV) cellular immunity by adoptive transfer of virus-specific cytotoxic T lymphocytes from HLA-matched sibling to a patient with severe chronic active EBV infection. *Clin Exp Immunol* 1996;103:192-198.
284. Jones JF, Ray CG, Minnich LL, et al. Evidence of active Epstein-Barr virus infection in patients with persistent unexplained illness: elevated anti-early antigen antibodies. *Ann Intern Med* 1985;102:1-7.
285. Holmes GP, Deplane JE, Stewart JA, et al. A cluster of patients with chronic mononucleosis-like syndrome; is Epstein-Barr virus the cause? *JAMA* 1987;257:2297-2302.

286. Straus SE, Dale JK, Tobi M, et al. Acyclovir treatment of the chronic fatigue syndrome: lack of efficacy in a placebo-controlled trial. *N Engl J Med* 1988;319:1692-1698.
287. Straus SE. Studies of herpesvirus infection in chronic fatigue syndrome. *Ciba Found Symp* 1993;173:132-145.
288. Harrington DS, Weisenburger DD, Purtilo DT. Epstein-Barr virus-associated lymphoproliferative lesions. *Clin Lab Med* 1988;8:97.
289. Seemayer TA, Gross TG, Egeler RM, et al. X-linked lymphoproliferative disease: twenty-five years after the discovery. *Pediatr Res* 1995;38:471-478.
290. Mroczek EC, Weisenburger DD, Grierson HL, et al. Fatal infectious mononucleosis and virus-associated hemophagocytic syndrome. *Arch Pathol Lab Med* 1987;111:530-535.
291. Filipovich AH, Zhang K, Snow AL, Marsh RA. X-linked lymphoproliferative syndromes: brothers or distant cousins? *Blood* 2010;116:3398-3408.
292. Quintanilla-Martinez L, Kumar S, Fend F, et al. Fulminant EBV⁺ T-cell lymphoproliferative disorder following acute/chronic EBV infection: a distinct clinicopathologic syndrome. *Blood* 2000;96:443-451.
293. Sullivan JL. Epstein-Barr virus and lymphoproliferative disorders. *Semin Hematol* 1988;25:269-279.
294. Seemayer TA, Gross TG, Hinrichs SH, et al. Massive diffuse histiocytic myocardial infiltration in Epstein-Barr virus-associated hemophagocytic syndrome and fulminant infectious mononucleosis. *Cell Vision* 1994;1:260.
295. Mroczek EC, Seemayer TA, Grierson HL, et al. Thymic lesions in fatal infectious mononucleosis. *Clin Immunol Immunopathol* 1987;43:243-255.
296. Ambruso DR, Hays T, Zwartjes WJ, et al. Successful treatment of lymphohistiocytic reticulosis with phagocytosis with epipodophyllotoxin VP16-213. *Cancer* 1980;45:2516.
297. Henter JI, Arico M, Egeler RM, et al. HLH-94: a treatment for hemophagocytic lymphohistiocytosis. HLH Study Group of the Histiocyte Society. *Med Pediatr Oncol* 1997;28:342.
298. Milone MC, Tsai DE, Hodinka RL, et al. Treatment of primary Epstein-Barr virus infection in patients with X-linked lymphoproliferative disease using B-cell-directed therapy. *Blood* 2005;105:994-996.
299. Horne A, Janka G, Egeler RM, et al. Haematopoietic stem cell transplantation in haemophagocytic lymphohistiocytosis. *Br J Hematol* 2005;129:622-630.
300. Filipovich AH. Life-threatening hemophagocytic syndromes: current outcomes with hematopoietic stem cell transplantation. *Pediatr Transplant* 2005;9(Suppl 7):87-91.
301. Purtilo DT, Cassel CK, Yang JPS, et al. X-linked recessive progressive combined variable immunodeficiency (Duncan's disease). *Lancet* 1975;1:935-941.
302. Saemundsen AK, Berkel AI, Henle W, et al. Epstein-Barr virus carrying lymphoma in a patient with ataxia telangiectasia. *BMJ* 1981;282:425-427.
303. Joncas J, Lapointe N, Gervais F, et al. Unusual prevalence of Epstein-Barr virus early antigen (EBV-EA) antibody in ataxia-telangiectasia. *J Immunol* 1977;119:1857-1859.
304. Okano M, Mizuno F, Osato T, et al. Wiskott- Aldrich syndrome and Epstein-Barr virus-induced lymphoproliferation. *Lancet* 1984;2:933-934.
305. Starzl TE, Nalesnik MA, Porter KA, et al. Reversibility of lymphomas and lymphoproliferative lesions developing under cyclosporine A-prednisolone immunosuppression. *Lancet* 1984;1:583-587.
306. Beral V, Peterman T, Berkelman R, Jaffe H. AIDS-associated non-Hodgkin lymphoma. *Lancet* 1991;337:805-809.
307. Okano M, Gross TG. A review of Epstein-Barr virus infection in patients with immunodeficiency disorders. *Am J Med Sci* 2000;319:392-396.
308. Sumegi J, Huang D, Lanyi A, et al. Correlation of mutations of the SH2D1A gene and Epstein-Barr virus infection with clinical phenotype and outcome in X-linked lymphoproliferative disease. *Blood* 2000;96:3118-3125.
309. Gross TG, Shiramizu B. Lymphoproliferative disorders and malignancies related to immunodeficiencies. In: Pizzo PA, Poplack DG, eds. *Principles and practice of pediatric oncology*, 5th ed. Philadelphia, PA: Lippincott Williams & Wilkins, 2005:748-767.

310. Filipovich AH, Gross TG. Immunodeficiency and cancer. In: Abeloff MD, Armitage JO, Niederhuber JE, et al., eds. *Clinical oncology*, 3rd ed. Portland, OR: Book News, 2004:287-298.
311. Hoffman T, Heilman C, Madsen HO, et al. Matched unrelated allogeneic bone marrow transplantation for recurrent malignant lymphoma in a patient with X-linked lymphoproliferative disease (XLP). *Bone Marrow Transplant* 1998;22:603-604.
312. Cohen JJ. Epstein-Barr virus lymphoproliferative disease associated with acquired immunodeficiency. *Medicine* 1991;70:137-160.
313. Sandoval C, Swift M. Treatment of lymphoid malignancies in patients with ataxia-telangiectasia. *Med Pediatr Oncol* 1998;31:491-497.
314. Seideman K, Tiemann M, Henze G, et al. Therapy for non-Hodgkin lymphoma in children with primary immunodeficiency; analysis of 19 patients from the BFM trials. *Med Pediatr Oncol* 1999;33:536-544.
315. Lankester A, Visser L, Bredius R, et al. Allogeneic stem cell transplantation in X-linked lymphoproliferative disease in different stages of disease: two cases in one family and review of the literature. *Bone Marrow Transplant* 2005;36:99-105.
316. Bar RS, delor CJ, Clausen KP, et al. Fatal infectious mononucleosis in a family. *N Engl J Med* 1974;290:363-367.
317. Purtilo DT, Cassels C, Yang JPS. Fatal infectious mononucleosis in familial lymphohistiocytosis. *N Engl J Med* 1974;291:736.
318. Grierson HL, Skare J, Hawk J, et al. Immunoglobulin class and subclass deficiencies prior to Epstein-Barr virus infection in males with X-linked lymphoproliferative disease. *Am J Med Genet* 1991;40:294-297.
319. Al-Alem U, Li C, Forey N, et al. Impaired Ig class switch in mice deficient for the X-linked lymphoproliferative disease gene Sap. *Blood* 2005;106: 2069-2075.
320. Harrington DS, Weisenburger DD, Purtilo DT. Malignant lymphoma in the X-linked lymphoproliferative syndrome. *Cancer* 1987;59:1419-1429.
321. Egeler RM, de Kraker J, Slater R, et al. Documentation of Burkitt lymphoma with t(8;14)(q24;q32) in X-linked lymphoproliferative disease. *Cancer* 1992;70:683-687.
322. Williams LL, Rooney CM, Conley ME, et al. Correction of Duncan's syndrome by allogeneic bone marrow transplantation. *Lancet* 1993;2:587-588.
323. Coffey AJ, Brooksbank RA, Brandau O, et al. The aberrant host response to EBV infection in X-linked lymphoproliferative disease results from mutations in a novel SH2-domain encoding gene, SH2D1A. *Nat Genet* 1998;20:129-135.
324. Sayos J, Wu C, Morra M, et al. The X-linked lymphoproliferative-disease gene product SAP regulates signals induced through the co-receptor SLAM. *Nature* 1998;395:462-469.
325. Nichols KE, Harkin DP, Levitz S, et al. Inactivating mutations in an SH2 domain-encoding gene in X-linked lymphoproliferative syndrome. *Proc Natl Acad Sci U S A* 1998;95:13765-13770.
326. Gilmour KC, Cranston T, Jones A, et al. Diagnosis of X-linked lymphoproliferative disease by analysis of SLAM-associated protein expression. *Eur J Immunol* 2000;30:1691-1697.
327. Conley ME, Sullivan JL, Neidich JA, et al. X chromosome inactivation patterns in obligate carriers of X-linked lymphoproliferative syndrome. *Clin Immunol Immunopathol* 1990;55:486-491.
328. Arico M, Imashuku S, Clementi R, et al. Hemophagocytic lymphohistiocytosis due to germline mutations in SH2D1A, the X-linked lymphoproliferative disease gene. *Blood* 2001;97:1131-1133.
329. Latour S, Gish G, Helgason CD, et al. Regulation of SLAM-mediated signal transduction by SAP, the X-linked lymphoproliferative gene product. *Nat Immunol* 2001;2:681-690.
330. Lewis J, Eiben LJ, Nelson DL, et al. Distinct interactions of the X-linked lymphoproliferative syndrome gene product SAP with cytoplasmic domains of members of the CD2 receptor family. *Clin Immunol* 2001;100:15-23.
331. Parolini S, Bottino C, Falco M, et al. X-linked lymphoproliferative disease. 2B4 molecules displaying inhibitory rather than activating function are responsible for the inability of natural killer cells to kill Epstein-Barr virus-infected cells. *J Exp Med* 2000;192:337-344.

332. Sylla BS, Murphy K, Cahir-McFarland E, et al. The X-linked lymphoproliferative syndrome gene product SH2D1A associates with p62dok (Dok1) and activates NF-kappa B. *Proc Natl Acad Sci U S A* 2000;97:7470-7475.
333. Seemayer TA, Greiner TG, Gross TG, et al. X-linked lymphoproliferative disease. In: Goedert JJ, ed. *Infectious causes of cancer, targets for intervention*. Totowa, NJ: Humana Press, 2000:51-61.
334. Czar MJ, Kersh EN, Mijares LA, et al. Altered lymphocyte responses and cytokine production in mice deficient in the X-linked lymphoproliferative disease gene SH2D1A/DSHP/SAP. *Proc Natl Acad Sci U S A* 2001;98:7449-7454.
335. Ziegner UH, Ochs HD, Schanen C, et al. Unrelated umbilical cord stem cell transplantation for X-linked immunodeficiencies. *J Pediatr* 2001;138:570-573.
336. Rigaud S, Fondaneche MC, Lambert N, et al. XIAP deficiency in humans causes an X-linked lymphoproliferative syndrome. *Nature* 2006;444:110-114.
337. Uren AG, Pakusch M, Hawkins CJ, Puls KL, Vaux DL. Cloning and expression of apoptosis inhibitory protein homologs that function to inhibit apoptosis and/or bind tumor necrosis factor receptor-associated factors. *Proc Natl Acad Sci U S A* 1996;93:4974-4978.
338. Swerdlow SH, Campo E, Harris NL, et al. *WHO classification of tumours of hematopoietic and lymphoid tissues*, 4th ed. Lyon: IARC Press, 2008.
339. Salloum E, Cooper DL, Howe G, et al. Spontaneous regression of lymphoproliferative disorders in patients treated with methotrexate for rheumatoid arthritis and other rheumatic diseases. *J Clin Oncol* 1996;6:1943-1949.
340. Patton DF, Shirley P, Raab-Traub N, et al. Defective viral DNA in Epstein-Barr virus-associated oral hairy leukoplakia. *J Virol* 1990;64:397-400.
341. Greenspan JS, Greenspan D, Lennette ET, et al. Replication of Epstein-Barr virus within the epithelial cells of oral "hairy" leukoplakia, an AIDS-associated lesion. *N Engl J Med* 1986;313:1564-1570.
342. Levine AM. Acquired immunodeficiency syndrome-related lymphoma. *Blood* 1992;80:8-20.
343. Schofer H, Ochsendorf FR, Helm EB, et al. Treatment of oral "hairy" leukoplakia in AIDS patients with vitamin A acid (topically) or acyclovir (systemically). *Dermatologica* 1987;174:150-151.
344. Biggar RJ, Frisch M, Goedert JJ. Risk of cancer in children with AIDS. AIDS-Cancer Match Registry Study Group. *JAMA* 2000;284:205-209.
345. Granovsky MO, Mueller BU, Nicholson HS, et al. Cancer in human immunodeficiency virus-infected children: a case series from the Children's Cancer Group and the National Cancer Institute. *J Clin Oncol* 1998;16:1729-1735.
346. Jenson HB, Leach CT, McClain KL, et al. Benign and malignant smooth muscle tumors containing Epstein-Barr virus in children with AIDS. *Leuk Lymphoma* 1997;27:303-314.
347. Sabatino D, Martinez S, Young R, et al. Simultaneous pulmonary leiomyosarcoma and leiomyoma in pediatric HIV infection. *Pediatr Hematol Oncol* 1991;8:355-359.
348. Chadwick EG, Connor EJ, Hanson IC, et al. Tumors of smooth-muscle origin in HIV-infected children. *JAMA* 1990;263:3182-3184.
349. MacMahon E, Glass J, Hayward S, et al. Epstein-Barr virus in AIDS-related primary central nervous system lymphoma. *Lancet* 1991;2:969-973.
350. Cesarman E, Chang Y, Moore PS, et al. Kaposi's sarcoma-associated herpes-virus-like DNA sequences in AIDS-related body-cavity-based lymphomas. *New Engl J Med* 1995;332:1186-1191.
351. Knowles DM. Etiology and pathogenesis of AIDS-related non-Hodgkin's lymphoma. *Hematol Oncol Clin North Am* 1996;10:1081-1109.
352. Matthews GV, Bower M, Mandalia S, et al. Changes in acquired immunodeficiency syndrome-related lymphoma since the introduction of highly active antiretroviral therapy. *Blood* 2000;96:2730-2734.
353. Highly active antiretroviral therapy and incidence of cancer in human immunodeficiency virus-infected adults. *J Natl Cancer Inst* 2000;92(22): 1823-1830.
354. Besson C, Goubar A, Gabarre J, et al. Changes in AIDS-related lymphoma since the era of highly active antiretroviral therapy. *Blood* 2001;98: 2339-2344.

355. Diamond C, Taylor TH, Im T, et al. Presentation and outcomes of systemic non-Hodgkin's lymphoma: a comparison between patients with acquired immunodeficiency syndrome (AIDS) treated with highly active antiretroviral therapy and patients without AIDS. *Leuk Lymphoma* 2006;47:1822-1829.
356. Nalesnik MA, Makowka L, Starzl TE. The diagnosis and treatment of posttransplant lymphoproliferative disorders. *Curr Probl Surg* 1998;25:367-472.
357. Frizzera G, Hanto DW, Gajl-Peczalska KJ, et al. Polymorphic diffuse B-cell hyperplasias and lymphomas in renal transplant recipients. *Cancer Res* 1981;41:4262-4279.
358. Knowles DM, Cesarman E, Chadburn A, et al. Correlative morphologic and molecular genetic analysis demonstrates three distinct categories of posttransplantation lymphoproliferative disorders. *Blood* 1995;85:552-565.
359. Malatack JJ, Gartner JC, Urbach AH, et al. Orthotopic liver transplantation, Epstein-Barr virus, cyclosporine, and lymphoproliferative disease: a growing concern. *J Pediatr* 1991;118:667-675.
360. Harris NL, Ferry JA, Swerdlow SH. Posttransplant lymphoproliferative disorders: summary of Society for Hematopathology Workshop. *Semin Diagn Pathol* 1997;14:8-14.
361. Greiner TC, Abou-Ellella AA, Smir BN, et al. EBNA-1 substrain and p53 mutation analysis in Epstein-Barr virus positive posttransplant lymphoproliferative disorders. *Leuk Lymphoma* 2000;38:563-576.
362. Dhir RK, Nalesnik MA, Demetris AJ, et al. Latent membrane protein expression in posttransplant lymphoproliferative disease. *Appl Immunohistochem* 1995;3:123.
363. Finn L, Reyes J, Bueno J, et al. Epstein-Barr virus infections in children after transplantation of the small intestine. *Am J Surg Pathol* 1998;22:299-309.
364. Collins MH, Montone KT, Leahey AM, et al. Autopsy pathology of pediatric posttransplant lymphoproliferative disorder. *Pediatrics* 2001;107:E89.
- P.1341
365. Gross TG, Steinbuch M, DeFor T, et al. B cell lymphoproliferative disorder following hematopoietic stem cell transplantation: risk factors, treatment and outcome. *Bone Marrow Transplant* 1999;23:251-258.
366. Hanson MN, Morrison VA, Peterson BA, et al. Posttransplant T-cell lymphoproliferative disorders-an aggressive, late complication of solid-organ transplantation. *Blood* 1996;88:3626-3633.
367. Bierman PJ, Vose JM, Langnas AN, et al. Hodgkin's disease following solid organ transplantation. *Ann Oncol* 1996;7:265-270.
368. Ranganathan S, Jaffe R. Is there a difference between Hodgkin's disease and a Hodgkin's-like post-transplant lymphoproliferative disorder, and why should that be of any interest? *Pediatr Transplant* 2004;8:6-8.
369. Curtis RE, Travis LB, Rowlings PA, et al. Risk of lymphoproliferative disorders after bone marrow transplantation: a multi-institutional study. *Blood* 1999;94:2208-2216.
370. Lucas KG, Small TN, Heller G, et al. The development of cellular immunity to Epstein-Barr virus after allogeneic bone marrow transplantation. *Blood* 1996; 87:2594-2603.
371. Dotti G, Fiocchi, Motts T, et al. Epstein-Barr virus-negative lymphoproliferative disorders in long-term survivors after heart, kidney and liver transplant. *Transplantation* 2000;69:827-833.
372. Leblond V, Davi F, Charlotte F, et al. Posttransplant lymphoproliferative disorders not associated with Epstein-Barr virus: a distinct entity? *J Clin Oncol* 1998;16:2052-2059.
373. Leblond V, Dhedin N, Mamzer Bruneel MF, et al. Identification of prognostic factors in 61 patients with posttransplantation lymphoproliferative disorders. *J Clin Oncol* 2001;19:772-778.
374. Paya CV, Fung JJ, Nalesnik MA, et al. Epstein-Barr virus-induced posttransplant lymphoproliferative disorders. *Transplantation* 1999;68:1517-1525.
375. Ho M, Jaffe R, Miller G, et al. The frequency of Epstein-Barr virus infection and associated lymphoproliferative syndrome after transplantation and its manifestations in children. *Transplantation* 1988;45:719-727.

376. Newell KA, Alonso EM, Whittington PF, et al. Posttransplant lymphoproliferative disease in pediatric liver transplantation. *Transplantation* 1996;62: 370-375.
377. Green M, Micheals MG, Webber SA, et al. The management of Epstein-Barr virus associated post-transplant lymphoproliferative disorders in pediatric solid organ transplant recipients. *Pediatr Transplant* 1999;3:271-281.
378. McDiarmid SV, Jordan S, Lee GS, et al. Prevention and preemptive therapy of posttransplant lymphoproliferative disease in pediatric liver recipients. *Transplantation* 1998;66:1604-1611.
379. Benkerrou M, Jais JP, Leblond V, et al. Anti-B-cell monoclonal antibody treatment of severe post-transplant B-lymphocyte disorder: prognostic factors and long-term outcome. *Blood* 1998;92:3137-3147.
380. Milpied N, Vasseur B, Parquet N, et al. Humanized anti-CD20 monoclonal antibody (rituximab) in post transplant B-lymphoproliferative disorder: a retrospective analysis on 32 patients. *Ann Oncol* 2000;11:113-116.
381. Pescovitz MD. Rituximab, an anti-CD20 monoclonal antibody, history and mechanism of action. *Am J Transpl* 2006;6:859-866.
382. Swinnen LJ, Mullen GM, Carr TJ, et al. Aggressive treatment for postcardiac lymphoproliferation. *Blood* 1995;86:3333-3340.
383. Buell JF, Gross TG, Hanaway MJ, et al. Chemotherapy for PTL: the Israel Penn International Transplant Tumor Registry experience. *Transplant Proc* 2005;37:956-957.
384. Gross TG, Bucuvalas J, Park J, et al. Low dose chemotherapy for the treatment of refractory post-transplant lymphoproliferative disease in children. *J Clin Oncol* 2005;23:6481-6488.
385. Smets F, Lattine D, Bazin H, et al. Ratio between Epstein-Barr viral load and anti-Epstein-Barr virus specific T-cell response as a predictive marker of posttransplant lymphoproliferative disease. *Transplantation* 2002;73: 1603-1610.
386. Papadopoulos EB, Ladanyi M, Emanuel D, et al. Infusions of donor leukocytes to treat Epstein-Barr virus-associated lymphoproliferative disorders after allogeneic bone marrow transplantation. *N Engl J Med* 1994;330: 1185-1191.
387. Rooney CM, Smith CA, Ng CC, et al. Infusion of cytotoxic T cells for prevention and treatment of Epstein-Barr virus-induced lymphoma in allogeneic transplant recipients. *Blood* 1998;92:1549-1555.
388. Khanna R, Bell S, Sherritt M, et al. Activation and adoptive transfer of Epstein-Barr virus-specific cytotoxic T cells in solid organ transplant patients with posttransplant lymphoproliferative disease. *Proc Natl Acad Sci U S A* 2000;96:10391-10396.
389. Savoldo B, Goss JA, Hammer MM, et al. Treatment of organ transplant recipients with autologous Epstein Barr virus-specific cytotoxic T lymphocytes (CTLs). *Blood* 2006;108:2942-2949.
390. Magrath I. The pathogenesis of Burkitt's lymphoma. *Adv Cancer Res* 1990;55:133-270.
391. Manolov G, Manolova Y, Klein G, et al. Alternative involvement of two cytogenetically distinguishable break-points on chromosome 8 in Burkitt's lymphoma associated translocations. *Cancer Genet Cytogenet* 1986;20:95-99.
392. Bernheim A, Berger R, Lenoir G. Cytogenetic studies on African Burkitt's lymphoma cell lines; t(8;14), t(2;8) and t(8;22) translocations. *Cancer Genet Cytogenet* 1981;3:307-315.
393. Klein G. Viral latency and transformation: the strategy of Epstein-Barr virus. *Cell* 1989;58:5-8.
394. Sample J, Brooks L, Sample C, et al. Restricted Epstein-Barr virus protein expression in Burkitt lymphoma is due to a different Epstein-Barr nuclear antigen-1 transcription initiation site. *Proc Natl Acad Sci U S A* 1991;88:6343-6347.
395. Kumano J, Maruo S, Kurozumi K, et al. Ebers have oncogenic functions in BL cells. *J Virol* 1999;73:9827-9831.
396. Polack A, Hortnael K, Pajic A, et al. C-myc activation renders proliferation of Epstein-Barr virus (EBV)-transformed cells independent of EBV nuclear antigen 2 and latent membrane protein 1. *Proc Natl Acad Sci U S A* 1996;93:10411-10416.
397. Kelly GL, Milner AE, Baldwin GS, et al. Three restricted forms of Epstein-Barr virus latency counteracting apoptosis in c-myc-expressing Burkitt lymphoma cells. *Proc Natl Acad Sci U S A* 2006;103:14935-14940.
398. Muir CS. Nasopharyngeal carcinoma in non-Chinese populations with special reference to South-East Asia and Africa. *Int J Cancer* 1971;8:351.
399. Raab-Traub N. Epstein-Barr virus in the pathogenesis of NPC. *Semin Cancer Biol* 2002;12:431-441.

400. Zeng Y, Zhang LG, Wu YC, et al. Prospective studies on nasopharyngeal carcinoma in Epstein-Barr virus IgA/VCA antibody-positive persons in Wuzhou City, China. *Int J Cancer* 1986;36:545-548.
401. Henle G, Henle W. Epstein-Barr virus-specific IgA serum antibodies as an outstanding feature of nasopharyngeal carcinoma. *Int J Cancer* 1976;17:1-7.
402. De-Vathaire F, Sancho-Garnier H, de-The H, et al. Prognostic value of EBV markers in the clinical management of nasopharyngeal carcinoma (NPC): a multicenter follow-up study. *Int J Cancer* 1988;42:176-181.
403. Lin J-C, Wang W-Y, Chen KY, et al. Quantification of plasma Epstein-Barr virus DNA in patients with advanced nasopharyngeal carcinoma. *N Engl J Med* 2004;350:2461-2470.
404. Pathmanathan K, Prasad U, Sadler R, et al. Clonal proliferations of cells infected with Epstein-Barr virus in preinvasive lesions related to nasopharyngeal carcinoma. *N Engl J Med* 1995;333:693-698.
405. Lo AK, Huang DP, Lo KW, et al. Phenotypic alterations induced by the Hong Kong-prevalent Epstein-Barr virus encoded LMP1 variant (2117-LMP1) in nasopharyngeal epithelial cells. *Int J Cancer* 2004;109:919-925.
406. Wei MX, de Turenne-Tessier M, Decaussin G, et al. Establishment of a monkey kidney epithelial cell line with BARF1 open reading frame from Epstein-Barr virus. *Oncogene* 1997;14:2401-2406.
407. Lo KW, Teo PM, Hui AB, et al. High resolution allelotyping of microdissected primary nasopharyngeal carcinoma. *Cancer Res* 2000;60:3348-3353.
408. Munoz N, Davidson RJL, Withoff B, et al. Infectious mononucleosis and Hodgkin's disease. *Int J Cancer* 1978;22:10-13.
409. Rosdahl N, Larsen SO, Clemmensen J. Hodgkin's disease in patients with previous infectious mononucleosis: 30 years experience. *BMJ* 1974;2:253-256.
410. Mueller N, Evans A, Harris N. Hodgkin's disease and Epstein-Barr virus. Altered antibody pattern before diagnosis. *N Engl J Med* 1989;320:689-695.
411. Gledhill S, Gallagher A, Jones D. Viral involvement in Hodgkin's disease: detection of clonal type A EBV genomes in tumor samples. *Br J Cancer* 1991;64:227-232.
412. Herbst H, Steinbacher E, Niedobitek G, et al. Distribution and phenotype of Epstein-Barr virus-harboring cells in Hodgkin's disease. *Blood* 1992;80: 484-491.
413. Deacon E, Pallesen G, Niedobitek G, et al. Epstein-Barr virus and Hodgkin's disease: transcriptional analysis of virus latency in the malignant cells. *J Exp Med* 1993;177:339-349.
414. Hjalgrim H, Askling J, Rostgaard K, et al. Characteristics of Hodgkin's lymphoma after infectious mononucleosis. *N Engl J Med* 2003;349:1324-1332.
415. Sauce D, Larsen LS, Curnow SJ, et al. EBV-associated mononucleosis leads to long-term global deficit in T-cell responsiveness to IL-15. *Blood* 2006;108: 11-18.
416. Knecht H, Bachmann E, Joske JL. Molecular analysis of the LMP (latent membrane protein) in Hodgkin's disease. *Leukemia* 1993;7:580-584.
417. Jones JF, Shurin S, Abramowsky C, et al. T-cell lymphomas containing Epstein-Barr viral DNA in patients with chronic Epstein-Barr virus infections. *N Engl J Med* 1988;318:733-741.
418. Su IJ, Hsieh HC, Lin KH, et al. Aggressive peripheral T cell lymphomas containing Epstein-Barr viral DNA: a clinicopathological and molecular genetic study. *Blood* 1991;77:799-808.
419. Fingerhuth J, Clabby M, Strominger J. Characterization of a T-lymphocyte Epstein-Barr virus/C3 receptor (CD21). *J Virol* 1988;62:1442-1447.
420. Kawa-Ha K, Ishihara S, Ninomiya T, et al. CD3-negative lymphoproliferative disease of granular lymphocytes containing Epstein-Barr viral DNA. *J Clin Invest* 1989;84:51-54.
421. Ishihara S, Oshima K, Tokura Y, et al. Hypersensitivity to mosquito bites conceals clonal lymphoproliferation of Epstein-Barr viral DNA-positive natural killer cells. *Jpn J Cancer Res* 1997;88:82-87.
422. Harabuchi Y, Yamanaka Y, Kataura A, et al. Epstein-Barr virus in nasal T-cell lymphoma in patients with lethal midline granuloma. *Lancet* 1990;335:128-130.

423. Rowlands DC, Ito M, Mangham DC, et al. Epstein-Barr virus and carcinomas: rare association of the virus with gastric adenocarcinomas. *Br J Cancer* 1993;68:1014-1019.
424. Osata T, Imai S. Epstein-Barr virus and gastric carcinoma. *Semin Cancer Biol* 1996;7:175-182.
425. Lee HS, Chang MS, Yang H-K, et al. Epstein-Barr virus-positive gastric carcinoma has a distinct protein expression profile in comparison with Epstein-Barr virus-negative carcinoma. *Clin Cancer Res* 2004;10:1698-1705.
426. Luo B, Wang Y, Wang XF, et al. Expression of Epstein-Barr virus genes in EBV-associated gastric carcinomas. *World J Gastroenterol* 2005;11:629-633.
427. Perrigoue JG, den Boon JA, Friedl A, et al. Lack of association between EBV and breast carcinoma. *Cancer Epidemiol Biomarkers Prev* 2005;14:809-814.
428. Thacker EL, Mirzaei F, Ascherio A. Infectious mononucleosis and risk for multiple sclerosis: a meta-analysis. *Ann Neurol* 2006;59:499-503.
429. Friedland R, Yahr M. Meningoencephalopathy secondary to infectious mononucleosis. *Arch Neurol* 1977;34:186-188.

Chapter 63 Primary Immunodeficiency Syndromes

> Table of Contents > Part VI - Benign Disorders of Leukocytes, The Spleen, and/or Immunoglobins > Chapter 63 - Primary Immunodeficiency Syndromes

Chapter 63

Primary Immunodeficiency Syndromes

Troy R. Torgerson

INTRODUCTION

The primary immunodeficiency disease (PIDD) are a group of clinical syndromes originally described in patients with marked susceptibility to particular types of infections. This group of disorders has now expanded to include more than 150 clinically defined entities that span the full spectrum of immune dysfunction ranging from virtually absent immune responses to overwhelming uncontrolled autoimmunity.¹ In this “genomic era” we have come to understand that the majority of immunodeficiency disorders are caused by defects in single genes. There are now approximately 200 known single gene defects associated with immune deficiency. It has also become evident that mutations in different genes can lead to a similar clinical phenotype. For example, defects in more than 20 different genes have now been associated with a clinical phenotype of severe combined immune deficiency (SCID).² This has led to an explosion in our understanding of the role of specific molecular pathways in the human immune system but has created some confusion when discussing the clinical syndromes themselves. Consequently, it has become the practice to refer to disorders by their molecular defect, either in combination with, or in lieu of, their clinical name or eponym (i.e., “ADA-deficiency” or “ADA-SCID” rather than “SCID”). This practice is followed here.

MAJOR COMPARTMENTS OF THE IMMUNE SYSTEM

To provide a framework for this overview of immunodeficiency, it is worthwhile to divide the immune system into four major compartments: complement, phagocytes, B cells and antibodies, and T cells. The complement and phagocyte compartments are part of the “innate” arm of the immune system, whereas the B-cell and T-cell compartments are components of the “adaptive” arm of the immune system (see Table 63.1). Many immunodeficiency disorders are caused by a defect in only one compartment of the immune system, whereas others are “combined” immunodeficiencies with defects in multiple compartments. In general, defects in each compartment of the immune system are associated with susceptibilities to particular types of infections. In addition, each specific immunodeficiency typically has unique features that differentiate it from other immunodeficiencies, often making it possible to identify the disorders based on clinical and laboratory findings (see Table 63.1).

TABLE 63.1 COMMON SYMPTOMS ASSOCIATED WITH DEFECTS IN EACH OF THE FOUR MAJOR IMMUNE COMPARTMENTS

Complement	Phagocytes	B Cells/Antibodies	T Cells
<ul style="list-style-type: none"> Invasive infections with encapsulated 	<ul style="list-style-type: none"> Skin and soft tissue 	<ul style="list-style-type: none"> Recurrent bacterial 	<ul style="list-style-type: none"> <i>Pneumocystis jiroveci</i> pneumonia

bacteria (<i>S. pneumoniae</i> , <i>H. influenzae</i> , etc.)	abscesses, boils, and lymphadenitis	sinopulmonary infections	• Recurrent, severe, or unusual viral infections (CMV, EBV, adenovirus, papillomavirus, etc.)
• Recurrent, invasive <i>Neisserial</i> infections	• Infections with Catalase ⁺ organisms (<i>S. aureus</i> , <i>Serratia</i> , <i>Aspergillus</i> , etc.)	• Unexplained bronchiectasis	• Invasive fungal or mycobacterial infections
• Hereditary angioedema	• Poor wound healing	• Chronic or recurrent gastroenteritis (giardia, cryptosporidium, enterovirus, etc.)	• GVHD (rash, abnormal LFTs, chronic diarrhea)
• Autoimmunity (lupus, glomerulonephritis)	• Chronic gingivitis and periodontal disease	• Echovirus encephalomyelitis	• Failure to thrive
• Familial hemolytic uremic syndrome (HUS)	• Mucosal ulcerations, colitis		
	• Delayed separation of the umbilical cord/omphalitis		

COMPLEMENT

The complement system consists of a series of proteins that are present in the plasma and become activated upon encountering pathogens. Activation of early complement components initiates a cascade of protein cleavage and activation events that ultimately leads to formation of the membrane attack complex (MAC) consisting of complement proteins C5, 6, 7, 8, and 9. A number of regulatory proteins including Factor H, Factor I, and membrane cofactor protein (MCP) control complement activation at the level of C3, thereby preventing inappropriate complement fixation. The complement cascade is activated via three major mechanisms: (1) the classical pathway, which is initiated by antigen/antibody complexes; (2) the alternative pathway, which is initiated directly by bacterial cell wall components; and (3) the lectin pathway, which is initiated by carbohydrate moieties present on bacteria.

Complement deficiencies make up only a small portion (~2%) of all primary immune deficiencies.³ Defective activation of the entire complement cascade can be caused by the absence or dysfunction of only 1 of more than 20 complement proteins. The proteins most often affected are C2, C3, and C4.⁴

Clinical Presentation

Patients with defects in the C1 esterase inhibitor have hereditary angioedema (HAE) in which allergic or mechanical stimuli can trigger massive, localized, severe attacks of edema that can be life-threatening if they involve the airway. Patients with deficiency of early complement components in the classical pathway (C1-C4) typically present with symptoms of autoimmunity (lupus or glomerulonephritis) or with recurrent invasive infections caused by encapsulated organisms (particularly *Streptococcus pneumoniae*). Patients with defects in the late complement components (C5-C9) that are involved in formation of the membrane attack complex typically present with recurrent or severe *Neisserial* infections.⁴ Patients with defects in complement regulatory proteins (Factor I, Factor H, and MCP) are at risk of developing familial hemolytic uremic syndrome and age-related macular degeneration (see Fig. 63.1).^{5, 6, 7}

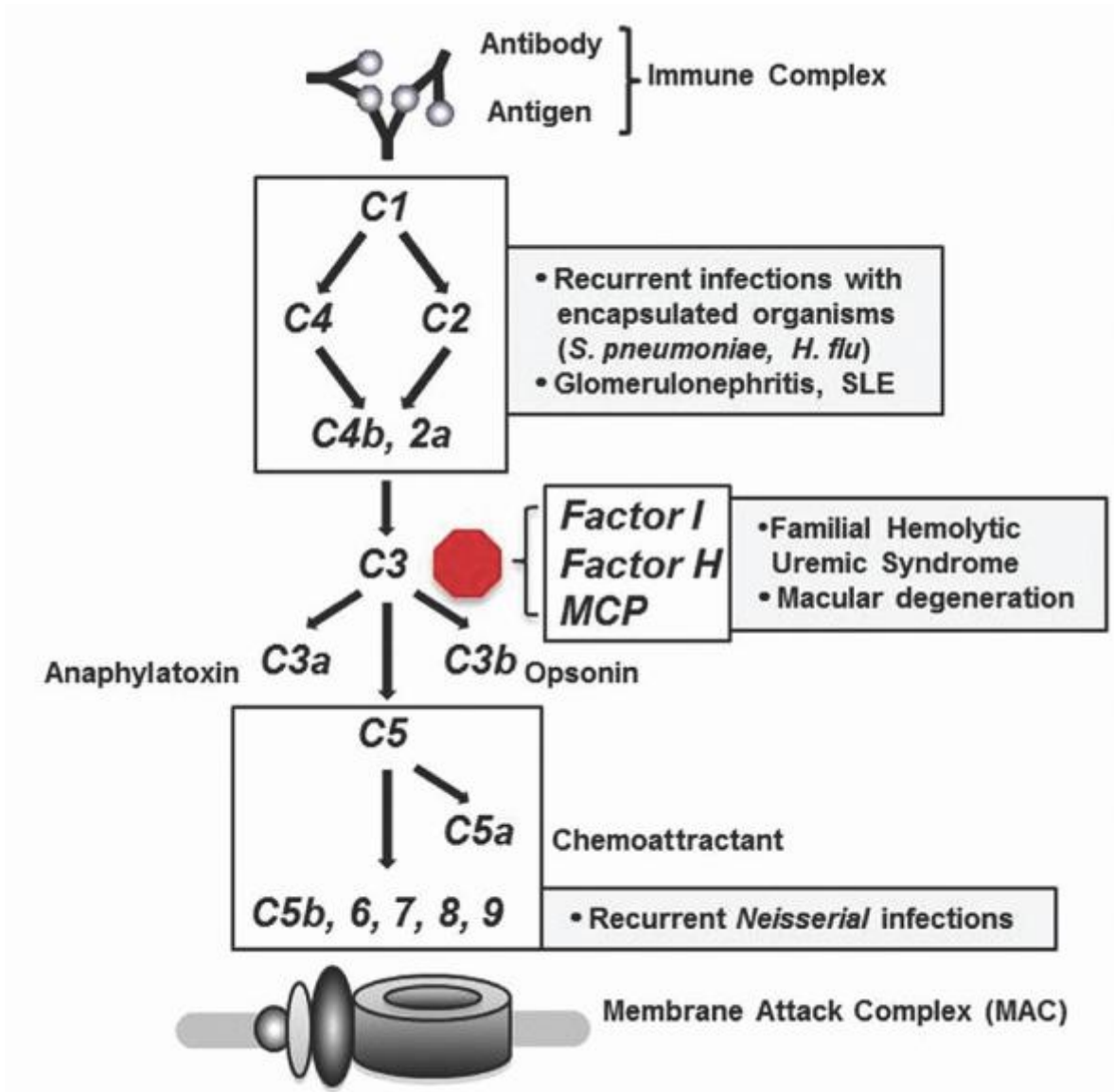

FIGURE 63.1. The classical complement pathway showing activation by immune complexes and ultimate formation of the membrane attack complex. Factor I, Factor H, and MCP (membrane cofactor protein) control complement activation primarily at the level of C3. Boxes indicate the clinical syndromes or infections that result from defects of the indicated complement proteins.

Specific Disorders

C1 Esterase Inhibitor Deficiency

Deficiency of C1 esterase inhibitor is the cause of HAE. Unlike many of the other early complement component deficiencies, absence of C1 esterase inhibitor does not lead to an increased risk for infection. Instead, this protein regulates the activity of kallikrein, blocking its ability to act on Factor XII and kininogen. As a consequence, minor irritants cause unabated production of bradykinin and other mediators of vascular permeability, leading to rapid swelling of the soft tissues (angioedema), severe abdominal pain, and at times, acute obstruction of the airway. Effective treatments are now available for HAE including purified C1 esterase inhibitor, a kallikrein inhibitor, and a bradykinin B2 receptor antagonist.^{8, 9, 10} Because of the expense of these agents, they are often administered at the beginning of an attack to abort symptoms rather than being administered prophylactically to prevent the onset of an attack.

C2 Deficiency

C2 deficiency is the most common complement component deficiency associated with susceptibility to infections, occurring in approximately 1 of 20,000 people. As indicated above, patients with early complement cascade defects (C1-C4) are susceptible to invasive infections with encapsulated organisms, *S. pneumoniae* being a particularly fulminant pathogen in these patients. The infectious susceptibility is compounded by functional antibody deficiency in some patients. In addition, patients with C1, C2, or C4 deficiency are at high risk of developing autoimmunity (lupus or glomerulonephritis). In the case of homozygous C2 deficiency, approximately 50% of patients develop lupus or glomerulonephritis.¹¹

Diagnosis

Screening for complement deficiency should be performed in patients with recurrent episodes of bacteremia, meningitis, or disseminated gonorrhea. Because more than 30% of patients with recurrent *Neisseria* infections have complement deficiency, it is imperative that prompt testing of the complement system be done in these individuals. The screening test of choice for complement deficiencies is the CH50 test, which measures functional complement activity in the plasma. The CH50 will only identify defects in the classical pathway, which is typically sufficient inasmuch as alternative pathway defects are exceedingly rare. If an alternative pathway defect is suspected, however, an analogous test (the AH50) can be performed. In order for the CH50 to give accurate results, the blood specimen needs to be handled carefully because complement is very heat labile. In general, it is recommended that any abnormal CH50 test should be repeated to confirm a complement deficiency. The CH50 is typically very low or absent in patients with a complement component deficiency. A CH50 result that is only moderately low is often seen in situations where the specimen was handled incorrectly or in patients with autoimmune disease such as lupus or mixed connective tissue disease. Once an abnormal CH50 test is confirmed, specialized testing to identify the specific complement component that is absent can be performed.

Treatment

Patients with complement deficiency are susceptible to fulminant sepsis and other deep-seated infections caused by encapsulated organisms. For this reason, patients should be given a letter or laminated card that they can keep with them at all times with contact information for their primary care physician and clinical immunologist, and a message indicating that they have a complement deficiency and there should be no delay in giving parenteral antibiotics should they be ill. For patients who live at a distance from skilled medical care, consideration should be given to providing a dose of parenteral antibiotic such as ceftriaxone that can be administered by the patient or a family member when they become ill, prior to a lengthy trip to the hospital. The efficacy of

P.1344

chronic prophylactic antibiotics to prevent infection in patients with complement deficiency is not well studied and remains a significant question in this group of disorders. In addition to preparing for and treating infections, patients should also be regularly screened for autoimmunity by history, physical exam (i.e., blood pressure monitoring), and laboratory testing including BUN, creatinine, and urinalysis to monitor for signs of glomerulonephritis inasmuch as this is a common autoimmune manifestation.

PHAGOCYTES

One of the major roles of phagocytic cells (neutrophils and macrophages) is to continuously survey the body for signs of infection. Upon sensing an infection, they migrate from the circulation into the tissues toward the site of the infection where they begin to ingest both opsonized and nonopsonized pathogens and debris. The ingested material is processed and fragments of digested proteins are loaded into class II MHC molecules that are presented at the cell surface where they can be recognized by cells of the adaptive immune system. Phagocytes that ingest pathogens and debris can either remain at the site of infection or migrate back to local draining lymph nodes to present antigen. Phagocytic disorders can occur in one of three ways: (1) a lack of phagocytes (congenital neutropenia); (2) defective phagocyte migration (leukocyte adhesion deficiency [LAD] and WHIM syndrome); and (3) inability of phagocytes to process or degrade organisms that have been ingested (chronic granulomatous disease [CGD]).

Clinical Presentation

Because of the role that phagocytes play in controlling bacterial and fungal pathogens, patients with phagocytic defects often present with infections and abscesses of skin, deep tissues, and organs caused by bacteria and fungi. Symptoms can include boils and/or cellulitis with or without pus, lymphadenitis, pneumonia, delayed shedding of the umbilical cord, hepatic abscesses, gastrointestinal disorders, gingivitis, and unexplained fever, malaise, and fatigue. The onset of symptoms of phagocytic cell disorders is typically in infancy or early childhood.

Specific Disorders

Severe Congenital Neutropenia

The congenital neutropenias are described in more detail elsewhere (Chapter 57) so are covered only briefly here. Mutations in five different genes have now been associated with severe congenital neutropenia (SCN): ELANE, which is inherited in an autosomal dominant manner, causes increased myeloid cell apoptosis and can present either with SCN or with a cyclic neutropenia phenotype; GFI1, which is also inherited in an autosomal dominant manner, causes defective myeloid cell differentiation; HAX1, which is inherited in an autosomal recessive manner, is associated with increased myeloid cell apoptosis, and is the cause of the classic "Kostmann" syndrome; G6PC3, which is inherited in an autosomal recessive manner, causes excessive myeloid cell apoptosis, and is associated with a variety of other congenital defects including cardiac, urogenital, endocrine, auditory, and facial anomalies; and WAS, in which specific activating mutations in the CDC42 binding domain are inherited in an X-linked recessive manner, leading to abnormal and dysregulated actin polymerization that causes defective neutrophil chemotaxis and increased apoptosis.¹²

In all cases, clinical management involves a heightened suspicion for infections and aggressive treatment if these arise. Treatment of acute infections may require antibiotics combined with G-CSF to increase neutrophil counts. Despite there being little evidence specifically in SCN supporting the use of prophylactic antibiotics, extrapolation from data in leukemic patients with neutropenia suggests a benefit so these are used in most patients. Prophylactic, long-term therapy with G-CSF is typically utilized only in those patients who have recurrent, severe bacterial infections in spite of antibiotic prophylaxis or in patients with fungal infections. Bone marrow transplantation is effective in SCN although there is little to no reported experience in those genetic disorders that are more rare such as G6PC3 deficiency.

Leukocyte Adhesion Deficiency

LAD is caused by the absence of functional adhesion receptors that are required for the migration of phagocytes from the circulation into the tissues. The characteristic clinical features of LAD include recurrent skin and soft tissue infections that often lead to development of deep ulcers despite there being highly elevated peripheral blood leukocyte counts. Interestingly, the inability of leukocytes to migrate to these sites of infection leads to an absence of pus in the lesions, which can be a useful diagnostic clue. Wound healing is also compromised and patients typically have marked gingivostomatitis. Three forms of LAD have been described: LAD-I, the most common form of LAD, is caused by mutations in the ITGB2 gene encoding the β 2-integrin CD18. Mutations cause an absence of the CD11/CD18 integrin complex on the surface of leukocytes, which can be readily discerned by flow cytometry. LAD-II is caused by mutations in the SLC35C1 gene encoding the GDP-fucose transporter. These mutations cause defective expression of Sialyl Lewis X (sLe^x), a fucose-containing ligand on neutrophils. sLe^x is the ligand for E- and P-selectins, which are expressed on the surface of cytokine-activated endothelial cells and allow neutrophil rolling. As a result of the fucose defect, all patients with LAD-II also have the rare Bombay blood group, which is a useful diagnostic test for suspected LAD-II. LAD-III is caused by mutations in the FERMT3 gene that encodes Kindlin-3, a coactivator that is required for activation and function of β 1-, β 2-, and β 3-integrins. Absence of functional Kindlin-3 leads to dysfunction of CD18 and causes an LAD phenotype (see LAD-I above). In addition, patients with LAD-III also have a Glanzmann-type bleeding disorder resulting from dysfunctional integrin-mediated aggregation of platelets.¹³

Patients with LAD-I and LAD-III typically present in childhood and often have a severe course with early mortality, whereas patients with LAD-II often have milder cases and may live into adulthood. Treatment of LAD can be more complicated than some of the other phagocytic disorders because in addition to treating infections aggressively with antibiotics, active soft tissue infections may require recurrent donor white cell infusions of functional neutrophils in order to clear the infection. The primary defects of LAD are intrinsic to hematopoietic cells, thus bone marrow transplantation can be curative.^{14, 15, 16}

WHIM Syndrome

WHIM syndrome (warts, hypogammaglobulinemia, recurrent bacterial infections, and myelokathexis [retention of neutrophils in the bone marrow]) is caused by autosomal dominant mutations in CXCR4, the receptor for the chemokine CXCL12 (SDF-1). Patients with WHIM typically present in childhood with recurrent bacterial otitis media, sinusitis, bronchitis, pneumonia, and cellulitis. The bacterial susceptibility is a result of the combination of hypogammaglobulinemia and neutropenia. In addition to bacterial infections, patients with WHIM have a particular susceptibility to papillomavirus infections, which can be severe and lead to early malignancy. The mechanisms that underlie the viral susceptibility are not entirely understood but are thought possibly to be intrinsic to the epithelial cells. In the hematopoietic system, CXCL12 causes homing of cells to the bone marrow and controls release of these cells from the marrow. Neutrophils and lymphocytes from patients

with WHIM have an increased chemotactic response to CXCL12, suggesting that the neutropenia and lymphopenia observed in WHIM are the result of inappropriate cell retention in the marrow.¹⁷ Treatment with G-CSF or GM-CSF can normalize the neutrophil counts although these often cause significant bone pain at the doses required.¹⁸ Recent studies using the CXCR4 antagonist plerixafor in adults with WHIM syndrome have shown promise for improving neutrophil counts by mobilizing neutrophils from the bone marrow.^{19, 20} Antibiotics and immunoglobulin replacement can significantly reduce the risk of bacterial infections. There is very little reported experience regarding bone marrow transplantation for WHIM although anecdotal evidence suggests that it may correct the neutropenia and hypogammaglobulinemia but may not alter the papillomavirus susceptibility.²¹

Chronic Granulomatous Disease

CGD is the most frequently diagnosed phagocytic cell immune defect. The most common form is X-linked, caused by mutations in the CYBB gene and accounting for approximately two thirds of all CGD patients. The remaining forms, caused by mutations in the CYBA, NCF1, NCF2, or NCF4 genes are all autosomal recessive. All mutations affect the formation or function of the NADPH oxidase complex, on neutrophil phagolysosomes. The NADPH oxidase is required to generate a burst of reactive oxygen species in response to phagocytosis of pathogens. Reactive oxygen species activate proteases in the phagolysosomes that destroy ingested bacteria. In CGD, the oxidative burst cannot be generated, leading to defective processing of ingested organisms and an inability to eliminate bacterial and fungal pathogens appropriately. Catalase-positive organisms including *Staphylococcus* species, *Aspergillus* species, *Burkholderia cepacia*, *Serratia marcescens*, and others are the most common pathogens. The most common types of infection at presentation are pneumonia, lymphadenitis, cellulitis, and hepatic abscesses (particularly with *Aspergillus* sp.). The most common cause of premature death is *Aspergillus* infection.²² In addition to the infectious susceptibilities of CGD, a substantial percentage of patients struggle with inflammatory complications that are common to this disorder including an inflammatory colitis that occurs in approximately 40%, hepatic dysfunction, gingivitis, and others.

Treatment of CGD revolves around aggressive management of acute infections followed by prophylaxis against future infections using a combination of daily antibiotic (typically trimethoprim-sulfamethoxazole), daily antifungal (typically itraconazole), and thrice-weekly Interferon- γ injections. This combination has dramatically improved outcomes in CGD; however, despite appropriate use of this regimen, some patients ultimately have increasing symptoms that lead to a decline in survival beginning in the late teens or early twenties. The prospects for long-term survival appear to be correlated with the amount of residual oxidative burst activity that can be generated by a particular patient's phagocytes.²³ This has led to a renewed interest in bone marrow transplantation for CGD, which has been quite successful in the modern era, likely due to improved antimicrobials and transplant-conditioning regimens with reduced toxicity. Many now recommend that for patients who have mutations that severely affect oxidative burst activity, bone marrow transplant should be considered preemptively, early in life before patients develop comorbidities.²⁴

Diagnosis

Assessment of patients for a possible phagocytic disorder requires that both the number and the function of phagocytes be evaluated. Numbers are easily evaluated using a complete blood count with differential. If there is a concern for cyclic neutropenia, neutrophil counts may need to be evaluated 3 times weekly for 3 to 4 weeks to identify the nadir.²⁵ Functional testing includes evaluation of CD11/CD18 integrin expression on myeloid cells by flow cytometry if the patient has symptoms suggestive of leukocyte adhesion deficiency. In cases of suspected CGD, evaluation of neutrophil oxidative burst function is essential. Traditionally this was done using nitroblue tetrazoleum (NBT) but is now performed using dihydrorhodamine (DHR), a reagent that permeates neutrophils and fluoresces when reduced by a normal neutrophil oxidative burst. Fluorescence is measured by flow cytometry. The DHR test is sensitive enough to differentiate most cases of X-linked CGD from autosomal recessive CGD, making it a particularly useful clinical assay.^{26, 27}

Treatment

As noted above, management of phagocytic disorders revolves around having a heightened suspicion for infections, aggressively treating acute infections using antibiotics and G-CSF as necessary, and developing a prophylaxis regimen that is both effective and reasonable from a patient standpoint. At times, patients continue to have recurrent or severe infections despite these efforts and require more definitive therapy. As indicated above, hematopoietic stem cell transplantation (HSCT) has been shown to be effective in many, but not all, phagocytic disorders. Gene therapy has been attempted for both X-linked CGD²⁸ and for LAD-1²⁹ but neither has been particularly successful thus far and at this point is considered to be experimental. Ongoing research to address the challenges of gene therapy that are unique to these two disorders is underway.

B CELLS/ANTIBODIES

The predominant role of B cells in the immune system is to make antibodies (immunoglobulins) in response to antigen challenge (pathogens, vaccines, etc.). The absence of functional antibodies causes susceptibility to bacterial and viral infections. Antibody deficiency can occur in one of three different ways: (1) hypogammaglobulinemia or low levels of one or more immunoglobulin classes (IgG, IgA, IgM, or IgE) occurring as a result of decreased antibody production, often associated with a specific single-gene defect; (2) hypogammaglobulinemia as a result of excessive antibody loss, typically through the kidneys as proteinuria or through the gut as protein-losing enteropathy; or (3) functional antibody deficiency, in which immunoglobulin levels are normal but the Ig lacks the quality required to bind and opsonize pathogens.

Clinical Presentation

Patients who lack sufficient levels of functional antibody present clinically with recurrent bacterial sinopulmonary infections (sinusitis, otitis media, bronchitis, and pneumonia). In addition, patients may develop bowel infections caused by microorganisms such as *Giardia* or *Cryptosporidium* that are often only modestly pathogenic to normal individuals. In addition to these symptoms, patients with certain antibody-deficiency disorders have characteristic clinical features that can provide clues to the specific diagnosis. These are covered below.

Specific Disorders

X-Linked Agammaglobulinemia

X-linked agammaglobulinemia (XLA) is caused by mutations in the Bruton's tyrosine kinase (BTK) gene. BTK is a member of the Tec family of cytoplasmic tyrosine kinases and is required for the maturation of B-cell precursors in the bone marrow.³⁰ Mutations in BTK therefore cause an arrest of B-cell development at the pre-B-cell stage leading to virtual absence of circulating B cells in the peripheral

P.1346

blood. Mutations that only partially interfere with the enzymatic function of BTK have also been described and are associated with milder forms of the disease that only have defects in the generation of specific antibody responses.

XLA is typically suspected in male patients with recurrent bacterial sinopulmonary infections and <2% circulating CD19⁺ B cells. Other infections that occur relatively frequently in patients with XLA prior to the initiation of IgG replacement therapy include skin infections (furunculosis, pyoderma, and cellulitis) and sepsis. The diagnosis can be confirmed either by identifying a mutation in the BTK gene or by demonstrating absence of the BTK protein in monocytes or platelets. A positive family history suggestive of an X-linked recessive mode of inheritance increases the suspicion for XLA. It is uncommon for patients with XLA to develop symptoms in the first months of life because newborns are protected from most infections by transplacentally acquired maternal IgG. There are few distinguishing physical features of XLA that can provide clues to the diagnosis but absence of visible tonsils or adenoids (by X-ray or CT scan) is a useful clue.

In addition to the common sinopulmonary pathogens, patients with XLA are also susceptible to infections by particular opportunistic organisms that are more rare and fastidious, which can cause unusual clinical syndromes. For example, *Helicobacter cinaedi* can cause a syndrome of dermatomyositis and cellulitis that presents with cutaneous ulcerations, particularly on the lower legs.^{31, 32} The organism can sometimes be recovered from the blood but is fastidious and difficult to culture using usual methods. The ability to culture the organism and evaluate its antibiotic sensitivity is crucial in many cases because it is frequently resistant to various antibiotics. A combination of antibiotics is often needed to clear the infection effectively.³³ Similarly, *Mycoplasma* species, including *M. hominis*, can cause lung, abdominal, or bone infections that are remarkably hard to eradicate and *Ureaplasma urealyticum* infections are a rare cause of arthritis, urethritis, and pneumonia.³⁴

Prior to the widespread use of IgG supplementation in these patients, opportunistic viral infections, particularly with viruses that require an extracellular phase, were especially problematic. For example, echovirus encephalitis was estimated to be the cause of death in ~10% of boys with XLA in the 1970s but that number has fallen dramatically with aggressive use of IgG supplementation. There continue to be rare cases of echovirus encephalitis in patients with XLA, even in those on adequate IgG replacement therapy, but these are thought to be caused by viral strains for which there may not be high antibody titers in the particular IgG preparation being used.^{35, 36} Similarly, a mink astrovirus strain was recently identified by deep sequencing from the brain of an XLA patient who developed a neurodegenerative disorder as a teen.³⁷ Interestingly, he had lived next to a mink farm as a child but was started on immunosuppression early in his teens for inflammatory bowel disease, which may have allowed the virus to escape control. Lastly, infections with vaccine-strain poliovirus were pathogenic in undiagnosed patients with XLA who were immunized with the live-viral vaccine after

transplacentally acquired maternal antibody had waned. The shift from live attenuated to killed poliovirus for immunization has essentially eliminated new cases.

Hyperimmunoglobulin M Syndromes

Under normal circumstances, binding of antigen to cell surface IgM on naive B cells induces activation of the B-cell. The antigen that is bound to surface IgM on the B-cell is ingested, proteolytically digested, and antigenic peptide fragments are displayed on the B-cell surface in MHC Class II molecules. Antigen-specific T cells then engage the B-cell via MHC II/TCR interactions. Once engaged, the activated helper T-cell (Th) provides additional costimulatory signals to the B-cell that are critical to promote immunoglobulin class-switching from IgM to IgG, IgA, and IgE. The most important of these costimulatory signals comes via the interaction of CD40 ligand on activated T cells with CD40 on B cells. Additional costimulatory signals come from ICOS on activated T cells and ICOS ligand (B7-H2) on B cells. Activation of the B-cell through CD40 and cytokines that are secreted by the helper T-cell cause it to undergo class-switch recombination (CSR) during which the μ -heavy chain gene segment within the immunoglobulin gene, is replaced by either a γ , α , or ϵ gene segment. This is accomplished by nicking and double-strand breakage of the DNA in the immunoglobulin heavy-chain locus, which requires a series of enzymatic steps that involve activation-induced cytidine deaminase (AID), uracil DNA glycosylase (UNG), and others. Genetic defects that affect CD40 ligand (CD40L), CD40, AID, or UNG can therefore prevent class-switch recombination thus thwarting the B-cell's ability to make significant amounts of any antibody isotype in addition to IgM.

The overwhelming majority of patients with hyper-IgM syndrome have the X-linked form caused by X-linked recessive mutations in the CD40 ligand (CD40L/CD154), which is encoded by the CD40L gene on the X-chromosome.³⁸ CD40L and its receptor CD40 are members of the tumor necrosis factor (TNF) superfamily of ligands and receptors. In lymphocytes, CD40L is expressed only on activated T cells but is also expressed on platelets where its role is unknown. Affected boys may present with recurrent bacterial sinopulmonary infections caused by low IgG, IgA, and IgE, whereas IgM is normal or elevated. In addition to the usual bacterial pathogens, patients with CD40L mutations also demonstrate unique susceptibilities to fungal infections, particularly *Pneumocystis jiroveci* (PJ) that causes pneumonia, and to a protozoan, *Cryptosporidium parvum* (CP) that causes bowel infections. B lymphocytes are present, and T-cell numbers are generally normal. In almost all cases, the diagnosis can be made by using flow cytometry to evaluate the expression and function of the CD40L protein on activated T cells. Expression is evaluated using antibodies specific to the CD40L protein and the function is evaluated by measuring the binding of a CD40-Ig heavy chain fusion protein to the expressed CD40L. Gene sequencing can then be performed in order to identify a specific mutation.

The susceptibility to *Pneumocystis* and possibly other fungal pathogens has been somewhat of a puzzle because patients do not have other signs of a significant cellular immune defect such as severe or recurrent viral infections. Interestingly, the susceptibility to *Pneumocystis jiroveci* pneumonia (PJP) appears to go away in most patients by the age of 5. PJP is almost always diagnosed by staining bronchoalveolar lavage fluid for the presence of the organism. PJP can be readily prevented by prophylactic trimethoprim-sulfamethoxazole administration and active disease is amenable to treatment using higher doses of the same drug. Recent data have suggested that the fungal susceptibility in CD40L deficiency may be a result of defective CD40L signaling into dendritic cells and monocytes that express CD40.³⁹

C. parvum bowel infections are more difficult to diagnose and manage in patients with CD40L deficiency. CP may cause abdominal pain, bloating, diarrhea, malabsorption, and weight loss. It may require multiple stool samples to identify the oocysts and occasionally, the diagnosis can only be made on endoscopically obtained biopsy specimens. Treatment with paromomycin or nitazoxanide can clear the infection although prolonged courses are typically needed in hyper IgM patients and treatment failures are not uncommon. CP infections can result in chronic inflammation of the gut and biliary tree, which seems a likely contributor to the high incidence of bile duct cancers seen in these patients.^{40, 41}

Treatment involves the use of IgG replacement therapy combined with prophylactic antibiotics for prevention of PJP at least until the age of 5. The role of bone marrow transplantation for CD40L deficiency is still being evaluated. Even though a number of patients have undergone successful bone marrow

P.1347

transplantation, the role of BMT remains somewhat controversial in this disease although in patients with ongoing CP infection, the prognosis for the patients who develop bile duct disease is so poor that the risks of transplantation are well justified.^{42, 43}

CD40 deficiency is inherited as an autosomal recessive defect that has been described primarily in two cohorts from Italy and the Middle East. It results in a syndrome that is almost identical to CD40L deficiency in which both sexes are affected.

Homozygosity for a null mutation occurs, but heterozygosity is more common and can result in a partial phenotype because CD40 functions as a trimer (defects of even one chain of the trimer interfere with its function).⁴⁴

Autosomal recessive mutations in AID and UNG also cause a hyper-IgM phenotype but it tends to be milder than either CD40L or CD40 deficiency, likely because the defect is limited to B cells, whereas CD40L/CD40 signaling plays a role in other cell types including dendritic cells and monocytes.^{45, 46} Patients with AID or UNG typically live into adulthood and do not demonstrate the same susceptibility to PJP and CP bowel infections. Patients with mutations in AID do, however, have a significant propensity to develop autoimmunity affecting various organ systems. Patients are typically treated with IgG replacement therapy and antibiotics for acute infections. There are no reports of bone marrow transplantation for AID or UNG deficiency.

Common Variable Immunodeficiency Syndromes

Common variable immunodeficiency (CVID) is a heterogeneous disorder that is likely caused by a variety of molecular mechanisms that ultimately lead to a similar clinical phenotype. The European Society of Immunodeficiency (ESID) has proposed diagnostic criteria in an effort to standardize the diagnosis of CVID. These include: (1) plasma IgG levels that are less than 2 standard deviations below the mean for age combined with a "marked decrease" in either IgM or IgA; (2) age of onset of immunodeficiency >2 years of age; (3) absent isohemagglutinins or poor responses to vaccines; and (4) defined causes of hypogammaglobulinemia have been excluded.

The peak age of onset of CVID is in the second or third decade of life and 50% to 60% of patients have a clinical phenotype consisting almost exclusively of increased bacterial sinopulmonary infections. With IgG supplementation, this group of patients has a relatively benign course with long-term survival that is not unlike the normal population. The other half of patients have a complicated disease course with autoimmunity or lymphoproliferative disease that can involve the hematopoietic system, lungs, lymph nodes, liver, and bowel. The long-term outcome of this population is significantly worse, approaching only 40% survival over 40 years.⁴⁷

Among the disorders seen in this population, a granulomatous, lymphoproliferative, interstitial lung disease (GLILD) affects approximately 30% to 40% of patients.⁴⁸ This often presents with decreasing lung function that is manifested by cough, decreased exercise tolerance, and sometimes hypoxemia. Typical findings on chest CT scan include diffuse nodules within the lung, opacities that have a "ground glass" appearance, bronchial wall thickening, and sometimes bronchiectasis. Lung biopsy generally demonstrates a lymphocytic interstitial pneumonitis with noncaseating granulomas and a follicular bronchiolitis with lymphoid aggregates of both B and T cells. This pattern is sometimes mistaken for sarcoidosis although there are differences. Over time, this inflammatory process in the lungs will cause destruction of alveoli and will contribute to development of bronchiectasis. There continues to be some debate among providers about whether this process should be treated if the patient is not demonstrating pulmonary compromise. If left unchecked, however, there is evidence that irreversible damage and fibrosis develops in many patients. High-dose steroids are often used as first-line therapy to treat this process and in many cases they are effective but do not typically lead to a lasting remission on their own. A recent study using a combination of anti-CD20 monoclonal antibody (rituximab) therapy and azathioprine in a small cohort of CVID patients with GLILD demonstrated dramatic responses with a prolonged remission of disease in many patients.⁴⁹

In addition to pulmonary symptoms, gastrointestinal complaints are common in CVID, affecting 20% to 30% of patients.⁴⁷ Patients who develop disease demonstrate a hypertrophic lymphoproliferation of Peyer's patches that causes a nodular lymphoid hyperplasia in the bowel. This is associated with abdominal discomfort, diarrhea, malabsorption, and weight loss and can cause significant morbidity. A variety of approaches have been taken to treat this process but none have offered particularly dramatic results although nonabsorbable steroid preparations have shown some benefit with minimal side effects. A more troubling complication observed in 5% to 10% of patients is a hepatitis that can cause severe hepatic dysfunction with development of hepatosplenomegaly and ascites.⁴⁷ Infectious causes are almost never identified and liver biopsy demonstrates a nodular lymphoid hyperplasia in the liver parenchyma, not unlike that observed in the bowel. Liver disease is among the complications associated with a poor outcome.

Some 20% of subjects have additional clinical findings that are suggestive of autoimmunity/immune dysregulation including immune thrombocytopenia and hemolytic anemia, neuropathy, endocrinopathies, and skin disease. Skin involvement ranges from alopecia and vitiligo to psoriasis and granuloma annulare.^{50, 51}

In most cases of CVID, the molecular etiology of disease is unknown. There has, however, been some progress in identifying genetic defects associated with a CVID phenotype. The most common mutations identified are autosomal recessive defects in the transmembrane activator, calcium modulator, and cyclophilin ligand interactor (TACI), which are found in 7% to 10% of patients with CVID. Unfortunately, even in patients who have mutations that abrogate protein

expression, the penetrance of disease seems to be highly variable with individuals from one family harboring the same mutation, having either a CVID phenotype, a selective IgA deficiency phenotype, or no disease. This inability to correlate disease phenotype or prognosis with the presence of a TACI mutation has raised the question of whether TACI genotyping offers clinical value. In addition to TACI, autosomal recessive mutations in the genes encoding the Baff receptor (BAFFR), the inducible T-cell co-stimulator (ICOS), CD19, CD20, CD21, CD81, and the LPS-responsive vesicle trafficking, beach- and anchor-containing protein (LRBA) have been identified in rare patients with features of CVID. These mutations have provided insight into basic immune mechanisms in humans but explain only a handful of all patients with CVID.^{52, 53} Lastly, hypomorphic mutations in BTK (X-linked agammaglobulinemia), CD40L (X-linked hyper-IgM syndrome), SAP/SH2D1A (X-linked lymphoproliferative syndrome), and RAG1/RAG2 can be associated with a CVID-like phenotype and according to the diagnostic criteria for CVID, need to be excluded prior to making this diagnosis.⁵²

B-cell numbers in peripheral blood are typically normal but a subset of CVID patients have B-cell lymphopenia. In those patients with normal B-cell numbers, B-cell maturation, memory development, and immunoglobulin class-switching are often abnormal and can be assessed by detailed flow-cytometry-based immunophenotyping of B cells. Varying classification schemes have been proposed to subtype patients according to their B-cell phenotype and these subsets have been correlated with differences in risk for autoimmunity, and the like. B-cell immunophenotyping has therefore become a useful clinical tool in caring for patients with CVID. In addition to the humoral immune deficiency, many patients with CVID have impaired T-cell function with decreased CD4 or CD8 T cell numbers as well as abnormal T-cell proliferative responses in vitro to mitogens and antigens. Regulatory T-cell numbers and function have also been found to be decreased in patients with CVID.^{54, 55, 56, 57, 58}

P.1348

Selective Immunoglobulin A Deficiency

There are two isoforms of IgA that are made predominantly at mucosal surfaces where they play a critical role in neutralizing pathogens and maintaining mucosal integrity. Subjects >4 years of age with serum IgA levels consistently <7 mg/dl but normal IgG and IgM levels are considered selectively IgA deficient. Selective immunoglobulin A deficiency (SIgAD) can be difficult to diagnose in childhood because adult blood levels of IgA (50 to 200 mg/dl) are not usually attained until 12 years of age or older. The molecular mechanisms by which this occurs are largely unknown. Interestingly, despite low IgA, the frequency of cell-surface IgA-positive B cells is normal in patients with SIgAD. Up to 20% of IgA-deficient subjects have reduced levels of at least one IgG subclass: mostly IgG₂.

Selective IgA deficiency is the most common immunodeficiency with an incidence as high as 1 in 300 in blood bank studies. The majority (>50%) of patients with selective IgA-deficiency have no apparent symptoms that can be directly linked to their immune defect. In the patients who do have symptoms, they are typically more suggestive of immune dysregulation and autoimmunity (allergy, arthritis, diarrhea, celiac disease, etc.) than immune deficiency (sinusitis, otitis media, bronchitis, and pneumonia). In patients who are truly IgA deficient, sensitization to IgA itself can be a problem, leading to anaphylactic reactions during infusions of blood products including IVIg, red blood cells, platelets, and so on. This is, however, quite uncommon and can often be managed by pretreatment with benadryl, acetaminophen, and steroids before the start of the infusion.⁵⁹

Transient Hypogammaglobulinemia

Maternal IgG is actively transported across the placenta from mother to infant. The rate of transfer increases in the last month of pregnancy. Premature infants will therefore have low IgG levels but term newborns have IgG concentrations virtually equal to their mother's. Because the half-life of IgG is approximately 21 days, the levels of maternal immunoglobulin fall as the infant grows and the IgG is catabolized. For most term infants, the IgG level in the blood reaches a nadir between 200 to 400 mg/dl, typically between 3 and 4 months of age. As the infant's own immune system matures and begins to generate more IgG of its own, the immunoglobulin levels begin to rise again. There are, however, children whose IgG levels dip below 200 mg/dl and may remain low for a prolonged period of time before they begin to rise into the normal range again. Despite this, the response to protein antigen vaccines is often normal. This phenomenon is termed transient hypogammaglobulinemia of infancy (THI) and immunoglobulin levels typically return to normal by 2 to 6 years of age. There are almost no data about the mechanism by which THI occurs although it has been suggested that it may be the result of delayed B-cell maturation. This has, however, not been borne out by B-cell immunophenotyping studies.⁶⁰ The true incidence of THI is unknown because immunoglobulin levels are usually only requested if patients are having symptoms (i.e., recurrent infections). There is no consensus on how to manage THI although most would agree

that if patients are having frequent infections, they might require IgG supplementation until their own IgG levels normalize. One approach has been to immunize affected infants with killed vaccines and to start supplemental IgG therapy on those who make no significant antibody response. Infants who do respond to immunization with a protective specific antibody titer are usually safe with symptomatic management or with prophylactic antibiotics alone.

Immunodeficiency, Centromere Instability, and Facial Anomalies Syndrome

Immunodeficiency, centromere instability, and facial anomalies (ICF) syndrome is a complex syndrome that includes centromeric instability, a variable immune deficiency (often with normal B-cell counts), facial anomalies including hypertelorism, a flat nasal bridge, and low-set ears, and developmental delay. The immunoglobulin deficiency is variable but IgA, IgG, and/or IgM are frequently low. Lymphocyte proliferation can also be abnormal. The centromeric instability leads to chromosomal breaks, deletions, and multiradial chromosome junctions in activated lymphocytes that typically affect chromosomes 1, 9, and 16. ICF syndrome typically presents in childhood with recurrent bacterial sinopulmonary infections and patients generally require chronic IgG supplementation. The diagnosis is usually suspected in patients who have the facial phenotype and recurrent infections. ICF syndrome is caused by mutations in the DNMT3B gene, which encodes one of a family of DNA methyltransferases. Hypomethylation of the DNA is hypothesized to cause disease but the precise mechanism by which this generates the facial and immune phenotypes is unknown.^{61, 62} Evaluating the karyotype of activated peripheral blood lymphocytes can demonstrate the characteristic chromosomal abnormalities in chromosomes 1, 9, and 16, which can be highly suggestive of the diagnosis. Ultimately, sequencing of the DNMT3B gene can confirm a diagnosis of ICF syndrome.

Diagnosis

The diagnosis of antibody deficiency needs to evaluate both the quantity and the quality of the antibody response. Quantity is easily evaluated by measuring quantitative immunoglobulin levels (IgG, IgM, IgA, and IgE) in the blood and comparing these to the age-appropriate normal ranges. Evaluating the quality of the antibody response can be done by measuring specific antibody titers to vaccines that the patient has received. Generally, responses to both protein antigens (tetanus, diphtheria, hepatitis B, etc.) and carbohydrate antigens (23-valent unconjugated Pneumovax) need to be assessed to confirm normal antibody responses. Patients who respond appropriately to protein antigens but do not respond to carbohydrate antigens may have specific antibody deficiency and may require additional workup. Recent guidelines regarding the interpretation and use of diagnostic vaccination have recently been published.⁶³

In addition to evaluating antibody quantity and quality, it is essential to determine whether patients have normal B-cell numbers by evaluating lymphocyte subsets. The use of more detailed B-cell immunophenotyping to evaluate B-cell development, the presence of CD27⁺ memory B cells, and the ability of memory B cells to undergo immunoglobulin class switching has become standard-of-care in many clinics as it provides valuable diagnostic and prognostic information.⁶⁴

Flow cytometry testing to assess the expression of specific proteins that are defective in B-cell and antibody deficiency disorders including BTK, CD40 ligand, CD40, ICOS, CD27, BAFF receptor, and the like, can be performed in specialty laboratories and offer the ability to rapidly obtain a molecular diagnosis. This is typically supplemented by sequencing of specific genes.

Treatment

Immunoglobulin Replacement

In patients with antibody deficiency, replacement of IgG is critical to maintaining health and preventing long-term complications associated with recurrent infections. Immunoglobulin replacement therapy has been found to be effective when administered intravenously (IVIg), subcutaneously (SCIg), and intramuscularly (IMIg) and there are currently FDA-approved products that support administration via any of these routes. That said, because of significant discomfort associated with IMIg administration, this route is rarely used in the United States. Most patients are maintained on either IVIg or SCIg depending on patient preference and

P.1349

provider recommendations related to each patient's clinical need. Because the half-life of IgG in the circulation is ~21 days under normal circumstances, IVIg is typically administered every 3 to 4 weeks providing high peak levels followed by a decline over the ensuing weeks to a trough prior to the next infusion. In contrast, SCIg is typically administered 1 to 2 times per week in smaller doses providing a more "steady-state" level of IgG in the circulation. IgG products are prepared from the pooled plasma collected from thousands of healthy donors and therefore they contain a broad range of antibodies. A reasonable starting dose of either IVIg or SCIg is 400 to 500 mg/kg/month. This can be divided into the

number of doses required to administer the necessary monthly volume (IgG preparations range in concentration from 5 g/100cc (5%) to 20 g/100cc (20%)). In most patients, a trough IgG level of 600 mg/dl in the blood is a reasonable initial target but the dose can then be increased or decreased to achieve a trough IgG level that prevents both acute infections and development of progressive lung disease. There is evidence that at least for bacterial pneumonia, higher IgG trough levels are directly correlated with a decreased risk of infection.⁶⁵ Supplemental IgG is generally very effective at preventing lower respiratory tract infections (bronchitis and pneumonia), but the response of upper tract disease (particularly sinusitis) is more variable. Some patients have persistent sinus symptoms that can be a significant clinical problem despite IgG therapy. In these patients, the addition of prophylactic antibiotic therapy or increasing the frequency or dose of IgG infusions may be beneficial.

Side effects with IVIg therapy are relatively common, occurring in as many as 25% of treated patients.⁶⁶ Side effects include headaches, nausea, vomiting, chills, fatigue, fever, rash, and aseptic meningitis. These can often be managed by changing the IgG product being used, pretreating with benadryl, acetaminophen, and steroids (0.5 to 1 mg/kg) prior to infusion, or slowing the rate of infusion. Patients who have persistent symptoms despite these measures can often tolerate subcutaneous IgG supplementation (SCIg).

Prophylactic Antibiotics

It has been increasingly recognized that in many patients with antibody deficiency, replacement of IgG (even to normal levels), may not prevent all clinically significant infections. The addition of prophylactic antibiotics has been used as an adjunct to IgG therapy to try to improve control of infections and decrease morbidity. Unfortunately, to date, there have been no well-performed studies that argue strongly either for or against the use of prophylactic antibiotics to improve outcomes. Similarly, there have been virtually no studies that support a particular antibiotic regimen as being superior for prophylaxis. Many patients with antibody deficiency have evidence of bronchiectasis and chronic lung disease, therefore some providers, extrapolating from the lung transplant and cystic fibrosis literature, have utilized thrice weekly macrolide antibiotics as a prophylactic regimen in an attempt to prevent progression of lung pathology. Further studies are needed to clarify the role of prophylactic antibiotics and to define the optimal regimen.

T CELLS

Disorders characterized by the absence of T cells have been known for some time but the identification of several new genetic defects has expanded this group of disorders. Some are characterized by significant, generalized T-cell lymphopenia whereas others are characterized by the absence of specialized subsets of T cells.

Clinical Presentation

In general, absence of T cells causes susceptibility to unusual or severe infections caused by viruses including cytomegalovirus (CMV), Epstein-Barr virus (EBV), and adenoviruses, fungal infections caused by organisms such as *P. jiroveci* that commonly causes pneumonias in this group of patients, and mycobacteria such as *Bacilli Calmette-Guerin* (BCG) in areas of the world where this is used. In addition, patients with T-cell deficiencies frequently have symptoms of autoimmunity including diarrhea (secondary to autoimmune enteropathy), cytopenias (autoimmune hemolytic anemia [AIHA] and idiopathic thrombocytopenic purpura [ITP]), and hepatitis.

Specific Disorders

22q11.2 Deletion Syndrome (DiGeorge Syndrome)

Deletions within the 22q11.2 region of the long arm of chromosome 22 have been associated with various clinical syndromes including DiGeorge syndrome (DGS), velocardiofacial syndrome (VCFS), conotruncal anomaly face syndrome (CTFS), CATCH22 syndrome, and others. DiGeorge syndrome is the name most commonly associated with immune deficiency and thus is the focus of this discussion. Although DGS is a complex syndrome that has been associated with a wide array of symptoms, the diagnostic criteria proposed by the European Society of Immune Deficiency (ESID) are relatively straightforward. These propose that a diagnosis of DGS should be strongly considered in patients who have <500 CD3⁺ T cells/mm³ and any two of the following three characteristics: (1) conotruncal cardiac defect (truncus arteriosus, tetralogy of Fallot, interrupted aortic arch, or aberrant right subclavian); (2) hypocalcemia requiring therapy for >3 weeks; (3) deletion of chromosome 22q11.2. This chromosomal deletion syndrome occurs in approximately 1 in 4,000 to 5,000 births and causes haploinsufficiency of the genes encompassed in the deletion that can extend to include as much as 3 Mb of the chromosome.^{67, 68}

The characteristic T-cell lymphopenia of DiGeorge syndrome is thought to arise primarily from the absence of adequate thymic tissue and at times, the diagnosis is suspected when the cardiac surgeon correcting a congenital heart defect finds little or no thymic tissue in the mediastinum. Most affected infants have low, but not absent T cells and absolute counts

tend to improve over the first year of life. Both CD4⁺ and CD8⁺ T cells are low, however, CD8⁺ T-cell numbers tend to be more affected in most patients. Despite low T-cell counts, most patients do not have significant problems with recurrent or severe viral or fungal infections. Some patients may have recurrent candidiasis. Bacterial infections of the upper respiratory tract including otitis media and sinusitis do occur but may be related more to anatomical issues associated with the facial anomalies than to the immunodeficiency per se. Rare patients have severe T-cell lymphopenia with essentially no T cells and are termed “complete” DiGeorge. These patients may have a clinical phenotype similar to SCID.^{67, 68}

Other prominent clinical features include: hypocalcemia that can be severe and persistent due to parathyroid hypoplasia, dysmorphic facial features that include small low-set ears, hypertelorism, and micrognathia, renal anomalies including horseshoe kidney and a duplicated collecting system, and developmental delay including problems with speech acquisition, learning disabilities, and behavioral problems. Patients with DiGeorge syndrome have also been found to have an increased incidence of autoimmunity including cytopenias (particularly affecting red cells and platelets), juvenile idiopathic arthritis (JIA), and thyroiditis.

In symptomatic patients, the diagnosis of DiGeorge syndrome is typically made by confirming a deletion within the 22q11.2 region by fluorescence in situ hybridization (FISH) or by quantitative PCR for deletion of the TBX1 gene that lies within the deletion.⁶⁹ In approximately 10% of patients, deletion of this region cannot be detected despite the presence of classic clinical features.

Treatment of DiGeorge initially involves supportive care that may include cardiac support and calcium supplementation. In P.1350

patients with severe T-cell lymphopenia or evidence of decreased T-cell function, prophylaxis against PJP pneumonia and IgG supplementation may be utilized. Blood for these patients should be irradiated to prevent the risk of graft-versus-host disease. For those patients with the severe “complete” form of the syndrome, grafting of allogeneic thymus slices into the thigh muscle has proven to be successful in recovering the T-cell lymphopenia, improving T-cell responses to mitogens, and correcting the infectious susceptibility.^{70, 71} HSCT has been utilized in a handful of patients with mixed results.^{72, 73} In general, HSCT restores the T-cell counts and protects patients against further infection but in the absence of a thymus, the T-cell graft is thought to consist primarily of long-lived committed lymphoid progenitor T cells and not of cells derived from donor bone marrow stem cells. As a result, there is concern that the T-cell grafts may senesce over time, once again leaving the patient lymphopenic and susceptible to infection. There are currently no long-term therapies that can successfully correct the parathyroid defect.

Severe Combined Immune Deficiency

Made famous by *The Boy in the Plastic Bubble*, a 1976 made-for-TV movie starring John Travolta, SCID is among the most severe immunodeficiencies. It is now known that this category of diseases is made up of a variety of related disorders caused by mutations in more than 20 different genes. The one thing that is common to all forms of SCID is deficiency of one or more subsets of T cells. In many cases, there are no circulating T cells. Depending on the genetic defect, patients may also lack B cells and/or NK cells. This has led to the useful convention of defining cases of SCID by their cellular phenotype (i.e., T^{neg}B⁺NK⁺, T^{neg}B⁺NK^{neg}, T^{neg}B^{neg}NK⁺, T^{neg}B^{neg}NK^{neg}, etc.). The cellular phenotype suggests what the underlying genetic defect may be (see Table 63.2).² Because of the absence of functional T cells, patients with SCID typically come to medical attention because of severe or chronic viral infections, fungal infections, or autoimmunity. In the overwhelming majority of SCID cases, this leads to death in infancy or early childhood if patients do not undergo curative treatment such as HSCT or gene therapy. Unfortunately, the presence of infections makes HSCT or gene therapy much more complicated and substantially decreases the chances of survival. Because of this, efforts have been underway in the United States and other countries to perform screening of all newborns using dried blood spot cards obtained at birth to identify those who may have SCID. These efforts have led to the recognition that the incidence of SCID is approximately 1 in 40,000 live births in the United States.^{74, 75}

X-Linked Severe Combined Immunodeficiency

The X-linked form of SCID is the most common type, accounting for ~40% of all SCID cases. It occurs as a result of mutations in the IL2RG gene, encoding the γ receptor chain (γ c) utilized by a number of cytokine receptors including those for IL-2, IL-4, IL-7, IL-9, IL-15, and IL-21 (see Fig. 63.2). In the absence of a functional γ c chain, cells are unable to respond to these cytokines. Because IL-2 and IL-7 are key growth factors for T cells, and IL-15 is the key growth factor for NK cells, patients with X-SCID lack T and NK cells but usually have normal numbers of B cells in their blood. The ability to make antibodies is nevertheless severely impaired due to the lack of T-cell help.

If not identified by newborn screening, infants with X-SCID typically present with severe infections. *P. jiroveci* pneumonia is common and often accompanied by severe viral infections with cytomegalovirus (CMV), EBV, respiratory syncytial virus (RSV), rotavirus, metapneumovirus, and others. Adenovirus is particularly lethal in SCID, causing not only pneumonitis but also a severe fulminant hepatitis. In countries where BCG is still used for vaccination, X-SCID patients may develop severe, systemic BCG-osis. Other symptoms that are frequently associated with X-SCID include diarrhea, failure to thrive, and candidiasis. The physical exam and associated studies offer few clues to the diagnosis of X-SCID other than a paucity of palpable lymph nodes and absence of a thymic shadow on a chest X-ray.

Flow cytometry testing to evaluate tyrosine phosphorylation of the STAT3 transcription factor in response to IL-21 stimulation can provide a rapid assessment of whether a patient may have an IL2RG or JAK3 defect (see below). Under normal circumstances, IL-21 stimulation of B cells causes rapid tyrosine phosphorylation in B cells that is absent in patients with IL2RG or JAK3 deficiency (see Fig. 63.2). The diagnosis is ultimately confirmed however by sequencing of the IL2RG gene.

HSCT has been the mainstay of therapy for X-SCID using a variety of pretransplant conditioning regimens. Some have strongly advocated the use of T-cell depleted grafts from one of the haploidentical parents because they are readily available but many patients transplanted using that approach have failed to obtain significant donor chimerism in the B-cell compartment, so have remained dependent on IgG supplementation posttransplant. X-SCID was also the first disorder successfully treated by gene therapy. Unfortunately, the retroviral gene therapy vector used to deliver the normal copy of the IL2RG gene had an unknown propensity to integrate within the T-cell oncogene LMO2, causing T-cell leukemias in a subset of treated patients.^{76, 77, 78} Further studies are underway using alternative viral vectors with the hope that these may have a better safety profile.

JAK3 Deficient Severe Combined Immune Deficiency

JAK3 is the tyrosine kinase immediately downstream of the common gamma chain (γ_c). It transduces signals from cytokine receptors to the STAT5 transcription factor and to other intracellular signaling molecules (see Fig. 63.2). Approximately 30 different mutations have been identified that impair JAK3 function to varying degrees. Those that are severe have a $T^{neg}B^+NK^{neg}$ cellular phenotype similar to mutations in IL2RG. Approximately one third of patients have milder mutations that allow some JAK3 function.^{79, 80} These patients can develop some T cells although the T cells that develop are functionally abnormal. The clinical presentation is similar to that observed in γ_c deficiency. Sequencing of the JAK3 gene is required to confirm the diagnosis.

Interleukin-7 Receptor, CD3 Components, and CD45-Deficient Severe Combined Immune Deficiency

Defects in the α -chain of the IL-7 receptor (IL7RA), CD3 subunits (γ, δ, ϵ), or CD45 can cause SCID with a $T^{neg}B^+NK^+$ phenotype. As noted above, IL-7 is one of the two key growth and differentiation factors for T cells. As a result, mutations in the IL-7 receptor α -chain (CD127) lead to selective T-cell deficiency but allow normal development of B and NK cells.

Similarly, absence of any of the CD3 subunits specifically affects the ability of T cells to develop because CD3 makes up an essential part of the T-cell receptor complex. The T-cell receptor, including CD3 subunits, assembles in the endoplasmic reticulum and Golgi complex before trafficking to the cell surface. If any of the receptor subunits are absent (including any of the CD3 chains), the receptor is recycled and never makes it to the outer cell membrane. As a result, cells are unable to receive the TCR stimulation needed as they traffic through the thymus and they die by "neglect." Because the number of T cells entering the thymus is normal, the CD3 defects are unusual among SCID disorders in that the size of the thymus is normal. Of the three known CD3 defects (γ, δ , and ϵ), CD3 γ deficiency may have a somewhat milder clinical phenotype that can present with moderate T-cell lymphopenia and recurrent pneumonia and otitis.

CD45 is a transmembrane tyrosine phosphatase present on most white blood cells. It regulates intracellular Src-family tyrosine kinases that are important for T-cell receptor function and

P.1351

activation. Autosomal recessive mutations of CD45 lead to T-cell deficiency and a SCID phenotype in affected infants.

TABLE 63.2 MOLECULAR DEFECTS ASSOCIATED WITH SPECIFIC CELLULAR PHENOTYPES IN SEVERE COMBINED IMMUNE DEFICIENCY (SCID)

Cellular Phenotype	Gene	Inheritance	Features
$T^{neg}B^{neg}NK^{neg}$			

• Adenosine deaminase deficiency	<i>ADA1</i>	AR	Costochondral abnormalities, neonatal hepatitis
• Purine nucleotide phosphorylase deficiency	<i>PNP</i>	AR	Progressive neurologic problems
• Reticular dysgenesis	<i>AK2</i>	AR	Also has deficiency of myeloid lineage cells, sensorineural deafness

T^{neg}B^{neg}NK⁺

• RAG1 deficiency	<i>RAG1</i>	AR	
• RAG2 deficiency	<i>RAG2</i>	AR	
• Artemis deficiency	<i>DCLRE1C</i>	AR	Radiosensitivity
• DNA-PKcs deficiency	<i>PRKDC</i>	AR	Radiosensitivity
• DNA ligase IV deficiency	<i>LIG4</i>	AR	Radiosensitivity, microcephaly, growth retardation
• Cernunnos/XLF deficiency	<i>NHEJ1</i>	AR	Radiosensitivity, microcephaly, growth retardation

T^{neg}B⁺NK^{neg}

• Common γ chain deficiency	<i>IL2RG</i>	XL	
• JAK3 deficiency	<i>JAK3</i>	AR	
• CD45	<i>PTPRC</i>	AR	Some NK cells may be present

T^{neg}B⁺NK⁺

• IL-7 receptor- α (CD127) deficiency	<i>IL7RA</i>	AR	
• DiGeorge syndrome	<i>22q11.2 del</i>	AD	Hypoparathyroidism, cardiac defects, dysmorphic facies
• CHARGE syndrome	<i>CHD7</i>	AD	Multiple anomalies make up the clinical complex of CHARGE syndrome
• CD3 δ deficiency	<i>CD3D</i>	AR	
• CD3 ϵ deficiency	<i>CD3E</i>	AR	
• CD3 γ deficiency	<i>CD3G</i>	AR	
• CD3 ζ deficiency	<i>CD3Z</i>	AR	
• P56lck deficiency	<i>LCK</i>	AR	
• Coronin-1A deficiency	<i>CORO1A</i>	AR	Lymphadenopathy

T⁺B⁺NK⁺

• MHC II deficiency	<i>CIITA</i>	AR	CD4 ⁺ T cells are typically decreased but not absent
	<i>RFXANK</i>	AR	
	<i>RFX5</i>	AR	
	<i>RFXAP</i>	AR	

• ORAI1 deficiency	<i>ORAI1</i>	AR	Myopathy, calcium flux defect in B and T cells so poor proliferation
• STIM1 deficiency	<i>STIM1</i>	AR	Myopathy, calcium flux defect in B and T cells so poor proliferation

AD, Autosomal dominant; AR, Autosomal recessive; XL, X-linked recessive.

Modified from Cossu F. Genetics of SCID. Ital J Pediatr 2010;36:76.

DNA Recombination and Repair Defects in Severe Combined Immune Deficiency

Rearrangement of the V, D, J, and constant regions of the T-cell receptor gene and the B-cell immunoglobulin gene requires that double-stranded breaks be made in the DNA and that these breaks then be repaired after removal of intervening chromosomal fragments. The recombinase activating genes RAG1 and RAG2 are expressed in T and B cells and play an essential role in creating the necessary double-stranded DNA breaks in the TCR and immunoglobulin loci. A large complex of proteins including Artemis (DCLRE1C), DNA-PKcs, Cernunnos/XLF (XRCC4-like factor), and DNA ligase IV (LIG4) then play a role in the repair of the DNA double-stranded breaks needed to create the final, recombined TCR or Ig locus. Inasmuch as productive rearrangement of the TCR or Ig locus is a necessary developmental step during T- and B-cell maturation, complete failure in one of these processes results in lymphopenia, with few if any T- or B cells

P.1352

in the blood, whereas generation of NK cells is generally unaffected. Because radiation induces double-strand breaks in DNA, cells from patients with mutations in any of the proteins involved in DNA repair (Artemis, DNA-PKcs, cernunnos, ligase IV) demonstrate decreased survival in vitro after radiation exposure (radiation-sensitivity). This can be a valuable diagnostic clue in making a diagnosis.

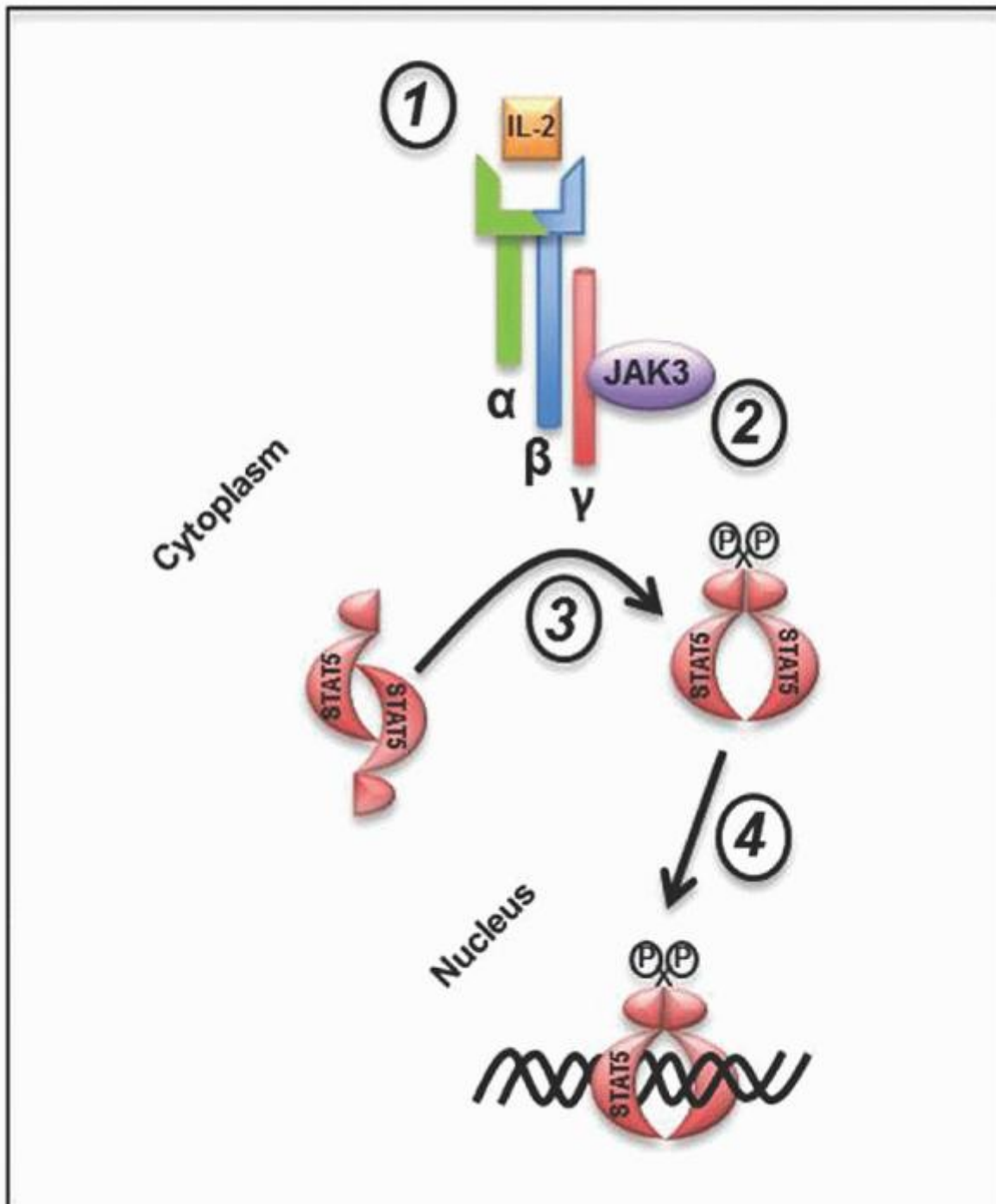

FIGURE 63.2. Interleukin-2 signaling. Under resting circumstances, the transcription factor STAT5 is present in the cytoplasm in a nonphosphorylated state. Upon binding of IL-2 to its receptor made up of α , β , and γ chains (1), the common γ chain is phosphorylated on tyrosine by the receptor-associated JAK3 kinase (2). STAT5 then binds to the phosphotyrosine residues on the receptor via its Src-homology 2 (SH2) domains, where it is also phosphorylated on key tyrosine residues by JAK3 (3). After undergoing a conformational change, the phosphorylated STAT5 dimer localizes to the nucleus where it binds DNA and mediates gene transcription. Mutations in the common IL-2 receptor γ chain or in JAK3 cause severe combined immunodeficiency (SCID).

Patients who have null mutations of any of these proteins have a clear $T^{\text{neg}}B^{\text{neg}}NK^+$ cell phenotype. There are, however, many mutations, particularly missense mutations or small inframe deletions that allow expression of a partially functional protein that can occasionally productively recombine a TCR or Ig gene locus. The cell in which this occurs is then able to

pass the developmental block and proliferate in an attempt to fill the lymphopenic void that is otherwise present in SCID. These forms of SCID are termed “leaky” because they allow a small number of T- (and occasionally B-) cells to “leak” past the developmental block. Omenn syndrome, originally described in leaky RAG1 or RAG2 mutants, is a clinical phenotype that results from this leaky form of SCID. Affected infants typically develop a desquamative erythroderma after birth that is associated with the presence of oligoclonal, activated T cells in the skin, hepatosplenomegaly, lymphadenopathy, eosinophilia, and elevated IgE. Some develop autoimmune enteropathy and cytopenias. Affected patients are typically treated with T-cell-directed immunosuppression such as cyclosporine or FK506, followed by bone marrow transplantation. Leaky forms of SCID have now been described in a number of SCID-associated molecular defects including RAG1, RAG2, Artemis, ligase IV, IL7RA, IL2RG, RMRP, and others.⁸¹

Adenosine Deaminase and Purine Nucleotide Phosphorylase Deficient Severe Combined Immune Deficiency

Adenosine deaminase (ADA) deficiency was the first molecularly defined immunodeficiency with discovery of patients with SCID who lacked the enzymatic activity of ADA in the peripheral blood in the early 1970s. ADA catalyzes the conversion of adenosine triphosphate (ATP), guanosine triphosphate (GTP), and their deoxy counterparts to adenosine diphosphate (ADP) and guanosinediphosphate (GDP). When enzyme activity is impaired or absent, intracellular levels of deoxy-ATP (dATP) rise to interfere with ribonucleotide reductase, such that DNA synthesis and repair are slowed and lymphocyte apoptosis is increased. Purine nucleotide phosphorylase (PNP) works farther down this same metabolic pathway to convert deoxyinosine to hypoxanthine. Mutations interfering with this function cause deoxy-GTP accumulation and the inhibition of ribonucleotide reductase and DNA synthesis. In both cases, affected infants typically have a T^{neg}B^{neg}NK^{neg/low} cellular phenotype due to the toxic nature of the accumulated metabolites on lymphocyte development. Patients typically present with severe or recurrent viral infections or recurrent sinopulmonary infections in the first year of life.

Both syndromes are associated with other, nonimmune symptoms including skeletal abnormalities and osseochondrosis dysplasia in ADA deficiency and neurologic deficits, developmental delay, and spasticity, in PNP deficiency. In both cases, the diagnosis can be made by detecting high levels of the toxic metabolites that build up in the peripheral blood in the absence of enzymatic activity. Sequencing of the ADA1 or PNP genes can be done to confirm the diagnosis. ADA deficiency accounts for 20% or more of autosomal-recessive SCID cases.

Aside from bone marrow transplantation, ADA deficient infants can be treated with polyethylene glycol-conjugated ADA, which is injected intramuscularly once per week. Treatment efficacy is gauged by measuring plasma ADA activity and red cell dATP levels. Enzyme treatment has the advantage of speed of response coupled with safety.^{82, 83} The treatment is very expensive and many treated patients develop antibodies to the bovine protein that may neutralize the effect of the enzyme. HSCT is effective in ADA deficiency but less so in PNP deficiency as it does not correct the neurologic deficits. Gene therapy for ADA deficiency has been quite successful and unlike X-linked SCID and WAS, there have been no reported cases of leukemia despite the retroviral gene therapy vector backbone being similar.⁸⁴

Zap-70 Deficient Severe Combined Immune Deficiency

Zap-70 is a tyrosine kinase that is downstream of CD3 in the T-cell receptor signaling pathway. Absence of functional enzyme results in a characteristic SCID phenotype with decreased CD4⁺ T cells but virtually absent CD8⁺ T cells. Immunoglobulin levels are often decreased and antibody responses to vaccination are typically absent because of the lack of effective T-cell help. The CD4⁺ T cells that are present do not respond to antigen or mitogen stimulation that utilizes the T-cell receptor but they do proliferate and make cytokines in response to phorbol and ionomycin stimulation, which mimics TCR stimulation by activating kinases and calcium flux through downstream mechanisms. Bone marrow transplantation is effective in this disorder.

Defects in Antigen Presentation by MHC I or MHC II

The class II MHC complex generally presents peptide antigen derived from ingested material (either by phagocytosis or via the B-cell antigen receptor). Defects that interfere with the assembly or cell-surface expression of the Class II MHC-peptide complex prevent effective antigen recognition by CD4⁺ T cells, resulting in a SCID syndrome that presents in infancy with chronic diarrhea, failure to thrive, and occasionally with autoimmune cytopenias. MHC II deficiency can result from defects in one of four

P.1353

DNA-binding proteins that regulate transcription of the MHC class II gene (CIITA, RFXANK, RFX5, and RFXAP). Founder mutations (particularly in RFXANK) that are common in the Mediterranean region have led to most affected patients

having some familial ties to this geographical area. Because MHC class II presentation of antigen is abnormal, CD4⁺ T-cell counts are often low whereas CD8 counts are normal. A rapid preliminary diagnosis can be made by evaluating peripheral blood cells for expression of the class II complex by flow cytometry, which will detect reduced expression. Some patients can have a mild disease course and can live well into adulthood with only supportive care although others with the same mutation (even in the same family) may have a more severe phenotype. Bone marrow transplantation for MHC II deficiency has been challenging with survival rates typically approaching approximately 50%. In addition, there is a high rate of severe graft-versus-host disease (GvHD) in these patients, possibly because thymic epithelial cells that play a role in positive and negative T-cell selection are not replaced by transplant and still do not express MHC II.⁸⁵

The class I MHC complex presents peptide antigens derived from intracellular proteins where proteolytically derived peptides are bound to the MHC I complex as it is generated and trafficked through the endoplasmic reticulum. Peptides that are generated in the cytosol are transported into the inner lumen of the endoplasmic reticulum by the peptide transporters TAP1 and TAP2. Mutations in either of these, or of Tapsin to which they bind, have been identified. TAP mutations are typically associated with recurrent viral infections, and recurrent sinusitis and bronchitis. The diagnosis is usually suspected when serologic typing for HLA Class I antigens fails to give interpretable results, but molecular typing indicates intact MHC DNA. CD8⁺ T-cell and NK-cell counts are frequently (but not uniformly) decreased in these patients. Other cell subsets are typically normal. Heterogeneity in the phenotype may reflect differences in the underlying mutation and in the gene affected. Some patients may survive into the third decade. The role of HSCT in MHC I deficiency is unclear.

Treatment of Severe Combined Immunodeficiency Syndromes

SCID was uniformly lethal in the first years of life until Good and colleagues successfully reconstituted an affected infant with a transplant of sibling bone marrow. Experience in subsequent years has shown that patients with B-cell-positive SCID (IL2RG, JAK3, IL7RA, etc.) readily reconstitute their T-cell deficiency but may not develop significant B-cell chimerism. The reasons for this are not entirely understood but various hypotheses have been put forward. From a practical standpoint, a lack of donor B-cell engraftment may lead to a chronic need for IgG replacement therapy even after transplant inasmuch as patients may not be able to mount sufficient antibody responses. Patients with B-cell-negative SCID are more likely to have successful donor engraftment of both T- and B-cell lineages and are more likely to recover full humoral immune function.

One of the most significant challenges in the treatment of SCID is that in the absence of a family history, most patients come to attention because of infections. These are most commonly PJP and severe viral infections (see above). PJP can be treated but may lead to lung damage, whereas the viral infections may or may not be controllable. In addition, many SCID infants have significant diarrhea and weight loss by the time they reach a transplant center. Together, these complications increase the risk of adverse outcomes during transplantation for SCID and have been the major impetus for adding SCID to state newborn screening panels. Initial management prior to transplant involves aggressive supportive care, antimicrobials to treat any intercurrent infections (bacterial, viral, and fungal), antimicrobial prophylaxis to prevent future infections, and IgG replacement therapy.

There is significant debate about the best pretransplant conditioning regimen for patients with SCID to balance safety and efficacy. In general, those patients that have a matched sibling donor receive no conditioning prior to receiving unmanipulated bone marrow. For other patients, a variety of conditioning regimens ranging from no conditioning to fully myeloablative regimens have been tried. Similarly, a range of manipulated and unmanipulated stem cell sources have been tried including matched bone marrow, matched peripheral blood, cord blood, and haploidentical. Last, a variety of prophylactic immunosuppressive regimens have been used in the early posttransplant period to limit GvHD and prevent graft rejection. Each option has advantages and disadvantages, which has led to the spectrum of transplant regimens that have been attempted for SCID. Current efforts are underway to assess which regimens offer the best outcomes and lowest risk.^{86, 87, 88, 89}

Cartilage-Hair Hypoplasia

Cartilage-hair hypoplasia (CHH) is a complex disorder characterized by skeletal dysplasia with short limbs (metaphyseal chondrodysplasia), sparse hypoplastic hair, gastrointestinal problems, and a variable immunodeficiency. CHH is caused by mutations in the RMRP gene, which encodes the 267 base-pair RNA component of the RNase MRP complex that plays a role in processing of precursor ribosomal RNA. The mechanism by which autosomal recessive mutations in RMRP cause the clinical features of CHH is unknown. The largest populations of CHH patients have been identified among the Old Order Amish and Finnish populations. Virtually all patients with CHH have some degree of immunodeficiency that can range from a mild humoral defect with decreased vaccine responses to a SCID-like phenotype associated with progressive lymphopenia and severe infections with bacteria, viruses, and fungi. A leaky-SCID phenotype has also been described in

RMRP deficiency. The diagnosis of CHH can be made based on the clinical phenotype and confirmed by sequencing of the RMRP gene. The immunologic features of CHH can be corrected by HSCT but the other features persist.⁹⁰

Immune Dysregulation, Polyendocrinopathy, Enteropathy, X-linked Syndrome

Immune dysregulation, polyendocrinopathy, enteropathy, X-linked (IPEX) is a syndrome of regulatory T-cell deficiency. Natural regulatory T cells comprise a subset of CD4⁺ T cells that regulate immune responses and play a critical role in peripheral immune tolerance. IPEX syndrome is caused by mutations in the FOXP3 gene located on the X chromosome that encodes a key transcription factor that is required for the generation of functional regulatory T cells (Treg). In the absence of FOXP3, patients present with severe, early-onset, systemic autoimmunity that is the result of having decreased Treg cell function. Almost all patients with IPEX syndrome present with enteropathy within the first 6 months of life. The enteropathy is typically characterized by profuse watery diarrhea (often nonbloody) and villus atrophy. The majority of patients have an eczematous dermatitis that typically begins in the first months of life. An early onset endocrinopathy that is almost exclusively either thyroiditis or Type I diabetes is also developed by 60% to 70% of patients. The most consistent laboratory abnormality among patients is a significantly elevated serum IgE level. In addition to these characteristic clinical and lab features, patients also have a high incidence of other severe autoimmune disorders including: hemolytic anemia, thrombocytopenia, neutropenia, hepatitis, renal disease, and others.

Recognition of the clinical features of IPEX syndrome is the first step in diagnosing this disorder. Sequencing of the FOXP3 gene remains the gold standard for making a diagnosis of IPEX syndrome although sequencing needs to encompass noncoding

P.1354

areas of the gene including the upstream noncoding exon and the polyadenylation signal sequence in order to cover all regions in which pathogenic mutations have been identified.^{91, 92} Flow cytometry to measure FOXP3 protein expression and FOXP3⁺ Treg is a helpful adjunct to gene sequencing although only ~25% of patients have mutations that are predicted to abrogate FOXP3 protein expression completely. The remainder of patients have varying degrees of FOXP3⁺ Treg deficiency due to the fact that mutant FOXP3 may not support normal Treg development. As a result, flow cytometry by itself is not considered to be a sufficiently reliable screening test for IPEX syndrome.

Initial therapy for IPEX syndrome typically consists of aggressive supportive care (parenteral nutrition, insulin, thyroid hormone, etc.) combined with T-cell-directed immune suppression using agents such as tacrolimus, cyclosporine, or rapamycin. HSCT is currently the only curative therapy for IPEX syndrome. Early HSCT using a nonmyeloablative conditioning regimen prior to the onset of autoimmune-mediated organ damage usually leads to the best outcome and limits the adverse effects of therapy.^{93, 94} Because Tregs constitutively express the high-affinity IL-2 receptor, they have a selective growth advantage in vivo. As a result, complete donor engraftment in all hematopoietic lineages may not be necessary because preferential engraftment of donor Treg cells can be sufficient to control the disease.⁹⁵

OTHER COMPLEX OR COMBINED IMMUNODEFICIENCY DISORDERS

Wiskott-Aldrich Syndrome

Wiskott-Aldrich syndrome (WAS) is unique among immunodeficiency disorders because affected patients have both an infectious susceptibility and a bleeding disorder. The bleeding problems are caused by the platelets being small (mean platelet volume <5 fl), dysfunctional, and decreased in number (usually platelet counts <70,000/ μ l). Patients with WAS typically present in infancy with bloody diarrhea and/or bruising, recurrent upper respiratory tract infections, and eczema. The incidence of hematopoietic malignancies is high. IgE levels are often elevated. Serum IgG levels and T-cell counts are often normal in infancy but may decrease over time. Responses to vaccination, particularly with carbohydrate antigens such as Pneumovax are often abnormal.

WAS is caused by mutations in the WAS gene that is located on the short arm of the X chromosome. Inheritance is X-linked recessive. There is a distinct genotype/phenotype correlation of mutations in WAS: Mutations that destroy WAS protein (WASp) expression lead to the full syndrome of immunodeficiency and platelet dysfunction. Mutations that allow expression of a mutant WASp protein are typically associated with a milder X-linked thrombocytopenia (XLT) phenotype in which the platelet dysfunction persists but the immunodeficiency is very mild. Point mutations in the CDC42 binding domain of the WASp protein lead to a third phenotype of X-linked neutropenia (XLN) that is generally not accompanied by bleeding abnormalities.^{96, 97}

The WASp protein is expressed primarily in lymphoid and myeloid cells where it functions to nucleate actin polymerization in the cell. Patients with WAS therefore have problems with directed migration of neutrophils and with clustering and

signaling through T-cell and B-cell antigen receptors (this causes decreased signaling into the cell and abnormal proliferative responses). A diagnosis of WAS can be confirmed by demonstrating the absence of WASp protein in cells by flow cytometry or western blotting, or by identifying a mutation in the WAS gene.

Treatment of WAS initially involves supportive care including treatment of any acute infections and management of any bleeding episodes. In general, repeated platelet transfusions are avoided because of the concern that patients will become sensitized to a wide array of HLA types, which may increase the risk of complications during subsequent HSCT. Splenectomy can increase platelet counts, however, it also increases the risk that patients may die of sepsis with encapsulated organisms so there continues to be significant controversy surrounding the role of splenectomy in WAS. Patients with the full WAS phenotype should be evaluated for HSCT with matched related or unrelated donor bone marrow or cord blood.⁹⁸ Haploidentical transplants have proven risky in this disease and therefore are generally avoided. The role of HSCT in XLT remains controversial.⁹⁹ Some have advocated that the benefits for curing the bleeding problems are worth the risk if a matched sibling donor is available. Gene therapy has been successful in a small number of patients with WAS but as in the X-SCID gene therapy trials, some treated patients developed T-cell leukemias as a result of integration of the viral gene therapy vector near an oncogene.¹⁰⁰

Radiation Sensitive Disorders: Ataxia Telangiectasia and Nijmegen Breakage Syndrome

Ataxia telangiectasia (AT) is a disorder associated with progressive neurologic decline, immunodeficiency, and propensity to malignancy. It is caused by autosomal recessive mutations in the ATM gene that encodes a serine/threonine kinase that acts together with the NBS1 protein as one of the major sensors of double-stranded DNA breaks in the cell. ATM phosphorylates key proteins involved in the activation of the DNA damage repair checkpoint, leads to cell-cycle arrest, and then double-stranded DNA break repair. In the absence of functional ATM or NBS1, cells have a marked sensitivity to ionizing radiation. Because rearrangement of the TCR gene and the immunoglobulin gene loci also require double-stranded DNA break repair, these processes may be affected as well.

Patients with AT usually present in early childhood (most commonly between 2 and 5 years of age) with cerebellar ataxia that progresses to unsteady gait and over time, to choreoathetosis. Telangiectasias (small tufts of dilated blood vessels under the surface of the skin or mucus membranes) typically develop first on the conjunctivae and later are seen on the nose, ears, and shoulders. They can be an important diagnostic clue in a child with progressive ataxia. The majority of patients have immunoglobulin deficiency of varying degrees and can develop sinopulmonary symptoms and sepsis. The progressive neurodegeneration can compromise coughing, thus it is hard to determine whether respiratory infections occur more as a result of the immunodeficiency or the motor defects. Most affected individuals have elevated serum α -fetoprotein levels, which can be useful diagnostically. Malignancies are an important complication as a result of the DNA-repair defect. Acute T-cell leukemias are common and often demonstrate chromosomal translocations that affect the chromosomal regions involved in T-cell receptor gene rearrangements. B-cell lymphomas also occur and are usually associated with 11q22-23 chromosomal deletions. There is also an increase in the frequency of epithelial tumors in both homozygotes and ATM mutation carriers. Affected patients usually die in the second or third decade of life.

Other DNA repair defects that cause varying degrees of ataxia and/or mild mental retardation include an ataxialike syndrome caused by mutations in MRE11 and the Nijmegen breakage syndrome (NBS), caused by mutations in NBS1. In addition to an immunodeficiency like that observed in AT, patients with NBS have marked microcephaly, mild developmental delay/mental

P.1355

retardation, and a strong propensity to develop lymphomas. Another DNA repair defect, Bloom syndrome, caused by mutations in a DNA helicase (RecQ proteinlike-3), results in excess sister chromatid exchanges; it is associated principally with lymphomas and cancer. Multiple primary tumors occurring at an early age are common. Reduced growth in childhood results in a proportional dwarfism that, with cutaneous telangiectasias, is a useful physical sign. Inheritance is autosomal recessive, and the disease occurs with increased frequency in Ashkenazi Jewish populations. Chronic lung disease occurs and may be related to the low levels of IgA and IgM.¹⁰¹

Mammalian Susceptibility to Mycobacterial Disease

Under normal circumstances, intracellular pathogens such as mycobacteria induce production of IL-12 and IL-23 that play a role in driving maturation of naive T cells into activated T helper type 1 (Th1) cells that produce interferon- γ (IFN- γ). IFN- γ then acts on a variety of cells including phagocytes (neutrophils, monocytes, and dendritic cells) to induce a number of interferon-inducible genes. Multiple molecules in this signaling pathway have been found to be defective in patients with intact cellular immunity who have invasive, nontuberculous mycobacterial infections. Mutations in the genes encoding the

IL12 p40 subunit (IL12B), the IL-12 receptor β 1 chain (IL12RB1), the TYK2 tyrosine kinase that is associated with the IL-12 receptor and required for phosphorylation of the STAT4 transcription factor (TYK2), the IFN- γ receptor subunits (IFNGR1&IFNGR2), and the STAT1 transcription factor that is activated in response to IFN- γ (STAT1), and the mutations in this pathway are also associated with other infections including invasive salmonellosis and severe viral infections (STAT1). In addition to these genetic defects, patients with invasive mycobacterial disease have now been identified with neutralizing autoantibodies to IFN- γ . Together these discoveries demonstrate a major role for the IL-12/IL-23/IFN- γ axis in normal human immunity.¹⁰² For patients with the milder, autosomal dominant IFN- γ receptor defects, IL-12 p40 defects, IL-12 receptor defects, and TYK2 defects, antimicrobial therapy and IFN- γ treatment are often sufficient to treat invasive mycobacterial infections and to prevent future infections. For patients with the more severe, autosomal recessive IFN- γ receptor defects, IFN- γ supplementation provides no benefit and HSCT is warranted.^{103, 104}

Susceptibility to Hemophagocytic Lymphohistiocytosis and Severe Epstein-Barr Virus Infection

Several defects affecting intracellular trafficking of vesicles and granules are associated with susceptibility to hemophagocytic lymphohistiocytosis (HLH). This group includes some phenotypes that are quite distinctive including Chédiak-Higashi (CHS) and Griscelli (GS) syndromes, which are both associated with a partial oculocutaneous albinism. Patients with CHS have pyogenic infections and periodontitis; their neutrophils have reduced chemotaxis and contain giant inclusion bodies (lysosomes). Patients with GS also have neurologic defects ranging from developmental delay to fatal neurodegeneration. Their neutrophils are dysfunctional, but they lack the giant granules of CHS. In vitro tests show low natural killer cell and cytotoxic cell function. CHS, GS, and X-linked lymphoproliferative syndrome (XLP) share susceptibility for HLH, an accelerated inflammatory process that in the case of XLP may be triggered by EBV. The genes responsible for these syndromes are LYST, RAB27A, SH2D1A, and XIAP/BIRC4, respectively, whereas genes for a further group of proteins (Perforin, Munc 13-D, and Syntaxin 11) are associated with familial hemophagocytic lymphohistiocytosis.¹⁰⁵

Toll-like Receptors and Innate Signaling Pathway Defects

The Toll-like receptors are a family of at least 10 pattern recognition receptors that are expressed in varying combinations on a broad array of immune and nonimmune cells. They recognize particular types (patterns) of molecules derived from pathogens (e.g., bacterial lipopolysaccharide, flagellin, mannan, CpG dinucleotides, viral dsDNA, etc.). Triggering of Toll-like receptors activates intracellular signaling pathways, many of which converge on a common pathway utilizing the IRAK proteins and MyD88, which in turn activate the I κ B kinase complex (NEMO/I κ K α /I κ K β), ultimately leading to phosphorylation and degradation of I κ B α and activation of the NF- κ B transcription factor complex.

Mutations in TLR signaling pathways have now been associated with major infectious susceptibilities: mutations in IRAK4 and MyD88 have been identified in patients with susceptibility to invasive pyogenic bacterial infections including particularly *S. pneumoniae*, *Staphylococcus aureus*, and *Pseudomonas aeruginosa*. Interestingly, patients with IRAK4 or MyD88 deficiency tend to have problems with invasive pyogenic bacterial infections in childhood but these subside over time, presumably as a result of the adaptive immune response covering for this innate defect. Mutations in TLR3, TRIF, TRAF3, and UNC-93B have been identified in patients with susceptibility to herpesvirus encephalitis. Defects in NEMO and I κ B α also cause susceptibility to infections with pyogenic bacteria and mycobacteria and are associated with an anhydrotic ectodermal dysplasia phenotype. The severity of immunodeficiency and ectodermal dysplasia is quite variable and depends on the specific mutation that is present.¹⁰⁶

Chronic Mucocutaneous Candidiasis Syndromes

Chronic mucocutaneous candidiasis (CMC) is a clinical syndrome associated with chronic and recurrent candidal infections of mucosae, particularly oral and vaginal, together with nailbed infections but generally without systemic infection. CMC can occur in isolation or as part of a broader clinical syndrome such as in APECED (autoimmune polyendocrinopathy, candidiasis, ectodermal dystrophy). Recent discoveries have determined that in almost all cases, CMC is associated with abnormalities in development of Th17 effector T cells or with the production of, or responses to, the cytokine IL-17. These include autosomal recessive mutations in IL-17F or the IL-17 receptor α -subunit, dominant loss-of-function mutations in STAT3, and dominant gain-of-function mutations in STAT1.¹⁰⁷

Recently, the CMC associated with APECED was found to be the result of autoantibodies to IL-17 and IL-22.^{108, 109} APECED is caused by mutations in AIRE1, a nuclear protein that regulates the expression of self-antigens by thymic medullary epithelial cells where it plays a role in T-cell selection and maturation. Other features of this disorder include endocrinopathies (hypoparathyroidism, adrenal insufficiency, and diabetes), alopecia areata, nail dystrophy, and vitiligo.

Autoimmune Lymphoproliferative Syndrome

The clinical phenotype of autoimmune lymphoproliferative syndrome (ALPS) is characterized by massive lymphadenopathy and hepatosplenomegaly in most cases. In addition, patients have problems with recurrent episodes of autoimmune hemolytic

P.1356

anemia and thrombocytopenia. The defects that have been identified in patients with this group of disorders are all associated with abnormalities in lymphocyte apoptosis. These include FAS (CD95), Fas ligand (FASL), FADD, caspase 10 (CASP10), NRAS, and KRAS. Peripheral blood T- and B-cell counts are generally normal, but in almost all cases, there is an increased percentage of $\alpha\beta$ -TCR⁺ double-negative T cells that lack expression of both CD4 and CD8. A predisposition to developing lymphoid malignancies has been described in ALPS but is thought to be primarily in those patients who have mutations in the death domain of FAS. In addition to elevated double-negative T cells, patients with ALPS frequently have elevated levels of IL-10 and vitamin B12 in the blood, which can be valuable diagnostically in patients with suspected ALPS. Patients with mutations in caspase 8 (CASP8), were previously classified as ALPS but are now considered to have a unique syndrome that may include lymphadenopathy and splenomegaly, but recurrent respiratory tract infections and mucocutaneous herpesvirus infections are prominent, both unusual features in ALPS.^{110, 111}

TABLE 63.3 SUGGESTED LAB TESTS FOR BASIC EVALUATION OF EACH COMPARTMENT OF THE IMMUNE SYSTEM

Complement	Phagocytes	B Cells/Antibodies	T Cells
Numbers:	Numbers:	Numbers:	Numbers:
<ul style="list-style-type: none"> Plasma levels of specific complement components (C1 esterase inhibitor, C2, C3, C4, etc.) 	<ul style="list-style-type: none"> CBC with differential: Are neutrophil counts normal? 	<ul style="list-style-type: none"> CBC with differential: Are lymphocyte counts normal? Lymphocyte subsets: Are T-, B-, and NK-cell counts normal? 	<ul style="list-style-type: none"> CBC with differential: Are lymphocyte counts normal? Lymphocyte subsets: Are T-, B-, and NK-cell counts normal?
Function:	Function:	Function:	Function:
<ul style="list-style-type: none"> CH50—functional test for classical pathway AH50—functional test for alternative pathway 	<ul style="list-style-type: none"> Expression of the CD11b/CD18 integrin on leukocytes Neutrophil oxidative burst test: dihydrorhodamine 123 (DHR) or Nitroblue tetrazolium (NBT) 	<ul style="list-style-type: none"> Vaccine titers: protein antigens (tetanus or diphtheria titers, etc.) Vaccine titers: carbohydrate antigens (Pneumococcal titers) 	<ul style="list-style-type: none"> T-cell proliferation to mitogens/antigens Vaccine titers: protein antigens (tetanus or diphtheria titers, etc.)

Note: The laboratory evaluation for immunodeficiency should be individualized to each patient's clinical presentation.

A variety of immunosuppressive therapies have been tried in ALPS to control the recurrent autoimmune cytopenias and severe hepatosplenomegaly. Most of these were only modestly successful as was splenectomy. Recent studies have, however, demonstrated a dramatic response to rapamycin therapy in many patients with ALPS, often causing shrinkage of the lymph nodes and spleen back to their normal size.^{112, 113}

BASIC LABORATORY WORK-UP FOR IMMUNE DEFICIENCY

A basic laboratory work-up to screen for significant defects in each of the four major compartments of the immune system can be done by most practitioners prior to making a referral to a clinical immunologist for further detailed

evaluation. In simple terms, this work-up should include evaluation of numbers and function for each of the four immune system compartments. A recommended work-up using this approach is outlined in Table 63.3.

USEFUL WEB SITES

www.primaryimmune.org

www.info4pi.org

www.nlm.nih.gov/medlineplus/immunesystemanddisorders.html

www.genome.gov/13014325

REFERENCES

1. Notarangelo L, Casanova JL, Conley ME, et al. Primary immunodeficiency diseases: an update from the International Union of Immunological Societies Primary Immunodeficiency Diseases Classification Committee Meeting in Budapest, 2005. *J Allergy Clin Immunol* 2006;117:883-896.
2. Cossu F. Genetics of SCID. *Ital J Pediatr* 2010;36:76.
3. Leiva LE, Zelazco M, Oleastro M, et al. Primary immunodeficiency diseases in Latin America: the second report of the LAGID registry. *J Clin Immunol* 2007;27:101-108.
4. Frank MM. Complement deficiencies. *Pediatr Clin North Am* 2000;47:1339-1354.
5. Hofer J, Janecke AR, Zimmerhackl LB, et al. Complement factor h-related protein 1 deficiency and factor h antibodies in pediatric patients with atypical hemolytic uremic syndrome. *Clin J Am Soc Nephrol* 2013;8:407-415.
6. Joseph C, Gattineni J. Complement disorders and hemolytic uremic syndrome. *Curr Opin Pediatr* 2013;25:209-215.
7. Westra D, Vernon KA, Volokhina EB, et al. Atypical hemolytic uremic syndrome and genetic aberrations in the complement factor H-related 5 gene. *J Hum Genet* 2012;57:459-464.
8. Kawalec P, Holko P, Paszulewicz A, et al. Administration of conestat alfa, human C1 esterase inhibitor and icatibant in the treatment of acute angioedema attacks in adults with hereditary angioedema due to C1 esterase inhibitor deficiency. Treatment comparison based on systematic review results. *Pneumonol Alergol Pol* 2013;81:95-104.
9. Patel NS, Fung SM, Zanichelli A, et al. Ecallantide for treatment of acute attacks of acquired C1 esterase inhibitor deficiency. *Allergy Asthma Proc* 2013;34:72-77.
10. Cole SW, Lundquist LM. Icatibant for the treatment of hereditary angioedema. *Ann Pharmacother* 2013;47:49-55.
11. Walport MJ, Davies KA, Morley BJ, et al. Complement deficiency and autoimmunity. *Ann N Y Acad Sci* 1997;815:267-281.
12. Boztug K, Klein C. Genetic etiologies of severe congenital neutropenia. *Curr Opin Pediatr* 2011;23:21-26.
13. Hanna S, Etzioni A. Leukocyte adhesion deficiencies. *Ann N Y Acad Sci* 2012;1250:50-55.
14. Farinha NJ, Duval M, Wagner E, et al. Unrelated bone marrow transplantation for leukocyte adhesion deficiency. *Bone Marrow Transplant* 2002;30:979-981.
15. Thomas C, Le Deist F, Cavazzana-Calvo M, et al. Results of allogeneic bone marrow transplantation in patients with leukocyte adhesion deficiency. *Blood* 1995;86:1629-1635.
16. Le Deist F, Blanche S, Keable H, et al. Successful HLA nonidentical bone marrow transplantation in three patients with the leukocyte adhesion deficiency. *Blood* 1989;74:512-516.
17. Gulino AV, Moratto D, Sozzani S, et al. Altered leukocyte response to CXCL12 in patients with warts hypogammaglobulinemia, infections, myelokathexis (WHIM) syndrome. *Blood* 2004;104:444-452.
18. Dotta L, Tassone L, Badolato R. Clinical and genetic features of Warts, Hypogammaglobulinemia, Infections and Myelokathexis (WHIM) syndrome. *Curr Mol Med* 2011;11:317-325.
19. McDermott DH, Liu Q, Ulrick J, et al. The CXCR4 antagonist plerixafor corrects panleukopenia in patients with WHIM syndrome. *Blood* 2011;118: 4957-4962.
20. Dale DC, Bolyard AA, Kelley ML, et al. The CXCR4 antagonist plerixafor is a potential therapy for myelokathexis, WHIM syndrome. *Blood* 2011;118: 4963-4966.

21. Krivan G, Erdos M, Kallay K, et al. Successful umbilical cord blood stem cell transplantation in a child with WHIM syndrome. *Eur J Haematol* 2010;84:274-275.
22. Segal BH, Leto TL, Gallin JI, et al. Genetic, biochemical, and clinical features of chronic granulomatous disease. *Medicine (Baltimore)* 2000;79:170-200.
23. Kuhns DB, Alvord WG, Heller T, et al. Residual NADPH oxidase and survival in chronic granulomatous disease. *N Engl J Med* 2010;363:2600-2610.
24. Seger RA. Hematopoietic stem cell transplantation for chronic granulomatous disease. *Immunol Allergy Clin North Am* 2010;30:195-208.
25. Boxer LA. How to approach neutropenia. *Hematol Am Soc Hematol Educ Program* 2012;2012:174-182.
26. Jirapongsananuruk O, Malech HL, Kuhns DB, et al. Diagnostic paradigm for evaluation of male patients with chronic granulomatous disease, based on the dihydrorhodamine 123 assay. *J Allergy Clin Immunol* 2003;111:374-379.
27. Vowells SJ, Sekhsaria S, Malech HL, et al. Flow cytometric analysis of the granulocyte respiratory burst: a comparison study of fluorescent probes. *J Immunol Methods* 1995;178:89-97.
28. Kang HJ, Bartholomae CC, Paruzynski A, et al. Retroviral gene therapy for X-linked chronic granulomatous disease: results from phase I/II trial. *Mol Ther* 2011;19:2092-2101.
29. Bauer TR Jr, Hickstein DD. Gene therapy for leukocyte adhesion deficiency. *Curr Opin Mol Ther* 2000;2:383-388.
30. Hussain A, Yu L, Faryal R, et al. TEC family kinases in health and disease-loss-of-function of BTK and ITK and the gain-of-function fusions ITK-SYK and BTK-SYK. *FEBS J* 2011;278:2001-2010.
31. Dua J, Elliot E, Bright P, et al. Pyoderma gangrenosum-like ulcer caused by *Helicobacter cinaedi* in a patient with X-linked agammaglobulinemia. *Clin Exp Dermatol* 2012;37:642-645.
32. Cuccherini B, Chua K, Gill V, et al. Bacteremia and skin/bone infections in two patients with X-linked agammaglobulinemia caused by an unusual organism related to *Flexispira/Helicobacter* species. *Clin Immunol* 2000;97:121-129.
33. Turvey SE, Leo SH, Boos A, et al. Successful approach to treatment of *Helicobacter bilis* infection in X-linked agammaglobulinemia. *J Clin Immunol* 2012;32:1404-1408.
34. Kainulainen L, Nikoskelainen J, Vuorinen T, et al. Viruses and bacteria in bronchial samples from patients with primary hypogammaglobulinemia. *Am J Respir Crit Care Med* 1999;159:1199-204.
35. Katamura K, Hattori H, Kunishima T, et al. Non-progressive viral myelitis in X-linked agammaglobulinemia. *Brain Dev* 2002;24:109-111.
36. Misbah SA, Spickett GP, Ryba PC, et al. Chronic enteroviral meningoencephalitis in agammaglobulinemia: case report and literature review. *J Clin Immunol* 1992;12:266-270.
37. Quan PL, Wagner TA, Briese T, et al. Astrovirus encephalitis in boy with X-linked agammaglobulinemia. *Emerg Infect Dis* 2010;16:918-925.
38. Lee WI, Torgerson TR, Schumacher MJ, et al. Molecular analysis of a large cohort of patients with the hyper immunoglobulin M (IgM) syndrome. *Blood* 2005;105:1881-1890.
39. Cabral-Marques O, Schimke LF, Pereira PV, et al. Expanding the clinical and genetic spectrum of human CD40L deficiency: the occurrence of paracoccidioidomycosis and other unusual infections in Brazilian patients. *J Clin Immunol* 2012;32:212-220.
40. Rodrigues F, Davies EG, Harrison P, et al. Liver disease in children with primary immunodeficiencies. *J Pediatr* 2004;145:333-339.
41. Jo EK, Kim HS, Lee MY, et al. X-linked hyper-IgM syndrome associated with *Cryptosporidium parvum* and *Cryptococcus neoformans* infections: the first case with molecular diagnosis in Korea. *J Korean Med Sci* 2002;17:116-120.
42. Isam H, Al-Wahadneh A. Successful Bone Marrow Transplantation in a Child with X-Linked Hyper-IgM Syndrome. *Saudi J Kidney Dis Transpl* 2004;15:489-493.
43. Duplantier JE, Seyama K, Day NK, et al. Immunologic reconstitution following bone marrow transplantation for X-linked hyper IgM syndrome. *Clin Immunol* 2001;98:313-318.

44. Ferrari S, Giliani S, Insalaco A, et al. Mutations of CD40 gene cause an autosomal recessive form of immunodeficiency with hyper IgM. *Proc Natl Acad Sci U S A* 2001;98:12614-12619.
45. Imai K, Slupphaug G, Lee WI, et al. Human uracil-DNA glycosylase deficiency associated with profoundly impaired immunoglobulin class-switch recombination. *Nat Immunol* 2003;4:1023-1028.
46. Revy P, Muto T, Levy Y, et al. Activation-induced cytidine deaminase (AID) deficiency causes the autosomal recessive form of the Hyper-IgM syndrome (HIGM2). *Cell* 2000;102:565-575.
47. Resnick ES, Moshier EL, Godbold JH, et al. Morbidity and mortality in common variable immune deficiency over 4 decades. *Blood* 2012;119: 1650-1657.
48. Bates CA, Ellison MC, Lynch DA, et al. Granulomatous-lymphocytic lung disease shortens survival in common variable immunodeficiency. *J Allergy Clin Immunol* 2004;114:415-421.
49. Chase NM, Verbsky JW, Hintermeyer MK, et al. Use of combination chemotherapy for treatment of granulomatous and lymphocytic interstitial lung disease (GLILD) in patients with common variable immunodeficiency (CVID). *J Clin Immunol* 2013;33:30-39.

P.1357

50. Podjasek JC, Abraham RS. Autoimmune cytopenias in common variable immunodeficiency. *Front Immunol* 2012;3:189.
51. Warnatz K, Voll RE. Pathogenesis of autoimmunity in common variable immunodeficiency. *Front Immunol* 2012;3:210.
52. van de Ven AA, Compeer EB, van Montfrans JM, et al. B-cell defects in common variable immunodeficiency: BCR signaling, protein clustering and hardwired gene mutations. *Crit Rev Immunol* 2011;31:85-98.
53. Orange JS, Glessner JT, Resnick E, et al. Genome-wide association identifies diverse causes of common variable immunodeficiency. *J Allergy Clin Immunol* 2011;127:1360-1367 e6.
54. Arumugakani G, Wood PM, Carter CR. Frequency of Treg cells is reduced in CVID patients with autoimmunity and splenomegaly and is associated with expanded CD21lo B lymphocytes. *J Clin Immunol* 2010;30:292-300.
55. Melo KM, Carvalho KI, Bruno FR, et al. A decreased frequency of regulatory T cells in patients with common variable immunodeficiency. *PLoS One* 2009;4:e6269.
56. Genre J, Errante PR, Kokron CM, et al. Reduced frequency of CD4(+) CD25(HIGH)FOXP3(+) cells and diminished FOXP3 expression in patients with Common Variable Immunodeficiency: a link to autoimmunity? *Clin Immunol* 2009;132:215-221.
57. Yu GP, Chiang D, Song SJ, et al. Regulatory T cell dysfunction in subjects with common variable immunodeficiency complicated by autoimmune disease. *Clin Immunol* 2009;131:240-253.
58. Fevang B, Yndestad A, Sandberg WJ, et al. Low numbers of regulatory T cells in common variable immunodeficiency: association with chronic inflammation in vivo. *Clin Exp Immunol* 2007;147:521-525.
59. Lilic D, Sewell WA. IgA deficiency: what we should-or should not-be doing. *J Clin Pathol* 2001;54:337-338.
60. Bukowska-Strakova K, Kowalczyk D, Baran J, et al. The B-cell compartment in the peripheral blood of children with different types of primary humoral immunodeficiency. *Pediatr Res* 2009;66:28-34.
61. de Greef JC, Wang J, Balog J, et al. Mutations in ZBTB24 are associated with immunodeficiency, centromeric instability, and facial anomalies syndrome type 2. *Am J Hum Genet* 2011;88:796-804.
62. Moarefi AH, Chedin F. ICF syndrome mutations cause a broad spectrum of biochemical defects in DNMT3B-mediated de novo DNA methylation. *J Mol Biol* 2011;409:758-772.
63. Orange JS, Ballou M, Stiehm ER, et al. Use and interpretation of diagnostic vaccination in primary immunodeficiency: a working group report of the Basic and Clinical Immunology Interest Section of the American Academy of Allergy, Asthma & Immunology. *J Allergy Clin Immunol* 2012;130:S1-S24.
64. Wehr C, Kivioja T, Schmitt C, et al. The EUROclass trial: defining subgroups in common variable immunodeficiency. *Blood* 2008;111:77-85.

65. Orange JS, Grossman WJ, Navickis RJ, et al. Impact of trough IgG on pneumonia incidence in primary immunodeficiency: a meta-analysis of clinical studies. *Clin Immunol* 2010;137:21-30.
66. Pierce LR, Jain N. Risks associated with the use of intravenous immunoglobulin. *Transfus Med Rev* 2003;17:241-251.
67. Bassett AS, McDonald-McGinn DM, Devriendt K, et al. Practical guidelines for managing patients with 22q11.2 deletion syndrome. *J Pediatr* 2011;159:332-339 e1.
68. McDonald-McGinn DM, Sullivan KE. Chromosome 22q11.2 deletion syndrome (DiGeorge syndrome/velocardiofacial syndrome). *Medicine (Baltimore)* 2011;90:1-18.
69. Tomita-Mitchell A, Mahnke DK, Larson JM, et al. Multiplexed quantitative real-time PCR to detect 22q11.2 deletion in patients with congenital heart disease. *Physiol Genomics* 2010;42A:52-60.
70. Ciupe SM, Devlin BH, Markert ML, et al. The dynamics of T-cell receptor repertoire diversity following thymus transplantation for DiGeorge anomaly. *PLoS Comput Biol* 2009;5:e1000396.
71. Markert ML, Devlin BH, Chinn IK, et al. Thymus transplantation in complete DiGeorge anomaly. *Immunol Res* 2009;44:61-70.
72. Matsumoto T, Amamoto N, Kondoh T, et al. Complete-type DiGeorge syndrome treated by bone marrow transplantation. *Bone Marrow Transplant* 1998;22:927-930.
73. Goldsobel AB, Haas A, Stiehm ER. Bone marrow transplantation in DiGeorge syndrome. *J Pediatr* 1987;111:40-44.
74. Puck JM. Laboratory technology for population-based screening for severe combined immunodeficiency in neonates: the winner is T-cell receptor excision circles. *J Allergy Clin Immunol* 2012;129:607-616.
75. Verbsky J, Thakar M, Routes J. The Wisconsin approach to newborn screening for severe combined immunodeficiency. *J Allergy Clin Immunol* 2012;129:622-627.
76. Yamada K, Tsukahara T, Yoshino K, et al. Identification of a high incidence region for retroviral vector integration near exon 1 of the LMO2 locus. *Retrovirology* 2009;6:79.
77. Rans TS, England R. The evolution of gene therapy in X-linked severe combined immunodeficiency. *Ann Allergy Asthma Immunol* 2009;102:357-362; quiz 63-5, 402.
78. Hacein-Bey-Abina S, Von Kalle C, Schmidt M, et al. LMO2-associated clonal T cell proliferation in two patients after gene therapy for SCID-X1. *Science* 2003;302:415-419.
79. O'Shea JJ, Husa M, Li D, et al. Jak3 and the pathogenesis of severe combined immunodeficiency. *Mol Immunol* 2004;41:727-737.
80. Roberts JL, Lengi A, Brown SM, et al. Janus kinase 3 (JAK3) deficiency: clinical, immunologic, and molecular analyses of 10 patients and outcomes of stem cell transplantation. *Blood* 2004;103:2009-2018.
81. Villa A, Notarangelo LD, Roifman CM. Omenn syndrome: inflammation in leaky severe combined immunodeficiency. *J Allergy Clin Immunol* 2008;122:1082-1086.
82. Booth C, Gaspar HB. Pegademase bovine (PEG-ADA) for the treatment of infants and children with severe combined immunodeficiency (SCID). *Biologics* 2009;3:349-358.
83. Lee CR, McKenzie CA, Webster KD, et al. Pegademase bovine: replacement therapy for severe combined immunodeficiency disease. *DICP* 1991;25:1092-1095.
84. Gaspar HB. Gene therapy for ADA-SCID: defining the factors for successful outcome. *Blood* 2012;120:3628-3629.
85. Nekrep N, Fontes JD, Geyer M, et al. When the lymphocyte loses its clothes. *Immunity* 2003;18:453-457.
86. Teigland CL, Parrott RE, Buckley RH. Long-term outcome of non-ablative booster BMT in patients with SCID. *Bone Marrow Transplant* 2013. Advance online publication Feb 11, 2013; doi:10.1038/bmt.2013.6.
87. Buckley RH, Win CM, Moser BK, et al. Post-transplantation B cell function in different molecular types of SCID. *J Clin Immunol* 2013;33:96-110.
88. Grunebaum E, Roifman CM. Bone marrow transplantation using HLA-matched unrelated donors for patients suffering from severe combined immunodeficiency. *Hematol Oncol Clin North Am* 2011;25:63-73.
89. Roifman CM, Grunebaum E, Dalal I, et al. Matched unrelated bone marrow transplant for severe combined immunodeficiency. *Immunol Res* 2007;38:191-200.

90. Guggenheim R, Somech R, Grunebaum E, et al. Bone marrow transplantation for cartilage-hair-hypoplasia. *Bone Marrow Transplant* 2006;38:751-756.
91. d'Hennezel E, Bin Dhuban K, Torgerson T, et al. The immunogenetics of immune dysregulation, polyendocrinopathy, enteropathy, X linked (IPEX) syndrome. *J Med Genet* 2012;49:291-302.
92. Torgerson TR, Ochs HD. Immune dysregulation, polyendocrinopathy, enteropathy, X-linked: forkhead box protein 3 mutations and lack of regulatory T cells. *J Allergy Clin Immunol* 2007;120:744-750; quiz 51-2.
93. Lucas KG, Ungar D, Comito M, et al. Submyeloablative cord blood transplantation corrects clinical defects seen in IPEX syndrome. *Bone Marrow Transplant* 2007;39:55-56.
94. Rao A, Kamani N, Filipovich A, et al. Successful bone marrow transplantation for IPEX syndrome after reduced-intensity conditioning. *Blood* 2007;109:383-385.
95. Seidel MG, Fritsch G, Lion T, et al. Selective engraftment of donor CD4+25high FOXP3-positive T cells in IPEX syndrome after nonmyeloablative hematopoietic stem cell transplantation. *Blood* 2009;113:5689-5691.
96. Ariga T. Wiskott-Aldrich syndrome; an x-linked primary immunodeficiency disease with unique and characteristic features. *Allergol Int* 2012;61: 183-189.
97. Cleland SY, Siegel RM. Wiskott-Aldrich syndrome at the nexus of autoimmune and primary immunodeficiency diseases. *FEBS Lett* 2011;585:3710-3714.
98. Moratto D, Giliani S, Bonfim C, et al. Long-term outcome and lineage-specific chimerism in 194 patients with Wiskott-Aldrich syndrome treated by hematopoietic cell transplantation in the period 1980-2009: an international collaborative study. *Blood* 2011;118:1675-1684.
99. Albert MH, Bittner TC, Nonoyama S, et al. X-linked thrombocytopenia (XLT) due to WAS mutations: clinical characteristics, long-term outcome, and treatment options. *Blood* 2010;115:3231-3238.
100. Boztug K, Schmidt M, Schwarzer A, et al. Stem-cell gene therapy for the Wiskott-Aldrich syndrome. *N Engl J Med* 2010;363:1918-1927.
101. de Miranda NF, Bjorkman A, Pan-Hammarstrom Q. DNA repair: the link between primary immunodeficiency and cancer. *Ann N Y Acad Sci* 2011;1246:50-63.
102. Al-Muhsen S, Casanova JL. The genetic heterogeneity of mendelian susceptibility to mycobacterial diseases. *J Allergy Clin Immunol* 2008;122: 1043-1051; quiz 52-3.
103. Moilanen P, Korppi M, Hovi L, et al. Successful hematopoietic stem cell transplantation from an unrelated donor in a child with interferon gamma receptor deficiency. *Pediatr Infect Dis J* 2009;28:658-660.
104. Chantrain CF, Bruwier A, Brichard B, et al. Successful hematopoietic stem cell transplantation in a child with active disseminated *Mycobacterium fortuitum* infection and interferon-gamma receptor 1 deficiency. *Bone Marrow Transplant* 2006;38:75-76.
105. Filipovich AH. The expanding spectrum of hemophagocytic lymphohistiocytosis. *Curr Opin Allergy Clin Immunol* 2011;11:512-516.
106. Casanova JL, Abel L, Quintana-Murci L. Human TLRs and IL-1Rs in host defense: natural insights from evolutionary, epidemiological, and clinical genetics. *Annu Rev Immunol* 2011;29:447-491.
107. Puel A, Cypowyj S, Marodi L, et al. Inborn errors of human IL-17 immunity underlie chronic mucocutaneous candidiasis. *Curr Opin Allergy Clin Immunol* 2012;12:616-622.
108. Kisand K, Lilic D, Casanova JL, et al. Mucocutaneous candidiasis and auto-immunity against cytokines in APECED and thymoma patients: clinical and pathogenetic implications. *Eur J Immunol* 2011;41:1517-1527.
109. Puel A, Doffinger R, Natividad A, et al. Autoantibodies against IL-17A, IL-17F, and IL-22 in patients with chronic mucocutaneous candidiasis and autoimmune polyendocrine syndrome type I. *J Exp Med* 2010;207:291-297.
110. Oliveira JB, Bleesing JJ, Dianzani U, et al. Revised diagnostic criteria and classification for the autoimmune lymphoproliferative syndrome (ALPS): report from the 2009 NIH International Workshop. *Blood* 2010;116:e35-e40.
111. Oliveira JB, Gupta S. Disorders of apoptosis: mechanisms for autoimmunity in primary immunodeficiency diseases. *J Clin Immunol* 2008;28 Suppl 1:S20-S28.

112. Teachey DT. Autoimmune lymphoproliferative syndrome: new approaches to diagnosis and management. *Clin Adv Hematol Oncol* 2011;9:233-235.

113. Teachey DT, Greiner R, Seif A, et al. Treatment with sirolimus results in complete responses in patients with autoimmune lymphoproliferative syndrome. *Br J Haematol* 2009;145:101-106.

Chapter 64 Acquired Immunodeficiency Syndrome

> Table of Contents > Part VI - Benign Disorders of Leukocytes, The Spleen, and/or Immunoglobins > Chapter 64 - Acquired Immunodeficiency Syndrome

Chapter 64

Acquired Immunodeficiency Syndrome

Ariela Noy

Roy M. Gulick

HUMAN IMMUNODEFICIENCY VIRUS INFECTION AND ACQUIRED IMMUNODEFICIENCY SYNDROME

Human immunodeficiency virus (HIV) infection is a true pandemic, an infection that affects individuals in every country of the world.¹ A diagnosis of acquired immunodeficiency syndrome (AIDS) is made when a person with HIV infection progresses to develop severe immunodeficiency as demonstrated by a CD4 lymphocyte count of less than 200/ μ l or the development of specific AIDS-associated diseases.² The first cases of AIDS were described in 1981 in five young gay men in Los Angeles.³ Since the beginning of the HIV pandemic, an estimated 70 million people worldwide acquired HIV infection and over half of them died.¹ Currently, an estimated 34 million people are living with HIV infection, with over two thirds of them living in sub-Saharan Africa. There are an estimated 1.1 million people currently living with HIV infection in the United States.⁴ The development of effective antiretroviral treatment in 1996 changed the natural history and clinical course of HIV infection dramatically, with remarkable decreases in HIV-associated illnesses and deaths.⁵ In parallel, many of the hematologic complications of HIV infection also occur much less commonly today. Cytopenias due to HIV disease or its treatment occurred frequently in the past, but now are uncommon. Coagulation abnormalities occur occasionally. Hematologic malignancies remain an important challenge, even in the setting of effective HIV treatment. This chapter discusses HIV infection and the diagnosis and management of associated hematologic complications. A complete discussion of antiretroviral therapy and opportunistic diseases can be found elsewhere.^{6, 7, 8}

Background

HIV-1 was discovered by two independent groups in 1983 to 1984.⁹ A related virus, HIV-2, was discovered in 1986, but remains localized to Western Africa and countries with historic ties to Western African countries.¹⁰ HIV is transmitted most commonly worldwide by sexual contact and also by intravenous drug use, transfusion of infected blood or blood products, and perinatally from an infected mother to her child. HIV may be transmitted by infected blood, blood products, bloody fluids, or genital secretions, but not by saliva, sweat, urine, other nonbloody fluids, or feces. In the absence of HIV treatment, the time from initial HIV infection to the development of severe immunodeficiency and AIDS is approximately 10 years.¹¹ The U.S. Centers for Disease Control and Prevention define AIDS in individuals who are HIV-1 antibody positive with a CD4 cell count <200/ μ L (regardless of symptoms) or have one of ~25 AIDS-defining illnesses, including opportunistic infections and malignancies.² Effective antiretroviral therapy changes the natural history of the disease and prevents HIV disease progression and prolongs survival.

Pathophysiology

HIV-1 is a retrovirus with a genome that contains the structural genes gag, pol, and env that code for viral core proteins that control viral replication (e.g., HIV reverse transcriptase, HIV integrase, and HIV protease), as well as the envelope glycoproteins, gp 160, 120, and 41.¹² Additional regulatory genes, rev and tat, code for viral-specific proteins that control viral transcription and processing of viral messenger RNA. Other viral genes mediate infectivity and interactions with the host cell (nef, vif, vpr, vpu).

HIV entry is the first step in HIV-1 infection and consists of three substeps: CD4 receptor binding, co-receptor binding, and membrane fusion.¹³ In the first substep, the viral outer membrane glycoprotein, gp120, binds to the CD4 receptor on the surface of the target cell. Cells that express CD4 receptors include the CD4 lymphocyte, macrophages, and dendritic cells. Following binding of gp120 to the CD4 receptor, gp120 undergoes a conformational change and allows binding to a second co-receptor, the chemokine receptor, either CCR5 or CXCR4.¹⁴ Individuals who lack the gene that codes for the

CCR5 receptor are relatively resistant to HIV infection; individuals who are heterozygotes for this gene demonstrate a slower progression of HIV disease.¹⁵ Following binding to the co-receptor, gp120 undergoes a second conformational change that allows a second HIV membrane glycoprotein, gp41, to bind and attach to the cell surface and then allows the viral membrane to fuse with the host cell membrane.

After HIV entry, the contents of the viral particle, including viral RNA and viral proteins, are extruded into the cytoplasm of the target cell. Viral RNA is transcribed to complementary viral DNA by the viral specific enzyme, HIV reverse transcriptase. The viral DNA forms a double-stranded complex that migrates to the nucleus of the cell where the viral-specific protein HIV integrase inserts the viral DNA randomly into the host cell genome. An HIV-infected CD4 lymphocyte may enter a latency period that can extend to 70 years, constituting a long-lived viral reservoir.¹⁶ The latently infected cell may be activated, and then genomic DNA along with incorporated viral DNA is transcribed to viral RNA that is translated to viral proteins, including gag and pol gene products that assemble at the surface of the cell and then bud off into new viral particles. Post-budding, precursor viral proteins are cleaved by another viral-specific enzyme, HIV protease, in a step that is required for viral maturation and infectiousness.¹⁷ A single latently infected cell can produce hundreds to thousands of virions. When enough viral particles have budded off from an infected cell, the membrane becomes compromised and cell death occurs.

The characteristic decrease in CD4 lymphocytes over the course of untreated HIV disease occurs from a combination of increased apoptosis and decreased lymphopoiesis, although this is not completely understood.¹⁸ An estimated one million latently infected CD4 lymphocytes exist in an HIV-infected individual with controlled infection on antiretroviral therapy.¹⁹ Although the relative number of latently infected CD4 cells is small, apoptosis may occur in uninfected CD4 cells. Untreated HIV infection also was recognized early on to be associated with immune activation, CD8 cell dysfunction, B-cell dysfunction and impaired antibody production and general immune dysregulation.^{20, 21}

Diagnosis

The U.S. Centers for Disease Control currently recommend routine HIV testing for all individuals aged 13 to 64, not based on risk.²² Standard HIV testing detects HIV-1 antibody by using a screening test, a repeatedly positive enzyme-linked immunosorbent assay (ELISA), followed by a confirmatory test, a Western blot that demonstrates at least two among three major HIV-1-specific bands: p24, gp41, and gp120/160.²³ False-positive ELISA may occur because of the low specificity of the test. False-negative HIV antibody tests can occur due to the window period (4 to 6 weeks), the

P.1359

time between viral infection and the development of the detectable antibody response.

Newer rapid tests use a technology similar to the ELISA to detect HIV antibody in blood or oral fluids and results are available within 20 minutes. Although the rapid test is very specific (>99%) with a high positive predictive value (≥90%), a positive rapid test must be confirmed by a conventional confirmatory Western blot.²⁴ Some rapid tests are now CLIA-waived and may be performed in nonhealth care settings (e.g., street fairs, mobile vans or even self-administered at home) allowing more widespread testing.

Another method of HIV testing detects the virus directly, either the viral p24 antigen or HIV RNA, and reduces the window period: p24 antigen testing was added to the standard HIV antibody ELISA test, the so-called 4th generation ELISA test, to detect HIV infections earlier.²⁵ Nucleic-acid-based testing has been used both in individual cases and in blood bank screening programs.²⁶ Using these newer tests along with pre-transfusion screening, the risk of acquiring HIV infection through a blood transfusion in the United States is less than 1 per 1.5 million units transfused and is decreasing.²⁷

Clinical Features of Hiv-1 Infection

Acute HIV infection can present as a nonspecific illness characterized by fever, oral ulcers, and maculopapular rash²⁸; however, at least 50% of newly infected individuals may be completely asymptomatic. The clinical illness will subside over several weeks and then the patient enters an asymptomatic phase, often with nonspecific generalized lymphadenopathy, that may last years as the CD4 lymphocyte count gradually declines over time. HIV-related diseases occurring at higher CD4 counts (>300/ μ L) include those caused by more aggressive pathogens (e.g., tuberculosis, herpes zoster, and pneumococcal pneumonia) as well as Kaposi's sarcoma. As the CD4 cell count declines below 300, other HIV-related illnesses also occur, including oral hairy leukoplakia, oral thrush, and seborrheic dermatitis. As the CD4 cell count declines below 200, the case definition of AIDS is met and AIDS-defining illnesses may also occur including *Pneumocystis jirovecii* (formerly *carinii*) pneumonia, central nervous system (CNS) toxoplasmosis, and cryptococcal meningitis. Multiple opportunistic illnesses can occur simultaneously in a single patient.

Hematologic disorders such as leucopenia, anemia, immune and thrombotic thrombocytopenia, bone marrow failure, coagulation disorders including thrombosis, and malignancies all occurred commonly in HIV-infected individuals.^{29, 30} Some of these complications were due to viremia and immune dysregulation, and others were due to toxicity from HIV therapies.³¹ With the development of effective antiretroviral therapy, hematologic disorders and HIV-associated malignancies have decreased markedly.³²

Treatment

In the 1980s and early 1990s, the average life expectancy of a patient with AIDS was less than 1 year. Today, it is estimated that an individual diagnosed with HIV infection and appropriately managed with antiretroviral treatment will live close to the average life expectancy of the general population.³³ Antiretroviral therapy changes the natural history of HIV infection by inhibiting viral replication. Currently, there are 27 U.S. Food and Drug Administration-approved unique drugs for the treatment of HIV infection; combination regimens with 3 or more drugs are standard treatment. Current U.S. HIV treatment guidelines recommend starting antiretroviral therapy in all HIV-infected individuals, regardless of symptoms, HIV viral load, or CD4 cell count.⁶ The life cycle of the virus and the specific sites targeted by antiretroviral therapy are shown in Figure 64.1.

The oldest mechanistic classes of drugs are the HIV reverse transcriptase inhibitors of two kinds, the nucleoside analogs and the nonnucleoside analogs. The nucleoside analogs mimic the structures of the four DNA bases and when bound to the active site and incorporated into the elongating viral DNA, result in chain termination: adenosine analogs, didanosine (ddI) and tenofovir (TDF); cytosine analogs, emtricitabine (FTC), lamivudine (3TC), zalcitabine (ddC); guanine analog, abacavir (ABC); and thymidine analogs, stavudine (d4T) and zidovudine (AZT, ZDV). The nonnucleoside analogs also inhibit the HIV reverse transcriptase enzyme, but do so by binding a site remote to the active site and include delavirdine (DLV), efavirenz (EFV), etravirine (ETR), nevirapine (NVP), and rilpivirine (RPV).

In the mid-1990s, the third antiretroviral drug class was approved, the HIV protease inhibitors that target a step late in the viral life cycle. Following budding of the viral particles from the infected cell, viral precursor proteins must be chemically cleaved by the viral-specific enzyme, HIV protease. These compounds were the most potent known against HIV and when used in combination regimens resulted in suppression of HIV RNA levels and dramatic decreases in morbidity and mortality.⁵ The 10 approved protease inhibitors bind in the active site of the protease and block this cleavage: amprenavir (APV) and its prodrug fosamprenavir (FPV), atazanavir (ATV), darunavir (DRV), indinavir (IDV), lopinavir (LPV), nelfinavir (NFV), ritonavir (RTV), saquinavir (SQV), and tipranavir (TPV).

The three newer mechanistic classes of approved HIV drugs are two different HIV entry inhibitors and the HIV integrase inhibitors. The approved chemokine receptor antagonist is maraviroc (MVC) that binds to the host cell CCR5 receptor and prevents viral binding. The approved HIV fusion inhibitor is a small peptide, enfuvirtide (ENF, T-20) that targets the viral glycoprotein gp41 and prevents fusion of the viral and cellular membranes; as a

P.1360

peptide it requires twice-daily subcutaneous dosing and is used uncommonly. Raltegravir (RAL) and elvitegravir (EVG) inhibits the viral-specific enzyme HIV integrase that inserts the viral DNA into the host cell DNA.

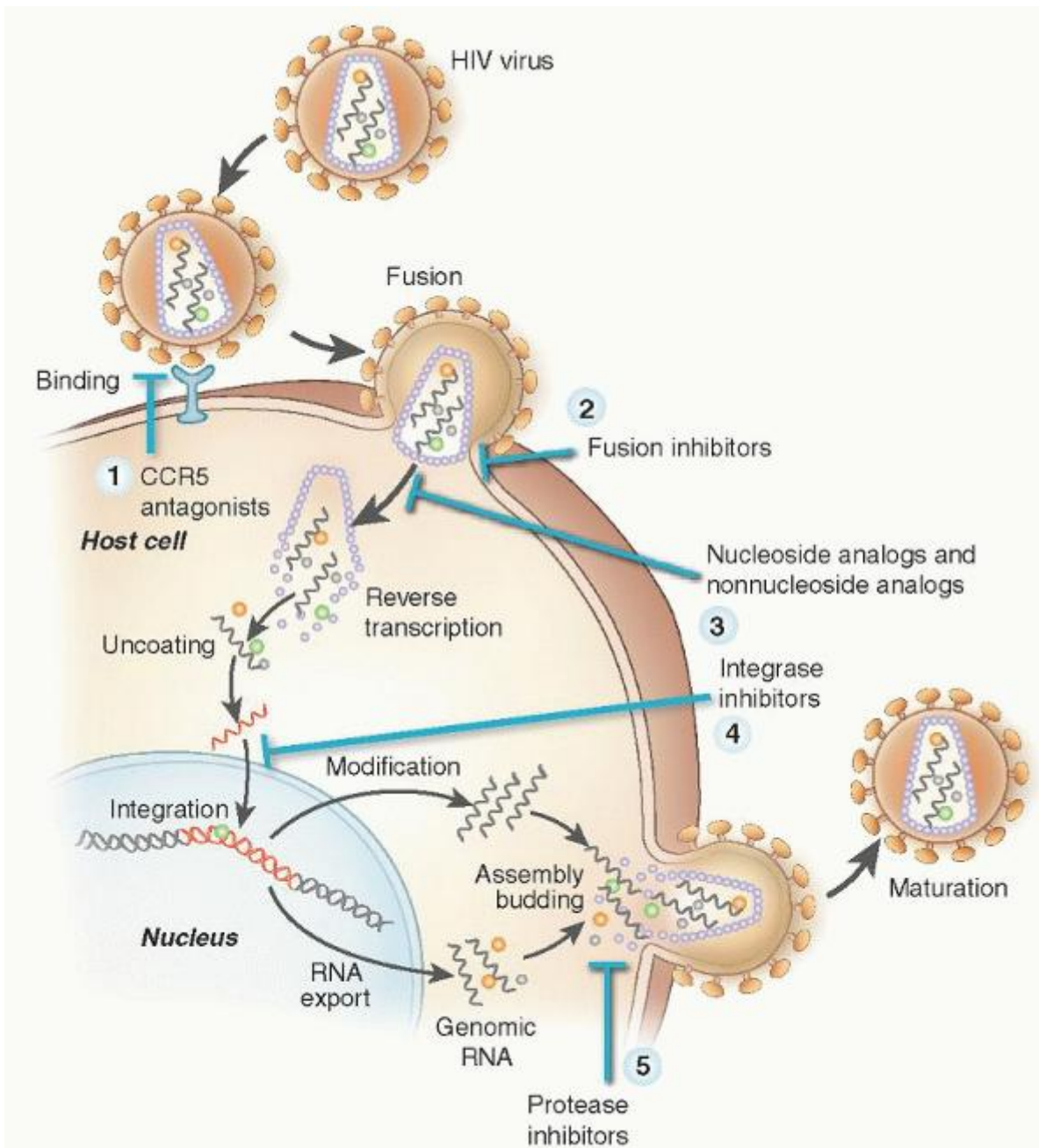

FIGURE 64.1. The human immunodeficiency virus (HIV) life cycle, deciphered with the help of genomic analyses, is unusually complex in its details, but all viruses undergo the same basic steps to infect cells and reproduce. Points at which antiretrovirals act are marked.

Current treatment guidelines recommend four preferred combination antiretroviral regimens on the basis of potency, tolerability, and convenience⁶: (1) tenofovir/emtricitabine/efavirenz (co-formulated as a single pill taken once daily); (2) tenofovir/emtricitabine (co-formulated) + atazanavir and ritonavir (given as a low-dose pharmacologic booster; 3 pills once daily); (3) tenofovir/emtricitabine (co-formulated) + darunavir and ritonavir (booster; 3 pills once daily); and (4) tenofovir/emtricitabine (co-formulated) + raltegravir (3 pills divided twice daily). The goal of current HIV treatment is maximal virologic suppression; current virologic suppression rates on initial therapy regimens approach 90%. CD4 cell counts typically increase 100/ μL over baseline in the first weeks or months following initiation of therapy and then continue to increase at a slower rate.³⁴ The reconstituted CD4 cells generally are of the memory type (CD45RO⁺ or CD34RA⁺), with naïve cells increasing more slowly; thymic function also improves. Immune reconstitution may result in IRIS, the immune-related inflammatory syndrome that is usually managed symptomatically.³⁵ Appropriate increases in CD4 cell counts allow discontinuation of opportunistic maintenance therapy and prophylaxes. Specific immune-based

therapies, including interleukin-2, have failed to demonstrate additional clinical benefits and are not recommended currently.³⁶

An HIV-infected individual who is stable taking antiretroviral therapy will typically see the treating physician every 3 to 6 months to check for side effects and monitor the HIV RNA and CD4 cell count.⁶ In the case of virologic failure, drug resistance testing is performed and a new regimen selected on the basis of treatment history, drug resistance testing results, and available drug options. The goal is to construct a regimen with 2 to 3 fully active drugs and this will result in resuppression of HIV RNA in the majority of patients. HIV therapy currently is lifelong. Treatment interruptions are associated with clinical events³⁷ and should be avoided.

Several ongoing challenges remain in the management of HIV disease. Despite suppression of virologic replication, some patients experience ongoing inflammation and immune activation and this has been linked to nontraditional HIV illnesses such as cardiac, hepatic, renal, neurologic, and non-AIDS malignancies. In addition, despite dramatic improvements in life expectancy, cure of HIV disease remains elusive. The unique case of a man with HIV disease virologically controlled on antiretroviral therapy who developed acute myelogenous leukemia necessitating totalbody irradiation, cytotoxic chemotherapy, and bone marrow transplant from a donor with a deletion in the gene coding for the CCR5-receptor who ultimately experienced a course complicated by rejection and a second transplant is thought to be the only patient cured successfully of HIV disease.³⁸ Cure, or complete eradication of HIV, remains challenging because of the long-lived latently infected CD4 cell reservoir; much current research is focused on this goal.³⁹

HEMATOLOGIC COMPLICATIONS OF HUMAN IMMUNODEFICIENCY VIRUS INFECTION

Anemia

Anemia is the most frequent cytopenia observed in HIV-1 infection. Striking anemia with transfusion dependence was common early in the epidemic when high doses of zidovudine (ZDV) were in use, but severe depression of hemoglobin levels are now rarely observed, except in patients with advanced disease.⁴⁰ In several large multicenter studies, persistent anemia was associated with shorter survival, independent of the degree of immunosuppression.^{41, 42}

As in other persons, anemia occurs due to one of three major factors: either ineffective hematopoiesis; blood loss due to involvement of the intestines by infection such as cytomegalovirus (CMV) or Kaposi's sarcoma; or red blood cell destruction.

Red blood cell production can be affected by HIV itself due to cytokines that interfere with hematopoiesis,^{43, 44, 45} highly active antiretroviral therapy (HAART) and medications used to treat HIV-associated infections (Table 64.1 including high-dose trimethoprim-sulfamethoxazole (TMP-SMX) for *P. carinii* pneumonia and ganciclovir for CMV), HIV-associated cancers such as lymphomatous infiltration of the marrow, low erythropoietin, or HIV-associated hypogonadism.⁴⁶

The Effect of HAART on Anemia

Nucleoside analogs other than ZDV are not associated with anemia. Zidovudine is commonly associated with marrow toxicity, particularly with long-term administration. Use of lower ZDV doses in combination with other nonmyelosuppressive antiviral drugs (such as the protease inhibitors or other nucleoside analogs) has significantly decreased the frequency of anemia, although patients with advanced disease on doses of ZDV of <500 mg/day still demonstrate significantly decreased hemoglobin levels when compared to similarly immunosuppressed HIV-infected patients not taking the drug.⁴⁷ Although the mechanism responsible for ZDV-associated anemia, inhibition of thymidine kinase, and DNA chain termination should theoretically also affect cells of other lineages, neutropenia is less frequent a toxicity and thrombocytopenia is very uncommon. In contradistinction to zidovudine, protease inhibitors, such as indinavir, ritonavir, crixivan, and nelfinavir, alone or in combination with ZDV or other nucleoside

P.1361

analog, have little or no effect on hematopoiesis.^{31, 48} It is important to note that HAART itself improves anemia as shown in a single center retrospective series in the HAART era. HAART was associated with hemoglobin levels >140 g/L in 42% of patients, irrespective of use of zidovudine as part of HAART regimen, compared with 31% of patients who did not use HAART.⁴⁹

TABLE 64.1 HEMATOLOGIC TOXICITIES OF ANTIRETROVIRAL DRUGS

Medication	Type of Activity	Hematologic Toxicity
Zidovudine	Nucleoside analogs,	Anemia, neutropenia (dose dependent)

	antiviral	
Stavudine	Nucleoside analogs, antiviral	Anemia, neutropenia (dose dependent)
Ganciclovir	Cytomegalovirus infection	Leukopenia, thrombocytopenia
Trimethoprim/sulfamethoxazole	Antibiotic, <i>Pneumocystis</i> pneumonia	Dose-related neutropenia, anemia; methemoglobinemia especially in persons with G6PD deficiency
Primaquine	Antibiotic, <i>Pneumocystis</i> pneumonia	Rare agranulocytosis, thrombocytopenia; methemoglobinemia especially in G6PD deficiency
Pentamidine	<i>Pneumocystis</i> pneumonia	Infrequent anemia, leukopenia, thrombocytopenia
Sulfadiazine	Toxoplasmosis	Leukopenia in 40%; thrombocytopenia in 12%
Clindamycin/pyrimethamine	Toxoplasmosis	Cytopenias in 31%
Amphotericin B	Antifungal, cryptococcal meningitis	Anemia

G6PD, glucose-6-phosphate dehydrogenase.

Treatable causes of anemia include nutritional/vitamin deficiency, gastrointestinal losses, parvovirus B19 infection,^{50, 51} HIV related kidney disease, and low erythropoietin levels independent of normal renal function. In HIV infection, erythropoietin levels are low in some patients, in part because tumor necrosis factor- α (TNF- α) acts to block erythropoietin release in response to low hemoglobin levels.⁵² Patients with low erythropoietin levels respond better to its administration than do patients with normal or elevated levels of the hormone. In one meta-analysis, patients with erythropoietin levels below 500 IU/L demonstrated significant increases in hemoglobin levels, decreases in transfusion requirements, and improvement in quality of life, whereas replacement was ineffective in patients with high erythropoietin levels.⁵³

Some patients with HIV infection have significant anemia, requiring frequent transfusion. Clinical and experimental evidence suggests transfusion may be associated with substantial morbidity in HIV-infected patients. In one study, transfused patients with advanced disease had an increased incidence of CMV infection and death.⁵⁴ Laboratory data suggest transfusion may be associated with HIV viral activation. Allogeneic lymphocytes present in transfused blood components activate viral production by HIV-infected lymphocytes in vitro.⁵⁵ When quantitative polymerase chain reaction (PCR) was used to measure circulating HIV, viral load was increased in HIV-infected patients 5 days after transfusion.⁵⁶ However when leuko-depleted blood components were used, no significant differences in viremia or infectious complications occurred.⁵⁷

Red Blood Cell Destruction

Red blood cells can be destroyed in the setting of HIV infection through a variety of mechanisms. This includes autoimmune disease,⁵⁸ hemophagocytic syndrome, disseminated intravascular coagulation typically seen with infection or cancer, sulfa use in the setting of G6PD deficiency, or thrombotic thrombocytopenic purpura (TTP) (dealt with separately below). Drugs can also cause hemolysis.

Parvovirus is a rare, but treatable cause of anemia. Parvovirus affects erythroid lineage cells. In immunocompetent patients this is a self-limited infection, but is serious in patients who cannot clear the infection, or have other hemolytic problems. For parvovirus infection, commercial immune globulin infusion (400 mg/kg/day for 5 to 10 days) is almost always associated with marked improvement in hemoglobin levels with resolution of anemia.^{51, 59} HIV-infected patients frequently develop repeated episodes of B19 infection and need repeated treatments with intravenous immune globulin.⁶⁰

Thrombocytopenia

Thrombocytopenia occurs in the setting of HIV infection due to decreased production, increased destruction, or splenic sequestration secondary to other causes such as lymphoma or hepatitis C. Although mild to moderate thrombocytopenia is common in patients with HIV, it is rarely associated with bleeding. Thrombocytopenia is generally associated with decreased platelet survival, except in patients with advanced disease where bone marrow failure is more prominent.⁶¹ Opportunistic infection, splenomegaly, and fever all decrease platelet survival.

Autoimmune thrombocytopenia (ITP) is a feature of HIV infection and is a diagnosis of exclusion. Notably, patients can present in advance of other symptoms of HIV. Consequently, HIV should be ruled out in new cases of ITP. CD4⁺ lymphocyte counts in reported series of patients with HIV-ITP have averaged between 0.3 and 0.6 × 10⁹/L.

Although platelet-associated antibodies increase in prevalence with HIV disease progression, it is not clear if they play a major role in most patients. Technical difficulties in detecting platelet-associated antibody have led to a very high false-positive rate.⁶² Furthermore, for any condition (including sepsis and TTP) associated with platelet injury, antibody can be detected on the platelet surface. Specific platelet-associated antibody has nonetheless been carefully characterized in a limited number of patients. One study demonstrated that platelet-associated immune complexes are made up of antiplatelet integrin, glycoprotein IIIa (β₃), antibody (Ab), and its anti-idiotypic blocking Ab.⁶³ Some of the antibodies also bound epitopes with homology to HIV-1 proteins nef, gag, env, and pol, suggesting molecular mimicry. The presence of this Ab was associated with thrombocytopenia and produced thrombocytopenia when infused into mice.⁶⁴ The associated platelet fragmentation was due to generation of the membrane-damaging peroxide and other reactive oxygen species. Antibodies to a cleavage product of talin, which can be generated by platelet activation or exposure to HIV-1 protease, have also been characterized. These may result from an immune response to talin-H, a neoantigen that may have been created by platelet fragmentation.⁶⁵

Defective megakaryocytopoiesis may also contribute to thrombocytopenia, particularly in patients with advanced disease. Megakaryocytes can be infected with certain strains of HIV, some of which can be cytopathic for the megakaryocytes.⁶⁶ In addition, megakaryocytes arising from HIV-1-infected CD34⁺ progenitor cells are defective in their ability to produce platelets.⁶⁷

Treatment

Generally, patients with modest thrombocytopenia (platelet count >50 × 10⁹/L) require no treatment. For others with clinically significant thrombocytopenia, short-term steroids produce rapid responses in 60% to 80% of patients. However, steroids are immunosuppressive and are associated with long-term infectious complications and can accelerate the development of Kaposi's sarcoma. HIV-specific antiretroviral therapy will result in improvements of platelet counts in most patients. Although most of the original work was done with ZDV, other antiretrovirals are effective. Both antiretroviral agents and steroids improve thrombocytopenia by increasing platelet production, without significantly affecting platelet survival.^{68, 69} Splenectomy will increase platelet counts in those not responding to antiretroviral therapy and does not appear to accelerate the underlying HIV disease.⁷⁰ Intravenous immune globulin also is effective but its high cost, limited availability, and short duration of action make this a less attractive treatment. Anti-Rh immune globulin has the advantages of wide availability and cheaper cost, but is also limited by its short duration of action⁷¹ and is associated with a mild hemolysis which can be clinically problematic in patients with pre-existing anemia, requiring transfusion prior to administration of anti-Rh immune globulin. Vincristine is effective when given monthly, although its administration is complicated by neuropathy. IL-11, a cytokine that promotes megakaryocyte maturation, is licensed for treatment of chemotherapy-related thrombocytopenia, but no studies have reported efficacy in HIV-infected patients. Rituximab is effective in some patients with idiopathic thrombocytopenic purpura (ITP) without HIV but has not been studied extensively in patients with HIV infection⁷² for this indication. Three newer treatments for ITP in the general population include the anti-B cell antibody rituximab, effective in 60% of patients, and the thrombopoietin mimetics, romiplostim and eltrombopag, each associated with a 60% to 85% response.⁷³ Remarkably, these drugs have not been systematically studied in HIV-associated ITP.

P.1362

Neutropenia

Mild neutropenia is relatively common in patients with HIV infection. Although generally not of clinical significance, a deficiency in bone marrow reserve may become clinically apparent when administration of cytotoxic chemotherapy or other marrowsuppressive drugs becomes necessary. In fact it is generally held that most cytotoxic chemotherapy requires prophylactic use of hematopoietic growth factors. Antineutrophil antibodies can frequently be seen,⁶² but their presence

does not correlate with the degree of neutropenia. Progenitor cell numbers are generally normal except in patients with advanced disease when they are modestly decreased.⁷⁴ Parenteral treatment with ganciclovir (GCV) or cytotoxic chemotherapy results in leukopenia in the majority of patients, frequently necessitating dose reduction and cytokine treatment.

Treatment

Neutropenic (absolute neutrophil count, $<1.0 \times 10^9/L$) HIV-positive patients may experience increased frequency of significant bacterial infections. In a case-controlled study, Tumbarello et al.⁷⁵ compared the neutrophil counts of groups of HIV-infected patients with and without bacteremia. An absolute neutrophil count of $<1.0 \times 10^9/L$ as present in 38% of bacteremic patients was compared with 19% of asymptomatic patients. A matched cohort study⁷⁶ found the frequency of bacteremia increased in neutropenic patients to 12.60 events per 100 patient months compared with 0.87 events per 100 patient months in the nonneutropenia controls. In another study of 1,645 patients with an absolute neutrophil count of $<0.5 \times 10^9/L$ the risk of Gramnegative infection increased eightfold.⁷⁷

A number of studies have looked at the effect of recombinant growth factors on the incidence of infection and number of hospitalizations. Granulocyte colony-stimulating factor (G-CSF) enhances the proliferation and differentiation of neutrophils and improves neutrophil function, whereas granulocyte-macrophage colony-stimulating factor (GM-CSF) stimulates the proliferation and differentiation of a variety of myeloid progenitor cells and inhibits migration of neutrophils, enhancing the function of mature neutrophils and macrophages.^{71, 78} G-CSF is the most widely used hematopoietic growth factor in HIV-infected patients, has fewer side effects, and increases the neutrophil count more rapidly. Although GM-CSF has been associated with an increase in HIV-1 replication in vitro, no consistent observation of acceleration of disease progression or increase in p24 antigen levels in patients receiving the drug has been demonstrated. G-CSF is primarily used to increase the tolerance of patients undergoing chemotherapy.

HIV-infected patients can also have a number of defects in neutrophil function. These include reduced L-selectin shedding and decreased H_2O_2 production⁷⁹ as well as defects in leukocyte migration, chemotaxis, and chemiluminescence during phagocytosis. These defects were more prominent in patients with advanced disease.⁸⁰ G-CSF and GM-CSF both improve leukocyte function in vitro. A number of studies have looked at potential benefits of these cytokines in animal models of immunosuppression. In a murine model of *Pneumocystis jiroveci* pneumonia, $CD4^+$ -depleted immunosuppressed mice that received G-CSF after experiential pulmonary infection with *P. jiroveci* demonstrated improved survival when compared with control mice receiving placebo. Similar benefits were demonstrated using mouse models of disseminated *Mycobacterium avium* infection, systemic candidiasis, and streptococcal pneumonia.⁸¹ No clinical study using either G-CSF or GM-CSF to enhance leukocyte function has been performed.

Lymphopenia

Increases in both $CD4$ and $CD8$ cell death and impairment in function are the sine qua non of HIV infection. IL-2 partially corrects the impaired lymphocyte proliferation and cytotoxicity seen in HIV infection in vitro. It also can partially block the enhanced tendency of lymphocytes obtained from HIV-infected patients to undergo programmed cell death (apoptosis).³⁸ In phase I trials of IL-2 in HIV-infected patients, it increased $CD4$ cell number and improved lymphocyte function.⁸² The development of a longacting polyethylene glycol-modified IL-2, which increases the half-life by 10- to 15-fold, allows for intermittent administration of the drug. Administration of doses of 1 to 5 million U/m², two to three times weekly, resulted in modest but sustained increases in $CD4$ counts and improvement in natural killer activity in a patient with $CD4$ counts $>0.4 \times 10^9/L$ ⁸³ in 3 to 6 months. Fever, rash, and capillary leak are the most common toxicities.⁸⁴ More recently, administration of very high doses of IL-2 (7.5 million IU twice daily to patients with early HIV infection) resulted in substantial increases in $CD4$ counts, compared with those seen in the group administered lower doses (1.5 million IU twice daily).⁸⁵ Of greater importance is the suggestion that intermittent administration of IL-2 in combination with HAART may lead to reduction in $CD4^+$ T-lymphocyte cells that contain replication-competent HIV.⁸⁶ None of these approaches is currently standard of care.

Thrombotic Thrombocytopenic Purpura

TTP is more common among patients with HIV infection. HIV-1 infection has been reported to account for up to 30% of TTP/hemolytic-uremic syndrome.⁸⁷ The risk of microangiopathy has declined significantly after institution of HAART for unclear reasons.⁸⁸ Although no controlled studies comparing HIV-related TTP with classic TTP have been conducted, HIV-related TTP is generally thought to be associated with a milder course and a better response to therapy than classic TTP.⁸⁹

A number of different possible pathophysiologic mechanisms have been proposed. HIV can infect endothelial cells, and viral p24 antigen has been detected by immunochemical stain in splenic endothelial cells, spinal cord specimens, and bone marrow microvascular endothelial cells.⁹⁰ Whether infection results in vascular dysfunction has not been clearly

demonstrated. TNF- α and IL-1 β , two cytokines that are increased in HIV infection, could potentially lead to increases in endothelial expression of certain adhesion molecules, such as vascular cell adhesion molecule-1, intercellular adhesion molecule, and E-selectin, promoting localization of inflammatory cells to the endothelium with transmigration of lymphocytes through the endothelial wall. CMV, a virus that appeared to be associated with TTP in one large AIDS Clinical Treatment Group drug study, increases procoagulant activity in cultures of endothelial cells, potentially by binding and activating coagulation factor X/Xa.⁹¹ Endothelial cells from small vessels undergo apoptosis when exposed to plasma from patients with TTP.^{91, 92, 93} Recently, severe ADAMTS13 (a disintegrinlike and metalloprotease with thrombospondin type 1 repeats) deficiency has been reported in TTP unassociated with HIV.⁹⁴

Treatment

Although the treatment of choice of TTP is plasmapheresis or plasma exchange, successes with antiplatelet agents, vincristine, splenectomy, and plasma infusion have been reported.⁹⁵ In one study of HIV-TTP, most patients undergoing plasma exchange in addition to other therapies achieved a complete response.⁸⁹ Others have reported significant responses in patients receiving plasma infusions alone.⁹⁶ Plasma exchange may allow infusion of greater amounts of plasma to the individual. However, the success of infusion alone has important implications for those in the developing world where plasma exchange is not available.⁹⁶ Plasma exchange is currently recommended to replace 35 to 40 ml/kg per exchange using the lactate dehydrogenase (LDH) values and platelet counts to follow the course of the disease. A

P.1363

platelet count above $50 \times 10^9/L$ and a normalized LDH are general aims of effective therapy. Platelets should not be transfused because doing so may lead to thrombotic events.

Pathophysiology of Bone Marrow Suppression in Human Immunodeficiency Virus Infection

Diverse factors responsible for impaired hematopoiesis in HIV infection include suppression of the bone marrow by the virus or by viral proteins, immune dysregulation, actual infection of the bone marrow progenitor cells by HIV, and alteration of stromal cell elements. A number of studies demonstrate that CD34 cells have both HIV receptors necessary for infection (i.e., CD4 and the chemokine receptors CXCR4 or CCR5).⁹⁷ Chemokines are cytokines that induce chemotaxis. CD4 expression, as well as CXCR4 and CCR5 co-receptor expression, increases with maturation of the CD34 cell, and the expression of each correlates with potential infectability.⁹⁸ In addition, CXCR5 may be up-regulated by a number of different cytokines. Although it is clear that the CD34 cell can be infected by HIV under a number of conditions, it appears that bone marrow progenitor cells do not represent a significant reservoir of infection.⁹⁹ In one study, HIV was detected in CD34 cells in only 14% of HIV-infected patients recruited in the United States and in 36% of HIV-infected persons in Zaire.¹⁰⁰ When found, CD34 infection was present in those patients with far-advanced disease. Many investigators could not detect HIV infection in any stem cells.^{101, 102} In another study, purified CD34⁺ cells were infected in vitro and cultured on allogeneic stroma for extended periods of time.¹⁰³ A highly sensitive PCR failed to detect HIV-1 in the most primitive long-term colony-initiating cells (i.e., the secondary colonies generated from clonogenic cells harvested from stroma). Thus, it appears that although some committed progenitor cells can be infected with HIV-1 under some circumstances, the most immature stem cells appear not to be susceptible to HIV-1 infection.

The effects of HIV-1 on colony formation have been studied, either using bone marrow cells derived from HIV-1-infected patients^{101, 104} or after in vitro infection of hematopoietic cells from bone marrow of normal donors.^{67, 101} Results have been surprisingly divergent. Although the growth potential of committed bone marrow progenitor cells in methylcellulose cultures after challenge with HIV-1 appears to be diminished, normal growth frequently has also been reported.¹⁰¹ Similar disparity exists in the results of studies performed with patient bone marrow. Such differences may be related to techniques in assaying colony growth (total bone marrow vs. purified CD34⁺ cells), culture conditions (use of specific cytokines or growth factors), or patient selection. In some reports, inhibition of colony formation by virus was only observed in cultures of total bone marrow cells and not with isolated CD34⁺ cells.¹⁰⁵ Of interest is one report of abnormal progenitor cell function in HIV-negative infants born to infected mothers,¹⁰⁶ implying that direct infection was not necessary for marrow suppression.

Marrow stromal function has been examined in patients with HIV infection. Stromal cells from some HIV-1-infected patients may be infected by the virus, demonstrating the importance of stromal infection in causing dysregulation of hematopoiesis. In one study,¹⁰⁷ decreased colony formation has been observed when stroma infected in vitro was used to support growth of normal uninfected bone marrow progenitor cells. In another study, stroma obtained from HIV-infected patients supported growth of normal CD34⁺ cells equally as well as stroma obtained from normal uninfected controls.⁷⁴

Although the stem cell compartment appears to be relatively well preserved early in the disease, in patients with low CD4 counts and history of OIs, there is a modest reduction of long-term colony-initiating cell numbers.⁷⁴ However, the long-term colony-initiating cell numbers were far better preserved in this population than in patients with aplastic anemia with similar blood counts, implying that OIs; pharmacotherapy with antiparasitic, antimicrobial, antiviral, or cytotoxic agents; vitamin deficiencies; or poorly understood virally mediated immunomodulatory changes were the major contributors to bone marrow failure in patients with advanced HIV disease.

Inconsistencies in the results of experiments attempting to demonstrate the role of direct infection of HIV-1 on hematopoiesis have stimulated further search for pathophysiologic mechanisms of bone marrow suppression. Several cytokines that are released during the course of HIV-1 infection are potent inhibitors of hematopoiesis. Not only native virus and productive infection,^{105, 108} but also viral products, such as gp120, gp160, and viral tat proteins, induce the secretion of an array of cytokines, including TNF- α , lymphotoxin- β (TNF- β), and IL-6.¹⁰⁹ Perhaps the most prominent cytokine implicated in an array of pathophysiologic reactions in AIDS is TNF- α (or cachexin).^{110, 111} In addition to its effect on body metabolism and the immune system, TNF- α has inhibitory effects on hematopoiesis.¹¹² High levels of interferon- γ (IFN- γ) were not only associated with a poor prognosis in HIV-1 infection, but also correlated with the degree of anemia.¹¹³ Although disordered cytokine production by both lymphoid tissue and bone marrow clearly occurs in HIV-1 infection, it is difficult to determine its ultimate role in suppression of hematopoiesis. Many inhibitory cytokines are produced in greatest quantities early in the course of HIV-1 infection when marrow suppression is least, and their levels decline as the disease progresses (when marrow suppression becomes most marked). In addition, increased levels of stimulatory cytokines have been observed in HIV-1 infection, and many cytokines never reach significant levels in the circulation. Local production of growth factors in bone marrow may be more important than systemically secreted factors. In support of this hypothesis, one study of genetically engineered stromal cells, designed to produce low levels of IFN- γ constitutively, showed significant suppression of normal hematopoietic colony growth on IFN- γ stroma, which could only be replicated by addition of large amounts of exogenous IFN- γ to marrow grown on normal stroma.

Apoptosis of hematopoietic progenitor cells through the Fas-L/Fas-R pathway is a mechanism by which activated T-cells can kill virus-infected cells.¹¹⁴ It is likely that Fas-L and other cytokine products of activated T-cells contribute to the hematopoietic inhibition seen in HIV-1 infection. Increased levels of Fas-L have been reported in patients with AIDS, and triggering of Fas-R on hematopoietic cells results in apoptosis.

Bone Marrow Examination in Human Immunodeficiency Virus 1 Infection

The majority of bone marrow samples from HIV-1-infected patients will exhibit morphologic abnormalities, but most are nonspecific except in OI, in which the bone marrow examination provides valuable diagnostic information. Therefore, the bone marrow examination rarely yields substantial clinical information except in the diagnosis of concurrent *M. avium-intracellulare*, tuberculosis, or fungal infection or as part of staging for malignancy.

The histopathologic findings in the bone marrow of HIV-1-infected patients are varied. In one large study of 216 bone marrow examinations performed in 178 HIV-1-infected patients for evaluation of cytopenia, 69% of patients exhibited hypercellular marrow, 69% showed myelodysplastic changes, and 20% showed significant fibrosis; only 5% of the biopsies were hypocellular. Granulomas were found in 13% and lymphoid aggregates in 36% (but in other studies, in up to 50%) of specimens. Higher numbers of plasma cells and elevated numbers of eosinophils were also present, especially in conjunction with increased reticulum. Hyperplasia involving the granulocytic and erythrocytic lineages has been most commonly reported; the myeloid-to-erythroid ratio has varied from 2:1 to 5:1.⁹⁴

P.1364

Morphologic changes tend to be more pronounced in more immunosuppressed patients and increase in frequency as disease progresses. All lineages can be involved. Megaloblastic changes and ringed sideroblasts are frequent. Using the morphologic criteria established for primary myelodysplastic syndromes, dysplasia involving at least one lineage was diagnosed in 69% of patients. Dysplastic changes increase with disease progression. However, in one study, the numbers of erythroid precursors and the morphology of megakaryocytes clearly differentiated patients with AIDS from those with myelodysplastic syndrome.⁹⁶ The cumulative effects of drug toxicities, direct HIV-1 infection of marrow cells, and dysregulated cytokine production may be responsible for the morphologic changes that occur late in AIDS. However, the dysplastic changes in an individual lineage and specific cytopenias are not correlated.

Coagulation Abnormalities

A number of retrospective epidemiologic studies^{115, 116, 117, 118, 119, 120, 121, 122, 123, 124} have found that the incidence of thrombosis in HIV-infected patients was increased two- to tenfold over what would be expected in a healthy control population of the same age. However, except for isolated cases of protein S deficiency, no study has compared these patients to equally sick uninfected patients whose immobility, lymphedema, and hypoalbuminemia predispose them to hypercoagulability. Patients with HIV are more likely to develop antiphospholipid antibodies such as lupus anticoagulant (found in 1% of patients)¹²⁵ and antiphosphatidylcholine and anticardiolipin autoantibodies antibody (found in about 50% of patients with HIV infection)^{126, 127}; however, many of these studies were performed before HAART became standard of care. Apart from diagnostic problems related to a falsely elevated partial prothrombin time, these antibodies do not appear to be associated with an increased frequency of thrombosis, as they are in uninfected patients.^{128, 129}

Increased levels of complement-binding protein 4, which attaches to protein S and renders the protein inactive, can be detected in as many as 27% to 73% of patients. These patients demonstrate decreased functional protein S when a functional assay is used to measure activity. The risk of thrombosis in these patients is substantially increased. No clear guidelines are available for treatment or other protein-S-deficient patients, but most hematologists recommend anticoagulation for an undefined period of time for those with a history of unprovoked thrombosis.

ACQUIRED IMMUNODEFICIENCY SYNDROME-RELATED MALIGNANCIES

Cancer is the leading cause of death for HIV-1-infected persons on HAART. Twenty-five to forty percent of HIV-positive patients will develop a malignancy.^{32, 33, 130, 131, 132, 133, 134, 135, 136, 137} Although Kaposi sarcoma, aggressive B-cell lymphomas, and cervical cancer are said to be AIDS defining when occurring in the setting of HIV infection and occur more frequently in HIV infection, death from non-AIDS-defining cancers is more common. The development of malignancies is related to a number of factors, including immunosuppression and concurrent infections with other viruses such as human herpes virus 8 (HHV8) and Epstein-Barr virus (EBV), or the human papillomavirus, which foster malignant transformation. These viruses carry oncogenic proteins and cytokines that contribute to malignant pathogenesis. Additionally, HIV infection reduces the ability to clear the viral infection. The SMART study demonstrated that HAART interruptions in so-called drug conservation strategies increase the risk of cancer sixfold.¹³⁸

Although the incidence of KS and certain lymphomas has decreased after HAART was introduced, the frequency of other tumors such as cervical cancer has undergone little change. CNS lymphoma, although once accounting for 18% of AIDS-related lymphomas, now is extremely rare. Several new drugs and therapies have been developed for KS and AIDS-related lymphomas, and these treatments, plus the development of HAART, have contributed to improvements in morbidity and mortality. Given the introduction of HAART and our increased ability to treat infections effectively, the life span of patients with HIV has increased, eventually leading to substantial increases in individuals living with HIV-1.¹¹⁹ One analysis projected a median life expectancy of 75 years assuming a high rate of HIV diagnosis (median CD4 cell count at diagnosis, $0.432 \times 10^9/L$), and 71.5 years with a low diagnosis rate (diagnosis only when symptomatic, median CD4 cell count $0.14 \times 10^9/L$). Cumulative risks of death by 5 and 10 years after infection were 2.3% and 5.2%, respectively.¹³⁹ This makes treating malignancies more attractive than in the pre-HAART era. Although these malignancies also occur in the HIV-uninfected population, their presentation, as well as their appropriate treatment, is quite different in the HIV-infected patient.

ACQUIRED IMMUNODEFICIENCY SYNDROME-RELATED LYMPHOMA

Non-Hodgkin lymphoma (NHL) and Hodgkin lymphoma (HL) occur with increased frequency in patients infected with HIV.¹²⁵ Approximately 10% of HIV-positive people will develop NHL, and although the incidence has greatly reduced during HAART, it is still increased 25- to 150-fold compared to the general population.^{140, 141, 142, 143} These recent studies also demonstrate the duration and depth of the CD4 nadir and the duration of viremia increase the incidence of NHL. Decreased immune surveillance, B-cell dysregulation¹⁴⁴ and, in certain subtypes, infections with HHV8 and EBV, are also involved in the pathophysiology of the disorder.

A number of changes have occurred in the HIV-related lymphomas since widespread institution of HAART. The overall incidence of HIV-associated lymphomas has declined for NHL. This decrease has primarily affected lymphomas occurring at low CD4 counts, whereas NHL occurring at higher CD4 counts has been relatively unaffected.¹⁴⁵ Among patients with systemic, AIDS-related NHL, there has been decreased high-grade histology and improved survival.^{146, 147} Three types of lymphoma are now recognized as AIDS-defining by the CDC: Burkitt lymphoma, immunoblastic lymphoma which is a subtype of diffuse large B-cell lymphoma, and primary CNS lymphoma. The World Health Organization (WHO) more recently provided a classification system for the HIV-associated lymphomas (Table 64.2; Fig. 64.2). The frequency of NHL increases with the degree of immunosuppression, particularly for CNS lymphoma. Thus CNS lymphoma is rarely seen in developed countries where HAART is available, except in socioeconomic sectors where standard of care HIV therapy is not ubiquitous. In addition, patients with poorer virologic control on HAART suffer a significantly higher incidence of

lymphoma and worse outcomes following therapy.¹⁴⁸ Some studies have suggested genetic factors play a role in the development of NHL. One study demonstrated that HIV-infected patients who are heterozygous for the CCR5D32 deletion are less likely to develop lymphoma, whereas those with stromal-cell-derived factor-1 mutations are more likely to develop lymphoma.¹⁴⁹

For patients receiving combination chemotherapy, the optimal timing of HAART with combination chemotherapy is controversial.¹⁵⁰ Many oncologists continue antiretrovirals during chemotherapy, and some temporarily discontinue them, citing fears of drug-drug interactions and increased toxicities. The latter stance has been challenged by six randomized studies in infections showing immune reconstitution occurring within the first month of HAART leading to a decrease in infection mortality.¹⁵¹ This suggests that HAART discontinuation or deferment of initiation after a concurrent HIV and lymphoma diagnosis could be detrimental. Nonetheless, in a retrospective Italian study comparing toxicities between patients receiving CHOP (cyclophosphamide, doxorubicin,

P.1365

vincristine, and prednisone) plus HAART versus CHOP or a comparable regimen without HAART, the group receiving HAART experienced greater neurotoxicity and anemia but a decreased frequency of infection.¹⁵² The differences in favor of HAART may have been due to improvements in supportive care gained during the 1990s. Moreover, with an expansion of the panoply of HAART medications, it is now possible to avoid specific HAART components to minimize drug-drug interaction. However, no controlled clinical trial has yet been performed to assess the contribution of continuing HAART therapy to improvement in viral replication and lymphoma control.¹⁵³ It is unlikely that such a study will be conducted.

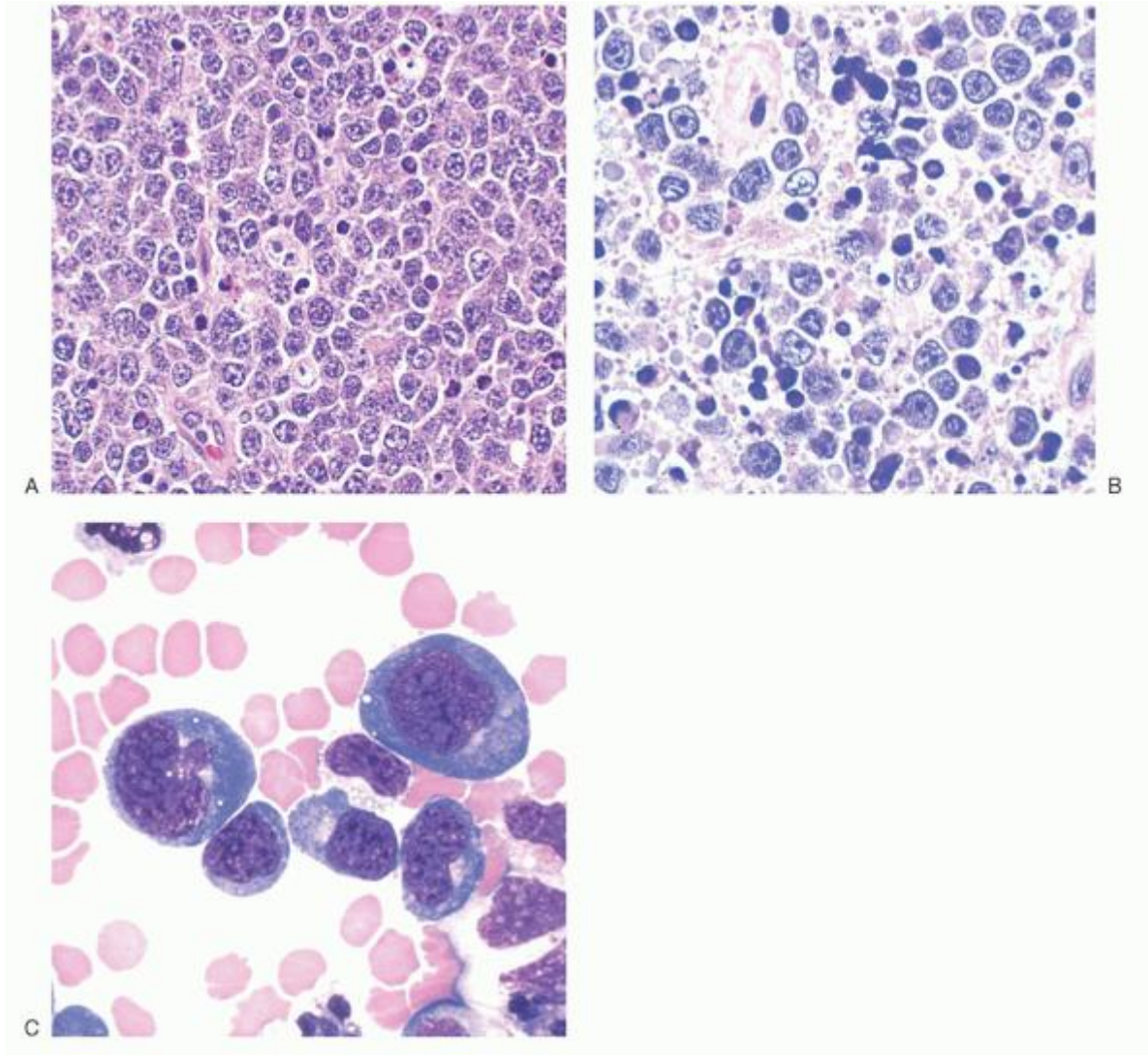

FIGURE 64.2. Human immunodeficiency virus (HIV)-associated lymphomas. A: HIV-associated Burkitt lymphoma. Tumor cells show plasmacytoid differentiation, which is often associated with positivity for HIV. B: Diffuse large B-cell lymphoma, immunoblastic variants. Lymphomas with this morphology often present in advanced AIDS. C: Primary effusion lymphoma, positive for human herpes virus 8/Kaposi sarcoma herpes virus. (Contributed by Dr. Elaine Jaffe, Chief Hematopathology Section and Acting Chief Laboratory of Pathology, National Cancer Institute.)

The three main pathologic types of HIV-NHL are the Burkitt and those with Burkitt features, diffuse large B-cell lymphomas, and primary effusion lymphomas (PELs). These differ in their clinical presentations, in their underlying pathogenesis, and in their response to therapy. The majority of HIV-related lymphomas are of B-cell origin. T-cell lymphomas are rare, as are PELs, which lack B-, T-, and hematopoietic cell markers. Burkitt and lymphomas with Burkitt features usually present with widespread disease and have a risk of CNS involvement. Other less common lymphomas include polymorphic lymphoproliferative disorders resembling post-transplant-associated lymphoproliferative disease and lymphomatoid granulomatosis.

The role of viruses in the pathophysiology of HIV-related lymphomas is dependent on subtype.¹⁵⁴ For example, CNS lymphomas are virtually always associated with EBV infection, and PEL is associated with HHV8 infection. EBV encodes for a number of cytokines promoting cell growth. AIDS-Burkitt is variably associated with EBV, but also contains activating mutations in the cMYC proto-oncogene, frequent inactivation of p53, as well as point mutations in BCL-6. One study showed that loss of EBV-specific CD8⁺ T-cells in subjects progressing to EBV-related NHL correlated with loss of CD4⁺ T cells and that these cells were better preserved in equally immunocompromised patients not developing lymphoma.¹⁵⁵

Patients with HIV-NHL frequently present with advanced stage III or IV disease. The majority will present with a rapidly growing mass or the development of systemic B symptoms (i.e., fever, night sweats, and unexplained weight loss). The clinical presentation is dependent on the site of involvement. Extranodal involvement including the bone marrow (25% to 40%), gastrointestinal tract (26%), and CNS (17% to 32%) is common.

P.1366

Leptomeningeal disease may be present and detected by flow cytometry only at a higher frequency than the immunocompetent population, where it is rare, with a surprising 22% among 51 newly diagnosed patients in one study in which 11 (22%) were detected by flow cytometry and only 1 by cytology.¹⁵⁶ Involvement of the small bowel and rectum is also prevalent, particularly in those with large cell histology. Several prognostic factors predict response to therapy and overall survival including CD4 count, Karnofsky performance, age, and LDH level.¹⁵⁷

TABLE 64.2 WORLD HEALTH ORGANIZATION CLASSIFICATION OF HUMAN IMMUNODEFICIENCY VIRUS (HIV)-ASSOCIATED LYMPHOMAS¹²⁵

1. Lymphomas that occur with reasonable frequency in the absence of HIV infection
 - a. Burkitt lymphoma
 - b. Diffuse large B-cell lymphoma
 - Centroblastic
 - Immunoblastic (includes primary central nervous system lymphoma)
 - c. Extranodal marginal zone B-cell lymphoma of the mucosa-associated lymphoid tissue^a
 - d. Peripheral T-cell lymphoma^a
 - e. Classic Hodgkin lymphoma
2. Unusual lymphoma occurring more specifically in HIV infection
 - a. Primary effusion lymphoma
 - b. Plasmablastic lymphoma
3. Lymphomas occurring in other immune deficiency states
 - a. Polymorphic B-cell lymphoma

^aOccur rarely in HIV.

From World Health Organization Classification of Tumours. Pathology and genetics: tumours of haematopoietic and lymphoid tissues. Lyon: IARC Press, 2001.

Clinical Manifestations

Therapy

Initially prior to HAART, patients with lymphoma were more debilitated and experienced significant toxicity associated with chemotherapy. Multiple trials focused on reduced-intensity chemotherapy, which generally resulted in shorter remission durations. Treatment of HIV lymphoma has changed radically after the institution of HAART and remission has been reported after institution of HAART alone. However, this is not the standard of care and most trials now focus on more intensive therapy.

The French Italian Cooperative Group recently tailored treatment to the level of pre-existing immunosuppression, examining low- versus high-dose therapy in patients with moderate and severe immunosuppression. Patients with CD4 counts over $0.2 \times 10^9/L$ received a dose-intensified regimen of ACVB (doxorubicin, cyclophosphamide, vindesine, bleomycin, methylprednisolone, methotrexate) versus standard CHOP because of evidence from previous trials of NHL unrelated to HIV showing that patients receiving an intensified regimen had more durable remissions.¹⁵⁸ Both groups of HIV-infected patients in this trial had comparable responses, but toxicity was better in the CHOP arm. Patients with one adverse prognostic factor were randomly assigned to CHOP or dose-reduced CHOP. High-risk patients were treated with dosereduced CHOP or vincristine plus prednisone. In the intermediaterisk group, standard-dose CHOP was superior to dose-reduced CHOP, but overall survival remained similar in the two groups. This risk-adapted approach has not been adapted universally due to the results of other trials.

A number of regimens administering chemotherapy by slow infusion appear effective without causing significant toxicity. Patients receiving cyclophosphamide, doxorubicin, and etoposide (CDE)¹⁵⁹ as an infusion had median survivals of 18.4 months. A multicenter phase II trial of infusional CDE in 48 systemic NHL patients not on HAART had only a 46% median survival at 8 months.¹⁶⁰ This infusion regimen has been combined with HAART with few problems other than increased mucositis in the HAART group.¹⁶¹

EPOCH (etoposide, prednisone vincristine, cyclophosphamide, and doxorubicin-cyclophosphamide dose adjusted to CD4 count) has produced responses of 79% in a preliminary study.¹⁶² Antiviral therapy was suspended during treatment in this protocol, for fear of concurrent toxicities, leading to transient increases in viral load and decreases in CD4 counts. A multicenter trial by the AIDS malignancy consortium investigated EPOCH with concurrent versus sequential rituximab and found the CR rate to be higher in the concurrent arm.¹⁶³ The vast majority of patients remained on HAART during treatment, challenging the earlier assertion that HAART must be suspended.

Anti-CD20 monoclonal antibody (rituximab) has become a ubiquitous component of B-cell NHL in the general population. Preliminary studies show that it can be added to EPOCH without evidence of added toxicity.¹⁶⁴ Rituximab administered with CDE and concomitant HAART has yielded 2-year survivals of 80%.¹⁶⁵ However, a randomized phase III study of CHOP with or without rituximab failed to demonstrate any added benefit of rituximab and suggested increased toxicity in those with a CD4 count less than $0.05 \times 10^9/L$.¹⁶⁶ In contrast, another study, rituximab adjunction to CHOP produced a complete response rate of 77% and a 2-year survival rate of 75% in patients with AIDS-related NHL, without increasing the risk of life-threatening infections.¹⁶⁷ The current standard of care is to use rituximab with attention to infection including hematopoietic growth factors and antibiotic prophylaxis in those at highest risk.

Primary Central Nervous System Lymphoma

Primary CNS NHL (PCNSL) typically affects the most immunocompromised with CD4⁺ lymphocyte counts $<0.05 \times 10^9/L$ and now is rarely seen in patients receiving HAART. Most are diffuse large B-cell lymphomas and are multifocal (reviewed in Ref. 168). Confusion, memory loss, lethargy, and focal neurologic findings are the most frequent presenting symptoms and signs. The response to therapy in patients with primary CNS lymphoma has been very disappointing. Palliation with steroids and whole-brain radiation (3,000 to 5,400 Gy) has response rates of 75% and treatment with high-dose methotrexate has reportedly given similar results, but the response duration is short with a median survival of 2 to 4 months regardless of CD4 count. A pilot study using only antivirals and immunomodulation was very promising with two of five patients treated remaining in complete remission at 28 months and 52 months, respectively, but closed early due to low accrual.¹⁶⁹

Primary Effusion Lymphoma

PEL comprises approximately 1% to 5% of AIDS-related lymphoma cases. Clinically, the disease is characterized by malignant effusions with the absence of nodal disease. Diagnosis is made by pericardiocentesis, thoracentesis, or paracentesis with cytologic examination of the fluid and immunohistochemical evaluation. PEL cells have pleomorphic morphology and lack expression of B-cell-associated genes, including surface immunoglobulin, although immunoglobulin gene rearrangements are usually positive, indicating a clonal B-cell origin. The gene expression profile of PEL cells suggests plasmablastic derivation.¹⁷⁰ The malignant clone is almost always found to be infected with HHV8, whereas concurrent infection with EBV is frequent. PEL may extend into tissues underlying the serous cavities, including the omentum, lymph nodes, mediastinum, and lung. In one study of 277 NHL

P.1367

patients, PEL was diagnosed in 11 patients (4%). Patients treated with doxorubicin, vincristine, and prednisone achieved a complete response rate of 42%. However, median survival time was only 6 months.¹⁷¹ The decision to undergo therapy should be based on the functional status of the patient, the degree of immunosuppression, and the likelihood that the quality of life would be improved. A report of antiviral therapy alone leading to sustained remission has been documented.¹⁷²

Burkitt Lymphoma

Burkitt lymphoma is highly overrepresented in patients living with HIV. Before the era of HAART, treatments were curtailed due to fears of prolonged and profound neutropenia associated with the intensive therapies that had become standard in the general population. One small retrospective¹⁷³ and one small prospective study¹⁷⁴ initially challenged the prevailing dogma and found that intensive therapies such as CODOX-M/IVAC or hyper-CVAD with methotrexate and high-dose cytarabine could be safely given with HAART with success rates of 80% to 90%. More recent publications have also suggested the same.^{175, 176} Another retrospective study has supported the use of R-EPOCH as more efficacious and less toxic.¹⁷⁷ A recently completed clinical trial by the AIDS Malignancy Consortium was designed to reduce toxicity while maintaining efficacy, and may confirm these results prospectively in a multicenter setting.¹⁷⁸ The NCI has also reported early results with EPOCH-rituximab in a prospective study.¹⁷⁹

Plasmablastic Lymphoma

Plasmablastic lymphoma is a very rare CD20 negative variant of HIV-associated NHL. It was originally described as almost exclusively associated with HIV and nearly always fatal in the pre-HAART era.¹⁸⁰ The sine qua non of stage I disease is a mass in the jaw, but disseminated disease including numerous bone lesions is common. A retrospective study suggested curability in the HAART era in both HIV-positive and HIV-negative patients.¹⁸¹ Optimal management will be difficult to define due to the rarity of the disease.

Hodgkin Lymphoma

Although HL is not considered an AIDS-defining illness, a marked increase is seen in HIV.^{182, 183, 184} Although risk of NHL has decreased with better therapy, the incidence of HL among patients with HIV infection has increased.^{182, 185} Unlike HL in HIV-uninfected patients, B symptoms are almost often present; mixed cellularity HL is the predominant pathologic subtype of disease; and advanced, extranodal disease is expected in the majority. One study showed 70% to 90% of patients present with B symptoms, and 74% to 96% of patients have advanced disease (stage III or IV) at the time of diagnosis with frequent involvement of extranodal sites (60%), including bone marrow, liver, and spleen involvement. Unlike those not infected with HIV, noncontiguous spread of disease is common and mediastinal involvement is far less. Bone marrow involvement occurs in 40% to 50% of patients and may be their first indication of the disease. Another characteristic distinguishing the HIV-associated HL from that not associated with HIV is the predominance of Reed-Sternberg cell-rich cases. AIDS-HL, like AIDS-NHL, is characterized by a high frequency of EBV infection when compared to HL in the HIV-negative population. The pathologic role of EBV in HL is evidenced by the Reed-Sternberg cell expression of EBV-transforming protein.

Treatment

Although standard multiagent chemotherapy may be curative in most HIV-negative patients with stage III or IV HL, the median survival for HIV-infected patients has been in the range of 1 to 2 years.¹⁸³ Response to standard chemotherapy ABVD (doxorubicin, bleomycin, vinblastine, and dacarbazine) is lower than that of patients without HIV infection, but may be better in the HAART era. Poor tolerance to chemotherapy results in dose reduction or delay of chemotherapy, but this may be ameliorated by the use of GCSF. The median overall survival of patients is approximately 1.5 years.^{184, 186, 187} Because 85% to 95% of HL patients have widespread disease, no data exist on the impact of radiation therapy in

treatment of AIDS-HL. Recent studies in the HAART era include trials suggesting better outcomes. Currently an ongoing US intergroup study (S0816) is examining midtreatment risk adaption and regimen modification based on interim PET scan after cycle 2 of ABVD. The novel and highly potent brentuximab vedotin, an anti-CD30 antibody conjugated to an antitubulin drug approved for relapsed and refractory non-HIV Hodgkin has not yet been tested in the setting of HIV, but will be investigated in an upcoming AIDS Malignancy Consortium study of untreated advanced stage HIV-HL.

Transplantation for Hodgkin Lymphoma and Non-Hodgkin Lymphoma

Myeloablative autologous transplants have been performed in patients with both NHL and HL. The City of Hope reported the first prospective study of 12 patients with NHL beyond first complete remission.¹⁸⁸ Opportunistic infections were seen in three patients; transient increases in viral load were seen in seven (related to HAART noncompliance). Three patients died, including two with relapsed lymphoma, but all others were alive at 18.5 months. Another study included eight patients with relapsed or resistant lymphoma, four with HL, and four with NHL. Seven of eight continued HAART during transplant and seven engrafted successfully. Although six of seven patients engrafted, only four patients went into complete remission.¹⁸⁹ Another pilot of 16 patients with relapsed and refractory lymphoma reported 6/16 alive at a median of 8 months after secondline therapy, high-dose conditioning and autologous stem cell support.¹⁹⁰ The European Cooperative Study Group on AIDS and Tumors (GECAT) reported the largest study and the only one enrolling patients before second-line therapy with 27/50 going onto autologous transplant and a median overall survival of 33 in all 50 eligible patients.¹⁹¹ In addition, two retrospective case control studies have suggested no difference in outcome between HIV-positive and HIV-negative patients undergoing autologous transplant for the same indications.^{192, 193} The AIDS Malignancy Consortium and Bone Marrow Clinical Trials Network have partnered in an ongoing trial to demonstrate multicenter feasibility and study biologic correlates. Finally, gene therapy pilot studies are ongoing to test the feasibility of engineered hematopoietic stem cell HIV resistance at the time of transplant for malignancy.¹⁹⁴

Nonmyeloablative allogeneic transplantation has been used in patients with refractory disease and has produced short-term remissions (12 months), but was associated with little toxicity and few opportunistic infections.¹⁹⁵ A case has been reported of simultaneous treatment of acute myelogenous leukemia and eradication of HIV infection using a donor with homozygous CCR5 deletion, a receptor necessary for HIV infection. However, the rarity of this deletion makes this approach unique. The AIDS Malignancy Consortium and Bone Marrow Clinical Trials Network have recently opened an allogeneic transplant pilot study for HIV-infected patients with a wide variety of hematologic malignancies.

CONCLUSION

Patients with HIV infections are living longer and having better quality of life than ever before. Life expectancy can approach the general population. Treatment of HIV-infected patients with

P.1368

HAART has altered the natural history of HIV infection by decreasing the frequency of opportunistic infections and altering the expected frequency of hematologic complications and AIDS-related malignancies. Cytopenia, particularly anemia, is more common in advanced stages of HIV and results both from bone marrow failure and peripheral destruction. With the development and application of HAART, both AIDS-defining and non-AIDS-defining malignancies represent an ever-increasing cause of death in this population. Lymphomas are highly prevalent among HIV-infected patients, although CNS lymphoma is now very rare on HAART. Intensive curative therapies are now the norm except in patients with advanced AIDS. In the future, different strategies directed toward controlling the underlying inciting viral infections associated with malignancy (EBV, HHV8) and focusing on immune reconstitution in addition to standard chemotherapy may improve response rates and survival.

ACKNOWLEDGMENTS

Elaine M. Soland and Jerome P. Groopman co-authored the previous version of this chapter which has been edited and updated.

REFERENCES

1. UNAIDS. World AIDS Day Report 2011. <http://www.unaids.org>. Accessed March 21, 2013.
2. CDC. 1993 Revised classification system for HIV infection and expanded surveillance case definition for AIDS among adolescents and adults. *MMWR* 1992;41(RR-17):1-19.
3. CDC. Pneumocystis pneumonia. Los Angeles. *MMWR* 1981;30:250-252.

4. Prejean J, Song R, Hernandez A, et al. Estimated HIV incidence in the United States, 2006-2009. *PLoS One* 2011;6:e17502.
5. Palella FJ Jr, Delaney KM, Moorman AC, et al. Declining morbidity and mortality among patients with advanced human immunodeficiency virus infection. HIV Outpatient Study Investigators. *N Engl J Med* 1998;338:853-860.
6. Panel on Antiretroviral Guidelines for Adults and Adolescents. Guidelines for the use of antiretroviral agents in HIV-1-infected adults and adolescents. Department of Health and Human Services. <http://aidsinfo.nih.gov/easyaccess1.lib.cuhk.edu.hk/contentfiles/lvguidelines/AdultandAdolescentGL.pdf>.
7. Thompson MA, Aberg JA, Hoy JF, et al. Antiretroviral treatment of adult HIV infection: 2012 recommendations of the International Antiviral Society-USA panel. *JAMA* 2012;308:387-402.
8. Centers for Disease Control and Prevention. Guidelines for Prevention and Treatment of Opportunistic Infections in HIV-Infected Adults and Adolescents. *MMWR* 2013;62(RR-1):1-207.
9. Gallo RC, Montagnier L. The discovery of HIV as the cause of AIDS. *New Engl J Med* 2003;349:2283-2285
10. Clavel F, Guetard D, Brun-Vezinet F, et al. Isolation of a new human retrovirus from West African patients with AIDS. *Science* 1986;233:343-346.
11. Grossman Z, Meier-Schellersheim M, Paul WE, Picker LJ. Pathogenesis of HIV infection: what the virus spares is as important as what it destroys. *Nat Med.* 2006;12(3):289-295.
12. Engelman A, Cherepanov P. The structural biology of HIV-1: mechanistic and therapeutic insights. *Nat Rev Microbiol* 2012;10:279-290.
13. Wilen CB, Tilton JC, Doms RW. Molecular mechanisms of HIV entry. *Adv Exp Med Biol* 2012;726:223-242.
14. Lederman MM, Penn-Nicholson A, Cho M, Mosier D. Biology of CCR5 and its role in HIV infection and treatment. *JAMA* 2006;296(7):815-826.
15. Marmor M, Sheppard HW, Donnell D, et al. Homozygous and heterozygous CCR5-Delta32 genotypes are associated with resistance to HIV infection. *J Acquir Immune Defic Syndr* 2001;27(5):472-481.
16. Finzi D, Blankson J, Siliciano JD, et al. Latent infection of CD4⁺ T cells provides a mechanism for lifelong persistence of HIV-1, even in patients on effective combination therapy. *Nat Med* 1999;5:512-517.
17. Kohl NE, Emini EA, Schleif WA, et al. Active human immunodeficiency virus protease is required for viral infectivity. *Proc Natl Acad Sci U S A* 1988;85:4686-4690.
18. Maldarelli F, Sato H, Berthold E, Orenstein J, Martin MA. Rapid induction of apoptosis by cell-to-cell transmission of human immunodeficiency virus type 1. *J Virol* 1995;69:6457-6465.
19. Ramratnam B, Mittler JE, Zhang L, et al. The decay of the latent reservoir of replication-competent HIV-1 is inversely correlated with the extent of residual viral replication during prolonged anti-retroviral therapy. *Nat Med* 2000;6:82-85.
20. Martínez-Maza O, Crabb E, Mitsuyasu RT, Fahey JL, Giorgi JV. Infection with the human immunodeficiency virus (HIV) is associated with an in vivo increase in B lymphocyte activation and immaturity. *J Immunol* 1987;138:3720-3724.
21. Margolick JB, Volkman DJ, Folks TM, Fauci AS. Amplification of HTLVIII/LAV infection by antigen-induced activation of T cells and direct suppression by virus of lymphocyte blastogenic responses. *J Immunol* 1987;138:1719-1723.
22. Branson BM, Handsfield HH, Lampe MA, et al. Revised recommendations for HIV testing of adults, adolescents, and pregnant women in health-care settings. *MMWR Recomm Rep* 2006;55(RR-14):1-17.
23. Centers for Disease Control (CDC). Interpretation and use of the Western blot assay for serodiagnosis of human immunodeficiency virus type 1 infections. *MMWR* 1989;38(Suppl 7):1-7.
24. Wesolowski LG, MacKellar DA, Facente SN, et al. Post-marketing surveillance of OraQuick whole blood and oral fluid rapid HIV testing. *AIDS* 2006;20:1661-1666.
25. Weber B, Fall EH, Berger A, Doerr HW. Reduction of diagnostic window by new fourth-generation human immunodeficiency virus screening assays. *J Clin Microbiol* 1998;36:2235-2239.
26. Pilcher CD, Fiscus SA, Nguyen TQ, et al. Detection of acute infections during HIV testing in North Carolina. *N Engl J Med* 2005;352:1873-1883.
27. Dodd RY. Current safety of the blood supply in the United States. *Int J Hematol* 2004;80:301-305.

28. Schacker T, Collier AC, Hughes J, Shea T, Corey L. Clinical and epidemiologic features of primary HIV infection. *Ann Intern Med* 1996;125:257-264.
29. Doweiko JP. Hematologic aspects of HIV infection. *AIDS* 1993;7:753-757.
30. Mitsuyasu R. Oncological complications of human immunodeficiency virus disease and hematologic consequences of their treatment. *Clin Infect Dis* 1999;29:35-43.
31. Pluda JM, Mitsuya H, Yarchoan R. Hematologic effects of AIDS therapies. *Hematol Oncol Clin North Am* 1991;5:229-248.
32. Bower M, Palmieri C, Dhillon T. AIDS-related malignancies: changing epidemiology and the impact of highly active antiretroviral therapy. *Curr Opin Infect Dis* 2006;19:14-19.
33. Bhaskaran K, Hamouda O, Sannes M, et al. Changes in the risk of death after HIV seroconversion compared with mortality in the general population. *JAMA* 2008;300:51-59.
34. Bartlett JA, Fath MJ, Demasi R, et al. An updated systematic overview of triple combination therapy in antiretroviral-naive HIV-infected adults. *AIDS* 2006;20:2051-2064.
35. Shelburne SA 3rd, Hamill RJ. The immune reconstitution inflammatory syndrome. *AIDS Rev* 2003;5:67-79.
36. INSIGHT-ESPRIT Study Group; SILCAAT Scientific Committee, Abrams D, et al. Interleukin-2 therapy in patients with HIV infection. *N Engl J Med* 2009;361:1548-1559.
37. Strategies for Management of Antiretroviral Therapy (SMART) Study Group, El-Sadr WM, Lundgren JD, et al. CD4+ count-guided interruption of antiretroviral treatment. *N Engl J Med* 2006;355:2283-2296.
38. Hütter G, Nowak D, Mossner M, et al. Long-term control of HIV by CCR5 Delta32/Delta32 stem-cell transplantation. *N Engl J Med* 2009;360(7):692-698.
39. Dieffenbach CW, Fauci AS. Thirty years of HIV and AIDS: future challenges and opportunities. *Ann Intern Med* 2011;154:766-771.
40. Murphy EL, Collier AC, Kalish LA, et al. Highly active antiretroviral therapy decreases mortality and morbidity in patients with advanced HIV disease. *Ann Intern Med* 2001;135:17-26.
41. Sullivan PS, Hanson DL, Chu SY, et al. Epidemiology of anemia in human immunodeficiency virus (HIV)-infected persons: results from the multistate adult and adolescent spectrum of HIV disease surveillance project. *Blood* 1998;91:301-308.
42. Saah AJ, Munoz A, Kuo V, et al. Predictors of the risk of development of acquired immunodeficiency syndrome within 24 months among gay men seropositive for human immunodeficiency virus type 1: a report from the Multicenter AIDS Cohort Study. *Am J Epidemiol* 1992;135:1147-1155.
43. Zauli G, Re MC, Visani G, Furlini G, Mazza P, Vignoli M, LaPlaca M. Evidence for a human immunodeficiency virus type-1 mediated suppression of uninfected hematopoietic (CD34+) cells in AIDS patients. *J Infect Dis* 1992;166:710.
44. Zauli G, Davis BR, Re MC, Visani G, Furlini G, LaPlaca M. Tat protein stimulates production of transforming growth factor- β 1 by bone marrow macrophages: a potential mechanism for human immunodeficiency virus-1-induced hematopoietic suppression. *Blood* 1992;80:3036.
45. Maciejewski JP, Weichold FF, Young NS. HIV-1 suppression of hematopoiesis in vitro mediated by envelope glycoprotein and TNF- α . *J Immunol* 1994;153:4303.
46. Dobs AS. Androgen therapy in AIDS wasting. *Baillieres Clin Endocrinol Metab* 1998;12(3):379-390. PMID:10332560.
47. Koch MA, Volberding PA, Lagakos SW, et al. Toxic effects of zidovudine in asymptomatic human immunodeficiency virus-infected individuals with CD4+ cell counts of $0.50 \times 10^9/L$ or less. Detailed and updated results from protocol 019 of the AIDS Clinical Trials Group. *Arch Intern Med* 1992;152:2286-2292.
48. Sandstrom EG, Kaplan JC. Antiviral therapy in AIDS. Clinical pharmacological properties and therapeutic experience to date. *Drugs* 1987;34:372-390.
49. Moore RD, Forney D. Anemia in HIV-infected patients receiving highly active antiretroviral therapy. *J Acquir Immune Defic Syndr* 2002;29(1):54-7.

50. Abkowitz JL, Brown KE, Wood RW, et al. Clinical relevance of parvovirus B19 as a cause of anemia in patients with human immunodeficiency virus infection. *J Infect Dis* 1997;176:269-273.
51. Frickhofen N, Abkowitz JL, Safford M, et al. Persistent B19 parvovirus infection in patients infected with human immunodeficiency virus type 1 (HIV-1): a treatable cause of anemia in AIDS. *Ann Intern Med* 1990;113:926-933.
52. Kreuzer KA, Rockstroh JK, Jelkmann W, et al. Inadequate erythropoietin response to anaemia in HIV patients: relationship to serum levels of tumour necrosis factor-alpha, interleukin-6 and their soluble receptors. *Br J Haematol* 1997;96:235-239.
53. Henry DH, Beall GN, Benson CA, et al. Recombinant human erythropoietin in the treatment of anemia associated with human immunodeficiency virus (HIV) infection and zidovudine therapy. Overview of four clinical trials. *Ann Intern Med* 1992;117:739-748.
54. Sloand E, Kumar P, Klein HG, et al. Transfusion of blood components to persons infected with human immunodeficiency virus type 1: relationship to opportunistic infection. *Transfusion* 1994;34:48-53.
55. Busch MP, Lee TH, Heitman J. Allogeneic leukocytes but not therapeutic blood elements induce reactivation and dissemination of latent human immunodeficiency virus type 1 infection: implications for transfusion support of infected patients. *Blood* 1992;80:2128-2135.
56. Mudido PM, Georges D, Dorazio D, et al. Human immunodeficiency virus type 1 activation after blood transfusion. *Transfusion* 1996;36:860-865.
57. Ariga H, Lee TH, Laycock ME, et al. Residual WBC subsets in filtered prestorage RBCs. *Transfusion* 2003;43:98-106.
58. McGinniss MH, Macher AM, Rook AH, Alter HJ. Red cell autoantibodies in patients with acquired immune deficiency syndrome. *Transfusion*. 1986;26(5):405.
59. Fuller A, Moaven L, Spelman D, et al. Parvovirus B19 in HIV infection: a treatable cause of anemia. *Pathology* 1996;28:277-280.
60. Chisaka H, Morita E, Yaegashi N, Sugamura K. 2003 Parvovirus B19 and the pathogenesis of anaemia. *Rev Med Virol* 13(6):347-359.
61. Savona S, Nardi MA, Lennette ET, et al. Thrombocytopenic purpura in narcotics addicts. *Ann Intern Med* 1985;102:737-741.
62. Klaassen RJ, Mulder JW, Vlekke AB, et al. Autoantibodies against peripheral blood cells appear early in HIV infection and their prevalence increases with disease progression. *Clin Exp Immunol* 1990;81:11-17.
63. Li Z, Nardi MA, Karpatkin S. Role of molecular mimicry to HIV-1 peptides in HIV-1-related immunologic thrombocytopenia. *Blood* 2005;106:572-576.
64. Nardi M, Feinmark SJ, Hu L, et al. Complement-independent Ab-induced peroxide lysis of platelets requires 12-lipoxygenase and a platelet NADPH oxidase pathway. *J Clin Invest* 2004;113:973-980.
65. Koefoed K, Ditzel HJ. Identification of talin head domain as an immunodominant epitope of the antiplatelet antibody response in patients with HIV-1-associated thrombocytopenia. *Blood* 2004;104:4054-4062.
66. Kunzi MS, Groopman JE. Identification of a novel human immunodeficiency virus strain cytopathic to megakaryocytic cells. *Blood* 1993;81:3336-3342.
67. Zauli G, Re MC, Davis B, et al. Impaired in vitro growth of purified (CD34+) hematopoietic progenitors in human immunodeficiency virus-1 seropositive thrombocytopenic individuals. *Blood* 1992;79:2680-2687.
68. Gernsheimer T, Stratton J, Ballem PJ, et al. Mechanisms of response to treatment in autoimmune thrombocytopenic purpura. *N Engl J Med* 1989;320: 974-980.
69. Ballem PJ, Belzberg A, Devine DV, et al. Kinetic studies of the mechanism of thrombocytopenia in patients with human immunodeficiency virus infection. *N Engl J Med* 1992;327:1779-1784.
70. Barbui T, Cortelazzo S, Minetti B, et al. Does splenectomy enhance risk of AIDS in HIV-positive patients with chronic thrombocytopenia? *Lancet* 1987;2: 342-343.
71. Oksenhendler E, Bierling P, Brossard Y, et al. Anti-RH immunoglobulin therapy for human immunodeficiency virus-related immune thrombocytopenic purpura. *Blood* 1988;71:1499-1502.

72. Ahmad HN, Ball C, Height SE, et al. Rituximab in chronic, recurrent HIV-associated immune thrombocytopenic purpura. *Br J Haematol* 2004;127:607-608.
73. Arnold DM, Nazi I, Kelton JG. New treatments for idiopathic thrombocytopenic purpura: rethinking old hypotheses. *Expert Opin Investig Drugs* 2009;18(6):805-819.
74. Sloand EM, Young NS, Sato T, et al. Secondary colony formation after long-term bone marrow culture using peripheral blood and bone marrow of HIV-infected patients. *AIDS* 1997;11:1547-1553.
75. Tumbarello M, Tacconelli E, Caponera S, et al. The impact of bacteraemia on HIV infection. Nine years experience in a large Italian university hospital. *J Infect* 1995;31:123-131.
76. Keiser P, Higgs E, Smith J. Neutropenia is associated with bacteremia in patients infected with the human immunodeficiency virus. *Am J Med Sci* 1996; 312:118-122.
77. Mathews WC, Caperna J, Toerner JG, et al. Neutropenia is a risk factor for gram-negative bacillus bacteremia in human immunodeficiency virus-infected patients: results of a nested case-control study. *Am J Epidemiol* 1998;148:1175-1183.
78. Pui CH, Boyett JM, Hughes WT, et al. Human granulocyte colony-stimulating factor after induction chemotherapy in children with acute lymphoblastic leukemia. *N Engl J Med* 1997;336:1781-1787.
79. Elbim C, Prevot MH, Bouscarat F, et al. Impairment of polymorphonuclear neutrophil function in HIV-infected patients. *J Cardiovasc Pharmacol* 1995;25(Suppl 2):S66-S70.
80. Flo RW, Naess A, Nilsen A, et al. A longitudinal study of phagocyte function in HIV-infected patients. *AIDS* 1994;8:771-777.
81. Coffey MJ, Phare SM, George S, et al. Granulocyte colony-stimulating factor administration to HIV-infected subjects augments reduced leukotriene synthesis and anticryptococcal activity in neutrophils. *J Clin Invest* 1998;102:663-670.
82. Kovacs JA, Vogel S, Albert JM, et al. Controlled trial of interleukin-2 infusions in patients infected with the human immunodeficiency virus. *N Engl J Med* 1996;335:1350-1356.
83. Levy Y, Capitani C, Houhou S, et al. Comparison of subcutaneous and intravenous interleukin-2 in asymptomatic HIV-1 infection: a randomised controlled trial. ANRS 048 study group. *Lancet* 1999;353:1923-1929.
84. Wood R, Montoya JG, Kundu SK, et al. Safety and efficacy of polyethylene glycol-modified interleukin-2 and zidovudine in human immunodeficiency virus type 1 infection: a phase I/II study. *J Infect Dis* 1993;167:519-525.
85. Davey RT Jr, Chaitt DG, Albert JM, et al. A randomized trial of high- versus low-dose subcutaneous interleukin-2 outpatient therapy for early human immunodeficiency virus type 1 infection. *J Infect Dis* 1999;179:849-858.
86. Chun TW, Fauci AS. Latent reservoirs of HIV-obstacles to the eradication of virus. *Proc Natl Acad Sci U S A* 1999;96:10958-10961.
87. Leaf AN, Laubenstein LJ, Raphael B, et al. Thrombotic thrombocytopenic purpura associated with human immunodeficiency virus type 1 (HIV-1) infection. *Ann Intern Med* 1988;109:194-197.
88. Gervasoni C, Ridolfo AL, Vaccarezza M, et al. Thrombotic microangiopathy in patients with acquired immunodeficiency syndrome before and during the era of introduction of highly active antiretroviral therapy. *Clin Infect Dis* 2002;35:1534-1540.
89. Bell WR, Chulay JD, Feinberg JE. Manifestations resembling thrombotic microangiopathy in patients with advanced human immunodeficiency virus (HIV) disease in a cytomegalovirus prophylaxis trial (ACTG 204). *Medicine (Baltimore)* 1997;76:369-380.
90. del AA, Martinez MA, Pena JM, et al. Thrombotic thrombocytopenic purpura associated with human immunodeficiency virus infection: demonstration of p24 antigen in endothelial cells. *Clin Infect Dis* 1993;17:360-363.
91. Laurence J, Mitra D, Steiner M, et al. Plasma from patients with idiopathic and human immunodeficiency virus-associated thrombotic thrombocytopenic purpura induces apoptosis in microvascular endothelial cells. *Blood* 1996;87:3245-3254.
92. Mitra D, Kim J, MacLow C, et al. Role of caspases 1 and 3 and Bcl-2-related molecules in endothelial cell apoptosis associated with thrombotic microangiopathies. *Am J Hematol* 1998;59:279-287.
93. Laurence J, Mitra D. Apoptosis of microvascular endothelial cells in the pathophysiology of thrombotic thrombocytopenic purpura/sporadic hemolytic uremic syndrome. *Semin Hematol* 1997;34:98-105.

94. Vesely SK, George JN, Lammle B, et al. ADAMTS13 activity in thrombotic thrombocytopenic purpura-hemolytic uremic syndrome: relation to presenting features and clinical outcomes in a prospective cohort of 142 patients. *Blood* 2003;102:60-68.
95. Eldor A. Thrombotic thrombocytopenic purpura: diagnosis, pathogenesis and modern therapy. *Baillieres Clin Haematol* 1998;11:475-495.
96. Novitzky N, Thomson J, Abrahams L, et al. Thrombotic thrombocytopenic purpura in patients with retroviral infection is highly responsive to plasma infusion therapy. *Br J Haematol* 2005;128:373-379.
97. Ruiz ME, Cicala C, Arthos J, et al. Peripheral blood-derived CD34+ progenitor cells: CXC chemokine receptor 4 and CC chemokine receptor 5 expression and infection by HIV. *J Immunol* 1998;161:4169-4176.
98. Chelucci C, Casella I, Federico M, et al. Lineage-specific expression of human immunodeficiency virus (HIV) receptor/coreceptors in differentiating hematopoietic precursors: correlation with susceptibility to T- and M-tropic HIV and chemokine-mediated HIV resistance. *Blood* 1999;94:1590-1600.
99. Kitano K, Abboud CN, Ryan DH, et al. Macrophage-active colony-stimulating factors enhance human immunodeficiency virus type 1 infection in bone marrow stem cells. *Blood* 1991;77:1699-1705.
100. Stanley SK, Kessler SW, Justement JS, et al. CD34+ bone marrow cells are infected with HIV in a subset of seropositive individuals. *J Immunol* 1992;149:689-697.
101. Molina JM, Scadden DT, Sakaguchi M, et al. Lack of evidence for infection of or effect on growth of hematopoietic progenitor cells after in vivo or in vitro exposure to human immunodeficiency virus. *Blood* 1990;76:2476-2482.
102. Neal TF, Holland HK, Baum CM, et al. CD34+ progenitor cells from asymptomatic patients are not a major reservoir for human immunodeficiency virus-1. *Blood* 1995;86:1749-1756.
103. Weichold FF, Zella D, Barabitskaja O, et al. Neither human immunodeficiency virus-1 (HIV-1) nor HIV-2 infects most-primitive human hematopoietic stem cells as assessed in long-term bone marrow cultures. *Blood* 1998;91:907-915.
104. Louache F, Henri A, Bettaieb A, et al. Role of human immunodeficiency virus replication in defective in vitro growth of hematopoietic progenitors. *Blood* 1992;80:2991-2999.
105. Maciejewski JP, Weichold FF, Young NS. HIV-1 suppression of hematopoiesis in vitro mediated by envelope glycoprotein and TNF-alpha. *J Immunol* 1994;153:4303-4310.
106. Nielsen SD, Jeppesen DL, Kolte L, et al. Impaired progenitor cell function in HIV-negative infants of HIV- positive mothers results in decreased thymic output and low CD4 counts. *Blood* 2001;98:398-404.
107. Rieckmann P, Poli G, Fox CH, et al. Recombinant gp120 specifically enhances tumor necrosis factor-alpha production and Ig secretion in B lymphocytes from HIV-infected individuals but not from seronegative donors. *J Immunol* 1991;147:2922-2927.
108. Voth R, Rossol S, Klein K, et al. Differential gene expression of IFN-alpha and tumor necrosis factor- alpha in peripheral blood mononuclear cells from patients with AIDS related complex and AIDS. *J Immunol* 1990;144:970-975.
109. Clouse KA, Cosentino LM, Weih KA, et al. The HIV-1 gp120 envelope protein has the intrinsic capacity to stimulate monokine secretion. *J Immunol* 1991;147:2892-2901.
110. Lau AS, Williams BR. The role of interferon and tumor necrosis factor in the pathogenesis of AIDS. *J Exp Pathol* 1990;5:111-122.
111. Odeh M. The role of tumour necrosis factor-alpha in the pathogenesis of complicated falciparum malaria. *Cytokine* 2001;14:11-18.
112. Selleri C, Sato T, Anderson S, et al. Interferon-gamma and tumor necrosis factor-alpha suppress both early and late stages of hematopoiesis and induce programmed cell death. *J Cell Physiol* 1995;165:538-546.
113. Fuchs D, Reibnegger G, Werner ER, et al. Low haemoglobin in haemophilia children is associated with chronic immune activation. *Acta Haematol* 1991;85:62-65.
114. Kagi D, Vignaux F, Ledermann B, et al. Fas and perforin pathways as major mechanisms of T cell-mediated cytotoxicity. *Science* 1994;265:528-530.
115. Feffer SE, Fox RL, Orsen MM, et al. Thrombotic tendencies and correlation with clinical status in patients infected with HIV. *South Med J* 1995;88:1126-1130.

116. Laing RB, Brettle RP, Leen CL. Venous thrombosis in HIV infection. *Int J STD AIDS* 1996;7:82-85.
117. George SL, Swindells S, Knudson R, et al. Unexplained thrombosis in HIV-infected patients receiving protease inhibitors: report of seven cases. *Am J Med* 1999;107:624-630.
118. Sullivan PS, Dworkin MS, Jones JL, et al. Epidemiology of thrombosis in HIV-infected individuals. The Adult/Adolescent Spectrum of HIV Disease Project. *AIDS* 2000;14:321-324.
119. Saber AA, Aboolian A, LaRaja RD, et al. HIV/AIDS and the risk of deep vein thrombosis: a study of 45 patients with lower extremity involvement. *Am Surg* 2001;67:645-647.
120. Saif MW, Bona R, Greenberg B. AIDS and thrombosis: retrospective study of 131 HIV-infected patients. *AIDS Patient Care STDS* 2001;15:311-320.
121. Jacobson MC, Dezube BJ, Aboulafia DM. Thrombotic complications in patients infected with HIV in the era of highly active antiretroviral therapy: a case series. *Clin Infect Dis* 2004;39:1214-1222.
122. Majluf-Cruz A, Silva-Estrada M, Sanchez-Barboza R, et al. Venous thrombosis among patients with AIDS. *Clin Appl Thromb Hemost* 2004;10:19-25.
123. Fultz SL, McGinnis KA, Skanderson M, et al. Association of venous thromboembolism with human immunodeficiency virus and mortality in veterans. *Am J Med* 2004;116:420-423.
124. Klein SK, Slim EJ, de Kruif MD, et al. Is chronic HIV infection associated with venous thrombotic disease? A systematic review. *Neth J Med* 2005;63:129-136.
125. Abuaf N, Laperche S, Rajoely B, et al. Autoantibodies to phospholipids and to the coagulation proteins in AIDS. *Thromb Haemost* 1997;77:856-861.
126. de Larranaga GF, Forastiero RR, Carreras LO, et al. Different types of antiphospholipid antibodies in AIDS: a comparison with syphilis and the antiphospholipid syndrome. *Thromb Res* 1999;96:19-25.
127. Weiss L, You JF, Giral P, et al. Anti-cardiolipin antibodies are associated with anti-endothelial cell antibodies but not with anti-beta 2 glycoprotein I antibodies in HIV infection. *Clin Immunol Immunopathol* 1995;77:69-74.
128. Falco M, Sorrenti A, Priori R, et al. Anti-cardiolipin antibodies in HIV infection are true antiphospholipids not associated with antiphospholipid syndrome. *Ann Ital Med Int* 1993;8:171-174.
129. Hassell KL, Kressin DC, Neumann A, et al. Correlation of antiphospholipid antibodies and protein S deficiency with thrombosis in HIV-infected men. *Blood Coagul Fibrinolysis* 1994;5:455-462.
130. Burgi A, Brodine S, Wegner S, et al. Incidence and risk factors for the occurrence of non-AIDS-defining cancers among human immunodeficiency virus-infected individuals. *Cancer* 2005; 104:1505.
131. Shiels MS, Pfeiffer RM, Gail MH et al. Cancer burden in the HIV-infected population in the United States. *J Natl Cancer Inst* 2011;103(9):753-762.
132. Patel P, Hanson DL, Sullivan PS, et al. Incidence of types of cancer among HIV-infected persons compared with the general population in the United States, 1992-2003. *Ann Intern Med* 2008;148:728-36.
133. Shiels, MS, Pfeiffer RM, Hall HI, et al. Proportions of Kaposi sarcoma, selected non-Hodgkin lymphomas, and cervical cancer in the United States occurring in persons with AIDS, 1980-2007. *JAMA* 2011;305(14):1450-1459.
134. D'Souza G, Wiley DJ, Li X, Chmiel JS, Margolick JB, Cranston RD, et al. Incidence and Epidemiology of Anal Cancer in the Multicenter AIDS Cohort Study. *J Acquir Immune Defic Syndr* 2008;48(4):491-499.
135. Puoti M, Bruno R, Soriano V, et al.; HIV HCC Cooperative Italian-Spanish Group. Hepatocellular carcinoma in HIV-infected patients: epidemiological features, clinical presentation and outcome. *AIDS* 2004;18(17):2285
136. Seaberg EC, Wiley D, Martinez-Maza O, et al. Cancer incidence in the multicenter aids cohort study before and during the HAART era: 1984 to 2007. *Cancer* 2010;116(23):5507-5516.
137. Simard EP, Pfeiffer RM, Engels EA. Spectrum of cancer risk late after AIDS onset in the United States. *Arch Intern Med* 2010;170(15):1337-1345.
138. Silverberg MJ, Neuhaus J, Bower M, et al. Epidemiology and social risk of cancers during interrupted antiretroviral therapy in the SMART study. *AIDS* 2007;21:1957-1963. doi:10.1097/QAD.0b013e3282ed6338.

139. Nakagawa F, Lodwick RK, Smith CJ, et al. Epidemiology and Social Projected life expectancy of people with HIV according to timing of diagnosis. *AIDS*;2012;26:335-343. doi:10.1097/QAD.0b013e32834dcec9.
140. Polesel J, Clifford GM, Rickenbach M, et al.; Swiss HIV Cohort Study. Non-Hodgkin lymphoma incidence in the Swiss HIV Cohort Study before and after highly active antiretroviral therapy. *AIDS* 2008;22(2):301-306.
141. Zoufaly A, Stellbrink HJ, Heiden MA, et al.; ClinSurv Study Group. Cumulative HIV viremia during highly active antiretroviral therapy is a strong predictor of AIDS-related lymphoma. *J Infect Dis* 2009;200(1):79-87.
142. Bower M, Fisher M, Hill T, et al.; UK CHIC Steering Committee. CD4 counts and the risk of systemic non-Hodgkin's lymphoma in individuals with HIV in the UK. *Haematologica* 2009;94(6):875-880. Epub 2009 Mar 31.
143. Lewden C, Bouteloup V, De Wit S, et al. All-cause mortality in treated HIV-infected adults with CD4 \geq 500/mm³ compared with the general population: evidence from a large European observational cohort collaboration{dagger}. The Collaboration of Observational HIV Epidemiological Research Europe (COHERE) in EuroCoord. *Int J Epidemiol* 2012;41(2):433-445. Epub 2011 Nov 28. PMID:22493325
144. Landgren O, Goedert J, Rabkin CS, et al. Circulating serum free light chains as predictive markers of AIDS-related lymphoma. *JCO* 2010;5:773-779.
145. Bernstein WB, Little RF, Wilson WH, et al. Acquired immunodeficiency syndrome-related malignancies in the era of highly active antiretroviral therapy. *Int J Hematol* 2006;84:3-11.
146. Diamond C, Taylor TH, Im T, et al. Improved survival and chemotherapy response among patients with AIDS-related non-Hodgkin's lymphoma receiving highly active antiretroviral therapy. *Hematol Oncol* 2006;24:139-145.
147. Diamond C, Taylor TH, Im T, et al. Highly active antiretroviral therapy is associated with improved survival among patients with AIDS-related primary central nervous system non-Hodgkin's lymphoma. *Curr HIV Res* 2006;4:375-378.
148. Wolf T, Brodt HR, Fichtlscherer S, et al. Changing incidence and prognostic factors of survival in AIDS-related non-Hodgkin's lymphoma in the era of highly active antiretroviral therapy (HAART). *Leuk Lymphoma* 2005;46:207-215.
149. Rabkin CS, Yang Qe, Goedert JJ, et al. Chemokine and chemokine receptor gene variants and risk of non-Hodgkin's lymphoma in human immunodeficiency virus-1-infected individuals. *Blood* 1999;93:1838-1842.
150. Lim ST, Levine AM. Recent advances in acquired immunodeficiency syndrome (AIDS)-related lymphoma. *CA Cancer J Clin* 2005;55:229-241.
151. Lawn SD, Török ME, Wood R. Optimum time to start antiretroviral therapy during HIV-associated opportunistic infections. *Curr Opin Infect Dis*. 2011;24(1):34-42.
152. Tirelli U, Bernardi D. Impact of HAART on the clinical management of AIDS-related cancers. *Eur J Cancer* 2001;37:1320-1324.
153. Rubinstein PG, Braik T, Jain S, et al. Ritonavir based highly active retroviral therapy (HAART) correlates with early neurotoxicity when combined with ABVD treated HIV associated hodgkin lymphoma but not non-hodgkin lymphoma. A retrospective study. *ASH Annu Meet Abstr* 2010:116.
154. Carbone A, Cesarman E, Spina M, Gloghini A, Schultz TF. HIV-associated lymphomas and gamma-herpesviruses. *Blood*;113(6):1213-1224.
155. Piriou E, van Dort K, Nanlohy NM, et al. Loss of EBNA1-specific memory CD4+ and CD8+ T cells in HIV-infected patients progressing to AIDS-related non-Hodgkin lymphoma. *Blood* 2005;106:3166-3174.
156. Hegde U, Filie A, Little RF, et al. High incidence of occult leptomeningeal disease detected by flow cytometry in newly diagnosed aggressive B-cell lymphomas at risk for central nervous system involvement: the role of flow cytometry versus cytology. *Blood* 2005;105(2):496-502.
157. Vaccher E, Tirelli U, Serraino D, et al. Human immunodeficiency virus (HIV) infection among prisoners in northeastern Italy. *Infection* 1988;16:251.
158. Gisselbrecht C, Oksenhendler E, Tirelli U, et al. Human immunodeficiency virus-related lymphoma treatment with intensive combination chemotherapy. French-Italian Cooperative Group. *Am J Med* 1993;95:188-196.
159. Sparano JA, Wiernik PH, Strack M, et al. Infusional cyclophosphamide, doxorubicin and etoposide in HIV-related non-Hodgkin's lymphoma: a follow-up report of a highly active regimen. *Leuk Lymphoma* 1994;14:263-271.

160. Sparano JA, Weller E, Nazeer T, et al. Phase 2 trial of infusional cyclophosphamide, doxorubicin, and etoposide in patients with poor-prognosis, intermediate-grade non-Hodgkin lymphoma: an Eastern Cooperative Oncology Group trial (E3493). *Blood* 2002;100:1634-1640.
161. Sparano JA, Wiernik PH, Hu X, et al. Saquinavir enhances the mucosal toxicity of infusional cyclophosphamide, doxorubicin, and etoposide in patients with HIV-associated non-Hodgkin's lymphoma. *Med Oncol* 1998;15:50-57.
162. Little RF, Pittaluga S, Grant N, et al. Highly effective treatment of acquired immunodeficiency syndrome-related lymphoma with dose-adjusted EPOCH: impact of antiretroviral therapy suspension and tumor biology. *Blood* 2003;101:4653-4659.
163. Sparano JA, Lee JY, Kaplan LD, et al.; AIDS Malignancy Consortium. Rituximab plus concurrent infusional EPOCH chemotherapy is highly effective in HIV-associated B-cell non-Hodgkin lymphoma. *Blood* 2010;115(15): 3008-3016.
164. Little RF, Gutierrez M, Jaffe ES, et al. HIV-associated non-Hodgkin lymphoma: incidence, presentation, and prognosis. *JAMA* 2001;285:1880-1885.
165. Tirelli U, Spina M, Jaeger U, et al. Infusional CDE with rituximab for the treatment of human immunodeficiency virus-associated non-Hodgkin's lymphoma: preliminary results of a phase I/II study. *Recent Results Cancer Res* 2002;159:149-153.
166. Kaplan LD, Lee JY, Ambinder RF, et al. Rituximab does not improve clinical outcome in a randomized phase 3 trial of CHOP with or without rituximab in patients with HIV-associated non-Hodgkin lymphoma: AIDS-Malignancies Consortium Trial 010. *Blood* 2005;106:1538-1543.
167. Boue F, Gabarre J, Gisselbrecht C, et al. Phase II trial of CHOP plus rituximab in patients with HIV-associated non-Hodgkin's lymphoma. *J Clin Oncol* 2006;24:4123-4128.
168. Navarro WH, Kaplan LD. AIDS-related lymphoproliferative disease. *Blood* 2006;107:13-20.
169. Aboulafia DM, Ratner L, Miles SA, Harrington WJ Jr; AIDS Associated Malignancies Clinical Trials Consortium. Antiviral and immunomodulatory treatment for AIDS-related primary central nervous system lymphoma: AIDS Malignancies Consortium pilot study 019. *Clin Lymphoma Myeloma*. 2006;6(5):399-402.
170. Klein U, Gloghini A, Gaidano G, et al. Gene expression profile analysis of AIDS-related primary effusion lymphoma (PEL) suggests a plasmablastic derivation and identifies PEL-specific transcripts. *Blood* 2003;101:4115-4121.
171. Simonelli C, Spina M, Cinelli R, et al. Clinical features and outcome of primary effusion lymphoma in HIV-infected patients: a single-institution study. *J Clin Oncol* 2003;21:3948-3954.
172. Ghosh SK, Wood C, Boise LH, et al. Potentiation of TRAIL-induced apoptosis in primary effusion lymphoma through azidothymidine-mediated inhibition of NF-kappa B. *Blood* 2003;101(6):2321-2327. Epub 2002 Oct 24. PMID:12406882
173. Wang ES, Straus DJ, Teruya-Feldstein J, et al. Intensive chemotherapy with cyclophosphamide, doxorubicin, high-dose methotrexate/ifosfamide, etoposide, and high-dose cytarabine (CODOX-M/IVAC) for human immunodeficiency virus-associated Burkitt lymphoma. *Cancer* 2003;98(6):1196-1205.
174. Cortes J, Thomas D, Rios A, et al. Hyperfractionated cyclophosphamide, vincristine, doxorubicin, and dexamethasone and highly active antiretroviral therapy for patients with acquired immunodeficiency syndrome-related Burkitt lymphoma/leukemia. *Cancer* 2002;94(5):1492-1499. PMID:11920506.
175. Rodrigo JA, Hicks LK, Cheung MC, et al. HIV-Associated Burkitt Lymphoma: good efficacy and tolerance of intensive chemotherapy including CODOX-M/IVAC with or without Rituximab in the HAART Era. *Adv Hematol* 2012;2012:735392. Epub 2011 Nov 14.
176. Yamamoto H, Hagiwara S, Kojima Y, et al. 1629 Rituximab did not improve clinical outcomes in AIDS-related Burkitt Lymphoma. Session: 623. Lymphoma—Chemotherapy, excluding Pre-Clinical Models: Poster I. Hall GH (San Diego Convention Center). Saturday, December 10, 2011.
177. Evans MW, Baer MR, Gojo I, Rapoport A, Kimball AS, Zimri A. Treatment of human immunodeficiency virus (HIV) - associated Burkitt lymphoma (BL) in the era of combined antiretroviral therapy (cART) and rituximab. *J Clin Oncol* 29:2011 (suppl; abstr e18521), ASCO 2011 Abstract No:e18521.
178. Noy A, Kaplan L, Lee J, Cesarman E, Tam W. Modified dose intensive R-CODOX-M/IVAC for HIV-associated burkitt (BL) (AMC 048) shows efficacy and tolerability, and predictive potential of IRF4/MUM1 expression. *Infect Agents Cancer* 2012;7(Suppl 1):O14. <http://www.infectagentscancer.com/content/7/S1/O14>.

179. Dunleavy K, Healey Bird BR, Pittaluga S, et al. Efficacy and toxicity of dose-adjusted EPOCH-rituximab in adults with newly diagnosed Burkitt lymphoma. *J Clin Oncol* 2007 ASCO Annual Meeting Proceedings (Post-Meeting Edition) 2007;25(18S):8035.
180. Delecluse HJ, Anagnostopoulos I, Dallenbach F, et al. Plasmablastic lymphomas of the oral cavity: a new entity associated with the human immunodeficiency virus infection. *Blood*. 1997;89(4):1413-1420.
181. Teruya-Feldstein J, Chiao E, Filippa DA, Lin O, Comenzo R, Coleman M, Portlock C, Noy A. CD20-negative large-cell lymphoma with plasmablastic features: a clinically heterogenous spectrum in both HIV-positive and -negative patients. *Ann Oncol* 2004;15(11):1673-1679.
182. Biggar RJ, Jaffe ES, Goedert JJ, et al. Hodgkin lymphoma and immunodeficiency in persons with HIV/AIDS. *Blood* 2006;108:3786-3791.
183. Levine AM. Hodgkin's disease in the setting of human immunodeficiency virus infection. *J Natl Cancer Inst Monogr* 1998;23:37-42.
184. Tirelli U, Vaccher E, Spina M, et al. Hodgkin's disease: clinical presentation and treatment. *Cancer Treat Res* 2001;104:247-265.
185. Engels E, Marks PW, Kazanjian P. Usefulness of bone marrow examination in the evaluation of unexplained fevers in patients infected with human immunodeficiency virus. *Clin Infect Dis* 1995;21:427-428.
186. Tirelli U, Errante D, Carbone A, et al. Malignant tumors in patients with HIV infection. *Crit Rev Oncol Hematol* 1996;24:165-184.
187. Errante D, Gabarre J, Ridolfo AL, et al. Hodgkin's disease in 35 patients with HIV infection: an experience with epirubicin, bleomycin, vinblastine and prednisone chemotherapy in combination with antiretroviral therapy and primary use of G-CSF. *Ann Oncol* 1999;10:189-195.
188. Krishnan A, Molina A, Zaia J, et al. Durable remissions with autologous stem cell transplantation for high-risk HIV-associated lymphomas. *Blood* 2005;105:874-878.
189. Gabarre J, Azar N, Autran B, et al. High-dose therapy and autologous haematopoietic stem-cell transplantation for HIV-1-associated lymphoma. *Lancet* 2000;355:1071-1072.
190. Re A, Cattaneo C, Michieli M, Casari S, et al. High-dose therapy and autologous peripheral-blood stem-cell transplantation as salvage treatment for HIV-associated lymphoma in patients receiving highly active antiretroviral therapy. *JCO* 2003;21(23):4423-4427.
191. Re A, Michieli M, Casari S, et al. High-dose therapy and autologous peripheral blood stem cell transplantation as salvage treatment for AIDS-related lymphoma: long-term results of the Italian Cooperative Group on AIDS and Tumors (GICAT) study with analysis of prognostic factors. *Blood* 2009;114(7):1306-1313.
192. Balsalobre P, Díez-Martín JL, Re A, et al. Autologous stem-cell transplantation in patients with HIV-related lymphoma. *JCO* 2009;2192-2198.
193. Krishnan A, Palmer JM, Zaia JA, Tsai N, Alvarnas J, Forman SJ. HIV status does not affect the outcome of autologous stem cell transplantation (ASCT) for non-Hodgkin lymphoma (NHL). *Biol Blood Marrow Transplant* 2010;16(9):1302-1308. Epub 2010 Mar 28. doi:10.1016/j.bbmt.2010.03.019.
194. DiGiusto DL, Krishnan A, Li L, et al. RNA-based gene therapy for HIV with lentiviral vector-modified CD34+ cells in patients undergoing transplantation for AIDS-related lymphoma. *Sci Transl Med* 2010;2(36):36ra43. doi:10.1126/scitranslmed.3000931.
195. Kang EM, De WM, Malech H, et al. Nonmyeloablative conditioning followed by transplantation of genetically modified HLA-matched peripheral blood progenitor cells for hematologic malignancies in patients with acquired immunodeficiency syndrome. *Blood* 2002;99:698-701.

Chapter 65 Disorders of the Spleen

> Table of Contents > Part VI - Benign Disorders of Leukocytes, The Spleen, and/or Immunoglobulins > Chapter 65 - Disorders of the Spleen

Chapter 65

Disorders of the Spleen

Matthew R. Porembka

Majella Doyle

William C. Chapman

The spleen is a small, purplish, sponge-like organ found in the left upper abdominal quadrant.¹ Although there is no mention of the spleen in the Bible, it receives considerable attention in the Talmud and post-Talmudic literature. Classically identified as the seat of laughter, there has been much debate over whether the spleen is truly necessary.² It is said that Galen called it an “organ full of mystery” as early as the second century A.D. Although we have come to understand much about the structure and function of the spleen since those times, much of what intrigued Galen still remains a mystery today. The spleen has been classified into different organ systems including the circulatory system, the hematopoietic system, the mononuclear phagocyte system, or the lymphatic system. However, it is probably more accurate to describe the spleen as a clearinghouse for circulating cellular elements—a place where multiple organ systems converge in both structure and function.

DEVELOPMENT AND ANATOMY

The spleen is derived from embryonic mesoderm. The developing organ first becomes apparent during the fifth week of gestation as mesodermal cells coalesce between the leaflets of the dorsal mesogastrium, posterior to the developing stomach. As development continues, independent lobules enveloped by mesogastrium become evident. In time, they fuse to form a multilobulated mass that eventually differentiates into a well-formed organ by late fetal life.³ Occasionally, a stray lobule may fail to fuse with the others, develop independently, and give rise to an accessory spleen, a functioning mass of splenic tissue set apart from the body of the organ proper. The mesogastrium enveloping the lobules eventually gives rise to the organ's capsule and trabecular skeleton, and the posterior and anterior attachments give rise to the primary supporting structures: the splenorenal and gastrosplenic ligaments, respectively.⁴ The colonization of the cellular elements of the spleen occurs first with the erythroid and myeloid progenitors, followed by the first hematopoietic stem cells. Finally, lymphoid-tissue-inducer cells are observed and provide the necessary local cellular signals to trigger the unique architecture of the splenic cellular elements. This development is highly similar to that of lymph nodes.⁵

Gross Anatomy

Grossly, the spleen may appear in a variety of shapes. It may be wedge-shaped (44%), tetrahedral (42%), or triangular (14%), depending on its relationships with the stomach, left kidney, pancreas, and colon. The average adult spleen measures 13 to 15 cm in length, 8 to 10 cm in width, and 4 cm in thickness, with a weight of 150 g and a corresponding blood volume of ~300 mL.⁴ However, the size of the spleen varies with age, immunologic status, and nutritional status.¹

The nonperfused organ appears purplish in color with a solid, sponge-like texture throughout. It is covered by a fibrous connective tissue capsule that is 1.5 mm thick and composed of collagen and elastin fibers.¹ This capsule surrounds all but the hilum of the spleen.⁴ Continuous with the capsule, involutions penetrate the body of the organ to form trabeculae, the fibrous supporting skeleton of the spleen.³ Finally, a serosal membrane, derived from peritoneum, covers the organ externally and adheres to the capsule. This mesothelial membrane covers the entire organ except at its hilum and the reflections of its primary supporting ligaments.¹

In the majority of people, the spleen is divided into the superior lobe and inferior lobe, but further division into subsegmental lobes can be seen.⁶ Avascular planes separate each lobe and they are defined by discrete, nonanastomosing circulatory pathways.^{1, 3, 6}

Location and Relationships

The spleen is located in the left upper quadrant of the abdominal cavity, posteriorly, at the level of the ninth to eleventh thoracic vertebrae. The superior, or diaphragmatic, surface of the organ is convex in shape, smooth, and related to the left hemidiaphragm; whereas the inferior, or visceral, surface is somewhat triangular and rests on the splenic flexure of the colon.^{1, 4}

The medial portion of the spleen is concave and divided by a longitudinal ridge into a gastric surface anteriorly and a renal surface posteriorly. The gastric surface contains the hilum of the organ and relates to the fundus of the stomach and the tail of the pancreas. The tail of the pancreas touches the spleen in 30% of cases and is within 1 cm of it in 73% of the population, contributing to the risk of pancreatic injury in patients undergoing splenectomy.⁷ The renal surface borders the superolateral surface of the left kidney and left adrenal gland. Figure 65.1 shows the gross appearance of the spleen as well as its relationship to the adjacent pancreatic tail and branch vessels of the splenic artery.

The spleen is supported by a number of suspensory ligaments: the splenorenal posteriorly, the gastrosplenic anteromedially, the splenophrenic superiorly, and the splenocolic inferiorly.¹ The splenorenal and gastrosplenic ligaments provide the majority of support to the organ and are considered primary. The splenorenal ligament supports the organ posteriorly and serves as a conduit for the organ's neurovascular bundle, whereas the gastrosplenic ligament stabilizes the spleen anteromedially to the greater curvature of the stomach and contains the short gastric and gastroepiploic vessels. The other ligaments of the spleen play a secondary role in the support of the organ and are generally

P.1370

avascular.^{1, 4} However, in certain pathologic states, such as portal hypertension, significant collateral circulation through these planes may occur.

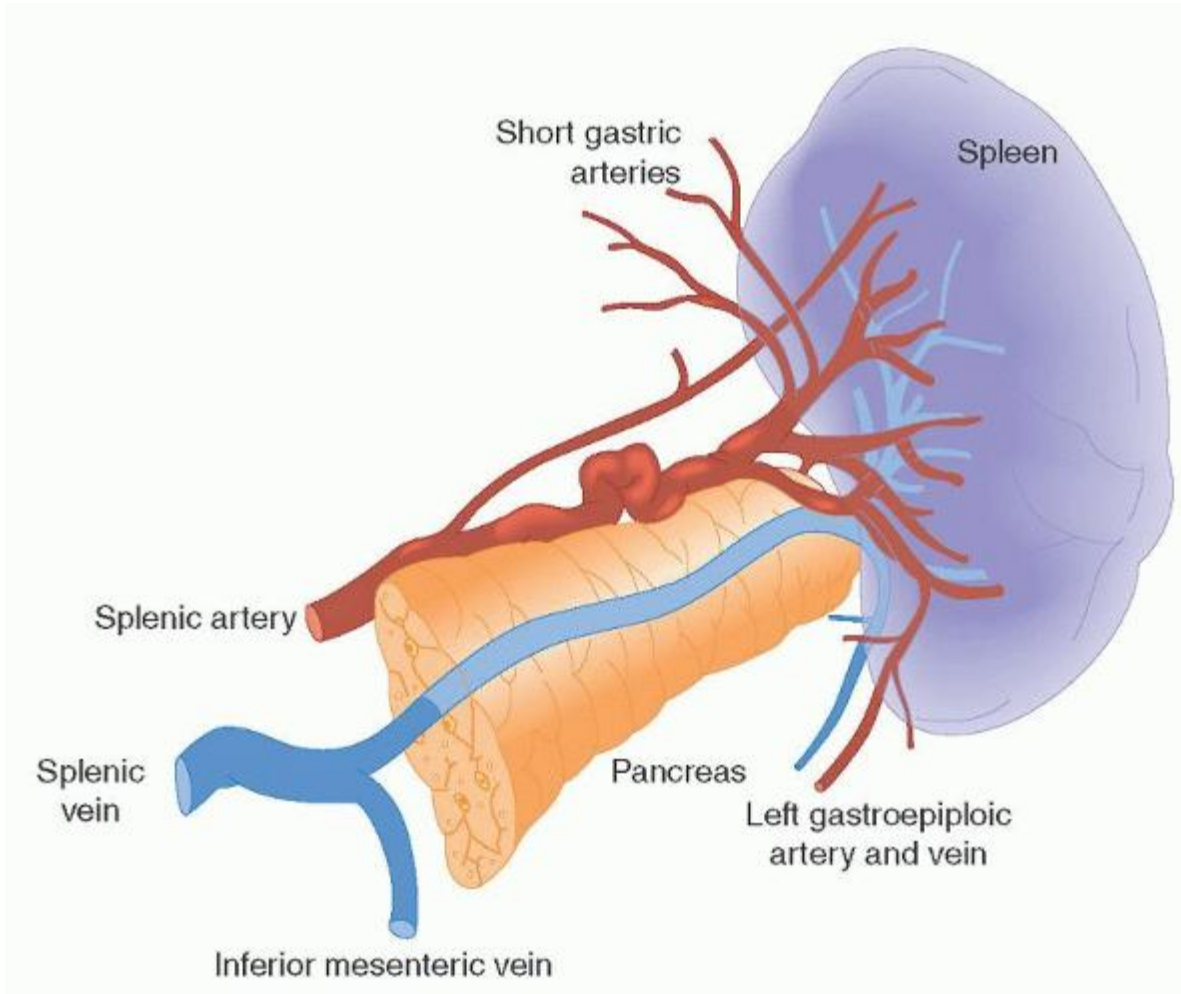

FIGURE 65.1. Illustration of the spleen and relationship to the adjacent pancreatic tail and branch vessels of the splenic artery and vein. (Redrawn and modified from Cameron JL, ed. Atlas of surgery. Philadelphia, PA: BC Decker, 1990.)

Vascular Supply

The spleen is a highly perfused organ. Although it represents only ~0.2% of the total body weight, it receives > 5% of the total cardiac output.⁸ The main blood supply to the spleen is the highly variable splenic artery, which delivers 250 to 300 ml of arterial blood per minute. It arises as a branch of the aorta's celiac trunk in the midline and follows a tortuous course to the left, enveloped within the splenorenal ligament, to supply the organ.¹

The splenic artery is a highly unpredictable vessel that displays variations in course and dimension. In 95% of the population, it travels along the upper border of the pancreas, but it may also travel in front of, within, or behind the pancreatic tissue. Along its tortuous course, the splenic artery gives rise to the left gastroepiploic artery and the short gastric arteries, both of which run within the gastrosplenic ligament. At its terminal end, the splenic artery branches into a number of smaller arteries, or segmental branches, before penetrating the hilum of the organ. These smaller arteries are

also highly variable but are most often four in number and include the superior polar, superior middle, inferior middle, and inferior polar splenic arteries. The segmental branches penetrate the organ by traveling within the trabeculae (sheaths of fibrous connective tissue derived from the involution of the spleen's fibrous capsule) and ramify within the body of the organ. Additional sources of arterial blood to the spleen include direct tributaries and collateral circulation provided by branches of the pancreatic and short gastric arteries.^{1, 4}

Venous drainage is facilitated primarily by the splenic vein. It is formed by the coalescence of the segmental splenic veins, as they leave the hilum of the organ, and the left gastroepiploic vein. Occasionally, short gastric veins may also participate. The splenic vein courses toward the midline along the superior border of the pancreas, where it joins the superior mesenteric vein to form the portal vein. Along the way, the splenic vein receives venous tributaries from the pancreas and, in 60% of cases, also receives the inferior mesenteric vein.^{1, 4}

Lymphatics

The spleen, which is considered by many to be a lymphatic organ, has no afferent lymphatics, yet a significant amount of lymph fluid is expressed by the organ and drains via efferent vessels that form around the arterioles. The lymphatics travel with the neurovascular bundle through the trabeculae, exiting at the hilum.^{3, 9} In turn, the lymphatic fluid is directed toward the nodes of the splenic hilum, the splenic artery, and the pancreas (the pancreaticosplenic nodes), and eventually drains to the nodes of the celiac axis.⁴

Innervation

The spleen is innervated by fibers of the sympathetic nervous system which originate at the level of T-6 to T-8 and pass with the greater thoracic splanchnic nerve to the celiac ganglion.¹⁵ From there, they pass to the organ via the arterial tree, with resulting vasomotor function.¹ It is believed that, similar to other mammals, the autonomic nervous system regulates changes in spleen volume, resulting in the expulsion of stored red blood cells during times of physiologic need.^{18, 25}

Of interest are studies that relate the sympathetic innervation of the spleen to the immune system.^{10, 11, 12} These studies suggest that spleen innervation also supplies branches to the lymphocytic tissue of the white pulp, and that the innervation is plastic and able to be remodeled depending on the host's current immune state.¹³ In this respect, these investigators argue, the central nervous system is hard-wired to the immune system and may mediate the observed immunosuppressive effects of stress.

Accessory Spleens

An accessory spleen is a functioning lobule of splenic tissue set apart from the body of the spleen proper. It is an anatomic variant present in 10% to 30% of the general population and appears to be found with greater frequency in patients with hematologic disorders. Figure 65.2 shows a typical example of an accessory spleen.

These supernumerary organs arise during embryologic development when an encapsulated lobule of precursor cells fails to fuse with others forming the spleen proper; they are solitary in ~88% but can be multiple in 10% of cases.¹⁴ In the majority of cases, accessory spleens receive their blood supply from a tributary of the splenic artery and are found most often near the hilum of the organ or within one of the primary supporting ligaments. However, they may be found within secondary supporting ligaments or within the greater omentum or even in as remote a location as the pelvis of the female or the scrotum of the male. They may be mistaken for malignancy on imaging studies, such as computed tomography (CT) or endoscopic ultrasound.

Because accessory spleens perform the same functions as the spleen proper, they are subject to the same pathologic conditions that affect the parent organ. Therefore, they may enlarge after splenectomy, causing a relapse of the disease process for which the spleen was removed. The presence of an unrecognized accessory spleen can account for failure of certain surgical procedures such as splenectomy for immune thrombocytopenic purpura (ITP).^{15, 16, 17, 18} In patients who continue to have thrombocytopenia after splenectomy, a search for a missed accessory spleen should be considered. Diagnosis may be made using abdominal sonography, CT, magnetic resonance imaging, nuclear scintigraphy, or Doppler sonography.¹⁹

Splenosis

In addition to accessory spleens, extrasplenic tissue may occur via traumatic autotransplantation in the form of splenosis. This is the migration and subsequent proliferation of dislodged splenic

P.1371

tissue, and it is reported to occur in up to 75% of patients who undergo splenectomy for traumatic injury. Rarely, splenosis

may be found in the gynecologic patient or in the thorax after rupture of the spleen and left hemidiaphragm.^{20, 21, 22} Histologic examination of splenic tissue reveals the same elements of the parent organ: white pulp, red pulp, and marginal zones.²⁰ It follows, therefore, that splenic tissue should preserve at least some splenic function. Indeed, it has been observed that postsplenectomy patients with splenic tissue do retain the ability to clear erythrocytes of undesirable inclusion bodies. However, it has not been demonstrated that this provides sufficient protection from postsplenectomy infectious complications, and the practice of splenic tissue reimplantation after splenectomy has been abandoned.²³

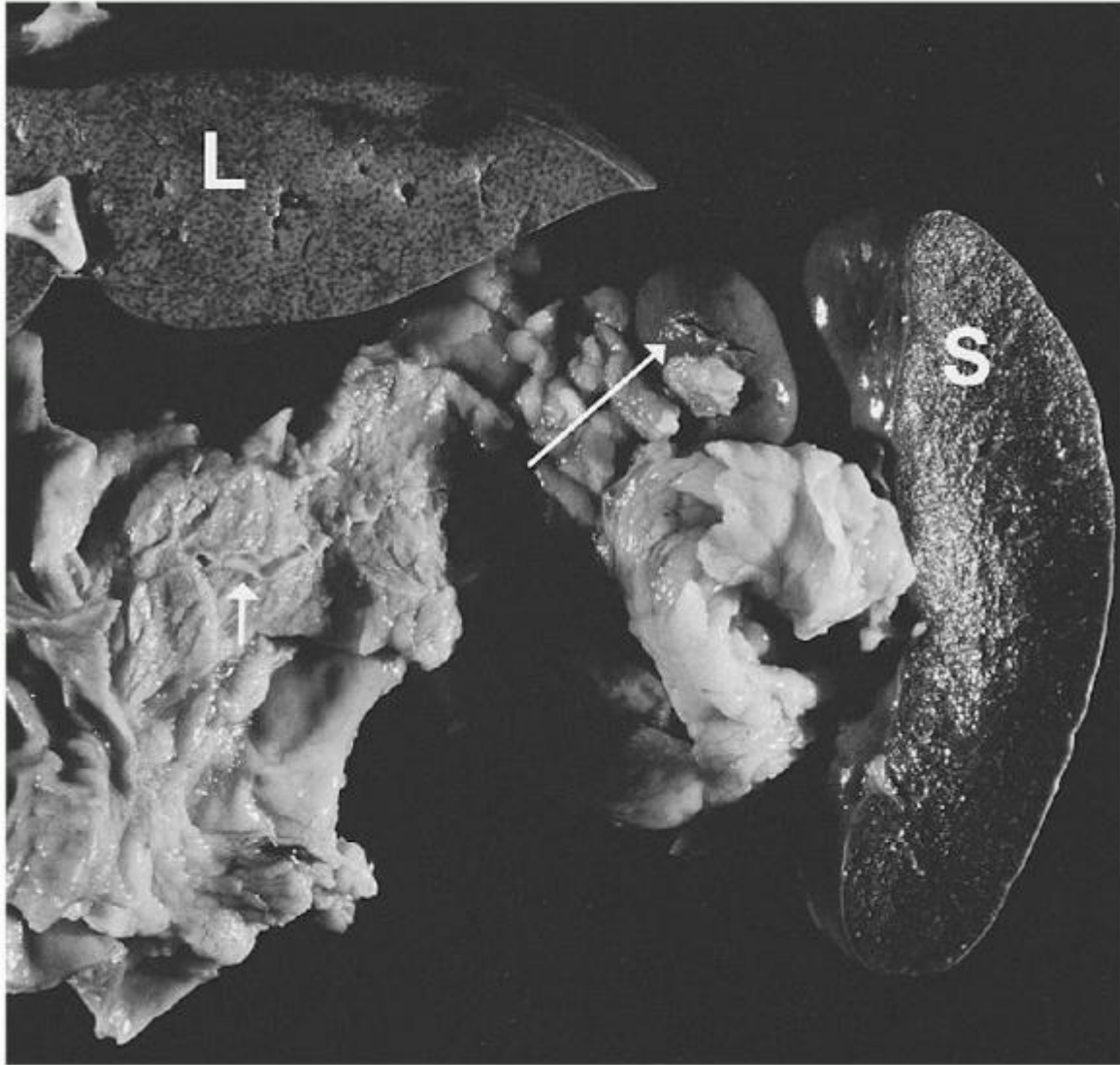

FIGURE 65.2. Autopsy photograph demonstrating accessory spleen (large arrow) and its relationship to the splenic hilum, pancreas (small arrow), and adjacent liver. L, liver; S, spleen. (Photograph provided by Hedi Wingard, M.D., Department of Pathology, Vanderbilt University Medical Center.)

Wandering Spleen

Wandering spleen refers to migration of the spleen from its normal location in the left upper quadrant. With an incidence of <0.5% in splenectomy series, the major complication of an ectopic spleen is torsion, either acutely or chronically. Signs and symptoms include vague or chronic abdominal discomfort and a tender abdominal mass; and CT assessment of viability leads to the decision of splenectomy versus splenopexy.

Microscopic Anatomy

Splenic tissue is supported by a scaffold of trabeculae, a dense, fibrous connective tissue skeleton that gives rise to an intrasplenic meshwork of collagen fibers. Vascular elements enter the spleen at the hilum, branch through the trabeculae,

and penetrate the body of the organ to supply the microcirculation.¹ As the arterial elements enter the parenchyma, they become surrounded by an aggregate of lymphoid tissue, which follows vessels in a sheathlike distribution. Aggregates of lymphoid tissue are collectively called the white pulp. White pulp may be arranged in this coaxial fashion, or it may appear as isolated follicles within the parenchyma of the organ. The balance of splenic tissue beneath the capsule is known as the red pulp. It is composed of vascular, circulatory, and mononuclear phagocytic elements. Additionally, an intermediate region can be observed at the junction between the white and red pulp; it is known as the marginal zone. Nerves and lymphatics follow the distribution of the larger vessels throughout the body of the organ.

White Pulp

The white pulp structure resembles that of a lymph node, with organized T and B cell compartments surrounding branching arterial vessels. The organization of the cellular elements within the white pulp is created and maintained by local chemokine gradients specific to T and B cells.^{3, 9} White pulp may be observed in one of two arrangements: a periarteriolar lymphatic sheath (PALS) or a lymphoid follicle. The PALS is a collection of T lymphocytes that surrounds intraparenchymal arterioles and follows these vessels in a coaxial fashion for several millimeters throughout their terminal distribution. Within the PALS, T cells interact with dendritic cells and passing B cells. The lymphoid follicles are spherical collections of B lymphocytes. These follicles are usually distributed along the length of the PALS in an eccentric fashion and house activated B cells undergoing clonal expansion.⁹

Red Pulp

The red pulp represents approximately three-fourths of the splenic volume and is composed primarily of vascular elements surrounded by a fibrocellular reticulum that contains mononuclear phagocytic cell lines and circulating elements of blood in transit.¹ The chief vascular component of the red pulp is the splenic sinus, a preliminary venous element whose structure is unique to this organ. The sinus is composed of an incomplete lining of elongated endothelial cells surrounded by a highly fenestrated basement membrane. The structure is supported externally by reticulin fibers wrapped in a transverse fashion. These stress fibers also have actin- and myosin-like filaments which regulate the porosity of the sinus. The unique architecture of the splenic sinus has been compared to the structure of a wooden barrel, with the elongated endothelial cells resembling the planks or staves and the external reticulin fibers representing the hoops.³

The splenic sinuses permeate the surrounding fibrocellular reticulum that supports them. Two-dimensional histologic observation reveals an intervening reticulum arranged in cords called splenic cords or cords of Billroth.¹ These cords actually are a three-dimensional meshwork of densely packed elements (fibroblasts, collagen fibers, and cells of the mononuclear phagocytic lines). Terminal arterioles and capillaries deliver circulating blood to this meshwork that percolates through the cord toward the sinuses. Thus, circulating elements of blood in transit are also packed within the cords: erythrocytes, platelets, macrophages, lymphocytes, plasma cells, and granulocytes.^{1, 3, 9}

Marginal Zone

The marginal zone is a transitional region between the white and red pulp and contains both lymphocytic and mononuclear phagocytic elements. Within this transitional zone, three distinct regions can be identified. Moving from white to red pulp are the marginal sinus, the marginal zone proper, and the perimarginal cavernous sinus plexus.³

The marginal sinus is a vascular sinus that surrounds the white pulp and is a region where arterioles terminate into an anastomosing complex of vascular spaces. External to the marginal sinus is the marginal zone. This transitional region contains elements of both white and red pulp and is where much of the circulating blood is presented to lymphocytic and mononuclear phagocytic cells.^{3, 24} Figure 65.3 illustrates a schematic view of the microcirculation within the spleen.

Many different cell types reside in the marginal zone. Its foundation is a framework of reticular fibroblasts which is continuous with the reticular fibroblasts of the red pulp and the cells lining the marginal sinus. The marginal zone macrophage, metallophilic macrophage, and B cell are the key cell types in this transitional zone. The marginal zone B cell is a specialized subset of B cells that differ phenotypically and functionally from follicular B cells and are considered a bridge between the innate and adaptive immune systems.²⁵ Interactions between these cells are key in the marginal zone's organization and integrity. Many transient cells

P.1372

pass through this area as they circulate into the red pulp and back into the blood stream. Diapedesis of lymphocytes and dendritic cells occurs through a barrier cell layer from the marginal sinus into the white pulp; however, the exact mechanism of this localization remains unknown.^{25, 26}

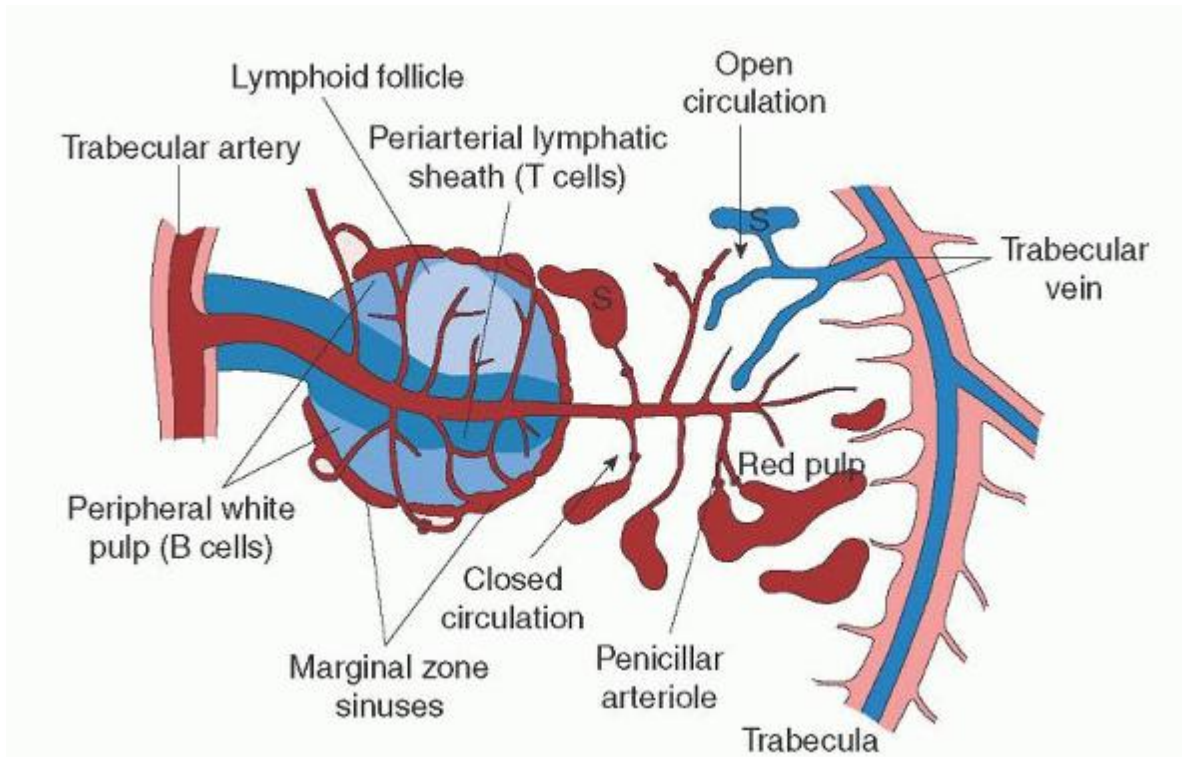

FIGURE 65.3. Schematic illustration of the microcirculation of the spleen. S, splenic sinus. (Redrawn and modified from Greep RO, ed. *The spleen*. New York: McGraw-Hill, 1966.)

Microvasculature

As the splenic artery approaches the body of the organ, it divides into a series of branches, the proper splenic arteries. On average, four proper splenic arteries then enter the organ at the hilum and branch into trabecular arteries, so named because they run within the framework of the fibrous connective tissue skeleton, the trabeculae. Trabecular arteries leave the fibrous trabeculae and penetrate the parenchyma by branching into central arteries that immediately become surrounded by a cuff of white pulp, the PALS.^{3, 9}

As the central arteries pass through the white pulp, they give off lateral branches at right angles, most of which terminate in and supply the marginal sinuses, and others that terminate within the marginal zone or red pulp.^{9, 27} The right angle by which these lateral tributaries branch off from the central artery is thought to mediate a plasma-skimming effect which functions to hemoconcentrate the blood with a greater number of cellular elements.^{27, 28, 29} This skimming effect may also help regulate plasma volume. Central arteries continue from the white pulp sheath through the marginal zone and eventually terminate in the red pulp, giving off additional lateral branches along the way that are known as penicillar arterioles.¹ The penicillar arterioles, which are named for their resemblance to *Penicillium* molds, terminate in one of three fashions: They may circle back and supply the marginal sinus; they may terminate in the red pulp, supplying the splenic cords; and a minority may terminate directly into the venous sinuses for direct venous return. Eventually, the central artery itself terminates within the red pulp.^{24, 27, 29}

Circulating elements of splenic blood flow begin their return by first entering the splenic sinuses, the preliminary venous vessels. Flow may enter the sinuses directly from arterial connections in a closed circulatory fashion. Alternatively, plasma and blood cells may reach the sinuses only after percolating through the reticulum of the parenchyma in an open circulatory fashion. Eventually, the venous sinuses coalesce and drain into trabecular veins that give rise to the segmental veins and, finally, the splenic vein.^{24, 27, 29}

The exact details of splenic microcirculation remain elusive despite much research since its first description in 1901. The currently accepted models that describe the flow of blood through the vessels of the spleen discuss this in terms of the pathway taken, or route, and the kinetics, or speed of flow. Closed circulation implies that blood passes directly from artery to capillary to vein. In terms of the spleen, blood traveling along a closed circulatory path follows the terminal arterioles to capillaries and, eventually, into the venous sinuses. Indeed, such direct connections have been observed.^{24, 27, 29}

The term open circulation implies that cells and plasma circulate outside of endothelium-lined vascular channels. As it pertains to the spleen, circulating blood may follow one of two open pathways: It may leave the endothelium-lined marginal sinus, traverse the white pulp, and drain into the open-ended sinuses of the perimarginal cavernous sinus plexus²⁷; or it may leave penicillar arterioles that terminate in stroma of the red pulp, traverse the splenic cords, and reenter the venous sinuses through their fenestrations. Indeed, the unique vascular channels and microarchitecture of the spleen can support these open circulatory pathways, which also have been observed.^{9, 24, 29}

Another model for discussing splenic microcirculation describes it in terms of kinetics or speed of flow.^{1, 27} Accordingly, intrasplenic circulation may be fast, intermediate, or slow, traversing the organ in seconds, minutes, or hours.¹ Fast flow occurs along paths of low resistance, traverses the organ in seconds, and accounts for ~90% of splenic flow.²⁴ Pathways that support fast flow include the open circulation of the marginal zone and, to a lesser extent, the closed circulation of direct arterial, capillary, and sinus connections.²⁷

Elements that flow at an intermediate speed cross the circulation within minutes rather than seconds and represent ~9% of flow across the organ. These elements are thought to follow the open circulation through the cords where red cell processing— pitting and culling—occurs.

Finally, slow-flowing elements may take more than a day to traverse the organ and represent 1% of splenic flow. This is thought to represent a pool of maturing reticulocytes, which travel to the spleen from the bone marrow and undergo maturation before being released into the circulation.²⁷ The role of the spleen in this function is well documented and supported by the fact that asplenic patients have a high concentration of immature reticulocytes in their peripheral circulation.³⁰

SPLENIC FUNCTION

The functions of the spleen are probably best understood in terms of its unique structure. Composed of several different tissue types, it lies at the crossroads between the arterial supply and venous return. In this respect, the spleen functions as a unique lymphoid organ where elements of the circulatory, reticuloendothelial, and immune systems interact. Thus, it is ideally suited to play a critical role in the surveillance of circulating blood.

The spleen functions as a filter of the circulating blood, a coordinator of the immune response, and a reservoir for circulating cells and platelets. Additionally, the spleen may have a number of other responsibilities, including hematopoiesis, hemoglobin degradation and iron recovery, and plasma volume regulation.

Filter Function

One of the primary functions of the spleen is to filter blood. Elements removed from circulation by the spleen include aging or abnormal red cells, intraerythrocyte inclusions, and foreign particulate matter.³

Culling

The removal of aging or abnormal red blood cells by the spleen occurs within the cords of Billroth and is known as culling. Cells bound for destruction become trapped within the reticulum meshwork and, as their splenic transit time increases, they succumb to phagocytosis by resident macrophages.

Another theory contends that as erythrocytes age, they lose significant amounts of cytoplasmic membrane. Senescent cells therefore lack the deformability necessary to negotiate the meshwork and ultimately become trapped. This theory applies to red cells that are morphologically abnormal secondary to congenital disorders such as sickle cell anemia and hereditary spherocytosis. Finally, it has been proposed that as erythrocytes age, they expose surface antigens that are recognized by self-directed antibodies. Once opsonized with antibody, senescent cells are easily trapped by cordal macrophages.^{3, 9, 30, 31}

Pitting

In addition to culling, the spleen also functions to remove intraerythrocyte inclusions from circulating red cells. The ability of the spleen to clear these inclusions while maintaining the integrity of the red cell itself is known as pitting and is an exclusive function of splenic tissue.

P.1373

Undesirable intracellular elements removed by the spleen include circulating particulate matter, Heinz bodies (denatured hemoglobin), Howell-Jolly bodies (nuclear remnants), and Pappenheimer bodies (iron granules). Pitting occurs as cells

within the cords attempt to reenter the circulation through the splenic sinuses. To do this, they must pass through slit-like fenestrations of the sinus endothelium. As this occurs, the deformable portion of the cell bends to negotiate the opening, whereas the inclusion, which is nondeformable, is unable to pass through the narrow passage; thus, it is left behind to be phagocytized by resident macrophages. The passage of red cells through the slits is mediated by active changes within the sinus endothelial cell stress fibers. These cells have been shown to have cytoskeletons that include the contractile protein components actin and myosin.^{3, 22, 31} Figure 65.4 is a schematic representation of the process of pitting.

Evidence that supports the role of the spleen in culling and pitting is found in the fact that, after splenectomy, asplenic and hyposplenic patients lose their ability to clear damaged red cells and intraerythrocyte inclusion bodies from the circulation. These patients display peripheral blood smears with an abnormal variety of erythrocytes, many with intracellular inclusions. In fact, determination of the percentage of pitted erythrocytes is a well-established method of assessing splenic function.^{30, 31}

Clearance of Particulate Matter

Another important filtering function of the spleen is its ability to remove particulate matter from the circulation. As blood travels through the meshwork of the cords, foreign particles are exposed to splenic macrophages that clear them by phagocytosis. Experiments with injected carbon particles have confirmed this process and have identified the cells chiefly responsible for this function: The macrophages surrounding the splenic sinuses.

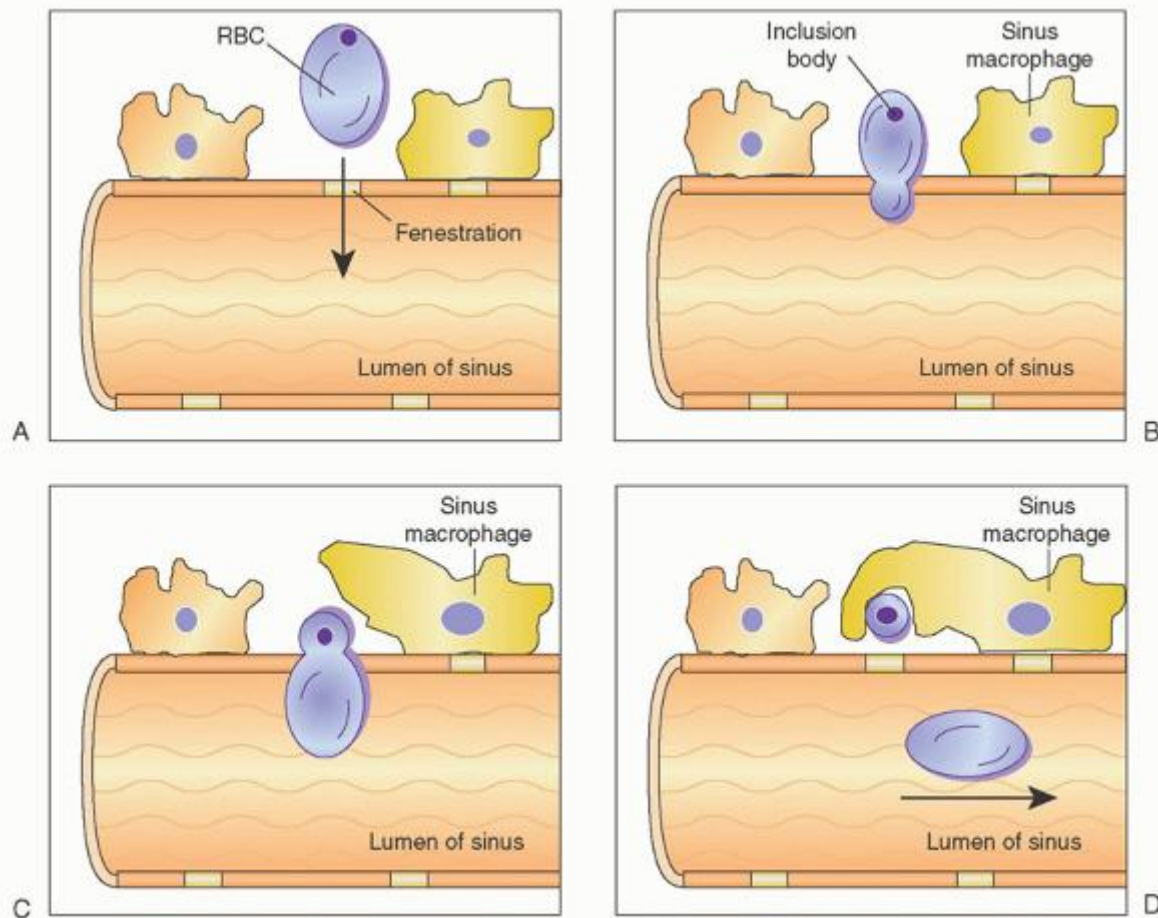

FIGURE 65.4. Schematic representation of process of pitting by the spleen. This process is believed to be responsible for removal of undesirable elements from circulation, including particulate matter, Heinz bodies (denatured hemoglobin), Howell-Jolly bodies (nuclear remnants), and Pappenheimer bodies (iron granules). A: Red blood cell (RBC) flows from open circulation and approaches fenestration of sinus. B: RBC begins to enter sinus through fenestration; note inclusion body within RBC. C: RBC transveres sinus; membrane-bound inclusion body lags behind. Sinus macrophage begins to approach inclusion body. D: RBC within sinus returns to venous circulation. Inclusion body succumbs to sinus macrophage. (Modified from Weintraub LR. Splenectomy: who, when, and why? *Hosp Pract (Off Ed)* 1994;29.)

Immune Function

Because the spleen is composed of lymphocytic tissue, circulatory elements, and mononuclear phagocytic cell lines, it is ideally suited to play a coordinating role in the immune response. The organ's function in this respect includes its role in the nonspecific as well as the specific arm of the immune response, making it an important organ for immune homeostasis. The nonspecific immune functions of the spleen include the clearance of pathogens, the clearance of opsonized erythrocytes and platelets, and the production of complement. The ability of the spleen to clear blood-borne microorganisms and debris combined with its highly organized lymphoid compartment makes the spleen the most important organ for antibacterial and antifungal immune reactivity.

The spleen plays a significant role in the removal of bloodborne pathogens from the circulation. Once coated with complement, bacteria and viruses become circulating immune complexes. Although the liver clears some of these complexes, many others are delivered to the spleen and eliminated by marginal zone cells expressing specific receptors including pattern-recognition receptors, C-type lectin SIGNR1, and type 1 scavenger receptor MARCO.³² Marginal zone metallophilic macrophages also function to concentrate pathogens in the spleen, leading to their opsonization, and produce high levels of interferon- α and interferon- β

P.1374

after viral exposure.²⁶ Marginal zone B cells are specialized to detect circulating pathogens, after which they rapidly differentiate into immunoglobulin (Ig) M producing plasma cells or antigen presenting cells capable of CD4⁺ T cell activation.²⁶ The contribution of the spleen to this process is supported by the fact that asplenic patients display a higher level of circulating immune complexes than do spleen-competent subjects.

The ability of the spleen to clear encapsulated bacteria is especially significant. Because these organisms have the ability to evade antibody and complement binding, their clearance depends on prolonged contact between pathogen and macrophage. It is well recognized that asplenic or hyposplenic patients are prone to a syndrome of fulminant septicemia, most often involving encapsulated bacteria: Overwhelming postsplenectomy sepsis.³¹

The spleen also plays a major role in the removal of opsonized erythrocytes and platelets from the circulation. In certain pathologic states, such as autoimmune hemolytic anemia or ITP, circulating elements become opsonized with IgG antibody. The resulting cell-antibody complexes enter the spleen and encounter Fc receptor-laden macrophages in the marginal zone, where they are destroyed.³

Several proteins and glycoproteins of the complement system are synthesized by mononuclear phagocytic cells in the spleen, namely properdin and tuftsin. Properdin is an opsonin that plays a critical role in the alternative pathway and has been detected in the monocytes of the spleen. Tuftsin stimulates interleukin-1 production and binds to granulocytes to initiate phagocytosis.³ Although these elements are also produced at other locations including tissue macrophages and the liver, the spleen's contribution is significant, and they are found in lower concentrations in the circulation of asplenic or hyposplenic patients. Patients who have lost their spleens also display a decreased concentration of C3 and factor B.³³

Specific Immune Response

The spleen is also uniquely suited to play a coordinating role in the specific arm of the immune response. Because white pulp and vascular elements lie adjacent to each other, this may serve as an interface between the lymphocytic populations of T and B cells and the elements of circulating blood.

As circulating blood enters the spleen, 90% of it passes through the marginal sinuses and surrounding zones.²⁷ Here, foreign antigens are exposed to the lymphocytic tissue of the PALS and the follicles, stimulating them to respond. After antigen-specific differentiation in the white pulp follicles, plasmablasts migrate to the bridging channels of the marginal zone within the red pulp.³⁴ The anatomic localization of the plasmablasts in the spleen resembles that found in lymph nodes. Antibodies produced at this location rapidly enter the circulation. The spleen also plays an important role in the induction of cell-mediated immunity. Once activated, antigen presenting cells enter the white pulp, resulting in the activation of T cells. Activated T cells then localize to the periphery of the B cell follicles where costimulatory signals are exchanged, resulting in B cell isotype switching in the follicle. These activated B cells then either migrate to the marginal zone, or remain in the germinal center. It should be noted that although these functions also occur within lymph nodes, asplenic patients demonstrate a specific response to blood-borne antigens. For example, the production of IgM in asplenic patients is both delayed and diminished. On the other hand, specific immune factors that rise in the circulation after a splenectomy include IgE and self-directed autoantibodies. This is likely due to structural differences between the lymph nodes and spleen which carry antigen to each. Antigens transported to the white pulp are from the circulating blood, whereas those delivered to lymph nodes are carried by the lymph.^{35, 36}

Cellular Reservoir Function

The ability of the spleen to function as a reservoir for circulating elements has been the subject of much study. Platelet sequestration by the spleen is well documented. Newer evidence supports the spleen as a primary site of production and a reservoir for white blood cells.³

The spleen is considered a reservoir for platelets because it can sequester large quantities of thrombocytes and, in turn, release them on demand. In nonpathologic states, the spleen sequesters ~30% of the body's platelets and can release them into the circulation in response to certain stimuli. For example, in response to an increase in circulating catecholamines, the spleen releases significant numbers of sequestered thrombocytes into the circulation.³⁷

The role of the spleen as a platelet reservoir is most dramatically demonstrated by the fact that pathologically enlarged spleens sequester greater quantities of platelets. In splenomegaly secondary to portal hypertension, the organ can sequester up to 90% of the body's reserves and result in severe thrombocytopenia. On the other hand, in the postoperative period after splenectomy, there is a significant rise in circulating platelet counts. Sometimes this effect is transient, possibly because the liver compensates by increasing its ability to sequester thrombocytes.³⁸

The spleen has been also demonstrated to sequester a significant portion of red cell volume during times of inactivity, reducing blood viscosity and heart workload.³⁹ Increases in the hematocrit after exercise reproducibly occur secondary to release of erythrocytes from the spleen. Splenic volume and the retention of erythrocytes in the splenic sinuses is thought to be mediated through the contractility of the stress fibers supporting the splenic sinuses.³ The mechanism of splenic volume change likely involves both direct innervation by autonomic fibers as well as the hormonal effects of catecholamines. α -Adrenergic blockade abolished the responses of the spleen to norepinephrine and direct neural stimulation.^{10, 11, 12}

The ability to produce and sequester various groups of leukocytes allows the spleen to act as a mediator between the different arms of the immune response. One study has shown that as blood enters the spleen, lymphocytes selectively migrate to their respective zones: T cells to the lymphatic tissue of the PALS, and B cells to the follicles and red pulp. Mitogen-stimulated B lymphocyte proliferation can be upregulated in the setting of inflammation by the serotonin-rich platelets located in the spleen.³ The spleen is also a reservoir for granulocytes, readily mobilized under stress, and memory B cells.⁴⁰ The spleen also plays an important role in the coordination of the cellular innate immune response. It has been shown that a subset of innate immune cells including undifferentiated myeloid cells reside in the spleen and greatly outnumber those cells found in the circulation. These myeloid cells cluster in the cords of the subcapsular red pulp and can be released in response to injury, inflammation, and sepsis to regulate the host's immune response.⁴¹ In addition, this population of undifferentiated myeloid cells has been implicated as an important mediator of tumor-induced immune suppression. In cancer patients, these cells have been termed myeloid-derived suppressor cells and are upregulated in the spleen and peripheral circulation. The degree of this upregulation correlates to the disease stage.⁴²

Erythropoietic Function

The spleen produces red blood cells during fetal development and during certain pathologic states. During the fifth month of fetal development, it is a major source of red blood cell production, after which it loses this ability. Pathologic states associated with splenic hematopoiesis include myeloid metaplasia. However, the production of cells by the spleen under these abnormal conditions results not from the reactivation of fetal stem cells but from displaced bone marrow cells that take up residence in the confines of the organ.¹⁴

P.1375

Iron Metabolism

As red blood cells are destroyed within the splenic cords, their contents are degraded in the phagolysosome of sinusoid macrophages. The hemoglobin is recycled into heme and sent to the bone marrow for use in the manufacture of new erythrocytes or stored as ferritin. Large complexes of ferritin form into hemosiderin, both of which can be mobilized into the circulation during times of iron deficiency.^{43, 44} The spleen's storage ability of iron is clearly demonstrated by the fact that asplenic patients display lower serum iron levels for a considerable amount of time after splenectomy.³¹

The spleen also scavenges hemoglobin that is released from intravascular destruction of erythrocytes. Intravascular hemoglobin is rapidly bound by haptoglobin, which is removed in the spleen through a receptor-mediated endocytosis directed by CD163, a hemoglobin-specific receptor on the surface of macrophages.⁴⁵

The ability to scavenge for iron also plays an important antibacterial role. Iron is a necessary nutrient for many bacterial pathogens which secrete siderophores to compete for iron in the host's serum and tissues. Specialized macrophages in the red pulp of the spleen can be stimulated by these bacteria through toll-like receptors resulting in the secretion lipocalin-2, a molecule that complexes with siderophores limiting bacterial growth.⁴⁶

SPLENIC DISORDERS AND INDICATIONS FOR SPLENECTOMY

The causes of splenomegaly and indications for splenectomy can often be confusing. There are many potential causes of splenomegaly that must be considered in any patient undergoing evaluation with an unknown diagnosis. It cannot be overstated that patients without a known cause of splenomegaly should rarely undergo splenectomy and then only after a thorough workup has been completed to assess the likely etiology of this finding.

Splenomegaly is often the result of some other condition, not the result of a primary pathologic state. The spleen rarely harbors a primary malignancy such as lymphoma that is not apparent at other sites after a careful survey by history, by physical examination, with limited imaging studies, and with peripheral blood studies. The temptation to perform a splenectomy for diagnostic purposes early in the workup of the stable patient should be strongly resisted. It is unlikely to yield a diagnosis, and, in some situations, may entail significant risk to the patient with no benefit (as in splenomegaly resulting from portal hypertension).

It is important to remember that splenic size is not always a reliable guide to splenic function, because palpable spleens are not always pathologic and abnormal spleens are not always palpable. In a survey of healthy first-year college students, 3% were found to have splenomegaly, and 5% of all hospitalized patients have been noted to have splenomegaly.⁴⁷ Patients with cirrhosis and portal hypertension almost always have splenomegaly, but even with significant thrombocytopenia, which is often present, no specific therapy is indicated because this condition rarely results in specific complications. The important clinical issue involves determining when abnormal splenic function is occurring, ascertaining the responsible etiology, if possible, and only then assessing therapeutic options.⁴⁸

Chauffard introduced the concept of hypersplenism in 1907, although the exact clinical definition remains confusing in practice even today. The criteria for this diagnosis generally include four features: cytopenia with anemia, thrombocytopenia, leukopenia, or some combination; compensatory bone marrow hyperplasia; splenomegaly; and improvement or resolution in these findings after splenectomy. Hypersplenism has been further classified into primary hypersplenism, when no etiologic factor for splenomegaly has been found; and secondary hypersplenism, when splenomegaly is the result of another recognized condition (such as portal hypertension or an infiltrative process). With continued progress in diagnosis of the causes of splenomegaly, there has been a continued drop in the frequency of cases of primary hypersplenism. Given the nonspecific nature of this diagnosis and uncertainties regarding its therapeutic implications, it is used less often today.

Perhaps a more useful guide in the assessment of splenomegaly is to consider the mechanisms responsible for the splenic enlargement. Eichner et al. divided the causes of splenomegaly into six major categories, listed in Table 65.1.⁴⁷ The likely mechanisms for resulting cytopenias in specific disease states are shown in Table 65.2. It is interesting that the degree of splenomegaly on physical examination, radiographic assessment, or at the time of splenectomy does not appear to correlate with the magnitude of cytopenia.

Although most attention regarding splenic dysfunction relates to splenomegaly and related cytopenias, occasionally patients develop hyposplenic conditions, usually from splenic infarction (such as sickle cell disease). In this group, consideration should be given to vaccination against encapsulated organisms, and potential infectious complications should be considered if unexplained fever or signs of sepsis develop, similar to postsplenectomy patients.

Indications for Splenectomy

A recent review of indications for splenectomy demonstrates the evolution of surgical management for splenic disorders. Over a 10-year period, the most common indications for splenectomy (trauma, incidental, hematologic malignancy, iatrogenic, and cytopenia) saw a drop of between 30% and 50%. In addition, the

P.1376

absolute number of splenectomies decreased over the period of review.⁷⁰ Nevertheless, splenectomy is an accepted and often definitive treatment modality for a number of diseases, as discussed below.

TABLE 65.1 CLASSIFICATION OF SPLENOMEGALY BY MECHANISM

Mechanism	Causative Diseases
Immune response work hypertrophy	Subacute bacterial endocarditis Infectious mononucleosis Felty syndrome
Red blood cell destruction work hypertrophy	Spherocytosis Thalassemia major Pyruvate kinase deficiency
Congestive (venous outflow obstruction)	Cirrhosis and portal hypertension Splenic vein thrombosis
Infiltrative	Sarcoidosis Amyloidosis Gaucher disease
Neoplastic	Lymphoproliferative Myeloproliferative Sarcoma Metastatic carcinoma
Miscellaneous	Trauma Splenic cysts Hemangioma

Data from Eichner ER, Whitfield CL. Splenomegaly. An algorithmic approach to diagnosis. JAMA 1981;246:2858-2861; Eichner ER. Splenic function: normal, too much and too little. Am J Med 1979;66:311-320; Sheldon GF, Croom RD, Meyer AA. The spleen. In: Sabiston DC, ed. Textbook of surgery, 14th ed. Philadelphia, PA: WB Saunders, 1991:1108-1133.

TABLE 65.2 ETIOLOGY OF SPLENOMEGALY AND CYTOPENIA IN SELECTED DISEASE STATES

Disease Condition	Probable Mechanism
Portal hypertension	Increased pooling of blood cells
Hairy cell leukemia	Retention of hairy cells in splenic pulp
Felty syndrome	Immune system work hypertrophy
Thalassemia major	Reticuloendothelial system work hypertrophy
Gaucher disease	Increased pooling and flow-induced dilutional anemia
Agnogenic myeloid metaplasia	Extramedullary hematopoiesis

Data from Eichner ER, Whitfield CL. Splenomegaly. An algorithmic approach to diagnosis. JAMA 1981;246:2858-2861; Eichner ER. Splenic function: normal, too much and too little. Am J Med 1979;66:311-320; Sheldon GF, Croom RD, Meyer AA. The spleen. In: Sabiston DC, ed. Textbook of surgery, 14th ed. Philadelphia, PA: WB Saunders, 1991:1108-1133.

Immune Thrombocytopenic Purpura

ITP is an acquired isolated thrombocytopenia in which circulating antiplatelet antibodies bind to platelets and are cleared by phagocytic cells from circulation (see Chapter 47). The humoral cause of the disease was established in 1951, when a hematologist in training infused himself with the plasma from a patient with ITP and developed thrombocytopenia and

platelet destruction. Today, between 40% and 80% of patients with ITP have identified autoantibodies to platelet-specific glycoproteins, including GPIIb/IIIa and GPIb/IX. In addition, dendritic cells with upregulated costimulatory molecules appear to play a major role in the pathophysiology of the disease through the enhancement of B and T cell responses to platelets.⁴⁹ Macrophage-mediated platelet destruction is believed to play an important role in refractory disease through the presentation of new antigens.⁵⁰ The spleen likely has a dual role in this disease by both producing IgG and providing the location for removal of platelets from the circulatory system.

ITP most commonly presents in women in their 20s and 30s, and they often present with bleeding after minor trauma, with nosebleeds or petechiae. There are often no physical findings, and importantly, the spleen is almost always normal in size. The primary laboratory abnormality is thrombocytopenia with platelet counts typically $<50 \times 10^9/L$ and sometimes as low as $10 \times 10^9/L$. There is evidence of immature platelets on peripheral smears, and bone marrow smears show increased numbers of megakaryocytes. ITP can occur in childhood and often follows a viral illness. Most cases are acute and resolve spontaneously within 6 months to 1 year. However, a small number is at risk for major bleeding, and ~5% of children develop chronic severe thrombocytopenia that requires treatment, including splenectomy in some cases.⁵⁰

First-line treatment of patients with ITP and symptomatic bleeding or platelet counts $<30 \times 10^9/L$ is with corticosteroids, with the goal of achieving and maintaining a hemostatic platelet count. Typical regimens include daily oral prednisone or pulses of high-dose dexamethasone. Both regimens are effective and currently are being compared in a randomized clinical trial (NCT00991939). For thrombocytopenic crises and overt bleeding, a rapid increase in platelet count may be achieved with IVIg (1 g/kg) or anti-D (for Rh-positive patients) followed by platelet transfusion and steroid administration.

Almost all patients with ITP will progress to second-line treatment as remission with corticosteroids is often not durable and the long-term side effects are unacceptable. Options for patients who fail steroid treatment include splenectomy, rituximab, and the TPO-receptor agonists. The timing of second-line treatments is not well studied, is inconsistent among recent consensus statements, and should be a shared decision between patient and physician that is tailored to fit the patient's condition and goals.^{16, 51, 52}

Splenectomy remains the most effective treatment of ITP. Initial response to splenectomy ranges from 40% to 86%. In a systematic review evaluating the efficacy of splenectomy in patients with ITP over 58 years of age, complete remission was achieved in 66% of patients, partial response in 22%, and recurrence was uncommon.¹⁷ Splenectomy can usually be performed electively unless patients have active, ongoing bleeding. Despite the thrombocytopenia, the circulating platelets function normally, and preoperative platelet transfusions are usually unnecessary and may be ineffective in raising the platelet count because of the rapid sequestration by the spleen.

Rituximab is a chimeric monoclonal antibody against B cells expressing CD20. Although normal platelet counts ($>150 \times 10^9/L$) were achieved in 44% of patients and a partial response was seen in 63% ($>30 \times 10^9/L$), median duration of response was only 10.5 months. Rituximab carries significant risks: 3.7% of patients experienced a severe or life-threatening toxicity and 2.9% died.^{53, 54, 55}

TPO-receptor agonists effectively achieve durable increases in platelet counts, but require continuous treatment. Platelet counts respond in approximately 80% of patients, including those who have failed splenectomy and rituximab. Although the risk profile appears to be favorable, long-term risks have not yet been fully studied.^{53, 54, 55}

When patients fail splenectomy or rituximab, third-line treatments with TPO-receptor agonists or immunosuppressive agents may be indicated. Failure after splenectomy should prompt a search for accessory spleens, as their removal may induce remission. Accessory spleens have been reported in 10% to 30% of patients with ITP.^{15, 18, 99} Technetium sulfur colloid scanning or ¹¹¹indium-labeled scanning is useful to demonstrate accessory splenic tissue.¹⁹

Thrombotic Thrombocytopenic Purpura

Thrombotic thrombocytopenic purpura (TTP) generally occurs between the ages of 10 and 40 years and is more common in women than in men (see Chapter 48). TTP is associated with genetic mutations in ADAMTS13 gene, the von Willebrand factor-cleaving protease, or acquired autoantibody inhibitors usually formed after therapy with ticlopidine or clopidogrel. The disorder occasionally occurs during pregnancy or in the postpartum period, and a familial form of the disease exists.⁵⁶ TTP is characterized by thrombocytopenia, microangiopathic hemolytic anemia, neurologic abnormalities, renal failure, and fever. TTP is likely to be the result of the abnormal presence of a platelet-aggregating agent in the circulation. Studies suggest that this agent is von Willebrand factor, which is found in excess in patients with TTP. Platelet aggregation leads to microvascular thrombi, typically in the brain, heart, spleen, kidneys, pancreas, and adrenals. Nearly 90% of adults with ADAMTS13 deficiency will respond to daily plasma exchange with plasmapheresis and transfusion of fresh-frozen plasma. Patients with acquired autoantibodies can be treated with high-dose glucocorticoids, rituximab, or splenectomy. Surgical

treatment is considered in patients who have frequent relapses of TTP and may prolong the disease-free interval.^{56, 57, 58, 59}

Hereditary Anemias

Hereditary spherocytosis is inherited as an autosomal dominant disease in which the red cell membrane includes a defective protein, spectrin (see Chapter 27). The spleen destroys the resulting

P.1377

defective, spherical red cells. These patients have an anemia and significant reticulocytosis. Peripheral smears demonstrate spherocytes, and these patients have a negative Coombs test. Elective splenectomy will correct the anemia. Ideally, splenectomy is performed after the age of 5 or 6 years to minimize the potential risks of postsplenectomy infections. Because of the rapid red cell turnover, these patients often develop calcium bilirubinate gallstones, and consideration should be given to concomitant cholecystectomy at the time of splenectomy if they are present.¹⁸

Sickle cell anemia is an autosomal recessive condition that also results in defective red blood cells (see Chapter 33). Because of the frequency of sludging and thrombosis in small vessels, these patients more often develop infarcts in the spleen, which over time results in autosplenectomy. In rare patients, however, splenectomy may be indicated for acute splenic sequestration crisis, hypersplenism, massive splenic infarction, and splenic abscess.⁶⁰ Unlike hereditary spherocytosis, splenectomy has little effect on anemia related to the sickle cell condition.

Thalassemia major is an autosomal dominant condition in which abnormal hemoglobin forms protein precipitates in the red cell, recognized as Heinz bodies on a peripheral smear. These patients can develop significant splenomegaly with resulting cytopenia. In this condition, splenectomy can lessen the need for transfusion.

Malignant Tumors of the Spleen

Malignant diseases affecting the spleen can be divided into lymphoproliferative disorders, myeloproliferative disorders, metastatic lesions, and primary splenic neoplasms. Metastatic disease is not uncommon. Melanoma, breast, lung, renal, and ovarian lesions are the main source. Metastatic lesions usually reflect vastly disseminated disease secondary to hematogenous spread. Autopsy series have demonstrated splenic metastasis in 2.3% to 7.1% of cancer patients.⁶¹

Primary tumors of the spleen are exceedingly rare. They include hemangiosarcoma, hemangiopericytoma, plasmacytomas, and malignant fibrous histiocytomas. All of these conditions may present with splenomegaly and are uniformly treated with splenectomy.

Lymphoma

Lymphoma is a common tumor leading to splenomegaly or a splenic mass (see Chapters 88 and 89), although the spleen is rarely the primary site. Non-Hodgkin lymphoma, including splenic marginal zone lymphoma, can present with massive splenomegaly. Although splenectomy has been shown to be a therapeutic treatment of hypersplenism by increasing blood counts, it has not improved long-term survival.⁶²

Hodgkin Lymphoma

Hodgkin lymphoma, described by Thomas Hodgkin in 1832, is a highly curable malignant lymphoma characterized by typical multinucleated giant cells (Reed-Sternberg) (see Chapters 93 and 94) and predictable stepwise progression from one lymph node basin to another. Histologic subtypes fall into five categories: lymphocyte-rich classical, lymphocyte-predominant, nodular sclerosing, mixed cellularity, and lymphocyte-depleted. Most patients initially present with asymptomatic peripheral lymphadenopathy, most often in the cervical region (60% to 80%). Other nodal regions, including the mediastinal, axillary, inguinal, and retroperitoneal regions, are less often involved at initial presentation. The presence of B symptoms, including fever, weight loss > 10%, and night sweats, is noted. Extralymphatic and splenic involvement is also used to stage patients. Below the diaphragm, the first nodal tissue involved is the spleen, with 35% of stage I or II patients having occult splenic disease.⁶³

Historically, staging laparotomy was used in patients with Hodgkin lymphoma suspected of harboring subdiaphragmatic disease. In this procedure, lymph nodes were sampled from the para-aortic, paracaval, and iliac regions, and liver biopsies were performed along with splenectomy. With the enhanced accuracy of CT and other imaging studies for staging purposes, the increased effectiveness of medical treatments, and the associated surgical risk, the need for surgical staging has essentially been eliminated.⁶³

Leukemia

In chronic lymphocytic leukemia and less often in chronic myelocytic leukemia, massive splenomegaly can result in significant symptoms from the mass effect of the enlarged spleen, necessitating splenectomy (see Chapters 90 and 81). Likewise, patients may develop significant cytopenia that is refractory to conventional medical measures (i.e., corticosteroids, immunosuppression) and may be candidates for splenectomy. The decision to undertake splenectomy must be made with caution, because these patients often are immunosuppressed and malnourished and have a higher operative mortality risk as well as a higher rate of perioperative complications.⁶⁴

Hairy cell leukemia can lead to infiltrative splenomegaly and pancytopenia, which may limit cytotoxic chemotherapy (see Chapter 91). With the introduction of effective medical therapies, the indications for splenectomy are now limited to spontaneous splenic rupture and severe thrombocytopenia with bleeding. Resistant disease should prompt investigations to confirm an accurate diagnosis.⁶⁵

Myelofibrosis

Myelofibrosis describes a group of disorders characterized by acquired mutations that target the hematopoietic stem cells, and induce dysregulation of cellular signaling, clonal proliferation, and abnormal cytokine signaling. Prominent bone marrow fibrosis and disruption of normal hematopoiesis results, and can be associated with enlargement of the liver and spleen as a result of extramedullary hematopoiesis⁶⁶ (see Chapter 83). Massive splenomegaly may lead to pancytopenia, portal hypertension, early satiety, and pain. Splenectomy remains a viable treatment for refractory, symptomatic massive splenomegaly in myelofibrosis. Approximately 50% of patients will be rendered transfusion-independent. In addition, most experience resolution of mechanical symptoms and subjective improvement in constitutional symptoms. The median response is 12 months.⁶⁷ Caution must be taken with splenectomy in patients with myelofibrosis, as the procedure carries a perioperative mortality rate of 5% to 10% and a morbidity rate of approximately 25%.⁶⁷

Splenic Cysts

Cystic lesions of the spleen are rare and represent a challenge for physicians to diagnose and treat. The number of asymptomatic cysts incidentally diagnosed continues to rise because of increased utilization of abdominal imaging, including computer tomography, ultrasound, and magnetic resonance.

Splenic cysts are categorized based on the presence or absence of an epithelial lining. Cysts with an epithelial lining are considered primary and can be further subdivided into parasitic or nonparasitic. Secondary cysts, or pseudocysts, lack an epithelial lining and are believed to result from trauma in the majority of cases^{68, 69} (Fig. 65.5).

Primary cysts possess an epithelial lined lumen and can be divided into parasitic and nonparasitic. Parasitic cysts are most often multilocular, associated with hepatic cysts, and occur after infection with *Echinococcus granulosus*. They make up

P.1378

the majority of splenic cysts worldwide and are endemic in South America and the Mediterranean. Parasitic cysts, however, are rare in the Western world. Surgery must be undertaken carefully, as rupture can result in anaphylactic shock or disseminated scoliceal infection. In the presence of large numbers of cysts, surgical treatment is contraindicated and medical therapy with mebendazole, an effective antiparasitic therapy, is an alternative. Treatment of a single or few cysts can be managed sequentially with medical treatment, chemical sterilization (cetrimide 0.1%), and cyst evacuation.⁷⁰

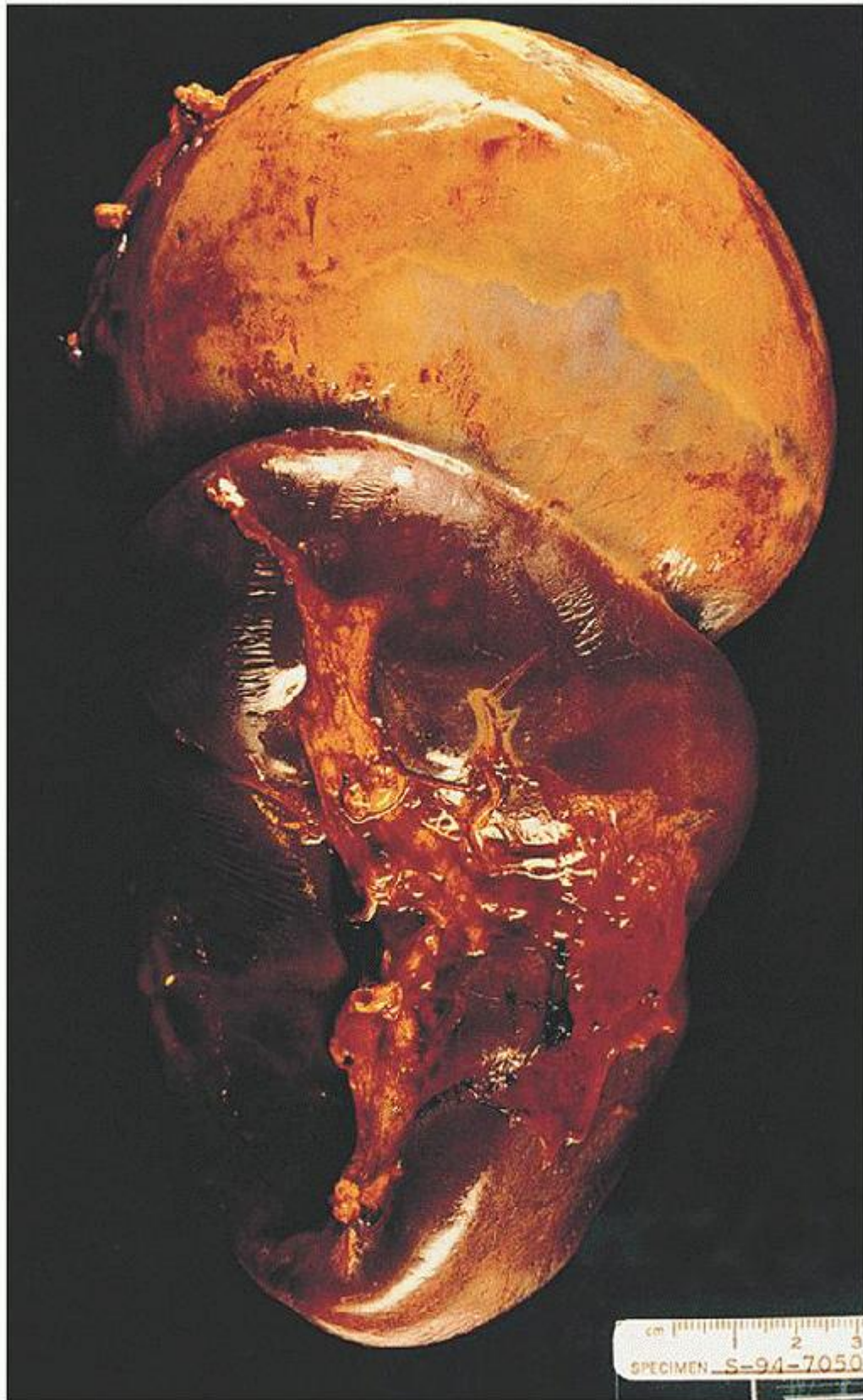

FIGURE 65.5. Large symptomatic splenic pseudocyst developing after blunt trauma to the spleen.

Nonparasitic cysts are usually congenital and can be further divided into endodermoid, dermoid, or epidermoid cysts. Epidermoid cysts are the most common congenital cysts (~90%) and present most often in children and young adults. They are derived from inclusions of splenic surface epithelial lining into the splenic parenchyma during development or from an accelerated secretion of lining cells from an unknown cause.⁷¹ Dermoid cysts are exceedingly rare; they contain all three embryonic germ layers and make up the remainder of nonparasitic congenital cysts. Endodermoid cysts are not true cysts, but rather cystic vascular lesions composed of several ectatic vessels that are best described as lymphangioma or hemangioma (Fig. 65.6). These benign tumors are most often incidental findings when imaging studies or laparotomy are performed, or they may be found at autopsy. Occasionally, the patient may develop significant splenomegaly and cytopenia, leading to the need for splenectomy. Usually, however, the diagnosis can be made on the basis of imaging studies alone and splenectomy avoided. In cases of doubt, follow-up imaging studies demonstrating the absence of change over time should avoid unnecessary splenectomy.⁶⁸

The spleen is the intraperitoneal organ that is most often injured after abdominal trauma. Although 75% of nonparasitic splenic cysts are posttraumatic, 30% of patients cannot recall the inciting event.⁶⁹ Pseudocysts may contain a mixture of blood and necrotic debris, as they commonly form after intraparenchymal or subcapsular hematomas organize and subsequently degenerate (Fig. 65.7). Pancreatic pseudocysts have been reported to burrow into the substance of the spleen, and this should be kept in mind in the patient with a history of pancreatic trauma or pancreatitis. Assessment of cyst fluid amylase levels may provide a clue to the pancreatic origin in such a case.⁷² Management of cysts in these cases is usually directed toward treatment of underlying pancreatitis.

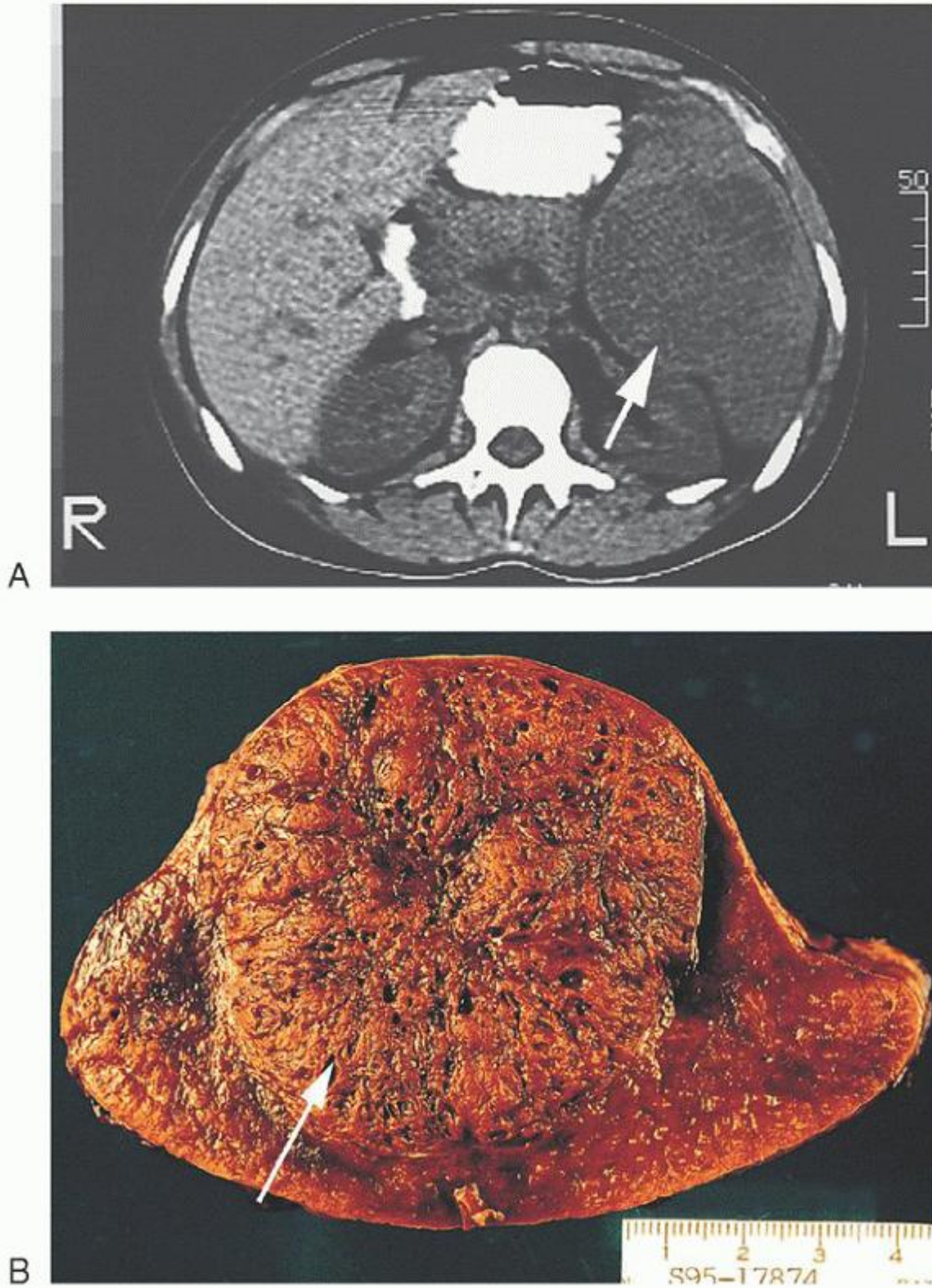

FIGURE 65.6. Computed tomographic scan (A) and gross photograph (B) of spleen in 35-year-old woman with marked splenomegaly from splenic hemangioma. The arrow demonstrates central hemangioma with surrounding uninvolved splenic parenchyma. This benign tumor had caused significant thrombocytopenia, resulting in spontaneous bleeding before splenectomy.

Splenic cysts are often asymptomatic (70%) but can also present with vague abdominal pain. The pain can be constant or intermittent, left-sided or epigastric, and occasionally radiates to the left shoulder. Physical exam can reveal a painless abdominal mass in 50% of patients. Radiologic examination with ultrasound, CT, or magnetic resonance imaging can characterize the cyst as unilocular or multilocular and provide insight into anatomic relationships. Prior to any invasive procedure, determination of parasitic antibody titers are of great importance to rule out parasitic infection. Ultrasound-guided percutaneous cyst aspiration may be useful for obtaining definitive diagnosis, decreasing the size of the cyst, and excluding communicating pancreatic origin.

The majority of patients with splenic cysts are asymptomatic and do not require specific treatment. Nonoperative treatment is recommended for small cysts up to 5 cm in diameter. In patients with symptomatic cysts, surgical intervention is recommended. Although percutaneous drainage and alcohol ablation is often successful in initially reducing the size of the cyst, the procedure is often plagued with a high incidence of recurrence, necessitating

P.1379

definitive surgical correction.^{73, 74} For single, unilocular superficial cysts, laparoscopic marsupialization or fenestration with splenic preservation should be undertaken. Deep cysts, or those located at either splenic pole, can be resected with partial splenectomy, which provides immunologic protection and improved outcomes when compared to splenic autotransplantation. Complete splenectomy is indicated in cases of giant cysts surrounded by splenic parenchyma or multilocular cysts.^{18, 69, 71}

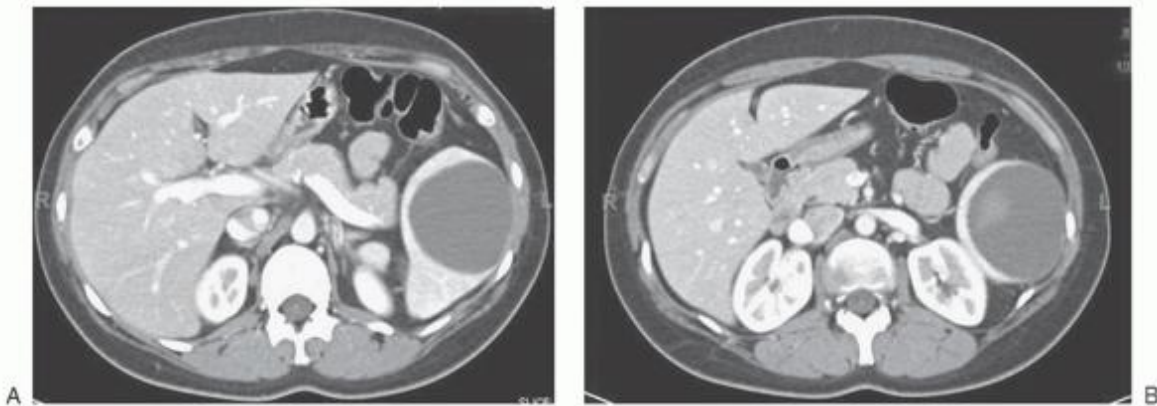

FIGURE 65.7. A: CT of a 43-year-old woman who was scanned after developing left upper quadrant pain. She had no history of trauma. CT showed a splenic pseudocyst. B: After aspiration, some blood is seen in the cyst lumen. The cyst rapidly reaccumulated, and the patient subsequently had a successful laparoscopic cyst deroofing.

Splenic Abscess

Splenic abscesses may also occur when a simple cyst is secondarily infected, for example, after aspiration, or as a primary abscess, usually from a hematogenous source. Splenic abscesses usually develop from hematogenous seeding, from a distant site of infection, in the setting of intravenous drug abuse, or after splenic infarction, as in patients with sickle cell disease. Immunocompromised patients are at higher risk. There are rarely specific symptoms present, suggesting the spleen as the specific site of infection, although left upper quadrant tenderness may be present in patients with significant abscess cavities. Abdominal CT scanning is the most helpful imaging technique, demonstrating low-density lesions in the spleen, which may contain gas and present peripheral enhancement.⁷⁴ CT can also be used to direct placement of percutaneous drainage catheters, which can provide successful treatment in the majority of cases. Multilocular abscesses with thick septations or necrotic debris generally require surgery, although percutaneous catheter drainage may lead to improvement of the patient's general condition without adverse effect on subsequent operation.^{73, 74} Antimicrobial therapy is based on aspirate culture data, with *Staphylococcus* and *Streptococcus* species being common pathogens.

Felty Syndrome

Felty syndrome composes a triad of rheumatoid arthritis, neutropenia, and splenomegaly in <1% of patients with rheumatoid arthritis. Clinically, patients present with severe joint destruction and other systemic manifestations such as leg ulcers, rheumatoid nodules, vasculitis, lymphadenopathy, and hepatomegaly. Antibody-coated neutrophils are cleared from the circulation in the spleen, and neutropenia can develop. Recurrent bacterial infections, a major source of morbidity, are due to the decreased granulopoiesis, increased peripheral destruction of neutrophils, and defects in

neutrophil function. Methotrexate, or other disease-modifying antirheumatic drugs (DMARDs), is the first-line treatment for Felty syndrome with granulocytopenia and increased infection rate. If DMARD treatment is unsuccessful, low-dose granulocyte colony-stimulating factor is recommended. Splenectomy is indicated only in treatment-resistant cases in which splenomegaly is present; splenectomy is contraindicated in patients with large granular lymphocyte (LGL) expansion, as the procedure has no effect and may actually cause deterioration.^{18, 75, 76}

Abdominal Trauma and Splenic Injury

Splenic preservation is the main goal of the modern management of blunt traumatic splenic injuries. Nonoperative management is often successful in about 90% of patients. The degree of splenic injury is measured using contrast-enhanced CT scans and graded according to the American Association for the Surgery of Trauma (AAST) criteria (Table 65.3). The finding of active arterial contrast extravasation from the spleen, referred to a “blush,” is an indicator of failure of conservative management in adults. Most injuries of grade 3 or less are successfully managed nonoperatively, whereas the presence of a high grade injury (Grade 4 or 5) or a contrast blush predicts the need for intervention (Fig. 65.8).⁷⁷ The primary requirement for nonoperative management is hemodynamic stability, and therefore close monitoring is required in all cases. A continued transfusion requirement and/or hypotension in the face of adequate resuscitation are indications for urgent intervention. A recent meta-analysis of 24,615 patients demonstrated that 12% of patients failed conservative management, ultimately requiring intervention. It also suggested that failure

P.1380

of conservative management in older patients may be associated with increased mortality.^{78, 79}

TABLE 65.3 AAST GRADES OF SPLENIC INJURY

Grade 1	Minor subcapsular tear 1 cm or subcapsular hematoma <10% SA
Grade 2	Capsular tear not involving trabecular vessels, <3 cm or subcapsular hematoma between 10% and 50% SA
Grade 3	Laceration >3 cm parenchymal depth involving trabecular vessels or subcapsular hematoma >50% S, or expanding or ruptured hematoma
Grade 4	Laceration involving the hilum with >25% devascularization of the spleen or intraparenchymal hemorrhage with active bleeding
Grade 5	Completely shattered spleen

SA, surface area.

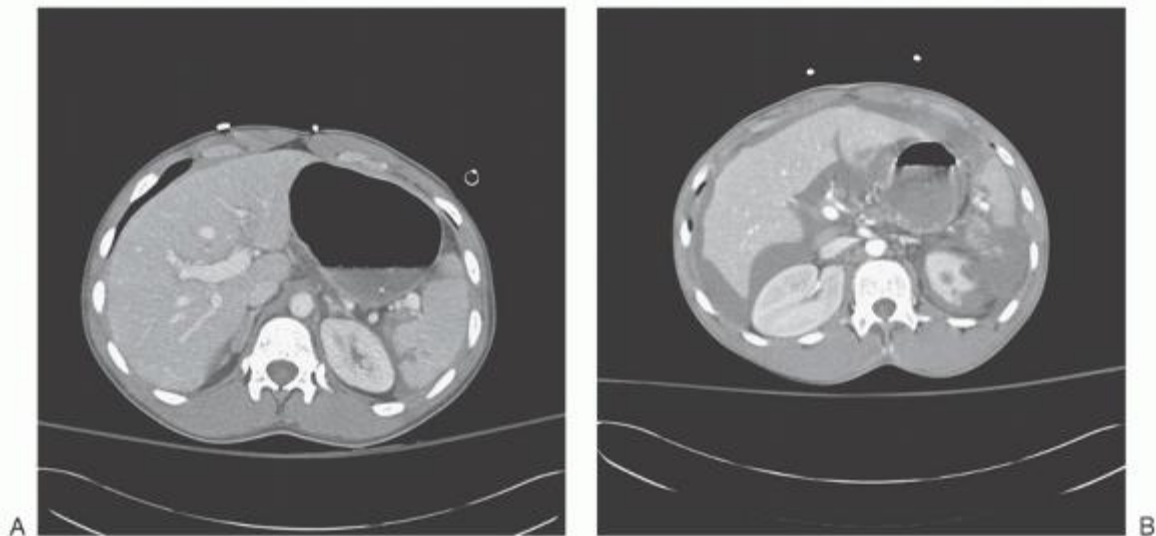

FIGURE 65.8. A: Contrast-enhanced CT showing a grade 1 splenic laceration in the inferior pole, with associated

hemoperitoneum; the patient was successfully managed conservatively. B: Contrast-enhanced CT showing a grade 5 splenic laceration with evidence of active extravasation and perisplenic hematoma. This patient required urgent splenectomy.

Options for operative intervention consist primarily of open splenectomy, with splenic repair and partial splenectomy utilized rarely. In addition to splenectomy, splenic artery embolization has become an integral adjunct in the management of high-grade splenic injuries and in patients with active contrast extravasation. With adequate patient selection, angioembolization has decreased the failure rate of nonoperative management to 4% in some recent series.⁷⁷

Delayed Splenic Rupture

Delayed splenic rupture has been reported in patients experiencing blunt abdominal trauma, a setting in which patients develop splenic hemorrhage >7 days after their original injury.⁸⁰ This problem most likely represents an injury in evolution, when the initial imaging study (most commonly CT or ultrasound) at the time of the trauma fails to demonstrate a significant injury. These patients usually have an initial splenic contusion that continues to slowly enlarge and, at some later date, results in disruption of the splenic capsule. This is an uncommon occurrence, but should be considered in any patient who develops significant left upper quadrant pain, distention, and signs of bleeding or shock after an episode of trauma.^{81, 82} The treatment is urgent intervention with angiography or splenectomy, depending on the patient's clinical picture.

Spontaneous Splenic Rupture

Spontaneous rupture of the spleen is extremely rare and for unknown reasons occurs predominantly in males. Predisposing conditions include splenic infarctions, coagulation disorders, thrombocytopenia, portal hypertension, vasculitis, venous thrombosis in the spleen and focal splenic lesions, lymphoma, and leukemia. Spontaneous rupture is most often secondary to a neoplastic etiology. Overall mortality with rupture is about 12% with splenomegaly, advanced age (>40 years), and a neoplastic etiology predicting an increased risk of death.⁸³

These patients usually develop acute left upper quadrant pain that may be associated with referred pain in the left shoulder. Initially, this may be contained beneath the splenic capsule as a subcapsular hematoma, but if intraperitoneal rupture occurs, patients may present with acute severe pain and hypovolemic shock. Ultrasonography or CT scanning is a confirmatory study, demonstrating intraperitoneal fluid (blood) and subcapsular hematoma. Urgent or emergent splenectomy is definitive treatment for these patients. Splenic conservation may be an option in some, because the grade of injury tends to be less severe compared to traumatic splenic injury.

SPLENECTOMY: SURGICAL TECHNIQUE

Open Splenectomy

Historically, splenectomy has been performed via a midline or left subcostal incision, depending on the surgeon's preference and the presence or absence of significant splenomegaly. In patients with massive splenomegaly (>2,000 g), a midline incision may be preferred to allow adequate mobilization and delivery of the spleen into the operative field.

Once the abdomen is entered, a careful search is made for accessory spleens, which may be found anywhere in the abdomen but are most often found in the splenic hilum or in the mesentery of the intestine.

In patients with significant splenomegaly, initial ligation of the splenic artery causes the spleen to decrease in size, lessen its distention, decrease the risk of capsular avulsions, and decrease splenic bleeding should a capsular tear occur. This portion of the procedure is performed by dividing the avascular gastrohepatic ligament above the pancreas and isolating the artery near its point of origin from the hepatic artery. Care must be taken to avoid injury to the adjacent pancreas. This step is optional and can be omitted if the artery is not readily accessible, because aggressive attempts at splenic artery ligation can result in pancreatic injury.

There are ligamentous attachments to the spleen that must then be divided before the inflow vessels in the hilum can be ligated. The phrenosplenic attachment is avascular and can be divided with sharp dissection. The gastrosplenic ligament (and short gastric vessels) and the splenocolic ligament are divided. Finally, the inflow vessels to the splenic hilum are individually ligated, taking care during this portion of the procedure to avoid injury to the tail of the pancreas. Closed suction drainage of the splenic bed is not routinely used, but a drain can be placed if there

P.1381

is suspicion of a possible pancreatic injury. If this occurs, evacuation of pancreatic fluid minimizes the risk of abscess formation and allows for a controlled pancreatic fistula that will usually seal with observation alone. Conversely, if a

symptomatic fluid collection develops in the bed of an undrained spleen in the postoperative period, then a percutaneous drain can be placed under CT or ultrasound guidance.

Partial splenectomy is unlikely to be a realistic option for patients with marked splenomegaly, but may be an option for patients with splenic pseudocysts in whom unroofing of the cyst is the primary objective. This may also be an option in patients with splenic trauma in whom splenorrhaphy may allow splenic preservation. Uranus et al. report successful partial splenectomy using a surgical stapler, and this may occasionally be helpful. Partial splenectomy has also been reported in patients undergoing splenectomy for Gaucher disease.

Laparoscopic Splenectomy

Since laparoscopic splenectomy was first described in 1991 by Delaitre et al.⁸⁴ it has become the standard operative approach for the elective treatment of many benign and malignant diseases of the spleen.^{15, 18} Numerous studies have demonstrated the advantages of the laparoscopic approach compared to open splenectomy, including decreased blood loss, shorter hospital stays, accelerated recovery, and decreased convalescence. As outcomes have continued to improve, the procedure has been applied to an increasing array of splenic pathologies, and is now one of the most common laparoscopic solid-organ procedures. The indications for laparoscopic splenectomy have been expanded and now include ITP, hereditary spherocytosis, hemolytic anemia, TTP, leukemias, splenic myelofibrosis, sickle cell disease, lymphomas, myelodysplastic syndrome, multiple myeloma, and accessory splenectomy.

Massive splenectomy is no longer an absolute contraindication for laparoscopic splenectomy. Superior outcomes over open splenectomy in patients with massive spleens have been demonstrated, including decreased blood loss, reduced transfusion requirement, fewer reoperations for bleeding, and an average reduction in hospital stay by 8 days. Decreased blood loss continues to be the greatest advantage of laparoscopic splenectomy in patients who are coagulopathic and at risk for massive hemorrhage.^{62, 85, 86} The decision to perform laparoscopic splenectomy in a patient with splenomegaly is a multifactorial decision that depends on the underlying disease process, comorbidities, and surgeon experience. The effect of the surgeon's learning curve has been clearly demonstrated in laparoscopic splenectomy, with the average conversion rate depending on experience and ranging from 1.2% to 15%.⁸⁵

The operative approach for laparoscopic splenectomy continues to evolve with the introduction of new surgical technology. After induction of general anesthesia, a nasogastric tube and Foley catheter are placed to decompress the stomach and bladder, respectively. The patient is placed into the right lateral decubitus position, and three or four working ports are placed for the introduction of the laparoscopic instruments, including an angled laparoscope. The lateral port is most often placed at the level of the eleventh rib tip, the medial port in midline, and the middle port halfway between the two, ~4 cm below the inferior tip of the spleen. In patients with a supramassive spleen (>22 cm in craniocaudal length or 19 cm in width), the addition of a hand port has been shown to greatly reduce operative time without increasing length of stay or convalescence. This approach allows the insertion of the surgeon's nondominant hand into the abdominal cavity while maintaining pneumoperitoneum. Positioning is slightly altered by placing the patient's side at a 45-degree angle. After positioning and setup is complete, a careful inspection of the abdomen is carried out to identify other disease or the presence of accessory spleens, focused on the hilum, omentum, and lesser sac.⁸⁶

The dissection then proceeds in five stages: division of the short gastric vessels, division of the splenocolic ligament, ligation of the inferior polar vessels, hilar control, and division of the phrenic attachments of the spleen. Much of the dissection may be carried out with harmonic shears, and the hilar structures are ligated and divided with an endoscopic stapling device. The spleen is then placed in an extraction bag, morcellated in situ, and the fragments removed.

COMPLICATIONS OF SPLENECTOMY

The overall complication rate for laparoscopic splenectomy is ~9%. The most common complications of splenectomy include bleeding, injury to the adjacent pancreas with resulting pancreatitis, and pancreatic pseudocyst, abscess, or fistula formation. These patients can also develop injury to the adjacent stomach or splenic flexure of the colon if care is not taken in dividing the ligamentous attachments to these structures.

Postoperative thrombocytosis can occur, and aspirin (one low-dose aspirin per day) should be considered if the platelet count is $>1,500 \times 10^9/L$, to minimize the risks of thrombosis or embolism. The thrombocytosis is usually transient, with return of platelet counts to normal ranges by 2 years after splenectomy.

Thrombosis of the portal venous system is a unique, and potentially life-threatening, complication after splenectomy. Although this complication was once believed to be rare, improvements in radiologic techniques have demonstrated portal venous thrombosis much more frequently than previously thought, with a number of cases occurring asymptotically. The reported incidence of portal venous thrombosis varies greatly within the literature. Initial

retrospective reviews demonstrated incidences between 5% and 15%. When prospectively analyzed, however, the incidence was found to be greatly unappreciated, with 19% to 55% of patients developing portal venous thrombosis. Asymptomatic thrombosis was observed in 33% to 66% of postsplenectomy patients. Patients with larger diameter splenic veins and those operated on for hematological malignancy were found to be at increased risk for thrombosis.^{87, 88, 89}

When symptomatic, portal venous thrombosis most often presents between 2 and 22 days postoperatively with vague, nonspecific complaints including decreased appetite, vague abdominal pain, nausea, and malaise. Abdominal pain is a rare sign that is present only in cases of severe ischemia. Fever and leukocytosis are common. Risk factors highly associated with portal venous thrombosis include splenomegaly, hematologic malignancy, and thrombocytosis. Normal D-dimer levels have a 98% negative predictive value. Contrast-enhanced CT scanning is the preferred method of evaluation as it can assess the portal circulation as well as other common etiologies of abdominal pain.^{89, 90}

Once the diagnosis of portal venous thrombosis is made, systemic anticoagulation should be started immediately. With prompt anticoagulation, recanalization can occur rapidly in over 90% of patients. However, patients who received treatment 10 days after the procedure uniformly failed.⁹¹ Although treatment with thrombolytics and antiplatelet agents has been reported, indications for routine use are still yet to be determined.^{89, 92}

Infection Risk Postsplenectomy

Infectious complications are increased after splenectomy, and this can occur both in the early postoperative period and after a significant time has passed. The rate of early postoperative infections is particularly high when multiple other procedures are performed (e.g., after complex injuries in the setting of multiple trauma).^{93, 94} The complication of overwhelming postsplenectomy infection (OPSI) has received significant attention. In addition to

P.1382

OPSI, postsplenectomy patients are at risk for multiple and recurrent episodes of severe infection requiring hospitalization.⁹⁵

Overwhelming Postsplenectomy Infection

One of the most important developments affecting the splenectomy procedure has been the recognition of the life-long increased risk of severe infection and sepsis after splenectomy. In 1969, Diamond described a case of postsplenectomy fulminant bacteremia leading to rapid death and popularized the term OPSI.⁹⁶

Pathophysiology

In the early postoperative period, infection is usually caused by Staphylococci and enteric Gram-negative bacilli. Outside this interval, the most common organisms responsible for OPSI are encapsulated bacteria, with *Pneumococcus* being most common (incidence, 50% to 90%).⁹⁷ Other responsible organisms include *Neisseria meningitidis*, *Escherichia coli*, *Haemophilus influenzae*, *Staphylococcus*, and *Streptococcus*; and infections occur at rates that range from 7% to 12%.⁹⁸

The special susceptibility of the asplenic patient to encapsulated organisms is likely due to compromised humoral immunity. After splenectomy, a subset of IgM memory B cells that responds to bacterial polysaccharides is severely depleted. These memory B cells have undergone mutation, selection, and class switch in response to a specific antigen and produce antibodies rapidly on second challenge from the same antigen. The IgM memory B cells are responsible for the T cell-independent response and require a functional spleen for their generation and survival.^{99, 100} Studies confirm that bacteria-specific IgM production in asplenic patients is both delayed and diminished.¹⁰¹

Also, it has been demonstrated that asplenic patients have lower circulating levels of certain complement factors, including properdin, tuftsin, C3, and factor B.¹⁰² Tuftsin is a tetrapeptide that stimulates phagocytosis by binding to specific receptors on granulocytes, monocytes, macrophages, and natural killer cell-modulating biologic activity. The spleen also produces properdin, a crucial factor in the alternative pathway of complement activation. The alternate pathway is activated in the absence of antibody and forms C3 convertase. Properdin binds to C3 convertase, preventing its rapid decay, and allows for conversion of C3 to C3b.

There is also evidence that splenectomy results in defects of cellular immunity. After splenectomy for trauma, a cohort of patients was found to have a significant reduction in the percentage of CD4⁺ T cells, specifically in the CD45RA⁺ subset. This was accompanied by impairment in primary immune responsiveness in a number of cellular and humoral assays.⁹⁹

Incidence

OPSI is most common in the very young, in patients with underlying malignancies or other medical conditions, and within the first 2 years after splenectomy, although it has been reported 20 to 40 years after surgery. The precise incidence of OPSI is controversial, but is estimated between 0.18 and 0.89 person-years^{95, 96, 97, 98, 102, 103}; published estimates vary widely secondary to different disease definition, duration of follow-up, age stratification, indication for splenectomy, and age. OPSI is greatest in the very young and diminishes with age: 15.7% in infants, 10.4% in children <5 years old, 4.4% in children <16 years old, and 0.9% in adults.⁸ Although the incidence in adults is similar to that of the general population, mortality from sepsis is increased 58-fold in the asplenic population, with a fatality rate between 50% and 90%.^{95, 96, 97, 98, 102, 103} Underlying pathology, like youth, also imparts an increased risk of OPSI with the highest risk associated with underlying immune disorders and Hodgkin lymphoma.⁹⁷

Clinical Course

OPSI usually presents with fever and brief upper respiratory tract infection, and pursues a rapid course with evolution to sepsis, shock, disseminated intravascular coagulation, and multiple organ failure within hours. Any asplenic patient with fever should be evaluated for possible OPSI. Key to successful treatment is prompt administration of broad-spectrum intravenous antibiotics. A complete septic workup, including routine laboratory tests, appropriate imaging, and microbiology cultures, should be performed, but should never delay the initiation of antibiotics. In fully developed OPSI, mortality rates of 50% to 90% have been reported; 80% of deaths occur within 48 hours.^{95, 97} More recent information suggests that when informed patients seek medical attention promptly, mortality rates may be reduced to 10%.

Prevention of Overwhelming Postsplenectomy Infection

The guidelines for the prevention of OPSI center around vaccination, antibiotic prophylaxis, patient education, and strategies aimed at preserving splenic function. Recommended vaccines include the meningococcal vaccine, 23-valent polysaccharide pneumococcal vaccine for patients between 2 and 64 years old, and the H. influenzae conjugate vaccine. For patients undergoing elective splenectomy, vaccination should be performed at least 2 weeks before surgery to maximize the antibody against T cell-dependent immunogens. In emergent cases, patients should be vaccinated 14 days after their surgery.^{98, 104}

Repeat vaccination is safe in those who mount an antibody response based on measurement of antibody levels.^{104, 105} Currently, a single revaccination with the 23-valent polysaccharide pneumococcal vaccine is recommended at least 5 years after the first dose, with no further dosing recommended routinely. Reimmunization against meningococcal and H. influenzae are not recommended.¹⁰⁶ Regardless, many patients do not receive any revaccination because of a general lack of understanding about their condition and the unclear role of revaccination.⁹⁴

Children <5 years old also require aggressive immunization and antibiotic prophylaxis after splenectomy. Initial vaccination is provided with the H. influenzae vaccine, meningococcal vaccine, and 7-valent pneumococcal conjugate vaccine. If not previously immunized against pneumococcus, an additional dose of the 7-valent vaccine is recommended no less than 6 to 8 weeks after the last dose, with a final 23-valent vaccine booster 3 to 5 years after the last dose. Daily antibiotic prophylaxis with penicillin V potassium (125 mg twice a day until 3 years of age and 250 mg twice a day thereafter) is recommended for all children under the age of 5 years. If no invasive pneumococcal infections are experienced, prophylaxis may be discontinued after the age of 5 after appropriate immunizations have been obtained.¹⁰⁶

One of the most important, and most overlooked, aspects of prevention is patient education. Up to 50% of asplenic patients are unaware of their increased risk of serious infection, and 30% to 40% do not recall being vaccinated.⁹⁷ Few are provided with antibiotics to take empirically at the onset of fever, and one-half would not spontaneously tell an uninformed emergency department doctor about their splenectomies.⁹⁸ Asplenic patients should be extensively counseled about their health risks, the need for reimmunization, and the importance of informing future caregivers of their condition.

Autotransplantation of Splenic Tissue

Extrasplenic tissue may emerge secondary to traumatic autotransplantation, known as splenosis. Although this tissue appears as normal spleen, with white pulp, red pulp, and marginal zones, extrasplenic tissue is insufficient to recapitulate the host immune response and is not a recommended practice for patients undergoing splenectomy.^{21, 23}

P.1383

REFERENCES

1. Spleen. In: Standring S, Borley NR, Collins P, et al, eds. *Gray's Anatomy: The Anatomical Basis of Clinical Practice*, 40th ed. New York: Churchill Livingstone Elsevier, 2008. Chapter 71, 1191-1195.
2. McClusky DA, Skandalakis LJ, Colborn GL, Skandalakis JE. Tribute to a triad: history of splenic anatomy, physiology, and surgery-part 2. *World J Surg* 1999;23(5):514-526.
3. Mebius RE, Kraal G. Structure and function of the spleen. *Nat Rev Immunol* 2005;5(8):606-616.
4. Skandalakis PN, Colborn GL, Skandalakis LJ, Richardson DD, Mitchell WE, Skandalakis JE. The surgical anatomy of the spleen. *Surg Clin North Am* 1993;73(4):747-768.
5. Seifert MF, Marks SC. The regulation of hemopoiesis in the spleen. *Experientia* 1985;41(2):192-199.
6. Liu DL, Xia S, Xu W, Ye Q, Gao Y, Qian J. Anatomy of vasculature of 850 spleen specimens and its application in partial splenectomy. *Surgery* 1996;119(1):27-33.
7. Poulin EC, Thibault C. The anatomical basis for laparoscopic splenectomy. *Can J Surg* 1993;36(5):484-488.
8. Oguro A, Taniguchi H, Koyama H, et al. Quantification of human splenic blood flow (quantitative measurement of splenic blood flow with H₂(15)O and a dynamic state method: 1). *Ann Nucl Med* 1993;7(4):245-250.
9. Cesta MF. Normal structure, function, and histology of the spleen. *Toxicol Pathol* 2006;34(5):455-465.
10. Wan W, Vriend CY, Wetmore L, Gartner JG, Greenberg AH, Nance DM. The effects of stress on splenic immune function are mediated by the splenic nerve. *Brain Res Bull* 1993;30(1-2):101-105.
11. Livnat S, Felten SY, Carlson SL, Bellinger DL, Felten DL. Involvement of peripheral and central catecholamine systems in neural-immune interactions. *J Neuroimmunol* 1985;10(1):5-30.
12. Nance DM, Sanders VM. Autonomic innervation and regulation of the immune system (1987-2007). *Brain Behav Immun* 2007;21(6):736-745.
13. Rosas-Ballina M, Tracey KJ. The neurology of the immune system: neural reflexes regulate immunity. *Neuron* 2009;64(1):28-32.
14. Varga I, Galfiova P, Adamkov M, et al. Congenital anomalies of the spleen from an embryological point of view. *Med Sci Monit* 2009;15(12):RA269-RA276.
15. Duperier T, Brody F, Felsher J, Walsh RM, Rosen M, Ponsky J. Predictive factors for successful laparoscopic splenectomy in patients with immune thrombocytopenic purpura. *Arch Surg* 2004;139(1):61-66; discussion 6.
16. George JN. Sequence of treatments for adults with primary immune thrombocytopenia. *Am J Hematol* 2012;87(Suppl 1):S12-S15.
17. Kojouri K, Vesely SK, Terrell DR, George JN. Splenectomy for adult patients with idiopathic thrombocytopenic purpura: a systematic review to assess long-term platelet count responses, prediction of response, and surgical complications. *Blood* 2004;104(9):2623-2634.
18. Rosen M, Brody F, Walsh RM, Tarnoff M, Malm J, Ponsky J. Outcome of laparoscopic splenectomy based on hematologic indication. *Surg Endosc* 2002;16(2):272-279.
19. Phom H, Kumar A, Tripathi M, et al. Comparative evaluation of Tc-99m-heatdenatured RBC and Tc-99m-anti-D IgG opsonized RBC spleen planar and SPECT scintigraphy in the detection of accessory spleen in postsplenectomy patients with chronic idiopathic thrombocytopenic purpura. *Clin Nucl Med* 2004;29(7):403-409.
20. Carr NJ, Turk EP. The histological features of splenosis. *Histopathology* 1992;21(6):549-553.
21. Fremont RD, Rice TW. Splenosis: a review. *South Med J* 2007;100(6): 589-593.
22. Naylor MF, Karstaedt N, Finck SJ, Burnett OL. Noninvasive methods of diagnosing thoracic splenosis. *Ann Thorac Surg* 1999;68(1):243-244.
23. Connell NT, Brunner AM, Kerr CA, Schiffman FJ. Splenosis and sepsis: The born-again spleen provides poor protection. *Virulence* 2011;2(1):4-11.
24. Schmidt EE, MacDonald IC, Groom AC. Comparative aspects of splenic microcirculatory pathways in mammals: the region bordering the white pulp. *Scanning Microsc* 1993;7(2):613-628.
25. Nolte MA, Arens R, Kraus M, et al. B cells are crucial for both development and maintenance of the splenic marginal zone. *J Immunol* 2004;172(6):3620-3627.

26. Lopes-Carvalho T, Kearney JF. Development and selection of marginal zone B cells. *Immunol Rev* 2004;197:192-205.
27. Groom AC, Schmidt EE, MacDonald IC. Microcirculatory pathways and blood flow in spleen: new insights from washout kinetics, corrosion casts, and quantitative intravital videomicroscopy. *Scanning Microsc* 1991;5(1): 159-173; discussion 73-74.
28. Jønsson V, Bock JE, Nielsen JB. Significance of plasma skimming and plasma volume expansion. *J Appl Physiol* 1992;72(6):2047-20451.
29. Steiniger B, Bette M, Schwarzbach H. The open microcirculation in human spleens: a three-dimensional approach. *J Histochem Cytochem* 2011;59(6):639-648.
30. Corazza GR, Ginaldi L, Zoli G, et al. Howell-Jolly body counting as a measure of splenic function. A reassessment. *Clin Lab Haematol* 1990;12(3):269-275.
31. Lammers AJ, de Porto AP, Bennink RJ, et al. Hyposplenism: comparison of different methods for determining splenic function. *Am J Hematol* 2012;87(5):484-489.
32. Gordon S. Pattern recognition receptors: doubling up for the innate immune response. *Cell* 2002;111(7):927-930.
33. Ge Y, Gao H, Kong XT. Immunoglobulins and complement in splenectomised and autotransplanted subjects. *Ann Med* 1989;21(4):265-267.
34. Sze DM, Toellner KM, García de Vinuesa C, Taylor DR, MacLennan IC. Intrinsic constraint on plasmablast growth and extrinsic limits of plasma cell survival. *J Exp Med* 2000;192(6):813-821.
35. Gretz JE, Norbury CC, Anderson AO, Proudfoot AE, Shaw S. Lymph-borne chemokines and other low molecular weight molecules reach high endothelial venules via specialized conduits while a functional barrier limits access to the lymphocyte microenvironments in lymph node cortex. *J Exp Med* 2000;192(10):1425-1440.
36. Nolte MA, Beliën JA, Schadee-Eestermans I, et al. A conduit system distributes chemokines and small blood-borne molecules through the splenic white pulp. *J Exp Med* 2003;198(3):505-512.
37. Toft P, Helbo-Hansen HS, Tønnesen E, Lillevang ST, Rasmussen JW, Christensen NJ. Redistribution of granulocytes during adrenaline infusion and following administration of cortisol in healthy volunteers. *Acta Anaesthesiol Scand* 1994;38(3):254-258.
38. Hill-Zobel RL, McCandless B, Kang SA, Chikkappa G, Tsan MF. Organ distribution and fate of human platelets: studies of asplenic and splenomegalic patients. *Am J Hematol* 1986;23(3):231-238.
39. Stewart IB, McKenzie DC. The human spleen during physiological stress. *Sports Med* 2002;32(6):361-369.
40. Toft P, Tønnesen E, Helbo-Hansen HS, Lillevang ST, Rasmussen JW, Christensen NJ. Redistribution of granulocytes in patients after major surgical stress. *APMIS* 1994;102(1):43-48.
41. Swirski FK, Nahrendorf M, Etzrodt M, et al. Identification of splenic reservoir monocytes and their deployment to inflammatory sites. *Science* 2009;325(5940):612-616.
42. Gabrilovich DI, Ostrand-Rosenberg S, Bronte V. Coordinated regulation of myeloid cells by tumours. *Nat Rev Immunol* 2012;12(4):253-268.
43. Knutson M, Wessling-Resnick M. Iron metabolism in the reticuloendothelial system. *Crit Rev Biochem Mol Biol* 2003;38(1):61-88.
44. Maines MD. The heme oxygenase system: a regulator of second messenger gases. *Annu Rev Pharmacol Toxicol* 1997;37:517-554.
45. Kristiansen M, Graversen JH, Jacobsen C, et al. Identification of the haemoglobin scavenger receptor. *Nature* 2001;409(6817):198-201.
46. Flo TH, Smith KD, Sato S, et al. Lipocalin 2 mediates an innate immune response to bacterial infection by sequestering iron. *Nature* 2004;432(7019):917-921.
47. Eichner ER. Splenic function: normal, too much and too little. *Am J Med* 1979;66(2):311-320.
48. Motyckova G, Steensma DP. Why does my patient have lymphadenopathy or splenomegaly? *Hematol Oncol Clin North Am* 2012;26(2):395-408.

49. Semple JW. Infections, antigen-presenting cells, T cells, and immune tolerance: their role in the pathogenesis of immune thrombocytopenia. *Hematol Oncol Clin North Am* 2009;23(6):1177-1192.
50. Cines DB, Bussel JB, Liebman HA, Luning Prak ET. The ITP syndrome: pathogenic and clinical diversity. *Blood* 2009;113(26):6511-6521.
51. Neunert C, Lim W, Crowther M, et al. The American Society of Hematology 2011 evidence-based practice guideline for immune thrombocytopenia. *Blood* 2011;117(16):4190-4207.
52. Provan D, Stasi R, Newland AC, et al. International consensus report on the investigation and management of primary immune thrombocytopenia. *Blood* 2010;115(2):168-186.
53. Arnold DM, Dentali F, Crowther MA, et al. Systematic review: efficacy and safety of rituximab for adults with idiopathic thrombocytopenic purpura. *Ann Intern Med* 2007;146(1):25-33.
54. Bennett CM, Rogers ZR, Kinnamon DD, et al. Prospective phase 1/2 study of rituximab in childhood and adolescent chronic immune thrombocytopenic purpura. *Blood* 2006;107(7):2639-2642.
55. Godeau B, Porcher R, Fain O, et al. Rituximab efficacy and safety in adult splenectomy candidates with chronic immune thrombocytopenic purpura: results of a prospective multicenter phase 2 study. *Blood* 2008;112(4):999-1004.
56. Zipfel PF, Heinen S, Skerka C. Thrombotic microangiopathies: new insights and new challenges. *Curr Opin Nephrol Hypertens* 2010;19(4):372-378.
57. Aqui NA, Stein SH, Konkle BA, Abrams CS, Strobl FJ. Role of splenectomy in patients with refractory or relapsed thrombotic thrombocytopenic purpura. *J Clin Apher* 2003;18(2):51-54.
58. Mori Y, Wada H, Gabazza EC, et al. Predicting response to plasma exchange in patients with thrombotic thrombocytopenic purpura with measurement of vWF-cleaving protease activity. *Transfusion* 2002;42(5):572-580.
59. Schwartz J, Eldor A, Szold A. Laparoscopic splenectomy in patients with refractory or relapsing thrombotic thrombocytopenic purpura. *Arch Surg* 2001;136(11):1236-1238; discussion 9.
60. Al-Salem AH. Splenic complications of sickle cell anemia and the role of splenectomy. *ISRN Hematol* 2011;2011:864257.
61. Hirst AE, Bullock WK. Metastatic carcinoma of the spleen. *Am J Med Sci* 1952;223(4):414-417.
62. Velanovich V, Shurafa MS. Clinical and quality of life outcomes of laparoscopic and open splenectomy for haematological diseases. *Eur J Surg* 2001;167(1):23-28.
63. Hoppe RT, Advani RH, Ai WZ, et al. Hodgkin lymphoma. *J Natl Compr Canc Netw* 2011;9(9):1020-1058.
64. Hodgson K, Ferrer G, Pereira A, Moreno C, Montserrat E. Autoimmune cytopenia in chronic lymphocytic leukaemia: diagnosis and treatment. *Br J Haematol* 2011;154(1):14-22.
65. Jones G, Parry-Jones N, Wilkins B, Else M, Catovsky D, Haematology BCFSi. Revised guidelines for the diagnosis and management of hairy cell leukaemia and hairy cell leukaemia variant. *Br J Haematol* 2012;156(2):186-195.
66. Mesa RA, Tefferi A. Palliative splenectomy in myelofibrosis with myeloid metaplasia. *Leuk Lymphoma* 2001;42(5):901-911.
67. Mesa RA, Nagorney DS, Schwager S, Allred J, Tefferi A. Palliative goals, patient selection, and perioperative platelet management: outcomes and lessons from 3 decades of splenectomy for myelofibrosis with myeloid metaplasia at the Mayo Clinic. *Cancer* 2006;107(2):361-370.
68. Hansen MB, Moller AC. Splenic cysts. *Surg Laparosc Endosc Percutan Tech* 2004;14(6):316-322.
69. Morgenstern L. Nonparasitic splenic cysts: pathogenesis, classification, and treatment. *J Am Coll Surg* 2002;194(3):306-314.
70. Khoury G, Abiad F, Geagea T, Nabout G, Jabbour S. Laparoscopic treatment of hydatid cysts of the liver and spleen. *Surg Endosc* 2000;14(3):243-245.
71. Cowles RA, Yahanda AM. Epidermoid cyst of the spleen. *Am J Surg* 2000;180(3):227.
72. Sperti C, Pasquali C, Guolo P, Polverosi R, Liessi G, Pedrazzoli S. Serum tumor markers and cyst fluid analysis are useful for the diagnosis of pancreatic cystic tumors. *Cancer* 1996;78(2):237-243.

73. Singh AK, Shankar S, Gervais DA, Hahn PF, Mueller PR. Image-guided percutaneous splenic interventions. *Radiographics* 2012;32(2):523-534.
74. Thanos L, Dailiana T, Papaioannou G, Nikita A, Koutrouvelis H, Kelekis DA. Percutaneous CT-guided drainage of splenic abscess. *AJR Am J Roentgenol* 2002;179(3):629-632.
75. Balint GP, Balint PV. Felty's syndrome. *Best Pract Res Clin Rheumatol* 2004;18(5):631-645.
76. Rashba EJ, Rowe JM, Packman CH. Treatment of the neutropenia of Felty syndrome. *Blood Rev* 1996;10(3):177-184.
77. Bhullar IS, Frykberg ER, Siragusa D, et al. Selective angiographic embolization of blunt splenic traumatic injuries in adults decreases failure rate of non-operative management. *J Trauma Acute Care Surg* 2012;72(5):1127-1134.
78. Bhangu A, Nepogodiev D, Lal N, Bowley DM. Meta-analysis of predictive factors and outcomes for failure of non-operative management of blunt splenic trauma. *Injury* 2012;43(9):1337-1346.
79. McIntyre LK, Schiff M, Jurkovich GJ. Failure of nonoperative management of splenic injuries: causes and consequences. *Arch Surg* 2005;140(6):563-568; discussion 8-9.
80. Clancy AA, Tiruta C, Ashman D, Ball CG, Kirkpatrick AW. The song remains the same although the instruments are changing: complications following selective non-operative management of blunt spleen trauma: a retrospective review of patients at a level I trauma centre from 1996 to 2007. *J Trauma Manag Outcomes* 2012;6(1):4.
81. Kluger Y, Paul DB, Raves JJ, et al. Delayed rupture of the spleen—myths, facts, and their importance: case reports and literature review. *J Trauma* 1994;36(4):568-571.
82. Görg C, Cölle J, Görg K, Prinz H, Zugmaier G. Spontaneous rupture of the spleen: ultrasound patterns, diagnosis and follow-up. *Br J Radiol* 2003;76(910):704-711.
83. Renzulli P, Hostettler A, Schoepfer AM, Gloor B, Candinas D. Systematic review of atraumatic splenic rupture. *Br J Surg* 2009;96(10):1114-1121.
84. Delaitre B, Maignien B. [Splenectomy by the laparoscopic approach. Report of a case]. *Presse Med* 1991;20(44):2263.
85. Grahn SW, Alvarez J, Kirkwood K. Trends in laparoscopic splenectomy for massive splenomegaly. *Arch Surg* 2006;141(8):755-761; discussion 61-62.
86. Kercher KW, Matthews BD, Walsh RM, Sing RF, Backus CL, Heniford BT. Laparoscopic splenectomy for massive splenomegaly. *Am J Surg* 2002;183(2):192-196.
87. Winslow ER, Brunt LM, Drebin JA, Soper NJ, Klingensmith ME. Portal vein thrombosis after splenectomy. *Am J Surg* 2002;184(6):631-635; discussion 5-6.
88. Danno K, Ikeda M, Sekimoto M, et al. Diameter of splenic vein is a risk factor for portal or splenic vein thrombosis after laparoscopic splenectomy. *Surgery* 2009;145(5):457-464; discussion 65-66.
89. James AW, Rabl C, Westphalen AC, Fogarty PF, Posselt AM, Campos GM. Portomesenteric venous thrombosis after laparoscopic surgery: a systematic literature review. *Arch Surg* 2009;144(6):520-526.
90. Ikeda M, Sekimoto M, Takiguchi S, et al. High incidence of thrombosis of the portal venous system after laparoscopic splenectomy: a prospective study with contrast-enhanced CT scan. *Ann Surg* 2005;241(2):208-216.
91. van't Riet M, Burger JW, van Muiswinkel JM, Kazemier G, Schipperus MR, Bonjer HJ. Diagnosis and treatment of portal vein thrombosis following splenectomy. *Br J Surg* 2000;87(9):1229-1233.
92. Stamou KM, Toutouzas KG, Kekis PB, et al. Prospective study of the incidence and risk factors of postsplenectomy thrombosis of the portal, mesenteric, and splenic veins. *Arch Surg* 2006;141(7):663-669.
93. Demetriades D, Scalea TM, Degiannis E, et al. Blunt splenic trauma: splenectomy increases early infectious complications: a prospective multicenter study. *J Trauma Acute Care Surg* 2012;72(1):229-234.
94. Rutherford EJ, Livengood J, Higginbotham M, et al. Efficacy and safety of pneumococcal revaccination after splenectomy for trauma. *J Trauma* 1995;39(3):448-452.
95. Kyaw MH, Holmes EM, Toolis F, et al. Evaluation of severe infection and survival after splenectomy. *Am J Med* 2006;119(3):276.e1-276.e7.
96. Diamond LK. Splenectomy in childhood and the hazard of overwhelming infection. *Pediatrics* 1969;43(5):886-889.

97. Sumaraju V, Smith LG, Smith SM. Infectious complications in asplenic hosts. *Infect Dis Clin North Am* 2001;15(2):551-565.
98. Moffett SL. Overwhelming postsplenectomy infection: managing patients at risk. *JAAPA* 2009;22(7):36-39, 45.
99. Wolf HM, Eibl MM, Georgi E, et al. Long-term decrease of CD4+CD45RA+ T cells and impaired primary immune response after post-traumatic splenectomy. *Br J Haematol* 1999;107(1):55-68.
100. Kruetzmann S, Rosado MM, Weber H, et al. Human immunoglobulin M memory B cells controlling *Streptococcus pneumoniae* infections are generated in the spleen. *J Exp Med* 2003;197(7):939-945.
101. Tracy ET, Haas KM, Gentry T, et al. Partial splenectomy but not total splenectomy preserves immunoglobulin M memory B cells in mice. *J Pediatr Surg* 2011;46(9):1706-1710.
102. Ram S, Lewis LA, Rice PA. Infections of people with complement deficiencies and patients who have undergone splenectomy. *Clin Microbiol Rev* 2010;23(4):740-780.
103. Price VE, Blanchette VS, Ford-Jones EL. The prevention and management of infections in children with asplenia or hyposplenia. *Infect Dis Clin North Am* 2007;21(3):697-710, viii-ix.
104. Davies JM, Lewis MP, Wimperis J, et al. Review of guidelines for the prevention and treatment of infection in patients with an absent or dysfunctional spleen: prepared on behalf of the British Committee for Standards in Haematology by a working party of the Haemato-Oncology task force. *Br J Haematol* 2011;155(3):308-317.
105. Landgren O, Björkholm M, Konradsen HB, et al. A prospective study on antibody response to repeated vaccinations with pneumococcal capsular polysaccharide in splenectomized individuals with special reference to Hodgkin's lymphoma. *J Intern Med* 2004;255(6):664-673.
106. Howdieshell TR, Heffernan D, Dipiro JT, Society TACotSI. Surgical infection society guidelines for vaccination after traumatic injury. *Surg Infect (Larchmt)* 2006;7(3):275-303.

Chapter 66 Tumors of the Spleen

> Table of Contents > Part VI - Benign Disorders of Leukocytes, The Spleen, and/or Immunoglobins > Chapter 66 - Tumors of the Spleen

Chapter 66

Tumors of the Spleen

Daniel A. Arber

A variety of tumors and tumorous proliferations may involve the spleen, and there are several that are unique to this organ. This chapter focuses on the unique proliferations as well as other neoplastic causes of splenomegaly. Splenomegaly, however, is not restricted to neoplastic causes and may occur with secondary hypersplenism, which may be secondary to autoimmune or para-neoplastic causes, infectious processes, and passive congestion due to other nonneoplastic medical disorders.

PATTERNS OF TUMOROUS SPLEEN PROLIFERATIONS

Although splenomegaly is often present with splenic neoplasia, some tumors and tumorous proliferations may be found incidentally in normal-sized spleens during radiologic staging or in spleens removed due to traumatic rupture or incidentally removed during other surgical procedures. The pattern of splenic infiltration may be helpful in the differential diagnosis of splenic tumors and the gross disease patterns tend to mimic histologic patterns (Fig. 66.1 and Table 66.1).¹ The most common disease patterns are diffuse, miliary, and nodular disease. Diffuse disease generally results in splenomegaly with complete infiltration of the splenic parenchyma. This often imparts a glassy and homogeneous red appearance to the cut surface of the spleen. This usually is due to obliteration of the normal splenic white pulp by a cellular proliferation of the red pulp. This disease pattern has traditionally been attributed to leukemic infiltration, T-cell lymphomas, and histiocytic tumors. Many of the red pulp proliferations previously considered to be histiocytic, however, have now been shown to represent T-cell neoplasms. The miliary pattern shows small, punctate tan or white areas throughout the cut surface of the spleen. These usually represent expansion of the splenic white pulp, the normal B-cell compartment of the spleen. However, a similar gross appearance may occur with granulomatous infections. The white pulp expansion pattern most commonly occurs in florid reactive hyperplasia and with low-grade B-cell lymphomas. The nodular disease pattern is characterized by one or more distinct tumor nodules in the spleen which may be identified

incidentally on imaging studies. These nodules are usually firm and tan or white in cases of large cell lymphoma, Hodgkin disease, or metastatic tumors, and are bloody with a beefy-red appearance in vascular proliferations. Cystic lesions of the spleen may also show a nodular pattern of involvement.

CYSTS AND ABSCESSSES

Cysts of the spleen are found in <1% of splenectomy specimens.² They occur most commonly in men in the third decade of life. They are usually asymptomatic; however, they may cause a splenic mass and be associated with abdominal pain. Splenic cysts may be essentially any size but are on average 10 cm in diameter.³ Splenic cysts may be designated as primary or secondary, also considered true and false cysts, respectively. Both types are usually unilocular, but some small primary cysts are multilocular. Primary cysts are reported to represent approximately 20% of all splenic cysts, but small primary cysts of the spleen are probably underrepresented in older studies and more extensive evaluation of nonparasitic cysts shows that the vast majority are true cysts.^{4, 5} Primary cysts have a firm, rough, and trabecular cyst wall that shows fibrosis and an epithelial lining on histologic examination (Fig. 66.2). The lining may be of mesothelial or squamous epithelium with the latter probably representing a metaplastic change.⁶ The epithelial lining of primary cysts may be patchy, with denuded areas present that may simulate a secondary cyst. Primary cysts can be further subdivided into parasitic and nonparasitic types. Primary parasitic cysts related to echinococcal infection (hydatid cysts) are common worldwide, but are uncommon in Western countries. Parasitic cysts are readily identified by the presence of parasite scolices in the cyst contents. Nonparasitic primary cysts appear to arise from congenital inclusions of capsular mesothelium.⁷ Small multilocular primary cysts of the spleen occurring at the splenic capsule have in the past been mistaken for lymphangiomas.⁸ Patients with primary cysts may have elevations of CA19-9 and carcinoembryonic antigen.^{9, 10} Primary cysts are usually treated with splenectomy, and partial resection by laparoscopic methods often leads to recurrence.^{11, 12}

Secondary cysts are reportedly more common, representing approximately 80% of splenic cysts in most studies, but more detailed evaluation can confirm many of these as having a focal epithelial lining and thus they are really primary.⁴ The true secondary cysts are often associated with a history of abdominal trauma and are probably acquired after hematoma or infection. The cysts are unilocular and usually have a smooth lining. They differ histologically from primary cysts by the complete absence of an epithelial lining, and are thus unlikely to recur even if only partially resected. The cyst wall may contain hemosiderin or calcification.

Some secondary cysts of the spleen may represent resolved abscesses. Multiple small splenic abscesses usually do not develop associated fibrosis with resolution, but larger abscesses are often single and develop a wall of surrounding fibrosis virtually identical to that seen in secondary cysts. Although relatively uncommon, splenic abscesses are most often associated with sepsis or

P.1385

endocarditis. They may also occur following abdominal trauma, including splenic rupture, by contiguous spread of infection from other organs, or in association with functional asplenia in sickle cell anemia.^{13, 14, 15} Most splenic abscesses are due to polymicrobial infection, but common organisms include *Streptococcus*, *Staphylococcus*, *Escherichia coli*, and *Salmonella*.¹⁶

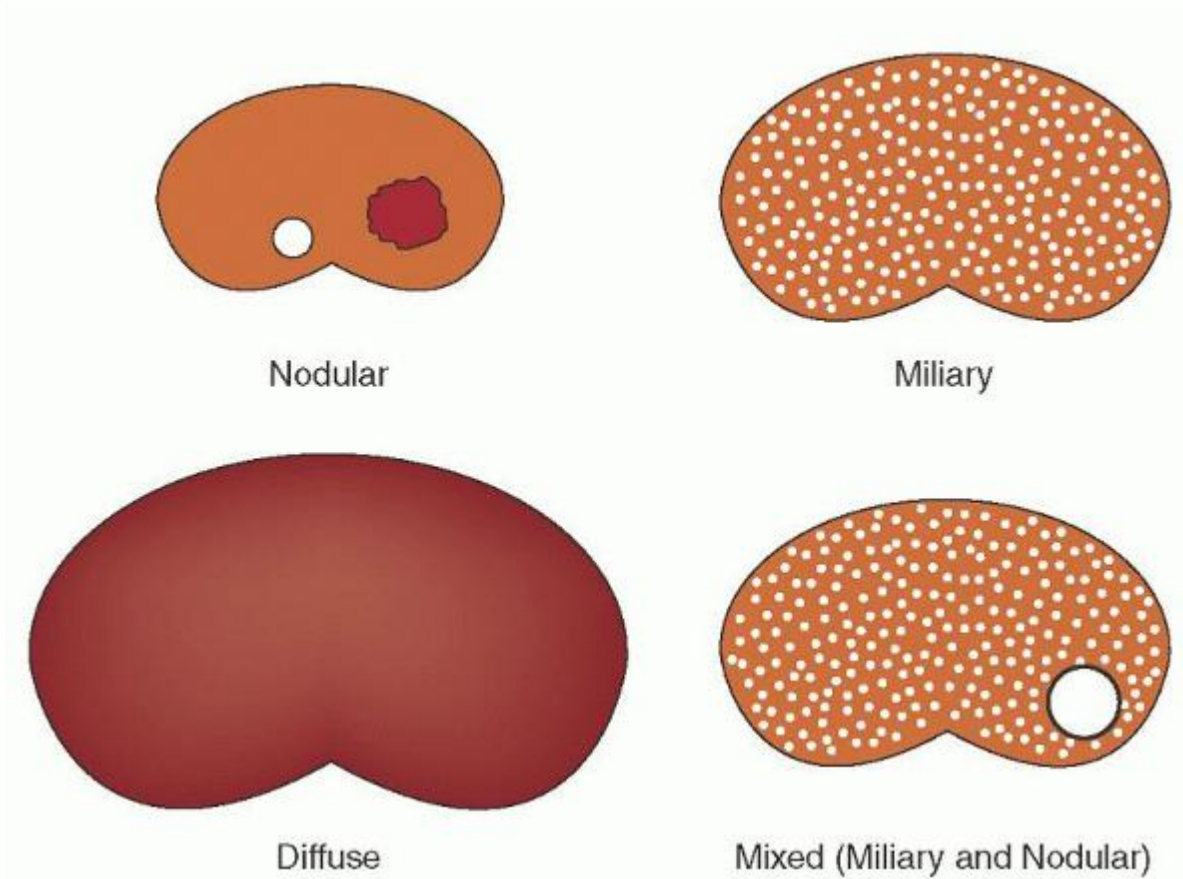

FIGURE 66.1. Gross patterns of splenic tumor involvement. Nodular tumor infiltrates may form solid firm masses or may be hemorrhagic masses. The miliary pattern shows small punctate white foci that usually correspond to expansions of the white pulp. The diffuse pattern shown is usually associated with massive splenomegaly and corresponds to a red pulp expansion. Mixed patterns may be seen when the spleen is involved by more than one process or when a low-grade lymphoma transforms to high-grade disease.

TABLE 66.1 PATTERNS OF SPLENIC TUMOR INVOLVEMENT

Diffuse (Predominantly Red Pulp) Disease	Miliary (Predominantly White Pulp) Disease	Predominantly Nodular Disease
Peliosis	Marked white pulp hyperplasia	Cysts
Hemangiomas	Chronic lymphocytic leukemia/small lymphocytic	Abscess
Lymphangiomas	lymphoma	Inflammatory pseudotumor
Acute leukemias	Prolymphocytic leukemia	Hamartoma
Hairy cell leukemia	Most follicular lymphomas	Hemangioma
Hairy cell leukemia variant	Mantle cell lymphoma	Sclerosing angiomatoid nodular transformation
Diffuse red pulp small B-cell lymphoma	Splenic marginal zone lymphoma	Littoral cell angioma
Chronic myeloproliferative neoplasms	Lymphoplasmacytic lymphoma ^a	Epithelioid hemangioendothelioma
Lymphoblastic lymphoma	Early involvement by large B-cell	Angiosarcoma

lymphoma

Hepatosplenic T-cell lymphoma

Large granular lymphocytosis

Lymphoplasmacytic lymphoma^a^a More than one pattern may occur with some diseases.Partial splenectomy has been used successfully in the treatment of nonparasitic splenic cysts.¹⁷

VASCULAR PROLIFERATIONS

Vascular tumors are the most common tumors of the spleen. Vascular proliferations may be diffuse or may form a tumor mass. Peliosis is a rare, diffuse vascular proliferation that is usually an incidental finding occurring in adults.^{18, 19, 20} It may be associated with hepatic peliosis and may occur with anabolic steroid use, in association with malignancies, and following solid organ transplantation, as well as in patients with hepatic cirrhosis, tuberculosis, and aplastic anemia. Peliosis results in dilated vascular spaces, usually 1 mm or less in diameter, that involve the entire splenic parenchyma (Fig. 66.3). Splenic peliosis appears to be associated with an increased risk of splenic rupture.^{19, 21, 22}

Hemangiomas are benign tumors that are also usually asymptomatic, but may cause splenomegaly, abdominal pain, and hypersplenism.^{2, 23, 24, 25} Most hemangiomas are localized and form single or multiple tumor nodules that contain cystic blood-filled spaces grossly. These spaces are lined by endothelial cells, and papillary projections may occur in areas with thrombi. The tumor nodules are usually surrounded by fibrosis and may show calcification. Plain abdominal radiographs, computed tomographic scans, and sonograms are nonspecific, but all show discrete solid and cystic masses, often with evidence of calcification.^{26, 27} Diffuse hemangiomatosis of the spleen is less common, is often associated with systemic hemangiomatosis, results in massive splenomegaly, and may be associated with coagulopathies.^{28, 29} Diffuse hemangiomatosis differs from peliosis by the presence of intervening fibrosis in hemangiomatosis, which is not a feature of peliosis.

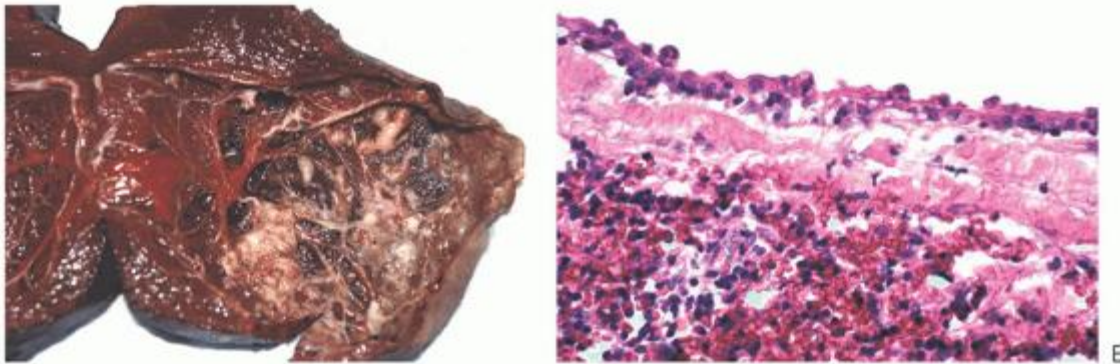

FIGURE 66.2. Primary cysts. A: Primary cyst of the spleen showing a trabeculated inner surface on gross examination. B: The cyst shows an epithelial lining on histologic sections, a feature that is definitional of a primary cyst.

Localized lymphangiomas of the spleen may be difficult to distinguish from hemangiomas or primary cysts, but usually contain proteinaceous fluid rather than the blood of an hemangioma.^{2, 23, 30} Diffuse lymphangiomatosis may be localized to the spleen, but is usually a systemic process and most commonly occurs in children and young adults with massive splenomegaly.^{30, 31, 32, 33, 34} The splenic parenchyma is replaced by multiple cysts, up to 3 cm in diameter, imparting a spongy appearance (Fig. 66.4). The cysts are filled with thick pink to brown fluid. Large localized lymphangiomas and lymphangiomatosis of the spleen may be treated with splenectomy.³⁰

P.1386

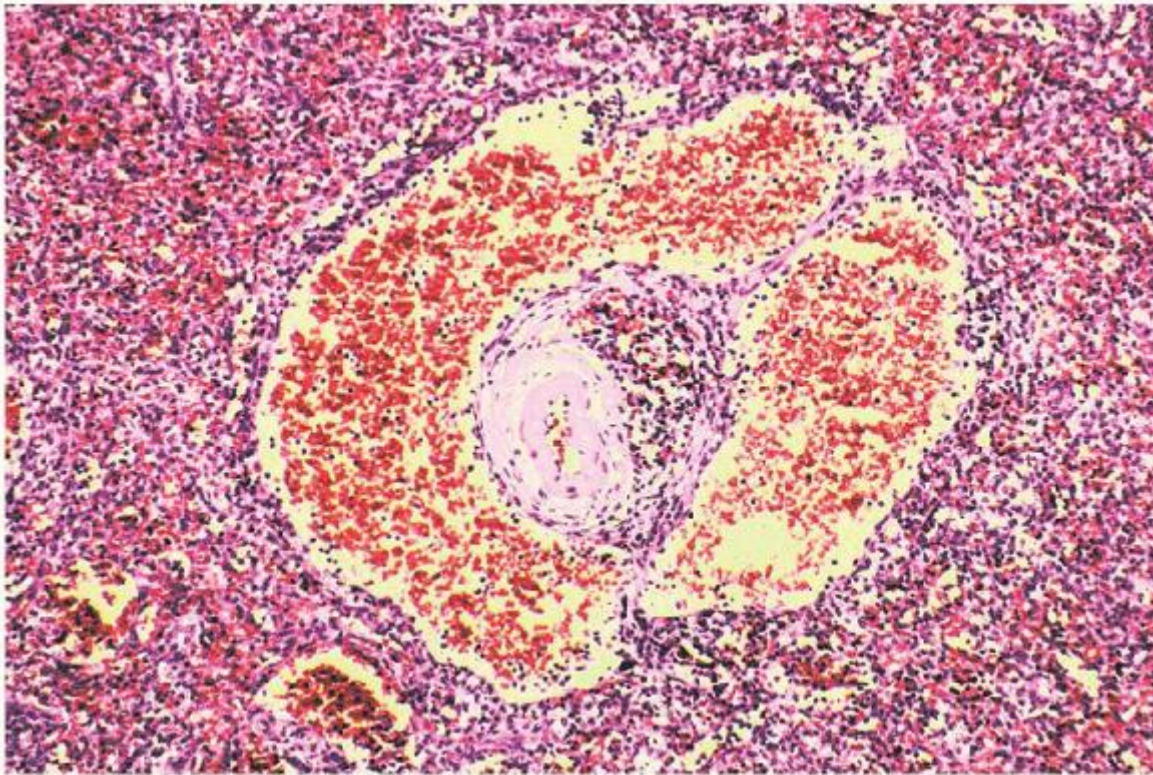

FIGURE 66.3. Splenic peliosis. Peliosis of the spleen shows expanded small vessels that diffusely involve the spleen without forming a nodular mass and without intervening fibrosis.

Although hemangiomas and lymphangiomas of the spleen are similar to those of other sites, there are two unique vascular proliferations of the spleen. Littoral cell angioma is a tumor presumably derived from the normal splenic lining cell, also known as the littoral cell.^{24, 35} These tumors may occur at any age and usually cause mild to moderate splenomegaly. Many tumors, however, are found incidentally. The tumor forms multiple spongy dark red nodules that can measure up to 9 cm in diameter (Fig. 66.5). Histologically these tumors differ from hemangiomas in that the vascular spaces are lined by plump cells with nuclear enlargement and often show papillary areas and lining cells sloughing into the vascular spaces. The lining cells of littoral cell angioma have a unique immunophenotype, expressing vascular, histiocytic, and dendritic-associated markers CD31, CD68, CD163, and CD21. In contrast to hemangiomas and normal sinus lining cells, the lining cells of littoral cell angioma do not express CD34 or CD8. Most cases of littoral cell angioma are treated with splenectomy without recurrence, but there are two reports of late abdominal and liver metastasis after 4 and 8 years.^{36, 37} Both cases showed solid foci of clear cells and probably represent littoral cell hemangioendotheliomas.

Sclerosing angiomatoid nodular transformation (SANT) is the other vascular proliferation unique to the spleen.^{38, 39, 40} To date, SANT has only been reported in adults, usually presenting as an incidental mass, and less commonly with splenomegaly or abdominal pain. It usually forms a single fibrotic nodule that contains vascular spaces, including slitlike spaces, fibrosis with spindled cells, and splenic sinus lining cells without nuclear atypia, mitotic figures, or necrosis. Cases of this type have been interpreted in the past as epithelioid and spindled hemangioendotheliomas or as inflammatory pseudotumors (see below), but they have not recurred or metastasized after splenectomy. SANT is now felt to be a reactive fibrous entrapment of altered red pulp, presumably following some form of splenic injury, rather than a true neoplasm. More recent reports have described an increase in IgG4-positive plasma cells in SANT and some studies suggest an association with Epstein-Barr virus (EBV) in this proliferation.^{39, 41, 42} However, the EBV-positive cases appear to be overlap proliferations with splenic inflammatory pseudotumor and SANT is typically EBV-negative.⁴³

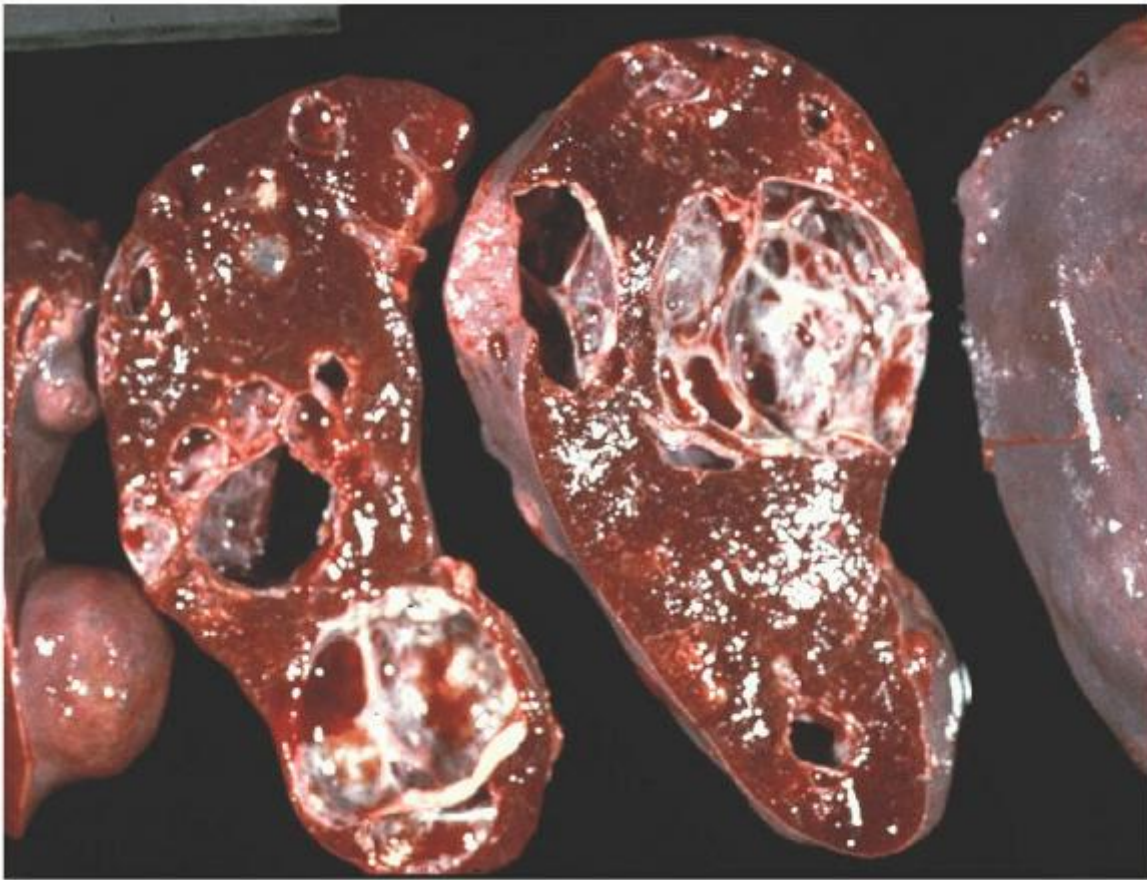

FIGURE 66.5. Littoral cell angioma. A: Multinodular hemorrhagic lesions of the spleen in littoral cell angioma. B: Microscopically, there are papillary vascular spaces with plump lining cells and histiocytes.

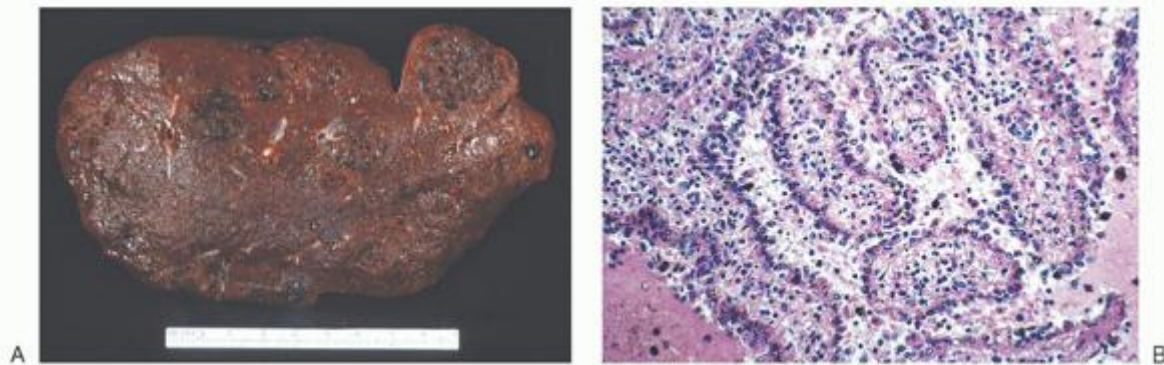

FIGURE 66.4. Lymphangiomatosis. Cut surface of a spleen. Multiple, variably sized cysts are present.

Angiosarcoma of the spleen occurs most commonly in adults and is usually associated with splenomegaly, abdominal pain, and cytopenias.^{24, 44, 45, 46} Splenic rupture is common in these patients. Because most angiosarcomas involving the spleen are high-grade sarcomas with dissemination, it is often difficult to determine whether the splenic tumor is primary or secondary. The tumor forms an infiltrating mass that may have areas of cystic hemorrhage. The histologic appearance may be varied; however, angiosarcomas characteristically show cytologic atypia, high mitotic activity, and necrosis. Many cases may be difficult to differentiate from other high-grade sarcomas, and immunohistochemical detection of vascular antigen expression, such as CD31, CD34,

P.1387

and von Willebrand factor, is necessary to diagnose such cases. High-grade angiosarcomas involving the spleen have a

generally poor prognosis, with most patients dying of disease within 1 year of diagnosis; however, rare cases with long-term survival following splenectomy have been reported.⁴⁶

Low-grade angiosarcomas, also known as epithelioid hemangioendotheliomas, are much less common than high-grade tumors.^{47, 48, 49} These are reported to occur in both children and adults, but some of the adult cases have features similar to those more recently described for SANT (see above). Patients usually present with anemia and may have hyper- or hyposplenism. These tumors are better circumscribed than high-grade angiosarcomas with more bland epithelioid cells, vascular spaces, and prominent fibrosis. They also usually lack necrosis. The cells may show intracellular lumina and will express vascular-associated antigens. These tumors may be incidental findings, are usually localized to the spleen, and do not tend to recur after splenectomy.

LYMPHOID PROLIFERATIONS

Essentially any lymphoproliferative disorder may involve the spleen and splenic involvement may be the first evidence of disease. Despite this, most lymphoid proliferations involving the spleen are disseminated at the time of splenic involvement and are accompanied by lymphadenopathy.^{50, 51, 52, 53} Two types of splenic lymphoma, however, are unique to the spleen and present with splenomegaly without lymphadenopathy.

Splenic marginal zone lymphoma was originally described as a splenic lymphoma with features that mimicked hairy cell leukemia.⁵⁴ Although sharing some morphologic and immunophenotypic features, splenic marginal zone lymphoma appears to be distinct from both nodal and extranodal (nonsplenic) marginal zone lymphomas.⁵⁵ It is the most common lymphoma type in patients with so-called splenic lymphoma with circulating villous lymphocytes.^{56, 57, 60} Splenic marginal zone lymphoma most commonly occurs in elderly patients with massive splenomegaly (Fig. 66.6).^{53, 61, 62, 63, 64, 65} Although splenic hilar lymph nodes are often involved by disease, other adenopathy is not usually present. Patients frequently have a lymphocytosis. The abnormal lymphoid cells may vary in appearance, but some cases have circulating lymphocytes with villous cytoplasmic projections that differ from hairy cell leukemia lymphocytes by having only unipolar or bipolar projections as opposed to the more uniform villous projections of hairy cell leukemia. The spleen is uniformly enlarged without a distinct mass. The white pulp is massively expanded by a biphasic population of small lymphocytes that may cause a gross miliary pattern of the spleen parenchyma. The central white pulp lymphocytes are small with scant cytoplasm and are surrounded by a bandlike proliferation of more irregular small lymphocytes with abundant clear to pink cytoplasm on histologic sections. These cells are CD20⁺ B cells that express BCL2, but do not express CD10, or CD43. A subset of cases may express CD5. The pattern of infiltration is distinct from hairy cell leukemia, which causes a diffuse red pulp infiltrate, and splenic marginal zone lymphoma does not usually demonstrate tartrate-resistant acid phosphatase (TRAP) positivity or expression of Annexin A1, CD25, or CD103 of hairy cell leukemia.

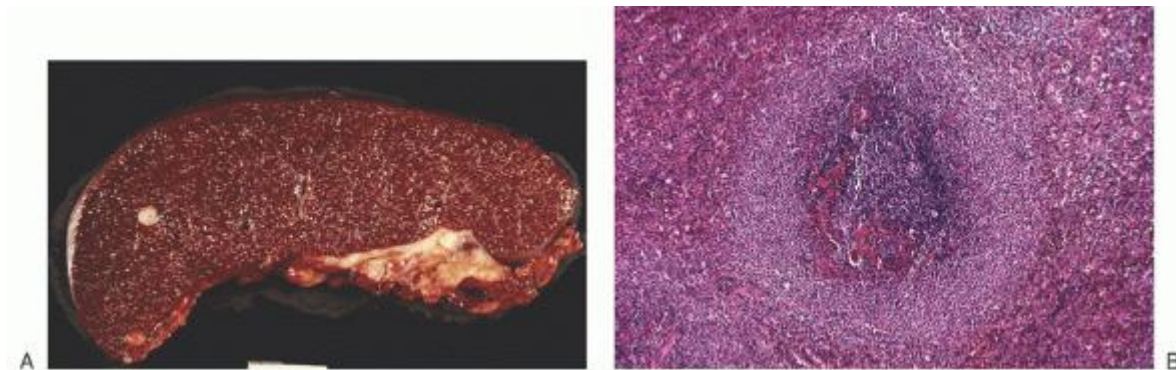

FIGURE 66.6. Splenic marginal zone lymphoma and metastatic carcinoma. A: Gross appearance of the miliary pattern of splenic involvement by splenic marginal zone lymphoma. Note the white, larger mucoid lesion at the left, which represents metastatic papillary serous ovarian carcinoma resulting in a mixed disease pattern of infiltration. B: The splenic marginal zone lymphoma shows biphasic white pulp with small round cells in the center and larger lymphocytes with more cytoplasm in the outer marginal zones. Similar cells with clear cytoplasm are also present in the adjacent red pulp.

Although peripheral blood and bone marrow involvement by splenic marginal zone lymphoma are common,⁶⁶ most cases are indolent and do well with splenectomy with or without chemotherapy.^{61, 67} In a series of 60 patients, all treated with splenectomy and almost half receiving chemotherapy, the overall survival was 103 months with a range of 2 to 164 months. The subset of more aggressive cases tended to show involvement of bone marrow and nonhematopoietic sites.⁶⁷ Other features reported to be associated with more aggressive disease include increased numbers of large lymphoma cells, p53 overexpression, and loss of chromosomal regions 7q and 17p.^{67, 68, 69, 70} A large series of 309 patients found a

76% 5-year cause-specific survival, with factors associated with worse survival on multivariate analysis being hemoglobin <12 g/dl, lactate dehydrogenase levels greater than normal, and albumin levels <3.5 g/dl.⁷¹ More recently, patients have shown excellent responses to rituximab alone or with chemotherapy without splenectomy.^{72, 73} Rare cases have recurred in lymph nodes with transformation to diffuse large B-cell lymphoma,^{74, 75} and one report described cases with transformation to micronodular T-cell-rich large B-cell lymphoma.⁷⁶ Cases of splenic marginal zone lymphoma with hepatitis C virus infection and mixed cryoglobulinemia are reported to have regressed with hepatitis C antiviral therapy.^{77, 78} Most cases, however, occur in the absence of hepatitis C infection, and rituximab with or without chemotherapy appears to have major activity in these patients.⁷⁹ Splenic red pulp small B-cell lymphoma and hairy cell leukemia variant share some similarities with splenic marginal zone lymphoma and are both considered as provisional entities in the 2008 World Health Organization classification.^{80, 81} They differ from splenic marginal zone lymphoma by being primarily red pulp small B-cell proliferations. All are CD5 and CD10 negative B-cell proliferations. Hairy cell leukemia variant is typically composed of cells similar to prolymphocytes with prominent nucleoli, but these cells also show cytoplasmic projections suggestive of hairy cells. Despite the morphologic similarity to hairy cell leukemia, hairy cell leukemia variant does not usually express CD25 or Annexin A1, markers typically expressed in hairy cell leukemia. It is important to distinguish hairy cell leukemia variant from splenic

P.1388

marginal zone lymphoma, because hairy cell leukemia variant is a more aggressive disease.⁸²

Hepatosplenic T-cell lymphoma is the other lymphoma type unique to the spleen. It also presents with massive splenomegaly as well as hepatomegaly and usually with bone marrow disease.^{83, 84, 85, 86, 87, 88, 89} This lymphoma most commonly occurs in young adults with a male predominance. Patients present with fever, weight loss, and jaundice in addition to hepatosplenomegaly and may have pancytopenia and circulating lymphoma cells in the peripheral blood. Rare cases have occurred after solid organ transplantation,^{90, 91} and recently cases associated with inflammatory bowel disease and rheumatoid arthritis have been reported. These latter cases may occur in older patients and are felt to be associated with immunomodulator and tumor necrosis factor- α inhibitor therapies.⁹² This tumor was originally described as erythrophagocytic T γ lymphoma⁹³ and has also been referred to as hepatosplenic $\gamma\delta$ T-cell lymphoma. The lymphoma diffusely expands the spleen without a discrete mass and medium-sized cells with irregular nuclear contours and abundant cytoplasm infiltrate the splenic red pulp (Fig. 66.7), often with loss of the splenic white pulp. The liver involvement is sinusoidal rather than forming a tumor mass. Hemophagocytosis may also be present and some cases in the past may have been interpreted as malignant histiocytosis. The cells express T-cell-associated markers, such as CD2, CD3, CD5, CD7, and CD43, but may show aberrant loss of one or more of these markers. The cells also usually express CD16, CD56, and TIA-1, but do not show other features of natural killer cells. The cells are negative for EBV, granzyme B, and perforin. Most cases are neoplasms of $\gamma\delta$ T-cells, which do not express CD4, CD8, or T-cell receptor β -chains. However, some cases are $\alpha\beta$ T-cell neoplasms and there appears to be no significance to subdividing this lymphoma by T-cell type⁸⁹; cases with both immunophenotypes show the characteristic combined cytogenetic abnormalities of isochromosome 7q and trisomy 8.^{94, 95, 96} Hepatosplenic T-cell lymphoma is an aggressive disease that may show initial improvement following splenectomy and/or chemotherapy, but usually behaves aggressively with a median survival of 8 months (range 0 to 42 months) reported in one study. Patients with longer survival have received a variety of combination chemotherapy and hematopoietic stem cell transplantation approaches.^{89, 97}

Secondary involvement of the spleen by lymphoproliferative disorders is also common.⁵³ Hairy cell leukemia is one that frequently presents with splenomegaly without lymphadenopathy. The patients are usually elderly, with pancytopenia that includes monocytopenia. Peripheral blood and bone marrow are virtually always involved to some degree, although blood involvement may be minimal. The spleen is enlarged by a diffuse or red pulp infiltrate of small lymphocytes. The white pulp is decreased or absent and dilated blood-filled spaces, often termed red blood cell "lakes," are common in the red pulp. The blood, bone marrow, and splenic lymphocytes are monotypic B cells that lack CD5 and express CD11c, CD25, Annexin A1, and CD103, as well as being positive by cytochemistry or immunohistochemistry for TRAP. A subset of cases shows expression of CD10 or lacks expression of CD11c, CD25, or CD103.⁹⁸ In the past TRAP cytochemistry was considered the gold standard for diagnosis of hairy cell leukemia, but it has been largely replaced by immunophenotypic evaluation. The blood changes of circulating lymphocytes with villous cytoplasmic projections may be difficult to distinguish from splenic lymphoma with villous lymphocytes, usually secondary to splenic marginal zone lymphoma. However, the pattern of the splenic infiltration between the two diseases differs, with a red pulp or diffuse pattern in hairy cell leukemia and a predominantly white pulp expansion in splenic marginal zone lymphoma.

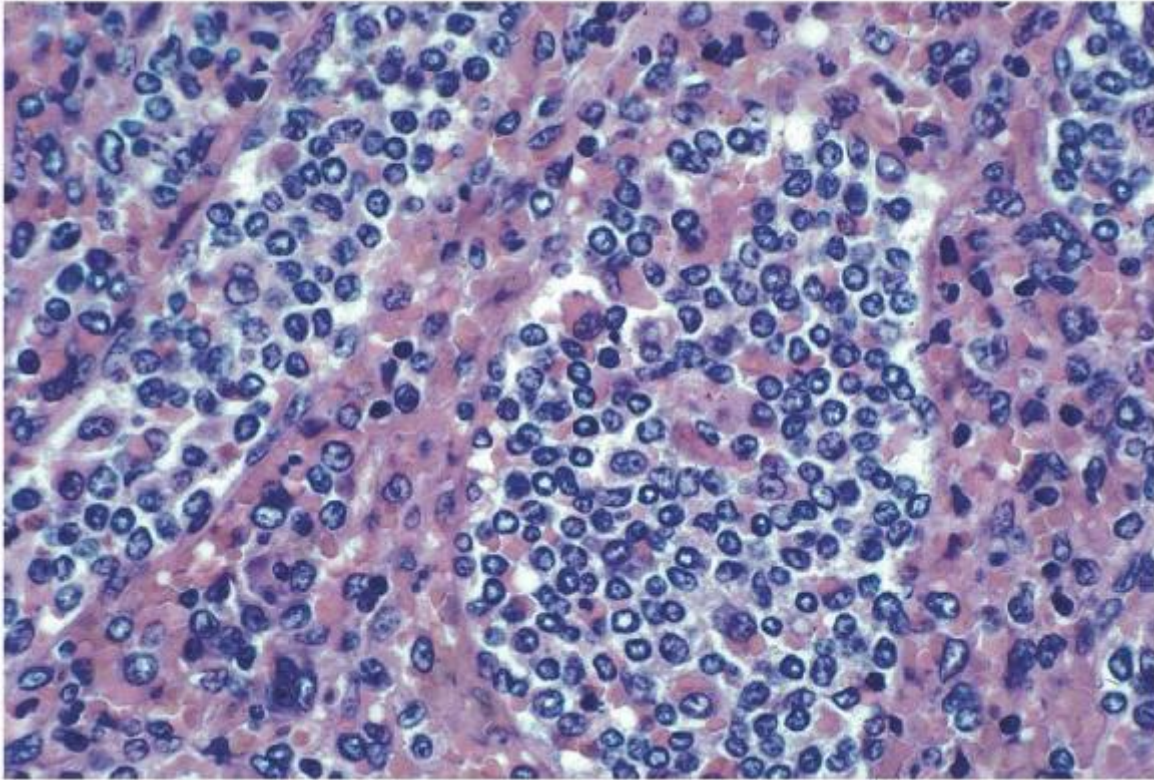

FIGURE 66.7. Hepatosplenic T-cell lymphoma. Medium-sized lymphoma cells are infiltrating the splenic red cords and sinuses of the red pulp.

Other lymphomas of small B lymphocytes may secondarily involve the spleen resulting in splenomegaly, and include chronic lymphocytic leukemia/small lymphocytic lymphoma, lymphoplasmacytic lymphoma, mantle cell lymphoma, and follicular lymphoma. With the exception of a subset of cases of lymphoplasmacytic lymphoma, these disorders all infiltrate and expand the splenic white pulp. The majority of large B-cell lymphomas and virtually all cases of Hodgkin lymphoma involving the spleen form distinct tumor nodules with adjacent uninvolved splenic tissue. A subset of large B-cell lymphomas and lymphoplasmacytic lymphomas will primarily involve the splenic red pulp and before immunophenotyping may mimic other disorders, including leukemic infiltrates in the case of red pulp large B-cell lymphoma and possibly hairy cell leukemia in the case of red pulp lymphoplasmacytic lymphoma. T-cell lymphomas and the rare histiocytic tumors typically enlarge the spleen by expanding the splenic red pulp in a diffuse manner.

ACUTE LEUKEMIA AND MYELOPROLIFERATIVE NEOPLASMS

In acute leukemia, splenomegaly may be due to an increase in either lymphoblasts or myeloblasts in the red pulp. This is rarely an isolated finding, and does not usually create diagnostic difficulty. Myeloproliferative neoplasms characteristically cause splenomegaly, and in some cases this enlargement is massive. Primary myelofibrosis most commonly causes massive splenomegaly, usually over 1,000 g.^{99, 100} The splenomegaly may be associated with a wasting syndrome that is improved with splenectomy. Splenectomy in this disorder, however, is associated with an increased risk for blast transformation.¹⁰¹ The cause of splenomegaly in most myeloproliferative neoplasms is expansion of the splenic red pulp by abnormal hematopoiesis. The red pulp cords and sinuses are filled with varying numbers of nucleated red blood cells, maturing granulocytes, and atypical megakaryocytes (Fig. 66.8). There may be other causes of noticeable splenomegaly in patients with myeloproliferative neoplasms. A rapidly enlarging spleen may signal accelerated phase or blast transformation. Detection of increased numbers of CD34⁺ immature cells in the red pulp may be a useful clue to such transformation. In essential thrombocythemia, the spleen may be enlarged due to increased numbers of platelet-filled macrophages in the red pulp. In the early phase of polycythemia vera, massive congestion by red blood cells may be the cause of splenomegaly.¹⁰²

OTHER TUMOROUS PROLIFERATIONS

Splenic hamartomas are also known as splenomas or spleen-in-spleen syndrome, and are benign splenic proliferations.^{103, 104, 105, 106, 107} They may occur at any age and are usually incidental findings,

P.1389

although up to 30% of patients have cytopenias due to hypersplenism. They form single or multiple, sometimes scarring masses of the splenic parenchyma. They are grossly bulging masses when the spleen is cut (Fig. 66.9), but are more indistinct on histologic sections because these proliferations represent a reduplication of splenic red pulp tissue with normal splenic sinus lining cells and a lack of normal white pulp. They are also associated with fibrosis, which may include bizarre stromal cells, but these proliferations have no malignant potential. It is not clear whether splenic hamartomas are actually neoplasms or represent an unusual reparative process.

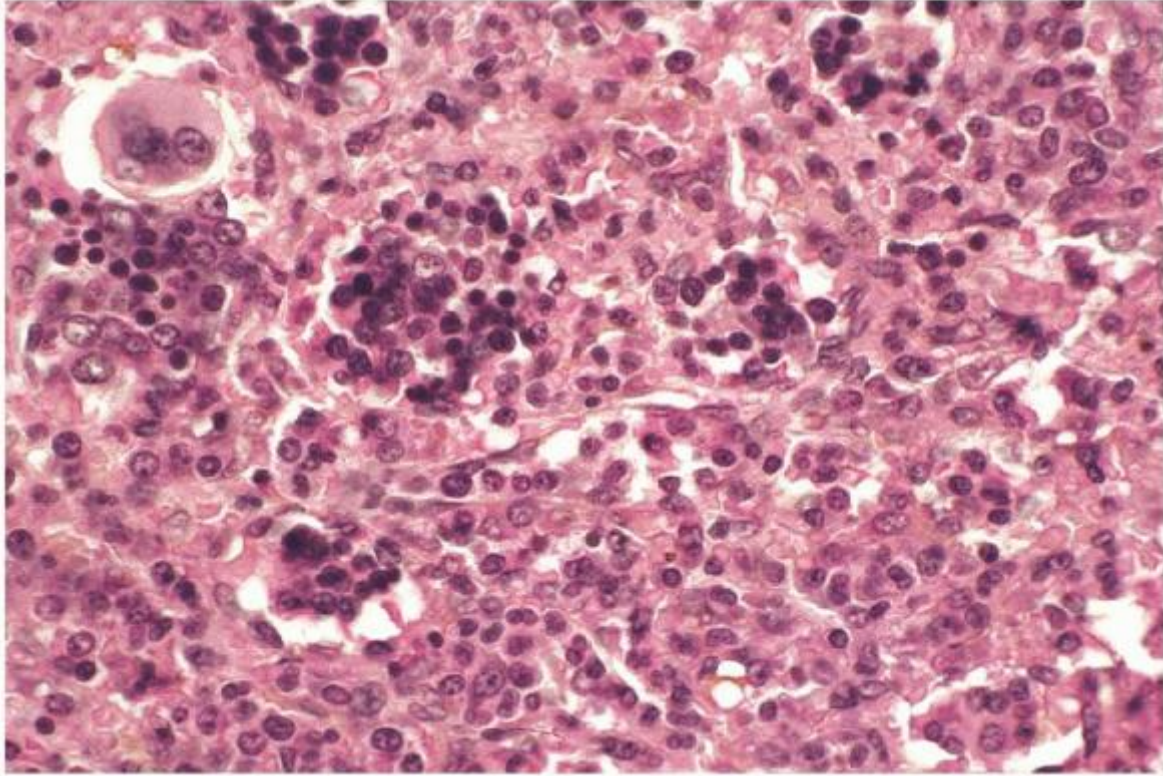

FIGURE 66.8. Chronic myelogenous leukemia involving the spleen. The red pulp is expanded by aggregates of erythroid and myeloid precursors admixed with scattered megakaryocytes.

Inflammatory pseudotumor of the spleen and liver are distinct from inflammatory pseudotumors or inflammatory myofibroblastic tumors of other sites.¹⁰⁸ In the spleen, these tumors occur more commonly in adult women who may present with symptoms that may include fever, weight loss, malaise, anemia, leukocytosis, thrombocytosis, polyclonal hypergammaglobulinemia, and an elevation of the erythrocyte sedimentation rate.^{109, 110, 111, 112, 113} Infectious disease evaluations are usually negative. The splenic mass is usually solitary and may be up to 12 cm in diameter. The tumor is a dense nodule containing a mixed inflammatory infiltrate and fibrosis. The spindled fibrotic cells of this unique tumor contain evidence of clonal EBV and the infected spindled cells in most cases express the follicular dendritic cell marker CD21. Some hepatic cases have recurred, but splenic cases treated with splenectomy have not. Some authors have suggested that these proliferations represent an unusual type of follicular dendritic cell tumor¹¹⁴ termed inflammatory pseudotumor-like follicular dendritic cell sarcoma, although other follicular dendritic cell tumors are not associated with the EBV.

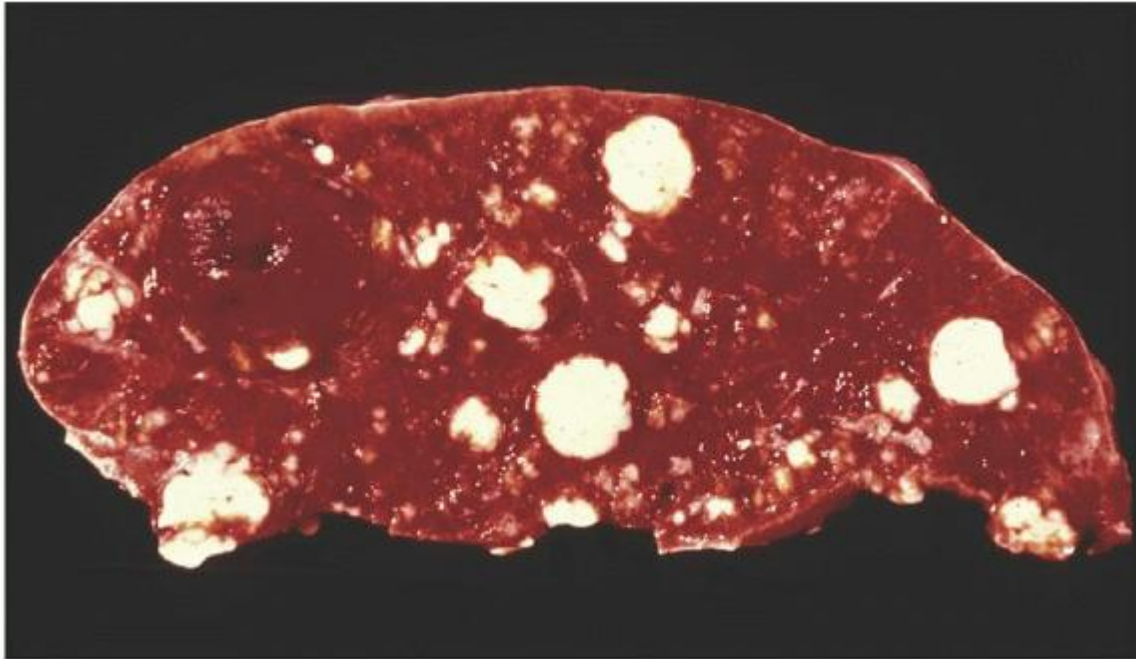

FIGURE 66.9. Splenic hamartoma and splenic involvement by classical Hodgkin lymphoma. The hamartoma represents a bulging red mass to the left, whereas the Hodgkin lymphoma forms multiple firm white nodules throughout the spleen. Hamartomas are often incidental findings in spleens removed for other reasons.

Primary sarcomas, other than angiosarcoma, and carcinomas of the spleen are extremely uncommon. Reported cases of sarcoma include malignant fibrous histiocytoma, fibrosarcoma, leiomyosarcoma, rhabdosarcoma, histiocytic sarcoma, interdigitating dendritic cell sarcoma, and fibroblastic reticular cell tumor.^{3, 115, 116, 117, 118, 119, 120, 121} Primary carcinomas reported include squamous cell carcinoma arising in a cyst, mucinous cystadenocarcinoma and carcinosarcoma both possibly arising from peritoneal surface epithelium, and primary transitional cell carcinoma.^{122, 123, 124, 125} Although still rare, carcinoma of the spleen from metastasis or direct tumor extension is more common than primary disease. One third of metastatic tumors are only identified on microscopic examination,¹²⁶ so the frequency of splenic involvement may be underestimated by imaging studies. Lung, gastric, ovarian, and breast carcinoma primaries are the most common to involve the spleen, and splenectomy may be performed for solitary splenic metastases.^{127, 128, 129}

REFERENCES

1. Arber DA. The spleen. In: Weidner N, Cote RJ, Suster S, Weiss LM, eds. *Modern surgical pathology*, 2nd ed. Philadelphia, PA: Saunders Elsevier, 2009:1512-1535.
2. McClure RD, Altemeier WA. Cysts of the spleen. *Ann Surg* 1942;116:98-102.
3. Garvin DF, King FM. Cysts and nonlymphomatous tumors of the spleen. *Pathol Annu* 1981;16:61-80.
4. Vajda P, Kereskai L, Czauderna P, et al. Re-evaluation of histological findings of nonparasitic splenic cysts. *Eur J Gastroenterol Hepatol* 2012;24:316-319.
5. Pang W-B, Zhang T-C, Chen Y-J, Zhang J-Z. Space-occupying benign lesions in spleen: experiences in a single institute. *Pediatr Surg Int* 2009;25:31-35.
6. Brrig K-F. Epithelial (true) splenic cysts. Pathogenesis of the mesothelial and so-called epidermoid cyst of the spleen. *Am J Surg Pathol* 1988;12:275-281.
7. Fowler RH. Nonparasitic benign cystic tumors of the spleen. *Int Abstr Surg* 1953;96:209-227.
8. Arber DA, Strickler JG, Weiss LM. Splenic mesothelial cysts mimicking lymphangiomas. *Am J Surg Pathol* 1997;21:334-338.
9. Trompetas V, Panagopoulos E, Priovolou-Papaevangelou M, et al. Giant benign true cyst of the spleen with high serum level of CA 19-9. *Eur J Gastroenterol Hepatol* 2002;14:85-88.

10. Higaki K, Jimi A, Watanabe J, et al. Epidermoid cyst of the spleen with CA19-9 or carcinoembryonic antigen productions: report of three cases. *Am J Surg Pathol* 1998;22:704-708.
11. Kalinova K, Stefanova P, Bosheva M. Surgery in children with hydatid disease of the spleen. *J Pediatr Surg* 2006;41:1264-1266.
12. Ganti AL, Sardi A, Gordon J. Laparoscopic treatment of large true cysts of the liver and spleen is ineffective. *Am Surg* 2002;68:1012-1017.
13. Paris S, Weiss SM, Ayers WH Jr, et al. Splenic abscess. *Am Surg* 1994;60: 358-361.
14. Chun CH, Raff MJ, Contreras L, et al. Splenic abscess. *Medicine* 1980;59:50-65.
15. Al-Salem AH, Qaisaruddin S, Jam'a AA, et al. Splenic abscess and sickle cell disease. *Am J Hematol* 1998;58:100-104.
16. Brook I, Frazier EH. Microbiology of liver and spleen abscesses. *J Med Microbiol* 1998;47:1075-1080.
17. Szczepanik AB, Meissner AJ. Partial splenectomy in the management of nonparasitic splenic cysts. *World J Surg* 2009;33:852-856.
18. Taxy JB. Peliosis: a morphologic curiosity becomes an iatrogenic problem. *Hum Pathol* 1978;9:331-340.
19. Tada T, Wakabayashi T, Kishimoto H. Peliosis of the spleen. *Am J Clin Pathol* 1983;79:708-713.
20. Tsokos M, Puschel K. Isolated peliosis of the spleen: report of 2 autopsy cases. *Am J Forensic Med Pathol* 2004;25:251-254.
21. Kohr RM, Haendiges M, Taube RR. Peliosis of the spleen: a rare cause of spontaneous splenic rupture with surgical implications. *Am Surg* 1993;59:197-199.
22. Raghavan R, Alley S, Tawfik O, et al. Splenic peliosis: a rare complication following liver transplantation. *Dig Dis Sci* 1999;44:1128-1131.
23. Morgenstern L, Rosenberg J, Geller SA. Tumors of the spleen. *World J Surg* 1985;9:468-476.
24. Arber DA, Strickler JG, Chen Y-Y, et al. Splenic vascular tumors: a histologic, immunophenotypic, and virologic study. *Am J Surg Pathol* 1997;21:827-835.
25. Willcox TM, Speer RW, Schlinkert RT, et al. Hemangioma of the spleen: presentation, diagnosis, and management. *J Gastrointest Surg* 2000;4:611-613.
26. Ros PR, Moser RP Jr, Dachman AH, et al. Hemangioma of the spleen: radiologic-pathologic correlation in ten cases. *Radiology* 1987;162:73-77.
27. Abbott RM, Levy AD, Aguilera NS, et al. From the archives of the AFIP: primary vascular neoplasms of the spleen: radiologic-pathologic correlation. *Radiographics* 2004;24:1137-1163.
28. Shiran A, Naschitz JE, Yeshurun D, et al. Diffuse hemangiomatosis of the spleen: splenic hemangiomatosis presenting with giant splenomegaly, anemia, and thrombocytopenia. *Am J Gastroenterol* 1990;85:1515-1517.
29. Ruck P, Horny H-P, Xiao J-C, et al. Diffuse sinusoidal hemangiomatosis of the spleen. A case report with enzyme-histochemical, immunohistochemical, and electron-microscopic findings. *Path Res Pract* 1994;190:708-714.
30. Morgenstern L, Bello JM, Fisher BL, et al. The clinical spectrum of lymphangiomas and lymphangiomatosis of the spleen. *Am Surg* 1992;58:599-604.
31. Marymont JV, Knight PJ. Splenic lymphangiomatosis: a rare cause of splenomegaly. *J Pediatr Surg* 1987;22:461-462.
32. Avigad S, Jaffe R, Frand M, et al. Lymphangiomatosis with splenic involvement. *JAMA* 1976;236:2315-2317.
33. Chan KW, Saw D. Distinctive, multiple lymphangiomas of spleen. *J Pathol* 1980;131:75-81.
34. O'Sullivan DA, Torres VE, de Groen PC, et al. Hepatic lymphangiomatosis mimicking polycystic liver disease. *Mayo Clin Proc* 1998;73:1188-1192.
35. Falk S, Stutte HJ, Frizzera G. Littoral cell angioma. A novel splenic vascular lesion demonstrating histiocytic differentiation. *Am J Surg Pathol* 1991;15:1023-1033.
36. Ben Izhak O, Bejar J, Ben Eliezer S, et al. Splenic littoral cell haemangioendothelioma: a new low-grade variant of malignant littoral cell tumour. *Histopathology* 2001;39:469-475.

37. Fernandez S, Cook GW, Arber DA. Metastasizing splenic littoral cell hemangioendothelioma. *Am J Surg Pathol* 2006;30:1036-1040.
38. Martel M, Cheuk W, Lombardi L, et al. Sclerosing angiomatoid nodular transformation (SANT): report of 25 cases of a distinctive benign splenic lesion. *Am J Surg Pathol* 2004;28:1268-1279.
39. Kuo T-T, Chen T-C, Lee L-Y. Sclerosing angiomatoid nodular transformation of the spleen (SANT): Clinicopathological study of 10 cases with or without abdominal disseminated calcifying fibrous tumors, and the presence of a significant number of IgG4+ plasma cells. *Pathol Int* 2009;59:844-850.
40. Koreishi AF, Saenz AJ, Fleming SE, Teruya-Feldstein J. Sclerosing angiomatoid nodular transformation (SANT) of the spleen: a report of 3 cases. *International Journal of Surgical Pathology* 2009;17:384-389.
41. Kashiwagi S, Kumasaka T, Bunsei N, et al. Detection of Epstein-Barr virus-encoded small RNA-expressed myofibroblasts and IgG4-producing plasma cells in sclerosing angiomatoid nodular transformation of the spleen. *Virchows Arch* 2008;453:275-282.
42. Weinreb I, Bailey D, Battaglia D, et al. CD30 and Epstein-Barr virus RNA expression in sclerosing angiomatoid nodular transformation of spleen. *Virchows Arch* 2007;451:73-79.
43. Diebold J, Le Tourneau A, Marmey B, et al. Is sclerosing angiomatoid nodular transformation (SANT) of the splenic red pulp identical to inflammatory pseudotumor? Report of 16 cases. *Histopathology* 2008;53:299-310.
44. Falk S, Krishnan J, Meis JM. Primary angiosarcoma of the spleen. A clinicopathologic study of 40 cases. *Am J Surg Pathol* 1993;17:959-970.
45. Sordillo EM, Sordillo PP, Hajdu SI. Primary hemangiosarcoma of the spleen: report of four cases. *Med Pediatr Oncol* 1981;9:319-324.
46. Hsu JT, Chen HM, Lin CY, et al. Primary angiosarcoma of the spleen. *J Surg Oncol* 2005;92:312-316.
47. Suster S. Epithelioid and spindle-cell hemangioendothelioma of the spleen. Report of a distinctive splenic vascular neoplasm of childhood. *Am J Surg Pathol* 1992;16:785-792.
48. Kaw YT, Duwaji MS, Kinsley RE, et al. Hemangioendothelioma of the spleen. *Arch Pathol Lab Med* 1992;116:1079-1082.
49. Budke HL, Breitfeld PP, Neiman RS. Functional hyposplenism due to a primary epithelioid hemangioendothelioma of the spleen. *Arch Pathol Lab Med* 1995;119:755-757.
50. Davey FP, Skarin AT, Moloney WC. Pathology of splenic lymphoma. *Am J Clin Pathol* 1973;59:95-103.
51. Kraemer BB, Osborne BM, Butler JJ. Primary splenic presentation of malignant lymphoma and related disorders. A study of 49 cases. *Cancer* 1984;54:1606-1619.
52. Falk S, Stutte HJ. Primary malignant lymphomas of the spleen. A morphologic and immunohistochemical analysis of 17 cases. *Cancer* 1990;66: 2612-2619.
- P.1390
53. Arber DA, Rappaport H, Weiss LM. Non-Hodgkin's lymphoproliferative disorders involving the spleen. *Mod Pathol* 1997;10:18-32.
54. Neiman RS, Sullivan AL, Jaffe R. Malignant lymphoma simulating leukemic reticuloendotheliosis. A clinicopathologic study of ten cases. *Cancer* 1979;43:329-342.
55. Sol Mateo M, Mollejo M, Villuendas R, et al. Analysis of the frequency of microsatellite instability and p53 gene mutation in splenic marginal zone and MALT lymphomas. *J Clin Pathol Mol Pathol* 1998;51:262-267.
56. Melo JV, Hegde U, Parreira A, et al. Splenic B cell lymphoma with circulating villous lymphocytes: differential diagnosis of B cell leukaemias with large spleens. *J Clin Pathol* 1987;40:642-651.
57. Melo JV, Robinson SF, Gregory C, et al. Splenic B cell lymphoma with "villous" lymphocytes in the peripheral blood: a disorder distinct from hairy cell leukemia. *Leukemia* 1987;1:294-299.
58. Mulligan SP, Matutes E, Dearden C, et al. Splenic lymphoma with villous lymphocytes: natural history and response to therapy in 50 cases. *Br J Haematol* 1991;78:206-209.

59. Troussard X, Valensi F, Duchayne E, et al. Splenic lymphoma with villous lymphocytes: clinical presentation, biology and prognostic factors in a series of 100 patients. *Br J Haematol* 1996;93:731-736.
60. Isaacson PG, Matutes E, Burke M, et al. The histopathology of splenic lymphoma with villous lymphocytes. *Blood* 1994;84:3828-3834.
61. Schmid C, Kirkham N, Diss T, et al. Splenic marginal zone cell lymphoma. *Am J Surg Pathol* 1992;16:455-466.
62. Pawade J, Wilkins BS, Wright DH. Low-grade B-cell lymphomas of the splenic marginal zone: a clinicopathologic and immunohistochemical study of 14 cases. *Histopathology* 1995;27:129-137.
63. Mollejo M, Menárguez J, Lloret E, et al. Splenic marginal zone lymphoma: a distinctive type of low-grade B-cell lymphoma—a clinicopathological study of 13 cases. *Am J Surg Pathol* 1995;19:1146-1157.
64. Hammer RD, Glick AD, Greer JP, et al. Splenic marginal zone lymphoma. A distinct B-cell neoplasm. *Am J Surg Pathol* 1996;20:613-626.
65. Ruiz-Ballesteros E, Mollejo M, Rodriguez A, et al. Splenic marginal zone lymphoma: proposal of new diagnostic and prognostic markers identified after tissue and cDNA microarray analysis. *Blood* 2005;106:1831-1838.
66. Arber DA, George TI. Bone marrow biopsy involvement by non-Hodgkin's lymphoma: frequency of lymphoma types, patterns, blood involvement, and discordance with other sites in 450 specimens. *Am J Surg Pathol* 2005;29:1549-1557.
67. Chacon JI, Mollejo M, Munoz E, et al. Splenic marginal zone lymphoma: clinical characteristics and prognostic factors in a series of 60 patients. *Blood* 2002;100:1648-1654.
68. Lloret E, Mollejo M, Mateo MS, et al. Splenic marginal zone lymphoma with increased number of blasts: an aggressive variant? *Hum Pathol* 1999;30:1153-1160.
69. Hernandez JM, Garcia JL, Gutierrez NC, et al. Novel genomic imbalances in B-cell splenic marginal zone lymphomas revealed by comparative genomic hybridization and cytogenetics. *Am J Pathol* 2001;158:1843-1850.
70. Algara P, Mateo MS, Sanchez-Beato M, et al. Analysis of the IgV(H) somatic mutations in splenic marginal zone lymphoma defines a group of unmutated cases with frequent 7q deletion and adverse clinical course. *Blood* 2002;99:1299-1304.
71. Arcaini L, Lazzarino M, Colombo N, et al. Splenic marginal zone lymphoma: a prognostic model for clinical use. *Blood* 2006;107:4643-4649.
72. Bennett M, Schechter GP. Treatment of splenic marginal zone lymphoma: splenectomy versus rituximab. *Semin Hematol* 2010;47:143-147.
73. Matutes E, Oscier D, Montalban C, et al. Splenic marginal zone lymphoma proposals for a revision of diagnostic, staging and therapeutic criteria. *Leukemia* 2008;22:487-495.
74. Camacho FI, Mollejo M, Mateo MS, et al. Progression to large B-cell lymphoma in splenic marginal zone lymphoma—a description of a series of 12 cases. *Am J Surg Pathol* 2001;25:1268-1276.
75. Cualing H, Steele P, Zellner D. Blastic transformation of splenic marginal zone B-cell lymphoma. *Arch Pathol Lab Med* 2000;124:748-752.
76. Wang SA, Olson N, Zukerberg L, et al. Splenic marginal zone lymphoma with micronodular T-cell rich B-cell lymphoma. *Am J Surg Pathol* 2006;30:128-132.
77. Hermine O, Lefrere F, Bronowicki JP, et al. Regression of splenic lymphoma with villous lymphocytes after treatment of hepatitis C virus infection. *N Engl J Med* 2002;347:89-94.
78. Saadoun D, Suarez F, Lefrere F, et al. Splenic lymphoma with villous lymphocytes, associated with type II cryoglobulinemia and HCV infection: a new entity? *Blood* 2005;105:74-76.
79. Tsimberidou AM, Catovsky D, Schlette E, et al. Outcomes in patients with splenic marginal zone lymphoma and marginal zone lymphoma treated with rituximab with or without chemotherapy or chemotherapy alone. *Cancer* 2006;107:125-135.
80. Mollejo M, Algara P, Mateo MS, et al. Splenic small B-cell lymphoma with predominant red pulp involvement: a diffuse variant of splenic marginal zone lymphoma?. *Histopathology* 2002; 40:22-30.

81. Matutes E, Wotherspoon A, Catovsky D. The variant form of hairy-cell leukaemia. *Best Pract Res Clin Haematol* 2003; 16:41-56.
82. Hockley SL, Else M, Morilla A, et al. The prognostic impact of clinical and molecular features in hairy cell leukaemia variant and splenic marginal zone lymphoma. *Br J Haematol Epub* May 18 2012.
83. Delsol G, Diebold J, Isaacson PG, et al. Pathology of the spleen: report of the workshop of the VIIIth meeting of the European Association for Haematopathology, Paris 1996. *Histopathology* 1998;32:172-179.
84. Gaulard P, Zafrani ES, Mavrier P, et al. Peripheral T-cell lymphoma presenting as predominant liver disease: a report of three cases. *Hepatology* 1986;6:864-868.
85. Gaulard P, Bourquelot P, Kanavaros P, et al. Expression of the alpha/beta and gamma/delta T-cell receptors in 57 cases of peripheral T-cell lymphomas. Identification of a subset of γ/δ T-cell lymphomas. *Am J Pathol* 1990;137: 617-628.
86. Cooke CB, Krenacs L, Stetler-Stevenson M, et al. Hepatosplenic T-cell lymphoma: a distinct clinicopathologic entity of cytotoxic $\gamma\delta$ T-cell origin. *Blood* 1996;88:4265-4274.
87. Salhany KE, Feldman M, Kahn MJ, et al. Hepatosplenic $\gamma\delta$ T-cell lymphoma: ultrastructural, immunophenotypic, and functional evidence for cytotoxic T lymphocyte differentiation. *Hum Pathol* 1997;28:674-685.
88. Belhadj K, Reyes F, Farcet JP, et al. Hepatosplenic gammadelta T-cell lymphoma is a rare clinicopathologic entity with poor outcome: report on a series of 21 patients. *Blood* 2003;102:4261-4269.
89. Macon WR, Levy NB, Kurtin PJ, et al. Hepatosplenic alpha beta T-cell lymphomas—a report of 14 cases and comparison with hepatosplenic gamma delta T-cell lymphomas. *Am J Surg Pathol* 2001;25:285-296.
90. Ross CW, Schnitzer B, Sheldon S, et al. Gamma/delta T-cell posttransplantation lymphoproliferative disorder primarily in the spleen. *Am J Clin Pathol* 1994;102:310-315.
91. Kraus MD, Crawford DF, Kaleem Z, et al. T γ/δ hepatosplenic lymphoma in a heart transplant patient after and Epstein-Barr positive lymphoproliferative disorder. A case report. *Cancer* 1998;82:983-992.
92. Parakkal D, Sifuentes H, Semer R, Ehrenpres ED. Hepatosplenic T-cell lymphoma in patients receiving TNF- α inhibitor therapy: expanding the groups at risk. *Eur J Gastroenterol Hepatol* 2011;23:1150-1156.
93. Kadin ME, Kamoun M, Lamberg J. Erythrophagocytic T γ lymphoma. A clinicopathologic entity resembling malignant histiocytosis. *N Engl J Med* 1981;304:648-653.
94. Wang C-C, Tien H-F, Lin M-T, et al. Consistent presence of isochromosome 7q in hepatosplenic T γ/δ lymphoma: a new cytogenetic-clinicopathologic entity. *Genes Chromosom Cancer* 1995;12:161-164.
95. Yao M, Tien H-F, Lin M-T, et al. Clinical and hematological characteristics of hepatosplenic T γ/δ lymphoma with isochromosome for long arm of chromosome 7. *Leuk Lymphoma* 1996;22:495-500.
96. Jonveaux P, Daniel MT, Martel V, et al. Isochromosome 7q and trisomy 8 are consistent primary, non-random chromosomal abnormalities associated with hepatosplenic T γ/δ lymphoma. *Leukemia* 1996;10:1453-1455.
97. Weidmann E. Hepatosplenic T cell lymphoma. A review on 45 cases since the first report describing the disease as a distinct lymphoma entity in 1990. *Leukemia* 2000;14:991-997.
98. Chen YH, Tallman MS, Goolsby C, et al. Immunophenotypic variations in hairy cell leukemia. *Am J Clin Pathol* 2006;125:251-259.
99. Falk S, Mix D, Stutte H-J. The spleen in osteomyelofibrosis. A morphologic and immunohistochemical study of 30 cases. *Virchows Archiv A Pathol Anat* 1990;416:437-442.
100. Theile J, Klein H, Falk S, et al. Splenic megakaryocytopoiesis in primary (idiopathic) osteomyelofibrosis. An immunohistochemical and morphometric study with comparison of corresponding bone marrow features. *Acta Haematol* 1992;87:176-180.
101. Barosi G, Ambrosetti A, Centra A, et al. Splenectomy and risk of blast transformation in myelofibrosis with myeloid metaplasia. *Blood* 1998;91: 3630-3636.
102. Wolf BC, Banks PM, Mann RB, et al. Splenic hematopoiesis in polycythemia vera. A morphologic and immunohistochemical study. *Am J Clin Pathol* 1988;89:69-75.
103. Falk S, Stutte HJ. Hamartomas of the spleen: a study of 20 biopsy cases. *Histopathology* 1989;14:603-612.

104. Steinberg JJ, Suhlrand M, Valensi Q. The spleen in the spleen syndrome: the association of splenoma with hematopoietic and neoplastic disease-compendium of cases since 1864. *J Surg Oncol* 1991;47:193-202.
105. Zukerberg LR, Kaynor BL, Silverman ML, et al. Splenic hamartoma and capillary hemangioma are distinct entities. Immunohistochemical analysis of CD8 expression by endothelial cells. *Hum Pathol* 1991;22:1258-1261.
106. Cheuk W, Lee AK, Arora N, et al. Splenic hamartoma with bizarre stromal cells. *Am J Surg Pathol* 2005;29:109-114.
107. Abramowsky C, Alvarado C, Wyly JB, et al. "Hamartoma" of the spleen (splenoma) in children. *Pediatr Dev Pathol* 2004;7:231-236.
108. Arber DA, Kamel OW, van de Rijn M, et al. Frequent presence of the Epstein-Barr virus in inflammatory pseudotumor. *Hum Pathol* 1995;26: 1093-1098.
109. Cotelingam JD, Jaffe ES. Inflammatory pseudotumor of the spleen. *Am J Surg Pathol* 1984;8:375-380.
110. Thomas RM, Jaffe ES, Zarate-Osorno A, et al. Inflammatory pseudotumor of the spleen. A clinicopathologic and immunophenotypic study of eight cases. *Arch Pathol Lab Med* 1993;117:921-926.
111. Selves J, Meggetto F, Brousset P, et al. Inflammatory pseudotumor of the liver. Evidence for follicular dendritic reticulum cell proliferation associated with clonal Epstein-Barr virus. *Am J Surg Pathol* 1996;20:747-753.
112. Prevot S, Sevestre M, Vercelli-Retta G, et al. Inflammatory pseudotumor of the spleen. A disease frequently associated with EBV latent infection. A study of 10 cases. 8th Meeting of the EAHP Paris, Abstract Book 1996;57.
113. Neuhauser TS, Derringer GA, Thompson LD, et al. Splenic inflammatory myofibroblastic tumor (inflammatory pseudotumor): a clinicopathologic and immunophenotypic study of 12 cases. *Arch Pathol Lab Med* 2001;125: 379-385.
114. Cheuk W, Chan JK, Shek TW, et al. Inflammatory pseudotumor-like follicular dendritic cell tumor: a distinctive low-grade malignant intra-abdominal neoplasm with consistent Epstein-Barr virus association. *Am J Surg Pathol* 2001;25:721-731.
115. Wick MR, Smith SL, Scheithauer BW, et al. Primary nonlymphoreticular malignant neoplasms of the spleen. *Am J Surg Pathol* 1982;6:229-242.
116. Feakins RM, Norton AJ. Rhabdomyosarcoma of the spleen. *Histopathology* 1996;29:577-579.
117. Song SY, Ko YH, Ahn G. Mediastinal germ cell tumor associated with histiocytic sarcoma of spleen: case report of an unusual association. *Int J Surg Pathol* 2005;13:299-303.
118. Martel M, Sarli D, Colecchia M, et al. Fibroblastic reticular cell tumor of the spleen: report of a case and review of the entity. *Hum Pathol* 2003;34:954-957.
119. Audouin J, Vercelli-Retta J, le Tourneau A, et al. Primary histiocytic sarcoma of the spleen associated with erythrophagocytic histiocytosis. *Pathol Res Pract* 2003;199:107-112.
120. Kawachi K, Nakatani Y, Inayama Y, et al. Interdigitating dendritic cell sarcoma of the spleen: report of a case with a review of the literature. *Am J Surg Pathol* 2002;26:530-537.
121. Colovic N, Cemerikic-Martinovic V, Colovic R, et al. Primary malignant fibrous histiocytoma of the spleen and liver. *Med Oncol* 2001;18:293-297.
122. Elit L, Aylward B. Splenic cyst carcinoma presenting in pregnancy. *Am J Hematol* 1989;32:57-60.
123. Morinaga S, Ohyama R, Koizumi J. Low-grade mucinous cystadenocarcinoma in the spleen. *Am J Surg Pathol* 1992;16:903-908.
124. Westra WH, Anderson BO, Klimstra DS. Carcinosarcoma of the spleen. An extragenital malignant mixed müllerian tumor? *Am J Surg Pathol* 1994;18:309-315.
125. Naik S, Kapoor S, Sharma S, et al. Primary transitional cell carcinoma of spleen. *Indian J Gastroenterol* 2006;25:215.
126. Marymont JH, Gross S. Patterns of metastatic cancer in the spleen. *Am J Clin Pathol* 1963;40:58-66.
127. Klein B, Stein M, Kuten A, et al. Splenomegaly and solitary spleen metastasis in solid tumors. *Cancer* 1987;60:100-102.
128. Yang CQ, Zhang ZC, Yu Q, et al. [Clinicopathologic characteristics of metastatic carcinomas to spleen]. *Zhonghua Bing Li Xue Za Zhi* 2006;35:281-284.

129. Lam KY, Tang V. Metastatic tumors to the spleen: a 25-year clinicopathologic study. Arch Pathol Lab Med 2000;124:526-530.

Part VII - Hematologic Malignancies

Section 1 - General Aspects

Chapter 67 Hematopoietic Neoplasms: Principles of Pathologic Diagnosis

> Table of Contents > Part VII - Hematologic Malignancies > Section 1 - General Aspects > Chapter 67 - Hematopoietic Neoplasms: Principles of Pathologic Diagnosis

Chapter 67

Hematopoietic Neoplasms: Principles of Pathologic Diagnosis

Daniel A. Arber

The hematopoietic neoplasms consist of acute and chronic leukemias, Hodgkin and non-Hodgkin lymphomas, plasma cell tumors, and the rare histiocytic and dendritic neoplasms. Each of these disease categories is now recognized to represent various heterogeneous disease groups that include a large number of distinct biologic entities.^{1, 2} With the great advances in targeted therapies and molecular genetic discoveries in the area of hematopoietic tumors, the number of distinct entities will continue to grow. Although the diagnosis and classification of these tumors were originally based primarily on morphologic features, sometimes supplemented by cytochemical studies,^{3, 4, 5, 6, 7} the diagnosis of hematopoietic tumors now requires a complex battery of specialized tools that almost always include immunophenotyping and frequently require cytogenetic and molecular genetic studies. Despite these advances, morphologic evaluation remains the cornerstone for the pathologic diagnosis for most diseases. Morphologic evaluation allows for cost-effective tissue processing and triaging for appropriate ancillary tests, which becomes increasingly important as the number of molecular genetic tests grows in this area.

PREOPERATIVE CONSIDERATIONS

Special considerations are often needed prior to sampling of tissue that is suspected to contain a hematopoietic neoplasm.^{8, 9, 10, 11, 12} The testing that will be needed depends on the clinical differential diagnosis as well as the initial pathologic impression of the sample. However, if the correct specimen types for ancillary tests are not saved prior to the initial pathologic review, the tissue may not be sufficient for these additional tests. Therefore, the hematologist, pathologist, or surgeon performing the procedure should have a clear understanding of the specimen requirements for the various tests that might be needed to rule in or out all suspected diseases. This often requires direct communication with the surgical pathologist or hematopathologist who will ultimately receive the sample prior to obtaining tissue. The submission of fresh tissue on saline-soaked gauze is ideal for tissue samples; however, this may not be feasible if the sample is taken at night or in a clinic that is physically separate from where the sample will be processed. Even in the latter setting, however, the sample may be sent by courier to a remote location quickly so that the tissue can be correctly triaged. In the absence of central processing of the sample, the physician performing the procedure must be aware of how to collect samples that are adequate for immunophenotyping studies, molecular and cytogenetic studies, and possible cultures. This problem is even more complicated when reference laboratories are used for different types of testing, an increasingly common practice, resulting in the need to split what may be very small samples prior to sending them out for these studies.

Ideally, the entire fresh sample is submitted to the pathology department within minutes of removal. There it may be received by a resident, technician, pathology assistant, or pathologist. No matter who receives the specimen, the clinical indication for the biopsy as well as any special clinical concerns or testing requirements needs to be clearly communicated. For tissues removed to rule out lymphoma, the specimens should be sampled in the fresh state. One protocol for lymph node sampling is provided in Figure 67.1⁸ and is discussed in more detail below. Hematologists and pathologists should work together to establish a suitable protocol for their institution. Special needs should be communicated to the pathologist in advance of obtaining the sample, to ensure that the supporting testing areas, such as cytogenetics or microbiology, are prepared to receive the sample or to make arrangements to send samples quickly to the

appropriate reference laboratory. It is worth noting that surgical pathologists receive lymph node specimens for a variety of indications, most of which do not require special processing and are simply formalin fixed. Without adequate clinical information and communication to alert them to a possibility of lymphoma or another hematopoietic tumor, tissue may not be sent for flow cytometry or cytogenetic studies, or saved for possible molecular genetic studies. Because the differential diagnosis of malignant lymphoma often includes infectious etiologies, the need for cultures or other infectious disease testing requiring fresh tissue or other special tissue preparation must also be communicated.

SPECIMEN PROCESSING

Triaging Protocols

How a sample for a suspected hematologic disorder is triaged often depends on the specimen type. Peripheral blood, bone marrow aspirate, and fine needle aspirate samples are often

P.1392

triaged at the bedside by the physician collecting the sample. In this setting, the treating physician often orders flow cytometry immunophenotyping, cytogenetics, molecular genetics, and even cultures on samples collected in different tubes. Because the diagnosis of most disorders is still based in large part on morphologic features, it is advisable to use the initial bone marrow aspirate material for fresh smears, prepared at the bedside, or to make touch preparations for morphology in all cases with inadequate aspirate material (see Chapter 1). Subsequent aspirations may be more hemodiluted, but are usually still suitable for ancillary studies. In contrast, the triaging of tissue biopsy specimens is usually performed after the sample is submitted to the laboratory, as mentioned above and illustrated in Figure 67.1.^{8, 9} If lymphoma is suspected, sections of fresh material should be fixed for morphologic evaluation. If enough tissue is obtained, a portion of fresh tissue may also be sent for flow cytometry, and possibly for cytogenetics or cultures. Additional material may be frozen for future molecular genetic studies. In the rare instance where electron microscopy may be needed, a small portion of fresh tissue should be saved in glutaraldehyde. The exact tests performed, however, will depend on the clinical indication for the biopsy and communication between the pathologist and the treating hematologist.

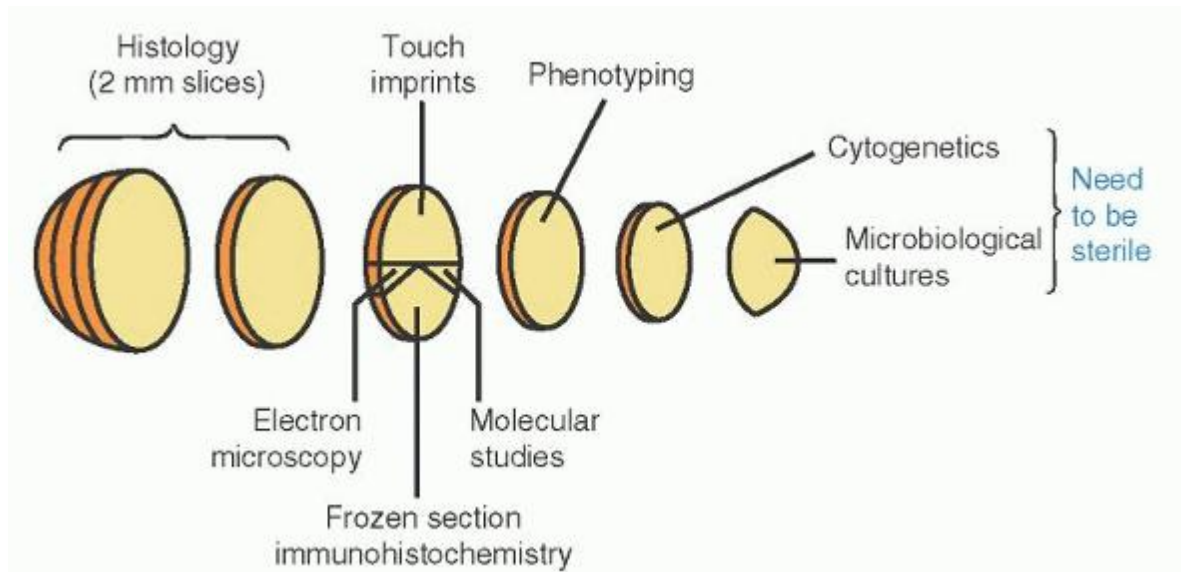

FIGURE 67.1. Schematic of protocol for processing lymph node biopsies from patients suspected of having lymphoid malignancies.

Tissue Fixation and Processing

Proper specimen fixation and processing are essential for morphologic evaluation as well as for the optimal performance of ancillary studies.^{10, 11, 12} If lymphoma is suspected, thin sections of fresh material should be fixed for morphologic evaluation. In the past, special fixatives containing heavy metals such as mercuric chloride were used to improve cell morphology, but these fixatives are less commonly employed today due to difficulties in disposing of the mercury. Such fixatives also disrupt nucleic acids, making molecular studies often impossible. More routine formalin fixation will usually provide appropriate sections, as long as the tissue is fixed adequately, usually meaning overnight fixation of thin sections

in fresh neutral buffered formalin. Formalin-fixed tissue is satisfactory for many DNA-based molecular assays, but some tests cannot be performed on fixed tissue. Tissue that is frozen should be stored at the lowest possible temperature (preferably -70°C to -80°C) and should not be stored in defrostable freezers.

Bone marrow aspirate specimens should be sent fresh after collection with minimal anticoagulant. Bone marrow biopsies should also be submitted fresh, or in fixative if delivery to the laboratory may be delayed. Again, heavy metal fixatives are less commonly available today and formalin or Bouin fixation is more frequently used. Bone marrow biopsies also must undergo decalcification, which may degrade some antigens and may reduce the ability to perform some assays. Decalcification in ethylenediaminetetraacetic acid is considered the most gentle for antigen preservation,¹³ but some methods take several days to obtain adequate decalcification and this method is not routinely performed in most laboratories.

SAMPLING METHODS AND THEIR LIMITATIONS

Open Biopsy

The ideal specimen for pathologic evaluation is a large portion of tissue, received fresh and taken from an open biopsy. Such samples allow the maximum amount of tissue for morphologic analysis and ancillary studies. However, the increasing use of less-invasive procedures requires different approaches for different specimen types.

Peripheral Blood

Peripheral blood is often the easiest sample to obtain for an initial evaluation for a hematologic malignancy. Analysis of blood may allow for a diagnosis of leukemia or even peripheral blood involvement by lymphoma, although the absence of neoplastic cells in the blood cannot exclude disease elsewhere. Limitations to blood analysis include the inability to classify blast proliferations with <20% circulating blasts, and the lack of architecture needed for classification of some lymphomas involving blood. Despite these limitations, when the blood is involved by a hematopoietic tumor, morphologic, immunophenotypic, and molecular genetic studies of the blood may be of value in some patients. However, if a bone marrow is to be performed, duplication of testing on both the blood and marrow is usually unnecessary.

Bone Marrow Aspirate and Biopsy

Evaluation of marrow material will often provide much more information than peripheral blood alone in terms of classifying leukemic processes and determining the marrow blast percentage. In addition, some acute leukemias with monocytic features will have an increase in marrow blasts, but show maturation of neoplastic cells in the blood that may mimic chronic myelomonocytic leukemia; therefore, bone marrow assessment is essential in that setting. Both aspirate and biopsy materials provide critical information. Some diseases, such as lymphomas and metastatic tumors, may focally involve the marrow and are often associated with fibrosis, both factors that may make them undetectable on aspirate smears alone. When such focal disease processes are suspected, biopsies from more than one site will produce a higher yield for disease detection.¹⁴

Fine-Needle Aspirate and Core Biopsy

Fine-needle aspiration has become common as an evaluation tool for solid tumors and even lymphoma due to it being a relatively noninvasive procedure. The technique is ideal for the evaluation of relapse of disease but is now often used for initial patient evaluation. Although fine-needle aspiration coupled with flow cytometry immunophenotyping is ideal for the diagnosis of many low-grade lymphomas,^{15, 16} it has significant limitations due to the inability to determine architectural features of the lymphoma, to grade some lymphomas properly, and to identify focal disease or transformation. The addition of needle biopsies with or without aspiration and immunophenotyping overcomes some of these limitations, but a significant number of cases will need to go on to open biopsy for diagnosis and/or classification. Because of these limitations, excisional biopsy of easily accessible lymph nodes, when available, is preferred over lymph node aspiration or needle biopsy as an initial diagnostic procedure.

Laparoscopic Biopsy

Laparoscopic biopsies and other more invasive biopsy techniques often obtain more tissue than core biopsies, but often fragment

P.1393

the specimen, especially with laparoscopic splenectomy specimens.¹⁷ Despite this, the fragments are usually large enough to determine the architectural pattern of the lymphoid infiltrate.

IMMUNOPHENOTYPING

Immunophenotyping is now essential in the diagnosis and classification of most hematopoietic tumors.² It is necessary to distinguish precursor B- from precursor T-lymphoblastic leukemia/lymphoma, to detect aberrant immunophenotypes in both lymphoid and myeloid leukemias, and to determine B-cell clonality and aberrancies in malignant lymphomas. Flow cytometry and immunohistochemistry are the primary methods currently used, and they have different advantages in the evaluation of these diseases.

Flow Cytometry

Flow cytometry is ideal for tumors involving blood and bone marrow because the cells are already in a cell suspension, a necessary factor for this analytic technique. This method, however, is also ideal for nonsclerotic lymph node specimens, in which a cell suspension can often be made easily. The method requires the processing of unfixed tissue, either fresh or in transport media. As described in Chapter 2, flow cytometry is ideal for evaluating surface antigen expression on cell suspensions and allows for the evaluation of multiple antigens on a given cell. This method is most helpful for acute leukemias and low-grade lymphomas in which aberrant antigen expression in combinations is common on the neoplastic cells.^{18, 19} Detection of nuclear and cytoplasmic antigens, such as cyclin D1 and BCL2, is more difficult with this methodology.¹⁶

Immunohistochemistry

Immunohistochemistry can be performed on fixed, paraffin-embedded tissue and allows for morphologic correlation with antigen expression. This is most useful in tumors with only scattered tumor cells, such as Hodgkin lymphoma, which is usually not detectable by current flow cytometry methods. Paraffin section immunohistochemistry also allows for detection of cytoplasmic and nuclear antigens that do not routinely work well by flow cytometry and allows fairly complete immunophenotyping of disorders that do not have fresh tissue available,²⁰ although the number of markers detectable by this method is still less than can be assessed by flow cytometry immunophenotyping. Table 67.1 lists the most commonly used antibodies in paraffin section immunohistochemistry for hematopoietic tumors.

GENETIC TESTING

Genetic analysis has become increasingly important in the diagnosis, classification, and prognosis assessment of hematopoietic tumors.^{21, 22} These techniques are described in more detail in other chapters; however, it is important to understand the general utility of the various assays that are currently available. Gene array analysis has contributed greatly to our understanding of a variety of hematopoietic tumors in recent years, but it is not used as a diagnostic tool in most laboratories and is being largely supplanted by sequencing methods in the research setting. Karyotype analysis is still the best overall screening method for most tumors and will detect most gross chromosomal abnormalities, including translocations, deletions, and aneuploidy. This method has the advantage of an overall screen of all chromosomes, compared to the more targeted detection of abnormalities with the other molecular genetic methods, and should be performed on all suspected acute leukemias or myeloproliferative neoplasms. The submission of samples for karyotype analysis in cases of suspected malignant lymphoma shows more institutional variability.

Many important genetic abnormalities, however, are cryptic at the karyotype level of detection and these include some translocations, such as the t(12;21)(p13;q22) of pediatric acute lymphoblastic leukemia; B- and T-cell antigen-receptor rearrangements of malignant lymphomas; and gene mutations, such as those seen in many acute myeloid leukemias. Karyotype analysis is also difficult on slower-growing tumors, such as low-grade lymphomas, and will not work on fixed tissues. Therefore, a variety of other techniques is also commonly used to evaluate the molecular genetic changes of these tumors. Although Southern blot analysis has traditionally been considered the gold standard for the detection of many abnormalities, gene rearrangement studies, the need for large amounts of fresh or frozen tumor tissue, the complexity of the assay, and the relatively long turnaround time of this assay have resulted in most diagnostic laboratories abandoning this method. Fluorescence in situ hybridization (FISH) is a commonly used technique that can be performed on metaphases or intact cell nuclei, and this method is ideal for the detection of translocations, deletions, and trisomies. FISH panels to detect common, disease-specific abnormalities with prognostic significance are now routine assays performed at diagnosis for cases of suspected chronic lymphocytic lymphoma and plasma cell myeloma and are becoming more common for other neoplasms. The various polymerase chain reaction (PCR) methods are rapid means of detecting translocations and gene rearrangements, and can detect lower tumor volumes than FISH methods. Quantitative PCR assays are used to determine levels of minimal residual disease, such as to monitor patients being treated for chronic myelogenous leukemia. Other in situ hybridization methods are useful to localize infectious agents, in particular the Epstein-Barr virus, in specific cell types and this method is often used in the diagnosis of classical Hodgkin lymphoma and nasal natural killer (NK)/T-cell lymphoma. The introduction of next-generation sequencing platforms into clinical

laboratories will increase the number of genetic targets for a given case in the near future. Therefore, a variety of molecular diagnostic tools is now available to supplement karyotype analysis in the evaluation of hematopoietic tumors.

OTHER ANCILLARY METHODS

New molecular genetic technology will certainly become available for diagnostic use in the future, yet other more traditional ancillary techniques are actually becoming less common in the routine diagnosis of hematopoietic tumors. Specifically, electron microscopy is rarely used and has been largely supplanted by immunophenotypic methods. Similarly, the diagnostic utility of many histochemical and cytochemical assays has also diminished. Although the proper classification of some of the acute myeloid leukemias in the “not otherwise specified” group of the World Health Organization (WHO) classification still have cytochemical criteria, it is now generally recognized that subgroups of acute myeloid leukemia defined solely by these methods have little clinical relevance.^{23, 24}

THE DIAGNOSTIC REPORT

The diagnostic report for hematopoietic tumors should ideally summarize all diagnostic material and testing from a sample.²⁵ This would include a combination of peripheral blood, marrow aspirate, and marrow biopsy for bone marrow samples. The morphologic review should be performed and interpreted in combination with immunophenotyping and cytogenetic and molecular genetic studies. The report should state the relevant

P.1394

P.1395

clinical information and indication for biopsy/aspiration. In addition, the report should clearly define the methodology used for any special studies (such as flow cytometry vs. immunohistochemistry; PCR vs. FISH, etc.), the antibodies studied and their results, a summary of the interpretation of each special study, and a final interpretation of the significance of all of the assays performed. The final diagnosis should clearly identify the site from which the specimen was obtained, and should, when possible, provide a diagnosis using the most current version of the WHO classification of hematopoietic tumors which is summarized in Table 67.2. Such comprehensive reports are more complicated to produce, but are necessary to classify most hematopoietic neoplasms properly. This approach may require amending initial interpretations, based on morphology and immunophenotyping, to provide the complete assessment that includes cytogenetic and molecular genetic results.

TABLE 67.1 COMMONLY USED MARKERS FOR THE CHARACTERIZATION OF HEMATOPOIETIC AND LYMPHOID NEOPLASMS IN PARAFFIN-EMBEDDED TISSUE SECTIONS

Category	CD Antigen or Antibody	Reactivity in Normal Cells^a	Reactivity in Neoplasms^a
Pan-leukocyte	CD45	B cells, most T cells, macrophages, and granulocytes	Most NHLs and leukemias
T cell	CD1a	Cortical thymocytes and Langerhans cells	Precursor T-cell lymphoblastic leukemia/lymphoma, Langerhans cell histiocytosis
	CD3	T cells	Most T-cell neoplasms
	CD5	T cells and subset of small B cells	Many T-cell lymphomas and leukemias and subset of diffuse small B-cell neoplasms, such as small lymphocytic lymphoma/chronic lymphocytic leukemia and mantle cell lymphoma
	CD7	Most T cells and NK cells	Many T-cell lymphomas and leukemias

	CD43	T and NK cells, some macrophages, granulocytes, and plasma cells	Most T-cell lymphomas, some B-cell lymphomas, acute myeloid leukemias, and plasma cell neoplasms
	CD45RO	Most T and NK cells, some macrophages, some myeloid cells	Most T-cell lymphomas, some B-cell lymphomas
	CD57	Some NK cells, subset of T cells	Some NK- and T-cell lymphomas/leukemias and some lymphoblastic lymphomas
	TCR β	α/β T cells	Many T-cell lymphomas
	TCR γ	γ/δ T cells	γ/δ T-cell lymphomas
B cell	CD10	Precursor B cells and germinal center B cells, some germinal center T cells	Many precursor B-lymphoblastic leukemias/lymphomas, some precursor T-lymphoblastic leukemias/lymphomas, angioimmunoblastic T-cell lymphoma, many follicular lymphomas, Burkitt lymphoma
	CD20	B cells	Most B-cell NHLs, L&H cell in LPHD; RS cells in some cases of classic Hodgkin disease
	CD21	Mantle and marginal zone B cells, FDC	Some mantle and marginal lymphomas, FDC tumors
	CD23	Mantle zone B cells, some FDC	Chronic lymphocytic leukemia/small lymphocytic lymphoma, some follicular lymphomas
	CD45RA	B cells and subset of T cells	B-cell NHL, L&H cells in LPHD, some T-cell lymphoid and myeloid leukemias
	CD79a	B cells	Most B-cell NHLs and many B-cell leukemias
	PAX5	B cells	Most B-NHL, L and H cell in LPHD; RS cells in classic Hodgkin disease, some acute myeloid leukemias
	Anti-immunoglobulin	B cells, plasma cells	B-cell NHL and plasma cell neoplasms
Hodgkin related	CD15	Granulocytes and some macrophages	RS cells in classical Hodgkin lymphoma; some T- and B- large cell lymphomas; some carcinomas
	CD30	Activated B and T cells	RS cells in classical Hodgkin lymphoma; most cases of ALCL; other T- and B-cell NHLs
Miscellaneous	CD34	Progenitor cells	Some acute myeloid leukemias and some precursor lymphoblastic

		leukemias/lymphomas
CD56	NK cells, few T cells	Many NK-cell neoplasms
CD123	Plasmacytoid dendritic cells	Blastic plasmacytoid dendritic cell tumors; some acute leukemias; hairy cell leukemia
CD138	Plasma cells	Multiple myeloma and plasmacytoid lymphomas
CD163	Macrophages and granulocytes	True malignant histiocytosis; some myeloid leukemias
S100	Langerhans cells, interdigitating dendritic reticular cells, sometimes FDC	Langerhans cell histiocytes, sinus histiocytosis with massive lymphadenopathy, rare T-cell lymphomas, myeloid leukemias
Terminal deoxyribonucleotidyl transferase	Precursor marrow cells, cortical thymocytes	Most precursor B- or T-lymphoblastic leukemias/lymphomas, some acute myeloid leukemias
Ki-67	Proliferating cells (not in G ₀ phase of cell cycle)	Proliferating cells
Myeloperoxidase	Myeloid cells	Myeloid leukemias
BCL2	Nonfollicular center B cells, T cells	Most follicular lymphomas, many other diffuse NHLs and leukemias
BCL6	Germinal center B cells	Most follicular lymphomas and some diffuse large B-cell lymphomas
ALK1	No expression in normal lymphoid cells	Subset of ALCL, DLBCL and inflammatory myofibroblastic tumor cases
Cyclin D1	Minimal to no expression in normal lymphoid cells	Mantle cell lymphoma, hairy cell leukemia, and some cases of plasma cell myeloma

ALCL, anaplastic large cell lymphoma; FDC, follicular dendritic cell; L&H, lymphocyte and histiocytic; LPHD, lymphocyte-predominant Hodgkin disease; NHL, non-Hodgkin lymphoma; NK, natural killer; RS, Reed-Sternberg.

^aIn most cases the immunoreactivity of each antibody is not exclusive to the cell type or neoplasm listed and positive results must be interpreted in the context of the entire immunophenotype.

TABLE 67.2 2008 WORLD HEALTH ORGANIZATION CLASSIFICATION OF HEMATOPOIETIC AND LYMPHOID NEOPLASMS

Myeloproliferative Neoplasms

Chronic myelogenous leukemia, *BCR-ABL1*

Chronic neutrophilic leukemia

Polycythemia vera

Primary myelofibrosis

Essential thrombocythemia

Chronic eosinophilic leukemia, not otherwise specified

Mastocytosis

Myeloproliferative neoplasms, unclassifiable

Myeloid and lymphoid neoplasms associated with eosinophilia and abnormalities of *PDGFRA*, *PDGFRB*, or *FGFR1*

Myelodysplastic/Myeloproliferative Neoplasms

Chronic myelomonocytic leukemia

Atypical chronic myeloid leukemia, *BCR-ABL1* negative

Juvenile myelomonocytic leukemia

Myelodysplastic/myeloproliferative neoplasm, unclassifiable

Myelodysplastic Syndromes

Refractory cytopenia with unilineage dysplasia

Refractory anemia with ring sideroblasts

Refractory cytopenia with multilineage dysplasia

Refractory anemia with excess blasts

Myelodysplastic syndrome with isolated del(5q)

Myelodysplastic syndrome, unclassifiable

Childhood myelodysplastic syndrome

Acute Myeloid Leukemia (AML) and Related Precursor Neoplasms

AML with recurrent genetic abnormalities

AML with t(8;21) (q22;q22) (*RUNX1-RUNX1T1*)

AML with inv(16)(p13.1q22) or t(16,16) (p13.1;q22) (*CBFB-MYH11*)

Acute promyelocytic leukemia with t(15;17)(q24.1;q21.1) (*PML-RARA*)

AML with t(9;11)(p22;q23) (*MLLT3-MLL*)

AML with t(6;9)(p23;q34) (*DEK-NUP214*)

AML with inv(3)(q21q26.2) or t(3;3)(q21;q26.2) (*RPNI-EVII*)

AML (megakaryoblastic) with t(1;22)(p13;q13) (*RBM15-MKLI*)

Provisional entity: AML with mutated *NPM1*

Provisional entity: AML with mutated *CEBPA*

AML with myelodysplasia-related changes

Therapy-related myeloid neoplasms

AML not otherwise specified

AML minimally differentiated

AML without maturation

AML with maturation

Acute myelomonocytic leukemia
Acute monoblastic and monocytic leukemia
Acute erythroid leukemia
Acute megakaryocytic leukemia
Acute basophilic leukemia
Acute panmyelosis with myelofibrosis

Myeloid sarcoma

Myeloid proliferations related to Down syndrome

Blastic plasmacytoid dendritic cell neoplasm

Acute Leukemias of Ambiguous Lineage

Precursor Lymphoid Neoplasms

B-lymphoblastic leukemia/lymphoma, not otherwise specified

B-lymphoblastic leukemia/lymphoma with t(v;11q23)(*MLL*)

B-lymphoblastic leukemia/lymphoma with t(12;21)(p13;q22) (*ETV6-RUNX1*)

B-lymphoblastic leukemia/lymphoma with t(5;14)(q31;q32) (*IL3-IGH@*)

B-lymphoblastic leukemia/lymphoma with t(1;19)(q23;p13.3) (*TCF3-PBX1*)

B-lymphoblastic leukemia/lymphoma with hyperdiploidy

B-lymphoblastic leukemia/lymphoma with hypodiploidy

T-lymphoblastic leukemia/lymphoma

Mature B-Cell Neoplasms

Chronic lymphocytic leukemia/small lymphocytic lymphoma

B-cell prolymphocytic leukemia

Splenic B-cell marginal zone lymphoma

Hairy cell leukemia

Splenic B-cell lymphoma/leukemia, unclassifiable

Lymphoplasmacytic lymphoma

Heavy-chain diseases

Plasma cell neoplasms

Extranodal marginal zone lymphoma of mucosa-associated lymphoid tissue (MALT lymphoma)

Nodal marginal zone lymphoma

Follicular lymphoma

Primary cutaneous follicle center lymphoma

Mantle cell lymphoma

Diffuse large B-cell lymphoma (DLBCL), not otherwise specified

T-cell/histiocyte-rich large B-cell lymphoma

Primary DLBCL of the central nervous system

Primary cutaneous DLBCL, leg type
EBV-positive DLBCL of the elderly
DLBCL associated with chronic inflammation
Lymphomatoid granulomatosis
Primary mediastinal (thymic) large B-cell lymphoma
Intravascular large B-cell lymphoma
ALK-positive large B-cell lymphoma
Plasmablastic lymphoma
Large B-cell lymphoma associated with HHV8-associated multicentric Castleman disease
Primary effusion lymphoma
Burkitt lymphoma
B-cell lymphoma, unclassifiable, with features intermediate between DLBCL and Burkitt lymphoma
B-cell lymphoma, unclassifiable, with features intermediate between DLBCL and classical Hodgkin lymphoma

Mature T- and NK-Cell Neoplasms

T-cell prolymphocytic leukemia
T-cell large granular lymphocytic leukemia
Chronic lymphoproliferative disorder of NK cells
Aggressive NK-cell leukemia
EBV-positive T-cell lymphoproliferative diseases of childhood
Adult T-cell leukemia/lymphoma
Extranodal NK/T-cell lymphoma, nasal type
Enteropathy-type T-cell lymphoma
Hepatosplenic T-cell lymphoma
Subcutaneous panniculitis-like T-cell lymphoma
Mycosis fungoides
Sézary syndrome
Primary cutaneous CD30-positive T-cell lymphoproliferative disorders
Primary cutaneous $\gamma\delta$ T-cell lymphoma
Primary cutaneous CD8⁺ aggressive epidermotropic cytotoxic T-cell lymphoma
Primary cutaneous CD4-positive small/medium T-cell lymphoma
Peripheral T-cell lymphoma, not otherwise specified
Angioimmunoblastic T-cell lymphoma
Anaplastic large cell lymphoma, *ALK*-positive
Anaplastic large cell lymphoma, *ALK*-negative

Hodgkin Lymphoma

Nodular lymphocyte-predominant Hodgkin lymphoma

Nodular sclerosis classical Hodgkin lymphoma

Mixed cellularity classical Hodgkin lymphoma

Lymphocyte-rich classical Hodgkin lymphoma

Lymphocyte-depleted classical Hodgkin lymphoma

Immunodeficiency-Associated Lymphoproliferative Disorders

Lymphoproliferative diseases associated with primary immune disorders

Lymphomas associated with HIV infection

Posttransplant lymphoproliferative disorders

Other iatrogenic immunodeficiency-associated B-cell lymphoproliferative disorders

Histiocytic and Dendritic Cell Neoplasms

Histiocytic sarcoma

Langerhans cell histiocytosis/sarcoma

Interdigitating dendritic cell sarcoma

Follicular dendritic cell sarcoma

Other rare dendritic cell tumors

Disseminated juvenile xanthogranuloma

AML, acute myeloid leukemia; DLBCL, diffuse large B-cell lymphoma; EBV, Epstein-Barr virus; HHV8, human herpes virus-8; HIV, human immunodeficiency virus; NK, natural killer.

The pathologic diagnosis of hematopoietic tumors now requires a broad approach that involves very close interactions between hematologists and pathologists as well as interactions with a variety of laboratories. Excellent communication between the physician performing the diagnostic procedure and the laboratories is needed to ensure that the specimen is handled in the most efficient manner and to obtain the most accurate and rapid diagnosis for the patient.

P.1396

P.1397

REFERENCES

1. Harris NL, Jaffe ES, Stein H, et al. A revised European-American classification of lymphoid neoplasms: a proposal from the International Lymphoma Study Group. *Blood* 1994;84:1361-1392.
2. Swerdlow SH, Campo E, Harris NL, et al., eds. WHO classification of tumours of haematopoietic and lymphoid tissues. Lyon: IARC, 2008.
3. Bennett JM, Catovsky D, Daniel M-T, et al. Proposals for the classification of the acute leukemias. *Br J Haematol* 1976;33:451-458.
4. Bennett JM, Catovsky D, Daniel MT, et al. Proposals for the classification of the myelodysplastic syndromes. *Br J Haematol* 1982;51:189-199.
5. Bennett JM, Catovsky D, Daniel MT, et al. Proposed revised criteria for the classification of acute myeloid leukemia. A report of the French-American-British Cooperative Group. *Ann Intern Med* 1985;103:626-629.
6. Rappaport H. Tumors of the hematopoietic system. Washington, DC: Armed Forces Institute of Pathology, 1966:1-442.

7. Non-Hodgkin's Lymphoma Pathologic Classification Project. National Cancer Institute sponsored study of classifications of non-Hodgkin's lymphomas: summary and description of a working formulation for clinical usage. *Cancer* 1982;49:2112-2135.
8. Collins RD. Lymph node examination. What is an adequate workup? *Arch Pathol Lab Med* 1985;109:797-799.
9. Cousar JB. Surgical pathology examination of lymph nodes. Practice survey by American Society of Clinical Pathologists. *Am J Clin Pathol* 1995;104:126-132.
10. Nguyen P. Collection, processing, and examination of bone marrow specimens. In: Jaffe ES, Harris NL, Vardiman JW, Campo E, Arber DA, eds. *Hematopathology*. St. Louis, MO: Elsevier, 2011:27-35.
11. Natkunam Y, Warnke RA. Processing of the lymph node biopsy specimen. In: Jaffe ES, Harris NL, Vardiman JW, Campo E, Arber DA, eds. *Hematopathology*. St. Louis, MO: Elsevier, 2011:3-13.
12. Foucar K. Procurement and indications for bone marrow examination. In: Foucar K, Reichard K, Czuchlewski D, eds. *Bone marrow pathology*, 3rd ed. Chicago: American Society Clinical Pathology Press, 2010:52-65.
13. Arber JM, Arber DA, Jenkins KA, et al. Effect of decalcification and fixation in paraffin-section immunohistochemistry. *Appl Immunohistochem* 1996;4:241-248.
14. Wang J, Weiss LM, Chang KL, et al. Diagnostic utility of bilateral bone marrow examination: significance of morphologic and ancillary technique study in malignant. *Cancer* 2002;94:1522-1531.
15. Zeppa P, Marino G, Troncone G, et al. Fine-needle cytology and flow cytometry immunophenotyping and subclassification of non-Hodgkin lymphoma: a critical review of 307 cases with technical suggestions. *Cancer* 2004;102:55-65.
16. Laane E, Tani E, Bjorklund E, et al. Flow cytometric immunophenotyping including Bcl-2 detection on fine needle aspirates in the diagnosis of reactive lymphadenopathy and non-Hodgkin's Lymphoma. *Cytometry B Clin Cytom* 2005;64:34-42.
17. Bernard T, Rhodes M, Turner GE, et al. Laparoscopic splenectomy: single-centre experience of a district general hospital. *Br J Haematol* 1999;106: 1065-1067.
18. Wood BL, Arroz M, Barnett D, et al. 2006 Bethesda International Consensus recommendations on the immunophenotypic analysis of hematolymphoid neoplasia by flow cytometry: optimal reagents and reporting for the flow cytometric diagnosis of hematopoietic neoplasia. *Cytometry B Clin Cytom*. 2007;72(Suppl 1):S14-S22.
19. Davis BH, Holden JT, Bene MC, et al. 2006 Bethesda International Consensus recommendations on the flow cytometric immunophenotypic analysis of hematolymphoid neoplasia: medical indications. *Cytometry B Clin Cytom*. 2007;72(Suppl 1):S5-S13.
20. Chu PG, Chang KL, Arber DA, et al. Immunophenotyping of hematopoietic neoplasms. *Semin Diagn Pathol* 2000;17:236-256.
21. Mariappan MR, Arber DA. Molecular diagnostics in hematopathology. In: Pfeifer JD, ed. *Molecular genetic testing in surgical pathology*. Philadelphia, PA: Lippincott Williams & Wilkins, 2006:250-274.

P.1398

22. Merker JD, Arber DA. Molecular diagnostics of non-Hodgkin lymphoma. *Exp Opin Med Diagnost* 2007;1:47-63.
23. Arber DA, Stein AS, Carter NH, et al. Prognostic impact of acute myeloid leukemia classification. Importance of detection of recurring cytogenetic abnormalities and multilineage dysplasia on survival. *Am J Clin Pathol* 2003;119:672-680.
24. Tallman MS, Kim HT, Paietta E, et al. Acute monocytic leukemia (French-American-British classification M5) does not have a worse prognosis than other subtypes of acute myeloid leukemia: a report from the Eastern Cooperative Oncology Group. *J Clin Oncol* 2004;22: 1276-1286.
25. Mohanty SK, Piccoli AL, Devine LJ, et al. Synoptic tool for reporting of hematological and lymphoid neoplasms based on World Health Organization classification and College of American Pathologists checklist. *BMC Cancer* 2007;7:144.

Chapter 68 Principles and Pharmacology of Chemotherapy

> Table of Contents > Part VII - Hematologic Malignancies > Section 1 - General Aspects > Chapter 68 - Principles and Pharmacology of Chemotherapy

Chapter 68

Principles and Pharmacology of Chemotherapy

Kenneth R. Hande

PRINCIPLES OF CHEMOTHERAPY

To optimally treat cancer patients, clinicians should understand the principles of cancer chemotherapy as well as the pharmacology of the drugs they are administering. The first section of this chapter reviews our understanding of (a) cancer biology, (b) mechanisms of antineoplastic drug action, (c) mechanisms of drug resistance, (d) drug toxicities, (e) pharmacologic principles (common and unique), and (f) potentials and limitations of therapy for individual patients. Specific drugs used to treat hematologic malignancies, their mechanism of action, and their toxicities are summarized in the second section of this chapter.

Cancer Biology

Most cancers are detected when there are 10^4 to 10^{11} neoplastic cells present.¹ The large number of cells present at diagnosis usually requires multiple courses of treatment or a long duration of therapy to result in a cure. Even if a drug, or a combination of drugs, is quite effective in killing cancer cells, such that it kills 999 of every 1,000 cells present (99.9% cell kill), one treatment will reduce a tumor population from 10^{11} to 10^8 cells. At least four treatments are therefore necessary to eliminate the final cancer cell, assuming there is no tumor cell growth during the treatment period. In fact, because of toxicity to normal tissues and the time needed for normal tissue recovery, cancer chemotherapy must be spaced out in treatment cycles. During the period between cycles, tumor regrowth occurs. Thus, most curative treatment regimens require prolonged therapy, often using multiple courses of chemotherapy, with the number of courses depending on the tumor mass at the time of diagnosis and the sensitivity of the tumor to the drugs. The fraction cell kill (e.g., 90%, 99%, 99.99% cell kill) depends on the sensitivity of cells to the antineoplastic drug and the dose of drug administered. Rapidly dividing cells are generally more sensitive to antineoplastic agents while nondividing cells are generally resistant.

Most cancers do not grow at a fixed rate throughout their course. Initial growth rates may be exponential. Gompertzian growth is sigmoid. In the Gompertzian model, the growth fraction of the tumor reduces as the tumor enlarges.² Because a significant proportion of cells in a large tumor mass are often in a resting or dormant phase, presumably as a result of lack of adequate nutrients or oxygen, they may not be affected by chemotherapy. The best opportunity for cell kill by chemotherapy is in the early portion of the growth curve, when all cells are dividing.

Recurrence of cancer after "complete remission" (disappearance of all detectable disease) can be explained by the inability of current staging methods to detect fewer than 10^3 to 10^4 tumor cells in the body even by the most sensitive means. Chemotherapy that kills several logs of tumor cells (e.g., from 10^{11} to 10^4) eliminates all visible evidence of cancer and prolongs survival, but the malignancy will recur at a later time. Examples of possible clinical courses associated with cancer chemotherapy are illustrated in Figure 68.1.

The growth fraction of a cancer represents the percentage of cells progressing actively through the cell cycle. A cell cycle is marked by two observable events. In S-phase (synthesis), DNA replication occurs; during M-phase (mitosis), cellular division into two daughter cells is noted.¹ G_1 (gap) is the time between the end of mitosis and the start of the next S-phase. G_2 is the time between the completion of S-phase and the start of M-phase. Cells that have ceased to proliferate for prolonged periods have entered a G_0 phase (or resting phase) of the cell cycle (Fig. 68.2). Some drugs are cytotoxic when exposed to cancer cells in any phase of the cell cycle. Other drugs are phase-specific; that is, they are cytotoxic to cells only in a particular phase of the cell cycle. Cytarabine, for example, is an S-phase-specific agent, whereas vincristine is M-phase-specific. For cells to be killed by cytarabine, the drug must be present when the cell is synthesizing DNA.

Mechanisms of Antineoplastic Drug Action

Antineoplastic agents have been discovered by many methods. Exposing cancer cells in culture to natural or synthetic compounds to screen for materials with antineoplastic activity has identified a number of active antineoplastic agents (drugs such as paclitaxel). Since DNA is important in cell division, compounds blocking DNA synthesis have been

developed. Over the past 20 years, genes and their protein products that regulate cell division have been identified. The molecular pathways by which these oncogenes cause cellular proliferation have been determined.³ Knowledge of molecular pathways critical to the growth of cancer cells has led to the targeted development of molecules altering specific pathways (e.g., tyrosine kinase inhibitors, angiogenesis inhibitors). During the past two decades, the development of cancer drugs has shifted from a screening process where active agents are identified and their mechanism of action later defined, to first identifying a targetable pathway, finding a compound to block that pathway, and then testing for antineoplastic activity.

No matter how an antineoplastic has been developed, these drugs interfere with an essential step required for cell growth or division. The initial target of antineoplastic drugs varies widely, from direct attack on the DNA molecule to inhibition of signal transduction molecules. However, all antineoplastic agents cause a disruption in a cellular process so significant to the cancer cell that it requires the cell to either quickly repair the damage or to initiate the process of apoptosis (programmed cell death). Essentially, all antineoplastic agents result in cancer cell death through initiation of apoptosis.⁴ Apoptosis is the normal physiologic process of cellular suicide, which occurs in all living organisms to eliminate unwanted, functionally abnormal, or harmful cells. In apoptosis, in contrast to cellular necrosis, the cell shrinks and condenses, fragmenting into multiple membrane-bound bodies (apoptotic bodies) that are engulfed by surrounding cells without inflammation or damage to the surrounding tissues. Biochemically, apoptosis is characterized by fragmentation of nuclear DNA, demonstrated by a typical ladder pattern on agarose gel electrophoresis.

To understand how cytotoxic agents initiate apoptosis, an understanding of the events that occur during the normal cell cycle is important. As previously mentioned, DNA synthesis is not continuous from one mitosis to the next but takes place in only a specific period of the cell cycle, the S-phase. Similarly, mitosis or the M-phase takes up only a small part of the cell cycle.¹ In most, if not all cells, the cell cycle is temporarily halted during the G₁-S-phase checkpoint and at the G₂-M-phase checkpoint. At these times, cells determine whether to continue into the S-phase, initiate the process of apoptosis, or undergo DNA repair. Passage into a new phase of the cell cycle requires activation of a series of enzymes called cyclin-dependent kinases, which activate another group of enzymes (the cyclins).⁵ If cells are damaged by

P.1400

chemotherapeutic agents and are unable to repair the damage, apoptosis is initiated at the G₁-S or G₂-M checkpoint, provided the mechanisms for apoptosis are in place. Several critical factors are needed for apoptosis to occur such as p53, p63, and p21. P53 is a nuclear phosphoprotein capable of binding to specific DNA sequences and activating selected target genes triggering apoptosis. Cells with a mutated P53 gene have a relative resistance to cancer chemotherapeutic agents and are unable to initiate apoptosis properly.⁶ P21 is a protein induced by p53 that binds to and inactivates the cyclins required for progression of cells into the S-phase. Other factors are known to affect the apoptotic pathway. A protein originally found in B cell lymphomas, bcl-2, blocks apoptosis. Caspases are the key machinery causing the breakdown of DNA and proteins. Caspases are specialized proteases existing as proenzymes, which can be rapidly activated by a number of factors. The Fas ligand and tumor necrosis factor stimulate the protease cascade. It is clear that antineoplastic agents provide the initial trigger for beginning the pathway to programmed cell death (Fig. 68.3). However, the presence, or absence, of apoptotic proteins is as important as the initial interaction between a cytotoxic drug and its effector in determining whether tumor cell kill occurs.⁴

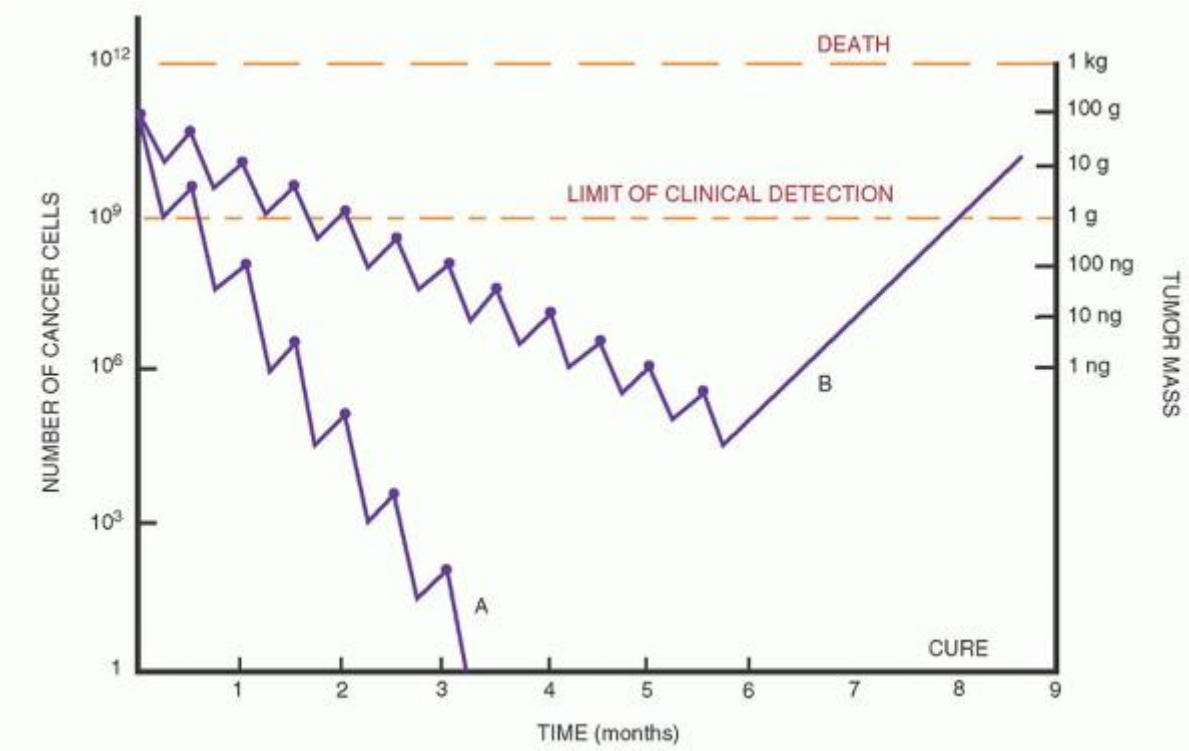

FIGURE 68.1. Schematic representation of clinical course of two patients with Hodgkin disease. Both patients A and B are diagnosed with a clinically detected tumor mass (10^{11} cells). Both patients are treated with ABVD (doxorubicin, bleomycin, vincristine, and DTIC) every 2 weeks. One course of therapy for patient A results in a 2-log tumor cell kill. Patient B's therapy results in only a 1-log tumor cell kill. Some tumor growth occurs while waiting for normal tissue recovery before initiation of the next treatment. Three months into therapy, neither patient A nor B has clinically detectable disease. Treatment is stopped after 6 months of therapy. Patient A is cured, whereas disease recurs in patient B 3 months after stopping therapy.

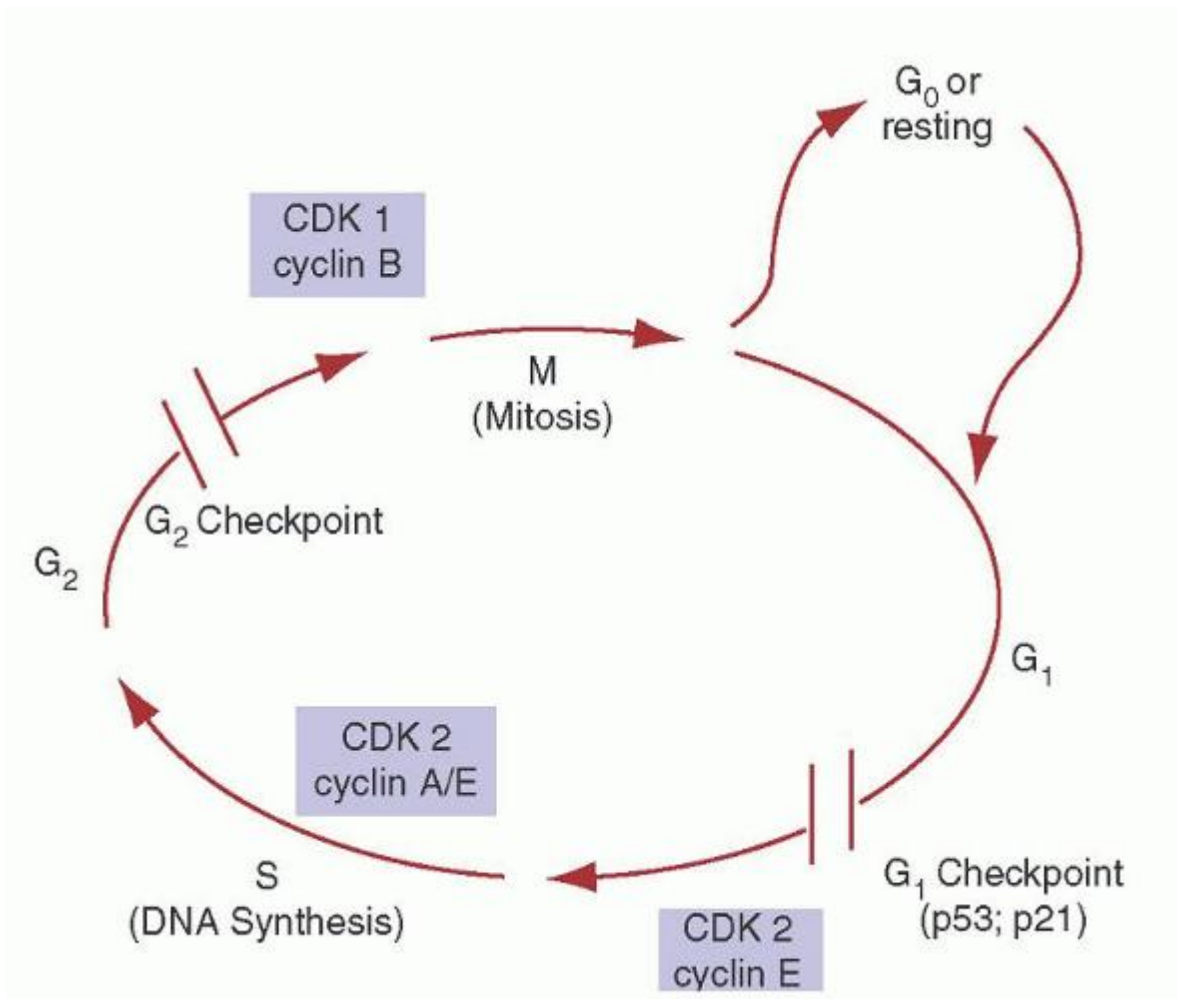

FIGURE 68.2. The cell cycle. The cell cycle is marked by two observable events. During S-phase (synthesis), DNA replication occurs; and during M-phase (mitosis), cells divide. G₁ and G₂ (gap) are times between completion of M-phase and start of S-phase and between completion of S-phase and start of M-phase, respectively. During G₁ and G₂, the cell prepares for the S- and M-phases of the cell cycle. Cells may temporarily cease to divide and enter a resting or G₀ phase of the cell cycle. The G₁-S checkpoint is a critical phase in the cell cycle, when directions for entering S-phase or committing to apoptosis (programmed cell death) are given.

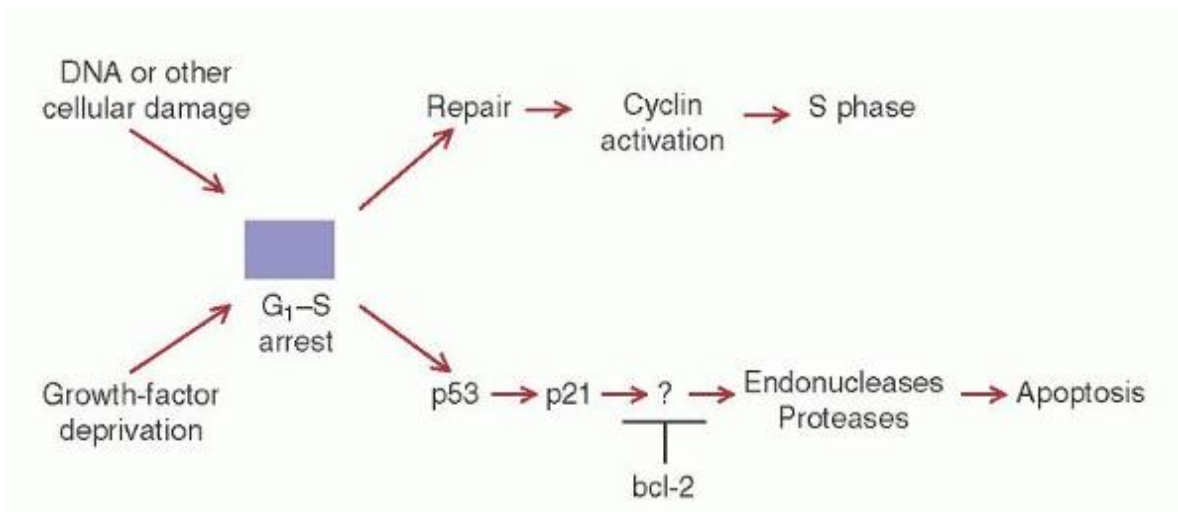

FIGURE 68.3. Potential pathways involved in cytotoxicity induced by chemotherapy. Chemotherapeutic drugs or growth factor deprivation damages cells. Cells are arrested at the G₁-S checkpoint. If the damage is sublethal, it may be repaired

and the cell proceeds to S-phase. If significant DNA damage is present, the process of programmed cell death is initiated. Critical factors, such as p53 and p21 gene products, are required for the cell to undergo apoptosis.

P.1401

Resistance to Anticancer Drugs

The presence of cancer cells that are resistant to chemotherapeutic agents is a common clinical occurrence. It has been postulated that by the time the number of cancer cells reaches 10^3 to 10^6 , a resistant clone has developed.⁷ Unfortunately, there are many ways in which cells can become resistant to an antineoplastic agent. Steps in antineoplastic drug disposition within the cell are represented schematically in Figure 68.4. For an anticancer drug to be active, it must (a) be taken up into a cancer cell and (b) be converted into an active agent. It must then make its way within the cell to its target without being (c) metabolically inactivated, (d) chemically inactivated, or (e) excreted from the cell. Once it interacts with its cellular target, the cell must not be able to (f) alter the target or (g) repair the damage to the target. Finally, (h) mechanisms for apoptosis must be in place, as discussed in the preceding section. Examples of drug resistance at all of these steps have been described.⁸ Not only are there multiple potential mechanisms for drug resistance, but an individual tumor cell can become resistant to a particular drug in many ways. For example, resistance to methotrexate (MTX) has been described in some cell lines with altered folate transport that limits MTX uptake into cells.⁹ In other cell lines, MTX resistance results from the overexpression of the target enzyme, dihydrofolate reductase (DHFR).

Cancer cells may become simultaneously resistant to several types of chemotherapeutic drugs. Cells that express the multidrug resistance gene (MDR) produce a glycoprotein of 170-kDa weight known as p-glycoprotein or p170.⁸ Originally described in 1976, this protein is a drug transporter that sits in the cell wall of resistant tumor cells. P-glycoprotein transports a number of antineoplastic agents, most of which are hydrophobic, including vinca alkaloids, epipodophyllotoxins, anthracyclines, actinomycin, and taxanes. Cells in which the MDR gene is activated develop simultaneous resistance to these antineoplastic agents. The presence of p-glycoprotein on tumor cells has been correlated with poor prognosis in hematologic tumors.¹⁰ Efforts have been directed at inhibiting p-glycoprotein. However, MDR inhibitors often block either the hepatic or renal excretion of anticancer drugs, thereby increasing drug toxicity.¹¹ Clinical effectiveness of these MDR inhibitors has not been demonstrated. Cancer cell lines have been characterized that do not overexpress p-glycoprotein but do display a similar cross-resistance pattern. These lines have different types of transport proteins, such as MDR-related protein (MRP) or breast cancer resistance protein (BCRP). MRP and BCRP, like p-glycoprotein, are members of the adenosine triphosphate (ATP) binding cassette gene superfamily, but are structurally dissimilar to p-glycoprotein and with different inhibitors.^{12, 13} In summary, tumor cells can develop resistance to antineoplastic drugs by numerous mechanisms. Resistance occurs as a result of random mutational changes in a population of cancer cells. Mutations to a drug-resistant cell line are estimated to occur at a population size of 10^4 to 10^6 tumor cells, a size smaller than is clinically detectable. Therefore, drug-resistant cancer cell populations will be present in the majority of tumors at diagnosis. The early presence of resistant tumor cells leads to the rationale for (a) early treatment of cancers to avoid multiple resistant populations and (b) use of multiple agents with differing mechanisms of action.

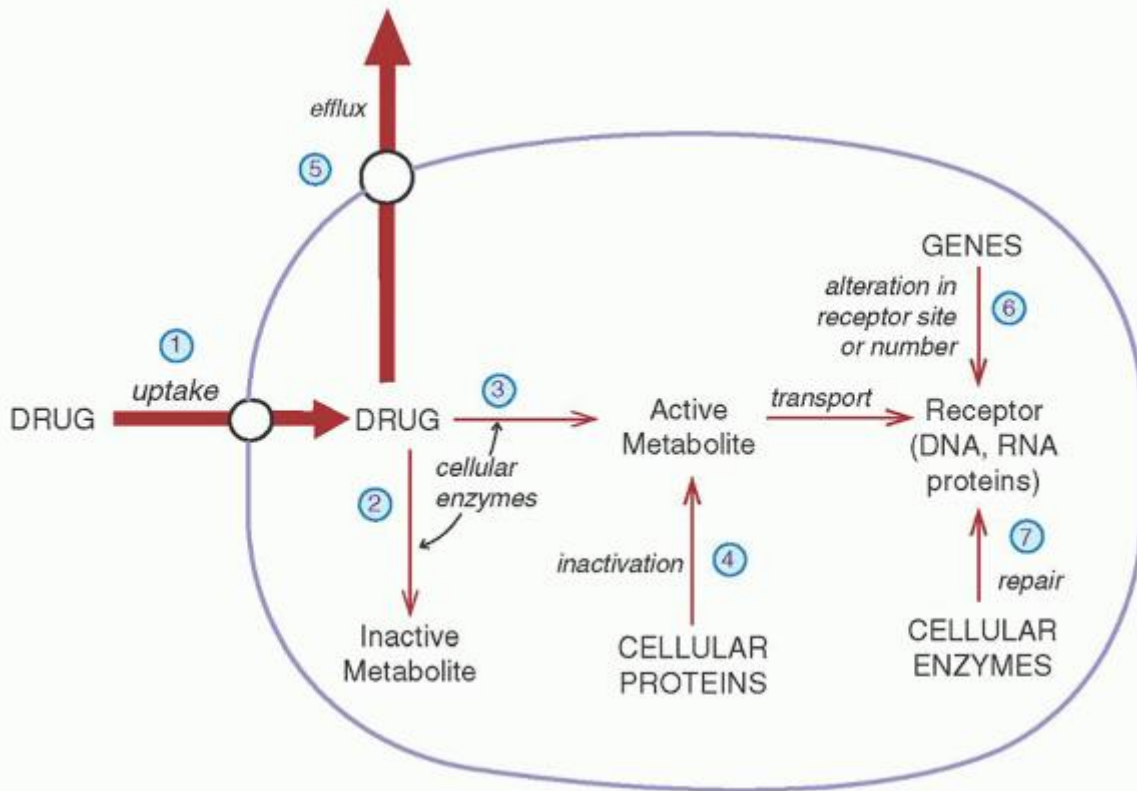

FIGURE 68.4. Potential pathways for antineoplastic drug disposition in tumor cells. For a drug to be effective, the drug, or its active metabolite, must reach its target site within the cell. Possible steps required for a drug to reach its receptor or to be inactivated include: (1) uptake into a cell through a particular transport protein; (2) enzymatic conversion of the drug to an inactive metabolite; (3) enzymatic conversion of the drug to its active metabolite; (4) binding of an active metabolite by a cellular protein or thiol, thereby inactivating drug; (5) excretion of the drug from the cell via an efflux transport pump; (6) alteration in the genetic makeup of the cell, changing the drug receptor site or number; and (7) changes in the ability of a cell to repair damage of a drug at its receptor.

Drug Toxicity

As opposed to many other classes of drugs, the therapeutic window for chemotherapeutic agents is narrow (Fig. 68.5). The dose of drug needed to achieve adequate tumor cell kill often causes toxicity to normal tissues. For many antineoplastic agents, a sigmoidal curve defining the relationship between toxicity and the dose of drug administered (or the area under the plasma drug concentration [AUC] versus time curve) has been demonstrated. At low drug concentrations, no cytotoxicity is observed. With increasing concentration, cell kill is proportional to dose. At higher concentrations, the effect plateaus. Similar relationships correlating the dose of drug and the antitumor response have also been demonstrated.¹⁴ A positive relationship between the drug dose administered and the tumor response rate has been found for many tumors, including the lymphomas. Higher response rates and an increased chance for cure are achieved with higher doses of selected agents.^{15, 16} For this reason, clinicians generally try to push doses of agents to toxicity to maximize the chance for cure. The optimal dose or AUC for an individual patient with a particular cancer is unknown.

Chemotherapeutic agents cause a wide variety of toxicities (Table 68.1). Myelosuppression and nausea are seen, to some degree, with many anticancer drugs. Nausea and vomiting, although generally self-limited and not life-threatening, are very distressing to patients. The emetogenic potential of antineoplastic

P.1402

agents varies from drug to drug and is dose-dependent¹⁷ (Table 68.2). Serotonin receptors, located within the vagal and splanchnic nerves of the gastrointestinal system and in the brain, are critical in the initiation of nausea by chemotherapeutic agents. The development of specific type 3 serotonin (5-hydroxytryptamine or 5HT₃) receptor blockers,

such as ondansetron, dolasetron, and granisetron, and NK-1 inhibitors, such as aprepitant, has resulted in major improvement in control of chemotherapy-induced emesis.^{17, 18}

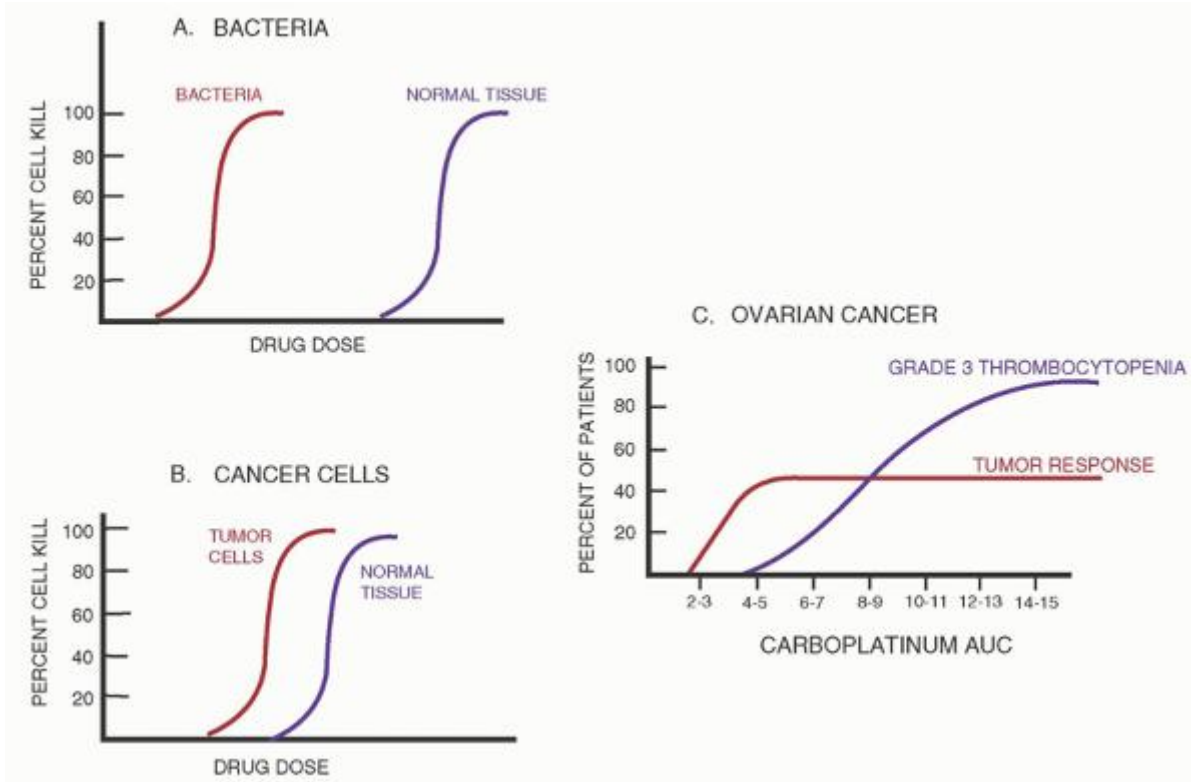

FIGURE 68.5. Schematic representation curves relating drug concentrations to response. Antibacterial agents (A) have a wide therapeutic window, with a significant difference in the dose that produces bacterial cell kill and the dose that causes toxicity to normal tissues. For antineoplastic drugs (B), the therapeutic window is narrow (e.g., doses adequate to produce tumor cell kill usually produce toxicity to normal tissues). For a few cancers, such as ovarian (C), the shape of the dose-response curve has been defined.¹⁴ For most tumors, however, a specific dose-response (or AUC-response curve) has not been defined.

Myelosuppression is the most common dose-limiting antineoplastic agent toxicity. The suppression of hematopoietic cell lines is determined by the kinetics of the specific cell line in the peripheral compartment. Anemia occurs as a late effect because of the long half-life of red blood cells (120 days). Thrombocytopenia occurs in an intermediate time frame (platelet half-life 5 to 7 days), whereas granulocyte suppression occurs earliest. Granulocytopenia is a more frequent occurrence than thrombocytopenia or anemia. The white blood cell count usually drops 5 to 14 days after drug administration, with recovery by 7 to 21 days. Several exceptions are recognized, such as a predominant thrombocytopenia seen with carboplatin and delayed myelosuppression with busulfan and the nitrosoureas (occurring 4 to 5 weeks posttherapy). The degree and duration of bone marrow suppression are related directly to the dose of drug administered. High-dose chemotherapy regimens, used with stem cell transplantation, generally result in 10 to 25 days with neutrophils $<500/\text{mm}^3$ and thrombocytopenia lasting for a more extended period. The length of cytopenias depend upon the stem cell source with peripheral blood shorter (10 to 14 days) than bone marrow (20 to 25 days). An increased risk of infectious complications occurs that is related directly to the degree and duration of granulocytopenia.¹⁹ The development of recombinant hematopoietic colony-stimulating factors (CSFs), such as erythropoietin, thrombopoietin, granulocyte-macrophage CSF, and granulocyte-CSF, has shortened the duration of bone marrow suppression but not eliminated it. CSFs are now commonly used prophylactically with regimens expected to produce an incidence of febrile neutropenia $>20\%$. Guidelines for the use of these important, yet expensive, factors are available and should be followed.²⁰

The range of toxicities associated with antineoplastic agents is too great to review in detail in this chapter. Readers are referred to reviews on endocrine,²¹ oral,²² renal,²³ neurologic,²⁴ hepatic,²⁵ pulmonary,²⁶ cardiac,²⁷ and cutaneous²⁸ toxicities of antineoplastic agents. Physicians must also remember that most antineoplastic agents have teratogenic and mutagenic potential. Alkylating agents are the most damaging to testicular and ovarian function. Damage is dependent on

drug dose, the age of the patient (older patients are more likely to experience toxicity), and sex (males more than females).²⁹ Second malignancies (primarily acute leukemia) have been associated with alkylating agents, epipodophyllotoxins, nitrosoureas, and anthracyclines.³⁰ Concomitant radiation therapy increases the risk of second malignancies (such as sarcomas or breast cancer) 5 to 20 years following therapy.

General Pharmacologic Principles

Antitumor activity of an antineoplastic agent is best correlated with the concentration of drug that reaches the site of drug action within the cancer cell (Fig. 68.5A). Several factors may affect what

P.1403

P.1404

happens to a drug following administration until it reaches its site of action (Fig. 68.6). Pharmacokinetics describes what happens to a drug following administration (what the body does to the drug). Pharmacokinetics represents an attempt to predict quantitatively how a patient will handle a given dose of drug.³¹ Important pharmacokinetic parameters include (a) bioavailability or absorption, (b) volume of distribution, (c) clearance or drug elimination, and (d) drug half-life (Fig. 68.7). Pharmacodynamics describes what effect the drug has on a particular tissue (what the drug does to the body).

TABLE 68.1 ANTINEOPLASTIC DRUG TOXICITY

Nausea/ Vomiting	Bone Marrows	Mucositi s	Alopecia	Neuro logic	Diarr hea	Hepati c	Vesican t	Pulmon ary	Renal	Cardiac	Hypers ensitivit y
Actinomycin	Actinomycin ^a	Actinomycin ^a	Actinomycin	Ara-C ^a	Arsenic trioxide	Asparaginase	Daunorubicin	Arsenic trioxide	5-Azacytidine	Arsenic trioxide	Asparaginase ^a
Asparaginase	Alemtuzumab	Ara-C	Amsacrine	Asparaginase	Asparaginase	Azathioprine	Doxorubicin	ATRA ^a	Bevacizumab	Cyclophosphamide	Bleomycin
Arsenic trioxide	Alkylating agents	Busulfan	Ara-C	Bortezomib ^a	Ara-C	Ara-C	DTIC	Ara-C ^a	Carboplatin	Desatinib	Denileukin diftitox ^a
Ara-C	Asparaginase	Bleomycin	Bleomycin	Busulfan	Denileukin diftitox	BCNU	Epirubicin	Azathioprine	Cisplatin	Daunorubicin	Docetaxel
Azacytidine	Ara-C ^a	Capcitabine	Busulfan	Carboplatin	Dasatinib	Busulfan	Idarubicin ^a	Bleomycin ^a	Cladribine	Doxorubicin	Etoposide
Bortezomib	Azacytidine	Cyclophosphamide	Cyclophosphamide	Cisplatin ^a	Doxorubicin	Clofarabine	Mechlorethamine	Busulfan	Fludarabine ^a	Epirubicin	Monoclonal antibodies
Carboplatin	Bendamustine	Daunorubicin ^a	Cytarabine	Cladribine	Fludarabine	Cytarabine	Mitomycin ^a	Chlorambucil	Gemcitabine	Fluorouracil	HMM
Carmustine ^a	Bortezomib	Docetaxel	Daunorubicin	Fludarabine	Fluorouracil	Dactinomycin	Mitomycin ^a	Cyclophosphamide	Ifosfamide ^a	Idarubicin ^a	Paclitaxel

	I ^a					de					
Cisplatin ^a	Busulfan ^a	Doxorubicin ^a	Docetaxel	Fluorouracil ^a	HMM	DTIC	Vinblastine ^a	Dasatinib	Interferon	Mitoxant	Teniposide
Cyclophosphamide ^a	Carboplatin	Epirubicin	DTIC	Gemcitabine	Idarubicin	Gemcitabine ^a	Vincristine ^a	Etoposide	Methotrexate	Trastuzumab	
Daunorubicin ^a	Chlorambucil ^a	Etoposide	Doxorubicin	HMM	Imatinib	Interferon	Vinorelbine ^a	Fludarabine	Mitomycin		
Decitabine	Cladribine	Fludarabine ^a	Etoposide	Ifosfamide ^a	Irinotecan ^a	Interleukin-2		Gemcitabine	Nitrosoureas		
Denileukinfiditox	Clotarabine	Hydroxyurea	Fluorouracil	Interferon	Methotrexate	L-Asparaginase ^a		Ifosfamide	Pentostatin		
Doxorubicin ^a	Cyclophosphamide ^a	Fluorouracil	Hydroxyurea	L-Asparaginase ^a	Thioguanin	Imatinib		Irinotecan	Sorafenib		
DTIC ^a	Daunorubicin ^a	Idarubicin	Idarubicin	Lenalidomide	Topotecan ^a	Interferon ^a		Lenalidomide	Streptozocin ^a		
Epirubicin	Decitabine	Ifosfamide	Ifosfamide	Methotrexate		Mercaptopurine		Mercaptopurine	Sunitinib		
Etoposide	Docetaxel ^a	Methotrexate ^a	Irinotecan	Nitrosoureas		Methotrexate ^a		Methotrexate ^a	Carboplatin		
Fludarabine	Doxorubicin ^a	Mercaptopurine	Methotrexate	Nelarabine		Paclitaxel		Melphalan	Cisplatin		
Fluorouracil	DTIC ^a	Mitomycin	Mitoxant	Oxaliplatin ^a		Mitomycin		Mitomycin ^a	Cladribine		
Gemcitabine	Etoposide ^a	Mitoxant	Mustard	Paclitaxel ^a		Nitrosoureas		Nitrosoureas ^a	Fludarabine ^a		
HMM ^a	Fludarabine ^a	Nitrosoureas	Nitrosoureas	Pentostatin		Sunitinib		Oxaliplatin	Gemcitabine		
Imatinib mesylate	Hydroxyurea ^a	Paclitaxel	Paclitaxel	Procabazine		Thioguanine		Procabazine			
Hydroxyurea	Ibitumomab	Procabazine	Procabazine	Rituzumab		Tretinoin		Paclitaxel			
Idarubicin	Idarubicin ^a	Taxotere	Vinblastine	Thalidomide ^a				Thalidomide			
Ifosfamide	Ifosfamide ^a	Thioguanine	Vincristine	Tretinoin				Vinca alkaloids			

Interferon	Interferon	Thiotepa (high-dose)	Vinorelbine	Vinblastine ^a
Irinotecan	Irinotecan	Vinblastine	Vincristine ^a	
Mechlorethamine ^a	Lenalidomide	Vincristine	Vinorelbine ^a	
Methotrexate	L-PAM ^a			
Mitomycin	Methotrexate			
Mitoxantrone	Mercaptopurine ^a			
Mustard ^a	Mitomycin ^a			
Nitrosoureas	Mitoxantrone ^a			
Irinotecan	Mustard ^a			
Pentostatin	Nelarabine			
Procarbazine	Nitrosoureas ^a			
Romidesonin	Paclitaxel ^a			
Streptozocin ^a	Pentostatin			
Thioguanine	Procarbazine			
Thiotepa	Romidesonin			
Topotecan	Teniposide ^a			
Vorinostat	Thioguanine			
	Thiotepa			
	Tositumomab			
	Vinblastine			
	Vinorelbine			

ne

Vorinostat

Ara-C, cytosine arabinoside; ATRA, all-*trans* retinoic acid; DTIC, decarbazine; HMM, hexamethylmelamine; l-PAM, L-phenylalanine mustard.

^aMajor toxicity.

TABLE 68.2 EMETIC POTENTIAL OF SELECTED ANTINEOPLASTIC AGENTS

High (>90% risk)

Carmustine	Dactinomycin
Cisplatin	Mechlorethamine
Cyclophosphamide (>1.5 mg/m ²)	Streptozocin
Dacarbazine	

Moderate (30-90% risk)

Alemtuzumab	Doxorubicin
Azacytidine	Epirubicin
Bendamustine	Idarubicin
Carbazitaxel	Ifosfamide
Carboplatin	Irinotecan
Clofaribine	Methotrexate (>250 mg/m ²)
Cyclophosphamide (>1.5 g/m ²)	Oxaliplatin
Cytarabine (>1 g/m ²)	Pralatrexate
Daunorubicin	Temozolomide

Low (10-30% risk)

Bortezomib	Mitomycin
Cytarabine (<1 g/m ²)	Mitoxantrone
Docetaxel	Paclitaxel
Eribulin	Panitumumab
Etoposide	Pegylated liposomal doxorubicin
5 Fluorouracil	Pemetrexed
Chlorambucil	Romidesin
Gemcitabine	Temsirolimus
Ixabepilone	Topotecan
Hydroxyurea	Trastuzumab
Melphalan	Vorinostat
Methotrexate (<250 mg/m ²)	

Minimal (<10% risk)

Bevacizumab	2-Chlorodeoxyadenosine
-------------	------------------------

Bleomycin	Fludarabine
Busulfan	Rituximab
Cetuximab	Vinca alkaloids

Bioavailability, the percentage of a dose of drug that reaches the plasma compartment, defines drug absorption (Fig. 68.7). Drugs given intravenously have, by definition, 100% bioavailability. Factors that decrease the bioavailability of orally administered drugs include poor solubility in aqueous solutions or metabolism of the drug by the intestine or liver before entry into the systemic circulation (first-pass effect). Bioavailability of poorly soluble drugs, such as etoposide, decreases at high oral drug doses.³² Bioavailability of orally administered 6-mercaptopurine (6-MP) and 5-fluorouracil is low because of extensive first-pass hepatic drug metabolism.^{33, 34} With poor or widely variable bioavailability of a particular agent, an intravenous route of administration is preferred. The most important factor regarding bioavailability is the variation from patient to patient in the amount of oral drug absorbed (coefficient of variation). If bioavailability of an oral anticancer drug were 50% in all patients, simply doubling the drug dose would produce an equivalent response to intravenously administered drug. However, the variation from patient to patient in the AUC achieved is usually greater with oral than with intravenously administered drug.³⁵ Therefore, variation in toxicity is also greater.

After a drug reaches the bloodstream, it is distributed into tissues. Figure 68.8 illustrates a plasma concentration-versustime curve for a drug with a typical two-phase (distribution and elimination) decline in plasma concentration. Distribution may be affected by drug binding to plasma proteins (usually albumin or α_1 -acid glycoprotein). Only free drug is biologically active. Decreasing the amount of bound drug by having a low serum albumin concentration or displacing drug from its binding site may increase toxicity (as seen with etoposide).³⁶ Distribution of drug into a "third space," such as ascites or a pleural effusion, may slow clearance and increase toxicity, as is noted with MTX.³⁷

Clearance is expressed as the volume of biologic fluid (usually plasma) from which a drug can be removed per unit of time. Clearance of most drugs is constant over a range of plasma concentrations, which means that the mechanism for elimination is not saturated. However, some drugs, such as paclitaxel, demonstrate saturable elimination at high plasma concentrations.³⁸ This means that a greater proportional drug effect is noted when high drug doses are employed. Clearance measurements allow physicians to maintain a particular plasma concentration because the dosage rate = clearance \times desired plasma concentration.

Removal of drugs from the circulation occurs primarily by metabolism, renal elimination, or hepatic excretion. If urinary excretion is an important route of elimination, renal failure results in slower removal of the drug from the body. Administration of the usual dosage of a drug cleared by the kidney to a patient with renal insufficiency leads to greater drug accumulation and an increased likelihood of toxicity. In such cases, drug dosage needs to be modified to prevent excess toxicity. Using available data on drug clearance, the appropriate dose in renal insufficiency may be calculated as follows: Dose in renal insufficiency = normal dose \times (clearance in renal insufficiency \div normal clearance)

In contrast to a predictable decline in renal drug clearance when glomerular filtration is reduced, it is not possible to make a general prediction of the effect of liver disease on hepatic biotransformation of drugs. Even in advanced hepatocellular disease, the magnitude of impairment in drug clearance usually is only two- to fivefold. The extent of such changes cannot be predicted by common tests of liver function. Consequently, even when it is suspected that drug elimination is altered in liver disease, there is no quantitative base on which to adjust the dosage regimen other than assessment of clinical response. Antineoplastic drugs for which dose modifications are indicated for renal or hepatic insufficiency are listed in Table 68.3.

The hepatic metabolism of drugs may be altered by genetic deficiency of a metabolizing enzyme or by inhibition of metabolism by another drug. Pharmacogenomics is the study of how a particular patient's genetic makeup affects drug metabolism. It is now recognized that some patients inherit a mutated gene which produces an inactive or much less active enzyme important in clearing a drug from the body.³⁹ Such patients have a markedly lower drug clearance and a higher incidence of toxicity. Examples include the inherited deficiencies of dihydropyrimidine dehydrogenase, the enzyme that degrades 5-fluorouracil⁴⁰; UGT1A1, the enzyme that inactivates irinotecan⁴¹; and thiopurine methyltransferase, the enzyme that degrades azathioprine and 6-MP.⁴²

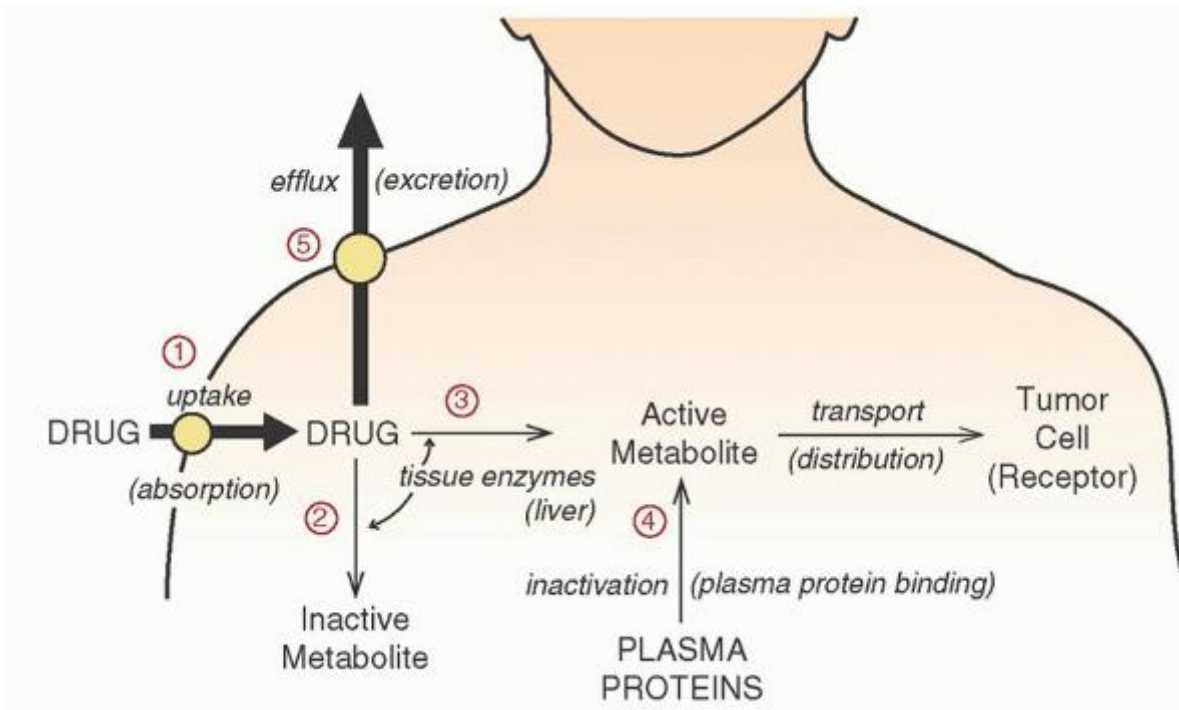

FIGURE 68.6. Schematic representation of drug disposition in the body. For a drug to function, it must be taken into the body (1) and the drug must avoid being cleared from the body by metabolism (2) or excretion (5). It must reach its site of action in active form (3), without being inactivated by protein binding (4).

Certain antineoplastic drugs are metabolized by the hepatic P-450 microsomal enzyme system (vincas, epipodophyllotoxins, cyclophosphamide, tyrosine kinase inhibitors, and the taxanes). The activity of the microsomal enzyme systems may be increased with concomitant use of phenobarbital, phenytoin, or other drugs. Use of anticonvulsants has been shown to increase the catabolism of teniposide, a drug eliminated from the body through hepatic microsomal metabolism.⁴³ Clearance of drugs metabolized by the hepatic P-450 enzyme system, such as paclitaxel or Taxotere, can be decreased with concomitant use of P-450 inhibitors, such as ketoconazole or selected antiretroviral agents.

It is important to recognize the unpredictable variation in the way chemotherapeutic drugs are handled by the body. Mean values for bioavailability, clearance, and volume of distribution of anticancer agents have standard deviations of 20%, 50%, and 30%, respectively. This means that target drug concentrations may vary widely from patient to patient, even those whose renal and hepatic function appears similar. This is particularly important for drugs with a low therapeutic index and necessitates that all patients receiving chemotherapy must be carefully monitored.

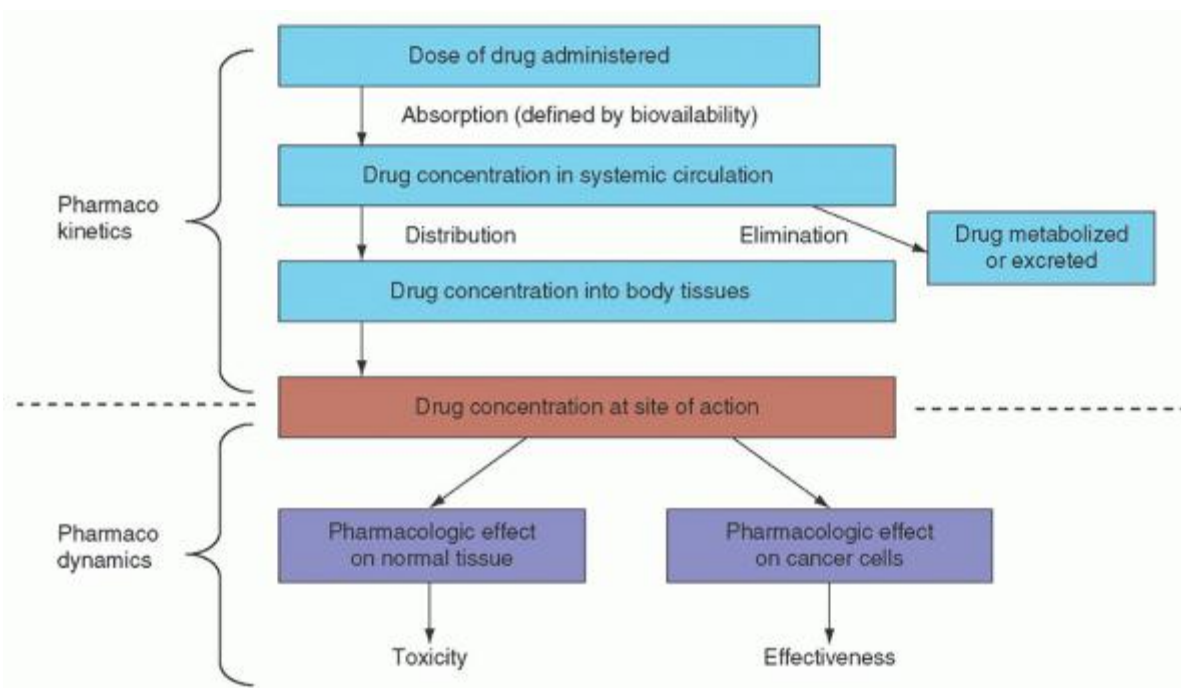

FIGURE 68.7. Pathway of a drug administered to a patient. Pharmacokinetics describes what the patient's body does to a drug. Pharmacodynamics describes what the drug does to the patient's tissues or cancer cells.

Approach to the Patient with Cancer

Before initiating cancer chemotherapy, a physician should (a) verify the accuracy of the diagnosis, (b) understand the natural history of the illness, and (c) identify, with the patient, the goals of therapy. Verification of the diagnosis, in nearly every case, requires histologic documentation of cancer. Once the diagnosis is established, the physician and patient must decide whether cure is possible or palliation is the optimal goal. If cure is the goal, the patient and physician may be willing to tolerate more severe toxicity. The patient must be a partner in such decisions. In many cases, several options may be reasonable and an informed patient can direct the physician as to whether intensive, potentially toxic therapy should be tried for a relatively small chance of cure.^{44, 45}

P.1406

Fortunately, curative therapy, even for disseminated disease, is available for many hematologic malignancies, including Hodgkin and non-Hodgkin lymphomas, and acute and chronic leukemia. In some illnesses, such as chronic lymphocytic leukemia and low-grade lymphomas, curative therapy may not be available, but the disease is often indolent. A discussion of these illnesses and their natural histories can reassure patients and help them understand why chemotherapy is not being immediately initiated. If high-dose, aggressive curative chemotherapy is planned, patients and their families need to be aware of anticipated and potential toxicities.

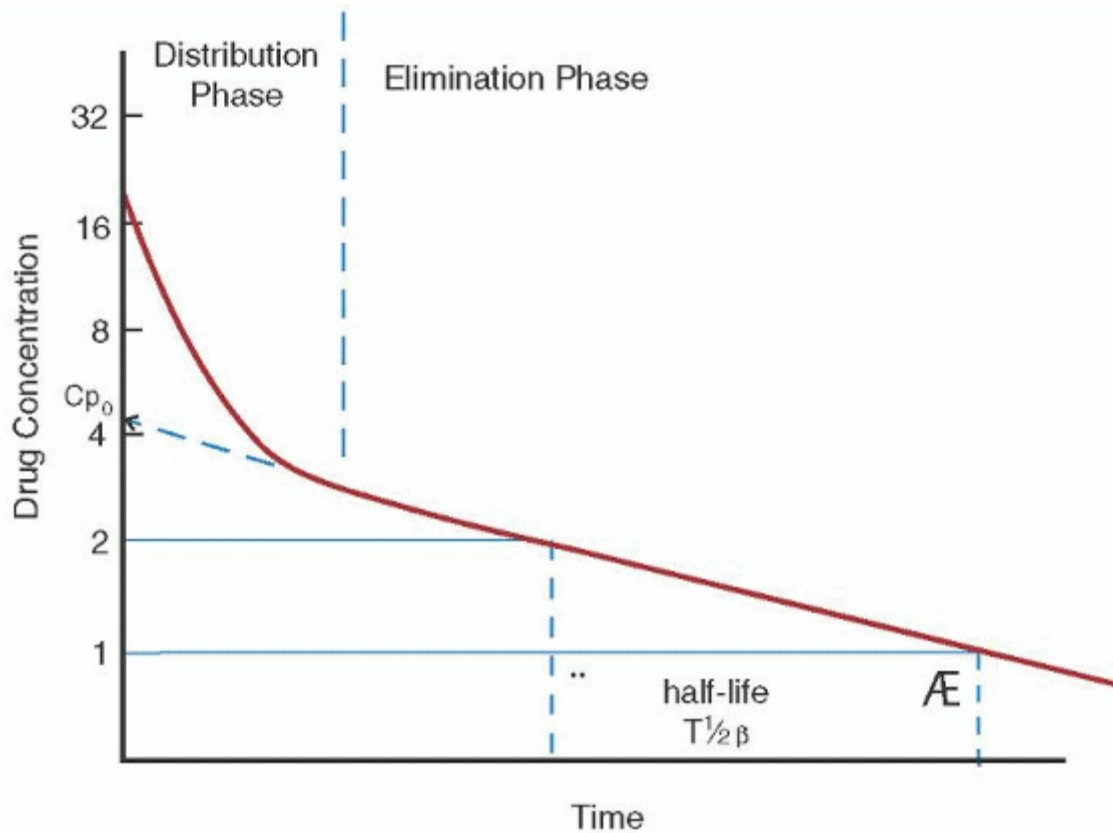

FIGURE 68.8. Plasma concentrations of a typical drug at various times following intravenous administration. Following an early distribution phase, drug concentrations decrease in a log-linear manner. C_{p0} is the hypothetical drug plasma concentration at time zero if equilibrium were achieved instantaneously. The drug's half-life is the time required for its concentration to decrease by half.

TABLE 68.3 DRUGS REQUIRING DOSE ALTERATIONS FOR ORGAN TOXICITY

Nephrotoxicity	Hepatic Toxicity
Arsenic trioxide	Bortezomib
Bleomycin	Cytarabine
Capecitabine	Daunorubicin ^a
Carboplatin ^a	Doxorubicin ^a
Cisplatin ^a	Docetaxel ^a
Cladribine	Epirubicin ^a
Cyclophosphamide (if CrCl < 20 ml/min)	Etoposide
Daunorubicin ^a	Everolimus
Deoxycoformycin	5 Fluorouracil
Etoposide	Idarubicin
Fludarabine	Imatinib
Hydroxyurea	Irinotecan ^a
Ifosfamide	Ixabepilone
Irinotecan	Nilotinib

Lenalidomide	Paclitaxel ^a
Methotrexate ^a	Procarbazine
Mithramycin	Temsirolimus
Mitomycin ^a	Vinblastine ^a
Nitrosoureas ^a	Vincristine ^a
Oxaliplatin (if CrCl < 20 ml/min)	Vinorelbine ^a
Pemetrexede	
Pentostatin	
Sorafenib	
Streptozocin	
Topotecan ^a	
Vandetanib	

^a Major dose adjustment.

The use of chemotherapy for treatment of an individual requires a detailed knowledge of the patient, including his or her medical and psychological status, specific knowledge of the drugs to be used, and the availability of appropriate laboratory and hospital support services. Combination chemotherapy (use of several drugs simultaneously) is usually employed and multiple cycles of drugs administered to achieve adequate tumor cell kill without life-threatening toxicity or the development of tumor cell resistance. Certain patient selection factors are important in planning treatment. Age alone is seldom a reason to exclude patients from chemotherapy.⁴⁶ However, age-related changes in organ function, including reduced marrow reserve, abnormal liver function tests, and decreased renal function, are commonly seen and may increase the risk of toxicity. The performance status of a patient (either Karnofsky or American Joint Committee on Cancer scale) usually correlates with response and tolerance to chemotherapy (Table 68.4).

The nutritional state of a patient is important. Malnourished patients with hypoalbuminemia may have increased toxicity when highly protein-bound drugs are used.³⁶

Guidelines for dosing of chemotherapy drugs in obese patients have been developed.⁴⁷ Doses based on actual body weight are generally recommended, as myelosuppression is the same or less pronounced in the obese than the non-obese cancer patient given full-weight-based doses. Fixed dosing of carboplatin, vincristine, and bleomycin is appropriate. Altered organ function may eliminate the opportunity to use certain drugs (e.g., doxorubicin in patients with heart failure or bleomycin in patients with severe pulmonary toxicity). Drug doses may require modification for decreases in blood counts (Table 68.5) and also for changes in renal and hepatic function (see General Pharmacologic Principles).

It is common to re-evaluate patients after two to four cycles of chemotherapy to determine treatment effectiveness. If a response is seen, therapy is usually continued for a set number of courses or two cycles past a complete response. If tumor progression is noted, therapy should generally be discontinued. For patients with stable disease, an assessment of drug toxicity is important. If therapy is tolerable, a decision to continue treatment is reasonable, with the understanding that disease progression will eventually occur. Physicians administering potentially toxic chemotherapy must make certain that they have appropriate monitoring and support facilities available for their patients in the event of untoward toxicity.

DRUGS USED TO TREAT CANCER

A comprehensive review of the pharmacology of all chemotherapeutic agents is beyond the scope of this chapter. This section focuses on those agents most commonly used in the therapy of hematologic malignancies. Important information necessary for the optimal use of these drugs requires knowledge of their (a) mechanism of action; (b) pharmacology, including bioavailability, routes of elimination, and important drug interactions; and (c) toxicities. Table 68.6 summarizes this information for the majority of antineoplastic agents. A more detailed review of the agents commonly used to treat hematologic malignancies follows.

TABLE 68.4 KARNOFSKY AND AMERICAN JOINT COMMITTEE ON CANCER (AJCC) PERFORMANCE STATUS SCALES

Karnofsky Description	Karnofsky Scale (%)	AJCC Scale	AJCC or ECOG Description
Normal; no complaints; no evidence of disease		1000	Normal activity
Able to carry on normal activity; minor signs or symptoms of disease	90		
Normal activity with effort; some signs or symptoms of disease	80	801	Symptomatic and ambulatory; cares for self
Cares for self; unable to carry on normal activity or to do active work	70		
Requires occasional assistance but is able to care for most of own needs	60	602	Ambulatory >50% of time; occasionally needs assistance
Requires considerable assistance and frequent medical care	50	503	Ambulatory 50% or less of time; nursing care needed less of time
Disabled; requires special care and assistance	40		
Severely disabled; hospitalization indicated although death not imminent	30		
Very sick; hospitalization necessary; active supportive treatment necessary	20	204	Bedridden; may need hospitalization
Moribund, fatal processes progressing rapidly	10		
Dead	0		

Alkylating Agents (Actinomycin-D, Bendamustine, Busulfan, Chlorambucil, Cyclophosphamide, Dacarbazine, Hexamethylmelamine, Ifosfamide, Melphalan, Mechlorethamine, Mitomycin C, Nitrosoureas (BCNU, CCNU), Procarbazine, Streptozocin, Temozolomide, Thiotepea)

Mechanism of Action

Alkylating agents covalently bind alkyl groups (one or more saturated carbon atoms) to cellular molecules, including DNA, RNA, and proteins. Alkylating agents form reactive carbonyl groups in plasma and within tissues. Attack at electron-rich sites on adenine or guanine (S_N1 agents) in DNA is the primary mechanism for cytotoxicity.⁴⁸ The pattern of DNA lesions generated by an alkylating agent depends on the number of reactive sites within the alkylating agent, its particular reactivity, the type of alkyl group addition (methyl or chloroethyl) and the DNA substrate (double- or single-strand). Many alkylating agents (bendamustine, chlorambucil, cyclophosphamide, ifosfamide, mustard, melphalan) contain two reactive nitrochloroethyl groups, which allow them to react with both strands of DNA, forming cross-linkage (Fig. 68.9). Other agents (procarbazine, dacarbazine, temozolomide) produce single-strand alkylation. Most alkylators preferentially attack the N^7 position of guanine. Nitrosoureas, procarbazine, and dacarbazine (DTIC) attack the O^6 position. Depending on the site of DNA binding, the base adducts produced by alkylating agents block DNA replication and transcription, leading to cell death. However, alkylating agents may also compromise genome integrity, inducing mutagenesis. Alkylating agents are cell cycle-nonspecific.

TABLE 68.5 GENERALIZED DOSE ADJUSTMENT GUIDELINES FOR HEMATOLOGIC TOXICITY^a

	100% Dose	75% Dose	50% Dose	Omit
--	------------------	-----------------	-----------------	-------------

Granulocyte	>2,000	1,500-1,999	1,000-1,499	<1,000
White blood cell	>3,500	3,000-3,500	2,500-2,999	<2,500
Platelet	>100,000	75,000-100,000	50,000-75,000	<50,000

“In selected circumstances, such as the treatment of leukemia, these guidelines do not apply. Specific guidelines accompanying individual protocols should be sought.

There are multiple enzymes that have been identified that can repair the genomic damage caused by alkylating agents.⁴⁸ An example is the repair of alkylation sites on DNA by O⁶ methyl transferase; the overexpression of this enzyme in a cancer cell produces resistance to nitrosoureas but not to nitrogen mustard or cyclophosphamide.⁴⁹ An imbalance of any one repair enzyme can increase or decrease the alkylation sensitivity of a cell. Inhibitors of DNA-repair enzymes (such as Poly ADP ribose polymerase or PARP) may increase cell sensitivity to alkylating agents.

The most widely used alkylating agents in hematology are the nitrogen mustards: mechlorethamine, cyclophosphamide, ifosfamide, melphalan, and chlorambucil. Thiotepa is an aziridine that is closely related to the mustards. Busulfan is an alkyl sulfonate that has a poorly understood selective toxicity for myeloid precursors. Procarbazine and DTIC are metabolized to reactive intermediates that decompose to produce methyl diazonium, which covalently binds DNA. The basis of cytotoxicity of these nonfunctional alkylating agents is probably the formation of DNA strand breaks and inhibition of DNA polymerase.⁵⁰ Bendamustine, a recently FDA-approved alkylating agent for treatment of chronic lymphocytic leukemia and lymphomas, regulates different genes compared to other alkylating agents.⁵¹ It is not cross resistant with other alkylators and is effective against both quiescent and dividing cells. It produces more durable and extensive DNA double-strand breaks than do cyclophosphamide or melphalan.

Cellular thiols can provide nucleophilic targets, which bind alkylating agents before they reach their DNA target. Increasing or decreasing the concentration of thiols can decrease or increase antineoplastic drug activity and/or toxicity. Buthione sulfonamide (BSO) decreases glutathione synthesis (a naturally occurring thiol) and increases alkylating agent cytotoxicity.⁵² Amifostine (WR2721) provides an exogenous nucleophilic thiol that can decrease alkylating agent toxicity.⁵³

P.1408

TABLE 68.6 CHEMOTHERAPEUTIC AGENTS (EXCLUDING HORMONAL AGENTS)

Name (Synonym)	Drug Class	Action	Clearance Route^a	Major Toxicity
Alemtuzumab (Campath [®])	Radioactive monoclonal antibody	Binds to CD ₅₂ to target radioactivity	Radioactive extinction	Myelosuppression Hypersensitivity reaction Infection
Altretamine (Hexalen [®] , hexamethylmelamine)	Nonclassical alkylating agent	Unknown, may alkylate DNA	Hepatic metabolism	Hypersensitivity reaction, deficient synthesis of key proteins (clotting factors, insulin), CNS depression, pancreatitis
Anagrelide (Agraylin [®])	Phospholipase inhibitor	Prevents megakaryocytes from maturing	Metabolism via CYP/A2	Palpitations, headache, nausea, abdominal pain, dizziness
Arsenic trioxide (Trisenox [®] , ATO)	Targeted drug	Degrades PML-RAR fusion protein	Hepatic metabolism	APL differentiation syndrome, Q-T prolongation, nausea,

Asparaginase (Elspar [®] , Oncaspar [®] , pegasparaginase)	Enzyme	Breaks down the amino acid asparagine; sensitive lymphocytes lack ability to synthesize asparagine	Hepatic metabolism	fatigue N&V, neurotoxicity, myelosuppression, diarrhea, diabetes, anticoagulation
Azacitidine (Vidaza [®])	Hypomethylating agent	Inhibitor of DNA methylation	Hepatic metabolism	Myelosuppression
Bexarotene (Targretin [®])	Retinoid	Binds to the retinoid X receptor to induce cellular differentiation	Oxidative hepatic metabolism	Hepatotoxicity, hyperlipidemia, hypothyroidism, photosensitivity, teratogenicity
Bendamustine (Trenda [®])	Alkylating agent	Forms DNA cross-links	Hydrolysis in plasma to inactive metabolites	Nausea, fatigue, myelosuppression, fever
Bevacizumab (Avastin [®])	Monoclonal antibody to VEGF	Decreases angiogenesis	Protein degradation	Hypertension, headache, bleeding, thrombosis, proteinuria
Bleomycin (Blenoxane [®])	Antibiotic	Single-strand DNA breaks	Renal	Hypersensitivity reaction, pulmonary fibrosis, skin and mucocutaneous reactions, fevers
Bortezomib (Velcade [®])	Proteasome inhibitor (targeted agent)	Inhibits protein destruction blocking NFK- β	Oxidative hepatic metabolism	Nausea, fatigue, diarrhea, peripheral neuropathy, thrombocytopenia
Brentuximab vedotin	Monoclonal antibody	Binds with CD30 antigen with toxin then internalized	Hepatic	Hypersensitivity reaction, neuropathy, fatigue, fever, diarrhea, neutropenia
Busulfan (Myleran [®] , Busulfex [®])	Alkylating agent	Forms DNA cross-links.	Metabolism	Myelosuppression, hepatotoxicity (venoocclusive disease), pulmonary fibrosis
Capecitabine (Xeloda [®])	Antimetabolite	A 5-FU prodrug	Hepatic metabolism	Diarrhea, myelosuppression, palmar-plantar erythrodysesthesia

Carboplatin (CBDCA, Platinum complex Paraplatin [®])		Produces DNA cross-links	Renal	Thrombocytopenia, leukopenia, nephrotoxicity, ototoxicity, neuropathy, N&V
Carmustine (BCNU)	Nitrosourea	Alkylates DNA at O ⁶ position of guanine	Hepatic metabolism	Delayed (4-6 wk) myelosuppression, pulmonary toxicity, hepatotoxicity
Cetuximab (Erbix [®])	Monoclonal antibody	Binds to the epidermal growth factor receptor	Binding of antibody to receptor	Anaphylactic reaction, skin rash, fevers
Chlorambucil (Leukeran)	Alkylating agent	Cross-links DNA	Metabolism	Myelosuppression, pulmonary toxicity, hepatotoxicity
Cisplatin (CDDP) (Platinol [®])	Platinum complex	Produces DNA cross-links	Protein binding	Nephrotoxicity, N&V, ototoxicity, alopecia, neuropathy
Cladribine (Leustatin [™]) (2-chlorodeoxy adenosine)	Antimetabolite (purine analog)	Incorporation into DNA; NAD consumption	Renal	Myelosuppression, fever, renal toxicity (high-dose)
Clofarabine (Clolar [®])	Antimetabolite	Incorporates into DNA; inhibits DNA polymerase	Renal	Nausea, hepatotoxicity, palmar-plantar erythrodysesthesia
Cyclophosphamide (Cytosan [®] , Neosar [®])	Alkylating agent	Cross-links DNA strands	Hepatic metabolism (renal)	Myelosuppression, N&V, cystitis, cardiac (high-dose)
Cytarabine (Cytosar [®] , ara-C, cytosine arabinoside, DepoCyt [™])	Antimetabolite (pyrimidine analog)	Incorporates into DNA; inhibits DNA polymerase	Hepatic metabolism	Myelosuppression, N&V, mucositis, ocular, hepatic
Dacarbazine (DTIC)	Nonclassical alkylating agent	DNA methylation	Renal (hepatic metabolism)	Vesicant, myelosuppression, N&V, hepatic
Dactinomycin (Cosmegen [®]) (actinomycin-D)	Antibiotic	DNA intercalation	Biliary	Myelosuppression, N&V, vesicant, mucositis
Dasatinib (Sprycel [™])	Targeted agent, signal transduction inhibitor	Inhibits the tyrosine kinase of several growth factor receptors including bcr-abl	Hepatic metabolism (CYP 3A4) and biliary excretion	Fluid retention, N&V, diarrhea, myelosuppression, hypothyroidism

Daunorubicin (Cerubidine [®] , DaunoXome [®])	Antibiotic (anthracycline)	Topoisomerase inhibition, DNA intercalation, free-radical formation	Biliary excretion, hepatic metabolism	Myelosuppression, N&V, cardiomyopathy, vesicant, red urine, mucositis
Decitabine (Dacogen [®])	Hypomethylating agent	Allows activation of tumor suppressor genes	Hepatic deamination	Myelosuppression, fatigue, nausea, teratogen
Denileukin diftitox (Ontak [®])	Toxin-fusion protein	Binds to the IL-2 receptor, where the diphtheria toxin is internalized	Proteolytic degradation	Infusion reactions (fever, hypotension, myalgias), skin rash, transaminitis, vascular leak syndrome, hypothyroidism
Docetaxel (Taxotere [®])	Tubulin binder	Mitotic spindle inhibitor	Hepatic metabolism, biliary excretion	Myelosuppression, hypersensitivity (steroids needed), fluid retention, neuropathy
Doxorubicin (Adriamycin [®] , Rubex [®] , Myocet [™] , Doxil [®])	Topoisomerase inhibitor (Anthracycline)	Topoisomerase inhibition, free-radical formation	Biliary excretion, hepatic metabolism	Myelosuppression, N&V, cardiomyopathy, vesicant, red urine, mucositis
Epirubicin (Ellence [™])	Topoisomerase inhibitor (Anthracycline)	Inhibits topoisomerase II	Hepatic metabolism and excretion	Nausea, vomiting, myelosuppression, cardiac toxicity
Erlotinib (Tarceva [®])	Targeted agent	Inhibits the tyrosine kinase of the epidermal growth factor receptor	Hepatic oxidative metabolism	Skin rash, diarrhea
Etoposide (VePesid [®] , VP-16, Etopophos [®] , Toposar [®] , etoposide phosphate)	Topoisomerase inhibitor	Inhibits topoisomerase II	Renal (hepatic metabolism)	Myelosuppression, mucositis, hypersensitivity reaction
Everolimus (Affinitor [®])	Targeted therapy	Blocks oncogenic pathway through m-TOR inhibition	Hepatic metabolism through CYP3A4	Edema, rash, stomatitis, diarrhea, myelosuppression, infection
Fludarabine (fludarabine phosphate, Fludara [®])	Antimetabolite (purine analog)	Inhibits DNA polymerase, incorporation into DNA and RNA, NAD depletion	Renal	Myelosuppression, mucositis, hypersensitivity reaction, neurologic

Fluorouracil (5-FU, Adrucil [®] , FUDR [®])	Antimetabolite (pyrimidine analog)	Inhibits thymidylate synthetase, incorporated into DNA and RNA	Hepatic metabolism	Myelosuppression (more with bolus), diarrhea & mucositis (more with continuous infusion), stomatitis, cardiac ischemia, CNS (cerebellar ataxia)
Gefitinib (Iressa [®])	Targeted therapy	Block the tyrosine kinase of EGFR	Hepatic metabolism via CYP3A4	Rash, diarrhea
Gemcitabine (Gemzar [®])	Antimetabolite	Inhibits ribonucleotide reductase, incorporated into DNA as false nucleotide	Metabolism	Myelosuppression, nausea, diarrhea, hepatic, fever
Hydroxyurea (Hydrea [®] , Droxia [™] , Mylocel [™])	Antimetabolite	Inhibits ribonucleotide reductase	Hepatic metabolism, renal	Myelosuppression, mucositis
Idarubicin (Idamycin [®])	Topoisomerase inhibitor (anthracycline)	Similar to doxorubicin	Hepatic	Similar to doxorubicin
Ifosfamide (Ifex [®])	Alkylating agent	Cross-links DNA strands through alkyl groups	Hepatic metabolism, renal excretion.	Myelosuppression, N&V, neurologic, alopecia, cystitis (must be given with MESNA)
Imatinib mesylate (Gleevec [™] , STI-575)	Targeted agent	Inhibits the tyrosine kinase of the bcr-abl and c-kit oncogenes	Hepatic metabolism	Nausea, diarrhea, fluid retention, abnormal LFTs, hypothyroidism
Interferon- α (INF- α , Intron A [®] , Roferon [®])	Biologic	Degradation of messenger RNAs, modulation of oncogene expression, increase in NK cells and other immunoregulatory elements	Renal metabolism	Fever, chills, myalgias, headache, fatigue, anorexia, myelosuppression, hepatic, CNS, depression
Ibritumomab (Zevalin [™])	Monoclonal antibody	Antibody to CD20 coupled to Y ⁹⁰	Radioactive decay	Myelosuppression, allergic reactions, hypothyroidism
Irinotecan (Camptosar [®] , CPT-11)	Topoisomerase I inhibitor	Inhibits topoisomerase I	Metabolism, biliary excretion	Myelosuppression, diarrhea, pneumonitis,

				stomatitis
Lenalidomide (Revlimid [®])	Immunomodulator	Uncertain—possible TNF- α inhibitor; inhibits angiogenesis	Renal	Teratogenicity, myelosuppression, DVTs, diarrhea, fatigue
Lomustine (CeeNU [®] , CCNU)	Alkylating nitrosourea	Same as carmustine	Same as carmustine	Same as carmustine
Mechlorethamine (nitrogen mustard, Mustargen [®])	Alkylating agent	Cross-links DNA via alkylation	Tissue binding	Vesicant, ototoxicity, myelosuppression, N&V
Melphelan (Alkeran [®] , L-PAM, phenylalanine mustard)	Alkylating agent	Cross-links DNA strands via alkylation	Spontaneous degradation, protein binding	Myelosuppression, pulmonary fibrosis (rare), N&V (high-dose)
Mercaptopurine (6-MP, Purinethol [®])	Antimetabolite (purine analog)	Incorporation into DNA	Hepatic metabolism	Myelosuppression, hepatotoxicity
Methotrexate (MTX)	Antimetabolite (folic acid analog)	Inhibits dihydrofolate reductase with decreased thymidylate and protein synthesis	Renal excretion	Myelosuppression, mucositis, hepatotoxicity (chronic low-dose), renal (high-dose), pulmonary
Mitomycin (Mutamycin [®])	Antibiotic	Cross-links DNA strands	Hepatic metabolism	Myelosuppression, N&V, vesicant, pulmonary, hepatic, renal
Mitoxantrone (Novantrone [®] , DHAD)	Anthraquinone	Similar to doxorubicin	Hepatic metabolism	Similar to doxorubicin, blue-green urine
Nelarabine (Arranon [®])	Antimetabolite (purine analog)	Incorporated into DNA and blocks DNA replication	Hepatic demethylation	Neurotoxicity including somnolence, fatigue, dizziness, headache, myelosuppression
Nilotinib (Tasigna [®])	Targeted therapy	Inhibits the tyrosine kinase of BCR/ABL	Hepatic metabolism via CYP3A4	Myelosuppression, QT prolongation, N & V, hepatic toxicity, edema
Ofatumumab (Arzerra [®])	Monoclonal antibody	Binds to CD20	Proteolytic degradation	Infusion reaction, infection, myelosuppression, HBV reactivation
Oxaliplatin (Eloxatin [®])	Platinum complex	Produces DNA cross-links	Renal and tissue binding	Hypersensitivity reaction, neuropathy,

				hepatitis, pulmonary fibrosis
Paclitaxel (Taxol [®] , Abraxane [®])	Plant alkaloid	Mitotic spindle inhibitor, stabilizes microtubulin.	Hepatic metabolism, biliary excretion	Myelosuppression, hypersensitivity syndrome (use with steroids and antihistamines), mucositis, neuropathy, myalgia
Panitumumab (Vectibix [™])	Monoclonal antibody	Binds to EGFR	Proteolytic degradation	Rash, infusion reaction, diarrhea
Pazopanib (Votrient [®])	Targeted agent	Inhibits the TKI of VEGF receptors	Hepatic metabolism via CYP3A4	Hypertension, hair color change, diarrhea, myelosuppression, QT prolongation, hepatotoxicity
Pemetrexed (Alimta [®])	Antimetabolite	An antifolate that inhibits dihydrofolate reductase, and thymidylate synthetase	Renal	Myelosuppression, fatigue, N&V
Pentostatin (Nipent [®] , 2-deoxycoformycin)	Antimetabolite (purine analog)	Adenosine deaminase inhibitor.	Renal	Myelosuppression, fever, rash, hepatotoxicity, pulmonary, CNS
Prelatexate (Folotyn [®])	Antimetabolite	Inhibits DHFR (see methotrexate)	Renal	Myelosuppression, mucositis
Procarbazine (Matulane)	Nonclassical alkylating agent	Alkylates DNA; DNA strand breaks	Hepatic metabolism	Myelosuppression, N&V, CNS (confusion, depression), MAO inhibition, hepatic, pulmonary
Rituximab (Rituxan [®])	Monoclonal antibody	Binds to CD20 on lymphocytes and initiates complement-mediated cytotoxicity	Proteolytic degradation	Fevers, hypersensitivity reaction, Hepatitis B reactivation, infection
Sorafenib (Nexavar [®])	Targeted therapy	Inhibits the tyrosine kinase of VEGFR, PDGFR, c-kit, and FLT-3	Hepatic metabolism: Oxidation and glucuronidation	Fatigue, palmar-plantar erythrodysesthesia, hypertension, hyperphosphatemia, rash proteinuria

Streptozocin (Zanosar [®])	Alkylating nitrosourea	Methylation of O ⁶ -guanine of DNA	Renal	Myelosuppression, N&V, renal, diabetes, vesicant
Sunitinib (Sutent [®])	Targeted therapy	Inhibits the tyrosine kinases of VEGFR, PDGFR, c-kit; inhibits angiogenesis	Hepatic oxidative metabolism	Hypertension, bleeding, diarrhea, mucositis, fatigue
Temozolomide (Temodar [®])	Atypical alkylating agent	Methylates DNA guanine resulting in strand breaks	Metabolism by hydrolysis	Myelosuppression, N & V, fatigue
Teniposide (VM-26, Vumon [®])	Microtubulin inhibitor	Binds to topoisomerase II, causing DNA strand breaks	Hepatic metabolism	Myelosuppression, hypersensitivity reactions
Temsirolimus (Torisel [®])	Targeted agent	Inhibits m-TOR	Hepatic metabolism and biliary excretion	Edema, hyperlipidemia, myelosuppression, hepatic toxicity, hyperglycemia
Thalidomide (Thalomid [®])	Immunomodulatory agent	Suppresses TNF, blocks angiogenesis, increases IL2 and interferon	Nonenzymatic hydrolysis	Birth defects, thrombosis, fatigue, somnolence, neuropathy
Thioguanine (6-thioguanine, 6-TG, Tabloid [®])	Antimetabolite (purine analog)	Incorporates into DNA as fraudulent nucleotide	Hepatic metabolism	Myelosuppression, hepatic venoocclusive disease
Thiotepa (Thioplex [®])	Alkylating agent	Trifunctional alkylating agent, cross-links DNA	Metabolism	Myelosuppression, stomatitis
Topotecan (Hycamtin [®])	Topoisomerase I inhibitor	Inhibits the enzyme topoisomerase I, causing DNA stand breaks	Renal	Myelosuppression, N&V
Tositumomab (Bexxar [®])	Monoclonal antibody	Radioactive drug that binds to CD20	Proteolytic degradation	Myelosuppression, fever, nausea, hypersensitivity reaction
Trastuzumab (Herceptin [®])	Monoclonal antibody	Binds to the Her2 ^{neu} oncogene, resulting in apoptosis	Protein binding and proteolytic degradation	Hypersensitivity reaction, cardiomyopathy, fever, diarrhea
Tretinoin (ATRA, Vesanoind [®])	Targeted retinoid therapy	Induces maturation of promyelocytes	Hepatic oxidative metabolism and	Fever, dyspnea, pulmonary infiltrates (retinoic acid)

				glucuronidation syndrome), headache, fever, neurologic, hepatic
Venmurafanib (Zelboraf [®])	Targeted agent	Inhibits the tyrosine kinase of the BRAF oncogene	Hepatic metabolism	Rash, erythema, squamous cell skin cancers, photosensitivity, abnormal LFTs, fatigue
Vinblastine (Velban [®] , VLB)	Microtubulin inhibitor	Binds to tubulin, prevents formation of mitotic spindle	Hepatic	Myelosuppression, vesicant, neurotoxin
Vincristine (Oncovin [®] , Vincasar [®] , VCR)	Microtubulin inhibitor	Binds to tubulin, prevents formation of mitotic spindle	Hepatic	Neurotoxin, vesicant, CNS
Vinorelbine (Navelbine [®])	Microtubulin inhibitor	Binds to tubulin, prevents formation of mitotic spindle	Hepatic	Myelosuppression, vesicant, neuropathy
Vismodegib (Erivedge [®])	Targeted agent	Inhibits the Hedgehog signaling pathway	Hepatic metabolism and excretion	Teratogenic, fatigue, muscle spasms, diarrhea, alopecia
Vorinostat (Zolinza [®])	Histone deacetylase inhibitor	Inhibits histone deacetylase to unmask DNA methylation	Hepatic	Fatigue, diarrhea, N&V pulmonary emboli

P.1409

P.1410

P.1411

Clinical Pharmacology

Binding of alkylating agents or their reactive intermediates to sulfhydryl groups on glutathione or proteins is the primary route of drug clearance. Dosage alterations for hepatic or renal function impairment are usually not needed.

Mechlorethamine rapidly degrades in solution and must be reconstituted just before administration. Cyclophosphamide and ifosfamide require activation via the cytochrome P-450 system to produce 4-hydroxy derivatives, which are taken up in tumor tissue⁵⁴ and decompose to form the active metabolite, phosphoramidate mustard (Fig. 68.10). Drugs that alter the microsomal enzyme system, such as phenobarbital, can alter the plasma kinetics of cyclophosphamide and its metabolites. However, these kinetics changes do not appear to affect the toxicity of this drug. Ifosfamide, a structural analog of cyclophosphamide, is activated less readily than cyclophosphamide, so higher drug doses are required.⁵⁵ Although only a small amount of a dichlorethyl metabolite is formed with cyclophosphamide,

P.1412

this metabolite is generated to a significant extent with ifosfamide and may account for the central nervous system (CNS)

toxicity seen with this drug. The release of acrolein and dichlorethyl metabolites into the bladder results in cystitis with both cyclophosphamide and ifosfamide. Mercaptoethane sulfonate (MESNA) is administered to all patients receiving ifosfamide and to patients receiving high-dose cyclophosphamide. MESNA binds to reactive urinary metabolites of these alkylating agents and prevents cystitis.⁵⁶ In plasma, MESNA circulates in an inactive dimesna form so that antineoplastic activity is not altered. Oral bioavailability of cyclophosphamide is excellent, whereas the bioavailability of melphalan (30%) and chlorambucil (50%) are reduced and variable. The AUC of melphalan is reduced by concomitant use of cimetidine.⁵⁷

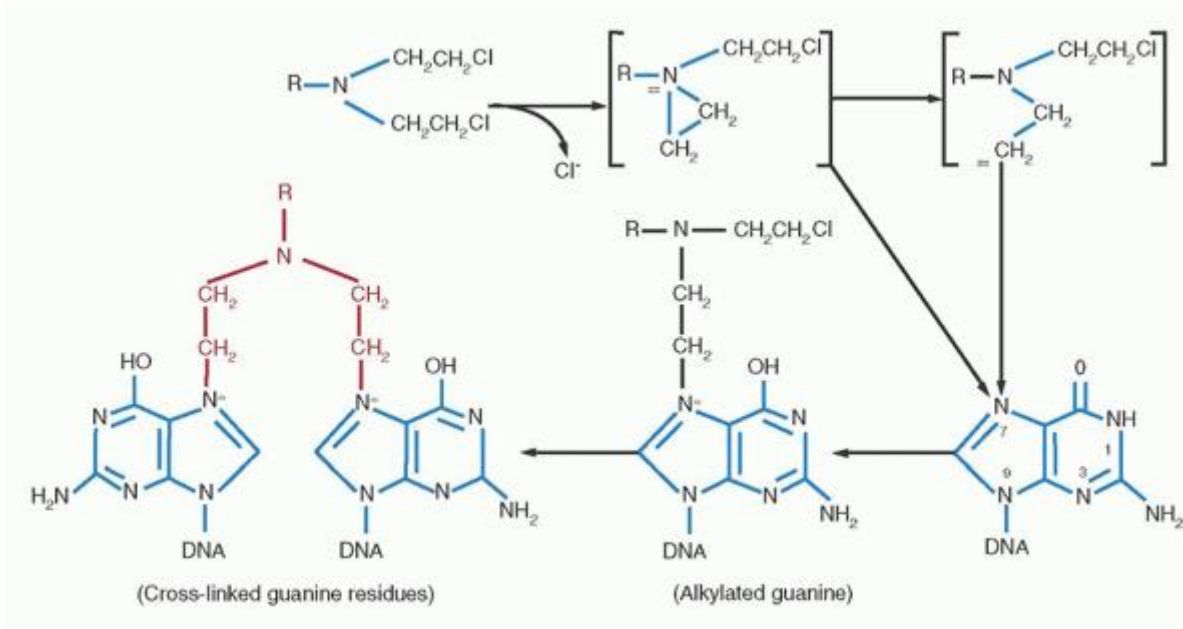

FIGURE 68.9. Mechanism of attachment of alkylating agents to DNA. Alkylating agents (in this case, those with two nitrochloroethyl groups) form reactive intermediates that bind to the N7 position of guanine. Bifunctional alkylating agents can bind to two guanine molecules, resulting in cross-linkage of DNA strands.

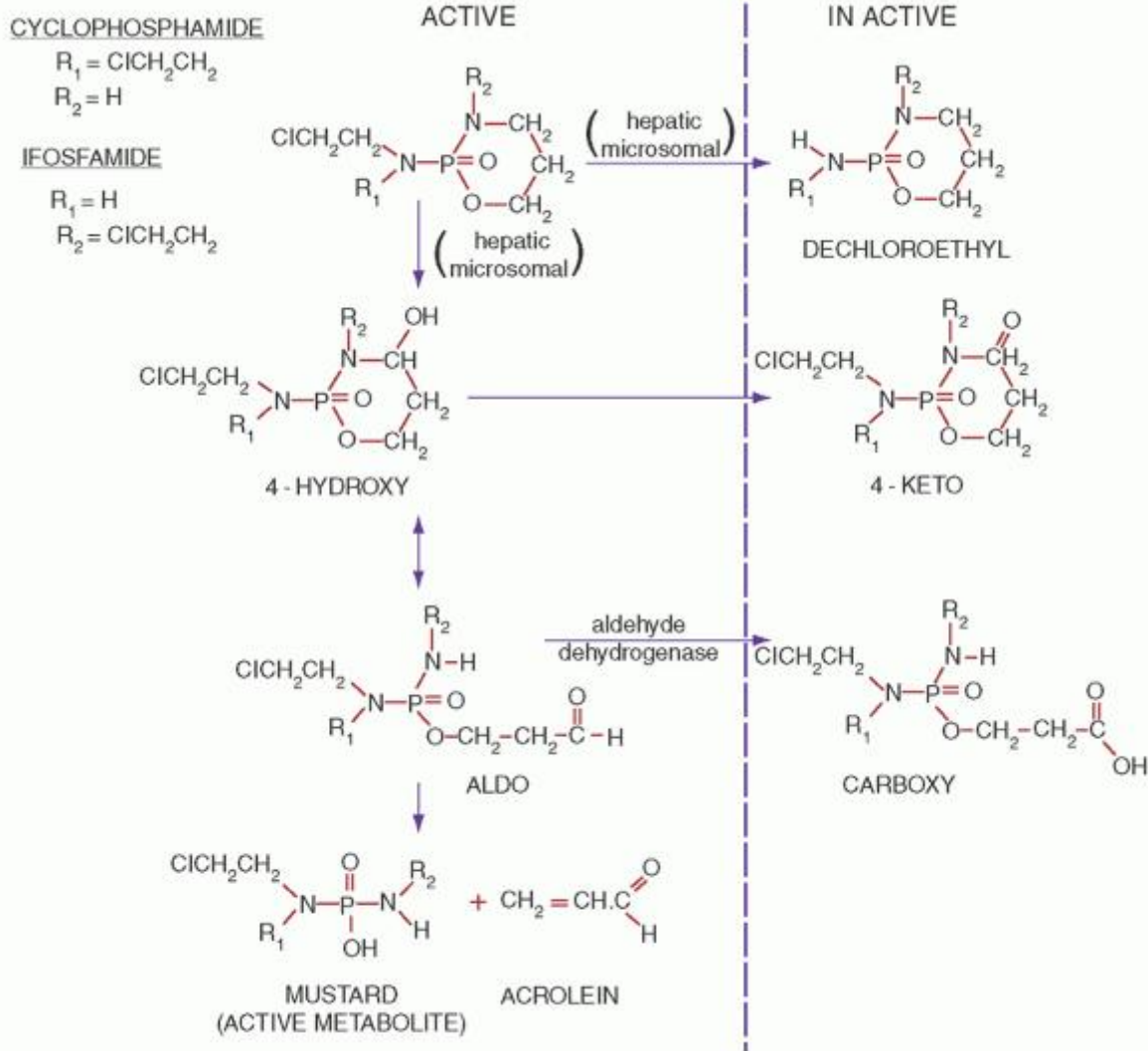

FIGURE 68.10. Metabolism of cyclophosphamide and ifosfamide. These drugs can be metabolized to the active agents (vertical metabolism) or to inactive metabolites (horizontal metabolism).

Toxicity

Although alkylating agents share a common mechanism of action, toxicity of alkylating agents varies significantly because of differences in pharmacokinetics, lipid solubility, membrane transport properties, and the presence of specific DNA-repair mechanisms. Marrow suppression occurs in all hematopoietic cell types. However, the pattern of suppression varies from drug to drug. A relative platelet- and stem cell-sparing effect occurs with cyclophosphamide. In contrast, busulfan is especially damaging to stem cells. The hematopoietic depression produced by the nitrosoureas is delayed (3 to 6 weeks). Nausea and vomiting are frequent with high doses of alkylators, but decrease with low-dose oral regimens. Alopecia is seen primarily with cyclophosphamide. Pulmonary fibrosis can be seen with all alkylating agents, but particularly with busulfan and the nitrosoureas.⁵⁸ Bladder toxicity is seen with ifosfamide and cyclophosphamide. Hepatic toxicity is noted with high-dose thiotepa, cyclophosphamide, busulfan, or BCNU therapy used in stem cell transplant regimens.⁵⁹ Ifosfamide, busulfan, and the nitrosoureas cause CNS toxicity, more frequently at high doses.⁶⁰ Renal toxicity is seen with the nitrosoureas and ifosfamide.⁶¹ High-dose cyclophosphamide produces water retention. All of the alkylating agents result in gonadal atrophy, and permanent loss of reproductive function can occur.⁶² All alkylating agents are teratogenic and carcinogenic. An increased risk of second cancers (usually acute myelogenous leukemia) has been reported with melphalan, procarbazine, and cyclophosphamide.

Antimetabolites (Azathioprine, Cladribine, Clofarabine, Cytarabine, Fludarabine, Gemcitabine, Hydroxyurea, Mercaptopurine, Methotrexate, Pentostatin, Thioguanine)

Antimetabolites prevent the synthesis of molecules required for DNA synthesis. Antimetabolites are cell cycle-specific agents that must be present during the S-phase of the cancer cell cycle for cytotoxicity. The schedule of drug administration is very important with these agents. Many antimetabolites are prodrugs that require metabolism to an active molecule. The pharmacology of selected antimetabolites most frequently used in the treatment of hematologic malignancies is reviewed in the following.

Methotrexate and Pralatrexate (Folotyn®)

Mechanism of Action

MTX, an analog of folic acid (Fig. 68.11), and pralatrexate are tight-binding inhibitors of DHFR, the enzyme required for converting folate to its active (tetrahydrofolate) form.⁶³ In the presence of MTX, tetrahydrofolates, needed as cofactors for purine and thymidine formation, are depleted, leading to inhibition of DNA synthesis and subsequent cell death. Cytotoxicity is related to the time MTX or MTX polyglutamate is present within the cell at

P.1413

concentrations great enough to inhibit DHFR.⁶⁴ 5-Formal tetrahydrofolate (calcium leucovorin or citrovorum factor), administered 24 hours after the administration of MTX, can rescue normal cells from the effects of MTX by providing a reduced form of folic acid to the cells. Resistance to MTX has been related to the presence of increased levels of the target enzyme, DHFR, as the result of increased expression or amplification of the DHFR gene.

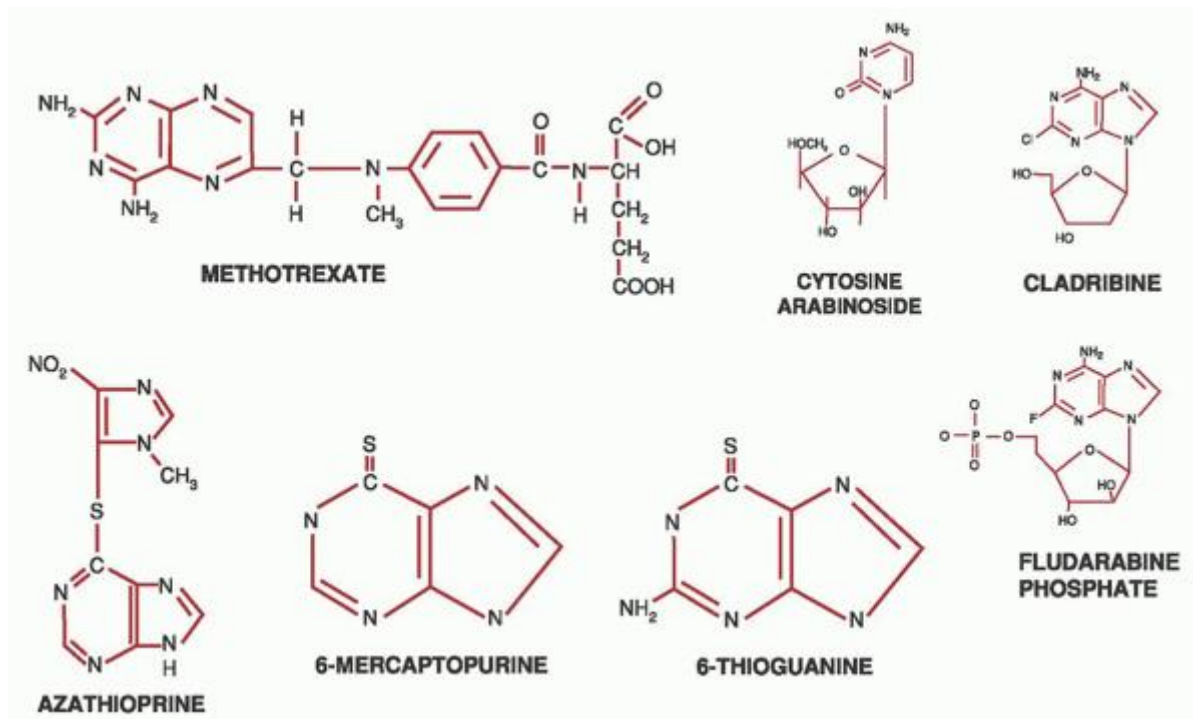

FIGURE 68.11. Structures of selected antimetabolites used for treatment of hematologic malignancies.

Clinical Pharmacology

MTX can be given orally, intravenously, or by intrathecal injection. With standard oral doses (7.5 to 20 mg/m²), absorption is variable, with bioavailability decreasing at higher doses.⁶⁵ MTX is primarily eliminated by glomerular filtration and renal tubular secretion. In patients with renal dysfunction, MTX clearance is delayed, resulting in prolonged exposure and increased toxicity.⁶⁶ Patients with renal insufficiency should not be given MTX or must have plasma drug concentrations closely monitored, with leucovorin rescue employed if clearance is delayed. Retention of drug in ascites or pleural effusions can prolong MTX half-life and increase toxicity.³⁷

Toxicity

The primary toxicities associated with MTX are myelosuppression and mucositis.⁶³ High-dose MTX can result in renal failure as a consequence of drug precipitation in renal tubules in the presence of acidic urine. The routine use of adequate prehydration, alkalization of the urine, and measurement of MTX concentrations is required with high-dose MTX

therapy.⁶⁷ Chronic MTX administration can be associated with liver disease, manifested by portal fibrosis and occasional cases of cirrhosis.⁶⁸ MTX is also associated with the development of pulmonary toxicity.⁶⁹ CNS toxicity has been reported with MTX, particularly with high doses of MTX and concomitant cranial irradiation. Intrathecal MTX administration may cause arachnoiditis.⁷⁰

Pyrimidine Analogs (Cytosine Arabinoside [ara-C and Liposomal ara-C], Gemcitabine, 5-Azacytidine, Decitabine)

The drugs listed above are all analogs of the naturally occurring pyrimidine, cytosine. Gemcitabine is occasionally used as third-line therapy for lymphomas but will not be further discussed. 5-Azacytidine and decitabine, although cytidine analogs, are believed to function through inhibition of histone deacetylase (HDAC) and will be discussed in a later section.

Mechanism of Action

Cytosine arabinoside (ara-C, cytarabine, liposomal ara-C, or DepoCyt™) is an analog of deoxycytidine with substitution of an arabinose sugar for the normally occurring deoxyribose sugar (Fig. 68.11). Once it enters a cell, ara-C must undergo metabolic activation to cytosine arabinoside triphosphate by a series of enzyme-mediated phosphorylation steps (Fig. 68.12). Cytosine arabinoside triphosphate competitively inhibits DNA polymerase- α . Cytosine arabinoside triphosphate is also incorporated into DNA, a feature that correlates closely with cytotoxicity. Incorporated ara-C inhibits both DNA template function and chain elongation.⁷¹ Ara-C-mediated DNA damage then induces apoptosis. Several mechanisms of resistance to ara-C have been described, including: (a) deletion of deoxycytidine kinase, the initial enzyme involved in ara-C activation; (b) increased levels of cytidine deaminase in tumor cells, resulting in rapid conversion of ara-C to inactive uracil arabinoside; and (c) decreased presence of nucleoside transport sites on tumor cells.

Clinical Pharmacology

Ara-C is rapidly converted to the inactive metabolite, ara-U, by the degradative enzyme, cytidine deaminase, present in the liver. The large capacity of the liver for metabolizing ara-C results in (a) a short plasma half-life of ara-C (2 to 3 hours), (b) adequate capacity for clearance of ara-C even in the presence of hepatic damage,

P.1414

and (c) urinary excretion of high concentrations of ara-U.⁷² Because of the short drug half-life and the S-phase specificity of ara-C, prolonged infusion or multiple-day administration schedules are required for cytotoxicity. Cytarabine encapsulated into multivesicular lipid-based capsules (DepoCyt™) has been developed as a means of sustaining cytotoxic ara-C concentrations at the tumor site. Liposomal ara-C acts as a depot form of ara-C and has been found useful in the therapy of neoplastic meningitis.⁷³

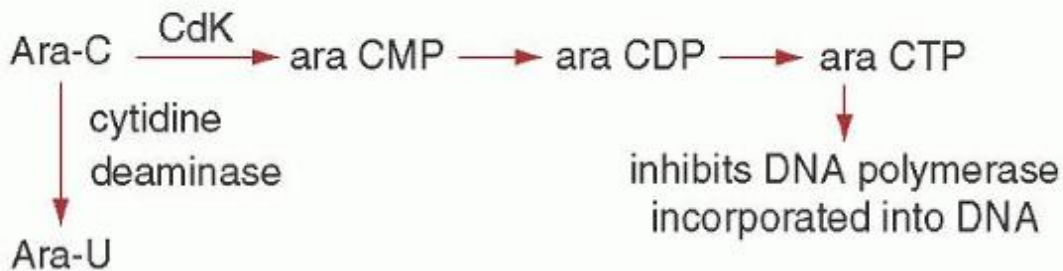

FIGURE 68.12. Metabolism of cytosine arabinoside (ara-C) by tumor cells. Ara-C is phosphorylated to its active metabolite, cytosine arabinoside triphosphate (ara-CTP), by a series of enzymatic steps, beginning with deoxycytidine kinase (CdK). Metabolism via the enzyme cytidine deaminase converts ara-C to the inactive metabolite, uracil arabinoside (ara-U).

Toxicity

Single high-dose boluses of ara-C are well tolerated but clinically ineffective because of the rapid inactivation of the agent. Continuous infusion or repeated administration of ara-C for 24 to 48 hours results in significant myelosuppression.⁷⁴ Nausea, vomiting, and diarrhea may occur after ara-C administration, especially with high-dose regimens. These symptoms typically subside quickly after the treatment. High-dose ara-C regimens (doses of 3 g/m² every 6 to 12 hours for 8 to 12 doses) have been associated with the development of cholestatic jaundice and elevations of hepatic transaminases. In addition, cerebral and cerebellar dysfunction has been reported in ~20% of patients receiving high-dose ara-C.⁷⁵ This toxicity is more common in patients >50 years of age and in patients with renal insufficiency. A steroid-

responsive conjunctivitis noted after high-dose ara-C has led to the routine prophylactic use of saline or steroid eye drops in patients receiving the high-dose regimens. Intrathecal injection of liposomal ara-C is associated with chemical arachnoiditis (headache, fever, nausea, vomiting) which can be treated with steroids.

Hydroxyurea

Mechanism of Action

Hydroxyurea inhibits ribonucleotide reductase, the enzyme responsible for the conversion of ribonucleotide diphosphates to the deoxyribonucleotides required for DNA synthesis and repair.⁷⁶ Hydroxyurea kills cells selectively in the S-phase of the cell cycle. Doses of 0.5 to 2.0 g/day result in a rapid (2 to 5 days) decrease in peripheral white blood counts. The rapid onset of effect on circulating leukemia cell populations and the brief duration of action have led to the routine use of this agent in patients with significantly elevated leukemic blast counts or in those with elevated platelet counts.⁷⁷

Clinical Pharmacology

Hydroxyurea is well absorbed orally (90% to 100% bioavailability), with minimal patient-to-patient variability.⁷⁸ It is excreted primarily in the urine with a plasma half-life of 4 hours.⁷⁹ Although precise guidelines are not available, patients with renal failure should have drug doses reduced.

Toxicity

Hydroxyurea's primary toxicity is myelosuppression.⁸⁰ Myelosuppression occurs 2 to 5 days following drug administration and is generally not severe. Reversal of myelosuppression is rapid following discontinuation of drug. Nausea, vomiting, anorexia, and diarrhea can be seen, but are typically mild. Uncommon toxicities include pulmonary fibrosis, hepatotoxicity, fever, and leg ulceration.

Purine Antimetabolites (6-Mercaptopurine, 6-Thioguanine, Azathioprine, Nelarabine, Cladribine, Clofarabine, Fludarabine)

6-Mercaptopurine, 6-thioguanine, azathioprine, nelarabine, cladribine, clofarabine, and fludarabine are all purine nucleoside analogs used in therapy of hematologic malignancies. The first four are guanine analogs, while the last three are analogs of adenine. All share many similarities. Nucleoside analogs are transported across cell membranes and phosphorylated to a triphosphate metabolite which is then incorporated into DNA. Once incorporated, nucleoside analogs interfere with DNA synthesis, lead to termination of DNA chain elongation, and inhibit DNA-repair mechanisms.⁸¹ Similarities and differences among these drugs are reviewed below.

Mechanism of Action of Guanine Nucleotides

6-Mercaptopurine is used in maintenance therapy for children with acute lymphoblastic leukemia. 6-Thioguanine is a second-line agent for therapy of acute myelogenous leukemia. Azathioprine, a prodrug of 6-MP, is used as an immunosuppressant. Nelarabine (Arranon[®]) is approved for the treatment of relapsed T cell acute lymphoblastic leukemias (ALL) and lymphoblastic lymphomas. The mechanism of action of these three agents is similar. These nucleoside analogs enter cells, are converted to triphosphates, and incorporated into DNA where they terminate DNA synthesis. 6-MP is an analog of hypoxanthine (Fig. 68.11). It is converted to 6-MP ribose triphosphate, which is incorporated into DNA (Fig. 68.13). 6-Thioguanine is activated in a manner similar to that outlined for 6-MP. Azathioprine is rapidly cleaved by nonenzymatic mechanisms to 6-MP and methyl-4-nitro-5-imidazole derivatives. The imidazole derivatives react with thiol and cysteine residues. Alkylation of lymphocyte thiol groups may be important in inducing immunosuppression.⁸² Ara-GTP, the active metabolite of nelarabine, is incorporated into T cell lines 20- to 40-fold more efficiently than into B cell lymphoblasts.⁸³

Clinical Pharmacology of Guanine Nucleotides

Azathioprine is rapidly cleaved to 6-MP after absorption. Clearance of 6-MP occurs primarily through two routes of catabolism. 6-MP is oxidized to the inactive metabolite, 6-thiouric acid, by xanthine oxidase (Fig. 68.13). 6-MP also undergoes S-methylation by the enzyme thiopurine methyl transferase (TPMT) to yield less active 6-methyl mercaptopurine.⁸⁴ Oral absorption of 6-MP is incomplete and highly variable. The low bioavailability (5% to 37%) is a result of a large first-pass effect as drug is absorbed into the portal circulation and metabolized by xanthine oxidase in the liver. The use of concomitant allopurinol (an inhibitor of xanthine oxidase) increases 6-MP bioavailability fivefold, increasing toxicity.⁸⁵ This important drug interaction must be remembered for 6-MP and azathioprine. Patient-to-patient variation in TPMT activity can result in significant changes in 6-MP metabolism and in drug toxicity. One in 300 subjects has absent TPMT activity. Patients with low TPMT activity are susceptible to severe 6-MP- and azathioprine-induced myelosuppression.⁸⁶ Patients with high TPMT concentrations may be a higher risk for relapse as a result of rapid drug inactivation. Genetic testing for the TPMT gene is available. Nelarabine is a water-soluble prodrug of ara-G. Following

intravenous administration, nelarabine is rapidly metabolized (<1 hour) by O-demethylation to ara-G, which is primarily transported into

P.1415

lymphoblasts, phosphorylated, and incorporated into DNA.⁸³ A small amount of ara-G is cleared via the kidneys so that increased toxicity may be expected in patients with creatinine clearance less than 50 ml/min. As an adenosine deaminase inhibitor, pentostatin can reduce conversion of nelarabine to ara-G, thereby reducing efficacy. Pentostatin and nelarabine should not be used in combination.

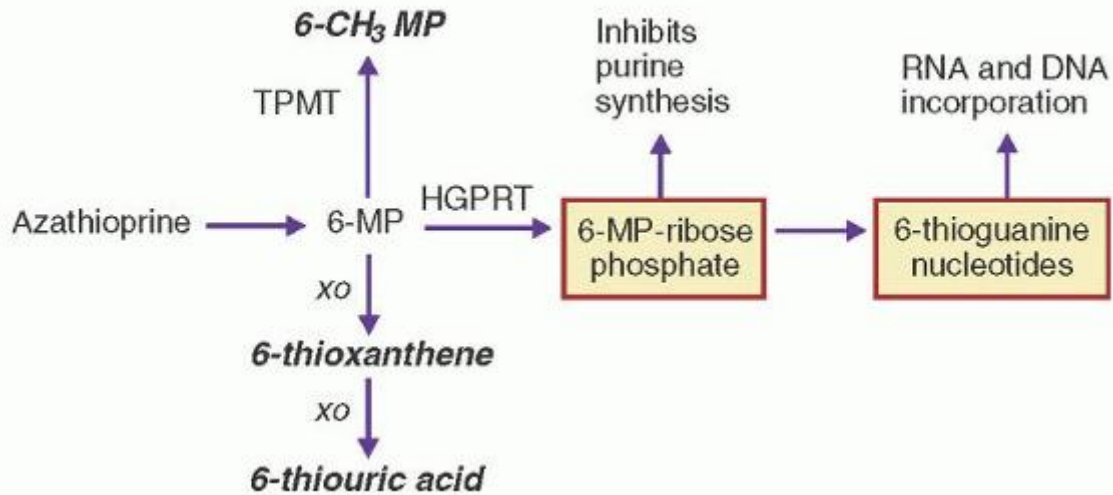

FIGURE 68.13. Mechanism of activation and catabolism of azathioprine and 6-mercaptopurine. Active metabolites are indicated by surrounding boxes. Inactive (or less active) metabolites are indicated by italic print. HGPRT, hypoxanthine-guanine phosphoribosyltransferase; TPMT, thiopurine methyltransferase; xo, xanthine oxidase.

Toxicity of Guanine Nucleotides

The dose-limiting toxicity of 6-MP, 6-thioguanine, azathioprine, and nelarabine is myelosuppression, occurring 1 to 4 weeks following onset of therapy and reversible when the drugs are discontinued.^{83, 84} Immunity to infectious agents or vaccines is subnormal. Gastrointestinal mucositis and stomatitis are modest but appear to be more common in adults than in children. Hepatotoxicity, seen in a small number of patients receiving 6-MP, is usually mild and reversible, with a clinical picture of cholestatic jaundice, although elevations of transaminases may be seen.⁸⁷ Frank hepatic necrosis and venoocclusive disease can occur. 6-MP and azathioprine are potentially teratogenic. Neurologic events (seizures, peripheral neuropathy) have been associated with nelarabine use.

Mechanism of Action of Adenine Nucleosides (Fludarabine, Cladribine, Clofarabine)

Fludarabine (Fludara[®]) (Fig. 68.11) is a fluoridated analog of 9-β-D-arabinofuranosyladenine (ara-A) used to treat CLL and refractory indolent lymphomas. When administered, fludarabine is dephosphorylated in plasma, enters cells, and then is again phosphorylated to 2-fluoro-ara-ATP (Fig. 68.14).⁸⁸ F-ara-ATP inhibits DNA polymerase, ribonucleotide reductase, DNA primase, and DNA ligase I, resulting in DNA deletions and mutations.⁸⁹ Fludarabine is also incorporated into DNA, where it is an effective DNA chain terminator. Cladribine (Leustatin[®] or 2-chlorodeoxyadenosine, 2CdA), an adenosine analog found to be more cytotoxic to lymphocytes than fludarabine, is used to treat hairy cell leukemia. The 5'-triphosphate metabolite (2-chloro-2'-deoxyadenosine 5'-triphosphate, 2-CdATP) accumulates in cells that are rich in deoxycytidine kinase, primarily lymphoid cells. 2-CdATP is incorporated into DNA, producing DNA strand breaks and inhibition of DNA synthesis in dividing cells.⁹⁰ Clofarabine, 2-chloro-9(2-deoxy-2-fluoro β-D arabinosyl) 9H purine-6 amine, is similar in structure to cladribine with the addition of a fluorine at the 2-carbon position of the sugar moiety.⁹¹ The addition of the fluorine molecule increases resistance to the cleavage of the glycosidic bond compared to cladribine. As with cladribine and fludarabine, clofarabine is phosphorylated intracellularly to the active triphosphate form. Clofarabine triphosphate inhibits DNA synthesis through its inhibitory action on ribonucleotide reductase and DNA polymerase. Clofarabine is approved for treatment of refractory ALL and AML.

Although the effects of F-ara-A and 2CdA on DNA synthesis account for their activity in dividing cells, these nucleosides are also cytotoxic to cancers with very low growth fractions, such as indolent lymphomas. Although the specific mechanism by which they induce cell death among quiescent cells is still under investigation, several proposed mechanisms of action include the ability to inhibit RNA polymerase and to deplete nicotinamide adenine dinucleotide (NAD), with resultant decrease in cellular energy stores and interference with normal DNA-repair processes.⁹²

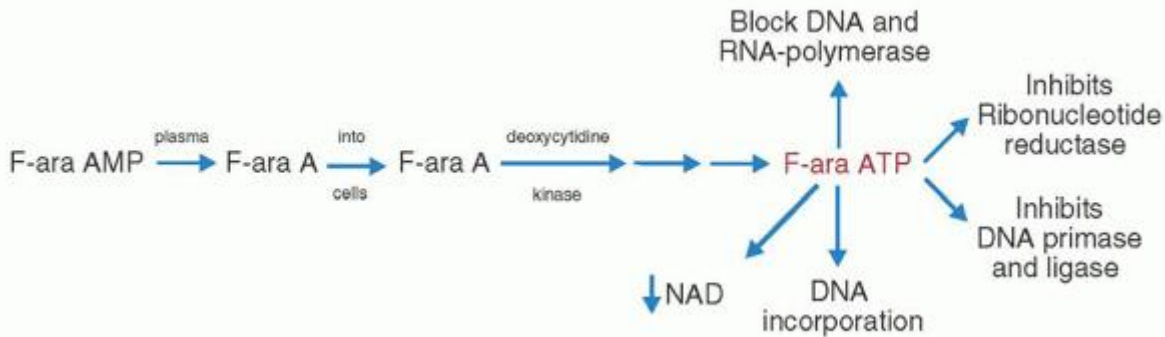

FIGURE 68.14. Activation pathway and mechanism of action of fludarabine.

Clinical Pharmacology of Adenine Nucleosides

Fludarabine undergoes rapid (2 to 4 minutes) conversion to 2F-ara-A. 2-F-ara-A is excreted primarily in the urine, with few metabolites noted. In patients with renal function impairment, clearance of 2-F-ara-A decreases significantly.⁸⁹ Dose reduction is recommended for patients with renal dysfunction. Oral bioavailability is ~75%. Bioavailability of subcutaneously administered cladribine is excellent. Oral bioavailability averages 50%.⁹³ Cladribine is cleared primarily by the kidneys (50% of total dose) via a cation organic carrier system. Although dose adjustment guidelines for patients with renal insufficiency are not available, caution should be used in giving cladribine to patients with renal failure. Significant patient-to-patient variability (+/-28%) exists in the AUC achieved following administration of drug by any method.⁹⁴ Roughly 50% of an administered clofarabine dose is excreted unchanged in the urine within 24 hours. This suggests that dose alteration will be needed for renal insufficiency, but studies in patients with renal failure have not been completed. The drug half-life is 5.2 hours.

Administration of clofarabine prior to cytarabine increases intracellular accumulation of ara-CTP in AML blasts.⁹⁵

Toxicity of Adenine Nucleosides

The dose-limiting toxicity of fludarabine is myelosuppression occurring a median of 12 to 16 days after beginning therapy. Cytopenias may be prolonged.⁹⁶ Other toxicities include mild nausea and vomiting (36% of patients), fever (60%), infection (33%), peripheral sensorimotor neuropathy (rare), autoimmune hemolytic anemia (rare), and hepatocellular toxicity with elevations in serum transaminases (rare).^{81, 89} An irreversible neurotoxicity syndrome has occurred in patients receiving high doses (>40 mg/m²/day for 5 days). Mild, reversible neurotoxicity has been seen at lower doses, with increased frequency and severity in older patients.⁹⁷ Pulmonary toxicity, characterized by fever, cough, hypoxia, and diffuse interstitial pneumonitis, has also been reported. Fludarabine is immunosuppressive and is associated with an increased risk of opportunistic infections.⁹⁸ CD4 and CD8 T-lymphocyte subpopulations drop to 150 to 200/mm³ after therapy.

The dose-limiting toxicity of cladribine is myelosuppression. Grade 3 or 4 neutropenia occurs in half of treated patients at standard doses. Fever (>100°F) has been seen in two-thirds of patients, often beginning 5 to 7 days into therapy or during the period of neutropenia.⁹⁹ Cladribine suppresses CD4⁺ lymphocytes. The CD4:CD8 ratio may remain depressed for up to 16 months after therapy, with associated opportunistic infections including *Candida* or *Aspergillus*.⁹⁸ After high-dose cladribine therapy (5 to 10 times the recommended therapeutic dose), renal failure and progressive irreversible motor weakness with paraparesis have been reported. Betticher et al.¹⁰⁰ have shown that

P.1416

reducing the dose of cladribine from 0.7 to 0.5 mg/kg per cycle decreases both the rate of grade 3 myelosuppression (33% to 8%) and the risk of infection (30% to 7%). No change in lymphoma response rate was noted with this dose reduction. The primary toxicity of clofarabine is myelosuppression leading to an increased risk of infection. Nausea and vomiting are

seen but are generally mild. Severe reversible hepatic toxicity is noted in 15% to 40% of patients receiving clofarabine.^{96, 101}

Pentostatin

Mechanism of Action

Pentostatin (deoxycoformycin, DCF) is a potent inhibitor of adenosine deaminase. It is active in the treatment of chronic lymphoid malignancies, particularly hairy cell leukemia.¹⁰² Inhibition of adenosine deaminase results in inability of the cell to catabolize adenosine and deoxyadenosine. Intracellular concentrations of deoxy-ATP increase and exert a negative feedback on ribonucleotide reductase, resulting in an imbalance in deoxynucleotide pools. This imbalance inhibits DNA synthesis and impairs replication, with arrest of cells in the G₁ and S phases of the cell cycle. The malignant cells of hairy cell leukemia and CLL have low levels of adenosine deaminase, making them particularly sensitive to the effects of pentostatin.¹⁰³

Clinical Pharmacology

Plasma pentostatin concentrations greatly exceed those needed to inhibit adenosine deaminase. Pentostatin's terminal half-life is 3 to 15 hours in humans. Forty to 80% of the drug is excreted unchanged in urine within 24 hours.¹⁰⁴ Plasma clearance correlates with creatinine clearance. Dosage reduction should be considered for patients with impairment in renal function. Pentostatin is not bioavailable by the oral route, because of its acid lability.

Toxicity

At doses used in hairy cell leukemia (4 mg/m² biweekly), therapy is usually well tolerated.¹⁰⁵ Toxicities include worsening of neutropenia, mild to moderate lethargy, anorexia, rash, and reactivation of herpes zoster late in therapy. Nausea, although usually mild, can occasionally be severe. Delayed emesis is seen.

Histone Deacetylase Inhibitors (Vorinostat, Romidepsin) and Hypomethylating Agents (5-Azacytidine, Decitabine)

Eukaryotic DNA is organized in a macromolecular complex wrapped around histone proteins. Amino acid residues on the histone tail can be modified by acetylation and by methylation. These modifications change the structure of the histone-DNA complex. Histone acetyltransferases (HATs) are enzymes that acetylate histone molecules, resulting in opening of the chromatin, thereby allowing transcription factors access to DNA promoter regions. In contrast, HDACs remove acetyl groups from histone proteins, leading to condensation of DNA and inactivation of gene transcription.¹⁰⁶ Increased HDAC activity has been associated with a decrease in tumor suppressor gene expression, alterations in intrinsic and extrinsic apoptotic pathways, and decreased apoptosis. Romidepsin (Istodax[®]) and vorinostat (Zolinz[®]) are HDAC inhibitors approved for treatment of cutaneous T cell lymphomas.

Similarly, a large number of genes are silenced by methylation in some cancers. This methylation may block the gene promoter region of tumor suppressor genes.¹⁰⁷ 5-Azacytidine (Vidaza[®]) and decitabine (Dacogen[®]) are methyltransferase inhibitors which block the methylation of DNA with the hope of activating tumor suppressor genes. 5-Azacytidine and decitabine have been approved for treatment of MDS and are being used in AML.

Mechanism of Action

Vorinostat is a potent inhibitor of several HDACs (1, 2, 3, and 6), while romidepsin inhibits class 1 HDAC enzymes.^{106, 108, 109} It is uncertain whether specificity of any HDAC inhibition impacts antineoplastic activity. Inhibition of HDAC induces genes that cause apoptosis or differentiation. Clinical studies have demonstrated hyperacetylation in tumor cells following vorinostat administration. However, no correlation between tumor acetylation status and response has been seen, suggesting that other mechanisms of action may impact on antineoplastic activity.¹⁰⁸ HDAC inhibitors also induce oxidative damage, have antiangiogenic effects, and disrupt cell cycle checkpoints. The specific mechanism of antineoplastic activity remains uncertain.

5-Azacytidine and decitabine (5-aza-deoxycytidine) are both nucleoside analogs. Like cytarabine, they undergo phosphorylation within the cell to a triphosphate form and then are incorporated into DNA. Once incorporated into DNA, these agents bind the enzyme DNA methyltransferase, inhibit methyltransferase activity, and result in DNA hypomethylation.¹¹⁰ Hypomethylation reverses silenced tumor suppressor gene loci. The silenced genes may play an important role in terminal differentiation, apoptosis, or senescence of leukemic cells.¹¹¹

Clinical Pharmacology

Vorinostat is available as an orally administered, 100-mg capsule that is generally given with food. Both vorinostat and romidepsin are primarily inactivated by metabolism (glucuronidation and hydrolysis) with metabolites excreted in the

urine. Vorinostat has a short half-life (2 hours); despite the short plasma half-life, accumulation of acetylated histones continues for over 10 hours after administration.¹⁰⁶ Use of vorinostat or romidepsin in patients with renal or hepatic insufficiency has not been studied. However, since drug clearance is primarily via metabolism, dose adjustment for renal insufficiency is not thought to be needed.

Following IV or subcutaneous administration, decitabine and 5-azacytidine are rapidly inactivated by hepatic metabolism (primarily via the enzyme cytidine deaminase). There is little protein binding. The half-lives of 5-azacytidine and decitabine are 4 hours and 30 minutes, respectively. The drugs do not have oral bioavailability because of rapid decomposition in acidic solutions. Because of an association between the length of drug exposure with DNA methylation and the short half-life of these drugs, continuous treatment of azanucleosides over several days is recommended.¹¹¹ Dose adjustments for hepatic or renal insufficiency have not been studied but are unlikely to be needed.

Toxicity

The most common toxicities of HDAC inhibitors include nausea, vomiting, diarrhea, thrombocytopenia, anemia, and taste disorders. Dose-limiting side effects are generally thrombocytopenia and dehydration.¹¹² Pulmonary emboli have been reported in 4% to 5% of cancer patients receiving vorinostat. QT prolongation is noted with both vorinostat and romidespin.¹⁰⁶ The primary toxicity of decitabine and azacytidine is myelosuppression. Gastrointestinal toxicities, including nausea, vomiting, and constipation, are seen, usually transient in nature (1 to 4 days), and improve over time.¹¹³

Hormonal Therapies

A comprehensive review of all hormonal therapies is beyond the space limitation of this chapter. Of the several types of hormonal agents used in cancer therapy, corticosteroids are the class of drugs used to treat hematologic malignancies. Corticosteroids are also useful in managing complications of cancer, including chemotherapy-induced emesis, hypercalcemia, and increased

P.1417

intracranial pressure. Prednisone and dexamethasone are synthetic glucocorticoids most commonly used in oncology. They are respectively 4- and 30-fold more potent than the naturally occurring glucocorticoid, cortisol. Prednisone and cortisol have roughly equivalent mineralocorticoid effects while dexamethasone lacks significant mineralocorticoid activity.

Mechanism of Action

Several cancers depend on specific hormones for growth and cellular integrity. Altering the hormonal balance can cause tumor regression in patients. The mechanism of corticosteroid cytotoxicity to lymphocytes is mediated via binding to the glucocorticoid receptors, which induces apoptosis in these hormone-sensitive cells.¹¹⁴

Clinical Pharmacology

Prednisone is an inactive prodrug that requires hepatic activation to produce prednisolone, the active moiety. Oral bioavailability of corticosteroids is excellent (>80%). The plasma half-life of prednisone is 1 hour for prednisolone and 4 hours for dexamethasone. In contrast to cortisol, synthetic glucocorticoids have little protein binding. Drugs activating the microsomal enzyme system (such as phenytoin) increase degradation, while cytochrome P450 inhibitors (such as aprepitant) increase glucocorticoid concentrations.¹¹⁵

Toxicity

Prednisone and dexamethasone have little mineralocorticoid activity; therefore most side effects are related to suppression of the hypothalamic-pituitary-adrenal (H-P-A) axis and the development of iatrogenic Cushing's syndrome. In general, suppression of the H-P-A axis is not seen in patients who have received glucocorticoids for less than 3 weeks. A gradual tapering of glucocorticoids is recommended for those on these agents for longer periods. Side effects are dose- and schedule-related.¹¹⁶ Commonly affected systems include: skin (purpura, thinning, acne), eye (cataracts), heart (hypertension, hyperlipidemia), endocrine (diabetes, adrenal insufficiency), GI (PUD, steatohepatitis), bone (osteoporosis), muscle (myopathy), psychiatric (euphoria, psychosis), and an increased risk of infections. Many of these toxicities are seen only with long-term therapy.

Microtubulin Agents

Two general classes of microtubulin inhibitors are used in cancer therapy: the vincas and the taxanes. The vinca alkaloids block microtubulin formation, while the taxanes (docetaxel, ixabepilone, and paclitaxel) stabilize microtubulin bundles,

leading to their dysfunction. Since taxanes are not generally used in therapy of leukemias and lymphomas, only the vinca alkaloids will be reviewed here.

Vinca Alkaloids (Vinblastine, Vincristine, and Vinorelbine)

Mechanism of Action

The vinca alkaloids vinblastine, vincristine, and vinorelbine bind to tubulin and prevent the formation of microtubulin, a protein that is essential for maintenance of cellular shape and for formation of the mitotic spindle.¹¹⁷ Vinca alkaloids bind to a site on microtubulin distinct from the taxanes. Cells treated with vinca alkaloids are arrested in metaphase.¹¹⁸ Disruption in microtubular formation leads to initiation of apoptosis. Differences in activity and toxicity of the vinca alkaloids result from variation in their pharmacokinetics, their differential effects on various tubulin isoforms, and variations in tissue penetration and cellular retention. Resistance is a result of the presence of p-glycoprotein or reduced tubulin binding resulting from mutations in tubulin.

Clinical Pharmacology

All vincas are rapidly taken up into cells. However, vincas differ in cellular retention (vinblastine greater than vincristine). All vincas are extensively bound to tissues and to proteins with long terminal half-lives (20 to 60 hours).¹¹⁹ CNS penetration is poor. All of the vinca alkaloids are metabolized by the liver via hepatic cytochrome P450 3A4 (CYP 3A4) and excreted into the bile. Drugs that block CYP 3A4 may inhibit vinca clearance, causing increased toxicity.¹²⁰ Doses of the vinca alkaloids should be reduced in patients with hepatic dysfunction, but not in patients with renal insufficiency. Specific dose reduction guidelines with impairment of hepatic function are not available.

Toxicity

Vincristine causes little myelosuppression. Its dose-limiting and most frequent toxicity is neurotoxicity,^{118, 121} manifested by a symmetric, distal, sensory-motor neuropathy. Loss of deep tendon reflexes in the lower extremities and paresthesias of the fingers and toes are common early findings. Continued use of the drug can result in further motor neuropathy, which may be only partially reversible when the drug is stopped. Neuropathies of the motor cranial nerves have also been reported, as have constipation, cramps, and paralytic ileus. Hair loss is commonly seen following vincristine administration. The dose-limiting toxicity of vinblastine is hematopoietic, with thrombocytopenia and leukopenia commonly occurring after administration of the drug.¹²² The onset of myelosuppression tends to occur earlier with this agent than with other antineoplastic agents, with the leukocyte nadir typically seen by day 4 to 7 and recovery by day 10 to 14. Severe neurotoxic symptoms are unusual with vinblastine, but use of the drug is associated with myalgias and an autonomic neuropathy manifested by orthostatic hypotension or paralytic ileus. The dose-limiting toxicity of vinorelbine is myelosuppression.¹²³ Vinorelbine is less neurotoxic than vincristine. Injection-site reactions of erythema, pain, and vein discoloration occur in one-third of patients, with severe vein toxicity seen in 2% of patients treated with vinorelbine. Respiratory reactions have been reported. All vincas are potent vesicants, with severe local tissue damage associated with extravasation of these drugs into soft tissues.

Monoclonal Antibodies

Monoclonal antibodies have been used in cancer therapy over 30 years. Initial monoclonal antibodies were produced in mice. The development of techniques to convert portions of the murine antibody to a human subclass (chimerization), to convert all of the antibody, except the hypervariable region, to human amino acid sequences (humanization), or to make a totally human monoclonal antibody have advanced the field.¹²⁴ The humanized proteins have a longer half-life and can better activate human complement stimulating complement-mediated cytotoxicity or activate antibody-dependent cell-mediated cytotoxicity (ADCC). Seven monoclonal antibodies (alemtuzumab, brentuximab vedotin, gemtuzumab, ibritumomab, atumumab, rituximab, and tositumomab) have been approved for treatment of hematologic malignancies and are briefly reviewed.

Rituximab (Rituxan®) and Ofatumumab (Arzerra™)

Mechanism of Action

Both rituximab and ofatumumab bind to the protein CD20. CD20 is a nonglycosylated protein of 33 to 35 daltons that is expressed on the surface of human B lymphocytes. CD20 is expressed on all B cell malignancies except most ALL and myeloma. Rituximab is a genetically engineered mouse/human chimeric IgG monoclonal

P.1418

antibody with human constant regions and mouse variable regions. Several mechanisms of cytotoxicity have been

demonstrated.^{124, 125} Antibody-mediated cellular toxicity (ADCC), resulting from the ligation of the Fc portion of the monoclonal antibody to Fc receptors expressed by accessory cells, occurs. Rituximab is also capable of binding complement and triggering complement-dependent cell lysis (CDC) of human B cells. Cross-linking of CD20 molecules can trigger apoptosis. Ofatumumab is a fully human monoclonal antibody which binds to a site on CD20 different from rituximab. Compared to rituximab, ofatumumab enhances in vitro CDC and ADCC due to greater reactivity with human complement and effector cells.^{126, 127} Head-to-head clinical trials comparing of rituximab to ofatumumab have not been performed.

Clinical Pharmacology

Rituximab and ofatumumab antibody concentrations in plasma following drug administration are proportional to the dose of drug administered, although there is marked inter-individual variation in maximal drug concentration (5- to 50-fold). Antibody half-life ranges from 30 to 400 hours for rituximab and 7 days for ofatumumab.^{128, 129} With weekly administration schedules, there is progressive accumulation of rituximab from week 1 to week 4. Drug clearance is not affected by chemotherapy. Drug elimination probably occurs by protein binding and proteolytic degradation. Clearance may be related to variable amounts of tumor cells present in the body and the concentration of CD20 antigens to which the drug binds.¹²⁹

Toxicity

Mild toxicity is seen in the majority of patients receiving rituximab or ofatumumab, but severe toxicity (NCI grade 3 or 4) is rare. Infusion reactions, resulting from release of cytokines occurring when antibody binds to CD20 cell, result in mild nausea, chills, rigors, tachycardia, fever, and skin rash within 1 to 3 hours following treatment in some patients. Slow drug administration is recommended for patients receiving their first cycle of drug to minimize such reactions. Serious infusion-related reactions (bronchospasm, hypotension, acute respiratory distress syndrome, and shock) have been reported during drug infusions in less than 1% of infusions. The incidence of infusion-related reactions decreases with subsequent infusions. Grade 3 to grade 4 neutropenia (2% to 6%), anemia (1% to 3%), and thrombocytopenia (1% to 2%) are uncommon. B cell lymphocyte counts are reduced for ~6 months.^{128, 129} Late onset neutropenia, occurring 40-350 days following therapy, has been noted in 3-7% of patients. Multifocal leukoencephalopathy has been reported with rituximab.¹³⁰ Interstitial lung disease and reactivation of hepatitis B have been noted with rituximab therapy. A late occurring neutropenia has been noted following rituximab therapy.

⁹⁰Y-Ibritumomab Tiuxetan (Zevalin®) and ¹³¹I-Tositumomab (Bexxar®)

Mechanism of Action

⁹⁰Y-ibritumomab and ¹³¹I-tositumomab are also monoclonal antibodies directed at the CD20 antigen but have an attached radioactive moiety designed to result in radiation-induced cytotoxicity to cells expressing the CD20 antigen.^{131, 132} Ibritumomab is a monoclonal antibody combined with tiuxetan, which acts as a chelation site for Indium-111 and Yttrium-90 (Y-90). Indium-111 is a gamma-emitter used to assess biodistribution of ibritumomab while Y-90 emits beta particles. Beta-emission induces cellular damage through the formation of free radicals (in both target cells and surrounding cells). Roughly 85% of non-Hodgkin lymphomas express the CD20 antigen on their surface.¹³³ A pretreatment therapy of unlabeled antibody to CD20 is given prior to administration of radioactive-tagged antibody to minimize targeting of radio labeled antibody to normal B cells in the circulatory system. ¹³¹I-Tositumomab is a radio-iodinated derivative of a murine IgA lambda monoclonal antibody covalently linked to iodine 131.

Clinical Pharmacology

⁹⁰Y-Ibitumomab is a pure β -emitter with a half-life of 64 hours. ¹³¹I-Tositumomab has both β and α radiation. Clearance of ¹³¹I-tositumomab-labeled antibodies varies significantly among patients, and dosing for an individual patient is derived from quantitative whole-body imaging of a test dose. The half-life of elimination averages 67 hours. More rapid clearance is noted in patients with a more extensive tumor burden.

Toxicity

The primary toxicity of both ¹³¹I-tositumomab and ⁹⁰Y-ibitumomab is myelosuppression occurring about 1 month after dosing. The median platelet and neutrophil nadirs are 43,000 and 690, respectively, with tositumomab. Using ⁹⁰Y-ibitumomab, grade 4 neutropenia, thrombocytopenia, and anemia occur in 35%, 14%, and 8% of patients, respectively.^{131, 133} Nadirs occur 7 to 9 weeks posttherapy. Nonhematologic toxicity includes asthenia, hypothyroidism, infusion reactions, and fevers. Infusion reactions including anaphylaxis are seen in 25% to 30% of patients (anaphylaxis less common). Myelodysplasia and mucocutaneous reactions (erythema multiforme) have been noted days to months following therapy.¹³⁴

Alemtuzumab (Campath®)

Alemtuzumab is a humanized monoclonal antibody directed against the CD52 antigen expressed not only by most lymphomas and lymphoid leukemias but also by normal B and T lymphocytes, NK cells, monocytes, macrophages, dendritic cells, and neutrophils. The CD52 antigen is not internalized after antibody binding; antitumor effects are mediated by antibody-dependent cell-mediated cytotoxicity.¹³⁵ Alemtuzumab also alters signal transduction, which may contribute to cytotoxicity. Because it binds to normal B and T cells and normal neutrophils (triggering complement lysis), transfusion reactions are frequent. The drug is therefore administered by slow infusion or by subcutaneous injection. Patients receiving subcutaneous alemtuzumab have local skin reactions which may be severe. Treatment results in myelosuppression and long-term immunosuppression. There is a high risk of opportunistic infections.¹³⁶

Brentuximab Vedotin—(Adcetris™)**Mechanism of Action**

Brentuximab vedotin is a conjugate of a chimeric IgG1 monoclonal antibody against CD 30 linked to a cytotoxic drug, monomethyl auristatin E. CD 30 is a member of the TNF family expressed on the tumor cells of Hodgkin's lymphoma and anaplastic large cell lymphoma. Monomethyl auristatin E (MMEA) is a synthetic inhibitor of tubulin polymerization. After binding to cells expressing CD30, the antibody-drug conjugate is internalized in lysosomes. The peptide linking the antibody to the drug is then cleaved, releasing MMEA into cells where it binds to tubulin and causes cell cycle arrest and apoptosis.¹⁴⁰ A small fraction of MMEA diffuses out of tumor cells where it results in cytotoxicity to cells in the microenvironment.¹⁴¹

Clinical Pharmacology

Brentuximab is administered intravenously every 3 weeks. The half-life of the antibody- drug conjugate is 4 to 6 days, while the half-life of MMEA is 3 to 4 days.¹³⁷ Steady state plasma levels are achieved in 21 days. Most MMEA is cleared via the liver into the stool (72%) as intact drug. There is modest metabolism via CYP 3A4. Information regarding dose adjustments or renal or hepatic insufficiency is not yet available, but it is unlikely that renal impairment would affect drug clearance.

P.1419

Toxicity

As with many monoclonal antibodies, infusion reactions can be seen during drug infusion (10%) with occasional anaphylaxis.^{138, 139} Peripheral neuropathy, which often improves with drug discontinuation, is noted in 20% to 50% of patients. Other toxicities seen with brentuximab vedotin include fatigue, fever, nausea and diarrhea, and neutropenia. Progressive multifocal leukoencephalopathy (PML) due to reactivation of JC virus has been seen. A high incidence of pulmonary toxicity was noted when brentuximab has been combined with bleomycin.

Gemtuzumab Ozogamicin (Mylotarg®)

Gemtuzumab is a monoclonal antibody to the CD33 antigen, found on myeloid cells, linked to the antibiotic calicheamicin. The postulated mechanism of action is through binding of the antibody to myeloblast with internalization of calicheamicin. Calicheamicin binds to DNA, resulting in DNA strand breaks. Because of lack of clinical studies clearly demonstrating antineoplastic activity, gemtuzumab was withdrawn from clinical use in the United States in 2010.

Molecularly Targeted Therapies

In the early years of cancer drug development, antineoplastic agents were often discovered by testing biologics or chemicals for ability to kill cancer cells in culture. If activity was identified, then the mechanism of action of that material was later determined. With advances in cancer biology and sequencing of the human genome, our understanding of how cancers develop and what processes are critical in cancer proliferation has grown. For the past two decades, most cancer drugs have been developed by identifying a critical pathway needed by a particular cancer and then identifying a drug which blocks that critical pathway. Molecular targeted therapies are drugs which selectively target specific molecular features of cancer cells such as aberrations in genes or proteins which regulate tumor cell growth. The best of these drugs target genes or proteins which are critically responsible for tumor growth or survival, such as the BCR-ABL protein in CML. Of the many target agents developed in the past 15 years, those used in treatment of hematologic malignancies will be reviewed here. The targets include: the IL-2 receptor (denileukin diftitox), the BCR-ABL oncoprotein (imatinib, dasatinib, nilotinib), the retinoic acid pathway (ATRA, arsenic trioxide), and the proteasome (bortezomib).

Denileukin Diftitox

Mechanism of Action

Denileukin diftitox (Ontak[®]) is a fusion protein containing peptide sequences for human interleukin (IL-2) and diphtheria toxin.¹⁴⁰ The IL-2 portion of this fusion protein binds to cells that express IL-2 receptors. Once bound to the IL-2 receptor, the diphtheria toxin protein is internalized, inhibits cellular protein synthesis, and results in cell death. Three types of IL-2 receptors exist: high-, intermediate-, and low-affinity. The fusion protein is internalized only with intermediate- or high-affinity IL-2 receptors. Expression of high-affinity IL-2 receptors is normally restricted to activated T lymphocytes and lymphomatous cells of T or B cell origin. Denileukin diftitox has been approved for use in cutaneous T cell lymphomas.¹⁴¹

Clinical Pharmacology

There is wide variation in serum concentrations of denileukin diftitox after intravenous administration (coefficient of variation >50%).¹⁴¹ A terminal half-life of ~75 minutes is seen with initial therapy, but this decreases to 43 minutes with continued therapy, as antibodies to denileukin diftitox appear. Animal studies have shown that the drug is cleared via hepatic protein degradation.

Toxicity

Hypersensitivity reactions, such as dyspnea, back pain, rash, hypertension, and chest tightness, occur during or within 24 hours of drug infusion in 60% of patients.^{141, 142} These symptoms resolve within 48 hours and can usually be controlled with use of steroids, antihistamines, or slowing of drug infusion. Constitutional and gastrointestinal symptoms (nausea/vomiting, asthenia, myalgias, headache, diarrhea) are seen in 92% of patients (grade 3 or 4 in one-third). A vascular leak syndrome (hypotension, edema hypoalbuminemia) occurs up to 2 weeks postinfusion in 25% of treated patients. The drug should not be given if the serum albumin is less than 3.0 g/dL. Myelosuppression is uncommon.

Retinoids

All-Trans Retinoic Acid or Tretinoin

Mechanism of Action. In acute promyelocytic leukemia, the retinoic acid receptor (RAR) is translocated next to a nuclear protein gene (PML). Fusion of RAR protein with the nuclear protein, PML, prevents normal differentiation of myeloid cell.¹⁴³ Retinoids are vitamin A derivatives that are essential for normal controlled cellular growth and development. ATRA binds to one or more nuclear receptors to decrease proliferation and induces differentiation of APL cells.¹⁴⁴ Pharmacologic concentrations of ATRA (1 μ M) reverse the inhibition of differentiation of the promyelocytes and induce remission of APL by providing retinoic acid to activate repressed genes.

Clinical Pharmacology. Tretinoin is well absorbed. Peak plasma ATRA concentrations of 350 ng/mL are achieved 1 to 2 hours following ATRA dosing and drop rapidly ($t_{1/2}$ = 50 minutes). ATRA is metabolized by the hepatic P450 microsomal enzyme system. Use of ATRA stimulates this degradative pathway. ATRA plasma concentrations, therefore, decrease with prolonged drug use.¹⁴⁵ Variation in hepatic microsomal metabolism accounts for significant patient-to-patient and day-to-day variation in ATRA clearance.¹⁴⁶

Toxicity. Many patients tolerate tretinoin with minimal morbidity. However, 20% to 25% of patients may develop a syndrome characterized by unexplained fever, leukocytosis, dyspnea with interstitial pulmonary infiltrates, peripheral edema, pleuropericardial effusions, hypotension, and acute renal failure.¹⁴⁷ Patients with 4 of these symptoms are classified as having a severe differentiation syndrome (also call retinoic acid syndrome), while those with 3 symptoms have intermediate syndrome. The differentiation syndrome occurs more frequently in patients with elevated WBC or renal insufficiency. Steroids are used to treat and prevent this syndrome. Pseudo-tumor cerebri, hyperlipidemia, and abnormal liver function tests have been observed with therapy. ATRA, like other retinoids, has significant teratogenic properties, particularly during the first trimester of pregnancy.¹⁴⁸

Bexarotene

Mechanism of Action. Bexarotene (Targretin[®]) is a retinoid approved for therapy of cutaneous T cell lymphoma. Retinoid modulation of tumor growth is mediated through binding to nuclear receptors that function as transcription factors to regulate gene expression in T cells. Two receptor families, retinoic acid nuclear receptors (RARs) and retinoid X nuclear receptors (RXRs) have been identified.¹⁴⁹ Bexarotene selectively binds and activates RXR receptors, inducing apoptosis in selected cell types through triggering of a variety of downstream events.¹⁵⁰

Clinical Pharmacology. Bexarotene is available as a topical gel for application to skin lesions or as an oral capsule for systemic therapy. Peak plasma concentrations are seen 2 to 3 hours after oral administration. Drug half-life is 4 to 7 hours. Bexarotene, like

P.1420

other retinoids, undergoes metabolism by the hepatic cytochrome P450 enzyme system (CYP3A4). Drug interactions with other CYP 3A4-metabolized drugs may occur. Gemfibrozil increases bexarotene concentrations and toxicity.

Toxicity. The most common bexarotene-associated toxicities are hyperlipidemia (82%), hypercholesterolemia (30%), central hypothyroidism (29%), headache (20%), asthenia (16%), pruritus (13%), and leukopenia (11%).^{151, 152} Side effects are more common at higher drug doses. Pancreatitis may result from hyperlipidemia. Use of lipid-lowering agents and thyroid replacement are often required. Thyroid function tests must be monitored.

Signal Transduction Inhibitors

Several antineoplastic agents have been FDA approved that inhibit a tyrosine kinase associated with signal transduction molecules activated in cancer cells. Inhibitors of the BCR-ABL (imatinib, dasatinib, nilotinib), PDGFR (sunitinib and sorafenib), EGFR (erlotinib, gefitinib), BRAF (vemurafenib), hedgehog (vismodegib), and VEGFR (sunitinib, pazopanib, and sorafenib) tyrosine kinases are clinically available. Imatinib mesylate, nilotinib, and dasatinib are currently approved for treatment of chronic myelogenous leukemia (CML). Other approved tyrosine kinase inhibitors are used primarily for treatment of solid tumors and will not be discussed in this chapter.

Imatinib Mesylate

Mechanism of Action

CML is characterized by a reciprocal exchange of genetic material between chromosomes 9 and 22 (t9; 22). A new gene is formed, the BCR-ABL proto-oncogene, which encodes a signal transduction protein that is autonomous. Increased activity of the BCR-ABL proto-oncogene leads to cellular proliferation, decreased apoptosis, or both.¹⁵³ The intracellular component of the BCR-ABL signal transduction protein contains a tyrosine kinase that activates subsequent signaling molecules by taking a phosphate from ATP and transferring it to a second signaling molecule. Imatinib mesylate (Gleevec[®]) binds to the ATP-binding site of the BCR-ABL oncoprotein and prevents transfer of phosphate from ATP to the second messenger (Fig. 68.15). Imatinib inhibits the tyrosine kinase of the BCR-ABL, c-kit, and PDGF oncogenes.¹⁵⁴

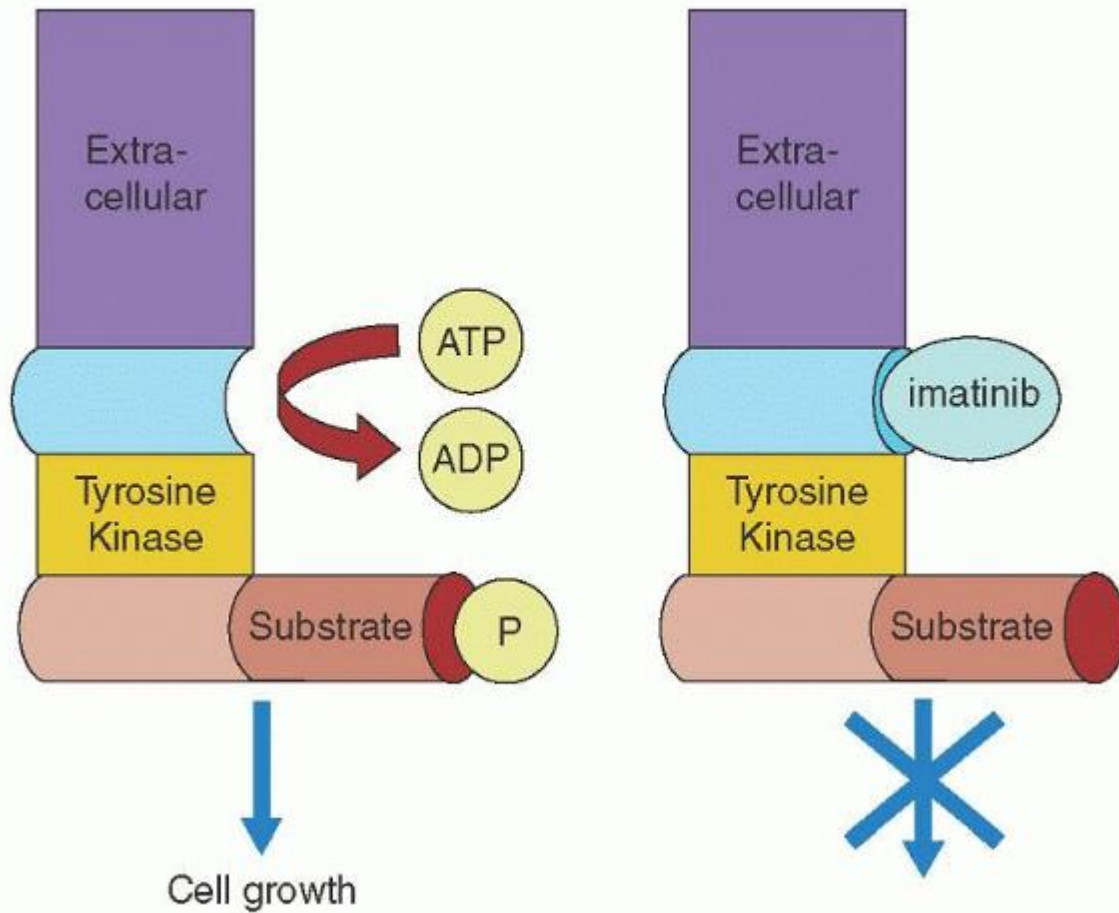

FIGURE 68.15. The BCR-ABL oncoprotein is shown schematically. This is a transmembrane protein with a tyrosine kinase on the intracellular part of the molecule. Imatinib mesylate binds to the tyrosine kinase, preventing activation of second-messenger proteins.

Clinical Pharmacology

Imatinib mesylate is given orally at doses of 400 to 800 mg/day. Bioavailability is 98%, with a drug half-life of 18 hours. Imatinib is cleared by hepatic microsomal cytochrome P450 metabolism (CYP 3A4) to a metabolite that has similar potency.¹⁵⁵ Biliary excretion of parent drug and metabolite account for 70% of drug clearance. However, no evidence of decreased clearance or increased drug toxicity has been seen in patients with hepatic or renal dysfunction.^{156, 157} Drugs that alter the hepatic CYP 3A4 metabolism have the potential to alter clearance of all BCR-ABL TKIs.¹⁵⁸

Toxicity

Mild nausea (70%), diarrhea (56%), and fluid retention are the most common toxicities associated with imatinib.^{154, 159} Edema can usually be managed with diuretics or dose reductions. Hematologic toxicity is mild and associated with a more advanced stage (e.g., CML blast crisis). Severe toxicity (grade 3 or 4) is rare (15% of patients). Abnormal liver function tests have been reported but require discontinuation of therapy in <0.5% of patients.

Dasatinib (Sprycel®)

Mechanism of Action

Roughly 25% to 45% of CML patients given imatinib discontinue this drug within 5 years either due to development of tumor resistance or to drug intolerance. To address this problem, several additional BCR-ABL TKIs have been developed. Dasatinib inhibits the ABL kinase present in patients with CML but differs from imatinib in that it can bind to both active and inactive conformations of the ABL kinase domain.¹⁶⁰ This less exacting requirement for binding allows dasatinib to

inhibit BCR-ABL mutations resistant to imatinib. Dasatinib also inhibits the SRC kinase.¹⁶¹ Dasatinib is a 100- to 300-fold more potent ABL kinase inhibitor than imatinib.

Clinical Pharmacology

Dasatinib is metabolized primarily by the hepatic cytochrome enzyme system (CYP 3A4). Concurrent use of drugs that induce or inhibit CYP 3A4 should be avoided if possible.¹⁶¹ Dasatinib's solubility is pH-dependent, so H₂ blockers and proton pump inhibitors should not be used with dasatinib. Antacids can be used, but 2 hours before or after administration of dasatinib.

Toxicity

Fluid retention, nausea, vomiting, and diarrhea are the most common toxicities seen with dasatinib use. Pleural effusions are noted in 8% of treated patients. Myelosuppression is common (50% grade 3 or 4).¹⁶² Grade 3 to 4 thrombocytopenia is seen in 35% to 80% of patients. Dasatinib may prolong the Q-T interval, increasing the risk of arrhythmias. Correcting hypokalemia and hypomagnesemia to minimize this effect is recommended.

Nilotinib (Tasigna®)

Mechanism of Action

Nilotinib is a second generation BCR-ABL TKI. It is similar in structure to imatinib but allows a better topologic fit with the ABL kinase and a 30-fold increase in potency.¹⁶³ Nilotinib also inhibits the KIT and platelet-derived growth factor tyrosine kinases, again more potent than imatinib.¹⁶⁴ Although both nilotinib and dasatinib are effective in most BCR-ABL mutants associated with resistance to imatinib (75% response rates), neither are effective against the T315I mutant.^{163, 164}

Clinical Pharmacology

Nilotinib is given orally at a dose of 400 mg twice daily. The plasma half-life is 15 to 17 hours and 98% of the drug is proteinbound. The metabolism of nilotinib is mainly hepatic. Drugs that inhibit CYP3A4 or prolong the QT interval should be avoided.

P.1421

Toxicity

Mild skin rash (28%), nausea (24%), pruritus (24%), and headache (19%) are common side effects, but rarely are severe.¹⁶³ Peripheral edema and pleural effusions seldom occur with nilotinib. Grade 3/4 neutropenia and thrombocytopenia were each reported in 29% of patients.¹⁶⁴ Typical biochemical abnormalities include increased serum lipase, hyperbilirubinemia (usually indirect), hyperglycemia and elevated transaminases. Prolongation of the Q-T interval is noted.

Proteasome Inhibitors—Bortezomib (Velcade®)

Mechanism of Action

Bortezomib targets and blocks the action of the proteasome. The proteasome is a large enzyme complex which breaks down proteins that have been selected for degradation.¹⁶⁵ The degradation process requires the proteins to transverse the regulatory gate of the proteasome. Bortezomib is a modified boronic peptide. It inhibits the chymotryptic site of the 26S proteasome, an enzyme that regulates protein degradation.¹⁶⁶ Bortezomib inhibits the degradation of proteins involved in regulation of cell proliferation and survival. It deregulates signaling molecules that are critical to the interaction of myeloma cells with the bone marrow microenvironment, leading to growth inhibition and apoptosis. Several intracellular molecules important in apoptosis, including NF-κB, JNK, Bcl-2, p53, and gp130 are modulated by proteasome degradation.

Clinical Pharmacology

The primary mechanism of bortezomib clearance is oxidative metabolism via the cytochrome P450 enzyme system (CYP 3A4, 2D6, 2C19, 2C9, and 1A2). Bortezomib penetrates poorly into the CNS. Dose adjustments are not needed with renal insufficiency.¹⁶⁷ Information regarding dose adjustments for hepatic insufficiency is lacking. Drug interactions could be expected with agents that inhibit cytochrome P450 metabolism.¹⁶⁸

Toxicity

The most frequent toxicities (>30%) associated with bortezomib treatment include fatigue/weakness, GI disturbances (nausea/anorexia/diarrhea/constipation), myelosuppression (neutropenia/thrombocytopenia), and peripheral neuropathy.¹⁶⁸ Peripheral neuropathy may be seen in up to 35% of patients; however, many myeloma patients have an underlying neuropathy prior to starting bortezomib. The neuropathy is related to the duration of treatment. Dose reductions based on the presence of neuropathy are needed and can result in improvement of neuropathy in 65% to 70% of patients.¹⁶⁹

Topoisomerase II Inhibitors (Doxorubicin, Daunorubicin, Epirubicin, Idarubicin, Mitoxantrone, Etoposide, and Teniposide)

Mechanism of Action

Topoisomerases are nuclear enzymes that make the transient strand breaks in DNA to allow the cell to manipulate DNA topology by passing an intact helix through a transient break in the DNA backbone.¹⁷⁰ This is a mechanism to relieve super coiling and tension on the DNA molecule. DNA topoisomerase I makes single-strand breaks in the DNA, whereas topoisomerase II makes double-strand breaks and passes double-stranded DNA through the break. Topoisomerase enzymes are needed for DNA replication, chromosome condensation, and chromosome segregation. Topoisomerase II inhibitors (doxorubicin, daunorubicin, epirubicin, idarubicin, mitoxantrone, etoposide, and teniposide) act by poisoning this enzyme to prevent it from relegating cleaved DNA (Fig. 68.16).¹⁷¹ This converts topoisomerase II into a toxin, by introducing high levels of transient protein-associated breaks in the genome of treated cells. Failures to repair the DNA break by the cell results in apoptosis. Currently available topoisomerase I inhibitors are irinotecan (CPT-11) and topotecan. As these agents are not frequently used in treatment of hematologic neoplasms, they will not be further discussed in this section. Topoisomerase II inhibitors include the anthracyclines, epipodophyllotoxins and mitoxantrone.

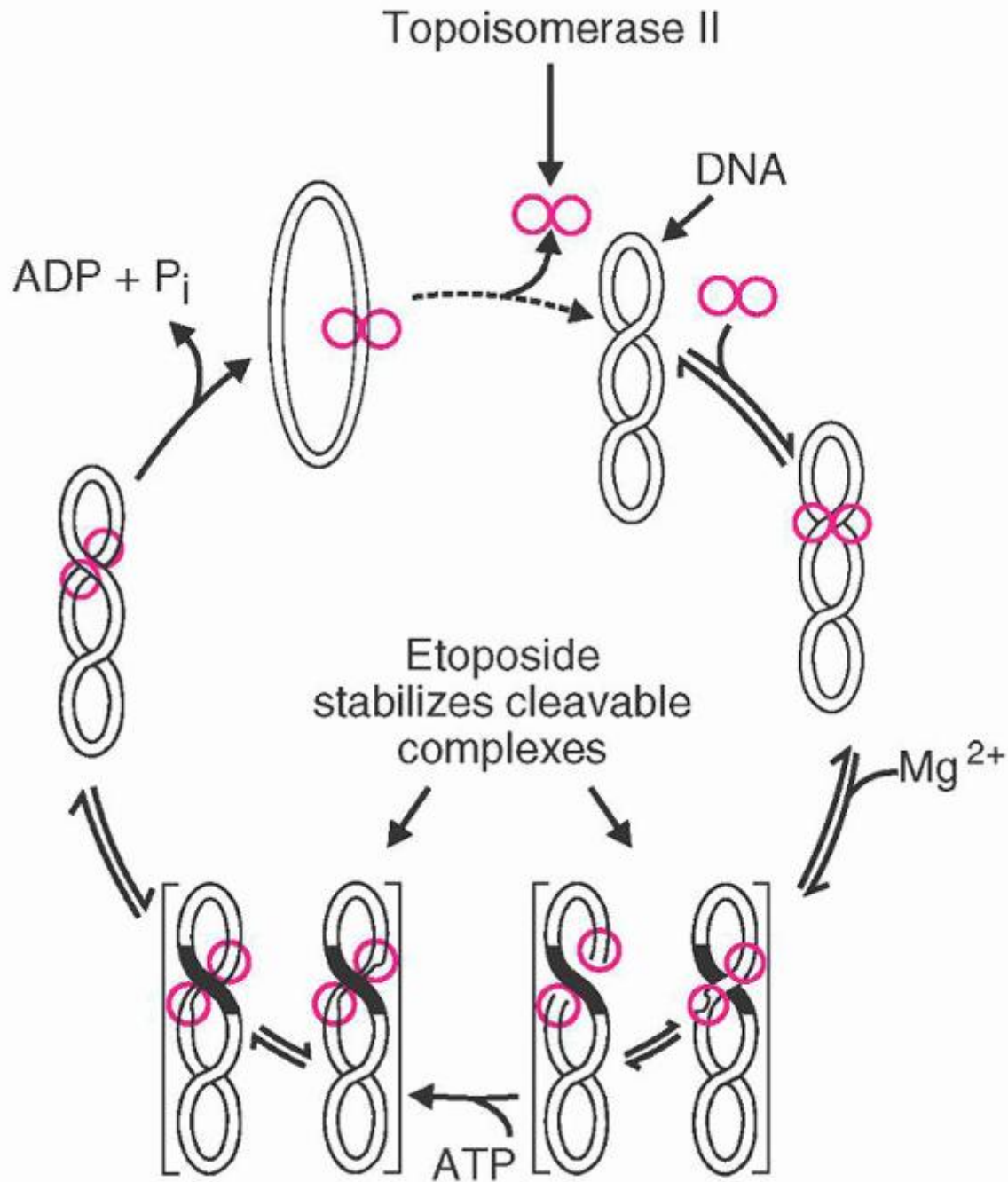

FIGURE 68.16. The catalytic cycle of topoisomerase II. Topoisomerase II binds to DNA. In the presence of magnesium and ATP, an intact DNA helix can pass through a temporary break in DNA with subsequent relegation. Topoisomerase II inhibitors block this cycle at the stage of DNA cleavage. (From Osheroff N, Zechiedrich EL, Gale KC. Catalytic functions of DNA topoisomerase II. *Bioassays* 1991;12:269-275.)

Anthracyclines (Doxorubicin, Daunorubicin, Epirubicin, and Idarubicin)

Clinical Pharmacology

Clearance of all anthracyclines occurs through hepatic metabolism and biliary excretion. Urinary excretion accounts for only ~10% of anthracycline clearance.^{172, 173, 174} Dose reduction is required for patients with jaundice, although specific dose reduction guidelines are not available. Use of doxorubicin in patients with hepatic dysfunction does not appear to increase cardiac toxicity, but an increase in mucositis and myelosuppression occurs. Liposomal-encapsulated anthracyclines (liposomal doxorubicin [Doxil[®], Myocet[™]] or liposomal daunomycin [DaunoXome[®]]) act as depot forms of

drug.^{175, 176} The delayed release of the anthracyclines from the liposome produces lower peak plasma concentrations and less cardiotoxicity.

Toxicity

The acute dose-limiting toxicity of the anthracyclines is myelosuppression, with a nadir in leukocytes expected around day 10 to 14, with recovery usually by day 21 to 28.¹⁷¹ Other acute systemic toxicities include nausea, vomiting, alopecia, and P.1422

mucositis. Anthracyclines cause severe local tissue reactions if extravasation occurs during infusion. The most serious toxicity associated with anthracyclines is cardiotoxicity. Anthracyclines cause a dose-dependent congestive cardiomyopathy that often leads to congestive heart failure. Late-onset cardiomyopathy can appear months to years after treatment is completed.¹⁷⁷ The mechanism underlying the cardiotoxic effects of anthracyclines remains uncertain but is thought to be via formation of free radicals, generated by iron-doxorubicin complexes that damage cardiac cellular membranes¹⁷⁸; cardiotoxicity may also be related to anthracycline damage to cardiac stem cells. The cardiac damage caused by anthracyclines is cumulative. With total doses of doxorubicin $<350 \text{ mg/m}^2$, heart failure is seen in $<5\%$ of cases. The risk of toxicity is related to the peak plasma concentration, so continuous infusions reduce the risk of heart failure compared to administration by large bolus injections. At equally myelosuppressive doses, epirubicin may be less cardiotoxic than doxorubicin.¹⁷⁸ Liposomal formulations of doxorubicin and daunorubicin have been investigated in the hopes of increasing tumor selectivity, which would allow an increase in the tolerated dose. The liposomal formulation of doxorubicin has reduced cardiotoxicity. Liposomal formulations of doxorubicin and daunorubicin are, however, associated with palmar-plantar erythrodysesthesia syndrome.^{175, 176}

Mitoxantrone

Clinical Pharmacology

Efforts to synthesize compounds with better antineoplastic activity and less toxicity than doxorubicin led to the discovery of mitoxantrone. Hepatic metabolism is the primary mechanism for mitoxantrone clearance, with only 6% to 11% being cleared by the kidney.¹⁷⁹

Toxicity

The primary dose-limiting toxicity of mitoxantrone is myelosuppression. Other potential toxicities include nausea, vomiting, alopecia, and cardiotoxicity. At doses that produce equivalent drops in white blood cell and platelet counts (75 mg/m^2 of doxorubicin vs. 15 mg/m^2 of mitoxantrone), nausea, vomiting, and alopecia are less frequent with mitoxantrone than with doxorubicin.^{179, 180} With commonly used dosages, approximately twice as much mitoxantrone can be given before heart failure develops as compared to doxorubicin. Acute leukemia is also a potential serious side effect of therapy using mitoxantrone.

Epipodophyllotoxins (Etoposide and Teniposide)

Clinical Pharmacology

Etoposide is poorly soluble in water. It is dissolved in a solubilizer composed of polysorbate 80, polyethylene glycol, and alcohol (Tween 80) and diluted to a concentration $<0.4 \text{ mg/mL}$ to avoid precipitation. These additives are believed to induce the hypersensitivity reactions occasionally seen with etoposide infusion. Approximately one-third of administered intravenous etoposide is excreted in the urine, and hepatic glucuronidation may account for another 25% of etoposide's metabolism.¹⁸¹ Etoposide is also hepatically metabolized to O-demethyl metabolites.¹⁸² Etoposide clearance is modestly decreased in patients with renal dysfunction, but not with hepatic obstruction. Biliary drug excretion is minimal so that only modest dose adjustment is required in the presence of obstructive jaundice. Etoposide is highly bound to plasma proteins, with only 6% to 8% of drug nonbound. Because free drug is biologically active, conditions that decrease protein binding or decrease albumin increase the pharmacologic effect of a given drug dose. Teniposide has less water solubility, decreased renal clearance (10%), and is even more tightly bound to plasma proteins than etoposide. Teniposide has a longer drug half-life and increased biliary clearance compared to etoposide. Anticonvulsants, such as phenobarbital and phenytoin, increase teniposide clearance, presumably by increasing hepatic metabolism.¹⁸³ This increased clearance results in a lower efficacy of chemotherapy in children with ALL receiving teniposide chemotherapy plus anticonvulsants. Etoposide is available as an oral capsule. Bioavailability of oral etoposide ranges from 40% to 80% and varies with the drug dose.³² Oral etoposide absorption is linear up to doses of 250 mg, but decreases with doses of $>300 \text{ mg}$. Oral etoposide

administration results in significantly greater variability in drug exposure than does intravenous administration.¹⁸⁴ Etoposide phosphate is a water-soluble prodrug that is rapidly changed to etoposide by endogenous phosphatases.¹⁸⁵

Toxicity

Common toxicities of etoposide and teniposide include bone marrow suppression, dose-dependent nausea or vomiting, and alopecia.¹⁸¹ Myelosuppression is the dose-limiting toxicity at usual therapeutic doses. At very high doses, such as those used with bone marrow transplantation regimens, mucositis becomes dose-limiting. Liver toxicity, fever, and chills are also seen with high-dose therapy. Hypersensitivity reactions, including vasomotor changes related to the pulmonary and gastrointestinal systems, although infrequent, can be life-threatening. These reactions may be due to hypersensitivity to the Tween 80 needed to solubilize the intravenous etoposide preparation. Hypersensitivity reactions can usually be ameliorated with histamine blockade and/or by using a slower infusion rate. Etoposide phosphate may reduce the risk of a hypersensitivity reaction, because no solubilizer is required. The most serious adverse event associated with etoposide and teniposide is the development of AML.¹⁸⁶ Therapy-related AML also occurs with other topoisomerase II inhibitors, but at a lower frequency. Leukemia develops relatively early after topoisomerase II inhibitor therapy (2 to 5 years) and can be distinguished from other therapy-related malignancies by a unique molecular marker: A balanced translocation involving the MLL (mixed-lineage leukemia) gene on chromosome 11 band q23.

Platinum Analogs (Cisplatin, Carboplatin, Oxaliplatin)

Mechanism of Action

The platinum analogs, cisplatin, carboplatin, and oxaliplatin, are heavy-metal complexes that induce tumor cell kill by cross-linking DNA strands in a manner analogous to the alkylating agents. Reactive aquated platinum intermediates are formed within cells, which directly and covalently bind to DNA, leading to DNA

P.1423

cross-links¹⁸⁷ (Fig. 68.17). Cisplatin is more reactive in water than carboplatin or oxaliplatin. The difference in aqueous stability, differences in the reactive groups, and spatial differences between platinum compounds appear to account for the variations in pharmacokinetics and toxicity among platinum agents. The amount of platinum bound to DNA after cisplatin, carboplatin, and oxaliplatin administration is similar, although the time frame for forming DNA adducts varies, with oxaliplatin and carboplatin taking more time than cisplatin.¹⁸⁸ Platinum compounds are effective in the treatment of solid tumors and are used as second-line agents in the treatment of lymphomas.¹⁸⁹

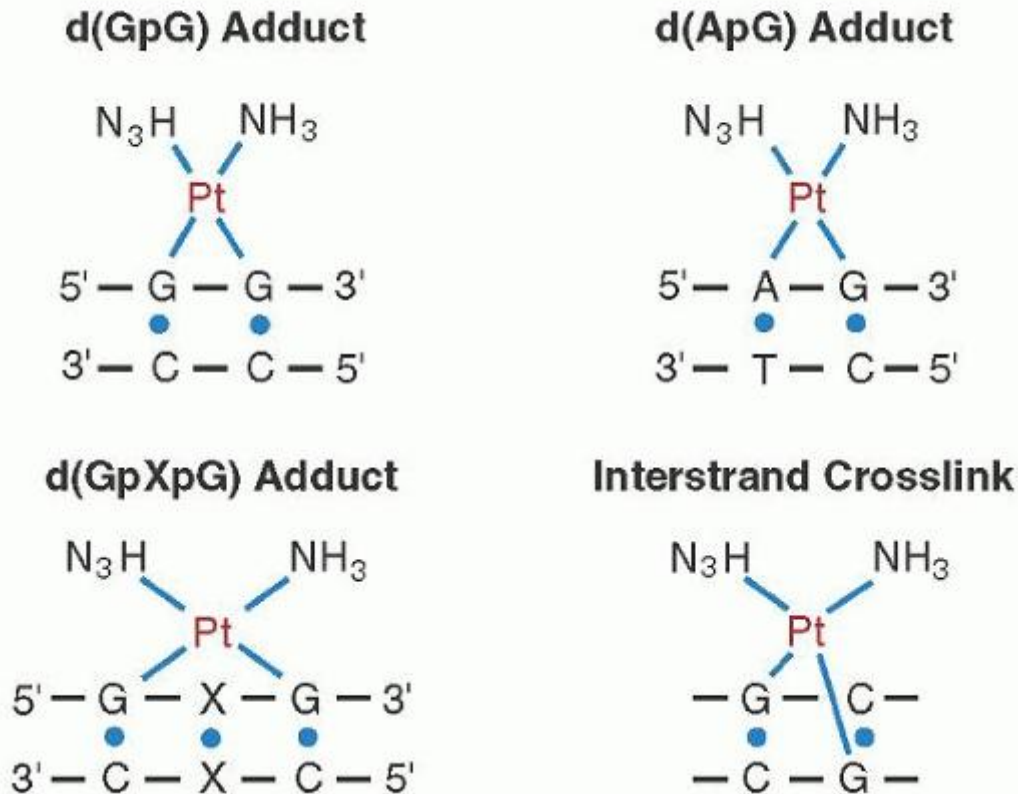

FIGURE 68.17. Sites of covalent binding of cisplatin to DNA. After forming an aquated reactive intermediate, cisplatin binds to guanine (and occasionally adenine) bases within the DNA molecule. Some adducts result in intrastrand DNA cross-links.

Clinical Pharmacology

The reactive intermediates of the platinum analogs rapidly bind to proteins and other nucleophilic compounds. Only the free (unbound) species are cytotoxic.¹⁹⁰ Over 90% of cisplatin is protein-bound and inactivated within 2 to 4 hours.¹⁹¹ Thus, protein binding represents the major route of cisplatin elimination. In contrast, only 20% to 40% of platinum is protein-bound at 2 hours following carboplatin administration. Renal excretion is the primary route of carboplatin elimination (70% to 90% of total clearance). Carboplatin clearance is highly correlated with creatinine clearance. Carboplatin doses should be calculated based on an individual patient's creatinine clearance.¹⁹² Oxaliplatin is also extensively cleared by the kidney (50%), but to a lesser degree than carboplatin. Increased toxicity following oxaliplatin therapy is not seen in patients with renal function impairment unless a patient's creatinine clearance falls to <20 mL/minute.¹⁹³

Toxicity

The toxicity profiles of cisplatin, oxaliplatin, and carboplatin differ. Myelosuppression is rare with cisplatin, although moderate anemia is common. Nausea and vomiting are common cisplatin toxicities, but the incidence can be reduced with decadron and serotonin antagonists.⁷⁷ Nephrotoxicity, manifest by azotemia and electrolyte disturbances (primarily hypomagnesemia and hypokalemia), is dose-related.¹⁹⁴ Although pre- and posttreatment hydration (with chloride-containing solutions) and diuresis reduce the incidence and severity of cisplatin nephrotoxicity, moderate and permanent reductions in glomerular filtration rate (GFR) may still occur.¹⁹⁵ Neurotoxicity from cisplatin is cumulative, dose-related, and usually begins as a "stocking-glove" type of peripheral neuropathy. The toxicity profile of carboplatin differs from cisplatin, with dose-limiting myelosuppression being the major toxicity following carboplatin administration.¹⁹⁶ Renal and ototoxicities noted with cisplatin are infrequent after carboplatin administration, although peripheral neuropathy is still seen. Nausea and vomiting after carboplatin usually are mild to moderate. Oxaliplatin results in neurotoxicity that is both acute and chronic. Reversible, cumulative peripheral sensory neuropathy is the primary dose-limiting factor of oxaliplatin

therapy. Hematologic and gastrointestinal toxicities occur but are mild to moderate. Ototoxicity and nephrotoxicity are uncommon.¹⁹⁷

Other Chemotherapeutic Agents Used in Hematology

Anagrelide (Agrylin®)

Mechanism of Action

Anagrelide is an oral imidazoquinazoline found to result in thrombocytopenia in the 1980s.¹⁹⁸ The precise mechanism of action is not known but anagrelide and its metabolite, 3-hydroxy anagrelide, block the maturation of platelets and reduce platelet counts. In contrast to hydroxyurea, anagrelide does not affect DNA or induce angiogenesis.¹⁹⁹

Clinical Pharmacology

Anagrelide is rapidly (2 hours) absorbed and then metabolized via the CYP1A2 to an active (3-hydroxy anagrelide) and inactive metabolite. Its half-life is 2 hours and that of the active metabolite is 4 hours.²⁰⁰

Toxicity

Because anagrelide and 3-hydroxy anagrelide inhibit phosphodiesterase, the main side effects (vasodilatation, tachycardia, headache, palpitations) are related to the positive inotropic effects of this drug.

Asparaginase

Mechanism of Action

Certain cells, particularly those of lymphocytic origin, lack the capacity to synthesize the amino acid asparagine. L-Asparaginase is an enzyme derived from bacteria that reduces blood asparagine to undetectable levels, thereby depriving cells of this amino acid. The cytotoxic effects of L-asparaginase on lymphoblasts result from the inhibition of protein synthesis when cells are depleted of asparagine.²⁰¹

Clinical Pharmacology

After intravenous enzyme administration, plasma asparagine levels fall rapidly and remain low for up to 10 days.²⁰⁰ Asparaginase can be detectable in the blood for 1 to 3 weeks, but as antibodies are formed, clearance of the drug is greatly accelerated. Asparaginase is degraded by protein metabolism. Trough asparaginase concentrations of 0.3 IU/ml are recommended for all leukemic patients.²⁰²

Toxicity

Toxic effects of asparaginase related to inhibition of protein synthesis include a decrease in circulating levels of albumin, clotting factors, insulin, and lipoproteins.²⁰³ Synthesis of anticoagulant proteins, such as antithrombin III, protein C, and protein S, is also reduced. Hypersensitivity reactions (urticaria, anaphylaxis, serum sickness) are common, with frequencies ranging from 20% to 40%. Conjugation of polyethylene glycol to asparaginase (pegasparaginase, Oncaspar®) prevents uptake of the drug by the reticuloendothelial system, making it less immunogenic and prolonging its circulating half-life. The incidence of hypersensitivity reactions to pegasparaginase in patients who have had reactions to Escherichia coli asparaginase is ~30%. The relative effectiveness and toxicity of asparaginase and pegasparaginase remain to be established.²⁰¹ Toxic reactions to both asparaginase and pegasparaginase include cerebral dysfunction (25% of patients), vomiting, chills (often an immediate reaction), pancreatitis (15% of patients), and liver function abnormalities.²⁰³

Arsenic Trioxide

Mechanism of Action

Arsenic trioxide (ATO, Trisenox®) is used for treatment of promyelocytic leukemia.²⁰⁴ Trivalent arsenic interacts with thiol groups in cells, primarily proteins that contain cysteine residues.²⁰⁵ The outcome of this interaction depends on the cell type and the dose and duration of arsenic exposure. The specific mechanism for ATO effects in APL has not clearly been defined, but As₂O₃ stimulates differentiation of APL cells, induces apoptosis, and inhibits NF-κB.

Clinical Pharmacology

Arsenic trioxide is methylated presumably in the liver and then excreted in the urine as metabolites.²⁰⁵ The antineoplastic effect of these metabolites is unknown. ATO has a half-life of 17 hours and distributes throughout the body. Drug penetration into the CNS is seen (14% of plasma concentrations).²⁰⁶ No dosage guidelines for patients with hepatic or renal insufficiency are currently available.

Toxicity

The most common ATO side effects include nausea, rash, fatigue, fever, headaches, diarrhea, and mild hepatotoxicity.^{204, 205, 206} The most common life-threatening toxicities include hypokalemia (13%), hyperglycemia (10%), the APL differentiation syndrome, and cardiac toxicity. Cardiac toxicity is primarily manifest by Q-T prolongation on the EKG, but Torsades de Pointe and sudden death have been reported. The “retinoid acid syndrome,” similar to that noted following ATRA treatment, is frequently seen (25% of patients). The incidence of myelosuppression is low. Although arsenic is a known carcinogen, neurotoxin, and renal toxin, secondary malignancies, renal toxicity, and neuropathy have rarely been complications of arsenic trioxide therapy to date.

Bleomycin

Mechanism of Action

Bleomycin is a mixture of low-molecular-weight glycopeptides of which bleomycin A₂ is the major species. Bleomycin can be administered subcutaneously, intramuscularly, or intravenously and has been instilled into pleural and pericardial spaces to act as a sclerosing agent in patients with malignant effusions. Bleomycin produces single- and double-strand DNA breaks, which result in chromosomal deletions and fragmentation.²⁰⁷ The DNA strand breaks are generated by production of free radicals by a Fe (II)-bleomycin complex, which intercalates into DNA and allows one bleomycin molecule to cleave both strands of DNA.²⁰⁸

Clinical Pharmacology

Absorption after intramuscular or subcutaneous injection of bleomycin is nearly complete. Renal clearance accounts for 65% of total drug clearance. Patients with renal failure have a prolonged drug half-life and an increased risk of developing pulmonary toxicity.^{209, 210} A 75% dose reduction has been recommended for patients with a creatinine clearance <25 mL/minute. Approximately 45% of an intracavitary dose of bleomycin is absorbed into the systemic circulation, and 30% is excreted in urine.²¹¹

Toxicity

Bleomycin is not myelosuppressive. Fever occurs within 48 hours of drug administration in ~25% of patients. Rare acute allergic reactions have been noted with this drug.²¹² The most prominent toxic effect of bleomycin is a chronic interstitial pneumonitis, which may continue on to fibrosis, hypoxia, and death.²¹³ Pulmonary toxicity, manifested by cough, dyspnea, and pulmonary infiltrates, occurs more often at higher cumulative drug doses but can occur following any dose. Approximately 10% of patients who receive a total drug dose of >400 mg develop pulmonary toxicity. Risk factors for pulmonary toxicity include individual doses >25 U/m², advancing age, underlying lung disease, and previous radiation therapy to the chest.²¹⁴ Patients who receive high oxygen concentrations during anesthesia following bleomycin therapy have been associated with increased frequency of bleomycin lung toxicity in some studies but not others. No specific therapy is effective, other than stopping the drug. Bleomycin can also result in cutaneous toxicities of hyperpigmentation, erythema, desquamation, nail changes, and alopecia. Reynaud's phenomena have been reported.

Interferon Mechanism of Action

Interferons (IFNs) are a family of glycoproteins of which some are inhibitors of viral replication and tumor growth. Type I interferons include α , β , and ω subtypes while type II interferon has only INF γ . Type I interferon α is used for treatment of hematologic malignancies. IFN- α 2b (Intron A[®]) and IFN- α 2a (Roferon[®]) are recombinant products that differ by one amino acid of 166. A pegylated interferon is also available. IFNs have multiple effects on cytokine production and regulation of tumor oncogenes and antioncogenes. The specific mechanism of antitumor activity of the IFNs is unclear, but the IFNs produce direct antiproliferative effects on tumor cells, increase host-mediated immune defenses, and inhibit angiogenesis.^{215, 216, 217} They stimulate activity of T cells, natural killer cells, dendritic cells, monocytes, and macrophages.

Clinical Pharmacology

The IFNs can be administered subcutaneously, intramuscularly, or intravenously. Following exposure to IFN, expression of >20 genes is altered. The optimal dose and administration route of IFN are not clear. IFN- α 2a is metabolized by the liver and filtered through the glomeruli, while INF- α 2b is metabolized and cleared by the kidney. The half-life of interferon α is 2 to 3 hours,²¹⁸ although its biologic effect is much longer. The half-life of pegylated interferon is 177 hours.

Toxicity

IFN- α use is associated with many toxicities, including a flulike syndrome manifested by myalgias and fatigue in patients who are not premedicated with antipyretics.^{219, 220} The severity of myalgias decreases with continued drug use. Nausea and vomiting are noted less often. Somnolence and lethargy occur when higher doses of IFN are used. Other, less common side effects include myelosuppression, diarrhea, mild alopecia, skin rashes, and elevated hepatic enzymes. Depression, anxiety, and suicidal ideation may occur with IFN therapy.²²¹ These toxic effects are readily reversed when administration of the IFN is stopped. Some of the immediate systemic toxicity associated with the use of this agent can be prevented by administration of acetaminophen or megestrol.

Thalidomide (Thalomid®) and Lenalidomide (Revlimid®)

Mechanism of Action

Thalidomide and lenalidomide are immunomodulatory drugs with a wide range of potential antineoplastic actions. Both drugs have similar immunomodulatory effects. Lenalidomide was developed after thalidomide and is more potent with fewer side effects. Thalidomide and lenalidomide activate T cells and stimulate endogenous cytokine release including IL-2, and IFN- α production.²²² They inhibit TNF- α synthesis and block the activation of NF- κ B kinase. They increase NK cell number and function. Thalidomide and lenalidomide also inhibit the action of vascular endothelial growth factor (VEGF) and block angiogenesis. The specific mechanism of antineoplastic immunomodulation of these two agents remains uncertain.

Clinical Pharmacology

The structure of thalidomide and its analog, lenalidomide, are shown in Figure 68.18. Thalidomide is a mixture of R and S enantiomers. It undergoes rapid spontaneous hydrolysis in plasma to multiple hydroxylated metabolites. Very little thalidomide undergoes hepatic metabolism via the cytochrome P450 system, so CYP-directed drug interactions are unlikely. Absorption of oral thalidomide is slow (3 to 4 hours) but extensive

P.1425

(80% bioavailability). Drug half-life is 6 hours. Ninety percent of the drug is excreted in the stool or urine within 48 hours, mostly as metabolites. The effect of food on thalidomide absorption is minimal. Repeat dosing does not affect kinetics. Because thalidomide is mainly hydrolyzed and passively excreted, its clearance is not expected to be altered in patients with impaired liver or renal function.²²³ Lenalidomide is rapidly absorbed when given by mouth ($t_{max} = 1.0$ hour). Food does not alter drug absorption but does slow oral absorption. In normal volunteers, two-thirds of an administered dose is excreted unchanged in the urine.²²⁴ Drug half-life is 3 hours. Lenalidomide is effective in myeloma patients with renal insufficiency but increased toxicity (myelosuppression and neuropathy) is noted in this population. Dose reductions may be needed for individuals with renal insufficiency.²²⁵

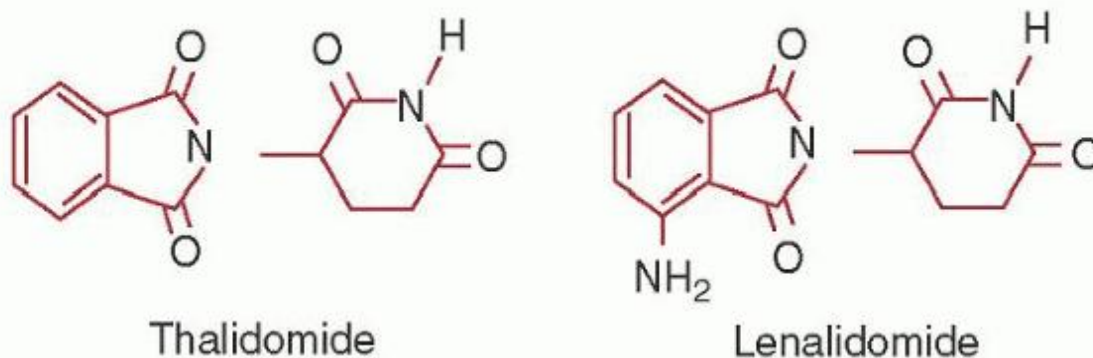

FIGURE 68.18. The chemical structures of thalidomide and lenalidomide.

Toxicity

Thalidomide is a potent teratogen. Use of thalidomide as a sedative in the late 1950s resulted in birth defects in >10,000 infants.²²⁶ Birth defects include absent or hypoplastic limbs, ear or eye deformities, and heart defects. Thalidomide administration to pregnant women is absolutely contraindicated. Women of child-bearing age must have a negative pregnancy test before starting thalidomide, use two effective forms of birth control, and have a pregnancy test every 4

weeks. Breastfeeding is prohibited. Men must use a condom or refrain from intercourse. Common thalidomide toxicities include neuropathy, somnolence, and constipation. The incidence of neuropathy is 38% at 6 months and 73% at 12 months.²²⁷ Clinical features are tingling or painful distal paresthesias affecting primarily the feet but sometimes the hands. The duration of thalidomide therapy correlates directly with the development of neurotoxicity. Some degree of sedation is universal, dose-dependent, and usually appears 2 weeks after initiation of therapy. Some patients suffer from depression. Tremors and/or headaches occur in 5% to 20% of patients. Venous thrombosis is seen in 2% to 23% of patients, with higher risk in patients >60 years of age. Sinus bradycardia is noted in 5% of patients. Constipation develops a few days after starting treatment in >50% of patients. Hypothyroidism occurs in 20% of patients occurring 1 to 6 months after starting therapy. A maculopapular skin rash or pruritus is seen in 20% to 50% of patients. Stevens-Johnson syndrome is occasionally seen (<1%).

Although lenalidomide does not cause birth defects in animal models, because of its similarity to thalidomide, this drug should not be given to pregnant women. The most common lenalidomide toxicity is a reversible myelosuppression (neutropenia and thrombocytopenia). Sedation is not seen with lenalidomide. Neuropathy has been noted but is felt to occur less frequently than with thalidomide.²²⁷ Skin rash and itching are seen in 25% of patients. Deep-vein thrombosis has been noted when lenalidomide has been used with dexamethasone.²²⁸ Hypothyroidism occurs in 5% to 10% of patients receiving lenalidomide. An increased risk of development of second malignancies has been reported with both thalidomide and lenalidomide.²²⁹

The Future

Additional genes, signaling pathway molecules, and posttranslational events important in the development and growth of hematologic cancers will continue to be discovered. Accruing knowledge of cancer biology identifies potential new pathways for therapy. In 2012, over 900 potential antineoplastic agents were in development. Readers are referred to websites: <http://www.clinicaltrials.gov> and www.phrma.org/research/new-medicines for details of potential antineoplastic agents in clinical development. While it is hard to predict the future, it is likely that drugs targeting additional signal transduction pathways^{230, 231, 232, 233, 234} and additional monoclonal antibodies or antibody-drug conjugates²³⁵ are likely to be developed. Drugs targeting new pathways such as the Flt-3 tyrosine kinase, present in one-third of AML patients,²³⁶ phosphatidylinositol kinase (PI3K), upregulated in B cell malignancies,²³⁷ and Bruton's tyrosine kinase (Btk)²³⁸ appear promising. New, less toxic and more specific IMiDs (pomalidamide) and proteasome inhibitors (carfilzomib)²³⁸ appear close to FDA review. Innovative immunomodulatory therapies are under development.^{239, 240} Readers will need to continue to monitor the medical literature to keep pace with these rapidly changing developments in treatments for hematologic cancers.

REFERENCES

1. Donovan JCH, Slingerland J, Tannock IF. Cell proliferation and tumor growth. In: Tannock IF, Hill R, Bristow R, Harrington L, eds. *The basic science of oncology*, 4th ed. 2005.
2. Norton LA. A Gompertzian model of human breast cancer growth. *Cancer Res* 1988;48:7067-7071.
3. Hanahan D, Weinberg RA. Hallmarks of cancer: the next generation. *Cell* 2011;144:646-64.
4. Herr I, Debatim KM. Cellular stress response and apoptosis in cancer therapy. *Blood* 2001;98:2603-2614.
5. Deshpande A, Sicinski P, Hinds PW. Cyclins and cdks in development and cancer. *Oncogene* 2005;24:2909-2915.
6. Mills AA. P53: link to the past, bridge to the future. *Genes Dev* 2005;19: 2091-2099.
7. Goldie JH. Scientific basis for adjuvant and primary (neoadjuvant) chemotherapy. *Semin Oncol* 1987;14:1-7.
8. Gottesman MM. How cancer cells evade chemotherapy: sixteenth Richard and Hinda Rosenthal Foundation award lecture. *Cancer Res* 1993;53:747-754.
9. Kessel D, Hall TC, Roberts D, et al. Uptake as a determinant of methotrexate response in mouse leukemia. *Science* 1995;150:752-754.
10. Marie JP. Drug resistance in hematologic malignancies. *Curr Opin Oncol* 2001;13:463-469.
11. Matheny CJ, Lamb MW, Brouwer KR, et al. Pharmacokinetic and pharmacodynamic implications of p-glycoprotein modulation. *Pharmacotherapy* 2001;21:778-796.
12. Merino V, Timenez-Tores NY, Menino-Sanjuan M. Relevance of multi-drug resistant protein on the clinical efficacy of cancer therapy. *Curr Drug Deliv* 2004;1:203-212.

13. Lage H, Dietel M, The effect of the breast cancer resistance protein on atypical multi-drug resistance. *Lancet Oncol* 2000;1:169-175.
14. Jodrell DI, Egorin MJ, Caretta RM, et al. Relationship between carboplatin exposure and tumor response and toxicity in patients with ovarian cancer. *J Clin Oncol* 1992;10:520-528.
15. Frei E, Canellos GP. Dose: a critical factor in cancer chemotherapy. *Am J Med* 1980;69:585-594.
16. Wood W, Korzan AH, Cooper R, et al. Dose and dose intensity of adjuvant chemotherapy for stage II node positive breast cancer. *N Engl J Med* 1994;330:1253-1259.
17. Basch E, Prestrud AA, Hesketh PJ, et al. Antiemetics: American Society of Clinical Oncology clinical practice guideline update. *J Clin Oncol* 2011;29:4189.
18. Hesketh P. Chemotherapy-induced nausea and vomiting. *N Engl J Med* 2008;358:2482-2494.
19. Bodey GP, Buckley M, Sathe YS, Freireich EJ. Quantitative relationships between circulating leukocytes and infection in patients with acute leukemia. *Ann Intern Med* 1966;64:328-340.
20. Smith TJ, Khatcheressian J, Lyman GH, et al. American Society of Clinical Oncology 2006 update of recommendations for the use of white blood cell growth factors: an evidence-based clinical practice guideline. *J Clin Oncol* 2006;24:3187-3205.
21. Hamnvik OPR, Larsen PR, Margusee E. Thyroid dysfunction from antineoplastic agents. *JNCI* 2011;103:1572-1587.
22. Keefe DM, Schubert MM, Elting LS, et al. Updated clinical practice guidelines for prevention and treatment of mucositis. *Cancer* 2007;109:820.
23. deJonge MJA, Verweij J. Renal toxicity of chemotherapy. *Semin Oncol* 2006;33:68-73.
24. Schiff D, Wen PY, van der Bent MJ. Neurological adverse events caused by cytotoxic and targeted therapies. *Nat Rev Clin Oncol* 2009;6:596-603.
25. Floyd J, Mirza I, Sachs B, Perry MC. Hepatotoxicity of chemotherapy. *Semin Oncol* 2006;33:50-67.
26. Meadors M, Floyd J, Perry MC. Pulmonary toxicity of chemotherapy. *Semin Oncol* 2006;33:98-105.
27. Monsuez JJ, Chariot JC, Vignat N, Atigou JY. Cardiac side effects of cancer chemotherapy. *Int J Card* 2010;144:3-15.
28. Payne AS, James WE, Weiss RB. Dermatologic toxicity of chemotherapeutic agents. *Semin Oncol* 2006;33:86-97.
29. Kropman JM, Papadopoulos EB, Grifio JA, et al. Surviving childhood and reproductive-age effects on fertility and future parenthood. *Lancet Oncol* 2010;11:490-498.
30. Sill H, Olipitz W, Zebisch A, et al. Therapy related myeloid neoplasms: pathobiology and clinical characteristics. *Brit J Pharmacol* 2011;162:792-805.
31. Holford NHG. Pharmacokinetics and pharmacodynamics: rational dosing and the time course of drug action. In: Katsung BG, Masters SB, Trevor AJ, eds. *Basic and clinical pharmacology*. Philadelphia, PA: McGraw-Hill, 2012.
32. Hande KR, Krozley MG, Greco FA, et al. Bioavailability of low dose oral etoposide. *J Clin Oncol* 1993;11:374-377.
33. Zimm S, Collins JM, Riccardi R, et al. Variable bioavailability of oral mercaptopurine. Is maintenance chemotherapy in acute lymphoblastic leukemia being optimally delivered? *N Engl J Med* 1983;308: 1005-1009.
34. Fraile RJ, Baker LH, Buroker TR, et al. Pharmacokinetics of fluorouracil administered orally, by rapid intravenous, and by slow infusion. *Cancer Res* 1980;40:2223-2228.
35. Hande KR, Messenger M, Wagner J, et al. Inter- and inpatient variability in etoposide kinetics with oral and intravenous drug administration. *Clin Cancer Res* 1999;5:2742-2747.
36. Stewart CF, Pieper JA, Arburk SG, Evans WE. Altered protein binding of etoposide in patients with cancer. *Clin Pharmacol Ther* 1989;45:49-55.
37. Chabner BA, Stoller RG, Hande KR, et al. Methotrexate disposition in humans: case studies in ovarian cancer following high dose infusion. *Drug Metal Rev* 1978;8:107-117.
38. Gianni L, Kearns CM, Giani A, et al. Nonlinear pharmacokinetics and metabolism of paclitaxel and its pharmacokinetic pharmacodynamic relationships in humans. *J Clin Oncol* 1995;13:180-190.
39. Paugh SW, Stocco G, McCorkle JR, et al. Cancer pharmacogenomics. *Clin Pharm Therapeut* 2011;90:461-466.

40. Diasio RB, Beavers TL, Carpenter JT. Familial deficiency of dihydropyrimidine dehydrogenase. *J Clin Invest* 1988;81:47-51.
41. Innocenti F, Kroetz DL, Schuetz E, et al. Comprehensive pharmacogenetic analysis of irinotecan neutropenia and pharmacokinetics. *J Clin Oncol* 2009;27:2604-2614.
42. Evans WE, Hon YY, Bomgars L, et al. Predominance of thiopurine 5-methyltransferase deficiency and heterogeneity among patients intolerant to 6-mercaptopurine or azathioprine. *J Clin Oncol* 2001;19:293-301.
43. Baker DK, Reiling MV, Pui CH, et al. Increased teniposide clearance with concomitant anticonvulsant therapy. *J Clin Oncol* 1992;10:311-315.
44. Richards MA, Ramirez LF, Degner LF, et al. Offering choice of treatment to patients with cancers. *Eur J Cancer* 1995;31A:112-116.
45. Samet J, Hunt WB, Key C, et al. Choice of cancer therapy varies with age of the patient. *JAMA* 1986;255:3385-3390.
46. Repetto L, Balducci L. The case for geriatric oncology. *Lancet Oncol* 2002;3: 289-297.
47. Griggs JL, Mangu PB, Anderson H, et al. Appropriate chemotherapy dosing for obese adult patients with cancer. American Society of Clinical Oncology clinical practice guideline. *J Clin Oncol* 2012;30:1553-1561.
48. Fu D, Calvo JA, Sampson LD. Balancing repair and tolerance of DNA damage caused by alkylating agents. *Nat Rev Cancer* 2012;12:104-120.
49. Brent TP, Houghton PJ, Houghton JA. O⁶-Alkyl guanine-DNA alkyltransferase activity correlates with the therapeutic response of human rhabdomyosarcoma xenografts to 1-(2-chloroethyl)-3-(trans-4-methylcyclohexyl)-l-nitrosourea. *Proc Natl Acad Sci U S A* 1985;82:2985-2989.
50. Diablos F, Feyzi E, Aas PA, et al. Alkylation damage in DNA and RNA—repair mechanisms and medical significance. *DNA Repair* 2004;3:1389-1407.
51. Garneck-Jones KP. Bendamustine: a review of its use in the management of indolent non-Hodgkin's lymphoma and mantle cell lymphoma. *Drugs* 2010;70:1703-1718.
52. O'Dwyer, Hamilton TC, Young RC, et al. Depletion of glutathione in normal and malignant human cells in vivo by butathione sulfonamide. *J Natl Cancer Inst* 1992;84:264-267.
53. Hospers GA, Eisenhauer EA, deVries EG. The sulfhydryl containing compound WR-2721 and glutathione as radio- and chemoprotective agents: a review, indications for use and prospects. *Br J Cancer* 1999;80:629-638.
54. Moore MJ. Clinical pharmacokinetics of cyclophosphamide. *Clin Pharmacokinet* 1991;20:194-208.
55. Boddy AV, Yule SM. Metabolism and pharmacokinetics of oxazaphosphorines. *Clin Pharmacokinet* 2000;38:291-304.
56. Shaw IC, Graham MI. Mesna—A short overview. *Cancer Treat Rev* 1987;14:67-86.
57. Sviland L, Robinson A, Proctor SF, et al. Interaction of cimetidine with oral melphalan. A pharmacokinetic study. *Cancer Chemother Pharmacol* 1987;20:173-175.
58. Twohig KJ, Matthay RA. Pulmonary effects of cytotoxic agents other than bleomycin. *Clin Chest Med* 1990;11:31-54.
59. Rollins BJ. Hepatic veno-occlusive disease. *Am J Med* 1986;81:297-306.
60. Goren MP, Right RK, Pratt CB, et al. Dechloroethylation of ifosfamide and neurotoxicity. *Lancet* 1986;2:219-220.
61. Loebstein R, Atanackovic G, Bishai R, et al. Risk factors for long-term outcome of ifosfamide- induced nephrotoxicity in children. *J Clin Pharm* 1999;39:454-461.
62. Kenney LB, Lauter MR, Grant FD, et al. High risk of infertility and long-term gonadal damage in males treated with high-dose cyclophosphamide for sarcoma during childhood. *Cancer* 2001;91:613-666.
63. Jolivet J, Cowan KH, Curt GA, et al. The pharmacology and clinical use of methotrexate. *N Engl J Med* 1983;309:1094-1104.
64. Evans WE, Crom WR, Abromowitch M. Clinical pharmacodynamics of high-dose methotrexate in acute lymphocytic leukemia: identification of a relation between concentration and effect. *N Engl J Med* 1986;314:471-477.
65. Balis FM, Savitch JL, Bleyer WA. Pharmacokinetics of oral methotrexate in children. *Cancer Res* 1983;43:2342-2345.
66. Schmiegelow K. Advances in individual prediction of methotrexate toxicity. *Brit J Haem* 2009;146:489-503.

67. Stoller RG, Hande KR, Jacobs SA, et al. Use of plasma pharmacokinetics to predict and prevent methotrexate toxicity. *N Engl J Med* 1977;297:630-634.
68. Zachariae H, Kragballe K, Sogaard H. Methotrexate-induced cirrhosis. *Br J Dermatol* 1980;102:407-412.
69. Imokawa S, Colby TV, Leslie KO, et al. Methotrexate pneumonitis: a review of the literature and histopathologic findings in nine patients. *Eur Respir J* 2000;15:373-381.
70. Blever WA, Drake JC, Chabner BA. Neurotoxicity and elevated cerebral-fluid methotrexate concentrations in meningeal leukemia. *N Engl J Med* 1973;289:770-773.
71. Grant S. Ara-C: cellular and molecular pharmacology. *Adv Cancer Res* 1998;72:197-233.
72. Ueda T, Matsuyama S, Yamauchi T, et al. Clinical pharmacology of intermediate and low-dose cytosine arabinoside (ara-C) therapy in patients with hematologic malignancies. *Adv Exp Med Biol* 1998;43:647-651.
73. Murry DF, Blancy SM. Clinical pharmacology of encapsulated sustained-released cytarabine. *Ann Pharmacol* 2000;34:1173-1178.
74. Stentoft J. The toxicity of cytarabine. *Drug Safety* 1990;5:7-27.
75. Baker WJ, Royer GL, Weiss RB. Cytarabine and neurologic toxicity. *J Clin Oncol* 1991;9:679-693.
76. Plagemann PGW, Erbe J. Intracellular conversion of deoxyribonucleotides by rat hepatoma cells and effect of hydroxyurea. *J Cell Physiol* 1994;83:321-336.
77. Donehower RL. An overview of the clinical experience with hydroxyurea. *Semin Oncol* 1992;19(suppl 9):11-19.
78. Rodriguez GI, Kuhn JG, Weiss GR, et al. A bioavailability and pharmacokinetic study of oral and intravenous hydroxyurea. *Blood* 1998;91:1533-1541.
79. Gwilt PR, Tracewell WG. Pharmacokinetics and pharmacodynamics of hydroxyurea. *Clin Pharmacokinet* 1998;34:347-358.
80. Strouse JL, Lanzkron S, Bench MC, et al. Hydroxyurea for sickle cell disease: a systematic review for efficacy and toxicity. *Pediatrics* 2008;122: 1332-1340.
81. Hande, KR. Purine antimetabolites. In: Chabner BA, Longs DL, eds. *Cancer chemotherapy and biotherapy: principles and practice*, 5th ed. Philadelphia, PA: Lippincott-William & Wilkins, 2011:192-2011.
82. Elion GB. Significance of azathioprine metabolites. *Proc R Soc Med* 1972;65:257-260.
83. Sanford M, Lyseng-Williamson KA. Nelarabine. *Drugs* 2008;68:439-447.
84. Van Scoik KG, Johnson CA, Porter WR. The pharmacology and metabolism of the thiopurine drugs 6-mercaptopurine and azathioprine. *Drug Metab Rev* 1985;16:157-174.
85. Zimm S, Collins JM, O'Neill D, et al. Inhibition of first-pass metabolism in cancer chemotherapy: interaction of 6-mercaptopurine and allopurinol. *Clin Pharmacol Ther* 1983;34:810-817.
86. Black AJ, McLeod HL, Capell HA, et al. Thiopurine methyltransferase gene type predicts therapy-limiting severe toxicity from azathioprine. *Ann Intern Med* 1998;129:716-718.
87. Einhorn M, Davidson I. Hepatotoxicity of 6-mercaptopurine. *JAMA* 1964;188:802-806.
88. Chun HC, Leyland-Jones B, Cheson BD. Fludarabine phosphate: a synthetic purine antimetabolite with significant activity against lymphoid malignancies. *J Clin Oncol* 1991;9:175-188.
89. Adkins JC, Peters DH, Markham A. Fludarabine: an update of its pharmacology and use in treatment of hematologic malignancies. *Drugs* 1997;53:1005-1037.
90. Plunkett W, Saunders PP. Metabolism and action of purine nucleoside analogs. *Pharmacol Ther* 1991;49:239-268.
91. Kline JP, Larson RA. Clofarabine in the treatment of acute leukemia: a review. *Expert Opin Pharmacother* 2005;6:2711-2718.
92. Robertson LE, Chubb S, Meyn RE, et al. Induction of apoptotic cell death in chronic lymphocytic leukemia by 2-chloro-2-deoxyadenosine and 9- β -D-arabinosyl-2-fluoroadenine. *Blood* 1993;81:143-150.
93. Liliemark J. The clinical pharmacokinetics of cladribine. *Clin Pharmacokinet* 1997;32:120-131.

94. Bryson HM, Sorkin EM. Cladribine: a review of its pharmacodynamic and pharmacokinetic properties and therapeutic potential in hematological malignancies. *Drugs* 1993;46:872-894.
95. Faderi S, Gandhi V, Kantarjian HM. Potential role of novel nucleoside analogs in the treatment of acute myeloid leukemia. *Curr Opin Hematol* 2008;15: 105-107.
96. Gill S, Carvey D, Ritchie D, et al. The frequency, manifestations and duration of prolonged cytopenias after first-line fludarabine combinations. *Ann Oncol* 2010;21:331-334.
97. Cheson BD, Vena DA, Foss FM, et al. Neurotoxicity of purine analogs: a review. *J Clin Oncol* 1994;12:2216-2228.
98. Cheson BD. Infectious and immunosuppressive complications of purine analog therapy. *J Clin Oncol* 1995;13:2431-2438.
99. Piro LD. Chlorodeoxyadenosine treatment of lymphoid malignancies. *Blood* 1992;79:843-845.
100. Betticher DC, von Rohr A, Ratschiller D, et al. Fewer infections, but maintained antitumor activity with lower-dose versus standard-dose cladribine in pretreated low-grade non-Hodgkin's lymphoma. *J Clin Oncol* 1998;16: 850-858.
101. Kantarjian H, Gandhi V, Cortez J, et al. Phase 2 clinical and pharmacologic study of clofarabine in patients with refractory or relapsed acute leukemia. *Blood* 2003;102:2379-2386.
102. Klohs WD, Kraker AJ. Pentostatin: future directions. *Pharmacol Rev* 1992;44:459-477.
103. Johnston JB. Mechanism of action of pentostatin and cladribine in hairy cell leukemia. *Leuk Lymph* 2011;52:43-45.
104. Malspeis L, Weinrib AB, Staubus AE, et al. Clinical pharmacokinetics of 2'-deoxycoformycin. *Cancer Treat Symp* 1984;2:7-15.
105. Kane BJ, Kuhn JG, Roush MK. Pentostatin: an adenosine deaminase inhibitor for the treatment of hairy cell leukemia. *Ann Pharmacother* 1992;26:939-946.
106. Lane AA, Chabner BA. Histone deacetylase inhibitors in cancer therapy. *J Clin Oncol* 2009;27:5454-5468.
107. Herman JC, Boylston SB. Gene silencing in cancer associated with promoter hypermethylation. *N Eng J Med* 2003;349:2042-2054.
108. Prince HM, Bishton MJ, Harrison SJ. Clinical studies of histone deacetylase inhibitors. *Clin Cancer Res* 2009;15:3958-3960.
109. Richon VM, Gargia-Vargas J, Hardwick JS. Development of vorinostat: current applications and future use. *Cancer Lett* 2009;280:201-2010.
110. Stressemann C, Lyko F. Modes of action of the DNA methyltransferase inhibitors azacytidine and decitabine. *Int J Cancer* 2008;123:8-13.
111. Momparler RL. Pharmacology of 5-aza-2--deoxycytidine (decitabine). *Semin Hematol* 2005;42:57-516.
112. Grant S, Easley C, Kirkpatrick P. Vorinostat. *Nat Rev Drug Discov* 2007;6:21-22.
113. Amigo LS, Osorio RF, Vilchez SM, et al. Azacytidine adverse events in patients with myelodysplastic syndromes. *Adv Ther* 2011;28:6-11.
114. Smets LA, van der Berg JD. BCL-2-expression and glucocorticoid-induced apoptosis of leukemia and lymphoma cells. *Leuk Lymphoma* 1996;20:199-205.
115. Melby JC. Clinical pharmacology of systemic corticosteroids. *Ann Rev Pharmacol Toxicol* 1977;17:511-527.
116. Fardet L, Flahault A, Kettaneh A, et al. Corticosteroid-induced clinical adverse events: frequency, risk factors and patient's opinion. *Br J Dermatol* 2007;157:142-148.
117. Correia JJ. Effect of antimetabolic agents on tubulin-nucleotide interactions. *Pharmacol Ther* 1991;52:127-147.
118. Gilding CE, Kallie SJ, Kamps WA, et al. Vincristine revisited. *Crit Rev Oncol-Hematol* 1999;29:267-287.
119. Zhou XJ, Rahmani R. Preclinical and clinical pharmacology of vinca alkaloids. *Drugs* 1992;44(Suppl 4):1-16.
120. Chan JD. Pharmacokinetic drug interactions of vinca alkaloids: summary of case reports. *Pharmacotherapy* 1998;18:1304-1307.
121. Legha SS. Vincristine neurotoxicity: pathophysiology and management. *Med Toxicol* 1986;1:421-427.

122. Rowinsky EK, Donehower RC. The clinical pharmacology and use of antimicrotubule agents in cancer chemotherapeutics. *Pharmacol Ther* 1991;52:35-84.
123. Budman DR. Vinorelbine (Navelbine): a third generation vinca alkaloid. *Cancer Invest* 1997;15:475-490.
124. Dillman RO. Cancer immunotherapy. *Cancer Biol Radiopharm* 2011;26:1-64.
125. Maloney DG. Anti-CD20 antibody therapy for B-cell lymphomas. *N Eng J Med* 2012;366:2008-2016.
126. Cheson BD. Ofatumumab, a novel anti-CD20 monoclonal antibody for the treatment of B-cell malignancies. *J Clin Oncol* 2010;28:3525-3530.
127. Pawluczkwycz AW, Beurskens FJ, Beum PV, et al. Binding of submaximal C1q promotes complement-dependent cytotoxicity (CDC) of B cells opsonized with anti-CD20 mAbs ofatumumab (OFA) or rituximab (RTX): considerably higher levels of CDC are induced by OFA than by RTX. *J Immunol* 2009;183:749.
128. Plosker GI, Figgitt OP. Rituximab: a review of its use in non-Hodgkin's lymphoma and chronic lymphocytic leukemia. *Drugs* 2003;63:803-843.
129. Sanford M, McCormack PL. Ofatumumab. *Drugs* 2010;70:1013-1019.
130. Bosch X, Saiz A, Ramos-Casais M. Monoclonal antibody therapy-associated neurological disorders. *Nat Rev Neurosci*. 2011;7:165-172.
131. Cheson BD. Radioimmunotherapy of non-Hodgkin lymphomas. *Blood* 2003;101:391-398.
132. Zelenetz AD, A clinical and scientific overview of tositumomab and iodine¹³¹ tositumomab. *Semin Oncol* 2003;30(Suppl 4):22-30.
133. Press OW, Eary JF, Appelbaum FR, et al. Radiolabeled-antibody therapy of B-cell lymphoma with autologous bone marrow support. *N Engl J Med* 1993;329:1219-1224.
134. Czuczman MS, Emmanouilides C, Darif M, et al. Treatment-related myelodysplastic syndrome and acute myelogenous leukemia in patients treated with ibritumomab Tiuxetan radioimmunotherapy. *J Clin Oncol* 2007;25:4285-4290.
135. Nuckel H, Frey UH, Roth A, et al. Alemtuzumab induces enhanced apoptosis in vitro in B-cells from patients with chronic lymphocytic leukemia by antibody-dependent cellular cytotoxicity. *Eur J Pharmacol* 2005;514:217-224.
136. Elter T, Hallek M, Montillo M. Alemtuzumab: what is the secret to safe therapy? *Clin Adv Hematol Oncol*. 2011;9:364-373.
137. Younes A, Yasothan U, Kirkpatrick P. Bentuximab vedotin. *Nature Rev Drug Discov* 2012;11:19-20
138. Pao B, Advani R, Brice P, et al. Bretuximab vedotin (SGN-35) in patients with relapsed or refractory systemic anaplastic large cell lymphoma: results of a phase II study. *J Clin Oncol* 2012;30:2190-2196.
139. Younas A, Bartlett NJ, Leonard JP, et al. Brentuximab vedotin (SGN-35) for relapsed CD30-positive lymphomas. *N Engl J Med* 2010;363:1812-1821.
140. Foss F. Clinical experience with denileuken diftitox (Ontak). *Semin Oncol* 2006;335(Suppl 1):11-16.
141. Manoukian G, Hagemester F. Denileukin diftitox: a novel immunotoxin. *Expert Opin Biol Ther*. 2009;9:1445-1451.
142. Olsen E, Duvic M, Frankel A, et al. Pivotal phase III trial of two dose levels of denileukin diftitox for the treatment of cutaneous T-cell lymphoma. *J Clin Oncol* 2001;19:376-388.
143. Warrel RP Jr, Frankel SR, Miller WH. Differentiation therapy of acute promyelocytic leukemia with tretinoin (all-trans-acid). *N Engl J Med* 1991;324:1385-1393.
144. Melnick A, Licht JD. Deconstructing a disease: RAR α , its fusion partners and their roles in promyelocytic leukemia. *Blood* 1999;93:3167-3215.
145. Rgazzi MD, Iacona I, Gervasutti C, et al. Clinical pharmacokinetics of tretinoin. *Clin Pharmacokinet* 1997;32:382-402.
146. Marill J, Idres N, Capron C, et al. Retinoic acid metabolism and mechanism of action: a review. *Curr Drug Metab* 2003;4:1-10.
147. Montesinos P, Bergua JM, Vellenga E, et al. Differentiation syndrome in patients with acute promyelocytic leukemia treated with all-trans retinoic acid and anthracycline chemotherapy: characteristics, outcomes, and prognostic factors. *Blood* 2009;113:775-796.

148. Jick SS, Terris BZ, Jick H. First trimester topical retinoic and congenital disorders. *Lancet* 1993;341:1181-1182.
149. Mangelsdorf DF, Thummel C, Beato M. The nuclear receptor superfamily: the second decade. *Cell* 1995;83:835-839.
150. Querfeld C, Nagelli LV, Rosen ST, et al. Bexarotene in the treatment of cutaneous T-cell lymphoma. *Expert Opin Pharmacother* 2006;7:907-915.
151. Duvic M, Hymes K, Heald P, et al. Bexarotene is effective and safe for treatment of refractory advanced-stage cutaneous T-cell lymphoma: multinational phase II-III trial results. *J Clin Oncol* 2001;19:2456-2471.
152. Wong SF. Oral bexarotene in the treatment of cutaneous T-cell lymphoma. *Ann Pharmacother* 2001;35:1056-1065.
153. Sawyers CL. Chronic myelogenous leukemia, *N Engl J Med* 1999;340: 1330-1340.
154. Savage DG, Antman KH. Imatinib mesylate—a new oral targeted therapy. *N Engl J Med* 2002;346:683-693.
155. Ping B, Lloyd P, Schran H. Clin pharmacokinetics of imatinib. *Clin Pharmacokinet* 2005;44:879-894.
156. Ramanathan RK, Egorin MJ, Takimoto CH, et al. Phase I and pharmacokinetic study of imatinib mesylate in patients with advanced malignancies and varying degrees of liver dysfunction: a study by the National Cancer Institute Organ Dysfunction Working Group. *J Clin Oncol* 2008;26:563-569.
157. Gibbons J, Egorin MJ, Ramanathan RK, et al. Phase I and pharmacokinetic study of imatinib mesylate in patients with advanced malignancies and varying degrees of renal dysfunction: a study by the National Cancer Institute Organ Dysfunction Working Group. *J Clin Oncol* 2008;26:570-576.
158. Haouala A, Widmer N, Durchosal MA, et al. Drug interactions with the tyrosine kinase inhibitors imatinib, dasatinib and nilotinib. *Blood* 2011;117: e75-e87.
159. Kantarjian H, Sawyers C, Hochhaus A, et al. Hematologic and cytogenetic responses to imatinib mesylate in chronic myelogenous leukemia. *N Engl J Med* 2002;346:645-652.
160. Shah NP, Tran C, Lee FY, et al. Overriding imatinib resistance with a novel ABL kinase inhibitor. *Science* 2004;305:399-401.
161. Shayani S. Dasatinib, a multikinase inhibitor: therapy, safety, and appropriate management of adverse events. *Ther Drug Monit* 2010;32:680-687.
162. Dasatinib (Sprycell) for CML and Ph⁺ ALL. *Med Lett* 2007;49:6-7.
163. Kantarjian H, Giles F, Gatterman N, et al. Nilotinib (formerly AMN107), a highly selective BCR-ABL tyrosine kinase inhibitor, is effective in patients with Philadelphia chromosome-positive chronic myelogenous leukemia in chronic phase following imatinib resistance and tolerance. *Blood* 2007;110:3540-3546.
164. Deininger MW. Nilotinib. *Clin Cancer Res* 2008;14:4027-4031.
165. Ruschak AM, Slassi M, Kay LE, et al. Novel proteasome inhibitors to overcome bortezomib resistance. *J. Natl Cancer Inst* 2011;103:1007-1117.
166. Voorhees PH, Orlowski RZ. The proteasome and proteasome inhibitors in cancer therapy. *Ann Rev Pharmacol Toxicol* 2006;46:189-213.
167. Jagannath D, Bartologie B, Berenson J, et al. Bortezomib in recurrent and/or refractory multiple myeloma. Initial experience in patients with impaired renal function. *Cancer* 2005;103:1195-1200.
168. Curran MP, McKeage K. Bortezomib: a review of its use in patients with multiple myeloma. *Drugs* 2009;69:859-888.
169. Richardson PG, Sonneveld P, Schuster MW, et al. Reversibility of symptomatic peripheral neuropathy with bortezomib in the Phase III APEX trial in relapsed multiple myeloma: impact of a dose modification guideline. *Brit J Hematol* 2009;144:895-903.
170. Pommier Y, Leo E, Zhang H, Marchand C. DNA topoisomerases and their poisoning by anticancer and antibacterial drugs. *Chem Biol.* 2010;17:421-433.
171. Osheroff N. Effect of antineoplastic agents on the DNA cleavage/relegation reaction of eukaryotic topoisomerase II: inhibition of DNA relegation by etoposide. *Biochemistry* 1989;28:6157-6160.
172. Johnson SA, Richardson DS. Anthracyclines in haematology: pharmacokinetics and clinical studies. *Blood Rev* 1998;12:52-71.

173. Borchmann P, Hubel K, Schnell R, et al. Idarubicin: a brief overview on pharmacology and clinical use. *Int J Clin Pharmacol Ther* 1997;35:80-83.
174. Coukell AJ, Faulds D. Epirubicin: an updated review of its pharmacodynamic and pharmacokinetic properties and therapeutic efficacy in the management of breast cancer. *Drugs* 1997;53:453-482.
175. Gill PS, Espina BM, Muggia F, et al. Phase I/II clinical and pharmacokinetic evaluation of liposomal daunorubicin. *J Clin Oncol* 1995;13:996-1003.
176. Gabizon A, Shmeeda H, and Barenholz Y. Pharmacokinetics of pegylated liposomal doxorubicin: review of animal and human studies. *Clin Pharmacokinet* 2003;42:419-436.
177. Smith LA, Cornelius VR, Plummer CJ, et al. Cardiotoxicity of anthracycline agents for the treatment of cancer: systematic review and meta-analysis of randomized controlled trials. *BMC Cancer* 2010;10:337.
178. Shadle SE, Bammell BP, Cusack BJ, et al. Daunorubicin cardiotoxicity: evidence for the importance of the quinone moiety in a free-radical-independent mechanism. *Biochem Pharmacol* 2000;60:1435-1444.
179. Faulds D, Balfour JA, Chrisp P, et al. Mitoxantrone: a review of its pharmacodynamic and pharmacokinetic properties, and therapeutic potential in the chemotherapy of cancer. *Drugs* 1991;41:400-449.
180. Posner LE, Dukart G, Goldberg J, et al. Mitoxantrone: an overview of safety and toxicity. *Invest New Drugs* 1985;3:123-132.
181. Hande KR. Etoposide: four decades of development of a topoisomerase II inhibitor. *Eur J Cancer* 1998;34:1514-1521.
182. Yang J, Bogni A, Schnetz EG, et al. Etoposide pathway. *Pharmacogenetics Genomics* 2009;19:552-553.
183. Relling MV, Pui CH, Sandlund JT, et al. Adverse effect of anticonvulsants on efficacy of chemotherapy for acute lymphoblastic leukaemia. *Lancet* 2000;356:285-290.
184. Hande KR, Messenger M, Wagner J, et al. Inter- and inpatient variability in etoposide kinetics with oral and intravenous drug administration. *Clin Cancer Res* 1999;5:2742-2747.
185. Thompson DS, Greco A, Miller AA, et al. A phase I study of etoposide phosphate administered as a daily 30-minute infusion for 5 days. *Clin Pharmacol Ther* 1995;57:499-507.
186. Pui CH, Relling MV. Topoisomerase II inhibitor-related acute myeloid leukemia. *Br J Haematol* 2000;109:13-23.
187. Reed E. Cisplatin. *Cancer Chemother Biol Res* 1996;16:88-110.
188. Saris CP, van der Vaart PJ, Reitelback RC, et al. In vitro formation of DNA adducts by cisplatin, lobaplatin and oxaliplatin in calf thymus DNA in solution and cultured cells. *Carcinogenesis* 1996;17:2763-2769.
189. Go RS, Adjei AA. Review of the comparative pharmacology and clinical activity of cisplatin and carboplatin. *J Clin Oncol* 1999;17:409-422.
190. Chu G. Cellular responses to cisplatin. The roles of DNA-binding proteins and DNA repair. *J Biol Chem* 1994;269:787-790.
191. O'Dwyer PJ, Stevenson JP, Johnson SW. Clinical pharmacokinetics and administration of established platinum drugs. *Drugs* 2000;59:19-27.
192. Calvert AH, Newell DR, Gimbrell LA, et al. Carboplatin dosage: prospective evaluation of a simple formula based on renal function. *J Clin Oncol* 1984;7: 1748-1756.
193. Takimoto C, Graham MA, Lockwood G, et al. Oxaliplatin pharmacokinetics and pharmacodynamics in adult cancer patients with impaired renal function. *Clin Cancer Res* 2007;13:4832-4839.
194. Blachley JD, Hill JB. Renal and electrolyte disturbances associated with cisplatin. *Ann Intern Med* 1981;95:628-632.
195. Lannay-Vacher V, Rey JB, Isnard-Bognis C, et al. Prevention of cisplatin nephrotoxicity: state of the art and recommendations of the ESCP. *Cancer Chemother Pharmacol* 2008;61:903-909.
196. McKeage MJ. Comparative adverse effect profiles of platinum drugs. *Drug Safety* 1995;13:228-244.
197. Cassidy J, Misset JL. Oxaliplatin-related side effects: characteristics and management. *Semin Oncol*, 2002;29(5 Suppl 15):11-20.

198. Silverstein MN, Pettitt RM, Solbert LA, et al. Anagrelide: a new drug for treating thrombosis. *N Engl J Med* 1988;318:1292-1294.
199. Ahluwalia M, Donovan H, Singh H, et al. Anagrelide represses GATA-1 and FOG-1 expression without interfering with thrombopoietin receptor signal transductions. *J Thromb Haemost* 2010;8:2252-2261.
200. Wagstaff AJ, Keating GM. Anagrelide: a review of its use in the management of essential thrombocytopenia. *Drugs* 2006;66:111-131.
201. Broome JD. Evidence that the L-asparaginase of guinea pig serum is responsible for its antilymphoma effects: properties of the L-asparaginase of guinea pig serum in relation to those of the antilymphoma substance. *J Exp Med* 1963;118:99-120.
202. Avramis VI, Panosynan E. Pharmacokinetic/pharmacodynamic relationships of asparaginase formulations: the past, the present and recommendations for the future. *Clin Pharmacokinet* 2005;44:367-393.
203. Oettgen HF, Stephenson PA, Schwartz MK, et al. Toxicity of *E. coli* L-asparaginase in man. *Cancer* 1970;25:253-278.
204. Soignet SL, Maslak P, Wang ZG, et al. Complete remission after treatment of acute promyelocytic leukemia with arsenic trioxide. *N Engl J Med* 1998;339:1341-1348.
205. Emadi A and Gore SD. Arsenic trioxide—an old drug rediscovered. *Blood Rev* 2010;24:191-199.
206. Fujisawa S, Ohno R, Shigeno K, et al. Pharmacokinetics of arsenic species in Japanese patients with relapsed or refractory acute promyelocytic leukemia treated with arsenic trioxide. *Cancer Chemother Pharmacol* 2007;59:485-493.
207. Lazo JS. Bleomycin. *Cancer Chemother Biol Res* 1999;18:39-45.
208. Chen J, Stubbe J. Bleomycins: towards better therapeutics. *Nat Rev Cancer* 2005;5:102-112.
209. Crooke ST, Comis RL, Einhorn LH, et al. Effects of variation in renal function on the clinical pharmacology of bleomycin administered as an IV bolus. *Cancer Treat Rep* 1977;61:6131-1636.
210. Dalglish AG, Woods RL, Levi JA. Bleomycin pulmonary toxicity: its relationship to renal dysfunction. *Med Pediatr Oncol* 1984;12:313-317.
211. Howell SB, Schiefer M, Andrews PA, et al. The pharmacology of intraperitoneally administered bleomycin. *J Clin Oncol* 1987;5:2009-2016.
212. Lam MSH. The need for routing bleomycin test dosing in the 21st century. *Ann Pharmacother* 2005;1897-1902.
213. Sleijfer S. Bleomycin-induced pneumonitis. *Chest* 2001;120:617-624.
214. Azambuja E, Fleck JF, Batista RG, et al. Bleomycin lung toxicity: who are the patients with increased risk? *Pulm Pharmacol Ther* 2005;18:363-366.
215. Graner D, Einhorn S. Interferon and malignant disease—how does it work and why doesn't it always? *Acta Oncol* 1998;37:331-338.
216. Bekisz J, Schmeisser H, Hernandez J, et al. Human interferons alpha, beta and omega. *Growth Factors* 2004;22:243-251.
217. Houglum JE. Interferon. mechanisms of action and clinical value. *Clin Pharm* 1983;2:20-28.
218. Radwanski E, Perentesis G, Jacobs S, et al. Pharmacokinetics of interferon alpha-2b in healthy volunteers. *J Clin Pharmacol* 1987;27:432-435.
219. Quesada JR, Talpaz M, Rios A, et al. Clinical toxicity of interferons in cancer patients: a review. *J Clin Oncol* 1986;7:234-243.
220. Borden EC, Parkinson D. Interferons: effectiveness, toxicities and cost. *Ann Intern Med* 1996;125:614-616.
221. Trosk PC, Esper P, Riba M, et al. Psychiatric side effects of interferon therapy; prevalence, proposed mechanisms and future direction. *J Clin Oncol* 2000;18:2316-2326.
222. Anderson KM. Lenalidomide and thalidomide: mechanism of action—similarities and differences. *Sem Hematol* 2005;42:3-8.
223. Teo SK, Colburn WA, Tracewell WG, et al. Clinical pharmacokinetics of thalidomide. *Clin Pharmacokinet* 2004;43:311-327.

224. Chen N, Wen L, Lau H, et al. Pharmacokinetics, metabolism and excretion of [¹⁴C]-lenalidomide following oral administration in healthy male subjects. *Cancer Chemother Pharmacol* 2012;69:789-797.
225. Scott LJ, Liseng-Williamson KA. Lenalidomide: a review of its use in the treatment of relapsed or refractory multiple myeloma. *Drugs* 2011;71:625-649.
226. Rajkumar SV. Thalidomide: tragic past and promising future. *Mayo Clin Proc* 2004;79:899-903.
227. Mileskin L, Stark R, Day B, et al. Development of neuropathy in patients with myeloma treated with thalidomide: patterns of occurrence and the role of electrophysiologic monitoring. *J Clin Oncol* 2006;24:4507-4514.
228. Musallam KM, Dahdaleh FS, Shamseddine AI, Taher AT. Incidence and prophylaxis of venous thromboembolic events in multiple myeloma patients receiving immunomodulatory therapy. *Thromb Res* 2009;123: 679-686.
229. Palumbo A, Hajek R, Delforge M, et al. Continuous lenalidomide for newly diagnosed multiple myeloma. *N Engl J Med* 2012;336:1759-1769.
230. Witzig TM, Gupta M. Signal transduction inhibitor therapy for lymphoma. *Hematology (ASH)* 2010;2010:265-270.
231. Irvine DA, Copland M. Targeting hedgehog in hematologic malignancy. *Blood* 2012;119:196-204.
232. Sansone p, Bromberg J. Targeting the interleukin 6/Jak/stat pathway in human malignancy. *J Clin Oncol* 2012;30:1005-1014.
233. Liu X, Newton RC, Scherle PA. Development of cMet pathway inhibitors. *Expert Opin Invest Drugs* 2011;20:1225-1241.
234. Bates S. Antibody conjugates: the future is now. *Clin Cancer Res* 2100;17:6388.
235. Topp MS, Kufer P, Gokbuget N, et al. Targeted therapy with the T-cell engaging antibody blinatumomab of chemotherapy-refractory minimal residual disease in B-lineage acute lymphoblastic leukemia patients results in high response rate and prolonged leukemia-free survival. *J Clin Oncol* 2011;29:2493-2498.
236. Swords R, Freeman C, Giles F. Targeting the FMS-like tyrosine kinase 3 in acute myeloid leukemia. *Leukemia* 2012; online 22 May: 1-10.
237. Lannutti BJ, Meadows SA, Herman SEM, et al. CAL-101, a p110δ selective phosphatidylinositol-3-kinase inhibitor for the treatment of B-cell malignancies, inhibits PI3K signaling and cellular viability. *Blood* 2011;117:594.
238. Anderson KC. The 39th David A. Karnofsky Lecture: bench to bedside translation of targeted therapies in multiple myeloma. *J Clin Oncol* 2012;30:445-452.
239. Lesterhuis JB, Haanen, AG, Cornelis JA, et al. Cancer immunotherapy—revisited. *Nat Rev Drug Discov* 2010;10:591-600.
240. Porter DL, Levine BL, Kalos M, et al. Chimeric antigen receptor-modified T cells in chronic lymphoid leukemia. *N Engl J Med* 2011;365:725-733.

Chapter 69 Supportive Care in Hematologic Malignancies

> Table of Contents > Part VII - Hematologic Malignancies > Section 1 - General Aspects > Chapter 69 - Supportive Care in Hematologic Malignancies

Chapter 69

Supportive Care in Hematologic Malignancies

Andrew J. Moore

Mary A. Vu

Stephen A. Strickland

Patients with hematologic neoplasms are at significant risk for complications both from the malignancy as well as the required therapy. The morbidity and mortality associated with the expected cytopenias, the therapeutic modalities, as well as the potential organ impairment present significant challenges to patients and health care providers alike. The frequency and severity of these complications vary among patients and according to the underlying disease process. Continued investigation and advances in antibiotics, antiemetics, and palliative therapies are allowing us to better meet the ever changing needs of our patients and ensure the provision of quality care. This chapter provides an overview of

current recommendations and recent advances in the management of challenges encountered in the care of patients with hematopoietic malignancies.

INFECTIOUS DISEASE ISSUES RELATED TO HEMATOLOGIC MALIGNANCY

Deficits in Host Defense

Patients with hematologic malignancies are at increased risk for infection due to impaired host defense from the underlying malignancy along with concomitant illnesses or extrinsic factors including marrow-suppressive therapy. Hematologic malignancies are often associated with specific or global immune abnormalities that result in increased frequency of infections or opportunistic infections even in the absence of treatment. Understanding the different risk factors in the individual patient allows appropriate preventive strategies and treatments to be implemented more effectively. Defects in host defense mechanisms associated with specific malignancy are outlined in Table 69.1, whereas Table 69.2 identifies opportunistic infections by the host defects, such as those caused by impairment of phagocytosis (mainly neutropenia), defective production of circulating antibody (humoral immunity), and impaired cellular immunity. Concomitant illnesses, such as diabetes, nephrotic syndrome, cardiac disease, and liver disease contribute to infection risk and influence management decisions.¹

Neutrophil Defects

Neutrophils play a critical role in the innate immune response, mediating both antimicrobial and inflammatory responses. They are produced in the bone marrow under the influence of an array of cytokines. Mature neutrophils circulate in the peripheral blood for only 3 to 6 hours, placing a demand on the marrow for an impressive capacity for constitutive neutrophil production that can be rapidly upregulated in response to acute bacterial, fungal, or inflammatory stresses.² Deficits in neutrophil number and functional defects of mature neutrophils predispose to life-threatening infections, while disruption of the maturation sequence underlies the pathophysiology of myelodysplasia and leukemia.

Neutropenia, defined as a decrease of the peripheral blood neutrophil count below $0.1 \times 10^9/L$, predisposes to bacterial and fungal infections. The severity ($0.1 \times 10^9/L$) and length of neutropenia (>2 weeks) contribute to the risk of serious infections.³ Neutropenia is usually caused by decreased production. Localizing signs and symptoms are often absent in the setting of severe neutropenia because of a lack of inflammatory response from absent granulocytes. Fever remains the most common sign of infection associated with neutropenia.

Neutropenia is a common complication of acute leukemia (AL) and is often prolonged during induction therapy.⁴ In chronic myeloid leukemia (CML), neutropenia typically occurs with the development of blast crisis, with the evolution of myelofibrosis (MF), or with therapy. Mild neutropenia is observed in patients with MF and multiple myeloma (MM), but it is uncommon during untreated phases. Neutropenia occurring in patients with Hodgkin lymphoma (HL) or non-Hodgkin lymphoma (NHL) is typically a result of marrow invasion with tumor or marrow fibrosis and occurs in conjunction with other cytopenias. Hairy cell leukemia patients may become neutropenic secondary to tumor cell invasion, splenomegaly, or both, but may also result from defects in cell-mediated immunity, monocytopenia, and decreased T cells after nucleoside analog therapy.⁵ In patients with T cell large granular lymphocytic leukemia, neutropenia may be the primary problem.

Functional defects in morphologically normal neutrophils have been described in hematologic malignancies, particularly myeloproliferative neoplasms (MPNs) and myelodysplastic syndrome (MDS).⁶ Such defects increase the susceptibility to infection.⁷ Neutrophils from untreated patients with CML may be mildly defective with respect to phagocytosis, oxygen consumption, and bactericidal capacity, and tend to have decreased concentrations of lactoferrin, elastase, collagenase, and peroxidase.⁸ Myeloblasts and lymphoblasts found in AL patients are of no benefit to the host against infection.

Deficient Immunoglobulin Production

The humoral immune response is one of the two main arms of the immune system. In this response, the immune system triggers specific B cells to proliferate and secrete their specific antibodies. Impaired humoral immunity is a major cause of frequent and severe infection in patients with hematologic malignancies. A decrease in Th2 CD4 T-lymphocyte-B-lymphocyte interaction results in decreased antibody production, complement-mediated damage, and phagocytosis. Diminished immunoglobulin synthesis is a major contributor to infection in patients with CLL, MM, and some B cell types of NHL.^{9,10,11} Myeloma and other plasma cell dyscrasias are often functionally hypogammaglobulinemic despite elevated total immunoglobulin. Splenectomized patients have impaired antibody response, reduced levels of tuftsin (natural activator of phagocyte cells), and are at increased risk for infections similar to those of patients with hypogammaglobulinemia, particularly encapsulated organisms (*Streptococcus pneumoniae*, *Haemophilus influenzae*, and *Neisseria meningitidis*).¹²

Defects in Cellular Immunity

Cellular immunity comprised of T lymphocytes, macrophages, and natural killer cells recognizes and combats pathogens that proliferate intracellularly. Cellular immune mechanisms are important in immunity to all classes of infectious agents, including most viruses and many bacteria (e.g., *Mycoplasma*, *Chlamydia*, *Listeria*, *Salmonella*, and *Mycobacterium*), parasites (e.g., *Trypanosoma*, *Toxoplasma*, and *Leishmania*), and fungi (e.g., *Histoplasma*, *Cryptococcus*, and *Coccidioides*).¹³ T lymphocytes are activated by dendritic cells, macrophages, and B lymphocytes, which present foreign antigens in the context of the host's own major histocompatibility complex antigen to the T cell receptor. Activated T cells then act in several ways to fight infection. Cytotoxic CD8⁺ T cells directly attack and lyse host cells that express foreign antigens. Helper CD4⁺ T cells stimulate the proliferation of B cells and the

P.1427

production of immunoglobulins. Defects in cell-mediated immunity characterized by impaired Th1 CD4⁺ T lymphocytes and/or macrophage function results in increased risk of infections with intracellular bacteria, fungi, parasites, and viruses (Table 69.2).

TABLE 69.1 HOST DEFECTS PREDISPOSING TO COMPLICATIONS IN HEMATOLOGIC MALIGNANCIES

Disease	Host Defect	Complications
Acute myeloid leukemia	Neutropenia	Bacterial infections, including perirectal abscess, typhlitis, sinusitis; superinfections when hospitalized; increasing problem of methicillin-resistant <i>Staphylococcus aureus</i> and coagulase-negative staphylococci; <i>Clostridium difficile</i> colitis; aspergillosis with prolonged neutropenia; viral infections (herpes simplex)
	Thrombocytopenia, disseminated intravascular coagulation	Hemorrhage
	Hyperleukocytosis	Leukostasis, tumor lysis
Acute lymphoblastic leukemia	Neutropenia	Bacterial infections (see Acute myeloid leukemia)
	Cellular immunity while on maintenance therapy	<i>Pneumocystis jirovecii</i> , disseminated varicella
	Thrombocytopenia	Hemorrhage
Chronic myeloid leukemia	Hyperleukocytosis	Tumor lysis, leukostasis
	Mild defects in neutrophil function	No increased risk of infections except in blast crisis
	Thrombocytosis, platelet dysfunction	Increased risk of thrombosis and hemorrhage, similar to other myeloproliferative disorders
Chronic lymphocytic leukemia	Decreased immunoglobulins	Infections with encapsulated organisms (pneumococcus, <i>Haemophilus influenzae</i> , meningococcus)
	Cellular immunity	Mycobacteria, fungal, viral (herpetic), <i>Salmonella</i>
Hodgkin lymphoma	Immune dysfunction	AIHA, ITP, red cell aplasia
	Cellular immunity	Viral (herpes zoster, other), <i>P. jiroveci</i> , fungal, mycobacteria, listeriosis, <i>Salmonella</i>

	Cytokine production	B symptoms, pruritus, eosinophilia
	Splenectomized	Encapsulated organisms (above), increased risk of leukemia
	Immune dysfunction	ITP, AIHA
	Mediastinal disease	SVC syndrome
Non-Hodgkin lymphoma		
Small B cell lymphoma	Decreased Igs	Similar infections to CLL
PTCL, particularly angioimmunoblastic and subcutaneous panniculitis like PTCL	Immune dysfunction	AIHA
	Cytokine production	B symptoms, hemophagocytic syndrome, eosinophilia
Large B cell lymphoma	Mediastinal disease	SVC syndrome, pericardial disease
T-lymphoblastic lymphoma	Mediastinal disease	SVC syndrome, tumor lysis, CNS disease
Mantle cell lymphoma	Colonic polyposis	Gastrointestinal bleed
Burkitt lymphoma	Gastrointestinal primary	Obstruction, perforation, tumor lysis, CNS disease with advanced-stage disease
Multiple myeloma	Paraprotein	Hyperviscosity, hemorrhage
	Decreased Igs	Similar infections to CLL
	Osteoclast overactivity	Hypercalcemia
Waldenström macroglobulinemia	IgM paraprotein	Hyperviscosity, hemorrhage
Hairy cell leukemia	Neutropenia	Bacterial and fungal infections
	Cellular immunity	<i>P. jirovecii</i> , atypical mycobacteria
	Immune dysfunction	Periarteritis nodosa, lymphocytic vasculitis
	Monocytopenia	—
T cell large granular lymphocyte leukemia	Neutropenia	Bacterial infections
	Immune dysregulation, positive rheumatoid factor, antinuclear antibody	ITP, AIHA, red cell aplasia
Adult T cell leukemia/lymphoma	Cellular immunity	Opportunistic infections (<i>Strongyloides stercoralis</i> , <i>P. jirovecii</i>)
	Parathyroid hormone-related protein	Hypercalcemia

AIHA, autoimmune hemolytic anemia; CLL, chronic lymphocytic leukemia; CNS, central nervous system; Ig, immunoglobulin; ITP, immune thrombocytopenic purpura; PTCL, peripheral T cell lymphoma; SVC, superior vena cava.

Multiple factors determine the severity and frequency of impaired cellular immunity. There may be differences in the stages of disease studied, the therapy used, and the sensitivity of the tests used to measure cellular immunity. Patients

with HL often do not respond to new antigens and lose prior sensitivity as well.^{13,14} Patients with CLL usually show reduced or absent lymphocyte transformation with phytohemagglutinin but do not lose skin hypersensitivity to antigens such as old tuberculin.¹⁵ Patients with HL do not mount

P.1428

either a primary or a secondary immune response, whereas those with CLL maintain secondary responses but cannot mount a primary response. Depressed cellular immunity is uncommon in AL¹⁶ except during maintenance therapy in ALL.¹⁷

TABLE 69.2 OPPORTUNISTIC INFECTIONS ASSOCIATED WITH DEFECTS IN IMMUNITY IN HEMATOLOGIC NEOPLASIA

Defect	Infections
Neutropenia	Gram-negative bacteremia (<i>Escherichia coli</i> , <i>Pseudomonas</i> , <i>Klebsiella</i> , <i>Proteus</i>) Gram-positive bacteremia (methicillin-resistant <i>Staphylococcus aureus</i> , coagulase-negative staphylococci, <i>Streptococcus viridans</i>) Fungemia (<i>Candida</i> species, aspergillosis)
Humoral immunity	Encapsulated organisms <i>Streptococcus pneumoniae</i> <i>Haemophilus influenzae</i> <i>Neisseria meningitidis</i>
Cellular immunity	Bacteria <i>Listeria monocytogenes</i> Mycobacteria <i>Legionella</i> species <i>Nocardia</i> species <i>Salmonella</i> species Viruses Herpes simplex Varicella zoster Parainfluenza, respiratory syncytial virus, cytomegalovirus Fungi <i>Cryptococcus neoformans</i> <i>Coccidioides immitis</i> <i>Histoplasma capsulatum</i> <i>Pneumocystis jirovecii</i> Parasites <i>Toxoplasma gondii</i> <i>Strongyloides stercoralis</i>

Approach to Infection in the Immunocompromised Host

The initial assessment of a febrile immunocompromised host is dependent on the underlying hematologic condition and other associated risk factors. It should focus on determining the potential sites and causative organisms and assessing the patient's severity of illness. Although fever remains the most important clue to an infectious process, the characteristic signs and symptoms of infection may be absent in more than one-half of infected neutropenic patients, and routine cultures are often negative.³ It is estimated that 60% or more of neutropenic patients who become febrile have an established or occult infection.¹⁸ No known factors accurately predict which patients with fever and neutropenia are most likely to have bacteremia. As a result, a careful history and screening physical examination must be performed with special attention to the most common sites of infection: skin, oropharynx, nares, sinuses, lungs, GI tract (including perianal area), soft tissues, and indwelling catheter devices.

Risk assessment should be performed as part of the initial evaluation as it helps stratify the severity and facilitate goal-directed therapies. Assessing risk may determine the type of empiric antibiotic therapy (oral vs. intravenous), venue of treatment (inpatient vs. outpatient) and duration of antibiotic therapy. The most commonly used index for the stratification of risk for complications in febrile neutropenic patients is the Multinational Association for Supportive Care in Cancer (MASCC) index (Table 69.3).¹⁹ The following independent factors were found to be predictive of lower risk for complications: (1) burden of illness characterized by low or moderate symptoms, (2) absence of hypotension, (3) absence of chronic obstructive pulmonary disease, (4) presence of solid tumor or absence of previous fungal infection in patients with hematologic malignancies, (5) outpatient status, (6) absence of dehydration, and (7) an age less than 60 years. These variables predicting low risk were assigned an integer weight, and a risk index score consisting of the sum of these integers was derived. A score of 21 or greater identified low-risk patients with a positive predictive value of 91%, specificity of 68%, and sensitivity of 71%; whereas those with scores less than 21 are at higher risk for complications.¹⁹

In general, most experts consider high-risk patients to be those with anticipated prolonged (>7 days duration) and profound neutropenia (ANC < 0.1 × 10⁹/L) or significant medical comorbid conditions, including hypotension, pneumonia, new abdominal pain, or neurologic changes. High-risk patients warrant inpatient therapy with intravenous antibiotics. Lower-risk patients, including those with anticipated brief (<7 days duration), neutropenic periods, and few comorbidities, are candidates for empiric oral therapy.

Initial evaluation of neutropenic fever (Table 69.4) should include blood cultures, a urinalysis and urinary Gram stain, complete blood count with a differential, and blood chemistry tests to assess liver and renal function. Chest radiographs should be obtained for all patients with respiratory signs or symptoms, as well as viral swabs, and cultures of aspirated or biopsy material from accessible body sites that appear infected. At least two sets of blood cultures are recommended, with a set collected simultaneously from each lumen of an existing central venous catheter (CVC), if present, and from a peripheral vein site according to the updated guidelines from the Infectious Diseases Society of America (IDSA).³ An aggressive diagnostic workup is warranted if any localizing signs or symptoms are elicited. Patients who are unable to undergo invasive diagnostic procedures to determine an infectious etiology should be treated with empiric antibiotics until the appropriate diagnostic workup can be safely performed, or until the neutropenia resolves. Additional radiographic tests, such as computed tomography (CT) scans of the sinuses, chest, and abdomen, as well

P.1429

as examination of cerebrospinal fluid, may be necessary in selected patients. Noninfectious causes such as drug reactions, mucositis, graft-versus-host disease (GVHD) should be considered in patients with persistent fever. Superinfection with fungi or *Clostridium difficile* needs to be considered as well. Frequent reassessment of the patient's clinical status will help determine whether there is a need for additional coverage or changes to the ongoing antimicrobial regimen.

TABLE 69.3 THE MASCC RISK INDEX SCORE: DETERMINING THE RISK OF SERIOUS COMPLICATIONS IN FEBRILE NEUTROPENIA

Category	Weight
Burden of illness: no or mild symptoms	5
No hypotension	5
No chronic obstructive pulmonary disease	4
Solid tumor or no previous invasive fungal infection	4
Outpatient status	3

Burden of disease: moderate symptoms	3
No dehydration	3
Age < 60 y	2

MASCC, Multinational Association of Supportive Care in Cancer. The maximum theoretical score is 26 because the maximum favorable weight for burden of disease is 5.

Adapted from Klastersky J, Paesmans M, Rubenstein EB, et al. The Multinational Association for Supportive Care in Cancer risk index: A multinational scoring system for identifying low-risk febrile neutropenic cancer patients. *J Clin Oncol* 2000;18:3038-3051.

TABLE 69.4 EVALUATION OF FEVER IN IMMUNOCOMPROMISED PATIENTS

	Cancer		Transplantation			Acquired Immunodeficiency Syndrome	
	Low Risk	High Risk	Bone Marrow	Solid Organ	Splenectomy	Children	Adults
History and physical examination	+	+	+	+	+	+	+
Hematologic							
Complete blood cell and differential counts	+	+	+	+	±	±	±
Platelets	+	+	±	±	±	±	±
Coagulation studies	-	±	+	±	±	-	-
Microbiologic							
Nose and throat	Sx	Sx	Sx	Sx	-	-	-
Urine	+	+	+	±	-	Sx	Sx
Stool	-	-	-	-	-	Sx	Sx
Blood	+	+	+	+	+	+	+
Cytomegalovirus PCR	-	-	+	+	-	Sx	Sx
Epstein-Barr virus PCR	-	-	Sx	Sx	-	Sx	Sx
Cerebrospinal fluid	-	-	-	-	±	±	Sx ^a
Radiologic							
Chest	Sx	+	+	+	+	+	+
Sinus	-	±	±	±	-	Sx	±
Special studies ^b	Sx	Sx ^c	Sx ^d	Sx	Sx	Sx	Sx

+, indicated; -, not necessary; ±, may be necessary; Sx, when symptoms are present. PCR, polymerase chain reaction.

^a An evaluation of cerebrospinal fluid is especially important in patients with persistent fever.

^b Special studies include computed tomography and magnetic resonance imaging.

^c Abdominal computed tomography or magnetic resonance imaging to detect hepatosplenic candidiasis

should be performed in patients recovering from neutropenia who have new or persistent fever.

^d Lung computed tomography to detect pulmonary aspergillosis should be performed in patients with persistent fever and neutropenia who have had more than 1 wk of empirical therapy with antibiotics. Adapted from Pizzo PA. Fever in immunocompromised patients. *N Engl J Med* 1999;341:893-900.

Empiric Antibiotic Therapy: Current Guidelines and Regimens

The goal of initial empiric antibiotic therapy is to prevent serious morbidity and mortality due to bacterial pathogens until further culture results are available. In the early 1970s combination regimens incorporating two or three additive or synergistic drugs were used, such as antipseudomonal penicillin and an aminoglycoside. Subsequent regimens included beta-lactam and beta-lactamase inhibitor such as ticarcillin-clavulanic acid and piperacillin-tazobactam. Decades of well-studied clinical trials have not yet identified a superior empiric therapeutic regimen for the initial treatment of febrile neutropenic patients.²⁰ Effective regimens (combination or monotherapy) share certain essential features, including bactericidal activity, antipseudomonal activity, and minimal toxicity. Initial choice of antimicrobials should be based on the risk status of the patient (low vs. high), on localizing signs or symptoms of infection, and on the epidemiology of pathogens and antibiotic susceptibility patterns in individual centers. Evidence-based guidelines are available for additional guidance on antibiotic therapy for neutropenic patients with fever.^{3,21,22} An algorithm for managing patients with febrile neutropenia is provided in Figure 69.1.

Initial Antibiotics for High-risk Patients

Monotherapy with selected broad-spectrum beta-lactams with activity against *Pseudomonas* species is as effective as combination antibiotic regimens (beta-lactam plus aminoglycoside) for empiric therapy of uncomplicated fever and neutropenia, and has fewer toxicities.^{23,24} Antibiotics recommended by the IDSA as appropriate monotherapy include the following: cefepime, imipenem-cilastatin, meropenem, and piperacillin-tazobactam.³ Many centers have found that ceftazidime is no longer reliable as empiric monotherapy for neutropenic fever because of decreasing potency against gram-negative organisms and poor activity against many gram-positive pathogens, such as streptococci.^{25, 26} and ²⁷ Other antimicrobials (aminoglycosides, fluoroquinolones, and/or vancomycin) may be added to the initial regimen for management of complications such as hypotension and pneumonia, or there are specific clinical indications including suspected catheter-related infections, skin or soft-tissue infections, or if antimicrobial resistance is suspected or proven.

A meta-analysis of randomized trials involving cefepime reported that cefepime was associated with increased 30-day mortality when used for empiric therapy for neutropenic fever; however, no increase in infection-related mortality was noted.²⁸ Subsequent analysis by the FDA failed to demonstrate a statistically significant increase in 30-day mortality for cefepime-treated

P.1430

patients compared with controls, and thus concluded that cefepime remains a reasonable option for treating febrile neutropenia.^{28,29}

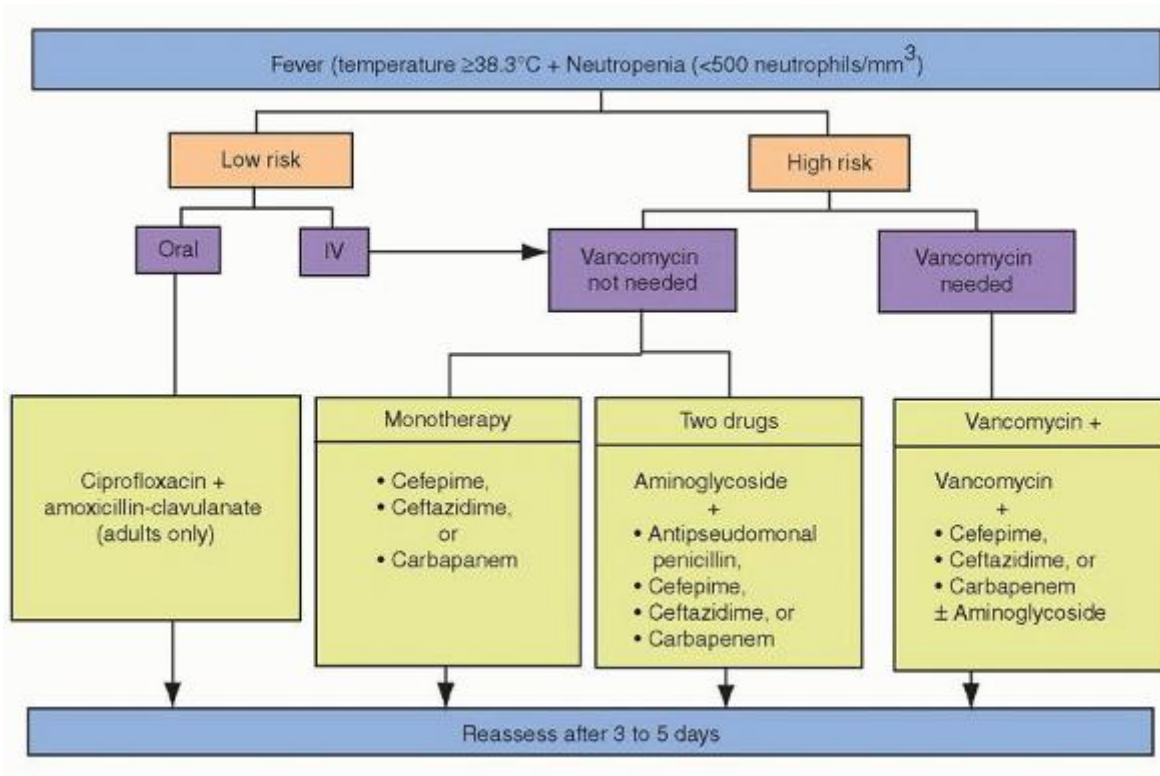

FIGURE 69.1. Empiric antibiotic regimens in febrile neutropenia.

Empiric combination therapy should be used in cases of severe sepsis or septic shock, or high prevalence of multidrug-resistant gram-negative bacilli. Effective antibiotic combinations include one of the aforementioned beta-lactams plus an aminoglycoside (choice based on local resistance, typically amikacin). Fluoroquinolones may be an acceptable alternative to aminoglycosides at institutions where prevalence of quinolone-resistant bacteria is low, or in patients with renal insufficiency. Febrile neutropenic patients with candiduria or oral thrush should also be covered by empiric antifungal therapy.

Role of Vancomycin and Other Agents in Gram-positive Coverage

Empiric vancomycin use in febrile neutropenia has led to considerable debate and concern, as the uncontrolled use of vancomycin facilitates vancomycin-resistant organisms. Randomized trial data provided by the European Organization for Research and Treatment of Cancer (EORTC) failed to demonstrate a true clinical advantage for empiric vancomycin in adults.³⁰ It decreased the number of days the patient had fever, but did not improve survival and was associated with increased incidence of nephrotoxicity and hepatotoxicity. Empiric vancomycin should therefore be reserved for specific settings during neutropenia, including (1) hypotension or septic shock without an identified pathogen, (2) clinically apparent catheter-related infection, (3) positive blood cultures with a gram-positive organism prior to identification and susceptibility testing (linezolid or daptomycin are reasonable alternatives in environments with high prevalence of vancomycin-resistant enterococcus [VRE]), or (4) known colonization with methicillin-resistant *Staphylococcus aureus* (MRSA) or penicillin-resistant *S. pneumoniae*. Consideration should also be given to discontinuation of the empiric vancomycin after 2 to 3 days if the initial cultures are negative. Vancomycin plus aztreonam is an acceptable regimen in febrile neutropenic patients with allergies to beta-lactams.³¹

Lower-risk Patients with Fever and Neutropenia

Patients with fever and neutropenia can be stratified according to their risk of developing life-threatening infectious complications.^{21,22} Outpatient management with close monitoring and follow-up may be feasible for patients with MASCC scores of 21 or greater given the lower risk of complications. The IDSA, the American Society of Clinical Oncology (ASCO), and the National Comprehensive Cancer Network (NCCN) support the use of outpatient oral antibiotic therapy in carefully selected lower-risk patients with neutropenic fever. Ciprofloxacin plus amoxicillin/clavulanate is recommended for adult patients. Clindamycin can be substituted for amoxicillin/clavulanate in patients allergic to penicillins.³ Fluoroquinolones have an importance in the outpatient management of febrile neutropenic adults since they are the only class of oral antibiotics with activity against *P. aeruginosa*.

Evaluation of Response and Duration of Therapy

Modifications of the initial antimicrobial regimen are made based on new physical findings, microbiologic data, or persistent fever that indicates a resistant organism. It often takes 3 to 5 days to determine the efficacy of the initial antibiotic regimen (Fig. 69.2). Low-risk patients may become afebrile as early as 2 days, and high-risk patients may take as long as 7 days to have a response to the antibiotics. Antibiotics should be continued for a minimum of 7 days or until the documented infection has been eradicated. It is preferable to have neutrophil recovery ($ANC > 0.5 \times 10^9/L$) before discontinuing therapy. If the patient continues to be febrile 3 to 5 days after the initiation of empiric antibiotics, one of three choices can be made: continue the same antibiotics if the patient is stable and no source of infection has been found; change or add antibiotics if the patient develops a new complication, there are new findings on evaluation, or the patient appears to worsen clinically; or add an antifungal drug.^{3,32}

Empiric amphotericin B has been replaced with the use of less toxic antifungals, such as caspofungin, micafungin, voriconazole, posaconazole, and the lipid formulations of amphotericin B. Risk of fungal infection (*Aspergillus* and *Candida*) rises precipitously in patients with profound neutropenia and persistent fevers after 7 to 10 days. Empiric antifungal therapy has been shown to reduce infectious mortality in patients with new or persistent fever occurring after 1 week of antibiotic therapy.^{33,34} Fluconazole is highly effective in the treatment of oropharyngeal and esophageal candidiasis and may be as effective as amphotericin B for systemic candidiasis in patients who are hemodynamically stable and have not been on antifungal prophylaxis. Broader spectrum antifungal agents are indicated in the setting of suspected *Aspergillus*,

P.1431

atypical fungi, and several clinically relevant *Candida* species (*C. krusei*, *C. tropicalis*, *C. lusitanae*, and *Torulopsis glabrata*) due to the absent or poor activity of fluconazole against these organisms.

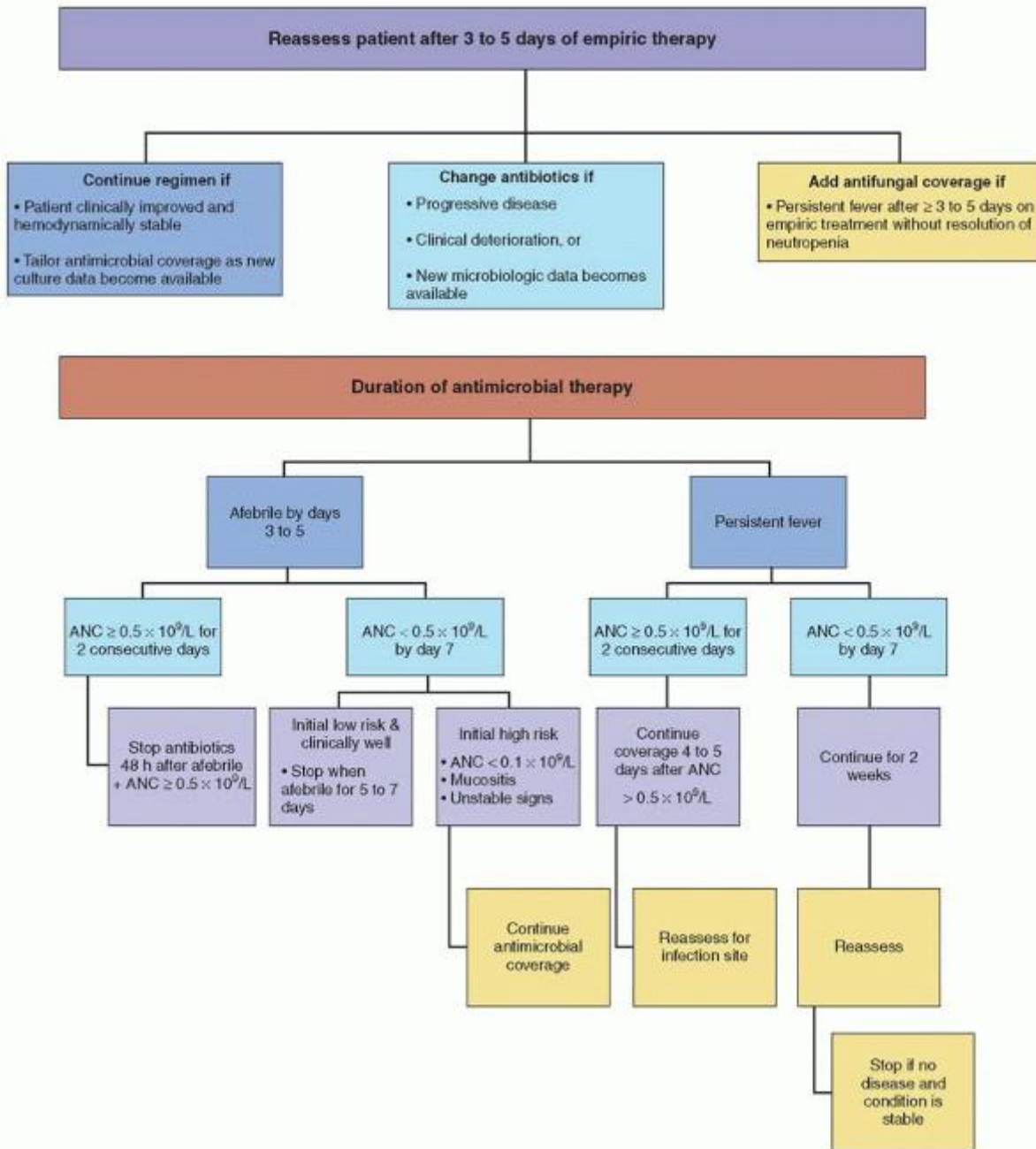

FIGURE 69.2. Common modifications of empiric antimicrobial therapy in the febrile neutropenic patient.

Echocardiography is recommended for *S. aureus* bloodstream infections to determine the presence or absence of endocarditis, and thus clarify the need for prolonged antibiotic therapy. Transesophageal echocardiography is more sensitive and preferred when compared with a transthoracic approach.³⁵

Myeloid Colony-stimulating Factors

Prophylactic use of myeloid colony-stimulating factors (CSFs) is common in the setting of intensive chemotherapy regimens such as stem cell transplantation. Multiple randomized clinical trials of prophylactic recombinant granulocyte colony-stimulating factor (G-CSF) and granulocyte-macrophage colony-stimulating factor (GM-CSF) have shown benefits in reducing the time to neutrophil recovery and the duration of fever and hospitalization in patients with hematologic neoplasms.^{36,37} Prophylactic G-CSF and GM-CSF in autologous and allogeneic hematopoietic stem cell transplantation (HSCT) recipients have been associated with a small reduction in the risk of documented infections but do not appear to affect infection-related or treatment-related mortality.³⁸ Empiric use of CSFs in the management of neutropenic fever is not standard practice, as no consistent benefit has been demonstrated in terms of morbidity or mortality among

randomized controlled trials of their use in patients with febrile neutropenia.^{39,40} Neither ASCO nor EORTC recommend the routine use of growth

P.1432

factors to treat episodes of febrile neutropenia unless patients are at high risk for infection-related complications, such as those older than 65 years, or those with prolonged (>10 days) and profound ($<0.1 \times 10^9/L$) neutropenia, active infection, hypotension, and/or multiorgan dysfunction^{39,40} (Fig. 69.3).

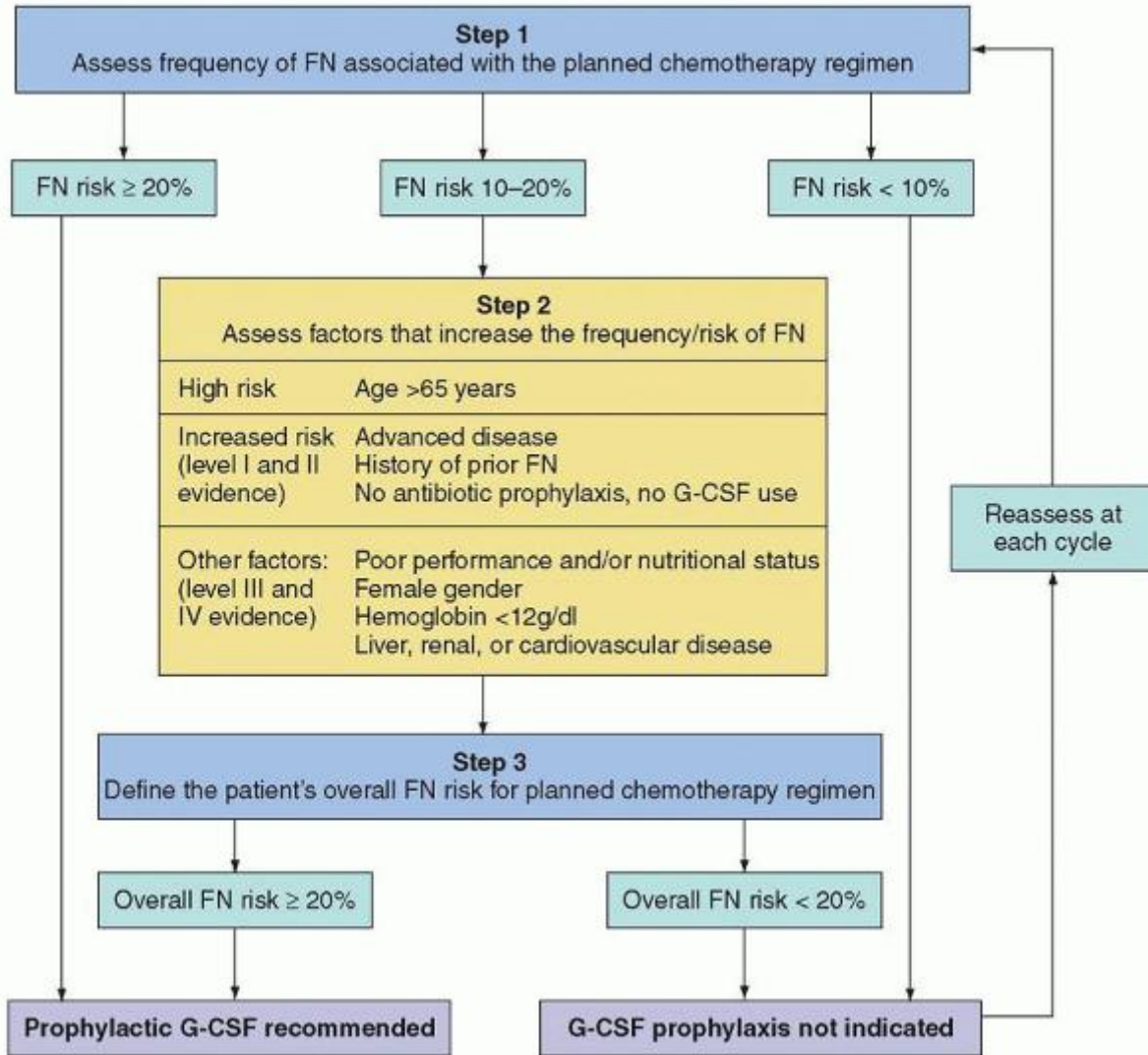

FIGURE 69.3. Algorithm to decide prophylactic G-CSF usage. FN, febrile neutropenia; G-CSF, granulocyte colony-stimulating factor. (With permission from Aapro MS, Bohlius J, Cameron DA, et al. 2010 update of EORTC guidelines for the use of granulocyte colony-stimulating factor to reduce the incidence of chemotherapy-induced febrile neutropenia in adult patients with lymphoproliferative disorders and solid tumours. *Eur J Cancer* 2011;47:8-32.)

G-CSF has a mild toxicity profile, with bone pain occurring 1 to 2 days prior to neutrophil recovery being the most common side effect. Recombinant yeast-derived GM-CSF reportedly has a better side effect profile than *E. coli*-derived GM-CSF (less fever, rash, and myalgias), although a randomized trial failed to reveal statistically significant differences.⁴¹ High-dose GM-CSF has been associated with hepatic transaminase elevation, serositis, fluid retention, venous thrombosis, and reactivation of autoimmune disease. A syndrome of hypoxemia, flushing, cardiovascular instability, musculoskeletal pain, nausea, and vomiting has also been described with intravenous GM-CSF.⁴²

Pegfilgrastim offers once-per-cycle administration compared to the required daily doses of the nonpegylated CSFs, and a single dose of pegfilgrastim has been shown to exert a prolonged effect lasting for approximately 14 days or until

neutrophil recovery.⁴³ Two small phase II trials involving lymphoma patients demonstrated similar efficacy of pegfilgrastim versus filgrastim in regards to reduction of febrile neutropenia after chemotherapy administration.^{44,45}

Granulocyte Transfusions

The role of granulocyte transfusions in the management of neutropenic fever is poorly defined. Although some small series and case report studies have attributed benefit to granulocyte transfusions in profoundly neutropenic patients with documented severe bacterial and fungal infections, others have failed to demonstrate significance.^{46,47} A Cochrane Review of 8 randomized controlled trials found the data inconclusive.^{46,48} The rationale for granulocyte transfusions is to provide support for the neutropenic patient with a life-threatening infection by augmenting the number of circulating neutrophils until autologous myeloid regeneration occurs. Rare adverse events associated with granulocyte transfusions include transmission of infections (commonly CMV), HLA alloimmunization, fever, potential transfusion associated graft-versus-host disease if granulocytes are not irradiated, and progressive platelet refractoriness. Appropriate patient selection is necessary prior to administration of granulocyte transfusions, given the risks and the marginal benefits reported.

SPECIFIC FEBRILE SYNDROMES, SELECTED PATHOGENS, AND TREATMENTS

Sepsis and Septic Shock

Severe sepsis and septic shock are associated with a high mortality rate. Published mortality rates vary between 20% and 60%.^{49,50} Common sequelae include acute respiratory distress syndrome (ARDS) and multisystem organ failure, which accounts for the high mortality of this syndrome. The source of septicemia is not apparent in 30% of cases, despite positive identification of an organism.^{50,51}

P.1433

Sepsis is defined as the presence of systemic inflammatory response syndrome (SIRS) associated with a confirmed infectious process.⁵² SIRS can be self-limited or can progress to severe sepsis and septic shock. Along this continuum, circulatory abnormalities (intravascular volume depletion, peripheral vasodilatation, myocardial depression, and increased metabolism) lead to an imbalance between systemic oxygen delivery and oxygen demand, resulting in global tissue hypoxia or shock. SIRS criteria include two or more of the following: (1) temperature greater than 38°C or less than 36°C, (2) heart rate greater than 90 beats per minute, (3) respiratory rate greater than 20 breaths per minute or a PCO₂ less than 32 mm Hg, or (4) white blood cell count greater than 12×10^9 /L or less than 4×10^9 /L, or the presence of more than 0.1×10^9 /L immature band neutrophils.⁵²

Bloodstream Infections

Bloodstream infection is a common complication of patients undergoing cytotoxic chemotherapy. Common sources include skin breakdown, intravenous catheters, as well as the digestive and respiratory tracts. Following documented bacteremia, repeat blood cultures should be obtained to confirm the effectiveness of therapy. Evaluation to identify the source of the infection should also be performed.

Gram-positive Bacteria

Staphylococcus species are the most common cause of bacteremia. Staphylococcus aureus is a coagulase positive bacteria, which commonly colonizes the nares and the skin of many individuals, and can cause both local disease (wound infection, cellulitis) and systemic disease (bacteremia, endocarditis, septic arthritis, and osteomyelitis). Removal of intravascular catheters should be considered in patients with S. aureus bacteremia. The risk of endocarditis following S. aureus bacteremia warrants a transesophageal echocardiogram to determine the absence or presence of heart valve vegetations and thus define the necessary duration of therapy.^{35,53,54,55,56} A 2-week course of intravenous antibiotics may be sufficient for S. aureus bacteremia with a negative transesophageal echocardiogram.³⁵ Nafcillin is the drug of choice for treating methicillin-susceptible S. aureus, whereas vancomycin should be reserved for MRSA or the treatment of penicillin-allergic patients.⁵⁷

Methicillin-resistant S. aureus (MRSA) is recognized as a major cause of infection in the health care setting and is now emerging in the community.⁵⁸ MRSA isolates are resistant to all beta-lactam antibiotics as well as cross-resistant to multiple classes of antibiotics. Community-acquired MRSA strains are generally susceptible to clindamycin and TMP/SMX. The standard treatment for MRSA is vancomycin. Clinical infections caused by vancomycin-intermediate and vancomycin-resistant S. aureus have been reported sporadically and generally occur only in patients receiving prolonged courses of vancomycin.⁵⁸ Failure of vancomycin in MRSA bacteremia has been associated with increasing vancomycin minimum

inhibitory concentrations well within what is currently considered the susceptible range.⁵⁹ New guidelines on vancomycin dosing and therapeutic monitoring have been published based on these observations. Serum vancomycin trough concentrations should be maintained above 10 mg/L to avoid development of resistance.⁶⁰

Linezolid and daptomycin are active against the majority of gram-positive organisms, including MRSA^{61, 62, 63, 64} and ⁶⁵; however, the use of these drugs should be limited to specific situations. Daptomycin, a bactericidal lipopeptide (6 mg/kg daily) is an acceptable option for *S. aureus* bacteremia.⁶⁶ Daptomycin is inactivated by lung surfactant and therefore should not be used to treat pneumonia. Linezolid should be used cautiously in patients with compromised bone marrow function, as myelosuppression has been associated with prolonged exposure. Thrombocytopenia occurs in 0.3% to 10% of those on linezolid and increases with the duration of use. Myeloid recovery of neutropenic cancer patients is not delayed with short courses; however, data for prolonged exposure (greater than 14 days) is limited.^{41,61} Linezolid is not approved for treatment of catheter-related infections or gram-negative infections, as these patients have a higher chance of death compared with those receiving vancomycin or oxacillin for intravascular catheter-related infection with gram-positive and gram-negative organisms.⁶⁷ Linezolid seems at least as effective as vancomycin against nosocomial MRSA pneumonia in most published studies, although a controversial post hoc subgroup analysis suggests linezolid has a slight advantage over vancomycin on survival and cure rates.^{68,69} The American Thoracic Society and IDSA guidelines on nosocomial MRSA pneumonia consider linezolid and vancomycin to each be acceptable options for suspected or proven MRSA pneumonia.⁷⁰

Neutropenic patients with severe mucositis are at increased risk for bacteremia with viridans group streptococci (VGS), a commensal normal oral flora. Other risk factors for VGS include prophylaxis with TMP/SMX or fluoroquinolones and the use of histamine-2 blockers.⁷¹ Neutropenic patients with VGS bacteremia may have a low-grade fever and facial flushing prodrome followed by high fever and chills. Complications include toxic-shock-like syndrome characterized by hypotension, respiratory distress, renal failure, and a centrifugal maculopapular rash usually starting on the trunk with subsequent desquamation of the palms and soles. Septic shock may be more common in children than in adults.⁷² Resistance of VGS to beta-lactams has been recognized and empiric use of vancomycin as initial therapy is recommended pending susceptibility testing.

Vancomycin-resistant enterococcus (VRE) bloodstream infection is an important cause of morbidity. The portal of entry for enterococcal bacteremia may be an indwelling central catheter or mucositis from chemotherapy or radiation toxicity. Risk factors for VRE include prolonged hospitalization, neutropenia, chemotherapy-induced mucositis, and use of vancomycin, cephalosporins, and metronidazole.⁷³ VRE bloodstream infections in cancer patients are associated with significant reduction in survival and frequent microbiologic failure, despite treatment with linezolid and/or daptomycin.⁷⁴ Optimal therapy for VRE infection in cancer patients is not well defined. Catheter removal from patients with indwelling lines and VRE bacteremia should always be considered. Linezolid, quinupristin-dalfopristin, and daptomycin have been used with variable success rates^{41,75,76}; and tigecycline has demonstrated activity in vitro.

Quinupristin/dalfopristin (a 30:70 mixture of two semisynthetic streptogramin antibiotics) has been shown to be safe and effective in serious vancomycin-resistant *E. faecium* infections, but is not active against *E. faecalis*. Common adverse effects including arthralgias, myalgias, and conjugated hyperbilirubinemia may limit its use in certain patients.⁷⁵

Gram-negative Bacteria

Infections caused by gram-negative bacilli typically occur in the lungs, in the urinary tract, and in the bloodstream and are a significant cause of morbidity and mortality.⁷⁷ Gram-negative bacilli most commonly responsible for infection in humans are *Enterobacter* species, *Klebsiella pneumoniae*, *Pseudomonas aeruginosa*, *Escherichia coli*, *Acinetobacter* species, and *Serratia marcescens*. Mortality related to infections caused by gram-negative bacilli ranges from 20% to 60% depending on the site of infection and a patient's comorbid conditions. Inappropriate initial antimicrobial therapy and a delay in drug administration are associated with poorer patient outcomes.^{78,79} Prompt treatment with adequate coverage, especially for *P. aeruginosa*, should be initiated until susceptibility results are available, to minimize mortality and morbidity.

P.1434

Double coverage for gram-negative bloodstream infections in combination with an aminoglycoside has been shown to result in increased toxicity and no improvement in overall survival.^{24,80,81} Empiric use of an aminoglycoside should therefore be limited to patients with hemodynamic instability and those in whom there is a high suspicion for antibiotic-resistant gram-negative bacterial infections. Fluoroquinolones with adequate antipseudomonal activity may be an acceptable alternative to an aminoglycoside as part of a combination regimen, depending on local susceptibility patterns.

Infections caused by *P. aeruginosa* remain the most lethal gram-negative pathogens in neutropenic patients. Empiric combination of an antipseudomonal beta-lactam antibiotic plus an aminoglycoside or antipseudomonal fluoroquinolone is recommended until susceptibility data is available, since no single antimicrobial is effective against 100% of *Pseudomonas* isolates.^{75,82} Infections due to strains of *P. aeruginosa* resistant to all common antipseudomonal agents are an increasing problem.⁸³ Ecthyma gangrenosum is the most characteristic skin lesion associated with systemic *P. aeruginosa* infection.

Escherichia coli and *Klebsiella* species are common gram-negative pathogens in neutropenic patients. The use of prophylactic antibiotics such as ciprofloxacin or TMP/SMX may increase the prevalence of resistant enteric organisms such as *Enterobacter*, *Citrobacter*, and *Serratia* species which may carry an inducible beta-lactamase that may contribute to treatment failure with third-generation cephalosporins like ceftazidime. Carbapenems, fluoroquinolones, and piperacillin-tazobactam may be used in this setting. *Stenotrophomonas maltophilia* is an increasingly common cause of infection in patients who have been on broad-spectrum antibiotics or who have intravascular catheters.⁷⁵ TMP/SMX is the treatment of choice for patients with this infection but ticarcillin-clavulanate or moxifloxacin may be effective in patients intolerant to TMP/SMX. *Acinetobacter baumannii* bacteremia is frequently associated with infected intravascular catheters and is often resistant to multiple antibiotics, including imipenem-cilastatin.⁸⁴ Ampicillin-sulbactam, tigecycline, or colistin may be effective, but consultation with an infectious diseases specialist is encouraged when dealing with *Acinetobacter* infections.

Fungemia

Pathogenic fungi include yeasts and molds. *Candida* species are yeasts that form part of the normal flora and typically gain access to the bloodstream through disruption of anatomic barriers (mucositis or indwelling catheters). Molds are ubiquitous soil inhabitants whose conidia or spores are inhaled. Aspergillosis is the most common mold infection in cancer patients, but other pathogenic fungi (e.g., zygomycetes, *Fusarium* and *Scedosporium* species) have also been reported.

Candidemia and Invasive Candidiasis

Candida species are the fourth most common cause of nosocomial bloodstream infections in the United States.^{85,86} Mortality rates of candidemia range between 20% and 40%.⁸⁶ *C. albicans* is the most common, although the frequency of non-*albicans* candidemia is increasing, presumably as a consequence of widespread fluconazole prophylaxis. Clinical findings vary from asymptomatic to full-blown septic shock. *C. tropicalis* is highly virulent in neutropenic hosts. *C. krusei* is generally resistant to fluconazole, and *C. glabrata* has variable susceptibility. *C. parapsilosis* is associated with the vascular catheters and lipid formulations used for total parenteral nutrition.

Comparison of IV fluconazole with amphotericin B as therapy for candidemia in neutropenic and nonneutropenic patients has found similar overall response rates, but less toxicity with fluconazole.^{87,88} Anidulafungin appears to be similar to fluconazole in treating invasive candidiasis.⁸⁹ Voriconazole provides equivalent benefit and has less nephrotoxicity compared to the sequential combination of amphotericin B followed by fluconazole in nonneutropenic patients.⁹⁰ Caspofungin has a slightly higher response rate and is less toxic than amphotericin B as initial therapy for invasive candidiasis, and micafungin has been shown to be as effective as amphotericin B.^{91,92,93}

IDSA guidelines for management of candidiasis recommend an echinocandin (caspofungin, micafungin, or anidulafungin) for treatment of candidemia in neutropenic patients.⁹⁴ Lipid formulations of amphotericin B are recommended in complicated infections such as endocarditis and meningitis or in hemodynamically unstable patients where invasive mold infection is suspected.⁹⁴ Echinocandins are also advised in patients who develop breakthrough candidemia while receiving an azole. Voriconazole should be considered for treatment of *C. krusei*, which is generally resistant to fluconazole, and when a mold-active agent is warranted. Patients with candidemia should undergo ophthalmologic evaluation with fundoscopic exam, and it is recommended that intravascular catheters be removed from patients with candidemia.⁹⁴

Aspergillosis is addressed in the pneumonia section; zygomycosis (mucormycosis) is covered under sinus infection; and cryptococcosis is under central nervous system (CNS) infections.

CENTRAL NERVOUS SYSTEM INFECTIONS

Infection of the CNS can present with subtle nonspecific findings such as fever, headache, photophobia, changes in mental status, or more dramatic findings such as loss of consciousness and seizure. Prompt diagnosis and initiation of therapy are crucial to minimize negative clinical outcomes. CNS infections can be divided into surgical- and nonsurgical-related complications and infections. The IDSA has published guidelines on the management of CNS infections.^{95,96}

Central Nervous System Infections Unrelated to Neurosurgery

Meningitis and encephalitis are part of a clinical spectrum of CNS disorders causing fever and meningismus. Encephalitis may manifest with signs and symptoms of meningeal inflammation, but is distinguished by the predominance of

alterations of consciousness and neurologic deficits. Initial evaluation generally involves head CT to rule out intracranial bleeding in addition to brain MRI and lumbar puncture (assuming no contraindication). Cerebrospinal fluid (CSF) studies should be tailored to specific host factors, epidemiologic exposures, and clinical presentation, but should generally include a cell count with differential, glucose, protein, Gram stain, cryptococcal antigen, fungal culture, and bacterial culture. Noninfectious causes of meningitis include carcinomatous meningitis, nonsteroidal antiinflammatory medications, TMP/SMX, and serum sickness (e.g., associated with antilymphocyte gammaglobulin or intravenous immunoglobulin [IVIG]).

Empiric treatment for suspected bacterial meningitis should include antimicrobial agents that penetrate the blood-brain barrier and enter the CSF, such as ceftriaxone, ampicillin, and vancomycin.⁹⁵ This regimen provides coverage against the most common causes of bacterial meningitis, including penicillin-resistant pneumococci and listeriosis. The combination of vancomycin and TMP/SMX may be used in patients allergic to penicillins.⁹⁵ Cefepime or meropenem should be used instead of ceftriaxone in patients at risk for *P. aeruginosa* meningitis (e.g., neutropenia, neurosurgery within the past 2 months, allogeneic HSCT, prior history of *P. aeruginosa* infection). Meropenem should also provide appropriate coverage against *Listeria*. Conflicting results have been reported regarding the use of dexamethasone as an adjuvant therapy in the management of bacterial meningitis. Data

P.1435

from a large meta-analysis found dexamethasone to not provide significant reductions in death or neurologic sequelae, although a statistically significant reduction in hearing loss was observed among surviving patients.⁹⁷ ISDA guidelines for the management of bacterial meningitis support the incorporation of adjuvant dexamethasone in pediatric patients with *H. influenzae* type B meningitis and in adult patients with pneumococcal meningitis.⁹⁵

Encephalitis in patients with cancer is most commonly caused by HSV. Intravenous acyclovir should be considered as empiric therapy for HSV in patients with suspected encephalitis (fever, mental status changes, CSF pleocytosis, and focal changes on EEG or MRI, especially in the temporal lobes). CSF studies should include PCR for HSV and CSF cytology. PCR for arboviruses should be considered in patients with exposure to endemic areas. The CSF should also be sent for nucleic acid amplification, adenosine deaminase level, and culture for tuberculosis in patients with known or suspected encephalitis. Patients with severe impairment of cellular immunity (e.g., allogeneic HSCT recipient, advanced AIDS) should be evaluated with PCR for CMV, VZV, HHV-6, and toxoplasmosis as well as culture for *Nocardia*. Most cases of encephalitis occur in HSCT patients and are due to reactivation of latent viral, bacterial, or parasitic infections: herpesviruses (HSV, VZV, CMV, EBV, human herpes virus [HHV]-6), adenovirus, mycobacteria, and *Toxoplasma gondii*.

Herpes viruses

HSV meningoencephalitis has been associated with older age, steroid therapy, and brain irradiation. The diagnosis is usually made by viral PCR from the CSF and enhancement of the temporal lobe on MRI. Intravenous acyclovir should be considered as empiric therapy for HSV.⁹⁶ Other, less common herpesvirus infections can also be diagnosed by PCR of viral DNA in the CSF. Detection of high levels of EBV DNA should raise suspicion of EBV-related lymphoproliferative disorder, but primary EBV encephalitis and myelitis have been described.^{98,99} HHV-6 has been associated with a characteristic syndrome in HSCT patients consisting of confusion, lethargy, fever, rash, and hippocampal enhancement on T2-weighted MRI FLAIR images.¹⁰⁰ The diagnosis is made by detection of HHV-6 DNA in the CSF by PCR. Ganciclovir or foscarnet may be used in treating HHV-6 infections.¹⁰¹ Adenoviral encephalitis in HSCT patients has been reported as part of disseminated adenoviral infection and treatment with cidofovir may be attempted.⁹⁶

Other uncommon but important causes of meningoencephalitis are due to new primary infections rather than reactivation. Advanced age and cancer are risk factors for encephalitis from West Nile virus (WNV) transmitted by mosquitoes and for which there is no proven therapy.¹⁰²

Brain Abscess

Brain abscesses that develop during neutropenia are typically caused by fungi (commonly *Aspergillus* and *Candida*).¹⁰³ Bacterial abscesses may occur as a local extension of infection of the sinuses or dental caries and are often caused by a mixed aerobic and anaerobic flora (*Streptococci*, *Staphylococcus*, *Bacteroides*). Other causes of CNS abscesses in patients with impaired cellular immunity include toxoplasmosis, nocardiosis, cryptococcosis, and mycobacterial infections.¹⁰³

Noninfectious etiologies include CNS malignancies, including secondary lymphomas and EBV-associated posttransplant lymphoproliferative disease (PTLD) in patients with impaired cellular immunity. Given the broad differential diagnosis of new focal CNS lesions in the highly immunocompromised patient, a brain biopsy is recommended if feasible. Cultures and

stains should include bacteria, fungi, mycobacteria, and Nocardia species. Serum galactomannan, CSF galactomannan, and beta-d-glucan testing are useful to facilitate a diagnosis of CNS aspergillosis.

Brain abscesses usually manifest with headache, focal neurologic findings, or seizures.^{104,105} MRI typically shows single or multiple lesions with edema and ring enhancement. Manifestations of CNS aspergillosis include focal seizures, hemiparesis, cranial nerve palsies, and hemorrhagic infarcts due to vascular invasion.¹⁰⁶ Aspergillus brain abscesses are typically multiple, hypodense, and nonenhancing with little mass effect. CT scans with contrast enhancement may initially fail to reveal focal lesions, but subsequently evolve focal ring-enhancing or hemorrhagic lesions.¹⁰⁷

Initial therapy with ceftriaxone plus metronidazole is advised in immunocompetent patients with a bacterial brain abscess.^{3,104,105,108} Patients with prolonged neutropenia should be treated with the combination of meropenem or cefepime plus metronidazole and voriconazole.^{3,104} Adjustments may be needed for patients requiring certain antiepileptic agents (e.g., phenytoin) due to the potential for significant drug-drug interactions with voriconazole (as well as itraconazole and posaconazole).¹⁰⁹ Empiric high-dose TMP/SMX (trimethoprim component: 5 mg/kg every 8 hours) should be considered to cover toxoplasmosis and nocardiosis in allogeneic HSCT recipients and patients with severe T cell impairment. Retrospective analysis of CNS aspergillosis treated with voriconazole as either primary or salvage therapy indicated that 34% had a complete or partial response¹¹⁰ and compares favorably to previous reports in which frequency of successful responses to amphotericin B in CNS aspergillosis was close to zero.¹¹¹

Cryptococcosis

Lymphoid malignancy and corticosteroid therapy are major risk factors for cryptococcal infection.¹¹² Host defense against cryptococcal infection is dependent on T cell immunity. Isolated neutropenia is rarely associated with cryptococcal infection. The principal portal of entry of this organism is by inhalation. Spread to the blood and then to the central nervous system is a prerequisite for subsequent development of cryptococcal meningitis. Although meningitis is the most common presentation of cryptococcal infection, other manifestations include pneumonia, fungemia, cutaneous infections, and visceral dissemination. Visual loss may be a consequence of endophthalmitis (a space-occupying lesion in the visual pathway), direct invasion of the optic nerve, and elevated intracranial pressure.¹¹³

The IDSA recommends a regimen of amphotericin B (0.7 to 1 mg/kg daily) plus 5-fluorocytosine (100 mg/kg daily) for the first 2 weeks, followed by life-long maintenance fluconazole therapy in AIDS-associated cryptococcal meningitis.¹¹⁴ In the absence of modern randomized studies, the same induction regimen is recommended in non-AIDS-associated cryptococcal meningitis, followed by fluconazole for at least 10 weeks or until immunosuppressive agents have been discontinued.¹¹⁴ Reduction of the dosage of 5-fluorocytosine may be considered to minimize delay of myeloid recovery in neutropenic patients.

Toxoplasmosis

Reactivation of previously acquired infections is responsible for the majority of opportunistic CNS infections caused by *T. gondii*. The organism can be acquired by ingestion of undercooked meat or through contact with feline feces. CNS toxoplasmosis is typically associated with disseminated infection, and risk factors include therapy with corticosteroids, alemtuzumab, cytotoxic agents, and/or radiation therapy, and poorly controlled malignancy. Although toxoplasmosis is an uncommon complication of HSCT, nearly all occurrences are associated with seropositivity prior to transplantation.¹¹⁵ It tends to occur in the presence of moderate to severe GVHD with a median day of onset of disease at 64 days post-HSCT.¹¹⁶

P.1436

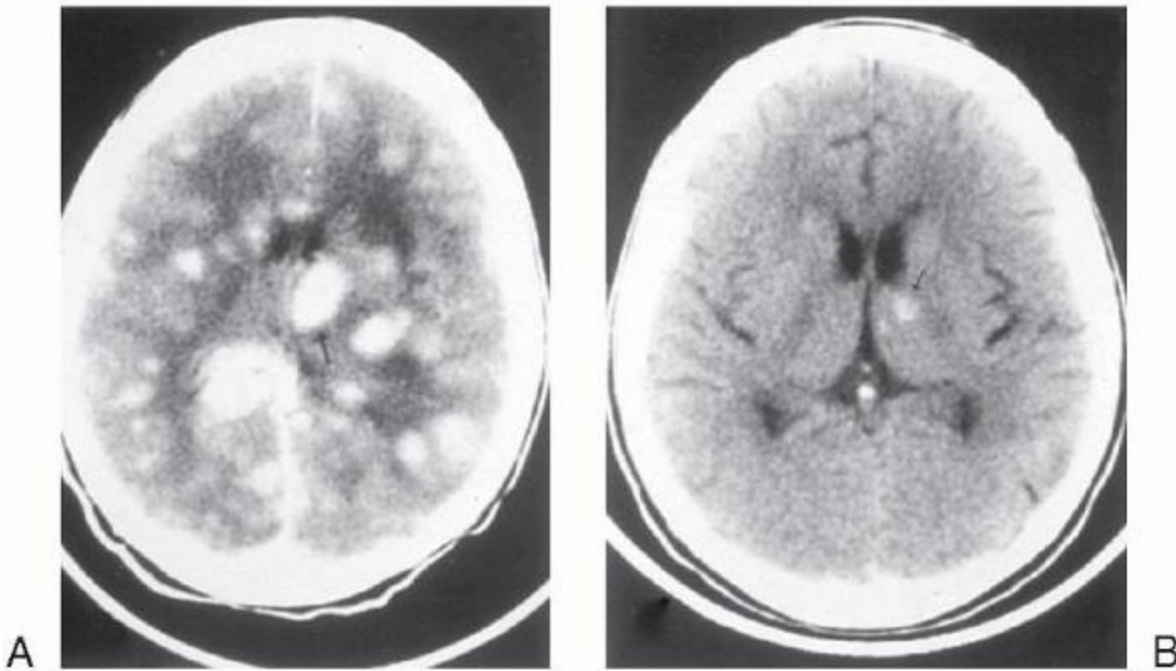

FIGURE 69.4. Central nervous system toxoplasmosis: magnetic resonance imaging study of the brain before therapy (A) and after therapy (B) with pyrimethamine and sulfadiazine.

Common clinical findings for CNS toxoplasmosis include altered mental status, coma, seizures, cranial nerve abnormalities, and motor weakness.¹¹⁷ MRI typically shows two or more lesions that may be ring-enhancing (Fig. 69.4). The differential diagnosis includes bacterial infection, invasive aspergillosis, nocardiosis, and malignancy. Differentiating toxoplasmosis from lymphoma is particularly difficult; [18F] fluorodeoxyglucose positron emission tomography typically shows increased metabolism in lymphoma.¹¹⁸ CSF in toxoplasmosis is usually normal but mononuclear pleocytosis and elevated protein levels may occur. In addition to CNS involvement, toxoplasma may also present with myocarditis, interstitial pneumonitis, culture-negative sepsis, and hemophagocytic syndrome. Definitive diagnosis of toxoplasmosis relies on demonstration of tachyzoites and cysts in histopathologic sections, but PCR testing of serum and CSF may facilitate earlier diagnosis.^{117,119} Oral sulfadiazine 1 to 1.5 g every 6 hours plus pyrimethamine (loading dose of 200 mg, followed by 75 mg daily) is the initial treatment of choice for toxoplasmosis. Folinic acid (10 to 20 mg daily) should be administered to reduce myeloid toxicity. At 4 to 6 weeks after resolution of symptoms and signs of infection and radiologic improvement, switching to a maintenance regimen (sulfadiazine 0.5 to 1 g four times daily plus pyrimethamine 50 mg/day) is reasonable. Maintenance therapy should be continued for the duration of immunosuppression and until radiologic resolution. Clindamycin and primaquine may be used instead, after verifying normal glucose-6-phosphate dehydrogenase activity in patients intolerant of sulfonamides. Atovaquone may also be used after exhausting other options.⁹⁶

Dementias

Progressive multifocal leukoencephalopathy (PML) is a demyelinating disease associated with lytic infection of oligodendrocytes by the human polyomavirus JC virus.⁴⁰ Patients may develop rapidly progressive dementia as well as focal motor neuropathy or cerebellar degeneration. This disease is most commonly seen in patients with advanced AIDS. However, PML is also seen in severely immunocompromised persons with hematologic malignancies and in HSCT recipients. Several reports have linked the use of rituximab with the development of PML and prompted an FDA advisory regarding a possible association.¹²⁰ PML has also been reported with other immunosuppressants and biologics including belatacept,¹²¹ brentuximab,¹²² efalizumab,¹²³ fludarabine,¹²⁴ infliximab,¹²⁵ and mycophenolate.¹²⁶ Brain MRI typically reveals unilateral or bilateral white matter disease without mass effect or enhancement. Diagnosis is generally confirmed by detection of the JC virus in spinal fluid by PCR (90% sensitivity) or by brain biopsy. There is no established therapy for PML and the prognosis is poor.

Infections Related to Neurosurgical Procedures and/or Devices

Neurosurgical procedures such as resection of tumor, insertion of a shunt for hydrocephalus, or insertion of an Ommaya reservoir each carry a risk for infectious complications. Infection risk is further increased with use of steroids and brain

irradiation. Early postoperative infections after placement of intraventricular devices are usually caused by skin flora: coagulase-negative staphylococci, *S. aureus*, streptococci, and *Propionibacterium acnes*. Enterobacteriaceae and *P. aeruginosa* account for approximately 10% of infections. Coagulase-negative staphylococci and *P. acnes* usually cause indolent late postoperative infections.

Infection of a shunt or an Ommaya reservoir may manifest with malfunction of the device, fever, or altered mental status. Overt signs of meningitis, such as meningismus and photophobia are often absent. CT imaging may suggest meningitis, ventriculitis, or a brain abscess if the device is infected at the proximal end. Evaluation of the CSF is required for diagnosis confirmation. Infections occurring in the distal region of the device may manifest as a soft tissue infection. In cases of ventriculoatrial shunts, distal infections may cause persistently positive blood cultures, thrombophlebitis, endocarditis, or septic pulmonary emboli. Distal ventriculoperitoneal shunt infections are associated with peritonitis and intraabdominal collections. Removal of the entire device plus systemic antibiotics is the most effective approach to eradicate infection. Use of parenteral and intraventricular instillation of antibiotics without hardware removal has demonstrated variable success, and recurrence of infection is common, particularly those caused by *S. aureus*.¹²⁷ Antibiotic therapy should be tailored to the specific pathogen isolated. In acutely ill patients with meningitis suspected to be related to prior neurosurgery, empiric therapy with parenteral vancomycin should be administered to cover *Staphylococcus*, *Streptococcus*, and *Propionibacterium* species in combination with an agent with activity against Enterobacteriaceae and *P. aeruginosa* such as ceftazidime or meropenem.⁹⁵

OROPHARYNGEAL AND SINUS INFECTIONS

The mucosal linings of the gastrointestinal and respiratory tracts constitute the first line of host defense against a variety of pathogens. During the course of treatment for hematologic malignancy these barriers often are compromised and expose patients to infections and invasions by local flora, resulting in bacteremia and candidemia. Chronic GVHD may further compromise mucosal immunity, including defective salivary immunoglobulin secretion.

Mucositis may extend into the esophagus, causing retrosternal chest discomfort. Mucosal lesions are usually caused by HSV and/or *Candida* species, but are occasionally caused by CMV, fungal (i.e., *Histoplasma*), or bacterial pathogens such as viridans group streptococcal infections and oral anaerobes (i.e., *Pseudomonas* species).

Oral mucosal candidiasis or thrush is common with T cell immunodeficiency. Cytotoxic chemotherapy, corticosteroids, and antibiotics predispose to oral candidiasis. The most common presentation is white adherent plaques on the palate, buccal mucosa, tongue, or gingiva. Pseudohyphae on a wet mount or Gram stain establish the diagnosis. Therapy includes local treatments such as clotrimazole troches or oral fluconazole.

Esophageal candidiasis may present as odynophagia and initial therapy with fluconazole is advised. Therapeutic options for fluconazole-resistant mucosal candidiasis include an echinocandin, voriconazole, posaconazole, or amphotericin B. Most fluconazole-resistant *Candida* isolates are susceptible to voriconazole and posaconazole, but cross-resistance may occur.

P.1437

Congestion, sinus tenderness, and fever are common nonspecific signs of sinusitis. Respiratory bacterial pathogens, including *S. pneumoniae*, *H. influenzae*, and *Moraxella catarrhalis* predominate the etiology of sinusitis in immunocompetent patients. Common pathogens in those that are immunocompromised include *P. aeruginosa*, *S. aureus*, Enterobacteriaceae, and molds, and warrant investigation with sinus and facial imaging. Treatment of sinusitis in immunocompetent patients involves standard antibiotic regimens, such as amoxicillin-clavulanate, azithromycin, clarithromycin, or a cephalosporin with activity against respiratory pathogens. In addition to standard antibiotic therapy, neutropenic patients with symptoms or signs of sinusitis should have a CT scan of the sinuses and an otolaryngologist consultation and consideration of endoscopy to assess the possibility of invasive mold. Endoscopy with or without mucosal biopsy is often helpful in distinguishing these entities when there is no response to empiric antifungal or antiviral therapy or if clinical deterioration follows initial response to therapy. Systemic azole or amphotericin B therapy is preferred in patients with AIDS, neutropenic cancer patients, patients with recurrent perineal candidiasis, or those with refractory proven oropharyngeal candidiasis.⁸⁷

The presence of a heterogeneous mass or bony erosion on CT is highly suggestive of invasive fungal sinusitis. Periorbital swelling and diplopia may be observed late in the course of infection. *Aspergillus* species are the most common isolate, but zygomycetes (e.g., *Mucor*, *Rhizopus*) as well as less common molds such as *Fusarium* are also being recognized.

Aggressive surgical debridement in addition to antifungal therapy with two broad-spectrum antifungals is usually required to optimize the chances of recovery. Empiric therapy should include a lipid formulation of amphotericin B (5 mg/kg/d) to ensure treatment against *Aspergillus* species and zygomycetes.¹²⁸ Antifungal therapy should be continued for weeks to months even if all of the visualized necrotic tissue is fully resected. Voriconazole may be substituted for many cases of fungal sinusitis, but should be avoided in zygomycetes (*Mucor*, *Rhizopus*) infections which are not susceptible to voriconazole. Posaconazole is an oral azole with activity against zygomycetes and may provide a useful alternative to an amphotericin B formulation for long-term therapy.¹²⁹ Posaconazole therapy does require adequate food intake for optimal absorption to reach therapeutic levels.¹³⁰

LUNG INFECTIONS

Pneumonia is the most common infectious cause of death in immunocompromised patients. Numerous noninfectious processes should also be considered in patients with pulmonary infiltrates: malignancy, its treatment (drug toxicity, radiation pneumonitis), congestive heart failure, pulmonary hemorrhage, pulmonary embolism with infarction, cryptogenic organizing pneumonia (also known as bronchiolitis obliterans organizing pneumonia), and acute respiratory distress syndrome. It is imperative that prompt empiric therapy should be initiated when an infectious cause is suspected. The differential diagnosis of pulmonary infiltrates in patients with hematologic malignancies is shown in Table 69.5. Noninfectious causes of interstitial pneumonitis (IP) in the febrile patient are diagnosed only after exclusion of infectious etiologies.

Pulmonary Infiltrates in Neutropenic Patients

Diagnosing the etiology of pulmonary infiltrates in neutropenic patients can be challenging for many clinicians. Physical findings of consolidation and sputum production may be absent as a result of the neutropenia. General work-up for suspected pneumonia should include routine blood cultures, a chest radiograph, and if possible, sputum culture and Gram stain. Respiratory viral pathogens should be considered during peak season and local pattern of infections. Rapid testing for influenza A and B may be performed using a throat or nasopharyngeal swab but viral culture is more definitive. Nasopharyngeal wash may also be used to diagnose respiratory viral infections. Legionellosis can be diagnosed based on urine antigen testing or sputum culture. While the urine antigen testing is more easily obtained, it only detects *Legionella pneumophila* type I.¹³¹ Broad-spectrum antibiotics should be initiated immediately and therapy tailored once culture data become available.

Initial Antimicrobial Therapy

In patients with less than 7 days of neutropenia, pulmonary infections are likely to be caused by Enterobacteriaceae, *P. aeruginosa*, and *S. aureus*. Community respiratory viruses should also be considered during winter months. If community-acquired pneumonia is suspected, a macrolide or fluoroquinolone should be given to cover for atypical pneumonia organisms. The addition of TMP/SMX should be considered if PJP is suspected. Vancomycin or linezolid should be added for pneumonia in patients colonized with MRSA and for nosocomial pneumonia. If clinical improvement occurs within 48 to 72 hours of therapy, the antibiotic regimen should be tailored based on available culture data and continued for at least 10 to 21 days and until neutropenia resolves. In the absence of clinical improvement, resistant bacterial and nonbacterial pathogens including filamentous fungi should be considered.

Pulmonary Infiltrates in Patients with Defects in Cell-mediated Immunity

In addition to the common bacterial causes of pneumonia, patients with defects in cell-mediated immunity are at risk for infections with *P. jirovecii*, *Nocardia* species, and viruses, as well as *Legionella*, mycobacteria, mold, and fungi. Invasive procedures, including bronchoscopy for bronchoalveolar lavage (BAL) and/or biopsy, should be considered to aid in diagnosis.

Fungal Pneumonia

Patients with allogeneic HSCT, prolonged high-dose systemic corticosteroids, immunosuppression with T cell suppressants and neutropenia for more than 10 days are at increased risk of fungal pneumonia. Chest CT imaging is recommended in patients failing to respond to initial empiric treatment or those in whom there is a high suspicion for fungal or mold infection.¹³² CT may disclose lesions missed by the chest radiograph as well as findings characteristic of invasive fungal disease: well-circumscribed, dense infiltrates, the "halo sign," and/or cavitation.¹³³ Other angioinvasive infections including *P. aeruginosa* may cavitate. The galactomannan assay is specific for invasive aspergillosis,¹³⁴ whereas the beta-D-glucan assay detects aspergillosis and other invasive fungal infections including invasive candidiasis, PJP, and fusariosis.¹³⁵ Galactomannan assay testing is associated with a sensitivity of 70% and specificity of 89% for invasive aspergillosis.¹³⁶ False-positive results may be more common in children and allogeneic HSCT recipients with concomitant use of

piperacillin/tazobactam.^{137,138} Rising serum galactomannan levels correlate with failure of antifungal therapy, whereas decreasing levels are associated with positive outcomes in patients with invasive aspergillosis.^{139,140}

Aspergillus species are by far the most common invasive mold infections (Fig. 69.5). Voriconazole is currently the treatment of choice for invasive aspergillosis.^{34,137} Amphotericin B is active against *Aspergillus* species (with the exception of *Aspergillus terreus*), but may be inferior to voriconazole in aspergillosis.¹³⁷ Initial antifungal therapy should be either with voriconazole or a lipid formulation of amphotericin B in patients at high risk for invasive mold diseases or with suspected pneumonia of unknown etiology. Echinocandins have not been evaluated as initial monotherapy for invasive aspergillosis, but have favorable response

P.1438

rates in patients refractory or intolerant to triazoles or amphotericin B.¹⁴¹ Posaconazole has been used successfully as salvage therapy for a variety of invasive fungal infections refractory to standard therapy.¹⁴² Posaconazole is currently approved by the FDA for prophylaxis of invasive *Aspergillus* and *Candida* infections, and in the European Union is indicated for treatment of invasive aspergillosis and other invasive fungal infections refractory to standard antifungal agents.¹⁴³

TABLE 69.5 DIFFERENTIAL DIAGNOSIS OF PULMONARY INFILTRATE IN THE IMMUNOCOMPROMISED PATIENT

Cause	Diagnosis
Infectious Causes	
Bacterial pneumonia	Lung infiltrate: positive culture from blood, BAL, or pleural fluid; resolution with antibiotics.
CMV pneumonia	Intranuclear or intracytoplasmic CMV inclusions in pulmonary epithelial cells in TBB specimen or BAL fluid, or positive BAL culture for CMV. Quantitative PCR can be monitored for response.
Other viral pneumonias	May be preceded by rhinorrhea, sore throat, and cough; diffuse interstitial pattern. Most common are RSV, influenza, parainfluenza, and adenovirus. Diagnosis can be made by detection of virus or viral antigen on throat swabs, nasal washes, or BAL fluid; immunologic and molecular techniques (PCR) are available.
<i>Legionella</i> pneumonia	Positive culture of <i>Legionella</i> species from sputum, BAL fluid, or pleural fluid, or positive test for <i>Legionella</i> antigen by DFA test in BAL fluid, or a positive urinary <i>Legionella pneumophila</i> antigen or <i>Legionella</i> titer $\geq 1:256$ with compatible clinical features.
Invasive pulmonary aspergillosis	Halo or crescent sign on high-resolution chest CT; positive galactomannan assay; pathologic evidence of invasion of lung tissue by acutely branching septate hyphae consistent with <i>Aspergillus</i> species, or isolation of <i>Aspergillus</i> species from BAL fluid or bronchial washing with consistent clinical and radiologic features.
<i>Pneumocystis jirovecii</i> Pneumonia	Fever and dyspnea may precede interstitial pneumonia. Detection of cysts or trophic forms of the organism in cytocentrifuge preparation in BAL fluid.
<i>Candida</i> and other fungal pneumonia	Histologic evidence of tissue invasion by <i>Candida</i> or other fungal species.
<i>Mycobacterium tuberculosis</i>	Positive culture of <i>M. tuberculosis</i> from sputum, bronchial washing, BAL fluid, or lung biopsy showing caseating granuloma with acid-fast organisms.
Nontuberculous mycobacteria (NTM) infection	Consistent clinical and radiologic findings with either: (a) isolation of NTM from sputum, bronchial washing, or BAL fluid and lung biopsy showing mycobacterial histopathology features; or (b) isolation of NTM from lung tissue,

blood, or bone marrow culture.

Nocardia pneumonia Presumptive diagnosis can be made if acid-fast filamentous rods are visualized on TBB or BAL fluid; also, *Nocardia* species are gram-positive rods. Requires 5-21 d for culture. Disseminated disease occurs in one-third of patients, with brain abscess as the most common site.

Noninfectious Causes

Diffuse alveolar hemorrhage	≥20% hemosiderin-laden macrophages in BAL fluid or hemosiderin-laden macrophages in lung tissue.
Chemotherapy-induced pneumonitis	History of receiving chemotherapeutic agent, with BAL or lung biopsy showing atypical type II pneumocytes with consistent clinical features and no evidence of lung infection.
Radiation pneumonitis	History of receiving radiation, with BAL lymphocytosis with consistent clinical and radiologic features and no evidence of lung infection.
Congestive heart failure (CHF)	Clinical diagnosis of CHF (bibasilar rales, left ventricular third sound, and radiologic evidence of pulmonary edema with resolution of symptoms with diuretics), or pulmonary artery occlusion pressure >18 mm Hg. Older age and prior chemotherapy, particularly with anthracyclines, are contributing factors.
Pulmonary emboli	Diagnostic confirmation strategy varies among institutions; suspected with clinical features, elevated D-dimer, and V/Q scan and confirmed by spiral CT pulmonary angiography.
Leukoagglutinin reaction	Sudden onset of respiratory distress after transfusion. The incidence of transfusion-related lung injury (TRALI) is 0.04%-0.1%; mortality is estimated at 5%-8%.
ARDS/diffuse alveolar damage	Acute-onset, bilateral lung infiltrates on chest radiography, pulmonary artery wedge pressure ≤ 18 mm Hg, or the absence of clinical evidence of left atrial hypertension, and PaO ₂ /FiO ₂ ≤ 300 (acute lung injury) or ≤ 200 (ARDS).
Nonspecific pneumonitis	Lung biopsy showing nonspecific inflammation and variable fibrosis with no evidence of lung infection, and without alternative clinical diagnosis.
Pulmonary infiltrates of unclear etiology	Data from imaging, cultures, serology, and FB inconclusive for a firm diagnosis.

ARDS, acute respiratory distress syndrome; BAL, bronchoalveolar lavage; CMV, cytomegalovirus; CT, computed tomography; DFA, direct immunofluorescent antibody; FB, fiberoptic bronchoscopy; PCR, polymerase chain reaction; RSV, respiratory syncytial virus; TBB, transbronchial biopsy.

Endemic Fungi

Commonly known endemic fungi include *Histoplasma capsulatum*, *Coccidioides immitis*, and *Blastomyces dermatitidis*. These dimorphic fungi exist in nature in the fruiting mycelial stage and then convert to the yeast stage at body temperature. Endemic mycoses in the central United States include histoplasmosis and blastomycosis. Immunocompetent hosts are typically asymptomatic following inhalation of *Histoplasma* microconidia but may manifest acute fever, pulmonary infiltrates, and hypoxia. Immunocompromised patients have a higher risk of disseminated histoplasmosis involving the liver, spleen, lymph nodes, bone marrow, adrenal glands, mucocutaneous tissues, gastrointestinal tract, and CNS. Chest radiographs may show a miliary reticulonodular appearance similar to that seen with tuberculosis. Blood cultures may be positive in disseminated histoplasmosis. Antigen detection in blood, urine, and BAL is both

sensitive and specific.¹⁴⁴ Antibody detection may also be useful, but false-negative results may occur in immunocompromised patients.¹⁴⁵ Biopsy specimens showing small intracellular or narrow budding yeast are suggestive of the diagnosis and should be confirmed by culture. IDSA guidelines recommend amphotericin B for severe pulmonary or disseminated histoplasmosis.¹⁴⁵ Prolonged therapy with itraconazole may be initiated after stabilization of disease, and should be continued for the duration of immunosuppression.¹⁴⁵

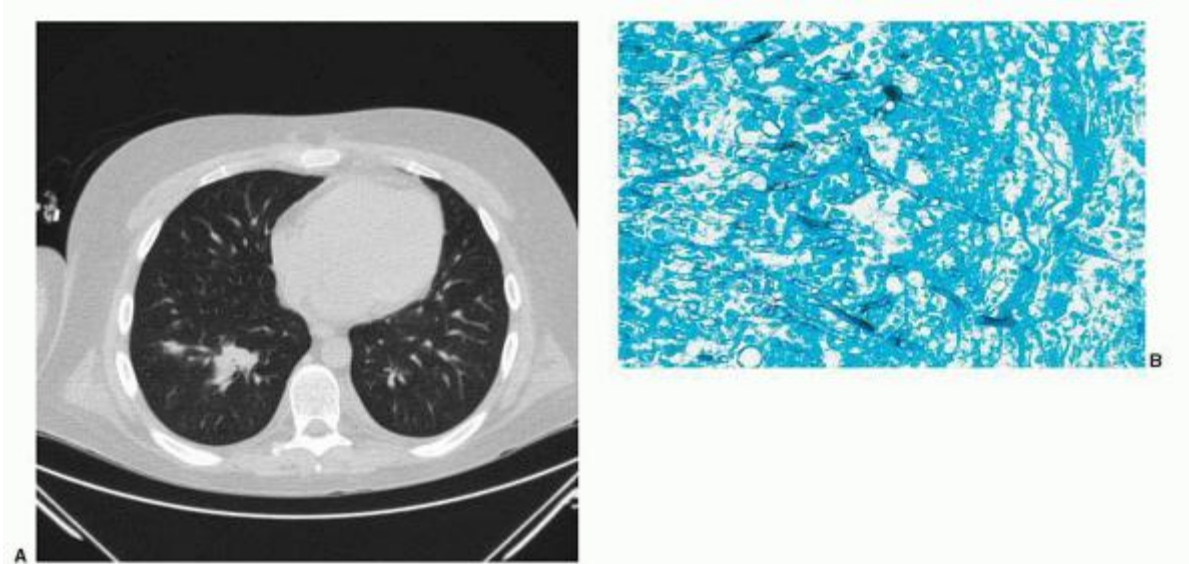

FIGURE 69.5. A: Chest CT of a hematopoietic cell transplant recipient who developed pulmonary *Aspergillus* infection after prolonged immunosuppression. B: Photomicrograph of the characteristic 45° angle branching of septate hyphal forms of *Aspergillus*. Gomori methenamine silver stain, × 400. (Courtesy of Margie Scott.)

Coccidioides immitis is endemic in the southwestern United States. *C. immitis* is more likely to be pathogenic in patients with compromised cell-mediated immunity. High rates of treatment failure and death have been reported in patients with hematologic malignancies.¹⁴⁶ The diagnosis is most often established by finding the fungus in BAL, sputum, or biopsies. Serology is positive in only 55% of patients. *Coccidioidomycosis* can involve virtually any organ in disseminated disease but has tropism for bone and the CNS. Therapy for disseminated disease generally requires amphotericin B followed by maintenance fluconazole.¹⁴⁷

Pneumocystis Jirovecii Pneumonia (PJP)

Pneumocystis jirovecii (formerly *P. carinii*) is classified as a fungus rather than a protozoan based on gene sequence data, although it lacks ergosterol, the main fungal cell-wall component. Defective T cell immunity and steroid use are risk factors for PJP. *Pneumocystis jirovecii* can have a fulminant course with rapid progression to respiratory failure in immunocompromised patients.¹⁴⁸ Patients with pneumonia from *P. jirovecii* usually present with rapid onset of dyspnea, nonproductive cough, hypoxemia, and fever. Radiologic studies generally show diffuse bilateral interstitial infiltrates but can show focal infiltrates. Pleural effusion is uncommon. Diagnosis of PJP relies on visualization of the organism microscopically, as it does not grow in culture. BAL is the standard diagnostic modality for PJP, but induced sputum has acceptable yield in some institutions.¹⁴⁹ Immunofluorescent staining with monoclonal antibodies is more sensitive than silver staining or Wright-Giemsa staining.¹⁵⁰ PJP frequently results in positive serum beta-d-glucan testing.¹⁵¹ Treatment should be started based on clinical suspicion, and TMP-SMX (5 mg/kg IV every 8 hours) remains the treatment of choice.³ Prednisone should be added to the empiric treatment regimen if the pO₂ is <70 mmHg.¹⁵² Alternatives for TMP/SMX-allergic/intolerant patients include dapsone, atovaquone, or clindamycin-primaquine for infections of moderate severity and IV pentamidine for infections of high severity.

Viral Pneumonia

Pneumonia due to respiratory viruses (respiratory syncytial virus [RSV], influenza, parainfluenza, adenovirus) is more common in patients with defects in cell-mediated immunity. Treatment with ribavirin (RSV, parainfluenza)^{153,154} with or without immunoglobulins or cidofovir (adenovirus)¹⁵⁵ has not been shown to change outcome. Prompt treatment of RSV upper respiratory illnesses in HSCT recipients with a combination of aerosolized ribavirin and IVIG prevents progression to

pneumonia in a pilot study.¹⁵⁶ Oseltamivir and zanamivir are effective in HSCT and immunocompromised patients with influenza and are recommended in documented or suspected influenza infections.^{3,157}

CMV pneumonia is a significant complication of allogeneic HSCT. It typically develops between 40 and 100 days posttransplant and presents with fever, dyspnea, hypoxemia, and diffuse interstitial infiltrates (Fig. 69.6). CMV pneumonia after day 100 is becoming more common and should be considered in patients with a history of previous CMV reactivation. In transplant patients the diagnosis is established by a compatible clinical syndrome with detection of CMV in BAL (by culture or cytopathology showing characteristic intracytoplasmic and intranuclear inclusions) or tissue (by culture or histologic diagnosis). CMV pneumonia is rare in nontransplant patients and the culture alone is not considered sufficient to make the diagnosis, as CMV can be shed from pulmonary secretions without causing invasive disease.^{158,159} Frontline treatment of CMV pneumonia typically consists of ganciclovir 5 mg/kg IV every 12 hours with IVIG 500 mg/kg every 48 hours for 3 weeks, although foscarnet (90 mg/kg every 12 hours) is an acceptable alternative to the ganciclovir.¹⁶⁰

Hospital-Acquired Pneumonia

Hospital-acquired pneumonia (HAP) is considered “early” when it happens within 4 days of admission or “late” when it occurs 5 days or more after admission.⁷⁰ Late HAP is more likely to be caused by multidrug-resistant pathogens. Risk factors for

P.1440

multidrug-resistant pathogens include previous antimicrobials in the preceding 90 days, hospitalization for 2 days or more in the preceding 90 days, residing within a nursing home, chronic dialysis, home wound care, and exposure to others with multidrug-resistant pathogens.⁷⁰ Initial therapy for HAP depends on severity of illness of the patient, previous antimicrobial exposures and hospitalizations, and institutional antibiogram data. Empiric therapy should include an antipseudomonal beta-lactam plus an antipseudomonal fluoroquinolone, or an aminoglycoside plus either linezolid or vancomycin to cover MRSA with subsequent tailoring of regimen once culture data becomes available.⁷⁰

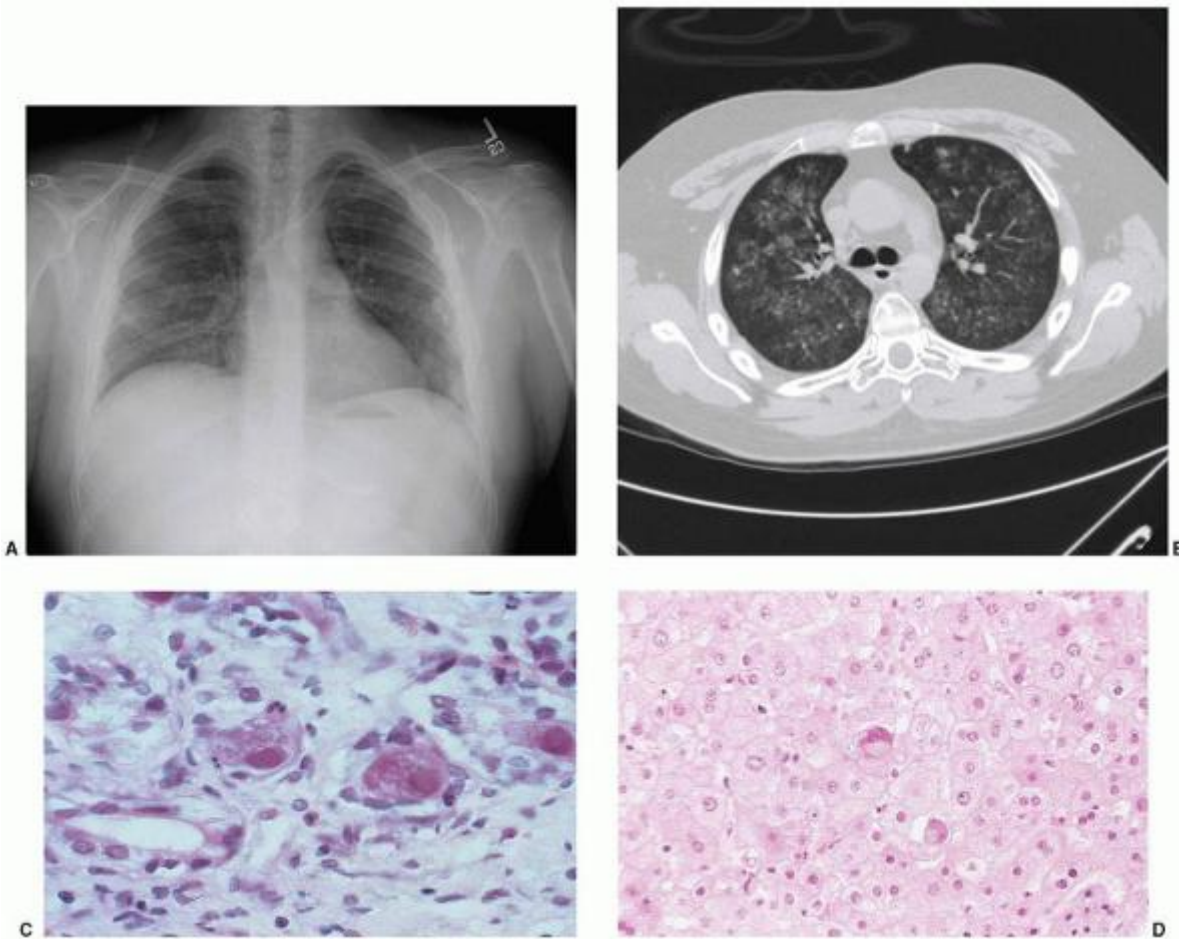

FIGURE 69.6. The spectrum of cytomegalovirus (CMV) disease in the abnormal human host. A: Chest radiograph demonstrating diffuse interstitial infiltrates in patient 60 days after cord blood transplant. B: Chest CT showing bilateral fine nodular infiltrates. C: CMV inclusion disease of the colon. Typical infected cells show cellular ballooning with dense primary nuclear inclusions surrounded by a thin, cleared rim; secondary inclusions appear as cytoplasmic granules after the nucleus has filled with virions. D: CMV hepatitis demonstrated on liver biopsy. Viral cytopathic effect may be difficult to establish, but rare viral inclusions with surrounding parenchymal changes are diagnostic of CMV. Hematoxylin and eosin stain $\times 400$. (Photomicrographs courtesy of Margie Scott.)

GASTROINTESTINAL INFECTIONS

Neutropenic Enterocolitis (Typhlitis)

Typhlitis refers to inflammation of the cecum and results from a combination of neutropenia and defects in the bowel mucosa related to cytotoxic chemotherapy. When it extends beyond the cecum, the broader term neutropenic enterocolitis is used.¹¹⁰ Differential diagnosis for etiology of typhlitis includes *C. difficile* colitis, CMV enteritis, bowel ischemia, and GI tract GVHD.¹⁶¹ Typhlitis is pathologically characterized by ulceration and necrosis of the bowel wall, hemorrhage, and masses of organisms. Clinical signs include fever, abdominal pain and tenderness, and radiologic evidence of right colonic inflammation. Nausea, vomiting, and diarrhea (bloody or nonbloody) are the most common associated symptoms. Abdominal distention, tenderness, and a right lower quadrant fullness or mass reflect a thickened bowel. Bacteremia with bowel flora, *P. aeruginosa*, and polymicrobial sepsis may occur. Clostridium species are the most common anaerobic pathogens. Typhlitis should be suspected if right lower quadrant pain and bloody diarrhea are present. Surgical intervention may be required in the event of an intraabdominal catastrophe.

An abdominal and pelvic CT scan should be performed in patients with suspected typhlitis or undiagnosed abdominal pain in the setting of neutropenia. Positive CT scan findings are present in about 80% of cases¹⁶² and include a right lower quadrant inflammatory mass, pericecal fluid, soft tissue inflammatory changes, localized bowel wall thickening and mucosal edema,

P.1441

and a paralytic ileus. All patients should be assessed for *C. difficile* infection. Treatment requires broad-spectrum antibiotics with activity against aerobic gram-negative bacilli and anaerobes (e.g., ceftazidime plus metronidazole, imipenem, meropenem, or piperacillin/tazobactam) and supportive care, including intravenous fluids or parental nutrition and bowel rest. The majority of patients will respond to antibiotic therapy and supportive care without the need for surgery. Indications for surgery often include (1) persistent gastrointestinal bleeding after resolution of neutropenia, thrombocytopenia, and clotting abnormalities; (2) intraperitoneal perforation; (3) uncontrolled sepsis despite fluid and vasopressor support; and (4) an intraabdominal process (such as appendicitis) that would require surgery in the absence of neutropenia.¹⁶³

Clostridium Difficile Colitis

Pseudomembranous enterocolitis that is caused by *Clostridium difficile* may occur as a complication of antibiotic therapy, and stool should be assayed for the *C. difficile* toxin.¹⁶⁴ The clinical presentation includes asymptomatic carriage, colitis without pseudomembrane formation, pseudomembranous colitis, and fulminant colitis with toxic megacolon. In severe *C. difficile* disease, paralytic ileus, toxic dilatation of the colon, and bowel perforation may occur. Abdominal radiographs may show nonspecific dilation of the colon with mucosal edema ("thumbprinting"). The mainstay of diagnosis is detection of *C. difficile* toxin A, toxin B, or both, in the stool with a cytotoxin test, enzyme immunoassay, or PCR for the toxin gene. Enzyme immunoassays have variable sensitivity, while DNA amplification testing for *C. difficile* has a reported sensitivity greater than 95%.¹⁶⁵ Empiric therapy for *C. difficile* enterocolitis should be instituted despite a negative stool evaluation if suspicion remains high and other causes of diarrhea have been excluded. Traditional options for the treatment of *C. difficile* include oral or intravenous metronidazole and oral vancomycin.

Metronidazole is recommended as frontline therapy for uncomplicated cases, as its efficacy is similar to oral vancomycin, and the selection pressure on other flora is less dangerous.¹⁶⁶ Oral vancomycin may be more efficacious in severe and refractory *C. difficile* colitis and should be considered for treatment in these cases.^{167,168} Fidaxomicin has also been found to be equivalent to oral vancomycin and is FDA approved for the treatment of *C. difficile*-associated diarrhea.¹⁶⁹ Nitazoxanide and rifaximin are under investigation. Patients in whom oral agents cannot be administered should receive intravenous metronidazole. In cases involving toxic dilatation of the colon or perforation, subtotal colectomy, diverting ileostomy, or colostomy may be required.

GENITOURINARY INFECTIONS

Neutropenic patients with a urinary tract infection often do not show pyuria and are far more likely to become bacteremic compared with nonneutropenic patients. While treatment is typically reserved for symptomatic episodes in nonneutropenic patients, intervention should be considered in neutropenic patients with asymptomatic bacteruria. Candiduria may represent colonization in a patient with an indwelling urinary catheter, particularly in the setting of broad-spectrum antibiotics. Removal of the urinary catheter is frequently sufficient therapy. Patients with neutropenic fever and candiduria should receive systemic antifungal therapy over concerns of potential occult invasive candidiasis. Fluconazole 400 mg/day for 1 to 2 weeks is the treatment of choice. In the case of non-*Albicans* candiduria, another azole or amphotericin should be used. Echinocandins are minimally present in the urine, and they are not effective in the treatment of candiduria.¹⁷⁰

Hemorrhagic cystitis is a common consequence of some cytotoxic regimens, particularly cyclophosphamide. A viral etiology should be considered in HSCT recipients and other immunocompromised patients with unexplained hematuria. Adenovirus, the polyomavirus BK, and CMV have been associated with hemorrhagic cystitis. Adenovirus hemorrhagic cystitis is usually self-limiting, but low-dose cidofovir (1 to 3 mg/kg/week, without probenecid) is occasionally used with the aim of preventing disseminated adenoviral disease.¹⁷¹ BK virus commonly reactivates after allogeneic HSCT, but only a minority of patients (typically those with high viral loads) develop hemorrhagic cystitis. Treatment consists of supportive care and reduction of immunosuppressants if possible.

SKIN AND SOFT TISSUE INFECTIONS

Skin eruption caused by infections must be distinguished from noninfectious ones such as drug reactions (including chemotherapy-induced hand-foot syndrome), Sweet syndrome, erythema multiforme, vasculitis, leukemia cutis, pyoderma gangrenosum, tumor, and GVHD. When evaluating the potential for a skin/soft tissue infection, careful examination of all line sites and perineal areas are essential. Early biopsy of skin lesions for histology and culture is recommended. Antimicrobial therapy should be tailored to the probable organisms: staphylococci and streptococci for catheter-associated processes and gram-negative and anaerobic organisms for perineal processes, respectively.

Vancomycin may be considered for cellulitis, disseminated papules/lesions, and wound infections. Acyclovir, famciclovir, or valacyclovir should be considered for vesicular lesions after appropriate diagnosis is made for HSV or VZV.

VZV and herpes simplex virus (HSV) generally present as vesicular lesions and may be indistinguishable. Scrapings from the base of vesicles should be sent for direct fluorescent antibody (DFA) testing to diagnose VZV and for shell-vial culture to diagnose HSV. Intravenous acyclovir is the treatment of choice for VZV and HSV in the immunocompromised host.¹⁷² In immunocompetent patients, oral acyclovir, valacyclovir, and famciclovir have been used successfully.

Gram-positive bacteria that cause skin and soft tissue infections include *Streptococcus* (group A and B) and *S. aureus*. Gram-negative bacilli with propensity to cause dermatologic infections include *P. aeruginosa*, *Stenotrophomonas maltophilia*, *Aeromonas hydrophila*, and *Vibrio vulnificus*. The latter classically presents with septicemia and secondary cellulitis with hemorrhagic bullae following ingestion of contaminated seafood by patients with underlying liver disease. *V. vulnificus* may also present as a primary cellulitis with bacteremia when an open wound is exposed to seawater.

Ecthyma gangrenosum is typically a manifestation of *P. aeruginosa* or other gram-negative bacilli. It can be variable in its appearance but often presents as a dark, necrotic lesion in neutropenic patients. Antibiotic therapy with an antipseudomonal agent should be initiated and early surgical consultation for possible debridement is imperative.¹⁷³

A rapidly progressive deep soft tissue infection with gas formation suggests clostridial myonecrosis (or polymicrobial necrotizing fasciitis) caused by *Clostridium* species. The lesions may become necrotic, bullous, and hemorrhagic. Systemic toxicity including fever, malaise, and mental status changes occur early. Extensive surgical debridement may be life-saving if initiated early, but the mortality rate remains high. Polymicrobial sepsis with enteric flora is commonly observed in association with clostridial bloodstream infection. In neutropenic patients, metronidazole plus an antipseudomonal cephalosporin or single-agent therapy with imipenem, meropenem, or piperacillin/tazobactam are recommended.¹⁷⁴

Skin lesions of disseminated candidiasis are small, raised discrete erythematous papules.¹⁷⁵ The lesions resemble those of heat rash early in their presentation. They are usually not tender.

P.1442

Concurrent myalgias raise the possibility of *Candida* myositis. Biopsy and fungal staining of cutaneous lesions can provide an immediate clue to the diagnosis, prompting the early addition of antifungal therapy. Blood cultures are typically positive.

VIRAL INFECTIONS

Respiratory viruses include influenza, parainfluenza, respiratory syncytial virus, human metapneumovirus, adenoviruses, rhinoviruses, and coronaviruses. Most respiratory viruses typically cause self-limited infection in healthy persons, but cause significant morbidity and mortality in immunocompromised patients with hematologic malignancies and HSCT recipients.¹⁷⁶ The role of empiric antiviral therapy in the treatment of neutropenic fevers is not well defined. Antiviral drugs are indicated in the management of neutropenic fevers only if there is clinical and laboratory evidence of active viral infection.³ Respiratory virus testing (including testing for influenza, parainfluenza, adenovirus, respiratory syncytial virus [RSV], and human metapneumovirus) and chest radiography are indicated for patients with upper respiratory symptoms such as cough and coryza. Although aerosolized and oral administration of ribavirin has been used, no antiviral agent has been proven to be effective against parainfluenza virus. Similarly, there is no clear indication for aerosolized or oral ribavirin or other antiviral against RSV pneumonia though modest effect has been observed in retrospective analysis.¹⁵⁴

Influenza Virus

Influenza results in annual epidemics of respiratory viral illness during the winter. Unlike the mild and typically self-limited disease seen in immunocompetent patients, immunocompromised patients frequently have a more severe course. Several existing antiinfluenza agents are commercially available. Amantadine and rimantadine are active against influenza A, but not influenza B. Resistance to these agents may rapidly develop during therapy. The neuraminidase inhibitors, zanamivir and oseltamivir, are active against both influenza A and B. They are effective in reducing the duration of influenza illness if started early after onset of symptoms, and they have a prophylactic benefit during community outbreaks.^{177,178} Oseltamivir appears to be both safe and effective against influenza infections among HSCT recipients. If influenza is suspected, empiric therapy with an antiinfluenza agent (e.g., oseltamivir and zanamivir) should be initiated while awaiting test results.^{3,178} Choice of drug should be based on the susceptibility patterns of the predominant influenza strain(s).

Respiratory Syncytial Virus

Respiratory syncytial virus (RSV) infection can cause high mortality in patients with acute leukemia and in HSCT recipients.¹⁷⁹ Upper respiratory symptoms (sinusitis, coryza, rhinorrhea) usually precede lower respiratory tract involvement (dyspnea, wheezing) and pneumonia, but may be absent. Uncontrolled studies suggest that aerosolized ribavirin and IVIG containing high RSV neutralizing titers for at least 24 hours prior to respiratory failure prevent respiratory failure and result in much better outcomes.¹⁸⁰ Inhaled ribavirin and immunoglobulin should be considered in patients with RSV infection at highest risk for severe complications, such as allogeneic HSCT recipients, patients with acute leukemia, and those with persistent neutropenia.³

Adenovirus

The spectrum of adenoviral infections in immunocompromised patients extends from asymptomatic shedding to fatal multisystem disease and includes upper respiratory tract infection, pneumonia, renal parenchymal disease, hemorrhagic cystitis, hepatitis, small and large bowel disease, and encephalitis. Viral shedding from throat secretions, urine, and stool is common, occurring in approximately 5% to 20% of HSCT recipients, and should not be equated with disease. Gastroenteritis and hemorrhagic cystitis are usually self-limited, whereas pneumonia and disseminated disease are associated with a high mortality rate. Adenoviral infection is more common in young transplant patients, those who receive T cell-depleted transplants, and those who receive stem cells from unrelated donors.¹⁵⁵ Supportive care is important, though cidofovir may be beneficial.¹⁷¹

Parvovirus B19

Parvovirus B19 is a DNA virus that is transmitted via respiratory secretions and blood products. Infection in immunocompromised persons unable to mount a protective antibody response may cause prolonged fever, chronic pure red cell aplasia, thrombocytopenia, or pancytopenia. Predisposing conditions include acute and chronic leukemias, myelodysplastic syndrome, lymphoma, HSCT, potent antineoplastic chemotherapy, and systemic steroids. Diagnosis of parvovirus B19 infection in the immunocompromised patient relies on PCR detection of viral DNA from serum; these patients may be incapable of antibody responses. Treatment often consists of IVIG.¹⁸¹

INFECTIONS IN HEMATOPOIETIC STEM CELL TRANSPLANTATION PATIENTS

Autologous and allogeneic HSCT recipients have a unique set of infectious disease problems. Infection is reported as the primary cause of death in 8% of autologous HSCT patients and 17% to 20% of allogeneic HSCT recipients.¹⁸² High-dose chemotherapy or chemoradiotherapy preparative regimen causes short-term cytopenias and often mucositis, followed by profound immunosuppression with weeks to months of defective T cell-mediated immunity. All HSCT recipients experience profound immunosuppression at some point and the degree of immunosuppression experienced by individual patients varies greatly and is influenced by several factors. GVHD severity correlates with the degree of immunosuppression and infectious complications. This correlation is due to a variety of factors, including damage to lymphoid microenvironments, adverse effects of GVHD on homeostatic peripheral expansion, as well as the impact that chronic immunosuppression has on a reconstituting immune system. Recipient factors such as age, comorbidities, and infectious exposure prior to transplant contribute substantially to the risk for posttransplant infectious complications. Graft-associated factors also play an important role. Peripheral blood stem cell graft recipients show more rapid immune reconstitution,¹⁸³ whereas umbilical cord blood transplantation in adults,^{184,185} and transplantation of profoundly T cell-depleted haploidentical grafts result in poor immune reconstitution and higher rates of infectious complications.

Most infections in autologous HSCT recipients occur during neutropenia or within the first few months after transplantation before reconstitution of cellular immunity. Recipients of CD34⁺ cell-enriched autografts appear to have a similar risk to allogeneic HSCT recipients for CMV and other opportunistic infections.¹⁸⁶ Recipients of allogeneic peripheral blood stem cell grafts undergo more rapid immune reconstitution than those who receive marrow.¹⁸⁷ Reconstitution of cellular and humoral immunity in allogeneic transplant patients occurs gradually over a period of 1 to 2 years. Duration of T cell immunity defects varies, depending on factors such as cancer type, manipulation of the stem cells preinfusion, and the age of the recipients.¹⁸⁸ Infectious disease risk profiles vary depending on the type of transplant as well as the many variants associated with an HSCT (conditioning regimen,

P.1443

degree of HLA matching, stem cell source, and GVHD prophylaxis). The spectrum of pathogens to which HSCT recipients are most susceptible follows a time line corresponding to the predominant immune defects as outlined in Figure 69.7.

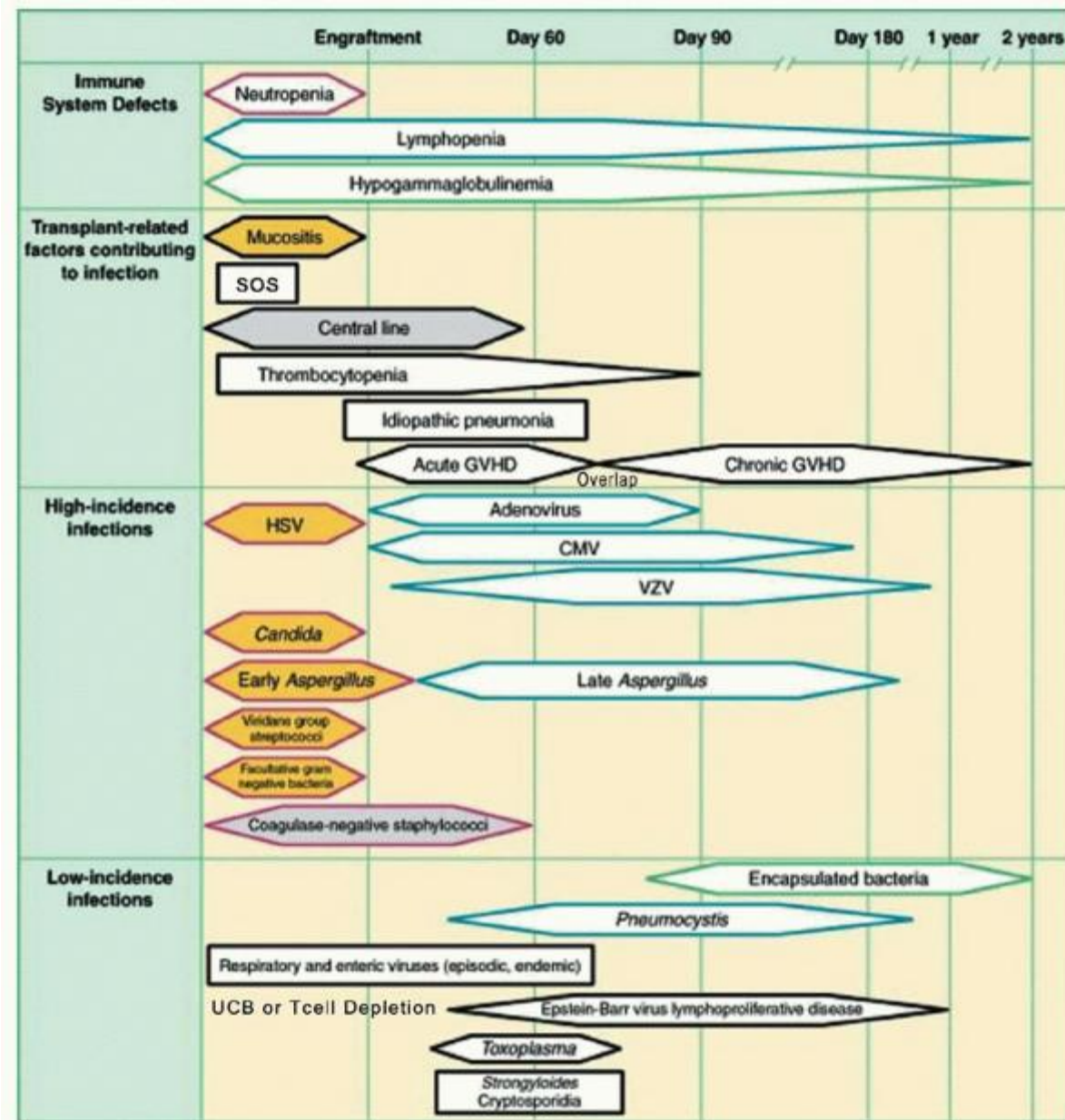

FIGURE 69.7. Phases of predictable opportunistic infections and complications among patients undergoing hematopoietic stem cell transplantation. CMV, cytomegalovirus; GVHD, graft-versus-host disease; HSV, herpes simplex virus; SOS, sinusoidal obstruction syndrome; UCB, umbilical cord blood; VZV, varicella zoster virus. Adapted from Van Burik J-AH, Freifeld AG. Infection in the severely immunocompromised host. In: Abeloff MD, Armitage JO, Niederhuber JE, et al., eds. Clinical oncology, 3rd ed. Philadelphia, PA: Churchill Livingstone; 2004:942.

Neutropenia is the principal host defect in the first few months after HSCT and predisposes patients to bacterial, fungal, and viral infections. The risk of bacterial infection, central venous catheter (CVC) infection, and reactivation of herpes simplex are highest in the preengraftment period. Prolonged neutropenia and antibiotic therapy leads to a steady rise in the risk of invasive fungal infection, which then decreases after engraftment. After myeloid engraftment, qualitative dysfunction of phagocytes persists because of immunosuppressive agents and corticosteroid. Cellular immune dysfunction peaks at approximately day 40 after engraftment and the typical onset of GVHD. The risk of opportunistic viruses and molds during this period is associated with the severity of GVHD and immunosuppressive regimens. Long-term venous access catheters continue to give rise to infection as long as the access is maintained. Continuation of prophylactic antimicrobials beyond 1 year depends on the individual patient's infection history and the ability to wean immunosuppressive therapy.¹⁸²

Preventing Early Infectious Disease (0 to 100 days after HSCT): Early after HSCT, neutropenia is the principal host defense defect, predisposing mainly to bacterial and fungal infections. Presence of a CVC remains as a risk factor for bacterial infection even after myeloid engraftment. Management of bacterial infections in the early neutropenic phase of the transplant is similar to the management of febrile neutropenia seen with any other myelosuppressive therapy. Bacterial infections account for over 25% of fevers in the preengraftment phase of allogeneic HSCT.¹⁸⁹ The source of infection is usually the gut and oral flora due to mucositis, even though the increased use of CVCs has increased the risk of gram-positive bacteremias from skin flora. Streptococcal infections may be seen in patients with severe mucositis. The risk of late bacterial infections (those that occur after engraftment) depends on the immune status of the patient. Allogeneic HSCT recipients are at risk for bacterial infections with encapsulated organisms (*Streptococcus pneumoniae*, *Haemophilus influenzae*, and *Neisseria meningitidis*) if they develop chronic GVHD or profound hypogammaglobulinemia.¹⁹⁰ Prophylactic fluoroquinolones are often maintained until marrow engraftment. This practice has been shown to reduce the incidence of infections, particularly

P.1444

those due to gram-negative organisms, but has not been shown to definitively decrease infection-related mortality.^{81,176} Antibiotic prophylaxis has been found to significantly decrease the risk for all-cause mortality when compared with placebo or no treatment in neutropenic patients,^{81,191} IDSA and ASBMT guidelines do recommend prophylactic fluoroquinolone in high-risk patients with expected duration of neutropenia >7 days.¹⁸²

Viral Infections

Cytomegalovirus

CMV infection has been a major source of morbidity and mortality in transplant recipients prior to the era of proper prophylaxis and monitoring for reactivation. Transplant recipients are at risk for reactivation (if CMV seropositive pre-HSCT) and also primary infection (from stem cells or blood products from CMV seropositive donors). Incidence of primary infection has decreased with the increasing use of leukofiltered blood products.

CMV infection is defined as the reactivation of the virus and the detection of the virus in the blood or other body fluids in the absence of organ-specific abnormalities (pneumonitis, hepatitis, colitis, and retinitis). CMV disease is defined as the isolation of the virus from body fluids or tissues in a symptomatic patient or the histopathologic evidence of CMV on tissue biopsy (see Fig. 69.6). Risk factors for the development of CMV disease include older recipient age, pretransplant seropositivity of the recipient or donor, or both, and severe acute GVHD.^{192,193} T cell depletion of the stem cell graft or treatment of the recipient with antithymocyte globulin for GVHD increases the likelihood of CMV reactivation.¹⁹⁴

The incidence of CMV reactivation in allogeneic transplant recipients who are seropositive before transplant is 60% to 70%, as compared to a 10% to 30% incidence of primary infection in seronegative recipients.^{195, 196} and ¹⁹⁷ Prior to the use of ganciclovir, CMV interstitial pneumonitis occurred in 15% to 30% of HSCT allograft recipients and the ensuing mortality was as high as 85%; however, mortality remained high at 30% to 50% even with the combined use of ganciclovir and CMV-specific immune globulin (Ig).¹⁹⁴

Administration of CMV-safe or leukofiltered blood products is recommended to all seronegative autologous or allogeneic HSCT recipients to prevent primary CMV infection.^{195,198} CMV surveillance starting at the time of engraftment is recommended in instances of recipient and/or donor CMV seropositivity. Tests used for CMV surveillance include CMV pp65 antigenemia assay, DNA PCR detection methods, or CMV blood cultures.¹⁹⁹ Detection of CMV in the blood is the strongest predictor of CMV disease, but 12% to 20% of patients with negative surveillance cultures still develop CMV disease. While high-dose intravenous acyclovir significantly reduces the incidence of all forms of CMV disease or delays the onset of CMV infection, it does not prevent CMV viremia.^{200,201}

There are two recommended strategies for prevention of CMV disease. One strategy is prophylaxis with ganciclovir, valganciclovir, or valacyclovir, starting from engraftment until day 100, or longer if the patient remains at risk for CMV reactivation (active GVHD, high-dose steroids, low CD4 count).^{199,202} The other strategy is close surveillance and preemptive therapy with ganciclovir or foscarnet when CMV reactivation is detected. Both strategies reduce the incidence of CMV disease in the first 100 days; however, the median onset of CMV disease has shifted from 50-60 days to 160-176 days post-HSCT in the preemptive era.¹⁹⁷

Preemptive therapy with ganciclovir for patients with positive CMV surveillance cultures (blood, urine, throat, or bronchoalveolar lavage fluid) has demonstrated improved survival at 100 and 180 days post-HSCT, but has failed to provide an overall survival advantage.²⁰³ Protracted ganciclovir prophylaxis can lead to emergence of resistant strains and

the failure of natural immunity against CMV to develop, thus resulting in late recrudescence.^{196,204,205} Optimal preemptive therapy appears to be 1 to 2 weeks of twice-a-day induction followed by maintenance until PCR or antigen negativity.¹⁸²

Ganciclovir is the drug of choice for CMV infection and disease, but its myelosuppressive effects may preclude its use in patients with significant cytopenias. Foscarnet is an equally effective alternative and can be used to treat ganciclovir-refractory CMV infections or in patients with significant cytopenias. Although it is not myelosuppressive, foscarnet is associated with renal toxicity and electrolyte imbalances.¹⁶⁰ Cidofovir is another nephrotoxic antiviral with efficacy against CMV, but there are few data on its use in the stem cell transplant patient population.²⁰⁶ Maribavir is the latest antiviral in the armamentarium of drugs available for management of CMV and has been found to decrease rates of CMV infection when used as prophylaxis in the stem cell transplant setting,²⁰⁷ but has failed to prevent CMV disease in a randomized phase III study.²⁰⁸

Herpes Simplex Virus

HSV reactivation occurs in as many as 80% of seropositive allogeneic transplant recipients, causing mucocutaneous oral or genital lesions, esophagitis, and, occasionally, pneumonia or encephalitis. Testing all transplant recipients for herpes simplex virus exposure (HSV IgG) is recommended. Antiviral prophylaxis with acyclovir, valacyclovir, or famciclovir is recommended for all seropositive patients until the time of engraftment. Although its use is not recommended past 1 month after transplant, some patients with recurrent lesions might benefit from longer use of the prophylaxis.^{209,210}

Varicella Zoster Virus

Impaired cellular immunity is the principal risk factor for VZV disease. Current recommendations are to test every transplant patient for varicella zoster virus serostatus (IgG). VZV reactivation may occur at any time after engraftment in autologous and allogeneic transplant recipients. Disseminated VZV is seen in as many as 30% of cases and is associated with a high mortality. Many centers administer oral acyclovir or valacyclovir for ~12 months after transplant to VZV-seropositive patients.²¹⁰ Seronegative patients should be given varicella zoster immune globulin within 96 hours of exposure to a VZV vaccine or upon contact with active infection.

Fungal Infections

Most fungal infections in the SCT population are due to *Candida* or *Aspergillus*. The etiology in the remaining <10% are uncommon fungi, such as *Fusarium*, *Scedosporium*, *Blastomyces*, and *Histoplasma*. Prevention of fungal infections in these patients is key. Fluconazole prophylaxis at a dose of 400 mg/day, beginning at the time of transplant and until the time of engraftment, provides adequate protection against invasive yeast infections.^{189,211,212} Failure of fluconazole prophylaxis against *Candida* is usually a result of the emergence of resistant yeast forms (*C. krusei*, *C. glabrata*). Empiric therapy for fungal infections in febrile neutropenic patients is considered the standard of care, and several studies are examining the preemptive approach.^{33,141} The toxicity of intravenous amphotericin B is substantial and it is no longer recommended for prophylaxis. Lipid formulations of amphotericin (Abelcet, Amphotec, and AmBisome) have fewer renal and infusional toxicities. Newer antifungal agents have changed the approach to prevention and treatment of fungal infections in SCT patients. Caspofungin, micafungin, and anidulafungin are echinocandins with a broad spectrum of activity against several species of *Candida* and *Aspergillus*. Triazoles such as voriconazole, posaconazole, and ravuconazole also have activity against *Aspergillus* and a wide variety of yeasts and molds.¹³⁷

P.1445

Pneumocystis jirovecii pneumonia (PJP) is not a protozoan, but resembles a fungus based on molecular studies. Prophylaxis against PJP is recommended in all allogeneic HSCT recipients from the time of engraftment until 6 months after transplant, or even longer if the patient is on high doses of immunosuppressive drugs for chronic GVHD. Oral TMP-SMX is the drug of choice, but aerosolized pentamidine, dapsone, dapsone in combination with trimethoprim or pyrimethamine, pyrimethamine and sulfadoxine, and atovaquone can be used as alternatives.^{213,214,215,216} Patients should be tested for glucose 6-phosphate dehydrogenase deficiency before initiation of dapsone. Guidelines for PJP prophylaxis in autologous SCT patients are less clear and should be considered in patients who are deemed high-risk, such as those who receive fludarabine or cladribine and those who have had prolonged steroid use before transplant.

Toxoplasmosis reactivation or infection is rare but can be life-threatening and usually occurs within the first year posttransplant. Toxoplasmosis prophylaxis is recommended for seropositive allogeneic recipients or those with a prior history of toxoplasmic infection.¹⁸² Oral TMP-SMX is the prophylactic agent of choice,¹⁸² but pyrimethamine-sulfadoxine (Fansidar) prophylaxis can be used.²¹⁷ For patients who are TMP-SMZ-intolerant, a combination of clindamycin,

pyrimethamine, and leucovorin can be substituted. Prophylaxis is recommended from the time of engraftment until 6 months after transplant.¹⁸² Pyrimethamine does not eradicate the cyst form of *T. gondii*.

STRATEGIES TO PREVENT INFECTIONS

Measures and practices to prevent nosocomial pathogen acquisition as well as the spread of infections play critical roles in the overall picture of managing febrile neutropenia as well as the well-being of all exposed to hospital settings.

Hand hygiene is the most effective means of preventing transmission of infection in the hospital.²¹⁸ All persons should sanitize their hands upon entering and leaving the rooms of neutropenic and other hospitalized patients.

No specific protective gear (e.g., gowns, gloves, and masks) is required during the routine care of neutropenic patients, but standard isolation and barrier precautions should be followed when specific infections occur or contact with body fluid is anticipated.²¹⁹ Single patient room occupancy is common practice, especially for HSCT.

Neutropenic diets are typically given to patients with neutropenia, though data are lacking. Studies comparing diets of cooked and uncooked foods indicate that avoidance of raw fruits and vegetables does not prevent major infection or death.^{220,221} While well-cooked foods are generally recommended, well-cleaned, uncooked raw fruits and vegetables are acceptable.

Many patients with neutropenia do not require specific room ventilation, but laminar airflow rooms and HEPA filtration are still considered important for certain high-risk patients, such as those undergoing HSCT. The use of laminar flow and HEPA filtration has been reported to decrease the incidence of *Aspergillus* infections.^{222,223} However, the use of reverse isolation has not been shown to significantly reduce the acquisition of nosocomial pathogens.²²⁴

Molds, including *Aspergillus* and *Fusarium* species, have been isolated from plants and dried or fresh flowers and therefore these should not be allowed in the rooms of neutropenic patients.^{225,226} Pets should also not be allowed in the area with neutropenic patients.²¹²

Prevention of Infections

Infection prophylaxis in cancer patients involves broad-spectrum antimicrobial therapy against the common bacterial, viral, and fungal pathogens in high-risk patients. Knowing the spectrum of infection-causing pathogens at individual hospitals or treatment centers is key to appropriate prophylaxis. A summary of prophylactic strategies in this patient population is provided in Table 69.6.

Antibacterial Prophylaxis

Historically, TMP-SMX has been used for many years for prophylaxis against bacterial infections. Initial studies showed efficacy in preventing PJP, whereas later studies demonstrated benefit in reducing the incidence of bacterial infections in patients with hematologic malignancies.^{227, 228, 229, 230} and ²³¹ Fluoroquinolones are the most commonly used antibiotics for prophylaxis against bacterial infections in neutropenic patients. They are broad-spectrum derivatives of nalidixic acid that are orally bioavailable with a broader spectrum of activity, preserve colonization resistance, and are well tolerated.

Quinolone-based prophylaxis has been successful in reducing the risk of aerobic gram-negative infections in neutropenic patients undergoing cytotoxic chemotherapy for AL and HSCT in several studies.^{232,233} An increased frequency of breakthrough gram-positive bacteremias, predominantly by viridans streptococci (*Streptococcus mitis*, *S. sanguis*) and coagulase-negative staphylococci, has been observed.^{71,233, 234} and ²³⁵ The newer fluoroquinolones (ciprofloxacin, levofloxacin) have broader gram-positive activity and have been variably effective in preventing infection with α -hemolytic streptococci when coadministered with roxithromycin or amoxicillin-clavulanate.²³⁶ Viridans group streptococcal bacteremia breakthroughs have been reported with ciprofloxacin prophylaxis.⁷¹ In comparison to placebo, fluoroquinolone prophylaxis significantly reduced the incidence of gram-negative infections.¹⁹¹ Fluoroquinolone prophylaxis was also associated with a statistically nonsignificant, yet clinically relevant, decrease in mortality in neutropenic patients.^{191,237} Gram-positive and fungal infection rates were not significantly affected by fluoroquinolone prophylaxis.¹⁹¹

Prophylactic levofloxacin in neutropenic patients with intermediate or high risk of infection has been shown to lead to a reduction in infections,¹⁷⁶ whereas the major benefit in low-risk neutropenic patients relates to the reduction in febrile episodes.²³⁸

Both the IDSA and NCCN recommend the consideration of fluoroquinolone prophylaxis (levofloxacin is preferred) in patients with an expected duration of neutropenia of more than 7 days. TMP/SMX should be used in specific patients at high risk for *P. jirovecii*. No antibiotic prophylaxis is recommended for patients with neutropenia expected to last 7 days or less and who are not receiving immunosuppressive regimens.^{3,239}

Emergence of secondary resistance remains a valid concern regarding the use of antibiotic prophylaxis. Gram-negative bacteremias in patients who receive fluoroquinolone prophylaxis are often caused by resistant *P. aeruginosa*, but infections that are caused by non-*P. aeruginosa* species, especially *E. coli*, and *Enterobacter* species, are being increasingly reported.^{240,241} The potential risks of quinolone prophylaxis regarding the development of *Clostridium difficile* colitis also warrants consideration^{77,164} and underscores the importance of judicious use of antimicrobial prophylaxis.

Prophylaxis against Pneumococcal Infection

Pneumococcal prophylaxis should be considered in asplenic patients and in allogeneic HSCT recipients with chronic GVHD. The risk of pneumococcal sepsis is greatest within the first 2 years after splenectomy, but a third of events may occur up to 5 years out, and cases of fulminant sepsis have been reported at more than 20 years.²⁴² Pneumococcal disease among allogeneic HSCT recipients typically occurs in the later transplant period, from 3 months to several years after transplant. Pneumococcal

P.1446

P.1447

prophylaxis with an oral penicillin or TMP/SMX is recommended for at least 6 months post-HSCT or until discontinuation of immunosuppressive therapy.²⁴³ Vaccination against *S. pneumoniae* is recommended for all HSCT recipients, preferably with pneumococcal 7-valent conjugate vaccine.²⁴³

TABLE 69.6 PROPHYLAXIS OF INFECTIONS IN HEMATOPOIETIC STEM CELL TRANSPLANT RECIPIENTS AND HEMATOLOGIC CANCER PATIENTS

Prophylaxis	Indication	Agent	Duration/Comments
BACTERIA			
Antibacterial prophylaxis	Patients who are expected to be neutropenic for >7 days	Levofloxacin 500 mg orally daily or TMP/SMX may be used for those allergic to or intolerant of fluoroquinolones	Start when ANC < 1.0 × 10 ⁹ /L and continue until resolution of neutropenia
FUNGAL AND MOLDS			
Antifungal prophylaxis	Induction therapy for AML and MDS	Posaconazole 200 mg orally tid is drug of choice if high risk for aspergillosis. Alternatives include itraconazole, voriconazole, lipid formulation of amphotericin B, or an echinocandin (may choose to use fluconazole prophylaxis if incidence of aspergillosis is low.)	Begin with initiation of chemotherapy and continue until resolution of neutropenia.
	Acute lymphoblastic leukemia	Fluconazole ^a or an echinocandin Azoles are inhibitors of cytochrome P-450 isoenzymes, and are	Continue prophylaxis for duration of neutropenia

		expected to interfere with metabolism of vinca alkaloids and other drugs; close monitoring is recommended	
	Autologous HSCT recipient during neutropenia	Fluconazole ^a or echinocandin	Continue prophylaxis for duration of neutropenia
	Allogeneic HSCT recipient during neutropenia	Fluconazole, ^a itraconazole, voriconazole, and micafungin have each been evaluated in this setting	Continue prophylaxis for duration of neutropenia
	Allogeneic HSCT with significant GVHD receiving intensive immunosuppressive therapy ^b	Posaconazole 200 mg orally tid is drug of choice. Alternatives include voriconazole, itraconazole, lipid formulation of amphotericin B, or an echinocandin	Continue prophylaxis for 16 wk and for at least the duration of intensive immuno-suppressive therapy, ^b whichever occurs later
<i>Pneumocystis jirovecii</i> Prophylaxis	Acute lymphocytic leukemia, allogeneic HSCT recipients, alemtuzumab recipients, fludarabine recipients, or patients receiving corticosteroids (≥ 20 mg of prednisone equivalent) for ≥ 1 mo in the presence of other immunosuppression or myelotoxic chemotherapy.	TMP/SMX 1 DS (TMP 160 mg + SMX 800 mg) orally daily or 3 days per week OR dapsone 100 mg orally daily OR inhaled pentamidine 300 mg every 4 wk OR atovaquone 1,500 mg/d.	In allo-HSCT, continue prophylaxis for 2 mo after stopping immunosuppression. In patients treated with alemtuzumab, continue prophylaxis for 2 mo after the last dose or until the CD4 count is >200 .

VIRUSES

Prophylaxis for HSV	HSCT recipients (HSV-seropositive recipients) Induction chemotherapy for acute leukemia (HSV-seropositive) Patients treated with alemtuzumab, or in patients with recurrent HSV reactivation following chemotherapy	Acyclovir 400 mg orally bid or tid OR 800 mg orally bid OR 250 mg/m ² /12 h or valacyclovir 500 mg orally once or twice (higher doses have been used up to 1,000 mg tid) or famciclovir 250 mg orally tid	Continue prophylaxis for HSV until resolution of neutropenia and mucositis. In patients treated with alemtuzumab, continue prophylaxis for 2 mo after the last dose or until the CD4 count is >200
Prophylaxis for VZV	Allogeneic HSCT recipients with a history of chicken pox or shingles	Acyclovir 800 mg orally bid OR valacyclovir 500 mg orally daily	
Prophylaxis for CMV (preemptive)	Patients requiring CMV surveillance 1. Allogeneic HSCT	Induction for 1 wk followed by maintenance for 1 wk as follows:	CMV surveillance: 1. Allogeneic HSCT recipients: day 30 to at least

therapy)	<p>recipients who are CMV⁺ or whose donor is CMV⁺ (standard of care)</p> <p>2. Autologous SCT recipients receiving a CD34-enriched autograft</p> <p>3. Patients treated with alemtuzumab</p>	<p>Ganciclovir 5 mg/kg IV q12h for 7 days (induction), followed by Ganciclovir 5 mg/kg IV daily 5 times a week (maintenance) OR Foscarnet^a 60 mg/kg IV q12h times 7 days (induction) followed by Foscarnet^c 60 mg/kg IV daily (maintenance) Oral valganciclovir (900 mg bid) is an acceptable alternative to IV formulations in patients who do not have severe gut GVHD (see text)</p>	<p>6 mo after allogeneic HSCT, during periods of GVHD, and until the CD4⁺ count is >100 μL.</p> <p>2. Recipients of CD34-enriched autologous grafts: day 30 to day 100 and until the CD4⁺ count is >100 μl.</p> <p>3. Alemtuzumab recipients: time of initiation until at least 2 mo after completion of therapy and until the CD4 count is >100 μl.</p> <p>The level of CMV reactivation that triggers preemptive therapy varies with the method. The CDC recommends any positive CMV antigenemia (pp65) or two consecutive qualitative PCR results within the first 100 days, and five cells per slide after the first 100 days</p> <p>Treatment is given for the first 100 days, then weekly or biweekly monitoring and preemptive management is initiated</p>
Prophylaxis against CMV		<p>Ganciclovir or foscarnet at the same dose as in preemptive regimen</p>	

ANC, absolute neutrophil count; AML, acute myelogenous leukemia; bid, twice daily; CDC, Centers for Disease Control and Prevention; CMV, cytomegalovirus; DS, double strength; GVHD, graft-versus-host disease; HSCT, hematopoietic stem cell transplant; HSV, herpes simplex virus; IV, intravenous; MDS, myelodysplastic syndrome; tid, 3 times a day; PCR, polymerase chain reaction; SCT, stem cell transplant; TMP/SMX, trimethoprim/sulfamethoxazole; VZV, varicella zoster virus.

^a Fluconazole is effective as prophylaxis against candidal, but not mold, infections. If prophylactic fluconazole is used in patients with prolonged neutropenia, a strategy of empirical modification to a mold-active drug in patients with persistent neutropenic fever should be considered. Doses apply to adults with normal renal function.

^b Criteria include acute grade II to IV GVHD, or extensive chronic GVHD, or treatment with intensive immunosuppressive therapy consisting of either high-dose corticosteroids (1 mg/kg of body weight per day for patients with acute GVHD or 0.8 mg/kg every other day for patients with chronic GVHD), antithymocyte globulin, or a combination of two or more immunosuppressive agents.

^c Doses apply to adults with normal renal function.

Adapted from the NCCN Clinical Practice Guidelines in Oncology. Prevention and Treatment of Cancer-Related Infection. NCCN. Version 1.2012, the clinical practice guideline for the use of

antimicrobial agents in neutropenic patients with cancer: 2010 update by the Infectious Diseases Society of America (IDSA), and the comprehensive guideline cosponsored by the Center for International Blood and Marrow Research, the National Marrow Donor program, the European Blood and Marrow Transplant Group, the American Society for Blood and Marrow Transplantation, the Canadian Blood and Marrow Transplant Group, the Infectious Diseases Society of America (IDSA), the Society for Healthcare Epidemiology of America, the Association of Medical Microbiology and Infectious Disease Canada, and the CDC makes evidence-based recommendations for HSCT that may be applicable to other cancer patients. Tomblyn M, Chiller T, Einsele H, et al. *J Am Soc Blood Marrow Transplant* 2009;15:1143-1238.

Antifungal Prophylaxis

Antifungal prophylaxis should be based on risk stratification and should target specific pathogens in different patient groups. Patients with hematologic malignancies or HSCT recipients have several risk factors for fungal infections: defects in cellular immunity, prolonged profound neutropenia, immunosuppressive therapy, use of broad-spectrum antibiotics, use of parenteral nutrition, and use of indwelling vascular devices. The Transplant Associated Infections Surveillance Network (TRANSNET) prospectively analyzed HSCT recipients with proven or probable invasive fungal disease. Aspergillosis (43%), candidiasis (28%), and zygomycosis (8%) were the most common.²⁴⁴ Preventive efforts should be directed toward the reduction of *Candida* and *Aspergillus* species, as they have traditionally been the most common causes of fungal disease in immunocompromised patients.^{196,244} Patients should be counseled to avoid dust or soil exposure when traveling to areas that are endemic for organisms such as *Blastomyces dermatitidis*, *Coccidioides immitis*, and *Histoplasma capsulatum* when possible. Most other pathogens such as *Aspergillus* species, *C. neoformans*, and the Mucorales order (Zygomycetes class) are ubiquitous in the environment. Hospital outbreaks of *Aspergillus* are more likely to occur during periods of construction or renovation.^{245,246} HEPA filtration, regular maintenance of ventilation systems, and floor-to-ceiling barriers around construction sites are important measures in reducing the risk of invasive aspergillosis.²⁴⁷

Prior to the development of the triazole class of drugs, few effective antifungal agents other than amphotericin B were available. Nystatin and clotrimazole may prevent oropharyngeal candidiasis but are not well tolerated in patients with severe mucositis. Oral polyenes (nystatin and oral amphotericin B) are not orally bioavailable and have failed to demonstrate a reduction of systemic fungal infections.^{248,249} Inhaled amphotericin B has shown promise in preventing colonization and infection with *Aspergillus* but tolerability remains a concern and direct comparison to systemic mold-active azoles has not been studied.^{250, 251} and ²⁵²

Multiple randomized trials in patients with leukemia and patients undergoing allogeneic HSCT have demonstrated that fluconazole prophylaxis at a dosage of 400 mg/day reduces the incidence of superficial and invasive candidal infections, excluding *C. krusei*.^{211,253,254} Fluconazole prophylaxis has also been found to confer improved survival in HSCT recipients,^{189,255} but may increase the risk of colonization by azole-resistant *Candida* strains.¹⁸⁹ Itraconazole prophylaxis for candidiasis has been shown to provide similar efficacy and may additionally reduce the risk of aspergillosis. However, itraconazole has also demonstrated higher toxicity (drug-drug interactions due to cytochrome P450 3A4 inhibition) and gastrointestinal intolerance. It is also contraindicated in patients with a decreased cardiac ejection fraction or a history of congestive heart failure.²⁵⁶ Micafungin appears to be as effective as fluconazole in prevention of candidiasis in HSCT recipients²⁵⁷ and may also reduce the risk of *Aspergillus*.

Prevention of aspergillosis requires prophylaxis with broader spectrum antifungals. Comparison of standard prophylaxis (fluconazole or itraconazole) versus posaconazole in AML/MDS patients receiving myelosuppressive induction therapy revealed that posaconazole prophylaxis led to fewer invasive fungal infections, including aspergillosis, and to improved survival.¹⁴² A similar comparison in HSCT recipients with severe GVHD demonstrated that prophylactic posaconazole also led to fewer cases of invasive aspergillosis but failed to impact overall survival.¹⁴² Comparison of voriconazole versus fluconazole prophylaxis in allogeneic HSCT recipients showed a trend toward reduction of aspergillosis infections in voriconazole recipients, but no difference in overall or fungal infection-free survival.³

Fluconazole is a well-studied agent and remains the standard drug of choice to prevent invasive candidiasis, but it has no activity against molds.²⁵⁸ Mold-active agents should be considered when there is significant risk of aspergillosis. Posaconazole is an oral agent with antimold activity and requires administration with food or enteral preparations to enhance bioavailability. The mold-active azoles (i.e., itraconazole, voriconazole, posaconazole) are potent inhibitors of cytochrome P450 3A4 isoenzymes and may lead to reduced clearance of other drugs, such as calcineurin inhibitors and vinca alkaloids. Close monitoring of drug-drug interactions and appropriate dose modifications are required.¹⁰⁹

P.1448

Histamine blockers and proton pump inhibitors, such as omeprazole, should be avoided, and serum levels must be monitored during therapy.²⁵⁹

Antiviral Prophylaxis

Opportunistic viral disease may occur by primary infection or by reactivation of latent infection. Herpesviruses, including CMV, VZV, and HSV-1 and -2, are by far the most common infection-causing viruses. Antiviral prophylaxis (acyclovir, valacyclovir, or famciclovir) against HSV is advised during the period of neutropenia in seropositive patients receiving chemotherapy for acute leukemia, and during neutropenia and at least 30 days after HSCT for both allogeneic and autologous transplant recipients.^{3,239} Prolonged prophylaxis should be considered in allogeneic HSCT recipients with GVHD or with frequent HSV reactivation before transplantation.²¹⁰ Acyclovir is an effective prophylaxis against reactivated HSV infections (gingivostomatitis, esophagitis) in patients who are receiving intensive chemotherapy for acute leukemia or BMT.^{260, 261} and ²⁶² Acyclovir or valacyclovir are each commonly used as prophylaxis, treatment, and suppressive therapy against HSV and VZV in immunocompromised patients.^{263,264} Although acyclovir has proven to be highly effective as prophylaxis, there are reports of acyclovir-resistant HSV developing while on therapy.^{265,266} Treatment with foscarnet or cidofovir is recommended in the setting of acyclovir-resistant HSV. Foscarnet-resistant HSV strains have been reported in allogeneic stem cell transplant patients and such patients have been treated with cidofovir.²⁶⁷ Newer nucleoside analogs (such as BV-ara U, Brovavir) are being studied. Acyclovir-related prodrugs (valacyclovir, famciclovir) appear as effective as acyclovir for HSV and VZV prophylaxis.^{160,172,268} Avoidance of close contact with infected or exposed individuals is advisable for immunocompromised seronegative patients. Prophylaxis should also be considered in patients receiving T cell-depleting agents (e.g., fludarabine, calcineurin inhibitors, and proteasome inhibitors).

Prevention of Viral Hepatitis

Reactivation of latent hepatitis B virus occurs in various settings (e.g., HSCT, cytotoxic chemotherapy, anti-CD20 monoclonal antibodies treatments). The immunosuppressive effect of the chemotherapy allows virus reactivation in the liver, and the subsequent immune reconstitution may result in hepatocellular damage.²⁶⁹ Patients with lymphoma, or who use steroids or receive anthracycline chemotherapy, seem to be at higher risk.²⁷⁰ Fulminant hepatitis and death may occur following HBV reactivation in immunocompromised patients. Evaluation of HBV surface antigen, core antibody, and surface antibody should be considered for those in whom intensive immunosuppressive therapy is planned.²⁷¹ Lamivudine prophylaxis has been shown to be relatively effective in the prevention of hepatitis B reactivation, though randomized trials are still needed.^{204,270,272}

Baseline quantitative PCR for HBV DNA should be obtained in HBsAg-positive individuals. Antiviral therapy should be strongly considered in patients with active HBV infection undergoing HSCT or other intensive immunosuppression therapies, but an optimal antiviral treatment regimen remains unclear.

Augmentation of Host Defense

Optimization of patients' immune status via prophylactic immunization is another consideration to assist in the reduction of infection risk. Table 69.7 summarizes the recommended vaccine schedule of patients with hematologic malignancies and HSCT recipients as per the Advisory Committee on Immunization Practices (ACIP), ASBMT, and EBMT.^{182,212,239,273,274}

Active Immunization

Patients with hematologic neoplasms are at increased risk for infection with polysaccharide-encapsulated bacteria, viruses, and fungi due to impaired T cell, granulocyte, and reticuloendothelial cell function, as well as to defective antibody responses. Immunization as a means of preventing infectious morbidity has been best studied in children with ALL or solid tumors, patients with HL with or without splenectomy, and marrow transplant recipients. Although the optimal timing of immunizations in these patients and specific recommendations for each type of cancer are still unclear, general guidelines have been established.

If indicated, the administration of inactivated vaccines should be completed more than 10 days before initiation of chemotherapy or 3 months after completion of chemotherapy in adults with hematologic malignancies, including acute leukemia and myeloproliferative diseases.²³⁹ CDC recommendations require all infants to be vaccinated for *Haemophilus influenzae* type B (Hib) and thus almost all adults in theory should possess adequate immunity against this organism. However, splenectomized Hodgkin's disease patients who were receiving antineoplastic therapy were found to have a significantly greater decrease in Hib titer at a 6- to 12-month period after the primary vaccination (given before starting chemotherapy) as compared to normal controls.²⁷⁵ Most children who receive maintenance chemotherapy for leukemia

or lymphoma are able to generate protective antibody responses to a single dose of conjugate polysaccharide Hib vaccine, although responses are less than those that are seen in healthy children.²⁷⁶ Recommendations for children are therefore to continue the primary series of Hib-conjugate vaccinations during chemotherapy treatment and to administer a booster immunization 1 year after completion of chemotherapy.²⁷⁷ For adults with hematologic malignancies, it is recommended that a dose of Hib vaccine be given before initiation of chemotherapy or before splenectomy, if one is planned.²⁷⁸ The need for a booster a year after chemotherapy in adults has yet to be determined, and further studies are warranted.^{275,278,279}

Pneumococcal vaccines are available as either a conjugate vaccine (PCV-7, PCV-13) or a polysaccharide vaccine (pneumococcal polysaccharide vaccine 23-valent, PPSV23). Conjugated vaccines elicit improved immune responses in HSCT recipients compared with pure polysaccharide vaccines, and are therefore preferred.^{274,280, 281, 282} and ²⁸³ Conjugated vaccines induce a robust T cell-dependent immune response and generate long-term memory loss. It is recommended that HSCT recipients receive 3 sequential doses of PCV-13 starting 3 to 6 months after transplant. A fourth vaccination with PPSV-23 is given 8 weeks after the third dose of PCV-13 to broaden the immune response to include serotypes not included in PCV-13. Given that patients with active chronic GVHD are likely to have a poor response to PPSV-23, a fourth dose of PCV-13 should be considered in these patients.¹⁸² One-time revaccination with PPSV-23 at 5 years after the first dose is currently recommended for immunocompromised patients.²⁷⁸ The ACIP recommends that adults 19 years of age or older with immunocompromising conditions who have not previously received PCV13 or PPSV23 should receive a dose of PCV13 first, followed by a dose of PPSV23 at least 8 weeks later. Complete protection might not be achieved if the vaccine is given within 3 years after antineoplastic therapy.^{284,285}

Immunization for *N. meningitidis* by using a polysaccharide vaccine is recommended in cancer patients requiring splenectomy.²⁸⁶ However, this vaccine offers no protection from serogroup B (which is responsible for one-third of cases). Ongoing studies are being conducted to test new meningococcal serogroup B vaccine.²⁸⁷

Children undergoing chemotherapy and who have not completed all of the diphtheria-tetanus (DT) (or diphtheria, pertussis, and tetanus; pertussis is included if the child is <7 years of age)

P.1449

and polio immunization series should complete the boosters as scheduled, although aggressive and prolonged chemotherapy may blunt the response. Only the inactivated polio vaccine (IPV) should be given to immunocompromised patients because of the risk of acquiring polio from the live attenuated oral polio vaccine. Booster doses of DT or diphtheria, acellular pertussis, and tetanus and the IPV should be administered 1 year after chemotherapy completion. It is recommended that adult cancer patients receive DaPT immunization boosters in the same dose and schedule as for healthy individuals, as responses can be elicited in immunocompromised patients.²³⁹

TABLE 69.7 RECOMMENDATIONS FOR ACTIVE IMMUNIZATION OF ADULTS WITH MALIGNANCIES

Vaccine	Persons Who Should Receive Vaccine	Timing in Relation to Chemotherapy	Regimen^a
<i>Haemophilus influenzae</i> type b	Lymphoma patients	Before staging splenectomy, >10 d before initiation of chemotherapy, or 3 mo after completion of chemotherapy	Single-dose
Hepatitis B ^b	Cancer patients with hepatitis B surface antigen (+) household contacts	Not during immunosuppressive therapy	3 doses: second dose 1-2 after the first, third dose 4-6 mo after the first
Influenza	All cancer patients	>2 wk before initiation or between cycles of intermittent chemotherapy	Annually each fall/winter
Measles, mumps, rubella	Nonimmune leukemic patients in remission and household contacts of all immuno-	For leukemic patients in remission, >3 mo after completion of therapy;	Once

	suppressed individuals	otherwise contraindicated in patients with leukemia, lymphoma, or those undergoing immunosuppressive therapy	
Meningococcal (<i>Neisseria meningitidis</i>)	Lymphoma patients	Before staging splenectomy	2 doses; second dose 3-5 y after the first
Poliomyelitis (inactivated poliovirus vaccine only) ^c	Adults at increased risk of infection; all susceptible household contacts of cancer patients	No data available; recommend each dose >10 d before initiating chemotherapy	3 doses; second dose 4-8 wk after the first, third dose 6-12 mo after the second
23-Valent polysaccharide pneumococcal (<i>Streptococcus pneumoniae</i>)	Any nonimmune cancer patient, especially lymphoma and multiple myeloma patients	Before staging splenectomy, >10 d before initiation of chemotherapy, or 3 mo after completion of chemotherapy	2 doses; second dose at least 5 y after the first
PCV13 (Pneumococcal Conjugate) Vaccine	19 yr of age or older with immunocompromising conditions who have not previously received PCV13 or PPSV23; 19 y of age or older with immunocompromising conditions, who have previously received one or more doses of PPSV23	Give a dose of PCV13 first followed by a dose of PPSV23 at least 8 wk later. Subsequent doses of PPSV23 should follow current PPSV23 recommendation. Give a dose of PCV13 one or more years after the last PPSV23 dose was received	
Tetanus and diphtheria toxoids combined	All cancer patients	No data available; recommend administration >10 d before initiating chemotherapy	Primary 3-dose series if not previously immunized; second dose 4-8 wk after the first, third dose 6-12 mo after the second; booster doses at 10-y intervals throughout life or with dirty wound if >5 y since last dose
Varicella	Nonimmune household contacts of cancer patients	Not applicable—contraindicated in patients with leukemia, lymphoma, or those undergoing immunosuppressive therapy	For persons >13 y of age, 2 doses separated by 4-8 wk

^a Adapted from the Centers for Disease Control and Prevention.

^b May be used in conjunction with hepatitis B immunoglobulin prophylaxis. ^c Live oral polio vaccine is no longer available for general use in the United States and is contraindicated in immunosuppressed

persons or their household contacts.

The inactivated influenza vaccine is generally recommended in immunocompromised patients on a yearly basis.²⁷⁸ Several studies have evaluated the efficacy of this vaccine in cancer patients; there is definite efficacy in patients with solid tumors, but the response may be blunted in patients with hematologic malignancies.²⁸⁸ Despite a lack of a clear-cut benefit in immunocompromised patients, the likelihood of at least partial protection has urged physicians to vaccinate all cancer patients with the inactivated influenza vaccine.

The live attenuated measles, mumps, and rubella (MMR) vaccine may be considered in previously unimmunized children with leukemia who are in remission, or who have been off or not received chemotherapy for at least 3 months; but it is otherwise contraindicated in immunocompromised individuals.^{239,277} The live attenuated varicella vaccine is not recommended for use in immunocompromised patients, except in seronegative children with HIV.^{239,289,290}

Protective antibodies to common childhood diseases (polio, tetanus, diphtheria, mumps, measles) wane after ablative therapy and autologous or allogeneic transplantation and thus necessitate revaccination.^{291, 292} and ²⁹³ All HSCT patients should be vaccinated with combined tetanus-diphtheria toxoids at 12, 14, and 24 months after transplant.^{243,292,294, 295} and ²⁹⁶ Antibody levels against *H. influenzae* gradually decline after transplant, and revaccination using the Hib-conjugate vaccine is recommended at 12, 14, and 24 months after transplant to restore immunity.²⁴³ The oral polio vaccine is contraindicated in all immunocompromised individuals.²⁷⁸ IPV and hepatitis B vaccines are recommended at 12, 14, and 24 months after transplant, owing to the loss of immunity against

P.1450

the virus by 1 year after transplant in the majority of transplant recipients.^{297,298} Vaccination against Meningococci, rabies, and hepatitis A is not routinely recommended in this patient population.¹⁸² Annual seasonal administration of inactivated influenza vaccine is recommended following 6 months posttransplant.¹⁸² The MMR vaccine, a live attenuated vaccine, may be given to BMT patients about 2 years after transplant and may be administered to household contacts before then. Patients with GVHD who are continuing to receive immunosuppressive therapy should not be given the MMR vaccine.²⁹¹ The varicella vaccine is a live attenuated vaccine and is contraindicated in transplant recipients. Use of the Bacille Calmette-Guérin vaccine is contraindicated during the first 2 years posttransplant.^{299,300}

Passive Immunization

Intravenous immunoglobulins (IVIG) therapy for prevention of infection has been evaluated primarily in patients with lymphoproliferative disorders and multiple myeloma and SCT recipients. Currently available IVIG preparations are safe, well tolerated, and consist primarily of IgG, although small amounts of IgA and IgM are present.³⁰¹ IgA-poor preparations must be used to prevent anaphylaxis in patients with known or suspected congenital IgA deficiency and/or those with high anti-IgA titers. IVIG (400 mg/kg given every 3 weeks) has been shown to reduce frequency of moderately severe bacterial infections in patients with CLL who have hypogammaglobulinemia or a history of recurrent infections.^{302, 303} and ³⁰⁴ However, this practice has not been proven to be cost-effective, to prolong survival, or to demonstrably improve the quality of life of patients with CLL.¹⁹⁴ Reduction in the number of symptomatic and life-threatening infections has also been reported in patients with multiple myeloma receiving monthly infusions of IVIG.^{201,305} A meta-analysis of multiple trials involving prophylactic IVIG in patients with CLL and MM illustrated a significant decrease in occurrence of major infections and reduction in clinically documented infections, but no survival benefit.³⁰⁶ Thus, prophylactic use of IVIG for patients with CLL or MM with hypogammaglobulinemia and/or recurrent infections should be considered on an individual basis.

In allogeneic HSCT patients, prophylactic use of IVIG has been shown to prevent grades II-IV acute GVHD,^{307,308} decrease gram-negative septicemia, and decrease local infections; but it does not improve mortality.^{309,310} Decisions to use IVIG in allogeneic transplant patients should be made on an individual basis because of the cost of IVIG and the availability of suitable antimicrobial alternatives. Autologous transplant recipients do not appear to benefit from prophylactic globulin therapy, and its use may actually lead to increased incidence of fatal hepatic venoocclusive disease in these patients.³¹¹

TABLE 69.8 DEFINITION OF CATHETER-ASSOCIATED INFECTIONS

Localized catheter colonization	•Significant growth of a microorganism (greater than 15 CFU) from the catheter tip, subcutaneous segment of the catheter, or catheter hub.
Exit site infection	•Erythema, or induration within 2 cm of the catheter exit site, in the absence of concomitant bloodstream infection (BSI) and without concomitant purulence.

Tunnel infection	•Tenderness, erythema, or site induration of more than 2 cm from the catheter exit site along the subcutaneous tract of a tunneled catheter (i.e., Hickman or Broviac) in the absence of concomitant BSI.
Pocket infection	•Purulent fluid in the pocket of a totally implanted intravascular catheter that may or may not be associated with spontaneous rupture and drainage or necrosis of the overlying skin in the absence of concomitant BSI.
Catheter-related bloodstream infection (CRBSI)	<ul style="list-style-type: none"> •Bacteremia or fungemia in a patient with an intravascular catheter with at least one positive blood culture obtained from a peripheral vein, clinical manifestations of infections (e.g., fever, chills, or hypotension) and no apparent source for the BSI except the catheter. •One of the following should be present: a positive semiquantitative (greater than 15 CFU/catheter segment) or quantitative (greater than 10² CFU/catheter segment) culture whereby the same organism (species and antibiogram) is isolated from the catheter segment and peripheral blood; simultaneous quantitative blood cultures with a 3:1 ratio for CVC versus peripheral; or differential period of CVC culture versus peripheral blood culture positivity of more than 2 hours.

IVIg and CMV hyperimmune globulin can confer passive immunity against CMV infection, but other methods of CMV prophylaxis, such as leukofiltration of blood products, may be more cost-effective.³¹²

Passive immunization with varicella zoster immune globulin is indicated in seronegative immunosuppressed patients who are exposed to an active case and should be given within 72 to 96 hours of the exposure.³¹³ Patients who are exposed to measles, mumps, or rubella may benefit from passive Ig prophylaxis if it is given within 6 days of exposure.^{314,315}

Intramuscular Ig is recommended for patients who travel to areas that are endemic for hepatitis A or for postexposure prophylaxis.³¹⁶ Two doses of hepatitis B Ig, given 1 month apart, are recommended for postexposure prophylaxis.

MANAGEMENT OF CATHETER-RELATED INFECTIONS

Catheter-related bloodstream infections (CRBSI) are associated with prolonged hospitalizations, increased healthcare costs, and increased morbidity and mortality.^{317,318} The incidence of device-associated infection varies depending on the type of device inserted, its length of use, and the extent of the patient's immunosuppression. Neutropenic patients, particularly those with a hematologic malignancy, have a greater risk for developing CRBSI and bacteremia.^{317,319,320}

Overall, the incidence of port-associated infections is low at 0.1 per 1,000 port-days, and that of tunneled catheters is approximately 1 to 3 per 1,000 days of patient use. Cumulative incidence of PICC-related blood stream infections is 1.1 per 1,000 PICC-days (range 0.9 to 1.3), but higher in the inpatient setting (2.1 per 1,000 PICC-days).³¹⁸ Number of lumens is an independent risk factor for CRBSI and multiple-lumen catheters have higher infection rates.^{142,321} Standardized infection control procedures as recommended by the CDC are increasingly being used to help reduce catheter-related bloodstream infections.³²²

Several types of catheter-related infections have been defined: exit site infection, tunnel infection (or pocket infection in the case of ports), septic phlebitis, and CRBSI (Table 69.8).⁵⁵ The majority of these infections are caused by gram-positive pathogens, with coagulase-negative staphylococci recovered most frequently.

P.1451

Catheter-related infections with *S. aureus*, gram-negative bacteria, corynebacteria, bacillus species, and mycobacterial and fungal organisms have also been reported.

Simultaneous cultures from peripheral sites and all catheter ports are helpful in distinguishing infection of the catheter itself from infection arising from another source. Successful treatment of CRBSIs caused by coagulase-negative staphylococcal or even gram-negative organisms does not always require catheter removal. Infections of the skin pocket of an implanted port also resolve in ~70% of patients without removal of the device.⁵⁵ Appropriate intravenous antibiotics should be administered for 1 to 3 weeks and should be rotated through all lumens. If clinical improvement is observed and surveillance cultures from each lumen remain negative after 3 days of antibiotic therapy, the catheter sterilization is likely.⁵⁵ Uncomplicated exit site infections will also usually resolve with aggressive local care and systemic antibiotic therapy. However, some bacterial infections (e.g., *S. aureus*, some *Bacillus* species, *Corynebacterium* group, and

Stenotrophomonas species) will require catheter removal in order to increase the likelihood of successful treatment. Other indications for immediate removal of the catheter include evidence of complicating endocarditis, osteomyelitis, septic thrombosis, septic pulmonary embolism, or sepsis with signs of shock/end-organ dysfunction. Certain organisms, such as Candida and fungi, are extremely difficult to eradicate and necessitate prompt catheter removal to avoid the complications of disseminated infection. Fungemia caused by Malassezia furfur (Pityrosporum orbiculare) tends to occur in patients who receive parenteral lipids and may be resistant to amphotericin B. This infection often manifests as fever, pulmonary infiltrates, and thrombocytopenia; discontinuation of the lipid, as well as removal of the catheter, is needed.³²³

Occlusion and Venous Thrombosis of Catheters

Although a clot is the most common cause of occlusion, inability to aspirate blood from the port or catheter does not always suggest clot formation. Other causes of impaired catheter flow include a malpositioned Huber needle, catheter compression on the wall of the vein, catheter kinking, catheter pinch-off, precipitation of drug solutions in the catheter lumen, development of fibrin sheaths, and catheter migration resulting in a malpositioned tip.³²⁴ Fibrin blockage is common, and simple repositioning of the patient and/or Valsalva maneuvers may allow blood to be withdrawn. If these strategies fail, the catheter position should be confirmed by chest radiograph after injection of contrast dye through the catheter. Patients in whom there is no contraindication to thrombolytic therapy may be given an infusion of urokinase at 200 U/kg/hour for as long as 12 hours to reopen the catheter. Otherwise, 5,000 U of urokinase (in 2 ml of sterile water) may be injected into the catheter, and a blood draw may be attempted again in 30 minutes. This procedure may be repeated twice in 24 hours if necessary. Recombinant tissue plasminogen activator (alteplase) at a dose of 2 mg/2 ml instilled for 30 minutes may also restore function in occluded venous catheters.^{325,326}

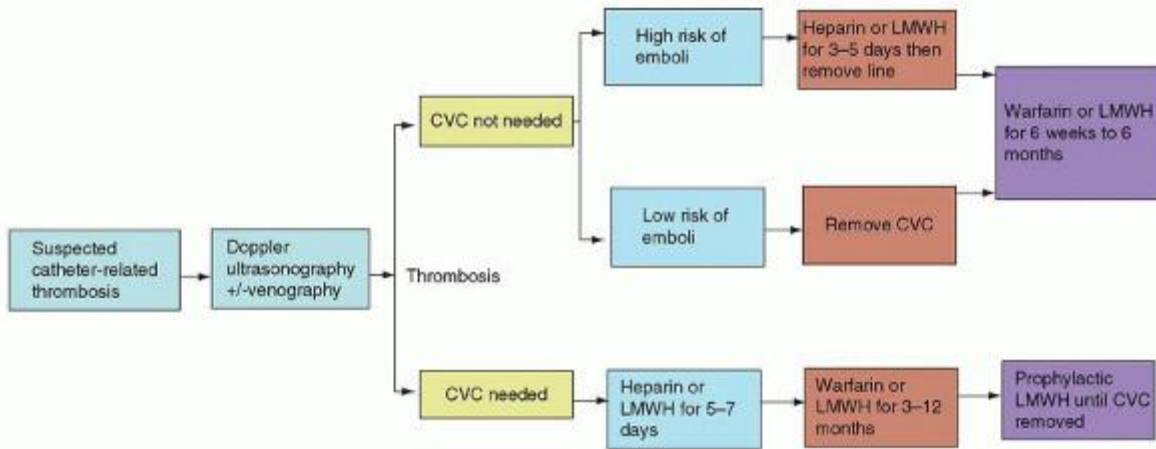

FIGURE 69.8. Algorithm for diagnosis and management of catheter-related thrombosis. (CVC, central venous catheter; LMWH, low-molecular-weight heparin.) Ultrasonography (U/S) can be used as the initial screening test for thrombosis, whereas venography may be required if U/S is negative or inconclusive. The duration of anticoagulation depends upon clinical factors, including the need for the CVC, the size of the clot, and the presence of a prothrombotic state. In patients with cancer, LMWH is preferred over warfarin, and duration of anticoagulation should be 6 months or longer. (Adapted from Baskin JL, Pi C-H, Reiss U, et al. Management of occlusion and thrombosis associated with long-term indwelling central venous catheters. Lancet 2009;374:159-169.)

Contrary to early reports, data from two randomized studies failed to demonstrate a benefit of low-dose warfarin³²⁷ or LMWH³²⁸ to reduce the incidence of symptomatic catheter-associated thrombotic events in patients with cancer. Prophylactic use of urokinase (5,000 IU/ml) every 1 to 2 weeks into long-term CVADs has shown reduced incidence of thrombosis and also of catheter-related infections.³²⁹

Thrombosis can occur in the catheter itself or in the superior vena cava or veins of the upper extremity. While asymptomatic thromboses have been reported in rates up to 60%, recent studies show a variable incidence of symptomatic catheter-related thrombosis of 4% to 5% up to 28% of adults and 12% of children with a CVC.^{325,330,331} Almost all central indwelling venous access devices become coated with a fibrin sheath within days of insertion and the majority of CVC-related thrombi arise within 30 days of initial placement.³³² Pain, ipsilateral extremity edema, and superficial venous dilation require evaluation with venography or noninvasive contrast imaging techniques. The catheter should be removed if it is no longer needed or if treatment with systemic anticoagulation fails. If the catheter remains functional and needed for clinical use, then the recommendation from the 2012 American College of Chest Physicians is to keep the catheter in place and to continue systemic anticoagulation with warfarin or low molecular weight heparin (LMWH) as long

as the catheter remains indwelling. If the catheter is removed, it is recommended to continue systemic anticoagulation for a total of 3 months regardless of diagnosis.³³³ Another recommendation has a variable length of anticoagulation, from 6 weeks to 6 months depending upon the size of the clot and whether the patient is considered prothrombotic³³¹ (Fig. 69.8).

P.1452

CHEMOTHERAPY-INDUCED NAUSEA AND VOMITING

Chemotherapy-induced nausea and vomiting (CINV) is a common adverse effect of cancer therapies. Nausea and vomiting can be very distressing to both patients and their caregivers. Nausea can have a negative impact on quality of life, both physical and cognitive functions, and may lead to critical delays in the administration of potentially curative therapy.^{334,335} Nausea and emesis can be induced by a number of factors besides chemotherapy, and thus it is important to investigate the underlying etiology. Radiation therapy, especially in those undergoing total body irradiation (TBI) prior to HSCT, infections, metabolic derangements, electrolyte abnormalities, metastases (especially brain and liver), medications (antibiotics, antifungals, opiates), and other psychological factors can all lead to nausea and vomiting in patients with cancer.³³⁶ Based upon the emetogenic potential of the chemotherapy administered and specific patient characteristics, personalized therapeutic decisions can be made to try to prevent CINV.³³⁷ A breakdown of the relative emetogenicity of commonly used chemotherapeutic agents can be found in Chapter 68, Table 68.2. Patient characteristics associated with increased risk for CINV include: age < 50, female gender, history of motion sickness, history of low prior chronic alcohol intake, and emesis during pregnancy.³³⁵ Coadministration of chemotherapeutic agents and repeated cycles of chemotherapy can also increase the potential for CINV.³³⁸

CINV can be broken down into 5 distinct yet related syndromes: (1) acute CINV, (2) delayed CINV, (3) anticipatory CINV, (4) breakthrough CINV, and (5) refractory CINV.³³⁸ Acute CINV is typically defined as occurring within the first 24 hours of chemotherapy administration. Delayed CINV is typically defined as occurring 1 to 5 days after chemotherapy administration. Anticipatory CINV occurs prior to the chemotherapy administration, and has been associated with just one episode of nausea and vomiting with a prior regimen. Breakthrough CINV occurs despite the use of appropriate preventative strategies, and refractory CINV occurs due to failure of preventative and rescue therapies.³³⁸

To understand the rationale behind different strategies for the prevention and treatment of CINV, it is helpful to understand the physiology of the emesis response. The current model of the emesis response (Fig. 69.9) is primarily mediated through neurotransmitters in the gastrointestinal (GI) system and the central nervous system (CNS).³³⁸ Afferent signals from the chemotherapy trigger zone (CTZ), cerebral cortex, and GI tract converge on the vomiting center (VC) within the medulla oblongata. Ultimately, the VC sends out efferent signals to the organs responsible for completing the motor events of emesis (esophagus, stomach, abdominal musculature).³³⁹ Serotonin and substance P are the main neurotransmitters implicated in CINV; however dopamine, histamine, endorphins, acetylcholine, and GABA have also been shown to be involved. Based upon the identification of active neurotransmitters and their receptors within the VC, control of CINV may depend ultimately upon blocking the neurotransmitter receptors in the VC from afferent inputs of the GI tract and CNS.³³⁸

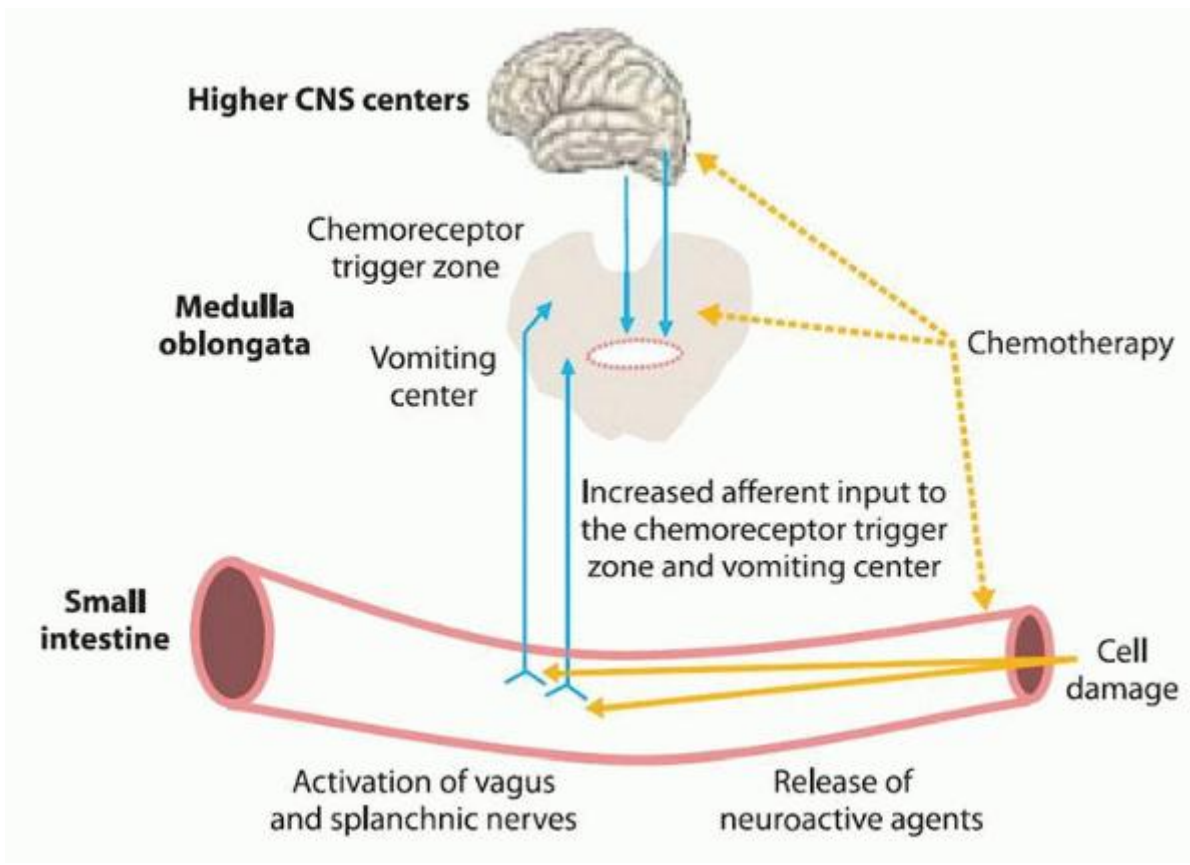

FIGURE 69.9. Model of the emesis response. (With permission from Navari RM. Pathogenesis-based treatment of chemotherapy-induced nausea and vomiting—two new agents. *J Support Oncol* 2003;1:89-103.)

Prevention is the key treatment of CINV. Development of effective preventative antiemetic regimens requires consideration of the emetic potential of the chemotherapy, dosing and duration of the chemotherapeutic regimen (1 day vs. multiday), single vs. multi-drug regimens, personal risk factors, and the mechanism of action of the prescribed antiemetic therapy. Maximum benefit from antiemetic therapy is achieved when it is initiated prior to chemotherapy and continued throughout the duration of the emetic response to each chemotherapeutic agent. Multiple organizations, including ASCO, NCCN, and MASCC, have developed guidelines for antiemetic prevention, and a summary of these recommendations is listed in Table 69.9.

Agents

5-HT₃ Receptor Antagonists

Perhaps the most significant advance in antiemetic therapy, as well as supportive therapy in general, has been the development of the 5-HT₃ receptor antagonists. Agents in this class (e.g., granisetron, ondansetron, palonosetron, and dolasetron mesylate) have all shown efficacy in controlling acute nausea associated with chemotherapy.^{340, 341 and 342} As well, both IV and PO routes of administration of these medications are effective when appropriate doses are given.³⁴³ While all 5-HT₃ receptor antagonists have been shown to be effective in controlling acute nausea and vomiting caused by chemotherapy, palonosetron has recently been shown to be much more effective than other available 5-HT₃ receptor antagonists in preventing delayed nausea and vomiting.^{344,345,346} A recent meta-analysis of randomized controlled trials comparing palonosetron with other 5-HT₃ receptor antagonists revealed that it was significantly more effective in preventing acute and delayed nausea and vomiting for highly emetogenic and moderately emetogenic chemotherapy.³⁴⁷ Palonosetron's half-life of 40 hours is much longer than that of the other 5-HT₃ receptor antagonists and it has an approximately 100-fold higher binding affinity to the 5-HT₃ receptor. These qualities likely explain palonosetron's superiority in preventing chemotherapy-induced nausea and vomiting, especially delayed onset nausea and vomiting.³⁴⁸ Palonosetron is currently FDA approved for use as a single infused dose on day 1 for the prevention of acute and delayed nausea and vomiting associated with highly and moderately emetogenic chemotherapy. While repeat dosing is considered safe based on NCCN guidelines, the additional benefit of repeated dosing for multiple-day chemotherapy regimens is unknown.

Adverse effects of 5-HT₃ receptor antagonists are usually mild and transient. Headache is the most common side effect, followed by gastrointestinal side effects of abdominal discomfort, diarrhea, and constipation, which occur less frequently.³⁴⁹ Association of IV dolasetron with increased risk for cardiac arrhythmias has been reported by the FDA, and thus IV dolasetron is not recommended.

Neurokinin 1 Receptor Antagonists

Substance P is a mammalian tachykinin found in vagal afferents that send impulses to the vomiting center and thus are involved in the vomiting response. Substance P induces emesis through its binding to neurokinin 1 (NK-1) receptors in the brainstem nucleus tractus solitarius, the area postrema, and the abdominal vagus nerves.^{338,350} Two randomized, double-blind, multicenter

P.1453

P.1454

controlled studies found the addition of aprepitant (125 mg po on day 1 and 80 mg po daily on days 2 and 3) to standard therapy (5-HT₃ receptor antagonist on day 1) and dexamethasone (prechemotherapy on day 1 and daily on days 2 to 4) improved rates of acute N/V and delayed N/V when compared to standard therapy alone in patients receiving cisplatin chemotherapy.^{351,352} Thus, in 2003, aprepitant became the first neurokinin-1 receptor antagonist to be approved for the prevention of acute and delayed nausea and vomiting with highly-emetogenic chemotherapy. Fosaprepitant, a parenteral NK-1 receptor antagonist, has since become available for the prevention of CINV associated with highly emetogenic chemotherapy. Unlike aprepitant, fosaprepitant is given at a dose of 150 mg IV 30 minutes prior to chemotherapy on day 1 only.³⁵³ Important to note is that NK-1 receptor antagonists are moderate inhibitors of the enzyme CYP3A4, the enzyme responsible for glucocorticoid metabolism, and thus in clinical trials the dosing of concurrent dexamethasone was reduced to 12 mg on day 1 and 8 mg on days 2 and 3.^{351,352}

TABLE 69.9 SUMMARY OF GUIDELINES FOR THE PREVENTION AND TREATMENT OF CINV

Group	High		Moderate		Low	Minimal
	Acute CINV ^a	Delayed CINV	Acute CINV	Delayed CINV	Acute/Delayed CINV	Acute/Delayed CINV
NCCN ¹	-5-HT ₃ RA ^c (palonosetron preferred) + dexamethasone + (fos)aprepitant ± lorazepam ± H ₂ d blocker or PPI ^e	± 5-HT ₃ RA (unless palonosetron given day 1) +Dexamethasone (8 mg po daily days 2-4 with aprepitant or fosaprepitant 150 mg IV day 1) (8 mg po day 2, then 8 mg po BID days 3 and 4 with fosaprepitant 150 mg IV	-5-HT ₃ RA (palonosetron preferred) +Dexamethasone ± Aprepitant or Fosaprepitant 150 mg IV day 1 ± lorazepam ± H ₂ blocker or PPI	-5-HT ₃ RA on days 2 and 3. (unless palonosetron given day 1) Or Dexamethasone Daily day 2-3 Or Aprepitant 80 mg po day 2-3 (if aprepitant given day 1)	(repeat daily for multiple-day regimens) - Dexamethasone 12 mg po/IV daily Or - Metoclopramide 10-40 mg PO/IV Or - Prochlorperazine	No routine prophylaxis before or after chemotherapy is recommended

		day 1)		±	10 mg PO/IV	
		+ Aprepitant 80mg po days 2 and 3 if aprepitant given on Day 1		±	dexamethasone ± lorazepam ± H2 blocker or PPI	
		± lorazepam day 2-4				
ASCO ²	-5-HT3 RA + Dexamethasone +(fos)aprepitant ±Lorazepam ±diphenhydramine	- Dexamethasone Day 2-3, or day 2-4 + Aprepitant day 2-3 if Fosaprepitant is NOT used day 1.	-5-HT3 RA (palonosetron preferred) + Dexamethasone ±aprepitant ±lorazepam ±diphenhydramine	- Dexamethasone day 2-3 ± aprepitant (if used on day 1)	- Dexamethasone 8 mg PO/IV prior to chemotherapy	No antiemetic should be administered routinely before or after chemotherapy
MASSC/ESMO ³	For HEC ^h and ACi regimens: -5-HT3 RA + Dexamethasone + (fos)aprepitant	- Dexamethasone day 2-4 + aprepitant day 2-3 if aprepitant given day 1	Non-AC regimens: -Palonosetron + Dexamethasone	- Dexamethasone day 2-3 RA or Dopamine antagonist prior to chemo	- Dexamethasone or 5-HT3 RA or Dopamine antagonist prior to chemo	-No routine prophylaxis is recommended

^a Chemotherapy Induced Nausea and Vomiting;

^b National Comprehensive Cancer Network; ^c 5 Hydroxytryptamine 3 receptor antagonist;

^d Histamine 2; ^e Proton Pump Inhibitor;

^f American Society of Clinical Oncology;

^g Multinational Association of Supportive Care in Cancer/European Society of Medical Oncology; ^h Highly Emetogenic Chemotherapy;

ⁱ Adriamycin/Cyclophosphamide.

Data from Ettinger DS, Armstrong DK, Barbour S, et al. Antiemesis. Clinical practice guidelines in oncology. J Natl Comp Cancer Netw: JNCCN 2009;7:572-595; Basch E, Prestrud AA, Hesketh PJ, et al. Antiemetics: American Society of Clinical Oncology Clinical Practice Guideline update. J Clin Oncol 2011;29:4189-4198; Roila F, Herrstedt J, Aapro M, et al. Guideline update for MASCC and

ESMO in the prevention of chemotherapy- and radiotherapy-induced nausea and vomiting: results of the Perugia Consensus Conference. *Ann Oncol/ESMO* 2010;21(Suppl 5):v232-v243.

Olanzapine

Olanzapine is an atypical antipsychotic with an affinity to multiple neurotransmitter receptors involved in the emetic response, including: dopaminergic, serotonergic, adrenergic, histaminergic, and muscarinic receptors, thus suggesting a potential benefit for the prevention and treatment of nausea and vomiting.^{354,355} In a pilot study, Passik et al. explored the antiemetic activity of olanzapine in patients with advanced cancer, with their results suggesting benefit. Subsequent trials, including a randomized phase III trial, confirmed these results.^{356, 357} and ³⁵⁸ Navari et al. conducted a randomized phase III trial comparing the efficacy of olanzapine vs. aprepitant, both in combination with palonosetron and dexamethasone, for the prevention of CINV in patients receiving highly emetogenic chemotherapy. Complete response rates, no emesis, and no need for rescue medications were similar results for both groups during the acute and delayed period; however, nausea was better controlled in the olanzapine group.³⁵⁸ The total dose of dexamethasone was also less in the olanzapine group, as this group received only a one-time dose of dexamethasone on day 1 vs. 4 days of dosing in the aprepitant group. This finding led the authors to conclude that the use of olanzapine for the prevention of CINV with highly emetogenic chemotherapy may be more beneficial, since the exposure to steroids and potential adverse effects of their use with multiple rounds of chemotherapy would be much less.

An increase in extrapyramidal symptoms (EPS) associated with olanzapine use has not been seen in studies evaluating olanzapine's efficacy in the prevention of CINV, and this lack of increase in EPS as compared to other neuroleptic drugs used for the treatment of nausea (e.g., prochlorperazine and metoclopramide) is another reason to consider its use. These preliminary studies also found an improvement in mood and appetite in patients who were treated with olanzapine.³⁵⁴ At this time, expert guidelines recommend the use of aprepitant along with 5HT-3 receptor antagonists and steroids for the prevention of CINV associated with highly emetogenic chemotherapy; however, further studies evaluating olanzapine's benefit in this group of patients are ongoing and the results of these studies may alter recommendations in the future.

Chemotherapy-induced Nausea and Vomiting with High-dose Chemotherapy/Hematopoietic Stem Cell Transplant

Controlling nausea and vomiting in patients undergoing HDC with HSCT rescue is a challenge. Many factors, including HDC, total body irradiation (TBI), medications to prevent graft-versus-host disease, antimicrobials, and opioids, can induce nausea and vomiting.³⁵⁹ Multiple studies have shown a benefit of 5-HT₃ receptor antagonists along with steroids in the prevention of CINV in patients undergoing HDC; however, complete responses with these regimens were seen in only 15% to 50% of patients.^{360, 361, 362} and ³⁶³ Given the suboptimal rate of control seen with 5HT-3 receptor antagonists and steroids, studies examining the addition of aprepitant, an NK-1 antagonist, to 5HT-3 receptor antagonists have been conducted.

The role of newer agents, such as aprepitant, in the prevention and treatment of CINV in patients undergoing HDC with stem cell rescue is less clear. There is data to support the efficacy and safety of aprepitant along with 5HT-3 receptor antagonists and steroids, albeit from small, single institution studies. Despite the small sample sizes, these studies have shown efficacy for a number of preparative regimens, including: BEAM (BCNU [carmustine] + etoposide + ARA-C [cytarabine] + melphalan), T-ICE (paclitaxel + ifosfamide + carboplatin + etoposide), BuCy (busulfan + cyclophosphamide), Cy/TBI (cyclophosphamide + total body irradiation), Cy/TBI/VP16, and BCV (BCNU + cyclophosphamide + VP16). The data so far has looked at multiple different dosing regimens for aprepitant, including the traditional 3-day regimen (125 mg po on day 1 followed by 80 mg po on days 2 and 3) and a 12-day regimen (125 mg po on day -7 followed by 80 mg po daily thereafter until day +4) conducted in a pilot study by Bubalo et al.³⁶⁴ As aprepitant is a moderate inhibitor of CYP3A4, busulfan doses need to be followed closely, and in pilot studies all patients required dose adjustments.^{365,366,367,368,369} These studies support the added benefit of aprepitant to standard antiemetic therapy without increasing toxicity. Because of the limited amount of data, ASCO guidelines currently recommend considering the use of aprepitant in patients undergoing HDC with HSCT until the results of larger phase III studies become available.

Miscellaneous

Multiday chemotherapy regimens and highly emetogenic radiation regimens are both commonly used in the management of hematologic malignancies. ASCO guidelines recommend the use of antiemetics appropriate for the emetogenic risk class of the chemotherapy being administered for each day of chemotherapy and for 2 days after, if appropriate.³⁷⁰ Both MASCC and ASCO guidelines recommend the use of a 5HT-3 receptor antagonist along with steroids for the treatment of highly emetogenic radiation therapy, such as TBI, with ASCO guidelines recommending a minimum of 5 days of steroid therapy.^{343,370}

CANCER-RELATED FATIGUE

Fatigue is one of the most common symptoms reported by cancer patients, and has a reported incidence of 60% to 90% among patients with cancer. Cancer-related fatigue (CRF) is defined as an unusual sense of tiredness that is persistent and not improved with rest, that can occur with cancer or cancer treatment, and that may affect physical and/or mental functioning.³⁷¹ Fatigue can negatively impact a patient's quality of life by interfering with their ability to perform activities of daily living, keep employment, and maintain financial stability.³⁷² CRF is more intense and more unpredictable than fatigue that was experienced before the cancer diagnosis.³⁷³

Multiple etiologies for CRF are often present in patients with cancer and include anemia, sleep disorders, depression, endocrinopathies, nutritional deficiencies, and uncontrolled pain. Anemia is likely the most common reversible cause of fatigue during active cancer treatment. Although CRF is often attributed to the initiation of cancer therapies, this fatigue may persist long after the completion of treatment with up to 30% of cancer survivors reporting loss of energy years after completion of treatment.^{372,374} Escalante and Manzullo recommend using the question "How

P.1455

would you rate your fatigue on a scale of 0 to 10 over the past week?" along with a simple visual analog scale from 0 to 10 (with 0 as no fatigue and 10 as the worst imaginable fatigue) to screen patients and to follow response to interventions. Specific causes for fatigue should be sought out, and once specific therapies for fatigue are initiated, then assessments for response should take place as the identified cause is being corrected.³⁷²

Multiple pharmacologic and nonpharmacologic interventions have been employed to treat CRF. Nonpharmacologic interventions include exercise programs, nutritional assessments, and sleep analysis. Exercise has been the most studied nonpharmacologic strategy for treating fatigue.³⁷² Schwartz et al. evaluated the effect of a moderate-intensity home exercise regimen in women with newly diagnosed breast cancer receiving active treatment with chemotherapy. Low- to moderate-intensity exercise significantly decreased fatigue in these patients, and the intensity of fatigue declined as exercise tolerance increased.³⁷³ Initiation of an exercise program should begin at low intensity levels and shortened intervals with gradual increase in intensity and duration based on the patient's physical conditioning. Patients with severe debilitation and extensive disease may require consultation with a physical therapist or a physical medicine and rehabilitation specialist to assist in developing a safe and effective exercise program.³⁷²

Pharmacologic strategies that have been used to combat CRF include stimulants, antidepressants, and low-dose steroids. Well-designed clinical trials evaluating the efficacy of these pharmacologic interventions to guide treatment decisions are unfortunately lacking. Methylphenidate, a stimulant, has been studied in CRF and may have a beneficial effect. Sarhill et al. studied the efficacy of methylphenidate for the treatment of fatigue in patients with advanced cancer. In this open labeled pilot study, 9 of 11 patients studied achieved benefit regardless of whether anemia was present. Only 1 patient stopped treatment because of adverse effects.^{375,376} Therapy is typically initiated at 5 mg in the morning and 5 mg in the early afternoon. Methylphenidate should not be administered in the late afternoon as it may interfere with sleep patterns. Patients may require titration of dosing over time in order to maintain a clinical benefit because of the potential development of tolerance. Tachycardia and hypertension are known adverse effects of methylphenidate and it is therefore not recommended for use in patients with known coronary artery disease, uncontrolled hypertension, or tachyarrhythmias.³⁷²

Modafinil, a nonamphetamine psychostimulant, has been studied in a randomized phase III trial to evaluate its effectiveness in the treatment of cancer-related fatigue.³⁷⁷ Jean-Pierre et al. reported a benefit from modafinil 200 mg daily in patients with severe fatigue at baseline; however, there was no statistically significant improvement in fatigue in patients with mild to moderate fatigue at baseline. Thus, it is recommended that intervention with modafinil be limited to those with severe fatigue at baseline.³⁷⁷

The inability of current pharmacologic interventions to produce significant improvements in CRF for the majority of cancer patients underscores the importance of a multidisciplinary approach to CRF that incorporates assessments for fatigue, recognition of underlying etiologies, coping strategies, nonpharmacologic therapies, and intervention with pharmacologic therapy only when necessary.

CANCER PAIN

Pain is one of the most feared symptoms of cancer by patients and family members.³⁷⁸ Sixty to eighty percent of patients with advanced cancer experience moderate to severe pain on a monthly basis, and control of cancer-related pain is one of the most important goals of supportive care. Management of cancer pain can be quite complex because the etiologies are

diverse and can adversely affect multiple domains of quality of life, including activities of daily living, psychological well-being, physical functioning, and social interactions.³⁷⁹ Coexisting cancer symptoms, such as weakness, fatigue, nausea, dyspnea, constipation, and impaired cognition, can magnify the perception of and exacerbate cancer pain. Modifying the source of the pain, altering the perception of pain, and blocking the transmission of pain to the central nervous system can effectively treat cancer pain in 85% to 95% of cases.³⁸⁰ A comprehensive patient-centered approach to pain management that assesses the patient's pain, barriers to pain control, concurrent medical problems, response to pharmacologic interventions, and psychosocial status is key to achieving adequate pain control.^{381, 382, 383} and ³⁸⁴

Types of Cancer Pain

To adequately address and control pain, it is imperative that the treating physician understand the pathophysiology of cancer pain. The majority of cancer-related pain can be classified as nociceptive, neuropathic, or both. The distinction between these 2 types of pain is important, as neuropathic pain is often refractory to opioid therapy. Nociceptive is the term used to describe pain that is propagated by continual tissue injury, and it is classified into somatic or visceral pain. Nociceptive pain is termed somatic when the continual tissue injury is relayed via primary afferent nerves in somatic tissues such as those of the musculoskeletal system. Somatic pain is classically described as being sharp or aching and localized to the area of tissue damage. Nociceptive pain is termed visceral when tissue injury is relayed via primary afferents of the viscera. Visceral pain tends to be poorly localized and intermittent, many times described as dull or aching.^{378,385,386} Neuropathic pain is a result of injury to peripheral or central nerves and typically causes paroxysmal burning, shooting, or aching sensations that may or may not be associated with paresthesias. In patients with malignancy, neuropathic pain can be caused by a number of different etiologies, such as direct nerve injury from the tumor itself, or the result of anticancer treatments such as surgery, radiation, and chemotherapy. Identification of neuropathic pain often indicates that nontraditional adjuvant therapies may be required to achieve adequate pain relief.^{385,387}

Barriers to Pain Control

Up to 50% of patients with cancer have uncontrolled pain.³⁸⁸ Several reasons for inadequate treatment of pain exist and can be classified as physician barriers or patient barriers to pain control.

Multiple studies have identified physician-related barriers to cancer pain management, and all have a recurring theme.^{389,390} Two large studies surveying US medical oncologists' attitudes and practices in cancer pain management have been undertaken over the past 20 years.^{391,392} Despite the almost 20-year time between the 2 studies, both concluded that knowledge deficits, inadequate training in pain management, inadequate opioid prescribing as recommended by established guidelines, and poor pain assessment are the main physician-related barriers to adequate pain management. The potential for addiction, the development of tolerance, scrutiny by regulatory agencies, and inadequate side effect management are other potential reasons for nonadherence to established pain management guidelines.

There are also many patient-related barriers that hinder patients' use of appropriate analgesics for cancer pain. Reluctance of patients to report pain and take pain medications have been shown to be the most prominent patient-related barriers to cancer pain management.^{393,394} The Barriers Questionnaire, a tool designed to identify patient-related barriers to cancer pain management, has identified 9 areas of concern that patients may have in reporting and taking pain medications. (1) Fatalism, belief that cancer pain is inevitable; (2) fear of addiction; (3) "desire to be a

P.1456

good patient" and not complain; (4) fear of distracting one's physician from treating the disease; (5) concern that increasing pain signifies disease progression; (6) concerns about drug tolerance; (7) concerns about side effects; (8) religious fatalism, the religious belief that pain is caused or given by a deity and that patients have to tolerate the pain in order to avoid carrying the pain into their next life; and (9) concerns that pain medications are better when given on an as needed basis.³⁹³

Patient education is one way to overcome patient barriers to cancer pain management. Multiple studies have proven the effectiveness of pain education programs in improving patient adherence to analgesic therapy and ultimately decreasing pain intensity.^{395, 396} and ³⁹⁷ Educational interventions for both physicians and patients will likely lead to more appropriate guideline-based analgesic prescribing and patient adherence to prescribed therapies.

Pain Assessment

A comprehensive pain assessment is crucial to adequate pain control and includes a detailed pain history that evaluates pain intensity, location, and type, as well as an assessment of psychological stressors and the patient's network of social support. A detailed physical exam paying close attention to impending oncologic emergencies is also important in

determining the etiology of pain so that timely and appropriate interventions can be initiated. Pain is subjective, and thus patient report is the “gold standard” for measurement. In order to try and make pain measurement objective and reliable, a number of scales have been developed.

Pain intensity has been shown to have an inverse correlation with quality of life and functioning. Pain intensity can be measured by a number of validated scales.^{398,399} Some scales are available to assess pain intensity for those with limited literacy as well as those who are cognitively impaired.^{378,400, 401} and ⁴⁰² Other scales, such as the Memorial Pain Assessment Card and the Wisconsin Brief Pain Inventory, have been developed to assess pain intensity as well as psychological distress. These two scales are not only multidimensional but also practical, given the efficiency in which they can be completed in a clinical setting.^{403,404} Numerical ratings of pain intensity obtained from the different scales can then be used to guide analgesic therapy.

Analgesic Management: World Health Organization Analgesic Ladder

The World Health Organization (WHO) “three-step analgesic ladder” (Fig. 69.10) developed in the 1980s continues to provide the framework for the management of cancer-related pain. The analgesic ladder introduced a stepwise approach to pain management and selection of appropriate analgesia based on pain intensity. Based on WHO recommendations, mild pain, rating 1 to 4, is treated with nonsteroidal antiinflammatory drugs (NSAIDs) and acetaminophen plus adjuvant analgesics; moderate pain, rating 5 to 6, is treated with weak opioids such as codeine and tramadol; and for severe pain, rating 7 to 10, strong opioids such as hydromorphone, morphine, fentanyl, oxycodone, and methadone are recommended.^{405,406} Additional principles endorsed by the WHO for optimal pain management include: (1) oral administration of pain medications if possible; (2) around-the-clock dosing for chronic pain; (3) pain severity should determine drug choice; (4) individualized treatment plans because of variability of response to analgesic agents among patients; and (5) frequent reassessments of patient's pain.⁴⁰⁶

NSAIDs and acetaminophen are the initial nonopioid step 1 analgesics recommended for use by the WHO guidelines for mild pain. NSAIDs block cyclooxygenase 1 and cyclooxygenase 2 enzymes (COX-1 and COX-2), thus decreasing prostaglandin synthesis. Prostaglandins and other inflammatory cytokines are produced within the tumor microenvironment and are responsible for pain associated with local tumor growth and infiltration.^{406,407} The benefit and role of NSAIDs in the treatment of cancer-related pain has been shown in two large meta-analyses.^{407,408} There does seem to be a ceiling effect for analgesia with NSAIDs and doses beyond the daily recommended maximum dose are not advised. Doses of nonopioid analgesics should be titrated to maximal daily doses or until adverse effects emerge, as long as mild to moderate pain persists. NSAIDs do carry a risk for GI toxicity, and cancer patients may be particularly susceptible to these toxicities, given concurrent medications that can lead to mucositis, gastritis, and anorexia. Selective COX-2 inhibitors are available and have been associated with less GI toxicity than nonselective NSAIDs; however, there have been reports of adverse GI effects with their use in cancer patients.⁴⁰⁹ For acetaminophen, it is not recommended to dose more than 6 g per day; however, for those with underlying

P.1457

hepatic dysfunction or those taking concomitant potentially hepatotoxic medications, 4 to 6 g per day may be more appropriate.

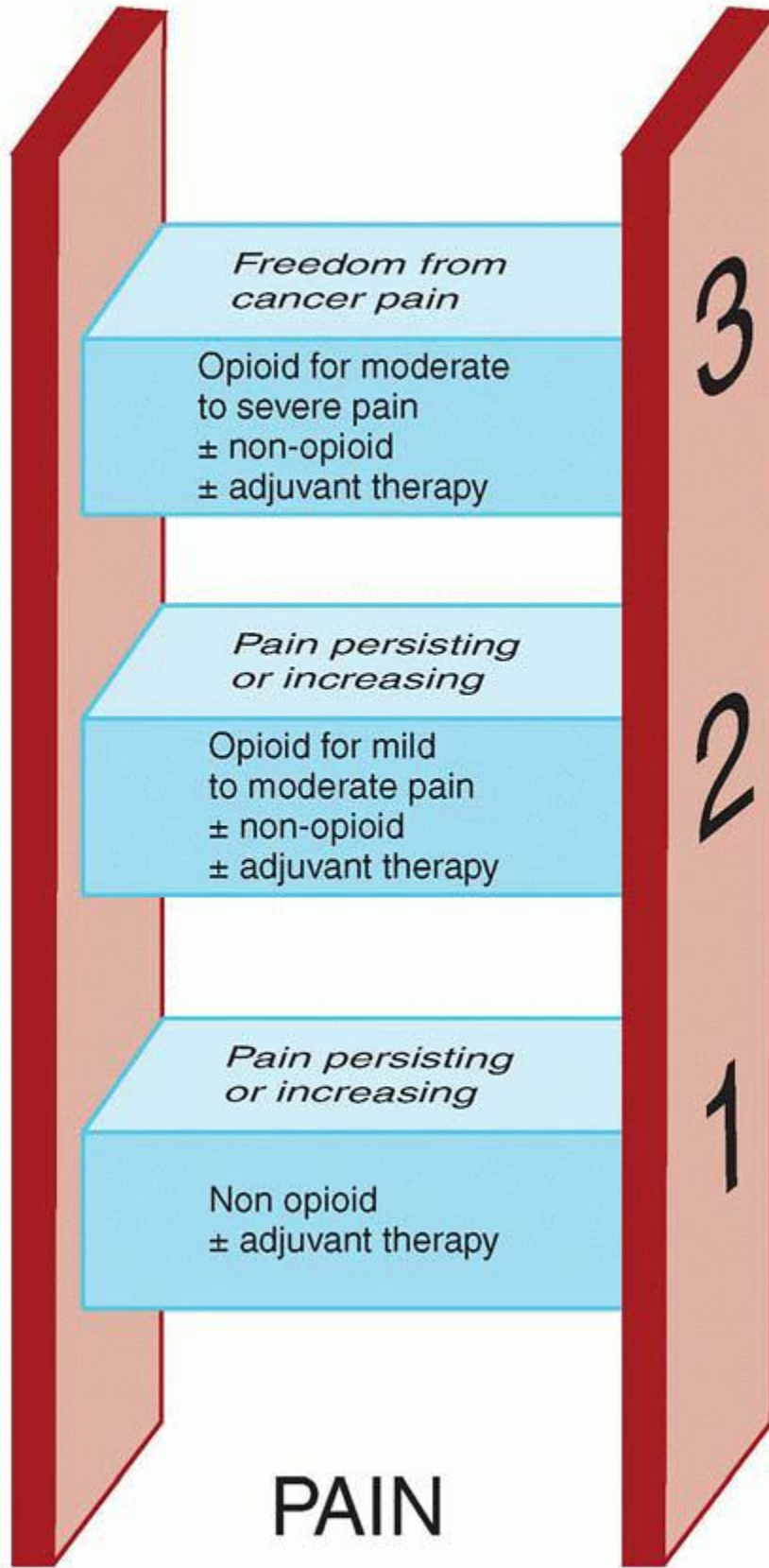

FIGURE 69.10. The WHO “three-step analgesic ladder.”

If pain remains uncontrolled with appropriate step 1 interventions, then the introduction of opioid therapy into the management of cancer pain is recommended by step 2 of the WHO analgesic ladder. Opioids are the backbone of pain management in patients with cancer. Interindividual variation in opioid receptors (polymorphisms of the mu, kappa, and/or delta receptors), absorption, intensity of the painful stimulus, administration of concurrent medications, and enzymes responsible for opioid metabolism underscore the importance of an individualized approach to opioid prescribing for patients experiencing cancer pain.^{410,411,412} Step 2 opioids, previously referred to as “weak opioids,” include codeine, tramadol, hydrocodone, and oxycodone. These opioids are typically combined with nonopioid analgesics such as NSAIDs or acetaminophen which limit their total daily dose. Codeine has a weak affinity for mu opioid receptors and its analgesic activity requires metabolism to morphine by CYP2D6. The time-to-peak effect for codeine is typically 1 to 2 hours, and it has an effective half-life of approximately 3 hours. Like many other opioids that require CYP2D6 metabolism to produce active metabolites, medications that induce or inhibit the CYP2D6 enzyme can alter the analgesic effects of codeine. In addition, some patients are “fast” or “slow” metabolizers, further adding to the variability in effectiveness.⁴¹³ Tramadol, a synthetic analog of codeine, is also considered a “weak opioid.” Tramadol is unique because it not only has analgesic properties that are mediated through mu receptor activation, but it also has serotonin and norepinephrine reuptake inhibitor activity. This dual mechanism is felt to be responsible for its effectiveness, especially in selected patients with chemotherapy-induced neuropathic pain.^{414,415} O-desmethyl tramadol, the active metabolite of tramadol, requires metabolism via the CYP2D6 enzyme and is thus subject to interactions to CYP2D6 inducers and inhibitors. Maximal daily dose is 400 mg per day, as doses above this can lead to neurotoxicity and seizures. Hydrocodone is an oral opiate that is indicated for the treatment of moderate pain and is available only as a combination product with an NSAID or acetaminophen. The metabolism of hydrocodone is through the CYP2D6 enzyme as well; however, its active metabolite, hydromorphone, is a very strong mu receptor agonist.⁴¹⁶ Given hydrocodone's prodrug properties, analgesic response is affected by different polymorphisms in the CYP2D6 gene, as well as inducers and inhibitors of this enzyme.⁴¹⁰

If pain persists at a level of 5 or greater after achieving the maximal daily dose of the step 2 analgesic, then the addition of a step 3 analgesic is recommended. Morphine, fentanyl, oxycodone, and hydromorphone are the most commonly used step 3 analgesics used for the management of moderate to severe cancer pain.

Morphine has classically been the opioid of choice for the treatment of moderate to severe cancer pain. Due to morphine's multiple routes of administration (oral tablets, oral solutions, parenteral, and rectal), formulations are available to appropriately treat acute pain crisis, chronic stable pain, and those in a terminal condition. Morphine can cause adverse effects that are classic for all opioids; however, it can also produce adverse effects that are unique to itself. Morphine can cause a histamine release, which can lead to bronchospasm and rash. Morphine can also decrease sympathetic tone that leads to peripheral vasodilatation and resultant orthostatic hypotension.^{410,413} It is metabolized through glucuronidation, producing active metabolites morphine-6 glucuronide (M6G) and morphine-3 glucuronide (M3G). M3G is associated with neurohyperexcitability and hyperalgesia. Both metabolites are excreted in the urine; thus, renal insufficiency can lead to an accumulation of these metabolites and result in oversedation and increased adverse effects.^{417,418}

Oxycodone is available in its pure form as well as in combination with acetaminophen or an NSAID. Combination products limit oxycodone's titration due to maximal daily doses of the nonopioid analgesic partner medication, thus limiting its efficacy to that of other step 2 analgesics. In its pure form, oxycodone has no ceiling effect, the same as the other step 3 opioids. Oxycodone is metabolized by CYP2D6 to oxymorphone, thus making it susceptible to drug-drug interactions that induce or inhibit CYP2D6.⁴¹⁰

Hydromorphone is a semisynthetic opioid that is approximately 5 times more potent than morphine once steady state oral and parenteral dosing is reached.⁴¹⁹ Hydromorphone has multiple routes of administration: intravenous, intramuscular, subcutaneous, oral, and rectal, and is extensively metabolized by the liver; thus its use may be preferred in patients with renal failure.⁴¹⁰

Fentanyl is another step 3 opioid that is a very strong opioid agonist, approximately 80 times more potent than morphine. Fentanyl is unique in that it not only has a parenteral form, but also has transdermal and transbuccal formulations. These preparations are particularly useful for patients with stable chronic pain who are unable to swallow pills, are noncompliant, or are in the terminally ill phase when swallowing may be difficult. When transitioning to transdermal fentanyl preparations it is important to note that there is a delay of 8 to 16 hours until the onset of analgesia, and thus initial overlap with other opioid medications may be required. Steady state of transdermal fentanyl is not reached until approximately 72 hours.^{410,420}

Fentanyl undergoes extensive metabolism in the liver, thus making it an attractive option for use in those with renal failure. There is some controversy as to the appropriate relative potency ratio to be used when converting oral morphine

to transdermal fentanyl. Donner et al. showed that an oral morphine to transdermal fentanyl ratio of 100:1 was safe and effective in converting patients with cancer pain from oral morphine to fentanyl; however, they noted that this ratio was too low and that the true ratio determined by their study was 70:1. Thus, if one uses 100:1 as a conversion ratio, then one should be aware that this will likely lead to insufficient dosing, and supplemental breakthrough medications will likely be necessary until appropriate doses can be achieved.⁴²¹

Oxymorphone, a newer strong opioid multireceptor agonist, is available in oral preparations and is 10 times more potent than morphine. Oxymorphone is not metabolized by CYP2D6 and thus is not as susceptible as some of the other aforementioned opioids to drug-drug interactions.⁴²²

Methadone is another effective opioid receptor agonist that has been used to treat chronic cancer pain. Due to its long half-life, erratic metabolism, and propensity for drug-drug interactions, it is recommended that methadone only be managed by providers with knowledge of its pharmacology and experience in its prescribing.⁴¹⁰

The oral route of administration is the most preferred as long as patients are able to swallow, and this route of administration is controlling the pain. Acute pain exacerbations should be treated with short-acting medications around the clock along with breakthrough dosing in order to ultimately come up with a total 24-hour opioid dose that will control the pain. As long as patients are experiencing severe unrelieved pain, the total opioid dose should be increased by 50% to 100% every 24 hours until the pain is controlled. If patients are experiencing unrelieved moderate pain, the total opioid dose should be increased by 25% to 50% every 24 hours until the pain is controlled. Once the patient's pain is adequately controlled, then long-acting preparations of oral opioid therapy can be incorporated. Appropriate doses of long-acting opioid medications can be calculated by taking the 24-hour total oral opioid requirement to control the pain and converting this into a long-acting opioid dose. Because of the individualized nature of the metabolism of different formulations of opioid pain medications, as a general rule it is safe to start with 75% of the total dose of the previous opioid when transitioning between opioids, and titrate the dose up as necessary. Once scheduled long-acting opioids are instituted, short-acting breakthrough

P.1458

medications should be made available to the patient on an as needed basis with dosing intervals determined by the medications' time to peak effect. Again, frequent reassessment of pain control is of paramount importance, especially during times of transition between different formulations of opioid medications.³⁸⁶

Despite aggressive and appropriate management with opioid and other adjuvant analgesic medications, a minority of patients will continue to have uncontrolled pain related to their malignancy. In these circumstances, a referral to an anesthesiologist or a neurosurgical pain specialist is warranted. Epidural nerve blocks, spinal cord stimulation, or implantable epidural catheters with opioid pain pumps may be needed to achieve adequate pain control.^{423,424}

Adjuvant Therapies

Opioid therapy alone may not be adequate to control all types of cancer-related pain, and thus throughout all steps of the WHO analgesic ladder adjuvant analgesic treatments are recommended when they are felt to benefit the patient (Table 69.10). Corticosteroids have long been used to treat pain due to spinal cord compression associated with metastatic disease; however, their benefit has been shown in the treatment of bone and neuropathic pain as well.^{425, 426} and ⁴²⁷ Anticonvulsants such as gabapentin and lamotrigine, as well as antidepressants such as amitriptyline and nortriptyline, have been shown to improve neuropathic pain and can be used in combination.^{428,429,430} As pain can be exacerbated by depression, and depression can be influenced by pain, it is crucial that prompt recognition and treatment of depressive symptoms occur when identified.⁴³¹ Pain that is caused by malignant bone involvement may respond to therapy with agents that limit osteoclast activity, such as bisphosphonates and Miacalcin, as well as agents such as NSAIDs and corticosteroids, which can decrease local inflammation caused by tumor invasion.^{432,433} There is some evidence to suggest that complementary therapies such as massage, acupuncture, and yoga are beneficial in the treatment of cancer-related pain; however, larger studies are needed to confirm these possible benefits.^{434, 435} and ⁴³⁶

TABLE 69.10 ADJUVANT ANALGESICS

Indication/Drug Class	Examples
Multipurpose Analgesics	
Tricyclic Antidepressants	Amitriptyline, Nortriptyline, Desipramine

Selective Serotonin Reuptake Inhibitors	Paroxetine, Citalopram
Noradrenaline/serotonin Reuptake Inhibitors	Venlafaxine
Others	
Corticosteroids	Dexamethasone, Prednisone
Neuroleptics	Olanzapine
For Neuropathic Pain	
Anticonvulsants	Gabapentin, Topiramate, Lamotrigine, Levetiracetam, Pregabalin
<i>N</i> -methyl-D-aspartate receptor antagonists	Ketamine, Dextromethorphan
Topical Drugs	Lidocaine/Prilocaine
For Bone Pain	Corticosteroids Dexamethasone, Prednisone
Calcitonin	Calcitonin
Bisphosphonates	Pamidronate, Zoledronic Acid
For Musculoskeletal Pain	
Muscle Relaxants	Cyclobenzaprine, Orphenadrine, Carisoprodol, Metaxalone
Baclofen	
Tizanidine	
Benzodiazepines	Diazepam, Lorazepam, Clonazepam

Adapted from Lussier D, Huskey AG, Portenoy RK. Adjuvant analgesics in cancer pain management. *Oncologist* 2004;9:571-591.

Adverse Effect Management

Despite the efficacy of opioids in the treatment of pain, almost all patients who use opioids for analgesia will experience side effects. The most common adverse effects of opiates are listed in Table 69.11. Prevention is the key to the management of these adverse effects; however, once side effects emerge, aggressive measures to abate these undesired effects, along with opioid titration and possible rotation, are necessary. Constipation is one of the most psychologically distressing side effects from opioid therapy that patients may experience and can lead to anorexia and bowel obstruction.⁴³⁷ All patients taking opioids should be on a prophylactic bowel regimen to try and prevent constipation. Methylnaltrexone, a peripheral opioid antagonist, has been demonstrated in multiple studies to be effective in relieving opioid-induced constipation. Weight-based subcutaneous dosing can be given as needed, however not to exceed 1 dose per 24-hour period. Inclusion criteria for randomized clinical trial enrollment were either < 3 bowel movements within the preceding week or >2 days without a bowel movement.^{438, 439, 440} and ⁴⁴¹ As methylnaltrexone is unable to cross the blood-brain barrier, it is able to reverse peripheral inhibition of opioid receptors of the GI tract without affecting analgesia.⁴⁴² Respiratory depression is a potentially fatal yet uncommon adverse effect of opioid treatment. Naloxone, a non-selective opioid antagonist, is the only therapy currently available for the reversal of opioid-induced respiratory depression.⁴⁴³ Due to its low bioavailability, naloxone is given by intravenous infusion. The extent and duration of naloxone's effect depends on the receptor affinity of the opioid being reversed. Due to its rapid elimination, naloxone many need to be dosed repeatedly or by continuous infusion to maintain reversal of respiratory depression.

Since naloxone is a nonselective opioid antagonist, reversal of respiratory depression results in reversal of analgesia, and thus research into therapies that can reverse respiratory depression while preserving analgesia are currently underway.⁴⁴⁴ Urinary retention can be relieved with insertion of a Foley catheter into the bladder. Excessive sedation can be combated by dose reduction of the opioid or with addition of a psychostimulant such as caffeine or methylphenidate.⁴⁴⁵ There is preliminary data that opioid-induced neurotoxicity, specifically hyperexcitability, can be managed with medications such

as lorazepam, baclofen, valproic acid, and midazolam. Small studies have shown improvement in opioid-induced nausea with centrally acting antiemetics such as

P.1459

metoclopramide and phenothiazines, as well as antipsychotics such as olanzapine and chlorpromazine.^{354,446}

TABLE 69.11 ADVERSE EFFECTS OF OPIOID TREATMENT

Common Adverse Effects of Opioid Therapy

Constipation	Hallucinations
Respiratory Depression	Impotence
Hyperexcitability	Fatigue
Urinary Retention	Sweating
Nausea	Vomiting
Pruritus	Myoclonus
Sedation	Xerostomia

Adapted from Cheung WY. Pharmacologic management of cancer-related pain, dyspnea, and nausea. *Semin Oncol* 2011;88:450-459.

MUCOSITIS

Mucositis is a common toxicity related to systemic chemotherapy, especially in those patients receiving HDC and HSCT, in which mucositis affects 80% to 100% of patients undergoing preparative regimens.⁴⁴⁷ Mucositis can make the host susceptible to infection, modulate the intensity of treatment able to be given, and hinder the ability for oral intake, all of which can have a negative impact on quality of life (QOL).⁴⁴⁸ The choice of chemotherapeutic agent (e.g., methotrexate, bleomycin, infusional 5-FU, cytarabine, etoposide), preexisting oral disease, and concurrent use of radiation therapy are all factors that can increase the likelihood of a patient developing treatment-related mucositis.^{449,450}

As with nausea, prevention is key; unfortunately, the data for effective preventative interventions is sparse. Pretreatment prophylactic oral care, consisting of a comprehensive oral examination that includes caries treatment, endodontic therapy, and tooth extraction if necessary, has been shown to decrease the frequency of treatment-related oral complications.⁴⁵¹ Other preventative therapies such as cryotherapy, palifermin, and low-level laser therapy have data to support their use in patients undergoing treatment for hematologic malignancies. The strongest data supporting oral cryotherapy (ice chips swished around the mouth for 30 minutes) for the prevention of treatment-related mucositis has been in patients receiving bolus 5-FU treatments.⁴⁵² There is also data supporting the use of oral cryotherapy in patients receiving high-dose melphalan and stem cell transplantation, and thus MASCC guidelines recommend the use of oral cryotherapy for the prevention of oral mucositis in this patient population.⁴⁵³

Palifermin is a recombinant human keratinocyte growth factor that stimulates the growth and differentiation of epithelial cells. Spielberger et al. evaluated the effectiveness of palifermin in preventing the development of severe mucositis in patients undergoing HDC and TBI followed by autologous HSCT in a double-blind phase III randomized controlled trial.⁴⁵⁴ Palifermin (60 µg/kg of body weight per day intravenously for 3 days before the initiation of conditioning therapy and for 3 days after autologous HSCT) was shown to decrease the incidence of WHO grade 3 or 4 mucositis, duration of mucositis, use of opioid analgesics, and need for total parenteral nutrition (TPN). These results led to clinical practice guidelines recommending the use of prophylactic palifermin in patients with hematologic malignancies who are undergoing high-dose chemotherapy with autologous HSCT.^{453,455} Palifermin's utility in allogeneic HSCT is not as well defined. Retrospective data from Goldberg et al. evaluated the safety and efficacy of palifermin in patients who underwent T cell-depleted allogeneic HSCT and found a benefit in those patients undergoing TBI-based conditioning regimens but not those undergoing chemotherapy-based conditioning regimens.⁴⁵⁶ Prospective studies to evaluate palifermin's role in allogeneic HSCT are currently underway and thus guideline-based recommendations currently advocate for palifermin's use in patients undergoing HDC with autologous HSCT.^{453,455,456}

Low-level laser therapy (LLLT) has also been reported to be an effective treatment for the prevention of oral mucositis associated with HDC and TBI conditioning regimens prior to HSCT. This type of low energy radiation therapy has been

shown to have analgesic, antiinflammatory, and wound healing properties.⁴⁵⁷ MASCC guidelines currently recommend the use of LLLT to reduce the incidence of oral mucositis associated with HDC or TBI conditioning regimens and HSCT. Unfortunately, LLLT requires expensive equipment and expert training, and thus few centers have the capability to support such therapy.⁴⁵³

Supersaturated calcium phosphate rinses (SCPRs) have been evaluated in the prevention of treatment-related oral mucositis. In a small randomized single-institution study of patients undergoing allogeneic HSCT comparing SCPR 4 times daily to a control group consisting of a solution made of saliva leaf extract, iodine-povidone, and fluconazole administered at the same frequency, SCPRs were found to decrease the incidence, severity, and duration of oral mucositis, as well as the need for analgesic and TPN interventions. Larger multicentered trials are needed to confirm these results.⁴⁵⁸

Once oral mucositis occurs, treatment is supportive and consists of appropriate oral care, mucosal protectants, and analgesia (topical and/or systemic); however, data to validate these interventions is limited. Routine oral care should focus on limiting trauma which could further damage the oral mucosa. Soft toothbrushes and gentle cleansing rinses such as salt and soda rinses (½ teaspoon of salt and 1 teaspoon of baking soda in a quart of water every 4 hours) should be used. In an open labeled pilot study conducted by Innocenti et al., Gelclair, a mucosal protectant, was found to be beneficial in reducing oral pain. Of note, only 3 of the 30 patients in this trial had chemotherapy-related mucositis.⁴⁵⁹ Studies of analgesic mouthwashes have documented pain relief with topical lidocaine and morphine preparations; however, if these preparations do not control the mucositis-related pain, patients should be treated with systemic analgesia by the oral route if possible, and if unable, through parenteral routes.^{460,461}

ANOREXIA

Cancer-related anorexia (CRA) leads to weight loss as a result of decreased appetite from the systemic effects of advanced cancer.⁴⁶² Anorexia is one of the most frequent and troubling symptoms experienced by patients and their family members, occurring in more than half of patients with advanced cancer.^{463,464} CRA and cachexia are provoked by metabolic changes induced by advanced malignancies in the host, with a milieu of proinflammatory cytokines felt to be responsible.⁴⁶⁵ Dramatic changes in weight and body habitus can occur when the hypermetabolic state of malignancy is coupled with decreased caloric intake associated with CRA. The resultant changes in body habitus can be quite psychologically distressing to patients and their families, and thus patient education and attempts to improve anorexia are of utmost importance.⁴⁶⁶

There are multiple nonpharmacologic and pharmacologic interventions that are effective in the treatment of CRA; however, the first step in the management of CRA is to evaluate for any reversible causes. Reversible causes of anorexia in patients with advanced cancers and those receiving directed therapies for advanced cancers include constipation, uncontrolled pain, nausea, vomiting, gastroparesis, depression, stomatitis, mucositis, and delirium. Evaluation for a possible reversible cause and its treatment should be the first step in management of CRA.⁴⁶⁶ If no reversible cause can be identified, then interventions directed toward management of CRA should be initiated. Nonpharmacologic measures include nutritional counseling, increasing physical activity, and encouraging the intake of caloriedense foods and supplements.

Corticosteroids, megestrol acetate (Megace), and cannabinoids have all been evaluated in the treatment of anorexia. Megestrol acetate at doses of 800 mg/day have been the most extensively studied and have been shown to be effective in treating anorexia associated with advanced malignancy and acquired immune deficiency syndrome (AIDS).^{467, 468, 469, 470, 471} and ⁴⁷² Jatoi et al. performed a large randomized controlled trial of more than 400 patients with advanced cancer, comparing the effectiveness of megestrol acetate (800 mg/day) vs. dronabinol (2.5 mg twice a day) vs. a combination of both agents for the treatment of cancer-associated anorexia. Megestrol acetate was found to improve appetite and induce weight gain more than dronabinol. Combination therapy did not provide an additional benefit over megestrol acetate therapy

P.1460

alone.⁴⁷¹ A study conducted by Navari et al. found that the addition of olanzapine (5 mg/day) to megestrol acetate (800 mg/day) led to improvements in weight gain, anorexia, and quality of life (QOL) when compared to megestrol acetate alone. No additional grade III or IV toxicities were observed in the group receiving megestrol acetate and olanzapine.⁴⁷³ Megestrol acetate is fairly well tolerated, with increased risk for thromboembolism being the most worrisome adverse effect. A prospective study of dexamethasone 4 to 16 mg daily has been shown to be effective in treating anorexia; however, given the multiple potential adverse effects of corticosteroids, the lowest effective dose should be used and treatment discontinued if no benefit is observed within 3 to 5 days of starting treatment.^{466,474} For patients unable to

consume all of their caloric needs by mouth, enteral tube feedings are the treatment of choice, as this method of delivery can help prevent mucosal atrophy of the gastrointestinal tract.

COMPLICATIONS OF HEMATOLOGIC MALIGNANCIES

There are numerous complications secondary to hematologic neoplasms, and selected topics on thrombocytopenia, anemia, and tumor burden are described in the subsequent section. Neutropenia was addressed in the preceding sections on neutrophil defects, febrile neutropenia, and myeloid colony-stimulating factors. Problems due to tumor burden include hyperleukocytosis, acute tumor lysis, hypercalcemia, and cord compression.

Thrombocytopenia

Thrombocytopenia may develop as a result of direct marrow infiltration, chemotherapy, infection, DIC, immune-mediated platelet destruction, and hypersplenism, as well as other idiopathic etiologies, and is considered the most common cause of serious hemorrhagic events in patients with acute or chronic leukemia.⁴⁷⁵ The relationship between spontaneous bleeding events and decreased platelet counts in the setting of induction chemotherapy or HSCT has been well described.^{476,477} As a result, prophylactic and/or therapeutic platelet transfusion to reduce bleeding risk is a generally accepted practice in these settings.^{478, 479, 480} and ⁴⁸¹ The optimal threshold for prophylactic platelet transfusion remains controversial, but levels in the 10 to $20 \times 10^9/L$ range have commonly been utilized with no major differences in outcome demonstrated between these levels.^{476,477,482} However, the risk of bleeding events in thrombocytopenia has been estimated to be increased 8-fold when counts are $< 5 \times 10^9/L$ and 2-fold with counts from 5 to $15 \times 10^9/L$ compared to platelets in the 20 to $29 \times 10^9/L$ range.⁴⁸³ Therapeutic (in the presence of bleeding) versus prophylactic (platelet count $< 10 \times 10^9/L$) platelet transfusion strategies have been compared in patients undergoing intensive chemotherapy for AML or autologous HSCT.⁴⁸⁴ The therapeutic platelet transfusion strategy led to a reduced number of platelet transfusions without an increased risk of major hemorrhage in autologous HSCT patients. However, nonfatal grade 4 (mostly CNS) bleeding was increased among AML patients, suggesting a continued role for prophylactic strategies in this population. Clinical practice guidelines set forth by ASCO currently recommend a threshold of $10 \times 10^9/L$ for prophylactic platelet transfusion in adult patients receiving therapy for acute leukemia.⁴⁸⁵

Patients with either chronic or recurrent thrombocytopenia requiring multiple platelet transfusion exposures are at increased risk for experiencing platelet refractoriness due to alloimmunization. The presence of fever is also associated with increased refractoriness to platelet transfusions⁴⁸⁶ and further compounds the risk of bleeding in this setting. When administering platelet transfusions to this population, the use of ABO-compatible platelet products is important in reducing alloimmunization as well as improving the incremental response to a given platelet transfusion.^{487,488} Platelets are generally available in the form of either single-donor apheresed products or pooled from multiple random donors. Each of these products may also be modified by either leukoreduction or irradiation. Reduction of leukocytes from platelet products by filtration has been demonstrated to be equally as effective as irradiation in the prevention of alloimmunization-related platelet refractoriness.⁴⁸⁹ Similarly, there is no difference in alloimmunization risk to support empiric use of leukoreduced single-donor (apheresed) platelet products compared to random donor platelets in this setting.⁴⁸⁹ Leukoreduction provides additional benefits by preventing CMV transmission⁴⁹⁰ and by reducing the incidence of febrile transfusion reactions.⁴⁹¹ The benefit of platelet irradiation for the prevention of transfusion-associated graft-versus-host disease (GVHD) appears limited. Use of irradiated platelet products should be restricted to patients receiving allogeneic HSCT, those receiving blood products from related donors, and those who are severely immunocompromised.⁴⁹²

Thrombocytopenia caused by accelerated platelet consumption can occur in patients with hematologic malignancies. ITP has been well described in the setting of CLL^{493, 494} and ⁴⁹⁵ and has been reported in patients with HL, NHL, MM, and ALL.^{494, 495, 496, 497} and ⁴⁹⁸ The mechanisms that contribute to the initiation of ITP in each of these situations are largely unknown, but it is presumed that pathogenic autoantibodies are produced and react to antigens present on the platelets. The prognostic significance of ITP in the setting of the various hematologic malignancies is unclear. Standard therapeutic interventions for ITP (Chapter 47) with steroids, intravenous immunoglobulin (IVIG), and/or splenectomy are typically employed in addition to definitive treatment for the underlying malignancy.

Diffuse intravascular coagulation (DIC) is well recognized to cause a consumptive thrombocytopenia associated with hematologic malignancies, most notably APL (Chapter 78). DIC is characterized by widespread intravascular activation of coagulation, intravascular fibrin deposition, and simultaneous consumption of coagulation factors and platelets which increase bleeding risk.⁴⁹⁹ APL-associated DIC is characterized by marked hyperfibrinolysis with a clinical presentation of severe bleeding and laboratory parameters consistent with hypofibrinogenemia, elevated fibrin split products, elevated fibrinogen degradation, quantitative D-dimers, and consumption of plasminogen and α_2 -antiplasmin.⁵⁰⁰ It is suspected

that the hyperfibrinolytic state in APL-associated DIC is superimposed on the prothrombotic characteristics known to occur in DIC as a result of coagulation activation and fibrin deposition, providing concurrent risk for both thrombotic and hemorrhagic complications. Chemotherapy administration to treat an underlying malignancy may transiently increase thrombotic risk by causing endothelial damage as well as release of procoagulant factors, cytokines, and proteases from damaged malignant cells.^{501,502,503,504} Therapeutic intervention for DIC remains largely supportive, with the focus on treatment of the underlying malignancy in these situations. Limited data exists to provide recommendations for the management of DIC-related complications. Transfusion support of platelets or plasma products is typically determined by active bleeding and/or the risk of hemorrhagic complications.⁵⁰⁵ The use of therapeutic heparin should be considered on an individual patient basis and may benefit those at risk for thrombotic complications.^{503,506}

Thrombocytopenia as a direct result of the malignant condition, or the aggressive chemotherapy that may be required, poses significant challenges in the treatment of patients. Recombinant human IL-11 (Oprelvekin) has been approved for the treatment and prevention of chemotherapy-induced thrombocytopenia in nonmyeloid malignancies.⁵⁰⁷ Randomized placebo-controlled testing in breast cancer patients receiving chemotherapy demonstrated reduced platelet transfusion events.⁵⁰⁸ Use of rIL-11 has

P.1461

also been shown to improve platelet nadirs and shorten duration of thrombocytopenia in patients receiving chemotherapy for hematologic malignancies.⁵⁰⁹ It is not indicated for use in children or in patients receiving myeloablative chemotherapy. Despite its proven effectiveness, the use of rIL-11 has been limited in part because of the potential for hypersensitivity reactions, ventricular arrhythmias, and papilledema associated with visual field defects and possibly blindness. Genetically modified recombinant human IL-11 (mIL-11) is under active investigation, but early reports suggest that it is able to provide equivalent thrombopoietic activity with an improved safety profile.⁵¹⁰

Romiplostim is a thrombopoietin (TPO) peptide mimetic which increases platelet counts by binding to and activating the TPO receptor (Chapter 47). Although approved for use in chronic ITP, off-label use has been reported for chemotherapy-induced thrombocytopenia⁵¹¹ and romiplostim's role in this setting is under active investigation (NCT01676961; NCT01516619). Eltrombopag is a nonpeptide TPO agonist also approved for chronic ITP. Eltrombopag increases platelet production by binding to and activating the TPO receptor, but also increases proliferation and differentiation of marrow progenitor cells by activation of intracellular signal transduction pathways. Increased platelet numbers have been reported with its use in patients with radiation-induced thrombocytopenia,⁵¹² patients receiving chemotherapy for advanced solid tumors,⁵¹³ and patients with refractory aplastic anemia.⁵¹⁴ Eltrombopag use in patients undergoing chemotherapy for hematopoietic malignancies is also an area of active investigation (NCT01656252, NCT01488565).

Anemia

Anemia commonly occurs as a result of the presence of a hematologic malignancy and/or the subsequent therapeutic interventions. Marrow infiltration and replacement with neoplastic cells is the primary cause, but other mechanisms must be considered.

Patients with inflammatory and/or malignant conditions commonly present with normocytic, normochromic or microcytic, hypochromic anemia. Laboratory findings are typically suggestive of a hypoproliferative state characterized by low reticulocyte counts and the absence of appropriate erythroid hyperplasia in the marrow in response to the anemia. Serum erythropoietin (EPO) levels tend to be inappropriately low in response to the malignancy-associated anemia,⁵¹⁵ which is suspected to result from proinflammatory cytokines that interfere with the regulation of EPO gene expression.⁵¹⁶ Erythroid marrow response to EPO is blunted, and higher doses of EPO supplementation are often required to improve anemia associated with hematologic neoplasms.^{475,517} The use of EPO stimulating agents has been curtailed because of an inferior survival in randomized trials for cancer patients and an increased risk for thrombosis.⁵¹⁸

Inflammatory cytokines have been demonstrated to increase hepcidin production,^{519,520} causing decreased intestinal iron absorption and impaired iron release from the reticuloendothelial system.⁵²¹ Increased IL-6 levels have been implicated in stimulating hepcidin production in patients with HL, MM, ALL, and AML, and provides insight into the pathophysiology of anemia commonly found in patients with various malignancies.^{522, 523} and ⁵²⁴ Targeting IL-6 in the treatment of cancer-related anemia has shown promise and remains an area of active investigation.^{525,526}

Macrocytic anemia is often seen in association with MDS and AML and is also commonly caused by exposure to cytotoxic chemotherapy. Agents such as cytarabine, hydroxyurea, methotrexate, and 6-mercaptopurine inhibit DNA syntheses and are frequently associated with the development of macrocytic anemia in exposed patients. In the absence of exposure to these types of agents, abnormal nucleated red cells may occur in AML or as part of the terminal phase of

myeloproliferative disorders. Certain morphologic features allow their differentiation from the megaloblasts resulting from vitamin deficiencies. The nuclear chromatin is typically not as fine as in true megaloblasts, and a greater proportion of the erythroid precursors are more immature in most patients with erythroleukemia than in those with vitamin B12 or folate deficiencies. In addition, the neutrophils characteristic of these vitamin deficiencies, such as hypersegmentation, giant metamyelocytes, and macropolycytes, are usually absent in the macrocytic anemia seen in AML/MDS.

Hemolytic anemias have been observed in association with various hematologic malignancies and may precede diagnosis of the malignant condition. While their presentation may be dramatic, concomitant hemolytic anemias do not carry prognostic significance. Warm antibody-mediated hemolytic anemia has been classically described to occur in 10% to 20% of patients with CLL but has also been observed in association with various other hematologic cancers.^{527, 528, 529} and ⁵³⁰ Therapy is directed at decreasing the production of antibody and the splenic destruction of red blood cells (Chapter 29). Glucocorticoids, transfusion support, and/or splenectomy are used in autoimmune hemolytic anemia of warm antibody type, in addition to therapy directed toward the underlying neoplasm. Anemia is usually mild in cold agglutinin disease, and intervention with steroids and splenectomy is of little benefit. Avoiding cold exposure, plasmapheresis, and treatment of the underlying lymphoproliferative disorder may be effective in improving the anemia associated with cold agglutinin disease. Microangiopathic hemolytic anemia is seen most often as part of the DIC syndrome but has been reported in patients with hematologic neoplasms without evidence of DIC. Erythrocyte trapping and/or destruction in the spleen may contribute to anemia in hematologic cancers such as low-grade lymphomas and CLL. Splenectomy has been used for treatment of nonautoimmune hemolytic anemias in lymphoid malignancies when this hypersplenism occurs.^{531,532}

Hemophagocytic syndrome is a rare but often dramatic cause of anemia in patients with a variety of hematologic malignancies. Its presence has been described in association with acute leukemias, lymphomas, and myeloma,^{533, 534, 535, 536} and ⁵³⁷ as well as a result of infectious complications of both bacterial and viral origin.^{538,539} The mechanism by which this potentially devastating macrophage activation occurs is poorly understood, but is felt to result from the inability to turn off the inflammatory response of the immune system to the particular inciting factor (malignancy, infection, etc.).⁵⁴⁰ Prognosis in these patients is quite poor.

Hyperleukocytosis and Leukostasis

Hyperleukocytosis has been variably defined as a white blood cell (WBC) count greater than $50 \times 10^9/L$ or $100 \times 10^9/L$ (Table 69.12).

P.1462

It is typically associated with increased morbidity and mortality in patients with leukemic diagnoses as a result of associated leukostasis and/or tumor lysis syndrome. The absolute count at which the hyperleukocytosis becomes clinically relevant is somewhat dependent on the specific underlying leukemic process. For instance, patients with AML may develop severe complications at a WBC count of $50 \times 10^9/L$, whereas patients with CLL may tolerate WBC counts above $400 \times 10^9/L$. Hyperleukocytosis has been estimated to occur in approximately 5% to 13% of AML and between 10% to 30% of ALL,⁵⁴¹ and has historically been associated with a poor prognosis when occurring in patients with acute leukemia.^{542, 543} and ⁵⁴⁴ Supportive care measures such as aggressive intravenous fluid support, allopurinol, and hydroxyurea are typically employed as temporizing measures until some form of cytoreductive therapy can be initiated.

TABLE 69.12 MANAGEMENT OF HYPERLEUKOCYTOSIS

1. Risk of leukostasis depends upon disease and level of WBC ($\times 10^9/L$). AML (monocyte variants) and CML, blast crisis ($>50-100$) $>$ ALL ($>150-300$) $>$ CML ($>150-250$) $>$ CLL (300-500)
2. Target organs for leukostasis are: brain (stupor, blurred vision), lungs (dyspnea), kidneys (azotemia), penis (priapism), heart (arrhythmia)
3. Spurious lab may occur with hyperleukocytosis: elevated platelet count, pseudohypoxemia ("leukocyte larceny"), pseudohyperkalemia, pseudohypoglycemia, prolonged coagulation tests
4. Transfusion: limit red cells due to risk of increasing viscosity; transfuse platelets due to increased risk of bleeding and loss of platelets with leukapheresis
5. Therapy: hydration, allopurinol or rasburicase, hydroxyurea, consider leukapheresis if symptomatic, dexamethasone, institute chemotherapy, manage tumor lysis

Leukostasis is a symptomatic manifestation of hyperleukocytosis which qualifies as a medical emergency caused by the “sludging” of the leukemic cells within the capillaries, leading to vascular obstruction and resultant tissue hypoxia (Fig. 69.11). Presenting symptoms of leukostasis are reflective of the location where this tissue hypoxia is occurring. CNS manifestations of confusion, headaches, visual disturbances, somnolence, delirium, or ataxia may occur. Respiratory findings may include bilateral infiltrates on chest imaging and associated dyspnea, tachypnea, hypoxia, and rhonchi on physical exam. Leukostasis remains a diagnosis of clinical suspicion rather than one confirmed by a laboratory test. Given the potential for catastrophic consequences, reasonable clinical suspicion of diagnosis should prompt emergent intervention. Hydroxyurea is an oral antimetabolite with the ability to rapidly lower leukocyte counts and whole blood viscosity.^{545,546} Definitive antileukemic therapy should be initiated as soon as possible. Some centers prefer to initiate leukapheresis prior to the initiation of chemotherapy in order to reduce the peripheral leukemic burden, ameliorate the symptoms of leukostasis, and minimize the risk of tumor lysis syndrome upon initiation of the chemotherapy.^{547,548} While retrospective data has shown that leukapheresis may reduce early mortality, it has failed to provide improvements in remission or overall survival.⁵⁴⁹

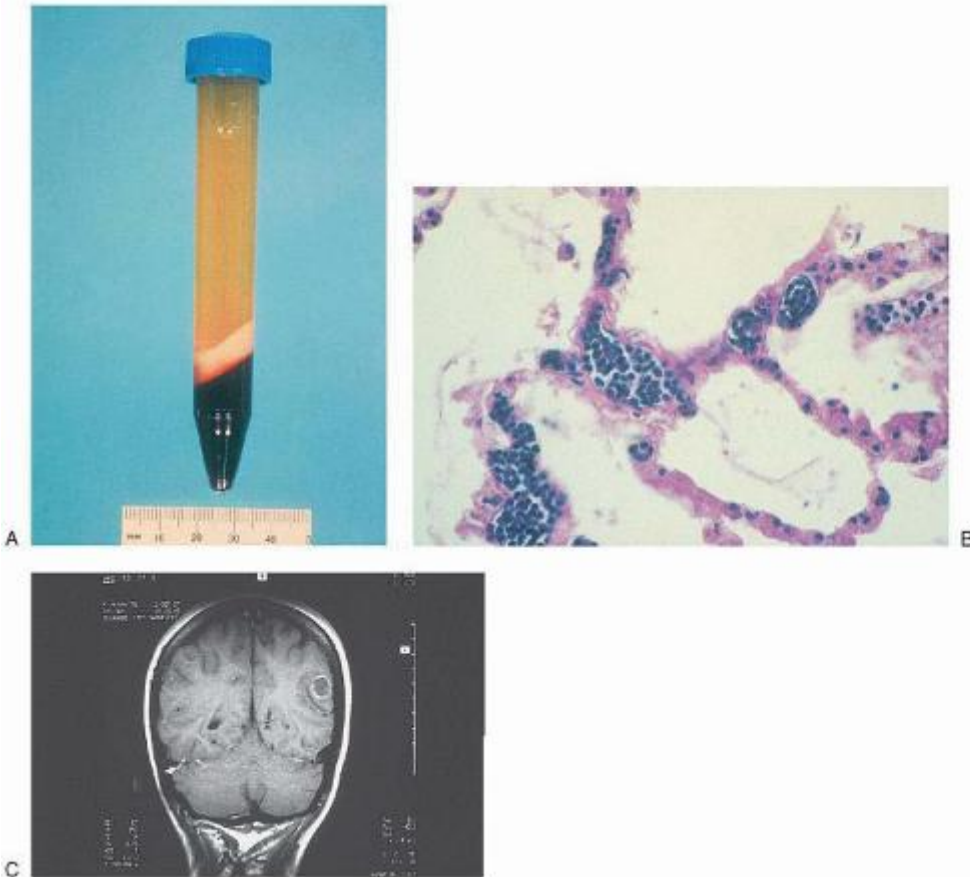

FIGURE 69.11. Hyperleukocytosis and leukostasis. A: An elevated leukocrit is present in this tube of centrifuged peripheral blood from a patient with T cell acute lymphoblastic leukemia who had a peripheral blood blast count of $250 \times 10^9/L$. B: Pulmonary alveolar capillaries are expanded by leukocyte aggregates indicative of leukostasis in patient with acute myeloid leukemia (hematoxylin and eosin stain). C: Ring-enhancing lesions on magnetic resonance imaging were attributed to hemorrhage in a patient with chronic granulocytic leukemia, hyperleukocytosis, and blurred vision (T1-weighted image).

Acute Tumor Lysis Syndrome

ATLS occurs most frequently in patients with rapidly proliferating neoplasms such as high-grade lymphomas (e.g., Burkitt) and acute leukemias (Fig. 69.12). ATLS may occur spontaneously and be observed at the time of initial diagnosis or in response to the initiation of cytotoxic chemotherapy. Tumor lysis results from the rapid breakdown of malignant cells and the subsequent abrupt release of the cellular contents (intracellular ions, nucleic acids, proteins, etc.) into the extracellular space. Laboratory evidence of tumor lysis is more commonly seen than the clinical manifestations.

Laboratory tumor lysis requires at least 2 of the following metabolic abnormalities occurring simultaneously within 3 days prior to or up to 7 days after the

P.1463

initiation of therapy: hyperuricemia, hyperkalemia, hyperphosphatemia, and hypocalcemia.^{550,551,552} The clinical tumor lysis syndrome is defined as the above abnormal laboratory findings in combination with acute renal failure, seizures, cardiac dysrhythmias, or death.

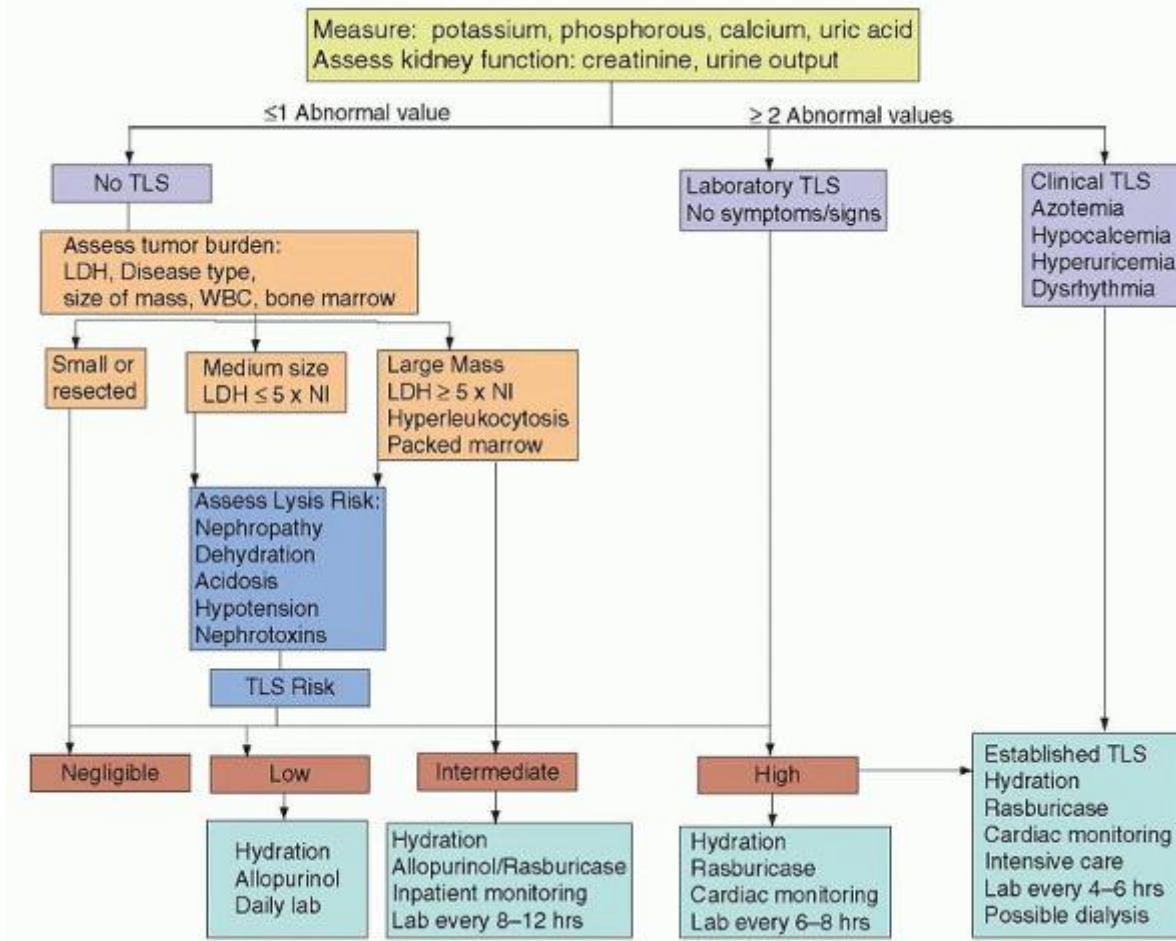

FIGURE 69.12. Management of tumor lysis syndrome (TLS). Serum chemistries and renal function are assessed when instituting therapy in any patient with a hematologic neoplasm. The risk of TLS is based on assessing laboratory values, disease type, and tumor burden. Patients at a high risk for TLS include the acute leukemias with hyperleukocytosis and the aggressive lymphomas with large masses or elevated LDH (lactate dehydrogenase). Volume repletion, agents to lower uric acid, and laboratory monitoring are warranted in all patients. As the risk of TLS increases, the interval of monitoring shortens and the level of care intensifies with cardiac monitoring and the possible requirement for dialysis. (Adapted from Howard SC, Jones DP, Pui C-H. The tumor lysis syndrome. *N Eng J Med* 2011;364:1844-1854.)

Hyperuricemia plays a major role in the development of the acute renal failure seen in ATLS. The etiology of the renal failure is presumably from crystal-induced tissue injury that occurs when calcium, uric acid, and xanthine precipitate in the renal tubules and lead to crystal-induced obstruction (Fig. 69.13). Allopurinol is commonly used in the prevention and treatment of ATLS. Allopurinol is a competitive inhibitor of xanthine oxidase and prevents the formation of uric acid. Allopurinol is available in both oral and IV preparations. If uric acid levels remain elevated despite allopurinol, rasburicase (recombinant uric acid oxidase) may be administered. Rasburicase converts uric acid to allantoin which is highly water soluble. Randomized data from high-risk pediatric patients receiving rasburicase versus allopurinol demonstrated reduction of uric acid levels by 86% within 4 hours of rasburicase administration versus only a 12% reduction in the allopurinol group ($P < 0.0001$).⁵⁵³ The FDA approved dosing schedule for rasburicase is 0.2 mg/kg intravenously over

P.1464

30 minutes daily for up to 5 days. Multiple reports in the literature suggest that lower fixed dose strategies may be sufficient and more cost-effective.^{554,555, 556} and ⁵⁵⁷

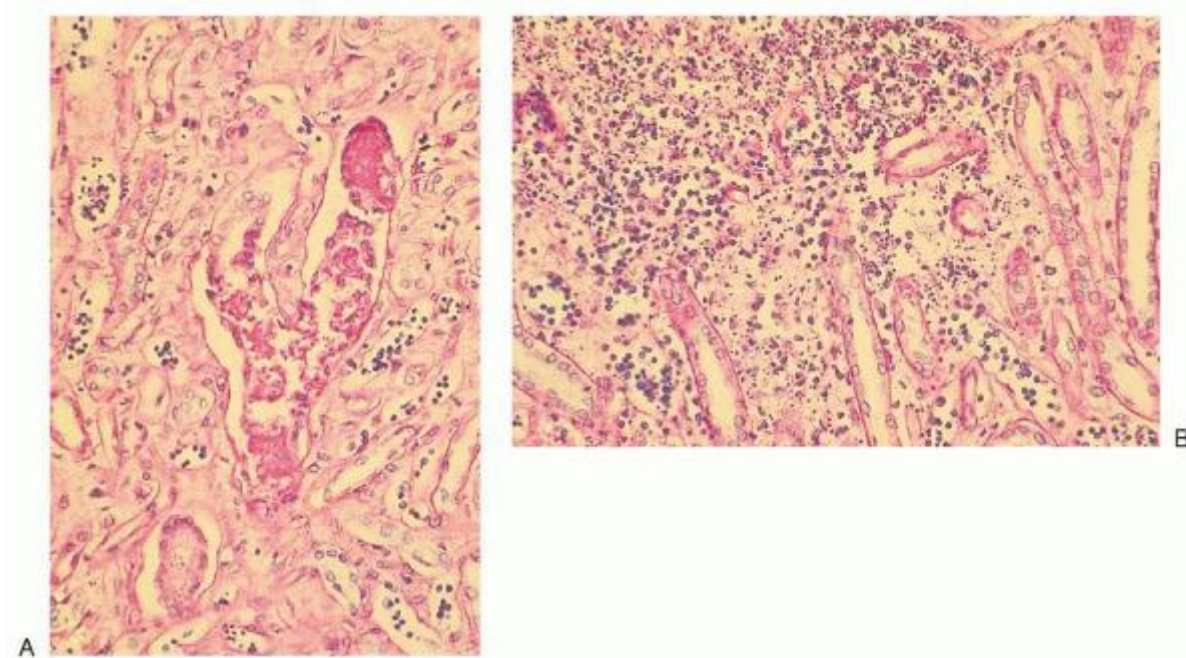

FIGURE 69.13. Tumor lysis: A: Karyorrhectic lymphoblast nuclei are present throughout the kidney in a patient with acute tumor lysis syndrome in whom cytolysis was initiated by administration of corticosteroids. B: Renal tubules contain calcium phosphate precipitates that contributed to acute lysis-associated renal failure (hematoxylin and eosin stain). (Courtesy of Dr. William R. Macon, Department of Pathology, Mayo Medical Center, Rochester, MN.)

Patients with significant electrolyte imbalances and/or renal insufficiency may require therapeutic dialysis support until resolution of the ATLS. Prophylactic dialysis prior to initiation of chemotherapy should also be considered in high-risk patients such as those with bulky high-grade tumors.

Hypercalcemia

Hypercalcemia can occur in association with many various hematologic malignancies but is more commonly seen in patients with either MM or human T cell leukemia virus type-1 (HTLV-1)-associated adult T cell leukemia/lymphoma (ATL). Hypercalcemia in patients with cancer is primarily due to increased bone resorption and release of calcium from bone. The 3 main mechanisms leading to hypercalcemia are increased osteolytic activity, tumor secretion of parathyroid hormone-related protein (PTHrP), and ectopic production of calcitriol (1, 25-dihydroxyvitamin D). The symptoms of hypercalcemia are generally nonspecific and include fatigue, anorexia, nausea, constipation, pain, frequent urination, and altered mental status. Correction of the calcium levels typically leads to rapid and effective palliation of these symptoms.⁵⁵⁸

MM has an affinity for diffuse bone involvement and releases osteoclast activating factors leading to osteoclast-induced bone resorption that present as lytic lesions which may occur throughout the skeleton.⁵⁵⁹ Myeloma has also been associated with osteoblast inhibition leading to decreased bone formation.⁵⁶⁰ This impaired bone formation in the setting of increased destruction disrupts calcium homeostasis and results in the hypercalcemia. Numerous molecules have been implicated in the development of lytic disease and hypercalcemia, including interleukin (IL)-6, the receptor activator of nuclear factor kappa-B ligand (RANKL), macrophage inflammatory protein 1a, osteoprotegerin, and IL-3.

Calcium homeostasis in the normal host involves conversion of 1-OH vitamin D to calcitriol in the kidney. Calcitriol leads to increased calcium absorption from the gastrointestinal tract as well as increased bone resorption and results in hypercalcemia. Ectopic production of calcitriol has been described in both HL and NHL.^{561,562}

Normal calcium metabolism is mediated by parathyroid hormone. In cases of HTLV-1-associated ATL,⁵⁶³ as well as other hematologic malignancies (AML,⁵⁶⁴ CML,^{565,566} HL,⁵⁶⁷ NHL,⁵⁶⁸ and MM⁵⁶⁹), the secretion of PTHrP stimulates osteoclasts,

causing increased calcium release from the bone and resulting in a process known as humeral hypercalcemia of malignancy (HHM). Endogenous PTH is typically suppressed secondary to the hypercalcemia, and serum PTH levels will be very low. Unlike PTH, PTHrP does not typically stimulate production of calcitriol⁵⁷⁰ and thus does not increase intestinal calcium absorption. The uncoupling of bone resorption and formation that occurs in HHM results in the influx of calcium into the circulation and resultant hypercalcemia.

Regardless of the mechanism leading to the cancer-related hypercalcemia, successful treatment ultimately requires antineoplastic therapy directed toward the underlying malignancy. The severity of the patient's symptoms and the prevention of catastrophic consequences will typically require interventions with more rapid impact. Patients with hypercalcemia often experience significant volume depletion as a result of an osmotic diuresis. Thus, aggressive volume repletion with isotonic intravenous fluids (e.g., normal saline) should be initiated upon discovery of the hypercalcemia. Once the patient is appropriately volume replete, loop diuretics may be added to increase calciuresis. Thiazide diuretics increase calcium resorption and should be avoided.

The effectiveness and availability of bisphosphonates have made them a mainstay of hypercalcemic therapy. These agents inhibit calcium release by disrupting osteoclast-mediated bone resorption.⁵⁷¹ Multiple intravenous bisphosphonate choices are available for the treatment of malignancy-associated hypercalcemia: pamidronate, zoledronic acid, and ibandronate. Intravenous administration of the bisphosphonates is generally well tolerated, but patients may experience flu-like symptoms (fever, arthralgias, myalgia, fatigue, and bone pain), uveitis, hypocalcemia, hypophosphatemia, impaired renal function, and osteonecrosis of the jaw.⁵⁷² Calcitonin results in rapid lowering of serum calcium levels and may be combined with bisphosphonates,^{573, 574} and⁵⁷⁵ but calcitonin tachyphylaxis is common and limits the benefit of repeated dosing. Cases of renal insufficiency have been reported in association with bisphosphonates, and caution should be employed with their use in the treatment of hypercalcemia in patients with impaired renal function.⁵⁷⁶

Denosumab is a fully human monoclonal antibody that targets RANKL and inhibits osteoclast maturation, activation, and function, leading to reduced bone resorption. It is approved for the treatment of osteoporosis and prevention of skeletal-related events in at-risk patient populations. Its effectiveness has been reported in the treatment of malignancy-associated hypercalcemia refractory to bisphosphonates.⁵⁷⁷ Denosumab has also demonstrated less nephrotoxicity than bisphosphonates,^{578,579} and its use has been reported in the setting of renal insufficiency.⁵⁸⁰ Common side effects of denosumab include fatigue, headache, hypophosphatemia, hypocalcemia, nausea, weakness, dyspnea, and cough.

Cord Compression

Spinal cord impingement is a medical emergency requiring rapid recognition and intervention in the hopes of minimizing complications. It has been frequently reported in patients with MM and is also known to occur in association with HL and NHL. Cord compression as a result of a leukemia diagnosis is rare but has been reported.^{581, 582} and⁵⁸³ Pain is the most common presenting symptom of patients with cord compression and may precede neurologic symptoms by several weeks. Radicular pain, pain not relieved with lying down, and proximal muscle weakness are of particular concern for the possibility of an underlying cord impingement. The development of autonomic symptoms such as urinary retention and fecal incontinence typically occurs late in the course and is predictive of poor outcomes.

Patients with known hematologic malignancies that complain of severe back pain and/or any neurologic symptom warrant urgent imaging to rule out cord compression. Emergent referrals for the possibility of surgical intervention should be considered for patients in whom there is a reasonable index of suspicion. Empiric steroids may be appropriate in clinical contexts of concern, or if there are unavoidable delays in being able to obtain imaging. It should be noted, however, that the initiation of steroids may cause rapid necrosis of the tumor and impair the ability to make a tissue diagnosis. Magnetic resonance imaging (MRI) is the imaging modality of choice and should include the entire spine, as multiple areas of compression can occur simultaneously⁵⁸⁴ (Fig. 69.14).

Intervention for cord compression is directed at pain control, avoidance of complications, and the preservation or improvement of neurologic function. Frontline therapy typically consists of urgent initiation of corticosteroids (dexamethasone). The optimal dose of steroids is not known. High-dose dexamethasone (up to 100 mg) has been shown to improve neurologic recovery and ambulatory status,^{426,585} but carries the risk of serious adverse events such as psychosis and gastrointestinal complications.^{586,587} In general, it is recommended that patients with suspected or confirmed cord compression be started on dexamethasone at an

P.1465

initial dose of 10 to 100 mg followed by at least 16 mg daily (in divided doses).⁵⁸⁸ Following the initiation of steroids and confirmation of cord impingement, definitive treatment with surgical intervention, radiation therapy, and/or

chemotherapy should be initiated.^{588,589} Surgery should be considered in those who are medically and surgically appropriate and/or those in whom a tissue diagnosis has not yet been established. Radiation therapy should be administered to those who are not candidates for surgical intervention.

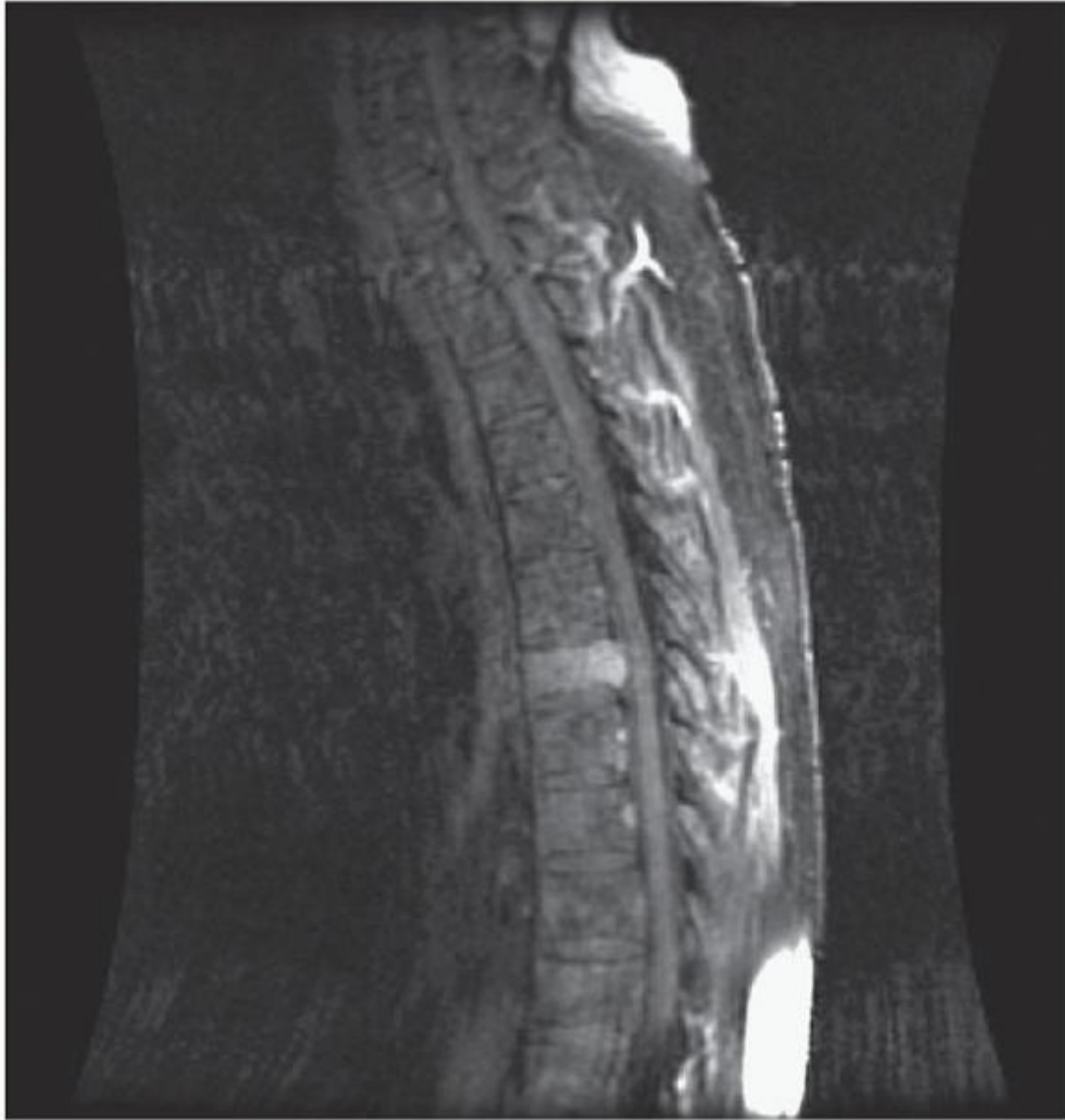

FIGURE 69.14. Spinal cord involvement shown by magnetic resonance imaging. Epidural mass on sagittal view with evidence of cord compression and cord impingement at &7 level (T1-weighted image). The diagnosis by biopsy was multiple myeloma.

SUMMARY

This chapter has addressed selected aspects of supportive care in hematologic malignancies. The improved prognosis for leukemias, lymphomas, and myeloma has been attributed to better drugs, including targeted therapy and immunotherapy; however, progress could not have occurred without the concomitant advances in supportive care, particularly in the management of infections and in transfusions.

The goals of supportive care are to prevent and reduce the toxicities of therapy and the complications of the diseases. There is an emphasis on survivorship, including rehabilitation after therapy and recognition of the long-term risks of

therapy. When therapeutic options no longer offer survival benefit, access to palliative care and end-of-life issues take precedence over other components of supportive care.

Resources for Supportive Care

- Multinational Association of Supportive Care in Cancer: www.mascc.org
- National Institutes of Health: www.cancer.gov/cancertopics/coping
- ASCO Supportive Care and Quality of Life
- NCCN Guidelines for Supportive Care

REFERENCES

1. Donnelly J, Blijlevens N, De Pauw B. Infections in the immunocompromised host: general principles. In: Mandell, Douglas, and Bennett's principles and practice of infectious diseases, 7th ed. Philadelphia, PA: Churchill Livingstone, Elsevier. 2009:3781-3791.
2. Witko-Sarsat V, Rieu P, Descamps-Latscha B, et al. Neutrophils: molecules, functions and pathophysiological aspects. *Lab Invest* 2000;80:617-653.
3. Freifeld AG, Bow EJ, Sepkowitz KA, et al. Clinical practice guideline for the use of antimicrobial agents in neutropenic patients with cancer: 2010 update by the infectious diseases society of america. *Clin Infect Dis* 2011;52:e56-e93.
4. Bodey GP, Buckley M, Sathe YS, et al. Quantitative relationships between circulating leukocytes and infection in patients with acute leukemia. *Ann Intern Med* 1966;64:328-340.
5. Seymour JF, Kurzrock R, Freireich EJ, et al. 2-chlorodeoxyadenosine induces durable remissions and prolonged suppression of CD4+ lymphocyte counts in patients with hairy cell leukemia. *Blood* 1994;83:2906-2911.
6. Boogaerts MA, Nelissen V, Roelant C, et al. Blood neutrophil function in primary myelodysplastic syndromes. *Br J Haematol* 1983;55:217-227.
7. Pomeroy C, Oken MM, Rydell RE, et al. Infection in the myelodysplastic syndromes. *Am J Med* 1991;90:338-344.
8. Olofsson T, Odeberg H, Olsson I. Granulocyte function in chronic granulocytic leukemia. II. Bactericidal capacity, phagocytic rate, oxygen consumption, and granule protein composition in isolated granulocytes. *Blood* 1976;48: 581-593.
9. Fiddes P, Penny R, Wells JV, et al. Clinical correlations with immunoglobulin levels in chronic lymphatic leukaemia. *Aust N Z J Med* 1972;2:346-350.
10. Morrison VA. Infectious complications in patients with chronic lymphocytic leukemia: pathogenesis, spectrum of infection, and approaches to prophylaxis. *Clin Lymphoma Myeloma* 2009;9:365-370.
11. Linton AL, Dunnigan MG, Thomson JA. Immune responses in myeloma. *Br Med J* 1963;2:86-89.
12. Schwartz PE, Sterioff S, Mucha P, et al. Postsplenectomy sepsis and mortality in adults. *JAMA* 1982;248:2279-2283.
13. McGee ZA, Schaffner W, Koenig MG. Superinfection in lymphoreticular diseases. *Annu Rev Med* 1971;22:25-38.
14. Hersh EV, Gutterman JU, Mavligit GM. Effect of haematological malignancies and their treatment on host defence factors. *Clin Haematol* 1976;5:425-448.
15. Winter GC, Osmond DG, Yoffey JM, et al. Leucocyte cultures with phytohaemagglutinin in chronic lymphatic leukaemia. *Lancet* 1964;2:563-565.
16. Jones LH, Hardisty RM, Wells DG, et al. Lymphocyte transformation in patients with acute lymphoblastic leukaemia. *Br Med J* 1971;4:329-330.
17. Campbell AC, Hersey P, MacLennan IC, et al. Immunosuppressive consequences of radiotherapy and chemotherapy in patients with acute lymphoblastic leukaemia. *Br Med J* 1973;2:385-388.
18. Lee JW, Pizzo PA. Management of the cancer patient with fever and prolonged neutropenia. *Hematol Oncol Clin North Am* 1993;7:937-960.
19. Klastersky J, Paesmans M, Rubenstein EB, et al. The Multinational Association for Supportive Care in Cancer risk index: a multinational scoring system for identifying low-risk febrile neutropenic cancer patients. *J Clin Oncol* 2000;18:3038-3051.

20. Antoniadou A, Giamarellou H. Fever of unknown origin in febrile leukopenia. *Infect Dis Clin North Am* 2007;21:1055-1090.
21. Lehrnbecher T, Phillips R, Alexander S, et al. Guideline for the management of fever and neutropenia in children with cancer and/or undergoing hematopoietic stem-cell transplantation. *J Clin Oncol* 2012;30:4427-4438.
22. Flowers CR, Seidenfeld J, Bow EJ, et al. Antimicrobial prophylaxis and outpatient management of fever and neutropenia in adults treated for malignancy: American Society of Clinical Oncology Clinical Practice Guideline. *J Clin Oncol* 2013;
23. Cometta A, Calandra T, Gaya H, et al. Monotherapy with meropenem versus combination therapy with ceftazidime plus amikacin as empiric therapy for fever in granulocytopenic patients with cancer. The International Antimicrobial Therapy Cooperative Group of the European Organization for Research and Treatment of Cancer and the Gruppo Italiano Malattie Ematologiche Maligne dell'Adulto Infection Program. *Antimicrob Agents Chemother* 1996;40:1108-1115.
24. Furno P, Bucaneve G, Del Favero A. Monotherapy or aminoglycoside-containing combinations for empirical antibiotic treatment of febrile neutropenic patients: a meta-analysis. *Lancet Infect Dis* 2002;2:231-242.
25. Paterson DL, Ko WC, Von Gottberg A, et al. Outcome of cephalosporin treatment for serious infections due to apparently susceptible organisms producing extended-spectrum beta-lactamases: implications for the clinical microbiology laboratory. *J Clin Microbiol* 2001;39:2206-2212.
26. Kang CI, Kim SH, Park WB, et al. Bloodstream infections due to extended-spectrum beta-lactamase-producing *Escherichia coli* and *Klebsiella pneumoniae*: risk factors for mortality and treatment outcome, with special emphasis on antimicrobial therapy. *Antimicrob Agents Chemother* 2004;48:4574-4581.
27. Fritsche TR, Sader HS, Jones RN. Comparative activity and spectrum of broad-spectrum beta-lactams (cefepime, ceftazidime, ceftriaxone, piperacillin/tazobactam) tested against 12,295 staphylococci and streptococci: report from the SENTRY Antimicrobial Surveillance Program (North America: 2001-2002). *Diagn Microbiol Infect Dis* 2003;47:435-440.
28. Nguyen TD, Williams B, Trang E. Cefepime therapy and all-cause mortality. *Clin Infect Dis* 2009;
29. Gomez L, Quintana S, Garau J. Mortality associated with cefepime therapy among neutropenic patients. *Clin Infect Dis* 2009;49:987.
30. Vancomycin added to empirical combination antibiotic therapy for fever in granulocytopenic cancer patients. European Organization for Research and Treatment of Cancer (EORTC) International Antimicrobial Therapy Cooperative Group and the National Cancer Institute of Canada Clinical Trials Group. *J Infect Dis* 1991;163:951-958.
31. Raad II, Whimbey EE, Rolston KV, et al. A comparison of aztreonam plus vancomycin and imipenem plus vancomycin as initial therapy for febrile neutropenic cancer patients. *Cancer* 1996;77:1386-1394.
32. Pizzo PA, Robichaud KJ, Gill FA, et al. Empiric antibiotic and antifungal therapy for cancer patients with prolonged fever and granulocytopenia. *Am J Med* 1982;72:101-111.
33. Walsh TJ, Pappas P, Winston DJ, et al. Voriconazole compared with liposomal amphotericin B for empirical antifungal therapy in patients with neutropenia and persistent fever. *N Engl J Med* 2002;346:225-234.
34. Walsh TJ, Anaissie EJ, Denning DW, et al. Treatment of aspergillosis: clinical practice guidelines of the Infectious Diseases Society of America. *Clin Infect Dis* 2008;46:327-360.
35. Baddour LM, Wilson WR, Bayer AS, et al. Infective endocarditis: diagnosis, antimicrobial therapy, and management of complications: a statement for healthcare professionals from the Committee on Rheumatic Fever, Endocarditis, and Kawasaki Disease, Council on Cardiovascular Disease in the Young, and the Councils on Clinical Cardiology, Stroke, and Cardiovascular Surgery and Anesthesia, American Heart Association: endorsed by the Infectious Diseases Society of America. *Circulation* 2005;111:e394-e434.
36. Rowe JM. Treatment of acute myeloid leukemia with cytokines: effect on duration of neutropenia and response to infections. *Clin Infect Dis* 1998;26:1290-1294.
37. Pettengell R, Gurney H, Radford JA, et al. Granulocyte colony-stimulating factor to prevent dose-limiting neutropenia in non-Hodgkin's lymphoma: a randomized controlled trial. *Blood* 1992;80:1430-1436.
38. Dekker A, Bulley S, Beyene J, et al. Meta-analysis of randomized controlled trials of prophylactic granulocyte colony-stimulating factor and granulocyte-macrophage colony-stimulating factor after autologous and allogeneic stem cell transplantation. *J Clin Oncol* 2006;24:5207-5215.

39. Smith TJ, Khatcheressian J, Lyman GH, et al. 2006 update of recommendations for the use of white blood cell growth factors: an evidence-based clinical practice guideline. *J Clin Oncol* 2006;24:3187-3205.
40. Aapro MS, Bohlius J, Cameron DA, et al. 2010 update of EORTC guidelines for the use of granulocyte-colony stimulating factor to reduce the incidence of chemotherapy-induced febrile neutropenia in adult patients with lymphoproliferative disorders and solid tumours. *Eur J Cancer* 2011;47:8-32.
41. Beveridge RA, Miller JA, Kales AN, et al. Randomized trial comparing the tolerability of sargramostim (yeast-derived RhuGM-CSF) and filgrastim (bacteria-derived RhuG-CSF) in cancer patients receiving myelosuppressive chemotherapy. *Support Care Cancer* 1997;5:289-298.
42. Lieschke GJ, Cebon J, Morstyn G. Characterization of the clinical effects after the first dose of bacterially synthesized recombinant human granulocyte-macrophage colony-stimulating factor. *Blood* 1989;74:2634-2643.
43. Yang BB, Kido A, Shibata A. Serum pegfilgrastim concentrations during recovery of absolute neutrophil count in patients with cancer receiving pegfilgrastim after chemotherapy. *Pharmacotherapy* 2007;27:1387-1393.
44. Vose JM, Crump M, Lazarus H, et al. Randomized, multicenter, open-label study of pegfilgrastim compared with daily filgrastim after chemotherapy for lymphoma. *J Clin Oncol* 2003;21:514-519.
45. Grigg A, Solal-Celigny P, Hoskin P, et al. Open-label, randomized study of pegfilgrastim vs. daily filgrastim as an adjunct to chemotherapy in elderly patients with non-Hodgkin's lymphoma. *Leuk Lymphoma* 2003;44: 1503-1508.
46. Peters C, Minkov M, Matthes-Martin S, et al. Leucocyte transfusions from rhG-CSF or prednisolone stimulated donors for treatment of severe infections in immunocompromised neutropenic patients. *Br J Haematol* 1999;106: 689-696.
47. Winston DJ, Ho WG, Gale RP. Therapeutic granulocyte transfusions for documented infections. A controlled trial in ninety-five infectious granulocytopenic episodes. *Ann Intern Med* 1982;97:509-515.
48. Stanworth SJ, Massey E, Hyde C, et al. Granulocyte transfusions for treating infections in patients with neutropenia or neutrophil dysfunction. *Cochrane Database Syst Rev* 2005:CD005339.
49. Martin GS, Mannino DM, Eaton S, et al. The epidemiology of sepsis in the United States from 1979 through 2000. *N Engl J Med* 2003;348:1546-1554.
50. Legrand M, Max A, Peigne V, et al. Survival in neutropenic patients with severe sepsis or septic shock. *Crit Care Med* 2012;40:43-49.
51. Hamalainen S, Kuittinen T, Matinlauri I, et al. Neutropenic fever and severe sepsis in adult acute myeloid leukemia (AML) patients receiving intensive chemotherapy: causes and consequences. *Leuk Lymphoma* 2008;49: 495-501.
52. Rangel-Frausto MS, Pittet D, Costigan M, et al. The natural history of the systemic inflammatory response syndrome (SIRS). A prospective study. *JAMA* 1995;273:117-123.
53. Rosen AB, Fowler VG Jr, Corey GR, et al. Cost-effectiveness of transesophageal echocardiography to determine the duration of therapy for intravascular catheter-associated *Staphylococcus aureus* bacteremia. *Ann Intern Med* 1999;130:810-820.
54. Mugge A, Daniel WG, Frank G, et al. Echocardiography in infective endocarditis: reassessment of prognostic implications of vegetation size determined by the transthoracic and the transesophageal approach. *J Am Coll Cardiol* 1989;14:631-638.
55. Mermel LA, Allon M, Bouza E, et al. Clinical practice guidelines for the diagnosis and management of intravascular catheter-related infection: 2009 update by the Infectious Diseases Society of America. *Clin Infect Dis* 2009;49:1-45.
56. Daniel WG, Mugge A, Martin RP, et al. Improvement in the diagnosis of abscesses associated with endocarditis by transesophageal echocardiography. *N Engl J Med* 1991;324:795-800.
57. Chang FY, Peacock JE Jr, Musher DM, et al. *Staphylococcus aureus* bacteremia: recurrence and the impact of antibiotic treatment in a prospective multicenter study. *Medicine (Baltimore)* 2003;82:333-339.
58. Appelbaum PC. The emergence of vancomycin-intermediate and vancomycin-resistant *Staphylococcus aureus*. *Clin Microbiol Infect* 2006;12(Suppl 1):16-23.
59. Sakoulas G, Moise-Broder PA, Schentag J, et al. Relationship of MIC and bactericidal activity to efficacy of vancomycin for treatment of methicillin-resistant *Staphylococcus aureus* bacteremia. *J Clin Microbiol* 2004;42: 2398-2402.

60. Rybak M, Lomaestro B, Rotschafer JC, et al. Therapeutic monitoring of vancomycin in adult patients: a consensus review of the American Society of Health-System Pharmacists, the Infectious Diseases Society of America, and the Society of Infectious Diseases Pharmacists. *Am J Health Syst Pharm* 2009;66:82-98.
61. Jaksic B, Martinelli G, Perez-Oteyza J, et al. Efficacy and safety of linezolid compared with vancomycin in a randomized, double-blind study of febrile neutropenic patients with cancer. *Clin Infect Dis* 2006;42:597-607.
62. Mave V, Garcia-Diaz J, Islam T, et al. Vancomycin-resistant enterococcal bacteraemia: is daptomycin as effective as linezolid? *J Antimicrob Chemother* 2009;64:175-180.
63. Moellering RC. Linezolid: the first oxazolidinone antimicrobial. *Ann Intern Med* 2003;138:135-142.
64. Moise PA, Forrest A, Birmingham MC, et al. The efficacy and safety of linezolid as treatment for *Staphylococcus aureus* infections in compassionate use patients who are intolerant of, or who have failed to respond to, vancomycin. *J Antimicrob Chemother* 2002;50:1017-1026.
65. Shorr AF, Kunkel MJ, Kollef M. Linezolid versus vancomycin for *Staphylococcus aureus* bacteraemia: pooled analysis of randomized studies. *J Antimicrob Chemother* 2005;56:923-929.
66. Fowler VG Jr, Boucher HW, Corey GR, et al. Daptomycin versus standard therapy for bacteremia and endocarditis caused by *Staphylococcus aureus*. *N Engl J Med* 2006;355:653-665.
67. U.S Food and Drug Administration. Information for Healthcare Professionals: Linezolid (marketed as Zyvox). Rockville M. 2007. Information for Healthcare Professionals: Linezolid (marketed as Zyvox) FDA ALERT [3/16/2007]: <http://www.fda.gov/Drugs/DrugSafety/PostmarketDrugSafetyInformationforPatientsandProviders/DrugSafetyInformationforHealthcareProfessionals/ucm085249.htm>.
68. Wunderink RG, Rello J, Cammarata SK, et al. Linezolid vs vancomycin: analysis of two double-blind studies of patients with methicillin-resistant *Staphylococcus aureus* nosocomial pneumonia. *Chest* 2003;124:1789-1797.
69. Powers JH, Ross DB, Lin D, et al. Linezolid and vancomycin for methicillin-resistant *Staphylococcus aureus* nosocomial pneumonia: the subtleties of subgroup analyses. *Chest* 2004;126:314-315; author reply 315-316.
70. Guidelines for the management of adults with hospital-acquired, ventilator-associated, and healthcare-associated pneumonia. *Am J Respir Crit Care Med* 2005;171:388-416.
71. Elting LS, Bodey GP, Keefe BH. Septicemia and shock syndrome due to viridans streptococci: a case-control study of predisposing factors. *Clin Infect Dis* 1992;14:1201-1207.
72. Tunkel AR, Sepkowitz KA. Infections caused by viridans streptococci in patients with neutropenia. *Clin Infect Dis* 2002;34:1524-1529.
73. Donskey CJ, Chowdhry TK, Hecker MT, et al. Effect of antibiotic therapy on the density of vancomycin-resistant enterococci in the stool of colonized patients. *N Engl J Med* 2000;343:1925-1932.
74. Weinstock DM, Conlon M, Iovino C, et al. Colonization, bloodstream infection, and mortality caused by vancomycin-resistant enterococcus early after allogeneic hematopoietic stem cell transplant. *Biol Blood Marrow Transplant* 2007;13:615-621.
75. Boktour M, Hanna H, Ansari S, et al. Central venous catheter and *Stenotrophomonas maltophilia* bacteremia in cancer patients. *Cancer* 2006;106:1967-1973.
76. Poutsika DD, Skiffington S, Miller KB, et al. Daptomycin in the treatment of vancomycin-resistant *Enterococcus faecium* bacteremia in neutropenic patients. *J Infect* 2007;54:567-571.
77. Gaynes R, Edwards JR. Overview of nosocomial infections caused by gram-negative bacilli. *Clin Infect Dis* 2005;41:848-854.
78. Kang CI, Kim SH, Kim HB, et al. *Pseudomonas aeruginosa* bacteremia: risk factors for mortality and influence of delayed receipt of effective antimicrobial therapy on clinical outcome. *Clin Infect Dis* 2003;37:745-751.
79. Ibrahim EH, Sherman G, Ward S, et al. The influence of inadequate antimicrobial treatment of bloodstream infections on patient outcomes in the ICU setting. *Chest* 2000;118:146-155.
80. Clark DA, Emery VC, Griffiths PD. Cytomegalovirus, human herpesvirus-6, and human herpesvirus-7 in hematological patients. *Semin Hematol* 2003;40: 154-162.

81. Gafter-Gvili A, Fraser A, Paul M, et al. Meta-analysis: antibiotic prophylaxis reduces mortality in neutropenic patients. *Ann Intern Med* 2005;142: 979-995.
82. Park SY, Park HJ, Moon SM, et al. Impact of adequate empirical combination therapy on mortality from bacteremic *Pseudomonas aeruginosa* pneumonia. *BMC Infect Dis* 2012;12:308.
83. Livermore DM. Multiple mechanisms of antimicrobial resistance in *Pseudomonas aeruginosa*: our worst nightmare? *Clin Infect Dis* 2002;34: 634-640.
84. Mera RM, Miller LA, Amrine-Madsen H, et al. *Acinetobacter baumannii* 2002-2008: increase of carbapenem-associated multiclass resistance in the United States. *Microb Drug Resist* 2010;16:209-215.
85. Edmond MB, Wallace SE, McClish DK, et al. Nosocomial bloodstream infections in United States hospitals: a three-year analysis. *Clin Infect Dis* 1999;29:239-244.
86. Wisplinghoff H, Bischoff T, Tallent SM, et al. Nosocomial bloodstream infections in US hospitals: analysis of 24,179 cases from a prospective nationwide surveillance study. *Clin Infect Dis* 2004;39:309-317.
87. Anaissie EJ, Darouiche RO, Abi-Said D, et al. Management of invasive candidal infections: results of a prospective, randomized, multicenter study of fluconazole versus amphotericin B and review of the literature. *Clin Infect Dis* 1996;23:964-972.
88. Rex JH, Bennett JE, Sugar AM, et al. A randomized trial comparing fluconazole with amphotericin B for the treatment of candidemia in patients without neutropenia. Candidemia Study Group and the National Institute. *N Engl J Med* 1994;331:1325-1330.
89. Reboli AC, Rotstein C, Pappas PG, et al. Anidulafungin versus fluconazole for invasive candidiasis. *N Engl J Med* 2007;356:2472-2482.
90. Kullberg BJ, Sobel JD, Ruhnke M, et al. Voriconazole versus a regimen of amphotericin B followed by fluconazole for candidaemia in non-neutropenic patients: a randomised non-inferiority trial. *Lancet* 2005;366:1435-1442.
91. Kuse ER, Chetchotisakd P, da Cunha CA, et al. Micafungin versus liposomal amphotericin B for candidaemia and invasive candidosis: a phase III randomised double-blind trial. *Lancet* 2007;369:1519-1527.
92. Mora-Duarte J, Betts R, Rotstein C, et al. Comparison of caspofungin and amphotericin B for invasive candidiasis. *N Engl J Med* 2002;347:2020-2029.
93. Pappas PG, Rotstein CM, Betts RF, et al. Micafungin versus caspofungin for treatment of candidemia and other forms of invasive candidiasis. *Clin Infect Dis* 2007;45:883-893.
94. Pappas PG, Kauffman CA, Andes D, et al. Clinical practice guidelines for the management of candidiasis: 2009 update by the Infectious Diseases Society of America. *Clin Infect Dis* 2009;48:503-535.
95. Tunkel AR, Hartman BJ, Kaplan SL, et al. Practice guidelines for the management of bacterial meningitis. *Clin Infect Dis* 2004;39:1267-1284.
96. Tunkel AR, Glaser CA, Bloch KC, et al. The management of encephalitis: clinical practice guidelines by the Infectious Diseases Society of America. *Clin Infect Dis* 2008;47:303-327.
97. van de Beek D, Farrar JJ, de Gans J, et al. Adjunctive dexamethasone in bacterial meningitis: a meta-analysis of individual patient data. *Lancet Neurol* 2010;9:254-263.
98. Kremer S, Matern JF, Bilger K, et al. EBV limbic encephalitis after allogeneic hematopoietic stem cell transplantation. *J Neuroradiol* 2010;37:189-191.
99. Kinch A, Oberg G, Arvidson J, et al. Post-transplant lymphoproliferative disease and other Epstein-Barr virus diseases in allogeneic haematopoietic stem cell transplantation after introduction of monitoring of viral load by polymerase chain reaction. *Scand J Infect Dis* 2007;39:235-244.
100. Chamberlain MC, Chowdhary S. Post-transplant acute limbic encephalitis: clinical features and relationship to HHV6. *Neurology* 2008;70:491-492; author reply 492-493.
101. Pohlmann C, Schetelig J, Reuner U, et al. Cidofovir and foscarnet for treatment of human herpesvirus 6 encephalitis in a neutropenic stem cell transplant recipient. *Clin Infect Dis* 2007;44:e118-e120.
102. Murray K, Baraniuk S, Resnick M, et al. Risk factors for encephalitis and death from West Nile virus infection. *Epidemiol Infect* 2006;134:1325-1332.

103. Hagensee ME, Bauwens JE, Kjos B, et al. Brain abscess following marrow transplantation: experience at the Fred Hutchinson Cancer Research Center, 1984-1992. *Clin Infect Dis* 1994;19:402-408.
104. Honda H, Warren DK. Central nervous system infections: meningitis and brain abscess. *Infect Dis Clin North Am* 2009;23:609-623.
105. Bernardini GL. Diagnosis and management of brain abscess and subdural empyema. *Curr Neurol Neurosci Rep* 2004;4:448-456.
106. Walsh TJ, Hier DB, Caplan LR. Aspergillosis of the central nervous system: clinicopathological analysis of 17 patients. *Ann Neurol* 1985;18:574-582.
107. Gabelmann A, Klein S, Kern W, et al. Relevant imaging findings of cerebral aspergillosis on MRI: a retrospective case-based study in immunocompromised patients. *Eur J Neurol* 2007;14:548-555.
108. Jansson AK, Enblad P, Sjolín J. Efficacy and safety of cefotaxime in combination with metronidazole for empirical treatment of brain abscess in clinical practice: a retrospective study of 66 consecutive cases. *Eur J Clin Microbiol Infect Dis* 2004;23:7-14.
109. Hope WW, Billaud EM, Lestner J, et al. Therapeutic drug monitoring for triazoles. *Curr Opin Infect Dis* 2008;21:580-586.
110. Moran H, Yaniv I, Ashkenazi S, et al. Risk factors for typhlitis in pediatric patients with cancer. *J Pediatr Hematol Oncol* 2009;31:630-634.
111. Denning DW. Therapeutic outcome in invasive aspergillosis. *Clin Infect Dis* 1996;23:608-615.
112. Diamond RD, Bennett JE. Prognostic factors in cryptococcal meningitis. A study in 111 cases. *Ann Intern Med* 1974;80:176-181.
113. Rex JH, Larsen RA, Dismukes WE, et al. Catastrophic visual loss due to *Cryptococcus neoformans* meningitis. *Medicine (Baltimore)* 1993;72:207-224.
114. Perfect JR, Dismukes WE, Dromer F, et al. Clinical practice guidelines for the management of cryptococcal disease: 2010 update by the Infectious Diseases Society of America. *Clin Infect Dis* 2010;50:291-322.
115. Martino R, Maertens J, Bretagne S, et al. Toxoplasmosis after hematopoietic stem cell transplantation. *Clin Infect Dis* 2000;31:1188-1195.
116. Matsuo Y, Takeishi S, Miyamoto T, et al. Toxoplasmosis encephalitis following severe graft-vs.-host disease after allogeneic hematopoietic stem cell transplantation: 17 yr experience in Fukuoka BMT group. *Eur J Haematol* 2007;79:317-321.
117. Israelski DM, Remington JS. Toxoplasmosis in patients with cancer. *Clin Infect Dis* 1993;17(Suppl 2):S423-S435.
118. Omuro AM, Leite CC, Mokhtari K, et al. Pitfalls in the diagnosis of brain tumours. *Lancet Neurol* 2006;5:937-948.
119. Lewis JS Jr, Khoury H, Storch GA, et al. PCR for the diagnosis of toxoplasmosis after hematopoietic stem cell transplantation. *Expert Rev Mol Diagn* 2002;2:616-624.
120. Carson KR, Evens AM, Richey EA, et al. Progressive multifocal leukoencephalopathy after rituximab therapy in HIV-negative patients: a report of 57 cases from the research on adverse drug events and reports project. *Blood* 2009;113:4834-4840.
121. Grinyo J, Charpentier B, Pestana JM, et al. An integrated safety profile analysis of belatacept in kidney transplant recipients. *Transplantation* 2010;90:1521-1527.
122. von Geldern G, Pardo CA, Calabresi PA, et al. PML-IRIS in a patient treated with brentuximab. *Neurology* 2012;79:2075-2077.
123. Kothary N, Diak IL, Brinker A, et al. Progressive multifocal leukoencephalopathy associated with efalizumab use in psoriasis patients. *J Am Acad Dermatol* 2011;65:546-551.
124. Vidarsson B, Mosher DF, Salamat MS, et al. Progressive multifocal leukoencephalopathy after fludarabine therapy for low-grade lymphoproliferative disease. *Am J Hematol* 2002;70:51-54.
125. Kumar D, Bouldin TW, Berger RG. A case of progressive multifocal leukoencephalopathy in a patient treated with infliximab. *Arthritis Rheum* 2010;62:3191-3195.

126. Manfro RC, Vedolin L, Cantarelli M, et al. Progressive multifocal leukoencephalopathy in a kidney transplant recipient after conversion to mycophenolic acid therapy. *Transpl Infect Dis* 2009;11:189-190.
127. Brown EM, Edwards RJ, Pople IK. Conservative management of patients with cerebrospinal fluid shunt infections. *Neurosurgery* 2008;62(Suppl 2): 661-669.
128. Slavin MA, Szer J, Grigg AP, et al. Guidelines for the use of antifungal agents in the treatment of invasive *Candida* and mould infections. *Intern Med J* 2004;34:192-200.
129. Goering P, Berlinger NT, Weisdorf DJ. Aggressive combined modality treatment of progressive sinonasal fungal infections in immunocompromised patients. *Am J Med* 1988;85:619-623.
130. Hussaini T, Ruping MJ, Farowski F, et al. Therapeutic drug monitoring of voriconazole and posaconazole. *Pharmacotherapy* 2011;31:214-225.
131. Mandell LA, Wunderink RG, Anzueto A, et al. Infectious Diseases Society of America/American Thoracic Society consensus guidelines on the management of community-acquired pneumonia in adults. *Clin Infect Dis* 2007;44(Suppl 2):S27-S72.
132. Commers JR, Robichaud KJ, Pizzo PA. New pulmonary infiltrates in granulocytopenic cancer patients being treated with antibiotics. *Pediatr Infect Dis* 1984;3:423-428.
133. Greene RE, Schlamm HT, Oestmann JW, et al. Imaging findings in acute invasive pulmonary aspergillosis: clinical significance of the halo sign. *Clin Infect Dis* 2007;44:373-379.
134. Rovira M, Jimenez M, De La Bellacasa JP, et al. Detection of *Aspergillus galactomannan* by enzyme immunoabsorbent assay in recipients of allogeneic hematopoietic stem cell transplantation: a prospective study. *Transplantation* 2004;77:1260-1264.
135. Ostrosky-Zeichner L, Alexander BD, Kett DH, et al. Multicenter clinical evaluation of the (1→3) beta-D-glucan assay as an aid to diagnosis of fungal infections in humans. *Clin Infect Dis* 2005;41:654-659.
136. Pfeiffer CD, Fine JP, Safdar N. Diagnosis of invasive aspergillosis using a galactomannan assay: a meta-analysis. *Clin Infect Dis* 2006;42:1417-1427.
137. Herbrecht R, Denning DW, Patterson TF, et al. Voriconazole versus amphotericin B for primary therapy of invasive aspergillosis. *N Engl J Med* 2002;347:408-415.
138. Sulahian A, Touratier S, Ribaud P. False positive test for aspergillus antigenemia related to concomitant administration of piperacillin and tazobactam. *N Engl J Med* 2003;349:2366-2367.
139. Boutboul F, Alberti C, Leblanc T, et al. Invasive aspergillosis in allogeneic stem cell transplant recipients: increasing antigenemia is associated with progressive disease. *Clin Infect Dis* 2002;34:939-943.
140. Maertens J, Verhaegen J, Lagrou K, et al. Screening for circulating galactomannan as a noninvasive diagnostic tool for invasive aspergillosis in prolonged neutropenic patients and stem cell transplantation recipients: a prospective validation. *Blood* 2001;97:1604-1610.
141. Maertens J, Raad I, Petrikos G, et al. Efficacy and safety of caspofungin for treatment of invasive aspergillosis in patients refractory to or intolerant of conventional antifungal therapy. *Clin Infect Dis* 2004;39:1563-1571.
142. Cornely OA, Maertens J, Winston DJ, et al. Posaconazole vs. fluconazole or itraconazole prophylaxis in patients with neutropenia. *N Engl J Med* 2007;356:348-359.
143. Karthaus M. Prophylaxis and Treatment of Invasive Aspergillosis With Voriconazole, Posaconazole and Caspofungin - Review of the Literature. *Eur J Med Res* 2011;16:145-152.
144. Hage CA, Davis TE, Fuller D, et al. Diagnosis of histoplasmosis by antigen detection in BAL fluid. *Chest* 2010;137:623-628.
145. Wheat LJ, Freifeld AG, Kleiman MB, et al. Clinical practice guidelines for the management of patients with histoplasmosis: 2007 update by the Infectious Diseases Society of America. *Clin Infect Dis* 2007;45:807-825.

146. Blair JE, Smilack JD, Caples SM. Coccidioidomycosis in patients with hematologic malignancies. *Arch Intern Med* 2005;165:113-117.
147. Galgiani JN, Ampel NM, Blair JE, et al. Coccidioidomycosis. *Clin Infect Dis* 2005;41:1217-1223.
148. Kovacs JA, Hiemenz JW, Macher AM, et al. Pneumocystis carinii pneumonia: a comparison between patients with the acquired immunodeficiency syndrome and patients with other immunodeficiencies. *Ann Intern Med* 1984;100:663-671.
149. LaRocque RC, Katz JT, Perruzzi P, et al. The utility of sputum induction for diagnosis of Pneumocystis pneumonia in immunocompromised patients without human immunodeficiency virus. *Clin Infect Dis* 2003;37:1380-1383.
150. Kovacs JA, Ng VL, Masur H, et al. Diagnosis of Pneumocystis carinii pneumonia: improved detection in sputum with use of monoclonal antibodies. *N Engl J Med* 1988;318:589-593.
151. Marty FM, Koo S, Bryar J, et al. (1->3)beta-D-glucan assay positivity in patients with Pneumocystis (carinii) jiroveci pneumonia. *Ann Intern Med* 2007;147:70-72.
152. Bozzette SA, Sattler FR, Chiu J, et al. A controlled trial of early adjunctive treatment with corticosteroids for Pneumocystis carinii pneumonia in the acquired immunodeficiency syndrome. California Collaborative Treatment Group. *N Engl J Med* 1990;323:1451-1457.
153. Nichols WG, Corey L, Gooley T, et al. Parainfluenza virus infections after hematopoietic stem cell transplantation: risk factors, response to antiviral therapy, and effect on transplant outcome. *Blood* 2001;98:573-578.
154. Small TN, Casson A, Malak SF, et al. Respiratory syncytial virus infection following hematopoietic stem cell transplantation. *Bone Marrow Transplant* 2002;29:321-327.
155. Symeonidis N, Jakubowski A, Pierre-Louis S, et al. Invasive adenoviral infections in T-cell-depleted allogeneic hematopoietic stem cell transplantation: high mortality in the era of cidofovir. *Transpl Infect Dis* 2007;9:108-113.
156. Ghosh S, Champlin RE, Englund J, et al. Respiratory syncytial virus upper respiratory tract illnesses in adult blood and marrow transplant recipients: combination therapy with aerosolized ribavirin and intravenous immunoglobulin. *Bone Marrow Transplant* 2000;25:751-755.
157. Harper SA, Bradley JS, Englund JA, et al. Seasonal influenza in adults and children—diagnosis, treatment, chemoprophylaxis, and institutional outbreak management: clinical practice guidelines of the Infectious Diseases Society of America. *Clin Infect Dis* 2009;48:1003-1032.
158. Ljungman P, Griffiths P, Paya C. Definitions of cytomegalovirus infection and disease in transplant recipients. *Clin Infect Dis* 2002;34:1094-1097.
159. Nguyen Q, Champlin R, Giral S, et al. Late cytomegalovirus pneumonia in adult allogeneic blood and marrow transplant recipients. *Clin Infect Dis* 1999;28:618-623.
160. Reusser P. Challenges and options in the management of viral infections after stem cell transplantation. *Support Care Cancer* 2002;10:197-203.
161. Kirkpatrick ID, Greenberg HM. Gastrointestinal complications in the neutropenic patient: characterization and differentiation with abdominal CT. *Radiology* 2003;226:668-674.
162. Sloas MM, Flynn PM, Kaste SC, et al. Typhlitis in children with cancer: a 30-year experience. *Clin Infect Dis* 1993;17:484-490.
163. Shamberger RC, Weinstein HJ, Delorey MJ, et al. The medical and surgical management of typhlitis in children with acute nonlymphocytic (myelogenous) leukemia. *Cancer* 1986;57:603-609.
164. Gorschluter M, Glasmacher A, Hahn C, et al. Clostridium difficile infection in patients with neutropenia. *Clin Infect Dis* 2001;33:786-791.
165. Cohen SH, Gerding DN, Johnson S, et al. Clinical practice guidelines for Clostridium difficile infection in adults: 2010 update by the Society for Healthcare Epidemiology of America (SHEA) and the Infectious Diseases Society of America (IDSA). *Infect Control Hosp Epidemiol* 2010;31: 431-455.
166. Zar FA, Bakkanagari SR, Moorthi KM, et al. A comparison of vancomycin and metronidazole for the treatment of Clostridium difficile-associated diarrhea, stratified by disease severity. *Clin Infect Dis* 2007;45:302-307.
167. Gerding DN, Johnson S, Peterson LR, et al. Clostridium difficile-associated diarrhea and colitis. *Infect Control Hosp Epidemiol* 1995;16:459-477.

168. Olson MM, Shanholtzer CJ, Lee JT Jr, et al. Ten years of prospective *Clostridium difficile*-associated disease surveillance and treatment at the Minneapolis VA Medical Center, 1982-1991. *Infect Control Hosp Epidemiol* 1994;15:371-381.
169. Louie TJ, Miller MA, Mullane KM, et al. Fidaxomicin versus vancomycin for *Clostridium difficile* infection. *N Engl J Med* 2011;364:422-431.
170. Malani AN, Kauffman CA. *Candida* urinary tract infections: treatment options. *Expert Rev Anti Infect Ther* 2007;5:277-284.
171. Ison MG. Adenovirus infections in transplant recipients. *Clin Infect Dis* 2006;43:331-339.
172. Jancel T, Penzak SR. Antiviral therapy in patients with hematologic malignancies, transplantation, and aplastic anemia. *Semin Hematol* 2009;46:230-247.
173. Sevinsky LD, Viegens C, Ballesteros DO, et al. Ecthyma gangrenosum: a cutaneous manifestation of *Pseudomonas aeruginosa* sepsis. *J Am Acad Dermatol* 1993;29:104-106.
174. Brook I. Microbiology and management of soft tissue and muscle infections. *Int J Surg* 2008;6:328-338.
175. Kressel B, Szewczyk C, Tuazon CU. Early clinical recognition of disseminated candidiasis by muscle and skin biopsy. *Arch Intern Med* 1978;138:429-433.
176. Bucaneve G, Micozzi A, Menichetti F, et al. Levofloxacin to prevent bacterial infection in patients with cancer and neutropenia. *N Engl J Med* 2005;353:977-987.
177. Monto AS, Robinson DP, Herlocher ML, et al. Zanamivir in the prevention of influenza among healthy adults: a randomized controlled trial. *JAMA* 1999;282:31-35.
178. Nicholson KG, Aoki FY, Osterhaus AD, et al. Efficacy and safety of oseltamivir in treatment of acute influenza: a randomised controlled trial. Neuraminidase Inhibitor Flu Treatment Investigator Group. *Lancet* 2000;355:1845-1850.
179. Bowden RA. Respiratory virus infections after marrow transplant: the Fred Hutchinson Cancer Research Center experience. *Am J Med* 1997;102:27-30; discussion 42-23.
180. Whimbey E, Champlin RE, Englund JA, et al. Combination therapy with aerosolized ribavirin and intravenous immunoglobulin for respiratory syncytial virus disease in adult bone marrow transplant recipients. *Bone Marrow Transplant* 1995;16:393-399.
181. Koch WC, Massey G, Russell CE, et al. Manifestations and treatment of human parvovirus B19 infection in immunocompromised patients. *J Pediatr* 1990;116:355-359.
182. Tomblyn M, Chiller T, Einsele H, et al. Guidelines for preventing infectious complications among hematopoietic cell transplantation recipients: a global perspective. *Biol Blood Marrow Transplant* 2009;15:1143-1238.
183. Storek J, Dawson MA, Storer B, et al. Immune reconstitution after allogeneic marrow transplantation compared with blood stem cell transplantation. *Blood* 2001;97:3380-3389.
184. Komanduri KV, St John LS, de Lima M, et al. Delayed immune reconstitution after cord blood transplantation is characterized by impaired thymopoiesis and late memory T-cell skewing. *Blood* 2007;110:4543-4551.
185. Thomson BG, Robertson KA, Gowan D, et al. Analysis of engraftment, graft-versus-host disease, and immune recovery following unrelated donor cord blood transplantation. *Blood* 2000;96:2703-2711.
186. Crippa F, Holmberg L, Carter RA, et al. Infectious complications after autologous CD34-selected peripheral blood stem cell transplantation. *Biol Blood Marrow Transplant* 2002;8:281-289.
187. Ottinger HD, Beelen DW, Scheulen B, et al. Improved immune reconstitution after allotransplantation of peripheral blood stem cells instead of bone marrow. *Blood* 1996;88:2775-2779.
188. Machatschek J, Duda J, Matthay K, et al. Immune reconstitution, infectious complications and post transplant supportive care measures after autologous blood and marrow transplantation in children. *Bone Marrow Transplant* 2003;32:687-693.
189. Junghanss C, Marr KA, Carter RA, et al. Incidence and outcome of bacterial and fungal infections following nonmyeloablative compared with myeloablative allogeneic hematopoietic stem cell transplantation: a matched control study. *Biol Blood Marrow Transplant* 2002;8:512-520.

190. Kulkarni S, Powles R, Treleaven J, et al. Chronic graft versus host disease is associated with long-term risk for pneumococcal infections in recipients of bone marrow transplants. *Blood* 2000;95:3683-3686.
191. Engels EA, Lau J, Barza M. Efficacy of quinolone prophylaxis in neutropenic cancer patients: a meta-analysis. *J Clin Oncol* 1998;16:1179-1187.
192. Momin F, Chandrasekar PH. Antimicrobial prophylaxis in bone marrow transplantation. *Ann Intern Med* 1995;123:205-215.
193. Wingard JR. Viral infections in leukemia and bone marrow transplant patients. *Leuk Lymphoma* 1993;11(Suppl 2):115-125.
194. Reusser P, Riddell SR, Meyers JD, et al. Cytotoxic T-lymphocyte response to cytomegalovirus after human allogeneic bone marrow transplantation: pattern of recovery and correlation with cytomegalovirus infection and disease. *Blood* 1991;78:1373-1380.
195. Boeckh M, Nichols WG. The impact of cytomegalovirus serostatus of donor and recipient before hematopoietic stem cell transplantation in the era of antiviral prophylaxis and preemptive therapy. *Blood* 2004;103:2003-2008.
196. Boeckh M, Nichols WG, Papanicolaou G, et al. Cytomegalovirus in hematopoietic stem cell transplant recipients: current status, known challenges, and future strategies. *Biol Blood Marrow Transplant* 2003;9:543-558.
197. Zaia JA. Cytomegalovirus infection. In: Blume KG, Forman SJ, Appelbaum FR, eds. *Thomas' hematopoietic cell transplantation*, 4th ed. United Kingdom: Wiley-Blackwell, 2008:1367-1381.
198. Gentile G, Picardi A, Capobianchi A, et al. A prospective study comparing quantitative cytomegalovirus (CMV) polymerase chain reaction in plasma and pp65 antigenemia assay in monitoring patients after allogeneic stem cell transplantation. *BMC Infect Dis* 2006;6:167.
199. Lilleri D, Gerna G, Furione M, et al. Use of a DNAemia cut-off for monitoring human cytomegalovirus infection reduces the number of preemptively treated children and young adults receiving hematopoietic stem-cell transplantation compared with qualitative pp65 antigenemia. *Blood* 2007;110:2757-2760.
200. Meyers JD, Reed EC, Shepp DH, et al. Acyclovir for prevention of cytomegalovirus infection and disease after allogeneic marrow transplantation. *N Engl J Med* 1988;318:70-75.
201. Chapel HM, Lee M, Hargreaves R, et al. Randomised trial of intravenous immunoglobulin as prophylaxis against infection in plateau-phase multiple myeloma. The UK Group for Immunoglobulin Replacement Therapy in Multiple Myeloma. *Lancet* 1994;343:1059-1063.
202. Ljungman P, de La Camara R, Milpied N, et al. Randomized study of valgacyclovir as prophylaxis against cytomegalovirus reactivation in recipients of allogeneic bone marrow transplants. *Blood* 2002;99:3050-3056.
203. Goodrich JM, Mori M, Gleaves CA, et al. Early treatment with ganciclovir to prevent cytomegalovirus disease after allogeneic bone marrow transplantation. *N Engl J Med* 1991;325:1601-1607.
204. Hamprecht K, Eckle T, Prix L, et al. Ganciclovir-resistant cytomegalovirus disease after allogeneic stem cell transplantation: pitfalls of phenotypic diagnosis by in vitro selection of an UL97 mutant strain. *J Infect Dis* 2003;187:139-143.
205. Springer KL, Chou S, Li S, et al. How evolution of mutations conferring drug resistance affects viral dynamics and clinical outcomes of cytomegalo-virus-infected hematopoietic cell transplant recipients. *J Clin Microbiol* 2005;43:208-213.
206. Ljungman P, Deliliers GL, Platzbecker U, et al. Cidofovir for cytomegalovirus infection and disease in allogeneic stem cell transplant recipients. The Infectious Diseases Working Party of the European Group for Blood and Marrow Transplantation. *Blood* 2001;97:388-392.
207. Winston DJ, Young JA, Pullarkat V, et al. Maribavir prophylaxis for prevention of cytomegalovirus infection in allogeneic stem cell transplant recipients: a multicenter, randomized, double-blind, placebo-controlled, dose-ranging study. *Blood* 2008;111:5403-5410.
208. Marty FM, Ljungman P, Papanicolaou GA, et al. Maribavir prophylaxis for prevention of cytomegalovirus disease in recipients of allogeneic stem-cell transplants: a phase 3, double-blind, placebo-controlled, randomised trial. *Lancet Infect Dis* 2011;11:284-292.
209. Liesveld JL, Abboud CN, Ifthikharuddin JJ, et al. Oral valgacyclovir versus intravenous acyclovir in preventing herpes simplex virus infections in autologous stem cell transplant recipients. *Biol Blood Marrow Transplant* 2002;8:662-665.

210. Sullivan KM, Dykewicz CA, Longworth DL, et al. Preventing opportunistic infections after hematopoietic stem cell transplantation: the Centers for Disease Control and Prevention, Infectious Diseases Society of America, and American Society for Blood and Marrow Transplantation practice guidelines and beyond. *Hematol Am Soc Hematol Educ Program* 2001;392-421.
211. Robenshtok E, Gafter-Gvili A, Goldberg E, et al. Antifungal prophylaxis in cancer patients after chemotherapy or hematopoietic stem-cell transplantation: systematic review and meta-analysis. *J Clin Oncol* 2007;25:5471-5489.
212. Guidelines for preventing opportunistic infections among hematopoietic stem cell transplant recipients. Recommendations of CDC, the Infectious Disease Society of America, and the American Society of Blood and Marrow Transplantation. *Cytotherapy* 2001;3:41-54.
213. De Castro N, Neuville S, Sarfati C, et al. Occurrence of *Pneumocystis jiroveci* pneumonia after allogeneic stem cell transplantation: a 6-year retrospective study. *Bone Marrow Transplant* 2005;36:879-883.
214. Maltezou HC, Petropoulos D, Choroszy M, et al. Dapsone for *Pneumocystis carinii* prophylaxis in children undergoing bone marrow transplantation. *Bone Marrow Transplant* 1997;20:879-881.
215. Colby C, McAfee S, Sackstein R, et al. A prospective randomized trial comparing the toxicity and safety of atovaquone with trimethoprim/sulfamethoxazole as *Pneumocystis carinii* pneumonia prophylaxis following autologous peripheral blood stem cell transplantation. *Bone Marrow Transplant* 1999;24:897-902.
216. Vasconcelles MJ, Bernardo MV, King C, et al. Aerosolized pentamidine as pneumocystis prophylaxis after bone marrow transplantation is inferior to other regimens and is associated with decreased survival and an increased risk of other infections. *Biol Blood Marrow Transplant* 2000;6:35-43.
217. Foot AB, Garin YJ, Ribaud P, et al. Prophylaxis of toxoplasmosis infection with pyrimethamine/sulfadoxine (Fansidar) in bone marrow transplant recipients. *Bone Marrow Transplant* 1994;14:241-245.
218. Boyce JM, Pittet D. Guideline for hand hygiene in health-care settings: recommendations of the Healthcare Infection Control Practices Advisory Committee and the HICPAC/SHEA/APIC/IDSA Hand Hygiene Task Force. *Infect Control Hosp Epidemiol* 2002;23:S3-S40.
219. Pizzo PA. The value of protective isolation in preventing nosocomial infections in high risk patients. *Am J Med* 1981;70:631-637.
220. Gardner A, Mattiuzzi G, Faderl S, et al. Randomized comparison of cooked and noncooked diets in patients undergoing remission induction therapy for acute myeloid leukemia. *J Clin Oncol* 2008;26:5684-5688.
221. DeMille D, Deming P, Lupinacci P, et al. The effect of the neutropenic diet in the outpatient setting: a pilot study. *Oncol Nurs Forum* 2006;33:337-343.
222. Hahn T, Cummings KM, Michalek AM, et al. Efficacy of high-efficiency particulate air filtration in preventing aspergillosis in immunocompromised patients with hematologic malignancies. *Infect Control Hosp Epidemiol* 2002;23:525-531.
223. Barnes RA, Rogers TR. Control of an outbreak of nosocomial aspergillosis by laminar air-flow isolation. *J Hosp Infect* 1989;14:89-94.
224. Humphreys H. Positive-pressure isolation and the prevention of invasive aspergillosis. What is the evidence? *J Hosp Infect* 2004;56:93-100; quiz 163.
225. Walsh TJ, Dixon DM. Nosocomial aspergillosis: environmental microbiology, hospital epidemiology, diagnosis and treatment. *Eur J Epidemiol* 1989;5:131-142.
226. Perlroth J, Choi B, Spellberg B. Nosocomial fungal infections: epidemiology, diagnosis, and treatment. *Med Mycol* 2007;45:321-346.
227. Pizzo PA, Robichaud KJ, Edwards BK, et al. Oral antibiotic prophylaxis in patients with cancer: a double-blind randomized placebo-controlled trial. *J Pediatr* 1983;102:125-133.
228. Hughes WT, Rivera GK, Schell MJ, et al. Successful intermittent chemoprophylaxis for *Pneumocystis carinii* pneumonitis. *N Engl J Med* 1987;316:1627-1632.
229. Enno A, Catovsky D, Darrell J, et al. Co-trimoxazole for prevention of infection in acute leukaemia. *Lancet* 1978;2:395-397.

230. Donnelly JP, Maschmeyer G, Daenen S. Selective oral antimicrobial prophylaxis for the prevention of infection in acute leukaemia-ciprofloxacin versus co-trimoxazole plus colistin. The EORTC-Gnotobiotic Project Group. *Eur J Cancer* 1992;28A:873-878.
231. De Pauw BE, Novakova IR, Ubachs E, et al. Co-trimoxazole in patients with haematological malignancies: a review of 10-years' clinical experience. *Curr Med Res Opin* 1988;11:64-72.
232. Lew MA, Kehoe K, Ritz J, et al. Prophylaxis of bacterial infections with ciprofloxacin in patients undergoing bone marrow transplantation. *Transplantation* 1991;51:630-636.
233. Bow EJ, Rayner E, Louie TJ. Comparison of norfloxacin with cotrimoxazole for infection prophylaxis in acute leukemia. The trade-off for reduced gram-negative sepsis. *Am J Med* 1988;84:847-854.
234. Horvathova Z, Spanik S, Sufliarsky J, et al. Bacteremia due to methicillin-resistant staphylococci occurs more frequently in neutropenic patients who received antimicrobial prophylaxis and is associated with higher mortality in comparison to methicillin-sensitive bacteremia. *Int J Antimicrob Agents* 1998;10:55-58.
235. Bochud PY, Calandra T, Francioli P. Bacteremia due to viridans streptococci in neutropenic patients: a review. *Am J Med* 1994;97:256-264.
236. Kerr KG, Armitage HT, McWhinney PH. Activity of quinolones against viridans group streptococci isolated from blood cultures of patients with haematological malignancy. *Support Care Cancer* 1999;7:28-30.
237. Imran H, Tleyjeh IM, Arndt CA, et al. Fluoroquinolone prophylaxis in patients with neutropenia: a meta-analysis of randomized placebo-controlled trials. *Eur J Clin Microbiol Infect Dis* 2008;27:53-63.
238. Cullen M, Steven N, Billingham L, et al. Antibacterial prophylaxis after chemotherapy for solid tumors and lymphomas. *N Engl J Med* 2005;353:988-998.
239. Recommended immunization schedules for persons aged 0 through 18 Years—United States, 2012. *MMWR Morb Mortal Wkly Rep* 2012;61:1-4.
240. Gomez L, Garau J, Estrada C, et al. Ciprofloxacin prophylaxis in patients with acute leukemia and granulocytopenia in an area with a high prevalence of ciprofloxacin-resistant *Escherichia coli*. *Cancer* 2003;97:419-424.
241. Hopkins KL, Davies RH, Threlfall EJ. Mechanisms of quinolone resistance in *Escherichia coli* and *Salmonella*: recent developments. *Int J Antimicrob Agents* 2005;25:358-373.
242. Brigden ML, Pattullo AL. Prevention and management of overwhelming postsplenectomy infection—an update. *Crit Care Med* 1999;27:836-842.
243. Guidelines for preventing infectious complications among hematopoietic cell transplant recipients: a global perspective. *Bone Marrow Transplant* 2009;44:453-558.
244. Kontoyiannis DP, Marr KA, Park BJ, et al. Prospective surveillance for invasive fungal infections in hematopoietic stem cell transplant recipients, 2001-2006: overview of the Transplant Associated Infection Surveillance Network (TRANSNET) Database. *Clin Infect Dis* 2010;50:1091-1100.
245. Chang CC, Athan E, Morrissey CO, et al. Preventing invasive fungal infection during hospital building works. *Intern Med J* 2008;38:538-541.
246. Weems JJ Jr, Davis BJ, Tablan OC, et al. Construction activity: an independent risk factor for invasive aspergillosis and zygomycosis in patients with hematologic malignancy. *Infect Control* 1987;8:71-75.
247. Partridge-Hinckley K, Liddell GM, Almyroudou NG, et al. Infection control measures to prevent invasive mould diseases in hematopoietic stem cell transplant recipients. *Mycopathologia* 2009;168:329-337.
248. Menichetti F, Del Favero A, Martino P, et al. Preventing fungal infection in neutropenic patients with acute leukemia: fluconazole compared with oral amphotericin B. *Ann Intern Med* 1994;120:913-918.
249. Bodey GP. Managing infections in the immunocompromised patient. *Clin Infect Dis* 2005;40(Suppl 4):S239.
250. Jeffery GM, Beard ME, Ikram RB, et al. Intranasal amphotericin B reduces the frequency of invasive aspergillosis in neutropenic patients. *Am J Med* 1991;90:685-692.
251. Behre GF, Schwartz S, Lenz K, et al. Aerosol amphotericin B inhalations for prevention of invasive pulmonary aspergillosis in neutropenic cancer patients. *Ann Hematol* 1995;71:287-291.

252. Rijnders BJ, Cornelissen JJ, Slobbe L, et al. Aerosolized liposomal amphotericin B for the prevention of invasive pulmonary aspergillosis during prolonged neutropenia: a randomized, placebo-controlled trial. *Clin Infect Dis* 2008;46:1401-1408.
253. Goodman JL, Winston DJ, Greenfield RA, et al. A controlled trial of fluconazole to prevent fungal infections in patients undergoing bone marrow transplantation. *N Engl J Med* 1992;326:845-851.
254. Rotstein C, Bow EJ, Laverdiere M, et al. Randomized placebo-controlled trial of fluconazole prophylaxis for neutropenic cancer patients: benefit based on purpose and intensity of cytotoxic therapy. The Canadian Fluconazole Prophylaxis Study Group. *Clin Infect Dis* 1999;28:331-340.
255. Slavin MA, Osborne B, Adams R, et al. Efficacy and safety of fluconazole prophylaxis for fungal infections after marrow transplantation—a prospective, randomized, double-blind study. *J Infect Dis* 1995;171:1545-1552.
256. Ahmad SR, Singer SJ, Leissa BG. Congestive heart failure associated with itraconazole. *Lancet* 2001;357:1766-1767.
257. van Burik JA, Ratanatharathorn V, Stepan DE, et al. Micafungin versus fluconazole for prophylaxis against invasive fungal infections during neutropenia in patients undergoing hematopoietic stem cell transplantation. *Clin Infect Dis* 2004;39:1407-1416.
258. van Burik JA. Role of new antifungal agents in prophylaxis of mycoses in high risk patients. *Curr Opin Infect Dis* 2005;18:479-483.
259. Lim SG, Sawyerr AM, Hudson M, et al. Short report: the absorption of fluconazole and itraconazole under conditions of low intragastric acidity. *Aliment Pharmacol Ther* 1993;7:317-321.
260. Saral R, Ambinder RF, Burns WH, et al. Acyclovir prophylaxis against herpes simplex virus infection in patients with leukemia. A randomized, double-blind, placebo-controlled study. *Ann Intern Med* 1983;99:773-776.
261. Selby PJ, Powles RL, Easton D, et al. The prophylactic role of intravenous and long-term oral acyclovir after allogeneic bone marrow transplantation. *Br J Cancer* 1989;59:434-438.
262. Anderson H, Scarffe JH, Sutton RN, et al. Oral acyclovir prophylaxis against herpes simplex virus in non-Hodgkin lymphoma and acute lymphoblastic leukaemia patients receiving remission induction chemotherapy. A randomised double blind, placebo controlled trial. *Br J Cancer* 1984;50:45-49.
263. Meyers JD. Chemoprophylaxis of viral infection in immunocompromised patients. *Eur J Cancer Clin Oncol* 1989;25:1369-1374.
264. Erard V, Wald A, Corey L, et al. Use of long-term suppressive acyclovir after hematopoietic stem-cell transplantation: impact on herpes simplex virus (HSV) disease and drug-resistant HSV disease. *J Infect Dis* 2007;196:266-270.
265. McLaren C, Chen MS, Ghazzouli I, et al. Drug resistance patterns of herpes simplex virus isolates from patients treated with acyclovir. *Antimicrob Agents Chemother* 1985;28:740-744.
266. Englund JA, Zimmerman ME, Swierkosz EM, et al. Herpes simplex virus resistant to acyclovir. A study in a tertiary care center. *Ann Intern Med* 1990;112:416-422.
267. Chen Y, Scieux C, Garrait V, et al. Resistant herpes simplex virus type 1 infection: an emerging concern after allogeneic stem cell transplantation. *Clin Infect Dis* 2000;31:927-935.
268. Griffiths PD. Tomorrow's challenges for herpesvirus management: potential applications of valacyclovir. *J Infect Dis* 2002;186(Suppl 1):S131-S137.
269. Lau JY, Lai CL, Lin HJ, et al. Fatal reactivation of chronic hepatitis B virus infection following withdrawal of chemotherapy in lymphoma patients. *Q J Med* 1989;73:911-917.
270. Yeo W, Chan PK, Ho WM, et al. Lamivudine for the prevention of hepatitis B virus reactivation in hepatitis B s-antigen seropositive cancer patients under-going cytotoxic chemotherapy. *J Clin Oncol* 2004;22:927-934.
271. Lok AS, McMahon BJ. Chronic hepatitis B. *Hepatology* 2007;45:507-539.
272. Rossi G, Pelizzari A, Motta M, et al. Primary prophylaxis with lamivudine of hepatitis B virus reactivation in chronic HbsAg carriers with lymphoid malignancies treated with chemotherapy. *Br J Haematol* 2001;115:58-62.
273. Hilgendorf I, Freund M, Jilg W, et al. Vaccination of allogeneic haematopoietic stem cell transplant recipients: report from the International Consensus Conference on Clinical Practice in Chronic GVHD. *Vaccine* 2011;29:2825-2833.

274. Ljungman P, Cordonnier C, Einsele H, et al. Vaccination of hematopoietic cell transplant recipients. *Bone Marrow Transplant* 2009;44:521-526.
275. Siber GR, Gorham C, Martin P, et al. Antibody response to pretreatment immunization and post-treatment boosting with bacterial polysaccharide vaccines in patients with Hodgkin's disease. *Ann Intern Med* 1986;104:467-475.
276. Ridgway D, Wolff LJ, Deforest A. Immunization response varies with intensity of acute lymphoblastic leukemia therapy. *Am J Dis Child* 1991;145:887-891.
277. Patel SR, Ortin M, Cohen BJ, et al. Revaccination with measles, tetanus, poliovirus, Haemophilus influenzae type B, meningococcus C, and pneumococcus vaccines in children after hematopoietic stem cell transplantation. *Clin Infect Dis* 2007;44:625-634.
278. Bridges CB, Woods L, Coyne-Beasley T. Advisory Committee on Immunization Practices (ACIP) Recommended immunization schedule for adults aged 19 years and older—United States, 2013. *MMWR Surveill Summ* 2013;62:9-19.
279. Issa NC, Baden LR. Current issues in vaccines for adult patients with hematologic malignancies. *J Natl Compr Canc Netw* 2012;10:1447-1454.
280. Lortan JE, Vellodi A, Jorges ES, et al. Class- and subclass-specific pneumococcal antibody levels and response to immunization after bone marrow transplantation. *Clin Exp Immunol* 1992;88:512-519.
281. Parkkali T, Kayhty H, Ruutu T, et al. A comparison of early and late vaccination with Haemophilus influenzae type B conjugate and pneumococcal polysaccharide vaccines after allogeneic BMT. *Bone Marrow Transplant* 1996;18:961-967.
282. Cordonnier C, Labopin M, Chesnel V, et al. Immune response to the 23-valent polysaccharide pneumococcal vaccine after the 7-valent conjugate vaccine in allogeneic stem cell transplant recipients: results from the EBMT IDWPO1 trial. *Vaccine* 2010;28:2730-2734.
283. Meisel R, Kuypers L, Dirksen U, et al. Pneumococcal conjugate vaccine provides early protective antibody responses in children after related and unrelated allogeneic hematopoietic stem cell transplantation. *Blood* 2007;109:2322-2326.
284. Molrine DC, George S, Tarbell N, et al. Antibody responses to polysaccharide and polysaccharide-conjugate vaccines after treatment of Hodgkin disease. *Ann Intern Med* 1995;123:828-834.
285. Siber GR, Weitzman SA, Aisenberg AC, et al. Impaired antibody response to pneumococcal vaccine after treatment for Hodgkin's disease. *N Engl J Med* 1978;299:442-448.
286. Updated recommendations for use of meningococcal conjugate vaccines—Advisory Committee on Immunization Practices (ACIP), 2010. *MMWR Morb Mortal Wkly Rep* 2011;60:72-76.
287. Gossger N, Snape MD, Yu LM, et al. Immunogenicity and tolerability of recombinant serogroup B meningococcal vaccine administered with or without routine infant vaccinations according to different immunization schedules: a randomized controlled trial. *JAMA* 2012;307:573-582.
288. Ortals DW, Liebhaber H, Presant CA, et al. Influenza immunization of adult patients with malignant diseases. *Ann Intern Med* 1977;87:552-557.
289. Arbeter AM, Granowetter L, Starr SE, et al. Immunization of children with acute lymphoblastic leukemia with live attenuated varicella vaccine without complete suspension of chemotherapy. *Pediatrics* 1990;85:338-344.
290. Hardy I, Gershon AA, Steinberg SP, et al. The incidence of zoster after immunization with live attenuated varicella vaccine. A study in children with leukemia. *Varicella Vaccine Collaborative Study Group. N Engl J Med* 1991;325:1545-1550.
291. Ljungman P, Fridell E, Lonnqvist B, et al. Efficacy and safety of vaccination of marrow transplant recipients with a live attenuated measles, mumps, and rubella vaccine. *J Infect Dis* 1989;159:610-615.
292. Ljungman P, Wiklund-Hammarsten M, Duraj V, et al. Response to tetanus toxoid immunization after allogeneic bone marrow transplantation. *J Infect Dis* 1990;162:496-500.
293. Guinan EC, Molrine DC, Antin JH, et al. Polysaccharide conjugate vaccine responses in bone marrow transplant patients. *Transplantation* 1994;57: 677-684.
294. Somani J, Larson RA. Reimmunization after allogeneic bone marrow transplantation. *Am J Med* 1995;98:389-398.
295. Barra A, Cordonnier C, Preziosi MP, et al. Immunogenicity of Haemophilus influenzae type b conjugate vaccine in allogeneic bone marrow recipients. *J Infect Dis* 1992;166:1021-1028.

296. Ljungman P, Duraj V, Magnus L. Response to immunization against polio after allogeneic marrow transplantation. *Bone Marrow Transplant* 1991;7:89-93.
297. Parkkali T, Stenvik M, Ruutu T, et al. Randomized comparison of early and late vaccination with inactivated poliovirus vaccine after allogeneic BMT. *Bone Marrow Transplant* 1997;20:663-668.
298. Nagler A, Ilan Y, Adler R, et al. Successful immunization of autologous bone marrow transplantation recipients against hepatitis B virus by active vaccination. *Bone Marrow Transplant* 1995;15:475-478.
299. The role of BCG vaccine in the prevention and control of tuberculosis in the United States. A joint statement by the Advisory Council for the Elimination of Tuberculosis and the Advisory Committee on Immunization Practices. *MMWR Recomm Rep* 1996;45:1-18.
300. Talbot EA, Perkins MD, Silva SF, et al. Disseminated bacille Calmette-Guerin disease after vaccination: case report and review. *Clin Infect Dis* 1997;24:1139-1146.
301. Todd AA, Yap PL. Applications of intravenous immunoglobulin in haematology. *Blood Rev* 1992;6:105-117.
302. Intravenous immunoglobulin for the prevention of infection in chronic lymphocytic leukemia. A randomized, controlled clinical trial. Cooperative Group for the Study of Immunoglobulin in Chronic Lymphocytic Leukemia. *N Engl J Med* 1988;319:902-907.
303. Boughton BJ, Jackson N, Lim S, et al. Randomized trial of intravenous immunoglobulin prophylaxis for patients with chronic lymphocytic leukaemia and secondary hypogammaglobulinaemia. *Clin Lab Haematol* 1995;17:75-80.
304. Molica S, Musto P, Chiurazzi F, et al. Prophylaxis against infections with low-dose intravenous immunoglobulins (IVIg) in chronic lymphocytic leukemia. Results of a crossover study. *Haematologica* 1996;81:121-126.
305. Musto P, Brugiatelli M, Carotenuto M. Prophylaxis against infections with intravenous immunoglobulins in multiple myeloma. *Br J Haematol* 1995;89:945-946.
306. Raanani P, Gafter-Gvili A, Paul M, et al. Immunoglobulin prophylaxis in chronic lymphocytic leukemia and multiple myeloma: systematic review and meta-analysis. *Leuk Lymphoma* 2009;50:764-772.
307. Sullivan KM. Immunomodulation in allogeneic marrow transplantation: use of intravenous immune globulin to suppress acute graft-versus-host disease. *Clin Exp Immunol* 1996;104(Suppl 1):43-48.
308. Sullivan KM, Storek J, Kopecky KJ, et al. A controlled trial of long-term administration of intravenous immunoglobulin to prevent late infection and chronic graft-vs.-host disease after marrow transplantation: clinical outcome and effect on subsequent immune recovery. *Biol Blood Marrow Transplant* 1996;2:44-53.
309. Petersen FB, Bowden RA, Thornquist M, et al. The effect of prophylactic intravenous immune globulin on the incidence of septicemia in marrow transplant recipients. *Bone Marrow Transplant* 1987;2:141-147.
310. Cordonnier C, Chevret S, Legrand M, et al. Should immunoglobulin therapy be used in allogeneic stem-cell transplantation? A randomized, double-blind, dose effect, placebo-controlled, multicenter trial. *Ann Intern Med* 2003;139:8-18.
311. Klaesson S, Ringden O, Ljungman P, et al. Does high-dose intravenous immune globulin treatment after bone marrow transplantation increase mortality in veno-occlusive disease of the liver? *Transplantation* 1995;60: 1225-1230.
312. Zikos P, Van Lint MT, Lamparelli T, et al. A randomized trial of high dose polyvalent intravenous immunoglobulin (HDIG) vs. Cytomegalovirus (CMV) hyperimmune IgG in allogeneic hemopoietic stem cell transplants (HSCT). *Haematologica* 1998;83:132-137.
313. Prevention of varicella: Recommendations of the Advisory Committee on Immunization Practices (ACIP). Centers for Disease Control and Prevention. *MMWR Recomm Rep* 1996;45:1-36.
314. Kay HE, Rankin A. Immunoglobulin prophylaxis of measles in acute lymphoblastic leukaemia. *Lancet* 1984;1:901-902.
315. Endo A, Izumi H, Miyashita M, et al. Current efficacy of postexposure prophylaxis against measles with immunoglobulin. *J Pediatr* 2001;138:926-928.
316. Lemon SM, Thomas DL. Vaccines to prevent viral hepatitis. *N Engl J Med* 1997;336:196-204.
317. Wisplinghoff H, Cornely OA, Moser S, et al. Outcomes of nosocomial bloodstream infections in adult neutropenic patients: a prospective cohort and matched case-control study. *Infect Control Hosp Epidemiol* 2003;24: 905-911.

318. Maki DG, Kluger DM, Crnich CJ. The risk of bloodstream infection in adults with different intravascular devices: a systematic review of 200 published prospective studies. *Mayo Clin Proc* 2006;81:1159-1171.
319. Mollee P, Jones M, Stackelroth J, et al. Catheter-associated bloodstream infection incidence and risk factors in adults with cancer: a prospective cohort study. *J Hosp Infect* 2011;78:26-30.
320. Howell PB, Walters PE, Donowitz GR, et al. Risk factors for infection of adult patients with cancer who have tunneled central venous catheters. *Cancer* 1995;75:1367-1375.
321. Dezfulian C, Lavelle J, Nallamotheu BK, et al. Rates of infection for single-lumen versus multilumen central venous catheters: a meta-analysis. *Crit Care Med* 2003;31:2385-2390.
322. O'Grady NP, Alexander M, Burns LA, et al. Guidelines for the prevention of intravascular catheter-related infections. *Clin Infect Dis* 2011;52:e162-e193.
323. Tragiannidis A, Bisping G, Koehler G, et al. Minireview: *Malassezia* infections in immunocompromised patients. *Mycoses* 2010;53:187-195.
324. Biffi R, de Braud F, Orsi F, et al. Totally implantable central venous access ports for long-term chemotherapy. A prospective study analyzing complications and costs of 333 devices with a minimum follow-up of 180 days. *Ann Oncol* 1998;9:767-773.
325. Blaney M, Shen V, Kerner JA, et al. Alteplase for the treatment of central venous catheter occlusion in children: results of a prospective, open-label, single-arm study (The Cathflo Activase Pediatric Study). *J Vasc Interv Radiol* 2006;17:1745-1751.
326. Shen V, Li X, Murdock M, et al. Recombinant tissue plasminogen activator (alteplase) for restoration of function to occluded central venous catheters in pediatric patients. *J Pediatr Hematol Oncol* 2003;25:38-45.
327. Couban S, Goodyear M, Burnell M, et al. Randomized placebo-controlled study of low-dose warfarin for the prevention of central venous catheter-associated thrombosis in patients with cancer. *J Clin Oncol* 2005;23: 4063-4069.
328. Verso M, Agnelli G, Bertoglio S, et al. Enoxaparin for the prevention of venous thromboembolism associated with central vein catheter: a double-blind, placebo-controlled, randomized study in cancer patients. *J Clin Oncol* 2005;23:4057-4062.
329. Ray CE Jr, Shenoy SS, McCarthy PL, et al. Weekly prophylactic urokinase instillation in tunneled central venous access devices. *J Vasc Interv Radiol* 1999;10:1330-1334.
330. Walshe LJ, Malak SF, Eagan J, et al. Complication rates among cancer patients with peripherally inserted central catheters. *J Clin Oncol* 2002;20:3276-3281.
331. Baskin JL, Pui CH, Reiss U, et al. Management of occlusion and thrombosis associated with long-term indwelling central venous catheters. *Lancet* 2009;374:159-169.
332. Kuter DJ. Thrombotic complications of central venous catheters in cancer patients. *Oncologist* 2004;9:207-216.
333. Guyatt GH, Akl EA, Crowther M, et al. Executive summary: Antithrombotic Therapy and Prevention of Thrombosis, 9th ed: American College of Chest Physicians Evidence-Based Clinical Practice Guidelines. *Chest* 2012;141: 7S-47S.
334. Osoba D, Zee B, Warr D, et al. Effect of postchemotherapy nausea and vomiting on health-related quality of life. The Quality of Life and Symptom Control Committees of the National Cancer Institute of Canada Clinical Trials Group. *Support Care Cancer* 1997;5:307-313.
335. Navari RM. Palonosetron for the prevention of chemotherapy-induced nausea and vomiting: approval and efficacy. *Cancer Manag Res* 2009;1:167-176.
336. Herrstedt J, Roila F. Chemotherapy-induced nausea and vomiting: ESMO clinical recommendations for prophylaxis. *Ann Oncol* 2009;20(Suppl 4):156-158.
337. Kris MG, Hesketh PJ, Herrstedt J, et al. Consensus proposals for the prevention of acute and delayed vomiting and nausea following high-emetic-risk chemotherapy. *Support Care Cancer* 2005;13:85-96.
338. Navari RM. Pathogenesis-based treatment of chemotherapy-induced nausea and vomiting—two new agents. *J Support Oncol* 2003;1:89-103.
339. Lohr L. Chemotherapy-induced nausea and vomiting. *Cancer J* 2008;14: 85-93.

340. Marty M. A comparative study of the use of granisetron, a selective 5-HT₃ antagonist, versus a standard anti-emetic regimen of chlorpromazine plus dexamethasone in the treatment of cytostatic-induced emesis. The Granisetron Study Group. *Eur J Cancer* 1990;26(Suppl 1):S28-S32.
341. Marty M. A comparison of granisetron as a single agent with conventional combination antiemetic therapies in the treatment of cytostatic-induced emesis. The Granisetron Study Group. *Eur J Cancer* 1992;28A(Suppl 1): S12-S16.
342. Grunberg SM. New developments in the management of chemotherapy-induced emesis: do they impact on existing guidelines? *Oncology (Williston Park)* 2004;18:15-19.
343. Roila F, Herrstedt J, Aapro M, et al. Guideline update for MASCC and ESMO in the prevention of chemotherapy- and radiotherapy-induced nausea and vomiting: results of the Perugia Consensus Conference. *Ann Oncol* 2010;21(Suppl 5):v232-v243.
344. Saito M, Aogi K, Sekine I, et al. Palonosetron plus dexamethasone versus granisetron plus dexamethasone for prevention of nausea and vomiting during chemotherapy: a double-blind, double-dummy, randomised, comparative phase III trial. *Lancet Oncol* 2009;10:115-124.
345. Aapro MS, Grunberg SM, Manikhas GM, et al. A phase III, double-blind, randomized trial of palonosetron compared with ondansetron in preventing chemotherapy-induced nausea and vomiting following highly emetogenic chemotherapy. *Ann Oncol* 2006;17:1441-1449.
346. Eisenberg P, Figueroa-Vadillo J, Zamora R, et al. Improved prevention of moderately emetogenic chemotherapy-induced nausea and vomiting with palonosetron, a pharmacologically novel 5-HT₃ receptor antagonist: results of a phase III, single-dose trial versus dolasetron. *Cancer* 2003;98: 2473-2482.
347. Botrel TE, Clark OA, Clark L, et al. Efficacy of palonosetron (PAL) compared to other serotonin inhibitors (5-HT₃R) in preventing chemotherapy-induced nausea and vomiting (CINV) in patients receiving moderately or highly emetogenic (MoHE) treatment: systematic review and meta-analysis. *Support Care Cancer* 2011;19:823-832.
348. Grunberg SM, Koeller JM. Palonosetron: a unique 5-HT₃-receptor antagonist for the prevention of chemotherapy-induced emesis. *Expert Opin Pharmacother* 2003;4:2297-2303.
349. Noble A, Bremer K, Goedhals L, et al. A double-blind, randomised, crossover comparison of granisetron and ondansetron in 5-day fractionated chemotherapy: assessment of efficacy, safety and patient preference. The Granisetron Study Group. *Eur J Cancer* 1994;30A:1083-1088.
350. Saito R, Takano Y, Kamiya HO. Roles of substance P and NK(1) receptor in the brainstem in the development of emesis. *J Pharmacol Sci* 2003;91:87-94.
351. Hesketh PJ, Grunberg SM, Gralla RJ, et al. The oral neurokinin-1 antagonist aprepitant for the prevention of chemotherapy-induced nausea and vomiting: a multinational, randomized, double-blind, placebo-controlled trial in patients receiving high-dose cisplatin—the Aprepitant Protocol 052 Study Group. *J Clin Oncol* 2003;21:4112-4119.
352. Poli-Bigelli S, Rodrigues-Pereira J, Carides AD, et al. Addition of the neurokinin 1 receptor antagonist aprepitant to standard antiemetic therapy improves control of chemotherapy-induced nausea and vomiting. Results from a randomized, double-blind, placebo-controlled trial in Latin America. *Cancer* 2003;97:3090-3098.
353. Navari RM. Fosaprepitant (MK-0517): a neurokinin-1 receptor antagonist for the prevention of chemotherapy-induced nausea and vomiting. *Expert Opin Investig Drugs* 2007;16:1977-1985.
354. Passik SD, Lundberg J, Kirsh KL, et al. A pilot exploration of the antiemetic activity of olanzapine for the relief of nausea in patients with advanced cancer and pain. *J Pain Symptom Manage* 2002;23:526-532.
355. Bymaster FP, Calligaro DO, Falcone JF, et al. Radioreceptor binding profile of the atypical antipsychotic olanzapine. *Neuropsychopharmacology* 1996;14:87-96.
356. Passik SD, Navari RM, Jung SH, et al. A phase I trial of olanzapine (Zyprexa) for the prevention of delayed emesis in cancer patients: a Hoosier Oncology Group study. *Cancer Invest* 2004;22:383-388.
357. Navari RM, Einhorn LH, Loehrer PJ Sr, et al. A phase II trial of olanzapine, dexamethasone, and palonosetron for the prevention of chemotherapy-induced nausea and vomiting: a Hoosier Oncology Group study. *Support Care Cancer* 2007;15:1285-1291.
358. Navari RM, Gray SE, Kerr AC. Olanzapine versus aprepitant for the prevention of chemotherapy-induced nausea and vomiting: a randomized phase III trial. *J Support Oncol* 2011;9:188-195.

359. Navari RM. Prevention of emesis from multiple-day and high-dose chemotherapy regimens. *J Natl Compr Canc Netw* 2007;5:51-59.
360. Musso M, Scalone R, Crescimanno A, et al. Palonosetron and dexamethasone for prevention of nausea and vomiting in patients receiving high-dose chemotherapy with auto-SCT. *Bone Marrow Transplant* 2010;45:123-127.
361. Mandanas RA, Beveridge R, Rifkin RM, et al. A randomized, multicenter, open-label comparison of the antiemetic efficacy of dolasetron versus ondansetron for the prevention of nausea and vomiting during high-dose myeloablative chemotherapy. *Support Cancer Ther* 2005;2:114-121.
362. Lopez-Jimenez J, Martin-Ballesteros E, Sureda A, et al. Chemotherapy-induced nausea and vomiting in acute leukemia and stem cell transplant patients: results of a multicenter, observational study. *Haematologica* 2006;91:84-91.
363. Ballen KK, Hesketh AM, Heyes C, et al. Prospective evaluation of antiemetic outcome following high-dose chemotherapy with hematopoietic stem cell support. *Bone Marrow Transplant* 2001;28:1061-1066.
364. Bubalo J, Leis JF, Curtin PT, et al. A randomized, double-blinded, pilot trial of aprepitant added to standard antiemetics during conditioning therapy for hematopoietic stem cell transplant (HSCT). *J Clin Oncol* 2007 ASCO Annu Meeting Proc Part I, 2007;25:9112
365. Bubalo JS, Cherala G, McCune JS, et al. Aprepitant pharmacokinetics and assessing the impact of aprepitant on cyclophosphamide metabolism in cancer patients undergoing hematopoietic stem cell transplantation. *J Clin Pharmacol* 2012;52:586-594.
366. Jordan K, Jahn F, Jahn P, et al. The NK-1 receptor-antagonist aprepitant in high-dose chemotherapy (high-dose melphalan and high-dose T-ICE: paclitaxel, ifosfamide, carboplatin, etoposide): efficacy and safety of a triple antiemetic combination. *Bone Marrow Transplant* 2011;46:784-789.
367. Jordan K, Kinitz I, Voigt W, et al. Safety and efficacy of a triple antiemetic combination with the NK-1 antagonist aprepitant in highly and moderately emetogenic multiple-day chemotherapy. *Eur J Cancer* 2009;45: 1184-1187.
368. Pielichowski W, Barzal J, Gawronski K, et al. A triple-drug combination to prevent nausea and vomiting following BEAM chemotherapy before autologous hematopoietic stem cell transplantation. *Transplant Proc* 2011; 43:3107-3110.
369. Pielichowski W, Gawronski K, Mlot B, et al. Triple drug combination in the prevention of nausea and vomiting following busulfan plus cyclophosphamide chemotherapy before allogeneic hematopoietic stem cell transplantation. *J BUON* 2011;16:541-546.
370. Basch E, Hesketh PJ, Kris MG, et al. Antiemetics: American Society of Clinical Oncology clinical practice guideline update. *J Oncol Pract* 2011;7:395-398.
371. Cella D, Davis K, Breitbart W, et al. Cancer-related fatigue: prevalence of proposed diagnostic criteria in a United States sample of cancer survivors. *J Clin Oncol* 2001;19:3385-3391.
372. Escalante CP. Treatment of cancer-related fatigue: an update. *Support Care Cancer* 2003;11:79-83.
373. Schwartz AL, Mori M, Gao R, et al. Exercise reduces daily fatigue in women with breast cancer receiving chemotherapy. *Med Sci Sports Exerc* 2001;33:718-723.
374. Escalante CP, Manzullo EF. Cancer-related fatigue: the approach and treatment. *J Gen Intern Med* 2009;24(Suppl 2):S412-S416.
375. Sarhill N, Walsh D, Nelson KA, et al. Methylphenidate for fatigue in advanced cancer: a prospective open-label pilot study. *Am J Hosp Palliat Care* 2001;18:187-192.
376. Wargin W, Patrick K, Kilts C, et al. Pharmacokinetics of methylphenidate in man, rat and monkey. *J Pharmacol Exp Ther* 1983;226:382-386.
377. Jean-Pierre P, Morrow GR, Roscoe JA, et al. A phase 3 randomized, placebo-controlled, double-blind, clinical trial of the effect of modafinil on cancer-related fatigue among 631 patients receiving chemotherapy: a University of Rochester Cancer Center Community Clinical Oncology Program Research Base Study. *Cancer* 2010;116:3513-3520.
378. Desandre PL, Quest TE. Management of cancer-related pain. *Hematol Oncol Clin North Am* 2010;24:643-658.
379. Zaza C, Baine N. Cancer pain and psychosocial factors: a critical review of the literature. *J Pain Symptom Manage* 2002;24:526-542.

380. Schug SA, Zech D, Dorr U. Cancer pain management according to WHO analgesic guidelines. *J Pain Symptom Manage* 1990;5:27-32.
381. Breivik H, Cherny N, Collett B, et al. Cancer-related pain: a pan-European survey of prevalence, treatment, and patient attitudes. *Ann Oncol* 2009;20: 1420-1433.
382. Levy MH. Pharmacologic treatment of cancer pain. *N Engl J Med* 1996;335:1124-1132.
383. Ferrer-Brechner T. Anesthesiology: recent advances in managing cancer pain-the anesthesiologist's role. *West J Med* 1986;144:597-598.
384. Green E, Zwaal C, Beals C, et al. Cancer-related pain management: a report of evidence-based recommendations to guide practice. *Clin J Pain* 2010;26: 449-462.
385. Portenoy RK, Lesage P. Management of cancer pain. *Lancet* 1999;353: 1695-1700.
386. Swarm R, Abernethy AP, Anghelescu DL, et al. Adult cancer pain. *J Natl Compr Canc Netw* 2010;8:1046-1086.
387. Ross JR, Goller K, Hardy J, et al. Gabapentin is effective in the treatment of cancer-related neuropathic pain: a prospective, open-label study. *J Palliat Med* 2005;8:1118-1126.
388. Ripamonti C, Bruera E. Pain and symptom management in palliative care. *Cancer Control* 1996;3:204-213.
389. Jacobsen R, Liubarskiene Z, Moldrup C, et al. Barriers to cancer pain management: a review of empirical research. *Medicina (Kaunas)* 2009;45: 427-433.
390. Jacobsen R, Sjogren P, Moldrup C, et al. Physician-related barriers to cancer pain management with opioid analgesics: a systematic review. *J Opioid Manag* 2007;3:207-214.
391. Von Roenn JH, Cleeland CS, Gonin R, et al. Physician attitudes and practice in cancer pain management. A survey from the Eastern Cooperative Oncology Group. *Ann Intern Med* 1993;119:121-126.
392. Breuer B, Fleishman SB, Cruciani RA, et al. Medical oncologists' attitudes and practice in cancer pain management: a national survey. *J Clin Oncol* 2011;29:4769-4775.
393. Chang MC, Chang YC, Chiou JF, et al. Overcoming patient-related barriers to cancer pain management for home care patients. A pilot study. *Cancer Nurs* 2002;25:470-476.
394. Jacox A, Carr DB, Payne R. New clinical-practice guidelines for the management of pain in patients with cancer. *N Engl J Med* 1994;330:651-655.
395. Rimer B, Levy MH, Keintz MK, et al. Enhancing cancer pain control regimens through patient education. *Patient Educ Couns* 1987;10:267-277.
396. Ferrell BR, Ferrell BA, Ahn C, et al. Pain management for elderly patients with cancer at home. *Cancer* 1994;74:2139-2146.
397. de Wit R, van Dam F, Zandbelt L, et al. A pain education program for chronic cancer pain patients: follow-up results from a randomized controlled trial. *Pain* 1997;73:55-69.
398. Caraceni A. Evaluation and assessment of cancer pain and cancer pain treatment. *Acta Anaesthesiol Scand* 2001;45:1067-1075.
399. Serlin RC, Mendoza TR, Nakamura Y, et al. When is cancer pain mild, moderate or severe? Grading pain severity by its interference with function. *Pain* 1995;61:277-284.
400. Ramer L, Richardson JL, Cohen MZ, et al. Multimeasure pain assessment in an ethnically diverse group of patients with cancer. *J Transcult Nurs* 1999;10:94-101.
401. DeWaters T, Faut-Callahan M, McCann JJ, et al. Comparison of self-reported pain and the PAINAD scale in hospitalized cognitively impaired and intact older adults after hip fracture surgery. *Orthop Nurs* 2008;27:21-28.
402. Zwakhalen SM, Hamers JP, Berger MP. The psychometric quality and clinical usefulness of three pain assessment tools for elderly people with dementia. *Pain* 2006;126:210-220.
403. Fishman B, Pasternak S, Wallenstein SL, et al. The Memorial Pain Assessment Card. A valid instrument for the evaluation of cancer pain. *Cancer* 1987;60:1151-1158.
404. Wu JS, Beaton D, Smith PM, et al. Patterns of pain and interference in patients with painful bone metastases: a brief pain inventory validation study. *J Pain Symptom Manage* 2010;39:230-240.

405. Jadad AR, Browman GP. The WHO analgesic ladder for cancer pain management. Stepping up the quality of its evaluation. *JAMA* 1995;274:1870-1873.
406. Cheung WY, Zimmermann C. Pharmacologic management of cancer-related pain, dyspnea, and nausea. *Semin Oncol* 2011;38:450-459.
407. Eisenberg E, Berkey CS, Carr DB, et al. Efficacy and safety of nonsteroidal antiinflammatory drugs for cancer pain: a meta-analysis. *J Clin Oncol* 1994;12:2756-2765.
408. Marret E, Kurdi O, Zufferey P, et al. Effects of nonsteroidal antiinflammatory drugs on patient-controlled analgesia morphine side effects: meta-analysis of randomized controlled trials. *Anesthesiology* 2005;102:1249-1260.
409. Deviere J. Do selective cyclo-oxygenase inhibitors eliminate the adverse events associated with nonsteroidal anti-inflammatory drug therapy? *Eur J Gastroenterol Hepatol* 2002;14(Suppl 1):S29-S33.
410. Trescot AM. Review of the role of opioids in cancer pain. *J Natl Compr Canc Netw* 2010;8:1087-1094.
411. Collin E, Poulain P, Gauvain-Piquard A, et al. Is disease progression the major factor in morphine "tolerance" in cancer pain treatment? *Pain* 1993;55: 319-326.
412. Pasternak GW. Molecular biology of opioid analgesia. *J Pain Symptom Manage* 2005;29:S2-S9.
413. Cascorbi I. Pharmacogenetics of cytochrome p4502D6: genetic background and clinical implication. *Eur J Clin Invest* 2003;33(Suppl 2):17-22.
414. Raffa RB, Friderichs E, Reimann W, et al. Opioid and nonopioid components independently contribute to the mechanism of action of tramadol, an "atypical" opioid analgesic. *J Pharmacol Exp Ther* 1992;260:275-285.
415. Xiao W, Naso L, Bennett GJ. Experimental studies of potential analgesics for the treatment of chemotherapy-evoked painful peripheral neuropathies. *Pain Med* 2008;9:505-517.
416. Otton SV, Schadel M, Cheung SW, et al. CYP2D6 phenotype determines the metabolic conversion of hydrocodone to hydromorphone. *Clin Pharmacol Ther* 1993;54:463-472.
417. Smith MT. Neuroexcitatory effects of morphine and hydromorphone: evidence implicating the 3-glucuronide metabolites. *Clin Exp Pharmacol Physiol* 2000;27:524-528.
418. Lotsch J, Geisslinger G. Morphine-6-glucuronide: an analgesic of the future? *Clin Pharmacokinet* 2001;40:485-499.
419. Davis MP, McPherson ML. Tabling hydromorphone: do we have it right? *J Palliat Med* 2010;13:365-366.
420. Lehmann KA, Zech D. Transdermal fentanyl: clinical pharmacology. *J Pain Symptom Manage* 1992;7:S8-S16.
421. Donner B, Zenz M, Tryba M, et al. Direct conversion from oral morphine to transdermal fentanyl: a multicenter study in patients with cancer pain. *Pain* 1996;64:527-534.
422. Sloan PA, Barkin RL. Oxymorphone and oxymorphone extended release: a pharmacotherapeutic review. *J Opioid Manag* 2008;4:131-144.
423. Yakovlev AE, Resch BE. Spinal cord stimulation for cancer-related low back pain. *Am J Hosp Palliat Care* 2011;
424. Cherny NI, Arbit E, Jain S. Invasive techniques in the management of cancer pain. *Hematol Oncol Clin North Am* 1996;10:121-137.
425. Ettinger AB, Portenoy RK. The use of corticosteroids in the treatment of symptoms associated with cancer. *J Pain Symptom Manage* 1988;3: 99-103.
426. Vecht CJ, Haaxma-Reiche H, van Putten WL, et al. Initial bolus of conventional versus high-dose dexamethasone in metastatic spinal cord compression. *Neurology* 1989;39:1255-1257.
427. Lussier D, Huskey AG, Portenoy RK. Adjuvant analgesics in cancer pain management. *Oncologist* 2004;9:571-591.
428. Dobecki DA, Schocket SM, Wallace MS. Update on pharmacotherapy guidelines for the treatment of neuropathic pain. *Curr Pain Headache Rep* 2006;10:185-190.
429. McQuay HJ, Tramer M, Nye BA, et al. A systematic review of antidepressants in neuropathic pain. *Pain* 1996;68:217-227.
430. Dworkin RH, O'Connor AB, Backonja M, et al. Pharmacologic management of neuropathic pain: evidence-based recommendations. *Pain* 2007;132: 237-251.

431. Torta RG, Munari J. Symptom cluster: depression and pain. *Surg Oncol* 2010;19:155-159.
432. Ripamonti C, Fulfaro F. Malignant bone pain: pathophysiology and treatments. *Curr Rev Pain* 2000;4:187-196.
433. Pereira J, Mancini I, Walker P. The role of bisphosphonates in malignant bone pain: a review. *J Palliat Care* 1998;14:25-36.
434. Galantino ML, Greene L, Archetto B, et al. A qualitative exploration of the impact of yoga on breast cancer survivors with aromatase inhibitor-associated arthralgias. *Explore (NY)* 2012;8:40-47.
435. O'Regan D, Filshie J. Acupuncture and cancer. *Auton Neurosci* 2010;157: 96-100.
436. Kutner JS, Smith MC, Corbin L, et al. Massage therapy versus simple touch to improve pain and mood in patients with advanced cancer: a randomized trial. *Ann Intern Med* 2008;149:369-379.
437. Dhingra L, Shuk E, Grossman B, et al. A qualitative study to explore psychological distress and illness burden associated with opioid-induced constipation in cancer patients with advanced disease. *Palliat Med* 2012;published online 15 June 2012.
438. Lang L. The Food and Drug Administration approves methylalntrexone bromide for opioid-induced constipation. *Gastroenterology* 2008;135:6.
439. Thomas J, Karver S, Cooney GA, et al. Methylalntrexone for opioid-induced constipation in advanced illness. *N Engl J Med* 2008;358:2332-2343.
440. Bharucha AE. Methylalntrexone reduced opioid-induced constipation in patients with terminal illness. *Evid Based Med* 2008;13:184.
441. Slatkin N, Thomas J, Lipman AG, et al. Methylalntrexone for treatment of opioid-induced constipation in advanced illness patients. *J Support Oncol* 2009;7:39-46.
442. Gatti A, Sabato AF. Management of opioid-induced constipation in cancer patients: focus on methylalntrexone. *Clin Drug Investig* 2012;32:293-301.
443. Martin WR. Naloxone. *Ann Intern Med* 1976;85:765-768.
444. Dahan A, Aarts L, Smith TW. Incidence, reversal, and prevention of opioid-induced respiratory depression. *Anesthesiology* 2010;112:226-238.
445. Bruera E, Brenneis C, Paterson AH, et al. Use of methylphenidate as an adjuvant to narcotic analgesics in patients with advanced cancer. *J Pain Symptom Manage* 1989;4:3-6.
446. Laugsand EA, Kaasa S, Klepstad P. Management of opioid-induced nausea and vomiting in cancer patients: systematic review and evidence-based recommendations. *Palliat Med* 2011;25:442-453.
447. Dreizen S. Oral complications of cancer therapies. Description and incidence of oral complications. *NCI Monogr* 1990:11-15.
448. Sonis ST, Elting LS, Keefe D, et al. Perspectives on cancer therapy-induced mucosal injury: pathogenesis, measurement, epidemiology, and consequences for patients. *Cancer* 2004;100:1995-2025.
449. Barasch A, Peterson DE. Risk factors for ulcerative oral mucositis in cancer patients: unanswered questions. *Oral Oncol* 2003;39:91-100.
450. Sonis ST, Sonis AL, Lieberman A. Oral complications in patients receiving treatment for malignancies other than of the head and neck. *J Am Dent Assoc* 1978;97:468-472.
451. Sonis S, Kunz A. Impact of improved dental services on the frequency of oral complications of cancer therapy for patients with non-head-and-neck malignancies. *Oral Surg Oral Med Oral Pathol* 1988;65:19-22.
452. Sorensen JB, Skovsgaard T, Bork E, et al. Double-blind, placebo-controlled, randomized study of chlorhexidine prophylaxis for 5-fluorouracil-based chemotherapy-induced oral mucositis with nonblinded randomized comparison to oral cooling (cryotherapy) in gastrointestinal malignancies. *Cancer* 2008;112:1600-1606.
453. Keefe DM, Schubert MM, Elting LS, et al. Updated clinical practice guidelines for the prevention and treatment of mucositis. *Cancer* 2007;109:820-831.
454. Spielberger R, Stiff P, Bensinger W, et al. Palifermin for oral mucositis after intensive therapy for hematologic cancers. *N Engl J Med* 2004;351: 2590-2598.

455. Hensley ML, Hagerty KL, Kewalramani T, et al. American Society of Clinical Oncology 2008 Clinical Practice Guideline update: use of chemotherapy and radiation therapy protectants. *J Clin Oncol* 2009;27:127-145.
456. Goldberg JD, Zheng J, Castro-Malaspina H, et al. Palifermin is efficacious in recipients of TBI-based but not chemotherapy-based allogeneic hematopoietic stem cell transplants. *Bone Marrow Transplant* 2013;48:99-104.
457. Braverman B, McCarthy RJ, Ivankovich AD, et al. Effect of helium-neon and infrared laser irradiation on wound healing in rabbits. *Lasers Surg Med* 1989;9:50-58.
458. Markiewicz M, Dzierzak-Mietla M, Frankiewicz A, et al. Treating oral mucositis with a supersaturated calcium phosphate rinse: comparison with control in patients undergoing allogeneic hematopoietic stem cell transplantation. *Support Care Cancer* 2012;
459. Innocenti M, Moscatelli G, Lopez S. Efficacy of gelclair in reducing pain in palliative care patients with oral lesions: preliminary findings from an open pilot study. *J Pain Symptom Manage* 2002;24:456-457.
460. Carnel SB, Blakeslee DB, Oswald SG, et al. Treatment of radiation- and chemotherapy-induced stomatitis. *Otolaryngol Head Neck Surg* 1990;102: 326-330.
461. Cerchietti LC, Navigante AH, Bonomi MR, et al. Effect of topical morphine for mucositis-associated pain following concomitant chemoradiotherapy for head and neck carcinoma. *Cancer* 2002;95:2230-2236.
462. Sarhill N, Mahmoud F, Walsh D, et al. Evaluation of nutritional status in advanced metastatic cancer. *Support Care Cancer* 2003;11:652-659.
463. Tchekmedyan NS, Zahyna D, Halpert C, et al. Clinical aspects of nutrition in advanced cancer. *Oncology* 1992;49(Suppl 2):3-7.
464. Walsh D, Donnelly S, Rybicki L. The symptoms of advanced cancer: relationship to age, gender, and performance status in 1,000 patients. *Support Care Cancer* 2000;8:175-179.
465. Mantovani G, Maccio A, Lai P, et al. Cytokine activity in cancer-related anorexia/cachexia: role of megestrol acetate and medroxyprogesterone acetate. *Semin Oncol* 1998;25:45-52.
466. Shoemaker LK, Estfan B, Induru R, et al. Symptom management: an important part of cancer care. *Cleve Clin J Med* 2011;78:25-34.
467. Bruera E, Macmillan K, Kuehn N, et al. A controlled trial of megestrol acetate on appetite, caloric intake, nutritional status, and other symptoms in patients with advanced cancer. *Cancer* 1990;66:1279-1282.
468. Lai YL, Fang FM, Yeh CY. Management of anorexic patients in radiotherapy: a prospective randomized comparison of megestrol and prednisolone. *J Pain Symptom Manage* 1994;9:265-268.
469. Loprinzi CL, Bernath AM, Schaid DJ, et al. Phase III evaluation of 4 doses of megestrol acetate as therapy for patients with cancer anorexia and/or cachexia. *Oncology* 1994;51(Suppl 1):2-7.
470. Oster MH, Enders SR, Samuels SJ, et al. Megestrol acetate in patients with AIDS and cachexia. *Ann Intern Med* 1994;121:400-408.
471. Jatoi A, Windschitl HE, Loprinzi CL, et al. Dronabinol versus megestrol acetate versus combination therapy for cancer-associated anorexia: a North Central Cancer Treatment Group study. *J Clin Oncol* 2002;20:567-573.
472. Pascual Lopez A, Roque i Figuls M, Urrutia Cuchi G, et al. Systematic review of megestrol acetate in the treatment of anorexia-cachexia syndrome. *J Pain Symptom Manage* 2004;27:360-369.
473. Navari RM, Brenner MC. Treatment of cancer-related anorexia with olanzapine and megestrol acetate: a randomized trial. *Support Care Cancer* 2010;18:951-956.
474. Mercadante S, Fulfaro F, Casuccio A. The use of corticosteroids in home palliative care. *Support Care Cancer* 2001;9:386-389.
475. Bick RL, Strauss JF, Frenkel EP. Thrombosis and hemorrhage in oncology patients. *Hematol Oncol Clin North Am* 1996;10:875-907.
476. Gaydos LA, Freireich EJ, Mantel N. The quantitative relation between platelet count and hemorrhage in patients with acute leukemia. *N Engl J Med* 1962; 266:905-909.

477. Rebulla P, Finazzi G, Marangoni F, et al. The threshold for prophylactic platelet transfusions in adults with acute myeloid leukemia. Gruppo Italiano Malattie Ematologiche Maligne dell'Adulto. *N Engl J Med* 1997;337: 1870-1875.
478. Han T, Stutzman L, Cohen E, et al. Effect of platelet transfusion on hemorrhage in patients with acute leukemia. An autopsy study. *Cancer* 1966;19:1937-1942.
479. Nevo S, Vogelsang GB. Acute bleeding complications in patients after bone marrow transplantation. *Curr Opin Hematol* 2001;8:319-325.
480. Pisciotto PT, Benson K, Hume H, et al. Prophylactic versus therapeutic platelet transfusion practices in hematology and/or oncology patients. *Transfusion* 1995;35:498-502.
481. Webert K, Cook RJ, Sigouin CS, et al. The risk of bleeding in thrombocytopenic patients with acute myeloid leukemia. *Haematologica* 2006;91:1530-1537.
482. Heckman KD, Weiner GJ, Davis CS, et al. Randomized study of prophylactic platelet transfusion threshold during induction therapy for adult acute leukemia: 10,000/microL versus 20,000/microL. *J Clin Oncol* 1997;15:1143-1149.
483. Cook RJ, Heddle NM, Rebulla P, et al. Methods for the analysis of bleeding outcomes in randomized trials of PLT transfusion triggers. *Transfusion* 2004;44:1135-1142.
484. Wandt H, Schaefer-Eckart K, Wendelin K, et al. Therapeutic platelet transfusion versus routine prophylactic transfusion in patients with haematological malignancies: an open-label, multicentre, randomised study. *Lancet* 2012;380:1309-1316.
485. Schiffer CA, Anderson KC, Bennett CL, et al. Platelet transfusion for patients with cancer: clinical practice guidelines of the American Society of Clinical Oncology. *J Clin Oncol* 2001;19:1519-1538.
486. Slichter SJ, Davis K, Enright H, et al. Factors affecting posttransfusion platelet increments, platelet refractoriness, and platelet transfusion intervals in thrombocytopenic patients. *Blood* 2005;105:4106-4114.
487. Carr R, Hutton JL, Jenkins JA, et al. Transfusion of ABO-mismatched platelets leads to early platelet refractoriness. *Br J Haematol* 1990;75:408-413.
488. Slichter SJ. Evidence-based platelet transfusion guidelines. *Hematol Am Soc Hematol Educ Program* 2007:172-178.
489. Leukocyte reduction and ultraviolet B irradiation of platelets to prevent alloimmunization and refractoriness to platelet transfusions. The Trial to Reduce Alloimmunization to Platelets Study Group. *N Engl J Med* 1997;337: 1861-1869.
490. Vamvakas EC. Is white blood cell reduction equivalent to antibody screening in preventing transmission of cytomegalovirus by transfusion? A review of the literature and meta-analysis. *Transfus Med Rev* 2005;19:181-199.
491. Heddle NM, Blajchman MA, Meyer RM, et al. A randomized controlled trial comparing the frequency of acute reactions to plasma-removed platelets and prestorage WBC-reduced platelets. *Transfusion* 2002;42:556-566.
492. Leitman SF. Use of blood cell irradiation in the prevention of posttransfusion graft-vs-host disease. *Transfusion Sci* 1989;10:219-232.
493. Kaden BR, Rosse WF, Hauch TW. Immune thrombocytopenia in lymphoproliferative diseases. *Blood* 1979;53:545-551.
494. Kim HD, Boggs DR. A syndrome resembling idiopathic thrombocytopenic purpura in 10 patients with diverse forms of cancer. *Am J Med* 1979;67: 371-377.
495. Carey RW, McGinnis A, Jacobson BM, et al. Idiopathic thrombocytopenic purpura complicating chronic lymphocytic leukemia. *Arch Intern Med* 1976;136:62-66.
496. Cohen JR. Idiopathic thrombocytopenic purpura in Hodgkin's disease: a rare occurrence of no prognostic significance. *Cancer* 1978;41:743-746.
497. Kedar A, Khan AB, Mattern JQ, et al. Autoimmune disorders complicating adolescent Hodgkin's disease. *Cancer* 1979;44:112-116.
498. Rao S, Pang EJ. Idiopathic thrombocytopenic purpura in acute lymphoblastic leukemia. *J Pediatr* 1979;94:408-409.
499. Levi M. Disseminated intravascular coagulation in cancer patients. *Best Pract Res Clin Haematol* 2009;22:129-136.
500. Rodeghiero F, Castaman G. The pathophysiology and treatment of hemorrhagic syndrome of acute promyelocytic leukemia. *Leukemia* 1994;8 (Suppl 2):S20-S26.

501. Barbui T, Falanga A. Disseminated intravascular coagulation in acute leukemia. *Semin Thromb Hemost* 2001;27:593-604.
502. Falanga A, Rickles FR. Pathophysiology of the thrombophilic state in the cancer patient. *Semin Thromb Hemost* 1999;25:173-182.
503. Chong BH, Lee SH. Management of thromboembolism in hematologic malignancies. *Semin Thromb Hemost* 2007;33:435-448.
504. Lee AY, Levine MN. The thrombophilic state induced by therapeutic agents in the cancer patient. *Semin Thromb Hemost* 1999;25:137-145.
505. Levi M, Toh CH, Thachil J, et al. Guidelines for the diagnosis and management of disseminated intravascular coagulation. British Committee for Standards in Haematology. *Br J Haematol* 2009;145:24-33.
506. Tallman MS, Abutalib SA, Altman JK. The double hazard of thrombophilia and bleeding in acute promyelocytic leukemia. *Semin Thromb Hemost* 2007;33:330-338.
507. Kaye JA. FDA licensure of NEUMEGA to prevent severe chemotherapy-induced thrombocytopenia. *Stem Cells* 1998;16(Suppl 2):207-223.
508. Isaacs C, Robert NJ, Bailey FA, et al. Randomized placebo-controlled study of recombinant human interleukin-11 to prevent chemotherapy-induced thrombocytopenia in patients with breast cancer receiving dose-intensive cyclophosphamide and doxorubicin. *J Clin Oncol* 1997;15:3368-3377.
509. Zhang XL, Cheng XZ, Ye X, et al. Therapeutic effect of interleukin-11 on thrombocytopenia in patients with hematologic malignancies after chemotherapy. *Zhonghua Zhong Liu Za Zhi* 2010;32:713-715.
510. Wu S, Zhang Y, Xu L, et al. Multicenter, randomized study of genetically modified recombinant human interleukin-11 to prevent chemotherapy-induced thrombocytopenia in cancer patients receiving chemotherapy. *Support Care Cancer* 2012;20:1875-1884.
511. Demeter J, Istenes I, Fodor A, et al. Efficacy of romiplostim in the treatment of chemotherapy-induced thrombocytopenia (CIT) in a patient with mantle cell lymphoma. *Pathol Oncol Res* 2011;17:141-143.
512. Duic JP, Grewal J, McConie K, et al. Eltrombopag for radiation-induced thrombocytopenia in a glioblastoma patient. *J Neurooncol* 2012;106: 427-429.
513. Kellum A, Jagiello-Grusfeld A, Bondarenko IN, et al. A randomized, double-blind, placebo-controlled, dose ranging study to assess the efficacy and safety of eltrombopag in patients receiving carboplatin/paclitaxel for advanced solid tumors. *Curr Med Res Opin* 2010;26:2339-2346.
514. Olnes MJ, Scheinberg P, Calvo KR, et al. Eltrombopag and improved hematopoiesis in refractory aplastic anemia. *N Engl J Med* 2012;367:11-19.
515. Miller CB, Jones RJ, Piantadosi S, et al. Decreased erythropoietin response in patients with the anemia of cancer. *N Engl J Med* 1990;322:1689-1692.
516. Adamson JW. The anemia of inflammation/malignancy: mechanisms and management. *Hematol Am Soc Hematol Educ Program* 2008:159-165.
517. Frenkel EP, Bick RL, Rutherford CJ. Anemia of malignancy. *Hematol Oncol Clin North Am* 1996;10:861-873.
518. Rizzo JD, Brouwers M, Hurley P, et al. American Society of Hematology/American Society of Clinical Oncology Clinical Practice Guideline update on the use of epoetin and darbepoetin in adult patients with cancer. *Blood* 2010;116:4045-4059.
519. Nemeth E, Rivera S, Gabayan V, et al. IL-6 mediates hypoferrremia of inflammation by inducing the synthesis of the iron regulatory hormone hepcidin. *J Clin Invest* 2004;113:1271-1276.
520. Kemna E, Pickkers P, Nemeth E, et al. Time-course analysis of hepcidin, serum iron, and plasma cytokine levels in humans injected with LPS. *Blood* 2005;106:1864-1866.
521. Weiss G. Iron metabolism in the anemia of chronic disease. *Biochim Biophys Acta* 2009;1790:682-693.
522. Hohaus S, Massini G, Giachelia M, et al. Anemia in Hodgkin's lymphoma: the role of interleukin-6 and hepcidin. *J Clin Oncol* 2010;28:2538-2543.

523. Sharma S, Nemeth E, Chen YH, et al. Involvement of hepcidin in the anemia of multiple myeloma. *Clin Cancer Res* 2008;14:3262-3267.
524. Cheng PP, Sun ZZ, Jiang F, et al. Hepcidin expression in patients with acute leukaemia. *Eur J Clin Invest* 2012;42:517-525.
525. Bayliss TJ, Smith JT, Schuster M, et al. A humanized anti-IL-6 antibody (ALD518) in non-small cell lung cancer. *Expert Opin Biol Ther* 2011;11: 1663-1668.
526. Kawabata H, Tomosugi N, Kanda J, et al. Anti-interleukin 6 receptor antibody tocilizumab reduces the level of serum hepcidin in patients with multicentric Castleman's disease. *Haematologica* 2007;92:857-858.
527. Eisner E, Ley AB, Mayer K. Coombs'-positive hemolytic anemia in Hodgkin's disease. *Ann Intern Med* 1967;66:258-273.
528. Kyle RA, Kiely JM, Stickney JM. Acquired hemolytic anemia in chronic lymphocytic leukemia and the lymphomas: survival and response to therapy in twenty-seven cases. *AMA Arch Intern Med* 1959;104:61-67.
529. Loughran TP Jr, Kadin ME, Starkebaum G, et al. Leukemia of large granular lymphocytes: association with clonal chromosomal abnormalities and auto-immune neutropenia, thrombocytopenia, and hemolytic anemia. *Ann Intern Med* 1985;102:169-175.
530. Tamura S, Kanamaru A. De novo acute myeloid leukemia with trilineage myelodysplasia (AML/TMDS) and myelodysplastic remission marrow (AML/MRM). *Leuk Lymphoma* 1995;16:263-270.
531. Gill PG, Souter RG, Morris PJ. Splenectomy for hypersplenism in malignant lymphomas. *Br J Surg* 1981;68:29-33.
532. Adler S, Stutzman L, Sokal J, et al. Splenectomy for hematologic depression in lymphocytic lymphoma and leukemia. *Cancer* 1975;35:521-528.
533. Ng CS, Chan JK, Cheng PN, et al. Nasal T-cell lymphoma associated with hemophagocytic syndrome. *Cancer* 1986;58:67-71.
534. Takasaki N, Kaneko Y, Maseki N, et al. Hemophagocytic syndrome complicating T-cell acute lymphoblastic leukemia with a novel t(11;14)(p15;q11) chromosome translocation. *Cancer* 1987;59:424-428.
535. Okuda T, Sakamoto S, Deguchi T, et al. Hemophagocytic syndrome associated with aggressive natural killer cell leukemia. *Am J Hematol* 1991;38:321-323.
536. Saeki A, Ogasawara Y, Otsubo H, et al. Acute myelomonocytic leukemia complicated with syndrome of inappropriate secretion of antidiuretic hormone, nephrotic syndrome, and hemophagocytic syndrome. *Rinsho Ketsueki* 1995;36:665-671.
537. Prieto E, Perez Sanchez I, Sanchez Guilarte J, et al. Hemophagocytic myeloma. Report of a case. *Sangre (Barc)* 1986;31:763-767.
538. Risdall RJ, Brunning RD, Hernandez JI, et al. Bacteria-associated hemophagocytic syndrome. *Cancer* 1984;54:2968-2972.
539. Wilson ER, Malluh A, Stagno S, et al. Fatal Epstein-Barr virus-associated hemophagocytic syndrome. *J Pediatr* 1981;98:260-262.
540. Grom AA. Natural killer cell dysfunction: a common pathway in systemic-onset juvenile rheumatoid arthritis, macrophage activation syndrome, and hemophagocytic lymphohistiocytosis? *Arthritis Rheum* 2004;50:689-698.
541. Porcu P, Cripe LD, Ng EW, et al. Hyperleukocytic leukemias and leukostasis: a review of pathophysiology, clinical presentation and management. *Leuk Lymphoma* 2000;39:1-18.
542. Vaughan WP, Kimball AW, Karp JE, et al. Factors affecting survival of patients with acute myelocytic leukemia presenting with high WBC counts. *Cancer Treat Rep* 1981;65:1007-1013.
543. Hug V, Keating M, McCredie K, et al. Clinical course and response to treatment of patients with acute myelogenous leukemia presenting with a high leukocyte count. *Cancer* 1983;52:773-779.
544. Hoelzer D, Thiel E, Loffler H, et al. Prognostic factors in a multicenter study for treatment of acute lymphoblastic leukemia in adults. *Blood* 1988;71: 123-131.

545. Schwartz JH, Cannellos GP. Hydroxyurea in the management of the hematologic complications of chronic granulocytic leukemia. *Blood* 1975;46:11-16.
546. Sharma K, Rao S, Bhat SV. Effect of hydroxyurea on blood viscosity in chronic myelogenous leukemia with hyperleukocytosis. *Physiol Chem Phys Med NMR* 1991;23:261-268.
547. Lane TA. Continuous-flow leukapheresis for rapid cytoreduction in leukemia. *Transfusion* 1980;20:455-457.
548. Eisenstaedt RS, Berkman EM. Rapid cytoreduction in acute leukemia. Management of cerebral leukostasis by cell pheresis. *Transfusion* 1978;18:113-115.
549. Giles FJ, Shen Y, Kantarjian HM, et al. Leukapheresis reduces early mortality in patients with acute myeloid leukemia with high white cell counts but does not improve long-term survival. *Leuk Lymphoma* 2001;42:67-73.
550. Cairo MS, Bishop M. Tumor lysis syndrome: new therapeutic strategies and classification. *Br J Haematol* 2004;127:3-11.
551. Hande KR, Garrow GC. Acute tumor lysis syndrome in patients with high-grade non-Hodgkin's lymphoma. *Am J Med* 1993;94:133-139.
552. Howard SC, Jones DP, Pui CH. The tumor lysis syndrome. *N Engl J Med* 2011;364:1844-1854.
553. Goldman SC, Holcenberg JS, Finklestein JZ, et al. A randomized comparison between rasburicase and allopurinol in children with lymphoma or leukemia at high risk for tumor lysis. *Blood* 2001;97:2998-3003.
554. Trifilio SM, Pi J, Zook J, et al. Effectiveness of a single 3-mg rasburicase dose for the management of hyperuricemia in patients with hematological malignancies. *Bone Marrow Transplant* 2011;46:800-805.
555. Reeves DJ, Bestul DJ. Evaluation of a single fixed dose of rasburicase 7.5 mg for the treatment of hyperuricemia in adults with cancer. *Pharmacotherapy* 2008;28:685-690.
556. McDonnell AM, Lenz KL, Frei-Lahr DA, et al. Single-dose rasburicase 6 mg in the management of tumor lysis syndrome in adults. *Pharmacotherapy* 2006;26:806-812.
557. Lee AC, Li CH, So KT, et al. Treatment of impending tumor lysis with single-dose rasburicase. *Ann Pharmacother* 2003;37:1614-1617.
558. Ralston SH, Gallacher SJ, Patel U, et al. Cancer-associated hypercalcemia: morbidity and mortality. Clinical experience in 126 treated patients. *Ann Intern Med* 1990;112:499-504.
559. Durie BG, Salmon SE, Mundy GR. Relation of osteoclast activating factor production to extent of bone disease in multiple myeloma. *Br J Haematol* 1981;47:21-30.
560. Taube T, Beneton MN, McCloskey EV, et al. Abnormal bone remodelling in patients with myelomatosis and normal biochemical indices of bone resorption. *Eur J Haematol* 1992;49:192-198.
561. Seymour JF, Gagel RF. Calcitriol: the major humoral mediator of hypercalcemia in Hodgkin's disease and non-Hodgkin's lymphomas. *Blood* 1993;82:1383-1394.
562. Mudde AH, van den Berg H, Boshuis PG, et al. Ectopic production of 1,25-dihydroxyvitamin D by B-cell lymphoma as a cause of hypercalcemia. *Cancer* 1987;59:1543-1546.
563. Motokura T, Fukumoto S, Matsumoto T, et al. Parathyroid hormone-related protein in adult T-cell leukemia-lymphoma. *Ann Intern Med* 1989;111: 484-488.
564. Bolodeoku J, Kusec R. Parathyroid hormone related protein (PTHrP) in acute myeloid leukaemia cells. *Br J Haematol* 1997;98:245-246.
565. Sasaki Y, Takahashi T, Tsuyuoka R, et al. Hypercalcemia mediated by parathyroid hormone-related protein in chronic myeloid leukemia. *Am J Hematol* 1994;47:251-252.
566. Seymour JF, Grill V, Martin TJ, et al. Hypercalcemia in the blastic phase of chronic myeloid leukemia associated with elevated parathyroid hormone-related protein. *Leukemia* 1993;7:1672-1675.
567. Bolo-Deoku J, Basu S, Lakhani S, et al. Parathyroid hormone-related protein in hypercalcaemia of Hodgkin's disease. *J Clin Pathol* 1992;45:541-542.
568. Schottker B, Heinz W, Weissinger F, et al. Parathyroid-hormone-related-protein-associated hypercalcemia in a patient with CLL-type low-grade leukemic B-cell lymphoma. *Haematologica* 2006;91:ECR45.

569. Shimizu H, Monden T, Tomotsune T, et al. A case of myeloma with hypercalcemia caused by high serum concentrations of both parathyroid hormone-related peptide (PTHrP) and macrophage inflammatory protein-1alpha (MIP-1alpha). *Intern Med* 2011;50:2993-2996.
570. Schilling T, Pecherstorfer M, Blind E, et al. Parathyroid hormone-related protein (PTHrP) does not regulate 1,25-dihydroxyvitamin D serum levels in hypercalcemia of malignancy. *J Clin Endocrinol Metab* 1993;76:801-803.
571. Carano A, Teitelbaum SL, Konsek JD, et al. Bisphosphonates directly inhibit the bone resorption activity of isolated avian osteoclasts in vitro. *J Clin Invest* 1990;85:456-461.
572. Tanvetyanon T, Stiff PJ. Management of the adverse effects associated with intravenous bisphosphonates. *Ann Oncol* 2006;17:897-907.
573. Sekine M, Takami H. Combination of calcitonin and pamidronate for emergency treatment of malignant hypercalcemia. *Oncol Rep* 1998;5:197-199.
574. Luce K, O'Donnell DE, Morton AR. A combination of calcitonin and bisphosphonate for the emergency treatment of severe tumor-induced hypercalcemia. *Calcif Tissue Int* 1993;52:70-71.
575. Ralston SH, Alzaid AA, Gardner MD, et al. Treatment of cancer associated hypercalcaemia with combined aminohydroxypropylidene diphosphonate and calcitonin. *Br Med J (Clin Res Ed)* 1986;292:1549-1550.
576. Hirschberg R. Renal complications from bisphosphonate treatment. *Curr Opin Support Palliat Care* 2012;6:342-347.
577. Boikos SA, Hammers HJ. Denosumab for the treatment of bisphosphonateresistant hypercalcemia. *J Clin Oncol* 2012;30:e299.
578. Stopeck AT, Lipton A, Body JJ, et al. Denosumab compared with zoledronic acid for the treatment of bone metastases in patients with advanced breast cancer: a randomized, double-blind study. *J Clin Oncol* 2010;28:5132-5139.
579. Henry DH, Costa L, Goldwasser F, et al. Randomized, double-blind study of denosumab versus zoledronic acid in the treatment of bone metastases in patients with advanced cancer (excluding breast and prostate cancer) or multiple myeloma. *J Clin Oncol* 2011;29:1125-1132.
580. Bech A, de Boer H. Denosumab for tumor-induced hypercalcemia complicated by renal failure. *Ann Intern Med* 2012;156:906-907.
581. Shimizu T, Seki S, Suyama Y, et al. An autopsy case of acute myelomonocytic leukemia with spinal cord compression and mycosis of *Cladosporium cladosporioides*. *Rinsho Ketsueki* 1982;23:1096-1102.
582. Hildebrand J, Leenaerts L, Nubourgh Y, et al. Epidural spinal cord compression in acute myelogenous leukemia. *Arch Neurol* 1980;37:319.
583. Degtiarev IP, Roshchupkin VN. Case of chloroma with spinal cord compression syndrome. *Vopr Neurokhir* 1967;31:4.
584. Bonner JA, Lichter AS. A caution about the use of MRI to diagnose spinal cord compression. *N Engl J Med* 1990;322:556-557.
585. Sorensen S, Helweg-Larsen S, Mouridsen H, et al. Effect of high-dose dexamethasone in carcinomatous metastatic spinal cord compression treated with radiotherapy: a randomised trial. *Eur J Cancer* 1994;30A:22-27.
586. Fadul CE, Lemann W, Thaler HT, et al. Perforation of the gastrointestinal tract in patients receiving steroids for neurologic disease. *Neurology* 1988;38:348-352.
587. Heimdal K, Hirschberg H, Slettebo H, et al. High incidence of serious side effects of high-dose dexamethasone treatment in patients with epidural spinal cord compression. *J Neurooncol* 1992;12:141-144.
588. Loblaw DA, Mitera G, Ford M, et al. A 2011 updated systematic review and clinical practice guideline for the management of malignant extradural spinal cord compression. *Int J Radiat Oncol Biol Phys* 2012;84:312-317.
589. Oviatt DL, Kirshner HS, Stein RS. Successful chemotherapeutic treatment of epidural compression in non-Hodgkin's lymphoma. *Cancer* 1982;49:2446-2448.

Chapter 70 Immunotherapy

> Table of Contents > Part VII - Hematologic Malignancies > Section 1 - General Aspects > Chapter 70 - Immunotherapy
Chapter 70

Immunotherapy

Adetola A. Kassim

Sattva S. Neelapu

Larry W. Kwak

Luc Van Kaer

HISTORY

There probably is no field in medicine that has provided as much hope, or as much disappointment, as the field of tumor immunology. A major relationship between the immune system and the oversight of neoplasms was postulated in the early part of the last century by Paul Ehrlich.¹ This theory of immunosurveillance envisioned that, in long-lived animals, inheritable genetic changes in somatic cells must be common, and some proportion of these changes must represent steps toward malignant transformation. It was considered an evolutionary necessity, therefore, that some mechanisms exist for eliminating or inactivating such potentially dangerous mutant cells. This mechanism was thought to be immunologic. The theory of immunosurveillance was restated in the 1950s by Lewis Thomas, then popularized and championed by Sir Macfarlane Burnet.² Supported by these powerful figures in medicine, the theory of immunosurveillance was so inherently appealing that it often was accepted uncritically, and evidence to the contrary often overlooked.³ For instance, although patients or animals who are immunosuppressed tend to have an increased incidence of tumors, these tumors are disproportionately of lymphoid origin or associated with an oncogenic virus. The development of common epithelial neoplasms (with the exception of certain skin cancers) in these patients occurs with much less impressive frequency.⁴

The most obvious evolutionary necessity of the immune system was to survey a variety of infections, especially viral infections. Early evidence seemed to indicate that immunity played a significant role in eradicating virally induced tumors.^{4,5} On the other hand, it appeared to play a less significant, or less effective, role in prevention of tumors induced by physical or chemical carcinogens.^{6,7}

Experimentation in the early part of the 20th century demonstrated that spontaneously arising tumors in outbred animals could occasionally be transplanted from one animal to another of the same species and propagated in that fashion. Attempts to immunize against transplantable tumors soon followed. Animals injected with a small number of tumor cells often were able to eliminate those tumor cells—that is, there appeared to be a threshold number of tumor cells required for tumor propagation. Animals that had eliminated a sublethal inoculum of tumor cells were often able to withstand inoculation with a large number of tumor cells that would have been lethal in a naive animal. Furthermore, preexposure to normal tissue of the donor often rendered the recipient resistant to challenge with a lethal number of tumor cells.⁸ These experiments brought into question the idea of tumor-specific antigens and ultimately led to the discovery of major histocompatibility complex (MHC) genes and their products.^{9,10}

Modern tumor immunology finds its roots in the classic experiments of Prehn and Main.¹¹ These investigators demonstrated, in genetically identical mice, that previous exposure to a chemically induced sarcoma rendered animals resistant to challenge with the same tumor, but that these animals would accept normal, nonneoplastic tissues transplanted from the tumor donor animal. Similarly, prior exposure to normal tissues from the donor animal did not render the recipient animal resistant to tumor challenge. These experiments revived the notion that tumor-specific (transplantation) antigens did exist. Subsequent experiments demonstrated that protection afforded by prior exposure to tumor cells was tumor specific.¹² Thus, the host response to transplanted tumors behaved like an adaptive immune response, demonstrating memory and specificity.

Tumor immunity could be passively conveyed from one animal to another by transfer of lymphoid cells.¹³ The relevant cells for protection were shown to be T lymphocytes.¹⁴ Thus, it should have been clear to workers in the field that the relevant tumor antigens were those that could be recognized by T lymphocytes. However, as this work was beginning there was little understanding of how T lymphocytes recognized antigens or how those antigens were processed and presented to the T lymphocyte by antigen-presenting cells (APCs) or the tumor target cells. Much time and effort were expended in search of membrane structures or tumor cell products that would distinguish the tumor from all others. Particularly after the description of monoclonal antibody technology,¹⁵ a fervent search was undertaken to define structures on tumor cells that would be tumor specific and potential targets for therapeutic intervention. Although many cell surface structures were defined, and the contribution to the understanding of biology cannot be overstated, this adventure produced only a single truly specific tumor antigen, the idiotype (Id) of clonally distributed immunoglobulin present on certain lymphomas.

Only recently has convincing evidence for an effect of immunosurveillance been produced.^{16,17,18} This new evidence relies, in great measure, on the availability of genetically manipulated animal systems. A variety of knockout mice with defects in components of immune activation or effector function develop, at high frequency, spontaneous tumors or tumors after carcinogen exposure. Interferon- γ receptor-deficient mice are more likely to develop methylcholanthrene-induced sarcomas and are more susceptible to spontaneous development of sarcomas and lymphomas after loss of p53 alleles.^{19,20} One in two aged perforin-deficient mice develops disseminated lymphomas.²¹ These tumors are rejected by histocompatible wild-type mice through a mechanism dependent on CD8⁺ T lymphocytes. A high incidence of lymphoma is also seen in aged mice deficient in Fas/Fas ligand interactions.²² Aged mice doubly deficient in signal transducer and activation of transcription (Stat) 1 and recombination activating gene (Rag) 2 develop adenocarcinomas (colon, breast, and lung) with high frequency.²³ The frequency and distribution of tumors are increased in the doubly deficient mice over the frequencies and distributions seen in singly deficient mice. Many of these observations have been interpreted as evidence that the primary (both first and predominant) mechanism underlying tumor immunosurveillance is the system of innate immunity.^{16,17,18}

INNATE IMMUNITY AGAINST TUMORS

The innate immune system is a widespread and evolutionarily ancient form of host defense against infection. In recent years, there has been an explosion of information regarding innate immunity, including its role in host defense and its regulation of inflammation and adaptive immunity.^{24,25,26} The innate immune system is made up of many cells. These include dendritic cells (DCs), macrophages, mast cells, neutrophils, eosinophils, natural killer (NK) cells, natural killer T (NKT) cells, and certain subsets of $\gamma\delta$ T cells. Each of these cell types has been implicated in immune responses against tumors.

Phagocytic Cells

Many cells of the innate immune system, including neutrophils, macrophages, and DCs, bear receptors that detect “danger”²⁷

P.1468

in the form of pathogen-associated molecular patterns (PAMPs). Examples of PAMPs include bacterial lipopolysaccharide, lipoprotein, peptidoglycan, and lipoteichoic acids; bacterial CpG DNA; and viral RNA and DNA. These PAMPs are recognized by a variety of pattern recognition receptors (PRRs) expressed by cells of the innate immune system.^{26,28} The innate immune system is said to distinguish “infectious nonself” from “noninfectious self.” The PRRs of the innate immune system are encoded in the germline. Unlike genes of the T cell antigen receptor and the immunoglobulins, these genes do not undergo rearrangement. They are fixed and detect critical microbial components. Engagement of PRRs with PAMPs can result in pathogen uptake and/or cellular activation.^{26,28} One important group of PRRs is the family of evolutionary conserved Toll-like receptors (TLRs), which are critically important for innate immune cell activation. Thirteen TLRs, each with specificity for a different PAMP, have been described in mammals. Other PRR families include the nucleotide-binding domain leucine-rich repeats (NLR) receptors and the caspase recruitment domain helicases.

Neutrophils and macrophages typically exert little antitumor activity, unless these cells are activated by bacteria, their products, or cytokines produced by tumor-specific T cells.^{29,30} Recent studies have suggested that dying tumor cells or damaged tissues can release damage-associated molecular patterns (DAMPs) that can interact with PRRs and thus serve as danger signals.³¹ NLR receptors such as NLRP3 (NLR family pyrin domain-containing 3), which form large cytoplasmic signaling complexes called inflammasomes, are thought to play a critical role in detecting DAMPs and might regulate the development of tumors either positively or negatively.^{32, 33} and ³⁴ Macrophages can kill tumor cells using the same mechanisms utilized for killing of microorganisms. These mechanisms include phagocytosis and release of cytotoxic molecules such as reactive oxygen intermediates and nitric oxide.³⁵ Activated macrophages also produce a variety of cytokines. Among these cytokines, tumor necrosis factor (TNF)- α plays a major role in the tumoricidal effects of macrophages in vitro.³⁶

Another important role of phagocytes in tumor immunity is to present tumor antigens to T lymphocytes. DCs (and other APCs such as macrophages) can phagocytose tumor cells and present tumor antigens in the context of MHC molecules and costimulatory signals to T lymphocytes.³⁷

Natural Killer Cells

It has been recognized for a long time that NK cells kill MHC class I-deficient tumor cells in vivo and in vitro.³⁸ However, the identity and characterization of receptors mediating NK activation proved elusive for many years. Activation of NK

cells now is understood to be dependent on the balance of activating and inhibitory signals emanating from activating and inhibitory receptors on the NK cell surface.^{39,40} These receptors fall into two major structural classes, those of the immunoglobulin superfamily (KIRs and LIRs) and those of the C-type lectin-like family (NKG2D, CD94/NKG2A, and Ly49). Most inhibitory receptors (e.g., CD94/NKG2A, KIR, and Ly49) recognize classic or nonclassic MHC molecules. An activating receptor on NK cells, NKG2D (also called KLRK1), has now been shown to recognize a variety of stress-induced MHC class I-like molecules (e.g., Rae-1, H60, and MICA/B). Of note, activated CD8⁺ T cells and mucosal $\gamma\delta$ T cells also express NKG2D. Another activation receptor on NK cells is Fc γ RIII, which can target NK cells to immunoglobulin G (IgG) antibody-coated tumor cells and induce antibody-dependent cell-mediated cytotoxicity.

NK cells can also discriminate between different allelic variants of MHC molecules.⁴¹ This phenomenon was originally identified in the context of the hybrid resistance transplant model in mice, where parental bone marrow grafts were rejected by a subset of host F1 NK cells. When faced with mismatched allogeneic targets, a subset of donor NK cells can sense the missing expression of self-human leukocyte antigen (HLA) class I alleles and mediate alloreactions. These alloreactive NK cells can improve engraftment and control the relapse of acute myeloid leukemia (AML) in mismatched hematopoietic transplants.^{41,42}

Natural Killer T Cells

NKT cells are a subset of T lymphocytes that share receptor structures and functions with the NK cell lineage.⁴³ Prototypical NKT cells, often referred to as invariant (i)NKT cells, express a semi-invariant T cell receptor (TCR), which is specific for glycolipid antigens presented by the MHC class I-like protein CD1d. Although NKT cells express an antigen-specific receptor that is generated by somatic DNA rearrangement, these cells belong to the innate rather than the adaptive arm of the immune system.⁴⁴ The invariant TCR expressed by NKT cells recognizes a limited set of self- and foreign antigens and, therefore, bears similarity to the PRRs expressed by cells of the innate immune system. Further, NKT cells have a natural, activated phenotype and are unable to generate classic memory responses against their cognate glycolipid antigens.

Mice that are deficient in NKT cells have increased susceptibility to MCA-induced sarcomas, indicating that these cells contribute to natural immunity against tumors.⁴⁵ NKT cells in mice and humans respond to the marine sponge-derived glycosphingolipid α -galactosylceramide (α -GalCer), which has potent antimetastatic activities in mice.⁴⁵ α -GalCer and related NKT cell antigens are being explored as potential cancer immunotherapies.⁴⁶

Mucosal $\gamma\delta$ T Cells

T cells expressing the $\gamma\delta$ TCR are enriched in mucosal tissues such as the mucosa of the gut and skin.⁴⁷ These mucosal $\gamma\delta$ T cells have a highly restricted TCR repertoire, suggesting specificity for a limited set of antigens selectively expressed in their respective epithelial compartments. Like NKT cells, mucosal $\gamma\delta$ T cells can be classified as being at the interface between innate and adaptive immunity.⁴⁴ Epidermal and intestinal $\gamma\delta$ T cells express NKG2D and become activated when NKG2D binds to stress-induced MHC class I-related molecules.

$\gamma\delta$ T cells play a crucial role in immune surveillance against malignant epidermal cells. The incidence of cutaneous malignancies after treatment with a combination of initiator and promoter carcinogens was substantially increased in mice lacking the TCR δ -chain.⁴⁸ Activation of $\gamma\delta$ T cells required both NKG2D and the $\gamma\delta$ TCR, suggesting that engagement of NKG2D with its ligand(s) synergizes with signals received through the autoreactive $\gamma\delta$ TCR.

ADAPTIVE IMMUNITY AGAINST TUMORS

The adaptive immune system is composed of B and T cells that express diverse antigen-specific receptors, immunoglobulins, and TCRs, respectively. Diversity of these receptors is generated by somatic DNA rearrangement, in a process referred to as VDJ recombination.^{49,50} Currently, there is little evidence that adaptive immunity plays a major role in natural immunity against tumors (with the exception of tumors induced by viruses). Although mice lacking T lymphocytes have increased susceptibility to the development of MCA-induced sarcomas, this might be largely due to the lack of iNKT cells and/or $\gamma\delta$ T cells.^{18,51} Nevertheless, it is clear that tumors can induce adaptive immune responses (Fig. 70.1), which can be exploited for the development of cancer immunotherapies.

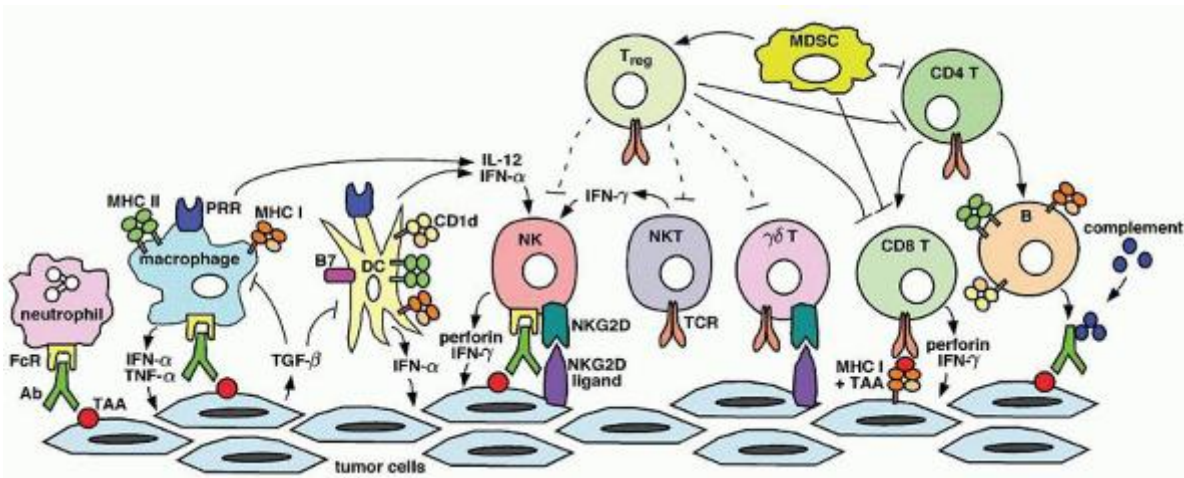

FIGURE 70.1. Immune responses against tumors. A variety of cells and soluble factors of innate and adaptive immunity can participate in immune responses against tumors. Examples of mechanisms that can suppress immune responses against tumors (i.e., production of TGF- β by tumor cells and induction of T_{reg} cells) are also depicted. Ab, Antibody; FcR, Fc receptor; IFN, interferon; MDSC, myeloid-derived suppressor cell; MHC I, major histocompatibility complex class I; MHC II, major histocompatibility complex class II; NK, natural killer; NKT, natural killer T; PRR, pattern recognition receptor; TAA, tumor-associated antigen; TCR, T cell receptor; TGF, transforming growth factor; TNF, tumor necrosis factor; T_{reg}, regulatory T cell.

Antibodies and B Cells

The role of B cells in regulating tumor immunity remains poorly understood. In some tumor models, B cells appear to be important for priming of T cell responses and tumor resistance, whereas in other models, B cells have an inhibitory effect on the generation of cytotoxic T lymphocyte (CTL) responses and tumor rejection.⁵² Nevertheless, it is clear that tumor-bearing hosts can produce antibodies against a variety of tumor antigens.⁵³ However, strong humoral responses rarely correlate with tumor resistance. Nevertheless, antibodies can be utilized for immunotherapy of cancer, in particular tumors of hematopoietic origin. Antibodies may kill tumor cells by activating complement and promoting phagocytosis by macrophages. Alternatively, antibody-coated tumor cells may be killed by antibody-dependent cell-mediated cytotoxicity, in which Fc receptor-bearing NK cells, macrophages, or neutrophils mediate the killing. In addition, in certain cases, antibodies may directly interfere with the growth of tumor cells, as illustrated by the beneficial effects of anti-HER-2/neu antibodies against breast cancer, which likely involves downregulation of the HER-2/neu growth factor receptor.⁵⁴

T Lymphocytes

Classic studies with transplantable tumors have demonstrated a critical role of T lymphocytes in tumor immunity.¹¹ CTLs play a particularly important role in tumor rejection, as these cells can directly lyse malignant cells that display tumor antigens in association with MHC class I molecules.^{55,56} The importance of CD4⁺ T cells in tumor immunity is less clear. CD4⁺ T cells may secrete cytokines that promote the development of CD8⁺ T cell responses, increase the sensitivity of tumor targets to CTL lysis by inducing MHC class I expression, and activate macrophages. Because of their critical role for the development of tumor immunotherapies, we will briefly describe the mechanisms that lead to the induction of T cell responses to tumors.

Antigen Processing and Presentation

T lymphocytes recognize peptide antigens in the context of MHC molecules. These peptides are derived from two distinct pathways.⁵⁷ Peptides representing proteins sampled from the extracellular world are generally presented in the context of class II MHC proteins, whereas peptides resulting from intracellular synthesis of proteins are presented in the peptide groove of the class I MHC proteins (Fig. 70.2). The binding cleft of MHC molecules has a β -pleated sheet floor and α -helical sides. An immunogenic peptide must be capable of forming noncovalent attachments to key residues along the cleft and interacting with the T cell antigen receptor with other residues. The MHC contact residues of the peptide tend to be near the amino and carboxy terminal ends of the peptide. The cleft of the class I MHC molecule has closed ends and accommodates only a peptide of proper length, 9 to 11 amino acids. The cleft of the class II MHC molecule, on the other hand, is open-ended and can bind peptides of more diverse lengths, 10 to 30 amino acids, with most being 12 to 19.⁵⁸

Peptides located in class II MHC molecules are derived from proteins that have been consumed by APCs⁵⁹ (Fig. 70.2A). The proteins are taken up by phagocytosis, or receptor-mediated endocytosis in clathrin-coated pits, or engulfed by pinocytosis. Once internalized, the antigens are located in membrane-bound vesicles called endosomes. The endosomes then become continuous with lysosomes. The enzymology of the endolysosome has been described in some detail.^{59,60} There, in an acidic environment, disulfide bonds in proteins are first reduced by the enzyme GILT (gamma interferon-inducible lysosomal thiol reductase), and the resulting products are subsequently cleaved to peptides by proteases, predominantly cathepsins. The endosome fuses with an exocytic vesicle budding from the Golgi apparatus that contains newly made class II MHC molecules associated with invariant chain, which has been shown to play a critical role in the assembly, intracellular transport, and function of MHC class II molecules.⁶¹ In addition, a chaperone, HLA-DM, plays a critical role in the loading of peptides onto MHC class II molecules. HLA-DM is a peptide exchange factor that binds with empty and peptide-loaded class II molecules in endosomal and lysosomal compartments.⁶¹ In the fused vesicle, peptides are loaded into the class II MHC molecules. Fusion of the endosome with the plasma membrane ultimately displays the class II MHC molecule-peptide complexes on the cell surface.

P.1470

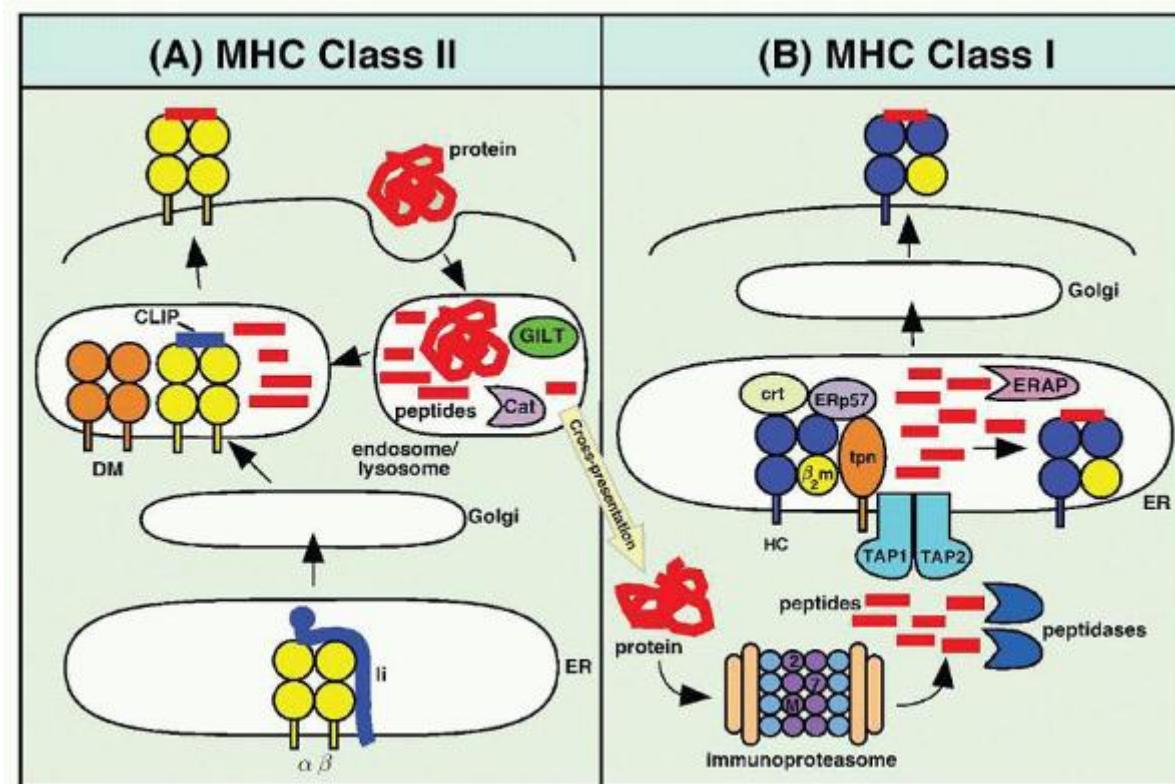

FIGURE 70.2. Presentation of peptides by major histocompatibility complex (MHC) molecules. A: MHC class II-restricted antigen processing and presentation to CD4 T cells. Exogenous protein antigens are taken up by antigen-presenting cells, disulfide bonds are reduced by the interferon (IFN)- γ -inducible lysosomal thiol reductase (GILT), and the proteins are then degraded in endosomal/lysosomal compartments by cathepsins (Cat). MHC class II α and β are synthesized in the endoplasmic reticulum (ER) and associate there with the MHC class II-associated invariant chain (Ii). The class II/Ii complexes then egress to endosomal compartments, where Ii is degraded by cathepsins, until only its class II-associated invariant chain (CLIP) region remains bound by class II. CLIP is then removed from class II by the human leukocyte antigen (HLA)-DM peptide exchange factor. Finally, class II is loaded with peptide and delivered to the cell surface for presentation to class II-restricted CD4 T cells. B: MHC class I-restricted antigen processing and presentation to CD8 T cells. Cytosolic proteins, derived from endogenously synthesized proteins or from cross-presented antigens (as indicated by the arrow), are degraded by immunoproteasomes that contain the interferon IFN- γ -inducible subunits LMP2 (2), LMP7 (7), and MECL-1 (M). Some of the resulting peptides are further processed in the cytoplasm by peptidases and then transported to the lumen of the endoplasmic reticulum (ER) by the transporter of antigen processing (TAP). Some of the peptides undergo

further processing in the ER by ER-associated aminopeptidases (ERAP). Peptide-receptive MHC class I heavy chain (HC)/ β_2 -microglobulin (β_2m) heterodimers in the ER associate with a variety of chaperones, including calreticulin (crt), ERp57, and tapasin (tpn). After binding with peptides, class I molecules undergo a conformational change, permitting their egress to the cell surface for presentation to class I-restricted CD8 T cells.

Peptides are prepared for presentation on class I molecules in a different fashion (Fig. 70.2B). These peptides are derived from intracellular protein synthesis.^{62,63} After protein synthesis, proteins introduced into the cytoplasm become the target of the proteasome, a cytoplasmic organelle whose major function is the degradation of proteins tagged for turnover by the addition of ubiquitin.^{64,65} During conditions of interferon- γ production such as infection, several proteasome subunits (LMP2, LMP7, and MECL-1) become upregulated and are incorporated into newly assembled proteasomes. Proteasomes that include these IFN- γ -inducible subunits are referred to as immunoproteasomes, whereas those that lack these subunits are called constitutive proteasomes. The IFN- γ -inducible proteasome subunits favor the generation of peptides that have increased affinity for MHC class I molecules.^{66, 67} and ⁶⁸ In addition to the proteasome, several cytoplasmic peptidases (e.g., TPPII, LAP, TOP) have been implicated in the generation of antigenic peptides, although they can cleave some epitopes as well.^{65,69} These peptides are then transported into the lumen of the endoplasmic reticulum (ER) by the transporter associated with antigen processing (TAP) proteins.⁶² Within the ER, peptides may be further trimmed by ER-resident aminopeptidases (i.e., ERAP1 and ERAP2).^{65,69,70} Assembly of class I MHC heavy chain molecules with β_2 -microglobulin requires the presence of peptides. Within the ER, empty MHC class I molecules are associated with a variety of chaperones, including calnexin, calreticulin, ERp57, and tapasin. Tapasin is a transmembrane protein that tethers empty class I molecules in the ER to TAP.⁷¹ Emerging evidence suggests that tapasin retains unstable MHC class I molecules within peptide-loading compartments until they bind with high-affinity peptides. The assembled MHC class I-peptide complex transits the Golgi apparatus, proceeds in a vesicle to the cell surface, and is displayed on the cell surface after fusion of the vesicle membrane with the plasma membrane.

There has been a lot of interest in the mechanisms whereby tumor cells initiate CD8⁺ T cell responses. Few tumors are derived from professional APCs and, therefore, do not effectively prime naive CD8⁺ T cells. It has now been established that tumor cells can be processed and presented by host APCs, particularly DCs, in a process that is referred to as cross-presentation (Fig. 70.2).^{72,73} Tumor antigens are then processed inside the APC, and peptides derived from these antigens are displayed on MHC class I molecules for recognition by CD8⁺ T cells. These APCs also express MHC class II molecules and can prime naive CD4⁺ T cells, which may be important for the generation of effective CD8⁺ memory responses. Once tumor antigen-specific CTLs are generated, they can kill tumor cells without the requirement for costimulation. While the precise mechanisms of cross-presentation remain poorly understood,⁷⁴ the concept of cross-presentation has important applications in the development of tumor vaccines.^{72,75}

T Lymphocyte Activation

The goal of antigen processing and presentation is the activation of appropriate T lymphocytes to proliferate, produce cytokines, and promote an immunologic reaction or become cytotoxic cells. Although the interaction of the T cell antigen receptor with antigen-MHC provides specificity of response and initiates the crucial events of activation, the interactions are few and have low affinity.⁷⁶ The interaction between T lymphocytes and APCs or target cells is initially stabilized by a number of nonspecific

P.1471

receptor-counterreceptor interactions, leading to development of an immunologic synapse with its central supramolecular activation cluster.^{77,78,79} Chief among these interactions is the coupling of CD2 on the T lymphocyte with lymphocyte function antigen-3 on the APC. Also involved is the interaction of the lymphocyte function antigen-1 molecule with intercellular adhesion molecule-1 and intercellular adhesion molecule-2. Once the cells have been apposed, the specific interaction of the T cell antigen receptor and the antigen-MHC can occur. It now appears that the T cell proceeds toward activation only if certain threshold numbers of TCR-MHC/antigen interactions occur.⁸⁰

The signal transduction pathways that result in T cell activation have been extensively reviewed,^{81, 82} and ^{83,84} and we will focus here on the most salient features (Fig. 70.3). Ligation of the TCR with an agonist peptide/MHC complex results in phosphorylation of the cytoplasmic portions of the CD3 and ζ components of the TCR. The cytoplasmic domains of CD3 and ζ contain several conserved peptide sequences called immunoreceptor tyrosine-based activation motifs (ITAMs) that are targets for intracellular protein tyrosine kinases that catalyze the phosphorylation of tyrosine residues in various protein substrates. The tyrosine kinase Ick interacts with the cytoplasmic domains of CD4 and CD8 and the tyrosine kinase fyn interacts with the TCR-CD3 complex. Binding of the TCR with peptide/MHC complexes results in receptor clustering,

bringing CD4/CD8 and Lck in close proximity of the ITAMs within the CD3 and ζ -chains. Lck and fyn subsequently phosphorylate tyrosine residues within the ITAMs, which become docking sites for the ζ -associated protein, ZAP-70, a member of the syk family of protein tyrosine kinases. The bound ZAP-70 then becomes a substrate for Lck, and phosphorylation of ZAP-70 results in its activation. Activated ZAP-70 phosphorylates several scaffolding proteins, including LAT (linker of activated T cells) and SLP-76, which, when phosphorylated, serve as docking sites for other proteins that, in turn, activate multiple signaling pathways. One of these signaling pathways involves changes in inositol lipid metabolism. Phospholipase C γ 1 (PLC γ 1) becomes tyrosine

P.1472

phosphorylated and activated as it associates with LAT. Activation of PLC γ 1 leads to the hydrolysis of a minor membrane lipid, phosphatidylinositol biphosphate (PIP $_2$), to yield inositol triphosphate (IP $_3$) and diacylglycerol (DAG). Each of these products activates downstream events. IP $_3$ induces a rapid increase of free Ca $^{2+}$ by release from membrane-sequestered Ca $^{2+}$ stores, whereas DAG and Ca $^{2+}$ activate protein kinase C (PKC) θ . T cell activation also results in the activation of the ras and rac signaling pathways. Adapter proteins that are activated by phosphorylated LAT and SLP-76 result in the activation of the guanine nucleotide exchange factors SOS (son of sevenless) and vav, which activate the ras and rac signaling pathways, respectively.

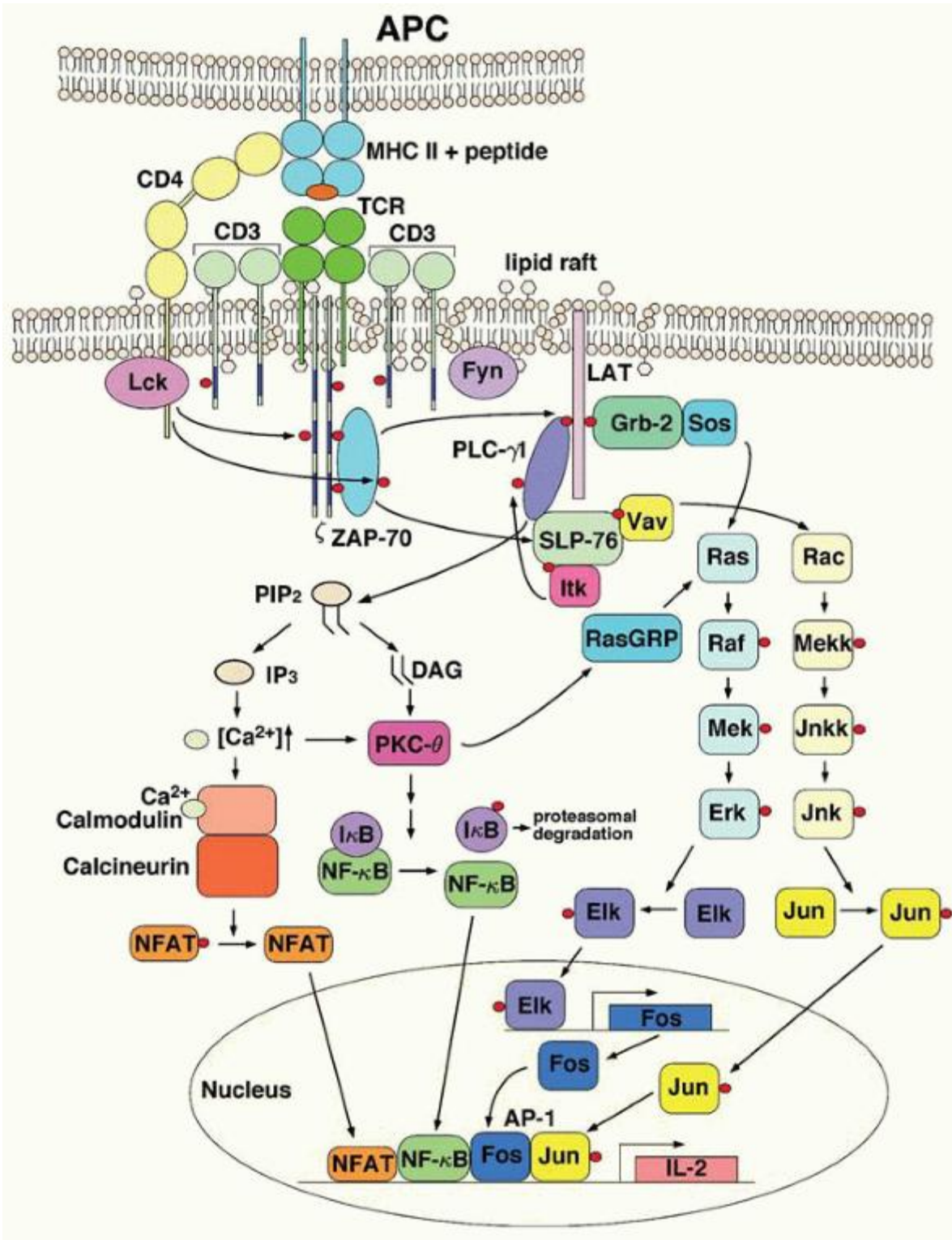

FIGURE 70.3. Overview of signal transduction events involved in T lymphocyte activation. Interaction of the T cell receptor (TCR) and coreceptors with major histocompatibility complex (MHC)-peptide complexes on antigen-presenting cells (APCs) results in multiple signaling events that lead to the activation of several transcription factors that stimulate expression of numerous genes (e.g., the interleukin-2 [IL-2] gene). Note that the precise interactions between different adaptor proteins that participate in proximal TCR signaling events remain incompletely understood. AP, activated protein; DAG, diacylglycerol; Elk, Ets-like transcription factor; Erk, extracellular signal-regulated kinase; Grb, growth factor receptor-bound protein; IκB, inhibitor of κB; IP₃, inositol triphosphate; Itk, interleukin-2-inducible tyrosine kinase; Jnk, Jun N-terminal kinase; Jnkk, Jnk kinase; LAT, linker of activated T cells; Lck, lymphocyte-specific protein tyrosine kinase; Mek,

Mapk/Erk kinase; Mekk, Mapk/Erk kinase; NF, nuclear factor; NFAT, nuclear factor of activated T cells; PIP₂, phosphatidylinositol biphosphate; PKC, protein kinase; PLC, phospholipase C; RasGRP, Ras guanyl nucleotide-releasing protein; SLP-76, SH2 domain-containing leukocyte protein, 76-kD; Sos, son of sevenless; ZAP-70, ζ-associated protein kinase, 70-kD.

These signaling events ultimately result in the activation of a number of transcription factors, including NFAT, NF-κ B, and AP-1. Cytosolic Ca²⁺ binds with the Ca²⁺-dependent protein calmodulin, and Ca²⁺-calmodulin complexes subsequently activate several enzymes, including the serine/threonine phosphatase calcineurin. Calcineurin then dephosphorylates NFAT, which uncovers a nuclear localization signal that permits NFAT to translocate to the nucleus. Activation of NF-κB is dependent, at least in part, on activated PKCθ. NF-κB is normally found in the cytoplasm in association with a protein called inhibitor of κB (IκB). TCR signals result in phosphorylation of IκB, which is then targeted for degradation by the proteasome. Release of IκB uncovers a nuclear translocation signal in NF-κB that permits its translocation to the nucleus. AP-1 is a transcription factor composed of the proteins Fos and Jun, which are activated by the ras and rac signaling pathways, respectively.

The net result of this extremely complex activation system is the expression of new proteins, the acquisition of functional capacity, or the ability to proliferate. T lymphocyte activation is best understood as a culmination of events leading to IL-2 production.⁸⁵ The constraints on production of this cytokine are more rigorous than those relevant for production of other gene products (such as IL-2 receptor α-chain and transcription factors). The promoter of the IL-2 gene is made up of a number of binding sites for transcription factors, including two NFAT sites, an NF-κB site, and an AP-1 site.⁸⁶ The combination of production of IL-2 receptor α-chain and IL-2 provides an adequate stimulus for the T lymphocyte to successfully proliferate, giving rise to the antigen-specific clonal expansion of lymphocytes characteristic of immunologic responses. However, there are extraordinary controls against inappropriate activation of T lymphocytes.⁸⁷ In addition to a first signal delivered via the T cell antigen receptor complex, full activation of T cells also requires a second signal.⁸⁸ The best characterized origin of these second signals is the interaction of CD28 on the T lymphocyte surface with its cognate ligands CD80 (B7-1) and CD86 (B7-2) on the APC, the most potent of which is the DC. Failure to receive a second signal can lead the T lymphocyte to undergo anergy or apoptosis. Activation of T cells is also regulated by a variety of negative signals, including inhibitory receptors of the CD28 family such as CTLA-4 (cytotoxic T lymphocyte-associated protein 4), which interacts with CD80 and CD86, and PD-1 (programmed death-1), which interacts with PD-L1 and PD-L2.⁸⁸

TUMOR-ASSOCIATED ANTIGENS

Tumor antigens are like all other antigens of adaptive immunity. That is, with few exceptions, they are peptides that are presented to T lymphocytes in the cleft of an MHC-encoded protein.⁵⁵ The nature of peptide antigens responsible for immune responses to tumors has been described in a classic set of experiments.⁵⁵ In essence, two approaches were used. Neither made assumptions regarding the nature of the antigenic peptides. In the first approach, tumor-derived cloned CTLs were established. Next, a library of tumor complementary DNA or genomic DNA was constructed and used to transfect cells expressing appropriate MHC molecules but lacking the tumor-specific epitope. Transfected cells were tested for their ability to activate the tumor-specific CTLs. The transfected DNA was then recovered and sequenced, thus identifying the gene of origin. In the second approach, MHC molecules were isolated from tumor cells. Subsequently, peptides were eluted from the MHC molecules and fractionated chromatographically. These peptide fractions were then used to load APCs and presented to tumor-specific CTLs. Peptide fractions that stimulated T cell responses were then sequenced using conventional Edman degradation or tandem mass spectrometry. These approaches have revealed some surprising characteristics of tumor-specific antigens. Most tumor-specific antigenic peptides discovered thus far have been derived from proteins not usually expressed in any normal adult tissues⁸⁹ (with the exception of testis and ovary), such as P1A^{90,91} and MAGE-1,^{92,93} or they represent differentiation antigens characteristic of the cellular lineage of the tumor, such as tyrosinase,^{94, 95} and ⁹⁶ gp100,^{97, 98} and ⁹⁹ and MART1/Aa^{100,101} in melanoma.

Early definition of tumor antigens focused on MHC class I-restricted peptides.¹⁰² This seemed to be the obvious approach because most tumors express MHC class I structures, but few express MHC class II molecules. Also, the point of immunotherapy was to eliminate tumors—a job for cytolytic cells (i.e., for CD8⁺ cytotoxic lymphocytes that recognize antigen in the context of class I MHC molecules). Early clinical immunization trials^{103, 104} and ¹⁰⁵ demonstrated the feasibility and the potential efficacy of immunotherapy with peptides recognized by CD8⁺ T cells. However, immune responses were, in general, weak and short-lived. At the same time that the trials were being conducted, there was a growing realization of the importance of CD4⁺ T cells in the immune response against tumors.^{102,106,107} Techniques similar to those used to define antigens recognized by CTLs have been used to define antigens for CD4⁺ T cells. However, these techniques are slow and labor intensive. A genetic targeting expression system has been designed to expedite antigen

screening.¹⁰⁷ It is likely that incorporation of both MHC class I- and II-restricted epitopes in tumor vaccines will be required to generate potent antitumor responses.¹⁰⁸

While this direct approach to tumor antigen recognition has proceeded, other investigators have asked whether certain appealing target proteins could be immunogenic. In particular, molecules involved in the process of malignant transformation provide attractive targets for therapeutic intervention.¹⁰⁹ Because loss variants of tumor cells bearing these oncogenic proteins would presumably be nonmalignant,¹¹⁰ an immunologic assault on these proteins might be particularly effective. Evidence has been provided that immune responses to both mutated and overexpressed oncogenic proteins can occur in patients with malignancy or can be elicited in animals. Target oncogenic proteins include mutated Ras,¹¹¹ HER-2/Neu,^{112,113} BCR-ABL,^{114,115} PML-RAR α ,¹¹⁶ and mutated p53.¹¹⁷

A newer approach to definition of tumor-specific antigen targets for humoral immunity, termed SEREX, has been introduced.¹¹⁸ In the SEREX approach, a complementary DNA library is prepared from a patient's tumor specimen, packaged into phage vectors, and expressed in bacteria. Recombinant proteins from bacterial clones are transferred to nitrocellulose membranes and identified as relevant antigens by reactivity with IgG antibodies present in the patient's serum. Early studies defined three classes of antigens: (a) known tumor antigens, such as MAGE-1, MAGE-4a, and tyrosinase; (b) products of known genes, such as restin; and (c) unknown gene products.^{119,120} Because the cellular and humoral arms of immunity work in concert, it is likely that targets of antibody production will also prove to be targets of cellular immunity. The SEREX method provides a direct approach to the definition of potentially relevant tumor antigens.

P.1473

TUMOR-HOST INTERACTIONS: BEYOND IMMUNOSURVEILLANCE

While the immune system can protect against the development of tumors, interactions between developing tumors and the host are complex. Tumors often develop means to evade immune responses, and tumors that develop in immunocompetent hosts are often more immunogenic than those that develop in immunodeficient hosts. Finally, it is now also well-recognized that the immune system can play both tumor-suppressing and tumor-promoting roles.

IMMUNE EVASION BY TUMORS

Many tumors have devised ways to evade immune responses.^{18, 56, 121} First, tumors may lose expression of the antigens that were recognized by antibodies or CTLs. Second, many tumors downregulate expression of MHC class I molecules, rendering these cells resistant to lysis by CTLs.^{122,123} Third, tumors may fail to induce effective CTL responses because of the absence of costimulatory molecules and/or resistance to uptake by APCs and cross-presentation.¹²⁴ Instead of inducing an effective immune response, some tumors may actively promote tolerance induction, by inducing anergy, exhaustion, or deletion of tumor antigen-specific T cells.^{125,126} This might involve the generation of tumor antigen-specific regulatory T cells (Tregs),¹²⁷ induction of inhibitory costimulatory molecules such as CTLA-4 and PD-1 on tumor antigen-specific T cells,¹²⁶ and/or expansion of myeloid-derived suppressor cells, a heterogeneous group of myeloid progenitor cells and immature myeloid cells that can inhibit lymphocyte function.¹²⁸ Fourth, tumor cells may actively suppress immune responses by secretion of suppressive cytokines such as TGF- β or by expression of the Fas ligand, which may engage with Fas on lymphocytes to induce apoptosis.¹²⁵ Fifth, the tumor microenvironment, most notably the tumor stroma, may be critical in preventing immunologic destruction of tumor cells by effectively generating an immune privileged site.

Immune Sculpting of Tumors

In 2001, an important study showed that the immune system not only can protect against the development of tumors, but also can influence the quality of tumors—that is, the immune system of the host in which a tumor develops influences the immunogenicity of the tumor.²³ These investigators showed that RAG2-deficient mice not only develop MCA-induced tumors at higher frequency, but that a substantial portion of these tumors was spontaneously rejected upon transplantation in syngeneic immunocompetent mice. In sharp contrast, tumors derived from immunocompetent mice usually grew progressively in immunodeficient mice. Thus, these findings demonstrated that the immune system not only protects the host from tumor formation but also sculpts the immunogenicity of the tumors, in a process that is now referred to as cancer immunoediting.^{17,18,129} Cancer immunoediting has been posited to proceed through three sequential stages: (a) an elimination phase where the immune system recognizes and destroys tumors before they become clinically apparent, (b) an equilibrium phase where tumor cells that escaped the elimination phase are continuously destroyed, with emergence of resistant tumor cell variants due to immune pressure, and (c) an escape phase where tumor cells that have

successfully evaded immune responses progressively grow. The cancer immunoeediting hypothesis represents an extension or modern version of the immunosurveillance hypothesis.

Tumor-promoting Immune Responses

Discussion of tumor-host interactions would not be complete without at least a mention of the tumor-promoting role of the immune system.¹³⁰ Many environmental factors, including chronic infections, tobacco smoke, and inhaled pollutants, as well as dietary factors and obesity, are associated with a low-level chronic inflammation and represent risk factors for cancer development. Chronic inflammation can contribute to tumor genesis at all stages, by generating nontoxic stress during the initiation of cancer, inducing cellular proliferation to promote cancer development, and enhancing angiogenesis and tumor invasion to promote cancer progression.¹³⁰

APPROACHES TO IMMUNOTHERAPY

Immunotherapy is the use of the immune system or its components to target and eradicate tumors. B cell lymphomas are considered to be the most immune responsive of all human cancers.¹³¹ They can undergo spontaneous regression,¹³² and partial responses have been elicited through the use of nonspecific immune activators, such as bacillus Calmette-Guérin and IL-2.^{133,134} Thus, follicular B cell lymphomas represent excellent candidates for immunotherapy.

Antibody Approaches

The most common form of immunotherapy employed in the treatment of cancer is passive immunotherapy, which involves the administration of manufactured antibodies that target a particular antigen (Table 70.1). Monoclonal antibodies have emerged as a potent and effective molecularly targeted therapy for human cancer, usually in combination with chemotherapy.^{135,136} Therapeutic mAbs, such as rituximab and alemtuzumab, are examples of a passive approach. Currently, several B lymphocyte antigens, including CD20, CD22, and CD52, have been utilized as targets for immunotherapy. These targets, while found uniformly on lymphoma cells, are also expressed on normal immune system components, such as normal B lymphocytes.^{134,137,138} Personalized immunotherapy, also referred to as Id vaccine therapy, is a patient- and tumor-specific approach. This modality targets unique protein determinants of the immunoglobulin molecules produced by the malignant B cell clone and does not appear to result in depletion of normal lymphocytes or subsequent impairment of the immune system. This technique stimulates the patient's immune system to attack the tumor through the use of both the humoral and cellular arms of the immune system. As a result, immunologic memory may be established which could translate into long-term remission. Some of these are being tested in phase II and III trials (Fig. 70.4).¹³⁹

TABLE 70.1 PERSONALIZED ACTIVE IMMUNOTHERAPY VERSUS PASSIVE IMMUNOTHERAPY

Personalized Active Immunotherapy	Passive Immunotherapy
Tumor-specific	Not tumor-specific
Stimulates host immuneresponse	Does not stimulate host immune response
Induces immunologic memory	Temporary antitumor effect
May produce long-term immunity	Requires retreatment
Induces both the cellular and humoral arms of the immune system	Induces the humoral arm of the immune system only (ADCC, CDC)
Requires patient tumor sample for production	Does not require patient tumor sample

ADCC, antibody-dependent cellular cytotoxicity; CDC, complement-dependent cytotoxicity.

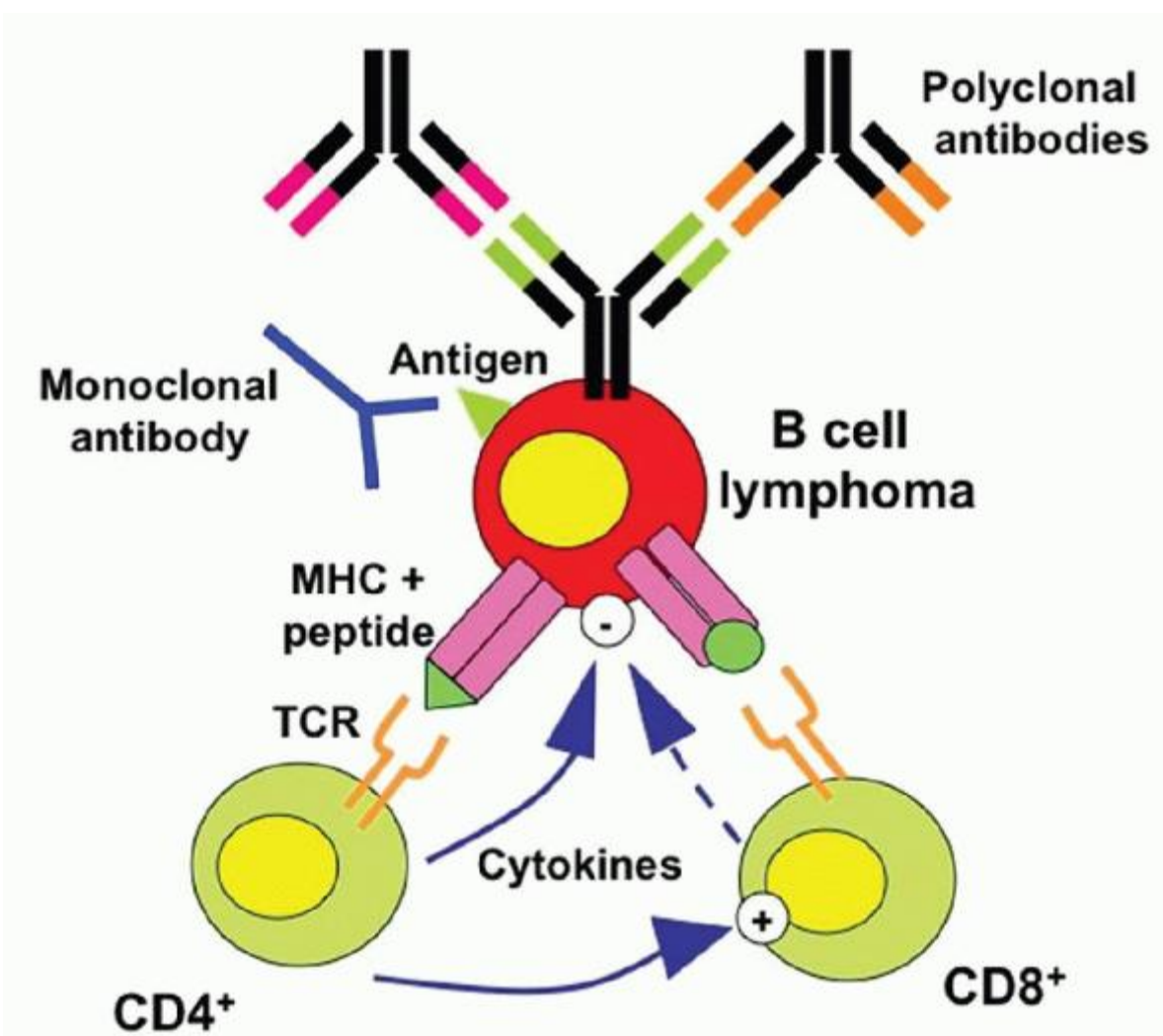

FIGURE 70.4. Idiotype as a tumor-specific antigen for B-lymphoma cells. Each B lymphocyte expresses an immunoglobulin molecule on its surface, the idiotype (Id) protein, which is capable of recognizing and binding to a unique antigen. When B lymphocytes undergo malignant transformation, the Id sequences are maintained by the malignant clones and can thus serve as tumor-specific antigen. MHC, major histocompatibility complex; TCR, T cell receptor. (Adapted from Vose JM. Personalized immunotherapy for the treatment of non-Hodgkin's lymphoma: a promising approach. *Hematol Oncol* 2006;24:47-55.)

Unconjugated Antibodies

Unaltered antibodies have been used since the earliest trials of monoclonal antibody therapy in humans.^{140, 141} and ¹⁴² In early trials, success was limited by the absence of suitable tumor cell surface targets, antigenicity of first-generation (murine) mAbs in humans, modulation of the target structure from the tumor cell surface, and poor recruitment of immune effector mechanisms.^{143,144} However, enthusiasm for this approach was rekindled by the enormous success of genetically engineered, chimeric, or fully humanized versions of mAbs, most notably rituximab for lymphoid malignancies and trastuzumab in solid tumors.¹⁴⁴

Rituximab is a chimeric monoclonal antibody with humanized framework and Fc regions. It is directed against the CD20, pan B cell antigen. CD20 is present on pre-B cells and mature B cells, but not on precursor cells or terminally differentiated plasma cells. The function of CD20 remains poorly understood,¹⁴⁵ although it has been implicated in B cell activation, regulation of B cell growth, and regulation of transmembrane calcium flux. The antibody fixes human complement and elicits antibody-dependent cellular cytotoxicity (ADCC). Rituximab was approved for use as monotherapy in patients with low-grade or follicular CD20⁺ non-Hodgkin lymphoma (NHL) in 1997. In the pivotal trial involving 166 patients, reported by McLaughlin et al.,¹⁴⁶ patients had relapsed or chemotherapy-resistant disease. Patients received four weekly infusions of rituximab at 375 mg/m². Rituximab produced a tumor response in one-half of the patients, with a median duration of

response of 11.8 months, comparable to the patients' response duration on the last chemotherapy treatment. Human antichimeric antibody responses were uncommon. The most common adverse experience associated with rituximab was a constellation of acute infusion-related events, including chills, fever, headache, rhinitis, pruritus, vasodilation, asthenia, and angioedema. This syndrome can progress to hypotension, urticaria, bronchospasm, and, rarely, death. The risk is particularly great in patients with high circulating white cell counts.¹⁴⁷ Other toxicities were, in general, mild and infrequent.¹⁴⁸ Neutropenia and thrombocytopenia were unusual. Circulating B cells were depleted and remained low until recovery at a median of 12 months. Immunoglobulin levels, however, remained normal. No increased incidence of infections was seen. Rituximab was evaluated again in the relapsed, refractory, low-grade, or follicular NHL patient population, using eight weekly infusions rather than four.¹⁴⁹ This extended regimen produced a response rate of 57% and a time to progression (TTP) in responding patients of more than 19.4 months. Adverse event reporting was commensurate with the longer treatment period.

Davis et al.¹⁵⁰ reported a response rate of 43% and a TTP of 8.1 months in the patients with a significant poor prognostic factor, importantly in patients with low-grade or follicular NHL who had bulky disease, using the standard 4-infusion regimen. These investigators also showed an overall response rate (ORR) of 40% in patients who had progressed after an initial response to rituximab, with an estimated median TTP for responding patients of 17.8 months.¹⁵¹

Rituximab has been used in the first-line treatment of patients with indolent lymphoma, both as monotherapy and in combination with chemotherapy. Hainsworth¹⁵⁰ reported the results of rituximab as monotherapy in 39 previously untreated patients. Patients received rituximab \times 4 at the usual dose and schedule, with an ORR of 54%. Patients who had responded or who had stable disease were treated with an additional four weekly treatments of rituximab at 6 months intervals to a maximum of 4 treatment cycles. The ORR rose to 72% after the second course of treatment. Progression-free survival (PFS) at 1 year was 77%. The addition of rituximab to cyclophosphamide, hydroxydaunomycin, oncovin (vincristine), and prednisone (CHOP) chemotherapy produced impressive results. Patients were treated with six infusions of rituximab, one associated with each of six cycles of CHOP. In 40 patients with newly diagnosed ($n = 31$) or relapsed/refractory ($n = 9$) low-grade or follicular NHL, rituximab plus CHOP produced an ORR of 95% and complete response (CR) rate of 55%. With a median follow-up of 29 months, median duration of response and median TTP had not been reached. Eight of 18 patients tested for the BCL-2 [t(14;18)] translocation by PCR testing were positive at initiation of therapy. Seven of these 8 patients, after therapy, became negative for the translocation. The authors concluded that the addition of rituximab to CHOP produced benefits in efficacy parameters without significant additional toxicity. Elimination of PCR positivity for the t(14;18) translocation had not been previously reported with CHOP alone.

Rituximab also has been used with success in patients with more aggressive lymphomas. Vose et al.¹⁵¹ reported the results of rituximab plus CHOP chemotherapy (again using 6 infusions of rituximab in association with 6 cycles of CHOP) in 33 previously untreated patients with advanced aggressive B cell NHL. The combination produced an ORR of 94% and a CR rate of 61%. With a median observation time of 26 months, 29 of 31 patients achieving a remission were in continuing remission at the time of the report. Thirteen patients were BCL-2 positive at study entry. Eleven of these 13 patients became BCL-2 negative after treatment, and 10 of the 11 remained BCL-2 negative. The authors concluded that the results were achieved without significant added toxicities above those expected with CHOP. The Groupe d'Etude des Lymphomes de l'Adulte undertook a study to compare the utility of CHOP with that of rituximab plus CHOP in elderly patients with diffuse B cell lymphoma.¹⁵² Patients between the ages of 60 and 80 years with untreated, diffuse large B cell lymphoma were eligible for the study. Patients were randomly assigned to receive 8 cycles of CHOP chemotherapy (197 patients) or to receive 8 cycles of CHOP, each given after an infusion of rituximab (202 patients). Rituximab plus CHOP produced a superior rate of remission, 76% versus 63% ($P = 0.005$). With

P.1475

a median follow-up of 2 years, event-free and overall survivals (OSs) were significantly higher in the rituximab plus CHOP group ($P < 0.001$ and $P = 0.007$, respectively). These results were achieved without a significant incremental increase in toxicity. The addition of rituximab to CHOP reduced the risk of treatment failure (risk ratio, 0.54; 95% confidence interval [CI]: 0.44, 0.77) and the risk of death (risk ratio, 0.64; CI: 0.45, 0.89). The addition of immunotherapy to standard chemotherapy had accomplished what 25 years of chemotherapy manipulation had failed to do (i.e., improve on the results of CHOP chemotherapy).^{153,154} Maintenance rituximab has also been found to prolong event-free survival (EFS) and response duration in follicular lymphoma.¹⁵⁵ In subsequent ongoing randomized phase III studies,^{156,157} rituximab maintenance regimen provided significant PFS and OS at 3-year¹⁵⁶ and 4-year¹⁵⁷ follow-up assessments in both previously treated¹⁵⁶ and untreated¹⁵⁷ patients with follicular NHL, compared with no further treatment, though no difference in OS has been reported by other investigators.¹⁵⁸

The mechanism by which rituximab produces these impressive results is less clear. A number of possible mechanisms have been considered: initiation of complement-mediated cell lysis, induction of ADCC, and signaling via CD20 leading to programmed cell death and/or sensitization to cytotoxic drugs. Pretreatment lymphoma cells from 29 patients were examined by flow cytometry for expression of complement inhibitors CD46, CD55, and CD59.¹⁵⁹ Expression of these cell surface inhibitors of complement activation was not predictive of outcome to rituximab therapy. Considerable evidence suggests that induction of ADCC plays an important role in rituximab's antilymphoma effects. A rituximab-like antibody for which an IgG4 γ framework was substituted for the IgG1 framework of rituximab was incapable of producing B cell depletion in primates.¹⁶⁰ Rituximab was relatively ineffective in eliminating Raji B cell implants in FcR γ -/-/nu/nu knockout mice compared to nu/nu mice.¹⁶¹ These mice lack the activating receptor for Fc portions of antibodies, a critical component of the antibody-dependent cell-mediated cytotoxicity mechanism. In patients, response to rituximab has been shown to be associated with homozygosity for the high-affinity allotype of the Fc γ R1IIa receptor.¹⁶² Evidence also exists that rituximab signaling or interference with normal signaling via CD20 may directly induce apoptosis or sensitize cells to the deleterious effects of chemotherapeutic agents.¹⁶³ A direct, growth inhibitory effect of rituximab, with accompanying apoptosis, on cell lines cultured in the absence of complement was demonstrated.¹⁶⁴ Anti-CD20-associated apoptosis has been associated with upregulation of the proapoptotic protein, Bax¹⁶⁵ and downregulation of antiapoptotic protein BCL-2 through inactivation of STAT3.¹⁶⁶ Downregulation of STAT3 appears to be a result of downregulation of an IL-10 autocrine pathway.¹⁶⁷ These changes and/or others may be responsible for increased sensitivity to chemotherapeutic agents.¹⁶⁸

In the wake of the success of rituximab, a number of other antilymphoma mAbs have entered the clinic.¹⁶⁹ Alemtuzumab is a humanized IgG1 κ monoclonal antibody directed against the CD52 cell surface antigen.¹⁴⁴ CD52 is expressed on normal and malignant lymphocytes of B- and T cell lineage, as well as NK cells, monocytes, and macrophages. Alemtuzumab is indicated for the treatment of B cell chronic lymphocytic leukemia (CLL) in patients who have been treated with alkylating agents and who have failed fludarabine therapy. The pivotal clinical trial was carried out in 93 patients with fludarabine-refractory CLL.¹⁷⁰ Alemtuzumab produced a response rate of 33%. Virtually all of the responders were partial responders; the CR rate was 2%. Median duration of response was 7 months. Median TTP was 4.7 months for the group as a whole; 9.5 months for responders. The most common adverse events were infusion related—most were grade 1 or 2 in severity, including rigors in 90% of patients (grade 3 in 14%), fever in 85% of patients (grade 3 or 4 in 20%), nausea in 53% of patients, and vomiting in 38% of patients. Infusion-associated side effects declined with subsequent infusions. During the study, 28% of patients experienced dyspnea, 17% experienced hypotension, and 3% experienced hypoxia. Overall, 55% of patients developed an infection during the study. Approximately one-half of these infections were considered serious (grade 3 or 4). Septicemia occurred in 15% of patients, and two deaths resulted. Opportunistic infections occurred in 12% of patients. Ten percent of patients died during or within 30 days of treatment—one-third of these were attributed to progressive disease. Twenty-four percent of patients discontinued treatment because of a drug-related side effect. Most patients who discontinued had not responded to therapy. Serious infusion-related events associated with alemtuzumab appear to result from ligation of CD16 on NK cells resulting in what has been termed cytokine storm—release of IL-6, TNF- α , and interferon.¹⁷¹ Prolonged immunosuppression after use of alemtuzumab can result in opportunistic infections.¹⁷² Treatment schemas now include the routine use of prophylaxis with both antibiotics and antivirals.

To improve on the immunogenicity and efficacy of rituximab, the last few years have seen the development of new generations of anti-CD20 monoclonal antibodies (mAbs) with enhanced antitumor activity resulting from increased complement-dependent cytotoxicity (CDC) and/or ADCC and increased Fc binding affinity for the low-affinity variants of the Fc γ R1IIa receptor (CD16) on immune effector cells. These second-generation mAbs, such as ofatumumab, veltuzumab, and ocrelizumab, are in clinical development. They are humanized or fully human to reduce immunogenicity, but with an unmodified Fc region. Ofatumumab is a fully human anti-CD20 IgG1 mAb in clinical development for hematologic malignancies and autoimmune diseases. Ofatumumab specifically recognizes an epitope encompassing both the small and large extracellular loops of the CD20 molecule, and is more effective than rituximab at CDC induction and killing target cells. Veltuzumab (IMMU-106, hA20) is a humanized anti-CD20 mAb with complementarity-determining regions similar to rituximab. This antibody has enhanced binding avidities and a stronger effect on CDC compared to rituximab. Ocrelizumab is a humanized mAb with the potential for enhanced efficacy in lymphoid malignancies compared to rituximab because of increased binding affinity for the low-affinity variants of the Fc γ R1IIa receptor. Third-generation mAbs are also in clinical development. They are also humanized mAbs, but in addition they have an engineered Fc to increase their binding affinity for the Fc γ R1IIa receptor. Third-generation mAbs also in clinical development include AME-133v, PRO131921, and GA-101 (Table 70.2), with enhanced affinity for the Fc γ R1IIa receptor and an enhanced ADCC activity compared to rituximab.¹⁷³

Two other mAbs with potential utility in the treatment of lymphoma are in early clinical development.^{169,174} Epratuzumab is a humanized IgG1 monoclonal antibody directed against the CD22 antigen. CD22 is a pan-B cell antigen with distribution similar to that of CD20. Epratuzumab has a favorable safety profile in early trials. Approximately 50% of follicular

lymphoma patients and 25% of diffuse large-cell lymphoma patients responded in a small phase II trial. Some of the responses have been long-lived. A recent phase II trial testing the safety and efficacy of combining epratuzumab with R-CHOP (ER-CHOP) in untreated DLBCL showed that the addition to standard R-CHOP, E 360 mg/m² intravenously, administered for 6 cycles in 107 patients, showed similar toxicity to standard R-CHOP. ORR in the 81 eligible patients was 96% (74% CR/CR unconfirmed [Cru]) by computed tomography scan and 88% by positron emission tomography. By intention to treat analysis, at a median follow-up of 43 months, the EFS and OS at 3 years in all 107 patients were 70% and 80%, respectively. Comparison with a cohort of 215 patients who were treated with R-CHOP showed improved EFS in the ER-CHOP

P.1476

patients. ER-CHOP was well tolerated and results appear promising as a combination therapy.¹⁷⁵

TABLE 70.2 ANTI-CD20 MONOCLONAL ANTIBODIES (mAbs) APPROVED OR POTENTIALLY USEFUL FOR LYMPHOID MALIGNANCIES

mAb	Company	Antibody characteristics	Direct Comparison with			rituximab
			ADCC	CDC	effects	
Rituximab (Rituxan [®] , Mabthera [®])	Hoffman La Roche	Type I, first-generation mouse/human chimeric IgG1	++	++	+	
Rituximab (Rituxan [®] , Mabthera [®])	GlaxoSmithKline plc/Genmab A/S	Type I, first-generation, human IgG1	++	+++++		Binding to different CD20 epitope; more effective at CDC
Veltuzumab (IMMU-106, hA20)	Immunomedics Inc.	Type I, second-generation, humanized IgG1	++	++	+	Slower off-rate, enhanced binding avidity, a superior CDC
Ocrelizumab	Genentech Inc./Biogen Idec Inc./Chugai Pharmaceutical Co. Ltd/Roche Holding Ag	Type I, second-generation, Humanized fusion IgG1	+++	+/-	+	Binding to different CD20 epitope, enhanced ADCC, reduced CDC, enhanced affinity for FcγRIIIa RIIIa
PRO131921	Genentech, Inc.	Type I, third-generation, humanized fusion IgG1	+++	+++	+	Improved binding to FcγRIIIa, better ADCC, superior antitumor efficacy
AME-133 v (LY2469298)	Lilly	Type I, third-generation, humanized fusion IgG1	+++	++	++	Enhanced affinity for FcγRIIIa, superior ADCC
GA-101 (RO5072759)	Glycart Biotechnology AG, Genentech, F Hoffmann-La Roche Ltd	Type II, third-generation, humanized IgG1	++++	-	++++	Superior ADCC and direct cell killing
TRU-015	Trubion Pharmaceuticals Inc.,	SMIP-derived humanized fusion	+++	+	?	Single-chain polypeptide, enhanced

Pfizer Inc.

protein

ADCC, reduced CDC

ADCC, antibody-dependent cellular cytotoxicity; CDC, complement-dependent cytotoxicity; IgG, immunoglobulin G; SMIP, small modular immunopharmaceutical; + indicates low cytotoxicity; ++ indicates intermediate cytotoxicity; +++ indicates high cytotoxicity; ++++ indicates very high cytotoxicity; +/- indicates very low cytotoxicity; - indicates lack of cytotoxicity; ? indicates cytotoxicity unknown.

Reproduced with permission from Robak et al. *BioDrugs* 2011;25:13-25.

Apolizumab is a humanized IgG1 monoclonal antibody that binds to a variant of the HLA-DR β -chain. The antibody induces complement-mediated lysis, ADCC, and tyrosine phosphorylation signaling events in cell lines in vitro. The antibody binds to approximately 70% of lymphoma specimens. Administration of the antibody to patients results in typical infusion-related side effects. Four of 8 patients with follicular lymphoma responded to apolizumab. A phase I/II dose-escalation study of thrice-weekly apolizumab (1.5, 3.0, 5.0 mg/kg/dose) for 4 weeks in relapsed CLL resulted in significant toxicity and lack of efficacy; thus, further clinical trials of apolizumab were discontinued, as were other trials in lymphoma and solid tumors.¹⁷⁶ Milatuzumab (hLL1, IMMU-115; Immunomedics) is a fully humanized mAb specific for CD74, a cell surface-expressed epitope of the HLA class II-associated invariant chain. CD74 plays an important role as an accessory signaling molecule and survival receptor in the maturation and proliferation of B cells by activating the PI3K/Akt and the NF- κ B pathways.¹⁷⁷ Milatuzumab demonstrated antiproliferative activity in transformed B cell lines, improved survival in preclinical models, and is presently being evaluated for the treatment of several hematologic malignancies.

Inroads are being made in other hematologic cancers. In multiple myeloma, it was recently reported that the cell surface glycoprotein CS1 (CD2 subset 1, CRACC, SLAMF7, CD319) was highly and universally expressed on myeloma cells while having restricted expression in normal tissues. Preclinical studies showed that elotuzumab (formerly known as HuLuc63), a humanized mAb targeting CS1, could induce patient-derived myeloma cell killing within the bone marrow microenvironment using a SCID-hu mouse model and that the CS1 gene and cell surface protein expression persisted on myeloma patient-derived plasma cells collected after bortezomib administration. In vitro bortezomib pretreatment of myeloma targets significantly enhanced elotuzumab-mediated ADCC, both for OPM2 myeloma cells using NK cells or peripheral blood mononuclear cells from healthy donors and for primary myeloma cells using autologous NK effector cells. In an OPM2 myeloma xenograft model, elotuzumab in combination with bortezomib exhibited significantly enhanced in vivo antitumor activity. Elotuzumab is currently in a phase I clinical trial in relapsed/refractory myeloma.¹⁷⁸ In AML, one strategy for the development of mAbs targeting human AML stem cells involves first identifying cell surface antigens preferentially expressed on AML LSC (leukemia stem cell) compared with normal hematopoietic stem cells. In recent years, a number of such antigens have been identified, including CD123, CD44, CLL-1, CD96, CD47, CD32, and CD25. Moreover, mAbs targeting CD44, CD123, and CD47 have demonstrated efficacy against AML LSC in xenotransplantation models. Hopefully, these antibodies will ultimately prove to be effective in the treatment of human AML.¹⁷⁹

Anti-idiotypic Therapy

Much time and energy were expended searching for tumor antigens, particularly after the development of mAb techniques.¹⁷ These brute-force immunization, hybridization, and screening procedures yielded little. They defined only a single truly tumor-specific antigen. That was the Id of clonally distributed antibody expressed on the surface of certain B cell lymphomas. Because it represents a unique protein structure within the combining site of the antibody, the Id can serve as an antigen for antibody production. This fact was demonstrated by Sirisinha and Eisen¹⁸⁰ in the early 1970s. Furthermore, they demonstrated that an immunologic response to Id could lead to tumor protection.¹⁸¹

Levy and Miller¹⁸² have explored the utility of anti-Id strategies in indolent B cell lymphoma over many years. Initially, these investigators raised custom-made anti-Id mAbs¹⁸³ for passive administration. A first patient with far advanced,

P.1477

chemotherapy-refractory disease received anti-Id mAbs. Gradual reductions in serum Id and tumor volume were noted. The patient then entered a long-term complete remission.¹⁸⁴ In an initial series of patients treated with anti-Id therapy, 11 patients were reported.¹⁸⁵ In this group, a second near-complete remission, four partial remissions, and five insignificant responses were seen. There was little toxicity associated with administration of the anti-Id antibodies. The most common side effects were chills and fever. Transient shortness of breath, headache, nausea, emesis, diarrhea, and myalgias were occasionally observed. Unusual toxicities included transient leukopenia or thrombocytopenia and transient elevations of hepatic enzymes. Several interesting problems of anti-Id therapy were noted in this early series: the interfering effect of

circulating Id, the development of human antimouse antibody, and the emergence of Id-negative tumor cell variants.^{186, 187, 188} and ¹⁸⁹ An attempt to reduce the incidence of emergence of Id-negative lymphoma variants with a short course of chlorambucil was unsuccessful.¹⁹⁰ The cumulative experience suggests that anti-Id therapy can result in a 15% CR rate and a 50% partial response rate. The mechanism of tumor response in these trials remains unclear. However, response in these trials correlated with anti-Id-induced signal transduction events in the lymphoma cells, suggesting that activation of apoptotic pathways may lead to lymphoma cell death after interaction of the anti-Id antibody with the lymphoma surface-bound immunoglobulin receptor.¹⁹¹ This group has turned to active immunization strategies in indolent lymphoma (see section “Immunization Strategies”).

Radioimmunotherapy

The use of immunoglobulin-radionuclide conjugates in cancer treatment represents appropriation of a classic guided-missile strategy. In theory, the antibody homes to its antigenic target and delivers a cytotoxic assault on the cell to which it attaches. Radionuclides offer certain advantages over other cytotoxic agents. They do not have to be internalized. Radioactive particles can deliver their effects over distances of 1 to 5 mm, thus limiting collateral damage to normal tissues while still potentially providing antitumor effects against antigen-negative variants in the vicinity in what has been termed a cross-fire effect. The principles of radiation physics underlying radioimmunotherapy (RIT) have been reviewed by Press and Rasey.¹⁹² Radiolabeled antibodies deliver continuous, exponentially decreasing, low-dose-rate radiation. Traditional external beam radiotherapy delivers intermittent, fractionated radiation at higher dose rates. The most commonly used isotopes for RIT have been iodine 131 (I-131) and yttrium 90 (Y-90). These radionuclides kill cells primarily through emission of β particles, resulting in DNA strand breaks. The β particles of Y-90 are more energetic than those of I-131. They affect cells in a radius of approximately 5 mm compared to approximately 1 mm for those of I-131. I-131 also emits γ rays. This allows direct imaging of the distribution of the radioconjugate but raises issues regarding shielding and health care worker and family member safety.

Several recent reviews attest to the evolution of this field.^{193,194} A number of theoretical and experimentally generated concerns with RIT appear to have been overcome in the successful clinical studies described below. There had been concern that effective delivery of radioimmunoconjugates would be impeded by heterogeneous tumor vasculature, slow diffusion of these large molecules in interstitial spaces, heterogeneous biodistribution in tumor nodules, and high intratumoral pressures.

The two products in clinical use presently, Y-90 ibritumomab tiuxetan (Zevalin) and I-131 tositumomab (Bexxar), are both directed against the anti-CD20 antigen of B lymphocytes, the same structure targeted by rituximab. Both products are based on murine mAbs. Both are administered after infusion of unconjugated anti-CD20 antibodies—rituximab in the case of Zevalin and tositumomab in the case of Bexxar. Both have used nuclear medicine imaging as a preparatory step to administration, but it is no longer required for Y-90 ibritumomab. Simple dosimetry is accomplished for I-131 tositumomab by capturing whole-body gamma counts after infusion of a 5 mCi “dosimetric dose” of the agent. Imaging was carried out in Y-90 ibritumomab tiuxetan-treated patients to assure normal biodistribution. Whole-body dosimetry is carried out in I-131 tositumomab-treated patients to allow calculation of a patient-specific activity (mCi) to deliver a desired total-body dose of radiation (cGy). Both have been studied most extensively in indolent lymphoma and have been approved for treatment of patients with relapsed or refractory follicular, including rituximab refractory, or transformed B (CD20⁺) NHL.

The approval for ibritumomab tiuxetan rested primarily on two clinical studies. The first was a randomized controlled comparison of the effectiveness of Y-90 ibritumomab tiuxetan to that of rituximab in patients with relapsed or refractory, follicular, or transformed B cell NHL.¹⁹⁵ The study involved 143 patients; 73 randomized to Y-90 ibritumomab tiuxetan (single administration), and 70 randomized to rituximab (weekly \times 4). The median number of prior therapies was 2. Approximately one-half of the patients failed to respond to or had a TTP of less than 6 months to their last chemotherapy regimen. Y-90 ibritumomab tiuxetan produced a statistically superior response rate (using the response definitions of the International Workshop), 80% versus 56% ($P = 0.002$). The number of durable responders at 6 months favored Y-90 ibritumomab tiuxetan-treated patients, but the significance of the observation was lost at 9 months and 12 months. Median TTP (estimated by Kaplan-Meier methods) was 11.2 months for patients treated with Y-90 ibritumomab tiuxetan and 10.1 months for patients treated with rituximab ($P = 0.173$). Grade 3 and 4 nonhematologic adverse events were unusual in both groups. Y-90 ibritumomab tiuxetan produced grade 3 or 4 neutropenia in 57% of patients, grade 3 or 4 thrombocytopenia in 60% of patients, and grade 3 or 4 anemia in 2% of patients. One patient in the Y-90 ibritumomab tiuxetan-treated group developed myelodysplasia. One patient in the rituximab-treated group developed pancreatic carcinoma. The second trial was a phase II experience in 57 patients who had failed to respond to rituximab or had a TTP of ≤ 6 months.¹⁹⁶ These patients had a median of 4 prior therapies, and 74% had bulky tumors (greatest diameter ≥ 5 cm).

In this patient population, Y-90 ibritumomab tiuxetan produced a response rate of 74% and CR rate of 15%. The median TTP was estimated at 6.8 months. Grade 4 neutropenia occurred in 35% of patients, grade 4 thrombocytopenia in 9% of patients, and grade 4 anemia in 4% of patients.

The pivotal study for I-131 tositumomab enrolled 60 patients with refractory or transformed low-grade NHL who had been treated with at least two different qualifying chemotherapy regimens.¹⁹⁷ Patients must also have failed to achieve an objective response or relapsed within 6 months after completion of their last qualifying chemotherapy (LQC) regimen. Median age was 60 years, and other poor prognostic features included: median of 4 prior therapies, bulky disease, bone marrow involvement, elevated serum lactate dehydrogenase, advanced stage, and transformation from an initial low-grade histology to a higher-grade histology in 38% of the patients. A statistically significant improvement in the primary endpoint was achieved, with a longer duration of response (>30 days) after I-131 tositumomab therapy (n = 26) compared to patients after their LQC (n = 5; P < 0.001). Improvements in secondary efficacy endpoints after I-131 tositumomab compared to those after LQC were also achieved: overall response (47% vs. 12%; P < 0.001), duration of response (11.7 vs. 4.1 months; P < 0.001), and CR (22% vs. 2%; P = 0.002). Fifteen of 60 patients (25%) were classified as long-term responders (patients with a MIRROR Panel-assessed TTP of a year or more). Nine (15%) of the 60 patients remained in CR, with TTP ranging from 41+ to 57+ months.

P.1478

A second trial examined the incremental benefit of the radioconjugate (I-131 tositumomab) compared to the nonradioactive antibody (tositumomab).¹⁹⁸ This study was a randomized, two-arm, open-label, multicenter study that enrolled patients with chemotherapy-relapsed or refractory low-grade or transformed low-grade NHL. Patients were randomized to receive either I-131 tositumomab therapy or unlabeled tositumomab alone. The primary endpoint was a comparison of the rates of CR. Secondary endpoints included ORR, duration of responses, and TTP. A total of 78 patients (18% with transformation) participated in the study. Patients had been previously treated with one to three chemotherapy regimens. One or more therapies must have included an anthracycline, anthracenedione, or alkylating agent. A significant difference was observed for the primary efficacy endpoint. The CR rate was 33% (14 of 42 patients) for the patients treated with I-131 tositumomab compared to 8% (3 of 36) for patients treated with unlabeled tositumomab (P = 0.012). In addition, the ORR was greater after treatment with I-131 tositumomab: 23 of 42 patients (55%) compared to 7 of 36 patients (19%; P = 0.002). Nineteen patients initially treated with the unlabeled antibody crossed over to receive I-131 tositumomab after disease progression. A CR then was observed in 42% (8 of 19 patients) and an ORR in 68% (13 of 19 patients) in the crossover patient population. A total of 20 patients (33%) from the I-131 tositumomab-treated populations, including patients in the crossover arm, were classified as having a long-term response, including ten patients continuing in CR, with TTP ranging from 23+ to 59+ months.

The efficacy of I-131 tositumomab was also evaluated in patients who had progressed after rituximab.^{199,200} Patients must have had prior treatment with at least four doses of rituximab without an objective response, or to have progressed during or after treatment. Twenty-four patients did not respond to their last treatment with rituximab, and, of the 16 patients who did respond to rituximab, five patients had a duration of response exceeding 6 months. A response occurred in 27 of 40 patients (68%), with a median duration of response of 14.7 months (95% CI; 10.6 months no response). A CR occurred in 12 of 40 patients (30%); the median duration of CR had not been reached (95% CI; 11 months no response). Twenty-four patients had a longer (at least 30 days) duration of response after I-131 tositumomab than after rituximab; 5 patients had a longer duration of response after rituximab than after I-131 tositumomab; 9 patients had equivalent durations of response; and 2 patients were censored (P < 0.001). A total of 14 patients (35%) had a TTP of 12 months or longer. The median PFS was 10.4 months (95% CI, 5.7 to 8.6) for all patients and 24.5 months for confirmed responders (95% CI, 16.8 to not reached [NR]). PFS for 15 confirmed CR patients was NR with an estimated 3 years PFS of 73%. Prior response to rituximab did not significantly affect the confirmed OR rate, duration of response, or median PFS.

Radioiodinated tositumomab and Y-90 ibritumomab tiuxetan have also been used at myeloablative doses, with stem cell rescue in patients with relapsed B cell lymphomas.^{201,202,203,204} Radioiodinated tositumomab was used initially as a single agent.²⁰² Twenty-five patients were imaged after a tracer dose of radioiodinated tositumomab. Twenty-two of these 25 patients achieved favorable biodistributions (i.e., had tumor doses in excess of doses to normal organs). These 21 patients received therapeutic infusions of radioiodinated tositumomab (345 to 785 mCi) followed by reinfusion of autologous hematopoietic stem cells. All patients achieved bone marrow engraftment (19 with bone marrow stem cells, two with peripheral blood stem cells). However, two patients died before full neutrophil recovery; one of sepsis, one of progressive lymphoma. Nonhematologic toxicities included nausea in most patients, mild mucositis in five patients, and partial

alopecia in four patients. One patient experienced reversible cardiomyopathy and interstitial pneumonitis. Eighteen patients responded to this therapy; 16 patients experienced a CR. With a median follow-up of 2 years, 2 years PFS was estimated at 62%, with OS estimated at 93%. Press et al. then combined radioiodinated tositumomab with chemotherapy and autologous stem cell transfusion in a series of patients with relapsed B cell lymphomas.²⁰³ Fifty-two patients received the planned therapy. Patients were again given tracer doses of radioiodinated tositumomab and underwent sequential gamma camera imaging. Absorbed doses of radiation to tumor sites and normal organs were determined. Thereafter, patients received a therapeutic infusion of radioiodinated tositumomab calculated to deliver between 20 and 27 Gy to normal organs (e.g., liver, kidneys, and lungs). Patients then received etoposide, 60 mg/kg, and cyclophosphamide, 100 mg/kg, followed by reinfusion of autologous hematopoietic stem cells. The maximal tolerated dose of radioiodinated tositumomab to be combined with chemotherapy was determined to be that dose that delivered 25 Gy to normal organs. Eight patients experienced 13 grade 3 or 4 toxic events. These included 3 patients with acute respiratory distress syndrome, 3 patients with severe mucositis or gastrointestinal toxicity, 1 patient with venoocclusive disease, and 4 patients with fatal infections. At 2 years, the Kaplan-Meier estimates of OS and PFS for all treated patients were 83% and 68%, respectively. These findings were considered superior to results previously observed in patients who had undergone conventional external beam total-body radiation with etoposide/cyclophosphamide preparation for transplantation in the same institution. Thirty-one patients with CD20⁺ NHL were treated with high-dose Y-90 ibritumomab tiuxetan in combination with high-dose etoposide and cyclophosphamide and were followed by autologous hematopoietic cell transplantation (HCT).²⁰⁴ Treatment also was well tolerated; there were 2 deaths and 5 relapses. At a median follow-up of 22 months, the 2 years estimated OS rates are 92% and 78%, respectively. Retreatment with tositumomab and I-131 tositumomab, has also been found possible in patients with progressive disease after treatment with I-131 tositumomab, who were able to receive subsequent therapy, including cytotoxic chemotherapy and stem cell transplantation.²⁰⁵ In patients with prior response, I-131 tositumomab can produce second responses that can be durable.²⁰⁶

Use of RIT is also being investigated in the allogeneic HCT setting.^{207,208,209} RIT with β -emitters has been successfully used for further dose intensification of myeloablative conditioning regimens for HCT. Using a canine model of nonmyeloablative HCT, Bethge et al. used pretransplant RIT with the α -emitter bismuth-213 coupled to anti-CD45 or anti-TCR $\alpha\beta$ mAb together with postgrafting immunosuppression with mycophenolate mofetil and cyclosporine, which resulted in stable engraftment and long-term mixed chimerism.²⁰⁸ In 2 relapsed patients with NHL, Y-90 ibritumomab tiuxetan was given as part of the conditioning for an HLA-matched donor transplant. Rituximab 250 mg/m² was given on days -21 and -14, 0.4 mCi/kg Y-90 ibritumomab tiuxetan on day -14 and fludarabine (30 mg/m²) plus cyclophosphamide (500 mg/m²) on days -7 and -3, resulting in fast and reliable engraftment, offering an attractive new therapeutic option for relapsed lymphoma patients.²⁰⁹ A method of dose-intensified RIT called "pretargeting" RIT (PRIT) dissociates the slow distribution phase of the antibody molecule from the delivery of the therapeutic radionuclide. This might achieve improved outcomes with less toxicity, and is being explored in preclinical studies of hematologic malignancies.²¹⁰ In a preclinical study using an acute leukemia xenograft model, comparing conventional and pretargeted anti-CD45 RIT, investigators showed clearly that anti-CD45 PRIT provided rapid tumor localization and improved biodistributions of radioactivity with significant improvements in efficacy compared with conventional anti-CD45 RIT.²¹¹

In allogeneic HCT, RIT is being explored to reduce toxicity associated with external γ -beam radiation. RIT with an anti-CD45 mAb labeled with the α -emitter astatine-211 has been used as a conditioning regimen in dog leukocyte antigen-identical HCT, resulting in good engraftment and minimal toxicity.²¹²

P.1479

Immunotoxins and Fusion Toxins

This category of treatment reagents resembles those guided missiles of RIT. In this case, however, the warheads are chemical rather than nuclear, and the targeting is provided by antibodies or by lymphokines, growth factors, and so on, that specifically bind receptors on the surfaces of target tumor cells. Attached to the targeting moiety is the cytolytic moiety. This is usually a toxin, derived from plants or bacteria, which works by inhibiting protein synthesis. They kill either resting or dividing cells and require fewer than ten molecules in the cytosol to be effective.^{213,214} Toxins of this type tested in phase I trials include ricin A-chain, blocked ricin, saporin, pokeweed antiviral protein, *Pseudomonas* exotoxin A, and diphtheria toxin. Recently, calicheamicin, a highly potent antitumor antibiotic that cleaves double-stranded DNA at specific sequences,²¹⁵ has been successfully targeted to leukemia cells.²¹⁶

A number of factors influence the efficacy of immunotoxins. These include the binding affinity of the ligand for its target and the target density on the tumor cell surface.²¹⁷ The epitope to which binding occurs can affect the potency of the immunotoxin.²¹⁸ Membrane-proximal epitopes appear to confer greater efficacy. Immunotoxin binding must lead to internalization of the target structure and the attached immunotoxin.²¹⁹ Once internalized, the toxin moiety must translocate to the cytoplasm to be effective. This process is aided by certain translocation sequences in the toxin. The need for translocation signals provides the rationale for using blocked ricin toxin; targeting via the binding subunit is eliminated but translocation signals are preserved.²²⁰ The site of translocation may vary for different toxins. Increasing lysosomal pH protects cells from *Pseudomonas* exotoxin and diphtheria toxin but increases sensitivity to ricin,^{221, 222} and²²³ suggesting that ricin may undergo translocation in the Golgi apparatus. Finally, these toxins affect protein synthesis by ADP-ribosylating elongation factor 2²²⁴ in the case of diphtheria toxin and *Pseudomonas* toxin, or by alteration of the 60S ribosomal subunit in the case of ricin.²²⁵

A number of phase I clinical trials using ricin-based, anti-pan B cell antibody immunotoxins have been reported in B cell lymphoma.^{226, 227, 228, 229, 230, 231, 232} and²³³ These trials demonstrated that therapeutic doses of immunotoxins can be delivered with tolerable, reversible side effects. Toxicities include systemic symptoms of fever, nausea, vomiting, headache, and muscle aches; evidence of hepatocyte damage with transaminase elevations; and significant problems with capillary leak syndrome.²³⁴ Again recognized were the problems of human antimouse antibody formation and rapid clearance of immunotoxin in the presence of circulating antigenemia. Sporadic responses were seen in these trials, with response rates perhaps approaching 25% and CRs approaching 10%. There were hints that targeting via CD22 might be more useful than targeting via CD19.²³⁵ Some experts have suggested that these agents will not become useful clinical tools until problems of their immunogenicity have been solved.^{143,214}

However, recent success has been reported for two agents of this class. A recombinant immunotoxin containing the anti-CD22 variable domain (Fv) fused to a truncated *Pseudomonas* exotoxin has produced CRs in patients with hairy-cell leukemia (HCL).²³⁶ Sixteen patients whose disease was resistant to nucleoside analogs were treated by intravenous infusion every other day for three doses. Thirteen of 16 patients responded—11 had CRs. The treatment was generally well tolerated. Common side effects included transient elevations of liver enzymes and hypoalbuminemia. Median follow-up was 16 months, during which 3 of the 11 complete responders relapsed. These three patients were retreated with the immunotoxin. Two of the three developed hemolytic uremic syndrome. Moxetumomab pasudotox, is an improved, more active form of a predecessor recombinant immunotoxin, BL22 (also called CAT-3888), and is up to 50-fold more active on lymphoma cell lines and leukemic cells from patients with CLL and HCL. A phase I trial was recently completed in HCL patients, who achieved response rates similar to those obtained with BL22 but without dose-limiting toxicity. In addition to further testing in HCL, moxetumomab pasudotox is being evaluated in phase I trials in patients with CLL, B cell lymphomas, and childhood ALL. Moreover, protein engineering is being used to increase its activity, decrease nonspecific side effects, and remove B cell epitopes.²³⁷

Gemtuzumab ozogamicin (Mylotarg) is an immunotoxin composed of a recombinant human IgG4κ monoclonal antibody conjugated with a cytotoxic antitumor antibiotic, calicheamicin,²³⁸ and was previously approved for the treatment of elderly patients with CD33-positive AML in first relapse. The antibody is directed against the CD33 antigen found on the surface of leukemic blasts and normal immature cells of myelomonocytic lineage, but not on hematopoietic stem cells. CD33 is a sialic acid-dependent adhesion molecule. In a phase I dose-escalation trial, treatment with gemtuzumab ozogamicin resulted in elimination of leukemic cells from peripheral blood and bone marrow in 8 of 40 patients.²³⁹ The basis for approval of the drug was the experience in 142 patients participating in one of three similar trials designed to examine the efficacy and safety of gemtuzumab ozogamicin in patients in first relapse of AML.²¹⁶ Across the three studies, 80 patients were 60 years of age or older. The median duration of first remission for the group was 11.1 months. All 142 patients received a first dose of drug, 109 patients received two doses (the recommended treatment course), and five patients received three doses. Roughly 40% of patients were treated as outpatients. Median duration of hospitalization was 24 days. The ORR was 30%. This included patients achieving a CR (defined as [a] leukemic blasts absent from peripheral blood, [b] bone marrow blasts <5% of cellular elements, [c] recovery of neutrophils and platelets, and [d] rbc transfusion independence) and patients achieving a CRp (CR as defined, except delayed platelet recovery). Median survival for the group as a whole was 5.9 months. Median relapse-free survival for responders was 6.8 months. Essentially, all patients had grade 3 or 4 neutropenia and thrombocytopenia. Fifteen percent of patients experienced grade 3 or 4 bleeding events. Infusion-associated events occurred in approximately 10% of patients. Sepsis occurred in 16% of patients; pneumonia in 7%. Grade 3 or 4 hypotension was seen in 9% of patients. Twenty-three percent of patients experienced grade 3 or 4 elevation of serum bilirubin levels, and 17% of patients had grade 3 or 4 elevations of hepatic transaminases. Two deaths were associated with liver abnormalities. Eleven patients died during the treatment period of causes other than disease progression. There was no treatment-associated cardiotoxicity, cerebellar dysfunction, or alopecia.

Gemtuzumab ozogamicin was withdrawn from the United States market in 2010 due to lack of clinical benefit in subsequent trials, but it remains available in Japan and for selected investigator-initiated research. Inotuzumab ozogamicin is a similar immunotoxin linking calicheamicin to an IgG4 antibody against CD22, and is in phase III trials in B cell lymphoma.²⁴⁰

Neoplasms bearing the high-affinity IL-2 receptor have been approached with a genetically engineered, bacterially expressed IL-2-diphtheria toxin fusion protein, denileukin diftitox.²⁴¹ Denileukin diftitox was approved in 1998 for the treatment of patients with relapsed cutaneous T cell lymphoma (CTCL). This was the first approval for drugs of the recombinant fusion toxin class. The development of this molecule is detailed in a recent review.²⁴² The basis of approval was a pivotal trial conducted in 73 patients with disease that was refractory to other therapy (patients having received three or more previous treatments).²⁴³ Patients were randomized to either a low dose (9 µg/kg/day) or high dose (18 µg/kg/day) of the fusion toxin. Patients were treated on 5 consecutive days in 21-day cycles for up to 8 cycles.

P.1480

Seventy-one patients received a drug. The ORR was 30%, and CR rate was 10%. Rates and durations of response did not differ between the two treatment groups. Adverse events included flu-like symptoms, acute infusion-related events, and vascular leak syndrome. Approximately three-fourths of the patients experienced transient elevations of hepatic transaminase levels and hypoalbuminemia; approximately 15% of patients experienced grade 3 or 4 elevations of liver enzymes or hypoalbuminemia. The success of this trial, to some extent, allays concern that a major problem with this family of fusion toxins would be previous immunization of most of the American population with diphtheria toxoid in childhood. Although approximately one-half of patients had antibodies against diphtheria toxin at baseline and almost all patients had antibodies after treatment, these did not appear to affect treatment outcome.^{243,244}

An anti-CD30 antibody, brentuximab vedotin, an antibodydrug conjugate composed of the anti-CD30 chimeric IgG1 monoclonal antibody cAC10 and the potent antimicrotubule drug monomethylauristatin E connected by a protease-cleavable linker, is increasingly being used in hematologic malignancies.²⁴⁵ Several trials have shown durable antitumor activity with a manageable safety profile in patients with relapsed/refractory Hodgkin lymphoma,²⁴⁶ systemic anaplastic large-cell lymphoma, or primary cutaneous CD30-positive lymphoproliferative disorders.²⁴⁷ Treatment with single-agent brentuximab vedotin resulted in objective response rates and CR rates of 75% and 34%, respectively, in relapsed or refractory Hodgkin lymphoma; and of 86% and 57%, respectively, in relapsed or refractory systemic anaplastic large-cell lymphoma patients.²⁴⁷ Peripheral sensory neuropathy and neutropenia were observed with brentuximab vedotin but were generally grade 1 and 2 in severity and manageable. In August 2011, brentuximab vedotin was approved in the United States for the treatment of Hodgkin lymphoma after failure of autologous stem cell transplant (ASCT) or after failure of at least two prior multiagent chemotherapy regimens in ASCT-ineligible candidates, and for the treatment of systemic anaplastic large-cell lymphoma after failure of at least one prior multiagent chemotherapy regimen.

Bispecific Antibodies

Bispecific antibodies are antibody constructions that recognize a tumor-associated antigen (TAA) with one arm and recognize and activate an immune effector cell structure with the other arm.^{248,249,250} In theory, approximation of a tumor cell with an activated immune effector could result in tumor cell elimination. These bispecific antibodies can be obtained either by chemical heteroconjugation or by fusion of 2 hybridomas of desired specificity to yield a tetradoma. With either approach, chromatographic or other separation techniques are required to isolate the desired product.

Strategies using antibodies to activate phagocytic cells, NK cells, and T lymphocytes have been examined. In preclinical models, anti-Id × anti-CD3 bispecific antibodies have demonstrated the ability to inhibit tumor cell growth.^{251, 252} and ²⁵³ Recognizing the need for costimulation in T cell response, other investigators have used a combination of bispecific antibodies, anti-CD3 × anti-TAA and anti-CD28 × anti-TAA, with interesting results.²⁴⁸

Blinatumomab, a new novel class of T cell engaging bispecific single-chain antibody (BiTE[®] antibodies) engages T cells for redirected lysis of CD19 positive target cells.²⁵⁴ CD19 is stably expressed on the majority of B cell malignancies. A phase I trial in patients with indolent NHL showed efficacy.²⁵⁵ A phase II study of blinatumomab patients with B-lineage ALL, with persistent or relapsed MRD, resulted in an 80% MRD response rate. After a median follow-up of 33 months, the RFS of the whole evaluable study cohort of 20 patients was 61%, while 9 patients who received allogeneic hematopoietic stem cell transplantation (HSCT) after blinatumomab treatment had a hematologic RFS rate of 65% (Kaplan-Meier estimate). Amongst patients who were Philadelphia (Ph)-negative, 4/6 MRD responders with no further therapy after blinatumomab were in ongoing hematologic and molecular remission. Thus, blinatumomab may have a role in inducing long-lasting CRs in B-lineage ALL patients with persistent or recurrent MRD.²⁵⁶

Bispecific antibodies have been used in the treatment of patients with refractory Hodgkin lymphoma.^{257,258} In an initial phase I/II trial,²⁵⁸ 15 patients were treated with an NK cell-activating bispecific monoclonal antibody directed against the Fcγ-receptor III (CD16 antigen) and the Hodgkin-associated CD30 antigen. The antibody was administered every 3 to 4 days × 4. Dose-limiting toxicity was not encountered up to and including the highest dose administered, 64 mg/m². Side effects were unusual, but included fever, pain in involved lymph nodes, and maculopapular rash. Nine of 15 patients developed a human antimouse antibody response that resulted in allergic reactions in four patients who were retreated. Duration of one CR was 16 months, and partial responses endured for a median of 3 months. These results prompted a second trial to investigate the effects of different administration schedules and the concomitant administration of cytokines on the effectiveness of the bispecific antibody.²⁵⁹ Sixteen patients were treated with 25 mg of the construct four times, either as a continuous infusion for 4 days or a 1 hour infusion every other day. Patients who exhibited response were retreated at 4-week intervals, if possible. Patients with stable disease received retreatment after administration of IL-2 and granulocyte-macrophage colony-stimulating factor (GM-CSF). Four patients responded to the treatment (three partial remissions and one complete remission). Durations of response were from 5 to 9 months.

Bispecific antibodies, as an approach to immunotherapy, appear to have garnered more enthusiasm and engendered more activity in the treatment of solid tumors.²⁶⁰ This approach as an immunotherapeutic strategy is also being explored in overcoming drug resistance cell lines in B cell malignancies,²⁶¹ as well as the allogeneic HCT setting, to enhance the graft-versus-tumor effect, while minimizing graft-versus-host disease (GVHD).²⁶² Relatively minor results have not given rise to large-scale trials. Gupta et al. in a preclinical study showed that two bispecific HexAbs (IgG-[Fab]4 constructed from velutuzumab [anti-CD20 IgG] and milatuzumab [anti-CD74 IgG]) show enhanced cytotoxicity in mantle cell lymphoma (MCL) and other lymphoma/leukemia cell lines, as well as patient tumor samples without a crosslinking Ab, compared with their parental mAb counterparts, alone or in combination. They may thus constitute a new class of therapeutic Abs by invoking the juxtaposition and engagement of 2 independent targets on a cancer cell.²⁶³ A trifunctional bispecific antibody, FBTA05, is now in preclinical studies.²⁶⁴ It is designed to target human CD20 and human CD3, simultaneously binding B cells and T cells by its variable regions and recruiting FcγR-positive accessory immune cells by its intact Fc region. The cytotoxicity of FBTA05 on ex vivo cells from patients with CLL was comparable with that induced by alemtuzumab, exceeded the antineoplastic effects of rituximab, and was effective in elimination of malignant B cells even if CD20 surface expression was low. Importantly, a high grade of cytotoxicity was associated with the induction of T cell proliferation and the concomitant release of interferon-γ and IL-6, thus overcoming the detrimental effects of an unfavorable effector:target cell ratio.²⁶⁵ These unique approaches appear to further improve the antineoplastic efficacy of mAbs in hematologic malignancies.

Cytokines

Interferons

The interferons (IFNs) constitute a family of cytokines that were initially recognized by their abilities to interfere with viral replication.¹⁹⁹ Two major classes of IFNs exist: type I,

P.1481

consisting primarily of IFN-α and IFN-β; and type II, consisting of IFN-γ. Type I IFNs are produced by many cell types. Type II IFN is produced by T lymphocytes. Signaling in this system involves the janus kinase (JAK) family and the STATs.²⁶⁶ Transmission of IFN-specific signals results in induction of a number of genes, including several transcription factors, MHC class I and class II (primarily in response to IFN-γ) molecules, and a number of proteins that are responsible for the antiviral activity of the IFNs, including the (2' to 5') oligoadenylate synthase-nuclease system.²⁶⁷ Promoters for these genes share an IFN-stimulated response element that has a consensus structure of AGTTTCNNTTTCNC/T.²⁶⁸ The nature of the IFN antitumor action is as yet ill defined. Early observations involving virally induced tumors demonstrated that IFNs could inhibit tumor growth.²⁶⁹ These observations were later extended to nonvirally induced tumors.²⁷⁰ The marriage of molecular biology and the entrepreneurial biotechnology industry produced recombinant IFNs early on, and these molecules have been used extensively in clinical trials since the early 1980s. IFN-α has found its way into the therapeutic armamentarium, but IFN-γ has not. The most successful applications of these substances have been in chronic myelogenous leukemia (CML) and HCL.

In chronic-phase CML, IFN-α has demonstrated the ability to control blood counts and to induce complete hematologic response in perhaps 70% of patients, and complete cytogenetic responses in 25% of patients.^{271,272, 273, 274} and ^{275,276,277,278} Typical administration schedules have been 5 × 10⁶ U/m²/day or three times weekly. These results have been achieved with significant side effects, including initial flu-like symptoms that abate at approximately 2 weeks, then later fatigue,

weight loss, neurotoxicity, depression, and insomnia. Rare cardiac and autoimmune side effects have occurred, including arrhythmias and congestive heart failure as well as hemolytic anemia, thrombocytopenia, rheumatologic disorders, hypothyroidism, and nephrotic syndrome. The role of IFN- α in the treatment of CML and its effect on remission duration and survival are controversial. One large multicenter trial failed to demonstrate a correlation between cytogenetic response to IFN- α and remission duration or survival,²⁷⁴ but in a head-to-head comparison of IFN- α with hydroxyurea, significantly improved survival was seen in the IFN- α -treated group.^{276,279,280} In this study, most of the benefit of IFN- α appeared to accrue to the patients who achieved a major cytologic response, all of whom were in the IFN- α -treated group. In the era of imatinib mesylate, the role for IFN- α remains to be defined.^{277,278}

In HCL, IFN- α became the first effective, nonsurgical treatment; splenectomy was the first treatment approach. A number of studies conducted with partially purified, then recombinant IFN- α demonstrated that approximately 75% of treated patients achieved a complete or partial response.^{281, 282, 283, 284} and ²⁸⁵ Median durations of response were 12 to 24 months, with virtually all patients eventually relapsing. However, most patients responded to a second treatment course of IFN- α . The mechanism of IFN- α action in this disease is unknown. Both antiproliferative²⁸⁶ and immunomodulatory^{287,288} events have been demonstrated in treated patients. Although IFN- α is an active agent in HCL, the remarkable effectiveness of short courses of cladribine in inducing sustained complete clinical remissions in this disease make it the treatment of choice for most patients with the disease.

Interferon- α also has been used in the treatment of NHL.¹⁴³ As a single agent, interferon- α has modest activity in indolent lymphomas, but toxicities are significant (at the doses generally used) and remission durations are generally short, with little effect on response rates and perhaps a reduction in the rate of transformation to higher-grade lymphoma,²⁸⁹ moderate prolongation of remission durations, but, with one exception,²⁹⁰ no effect on OS.

IFN- α may also be a useful agent in the treatment of multiple myeloma.^{291,292} When used in combination with chemotherapy, IFN- α may improve initial response rate and PFS. A pilot trial conducted by the Eastern Cooperative Oncology Group suggested that IFN- α treatment in combination with chemotherapy led to increased response rates and prolonged disease-free interval by 12 months over that expected.²⁹³ In a large randomized trial of 256 patients,²⁹⁴ IFN- α maintenance treatment produced improved disease-free survival of 17.8 versus 8.2 months for the control group and OS of 50.6 versus 34.4 months. Both differences were statistically significant. Inclusion of IFN- α during induction therapy appeared to confer further benefit. However, in a large cooperative group trial,²⁹⁵ no benefit was seen to IFN- α maintenance therapy. A meta-analysis of 24 randomized studies involving more than 4,000 subjects indicated that IFN- α improves relapse-free survival to a moderate degree and OS to a marginal degree in multiple myeloma. Therefore, the role of IFN- α in the treatment of multiple myeloma remains controversial. Its cost and side effects must be considered when contemplating the use of IFN- α . Furthermore, its usefulness has been questioned in melphalanprednisone-treated patients,²⁹⁶ in patients receiving high-dose steroids,²⁹⁷ and in the elderly.²⁹⁸ Recombinant IFN- γ 1b has been used to enhance the immune system in high risk cancer patients treated with granulocyte transfusions, as well as to treat fungal infections in the allogeneic hematopoietic stem cell transplant setting.²⁹⁹ Type I IFN (HLBI, IFN- α 2b and IFN- β) has been shown to enhance antileukemic cytotoxicity of $\gamma\delta$ T cells in in vitro models.³⁰⁰ IFN- α is effective in polycythemia rubra vera, particularly in the young or pregnant patient.³⁰¹

Interleukin-2

IL-2 was first recognized as a growth factor for T lymphocytes.^{302,303} Its discovery allowed the cloning and long-term propagation of antigen-specific T cell clones.^{304,305} In addition, it was determined that IL-2 treatment led to gain of function, particularly increased cytotoxicity in T lymphocytes³⁰⁶ and NK cells.³⁰⁷ The possibility of generating or potentiating specific immune responses for clinical applications made the production of IL-2 one of the earliest targets of the biotechnology industry. Recombinant IL-2 was available for clinical application by 1983,³⁰⁸ only 5 years after the activity was first described.

IL-2 binds specifically to receptors (IL-2R) on target cell surfaces.³⁰⁹ Most resting lymphocytes display only intermediate-affinity receptors made up of IL-2R β and IL-2R γ polypeptide chains. A number of stimulatory signals lead to production of IL-2R α chains and the display of high-affinity heterotrimeric receptors of IL-2R α , IL-2R β , and IL-2R γ chains. IL-2R α contributes a rapid association rate with IL-2, whereas the IL-2R β and IL-2R γ chains provide a slow dissociation rate. The resulting rapid on rate and slow off rate results in an equilibrium dissociation constant ($K_d = 10^{-1}$ mol).³¹⁰ With approximately 750 receptors per cell surface, an endocytosis-related half-life of approximately 15 minutes, and an apparent requirement of 10,000 occupied receptors before commitment to cell cycle progression, it is likely that optimal treatment strategies will require prolonged, continuous administration of the cytokine.³¹¹

Early experience with IL-2 used increasing doses, seeking optimal effect. However, at high intravenous dose (greater than 10^{-8} mol peak concentration, attempting to saturate intermediate-affinity IL-2R on target cells), IL-2 produced significant, life-threatening toxicities.³¹² These side effects included fever and chills initially followed by a constellation of problems resulting from a capillary leak syndrome, including hypotension requiring pressor support in a majority of patients, significant weight gain, respiratory distress occasionally requiring intubation, oliguria, renal dysfunction, and death in approximately 1% of patients. Additional side effects included nausea, vomiting, diarrhea, cardiac arrhythmia, liver dysfunction, mental status changes, anemia, and thrombocytopenia. Because of

P.1482

these severe side effects, arbitrary ad hoc dose adjustments and well-controlled clinical trials have attempted to reduce dose while maintaining clinical efficacy. At doses approximately 300 to 500 times less than those initially used, marked increases in circulating levels of NK cells without induction of immune-mediated pathology have been demonstrated.³¹³ Continuous intradermal and intermittent subcutaneous administration schedules have been evaluated.³¹¹

IL-2 has been used in the treatment of AML. A few studies have been conducted in patients with active disease.^{314, 315, 316} and³¹⁷ Of these patients, a small minority had complete remissions, which were generally of brief duration. However, in several instances the IL-2-induced/maintained remission duration exceeded that of previous remission durations. This experience prompted an examination of IL-2's ability to prolong remission after chemotherapy.³¹⁸ Seventeen patients with AML were treated with IL-2 or IL-2 plus lymphokine-activated killer (LAK) cells after autologous bone marrow transplantation (BMT). Five of these patients relapsed between 2 to 10 months, one died in therapy, but 11 remained in complete remission 12 to 54 months after BMT. All of the surviving patients demonstrated remission inversion. Similar results were reported in seven patients treated with polyethylene glycol-conjugated IL-2 administered as the sole postremission therapy after induction of a second complete remission.³¹⁹ More recently, a pilot study of IL-2 in patients in first remission has been reported.³²⁰ The results suggest that more patients were alive at 3 years than would have been predicted by observations in historical controls. These results suggest that consolidative IL-2 administered early in remission induction can decrease relapse rate and suggest that prospective randomized comparisons are warranted.

Despite difficulty meeting accrual goals in several studies,³²¹ some experience has been gained using IL-2 in NHL, Hodgkin disease, and CTCL. In general, response durations in these diseases are brief and clinically insignificant.¹⁴³ However, a few remissions of prolonged duration have been reported. European investigators examined continuous-infusion high-dose IL-2 alone in patients with heavily pretreated lymphomas of various subtypes.³²² In 24 patients with low-grade lymphomas resistant to anthracycline-containing regimens, one CR was seen. In 23 patients with intermediate- or high-grade lymphomas refractory to primary therapy or salvage therapy, three complete remissions and two partial remissions were documented. No responses were seen in seven patients with Hodgkin disease. In seven patients with mycosis fungoides refractory to chemotherapy, one complete remission and four partial remissions were seen. These authors concluded that further testing with IL-2 in patients with aggressive lymphoma and CTCL was warranted. This experience with CTCL is particularly provocative because a direct effect of IL-2 on tumor cells, which often bear the IL-2R, is likely and may relate to the mechanism by which the IL-2 effect was manifest in this trial.

Use of IL-2 has been investigated in myelodysplastic syndrome (MDS).³²³ Its utility, in this setting, remains to be defined. IL-2 is critical for Treg cell development, expansion, activity, and survival.^{324,325} Investigators found that the administration of daily subcutaneous low-dose IL-2 in patients with active chronic GVHD rapidly induced preferential and sustained Treg cell expansion, reversed advanced manifestations of chronic GVHD, and permitted a substantial reduction in the glucocorticoid dose.³²⁶ Conversely, the binding of basiliximab and daclizumab, two IL-2 receptor antagonists (IL-2RAs) that bind to the α -subunit of the IL-2R (CD25), found predominantly on the surface of activated cytotoxic T cells, induced proliferation and provides selected immunosuppression, prevents GVHD efficiently and feasibly following unrelated donor-peripheral blood stem cell transplantation (URDPB SCT) and contributes to favorable outcome.³²⁷

Cellular Approaches

Graft-versus-leukemia Effect

Despite the fact that early studies in murine leukemia suggested that allogeneic HCT would confer a lower risk of relapse than syngeneic HCT,³²⁸ and this information was used as part of the rationale for early clinical HCT,³²⁹ the reality of a graft-versus-leukemia (GVL) effect in human transplantation was slowly recognized.^{330,331} Significant indirect evidence for a GVL effect can now be cited.³³² Anecdotal reports have documented remission reinduction after a flare of GVHD³³³ or on rapid withdrawal of immunosuppression.³³⁴ Furthermore, a number of studies have confirmed that syngeneic HCT is associated with a higher risk of relapse than allogeneic HCT.^{335,336} Other studies, including large retrospective analyses by the

International Bone Marrow Transplant Registry,³³⁷ have demonstrated a protective effect of GVHD. Non-T cell-depleted transplant recipients with acute, chronic, and acute plus chronic GVHD had a lower likelihood of relapse than did patients receiving non-T cell-depleted HCT who had no GVHD. Patients who received non-T cell-depleted HCT and experienced no GVHD still had a lower likelihood of relapse than patients receiving syngeneic HCT. These data have been interpreted to support the notion that graft-versus-leukemia effects can be seen in the absence of GVHD. Of note, it appears that the potency of the graft-versus-tumor effect differs among neoplasms.³³⁸ The graft-versus-tumor effect is obvious in AML and CML, has been suggested in lymphoma,³³⁹ but at least in one study was absent in ALL,³⁴⁰ and has been less apparent in myeloma.³⁴¹

The molecular and cellular mechanisms that underlie the GVL effect are becoming better understood.^{332,338,341,342} Furthermore, the relationship between the GVL effect and GVHD is becoming better defined. Some antigens relevant to these processes have been identified. Although MHC differences have long been associated with GVHD, the role of minor histocompatibility antigen expression in GVHD and the GVL effect is becoming apparent^{338,340,341,343,344,345} (Fig. 70.5). In a murine model, administration of allogeneic T cells specific for a single minor histocompatibility antigen resulted in an antileukemic response without a graft-versus-host response.³⁴⁶ Other antigens may be important as well.³⁴⁶ Immune responses against the neoantigens expressed from the BCR/ABL fusion in CML^{347,348} and the PML/RαRα fusion in acute promyelocytic leukemia³⁴⁹ have been demonstrated. Their relevance is suggested by the disease-specific efficacy of DLI, but their true relevance in the clinical setting remains to be defined.

The immunologic effectors of GVHD and GVL are also being dissected. It is apparent that T lymphocytes must play a large role in these reactions, for their removal results in a marked decrease in GVHD and marked increases in relapse frequencies.³⁵⁰ The role of NK cells in mediating the GVL effect is increasingly being investigated.^{351,352} Preclinical studies in mice have shown that different combinations of activating and inhibitory receptors on NK cells can reduce GVHD, promote engraftment, and provide superior graft-versus-tumor responses. Emerging clinical data have shown that the use of KIR-ligand incompatibility produces a potent graft-versus-leukemia effect in patients with AML at high risk of relapse.³⁵² Recent evidence suggests that CD4⁺ T lymphocytes may be particularly important in the GVL effect.^{353,354} Allografts selectively depleted of CD8⁺ T lymphocytes (CD4⁺ T lymphocytes preserved) demonstrated a low incidence of GVHD yet a preserved GVL effect similar to that seen with unfractionated HCT in patients with CML. These clinical findings are supported by similar findings in animal models³⁵⁵ and by the demonstration of donor-derived, HLA-identical, cytotoxic CD4⁺ T cell clones of multiple specificities in a patient with severe GVHD after transplantation for CML.³⁵⁶ T-helper subset 2 and T-cytotoxic subset 2 may be particularly important in the regulation of GVHD and

P.1483

mediation of GVL effects.³⁵⁷ Development of MHC-tetramer technology has provided a means to visualize antigen-specific T cell responses.³⁵⁸ This technology can be used to correlate individual T cell responses with a clinical course. In an early application of the approach, Mutis et al.³⁵⁹ demonstrated that the frequencies of T cells specific for the HY and HA-1 minor histocompatibility antigens correlated with the severity of GVHD.

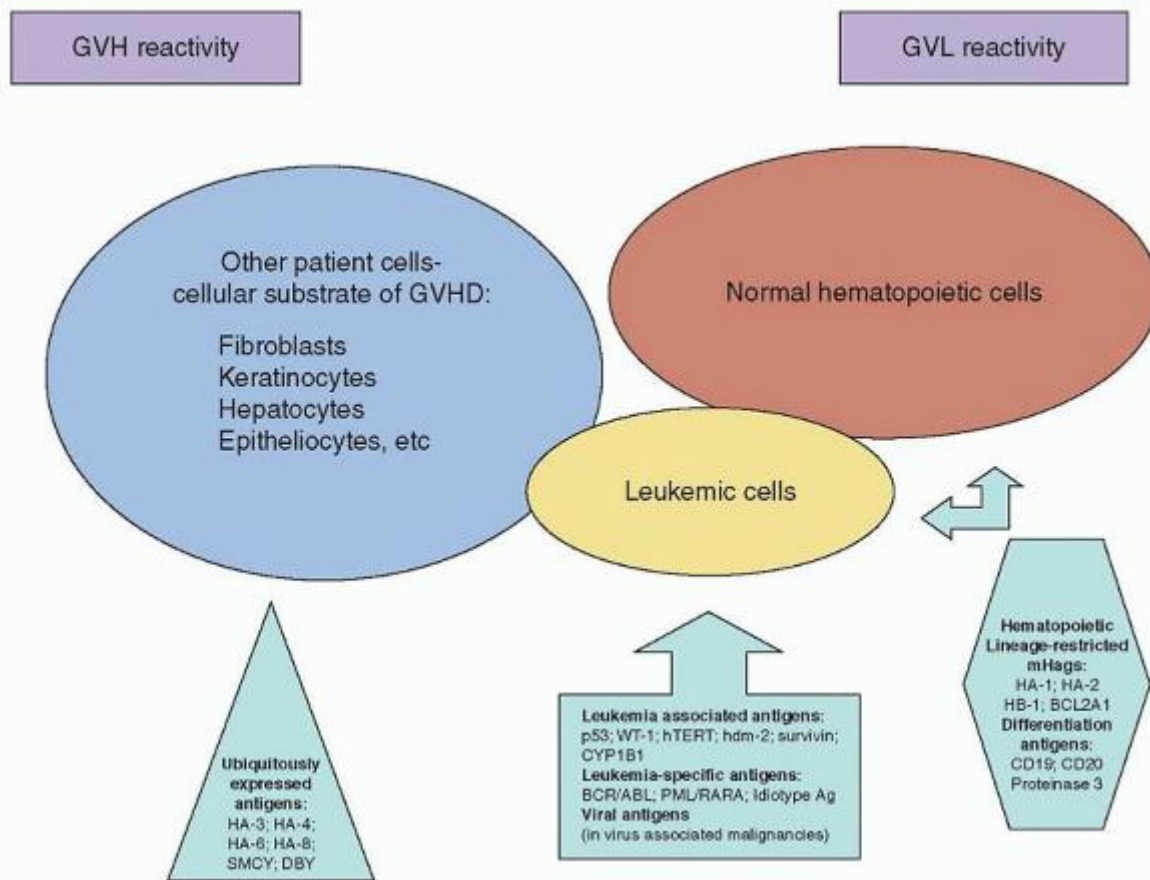

FIGURE 70.5. Antigenic basis of graft-versus-leukemia (GVL) and graft-versus-host (GVH) immune responses. Graft-versus-leukemia reactivity is mediated by immune responses specific to antigens with expression restricted to leukemic cells (leukemia-specific and certain viral antigens) and patient hematopoietic cells (hematopoietic lineage-restricted minor histocompatibility antigens, hematopoietic differentiation antigens). Reactivity to leukemia-associated antigens contributes to GVL mostly, although these antigens are expressed at low levels in normal tissues. Ubiquitously expressed antigens are a substrate of GVH disease. Ag, antigen; GVHD, graft-versus-host disease; mHags, minor histocompatibility antigens. (Adapted from Ivanov R, Hagenbeek A, Ebeling S. Towards immunogene therapy of hematologic malignancies. *Exp Hematol* 2006;34:251-263).

A number of strategies have been proposed to enhance the GVL effect and reduce GVHD.^{338,360} These include a reduction in the total number of T lymphocytes used in transplantation, delayed transfusion of donor lymphocytes,³⁶¹ CD8⁺ T lymphocyte depletion, ablation of thymidine kinase gene-transfected donor T lymphocytes with ganciclovir administration in case of GVHD,^{362,363} administration of IL-2³⁶⁴ and use of IL-2 receptor antagonists,³²⁷ functional depletion of antihost lymphocytes without depletion of antimyeloid lymphocytes,^{365,366} and ex vivo generation of leukemia-specific T lymphocytes.³⁶⁷

The approach that has garnered the most attention recently has been mini-allografting.^{368,369,371} High-dose chemotherapy with stem cell rescue has proven to be an effective, potentially curative approach to the treatment of several malignancies. However, this technique is associated with significant morbidity and mortality. The success of DLI (see section "Donor Leukocyte Infusions") for the treatment of CML and other hematologic malignancies has suggested that much of the benefit of allogeneic HCT is mediated by the graft-versus-malignancy effect. Several groups have evaluated the effects of safer, less toxic approaches to HCT. Shimoni et al.³⁶⁹ described their experience with allogeneic HCT using nonmyeloablative regimens in 116 patients. These low-dose regimens were designed, not to eradicate host hematopoiesis, but to allow induction of the GVL effect as the primary treatment mechanism. Forty-six patients with advanced age or significant organ dysfunction and diagnoses of CML, AML, or myelodysplasia, were treated with purine analog/cytarabine combinations to provide sufficient immunosuppression to allow engraftment of allogeneic progenitor cells. Thirty-six of 40 evaluable patients receiving related-donor HCT engrafted with donor cells—23 patients—achieved complete donor chimerism, and 13 patients were mixed chimeras. Death attributed to treatment-related causes occurred

in 8 patients. Twenty-eight of 31 evaluable patients with AML or MDS achieved a CR. Three patients died in remission. Fifteen patients relapsed. Six of the 15 patients received donor leukocyte infusion, but none responded. Eleven patients had CML. Eight of nine patients who received related-donor grafts achieved complete hematologic and cytogenetic remission. Two-thirds of patients treated in chronic phase were alive at 2 years. Seventy patients were treated with purine analog/melphalan nonmyeloablative regimens in an attempt to improve outcomes for patients with active chemorefractory leukemia at the time of HCT. Sixty-two of 64 evaluable patients had engraftment of donor hematopoietic cells. Treatment-related mortality was estimated at 45%. Median survival for the group was 4.5 months. Survival at 1 year was 37% and at 2 years was 31%. Investigators at the Center for International Blood and Marrow Transplant Research (CIBMTR) found that following HCT using myeloablative conditioning (MAC), GVHD had an adverse effect on transplant-related mortality (TRM) with early modest augmentation of GVHD-associated GVL. While following reduced-intensity conditioning (RIC), GVL may be important in limiting both early and late leukemia recurrence.³⁷²

Donor Leukocyte Infusions

A number of authorities consider the success of DLI to be the most compelling proof of a GVL effect.³⁷³ In 1990, Kolb et al.³⁷⁴ reported three patients with relapsed CML after marrow transplantation that were treated with infusion of buffy coat leukocytes from the donor and IFN- α . Complete hematologic and cytogenetic responses were seen in these patients. Since then, the phenomenon has been replicated and extended by many investigators.^{373,375,376} A broad experience of 25 North American transplant centers has been reported,^{377,378} confirming the remarkable efficacy of this approach in patients with relapsed chronic-phase CML and the less impressive response rates in advanced CML and acute leukemia. The collective experience suggests that in cytogenetic relapse or clinical chronic-phase relapse of CML,

P.1484

complete cytogenetic remission can be attained in 80% of patients. However, patients with more advanced disease have a much lower, perhaps 25%, chance of remission. When the technique has been applied to patients with AML relapsing after allogeneic BMT, response rates have been only 15% to 20%.³⁷⁶

The timing and application of DLI in other hematologic malignancies following hematopoietic stem cell transplant is still being explored. The clinical benefit of DLI in AML was explored in a retrospective analysis on the role of DLI in the treatment of relapsed AML after allogeneic HSCT by the European Group for Blood and Marrow Transplantation (EBMT) Acute Leukemia Working Party. They analyzed the data of 399 patients with AML in the first hematologic relapse after HSCT whose treatment did (n = 171) or did not (n = 228) include DLI. After a median follow-up of 27 to 40 months, respectively, estimated survival at 2 years was about 21% for patients who received DLI and 9% for patients who did not receive DLI. Improved outcome was associated with younger age (<37 years; P = 0.008), relapse occurring more than 5 months after HSCT (P < 0.0001), and use of DLI (P = 0.04). Among DLI recipients, a lower tumor burden at relapse (<35% of bone marrow blasts; P = 0.006), female sex (P = 0.02), favorable cytogenetics (P = 0.004), and remission at time of DLI (P < 0.0001) were predictive for survival in a multivariate analysis. Two-year survival was 56% if the DLI was performed in remission or with favorable karyotype, compared to 15% if the DLI was given in aplasia or with active disease.³⁷⁸ Anecdotal reports of responses have been generated in multiple myeloma, CLL, Fanconi anemia, and polycythemia vera.³⁷⁶ When applied to patients with ALL, Hodgkin lymphoma, and NHL, few responses have been seen.³⁷⁶

DLI are not without complications. The two most worrisome are GVHD and pancytopenia occurring weeks after infusion. Predictors of GVHD after donor leukocytes were T lymphocyte depletion in the original transplant marrow and concomitant IFN- α usage. The GVHD induced by DLI appears to respond more readily to immunosuppressive measures than does the GVHD seen with transplantation. Predictors of myelosuppression include frank hematologic relapse and T lymphocyte depletion.^{373,377,378,379}

The optimal dose and timing of DLI have yet to be determined.³⁸⁰ Administered dosage of leukocytes does not necessarily correlate with response,^{373,381,382} but there is some evidence that the incidence of GVHD does correlate with dosage,³⁸² making the notion of infusing fewer cells attractive. Regarding timing, the ability to detect relapse with molecular biologic techniques, such as PCR, allows definition of relapse long before it becomes hematologically apparent. Yet whether DLI should be used before hematologic relapse remains a matter for clinical investigation because transient molecular relapses have been documented.³⁷⁹ Similarly, the requisite concomitant use of IFN- α has been questioned. In the European trials, use of IFN- α did not appear to improve the response rate to DLI,³³⁷ and a number of studies have documented responses without the use of the cytokine.^{379,382}

Adoptive Cellular Immunotherapy

The field of immunotherapy was rejuvenated in the early 1980s by reports of clinical trials with transfer of antitumor cells to tumor-bearing patients.^{383,384} Rosenberg et al. pioneered the use of LAK cells plus IL-2.^{385,386} LAK cells were derived from resting, autochthonous, peripheral blood mononuclear cells by culture *ex vivo* in high concentrations of IL-2. After culture, these cells were capable of lysing fresh tumor cells in an MHC-nonrestricted fashion.³⁸⁷ They were returned to tumor patients with concomitantly administered high-dose IL-2. Although the tumor target structure remains undefined, these determinants appear to be broadly distributed on fresh and culture tumor cells and not expressed on normal cells *in vivo*. LAK cells appear to be derived from the NK subset of human lymphocytes bearing the NK markers CD16 and CD56, and usually lacking the CD3 structure.^{388,389} Initial reports with LAK plus IL-2 in patients suggested a significant response rate in NHL, but most emphasis has been given to solid tumors, particularly renal cell carcinoma and melanoma.^{390,391} Studies suggested that LAK cells do not consistently home to the site of tumor involvement, significantly limiting their therapeutic efficacy,³⁹² and have demonstrated no advantage for the administration of LAK plus IL-2 over administration of IL-2 alone.³⁹⁰

A search for more potent killer cells resulted in the description of tumor-infiltrating lymphocytes (TILs).³⁹³ These cells could be isolated and grown from single-cell suspensions of tumor specimens in IL-2. They have the phenotype of classical cytotoxic T cells and kill tumor cells in an MHC-restricted manner. In animal studies, TILs are approximately 50 to 100 times more potent killers than are LAK cells. TILs also more efficiently home to and accumulate in tumor deposits.^{394,395} Pilot trials^{386,396} have demonstrated a response rate of approximately 35% in patients with melanoma.

The rather modest response rates, the extremely laborintensive nature of these treatments, and the serious toxicity of systemically administered IL-2 have markedly limited enthusiasm for these approaches to treatment, but they stand as important milestones on the road to effective immunologic treatments for neoplastic hematologic diseases and solid tumors. The remarkable success of adoptively transferred, virally specific, *ex vivo* expanded T lymphocytes for control of cytomegalovirus infection in patients after allogeneic HCT³⁹⁷ and^{398,399} suggests that, if appropriate tumor cell antigens can be found and exploited, this form of therapy may become a useful modality in the treatment of hematologic malignancies.^{400,401}

Engineered cells, using autologous chimeric antigen receptor-modified T cells reinfused into a patient with refractory CLL, expanded to a level that was more than 1,000 times as high as the initial engraftment level *in vivo*, with delayed development of the tumor lysis syndrome and with complete remission. A specific immune response was detected in the bone marrow, accompanied by loss of normal B cells and leukemia cells that express CD19. Remission was ongoing 10 months after treatment. Hypogammaglobulinemia was an expected chronic toxic effect.⁴⁰² Also, transplants using lectin-separated, E-rosette-depleted (SBA-E-) allogeneic marrow- or granulocyte colony-stimulating factor-mobilized CD34⁺ peripheral blood progenitor cells, which were adequately depleted of T cells and administered without posttransplant immunosuppression, have been shown to induce consistent engraftment with low incidences of acute and chronic GVHD, both in HLA-matched and HLA-disparate recipients. Furthermore, the incidence of relapse posttransplant is not increased in patients transplanted for AML, MDS, or ALL.⁴⁰³

Immunization Strategies

The central hypothesis of active immunotherapy for cancer is that either the tumor cell itself or antigens derived from the tumor cell (which are specific, or at least selective, for the tumor cell) can be modified and injected back into the patient as a therapeutic vaccine. The desired result is activation of both major arms of the immune response, the host antibody response and a host T cell response, against the target tumor cell or antigen, to aid in the eradication of the disease (Fig. 70.6).

Active Immunotherapy for Lymphomas

Vaccine strategies targeting NHL have largely focused on using the tumor-specific Id as an antigen. The variable regions of the heavy and light chains of the immunoglobulin molecules expressed on the surface of B cells contain unique determinants termed Id that can be recognized as an antigen. Since malignancies of mature and resting B cells arise from clonal proliferation of cells that

P.1485

express immunoglobulins with unique variable region sequences on their surface, the Id of a given B cell malignancy can serve as a tumor-specific antigen and has been exploited as a target for active specific immunotherapy.

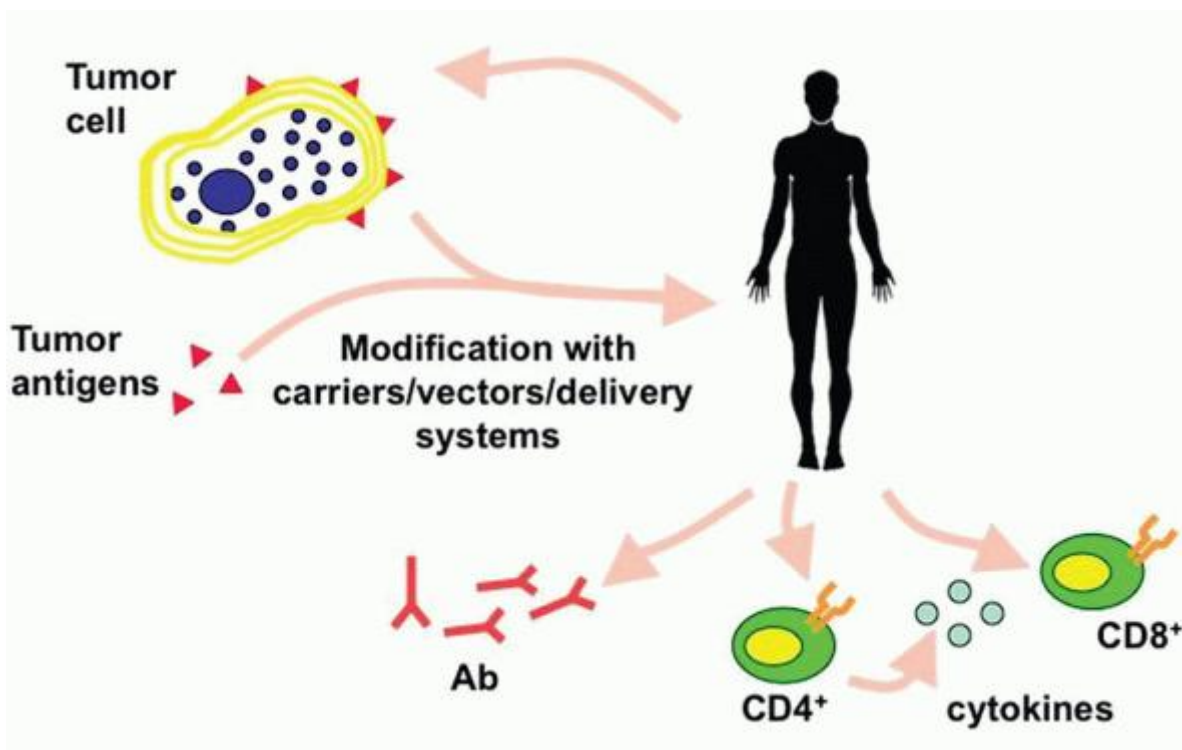

FIGURE 70.6. Therapeutic vaccination against cancer. Active immunotherapy against cancer typically involves the use of tumor cells or antigens derived from the tumor cells that are modified and injected back into the patients to elicit a potent host $CD4^+$ and $CD8^+$ T cell response and possibly a host antibody response against the targeted tumor to aid in the eradication of the disease. Ex vivo modification of tumor antigens or tumor cells may involve the use of conjugation to a carrier molecule, incorporation into viral vectors, transduction of tumor cells with cytokine genes, and/or administration with adjuvants. Ab, antibody.

Preclinical Studies of Idiotype Vaccines

In the early 1970s, Lynch and Eisen demonstrated in mice that active immunization with purified immunoglobulins from mineral oil-induced plasmacytomas induced Id-specific tumor resistance.^{180,181} This phenomenon has been reproduced subsequently in a number of lymphoma, myeloma, and leukemia models.^{404, 405, 406, 407, 408} and ⁴⁰⁹ In 1987, Kaminski et al. demonstrated that optimal immunization required conjugation to a strongly immunogenic carrier protein, such as keyhole limpet hemocyanin (KLH).⁴⁰⁷ Subsequently, Kwak et al. demonstrated that the use of GM-CSF factor as an adjuvant facilitated the induction of tumor-specific $CD8^+$ T cells and enhanced the efficacy of the vaccine in a murine 38C13 lymphoma model.⁴⁰⁹ GM-CSF likely acts by recruiting and promoting maturation of professional APCs such as DCs, which may in turn activate pathways of antigen processing that allow exogenous proteins to be presented by class I molecules. Animal studies also demonstrated that idiotypic vaccination conferred protection against tumor challenge and could cause regression of established tumors. Taken together, these results provided the rationale for testing autologous tumor-derived idiotypic surface immunoglobulin as a therapeutic “vaccine” against human B cell NHL.

Pilot Clinical Trial of Idiotype Vaccine

The first human study of Id vaccination was pioneered by Kwak et al., in patients with follicular lymphoma (Table 70.3), which was a pilot study designed to determine whether it was possible to immunize against the Id portion of the protein.⁴¹⁰ Follicular lymphoma patients, in minimal residual disease or complete remission after chemotherapy, were immunized with subcutaneous injections of autologous purified tumor-derived immunoglobulin, conjugated to KLH. Because no Id-specific immune responses were observed before the addition of an immunologic adjuvant to the first group of patients, patients (9 patients) subsequently received the entire series of immunizations with a standard emulsion adjuvant (Syntex adjuvant formulation-1 [SAF-1]). In all, 41 patients were treated in this pilot study, and 41% demonstrated specific anti-Id antibody and 17% demonstrated cellular proliferative responses.⁴¹¹ Of the 20 patients with residual disease following chemotherapy, two patients had complete regression of the tumor in association with the development of a specific immune response. Thus, these results were important because they demonstrated that patients with lymphoma could be induced to make sustained Id-specific immune responses by active immunization with purified

autologous tumor-derived surface immunoglobulin conjugated to the immunogenic carrier KLH. Furthermore, the induction of Id-specific immune responses was demonstrated in the setting of minimal tumor burden after conventional chemotherapy. However, it is important to recognize that convincing T cell responses (CD8⁺) were not observed, and this single-arm trial was not designed to answer the question of clinical efficacy.

Idiotype Keyhole Limpet Hemocyanin + Granulocyte-macrophage Colony-stimulating Factor Vaccine-induced Molecular Remissions in Follicular Lymphoma

Based on the preclinical observation that the addition of GM-CSF as an adjuvant to the vaccine-induced tumor-specific CD8⁺ T cells,⁴⁰⁹ Bendandi et al. conducted a phase II clinical trial where 20 previously untreated follicular lymphoma patients were treated with autologous tumor-derived Id-KLH + GM-CSF vaccine (in normal saline) following induction of clinical remission with a uniform chemotherapy regimen (prednisone, doxorubicin, cyclophosphamide, and etoposide [PACE])⁴¹² (Table 70.3). This produced a homogeneous group of patients, all in first CR, who were given vaccine treatment in the setting of minimal residual disease. The vaccine was injected subcutaneously in 5 monthly doses starting approximately 6 months after completing chemotherapy to allow time for immunologic recovery. The vaccine was well tolerated, with the main adverse effects being injection site reactions such as erythema, induration, and pruritus. There were no long-term adverse effects due to the vaccine.

Following vaccination, anti-KLH antibody and cellular responses were induced in all patients. Anti-Id antibody responses were induced in 15 of 20 patients (75%) and Id-specific and/or tumor-specific CD4⁺ and CD8⁺ T cell responses were observed in 19 of 20 patients (95%).⁴¹² Further characterization of anti-Id cellular immune responses demonstrated that the T cells specifically recognized multiple unique immunodominant epitopes within the hypervariable complementarity-determining

P.1486

regions, but not framework regions of immunoglobulin heavy chain.⁴¹³

TABLE 70.3 KEY PHASE I/II CLINICAL TRIALS OF IDIOTYPE VACCINATION IN LYMPHOMA

Immune Responses (%)

Formulation	No.	Histology	T		Comments	Ref.
			Ab	Cell		
Id-KLH + SAF	41	FL	41	17	First human trial of idiotype vaccine	410,411
Id-KLH + GM-CSF	20	FL	75	95	Molecular remissions in 8 of 11 patients	412,414
Id-DC/Id-KLH-DC	35	FL	26	49	Clinical responses in 22% of patients	412,414
Liposomal Id/IL-2	10	FL	40	100	Sustained T cell responses beyond 18 mo	441
Id-KLH + GM-CSF	26	MCL	30	87	T cell responses induced in the absence of B cells	430,432
Id-KLH + GM-CSF	32	FL	20	67	Clinical responses observed in 4 patients	442
Id-KLH + GM-CSF	25	FL	52	72		487
Id-KLH + GM-CSF	92	FL	20	72	Improved disease-free survival	431
Id (Fab) + MF59 + GM-CSF	42	B cell lymphomas	46	56	Improved response rate Clinical responses observed in 6 of 15 FL patients	444

DC, dendritic cell; Fab, Fragment antibody binding; FL, follicular lymphoma; GM-CSF, granulocyte-macrophage colony-stimulating factor; Id, idiotype; IL-2, interleukin-2; KLH, keyhole limpet hemocyanin; MCL, mantle cell lymphoma; SAF, Syntex adjuvant formulation.

Monitoring of the patients for minimal residual disease showed that 8 of 11 patients with PCR-positive t(14;18) chromosomal translocation breakpoints converted to PCR negativity in their blood immediately after completing vaccination, and sustained their molecular remissions for a median of 18+ months (range: 8+ to 32+ months).⁴¹² Thus, these results provided the first convincing evidence for an antitumor effect of Id vaccination.

Analysis of time to relapse also provided an independent indication of clinical benefit. With a median follow-up of 9.2 years, median DFS is 8 years, and the OS rate is 95%.⁴¹⁴ While definitive statements cannot be made because this was not a randomized trial, the DFS appears superior to that of a historical, ProMACE chemotherapy-treated control group (median DFS, about 2.2 years).⁴¹⁵ Additional studies have also shown that Id vaccines may have potential clinical utility.

TABLE 70.4 PHASE III CLINICAL TRIALS OF IDIOTYPE VACCINATION IN FOLLICULAR LYMPHOMA

	NCI/Biovest	Genitope	Favrille
No. of patients randomized	177	287	349
Induction therapy	PACE	CVP	Rituximab
Randomized patients	CR/Cru	CR/CRu/PR	CR/CRu/PR/SD
No. of patients vaccinated	117	277	315
Vaccination	Id-KLH + GM-CSF or KLH + GM-CSF	Id-KLH + GM-CSF or KLH + GM-CSF	Id-KLH + GM-CSF or Placebo + GM-CSF
Id protein production method	Hybridoma technology	Recombinant DNA technology	Recombinant DNA technology
Isotype of vaccinated Id protein	IgM or IgG	IgG	IgG
Primary endpoint	Disease-free survival	Progression-free survival	Time to progression
Outcome	Positive	Negative	Negative
Reference	416	418	417

CR, complete remission; CRu, complete remission unconfirmed; CVP, Cyclophosphamide, Vincristine, Prednisone; GM-CSF, granulocyte-monocyte colony-stimulating factor; Id, idiotype; Ig, immunoglobulin; KLH, keyhole limpet hemocyanin; NCI, National Cancer Institute; PACE, Prednisone, Doxorubicin, Cyclophosphamide, Etoposide; PR, partial remission; SD, stable disease.

Idiotype Vaccine Improved Disease-free Survival in Follicular Lymphoma in a Phase III Trial

The encouraging immunologic and clinical outcome of the Id-KLH + GM-CSF vaccine in the phase II clinical trial led to the initiation of a randomized double-blind placebo-controlled multicenter phase III clinical trial sponsored initially by the National Cancer Institute (NCI) and later by Biovest International, Inc. to definitively answer the question of clinical benefit induced by Id vaccination in patients with follicular lymphoma (Table 70.4).⁴¹⁶ Patient population, induction chemotherapy, vaccine formulation, and trial design were similar to the phase II trial. Following induction of PACE chemotherapy, patients that achieved a CR or CRu were randomized 2:1 to receive either the specific vaccine, Id-KLH + GM-CSF, or the nonspecific immune stimulant, KLH + GM-CSF. Of 117 vaccinated patients, 76 received Id vaccine and 41 received control. After a median follow-up of 56.6 months, median DFS was 44.2 months for the Id vaccine arm and 30.6 months for the

P.1487

control arm (P = 0.047). Interestingly, in an unplanned subgroup analysis, the clinical benefit appeared to be restricted to the group of patients that had IgM isotype on their tumors. Median DFS for IgM-Id vaccinated group v control was 52.9 v 28.7 months (P = 0.001), and for IgG-Id vaccinated group v control was 35.1 v 32.4 months (P = 0.807). In summary, this

trial showed for the first time that therapeutic vaccination could induce meaningful clinical benefit in patients with lymphoma.⁴¹⁶

However, two other phase III clinical trials of Id vaccine in follicular lymphoma sponsored by Genitope and Favrilie failed to show clinical benefit (Table 70.4).^{417,418} Differences in the nature of vaccine products, trial design, and requirement for complete remission status after induction therapy may explain differences in outcomes between these 3 trials. For example, the NCI/Biovest study used the traditional hybridoma technology to generate the vaccine for each patient.⁴¹⁹ This results in production of the native IgM or IgG-Id, depending on the isotype of the Id on each tumor. In contrast, the Favrilie and Genitope studies used recombinant DNA technology to clone the variable regions of the tumor Id and fuse them to a common IgG Fc.⁴²⁰ Ids that have switched to IgG were previously shown to be tolerogenic, whereas Ids of their IgM progenitors were highly immunogenic.^{421,422} Moreover, the Fc fragment of IgG has been shown to have highly promiscuous MHC class II T cell epitopes that specifically activate Tregs and tip the immune responses toward tolerance rather than immunogenicity.⁴²³ The use of less intensive induction chemotherapy and vaccinating patients with partial remission and/or stable disease may also have contributed to persistence of tumor-induced immunosuppression at the time of vaccination in the Genitope and Favrilie studies.

Idiotype Vaccination in Combination with Rituximab

Although the NCI/Biovest study demonstrated that Id vaccination might improve clinical outcome, demonstration of vaccine efficacy after rituximab-containing induction therapy is necessary to integrate Id vaccination into standard of care for lymphomas. Rituximab is an anti-CD20 monoclonal antibody that depletes both normal and malignant B cells.^{146,424} Consequently, patients treated with rituximab are unlikely to have peripheral blood B cells and therefore unlikely to generate humoral immune responses following active immunotherapy. Animal studies have yielded conflicting results on the role of B cells in the priming of naive T cells.^{52,425, 426, 427, 428} and ⁴²⁹ To determine the effects of B cell depletion induced by rituximab on immune responses to Id vaccines, twenty-six previously untreated mantle cell lymphoma patients were treated with 6 cycles of dose-adjusted rituximab, etoposide, vincristine, doxorubicin, cyclophosphamide, and prednisone (EPOCH-R), followed 12 weeks later with 5 monthly cycles of autologous tumor-derived Id-KLH + GM-CSF vaccination (Table 70.3).⁴³⁰ As expected following EPOCH-R, peripheral blood B cells were completely depleted in all patients, began to recover at approximately 6 months, and returned to baseline levels by 1 year in most patients. In contrast, CD4⁺ T cell numbers decreased only slightly and recovered by the start of vaccination with a median time of 3 months; CD8⁺ T cell numbers did not change substantially.⁴³⁰

Unexpectedly, despite rituximab administration, antibody responses against the carrier molecule KLH and Id were detected in 17 of 23 (74%) and 7 of 23 (30%) evaluable patients, respectively. The humoral responses were delayed and correlated with B cell recovery, with most detected after the fourth or fifth vaccination, compared with after the first or second vaccination in the follicular lymphoma study in which rituximab was not administered.⁴¹² In contrast, vigorous CD4⁺ and CD8⁺ antitumor and KLH T cell responses were not delayed and were induced in 20 of 23 patients (87%) and 23 of 23 (100%), respectively, in the absence of circulating B cells,⁴³⁰ suggesting that professional APCs such as DCs may effectively present antigen to T cells in the absence of B cells. This result was independently confirmed in another clinical trial where induction of anti-KLH and anti-Id or tumor T cell responses was observed in >70% of follicular lymphoma patients vaccinated with autologous tumor-derived Id-KLH + GM-CSF vaccine following treatment with rituximab.⁴³¹ Although the median PFS of 24 months was not significantly different from historical controls of mantle cell lymphoma, the median OS of 104 months was markedly better. More interestingly, an antitumor T cell GM-CSF response but not antibody response was significantly associated with OS and time to next treatment, suggesting that antitumor cellular immune responses may significantly delay tumor growth.⁴³² Taken together, these results indicate that Id vaccines could be administered in the setting of B cell depletion induced by rituximab and may potentially improve clinical outcome.

The Relative Role of Humoral versus Cellular Immunity in Idiotype Vaccine Efficacy

While some murine lymphoma models have demonstrated that the antitumor efficacy of Id vaccine is dependent on the induction of an antibody response,^{407,433,434} other lymphoma models have shown that protection against tumor challenge or eradication of established tumors requires a CD4⁺ and/or a CD8⁺ T cell response.^{409,435,436} An analysis of 136 patients with follicular lymphoma treated with Id vaccination showed that the induction of specific anti-Id antibody responses was associated with significantly prolonged PFS.⁴³⁷ This study also demonstrated that patients with a favorable FcγRIIIa polymorphism that predicts stronger binding of the Fc of antibodies to effector cells had a longer PFS. Thus, patients with FcγRIIIa 158 valine/valine (V/V) genotype had a longer PFS than those with valine/phenylalanine (V/F) or phenylalanine/phenylalanine (F/F) genotypes. In contrast, no significant correlation was observed between the development of a cellular anti-Id immune response and PFS. However, it is possible that this study may have underestimated the value of an antitumor T cell response for several reasons. First, cellular responses on this study were

measured by a T cell proliferation assay, which is relatively insensitive, compared with assays such as ELISPOT and cytokine flow cytometry.⁴³⁸ Second, the proliferation assay detects primarily a CD4⁺ T cell response and may fail to detect a CD8⁺ T cell response. Third, immunologic assays that demonstrate recognition of native tumors (tumor-specific) may be more clinically relevant to assess T cell responses following cancer vaccination, compared with assays that demonstrate recognition of tumor antigens presented on appropriate APCs (antigen-specific). Finally, 86 of 136 patients (63%) in this study received a chemical adjuvant with the Id vaccine that predominantly induced a humoral immune response.^{410,411} In contrast, Id vaccine formulations using DCs^{439,440} or cytokines such as GM-CSF^{412,430} or IL-2⁴⁴¹ as adjuvants significantly enhanced the induction of cellular immune responses.

Following Id-pulsed DC vaccinations, clinical tumor regressions were associated with the induction of cellular responses, but without an antibody response^{439,440} (Table 70.3). Similarly, following Id-KLH + GM-CSF vaccination, patients achieved molecular remissions⁴¹² or CR⁴⁴² without a detectable antibody response, suggesting that cell-mediated antitumor immune responses are important for vaccine efficacy. Clinical tumor regression was also observed in a follicular lymphoma patient after administration of a novel liposomal Id/IL-2 vaccine (OncoVAX-Id/IL-2) in the absence of an antibody response.⁴⁴¹ The liposomal vaccine study also showed that the tumor-specific CD4⁺ and CD8⁺ T cell responses induced by the vaccine were sustained 18 months beyond the completion of vaccination and were associated with prolonged DFS⁴⁴¹ (Table 70.3). In another study, Nelson et al. demonstrated that the precursor frequency of tumor-specific CTL correlated with freedom from progression following Id vaccination.⁴⁴³ In treatment of naive indolent B cell lymphoma patients, cellular responses after immunization with Id Fab fragment correlated with tumor

P.1488

regression and PFS.⁴⁴⁴ As mentioned above, antitumor cellular but not humoral immune responses were associated with prolonged survival in mantle cell lymphoma.⁴³² Taken together, these results suggested that T cell responses could induce tumor regression independent of a humoral response and support the use of lymphoma vaccines in the setting of B cell depletion induced by rituximab-based induction regimens. However, because the relative role of cellular versus humoral immunity for vaccine efficacy is uncertain, it may be advisable to administer booster vaccinations following B cell recovery to optimize humoral responses.

Second-generation Lymphoma Vaccines

The results of clinical trials described above suggest that Id vaccination is safe, induces antitumor humoral and cellular immune responses, and is associated with improved disease-free survival in patients with follicular lymphoma. However, rapid progress in the development of active immunotherapeutic approaches for lymphoma has been hindered by the need to generate a custom-made product for each patient, by a process that is expensive, laborious, and time consuming. An alternative to Id protein vaccination is to directly extract selected membrane proteins from the tumor cells and incorporate them into liposomes along with IL-2. This novel membrane proteoliposome vaccine (Oncoquest-L) could be produced within 24 hours, was observed to be safe in a pilot clinical trial in follicular lymphoma patients, and induced tumor-specific CD4⁺ and CD8⁺ T cell responses.⁴⁴⁵ Other individualized tumor vaccine formulations in development for NHL include GM-CSF-transduced tumor/bystander cells,⁴³⁵ CD40-activated tumor cells,⁴⁴⁶ and tumor lysate-pulsed DCs.^{447,448} However, as with Id protein vaccination, these vaccine formulations also require generating a custom-made product for each patient and therefore may limit the broad applicability of this approach.

Identification of universally expressed lymphoma-specific antigens would lead to development of vaccine formulations that can be used in all lymphoma patients and are therefore easier and less costly to produce. Recently, T cell leukemia lymphoma 1 (TCL1), a coactivator of Akt that promotes cell proliferation and survival and has been shown to be aberrantly expressed in multiple B cell lymphomas, has been suggested as a possible shared TAA for common B cell lymphomas, including follicular lymphoma, CLL, mantle cell lymphoma, diffuse large B cell lymphoma, and splenic marginal zone lymphoma.⁴⁴⁹ TCL171-78 peptide-specific CD8⁺ T cells were shown to lyse autologous primary tumor cells in an HLA-A*0201-restricted manner, suggesting that TCL1 is naturally processed and presented on the surface of lymphoma cells for recognition by cytotoxic T cells. Additional preclinical studies are needed to determine the safety of TCL1 vaccine prior to evaluation in clinical trials.

Active Immunotherapy for Myeloma

Multiple myeloma is characterized by clonal proliferation of plasma cells, all of which secrete the same immunoglobulin molecule (M-protein). Similar to B cell lymphomas, the variable regions of the heavy and light chains of the immunoglobulin molecule secreted by the myeloma tumor cells contain unique idiotypic sequences that can be recognized as an antigen. Therefore, the Id of the myeloma can serve as a tumor-specific antigen and has been exploited

as a target for active specific immunotherapy in animal models.^{181,405} In addition, the M-protein can be easily isolated from human plasma and purified into a highly refined, safe protein vaccine. Id-specific CTL lines generated from myeloma patients by repeated in vitro stimulation with Id-pulsed DCs specifically recognized and lysed autologous primary myeloma cells,^{450,451} validating human myeloma cells as targets of an Id-specific T cell response.

Immunization of myeloma patients with Id vaccine following autologous stem cell transplantation was generally safe. However, Id-specific cellular immune responses were weak and clinical responses were transient or rare,^{452, 453} and^{454,455,456} possibly due to the immunocompromised state of myeloma patients from the underlying disease or treatment. Immunization with human telomerase reverse transcriptase and survivin-derived peptides similarly showed low immunogenicity.⁴⁵⁷ An alternative strategy is to immunize HLA-matched healthy donors prior to stem cell harvest and transfer the resulting tumor antigen-specific immunity to the patients by stem cell transplantation, with the goal of enhancing the graft-versus-tumor effect without increasing the risk of GVHD. This approach was tested in HLA-matched donor-recipient pairs in the setting of allogeneic stem cell transplantation.^{458, 459} and⁴⁶⁰ These studies demonstrated that immunization of healthy HLA-matched stem cell donors with the Id purified from the plasma of the myeloma patients conjugated to KLH was safe, induced KLH and Id-specific T cell immunity in the donors, and could be transferred passively to recipients. Interestingly, donor-derived KLH- and Id-specific humoral, and central and effector memory T cell responses were detectable relatively early after allotransplant, within the first 30 days, despite iatrogenic immunosuppression for GVHD prophylaxis, and were boosted by posttransplant vaccinations in most recipients.⁴⁶⁰ Furthermore, transfer of Id-specific immunity from the donors to the recipients was associated with prolonged DFS in the recipients.^{458, 459} and⁴⁶⁰ However, a randomized study is necessary to definitively determine whether Id vaccination of the donors is associated with improved clinical outcome in myeloma patients. Nevertheless, vaccination of stem cell transplant donors may represent a safe and novel strategy to improve outcomes of allotransplant by reducing relapse in malignancies for which tumor-specific antigens have been defined, and by protecting against infectious pathogens.

Recently, Dickkopf-1 (DKK1) has been suggested as a shared TAA for myeloma.^{461,462} DKK1 is highly expressed by the tumor cells of almost all myeloma patients, and is absent from normal tissues and organs except placenta, uterus, testis, and prostate.⁴⁶¹ DKK1 was shown to suppress osteoblast formation and increase bone destruction in myeloma; and inhibiting DKK1 activity by specific antibodies resulted in increased osteoblast number and bone formation, reduced osteoclast activity, and inhibited myeloma growth in a myeloma mouse model, suggesting a major role for DKK1 in the pathogenesis of myeloma.⁴⁶³ DKK1 peptide-specific T cell lines and clones generated from HLA-A*0201⁺ blood donors and myeloma patients effectively lysed primary myeloma cells in vitro and eradicated myeloma xenografts mice.⁴⁶¹ Furthermore, DKK1 vaccine protected mice from developing myeloma and had therapeutic effects against established myeloma in a murine myeloma model, suggesting its potential utility for myeloma patients.⁴⁶²

Active Immunotherapy for Leukemias

The identification of several leukemia-associated antigens has generated interest in developing vaccines for leukemia. One of the most studied leukemia antigens is the CML-associated BCR-ABL fusion protein resulting from the reciprocal translocation t(9;22). The demonstration of binding of the peptides derived from the fusion region to several HLA molecules and the induction of T cells that recognize peptide-pulsed target cells in vitro validated this fusion protein as a potential target for immunotherapy. Immunization of the CML patients with the peptides derived from the fusion region in clinical trials showed induction of specific BCR-ABL cellular immune responses and was associated with improved cytogenetic responses in some of the patients.^{464,465,466,467} However, additional trials are needed to determine the clinical efficacy of these vaccines, since most patients also received IFN and/or imatinib at the time of vaccination.

Active immunization strategies have also been evaluated in patients with AML and MDS using peptides derived from P.1489

overexpressed proteins in leukemia cells such as the WT1, proteinase 3, and neutrophil elastase. A nonamer peptide PR1 derived from both proteinase 3 and neutrophil elastase that had high-affinity binding for the HLA-A*0201 molecule was tested in a phase I/II study in 66 patients with AML, CML, or MDS. Preliminary data suggest a significant increase in the PR1-specific T cells in 25 of 53 patients (47%) with measurable disease and clinical remission in 9 of 25 immune responder patients (36%), including durable molecular remissions in patients with refractory AML.⁴⁶⁸ Immunization of patients with AML or MDS with WT1 peptide-based immunotherapy showed a correlation between CTL immune responses and reduction of leukemic blast cells and/or WT1 transcripts.^{469,470,471,472,473}

FUTURE DIRECTIONS

The demonstration of induction of antitumor T cell responses by Id vaccination following B cell depletion induced by rituximab^{430,431} suggests that active immunotherapy strategies may be combined with passive immunotherapy strategies. Indeed, the use of passively administered antitumor mAbs such as rituximab with vaccines is likely to be complementary. Compared with mAbs, vaccines are likely to target different tumor antigens, can induce immunologic memory, and can induce polyclonal humoral and cellular immune responses, thereby minimizing the emergence of immune escape variants. However, with the increased use of rituximab for the treatment of B cell NHL, further improvement in the potency of the vaccines would require strategies to enhance the T cell responses, since rituximab depletes normal B cells and impairs the generation of antibody responses following vaccination. As described below, several strategies are being explored to achieve this goal.

Over the past two decades, preclinical studies have demonstrated that the induction of an optimal antitumor immune response requires the incorporation of tumor antigen, carrier molecule, and adjuvant as essential components of a cancer vaccine. Consequently, several cancer vaccine clinical trials were conducted to test and define a better tumor antigen, carrier molecule, and adjuvant. While such strategies were successful in enhancing the potency of the cancer vaccines and in inducing remissions in patients with minimal residual disease or small-volume disease, they do not appear to be effective for the treatment of patients with large tumor burdens. Although novel adjuvants such as TLR ligands may prove to be more potent than cytokine adjuvants,^{474, 475} and ⁴⁷⁶ further improvement of the cancer vaccines would probably also require disruption of the immunoregulatory pathways that modulate the magnitude and duration of the immune response.

Studies in animal models suggest that the T cell immune responses against foreign or self-antigens are regulated by several immunoregulatory pathways and/or peripheral tolerance mechanisms.^{121,477,478} For example, Tregs have been shown to downregulate T cell responses against foreign antigens as well as tumor antigens.⁴⁷⁹ Similarly, CTLA-4, a molecule that is expressed on activated T cells and Tregs, was shown to down-regulate T cell responsiveness and prevent the initiation and/or limit the magnitude of autoreactive T cell responses.⁴⁸⁰ A host of other mechanisms such as PD-1, B7-H1, and B7-H4 were recently described to negatively regulate T cell responses.^{121,481} These new insights have led several investigators to hypothesize that the potency of cancer vaccines can be further enhanced by concurrent suppression or blocking of peripheral tolerance mechanisms and/or suppressive immunoregulatory pathways. Dannull et al. have demonstrated that vaccine-mediated antitumor immunity is significantly enhanced in renal cell cancer patients after depletion of Tregs using denileukin diftitox⁴⁸² (a recombinant IL-2 diphtheria toxin conjugate; also known as Ontak), a Food and Drug Administration-approved drug for the treatment of CTCLs. Similarly, blockade of CTLA-4 in combination with peptide vaccination has resulted in enhanced cancer immunity and durable objective responses in patients with metastatic melanoma.^{483,484} Another strategy to enhance the potency of vaccines is to combine them with novel immunomodulatory agents. Lenalidomide, an immunomodulatory drug used for the treatment of myeloma, has been shown to enhance immune responses to pneumococcal vaccine in myeloma patients.⁴⁸⁵ Lenalidomide was also demonstrated to augment effects of Id vaccine by enhancing T cell responses and reversing systemic immunosuppression in a mouse model of lymphoma.⁴⁸⁶ Taken together, these preclinical and early-phase clinical results support the evaluation of combination immunotherapy strategies in future clinical trials with the cancer vaccine to stimulate an antitumor T cell response, and the simultaneous suppression of immune regulatory pathways to augment the induced T cell response. The existence of multiple immune regulatory pathways necessitates systematic evaluation of these approaches in clinical trials to determine the optimal combination immunotherapy regimen.

WEB SITES

<http://www.anticancer.net/reviews/>

<http://www.cancerresearch.org/>

ACKNOWLEDGEMENTS

This chapter represents an edited and updated version of the chapter on "Immunotherapy" included in the 11th edition of this book. We therefore gratefully acknowledge the author of the original chapter, Dr. Stanford Stewart (Acrogenic, Inc., Rockville, MD), for his important contributions.

REFERENCES

1. Ehrlich P. Ueber den jetzigen stand der karzinomforschung. *Ned Tijdschr Geneesk* 1909;5:273-290.
2. Burnet F. The concept of immunological surveillance. *Prog Exp Tumor Res* 1970;13:1-27.
3. Moller G, Moller E. The concept of immunological surveillance against neoplasia. *Transplant Rev* 1976;28:3-16.

4. Penn I. Tumors of the immunocompromised patient. *Annu Rev Med* 1988;39:63-73.
5. Old LJ, Boyse EA. Antigens of tumors and leukemias induced by viruses. *Fed Proc* 1965;24(5):1009-1017.
6. Stutman O. Tumor development after 3-methylcholanthrene in immunologically deficient athymic-nude mice. *Science* 1974;183(124):534-536.
7. Groopman JE. Neoplasms in the acquired immune deficiency syndrome: the multidisciplinary approach to treatment. *Semin Oncol*, 1987;14 (2 Suppl 3):1-6.
8. Woglom W. Immunity to transplantable tumors. *Cancer Res* 1929;4:129-214.
9. Gorer P. Some recent work on tumor immunity. *Adv Cancer Res* 1956;4: 149-186.
10. Snell GD. Studies in histocompatibility. *Science* 1981;213:172-178.
11. Prehn R, Main J. Immunity to methylcholanthrene-induced sarcomas. *J Natl Cancer Inst* 1957;18:769-778.
12. Old LJ, Boyse EA, Clarke D, Carsswell E. Antigenic properties of chemically induced tumors. *Ann N Y Acad Sci* 1962;101:80-106.
13. Mitchison N. Passive transfer of transplantation immunity. *Proc R Soc Lond* 1954;B142:72-87.
14. Rouse BT, Rollinghoff M, Warner NL. Anti-theta serum-induced suppression of the cellular transfer of tumour-specific immunity to a syngeneic plasma cell tumour. *Nat New Biol* 1972;238(82):116-117.
15. Kohler G, Milstein C. Continuous cultures of fused cells secreting antibody of predefined specificity. *Nature* 1975;256:495-497.
16. Smyth MJ, Godfrey DI, Trapani JA. A fresh look at tumor immunosurveillance and immunotherapy. *Nat Immunol* 2001;2(4):293-299.
17. Dunn GP, Old LJ, Schreiber RD. The immunobiology of cancer immunosurveillance and immunoediting. *Immunity* 2004;21(2):137-148.
18. Vesely MD, Kershaw MH, Schreiber RD, Smyth MJ. Natural innate and adaptive immunity to cancer. *Annu Rev Immunol* 2011;29:235-271.
19. Street SE, Cretney E, Smyth MJ. Perforin and interferon-gamma activities independently control tumor initiation, growth, and metastasis. *Blood* 2001;97(1):192-127.
20. Kaplan DH, Shankaran V, Dighe AS, et al. Demonstration of an interferon g-dependent tumor surveillance system in immunocompetent mice. *Proc Natl Acad Sci USA* 1998;95(13):7556-7561.
21. Smyth MJ, Thia KY, Street SE, MacGregor D, Godfrey DI, Trapani JA. Perforin-mediated cytotoxicity is critical for surveillance of spontaneous lymphoma. *J Exp Med* 2000;192(5):755-760.
22. Davidson WF, Giese T, Fredrickson TN. Spontaneous development of plasmacytoid tumors in mice with defective Fas-Fas ligand interactions. *J Exp Med* 1998;187(11):1825-1838.
23. Shankaran V, Ikeda H, Bruce AT, et al. IFN γ and lymphocytes prevent primary tumour development and shape tumour immunogenicity. *Nature* 2001;410(6832):1107-1111.
24. Fearon DT, Locksley RM. The instructive role of innate immunity in the acquired immune response. *Science* 1996;272(5258):50-53.
25. Janeway CA Jr, Medzhitov R. Innate immune recognition. *Annu Rev Immunol* 2002;20:197-216.
26. Kawai T, Akira S. The roles of TLRs, RLRs and NLRs in pathogen recognition. *Int Immunol* 2009;21(4):317-337.
27. Matzinger P. The danger model: a renewed sense of self. *Science* 2002;296(5566):301-305.
28. Akira S, Uematsu S, Takeuchi O. Pathogen recognition and innate immunity. *Cell* 2006;124(4):783-801.
29. Hibbs JB Jr, Lambert LH Jr, Remington JS. Possible role of macrophage mediated nonspecific cytotoxicity in tumour resistance. *Nat New Biol* 1972;235(54):48-50.
30. Lichtenstein A. Granulocytes as possible effectors of tumor immunity. *Immunol Allergy Clin North Am* 1990;10:731-746.

31. Sims GP, Rowe DC, Rietdijk ST, Herbst R, Coyle AJ. HMGB1 and RAGE in inflammation and cancer. *Annu Rev Immunol* 2010;28:367-388.
32. Allen IC, TeKippe EM, Woodford RM, et al. The NLRP3 inflammasome functions as a negative regulator of tumorigenesis during colitis-associated cancer. *J Exp Med* 2010;207(5):1045-1056.
33. Dostert C, Petrilli V, Van Bruggen R, Steele C, Mossman BT, Tschopp J. Innate immune activation through Nalp3 inflammasome sensing of asbestos and silica. *Science* 2008;320(5876): 674-677.
34. Chow MT, Moller A, Smyth MJ. Inflammation and immune surveillance in cancer. *Semin Cancer Biol* 2012;22(1):23-32.
35. Nathan CF, Murray HW, Cohn ZA. The macrophage as an effector cell. *New Engl J Med* 1980;303(11):622-626.
36. Carswell EA, Old LJ, Kassel RL, Green S, Fiore N, Williamson B. An endotoxin-induced serum factor that causes necrosis of tumors. *Proc Natl Acad Sci USA* 1975;72(9):3666-3670.
37. Banchereau J, Palucka AK. Dendritic cells as therapeutic vaccines against cancer. *Nat Rev Immunol* 2005;5:296-306.
38. Ljunggren HG, Karre K. In search of the 'missing self': MHC molecules and NK cell recognition. *Immunol Today* 1990;11:237-244.
39. Lanier LL. NK cell recognition. *Annu Rev Immunol* 2005;23:225-274.
40. Lanier LL. Up on the tightrope: natural killer cell activation and inhibition. *Nat Immunol* 2008;9(5):495-502.
41. Ruggeri L, Mancusi A, Capanni M, Martelli MF, Velardi A. Exploitation of alloreactive NK cells in adoptive immunotherapy of cancer. *Curr Opin Immunol* 2005;17(2):211-217.
42. Welniak LA, Blazar BR, Murphy WJ. Immunobiology of allogeneic hematopoietic stem cell transplantation. *Annu Rev Immunol* 2007;25:139-170.
43. Van Kaer L, Parekh VV, Wu L. Invariant natural killer T cells: bridging innate and adaptive immunity. *Cell Tissue Res* 2011;343(1):43-55.
44. Bendelac A, Bonneville M, Kearney JF. Autoreactivity by design: innate B and T lymphocytes. *Nat Rev Immunol* 2001;1(3):177-186.
45. Smyth MJ, Crowe NY, Hayakawa Y, Takeda K, Yagita H, Godfrey DI. NKT cells—conductors of tumor immunity? *Curr Opin Immunol* 2002;14(2): 165-171.
46. Van Kaer L, Parekh VV, Wu L. Invariant NK T cells: potential for immunotherapeutic targeting with glycolipid antigens. *Immunotherapy* 2011;3(1):59-75.
47. Hayday AC. $\gamma\delta$ cells: a right time and a right place for a conserved third way of protection. *Annu Rev Immunol* 2000;18:975-1026.
48. Girardi M, Oppenheim DE, Steele CR, et al. Regulation of cutaneous malignancy by $\gamma\delta$ T cells. *Science*, 2001;294:605-609.
49. Tonegawa S. Somatic generation of antibody diversity. *Nature* 1983;302(5909):575-581.
50. Davis MM, Bjorkman PJ. T-cell antigen receptor genes and T-cell recognition. *Nature* 1988;334:395-402.
51. Smyth MJ, Crowe NY, Godfrey DI. NK cells and NKT cells collaborate in host protection from methylcholanthrene-induced fibrosarcoma. *Int Immunol* 2001;13(4):459-463.
52. Qin Z, Richter G, Schuler T, Ibe S, Cao X, Blankenstein T. B cells inhibit induction of T cell-dependent tumor immunity. *Nat Med* 1998;4(5):627-630.
53. Old LJ. Cancer Immunology: the search for specificity—G.H.A. Clowes Memorial Lecture. *Cancer Res* 1981;41:361-375.
54. Slamon DJ, Leyland-Jones B, Shak S, et al. Use of chemotherapy plus a monoclonal antibody against HER2 for metastatic breast cancer that overexpresses HER2. *New Engl J Med* 2001;344:783-792.
55. Boon T, Cerottini JC, Van den Eynde B, Van Der Bruggen P, Van Pel A. Tumor antigens recognized by T cells. *Annu Rev Immunol* 1994;12:337-365.
56. Restifo NP, Robbins PF, Rosenberg SA. Tumor Immunology. In: Paul WE, ed. *Fundamental immunology*, 6th ed. Philadelphia: Lippincott Williams & Wilkins 2008;45:1489-1522.

57. Germain RN. MHC-dependent antigen processing and peptide presentation: providing ligands for T lymphocyte activation. *Cell* 1994;76:287-299.
58. Engelhard VH. Structure of peptides associated with class I and class II MHC molecules. *Annu Rev Immunol* 1994;12:181-207.
59. Wolf PR, Ploegh HL. How MHC class II molecules acquire peptide cargo: biosynthesis and trafficking through the endocytic pathway. *Annu Rev Cell Dev Biol* 1995;11:267-306.
60. Lennon-Dumenil AM, Bakker AH, Wolf-Bryant P, Ploegh HL, and Lagaudriere-Gesbert C. A closer look at proteolysis and MHC-class-II-restricted antigen presentation. *Curr Opin Immunol* 2002;14(1):15-21.
61. Van Kaer L. Accessory proteins that control the assembly of MHC molecules with peptides. *Immunol Res* 2001;23(2-3):205-214.
- P.1490
62. Van Kaer L. Major histocompatibility complex class I-restricted antigen processing and presentation. *Tissue Antigens* 2002;60(1):1-9.
63. Pamer E, Cresswell P. Mechanisms of MHC class I-restricted antigen processing. *Annu Rev Immunol* 1998;16:323-358.
64. Rock KL, Goldberg AL. Degradation of cell proteins and the generation of MHC class I-presented peptides. *Annu Rev Immunol* 1999;17:739-779.
65. Kloetzel PM, Ossendorp F. Proteasome and peptidase function in MHC-class-I-mediated antigen presentation. *Curr Opin Immunol* 2004;16(1): 76-81.
66. Van Kaer L, Ashton-Rickardt PG, Eichelberger M, et al. Altered peptidase and viral-specific T cell response in LMP2 mutant mice. *Immunity* 1994;1(7): 533-541.
67. Fehling HJ, Swat W, Laplace C, et al. MHC class I expression in mice lacking the proteasome subunit LMP-7. *Science* 1994;265(5176):1234-1237.
68. Kincaid EZ, Che JW, York I, et al. Mice completely lacking immunoproteasomes show major changes in antigen presentation. *Nat Immunol* 2012;13(2): 129-135.
69. Rock KL, York IA, Goldberg AL. Post-proteasomal antigen processing for major histocompatibility complex class I presentation. *Nat Immunol* 2004;5(7):670-677.
70. Yan J, Parekh VV, Mendez-Fernandez Y, et al. In vivo role of ER-associated peptidase activity in tailoring peptides for presentation by MHC class Ia and class Ib molecules. *J Exp Med* 2006;203(3):647-659.
71. Grandea AG 3rd, Van Kaer L. Tapasin: an ER chaperone that controls MHC class I assembly with peptide. *Trends Immunol* 2001;22(4):194-199.
72. Shen L, Rock KL. Priming of T cells by exogenous antigen cross-presented on MHC class I molecules. *Curr Opin Immunol* 2006;18(1):85-91.
73. Amigorena S, Savina A. Intracellular mechanisms of antigen cross presentation in dendritic cells. *Curr Opin Immunol* 2010;22(1):109-117.
74. Groothuis TA, Neefjes J. The many roads to cross-presentation. *J Exp Med* 2005;202(10):1313-1318.
75. Melief CJ. Cancer immunotherapy by dendritic cells. *Immunity* 2008;29(3):372-383.
76. Fremont DH, Rees WA, Kozono H. Biophysical studies of T-cell receptors and their ligands. *Curr Opin Immunol* 1996;8(1):93-100.
77. Bromley SK, Burack WR, Johnson KG, et al. The immunological synapse. *Annu Rev Immunol* 2001;19:375-396.
78. Dustin ML. A dynamic view of the immunological synapse. *Semin Immunol* 2005;17(6):400-410.
79. Dustin ML, Depoil D. New insights into the T cell synapse from single molecule techniques. *Nat Rev Immunol* 2011;11(10):672-684.

80. Viola A, Lanzavecchia A. T cell activation determined by T cell receptor number and tunable thresholds. *Nature* 1996;273:104-106.
81. Samelson LE. Signal transduction mediated by the T cell antigen receptor: the role of adapter proteins. *Annu Rev Immunol* 2002;20:371-394.
82. Simeoni L, Kliche S, Lindquist J, Schraven B. Adaptors and linkers in T and B cells. *Curr Opin Immunol* 2004;16(3):304-313.
83. Zamoyska R, Lovatt M. Signalling in T-lymphocyte development: integration of signalling pathways is the key. *Curr Opin Immunol* 2004;16(2):191-196.
84. Smith-Garvin JE, Koretzky GA, Jordan MS. T cell activation. *Annu Rev Immunol* 2009;27:591-619.
85. Cantrell D. T cell antigen receptor signal transduction pathways. *Annu Rev Immunol* 1996;14:259-274.
86. Jain J, Loh C, Rao A. Transcriptional regulation of the IL-2 gene. *Curr Opin Immunol* 1995;7(3):333-342.
87. Veillette A, Latour S, Davidson D. Negative regulation of immunoreceptor signaling. *Annu Rev Immunol* 2002;20:669-707.
88. Greenwald RJ, Freeman GJ, Sharpe AH. The B7 family revisited. *Annu Rev Immunol* 2005;23:515-548.
89. Pardoll DM. Tumour antigens. A new look for the 1990s. *Nature* 1994;369: 357-358.
90. Lethe B, van den Eynde B, van Pel A, Corradin G, Boon T. Mouse tumor rejection antigens P815A and P815B: two epitopes carried by a single peptide. *Eur J Immunol* 1992;22(9):2283-2288.
91. Van den Eynde B, Mazarguil H, Lethe B, Laval F, Gairin JE. Localization of two cytotoxic T lymphocyte epitopes and three anchoring residues on a single nonameric peptide that binds to H-2Ld and is recognized by cytotoxic T lymphocytes against mouse tumor P815. *Eur J Immunol* 1994;24(11): 2740-2745.
92. Traversari C, van der Bruggen P, Luescher IF, et al. A nonapeptide encoded by human gene MAGE-1 is recognized on HLA-A1 by cytolytic T lymphocytes directed against tumor antigen MZ2-E. *J Exp Med* 1992;176(5):1453-1457.
93. van der Bruggen P, Szikora JP, Boel P, et al. Autologous cytolytic T lymphocytes recognize a MAGE-1 nonapeptide on melanomas expressing HLA-Cw*1601. *Eur J Immunol* 1994;24(9):2134-2140.
94. Wolfel T, Van Pel A, Brichard V, et al., Two tyrosinase nonapeptides recognized on HLA-A2 melanomas by autologous cytolytic T lymphocytes. *Eur J Immunol* 1994;24(3):759-764.
95. Robbins PF, el-Gamil M, Kawakami Y, Stevens E, Yannelli JR, Rosenberg SA. Recognition of tyrosinase by tumor-infiltrating lymphocytes from a patient responding to immunotherapy. *Cancer Res* 1994;54(12):3124-3126.
96. Topalian SL, Rivoltini L, Mancini M, et al. Human CD4⁺ T cells specifically recognize a shared melanoma-associated antigen encoded by the tyrosinase gene. *Proc Natl Acad Sci USA* 1994;91(20):9461-9465.
97. Cox AL, Skipper J, Chen Y, et al. Identification of a peptide recognized by five melanoma-specific human cytotoxic T cell lines. *Science* 1994;264(5159): 716-719.
98. Kawakami Y, Eliyahu S, Delgado CH, et al. Identification of a human melanoma antigen recognized by tumor-infiltrating lymphocytes associated with in vivo tumor rejection. *Proc Natl Acad Sci USA* 1994;91(14):6458-6462.
99. Kawakami Y, Eliyahu S, Jennings C, et al. Recognition of multiple epitopes in the human melanoma antigen gp100 by tumor-infiltrating T lymphocytes associated with in vivo tumor regression. *J Immunol* 1995;154(8): 3961-3968.
100. Kawakami Y, Eliyahu S, Sakaguchi K, et al. Identification of the immunodominant peptides of the MART-1 human melanoma antigen recognized by the majority of HLA-A2-restricted tumor infiltrating lymphocytes. *J Exp Med* 1994;180(1):347-352.
101. Castelli C, Storkus WJ, Maeurer MJ, et al. Mass spectrometric identification of a naturally processed melanoma peptide recognized by CD8⁺ cytotoxic T lymphocytes. *J Exp Med* 1995;181(1):363-368.
102. Toes RE, Ossendorp F, Offringa R, Melief CJ. CD4 T cells and their role in antitumor immune responses. *J Exp Med* 1999;189:753-756.
103. Rosenberg SA, Yang JC, Schwartzentruber DJ, et al. Immunologic and therapeutic evaluation of a synthetic peptide vaccine for the treatment of patients with metastatic melanoma. *Nat Med* 1998;4:321-327.

104. Nestle FO, Alijagic S, Gilliet M, et al. Vaccination of melanoma patients with peptide- or tumor lysate-pulsed dendritic cells. *Nat Med* 1998;4:328-332.
105. Marchand M, van Baren N, Weynants P, et al. Tumor regressions observed in patients with metastatic melanoma treated with an antigenic peptide encoded by gene MAGE-3 and presented by HLA-A1. *Int J Cancer* 1999;80(2):219-230.
106. Cohen PA, Peng L, Plautz GE, et al. CD4⁺ T cells in adoptive immunotherapy and the indirect mechanism of tumor rejection. *Crit Rev Immunol* 2000;20(2):17-56.
107. Wang RF, Wang X, Atwood AC, Topalian SL, Rosenberg SA. Cloning genes encoding MHC class II-restricted antigens: mutated CDC27 as a tumor antigen. *Science* 1999;284(5418):1351-1354.
108. Wang RF. The role of MHC class II-restricted tumor antigens and CD4⁺ T cells in antitumor immunity. *Trends Immunol* 2001;22:269-276.
109. Cheever MA, Disis ML, Bernhard H, et al. Immunity to oncogenic proteins. *Immunol Rev* 1995;145:33-59.
110. Weinstein IB. Cancer. Addiction to oncogenes—the Achilles heel of cancer. *Science* 2002;297:63-64.
111. Peace DJ, Smith JW, Chen W, et al. Lysis of ras oncogene-transformed cells by specific cytotoxic T lymphocytes elicited by primary in vitro immunization with mutated ras peptide. *J Exp Med* 1994;179(2):473-479.
112. Disis ML, Calenoff E, McLaughlin G, et al. Existent T-cell and antibody immunity to HER-2/neu protein in patients with breast cancer. *Cancer Res* 1994;54(1):16-20.
113. Ioannides CG, Fisk B, Fan D, Biddison WE, Wharton JT, O'Brian CA. Cytotoxic T cells isolated from ovarian malignant ascites recognize a peptide derived from the HER-2/neu proto-oncogene. *Cell Immunol* 1993;151(1):225-234.
114. Chen W, Peace DJ, Rovira DK, You SG, Cheever MA. T-cell immunity to the joining region of p210BCR-ABL protein. *Proc Natl Acad Sci USA* 1992;89(4):1468-1472.
115. Bocchia M, Korontsvit T, Xu Q, et al. Specific human cellular immunity to bcr-abl oncogene-derived peptides. *Blood* 1996;87(5):3587-3592.
116. Gambacorti-Passerini C, Grignani F, Arienti F, Pandolfi PP, Pelicci PG, Parmiani G. Human CD4 lymphocytes specifically recognize a peptide representing the fusion region of the hybrid protein pml/RAR alpha present in acute promyelocytic leukemia cells. *Blood* 1993;81(5):1369-1375.
117. Yanuck T, Carbone DP, Pendleton CD, et al. A mutant p53 tumor suppressor protein is a target for peptide induced CD8⁺ cytotoxic T-cells. *Blood* 1993;53: 3257-3261.
118. Old LJ, Chen YT. New paths in human cancer serology. *J Exp Med* 1998;187:1163-1167.
119. Sahin U, Tureci O, Schmitt H, et al. Human neoplasms elicit multiple specific immune responses in the autologous host. *Proc Natl Acad Sci USA* 1995;92(25): 11810-11813.
120. Tureci O, Sahin U, Schobert I, et al. The SSX-2 gene, which is involved in the t(X;18) translocation of synovial sarcomas, codes for the human tumor antigen HOM-MEL-40. *Cancer Res* 1996;56(20):4766-4772.
121. Zou W. Immunosuppressive networks in the tumour environment and their therapeutic relevance. *Nat Rev Cancer* 2005;5(4):263-274.
122. Chen HL, Gabrilovich D, Tampe R, Girgis KR, Nadaf S, Carbone DP. A functionally defective allele of TAP1 results in loss of MHC class I antigen presentation in a human lung cancer. *Nat Genet* 1996;13(2):210-213.
123. Garrido F, Algarra I. MHC antigens and tumor escape from immune surveillance. *Adv Cancer Res* 2001;83:117-158.
124. Arceci RJ. Tumor cell survival and resistance to therapy. *Curr Opin Hematol* 1996;3(4):279-287.
125. Rabinovich GA, Gabrilovich D, Sotomayor EM. Immunosuppressive strategies that are mediated by tumor cells. *Annu Rev Immunol* 2007;25:267-296.
126. Norde WJ, Hobo W, van der Voort R, Dolstra H. Co-inhibitory molecules in hematological malignancies: targets for therapeutic intervention. *Blood* 2012;120:728-736.
127. Beyer M, Schultze JL. Regulatory T cells: major players in the tumor microenvironment. *Curr Pharm Des* 2009;15(16):1879-1892.
128. Gabrilovich DI, Nagaraj S. Myeloid-derived suppressor cells as regulators of the immune system. *Nat Rev Immunol* 2009;9(3):162-174.

129. Dunn GP, Old LJ, Schreiber RD. The three Es of cancer immunoediting. *Annu Rev Immunol* 2004;22:329-360.
130. Grivennikov SI, Greten FR, Karin M. Immunity, inflammation, and cancer. *Cell* 2010;140(6):883-899.
131. Timmerman JM. Immunotherapy for lymphomas. *Int J Hematol* 2003; 77(5):444-455.
132. Anonymous. Biologic response modifiers: a report. *Natl Cancer Inst Monogr* 1983;63:57-59.
133. Fefer A. Interleukin-2: clinical applications-hematologic malignancies. In: Rosenberg SA, ed. *Principles and practice of the biologic therapy of cancer*. Philadelphia, PA: Lippincott, Williams & Wilkins, 2000.
134. Tedder TF, Tuscano J, Sato S, Kehrl JH. CD22, a B lymphocyte-specific adhesion molecule that regulates antigen receptor signaling. *Annu Rev Immunol* 1997;15:481-504.
135. Adams GP, Weiner LM. Monoclonal antibody therapy of cancer. *Nat Biotechnol* 2005;23(9):1147-1157.
136. Finn OJ. Cancer immunology. *N Engl J Med* 2008;358(25):2704-2715.
137. Tedder TF, Engel P. CD20: a regulator of cell-cycle progression of B lymphocytes. *Immunol Today* 1994;15(9):450-454.
138. Domagala A, Kurpisz M. CD52 antigen—a review. *Med Sci Monit* 2001;7(2):325-331.
139. Vose JM. Personalized immunotherapy for the treatment of non-Hodgkin's lymphoma: a promising approach. *Hematol Oncol* 2006;24(2):47-55.
140. Nadler LM, Stashenko P, Hardy R, et al. Serotherapy of a patient with a monoclonal antibody directed against a human lymphoma-associated antigen. *Cancer Res* 1980;40(9):3147-3154.
141. Ritz J, Pesando JM, Sallan SE, et al. Serotherapy of acute lymphoblastic leukemia with monoclonal antibody. *Blood* 1981;58(1):141-152.
142. Miller RA, Levy R. Response of cutaneous T cell lymphoma to therapy with hybridoma monoclonal antibody. *Lancet* 1981;2(8240):226-230.
143. Longo DL. Immunotherapy for non-Hodgkin's lymphoma. *Curr Opin Oncol* 1996;8(5):353-359.
144. Glennie MJ, Johnson PWM. Clinical trials of antibody therapy. *Immunol Today* 2000;21:403-410.
145. Riley JK, Sliwkowski MX. CD20: a gene in search of a function. *Semin Oncol* 2000;27(6 Suppl 12):17-24.
146. McLaughlin P, Grilo-Lopez AJ, Link BK, Levy R. Rituximab chimeric anti-CD20 monoclonal antibody therapy for relapsed indolent lymphoma: half of patients respond to a four-dose treatment program. *J Clin Oncol* 1998;16:2825-2833.
147. Byrd JC, Waselenko JK, Maneatis TJ, et al. Rituximab therapy in hematologic malignancy patients with circulating blood tumor cells: association with increased infusion-related side effects and rapid blood tumor clearance. *J Clin Oncol* 1999;17(3):791-795.
148. Kunkel L, Wong A, Maneatis T, et al. Optimizing the use of rituximab for treatment of B-cell non-Hodgkin's lymphoma: a benefit-risk update. *Semin Oncol* 2000;27 (6 Suppl 12):53-61.
149. Piro LD, White CA, Grillo-Lopez AJ, et al. Extended rituximab (anti-CD20 monoclonal antibody) therapy for relapsed or refractory low-grade or follicular non-Hodgkin's lymphoma. *Ann Oncol* 1999;10(6):655-661.
150. Hainsworth JD. Rituximab as first-line systemic therapy for patients with low-grade lymphoma. *Semin Oncol* 2000;27(6 Suppl 12):25-29.
151. Vose JM, Link BK, Grossbard ML, et al. Phase II study of rituximab in combination with chop chemotherapy in patients with previously untreated, aggressive non-Hodgkin's lymphoma. *J Clin Oncol* 2001;19(2):389-397.
152. Coiffier B, Lepage E, Briere J, et al. CHOP chemotherapy plus rituximab compared with CHOP alone in elderly patients with diffuse large-B-cell lymphoma. *N Engl J Med* 2002;346(4):235-242.
153. Cheson BD. CHOP plus rituximab—balancing facts and opinion. *New Engl J Med* 2002;346:280-281.
154. Fisher RI, Gaynor ER, Dahlberg S, et al. Comparison of a standard regimen (CHOP) with three intensive chemotherapy regimens for advanced non-Hodgkin's lymphoma. *N Engl J Med* 1993;328(14):1002-1006.
155. Ghielmini M, Schmitz SF, Cogliatti SB, et al. Prolonged treatment with rituximab in patients with follicular lymphoma significantly increases event-free survival and response duration compared with the standard weekly x 4 schedule. *Blood* 2004;103(12):4416-4423.

156. van Oers MHJ, van Glabbeke M, Teodorovic I, Rozewicz C, Klasa R, Marcus RE. Chimeric anti-CD20 monoclonal antibody (rituximab: Mabthera) in remission induction and maintenance treatment of relapsed resistant follicular non-Hodgkin's lymphoma: final analysis of a phase III randomized intergroup clinical trial. *Blood* 2005;106:107a.
157. Hochster HS, Weller E, Gascoyne RD, et al. Maintenance rituximab after CVP results in superior clinical outcome in advanced follicular lymphoma (FL): results of the E1496 phase III trial from the Eastern Cooperative Oncology Group and the Cancer and Leukemia Group B. *Blood* 2005;106:106a.
158. Sohn BS, Kim SM, Yoon DH, et al. The comparison between CHOP and R-CHOP in primary gastric diffuse large B cell lymphoma. *Ann Hematol* 2012;91(11):1731-1739.
159. Weng WK, Levy R. Expression of complement inhibitors CD46, CD55, and CD59 on tumor cells does not predict clinical outcome after rituximab treatment in follicular non-Hodgkin lymphoma. *Blood* 2001;98(5):1352-1357.
160. Reff ME, Carner K, Chambers KS, et al. Depletion of B cells in vivo by a chimeric mouse human monoclonal antibody to CD20. *Blood* 1994;83(2): 435-445.
161. Clynes RA, Towers TL, Presta LG, Ravetch JV. Inhibitory Fc receptors modulate in vivo cytotoxicity against tumor targets. *Nat Med* 2000;6(4):443-446.
162. Cartron G, Dacheux L, Salles G, et al. Therapeutic activity of humanized anti-CD20 monoclonal antibody and polymorphism in IgG Fc receptor FcγRIIIa gene. *Blood* 2002;99(13):754-758.
163. Wilson WH. Chemotherapy sensitization by rituximab: experimental and clinical evidence. *Semin Oncol* 2000;27(1 Suppl 2):30-36.
164. Shan D, Ledbetter JA, Press OW. Apoptosis of malignant human B cells by ligation of CD20 with monoclonal antibodies. *Blood* 1998;91(5): 1644-1652.
165. Mathas S, Rickers A, Bommert K, Dorken B, Mapara MY. Anti-CD20- and B-cell receptor-mediated apoptosis: evidence for shared intracellular signaling pathways. *Cancer Res* 2000;60(24):7170-7176.
166. Alas S, Bonavida B. Rituximab inactivates signal transducer and activation of transcription 3 (STAT3) activity in B-non-Hodgkin's lymphoma through inhibition of the interleukin 10 autocrine/paracrine loop and results in down-regulation of Bcl-2 and sensitization to cytotoxic drugs. *Cancer Res* 2001;61(13):5137-5144.
167. Alas S, Emmanouilides C, Bonavida B. Inhibition of interleukin 10 by rituximab results in down-regulation of bcl-2 and sensitization of B-cell non-Hodgkin's lymphoma to apoptosis. *Clin Cancer Res* 2001;7(3):709-723.
168. Alas S, Bonavida B, Emmanouilides C. Potentiation of fludarabine cytotoxicity on non-Hodgkin's lymphoma by pentoxifylline and rituximab. *Anticancer Res* 2000;20(5A):2961-2966.
169. Press OW, Leonard JP, Coiffier B, Levy R, Timmerman J. Immunotherapy of non-Hodgkin's lymphomas. *Hematology* 2001:221-240.
170. Keating MJ, Flinn I, Jain V, et al. Therapeutic role of alemtuzumab (Campath-1H) in patients who have failed fludarabine: results of a large international study. *Blood* 2002;99:3554-3561.
171. Wing MG, Moreau T, Greenwood J, et al. Mechanism of first-dose cytokine-release syndrome by CAMPATH 1-H: involvement of CD16 (FcγRIII) and CD11a/CD18 (LFA-1) on NK cells. *J Clin Invest* 1996;98(12):2819-2826.
172. Kennedy B, Rawstron A, Richards S, Hillmen P. CAMPATH-1H in CLL: immune reconstitution and viral infections during and after therapy. *Blood* 2000;96:164a.
173. Robak T, Robak E. New anti-CD20 monoclonal antibodies for the treatment of B-cell lymphoid malignancies. *BioDrugs* 2011;25(1):13-25.
174. Leonard JP, Link BK. Immunotherapy of non-Hodgkin's lymphoma with hLL2 (epratuzumab, an anti-CD22 monoclonal antibody) and Hu1D10 (apolizumab). *Semin Oncol* 2002;29(1 Suppl 2):81-86.
175. Micallef IN, Maurer MJ, Wiseman GA, et al. Epratuzumab with rituximab, cyclophosphamide, doxorubicin, vincristine, and prednisone chemotherapy in patients with previously untreated diffuse large B-cell lymphoma. *Blood* 2011;118(15):4053-4061.
176. Lin TS, Stock W, Xu H, et al. A phase I/II dose escalation study of apolizumab (Hu1D10) using a stepped-up dosing schedule in patients with chronic lymphocytic leukemia and acute leukemia. *Leuk Lymphoma* 2009;50(12): 1958-1963.

177. Stein R, Mattes MJ, Cardillo TM, et al. CD74: a new candidate target for the immunotherapy of B-cell neoplasms. *Clin Cancer Res* 2007; 13(18 Pt 2):5556s-5563s.
178. van Rhee F, Szmania SM, Dillon M, et al. Combinatorial efficacy of anti-CS1 monoclonal antibody elotuzumab (HuLuc63) and bortezomib against multiple myeloma. *Mol Cancer Ther* 2009;8(9):2616-2624.
179. Majeti R. Monoclonal antibody therapy directed against human acute myeloid leukemia stem cells. *Oncogene* 2011;30(9):1009-1019.
180. Sirisinha S, Eisen HN. Autoimmune-like antibodies to the ligand-binding sites of myeloma proteins. *Proc Natl Acad Sci USA* 1971;68(12):3130-3135.
181. Lynch RG, Graff RJ, Sirisinha S, Simms ES, Eisen HN. Myeloma proteins as tumor-specific transplantation antigens. *Proc Natl Acad Sci USA* 1972;69(6):1540-1544.
182. Levy R, Miller RA. Therapy of lymphoma directed at idiotypes. *J Natl Cancer Inst Monogr* 1990:61-68.
183. Thielemans K, Maloney DG, Meeker T, et al. Strategies for production of monoclonal anti-idiotypic antibodies against human B cell lymphomas. *J Immunol* 1984;133(1):495-501.
184. Miller RA, Maloney DG, Warnke R, Levy R. Treatment of B-cell lymphoma with monoclonal anti-idiotypic antibody. *New Engl J Med* 1982;306(9): 517-522.
185. Meeker TC, Lowder J, Maloney DG, et al. A clinical trial of anti-idiotypic therapy for B cell malignancy. *Blood* 1985;65(6):1349-1363.
186. Meeker T, Lowder J, Cleary ML, et al. Emergence of idiotypic variants during treatment of B-cell lymphoma with anti-idiotypic antibodies. *New Engl J Med* 1985;312(26):1658-1665.
187. Cleary ML, Meeker TC, Levy S, et al. Clustering of extensive somatic mutations in the variable region of an immunoglobulin heavy chain gene from a human B cell lymphoma. *Cell* 1986;44(1):97-106.
188. Carroll WL, Lowder JN, Streifer R, Warnke R, Levy S, Levy R. Idiotypic variant cell populations in patients with B cell lymphoma. *J Exp Med* 1986;164(5):1566-1580.
189. Levy S, Mendel E, Kon S, Avnur Z, Levy R. Mutational hot spots in Ig V region genes of human follicular lymphomas. *J Exp Med* 1988;168(2):475-489.
190. Maloney DG, Brown S, Czerwinski DK, et al. Monoclonal anti-idiotypic antibody therapy of B-cell lymphoma: the addition of a short course of chemotherapy does not interfere with the antitumor effect nor prevent the emergence of idiotypic-negative variant cells. *Blood* 1992;80(6):1502-1510.
191. Vuist WM, Levy R, Maloney DG. Lymphoma regression induced by monoclonal anti-idiotypic antibodies correlates with their ability to induce Ig signal transduction and is not prevented by tumor expression of high levels of bcl-2 protein. *Blood* 1994;83(4):899-906.
192. Press OW, Rasey J. Principles of radioimmunotherapy for hematologists and oncologists. *Semin Oncol* 2000;27(6 Suppl 12):62-73.
193. Stevens PL, Oluwole O, Reddy N. Advances and application of radioimmunotherapy in non-Hodgkin lymphoma. *Am J Blood Res* 2012;2(2):86-97.
194. Illidge T, Morschhauser F. Radioimmunotherapy in follicular lymphoma. *Best Pract Res Clin Haematol* 2011;24(2):279-293.
195. Witzig TE, Gordon LI, Cabanillas F, et al. Randomized controlled trial of yttrium-90-labeled ibritumomab tiuxetan radioimmunotherapy versus rituximab immunotherapy for patients with relapsed or refractory low-grade, follicular, or transformed B-cell non-Hodgkin's lymphoma. *J Clin Oncol* 2002;20(12):2453-2463.
196. Witzig TE, Flinn IW, Gordon LI, Ristow KM, Habermann TM, Wiseman GA. Treatment with ibritumomab tiuxetan radioimmunotherapy in patients with rituximab-refractory follicular non-Hodgkin's lymphoma. *J Clin Oncol* 2002;20(18):3262-3269.
197. Kaminski MS, Zelenetz AD, Press OW, et al. Pivotal study of iodine I 131 tositumomab for chemotherapy-refractory low-grade or transformed low-grade B-cell non-Hodgkin's lymphomas. *J Clin Oncol* 2001;19(19):3918-3928.

198. Davis TA, Kaminski MS, Leonard JP, et al. Results of a randomized study of Bexxar (TM) (tositumomab and iodine I-131 tositumomab) vs. unlabeled tositumomab in patients with relapsed or refractory low-grade or transformed non-Hodgkin's lymphoma (NHL). *Blood* 2001;98(11):843A.
199. Horning SJ, Lucas JB, Younes A, et al. Iodine-131 tositumomab for non-Hodgkin's lymphoma (NHL) patients who progressed after treatment with rituximab: results of a multicenter phase II study. *Blood* 2000;96(11):508A.
200. Horning SJ, Younes A, Jain V, et al. Efficacy and safety of tositumomab and iodine-131 tositumomab (Bexxar) in B-cell lymphoma, progressive after rituximab. *J Clin Oncol* 2005;23(4):712-719.
201. Press OW. Radiolabeled antibody therapy of B-cell lymphomas. *Semin Oncol* 1999;26(11):58-65.
202. Press OW, Eary JF, Appelbaum FR, et al. Phase II trial of 131I-B1 (anti-CD20) antibody therapy with autologous stem cell transplantation for relapsed B cell lymphomas. *Lancet* 1995;346(8971):336-340.
203. Press OW, Eary JF, Gooley T, et al. A phase I/II trial of iodine-131-tositumomab (anti-CD20), etoposide, cyclophosphamide, and autologous stem cell transplantation for relapsed B-cell lymphomas. *Blood* 2000;96(22):2934-2942.
204. Nademanee A, Forman S, Molina A, et al. A phase 1/2 trial of high-dose yttrium-90-ibritumomab tiuxetan in combination with high-dose etoposide and cyclophosphamide followed by autologous stem cell transplantation in patients with poor-risk or relapsed non-Hodgkin lymphoma. *Blood* 2005;106(8):2896-2902.
205. Dosik AD, Coleman M, Kostakoglu L, et al. Subsequent therapy can be administered after tositumomab and iodine I-131 tositumomab for non-Hodgkin lymphoma. *Cancer* 2006;106(3):616-622.
206. Kaminski MS, Radford JA, Gregory SA, et al. Re-treatment with I-131 tositumomab in patients with non-Hodgkin's lymphoma who had previously responded to I-131 tositumomab. *J Clin Oncol* 2005;23(31):7985-7993.
207. Gopal AK, Pagel JM, Rajendran JG, et al. Improving the efficacy of reduced intensity allogeneic transplantation for lymphoma using radioimmunotherapy. *Biol Blood & Marrow Transplant* 2006;12(7):697-702.
208. Bethge WA, Wilbur DS, Sandmaier BM. Radioimmunotherapy as nonmyeloablative conditioning for allogeneic marrow transplantation. *Leuk Lymphoma* 2006;47:1205-1214.
209. Fietz T, Uharek L, Gentilini C, et al. Allogeneic hematopoietic cell transplantation following conditioning with ⁹⁰Y-ibritumomab-tiuxetan. *Leukemia & Lymphoma*, 2006;47(1):59-63.
210. Lin Y, Pagel JM, Axworthy D, Pantelias A, Hedin N, Press OW. A genetically engineered anti-CD45 single-chain antibody-streptavidin fusion protein for pretargeted radioimmunotherapy of hematologic malignancies. *Cancer Res* 2006;66(5):3884-3892.
211. Pagel JM, Matthews DC, Kenoyer A, et al. Pretargeted radioimmunotherapy using anti-CD45 monoclonal antibodies to deliver radiation to murine hemolymphoid tissues and human myeloid leukemia. *Cancer Res* 2009;69(1): 185-192.
212. Chen Y, Kornblit B, Hamlin DK, et al. Durable donor engraftment after radioimmunotherapy using alpha-emitter astatine-211-labeled anti-CD45 antibody for conditioning in allogeneic hematopoietic cell transplantation. *Blood* 2012;119(5):1130-1138.
213. Ghetie MA, Vitetta ES. Recent developments in immunotoxin therapy. *Curr Opin Immunol* 1994;6(3):707-714.
214. Kreitman RJ. Immunotoxins in cancer therapy. *Curr Opin Immunol* 1999;11(5):570-578.
215. Zein N, Poncin M, Nilakantan R, Ellestad GA. Calicheamicin gamma 1I and DNA: molecular recognition process responsible for site-specificity. *Science* 1989;244(4905):697-699.
216. Sievers EL, Larson RA, Stadtmauer EA, et al. Efficacy and safety of gemtuzumab ozogamicin in patients with CD33-positive acute myeloid leukaemia in first relapse. *J Clin Oncol* 2001;19(5):3244-3254.
217. Vallera DA. Immunotoxins: will their clinical promise be fulfilled? *Blood* 1994;83(2):309-317.
218. May RD, Finkelman FD, Wheeler HT, Uhr JW, Vitetta ES. Evaluation of ricin A chain-containing immunotoxins directed against different epitopes on the delta-chain of cell surface-associated IgD on murine B cells. *J Immunol* 1990;144(9):3637-3642.
219. Olsnes S, Sandvig K, Petersen OW, van Deurs B. Immunotoxins—entry into cells and mechanisms of action. *Immunol Today* 1989;10(9):291-295.

220. Lambert JM, McIntyre G, Gauthier MN, et al. The galactose-binding sites of the cytotoxic lectin ricin can be chemically blocked in high yield with reactive ligands prepared by chemical modification of glycopeptides containing triantennary N-linked oligosaccharides. *Biochemistry*, 1991;30(13):3234-3247.
221. Casellas P, Bourrie BJ, Gros P, Jansen FK. Kinetics of cytotoxicity induced by immunotoxins. Enhancement by lysosomotropic amines and carboxylic ionophores. *J Biol Chem* 1984;259(15):9359-9364.
222. Ramakrishnan S, Houston LL. Inhibition of human acute lymphoblastic leukemia cells by immunotoxins: potentiation by chloroquine. *Science* 1984;223(4631):58-61.
223. Sandvig K, Tonnessen TI, Olsnes S. Ability of inhibitors of glycosylation and protein synthesis to sensitize cells to abrin, ricin, Shigella toxin, and Pseudomonas toxin. *Cancer Res* 1986;46(12 Pt 1):6418-6422.
224. Pappenheimer AM Jr. Diphtheria toxin. *Annu Rev Biochem* 1977;46:69-94.
225. Endo Y, Mitsui K, Motizuki M, Tsurugi K. The mechanism of action of ricin and related toxic lectins on eukaryotic ribosomes. The site and the characteristics of the modification in 28 S ribosomal RNA caused by the toxins. *J Biol Chem* 1987;262(12):5908-5912.
226. Grossbard ML, Fidas P. Prospects for immunotoxin therapy of non-Hodgkin's lymphoma. *Clin Immunol Immunopathol* 1995;76(2):107-114.
227. Uckun FM, Rearman G. Immunotoxins for treatment of leukemia and lymphoma. *Leuk Lymphoma* 1995;18(11):195-201.
228. Amlot PL, Stone MJ, Cunningham D, et al. A phase I study of an anti-CD22-deglycosylated ricin A chain immunotoxin in the treatment of B-cell lymphomas resistant to conventional therapy. *Blood* 1993;82(9):2624-2633.
229. Vitetta ES, Stone M, Amlot P, et al. Phase I immunotoxin trial in patients with B-cell lymphoma. *Cancer Res* 1991;51(15):4052-4058.
230. Grossbard ML, Fidas P, Kinsella J, et al. Anti-B4-blocked ricin: a phase I trial of 7-day continuous infusion in patients with B-cell neoplasms. *J Clin Oncol* 1993;11(4):726-737.
231. Grossbard ML, Gribben JG, Freedman AS, et al. Adjuvant immunotoxin therapy with anti-B4-blocked ricin after autologous bone marrow transplantation for patients with B-cell non-Hodgkin's lymphoma. *Blood* 1993;81(9):2263-2271.
232. Scadden DT, Schenkein DP, Bernstein Z, et al. Immunotoxin combined with chemotherapy for patients with AIDS-related non-Hodgkin's lymphoma. *Cancer* 1998;83(12):2580-2587.
233. Multani PS, O'Day S, Nadler LM, Grossbard ML. Phase II clinical trial of bolus infusion anti-B4 blocked ricin immunoconjugate in patients with relapsed B-cell non-Hodgkin's lymphoma. *Clin Cancer Res* 1998;4(11):2599-2604.
234. Soler-Rodriguez AM, Ghetie MA, Oppenheimer-Marks N, Uhr JW, Vitetta ES. Ricin A-chain and ricin A-chain immunotoxins rapidly damage human endothelial cells: implications for vascular leak syndrome. *Exp Cell Res* 1993;206(2):227-234.
235. Senderowicz AM, Vitetta E, Headlee D, et al. Complete sustained response of a refractory, post-transplantation, large B-cell lymphoma to an anti-CD22 immunotoxin. *Ann Intern Med* 1997;126(11):882-885.
236. Kreitman RJ, Wilson WH, Bergeron K, et al. Efficacy of the anti-CD22 recombinant immunotoxin BL22 in chemotherapy-resistant hairy-cell leukemia. *New Engl J Med* 2001;345(4):241-247.
237. Kreitman RJ, Pastan I. Antibody fusion proteins: anti-CD22 recombinant immunotoxin moxetumomab pasudotox. *Clin Cancer Res* 2011;17(20): 6398-6405.
238. Hamann PR. Anti-CD33 calicheamicin hybrid conjugates for the treatment of acute myelogenous leukemia. *Proc Am Assoc Cancer Res* 1996;37:471.
239. Sievers EL, Appelbaum FR, Spielberger RT, et al. Selective ablation of acute myeloid leukemia using antibody-targeted chemotherapy: a phase I study of an anti-CD33 calicheamicin immunoconjugate. *Blood* 1999;93(11): 3678-3684.
240. Ricart AD. Antibody-drug conjugates of calicheamicin derivative: gemtuzumab ozogamicin and inotuzumab ozogamicin. *Clin Cancer Res* 2011;17(20): 6417-6427.
241. Kreitman RJ, Pastan I. Recombinant single-chain immunotoxins against T and B cell leukemias. *Leuk Lymphoma* 1994;13:1-10.

242. Apisarnthanarax N, Talpur R, Duvic M. Treatment of cutaneous T cell lymphoma: current status and future directions. *Am J Clin Derm* 2002;3(5): 193-215.
243. Olsen E, Duvic M, Frankel A, et al. Pivotal phase III trial of two dose levels of denileukin diftitox for the treatment of cutaneous T-cell lymphoma. *J Clin Oncol* 2001;19(2):376-388.
244. Duvic M, Cather J. Immunotoxin DAB389-interleukin 2 (Ontak) in the management of cutaneous T cell lymphoma. *Curr Pract Med* 1999;2:7-9.
245. Gualberto A. Brentuximab Vedotin (SGN-35), an antibody-drug conjugate for the treatment of CD30-positive malignancies. *Expert Opin Investig Drugs* 2012;21(2):205-216.
246. Younes A, Gopal AK, Smith SE, et al. Results of a pivotal phase II study of brentuximab vedotin for patients with relapsed or refractory Hodgkin's lymphoma. *J Clin Oncol* 2012;30(18):2183-2189.
247. Fanale MA, Forero-Torres A, Rosenblatt JD, et al. A phase I weekly dosing study of brentuximab vedotin in patients with relapsed/refractory CD30-positive hematologic malignancies. *Clin Cancer Res* 2012;18(1):248-255.
248. Renner C, Pfreundschuh M. Tumor therapy by immune recruitment with bispecific antibodies. *Immunol Rev* 1995;145(5):179-209.
249. Weiner LM. Bispecific antibodies in cancer therapy. *Cancer J* 2000; 6:S265-S271.
250. van Spriël AB, van Ojik HH, van De Winkel JG. Immunotherapeutic perspective for bispecific antibodies. *Immunol Today* 2000;21(8):391-397.
251. Demanet C, Brissinck J, Van Mechelen M, Leo O, Thielemans K. Treatment of murine B cell lymphoma with bispecific monoclonal antibodies (anti-idiotypic x anti-CD3). *J Immunol* 1991;147(3):1091-1097.
252. Brissinck J, Demanet C, Moser M, Leo O, Thielemans K. Treatment of mice bearing BCL1 lymphoma with bispecific antibodies. *J Immunol* 1991;147(11):4019-4026.
253. Weiner GJ, Hillstrom JR. Bispecific anti-idiotypic/anti-CD3 antibody therapy of murine B cell lymphoma. *J Immunol* 1991;147(11):4035-4044.
254. Löffler A, Kufer P, Lutterbuse R, et al. A recombinant bispecific single-chain antibody, CD19 x CD3, induces rapid and high lymphoma-directed cytotoxicity by unstimulated T lymphocytes. *Blood* 2000;95(6):2098-2103.
255. Bargou R, Leo E, Zugmaier G, et al. Tumor regression in cancer patients by very low doses of a T cell-engaging antibody. *Science* 2008;321(5891):974-977.
256. Topp MS, Gokbuget N, Zugmaier G, et al. Long-term follow-up of hematological relapse-free survival in a phase 2 study of blinatumomab in patients with minimal residual disease (MRD) of B-precursor acute lymphoblastic leukemia (ALL). *Blood* 2012.
257. Koon HB, Junghans RP. Anti-CD30 antibody-based therapy. *Curr Opin Oncol* 2000;12(6):588-593.
258. Hartmann F, Renner C, Jung W, et al. Treatment of refractory Hodgkin's disease with an anti-CD16/CD30 bispecific antibody. *Blood* 1997;89(3-4): 2042-2047.
259. Hartmann F, Renner C, Jung W, Pfreundschuh M. Anti-CD16/CD30 bispecific antibody treatment for Hodgkin's disease: role of infusion schedule and costimulation with cytokines. *Clin Cancer Res* 2001;7:1873-1881.
260. Booy EP, Johar D, Maddika S, et al. Monoclonal and bispecific antibodies as novel therapeutics. *Arch Immunol Ther Exp* 2006;54(2):85-101.
261. Gall JM, Davol PA, Grabert RC, Deaver M, Lum LG. T cells armed with anti-CD3 x anti-CD20 bispecific antibody enhance killing of CD20+ malignant B cells and bypass complement-mediated rituximab resistance in vitro. *Exp Hematol* 2005;33(4):452-459.
262. Morecki S, Lindhofer H, Yacovlev E, Gelfand Y, Slavin S. Use of trifunctional bispecific antibodies to prevent graft versus host disease induced by allogeneic lymphocytes. *Blood* 2006;107(4):1564-1569.
263. Gupta P, Goldenberg DM, Rossi EA, et al. Dual-targeting immunotherapy of lymphoma: potent cytotoxicity of anti-CD20/CD74 bispecific antibodies in mantle cell and other lymphomas. *Blood* 2012;119(16):3767-3778.

264. Stanglmaier M, Faltin M, Ruf P, Bodenhausen A, Schroder P, Lindhofer H. Bi20 (FBTA05), a novel trifunctional bispecific antibody (anti-CD20 x anti-CD3), mediates efficient killing of B-cell lymphoma cells even with very low CD20 expression levels. *Int J Cancer* 2008;123(5):1181-1189.
265. Boehrer S, Schroeder P, Mueller T, Atz J, Chow KU. Cytotoxic effects of the trifunctional bispecific antibody FBTA05 in ex-vivo cells of chronic lymphocytic leukaemia depend on immune-mediated mechanism. *Anticancer Drugs* 2011;22(6):519-530.
266. Darnell JE Jr, Kerr IM, Stark GR. Jak-STAT pathways and transcriptional activation in response to IFNs and other extracellular signaling proteins. *Science* 1994;264(5164):1415-1421.
267. Sen GC, Lengyel P. The interferon system. A bird's eye view of its biochemistry. *J Biol Chem* 1992;267(8):5017-5020.
268. Cohen B, Peretz D, Vaiman D, Benesh P, Chebath J. Enhancer-like interferon responsive sequences of the human and murine (2'-5') oligoadenylate synthetase gene promoters. *EMBO J* 1988;7(5):1411-1419.
269. Gresser I, Berman L, De The G, Brouty-Boye D, Coppey J, Falcoff E. Interferon and murine leukemia. V. Effect of interferon preparations on the evolution of Rauscher disease in mice. *J Natl Cancer Inst* 1968;41(2):505-522.
270. Gresser I, Bourali C. Exogenous interferon and inducers of interferon in the treatment Balb-c mice inoculated with RC19 tumour cells. *Nature* 1969;223(208):844-845.
271. Talpaz M, Kantarjian HM, McCredie K, Trujillo JM, Keating MJ, Gutterman JU. Hematologic remission and cytogenetic improvement induced by recombinant human interferon alpha A in chronic myelogenous leukemia. *N Engl J Med* 1986;314(17):1065-1069.
272. Talpaz M, Kantarjian HM, McCredie KB, Keating MJ, Trujillo J, Gutterman J. Clinical investigation of human alpha interferon in chronic myelogenous leukemia. *Blood* 1987;69(5):1280-1288.
273. Alimena G, Morra E, Lazzarino M, et al. Interferon alpha-2b as therapy for Ph⁺-positive chronic myelogenous leukemia: a study of 82 patients treated with intermittent or daily administration. *Blood* 1988;72(2):642-647.
274. Ozer H, George SL, Schiffer CA, et al. Prolonged subcutaneous administration of recombinant alpha 2b interferon in patients with previously untreated Philadelphia chromosome-positive chronic-phase chronic myelogenous leukemia: effect on remission duration and survival: cancer and leukemia group B study 8583. *Blood* 1993;82(10):2975-2984.
275. Freund M, von Wussow P, Diedrich H, et al. Recombinant human interferon (IFN) alpha-2b in chronic myelogenous leukaemia: dose dependency of response and frequency of neutralizing anti-interferon antibodies. *Br J Haematol* 1989;72(3):350-356.
276. The Italian Cooperative Study Group on Chronic Myeloid Leukemia. Interferon alfa-2a as compared with conventional chemotherapy for the treatment of chronic myeloid leukemia. *N Engl J Med* 1994;330(12):820-825.
277. Kalidas M, Kantarjian H, Talpaz M. Chronic myelogenous leukemia. *JAMA* 2001;286(8):895-898.
278. Appelbaum FR. Perspectives on the future of chronic myeloid leukemia treatment. *Semin Hematol* 2001;38(3 Suppl 8):35-42.
279. Hehlmann R, Heimpel H, Hasford J, et al. Randomized comparison of interferon-alpha with busulfan and hydroxyurea in chronic myelogenous leukemia. The German CML Study Group. *Blood* 1994;84(12):4064-4077.
280. Interferon alfa versus chemotherapy for chronic myeloid leukemia: a meta-analysis of seven randomized trials: Chronic Myeloid Leukemia Trialists' Collaborative Group. *J Natl Cancer Inst* 1997;89(21):1616-1620.
281. Quesada JR, Reuben J, Manning JT, Hersh EM, Gutterman JU. Alpha interferon for induction of remission in hairy-cell leukemia. *New Engl J Med* 1984;310(1):15-18.
282. Worman CP, Catovsky D, Cawley JC, Bevan PC, Bottomley JM, Nethersell AB. The U.K. experience with human lymphoblastoid interferon in HCL: a report of the first 50 cases. *Leukemia* 1987;1(4):320-322.
283. Damasio EE, Bernasconi C, Castoldi GL, et al. Human lymphoblastoid interferon for hairy cell leukemia: results from the Italian Cooperative Group. *Leukemia* 1987;1(4):331-333.
284. Foon KA, Princler GL, Rossio JL, Ruscetti FW, Maluish AE, Abrams PG. Recombinant leukocyte A interferon therapy for advanced hairy cell leukemia. Therapeutic and immunologic results. *Am J Med* 1986;80(4):351-356.
285. Golomb HM, Jacobs A, Fefer A, et al. Alpha-2 interferon therapy of hairy-cell leukemia: a multicenter study of 64 patients. *J Clin Oncol* 1986;4(6):900-905.

286. Paganelli KA, Evans SS, Han T, Ozer H. B cell growth factor-induced proliferation of hairy cell lymphocytes and inhibition by type I interferon in vitro. *Blood* 1986;67(4):937-942.
287. Baldini L, Cortelezzi A, Polli N, et al. Human recombinant interferon alpha-2C enhances the expression of class II HLA antigens on hairy cells. *Blood* 1986;67(2):458-464.
288. Gressler VH, Weinkauff RE, Franklin WA, Golomb HM. Modulation of the expression of major histocompatibility antigens on splenic hairy cells—differential effect upon in vitro treatment with alpha-2b-interferon, gamma-interferon, and interleukin-2. *Blood* 1988;72(3):1048-1053.
289. VanderMolen LA, Steis RG, Duffey PL, et al. Low- versus high-dose interferon alfa-2a in relapsed indolent non-Hodgkin's lymphoma. *J Natl Cancer Inst* 1990;82(3):235-238.
290. Solal-Celigny P. GELF studies of intron A in follicular lymphomas: an update on the clinical data. *Ann Oncol* 1996;7:(Suppl 3)229.
291. Greipp PR, Witzig TE. Biology and treatment of myeloma. *Curr Opin Oncol* 1996;8:20-27.
292. Kirkwood J. Cancer immunotherapy: the interferon-alpha experience. *Semin Oncol* 2002;29(3 Suppl 7):18-26.
293. Oken MM. New agents for the treatment of multiple myeloma and non-Hodgkin lymphoma. *Cancer* 1992;70(4 Suppl):946-948.
294. Ludwig H, Cohen AM, Polliack A, et al. Interferon-alpha for induction and maintenance in multiple myeloma: results of two multicenter randomized trials and summary of other studies. *Ann Oncol* 1995;6(11):467-476.
295. Salmon SE, Crowley JJ, Grogan TM, Finley P, Pugh RP, Barlogie B. Combination chemotherapy, glucocorticoids, and interferon alfa in the treatment of multiple myeloma: a Southwest Oncology Group study. *J Clin Oncol* 1994;12: 2405-2414.
296. Cooper MR, Dear K, McIntyre OR, et al. A randomized clinical trial comparing melphalan/prednisone with or without interferon alfa-2b in newly diagnosed patients with multiple myeloma: a Cancer and Leukemia Group B study. *J Clin Oncol* 1993;11(1):155-160.
297. Alexanian R, Dimopoulos MA. Management of multiple myeloma. *Semin Hematol* 1995;32(1):20-30.
298. Tomiyama J, Kudo H, Nakamura N, et al. Clinical-study of multiple-myeloma in the elderly. *Oncol Rep* 1995;2(4):669-673.
299. Watanabe N, Narita M, Yokoyama A, et al. Type I IFN-mediated enhancement of anti-leukemic cytotoxicity of gammadelta T cells expanded from peripheral blood cells by stimulation with zoledronate. *Cytotherapy* 2006;8(2):118-129.
300. Safdar A, Rodriguez GH, Lichtiger B, et al. Recombinant interferon gamma1b immune enhancement in 20 patients with hematologic malignancies and systemic opportunistic infections treated with donor granulocyte transfusions. *Cancer* 2006;106(12):2664-2671.
301. Kiladjian JJ, Cassinat B, Chevret S, et al. Pegylated interferon-alfa-2a induces complete hematologic and molecular responses with low toxicity in polycythemia vera. *Blood* 2008;112(8):3065-3072.
302. Morgan DA, Ruscetti FW, Gallo R. Selective in vitro growth of T lymphocytes from normal human bone marrows. *Science* 1976;193(4257):1007-1008.
303. Ruscetti FW, Morgan DA, Gallo RC. Functional and morphologic characterization of human T cells continuously grown in vitro. *J Immunol* 1977;119(1): 131-138.
304. Gillis S, Smith KA. Long term culture of tumour-specific cytotoxic T cells. *Nature* 1977;268(5616):154-156.
305. Baker PE, Gillis S, Smith KA. Monoclonal cytolytic T-cell lines. *J Exp Med* 1979;149(1):273-278.
306. Gillis S, Union NA, Baker PE, Smith KA. The in vitro generation and sustained culture of nude mouse cytolytic T-lymphocytes. *J Exp Med* 1979;149(6): 1460-1476.
307. Lotze MT, Grimm EA, Mazumder A, Rosenstein M. Lysis of fresh and cultured autologous tumor by human lymphocytes cultured in T-cell growth factor. *Cancer Res* 1981;41(2):4420-4425.
308. Taniguchi T, Matsui H, Fujita T, et al. Structure and expression of a cloned cDNA for human interleukin-2. *Nature* 1983;302(5906):305-310.

309. Smith KA. The interleukin 2 receptor. *Annu Rev Cell Biol* 1989;5:397-425.
310. Wang HM, Smith KA. The interleukin 2 receptor. Functional consequences of its bimolecular structure. *J Exp Med* 1987;166(4):1055-1069.
311. Smith K. Interleukin-2 immunotherapy. In: Strom T, ed. *Therapeutic immunology*. Cambridge, MA: Blackwell Science, 1996.
312. Siegel JP, Puri RK. Interleukin-2 toxicity. *J Clin Oncol* 1991;9(4):694-704.
313. Caligiuri MA, Murray C, Robertson MJ, et al. Selective modulation of human natural killer cells in vivo after prolonged infusion of low dose recombinant interleukin 2. *J Clin Invest* 1993;91(1):123-132.
314. Maraninchi D, Blaise D, Viens P, et al. High-dose recombinant interleukin-2 and acute myeloid leukemias in relapse. *Blood* 1991;78(6):2182-2187.
315. Foa R, Meloni G, Tosti S, et al. Treatment of acute myeloid leukaemia patients with recombinant interleukin 2: a pilot study. *Br J Haematol* 1991;77(4): 491-496.
316. Lim SH, Newland AC, Kelsey S, et al. Continuous intravenous infusion of high dose recombinant interleukin 2 for advanced lymphomas—a phase II study. *Cancer Immunol Immunother* 1992;347(4):337-342.
317. Meloni G, Foa R, Vignetti M, et al. Interleukin-2 may induce prolonged remissions in advanced acute myelogenous leukemia. *Blood* 1994;84(7): 2158-2163.
318. Benyunes MC, Thompson JA, York A, et al. Immunotherapy with interleukin-2 after autologous bone marrow transplantation for hematologic malignancies. *Prog Clin Biol Res* 1994;389(3):229-238.
319. Wiernik PH, Dutcher JP, Todd M, Caliendo G, Benson L. Polyethylene glycolated interleukin-2 as maintenance therapy for acute myelogenous leukemia in second remission. *Am J Hematol* 1994;47(1):41-44.
320. Cortes JE, Kantarjian HM, O'Brien S, et al. A pilot study of interleukin-2 for adult patients with acute myelogenous leukemia in first complete remission. *Cancer* 1999;85:1506-1513.
321. Sznol M, Parkinson DR. Interleukin-2 in therapy of hematologic malignancies. *Blood* 1994;83(6):2020-2022.
322. Gisselbrecht C, Maraninchi D, Pico JL, et al. Interleukin-2 treatment in lymphoma: a phase II multicenter study. *Blood* 1994;83(8):2081-2085.
323. Ogata K, Yokose N, Nomura T. Interleukin-2 therapy for myelodysplastic syndrome: does it work? *Leuk Lymphoma* 1995;17(1):411-415.
324. Malek TR, Bayer AL. Tolerance, not immunity, crucially depends on IL-2. *Nat Rev Immunol* 2004;4(9):665-674.
325. Nelson BH. IL-2, regulatory T cells, and tolerance. *J Immunol* 2004;172(7): 3983-3988.
326. Koreth J, Matsuoka K, Kim HT, et al. Interleukin-2 and regulatory T cells in graft-versus-host disease. *N Engl J Med* 2011;365(22):2055-2066.
327. Fang J, Hu C, Hong M, et al. Prophylactic effects of interleukin-2 receptor antagonists against graft-versus-host disease following unrelated donor peripheral blood stem cell transplantation. *Biol Blood Marrow Transplant* 2012;18(5):754-762.
328. Barnes DW, Loutit JF. Treatment of murine leukaemia with x-rays and homologous bone marrow. II. *Br J Haematol* 1957;3(3):241-252.
329. Mathe G, Amiel JL, Schwarzenberg L, Cattani A, Schneider M. Adoptive immunotherapy of acute leukemia: experimental and clinical results. *Cancer Res* 1965;25(9):1525-1531.
330. Fefer A, Sullivan KM, Weiden P, et al. Graft versus leukemia effect in man: the relapse rate of acute leukemia is lower after allogeneic than after syngeneic marrow transplantation. *Prog Clin Biol Res* 1987;244:401-408.
331. Antin JH. Graft-versus-leukemia: no longer an epiphenomenon. *Blood* 1993;82(8):2273-2277.
332. Porter D, Antin J. Graft-versus leukemia effect in bone marrow transplantation. In: Sheridan W, ed. *Cell therapy: stem cell transplantation, gene therapy, and cellular immunotherapy*. Cambridge, MA: University Press, 1996: 568-585.
333. Odom LF, August CS, Githens JH, et al. Remission of relapsed leukaemia during a graft-versus-host reaction. A "graft-versus-leukaemia reaction" in man? *Lancet* 1978;2(8089):537-540.

334. Collins RHJ, Rogers ZR, Bennett M, et al. Hematologic relapse of chronic myelogenous leukemia following allogeneic bone marrow transplantation: apparent graft-versus-leukemia effect following abrupt discontinuation of immunosuppression. *Bone Marrow Transplant* 1992;10(4):391-395.
335. Gale RP, Champlin RE. How does bone-marrow transplantation cure leukaemia? *Lancet* 1984;2(8393):28-30.
336. Gale RP, Horowitz MM, Ash RC, et al. Identical-twin bone marrow transplants for leukemia. *Ann Intern Med* 1994;120(2):646-652.
337. Horowitz MM, Gale RP, Sondel PM, et al. Graft-versus-leukemia reactions after bone marrow transplantation. *Blood* 1990;75(3):555-562.
338. Barrett J, Malkovska V. The graft-versus-leukemia effect. *Curr Opin Oncol* 1996;8(2):89-95.
339. Jones RJ, Ambinder RF, Piantadosi S, Santos GW. Evidence of a graft-versus-lymphoma effect associated with allogeneic bone marrow transplantation. *Blood* 1991;77(3):649-653.
340. Goulmy E. Minor histocompatibility antigens and their role in transplantation. *Transplant Rev* 1988;2:29-53.
341. den Haan JM, Sherman NE, Blokland E, et al. Identification of a graft versus host disease-associated human minor histocompatibility antigen. *Science* 1995;268(5230):1476-1479.
342. Kessels HW, Wolkers MC, Schumacher TN. Adoptive transfer of T-cell immunity. *Trends Immunol* 2002;23(5):264-269.
343. Marijt WA, Kernan NA, Diaz-Barrientos T, et al. Multiple minor histocompatibility antigen-specific cytotoxic T lymphocyte clones can be generated during graft rejection after HLA-identical bone marrow transplantation. *Bone Marrow Transplant* 1995;16(1):125-132.
344. van der Harst D, Goulmy E, Falkenburg JH, et al. Recognition of minor histocompatibility antigens on lymphocytic and myeloid leukemic cells by cytotoxic T-cell clones. *Blood* 1994;83(4):1060-1066.
345. Ivanov R, Hagenbeek A, Ebeling S. Towards immunogene therapy of hematological malignancies. *Exp Hemat* 2006;34(3):251-263.
346. Fontaine P, Roy-Proulx G, Knafo L, Baron C, Roy DC, Perreault C. Adoptive transfer of minor histocompatibility antigen-specific T lymphocytes eradicates leukemia cells without causing graft-versus-host disease. *Nat Med* 2001;7: 789-794.
347. Disis ML, Cheever MA. Oncogenic proteins as tumor antigens. *Curr Opin Immunol* 1996;8(5):637-642.
348. Bosch GJ, Joosten AM, Kessler JH, Melief CJ, Leeksa OC. Recognition of BCR-ABL positive leukemic blasts by human CD4⁺ T cells elicited by primary in vitro immunization with a BCR-ABL breakpoint peptide. *Blood* 1996;88(9):3522-3527.
349. Krikorian JG, Portlock CS, Cooney P, Rosenberg SA. Spontaneous regression of non-Hodgkin's lymphoma: a report of nine cases. *Cancer* 1980;46(9): 2093-2099.
350. Maraninchi D, Gluckman E, Blaise D, et al. Impact of T-cell depletion on outcome of allogeneic bone-marrow transplantation for standard-risk leukaemias. *Lancet* 1987;2:175-178.
351. Hercend T, Takvorian T, Nowill A, et al. Characterization of natural killer cells with antileukemia activity following allogeneic bone marrow transplantation. *Blood* 1986;67(3):722-728.
352. Hallett WH, Murphy WJ. Natural killer cells: biology and clinical use in cancer therapy. *Cell Mol Immunol* 2004;1(1):12-21.
353. Nimer SD, Giorgi J, Gajewski JL, et al. Selective depletion of CD8⁺ cells for prevention of graft-versus-host disease after bone marrow transplantation. A randomized controlled trial. *Transplantation* 1994;57(1):82-87.
354. Giralt S, Hester J, Huh Y, et al. CD8-depleted donor lymphocyte infusion as treatment for relapsed chronic myelogenous leukemia after allogeneic bone marrow transplantation. *Blood* 1995;86(11):4337-4343.
355. Korngold R, Leighton C, Manser T. Graft-versus-myeloid leukemia responses following syngeneic and allogeneic bone marrow transplantation. *Transplantation* 1994;58(3):278-287.
356. Faber LM, van Luxemburg-Heijs SA, Veenhof WF, Willemze R, Falkenburg JH. Generation of CD4⁺ cytotoxic T-lymphocyte clones from a patient with severe graft-versus-host disease after allogeneic bone marrow transplantation: implications for graft-versus-leukemia reactivity. *Blood* 1995;86(7):2821-2828.

357. Fowler DH, Gress RE. Th2 and Tc2 cells in the regulation of GVHD, GVL, and graft rejection: considerations for the allogeneic transplantation therapy of leukemia and lymphoma. *Leuk Lymphoma* 2000;238(3):221-234.
358. Altman JD, Moss PA, Goulder PJ, et al. Phenotypic analysis of antigen-specific T lymphocytes. *Science* 1996;274(5284):94-96.
359. Mutis T, Gillespie G, Schrama E, Falkenburg JH, Moss P, Goulmy E. Tetrameric HLA class I-minor histocompatibility antigen peptide complexes demonstrate minor histocompatibility antigen-specific cytotoxic T lymphocytes in patients with graft-versus-host disease. *Nat Med* 1999;5(7):839-842.
360. Morecki S, Slavin S. Toward amplification of a graft-versus-leukemia effect while minimizing graft-versus-host disease. *J Hematother Stem Cell Res* 2000;9(3):355-366.
361. Johnson BD, Truitt RL. Delayed infusion of immunocompetent donor cells after bone marrow transplantation breaks graft-host tolerance allows for persistent antileukemic reactivity without severe graft-versus-host disease. *Blood* 1995;85(11):3302-3312.
362. Tiberghien P, Reynolds CW, Keller J, et al. Ganciclovir treatment of herpes simplex thymidine kinase-transduced primary T lymphocytes: an approach for specific in vivo donor T-cell depletion after bone marrow transplantation? *Blood* 1994;84(4):1333-1341.
363. Litvinova E, Maury S, Boyer O, et al. Graft-versus-leukemia effect after suicide-gene-mediated control of graft-versus-host disease. *Blood* 2002;100(6): 2020-2025.
364. Sykes M, Harty MW, Szot GL, Pearson DA. Interleukin-2 inhibits graft-versus-host disease-promoting activity of CD4+ cells while preserving CD4- and CD8-mediated graft-versus-leukemia effects. *Blood* 1994;83(9):2560-2569.
365. Cavazzana-Calvo M, Stephan JL, Sarnacki S, et al. Attenuation of graft-versus-host disease and graft rejection by ex vivo immunotoxin elimination of alloreactive T cells in an H-2 haplotype disparate mouse combination. *Blood* 1994;83(1):288-298.
366. Datta AR, Barrett AJ, Jiang YZ, et al. Distinct T cell populations distinguish chronic myeloid leukaemia cells from lymphocytes in the same individual: a model for separating GVHD from GVL reactions. *Bone Marrow Transplant* 1994;14(4):517-524.
367. Falkenburg JH. Generation of donor-derived antileukemic cytotoxic T-lymphocyte responses for treatment of relapsed leukemia after allogeneic HLA-identical bone marrow transplantation. *J Immunother* 1993;14: 305-309.
368. Porter DL, Antin JH. The graft-versus-leukemia effects of allogeneic cell therapy. *Annu Rev Med* 1999;50:369-386.
369. Shimoni A, Giralt S, Khouri I, et al. Allogeneic hematopoietic transplantation for acute and chronic myeloid leukemia: non-myeloablative preparative regimens and induction of the graft-versus-leukemia effect. *Curr Oncol Rep* 2000;2: 132-139.
370. Carella AM, Champlin R, Slavin S, McSweeney P, Storb R. Mini-allografts: ongoing trials in humans. *Bone Marrow Transplant* 2000;25(4):345-350.
371. Burroughs L, Storb R. Low-intensity allogeneic hematopoietic stem cell transplantation for myeloid malignancies: separating graft-versus-leukemia effects from graft-versus-host disease. *Curr Opin Hematol* 2005;12(1):45-54.
372. Weisdorf D, Zhang MJ, Arora M, Horowitz MM, Rizzo JD, Eapen M. Graft-versus-Host disease induced graft-versus-leukemia effect: greater impact on relapse and disease-free survival after reduced intensity conditioning. *Biol Blood Marrow Transplant* 2012.
373. Kolb HJ, Schattenberg A, Goldman JM, et al. Graft-versus-leukemia effect of donor lymphocyte transfusions in marrow grafted patients. *Blood* 1995;86:2041-2050.
374. Kolb HJ, Schattenberg A, Goldman JM, et al. Donor leukocyte transfusions for treatment of recurrent chronic myelogenous leukemia in marrow transplant patients. *Blood* 1990;76(5):2462-2465.
375. Dazzi F, Goldman JM. Adoptive immunotherapy following allogeneic bone marrow transplantation. *Annu Rev Med* 1998;49(10):329-340.
376. Giralt SA, Kolb HJ. Donor lymphocyte infusions. *Curr Opin Oncol* 1996;8(2): 96-102.
377. Collins RHJ, Shpilberg O, Drobyski WR, et al. Donor leukocyte infusions in 140 patients with relapsed malignancy after allogeneic bone marrow transplantation. *J Clin Oncol* 1997;15(3):433-444.

378. Soiffer RJ. Donor lymphocyte infusions: the door is open. *J Clin Oncol* 1997;15:416-417.
379. van Rhee F, Lin F, Cullis JO, Cross NC, Goldman JM. Relapse of chronic myeloid leukemia after allogeneic bone marrow transplant: the case for giving donor leukocyte transfusions before the onset of hematologic relapse. *Blood* 1994;83(2):3377-3383.
380. Van Rhee F, Goldman J. Donor lymphocyte therapy in bone-marrow transplantation. In: Sheridan W, ed., *Cell therapy: stem cell transplantation, gene therapy, and cellular immunotherapy*. Cambridge, MA: Cambridge University Press, 1996:513-519.
381. Bar BM, Schattenberg A, Mensink EJ, et al. Donor leukocyte infusions for chronic myeloid leukemia relapsed after allogeneic bone marrow transplantation. *J Clin Oncol* 1993;11(3):513-519.
382. Drobyski WR, Keever CA, Roth MS, et al. Salvage immunotherapy using donor leukocyte infusions as treatment for relapsed chronic myelogenous leukemia after allogeneic bone marrow transplantation: efficacy and toxicity of a defined T-cell dose. *Blood* 1993;82(2):2310-2318.
383. Lotze MT, Grimm EA, Mazumder A, Strausser JL, Rosenberg SA. In vitro growth of cytotoxic human lymphocytes. IV. Lysis of fresh and cultured autologous tumor by human lymphocytes cultured in T-cell growth factor. *Cancer Res* 1981;41(11 Pt 1):4420-4425.
384. Rayner AA, Grimm EA, Lotze MT, Chu EW, Rosenberg SA. Lymphokine-activated killer (LAK) cells. Analysis of factors relevant to the immunotherapy of human cancer. *Cancer* 1985;55(6):1327-1333.
385. Rosenberg SA, Lotze MT, Muul LM, et al. Observations on the systemic administration of autologous lymphokine-activated killer cells and recombinant interleukin-2 to patients with metastatic cancer. *New Engl J Med* 1985;313(23):1485-1492.
386. Rosenberg SA, Packard BS, Aebersold PM, Solomon D. Use of tumor-infiltrating lymphocytes and interleukin-2 in the immunotherapy of patients with metastatic melanoma. A preliminary report. *New Engl J Med* 1988;319:1676-1680.
387. Rosenstein M, Yron I, Kaufmann Y, Rosenberg SA. Lymphokine-activated killer cells: lysis of fresh syngeneic natural killer-resistant murine tumor cells by lymphocytes cultured in interleukin 2. *Cancer Res* 1984;44(5):1946-1953.
388. Grimm EA, Ramsey KM, Mazumder A, Wilson DJ, Djeu JY, Rosenberg SA. Lymphokine-activated killer cell phenomenon. II. Precursor phenotype is serologically distinct from peripheral T lymphocytes, memory cytotoxic thymus-derived lymphocytes, and natural killer cells. *J Exp Med* 1983;157(3):884-897.
389. Phillips JH, Lanier LL. Dissection of the lymphokine-activated killer phenomenon. Relative contribution of peripheral blood natural killer cells and T lymphocytes to cytotoxicity. *J Exp Med* 1986;164(3):814-825.
390. Rosenberg SA, Lotze MT, Muul LM, et al. A progress report on the treatment of 157 patients with advanced cancer using lymphokine-activated killer cells and interleukin-2 or high-dose interleukin-2 alone. *New Engl J Med* 1987;316(15):889-897.
391. Rosenberg SA, Lotze MT, Yang JC, et al. Experience with the use of high-dose interleukin-2 in the treatment of 652 cancer patients. *Ann Surg* 1989;210(4):474-484;discussion 484-485.
392. Carson W, Caligiuri M. Cellular adoptive immunotherapy with natural killer cells. In: Sheridan W, Ed. *Cell therapy: stem cell transplantation, gene therapy, and cellular immunotherapy*. Cambridge, MA, Cambridge University Press, 1996:451-474.
393. Rosenberg SA, Spiess PJ, Lafreniere R. A new approach to the adoptive immunotherapy of cancer with tumor-infiltrating lymphocytes. *Science* 1986;223(3):1318-1321.
394. Fisher B, Packard BS, Read EJ, et al. Tumor localization of adoptively transferred indium-111 labeled tumor infiltrating lymphocytes in patients with metastatic melanoma. *J Clin Oncol* 1989;7(2):250-261.
395. Griffith KD, Read EJ, Carrasquillo JA, et al. In vivo distribution of adoptively transferred indium-111-labeled tumor infiltrating lymphocytes and peripheral blood lymphocytes in patients with metastatic melanoma. *J Natl Cancer Inst* 1989;81(22):1709-1717.
396. Rosenberg SA, Yannelli JR, Yang JC. Treatment of patients with metastatic melanoma with autologous tumor-infiltrating lymphocytes and interleukin 2. *J Natl Cancer Inst* 1994;86:1159-1166.
397. Riddell SR, Watanabe KS, Goodrich JM, Li CR, Agha ME, Greenberg PD. Restoration of viral immunity in immunodeficient humans by the adoptive transfer of T cell clones. *Science* 1992;257:238-241.

398. Riddell SR, Greenberg PD. Principles for adoptive T cell therapy of human viral diseases. *Annu Rev Immunol* 1995;13(6602):545-586.
399. Walter EA, Greenberg PD, Gilbert MJ, et al. Reconstitution of cellular immunity against cytomegalovirus in recipients of allogeneic bone marrow by transfer of T-cell clones from the donor. *New Engl J Med* 1995;333:1038-1044.
400. Yee C, Riddell SR, Greenberg PD. Prospects for adoptive T cell therapy. *Curr Opin Immunol* 1997;9:702-708.
401. Rosenberg SA. Progress in human tumour immunology and immunotherapy. *Nature* 2001;411(6835):380-384.
402. Porter DL, Levine BL, Kalos M, Bagg A, June CH. Chimeric antigen receptor-modified T cells in chronic lymphoid leukemia. *New Engl J Med* 2011;365(8):725-733.
403. O'Reilly SE, Connors JM, Howdle S, et al. In search of an optimal regimen for elderly patients with advanced-stage diffuse large-cell lymphoma: results of a phase II study of P/DOCE chemotherapy. *J Clin Oncol* 1993;11(11): 2250-2257.
404. Stevenson GT, Stevenson FK. Antibody to a molecularly-defined antigen confined to a tumour cell surface. *Nature* 1975;254(5502):714-716.
405. Freedman PM, Autry JR, Tokuda S, Williams RC Jr. Tumor immunity induced by preimmunization with BALB/c mouse myeloma protein. *J Natl Cancer Inst* 1976;56(4):735-740.
406. Stevenson GT, Elliott EV, Stevenson FK. Idiotypic determinants on the surface immunoglobulin of neoplastic lymphocytes: a therapeutic target. *Fed Proc* 1977;36(9):2268-2271.
407. Kaminski MS, Kitamura K, Maloney DG, Levy R. Idiotype vaccination against murine B cell lymphoma. Inhibition of tumor immunity by free idiotype protein. *J Immunol* 1987;138(4):1289-1296.
408. KwakLW, Campbell MJ, Zelenetz AD, Levy R. Combined syngeneic bone marrow transplantation and immunotherapy of a murine B-cell lymphoma: active immunization with tumor-derived idiotypic immunoglobulin. *Blood* 1990;76(11):2411-2417.
409. Kwak LW, Young HA, Pennington RW, Weeks SD. Vaccination with syngeneic, lymphoma-derived immunoglobulin idiotype combined with granulocyte/macrophage colony-stimulating factor primes mice for a protective T-cell response. *Proc Natl Acad Sci USA* 1996;93(20):10972-10977.
410. Kwak LW, Campbell MJ, Czerwinski DK. Induction of immune responses in patients with B-cell lymphoma against the surface-immunoglobulin idiotype expressed by their tumors. *New Engl J Med* 1992;327:1209-1215.
411. Hsu FJ, Caspar CB, Czerwinski D, et al. Tumor-specific idiotype vaccines in the treatment of patients with B-cell lymphoma—long-term results of a clinical trial. *Blood* 1997;89(9):3129-3135.
412. Bendandi M, Gocke CD, Kobrin CB, et al. Complete molecular remissions induced by patient-specific vaccination plus granulocyte-monocyte colony-stimulating factor against lymphoma. *Nat Med* 1999;5(10):1171-1177.
413. Baskar S, Kobrin CB, Kwak LW. Autologous lymphoma vaccines induce human T cell responses against multiple, unique epitopes. *J Clin Invest* 2004;113(10):1498-1510.
414. Santos C, Stern L, Katz L, Watson T, Barry G. BiovaxIDTM vaccine therapy of follicular lymphoma in first remission: long-term follow-up of a phase II trial and status of a controlled, randomized phase III trial. *Blood* 2005;106:a2441.
415. Longo DL, Duffey PL, Gribben JG, et al. Combination chemotherapy followed by an immunotoxin (anti-B4-blocked ricin) in patients with indolent lymphoma: results of a phase II study. *Cancer J* 2000;6(3):146-150.
416. Schuster SJ, Neelapu SS, Gause BL, et al. Vaccination with patient-specific tumor-derived antigen in first remission improves disease-free survival in follicular lymphoma. *J Clin Oncol* 2011;29(20):2787-2794.
417. Freedman A, Neelapu SS, Nichols C, et al. Placebo-controlled phase III trial of patient-specific immunotherapy with mitumprotimut-T and granulocyte-macrophage colony-stimulating factor after rituximab in patients with follicular lymphoma. *J Clin Oncol* 2009;27(18):3036-3043.
418. Levy R, Robertson MJ, Ganjoo K, Leonard J, Vose J, Denney D. Results of a phase 3 trial evaluating safety and efficacy of specific immunotherapy, recombinant idiotype (Id) conjugated to KLH (Id-KLH) with GM-CSF, compared with non-specific immunotherapy, KLH with GM-CSF, in patients with follicular non-Hodgkin's lymphoma (FNHL). *Ann Oncol* 2008;19(Suppl 4):v101-v102.
419. Carroll WL, Thielemans K, Dille J, Levy R. Mouse x human heterohybridomas as fusion partners with human B cell tumors. *J Immunol Meth* 1986;89(1):61-72.

420. Park HJ, Neelapu SS. Developing idiotype vaccines for lymphoma: from preclinical studies to phase III clinical trials. *Brit J Haematol* 2008;142(2): 179-191.
421. Reitan SK, Hannestad K. A syngeneic idiotype is immunogenic when borne by IgM but tolerogenic when joined to IgG. *Eur J Immunol* 1995;25(6): 1601-1608.
422. Reitan SK, Hannestad K. Immunoglobulin heavy chain constant regions regulate immunity and tolerance to idiotypes of antibody variable regions. *Proc Natl Acad Sci USA* 2002;99(11):7588-7593.
423. De Groot AS, Moise L, McMurry JA, et al. Activation of natural regulatory T cells by IgG Fc-derived peptide "Tregitopes". *Blood* 2008;112(8):3303-3311.
424. Maloney DG, Liles TM, Czerwinski DK, et al. Phase I clinical trial using escalating single-dose infusion of chimeric anti-CD20 monoclonal antibody (IDEC-C2B8) in patients with recurrent B-cell lymphoma. *Blood* 1994;84(8):2457-2466.
425. Eynon EE, Parker DC. Small B cells as antigen-presenting cells in the induction of tolerance to soluble protein antigens. *J Exp Med* 1992;175(1):131-138.
426. Bennett SR, Carbone FR, Toy T, Miller JF, Heath WR. B cells directly tolerize CD8(+) T cells. *J Exp Med* 1998;188(11):1977-1983.
427. Yang X, Brunham RC. Gene knockout B cell-deficient mice demonstrate that B cells play an important role in the initiation of T cell responses to *Chlamydia trachomatis* (mouse pneumonitis) lung infection. *J Immunol* 1998;161(3):1439-1446.
428. Rivera A, Chen CC, Ron N, Dougherty JP, Ron Y. Role of B cells as antigen-presenting cells in vivo revisited: antigen-specific B cells are essential for T cell expansion in lymph nodes and for systemic T cell responses to low antigen concentrations. *Int Immunol* 2001;13(12):1583-1593.
429. Linton PJ, Harbertson J, Bradley LM. A critical role for B cells in the development of memory CD4 cells. *J Immunol* 2000;165(10):5558-5565.
430. Neelapu SS, Kwak LW, Kobrin CB, et al. Vaccine-induced tumor-specific immunity despite severe B-cell depletion in mantle cell lymphoma. *Nat Med* 2005;11(9):986-991.
431. Koc ON, Redfern C, Wiernik PH, et al. A phase 2 trial of immunotherapy with mitumprotimut-T (Id-KLH) and GM-CSF following rituximab in follicular B-cell lymphoma. *J Immunother* 2010;33(2):178-184.
432. Dunleavy K, Neelapu SS, Kwak LW, et al. Association of idiotype vaccine-induced T-cell response with improved survival and time-to-next treatment (TTNT) in untreated mantle cell lymphoma (MCL). *J Clin Oncol* 2012;30:a2528.
433. Timmerman JM, Caspar CB, Lambert SL, Syrengelas AD, Levy R. Idiotype-encoding recombinant adenoviruses provide protective immunity against murine B-cell lymphomas. *Blood* 2001;97(5):1370-1307.
434. Timmerman JM, Levy R. Linkage of foreign carrier protein to a self-tumor antigen enhances the immunogenicity of a pulsed dendritic cell vaccine. *J Immunol* 2000;164(9):4797-4803.
435. Levitsky HI, Montgomery J, Ahmadzadeh M, et al. Immunization with granulocyte-macrophage colony-stimulating factor-transduced, but not B7-1-transduced, lymphoma cells primes idiotype-specific T cells and generates potent systemic antitumor immunity. *J Immunol* 1996;156(10):3858-3865.
436. Kwak LW, Pennington R, Boni L, Ochoa AC, Robb RJ, Popescu MC. Liposomal formulation of a self lymphoma antigen induces potent protective antitumor immunity. *J Immunol* 1998;160(8):3637-3641.
437. Weng WK, Czerwinski D, Timmerman J, Hsu FJ, Levy R. Clinical outcome of lymphoma patients after idiotype vaccination is correlated with humoral immune response and immunoglobulin G Fc receptor genotype. *J Clin Oncol* 2004;22(23):4717-4724.
438. Keilholz U, Weber J, Finke JH, et al. Immunologic monitoring of cancer vaccine therapy: results of a workshop sponsored by the Society for Biological Therapy. *J Immunother* 2002;25(2):97-138.
439. Hsu FJ, Benike C, Fagnoni F, et al. Vaccination of patients with B-cell lymphoma using autologous antigen-pulsed dendritic cells. *Nat Med* 1996;2(1):52-58.

440. Timmerman JM, Czerwinski DK, Davis TA, et al. Idiotype-pulsed dendritic cell vaccination for B-cell lymphoma: clinical and immune responses in 35 patients. *Blood* 2002;99(5):1517-1526.
441. Neelapu SS, Baskar S, Gause BL, et al. Human autologous tumor-specific T-cell responses induced by liposomal delivery of a lymphoma antigen. *Clin Cancer Res* 2004;10(24):8309-8317.
442. Redfern CH, Guthrie TH, Bessudo A, et al. Phase II trial of idiotype vaccination in previously treated patients with indolent non-Hodgkin's lymphoma resulting in durable clinical responses. *J Clin Oncol* 2006;24(19):3107-3112.
443. Nelson EL, Li X, Hsu FJ, et al. Tumor-specific, cytotoxic T-lymphocyte response after idiotype vaccination for B-cell, non-Hodgkin's lymphoma. *Blood* 1996;88(2):580-589.
444. Navarrete MA, Heining-Mikesch K, Schuler F, et al. Upfront immunization with autologous recombinant idiotype Fab fragment without prior cytoreduction in indolent B-cell lymphoma. *Blood* 2011;117(5):1483-1491.
445. Neelapu SS, Gause BL, Harvey L, et al. A novel proteoliposomal vaccine induces antitumor immunity against follicular lymphoma. *Blood* 2007;109(12): 5160-5163.
446. Wierda WG, Cantwell MJ, Woods SJ, Rassenti LZ, Prussak CE, Kipps TJ. CD40-ligand (CD154) gene therapy for chronic lymphocytic leukemia. *Blood* 2000;96(9):2917-2924.
447. Maier T, Tun-Kyi A, Tassis A, et al. Vaccination of patients with cutaneous T-cell lymphoma using intranodal injection of autologous tumor-lysate-pulsed dendritic cells. *Blood* 2003;102(7):2338-2344.
448. Di Nicola M, Zappasodi R, Carlo-Stella C, et al. Vaccination with autologous tumor-loaded dendritic cells induces clinical and immunologic responses in indolent B-cell lymphoma patients with relapsed and measurable disease: a pilot study. *Blood* 2009;113(1):18-27.
449. Weng J, Rawal S, Chu F, et al. TCL1: a shared tumor-associated antigen for immunotherapy against B-cell lymphomas. *Blood* 2012;120(8): 1613-1623.
450. Li Y, Bendandi M, Deng Y, et al. Tumor-specific recognition of human myeloma cells by idiotype-induced CD8(+) T cells. *Blood* 2000;96(8): 2828-2833.
451. Wen YJ, Barlogie B, Yi Q. Idiotype-specific cytotoxic T lymphocytes in multiple myeloma: evidence for their capacity to lyse autologous primary tumor cells. *Blood* 2001;97(6):1750-1755.
452. Reichardt VL, Okada CY, Liso A, et al. Idiotype vaccination using dendritic cells after autologous peripheral blood stem cell transplantation for multiple myeloma—a feasibility study. *Blood* 1999;93(7):2411-2419.
453. Massaia M, Borriero P, Battaglio S, et al. Idiotype vaccination in human myeloma: generation of tumor-specific immune responses after high-dose chemotherapy. *Blood* 1999;94(2):673-683.
454. Rasmussen T, Hansson L, Osterborg A, Johnsen HE, Mellstedt H. Idiotype vaccination in multiple myeloma induced a reduction of circulating clonal tumor B cells. *Blood* 2003;101(11):4607-4610.
455. Curti A, Tosi P, Comoli P, et al. Phase I/II clinical trial of sequential subcutaneous and intravenous delivery of dendritic cell vaccination for refractory multiple myeloma using patient-specific tumour idiotype protein or idiotype (VDJ)-derived class I-restricted peptides. *Brit J Haematol* 2007;139(3):415-424.
456. Yi Q, Szmania S, Freeman J, et al. Optimizing dendritic cell-based immunotherapy in multiple myeloma: intranodal injections of idiotype-pulsed CD40 ligand-matured vaccines led to induction of type-1 and cytotoxic T-cell immune responses in patients. *Brit J Haematol* 2010;150(5):554-564.
457. Rapoport AP, Aqui NA, Stadtmauer EA, et al. Combination immunotherapy using adoptive T-cell transfer and tumor antigen vaccination on the basis of hTERT and survivin after ASCT for myeloma. *Blood* 2011;117(3):788-797.
458. Kwak LW, Taub DD, Duffey PL, et al. Transfer of myeloma idiotype-specific immunity from an actively immunised marrow donor. *Lancet* 1995;345(8956): 1016-1020.
459. Neelapu SS, Munshi NC, Jagannath S, et al. Tumor antigen immunization of sibling stem cell transplant donors in multiple myeloma. *Bone Mar Transplant* 2005;36(4):315-323.
460. Foglietta M, Neelapu S, Kwak LW, et al. Neoantigen and tumor antigen-specific immunity transferred from immunized donors is detectable early after allogeneic transplantation in myeloma patients. *Bone Mar Transpl* 2012. doi:10.1038/bmt.2012.132.

461. Qian J, Xie J, Hong S, et al. Dickkopf-1 (DKK1) is a widely expressed and potent tumor-associated antigen in multiple myeloma. *Blood* 2007;110(5):1587-1594.
462. Qian J, Zheng Y, Zheng C, et al. Active vaccination with Dickkopf-1 induces protective and therapeutic antitumor immunity in murine multiple myeloma. *Blood* 2012;119(1):161-169.
463. Yaccoby S, Ling W, Zhan F, Walker R, Barlogie B, Shaughnessy JD Jr. Antibody-based inhibition of DKK1 suppresses tumor-induced bone resorption and multiple myeloma growth in vivo. *Blood* 2007;109(5):2106-2111.
464. Pinilla-Ibarz J, Cathcart K, Korontsvit T, et al. Vaccination of patients with chronic myelogenous leukemia with bcr-abl oncogene breakpoint fusion peptides generates specific immune responses. *Blood* 2000;95(5):1781-1787.
465. Cathcart K, Pinilla-Ibarz J, Korontsvit T, et al. A multivalent bcr-abl fusion peptide vaccination trial in patients with chronic myeloid leukemia. *Blood* 2004;103(3):1037-1042.
466. Bocchia M, Gentili S, Abruzzese E, et al. Effect of a p210 multi-peptide vaccine associated with imatinib or interferon in patients with chronic myeloid leukaemia and persistent residual disease: a multicentre observational trial. *Lancet* 2005;365:657-662.
467. Rojas JM, Knight K, Wang L, Clark RE. Clinical evaluation of BCR-ABL peptide immunisation in chronic myeloid leukaemia: results of the EPIC study. *Leukemia* 2007;21(11):2287-2295.
468. Qazilbash MH, Wieder ED, Thall PF, et al. PR1 peptide vaccine-induced immune response is associated with better event-free survival in patients with myeloid leukemia. *Blood* 2007;110:a283.
469. Rezvani K, Yong AS, Mielke S, et al. Leukemia-associated antigen-specific T-cell responses following combined PR1 and WT1 peptide vaccination in patients with myeloid malignancies. *Blood* 2008;111(1):236-242.
470. Keilholz U, Letsch A, Busse A, et al. A clinical and immunologic phase 2 trial of Wilms tumor gene product 1 (WT1) peptide vaccination in patients with AML and MDS. *Blood* 2009;113(26):6541-6548.
471. Maslak PG, Dao T, Krug LM, et al. Vaccination with synthetic analog peptides derived from WT1 oncoprotein induces T-cell responses in patients with complete remission from acute myeloid leukemia. *Blood* 2010;116(2): 171-179.
472. Oka Y, Tsuboi A, Taniguchi T, et al. Induction of WT1 (Wilms' tumor gene)-specific cytotoxic T lymphocytes by WT1 peptide vaccine and the resultant cancer regression. *Proc Natl Acad Sci USA* 2004;101:13885-13890.
473. Van Tendeloo VF, Van de Velde A, Van Driessche A, et al. Induction of complete and molecular remissions in acute myeloid leukemia by Wilms' tumor 1 antigen-targeted dendritic cell vaccination. *Proc Natl Acad Sci USA* 2010;107(31):13824-13829.
474. Pashine A, Valiante NM, Ulmer JB. Targeting the innate immune response with improved vaccine adjuvants. *Nat Med* 2005;11(4 Suppl):S63-S68.
475. Shackleton M, Davis ID, Hopkins W, et al. The impact of imiquimod, a Toll-like receptor-7 ligand (TLR7L), on the immunogenicity of melanoma peptide vaccination with adjuvant Flt3 ligand. *Cancer Immun* 2004;4:9.
476. Speiser DE, Lienard D, Rufer N, et al. Rapid and strong human CD8+ T cell responses to vaccination with peptide, IFA, and CpG oligodeoxynucleotide 7909. *J Clin Invest* 2005;115(3):739-746.
477. Walker LS, Abbas AK. The enemy within: keeping self-reactive T cells at bay in the periphery. *Nat Rev Immunol* 2002;2(1):11-19.
478. Chen L. Co-inhibitory molecules of the B7-CD28 family in the control of T-cell immunity. *Nat Rev Immunol* 2004;4(5):336-347.
479. Sakaguchi S. Naturally arising Foxp3-expressing CD25+CD4+ regulatory T cells in immunological tolerance to self and non-self. *Nat Immunol* 2005;6(4):345-352.
480. Carter LL, Carreno BM, Panoskaltsis-Mortari A, et al. Cytotoxic T-lymphocyte antigen-4 and programmed death-1 function as negative regulators of lymphocyte activation. *Immuol Res* 2003;28(3):49-59.
481. Pardoll DM. The blockade of immune checkpoints in cancer immunotherapy. *Nat Rev Cancer* 2012;12(4):252-264.
482. Dannull J, Su Z, Rizzieri D, et al. Enhancement of vaccine-mediated antitumor immunity in cancer patients after depletion of regulatory T cells. *J Clin Invest* 2005;115(12):3623-3633.

483. Phan GQ, Yang JC, Sherry RM, et al. Cancer regression and autoimmunity induced by cytotoxic T lymphocyte-associated antigen 4 blockade in patients with metastatic melanoma. *Proc Natl Acad Sci USA* 2003;100(14): 8372-8377.

484. Hodi FS, Mihm MC, Soiffer RJ, et al. Biologic activity of cytotoxic T lymphocyte-associated antigen 4 antibody blockade in previously vaccinated metastatic melanoma and ovarian carcinoma patients. *Proc Natl Acad Sci USA* 2003;100(17):4712-4717.

485. Noonan K, Rudraraju L, Ferguson A, et al. Lenalidomide-induced immunomodulation in multiple myeloma: impact on vaccines and antitumor responses. *Clin Cancer Res* 2012;18(5):1426-1434.

486. Sakamaki I, Kaplan B, Cha SC, Qin H, Kwak LW. Potent immunomodulatory effects of Lenalidomide on effector T cells and Treg improve the effectiveness of a therapeutic lymphoma vaccine. *Blood* 2011;118(21):a108.

487. Inoges S, Rodriguez-Calvillo M, Zabalegui N, et al. Clinical benefit associated with idiotypic vaccination in patients with follicular lymphoma. *J Natl Cancer Inst* 2006;98(18):1292-1301.

Chapter 71 Gene Therapy for Hematologic Disorders

> Table of Contents > Part VII - Hematologic Malignancies > Section 1 - General Aspects > Chapter 71 - Gene Therapy for Hematologic Disorders

Chapter 71

Gene Therapy for Hematologic Disorders

Andre Larochelle

Cynthia E. Dunbar

John Tisdale

INTRODUCTION

The molecular characterization of congenital and acquired human disease over the past several decades has stimulated scientists and clinicians to envision genetic therapy as a new and exciting possibility.¹ By the 1990s, gene transfer technologies had progressed sufficiently to offer real hope for successful widespread clinical application.^{2, 3} and ⁴ The first replication-defective retroviral vector was described in 1983, offering a safe and feasible route for transfer of exogenous genes to nontransformed human cells.⁵ By 1989-1990, clinical studies using gene transfer began.^{6,7,8} Hundreds of clinical trials have been completed or are in progress (Fig. 71.1). Although surrounded by expectations, none of the early trials had even minimal evidence for clinical benefit, and in 1996 an expert panel convened by the director of the National Institutes of Health was critical of the premature initiation of clinical gene therapy trials and the subsequent overselling of results by investigators and the media.⁹ At the time of the report, no clinical gene “therapy” trial had shown clinical efficacy. The focus thus turned to rationally designed, small-scale clinical trials in diseases for which the pathophysiology is well understood, as well as the more important need for continued basic science investigations into vector systems and target cell biology.^{10, 11} and ¹²

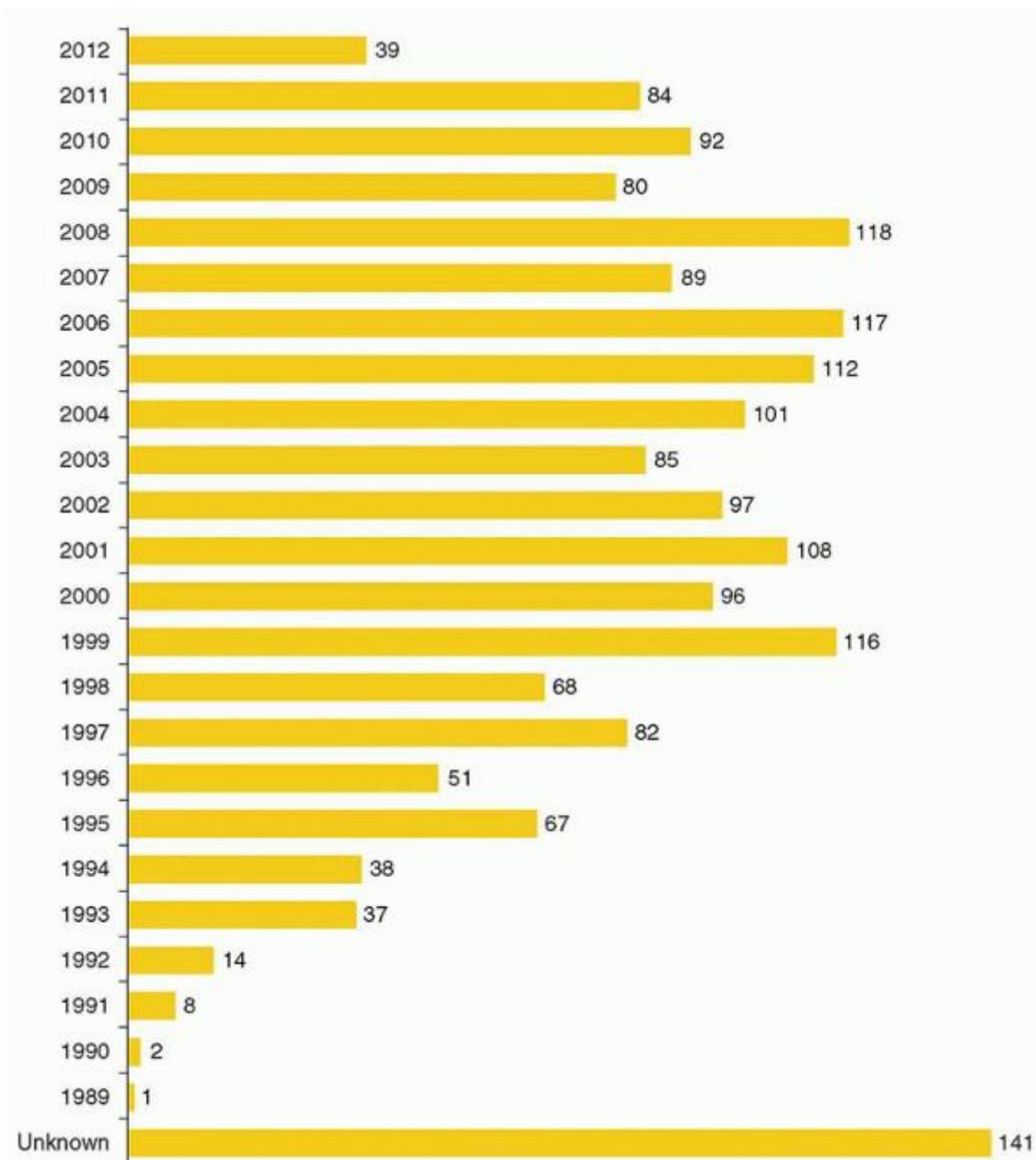

FIGURE 71.1. Number of gene therapy clinical trials approved worldwide from 1989 through part of 2012. (From The Journal of Gene Medicine, © 2012 John Wiley and Sons Ltd, www.wiley.co.uk/genemed/clinical. Reproduced with permission of John Wiley and Sons, Inc.)

Hematopoietic stem cells (HSCs) and lymphocytes have remained central target cell populations for two major reasons: first, they are relatively easy to manipulate *ex vivo*, and second, many acquired and congenital diseases are potentially curable by their genetic correction.^{13,14} A significant fraction of ongoing human clinical trials target hematopoietic cells or are designed to treat congenital or acquired diseases of the hematopoietic or immune system (Fig. 71.2). Moreover, many important experimental advances in our understanding of hematologic physiology have resulted from the application of gene transfer techniques *in vitro* or in animal models.^{15,16,17, 18, 19} and ^{20,21} For instance, retroviral tagging of HSCs has allowed tracking and quantitative analysis of murine and nonhuman primate stem cell behavior, and experiments overexpressing oncogenes or cytokines in primary hematopoietic

cells using similar techniques has helped elucidate the *in vivo* role of these proteins. Significant advances in gene transfer technology have occurred through systematic preclinical testing in large animal models, and clinically relevant gene transfer levels have now been achieved in these models. These results predicted success in humans, at least for disorders for which modest transfer rates of genes not requiring complex regulation could be curative, and unequivocal efficacy has since been realized.^{22,23} These longanticipated results represented a significant advance for the field, providing not only restoration of immunity in children with severe combined immunodeficiency (SCID), but proof of principle in the context of a human disorder, and a great deal of enthusiasm for returning to the clinic for these and other disorders quickly developed. However, serious adverse events arising as a direct result of insertional mutagenesis have since been reported and efforts to understand these events more fully, develop additional safeguards, and adjust the risk-benefit assessment have now become necessary. Thus, it is particularly important for hematologists to have a general understanding of the field, even if widespread clinical applications may be a decade or more in the future. This chapter reviews the fundamental features of gene transfer technologies and their applications in preclinical and early clinical trials. The pace of the field is rapid, and many details may become obsolete, but the central concepts should remain relevant to any future gene therapy applications.

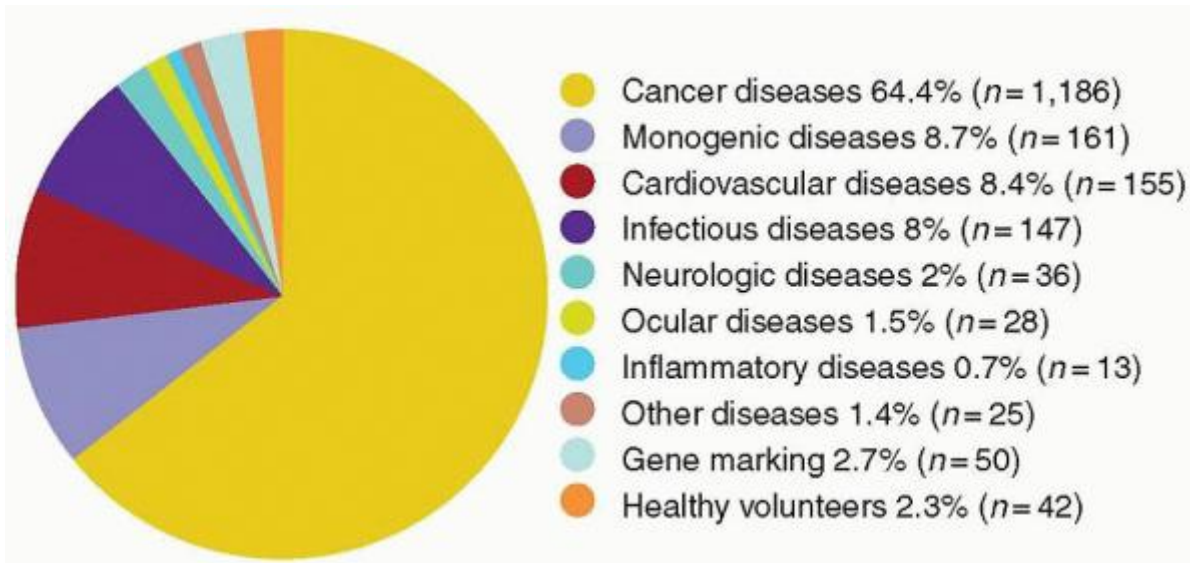

FIGURE 71.2. Indications for gene therapy clinical trials. (From *The Journal of Gene Medicine*, © 2012 John Wiley and Sons Ltd, www.wiley.co.uk/genemed/clinical. Reproduced with permission of John Wiley and Sons, Inc.)

OVERVIEW OF BASIC CONCEPTS

Gene therapy can be defined as the transfer of a gene or genetic material (DNA or RNA) into a cell with therapeutic intent (Fig. 71.3). The genotype of the cell is thus altered, with subsequent gene expression altering the phenotype of the cell. The therapeutic agent is the gene product, generally a protein, or less frequently RNA, for example, ribozymes or antisense molecules. This is in contrast to conventional therapies that act by directly altering the phenotype, even if the congenital or acquired defect is a genetic one. Three examples illustrate the conventional approach to underlying genetic disorders. Dietary avoidance of phenylalanine can prevent the consequences of phenylketonuria by circumventing the genetic deficiency of phenylhydroxylase. Cancer chemotherapy acts by preferentially killing tumor cells based on their cell cycle characteristics, thus removing cells with an acquired genetic defect. And factor replacement in hemophilia directly replaces the defective or missing gene product by infusion of an exogenously manufactured or isolated protein. Gene therapy strategies instead attempt to alter the underlying genetic abnormality to circumvent the need for these therapies.

The identification and cloning (isolation) of genes responsible for many congenital disorders, as well as of the cellular genes mutated in acquired disorders such as cancer has led to the concept of genetic correction of affected cell populations. Ideally, actual substitution of a defective gene with a therapeutic gene would be the most desirable method for returning target cells to a normal genotype and phenotype (gene replacement). However, this goal requires homologous recombination, a complex and inefficient process, and current gene transfer methods predominantly rely on either insertion of new genes into the chromosomes, or on extrachromosomal (episomal) maintenance of a newly introduced gene (gene addition).^{24, 25} and ²⁶ To date, efforts have focused on somatic (nongerm cell) therapy, with genotypic alteration of only the diseased target tissue. Manipulation of germ cells, with transmission of altered genetic

material to subsequent generations, is not yet feasible in humans, but the profound ethical and societal implications need to be addressed through the political process before the technology progresses much further.²⁷ The recent development of induced pluripotent stem cells (iPS cells), whose behavior is analogous to embryonic stem cells (ESCs) but can be derived from somatic cells, has introduced the possibility of genetic manipulation of autologous pluripotent stem cells, circumventing the ethical issues surrounding ESCs.

The vehicle for transferring new genetic material into a target cell is called a vector. At a minimum, a vector contains the gene or genes of interest along with regulatory elements such as promoters or enhancers that govern expression of the gene product.

P.1494

A vector may be a simple particle consisting of a fragment of DNA encapsulated within a liposome or conjugated to proteins that facilitate uptake into cells, or may be a more complex viral vector, capitalizing on the ability of viruses to enter cells easily and express genes robustly. Characteristics of the major vector systems are summarized in Fig. 71.4 and Table 71.1, and are detailed in subsequent sections. The successful interaction of a vector with a target cell, leading to an alteration in that cell's genotype, is termed transduction.

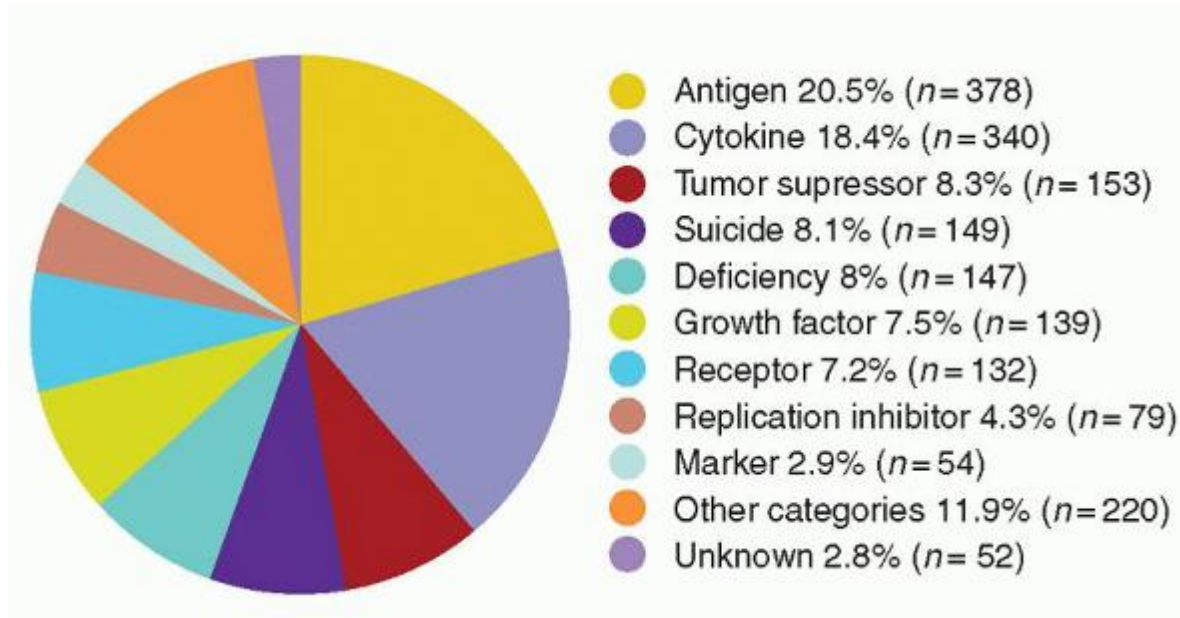

FIGURE 71.3. Gene types transferred in gene therapy clinical trials. (From The Journal of Gene Medicine, © 2012 John Wiley and Sons Ltd, www.wiley.co.uk/genemed/clinical. Reproduced with permission of John Wiley and Sons, Inc.)

Vector production procedures are unique to each system, but a number of considerations are common to all, especially those being developed for actual clinical use. A clinical vector must be feasible and practical to produce safely at pharmaceutical grade.^{28,29} To prevent indiscriminate spread of viral genomes, most viral vectors designed for clinical applications must be rendered replication-defective meaning that once a viral vector enters a target cell, the cell will produce no new viral particles. High-titer vector preparations, containing a high concentration of functional vector particles, are also very important, allowing exposure of target cells to the highest possible multiplicity of infection (MOI), defined as the ratio of vector particles to target cells; this increases the probability of successful vector-cell interaction.

Exposure of target cells to vectors can occur either *ex vivo* or *in vivo*. Autologous hematopoietic targets such as stem cells or lymphocytes are generally transduced *ex vivo*, because these cells can be easily collected, manipulated in culture, and then re-infused intravenously. *Ex vivo* transduction allows for a controlled exposure of only the desired target cells to large concentrations of vector, and is less likely to generate an inflammatory or immune response or be hindered by vector inactivation by complement. Other cellular targets for *ex vivo* transduction have included hepatocytes, keratinocytes, tumor cells, and muscle progenitor cells.

In vivo gene transfer has been used for applications involving cells that cannot successfully or easily be harvested and manipulated *ex vivo*, such as airway epithelium, vascular endothelium, differentiated muscle cells, retinal pigment

epithelium, and neurons. The ideal *in vivo* system would allow intravenous injection of a vector followed by rapid and safe specific transduction of target cells around the body.

A number of important steps must occur between exposure of a target cell to a vector and successful transduction of that cell, with persistence of the transferred genetic material in the correct cellular compartment and expression of the gene of interest or transgene. The vector must cross the plasma membrane efficiently and without damaging the cell. Most viral vectors enter cells via specific cell-surface receptors, and an important consideration is the number of functional receptors on the proposed target cell for the vector being used.³⁰ A process called pseudotyping can be used to redirect viral vectors to different cell-surface receptors by substituting alternative viral envelope proteins during the vector production process.^{31,32,33,34} Nonviral vectors may cross the plasma membrane without need for a specific receptor.

After crossing the plasma membrane, the vector must then travel through the cytoplasm and cross the nuclear membrane in order to enter the nucleus and utilize the cell's transcriptional machinery for expression of the transgene. Nuclear entry of some vectors may be dependent on mitosis, with temporary breakdown of the nuclear membrane; others carry nuclear localization determinants that result in specific conveyance across the intact membrane. The transferred genetic material may integrate permanently into the target cell's own chromosomal DNA, ensuring passage of the new gene to all daughter cells with every cell division. The need for integration depends on the target cell and therapeutic application: it is absolutely required for gene transfer into HSCs where the transgene must be transmitted to all progeny cells, but is superfluous for cellular targets such as neurons or muscle cells that are not mitotic.

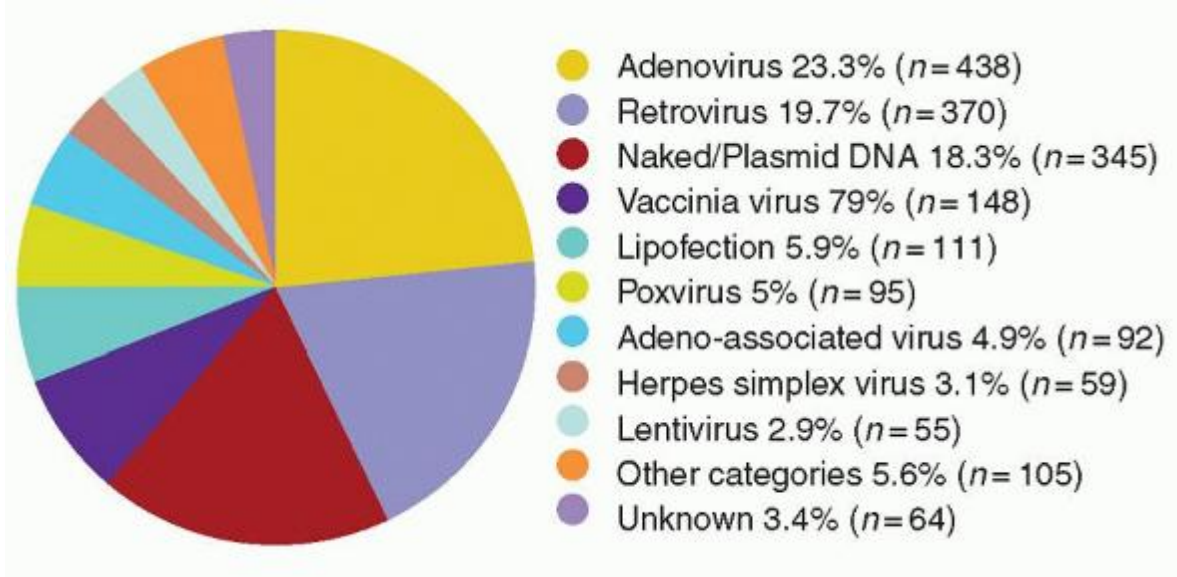

FIGURE 71.4. Vectors used in gene therapy clinical trials. (From *The Journal of Gene Medicine*, © 2012 John Wiley and Sons Ltd, www.wiley.co.uk/genemed/clinical. Reproduced with permission of John Wiley and Sons, Inc.)

Alternatively, the gene may remain episomal, or nonintegrated. Some vectors are very stable as nuclear episomes, with prolonged persistence of transgene expression as long as the cell does not undergo mitosis. Unless the episome can reproduce itself, cell division will eventually dilute out episomal DNA, limiting the application of nonintegrating vectors to nonmitotic tissues or to situations requiring only transient expression.

The level of transgene expression and the ability to restrict expression to specific target cell types are also important factors to consider. Expression of the transduced gene is dependent on both vector and target cell determinants. Transcriptional promoters must be included along with the actual transgene protein coding sequences in the vector, and often lineage or tissue-specific promoter and enhancer elements are used to limit expression to a particular cell lineage derived from a target cell population.^{35, 36} and ³⁷ For instance, hemoglobin gene regulatory sequences are required to drive transgene expression specifically in erythroid cells in strategies targeting the globin disorders. In other situations, constitutive control elements that can drive transcription continuously in most cell types can be used. Genetic control elements that are inducible, or turned on by some exogenous manipulation such as the administration of an antibiotic, are also under development for inclusion in gene transfer vectors.^{38,39} Endogenous cellular factors may shut off expression of transferred genes in some situations.^{40,41} These factors have not been fully elucidated, and vary from vector to vector. Silencing of transferred genes via methylation of vector sequences is one possible mechanism.⁴² The level of expression

necessary for the desired therapeutic effect is very important to determine during in vitro and animal experiments and varies greatly depending on the target cell type and the proposed clinical application.

Nonviral Vectors

The simplest approach to gene transfer is to use only the DNA of the transgene, with the necessary control sequences, as the vector.^{29,43} Recombinant DNA production in bacteria can result in purified plasmids containing the gene(s) of interest along with regulatory elements. For over two decades, scientists have introduced purified DNA into target cells ex vivo by a variety of physical and chemical means. The least complex technique is direct microinjection into individual cells, which has little clinical

P.1495

utility due to the impossibility of injecting enough cells to produce most of the desired effects. One exception is the observation that direct DNA injection into muscle or skin can stimulate a very potent immune response against antigens introduced as plasmid transgenes.^{44,45} This observation led to preclinical and clinical development of genetic vaccination strategies against bacterial and viral pathogens.⁴⁶

TABLE 71.1 GENE TRANSFER VECTOR SYSTEMS

Vector System	Integration	Cell Cycle Dependence	Insert Size Limit	Clinical Experience	Advantages	Disadvantages	Major Applications
Murine retrovirus	Yes	Yes	8-10 kb	Extensive	Stable producer lines No viral genes in vector Low immunogenicity Well-understood biology Efficient entry and integration in many cell types Proven clinical safety	Low titer, fragile vector Requirement for cycling expression Erratic Insertional mutagenesis	Ex vivo—stem cells, lymphocytes, tumor cells, hepatocytes, myoblasts In vivo—producer cell or vector injection into tumors
HIV-based lentivirus	Yes	No		None	Faithful delivery of complex genes Well understood Efficient entry and integration Pseudotyping allows broad tissue range	Production labor-intensive Erratic expression Insertional mutagenesis Recombination with wildtype HIV	Ex vivo—stem cells, lymphocytes, tumor cells, nondividing cells
Adenovirus	No	No	8-10 kb	Moderate	High titer, stable vector High-level transgene expression Efficient entry	No stable producer lines Potential for recombination and replication-competent virus Multiple viral	In vivo—pulmonary epithelium, tumor cells, muscle, liver

					into many cell types	genes expressed from vector High immunogenicity (may be advantage as a vaccine vector!) Pre-existing immunity Inflammatory responses	
AAV	Yes— inefficient	Yes— controversial	4.5 kb	Minimal	Stable vector, extra- and intracellularly High titer High-level transgene expression No expressed viral genes in vector	No stable producer cell lines High percentage of defective particles Requirement for helper adenovirus during production Very limited insert size Pre-existing immunity	Undefined
Naked DNA	No	No	No	Moderate limit	Ease of production High level of safety No extraneous expressed vector genes No immunogenicity of vector	Inefficient cell entry, uptake into nucleus Poor stability within cell Low-expression level	In vivo—tissues accessible to injection, for Low-transient expression or vaccination
Facilitated DNA (liposomes, polylysine conjugates, inactivated adenovirus, etc.)	No	No	No	Moderate limit	Same as naked DNA plus: Can be targeted to specific cell types More efficient uptake and intracellular	No mechanism for persistence	Same as naked DNA, plus in vivo tumor cells, vascular endothelium

stability

AAV, adeno-associated virus, kb, kilobases.

A number of other methods have been explored for getting plasmid DNA into cells. Liposomes, composed of phospholipid bilayers enclosing an aqueous space loaded with DNA, can directly fuse with the plasma membrane, releasing DNA into the cytoplasm.⁴⁷ The gene gun technique involves bombardment of the cell membrane with gold microparticles complexed to DNA.^{48,49, 50, 51} and ⁵² Electroporation and calcium phosphate precipitation are generally too toxic and inefficient for use in gene transfer strategies aimed at primary human cells.^{53, 54} and ⁵⁵

All of these methods lack mechanisms to stabilize intracellular vector DNA, nor do they allow transport into the nucleus; they therefore rarely result in chromosomal integration or long-term persistence and expression. The development of cationic liposomes has improved cellular uptake of plasmid DNA and has circumvented cytoplasmic degradation.^{56,57} In aqueous solution these positively charged liposomes bind with up to 100% of negatively charged DNA without size restrictions and can deliver DNA to the cell nucleus, albeit inefficiently, where it remains primarily episomal.⁵⁸ If administered *in vivo*, liposomes demonstrate no target cell tropism and are rapidly cleared by the reticuloendothelial system. However, after intravenous injection of cationic liposomes, long-term low-level persistence of vector sequences in many murine organs has been demonstrated.^{59,60}

Nonviral plasmid DNA transfer has been improved by conjugation of vector DNA to substances that improve cellular transport

P.1496

and allow target cell specificity via cell-surface receptors.^{61,62} For example, adenoviral capsid elements (especially the penton base protein) help disrupt endosomes, releasing DNA more efficiently into the cytoplasm, and inclusion of transferrin or other ligands in DNA-polylysine conjugates allows specific uptake via cell-surface receptors.^{63, 64, 65, 66} and ⁶⁷

Manufacturing nonviral vectors is much simpler than manufacturing viral vectors, and cannot generate potentially dangerous replication-competent infectious particles.^{29,68} Transduction is not dependent on target cell cycling, and no viral proteins are present to induce an antivector immune response. There are no size constraints. Limitations include a generally lower transduction efficiency than with viral systems. Most important, transgene integration is poor and persistent expression rare, limiting utility to situations allowing transient transgene expression.

Viral Vectors

Viral vectors are Trojan horses, taking advantage of the viral capsid or envelope and of the viral machinery to deliver nonviral transgene sequences efficiently to target cells.⁶⁹ In general, the external capsid or envelope of the virus is unaltered in a viral vector, but the genome of the virus is in large part replaced by a transgene or genes. This strategy is limited by the space available in a viral particle for new genetic material. Viral vectors also depend on the presence of a specific viral receptor on target cells. The efficiency of gene transfer utilizing viral vectors is the main advantage when compared to some of the physical and chemical cell entry methods described above. Furthermore, the relatively low toxicity of transduction of cells with certain viral vectors (e.g., retroviruses, lentiviruses, and adeno-associated viruses [AAV]) is another advantage when compared to physical or chemical methods. In order to modify a virus into a vector system, detailed understanding of the viral genome and life cycle is necessary to retain viral genome sequences required for packaging of vector nucleic acids into viral particles and for appropriate trafficking in the target cell, while removing sequences that might allow production of replication-competent viral particles.

Retroviral Vectors

The murine retroviruses exemplified by the Moloney murine leukemia virus (MLV) were the basis of the first practical viral vector system.^{70, 71} and ⁷² These retroviruses consist of two single strands of linear viral RNA bound to protein core and coated by a lipid envelope that is acquired from the plasma membrane of the infected cell upon viral release. The linear RNA genome can contain 2 to 9 kilobases (kb) of coding and regulatory sequences, flanked on each end by sequences termed long terminal repeats (LTRs) that permit integration into chromosomes and contain strong promoter/enhancer elements that normally drive expression of full-length viral RNA genomes, or via alternative splicing, the individual retroviral genes. These simple murine retroviruses contain only three genes necessary for viral replication and packaging: gag, pol, and env. The retrovirus enters a cell after binding to a specific cell-surface receptor via the env gene product. These receptors are large, widely expressed proteins involved in phosphate transport and other cellular homeostatic

functions.³⁰ The amphotropic receptor is found on both rodent and primate cells, and is the entry site for most murine retroviral vectors directed at human cells.^{73, 74 and 75}

After cell entry, the viral RNA is reverse transcribed via the pol gene product into proviral cDNA and enters the nucleus. The LTR sequences allow random integration of the viral cDNA into the host chromosomes. The integrated retroviral genome, or provirus, relies on the host cell's transcriptional machinery for expression of proviral genes and production of full-length viral RNA. The gag, pol, and env gene products are packaged along with the new viral RNA into viral particles, dependent on the presence of a packaging (ψ) sequence in the viral RNA, and viral particles are released from the cell via budding through the plasma membrane, without damaging the infected cell.

Recombinant retroviral vectors are constructed by removing the gag, pol, and env gene sequences from the viral nucleic acid backbone and replacing them with up to 7 to 8 kb of a gene or genes of interest, retaining only the LTRs and the packaging signal (ψ).⁵ The resulting recombinant viral vector can integrate and express the gene or genes of interest, but cannot replicate and produce new retrovirus once within a target cell, because of the lack of gag, pol, and env genes within its genome. Thus it is termed replication defective. Figure 71.5 diagrams the steps involved in making a retroviral vector. A packaging cell line is created by introducing a plasmid containing gag, pol, and env sequences but no ψ sequence into an immortalized cell line such as NIH3T3. The lack of the ψ sequence prevents these helper genes from being packaged into viral particles. A second plasmid containing the recombinant vector sequences (LTRs flanking the transgene or genes) is then introduced into these cells to create a producer cell line. Full-length vector RNA is transcribed from the vector plasmid sequences and packaged into viral particles using the gag, pol, and env proteins encoded by helper plasmid sequences. In this way, producer cell lines release helper-free replication-defective vector particles containing the recombinant genome into cell culture media at a titer of up to 10⁷ particles/ml. These particles contain the full-length vector RNA, consisting of the viral LTRs flanking the transgene or genes, and the env, gag, and pol proteins, but because they do not contain any actual gag, pol, or env viral gene sequences, no further infectious virus can be made once the vector infects the target cell.

The potential for generation of replication-competent virus through recombination events between the vector and helper sequences in the producer cell line is a significant safety concern.^{28,76} In order to allow packaging of replication-competent viral particles these recombination events must result in the transfer of an intact ψ packaging sequence being transferred into the helper sequences containing the gag, pol, and env genes. The presence of replication-competent virus could allow spread of vector and helper particles indiscriminately to nontarget cells in vivo, thus greatly increasing the risk of insertional mutagenesis by repeated infection of susceptible cell populations.^{76,77} The absolute need for avoidance of replication-competent viral particles in clinical vector preparations was inadvertently demonstrated when high-grade lymphomas occurred in rhesus monkeys transplanted with HSCs transduced with a vector preparation contaminated with high levels of replication-competent virus.⁷⁸ Over the next several years, a number of modifications in the organization of genetic sequences included in the packaging cell lines has greatly decreased the risk of recombination events, and sensitive systems for detecting replication-competent virus have been developed.^{28,79,80,81} A number of investigators have used packaging cell lines derived from human instead of murine cells to make producer cell lines, in hopes that lower levels of endogenous retroviral sequences in human cells would also decrease recombination events and thus replication-competent viral contamination.^{82,83}

As described below, retroviral vectors are capable of stable integrated transduction of a large number of cell types, including repopulating stem cells, but have a number of important limitations. Stable transduction and integration requires passage of the target cell through the S phase of the cell cycle, preventing transduction of quiescent cells.⁸⁴ The amphotropic receptor density on certain target cell types may be too low to allow efficient transduction.⁸⁵ Thus, redirection of receptor specificity via pseudotyping with alternative envelope proteins has been explored, with some success.^{32,86, 87, 88, 89 and 90}

Biophysical considerations may also limit vector-target interactions. Vector particles are very fragile, and degrade quickly in

P.1497

P.1498

solution or within cells if cell division allowing nuclear entry and integration does not occur. A number of investigators have tried to increase the likelihood of successful transduction by flowing vector solution continuously over target cells or

co-localizing vector and target cells using culture dishes coated with fibronectin fragments.^{91,92} New methods of concentrating and stabilizing vector preparations are also under development.^{33,87,93}

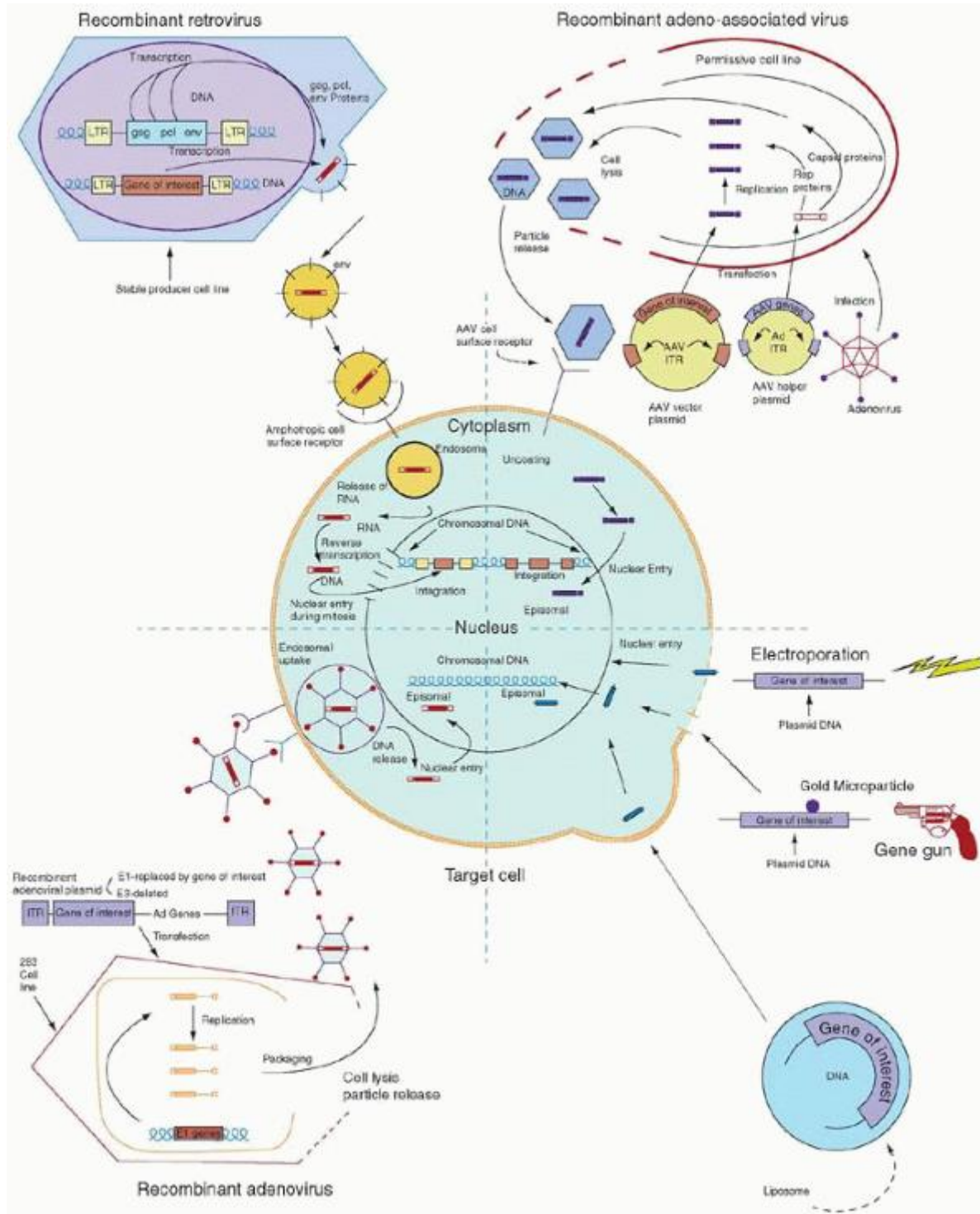

FIGURE 71.5. Schematic representation of transduction of a generic target cell by the four major gene transfer vector systems. The same “gene of interest” is shown being transferred with each vector. AAV, adeno-associated virus; Ad, adenovirus; ITR, inverted terminal repeat; LTR, long terminal repeat.

Lentiviral Vectors

There has been real progress toward the development of alternative retroviral systems that may overcome some of the limitations of the MLV vectors. HIV-derived lentivirus vectors have been most actively pursued. Relatively high-titer

vectors have been reported using production strategies with numerous safeguards against recombination events that could result in generation of wildtype HIV.^{94,95,96} Vectors retaining the HIV gp120 envelope protein could be used to transduce CD4⁺ T-cells, monocyte/macrophages, or glial cells, and pseudotyping with alternative envelope proteins such as vesicular stomatitis virus (VSV) or amphotropic leukemia virus envelope proteins could be used for transduction of a wider range of cells. Lentiviral vectors can traverse an intact nuclear membrane, requiring the HIV gag protein and an accessory VpR protein, thus allowing transduction of nondividing cells.^{97,98} The promise for more efficient HSC transduction using lentiviral vectors remains an attractive feature, however, other features of HIV-based vectors have also stimulated interest. Specifically, the faithful delivery of nonrearranged genes with complex regulatory elements appears superior, and success in delivering the human β -globin gene along with large portions of the locus control region has finally been achieved with HIV-based vectors.⁹⁹ A number of additional safety modifications have been employed, including deletions in the 3' LTR reducing the risk of insertional mutagenesis by self-inactivation of the integrated LTRs. Indeed, the first clinical trial employing lentiviral vectors for the treatment of HIV have been carried out,^{100,101} and subsequent trials have demonstrated clear efficacy in adrenoleukodystrophy (ALD)¹⁰² and thalassemia.¹⁰³

Human Foamy Viral Vectors

The other member of the retroviridae under consideration as a gene transfer vector is the human foamy virus (HFV). HFV, a poorly characterized retrovirus, has three potential advantages. It has never been associated with pathology in animals or humans, it infects a wide variety of primate cell types, and it has the capacity to package longer transgene(s).¹⁰⁴ It does not appear, however, to transduce nondividing cells, although it may be more stable than conventional retroviruses within a target cell, tolerating a more prolonged period before cell division and then integration.¹⁰⁵ Virologists are trying to define the packaging signal and other important elements necessary for engineering a replication-incompetent HFV vector,^{106,107} and a method for the production of helper-free vector stocks has recently been described.¹⁰⁸ Third-generation vectors have now been developed, and these foamy virus vectors appear efficient for transducing HSCs, with high gene transfer rates observed in human cord blood (CB) *in vitro*, and in murine BM (BM) *in vivo* after a single, overnight vector exposure.¹⁰⁹ Recently, HFV vectors have proven highly efficient in a canine model of leukocyte adhesion deficiency (LAD).¹¹⁰

Adenoviral Vectors

Adenoviruses are nonenveloped double-stranded large DNA viruses.¹¹¹ The linear adenovirus genome contains 36 kb with an inverted terminal repeat (ITR) of 100 to 165 base pairs at each terminus. A set of early genes encodes for regulatory proteins that serve to initiate cell proliferation, DNA replication, and down-modulation of host immune defenses, whereas the late genes encode for structural proteins. Adenovirus readily crosses the plasma membrane of many cell types, whether replicating or not, via receptor-mediated endocytosis¹¹² through the receptor, common to two distinct viral pathogens, coxsackie B and adenovirus 2 and 5, termed the coxsackie and adenovirus receptor.¹¹³ Adenovirus escapes the endosome by altering the pH and then enters the nucleus where it remains as a linear episome. In permissive cells, adenovirus replicates and then enters a lytic cycle, destroying the host cell and releasing daughter viral particles. Of the 42 adenovirus serotypes, most are known to cause mild respiratory, gastrointestinal, and conjunctival infections in immunocompetent humans; no associated malignancies in humans have been reported, although some serotypes can transform cells in culture. The human embryonic kidney cell line HEK293 was, in fact, immortalized by transfection of kidney cells with sheared adenovirus serotype 5 DNA; the E1 gene that is integrated into the cellular genomic DNA is apparently responsible for the immortalization of the cell line.

Recombinant adenovirus vectors have been engineered from adenovirus (usually serotype 5) by the removal of the E1 and E3 genes (regulating replication and immune recognition) and replacement by the gene or genes of interest, with space for 7 to 8 kb of new genetic material.^{114,115,116,117,118} High-titer adenovirus vectors, up to 10¹² plaque-forming units (pfu) per ml, can be reliably packaged through the use of a human embryonic kidney transformed cell line,²⁹³ which provide the helper or replication E1 genes, followed by purification and concentrating procedures. The final product is a replication-defective adenovirus vector which is free of helper or wildtype virus that can efficiently transduce nondividing cells.¹¹⁶ These vectors do not integrate into the target cell genome, avoiding insertional mutagenesis and resulting in only transient transgene expression in proliferative tissues. Because of the tropism of adenovirus for epithelial cells, these vectors were initially investigated for the treatment of pulmonary diseases and diseases in which liver gene transfer is desirable.^{119,120}

Transient transgene expression also may result from host cellular and humoral immune responses directed at either transgene-encoded antigens or adenovirus proteins expressed from the large portions of the adenovirus genome retained in these vectors.^{121,122} Another concern is inflammation resulting from *in vivo* transduction of certain cell types, especially airway epithelium.¹²³ *In vivo* use may also be compromised by pre-existing or new antiviral neutralizing antibodies,

limiting the efficacy of repeated dosing, which may be required for applications directed at mitotic tissues.¹²⁴ Nonessential adenoviral sequences are being gradually eliminated from the vectors.^{125,126} The use of adenovirus vectors in which essentially all viral genes are removed is the ultimate goal of such a strategy. Unfortunately, although these vectors have little except the capsid proteins to mark themselves as foreign, there is evidence that they can trigger innate immunity by recognition through the toll-like receptor 9 pathway in target cells.¹²⁷ Further technical issues that are important include the decreased efficiency of vector production as more viral genes are deleted, inasmuch as these functions need to be provided by accessory plasmids through transfection of vector-producing cells. Hence, these highly deleted vectors are often called “helper-dependent.” Specific dosage schedules (e.g., neonatal or embryonic exposure) or co-administration of immune modulators such as cyclosporine or IL12 may also prevent sensitization.^{128, 129, 130, 131} and ¹³² Another strategy being explored is use of different vectors based on adenovirus serotypes other than adenovirus 5. One survey of unusual group B and group D adenovirus serotypes that might be considered for use as HIV vaccines indicates that in a target population in sub-Saharan Africa the existing immunity to adenovirus serotypes 11, 35, and 50 from group B and adenovirus serotypes 26, 48, and 49 from group D are substantially less than that of the commonly studied adenovirus 5 serotype from group C.¹³³ By employing alternatives to adenovirus 5, it might be possible to get around the barrier of pre-existing antivector antibodies for vaccination

P.1499

efforts. Furthermore, it might be possible to alternate the vector type with subsequent vaccinations to thwart neutralizing antiadenovirus immunity to the vaccine vector. Recently, investigators developing HIV vaccination strategies have reported an adenovirus 41 serotype vector that can express HIV envelope protein.¹³⁴ The adenovirus 41 serotype virus is an enterotropic pathogen that causes diarrhea in its wildtype form; the use of a gene transfer vector with tropism for a mucosal surface may present advantages for vaccination against HIV, a pathogen that is normally encountered by the host in the mucosa. This vector has not yet been clinically tested.

In initial clinical trials, adenovirus vectors were used to transfer a normal cystic fibrosis transmembrane conductance regulator (CFTR) gene into airway cells (bronchial or nasal) of patients with cystic fibrosis.^{135, 136} and ¹³⁷ Despite the demonstration that airway cells could be transduced with these vectors in vivo with correction of the chloride transport defect, clinical utility has been precluded by the harmful immune and inflammatory responses noted above. However, the active immune response induced by adenoviral vectors is also being explored as a possible advantage for adenovirus vectors when they are used to transduce tumor cells with cytokines or other immune modulators for tumor vaccine protocols.^{138, 139} and ¹⁴⁰ The fact that most adenoviral gene transfer results in transient transgene expression (in contrast to retroviral-mediated gene transfer) has limited their use for congenital diseases in which permanent expression of a missing protein is desirable, such as hemophilia, ornithine transcarbamylase (OTC)-deficiency, or α -1-antitrypsin inhibitor deficiency. The use of alternating serotypes for repeated administration can only increase the number of administrations so much before immunity to the vectors neutralizes further administration. The powerful and often toxic immune reaction against viral vectors makes their use for vaccination or antitumor therapy more likely than for correction of metabolic disorders.¹⁴¹ The tragic death of a subject who received the OTC-adenovirus vector was mediated in a large part by the “cytokine storm” and resultant systemic immune response that led to widespread capillary leak multiorgan failure.¹⁴¹

Adeno-Associated Viral Vectors

AAV are small nonenveloped single-stranded DNA viruses in the parvovirus family, dependovirus subfamily, that require a helper virus (typically a double-stranded DNA virus such as adenovirus or herpes simplex virus) for production of new viral particles.^{142, 143} and ¹⁴⁴ The linear AAV genome is approximately 4.7 kb long and consists of two homologous ITRs of 145 bp flanking two groups of genes: the rep or nonstructural genes and the cap or structural genes. There are at least eleven serotypes of AAV that differ mainly on the basis of their external capsid proteins. AAV-2 is the best characterized serotype. AAV-2 enters host cells primarily through interaction with the heparin sulfate proteoglycan protein on the cell-surface, and by interaction with the α V β 5 integrin and fibroblast growth-factor receptor proteins. AAV has oncoprotective and HIV-suppressive properties, and is not known to cause disease in humans or other animals.^{145, 146} and ¹⁴⁷ Prior infection with AAV-2 in humans is common: seroepidemiologic studies demonstrate that 80% of the adult population has antibodies.^{143,148}

After cell entry mediated by the capsid protein, wildtype AAV integrates within the host chromosome.¹⁴⁹ Integration of multiple copies in tandem occurs in a site-specific manner within a relatively small area on chromosome 19: this site specificity appears to require rep protein.^{150,151} Specifics of replication and integration are less well understood than for retroviruses.

Recombinant AAV vector DNA contains the AAV ITRs flanking a gene of interest replacing the rep and cap genes. This plasmid is introduced into a cell line permissive for adenovirus, along with a helper plasmid containing the AAV rep and cap genes but no ITRs. Upon exposure to adenovirus or transfection with adenovirus genes such as E4 (particularly open reading frame 6), the cell line packages the recombinant vector sequences using the rep and cap gene products produced by the helper plasmid, and recombinant vector particles are released as the producer cell lyses.^{152,153, 154, 155} and ¹⁵⁶ Recombinant AAV vectors have size constraints: vector sequences longer than 115% of the wildtype length are not packaged or encapsidated efficiently. Very high titers of recombinant AAV particles can be produced, but often a significant percentage of capsids are empty or otherwise defective.

The need for replication-competent adenovirus during AAV vector production complicates the manufacturing and safety issues, inasmuch as the adenovirus must be inactivated or (preferably) removed before use. Some progress is being made toward introducing only the specific adenovirus genes necessary for AAV replication into producer cell lines, avoiding live adenovirus. The inability to harvest AAV vector without actual lysis and death of the producer cells also complicates production of pure and defined vector preparations. Generation of stable packaging cell lines is also hindered because the AAV rep gene product harms most cell types; but recently producer cell lines expressing rep from an inducible promoter have been isolated.^{157,158} Another approach to avoid the issue of helper-virus contamination is to transfect cells with multiple plasmids that separately encode the desired transgene nucleic acid as well as the structural and replication proteins.^{159,160}

Integration of the recombinant vectors into target cell chromosomes appears to be very inefficient, and thus these vectors prove more useful in situations not requiring integration, inasmuch as they have been shown to be stable as episomes for long periods.^{156,161,162} Site-specific integration in chromosome 19, very desirable to avoid random insertional mutagenesis, does not occur with the recombinant AAV vectors, presumably due to lack of rep protein in the vector particle.¹⁶² Many cell types can be efficiently transduced, including nondividing cells such as neurons, but integration and increased efficiency of transduction still appears to depend on cell division or other DNA-disrupting events, although this conclusion is very controversial.^{163, 164, 165, 166} and ¹⁶⁷

Recently, there has been a great deal of interest in the use of vectors based on serotypes other than AAV-2, especially AAV-6, AAV8, and AAV-9, although the work thus far has consisted of in vitro vector production development¹⁶⁰ and preclinical animal studies.^{168, 169} and ¹⁷⁰ It is possible that a number of other parvoviruses can be developed as vectors, including AAV-3, nonpathogenic strains of B19, or novel autonomous parvoviruses isolated from nonhuman primates or other animal species.^{171, 172} and ¹⁷³ These viruses are similar to AAV, but some, such as B19, never integrate. Self-complementary AAV vectors based upon serotypes with high-efficiency delivery to liver cells have been utilized recently to deliver factor IX as a potential treatment for hemophilia B in the canine model with correction of the bleeding abnormalities.^{174,175} These results supported the first successful clinical trials in humans described in detail below.¹⁷⁶

Miscellaneous Other Vectors

Herpes viruses are large DNA viruses with marked neurotropism, generating intense interest in their potential as vectors targeted at the nervous system.^{177, 178, 179} and ¹⁸⁰ They can accommodate very large DNA sequences (up to 30 kb). More recently, these vectors have been reported to transduce some types of hematopoietic cells, including monocytes, leukemic blasts, and progenitor cells.^{181,182} However, these vectors result in only transient expression in dividing cells, and cause cytotoxicity, limiting clinical utility, at least for hematologic applications.

Vaccinia virus, a large DNA virus that replicates cytoplasmically, has also been considered for gene therapy applications.^{183,184} It can accommodate very large transgenes (up to 30 kb) and expresses these genes at very high levels, but expression is

P.1500

transient, and production of replication-incompetent vectors has not yet been possible. Very high immunogenicity limits most clinical applications, but may be advantageous for in vivo vaccination with vaccinia-transduced tumor cells.^{184, 185, 186} and ¹⁸⁷

Genome Editing

Current vectors and protocols have attempted phenotypic correction or modification by gene addition, generally randomly in the genome. A different process, gene correction by homologous recombination, in hematopoietic tissues has been proposed as an alternative.¹⁸⁸ Correction of the genetic defect in lymphoblastoid cell lines derived from patients

with sickle cell disease was described¹⁸⁹ using a RNA-DNA oligonucleotide, yet the applicability of this approach remains elusive.

An alternative corrective approach for some disorders has recently been described. Constructs targeting aberrant splice sites in the form of oligonucleotides, morpholinos, or U7 snRNAs lead to increased levels of correctly spliced β -globin mRNA by effectively blocking the aberrant splice site through the use of sequences complementary to the corrected sequence.^{190, 191} and ¹⁹² A major problem with this approach has remained the difficulty in delivering such constructs in vivo with sufficient efficiency to correct the phenotype and recently, lentiviral vectors designed to deliver modified U7 snRNAs permanently have been tested in cell lines and in primary cells from individuals with thalassemia with encouraging early results.¹⁹³

Targeted DNA double-strand breaks through the use of artificial nucleases was recently shown to increase the efficiency of homologous recombination by several logs, renewing enthusiasm for this approach. The development of zinc finger nucleases (ZFNs) that allow cleavage of DNA in a sequence-specific manner allows the potential for genome editing at virtually any site. These artificial endonucleases mediate DNA cleavage at targeted sites and have been utilized successfully in a broad range of experimental systems including plants, flies, worms, rodents, ESCs, and primary human cells.¹⁹⁴ The ideal set of ZFNs would target double-strand DNA breaks at high efficiency, and more importantly, with high specificity. Specificity has thus far been difficult to achieve. ZFNs can also be utilized to modify normal genes, such as the CCR5 (required for HIV entry), and a clinical trial is now underway testing this approach as a potential therapy for HIV.¹⁹⁵ Transcriptional activatorlike effector nucleases are a new class of nucleases that allow tailored genome editing in a variety of cell types with the potential for increased specificity.¹⁹⁶ The advent of iPS cells that can be generated from individuals with genetic diseases raises the possibility of genome editing followed by differentiation to a cell type of interest as a form of therapy for a number of diseases, and proof of concept has already been achieved in a murine model of sickle cell disease in which iPS cells were corrected with homologous recombination and transplanted after differentiation into hematopoietic progenitors.¹⁹⁷

HEMATOPOIETIC STEM AND PROGENITOR CELLS AS TARGETS FOR GENE TRANSFER

Since the development of helper-free retroviral gene transfer technology, now decades ago, the HSC has been a primary target for gene therapy applications. The curative potential of HSCs carrying corrective genes has been well established through the use of allogeneic bone marrow (BM) transplantation in genetic disorders whereby an individual carrying a normal genotype serves as the stem cell donor, yet procedural toxicities and finite donor availability limit this approach. The prospect of a curative, one-time therapy using genetically modified autologous stem cells for the treatment of a wide variety of congenital disorders such as hemoglobinopathies, immunodeficiencies, or metabolic storage diseases, and of a new weapon against malignancies and HIV infection, has proven irresistible.^{13,14,198, 199, 200} and ²⁰¹ Gene therapy directed at HSCs must utilize an integrating vector, because ongoing self-renewal or proliferation/differentiation would rapidly dilute out an episomal vector in daughter cells. Initial preclinical studies in the 1980s reported the introduction of genetic markers and clinically relevant genes into mouse HSCs using integrating retroviral vectors, providing both conceptual and methodologic insights that led to first-, second-, and third-generation human gene therapy clinical trials (Fig. 71.6).

Gene Therapy Preclinical Evaluation Using Standard Mouse Transplantation Models

Retroviral gene transfer into murine hematopoietic repopulating stem cells has become routine in many laboratories.^{202,203,204} The isolation and availability of various hematopoietic growth factors has allowed *ex vivo* maintenance and increased retroviral gene transfer into hematopoietic target cells. Several different combinations of growth factors have been successful, including at least two or three cytokines that are active on primitive cells, such as interleukin-3 (IL-3), interleukin-6 (IL-6), and stem cell factor (SCF). Their mechanism of action probably includes both induction of cell cycling, a necessity for retroviral transduction and integration, and up-regulation of retroviral cell-surface receptors.^{85,205,206, 207, 208} and ²⁰⁹ Other manipulations that have been found to increase gene transfer efficiency to murine stem cells include co-culture of target cells directly on a layer of retroviral producer cells, use of high-titer ($>10^5$ viral particles/ml) vectors, induction of stem cell cycling by pre-treatment of donor mice with 5-fluorouracil, and co-localization of vector and target cells using fibronectin-coated culture dishes.^{92,210, 211, 212} and ²¹³ Using these techniques, successful gene transfer can now be achieved in virtually all mice transplanted with transduced syngeneic BM stem cells, with long-term persistence of the vector sequences in 10% to 100% of cells from all hematopoietic lineages.^{206,210,211,213,214} The continued presence of vector sequences in short-lived granulocytes for the lifespan of the mouse and in multiple lineages of the blood of serial transplant recipients indicates that murine repopulating stem cells can be successfully modified with retroviral vectors.^{15,17,206,215,216,217} Documentation of the shared single-cell ancestry of gene-modified cells from different lineages by examining retroviral integration sites among transduced cell progeny has also supported this contention.

The ability of retroviral vectors to introduce marker genes permanently into murine cells with lifelong repopulating ability led investigators to test whether this approach was feasible when clinically relevant genes were used. Genetic disorders with high morbidity and mortality and with no effective conventional treatments were considered prime candidates for preclinical evaluation.

Severe Combined Immunodeficiency Disease

SCID resulting from adenosine deaminase (ADA) deficiency was initially chosen and stable expression of functional human ADA was demonstrated in all hematopoietic lineages at levels near endogenous murine levels in reconstituted murine transplants.^{202,218, 219, 220, 221} and ²²² The efficiencies of gene transfer and ADA levels achieved in these preclinical models, together with the anticipated in vivo selective survival advantage of transduced T-cells, were thought to be predictive of successful correction of lymphoid dysfunction in patients with ADA deficiency.¹³ Retroviral vector-mediated gene transfer has also been used successfully to evaluate gene therapy strategies in several murine models of human immunodeficiencies, including those caused by deficiency

P.1501

of the common γ -chain expressed in T-cell cytokine receptors (X-SCID),²²³ and ^{224,225} JAK3 kinase deficiency,²²⁶ deficiency in the ZAP70 protein,²²⁷ and recombination-activating gene-2 (RAG-2) deficiency.²²⁸

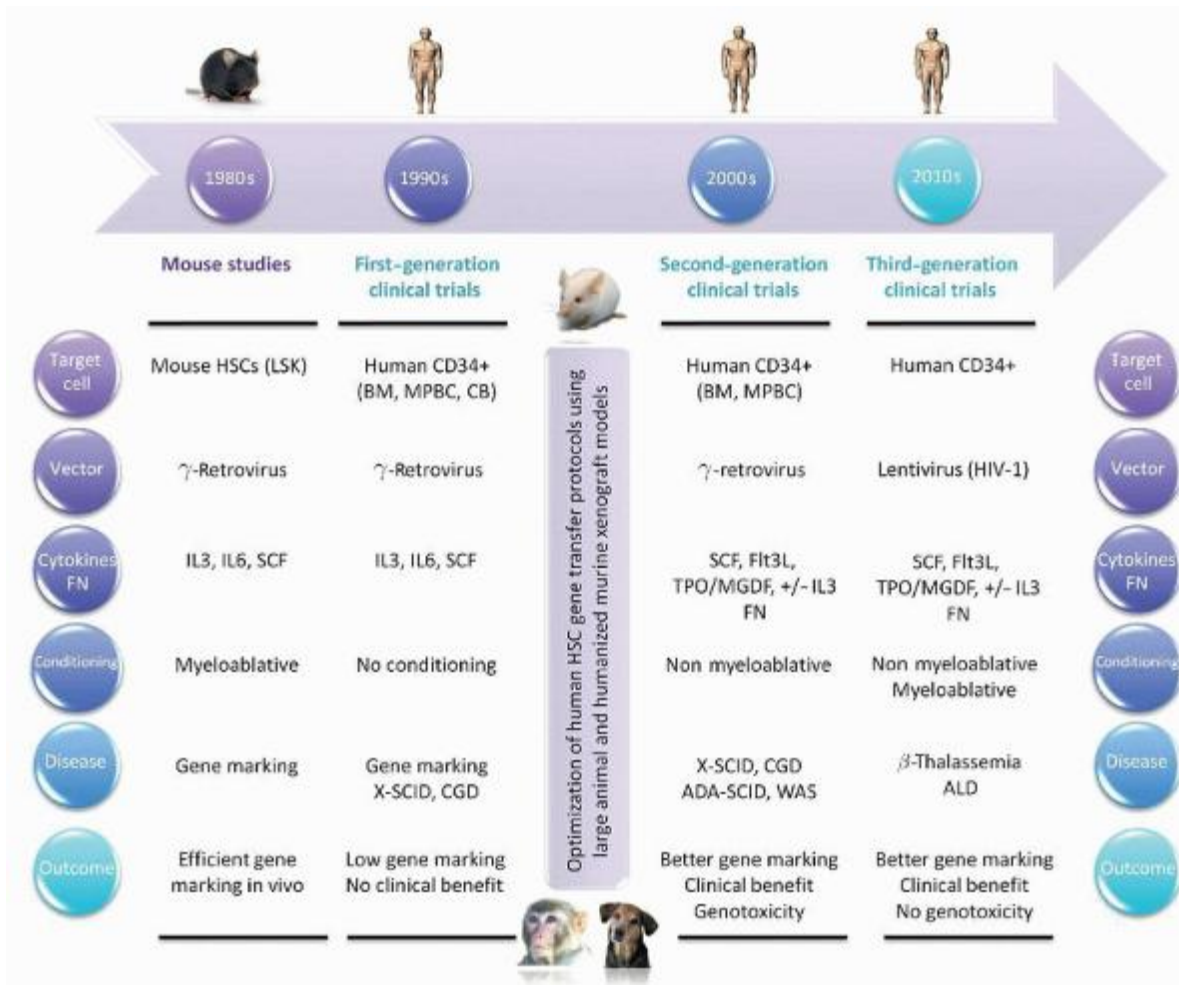

FIGURE 71.6. Timeline for the development of human gene therapy protocols targeting hematopoietic stem cells (HSCs). The main phases in the evolution of HSC gene therapy clinical trials are ordered chronologically. The six principal features defining each phase are outlined. ADA (adenosine deaminase); ALD (adrenoleukodystrophy); BM (bone marrow); CB (cord blood); CGD (chronic granulomatous disease); Flt3L (fms-related tyrosine kinase 3 ligand); FN (fibronectin); HIV (human immunodeficiency virus); IL3 (interleukin 3); IL6 (interleukin 6); LSK (Lin⁻, Sca1⁺, Kit⁺); MGDF (megakaryocyte growth and development factor); MPBC (mobilized peripheral blood cells); SCF (stem cell factor); SCID (severe combined

immunodeficiency disease); TPO (thrombopoietin); WAS (Wiskott-Aldrich syndrome).

Gaucher Disease

Gaucher disease is an inherited deficiency of the lysosomal enzyme glucocerebrosidase (GC) and the associated accumulation of glucocerebroside in the lysosomes of macrophages results in multisystem damage, including hepatosplenomegaly, gradual replacement of bone marrow (BM), skeletal deterioration, and neuropathology in some cases of Gaucher disease. Correction of enzyme deficiency in macrophages by HSC gene therapy has been considered an attractive therapeutic option for these patients. Mouse BM transplant models have been invaluable for initial evaluation of retrovirus-based gene transfer vectors developed for Gaucher disease.^{206,214,229, 230, 231} and ²³² These studies established the feasibility of efficient transfer of the GC gene to normal mouse HSCs and long-term expression in their progeny after reconstitution, strengthening the rationale for gene therapy as a treatment option for Gaucher disease.

Hemoglobinopathies

Hemoglobinopathies, including β -thalassemia and sickle cell disease, were also among the first diseases selected as targets for genetically based therapeutic approaches. Transfer of the human β -globin gene into murine HSCs proved more challenging due to the requirement to include specific endogenous regulatory elements from the β -globin locus that were obligatory to achieve clinically relevant expression. Early preclinical studies demonstrated that retroviral vectors containing the β -globin gene and its promoter could transduce murine HSCs. However, human β -globin gene expression was either absent or very low, usually varying between 0% and 2% of mouse β -globin RNA levels.^{205,233, 234, 235, 236, 237} and ²³⁸ As outlined below, it is not until new vector designs became available that successful genetic correction of β -thalassemia was first demonstrated in murine preclinical models, laying the foundation for a recent clinical trial of gene therapy for β -thalassemia.¹⁰³

P.1502

Chronic Granulomatous Disease

Chronic Granulomatous Disease (CGD) results from mutations in any one of four genes encoding the essential subunits of the phagocytic antimicrobial system NADPH phagocyte oxidase (phox),²³⁹ including gp91phox, p22phox, p47phox, and p67phox, rendering individuals born with CGD particularly susceptible to bacterial and fungal micro-organisms. Retrovirus-based gene transfer vectors have been tested in two CGD knockout mouse models.^{240, 241} and ²⁴² These studies indicated that gene transfer into murine HSCs is feasible and that partial reconstitution of NADPH oxidase activity achieved after retroviral gene transfer can improve host defense if an adequate number of phagocytes exhibit enzyme activity.

Wiskott-Aldrich Syndrome

Wiskott-Aldrich Syndrome (WAS) is an X-linked complex primary immunodeficiency disorder caused by mutations in the gene that encodes the WAS protein (WASP).²⁴³ It is characterized by an increased susceptibility to recurrent infections associated with adaptive and innate immune deficiency, thrombocytopenia, eczema, and autoimmunity.^{244,245} The generation of two Wasp-deficient mice has facilitated preclinical safety and efficacy studies of retroviral vectors for the treatment of WAS. In one study,²⁴⁶ vector-mediated WASP expression was shown to correct the T-cell defect in Wasp mice. In another study, investigators demonstrated rescue of T-cell signaling and amelioration of colitis upon transplantation of transduced WAS HSCs in mice, supporting the development of gene therapy approaches for WAS.²⁴⁷

First-Generation Human Gene Therapy Trials

Because of the absence of *in vivo* assays that measure the repopulating capacity of human HSCs, gene transfer protocols employed in early clinical trials were adapted from the murine studies described above, and initially tested using human *in vitro* colony-forming cell (CFC) assays that detect committed progenitor cells, and long-term BM culture assays that detect a cell capable of maintaining production of CFC for at least 5 weeks on a layer of stromal cells. Notwithstanding the fact that progenitors do not have the same biologic properties as stem cells, investigators were initially encouraged when high gene transfer efficiency (up to 100%) was observed in these *in vitro* progenitor assays using gene transfer vectors and transduction conditions comparable to those employed in the mouse.^{248,249,250} Demonstration of correction of GC and ADA deficiency after retroviral vector-mediated gene transfer into progenitors from patients with Gaucher disease²⁵¹ and ADA-SCID,²⁵² respectively, provided even further impetus to regulators and investigators to initiate a first generation of human HSC gene transfer clinical trials, including gene marking studies and gene therapy trials with therapeutic intent (see Table 71.2).

Genetic Marking Trials

The first human clinical gene transfer trials used retroviral vectors carrying nontherapeutic marker genes, and were critical for establishing proof of principle and allaying safety concerns (Table 71.2).^{7,253} Patients already undergoing autologous transplantation as therapy for an underlying malignancy received genetically marked hematopoietic stem and progenitor cells to determine whether re-infused tumor cells contribute to relapse after autologous transplantation and to establish if transduced HSCs could contribute to long-term hematopoietic reconstitution.^{254,255,256, 257} and ²⁵⁸ Genetically marked tumor cells were unequivocally demonstrated in several patients at the time of relapse, suggesting that the re-infused marrow had contributed to progression, and that investigation of therapeutic purging strategies was worthwhile. The presence of the marker gene was also followed in nonmalignant hematopoietic cells. Gene-marked cells contributed only 0.1% to 1% of the total BM but detection of the marker gene in T-cells and B-cells for as long as 18 months after transplantation was consistent with low-level transduction of primitive hematopoietic cells with multilineage capacity.

In a similar marking study, investigators determined that autologous BM used for transplantation in patients with chronic myelogenous leukemia following intensive therapy also contained cells that contributed to relapse.²⁵⁹ Other gene marking trials involving patients with multiple myeloma,^{260,261,262} breast cancer,^{261,262} follicular lymphoma,²⁶³ and AML²⁶⁴ failed to show stable levels of marked cells of more than 0.1% after transplantation with autologous gene-marked grafts, contrasting with the high-level marking observed in preclinical mouse models. Although valuable in the early stages, the perceived level of risk related to retroviral-marking clinical trials was altered dramatically after the first report of leukemia in a patient receiving retroviral gene therapy for X-SCID,²⁶⁵ and given the lack of any possible benefit to the patient related to use of marking vectors, this type of trial has been completely abandoned.

Gene Therapy Trials with Therapeutic Intent

Despite the low efficiencies of gene transfer into long-term repopulating stem cells achieved in early human marking trials, several Phase I/II clinical trials investigating the transfer of potentially therapeutic genes were initiated (Table 71.2). Important information was obtained on both the safety and feasibility of stem cell engraftment without ablation, and although these initial trials were largely disappointing, there were glimmers of hope regarding clinical benefit.

Severe Combined Immunodeficiency Disease

SCID due to ADA deficiency has been a prototype target disease for gene therapy since the initial development of retroviral vectors over a decade ago,²⁶⁶ and children with ADA-deficient SCID were the subjects of the first clinical trial utilizing a vector carrying a therapeutic gene directed at T-lymphocyte targets (see below). HSCs would be theoretically preferable to T-cells as gene correction targets in this and other immunodeficiency disorders, because of the potential for permanent and complete reconstitution of the T-cell repertoire.

To address this hypothesis directly, two ADA-deficient children received autologous BM and mature lymphocytes transduced with two different retroviral vectors carrying the therapeutic ADA gene and the Neo gene and then repeatedly re-infused without conditioning.²⁶⁷ In the first year after initiation of these infusions, vector-containing T-cells originating from the transduced T-cells were observed, but with time, there was a shift to vector-containing T-cells originating from transduced BM cells. The proportion of gene-corrected clonable T-cells was 2% to 4%, and analysis of T-cell-receptor gene rearrangements indicated a wide repertoire of corrected clones. A surprisingly high number of marrow myeloid colonies resistant to neomycin were also reported, despite lack of conditioning, and an in vivo selective advantage for gene-corrected cells of all lineages was hypothesized.

For genetic disorders diagnosed in utero, the use of CB cells as targets for gene transduction represents an exciting alternative approach.^{268,269} CB may contain greater numbers of primitive reconstituting cells with higher proliferative potential that may prove more susceptible to retroviral transduction. Moreover, early treatment is crucial in diseases that progress to irreversible damage before a child is old enough to allow collection of mobilized peripheral blood or BM cells.²⁷⁰ Three infants diagnosed in utero with ADA deficiency allowed the testing of this concept, and CB was collected at the time of delivery. The cells were CD34-enriched and transduced with an ADA/Neo

P.1503

P.1504

retroviral vector and infused in the absence of conditioning.²⁷¹ Vector sequences were initially detected in circulating myeloid and lymphoid cells at low levels of <0.1% in all three children for >18 months. As expected if corrected lymphocytes have an in vivo advantage, 4 years after the newborns were given infusions of transduced autologous CB CD34⁺ cells, the frequency of gene-containing T lymphocytes rose to 1% to 10%, whereas the frequencies of other hematopoietic and lymphoid cells containing the gene remained <0.1%. Cessation of polyethylene glycol-conjugated ADA enzyme replacement in one subject led to a decline in immune function, despite the persistence of gene-containing T lymphocytes. Thus, despite the long-term engraftment of transduced HSCs and selective accumulation of gene-containing T lymphocytes, this study indicated that improved gene transfer and expression were needed to attain a therapeutic effect.²⁶⁷

TABLE 71.2 FIRST-, SECOND-, AND THIRD-GENERATION HSC GENE THERAPY CLINICAL TRIALS

First-Generation HSC Gene Therapy Clinical Trials

Reference	Indication	Gene	Transduction					Outcome	
			CD34 ⁺ cells	Cytokines and FN	Durati on (MOI)	Vector	Conditioning	Gene Marking (No. Patients)	Genotoxicity (No. Patients)
Brenner et al. (1993) ²⁵	Gene marking (AML)	Neo ^R BM	No FN	P: 0 h T: 6 h (MOI=10)	γ -RV Ampho env MLV-LTR promoter	Busulfan Cyclophosphamide	Low long-term gene marking	No	
Brenner et al. (1993) ²⁵	Gene marking (AML, neuroblastoma)	Neo ^R BM	No cytokines FN	P: 0 h T: 6 h (MOI=10)	γ -RV Ampho env MLV-LTR promoter	Bu/Cy (AML) Carboplatin/Etoposide (neuroblastoma)	Low long-term gene marking	No	
Rill et al. (1994) ²⁵	Gene marking (Neuroblastoma)	Neo ^R BM MN C	No cytokines FN	P: 0 h T: 6 h (MOI=10)	γ -RV Ampho env MLV-LTR promoter	Carboplatin Etoposide	Low long-term gene marking	No	
Deisseroth et al. (1994) ²⁵	Gene marking (CML)	Neo ^R BM	No cytokines FN	P: 0 h T: 6 h (MOI=10)	γ -RV Ampho env MLV-LTR promoter	TBI Cyclophosphamide Etoposide	Low long-term gene marking	No	
Dunbar et al. (1995) ²⁶	Gene marking (MM and BC)	Neo ^R BM MP BC	IL3, SCF +/- IL6 No FN	P: 0 h T: 72 h (MOI=10)	γ -RV Ampho env MLV-LTR promoter	Melphalan/TBI (MM) or ICE chemotherapy (BC)	Low long-term gene marking	No	
Cornetta et al. (1996) ²⁶	Gene marking (AML and neuroblastoma)	Neo ^R BM	No cytokines FN	P: 0 h T: 4 h (MOI=10)	γ -RV Ampho env MLV-LTR promoter	Busulfan Cyclophosphamide	Low long-term gene marking	No	

4	ALL)					promoter		marking		
Emmons RV et al. (1997) ²⁶ 2	Gene marking (MM and BC)	Neo ^R	BM MP BC	No cytokines +/- Stroma No FN	P: 0 h T: 6-72 h	γ -RV env MLV- LTR promoter	Ampho (MM) or ICE chemotherapy (BC)	Low long-term gene marking	No	
Bachier CR et al. (1999) ²⁶ 3	Gene marking (NHL)	Neo ^R	BM MP BC	No cytokines No FN	P: 0 h T: 6 h (MOI= 10)	γ -RV env MLV- LTR promoter	Ampho TBI Cyclophospham ide Etoposide	Low long-term gene marking	No	
Alici E et al. (2007) ²⁶ 0	Gene marking (MM)	Neo ^R	BM MP BC	IL3, IL6, SCF, bFGF FN	P: 0 h T: 12 h (MOI= 5)	γ -RV env MLV- LTR promoter	Ampho Melphalan	Low long-term gene marking	No	
Bordign on C et al. (1995) ⁴³ 9	ADA-SCID ADA	ADA	BM	Co- culture No cytokines No FN	P: 0 h T: 72 h	γ -RV env MLV- LTR promoter	Ampho No conditioning	Low long-term gene marking	No	
Kohn DB et al. (1995 1998) ²⁶⁷ , 271	ADA-SCID ADA	ADA	CB	IL3, IL6, SCF FN	P: 0 h T: 72 h	γ -RV env MLV- LTR promoter	Ampho No conditioning	Low long-term gene marking	No	
Malech HL et al. (1997) ²⁷ 8	CGD	P47 ^{pho} x	MP BC	PIXY321P, G-CSF No FN	P: 18 h T: 72 h	γ -RV env MLV- LTR promoter	Ampho No conditioning	Low long-term gene marking	No	
Hesdorff er C et al. (1998) ⁶³ 3	Breast CA Ovarian CA Glioblastom a	MDR1	BM MP BC	IL3, IL6, SCF FN	P: 48 h T: 24 h	γ -RV env MLV- LTR promoter	Ampho High dose chemotherapy	Low long-term gene marking	No	
Dunbar CE et al. (1998) ²⁷ 7	Gaucher	GC	BM MP BC	IL3, IL6, SCF FN	P: 0 h T: 72 h	γ -RV env MLV- LTR promoter	Ampho No conditioning	Low long-term gene marking	No	
Kohn DB et al. (1999) ⁶³ 4	HIV	RRED	BM	IL3, IL6, SCF +/- FN	P: 0 h T: 72 h	γ -RV env MLV- LTR promoter	Ampho No conditioning	Low long-term gene marking	No	
Cowan KH et al. (1999) ⁶³	Breast CA	MDR1	BM MP BC	IL3, IL6, SCF FN	P: 0 h T: 72 h	γ -RV env MLV- LTR promoter	Ampho ICE chemotherapy	Low long-term gene marking	No	

Liu JM FA et al. (1999) ²⁷ 6	FANC BM C MP SCF No BC FN	IL3, IL6, P: 0 h T: 72 h	γ -RV Ampho env MLV- LTR promoter	No conditioning	Low long-term gene marking	No
--	---------------------------------	-----------------------------	---	-----------------	-------------------------------------	----

Second-Generation HSC Gene Therapy Clinical Trials

Referen ce	Indication	Gene	Transduction				Outcome		
			CD3 4 ⁺ cells	Cytokin es and FN	Durati on (MOI)	Vector	Conditioning	Gene marking (No. Patients)	Genotoxic ity (No. Patients)
Cavazza na- Calvo M et al. (2000) ²² , 450, 451	X-SCID	IL2R γ	BM	SCF, Flt3L, MGDF, IL3 FN	P: 24 h T: 72 h	γ -RV Ampho env MLV- LTR promoter	No conditioning	Correctio n of X- SCID (9/10)	T-ALL (4/9) LMO2, CCND2, BMI1 gene insertions ² 65, 450, 451
Abonour R et al. (2000) ⁴² 2	Germ cell tumors	MDR1	MP BC	SCF, IL6 or SCF, MG DF, G- CSF FN	P: 48 h T: 48 h	γ -RV Ampho env HaMSV- LTR promoter	Etoposide 2,250 mg/m ² Carboplatin 2,100 mg/m ²	Low long-term gene marking (6/11)	No
Aiuti A et al. (2002) ²³	ADA-SCID	ADA	BM	SCF, Flt3L, TPO, IL3 FN	P: 24 h T: 72 h	γ -RV Ampho env MLV- LTR promoter	Busulfan 4 mg/Kg	Correctio n of ADA- SCID (2/2)	No
Amado RG et al.I) (2004) ⁶³ 6,637	HIV (Phase I)	Anti- HIV1 ribozy me	MP BC	MGDF, SCF +/- FN	P: 18 h T: 72 h	γ -RV Ampho env MLV- LTR promoter	No conditioning	Low long-term gene marking (10/10)	No
Gaspar HB et al. (2004) ⁴⁴ 4, 452, 455	X-SCID	IL2R γ	BM	SCF, Flt3L, TPO, IL3 FN	P: 40 h T: 56 h	γ -RV GALV env MLV- LTR promoter	No conditioning	Correctio n of X- SCID (10/10)	T-ALL (1/10) LMO2 gene insertion ⁴⁵⁴
Thrasher AJ et al. (2005) ⁴⁵ 6	X-SCID	IL2R γ	BM	SCF, Flt3L, MGDF, IL3 FN	P: 24 h T: 72 h	γ -RV Ampho env MLV- LTR promoter	No conditioning	Failure to correct X-SCID in older patients (2/2)	No

Ott MG et al. (2006) ⁴⁴ ₆	X-CGD	gp91 ^{ph} _{ox}	MP BC	SCF, Flt3L, TPO, IL3 FN	P: 36 h T: 72 h	γ -RV env LTR promoter	Ampho SFFV-	Busulfan 8 mg/Kg	Correction of X-CGD (2/2)	MDS (2/2) MDS1-EVI1, PRDM16, SETBP1 gene insertions ⁴ _{57,458}
Gaspar HB et al. (2006) ⁴⁴ ₁	ADA-SCID	ADA	BM	SCF, Flt3L, TPO, IL3 FN	P: 40 h T: 56 h	γ -RV env LTR promoter	GALV SFFV-	Melphalan 140 mg/m ²	Correction of ADA-SCID (1/1)	No
Chinen et al. (2007) ⁴⁵ ₅	JX-SCID	IL2R γ	MP BC	SCF, Flt3L, TPO, IL3 FN	P: 16 h T: 96 h	γ -RV env LTR promoter	GALV MLV-	No conditioning	Clinical improvement (3/3)	No
Mitsuya et al. (2009) ⁶³ _{7,638}	HIV (Phase RT et II)	Anti-HIV1 ribozyme	MP BC	MGDF, SCF FN	P: 36 h T: 48 h	γ -RV env LTR promoter	Ampho MLV-	No conditioning	Lower HIV-1 viral load (10/10)	No
Aiuti et al. (2009) ⁴⁴ ₀	ADA-SCID	ADA	BM	SCF, Flt3L, TPO, IL3 FN	P: 24 h T: 72 h	γ -RV env LTR promoter	Ampho MLV-	Busulfan 4 mg/Kg	Correction of ADA-SCID (9/10)	No
Boztug K et al. (2010) ⁴⁴ ₇	WAS	WAS	MP BC	SCF, Flt3L, TPO, IL3 No FN	P: 48 h T: 48 h	γ -RV env LTR promoter	GALV MPSV	Busulfan 8 mg/Kg	Correction of WAS (9/10)	T-ALL (4/9) LMO2 +/- other gene insertions
Kang EM et al. (2010) ⁴⁴ ₄	X-CGD	gp91 ^{ph} _{ox}	MP BC	SCF, Flt3L, TPO, IL3 FN	P: 18 h T: 96 h	γ -RV env LTR promoter	Ampho MLV-	Busulfan 10 mg/Kg	Long-term clinical benefits (2/3)	No
Kang et al. (2011) ⁴⁴ ₅	HJX-CGD	gp91 ^{ph} _{ox}	MP BC	SCF, Flt3L, TPO, IL3 FN	P: 40 h T: 40 h	γ -RV env LTR promoter	Ampho MLV-	Fludarabine 120 mg/m ² + Busulfan 1.6 mg/Kg	Short-term clinical benefit (2/2)	No
Gaspar et al. (2011) ⁴⁴ ₃	ADA-SCID	ADA	BM	SCF, Flt3L, TPO, IL3 FN	P: 40 h T: 56 h	γ -RV env LTR promoter	GALV SFFV-	Melphalan 140 mg/Kg or Busulfan 4 mg/Kg	Correction of ADA-SCID (4/6)	No

Third-Generation HSC Gene Therapy Clinical Trials

Reference	Indication	Gene	Transduction				Outcome		
			CD3 ⁺ cells	Cytokines and FN	Durati on (MOI)	Vector	Conditioning	Gene marking	Genotoxicity
Cartier N et al. (2009) ¹⁰ ₂	X-ALD	ABCDMP1	MP BC	SCF, Flt3L, MGDF, IL3, FN	P: 19 h T: 17 h (MOI= 25)	SIN-HIV-1 VSV-G env promoter	Busulfan 16 mg/Kg + Cyclophos 200 mg/Kg	Correctio n of X-ALD (2/2)	No
Cavazza Calvo et al. (2010) ¹⁰ ₃	β -thalassemia	β -globin	BM	SCF, Flt3L, TPO, IL3, FN	P: 34 h T: 18 h	SIN-HIV-1 VSV-G env β -globin promoter β -LCR	Busulfex 12.8 mg/Kg	Correctio n of β -thalassemia (1/1)	Clonal dominance (1/1) HMGA2 insertion ¹⁰³

ADA, adenosine deaminase; ALD, adrenoleukodystrophy; ALL, acute lymphoblastic leukemia; AML, acute myelogenous leukemia; Ampho, amphotropic; BC, breast cancer; bFGF, basic fibroblast growth factor; BM, bone marrow; BMI1, B lymphoma MLV insertion region 1 homolog; Bu, busulfan; CA, cancer; CB, cord blood; CCND2, cyclin D2; CGD, chronic granulomatous disease; CML, chronic myelogenous leukemia; Cy, cyclophosphamide; Env, envelope; EVI1, ecotropic virus integration site 1 protein homolog; FA, Fanconi anemia; FANCC, Fanconi anemia complementation group C; Flt3L, *fms*-related tyrosine kinase 3 ligand; FN, fibronectin; GALV, gibbon ape leukemia virus; GC, glucocerebrosidase; G-CSF, granulocyte-colony stimulating factor; HaMSV, Harvey murine sarcoma virus; HIV, human immunodeficiency virus; HMGA2, high mobility group AT-hook 2; ICE, ifosfamide, carboplatin, etoposide; IL2R γ , interleukin 2 receptor γ chain; ABCD1, ATP binding cassette subfamily D, member 1; IL3, interleukin 3; IL6, interleukin 6; LCR, locus control region; LMO2, LIM domain only 2; LTR, long terminal repeat; MDR1, multidrug resistance gene 1; MDS, myelodysplastic syndrome; MGDF, megakaryocyte growth and development factor; MLV, murine leukemia virus; MM, multiple myeloma; MNC, mononuclear cells; MND, myeloproliferative sarcoma virus enhancer, negative control region deleted, dl587rev primer binding site substituted; MOI, multiplicity of infection; MPBC, mobilized peripheral blood cells; MPSV, myeloproliferative sarcoma virus; Neo^R, neomycin resistance; NHL, non-Hodgkin's lymphoma; P, prestimulation; Phox, phagocyte oxidase; PRDM16, PR domain containing 16; RRED, rev-responsive element decoy; RV, retroviruses; SCF, stem cell factor; SCID severe combined immunodeficiency disease; SETBP1, SET binding protein 1; SFFV, spleen focus forming virus; SIN, self-inactivating; T, transduction; T-ALL, T-lineage acute lymphoblastic leukemia; TBI, total body irradiation; TPO, thrombopoietin; VSV-G, vesicular stomatitis virus-G protein; WAS, Wiskott-Aldrich syndrome.

P.1506

Fanconi Anemia

Fanconi Anemia (FA) is another genetic disorder of the hematopoietic system that appears to be an excellent candidate for gene therapy. This congenital syndrome is characterized by BM failure, physical anomalies, and an increased susceptibility to marrow failure and leukemias. Cells from these patients are abnormally sensitive to chemically induced DNA cross-linking. Many of the complementation groups have been cloned and sequenced, making a genetic approach feasible for this disorder.²⁷² Phenotypic correction of this abnormality in cells from one patient group was successful after

transduction with viral vectors carrying the Fanconi anemia complementation group C gene (FACC).^{273,274} A possible *in vivo* survival advantage for gene-corrected primitive cells and their progeny has made FA an attractive candidate disease for stem cell gene therapy. Even a very low efficiency of transduction might result in gradual *in vivo* expansion of corrected progenitor and stem cell populations. A clinical trial testing this hypothesis using granulocyte-colony stimulating factor (G-CSF)-mobilized peripheral-blood CD34⁺ cells as targets yielded disappointing results, in part because of the very poor mobilization in these subjects,²⁷⁵ yet engraftment with corrected progenitor cells was demonstrated.²⁷⁶

Gaucher Disease

Modeling preclinical murine transplantation models, gene therapy was also attempted for Gaucher disease.²⁷⁷ Akin to the previous gene therapy trials, no conditioning was used in these patients prior to infusion of G-CSF mobilized or BM CD34⁺ cells transduced with standard retroviral vectors carrying a normal GC cDNA. Unlike results obtained in the mouse, low numbers of gene-corrected cells were again detected, with little or no expression and no disease correction following transplantation.

Chronic Granulomatous Disease

Similar results were obtained in a clinical trial for an autosomal recessive form of CGD.²⁷⁸ Five patients received transduced G-CSF mobilized CD34⁺ cells without pre-conditioning. Corrected granulocytes were detected in the peripheral blood of all individuals for up to 6 months after infusion but the levels (0.004% to 0.05%) were below the desired 5% to 10% required for therapeutic effects.

Optimization of Human Gene Therapy Protocols

Although the first-generation human gene therapy trials established the proof of principle of transduction of primitive human repopulating hematopoietic cells, they uniformly failed to reach and maintain therapeutically relevant levels of genetically modified cells. This striking difference in outcome observed between mouse and human studies was proposed to result from intrinsic differences between mice and humans, resulting in a different susceptibility to retroviral transduction and a different ability of transduced HSCs to engraft. Other considerations included loss of stem cell activity by forced *ex vivo* division, immune recognition of cells expressing foreign transgene products, toxicity from the constitutive expression of the transferred gene products on HSC differentiation *in vivo*, lack of conditioning in the clinical settings, and the minimal expression of amphotropic surface receptors used by retrovirus-based gene transfer vectors on human HSCs.⁸⁵

The recognition of differences in HSC behavior between mice and humans and the disappointing results in the early human HSC gene therapy clinical trials underscored the need for alternative assays similar to those available in mice that permit direct identification and characterization of human long-term reconstituting cells and their susceptibility to gene transfer. These alternative assays provided the necessary platform for the optimization of human gene therapy protocols, leading to the first clinical trials with therapeutic benefits.

Development of Preclinical Animal Models for Investigating Gene Transfer into Human Hematopoietic Stem Cells

Large Animal Models

Inasmuch as prolonged follow-up of *in vivo* hematopoiesis is the most reliable parameter to identify human HSCs, large animals are more adapted than mice for evaluation of gene transfer to long-term repopulating cells, given their lifespan and their size, allowing repetitive blood and marrow sampling.

Fetal Sheep

The group of E. Zanjani, capitalizing on the immunologically tolerant environment of the fetal sheep between 50 and 60 days of gestation, successfully showed engraftment and persistence of human cells several years after intraperitoneal administration *in utero* of primitive human hematopoietic cells from CB or BM.^{279,280,281} Among fetuses reaching maturity, at least 50% showed long-term persistence of human cells and demonstration that retrovirally transduced human cells could be detected,²⁸² suggesting transduction of primitive human HSCs. However, the procedure was hampered by low-level engraftment, a high rate of fetal loss, and impracticality for most research groups.

Nonhuman Primates

Given their phylogenetic proximity to humans, nonhuman primates, including baboons and Old-World rhesus macaques, have been employed extensively for the preclinical testing of promising gene therapy strategies.^{283,284} The cross-reactivity of reagents employed for human application adds to the practicality of these models. In contrast to murine studies, much lower levels of gene-modified circulating cells than in the murine experiments were reported using similar vector systems and transduction conditions, generally <0.01% to 1%.^{285, 286, 287} and ²⁸⁸ These results were very similar to data obtained in

first-generation clinical trials, validating the importance of large animal models for the optimization of gene therapy strategies in humans. The value of these models for preclinical testing was also illustrated when aggressive T-cell lymphomas developed in 3 of 10 rhesus macaques as a result of insertional mutagenesis following transplantation with BM cells transduced with retroviral vector stocks contaminated with replication-competent helper virus capable of continued gene transfer in vivo.^{78,289} This setback led to a reassessment of safety issues and increased regulatory oversight of human clinical trials, with consensus that it is absolutely necessary to use producer cell lines and vector stocks that have been confirmed to be free of helper-virus contamination in any clinical application.

Canine Models

The canine autologous transplantation model has also been used to test retroviral gene transfer strategies. Successful transduction of G-CSF-mobilized peripheral-blood engrafting cells was first demonstrated in the dog, as was the importance of partially or fully ablative conditioning radiation or chemotherapy for detectable engraftment with transduced primitive hematopoietic cells.^{290, 291} and ²⁹² Cross-reactivity of human reagents has proven more problematic in the dog model, yet continued progress in this model has led to a clinically relevant gene transfer technique.^{293,294} Recently, further progress in this model has allowed the attainment of very high levels of genetically modified cells, approaching 100%.^{293,295, 296} and ^{297,298,299} The value of the dog model as a large animal model is further strengthened by the presence of several disease states that mimic those in humans, which could

P.1507

allow stringent preclinical testing, as recently shown in a canine model of LAD¹¹⁰ and pyruvate kinase deficiency.³⁰⁰

Large animal models thus became a focus, but outbred animals introduce significant experimental variability and the high costs limit the breadth of experiments that can be performed. For this reason, a competitive re-population model in which each animal serves as its own control has been utilized for the majority of subsequent comparative studies. In this model, hematopoietic progenitors are isolated and divided equally for transduction under two (or more) distinct experimental conditions using marking vectors that can be distinguished in vivo following reconstitution. Loss of stem cell activity during the ex vivo culture required to achieve gene transfer was a major concern generated by the early human clinical trials, a concern supported by studies in the mouse in which ex vivo culture of HSCs resulted in a significant engraftment defect.³⁰¹ Competitive experiments in the nonhuman primate tracking genetically modified cells subjected to either short or extended ex vivo culture supported this notion.³⁰²

Immunodeficient Mice

Although results from the large animal models have correlated better with results from early human clinical trials, the rhesus and canine experiments are expensive, slow, and technically difficult, not allowing large-scale testing of new approaches. Over the past 20 years, xenograft mouse models have gained in popularity, in part due to access, and investigators have begun to employ engraftment of transduced human hematopoietic cell populations in immunodeficient mice as an alternative experimental model.^{303, 304, 305, 306} and ³⁰⁷ Initially, large numbers of human BM cells were intravenously injected into sublethally irradiated mice lacking a functional immune system to prevent rejection of the injected human cells, including severe combined immunodeficient (Scid) and beige/nude/xid (bnx) mice.^{308,309} With regular treatment of engrafted Scid mice with a combination of human hematopoietic cytokines, human BM cells that migrated to the mouse marrow and spleen gave rise to a small but sustained pool of myeloid progenitors and B-cells for several months, indicating that the engraftment was long-term and multipotent, fulfilling two key criteria used to define HSCs.

The Scid mouse used in these initial studies can spontaneously generate murine T- and B-cells with age and has high levels of natural killer (NK) cell activity, both impeding efficient and prolonged xenograft. To improve upon the available immunodeficient mouse strains, the Scid mutation was backcrossed onto the nonobese diabetic (NOD) background.³¹⁰ The resultant NOD-Scid mouse had reduced innate immunity and superior engraftment of human hematopoietic cells. However, further improvements were sought due to the high incidence of spontaneous thymic lymphomas that shortened their lifespan, a striking preferential development of human B-cells after transplantation, and a persistence of murine NK-cells resulting in a lack of human T- and NK-cell differentiation in this strain. By reducing or abolishing NK activity in NOD-Scid mice a new strain, NSG or NOG mice, was developed and is currently the most widely used humanized mouse model for gene therapy preclinical testing.^{311,312,313,314}

The immunodeficient mouse model assays a human cell population, operationally defined as Scid repopulating cells (SRCs), that is distinct from hematopoietic progenitors identified using in vitro methodology, including long-term culture initiating cells and CFCs.²⁵⁰ Using a gene marking approach similar to that used in mouse transplant studies and early

clinical trials, Guenechea et al.³¹⁵ showed that individual engrafted and marked human SRCs could produce a large clone of differentiated progeny with engraftment potential in secondary NOD-Scid recipients, demonstrating the proliferative and self-renewal capacity of SRCs, respectively. Although this study did not contain a direct analysis of individual lineages, a recent investigation by the same group³¹⁶ successfully tracked self-renewal and multilineage output of single human cells purified using a complex set of markers (CD34+CD38-CD45RA-CD90+CD49f+Rhlo) for at least 8 months after transplantation in NSG mice. Together, these studies fulfilled the proliferative, self-renewal, and multipotential criteria previously used to define murine HSCs, providing a compelling characterization of human HSCs. Although, in practical terms, the above studies served to validate the murine xenotransplant model as a sound surrogate assay system for human stem cells, the predictive value of these xenograft models remains questionable, as a direct comparison of engraftment of genetically modified autologous baboon cells in both the baboon and the NOD/SCID mouse suggests distinct populations contributing to hematopoiesis, with short-term progenitors only read out in the immunodeficient mouse.³¹⁷

The development of better assays for evaluating gene transfer efficiency in human repopulating cells has culminated over the past two decades in various strategies to improve gene transfer protocols, including: (1) new retroviral vector designs, (2) optimized transduction conditions, and (3) use of conditioning regimens to favor engraftment of transduced cells.

Use of Alternative Gene Transfer Vectors

Standard retroviral vector systems have been used extensively in small and large animal models and have dominated clinical trials based on ex vivo transduction of autologous CD34⁺ cells. However, the dependence of these vectors on cell cycling for efficient transduction has limited their utility in quiescent HSCs. Thus, alternative viral vector systems have been explored, including AAV and retroviral vectors based on various members of the Retroviridae family (e.g., lentiviruses and spumaviruses). The need for integration has precluded extensive investigation of nonviral delivery systems for hematopoietic applications requiring long-term expression.

Adeno-associated Viruses

Despite a great deal of initial enthusiasm for the use of AAV as a clinical gene transfer vector, more recent data argue against the use of AAV for most applications requiring stable integration in hematopoietic cells and their progeny. Several laboratories have reported high transduction efficiency of both human and murine hematopoietic progenitors, as assayed by PCR or transgene expression analysis on individual CFC.^{162,318,319} These are difficult to interpret, however, given the stability of the AAV vector DNA and the very high efficiency of transient expression of transgenes for days to weeks without integration.^{161,318,319} Although these studies indicate no advantage over retroviral vectors in terms of gene transfer into repopulating stem cells, efficient transfer to hematopoietic cells can be obtained by using AAV vectors.^{320,321}

Human Foamy Viruses

HFV are retroviruses that specifically belong to the genera Spumavirus. The nonpathogenic nature of HFV makes vectors based on this virus more palatable. Because problems encountered in the production of replication-competent, retrovirus-free vector have been overcome, vectors based on the HFV have been used to transduce hematopoietic cells efficiently. They were employed to phenotypically correct CD18 integrin deficiency in a canine model of LAD,¹¹⁰ gp91phox deficiency in a mouse model of X-CGD,³²² and hemolytic anemia in a canine model of pyruvate kinase deficiency³⁰⁰ but it has not yet been used in clinical trials. However, they do not appear to transduce hematopoietic stem and progenitor cells more efficiently than standard retroviruses.

Lentiviral Vectors

Unlike vectors based on standard retroviruses, lentiviral vectors harbor a pre-integration complex that appears more stable and

P.1508

able to cross an intact nuclear membrane, thus allowing transduction of nondividing cells such as HSCs. However, it is also generally agreed that cells must exit G0 and enter G1 for efficient transduction by HIV-1 based vectors.

Self/inactivating Feature of Lentiviral Vectors

Because of safety concerns regarding recombination with endogenous HIV, a safety or "self-inactivating (SIN)" feature was incorporated in these vectors by eliminating a portion of the 3'-LTR, which on proviral integration replaces and thus inactivates the 5'-LTR. For these SIN vectors, the efficiency of transgene expression is highly dependent on the addition of ubiquitous internal promoters, such as the murine stem cell virus (MSCV), the human elongation -1a (EF1-a), human

phosphoglycerate kinase (PGK), spleen focus forming virus (SFFV), gibbon ape leukemia virus (GALV), or the hybrid chicken actin promoter containing the CMV enhancer region (CAG).

Altering Tropism of Lentiviral Vectors through Pseudotyping

Wildtype HIV-1 virions infect cells that express the CD4 receptor and an appropriate co-receptor. Expansion of the cellular tropism of HIV-1-based vectors can be accomplished by substituting the wildtype envelope protein with an envelope protein from a different virus, a process referred to as pseudotyping.³²³ The MLV amphotropic envelope used in most clinical gene therapy trials employing standard retroviral vectors was also chosen in early experiments with HIV-derived vectors.⁹⁵ However, its receptor, Pit-2, is only present at very low levels on HSCs, correlating with the low efficiency of lentiviral transduction in this cell type.⁸⁵ Screening of an extensive panel of pseudotyped MLV-based vectors using the xenograft murine and nonhuman primate models established the superiority of the GALV, the cat endogenous retroviral glycoprotein (RD114) and the VSV-G protein for the transduction of HSCs.^{89,324, 325} and ³²⁶ However, pseudotyping lentiviral vectors with alternate envelope proteins, namely GALV and RD114, has proven more difficult due to refractory residues within the cytoplasmic tail of both envelopes that limits their cleavage by lentiviral proteases. To improve the lentiviral packaging efficiency of GALV and RD114, chimeras of each envelope have been constructed by replacing the tail region of GALV and RD114 with the corresponding region from MLV. The resulting chimeras, GALV-TR and RD114-TR, have been shown to pseudotype lentiviral vectors with increased efficiency.^{327, 328} and ³²⁹

In contrast to native GALV and RD114, VSV-G is efficiently incorporated in HIV-1 virions. VSV-G pseudotyping confers high vector particle stability, allowing for repeated freeze-thaw cycles and concentration by ultracentrifugation to titers exceeding 10⁹ particles/ml.^{32,95,330} Pseudotypes based on VSV-G have broad tropism long thought to be conferred by interaction with phosphatidylserine (PS), a ubiquitous cellular lipid, but the role of PS as a cell "receptor" for VSV-G particles has been refuted.³³¹ When directly compared to amphotropic or RD114-pseudotyped lentiviral vectors using the NSG preclinical assay, vectors bearing the VSV-G envelope protein showed higher efficiency of transduction in human repopulating cells.³³² Toxicity of the VSV-G protein to cells in which it is expressed is perhaps the most significant shortcoming of this envelope protein. However, success has been obtained in deriving a stable packaging cell line by expressing VSV-G from a tetracycline-inducible promoter although this methodology has not yet been used clinically.^{333,334} Moreover, notwithstanding the observed toxicity of VSV-G and the demonstration that VSV-G-pseudotyped vectors produced in human cells were rapidly inactivated by human serum,³³⁵ two recent gene therapy trials^{102,103} have reported successful long-term transduction of human HSCs using HIV-1-based vectors pseudotyped with VSV-G.

Altering the Tropism of Lentiviral Vectors for Selective Targeting of CD34⁺ Cells

Envelope proteins made chimeric by the addition of a ligand, such as the early-acting cytokines SCF and thrombopoietin (TPO), have been explored as a mechanism for specifically targeting lentiviral vectors to primitive hematopoietic cells expressing the SCF receptor KIT. These vectors could be used for *in vivo* targeted gene delivery to HSCs, eliminating the risk of inducing cell differentiation and loss of the homing/engraftment potential of these cells as observed in *ex vivo* targeted HSC gene delivery approaches. The selective transduction of HSCs by VSV-G/TPO/SCF-displaying vectors was demonstrated by their capacity to promote selective transduction of long-term NOD/SRCs.³³⁶ However, the fusion glycoprotein VSV-G in VSV-G/TPO/SCF-co-displaying lentiviral vectors is sensitive to human immune/complement system, rendering these vectors unsuited for *in vivo* gene delivery.³²⁹ Recently, complement-resistant vectors capable of specifically targeting the very rare immature progenitor cells in an immunodeficient murine model were produced by substituting VSV-G for the complement-resistant glycoprotein mutant RD114-TR.³³⁷ Completely obviating *ex vivo* manipulation of HSCs may be of particular interest for gene therapy of BM failure syndromes for which the number of stem cells is limited.

Preclinical Evaluation of Lentiviral Vectors

Given the established lack of predictability of standard murine transplantation models for evaluation of HSC transduction efficiency in humans, investigators initially chose the murine xenotransplant assay to validate the ability of HIV-1-based vectors to efficiently transduce human hematopoietic cells, including CD34⁺ cells and the more primitive CD34⁺/CD38⁻ subset. Several groups reported efficient gene transfer of SRC derived from human CB,^{338,339,340,341,342} BM³³⁸ and mobilized peripheral blood^{343,344} under conditions where standard retroviral vectors were ineffective. High-level green fluorescent protein (GFP) transgene expression in SRC capable of secondary³⁴² and tertiary³⁴¹ multilineage re-population in NOD-Scid mice suggested transduction of primitive human HSCs with pluripotential, proliferative, and self-renewing capabilities. As outlined below, these preclinical data have recently been confirmed in the context of clinical trials for ALD¹⁰² and β -thalassemia.¹⁰³

Demonstration of the utility of HIV-1-based lentiviral vectors to transduce hematopoietic cells with long-term repopulating potential was initially met with limited success in rhesus macaques^{345,346} and baboons.³⁴⁷ These Old-World monkeys were found to possess cellular antiviral factors responsible for the observed resistance to HIV-1 infection. In contrast, HIV-1-based lentiviral vectors could mediate efficient gene transfer to long-term repopulating cells in the canine²⁹⁵ and pigtailed macaque models.³⁴⁸ The restriction to HIV-1 infection in rhesus macaques was alleviated by modification of HIV-1-based vectors^{349, 350} and³⁵¹ or by the use of an alternative lentiviral vector based on the simian immunodeficiency virus (SIV).^{352,353, 354, 355} and³⁵⁶

Despite the lack of predictability of standard murine transplantation studies for evaluation of gene transfer into human HSCs, mouse disease models developed by gene targeting or arising from spontaneous gene mutations may represent the only available option for preclinical testing of the impact of gene transfer vectors on disease phenotype; large animal disease models do not exist for most disorders treated by gene therapy, and for a number of orphan diseases that are common targets of gene transfer protocols, it is impractical to obtain biospecimens from a large cohort of patients to perform preclinical murine xenotransplant efficacy studies. All disorders with active HSC gene therapy clinical trials have employed murine models of human diseases to evaluate efficacy of lentiviral vectors for correction of disease phenotype, including ALD,¹⁰² WAS,^{357, 358, 359, 360, 361} and³⁶² β -thalassemia,^{363, 364, 365} and³⁶⁶ SCID,^{367, 368, 369, 370} and³⁷¹ and CGD³⁷².

P.1509

Gene Transfer Vectors with In Vivo Selectable Markers

One strategy to increase the efficiency of gene transfer entails the inclusion of selectable genes in vectors to confer an in vivo advantage to transduced cells. Successful in vivo selection has previously been documented in murine HSC transplantation models using several drug resistance genes, including multi-drug resistance protein-1 (MDR-1),^{213,373} dihydrofolate reductase (DHFR),³⁷⁴ and O6-methylguanine-DNA methyltransferase (MGMT)^{375, 376} and³⁷⁷ However, in more clinically relevant large animal models, in vivo selection using DHFR³⁷⁸ and MDR-1^{379,380} was variable and transient, with levels of gene-modified cells returning to baseline within a few weeks. MGMT is one of the most promising drug resistance genes that encodes for the DNA repair protein O6-alkylguanine-DNA-alkyl-transferase (AGT). This protein confers resistance to the cytotoxic effects of alkylating agents, including nitrosoureas (e.g., BCNU) and temozolomide. Incorporation of a mutant form of MGMT in the gene transfer retroviral vectors can facilitate a greater selective advantage for primitive hematopoietic cells containing the vector after in vivo administration of an alkylating agent. In vivo selection of HSCs using MGMT was successfully achieved in murine,^{376,377} nonhuman primate^{298,381} and canine models,^{297,298,382,383} and in human NOD/SRCs.^{384,385} However, results in large animals were not uniformly positive³⁵⁴ and, although no evidence of leukemic transformation was seen using this approach, the cumulative genotoxicity resulting from the combined use of alkylating agents and retroviral vectors needs to be considered.

Gene Transfer Vectors with Ex Vivo Selectable Markers

Positive selection of transduced cells in vitro before re-infusion is another strategy to increase re-population with gene-modified cells. Vectors containing genes for various cell-surface proteins have allowed flow cytometric sorting of successfully transduced cells. A number of studies have utilized the human cell-surface protein CD24, or the murine homolog heat-stable antigen (HSA). There is limited sequence homology between the murine and human forms, and noncross-reactive antibodies are available for selection. Their small size means they take up little space in the vector construct. Murine marrow cells transduced with a vector-containing human CD24 and sorted before re-infusion resulted in greatly increased long-term reconstitution with vector-containing cells.³⁸⁶ A vector expressing murine HSA allowed enrichment for transduced human progenitor cells.³⁸⁷ However, CD24 and HSA are GPI-linked surface proteins, a class of proteins that has been shown to be transferred from cell to cell both in vitro and in vivo, clouding the specificity of this marker and raising concerns about ectopic expression of these genes in vivo.^{161,386,387}

Retroviral vectors carrying a truncated nonfunctional form of the human nerve growth-factor receptor have also been developed as a selectable marker for use on hematopoietic targets, because hematopoietic cells do not express endogenous nerve growth-factor receptor. The introduction of new cell-surface proteins has the theoretical disadvantage of altering trafficking or cell-cell interactions upon infusion of transduced cells. Alternative cytoplasmic markers such as GFP and mutated murine protein are naturally fluorescent, avoiding the need for pre-selection antibody staining.³⁸⁸ However, prolonged stable expression of these proteins has proved difficult, and there is evidence that these proteins are toxic to primary mammalian cells.^{389,390} The use of selection for GFP after retroviral-mediated transduction in the nonhuman primate model to increase engraftment by genetically modified cells resulted in increased short-term

engraftment only, raising another concern that expression of transferred genes may be more efficient in differentiated rather than stem cells, effectively enriching for progenitors with only short-term potential.³⁹¹

Low transduction efficiency of primitive human HSCs may preclude post-transduction sorting for a marker gene if, after sorting, too few stem cells remain to allow safe and rapid hematopoietic reconstitution; this is especially problematic after ablative chemotherapy. A potential solution to this problem would be ex vivo expansion of selected transduced cells prior to re-infusion. However, when ex vivo cultured cells compete against endogenous stem cells in a nonablative model, a significant engraftment defect is evident,^{301,392} indicating that true long-term repopulating cells cannot be expanded efficiently or even maintained ex vivo using current culture conditions.^{302,393, 394, 395} and ³⁹⁶

Gene Transfer Vectors with Genes Promoting Selective Growth Advantage to Transduced Cells

In most diseases considered to be suitable targets for gene therapy, corrected cells do not themselves have an inherent growth advantage, providing an impetus to arm retroviral vectors with genes capable of conferring a selective growth advantage to transduced HSCs and their progeny. For example, mouse HSCs transduced with the homeobox gene, HOXB4, possess more than tenfold greater repopulating ability than that of nontransduced BM.³⁹⁷ Furthermore, transgenic overexpression of the antiapoptotic protein Bcl-2 results in increased HSC numbers,³⁹⁸ and expression of a truncated form of the human erythropoietin (Epo) receptor can augment HSC engraftment through the use of exogenous Epo.³⁹⁹ Blau et al. have utilized inactive monomeric signaling domains derived from receptors such as Epo or TPO to permit controlled growth of genetically modified cells through the use of chemical inducers of dimerization.^{400,401} Another approach involves selective enrichment of genetically modified cells using vectors encoding a fusion protein between the growth-signaling portion of the G-CSF receptor and the hormone-binding domain of the estrogen receptor. This approach allows controlled growth of genetically modified cells using exogenous estrogen, and preclinical testing in the nonhuman primate demonstrated the feasibility of this approach.^{402,403}

However, the risk of combining integrating vectors and growth-promoting genes for clinical applications has recently been highlighted in large animal model preclinical studies. Investigators transduced monkey CD34⁺ cells with either a HOXB4-expressing vector or a control vector expressing only a marker gene and analyzed the competitive repopulating ability of these cells in vivo. As hoped, there was an early very significant advantage for the HOXB4-transduced cells following engraftment of the monkeys, but in contrast to mouse studies, a much less significant advantage for the HOXB4-transduced cells was observed long-term after transplantation.⁴⁰⁴ However, approximately 2 years after transplant, they reported the first instances of leukemia linked to HOXB4 expression, both in the original group of monkeys and in dogs that received cells transduced with HOXB4-expressing vectors.⁴⁰⁵ Myelodysplasia in two additional nonhuman primates was subsequently reported in association with retroviral vector-mediated insertional mutagenesis and overexpression of HOXB4.⁴⁰⁶ Overall, these studies strongly indicated that overexpression of HOXB4 using integrating retroviral vectors is much too risky to be contemplated in any clinical settings.

Optimization of Transduction Conditions

Cytokine Combination

Various procedures have been refined by different laboratories to optimize retrovirus-mediated transduction in HSCs. A delicate balance must be reached to reconcile the needs for cell cycling for

P.1510

productive transduction without impairing the repopulating ability of HSCs. The current consensus based on large animal and murine xenograft models favors a transduction step in the presence of an early-acting cytokine cocktail composed of SCF, FLT-3L, and TPO, with the optional addition of IL-3. The mechanism of action of these early-acting cytokines is generally related to their effect on cell cycle status but they have also been proposed to enhance transduction by down-regulating proteasome activity in HSCs.^{407,408} Transduction with standard retroviral vectors is typically performed over 72 hours with an obligatory 24-hour cytokine-mediated prestimulation step to favor cell cycling. For lentiviral vectors, a 24-hour prestimulation followed by a single 24-hour transduction in serum-free medium with cytokines has been proposed as an optimal protocol for transduction of human CD34⁺ cells using the humanized NSG mouse xenograft model.^{409,410}

Use of Fibronectin during Transduction

The function of HSCs depends upon the signals from surrounding stromal cells (e.g., fibroblasts, osteoblasts) and extracellular matrix molecules (e.g., fibronectin) found within the highly specialized BM microenvironment. In murine studies, co-culture of the hematopoietic target cells with the fibroblast-derived retroviral producer cells has been shown

to be the most efficient gene transfer method. However, this approach is inappropriate for use in human clinical trials because of the risk of co-infusing the producer cells into patients along with the transduced hematopoietic cells.

To expand clinical applicability of murine gene transfer protocols, several investigators showed increased gene transfer to human hematopoietic cells adherent to autologous or allogeneic BM stromal cells using *in vitro* assays.^{411, 412} and ⁴¹³ Similarly, addition of autologous stromal cells during the transduction period promoted gene transfer into HSCs in the rhesus macaque model.³⁰² However, the technical difficulties associated with extensive scale-up have limited widespread clinical application of this approach. Moritz et al. took a different tactic by transducing human hematopoietic cells cultured in vessels coated with the chemotryptic 35-kd carboxy-terminal fragment of human fibronectin (FN35) and noted enhanced transduction by retroviral vectors.⁴¹⁴ A recombinant version of this fragment (CH-296), commercially available as Retronectin (Takara Biomedical, Otsu, Japan), was shown to enhance gene transfer in human CD34⁺ cells by co-localization of the cells with the vector,^{212,415,416} unless an excess of retroviral particles was used during transduction.⁴¹⁷ The co-localization of vectors and target cells can be enhanced using spinoculation, a neologism coined to describe low-speed centrifugation used at the start of transduction to augment gene transfer.⁹³ The enhancement effect achieved with fibronectin was also attributed to biologic effects on HSCs, such as preservation of repopulating potential^{212,418, 419} and ⁴²⁰ and decreased apoptosis.⁴²¹ Extensive preclinical studies showed successful gene transfer into murine long-term repopulating stem cells as well as into human and nonhuman primate CD34⁺ cells derived from BM, CB, or mobilized peripheral blood when transduction was performed *in vitro*^{421,422,423,424} or *in vivo*⁴²⁴ with retroviral vectors and Retronectin. Correspondingly, in all recent clinical gene therapy trials showing therapeutic benefits, retroviral transduction of human CD34⁺ cells was conducted in the presence of human recombinant fibronectin.

Conditioning Regimens to Enhance *In Vivo* Gene Marking

Engraftment of HSCs is a competitive process between endogenous and infused stem cells. For disorders such as SCID, a growth advantage conferred on genetically corrected cells enables engraftment without conditioning, yet for the majority of disorders in which HSC gene transfer may be applicable, no such advantage to the modified cells is conferred and most investigators have relied instead on toxic myeloablative conditioning to damage or destroy endogenous stem cells and thus provide a competitive advantage to the infused genetically modified stem cells. In preclinical models³⁰² and in patients with malignancies,^{254,261,262} myeloablative regimens have been used routinely to enable engraftment of gene-modified primitive hematopoietic cells. However, many of the diseases that could be targeted by gene therapy are chronic indolent disorders in which the risks of myeloablative regimens may outweigh the potential benefits.

Preclinical Evaluation of Nonmyeloablative Conditioning Regimen in Murine Models

Reduced intensity (nonmyeloablative) conditioning regimens were tested in preclinical models to assess engraftment of marked HSCs while reducing transplant-related toxicities. Engraftment of corrected cells can be achieved in mice in the absence of conditioning by using extremely large BM grafts but this approach is not clinically feasible.^{353, 354, 355, 356} and ³⁵⁷ Moderate-dose irradiation or antimetabolite-based nonmyeloablative conditioning allowed correction of CGD^{242,425, 426, 427} and ⁴²⁸ and X-SCID⁴²⁹ in mouse models of these disorders. Alternative conditioning strategies to promote engraftment of infused HSCs with increased safety have been investigated in mice and are of potential relevance for gene therapy applications. For instance, administration of an antibody that blocks c-kit, the receptor for SCF, transiently reduced endogenous murine stem cells, facilitating engraftment with donor HSCs in immunodeficient Rag2^{-/-}/γc^{-/-} mice but not in immunocompetent mice.⁴³⁰ Combination of this antibody with low-dose irradiation profoundly decreased endogenous repopulating activity, enabling efficient and durable engraftment of fresh or lentivirus-transduced BM cells in wildtype and CGD mice.⁴³¹ In another study, HSC mobilization with AMD3100, a CXCR4 antagonist with a favorable safety profile in clinical studies, was shown to vacate niches in the mouse BM microenvironment and thus could be used in this model as a preparative regimen for stem cell transplantation (SCT).⁴³²

Preclinical Evaluation of Nonmyeloablative Conditioning Regimen in Large Animal Models

In large animal models, no engraftment with genetically modified cells has been observed without conditioning. In one study using a nonmyeloablative regimen, 12% gene-marked leukocytes persisted in the peripheral blood of a rhesus macaque for up to 33 weeks after transplant.⁴³³ In other studies, autologous transplantation of transduced HSCs in nonhuman primates conditioned with low-dose irradiation or busulfan have generally resulted in low but measurable (~1%) long-term marking,^{355,434, 435, 436} and ⁴³⁷ providing proof of principle that partial marrow cytoablation allows engraftment of gene-modified cells without significant toxicity. A possible concern, however, is the unexpected finding that in partially ablated recipient mice, where the BM is a more competitive environment for re-population compared to the fully ablated marrow, HSCs carrying survival- or proliferation-activating lentiviral insertions had an advantage for engraftment, perhaps increasing the risk of leukemic progression.⁴³⁸

Conditioning Regimen in Gene Therapy Clinical Trials

Initial gene therapy efforts using HSCs did not administer preparative regimens to avoid potential toxicities from chemotherapy agents when benefits of the procedure were unproven.^{271,278,439} It was hypothesized that the low marking levels achieved in HSCs in these trials could only lead to clinical benefits if the cells derived from the transduced HSCs had a biologic selective advantage in vivo. Modeling conditioning protocols developed in preclinical models, subsequent gene therapy trials for ADA-SCID,^{23,440,441,442,443} X-CGD,^{444, 445} and WAS,⁴⁴⁶ and

P.1511

β -thalassemia¹⁰³ introduced partial myeloablation with busulfan or melphalan prior to infusion of the genetically corrected cells. As outlined below, in most cases, successes were detected after nonmyeloablative conditioning when augmented by a recognized biologic selection for successfully treated cells in vivo or by retroviral-mediated clonal expansion. It appears that reduced intensity regimens employed to date for disorders that lack a biologic selective advantage in gene-corrected cells, such as CGD, may be insufficient to mediate substantial HSC engraftment and that more ablative approaches may be necessary. The recent clinical success achieved in X-linked ALD using a conventional myeloablative conditioning (cyclophosphamide 200 mg/Kg and busulfan 16 mg/Kg) is a useful example of a suitable regimen that resulted in clinically relevant levels of HSC marking and long-term myeloid engraftment (10% to 15%).

Optimized Gene Therapy Protocols

The preclinical studies above, augmented by the clinical experience of the early gene therapy efforts, have led to an optimized protocol for ex vivo manipulation of HSCs that has been employed with success in recent clinical trials (Fig. 71.7). Hematopoietic stem and progenitor cells expressing the CD34 cell-surface marker are purified from BM harvests or G-CSF-mobilized peripheral blood cell collections. Following a brief (24 hours) ex vivo culture in conditions that favor cell cycle transition from G0 to G1 (e.g., culture medium supplemented with SCF, Flt3L, and TPO), the CD34⁺ cells are incubated on a surface coated with the C-terminal fragment of fibronectin in the presence of the same cytokines for an additional 72 hours with standard retroviral vectors or, preferably, for an additional 24 hours with VSV-G pseudotyped SIN HIV-1-based vectors expressing the desired therapeutic gene from an internal promoter. For disorders in which corrected cells do not have a competitive repopulating advantage over uncorrected endogenous HSCs and their progeny, the patient is conditioned with a reduced intensity or myeloablative regimen prior to intravenous re-infusion of the treated cells. After autologous transplantation, transduced cells home to the BM where they initiate hematopoiesis. Transduction efficiency and safety of the procedure are evaluated by periodic collection of peripheral blood samples over extended periods of time.

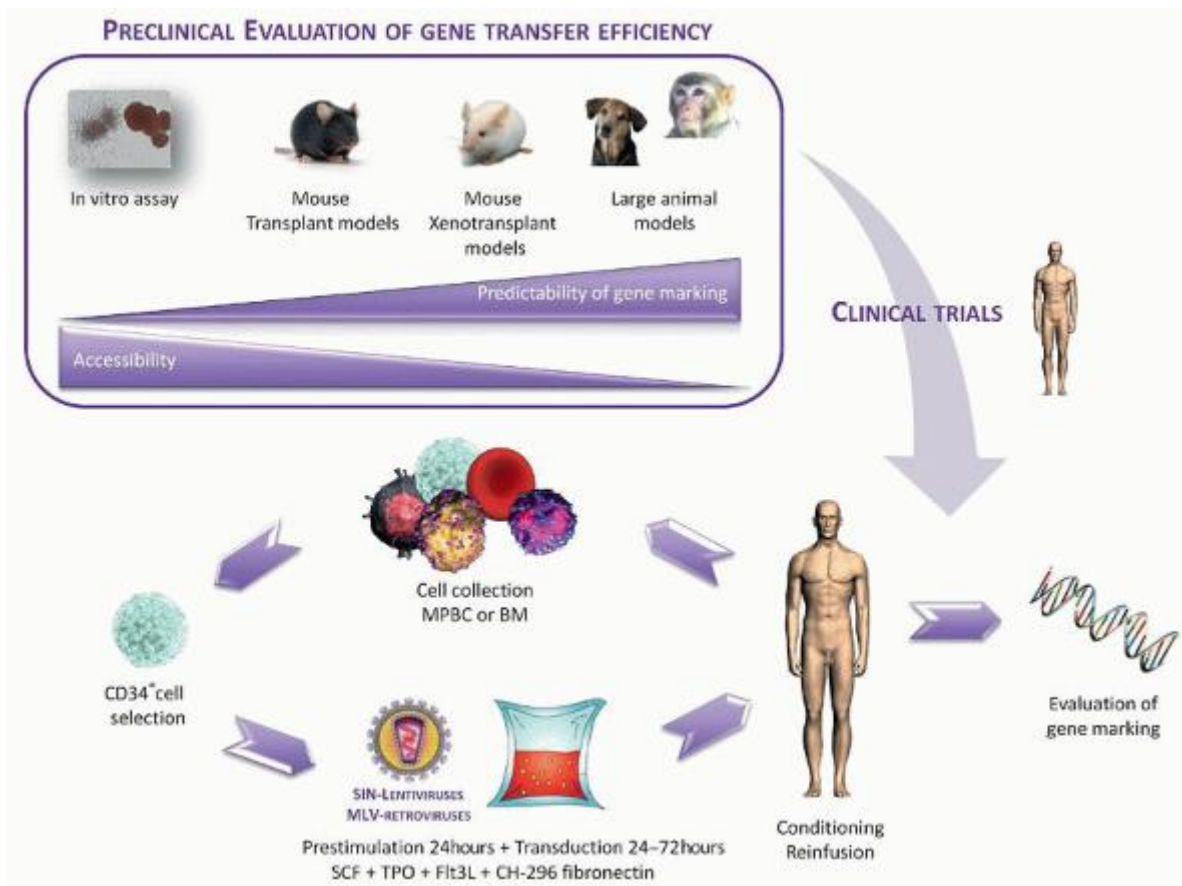

FIGURE 71.7. Approach for the genetic manipulation of hematopoietic stem cells (HSCs). The upper panel compares the predictive value and accessibility of various preclinical models in the evaluation of gene transfer efficiency of vectors used in HSC gene therapy trials. The lower panel depicts the optimized protocol for transduction of hematopoietic stem and progenitor cells, as used in recent clinical trials. BM (bone marrow); Flt3L (fms-related tyrosine kinase 3 ligand); MLV (murine leukemia virus); MPBC (mobilized peripheral blood cells); SCF (stem cell factor); SIN (self-inactivating); TPO (thrombopoietin).

Second-Generation Gene Therapy Trials

The advances derived from preclinical models were rapidly applied in a second generation of clinical trials, with actual therapeutic intent, for immunodeficiency disorders, including X-SCID, ADA-SCID, CGD, and WAS (Fig. 71.6 and Table 71.2). P.1512

Severe Combined Immunodeficiency Disease

The first HSC gene therapy trial demonstrating unequivocal clinical benefit was led by Fischer and Cavazzana-Calvo at the Necker Hospital in France.^{22,448,449} Eleven boys with X-SCID were treated, and each patient received autologous CD34⁺ BM cells, transduced with a standard retroviral vector expressing the corrective IL2R γ gene and re-infused without conditioning. Rapid functional B- and T-cell immune reconstitution and clinical improvement were observed in all but one child. The same vector insertion site could be detected in both myeloid and lymphoid cells, suggesting that at least some true HSCs had been corrected. Unfortunately, as outlined in details below, the elation after this success was short-lived; four subjects in the trial developed acute T-cell leukemia as a result of insertion of the gene therapy vector near proto-oncogenes resulting in increased expression of these genes through the vector's enhancer activity.^{265,450,451}

A similar gene therapy trial was also conducted in London on 10 children with X-SCID. All patients experienced substantial immunologic recovery and in most patients this was accompanied by recovery of humoral immunity and withdrawal of immunoglobulin supplementation.^{442,452,453} Similar to the first clinical study of gene therapy for X-SCID, a single insertion of the gene transfer vectors caused substantial overexpression of proto-oncogenes in 1 of 10 patients, resulting in

leukemogenesis.⁴⁵⁴ These data indicated that conventional murine retroviral vectors (based on MLV) present a high risk of leukemogenesis as a result of their powerful enhancer sequences in the intact LTR regions. Although gene therapy has been effective in infants with X-SCID, minimal clinical improvement was detected in 2 of 3 pre-adolescents despite effective transduction and engraftment of G-CSF mobilized CD34⁺ cells,⁴⁵⁵ and complete failure of gene therapy in 2 adult patients was reported after transplantation of transduced BM CD34⁺ cells.⁴⁵⁶

Bordignon's and Thrasher's group also reported sustained engraftment of engineered HSCs and good immune reconstitution in patients with SCID resulting from ADA enzyme deficiency following transplantation of BM-derived transduced CD34⁺ cells.^{23,440,441} No cases of leukemia have been reported to date in these trials consistent with the long-term analysis of integration sites revealing a polyclonal pattern along with a lack of *in vivo* skewing for risky insertions.

Chronic Granulomatous Disease

In an attempt to genetically correct the defect in CGD patients, investigators obtained G-CSF mobilized CD34⁺ cells from two CGD patients and, using a vector similar to that used in the X-SCID trials, inserted a corrective copy of one gp91phox gene needed to make a functional NADPH oxidase.⁴⁴⁶ Unlike other CGD trials,^{278,444,445} 3 weeks after the cells were re-infused into the patients, a surprisingly large fraction of circulating myeloid cells, more than 20%, carried the corrective gene. This sustained engraftment of functionally corrected cells with therapeutically relevant levels of NADPH oxidase was unexpectedly followed by further *in vivo* expansion of cell clones containing insertionally activated growth-promoting genes. Clinically, the patients were doing well, clearing chronic infections after engrafting with corrected cells. However, as outlined below, a progressive decline in blood counts was observed in both CGD patients at 15 and 28 months, respectively, after gene therapy as a result of genotoxicity from the gene transfer vectors.^{457,458}

Wiskott-Aldrich Syndrome

A German group has recently reported long-term (up to 5 years) correction of WAS in 9 of 10 patients through standard retroviral infection of G-CSF mobilized CD34⁺ cells transfused after busulfan-induced transient myelosuppression, as evidenced by a decreased frequency and severity of infections, and resolution of signs and symptoms of autoimmunity, including autoimmune hemolytic anemia, thrombocytopenia, neutropenia, and eczema.⁴⁴⁷ However, as described in more detail below, leukemia has now developed in several patients as a result of gene transfer vector activation of a growth-promoting gene.

Third-generation Gene Therapy Clinical Trials

Third-generation HSC gene therapy trials have recently emerged, supported by preclinical data suggesting that HIV-derived lentiviral vectors may be safer and more efficient for transduction of stem cells than vectors based on γ -retroviral vectors.^{340,348,353,459,460,461,462,463} This new generation of clinical trials has pioneered the use of SIN-lentiviral vectors for correction of ALD¹⁰² and β -thalassemia¹⁰³ (Fig. 71.6 and Table 71.2)

Adrenoleukodystrophy

The first use of a lentiviral vector for HSC gene therapy was reported for the treatment of two children with X-linked ALD.¹⁰² This is also the first study using a conventional myeloablative conditioning regimen before re-infusion of the genetically manipulated G-CSF mobilized CD34⁺ cells. Functional myelomonocytic cells derived from corrected CD34⁺ cells migrated into the patient's central nervous system to replace diseased microglia cells. At 24 and 30 months post-transplantation, both patients had highly polyclonal reconstitution of hematopoiesis and normal levels of ALD protein, which appeared to retard the progressive cerebral demyelination process. No evidence of genotoxicity has yet been reported in this trial.

β -Thalassemia

Cavazzana-Calvo and colleagues¹⁰³ have recently provided another example of the clinical potential of gene therapy using lentiviral vectors by treating an 18-year-old male patient suffering from transfusion-dependent β^E/β^0 -thalassemia. CD34⁺ cells were isolated from the individual's BM and transduced with an HIV-derived lentiviral vector containing a functional β -globin gene. Compared to previous trials, a conditioning regimen with higher doses of busulfan was used in this study. The levels of genetically modified cells gradually rose up to 11% at 33 months post-transplant with concomitant increases in levels of the normal β -globin protein and improved production and quality of normal RBCs. Remarkably, a year after treatment, the patient no longer needed RBC transfusions. This therapeutic benefit, however, was observed in the setting of clonal expansion resulting from integration of lentiviral vectors in the high mobility group AT-hook 2 (HMGA2) gene.⁴⁶⁴ Marked expansion of a single corrected clone, persisting without malignant transformation for many years, has been documented in an early ADA-SCID gene therapy trial,⁴⁶⁵ suggesting that clonal expansion does not irrevocably progress to

malignancy, but the known association between HMGA2 overexpression and benign/malignant neoplasias imposes further caution.^{464,466,467}

LYMPHOCYTES AS TARGETS FOR GENE TRANSFER

T lymphocytes have several features that make them potentially attractive targets for gene and cell therapies. T-cells circulate in large numbers and are easily harvested, functional subsets have been identified and can be purified via cell-surface antigen selection, and immune responsiveness against specific organisms or target cells can be enhanced via manipulation of culture conditions or genetic modification. A great deal has been learned in the past two decades regarding the optimal culture conditions

P.1513

for enhancing proliferation while retaining function and in vivo survival.⁴⁶⁸ Ablative conditioning is not necessary for persistence of infused T-cells, however, lymphodepletion and/or hematopoietic stem cell transplantation prior to lymphocyte infusion has been reported to improve the persistence and antitumor efficacy of adoptive T-cell therapies.^{469,470} These characteristics have stimulated investigators to target lymphocytes for many gene therapy applications. A series of in vivo human clinical trials have yielded very important and often surprising information on the lifespan of these "terminally" differentiated cells in the body, but also worrisome evidence of a strong immune response against exogenous genes expressed by these cells. Striking evidence for clinical efficacy has been obtained in studies redirecting immune reactivity of T-cells toward specific antigens.^{471,472}

Gene Marking Studies

The first infusion of genetically modified cells into a human enrolled in a clinical trial used genetic marking to monitor the fate of tumor-infiltrating T lymphocytes (TIL) in vivo. Persistence of low-level gene-marked T-cells was demonstrated, including within tumor deposits, although marking levels were too low to assess whether preferential trafficking of TIL cells to residual tumor occurred.⁷ More recently, gene marking studies in humans undergoing allogeneic SCT have helped to further characterize the behavior of lymphocytes that have been cultured ex vivo. Epstein-Barr virus (EBV)-specific donor T-cells from SCT donors used to transplant patients at high risk for post-allogeneic SCT EBV-lymphoproliferation were isolated, expanded, and gene-marked ex vivo during co-culture with EBV-transformed donor lymphoblasts.^{473,474} After transplantation, the EBV antigen exposed donor T-cells were infused into the patients, and gene-marked cells were detectable at levels suggesting expansion of two- to threefold in vivo. EBV-specific cytotoxicity in the peripheral blood was greatly enhanced after the infusions. Although circulating marked cells fell below the limit of detection 4 to 5 months later, the continued presence of memory cells derived from the infusion product was inferred in one patient who had an increase in marked lymphocytes in the blood after reactivation of latent EBV.⁴⁷⁴

Suicide Gene Modification of T-cells

The next iteration of genetically modified T-cell therapies in patients undergoing allogeneic SCT incorporated the herpes thymidine kinase (tk) gene into the retroviral vector.⁴⁷⁵ This "suicide gene" encoded viral protein converts the nontoxic pro-drug ganciclovir to a toxic metabolite that kills the cell by interfering with DNA synthesis.^{476,477} A major cause of morbidity and mortality post-allogeneic SCT is graft-versus-host disease (GVHD). By incorporating the tk suicide gene into donor T-cells, high doses of T-cells can be administered to confer antiviral or antitumor immunity. If and when significant GVHD occurs, donor T-cells can be destroyed by an infusion of ganciclovir. This strategy depends on inclusion of a cell-surface marker gene or a drug resistance gene within the vector to allow enrichment of transduced cells by flow cytometry or drug selection, before re-infusion, so that almost all infused cells will contain the tk suicide gene.^{475,478}

A landmark study demonstrating the safety and feasibility of this approach in patients following allogeneic SCT from matched donors was reported from Italy, and confirmed in several similar trials in Europe and the United States.⁴⁷⁹ Most recently, this approach has been shown to be very promising in haplo-identical SCTs, transplants with an extremely high risk of both severe GVHD and poor immune reconstitution.⁴⁸⁰

One issue that has arisen in these trials is development of immunity against the foreign tk protein, with eventual destruction of vector-containing cells even in the absence of ganciclovir in some.⁴⁸¹ Anti-tk immunity also developed in a subset of patients with HIV infection who received autologous HIV-reactive cytotoxic T-cells expanded ex vivo and transduced with a tk vector.⁴⁸² These observations serve as an important caveat that foreign proteins such as tk introduced via lymphocytes may stimulate immune recognition and rejection. Use of ganciclovir as the suicide activator is not ideal, given that this drug is a powerful antiviral agent and the drug of choice to treat some common viral infections in SCT- or HIV-infected patients. To circumvent both of these problems, the gene encoding the endogenous human cellular

proapoptotic protein caspase 9 was modified to allow dimerization and activation by the small molecule AP1903.⁴⁸³ In a recent trial, patients received a T-depleted haplo-identical stem cell transplant, followed by infusion of donor T-cells transduced with the inducible caspase 9 transgene. These cells persisted and expanded in vivo, but with the development of GVHD, more than 90% of T-cells were ablated within 30 minutes of AP1903 infusion, resulting in abrogation of GVHD.⁴⁸⁴

Therapy of Immunodeficiency Disorders

T lymphocytes were the targets in the first human clinical gene transfer trial utilizing a potentially therapeutic gene, initiated in 1990.^{8,485} Two children with SCID due to ADA deficiency received multiple infusions of autologous T-cells transduced with a retroviral vector encoding human ADA.⁶ Both patients showed improvements in circulating T numbers and some evidence for improvement in cellular and humoral immunity. In one child, over 30% of the circulating T-cells were positive for the transgene and ADA levels approached the normal range for more than 2 years. The second child had only 0.1% to 1% of circulating T-cells containing the vector even after multiple infusions, clouding interpretation of how much of the clinical improvement in the initial patient was due to the gene transfer, and how much to other factors, including the ex vivo lymphocyte expansion. The more convincing results and theoretical advantages of correcting HSCs as compared to T-cells, as detailed above, combined with the impossibility of obtaining target T-cells to correct in patients with many forms of SCID, has resulted in a shift to HSC instead of T-cell targets for the gene therapy of immunodeficiency disorders.

T-cell Gene Therapy for HIV Infection

A number of ongoing and completed human T-cell gene therapy clinical trials have enrolled patients with HIV disease, based on identification of a number of potential targets for genetic intervention.⁴⁸⁶ The concept of intracellular immunization against HIV, conceived more than two decades ago, hypothesizes that an effective gene therapy strategy for HIV could be to confer nonimmunologic HIV resistance to mature cell populations by introducing a gene that interferes with the HIV life cycle or prevents infection of progeny cells into HSCs or lymphocyte precursors.⁴⁸⁷ Striking proof of principle of this concept was reported when an HIV patient with leukemia received an allogeneic SCT from a donor with a CCR5 variant, preventing HIV cellular entry into all donor hematopoietic cells. The patient had complete disappearance of HIV post-transplantation.⁴⁸⁸ A second approach uses gene transfer to introduce genes that will result in killing of infected cells, either directly or via enhanced immunity, thus destroying the HIV viral reservoir.

A number of T-cell gene therapy approaches to HIV were tested in a unique clinical model pursued at the United States National Institutes of Health. A cohort of syngeneic twins with one infected and one uninfected twin was identified. T-cells from the uninfected twin were collected by apheresis, and then transduced with vectors encoding potential anti-HIV genes. Comparison of survival of these transduced cells in the infected twin with survival of cells transduced with a control vector was an elegant approach to testing various anti-HIV gene therapy strategies.⁴⁸⁹ Marked

P.1514

cells could be detected and studied in the HIV-infected twin.⁴⁹⁰ Unfortunately, none of the anti-HIV strategies tested in this model were shown to result in preferential survival of the genetically modified cells or clear improvement of viral control.⁴⁹¹

Mutant HIV Rev proteins have been reported to interfere with Rev function, either by binding to and inactivating wildtype Rev, or by competitively blocking binding of wildtype Rev to the RRE.^{55,492} Production of HIV either from normal lymphocytes exposed to HIV in culture, or from HIV-infected patient lymphocytes, was decreased after either retroviral or gene gun particle-mediated transduction of T-cells with a vector expressing the Rev M10 mutant, compared to a nontranslated inactive control Rev mutant.⁵⁰ A clinical trial used the gene gun to transduce autologous lymphocytes from HIV-infected patients with either the active Rev M10 vector or the inactive control Rev vector. These cells were then expanded in vitro and re-infused. The lymphocytes containing the active Rev M10 sequences survived preferentially in vivo, suggesting that the Rev M10 transgene improved T-cell survival in infected individuals.⁴⁹³ In another protocol, individuals with HIV infection and a refractory hematologic malignancy were offered allogeneic peripheral blood SCT and an aliquot of the allogeneic graft was CD34 selected, transduced with a transdominant Rev encoding vector, and infused along with the unmanipulated allograft. Overall marking was also low in the only recipient of genetically modified cells, however, rising vector copy number and nondetectable HIV over extended follow-up was encouraging.⁴⁹⁴

Another anti-HIV T-cell gene therapy strategy involved the use of "defective-interfering viruses" known to interfere with wildtype HIV replication and spread.⁴⁹⁵ The first lentiviral gene therapy trial in humans transduced T-cells with a "defective-interfering" vector that incorporated an antisense sequence targeting the HIV envelope gene.⁴⁹⁶ The use of a lentiviral vector in patients with HIV infection generated concern regarding the potential for recombination between the

vector and endogenous HIV virus in patients or HIV genes in the packaging cells, or the inadvertent transfer of a mobilized lentiviral vector to others via sexual or other modes of transmission, requiring further development of sensitive RCR testing development prior to clinical use and extensive safety testing of patients enrolled in the trial.¹⁰⁰ Preliminary results in the first five patients demonstrated the feasibility of this approach, with all patients tolerating the infusion well. In one subject, a sustained decrease in viral load was observed.⁴⁹⁷

T-cell Gene Therapies for Cancer

The most common clinical application for genetically modified T-cells has been for tumor immunotherapy. There are a number of challenges for cancer immunotherapies, most notably the low frequency of tumor-specific autologous T-cells, negative selection against high-affinity T-cell receptors (TCRs) binding to autologous tumor antigens during T-cell development, and the myriad mechanisms tumor cells have evolved to evade and cripple antitumor immune responses. Although early studies of the adoptive transfer of ex vivo expanded T-cells or in vivo stimulated T-cells with cytokines such as IL2 resulted in proof of principle that antitumor immunity existed and could be effective, investigators began searching for ways to enhance specific antitumor immunity via genetic modification.⁴⁹⁸

One approach begins by cloning high-affinity TCRs from cytotoxic T-cells shown to be reactive with tumor-specific antigens, generally from T-cells initially isolated from tumors (TILs), then further expanded and selected in vitro. The cloned transgenic α and β TCR subunit genes can then be incorporated into a retroviral or lentiviral vector and used to transduce patient T-cells, resulting in large numbers of T-cells reactive with a specific tumor antigen. Four of 31 melanoma patients receiving autologous T-cells transduced with a cloned high-affinity TCR reactive with a melanoma antigen (MART1) had objective tumor responses, as did one of three patients with colon cancer receiving T-cells transduced with a CEA-reactive TCR.^{470,499}

One major drawback of this approach is the HLA-restriction of TCRs, thus requiring a different TCR construct for each HLA class 1 target, and effectively limiting this approach to patients with common HLA haplotypes. There is also the potential for mispairing between the transgenic TCR and the endogenous TCR chains that are still expressed by the target T-cell, resulting in unpredictable adverse events such as autoimmunity/GVHD.⁵⁰⁰ Although this complication was observed in a murine model, there is no evidence to date for a similar phenomenon in hundreds of patients enrolled in transgenic TCR clinical trials.⁵⁰¹ However, administration of large numbers of high-avidity TCR-expressing T-cells reacting with tumor antigens that may also be expressed at low levels on normal tissues can result in toxicity such as colitis following anti-CEA T-cells given to target colon cancer, or skin/eye and ear toxicity following administration of TCR chimeric T-cells reactive with melanoma antigens.^{499,502}

A second and perhaps more promising approach to enhancing antitumor activity of T-cells was first conceptualized in 1993, and involves transduction of T-cells with genes encoding fusion molecules termed "chimeric antigen receptors" (CARs)^{503,504} (Fig. 71.8A). Engineered cell-surface molecules consisting of a specific antigen-binding domain from a monoclonal antibody, or some other specific ligand-binding domain, fused to intracellular signaling moieties from the T-cell receptor (generally the ζ chain) or the Fc ϵ RI receptor are introduced into T-cells via retroviral or lentiviral vectors. When the CAR binds to antigen or ligand, the T-cell signaling cascade is activated, resulting in cytotoxicity toward the antigen-bearing target cell. There are a number of advantages of CARs as compared to TCRs for genetic enhancement of T-cell antitumor immunity. Most important, the CAR approach is "universal" and not MHC-restricted, thus the same CAR can recognize the target in any patient. Second, tumors often down-regulate MHC molecules, and thus can evade TCR-dependent recognition, in contrast to CARs, which do not require MHC engagement for their activity. Third, nonprotein targets can be recognized by CARs. One disadvantage of CARs in comparison to TCRs is that intracellular antigens cannot be targeted by CARs, because these antigens require presentation as peptides on the cell surface via MHC molecules. A recent review catalogs the large diversity of CARs that have been developed for preclinical and clinical applications.⁵⁰⁵

Initial CAR clinical gene therapy studies were completed in the late 1990s, utilizing autologous or syngeneic T-cells transduced with constructs fusing the gp120 binding domain of CD4 to the TCR ζ chain, to promote killing of HIV-infected T-cells. Despite encouraging animal model and in vitro data, the infused cells were present at very low levels, disappeared over time, and were not associated with clinical benefit.^{491,506} A series of clinical trials in patients with cancer, targeting cell-surface proteins on ovarian cancer, neuroblastoma or lymphoma tumor cells were also disappointing, with no evidence for in vivo expansion and little persistence of infused CAR-modified cells.⁵⁰³ There was some evidence that CARs themselves could be immunogenic, and that ex vivo culture conditions used during transduction and expansion were suboptimal, but a more important difference between CAR-mediated and endogenous TCR-mediated signaling is the lack of co-stimulatory signaling during CAR engagement. T-cell stimulation in the absence of co-stimulatory signals, normally provided by antigen-presenting cells, results in T-cell death or tolerance, instead of expansion and a productive immune response (Fig. 71.8B). Therefore, a second generation of CARs was designed, incorporating co-stimulatory signaling

domains as part of the CAR fusion molecule itself, for instance, domains from CD28 or CD137. T-cells transduced with these enhanced CARs were found to be more effective in vitro and in animal models.⁵⁰⁷

P.1515

P.1516

A number of other strategies have also been pursued to enhance co-stimulation and in vivo survival of CAR-modified T-cells, including targeting CARs to T-cells already primed to respond to a common antigen such as EBV, administering T-cell supportive cytokines such as IL2, IL7, or IL15, or lymphodepleting the patient prior to CAR-T administration (Fig. 71.8A,B).⁵⁰³

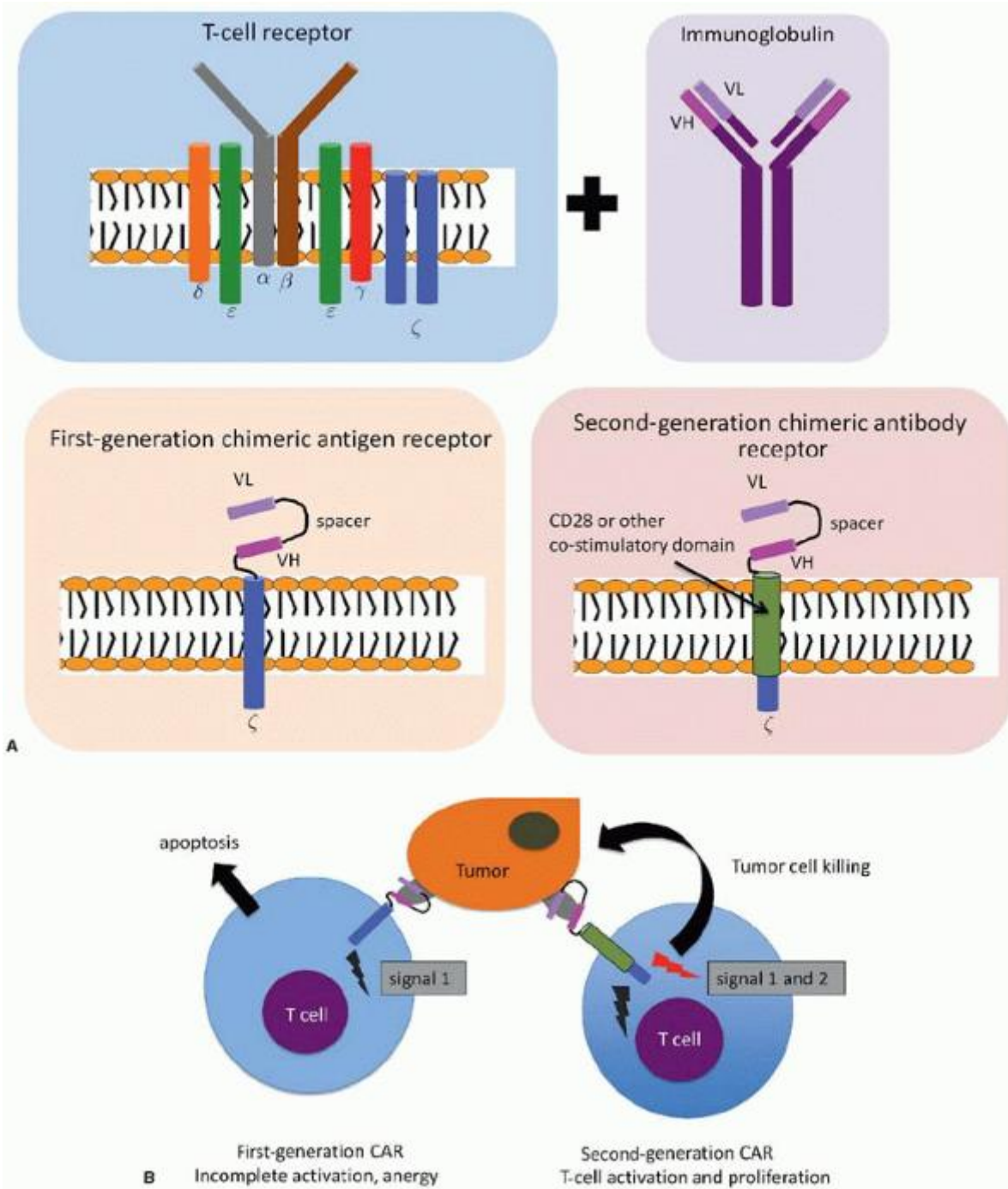

FIGURE 71.8. Gene transfer of chimeric antigen receptors for tumor immunotherapy. A: The sources of components used to construct an artificial chimeric antigen receptor are shown. The signaling ζ subunit of the T-cell receptor is connected to the variable heavy chain(VH) and variable light chain(VL) domains of a monoclonal antibody generated against the desired tumor antigen. In the second-generation CARs, an additional transmembrane domain from CD28 or an alternative co-stimulatory molecule is added between the cytoplasmic signaling domain of the TCR ζ subunit and the extracellular VH/VL antigen-binding moieties. B: When a T-cell transduced with a first-generation CAR encounters a tumor cell bearing an antigen recognized by the VH/VL domain of the CAR, the ζ subunit is stimulated to signal (signal 1) but in the absence of a co-stimulatory signal, the T-cell is often diverted to an apoptosis or energy pathway. In contrast, the inclusion of a costimulatory signaling domain in the second-generation CAR ensures that when tumor antigen is encountered, both signal 1 generated from the ζ subunit and signal 2 generated from the CD28 domain are activated, and the T-cell proliferates and is stimulated to kill the tumor cell.

A series of clinical trials utilizing CARs targeting CD19 in patients with chronic lymphocytic leukemia (CLL) or other advanced chronic B-cell malignancies have provided proof of principle for the potential efficacy of this approach. A lentiviral vector expressing an anti-CD19 antibody domain fused to a CD137 co-stimulatory region and the CD3 ζ signaling component of the TCR was used to transduce autologous T-cells from a patient with CLL, and following re-infusion, there was rapid 1,000-fold in vivo expansion of the cells, tumor lysis, and complete remission of the CLL, persisting for at least 10 months to date.⁴⁷¹ A dramatic response was also reported in a patient with follicular lymphoma.⁵⁰⁸ Larger case series confirmed these encouraging results.^{509,510} However, the potent and persistent anti-CD19 response also resulted in profound depletion of normal B-cells and hypogammaglobulinemia. This very promising approach is now being developed for treatment of a variety of tumors.

GENE THERAPY FOR BLEEDING DISORDERS

The primary bleeding disorders most commonly result from genetic deficiencies of specific clotting factors. Classic hemophilia, or hemophilia A, results from a deficiency of factor VIII, which is normally produced by hepatocytes and vascular endothelial cells. Hemophilia B results from a deficiency of factor IX, which is normally made by hepatocytes. Thus, both diseases are hematologic disorders resulting from deficiencies of soluble plasma proteins synthesized by nonhematopoietic cells. Each of these coagulation factors may be found in circulating platelets' storage granules⁵¹¹ but the megakaryocyte is not likely a site of synthesis of either factor, and granule storage is likely to occur after uptake of the protein from plasma.

Hemophilia A and B have attracted a significant amount of attention from those interested in gene therapy, for a variety of reasons. First, they are monogenic diseases for which numerous mutations are known^{512,513} (<http://europium.csc.mrc.ac.uk/WebPages/Main/main.htm>, <http://www.kcl.ac.uk/ip/petergreen/haemBdatabase.html>) and their cDNAs were cloned decades ago.^{514,515} Second, functional factor VIII and factor IX gene products may be produced in nearly any cell type as long as the appropriate post-translational modifications are made and the protein is secreted into the circulation. Most important, epidemiologic data and experience with factor replacement therapy have demonstrated that the level of circulating factor VIII or factor IX required to prevent clinically significant bleeding may be as little as 1% to 2% of normal plasma levels. And finally, there may be a substantial margin for error with regard to overexpression of these factors, due to regulation of the "tenase" (factor VIII/factor IX) enzyme complex and "prothrombinase" (factor V/factor X) complex by the protein C/protein S anticoagulant proteins and antithrombin III. Epidemiologic analyses suggests that elevated factor VIII or factor IX levels may be risk factors for thrombotic diseases,^{516,517} but thus far it seems unlikely that overshooting to supraphysiologic levels of factor VIII or factor IX could occur following gene therapy.

Preclinical testing of hemophilia gene therapies have been facilitated by the existence of several animal models of hemophilia, including factor VIII and factor IX knockout mice^{518, 519, 520} and⁵²¹ and inbred dog colonies with spontaneous hemophilia A and B mutations.^{522, 523, 524, 525} and⁵²⁶ Furthermore, it has proved possible to detect epitope-tagged human factor VIII⁵²⁷ or normal human factor IX^{528, 529, 530} and⁵³¹ in normal rhesus macaques after gene transfer with various vectors, which permits not only safety testing of gene transfer, but also some assessment of gene expression in vivo.

Potential cell types targeted to become "cell factories" for gene transfer of factor VIII or IX include skin fibroblasts or keratinocytes, myocytes, hepatocytes, and BM stem and progenitor cells. Skin fibroblasts are readily propagated in tissue culture and can be transduced by vectors that may include selectable markers. Cells selected in vitro can then be re-introduced to the host, resulting in secretion of the therapeutic protein into the bloodstream. Preclinical studies utilizing skin fibroblasts transduced with factor IX or factor VIII retroviral vectors^{532, 533, 534, 535, 536, 537} and⁵³⁸ in rodents have achieved therapeutic levels of factor IX or factor VIII (>1% of normal). However, a recurring issue in these models has been lack of sustained expression of the transgene, which may be due to loss of transduced cells due to cell-mediated immunity or to promoter shutdown in implanted cells.⁵³⁹ One clinical trial has been performed in which factor VIII transfected skin fibroblasts were implanted in the omentum. The peak factor VIII levels achieved were marginally therapeutic and were not sustained.⁵⁴⁰

Gene transfer of secreted proteins to muscle cells can be performed using muscle-specific and/or nonspecific constitutive promoters to direct gene expression, with direct in vivo delivery of vectors to muscle cells via intramuscular injection. The most extensively studied and successful application of this approach has been through gene transfer utilizing adeno-associated virus vectors. AAV vectors can only package DNA with a total length of ~4.5 kb or less, which is sufficient for transfer of the small factor IX gene, but of limited use for transfer of the much larger factor VIII gene. AAV vectors form stable and long-lasting episomes, and in nondividing tissues such as muscle and liver, can produce long-term stable transgene expression. In vivo preclinical studies with AAV vectors in hemophilia B knockout mice and dogs have shown that it is possible to achieve clinically relevant levels of factor IX and correction of the bleeding phenotype for significant

periods of time following intramuscular injection of FIX-AAV vectors.^{541, 542, 543, 544, 545, 546, 547, 548} and ⁵⁴⁹ These encouraging animal results led directly to a clinical trial of AAV-factor IX gene transfer, involving multiple intramuscular injections of FIX-AAV particles in patients with severe hemophilia B. Plasma factor IX levels (~1% of normal) at doses of 2×10^{11} vector genomes per kg were achieved.⁵⁵⁰ Although the trial was an open label study and a placebo effect cannot be ruled out, there was a lower frequency of joint bleeds as reported by patients.⁵⁵⁰ Unfortunately, higher doses of the vector did not result in a greater therapeutic effect, perhaps due to binding of factor IX to type IV collagen present in muscle, and the intramuscular injection route, requiring very large numbers of individual injections, is impractical and potentially risky in patients with bleeding disorders, even with exogenous factor administration at the time of the procedures.⁵⁵¹ Very prolonged expression from the AAV vector construct was documented on muscle biopsy specimens obtained more than 3 years following the injection of vector.⁵⁵²

Liver hepatocytes synthesize most of the plasma proteins including factors VIII and IX, and synthesize certain proteins (e.g., albumin) in tremendous quantities, thus they are natural factories for secreted proteins. Hepatocytes are readily transducible by various vectors in vitro and in vivo, and gene transfer to liver is currently the most promising approach under investigation for gene therapy of hemophilia. Adenovirus vectors are capable of nearquantitative gene transfer to hepatocytes in vivo when administered intravenously and can accommodate large genes such as factor VIII. It is not surprising that adenovirus vectors have been used for in vivo gene transfer of factor VIII or factor IX to liver cells in various animal models, including mice,^{131,553, 554, 555, 556, 557, 558, 559, 560} and ^{561,562,563,564} monkeys,^{527,528,530} and hemophilic dogs.^{130,565, 566, 567} and ⁵⁶⁸ Unfortunately, adenovirus-mediated gene transfer is typically characterized by gradual loss of gene expression because these vectors do not

P.1517

form stable episomes and do not integrate, and the presence of the adenovirus vector proteins in immune-competent animals induces a cytokine cascade⁵⁶⁹ and has a significant adjuvant effect that may induce antibodies to the expressed gene.^{528,566,567,570} Based on the observation that deletion of adenovirus vector genes may result in longer periods of gene expression and a decreased immune response,⁵⁷⁰ efforts have been made to create and test vectors with most or nearly all of the adenovirus genes removed for gene therapy of hemophilia.^{558,561,571, 572, 573} and ⁵⁷⁴ Any clinical use of adenovirus vectors will be limited by neutralizing antibodies to most common serotypes that are routinely present in most humans and which would be boosted substantially with administration of an adenovirus vector.⁵⁷⁵

Vectors based on various serotypes of AAV have been studied for gene delivery to hepatocytes in hemophilia A and B mice and dogs, and in humans with hemophilia B. The earliest reports of AAV-mediated hepatocyte gene transfer focused on serotypes 1 and 2 vectors expressing factor VIII^{576, 577} and ⁵⁷⁸ and factor IX^{42,267,531,579,580,581, 582, 583, 584, 585, 586, 587, 588} and ⁵⁸⁹ in mice, dogs, and nonhuman primates. These preclinical studies demonstrated levels and duration of factor IX expression sufficient to justify clinical trials of hepatic artery infusion of AAV-2 factor IX vector in patients with severe hemophilia B. The initial trial was temporarily put on hold due to vector shedding in the semen of the first subject enrolled.⁵⁹⁰ After demonstration that the AAV vector was not incorporated in germline DNA, the trial was resumed. The results showed peak expression of 11% of normal factor IX levels in one of seven subjects who was treated with the maximum 2×10^{12} vector genomes/kg dose.⁵⁹¹ Unfortunately, although no inhibitor antibody to factor IX developed, factor IX expression declined and plasma factor IX activity levels returned to baseline within a period of 8 weeks. The decline in factor IX levels was associated with transient elevation of liver transaminases likely due to cell-mediated immune elimination of AAV-transduced hepatocytes. One other subject treated at the maximum achieved a factor IX plasma level of 3% of normal, but also had loss of factor IX expression and elevation of liver enzymes. T-cell responses to the AAV2 capsid protein but not to factor IX were documented in these patients, and it is likely that transient presence of the AAV-2 capsid, brought into the hepatocytes during transduction, stimulated a potent recall immune response in patients previously exposed to wildtype AAV2 viruses in the environment, resulting in immunologic elimination of transduced hepatocytes.⁵⁹² This finding had not been predicted from preclinical studies in large animals, which are not naturally infected by AAV2, underscoring the need for caution in predicting results of clinical trials from animal studies.

Alternative strategies to circumvent these problems tested in animal models have included transient immunomodulation at the time of vector administration, use of alternate AAV serotypes such as 6, 8, or 9 not known to normally infect humans and thus rarely associated with seropositivity, and design of optimized vectors able to express much higher levels of factor IX per genome.^{168, 169} and ^{170,593} The combination of all these strategies has finally resulted in what appears to be unequivocal clinical success. Six patients with hemophilia B received intravenous infusions of AAV8 vectors expressing codon-optimized and self-complementary factor IX genes.¹⁷⁶ All had sustained levels of factor IX of 2% to 11%, and four of the six were able to discontinue prophylactic factor IX infusions. Two patients had transient elevations of liver enzymes, in

one associated with detection of AAV capsid-specific T-cells, but a brief course of methylprednisolone in both led to rapid decrease in transaminases, and no loss of factor IX expression.

Although typical Moloney-based retroviral vectors are not particularly effective at *in vivo* gene transfer to hepatocytes due to the relatively low rate of cell division, lentivirus vectors (which do not require cell division for gene transfer) may prove to be useful for hemophilia gene therapy, and can accommodate larger transgenes and thus are more conducive to factor VIII gene therapy than AAV vectors, particularly B domain-deleted factor VIII, encoding a smaller but still functional protein. Several groups have used pseudotyped lentiviral vectors to transfer the factor VIII cDNA to liver.^{594, 595, 596} and⁵⁹⁷ The efficiency of *in vivo* gene transfer with lentivirus vectors has been far less than that of adenovirus or AAV vectors, but persistent expression has been achieved in some animal models. In some cases, injection of vector into the portal vein is employed to improve efficiency.⁵⁹⁸

Cells of hematopoietic origin are also logical targets for *ex vivo* gene transfer and re-introduction by marrow transplantation to treat hemophilia, because these cells circulate in the blood and, in the case of platelets, are concentrated at the site of vascular injury. This approach may be particularly relevant in patients with existing factor VIII or IX inhibitors, who have been excluded from all prior muscle and hepatocyte gene therapy trials. *Ex vivo* Moloney-based retroviral gene transfer of the human factor VIII gene into hemophilia A knockout mouse BM was not efficient enough to result in detectable plasma levels of human factor VIII after transplantation; however, the animals were rendered tolerant to human factor VIII.⁵⁹⁹ Expression of xenogenic or otherwise completely foreign genes in hematopoietic stem and progenitor cells via gene transfer is known to result in induction of tolerance.^{600,601} Investigators have been able to show expression of factor VIII in platelets produced from lentivirus-transduced BM in hemophilia A mice.^{602,603} The latter approach utilized a promoter for the α IIb glycoprotein (normally expressed on the surface of platelets) to restrict expression of factor VIII to the platelet, and to target expression of factor VIII to sites of vascular injury.

Future issues to be addressed in the field of hemophilia gene therapy include minimizing the risk of inhibitor formation or immune rejection of transduced cells (especially with viral gene transfer vectors), development of vectors capable of sustained high levels of coagulation factor expression, and avoidance of unintentional germline transmission of vector sequences. Strategies are being explored allowing expression of functional factor VIII despite its prohibitory large gene size, including deletion of certain nonfunctional domains (B domain deleted), splitting of the gene into two portions encoded by two independent AAV vectors with transcripts that are spliced *in vivo* prior to protein translation, or expression of the light and heavy chain of factor VII in two independent vectors.^{604,605}

SAFETY AND FEASIBILITY HURDLES TO CLINICAL GENE THERAPY

Immune Responses to Vectors and Transgenes

Immune responses against vector proteins or the transgene-encoded protein itself have only recently become the focus of intensive investigation. For *in vivo* vector administration, pre-existing immunity to a vector such as adenovirus is at least a theoretical concern. Repeated *in vivo* administration of complex vectors clearly stimulates an active immune response to vector proteins, and greatly hinders success. The expression of viral genes remaining in the vector sequences could also stimulate an immune response against transduced target cells. This is not a problem for retroviral vectors; as well, newer modifications of adenoviral vectors have been developed that no longer contain or express residual adenoviral genes.^{125,126} Nonhuman marker genes such as the neomycin resistance gene, or viral suicide genes such as tk included in vectors for positive or negative selection may also induce an immune response.⁶⁰⁶ Finally, the therapeutic gene product itself may induce an immune response if the patient completely lacks the endogenous gene product or the transgenic protein is processed or post-translationally modified.¹²¹

Rejection of the foreign transgene itself can be the primary problem, even when highly immunogenic adenoviral vectors are

P.1518

used. Recombinant adenoviral vectors encoding either murine or human Epo genes or a control vector without an expressed gene were injected into murine muscle and the mice were followed for several months for Epo expression and presence of the vector sequences in muscle.¹²¹ Mice expressing either human or murine Epo transgenes developed high hematocrits, but the effect was transient in those expressing human Epo, as profound anemia, surprisingly, developed after the transient polycythemia. Immune responses to both the vector-expressed human Epo and endogenous murine Epo were documented in these animals, indicating that the active immune reaction against the human Epo had also generated cross-reactivity toward endogenous Epo. Adenoviral genomes were detectable long term in the muscles of the

murine Epo and of the control mice, but not in the human Epo mice. This suggested that the immune response was elicited by expression of the foreign transgene, not by viral proteins.

In a murine model of allogeneic skin graft survival, foreign genes expressed by HSCs and their progeny may be capable of inducing tolerance even across MHC barriers.⁶⁰⁷ This evidence, and documentation in mice of very long-term persistence of expression of completely xenogeneic genes such as human GC, suggests that immune responses against genes introduced via repopulating stem cells will not induce immune responses.^{206,608} On the other hand, immune responses to a retroviral vector-introduced transgene in the canine MPS-1 autologous transplantation model have been shown to limit efficiency.⁶⁰⁹

In the murine model, tolerance to xenogeneic genes can be achieved by introduction through the hematopoietic compartment.⁶¹⁰ Long-term persistence of genetically modified cells at clinically relevant levels can be achieved after very low-dose irradiation with 100 cGy, even when highly immunogenic genes are transferred. Large animal testing in the nonhuman primate confirmed these observations, with equivalent levels of long-term engraftment of cells transduced with either a vector encoding the neomycin phosphotransferase (neo) or a vector carrying but not expressing this gene product, but the overall levels of engraftment were much lower.⁶¹¹ Transduction of lymphocytes in the absence of conditioning, however, resulted in rapid clearance of the neo expressing cells. However, if HSCs were transduced and transplanted first, long-term persistence of lymphocytes transduced with the neo expressing vector were observed.⁶⁰⁰

Various methods of immunosuppression have been at least partially successful in avoiding immune rejection of transduced cells. Neonatal exposure to vector has allowed repeated treatments with adenoviral vectors.¹³¹ Treatment with cyclosporine, cyclophosphamide, or IL-12 have all been reported to prolong survival of transduced cells.^{128, 129, 130, 131} and ¹³² But these general pharmacologic approaches are not desirable or practical for most gene therapy applications, which are attractive only if they prevent lifelong reliance on toxic pharmacologic agents. Instead, improved vector design and possible inclusion of antirejection mechanisms in the vectors themselves are more attractive approaches.

Safety Considerations

The number of individuals who have safely received genetic material in the form of vectors or vector-modified cells now numbers in the many thousands, suggesting that current gene transfer approaches generally carry a low risk to subjects, however, all but a small minority of these patients likely had no clinical benefit, and risks must therefore be considered in this context. Only recently have trials moved beyond safety testing into pilot studies of efficacy for a number of hematologic diseases. Pioneering trials, as detailed above, have provided encouraging results regarding efficacy of gene therapy for congenital immunodeficiency disorders, hemophilia, thalassemia, and metabolic disorders. However, very serious and in some cases fatal severe adverse events directly linked to gene therapy have occurred, and have had significant repercussions from regulatory, clinical, and scientific standpoints.

Phase 1 Gene Therapy Trial for Ornithine Transcarbamylase

Side effects of gene transfer can result from all aspects of the process, including those inherent to a specific vector system, vector production methodology, target cell identification and manipulation, vector integration, transgene expression, or selective pressure applied after transfer.⁶¹² The first reported serious complication of gene therapy occurred when an 18-year-old patient with relatively mild manifestations of OTC deficiency volunteered for a Phase 1 dose escalation gene therapy trial and received a catheter-directed infusion of a high dose of an adenoviral vector encoding the corrective gene into the hepatic artery. Within hours of the infusion, signs and symptoms of a systemic immune response syndrome appeared, and soon thereafter the patient died from multiorgan system failure. Studies infusing similar adenoviral vectors into nonhuman primates have shown evidence for activation of the innate immune response attributable to the adenovirus capsids as well as a vigorous proinflammatory IL-6 and IL-1 cytokine response, with evidence for endothelial damage and disseminated intravascular coagulation.^{528,530,613} The induction of acute phase reactants was anticipated from the preclinical data in nonhuman primates; however, the severity and duration of the fatal reaction observed in this patient was not expected at the dose level reached. As a result of the death, many clinical gene therapy trials were temporarily put on hold and the maximum doses of adenovirus (or other) vectors to be given to humans were scaled back as a precautionary measure. Furthermore, a number of issues with respect to the pace of clinical gene therapy trials, the informed consent process, subject eligibility, reporting of adverse events, and oversight of clinical gene therapy trials were raised, and measures to increase the protection of research subjects were uniformly instituted across all gene therapy trials.^{614,615}

Gene Therapy for X-SCID

Soon after the first unequivocal demonstration of clinical efficacy in a human gene therapy trial in which 10 of 11 children with SCID who received retrovirally transduced autologous BM cells were apparently cured,²² two patients developed a

precipitous rise in T-cell counts which progressed to overt leukemia 3 years following infusion of gene-corrected autologous CD34⁺ cells.²⁶⁵ Retroviral integration site analysis in the leukemia cells from both patients demonstrated vector insertions within or just upstream of the LMO2 gene activating expression.⁴⁵¹ LMO2 is a transcription factor required for fetal hematopoietic development and was already known to be activated by chromosomal translocations in some cases of spontaneous childhood T-cell leukemia.⁶¹⁶ Since that time, an additional two of the eleven X-SCID patients enrolled in the original French trial and one of ten patients enrolled in a similar trial in England have developed clonal vector-associated T-cell leukemias.^{448,454} Strikingly, four of the five patients had vector insertions activating LMO2, and the fifth had a vector insertion activating the CCND2 gene, encoding cyclin D, a protein known to control cell cycle entry and to be associated with cancer when dysregulated. One of the four patients has died of complications related to the leukemic process and its treatment, and the others have been successfully treated with chemotherapy.

The first report of these adverse events in 2003 resulted in a rapid response from investigators and regulatory agencies worldwide, with most gene therapy trials utilizing integrating MLV-derived retroviral vectors to transduce hematopoietic stem and progenitor cells put on hold. The occurrence of these events was not predicted. Prior to the sequencing of the murine and human genomes, retroviral insertion was thought to be random,

P.1519

based on the lack of any specific motif at the few insertion sites that had been mapped. It was predicted that just one or a few insertions into a cell's genome was unlikely to activate a proto-oncogene, based on the size of the genome and assumed random insertion.⁶¹⁷ Vector-containing leukemias and lymphomas had previously been reported in animal models utilizing HSC gene transfer, but were attributed to contamination by replication-competent viruses in a nonhuman primate study, resulting in multiple proviral insertions and eventual activation of a proto-oncogene, or overexpression of a signaling receptor in a murine model.^{78,618}

There was initially an intense focus on whether specific aspects of X-SCID patients themselves or constitutive expression of the IL2R γ transgene predisposed to vector-associated leukemia. One murine study suggested a greatly increased risk of leukemia when an IL2r γ transgene was overexpressed, and another reported a nonrandom relationship between activation of the Lmo2 and IL2r γ genes and leukemias and lymphomas in susceptible neonatal mice.^{619,620} Other unique aspects of the X-SCID clinical situation were proposed to have contributed to increasing risk, including the rapid expansion of lymphoid progenitors and mature T-cells into an "empty" lymphoid compartment, very high doses of transduced CD34⁺ cells, and impaired antitumor immunity. To date none of the patients enrolled in ADA gene therapy trials, even those receiving transduced CD34⁺ cells, have developed leukemia. A large survey of rhesus macaques, dogs, and baboons transplanted with CD34⁺ cells transduced with standard retrovirus vectors containing marker genes or drug resistance genes failed to document any hematologic abnormalities, or progression to clonal or oligoclonal hematopoiesis, with a median follow-up of over 3 years.⁶²¹ And it is of interest that there have been no vector-related clonal expansions or malignant transformations detected in patients receiving transduced T-cells, or undergoing in vivo gene therapy targeting hepatocytes, muscle cells, or other nonhematopoietic targets. It appears that HSCs are much more susceptible than differentiated cells to vector-related tumorigenesis.⁶²²

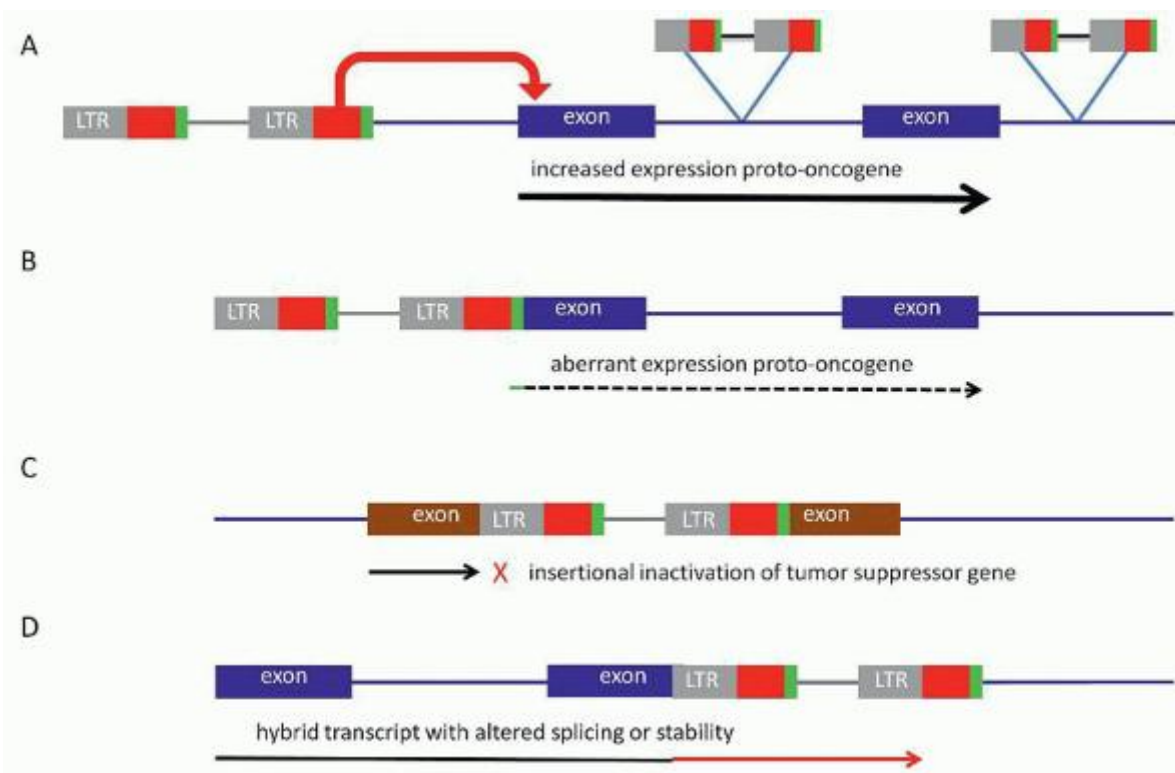

FIGURE 71.9. Mechanisms of gene dysregulation and oncogenesis via vector integration into genomic DNA. The reverse-transcribed retroviral or lentiviral DNA permanently integrates into the genome, and can disrupt endogenous gene expression via a number of mechanisms. The integrated vector consists of two identical long terminal repeats (LTR) that contain a strong enhancer (red) and a promoter (green). A: If the vector lands upstream, downstream, or within an intron of a proto-oncogene, the LTR enhancer can up-regulate expression of the proto-oncogene. B: If the vector integrates within the first exon of a proto-oncogene, a constitutively expressed fusion transcript can result, with loss of endogenous control of expression. C: Vector integration within an exon can completely inactivate expression of a tumor suppressor gene via production of a truncated or fusion transcript. D: Vector integration can disrupt normal exon/intron or isoform splicing, resulting in an aberrantly regulated transcript, and up-regulation of a proto-oncogene or down-regulation of a tumor suppressor gene.

Large-Scale Mapping of Gene Transfer Vector Insertion Sites

Concurrent with these adverse events, the entire human and murine genome sequences were published and new technologies were developed that permitted large-scale mapping of vector insertion sites. The insertion of a vector proviral form into the genome can affect gene expression and thus potentially promote malignant transformation via several different mechanisms, as detailed in Fig. 71.9 and discussed in detail in a number of reviews.^{462,623} The Moloney MLV proviral LTR contains a strong promoter and enhancer, able to activate expression of upstream or downstream genes at distances of up to 200 kb, or directly drive expression of gene via fusion or replacement of the endogenous promoter. Internal promoters or enhancers, included to enhance transgene expression, can also activate nearby genes. A proviral insertion can inactivate a tumor-repressor gene. Vector insertion can disrupt normal exon splicing and alter

P.1520

relative levels of transcript isoforms or stability. Detailed large-scale mapping studies in cell lines and in primary hematopoietic cells revealed clear biases in integration site preferences for both standard retroviral as well as lentiviral vectors. MLV retroviral vectors were more likely to integrate near transcription start sites of genes, and HIV and SIV vectors were likely to integrate in generic regions and within actual genes.^{624, 625} and ⁶²⁶

Integration patterns were also assessed over time in mice, large animals, and patients receiving transduced cells. Murine studies using high-titer retroviral vectors and performing much longer follow-up than previous studies documented a high rate of progression to clonal or oligoclonal hematopoiesis, specifically from clones with insertions into proto-oncogenes or other growth-altering loci, and frequent leukemias in secondary and tertiary recipients of transduced cells, associated

with insertions into proto-oncogenes.^{627, 628} A rhesus macaque transplanted 5 years previously with retroviral vector-transduced CD34⁺ cells developed a clonal myeloid leukemia containing a vector insertion in the antiapoptotic gene BCL2A1.⁶²⁹ A large-scale survey of retrovirus vector insertion sites in long-term repopulating cells of rhesus macaques uncovered one locus that was markedly overrepresented, with nine independent insertions into the MDS1/EVI1 proto-oncogene, accounting for 2% of all insertions mapped.⁶²⁶ Proviral insertions at this locus were also identified in immortalized myeloid cell lines generated in vitro from retrovirus vector transduced primary murine BM cells.⁶³⁰

Gene Therapy for Chronic Granulomatous Disease

Even more striking dominance of myeloid hematopoiesis derived from progenitors with vector insertions in the MDS1/EVI1 locus was reported in a clinical trial for CGD. As described above, two patients received CD34⁺ cells transduced with a retroviral vector expressing the corrective phox91 transgene. Initially the patients did very well but the level of vector-containing cells began to increase in the myeloid lineage beginning several months after transplantation, eventually reaching levels of 60% to 70%. This expansion was found to be almost entirely accounted for by contributions from clones with insertions in the MDS1/EVI1 locus.⁴⁴⁶ Both patients then progressed to clonal myelodysplasia/myeloid leukemia, derived from one of their MDS1/EVI1 clones, and associated with a secondary loss of chromosome 7 in the malignant cells.⁴⁵⁸ Despite the persistent high frequency of vector-corrected neutrophils, expression of NADPH oxidase dropped precipitously in both subjects over time. The silencing of NADPH oxidase occurred through progressive CpG methylation of the promoter contained in the LTR of the vector. These events led to a series of infections and eventual death of one patient. The second subject was referred for unrelated donor SCT while still infection free.

Gene Therapy for Wiskott-Aldrich Syndrome

In nine of ten patients with WAS treated by gene therapy, clinical improvement was initially demonstrated. However, in a subsequent report, two of nine patients who achieved an efficient correction of the disease developed T-ALL 5 years and 16 months after gene therapy, respectively. Two additional patients also developed T-ALL more recently (unpublished data). In three of four patients with T-ALL analyzed to date, an increase of a cell clone harboring an integration site upstream of LMO2 could be observed at the onset of leukemia, the same gene locus activated by vector insertion in most of the X-SCID patients that developed T-ALL. One patient underwent an allogeneic stem cell transplant and the other individuals have responded to chemotherapy with recovery of a polyclonal integration site pattern.

Approaches to Decreasing the Risk of Insertional Genotoxicity

The insertion pattern of lentiviral vectors based on HIV or SIV is potentially safer, given that transcription start sites are not targeted. HIV/SIV vectors also have all endogenous promoter/enhancer elements deleted from the LTR, and thus should be much less likely to activate an adjacent proto-oncogene. A lower rate of leukemic transformation or cellular immortalization with HIV as compared to standard MLV-based retroviral vectors has been reported using several preclinical models, and long-term follow-up of nonhuman primates receiving SIV-transduced cells has not revealed any clonal dominance.^{353,631,632} Highly polyclonal patterns have persisted long-term in several patients receiving HIV vector-transduced CD34⁺ cells on a clinical trial for ALD.¹⁰² However, a single patient enrolled in a lentiviral vector-based gene therapy trial for thalassemia has developed clonal expansion of cells containing an insertion in the HMG2A gene,¹⁰³ indicating that we do not yet fully understand the possible pathways to clonal dominance and associated risks with any integrating vector system.

The clinical adverse events and these laboratory findings strongly support the need for long-term toxicity assessment in predictive preclinical models, development of vector systems less likely to activate or otherwise alter the behavior of adjacent genes, and careful risk-benefit analysis of gene therapy target diseases and patient populations. Use of standard retroviral vectors with strong enhancers in their LTRs is no longer considered prudent for HSC-targeted gene therapy, but whether lentiviral vectors, enhancer-deleted retroviral vectors, novel vector systems such as HFV or avian leukosis sarcoma virus, or gene targeting approaches will be safer and sufficiently efficacious is not yet known, and may vary depending on patient, target cell, and disease-specific characteristics. Well-designed pilot clinical trials in patients with sufficient disease severity to justify participation in a potentially risky protocol and a level of understanding allowing authentic informed consent will in the end provide the relevant path forward for gene therapy, no matter how many careful preclinical studies have been performed.

CONCLUSIONS

A wide variety of imaginative approaches involving genetic manipulation of hematopoietic or other targets have led to the first clinical successes of gene therapy approaches to hematologic diseases such as the hemophilias and the immunodeficiencies and are certain to eventually revolutionize therapy for a number of currently fatal or disabling

conditions. Continued basic scientific investigation of target cell biology and vector systems along with carefully designed clinical trials will drive the eventual application of gene therapy on a large scale.

REFERENCES

1. Blau HM, Springer ML. Gene therapy-a novel form of drug delivery. *N Engl J Med* 1995;333(18):1204-1207.
2. Mulligan RC. The basic science of gene therapy. *Science* 1993;260(5110): 926-932.
3. Miller AD. Human gene therapy comes of age. *Nature* 1992;357(6378):455-460.
4. Kerr WG, Mule JJ. Gene therapy: current status and future prospects. *J Leukoc Biol* 1994;56(2):210-214.
5. Mann R, Mulligan RC, Baltimore D. Construction of a retrovirus packaging mutant and its use to produce helper-free defective retrovirus. *Cell* 1983;33(1):153-159.
6. Blaese RM, Culver KW, Miller AD, et al. T lymphocyte-directed gene therapy for ADA- SCID: initial trial results after 4 years. *Science* 1995;270(5235): 475-480.
7. Rosenberg SA, Aebersold P, Cornetta K, et al. Gene transfer into humans-immunotherapy of patients with advanced melanoma, using tumor-infiltrating lymphocytes modified by retroviral gene transduction. *N Engl J Med* 1990;323(9):570-578.
8. Anderson WF, Blaese RM, Culver K. The ADA human gene therapy clinical protocol: points to Consider response with clinical protocol, July 6 1990. *Hum Gene Ther* 1990;1(3):331-362.
9. Orkin SH, Motulsky AG. Report and recommendations of the panel to assess the NIH investment in research on gene therapy, Report to the NIH Director 1995.
10. Greenberg DS Gene therapy: caution and hope. *Lancet* 1995;346(8990):1617.
11. Leiden JM. Gene therapy--promise, pitfalls, and prognosis. *N Engl J Med* 1995;333(13):871-873.
12. Marshall E. Less hype, more biology needed for gene therapy. *Science* 1995;270(5243):1751.
13. Karlsson S. Treatment of genetic defects in hematopoietic cell function by gene transfer. *Blood* 1991;78(10):2481-2492.
14. Dunbar CE. Gene transfer to hematopoietic stem cells: implications for gene therapy of human disease. *Annu Rev Med* 1996;47:11-20.
15. Jordan CT, Lemischka IR. Clonal and systemic analysis of long-term hematopoiesis in the mouse. *Genes Dev* 1990;4(2):220-232.
16. Lemischka IR, Raulet DH, Mulligan RC. Developmental potential and dynamic behavior of hematopoietic stem cells. *Cell* 1986;45(6):917-927.
17. Lemischka IR. What we have learned from retroviral marking of hematopoietic stem cells. *Curr Top Microbiol Immunol* 1992;177:59-71.
18. Daley GQ, Van Etten RA, Baltimore D. Induction of chronic myelogenous leukemia in mice by the P210bcr/abl gene of the Philadelphia chromosome. *Science* 1990;247(4944):824-830.
19. Brandt SJ, Bodine DM, Dunbar CE, et al. Dysregulated interleukin 6 expression produces a syndrome resembling Castleman's disease in mice. *J Clin Invest* 1990;86(2):592-599.
20. Wong PM, Chung SW, Dunbar CE, et al. Retrovirus-mediated transfer and expression of the interleukin-3 gene in mouse hematopoietic cells result in a myeloproliferative disorder. *Mol Cell Biol* 1989;9(2):798-808.
21. Wilson JM. Animal models of human disease for gene therapy. *J Clin Invest* 1996;97(5):1138-1141.
22. Cavazzana-Calvo M, Hacein-Bey S, de Saint Basile G, et al. Gene therapy of human severe combined immunodeficiency (SCID)-X1 disease [see comments]. *Science* 2000;288(5466):669-672.
23. Aiuti A, Slavin S, Aker M, et al. Correction of ADA-SCID by stem cell gene therapy combined with nonmyeloablative conditioning. *Science* 2002;296(5577): 2410-2413.
24. Capecchi MR. Altering the genome by homologous recombination. *Science* 1989;244(4910):1288-1292.
25. Camerini-Otero RD, Hsieh P. Homologous recombination proteins in prokaryotes and eukaryotes. *Annu Rev Genet* 1995;29:509-552.

26. Stasiak A. Getting down to the core of homologous recombination. *Science* 1996;272(5263):828-829.
 27. Peters T. "Playing God" and germline intervention. *J Med Philos* 1995;20(4): 365-386.
 28. Cornetta K, Morgan RA, Anderson WF. Safety issues related to retroviral-mediated gene transfer in humans. *Hum Gene Ther* 1991;2(1):5-14.
 29. Cooper MJ. Noninfectious gene transfer and expression systems for cancer gene therapy. *Semin Oncol* 1996;23(1):172-187.
 30. Miller AD. Cell-surface receptors for retroviruses and implications for gene transfer. *Proc Natl Acad Sci U S A* 1996;93(21):11407-11413.
 31. Yang Y, Vanin EF, Whitt MA, et al. Inducible, high-level production of infectious murine leukemia retroviral vector particles pseudotyped with vesicular stomatitis virus G envelope protein. *Hum Gene Ther* 1995;6(9):1203-1213.
- P.1521
32. Burns JC, Friedmann T, Driever W, et al. Vesicular stomatitis virus G glycoprotein pseudotyped retroviral vectors: concentration to very high titer and efficient gene transfer into mammalian and nonmammalian cells. *Proc Natl Acad Sci U S A* 1993;90(17):8033-8037.
 33. Hopkins N. High titers of retrovirus (vesicular stomatitis virus) pseudotypes, at last. *Proc Natl Acad Sci U S A* 1993;90(19):8759-8760.
 34. Kasahara N, Dozy AM, Kan YW. Tissue-specific targeting of retroviral vectors through ligand-receptor interactions. *Science* 1994;266(5189): 1373-1376.
 35. Holland CA, Anklesaria P, Sakakeeny MA, et al. Enhancer sequences of a retroviral vector determine expression of a gene in multipotent hematopoietic progenitors and committed erythroid cells. *Proc Natl Acad Sci U S A* 1987;84(23):8662-8666.
 36. Miller JL, Walsh CE, Ney PA, et al. Single-copy transduction and expression of human gamma-globin in K562 erythroleukemia cells using recombinant adeno-associated virus vectors: the effect of mutations in NF-E2 and GATA-1 binding motifs within the hypersensitivity site 2 enhancer. *Blood* 1993;82(6):1900-1906.
 37. Wu X, Holschen J, Kennedy SC, et al. Retroviral vector sequences may interact with some internal promoters and influence expression. *Hum Gene Ther* 1996;7(2):159-171.
 38. Hofmann A, Nolan GP, Blau HM. Rapid retroviral delivery of tetracycline-inducible genes in a single autoregulatory cassette. *Proc Natl Acad Sci U S A* 1996;93(11):5185-5190.
 39. Gossen M, Freundlieb S, Bender G, et al. Transcriptional activation by tetracyclines in mammalian cells. *Science* 1995;268(5218):1766-1769.
 40. Williams DA, Lim B, Spooner E, et al. Restriction of expression of an integrated recombinant retrovirus in primary but not immortalized murine hematopoietic stem cells. *Blood* 1988;71(6):1738-1743.
 41. Lu M, Maruyama M, Zhang N, et al. High efficiency retroviral-mediated gene transduction into CD34+ cells purified from peripheral blood of breast cancer patients primed with chemotherapy and granulocyte-macrophage colony-stimulating factor. *Hum Gene Ther* 1994;5(2):203-208.
 42. Challita PM, Kohn DB. Lack of expression from a retroviral vector after transduction of murine hematopoietic stem cells is associated with methylation in vivo. *Proc Natl Acad Sci U S A* 1994;91(7):2567-2571.
 43. Zhang WW, Fujiwara T, Grimm EA, et al. Advances in cancer gene therapy. *Adv Pharmacol* 1995;32:289-341.
 44. Wolff JA, Malone RW, Williams P, et al. Direct gene transfer into mouse muscle in vivo. *Science* 1990;247(4949 Pt 1):1465-1468.
 45. McDonnell WM, Askari FK. DNA vaccines. *N Engl J Med* 1996;334(1): 42-45.
 46. Donnelly JJ, Friedman A, Martinez D, et al. Preclinical efficacy of a prototype DNA vaccine: enhanced protection against antigenic drift in influenza virus. *Nat Med* 1995;1(6):583-587.
 47. Mannino RJ, Gould-Fogerite S. Liposome mediated gene transfer. *Biotechniques* 1988;6(7):682-690.

48. Yang NS, Sun WH. Gene gun and other non-viral approaches for cancer gene therapy. *Nat Med* 1995;1(5):481-483.
49. Johnston SA, Tang DC. Gene gun transfection of animal cells and genetic immunization. *Methods Cell Biol* 1994;43 Pt A:353-365.
50. Woffendin C, Yang ZY, Udaykumar, et al. Nonviral and viral delivery of a human immunodeficiency virus protective gene into primary human T cells. *Proc Natl Acad Sci U S A* 1994;91(24):11581-11585.
51. Klein RM, Wolf ED, Wu R, et al. High-velocity microprojectiles for delivering nucleic acids into living cells. 1987. *Biotechnology* 1992;24:384-386.
52. Yang NS, Burkholder J, Roberts B, et al. In vivo and in vitro gene transfer to mammalian somatic cells by particle bombardment. *Proc Natl Acad Sci U S A* 1990;87(24):9568-9572.
53. Shigekawa K, Dower WJ. Electroporation of eukaryotes and prokaryotes: a general approach to the introduction of macromolecules into cells. *Biotechniques* 1988;6(8):742-751.
54. Chen CA, Okayama H. Calcium phosphate-mediated gene transfer: a highly efficient transfection system for stably transforming cells with plasmid DNA. *Biotechniques* 1988;6(7):632-638.
55. Andreason GL, Evans GA. Introduction and expression of DNA molecules in eukaryotic cells by electroporation. *Biotechniques* 1988;6(7):650-660.
56. Farhood H, Gao X, Son K, et al. Cationic liposomes for direct gene transfer in therapy of cancer and other diseases. *Ann N Y Acad Sci* 1994;716:23-34; discussion 34-35.
57. Felgner PL, Tsai YJ, Sukhu L, et al. Improved cationic lipid formulations for in vivo gene therapy. *Ann N Y Acad Sci* 1995;772:126-139.
58. Labat-Moleur F, Steffan AM, Brisson C, et al. An electron microscopy study into the mechanism of gene transfer with lipopolyamines. *Gene Ther* 1996;3(11):1010-1017.
59. Zhu N, Liggitt D, Liu Y, et al. Systemic gene expression after intravenous DNA delivery into adult mice. *Science* 1993;261(5118):209-211.
60. Baudard M, Flotte TR, Aran JM, et al. Expression of the human multidrug resistance and glucocerebrosidase cDNAs from adeno-associated vectors: efficient promoter activity of AAV sequences and in vivo delivery via liposomes. *Hum Gene Ther* 1996;7(11):1309-1322.
61. Cristiano RJ, Roth JA. Molecular conjugates: a targeted gene delivery vector for molecular medicine. *J Mol Med* 1995;73(10):479-486.
62. Cristiano RJ, Curiel DT. Strategies to accomplish gene delivery via the receptor-mediated endocytosis pathway. *Cancer Gene Ther* 1996;3(1): 49-57.
63. Cotten M, Wagner E, Zatloukal K, et al. High-efficiency receptor-mediated delivery of small and large (48 kilobase gene constructs using the endosomedisruption activity of defective or chemically inactivated adenovirus particles. *Proc Natl Acad Sci U S A* 1992;89(13):6094-6098.
64. Wagner E, Zatloukal K, Cotten M, et al. Coupling of adenovirus to transferrin-polylysine/DNA complexes greatly enhances receptor-mediated gene delivery and expression of transfected genes. *Proc Natl Acad Sci U S A* 1992;89(13):6099-6103.
65. Michael SI, Huang CH, Romer MU, et al. Binding-incompetent adenovirus facilitates molecular conjugate-mediated gene transfer by the receptor-mediated endocytosis pathway. *J Biol Chem* 1993;268(10):6866-6869.
66. Schwarzenberger P, Spence SE, Gooya JM, et al. Targeted gene transfer to human hematopoietic progenitor cell lines through the c-kit receptor. *Blood* 1996;87(2):472-478.
67. Curiel DT. Adenovirus facilitation of molecular conjugate-mediated gene transfer. *Prog Med Virol* 1993;40:1-18.
68. Ledley FD. Nonviral gene therapy: the promise of genes as pharmaceutical products. *Hum Gene Ther* 1995;6(9):1129-1144.
69. Smith AE. Viral vectors in gene therapy. *Annu Rev Microbiol* 1995;49:807-838.
70. Gunzburg WH, Salmons B. Development of retroviral vectors as safe, targeted gene delivery systems. *J Mol Med* 1996;74(4):171-182.

71. Miller AD. Retroviral vectors. *Curr Top Microbiol Immunol* 1992;158:1-24.
72. Coffin JM, ed. Retroviridae: the viruses and their replication. In Fields BN, Knipe DM, Howley PM, eds. *Field's virology*. Philadelphia, PA: Lippincott-Raven, 1996:1767-1847.
73. Kozak SL, Siess DC, Kavanaugh MP, et al. The envelope glycoprotein of an amphotropic murine retrovirus binds specifically to the cellular receptor/phosphate transporter of susceptible species. *J Virol* 1995;69(6):3433-3440.
74. Miller DG, Edwards RH, Miller AD. Cloning of the cellular receptor for amphotropic murine retroviruses reveals homology to that for gibbon ape leukemia virus. *Proc Natl Acad Sci U S A* 1994;91(1):78-82.
75. Kavanaugh MP, Miller DG, Zhang W, et al. Cell-surface receptors for gibbon ape leukemia virus and amphotropic murine retrovirus are inducible sodium-dependent phosphate symporters. *Proc Natl Acad Sci U S A* 1994;91(15):7071-7075.
76. Boris-Lawrie K, Temin HM. The retroviral vector. Replication cycle and safety considerations for retrovirus-mediated gene therapy. *Ann N Y Acad Sci* 1994;716:59-70; discussion 71.
77. Kurth R. Risk potential of the chromosomal insertion of foreign DNA. *Ann N Y Acad Sci* 1995;772:140-151.
78. Donahue RE, Kessler SW, Bodine D, et al. Helper virus induced T cell lymphoma in nonhuman primates after retroviral mediated gene transfer. *J Exp Med* 1992;176(4):1125-1135.
79. Miller AD, Buttimore C. Redesign of retrovirus packaging cell lines to avoid recombination leading to helper virus production. *Mol Cell Biol* 1986;6(8):2895-2902.
80. Miller AD. Retrovirus packaging cells. *Hum Gene Ther* 1990;1(1):5-14.
81. Markowitz D, Goff S, Bank A. A safe packaging line for gene transfer: separating viral genes on two different plasmids. *J Virol* 1988;62(4):1120-1124.
82. Ory DS, Neugeboren BA, Mulligan RC. A stable human-derived packaging cell line for production of high titer retrovirus/vesicular stomatitis virus G pseudotypes. *Proc Natl Acad Sci U S A* 1996;93(21):11400-11406.
83. Rigg RJ, Chen J, Dando JS, et al. A novel human amphotropic packaging cell line: high titer, complement resistance, and improved safety. *Virology* 1996;218(1):290-295.
84. Miller DG, Adam MA, Miller AD. Gene transfer by retrovirus vectors occurs only in cells that are actively replicating at the time of infection. *Mol Cell Biol* 1990;10(8):4239-4242.
85. Orlic D, Girard LJ, Jordan CT, et al. The level of mRNA encoding the amphotropic retrovirus receptor in mouse and human hematopoietic stem cells is low and correlates with the efficiency of retrovirus transduction. *Proc Natl Acad Sci U S A* 1996;93(20):11097-11102.
86. Cosset FL, Morling FJ, Takeuchi Y, et al. Retroviral retargeting by envelopes expressing an N-terminal binding domain. *J Virol* 1995;69(10): 6314-6322.
87. Yee JK, Friedmann T, Burns JC. Generation of high-titer pseudotyped retroviral vectors with very broad host range. *Methods Cell Biol* 1994;43 Pt A:99-112.
88. Horn PA, Topp MS, Morris JC, et al. Highly efficient gene transfer into baboon marrow repopulating cells using GALV-pseudotype oncoretroviral vectors produced by human packaging cells. *Blood* 2002;100(12):3960-3967.
89. Kelly PF, Vandergriff J, Nathwani A, et al. Highly efficient gene transfer into cord blood nonobese diabetic/severe combined immunodeficiency repopulating cells by oncoretroviral vector particles pseudotyped with the feline endogenous retrovirus (RD114) envelope protein. *Blood* 2000;96(4):1206-1214.
90. Kiem HP, Heyward S, Winkler A, et al. Gene transfer into marrow repopulating cells: comparison between amphotropic and gibbon ape leukemia virus pseudotyped retroviral vectors in a competitive repopulation assay in baboons. *Blood* 1997;90(11):4638-4645.
91. Chuck AS, Palsson BO. Consistent and high rates of gene transfer can be obtained using flow-through transduction over a wide range of retroviral titers. *Hum Gene Ther* 1996;7(6):743-750.
92. Moritz T, Dutt P, Xiao X, et al. Fibronectin improves transduction of reconstituting hematopoietic stem cells by retroviral vectors: evidence of direct viral binding to chymotryptic carboxy-terminal fragments. *Blood* 1996;88(3): 855-862.

93. Kotani H, Newton PB 3rd, Zhang S, et al. Improved methods of retroviral vector transduction and production for gene therapy. *Hum Gene Ther* 1994;5(1):19-28.
94. Shimada T, Fujii H, Mitsuya H, et al. Targeted and highly efficient gene transfer into CD4+ cells by a recombinant human immunodeficiency virus retroviral vector. *J Clin Invest* 1991;88(3):1043-1047.
95. Naldini L, Blomer U, Gallay P, et al. In vivo gene delivery and stable transduction of nondividing cells by a lentiviral vector. *Science* 1996;272(5259): 263-267.
96. Reiser J, Harmison G, Kluepfel-Stahl S, et al. Transduction of nondividing cells using pseudotyped defective high-titer HIV type 1 particles. *Proc Natl Acad Sci U S A* 1996;93(26):15266-15271.
97. Heinzinger NK, Bukinsky MI, Haggerty SA, et al. The Vpr protein of human immunodeficiency virus type 1 influences nuclear localization of viral nucleic acids in nondividing host cells. *Proc Natl Acad Sci U S A* 1994;91(15): 7311-7315.
98. Naldini L, Blomer U, Gage FH, et al. Efficient transfer, integration, and sustained long-term expression of the transgene in adult rat brains injected with a lentiviral vector. *Proc Natl Acad Sci U S A* 1996;93(21):11382-11388.
99. May C, Rivella S, Callegari J, et al. Therapeutic haemoglobin synthesis in betathalassaemic mice expressing lentivirus-encoded human beta-globin. *Nature* 2000;406(6791):82-86.
100. Podsakoff GM. Lentiviral vectors approach the clinic but fall back: National Institutes of Health Recombinant DNA Advisory Committee review of a first clinical protocol for use of a lentiviral vector. *Mol Ther* 2001;4(4):282-283.
101. Manilla P, Rebello T, Afable C, et al. Regulatory considerations for novel gene therapy products: a review of the process leading to the first clinical lentiviral vector. *Hum Gene Ther* 2005;16(1):17-25.
102. Cartier N, Hacein-Bey-Abina S, Bartholomae CC, et al. Hematopoietic stem cell gene therapy with a lentiviral vector in X-linked adrenoleukodystrophy. *Science* 2009;326(5954):818-823.
103. Cavazzana-Calvo M, Payen E, Negre O, et al. Transfusion independence and HMGA2 activation after gene therapy of human beta-thalassaemia. *Nature* 2010;467(7313):318-322.
104. Yu SF, Baldwin DN, Gwynn SR, et al. Human foamy virus replication: a pathway distinct from that of retroviruses and hepadnaviruses. *Science* 1996;271(5255):1579-1582.
105. Bieniasz PD, Weiss RA, McClure MO. Cell cycle dependence of foamy retrovirus infection. *J Virol* 1995;69(11):7295-7299.
106. Russell DW, Miller AD. Foamy virus vectors. *J Virol* 1996;70(1):217-222.
107. Hirata RK, Miller AD, Andrews RG, et al. Transduction of hematopoietic cells by foamy virus vectors. *Blood* 1996;88(9):3654-3661.
108. Trobridge GD, Russell DW. Helper-free foamy virus vectors. *Hum Gene Ther* 1998;9(17):2517-2525.
109. Vassilopoulos G, Trobridge G, Josephson NC, et al. Gene transfer into murine hematopoietic stem cells with helper-free foamy virus vectors. *Blood* 2001;98(3):604-609.
110. Bauer TR, Jr. Allen JM, Hai M, et al. Successful treatment of canine leukocyte adhesion deficiency by foamy virus vectors. *Nat Med* 2008;14(1):93-97.
111. Shenk T. Adenoviridae: the viruses and their replication. In: Fields BN, Knipe DM, Howley, PM, eds. *Fields virology*. Philadelphia, PA: Lippincott-Raven, 1996:2111-2148.
112. Huang S, Kamata T, Takada Y, et al. Adenovirus interaction with distinct integrins mediates separate events in cell entry and gene delivery to hematopoietic cells. *J Virol* 1996;70(7):4502-4508.
113. Bergelson JM, Cunningham JA, Droguett G, et al. Isolation of a common receptor for Coxsackie B viruses and adenoviruses 2 and 5. *Science* 1997;275(5304): 1320-1323.
114. Berns KI, Giraud C. Adenovirus and adeno-associated virus as vectors for gene therapy. *Ann N Y Acad Sci* 1995;772:95-104.
115. Berkner KL. Expression of heterologous sequences in adenoviral vectors. *Curr Top Microbiol Immunol* 1992;158:39-66.
116. Wilson JM. Adenoviruses as gene-delivery vehicles. *N Engl J Med* 1996;334(18):1185-1187.

117. Brody SL, Crystal RG. Adenovirus-mediated in vivo gene transfer. *Ann N Y Acad Sci* 1994;716:90-101; discussion 101-103.
118. Siegfried W. Perspectives in gene therapy with recombinant adenoviruses. *Exp Clin Endocrinol* 1993;101(1):7-11.
119. Rosenfeld MA, Collins FS. Gene therapy for cystic fibrosis. *Chest* 1996;109(1):241-252.
120. Rosenfeld MA, Yoshimura K, Trapnell BC, et al. In vivo transfer of the human cystic fibrosis transmembrane conductance regulator gene to the airway epithelium. *Cell* 1992;68(1):143-155.
121. Tripathy SK, Black HB, Goldwasser E, et al. Immune responses to transgeneencoded proteins limit the stability of gene expression after injection of replication-defective adenovirus vectors. *Nat Med* 1996;2(5):545-550.
122. Yang Y, Su Q, Wilson JM. Role of viral antigens in destructive cellular immune responses to adenovirus vector-transduced cells in mouse lungs. *J Virol* 1996;70(10):7209-7212.
123. Crystal RG, McElvaney NG, Rosenfeld MA, et al. Administration of an adenovirus containing the human CFTR cDNA to the respiratory tract of individuals with cystic fibrosis. *Nat Genet* 1994;8(1):42-51.
124. Yang Y, Li Q, Ertl HC, et al. Cellular and humoral immune responses to viral antigens create barriers to lung-directed gene therapy with recombinant adenoviruses. *J Virol* 1995;69(4):2004-2015.
125. Amalfitano A, Begy CR, Chamberlain JS. Improved adenovirus packaging cell lines to support the growth of replication-defective gene-delivery vectors. *Proc Natl Acad Sci U S A* 1996;93(8):3352-3356.
126. Clemens PR, Kochanek S, Sunada Y, et al. In vivo muscle gene transfer of full-length dystrophin with an adenoviral vector that lacks all viral genes. *Gene Ther* 1996;3(11):965-972.
127. Cerullo V, Seiler MP, Mane V, et al. Toll-like receptor 9 triggers an innate immune response to helper-dependent adenoviral vectors. *Mol Ther* 2007; 15(2):378-385.
128. Yang Y, Trinchieri G, Wilson JM. Recombinant IL-12 prevents formation of blocking IgA antibodies to recombinant adenovirus and allows repeated gene therapy to mouse lung. *Nat Med* 1995;1(9):890-893.
129. Dai Y, Schwarz EM, Gu D, et al. Cellular and humoral immune responses to adenoviral vectors containing factor IX gene: tolerization of factor IX and vector antigens allows for long-term expression. *Proc Natl Acad Sci U S A* 1995;92(5):1401-145.
130. Fang B, Eisensmith RC, Wang H, et al. Gene therapy for hemophilia B: host immunosuppression prolongs the therapeutic effect of adenovirus-mediated factor IX expression. *Hum Gene Ther* 1995;6(8):1039-1044.
131. Walter J, You Q, Hagstrom JN, et al. Successful expression of human factor IX following repeat administration of adenoviral vector in mice. *Proc Natl Acad Sci U S A* 1996;93(7):3056-3061.
132. Smith TA, White BD, Gardner JM, et al. Transient immunosuppression permits successful repetitive intravenous administration of an adenovirus vector. *Gene Ther* 1996;3(6):496-502.
133. Abbink P, Lemckert AA, Ewald BA, et al. Comparative seroprevalence and immunogenicity of six rare serotype recombinant adenovirus vaccine vectors from subgroups B and D. *J Virol* 2007;81(9):4654-4663.
134. Lemiale F, Haddada H, Nabel GJ, et al. Novel adenovirus vaccine vectors based on the enteric-tropic serotype 41. *Vaccine* 2007;25(11):2074-2084.
135. Zabner J, Couture LA, Gregory RJ, et al. Adenovirus-mediated gene transfer transiently corrects the chloride transport defect in nasal epithelia of patients with cystic fibrosis. *Cell* 1993;75(2):207-216.
136. Crystal RG, Jaffe A, Brody S, et al. A phase 1 study, in cystic fibrosis patients, of the safety, toxicity, and biological efficacy of a single administration of a replication deficient, recombinant adenovirus carrying the cDNA of the normal cystic fibrosis transmembrane conductance regulator gene in the lung. *Hum Gene Ther* 1995;6(5):643-666.
137. Crystal RG, Mastrangeli A, Sanders A, et al. Evaluation of repeat administration of a replication deficient, recombinant adenovirus containing the normal cystic fibrosis transmembrane conductance regulator cDNA to the airways of individuals with cystic fibrosis. *Hum Gene Ther* 1995;6(5):667-703.
138. Descamps V, Duffour MT, Mathieu MC, et al. Strategies for cancer gene therapy using adenoviral vectors. *J Mol Med* 1996;74(4):183-189.

139. Clayman GL, el-Naggar AK, Roth JA, et al. In vivo molecular therapy with p53 adenovirus for microscopic residual head and neck squamous carcinoma. *Cancer Res* 1995;55(1):1-6.
140. Caruso M, Pham-Nguyen K, Kwong YL, et al. Adenovirus-mediated interleukin-12 gene therapy for metastatic colon carcinoma. *Proc Natl Acad Sci U S A* 1996;93(21):11302-11306.
141. Raper SE, Chirmule N, Lee FS, et al. Fatal systemic inflammatory response syndrome in a ornithine transcarbamylase deficient patient following adenoviral gene transfer. *Mol Genet Metab* 2003;80(1-2):148-158.
142. Flotte TR, Carter BJ. Adeno-associated virus vectors for gene therapy. *Gene Ther* 1995;2(6):357-362.
143. Berns KI. Parvoviridae: the viruses and their replication. In Fields BN, ed. *Fields virology*. Philadelphia, PA: Lippincott-Raven, 1996:2173-2198.
144. Bartlett JS, Samulski RJ. Genetics and biology of adeno-associated virus. In: Kaplitt MG, Loewy AD, eds. *Viral vectors: gene therapy and neuroscience applications*. San Diego, CA: Academic Press, 1995:55-73.
145. Mayor HD. Defective parvoviruses may be good for your health! *Prog Med Virol* 1993;40:193-205.
146. Hermonat PL. Inhibition of H-ras expression by the adeno-associated virus Rep78 transformation suppressor gene product. *Cancer Res* 1991;51(13): 3373-3377.
147. Antoni BA, Rabson AB, Miller IL, et al. Adeno-associated virus Rep protein inhibits human immunodeficiency virus type 1 production in human cells. *J Virol* 1991;65(1):396-404.
148. Georg-Fries B, Biederlack S, Wolf J, et al. Analysis of proteins, helper dependence, and seroepidemiology of a new human parvovirus. *Virology* 1984;134(1): 64-71.
149. Cheung AK, Hoggan MD, Hauswirth WW, et al. Integration of the adenoassociated virus genome into cellular DNA in latently infected human Detroit 6 cells. *J Virol* 1980;33(2):739-748.
150. Samulski RJ, Zhu X, Xiao X, et al. Targeted integration of adeno-associated virus (AAV) into human chromosome 19. *Embo J* 1991;10(12):3941-3950.
151. Linden RM, Ward P, Giraud C, et al. Site-specific integration by adeno-associated virus. *Proc Natl Acad Sci U S A* 1996;93(21):11288-11294.
152. Kotin RM. Prospects for the use of adeno-associated virus as a vector for human gene therapy. *Hum Gene Ther* 1994;5(7):793-801.
153. Muzyczka N. Use of adeno-associated virus as a general transduction vector for mammalian cells. *Curr Top Microbiol Immunol* 1992;158:97-129.
154. Samulski RJ, Chang LS, Shenk T. Helper-free stocks of recombinant adenoassociated viruses: normal integration does not require viral gene expression. *J Virol* 1989;63(9):3822-3828.
155. Tratschin JD, Miller IL, Smith MG, et al. Adeno-associated virus vector for high-frequency integration, expression, and rescue of genes in mammalian cells. *Mol Cell Biol* 1985;5(11):3251-3260.
156. Shaughnessy E, Lu D, Chatterjee S, et al. Parvoviral vectors for the gene therapy of cancer. *Semin Oncol* 1996;23(1):159-171.
157. Tamayose K, Hirai Y, Shimada T. A new strategy for large-scale preparation of high-titer recombinant adeno-associated virus vectors by using packaging cell lines and sulfonated cellulose column chromatography. *Hum Gene Ther* 1996;7(4):507-513.
158. Qiao C, Li J, Skold A, et al. Feasibility of generating adeno-associated virus packaging cell lines containing inducible adenovirus helper genes. *J Virol* 2002;76(4):1904-1913.
159. Cao L, Liu Y, During MJ, et al. High-titer, wild-type free recombinant adenoassociated virus vector production using intron-containing helper plasmids. *J Virol* 2000;74(24):11456-11463.
160. Grimm D, Kay MA, Kleinschmidt JA. Helper virus-free, optically controllable, and two-plasmid-based production of adeno-associated virus vectors of serotypes 1 to 6. *Mol Ther* 2003;7(6):839-850.
161. Anderson SM, Yu G, Giattina M, et al. Intercellular transfer of a glycosylphosphatidylinositol (GPI)-linked protein: release and uptake of CD4-GPI from recombinant adeno-associated virus-transduced HeLa cells. *Proc Natl Acad Sci U S A* 1996;93(12):5894-5898.

162. Goodman S, Xiao X, Donahue RE, et al. Recombinant adeno-associated virus-mediated gene transfer into hematopoietic progenitor cells. *Blood* 1994;84(5):1492-1500.
163. Podsakoff G, Wong KK, Jr, Chatterjee S. Efficient gene transfer into nondividing cells by adeno-associated virus-based vectors. *J Virol* 1994;68(9): 5656-5666.
164. Russell DW, Miller AD, Alexander IE. Adeno-associated virus vectors preferentially transduce cells in S phase. *Proc Natl Acad Sci U S A* 1994;91(19): 8915-8919.
165. Alexander IE, Russell DW, Miller AD. DNA-damaging agents greatly increase the transduction of nondividing cells by adeno-associated virus vectors. *J Virol* 1994;68(12):8282-8287.
166. Russell DW, Alexander IE, Miller AD. DNA synthesis and topoisomerase inhibitors increase transduction by adeno-associated virus vectors. *Proc Natl Acad Sci U S A* 1995;92(12):5719-5723.
167. Fisher-Adams G, Wong KK, Jr, Podsakoff G, et al. Integration of adeno-associated virus vectors in CD34+ human hematopoietic progenitor cells after transduction. *Blood* 1996;88(2):492-504.
168. Jiang H, Lillcrap D, Patarroyo-White S, et al. Multiyear therapeutic benefit of AAV serotypes 2, 6, and 8 delivering factor VIII to hemophilia A mice and dogs. *Blood* 2006;108(1):107-115.
169. Sarkar R, Mucci M, Addya S, et al. Long-term efficacy of adeno-associated virus serotypes 8 and 9 in hemophilia A dogs and mice. *Hum Gene Ther* 2006;17(4):427-439.
170. Vandendriessche T, Thorrez L, Acosta-Sanchez A, et al. Efficacy and safety of adeno-associated viral vectors based on serotype 8 and 9 vs. lentiviral vectors for hemophilia B gene therapy. *J Thromb Haemost* 2007;5(1):16-24.
171. Brown KE, Green SW, Young NS. Goose parvovirus--an autonomous member of the dependovirus genus? *Virology* 1995;210(2):283-291.
172. Muramatsu S, Mizukami H, Young NS, et al. Nucleotide sequencing and generation of an infectious clone of adeno-associated virus 3. *Virology* 1996;221(1):208-217.
173. Brown KE, Green SW, O'Sullivan MG, et al. Cloning and sequencing of the simian parvovirus genome. *Virology* 1995;210(2):314-322.
174. Niemeyer GP, Herzog RW, Mount J, et al. Long-term correction of inhibitor-prone hemophilia B dogs treated with liver-directed AAV2-mediated factor IX gene therapy. *Blood* 2009;113(4):797-806.
175. Sabatino DE, Lange AM, Altynova ES, et al. Efficacy and safety of long-term prophylaxis in severe hemophilia A dogs following liver gene therapy using AAV vectors. *Mol Ther* 2011;19(3):442-449.
176. Nathwani AC, Tuddenham EG, Rangarajan S, et al. Adenovirus-associated virus vector-mediated gene transfer in hemophilia B. *N Engl J Med* 2011;365(25):2357-2365.
177. Breakefield XO, DeLuca NA. Herpes simplex virus for gene delivery to neurons. *New Biol* 1991;3(3):203-218.
178. Ali M, Lemoine NR, Ring CJ. The use of DNA viruses as vectors for gene therapy. *Gene Ther* 1994;1(6):367-384.
179. Glorioso JC, DeLuca NA, Fink DJ. Development and application of herpes simplex virus vectors for human gene therapy. *Annu Rev Microbiol* 1995;49:675-710.
180. Glorioso J, Bender MA, Fink D, et al. Herpes simplex virus vectors. *Mol Cell Biol Hum Dis Ser* 1995;5:33-63.
181. Weir JP, Dacquel EJ, Aronovitz J. Herpesvirus vector-mediated gene delivery to human monocytes. *Hum Gene Ther* 1996;7(11):1331-1338.
182. Dilloo D, Rill D, Entwistle C, et al. A novel herpes vector for the high-efficiency transduction of normal and malignant human hematopoietic cells. *Blood* 1997;89(1):119-127.
183. Moss B. Poxvirus expression vectors. *Curr Top Microbiol Immunol* 1992;158: 25-38.
184. Whitman ED, Tsung K, Paxson J, et al. In vitro and in vivo kinetics of recombinant vaccinia virus cancer-gene therapy. *Surgery* 1994;116(2):183-188.
185. Qin HX, Chatterjee SK. Construction of recombinant vaccinia virus expressing GM-CSF and its use as tumor vaccine. *Gene Ther* 1996;3(1):59-66.
186. Hodge JW, Abrams S, Schlom J, et al. Induction of antitumor immunity by recombinant vaccinia viruses expressing B7-1 or B7-2 costimulatory molecules. *Cancer Res* 1994;54(21):5552-5555.

187. Lattime EC, Lee SS, Eisenlohr LC, et al. In situ cytokine gene transfection using vaccinia virus vectors. *Semin Oncol* 1996;23(1):88-100.
188. Boggs SS. Targeted gene modification for gene therapy of stem cells. *Int J Cell Cloning* 1990;8(2):80-96.
189. Cole-Strauss A, Yoon K, Xiang Y, et al. Correction of the mutation responsible for sickle cell anemia by an RNA-DNA oligonucleotide. *Science* 1996;273(5280):1386-1389.
190. Sierakowska H, Sambade MJ, Agrawal S, et al. Repair of thalassemic human beta-globin mRNA in mammalian cells by antisense oligonucleotides. *Proc Natl Acad Sci U S A* 1996;93(23):12840-12844.
191. Gorman L, Mercatante DR, Kole R. Restoration of correct splicing of thalassemic beta-globin pre-mRNA by modified U1 snRNAs. *J Biol Chem* 2000;275(46):35914-35919.
192. Lacerra G, Sierakowska H, Carestia C, et al. Restoration of hemoglobin A synthesis in erythroid cells from peripheral blood of thalassemic patients. *Proc Natl Acad Sci U S A* 2000;97(17):9591-9596.
193. Vacek MM, Ma H, Gemignani F, et al. High-level expression of hemoglobin A in human thalassemic erythroid progenitor cells following lentiviral vector delivery of an antisense snRNA. *Blood* 2003;101(1):104-111.
194. Cathomen T, Schambach A. Zinc-finger nucleases meet iPSC cells: zinc positive: tailored genome engineering meets reprogramming. *Gene Ther* 2010; 17(1):1-3.
195. Holt N, Wang J, Kim K, et al. Human hematopoietic stem/progenitor cells modified by zinc-finger nucleases targeted to CCR5 control HIV-1 in vivo. *Nat Biotechnol* 2010;28(8):839-847.
196. Mussolino C, Cathomen T. TALE nucleases: tailored genome engineering made easy. *Curr Opin Biotechnol* 2012;23(5):644-650.
197. Wu LC, Sun CW, Ryan TM, et al. Correction of sickle cell disease by homologous recombination in embryonic stem cells. *Blood* 2006;108(4):1183-1188.
198. Brenner MK. Gene transfer to hematopoietic cells. *N Engl J Med* 1996;335(5): 337-339.
199. Dunbar CE, Emmons RV. Gene transfer into hematopoietic progenitor and stem cells: progress and problems. *Stem Cells* 1994;12(6):563-576.
200. Hania EG, Kavanagh J, Hortobagyi G, et al. Recent advances in the application of gene therapy to human disease. *Am J Med* 1995;99(5):537-552.
201. Yu M, Poeschla E, Wong-Staal F. Progress towards gene therapy for HIV infection. *Gene Ther* 1994;1(1):13-26.
202. Lim B, Apperley JF, Orkin SH, et al. Long-term expression of human adenosine deaminase in mice transplanted with retrovirus-infected hematopoietic stem cells. *Proc Natl Acad Sci U S A* 1989;86(22):8892-8896.
203. Lim B, Williams DA, Orkin SH. Retrovirus-mediated gene transfer of human adenosine deaminase: expression of functional enzyme in murine hematopoietic stem cells in vivo. *Mol Cell Biol* 1987;7(10):3459-3465.
204. Williams DA, Lemischka IR, Nathan DG, et al. Introduction of new genetic material into pluripotent haematopoietic stem cells of the mouse. *Nature* 1984;310(5977):476-480.
205. Bodine DM, Karlsson S, Nienhuis AW. Combination of interleukins 3 and 6 preserves stem cell function in culture and enhances retrovirus-mediated gene transfer into hematopoietic stem cells. *Proc Natl Acad Sci U S A* 1989;86(22):8897-8901.
206. Correll PH, Colilla S, Dave HP, et al. High levels of human glucocerebrosidase activity in macrophages of long-term reconstituted mice after retroviral infection of hematopoietic stem cells. *Blood* 1992;80(2):331-336.
207. Crooks GM, Kohn DB. Growth factors increase amphotropic retrovirus binding to human CD34+ bone marrow progenitor cells. *Blood* 1993;82(11):3290-3297.
208. Fraser P, Hurst J, Collis P, et al. DNaseI hypersensitive sites 1, 2 and 3 of the human beta-globin dominant control region direct position-independent expression. *Nucleic Acids Res* 1990;18(12):3503-3508.
209. Luskey BD, Rosenblatt M, Zsebo K, et al. Stem cell factor, interleukin-3, and interleukin-6 promote retroviral-mediated gene transfer into murine hematopoietic stem cells. *Blood* 1992;80(2):396-402.
210. Bodine DM, McDonagh KT, Seidel NE, et al. Survival and retrovirus infection of murine hematopoietic stem cells in vitro: effects of 5-FU and method of infection. *Exp Hematol* 1991;19(3):206-212.

211. Fraser CC, Eaves CJ, Szilvassy SJ, et al. Expansion in vitro of retrovirally marked totipotent hematopoietic stem cells. *Blood* 1990;76(6):1071-1076.
212. Hanenberg H, Xiao XL, Dilloo D, et al. Colocalization of retrovirus and target cells on specific fibronectin fragments increases genetic transduction of mammalian cells. *Nat Med* 1996;2(8):876-882.
213. Sorrentino BP, Brandt SJ, Bodine D, et al. Selection of drug-resistant bone marrow cells in vivo after retroviral transfer of human MDR1. *Science* 1992;257(5066):99-103.
214. Correll PH, Kew Y, Perry LK, et al. Expression of human glucocerebrosidase in long-term reconstituted mice following retroviral-mediated gene transfer into hematopoietic stem cells. *Hum Gene Ther* 1990;1(3):277-287.
215. de Revel T, Appelbaum FR, Storb R, et al. Effects of granulocyte colony-stimulating factor and stem cell factor, alone and in combination, on the mobilization of peripheral blood cells that engraft lethally irradiated dogs. *Blood* 1994;83(12):3795-3799.
216. Hanania EG, Deisseroth AB. Serial transplantation shows that early hematopoietic precursor cells are transduced by MDR-1 retroviral vector in a mouse gene therapy model. *Cancer Gene Ther* 1994;1(1):21-25.
217. Jordan CT, McKearn JP, Lemischka IR. Cellular and developmental properties of fetal hematopoietic stem cells. *Cell* 1990;61(6):953-963.
218. Kaleko M, Garcia JV, Osborne WR, et al. Expression of human adenosine deaminase in mice after transplantation of genetically-modified bone marrow. *Blood* 1990;75(8):1733-1741.
219. Moore KA, Fletcher FA, Villalon DK, et al. Human adenosine deaminase expression in mice. *Blood* 1990;75(10):2085-2092.
220. Osborne WR, Hock RA, Kaleko M, et al. Long-term expression of human adenosine deaminase in mice after transplantation of bone marrow infected with amphotropic retroviral vectors. *Hum Gene Ther* 1990;1(1):31-41.
221. van Beusechem VW, Kukler A, Einerhand MP, et al. Expression of human adenosine deaminase in mice transplanted with hemopoietic stem cells infected with amphotropic retroviruses. *J Exp Med* 1990;172(3):729-736.
222. Wilson JM, Danos O, Grossman M, et al. Expression of human adenosine deaminase in mice reconstituted with retrovirus-transduced hematopoietic stem cells. *Proc Natl Acad Sci U S A* 1990;87(1):439-443.
223. Lo M, Bloom ML, Imada K, et al. Restoration of lymphoid populations in a murine model of X-linked severe combined immunodeficiency by a gene-therapy approach. *Blood* 1999;94(9):3027-3036.
224. Otsu M, Anderson SM, Bodine DM, et al. Lymphoid development and function in X-linked severe combined immunodeficiency mice after stem cell gene therapy. *Mol Ther* 2000;1(2):145-153.
225. Soudais C, Shiho T, Sharara LI, et al. Stable and functional lymphoid reconstitution of common cytokine receptor gamma chain deficient mice by retroviral-mediated gene transfer. *Blood* 2000;95(10):3071-3077.
226. Bunting KD, Sangster MY, Ihle JN, et al. Restoration of lymphocyte function in Janus kinase 3-deficient mice by retroviral-mediated gene transfer. *Nat Med* 1998;4(1):58-64.
227. Otsu M, Steinberg M, Ferrand C, et al. Reconstitution of lymphoid development and function in ZAP-70-deficient mice following gene transfer into bone marrow cells. *Blood* 2002;100(4):1248-1256.
228. Yates F, Malassis-Seris M, Stockholm D, et al. Gene therapy of RAG-2^{-/-} mice: sustained correction of the immunodeficiency. *Blood* 2002;100(12):3942-3949.
229. Correll PH, Fink JK, Brady RO, et al. Production of human glucocerebrosidase in mice after retroviral gene transfer into multipotential hematopoietic progenitor cells. *Proc Natl Acad Sci U S A* 1989;86(22):8912-8916.
230. Nolte JA, Sender LS, Barranger JA, et al. Expression of human glucocerebrosidase in murine long-term bone marrow cultures after retroviral vector-mediated transfer. *Blood* 1990;75(3):787-797.
231. Ohashi T, Boggs S, Robbins P, et al. Efficient transfer and sustained high expression of the human glucocerebrosidase gene in mice and their functional macrophages following transplantation of bone marrow transduced by a retroviral vector. *Proc Natl Acad Sci U S A* 1992;89(23):11332-11336.
232. Weinthal J, Nolte JA, Yu XJ, et al. Expression of human glucocerebrosidase following retroviral vector-mediated transduction of murine hematopoietic stem cells. *Bone Marrow Transplant* 1991;8(5):403-412.

233. Bender MA, Gelinus RE, Miller AD. A majority of mice show long-term expression of a human beta-globin gene after retrovirus transfer into hematopoietic stem cells. *Mol Cell Biol* 1989;9(4):1426-1434.
234. Cone RD, Weber-Benarous A, Baorto D, et al. Regulated expression of a complete human beta-globin gene encoded by a transmissible retrovirus vector. *Mol Cell Biol* 1987;7(2):887-897.
235. Dzierzak EA, Papayannopoulou T, Mulligan RC. Lineage-specific expression of a human beta-globin gene in murine bone marrow transplant recipients reconstituted with retrovirus-transduced stem cells. *Nature* 1988;331(6151):35-41.
236. Karlsson S, Bodine DM, Perry L, et al. Expression of the human beta-globin gene following retroviral-mediated transfer into multipotential hematopoietic progenitors of mice. *Proc Natl Acad Sci U S A* 1988;85(16):6062-6066.
237. Karlsson S, Papayannopoulou T, Schweiger SG, et al. Retroviral-mediated transfer of genomic globin genes leads to regulated production of RNA and protein. *Proc Natl Acad Sci U S A* 1987;84(8):2411-2415.
238. Li CL, Dwarki VJ, Verma IM. Expression of human alpha-globin and mouse/human hybrid beta-globin genes in murine hemopoietic stem cells transduced by recombinant retroviruses. *Proc Natl Acad Sci U S A* 1990;87(11):4349-4353.
239. Jirapongsananuruk O, Niemela JE, Malech HL, et al. CYBB mutation analysis in X-linked chronic granulomatous disease. *Clin Immunol* 2002;104(1):73-76.
240. Bjorgvinsdottir H, Ding C, Pech N, et al. Retroviral-mediated gene transfer of gp91phox into bone marrow cells rescues defect in host defense against *Aspergillus fumigatus* in murine X-linked chronic granulomatous disease. *Blood* 1997;89(1):41-48.
241. Dinauer MC, Li LL, Bjorgvinsdottir H, et al. Long-term correction of phagocyte NADPH oxidase activity by retroviral-mediated gene transfer in murine X-linked chronic granulomatous disease. *Blood* 1999;94(3):914-922.
242. Mardiney M 3rd, Jackson SH, Spratt SK, et al. Enhanced host defense after gene transfer in the murine p47phox-deficient model of chronic granulomatous disease. *Blood* 1997;89(7):2268-2275.
243. Derry JM, Ochs HD, Francke U. Isolation of a novel gene mutated in Wiskott-Aldrich syndrome. *Cell* 1994;78(4):635-644.
244. Notarangelo LD, Miao CH, Ochs HD. Wiskott-Aldrich syndrome. *Curr Opin Hematol* 2008;15(1):30-36.
245. Puck JM, Candotti F. Lessons from the Wiskott-Aldrich syndrome. *N Engl J Med* 2006;355(17):1759-1761.
246. Strom TS, Turner SJ, Andreansky S, et al. Defects in T-cell-mediated immunity to influenza virus in murine Wiskott-Aldrich syndrome are corrected by oncoretroviral vector-mediated gene transfer into repopulating hematopoietic cells. *Blood* 2003;102(9):3108-3116.
247. Klein C, Nguyen D, Liu CH, et al. Gene therapy for Wiskott-Aldrich syndrome: rescue of T-cell signaling and amelioration of colitis upon transplantation of retrovirally transduced hematopoietic stem cells in mice. *Blood* 2003;101(6): 2159-2166.
248. Cassel A, Cottler-Fox M, Doren S, et al. Retroviral-mediated gene transfer into CD34-enriched human peripheral blood stem cells. *Exp Hematol* 1993;21(4):585-591.
249. Hughes PF, Eaves CJ, Hogge DE, et al. High-efficiency gene transfer to human hematopoietic cells maintained in long-term marrow culture. *Blood* 1989;74(6): 1915-1922.
250. Larochelle A, Vormoor J, Hanenberg H, et al. Identification of primitive human hematopoietic cells capable of repopulating NOD/SCID mouse bone marrow: implications for gene therapy. *Nat Med* 1996;2(12):1329-1337.
251. Fink JK, Correll PH, Perry LK, et al. Correction of glucocerebrosidase deficiency after retroviral-mediated gene transfer into hematopoietic progenitor cells from patients with Gaucher disease. *Proc Natl Acad Sci U S A* 1990;87(6):2334-2338.
252. Bordignon C, Mavilio F, Ferrari G, et al. Transfer of the ADA gene into bone marrow cells and peripheral blood lymphocytes for the treatment of patients affected by ADA-deficient SCID. *Hum Gene Ther* 1993;4(4):513-520.
253. Cai Q, Rubin JT, Lotze MT. Genetically marking human cells--results of the first clinical gene transfer studies. *Cancer Gene Ther* 1995;2(2):125-136.
254. Brenner MK, Rill DR, Holladay MS, et al. Gene marking to determine whether autologous marrow infusion restores long-term haemopoiesis in cancer patients. *Lancet* 1993;342(8880):1134-1137.

255. Brenner MK, Rill DR, Moen RC, et al. Gene-marking to trace origin of relapse after autologous bone-marrow transplantation. *Lancet* 1993;341(8837):85-86.
256. Rill DR, Buschle M, Foreman NK, et al. Retrovirus-mediated gene transfer as an approach to analyze neuroblastoma relapse after autologous bone marrow transplantation. *Hum Gene Ther* 1992;3(2):129-136.
257. Rill DR, Moen RC, Buschle M, et al. An approach for the analysis of relapse and marrow reconstitution after autologous marrow transplantation using retrovirus-mediated gene transfer. *Blood* 1992;79(10):2694-2700.
258. Rill DR, Santana VM, Roberts WM, et al. Direct demonstration that autologous bone marrow transplantation for solid tumors can return a multiplicity of tumorigenic cells. *Blood* 1994;84(2):380-383.
259. Deisseroth AB, Zu Z, Claxton D, et al. Genetic marking shows that Ph⁺ cells present in autologous transplants of chronic myelogenous leukemia (CML) contribute to relapse after autologous bone marrow in CML. *Blood* 1994;83(10):3068-3076.
260. Alici E, Bjorkstrand B, Treschow A, et al. Long-term follow-up of gene-marked CD34⁺ cells after autologous stem cell transplantation for multiple myeloma. *Cancer Gene Ther* 2007;14(3):227-232.
261. Dunbar CE, Cottler-Fox M, O'Shaughnessy JA, et al. Retrovirally marked CD34-enriched peripheral blood and bone marrow cells contribute to long-term engraftment after autologous transplantation. *Blood* 1995;85(11):3048-3057.
262. Emmons RV, Doren S, Zujewski J, et al. Retroviral gene transduction of adult peripheral blood or marrow-derived CD34⁺ cells for six hours without growth factors or on autologous stroma does not improve marking efficiency assessed in vivo. *Blood* 1997;89(11):4040-4046.
263. Bachier CR, Giles RE, Ellerson D, et al. Hematopoietic retroviral gene marking in patients with follicular non-Hodgkin's lymphoma. *Leuk Lymphoma* 1999;32(3-4):279-288.
264. Cornetta K, Srour EF, Moore A, et al. Retroviral gene transfer in autologous bone marrow transplantation for adult acute leukemia. *Hum Gene Ther* 1996;7(11):1323-1329.
265. Hacein-Bey-Abina S, von Kalle C, Schmidt M, et al. A serious adverse event after successful gene therapy for X-linked severe combined immunodeficiency. *N Engl J Med* 2003;348(3):255-256.
266. Blaese RM. What is the status of gene therapy for primary immunodeficiency? *Immunol Res* 2007;38(1-3):274-284.
267. Kohn DB, Hershfield MS, Carbonaro D, et al. T lymphocytes with a normal ADA gene accumulate after transplantation of transduced autologous umbilical cord blood CD34⁺ cells in ADA-deficient SCID neonates. *Nat Med* 1998;4(7):775-780.
268. Lu L, Shen RN, Broxmeyer HE. Stem cells from bone marrow, umbilical cord blood and peripheral blood for clinical application: current status and future application. *Crit Rev Oncol Hematol* 1996;22(2):61-78.
269. Gluckman E. Umbilical cord blood biology and transplantation. *Curr Opin Hematol* 1995;2(6):413-416.
270. Lu L, Xiao M, Shen RN, et al. Enrichment, characterization, and responsiveness of single primitive CD34 human umbilical cord blood hematopoietic progenitors with high proliferative and replating potential. *Blood* 1993;81(1):41-48.
271. Kohn DB, Weinberg KI, Nolta JA, et al. Engraftment of gene-modified umbilical cord blood cells in neonates with adenosine deaminase deficiency. *Nat Med* 1995;1(10):1017-10123.
272. Strathdee CA, Gavish H, Shannon WR, et al. Cloning of cDNAs for Fanconi's anaemia by functional complementation. *Nature* 1992;356(6372):763-767.
273. Walsh CE, Grompe M, Vanin E, et al. A functionally active retrovirus vector for gene therapy in Fanconi anemia group C. *Blood* 1994;84(2):453-459.
274. Walsh CE, Nienhuis AW, Samulski RJ, et al. Phenotypic correction of Fanconi anemia in human hematopoietic cells with a recombinant adeno-associated virus vector. *J Clin Invest* 1994;94(4):1440-1448.
275. Croop JM, Cooper R, Fernandez C, et al. Mobilization and collection of peripheral blood CD34⁺ cells from patients with Fanconi anemia. *Blood* 2001;98(10):2917-2921.
276. Liu JM, Kim S, Read EJ, et al. Engraftment of hematopoietic progenitor cells transduced with the Fanconi anemia group C gene (FANCC). *Hum Gene Ther* 1999;10(14):2337-2346.

277. Dunbar CE, Kohn DB, Schiffmann R, et al. Retroviral transfer of the glucocerebrosidase gene into CD34+ cells from patients with Gaucher disease: in vivo detection of transduced cells without myeloablation. *Hum Gene Ther* 1998;9(17):2629-2640.
278. Malech HL, Maples PB, Whiting-Theobald N, et al. Prolonged production of NADPH oxidase-corrected granulocytes after gene therapy of chronic granulomatous disease. *Proc Natl Acad Sci U S A* 1997;94(22):12133-12138.
279. Zanjani ED, Almeida-Porada G, Flake AW. The human/sheep xenograft model: a large animal model of human hematopoiesis. *Int J Hematol* 1996;63(3):179-192.
280. Zanjani ED, Flake AW, Rice H, et al. Long-term repopulating ability of xenogeneic transplanted human fetal liver hematopoietic stem cells in sheep. *J Clin Invest* 1994;93(3):1051-1055.
281. Zanjani ED, Pallavicini MG, Ascensao JL, et al. Engraftment and long-term expression of human fetal hematopoietic stem cells in sheep following transplantation in utero. *J Clin Invest* 1992;89(4):1178-1188.
282. Porada CD, Tran ND, Almeida-Porada G, et al. Transduction of long-term-engrafting human hematopoietic stem cells by retroviral vectors. *Hum Gene Ther* 2002;13(7):867-879.
283. Donahue RE, Dunbar CE. Update on the use of nonhuman primate models for preclinical testing of gene therapy approaches targeting hematopoietic cells. *Hum Gene Ther* 2001;12(6):607-617.
284. Van Beusechem VW, Valerio D. Gene transfer into hematopoietic stem cells of nonhuman primates. *Hum Gene Ther* 1996;7(14):1649-1668.
285. van Beusechem VW, Kukler A, Heidt PJ, et al. Long-term expression of human adenosine deaminase in rhesus monkeys transplanted with retrovirusinfected bone-marrow cells. *Proc Natl Acad Sci U S A* 1992;89(16):7640-7644.
286. van Beusechem VW, Bart-Baumeister JA, Hoogerbrugge PM, et al. Influence of interleukin-3, interleukin-6, and stem cell factor on retroviral transduction of rhesus monkey CD34+ hematopoietic progenitor cells measured in vitro and in vivo. *Gene Ther* 1995;2(4):245-255.
287. Bodine DM, Moritz T, Donahue RE, et al. Long-term in vivo expression of a murine adenosine deaminase gene in rhesus monkey hematopoietic cells of multiple lineages after retroviral mediated gene transfer into CD34+ bone marrow cells. *Blood* 1993;82(7):1975-1980.
288. Xu LC, Karlsson S, Byrne ER, et al. Long-term in vivo expression of the human glucocerebrosidase gene in nonhuman primates after CD34+ hematopoietic cell transduction with cell- free retroviral vector preparations. *Proc Natl Acad Sci U S A* 1995;92(10):4372-4376.
289. Vanin EF, Kaloss M, Broscius C, et al. Characterization of replication-competent retroviruses from nonhuman primates with virus-induced T-cell lymphomas and observations regarding the mechanism of oncogenesis. *J Virol* 1994;68(7):4241-4250.
290. Schuening FG, Kawahara K, Miller AD, et al. Retrovirus-mediated gene transduction into long-term repopulating marrow cells of dogs. *Blood* 1991;78(10): 2568-2576.
291. Kiem HP, Darovsky B, von Kalle C, et al. Retrovirus-mediated gene transduction into canine peripheral blood repopulating cells. *Blood* 1994;83(6): 1467-1473.
292. Barquinero J, Kiem HP, von Kalle C, et al. Myelosuppressive conditioning improves autologous engraftment of genetically marked hematopoietic repopulating cells in dogs. *Blood* 1995;85(5):1195-1201.
293. Goerner M, Bruno B, McSweeney PA, et al. The use of granulocyte colony-stimulating factor during retroviral transduction on fibronectin fragment CH-296 enhances gene transfer into hematopoietic repopulating cells in dogs. *Blood* 1999;94(7):2287-2292.
294. Kiem HP, McSweeney PA, Bruno B, et al. Improved gene transfer into canine hematopoietic repopulating cells using CD34-enriched marrow cells in combination with a gibbon ape leukemia virus-pseudotype retroviral vector. *Gene Ther* 1999;6(6):966-972.
295. Horn PA, Keyser KA, Peterson LJ, et al. Efficient lentiviral gene transfer to canine repopulating cells using an overnight transduction protocol. *Blood* 2004;103(10):3710-3716.
296. Kiem HP, Allen J, Trobridge G, et al. Foamy-virus-mediated gene transfer to canine repopulating cells. *Blood* 2007;109(1):65-70.

297. Neff T, Beard BC, Peterson LJ, et al. Polyclonal chemoprotection against temozolomide in a large-animal model of drug resistance gene therapy. *Blood* 2005;105(3):997-1002.
298. Neff T, Horn PA, Peterson LJ, et al. Methylguanine methyltransferasemediated in vivo selection and chemoprotection of allogeneic stem cells in a large-animal model. *J Clin Invest* 2003;112(10):1581-1588.
299. Neff T, Horn PA, Valli VE, et al. Pharmacologically regulated in vivo selection in a large animal. *Blood* 2002;100(6):2026-2031.
300. Trobridge GD, Beard BC, Wu RA, et al. Stem cell selection in vivo using foamy vectors cures canine pyruvate kinase deficiency. *PLoS One* 2012;7(9):e45173.
301. Peters SO, Kittler EL, Ramshaw HS, et al. Murine marrow cells expanded in culture with IL-3, IL-6, IL-11, and SCF acquire an engraftment defect in normal hosts. *Exp Hematol* 1995;23(5):461-469.
302. Tisdale JF, Hanazono Y, Sellers SE, et al. Ex vivo expansion of genetically marked rhesus peripheral blood progenitor cells results in diminished long-term repopulating ability. *Blood* 1998;92(4):1131-1141.
303. Bock TA, Orlic D, Dunbar CE, et al. Improved engraftment of human hematopoietic cells in severe combined immunodeficient (SCID) mice carrying human cytokine transgenes. *J Exp Med* 1995;182(6):2037-2043.
304. Dick JE. Immune-deficient mice as models of normal and leukemic human hematopoiesis. *Cancer Cells* 1991;3(2):39-48.
305. Dick JE, Kamel-Reid S, Murdoch B, et al. Gene transfer into normal human hematopoietic cells using in vitro and in vivo assays. *Blood* 1991;78(3): 624-634.
306. Larochelle A, Vormoor J, Lapidot T, et al. Engraftment of immune-deficient mice with primitive hematopoietic cells from beta-thalassemia and sickle cell anemia patients: implications for evaluating human gene therapy protocols. *Hum Mol Genet* 1995;4(2):163-172.
307. Nolte JA, Hanley MB, Kohn DB. Sustained human hematopoiesis in immunodeficient mice by cotransplantation of marrow stroma expressing human interleukin-3: analysis of gene transduction of long-lived progenitors. *Blood* 1994;83(10):3041-3051.
308. Kamel-Reid S, Dick JE. Engraftment of immune-deficient mice with human hematopoietic stem cells. *Science* 1988;242(4886):1706-1709.
309. Lapidot T, Pflumio F, Doedens M, et al. Cytokine stimulation of multilineage hematopoiesis from immature human cells engrafted in SCID mice. *Science* 1992;255(5048):1137-1141.
310. Shultz LD, Schweitzer PA, Christianson SW, et al. Multiple defects in innate and adaptive immunologic function in NOD/LtSz-scid mice. *J Immunol* 1995;154(1):180-191.
311. Hiramatsu H, Nishikomori R, Heike T, et al. Complete reconstitution of human lymphocytes from cord blood CD34+ cells using the NOD/SCID/gammacnull mice model. *Blood* 2003;102(3):873-880.
312. Ito M, Hiramatsu H, Kobayashi K, et al. NOD/SCID/gamma(c)(null) mouse: an excellent recipient mouse model for engraftment of human cells. *Blood* 2002;100(9):3175-3182.
313. Ito R, Katano I, Ida-Tanaka M, et al. Efficient Xenoengraftment in Severe Immunodeficient NOD/Shi-scid IL2rgammanull Mice Is Attributed to a Lack of CD11c+B220+CD122+ Cells. *J Immunol* 2012;189(9):4313-4320.
314. Shultz LD, Lyons BL, Burzenski LM, et al. Human lymphoid and myeloid cell development in NOD/LtSz-scid IL2R gamma null mice engrafted with mobilized human hemopoietic stem cells. *J Immunol* 2005;174(10):6477-6489.
315. Guenechea G, Gan OI, Dorrell C, et al. Distinct classes of human stem cells that differ in proliferative and self-renewal potential. *Nat Immunol* 2001;2(1):75-82.
316. Notta F, Doulatov S, Laurenti E, et al. Isolation of single human hematopoietic stem cells capable of long-term multilineage engraftment. *Science* 2011;333(6039):218-221.
317. Horn PA, Thomasson BM, Wood BL, et al. Distinct hematopoietic stem/progenitor cell populations are responsible for repopulating NOD/SCID mice compared with nonhuman primates. *Blood* 2003;102(13):4329-4335.
318. Miller JL, Donahue RE, Sellers SE, et al. Recombinant adeno-associated virus (rAAV)-mediated expression of a human gamma-globin gene in human progenitor-derived erythroid cells. *Proc Natl Acad Sci U S A* 1994;91(21): 10183-10187.

319. Zhou SZ, Broxmeyer HE, Cooper S, et al. Adeno-associated virus 2-mediated gene transfer in murine hematopoietic progenitor cells. *Exp Hematol* 1993;21(7):928-933.
320. Chatterjee S, Li W, Wong CA, et al. Transduction of primitive human marrow and cord blood-derived hematopoietic progenitor cells with adeno-associated virus vectors. *Blood* 1999;93(6):1882-1894.
321. Nathwani AC, Hanawa H, Vandergriff J, et al. Efficient gene transfer into human cord blood CD34+ cells and the CD34+CD38- subset using highly purified recombinant adeno-associated viral vector preparations that are free of helper virus and wild-type AAV. *Gene Ther* 2000;7(3):183-195.
322. Chatziandreou I, Siapati EK, Vassilopoulos G. Genetic correction of X-linked chronic granulomatous disease with novel foamy virus vectors. *Exp Hematol* 2011;39(6):643-652.
323. Cronin J, Zhang XY, Reiser J. Altering the tropism of lentiviral vectors through pseudotyping. *Curr Gene Ther* 2005;5(4):387-398.
324. Porter CD, Collins MK, Taylor CS, et al. Comparison of efficiency of infection of human gene therapy target cells via four different retroviral receptors. *Hum Gene Ther* 1996;7(8):913-919.
325. Movassagh M, Desmyter C, Baillou C, et al. High-level gene transfer to cord blood progenitors using gibbon ape leukemia virus pseudotype retroviral vectors and an improved clinically applicable protocol. *Hum Gene Ther* 1998;9(2):225-234.
326. Marandin A, Dubart A, Pflumio F, et al. Retrovirus-mediated gene transfer into human CD34+38low primitive cells capable of reconstituting long-term cultures in vitro and nonobese diabetic-severe combined immunodeficiency mice in vivo. *Hum Gene Ther* 1998;9(10):1497-1511.
327. Bouard D, Sandrin V, Boson B, et al. An acidic cluster of the cytoplasmic tail of the RD114 virus glycoprotein controls assembly of retroviral envelopes. *Traffic* 2007;8(7):835-847.
328. Christodoulopoulos I, Cannon PM. Sequences in the cytoplasmic tail of the gibbon ape leukemia virus envelope protein that prevent its incorporation into lentivirus vectors. *J Virol* 2001;75(9):4129-4138.
329. Sandrin V, Boson B, Salmon P, et al. Lentiviral vectors pseudotyped with a modified RD114 envelope glycoprotein show increased stability in sera and augmented transduction of primary lymphocytes and CD34+ cells derived from human and nonhuman primates. *Blood* 2002;100(3):823-832.
330. Bartz SR, Rogel ME, Emerman M. Human immunodeficiency virus type 1 cell cycle control: Vpr is cytostatic and mediates G2 accumulation by a mechanism which differs from DNA damage checkpoint control. *J Virol* 1996;70(4): 2324-2331.
331. Coil DA, Miller AD. Phosphatidylserine is not the cell surface receptor for vesicular stomatitis virus. *J Virol* 2004;78(20):10920-10926.
332. Kim YS, Wielgosz MM, Hargrove P, et al. Transduction of human primitive repopulating hematopoietic cells with lentiviral vectors pseudotyped with various envelope proteins. *Mol Ther* 2010;18(7):1310-1317.
333. Broussau S, Jabbour N, Lachapelle G, et al. Inducible packaging cells for large-scale production of lentiviral vectors in serum-free suspension culture. *Mol Ther* 2008;16(3):500-507.
334. Throm RE, Ouma AA, Zhou S, et al. Efficient construction of producer cell lines for a SIN lentiviral vector for SCID-X1 gene therapy by concatemeric array transfection. *Blood* 2009;113(21):5104-5110.
335. DePolo NJ, Reed JD, Sheridan PL, et al. VSV-G pseudotyped lentiviral vector particles produced in human cells are inactivated by human serum. *Mol Ther* 2000;2(3):218-222.
336. Verhoeven E, Wiznerowicz M, Olivier D, et al. Novel lentiviral vectors displaying "early-acting cytokines" selectively promote survival and transduction of NOD/SCID repopulating human hematopoietic stem cells. *Blood* 2005;106(10):3386-3395.
337. Frecha C, Costa C, Negre D, et al. A novel lentiviral vector targets gene transfer into human hematopoietic stem cells in marrow from patients with bone marrow failure syndrome and in vivo in humanized mice. *Blood* 2012;119(5):1139-1150.
338. Guenechea G, Gan OI, Inamitsu T, et al. Transduction of human CD34+ CD38- bone marrow and cord blood-derived SCID-repopulating cells with third-generation lentiviral vectors. *Mol Ther* 2000;1(6):566-573.

339. Liu Y, Hangoc G, Campbell TB, et al. Identification of parameters required for efficient lentiviral vector transduction and engraftment of human cord blood CD34(+) NOD/SCID-repopulating cells. *Exp Hematol* 2008;36(8):947-956.
340. Miyoshi H, Smith KA, Mosier DE, et al. Transduction of human CD34+ cells that mediate long-term engraftment of NOD/SCID mice by HIV vectors. *Science* 1999;283(5402):682-686.
341. Piacibello W, Bruno S, Sanavio F, et al. Lentiviral gene transfer and ex vivo expansion of human primitive stem cells capable of primary, secondary, and tertiary multilineage repopulation in NOD/SCID mice. *Nonobese diabetic/severe combined immunodeficient*. *Blood* 2002;100(13):4391-4400.
342. Woods NB, Fahlman C, Mikkola H, et al. Lentiviral gene transfer into primary and secondary NOD/SCID repopulating cells. *Blood* 2000;96(12): 3725-3733.
343. Benhamida S, Pflumio F, Dubart-Kupperschmitt A, et al. Transduced CD34+ cells from adrenoleukodystrophy patients with HIV-derived vector mediate long-term engraftment of NOD/SCID mice. *Mol Ther* 2003;7(3):317-324.
344. Tesio M, Gammaitoni L, Gunetti M, et al. Sustained long-term engraftment and transgene expression of peripheral blood CD34+ cells transduced with third-generation lentiviral vectors. *Stem Cells* 2008;26(6):1620-1627.
345. An DS, Kung SK, Bonifacino A, et al. Lentivirus vector-mediated hematopoietic stem cell gene transfer of common gamma-chain cytokine receptor in rhesus macaques. *J Virol* 2001;75(8):3547-3555.
346. An DS, Wersto RP, Agricola BA, et al. Marking and gene expression by a lentivirus vector in transplanted human and nonhuman primate CD34(+) cells. *J Virol* 2000;74(3):1286-1295.
347. Horn PA, Morris JC, Bukovsky AA, et al. Lentivirus-mediated gene transfer into hematopoietic repopulating cells in baboons. *Gene Ther* 2002;9(21): 1464-1471.
348. Trobridge GD, Beard BC, Gooch C, et al. Efficient transduction of pigtailed macaque hematopoietic repopulating cells with HIV-based lentiviral vectors. *Blood* 2008;111(12):5537-5543.
349. Uchida N, Washington KN, Hayakawa J, et al. Development of a human immunodeficiency virus type 1-based lentiviral vector that allows efficient transduction of both human and rhesus blood cells. *J Virol* 2009;83(19): 9854-9862.
350. Rits MA, van Dort KA, Munk C, et al. Efficient transduction of simian cells by HIV-1-based lentiviral vectors that contain mutations in the capsid protein. *Mol Ther* 2007;15(5):930-937.
351. Kootstra NA, Munk C, Tonnu N, et al. Abrogation of postentry restriction of HIV-1-based lentiviral vector transduction in simian cells. *Proc Natl Acad Sci U S A* 2003;100(3):1298-1303.
352. Hanawa H, Hematti P, Keyvanfar K, et al. Efficient gene transfer into rhesus repopulating hematopoietic stem cells using a simian immunodeficiency virus-based lentiviral vector system. *Blood* 2004;103(11):4062-4069.
353. Kim YJ, Kim YS, Larochelle A, et al. Sustained high-level polyclonal hematopoietic marking and transgene expression 4 years after autologous transplantation of rhesus macaques with SIV lentiviral vector-transduced CD34+ cells. *Blood* 2009;113(22):5434-5443.
354. Larochelle A, Choi U, Shou Y, et al. In vivo selection of hematopoietic progenitor cells and temozolomide dose intensification in rhesus macaques through lentiviral transduction with a drug resistance gene. *J Clin Invest* 2009;119(7):1952-1963.
355. Tarantal AF, Giannoni F, Lee CC, et al. Nonmyeloablative conditioning regimen to increase engraftment of gene-modified hematopoietic stem cells in young rhesus monkeys. *Mol Ther* 2012;20(5):1033-1045.
356. Verhoeven E, Relouzat F, Cambot M, et al. Stem cell factor-displaying simian immunodeficiency viral vectors together with a low conditioning regimen allow for long-term engraftment of gene-marked autologous hematopoietic stem cells in macaques. *Hum Gene Ther* 2012;23(7):754-768.
357. Astrakhan A, Sather BD, Ryu BY, et al. Ubiquitous high-level gene expression in hematopoietic lineages provides effective lentiviral gene therapy of murine Wiskott-Aldrich syndrome. *Blood* 2012;119(19):4395-4407.
358. Blundell MP, Bouma G, Calle Y, et al. Improvement of migratory defects in a murine model of Wiskott-Aldrich syndrome gene therapy. *Mol Ther* 2008;16(5):836-844.
359. Bosticardo M, Draghici E, Schena F, et al. Lentiviral-mediated gene therapy leads to improvement of B-cell functionality in a murine model of Wiskott-Aldrich syndrome. *J Allergy Clin Immunol* 2011;127(6):1376-1384 e5.

360. Charrier S, Stockholm D, Seye K, et al. A lentiviral vector encoding the human Wiskott-Aldrich syndrome protein corrects immune and cytoskeletal defects in WASP knockout mice. *Gene Ther* 2005;12(7):597-606.
361. Dupre L, Marangoni F, Scaramuzza S, et al. Efficacy of gene therapy for Wiskott-Aldrich syndrome using a WAS promoter/cDNA-containing lentiviral vector and nonlethal irradiation. *Hum Gene Ther* 2006;17(3):303-313.
362. Marangoni F, Bosticardo M, Charrier S, et al. Evidence for long-term efficacy and safety of gene therapy for Wiskott-Aldrich syndrome in preclinical models. *Mol Ther* 2009;17(6):1073-1082.
363. Imren S, Payen E, Westerman KA, et al. Permanent and panerythroid correction of murine beta thalassemia by multiple lentiviral integration in hematopoietic stem cells. *Proc Natl Acad Sci U S A* 2002;99(22):14380-14385.
364. Negre O, Fusil F, Colomb C, et al. Correction of murine beta-thalassemia after minimal lentiviral gene transfer and homeostatic in vivo erythroid expansion. *Blood* 2011;117(20):5321-5331.
365. Persons DA, Allay ER, Sawai N, et al. Successful treatment of murine betathalassemia using in vivo selection of genetically modified, drug-resistant hematopoietic stem cells. *Blood* 2003;102(2):506-513.
366. Zhao H, Pestina TI, Nasimuzzaman M, et al. Amelioration of murine betathalassemia through drug selection of hematopoietic stem cells transduced with a lentiviral vector encoding both gamma-globin and the MGMT drug-resistance gene. *Blood* 2009;113(23):5747-5756.
367. Almarza E, Rio P, Meza NW, et al. Characteristics of lentiviral vectors harboring the proximal promoter of the vav proto-oncogene: a weak and efficient promoter for gene therapy. *Mol Ther* 2007;15(8):1487-1494.
368. Benjelloun F, Garrigue A, Demerens-de Chappedelaine C, et al. Stable and functional lymphoid reconstitution in artemis-deficient mice following lentiviral artemis gene transfer into hematopoietic stem cells. *Mol Ther* 2008;16(8):1490-1499.
369. Mostoslavsky G, Fabian AJ, Rooney S, et al. Complete correction of murine Artemis immunodeficiency by lentiviral vector-mediated gene transfer. *Proc Natl Acad Sci U S A* 2006;103(44):16406-16411.
370. Zhang F, Thornhill SI, Howe SJ, et al. Lentiviral vectors containing an enhancer-less ubiquitously acting chromatin opening element (UCOE) provide highly reproducible and stable transgene expression in hematopoietic cells. *Blood* 2007;110(5):1448-1457.
371. Zhou S, Mody D, DeRavin SS, et al. A self-inactivating lentiviral vector for SCID-X1 gene therapy that does not activate LMO2 expression in human T cells. *Blood* 2010;116(6):900-908.
372. Barde I, Laurenti E, Verp S, et al. Lineage- and stage-restricted lentiviral vectors for the gene therapy of chronic granulomatous disease. *Gene Ther* 2011;18(11):1087-1097.
373. Podda S, Ward M, Himelstein A, et al. Transfer and expression of the human multiple drug resistance gene into live mice. *Proc Natl Acad Sci U S A* 1992;89(20):9676-9680.
374. Allay JA, Persons DA, Galipeau J, et al. In vivo selection of retrovirally transduced hematopoietic stem cells. *Nat Med* 1998;4(10):1136-1143.
375. Davis BM, Koc ON, Gerson SL, Limiting numbers of G156A O(6)-methylguanine-DNA methyltransferase-transduced marrow progenitors repopulate nonmyeloablated mice after drug selection. *Blood* 2000;95(10):3078-3084.
376. Ragg S, Xu-Welliver M, Bailey J, et al. Direct reversal of DNA damage by mutant methyltransferase protein protects mice against dose-intensified chemotherapy and leads to in vivo selection of hematopoietic stem cells. *Cancer Res* 2000;60(18):5187-5195.
377. Sawai N, Zhou S, Vanin EF, et al. Protection and in vivo selection of hematopoietic stem cells using temozolomide, O6-benzylguanine, and an alkyltransferase-expressing retroviral vector. *Mol Ther* 2001;3(1):78-87.
378. Persons DA, Allay JA, Bonifacino A, et al. Transient in vivo selection of transduced peripheral blood cells using antifolate drug selection in rhesus macaques that received transplants with hematopoietic stem cells expressing dihydrofolate reductase vectors. *Blood* 2004;103(3):796-803.
379. Hibino H, Tani K, Ikebuchi K, et al. The common marmoset as a target preclinical primate model for cytokine and gene therapy studies. *Blood* 1999;93(9):2839-2848.

380. Licht T, Haskins M, Henthorn P, et al. Drug selection with paclitaxel restores expression of linked IL-2 receptor gamma-chain and multidrug resistance (MDR1) transgenes in canine bone marrow. *Proc Natl Acad Sci U S A* 2002;99(5):3123-3128.
381. Beard BC, Trobridge GD, Ironside C, et al. Efficient and stable MGMT-mediated selection of long-term repopulating stem cells in nonhuman primates. *J Clin Invest* 2010;120(7):2345-2354.
382. Gerull S, Beard BC, Peterson LJ, et al. In vivo selection and chemoprotection after drug resistance gene therapy in a nonmyeloablative allogeneic transplantation setting in dogs. *Hum Gene Ther* 2007;18(5):451-456.
383. Gori JL, Beard BC, Ironside C, et al. In vivo selection of autologous MGMT gene-modified cells following reduced-intensity conditioning with BCNU and temozolomide in the dog model. *Cancer Gene Ther* 2012;19(8):523-529.
384. Pollok KE, Hartwell JR, Braber A, et al. In vivo selection of human hematopoietic cells in a xenograft model using combined pharmacologic and genetic manipulations. *Hum Gene Ther* 2003;14(18):1703-1714.
385. Zielske SP, Reese JS, Lingas KT, et al. In vivo selection of MGMT(P140K) lentivirus-transduced human NOD/SCID repopulating cells without pretransplant irradiation conditioning. *J Clin Invest* 2003;112(10):1561-1570.
386. Pawliuk R, Kay R, Lansdorp P, et al. Selection of retrovirally transduced hematopoietic cells using CD24 as a marker of gene transfer. *Blood* 1994;84(9):2868-2877.
387. Medin JA, Migita M, Pawliuk R, et al. A bicistronic therapeutic retroviral vector enables sorting of transduced CD34+ cells and corrects the enzyme deficiency in cells from Gaucher patients. *Blood* 1996;87(5):1754-1762.
388. Cheng L, Fu J, Tsukamoto A, et al. Use of green fluorescent protein variants to monitor gene transfer and expression in mammalian cells. *Nat Biotechnol* 1996;14(5):606-609.
389. Hanazono Y, Yu JM, Dunbar CE, et al. Green fluorescent protein retroviral vectors: low titer and high recombination frequency suggest a selective disadvantage. *Hum Gene Ther* 1997;8(11):1313-1319.
390. Persons DA, Allay JA, Allay ER, et al. Retroviral-mediated transfer of the green fluorescent protein gene into murine hematopoietic cells facilitates scoring and selection of transduced progenitors in vitro and identification of genetically modified cells in vivo. *Blood* 1997;90(5):1777-1786.
391. Kiem HP, Rasko JE, Morris J, et al. Ex vivo selection for oncoretrovirally transduced green fluorescent protein-expressing CD34-enriched cells increases short-term engraftment of transduced cells in baboons. *Hum Gene Ther* 2002;13(8):891-899.
392. van der Loo JC and Ploemacher RE. Marrow- and spleen-seeding efficiencies of all murine hematopoietic stem cell subsets are decreased by preincubation with hematopoietic growth factors. *Blood* 1995;85(9):2598-2606.
393. Spangrude GJ, Brooks DM, and Tumas DB. Long-term repopulation of irradiated mice with limiting numbers of purified hematopoietic stem cells: in vivo expansion of stem cell phenotype but not function. *Blood* 1995;85(4):1006-1016.
394. Sellers S, Tisdale J, Agricola B, et al. Genetically-marked rhesus peripheral blood progenitor cells (PBPC) ex vivo expanded in the presence of fibronectin 296 contribute to both short and long term engraftment. *Blood* 2000;96(11):589a.
395. Li CL, Johnson GR. Stem cell factor enhances the survival but not the self-renewal of murine hematopoietic long-term repopulating cells. *Blood* 1994;84(2):408-414.
396. Bodine DM, Seidel NE, Zsebo KM, et al. In vivo administration of stem cell factor to mice increases the absolute number of pluripotent hematopoietic stem cells. *Blood* 1993;82(2):445-455.
397. Thorsteinsdottir U, Sauvageau G, Humphries RK. Enhanced in vivo regenerative potential of HOXB4-transduced hematopoietic stem cells with regulation of their pool size. *Blood* 1999;94(8):2605-2612.
398. Domen J, Weissman IL. Hematopoietic stem cells need two signals to prevent apoptosis; BCL-2 can provide one of these, Kitl/c-Kit signaling the other. *J Exp Med* 2000;192(12):1707-1718.
399. Kirby S, Walton W, Smithies O. Hematopoietic stem cells with controllable tEpoR transgenes have a competitive advantage in bone marrow transplantation. *Blood* 2000;95(12):3710-3715.
400. Blau CA, Neff T, Papayannopoulou T. Cytokine prestimulation as a gene therapy strategy: implications for using the MDR1 gene as a dominant selectable marker. *Blood* 1997;89(1):146-154.

401. Jin L, Asano H, Blau CA. Stimulating cell proliferation through the pharmacologic activation of c-kit. *Blood* 1998;91(3):890-897.
402. Hanazono Y, Nagashima T, Shibata H, et al. In Vivo Expansion of Gene-modified Hematopoietic Cells by the Selective Amplifier Gene in a Nonhuman Primate Model. *Blood* 2000;96(11):524a.
403. Ito K, Ueda Y, Kokubun M, et al. Development of a novel selective amplifier gene for controllable expansion of transduced hematopoietic cells. *Blood* 1997;90(10):3884-3892.
404. Zhang XB, Beard BC, Beebe K, et al. Differential effects of HOXB4 on nonhuman primate short- and long-term repopulating cells. *PLoS Med* 2006;3(5):e173.
405. Zhang XB, Beard BC, Trobridge GD, et al. High incidence of leukemia in large animals after stem cell gene therapy with a HOXB4-expressing retroviral vector. *J Clin Invest* 2008;118(4):1502-1510.
406. Murnane R, Zhang XB, Hukkanen RR, et al. Myelodysplasia in 2 pig-tailed macaques (*Macaca nemestrina*) associated with retroviral vector-mediated insertional mutagenesis and overexpression of HOXB4. *Vet Pathol* 2011;48(5): 999-1001.
407. Leuci V, Mesiano G, Gammaitoni L, et al. Transient proteasome inhibition as a strategy to enhance lentiviral transduction of hematopoietic CD34(+) cells and T lymphocytes: implications for the use of low viral doses and large-size vectors. *J Biotechnol* 2011;156(3):218-226.
408. Santoni de Sio FR, Cascio P, Zingale A, et al. Proteasome activity restricts lentiviral gene transfer into hematopoietic stem cells and is down-regulated by cytokines that enhance transduction. *Blood* 2006;107(11):4257-4265.
409. Millington M, Arndt A, Boyd M, et al. Towards a clinically relevant lentiviral transduction protocol for primary human CD34 hematopoietic stem/progenitor cells. *PLoS One* 2009;4(7):e6461.
410. Uchida N, Hsieh MM, Hayakawa J, et al. Optimal conditions for lentiviral transduction of engrafting human CD34+ cells. *Gene Ther* 2011;18(11):1078-1086.
411. Moore KA, Deisseroth AB, Reading CL, et al. Stromal support enhances cell-free retroviral vector transduction of human bone marrow long-term culture-initiating cells. *Blood* 1992;79(6):1393-1399.
412. Wells S, Malik P, Pensiero M, et al. The presence of an autologous marrow stromal cell layer increases glucocerebrosidase gene transduction of long-term culture initiating cells (LTCICs) from the bone marrow of a patient with Gaucher disease. *Gene Ther* 1995;2(8):512-520.
413. Xu LC, Kluepfel-Stahl S, Blanco M, et al. Growth factors and stromal support generate very efficient retroviral transduction of peripheral blood CD34+ cells from Gaucher patients. *Blood* 1995;86(1):141-146.
414. Moritz T, Patel VP, Williams DA. Bone marrow extracellular matrix molecules improve gene transfer into human hematopoietic cells via retroviral vectors. *J Clin Invest* 1994;93(4):1451-1457.
415. Carstanjen D, Dutt P, Moritz T. Heparin inhibits retrovirus binding to fibronectin as well as retrovirus gene transfer on fibronectin fragments. *J Virol* 2001;75(13):6218-6222.
416. Lei P, Bajaj B, Andreadis ST. Retrovirus-associated heparan sulfate mediates immobilization and gene transfer on recombinant fibronectin. *J Virol* 2002;76(17):8722-8728.
417. Relander T, Brun A, Hawley RG, et al. Retroviral transduction of human CD34+ cells on fibronectin fragment CH-296 is inhibited by high concentrations of vector containing medium. *J Gene Med* 2001;3(3):207-218.
418. Dao MA, Hashino K, Kato I, et al. Adhesion to fibronectin maintains regenerative capacity during ex vivo culture and transduction of human hematopoietic stem and progenitor cells. *Blood* 1998;92(12):4612-4621.
419. Sagar BM, Rentala S, Gopal PN, et al. Fibronectin and laminin enhance engraftability of cultured hematopoietic stem cells. *Biochem Biophys Res Commun* 2006;350(4):1000-1005.
420. Yokota T, Oritani K, Mitsui H, et al. Growth-supporting activities of fibronectin on hematopoietic stem/progenitor cells in vitro and in vivo: structural requirement for fibronectin activities of CS1 and cell-binding domains. *Blood* 1998;91(9):3263-3272.
421. Donahue RE, Sorrentino BP, Hawley RG, et al. Fibronectin fragment CH-296 inhibits apoptosis and enhances ex vivo gene transfer by murine retrovirus and human lentivirus vectors independent of viral tropism in nonhuman primate CD34+ cells. *Mol Ther* 2001;3(3):359-367.

422. Abonour R, Williams DA, Einhorn L, et al. Efficient retrovirus-mediated transfer of the multidrug resistance 1 gene into autologous human long-term repopulating hematopoietic stem cells [see comments]. *Nat Med* 2000;6(6): 652-658.
423. Hanenberg H, Hashino K, Konishi H, et al. Optimization of fibronectin-assisted retroviral gene transfer into human CD34+ hematopoietic cells. *Hum Gene Ther* 1997;8(18):2193-2206.
424. Lee HJ, Lee YS, Kim HS, et al. Retronectin enhances lentivirus-mediated gene delivery into hematopoietic progenitor cells. *Biologicals* 2009;37(4):203-209.
425. Barese C, Pech N, Dirscherl S, et al. Granulocyte colony-stimulating factor prior to nonmyeloablative irradiation decreases murine host hematopoietic stem cell function and increases engraftment of donor marrow cells. *Stem Cells* 2007;25(6):1578-1585.
426. Goebel WS, Pech NK, Dinauer MC. Stable long-term gene correction with low-dose radiation conditioning in murine X-linked chronic granulomatous disease. *Blood Cells Mol Dis* 2004;33(3):365-371.
427. Goebel WS, Pech NK, Meyers JL, et al. A murine model of antimetabolite-based, submyeloablative conditioning for bone marrow transplantation: biologic insights and potential applications. *Exp Hematol* 2004;32(12): 1255-1264.
428. Goebel WS, Yoder MC, Pech NK, et al. Donor chimerism and stem cell function in a murine congenic transplantation model after low-dose radiation conditioning: effects of a retroviral-mediated gene transfer protocol and implications for gene therapy. *Exp Hematol* 2002;30(11):1324-1332.
429. Huston MW, van Til NP, Visser TP, et al. Correction of murine SCID-X1 by lentiviral gene therapy using a codon-optimized IL2RG gene and minimal pretransplant conditioning. *Mol Ther* 2011;19(10):1867-1877.
430. Czechowicz A, Kraft D, Weissman IL, et al. Efficient transplantation via antibody-based clearance of hematopoietic stem cell niches. *Science* 2007;318(5854):1296-1299.
431. Xue X, Pech NK, Shelley WC, et al. Antibody targeting KIT as pretransplantation conditioning in immunocompetent mice. *Blood* 2010;116(24):5419-5422.
432. Chen J, Larochelle A, Fricker S, et al. Mobilization as a preparative regimen for hematopoietic stem cell transplantation. *Blood* 2006;107(9):3764-3771.
433. Huhn RD, Tisdale JF, Agricola B, et al. Retroviral marking and transplantation of rhesus hematopoietic cells by nonmyeloablative conditioning. *Hum Gene Ther* 1999;10(11):1783-1790.
434. Brenner S, Whiting-Theobald NL, Linton GF, et al. Concentrated RD114-pseudotyped MFGS-gp91phox vector achieves high levels of functional correction of the chronic granulomatous disease oxidase defect in NOD/SCID/beta⁻microglobulin^{-/-} repopulating mobilized human peripheral blood CD34+ cells. *Blood* 2003;102(8):2789-2797.
435. Kahl CA, Tarantal AF, Lee CI, et al. Effects of busulfan dose escalation on engraftment of infant rhesus monkey hematopoietic stem cells after gene marking by a lentiviral vector. *Exp Hematol* 2006;34(3):369-381.
436. Kang EM, Hsieh MM, Metzger M, et al. Busulfan pharmacokinetics, toxicity, and low-dose conditioning for autologous transplantation of genetically modified hematopoietic stem cells in the rhesus macaque model. *Exp Hematol* 2006;34(2):132-139.
437. Rosenzweig M, MacVittie TJ, Harper D, et al. Efficient and durable gene marking of hematopoietic progenitor cells in nonhuman primates after nonablative conditioning. *Blood* 1999;94(7):2271-2286.
438. Sadat MA, Dirscherl S, Sastry L, et al. Retroviral vector integration in post-transplant hematopoiesis in mice conditioned with either submyeloablative or ablative irradiation. *Gene Ther* 2009;16(12):1452-1464.
439. Bordignon C, Notarangelo LD, Nobili N, et al. Gene therapy in peripheral blood lymphocytes and bone marrow for ADA- immunodeficient patients. *Science* 1995;270(5235):470-475.
440. Aiuti A, Cattaneo F, Galimberti S, et al. Gene therapy for immunodeficiency due to adenosine deaminase deficiency. *N Engl J Med* 2009;360(5):447-458.
441. Gaspar HB, Bjorkegren E, Parsley K, et al. Successful reconstitution of immunity in ADA-SCID by stem cell gene therapy following cessation of PEG-ADA and use of mild preconditioning. *Mol Ther* 2006;14(4):505-513.
442. Gaspar HB, Cooray S, Gilmour KC, et al. Long-term persistence of a polyclonal T cell repertoire after gene therapy for X-linked severe combined immunodeficiency. *Sci Transl Med* 2011;3(97):97ra79.

443. Gaspar HB, Cooray S, Gilmour KC, et al. Hematopoietic stem cell gene therapy for adenosine deaminase-deficient severe combined immunodeficiency leads to long-term immunological recovery and metabolic correction. *Sci Transl Med* 2011;3(97):97ra80.
444. Kang EM, Choi U, Theobald N, et al. Retrovirus gene therapy for X-linked chronic granulomatous disease can achieve stable long-term correction of oxidase activity in peripheral blood neutrophils. *Blood* 2010;115(4):783-791.
445. Kang HJ, Bartholomae CC, Paruzynski A, et al. Retroviral gene therapy for X-linked chronic granulomatous disease: results from phase I/II trial. *Mol Ther* 2011;19(11):2092-2101.
446. Ott MG, Schmidt M, Schwarzwaelder K, et al. Correction of X-linked chronic granulomatous disease by gene therapy, augmented by insertional activation of MDS1-EVI1, PRDM16 or SETBP1. *Nat Med* 2006;12(4):401-409.
447. Boztug K, Schmidt M, Schwarzer A, et al. Stem-cell gene therapy for the Wiskott-Aldrich syndrome. *N Engl J Med* 2010;363(20):1918-1927.
448. Hacein-Bey-Abina S, Hauer J, Lim A, et al. Efficacy of gene therapy for X-linked severe combined immunodeficiency. *N Engl J Med* 2010;363(4): 355-364.
- P.1522
449. Hacein-Bey-Abina S, Le Deist F, Carlier F, et al. Sustained correction of X-linked severe combined immunodeficiency by ex vivo gene therapy. *N Engl J Med* 2002;346(16):1185-1193.
450. Hacein-Bey-Abina S, Garrigue A, Wang GP, et al. Insertional oncogenesis in 4 patients after retrovirus-mediated gene therapy of SCID-X1. *J Clin Invest* 2008;118(9):3132-3142.
451. Hacein-Bey-Abina S, Von Kalle C, Schmidt M, et al. LMO2-associated clonal T cell proliferation in two patients after gene therapy for SCID-X1. *Science* 2003;302(5644):415-419.
452. Gaspar HB, Parsley KL, Howe S, et al. Gene therapy of X-linked severe combined immunodeficiency by use of a pseudotyped gammaretroviral vector. *Lancet* 2004;364(9452):2181-2187.
453. Schwarzwaelder K, Howe SJ, Schmidt M, et al. Gammaretrovirus-mediated correction of SCID-X1 is associated with skewed vector integration site distribution in vivo. *J Clin Invest* 2007;117(8):2241-2249.
454. Howe SJ, Mansour MR, Schwarzwaelder K, et al. Insertional mutagenesis combined with acquired somatic mutations causes leukemogenesis following gene therapy of SCID-X1 patients. *J Clin Invest* 2008;118(9):3143-3150.
455. Chinen J, Davis J, De Ravin SS, et al. Gene therapy improves immune function in preadolescents with X-linked severe combined immunodeficiency. *Blood* 2007;110(1):67-73.
456. Thrasher AJ, Hacein-Bey-Abina S, Gaspar HB, et al. Failure of SCID-X1 gene therapy in older patients. *Blood* 2005;105(11):4255-4257.
457. Dunbar CE, Larochelle A. Gene therapy activates EVI1, destabilizes chromosomes. *Nat Med* 2010;16(2):163-165.
458. Stein S, Ott MG, Schultze-Strasser S, et al. Genomic instability and myelodysplasia with monosomy 7 consequent to EVI1 activation after gene therapy for chronic granulomatous disease. *Nat Med* 2010;16(2):198-204.
459. Baum C. Insertional mutagenesis in gene therapy and stem cell biology. *Curr Opin Hematol* 2007;14(4):337-342.
460. Case SS, Price MA, Jordan CT, et al. Stable transduction of quiescent CD34(+) CD38(-) human hematopoietic cells by HIV-1-based lentiviral vectors. *Proc Natl Acad Sci U S A* 1999;96(6):2988-2993.
461. Mazurier F, Gan OI, McKenzie JL, et al. Lentivector-mediated clonal tracking reveals intrinsic heterogeneity in the human hematopoietic stem cell compartment and culture-induced stem cell impairment. *Blood* 2004;103(2): 545-552.
462. Nienhuis AW, Dunbar CE, Sorrentino BP. Genotoxicity of retroviral integration in hematopoietic cells. *Mol Ther* 2006;13(6):1031-1049.
463. Uchida N, Sutton RE, Frieri AM, et al. HIV, but not murine leukemia virus, vectors mediate high efficiency gene transfer into freshly isolated G0/G1 human hematopoietic stem cells. *Proc Natl Acad Sci U S A* 1998;95(20): 11939-11944.
464. Ikeda K, Mason PJ, Bessler M. 3'UTR-truncated Hmga2 cDNA causes MPNlike hematopoiesis by conferring a clonal growth advantage at the level of HSC in mice. *Blood* 2011;117(22):5860-5869.

465. Schmidt M, Carbonaro DA, Speckmann C, et al. Clonality analysis after retroviral-mediated gene transfer to CD34+ cells from the cord blood of ADA-deficient SCID neonates. *Nat Med* 2003;9(4):463-468.
466. Inoue N, Izui-Sarumaru T, Murakami Y, et al. Molecular basis of clonal expansion of hematopoiesis in 2 patients with paroxysmal nocturnal hemoglobinuria (PNH). *Blood* 2006;108(13):4232-4236.
467. Murakami Y, Inoue N, Shichishima T, et al. Deregulated expression of HMGA2 is implicated in clonal expansion of PIGA deficient cells in paroxysmal nocturnal haemoglobinuria. *Br J Haematol* 2012;156(3):383-387.
468. Restifo NP, Dudley ME, Rosenberg SA. Adoptive immunotherapy for cancer: harnessing the T cell response. *Nature reviews. Immunology* 2012;12(4):269-281.
469. Wrzesinski C, Paulos CM, Gattinoni L, et al. Hematopoietic stem cells promote the expansion and function of adoptively transferred antitumor CD8 T cells. *J Clin Invest* 2007;117(2):492-501.
470. Morgan RA, Dudley ME, Wunderlich JR, et al. Cancer regression in patients after transfer of genetically engineered lymphocytes. *Science* 2006;314(5796):126-129.
471. Porter DL, Levine BL, Kalos M, et al. Chimeric antigen receptor-modified T cells in chronic lymphoid leukemia. *N Engl J Med* 2011;365(8):725-733.
472. Scholler J, Brady TL, Binder-Scholl G, et al. Decade-long safety and function of retroviral-modified chimeric antigen receptor T cells. *Sci Transl Med* 2012;4(132):132ra53.
473. Rooney CM, Smith CA, Ng CY, et al. Use of gene-modified virus-specific T lymphocytes to control Epstein-Barr-virus-related lymphoproliferation. *Lancet* 1995;345(8941):9-13.
474. Heslop HE, Ng CY, Li C, et al. Long-term restoration of immunity against Epstein-Barr virus infection by adoptive transfer of gene-modified virus-specific T lymphocytes. *Nat Med* 1996;2(5):551-555.
475. Bordignon C, Bonini C, Verzeletti S, et al. Transfer of the HSV-tk gene into donor peripheral blood lymphocytes for in vivo modulation of donor antitumor immunity after allogeneic bone marrow transplantation. *Hum Gene Ther* 1995;6(6):813-819.
476. Mullen CA, Metabolic suicide genes in gene therapy. *Pharmacol Ther* 1994;63(2):199-207.
477. Lupo-Stanghellini MT, Provasi E, Bondanza A, et al. Clinical impact of suicide gene therapy in allogeneic hematopoietic stem cell transplantation. *Human Gene Ther* 2010;21(3):241-250.
478. Mavilio F, Ferrari G, Rossini S, et al. Peripheral blood lymphocytes as target cells of retroviral vector-mediated gene transfer. *Blood* 1994;83(7):1988-1997.
479. Bonini C, Ferrari G, Verzeletti S, et al. HSV-TK gene transfer into donor lymphocytes for control of allogeneic graft-versus-leukemia. *Science* 1997;276(5319):1719-1724.
480. Ciceri F, Bonini C, Stanghellini MT, et al. Infusion of suicide-gene-engineered donor lymphocytes after family haploidentical haemopoietic stem-cell transplantation for leukaemia (the TK007 trial): a non-randomised phase I-II study. *Lancet Oncol* 2009;10(5):489-500.
481. Traversari C, Marktel S, Magnani Z, et al. The potential immunogenicity of the TK suicide gene does not prevent full clinical benefit associated with the use of TK-transduced donor lymphocytes in HSCT for hematologic malignancies. *Blood* 2007;109(11):4708-4715.
482. Riddell SR, Elliott M, Lewinsohn DA, et al. T-cell mediated rejection of gene-modified HIV-specific cytotoxic T lymphocytes in HIV-infected patients [see comments]. *Nat Med* 1996;2(2):216-223.
483. Straathof KC, Pule MA, Yotnda P, et al. An inducible caspase 9 safety switch for T-cell therapy. *Blood* 2005;105(11):4247-4254.
484. Di Stasi A, Tey SK, Dotti G, et al. Inducible apoptosis as a safety switch for adoptive cell therapy. *N Engl J Med* 2011;365(18):1673-1683.
485. Anderson WF. September 14 1990: the beginning. *Hum Gene Ther* 1990;1(4):371-372.
486. Luciw P. Human immunodeficiency viruses and their replication. In: Fields BN, Knipe DM, Howley PM, eds. *Fields virology*. Philadelphia, PA: Lippincott-Raven, 1996:1881-1952.
487. Baltimore D. Gene therapy: intracellular immunization. *Nature* 1988;335: 396-398.

488. Allers K, Hutter G, Hofmann J, et al. Evidence for the cure of HIV infection by CCR5Delta32/Delta32 stem cell transplantation. *Blood* 2011;117(10): 2791-2799.
489. Walker RE. A phase I/II pilot study of the safety of the adoptive transfer of syngeneic gene-modified cytotoxic T lymphocytes in HIV-infected identical twins. *Hum Gene Ther* 1996;7(3):367-400.
490. Walker RE, Carter CS, Muul L, et al. Peripheral expansion of pre-existing mature T cells is an important means of CD4+ T-cell regeneration HIV-infected adults. *Nat Med* 1998;4(7):852-856.
491. Walker RE, Bechtel CM, Natarajan V, et al. Long-term in vivo survival of receptor-modified syngeneic T cells in patients with human immunodeficiency virus infection. *Blood* 2000;96(2):467-474.
492. Malim MH, Bohnlein S, Hauber J, et al. Functional dissection of the HIV-1 Rev trans-activator--derivation of a trans-dominant repressor of Rev function. *Cell* 1989;58(1):205-214.
493. Woffendin C, Ranga U, Yang Z, et al. Expression of a protective gene--prolongs survival of T cells in human immunodeficiency virus-infected patients. *Proc Natl Acad Sci U S A* 1996;93(7):2889-2894.
494. Kang EM, de Witte M, Malech H, et al. Nonmyeloablative conditioning followed by transplantation of genetically modified HLA-matched peripheral blood progenitor cells for hematologic malignancies in patients with acquired immunodeficiency syndrome. *Blood* 2002;99(2):698-701.
495. Dropulic B, Hermankova M, Pitha PM, A conditionally replicating HIV-1 vector interferes with wild-type HIV-1 replication and spread. *Proc Natl Acad Sci U S A* 1996;93(20):11103-11108.
496. Dropulic B. Lentivirus in the clinic. *Mol Ther* 2001;4(6):511-512.
497. Levine BL, Humeau LM, Boyer J, et al. Gene transfer in humans using a conditionally replicating lentiviral vector. *Proc Natl Acad Sci U S A* 2006;103(46): 17372-17377.
498. Ngo MC, Rooney CM, Howard JM, et al. Ex vivo gene transfer for improved adoptive immunotherapy of cancer. *Human Mol Genet* 2011;20(R1):R93-R99.
499. Parkhurst MR, Yang JC, Langan RC, et al. T cells targeting carcinoembryonic antigen can mediate regression of metastatic colorectal cancer but induce severe transient colitis. *Mol Ther J AmSoc Gene Ther* 2011;19(3):620-626.
500. Bendle GM, Linnemann C, Hooijkaas AI, et al. Lethal graft-versus-host disease in mouse models of T cell receptor gene therapy. *Nat Med* 2010;16(5): 565-570.
501. Rosenberg SA. Of mice, not men: no evidence for graft-versus-host disease in humans receiving T-cell receptor-transduced autologous T cells. *Mol Ther J AmSoc Gene Ther* 2010;18(10):1744-1745.
502. Morgan RA, Yang JC, Kitano M, et al. Case report of a serious adverse event following the administration of T cells transduced with a chimeric antigen receptor recognizing ERBB2. *Mol Ther J AmSoc Gene Ther* 2010;18(4): 843-851.
503. Dotti G, Savoldo B, Brenner M. Fifteen years of gene therapy based on chimeric antigen receptors: "are we nearly there yet?". *Human Gene Ther* 2009;20(11):1229-1239.
504. Eshhar Z, Waks T, Gross G, et al. Specific activation and targeting of cytotoxic lymphocytes through chimeric single chains consisting of antibody-binding domains and the gamma or zeta subunits of the immunoglobulin and T-cell receptors. *Proc Natl Acad Sci U S A* 1993;90(2):720-724.
505. Sadelain M, Brentjens R, Riviere I. The promise and potential pitfalls of chimeric antigen receptors. *Curr Opin Immunol* 2009;21(2):215-223.
506. Mitsuyasu RT, Anton PA, Deeks SG, et al. Prolonged survival and tissue trafficking following adoptive transfer of CD4zeta gene-modified autologous CD4(+) and CD8(+) T cells in human immunodeficiency virus-infected subjects. *Blood* 2000;96(3):785-793.
507. Maher J, Brentjens RJ, Gunset G, et al. Human T-lymphocyte cytotoxicity and proliferation directed by a single chimeric TCRzeta /CD28 receptor. *Nat Biotechnol* 2002;20(1):70-75.
508. Kochenderfer JN, Wilson WH, Janik JE, et al. Eradication of B-lineage cells and regression of lymphoma in a patient treated with autologous T cells genetically engineered to recognize CD19. *Blood* 2010;116(20):4099-4102.
509. Kochenderfer JN, Dudley ME, Feldman SA, et al. B-cell depletion and remissions of malignancy along with cytokine-associated toxicity in a clinical trial of anti-CD19 chimeric-antigen-receptor-transduced T cells. *Blood* 2012;119(12):2709-2720.

510. Kalos M, Levine BL, Porter DL, et al. T cells with chimeric antigen receptors have potent antitumor effects and can establish memory in patients with advanced leukemia. *Sci Transl Med* 2011;3(95):95ra73.
511. Romp KG, Monroe DM, Hoffman M. Platelets contain releasable coagulation factor IX antigen. *Blood Coag Fibrinolys* 1993;4:905-910.
512. Kembball-Cook G, Tuddenham EG. The Factor VIII Mutation Database on the World Wide Web: the haemophilia A mutation, search, test and resource site. HAMSTeRS update (version 3.0). *Nucleic Acids Res* 1997;25(1):128-132.
513. Giannelli F, Green PM, Sommer SS, et al. Haemophilia B: database of point mutations and short additions and deletions, 7th edition. *Nuc Acid Res* 1997;25:133-135.
514. Wood WI, Capon DJ, Simonsen CC, et al. Expression of active human factor VIII from recombinant DNA clones. *Nature* 1984;312:330-337.
515. Choo KH, Gould KG, Rees DJ, et al. Molecular cloning of the gene for human anti-haemophilic factor IX. *Nature* 1982;299(5879):178-180.
516. Lensen R, Bertina RM, Vandenbroucke JP, et al. High factor VIII levels contribute to the thrombotic risk in families with factor V Leiden. *Br J Haematol* 2001;114(2):380-386.
517. van H, V, van, d.L. I, Bertina RM, et al. High levels of factor IX increase the risk of venous thrombosis. *Blood* 2000;95(12):3678-3682.
518. Bi L, Lawler AM, Antonarakis SE, et al. Targeted disruption of the mouse factor VIII gene produces a model of haemophilia A. *Nat Genet* 1995;10:119-121.
519. Wang L, Zoppe M, Hackeng TM, et al. A factor IX-deficient mouse model for hemophilia B gene therapy. *Proc Natl Acad Sci USA* 1997;94:11563-11566.
520. Lin H-F, Maeda N, Smithies O, et al. A coagulation factor IX-deficient mouse model for human hemophilia B. *Blood* 1997;90:3962-3966.
521. Kundu RK, Sangiorgi F, Wu LY, et al. Targeted inactivation of the coagulation factor IX gene causes hemophilia B in mice. *Blood* 1998;92(1):168-174.
522. Lozier JN, Dutra A, Pak E, et al. The Chapel Hill hemophilia A dog colony exhibits an inversion of the factor VIII gene. *Proc Natl Acad Sci U S A*. 99(20):12991-12996.
523. Graham JB, Buckwalter JA, Hartley LJ, et al. Canine hemophilia: observations on the course, the clotting anomaly, and the effects of blood transfusion. *J Exp Med* 1949;90(2):97-111.
524. Brinkhous KM, Graham JB. Hemophilia in the female dog. *Science* 1950; 111:723.
525. Giles AR, Tinlin S, Greenwood R. A canine model of hemophilic (factor VIII:C deficiency) bleeding. *Blood* 1982;60:727-730.
526. Hough C, Kamisue S, Cameron C, et al. Aberrant splicing and premature termination of transcription of the FVIII gene as a cause of severe canine hemophilia A: similarities with the intron 22 inversion mutation in human hemophilia. *Thromb Haemost* 2002;87:659-665.
527. Andrews JL, Shirley PS, Iverson WO, et al. Evaluation of the Duration of Human Factor VIII Expression in Nonhuman Primates After Systemic Delivery of an Adenoviral Vector. *Hum Gene Ther* 2002;13(11):1331-1336.
528. Lozier JN, Metzger ME, Donahue RE, et al. Adenovirus-mediated expression of human coagulation factor IX in the rhesus macaque is associated with dose-limiting toxicity. *Blood* 1999;94(12):3968-3975.
529. Lozier JN, Metzger ME, Donahue RE, et al. The rhesus macaque as an animal model for hemophilia B gene therapy. *Blood* 1999;93(6):1875-1881.
530. Lozier JN, Csako G, Mondoro TH, et al. Toxicity of a first-generation adenoviral vector in rhesus macaques. *Hum Gene Ther* 2002;13(1):113-124.
531. Nathwani AC, Davidoff AM, Hanawa H, et al. Sustained high-level expression of human factor IX (hFIX) after liver-targeted delivery of recombinant adeno-associated virus encoding the hFIX gene in rhesus macaques. *Blood* 2002;100(5):1662-1669.

532. Palmer TD, Thompson AR, Miller AD. Production of Human Factor IX in Animals by Genetically Modified Skin Fibroblasts: potential Therapy for Hemophilia B. *Blood* 1989;73(2):438-445.
533. Axelrod JH, Read MS, Brinkhous KM, et al. Phenotypic correction of factor IX deficiency in skin fibroblasts of hemophilic dogs. *Proc Natl Acad Sci USA* 1990;87:5173-5177.
534. Hoeben RC, Einerhand MP, Briet E, et al. Toward gene therapy in haemophilia A: retrovirus-mediated transfer of a factor VIII gene into murine haematopoietic progenitor cells. *Thromb Haemost* 1992;67(3):341-345.
535. Gerrard AJ, Hudson DL, Brownlee GG, et al. Towards gene therapy for haemophilia B using primary human keratinocytes. *Nat Genet* 1993;3(2): 180-183.
536. Gerrard AJ, Austen DEG, Brownlee GG. Recombinant factor IX secreted by transduced human keratinocytes is biologically active. *Br J Haematol* 1996;95(3):561-563.
537. White SJ, Page SM, Margaritis P, et al. Long-term expression of human clotting factor IX from retrovirally transduced primary human keratinocytes in vivo. *Hum Gene Ther* 1998;9(8):1187-1195.
538. Fakharzadeh SS, Zhang Y, Sarkar R, et al. Correction of the coagulation defect in hemophilia A mice through factor VIII expression in skin. *Blood* 2000;95(9):2799-2805.
539. Palmer TD, Rosman GJ, Osborne WRA, et al. Genetically modified skin fibroblasts persist long after transplantation but gradually inactivate introduced genes. *Proc Natl Acad Sci USA* 1991;88:1330-1334.
540. Roth DA, Tawa NE, Jr, O'Brien JM, et al. Nonviral transfer of the gene encoding coagulation factor VIII in patients with severe hemophilia A. *N Engl J Med* 2001;344(23):1735-1742.
541. Chao H, Samulski RJ, Bellinger D, et al. Persistent expression of canine factor IX in hemophilia B canines. *Gene Ther* 1999;6(10):1695-1704.
542. Herzog RW, Yang EY, Couto LB, et al. Long-term correction of canine hemophilia B by gene transfer of blood coagulation factor IX mediated by adeno-associated viral vector. *Nat Med* 1999;5(1):56-63.
543. Monahan PE, Samulski RJ, Tazelaar J, et al. Direct intramuscular injection with recombinant AAV vectors results in sustained expression in a dog model of hemophilia. *Gene Ther* 1998;5(1):40-49.
544. Hagstrom JN, Couto LB, Scallan C, et al. Improved muscle-derived expression of human coagulation factor IX from a skeletal actin/CMV hybrid enhancer/promoter. *Blood* 2000;95(8):2536-2542.
545. Fields PA, Arruda VR, Armstrong E, et al. Risk and prevention of anti-factor IX formation in AAV-mediated gene transfer in the context of a large deletion of F9. *Mol Ther* 2001;4(3):201-210.
546. Herzog RW, Mount JD, Arruda VR, et al. Muscle-directed gene transfer and transient immune suppression result in sustained partial correction of canine hemophilia B caused by a null mutation. *Mol Ther* 2001;4(3):192-200.
547. Chao H, Monahan PE, Liu Y, et al. Sustained and complete phenotype correction of hemophilia B mice following intramuscular injection of AAV1 serotype vectors. *Mol Ther* 2001;4(3):217-222.
548. Chao H, Liu Y, Rabinowitz J, et al. Several log increase in therapeutic transgene delivery by distinct adeno-associated viral serotype vectors. *Mol Ther* 2000;2(6):619-623.
549. Liu YL, Mingozzi F, Rodriguez-Colon SM, et al. Therapeutic levels of factor IX expression using a muscle-specific promoter and adeno-associated virus serotype 1 vector. *Hum Gene Ther* 2004;15(8):783-792.
550. Kay MA, Manno CS, Ragni MV, et al. Evidence for gene transfer and expression of factor IX in haemophilia B patients treated with an AAV vector. *Nat Genet* 2000;24(3):257-261.
551. Manno CS, Chew AJ, Hutchison S, et al. AAV-mediated factor IX gene transfer to skeletal muscle in patients with severe hemophilia B. *Blood* 2003;101(8):2963-2972.
552. Jiang H, Pierce GF, Ozelo MC, et al. Evidence of multiyear factor IX expression by AAV-mediated gene transfer to skeletal muscle in an individual with severe hemophilia B. *Mol Ther* 2006;14(3):452-455.
553. Connelly S, Smith TAG, Dhir G, et al. In vivo gene delivery and expression of physiological levels of functional human factor VIII in mice. *Hum Gene Ther* 1995;6:185-193.
554. Bristol JA, Shirley P, Idamakanti N, et al. In vivo dose threshold effect of adenovirus-mediated factor VIII gene therapy in hemophilic mice. *Mol Ther* 2000;2(3):223-232.

555. Connelly S, Gardner JM, McClelland A, et al. High-level tissue-specific expression of functional human factor VIII in mice. *Hum Gene Ther* 1996;7:183-195.
556. Connelly S, Gardner JM, Lyons RM, et al. Sustained expression of therapeutic levels of human factor VIII in mice. *Blood* 1996;87(11):4671-4677.
557. Connelly S, Andrews JL, Gallo AM, et al. Sustained phenotypic correction of murine hemophilia A by in vivo gene therapy. *Blood* 1998;91(9):3273-3281.
558. Gorziglia MI, Lapcevic C, Roy S, et al. Generation of an adenovirus vector lacking E1, e2a, E3, and all of E4 except open reading frame 3. *J Virol* 1999;73(7):6048-6055.
559. Smith T, Idamakanti N, Kylefjord H, et al. In vivo hepatic adenoviral gene delivery occurs independently of the coxsackievirus-adenovirus receptor. *Mol Ther* 2002;5(6):770-779.
560. Connelly S, Andrews JL, Gallo-Penn AM, et al. Evaluation of an adenoviral vector encoding full-length human factor VIII in hemophiliac mice. *Thromb Haemost* 1999;81(2):234-239.
561. Balague C, Zhou J, Dai Y, et al. Sustained high-level expression of full-length human factor VIII and restoration of clotting activity in hemophilic mice using a minimal adenovirus vector. *Blood* 2000;95(3):820-828.
562. Smith TA, Mehaffey MG, Kayda DB, et al. Adenovirus mediated expression of therapeutic plasma levels of human factor IX in mice. *Nat Genet* 1993;5(4):397-402.
563. Kay MA, Holterman A-I, Meuse L, et al. Long-term hepatic adenovirus-mediated gene expression in mice following CTLA4lg administration. *Nat Genet* 1995;11:191-197.
564. Yao SN, Farjo A, Roessler BJ, et al. Adenovirus-mediated transfer of human factor IX gene in immunodeficient and normal mice: evidence for prolonged stability and activity of the transgene in liver. *Viral Immunol* 1996;9(3):141-153.
565. Connelly S, Mount J, Mauser A, et al. Complete short-term correction of canine hemophilia A by in vivo gene therapy. *Blood* 1996;88:3846-3853.
566. Gallo-Penn AM, Shirley PS, Andrews JL, et al. Systemic delivery of an adenoviral vector encoding canine factor VIII results in short-term phenotypic correction, inhibitor development, and biphasic liver toxicity in hemophilia A dogs. *Blood* 2001;97(1):107-113.
567. Gallo-Penn AM, Shirley PS, Andrews JL, et al. In vivo evaluation of an adenoviral vector encoding canine factor VIII: high-level, sustained expression in hemophiliac mice. *Hum Gene Ther* 1999;10(11):1791-1802.
568. Kay MA, Landen CN, Rothenberg SR, et al. In vivo hepatic gene therapy: complete albeit transient correction of factor IX deficiency in hemophilia B dogs. *Proc Natl Acad Sci U S A* 1994;91(6):2353-2357.
569. Schnell MA, Zhang Y, Tazelaar J, et al. Activation of innate immunity in nonhuman primates following intraportal administration of adenoviral vectors. *Mol Ther* 2001;3(5 Pt 1):708-722.
570. Bristol JA, Gallo-Penn A, Andrews J, et al. Adenovirus-mediated factor VIII gene expression results in attenuated anti-factor VIII-specific immunity in hemophilia A mice compared with factor VIII protein infusion. *Hum Gene Ther* 2001;12(13):1651-1661.
571. Andrews JL, Kadan MJ, Gorziglia MI, et al. Generation and characterization of E1/E2a/E3/E4-deficient adenoviral vectors encoding human factor VIII. *Mol Ther* 2001;3(3):329-336.
572. Reddy PS, Sakhuja K, Ganesh S, et al. Sustained human factor VIII expression in hemophilia A mice following systemic delivery of a gutless adenoviral vector. *Mol Ther* 2002;5(1):63-73.
573. Ehrhardt A, Kay MA. A new adenoviral helper-dependent vector results in long-term therapeutic levels of human coagulation factor IX at low doses in vivo. *Blood* 2002;99(11):3923-3930.
574. Brunetti-Pierri N, Nichols TC, McCorquodale S, et al. Sustained phenotypic correction of canine hemophilia B after systemic administration of helper-dependent adenoviral vector. *Hum Gene Ther* 2005;16(7):811-820.
575. Nunes FA, Furth EE, Wilson JM, et al. Gene transfer into the liver of nonhuman primates with E1-deleted recombinant adenoviral vectors: safety of readministration. *Hum Gene Ther* 1999;10(15):2515-2526.
576. Chao H, Mao L, Bruce AT, et al. Sustained expression of human factor VIII in mice using a parvovirus-based vector. *Blood* 2000;95(5):1594-1599.

577. Chao H, Walsh CE. Induction of tolerance to human factor VIII in mice. *Blood* 2001;97(10):3311-3312.
578. Chao H, Sun L, Bruce A, et al. Expression of Human Factor VIII by Splicing between Dimerized AAV Vectors. *Mol Ther* 2002;5(6):716-722.
579. Snyder RO, Miao CH, Patijn GA, et al. Persistent and therapeutic concentrations of human factor IX in mice after hepatic gene transfer of recombinant AAV vectors. *Nat Genet* 1997;16:270-276.
580. Snyder RO, Miao C, Meuse L, et al. Correction of hemophilia B in canine and murine models using recombinant adeno-associated viral vectors. *Nat Med* 1999;5(1):64-70.
581. Ge Y, Powell S, Van Roey M, et al. Factors influencing the development of an anti-factor IX (FIX) immune response following administration of adenoassociated virus-FIX. *Blood* 2001;97(12):3733-3737.
582. Miao CH, Snyder RO, Schowalter DB, et al. The kinetics of rAAV integration in the liver [letter]. *Nat Genet* 1998;19(1):13-15.
583. Nakai H, Herzog RW, Hagstrom JN, et al. Adeno-associated viral vector-mediated gene transfer of human blood coagulation factor IX into mouse liver. *Blood* 1998;91(12):4600-4607.
584. Nakai H, Thomas CE, Storm TA, et al. A limited number of transducible hepatocytes restricts a wide-range linear vector dose response in recombinant adeno-associated virus-mediated liver transduction. *J Virol* 2002;76(22): 11343-11349.
585. Wang L, Takabe K, Bidlingmaier SM, et al. Sustained correction of bleeding disorder in hemophilia B mice by gene therapy. *Proc Natl Acad Sci U S A* 1999;96(7):3906-3910.
586. Nathwani AC, Davidoff A, Hanawa H, et al. Factors influencing in vivo transduction by recombinant adeno-associated viral vectors expressing the human factor IX cDNA. *Blood* 2001;97(5):1258-1265.
587. Koeberl DD, Alexander IE, Halbert CL, et al. Persistent expression of human clotting factor IX from mouse liver after intravenous injection of adenoassociated virus vectors. *Proc Natl Acad Sci U S A* 1997;94:1426-1431.
588. Mount JD, Herzog RW, Tillson DM, et al. Sustained phenotypic correction of hemophilia B dogs with a factor IX null mutation by liver-directed gene therapy. *Blood* 2002;99(8):2670-2676.
589. Wang L, Nichols TC, Read MS, et al. Sustained expression of therapeutic level of factor IX in hemophilia B dogs by AAV-mediated gene therapy in liver. *Mol Ther* 2000;1(2):154-158.
590. Marshall E. Gene therapy. Panel reviews risks of germ line changes. *Science* 2001;294(5550):2268-2269.
591. Manno CS, Pierce GF, Arruda VR, et al. Successful transduction of liver in hemophilia by AAV-Factor IX and limitations imposed by the host immune response. *Nat Med* 2006;12(3):342-347.
592. Mingozzi F, Maus MV, Hui DJ, et al. CD8(+) T-cell responses to adeno-associated virus capsid in humans. *Nat Med* 2007;13(4):419-422.
593. Nathwani AC, Gray JT, Ng CY, et al. Self-complementary adeno-associated virus vectors containing a novel liver-specific human factor IX expression cassette enable highly efficient transduction of murine and nonhuman primate liver. *Blood* 2006;107(7):2653-2661.
594. Vandendriessche T, Vanslembrouck V, Goovaerts I, et al. Long-term expression of human coagulation factor VIII and correction of hemophilia A after in vivo retroviral gene transfer in factor VIII-deficient mice. *Proc Natl Acad Sci U S A* 1999;96(18):10379-10384.
595. Park F, Ohashi K, Kay MA. Therapeutic levels of human factor VIII and IX using HIV-1-based lentiviral vectors in mouse liver. *Blood* 2000;96(3): 1173-1176.
596. Stein CS, Kang Y, Sauter SL, et al. In vivo treatment of hemophilia A and mucopolysaccharidosis type VII using nonprimate lentiviral vectors. *Mol Ther* 2001;3(6):850-856.
597. Kang Y, Xie L, Tran DT, et al. Persistent expression of factor VIII in vivo following nonprimate lentiviral gene transfer. *Blood* 2005;106(5):1552-1558.
598. Park F. Correction of bleeding diathesis without liver toxicity using arenaviral-pseudotyped HIV-1-based vectors in hemophilia A mice. *Hum Gene Ther* 2003;14(15):1489-1494.

599. Evans GL, Morgan RA. Genetic induction of immune tolerance to human clotting factor VIII in a mouse model for hemophilia A. *Proc Natl Acad Sci U S A* 1998;95(10):5734-5739.
600. Heim DA, Hanazono Y, Giri N, et al. Introduction of a xenogeneic gene via hematopoietic stem cells leads to specific tolerance in a rhesus monkey model. *Mol Ther* 2000;1(6):533-544.
601. Bagley J, Bracy JL, Tian C, et al. Establishing immunological tolerance through the induction of molecular chimerism. *Front Biosci J Virtual Library* 2002;7:d1331-d1337.
602. Shi Q, Wilcox DA, Fahs SA, et al. Lentivirus-mediated platelet-derived factor VIII gene therapy in murine haemophilia A. *J Thromb Haemost* 2007;5(2):352-361.
603. Shi Q, Wilcox DA, Fahs SA, et al. Factor VIII ectopically targeted to platelets is therapeutic in hemophilia A with high-titer inhibitory antibodies. *J Clin Invest* 2006;116(7):1974-1982.
604. Burton M, Nakai H, Colosi P, et al. Coexpression of factor VIII heavy and light chain adeno-associated viral vectors produces biologically active protein. *Proc Natl Acad Sci U S A* 1999;96(22):12725-12730.
605. Nakai H, Storm TA, Kay MA. Increasing the size of rAAV-mediated expression cassettes in vivo by intermolecular joining of two complementary vectors. *Nat Biotechnol* 2000;18(5):527-532.
606. Riddell SR, Elliott M, Lewinsohn DA, et al. T-cell mediated rejection of gene-modified HIV-specific cytotoxic T lymphocytes in HIV-infected patients. *Nat Med* 1996;2(2):216-223.
607. Sykes M, Sachs DH, Nienhuis AW, et al. Specific prolongation of skin graft survival following retroviral transduction of bone marrow with an allogeneic major histocompatibility complex gene. *Transplantation* 1993;55(1):197-202.
608. Ally BA, Hawley TS, McKall-Faienza KJ, et al. Prevention of autoimmune disease by retroviral-mediated gene therapy. *J Immunol* 1995;155(11):5404-5408.
609. Shull R, Lu X, Dube I, et al. Humoral immune response limits gene therapy in canine MPS I. *Blood* 1996;88(1):377-379.
610. Kang E, Giri N, Wu T, et al. In vivo persistence of retrovirally transduced murine long-term repopulating cells is not limited by expression of foreign gene products in the fully or minimally myeloablated setting. *Hum Gene Ther* 2001;12(13):1663-1672.
611. Kang EM, Hanazano Y, Frare P, et al. Persistent low-level engraftment of rhesus peripheral blood progenitor cells transduced with the Fanconi anemia c gene after conditioning with low-dose irradiation. *Mol Ther* 2001;3(6):911-919.
612. Baum C, Dullmann J, Li Z, et al. Side effects of retroviral gene transfer into hematopoietic stem cells. *Blood* 2003;101(6):2099-2113.
613. Morral N, O'Neal WK, Rice K, et al. Lethal toxicity, severe endothelial injury, and a threshold effect with high doses of an adenoviral vector in baboons. *Hum Gene Ther* 2002;13(1):143-154.
614. Wilson JM. Lessons learned from the gene therapy trial for ornithine transcarbamylase deficiency. *Mol Genet Metabol* 2009;96(4):151-157.
615. Yarborough M, Sharp RR. Public trust and research a decade later: what have we learned since Jesse Gelsinger's death? *Mol Genet Metabol* 2009;97(1):4-5.
616. Boehm T, Foroni L, Kaneko Y, et al. The rhombotin family of cysteine-rich LIM-domain oncogenes: distinct members are involved in T-cell translocations to human chromosomes 11p15 and 11p13. *Proc Natl Acad Sci U S A* 1991;88(10):4367-4371.
617. Cornetta K. Safety aspects of gene therapy. *Br J Haematol* 1992;80(4):421-426.
618. Li Z, Dullmann J, Schiedlmeier B, et al. Murine Leukemia Induced by Retroviral Gene Marking. *Science* 2002;296(5567):497-.
619. Woods NB, Bottero V, Schmidt M, et al. Gene therapy: therapeutic gene causing lymphoma. *Nature* 2006;440(7088):1123.
620. Dave UP, Jenkins NA, Copeland NG. Gene therapy insertional mutagenesis insights. *Science* 2004;303(5656):333.
621. Kiem HP, Sellers S, Thomasson B, et al. Long-term clinical and molecular follow-up of large animals receiving retrovirally transduced stem and progenitor cells: no progression to clonal hematopoiesis or leukemia. *Mol Ther* 2004;9(3):389-395.

622. Newrzela S, Cornils K, Li Z, et al. Resistance of mature T cells to oncogene transformation. *Blood* 2008;112(6):2278-2286.
623. Baum C. Parachuting in the epigenome: the biology of gene vector insertion profiles in the context of clinical trials. *EMBO Mol Med* 2011;3(2):75-77.
624. Schroder AR, Shinn P, Chen H, et al. HIV-1 integration in the human genome favors active genes and local hotspots. *Cell* 2002;110(4):521-529.
625. Wu X, Li Y, Crise B, et al. Transcription start regions in the human genome are favored targets for MLV integration. *Science* 2003;300(5626):1749-1751.
626. Hematti P, Hong BK, Ferguson C, et al. Distinct genomic integration of MLV and SIV vectors in primate hematopoietic stem and progenitor cells. *PLoS Biol* 2004;2(12):e423.
627. Kustikova O, Fehse B, Modlich U, et al. Clonal dominance of hematopoietic stem cells triggered by retroviral gene marking. *Science* 2005;308(5725): 1171-1174.
628. Kustikova OS, Geiger H, Li Z, et al. Retroviral vector insertion sites associated with dominant hematopoietic clones mark "stemness" pathways. *Blood* 2007;109(5):1897-1907.
629. Seggewiss R, Pittaluga S, Adler RL, et al. Acute myeloid leukemia is associated with retroviral gene transfer to hematopoietic progenitor cells in a rhesus macaque. *Blood* 2006;107(10):3865-3867.
630. Du Y, Jenkins NA, Copeland NG. Insertional mutagenesis identifies genes that promote the immortalization of primary bone marrow progenitor cells. *Blood* 2005;106(12):3932-3939.
631. Modlich U, Navarro S, Zychlinski D, et al. Insertional transformation of hematopoietic cells by self-inactivating lentiviral and gammaretroviral vectors. *Mol Ther* 2009;17(11):1919-1928.
632. Montini E, Cesana D, Schmidt M, et al. The genotoxic potential of retroviral vectors is strongly modulated by vector design and integration site selection in a mouse model of HSC gene therapy. *J Clin Invest* 2009;119(4): 964-975.
633. Hesdorffer, C., Ayello, J., Ward, M., Kaubisch, A., Vahdat, L., Balmaceda, C., Garrett, T., Fetell, M., Reiss, R., Bank, A., et al. 1998. Phase I trial of retroviral-mediated transfer of the human MDR1 gene as marrow chemoprotection in patients undergoing high-dose chemotherapy and autologous stem-cell transplantation. *J Clin Oncol* 16:165-172.
634. Kohn, D.B., Bauer, G., Rice, C.R., Rothschild, J.C., Carbonaro, D.A., Valdez, P., Hao, Q., Zhou, C., Bahner, I., Kearns, K., et al. 1999. A clinical trial of retroviral-mediated transfer of a rev-responsive element decoy gene into CD34(+) cells from the bone marrow of human immunodeficiency virus-1-infected children. *Blood* 94:368-371.
635. Cowan, K.H., Moscow, J.A., Huang, H., Zujewski, J.A., O'Shaughnessy, J., Sorrentino, B., Hines, K., Carter, C., Schneider, E., Cusack, G., et al. 1999. Paclitaxel chemotherapy after autologous stem-cell transplantation and engraftment of hematopoietic cells transduced with a retrovirus containing the multidrug resistance complementary DNA (MDR1) in metastatic breast cancer patients. *Clin Cancer Res* 5:1619-1628.
636. Amado, R.G., Mitsuyasu, R.T., Rosenblatt, J.D., Ngok, F.K., Bakker, A., Cole, S., Chorn, N., Lin, L.S., Bristol, G., Boyd, M.P., et al. 2004. Anti-human immunodeficiency virus hematopoietic progenitor cell-delivered ribozyme in a phase I study: myeloid and lymphoid reconstitution in human immunodeficiency virus type-1-infected patients. *Hum Gene Ther* 15:251-262.
637. Mitsuyasu, R.T., Zack, J.A., Macpherson, J.L., and Symonds, G.P. 2011. Phase I/II Clinical Trials Using Gene-Modified Adult Hematopoietic Stem Cells for HIV: Lessons Learnt. *Stem Cells Int* 2011:393698.
638. Mitsuyasu, R.T., Merigan, T.C., Carr, A., Zack, J.A., Winters, M.A., Workman, C., Bloch, M., Lalezari, J., Becker, S., Thornton, L., et al. 2009. Phase 2 gene therapy trial of an anti-HIV ribozyme in autologous CD34+ cells. *Nat Med* 15:285-292.

Section 2 - The Acute Leukemias

Chapter 72 Molecular Genetics of Acute Leukemia

> Table of Contents > Part VII - Hematologic Malignancies > Section 2 - The Acute Leukemias > Chapter 72 - Molecular Genetics of Acute Leukemia

Chapter 72

Molecular Genetics of Acute Leukemia

Mary Ann Thompson

Utpal P. Davé

INTRODUCTION

Acute leukemia results when a normal hematopoietic stem or progenitor cell sequentially acquires mutations which confer clonal growth advantage. This clonal evolution model of cancer development involves gain of function of oncogenes and loss of function of tumor suppressor genes that cooperate to induce fulminant disease. The earliest view of the genome of acute leukemia was provided by cytogeneticists who karyotyped leukemic blasts, revealing recurrent chromosomal translocations. Cloning these translocation breakpoints led to the identification of genes whose altered activity could be directly linked to leukemogenesis. More recently, the genomes of acute leukemias have been probed at an unprecedented depth, revealing various lesions at the base pair level, such as amplifications, deletions, insertions/deletions, and point mutations, that can deregulate oncogene or tumor suppressor gene function. Acute leukemias of either myeloid or B-cell origin (i.e., acute myeloid leukemia [AML] and B-cell acute lymphoblastic leukemia [B-ALL]) have been classified by the World Health Organization (WHO) by the presence of recurrent chromosomal rearrangements which affect the choice of therapy and have significant prognostic value. Acute leukemias without recurrent chromosomal rearrangement have been traditionally classified by their cell of origin, but recently these leukemias have been subjected to whole genome analyses, revealing the presence of novel recurrent molecular lesions. As clinical data matures, the list of oncogenes and tumor suppressors deregulated by mechanisms other than chromosomal rearrangement may be incorporated into a new classification schema. In this chapter, we focus on the more common recurrent genetic abnormalities found in acute leukemias, with special emphasis on how the genetic defects inform our concept of leukemia pathogenesis. We provide specific examples where the genetic lesions have led to the development of targeted therapies with fewer side effects than traditional cytotoxic chemotherapy. This is truly an exhilarating time for hematologic oncology, where laboratory findings have direct relevance to current treatment modalities.

Reasons for Studying Molecular Genetics of Acute Leukemia

A major reason for understanding the molecular genetics of acute leukemia is to develop novel molecular treatments for this disease. The paradigm for the translation of basic research knowledge to clinical treatment has been chronic myelogenous leukemia (CML). The first leukemia to be associated with a recurrent translocation, t(9;22)(q34;q11.2) (the Philadelphia chromosome),¹ CML was also the first leukemia where the product of the translocation, breakpoint cluster region (BCR-ABL1) was characterized.² In addition, CML was the first leukemia for which a specific molecular inhibitor, imatinib (Gleevec), was designed.³ Research and clinical trials are currently underway to increase the armamentarium of targeted molecular therapies. An additional benefit of being able to identify the molecular lesions in a given acute leukemia is the ability to carry out more accurate risk stratification of newly diagnosed patients. Numerous clinical studies have correlated clinical prognosis with the set of genes that are altered in a patient's leukemic blasts. Results from the initial cytogenetic and molecular studies on a patient's leukemic blasts are used to stratify the leukemia as favorable or unfavorable, as listed in Tables 72.1 and 72.2 for adult AML and pediatric B-cell ALL, respectively. Finally, the particular array of mutated genes in the leukemic blasts provides a very sensitive method for determining efficacy of treatment by using these aberrant molecular markers to quantify minimal residual disease after treatment.

A large number of the genes altered by translocation encode transcriptional regulatory proteins that often preserve the original DNA-binding specificity of one of the fusion partners, but have altered properties of transcriptional activation or repression. The search to understand these altered properties has led investigators to basic discoveries of how transcriptional regulatory proteins modify chromatin structure to open up or inhibit the transcription of target genes. However, the genes that are recurrently mutated in acute leukemias also belong to other functional classes of proteins. Kinases which are rendered constitutively active by mutation can deregulate the cell's signal transduction pathways and lead to uncontrolled proliferation. Mutations in genes encoding proteins involved in modification of histones or methylation of DNA can lead to altered expression of groups of genes that can have effects as dramatic as those caused by mutations in transcription factors. Additional functional categories of genes that are recurrently mutated in leukemia are inhibitors of apoptosis and nuclear pore proteins. This chapter will focus on the mechanisms by which mutations in genes in each of these major functional classes may contribute to the pathogenesis of leukemia. If we understand the mechanism by which "driver" mutations work, we may be able to reverse or inhibit their actions to develop novel treatment modalities for leukemia.

Multiple Hit Model of Leukemia

Another theme that emerges from the study of the molecular genetics of leukemia is that usually more than one genetic hit is necessary for the development of leukemia.⁴ This principle has been repeatedly demonstrated in mouse models, where introduction of the fusion gene found in acute leukemia by transgenic technology or retroviral transduction results in predisposition to acute leukemia with long latency, unless the accumulation of additional genetic hits is facilitated by treatment with a mutagenic agent. The multistep model of carcinogenesis is not limited to leukemias, and is reviewed in Hanahan and Weinberg's recent update⁵ of their original paper⁶ first outlining the six hallmarks of cancer. These hallmarks, now updated to eight, are properties that cancer cells must acquire through multiple mutations in order to become malignant: sustained proliferative signaling, evading growth suppression, enabling replicative immortality, resisting cell death, inducing angiogenesis, activating invasion and metastasis, avoiding immune destruction, and deregulating

P.1524

cellular energetics.⁵ In the field of leukemia research, attention has been focused on deregulation of proliferation (Class I mutations), and a block in differentiation (Class II mutations).⁴ The block in differentiation is visually striking under the microscope, as blasts have morphologic characteristics of hematopoietic stem cells (HSCs). However, what is relevant to leukemogenesis is that HSCs have self-renewal. Many of the well-characterized recurrent translocations in acute leukemia produce fusion genes that encode mutant transcription factors that can no longer activate the genes required for differentiation. However, some translocations (notably BCR-ABL1), and some of the genes most commonly affected by point mutations (FLT3) encode kinases that cause deregulated proliferation.⁴ Through new advances in technology outlined in the next section scientists have discovered a host of additional gene mutations that occur in leukemia, suggesting many more than two hits in the path toward leukemia. In addition, a further layer of regulation at the epigenetic level has been hypothesized due to the number of genes mutated in leukemia that are active in modification of histones or in regulation of DNA methylation.

TABLE 72.1 RISK GROUPS IN ADULT ACUTE MYELOID LEUKEMIA BASED ON CYTOGENETIC AND MOLECULAR ANALYSIS

Cytogenetic Classification	Cytogenetic Abnormality	Mutation in FLT3	Other Mutations	Overall Risk Profile
Favorable	<i>RUNX1-RUNX1T1</i> <i>CBFB-MYH11</i>	<i>FLT3</i> -ITD-neg or positive	Any	Favorable
Intermediate-I and -II	Normal karyotype <i>MLL3-MLL</i>	<i>FLT3</i> -ITD-neg	Mutant <i>NPM1</i> or <i>IDH1/2</i>	Intermediate
	Unclassified cytogenetics	<i>FLT3</i> -ITD-neg	Wild-type <i>ASXL1</i> , <i>MLL</i> -PTD, <i>PHF6</i> , or <i>TET2</i>	
		<i>FLT3</i> -ITD-neg or positive	Mutant <i>CEBPA</i>	
		<i>FLT3</i> -ITD-positive	Wild-type <i>MLL</i> -PTD, <i>TET2</i> , and <i>DNMT3A</i> , or trisomy 8-negative	
		<i>FLT3</i> -ITD-neg	Mutant <i>TET2</i> , <i>MLL</i> -PTD, <i>ASXL1</i> , or <i>PHF6</i>	Unfavorable
		<i>FLT3</i> -ITD-positive	Mutant <i>TET2</i> , <i>MLL</i> -PTD, <i>DNMT3A</i> , or trisomy 8, without mutant <i>CEBPA</i>	
Unfavorable	<i>RPN1-EV11</i> <i>DEK-NUP214</i>	<i>FLT3</i> -ITD-	Any	

MLL rearranged -5 or del(5q), neg or
-7 Abnl (17p) Complex positive
karyotype

From Patel JP, Gonen M, Figueroa ME, et al. Prognostic relevance of integrated genetic profiling in acute myeloid leukemia. *NEJM* 2012;366: 1079-1089 and Mrozek K, Marcucci G, Nocolet D, et al. Prognostic significance of the European LeukemiaNet standardized system for reporting cytogenetic and molecular alterations in adults with acute myeloid leukemia. *J Clin Oncol* 2012. doi:10.1200/JCO.2012.43.4738.

TABLE 72.2 RISK GROUPS IN PEDIATRIC B-CELL ACUTE LYMPHOBLASTIC LEUKEMIA BASED ON CYTOGENETIC AND MOLECULAR ANALYSIS

Risk Group	Cytogenetic or Molecular Abnormality	Target Genes
<i>Favorable</i>	t(12;21)(p13;q22.3) Hyperdiploid > 50 chromosomes Simultaneous trisomies of 4, 10, and 17	<i>ETV6-RUNX1</i>
<i>Unfavorable</i>	t(9;22)(q34.1;q11) t(4;11)(q21.3;q23) Hypodiploidy < 44 chromosomes iAMP21 Deletion 7(q13) Mutation in <i>JAK1/2</i> Deletion/translocation of <i>CRLF2</i>	<i>BCR-ABL1</i> <i>MLL-AFF1</i> <i>RUNX1</i> <i>IKZF1</i> <i>JAK1/2</i> <i>CRLF2</i>

From Pui C-H, Evans WE. Acute lymphoblastic leukemia. *NEJM* 1998;339:605-615 and Zhou Y, You MJ, Yong KH, et al. Advances in the molecular pathobiology of B lymphoblastic leukemia. *Hum Pathol* 2012;43:1347-1362.

Advances in Technology: A Genomic Perspective of Acute Leukemia

The tremendous advances in technology in the few years since the previous version of this chapter have revolutionized our ability to analyze individual genomes (Table 72.3). As mentioned above, G-banding of chromosomes was our first view of the leukemia genome and is still highly informative in identifying translocations, aneuploidy, and other gross chromosomal rearrangements (>4 megabases).^{7,8} More focused analyses such as interphase fluorescence in situ hybridization (FISH) have improved the resolution of standard cytogenetics so that amplifications or deletions of 100 kilobases may be visualized.⁹ In the last 10 years, oligonucleotides covering the entire human genome have been printed onto arrays allowing hybridization of fluorescently labeled leukemic and control genomic DNA.^{10,11} This array comparative genomic hybridization (CGH) can identify copy number variation (CNV), and has been powerfully employed in identifying recurrent

P.1525

deletions and amplifications in acute leukemias. Similar microarrays were designed to cover common single nucleotide polymorphisms (SNPs) for genotyping purposes, but they too have been used to identify CNVs, particularly copy number neutral loss of heterozygosity (also known as uniparental disomy) in leukemia.¹² Array CGH and SNP arrays display the human genome as small probes and will not detect balanced translocations. Most excitingly, major advances in whole genome sequencing now provide single base pair resolution so that point mutations may be identified as well as chromosomal rearrangements.¹³ These powerful technologies are readily deployed in the diagnosis of acute leukemia and provide a complete genomic perspective of the disease; however, there are important caveats. Human genomes are full of rare and common structural variants and SNPs.^{14, 15, 16, 17} and ¹⁸ Therefore, mutations can only be interpreted as being

acquired in leukemogenesis if they are not present in normal somatic tissue. Thus, matched normal somatic tissue is frequently subjected to the same genomic analyses as leukemic blasts.

TABLE 72.3 RESOLUTION OF TECHNOLOGIES AVAILABLE TO IDENTIFY GENETIC ALTERATIONS IN ACUTE LEUKEMIA

Technique	Resolution	Molecular Lesion	References
Whole genome sequencing	1 bp	Point mutations, amplifications, insertions, deletions, translocations	13,325
Whole exome sequencing	1 bp	Point mutations, amplifications, deletions	326,327
Transcriptome sequencing	1 bp	Gene expression, fusion transcript detection, point mutations	328,329
Gene expression microarray	-	Gene expression	244,246,330
Interphase FISH	100 kb	Focal amplifications or deletions	9
Array comparative genomic hybridization	100 kb amplification 3-5 Mb deletion	Amplifications, deletions	10,11
SNP array	100 kb	Amplifications, deletions	11,12,331
Cytogenetics/karyotyping	3-4 Mb	Amplifications, deletions, translocations	8,332

FISH, fluorescence in situ hybridization; SNP, single nucleotide polymorphism.

The sequence of the human genome was completed in 2001 at 90% coverage after 10 years of collaborative and arduous work from multiple laboratories for a cost of 1 billion dollars; the draft genome sequence contained gaps that were filled in 2004, resulting in a highly accurate reference sequence currently at build 37(2012).^{19, 20} and ²¹ At this writing, a sample human genome can be sequenced in 6 weeks for approximately 40 thousand dollars.²² This remarkably short processing time and reduction in cost were made possible by massively parallel sequencing technologies, collectively known as next generation (or second generation) sequencing.²³ The original draft human genome sequence was generated by Sanger sequencing or dideoxynucleotide chain termination and capillary electrophoresis, first generation technologies. In second generation technologies, the addition of nucleotides occurs in parallel on multiple DNA strands and is multiplexed frequently on microchips or beads.²⁴ This has resulted in an incredible information glut. As DNA sequencing technologies race toward the \$1,000 genome, the burden has shifted toward efficient and timely informatics analysis. Some of the complexity of genome assembly can be avoided by targeted sequencing or whole exome sequencing. Here, capture technologies utilize DNA hybridization to purify all the exons of a given genome. These are then fully sequenced; of course, in this case the mutations discovered are limited only to the coding regions of the genome, and mutations within regulatory regions may also be present. Besides mutation analysis, next generation sequencing has expedited our ability to define whole genome chromatin marks,²⁵ CpG methylation,^{25,26} microRNAs,²⁷ and noncoding RNAs.²⁸ For chromatin analysis, immunopurification can enrich for genomic DNA that is associated with specific histone marks that denote active or inactive gene expression. These tools will be important in analyzing the effects of mutant leukemia proteins that modify histone residues.

In 2008 the entire genome sequence of a cytogenetically normal AML patient was completed for the first time.²⁹ In 2009 further refined techniques were used to sequence a second AML genome to a higher level of coverage (98%),³⁰ and in 2010 DNA from the first patient was subjected to deeper sequencing.³¹ In each patient multiple acquired somatic mutations were identified by comparison to normal skin from the same patient. Somatic mutations unique to the leukemia cells were found in coding sequences, as well as in conserved or regulatory portions of genes. All of the mutations were shown to be heterozygous and were present in the majority of the blasts. Screening of a large panel of AML samples for novel coding region mutations identified in the two sequenced genomes demonstrated two genes not previously thought to be involved in leukemogenesis that were recurrently mutated: IDH1, (mutated in 16% of cytogenetically normal AML samples),³² and DNMT3A (mutated in 22% of AML samples).³¹

A recent study greatly expanded this breakthrough work by deep sequencing the genomes of 12 patients with AML with a normal karyotype and 12 patients with acute promyelocytic leukemia (APL) with the t(15;17).³³ Again, bone marrow and skin samples were compared, and all single nucleotide variations (SNVs) were validated by Illumina sequencing. An average of 440 SNVs per genome were identified. The number of SNVs per genome was not different between the cytogenetically normal leukemia cases and the t(15;17) leukemia cases, and the number was proportional to age. Interestingly, the number of mutations detected in HSCs from normal patients was similar and also varied with age, suggesting that mutations randomly accumulate in stem cells and that the hundreds of mutations in the AML genomes most likely preexisted before the initiating mutation that gave growth advantage to the AML clone.³³ Thus only a few mutations may be relevant to the pathogenesis of the clone. An average of 11 mutations with translational consequences were present in cytogenetically normal AML genomes and 10 in APL (counting promyelocytic leukemia-retinoic acid receptor- α [PML-RARA] itself). Only a few were recurring in other AMLs, with an average of 3 recurring mutations in each cytogenetically normal AML genome and 2 recurring mutations, including PML-RARA, in the AML genomes with t(15;17).³³

The complexity of mutations that contribute to the leukemic phenotype is visually appreciated in Figure 72.1, a summary of coexpression of mutations in a cohort of 398 patients with AML that were screened for mutations of eighteen gene loci.³⁴

P.1526

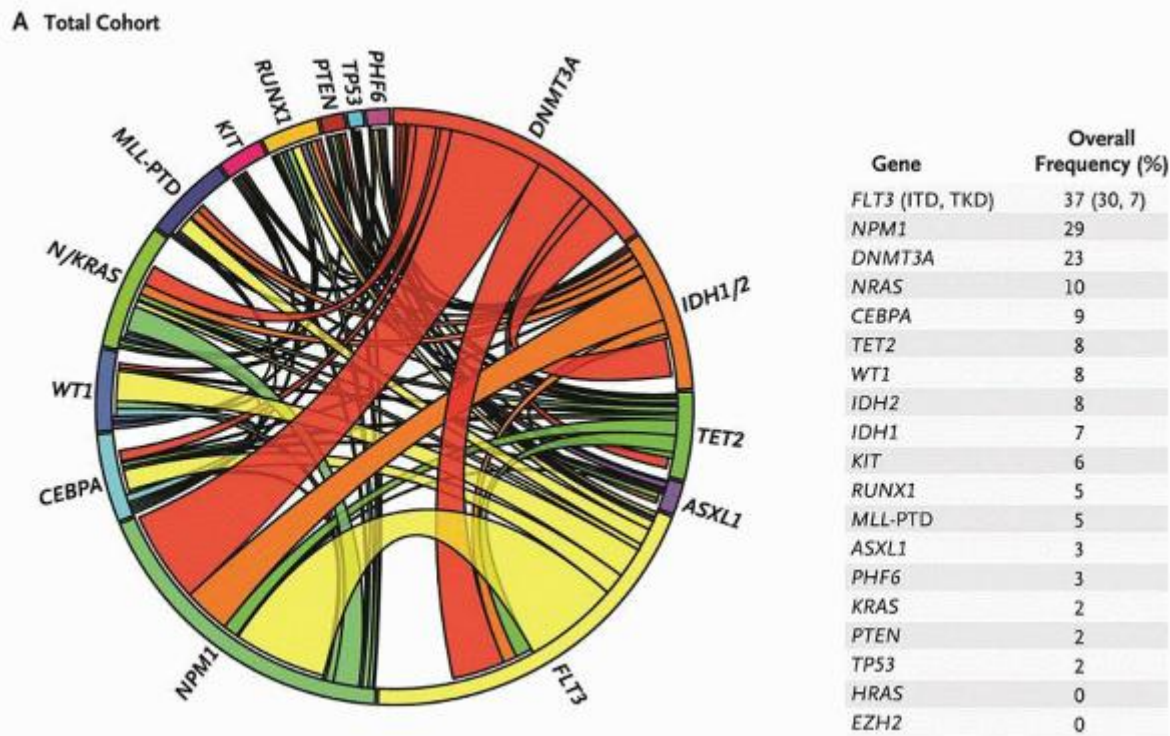

FIGURE 72.1. Mutational complexity of acute myeloid leukemia (AML). The Circos diagram depicts the relative frequency and pairwise co-occurrence of mutations in patients with newly diagnosed AML who were enrolled in the Eastern Cooperative Oncology Group E1900 clinical trial. The length of the arc along the outer circle corresponds to the frequency of mutations in the first gene, and the width of the ribbon corresponds to the percentage of patients who also had a mutation in the second gene listed on the opposite end of the ribbon. Pairwise co-occurrence of mutations is denoted only once, going in the clockwise direction. The frequency of occurrence in the test cohort of the 18 genes in the test panel is listed to the right of the Circos diagram. From Patel JP, Gonen M, Figueroa ME, et al. Prognostic relevance of integrated genetic profiling in acute myeloid leukemia *NEJM* 2012;366:1079-1089, Copyright 2012 Massachusetts Medical Society. Reprinted with permission from Massachusetts Medical Society.

ACUTE MYELOID LEUKEMIA

World Health Organization Classification

A subset of the new WHO classification of acute myeloid leukemia is entitled “acute myeloid leukemia with recurrent genetic abnormalities”³⁵ (see Table 72.4). These recurrent translocations occur most often in de novo acute leukemia, but are not restricted to this category. Another major category of acute myeloid leukemia is AML with myelodysplasia-related changes,³⁵ where genetic mutations and chromosomal deletions occur secondary to the mutator phenotype of the underlying myelodysplastic syndrome (MDS) in some cases.

TABLE 72.4 WORLD HEALTH ORGANIZATION CLASSIFICATION OF ACUTE MYELOID LEUKEMIA

AML with recurrent genetic abnormalities
AML with t(8;21)(q22;q22); <i>RUNX1-RUNX1T1</i>
AML with inv(16)(p13.1q22) or t(16;16)(p13.1;q22); <i>CBFB-MYH11</i>
Acute promyelocytic leukemia with t(15;17)(q24.1;q21.1); <i>PML-RARA</i>
AML with t(9;11)(p22;q23); <i>MLLT3-MLL</i>
AML with t(6;9)(p23;q34); <i>DEK-NUP214</i>
AML with inv(3)(q21q26.2) or t(3;3)(q21;q26.2); <i>RPN1-EVII</i>
AML (megakaryoblastic) with t(1;22)(p13;q13); <i>RBM15-MKLI</i>
AML with mutated <i>NPM1</i>
AML with mutated <i>CEBPA</i>
AML with myelodysplasia-related changes
Therapy-related myeloid neoplasms
AML, NOS
Myeloid sarcoma
Myeloid proliferations related to Down syndrome

AML, acute myeloid leukemia; NOS, not otherwise specified. From Swerdlow, SH, Campo, E, Harris, NL, et al., Eds. WHO classification of tumours of haematopoietic and lymphoid tissues. Lyon, France: IARC Press, 2008.

Whole genome sequencing has clarified our understanding of the clonal evolution from MDS to AML. Walter et al compared seven sets of samples from patients for whom there were paired samples of normal skin, preleukemic bone marrow diagnosed as MDS, and bone marrow involved by secondary AML.³⁶ In each genome there were 304 to 872 somatic point mutants in coding regions or consensus splice site regions, and those point mutations with translational consequences comprised an average of 24 mutations per genome. These functional mutations occurred in a total of 168 genes over the 7 genomes. The strength of the study was that the number of mutations allowed study of clonal evolution from MDS to secondary AML. The clonal evolution described by the sequential acquisition of mutations (defined as five mutation clusters by unsupervised clustering analysis) is visually shown in Figure 72.2. A majority of the cells in the MDS sample contained the same cluster of mutations, meaning that before blasts were even detected morphologically, the marrow was involved by a clonal process. At the secondary AML stage, all the samples contained several clones, all of which had the original set of mutations, but which were defined by acquisition of new sets of mutations as well. Presumably most of these somatic mutations are “passenger” mutations, but the multiplicity of mutations tracked adds credence to the description of clonal evolution.³⁶ The mutations that were in characterized genes ranged the gamut of genes involved in adhesion, cell death, cell cycle, differentiation, metabolism, motility, signaling, transcription, and transporters.³⁶ In the subsequent sections, we will discuss how alterations of genes that fall in these functional classes contribute to leukemogenesis.

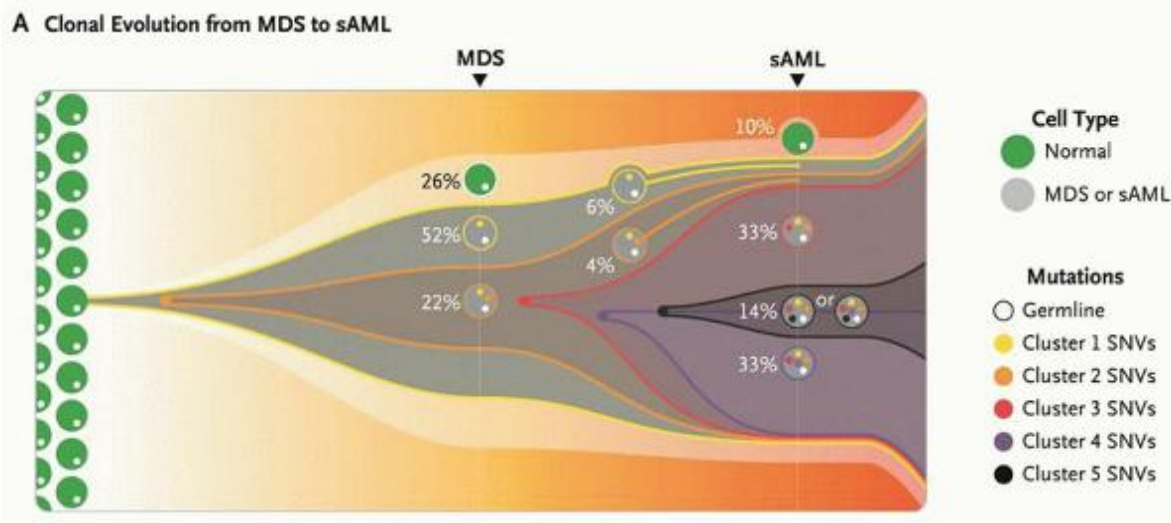

FIGURE 72.2. Clonal progression of MDS to secondary acute myeloid leukemia (AML). This model summarizes the clonal evolution from MDS to secondary AML (sAML) in one patient. Cells in clone 1 (yellow) contain cluster 1 mutations, 323 somatic single nucleotide variants (SNVs) present in approximately 74% of the bone marrow cells. Cells in clone 2 (orange) originated from a single cell in clone 1 and therefore contain all cluster 1 and 2 mutations. This clone became dominant in the sAML sample, in which three subsequent subclones (red, purple, and black) evolved through serial acquisition of SNVs (clusters 3, 4, and 5). From Walter MJ, Shen D, Ding L, et al. Clonal architecture of secondary acute myeloid leukemia. *NEJM* 2012;366:1090-1098. Copyright 2012 Massachusetts Medical Society. Reprinted with permission from Massachusetts Medical Society.

P.1527

Transcription Factors

Promyelocytic Leukemia-Retinoic Acid Receptor- α

One of the most elegant examples of the interaction between clinical and molecular advances in the treatment of acute leukemia is APL. The association between the t(15;17)(q24.1;q21.1) translocation and the characteristic morphology of APL (hypergranular blasts with frequent Auer rods or microgranular variant with dumbbell-shaped nuclei) has been known for a long time. The ability to treat APL with retinoic acid (RA) and the understanding of the molecular basis for this treatment is a compelling example of the power of molecular medicine. The initial report from China³⁷ that all-trans retinoic acid (ATRA) could induce complete remission (CR) in APL patients actually preceded the discovery that the t(15;17) translocation involved the RARA gene on chromosome 17.^{38,39,40}

Of four translocations associated with APL, the most common is t(15;17)(q24.1;q21.1), in which the 5' portion of the fusion protein is encoded by the PML gene from 15q24.1 and the 3' portion is encoded by the RARA gene from 17q21.1. The RARA gene is a ligand-dependent steroid receptor that mediates the effects of the ligand, RA, on the cell. The breakpoint is invariant in intron 2 of RARA, yielding the C-terminal portion of the fusion protein, which includes the DNA-binding, ligand-binding, dimerization, and repression domains of RARA. There are three major breakpoints in the PML gene. The most common generates PML(L)-RARA, which includes the first six exons of PML encoding 554 amino acids of PML.⁴¹

The wild-type RARA is a nuclear receptor that acts as a transcription factor and binds to retinoic acid response elements (RAREs) in the promoters of many genes, including genes important in myeloid differentiation. RARA binds as a heterodimer with retinoid X receptor protein (RXR) and acts as a transcriptional repressor until ligand (RA) binding occurs, changing the conformation of the protein and resulting in transcriptional activation.⁴² Target genes important for myeloid differentiation include colony-stimulating factors (granulocyte colony-stimulating factor [G-CSF]), colony-stimulating factor receptors (G-CSFRs), neutrophil granule proteins (leukocyte alkaline phosphatase, lactoferrin), cell-surface adhesion molecules (CD11b, CD18), regulators of the cell cycle, regulators of apoptosis (BCL2), and transcription factors (RARs, STATs, HOX genes) (reviewed in Ref. 43). Expression of a dominant negative RARA in either a murine hematopoietic cell

line or primary murine bone marrow cells, followed by stimulation with granulocyte-macrophage colony-stimulating factor (GM-CSF), results in arrest of granulocytic differentiation at the promyelocyte stage.⁴⁴

In the absence of RA, the wild-type RARA, present as a heterodimer with RXR on the RARE, binds to the corepressor proteins SMRT, N-CoR, mSin3, and histone deacetylases (HDACs). Deacetylation of the histones at the target gene promoter results in transcriptional repression. Ligand binding at physiologic concentrations of ATRA causes a conformational change that results in release of corepressors and recruitment of a coactivator complex (SRC-1), which associates with histone acetyltransferases (Fig. 72.3A).⁴⁵ Acetylation of the histones at the target gene promoter is associated with transcriptional activation (reviewed in Ref. 43).

Wild-type PML protein is normally localized in subnuclear PML oncogenic domains, also called nuclear bodies (NBs), in which other nuclear factors colocalize.⁴⁶ PML may act as a tumor suppressor protein and is involved in growth suppression as well as in induction of apoptosis (reviewed in Ref. 43). Although it does not bind DNA directly, it influences transcription by interacting with both CREB-binding protein (CBP),⁴⁷ a transcriptional activator, and HDACs, transcriptional repressors, possibly within the NBs. The protein encoded by the PML-RARA fusion transcript resulting from the t(15;17) is delocalized from the NBs to a microspeckled nuclear pattern.⁴⁸

In APL, the PML-RARA protein binds to RAREs with similar affinity to the RARA protein and is able to heterodimerize with RXR. It acts in a dominant negative manner, competing with wild-type RARA for binding to the RAREs. It binds corepressor proteins in the absence of ligand (via the RARA portion of the protein). However, physiologic levels of ATRA (10^{-8} M) are not able to convert PML-RARA into a transcriptional activator; pharmacologic concentrations are required (10^{-6} M; Fig. 72.3B).^{45,49} This provides the mechanistic basis for the efficacy of treatment of APL patients with ATRA to include differentiation of the promyelocytes.

Understanding of the mechanism of the response of APL to ATRA was furthered by studies of an alternative translocation, t(11;17)(q23;q21.1), which is rarely seen in patients with APL.⁵⁰ Patients with this translocation are resistant to treatment with pharmacologic doses of ATRA. The fusion partner gene on chromosome 11q23 encodes ZBTB16 (previously known P.1528

as promyelocytic zinc finger), a transcriptional repressor. The N-terminal portion of the fusion protein encoded by ZBTB16 includes the N-terminal POZ/BTB protein interaction domain, transcriptional activation and repression domains, and a variable number of zinc fingers important for protein and DNA interactions (reviewed in Refs. 43,45). ZBTB16 interacts with N-CoR, SMRT, mSin3A, and HDAC1 via the POZ/BTB domain,^{51,52} and therefore contributes a second binding site for corepressor proteins. Therefore, although pharmacologic doses of ATRA induce release of corepressors from the RARA portion of the fusion protein, the corepressors binding to ZBTB16 are unaffected (Fig. 72.3C).^{43,53} Significantly, concomitant treatment of cells with HDAC inhibitors such as trichostatin A (TSA) restores ATRA sensitivity, since TSA inhibits the deacetylase activity of the corepressors on the ZBTB16 moiety.^{49,52}

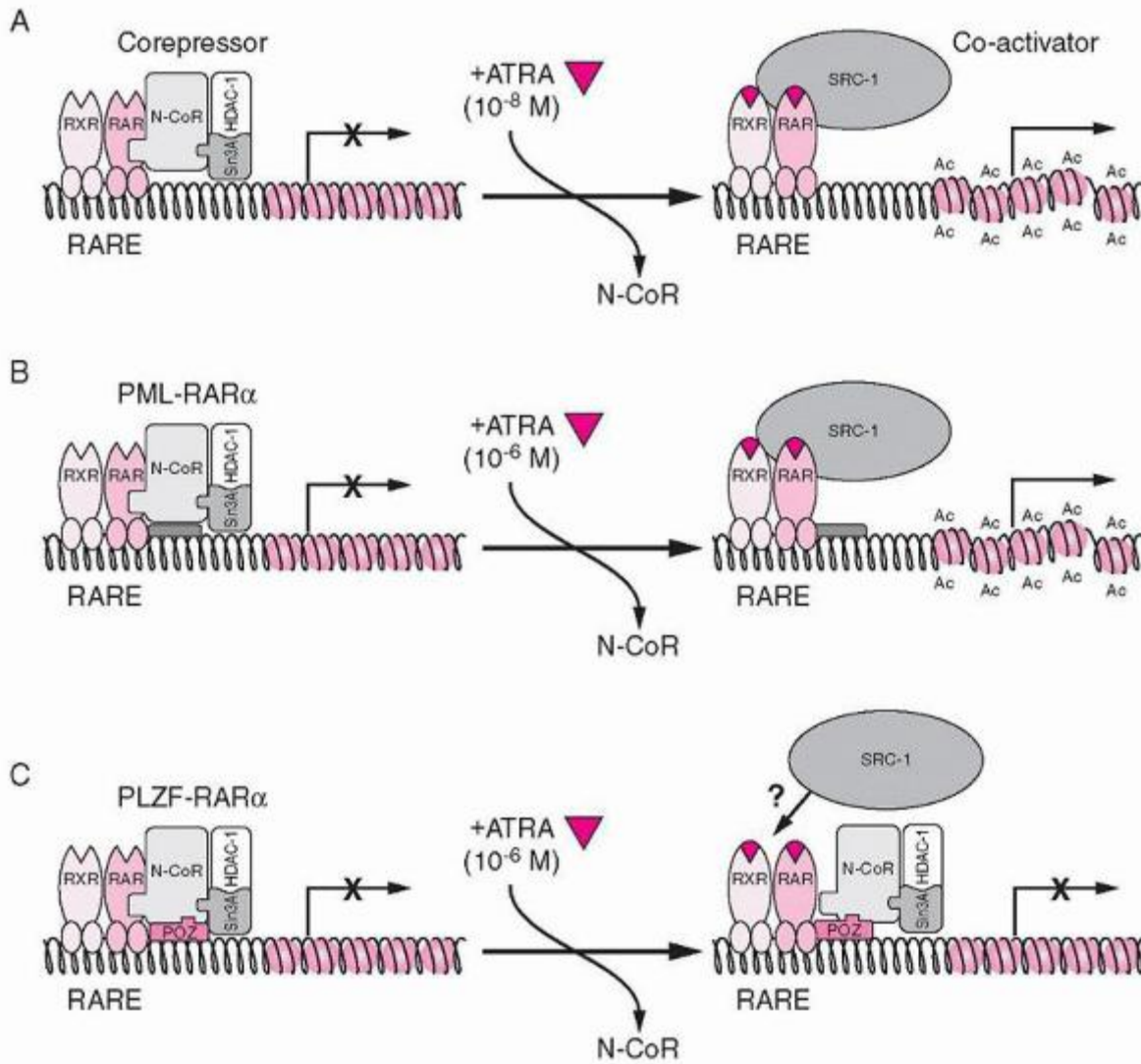

FIGURE 72.3. Model for the role of nuclear corepressors and retinoid acid receptor α (RARA) fusion proteins in the pathogenesis and treatment of acute promyelocytic leukemia. A: In the absence of all-trans retinoic acid (ATRA), RARA, promyelocytic leukemia (PML)-RARA, and promyelocytic leukemia zinc finger (PLZF; now known as ZBTB16)-RARA associate with N-CoR/sin3A/HDAC1 corepressor complex, which deacetylates histone tails, resulting in a compressed chromatin and transcriptional repression. Binding of ATRA at a physiologic concentration induces a conformational change in RARA, causing release of the corepressor complex and binding of coactivator (SRC-1) with histone acetyltransferase activity. Acetylation (Ac) of histone tails opens up the chromatin, facilitating transcriptional activation. B: In the case of PML-RARA protein, pharmacologic doses of ATRA are required to achieve dissociation of the N-CoR repressor complex. C: Because of additional interactions of the PLZF (ZBTB16) moiety of PLZF-RARA fusion protein with corepressors, they do not dissociate even in the presence of pharmacologic doses of ATRA. Therefore, the chromatin still remains in the repressed state. From Guidez F, Ivins S, Jhu J, et al. Reduced retinoic acid-sensitivities of nuclear receptor corepressor binding to PML- and PLZF-RAR α underlie molecular pathogenesis and treatment of acute promyelocytic leukemia. *Blood* 1998;91:2634-2642, with permission.

Subsequent studies have demonstrated that PML-RARA recruits the polycomb-repressive complex 2 (PRC2) to the promoters of its gene targets. The PRC2 has a H3K27 methylase activity and can initiate gene repression through trimethylation of H3K27.⁵⁴ ZBTB16-RARA additionally recruits polycomb-repressive complex 1 (PRC1); treatment with RA releases PRC2 from both PML-RARA and ZBTB16-RARA, but does not release PRC1 from ZBTB16-RARA.⁵⁵

Core-Binding Factor Translocations

The t(8;21) is present in approximately 15% of patients with acute myeloid leukemia,^{56,57} and the RUNX1 (runt-related transcription factor 1, formerly called AML1) gene, cloned from the t(8;21) (q22.3;q22) breakpoint,^{58,59} is mutated in another 3% of AML. The activity of the murine counterpart of RUNX1 was first described as part of the core-binding factor (CBF), which binds to a core enhancer sequence of the Moloney murine leukemia virus long terminal repeat.⁶⁰ Another component of CBF, the non-DNA-binding CBF β was found to be associated with inversion 16 in AML.⁶¹ Finally, the fusion partner of RUNX1 in t(8;21), named RUNX1T1, or ETO (eight-twenty-one), also encodes a transcriptional regulator.⁶² A gene related to RUNX1T1, CBFA2T3 (or MTG16), is involved in yet another translocation involving RUNX1, t(16;21).⁶³ The structures of the fusion proteins resulting from these CBF translocations are shown in Figure 72.4.

RUNX1 is located at chromosome 21q22.3 and is encoded by 12 exons over 260 kb of DNA. The N-terminal portion of the protein contains the runt homology domain (RHD), which is homologous to the *Drosophila* runt protein⁶⁴ and is responsible for the official HUGO name, RUNX1. This is the DNA-binding domain and it is mutated in familial platelet disorder (FPD) and in AML associated with RUNX1 mutations.^{65,66} CBF β interacts via this domain and changes the conformation of RUNX1 to increase DNA-binding affinity.⁶⁷ C-terminal to the RHD are potential MAP kinase phosphorylation sites, followed by three weak activation domains, a nuclear matrix target signal, a dimerization domain, and sequences that are recognized by corepressor proteins (reviewed in Ref. 68).

The CBFs are essential for hematopoietic development. Gene deletion of either Runx1⁶⁹ or Cbfb⁷⁰ in mice results in fetal death at E11.5 to 12.5. These embryos lack all fetal hematopoiesis. Further transgenic experiments have demonstrated that Runx1 is essential for development of HSCs in the aorta/gonadal/mesodermal (AGM) region, the source of definitive hematopoiesis.⁷¹ The essential role of RUNX1 in hematopoietic development appears to be through its function as a transcriptional activator. It regulates lymphoid genes such as B-cell tyrosine kinase, T-cell receptor α and β ,⁷² cytokines (interleukin-3 [IL3],⁷³ GM-CSF⁷⁴), and granulocyte proteins (myeloperoxidase and neutrophil elastase),⁷⁵ to name a few. In addition, RUNX1 acts as a transcriptional repressor of genes such as p21Waf1/Cip1 via interactions with the mSin3a corepressor⁷⁶ and with SUV39H1, a histone methyltransferase.⁷⁷

The ETO gene, now called RUNX1T1, was cloned from the t(8;21) fusion⁵⁸ and is the mammalian homolog of the *Drosophila*

P.1529

nervy gene.⁷⁸ The four homology domains shared with the *Drosophila* protein include a region of similarity to TAF110, a hydrophobic heptad repeat (HHR), an ND domain of undetermined function, and two zinc finger motifs that may be a protein-protein interaction domain (Fig. 72.4A).⁶⁸ RUNX1T1 does not appear to bind DNA specifically on its own. However, it may act as a corepressor protein.⁷⁹ It associates with N-CoR and mSin3A, and directly binds to the Class I HDACs, HDAC-1, HDAC-2, and HDAC-3 (Fig. 72.4A).⁸⁰

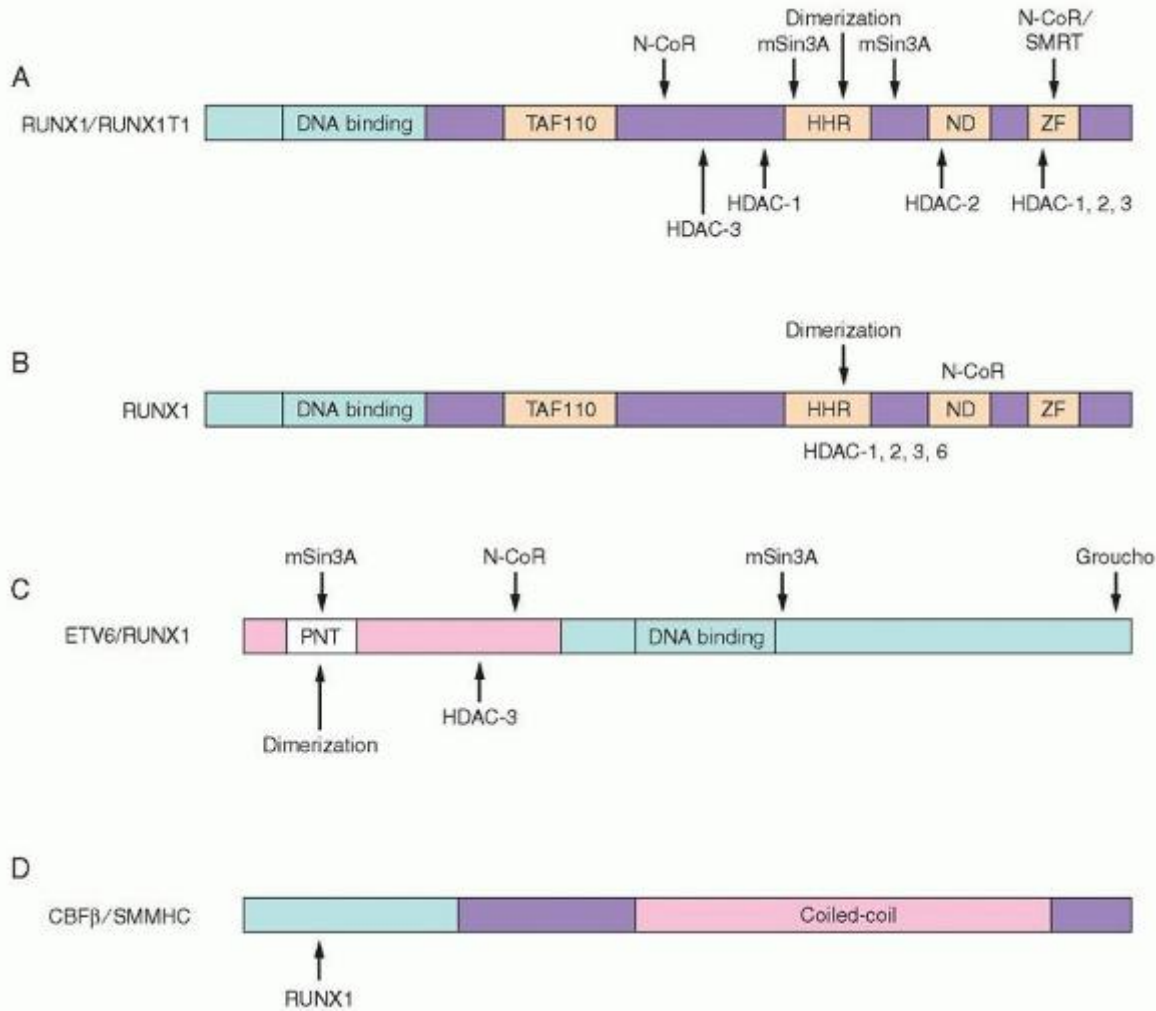

FIGURE 72.4. Schematic diagram of the t(8;21), t(16;21), t(12;21), and inv(16) fusion proteins with known corepressor contacts. A: t(8;21) RUNX1/RUNX1T1. The RUNX1 portion is shown in light pink, with the DNA-binding domain indicated. The RUNX1T1 portion is the dark pink box with domains conserved between RUNX1T1 and its *Drosophila* homolog in light gray boxes. Known contacts with corepressors and histone deacetylases are shown. B: t(16;21) RUNX1-MTG16 (now known as CBFA2T3). RUNX1 is shown as a light pink box, and MTG16 is shown in a similar manner to RUNX1T1 in A. C: t(12;21) ETV6-RUNX1. ETV6 is the dark pink box, with the conserved pointed (PNT) domain indicated. The RUNX1 portion is the light pink box. Interactions with corepressors and HDACs are shown. D: Inv(16) CBFβ-SMMHC (now known as MYH11). The CBFβ portion, which interacts with RUNX1, is light pink, and the SMMHC is dark pink, with the coiled-coil domain indicated as well as the C-terminal portion, which is necessary for interaction with mSin3A and HDAC8.⁷⁷ HHR, hydrophobic heptad repeat; ND, nery domain; TAF110, a domain with homology to the TAF110 coactivator; ZF, zinc finger domain. From Hiebert SW, Lutterbach B, Amann J. Role of corepressors in transcriptional repression mediated by the t(8;21), t(16;21), t(12;21), and inv(16) fusion proteins. *Curr Opin Hematol* 2001;8:197-200, with permission.

In the t(8;21) translocation, the RUNX1 gene is fused to the RUNX1T1 gene on chromosome 8. The breakpoint in the RUNX1 locus is between exons 5 and 6,⁸¹ yielding a fusion protein with the N-terminal 177aa of RUNX1.⁵⁸ In this fusion protein, the DNA-binding domain is present, but the C-terminal activation domains, corepressor interaction sites, and nuclear localization signals (NLSs) of the wild type are not present (Fig. 72.4A).⁶⁸ The breakpoint in the RUNX1T1 gene occurs in the introns between the first two alternative exons of RUNX1T1, resulting in the inclusion of almost all of the coding region for RUNX1T1 in the fusion transcript.⁵⁸

The RUNX1-RUNX1T1 protein specifically binds to the same DNA-binding site as RUNX1 and can heterodimerize with CBFβ.⁸² Therefore, the RUNX1-RUNX1T1 protein can act as a dominant negative inhibitor of wild-type RUNX1. However, cotransfection experiments demonstrated that RUNX1-RUNX1T1 can also function as an active transcriptional repressor, not only inhibiting activation of a reporter gene containing the GM-CSF receptor promoter by cotransfected RUNX1, but

also reducing the expression of the reporter gene below baseline.⁸³ The ability of RUNX1-RUNX1T1 to act as a transcriptional repressor depends on its association with HDACs (via RUNX1T1; Fig. 72.4A), since the HDAC inhibitor TSA can abrogate effects of RUNX1-RUNX1T1 on the cell cycle.⁸⁰ In addition, examination of the M-CSFR gene in Kasumi-1 cells (high expressors of RUNX1-RUNX1T1) reveals an increase in histone H3Lys9 methylation.⁸⁴ Targets of RUNX1-RUNX1T1 repression are presumed to include genes important for granulocyte differentiation. In addition, RUNX1-RUNX1T1 represses the tumor suppressor genes P14ARF and NF1.^{85,86} P14ARF stabilizes TP53 by antagonizing MDM2, an inhibitor of TP53.⁸⁷ Therefore, repression of P14ARF reduces the checkpoint control path of TP53, and may be a key event in t(8;21) leukemogenesis. The promoter of P14ARF has eight RUNX1 DNA-binding sites, and wild-type RUNX1 can activate P14ARF. However, transfection of RUNX1-RUNX1T1 into cells that have only low levels of RUNX1 and high endogenous levels of P14ARF results in repression of P14ARF. Samples of bone marrow from patients with t(8;21) leukemia have low levels of P14ARF transcript by quantitative real-time polymerase chain reaction analysis.⁸⁵ Surprisingly, expression of RUNX1-RUNX1T1 in myeloid progenitor cells inhibits cell cycle progression. However, this may contribute to leukemogenesis by allowing time for accumulation of mutations in a cell immune from TP53-induced apoptosis due to inactivation of P14ARF.⁸⁵

P.1530

Finally, inversion 16, present in about 8% of AML cases, involves the CBF complex member CBFβ and is associated with a morphologically distinct subset of AML, previously considered M4Eo in the French-American-British Cooperative Group Classification. This disease is a myelomonocytic leukemia with abnormal eosinophils that have dark purple as well as orange granules.³⁵ This cytogenetic abnormality in which the CBFβ gene is fused to the smooth muscle myosin heavy-chain (SMMHC) gene, MYH11, results in fusion of the first 165aa of CBFβ to the C-terminal coiled-coil region of SMMHC protein (Fig. 72.4D).⁶¹ A C-terminal region of SMMHC/MYH11 is necessary for the activity of CBFβ/MYH11 as a transcriptional corepressor, and this region also associates with mSin3a and HDAC8. Presumably CBFβ/MYH11, which cannot bind DNA on its own, interacts with RUNX1 to form a transcriptional repressor complex.⁸⁸

A number of experiments demonstrate that the CBF translocations are necessary but not sufficient for induction of leukemia. In order to determine whether expression of RUNX1-RUNX1T1 is sufficient to produce leukemia, mice were generated with a conditional Runx1-Runx1t1 knock-in allele using the Lox-Cre system. This obviates the embryonic lethality that results when Runx1-Runx1t1 is introduced into transgenic mice (recapitulating the phenotype of the Runx1 null mouse). No leukemia developed in 20 Runx1-Runx1t1+ mice in 11 months, and no hematologic abnormality was detected except for a slight increase in the number of hematopoietic colony-forming cells. Interestingly, expression of Runx1-Runx1t1 did not cause a significant block in differentiation of hematopoietic precursors. When the mice were mutagenized with the DNA alkylating agent, ethylnitrosourea (ENU), 31% of the mice developed granulocytic sarcoma or AML.⁸⁹ This supports the hypothesis that several genetic “hits” are necessary for the development of leukemia.

Another study used retroviral transduction of CD34⁺ human hematopoietic progenitor cells to investigate the effect of RUNX1-RUNX1T1 on proliferation and differentiation.⁹⁰ In mice reconstituted with RUNX1-RUNX1T1 expressing HSCs there was an expansion of the HSC population and immature myeloid cell populations, although the mice did not develop acute leukemia.⁹¹ Therefore, the expression of RUNX1-RUNX1T1 promotes accumulation of immature cells and prolongs the period of time during which progenitor cells may accumulate additional mutations.

Further support for the hypothesis that genetic mutations besides a mutant RUNX1 locus are necessary for development of acute leukemia comes from the study of patients with FPD with a propensity to develop AML (FPD/AML). These patients have mutations in one allele of RUNX1.⁹² They have defective platelets and progressive pancytopenia, and develop myelodysplasia and a high incidence of AML with age. However, second mutations appear to be necessary before progression to AML occurs. This implies that acquisition of additional mutations is necessary for development of leukemia.

CCAAT/Enhancer Binding Protein-α

CCAAT/enhancer binding protein-α (CEBPA) is a transcription factor that regulates granulocytic differentiation.⁹³ Cytogenetically silent mutations of CEBPA have been identified in about 10% of AML cases.⁹⁴ In addition, mutations in other oncogenes in leukemia often lead to CEBPA downregulation. For example, RUNX1-RUNX1T1 represses the CEBPA promoter.⁹⁵ FLT3-ITD activation of ERK leads to modification of CEBPA which reduces its activity.⁹⁶

In addition, the CEBPA promoter is methylated in half of AML cases.⁹⁷ The importance of CEBPA in granulocyte differentiation is demonstrated by the lack of mature granulocytes in Cebpa knockout mice,⁹⁸ while its conditional expression triggers granulocyte differentiation in bipotential precursors.⁹⁹ CEBPA transactivates the genes for G-CSF and

GM-CSF receptors and several granulocyte-specific proteins. The gene produces two proteins using alternative start sites. The larger and predominant 42-kD protein consists of two N-terminal transactivating domains, with a C-terminal bZIP domain consisting of a basic (b) region that mediates DNA sequence binding and a leucine zipper (ZIP) domain that mediates dimerization.¹⁰⁰ The shorter 30-kD protein is transcribed from an alternative internal start site, and retains its bZIP domain but lacks the first transactivation domain. Mutations in CEBPA are of two types: C-terminal bZIP domain mutations and N-terminal truncating mutations that lead to enhanced production of the 30-kD protein.^{101,102,103} The former type inhibits dimerization and DNA binding. The latter type dimerizes with the long form, but inhibits transactivation by the dimer, functioning in a dominant negative manner. In two-thirds of AML with CEBPA gene mutations, one allele has an N-terminal mutation and the other allele has a C-terminal variant. Several families with familial AML have been documented to have germline CEBPA N-terminal mutations, and progression to AML has been shown to correlate with a somatic mutation in the C-terminus.¹⁰⁴ CEBPA mutations most often occur in intermediate-risk AML with normal cytogenetics, and these patients have a significantly improved outcome.⁹⁴ Interestingly, mutation of CEBPA at both alleles is associated with a better overall survival than mutation of CEBPA at a single allele.¹⁰⁵ Approximately one-third of AML with CEBPA mutations also have FLT3 mutations, and the CEBPA mutation confers a more favorable prognosis in this group of AML patients as well.³⁴

GATA1

GATA1 is a zinc finger transcription factor that regulates erythroid and megakaryocytic differentiation. In the acute megakaryoblastic leukemia (AMkL) that occurs in children with Down syndrome (DS), mutations of GATA1 have been described in all tested cases.^{106,107,108} Familial missense mutations in GATA1 result in a syndrome of dyserythropoietic anemia and thrombocytopenia, while conditional knockout of Gata1 in megakaryocyte precursors in mice leads to thrombocytopenia and megakaryoblast proliferation. Approximately 10% of DS patients develop transient myeloproliferative disorder (TMD) in the neonatal period (usually in the first week, almost always within the first 2 months of life), and these patients have mutations in GATA1.^{106,109} About one-third of DS patients with TMD later develop AMkL within 5 years, and identical GATA1 mutations have been identified in the AMkL blasts as were present in the TMD. A large study demonstrated that there is no difference in the GATA1 mutations present in patients who just developed TMD compared to patients who went on to AMkL.¹¹⁰ The mutations in GATA1 result in transcription of a truncated form that lacks its N-terminal transactivation domain, GATA-1s. This shorter form has similar DNA-binding activity but reduced transactivation compared to wild-type, and it therefore can act in a dominant negative manner. By introducing the truncated GATA1 into GATA1-deficient fetal liver progenitor cells by retroviral transduction, Muntean and Crispino demonstrated that GATA-1s restored terminal differentiation but that abnormal proliferation occurred.¹¹¹ Interestingly, analysis of a knock-in mouse model where Gata-1s replaces wild-type Gata-1 demonstrates that fetal liver megakaryocytes abnormally proliferate, but that megakaryocyte proliferation is normal in adult bone marrow.¹¹² This may explain why TMD occurs in the neonatal period in DS patients. Research into the gene(s) on chromosome 21 that cooperate with mutant GATA1 to produce AMkL in DS children is ongoing; a recent mouse study reported evidence that Dyrk1a (dual-specificity tyrosine-phosphorylation-regulated kinase 1A) can cooperate with mutant Gata1 to promote megakaryoblast expansion.¹¹³

P.1531

AMkL in Down syndrome is sensitive to cytosine arabinoside/anthracycline-based chemotherapy, with event-free survival rates of 80% to 100%.¹¹⁴ Interestingly, a putative target of GATA1 regulation is cytidine deaminase (CDA), which inactivates ara-C by deamination to the inactive uridine arabinoside. Presumably failure of GATA-1s to transactivate CDA increases the efficacy of ara-C treatment.¹¹¹

Epigenetic Factors Modifying Chromatin and DNA

IDH1/2 and TET2 Mutations

In the whole genome sequencing of blasts from a patient with cytogenetically normal AML, mutations in isocitrate dehydrogenase 1 (IDH1) were detected and were found to be present in 16% of a panel of 80 cytogenetically normal AML samples.³⁰ IDH1 mutations had previously not been described in AML, though IDH1/2 mutations are common in gliomas.¹¹⁵ In a further screen of AML DNA, it was found that IDH1/2 mutations are mutually exclusive with mutations in TET2 (ten-eleven translocation 2) in de novo AML (Fig. 72.5). Additional findings suggesting a functional link between the products of these two genes are that AMLs with mutations in IDH1 have similar patterns of DNA hypermethylation as AMLs with mutations in TET2.¹¹⁶ In addition, these two mutational categories of AML share patterns of aberrant gene expression at

the level of 93%.¹¹⁶ The link became clear upon further investigation of the enzymatic activity of IDH1/2 and TET1/2. Wild-type IDH1/2 catalyzes production of α -ketoglutarate (α -KG), whereas the neomorphic enzymatic activity of mutant IDH1/2 produces 2-hydroxyglutarate (2-HG). α -KG-dependent enzymes such as histone demethylases and TET1/2 are inhibited by 2-HG, which is structurally similar enough to α -KG that it can bind in place of α -KG and inhibit these enzymes.¹¹⁷ The TET proteins catalyze the conversion of 5-methyl cytosine (5mC) to 5-hydroxymethyl cytosine (5hmC), which is thought to be a first step in demethylation of the cytosine.¹¹⁸ Experiments using a fluorescent-tagged antibody to 5hmC demonstrate that cotransfection of plasmids encoding IDH1 and TET2 result in a global increase in 5hmC, whereas cotransfection of plasmids encoding mutant IDH1 and wild-type TET2 fail to demonstrate an increase in 5hmC.¹¹⁷ Therefore, mutations in IDH1 and TET2 both produce increased DNA methylation: mutant IDH1 by inhibiting TET2, and mutant TET2 by loss of its ability to convert 5mC to 5hmC, and thereby promote demethylation.^{116, 117, 118} and ¹¹⁹ The significance of these changes for pathogenesis of AML is demonstrated by experiments in which either stable expression of mutant IDH1 or shRNA-mediated knock-down of TET2 in primary mouse bone marrow cells resulted in increased c-kit expression and decreased expression of the mature myeloid markers Mac-1 and Gr-1 by flow cytometric analysis.¹¹⁶ Therefore, the hypermethylation and resultant silencing of genes as a result of IDH1 and TET2 mutations presumably inhibit myeloid differentiation and thereby promote development of AML. This mechanism suggests new avenues of molecular therapy in that drugs that mimic α -KG or that inhibit the mutant IDH1/2 may restore proper enzymatic function to histone demethylases and TET2, promoting normal histone and DNA methylation patterns.¹¹⁷ In studies performed to date, mutations in IDH1 and TET2 have not been shown to have a significant impact on survival.¹⁰⁵

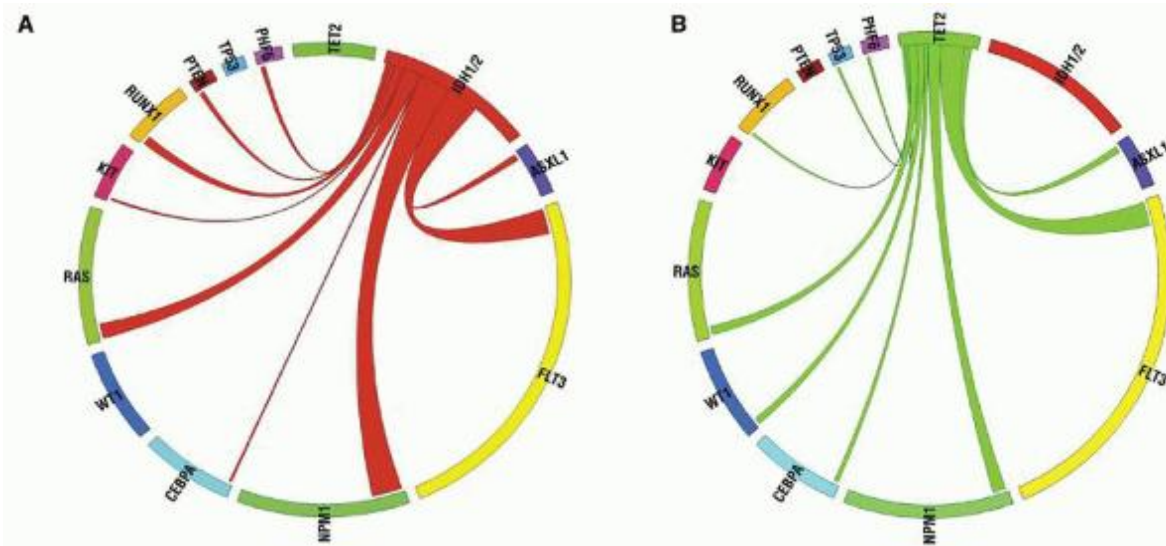

FIGURE 72.5. IDH1/2 mutations are mutually exclusive with mutations in TET2 in de novo AML. A: Circos diagram revealing relative frequency and pairwise co-occurrences of mutations in IDH1 and IDH2 in a cohort of 385 patients with de novo AML. B: Circos diagram revealing relative frequency and pairwise co-occurrences of mutations in TET2 in a cohort of 385 patients with de novo AML. Reprinted from Figueroa ME, Abdel-Wahab O, Lu C, et al. Leukemic IDH1 and IDH2 mutations result in a hypermethylation phenotype, disrupt TET2 function, and impair hematopoietic differentiation. *Cancer Cell* 2010;18:553-567, with permission from Elsevier.

DNMT3A

Deep sequencing of DNA from the first AML patient with a normal karyotype revealed additional mutations, including a mutation in DNA methyltransferase (DNMT3A). Sequencing of the DNMT3A gene in DNA from 281 AML patients revealed a mutation rate of 22.1%. The DNMT3A mutations were found in patients with intermediate-risk cytogenetics. As a group these patients had a mean overall survival significantly shorter than the patients with wild-type DNMT3A: 12.3 months compared to 41.1 months.³¹ The mutations detected in patients with AML map predominantly at the interface where they disrupt tetramerization of the DNMT3A molecules. Dimeric DNMT3A molecules still have methylase activity, but they dissociate from DNA more quickly than wild-type, so

P.1532

that fewer cytosines in a CpG island are methylated.¹²⁰ The effect on tetramerization explains why the DNMT3A mutations are dominant negative, usually occurring in just one allele. Global methylation does not seem to be affected in DNA from

AML with mutated DNMT3A, but analysis of DNA methylation by MeDIP-Chip (methylated DNA immunoprecipitation-Chip) analysis in a matched set of DNAs from 5 AML patients with mutated DNMT3A and 5 AML patients with wild-type DNMT3A demonstrated 182 genomic sites where the DNA from patients with mutated DNMT3A was hypomethylated.³¹ Studies of DNA methylation in Dnmt3a-null murine HSCs demonstrated a complex story with poor correlation between changes in methylation sites and changes in gene expression comparing wild-type to Dnmt3a-null HSCs. However, changes in gene expression patterns may be due to changes in methylation of regulatory regions of directly affected genes, whose expression then alters regulation of many other genes by mechanisms other than methylation. Transcriptional profiling of Dnmt3a-null HSCs did reveal that genes involved in the multipotency of normal HSCs were upregulated, whereas genes necessary for differentiation of the HSCs were downregulated. This suggests that the DNMT3A mutations may contribute to the block in differentiation that occurs in leukemic blasts. Interestingly the Dnmt3a-null mice have not yet developed leukemia, suggesting that DNMT3A mutation alone is not sufficient for leukemogenesis.¹²¹

Mixed Lineage Leukemia: 11q23 Translocations

A transcriptional activator that is characteristically rearranged in infant leukemia, therapy-related leukemia, and mixed phenotype acute leukemia is the mixed lineage leukemia gene (MLL), which maps to chromosome 11q23 (reviewed in Ref. 122). The MLL gene consists of 34 exons over 100 kb encoding a 3,969 aa protein.¹²² MLL is the mammalian homolog of trithorax, a Drosophila transcriptional regulator that positively regulates homeobox genes.¹²³ Homeobox genes are a large family of genes which are developmental regulators essential for growth and differentiation. They were first identified in Drosophila during the study of genes whose mutations led to developmental abnormalities involving misassignment of body segment identity.¹²⁴ The mammalian homologs consist of 39 HOX genes, which are important in mammalian development and cell fate determination.¹²⁵ Analysis of chimeric mice reconstituted with MLL-deficient embryonic stem cells demonstrates that MLL expression is required for definitive hematopoiesis and expansion of HSCs in the AGM region.¹²⁶ Wild-type MLL appears to be responsible for the regulation of homeobox gene expression during development, including HOXA9, HOXC8, HOXA7, HOXA10, HOXC6, and HOXC9.^{126,127,128,129} Wild-type MLL regulates HOX gene expression by methylation of histone H3 lysine (H3K4), requiring the SET domain. The SET domain is a protein domain shared by a number of transcriptional regulators that have histone methyltransferase activity.¹³⁰ H3K4 methylation is associated with transcriptional activation.

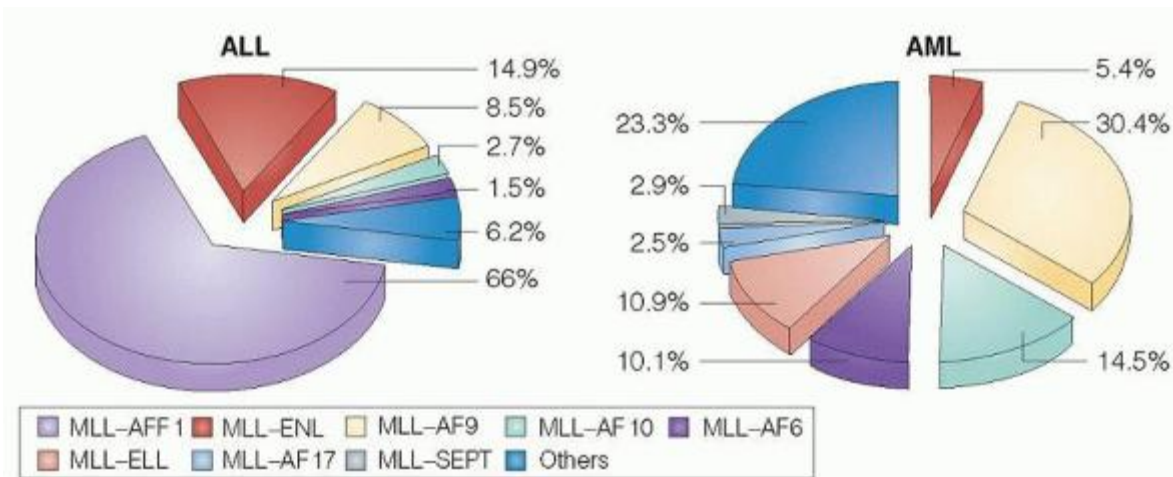

FIGURE 72.6. The distribution of the most common MLL chimeras in acute lymphoid and myeloid leukemias. In MLL-rearranged ALL, AFF1, AF9 (now known as MLLT3), ENL (now known as MLLT1), and AF10 (now known as MLLT10) account for 90% of all the translocations, and in AML 70% of MLL translocations involve AF9 (MLLT3), ENL (MLLT1), AF10 (MLLT10), ELL, and AF17 (now known as MLLT6). AFF1 is the most frequent translocation partner of MLL, which is typically associated with ALL. Reprinted by permission from Macmillan Publishers Ltd: Mohan M, Lin C, Guest E, Shilatifard A. Licensed to elongate: a molecular mechanism for MLL-based leukaemogenesis. *Nat Rev Cancer* 10:721-728, copyright 2010.

MLL rearrangements involve approximately 10% of chromosomal rearrangements overall in patients with ALL, AML, and MDS, and are associated with poor prognosis.¹³¹ More than 60 different partner loci have been identified¹³²; the 10 most common translocation partners are listed in Figure 72.6, along with a pie chart demonstrating the frequency of the translocation in pediatric vs. adult leukemia and AML vs. ALL. In pediatric and adult ALL, the most common translocation partners are the AFF1 gene (previously known as AF4) at 4q21.3 in t(4;11), the MLLT3 gene (previously known as AF9) at

9p22 in t(9;11), and the MLLT1 (ENL) or ELL genes at 19p13.3 and 19p13.1, respectively, in t(11;19). Interestingly, the t(9;11) and t(11;19) are also associated with AML¹³³; thus the name mixed lineage leukemia, since the gene is involved with leukemias of both myeloid and lymphoid origins. The breakpoints of 11q23 usually occur between exons 8 and 11 of MLL (Fig. 72.7),¹²² leaving approximately the N-terminal 1,400 amino acids of the MLL protein.¹³⁴ The retained protein contains three AT-hook sequences thought to bind DNA at the minor groove,¹³⁵ the CxxC domain that specifically binds unmethylated DNA, and a lysine-rich RD2 region. The conserved C-terminal SET domain is usually lost, though it is the domain that has the H3K4 histone methyltransferase activity that is the mechanism by which the wild-type protein activates HOX gene transcription (Fig. 72.7).¹²²

There has been much investigation as to the role of the multiplicity of fusion partners of MLL. Two of the most common fusion partners, MLLT10 (AF10) and MLLT1, associate with DOT1L, which is a histone methyltransferase with a different activity than wild-type MLL, as it methylates histone H3 lysine 79 (H3K79me).¹³⁶ This histone modification is also associated with transcriptional activation, however. DOT1L is one of many proteins in a Dot.com complex, which consists of DOT1L, AF10 (MLLT10), AF17 (MLLT6), and ENL (MLLT1) (Fig. 72.8).^{122,136} Thus the plethora of MLL fusion partners begins to make sense, as many of them normally associate together in complexes that regulate transcription. Therefore the fusion protein associates with its usual partners, but the H3K79me marking occurs at different sites than usual, as the N-terminal MLL protein has the DNA-binding sites that bring the activating histone methyltransferase activity to MLL target genes. Demonstration of an abnormal increase in the H3K79 methylation pattern at target HOXA genes confirms this hypothesis, and this increase was shown to be dependent on DOT1L function.¹³⁷ Dependence on functional DOT1L not only for the H3K79 methylation pattern but also for the development of leukemia has been demonstrated with a conditional knockout mouse model for Dot1L expression.¹³⁷ If cells

P.1533

are transduced by a retrovirus expressing MLL-MLLT3, smaller colonies of blast-like cells grow if the Dot1L is inactivated by the introduction of Cre. In addition, the colonies then demonstrate morphologic signs of differentiation. If the MLL-MLLT3 cells are transplanted into irradiated mice, in vivo colonies are also reduced if Dot1L is inactivated, and these colonies have more differentiation and fewer proliferating cells.¹³⁷ In addition, methylation analysis of HOXA and MEIS1, target genes of MLL, demonstrate reduced H3K79me2 modification after disruption of DOT1L. Even more dramatic is the effect of a small molecule inhibitor of DOT1L, EPZ004777, which specifically inhibits DOT1L and prevents its H3K79 methylase activity.¹³⁸ The growth of MLL-rearranged cell lines such as MV4-11 and MOLM-13 is inhibited by EPZ004777 after several days of exposure in cell culture, and levels of HOXA9 and MEIS1 expression are decreased. However, the growth of a leukemia cell line in which MLL is not rearranged (Jurkat) was not affected by EPZ004777. In addition, treatment of a mouse xenograft model of MLL with EPZ004777 resulted in a statistically significant increase in median survival. Therefore, inhibition of DOT1L holds promise for targeted treatment of MLL leukemia.¹³⁸

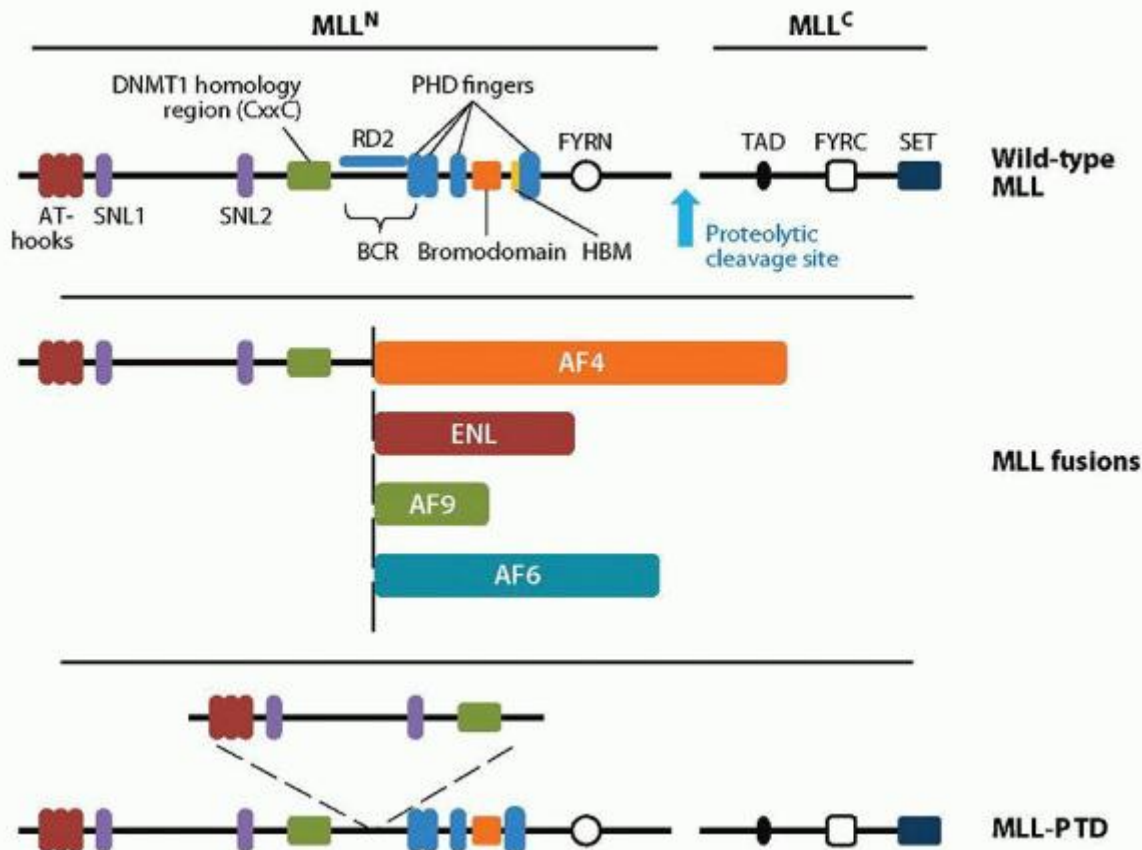

FIGURE 72.7. Structure of wild-type and leukemia-associated mixed lineage leukemia (MLL) proteins. Top: Domain architecture of wild-type MLL. Cleavage of MLL (denoted by the blue arrow) results in 320-kDa MLL^N and 180 kDa MLL^C fragments, which noncovalently associate. Domains within MLL^N include three AT-hooks (red), two subnuclear localization motifs (SNL1 and -2) (purple), a DNMT1 homology region (CxxC) (green), four plant homeodomain (PHD) fingers (blue), an atypical bromodomain (orange), and a FYRN domain (open circle). The breakpoint cluster region (BCR) spans an 8.3-kb region encompassing exons 7 to 13 (according to the new nomenclature) and is the site of chromosomal translocations involving MLL. Between the CxxC and the first PHD finger is repression domain 2 (RD2). A host cell factor-binding motif (HBM) (yellow) is found between the bromodomain and PHD3. MLL^C contains a transactivation domain (TAD) (filled oval), a FYRC domain (open square), and a C-terminal SET domain (dark blue). Middle: Chromosomal translocations involving MLL result in chimeric MLL-fusion proteins that include the N-terminal sequence of MLL up to the BCR (dotted vertical line), followed by one of several different fusion partners. Also shown are examples of fusion partner proteins. MLL-fusion proteins invariably retain AT-hooks, SNL and -2, and the CxxC domain of MLL^N, while losing the downstream PHD fingers and further C-terminal domains, including the SET domain. Bottom: MLL is also prone to internal partial tandem duplications (MLL-PTD), leading to duplication of MLL sequences comprising the AT-hooks, SNL1 and -2, and the CxxC domain, that are inserted at the BCR. Republished with permission of Annual Reviews, Inc. Muntean AG, Hess JL. The pathogenesis of mixed lineage leukemia. *Annu Rev Pathol Mech Dis* 2012;7:283-301.

Data also exists for participation of MLL fusion proteins with other transcriptional regulatory complexes. Purification of the proteins involved in the super elongation complex (SEC) revealed participation of several of the MLL translocation partners, including AFF1 (AF4), MLLT3 (AF9), MLLT1 (ENL), and ELL (Fig. 72.8).¹³⁹ The SEC complex also contains elongation factors such as ELL2, ELL3, P-TEFb, EAF1, and EAF2, and it functions to promote transcriptional elongation by RNA polymerase II. Therefore, interaction of this complex with the MLL fusion protein may provide another mechanism for increasing HOX target gene transcription.^{122,139}

The end result of the recruitment of these transcriptional regulatory complexes by the MLL fusion protein is thought to be abnormally sustained homeobox (HOX) gene expression. Usually HOX genes are expressed highly during early development, but then are downregulated during hematopoiesis. However, the MLL fusion protein inappropriately activates the HOX genes.¹²² Microarray analysis of MLL leukemia cells supports this hypothesis, as high levels of HOXA9,

HOXA5, HOXA4, and HOXA10, as well as MEIS1, characterize the gene expression profile of leukemias with MLL translocations.^{140,141}

MLL rearrangements are associated with several unique types of leukemia. First, in infant acute leukemia (birth to 1 year), there is a 60% to 80% incidence of 11q23 rearrangement.¹⁴² Second, in acute leukemias related to treatment with DNA topoisomerase II inhibitors, there is a 70% to 90% incidence of MLL rearrangements, particularly t(4;11)(q21;q23) and t(9;11)(p21-22;q23).^{143,144} Topoisomerase II is an enzyme involved in unwinding of DNA during replication and transcription. It does so by producing double-stranded in the DNA, after which (ds) breaks the ends are rejoined by a ligase activity of topoisomerase II. Topoisomerase II inhibitors such as epipodophyllotoxins inhibit this ligase function so DNA double strand breaks accumulate, triggering apoptotic events. In MLL there are 11 sites similar to topoisomerase II consensus binding sites in the breakpoint cluster area.¹⁴⁵ Therefore, if DNA ds breaks created by the topoisomerase II are incorrectly religated, translocations in MLL are likely to

P.1534

occur. Interestingly, infant leukemia with MLL translocations has a similar distribution of breakpoints, whereas sporadic cases of acute leukemia have more random breakpoints.¹⁴⁶ This observation has triggered speculation that in utero exposure to environmental topoisomerase II inhibitors such as flavonoids may have a role in the etiology of infant leukemia.¹⁴⁷

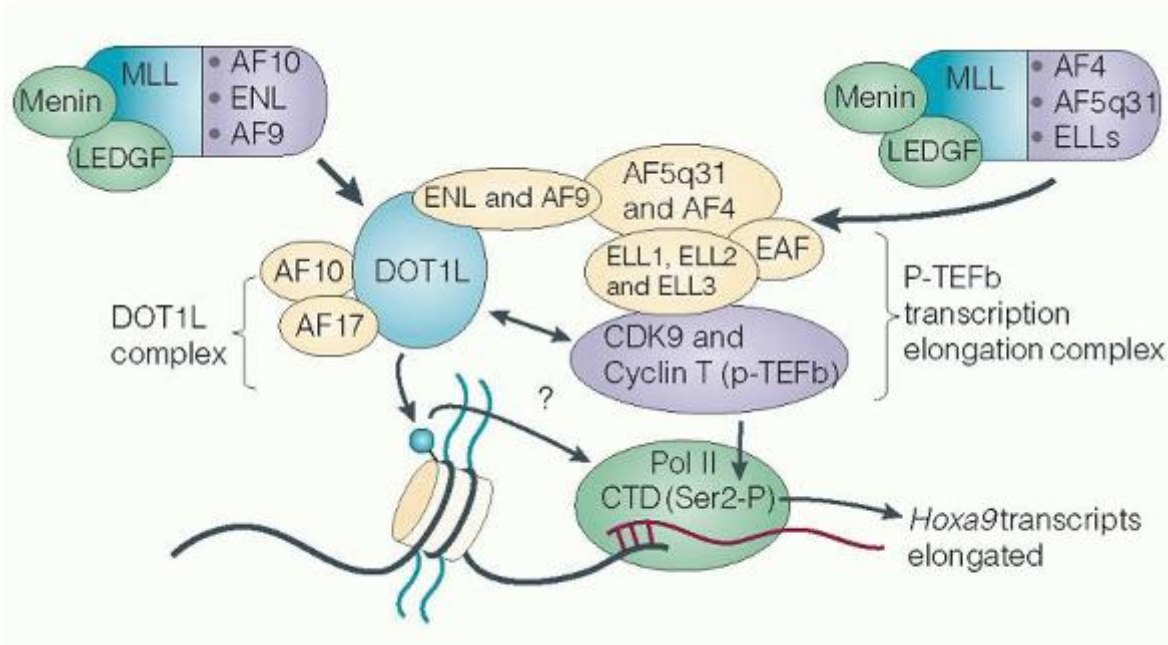

FIGURE 72.8. Proposed mechanism by which mixed lineage leukemia (MLL) fusion proteins increase transcription of HOXA9. MLL fusion proteins lose a large carboxy-terminal portion that includes the H3K4me3 writing methyltransferase SET domain, retain the chromatin-targeting property, and also acquire aberrant transactivation mechanisms through MLL fusion partners. On the left, a subset of MLL fusions MLL-AF10 (MLLT10), MLL-ENL (MLLT1), and MLL-AF9 (MLLT3), directly interact with DOT1L through the MLL fusion partner and induce the methylation of H3K79 at HOXA9. Some other MLL fusions, MLL-AF4 (AFF1), MLL-AF5q31 (AFF4), and MLL-ELL, interact with and recruit the P-TEFb transcription elongation complexes to HOXA9. On the right, DOT1L complexes (DOT1L-AF10-AF17-ENL [or AF9]) associate with P-TEFb complexes through the shared component ENL. Reprinted by permission from Macmillan Publishers Ltd: Chi P, Allis CD, Wang GG. Covalent histone modifications—miswritten, misinterpreted and mis-erased in human cancers. *Nat Rev Cancer* 2010;10:457-469, copyright 2010.

Recently a different type of MLL gene alteration involving an in-frame partial tandem duplication of exons 5 to 11 has been described in approximately 4% to 7% of patients with AML¹⁴⁸ (Fig. 72.7). This occurs in the absence of visible chromosome abnormalities and is often associated with FLT3 mutations.¹⁴⁸ This mutation retains the C-terminal SET domain, unlike all known MLL fusions resulting from balanced translocations. A mouse knock-in model replacing one copy of Mll with the Mll-PTD (MllPTD/WT mice) results in overexpression of Hoxa7, Hoxa9, and Hoxa10 in bone marrow, blood,

and spleen.¹⁴⁹ Inspection of the promoter of *Hoxa7* and *Hoxa9* by chromatin immunoprecipitation assay demonstrates an increase in H3K4 methylation, as would be predicted due to the retention of the SET domain (Fig. 72.7).

The latency of development of leukemia appears to be shorter for MLL rearrangements than for other leukemogenic rearrangements. In studies of twins who develop infant leukemia, those bearing a shared MLL rearrangement have a concordance of nearly 100% in the first year of life, whereas in twins sharing another rearrangement, the concordance is 25% and the time to development of leukemia may be years instead of months.^{150,151} Similarly, therapy-related leukemias based on MLL rearrangement occur sooner after therapy than those occurring after alkylating agents or radiation, usually with 7q- or 5q-cytogenetics.^{144,152} This suggests that the oncogenic fusion protein produced by the MLL rearrangement can deregulate the cell without the accumulation of many secondary mutations. However, in genetic experiments in mice where the MLL-Mllt3 fusion gene is knocked in, there is still a latency of 6 months before development of acute leukemia, suggesting that some secondary mutations are necessary.¹⁵³ An additional reflection of the potency of MLL rearrangements is that they are a poor prognostic indicator in infant leukemia, ALL, and most AML cases.¹⁴²

This section demonstrates that mutations in genes involved in epigenetic regulation have emerged as a significant mechanism of leukemic transformation. In addition to the genes discussed above, mutations in ASXL1 (addition of sex combs-like 1), a member of the polycomb-repressive deubiquitylase complex, and mutations in EZH2 (enhancer of zeste homolog 2), an H3K27 methyltransferase in the PRC2, have been found in AML that is secondary to MDS or myeloproliferative diseases. This enlarging group of genes has led Shih et al. to propose two additional categories of genes involved in the pathogenesis of AML besides the Class I genes promoting proliferation and the Class II genes promoting block in differentiation. These two additional categories are: (1) Mutations in genes involved in the hydroxymethylation pathway (IDH1/2, TET2), and (2) Mutations in genes involved in epigenetic modification (DNMT3A, ASXL1, MLL).¹⁵⁴

Kinases

FLT3 Mutations

FLT3 may be the single most commonly mutated gene in AML (reviewed in 155). Originally cloned from CD34⁺ HSCs, it encodes a type III receptor tyrosine kinase. FLT3 ligand (FL) is a type I transmembrane protein that is expressed on the surface of support and hematopoietic cells in the bone marrow. It normally stimulates growth of immature myeloid cells and stem cells.¹⁵⁶ When FL ligand binds to the FLT3 receptor, FLT3 dimerizes and autophosphorylates intracytoplasmic tyrosine residues. The phosphorylated, activated FLT3 then activates downstream signal transduction pathways, including PI3K/AKT, MAPK/ERK, and STAT5.^{157,158} Several types of mutations in FLT3 have been cloned from leukemic cells. The most common are internal tandem repeat (ITD) mutations, in which head-to-tail duplications of various lengths and positions occur in the juxtamembrane (JM) portion of the molecule (Fig. 72.9).¹⁵⁹ These elongation mutations may occur due to DNA replication errors as a result of a potential palindromic intermediate that may form at that site.¹⁶⁰ The JM domain is an autoinhibitory domain whose inhibitory function is usually relieved by autophosphorylation after ligand binding.¹⁵⁵ The in-frame insertions in the JM domain produce mutant proteins that are constitutively activated; they are able to dimerize

P.1535

and autophosphorylate in the absence of ligand.¹⁶⁰ Other types of mutations include activation loop mutations, usually an Asp825Tyr substitution resulting from a point mutation in the second tyrosine kinase domain (TKD), producing constitutive activation of FLT3.¹⁵⁵

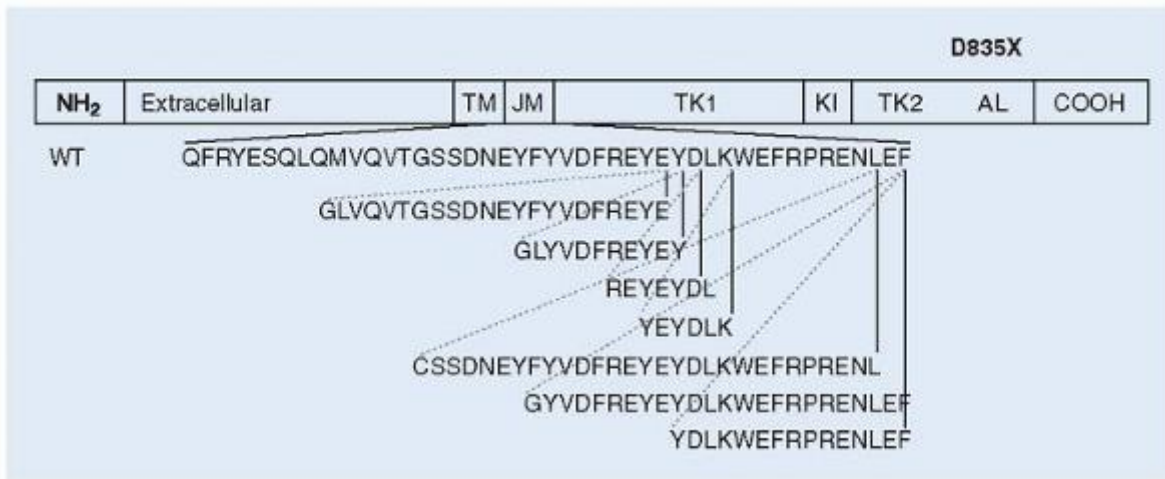

FIGURE 72.9. Schematic of the internal tandem repeat (ITD) and activation loop FLT3 mutations in acute myelogenous leukemia (AML). The structure of the FLT3 receptor tyrosine kinase is shown, with the position of the transmembrane domain (TM), the juxtamembrane (JM) domain, the kinase domains (TK1 and TK2), kinase insert (KI), and activation loop (AL). The amino acid sequence of the wild-type JM domain is listed, and underneath are the tandem duplication sequences found in individual patients with AML. These are always in-frame insertions. The position of the amino acid that is commonly substituted in activation loop mutations is indicated above the schematic of the protein domains. From Mizuki M, Fenski R, Halfter H, et al. FLT3 mutations from patients with acute myeloid leukemia induce transformation of 32D cells mediated by the RAS and STAT5 pathways. *Blood* 2000;96:3907-3914 and Kelly LM, Liu Q, Kutok JL, et al. FLT3 internal tandem duplication mutations associated with human acute myeloid leukemias induce myeloproliferative disease in a murine bone marrow transplant model. *Blood* 2002;99:310-318.

The overall frequency of FLT3-ITD in adult AML is 24% of patients, while in pediatric AML the frequency is somewhat lower at 10% to 15% (reviewed in Ref. 155). The frequency is very low in MDS and ALL. In contrast, the FLT3 activation loop mutation is reported in 7% of AML, 3% of MDS, and 3% of ALL patients.¹⁶¹ FLT3-ITD is detected most frequently in APL, but has been detected in all AML subtypes.¹⁵⁵ In addition, FLT3 is overexpressed at the mRNA and protein levels in many cases of AML and ALL.¹⁶²

The role of the FLT3-ITD in leukemogenesis has been investigated by retroviral transduction of murine bone marrow stem cells followed by transplantation into mice. These mice develop a myeloproliferative disease with predominantly maturing myeloid elements, but they do not develop acute leukemia.¹⁶³ Therefore, the FLT3 mutations may confer the proliferative signal in patients with acute leukemia, whereas a concomitant balanced translocation or other genetic defect confers the block in differentiation necessary for development of acute leukemia.¹⁵⁵

Mutation of FLT3 is a significant independent prognostic factor for poor outcome in patients younger than 60 years. In a study of 91 pediatric AML patients on the Children's Cancer Group (CCG) protocol, the remission induction rate was 40% in patients with FLT3-ITD compared to 74% with wild-type FLT3. The difference in event-free survival at 8 years was even more striking, at 7% for patients with FLT3-ITD compared to 44% for patients with wild-type FLT3.¹⁶⁴ In a study of 398 patients younger than 60 with AML, FLT3-ITD mutations were the primary predictor of outcome in patients with intermediate-risk cytogenetics and were associated with reduced overall survival.³⁴ As with BCR-ABL1 for CML, the implication of a mutant constitutively active tyrosine kinase receptor in the pathogenesis of AML opens up the possibility of identifying a selective kinase inhibitor as a specific treatment for AML patients with a mutant FLT3. Several kinase inhibitors have been identified by inhibition of IL3-independent growth of cell lines expressing FLT3-ITD in culture.^{165,166} Eight of these FLT3 inhibitors (FLT3-TKI) have been tested in phase I/II trials as single agents (reviewed in Ref. 167). In each study a majority of patients achieved >50% reduction in peripheral blast count, but these reductions were transient, lasting several weeks to months. The partial efficacy may be in part due to the refractory nature of the phase I/II patient population. However, a study performed by Piloto et al.¹⁶⁸ on resistant human cell lines developed through prolonged coculture with FLT3 tyrosine kinase inhibitors demonstrated that although FLT3 phosphorylation was still inhibited, downstream signaling pathways were activated. In two cell lines, activating NRAS mutations were detected. No mutations in FLT3 were detected. However, in other studies, SMRT sequencing was used to demonstrate secondary FLT3 kinase domain mutations in 4 of 8 patients who relapsed after treatment with FLT3-TKI. The mutation frequency in the patients' blasts was 20% to 50%, consistent with most of the leukemic blasts having a mutation on one allele. This degree of

mutation in relapsed patients supports the idea that FLT3 mutations are “driver” mutations necessary for growth of the leukemic clone. From the crystal structure of FLT3 several of the mutations would force the molecule into an active kinase confirmation which is not recognized by the AC220 type II kinase inhibitor used in the study.¹⁶⁹

Nuclear Pore Proteins

Nucleophosmin

Nucleophosmin (NPM) is a molecular chaperone that shuttles between cytoplasm and nucleus, with particular nucleolar concentration of protein.¹⁷⁰ While NPM appears to function to transport preribosomal particles from the nucleolus to cytoplasm, other functions have also been described, including regulation of centrosome duplication, regulation of p53, and functional regulation and stabilization of P19ARF (reviewed in Ref. 171). Cytogenetically silent mutations of NPM1 have now been identified in 35% of adult AML with normal karyotype. The frequency is less (9% to 27%) in pediatric AML with normal karyotype.^{171,172,173} The NPM1 mutation is stably expressed, being consistently present in leukemic blasts at relapse.¹⁷⁴ The wild-type NPM has two NLSs and two nuclear export signals (NES) that mediate the nuclear-cytoplasmic shuttling of wild-type NPM. Over 50 different mutations in NPM1 have been found in patients with AML; all of these mutations cause changes in the C-terminus of the NPM protein, including generation of a new NES motif, and loss of tryptophan residues 288 and 290, or 290 alone, causing unfolding of the C-terminal domain and disruption of binding to the nucleolus.^{174,175} The presence of a mutation correlates absolutely with abnormal subcellular localization of NPM, with relocation from its normal predominantly nucleolar location to the cytoplasm; this can be detected in tissue sections by immunohistochemistry. The mutation is always heterozygous, which may be related to the fact that the homozygous mutant is embryonic lethal.¹⁷⁶ The mutant NPM appears to function in a dominant negative manner through heterodimerization with normal NPM, to cause relocation of some of the normal NPM, as well as the mutant NPM, to the cytoplasm.¹⁷⁷ The mechanism by which the cytoplasmically located NPM promotes leukemia is under investigation. Conditional expression of mutated NPM in transgenic mice results in overexpression of HOX genes in Lin⁻ marrow progenitor cells.¹⁷⁸ Another mechanism by which mutant NPM1 may promote leukemogenesis is by destabilizing the tumor suppressor protein P14ARF, which regulates the TP53 response. P14ARF colocalizes with NPM to the nucleolus, and their interaction stabilizes P14ARF. Without this interaction and nuclear location, p19Arf (the mouse homolog) is more rapidly degraded by proteasomes. By this mechanism, mutant NPM may indirectly cause decreased amounts of the tumor suppressor protein P14ARF.¹⁷⁴ NPM1 mutations frequently occur in conjunction with IDH1 and IDH2 mutations and with DNMT3A mutations (see Fig. 72.1).^{34,173} Several studies have shown that patients with NPM mutations in the absence of FLT3 mutations have a favorable response to chemotherapy.^{173,175} Patients with intermediate-risk cytogenetics and mutations in NPM1 and either IDH1 or IDH2 mutations have an improved rate of overall survival and are considered to have an overall favorable risk.³⁴

Risk Stratification of Acute Myeloid Leukemia

A major purpose of molecular genetic testing performed on clinical AML samples in the molecular diagnostics laboratory is to have enough information to choose the optimal therapy and to assess the prognosis of the patient. Besides determining information about BCR-ABL1 or PML-RARA rearrangements that have an obvious impact on treatment decisions, the risk stratification of the patient helps the doctor determine whether it is best to treat with aggressive therapy, to adopt a gentler chemotherapy regimen, or to rush the patient to transplant. A recently published attempt to integrate the newly expanded knowledge of molecular defects, both mutations and translocations, that occur in AML reported the results of testing for mutations in a panel of 18 genes in 398 patients with AML at diagnosis. 97.3% of the patients had at least one somatic mutation. The frequency of each of the 18 mutations tested is demonstrated in Figure 72.1, as well as the Circos diagram depicting the interrelationships between the mutations.³⁴ The Circos diagram visually conveys the multiplicity of mutations that occur in most patients. This integrated mutational analysis demonstrated patterns of co-occurring mutations and

P.1536

also mutually exclusive mutations. Some of the more important co-occurrences are KIT mutations and CBF alterations, co-occurrence of IDH1/2 mutations and NPM1 mutations, and DNMT3A mutations with NPM1, FLT3, and IDH1 mutations. As mentioned previously, IDH1/2 mutations do not occur in patients with TET2 mutations (Fig. 72.5). In addition, IDH1/2 and WT1 mutations are mutually exclusive, as well as DNMT3A mutations and MLL translocations.³⁴ The effect of multiple mutations and the interplay with underlying cytogenetic changes on risk stratification are shown in Table 72.1.^{34,179} The most statistically significant predictors of overall survival are as follows: FLT3-ITD and MLL-PTD mutations are associated with reduced overall survival. CEBPA mutations and CBF translocations are associated with improved overall survival.

PHF6 and ASXL1 mutations are associated with reduced survival. IDH2 mutations (R140Q) confer a favorable outcome. In intermediate-risk AML, FLT3-ITD mutations are the primary factor influencing outcome. In this cohort of patients the group with favorable risk had a 3-year overall survival of 64%, whereas the group with intermediate risk had a 3-year overall survival of 42% and the group with adverse risk had a 12% overall survival. Multivariate analysis demonstrated that outcomes predicted from the risk stratification are independent of age, WBC, induction dose, transplantation status, and post-remission therapy.³⁴

Grossman et al.¹⁰⁵ developed a similar prognostic model based entirely on molecular mutational analysis rather than karyotype, in which they constructed an algorithm with 5 prognostic subgroups based upon analysis of 1,000 patients for mutations in: PML-RARA, RUNX1-RUNX1T1, CBFβ, MYH11, FLT3-ITD, MLL-PTD, NPM1, CEBPA, RUNX1, ASXL1, and TP53. The very favorable prognostic group (overall survival at 3 years of 82.9%) consisted of patients with PML-RARA rearrangement or CEBPA double mutations, and the very unfavorable group with an overall survival of 0% at 3 years consisted of patients with TP53 mutations. TP53, a well-characterized tumor suppressor gene, is mutated in many cancers, and mutations in TP53 are the basis of the cancer-prone Li-Fraumeni syndrome.¹⁸⁰ However, this study is the first to characterize the frequency of TP53 mutations in AML (11.5%) and its prognostic significance.¹⁰⁵

The particular combination of mutations and percentage survival will change with the discovery of additional mutations, new treatment trials, and additional patient cohorts, but the principle is important that risk stratification must take into account a multiplicity of genetic events, both translocations and mutations. The role of the molecular diagnostics lab will certainly increase; the difficult question will be what is the most prognostically significant and cost effective panel of molecular tests to perform on an AML patient at diagnosis.

B-ACUTE LYMPHOBLASTIC LEUKEMIA

Introduction

Table 72.5 outlines the WHO classification for B-ALL, which lists several of the major translocations that have been repeatedly seen in B-ALL. Recent genome-wide analysis of DNA from multiple B-ALL cases has demonstrated, as in AML, that there are multiple deletions and mutations in many other genes besides the well-characterized translocations. A recent survey of 242 cases of pediatric ALL using Affymetrix SNP arrays identified an average of 6.46 somatic copy number alterations per case, predominantly deletions.¹⁸¹ Interestingly, alterations in genes regulating B-lymphocyte differentiation were noted in 40% of B-ALL cases. The B-cell differentiation genes most commonly translocated or mutated include EBF1, PAX5, and IKZF1. Copy number changes in PAX5 occurred in 29.7% of this series, with the most common alteration being mono-allelic deletion of PAX5. PAX5 is essential for B-cell development, and it controls B-cell-specific transcription of B-lineage-specific genes such as CD19, CD79a, BLNK, and CD72.¹⁸¹ In Pax5^{-/-} mice, B-cell development is arrested prior to the B220⁺ pro-B-cell stage, and these pro-B cells are uncommitted lymphoid progenitors.¹⁸² Mutations in genes necessary for B-cell differentiation are a perfect example of Class II mutations that cause a block in cell differentiation in the classic model of acute leukemia pathogenesis.

TABLE 72.5 WORLD HEALTH ORGANIZATION CLASSIFICATION OF PRECURSOR LYMPHOID NEOPLASMS

B lymphoblastic leukemia/lymphoma

B lymphoblastic leukemia/lymphoma, NOS

B lymphoblastic leukemia/lymphoma with recurrent genetic abnormalities

B-ALL with t(9;22)(q34;q11.2); *BCR-ABL1*

B-ALL with t(v;11q23); *MLL* rearranged

B-ALL with t(12;21)(p13;q22.3); *ETV6-RUNX1*

B-ALL with hyperdiploidy

B-ALL with hypodiploidy

B-ALL with t(5;14)(q31;q32); *IL3-IGH@*

B-ALL with t(1;19)(q23;p13.3); *TCF3-PBX1*

T-lymphoblastic leukemia/lymphoma

B-ALL, B-cell acute lymphoblastic leukemia; NOS, not otherwise specified. From Swerdlow SH,

Campo E, Harris NL, et al., Eds. WHO classification of tumours of haematopoietic and lymphoid tissues. Lyon, France: IARC Press, 2008.

Transcription Factors

PAX5

In the above-mentioned study, the PAX5 gene was altered by deletion or mutation in 31.7% of cases in a series of 242 B-ALLs.¹⁸¹ It is rearranged in 2.6% of pediatric B-ALL cases, with 17 different fusion partners documented. PAX5 is a paired box domain (PRD) transcription factor, encoded by the PAX5 gene at chromosome 9p13, and consists of 10 exons that encode a 391 amino acid protein. In all the fusion proteins, the paired box domain DNA-binding region and nuclear localization region are retained, but the C-terminal transactivation domain is deleted.¹⁸³ The C-terminal fusion proteins may act in contrast as transcriptional repressors, which would be brought to PAX5 target gene promoters by the retained PAX5 DNA-binding region. The PAX5 fusion proteins may act as dominant negative molecules in conjunction with the product of the wild-type PAX5 allele, and in this way may repress genes whose products are necessary for B-cell differentiation. The PAX5 translocations are correlated with a relatively normal karyotype, suggesting that they have a major role as a driver mutation; PAX5 deletions, however, are usually associated with a complex karyotype.¹⁸⁴

Core Binding Factors

RUNX1 is also involved in a translocation that is present in 25% of pediatric B-ALL, t(12;21)(p13;q22.3).¹⁸⁵ This translocation is associated with a good prognosis, although it is often missed by standard karyotype analysis. In this translocation, the N-terminus of ETV6, formerly called TEL (translocation-ETS-leukemia), is fused to most of the coding region of RUNX1.¹⁸⁶ ETV6 contains a DNA-binding ETS domain and a "pointed" domain homologous to the Drosophila development protein, pointed.¹⁸⁷ ETV6 is a transcriptional repressor and as such it contains a DNA-binding ETS domain and domains that interact with mSin3A (pointed domain), N-CoR, and HDAC-3 (Fig. 72.4C).¹⁸⁸ The functional significance of these interactions with HDACs was demonstrated by the ability of TSA to inhibit two properties of 3T3 fibroblast cells transformed with ETV6 and Ras: expression of the stromelysin-1 gene and aggregation.¹⁸⁸

P.1537

Another chromosomal alteration involving the RUNX1 locus that occurs in approximately 2% of pediatric patients with B-ALL is the intrachromosomal amplification of chromosome 21 (iAMP21). The significance of recognizing this cytogenetic abnormality is that it is associated with a dismal prognosis if treated with standard chemotherapy. There is a 6.6 Mbp common region of amplification (CRA) on chromosome 21, and in the majority of cases an associated 3.3 Mbp common region of deletion at the telomere. The average copy number of this CRA is 4.8, and the amplification is usually detected by FISH using the RUNX1 probe. Although RUNX1 is in the CRA, gene expression studies do not reveal increased transcription of RUNX1. This cytogenetic abnormality is associated with a complex karyotype and multiple mutations; however, clonal analysis indicates that the precipitating genetic event is the iAMP21 amplification.¹⁸⁹

TCF3 (E2A) Translocations

A common translocation in childhood B-ALL, present in 5% of pre-B-ALL cases,¹⁹⁰ is the t(1;19)(q23.3;p13.3) translocation, which fuses the TCF3 (E2A) gene on chromosome 19p13.3 with the PBX1 gene on chromosome 1q23.3 (Fig. 72.10).^{191,192} The TCF3 locus encodes three transcripts, E12, E47, and E2-5, which are generated by alternative splicing.¹⁹³ They belong to class I of the basic helix-loop-helix (bHLH) family of transcription factors which bind to specific E-box (CANNTG) sequences in promoters and enhancers, the first of which were identified in the enhancer regions of the immunoglobulin heavy-chain and κ -chain genes.¹⁹³ Usually the ubiquitous E2A proteins heterodimerize through the HLH domain with members of the class II bHLH proteins, most of which are tissue specific in expression. These heterodimers are crucial in transcriptional regulation of tissue-specific genes during development. Although E2A proteins are ubiquitous, they are preferentially expressed in B lymphocytes,¹⁹⁴ and E47 forms homodimers exclusively in B cells.¹⁹⁵ The requirement for E2A proteins in B-cell development is demonstrated by Tcf3^{-/-} null mice, which exhibit a complete block in B-cell differentiation at the pro-B-cell stage prior to immunoglobulin gene rearrangement, as well as defective thymocyte differentiation.^{196,197} These mice have an increased frequency of T-lymphoblastic lymphoma.¹⁹⁶

PBX1 (pre-B-cell leukemic homeobox 1), identified as the fusion partner of TCF3 in t(1;19),¹⁹⁸ encodes a member of the homeodomain family of transcription factors, encoded by homeobox (HOX) genes. The PBX1 gene is the mammalian homolog of the Drosophila gene Extradenticle, whose protein product cooperates with other homeodomain proteins

during development.¹⁹⁹ Likewise, PBX1 forms heterodimers with other homeodomain proteins via the homeodomain and the C-terminal HOX cooperativity motif (HCM).²⁰⁰ Cotransfection experiments with reporter genes containing DNA-binding sites for PBX1 have demonstrated that PBX1 is not a strong transcriptional activator.²⁰¹ The *Pbx1*^{-/-} mice have late embryonic lethality associated with multiple organ abnormalities,²⁰² supporting the hypothesis that PBX1 interactions regulate homeodomain protein function. PBX1 is not normally expressed in lymphocytes.

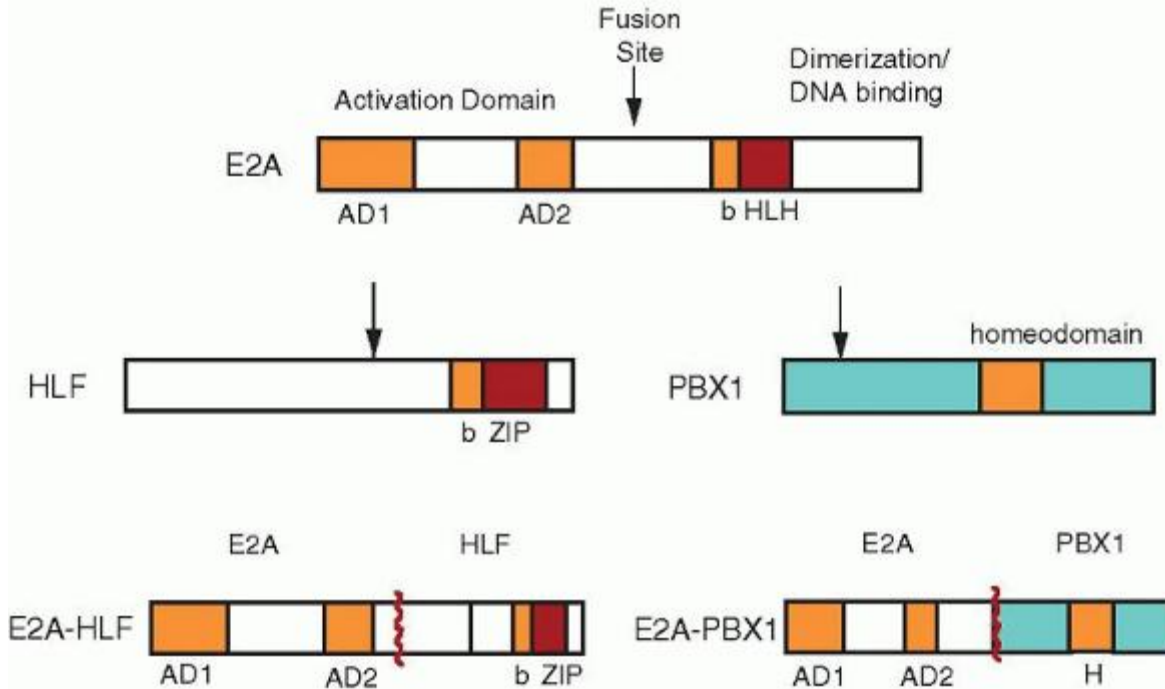

FIGURE 72.10. Structural features of E2A (TCF3) fusion proteins. The N-terminus of the E2A (TCF3) gene encodes a transcriptional activation domain that is translocated to hepatic leukemia factor (HLF) or pre-B-cell leukemic homeobox1 (PBX1) by chromosome translocations in acute lymphoblastic leukemia. In the case of E2A (TCF3)-HLF, the DNA-binding and dimerization domains of E2A (TCF3) are replaced by similar domains in HLF. For E2A(TCF3)-PBX1, the same DNA-binding and dimerization domains of E2A (TCF3) are replaced with the DNA-binding homeodomain of PBX1. AD, activation domain; b HLH, basic helix-loop-helix; bZIP, basic leucine zipper domain; H, homeodomain.

In the t(1;19) translocation, the breakpoint on chromosome 19 occurs within the intron between exons 13 and 14 of TCF3, so that the N-terminal two-thirds of TCF3 (E2A), aa1-483, are included in the fusion protein.¹⁹² This includes both of the transcriptional activation domains (AD1 and AD2), but excludes the bHLH DNA-binding and dimerization domains (Fig. 72.10). Therefore, the TCF3-PBX1 fusion protein depends on the homeodomain of PBX1 for DNA-binding specificity. The most straightforward model for how expression of the TCF3-PBX1 fusion protein results in the development of leukemia is that fusion of the TCF3 activation domains onto the PBX1 sequence results in abnormally strong transactivation of target genes recognized by the PBX1 homeodomain.²⁰³ These target genes would be activated in lymphocytes, where PBX1 is usually not expressed. Mapping experiments demonstrate that the activation domains AD1 and AD2 of TCF3 are necessary for transactivation of reporter genes containing PBX1 binding sites, and they are also necessary for transformation of NIH 3T3 cells.²⁰⁴ Gene expression profiling of a pre-B-cell line inducibly expressing TCF3-PBX1 demonstrated upregulation of BMI1,²⁰⁵ a gene which is expressed in normal HSCs, but whose expression normally decreases during hematopoietic development.²⁰⁶ *Bmi1*^{-/-} mice have a reduced number of HSCs, with defective adult self-renewal of HSCs.²⁰⁶ Cells from *Bmi1*^{-/-} mice are resistant to transformation by Tcf3-Pbx1,²⁰⁵ suggesting that the mechanism by which TCF3-PBX1 transforms cells is through overexpression of BMI1. Interestingly, BMI1 is a transcriptional repressor of the CDKN2A locus,²⁰⁵ which encodes the two tumor suppressor genes P16INK4A and P14ARF.²⁰⁷ P16INK4A binds to CDK4 and 6, preventing association with cyclins and phosphorylation of Rb. Therefore, repression of P16INK4A results in increased phosphorylation of Rb, which loses its affinity for the transcription factor E2F, increasing expression of E2F target genes necessary for progression to the S phase and proliferation.^{208,209} The tumor suppressor P14ARF inhibits MDM2, a repressor of TP53⁸⁷; therefore, inhibition of P14ARF results in increased MDM2, repression of TP53, and loss of the checkpoint functions of TP53 in preventing propagation of cells with DNA damage.⁸⁷ Therefore, activation of BMI1 by TCF3-PBX1 results in downregulation of two powerful tumor suppressor pathways.

Another translocation involving TCF3 occurs in approximately 1% of pediatric ALL, t(17;19)(q22;p13.3), which fuses TCF3 to HLF (hepatic leukemia factor).^{210,211} Clinically, these patients are adolescents; they may present with disseminated intravascular coagulation and hypercalcemia and usually have a poor prognosis. HLF encodes a transcription factor of the basic leucine zipper (bZIP) family, in which the basic region is the DNA-binding region and the leucine zipper refers to an amphipathic α -helical domain through which HLF can homodimerize or heterodimerize with other bZIP proteins. HLF is usually expressed in liver, kidneys, and central nervous system neurons, but not in hematopoietic cells.²¹²

The TCF3-HLF fusion protein is homologous to the TCF3-PBX1 fusion protein, in that the N-terminal 483 amino acids of TCF3, contributing the activation domains AD1 and AD2, are fused to the C-terminal portion of HLF, which contains the bZIP DNA-binding and dimerization domains (Fig. 72.10).²¹³ Unlike PBX1, wild-type HLF is a strong transactivator, but the alteration in cell type expression and alterations in DNA-binding affinity and protein interactions by virtue of fusion to TCF3 may contribute to the transforming properties of TCF3-HLF.²¹⁴

P.1538

Recent experiments using BaF3 cells inducibly expressing TCF3-HLF have implicated LMO2 and BCL2 as transcriptional targets of the abnormal TCF3-HLF transcription factor.²¹⁵ Microarray analysis was performed on RNA from the cell lines before and after induction of TCF3-HLF expression; subsequent CHIP experiments demonstrated that TCF3-HLF directly binds to the promoters of these two genes to transcriptionally activate them. Relevant to potential new therapies of this poor prognosis leukemia is the finding that knock-down of LMO2 expression or inhibition of BCL2 activity in the cells expressing TCF3-HLF reduces the proliferation of these immortalized cells.²¹⁵ LMO2 is a transcription factor expressed in hematopoietic progenitors and is known to play a role in development of T-ALL.²¹⁶ BCL2 is an antiapoptotic protein with a well-known role in the pathogenesis of B-cell lymphoma (reviewed in Ref. 217).

IKAROS

SNP array studies first demonstrated that IKZF1, encoding the transcription factor IKAROS, is deleted in 76.2% of pediatric Ph⁺ B-ALL and 90.9% of adult Ph⁺ B-ALL.²¹⁸ A subsequent study of adult B-ALL cases demonstrated that 75% of adult Ph⁺ B-ALL cases had alterations of the IKZF1 gene, compared to 58% of adult Ph⁻ B-ALL cases.²¹⁹ IKAROS is a zinc finger-containing transcription factor that is required for lymphoid lineage commitment. It is expressed in multipotent, self-renewing HSCs and is necessary for induction of genes important for the lymphoid lineage, as well as repression of genes responsible for self-renewal and multipotency in the differentiating progeny of HSCs.²²⁰ Deletions are usually of one allele, and in most cases the deletion involves a subset of exons, most commonly exons 4 to 7.²¹⁹ Sequencing of the deletion sites demonstrates the presence of heptamer recombination signal sequences that are recognized by RAG enzymes during immunoglobulin gene recombination.²¹⁸ These deletions result in loss of the DNA-binding domain but preservation of the dimerization domain of the protein, creating a dominant negative molecule.²¹⁹ Use of gene expression arrays to compare RNA from B-ALL cases with intact or mutated IKZF1 loci demonstrates that IKZF1 mutations are associated with downregulation of several genes in the B-cell differentiation pathway and upregulation of genes involved in cell cycle regulation, apoptosis regulation, DNA damage, and the JAK-STAT signaling pathway. In addition, in B-ALL with IKZF1 mutations, there is downregulation of RAG and EBF1, two genes whose products are involved in IgH VDJ recombination.²¹⁹ Downregulation of genes involved in normal B-cell differentiation may cause the arrest of B-cell maturation that occurs in B-ALL. As the gene expression patterns in B-ALL with mutations in IKZF1 are similar to gene expression patterns in BCR-ABL1 positive ALL, these cases are referred to as Ph-like ALL.²²¹ Though the prognosis of these cases is poor, discovery of frequent concomitant mutations in cytokine receptors such as CRLF2 and other signaling molecules such as JAK2 suggests that use of kinase inhibitors may play a role in treating this subset of B-ALL.²²²

Kinases

BCR-ABL1

The Philadelphia chromosome is the result of the t(9;22) (q34;q11.2) translocation in which the 5' domain of the BCR gene from chromosome 22 is fused with the 3' TKD of the ABL1 gene from chromosome 9.^{223,224} The Philadelphia chromosome is the resultant shortened chromosome 22. It is the most frequent recurring translocation in adult ALL, occurring in 15% to 30% of patients,²²⁵ and also is present in 5% of pediatric B-ALL.²²⁶ Unfortunately, it is an adverse prognostic factor in children and adults.

The BCR-ABL1 fusion gene is associated most commonly with CML. The pathogenesis of CML will be discussed in Chapter 81. A lymphoid blast crisis arising from CML may be difficult to distinguish from a Philadelphia chromosome-positive (Ph⁺)

ALL. The size of the BCR-ABL1 fusion protein and whether it is restricted in expression to lymphoid cells may be helpful in making this distinction. The most common breakpoint region, the major breakpoint cluster region (M-bcr), spans almost 6 kb between exons 12 and 16 of BCR and results in a fusion protein of 210 kD, referred to as p210bcr-abl.²²⁷ A minor breakpoint, the m-bcr, is farther 5', after exon 2 of BCR, resulting in a truncated fusion protein of 190 kD that contains only the first two exons of BCR (p190bcr-abl).² Interestingly, p210bcr-abl is much more common in CML and CML with lymphoid blast crisis, whereas p190bcr-abl is much more commonly expressed in Ph⁺ ALL. p190bcr-abl is present in 80% to 90% of pediatric Ph⁺ ALL and 50% of adult Ph⁺ ALL.²²⁵ However, some cases of Ph⁺ ALL contain both p190bcr-abl and p210bcr-abl. Transgenic mice expressing p190bcr-abl develop an aggressive leukemia restricted to pre-B cells, whereas transgenic mice expressing p210bcr-abl develop a more chronic disease involving B and T cells and myeloid lineages.²²⁸ In some cases of Ph⁺ ALL the aberrant fusion protein is present in lymphoid and myeloid marrow cells, whereas in other cases the aberrant fusion protein, usually p190bcr-abl, is restricted to lymphoid cells. Those cases in which p210bcr-abl is present in both lymphoid and myeloid cells are most likely to represent a CML lymphoid blast crisis.²²⁹

Studies of BCR-ABL1 expression in CML have demonstrated the leukemogenic properties of BCR-ABL1 as a constitutive tyrosine kinase.²³⁰ This constitutive kinase activates by phosphorylation multiple downstream signal transduction intermediates, including RAS, PLC γ , and PI3 kinase.²³¹ Activation of these pathways results in proliferation and resistance to apoptosis.²³² Presumably similar mechanisms are at work in Ph⁺ ALL. Restriction of expression of BCR-ABL1 to the lymphoid lineage would explain the development of ALL. However, in those cases of Ph⁺ ALL in which BCR-ABL1 is expressed in the stem cell compartment, it is unclear why ALL has resulted instead of CML. A high percentage of Ph⁺ ALL, as well as B lymphoid blast crisis of CML, have concomitant mutations in IKAROS, as described above.^{218,219,233}

Treatment of Ph⁺ ALL remains problematic. Initial response to chemotherapy is similar in Ph⁺ ALL and Ph⁻ ALL, but remissions tend to be short lived. Transplantation appears to be the best means of attaining a lasting remission. In a phase II trial of imatinib in relapsed or refractory Ph⁺ ALL, 60% of patients achieved a hematologic response, but it was usually short lived.²³⁴ However, trials using imatinib in conjunction with standard chemotherapy followed by bone marrow transplant in CR have proven more successful. The combination approach induces CR in 96% of patients with a 30% incidence of relapse and 65% overall survival rate at 18 months.^{235,236} Posttransplant BCR-ABL1 positivity has a poor prognosis; therefore in current protocols imatinib therapy is usually reinitiated 6 to 8 weeks after transplant.²³³

Secondary resistance to imatinib is common, however, and occurs in approximately 70% of relapse patients with CML blast crisis or Ph⁺ ALL. In 50% to 90% of relapse patients, point mutations have been identified in the adenosine triphosphate-binding pocket of BCR-ABL1 that is targeted by imatinib.²³⁷ New kinase inhibitors that can bind to the mutated as well as wild-type BCR-ABL1, such as dasatinib and nilotinib, are being utilized in patients who develop resistance to imatinib.²³³

T-CELL ACUTE LYMPHOBLASTIC LEUKEMIA/LYMPHOMA

T-ALL is an uncommon acute leukemia but its genetics have been studied in considerable depth. The driver mutations in T-ALL were first identified by cloning the breakpoints at chromosomal

P.1539

translocations.^{238,239,240,241} These experiments revealed oncogenes whose expression was deregulated by rearrangement with the promoters and enhancers of T-cell receptor genes. Subsequently, it was shown that these same oncogenes are overexpressed by mechanisms other than translocation.^{242,243,244,245} Indeed, gene expression clustering based on these oncogene signatures has been highly informative in classifying T-ALL into distinct subtypes that relate to cell of origin.^{244,246,247} Whole exome sequencing and targeted sequencing have revealed numerous important mutations in T-ALL. As shown in Table 72.6, these oncogenes and tumor suppressor genes are divided into major gene classes. The CDKN2A locus encodes cell cycle regulatory genes P14ARF and P16INK4A, and is the most commonly inactivated gene in human T-ALL.²³⁸ CDKN2A is located on 9p21 which shows homozygous deletion in more 72% of patients.^{182,241} CDKN2A is also inactivated by other mechanisms.^{248,249} Deletions of 13q14.2 including the RB1 gene occur in up to 12% of T-ALL patients¹⁸²; these deletions are found in patients with intact CDKN2A, an expected finding since both of these tumor suppressors act in the same pathway.^{244,250} Mutations in TP53 and CDKN1B (p27) are uncommon, each occurring in less than 1% of T-ALL patients.

Notch

The NOTCH pathway is mutated in the majority of T-ALL patients. NOTCH1 is a regulatory protein that is important in many cell fate decisions, including commitment to T-cell lineage and choice of $\alpha\beta$ lineage.^{251,252,253} It was first cloned from a t(7;9)(q34;q34) translocation occurring in a T-ALL patient that involved NOTCH1 on chromosome 9q34 and the T-cell

receptor β -chain gene on chromosome 7q34.3.²⁵⁴ The t(7;9) translocation turned out to be rare in T-ALL but targeted sequencing revealed that over 60% of T-ALL patients have activating mutations in NOTCH1.²⁵⁵ NOTCH1 is synthesized as a single polypeptide protein that is cleaved in the Golgi at site S1 into two subunits, the ligand-binding NEC (extracellular) and NTM (transmembrane), which bind noncovalently at the heterodimerization domain. Upon ligand binding to NEC, NTM is cleaved at site S2 by a metalloprotease, and cleaved at S3 by regulated intramembrane proteolysis catalyzed by a multiprotein enzyme, the gamma (γ) secretase.²⁵⁶ The remaining intracellular portion, ICN1, translocates to the nucleus, where it acts as a transcriptional regulator with the DNA-binding protein CSL and with coactivators of the Mastermind-like family.²⁵⁷ The majority of the activating mutations in NOTCH1 found in T-ALL occur in the heterodimerization domain or in the PEST domain.²⁵⁵ The PEST domain regulates the turnover of NOTCH1. Therefore, the heterodimerization domain mutants uncouple NOTCH1 activation from ligand binding and the PEST domain mutants increase NOTCH1 protein stability.²⁵⁵ The NOTCH1/CSL complex has numerous transcriptional targets that affect diverse pathways required for cell transformation; among these, MYC and HES1 appear to be important for T-cell leukemogenesis.^{258,259,260,261} The FBXW7 gene is mutated in T-ALL and fits into the NOTCH pathway since it encodes a component of a multiprotein E3 ubiquitin ligase that targets NOTCH1, MYC, and CCNE for degradation.^{262,263,264} Inactivating mutations in FBXW7 are present in 9% to 16% of T-ALL patients.^{265,266} The unique proteolytic pathway leading to activated NOTCH1 can be targeted by small molecule inhibitors of the gamma-secretase enzyme that is required for S3 cleavage.^{267,268,269} These inhibitors have been used in clinical testing; however, since NOTCH1 regulates cell fate decisions for intestinal epithelial cells, patients have experienced significant gut toxicity.²⁶⁷

TABLE 72.6 FUNCTIONAL CLASSES OF GENES MUTATED IN T-LYMPHOBLASTIC LEUKEMIA

Gene Class	Frequency (%)	Oncogene or Tumor Suppressor
Cell cycle genes	85	<i>CDKN2A, RB1, TP53, CDKN1B</i>
Notch and its targets	70	<i>NOTCH1, FBW7, MYC</i>
bHLH and partners	35	<i>TAL1, TAL2, LYL1, OLIG2, LMO1-3</i>
Homeobox genes	35	<i>TLX1, TLX3, HOXA cluster, MLL, CALM</i>
Other transcription factors and chromatin modifiers	5-15	<i>MYB, BCL11B, PHF6, EZH2</i>
Cytokine and signal transduction	5-15	<i>ABL1, FLT3, IL7R, JAK1, LCK, NRAS, IGF1R</i>

The frequency shown is the estimated mean of all the frequencies reported for each individual gene mutation in a given class.

Transcription Factors

TAL1 and LMO Factors

Class B bHLH transcription factors, TAL (SCL) (T-cell acute lymphoblastic leukemia 1/stem cell leukemia), TAL2, LYL1, and OLIG2 are frequently deregulated in T-ALL.²⁴¹ The TAL1 gene is deregulated in 25% of T-ALL. TAL1 was originally cloned from a translocation, t(1;14)(p32;q11), present in 3% of patients with T-ALL.²⁷⁰ In the translocation, the breakpoint is 5' to the coding region of TAL1 on chromosome 1, and the translocation places TAL1 under the regulation of the T-cell receptor α/β genes on chromosome 14.^{271,272} A second series of rearrangements that occurs in 26% of patients with T-ALL results in deletion of 90 to 100 kb of DNA from the 5' upstream region of TAL1, placing the gene under the control of the upstream constitutively active SIL promoter.²⁷³ In both cases, the coding region of TAL1 is intact, unlike the fusion proteins that are usually expressed in other acute leukemias. Also, in some cases of T-ALL, overexpression of TAL1 occurs when there is no evident gene rearrangement by Southern blot analysis, suggesting a mutation in regulatory sequences.²⁷⁴

During development, TAL1 is expressed in early hematopoietic elements, in both the yolk sac blood islands and the definitive blood cells of the AGM region and fetal liver.²⁷⁵ Postnatally, it is expressed in erythroid, megakaryocyte, and mast cell lineages, but not in T cells. In nonerythroid cells, TAL1 is expressed in stem cells but is not expressed as the cells differentiate; however, in erythroid cells, TAL1 expression increases with early erythroid differentiation but decreases with terminal differentiation.²⁷⁶ The essential role of TAL1 in hematopoietic development is demonstrated by mice made

null for Tal1; embryonic lethality occurs due to a total deficiency in hematopoietic progenitors.^{277,278} Conditional gene targeting experiments using the *Lox-Cre* system to delete *Tal1* in adult mice demonstrate that continued expression P.1540

of TAL1 is not necessary for maintenance of HSCs, but it is necessary for erythrocyte and megakaryocyte differentiation.²⁷⁹ TAL1, like LYL1, OLIG2, and TAL2, binds E-box sequences in DNA by heterodimerizing with class I bHLH transcription factors TCF3. Tandem E boxes or E-box GATA sequences can be bound by two TAL1/TCF3 heterodimers that are bridged by LIM-domain-only 1 or 2 (LMO1/2) proteins. Interestingly, LMO1-3 genes are also important drivers of T-ALL which can be deregulated by chromosomal rearrangements with T-cell receptor genes and other mechanisms.^{216,280,281} Other TAL1 protein partners include GATA1, LDB1, coactivators p300 and pCAF, and corepressors mSin3A and HDAC1.^{282,283} Interestingly, LMO2 can be coimmunoprecipitated with TAL1 from T-ALL cell lines,²⁸⁴ and mice overexpressing both *Tal1* and *Lmo2* develop T-ALL with shorter latency than transgenic mice overexpressing either gene alone, providing evidence for cooperativity.^{285, 286} and ²⁸⁷ The transcriptional targets of activation or repression by TAL1 that are required for T-ALL have not been fully elucidated.^{288,289,290} Alternatively, TAL1 may act as a dominant negative inhibitor of the TCF3 transcription factors.^{291,292} Human and murine T-ALLs induced by bHLH or LMO gene overexpression show repression of TCF3 target genes.²⁹³ LYL1, OLIG2, and TAL2 may all behave similarly to TAL1 in that they cooperate with LMO proteins to regulate gene expression, although LYL1-overexpressing T-ALLs are more immature in the T-cell differentiation hierarchy than TAL1-overexpressing T-ALLs.^{294,295,296,297} The expression of these bHLH genes was quantified in a large panel of T-ALLs showing mutually exclusive expression patterns, which also argues for functional redundancy in leukemia pathogenesis. Interestingly, LYL1 and TAL1 are also functionally redundant in the maintenance of adult hematopoietic stem and progenitor cells.^{244,298}

Homeodomain Proteins

The homeobox genes are a major group of genes deregulated in T-ALL, mutually exclusive to the bHLH genes and LMO genes discussed above.²⁴⁴ TLX1 (HOX11) is overexpressed by chromosomal rearrangement or other mechanisms in 7% of T-ALL.^{242,299} TLX3 (HOX11L2) is deregulated most commonly by a t(5;14)(q35.1;q32) in 20% of adult T-ALL cases.^{300,301} Finally, the HOXA gene cluster is deregulated in 5% of T-ALL cases by inv(7)(p15.2q34) and other transcriptional mechanisms.^{302, 303} and ³⁰⁴ TLX1-overexpressing T-ALLs have a distinctive block at the cortical stage of T-cell differentiation. Recent data using transgenic mice overexpressing *Tlx1* show that the protein may repress mitotic checkpoint genes, leading to aneuploidy, and may disrupt the normal factors needed for T-cell receptor α rearrangement.^{305,306} MLL and its fusion partners PICALM and MLLT10 are rearranged and overexpressed in 5% to 10% of T-ALL cases and may function by deregulating the expression of the HOXA gene cluster.^{140,304,307,308}

Other transcription factors mutated in T-ALL include the MYB oncogene, which is duplicated in 8.4% of T-ALL cases as analyzed by array CGH and fiber FISH studies.^{309,310} Array CGH, SNP arrays, and sequencing revealed deletion or missense mutation in the BCL11B gene in 9% of T-ALL patients.³¹¹ *Bcl11b* knockout mice show major defects in T-cell differentiation consistent with a role in T-cell progenitor transformation.³¹² Loss of function mutations were found in PHF6, a transcription factor gene encoded on Xq26. This finding was very intriguing in that the mutations were 10-fold more prevalent in males than females, which correlates with the higher prevalence of the disease in males; however, the PHF6 mutations were highly concordant with TLX gene deregulation and uncommon in TLX-negative cases.³¹³ EZH2 and SUZ12 loss of function mutations occur in 25% of T-ALL cases. These two genes encode protein components of the PRC2. PRC2 is responsible for methylation of Lysine-27 on histone H3, a mark associated with silenced genes.³¹⁴

Mutations in Signaling Pathways

T-ALL, like most acute leukemias, harbors mutations predominantly in transcription factors. These proteins are difficult therapeutic targets in comparison to cytokine receptors and signal transducing tyrosine kinases. The latter group of genes was very recently implicated in T-ALL with targeted sequencing approaches. For example, gain of function mutations in the IL7R gene have been described in 5% to 10% of T-ALL patients.^{295,315,316} Some of the missense substitutions in IL7R introduce a cysteine residue in place of the wild-type amino acid in the JM domain. This creates a disulfide bond linking two receptors, resulting in constitutive phosphorylation of STAT5 and other downstream substrates.³¹⁶ The IL7R protein utilizes the nonreceptor tyrosine kinases, JAK1 and JAK3, for signal transduction, and these too are mutated in 5% to 10% of T-ALL cases.^{295,317,318,319} FLT3-ITD mutations similar to those found in AML are also found in T-ALL. NRAS mutations have also been described in ~10% of patients.^{181,320,321} The ABL1 gene is amplified involving simple translocations and complex rearrangements in 5% to 10% of T-ALLs.³²² Mutations in signaling pathways are more common in early T-cell precursor ALL, a form of T-ALL that is resistant to induction chemotherapy and prone to relapse.^{295,296} Some of the oncogenes and

tumor suppressor genes involved in T-ALL pathogenesis are also targeted by a group of microRNAs, offering yet another pathway toward regulation of expression.^{323,324}

SUMMARY

This chapter has reviewed the major translocations found in acute leukemia, with a focus on understanding the function of the fusion proteins encoded by the translocated genes. In addition, genes that are common sites of point mutations or deletions in acute leukemia are reviewed. A major theme has been alteration of transcriptional regulation. A major focus of future research will be identification of downstream targets of these aberrant transcription factors. Study of the aberrant transcription factors resulting from translocations and mutations has increased our understanding of the importance of histone acetylation, deacetylation, and methylation in transcriptional regulation. Study of mutated tyrosine kinases present in leukemia led to the first specifically engineered kinase inhibitor for the therapy of CML and Ph⁺ ALL. Kinase inhibitors have also been developed for the relatively common mutant FLT3 protein present in AML. This is a truly exciting time for hematologic oncology, where elucidation of the pathogenesis of acute leukemia is leading to development of new therapeutic agents. However, powerful genomic methods have revealed the incredible complexity of the mutational events necessary for the development of acute leukemia.

REFERENCES

1. Nowell PC, Hungerford DA. A minute chromosome in human chronic granulocytic leukemia. *Science* 1960;132:1497.
2. Kurzrock R, Shtalrid M, Romero P, et al. A novel c-abl protein product in Philadelphia-positive acute lymphoblastic leukemia. *Nature* 1987;325:631-635.
3. Druker BJ, Talpaz M, Resta DJ, et al. Efficacy and safety of a specific inhibitor of the BCR-ABL tyrosine kinase in chronic myeloid leukemia. *N Engl J Med* 2001;344:1031-1037.
4. Kelly LM, Gilliland DG. Genetics of myeloid leukemias. *Annu Rev Genomics Hum Genet* 2002;3:179-198.
5. Hanahan D, Weinberg RA. Hallmarks of cancer: the next generation. *Cell* 2011;144:646-674.
6. Hanahan D, Weinberg RA. The hallmarks of cancer. *Cell* 2000;100:57-70.
7. Rowley JD. Chromosomes in leukemia and beyond: from irrelevant to central players. *Annu Rev Genomics and Hum Genet* 2009;10:1-18.
8. Godley LA, Cunningham J, Dolan ME, et al. An integrated genomic approach to the assessment and treatment of acute myeloid leukemia. *Semin Oncol* 2011;38:215-224.
9. Rautenstrauss BW, Liehr T. FISH technology. Berlin and New York: Springer, 2002.
10. Bullinger L, Frohling S. Array-based cytogenetic approaches in acute myeloid leukemia: clinical impact and biological insights. *Semin Oncol* 2012;39:37-46.
11. Gresham D, Dunham MJ, Botstein D. Comparing whole genomes using DNA microarrays. *Nat Rev Genet* 2008;9:291-302.
12. Gondek LP, Tiu R, O'Keefe CL, Sekeres MA, Theil KS, Maciejewski JP. Chromosomal lesions and uniparental disomy detected by SNP arrays in MDS, MDS/MPD, and MDS-derived AML. *Blood* 2008;111:1534-1542.
13. Campbell PJ, Stephens PJ, Pleasance ED, et al. Identification of somatically acquired rearrangements in cancer using genome-wide massively parallel paired-end sequencing. *Nat Genet* 2008;40:722-729.
14. Marth GT, Yu F, Indap AR, et al. The functional spectrum of low-frequency coding variation. *Genome Biol* 2011;12:R84.
15. Lander ES. Initial impact of the sequencing of the human genome. *Nature* 2011;470:187-197.
16. McCarroll SA. Copy number variation and human genome maps. *Nat Genet* 2010;42:365-366.
17. Sebat J, Lakshmi B, Troge J, et al. Large-scale copy number polymorphism in the human genome. *Science* 2004;305:525-528.
18. Sachidanandam R, Weissman D, Schmidt SC, et al. A map of human genome sequence variation containing 1.42 million single nucleotide polymorphisms. *Nature* 2001;409:928-933.
19. International Human Genome sequencing Consortium, Finishing the euchromatic sequence of the human genome. *Nature* 2004;431:931-945.
20. Lander ES, Linton LM, Birren B, et al. Initial sequencing and analysis of the human genome. *Nature* 2001;409:860-921.

21. Venter JC, Adams MD, Myers EW, et al. The sequence of the human genome. *Science* 2001;291:1304-1351.
P.1541
22. Welch JS, Link DC. Genomics of AML: clinical applications of next-generation sequencing. *Hematol Am Soc Hematol Educ Program* 2011;2011:30-35.
23. Shendure J, Porreca GJ, Reppas NB, et al. Accurate multiplex polony sequencing of an evolved bacterial genome. *Science* 2005;309:1728-1732.
24. Metzker ML. Sequencing technologies—the next generation. *Nat Rev Genet* 2010;11:31-46.
25. Baylin SB, Jones PA. A decade of exploring the cancer epigenome—biological and translational implications. *Nat Rev Cancer* 2011;11:726-734.
26. Esteller M. Cancer epigenomics: DNA methylomes and histone-modification maps. *Nat Rev Genet* 2007;8:286-298.
27. Kent OA, Mendell JT. A small piece in the cancer puzzle: microRNAs as tumor suppressors and oncogenes. *Oncogene* 2006;25:6188-6196.
28. Harries LW. Long non-coding RNAs and human disease. *Biochem Soc Trans* 2012;40:902-906.
29. Ley TJ, Mardis ER, Ding L, Fulton B. DNA sequencing of a cytogenetically normal acute myeloid leukaemia genome. *Nature* 2008;456:66-72.
30. Mardis ER, Ding L, Dooling DJ, et al. Recurring mutations found by sequencing an acute myeloid leukemia genome. *NEJM* 2009;361:1058-1066.
31. Ley TJ, Ding L, Walter MJ, et al. DNMT3A mutations in acute myeloid leukemia. *NEJM* 2010;363:2424-2433.
32. Parsons DW, Jones S, Zhang X, et al. An integrated genomic analysis of human glioblastoma multiforme. *Science* 2008;321:1807-1812.
33. Welch JS, Ley TJ, Link DC, et al. The origin and evolution of mutations in acute myeloid leukemia. *Cell* 2012;150:264-278.
34. Patel JP, Gonen M, Figueroa ME, et al. Prognostic relevance of integrated genetic profiling in acute myeloid leukemia. *NEJM* 2012;366:1079-1089.
35. Swerdlow SH, Campo E, Harris NL, et al., eds. WHO classification of tumours of haematopoietic and lymphoid tissues. Lyon, France: IARC Press, 2008.
36. Walter MJ, Shen D, Ding L, et al. Clonal architecture of secondary acute myeloid leukemia. *NEJM* 2012;366:1090-1098.
37. Huang ME, Ye YC, Chen SR, et al. Use of all trans retinoic acid in the treatment of acute promyelocytic leukemia. *Blood* 1988;72:567-572.
38. Borrow J, Goddard AD, Sheer D, et al. Molecular analysis of acute promyelocytic leukemia breakpoint cluster region on chromosome 17. *Science* 1990;249:1577-1580.
39. de The H, Chomienne C, Lanotte M, et al. The t(15;17) translocation of acute promyelocytic leukaemia fuses the retinoic acid receptor a gene to a novel transcribed locus. *Nature* 1990;347:558-561.
40. Longo L, Pandolfi PP, Biondi A, et al. Rearrangements and aberrant expression of the RARa gene in acute promyelocytic leukemia. *J Exp Med* 1990;172:1571-1575.
41. Geng JP, Tong JH, Dong S, et al. Localization of the chromosome 15 breakpoints and expression of multiple PML-RAR alpha transcripts in acute promyelocytic leukemia: a study of 28 Chinese patients. *Leukemia* 1993;7:20-26.
42. Schulman IG, Juguilon H, Evans RM. Activation and repression by nuclear hormone receptors—hormone modulates an equilibrium between active and repressive states. *Mol Cell Biol* 1996;16:3807.
43. Melnick A, Licht JD. Deconstructing a Disease: RARa, its fusion partners, and their roles in the pathogenesis of acute promyelocytic leukemia. *Blood* 1999;93:3167-3215.
44. Tsai S, Collins SJ. A dominant negative retinoic acid receptor blocks neutrophil differentiation at the promyelocyte stage. *PNAS* 1993;90:7153.

45. Guidez F, Ivins S, Zhu J, Soderstrom M, Waxman S, Zelent A. Reduced retinoic acid-sensitivities of nuclear receptor co-repressor binding to PML-and PLZF-RARa underlie molecular pathogenesis and treatment of acute promyelocytic leukemia. *Blood* 1998;91:2634.
46. Zhong S, Muller S, Ronchetti S, et al. Role of SUMO-1-modified PML in nuclear body formation. *Blood* 2000;95:2748-2752.
47. Doucas V, Tini M, Egan DA, et al. Modulation of CREB binding protein function by the promyelocytic (PML) oncoprotein suggests a role for nuclear bodies in hormone signaling. *PNAS* 1999;96:2627-2632.
48. Weis K, Rambaud S, Lavau C, et al. Retinoic acid regulates aberrant nuclear localization of PML-RARa in acute promyelocytic leukemia cells. *Cell* 1994;76:345-356.
49. Lin RJ, Nagy L, Inoue S, Shao W, Miller WHJ, Evans RM. Role of the histone deacetylase complex in acute promyelocytic leukemia. *Nature* 1998;391:811.
50. Licht J, Chomienne C, Goy A, et al. Clinical and molecular characterization of a rare syndrome of acute promyelocytic leukemia associated with translocation (11;17). *Blood* 1995;85:1083.
51. David G, Alland L, Hong SH, Wong CW, DePinho RA, Dejean A. Histone deacetylase associated with mSin3A mediates repression by the acute promyelocytic leukemia-associated PLZF protein. *Oncogene* 1998;16:2549.
52. Grignani F, De Metteis S, Nervi C, et al. Fusion proteins of the retinoic acid receptor-a recruit histone deacetylase in promyelocytic leukemia. *Nature* 1998;391:815.
53. He L-Z, Guidez F, Triboli C, et al. Distinct interactions of PML-RARa and PLZF-RARa with co-repressors determine differential responses to RA in APL. *Nat Genet* 1998;18:126.
54. Villa R, Pasini D, Gutierrez A, Morey L, et al. Role of the polycomb repressive complex 2 in acute promyelocytic leukemia. *Cancer Cell* 2007;11:513-525.
55. Boukarablia H, Saurin AJ, Batsche E, et al. The PRC1 polycomb group complex interacts with PLZF/RARA to mediate leukemic transformation. *Genes Dev* 2009;23:1195-1206.
56. Look AT. Oncogenic transcription factors in the human acute leukemias. *Science* 1997;278:1059-1064.
57. Rowley JD. The role of chromosome translocations in leukemogenesis. *Semin Hematol* 1999;36:59-72.
58. Erickson P, Gao J, Chang KS, et al. Identification of breakpoints in t(8;21) acute myelogenous leukemia and isolation of a fusion transcript, AML1/ETO, with similarity to Drosophila segmentation gene, runt. *Blood* 1992;80:1825-1831.
59. Miyoshi H, Kozu T, Shimizu K, et al. The t(8;21) translocation in acute myeloid leukemia results in production of an AML1-MTG8 fusion transcript. *EMBO J* 1993;12:2715-2721.
60. Golemis EA, Speck NA, Hopkins N. Alignment of U3 region sequences of mammalian type C viruses: identification of highly conserved motifs and implications for enhancer design. *J Virol* 1990;64:534-542.
61. Liu P, Tarle SA, Hajra A, et al. Fusion between transcription factor CBFbeta/PEPB2 beta and a myosin heavy chain in acute myeloid leukemia. *Science* 1993;261:1041-1044.
62. Erickson P, Robinson M, Owens G, Drabkin HA. The ETO portion of acute myeloid leukemia t(8;21) fusion transcript encodes a highly evolutionarily conserved, putative transcription factor. *Cancer Res* 1994;54:1782-1786.
63. Gamou T, Kitamura E, Hosoda F, et al. The partner gene of AML1 in t(16;21) myeloid malignancies is a novel member of the MTG8(ETO) family. *Blood* 1998;91:4028-4037.
64. Levanon D, Negreanu V, Bernstein Y, Bar-Am I, Avivi L, Groner Y. AML1, AML2, and AML3, the human members of the runt domain gene-family: cDNA structure, expression, and chromosomal localization. *Genomics* 1994;23:425-432.
65. Michaud J, Wu F, Osato M, et al. In vitro analyses of known and novel RUNX1/AML1 mutations in dominant familial platelet disorder with predisposition to acute myelogenous leukemia: implications for mechanisms of pathogenesis. *Blood* 2002;99:1364-1372.
66. Osato M, Asou N, Abdalla E, et al. Biallelic and heterozygous point mutations in the runt domain of the AML1/PEBP2alphaB gene associated with myeloblastic leukemias. *Blood* 1999;93:1817-1824.
67. Tahirov TH, Inoue-Bungo T, Morii H, et al. Structural analyses of DNA recognition by the AML1/Runx-1 Runt domain and its allosteric control by CBFbeta. *Cell* 2001;104:755-767.

68. Licht J. AML1 and the AML1-ETO fusion protein in the pathogenesis of t(8;21) AML. *Oncogene* 2001;20:5660-5679.
69. Okuda T, van Deursen V, Hiebert SW, Grosveld G, Downing JR. AML1, the target of multiple chromosomal translocations in human leukemia, is essential for normal fetal liver hematopoiesis. *Cell* 1996;84:321-330.
70. Wang Q, Stacy T, Miller JD, et al. The CBFbeta subunit is essential for CBFalpha2 (AML1) function in vivo. *Cell* 1996;87:697-708.
71. North T, Gu TL, Stacy T, et al. Cbfa2 is required for the formation of intra-aortic hematopoietic clusters. *Development* 1999;126:2563-2575.
72. Libermann TA, Pan Z, Akbarali Y, et al. AML1 (CBFalpha2) cooperates with B cell-specific activating protein (BSAP/PAX5) in activation of the B cell-specific BLK gene promoter. *J Biol Chem* 1999;274:24671-24676.
73. Uchida H, Zhang J, MNimer SD. AML1A and AML1B can transactivate the human IL-3 promoter. *J Immunology* 1997;158:2251-2258.
74. Takahashi A, Satake M, Yamaguchi-Iwai Y, et al. Positive and negative regulation of granulocyte-macrophage colony-stimulating factor promoter activity by AML1-related transcription factor, PEBP2. *Blood* 1995;86:607-616.
75. Nuchprayoon I, Meyers S, Scott LM, Suzow J, Hiebert S, Friedman AD. PEBP2/CBF, the murine homolog of the human myeloid AML1 and PEBP2 beta/CBF beta proto-oncoproteins, regulates the murine myeloperoxidase and neutrophil elastase genes in immature myeloid cells. *Mol Cell Biol* 1994;14: 5558-5568.
76. Lutterbach B, Westendorf JJ, Linggi B, Isaac S, Seto E, Hiebert SW. A mechanism of repression by acute myeloid leukemia-1, the target of multiple chromosomal translocations in acute leukemia. *J Biol Chem* 2000;275:651-656.
77. Reed-Inderbitzin E, Moreno-Miralles I, Vanden-Eynden SK, et al. RUNX1 associates with histone deacetylases and SUV39H1 to repress transcription. *Oncogene* 2006;25:5777-5786.
78. Feinstein PG, Kornfeld K, Hogness DS, Mann RS. Identification of homeotic target genes in *Drosophila melanogaster* including *nervy*, a protooncogene homologue. *Genetics* 1995;140:573-586.
79. Melnick A, Westendorf JJ, Polinger G, et al. The ETO protein disrupted in t(8;21)-associated acute myeloid leukemia is a corepressor for the promyelocytic leukemia zinc finger protein. *Mol Cell Biol* 2000;20:2075-2086.
80. Amann JM, Nip J, Strom D, et al. ETO, a target of t(8;21) in acute leukemia, makes distinct contacts with multiple histone deacetylases and binds mSin3A through its oligomerization domain. *Mol Cell Biol* 2001;21:6470-6483.
81. de Greef GE, Hagemeyer A, Morgan R, et al. Identical fusion transcript associated with different breakpoints in the AML1 gene in simple and variant t(8;21) acute myeloid leukemia. *Leukemia* 1995;9:282-287.
82. Meyers S, Downing JR, Hiebert SW. Identification of AML-1 and the (8;21) translocation protein (AML-1/ETO) as sequence-specific DNA-binding proteins: the runt homology domain is required for DNA binding and protein-protein interactions. *Mol Cell Biol* 1993;13:6336-6345.
83. Frank R, Zhang J, Uchida H, Meyers S, Hiebert SW, Nimer SD. The AML1/ETO fusion protein blocks transactivation of the GM-CSF promoter by AML1B. *Oncogene* 1995;11:2667-2674.
84. Follows GA, Togoh H, Lefevre P, Hodge D, Morgan G, Bonifer C. Epigenetic consequences of AML1-ETO action at the human c-FMS locus. *EMBO J* 2003;22:2798-2809.
85. Linggi B, Muller-Tidow C, van de Locht L, et al. the t(8;21) fusion protein, AML1-ETO, specifically represses the transcription of the p14_{ARF} tumor suppressor in acute myeloid leukemia. *Nat Med* 2002;8:743-750.
86. Linggi BE, Brandt SJ, Sun ZW, Hiebert SW. Translating the histone code into leukemia. *J Cell Biochem* 2005;96:938-950.
87. Zhang Y, Xiong Y, Yarbrough WG. ARF promotes MDM2 degradation and stabilizes p53: ARF-INK4a locus deletion impairs both the Rb and p53 tumor suppression pathways. *Cell* 1998;92:725-734.
88. Durst KL, Lutterbach B, Kummalue T, Friedman AD, Hiebert SW. The inv(16) fusion protein associates with corepressors via a smooth muscle myosin heavy-chain domain. *Mol Cell Biol* 2003;23:607-619.
89. Higuchi M, O'Brien D, Kumaravelu P, Lenny N, Yeoh E-J, Downing JR. Expression of a conditional AML1-ETO oncogene bypasses embryonic lethality and establishes a murine model of human t(8;21) acute myeloid leukemia. *Cancer Cell* 2002;1:63-74.

90. Mulloy JC, Cammenga J, MacKenzie KL, Berguido FJ, Moore M, Nimer SD. The AML1-ETO fusion protein promotes the expansion of human hematopoietic stem cells. *Blood* 2002;99:15-23.
91. de Guzman CG, Warren AJ, Zhang Z, et al. Hematopoietic stem cell expansion and distinct myeloid developmental abnormalities in a murine model of the AML1-ETO translocation. *Mol Cell Biol* 2002;22:5506-5517.
92. Song W-J, Sullivan MG, Legare RD, et al. Haploinsufficiency of CBFA2 causes familial thrombocytopenia with propensity to develop acute myelogenous leukaemia. *Nat Genet* 1999;23:166-175.
93. Tenen DG, Hromas R, Licht JD, Zhang DE. Transcription factors, normal myeloid development, and leukemia. *Blood* 1997;90:489-519.
94. Paz-Priel I, Friedman AD. C/EBPa dysregulation in AML and ALL. *Crit Rev Oncogenet* 2011;16:93-102.
95. Pabst T, Mueller B, Harakawa N, Schoch C, et al. AML1-ETO downregulates the granulocytic differentiation factor C/EBPa in t(8;21) myeloid leukemia. *Nat Med* 2001;7:444-451.
96. Radomska HS, Basseres DS, Zheng R, Zhang P, Dayaram T, et al. Block of C/EBPa function by phosphorylation in acute myeloid leukemia with FLT3 activating mutations. *J Exp Med* 2006;203:371-381.
97. Hackanson B, Bennett KI, Brena RM, Jiang J, Caus R, et al. Epigenetic modification of CCAAT/enhancer binding protein expression in acute myeloid leukemia. *Cancer Res* 2008;68:3142-3151.
98. Zhang DE, Zhang P, Wang ND, Hetherington CJ, Darlington GJ, Tenen DG. Absence of granulocyte colony-stimulating factor signaling and neutrophil development in CCAAT enhancer binding protein alpha-deficient mice. *Proc Natl Acad Sci U S A* 1997;94:569-574.
99. Radomska HS, Huettner CS, Zhang P, Cheng T, Scadden DT, Tenen DG. CCAAT/enhancer binding protein alpha is a regulatory switch sufficient for induction of granulocytic development from bipotential myeloid progenitors. *Mol Cell Biol* 1998;18:4301-4314.
100. Vinson CR, Sigler PB, McKnight SL. Scissors-grip model for DNA recognition by a family of leucine zipper proteins. *Science* 1989;246:911-916.
101. Gombart AF, Hofmann WK, Kawano S, et al. Mutations in the gene encoding the transcription factor CCAAT/enhancer binding protein alpha in myelodysplastic syndromes and acute myeloid leukemias. *Blood* 2002;99:1332-1340.
102. Pabst T, Mueller BU, Zhang P, et al. Dominant-negative mutations of CEBPA, encoding CCAAT/enhancer binding protein-alpha (C/EBPalpha), in acute myeloid leukemia. *Nat Genet* 2001;27:263-270.
103. Preudhomme C, Sagot C, Boissel N, et al. Favorable prognostic significance of CEBPA mutations in patients with de novo acute myeloid leukemia: a study from the Acute Leukemia French Association (ALFA). *Blood* 2002;100:2717-2723.
104. Pabst T, Eyholzer M, Haefliger S, Schardt J, Mueller BU. Somatic CEBPA mutations are a frequent second event in families with germline CEBPA mutations and familial acute myeloid leukemia. *J Clin Oncol* 2008;26:5088-5093.
105. Grossmann V, Schnittger S, Kohlmann A, et al. A novel hierarchical prognostic model of AML solely based on molecular mutations. *Blood* 2012;120:2963-2972.
106. Greene ME, Mundschau G, Wechsler J, et al. Mutations in GATA1 in both transient myeloproliferative disorder and acute megakaryoblastic leukemia of Down syndrome. *Blood Cells Mol Dis* 2003;31:351-356.
107. Gurbuxani S, Vyas P, Crispino JD. Recent insights into the mechanisms of myeloid leukemogenesis in Down syndrome. *Blood* 2004;103:399-406.
108. Wechsler J, Greene M, McDevitt MA, et al. Acquired mutations in GATA1 in the megakaryoblastic leukemia of Down syndrome. *Nat Genet* 2002;32:148-152.
109. Roy A, Roberts I, Norton A, Vyas P. Acute megakaryoblastic leukaemia (AMKL) and transient myeloproliferative disorder (TMD) in Down syndrome: a multistep model of myeloid leukaemogenesis. *Br J Haematol* 2009;147:3-12.
110. Alford K, Reinhardt K, Garnett C, Norton A, Bohmer K, et al. Analysis of GATA1 mutations in Down syndrome transient myeloproliferative disorder and myeloid leukemia. *Blood* 2011;118:2222-2238.
111. Muntean AG, Crispino JD. Differential requirements for the activation domain and FOG-interaction surface of GATA-1 in megakaryocyte gene expression and development. *Blood* 2005;106:1223-1231.

112. Li Z, Godinho FJ, Klusmann JH, Garriga-Canut M, Yu C, Orkin SH. Developmental stage-selective effect of somatically mutated leukemogenic transcription factor GATA1. *Nat Genet* 2005;37:613-619.
113. Malinge S, Bliss-Moreau M, Kirsammer G, et al. Increased dosage of the chromosome 21 ortholog Dyrk1a promotes megakaryoblastic leukemia in a murine model of Down syndrome. *J Clin Invest* 2012;122:948-962.
114. Creutzig U, Reinhardt D, Diekamp S, Dworzak M, Stary J, Zimmermann M. AML patients with Down syndrome have a high cure rate with AML-BFM therapy with reduced dose intensity. *Leukemia* 2005;19:1355-1360.
115. Shibahara I, Sonoda Y, Kanamori M, Saito R, Kumabe T, Tominaga T. New insights into glioma classification based on isocitrate dehydrogenase 1 and 2 gene status. *Brain Tumor Pathol* 2011;28:203-208.
116. Figueroa ME, Abdel-Wahab O, Lu C, et al. Leukemic IDH1 and IDH2 mutations result in a hypermethylation phenotype, disrupt TET2 function, and impair hematopoietic differentiation. *Cancer Cell* 2010;18:553-567.
117. Xu W, Yang H, Ying L, Yang Y, et al. Oncometabolite 2-hydroxyglutarate is a competitive inhibitor of α -ketoglutarate-dependent dioxygenases. *Cancer Cell* 2011;19:17-30.
118. Williams K, Christensen J, Henin K. DNA methylation: TET proteins—guardians of CpG islands? *EMBO Rep* 2012;13:28-35.
119. Lu C, Ward PS, Kapoor GS, Rohle D, et al. IDH mutation impairs histone demethylation and results in a block to cell differentiation. *Nature* 2012;483:474-478.
120. Holz-Schietinger C, Matje DM, Reich NO. Mutations in DNA methyltransferase (DNMT3A) observed in acute myeloid leukemia patients disrupt processive methylation. *JBC* 2012;287:30941-30951.
121. Challen GA, Sun D, Jeong M, et al. DNMT3A is essential for hematopoietic stem cell differentiation. *Nat Genet* 2012;44:23-31.
122. Muntean AG, Hess JL. The pathogenesis of mixed-lineage leukemia. *Annu Rev Pathol Mech Dis* 2012;7:283-301.
123. Ingham PW. Trithorax and the regulation of homeotic gene expression in *Drosophila*: a historical perspective. *Int J Dev Biol* 1998;42:423-429.
124. Gehring WJ, Affolter M, Burglin T. Homeodomain proteins. *Annu Rev Biochem* 1994;63:487-526.
125. Maconochie M, Nonchev S, Morrison A, Krumlauf R. Paralogous Hox genes: function and regulation. *Annu Rev Genet* 1996;30:529-556.
126. Ernst P, Fisher JK, Avery W, Wade S, Foy D, Korsmeyer SJ. Definitive hematopoiesis requires the mixed-lineage leukemia gene. *Dev Cell* 2004;6:437-443.
127. Hess JL. MLL: a histone methyltransferase disrupted in leukemia. *Trends Mol Med* 2004;10:500-507.
128. Yu BD, Hanson RD, Hess JL, et al. MLL, a mammalian trithorax-group gene, functions as a transcriptional maintenance factor in morphogenesis. *PNAS* 1998;95:10632-10636.
129. Yu BD, Hess JL, Horning SE, et al. Altered Hox expression and segmental identity in Mll-mutant mice. *Nature* 1995;378:505-508.
130. Jenuwein T, Allis CD. Translating the histone code. *Science* 2001;293: 1074-1080.
131. Krivtsov AV, Armstrong SA. MLL translocations, histone modifications and leukaemia stem-cell development. *Nat Rev Cancer* 2007;7:823-833.
132. Meyer C, Kowarz E, Hofmann J, et al. New insights to the MLL recombinome of acute leukemias. *Leukemia* 2009;23:1490-1499.
133. Bernt KM, Armstrong SA. Targeting epigenetic programs in MLL-rearranged leukemias. *ASH Educ Book* 2011:354-360.
134. Ernst P, Wang J, Korsmeyer SJ. The role of MLL in hematopoiesis and leukemia. *Curr Opin Hematol* 2002;9:282-287.
135. Tkachuk DC, Kohler S, Cleary ML. Involvement of a homology of *Drosophila* trithorax by 11q23 chromosomal translocations in acute leukemias. *Cell* 1992;71:691-700.
136. Chi P, Allis CD, Wang GG. Covalent histone modifications—miswritten, misinterpreted and mis-erased in human cancers. *Nat Rev Cancer* 2010;10: 457-469.

137. Bernt KM, Zhu N, Sinha AU, et al. MLL-rearranged leukemia is dependent on aberrant H3K79 methylation by DOT1L. *Cancer Cell* 2011;20:66-78.
138. Daigle SR, Olhava EJ, Therkelsen CA, Majer CR, et al. Selective killing of mixed lineage leukemia cells by a potent small-molecule DOT1L inhibitor. *Cancer Cell* 2011;20:53-65.
139. Mohan M, Lin C, Guest E, Shilatifard A. Licensed to elongate: a molecular mechanism for MLL-based leukaemogenesis. *Nat Rev Cancer* 2010;10: 721-728.
140. Ferrando AA, Armstrong SA, Neuberg DS, et al. Gene expression signatures in MLL-rearranged T-lineage and B-precursor acute leukemias: dominance of HOX dysregulation. *Blood* 2003;102:262-268.
141. Kohlmann A, Schoch C, Dugas M, et al. New insights into MLL gene rearranged acute leukemias using gene expression profiling: shared pathways, lineage commitment, and partner genes. *Leukemia* 2005;19:953-964.
142. Rubnitz JE, Link MP, Shuster JJ, et al. Frequency and prognostic significance of HRX rearrangements in infant acute lymphoblastic leukemia; a Pediatric Oncology Group study. *Blood* 1994;84:570-573.
143. Secker-Walker LM. General report on the European Union Concerted Action Workshop on 11q23, U.K., May 1997. *Leukemia* 1998;12:776-778.
144. Hunger SP, Tkachuck DC, Amylon MD, et al. HRX involvement in de novo and secondary leukemias with diverse chromosome 11q23 abnormalities. *Blood* 1993;81:3197-3203.
145. Strissel PL, R. S, Rowley JD, Zeleznik-Le NJ. An in vivo topoisomerase II cleavage site and a DNase I hypersensitive site colocalize near exon 9 in the MLL breakpoint cluster region. *Blood* 1998;92:3793-3803.
146. Cimino G, Rapanotti MC, Biondi A, et al. Infant acute leukemias show the same biased distribution of ALL1 gene breaks as topoisomerase II related secondary leukemias. *Cancer Res* 1997;57:2879-2883.
147. Ross JA, Potter JD, Reaman GH, Pendergrass TW, Robison LL. Maternal exposure to potential inhibitors of DNA topoisomerase II and infant leukemia (United States): a report from the Children's Cancer Group. *Cancer Causes Control* 1996;7:581-590.
148. Basecke J, Whelan JT, Griesinger F, Bertrand FE. The MLL partial tandem duplication in acute myeloid leukaemia. *Br J Haematol* 2006;135:438-449.
149. Dorrance AM, Liu S, Yuan W, et al. MLL partial tandem duplication induces aberrant Hox expression in vivo via specific epigenetic alterations. *J Clin Invest* 2006;116:2707-2716.
150. Ford AM, Bennett CA, Price CM, Gruin MC, Van Wering ER, Greaves MF. Fetal origins of the TEL-AML1 fusion gene in identical twins with leukemia. *PNAS* 1998;95:4584-4588.
151. Ford AM, Ridge SA, Cabrera ME, et al. In utero rearrangements in the trithorax-related oncogene in human leukaemias. *Nature* 1993;363:358-360.
152. Gill Super H, McCabe NR, Thirman MJ, et al. Rearrangements of the MLL gene in therapy-related acute myeloid leukemia in patients previously treated with agents targeting DNA-topoisomerase II. *Blood* 1993;82:3705-3711.
153. Dobson CL, Warren AJ, Pannell R, et al. The mll-AF9 gene fusion in mice controls myeloproliferation and specifies acute myeloid leukaemogenesis. *EMBO J* 1999;19:3564-3574.
154. Shih AH, Abdel-Wahab O, Patel JP, Levine RL. The role of mutations in epigenetic regulators in myeloid malignancies. *Nat Rev Cancer* 2012;12:599-612.
155. Gilliland DG, Griffin JD. The roles of FLT3 in hematopoiesis and leukemia. *Blood* 2002;100:1532-1542.
156. Brasel K, Escobar S, Anderberg R, de Vries P, et al. Expression of the FLT3 receptor and its ligand on hematopoietic cells. *Leukemia* 1995;9:1212-1218.
157. Brandts CH, Sargin B, Rode M, et al. Constitutive activation of Akt by Flt3 internal tandem duplications is necessary for increased survival, proliferation, and myeloid transformation. *Cancer Res* 2005;65:9643-9650.
158. Mizuki M, Fenski R, Halfter H, et al. FLT3 mutations from patients with acute myeloid leukemia induce transformation of 32D cells mediated by the Ras and STAT5 pathways. *Blood* 2000;96:3907-3914.
159. Nakao M, Yokota S, Iwai T, et al. Internal tandem duplication of the FLT3 gene found in acute myeloid leukemia. *Leukemia* 1996;10:1911-1918.

160. Kiyoi H, Towatari M, Yokota S, et al. Internal tandem duplication of the FLT3 gene is a novel modality of elongation mutation which causes constitutive activation of the product. *Leukemia* 1998;12:1333-1337.
161. Yamamoto Y, Kiyoi H, Nakano Y, et al. Activating mutation of D835 within the activation loop of FLT3 in human hematologic malignancies. *Blood* 2001;97:2434-2439.
162. Sternberg DW, Licht JD. Therapeutic intervention in leukemias that express the activated fms-like tyrosine kinase 3 (FLT3): opportunities and challenges. *Curr Opin Hematol* 2005;12:7-13.
163. Kelly LM, Liu Q, Kutok JL, Williams IR, Boulton CL, Gilliland DG. FLT3 internal tandem duplication mutations associated with human acute myeloid leukemias induce myeloproliferative disease in a murine bone marrow transplant model. *Blood* 2002;99:310-318.
164. Meshinchi S, Woods WG, Stirewalt DL, et al. Prevalence and prognostic significance of Flt3 internal tandem duplication in pediatric acute myeloid leukemia. *Blood* 2001;97:89-94.
165. Kelly LM, Yu JC, Boulton CL, et al. CT53518, a novel selective FLT3 antagonist for the treatment of acute myelogenous leukemia (AML). *Cancer Cell* 2002;1:421-432.
166. Weisberg E, Boulton C, Kelly LM, et al. Inhibition of mutant FLT3 receptors in leukemia cells by the small molecule tyrosine kinase inhibitor PKC412. *Cancer Cell* 2002;1:433-443.
167. Kinder T, Lipka DB, Fischer T. FLT3 as a therapeutic target in AML: still challenging after all these years. *Blood* 2010;116:5089-5102.
168. Piloto O, Wright M, Brown P, Kim KT, Levis M, Small D. Prolonged exposure to FLT3 inhibitors leads to resistance via activation of parallel signaling pathways. *Blood* 2007;109:1643-1652.
169. Smith CC, Wang Q, Chin C-S, Salerno S, et al. Validation of ITD mutations in FLT3 as a therapeutic target in human acute myeloid leukaemia. *Nature* 2012;485:260-263.
170. Ruggero D, Pandolfi PP. Does the ribosome translate cancer? *Nat Rev Cancer* 2003;3:179-192.
171. Grisendi S, Pandolfi PP. NPM mutations in acute myelogenous leukemia. *N Engl J Med* 2005;352:291-292.
172. Boissel N, Renneville A, Biggio V, et al. Prevalence, clinical profile, and prognosis of NPM mutations in AML with normal karyotype. *Blood* 2005;106: 3618-3620.
173. Falini B, Mecucci C, Tiacci E, et al. Cytoplasmic nucleophosmin in acute myelogenous leukemia with a normal karyotype. *N Engl J Med* 2005; 352:254-266.
174. Falini B, Bolli N, Liso A, et al. Altered nucleophosmin transport in acute myeloid leukaemia with mutated NPM1: molecular basis and clinical implications. *Leukemia* 2009;23:1731-1743.
175. Falini B, Nicoletti I, Martelli MF, Mecucci C. Acute myeloid leukemia carrying cytoplasmic/mutated nucleophosmin (NPMc+ AML): biological and clinical features. *Blood* 2006.
176. Bolli N, De Marco MF, Martelli MP, Bigerna B, et al. A dose-dependent tug of war involving the NPM1 leukaemic mutant, nucleophosmin, and ARF. *Leukemia* 2009;23:501-509.
177. Falini B, Martelli MP, Bolli N, et al. Immunohistochemistry predicts nucleophosmin (NPM) mutations in acute myeloid leukemia. *Blood* 2006;108:1999-2005.
178. Vassiliou GS, Copper JL, Rad R, Li J, Rice S, Uren A. Mutant nucleophosmin and cooperating pathways drive leukemia initiation and progression in mice. *Nat Genet* 2011;43:470-475.
179. Dohner H, Estey E, Amadori S, et al. Diagnosis and management of acute myeloid leukemia in adults: recommendations from an international expert panel, on behalf of the European Leukemia Net. *Blood* 2010;115:453-474.
180. Malkin D, Li FP, Strong LC, et al. Germ line p53 mutations in a familial syndrome of breast cancer, sarcomas, and other neoplasms. *Science* 1990;250:1233-1238.
181. Mullighan CG, Goorha S, Radtke I, et al. Genome-wide analysis of genetic alterations in acute lymphoblastic leukaemia. *Nature* 2007;446:758-764.
182. Nutt S, Urbanek P, Rolink A, Busslinger M. Essential functions of Pax5 (BSAP) in pro-B cell development: difference between fetal and adult B lymphopoiesis and reduced V-to-DJ recombination at the IgH locus. *Genes Dev* 1997;11:476-491.

183. Medvedovic J, Ebert A, Tagoh H, Busslinger M. Pax5: a master regulator of B cell development and leukemogenesis. *Adv Immunol* 2011;111:179-206.
184. Coypaud E, Struski S, Prade N, et al. Wide diversity of PAX5 alterations in B-ALL: a Groupe Francophone de Cytogenetique Hematologique study. *Blood* 2010;115:3089-3097.
185. Romana SP, Mauchauffe M, Le Coniat M, et al. The t(12;21) of acute lymphoblastic leukemia results in a TEL-AML1 gene fusion. *Blood* 1995;85:3662-3670.
186. Golub TR, Barker GF, Bohlander SK, et al. Fusion of the TEL gene on 12p13 to the AML1 gene on 21q22 in acute lymphoblastic leukemia. *Proc Natl Acad Sci U S A* 1995;92:4917-4921.
187. Scholz H, Deatrick J, Klaes A, Klambt C. Genetic dissection of pointed, a Drosophila gene encoding two ETS-related proteins. *Genetics* 1993;135:455-468.
188. Wang L, Hiebert SW. TEL contacts multiple co-repressors and specifically associates with histone deacetylase-3. *Oncogene* 2001;20:3716-3725.
189. Rand V, Parker H, Russell LJ, et al. Genomic characterization implicates iAMP21 as a likely primary genetic event in childhood B-cell precursor acute lymphoblastic leukemia. *Blood* 2011;117:6848-6855.
190. Pui C-H, Evans WE. Acute lymphoblastic leukemia. *N Engl J Med* 1998;339:605-615.
191. Hunger SP, Galili N, Carroll AJ, Crist WM, Link MP, Cleary ML. The t(1;19) (q23;p13) results in consistent fusion of E2A and PBX1 coding sequences in acute lymphoblastic leukemias. *Blood* 1991;77:687-693.
192. Kamps MP, Look AT, Baltimore D. The human t(1;19) translocation in pre-B ALL produces multiple nuclear E2A-Pbx1 fusion proteins with differing transforming potentials. *Genes Dev* 1991;5:358-368.
193. Murre C, McCaw PS, Baltimore D. A new DNA binding and dimerization motif in immunoglobulin enhancer binding, daughterless, MyoD, and myc proteins. *Cell* 1989;56:777-783.
194. Rutherford MN, LeBrun DP. Restricted expression of E2A protein in primary human tissues correlates with proliferation and differentiation. *Am J Pathol* 1998;153:165-173.
195. Shen CP, Kadsch T. B-cell specific DNA binding by an E47 homodimer. *Mol Cell Biol* 1995;15:4518-4524.
196. Bain F, Engel I, Robanus EC, et al. E2A deficiency leads to abnormalities in ab T-cell development and to rapid development of T-cell lymphomas. *Mol Cell Biol* 1997;17:4782-4791.
197. Zhuang Y, Soriano P, Weintraub H. The helix-loop-helix gene E2A is required for B cell formation. *Cell* 1994;79:875-884.
198. Nourse J, Mellentin JD, Galili N, et al. Chromosomal translocation t(1;19) results in synthesis of a homeobox fusion mRNA that codes for a potential chimeric transcription factor. *Cell* 1990;60:535-545.
199. Rauskolb C, Peifer M, Wieschaus E. Extradenticle, a regulator of homeotic gene activity, is a homolog of the homeobox-containing human protooncogene pbx1. *Cell* 1993;74:1101.
200. Chang CP, DeVivo I, Cleary ML. The Hox cooperativity motif of the chimeric oncoprotein E2a-Pbx1 is necessary and sufficient for oncogenesis. *Mol Cell Biol* 1997;17:81-88.
201. van Dijk MA, Voorhoeve PM, Murre C. Pbx1 is converted into a transcriptional activator upon acquiring the N-terminal region of E2A in pre-B-cell acute lymphoblastoid leukemia. *Proc Natl Acad Sci U S A* 1993;90:6061-6065.
202. Salleri L, Depew MJ, Jacobs Y, et al. Requirement for Pbx1 in skeletal patterning and programming chondrocyte proliferation and differentiation. *Development* 2001;128:3543-3557.
203. LeBrun DP. E2A basic helix-loop-helix transcription factors in human leukemia. *Front Biosci* 2003;8:s206-s222.
204. Monica K, LeBrun DP, Dederda DA, et al. Transformation properties of the E2A-PBX1 chimeric oncoprotein: fusion with E2a is essential, but the Pbx1 homeodomain is dispensable. *Mol Cell Biol* 1994;14:8304-8314.
205. Smith KS, Chandra SK, Lingbeek M, Ross DT, et al. Bmi-1 regulation of INK4A-ARF is a downstream requirement for transformation of hematopoietic progenitors by E2a-Pbx1. *Mol Cell* 2003;12:393-400.
206. Park I-K, Qian D, Kiel M, Becker MW, Pihalja M, et al. Bmi-1 is required for maintenance of adult self-renewing haematopoietic stem cells. *Nature* 2003;423:302-305.

207. Chin L, Pomerantz J, DePinho RA. The INK4a/ARF tumor suppressor: one gene-two products-two pathways. *Trends Biochem Sci* 1998;8:291-296.
208. Dyson N. The regulation of E2F by pRB-family proteins. *Genes Dev* 1998;12:2245-2262.
209. Talluri S, Dick FA. Regulation of transcription and chromatin structure by pRB. *Cell Cycle* 2012;11:3189-3198.
210. Raimondi SC, Privitera E, Williams DL, et al. New recurring chromosomal translocations in childhood acute lymphoblastic leukemia. *Blood* 1991;77:2016-2022.
211. Inaba T, Roberts WM, Shapiro LH, et al. Fusion of the leucine zipper gene HLF to the E2A gene in human acute B-lineage leukemia. *Science* 1992;257:531.
212. Hunger SP, Ohyashiki K, Toyama K, Cleary ML. Hlf, a novel hepatic bZIP protein, shows altered DNA-binding properties following fusion to E2A in t(17;19) acute lymphoblastic leukemia. *Genes Dev* 1992;6:1608-1620.
213. Yoshihara T, Inaba T, Shapiro LH, et al. E2A-HLF-mediated cell transformation requires both the trans-activation domain of E2A and the leucine zipper dimerization domain of HLF. *Mol Cell Biol* 1995;15:3247.
214. Inaba T, Shapiro LH, Funabiki T, et al. DNA-binding specificity and trans-activating potential of the leukemia-associated E2A-hepatic leukemia factor fusion protein. *Mol Cell Biol* 1994;14:3403-3413.
215. de Boer J, Yeung J, Ellu J, Ramanujachar R, et al. The E2A-HLF oncogenic fusion protein acts through Lmo2 and Bcl-2 to immortalize hematopoietic progenitors. *Leukemia* 2011;25:321-330.
216. Nam CH, Rabbitts TH. The role of LMO2 in development and in T cell leukemia after chromosomal translocation or retroviral insertion. *Mol Ther* 2006;13:15-25.
217. Kirkin V, Joose S, Zornig M. The role of Bcl-2 family members in tumorigenesis. *Biochim Biophys Acta* 2004;1644:229-49.
218. Mullighan CG, Miller CB, Radtke F, Phillips LA. BCR-ABL1 lymphoblastic leukaemia is characterized by the deletion of IKAROS. *Nature* 2008;453:110-114.
219. Iacobucci I, Iraci N, Messina M, Lonetti A, Chiaretti S, et al. IKAROS deletions dictate a unique gene expression signature in patients with adult B-cell acute lymphoblastic leukemia. *PLOS One* 2012;7:1-10.
220. Ng S, Yoshida T, Xhang J, Georgopoulos K. Genome-wide lineage-specific transcriptional networks underscore IKAROS-dependent lymphoid priming in hematopoietic stem cells. *Immunity* 2009;30:493-507.
221. Mullighan CG, Su X, Zhang J, et al. Deletion of IKZF1 and prognosis in acute lymphoblastic leukemia. *N Engl J Med* 2009;360:470-480.
222. Roberts KG, Morin RD, Zhang J, et al. Genetic alterations activating kinase and cytokine receptor signaling in high-risk acute lymphoblastic leukemia. *Cancer Cell* 2012;22:153-166.
223. Bartram CR, de Klein A, Hagemeyer A, et al. Translocation of c-abl oncogene correlates with the presence of a Philadelphia chromosome in chronic myelocytic leukaemia. *Nature* 1983;243:290-293.
224. Groffen J, Stephenson JR, Heisterkamp N, de Klein A, Bartram CR, Grosveld G. Philadelphia chromosomal breakpoints are clustered within a limited region, bcr, on chromosome 22. *Cell* 1984;36:93-99.
225. Secker-Walker LM, Craig JM, Hawkins JM, et al. Philadelphia positive acute lymphoblastic leukemia in adults: age distribution, BCR breakpoint and prognostic significance. *Leukemia* 1991;5:196-199.
226. Uckun FM, Nachman JB, Sather HN, et al. Clinical significance of Philadelphia chromosome-positive pediatric acute lymphoblastic leukemia in the context of contemporary intensive therapies: a report from the Children's Cancer Group. *Cancer* 1998;83:2030-2039.
227. Kurzrock R, Gutterman JU, Talpaz M. The molecular genetics of Philadelphia chromosome-positive leukemias. *N Engl J Med* 1988;319:990-998.
228. Voncken JW, Kaartinen V, Pattengale PK, et al. BCR/ABL p210 and p190 cause distinct leukemia in transgenic mice. *Blood* 1995;86:4603-4611.
229. Radich JP. Philadelphia Chromosome-positive acute lymphocytic leukemia. *Hematol Oncol Clin North Am* 2001;15:21-36.
230. Laneuville P. Abl tyrosine protein kinase. *Semin Immunol* 1995;74:255-266.

231. Pendergast AM, Quilliam LA, Cripe LD, et al. BCR-ABL-induced oncogenesis is mediated by direct interaction with the SH2 domain of the GRB-2 adaptor protein. *Cell* 1993;75:175-185.
232. Faderl S, Talpaz M, Estrov X, O'Brien S, Kurzrock R, Kantarjian HM. The biology of chronic myeloid leukemia. *N Engl J Med* 1999;341:164-172.
- P.1542
233. Ribera J-M. Advances in acute lymphoblastic leukemia in adults. *Curr Opin Oncol* 2011;23:692-699.
234. Ottmann OG, Druker BJ, Sawyers CL, et al. A phase 2 study of imatinib in patients with relapsed or refractory Philadelphia chromosome-positive acute lymphoid leukemias. *Blood* 2002;100:1965-1971.
235. de Labarthe A, Rousselot P, Huguet-Rigal F, et al. Imatinib combined with induction or consolidation chemotherapy in patients with de novo Philadelphia chromosome-positive acute lymphoblastic leukemia—results of the GRAAPH-2003 study. *Blood* 2007;109:1408-1413.
236. Yanada M, Naoe T. Imatinib combined chemotherapy for Philadelphia chromosome-positive acute lymphoblastic leukemia: major challenges in current practice. *Leuk Lymphoma* 2006;47:1747-1753.
237. Hofmann WK, Jones LC, Lemp NA, et al. Ph(+) acute lymphoblastic leukemia resistant to the tyrosine kinase inhibitor STI571 has a unique BCR-ABL gene mutation. *Blood* 2002;99:1860-1862.
238. Rabbitts TH, Axelson H, Forster A, et al. Chromosomal translocations and leukaemia: a role for LMO2 in T cell acute leukaemia, in transcription and in erythropoiesis. *Leukemia* 1997;11(Suppl 3):271-272.
239. Raimondi SC. T-lineage acute lymphoblastic leukemia (T-ALL). *Atlas Genet Cytogenet Oncol Haematol* 2007;11:69-81.
240. Armstrong SA, Look AT. Molecular genetics of acute lymphoblastic leukemia. *J Clin Oncol* 2005;23:6306-6315.
241. De Keersmaecker K, Marynen P, Cools J. Genetic insights in the pathogenesis of T-cell acute lymphoblastic leukemia. *Haematologica* 2005;90:1116-1127.
242. Ferrando AA, Herblot S, Palomero T, et al. Biallelic transcriptional activation of oncogenic transcription factors in T-cell acute lymphoblastic leukemia. *Blood* 2004;103:1909-1911.
243. Ferrando AA, Look AT. Gene expression profiling in T-cell acute lymphoblastic leukemia. *Semin Hematol* 2003;40:274-280.
244. Ferrando AA, Neuberg DS, Staunton J, et al. Gene expression signatures define novel oncogenic pathways in T cell acute lymphoblastic leukemia. *Cancer Cell* 2002;1:75-87.
245. Nagel S, Venturini L, Meyer C, et al. Multiple mechanisms induce ectopic expression of LYL1 in subsets of T-ALL cell lines. *Leukemia Res* 2010;34(4):521-528.
246. Yeoh EJ, Ross ME, Shurtleff SA, et al. Classification, subtype discovery, and prediction of outcome in pediatric acute lymphoblastic leukemia by gene expression profiling. *Cancer Cell* 2002;1:133-143.
247. Chiaretti S, Li X, Gentleman R, et al. Gene expression profile of adult T-cell acute lymphocytic leukemia identifies distinct subsets of patients with different response to therapy and survival. *Blood* 2004;103:2771-2778.
248. Okamoto A, Demetrick DJ, Spillare EA, et al. Mutations and altered expression of p16INK4 in human cancer. *Proc Natl Acad Sci U S A* 1994;91:11045-11049.
249. Merlo A, Herman JG, Mao L, et al. 5' CpG island methylation is associated with transcriptional silencing of the tumour suppressor p16/CDKN2/MTS1 in human cancers. *Nat Med* 1995;1:686-692.
250. Lowe SW, Sherr CJ. Tumor suppression by Ink4a-Arf: progress and puzzles. *Curr Opin Genet Dev* 2003;13:77-83.
251. Washburn T, Schweighoffer E, Gridley T, et al. Notch activity influences the alphabeta versus gammadelta T cell lineage decision. *Cell* 1997;88:833-843.
252. Sambandam A, Maillard I, Zediak VP, et al. Notch signaling controls the generation and differentiation of early T lineage progenitors. *Nat Immunol* 2005;6:663-670.
253. Pui JC, Allman D, Xu L, et al. Notch1 expression in early lymphopoiesis influences B versus T lineage determination. *Immunity* 1999;11:299-308.

254. Ellisen LW, Bird J, West DC, et al. TAN-1, the human homolog of the *Drosophila* notch gene, is broken by chromosomal translocations in T lymphoblastic neoplasms. *Cell* 1991;66:649-661.
255. Weng AP, Ferrando AA, Lee W, et al. Activating mutations of NOTCH1 in human T cell acute lymphoblastic leukemia. *Science* 2004;306:269-271.
256. Aster JC, Pear WS, Blacklow SC. Notch signaling in leukemia. *Annu Rev Pathol Mech Dis* 2008;3:587-613.
257. Roy M, Pear WS, Aster JC. The multifaceted role of Notch in cancer. *Curr Opin Genet Dev* 2007;17:52-59.
258. Palomero T, Lim WK, Odom DT, et al. NOTCH1 directly regulates c-MYC and activates a feed-forward-loop transcriptional network promoting leukemic cell growth. *Proc Natl Acad Sci U S A* 2006;103:18261-18266.
259. Sharma VM, Calvo JA, Draheim KM, et al. Notch1 contributes to mouse T-cell leukemia by directly inducing the expression of c-myc. *Mol Cell Biol* 2006;26:8022-8031.
260. Weng AP, Millholland JM, Yashiro-Ohtani Y, et al. c-Myc is an important direct target of Notch1 in T-cell acute lymphoblastic leukemia/lymphoma. *Genes Dev* 2006;20:2096-2109.
261. Wendorff AA, Koch U, Wunderlich FT, et al. Hes1 is a critical but context-dependent mediator of canonical Notch signaling in lymphocyte development and transformation. *Immunity* 2010;33:671-684.
262. Reavie L, Gatta GD, Crusio K, et al. Regulation of hematopoietic stem cell differentiation by a single ubiquitin ligase-substrate complex. *Nat Immunol* 2010;11:207-215.
263. Welcker M, Clurman BE. FBW7 ubiquitin ligase: a tumour suppressor at the crossroads of cell division, growth and differentiation. *Nat Rev Cancer* 2008;8:83-93.
264. O'Neil J, Grim J, Strack P, et al. FBW7 mutations in leukemic cells mediate NOTCH pathway activation and resistance to gamma-secretase inhibitors. *J Exp Med* 2007;204:1813-1824.
265. Thompson BJ, Buonamici S, Sulis ML, et al. The SCFFBW7 ubiquitin ligase complex as a tumor suppressor in T cell leukemia. *J Exp Med* 2007;204:1825-1835.
266. Kox C, Zimmermann M, Stanulla M, et al. The favorable effect of activating NOTCH1 receptor mutations on long-term outcome in T-ALL patients treated on the ALL-BFM 2000 protocol can be separated from FBXW7 loss of function. *Leukemia* 2010;24:2005-2013.
267. Real PJ, Tosello V, Palomero T, et al. Gamma-secretase inhibitors reverse glucocorticoid resistance in T cell acute lymphoblastic leukemia. *Nat Med* 2009;15:50-58.
268. Weng AP, Nam Y, Wolfe MS, et al. Growth suppression of pre-T acute lymphoblastic leukemia cells by inhibition of notch signaling. *Mol Cell Biol* 2003;23:655-664.
269. De Keersmaecker K, Lahortiga I, Mentens N, et al. In vitro validation of gamma-secretase inhibitors alone or in combination with other anti-cancer drugs for the treatment of T-cell acute lymphoblastic leukemia. *Haematologica* 2008;93:533-542.
270. Carroll AJ, Crist WM, Link MP, et al. The t(1;14)(p34;q11) is nonrandom and restricted to T-cell acute lymphoblastic leukemia: a Pediatric Oncology Group study. *Blood* 1990;76:1220-1224.
271. Bernard OA, Guglielmi P, Jonveaux P, Cherif D. Two distinct mechanisms for the SCL gene activation in the t(1;14) translocation of T-cell leukemias. *Genes Chrom Cancer* 1990;1:194-208.
272. Chen Q, Cheng J-T, Tsai L-H, et al. The tal gene undergoes chromosome trans-location in T cell leukemia and potentially encodes a helix-loop-helix protein. *EMBO J* 1990;9:415-424.
273. Brown L, Cheng J-T, Chen Q, et al. Site-specific recombination of the tal-1 gene is a common occurrence in human T cell leukemia. *EMBO J* 1990;9: 3343-3351.
274. Xia Y, Brown L, Tsan JT, et al. The translocation (1;14)(p34;q11) in human T-cell leukemia: chromosome breakage 25 kilobase pairs downstream of the TAL1 protooncogene. *Genes Chrom Cancer* 1992;4:211-216.
275. Labastie MC, Cortes F, Romeo PH, Dulac C, Peault B. Molecular identity of hematopoietic precursor cells emerging in the human embryo. *Blood* 1998;92:3624-3635.
276. Cheng T, Shen H, Giokas D, Gere J, Tenen DG, Scadden DT. Temporal mapping of gene expression levels during the differentiation of individual primary hematopoietic cells. *PNAS* 1996;93:13158-13163.

277. Robb L, Lyons I, Li R, et al. Absence of yolk sac hematopoiesis from mice with a targeted disruption of the scl gene. *PNAS* 1995;92:7075-7079.
278. Shivdasani RA, Mayer EL, Orkin SH. Absence of blood formation in mice lacking the T-cell leukaemia oncoprotein tal-1/SCL. *Nature* 1995;373:432-434.
279. Mikkola HK, Klintman J, Yang H, et al. Haematopoietic stem cells retain long-term repopulating activity and multipotency in the absence of stem-cell leukaemia SCL/tal-1 gene. *Nature* 2003;421:547-551.
280. McCormack MP, Forster A, Drynan L, Pannell R, Rabbitts TH. The LMO2 T-cell oncogene is activated via chromosomal translocations or retroviral insertion during gene therapy but has no mandatory role in normal T-cell development. *Mol Cell Biol* 2003;23:9003-9013.
281. Van Vlierberghe P, Beverloo H, Buijs-Gladdines J, et al. Monoallelic or biallelic LMO2 expression in relation to the LMO2 rearrangement status in pediatric T-cell acute lymphoblastic leukemia. *Leukemia* 2007;22:1434-1437.
282. Grutz GG, Bucher K, Lvenir I, Larson T, Larson RA, Rabbitts TH. The oncogenic T cell LIM-protein Lmo2 forms part of a DNA-binding complex specifically in immature T cells. *EMBO J* 1998;17:4594-4605.
283. Osada H, Grutz GG, Axelson H, Forster A, Rabbitts TH. Association of erythroid transcription factors: complexes involving the LIM protein RBTN2 and the zinc-finger protein GATA1. *PNAS* 1995;92:9585-9589.
284. Valge-Archer VE, Forster A, Rabbitts TH. The LMO1 and LDB1 proteins interact in human T cell acute leukaemia with the chromosomal translocation t(1;14)(p15;q11). *Oncogene* 1998;17:3199-3202.
285. Larson RC, Lavenir I, Larson TA, et al. Protein dimerization between Lmo2(Rbtn2) and Tal1 alters thymocyte development and potentiates T cell tumorigenesis in transgenic mice. *EMBO J* 1996;15:1021-1027.
286. Huang S, Qiu Y, Stein RW, Brandt SJ. p300 functions as a transcriptional coactivator for the TAL1/SCL oncoprotein. *Oncogene* 1999;18:4958-4967.
287. Huang S, Brandt SJ. mSin3A regulates murine erythroleukemia cell differentiation through association with the TAL1/SCL transcription factor. *Mol Cell Biol* 2000;20:2248-2259.
288. Ono Y, Fukuhara N, Yoshie O. Transcriptional activity of TAL1 in T cell acute lymphoblastic leukemia (T-ALL) requires RBTN1 or -2 and induces TALLA1, a highly specific tumor marker of T-ALL. *J Biol Chem* 1997;272:4576-4581.
289. Ono Y, Fukuhara N, Yoshie O. TAL1 and LIM-only proteins synergistically induce retinaldehyde dehydrogenase 2 expression in T-cell acute lymphoblastic leukemia by acting as cofactors for GATA3. *Mol Cell Biol* 1998;18:6939-6950.
290. Palomero T, Odom DT, O'Neil J, et al. Transcriptional regulatory networks downstream of TAL1/SCL in T-cell acute lymphoblastic leukemia. *Blood* 2006;108:986-992.
291. Park ST. The Tal1 Oncoprotein inhibits E47-mediated transcription. MECHANISM OF INHIBITION. *J Biol Chem* 1998;273:7030-7037.
292. O'Neil J, Shank J, Cusson N, Murre C, Kelliher M. TAL1/SCL induces leukemia by inhibiting the transcriptional activity of E47/HEB. *Cancer Cell* 2004;5:587-596.
293. Dave UP, Akagi K, Tripathi R, et al. Murine leukemias with retroviral insertions at Lmo2 are predictive of the leukemias induced in SCID-X1 patients following retroviral gene therapy. *PLoS Genet* 2009;5:e1000491.
294. Lin YW, Deveney R, Barbara M, et al. OLIG2 (BHLHB1), a bHLH transcription factor, contributes to leukemogenesis in concert with LMO1. *Cancer Res* 2005;65:7151-7158.
295. Zhang J, Ding L, Holmfeldt L, et al. The genetic basis of early T-cell precursor acute lymphoblastic leukaemia. *Nature* 2012;481:157-163.
296. Coustan-Smith E, Mullighan CG, Onciu M, et al. Early T-cell precursor leukaemia: a subtype of very high-risk acute lymphoblastic leukaemia. *Lancet Oncol* 2009;10:147-156.
297. Asnafi V, Beldjord K, Libura M, et al. Age-related phenotypic and oncogenic differences in T-cell acute lymphoblastic leukemias may reflect thymic atrophy. *Blood* 2004;104:4173-4180.
298. Souroullas GP, Salmon JM, Sablitzky F, Curtis DJ, Goodell MA. Adult hematopoietic stem and progenitor cells require either Lyl1 or Scl for survival. *Stem Cell* 2009;4:180-186.

299. Ferrando AA, Neuberg DS, Dodge RK, et al. Prognostic importance of TLX1 (HOX11) oncogene expression in adults with T-cell acute lymphoblastic leukaemia. *Lancet* 2004;363:535-536.
300. Bernard OA, Busson-LeConiat M, Ballerini P, et al. A new recurrent and specific cryptic translocation, t(5;14)(q35;q32), is associated with expression of the Hox11L2 gene in T acute lymphoblastic leukemia. *Leukemia* 2001;15:1495-1504.
301. Su XY, Della-Valle V, Andre-Schmutz I, et al. HOX11L2/TLX3 is transcriptionally activated through T-cell regulatory elements downstream of BCL11B as a result of the t(5;14)(q35;q32). *Blood* 2006;108:4198-4201.
302. Cauwelier B, Cave H, Gervais C, et al. Clinical, cytogenetic and molecular characteristics of 14 T-ALL patients carrying the TCRbeta-HOXA rearrangement: a study of the Groupe Francophone de Cytogenetique Hematologique. *Leukemia* 2007;21:121-128.
303. Speleman F, Cauwelier B, Dastugue N, et al. A new recurrent inversion, inv(7) (p15q34), leads to transcriptional activation of HOXA10 and HOXA11 in a subset of T-cell acute lymphoblastic leukemias. *Leukemia* 2005;19:358-366.
304. Bergeron J, Clappier E, Cauwelier B, et al. HOXA cluster deregulation in T-ALL associated with both a TCRD-HOXA and a CALM-AF10 chromosomal translocation. *Leukemia* 2006;20:1184-1187.
305. Dadi S, Le Noir S, Payet-Bornet D, et al. TLX homeodomain oncogenes mediate T cell maturation arrest in T-ALL via interaction with ETS1 and suppression of TCRalpha gene expression. *Cancer Cell* 2012;21:563-576.
306. De Keersmaecker K, Ferrando AA. TLX1-induced T-cell acute lymphoblastic leukemia. *Clin Cancer Res* 2011;17:6381-6386.
307. Dik WA, Brahim W, Braun C, et al. CALM-AF10+ T-ALL expression profiles are characterized by overexpression of HOXA and BMI1 oncogenes. *Leukemia* 2005;19:1948-1957.
308. Soulier J, Clappier E, Cayuela JM, et al. HOXA genes are included in genetic and biologic networks defining human acute T-cell leukemia (T-ALL). *Blood* 2005;106:274-286.
309. O'Neil J, Tchinda J, Gutierrez A, et al. Alu elements mediate MYB gene tandem duplication in human T-ALL. *J Exp Med* 2007;204:3059-3066.
310. Lahortiga I, De Keersmaecker K, Van Vlierberghe P, et al. Duplication of the MYB oncogene in T cell acute lymphoblastic leukemia. *Nat Genet* 2007;39:593-595.
311. Gutierrez A, Kentsis A, Sanda T, et al. The BCL11B tumor suppressor is mutated across the major molecular subtypes of T-cell acute lymphoblastic leukemia. *Blood* 2011;118:4169-4173.
312. Li L, Leid M, Rothenberg EV. An early T cell lineage commitment checkpoint dependent on the transcription factor Bcl11b. *Science* 2010;329:89-93.
313. Van Vlierberghe P, Palomero T, Khiabani H, et al. PHF6 mutations in T-cell acute lymphoblastic leukemia. *Nat Genet* 2010;42:338-342.
314. Beisel C, Paro R. Silencing chromatin: comparing modes and mechanisms. *Nat Rev Genet* 2011;12:123-135.
315. Shochat C, Tal N, Bandapalli OR, et al. Gain-of-function mutations in interleukin-7 receptor-alpha (IL7R) in childhood acute lymphoblastic leukemias. *J Exp Med* 2011;208:901-908.
316. Zenatti PP, Ribeiro D, Li W, et al. Oncogenic IL7R gain-of-function mutations in childhood T-cell acute lymphoblastic leukemia. *Nat Genet* 2011;43:932-939.
317. Mullighan CG, Zhang J, Harvey RC, et al. JAK mutations in high-risk childhood acute lymphoblastic leukemia. *Proc Natl Acad Sci U S A* 2009; 106:9414-9418.
318. Flex E, Petrangeli V, Stella L, et al. Somatic acquired JAK1 mutations in adult acute lymphoblastic leukemia. *J Exp Med* 2008;205:751-758.
319. Asnafi V, Le Noir S, Lhermitte L, et al. JAK1 mutations are not frequent events in adult T-ALL: a GRAALL study. *Br J Haematol* 2010;148:178-179.
320. Yokota S, Nakao M, Horiike S, et al. Mutational analysis of the N-ras gene in acute lymphoblastic leukemia: a study of 125 Japanese pediatric cases. *Int J Hematol* 1998;67:379-387.

321. Perentesis JP, Bhatia S, Boyle E, et al. RAS oncogene mutations and outcome of therapy for childhood acute lymphoblastic leukemia. *Leukemia* 2004;18:685-692.
322. Hagemeyer A, Graux C. ABL1 rearrangements in T-cell acute lymphoblastic leukemia. *Genes Chromosomes Cancer* 2010;49:299-308.
323. Mavrakis KJ, Van Der Meulen J, Wolfe AL, et al. A cooperative microRNA tumor suppressor gene network in acute T-cell lymphoblastic leukemia (T-ALL). *Nat Genet* 2011;43:673-678.
324. Xu Y, Sengupta T, Kukreja L, Minella AC. MicroRNA-223 regulates cyclin E activity by modulating expression of F-box and WD-40 domain protein 7. *J Biol Chem* 2010;285:34439-34446.
325. Meyerson M, Gabriel S, Getz G. Advances in understanding cancer genomes through second-generation sequencing. *Nat Rev Genet* 2010;11:685-696.
326. Bamshad MJ, Ng SB, Bigham AW, et al. Exome sequencing as a tool for Mendelian disease gene discovery. *Nat Rev Genet* 2011;12:745-755.
327. Ng SB, Bigham AW, Buckingham KJ, et al. Exome sequencing identifies MLL2 mutations as a cause of Kabuki syndrome. *Nat Genet* 2010;42:790-793.
328. Wang Z, Gerstein M, Snyder M. RNA-Seq: a revolutionary tool for transcriptomics. *Nat Rev Genet* 2009;10:57-63.
329. Mortazavi A, Williams BA, McCue K, Schaeffer L, Wold B. Mapping and quantifying mammalian transcriptomes by RNA-Seq. *Nat Methods* 2008;5:621-628.
330. Alizadeh AA, Eisen MB, Davis RE, et al. Distinct types of diffuse large B-cell lymphoma identified by gene expression profiling. *Nature* 2000;403:503-511.
331. Tiu RV, Gondek LP, O'Keefe CL, et al. Prognostic impact of SNP array karyotyping in myelodysplastic syndromes and related myeloid malignancies. *Blood* 2011;117:4552-4560.
332. Grimwade D, Mrozek K. Diagnostic and prognostic value of cytogenetics in acute myeloid leukemia. *Hematol Oncol Clin North Am* 2011;25:1135-1161.

Chapter 73 Diagnosis and Classification of the Acute Leukemias and Myelodysplastic Syndromes

> Table of Contents > Part VII - Hematologic Malignancies > Section 2 - The Acute Leukemias > Chapter 73 - Diagnosis and Classification of the Acute Leukemias and Myelodysplastic Syndromes

Chapter 73

Diagnosis and Classification of the Acute Leukemias and Myelodysplastic Syndromes

Daniel A. Arber

Attilio Orazi

INTRODUCTION

The diagnosis and classification of acute leukemias and myelodysplastic syndromes (MDSs) has grown increasingly complex.^{1,2} Cases can no longer be fully classified by the use of only morphologic evaluation and cytochemical studies. Historic information, such as the presence of Down syndrome, prior therapy, or prior MDS all impact the final diagnosis. Additionally, immunophenotypic studies are needed for many cases; and cytogenetic, with possible molecular genetic, studies are required for essentially all cases.

This increase in complexity in the evaluation of these neoplasms has resulted in more precise diagnostic categories and recognition that the broad categories of acute myeloid leukemia (AML), acute lymphoblastic leukemia (ALL), and MDS actually represent heterogeneous groups of diseases. The newer disease categories are more predictive of outcome than older classification systems, in part because of their ability to separate disease groups within each category.^{3, 4, 5} and ⁶ Unfortunately, many physicians continue to use older terminology for these diseases, relying on terminology from the French-American-British Cooperative Group (FAB) classification^{7,8,9,10} of these neoplasms. While the FAB classification provided firm diagnostic criteria and useful terminology for communication of findings using the methods available at the time, its use is no longer appropriate. The third (2001) and fourth (2008) editions of the World Health Organization (WHO)

classification of hematopoietic tumors have dramatically changed the approach to diagnosis of many of these neoplasms, and the WHO system should be considered the current standard of care. Modifications from the LeukemiaNet group and others will certainly continue to aid in the refinement of our classification systems.^{11,12,13} This evolution from the FAB to the WHO is reminiscent of changes in lymphoma classification with evolution from the Rappaport¹⁴ and Kiel¹⁵ classifications to the Working Formulation¹⁶ to the REAL¹⁷ classification and finally to the WHO classification.^{2,18} Perhaps because the changes in lymphoma classification were more stepwise with shorter time intervals between the changes than the leukemia classification changes, they have been more widely adopted. We no longer refer to diffuse large B-cell lymphoma as histiocytic lymphoma and should no longer refer to AML with t(8;21)q22;q22) as M2, or to B-lymphoblastic leukemia with BCR-ABL1 as L2.

Several discoveries have impacted the classification of these neoplasms and many of them are covered in great detail in other chapters, but genetic discoveries associated with the acute leukemias and MDSs are probably the most significant. The finding of recurrent cytogenetic abnormalities with prognostic significance impacts all of these diseases.^{19,20,21, 22, 23} and²⁴ While balanced translocations are more common in the acute leukemias, the presence of single and complex abnormalities in the MDS has helped define disease prognosis as well as defining a specific disease category of MDS with isolated del(5q).^{5,6} The more recent discoveries of specific gene mutations have further impacted both acute leukemia and MDS diagnosis.^{13,25, 26, 27, 28, 29, 30} and³¹ While many of these mutations have their greatest frequency in AMLs with a normal karyotype, others offer prognostic significance that complements other morphologic and karyotypic features.

The classification of AML and MDS has also been impacted greatly by the understanding of similarities between the two. The so-called myelodysplasia-related AML and de novo AML described by Head³² helped lead to a new way of thinking about this disease; especially AML occurring in older patients.

This chapter will highlight key classification issues in the acute leukemias and MDSs, which are discussed in detail in the chapters that follow.

DIAGNOSTIC EVALUATION

The diagnostic approach to acute leukemia and MDSs still begins with a morphologic evaluation, but requires careful integration of the morphologic findings with clinical information and relevant laboratory data, including cytogenetic and molecular results.³³ Laboratory data, particularly results of a recent complete blood count (CBC) must be reviewed with the samples. Morphologic evaluation requires a well-stained (usually Wright-stained) peripheral blood (PB) smear prepared from a recent sample (less than 2 hours from procurement). A 200-cell manual differential count is required for PB smears. The bone marrow (BM) aspirate smears are best prepared at the bedside immediately after procurement and promptly stained. The review of BM aspirate smear includes a 500-cell differential count. In patients with inaspirable marrow, touch preparation of the BM biopsy can be used in lieu of an aspirate smear. The BM biopsy is usually stained with hematoxylin and eosin (H&E) or Giemsa and is useful in many settings.³⁴ The morphologic assessment allows for the appropriate use of ancillary tests in these disorders. Details of the ancillary tests used for the workup of the various diseases are provided in Chapters 2, 3 and 4 and will not be repeated here.

Cytochemical studies are still performed at many institutions and can often provide quick general information about the cell type of an acute leukemia (myeloid versus myeloperoxidase negative), but because more detailed information can now be obtained by flow cytometry in the same time frame, the use of these less specific cytochemical studies has decreased. Immunophenotyping, usually by multicolor flow cytometry, is now standard for acute leukemias and is absolutely required to accurately diagnose the lymphoblastic leukemias and some AMLs.^{7,11,12,35,36} In cases of acute leukemia with marrow fibrosis, as may occur with some acute megakaryoblastic leukemias and with acute panmyelosis with myelofibrosis (APMF) (see Fig. 73.1), paraffin section immunohistochemistry performed on a BM trephine biopsy is essential.³⁷ The use of flow cytometry immunophenotyping in the MDSs is the subject of much study, and many centers have incorporated this technique into the evaluation of patients with potential MDS not only to help quantitate blood and marrow blast cell percentages, but also to detect abnormal maturing cell populations.^{11,38,39} These methods, however, do not replace morphologic evaluation, including morphologic blast cell counts on smears.

Cytogenetic studies should also be performed on all cases of suspected acute leukemia or MDS.^{21,40,41} While specific gene mutations and some structural abnormalities will be missed by this method, karyotype analysis currently provides the best overall assessment of chromosomal abnormalities and should not be supplanted by other studies. Fluorescence in situ hybridization (FISH) or polymerase chain reaction (PCR) studies are often helpful to detect cryptic abnormalities that may be missed by karyotype analysis and are often added in panels for suspected

acute leukemia or MDS.⁴² Finally, molecular studies for specific gene mutations are now routinely performed on samples from patients with these disorders, but when each mutation is studied individually the specific tests performed should be ordered based on the findings of other studies. However, with the rapid growth of next-generation sequencing technology,⁴³ more cost-effective gene mutation panels will become available that may reduce the need for selective testing.

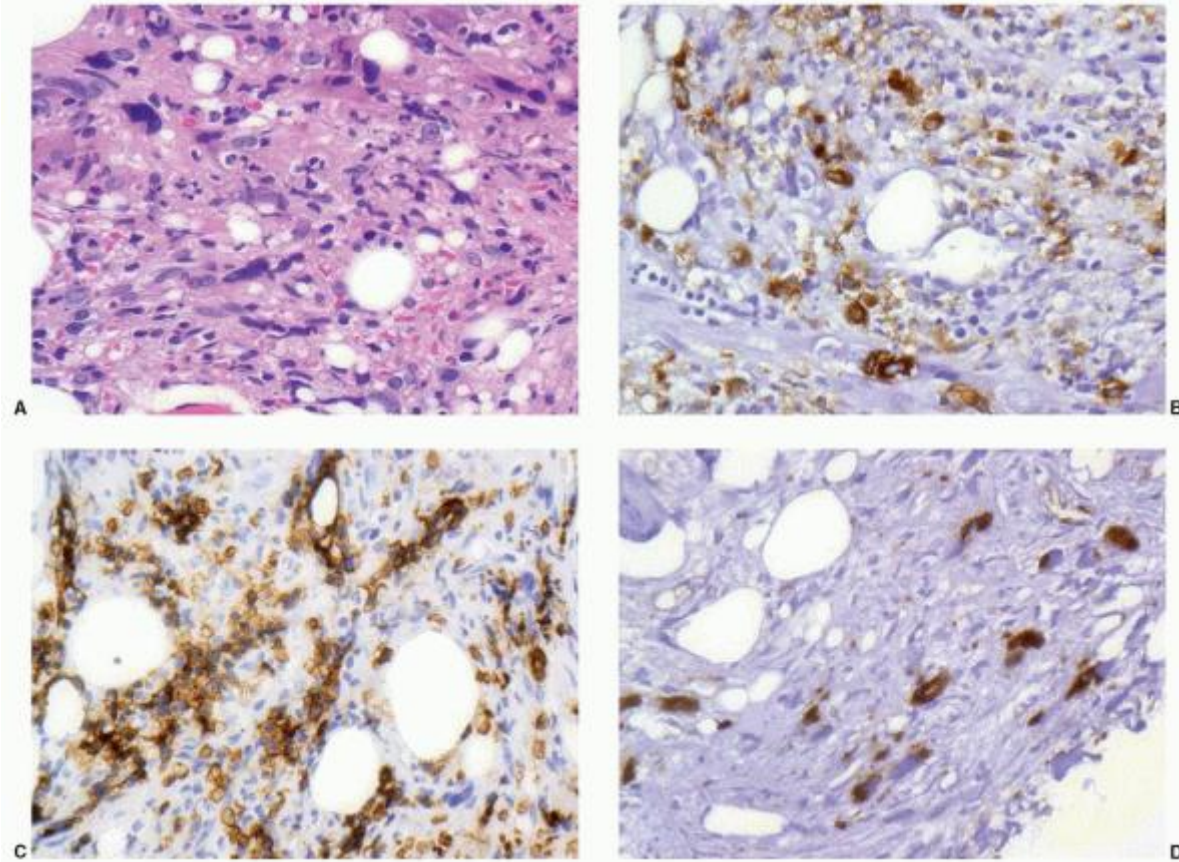

FIGURE 73.1 Acute panmyelosis with myelofibrosis illustrating the use of immunohistochemistry in diagnosis. The marrow is inaspirable due to marked marrow fibrosis (A) with a mixed cellular population that includes immature mononuclear cells. The cells show a mix of granulocyte precursors marking with myeloperoxidase (B), erythroid precursors marking with glycophorin B (C), and immature megakaryocytes marking with von Willebrand's factor (D).

Once this broad array of studies is complete, the results should be incorporated into a single report with a final diagnosis. Because they cannot always be completed in the time interval needed to begin therapy, this approach requires the use of preliminary and amended reports. Because the WHO classification relies on use of cytogenetic studies and some prognostic risk groups are defined by mutation analysis, the diagnosis often needs to be refined, and thus amended, when these studies are complete.

MYELOYDYSPLASTIC SYNDROMES

Patients with MDS typically show persistent (>6 months) unexplained cytopenias. The majority of MDS patients present with anemia. Neutropenia and thrombocytopenia are less common presenting symptoms. The cytopenias are defined by a hemoglobin level of less than 10 g/dL, an absolute neutrophil count of less than $1.8 \times 10^9/L$, and a platelet count of less than $100 \times 10^9/L$.^{33,44} Of note, CBC values higher than those listed above are not exclusionary for a diagnosis of MDS if definitive morphologic and/or cytogenetic findings are consistent with such a diagnosis. Since the presence of cytopenia(s) is required for the diagnosis, the most current and preferably previous CBCs have to be reviewed at the time of BM exam. Other pertinent data include medications, chemical exposure history, and previous and current illnesses, since all of these can cause morphologic dysplasia indistinguishable from MDS. Comorbidities associated with morphologic dysplasia are frequent in elderly patients affected by MDS, and include liver and kidney failure, autoimmune disorders, neoplasms, and systemic infections. In particular, morphologic evaluation is best performed when the patient is off medication.

Dysplastic features can be present in a single hematopoietic lineage (unilineage dysplasia) or involve all marrow populations (multilineage dysplasia) (Fig. 73.2). At least 10% of all cells in a given lineage (erythroid, myeloid, megakaryocytic) have to be dysplastic for establishing the presence of MDS-associated dysplasia. The majority of MDS subtypes show dyserythropoiesis. PB shows normocytic, normochromic, or macrocytic anemia with macroovalocytes. Microcytosis can be present in rare cases of MDS (e.g., cases associated with congenital or acquired alpha thalassemia).⁴⁵ The most common dysplastic features seen in erythroid precursors include nuclear abnormalities such as nuclear

P.1545

budding, nuclear fragmentation, irregular nuclear outlines, karyorrhexis, internuclear bridging, multinucleation, and megaloblastoid, coarsely condensed chromatin. Cytoplasmic vacuoles with coalescing vacuoles, defective hemoglobinization and increased numbers of ring sideroblasts can also be encountered. Similarly, dysgranulopoiesis is often manifested by abnormal nuclear features including hypolobation (pseudo-Pelger-Huët or monolobated neutrophils), hypersegmented and/or enlarged nuclei, nuclear sticks or fragments, macropolycytes, and abnormally condensed chromatin, which often coexists with nuclear hypolobation.

P.1546

Cytoplasmic features of neutrophil dysplasia include hypogranulation, pseudo-Chediak-Higashi granules, and rarely Auer rods. Hypogranulation occurs frequently and is related to the defective formation of secondary granules. However, the evaluation of this feature is highly subjective and dependent on the staining quality. A well-stained segmented neutrophil or neutrophilic precursor with well-developed secondary granules present, preferably in the same microscopic field, can be used as an internal control. Megakaryocyte morphology can be evaluated using both aspirate smear and the histologic sections (biopsy or clot section) with careful examination of at least 30 megakaryocytes.^{33,44} Dysplastic features include monolobated, hypolobated, and hyperlobated nuclei, and multiple, widely separated nuclei including "pawn-ball" forms. Normal size or small megakaryocytes with a single (nonlobated) eccentrically placed nucleus are common in 5q- syndrome and in cases with abnormalities of chromosome 3. The latter also shows typically numerous bilobated forms. Megakaryocytic dysplasia is often associated with thrombocytopenia and platelets of variable size, including large forms occasionally showing hypogranulation.

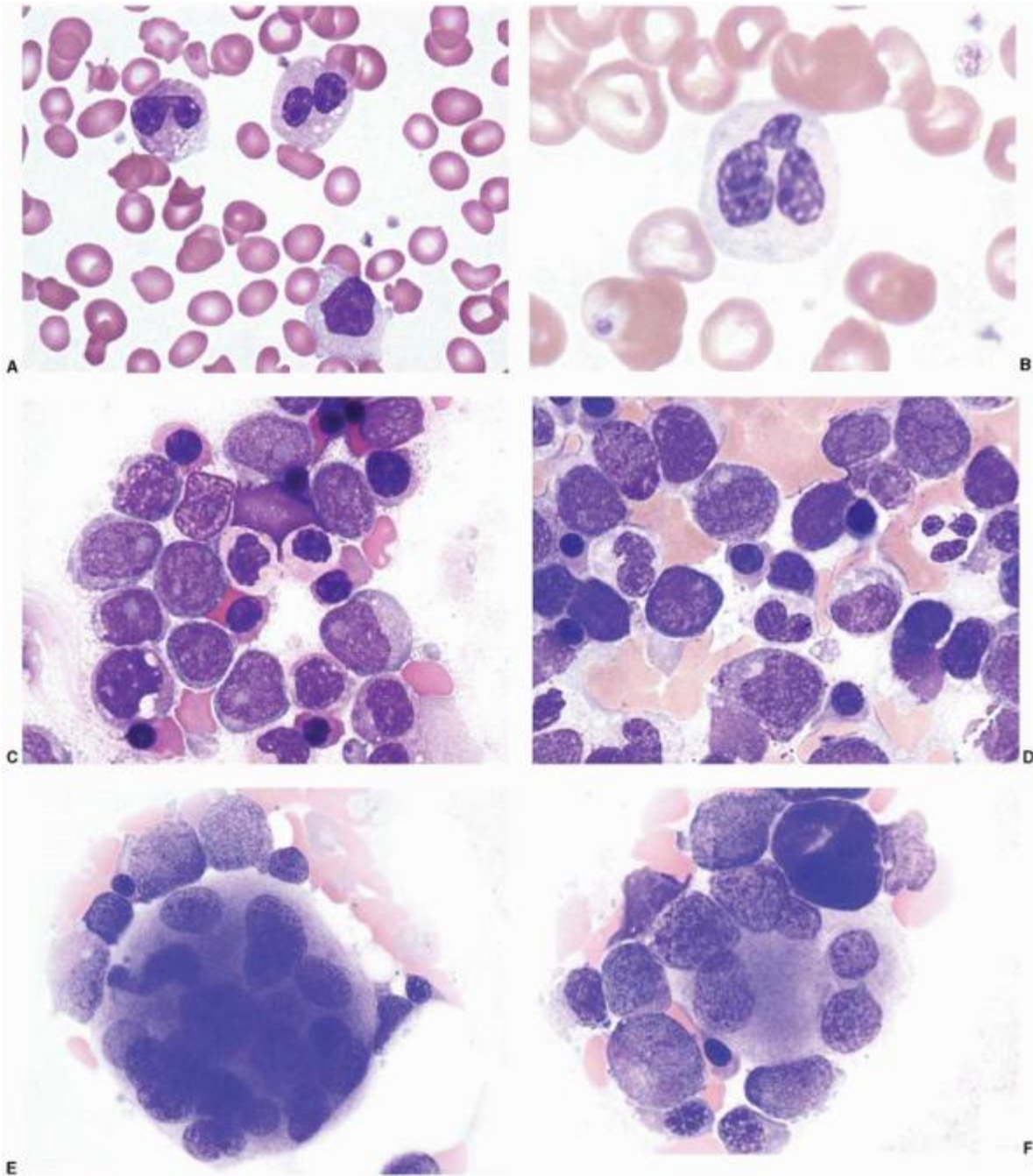

FIGURE 73.2 Dyspoietic changes in myelodysplastic syndrome and acute myeloid leukemia. Peripheral blood (A, B) and bone marrow (C, D) neutrophils may show cytoplasmic hypogranulation, clumped nuclear chromatin, and hypossegmentation, including pseudo-Pelger-Huët anomaly as shown in image A. Dyserythropoiesis may include nuclear-cytoplasmic asynchrony and irregular nuclear shapes in the marrow erythroid precursors (C, D). Megakaryocyte changes include hypersegmented cells (E) and smaller, hypolobated cells (F).

The biopsy allows for the evaluation of cellularity, architectural features, fibrosis, and the presence of previously undiagnosed focal lesions such as metastatic neoplasms or infections. In MDS marrows, the typical architectural organization is lost. Clusters of immature cells are frequently found in the center of the marrow space. This finding was originally termed abnormal localization of immature precursors and is more frequently seen in cases of high-grade MDS. The identification of blast clusters is facilitated by CD34 immunohistochemistry, which is also useful to determine the number of blasts in cases with inaspirable marrows. The presence of CD34 positive cell clusters is a prognostically significant finding that is predominantly seen in high-risk MDS.⁴⁶ The BM biopsy is necessary for the assessment of BM fibrosis by the Gomori silver impregnation method. Significant fibrosis occurs predominantly in high-risk and therapy-

related MDS; however, it may also occur in low-risk disease. Finally, BM biopsy is critical for the exclusion of other hematologic and also nonhematologic diseases associated with unexplained cytopenia(s) which can clinically mimic MDS.

In addition to dysplasia, the evaluation of blasts constitutes a cornerstone of morphologic diagnosis of MDS. The optimal quality of BM aspirate and PB smears cannot be overemphasized.³³ The blast percentage is derived from the 500-cell differential count of marrow aspirate smear and 200-cell PB manual differential count. Both differential counts are essential for the subclassification of individual cases. The agranular and granular (type II and type III blasts), and, if present, monoblasts, promonocytes, and megakaryoblasts are included in the blast category.⁴⁷ In the absence of adequate BM aspirate smears due to causes such as an inaspirable marrow, careful inspection of the histologic material aided by a CD34 immunohistochemical stain can be used. The latter is particularly helpful in cases with significant marrow fibrosis or in hypoplastic marrows, which often yield hemodilute marrow aspirates.^{48,49,50} Of note, blasts in MDS can be negative for CD34, therefore careful correlation with the visual blast identification is required in all cases. It is also important to emphasize that morphologic dysplasia is not equivalent to the diagnosis of MDS. Megakaryocytic and erythroid dysplasia are commonly seen in individuals in a variety of conditions. Nutritional deficiencies, heavy metal exposure, medications, and systemic diseases can produce morphologic changes resembling those seen in MDS. Therefore, as discussed previously, the correlation with clinical history is critical.

Cytogenetics is crucial and is also required for proper classification. The MDS-associated abnormalities are listed in Table 73.1. In addition, mutational analysis is becoming an important additional tool in the prognostic assessment of MDS^{30,51}; but mutation studies are not routinely performed in the evaluation for MDS at this time.

TABLE 73.1 RECURRENT CHROMOSOMAL ABNORMALITIES AND THEIR FREQUENCY IN MYELOYDYSPLASTIC SYNDROME

Abnormality	Frequency (%)
<i>Unbalanced</i>	
+8	10
-7 or del(7q)	10
-5 or del(5q)	10
del(20q)	5-8
-Y	5
i(17q) or t(17q)	3-5
-13 or del(13q)	3
del(11q)	3
del(12q) or t(12q)	3
del(9q)	1-2
idic(X)(q13)	1-2
<i>Balanced</i>	
t(1; 3)(p36.3;q21.2)	1
t(2; 11)(p21;q23)	1
inv(3)(q21;q26.2)	1
t(6;9)(p23;q34)	1

The 2008 WHO classification further refined the criteria for diagnosis and classification of MDS, and seven categories are now recognized (Table 73.2). Cases currently recognized as refractory cytopenia with unilineage dysplasia (RCUD) were considered as refractory anemia (RA) or MDS, unclassifiable in the 2001 WHO classification. Such cases encompass patients with one isolated cytopenia or bicytopenia associated with unilineage dysplasia. An advantage of the new category of RCUD is that one can further specify the lineage: refractory anemia, refractory neutropenia, or refractory thrombocytopenia. Regardless of the lineage involved in RCUD, blasts are absent or represent less than 1% of the PB differential count. Patients with 1% blasts in PB or patients with unilineage dysplasia associated with pancytopenia are

now classified as having unclassifiable MDS (MDS-U), owing to the uncertain but presumably more severe clinical significance of these findings.² Overall, the category of MDS-U is currently better defined and also includes cytopenic patients lacking significant dysplasia, but presenting with cytogenetic abnormalities considered presumptive evidence of MDS.

The 2008 WHO classification acknowledged a subset of pediatric patients with specific MDS features different from those commonly seen in adults, and included a separate category of childhood MDS termed refractory cytopenia of childhood. This category encompasses children with MDS that have persistent cytopenia with less than 2% blasts in the PB and less than 5% blasts in the BM.^{52,53}

Some subtypes or presentations of MDS are more challenging and will be discussed in more detail. MDS-U includes cases which do not fulfill criteria of other MDS subtypes. MDS-U can be diagnosed in patients fulfilling the following criteria: (1) patients who fit the criteria for a diagnosis of RCUD or refractory cytopenia with multilineage dysplasia (RCMD), but in whom 1% blasts in the blood are found on at least two consecutive occasions; (2) patients with MDS with pancytopenia and morphologic dysplasia limited to one hematopoietic lineage; (3) patients with persistent cytopenias, no increase in blasts, and lacking diagnostic morphologic features of MDS (less than 10% dysplastic cells in any lineage), but with clonal cytogenetic abnormalities considered as a presumptive

P.1547

evidence of MDS. According to the 2008 WHO classification, if characteristic features of a specific subtype of MDS develop later in the course of the disease, the case initially classified as MDS-U should be reclassified accordingly. The prognosis of MDS-U varies and close follow-up is warranted.

TABLE 73.2 THE WHO 2008 CLASSIFICATION OF MDS

Subtype	Blood findings	Bone marrow findings
Refractory cytopenias with unilineage dysplasia (RCUD)		Unilineage dysplasia;
Refractory anemia (RA)	Unicytopenia or bicytopenia ^a	≥10% of the cells of the affected lineage are dysplastic
Refractory neutropenia (RN)	No or rare blasts (<1%)	<5% blasts
Refractory thrombocytopenia (RT)		<15% ring sideroblasts
Refractory anemia with ring sideroblasts (RARS)	Anemia No blasts	Erythroid dysplasia only <5% blasts ≥15% ringed sideroblasts
Refractory cytopenia with multilineage dysplasia (RCMD)	Cytopenia(s) No or rare blasts (<1%) No Auer rods <1 × 10 ⁹ L monocytes	Dysplasia in ≥10% of cells in two or more myeloid lineages <5% blasts No Auer rods ±15% ring sideroblasts
Refractory anemia with excess blasts-1 (RAEB-1)	Cytopenias <5% blasts No Auer rods <1 × 10 ⁹ L monocytes	Unilineage or multilineage dysplasia 5-9% blasts No Auer rods
Refractory with excess blasts-2	Cytopenias	Unilineage or multilineage dysplasia

(RAEB-2)	5-19% blasts ±Auer rods <1 × 10 ⁹ L monocytes	10-19% blasts ±Auer rods ^b
Myelodysplastic syndrome, unclassified (MDS-U)	Cytopenias No or rare blasts (≤1%) No Auer rods	Unequivocal dysplasia in <10% of cells in one or more myeloid cell lines <5% blasts
MDS associated with isolated del(5q)	Anemia No or rare blasts (<1%) Platelet count usually normal or increased	Normal to increased megakaryocytes with hypolobated nuclei <5% blasts Isolated del(5q) cytogenetic abnormality No Auer rods

^a Bicytopenia may occasionally be observed. Cases with pancytopenia should be classified as MDS-U.

^b If the diagnostic criteria for MDS are fulfilled and Auer rods are present, the patient should always be categorized as RAEB-2.

MDS with fibrosis (MDS-F) is defined by the presence of significant fibrosis (at least 3+ reticulin fibrosis according to the Manoharan scoring system, or at least 2+ reticulin fibrosis according to the European consensus grading system).^{44,54,55} In the past, select cases with 2+ reticulin fibrosis according to Manoharan scoring may have been classified as MDS-F. Approximately 10% to 15% of MDS patients show a significant increase in reticulin fibers and/or collagen fibrosis at presentation.⁵⁴ These patients are diagnosed with an MDS subtype according to the 2008 WHO classification, with the annotation to indicate the presence of fibrosis. The majority of MDS-F cases fall into the category of refractory anemia with excess blasts (RAEB). Therapy-related MDS cases frequently show significant marrow fibrosis, but are excluded from the MDS-F category in favor of placing them in a special entity of therapy-related myeloid neoplasms. The majority of MDS-F patients present with severe pancytopenia. Organomegaly is minimal or absent. The patients with MDS-F are reported to have shorter overall survival and disease-free survival times than those without fibrosis, even in the absence of excess blasts.^{54,56,57} BM fibrosis is also associated with a poor outcome after BM transplantation.⁵⁸ BM and PB often show trilineage dysplasia with excess blasts. There is prominent dysmegakaryopoiesis, often associated with increased numbers of megakaryocytes. Cellular streaming is frequently seen on H&E biopsy section and is indicative of significant fibrosis. CD34 immunostaining may be helpful in assessing the number of blasts, since the aspirate smears are often inadequate in patients with fibrotic marrows. Differential diagnoses of MDS-F include other myelofibrotic myeloid neoplasms such as APMF, myeloproliferative, and myelodysplastic/myeloproliferative neoplasms. Similar to MDS-F, APMF, a subtype of AML-NOS (not otherwise specified), shows marked fibrosis, trilineage dysplasia, and dwarf megakaryocytes. The higher number of blasts (in the range of 20% to 25%), abrupt onset with fever and bone pain, and rapidly progressive course seen in APMF are helpful in establishing the definitive diagnosis.³⁷ Classic myeloproliferative neoplasms, such as primary myelofibrosis, can usually be easily distinguished from MDS-F by their morphologic characteristics (e.g., large-to-giant megakaryocytes with cloud-like nuclei, lack of other myelodysplastic features), and by the presence of significant splenomegaly.^{33,59} Myelodysplastic/myeloproliferative neoplasms such as chronic myelomonocytic leukemia may show morphologic features similar to MDS, yet demonstrate laboratory and clinical features of a proliferative process such as elevated WBC and monocytosis.

Hypoplastic MDS (h-MDS), which is defined by its low marrow cellularity (cellularity of less than 20% for patients older than 70 years of age and less than 30% for individuals younger than 70 years), accounts for 5% to 10% of MDS patients.^{2,60} Similar to typical cases of MDS, h-MDS is a disease of the elderly. It is more common in women. H-MDS has a prognosis and rate of transformation to AML similar to the corresponding

P.1548

WHO-classified MDS subtypes. The major differential diagnosis of h-MDS is aplastic anemia.^{60,61} The typically hemodilute

marrow aspirates obtained from hypoplastic marrow limit the evaluation of cytologic features, and in this context the information derived from BM biopsy/clot section is of paramount importance. The majority of patients with h-MDS present with dyserythropoiesis and no increase in blasts, and are classified as RA.^{60,61} Dysgranulopoiesis, dysmegakaryopoiesis, and increase in blasts occur less frequently. Patients with h-MDS can show mast cell hyperplasia, interstitial lymphocytosis, and lymphoid follicles. In the absence of significant multilineage dysplasia and/or increased blast population, the distinction from aplastic anemia can be challenging. The presence of megakaryocytes, increased reticulin fibers, and focally increased CD34 positive cells all suggest h-MDS. The immunohistochemical stains for CD34 and megakaryocytic antigens (CD42b and CD61) and reticulin stain are recommended to highlight the presence of these features.^{60,61} Additional findings such as immunophenotypic abnormalities by flow cytometry or the presence of select cytogenetic markers such as losses of chromosomes 5 and/or 7, which are uncommon in aplastic anemia, are also helpful. The applications of novel technologies may help to better differentiate aplastic anemia from h-MDS, and aid in early detection of transformation in the former entity.⁶² The diagnostic challenges might be related to the overlap in pathogenesis as demonstrated by the T-cell-mediated suppression of hematopoiesis or the coexistence of clones of paroxysmal nocturnal hemoglobinuria cells documented to occur in both diseases.⁶³

Erythroid-predominant MDS (MDS-E) can also cause diagnostic difficulties. By definition, these patients have less than 20% of blasts both as enumerated from the total marrow cellularity and from the nonerythroid BM population. The latter is necessary to exclude a diagnosis of erythroleukemia. In MDS-E, similar to other cases of MDS, blasts are enumerated as a percentage of all BM cells and their number is used to classify cases into one of the MDS subtypes.^{2,33} However, recent studies suggested that the alternative approach of calculating the percentage of blasts as a proportion of nonerythroid cells might provide a more accurate assessment of overall prognosis in MDS-E.⁶⁴ If blasts are calculated as a percentage of nonerythroid cells, the upgrade to a higher-risk subtype of MDS occurs mainly between the categories of RCMD and RAEB-1 and between RAEB-1 and RAEB-2. Changes from low-risk to high-risk MDS categories are exceedingly rare. Until more evidence is published, it is currently recommended to use the standard WHO criteria, using blast percentages based on all cells, to classify cases of MDS-E.

ACUTE MYELOID LEUKEMIA

The classification of AML has changed dramatically from the FAB classification^{7,8,10,65} to the WHO classification.² While the FAB classification was based primarily on morphologic and cytochemical features of the blast cells, the WHO uses a combined approach in an attempt to define prognostically significant and biologically relevant disease groups. While many of the WHO categories rely heavily on cytogenetic findings, most still retain distinctive morphologic and immunophenotypic findings. The specific AML disease categories are listed in Table 73.3, and some of the distinctive morphologic and immunophenotypic features of specific types are illustrated in Figures 73.1, 73.3, and 73.4 and described in Table 73.4.

For most cases, a blast cell count of 20% or more in either the PB or BM aspirate is necessary for a diagnosis of AML. For cases with one of three recurring cytogenetic abnormalities (t(15;17) (q24.1;q21.1) PML-RARA; t(8;21)(q22;q22) RUNX1-RUNX1T1; and inv(16)(p13.1q22) or t(16;16)(p13.1;q22) CBFβ-MYH11), however, a diagnosis of AML can be made with a lower blast count. These low blast count cases are uncommon and still have abnormal blood and marrow findings. The detection of the cytogenetic abnormality would indicate AML over a diagnosis of MDS in these cases. Acute erythroid leukemia (erythroid myeloid type) is also diagnosed with less than 20% blood or marrow blasts (see below).

TABLE 73.3 2008 WORLD HEALTH ORGANIZATION CLASSIFICATION OF ACUTE MYELOID LEUKEMIA AND RELATED PRECURSOR NEOPLASMS

AML with recurrent genetic abnormalities

AML with t(8;21) (q22;q22) (*RUNX1-RUNX1T1*)

AML with inv(16)(p13.1q22) or t(16;16) (p13.1;q22) (*CBFβ-MYH11*)

Acute promyelocytic leukemia with t(15;17)(q24.1;q21.1) (*PML-RARA*)

AML with t(9;11)(p22;q23) (*MLLT3-MLL*)

AML with t(6;9)(p23;q34) (*DEK-NUP214*)

AML with inv(3)(q21q26.2) or t(3;3)(q21;q26.2) (*RPNI-EVI1*)

AML (megakaryoblastic) with t(1;22)(p13;q13) (*RBM15-MKLI*)

Provisional entity: AML with mutated *NPM1*

Provisional entity: AML with mutated *CEBPA*

AML with myelodysplasia-related changes

Therapy-related myeloid neoplasms

AML not otherwise specified

AML minimally differentiated

AML without maturation

AML with maturation

Acute myelomonocytic leukemia

Acute monoblastic and monocytic leukemia

Acute erythroid leukemia

Acute megakaryocytic leukemia

Acute basophilic leukemia

Acute panmyelosis with myelofibrosis

Myeloid sarcoma

Myeloid proliferations related to Down syndrome

Blastic plasmacytoid dendritic cell neoplasm

AML, acute myeloid leukemia.

The WHO classification defines AML types by recurring genetic abnormalities,⁶⁶ by recognizing cases related to MDS,⁶⁷ and by separating diseases related to prior therapy⁶⁸ or associated with Down syndrome.⁶⁹ Cases that do not fall into any of those groups are placed in the AML-NOS group⁷⁰ and can be subdivided by morphologic features. Many of these cases, however, have normal karyotypes, and the search for predictive markers to better categorize them is ongoing.⁷¹

AML with recurring genetic abnormalities was expanded in the 2008 WHO classification to include more disease groups and to attempt to incorporate disease-defining mutations. AML with mutated *CEBPA* and AML with mutated *NPM1* are provisional disease categories based on the hypothesis that these mutations are disease-defining events,^{72, 73, 74, 75} and similar to the other recurring cytogenetic abnormalities in this category, and not merely secondary events that impact prognosis.

AML with myelodysplasia-related changes of the 2008 WHO classification (Table 73.5) is an expansion and revision of the category of AML with multilineage dysplasia in the 2001 classification.^{3,67} The use of multilineage dysplasia as the sole source of classifying AML is controversial. Certainly cases of AML arising from MDS can lack sufficient background cells to diagnose multilineage dysplasia and the expansion of this category now allows cases to be diagnosed as AML with myelodysplasia-related changes by demonstrating the presence of multilineage dysplasia, presence of an MDS-associated cytogenetic abnormality (Table 73.6), a history of prior MDS or a myelodysplastic/myeloproliferative neoplasm, or a combination of such findings. This combined approach captures more cases of AML and defines a group with a particularly poor prognosis in adults.

P.1549

Cases with a normal karyotype and no history, but the presence of multilineage dysplasia, defined as two or more cell lines with 50% or more dysplastic cells, is the major area of controversy. While some large series have failed to find prognostic significance for this group,^{77,78} other studies find multilineage dysplasia to still independently predict a worse outcome compared to AML-NOS.^{3,78}

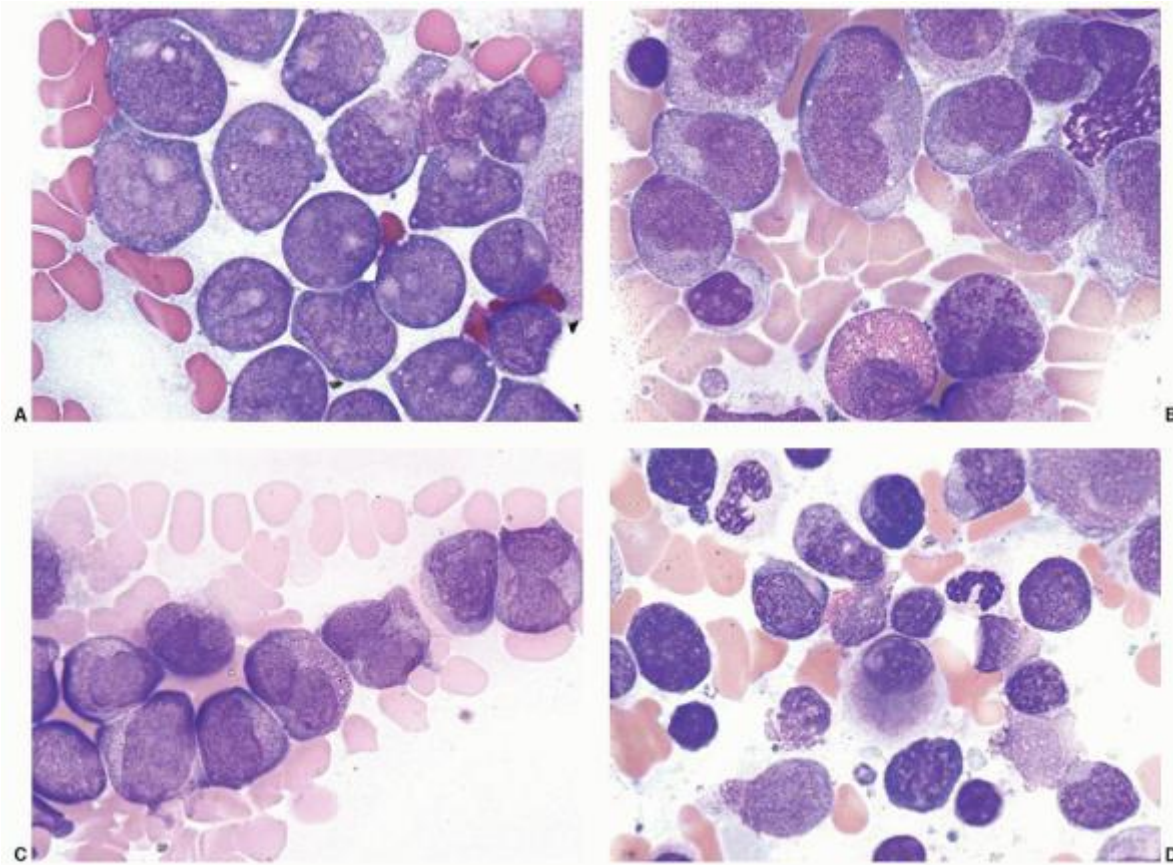

FIGURE 73.3 Morphologic features of more common acute myeloid leukemia types with recurrent cytogenetic abnormalities. A: Acute myeloid leukemia with $t(8;21)(q22;q22)$ (RUNX1-RUNX1T1) with blasts containing abundant cytoplasm with large granules and perinuclear clearing (hofs). B: Acute myeloid leukemia with $inv(16)(p13.1q22)$ or $t(16,16)(p13.1;q22)$ (CBFB-MYH11) with an abnormal eosinophil containing large basophilic granules (lower right). C: Acute promyelocytic leukemia with $t(15;17)(q24.1;q21.1)$ (PML-RARA) typically shows blasts with bilobed nuclei, cytoplasmic granules and Auer rods (far right). D: Acute myeloid leukemia with $inv(3)(q21q26.2)$ (RPN1-EVI1) with background dyspoiesis and a small, monolobated megakaryocyte (center).

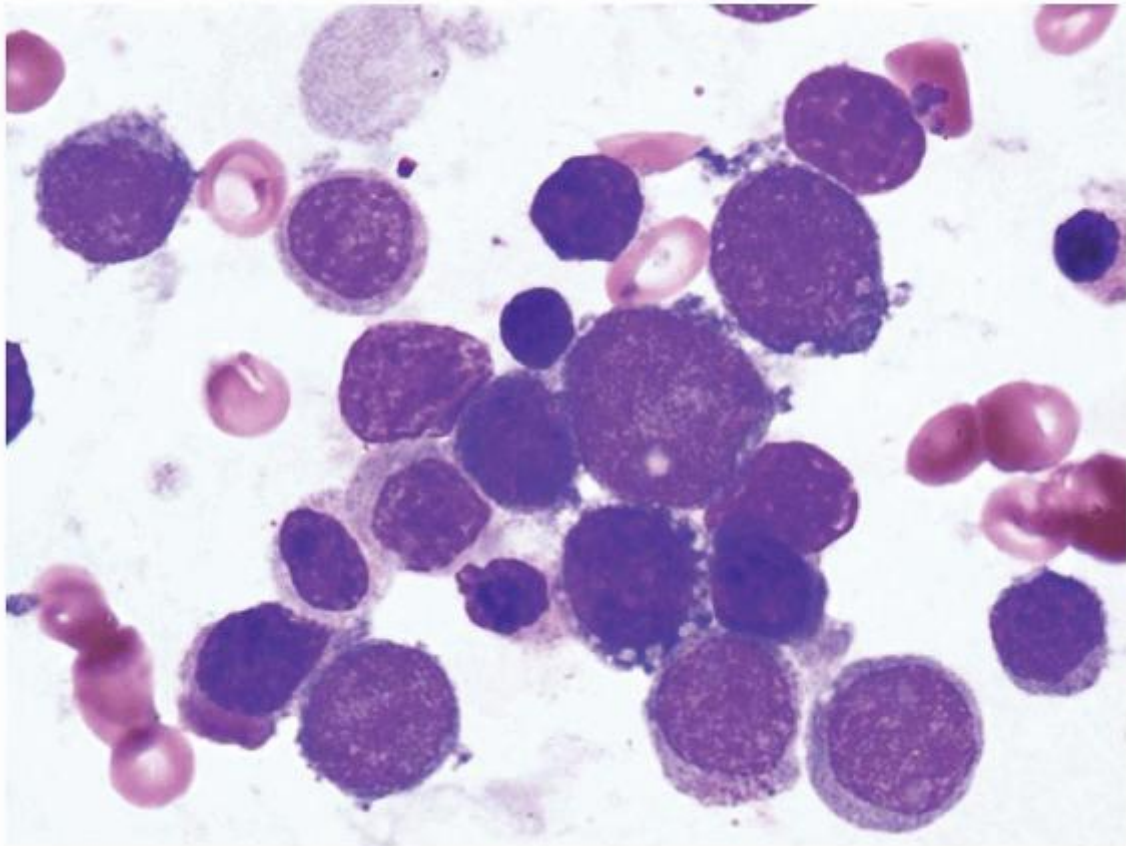

FIGURE 73.4 Acute erythroid leukemia, mixed myeloid erythroid type. Over 50% erythroid precursors are present in the bone marrow with dyspoietic changes that include cytoplasmic vacuolization (lower center). In addition, scattered blasts, which mark as myeloblasts, are present in the background (upper left and lower right) representing over 20% of the nonerythroid cells in the marrow.

Therapy-related myeloid neoplasms and the myeloid neoplasms associated with Down syndrome are also felt to be distinct from other AML types, and these also tend to show a continuum between cases with features of AML and MDS. For this reason, they are now considered separate disease entities, respectively, from the non-therapy or-Down-related leukemias.

The remaining cases are placed into the category of AML-NOS and this category includes many normal karyotype cases and cases that are diagnosed as AML with unique features. The subcategories of AML-NOS are probably of little significance, and mutation analysis is probably most important in this group. Selected mutations (FLT3 and KIT) are included as prognostic markers for different AML types in the WHO classification. While the utility of KIT mutations is primarily in the core binding factor leukemias (those with t(8;21)(q22;q22) RUNX1-RUNXT1; and inv(16)(p13.1q22) or t(16;16)(p13.1;q22) CBFβ-MYH11),⁷⁹ FLT3 and NPM1 mutations are prognostically predictive in most

P.1550

cases of AML-NOS.^{28,72,73,80, 81, 82, 83} and ⁸⁴ In addition to the mutations included in the 2008 WHO classification, other mutations have been described and validated as potential prognostic markers.^{27,85,86,87,88} Some of the most frequently occurring in AML include DNMT3A, IDH1, IDH2, TET2, RUNX1, NRAS, and WT1. Table 73.7 demonstrates one approach to combining cytogenetic studies and mutation analysis to develop prognostic categories in AML, but this approach will have to be frequently updated to include new discoveries.⁸⁵

TABLE 73.4 DISTINCTIVE CLINICAL, MORPHOLOGIC, AND IMMUNOPHENOTYPIC FEATURES OF ACUTE MYELOID LEUKEMIA CYTOGENETIC SUBTYPES

AML Subtype

Distinctive Features

AML with t(8;21) (q22;q22) (<i>RUNX1-RUNX1T1</i>)	Granular blasts with perinuclear hofs, large salmon-colored granules, aberrant CD19 expression on CD34 ⁺ myeloblasts
AML with inv(16)(p13.1q22) or t(16,16) (p13.1;q22) (<i>CBFB-MYH11</i>)	Presence of abnormal eosinophils with basophilic granules
Acute promyelocytic leukemia with t(15;17)(q24.1;q21.1) (<i>PML-RARA</i>)	Bilobed nuclei with blasts lacking HLA-DR and usually CD34-negative
AML with t(6;9)(p23;q34) (<i>DEK-NUP214</i>)	Multilineage dysplasia and associated basophilia
AML with inv(3)(q21q26.2) or t(3;3) (q21;q26.2) (<i>RPNI-EVII</i>)	Multilineage dysplasia and increased numbers of small mono- or bilobed megakaryocytes
AML (megakaryoblastic) with t(1;22) (p13;q13) (<i>RBM15-MKLI</i>)	Infant without Down syndrome with CD41+ and CD61+ blasts

AML, acute myeloid leukemia.

Categories of AML-NOS that offer the greatest diagnostic challenge are probably acute erythroleukemia and APMF. Acute erythroleukemia can be the pure erythroid leukemia with over 80% immature erythroid cells and no myeloblasts or a mixed myeloid erythroid type.⁸⁹ The latter type (Fig. 73.4) has 50% or more BM erythroid precursors; and of the nonerythroid marrow cells, 20% or more myeloblasts. The differential diagnosis of both types is with MDS, and both are probably closely related to aggressive MDS. APMF usually involves an inaspirable marrow with marked fibrosis and a mix of immature myeloid, erythroid, and megakaryocytic cells (Fig. 73.1).^{37,90} This rare disorder is also difficult to distinguish from MDS-F and may be related to such proliferations.

TABLE 73.5 CRITERIA FOR DIAGNOSIS OF ACUTE MYELOID LEUKEMIA WITH MYELODYSPLASIA-RELATED CHANGES

- 1) At least 20% blasts in the blood or bone marrow
- 2) No history of prior cytotoxic therapy for other disease
- 3) Absence of a recurring chromosomal rearrangement as delineated in [Table 73.3](#)

AND, one or more of the following features:

- 1) Previous history of myelodysplastic syndrome or myelodysplastic/myeloproliferative disorder
- 2) Multilineage dysplasia (dyspoiesis in at least 50% of the elements from two or more lineages)
- 3) Presence of an MDS-associated cytogenetic abnormality (see [Table 73.6](#))

MDS, myelodysplastic syndrome.

TABLE 73.6 CYTOGENETIC ABNORMALITIES SUFFICIENT TO DIAGNOSE ACUTE MYELOID LEUKEMIA WITH MYELODYSPLASIA-RELATED CHANGES WHEN ≥20% BLASTS ARE PRESENT IN BLOOD OR BONE MARROW IN THE ABSENCE OF PRIOR CYTOTOXIC THERAPY

Complex karyotype	≥3 unrelated chromosomal abnormalities, not including any rearrangements that would define a subtype of AML with recurrent cytogenetic abnormalities	
Unbalanced abnormalities	-7/del(7q)	del(11q)
	-5/del(5q)	del(12p)/t(12p)
	i(17q)/t(17p)	del(9q)
	-13/del(13q)	idic(X)(q13)
Balanced abnormalities	t(11;16)(q23;p13.3)	t(5;12)(q33;p12)
	t(3;21)(q26.2;q22.1)	t(5;7)(q33;q11.2)
	t(1;3)(p26.3;q21.1)	t(5;17)(q33;p13)

t(2;11)(p21;q23)

t(5;10)(q33;q21)

t(3;5)(q25;q34)

In addition to new gene mutations, gene expression (i.e., BAALC and ERG), often altered by epigenetic changes in AML, is now recognized to have a prognostic impact on this disease.^{91,92,93} Our understanding of the role of miRNAs and gene methylation in the diagnosis and prognosis of AML will also clearly grow in the near future.

ACUTE LYMPHOBLASTIC LEUKEMIA

The diagnostic approach to ALL has also changed dramatically over time. While the immunophenotype of ALL was not part of the FAB classification,¹⁰ it is now essential for diagnosing these disorders. Also, the relationship between lymphoblastic lymphoma and ALL is now recognized, and these disorders are grouped together in the WHO classification.⁹⁴ Cases diagnosed in the past as ALL with a mature B-cell phenotype (FAB L3) are no longer considered as ALL and are best classified as leukemic variants of the mature B-cell lymphomas.

While morphologic evaluation is important in ALL to identify a blast cell proliferation, immunophenotyping must be performed because lymphoblasts cannot be distinguished reliably from undifferentiated myeloblasts by morphology alone. In fact some

P.1551

lymphoblasts will contain cytoplasmic granules that may incorrectly suggest myeloid lineage.⁹⁵ Cytochemical studies are also not sufficient for such a diagnosis, because the absence of myeloperoxidase or Sudan black B by these methods does not exclude undifferentiated myeloblasts and the detection of PAS-positive granules in blasts is not specific for lymphoblasts.

TABLE 73.7 LEUKEMIANET PROGNOSTIC GENETIC CATEGORIES OF ACUTE MYELOID LEUKEMIA

Genetic GroupSubsets

Favorable	<ul style="list-style-type: none"> t(8;21)(q22;q22); <i>RUNX1-RUNX1T1</i> inv(16)(p13.1q22) or t(16;16)(p13.1;q22); <i>CBFB-MYH11</i> Mutated <i>NPM1</i> without <i>FLT3-ITD</i> (normal karyotype) Mutated <i>CEBPA</i> (normal karyotype)
Intermediate-I	<ul style="list-style-type: none"> Mutated <i>NPM1</i> and <i>FLT3-ITD</i> (normal karyotype) Wild-type <i>NPM1</i> and <i>FLT3-ITD</i> (normal karyotype) Wild-type <i>NPM1</i> without <i>FLT3-ITD</i> (normal karyotype)
Intermediate-II	<ul style="list-style-type: none"> t(9;11)(p22;q23); <i>MLLT3-MLL</i> Cytogenetic abnormalities not classified as favorable or adverse
Adverse	<ul style="list-style-type: none"> inv(3)(q21q26.2) or t(3;3)(q21;q26.2); <i>RPNI-EVII</i> t(6;9)(p23;q34); <i>DEK-NUP214</i> t(v;11)(v;q23); <i>MLL</i> rearranged -5 or del(5q); -7; abnl(17p); complex karyotype

TABLE 73.8 2008 WORLD HEALTH ORGANIZATION CLASSIFICATION OF PRECURSOR LYMPHOID NEOPLASMS

B-lymphoblastic leukemia/lymphoma, not otherwise specified

B-lymphoblastic leukemia/lymphoma with t(9;22)(q34;q11.2)(*BCR-ABL1*)

B-lymphoblastic leukemia/lymphoma with t(v;11q23)(*MLL*)

B-lymphoblastic leukemia/lymphoma with t(12;21)(p13;q22) (*ETV6-RUNX1*)

B-lymphoblastic leukemia/lymphoma with t(5;14)(q31;q32) (*IL3-IGH@*)

B-lymphoblastic leukemia/lymphoma with t(1;19)(q23;p13.3) (*TCF3-PBX1*)

B-lymphoblastic leukemia/lymphoma with hyperdiploidy

B-lymphoblastic leukemia/lymphoma with hypodiploidy

T-lymphoblastic leukemia/lymphoma

The 2008 WHO classification (see Table 73.8) introduced cytogenetic subtypes of B-lymphoblastic leukemia and these studies are also essential for a complete diagnosis of ALL.⁹⁶ There are no specific morphologic features for these ALL types (Fig. 73.5), with the exception that the very rare ALL with t(5;14)(q31;q32) (IL3-IGH@) is associated with a marked proliferation of normal appearing eosinophils.⁹⁷ While there are no specific morphologic features to most of these disorders, there are some characteristic immunophenotypic features that provide clues to the diagnosis, some of which are listed in Table 73.9. While many of these categories are defined by the detection of recurring cytogenetic abnormalities, the translocation of B-lymphoblastic leukemia/lymphoma with t(12;21)(p13;q22) (ETV6-RUNX1) is cryptic,⁹⁸ and FISH or PCR testing must be performed to detect this category. Because this cytogenetic abnormality primarily occurs in children, routine molecular or FISH testing for this fusion is indicated in all pediatric B-ALL cases. Similarly, there are no morphologic clues to reliably distinguish T-lymphoblastic leukemia/lymphoma from B-lymphoblastic leukemia/lymphoma. Although nuclear convolutions are described as more common with a T-cell immunophenotype, this finding is not sufficiently reliable to replace immunophenotyping studies.

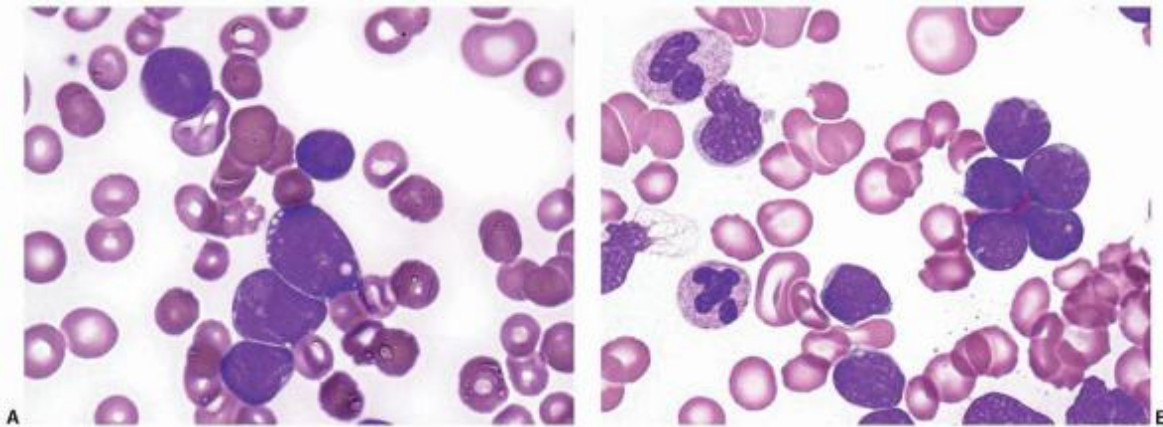

FIGURE 73.5 Acute lymphoblastic leukemia with blasts containing scant, agranular cytoplasm. The morphologic features are not specific and may also be present in minimally differentiated acute myeloid leukemia. Part A is from a case of B-lymphoblastic leukemia, while part B is from T-lymphoblastic leukemia; both showing similar morphologic changes.

While mutations studies are not part of the 2008 classification of ALL, numerous genetic alterations have been described in recent years for this disease and will further impact classification. Interestingly, and in contrast to most mutations that are common in AML, many individual mutations in ALL have been shown not to have prognostic impact as a sole marker, but may define prognostic groups when they occur in combination.⁹⁹ PAX5 mutations at 9p13 occur in approximately 30% of B-ALL cases and often occur in combination with other abnormalities; but this mutation alone does not appear to be clinically significant, and routine testing for this abnormality is probably not indicated. In contrast, deletions of IKZF1 at 7p12 often occur in combination with PAX5 mutations and are seen in over 80% of patients with B-ALL with t(9;22)(q34;q11.2)(BCR-ABL1). Even in the absence of the Philadelphia chromosome, children with this deletion (representing almost 30% of all Philadelphia chromosome negative ALLs in one study) have a poor outcome that is similar to B-ALL with t(9;22)(q34;q11.2). The poor prognosis of IKZF1 deleted ALL appears to be independent of age, white blood cell count, or cytogenetic subgroup.^{100,101} Mutations of JAK2, found in approximately 8% of B-ALL cases, in combination with IKZF1 deletions are associated with an even worse prognosis.¹⁰²

A new recurring cytogenetic abnormality, not included in the WHO classification, involves CRLF2 located at Xp22.3/Yp11.3 and most often translocated with IGH@.^{26,103} These translocations occur in 7% to 14% of B-ALL cases, but are associated with either ALL of Down syndrome or ALL in Hispanic patients. They are commonly associated with JAK1 or JAK2 mutations and IKZF1 deletions and have a very poor prognosis.

In contrast to AML, there is no category of ALL for therapy-related disease. Despite this, it is now recognized that ALL may occur after cytotoxic therapy although the relationship to the prior therapy and the leukemia may be under-

appreciated.^{104,105} Most cases of therapy-related ALL are of precursor B lineage and some studies suggest that they are most often associated with MLL translocations involving 11q23.

Recurring cytogenetic abnormalities also occur in T-ALL, but are not included as diagnostic subcategories in the WHO classification. These translocations most often involve T-cell receptor genes at 7q32 (TRB@) and 14q11 (TRA@, TRD@) and TLX1, TLX3 and TAL1, but many other genes may be involved in a smaller percentage of cases.^{106,107} Prognostic significance has not been determined for many of these genetic changes, although TLX1

P.1552

translocations appear to confer a good prognosis. Mutations are also common in T-ALL, with mutations of NOTCH1 found in 50% to 60% of adult and pediatric disease.^{106, 107, 108, 109} and ¹¹⁰ Mutations of FBXW7, a gene involved in NOTCH signaling, occurs in 10% to 20% of cases.^{108, 109} and ¹¹⁰ Mutations of either gene appear to have some prognostic significance in children, at least predicting a favorable treatment response with protocols that include cranial irradiation, but appear to be of less significance in adult patients. FLT3 mutations are rare in T-ALL, found in about 4% of cases.^{111,112} However, these mutations are much more frequent in cases described as early T-cell precursor (ETP)-ALL. These cases are considered to represent a particularly high-risk type of T-ALL^{111, 112} and ¹¹³ that expresses CD7, but lacks CD1a and CD8, shows only weak expression of CD5, expresses CD34, HLA-DR, and CD117, and often expresses myeloid-associated antigens such as CD13, CD33, and CD65s. Some cases in the past were probably diagnosed as undifferentiated, mixed phenotype or biphenotypic acute leukemia. While often FLT3 mutated, ETP-ALL typically lacks mutations of NOTCH1 or FBXW7.¹¹¹

TABLE 73.9 DISTINCTIVE CLINICAL, MORPHOLOGIC, AND IMMUNOPHENOTYPIC FEATURES OF B-LYMPHOBLASTIC LEUKEMIA CYTOGENETIC SUBTYPES

B-ALL Subtype	Distinctive Features
B-lymphoblastic leukemia/lymphoma with t(9;22)(q34;q11.2)(<i>BCR-ABL1</i>)	Precursor B-cell lineage with aberrant expression of CD13, CD33, CD38, and CD25
B-lymphoblastic leukemia/lymphoma with t(v;11q23)(<i>MLL</i>)	CD10-negative precursor B-cell lineage with aberrant CD15 expression
B-lymphoblastic leukemia/lymphoma with t(12;21)(p13;q22) (<i>ETV6-RUNX1</i>)	Childhood leukemia with precursor B-cell lineage with CD34, bright CD10, and aberrant expression of CD13
B-lymphoblastic leukemia/lymphoma with t(5;14)(q31;q32) (<i>IL3-IGH@</i>)	Precursor B-cell lineage associated with marked eosinophilia
B-lymphoblastic leukemia/lymphoma with t(1;19)(q23;p13.3) (<i>TCF3-PBX1</i>)	Precursor B-cell lineage lacking CD34 with cytoplasmic mu expression
B-ALL, B-cell acute lymphoblastic leukemia.	

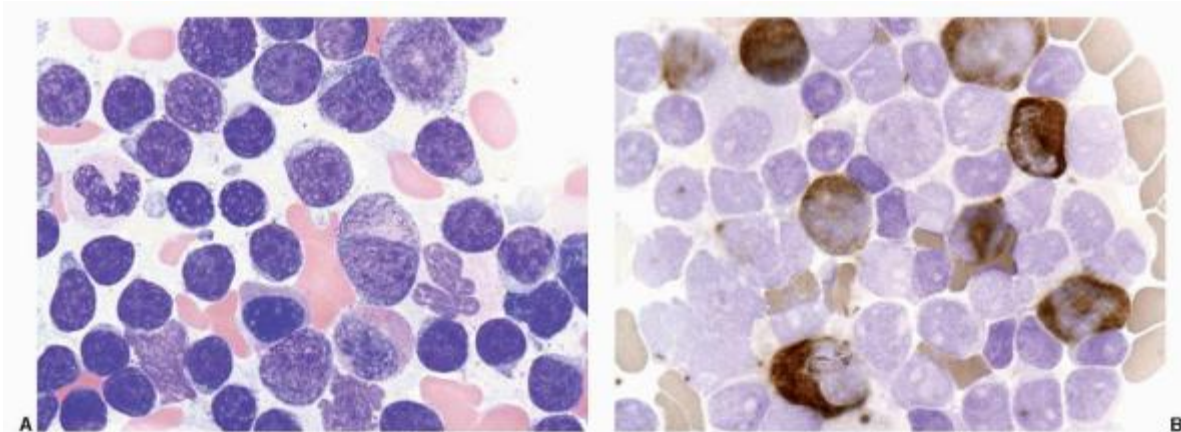

FIGURE 73.6 Mixed phenotype acute leukemia with a bilineal appearance. A mixture of small lymphocytes, small undifferentiated blast cells and larger blasts with granular cytoplasm are present (A). The small blasts mark as B

lymphoblasts, while the larger cells are myeloperoxidase positive by flow cytometry and cytochemistry (B).

ACUTE LEUKEMIAS OF AMBIGUOUS LINEAGE

Despite extensive immunophenotyping studies, a small subset of acute leukemias cannot be definitely classified as being derived from myeloid or lymphoid lineage.^{114,115} These acute leukemias are either acute undifferentiated leukemias or mixed phenotype acute leukemias (MPAL) (Table 73.10). Acute undifferentiated leukemias have become extremely rare with modern immunophenotyping panels and are defined as lacking expression of markers specific for myeloid or lymphoid lineage. They often express non-specific markers such as HLA-DR, CD34, CD38, CD7 or TdT, but lack expression of cytoplasmic CD3, myeloperoxidase, cytoplasmic CD22, cytoplasmic CD79a, or strong expression of CD19, as well as markers of plasmacytoid dendritic cell tumors. No specific cytogenetic abnormalities are associated with these tumors.

The MPAL are slightly more common and are known by a variety of names that include mixed lineage acute leukemia, biphenotypic acute leukemia, and bilineal acute leukemia (Fig. 73.6). The diagnostic criteria for these disorders have been vague in the past, and the frequency of diagnosis has increased with the use of multicolor flow cytometry using large panels of antibodies. Lineage infidelity is common in acute leukemias, and determining how many aberrant markers are sufficient to make a diagnosis

P.1553

of MPAL creates a challenge in many cases. A variety of diagnostic criteria have been proposed for these disorders, but the criteria proposed by the European Group for the Immunologic Classification of Leukemia (EGIL)^{116,117} and the 2008 WHO^{118,119} criteria are most often used, with the WHO criteria currently preferred. The EGIL criteria (Table 73.11) provided the ability to weight the significance of different markers and reduced the number of cases diagnosed as MPAL. However, as new markers became available, the scoring system became less useful and it was not clear that the criteria resulted in a biologically distinct disease entity.

TABLE 73.10 2008 WORLD HEALTH ORGANIZATION CLASSIFICATION OF ACUTE LEUKEMIAS OF AMBIGUOUS LINEAGE

Acute undifferentiated leukemia

Mixed phenotype acute leukemia with t(9;22)(q34;q11.2)(*BCR-ABL1*)

Mixed phenotype acute leukemia with t(v;11q23)(*MLL*)

Mixed phenotype acute leukemia, B/myeloid, NOS

Mixed phenotype acute leukemia, T/myeloid, NOS

Mixed phenotype acute leukemia, NOS—rare types

NOS, not otherwise specified.

TABLE 73.11 EUROPEAN GROUP FOR THE IMMUNOLOGIC CLASSIFICATION OF LEUKEMIA (EGIL) SCORING SYSTEM FOR BIPHENOTYPIC ACUTE LEUKEMIA

Points/LineageB		T	Myeloid
2	CD79a	CD3 (membrane or cytoplasmic)Myeloperoxidase	
	Cytoplasmic IgMT	TCR α/β	
	Cytoplasmic CD22	TCR γ/δ	
1	CD19	CD2	CD117
	CD10	CD5	CD13
	CD20	CD8	CD33
			CD10
0.5	TdT	TdT	CD14

CD24	CD7	CD15
	CD1a	CD64

More than two points for an individual lineage is required.

The WHO criteria (Table 73.12) are actually simpler to use, based on fewer markers, and specify two cytogenetic abnormalities [t(9;22)(q34;q11.2) BCR-ABL1; t(v;11q23) MLL rearranged] that are often reported in cases of MPAL. The WHO definition of MPAL does not separate cases with a single blast cell population showing a mixed phenotype (biphenotypic) from cases with two distinct blast cell populations (bilineal), since there is great overlap between these case types with some presenting with one pattern and relapsing with another. While the two cytogenetic categories are similar to other acute leukemia categories in the WHO classification, it is not clear these MPAL variants are distinct from other acute leukemias with the same cytogenetic abnormality (i.e., MPAL with t(9;22)(q34;q11.2) BCR-ABL1 versus ALL with t(9;22)(q34;q11.2) BCR-ABL1). The great variability of these disorders based on immunophenotype and recurring genetic changes suggests that immunophenotypic methods may not be the ideal means of classifying these tumors and future diagnostic methods may supplant this category in the future.

TABLE 73.12 2008 WORLD HEALTH ORGANIZATION CRITERIA FOR ASSIGNING LINEAGE FOR MIXED PHENOTYPE ACUTE LEUKEMIA

Lineage Criteria

Myeloid Myeloperoxidase

or

Monocytic differentiation (two or more: NSE, CD11c, CD14, CD64, lysozyme)

T lineage Cytoplasmic or surface CD3

B lineage Strong CD19 plus strong expression of at least one of CD79a, cCD22, CD10

or

Weak CD19 plus strong expression of at least two of CD79a, cCD22, CD10

SUMMARY

The diagnostic evaluation for acute leukemia and MDSs has become increasingly complex. It requires careful coordination between the treating hematologist and hematopathologist to ensure that all sample types needed for diagnosis are collected and appropriately tested. Because the various tests needed for diagnosis and prognosis will be resulted at different times, consolidated reporting of all results using amended reports is suggested to ensure that all results are interpreted in the context of the entire specimen.

REFERENCES

1. Vardiman JW, Thiele J, Arber DA, et al. The 2008 revision of the WHO classification of myeloid neoplasms and acute leukemia: rationale and important changes. *Blood* 2009;114(5):937-951.
2. WHO Classification of Tumours of Haematopoietic and Lymphoid Tissues. Swerdlow SH, Campo E, Harris NL, et al. eds. Lyon: IARC, 2008.
3. Weinberg OK, Seetharam M, Ren L, et al. Clinical characterization of acute myeloid leukemia with myelodysplasia-related changes as defined by the 2008 WHO classification system. *Blood* 2009;113(9):1906-1908.
4. Arber DA, Stein AS, Carter NH, Ikle D, Forman SJ, Slovak ML. Prognostic impact of acute myeloid leukemia classification. Importance of detection of recurring cytogenetic abnormalities and multilineage dysplasia on survival. *Am J Clin Pathol* 2003;119(5):672-680.
5. Germing U, Strupp C, Kuendgen A, et al. Prospective validation of the WHO proposals for the classification of myelodysplastic syndromes. *Haematologica* 2006;91(12):1596-1604.
6. Muller-Berndorff H, Haas PS, Kunzmann R, Schulte-Monting J, Lubbert M. Comparison of five prognostic scoring systems, the French-American-British (FAB) and World Health Organization (WHO) classifications in patients with myelodysplastic syndromes: results of a single-center analysis. *Ann Hematol* 2006;85(8):502-513. Prepublished on May 23, 2006 as doi:10.1007/s00277-005-0030-z.

7. Bennett JM, Catovsky D, Daniel MT, et al. Proposal for the recognition of minimally differentiated acute myeloid leukaemia (AML-M0). *Br J Haematol* 1991;78:325-329.
 8. Bennett JM, Catovsky D, Daniel MT, et al. Proposed revised criteria for the classification of acute myeloid leukemia. A report of the French-American-British Cooperative Group. *Ann Intern Med* 1985;103(4):626-629.
 9. Bennett JM, Catovsky D, Daniel MT, et al. Proposals for the classification of the myelodysplastic syndromes. *Br J Haematol* 1982;51:189-199.
 10. Bennett JM, Catovsky D, Daniel MT, et al. Proposals for the classification of the acute leukemias. *Br J Haematol* 1976;33:451-458.
 11. Westers TM, Ireland R, Kern W, et al. Standardization of flow cytometry in myelodysplastic syndromes: a report from an international consortium and the European LeukemiaNet Working Group. *Leukemia* 2012;26(7): 1730-1741. Prepublished on February 7, 2012 as doi:10.1038/leu.2012.30.
 12. Bene MC, Nebe T, Bettelheim P, et al. Immunophenotyping of acute leukemia and lymphoproliferative disorders: a consensus proposal of the European LeukemiaNet Work Package 10. *Leukemia* 2011;25(4):567-574. Prepublished on January 22, 2011 as doi:10.1038/leu.2010.312.
 13. Dohner H, Estey EH, Amadori S, et al. Diagnosis and management of acute myeloid leukemia in adults: recommendations from an international expert panel, on behalf of the European LeukemiaNet. *Blood* 2010;115(3):453-474.
 14. Rappaport H. Tumors of the hematopoietic system. Washington, DC: Armed Forces Institute of Pathology, 1966.
 15. Stansfeld AG, Diebold J, Kapanci Y, et al. Updated Kiel classification for lymphomas (letter). *Lancet* 1988;1:292-293.
 16. Non-Hodgkin's lymphoma pathologic classification project. National Cancer Institute sponsored study of classifications of non-Hodgkin's lymphomas: summary and description of a working formulation for clinical usage. *Cancer* 1982;49:2112-2135.
 17. Harris NL, Jaffe ES, Stein H, et al. A revised European-American classification of lymphoid neoplasms: a proposal from the International Lymphoma Study Group. *Blood* 1994;84(5):1361-1392.
 18. Jaffe ES, Harris NL, Stein H, Vardiman JW. Tumors of haematopoietic and lymphoid tissues. Lyon: IARC Press, 2001.
 19. Raimondi SC, Chang MN, Ravindranath Y, et al. Chromosomal abnormalities in 478 children with acute myeloid leukemia: clinical characteristics and treatment outcome in a cooperative Pediatric Oncology Group study—POG 8821. *Blood* 1999;94(11):3707-3716.
 20. Rubnitz JE, Behm FG, Pui CH, et al. Genetic studies of childhood acute lymphoblastic leukemia with emphasis on p16, MLL, and ETV6 gene abnormalities: results of St. Jude Total Therapy Study XII. *Leukemia* 1997;11:1201-1206.
 21. Moorman AV, Harrison CJ, Buck GA, et al. Karyotype is an independent prognostic factor in adult acute lymphoblastic leukemia (ALL): analysis of cytogenetic data from patients treated on the Medical Research Council (MRC) UKALLXII/Eastern Cooperative Oncology Group (ECOG) 2993 trial. *Blood* 2007;109(8):3189-3197.
 22. Grimwade D, Walker H, Harrison G, et al. The predictive value of hierarchical cytogenetic classification in older adults with acute myeloid leukemia (AML): analysis of 1065 patients entered into the United Kingdom Medical Research Council AML11 trial. *Blood* 2001;98(5):1312-1320.
 23. Grimwade D, Walker H, Oliver F, et al. The importance of diagnostic cytogenetics on outcome in AML: analysis of 1,612 patients entered into the MRC AML 10 trial. *Blood* 1998;92(7):2322-2333.
- P.1554
24. Chessells JM, Swansbury GJ, Reeves B, Bailey CC, Richards SM. Cytogenetics and prognosis in childhood lymphoblastic leukaemia: results of MRC UKALL X. *Br J Haematol* 1997;99:93-100.
 25. Harvey RC, Mullighan CG, Wang X, et al. Identification of novel cluster groups in pediatric high-risk B-precursor acute lymphoblastic leukemia with gene expression profiling: correlation with genome-wide DNA copy number alterations, clinical characteristics, and outcome. *Blood* 2010;116(23):4874-4884.

26. Harvey RC, Mullighan CG, Chen IM, et al. Rearrangement of CRLF2 is associated with mutation of JAK kinases, alteration of IKZF1, Hispanic/Latino ethnicity, and a poor outcome in pediatric B-progenitor acute lymphoblastic leukemia. *Blood* 2010;115(26):5312-5321.
27. Marcucci G, Maharry K, Wu YZ, et al. IDH1 and IDH2 gene mutations identify novel molecular subsets within de novo cytogenetically normal acute myeloid leukemia: a Cancer and Leukemia Group B study. *J Clin Oncol* 2010;28(14):2348-2355.
28. Baldus CD, Mrozek K, Marcucci G, Bloomfield CD. Clinical outcome of de novo acute myeloid leukaemia patients with normal cytogenetics is affected by molecular genetic alterations: a concise review. *Br J Haematol* 2007;137(5):387-400.
29. Welch JS, Ley TJ, Link DC, et al. The origin and evolution of mutations in acute myeloid leukemia. *Cell* 2012;150(2):264-278. Prepublished on July 24, 2012 as doi:10.1016/j.cell.2012.06.023.
30. Bejar R, Stevenson K, Abdel-Wahab O, et al. Clinical effect of point mutations in myelodysplastic syndromes. *New Engl J Med* 2011;364(26):2496-2506. Prepublished on July 1, 2011 as doi:10.1056/NEJMoa1013343.
31. Papaemmanuil E, Cazzola M, Boultwood J, et al. Somatic SF3B1 mutation in myelodysplasia with ring sideroblasts. *New Engl J Med* 2011;365(15):1384-1395. Prepublished on October 15, 2011 as doi:10.1056/NEJMoa1103283.
32. Head DR. Revised classification of acute myeloid leukemia. *Leukemia* 1996;10:1826-1831.
33. Komrokji RS, Bennett JM. Evolving classifications of the myelodysplastic syndromes. *Curr Opin Hematol* 2007;14(2):98-105. Prepublished on January 27, 2007 as doi:10.1097/MOH.0b013e328017f633.
34. Orazi A. Histopathology in the diagnosis and classification of acute myeloid leukemia, myelodysplastic syndromes, and myelodysplastic/myeloproliferative diseases. *Pathobiology* 2007;74(2):97-114. Prepublished on June 26, 2007 as doi:10.1159/000101709.
35. Khalidi HS, Chang KL, Medeiros LJ, et al. Acute lymphoblastic leukemia. Survey of immunophenotype, French-American-British classification, frequency of myeloid antigen expression, and karyotypic abnormalities in 210 pediatric and adult cases. *Am J Clin Pathol* 1999;111:467-476.
36. Kotylo PK, Seo IS, Smith FO, et al. Flow cytometric immunophenotypic characterization of pediatric and adult minimally differentiated acute myeloid leukemia (AML-M0). *Am J Clin Pathol* 2000;113(2):193-200.
37. Orazi A, O'Malley DP, Jiang J, et al. Acute panmyelosis with myelofibrosis: an entity distinct from acute megakaryoblastic leukemia. *Mod Pathol* 2005;18(5):603-614.
38. Stetler-Stevenson M, Arthur DC, Jabbour N, et al. Diagnostic utility of flow cytometric immunophenotyping in myelodysplastic syndrome. *Blood* 2001;98(4):979-987.
39. Della Porta MG, Picone C, Pascutto C, et al. Multicenter validation of a reproducible flow cytometric score for the diagnosis of low-grade myelodysplastic syndromes: results of a European Leukemia NET study. *Haematologica* 2012;97(8):1209-1217. Prepublished on February 9, 2012 as doi:10.3324/haematol.2011.048421.
40. Deeg HJ, Scott BL, Fang M, et al. Five-group cytogenetic risk classification, monosomal karyotype and outcome after hematopoietic cell transplantation for MDS or acute leukemia evolving from MDS. *Blood* 2012. Prepublished on July 7, 2012 as doi:10.1182/blood-2012-04-423046.
41. Slovak ML, Kopecky KJ, Cassileth PA, et al. Karyotypic analysis predicts outcome of preremission and postremission therapy in adult acute myeloid leukemia: a Southwest Oncology Group/Eastern Cooperative Oncology Group Study. *Blood* 2000;96(13):4075-4083.
42. Coleman JF, Theil KS, Tubbs RR, Cook JR. Diagnostic yield of bone marrow and peripheral blood FISH panel testing in clinically suspected myelodysplastic syndromes and/or acute myeloid leukemia: a prospective analysis of 433 cases. *Am J Clin Pathol* 2011;135(6):915-920. Prepublished on May 17, 2011 as doi:10.1309/AJCPW10YBRMWSWYE.
43. Patel JP, Gonen M, Figueroa ME, et al. Prognostic relevance of integrated genetic profiling in acute myeloid leukemia. *New Engl J Med* 2012;366(12):1079-1089. Prepublished on March 16, 2012 as doi:10.1056/NEJMoa1112304.
44. Valent P, Horny HP, Bennett JM, et al. Definitions and standards in the diagnosis and treatment of the myelodysplastic syndromes: consensus statements and report from a working conference. *Leuk Res* 2007;31(6):727-736. Prepublished on January 30, 2007 as doi:10.1016/j.leukres.2006.11.009.

45. Steensma DP, Gibbons RJ, Higgs DR. Acquired alpha-thalassemia in association with myelodysplastic syndrome and other hematologic malignancies. *Blood* 2005;105(2):443-452. Prepublished on September 9, 2004 as doi:10.1182/blood-2004-07-2792.
46. Verburgh E, Achten R, Maes B, et al. Additional prognostic value of bone marrow histology in patients subclassified according to the International Prognostic Scoring System for myelodysplastic syndromes. *J Clin Oncol* 2003;21(2):273-282. Prepublished on January 15, 2003 as doi.
47. Goasguen JE, Bennett JM, Cox C, Hambley H, Mufti G, Flandrin G. Prognostic implication and characterization of the blast cell population in the myelodysplastic syndrome. *Leuk Res* 1991;15(12):1159-1165. Prepublished on January 1, 1991 as doi.
48. Verhoef G, De Wolf-Peeters C, Kerim S, et al. Update on the prognostic implication of morphology, histology, and karyotype in primary myelodysplastic syndromes. *Hematol Pathol* 1991;5(4):163-175. Prepublished on January 1, 1991 as doi.
49. Soligo DA, Oriani A, Annaloro C, et al. CD34 immunohistochemistry of bone marrow biopsies: prognostic significance in primary myelodysplastic syndromes. *Am J Hematol* 1994;46(1):9-17. Prepublished on May 1, 1994 as doi.
50. Horny HP, Sotlar K, Valent P. Diagnostic value of histology and immunohistochemistry in myelodysplastic syndromes. *Leuk Res* 2007;31(12):1609-1616. Prepublished on July 3, 2007 as doi:10.1016/j.leukres.2007.05.010.
51. Bejar R, Stevenson KE, Caughey BA, et al. Validation of a prognostic model and the impact of mutations in patients with lower-risk myelodysplastic syndromes. *J Clin Oncol* 2012. Prepublished on August 8, 2012 as doi:10.1200/jco.2011.40.7379.
52. Niemeyer CM, Baumann I. Classification of childhood aplastic anemia and myelodysplastic syndrome. *Hematology Am Soc Hematol Educ Program* 2011;2011:84-89. Prepublished on December 14, 2011 as doi:10.1182/asheducation-2011.1.84.
53. Baumann I, Fuhrer M, Behrendt S, et al. Morphological differentiation of severe aplastic anaemia from hypocellular refractory cytopenia of childhood: reproducibility of histopathological diagnostic criteria. *Histopathology* 2012;61(1):10-17. Prepublished on March 31, 2012 as doi:10.1111/j.1365-2559.2011.04156.x.
54. Lambertenghi-Delilieri G, Orazi A, Luksch R, Annaloro C. Myelodysplastic syndrome with increased marrow fibrosis: a distinct clinico-pathological entity. *Br J Haematol* 1991;78:161-166.
55. Steensma DP, Hanson CA, Letendre L, Tefferi A. Myelodysplasia with fibrosis: a distinct entity? *Leuk Res* 2001;25(10):829-838. Prepublished on September 5, 2001 as doi.
56. Buesche G, Teoman H, Wilczak W, et al. Marrow fibrosis predicts early fatal marrow failure in patients with myelodysplastic syndromes. *Leukemia* 2008;22(2):313-322. Prepublished on November 23, 2007 as doi:10.1038/sj.leu.2405030.
57. Della Porta MG, Malcovati L, Boveri E, et al. Clinical relevance of bone marrow fibrosis and CD34-positive cell clusters in primary myelodysplastic syndromes. *J Clin Oncol* 2009;27(5):754-762. Prepublished on December 24, 2008 as doi:10.1200/jco.2008.18.2246.
58. Kroger N, Zabelina T, van Biezen A, et al. Allogeneic stem cell transplantation for myelodysplastic syndromes with bone marrow fibrosis. *Haematologica* 2011;96(2):291-297. Prepublished on October 26, 2010 as doi:10.3324/haematol.2010.031229.
59. Thiele J, Kvasnicka HM, Orazi A. Bone marrow histopathology in myeloproliferative disorders—current diagnostic approach. *Semin Hematol* 2005;42(4):184-195. Prepublished on October 8, 2005 as doi:10.1053/j.seminhematol.2005.05.020.
60. Orazi A, Albitar M, Heerema NA, Haskins S, Neiman RS. Hypoplastic myelodysplastic syndromes can be distinguished from acquired aplastic anemia by CD34 and PCNA immunostaining of bone marrow biopsy specimens. *Am J Clin Pathol* 1997;107:268-274.
61. Bennett JM, Orazi A. Diagnostic criteria to distinguish hypocellular acute myeloid leukemia from hypocellular myelodysplastic syndromes and aplastic anemia: recommendations for a standardized approach. *Haematologica* 2009;94(2):264-268. Prepublished on January 16, 2009 as doi:10.3324/haematol.13755.

62. Afable MG 2nd, Wlodarski M, Makishima H, et al. SNP array-based karyotyping: differences and similarities between aplastic anemia and hypocellular myelodysplastic syndromes. *Blood* 2011;117(25):6876-6884. Prepublished on April 30, 2011 as doi:10.1182/blood-2010-11-314393.
63. Luzzatto L, Gianfaldoni G. Recent advances in biological and clinical aspects of paroxysmal nocturnal hemoglobinuria. *Int J Hematol* 2006;84(2):104-112. Prepublished on August 24, 2006 as doi:10.1532/ijh97.06117.
64. Wang SA, Tang G, Fadare O, et al. Erythroid-predominant myelodysplastic syndromes: enumeration of blasts from nonerythroid rather than total marrow cells provides superior risk stratification. *Mod Pathol* 2008;21(11):1394-1402. Prepublished on October 8, 2008 as doi:10.1038/modpathol.2008.142.
65. Bennett JM, Catovsky D, Daniel MT, et al. Criteria for the diagnosis of acute leukemia of megakaryocytic lineage (M7). A report of the French-American-British cooperative group. *Ann Intern Med* 1985;103:460-462.
66. Arber DA, Brunning RD, Le Beau MM, et al. Acute myeloid leukaemia with recurrent genetic abnormalities. In: Swerdlow SH, Campo E, Harris NL, et al., eds. WHO classification of tumours of haematopoietic and lymphoid tissues. Lyon: IARC, 2008:110-123.
67. Arber DA, Brunning RD, Orazi A, et al. Acute myeloid leukemia with myelodysplasia-related changes. In: Swerdlow SH, Campo E, Harris NL, et al., eds. WHO classification of Tumours of haematopoietic and lymphoid tissues. Lyon: IARC, 2008:124-126.
68. Vardiman JW, Arber DA, Brunning RD, et al. Therapy-related myeloid neoplasms. In: Swerdlow SH, Campo E, Harris NL, et al., eds. WHO classification of tumours of haematopoietic and lymphoid tissues. Lyon: IARC, 2008: 127-129.
69. Baumann I, Niemeyer CM, Brunning RD, Arber DA, Porwit A. Myeloid proliferations related to Down syndrome. In: Swerdlow SH, Campo E, Harris NL, et al., eds. WHO classification of tumors of haematopoietic and lymphoid tissues. Lyon: IARC, 2008:142-144.
70. Arber DA, Brunning RD, Orazi A, et al. Acute myeloid leukaemia, not otherwise specified. In: Swerdlow SH, Campo E, Harris NL, et al., eds. WHO classification of tumours of haematopoietic and lymphoid tissues. Lyon: IARC Press, 2008:130-139.
71. Mawad R, Estey EH. Acute myeloid leukemia with normal cytogenetics. *Curr Oncol Rep* 2012. Prepublished on July 19, 2012 as doi:10.1007/s11912-012-0252-x.
72. Falini B, Nicoletti I, Martelli MF, Mecucci C. Acute myeloid leukemia carrying cytoplasmic/mutated nucleophosmin (NPMc+ AML): biologic and clinical features. *Blood* 2007;109(3):874-885.
73. Thiede C, Koch S, Creutzig E, et al. Prevalence and prognostic impact of NPM1 mutations in 1485 adult patients with acute myeloid leukemia (AML). *Blood* 2006;107(10):4011-4020.
74. Renneville A, Boissel N, Gachard N, et al. The favorable impact of CEBPA mutations in patients with acute myeloid leukemia is only observed in the absence of associated cytogenetic abnormalities and FLT3 internal duplication. *Blood* 2009;113(21):5090-5093.
75. Preudhomme C, Sagot C, Boissel N, et al. Favorable prognostic significance of CEBPA mutations in patients with de novo acute myeloid leukemia: a study from the Acute Leukemia French Association (ALFA). *Blood* 2002;100(8):2717-2723.
76. Pabst T, Mueller BU, Zhang P, et al. Dominant-negative mutations of CEBPA, encoding CCAAT/enhancer binding protein-alpha (C/EBPalpha), in acute myeloid leukemia. *Nat Genet* 2001;27(3):263-270.
77. Wandt H, Schakel U, Kroschinsky F, et al. MLD according to the WHO classification in AML has no correlation with age and no independent prognostic relevance as analyzed in 1766 patients. *Blood* 2008;111(4):1855-1861.
78. Park SH, Chi HS, Park SJ, Jang S, Park CJ. Clinical importance of morphological multilineage dysplasia in acute myeloid leukemia with myelodysplasia related changes. *The Korean J Lab Med* 2010;30(3):231-238. Prepublished on July 7, 2010 as doi:10.3343/kjlm.2010.30.3.231.
79. Paschka P, Marcucci G, Ruppert AS, et al. Adverse prognostic significance of KIT mutations in adult acute myeloid leukemia with inv(16) and t(8;21): a Cancer and Leukemia Group B Study. *J Clin Oncol* 2006;24(24): 3904-3911.
80. Gale RE, Hills R, Pizzey AR, et al. Relationship between FLT3 mutation status, biologic characteristics, and response to targeted therapy in acute promyelocytic leukemia. *Blood* 2005;106(12):3768-3776.

81. Schnittger S, Schoch C, Dugas M, et al. Analysis of FLT3 length mutations in 1003 patients with acute myeloid leukemia: correlation to cytogenetics, FAB subtype, and prognosis in the AMLCG study and usefulness as a marker for the detection of minimal residual disease. *Blood* 2002;100(1):59-66.

P.1555

82. Thiede C, Steudel C, Mohr B, et al. Analysis of FLT3-activating mutations in 979 patients with acute myelogenous leukemia: association with FAB subtypes and identification of subgroups with poor prognosis. *Blood* 2002;99(12):4326-4335.

83. Dohner K, Schlenk RF, Habdank M, et al. Mutant nucleophosmin (NPM1) predicts favorable prognosis in younger adults with acute myeloid leukemia and normal cytogenetics: interaction with other gene mutations. *Blood* 2005;106(12):3740-3746.

84. Suzuki T, Kiyoi H, Ozeki K, et al. Clinical characteristics and prognostic implications of NPM1 mutations in acute myeloid leukemia. *Blood* 2005;106(8):2854-2861.

85. Metzeler KH, Maharry K, Radmacher MD, et al. TET2 mutations improve the new European LeukemiaNet risk classification of acute myeloid leukemia: a Cancer and Leukemia Group B study. *J Clin Oncol* 2011;29(10):1373-1381. Prepublished on February 24, 2011 as doi:10.1200/JCO.2010.32.7742.

86. Paschka P, Schlenk RF, Gaidzik VI, et al. IDH1 and IDH2 mutations are frequent genetic alterations in acute myeloid leukemia and confer adverse prognosis in cytogenetically normal acute myeloid leukemia with NPM1 mutation without FLT3 internal tandem duplication. *J Clin Oncol* 2010;28(22):3636-3643.

87. Abbas S, Lugthart S, Kavelaars FG, et al. Acquired mutations in the genes encoding IDH1 and IDH2 both are recurrent aberrations in acute myeloid leukemia: prevalence and prognostic value. *Blood* 2010;116(12):2122-2126.

88. Ley TJ, Ding L, Walter MJ, et al. DNMT3A mutations in acute myeloid leukemia. *New Engl J Med* 2010;363:2424-2433.

89. Hasserjian RP, Zuo Z, Garcia C, et al. Acute erythroid leukemia: a re-assessment using criteria refined in the 2008 WHO classification. *Blood* 2010;115(10):1985-1992. Prepublished on December 31, 2009 as doi:10.1182/blood-2009-09-243964.

90. Thiele J, Kvasnicka HM, Zerhusen G, et al. Acute panmyelosis with myelofibrosis: a clinicopathological study on 46 patients including histochemistry of bone marrow biopsies and follow-up. *Ann Hematol* 2004;83(8):513-521. Prepublished on June 3, 2004 as doi:10.1007/s00277-004-0881-8.

91. Eisfeld AK, Marcucci G, Maharry K, et al. miR-3151 interplays with its host gene BAALC and independently affects outcome of patients with cytogenetically normal acute myeloid leukemia. *Blood* 2012;120(2):249-258. Prepublished on April 25, 2012 as doi:10.1182/blood-2012-02-408492.

92. Sun SM, Rockova V, Bullinger L, et al. The prognostic relevance of miR-212 expression with survival in cytogenetically and molecularly heterogeneous AML. *Leukemia* 2012. Prepublished on June 14, 2012 as doi:10.1038/leu.2012.158.

93. Akalin A, Garrett-Bakelman FE, Kormaksson M, et al. Base-pair resolution DNA methylation sequencing reveals profoundly divergent epigenetic landscapes in acute myeloid leukemia. *PLoS Genet* 2012;8(6):e1002781. Prepublished on June 28, 2012 as doi:10.1371/journal.pgen.1002781.

94. Borowitz MJ, Chan JKC. B lymphoblastic leukaemia/lymphoma, not otherwise specified. In: Swerdlow SH, Campo E, Harris NL, et al., eds. WHO classification of tumours of haematopoietic and lymphoid tissues. Lyon: IARC, 2008:168-170.

95. Cerezo L, Shuster JJ, Pullen DJ, et al. Laboratory correlates and prognostic significance of granular acute lymphoblastic leukemia in children. A Pediatric Oncology Group study. *Am J Clin Pathol* 1991;95(4):526-531.

96. Borowitz MJ, Chan JKC. B lymphoblastic leukaemia/lymphoma with recurrent genetic abnormalities. In: Swerdlow SH, Campo E, Harris NL, et al., eds. WHO classification of tumours of haematopoietic and lymphoid tissues. Lyon: IARC, 2008:171-175.

97. Hogan TF, Koss W, Murgo AJ, Amato RS, Fontana JA, VanScoy FL. Acute lymphoblastic leukemia with chromosomal 5;14 translocation and hypereosinophilia: case report and literature review. *J Clin Oncol* 1987;5(3):382-390. Prepublished on March 1, 1987 as doi.

98. Shurtleff SA, Buijs A, Behm FG, et al. TEL/AML1 fusion resulting from a cryptic t(12;21) is the most common genetic lesion in pediatric ALL and defines a subgroup of patients with an excellent prognosis. *Leukemia* 1995;9(12):1985-1989.

99. Mullighan CG, Goorha S, Radtke I, et al. Genome-wide analysis of genetic alterations in acute lymphoblastic leukaemia. *Nature* 2007;446(7137):758-764.
100. Mullighan CG, Su X, Zhang J, et al. Deletion of IKZF1 and prognosis in acute lymphoblastic leukemia. *New Engl J Med* 2009;360(5):470-480.
101. Mullighan CG, Miller CB, Radtke I, et al. BCR-ABL1 lymphoblastic leukaemia is characterized by the deletion of Ikaros. *Nature* 2008;453(7191):110-114.
102. Mullighan CG, Zhang J, Harvey RC, et al. JAK mutations in high-risk childhood acute lymphoblastic leukemia. *Proc Natl Acad Sci U S A* 2009;106(23): 9414-9418.
103. Mullighan CG, Collins-Underwood JR, Phillips LA, et al. Rearrangement of CRLF2 in B-progenitor- and Down syndrome-associated acute lymphoblastic leukemia. *Nat Genet* 2009;41(11):1243-1246. Prepublished on October 20, 2009 as doi:10.1038/ng.469.
104. Ishizawa S, Slovak ML, Popplewell L, et al. High frequency of pro-B acute lymphoblastic leukemia in adults with secondary leukemia with 11q23 abnormalities. *Leukemia* 2003;17(6):1091-1095.
105. Chen W, Wang E, Lu Y, Gaal KK, Huang Q. Therapy-related acute lymphoblastic leukemia without 11q23 abnormality: report of six cases and a literature review. *Am J Clin Pathol* 2010;133(1):75-82. Prepublished on December 22, 2009 as doi:10.1309/AJCPYWC6AQC7BAVJ.
106. Graux C, Cools J, Michaux L, Vandenberghe P, Hagemeijer A. Cytogenetics and molecular genetics of T-cell acute lymphoblastic leukemia: from thymocyte to lymphoblast. *Leukemia* 2006;20(9):1496-1510. Prepublished on July 11, 2006 as doi:10.1038/sj.leu.2404302.
107. Kraszewska MD, Dawidowska M, Szczepanski T, Witt M. T-cell acute lymphoblastic leukaemia: recent molecular biology findings. *Br J Haematol* 2012;156(3):303-315. Prepublished on December 8, 2011 as doi:10.1111/j. 1365-2141.2011.08957.x.
108. Clappier E, Collette S, Grardel N, et al. NOTCH1 and FBXW7 mutations have a favorable impact on early response to treatment, but not on outcome, in children with T-cell acute lymphoblastic leukemia (T-ALL) treated on EORTC trials 58881 and 58951. *Leukemia* 2010;24(12):2023-2031. Prepublished on September 24, 2010 as doi:10.1038/leu.2010.205.
109. Baldus CD, Thibaut J, Goekbuget N, et al. Prognostic implications of NOTCH1 and FBXW7 mutations in adult acute T-lymphoblastic leukemia. *Haematologica* 2009;94(10):1383-1390. Prepublished on October 2, 2009 as doi:10.3324/haematol.2008.005272.
110. Mansour MR, Sulis ML, Duke V, et al. Prognostic implications of NOTCH1 and FBXW7 mutations in adults with T-cell acute lymphoblastic leukemia treated on the MRC UKALLXII/ECOG E2993 protocol. *J Clin Oncol* 2009;27(26): 4352-4356. Prepublished on July 29, 2009 as doi:10.1200/JCO.2009.22.0996.
111. Neumann M, Heesch S, Gokbuget N, et al. Clinical and molecular characterization of early T-cell precursor leukemia: a high-risk subgroup in adult T-ALL with a high frequency of FLT3 mutations. *Blood Cancer J* 2012;2(1):e55. Prepublished on July 26, 2012 as doi:10.1038/bcj.2011.49.
112. Zarella CM, Oliver D, Cavalier M, Fuda F, Karandikar NJ, Chen W. Distinct immunophenotype of early T-cell progenitors in T lymphoblastic leukemia/lymphoma may predict FMS-like tyrosine kinase 3 mutations. *Ann Diagn Pathol* 2012;16(1):16-20. Prepublished on November 5, 2011 as doi:10.1016/j.anndiagpath.2011.07.005.
113. Inukai T, Kiyokawa N, Campana D, et al. Clinical significance of early T-cell precursor acute lymphoblastic leukaemia: results of the Tokyo Children's Cancer Study Group Study L99-15. *Br J Haematol* 2012;156(3):358-365. Prepublished on December 2, 2011 as doi:10.1111/j.1365-2141.2011.08955.x.
114. Weinberg OK, Arber DA. Mixed-phenotype acute leukemia: historical overview and a new definition. *Leukemia* 2010; 24(11):1844-1851
115. Bene MC, Porwit A. Acute leukemias of ambiguous lineage. *Semin Diagn Pathol* 2012;29(1):12-18. Prepublished on March 1, 2012 as doi.
116. Bene MC, Castoldi G, Knapp W, et al. Proposal for the immunologic classification of acute leukemias. *Leukemia* 1995;9:1783-1786.
117. European Group for the Immunological Classification of Leukemia. The value of c-kit in the diagnosis of biphenotypic acute leukemia. *Leukemia* 1998;12(12):2038.

118. Matutes E, Pickl WF, Van't Veer M, et al. Mixed-phenotype acute leukemia: clinical and laboratory features and outcome in 100 patients defined according to the WHO 2008 classification. *Blood* 2011;117(11):3163-3171. Prepublished on January 14, 2011 as doi:10.1182/blood-2010-10-314682.

119. Borowitz MJ, Bene MC, Harris NL, Porwit A, Matutes E. Acute leukaemias of ambiguous lineage. In: Swerdlow SH, Campo E, Harris NL, et al., eds. WHO classification of tumours of haematopoietic and lymphoid tissues. Lyon: IARC, 2008:150-155.

Chapter 74 Acute Lymphoblastic Leukemia in Adults

> Table of Contents > Part VII - Hematologic Malignancies > Section 2 - The Acute Leukemias > Chapter 74 - Acute Lymphoblastic Leukemia in Adults

Chapter 74

Acute Lymphoblastic Leukemia in Adults

Steven E. Coutre

Acute lymphoblastic leukemia (ALL) is a neoplastic disorder that is rapidly fatal if untreated. In children, ALL is the most common malignancy, and considerable advances have led to the cure of most children with the disease. Historically, treatment outcomes in adults have not been as favorable. Although improved prognostic stratification has led to a better understanding of the biologic heterogeneity of the disease, targeted therapies exploiting these differences have not yet emerged as part of standard therapy for most patients. However, dramatic advances in whole genome sequencing as well as the development of novel immunotherapies promises to improve both the fundamental understanding of the biology of the disease and treatment outcomes.

The clinical onset of ALL is rarely insidious, and presenting signs and symptoms reflect bone marrow as well as extramedullary involvement by leukemia. Examination of the peripheral blood smear is often sufficient to establish the diagnosis of ALL, but additional clinical and laboratory tests are essential for formulating a treatment plan and provide important prognostic information. Current therapy for adults involves a scheduled sequence that starts with remission induction chemotherapy, followed by one or more cycles of intensification, prophylaxis of the central nervous system (CNS), and prolonged maintenance lasting 2 to 3 years. With this multiagent, multicycle approach, between 25% and 40% of adults with ALL are cured of their disease. Modifications to this general scheme, based on an appreciation of the high risk for disease relapse, have improved outcome for adult ALL patients who have the mature B-cell phenotype as well as those with the Philadelphia (Ph) chromosome. Age remains a significant limitation to treatment intensity as one third of adults with ALL are over the age of 60 years.

Most adult patients with ALL experience relapse of their disease. Successful treatment options for relapsed or refractory ALL are few.

HISTORICAL BACKGROUND

Only a few decades ago, ALL was an incurable disease in all but a small minority of patients. Progress in the treatment of pediatric ALL has been substantial. This is clearly illustrated in the results reported from a series of successive clinical protocols from St. Jude Children's Research Hospital.^{1,2,3} Sequential treatment modifications in successive cohorts of children show a steady improvement in survival outcome as shown in Figure 74.1A. The initial clinical trials from 1962 to 1969 introduced multiagent chemotherapy regimens into pediatric ALL therapy. This proved superior to single-agent therapy, but, still, few children experienced long-term survival. The next era, from 1967 to 1979, saw effective prevention of leukemia relapse in sanctuary sites in the CNS through the use of cranial irradiation and intrathecal chemotherapy. Intensification of post-remission therapy with administration of non-cross-resistant drugs was responsible for improving survival in subsequent cohorts. With further refinements, as well as general improvement in supportive care, approximately 85% of children with ALL are now cured of the disease (Chapter 76).

The success demonstrated in the pediatric ALL trials led to similar approaches in the treatment of adults. As shown in Figure 74.1B, outcomes in consecutive cohorts of adults with ALL treated by the United Kingdom Acute Lymphoblastic Leukemia (UKALL) collaborative study group gradually improved as treatment was intensified and extended. Compared with the success in treating childhood ALL, however, the degree of improvement was only modest. The British Medical Research Council initiated the UKALL trials in 1971.⁴ The first trial, UKALL I, evaluated CNS prophylaxis but only enrolled 16 adults. Subsequent trials examined both the addition of active agents and more sustained intensive post-remission therapy, and participation of adult patients progressively expanded. Survival for adults with ALL was still only 20% at the

time the UKALL IX trial opened for patient accrual in 1980. It was the first trial in the series to enroll adults separately from children. UKALL IX and the subsequent trial, UKALL XA, saw further, although minor, incremental improvement in the survival rate but provided important systematic analyses of prognostic indicators based on clinical, immunophenotypic, and cytogenetic characteristics.⁵ The subsequent study, UKALL XII/ECOG 2993, was the largest treatment study of newly diagnosed ALL in adults. It compared post-remission chemotherapy with autologous or related donor transplant. The complete remission (CR) rate was 90% in the 1,646 Philadelphia chromosome negative patients; overall survival at 5 years was 43% and 39% if all 1,913 eligible patients were included.⁶ Patients up to age 50 were eligible for allogeneic hematopoietic stem cell transplantation (HSCT). Survival at 5 years was 54% for all Philadelphia chromosome-negative patients with a donor, versus 44% for those without ($P = 0.007$) and 63% versus 52% for standard risk patients ($P = 0.02$). There was no benefit to allogeneic transplant for high-risk Philadelphia chromosome-negative patients. Patients without a donor who underwent autologous transplant did no better than those who received chemotherapy alone. These series of studies, along with other national cooperative group studies have led to remarkably similar long-term survival rates among adults who receive chemotherapy without transplant. These outcomes are distinctly inferior to those achieved in the pediatric age group.^{7, 8, 9} and ¹⁰

PATHOPHYSIOLOGY

The cause of ALL is essentially unknown, and few clues can be derived from epidemiologic studies. The molecular pathogenesis of ALL is reviewed in Chapter 72. Points relevant to adult ALL concerning these issues are briefly highlighted here.

Epidemiology

The overall age-adjusted incidence of ALL in the United States based on the most recent National Cancer Institute (NCI) report (1975 to 2009) is 1.34 in 100,000.¹¹ The incidence of ALL in blacks is significantly less than in whites, 0.81 versus 1.34. There is a slight male predominance with a male to female ratio of 1.56:1.14. The majority of the approximately 6,000 new cases each year in the United States are diagnosed in persons younger than 20-years old with a peak between the ages of 2 and 5 years; the median age at diagnosis was 14 years in the NCI SEER Cancer Statistic Review between 2005 and 2009.¹¹ The incidence decreases sharply thereafter, a trend that continues through adolescence and adulthood until after age 50, when the incidence again starts to rise steadily (Fig. 74.2). Geographic differences in the incidence of ALL are reflected by higher rates in North America and Europe and lower rates in African and Asian populations.¹²

P.1557

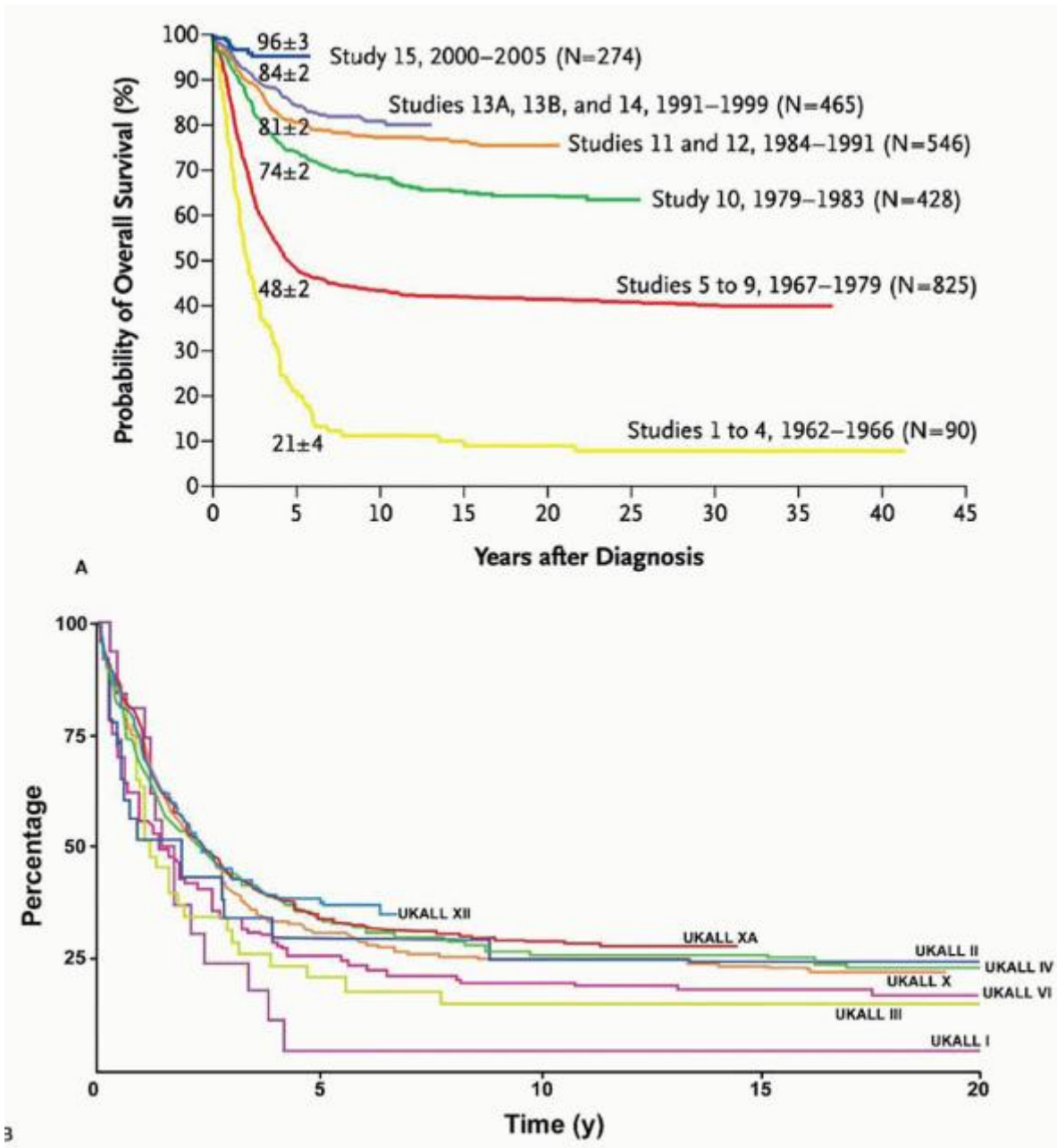

FIGURE 74.1. Overall survival in successive acute lymphoblastic leukemia patient cohorts. A: Childhood acute lymphoblastic leukemia patients treated at the St. Jude Children's Research Hospital. (With permission from Pui CH, Evans WE. Treatment of acute lymphoblastic leukemia. *N Engl J Med* 2006;354:166-178.) B: Adult acute lymphoblastic leukemia patients treated by the UKALL collaborative study group. (With permission from Durrant IJ, Richards SM, Prentice HG, et al. The Medical Research Council trials in adult acute lymphocytic leukemia. *Hematol Oncol Clin North Am* 2000;14:1327-1352.)

Etiology

The cause of ALL in adults is largely unknown.¹³ Inherited factors and genetic predisposition syndromes are more relevant to childhood ALL. Survivors of the nuclear fallout from the atomic bombing in Hiroshima and Nagasaki have an overall relative risk of 9.1 for ALL, greater among those exposed in childhood, with the peak incidence occurring 6 to 7 years after radiation exposure.¹⁴ Somewhat more relevant to adult ALL is the association between occupational exposure to low-dose ionizing radiation among nuclear workers in the United States and Europe and a slightly increased risk for leukemia, although findings were inconsistent across populations.^{15, 16 and 17}

Among chemical environmental exposures, high-level benzene exposure that occurred before contemporary occupational safety standards is generally accepted as a cause of bone marrow aplasia, chromosome damage, and leukemia.^{18,19} Cigarette smoking was linked to a small increase in risk for ALL among persons older than 60 years in one report.²⁰ Secondary acute leukemias occurring after exposure to chemotherapeutic agents are usually myeloid, although rare cases of therapy-related ALL have been observed.^{21, 22} and ²³

Molecular Pathogenesis

Molecular abnormalities can be grouped according to the functional consequence of oncogenic mutation. Acquired constitutive activation of the ABL protein kinase by rearrangement with the BCR gene is an example of a mutation that confers a proliferative advantage.²⁴ The fusion gene is the consequence of the t(9;22)(q34;q11) balanced chromosomal translocation,

P.1558

which is the most common cytogenetic abnormality in adult ALL. ABL is a nonreceptor tyrosine protein kinase that enzymatically transfers phosphate molecules to substrate proteins, thereby activating downstream signal transduction pathways important in regulating cell growth and proliferation.²⁵ Other gene rearrangements result in loss- or gain-of-function mutations involving transcription factors that are important for normal hematopoietic development.²⁶ An example is the t(12;21) (p13;q22) chromosomal translocation, which juxtaposes the ETV6 (TEL) and RUNX1 (AML) genes.²⁷ Excluding numerical aberrations, ETV6-RUNX1 is the most frequent cytogenetic abnormality in childhood ALL, although it is uncommon in adults. Another general mechanism of cancer formation involves loss or inactivation of tumor-suppressor genes, many of which have key regulatory functions in controlling cell cycle progression.²⁸ Examples are p16(CDKN2A) and p15(CDKN2B). Stock et al. investigated the incidence of cell cycle regulatory gene abnormalities in adult patients with de novo ALL treated by the Cancer and Leukemia Group B (CALGB) study group.²⁹ Deletions, microdeletions, and gene rearrangements involving p16(CDKN2A) and p16(CDKN2B) were common occurrences. Even more frequent was aberrant expression of RB1 and TP53, two other tumor-suppressor genes. Concurrent abnormalities involving two or more of these genes were found in one third of adult ALL patients.

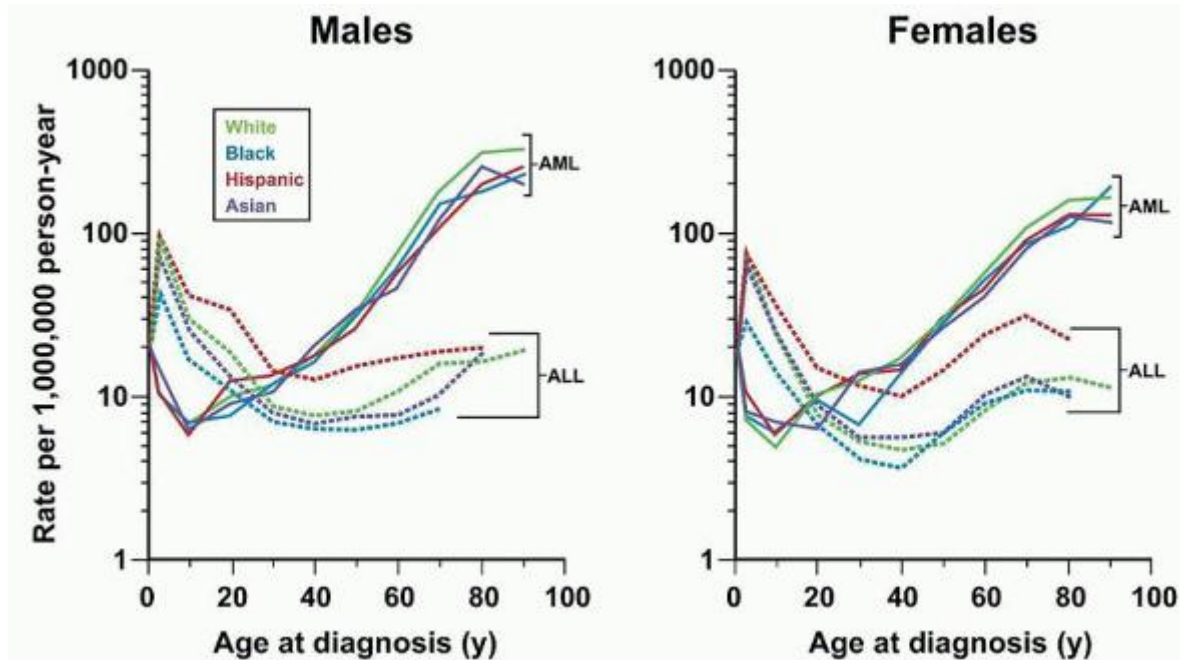

FIGURE 74.2. Age-specific incidence rates of acute lymphoblastic leukemia (ALL) (dotted lines) and AML (solid lines) according to sex and race/ethnicity, SEER-17, 2001 to 2007. (With permission from Dores GM, Devesa SS, Curtis RE, et al. Acute leukemia incidence and patient survival among children and adults in the United States, 2001-2007. *Blood* 2012;119:34-43.)

Aberrant expression of NOTCH1 has also been linked to ALL leukemogenesis. NOTCH1 encodes a transmembrane receptor that regulates normal T-cell development. Upon proteolytic cleavage, NOTCH1 translocates to the nucleus and binds to a nuclear transcription factor, ultimately stimulating the transcription of target genes.³⁰ Although the association of a

previously described t(7;9)(q34;q34.3) translocation, which fuses part of NOTCH1 to the TCRB locus, is restricted to less than 1% of T-ALL, activating mutations of NOTCH1 that produce aberrant NOTCH1 signaling independently of t(7;9) have been reported in over 50% of human T-ALL.³¹ The exact mechanism for its role in leukemogenesis is not fully understood, although some evidence suggests that NOTCH contributes to TP53 suppression or nuclear factor- κ B pathway activation, promoting deregulated T-cell proliferation.^{32, 33} and ³⁴

CLINICAL FEATURES

Although the clinical presentation is variable and may develop insidiously, virtually all adults diagnosed with ALL present with symptoms of only a few weeks duration. The symptoms generally reflect bone marrow failure or involvement of extramedullary sites by leukemia (Table 74.1). Up to one-half of patients with ALL have fever or documented infections. One third have bleeding symptoms at diagnosis, which is less frequent than in patients presenting with acute myeloid leukemia. Severe hemorrhage is uncommon.³⁴ Fatigue, lethargy, dizziness, or even dyspnea and cardiac angina may reflect anemia in adults with ALL. Marrow expansion by

P.1559

leukemic blasts may produce bone pain and arthralgias, but marrow necrosis is much less frequently found in adults as compared with children who have ALL.³⁵ Approximately one half of adult patients have hepatomegaly, splenomegaly, or lymphadenopathy at diagnosis that can be appreciated on physical examination. Mediastinal masses are detected by chest radiographs or computed tomography scans primarily in patients with T-lineage ALL, who also frequently have pleural involvement and may complain of chest pain.³⁶ The fewer than 10% of ALL patients who have CNS involvement infrequently present with referable symptoms, such as headache, vomiting, neck stiffness, alteration in mental status, and focal neurologic abnormalities. Other sites of extramedullary involvement include testis, retina, and skin, although virtually any organ can be infiltrated by leukemic blast cells.

TABLE 74.1 CLINICAL FINDINGS AT DIAGNOSIS IN ADULTS WITH ACUTE LYMPHOBLASTIC LEUKEMIA

Findings	Patients (%)
Male	59-63
Symptoms	
Fever/infection	3-56
Bleeding	33
Lymphadenopathy	40-57
Hepatomegaly	24-47
Splenomegaly	31-56
Mediastinal mass	10-15
Central nervous system leukemia	1-7
Other organ involvement	
Pleura	2.9
Pericardium	1.0
Retina	1.0
Skin	0.6
Tonsils	0.6
Testis	0.3

Data are based on collaborative trials reported by the CALGB,⁷ MRC,⁸ GIMEMA,⁹ and GMALL.¹⁰

LABORATORY FEATURES

In addition to a complete medical history and physical examination, patients with ALL should have a battery of diagnostic laboratory tests to confirm the diagnosis, subcategorize the patient's disease for prognostic classification, and plan for appropriate therapy (Table 74.2). These studies include a complete blood count with examination of the peripheral blood smear, electrolyte measurements, creatinine, hepatic enzymes, uric acid, calcium, and albumin. Therapy-related declines in anticoagulation factors, including fibrinogen, occur with L-asparaginase, a drug commonly used in the treatment of ALL, and baseline levels should therefore be obtained. A mediastinal mass may be detected with a chest radiograph. A lumbar puncture for examination of the CSF to assess for leukemic involvement should be performed if patients present with neurologic symptoms. A bone marrow examination is mandatory and should include a complete cytogenetic assessment and immunologic phenotyping. Morphologic, cytogenetic, and immunophenotypic characteristics of ALL are detailed in Chapter 73. This section emphasizes features pertinent to adults diagnosed with the disease.

Routine Laboratory Evaluation

Routine laboratory evaluation reveals that a substantial number of adult patients with ALL have normal or only modestly elevated white blood cell (WBC) counts at the time of diagnosis (Table 74.3). Hyperleukocytosis ($>100 \times 10^9/L$) occurs in approximately 15% of patients and may exceed $200 \times 10^9/L$. Some degree of anemia is present in the majority of adults. Approximately one third of patients have a platelet count less than $25 \times 10^9/L$, which is approximately the same proportion that present with bleeding symptoms. Circulating leukemic blasts may not be evident on examination of the peripheral smear in a significant number of patients. Coagulation parameters are typically normal, and disseminated intravascular coagulation is rarely observed.³⁷ Metabolic abnormalities, including hyperuricemia, can occur, especially in patients with rapidly dividing leukemia cells and high tumor burden.

TABLE 74.2 DIAGNOSTIC APPROACH FOR ADULT ACUTE LYMPHOBLASTIC LEUKEMIA

Medical history

Physical examination

Laboratory studies

Complete blood count, peripheral smear, coagulation studies, fibrinogen level, serum chemistry (renal and hepatic function, electrolytes, calcium, phosphate, uric acid, LDH), ABO and Rh blood group, HLA typing
Appropriate cultures in the setting of fever

Chest radiograph or computed tomography

Cardiac assessment

(EKG, ECHOCardiogram or MUGA)

Lumbar puncture

Bone marrow aspiration and biopsy

Immunophenotype analysis (\pm cytochemical stains); cytogenetic analysis (FISH probes for specific genes, translocations, and/or chromosome abnormalities); *BCR-ABL* molecular analysis (p190 and p210); minimal residual disease markers (by flow cytometry or PCR)

Pregnancy test

Information about fertility

TABLE 74.3 LABORATORY FINDINGS AT DIAGNOSIS IN ADULTS WITH ACUTE LYMPHOBLASTIC LEUKEMIA

Laboratory Finding	Patients (%)
White blood cell count ($\times 10^9/L$)	
<10	41
<30	66
50-100	10-13
>100	14-16

>200	6
Hemoglobin (g/g/L)	
<50	11
<100	55-62
≥100	38-45
Platelet ($\times 10^9/L$)	
<25	30
<50	41-55
≥50	48-59
>150	15
Blast cells in peripheral blood	
Present	92
None	8
Blast cells in bone marrow (%)	
<90	28-29
≥90	71-72
100	7

Note: Data are based on collaborative trials reported by the CALGB,⁷ MRC,⁸ GIMEMA,⁹ and GMALL.¹⁰

Lumbar Puncture

A lumbar puncture is often performed at the time of diagnosis to examine the cerebrospinal fluid (CSF). CNS involvement is traditionally defined as greater than 5 WBC/ μ l of CSF with morphologically unequivocal leukemic blasts on the cytocentrifuged specimen.³⁸ Patients at risk for bleeding complications due to thrombocytopenia should be transfused to an adequate platelet count before the procedure. Whether to perform a lumbar puncture in patients with a high circulating blast count is controversial. This is due to concerns of iatrogenic "seeding" of the CNS with leukemic cells. Studies in pediatric ALL have shown that when the procedure is complicated by a traumatic tap, the finding of blast cells in the CSF occurs more frequently in children with higher presenting WBC count.³⁹ Among the patients who had traumatic lumbar punctures, those with leukemic blasts in the CSF were more likely to have subsequent CNS relapse.

P.1560

Bone Marrow Evaluation

All patients with ALL should undergo a bone marrow aspiration and core biopsy procedure. The specimens must be submitted for histologic, cytogenetic, and immunophenotypic analysis. Morphologically, the marrow space is usually densely packed with leukemic blasts, which account for greater than 90% of nucleated cells in many adult ALL patients. As a result, the marrow biopsy sections are generally hypercellular, and, in 7% of adult patients with ALL, the normal marrow is completely replaced by leukemic blasts. This may prevent a successful aspiration, and a touch imprint of the biopsy tissue then becomes useful in evaluating cytologic features. Although increased reticulin deposits are common, marrow fibrosis is rarely present.^{40,41}

Cytogenetics

Historically, poor chromosomal morphology in ALL made banding studies challenging, and karyotypic abnormalities were not reliably detected in early studies.⁴² The implementation of modern metaphase spreading, banding, and molecular cytogenetic techniques now reveals prognostically significant abnormal karyotypes in the majority of adult patients with

ALL.⁴³ These molecular techniques include fluorescent in situ hybridization using chromosome- and gene-specific probes for gene rearrangements that are difficult to identify, such as the t(12;21) chromosomal translocation.⁴⁴ Application of these sensitive methods has revealed, for instance, that the t(12;21) translocation is much less common in adults with ALL than in children.^{45,46} Other age-related differences include fewer occurrences of numerical chromosome abnormalities and a higher incidence of the Ph chromosome in adults (Table 74.4).

Because of the profound prognostic implication of the Ph chromosome, molecular testing for the BCR-ABL gene rearrangement should be performed for all patients diagnosed with ALL. The Ph chromosome was originally identified in a patient with chronic myeloid leukemia (CML), in whom the BCR and ABL genes juxtaposed within the so-called major breakpoint region.²⁴ This transcribes a 7-kb messenger RNA that is expressed as a 210-kd fusion protein, or p210BCR-ABL. In ALL, a variant breakpoint location, which results in the smaller p190BCR-ABL oncoprotein, is commonly found.⁴⁷ A polymerase chain reaction (PCR) -based laboratory test capable of detecting both the p210BCR-ABL and p190^{BCR-ABL} gene transcripts is now readily available to most clinicians and should always be performed in all newly diagnosed patients.

TABLE 74.4 CHROMOSOMAL ABNORMALITIES AT DIAGNOSIS IN ACUTE LYMPHOBLASTIC LEUKEMIA

Chromosomal Abnormalities	Gene(s)	Patients (%)	
		Adults	Children
Normal karyotype		16-34	31-42
Numerical abnormalities			
Hypodiploid		4-9	1-2
Hyperdiploid (>50 chromosomes)		2-9	25
Structural abnormalities (abn)			
12p abnormal		4-5	3-9
9p abnormal	<i>CDKN2A/2B</i>	5-16	7-13
6q abnormal	-	2-6	4-6
Pre-B-Lineage (e.g.,)			
t(1;19) (q23; p13)	<i>TCF3-PBX1</i>	1-3	5-6
t(4;11) (q21; q23)	<i>AFF1-MLL</i>	3-7	1-2
t(9;22) (q34; q11)	<i>BCR-ABL1</i>	11-30	1-2
t(12;21) (p13; q22)	<i>ETV6-RUNX1</i>	4-5	15-25
T-Lineage (e.g.,)			
t(1;14) (p32; q11)	<i>TALI-TRD@</i>	1-2	3-5
t(5;14) (q35; q32)	<i>TLX3-BCL11B</i>	1-2	2-4
t(7;7) or inv7(p15; q34)	<i>HOXA-TRB@</i>	1-2	1-2
t(10;14) (q24; q11)	<i>TLX1-TRA@/TRD@</i>	4-6	2-3
Mature B			
t(8;14) (q24; q32)	<i>MYC-IGH@</i>	4	2
t(2;8) (p12; q24)	<i>MYC-IGK</i>	Rare	
t(8;22) (q24; q11)	<i>MYC-IGL</i>	Rare	
Immunophenotype			

The primary basis of initial treatment strategies for ALL depends on antigenic parameters, and, hence, all patients should have their leukemic blasts characterized by immunophenotypic analysis. By current World Health Organization classification, the majority of adult ALL cases involve the precursor lymphoid neoplasms.⁴⁸ Approximately 70% of cases are B-cell ALL, and 25% are T-cell ALL. The remaining 5% are a mature B-cell neoplasm, Burkitt leukemia.⁴⁹ Compared with adults, children less often present with T-lineage ALL. There is also a slightly higher incidence of myeloid antigen expression in adult ALL patients, with reported incidences ranging from 15% to 54% compared with 4% to 35% in children.^{50,51} Commonly detected myeloid antigens include CD13, CD15, and CD33.

Rare cases with co-expression of multiple lymphoid and myeloid antigens may be considered acute biphenotypic leukemia according to criteria suggested by a European group.⁵² The clinical course appears to be poor; however, there is no uniform consensus on whether to manage these cases as acute myeloid or lymphoid leukemia.⁵³ The Royal Marsden Hospital group identified 25 acute biphenotypic leukemia patients whom they treated over a 7-year period.^{54,55} The patients variably underwent remission induction with ALL-like regimens, AML-like regimens, or hybrid regimens containing elements of both with equal success, except for an excess of treatment-related mortality with the combined regimen. Overall survival was 39.4% at 2 years. They observed a high incidence of the Ph chromosome (41%) that partially accounted for the unfavorable outcome and emphasized the importance of aggressive risk-adapted therapy for these cases.

DIFFERENTIAL DIAGNOSIS

The differential diagnosis of ALL in adult patients is rarely difficult. Most commonly, patients are diagnosed after an acute symptomatic presentation. ALL can be distinguished from the lymphocytosis, lymphadenopathy, and hepatosplenomegaly associated with viral infections and from lymphoma by the presence of leukemic blasts in peripheral blood or bone marrow specimens. This is followed by definitive diagnosis with immunophenotypic studies.

Difficulty may arise when patients present with an antecedent or overlapping period of pancytopenia before developing ALL, as has been sporadically reported.^{56, 57, 58} and ⁵⁹ It may be impossible to distinguish "aleukemic" pancytopenic ALL from aplastic anemia based on examination of the peripheral blood smear. Bone marrow evaluation and vigilant observation of the patient's clinical course are mandatory in these instances.

Patients in lymphoid blast crisis of CML are usually initially diagnosed in the chronic phase and later progress to acute leukemia. Characterization of the breakpoint region for Philadelphia-positive (Ph+) ALL patients is of no use in distinguishing de novo ALL from CML lymphoid blast crisis, as both p190BCR-ABL and p210BCR-ABL are found in even distribution in patients with Ph+ ALL.⁶⁰

P.1561

PROGNOSTIC FACTORS

Many clinical and biologic characteristics previously identified as prognostic factors for adult patients with ALL have lost predictive value as therapy has evolved and become more intensive. In contrast, age, WBC count at presentation, and immunophenotype remain strong predictors of disease-free and overall survival for Ph-negative patients.⁶¹ (Table 74.5). More sophisticated assessment of the response to therapy, such as molecular detection of minimal residual disease (MRD), is becoming increasingly important in the management of adult ALL patients. The German Multicenter Study Group for Adult ALL (GMALL) prospectively assessed MRD evaluation in two consecutive trials.⁶² The complete response rate was 89% after induction, but the molecular CR rate was only 70% in 580 evaluable patients. After consolidation molecular CR was highly predictive of continuous complete remission (CCR; 74% vs. 35%; $P < 0.0001$) and of overall survival (80% vs. 42%; $P = 0.0001$) compared with patients with molecular persistence. These results justify the routine assessment of MRD in the treatment of adult ALL and define a new high-risk group based on molecular persistence of disease.⁶³

Clinical Features

Advanced age and high WBC count at the time of diagnosis have held up as significant adverse prognostic factors in all modern adult ALL multicenter collaborative trials.^{5, 7, 8} and ^{9,61,64 65, 66, 67, 68, 69, 70, 71, 72} and ⁷³ Both advanced age and high WBC count were inversely correlated with more frequent occurrences of CR, longer duration of CR, or better overall survival in either the majority or all of the collaborative studies. Advanced age was variably defined as greater than 30 or 35 years. When included in multivariate analysis as a continuous variable, increasing age predicted worse outcome across the entire age range, making it difficult to choose a cut-off separating standard-risk from high-risk patients. The cut-off for

high WBC count was either $30 \times 10^9/L$ or $50 \times 10^9/L$. In the trial conducted by the CALGB study group, patients with advanced age (30 to 59 years) and high WBC count had an overall survival of 39% and 34%, respectively, compared with 69% and 59% for patients without these adverse prognostic factors.⁷

TABLE 74.5 PROGNOSTIC FACTORS FOR REMISSION DURATION IN ADULTS WITH ACUTE LYMPHOBLASTIC LEUKEMIA (ALL)

Patient Features	Prognostic Factor
Age (y)	
<25, <35	Favorable
>35, >55, >70	Unfavorable
White blood cell count ($\times 10^9/L$)	
<30	Favorable
≥ 30 (≥ 100 for T cell)	Unfavorable
Immunophenotype	
Thymic T	Favorable
Early T (CD1a-, SCD3-)	Unfavorable
Mature T (CD1a-, SCD3+)	Unfavorable
Pro B (CD10-)	Unfavorable
Cytogenetics/Molecular genetics/gene expression profiles	
Hyperdiploidy >50	Intermediate to favorable
Hypodiploidy <44	Unfavorable
9p abnormality	Intermediate to favorable
deletion 6q	Intermediate
Normal	Intermediate
Complex (≥ 5 abnormalities)	Unfavorable
B Lineage (e.g.,)	
t(12;21) (p13; q22) (<i>ETV6-RUNX1</i>)	Favorable
t(4;11) (q21; q23) (<i>MLL-AFF1</i>)	Unfavorable
t(1;19) (q23;p13) (<i>TCF3-PBX1</i>)	Unfavorable
t(9;22) (q34; q11) (<i>BCR-ABL1</i>)	Unfavorable ^a
<i>IKZF1</i> deletions/mutations	Unfavorable
T Lineage (e.g.,)	
<i>NOTCH1/FBXW7</i> mutations	Favorable
<i>TLX1</i> or t(10;14) (q24; q11) (<i>TLX1-TCRA/D</i>)	Favorable
t(10;11) (p13; q14) (<i>PICALM-MLLT10</i>)	Unfavorable
t(5;14) (q35; q32) (<i>TLX3-BCL11B</i>)	Unfavorable
Response to therapy	
Complete remission within 4 wk	Favorable

Persistent minimal residual disease

Unfavorable

^a Improved prognosis with tyrosine kinase inhibitors.

Laboratory Features

Immunophenotype

The major immunophenotypic subgroup with prognostic value and therapeutic importance is the mature B-cell neoplasm, Burkitt leukemia. Burkitt leukemia is characterized by strong expression of surface immunoglobulin in addition to other markers common to B-lineage ALL, including CD10, CD19, CD20, and CD22.⁵² These patients respond poorly to standard ALL therapy, and outcome was dismal until brief, dose-intensified treatment programs were established as standard therapy.^{74,75,76} The substantial improvement in survival that resulted has negated the adverse prognostic value of this feature if patients are optimally managed.

T-cell ALL is another formerly unfavorable prognostic subgroup that, due to changes in treatment approach, is no longer a poor risk feature.⁷⁷ In fact, with many modern treatment programs, the T-cell immunophenotype has become prognostically favorable.^{7,68,78} High WBC count does not adversely affect survival in T-cell ALL unless the WBC is $>100 \times 10^9/L$.^{66,67,79} In addition, more detailed examination of prospective immunophenotypic data collected by the CALGB identified a subset characterized by expression of fewer than three T-cell markers that had an unfavorable prognosis.⁸⁰ Leukemic blasts from these patients also infrequently expressed mature T-cell surface markers such as CD1a, CD2, CD3, CD4, and CD8, and, hence, would be consistent with the "early" T-cell ALL immunophenotype also reported to be unfavorable by the GMALL.^{81,82} The distinction between early T-ALL (sCD3-, CD1a-), thymic T-ALL (sCD3-/+, CD1a+), and mature T-ALL (sCD3+, CD1a-) described by GMALL may serve as an example of a clinically significant, risk-adapted treatment stratification.⁸³

Other immunophenotypic markers have variably been shown to have prognostic value but are less well established. CD34 is expressed more frequently in adults with B-lineage ALL and was reported to affect outcome by the CALGB adversely.⁸⁰ However, CD34 expression overlapped with both a high WBC and the presence of the Ph chromosome, and findings from other smaller series have yielded conflicting results.^{84, 85, 86, 87} and ⁸⁸ Expression of myeloid antigen markers was slightly more frequent in B-lineage ALL than in T-lineage ALL but had no prognostic value in either instance.^{64, 80, 89}

Cytogenetics

Unfavorable cytogenetic abnormalities in adult ALL include t(9;22) [BCR-ABL], observed in up to 30% of cases, t(4;11)(q21;q23)[MLL-AFF1], rare in adult ALL, t(1;19)(q23;p13)[TCF3-PBX1], also rare, and a hypodiploid karyotype, seen in 5% to 6%. Translocations involving chromosomal band 14q11 and abnormalities of the short arm of chromosome 12, including t(12;21)[ETV6-RUNX1], observed in 3% of cases, are favorable cytogenetic abnormalities. Results from collaborative studies providing karyotypic data generally indicate disease-free survival rates less than 25% for P.1562

patients with unfavorable abnormalities, as opposed to greater than 75% for those with favorable cytogenetic findings.^{60,65,90, 91, 92, 93} and ⁹⁴ Additional reports from single institutions have provided similar outcome data.^{95,96}

Cytogenetic findings commonly identified in adult ALL with an intermediate prognosis include normal karyotype, hyperdiploidy, and abnormalities at 6q or 9p. The t(8;14) (q24;q32)[MYC-IGH] and other MYC gene rearrangements are associated with the Burkitt leukemia subtype and are not prognostically unfavorable markers with optimal treatment.

In the UKALL XII/ECOG 2993 trial, 41 patients (5%), without an established translocation, had a complex karyotype with 5 or more chromosomal abnormalities. Four patients were primary induction failures and 19 of 37 CR patients relapsed. All but 3 of these 19 patients relapsed within 2 years of diagnosis and 17 of the 19 died. EFS and OS were significantly inferior in this group. These results established complex karyotype as a poor prognostic indicator.⁹⁷

Adult Ph-positive patients achieve CR rates comparable to Ph-negative ALL patients, but the remissions are short and survival poor with standard therapy. The most frequent translocation in adults involving the MLL gene, located at chromosome band 11q23, is t(4;11) and is also associated with poor survival.⁹⁴ The t(1;19) translocation results in the TCF3-PBX gene rearrangement, and patients with this abnormality were found to have a 3-year disease-free survival rate of only 20%.⁹² Patients with hypodiploidy ranging from 30 to 39 chromosomes have a disease-free interval of only 2 to 4 months from the start of treatment.⁹²

Deletions and translocations involving 12p include the ETV6-RUNX1 gene rearrangement. ETV6 gene rearrangements are much less frequent in adults than in children but are prognostically favorable in both. Translocations involving the TCR- α/β

loci at chromosome 14q11 most frequently result in rearrangement with the TLX1 (HOX1) gene at 10q24.⁹⁸ Adult ALL patients with t(10;14)(q24;q11) experience long survival, but this may reflect an association with T-cell ALL subtypes.^{65,92}

Oncogenes

The absence of chromosomal abnormalities does not preclude the less conspicuous presence of aberrantly expressed oncogenes that promote leukemogenesis. Oligonucleotide microarrays, and more recently, next-generation sequencing technologies have led to a revolution in analysis of the leukemia genome and will undoubtedly add to cytogenetic profiling in the risk stratification of ALL. These are discussed in detail in Chapter 72. Using oligonucleotide microarrays, Ferrando et al. identified T-cell oncogenes—TLX1, TLX3, TAL1, and LYL1—that may have prognostic relevance in T-cell ALL.⁹⁹ These genes normally function as a homeobox gene (TLX1) or encode developmentally essential transcription factors (TAL1, LYL1) in normal thymocyte maturation. Their dysregulated expression is thought to foster leukemogenicity and can be detected as a signature genetic profile, which not only has the ability to provide insight into their pathogenetic heterogeneity, but also render important prognostic information. Overexpression of TLX1, present in approximately 30% of adult T-ALL cases, has been associated with a favorable prognosis, and in one study, demonstrated a leukemia-specific survival rate of 88% in TLX1-positive patients compared with 56% in TLX1-negative patients at a median follow-up of 4.7 years.¹⁰⁰ In contrast, the overexpression of TAL1 or LYL1 has been linked to poor response to treatment, and the predictive value of TLX3, another homeobox factor related to TLX1, is conflicting.^{101,102}

Another mechanism for ALL leukemogenesis is the constitutive activation of tyrosine kinase via the NUP214-ABL1 fusion episome. The juxtaposition of the two oncogenes leads to the familiar amplification of ABL1 on the chromosome band 9q34. However, the NUP214-ABL1 fusion escapes detection by conventional cytogenetics by virtue of its extrachromosomal position and requires molecular analysis for delineation. The fusion episome has been detected in approximately 6% of individuals with T-ALL.¹⁰³ Because of its sensitivity to abl tyrosine kinase inhibitors, the subset of T-ALL patients with this molecular feature is predicted to benefit from early identification.¹⁰⁴ The known presence of TLX1 or TLX3 may also merit exploration for the NUP214-ABL1 fusion given their tendency for co-expression.¹⁰⁵

Response to Therapy

Response to therapy can be assessed by determination of time to attainment of CR, quantitation of early leukemic blast clearance, or detection of MRD. These measurements provide a direct assessment of biologic susceptibility to antileukemic agents, and, as such, prognostic factors based on them have inherently high heuristic power. In addition, prospective evaluation of their utility as predictors of outcome in clinical trials has established that they also have high explanatory power. However, until recently, virtually all of the clinical studies measuring these outcomes have been performed in pediatric ALL. Assessments of response to therapy have become crucial prognostic factors in adult ALL, but remain underutilized in clinical practice. These should aid in refining prognostic models with the goal of improving outcome with risk-adapted therapy.

Early Complete Remission

Failure to achieve CR within 4 weeks of starting treatment or after one course of induction chemotherapy has been considered an independent unfavorable prognostic factor, confirmed in most adult ALL studies.^{7,73} An exception is the international, multicenter UKALL XII/ECOG E2993 trial, which could not confirm its importance in its 1,500 patient cohort.⁶¹ When significant, early CR held predictive value for standard ALL programs as well as for newer, dose-intensified treatment protocols.^{5,67,78,106,107,108} Patients requiring greater than 4 weeks to achieve CR were at least twice as likely to relapse, depending on the study. In one study, patients who did not achieve CR by week 4 of induction had a 5-year disease-free survival of 0% as compared with 46% for the remainder of the complete responders.⁷⁸ In this study, the number of weeks required to achieve CR was only marginally worse than the Ph chromosome as an unfavorable variable.

Early Leukemic Blast Clearance

Evaluation for persistence of leukemic blasts at even earlier time-points, between days 7 and 21 of induction, has been firmly established as an important prognostic indicator for outcome in pediatric ALL.^{109, 110} and ¹¹¹ Early persistence of leukemic blasts at 7 days after starting induction is thought to represent corticosteroid resistance.¹¹² In contrast, persistence at time-points after 21 days is considered a reflection of cytotoxic chemotherapy resistance. Numerous prospective studies in pediatric ALL have shown that a substantial unfavorable influence on outcome is associated with the morphologic detection of blood or marrow leukemic blasts persisting during induction therapy at day 7, day 21, or at other time-points in between. Persistence of leukemia was usually defined as the finding of greater than 1×10^9 /L blast cells in a peripheral blood sample or leukemic blasts greater than 5% of normal cells in a marrow specimen.

Although pediatric protocols already incorporate early treatment response assessment by a day 7 or day 14 bone marrow examination into risk classification, similar data in adult ALL are limited.¹¹³ Results from the few reported studies agree with findings from the pediatric experience. Sebban et al. prospectively evaluated persistence of marrow blasts, defined as greater than 5% of nucleated cells, at day 15 of induction for influence on outcome.¹⁰⁷ Among 437 adult ALL patients, one third were found

P.1563

to have persistent blast cells. These patients were less likely to achieve CR after 4 weeks of therapy. Even among only the patients who achieved CR within 4 weeks, an otherwise favorable feature, those who had persistent blasts at day 15 fared significantly worse. Among all complete remitters, the 5-year disease-free survival was 34% for those who cleared marrow blasts at day 15, compared with 19% for those who did not. Annino et al. and the Italian collaborative study group evaluated the early corticosteroid response by giving a 7-day course of prednisone immediately before induction.⁹ The pre-induction response was previously shown to have strong prognostic value in pediatric ALL.^{114,115} In the adult ALL study, prednisone response was defined by reduction of peripheral blood blasts to less than or equal to $1 \times 10^9/L$. Lack of a prednisone response was found to affect overall survival negatively, as it did in the pediatric ALL studies, and, among CR patients, it also adversely influenced remission duration.

Minimal Residual Disease

MRD refers to the post-remission persistence of leukemia that cannot be detected by histomorphologic assessment. Immunophenotypic, cytogenetic, or molecular techniques can be used to detect MRD.¹¹⁶ Samples from peripheral blood are generally one log₁₀ less sensitive than bone marrow, perhaps as post-treatment BCR-ABL transcripts from peripheral blood clear more rapidly,¹¹⁷ but may have comparable sensitivity in T-lineage ALL.^{118,119,120} Fluorescence in situ hybridization is better than conventional banding analysis for detecting chromosomal translocations and numerical abnormalities, but both techniques are limited by low sensitivity.^{121, 122, 123} and ¹²⁴ Flow cytometry, used in four or more color combinations and taking advantage of new reagents, detects aberrant antigen expression on leukemic cells and can unambiguously distinguish one leukemic blast among more than 104 normal cells in 90% of all patients.^{125,126} This level of sensitivity is sufficient for prognostically significant MRD detection.¹²⁷ Additionally, flow cytometry is rapid, reliable, and allows accurate quantitation, and the technical requirements for the assay are already in place at most centers, making it an attractive diagnostic tool. The most sensitive assays for detecting MRD, however, are based on PCR techniques, which can detect one leukemic blast in up to 106 normal cells. PCR targets using fusion gene transcripts such as BCR-ABL, ETV6-RUNX1, AFF1-MLL, and E2A-PBX are relatively standardized, but each alone can only be used for patient subsets.^{128, 129} and ¹³⁰ PCR targets based on immunoglobulin and T-cell receptor gene rearrangements can be used to detect MRD in theoretically all patients, but lose sensitivity if consensus rather than patient-specific primers are used.^{128,131} On the other hand, generating patient allele-specific primers requires DNA sequencing capability. Although a number of clinical studies have suggested the prognostic significance of threshold values of MRD,^{132,133} early experience with accurate quantitation of leukemia-specific residual disease with the PCR assay was fraught with technical challenges, and standardization of assay sensitivity among testing facilities was of major concern.¹³⁰ Where available, however, real-time quantitative PCR technology utilizing newer automated methods has proven to be technically simple, yielding precise and consistent quantitation of residual leukemic clones, and is gaining widespread acceptance.^{134,135} Information from pediatric ALL trials using PCR and flow cytometry in tandem may help determine more definitively the role of each for evaluating MRD.¹³⁶

The prognostic utility of MRD detection was first described in studies conducted on children with ALL.^{109,128,137} Three of the pediatric studies stand out for having large patient numbers, inclusion of both B- and T-lineage ALL, and for including patients with poor risk features.^{127,132,133} The European studies were multicentered and used PCR detection of patient-specific antigen receptor gene rearrangement, whereas Coustan-Smith et al. used multicolor flow cytometry in an unselected patient cohort treated at the St. Jude Children's Research Hospital. MRD was determined at the end of induction and at various time-points thereafter. The testing was technically challenging, as 1,254 of 1,914 (66%) combined patients treated during the study period did not have suitable PCR targets, serial PCR performed, or an immunophenotype suitable for MRD assessment. Nonetheless, all three studies demonstrated an unfavorable influence of persistent MRD on relapse-free survival. By multivariate analyses in the St. Jude study, sequential detection of persistent MRD remained a poor prognostic marker after controlling for age, WBC count, and adverse cytogenetics including the Ph chromosome and MLL gene rearrangement.¹²⁷ Detection of MRD during maintenance therapy tended to have the strongest positive predictive value for relapse. Conversely, absence of MRD at the end of induction negated the unfavorable influence of persistent leukemic blasts at day 7 as a prognostic factor.

Studies assessing the predictive value of MRD in adult ALL have generally echoed findings of pediatric studies.^{138, 139} and¹⁴⁰ Mortuza et al. reported results for 66 Ph-negative adult B-lineage ALL patients treated at a single institution, for whom MRD was assessed with PCR using consensus immunoglobulin heavy chain gene primers.¹³⁸ Detection of residual leukemia at the 10⁻³ level, the limit of sensitivity of the assay, independently correlated with inferior disease-free survival when measured 3 to 5 months after induction therapy. The kinetics of MRD clearance has also gained much attention with respect to predicting relapse risk. Among the 196 standard-risk ALL patients monitored by quantitative PCR during their first year of treatment in the German Multicenter Acute Lymphoblastic Leukemia (GMALL) study, the 3-year relapse rate was 0% if MRD declined rapidly to lower than 10⁻⁴ at day 11, or below detection threshold at day 24, compared with a relapse rate of 94% if the MRD was at a level of 10⁻⁴ or higher until week 16.¹⁴¹ Based on these results, they defined three risk groups based on MRD assessment in this otherwise homogeneous standard risk group. Scheuring et al. suggested that the magnitude and rate of BCR-ABL increase, as well as the absolute number of transcripts, could predict relapse within 2 months.¹⁴² Another large cooperative group study reported that a 2-log reduction of MRD after induction, and a greater than 3-log reduction after consolidation therapy were associated with a 2-year actuarial probability of overall, disease-free, and relapse-free survival of 48%, 27%, and 38%, respectively, compared with 0% survival with smaller reductions.¹⁴³ The increasingly recognized prognostic significance of MRD has prompted a large cooperative group study to evaluate prospectively the utility of MRD in selecting patients for stem cell transplantation in first CR as a model for risk-adapted treatment strategy.¹⁴⁴

PRIMARY THERAPY

Current management strategies for adult patients with ALL require a careful assessment of relapse risk at the time treatment is initiated. Most adult ALL patients have the precursor B-cell or T-cell subtype and can be managed with established treatment programs that start with remission induction, followed by blocks of intensification, CNS relapse prophylaxis, and prolonged maintenance therapy. With modern multiagent regimens, up to 90% of patients achieve CR, and 25% to 40% can be cured. The disease-free survival figure obviously needs improvement, and, hence, therapy should be tailored for patients who have an adverse prognostic profile. Risk-adapted therapy has proven remarkably effective for certain poor-risk groups, such as brief dose-intensive protocols for adult patients with Burkitt leukemia. Other patient groups known to have high risk for disease relapse should undergo allogeneic stem cell transplantation

P.1564

(SCT) in first remission, given an available donor and eligibility status. Considerable clinical data suggest that this strategy has been effective, particularly with Ph+ patients. The ECOG/MRCXII trial also demonstrated the benefit of transplant in standard risk patients under age 50. Elderly ALL patients pose special treatment considerations that are discussed in this chapter. General issues relating to supportive care of the patient with leukemia are discussed in Chapter 69.

General Principles

On presentation, certain pre-treatment considerations should be addressed before initiating therapy. Leukemia therapy is guided by an estimate of relapse risk, although there is no formal risk assessment tool for adult ALL. In reviewing the list of agents used to induce remission and protect against relapse, it can be appreciated that the individual superiority of one drug over another in many instances has not been established. Complicating management decisions are similarly conflicting outcome results for SCT in first remission for high-risk patients, although the general consensus is that allogeneic SCT from a sibling donor is best therapy.

Pre-treatment Considerations

Attention should be paid to metabolic, infectious, and hematologic issues before starting leukemia-specific therapy. Hyperuricemia, hyperphosphatemia, and secondary hypocalcemia may be pronounced with high leukemic cell burden and require intravenous hydration, alkalinization, and administration of allopurinol. In addition to myelosuppression during intensive treatment blocks, ALL therapy suppresses cell-mediated immunity, and some protocols have provisions for prophylaxis against herpes simplex virus and *Pneumocystis jiroveci* infections.¹⁰⁶ The clinical consequences of hyperleukocytosis ($\geq 100 \times 10^9/L$) in adult ALL patients are not well understood. Patients with MLL gene rearrangements and Burkitt leukemia are at higher risk for hyperleukocytosis at presentation.⁶⁰ In children, pronounced hyperleukocytosis involving lymphoid blasts are better tolerated than myeloid blasts, as reflected by fewer complications attributable to leukostasis or hemorrhage.¹⁴⁵ In one series, leukapheresis for pediatric ALL patients having blast counts greater than or equal to $2 \times 10^9/L$ led to outcomes equivalent to those for children who did not have this degree of hyperleukocytosis.¹⁴⁶ A similar policy is reasonable for adult ALL patients. Alternatively, immediate administration of prednisone or vincristine can rapidly reduce the circulating blast count. In an adult series, the WBC count dropped from greater than $100 \times 10^9/L$ to less

than 1×10^9 in 39% of patients given a 7-day course of prednisone immediately preceding remission induction chemotherapy.⁹

Risk Assessment Model

There are no useful clinical staging or prognostic scoring systems for adult ALL patients as there are for other hematologic malignancies, and there are no agreed-on uniform risk criteria as there are for pediatric ALL.^{147, 148, 149, 150} and ¹⁵¹ A prognostic model based on CALGB data suggested an additive effect of multiple adverse prognostic features on outcome, and, conversely, those without any poor prognostic factors did exceptionally well with few relapses.⁷ Others have described similar analyses.^{66,78} Based on these models and the current clinical evidence, a general framework for risk assessment may consider placing adults with ALL in different risk prognostic categories (Fig. 74.3). All patients with at least one established poor prognosis factor based on clinical, immunophenotypic, cytogenetic, or molecular features and response to induction therapy should be considered at high risk for relapse. Adding response to therapy, based on MRD detection, as a risk criterion for adapting therapy has been validated in several adult studies. In two consecutive GMALL trials (GMALL 06/99 and 07/03) involving 1,648 patients, prospective MRD evaluation was used at several time-points. MRD absence after consolidation therapy was highly predictive of continuous complete remission after 5 years (74% vs. 35%) as well as OS (80% vs. 42%). A multivariate analysis of prognostic factors, including age, immunophenotype, risk group, and MRD status after consolidation, found that only the MRD status was predictive of CCR after 5 years with a hazard ratio of 4.5 ($P < 0.0001$). Both age, with a hazard ratio of 1.3 ($P = 0.0007$), and MRD status, with a hazard ratio of 4.0 ($P < 0.0001$), influenced overall survival.⁶²

In addition, patients with persistent MRD undergoing HSCT in first CR experienced higher rates of CCR than those without HSCT (66% vs. 11%), which led to better survival (54% vs. 32%). The Northern Italian Study Group also reported an advantage for patients positive for MRD treated with HSCT ($n = 36$) compared with non-HSCT ($n = 18$) with approximately 50% compared with 10% long-term disease-free survival.¹⁵²

Remission Induction

The goal of remission induction therapy is hematologic complete remission (CR), as defined by the eradication of morphologically detectable leukemia cells in blood and bone marrow and the return of normal hematopoiesis. The importance of achieving CR after induction was highlighted in a study that demonstrated a 5-year overall survival rate of 45% in CR patients compared with 5% in patients who did not achieve CR.⁶¹ Remission induction chemotherapy for adults with ALL is most commonly built around a backbone of vincristine and prednisone. Remission induction with these two drugs in combination produces CR in approximately one half of patients with de novo ALL. The CR rate improves to 70% to 85% when an anthracycline is added, which was proven in a landmark CALGB trial to be superior to vincristine and prednisone alone.¹⁵³ Induction failures are evenly divided between refractory disease and toxicity-related mortality.^{5,7,9,66,78} The efficacy of various anthracyclines in adults, including daunorubicin, doxorubicin, zorubicin, and mitoxantrone, has been similar.^{77,154, 155} and ¹⁵⁶

Many alterations to the basic induction regimen have been evaluated.^{82,157, 158, 159} and ¹⁶⁰ A critical evaluation of the individual merits of these modifications is challenging. Improvement to CR rates that already exceed 80% would be difficult to detect at a satisfactory level of significance. Modern treatment protocols are complex, and it is difficult to attribute outcome results to any one component or to make comparisons of significant findings between any two trials. For example, some modern induction protocols also incorporate L-asparaginase, cyclophosphamide, or both, although neither has been proven by controlled trials to be beneficial in adult ALL when added to standard three-drug induction regimens. The one randomized trial with L-asparaginase found no improvement in frequency or duration of CR with the addition of L-asparaginase to doxorubicin, vincristine, and prednisone during induction.¹⁶¹ Nonetheless, L-asparaginase has a mechanism of action that is close to being ALL-specific, causes minimal myelosuppression, and has been shown to be efficacious in pediatric ALL.¹⁶² An Italian Gruppo Italiano Malattie Ematologiche dell' Adulto (GIMEMA) trial randomized adult ALL patients to induction with daunorubicin, vincristine, prednisone, and L-asparaginase with or without cyclophosphamide.⁹ The rate and durability of remission, as well as overall survival, did not differ between the two randomized treatment groups or for any subtype analyzed. In contrast, other studies have suggested a benefit with the inclusion of cyclophosphamide during induction, especially for patients with T-cell ALL, and, conversely, worse outcome with its omission.^{7,163}

Dose-intensified anthracycline and high-dose cytarabine induction regimens have been evaluated as alternatives to traditional

induction protocols. These treatment programs were intended to improve outcome by inducing rapid reduction of leukemic cell mass to achieve early CR.¹⁶⁴ Todeschini et al. generated considerable interest with reports from two sequential trials showing that dose escalation of daunorubicin to 225 mg/m² and, subsequently, to 270 mg/m² significantly improved disease-free survival.^{165, 166} and ¹⁶⁷ Multicenter implementation of this protocol by the GIMEMA group, however, failed to reproduce the earlier experience based on an interim analysis of 460 of 501 total patients enrolled.¹⁶⁸ Weiss et al. investigated a different approach using high-dose mitoxantrone given with high-dose cytarabine during induction.^{169,170} The results from their expanded randomized trial at seven study sites in the United States demonstrated improved remission (83% vs. 70%) and 5-year overall survival rates (35% vs.

P.1566

22%), as well as less resistance and more activity in Ph+ disease, compared with a standard regimen,¹⁷¹ establishing the activity of the combination of high-dose cytarabine and mitoxantrone in ALL. The standard L-20 regimen (vincristine, prednisone, cyclophosphamide, doxorubicin) used in this study did not use asparaginase during induction, and the results of the standard treatment arm are somewhat inferior to other contemporary regimens.

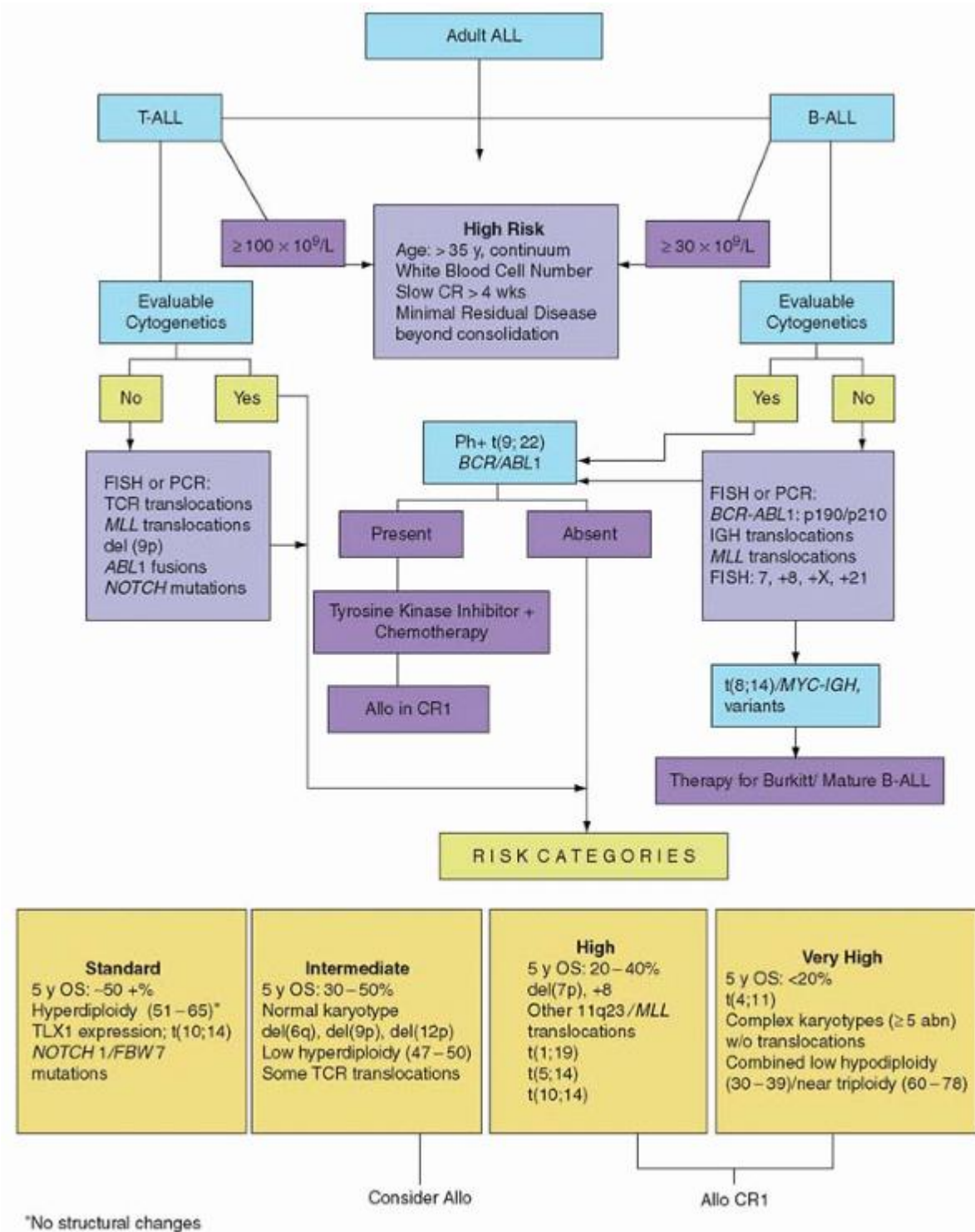

FIGURE 74.3. Risk assessment for adult acute lymphoblastic leukemia (ALL). Clinical, immunophenotypic, and cytogenetic features may be combined with the initial response criteria to classify patients into risk categories (Adapted from Pullarkat V, Slovak ML, Kopecky KJ, et al. Impact of cytogenetics on the outcome of adult acute lymphoblastic leukemia: results of Southwest Oncology Group 9400 study. *Blood* 2008;111:2563-2572.)

Dexamethasone has been substituted for prednisone in standard-risk pediatric patients in a large randomized trial.¹⁷² The use of dexamethasone achieved a 34% reduction in relapse risk as well as a significant decrease in isolated CNS relapse. However, dexamethasone is associated with an increased risk of avascular necrosis in children. Current pediatric protocols

use prednisone for all children >10 years old during induction and dexamethasone for those ≤10. This has not yet been studied in a comparable adult population.

Patients with Burkitt leukemia have poor initial responses to these conventional regimens and require special dose-intensified remission induction programs that are discussed below.^{74,75,173,174,175}

Granulocyte colony-stimulating factor started after completion of the first few days of ALL induction chemotherapy did not improve survival or ultimate outcome in randomized trials. It did, however, shorten the duration of neutropenia by 5 to 6 days and appeared to reduce the incidence of associated complications, particularly infections.^{64,176,177} and ¹⁷⁸

Intensification Therapy

Post-remission intensification or consolidation therapy after the attainment of CR is standard treatment for adult patients with ALL. This therapy refers to the administration of non-cross-resistant drugs aimed at eliminating residual leukemia to prevent relapse as well as the emergence of drug-resistant cells. Variably myelosuppressive doses of different drugs are given according to various schedules depending on the protocol. Due to the heterogeneity of approaches, it is difficult to assess the effect of any individual drug, and only a general assessment of the overall value of intensification can be made.

A randomized trial in childhood ALL clearly demonstrated that administration of both early (given immediately after CR) and late (week 20) intensification therapy was better than either early or late intensification alone and better than no intensification at all.¹⁷⁹ Two other pediatric trials confirmed the benefit of intensification.^{180,181} Results from comparative trials in adults have been less clear and again highlight the difficulty of comparing findings from discordantly designed studies. The pediatric study was conducted by the British UKALL study group, which also enrolled adult patients in a concurrent trial using essentially identical treatment regimens.⁵ There was a significant decrease in relapse incidence for adult patients who received the early intensification block, but this was not reflected by a statistically significant improvement in disease-free survival, possibly due to an increased number of deaths during remission. Likewise, two GIMEMA studies randomizing adult ALL patients to intensive versus standard consolidation and maintenance saw no advantage in disease-free survival for intensified post-remission treatment.^{9,72} No benefit was observed with extending consolidation started early in the post-remission period from 1 month to 4 consecutive months.¹⁸² Adding two myelosuppressive consolidation courses patterned after acute myeloid leukemia, "3 + 7" daunorubicin and cytarabine, to maintenance alone made no difference in the duration of remission.¹⁸³ Lastly, very late intensification given at 6 months or 11 months after CR, in two separate trials, led to no reduction in relapse compared with standard post-remission therapy alone.^{184,185}

In contrast, clinical data from nonrandomized trials provide evidence that adult ALL patients benefit from intensification.^{7,66,67} In the CALGB study, patients who achieved CR received two blocks of early intensification in addition to an 8-week late intensification therapy.⁵⁹ The reported medians of remission duration and survival, 29 months and 36 months, respectively, were substantially better than those observed in prior CALGB trials that did not use intensification blocks. Outcomes better than historical comparison groups were reported by the GMALL studies that consolidated remission patients with a late "re-induction" of drugs identical to initial therapy given 21 weeks after starting treatment.^{7,63}

Maintenance Therapy

As with post-remission intensification, the value of long-term, continuous maintenance therapy for adult ALL has not been established by randomized trials as it has for pediatric ALL.¹⁸⁶ Patterned after the childhood ALL experience, maintenance therapy usually consists of daily 6-mercaptopurine and weekly methotrexate for a total treatment period of 2 to 3 years. There is no information from adult ALL trials regarding the proper duration of maintenance therapy, but children who receive less than 18 months of therapy have worse outcome. The addition of monthly pulses of vincristine and prednisone reduced relapses in controlled childhood ALL studies and has been adopted in some adult maintenance therapy regimens. From a mechanism-of-action perspective, it may be that long-term drug exposure is required to eradicate residual, slowly dividing, or drug-resistant ALL clones.¹⁸⁷ This could explain why maintenance is not necessary for optimally treated patients with Burkitt leukemia, which is a highly mitotically active leukemia.^{2,74,75,173,174}

Relatively strong evidence that adult ALL patients benefit from maintenance therapy comes from a number of studies showing inferior outcome when prolonged maintenance was completely omitted.^{154,188,189} and ¹⁹⁰ The CALGB study was intended to evaluate the efficacy of mitoxantrone during induction and consolidation given over a 7- to 9-month period without maintenance.¹⁵⁴ Patient accrual on this trial was terminated at interim analysis because the median duration of remission (11 months) was much shorter than in previous protocols. Similarly, another American cooperative study group investigated high-dose cytarabine intensification followed by 8 cycles of multiagent consolidation.¹⁸⁹ Without maintenance, the median duration of remission was 10 months, and the disease-free survival at 4 years was only 13%.

Central Nervous System Therapy

CNS prophylaxis is essential in the treatment of ALL. Approximately one third of adult patients will eventually have CNS involvement at relapse without prophylactic therapy.^{191,192} The advantage of CNS prophylaxis in adult ALL was established by the Southeastern Cancer Group in a randomized trial comparing cranial irradiation plus intrathecal methotrexate versus no prophylaxis.¹⁹³ CNS prophylaxis may involve combinations of intrathecal chemotherapy, cranial irradiation, and systemic administration of drugs with high CNS bioavailability, such as high-dose methotrexate and high-dose cytarabine. Although the best combination of modalities and the preferred timing have not been established in controlled trials, a number of different approaches have all proved equally effective. Intrathecal chemotherapy alone or high-dose chemotherapy alone, however, has been associated with poor protection from CNS relapse.^{194,195} On the other hand, more aggressive approaches combining all three modalities do not yield clearly superior results.⁶⁶ Cranial irradiation between 1,800 and 2,400 cGy plus intrathecal methotrexate started after achievement of CR has been used as CNS prophylaxis in several studies, with CNS relapse rates between 0% and 11%.^{7,69,78,163} Similar results were achieved in other studies that were able to omit cranial irradiation by starting intrathecal chemotherapy concurrent with induction and incorporating high-dose methotrexate, high-dose cytarabine, or both.^{72,108,183}

P.1567

Adult ALL patients with CNS involvement at diagnosis require additional CNS-directed therapy, as it can adversely affect survival. In the UKALL XII/ECOG 2993 trial evaluating post-remission therapies, overall survival at 10 years was inferior in patients with CNS disease at diagnosis compared to those without (34% vs. 29%, $P = 0.03$).¹⁹⁶ Up to 10% of adults present with CNS leukemia at the time of diagnosis.^{7,67,156,195} Patients with Burkitt leukemia are at high risk for both CNS disease at presentation and subsequent CNS relapse.^{74,75} The treatment of CNS leukemia has generally involved early and repeated dosing of intrathecal chemotherapy started during induction therapy.^{67,78,106} Kantarjian et al. gave twice weekly alternating intrathecal methotrexate and cytarabine until the CSF showed no leukemic blasts, followed by the standard intrathecal prophylaxis regimen.¹⁰⁶ Linker et al. gave intrathecal methotrexate injections weekly for 10 weeks, then monthly for the remainder of the first year.⁷⁸ The cranial irradiation dose was also increased to 2,800 or 3,000 cGy when included as CNS prophylaxis during the treatment protocol.^{67,78} With either approach, the presence of CNS leukemia did not adversely affect subsequent outcome.

Hematopoietic Stem Cell Transplantation

Allogeneic SCT in first remission improves outcome for adult ALL patients with high-risk features and should be pursued for all eligible patients. Outcome data from most uncontrolled individual trials indicate disease-free survival between 40% and 60% with matched sibling allogeneic SCT.^{197, 198, 199} and ^{200, 201} Some centers reported exceptionally impressive results. In a transplant study performed by Stanford University and the City of Hope National Cancer Center, high-risk inclusion criteria were defined as age greater than 30 years, a WBC count greater than $25 \times 10^9/L$, failure to achieve CR within 6 weeks of starting induction, or the presence of unfavorable cytogenetic abnormalities. Blume et al. initially reported a disease-free survival rate of 63%, which held up at 61% with longer follow-up of an expanded patient cohort, as reported by Chao et al.^{197,198}

Registry data from the International Bone Marrow Transplant Registry (IBMTR) provide additional information. Registry data are useful in limiting the influence of selection bias and heterogeneity between patient groups at different institutions, especially when based on large patient numbers. Reporting on 243 adult patients with high-risk ALL undergoing sibling donor allogeneic SCT, the 5-year estimate of disease-free survival was 39%.²⁰² Treatment-related mortality (37%) exceeded disease relapse (30%) as the cause of treatment failure. In additional analyses by the IBMTR, patients were found to be half as likely to relapse if they developed either acute or chronic graft-versus-host disease.²⁰³ Others have also described similar evidence for a significant graft-versus-leukemia effect, which may have contributed to the relatively low relapse rate, although to a lesser degree in comparison to chronic and acute myeloid leukemias.^{204,205} Several comparisons of IBMTR data with outcome after standard therapy have been reported.^{206,207,208} In these indirect comparisons with historical control groups, allogeneic SCT in first CR proved superior for survival due to protection from relapse.

The first study providing controlled outcome data for allogeneic SCT versus standard therapy was the French Leucémie Aiguë Lymphoblastique de l'Adulte (LALA)-87.^{70,71,156} The study genetically randomized adult patients with ALL to sibling donor allogeneic SCT in first CR versus consolidation and maintenance chemotherapy, regardless of risk category. Risk categorization was based on criteria set by the German study group.^{67,68} Allogeneic SCT was found to be significantly

superior to standard therapy but only for high-risk patients. Disease-free survival at 10 years for these patients was 44% with allogeneic SCT versus 11% for conventional therapy. For standard-risk patients, disease-free survival with allogeneic SCT was similar (49%) but no better than conventional therapy (43%). The subsequent LALA-94 study also favored allogeneic SCT over standard chemotherapy for high-risk patients, with respective 5-year overall survival rates of 51% and 21%.²⁰⁹ The benefit of allogeneic SCT from a related donor in first CR even in standard-risk patients was demonstrated in the UKALL XII/ECOG 2993 trial.⁶

Allogeneic SCT from unrelated donors for adults in first CR can be successfully performed. Various individual trials have been reported, as well as results reported to the National Marrow Donor Program (NMDP). When 64 patients with high-risk features, including the t(4;11) and t(1;19) translocations, received matched unrelated donor allogeneic SCT in first CR, transplant-related mortality was 54%, but relapse at 4 years was only 19%. Only 1 of 17 patients surviving beyond the first year had relapsed at the time of last follow-up.²¹⁰ Subsequently, Weisdorf et al. reported the outcome of 517 patients, ranging in age from 0 to 51 years, with high-risk ALL, including relapsed status and the t(4;11) and t(1;19) translocations, who received matched unrelated donor allogeneic SCT in first or second CR.²¹¹ Transplant-related mortality was 42%, but relapse at 5 years was only 14% for those transplanted in first CR, and 25% for those in second CR. The 5-year probability of disease-free survival rates for those transplanted in first and second CR were 44% and 36%, respectively. Similarly, in a large European study, 5-year disease-free survival did not differ between patients receiving a graft from a matched related or unrelated donor as long as the SCT occurred in first CR (42% vs. 45%, respectively).²¹² Treatment-related mortality also did not differ between the two donor types of SCT.

The role for autologous SCT as an option for post-remission therapy in high-risk ALL patients is difficult to evaluate. The French LALA-87 group performed a trial, parallel to the allogeneic SCT study that randomly assigned patients younger than 50 years who did not have a matched sibling donor to autologous SCT versus standard therapy, regardless of disease risk.^{71,156} Conventional therapy was found to be equivalent to autologous SCT for standard-risk patients. For high-risk patients, autologous SCT and conventional therapy both proved equally ineffective, with 10-year disease-free survival rates of 10% and 16%, respectively. Patients on the SCT arm were transplanted after three consolidation courses, and the autografts were purged with monoclonal antibodies and complement or mafosfamide. The LALA-94 study compared the outcomes of high-risk ALL patients who were assigned to allogeneic SCT if they had an HLA-identical sibling, or randomized to autologous SCT versus standard therapy if they did not. Autologous SCT conferred no advantage over chemotherapy in this high-risk population, and the respective 5-year overall survival rates of 32% and 21% were not significantly different in statistical analysis.²⁰⁷ In the UKALL XII/ECOG 2993 trial, conventional chemotherapy was superior to autologous transplant, with a 46% versus 37% 5-year survival.⁶ Many autologous transplant studies compare individual trials with registry data and report significantly better results. Trials that compare registry data differ considerably from one another and from the French randomized studies with respect to timing of transplant, purging method, intensity of preparative regimen, and whether post-transplant maintenance therapy is given.^{213,214} Taken together, disease-free survival for autologous SCT in first CR from individual trials ranges from 26% to 65%, a wide degree of variability likely reflecting the above considerations.^{201, 215} In some studies, transplant-related mortality approached 20% and seems high relative to contemporary experience with autologous SCT.^{216, 217} and ²¹⁸

A comparative analysis of data from two registries—the NMDP and the Autologous Blood and Marrow Transplant Registry—reported the outcomes of 517 patients who received matched unrelated donor allogeneic transplants and 195 patients who underwent autologous SCT. Transplantation-related mortality was higher after unrelated donor SCT (42%) compared with

P.1568

autologous SCT (20%), but relapse rate was higher in the latter group (49%) compared with the former (14%). Five-year disease-free survival rates were similar (44% for unrelated donor SCT vs. 31% for autologous SCT) when transplanted in first CR or second CR (36% after unrelated SCT vs. 27% after autologous SCT). Net survival outcomes were, therefore, considered similar between the two transplant types, with the sole exception of a subset of patients with no high-risk features who enjoyed superior outcome with allogeneic compared to autologous SCT.²¹¹ In contrast, a trial genetically randomizing adult patients in first CR to sibling donor allogeneic versus autologous SCT found the former superior by a substantial margin.²¹⁹ The French Groupe Ouest-Est des Leucémies et Autres Maladies du Sang (GOELAMS) trial prospectively compared matched sibling allogeneic SCT in first CR with unpurged autologous SCT following sequential re-induction in patients who had no HLA-matched sibling donor or who were older than 50 years. Matched-sibling SCT significantly improved the 6-year overall survival (75% vs. 40% after autologous SCT).²²⁰

Tailoring post-remission strategies in a risk-adapted manner has become an accepted approach in the management of patients with ALL. There is general agreement that, at least in the high-risk patient population, in whom conventional therapies are known to be inferior, expeditious administration of allogeneic transplantation with a matched related donor, whenever possible, can afford the best chance for long-term survival. In contrast, autologous transplant does not seem to be superior to standard chemotherapy approaches.

Adult B-Cell and T-Cell Acute Lymphoblastic Leukemia

Adult ALL patients with the B-cell or T-cell immunophenotype should enter into chemotherapy treatment programs that start with multiagent remission induction chemotherapy. Prophylaxis against CNS relapse is indicated for all patients. Standard-risk patients who achieve remission, who are the majority, should continue with intensification and maintenance therapy or consider allogeneic SCT. Patients at high risk for relapse are best managed with allogeneic SCT in first CR.

Modern adult ALL treatment regimens that have been established by major collaborative study groups are illustrated in Figure 74.4.^{5,7,9,66,67} Clinical outcome results from adult trials are summarized in Table 74.6. Almost all modern multiagent, multiphasic adult ALL treatment protocols are variations on the same basic treatment theme.^{6,9,73,77,78 152 156,161,183 209 220 221, 222, 223, 224, 225, 226 and 227 228 229 230 231,232 233,234} Two exceptions are the GMALL B-NHL 86 and hyper-CVAD (hyperfractionated cyclophosphamide, vincristine, doxorubicin, and dexamethasone) protocols, which are brief, intensive treatment regimens that have particularly improved outcomes for adult mature B-cell ALL. Although these protocols are further discussed separately in this chapter,^{74,75} the hyper-CVAD regimen also has high activity in non-Burkitt B-cell ALL subtypes.²²⁸ Maintenance therapy, delayed intensive cycles, and rituximab (if CD20+) are added to HyperCVAD in pre-B ALL.²³⁵

The remission induction regimens are built around the fourdrug combination of vincristine, prednisone, l-asparaginase, and an anthracycline, most commonly daunorubicin. The American CALGB 8811 and Italian GIMEMA 0288 protocols added cyclophosphamide to the induction regimen. For those who achieve remission, induction is followed by various intensification or consolidation treatment blocks, generally completed within 6 months of starting treatment. Prolonged maintenance with 6-mercaptopurine and methotrexate is continued for a total of 2 years of scheduled therapy. Intermittent pulses of vincristine and prednisone are also given during maintenance in the CALGB, GIMEMA, and the British UKALL protocols. Cranial irradiation is administered early in the German GMALL treatment program and during interim maintenance in the CALGB and UKALL programs, but omitted in the GIMEMA trial.

The CALGB 8811 trial was conducted between September 1988 and June 1991 at 25 institutions in the United States. Larson et al. reported the results of this study, which showed an 85% CR rate, median remission duration of 29 months, and disease-free survival of 46% but with relatively short median follow-up of 43 months.⁷ Of these patients, 6% failed therapy due to death during induction, and an additional 7% due to refractory disease. Intensification of standard induction with cyclophosphamide was felt to contribute to favorable outcome with T-cell ALL but contributed to myelosuppression, requiring dose reduction in patients older than 60 years and hospital stays averaging 26 days during the induction phase. Prospective karyotype and immunophenotypic data were collected from patients on this and subsequent CALGB protocols for analysis of prognostic markers and were reported separately.^{65,80}

The German GMALL 02/84 trial evaluated sequential blocks of intensive induction and consolidation therapy that extended for nearly a year before beginning maintenance. CNS therapy was aggressive and incorporated intrathecal chemotherapy and cranial irradiation, as well as systemic high-dose cytarabine and methotrexate. International application of this treatment protocol confirmed the high CR rate and disease-free survival of 39% that was reported by Hoelzer et al.^{66,67,194,219,236, 237 and 238}

The British UKALL XA trial was designed to evaluate the benefit of post-remission therapy with early and late intensification blocks. Results were reported by Durrant et al.⁴ CR was achieved in 88% of adult patients, and disease-free survival at 5 years was 28%. As previously mentioned, there was a reduction in relapse for patients randomized to receive the early intensification block, but this did not lead to a superior disease-free survival rate. Additional analyses of this patient cohort describing clinical, immunophenotypic, and cytogenetic prognostic factors were detailed in separate reports.^{69,93}

The GIMEMA 0288 trial tested the prognostic value of response to pre-induction prednisone and the efficacies of cyclophosphamide inclusion during induction followed by intensification of post-remission therapy. An 82% CR rate was observed in 794 adult patients with ALL, which was not better among patients randomized to receive cyclophosphamide during induction.⁹ The response to prednisone was shown to have prognostic significance. Prednisone responders had an overall survival rate of 33% at 8 years compared with 17% among nonresponders. The disease-free survival rate was 29%,

which was no better for patients who were randomized to an additional eight-drug consolidation after intensification, as opposed to proceeding directly to maintenance therapy.

In a single-institution study of 288 patients, dose-intensive hyper-CVAD courses alternating with high-dose methotrexate and cytarabine, with concomitant intrathecal CNS prophylaxis, achieved a CR rate of 92%. With a median follow-up of 63 months, the 5-year disease-free and overall survival rates were both 38%,²²⁸ demonstrating activity comparable with other established protocols. A smaller single-institution study evaluated the outcome of 84 patients using an intensified and shortened chemotherapy regimen consisting of an induction program with daunorubicin, vincristine, prednisone, and asparaginase, followed by cyclical post-remission therapy with high-dose cytarabine/etoposide, high-dose methotrexate/6-mercaptopurine, and the four drugs used in induction,²³⁹ along with intrathecal CNS prophylaxis. Despite eliminating prophylactic cranial irradiation and reducing the total dose of daunorubicin, the CR rate was 93%, and the 5-year disease-free survival rates for patients with B-lineage ALL, with and without high risk factors, were 34% and 66%, respectively.

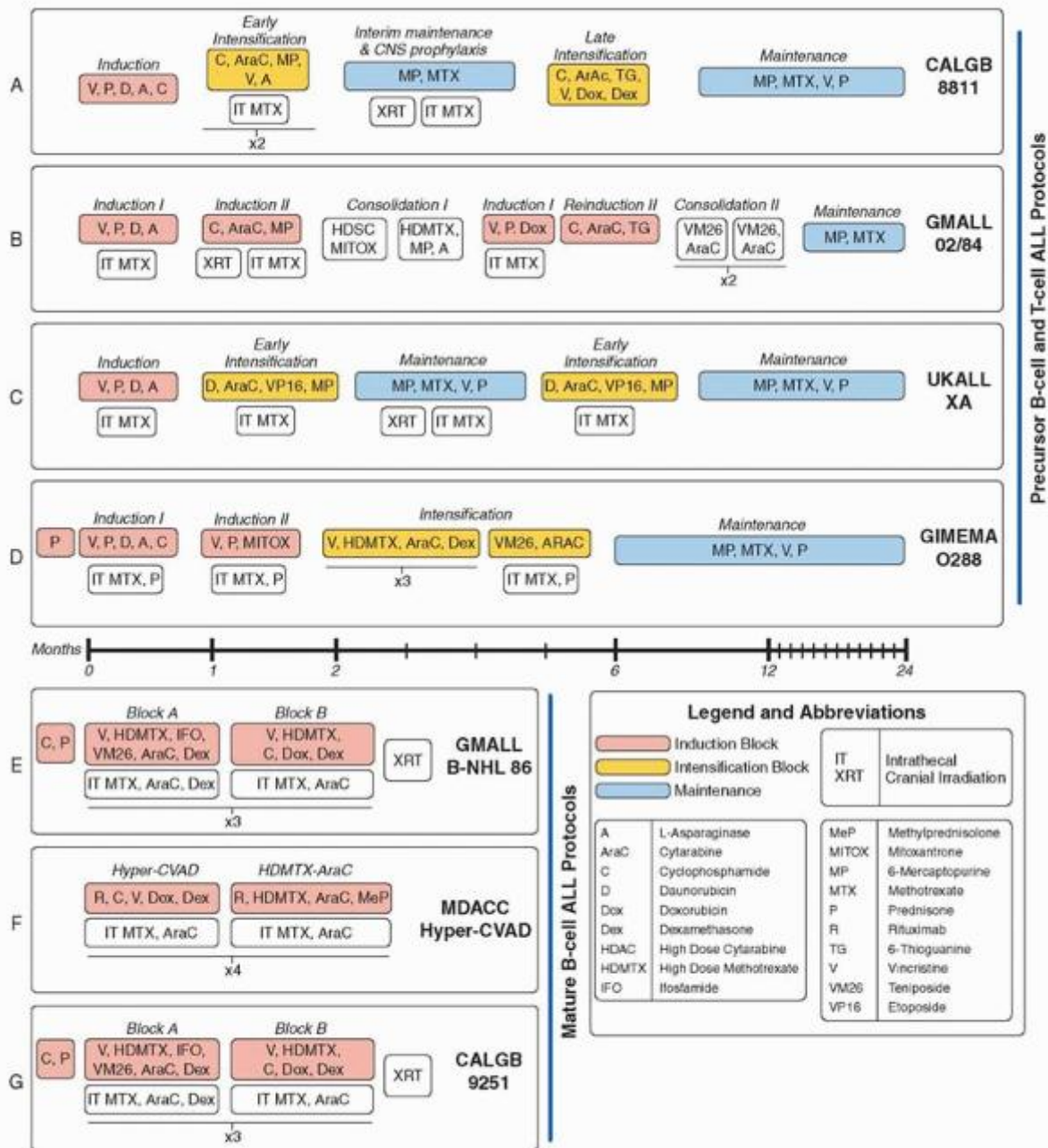

FIGURE 74.4. Established treatment protocols for adult acute lymphoblastic leukemia (ALL). Protocols for patients with precursor B-cell or T-cell ALL shown are adapted from (A) CALGB 8811 trial;⁷ (B) GMALL 02/84 trial;⁶⁶ (C) UKALL XA trial;⁵

and (D) GIMEMA 0288.⁹ Protocols for patients with mature B-cell ALL shown are adapted from (E) GMALL B-NHL 86;⁷⁴ (F) Rituximab plus hyper-CVAD from the M.D. Anderson Cancer Center (MDACC);²⁴⁸ and (G) modified CALGB 9251.⁷⁵ Timeline drawn to semi-logarithmic scale. CNS, central nervous system.

P.1569

Adult Mature B-Cell Acute Lymphoblastic Leukemia (Burkitt Leukemia)

The mature B-cell phenotype is found in 5% of adult ALL cases, and most are not cured with the majority of conventional ALL regimens such as those just described. Diagnosis is made by morphologic and immunophenotypic features, as has been discussed. Compared with other ALL subtypes, there is a more pronounced male predominance and higher incidence of extramedullary disease, including CNS involvement.^{240, 241} and ²⁴² As is the case with other high-grade malignancies, the blast cells have a rapid doubling time, and vigorous supportive care must be pursued to prevent or treat tumor lysis syndrome.²⁴³ The high proliferative rate exhibited by the leukemic cells served as the rationale for a treatment strategy based on repeated administration (hyperfractionation) of high-dose cyclophosphamide plus methotrexate, also given at high dose, which proved highly successful in pediatric studies.^{173,244}

P.1570

TABLE 74.6 RESULTS OF TREATMENT PROGRAMS FOR ADULT ALL

Study	Year	No. of Pts.	Age (years)		CR (%)	DFS, Years	OS, Years	HSCT Outcome
			Median	Range				
UCSF ⁷⁸	1991	109	25	16-49	88	35%, 5	40%, 5	7% went to HSCT
CALGB 8811 ⁷	1995	197	32	16-80	85	46%, 3	50%, 3	5% went to HSCT in CR1
SWOG 8417/19 ²²⁴	2001	353	32	15-84	62	25-32%, 5	25%, 5	—
NILG 08/96 ¹⁵²	2001	121	35	15-74	84	48%, 3	49%, 3	DFS donor 38% vs. no donor 43% (<i>P</i> = NS)
JALSG 93 ²²⁶	2002	263	31	15-59	78	23%, 6	33%, 6	No difference between allo vs. chemo except in Ph+
Sweden ²²⁷	2002	153	42	16-82	86	30%, 3	29%, 3	3 y DFS of HSCT was 39%
GIMEMA 0288 ⁹	2002	778	28	12-60	82	33%, 9	27%, 9	7% went to HSCT in CR1
MDACC ²²⁸	2004	288	40	15-92	92	38%, 5	38%, 5	11 Ph+ pts. went to HSCT
EORTC ALL3 ²²⁹	2004	340	33	14-79	74	36%, 6	36%, 6	DFS donor 38% vs. no donor 37% (<i>P</i> = NS)
LALA 94 ²⁰⁹	2004	922	33	15-55	84	30%, 5	33%, 5	Ph-: DFS donor 45% vs. no donor 18% (<i>P</i> = 0.007); no benefit of auto vs. chemo
GOELAMS 02 ²²⁰	2004	198	33	15-57	80	NR	41%, 6	OS allo 75% vs. auto 43% (<i>P</i> = 0.003)
PETHEMA ALL-93 ²²²	2005	222	27	15-50	82	35%, 5	34%, 5	DFS donor 33% vs. no donor 39% (<i>P</i> = NS)
GMALL	2007	713	34	15-55	89	NR	54%, 5	68% HR and 71% VHR went to

07/03 ²³¹								HSCT: 55% and 49% 3 y DFS ^a
JCOG 9004 ²³²	2007	143	41	15-69	83	26%, 5	32%, 5	5 y OS 58% (allo + auto)
MRC-ECOG ⁶	2008	1,646 (Ph-)	NR	15-64	90	NR	39%, 5	OS donor 53% vs. no donor 45% (<i>P</i> = 0.01); chemo 46% vs. auto 37% (<i>P</i> = 0.03)
NILG 09/00 ²²¹	2009	280	38	16-66	84	33%, 5	34%, 5	5 y OS/DFS 75%/72% for MRD neg vs. 33%/13% MRD pos (<i>P</i> = 0.001)
HOVON ²³³	2009	433	NR	—	NR ^b	NR	37%, 5	DFS donor 60% vs. no donor 42% (<i>P</i> = 0.01)
JCOG 9402 ²³⁴	2012	108	33.5	15-69	81	29%, 5	28%, 5	5 y OS 51% (allo + auto)

ALL, acute lymphoblastic leukemia; CALGB, Cancer and Leukemia Group B; CR, complete response; DFS, disease-free survival; ECOG, Eastern Cooperative Oncology Group; EORTC, European Organization for the Research and Treatment of Cancer; GIMEMA, Gruppo Italiano Malattie Ematologiche dell'Adulto; GMALL, German Multicenter Study for Adult Group for Adult ALL; GOELAMS, Groupe Quest-Est des Léucémies et Autres Maladies du Sang; HOVON, Dutch-Belgian Cooperative Trial Group for Hematology/Oncology; HSCT, hematopoietic stem cell transplantation; JALSG, Japan Adult Leukemia Study Group; JCOG, Japan Clinical Oncology Group; LALA, Leucémie Aiguës Lymphoblastique de l'Adulte; MDACC, MD Anderson Cancer Center; MRC, Medical Research Council; MRD, minimal residual disease; NILG, Northern Italy Leukemia Group; NR, not reported; NS, not significant; OS, overall survival; NR, not reported; PETHEMA, Programa Espanol de Tratamiento en Hematologia; Ph+, Philadelphia chromosome positive; SWOG, Southwest Oncology Group; University of California, San Francisco.

^a HR, high risk (≥ 1 factor): WBC $> 30 \times 10^9/L$ (pre-B); pro-B, early T, mature T-ALL; t(4;11); VHR, very high risk: t(9;22).

^b 288 CR patients satisfied HSCT criteria (age < 55 + donor; others to auto).

Adapted from Bassan R, Hoelzer D. Modern therapy of acute lymphoblastic leukemia J Clin Oncol 2011;29:532-543.

Studies performed by European and American groups have established that these brief, cyclical, dose-intensive protocols are the preferred approach to treating adult patients with mature B-cell ALL (Table 74.7).^{74,75,76,245, 246} and ^{247, 248, 249, 250, 251} and ²⁵² Adapted from the pediatric regimens, the B-NHL 86 protocol was used by the German study group (Fig. 74.4) and the hyper-CVAD treatment program was evaluated at the M.D. Anderson Cancer Center. Both use alternating blocks of intensive chemotherapy given monthly for a total of 6 or 8 months without subsequent maintenance. The hyper-CVAD regimen rotated fractionated high-dose cyclophosphamide with high-dose methotrexate. The B-NHL 86 protocol gave high-dose methotrexate with every treatment block and alternated cyclophosphamide with ifosfamide. CNS prophylaxis with intrathecal chemotherapy was started early, but cranial irradiation was omitted in the hyper-CVAD protocol. Similar outcome was reported by both studies. Remarkably similar results were also reported by the CALGB, which implemented the German protocol in a study involving 24 adult patients, with the exception that excess neurotoxicity was reported by the CALGB.²⁴⁶ By reserving intensive CNS prophylaxis for only high-risk individuals, however, the modified CALGB study was able to minimize neurologic toxicity without compromising efficacy.⁷⁶ Overall, with the use of such dose-intensive, short-duration combination chemotherapy treatment regimens, CR rates of 75% to 90% and overall survival rates of 50% to 70% have been achievable,^{175,253} substantially improving the outcome in a highly aggressive disease once considered incurable.

There are currently no effective treatment options for mature B-cell ALL patients who have refractory or relapsed disease. From the recent studies, predictors for relapse or poor outcome include high WBC count ($> 50 \times 10^9/L$), severe anemia, older age, elevated LDH, and poor performance status.^{74,75,245,247} In the report by Thomas et al., nine patients relapsed in

CR, for whom the median remission duration was only 7 months. Progression after relapse was rapid, with two deaths occurring before treatment could be initiated. The remaining patients were resistant to salvage therapy that included re-treatment with hyper-CVAD. After relapse, the median survival for the group was 1 month.

Philadelphia Chromosome-positive Acute Lymphoblastic Leukemia

Ph+ ALL accounts for at least 20% of adult cases^{60,254,255} and is associated with a poor prognosis.²⁵⁶ Patients tend to be older and have a higher WBC count and are more likely to present with

P.1571

hepatosplenomegaly and lymphadenopathy. Virtually all have the B-cell immunophenotype. Earlier experiences with standard ALL induction chemotherapy demonstrated that most achieved CR, but few were long-term survivors due to relapse. The median duration of survival ranged from 8 to 16 months, and disease-free survival did not exceed 10%.^{65,91, 92} and^{93,257} The hyper-CVAD regimen led to improved response rates and duration of CR, but not to advantage in overall survival.²⁵⁴ Incorporation of maintenance therapy to the regimen yielded potentially encouraging results for subtypes of adult ALL other than mature B-cell ALL but had no impact on survival for the 32 Ph+ patients in the series reported by Kantarjian et al.¹⁰⁶ In the LALA-94 and UKALLXII/ECOG 2993 trials the median OS was 5 months and the 5-year OS was only 3% to 6% in patients treated after relapse with Ph+ disease.²⁵⁸

TABLE 74.7 DOSE-INTENSIVE THERAPY IN ADULTS WITH BURKITT ACUTE LYMPHOBLASTIC LEUKEMIA AND LYMPHOMA

Trial	Patients Year (no.)	Median Age (years)	Complete Remission (%)	Induction Death (%)	Overall Survival (%)	Disease-Free Survival (%)
LMB 84/86 ²⁴⁵	1995 24	30	79	8	58 (3 y)	57 (3 y)
B-NHL 8674	1996 35	36	74	9	51 (4 y)	71 (4 y)
Hyper-CVAD ⁷⁵	1999 26	58	81	19	49 (3 y)	61 (3 y)
CALGB 9251 ²⁴⁶	2004 54	44	80	4	52 (4 y)	50 (4 y)
Modified CALGB 9251 ⁷⁶	2004 40	50	68	15	50 (3 y)	67 (3 y)
LMB ²⁴⁷	2005 72	33	65	3	65 (2 y)	70 (2 y)
R-HyperCVAD ²⁴⁸	2006 31	46	86	0	89 (3 y)	88 (3 y)
B-ALL/NHL 2002 ²⁴⁹	2007 36 ^a 36/39	86	3	77 (2 y)	90 (2 y)	
dmCODOX- M/IVAC ²⁵⁰	2008 53	37	NR	5	67 (2 y)	64 (2 y)
CALGB 10002 ²⁵¹	2010 105	43	82	7 ^b	79 (2 y)	77 (2 y)
RD-CODOX- M/IVAC ^c , ²⁵²	2012 30	52	93	0	82 (4 y)	78 (4 y)

LMB: B-NHL and B-ALL protocols of the Societe Francaise d'Oncologie Pediatrique; HyperCVAD: alternating courses of cyclophosphamide, vincristine, doxorubicin (Adriamycin), and dexamethasone (course A) with methotrexate and cytarabine (course B); CALGB: Cancer and Leukemia Group B; R: rituximab; dmCODOX-M/IVAX: dose modified, alternating courses of cyclophosphamide, vincristine, doxorubicin, and methotrexate with ifosfamide, etoposide, and cytarabine; D: liposome-encapsulated cytarabine.

^a 53% HIV positive.

^b Treatment-related deaths.

^c Only patients with Burkitt and unclassifiable lymphoma (no leukemia).

Given the dismal prospect for long-term survival with combination chemotherapy alone, early allogeneic SCT in first CR has long been the recommended treatment for patients with Ph+ ALL. The benefits of transplantation derive from the intense myeloablative therapy combined with the graft-versus-leukemia effect.²⁵⁹ Results vary from center to center, but with allogeneic SCT, 30% to 65% of Ph+ patients can expect long-term survival.^{260, 261, 262} and²⁶³ Registry data from the IBMTR show rates at 2 years of 38% for disease-free survival and 34% for relapse.²⁶⁴ A large retrospective review of children who were Ph+, an equally unfavorable marker in pediatric ALL, suggested that allogeneic SCT substantially improved survival compared with chemotherapy alone.²⁶⁵ In the prospective, multicenter LALA-94 trial of 154 patients with Ph+ ALL, both the absence of MRD and presence of allogeneic SCT were independent predictors of disease-free and overall survival.²⁶⁶ In the study of 267 Ph+ ALL patients in the prospective multicenter trial UKALLXII/ECOG 2993, the actuarial 5-year relapse risk was lowest for those undergoing allogeneic SCT (32%) compared with those treated only with chemotherapy or with autologous SCT (81%).²⁵⁸ Recipients of allogeneic transplants experienced higher event-free and overall survival rates at 5 years (36% and 42%, respectively) compared to their counterpart (17% and 19%, respectively).

The probability of cure, although small in this patient population, further diminishes with advanced disease. Among 38 patients studied by Chao et al., the disease-free survival for Ph+ ALL patients transplanted in first remission was 46% at 10 years, compared with 28% in those transplanted after relapse.²⁶⁷ In another study of 127 patients with poor-risk cytogenetics, the National Marrow Donor Program reported that the overall survival at 2 years following matched unrelated SCT was 40% for patients in first CR, 17% in second or third CR, and 5% for primary refractory disease or relapse. The high treatment-related mortality associated with unrelated transplantation did not appear to overshadow the 37% disease-free survival at 2 years for patients in first CR.²¹⁰

A paradigm shift in the treatment of Ph+ ALL patients has occurred with the introduction of the oral tyrosine kinase inhibitor imatinib mesylate, with a reported response rate of 70% as a single agent.²⁶⁸ Although imatinib monotherapy in relapsed or refractory disease resulted in disappointingly poor durability,²⁶⁹ immediate post-remission SCT²⁷⁰ and integration into combination chemotherapy regimens have improved its therapeutic outlook. In the evaluation of concurrent hyper-CVAD and imatinib in 26 newly diagnosed Ph+ ALL patients, 96% achieved CR and five entered molecular remission, or RT-PCR negativity for the BCR-ABL transcript. Even without post-remission SCT, the 2-year disease-free survival rate was 87% for the combination imatinib-chemotherapy group compared with 12% to 28% with conventional chemotherapy regimens.²⁷¹ The value of incorporating imatinib into chemotherapy regimens in the treatment of newly diagnosed Ph+ or BCR-ABL-positive adult ALL patients was reiterated in another study that demonstrated a CR rate of 96%, molecular response exceeding 71%, and 1-year event-free and overall survival rates of 60% and 76%, respectively.²⁷² With a reduced risk of relapse compared with chemotherapy alone (3.5% vs. 42.3%)²⁷³ and no adverse impact on subsequent SCT,²⁷⁴ imatinib combined with chemotherapy can serve as a bridging strategy to SCT, the only known therapy with curative potential. When including imatinib, concurrent administration with chemotherapy appears to be superior to an alternating schedule,²⁷⁵ and attention to CNS prophylaxis remains paramount given its poor CNS penetrance.²⁷⁶

The second-generation BCR-ABL tyrosine kinase inhibitors dasatinib and nilotinib have also shown efficacy when used either as single agents or in combination with chemotherapy in this patient population.^{277,278} Dasatinib has been incorporated into

P.1572

treatment programs for adults with Ph-positive ALL. In a phase II study of dasatinib with hyper-CVAD in previously untreated Ph-positive patients 94% of 35 patients achieved CR.²⁷⁸ With a median follow-up of 14 months, median DFS and OS had not been reached. In another trial that involved initial treatment, dasatinib was given along with steroids to 53 newly diagnosed patients and all patients achieved complete hematologic response.²⁷⁷ Although these results show that significantly less toxic regimens that include TKIs can achieve very high CR rates and survival has improved, the general recommendation is for eligible adult patients with Ph-positive ALL to undergo allogeneic SCT.

Ponatinib is the newest approved BCR-ABL inhibitor with activity against all known abl mutations including the resistant T315I mutation. A phase II trial consisted of 94 patients with CML lymphoid blast phase or Ph+ ALL, resistant or intolerant to other TKIs.²⁷⁹ With a median follow-up of 12 months, the major hematologic responses were noted to be 35% and 33% in patients with resistance/intolerance to prior TKI and those with T315I mutation, respectively.

MRD following SCT for Ph+ ALL portends imminent relapse. Imatinib given in this setting was found to be effective in suppressing frank relapse in one study, inducing molecular negativity in 52% of 27 patients for the duration of

treatment.²⁸⁰ Relapse was observed if imatinib was unable to achieve molecular remission or in those who discontinued imatinib. Disease-free survival rates in those achieving molecular remission was 91% at 12 months and 54% at 24 months, compared with 8% at 12 months for those with remaining MRD.

Acute Lymphoblastic Leukemia in Elderly Patients

One third of adults diagnosed with ALL are older than 60 years according to US prevalence data.²⁸¹ Advanced age is itself an adverse prognostic factor for ALL, and survival decreases continuously with increasing age (Fig. 74.5). Although older age is independently predictive of inferior outcome, a number of factors can be identified that may account for the poor prognosis.^{282, 283, 284} and ²⁸⁵ Elderly ALL patients tend to have worse performance status, in part, reflecting co-morbid medical conditions. As a result, these patients have limited tolerance for intensive therapy, which may contribute to a high rate of treatment-related mortality. In addition, aspects reflecting the underlying biology of the leukemia likely have an influence as well. Elderly patients are more likely to be Ph+, be underrepresented in the favorable T-cell subgroup, and have disease refractory to standard chemotherapy drugs used to treat ALL.

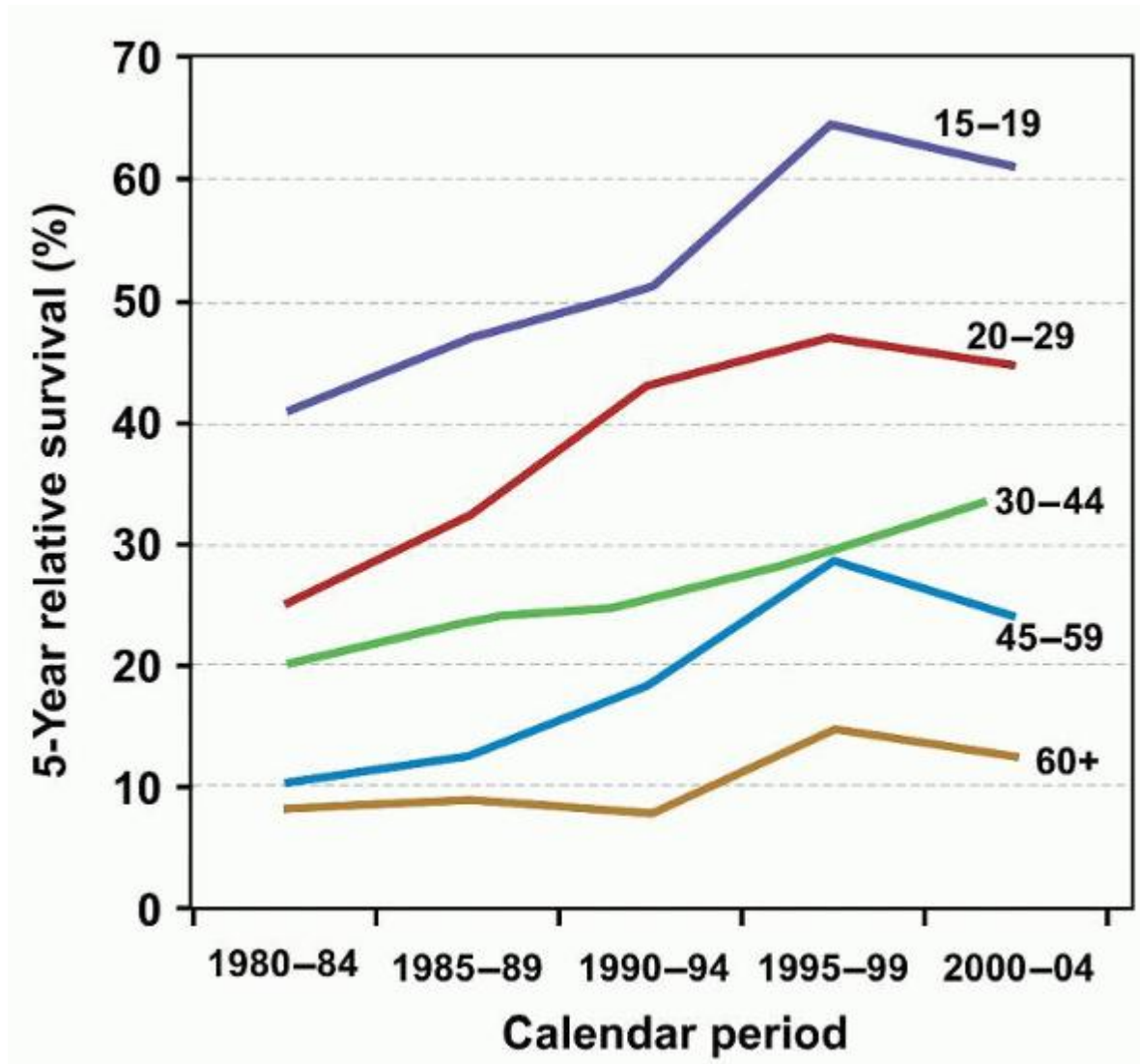

FIGURE 74.5. Five-year relative survival of patients with acute lymphoblastic leukemia (ALL) by major age groups in calendar periods from 1980-1984 to 2000-2004. (With permission from Pulte D, Gondos A, Brenner H. Improvement in survival in younger patients with acute lymphoblastic leukemia from the 1980s to the early 21st century. *Blood* 2009;113:1408-1411.)

At present, there is no satisfactory approach for managing elderly patients with ALL. Several groups have described treatment outcome for these patients, and the results are summarized in Table 74.8.^{284,286, 287, 288, 289, 290, 291, 292, 293, 294, 295} and ²⁹⁶ Elderly ALL patients given no therapy may not survive more than a few weeks.²⁸⁷ Palliative therapy, usually

moderate-dose prednisone and intermittent vincristine, has been used.²⁸⁶ Modest responses were observed, with survival extending to a few months. A retrospective review of one cooperative group member institution's 13-year experience revealed that only one half of their ALL patients older than 60 years were enrolled in their active study protocol.²⁸³ In these instances, risk-adapted therapy often meant limiting treatment intensity on a case-by-case basis. Many of these elderly patients were given ad hoc induction regimens of variably dosed vincristine and prednisone, with or without a third drug.^{288,289, 297} Complete responses were reported in up to 40%, but median survival remained only several months. Several groups uniformly treated fairly large cohorts (40 to 60) of elderly patients with "age-adjusted" chemotherapy programs.^{291,292,298} Impressive CR rates were sometimes observed, and median survival extended to 12 to 14 months. The patient numbers were still small, and it is difficult to evaluate the influence of patient selection bias, as conflicting results have been reported by the same institution treating patients with essentially the same protocol.^{291,292} Data from major collaborative groups treating selected, elderly ALL patients suggest that up to one half may achieve CR with intensive therapy.^{290,293} Resistant disease and toxic deaths were frequent, but a median survival of 10 months may be reasonably expected.

Although the prognosis remains generally grim for elderly patients with ALL, new therapeutic options are becoming available to the subset with the worst prognosis, that is, those with Ph-positivity. Given the generally favorable toxicity profile of imatinib, a number of studies have embarked on the evaluation of its efficacy in elderly patients with Ph+ ALL. In a study of 12 patients, who were older than 60 and not eligible for intensive therapy, treatment with daily imatinib at 800 mg and prednisone, followed by single-agent imatinib consolidation therapy yielded a CR rate of 92%, whereas 67% remained in CR at a median follow-up of 7 months.²⁹⁹ In the prospective, multicenter GMALL study, 32 elderly patients (median age, 67 years) with newly diagnosed Ph+ ALL were randomized to daily imatinib at 400 mg or ageadapted, multiagent induction chemotherapy followed by imatinib in consolidation and re-induction cycles. CR rates were 92% and 53%, respectively, with death and severe infectious complications during induction occurring only in the chemotherapy-assigned group.³⁰⁰

The accumulated literature is still sparse, and much remains to be learned about treating elderly patients with ALL. Ongoing evaluations of tyrosine kinase inhibitors, as well as the investigation of other new therapies, such as monoclonal antibodies and small molecule-based targeted approaches, are vital in the process of improving outcomes and the prognostic outlook for this growing demographic group. Elderly patients should be referred for investigational protocols at study centers whenever feasible.

SALVAGE THERAPY

The prospect of salvage therapy for refractory or relapsing disease will eventually have to be considered for most adult ALL patients. Primary resistance to induction chemotherapy reported by collaborative trials ranges from 8% to 15%.^{5,7,9,66,73,78} Although most

P.1573

patients achieve a first CR, only 20% to 40% become long-term survivors, and the principal cause of treatment failure is disease relapse. Although a second or salvaged CR can be obtained for a slight majority with chemotherapy, the durability of remission is likely short unless an allogeneic SCT is subsequently performed, and, even then, remission duration is limited for most patients.

TABLE 74.8 TREATMENT OUTCOME IN ELDERLY PATIENTS WITH ACUTE LYMPHOBLASTIC LEUKEMIA

Author	Year	Patient (no.)	Median Age (y)	Complete Remission (%)	Refractory (%)	Toxic Death (%)	Median Survival (mo)
Delannoy ²⁸⁶	1990	18	70	44	28	28	3
Taylor ²⁸⁷	1992						
Curative		19	68	32	47	21	3
Palliative		22	74	14	73	0	1
No therapy		5	83	0	NA	NA	<1
Spath-Schwalbe ²⁸⁸	1994	28	65	43	NR	37	5

Kantarjian ²⁸³	1994	52	>60	65	23	12	10
Ferrari ²⁸⁹	1995						
Curative		13	66	77	0	23	4
Palliative		36	73	53	25	22	10
Mandelli ²⁹⁰	1995	80	65	47	11	42	19% (2 y)
Delannoy ²⁹¹	1997	40	67	85	7.5	7.5	14.2
Goekbuget ²⁹³	2000	63	69	46	24	22	11
Delannoy ²⁹²	2002	58	65	58	29	12	9.2
Offidani ²⁹⁴	2005 ^a	17	70	41	24	35	4.5
		17	69	76	6	17	21
Goekbuget ²⁹⁵	2008	54	66	85 ^b	16	0	61% (1 y)
Shin ²⁹⁶	2011	26	65	58	23	27	10

NA, not applicable; NR, not reported.

^a The top row involved induction with vincristine, daunoxome, and dexamethasone and was superior to the next row showing the results in elderly patients receiving GIMEMA ALL 0288 protocol.

^b CR% was from 40 patients evaluable after induction.

Recent studies yield some insight into the biologic and clinical features of disease relapse in adult ALL patients. Thomas et al. reviewed the presenting characteristics at relapse in patients referred for therapy at a single institution over a 17-year period.³⁰¹ The duration of CR was less than 1 year in 61%. Essentially all patients had marrow relapses, although one third had concurrent extramedullary involvement, including CNS leukemia in 16%. In other studies, the cytogenetic, immunophenotypic, and molecular changes at relapse compared with initial presentation were examined.^{302,303} Clonal cytogenetic changes were the most common finding. One half of the cytogenetic findings were believed to represent clonal evolution, and the remainder were karyotypic changes. Two entirely different abnormal karyotypes were never found. Immunophenotypic changes were twice as likely in patients with T-cell versus B-cell ALL and were marked by gain or loss of one or two antigens but no complete shift from B- to T-lineage ALL, or vice versa. Neither the presence of a karyotypic shift nor an immunophenotypic shift adversely influenced survival from the time of relapse. Patterns of persistence and clearance of BCR-ABL transcripts also characterize the assessment of MRD and appear to predict relapse in Ph+ ALL (see section on MRD).

Chemotherapy

Reinduction of remission, or attainment of a first CR for refractory patients, can be expected in slightly more than one half of patients with salvage chemotherapy. However, in the majority, remissions do not extend beyond 3 to 6 months, and long-term survival is well below 10% whether or not post-remission therapy is given. The numerous reports describing generally single-institution studies involving small numbers of patients have been exhaustively catalogued in excellent reviews.^{304, 305} and ³⁰⁶ In general, single-agent chemotherapy is inferior to multiagent protocols. Two or three drugs have been added to L-asparaginase or an anthracycline with good responses, but the best results are produced by combinations based on intermediate- to high-dose cytarabine. In one of the larger patient series, doxorubicin combined with vincristine and dexamethasone induced CR in 39% of 64 refractory patients.³⁰⁷ Treatment failure was due to resistant disease in 41%, whereas induction mortality was only 6%, reflective of a correlation between toxicity-related death and antileukemic activity.

Salvage regimens based on high-dose cytarabine, which have been much more extensively studied, produce CR rates that vary widely but have occasionally exceeded 70%. Additional drugs have included anthracycline, mitoxantrone, and fludarabine. The hyper-CVAD regimen, which incorporates doxorubicin and high-dose cytarabine in addition to fractionated cyclophosphamide, was used to salvage 66 relapsed patients and induced remissions in 44%.³⁰⁸ A separate study reported a more modest response, with a CR rate of 38%, in 29 patients with refractory or recurrent disease treated

with high-dose cytarabine and a single high dose of idarubicin,³⁰⁹ whereas standard-dose cytarabine and idarubicin led to a 30% CR rate in refractory patients in another study.³¹⁰ Hiddemann et al. reported a 50% CR rate in 24 refractory patients with the mitoxantrone and high-dose cytarabine two-drug combination.³¹¹ Other studies with these two drugs have reported CR rates of 17% to 80%. Fludarabine is a purine analogue that enhances bioavailability of the active metabolite of cytarabine, and, as a salvage regimen, the combination yields CR in 30% to 83%, with the higher response rates reported when cytarabine was used at high rather than intermediate dose.^{312, 313} and ³¹⁴

In a large single-institution review, Thomas et al. described treatment outcome for 314 adult patients with relapsed or refractory ALL who received various salvage therapy regimens. Overall CR was achieved in 31%.³⁰¹ Patients with long first remissions received the customary front-line study salvage regimen, which

P.1574

varied depending on the study period, whereas patients resistant to or relapsing on therapy were treated with new drug combinations. This approach to treatment regimen selection, based on timing of relapse and prior induction programs, can be regarded as reasonable recommendations for all adult ALL patients requiring salvage therapy. Patients with primary refractory disease and those with relapsed disease were found to achieve CR equally well. Death occurred without achieving remission in 21%. Patients with long first CR duration (>2 years) were more likely to achieve CR and have longer durations of second remission, a finding confirming observations made by other investigators.^{315,316} For the entire group, the median durations of remission and survival from the start of salvage therapy were 6 months and 5 months, respectively. Although salvage regimens in resistant or relapsed disease offer only modest effects with short duration, they allow a bridge to HSCT, which has curative potential for select patients who achieve remission.

Novel Agents

The emergence of newer agents has rejuvenated some optimism that incremental improvements can still be effected in certain patient subgroups. Nelarabine was approved for the treatment of refractory or relapsed T-ALL or T-cell lymphoblastic lymphoma (T-LBL) in patients who have undergone at least two prior chemotherapy treatments. As a prodrug, it is converted to the deoxyguanosine analogue, 9- β -D-arabinofuranosylguanine (ara-G), which selectively induces apoptosis in T-cells by incorporating its phosphorylated form into DNA and inhibiting synthesis. Following a phase I study, which showed significant cytotoxicity against T-cells,³¹⁷ two phase II studies of single-agent nelarabine demonstrated CR rates of up to 23% in patients with refractory or relapsed T-ALL or T-LBL.^{318,319} Neurotoxicity is the dose-limiting toxicity, for which close patient monitoring is strongly encouraged. There are ongoing trials incorporating nelarabine into frontline treatment protocols for T-cell disease including a very large Children's Oncology Group study, AALL0434.

Clofarabine is another deoxyadenosine analogue that was approved by the FDA for the treatment of pediatric patients (ages 1 to 21 years) with relapsed or refractory ALL. It demonstrated activity as a single agent, with a 30% overall response rate, in a phase II study of 61 heavily pre-treated children.³²⁰ Pilot studies combined with cytarabine, or with epratuzumab, an anti-CD22 antibody are being explored in adult ALL.

Two promising antibody therapeutics offer great hope for improving outcomes in ALL. Inotuzumab ozogamicin is an anti-CD22-calceamicin conjugate with significant activity, even in heavily pre-treated individuals.³²¹ In a phase II experience 49 previously treated patients received a 1-hour infusion of the study drug every 3 to 4 weeks for one to five courses. A CR was achieved in 9 patients with an additional 19 with a bone marrow complete response. Nineteen had resistant disease. Duration of response was short, with median overall survival of 5.1 months in all patients and 7.9 months in the 28 responding patients. Due to the significant efficacy observed, once-weekly dosing regimens are being pursued as are protocols incorporating inotuzumab in frontline regimens.

Blinatumomab is a bispecific single-chain antibody that binds both cytotoxic CD3 T lymphocytes and CD19 on the surface of the B-cell leukemic blast. In a phase II trial of B ALL patients with persistent or relapsed MRD, 80% of patients responded. With a median follow-up of 33 months, the hematologic relapse-free survival of the 20 evaluable patients was 61%.³²² These long-lasting remissions would be unusual for patients with MRD detectable disease. Another study included patients with overt hematologic relapse. Complete remission including MRD eradication was observed in 17 of 25 patients.³²³ On the basis of this promising activity, additional trials are planned not only for recurrent disease but also in combination with chemotherapy as part of initial treatment regimens.

Although imatinib mesylate has begun to change the landscape of treatment options for Ph+ ALL by dramatically improving remission rates and overall outcome, emergence of drug resistance warns against complacency.³²⁴ Among the several known mechanisms of imatinib resistance is the development of one of numerous kinase domain mutations of

BCR-ABL which prevent imatinib from engaging and competitively inhibiting the kinase at the ATP-binding site.^{325, 326, 327} and^{328,329} Three other tyrosine kinase inhibitor compounds have since been developed that are active against the majority of the imatinib-resistant BCR-ABL mutants and promise significant antileukemic activity against BCR-ABL-positive leukemias. All have significantly increased potency compared with imatinib, but differ from each other in that nilotinib is a selective inhibitor of BCR-ABL,³³⁰ whereas dasatinib and bosutinib are dual SRC-ABL kinase inhibitors.^{331,332} Early phase studies showed promising activity against BCR-ABL positive leukemia, with the exception of a single BCR-ABL mutation within the ATP-binding pocket of the tyrosine kinase, T315I, which confers a high degree of universal resistance to imatinib, nilotinib, bosutinib, and dasatinib.^{332,333,334} Safety profiles were generally favorable. The main adverse effects for nilotinib were dose-dependent grade 3 or 4 thrombocytopenia and neutropenia, transient indirect hyperbilirubinemia, pruritis, and rash. Side effects associated with dasatinib included grades 3 and 4 thrombocytopenia and neutropenia, pleural effusions, diarrhea, peripheral edema, and headache; none were dose-limiting. The US FDA approved dasatinib for Ph+ ALL.³³⁵ This approval included newly diagnosed patients, reflecting the unmet medical need in this difficult-to-treat population. Ponatinib was recently approved for these difficult-to-treat patients. Unlike the other abl inhibitors, ponatinib does not bind directly to the T315 abl active site.

Recent improvements in the outcomes for mature B-cell ALL do not obviate the need for novel salvage strategies for those with refractory or relapsed disease. In light of the highly expressed CD20 in mature B-cell ALL, recent studies have incorporated the monoclonal anti-CD20 antibody rituximab in intensive, multiagent chemotherapy regimens, yielding promising results (Fig. 74.4).³³⁶ A total of 31 newly diagnosed patients were given rituximab on each of two noncontiguous days in four cycles of hyper-CVAD. Of the 23 evaluable patients, the CR rate was 86% for those less than 60 years of age and 100% for older patients. Compared with historical controls treated on hyper-CVAD alone, inclusion of rituximab led to a 2-year overall survival rate of 89% (versus 58%).

Stem Cell Transplantation

Given the dismal outlook for relapsed disease, allogeneic SCT should be attempted for all eligible adult ALL patients as soon as possible after second or salvaged remission is achieved. The logistics may be difficult given the narrow window before impending relapse. This was examined by Davies et al., who described finding matched related donors for only 35% of 115 consecutive relapsed ALL referrals to a single institution over a 2-year period.³³⁷ An unrelated marrow donor search was initiated in most of the remainder, which was successful in another one third, but required a median of 10 weeks before a donor was identified. Overall, allogeneic SCT was not performed in the majority of the patients, and the reason in 19% was death before transplant despite all efforts to expedite SCT. This point was highlighted by a study at 12 GIMEMA institutions, which re-induced CR in 56% of adult ALL patients in first relapse with a combination of idarubicin and intermediate-dose cytarabine.³³⁸ This was to be followed by a scheduled SCT that could not be performed in 44% due to relapse and in another 26.5% due to persistent infection acquired during induction.

P.1575

Even if a patient is transplanted, the available data suggest that few will be effectively salvaged with allogeneic SCT. Outcome reported from individual trials indicates long-term disease-free survival in 15% to 45% after sibling donor allogeneic SCT in second or greater CR.^{200,339,340} Registry data from the IBMTR show a 5-year disease-free survival estimate of 26%.³⁴¹ Unlike allogeneic SCT for adult ALL in first remission, however, relapse (52%) outranked treatment-related mortality (36%) as the cause of treatment failure.

Allogeneic SCT for active disease appears to yield inferior results. Results for individual trials reporting sibling-donor allogeneic SCT for untreated refractory or relapsed disease indicate disease-free survival of 12% to 43%.^{340,342} The IBMTR reported a 4-year disease-free survival of 13% with 71% of patients relapsing.³⁴¹ In the study of imatinib therapy used as a bridge to SCT in relapsed or refractory Ph+ ALL patients, the disease-free survival at 12 months was 51% for patients transplanted in remission, compared with 8.3% at 7 months in those with active disease, further underscoring the importance of remission status at transplant on post-SCT survival.²⁷⁰ Not surprisingly, worse outcomes characterized transplantation performed for advanced disease (in or after second CR) or with highest tumor burden (in relapse).²¹²

Unrelated donor SCT is associated with a very high transplant-related mortality, compounding the difficulties of finding a matched donor. Based on registry data from the NMDP, transplant-related mortality was 75% for patients transplanted in second or greater CR and 64% for patients transplanted in relapse.²¹⁰ Another study, also based on NMDP data, demonstrated the significance of three factors in a multivariate analysis: unrelated donor transplantation, age greater than 20 years, and SCT performed between 1989 and 1995.²¹¹ Recent advances in histocompatibility antigen matching

based on molecular typing techniques may also improve transplant outcomes through a more precise selection of better-matched donors.³⁴³

A benefit from autologous SCT for patients in second or subsequent CR is difficult to determine. There are many individual studies, generally with short follow-up, reporting disease-free survival ranging from 10% to 31%.^{216,344, 345, 346} and ³⁴⁷ Almost all failures are due to treatment relapse, however, and no study has demonstrated a disease-free survival plateau.

SUMMARY AND FUTURE DIRECTIONS

Considerable progress has been made in the management of ALL in adult patients. Multiagent induction chemotherapy induces CR in over 85% of adult ALL patients. With the institution of post-remission therapy and prophylaxis against CNS relapse, up to 40% may be cured of the disease. There is no compelling reason to believe, however, that further modification of modern multiagent regimens with the addition of currently available chemotherapy drugs will lead to any substantial improvement in outcome for these patients, with the possible exception of nelarabine.

Tailoring therapy adapted for each individual patient on the basis of anticipated relapse risk is a strategy that has gained general acceptance. This approach has proved to be remarkably successful for two adult ALL subgroups, namely, those with Burkitt ALL and those with Ph+ ALL. Ongoing prospectively randomized clinical trials will establish the role of risk-adapted therapy for patients with high-risk features according to other criteria. Coupled with translational research, these trials will also help define the role of new technologies, such as whole genome sequencing and molecular MRD assessment, in refining and improving the ability to evaluate disease activity and relapse risk with greater accuracy.

Targeted molecular therapy, such as the small molecule inhibitors of the BCR-ABL tyrosine kinase, has emerged as an essential aspect of care in patients with Ph+ ALL. Whether the use of second-generation agents will translate into survival advantage remains to be seen. The success with improving outcomes for Ph+ ALL, although satisfying, is tempered by the fact that, at present, allogeneic SCT remains the only known viable intervention with curative potential for high-risk patients. Newer approaches with allogeneic SCT using dose-attenuated nonmyeloablative recipient conditioning are promising and can extend the procedure to patients who might otherwise not be eligible for conventional transplantation.^{348,349} Clinical outcome data are not mature, however, and, at present, the procedure is still investigational.

Other targeted therapies, including monoclonal antibodies directed against surface antigens expressed by malignant cells and chimeric antigen receptor-modified T-cells targeted to B-cell-specific CD19 antigen, have proven extremely effective for other lymphoproliferative disorders and are currently undergoing clinical trials to assess their utility in ALL.³⁵⁰

Discovery of additional, much-needed, state-of-the-art novel therapies depends upon the progressive understanding of the underlying biology and delineation of the critical molecular pathways that are responsible for ALL leukemogenesis.

REFERENCES

1. Rivera GK, Pinkel D, Simone JV, et al. Treatment of acute lymphoblastic leukemia. 30 years' experience at St. Jude Children's Research Hospital. *N Engl J Med* 1993;329:1289-1295.
2. Pui CH, Evans WE. Acute lymphoblastic leukemia. *N Engl J Med* 1998;339: 605-615.
3. Pui CH, Evans WE. Treatment of acute lymphoblastic leukemia. *N Engl J Med* 2006;354:166-178.
4. Durrant IJ, Richards SM, Prentice HG, et al. The Medical Research Council trials in adult acute lymphocytic leukemia. *Hematol Oncol Clin North Am* 2000;14:1327-1352.
5. Durrant IJ, Prentice HG, Richards SM. Intensification of treatment for adults with acute lymphoblastic leukaemia: results of U.K. Medical Research Council randomized trial UKALL XA. Medical Research Council Working Party on Leukaemia in Adults. *Br J Haematol* 1997;99:84-92.
6. Goldstone AH, Richards SM, Lazarus HM, et al. In adults with standard-risk acute lymphoblastic leukemia, the greatest benefit is achieved from a matched sibling allogeneic transplantation in first complete remission, and an autologous transplantation is less effective than conventional consolidation/maintenance chemotherapy in all patients: final results of the International ALL Trial (MRC UKALL XII/ECOG E2993). *Blood* 2008;111:1827-1833.
7. Larson RA, Dodge RK, Burns CP, et al. A five-drug remission induction regimen with intensive consolidation for adults with acute lymphoblastic leukemia: cancer and leukemia group B study 8811. *Blood* 1995;85:2025-2037.
8. Chessells JM, Hall E, Prentice HG, et al. The impact of age on outcome in lymphoblastic leukaemia; MRC UKALL X and XA compared: a report from the MRC Paediatric and Adult Working Parties. *Leukemia* 1998;12:463-473.

9. Annino L, Vegna ML, Camera A, et al. Treatment of adult acute lymphoblastic leukemia (ALL): long-term follow-up of the GIMEMA ALL 0288 randomized study. *Blood* 2002;99:863-871.
10. Hoelzer D, Gokbuget N. Diagnosis and treatment of adult acute lymphoblastic leukemia. In: Wiernik PH, Goldman JM, Dutcher JP, et al., eds. *Neoplastic diseases of the blood*, 4th ed. Cambridge University Press, 2003:273-305.
11. Howlader N, Noone AM, Krapcho M. eds. *SEER Cancer Review, 1975-2009 (Vintage 2009 Populations)*. http://seer.cancer.gov/csr/1975_2009_pops09/ based on November 2011 SEER data submission, posted to SEER web site, April 2012.
12. Parkin DM, Muir CS. cancer incidence in five continents. Comparability and quality of data. *IARC Sci Publ* 1992;45-173.
13. Sandler DP, Collman GW. Cytogenetic and environmental factors in the etiology of the acute leukemias in adults. *Am J Epidemiol* 1987;126:1017-1032.
14. Preston DL, Kusumi S, Tomonaga M, et al. Cancer incidence in atomic bomb survivors. Part III. Leukemia, lymphoma and multiple myeloma, 1950-1987. *Radiat Res* 1994;137:S68-S97.
15. Wilkinson GS, Dreyer NA. Leukemia among nuclear workers with protracted exposure to low-dose ionizing radiation. *Epidemiology* 1991;2:305-309.
16. Kendall GM, Muirhead CR, MacGibbon BH, et al. Mortality and occupational exposure to radiation: first analysis of the National Registry for Radiation Workers. *BMJ* 1992;304:220-225.
17. Schubauer-Berigan MK, Wenzl TB. Leukemia mortality among radiation-exposed workers. *Occup Med* 2001;16:271-287.
18. Sole F, Caballin MR, Coll MD, et al. Acute lymphoblastic leukemia with t(4;11) in a patient previously exposed to a carcinogen. *Cancer Genet Cytogenet* 1990;49:133-136.
19. Cronkite EP. Chemical leukemogenesis: benzene as a model. *Semin Hematol* 1987;24:2-11.
20. Sandler DP, Shore DL, Anderson JR, et al. Cigarette smoking and risk of acute leukemia: associations with morphology and cytogenetic abnormalities in bone marrow. *J Natl Cancer Inst* 1993;85:1994-2003.
21. Pagano L, Pulsoni A, Tosti ME, et al. Acute leukemia following a previous malignancy: do acute lymphoid leukemia and acute myeloid leukemia have common risk factors? *Hematol J* 2000;1:329-332.
22. Andersen MK, Christiansen DH, Jensen BA, et al. Therapy-related acute lymphoblastic leukaemia with MLL rearrangements following DNA topoisomerase II inhibitors, an increasing problem: report on two new cases and review of the literature since 1992. *Br J Haematol* 2001;114:539-543.
23. Bigoni R, Cuneo A, Roberti MG, et al. Therapy-related adult acute lymphoblastic leukemia with t(4;11)(q21; q23): MLL rearrangement, p53 mutation and multilineage involvement. *Leukemia* 1999;13:704-707.
24. de Klein A, van Kessel AG, Grosveld G, et al. A cellular oncogene is trans-located to the Philadelphia chromosome in chronic myelocytic leukaemia. *Nature* 1982;300:765-767.
25. Druker BJ, Lydon NB. Lessons learned from the development of an abl tyrosine kinase inhibitor for chronic myelogenous leukemia. *J Clin Invest* 2000;105:3-7.
26. Look AT. Oncogenic transcription factors in the human acute leukemias. *Science* 1997;278:1059-1064.
27. Golub TR, Barker GF, Bohlander SK, et al. Fusion of the TEL gene on 12p13 to the AML1 gene on 21q22 in acute lymphoblastic leukemia. *Proc Natl Acad Sci U S A* 1995;92:4917-4921.
28. Sherr CJ. Cancer cell cycles. *Science* 1996;274:1672-1677.
29. Stock W, Tsai T, Golden C, et al. Cell cycle regulatory gene abnormalities are important determinants of leukemogenesis and disease biology in adult acute lymphoblastic leukemia. *Blood* 2000;95:2364-2371.
30. Weerkamp F, van Dongen JJ, Staal FJ. Notch and Wnt signaling in T-lymphocyte development and acute lymphoblastic leukemia. *Leukemia* 2006;20:1197-1205.
31. Weng AP, Ferrando AA, Lee W, et al. Activating mutations of NOTCH1 in human T cell acute lymphoblastic leukemia. *Science* 2004;306:269-271.
32. Beverly LJ, Felsher DW, Capobianco AJ. Suppression of p53 by Notch in lymphomagenesis: implications for initiation and regression. *Cancer Res* 2005;65:7159-7168.

33. Vacca A, Felli MP, Palermo R, et al. Notch3 and pre-TCR interaction unveils distinct NF-kappaB pathways in T-cell development and leukemia. *EMBO J* 2006;25:1000-1008.
34. Beutler E. Platelet transfusions: the 20,000/microL trigger. *Blood* 1993;81:1411-1413.
35. Pui CH, Stass S, Green A. Bone marrow necrosis in children with malignant disease. *Cancer* 1985;56:1522-1525.
36. Hoelzer D, Gokbuget N, Digel W, et al. Outcome of adult patients with T-lymphoblastic lymphoma treated according to protocols for acute lymphoblastic leukemia. *Blood* 2002;99:4379-4385.
37. Hoelzer D. Diagnosis and treatment of adult acute lymphocytic leukemia. In Wiernik PH, Canellos GP, Dutcher JP, et al., eds. *Neoplastic disease of the blood*, 3rd ed. New York, NY: Churchill Livingstone, 1996:295-319.
38. Mastrangelo R, Poplack D, Bleyer A, et al. Report and recommendations of the Rome workshop concerning poor-prognosis acute lymphoblastic leukemia in children: biologic bases for staging, stratification, and treatment. *Med Pediatr Oncol* 1986;14:191-194.
39. Gajjar A, Harrison PL, Sandlund JT, et al. Traumatic lumbar puncture at diagnosis adversely affects outcome in childhood acute lymphoblastic leukemia. *Blood* 2000;96:3381-3384.
40. Yokoyama K, Amamiya T, Kawai Y, et al. Acute lymphocytic leukemia associated with severe myelofibrosis. *Keio J Med* 1997;46:196-204.
41. Wallis JP, Reid MM. Bone marrow fibrosis in childhood acute lymphoblastic leukaemia. *J Clin Pathol* 1989;42:1253-1254.
42. Chromosomal abnormalities and their clinical significance in acute lymphoblastic leukemia. Third International Workshop on Chromosomes in Leukemia. *Cancer Res* 1983;43:868-873.
43. Harrison CJ, Martineau M, Secker-Walker LM. The Leukaemia Research Fund/United Kingdom Cancer Cytogenetics Group Karyotype Database in acute lymphoblastic leukaemia: a valuable resource for patient management. *Br J Haematol* 2001;113:3-10.
44. Raynaud S, Cave H, Baens M, et al. The 12;21 translocation involving TEL and deletion of the other TEL allele: two frequently associated alterations found in childhood acute lymphoblastic leukemia. *Blood* 1996;87:2891-2899.
45. Kwong YL, Wong KF. Low frequency of TEL/AML1 in adult acute lymphoblastic leukemia. *Cancer Genet Cytogenet* 1997;98:137-138.
46. Raynaud S, Mauvieux L, Cayuela JM, et al. TEL/AML1 fusion gene is a rare event in adult acute lymphoblastic leukemia. *Leukemia* 1996;10:1529-1530.
47. Kurzrock R, Shtalrid M, Romero P, et al. A novel c-abl protein product in Philadelphia-positive acute lymphoblastic leukaemia. *Nature* 1987;325: 631-635.
48. Harris NL, Jaffe ES, Diebold J, et al. The World Health Organization classification of neoplasms of the hematopoietic and lymphoid tissues: report of the Clinical Advisory Committee meeting—Airlie House, Virginia, November, 1997. *Hematol J* 2000;1:53-66.
49. Riley RS, Massey D, Jackson-Cook C, et al. Immunophenotypic analysis of acute lymphocytic leukemia. *Hematol Oncol Clin North Am* 2002;16:245-299, v.
50. Den Boer ML, Kapaun P, Pieters R, et al. Myeloid antigen co-expression in childhood acute lymphoblastic leukaemia: relationship with in vitro drug resistance. *Br J Haematol* 1999;105:876-882.
51. Pui CH, Rubnitz JE, Hancock ML, et al. Reappraisal of the clinical and biologic significance of myeloid-associated antigen expression in childhood acute lymphoblastic leukemia. *J Clin Oncol* 1998;16:3768-3773.
52. Bene MC, Castoldi G, Knapp W, et al. Proposals for the immunological classification of acute leukemias. European Group for the Immunological Characterization of Leukemias (EGIL). *Leukemia* 1995;9:1783-1786.
53. Legrand O, Perrot JY, Simonin G, et al. Adult biphenotypic acute leukaemia: an entity with poor prognosis which is related to unfavourable cytogenetics and P-glycoprotein over-expression. *Br J Haematol* 1998;100:147-155.
54. Killick S, Matutes E, Powles RL, et al. Outcome of biphenotypic acute leukemia. *Haematologica* 1999;84:699-706.
55. Matutes E, Morilla R, Farahat N, et al. Definition of acute biphenotypic leukemia. *Haematologica* 1997;82:64-66.
56. Sturgeon P. Leukemia presenting as aplastic anemia. *J Pediatr* 1972;80:159.

57. Nakamori Y, Takahashi M, Moriyama Y, et al. The aplastic presentation of adult acute lymphoblastic leukemia. *Br J Haematol* 1986;62:782-783.
58. Dalton RG. Aplastic presentation of acute lymphoblastic leukemia. *J R Soc Med* 1987;80:465.
59. D'Alessio A, Invernizzi R, Bernuzzi S, et al. Transient aplasia preceding adult acute lymphoblastic leukemia. *Haematologica* 1993;78:127-128.
60. Faderl S, Kantarjian HM, Talpaz M, et al. Clinical significance of cytogenetic abnormalities in adult acute lymphoblastic leukemia. *Blood* 1998;91: 3995-4019.
61. Rowe JM, Buck G, Burnett AK, et al. Induction therapy for adults with acute lymphoblastic leukemia: results of more than 1500 patients from the international ALL trial: MRC UKALL XII/ECOG E2993. *Blood* 2005;106:3760-3767.
62. Gokbuget N, Kneba M, Raff T, et al. Adult patients with acute lymphoblastic leukemia and molecular failure display a poor prognosis and are candidates for stem cell transplantation and targeted therapies. *Blood* 2012;120: 1868-1876.
63. Bruggemann M, Raff T, Kneba M. Has MRD monitoring superseded other prognostic factors in adult ALL? *Blood* 2012;120:4470-4481.
64. Larson RA, Dodge RK, Linker CA, et al. A randomized controlled trial of filgrastim during remission induction and consolidation chemotherapy for adults with acute lymphoblastic leukemia: CALGB study 9111. *Blood* 1998;92:1556-1564.
65. Wetzler M, Dodge RK, Mrozek K, et al. Prospective karyotype analysis in adult acute lymphoblastic leukemia: the cancer and leukemia Group B experience. *Blood* 1999;93:3983-3993.
66. Hoelzer D, Thiel E, Ludwig WD, et al. Follow-up of the first two successive German multicentre trials for adult ALL (01/81 and 02/84). German Adult ALL Study Group. *Leukemia* 1993;7(suppl 2):S130-S134.
67. Hoelzer D, Thiel E, Loffler H, et al. Prognostic factors in a multicenter study for treatment of acute lymphoblastic leukemia in adults. *Blood* 1988;71: 123-131.
68. Hoelzer D, Thiel E, Loffler H, et al. Intensified therapy in acute lymphoblastic and acute undifferentiated leukemia in adults. *Blood* 1984;64:38-47.
69. Durrant IJ, Richards SM. Results of Medical Research Council trial UKALL IX in acute lymphoblastic leukaemia in adults: report from the Medical Research Council Working Party on Adult Leukaemia. *Br J Haematol* 1993;85:84-92.
70. Sebban C, Lepage E, Vernant JP, et al. Allogeneic bone marrow transplantation in adult acute lymphoblastic leukemia in first complete remission: a comparative study. French Group of Therapy of Adult Acute Lymphoblastic Leukemia. *J Clin Oncol* 1994;12:2580-2587.
71. Thiebaut A, Vernant JP, Degos L, et al. Adult acute lymphocytic leukemia study testing chemotherapy and autologous and allogeneic transplantation. A follow-up report of the French protocol LALA 87. *Hematol Oncol Clin North Am* 2000;14:1353-1366, x.
72. Mandelli F, Annino L, Rotoli B. The GIMEMA ALL 0183 trial: analysis of 10-year follow-up. GIMEMA Cooperative Group, Italy. *Br J Haematol* 1996;92:665-672.
73. Hussein KK, Dahlberg S, Head D, et al. Treatment of acute lymphoblastic leukemia in adults with intensive induction, consolidation, and maintenance chemotherapy. *Blood* 1989;73:57-63.
74. Hoelzer D, Ludwig WD, Thiel E, et al. Improved outcome in adult B-cell acute lymphoblastic leukemia. *Blood* 1996;87:495-508.
75. Thomas DA, Cortes J, O'Brien S, et al. Hyper-CVAD program in Burkitt's-type adult acute lymphoblastic leukemia. *J Clin Oncol* 1999;17:2461-2470.
76. Rizzieri DA, Johnson JL, Niedzwiecki D, et al. Intensive chemotherapy with and without cranial radiation for Burkitt leukemia and lymphoma: final results of Cancer and Leukemia Group B Study 9251. *Cancer* 2004;100:1438-1448.
77. Schauer P, Arlin ZA, Mertelsmann R, et al. Treatment of acute lymphoblastic leukemia in adults: results of the L-10 and L-10M protocols. *J Clin Oncol* 1983;1:462-470.
78. Linker CA, Levitt LJ, O'Donnell M, et al. Treatment of adult acute lymphoblastic leukemia with intensive cyclical chemotherapy: a follow-up report. *Blood* 1991;78:2814-2822.

79. Marks DI, Paietta EM, Moorman AV, et al. T-cell acute lymphoblastic leukemia in adults: clinical features, immunophenotype, cytogenetics, and outcome from the large randomized prospective trial (UKALL XII/ECOG 2993). *Blood* 2009;114:5136-5145.
80. Czuczman MS, Dodge RK, Stewart CC, et al. Value of immunophenotype in intensively treated adult acute lymphoblastic leukemia: cancer and leukemia Group B study 8364. *Blood* 1999;93:3931-3939.
81. Ludwig WD, Reiter A, Loffler H, et al. Immunophenotypic features of childhood and adult acute lymphoblastic leukemia (ALL): experience of the German Multicentre Trials ALL-BFM and GMALL. *Leuk Lymphoma* 1994;13(suppl 1):71-76.
82. Gokbuget N, Hoelzer D. Recent approaches in acute lymphoblastic leukemia in adults. *Rev Clin Exp Hematol* 2002;6:114-141; discussion 200-212.
83. Neumann M, Heesch S, Gokbuget N, et al. Clinical and molecular characterization of early T-cell precursor leukemia: a high-risk subgroup in adult T-ALL with a high frequency of FLT3 mutations. *Blood Cancer J* 2012;2:e55.
84. Thomas X, Archimbaud E, Charrin C, et al. CD34 expression is associated with major adverse prognostic factors in adult acute lymphoblastic leukemia. *Leukemia* 1995;9:249-253.
85. Vanhaeke DR, Bene MC, Garand R, et al. Expression and long-term prognostic value of CD34 in childhood and adult acute lymphoblastic leukemia. *Leuk Lymphoma* 1995;20:137-142.
86. Cascavilla N, Musto P, D'Arena G, et al. Adult and childhood acute lymphoblastic leukemia: clinico-biological differences based on CD34 antigen expression. *Haematologica* 1997;82:31-37.
87. Fruchart C, Lenormand B, Bastard C, et al. Correlation between CD34 expression and chromosomal abnormalities but not clinical outcome in acute myeloid leukemia. *Am J Hematol* 1996;53:175-180.
88. Cacciola E, Guglielmo P, Cacciola E, et al. CD34 expression in adult acute lymphoblastic leukemia. *Leuk Lymphoma* 1995;18(suppl 1):31-36.
89. Lauria F, Raspadori D, Martinelli G, et al. Increased expression of myeloid antigen markers in adult acute lymphoblastic leukaemia patients: diagnostic and prognostic implications. *Br J Haematol* 1994;87:286-292.
90. Ferrando AA, Look AT. Clinical implications of recurring chromosomal and associated molecular abnormalities in acute lymphoblastic leukemia. *Semin Hematol* 2000;37:381-395.
91. Bloomfield CD, Secker-Walker LM, Goldman AI, et al. Six-year follow-up of the clinical significance of karyotype in acute lymphoblastic leukemia. *Cancer Genet Cytogenet* 1989;40:171-185.
92. Cytogenetic abnormalities in adult acute lymphoblastic leukemia: correlations with hematologic findings outcome. A Collaborative Study of the Group Francais de Cytogenetique Hematologique. *Blood* 1996;87:3135-3142.
93. Secker-Walker LM, Prentice HG, Durrant J, et al. Cytogenetics adds independent prognostic information in adults with acute lymphoblastic leukaemia on MRC trial UKALL XA. MRC Adult Leukaemia Working Party. *Br J Haematol* 1997;96:601-610.
94. Mancini M, Cimio G, Vegna ML. An integrated molecular-cytogenetic classification is highly predictive of outcome in adult acute lymphoblastic leukemia (ALL): analysis of 395 cases enrolled in the GIMEMA 0496 trial. *Blood* 2001;98:3492a.
95. Fenaux P, Lai JL, Morel P, et al. Cytogenetics and their prognostic value in childhood and adult acute lymphoblastic leukemia (ALL) excluding L3. *Hematol Oncol* 1989;7:307-317.
96. Walters R, Kantarjian HM, Keating MJ, et al. The importance of cytogenetic studies in adult acute lymphocytic leukemia. *Am J Med* 1990;89:579-587.
- P.1576
97. Pullarkat V, Slovak ML, Kopecky KJ, et al. Impact of cytogenetics on the outcome of adult acute lymphoblastic leukemia: results of Southwest Oncology Group 9400 study. *Blood* 2008;111:2563-2572.
98. Hatano M, Roberts CW, Minden M, et al. Dereglulation of a homeobox gene, HOX11, by the t(10;14) in T cell leukemia. *Science* 1991;253:79-82.

99. Ferrando AA, Look AT. Gene expression profiling in T-cell acute lymphoblastic leukemia. *Semin Hematol* 2003;40:274-280.
100. Ferrando AA, Neuberg DS, Dodge RK, et al. Prognostic importance of TLX1 (HOX11) oncogene expression in adults with T-cell acute lymphoblastic leukaemia. *Lancet* 2004;363:535-536.
101. Ballerini P, Blaise A, Busson-Le Coniat M, et al. HOX11L2 expression defines a clinical subtype of pediatric T-ALL associated with poor prognosis. *Blood* 2002;100:991-997.
102. Cave H, Suci S, Preudhomme C, et al. Clinical significance of HOX11L2 expression linked to t(5;14)(q35;q32), of HOX11 expression, and of SIL-TAL fusion in childhood T-cell malignancies: results of EORTC studies 58881 and 58951. *Blood* 2004;103:442-450.
103. Graux C, Cools J, Melotte C, et al. Fusion of NUP214 to ABL1 on amplified episomes in T-cell acute lymphoblastic leukemia. *Nat Genet* 2004;36:1084-1089.
104. Deenik W, Beverloo HB, van der Poel-van de Luytgaarde SC, et al. Rapid complete cytogenetic remission after upfront dasatinib monotherapy in a patient with a NUP214-ABL1-positive T-cell acute lymphoblastic leukemia. *Leukemia* 2009;23:627-629.
105. Ballerini P, Busson M, Fasola S, et al. NUP214-ABL1 amplification in t(5;14)/HOX11L2-positive ALL present with several forms and may have a prognostic significance. *Leukemia* 2005;19:468-470.
106. Kantarjian HM, O'Brien S, Smith TL, et al. Results of treatment with hyper-CVAD, a dose-intensive regimen, in adult acute lymphocytic leukemia. *J Clin Oncol* 2000;18:547-561.
107. Sebban C, Browman GP, Lepage E, et al. Prognostic value of early response to chemotherapy assessed by the day 15 bone marrow aspiration in adult acute lymphoblastic leukemia: a prospective analysis of 437 cases and its application for designing induction chemotherapy trials. *Leuk Res* 1995;19:861-868.
108. Kantarjian HM, Walters RS, Keating MJ, et al. Results of the vincristine, doxorubicin, and dexamethasone regimen in adults with standard- and high-risk acute lymphocytic leukemia. *J Clin Oncol* 1990;8:994-1004.
109. Donadieu J, Hill C. Early response to chemotherapy as a prognostic factor in childhood acute lymphoblastic leukaemia: a methodological review. *Br J Haematol* 2001;115:34-45.
110. Lilleyman JS. Clinical importance of speed of response to therapy in childhood lymphoblastic leukaemia. *Leuk Lymphoma* 1998;31:501-506.
111. Gaynon PS, Desai AA, Bostrom BC, et al. Early response to therapy and outcome in childhood acute lymphoblastic leukemia: a review. *Cancer* 1997;80:1717-1726.
112. Kaspers GJ, Pieters R, Klumper E, et al. Glucocorticoid resistance in childhood leukemia. *Leuk Lymphoma* 1994;13:187-201.
113. Pui CH, Sallan S, Relling MV, et al. International Childhood Acute Lymphoblastic Leukemia Workshop: Sausalito CA, 30 November-1 December 2000. *Leukemia* 2001;15:707-715.
114. Dordelmann M, Reiter A, Borkhardt A, et al. Prednisone response is the strongest predictor of treatment outcome in infant acute lymphoblastic leukemia. *Blood* 1999;94:1209-1217.
115. Riehm H, Reiter A, Schrappe M, et al. [Corticosteroid-dependent reduction of leukocyte count in blood as a prognostic factor in acute lymphoblastic leukemia in childhood (therapy study ALL-BFM 83)]. *Klin Padiatr* 1987;199:151-160.
116. Campana D, Pui CH. Detection of minimal residual disease in acute leukemia: methodologic advances and clinical significance. *Blood* 1995;85:1416-1434.
117. Scheuring UJ, Pfeifer H, Wassmann B, et al. Early minimal residual disease (MRD) analysis during treatment of Philadelphia chromosome/Bcr-Abl-positive acute lymphoblastic leukemia with the Abl-tyrosine kinase inhibitor imatinib (STI571). *Blood* 2003;101:85-90.
118. Coustan-Smith E, Sancho J, Hancock ML, et al. Use of peripheral blood instead of bone marrow to monitor residual disease in children with acute lymphoblastic leukemia. *Blood* 2002;100:2399-2402.
119. Brisco MJ, Sykes PJ, Hughes E, et al. Monitoring minimal residual disease in peripheral blood in B-lineage acute lymphoblastic leukaemia. *Br J Haematol* 1997;99:314-319.

120. Martin H, Atta J, Bruecher J, et al. In patients with BCR-ABL-positive ALL in CR peripheral blood contains less residual disease than bone marrow: implications for autologous BMT. *Ann Hematol* 1994;68:85-87.
121. El-Rifai W, Ruutu T, Vettenranta K, et al. Follow-up of residual disease using metaphase-FISH in patients with acute lymphoblastic leukemia in remission. *Leukemia* 1997;11:633-638.
122. Heerema NA, Argyropoulos G, Weetman R, et al. Interphase in situ hybridization reveals minimal residual disease in early remission and return of the diagnostic clone in karyotypically normal relapse of acute lymphoblastic leukemia. *Leukemia* 1993;7:537-543.
123. Kasprzyk A, Secker-Walker LM. Increased sensitivity of minimal residual disease detection by interphase FISH in acute lymphoblastic leukemia with hyperdiploidy. *Leukemia* 1997;11:429-435.
124. White DM, Crolla JA, Ross FM. Detection of minimal residual disease in childhood acute lymphoblastic leukaemia using fluorescence in-situ hybridization. *Br J Haematol* 1995;91:1019-1024.
125. Chen JS, Coustan-Smith E, Suzuki T, et al. Identification of novel markers for monitoring minimal residual disease in acute lymphoblastic leukemia. *Blood* 2001;97:2115-2120.
126. Campana D, Coustan-Smith E. The use of flow cytometry to detect minimal residual disease in acute leukemia. *Eur J Histochem* 1996;40(suppl 1):39-42.
127. Coustan-Smith E, Sancho J, Hancock ML, et al. Clinical importance of minimal residual disease in childhood acute lymphoblastic leukemia. *Blood* 2000;96:2691-2696.
128. Foroni L, Harrison CJ, Hoffbrand AV, et al. Investigation of minimal residual disease in childhood and adult acute lymphoblastic leukaemia by molecular analysis. *Br J Haematol* 1999;105:7-24.
129. Morgan GJ, Pratt G. Modern molecular diagnostics and the management of haematological malignancies. *Clin Lab Haematol* 1998;20:135-141.
130. van Dongen JJ, Macintyre EA, Gabert JA, et al. Standardized RT-PCR analysis of fusion gene transcripts from chromosome aberrations in acute leukemia for detection of minimal residual disease. Report of the BIOMED-1 Concerted Action: investigation of minimal residual disease in acute leukemia. *Leukemia* 1999;13:1901-1928.
131. Gleissner B, Thiel E. Detection of immunoglobulin heavy chain gene rearrangements in hematologic malignancies. *Expert Rev Mol Diagn* 2001;1:191-200.
132. Cave H, van der Werff ten Bosch J, Suci S, et al. Clinical significance of minimal residual disease in childhood acute lymphoblastic leukemia. European Organization for Research and Treatment of Cancer—Childhood Leukemia Cooperative Group. *N Engl J Med* 1998;339:591-598.
133. van Dongen JJ, Seriu T, Panzer-Grumayer ER, et al. Prognostic value of minimal residual disease in acute lymphoblastic leukaemia in childhood. *Lancet* 1998;352:1731-1738.
134. Verhagen OJ, Willemse MJ, Breunis WB, et al. Application of germline IGH probes in real-time quantitative PCR for the detection of minimal residual disease in acute lymphoblastic leukemia. *Leukemia* 2000;14:1426-1435.
135. Bruggemann M, Droese J, Bolz I, et al. Improved assessment of minimal residual disease in B cell malignancies using fluorogenic consensus probes for real-time quantitative PCR. *Leukemia* 2000;14:1419-1425.
136. Neale GA, Coustan-Smith E, Pan Q, et al. Tandem application of flow cytometry and polymerase chain reaction for comprehensive detection of minimal residual disease in childhood acute lymphoblastic leukemia. *Leukemia* 1999;13:1221-1226.
137. Stock W, Estrov Z. Studies of minimal residual disease in acute lymphocytic leukemia. *Hematol Oncol Clin North Am* 2000;14:1289-1305, viii-ix.
138. Mortuza FY, Papaioannou M, Moreira IM, et al. Minimal residual disease tests provide an independent predictor of clinical outcome in adult acute lymphoblastic leukemia. *J Clin Oncol* 2002;20:1094-1104.
139. Brisco J, Hughes E, Neoh SH, et al. Relationship between minimal residual disease and outcome in adult acute lymphoblastic leukemia. *Blood* 1996;87:5251-5256.
140. Foroni L, Coyle LA, Papaioannou M, et al. Molecular detection of minimal residual disease in adult and childhood acute lymphoblastic leukaemia reveals differences in treatment response. *Leukemia* 1997;11:1732-1741.

141. Bruggemann M, Raff T, Flohr T, et al. Clinical significance of minimal residual disease quantification in adult patients with standard-risk acute lymphoblastic leukemia. *Blood* 2006;107:1116-1123.
142. Scheuring UJ, Pfeifer H, Wassmann B, et al. Serial minimal residual disease (MRD) analysis as a predictor of response duration in Philadelphia-positive acute lymphoblastic leukemia (Ph+ALL) during imatinib treatment. *Leukemia* 2003;17:1700-1706.
143. Pane F, Cimino G, Izzo B, et al. Significant reduction of the hybrid BCR/ABL transcripts after induction and consolidation therapy is a powerful predictor of treatment response in adult Philadelphia-positive acute lymphoblastic leukemia. *Leukemia* 2005;19:628-635.
144. Avivi I, Rowe JM, Goldstone AH. Stem cell transplantation in adult ALL patients. *Best Pract Res Clin Haematol* 2002;15:653-674.
145. Bunin NJ, Pui CH. Differing complications of hyperleukocytosis in children with acute lymphoblastic or acute nonlymphoblastic leukemia. *J Clin Oncol* 1985;3:1590-1595.
146. Eguiguren JM, Schell MJ, Crist WM, et al. Complications and outcome in childhood acute lymphoblastic leukemia with hyperleukocytosis. *Blood* 1992;79:871-875.
147. Greenberg P, Cox C, LeBeau MM, et al. International scoring system for evaluating prognosis in myelodysplastic syndromes. *Blood* 1997;89:2079-2088.
148. Durie BG, Salmon SE. A clinical staging system for multiple myeloma. Correlation of measured myeloma cell mass with presenting clinical features, response to treatment, and survival. *Cancer* 1975;36:842-854.
149. The International Symposium on Genetic Factors in Predictive and Preventive Oncology-Cofactor Interactions and Cancer Prevention, 8th International Symposium on Prevention and Detection of Cancer. Nice, France, March 1993. Abstracts. *Cancer Detect Prev* 1993;17:1-260.
150. Hasenclever D, Diehl V. A prognostic score for advanced Hodgkin's disease. International Prognostic Factors Project on Advanced Hodgkin's Disease. *N Engl J Med* 1998;339:1506-1514.
151. Smith M, Arthur D, Camitta B, et al. Uniform approach to risk classification and treatment assignment for children with acute lymphoblastic leukemia. *J Clin Oncol* 1996;14:18-24.
152. Bassan R, Spinelli O, Oldani E, et al. Improved risk classification for risk-specific therapy based on the molecular study of minimal residual disease (MRD) in adult acute lymphoblastic leukemia (ALL). *Blood* 2009;113:4153-4162.
153. Gottlieb AJ, Weinberg V, Ellison RR, et al. Efficacy of daunorubicin in the therapy of adult acute lymphocytic leukemia: a prospective randomized trial by cancer and leukemia group B. *Blood* 1984;64:267-274.
154. Cuttner J, Mick R, Budman DR, et al. Phase III trial of brief intensive treatment of adult acute lymphocytic leukemia comparing daunorubicin and mitoxantrone: a CALGB Study. *Leukemia* 1991;5:425-431.
155. Peterson BA, Bloomfield CD, Bosl GJ, et al. Intensive five-drug combination chemotherapy for adult acute non-lymphocytic leukemia. *Cancer* 1980;46:663-668.
156. Fiere D, Lepage E, Sebban C, et al. Adult acute lymphoblastic leukemia: a multicentric randomized trial testing bone marrow transplantation as postremission therapy. The French Group on Therapy for Adult Acute Lymphoblastic Leukemia. *J Clin Oncol* 1993;11:1990-2001.
157. Laport GF, Larson RA. Treatment of adult acute lymphoblastic leukemia. *Semin Oncol* 1997;24:70-82.
158. Cortes JE, Kantarjian HM. Acute lymphoblastic leukemia. A comprehensive review with emphasis on biology and therapy. *Cancer* 1995;76:2393-2417.
159. Copelan EA, McGuire EA. The biology and treatment of acute lymphoblastic leukemia in adults. *Blood* 1995;85:1151-1168.
160. Hoelzer D. Treatment of acute lymphoblastic leukemia. *Semin Hematol* 1994;31:1-15.
161. Nagura E, Kimura K, Yamada K, et al. Nation-wide randomized comparative study of doxorubicin, vincristine and prednisolone combination therapy with and without L-asparaginase for adult acute lymphoblastic leukemia. *Cancer Chemother Pharmacol* 1994;33:359-365.
162. Muller HJ, Boos J. Use of L-asparaginase in childhood ALL. *Crit Rev Oncol Hematol* 1998;28:97-113.

163. Radford JE Jr, Burns CP, Jones MP, et al. Adult acute lymphoblastic leukemia: results of the Iowa HOP-L protocol. *J Clin Oncol* 1989;7:58-66.
164. Bassan R, Lerede T, Rambaldi A, et al. The role of anthracyclines in adult acute lymphoblastic leukaemia. *Leukemia* 1996;10(suppl 2):S58- S61.
165. Todeschini G, Meneghini V, Pizzolo G, et al. Relationship between Daunorubicin dosage delivered during induction therapy and outcome in adult acute lymphoblastic leukemia. *Leukemia* 1994;8:376-381.
166. Todeschini G, Tecchio C, Meneghini V, et al. Estimated 6-year event-free survival of 55% in 60 consecutive adult acute lymphoblastic leukemia patients treated with an intensive phase II protocol based on high induction dose of daunorubicin. *Leukemia* 1998;12:144-149.
167. Todeschini G. High-dose anthracycline induction in adult acute lymphocytic leukemia. *Hematol Oncol Clin North Am* 2001;15:9-20.
168. Mandelli MF, Annino L, Vegna ML. Interim analysis of the GIMEMA ALLO496 trial for adult acute lymphoblastic leukemia (ALL). *The Hematol J* 2001;1:629a.
169. Weiss M, Maslak P, Feldman E, et al. Cytarabine with high-dose mitoxantrone induces rapid complete remissions in adult acute lymphoblastic leukemia without the use of vincristine or prednisone. *J Clin Oncol* 1996;14:2480-2485.
170. Weiss M. Induction therapy of adult acute lymphocytic leukemia without the use of vincristine or prednisone. *Hematol Oncol Clin North Am* 2001;15:1-7, v.
171. Lamanna N, Heffner LT, Kalaycio M, et al. Treatment of adults with acute lymphoblastic leukemia: do the specifics of the regimen matter?: results from a prospective randomized trial. *Cancer* 2013;119:1186-1194.
172. Bostrom BC, Sensel MR, Sather HN, et al. Dexamethasone versus prednisone and daily oral versus weekly intravenous mercaptopurine for patients with standard-risk acute lymphoblastic leukemia: a report from the Children's Cancer Group. *Blood* 2003;101:3809-3817.
173. Murphy SB, Bowman WP, Abromowitch M, et al. Results of treatment of advanced-stage Burkitt's lymphoma and B cell (SIg+) acute lymphoblastic leukemia with high-dose fractionated cyclophosphamide and coordinated high-dose methotrexate and cytarabine. *J Clin Oncol* 1986;4:1732-1739.
174. Patte C, Michon J, Frappaz D, et al. Therapy of Burkitt and other B-cell acute lymphoblastic leukaemia and lymphoma: experience with the LMB protocols of the SFOP (French Paediatric Oncology Society) in children and adults. *Baillieres Clin Haematol* 1994;7:339-348.
175. Blum KA, Lozanski G, Byrd JC. Adult Burkitt leukemia and lymphoma. *Blood* 2004;104:3009-3020.
176. Geissler K, Koller E, Hubmann E, et al. Granulocyte colony-stimulating factor as an adjunct to induction chemotherapy for adult acute lymphoblastic leukemia—a randomized phase-III study. *Blood* 1997;90:590-596.
177. Ottmann OG, Hoelzer D, Gracien E, et al. Concomitant granulocyte colony-stimulating factor and induction chemoradiotherapy in adult acute lymphoblastic leukemia: a randomized phase III trial. *Blood* 1995;86:444-450.
178. Smith TJ, Khatcheressian J, Lyman GH, et al. 2006 update of recommendations for the use of white blood cell growth factors: an evidence-based clinical practice guideline. *J Clin Oncol* 2006;24:3187-3205.
179. Chessells JM, Bailey C, Richards SM. Intensification of treatment and survival in all children with lymphoblastic leukaemia: results of UK Medical Research Council trial UKALL X. Medical Research Council Working Party on Childhood Leukaemia. *Lancet* 1995;345:143-148.
180. Ortega JJ, Ribera JM, Oriol A, et al. Early and delayed consolidation chemotherapy significantly improves the outcome of children with intermediate risk acute lymphoblastic leukemia. Final results of the prospective randomized PETHEMA ALL-89 TRIAL. *Haematologica* 2001;86:586-595.
181. Kamps WA, Veerman AJ, van Wering ER, et al. Long-term follow-up of Dutch Childhood Leukemia Study Group (DCLSG) protocols for children with acute lymphoblastic leukemia, 1984-1991. *Leukemia* 2000;14:2240-2246.
182. Stryckmans P, De Witte T, Marie JP, et al. Therapy of adult ALL: overview of 2 successive EORTC studies: (ALL-2 & ALL-3). The EORTC Leukemia Cooperative Study Group. *Leukemia* 1992;6 Suppl 2:199-203.

183. Ellison RR, Mick R, Cuttner J, et al. The effects of postinduction intensification treatment with cytarabine and daunorubicin in adult acute lymphocytic leukemia: a prospective randomized clinical trial by Cancer and Leukemia Group B. *J Clin Oncol* 1991;9:2002-2015.
184. Omura GA, Vogler WR, Martelo O, et al. Late intensification therapy in adult acute lymphoid leukemia: long-term follow-up of the Southeastern Cancer Study Group experience. *Leuk Lymphoma* 1994;15:71-78.
185. Ribera JM, Ortega JJ, Oriol A, et al. Late intensification chemotherapy has not improved the results of intensive chemotherapy in adult acute lymphoblastic leukemia. Results of a prospective multicenter randomized trial (PETHEMA ALL-89). *Spanish Society of Hematology. Haematologica* 1998;83:222-230.
186. Duration and intensity of maintenance chemotherapy in acute lymphoblastic leukaemia: overview of 42 trials involving 12 000 randomised children. Childhood ALL Collaborative Group. *Lancet* 1996;347:1783-1788.
187. Pui CH, Crist WM. Biology and treatment of acute lymphoblastic leukemia. *J Pediatr* 1994;124:491-503.
188. Dekker AW, van't Veer MB, Sizoo W, et al. Intensive postremission chemotherapy without maintenance therapy in adults with acute lymphoblastic leukemia. Dutch Hemato-Oncology Research Group. *J Clin Oncol* 1997;15:476-482.
189. Cassileth PA, Andersen JW, Bennett JM, et al. Adult acute lymphocytic leukemia: the Eastern Cooperative Oncology Group experience. *Leukemia* 1992;6(suppl 2):178-181.
190. Wernli M, Tichelli A, von Flidner V, et al. Intensive induction/consolidation therapy without maintenance in adult acute lymphoblastic leukaemia: a pilot assessment. Working Party on Leukaemia of the Swiss Group for Epidemiologic and Clinical Cancer Research (SAKK). *Br J Haematol* 1994;87:39-43.
191. Cortes J. Central nervous system involvement in adult acute lymphocytic leukemia. *Hematol Oncol Clin North Am* 2001;15:145-162.
192. Gokbuget N, Hoelzer D. Meningeosis leukaemica in adult acute lymphoblastic leukaemia. *J Neurooncol* 1998;38:167-180.
193. Omura GA, Moffitt S, Vogler WR, et al. Combination chemotherapy of adult acute lymphoblastic leukemia with randomized central nervous system prophylaxis. *Blood* 1980;55:199-204.
194. Lluesma-Gonalons M, Pavlovsky S, Santarelli MT, et al. Improved results of an intensified therapy in adult acute lymphocytic leukemia. *Ann Oncol* 1991;2:33-39.
195. Cortes J, O'Brien SM, Pierce S, et al. The value of high-dose systemic chemotherapy and intrathecal therapy for central nervous system prophylaxis in different risk groups of adult acute lymphoblastic leukemia. *Blood* 1995;86:2091-2097.
196. Lazarus HM, Richards SM, Chopra R, et al. Central nervous system involvement in adult acute lymphoblastic leukemia at diagnosis: results from the international ALL trial MRC UKALL XII/ECOG E2993. *Blood* 2006;108: 465-472.
197. Blume KG, Forman SJ, Snyder DS, et al. Allogeneic bone marrow transplantation for acute lymphoblastic leukemia during first complete remission. *Transplantation* 1987;43:389-392.
198. Chao NJ, Forman SJ, Schmidt GM, et al. Allogeneic bone marrow transplantation for high-risk acute lymphoblastic leukemia during first complete remission. *Blood* 1991;78:1923-1927.
199. Vernant JP, Marit G, Maraninchi D, et al. Allogeneic bone marrow transplantation in adults with acute lymphoblastic leukemia in first complete remission. *J Clin Oncol* 1988;6:227-231.
200. Wingard JR, Piantadosi S, Santos GW, et al. Allogeneic bone marrow transplantation for patients with high-risk acute lymphoblastic leukemia. *J Clin Oncol* 1990;8:820-830.
201. Forman SJ. Allogeneic hematopoietic cell transplantation for acute lymphoblastic leukemia in adults. *Hematol Oncol Clin North Am* 2009;23:1011-1031.
202. Barrett AJ, Horowitz MM, Gale RP, et al. Marrow transplantation for acute lymphoblastic leukemia: factors affecting relapse and survival. *Blood* 1989;74:862-871.
203. Passweg JR, Tiberghien P, Cahn JY, et al. Graft-versus-leukemia effects in T lineage and B lineage acute lymphoblastic leukemia. *Bone Marrow Transplant* 1998;21:153-158.
204. Appelbaum FR. Graft versus leukemia (GVL) in the therapy of acute lymphoblastic leukemia (ALL). *Leukemia* 1997;11(suppl 4):S15-S17.

205. Horowitz MM, Gale RP, Sondel PM, et al. Graft-versus-leukemia reactions after bone marrow transplantation. *Blood* 1990;75:555-562.
206. Oh H, Gale RP, Zhang MJ, et al. Chemotherapy vs HLA-identical sibling bone marrow transplants for adults with acute lymphoblastic leukemia in first remission. *Bone Marrow Transplant* 1998;22:253-257.
207. Zhang MJ, Hoelzer D, Horowitz MM, et al. Long-term follow-up of adults with acute lymphoblastic leukemia in first remission treated with chemotherapy or bone marrow transplantation. The Acute Lymphoblastic Leukemia Working Committee. *Ann Intern Med* 1995;123:428-431.
208. Horowitz MM, Messerer D, Hoelzer D, et al. Chemotherapy compared with bone marrow transplantation for adults with acute lymphoblastic leukemia in first remission. *Ann Intern Med* 1991;115:13-18.
209. Thomas X, Boiron JM, Huguet F, et al. Outcome of treatment in adults with acute lymphoblastic leukemia: analysis of the LALA-94 trial. *J Clin Oncol* 2004;22:4075-4086.
210. Cornelissen JJ, Carston M, Kollman C, et al. Unrelated marrow transplantation for adult patients with poor-risk acute lymphoblastic leukemia: strong graft-versus-leukemia effect and risk factors determining outcome. *Blood* 2001;97:1572-1577.
211. Weisdorf D, Bishop M, Dharan B, et al. Autologous versus allogeneic unrelated donor transplantation for acute lymphoblastic leukemia: comparative toxicity and outcomes. *Biol Blood Marrow Transplant* 2002;8:213-220.
212. Kiehl MG, Kraut L, Schwerdtfeger R, et al. Outcome of allogeneic hematopoietic stem-cell transplantation in adult patients with acute lymphoblastic leukemia: no difference in related compared with unrelated transplant in first complete remission. *J Clin Oncol* 2004;22:2816-2825.
213. Gorin NC. Autologous stem cell transplantation in acute lymphocytic leukemia. *Stem Cells* 2002;20:3-10.
214. Martin TG, Linker CA. Autologous stem cell transplantation for acute lymphocytic leukemia in adults. *Hematol Oncol Clin North Am* 2001;15:121-143.
215. Simonsson B, Burnett AK, Prentice HG, et al. Autologous bone marrow transplantation with monoclonal antibody purged marrow for high risk acute lymphoblastic leukemia. *Leukemia* 1989;3:631-636.
216. Doney K, Buckner CD, Fisher L, et al. Autologous bone marrow transplantation for acute lymphoblastic leukemia. *Bone Marrow Transplant* 1993;12:315-321.
217. Tiley C, Powles R, Treleaven J, et al. Feasibility and efficacy of maintenance chemotherapy following autologous bone marrow transplantation for first remission acute lymphoblastic leukaemia. *Bone Marrow Transplant* 1993;12:449-455.
218. Blume KG, Thomas ED. A review of autologous hematopoietic cell transplantation. *Biol Blood Marrow Transplant* 2000;6:1-12.
219. Attal M, Blaise D, Marit G, et al. Consolidation treatment of adult acute lymphoblastic leukemia: a prospective, randomized trial comparing allogeneic versus autologous bone marrow transplantation and testing the impact of recombinant interleukin-2 after autologous bone marrow transplantation. BGMT Group. *Blood* 1995;86:1619-1628.
220. Hunault M, Harousseau JL, Delain M, et al. Better outcome of adult acute lymphoblastic leukemia after early genotypical allogeneic bone marrow transplantation (BMT) than after late high-dose therapy and autologous BMT: a GOELAMS trial. *Blood* 2004;104:3028-3037.
221. Bassan R, Pogliani E, Lerede T, et al. Fractionated cyclophosphamide added to the IVAP regimen (idarubicin-vincristine-L-asparaginase-prednisone) could lower the risk of primary refractory disease in T-lineage but not B-lineage acute lymphoblastic leukemia: first results from a phase II clinical study. *Haematologica* 1999;84:1088-1093.
222. Ribera JM, Ortega JJ, Oriol A, et al. Prognostic value of karyotypic analysis in children and adults with high-risk acute lymphoblastic leukemia included in the PETHEMA ALL-93 trial. *Haematologica* 2002;87:154-166.
223. Gaynor J, Chapman D, Little C, et al. A cause-specific hazard rate analysis of prognostic factors among 199 adults with acute lymphoblastic leukemia: the Memorial Hospital experience since 1969. *J Clin Oncol* 1988;6:1014-1030.
224. Petersdorf SH, Kopecky KJ, Head DR, et al. Comparison of the L10M consolidation regimen to an alternative regimen including escalating methotrexate/L-asparaginase for adult acute lymphoblastic leukemia: a Southwest Oncology Group Study. *Leukemia* 2001;15:208-216.

225. Bassan R, Pogliani E, Casula P, et al. Risk-oriented post-remission strategies in adult acute lymphoblastic leukemia: prospective confirmation of anthracycline activity in standard-risk class and role of hematopoietic stem cell transplants in high-risk groups. *Hematol J* 2001;2:117-126.
226. Takeuchi J, Kyo T, Naito K, et al. Induction therapy by frequent administration of doxorubicin with four other drugs, followed by intensive consolidation and maintenance therapy for adult acute lymphoblastic leukemia: the JALSGALL93 study. *Leukemia* 2002;16:1259-1266.
227. Hallbook H, Simonsson B, Ahlgren T, et al. High-dose cytarabine in upfront therapy for adult patients with acute lymphoblastic leukaemia. *Br J Haematol* 2002;118:748-754.
228. Kantarjian H, Thomas D, O'Brien S, et al. Long-term follow-up results of hyperfractionated cyclophosphamide, vincristine, doxorubicin, and dexamethasone (Hyper-CVAD), a dose-intensive regimen, in adult acute lymphocytic leukemia. *Cancer* 2004;101:2788-2801.
229. Labar B, Suci S, Zittoun R, et al. Allogeneic stem cell transplantation in acute lymphoblastic leukemia and non-Hodgkin's lymphoma for patients ≤ 50 years old in first complete remission: results of the EORTC ALL-3 trial. *Haematologica* 2004;89:809-817.
230. Ribera JM, Oriol A, Bethencourt C, et al. Comparison of intensive chemotherapy, allogeneic or autologous stem cell transplantation as post-remission treatment for adult patients with high-risk acute lymphoblastic leukemia. Results of the PETHEMA ALL-93 trial. *Haematologica* 2005;90:1346-1356.
231. Gokbuget N, Arnold R, Bohme A, et al. Improved Outcome in High Risk and Very High Risk ALL by Risk Adapted SCT and in Standard Risk ALL by Intensive Chemotherapy in 713 Adult ALL Patients Treated According to the Prospective GMALL Study 07/2003. *Blood ASH Annu Meet Abstr* 2007;110:12.
232. Tobinai K, Takeyama K, Arima F, et al. Phase II study of chemotherapy and stem cell transplantation for adult acute lymphoblastic leukemia or lymphoblastic lymphoma: Japan Clinical Oncology Group Study 9004. *Cancer Sci* 2007;98:1350-1357.
233. Cornelissen JJ, van der Holt B, Verhoef GE, et al. Myeloablative allogeneic versus autologous stem cell transplantation in adult patients with acute lymphoblastic leukemia in first remission: a prospective sibling donor versus no-donor comparison. *Blood* 2009;113:1375-1382.
234. Azuma T, Tobinai K, Takeyama K, et al. Phase II study of intensive post-remission chemotherapy and stem cell transplantation for adult acute lymphoblastic leukemia and lymphoblastic lymphoma: Japan Clinical Oncology Group Study, JCOG9402. *Jpn J Clin Oncol* 2012;42:394-404.
235. Thomas DA, O'Brien S, Faderl S, et al. Chemoimmunotherapy with a modified hyper-CVAD and rituximab regimen improves outcome in de novo Philadelphia chromosome-negative precursor B-lineage acute lymphoblastic leukemia. *J Clin Oncol* 2010;28:3880-3889.
236. Scherrer R, Geissler K, Kyrle PA, et al. Granulocyte colony-stimulating factor (G-CSF) as an adjunct to induction chemotherapy of adult acute lymphoblastic leukemia (ALL). *Ann Hematol* 1993;66:283-289.
237. Bosco I, Teh A. Outcome of treatment in adult acute lymphoblastic leukaemia in an Asian population: comparison with previous multicentre German study. *Leukemia* 1995;9:951-954.
238. Chim CS, Kwong YL, Chu YC, et al. Improved treatment outcome in adult acute lymphoblastic leukemia using the intensive German protocol, a preliminary report. *Hematol Oncol* 1997;15:19-26.
239. Linker C, Damon L, Ries C, et al. Intensified and shortened cyclical chemotherapy for adult acute lymphoblastic leukemia. *J Clin Oncol* 2002;20: 2464-2471.
240. Fenaux P, Lai JL, Miaux O, et al. Burkitt cell acute leukaemia (L3 ALL) in adults: a report of 18 cases. *Br J Haematol* 1989;71:371-376.
241. Bernasconi C, Brusamolino E, Pagnucco G, et al. Burkitt's lymphoma/leukemia: a clinicopathologic study on 24 adult patients. *Leukemia* 1991;5(suppl 1):90-94.
242. Gill PS, Meyer PR, Pavlova Z, et al. B cell acute lymphocytic leukemia in adults. Clinical, morphologic, and immunologic findings. *J Clin Oncol* 1986;4:737-743.
243. Schiffer CA. Treatment of high-grade lymphoid malignancies in adults. *Semin Hematol* 2001;38:22-26.

244. Patte C, Philip T, Rodary C, et al. Improved survival rate in children with stage III and IV B cell non-Hodgkin's lymphoma and leukemia using multi-agent chemotherapy: results of a study of 114 children from the French Pediatric Oncology Society. *J Clin Oncol* 1986;4:1219-1226.
245. Soussain C, Patte C, Ostronoff M, et al. Small noncleaved cell lymphoma and leukemia in adults. A retrospective study of 65 adults treated with the LMB pediatric protocols. *Blood* 1995;85:664-674.
246. Lee EJ, Petroni GR, Schiffer CA, et al. Brief-duration high-intensity chemotherapy for patients with small noncleaved-cell lymphoma or FAB L3 acute lymphocytic leukemia: results of cancer and leukemia group B study 9251. *J Clin Oncol* 2001;19:4014-4022.
247. Divine M, Casassus P, Koscielny S, et al. Burkitt lymphoma in adults: a prospective study of 72 patients treated with an adapted pediatric LMB protocol. *Ann Oncol* 2005;16:1928-1935.
248. Thomas DA, Faderl S, O'Brien S, et al. Chemoimmunotherapy with hyper-CVAD plus rituximab for the treatment of adult Burkitt and Burkitt-type lymphoma or acute lymphoblastic leukemia. *Cancer* 2006;106:1569-1580.
249. Oriol A, Ribera JM, Bergua J, et al. High-dose chemotherapy and immunotherapy in adult Burkitt lymphoma: comparison of results in human immunodeficiency virus-infected and noninfected patients. *Cancer* 2008;113:117-125.
250. Mead GM, Barrans SL, Qian W, et al. A prospective clinicopathologic study of dose-modified CODOX-M/IVAC in patients with sporadic Burkitt lymphoma defined using cytogenetic and immunophenotypic criteria (MRC/NCRI LY10 trial). *Blood* 2008;112:2248-2260.
251. Rizzieri DA, Johnson JL, Byrd JC, et al. Efficacy and Toxicity of Rituximab and Brief Duration, High Intensity Chemotherapy with Filgrastim Support for Burkitt or Burkitt—Like Leukemia/Lymphoma: Cancer and Leukemia Group B (Calgb) Study 10002. *Blood ASH Annu Meet Abstr* 2010;116:858a.
252. Corazzelli G, Frigeri F, Russo F, et al. RD-CODOX-M/IVAC with rituximab and intrathecal liposomal cytarabine in adult Burkitt lymphoma and "unclassifiable" highly aggressive B-cell lymphoma. *Br J Haematol* 2012;156: 234-244.
253. Kasamon YL, Swinnen LJ. Treatment advances in adult Burkitt lymphoma and leukemia. *Curr Opin Oncol* 2004;16:429-435.
254. Faderl S, Kantarjian HM, Thomas DA, et al. Outcome of Philadelphia chromosome-positive adult acute lymphoblastic leukemia. *Leuk Lymphoma* 2000;36:263-273.
255. Faderl S, Garcia-Manero G, Thomas DA, et al. Philadelphia chromosome-positive acute lymphoblastic leukemia-current concepts and future perspectives. *Rev Clin Exp Hematol* 2002;6:142-160; discussion 200-142.
256. Gleissner B, Gokbuget N, Bartram CR, et al. Leading prognostic relevance of the BCR-ABL translocation in adult acute B-lineage lymphoblastic leukemia: a prospective study of the German Multicenter Trial Group and confirmed polymerase chain reaction analysis. *Blood* 2002;99:1536-1543.
257. Secker-Walker LM, Craig JM, Hawkins JM, et al. Philadelphia positive acute lymphoblastic leukemia in adults: age distribution, BCR breakpoint and prognostic significance. *Leukemia* 1991;5:196-199.
258. Fielding AK, Rowe JM, Richards SM, et al. Prospective outcome data on 267 unselected adult patients with Philadelphia chromosome-positive acute lymphoblastic leukemia confirms superiority of allogeneic transplantation over chemotherapy in the pre-imatinib era: results from the International ALL Trial MRC UKALLXII/ECOG2993. *Blood* 2009;113:4489-4496.
259. Uzunel M, Mattsson J, Jaksch M, et al. The significance of graft-versus-host disease and pretransplantation minimal residual disease status to outcome after allogeneic stem cell transplantation in patients with acute lymphoblastic leukemia. *Blood* 2001;98:1982-1984.
260. Snyder DS, Nademanee AP, O'Donnell MR, et al. Long-term follow-up of 23 patients with Philadelphia chromosome-positive acute lymphoblastic leukemia treated with allogeneic bone marrow transplant in first complete remission. *Leukemia* 1999;13:2053-2058.
261. Sierra J, Radich J, Hansen JA, et al. Marrow transplants from unrelated donors for treatment of Philadelphia chromosome-positive acute lymphoblastic leukemia. *Blood* 1997;90:1410-1414.
262. Dunlop LC, Powles R, Singhal S, et al. Bone marrow transplantation for Philadelphia chromosome-positive acute lymphoblastic leukemia. *Bone Marrow Transplant* 1996;17:365-369.

263. Stockschlader M, Hegewisch-Becker S, Kruger W, et al. Bone marrow transplantation for Philadelphia-chromosome-positive acute lymphoblastic leukemia. *Bone Marrow Transplant* 1995;16:663-667.
264. Barrett AJ, Horowitz MM, Ash RC, et al. Bone marrow transplantation for Philadelphia chromosome-positive acute lymphoblastic leukemia. *Blood* 1992;79:3067-3070.
265. Arico M, Valsecchi MG, Camitta B, et al. Outcome of treatment in children with Philadelphia chromosome-positive acute lymphoblastic leukemia. *N Engl J Med* 2000;342:998-1006.
266. Dombret H, Gabert J, Boiron JM, et al. Outcome of treatment in adults with Philadelphia chromosome-positive acute lymphoblastic leukemia—results of the prospective multicenter LALA-94 trial. *Blood* 2002;100:2357-2366.
267. Chao NJ, Blume KG, Forman SJ, et al. Long-term follow-up of allogeneic bone marrow recipients for Philadelphia chromosome-positive acute lymphoblastic leukemia. *Blood* 1995;85:3353-3354.
268. Druker BJ, Sawyers CL, Kantarjian H, et al. Activity of a specific inhibitor of the BCR-ABL tyrosine kinase in the blast crisis of chronic myeloid leukemia and acute lymphoblastic leukemia with the Philadelphia chromosome. *N Engl J Med* 2001;344:1038-1042.
269. Ottmann OG, Druker BJ, Sawyers CL, et al. A phase 2 study of imatinib in patients with relapsed or refractory Philadelphia chromosome-positive acute lymphoid leukemias. *Blood* 2002;100:1965-1971.
270. Wassmann B, Pfeifer H, Scheuring U, et al. Therapy with imatinib mesylate (Glivec) preceding allogeneic stem cell transplantation (SCT) in relapsed or refractory Philadelphia-positive acute lymphoblastic leukemia (Ph+ALL). *Leukemia* 2002;16:2358-2365.
271. Thomas DA, Faderl S, Cortes J, et al. Update of the Hyper-CVAD and Imatinib Mesylate Regimen in Philadelphia (Ph) Positive Acute Lymphocytic Leukemia (ALL). *Blood ASH Annu Meet Abstr* 2004;104:2738.
272. Yanada M, Takeuchi J, Sugiura I, et al. High complete remission rate and promising outcome by combination of imatinib and chemotherapy for newly diagnosed BCR-ABL-positive acute lymphoblastic leukemia: a phase II study by the Japan Adult Leukemia Study Group. *J Clin Oncol* 2006;24:460-466.
273. Lee S, Kim YJ, Min CK, et al. The effect of first-line imatinib interim therapy on the outcome of allogeneic stem cell transplantation in adults with newly diagnosed Philadelphia chromosome-positive acute lymphoblastic leukemia. *Blood* 2005;105:3449-3457.
274. Deininger M, Schleuning M, Greinix H, et al. The effect of prior exposure to imatinib on transplant-related mortality. *Haematologica* 2006;91:452-459.
275. Wassmann B, Pfeifer H, Goekbuget N, et al. Alternating versus concurrent schedules of imatinib and chemotherapy as front-line therapy for Philadelphia-positive acute lymphoblastic leukemia (Ph+ ALL). *Blood* 2006;108:1469-1477.
276. Pfeifer H, Wassmann B, Hofmann WK, et al. Risk and prognosis of central nervous system leukemia in patients with Philadelphia chromosome-positive acute leukemias treated with imatinib mesylate. *Clin Cancer Res* 2003;9:4674-4681.
277. Foa R, Vitale A, Vignetti M, et al. Dasatinib as first-line treatment for adult patients with Philadelphia chromosome-positive acute lymphoblastic leukemia. *Blood* 2011;118:6521-6528.
278. Ravandi F, O'Brien S, Thomas D, et al. First report of phase 2 study of dasatinib with hyper-CVAD for the frontline treatment of patients with Philadelphia chromosome-positive (Ph+) acute lymphoblastic leukemia. *Blood* 2010;116:2070-2077.
279. Cortes JE, Dong-Wook K, Pinill-Ibarz J, et al. A pivotal phase 2 trial of ponatinib in patients with chronic myeloid leukemia (CML) and Philadelphia chromosome-positive acute lymphoblastic leukemia (Ph+ALL) resistant or intolerant to dasatinib or nilotinib, or with the T315I BCR-ABL mutation: 12-month follow-up of the PACE trial. . *Blood ASH Annu Meet Abstr* 2012;120:163.
280. Wassmann B, Pfeifer H, Stadler M, et al. Early molecular response to post-transplantation imatinib determines outcome in MRD+ Philadelphia-positive acute lymphoblastic leukemia (Ph+ ALL). *Blood* 2005;106:458-463.
281. Robak T. Acute lymphoblastic leukaemia in elderly patients: biological characteristics and therapeutic approaches. *Drugs Aging* 2004;21:779-791.
282. Thomas X, Olteanu N, Charrin C, et al. Acute lymphoblastic leukemia in the elderly: The Edouard Herriot Hospital experience. *Am J Hematol* 2001;67:73-83.

283. Legrand O, Marie JP, Marjanovic Z, et al. Prognostic factors in elderly acute lymphoblastic leukaemia. *Br J Haematol* 1997;97:596-602.
284. Kantarjian HM, O'Brien S, Smith T, et al. Acute lymphocytic leukaemia in the elderly: characteristics and outcome with the vincristine-adriamycin-dexamethasone (VAD) regimen. *Br J Haematol* 1994;88:94-100.
285. Taylor PR, Reid MM, Proctor SJ. Acute lymphoblastic leukaemia in the elderly. *Leuk Lymphoma* 1994;13:373-380.
286. Delannoy A, Ferrant A, Bosly A, et al. Acute lymphoblastic leukemia in the elderly. *Eur J Haematol* 1990;45:90-93.
287. Taylor PR, Reid MM, Bown N, et al. Acute lymphoblastic leukemia in patients aged 60 years and over: a population-based study of incidence and outcome. *Blood* 1992;80:1813-1817.
288. Spath-Schwalbe E, Heil G, Heimpel H. Acute lymphoblastic leukemia in patients over 59 years of age. Experience in a single center over a 10-year period. *Ann Hematol* 1994;69:291-296.
289. Ferrari A, Annino L, Crescenzi S, et al. Acute lymphoblastic leukemia in the elderly: results of two different treatment approaches in 49 patients during a 25-year period. *Leukemia* 1995;9:1643-1647.
290. Mandelli F, Annino L, Ferrari A. ALL in elderly: The GIMEMA trials. *Ann Hematol* 1995;70:105-113.
291. Delannoy A, Sebban C, Cony-Makhoul P, et al. Age-adapted induction treatment of acute lymphoblastic leukemia in the elderly and assessment of maintenance with interferon combined with chemotherapy. A multicentric prospective study in forty patients. French Group for Treatment of Adult Acute Lymphoblastic Leukemia. *Leukemia* 1997;11:1429-1434.
292. Delannoy A, Cazin B, Thomas X, et al. Treatment of acute lymphoblastic leukemia in the elderly: an evaluation of interferon alpha given as a single agent after complete remission. *Leuk Lymphoma* 2002;43:75-81.
293. Goekbuget N, Wit M, Gerhardt A. Results of a shortened, dose reduced treatment protocol in elderly patients with acute lymphoblastic leukemia (ALL). *Blood* 2000;96:718.
294. Offidani M, Corvatta L, Malerba L, et al. Comparison of two regimens for the treatment of elderly patients with acute lymphoblastic leukaemia (ALL). *Leuk Lymphoma* 2005;46:233-238.
295. Goekbuget N, Leguay T, Hunault M, et al. First European chemotherapy schedule for elderly patients with acute lymphoblastic leukemia: promising remission rate and feasible moderate dose intensity consolidation. *Blood ASH Annu Meet Abstr* 2008;112:304a.
296. Shin DY, Kim I, Kim KH, et al. Acute lymphoblastic leukemia in elderly patients: a single institution's experience. *Korean J Intern Med* 2011;26:328-339.
297. Pagano L, Mele L, Casorelli I, et al. Acute lymphoblastic leukemia in the elderly. A twelve-year retrospective, single center study. *Haematologica* 2000;85:1327-1329.
298. Bassan R, Di Bona E, Lerede T, et al. Age-adapted moderate-dose induction and flexible outpatient postremission therapy for elderly patients with acute lymphoblastic leukemia. *Leuk Lymphoma* 1996;22:295-301.
299. Vignetti M, Fazi P, Meloni G, et al. Dramatic Improvement in CR Rate and CR Duration with Imatinib in Adult and Elderly Ph+ ALL Patients: Results of the GIMEMA Prospective Study LAL0201. *Blood ASH Annu Meet Abstr* 2004;104:2739a.
300. Ottmann O, Wassmann B, Gokbuget N, et al. A randomized phase II study comparing imatinib with chemotherapy as induction therapy in elderly patients with newly diagnosed Philadelphia-positive acute lymphoid leukemias (Ph+ALL) *Hematol J* 2004;5:S112.
301. Thomas DA, Kantarjian H, Smith TL, et al. Primary refractory and relapsed adult acute lymphoblastic leukemia: characteristics, treatment results, and prognosis with salvage therapy. *Cancer* 1999;86:1216-1230.
302. Chucrallah AE, Stass SA, Huh YO, et al. Adult acute lymphoblastic leukemia at relapse. Cytogenetic, immunophenotypic, and molecular changes. *Cancer* 1995;76:985-991.
303. Guglielmi C, Cordone I, Boecklin F, et al. Immunophenotype of adult and childhood acute lymphoblastic leukemia: changes at first relapse and clinicoprognostic implications. *Leukemia* 1997;11:1501-1507.
304. Welborn JL. Impact of reinduction regimens for relapsed and refractory acute lymphoblastic leukemia in adults. *Am J Hematol* 1994;45:341-344.

305. Bassan R, Lerede T, Barbui T. Strategies for the treatment of recurrent acute lymphoblastic leukemia in adults. *Haematologica* 1996;81:20-36.
306. Garcia-Manero G, Thomas DA. Salvage therapy for refractory or relapsed acute lymphocytic leukemia. *Hematol Oncol Clin North Am* 2001;15:163-205.
307. Kantarjian HM, Walters RS, Keating MJ, et al. Experience with vincristine, doxorubicin, and dexamethasone (VAD) chemotherapy in adults with refractory acute lymphocytic leukemia. *Cancer* 1989;64:16-22.
308. Koller CA, Kantarjian HM, Thomas D, et al. The hyper-CVAD regimen improves outcome in relapsed acute lymphoblastic leukemia. *Leukemia* 1997;11:2039-2044.
309. Weiss MA, Aliff TB, Tallman MS, et al. A single, high dose of idarubicin combined with cytarabine as induction therapy for adult patients with recurrent or refractory acute lymphoblastic leukemia. *Cancer* 2002;95:581-587.
310. Karbasian-Esfahani M, Wiernik PH, Novik Y, et al. Idarubicin and standard-dose cytosine arabinoside in adults with recurrent and refractory acute lymphocytic leukemia. *Cancer* 2004;101:1414-1419.
311. Hiddemann W, Buchner T, Heil G, et al. Treatment of refractory acute lymphoblastic leukemia in adults with high dose cytosine arabinoside and mitoxantrone (HAM). *Leukemia* 1990;4:637-640.
312. Suki S, Kantarjian H, Gandhi V, et al. Fludarabine and cytosine arabinoside in the treatment of refractory or relapsed acute lymphocytic leukemia. *Cancer* 1993;72:2155-2160.
313. Visani G, Tosi P, Zinzani PL, et al. FLAG (fludarabine, cytarabine, G-CSF) as a second line therapy for acute lymphoblastic leukemia with myeloid antigen expression: in vitro and in vivo effects. *Eur J Haematol* 1996;56:308-312.
314. Montillo M, Tedeschi A, Centurioni R, et al. Treatment of relapsed adult acute lymphoblastic leukemia with fludarabine and cytosine arabinoside followed by granulocyte colony-stimulating factor (FLAG-GCSF). *Leuk Lymphoma* 1997;25:579-583.
315. Giona F, Testi AM, Amadori S, et al. Idarubicin and high-dose cytarabine in the treatment of refractory and relapsed acute lymphoblastic leukemia. *Ann Oncol* 1990;1:51-55.
316. Freund M, Diedrich H, Ganser A, et al. Treatment of relapsed or refractory adult acute lymphocytic leukemia. *Cancer* 1992;69:709-716.
317. Kurtzberg J, Ernst TJ, Keating MJ, et al. Phase I study of 506U78 administered on a consecutive 5-day schedule in children and adults with refractory hematologic malignancies. *J Clin Oncol* 2005;23:3396-3403.
318. Berg SL, Blaney SM, Devidas M, et al. Phase II study of nelarabine (compound 506U78) in children and young adults with refractory T-cell malignancies: a report from the Children's Oncology Group. *J Clin Oncol* 2005;23:3376-3382.
319. U.S. FDA New drug to treat rare leukemia and lymphoma. 2006 Jan-Feb Report No. 0362-1332 (Print).
320. Jeha S, Gaynon PS, Razzouk BI, et al. Phase II study of clofarabine in pediatric patients with refractory or relapsed acute lymphoblastic leukemia. *J Clin Oncol* 2006;24:1917-1923.
321. Kantarjian H, Thomas D, Jorgensen J, et al. Inotuzumab ozogamicin, an anti-CD22-calecheamicin conjugate, for refractory and relapsed acute lymphocytic leukaemia: a phase 2 study. *Lancet Oncol* 2012;13:403-411.
322. Topp MS, Gokbuget N, Zugmaier G, et al. Long-term follow-up of hematologic relapse-free survival in a phase 2 study of blinatumomab in patients with MRD in B-lineage ALL. *Blood* 2012;120:5185-5187.
323. Topp M, Goekbuget N, Zugmaier G, et al. Anti-CD19 BiTE blinatumomab induces high complete remission rate and prolongs overall survival in adult patients with relapsed/refractory B-precursor acute lymphoblastic leukemia (ALL). *Haematologica* 2012;97:462.
324. Hofmann WK, Komor M, Hoelzer D, et al. Mechanisms of resistance to STI571 (Imatinib) in Philadelphia-chromosome positive acute lymphoblastic leukemia. *Leuk Lymphoma* 2004;45:655-660.
325. Gorre ME, Mohammed M, Ellwood K, et al. Clinical resistance to STI-571 cancer therapy caused by BCR-ABL gene mutation or amplification. *Science* 2001;293:876-880.
326. Willis SG, Lange T, Demehri S, et al. High-sensitivity detection of BCR-ABL kinase domain mutations in imatinib-naive patients: correlation with clonal cytogenetic evolution but not response to therapy. *Blood* 2005;106:2128-2137.

327. Hochhaus A, Kreil S, Corbin AS, et al. Molecular and chromosomal mechanisms of resistance to imatinib (STI571) therapy. *Leukemia* 2002;16:2190-2196.
328. von Bubnoff N, Schneller F, Peschel C, et al. BCR-ABL gene mutations in relation to clinical resistance of Philadelphia-chromosome-positive leukaemia to STI571: a prospective study. *Lancet* 2002;359:487-491.
329. Deininger M, Buchdunger E, Druker BJ. The development of imatinib as a therapeutic agent for chronic myeloid leukemia. *Blood* 2005;105:2640-2653.
330. Weisberg E, Manley PW, Breitenstein W, et al. Characterization of AMN107, a selective inhibitor of native and mutant Bcr-Abl. *Cancer Cell* 2005;7:129-141.
331. Shah NP, Tran C, Lee FY, et al. Overriding imatinib resistance with a novel ABL kinase inhibitor. *Science* 2004;305:399-401.
332. Cortes JE, Kim DW, Kantarjian HM, et al. Bosutinib versus imatinib in newly diagnosed chronic-phase chronic myeloid leukemia: results from the BELA trial. *J Clin Oncol* 2012;30:3486-3492.
333. O'Hare T, Walters DK, Stoffregen EP, et al. In vitro activity of Bcr-Abl inhibitors AMN107 and BMS-354825 against clinically relevant imatinib-resistant Abl kinase domain mutants. *Cancer Res* 2005;65:4500-4505.
334. Talpaz M, Shah NP, Kantarjian H, et al. Dasatinib in imatinib-resistant Philadelphia chromosome-positive leukemias. *N Engl J Med* 2006;354: 2531-2541.
335. U.S. FDA. FDA Gives Rapid Approval for a New Treatment For a Rare Type of Leukemia. *FDA News*. Vol. 2006: U.S. Department of Health and Human Services; 2006.
336. Thomas D, Cortes J, Faderl S, et al. Hyper-CVAD and Rituximab Therapy in HIV-Negative Burkitt (BL) or Burkitt-like (BLL) Leukemia/Lymphoma and Mature B cell Acute Lymphocytic Leukemia (B-ALL). *J CLIN Oncol (ASCO)* 2005;23:6531.
337. Davies SM, Ramsay NK, Weisdorf DJ. Feasibility and timing of unrelated donor identification for patients with ALL. *Bone Marrow Transplant* 1996;17:737-740.
338. Giona F, Annino L, Rondelli R, et al. Treatment of adults with acute lymphoblastic leukaemia in first bone marrow relapse: results of the ALL R-87 protocol. *Br J Haematol* 1997;97:896-903.
339. Blume KG, Schmidt GM, Chao NJ, et al. Bone marrow transplantation from histocompatible sibling donors for patients with acute lymphoblastic leukemia. *Haematol Blood Transfus* 1990;33:636-637.
340. Doney K, Fisher LD, Appelbaum FR, et al. Treatment of adult acute lymphoblastic leukemia with allogeneic bone marrow transplantation. Multivariate analysis of factors affecting acute graft-versus-host disease, relapse, and relapse-free survival. *Bone Marrow Transplant* 1991;7:453-459.
341. Report from the International Bone Marrow Transplant Registry. Advisory Committee of the International Bone Marrow Transplant Registry. *Bone Marrow Transplant* 1989;4:221-228.
342. Forman SJ, Schmidt GM, Nademanee AP, et al. Allogeneic bone marrow transplantation as therapy for primary induction failure for patients with acute leukemia. *J Clin Oncol* 1991;9:1570-1574.
343. Petersdorf EW, Hansen JA, Martin PJ, et al. Major-histocompatibility-complex class I alleles and antigens in hematopoietic-cell transplantation. *N Engl J Med* 2001;345:1794-1800.
344. Weisdorf DJ, Billett AL, Hannan P, et al. Autologous versus unrelated donor allogeneic marrow transplantation for acute lymphoblastic leukemia. *Blood* 1997;90:2962-2968.
345. Santos GW, Yeager AM, Jones RJ. Autologous bone marrow transplantation. *Annu Rev Med* 1989;40:99-112.
346. Meloni G, De Fabritiis P, Pulsoni A, et al. Results of two different conditioning regimens followed by ABMT in refractory acute lymphoblastic leukemia. *Haematologica* 1989;74:67-70.
347. Granena A, Castellsague X, Badell I, et al. Autologous bone marrow transplantation for high risk acute lymphoblastic leukemia: clinical relevance of ex vivo bone marrow purging with monoclonal antibodies and complement. *Bone Marrow Transplant* 1999;24:621-627.
348. Marks DI, Wang T, Perez WS, et al. The outcome of full-intensity and reduced-intensity conditioning matched sibling or unrelated donor transplantation in adults with Philadelphia chromosome-negative acute lymphoblastic leukemia in first and second complete remission. *Blood* 2010;116:366-374.

349. Paulson K, Szwajcer D, Seftel MD. The role of allogeneic stem cell transplantation for adult acute lymphoblastic leukemia. *Transfus Apher Sci* 2011;44:197-203.

350. Brentjens RJ, Curran KJ. Novel cellular therapies for leukemia: CAR-modified T cells targeted to the CD19 antigen. *Hematology Am Soc Hematol Educ Program* 2012;2012:143-151.

Chapter 75 Acute Myeloid Leukemia in Adults

> Table of Contents > Part VII - Hematologic Malignancies > Section 2 - The Acute Leukemias > Chapter 75 - Acute Myeloid Leukemia in Adults

Chapter 75

Acute Myeloid Leukemia in Adults

Ashkan Emadi

Maria R. Baer

Acute myeloid leukemia, acute myelogenous leukemia, and acute nonlymphocytic leukemia are equivalent terms for a hematopoietic neoplasm that is uniformly characterized by the presence of a malignant clone of myeloid cells in the bone marrow with maturation arrest at the level of blast. Acute myeloid leukemia (AML) is the term used in the World Health Organization (WHO) classification of the myeloid neoplasms^{1,2,3} and is the current recommended term.⁴

AML may follow a myelodysplastic syndrome (MDS) (Chapter 79) or a myeloproliferative neoplasm (MPN; Chapters 80, 81, 82 and 83). AML should be distinguished from acute lymphoblastic leukemia (ALL; Chapter 74), in which blasts are of lymphoid rather than myeloid lineage. AML should also be distinguished from chronic myelogenous leukemia (CML; Chapter 81), in which, in the initial phase of the disease, myeloid cells are expanded but do not exhibit maturation arrest. In addition, CML is a uniform disease, whereas AML has heterogeneous clinical, morphologic, immunophenotypic, cytogenetic, and molecular features. Chapter 77 addresses presentation and therapy of AML in children. Chapter 78 addresses the biology, presentation, and management of the acute promyelocytic leukemia (APL) subtype of AML in adults and children.

AML occurs at any age, but is more common in adults, with increased frequency as age advances. Patients typically present with manifestations of anemia, neutropenia, and/or thrombocytopenia resulting from impaired hematopoiesis due to replacement or suppression of normal marrow elements by malignant blasts. The total white blood cell count is variable, ranging from leukopenia to hyperleukocytosis with an elevated blood blast count that represents a medical emergency.

The malignant cell in AML is a blast that most often shows myeloid or monocytic differentiation, but shows erythroid or megakaryocytic differentiation in approximately 5% to 10% of cases. The myeloid blast can be identified by the presence of granules and/or Auer rods by Wright Giemsa staining, by Sudan black, myeloperoxidase (MPO), chloroacetate esterase, or nonspecific esterase cytochemical staining, and/or by an immunophenotype demonstrating expression of myeloid antigens. Immunophenotyping by flow cytometry is currently in widespread use^{4,5} and serves to define lineage in the absence of defining morphologic and cytochemical features.⁶ In addition, ultrastructural features characteristic of AML may be demonstrated by electron microscopy,⁷ although this modality is not generally a component of clinical diagnostics.

Immunophenotyping by flow cytometry has shown that AML is markedly heterogeneous, variably expressing antigens expressed on stem cells and on more mature myeloid cells, also with infrequent co-expression of lymphoid antigens.⁸ Moreover AML generally exhibits aberrant patterns of antigen expression or co-expression in relation to normal myeloid cells.^{9,10} Detection of aberrant phenotypes by flow cytometry has been applied toward monitoring of residual disease.¹¹

Cytogenetic abnormalities are present in leukemia cells of most patients with AML,¹² and are currently the most powerful predictors of treatment outcome.^{13,14} Because of the importance of cytogenetics in diagnosis and prognosis in AML, several recurrent cytogenetic abnormalities, including t(8;21)(q22;q22), inv(16) (p13.1q22), or t(16;16)(p13.1;q22), t(15;17)(q22;q12), t(9;11) (p22;q23), t(6;9)(p23;q34), inv(3)(q21q26.3), or t(3;3)(q21;q26.2) and t(1;22)(p13;q13), have been incorporated into the WHO classification of AML.² Moreover, cytogenetic abnormalities have been classified as favorable, intermediate, and unfavorable with regard to AML treatment outcomes,^{13,14} and this information is used to assist in the choice of initial and subsequent therapies. New diagnostic tools, including fluorescence in situ hybridization (FISH), polymerase chain reaction (PCR), comparative genomic hybridization (CGH), and microarray analysis, have improved the sensitivity of detection of genetic abnormalities and the ability to subclassify AML and to detect residual disease. Diverse molecular abnormalities are also being demonstrated in AML and predict treatment response,

particularly in AML with a normal karyotype. Molecular abnormalities are also serving as a basis for development of targeted therapies.

Advances in therapy have changed cure rates in AML from less than 20% in 1960 to 1980 to 40% to 70% for selected groups in the 2000s. The cure rate of APL is very high with the addition of all-trans-retinoic acid (ATRA) to chemotherapy and, in some regimens including in the relapse setting, use of arsenic trioxide (Chapter 78). For other types of AML, outcomes have improved significantly for younger, but not older, adult patients (Fig. 75.1). The highest cure rates have resulted from allogeneic stem cell transplantation (alloSCT) in first remission but, with improved survival of patients receiving high-dose cytosine arabinoside (cytarabine or ara-C) post-remission chemotherapy, the question of what is the best post-remission therapy in AML remains unanswered, and stratification based on patient and leukemia characteristics is indicated. Novel targeted approaches are currently being tested in AML, and their ultimate roles remain to be determined.

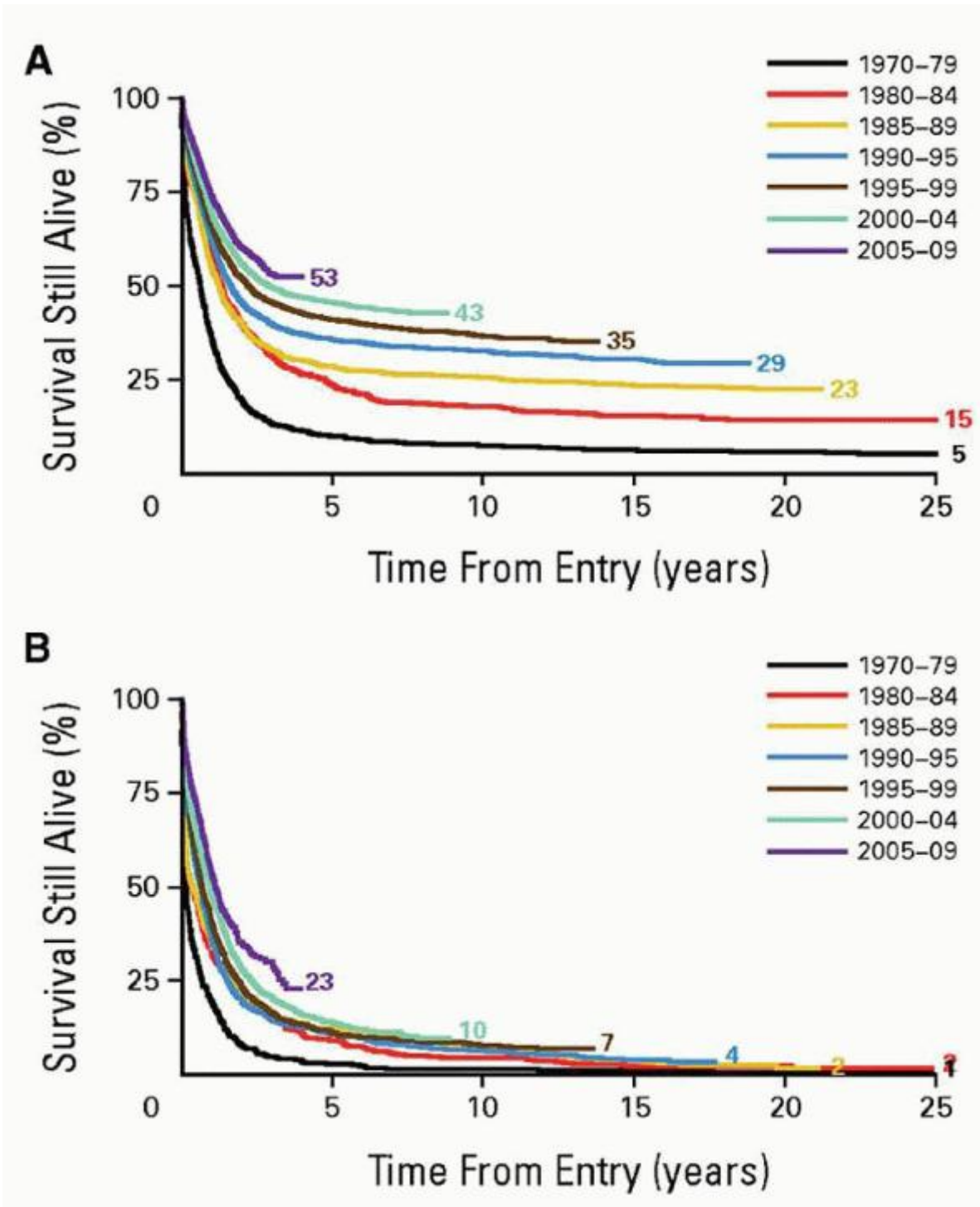

FIGURE 75.1. Change in overall survival of AML patients with time. A: Age 15 to 59 years. B: 60 or more years. (From Burnett A, Wetzler M, Löwenberg B. Therapeutic advances in acute myeloid leukemia. *J Clin Oncol* 2011;29(5):487-494.) P.1578

In this chapter, epidemiologic, clinical, biologic, cytogenetic, and molecular features of adult AML are addressed in the context of therapeutic principles and prognosis.

HISTORICAL PERSPECTIVE

The terms “weisses Blut” and “leukämie” were first used by Virchow in the middle of the 19th century, following initial descriptions of patients with an excess of white blood cells and splenomegaly at autopsy.^{15,16} Ebstein introduced the term “acute leukemia” in 1889 to differentiate rapidly progressive leukemias from more indolent “chronic” leukemias. Naegeli identified the myeloblast in leukemia in 1900¹⁷ and divided leukemias into “myeloid” and “lymphocytic.” During the first half of the 20th century, most of the subcategories of AML were identified by light microscopy with the aid of cytohistochemical stains and were described based on resemblance to normal hematopoietic precursors. Reschad and Schilling described acute monoblastic leukemia in 1913;¹⁸ DiGugliemo described acute erythroleukemia in 1917;¹⁹ Von Boros and Karenyi described acute megakaryocytic leukemia in 1931;²⁰ and Hilstad described APL in 1957.²¹

The initial classification of AML developed by the French-American-British (FAB) cooperative group in 1976²² was based on morphology. It was subsequently expanded to include new morphologic and immunogenotypic subsets, notably minimally differentiated disease with myeloid antigen expression.⁶ The WHO classification, published in 1997 and updated in 2002 and 2008,^{1,2,23,24} incorporates clinical and cytogenetic data, distinguishes therapy-related AML and AML with MDS-related changes from de novo AML, and uses several recurring structural cytogenetic abnormalities to define AML subtypes.

Numerous cytogenetic abnormalities, both structural and numerical, have been identified in AML, beginning with the t(8;21)²⁵ and t(15;17)²⁶ translocations. Several of these recurring abnormalities were incorporated into the WHO classification, serving to define new subtypes.^{1,2,24} Cytogenetic findings in AML are the strongest predictors of treatment outcomes.^{13,14,27,28,29,30, 31, 32, 33} and ³⁴ Structural cytogenetic abnormalities have been characterized at the molecular level, resulting in increased understanding of AML pathogenesis, and establishment of potential therapeutic targets, as well as molecular markers for quantitative monitoring of residual disease.¹¹ Increasing numbers of gene mutations are also being described in AML, also enhancing our understanding of its molecular pathogenesis, providing new prognostic categories,^{35,36,37,38, 39, 40} and ^{41,42,43,44,45,46,47,48,49,50} and identifying new therapeutic targets.

The European LeukemiaNet has developed a new prognostic classification of AML incorporating cytogenetic and molecular data.^{51,52}

Full sequencing of cytogenetically normal AML genomes was first reported in 2008⁵³ and 2009,⁵⁴ demonstrating 10 and 12 genes with acquired mutations, respectively. Finally, microRNAs, or small noncoding RNA molecules that hybridize to target messenger RNA species and regulate their translation, have also been found to have distinct expression patterns in AML, with prognostic significance, and may represent new therapeutic targets.^{55,56,57}

EPIDEMIOLOGY

It is estimated that 13,780 individuals (7,350 men and 6,430 women) were diagnosed with AML and 10,200 died of AML in the United States in 2012.^{58,59} Lifetime risk of AML based on rates from 2007 through 2009 is 0.39%, which means that 1 in 254 men and women born today will be diagnosed with AML during their lifetime.

TABLE 75.1 AGE DISTRIBUTION OF ACUTE MYELOID LEUKEMIA (AML) AT DIAGNOSIS

Age (Years)AML Incidence (%)

<20	6.0
20 and 34	6.6
35 and 44	6.6
45 and 54	11.8
55 and 64	15.5
65 and 74	20.1
75 and 84	23.3
>85	10.2

The incidence of AML increases with age. AML accounts for 80% to 90% of cases of acute leukemia in adults, but less than 15% of cases of leukemia in children younger than 10 years and 25% to 30% in those between 10 and 15 years.^{60,61} From 2005 through 2009, the median age at diagnosis of AML was 66 years.⁶² Table 75.1 shows the age distribution for diagnosis of AML.⁵⁸

The increased incidence of AML in the elderly is likely related to a combination of improved diagnosis, recognition of AML after MDS, and longer life expectancy, with consequent increased environmental exposures. Based on the number of

patients diagnosed from 2005 through 2009 in 18 Surveillance Epidemiology and End Results (SEER) geographical areas, the age-adjusted incidence of AML is 3.6 per 100,000 subjects per year.⁵⁸ The incidence is higher in males than in females and higher in whites than in blacks (Table 75.2).^{58,61} There is an increased risk for Eastern European Jews and a decreased risk for Asian populations.⁶³

The overall 5-year relative survival for AML from 2002 through 2008 in 18 SEER geographic areas was 23.4%.⁵⁸ As with incidence, mortality rates in AML vary with age, gender, and race. Table 75.3 summarizes the age distribution of AML-related death.⁵⁸ The median age at death from AML was 72 years in 2005 to 2009,⁶⁴ and the age-adjusted mortality rate was 2.8 per 100,000 subjects per year.⁵⁸ Table 75.4 summarizes mortality rates by race and gender.⁵⁸ From 2002 through 2008, 5-year relative survival by race and sex was 21.3% for white men, 24.6% for white women, 23.2% for black men, and 24.8% for black women.⁵⁸

RISK FACTORS

Risk factors for AML include both exposures that result in DNA damage, and congenital diseases and gene polymorphisms associated with impaired repair of DNA damage. Epidemiologic studies

P.1579

have identified genetic, environmental, and occupational factors that may contribute to the pathogenesis of AML.^{60,63,65} In addition, AML arising following cytotoxic therapy for prior malignancies or benign conditions, termed therapy-related AML (t-AML), is an increasing problem in the face of successful therapy for lymphomas and solid tumors, as well as leukemias, and decreasing the risk of this devastating complication is an important goal in the evolution of oncology treatment regimens and strategies.

TABLE 75.2 ACUTE MYELOID LEUKEMIA (AML) INCIDENCE RATES (PER 100,000 INDIVIDUALS) BY RACE AND BY GENDER

Race/Ethnicity	Male	Female
All Races	4.3	3.0
White	4.5	3.1
Black	3.5	2.8
Asian/Pacific Islander	3.5	2.8
American Indian/Alaska Native	2.5	3.1
Hispanic	3.5	2.7

TABLE 75.3 AGE DISTRIBUTION OF ACUTE MYELOID LEUKEMIA (AML)-RELATED DEATH

Age (Years)	AML-Related Death (%)
<20	2.2
20 and 34	3.2
35 and 44	3.8
45 and 54	8.1
55 and 64	15.7
65 and 74	24.6
75 and 84	29.9
>85	12.4

Identified occupational, environmental, lifestyle-related, and medical risk factors for development of AML are discussed below. Multiple factors may contribute and interact. A recent case-control study of risk factors for de novo AML at MD Anderson Cancer Center demonstrated multiple factors, joint effects, and differences by sex and WHO subtype.⁶⁶ Heavy smoking (≥30 pack-years; odds ratio [OR], 1.86) and low-level (OR, 2.87) or moderate/high-level (OR, 4.13) occupational

solvent exposure increased the risk of AML in men, whereas obesity (OR, 1.62) and low-level (OR, 2.73) or moderate/high-level (OR, 3.90) occupational solvent exposure increased the risk in women.

Occupational Exposures

Occupational exposures are risk factors for the development of AML. In recent literature, an increased risk of AML has been reported in workers manufacturing, or exposed to, rubber, paint, embalming fluids, pesticides, ethylene oxide, petroleum, poultry, munitions, automobiles, nuclear power, plastics and electrical wiring, as well as gasoline station attendants, beauticians, barbers, and cosmetologists.⁶⁷ Most of these reports are based on retrospective and cross-sectional studies, which makes establishing causal relationships difficult. Older literature also implicated employment in shoe-making, painting, furniture manufacturing or repair, paper mill, clothing or textile industry, chemical manufacturing, printing, nursing, and biologic laboratories,⁶⁷ and it can be speculated that enforcement of regulations pertaining to occupational exposures has altered the occupational risk profile. Of note, an association with hobbies, including artistic painting, car repair, ceramics or pottery, furniture repair, model building, photography, shooting or hunting, or wood working, has not been reported.^{67, 68, 69, 70, 71 and 72}

TABLE 75.4 ACUTE MYELOID LEUKEMIA (AML)-RELATED DEATH RATES (PER 100,000 INDIVIDUALS) BY RACE AND BY GENDER

Race/Ethnicity	Male	Female
All Races	3.7	2.2
White	3.8	2.3
Black	2.7	1.9
Asian/Pacific Islander	2.4	1.6
American Indian/Alaska Native	2.6	1.2
Hispanic	2.3	1.5

The most fully characterized occupational exposure associated with AML is to the aromatic hydrocarbon benzene.^{73, 74} and ⁷⁵ Benzene is absorbed through the skin and lungs and can accumulate in the body fat and neurologic tissues. Toxicity is related to cumulative dosage, and the risk of leukemia was high before safety controls were put into place in the workplace. Chromosome damage can occur at 1 to 10 ppm, and leukemogenic risk is considerable at 124 to 200 ppm. In surveys of factories in China, the leukemogenic risk was four to seven times higher in workers exposed to benzene than in the general population, and the average latency was 11.4 years.^{76,77} A dose-response pattern was suggested, with the highest risk in Chinese workers exposed at constant levels of 25 ppm or higher.⁷⁷ Increased risk of AML with occupational exposure to benzene was confirmed in a recent systematic review and meta-analysis,⁷⁸ and occupational benzene exposure was found to be associated with specific aneuploidies.⁷⁹

Environmental Factors

Ionizing radiation is carcinogenic primarily via induction of double-strand DNA breaks. The risk of leukemia correlates with radiation dosage and age at exposure, with a more rapid peak early in life (<15 years), as well as a more rapid decline than in those exposed at older ages (Fig. 75.2).⁸⁰

Fallout from atomic tests and exposure to nuclear reactors has been a concern in the second half of the 20th century and the start of the 21st century. Atomic bombs were released over Hiroshima and Nagasaki in 1945, and an excess risk of leukemia was reported in 1952.⁸¹ The excess relative rate, per Gray (Gy), of AML among Japanese atomic bomb survivors was best described by a quadratic dose-response function that peaked approximately 10 years after exposure, but with the effect persisting for more than five decades.⁸² Whereas little radioactivity was released

P.1580

into the environment at Three Mile Island, there was extensive exposure to radioactivity after Chernobyl,^{83,84} and increased AML incidence has been reported in Chernobyl clean-up workers.⁸⁵ Of note, one Gray is the absorption of one joule of ionizing radiation energy, per kilogram of body matter.

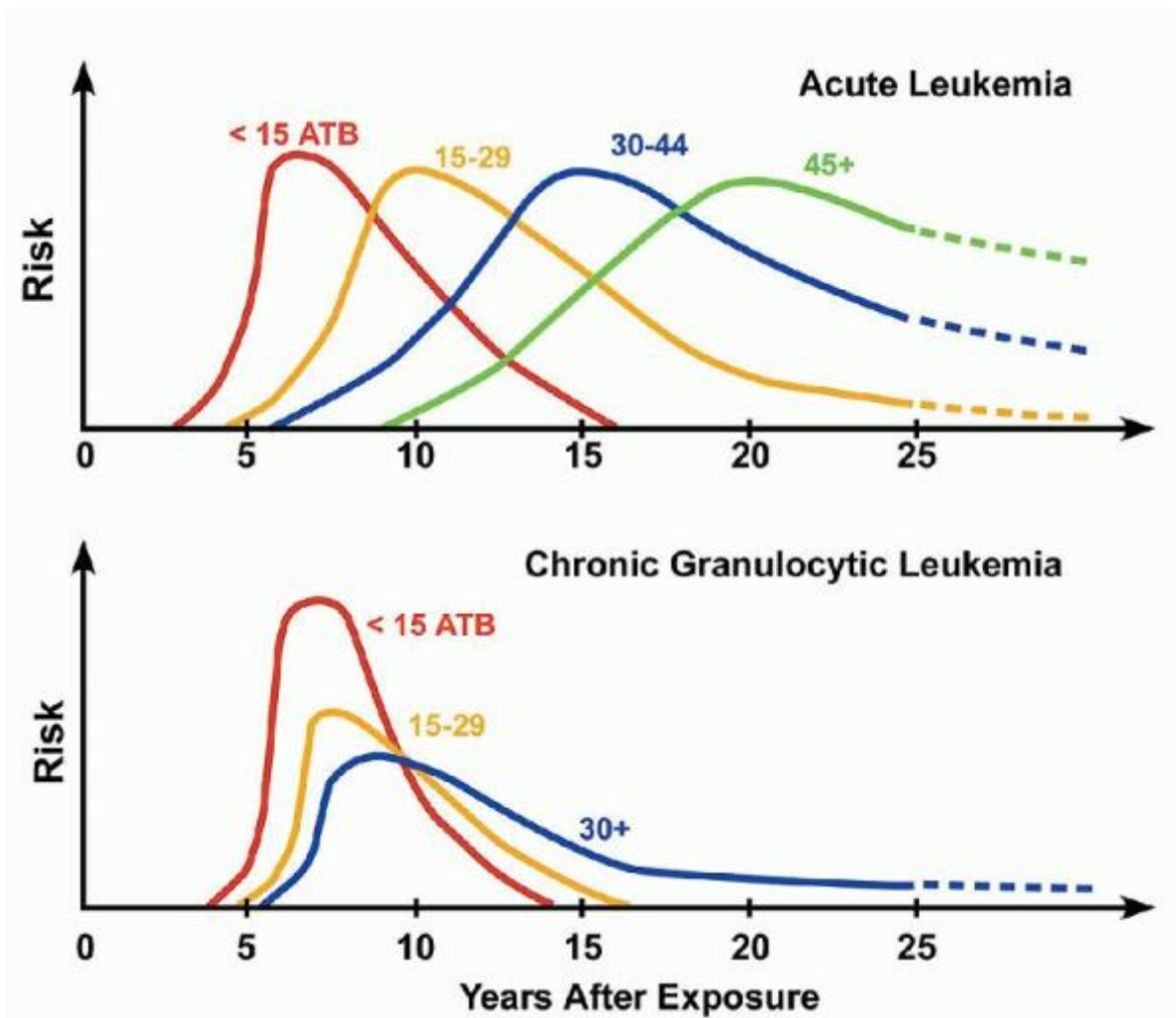

FIGURE 75.2. Effect of age at exposure and temporal pattern of developing leukemia according to cell type (acute vs. chronic granulocytic leukemia). ATB, at time of bomb. (From Okada S, Hamilton HB, Egami N, et al., eds. A review of thirty years of Hiroshima and Nagasaki atomic bomb survivors. *J Radiat Res* 1975;16(Suppl):1-164.)

Radon, cosmic radiation, and nonionizing radiation have been implicated as possible etiologic factors in AML but are unlikely to contribute a major risk.

Lifestyle-related Factors

Lifestyle-related risk factors for AML include smoking, obesity, and use of some hair dyes. Smoking has been repeatedly identified as a risk factor for AML in an extensive literature.^{86, 87, 88, 89, 90, 91} and ⁹² Cigarette smoke contains more than 4,000 chemical compounds, of which 60 have been found to be carcinogenic and leukemogenic, including benzene, urethane, nitrosamines, and polyaromatic hydrocarbons such as benz[a]anthracene, benzo[a]pyrene, benzo[b]fluoranthene, benzo[c]phenanthrene, benzo[e]pyrene, and benzo[j]fluoranthene. Meta-analyses have estimated a relative risk for AML of 1.3 to 1.5 in smokers.^{87,93} The risk of developing AML is two to three times higher in male smokers who have exceeded 20 pack-years.^{86,94} Smokers of more than 40 cigarettes per day who develop AML have an increased incidence of unfavorable cytogenetic abnormalities, including -7/7q.^{88,92} In a recent case control study at MD Anderson Cancer Center, a history of heavy smoking was associated with AML in men, and current smoking was associated with an increased risk of AML in women, and there was a joint effect of smoking and solvent exposure.⁶⁶

Obesity has been reported as a risk factor for AML.^{66,95, 96} and ⁹⁷ In a large cohort of male US veterans, obesity was associated with a higher incidence of AML in both white and black populations.⁹⁶ Similarly, among over 40,000 women ages 55 to 69 years in the Iowa Women's Health Study, the risk of AML was increased among women who reported being overweight or obese (relative risk, 1.9; 95% confidence interval [CI], 1.0 to 3.4; relative risk, 2.4; 95% CI, 1.3 to 4.5;

P(trend) = 0.006, respectively), compared with women of normal weight.⁹⁷ Findings were similar in a Canadian population.⁹⁵

Finally, there is evidence of an association between use of permanent, but not nonpermanent, dark hair dye and AML.⁹⁸

Therapy-related Acute Myeloid Leukemia

Antineoplastic therapy is associated with an increased risk of subsequent development of AML, and AML diagnosed following cytotoxic therapy for a prior malignant or benign condition is considered to be t-AML.

AML most commonly develops following treatment with alkylating agents or topoisomerase II inhibitors, but nucleoside analogs, antitubulins, and radiation are also associated with t-AML.^{99,100,101}

Radiation used for medical purposes may be leukemogenic. Smith and Doll reported a fivefold increased risk of leukemia in patients with ankylosing spondylitis receiving a single dose of pelvic radiation; the risk peaked 3 to 5 years after radiotherapy.¹⁰² A twofold increased risk has been reported after pelvic radiation for menorrhagia, a treatment commonly used during the 1930s and 1940s.¹⁰³ Small increases in risk have also been reported after radiation for tinea capitis¹⁰⁴ and peptic ulcer disease.¹⁰⁵

t-AML presentation and treatment response differ based on the setting in which it arises and the likely causative agent. Most therapy-related leukemias occur 3 to 10 years after initial therapy, with a longer latency for alkylating agents (5 to 9 years) than for topoisomerase II inhibitors (6 months to 5 years).^{99,101} Alkylating agents cause point mutations, as well as chromosome deletions and unbalanced translocations.¹⁰⁰ Topoisomerase II inhibitors result in loss of a critical enzyme involved in DNA replication, leading to balanced chromosomal translocations usually involving 11q23, and less frequently 21q22, with the formation of fusion genes.¹⁰⁶

The prognosis for t-AML is poor, with a median survival of 7 to 10 months and usually less than 10% 5-year survival.¹⁰⁰ Patients with chromosome 5 and 7 abnormalities have the worst prognosis. Alkylating agent-associated t-AML, generally characterized by deletions or monosomies of chromosomes 5 and/or 7 or complex karyotypes, frequently evolves from t-MDS, and has a low complete remission rate and short disease-free and overall survival. In contrast, topoisomerase II-associated t-AML, most commonly with 11q23 translocations, is typically not preceded by t-MDS and has a high complete remission rate, but short disease-free and overall survival. More rarely, patients treated with antineoplastic agents may develop t-AML with t(8;21), inv(16), or t(15;17).^{101,107} An early report suggests similar prognosis for t-AML and de novo AML with t(8;21) or inv(16),¹⁰⁸ whereas a more recent report suggests a worse outcome for t-AML than for de novo AML with t(8;21).¹⁰⁹

Alkylating agent-associated t-AML has been extensively described. Cumulative drug dose is a primary determinant in causing leukemia, and alkylators differ in their leukemogenicity. Mechlorethamine and melphalan are more leukemogenic than cyclophosphamide. Germline mutations in tumor suppressor genes (NF-1, TP53), genetic variations in enzymes (cytochrome P450, glutathione S-transferase, and NAD(P)H: quinone oxidoreductase 1) that are involved in drug metabolism, and genetic variations in genes such as XRCC1 and hMSH2, encoding DNA repair proteins, can all contribute to an increased risk for t-MDS/t-AML.^{110,111} and ¹¹² Alkylating agent-associated t-AML was initially best characterized following treatment of Hodgkin lymphoma (HL), one of the first malignancies for which curative therapy was developed,^{113,114} and ¹¹⁵ but has now been described after therapy of multiple neoplasms, including but not limited to breast cancer, multiple myeloma, ovarian cancer, and non-Hodgkin lymphoma (NHL),^{101,116,117} and ¹¹⁸ as well as in nonneoplastic disorders such as collagen vascular diseases.¹⁰¹

In HL, radiation can be a contributing factor, but the risk in patients treated with radiation alone is usually less than 1.0%, compared to 1.5% to 5.0% for those who received both radiation therapy and chemotherapy, particularly when chemotherapy is administered as salvage therapy for relapse after radiation.^{119,120} The risk of leukemia after HL ranges from an 11- to a 136-fold increase over that in the general population.¹²⁰ With the increased use of autologous transplantation as salvage therapy for lymphomas, t-MDS/t-AML is being recognized in 5% to 15% of patients and is associated with a poor prognosis.^{101,121} The time of leukemia onset after alkylating agent exposure has ranged from 1 to 28 years and is most commonly in the 5- to 9-year range.¹²² The risk is greater and the latency is shorter in older patients with HL (>50 years of age).¹²³ Splenectomy has been suggested as a contributing factor to leukemia in some, but not all, studies.^{122,123} Elevation in the mean corpuscular volume (MCV) may be an early sign of development of myelodysplastic changes, and up to two thirds of patients who develop leukemia have a preceding myelodysplastic phase that lasts approximately 6 months.^{122,124} Clonal cytogenetic abnormalities are often complex; the most common single abnormality is monosomy 7 (-7), followed by del(5q) and -5.¹²²

Topoisomerase II inhibitors, particularly etoposide and teniposide, were recognized as leukemogenic agents in survivors of lung cancer,^{125,126} germ cell cancer,¹²⁷ ALL,¹²⁸ neuroblastoma,¹²⁹ and osteosarcoma¹³⁰ in the 1980s. Large cumulative doses and prolonged courses have been implicated as increasing the risk of leukemia. The latency period is short, with most cases occurring between 6 months and 5 years after initial therapy. There is no myelodysplastic phase, and the majority of cases are myelomonocytic (FAB M4) or monoblastic (FAB M5). The most common cytogenetic abnormality involves a translocation of

P.1581

the mixed lineage leukemia (MLL) gene at chromosome band 11q23.¹²² Over 40 partner genes that encode different proteins are involved in MLL translocations. Patients with AML and 11q23 abnormalities after topoisomerase II inhibitors tend to be chemosensitive but are rarely long-term survivors because of a high relapse rate.¹²²

Breast cancer is treated with both alkylating agents and topoisomerase II inhibitors, as well as antitubulins. Cytogenetic abnormalities in t-AML after breast cancer therapy are heterogeneous and include those associated with either alkylating agent or topoisomerase II inhibitor therapy.¹³¹ Use of G-CSF has been implicated in increasing the risk of t-AML following breast cancer adjuvant therapy^{131,132,133} and radiation therapy may also contribute.^{131,134, 135} and ¹³⁶

Nucleoside analogs have also been implicated in t-AML. Fludarabine in chronic lymphocytic leukemia is associated with t-AML, particularly when combined with chlorambucil¹³⁷ or mitoxantrone.¹³⁸ Nucleoside analogs are also associated with an increased risk of t-AML in Waldenström macroglobulinemia.¹³⁹ Azathioprine is associated with t-AML, frequently with chromosome 7 abnormalities, in patients with rheumatologic disorders and in solid organ transplant recipients.¹⁴⁰ 6-Mercaptopurine is also associated with t-AML.¹⁴¹ In addition, MDS/AML with dysplasia and chromosome 7 abnormalities has been seen in patients treated for de novo AML and may represent t-MDS/t-AML associated with cytarabine.¹⁴²

An increasing literature is also documenting t-MDS/t-AML occurring following therapy for APL with ATRA and diverse chemotherapy drugs. Many of these cases of t-MDS/t-AML have chromosome 5 and/or 7 abnormalities, but others have 11q23 translocations, and miscellaneous abnormalities are also seen.¹⁴³

Although less leukemogenic than chemotherapy, radiation therapy is leukemogenic, as evidenced by an increased leukemia risk in patients receiving radiation in the past for ankylosing spondylitis,¹⁰² menorrhagia,¹⁰³ tinea capitis¹⁰⁴ and peptic ulcer disease.¹⁰⁵ The risk of leukemia (latency period of 2 to 11 years) is approximately 2 times higher in patients who have received either radium implants or external beam radiation for cervical, ovarian, or endometrial cancer.^{144, 145} and ¹⁴⁶ Similarly, a twofold increase in risk has been reported in breast cancer patients receiving adjuvant radiotherapy, compared to a tenfold increase in risk after chemotherapy; combined radiation and chemotherapy resulted in a seventeenfold risk.^{131,136} Radiation therapy has been associated with only a small increase in risk of leukemia in patients with HL and NHL, unless the radiation is extensive and encompasses a large volume of bone marrow.^{115,147}

In a recent report, patients who developed MDS/AML following radiation alone were found to have a lower incidence of high-risk karyotypes and longer survival than those who developed MDS/AML following chemotherapy or chemotherapy and radiation. Karyotypes did not differ from those in de novo MDS/AML, suggesting that post-radiation MDS/AML may not represent a direct consequence of radiation toxicity and may warrant a therapeutic approach similar to de novo disease.¹⁴⁸

Medical exposure to radioactivity is leukemogenic. In a recent meta-analysis, the relative risk of leukemia in thyroid cancer survivors treated with radioactive iodine (RAI) was 2.5 (95% CI 1.13, 5.53, $p = 0.024$).¹⁴⁹ A standardized incidence ratio (SIR) of 5.68 (95% CI, 2.09 to 12.37) was recently reported in patients with low-risk (T1N0) well-differentiated thyroid cancer, with the excess risk of leukemia significantly greater in patients aged <45 years (SIR = 5.32; 95% CI, 2.75 to 9.30) than in older patients (SIR = 2.26; 95% CI, 1.43 to 3.39).¹⁵⁰ Increased leukemia risk has also been previously reported following therapy with radioactive phosphorus (³²P) for polycythemia vera, as well as following exposure to Thorotrast, a radioactive contrast agent containing thorium (²³²Th).¹⁵¹

Chromosome Instability or Defective DNA Repair

The incidence of AML is increased in patients with syndromes characterized by chromosome instability or defective DNA repair,¹⁵² notably Bloom syndrome,⁵⁹ an autosomal recessive disorder with excessive chromosomal breakage, including quadriradial formation, and increased sister chromatid exchanges, caused by alterations in a gene on chromosome 15q26.1 encoding a protein with helicase activity that is central to DNA repair.¹⁵³

An increasing recent literature also associates polymorphisms in genes encoding detoxifying enzymes and DNA repair proteins with incidence of AML, as well as with treatment outcomes. Glutathione S-transferases (GSTs), including GSTM,

GSTP, and GSTT, are detoxification enzymes involved in metabolism of carcinogens. A recent meta-analysis of the association of GST polymorphisms with risk of AML supported a significant risk of AML in the presence of null genotypes of GSTM1 and GSTT1.¹⁵⁴ Associations with treatment outcomes were also suggested.^{155,156}

Polymorphisms in the RAD51 and XRCC3 genes, encoding proteins involved in repair of DNA double-strand breaks via homologous recombination, have been associated with increased risk of development of AML, and the association is additionally strong for t-AML and in the setting of coincident polymorphic deletion of the GSTM1 detoxification gene.¹¹⁰ Other work implicates polymorphisms of the XRCC1 gene, encoding a protein involved in base excision repair,¹⁵⁷ and of RAD51¹¹¹ in the risk of t-AML, and of polymorphisms in the xeroderma pigmentosum group D (XPD) DNA repair gene, encoding a protein involved in nucleotide excision repair, in AML with 5q and 7q chromosome deletions.¹⁵⁸ Additionally, XPD polymorphisms have been associated with AML treatment outcome, and ERCC1 and XRCC3 polymorphisms with treatment toxicities.¹⁵⁹

Heritable Genetic Factors

Heritable syndromes associated with increased risk of AML are usually recognized in childhood and are discussed in Chapter 77. In addition to Bloom syndrome,⁵⁹ they include Fanconi anemia (FA),¹⁶⁰ familial platelet disorder (FPD),^{161, 162} and¹⁶³ Schwachman-Diamond syndrome,^{164,165} amegakaryocytic thrombocytopenia, which may be X-linked, as well as Blackfan-Diamond syndrome, familial aplastic anemia,¹⁶⁶ and Kostmann syndrome.¹⁶⁷ Severe congenital neutropenia (SCN), with mutations in the neutrophil elastase (ELA2) gene, when treated with G-CSF increases risk for AML, associated with acquired somatic mutations in the G-CSF receptor.¹⁶⁸

Inherited mutations of tumor suppressor genes predispose patients to malignancies, including those of myeloid origin. The Li-Fraumeni syndrome, described in 1969, is an autosomal dominant cancer family syndrome with an increased risk for sarcomas, breast cancer, and other neoplasms, including leukemia, due to germline mutations in the TP53 gene.^{169,170}

CLINICAL PRESENTATION

AML presenting symptoms and signs are related to failure of normal hematopoiesis, resulting in anemia, neutropenia, and thrombocytopenia. The most common complaint is nonspecific fatigue or malaise that may have been present for several months. Pallor and weakness are caused by anemia. Fever is common and is the presenting feature in 15% to 20% of patients, often associated with sweats, and may result from infection secondary to neutropenia or from leukemia itself. Hemorrhagic signs and symptoms, including petechiae, epistaxis, and easy bruising, may be found in up to one half of patients at diagnosis. Petechiae correlate with the severity of thrombocytopenia, and ecchymoses with the presence

P.1582

of disseminated intravascular coagulation (DIC), which is most common in APL, but also occurs in other AML subtypes. Weight loss is present in up to 50% of patients, but is usually not severe. Bone pain occurs in less than 20% of patients. Organomegaly and adenopathy have been reported in up to one half of patients with AML, but are less common than in ALL.

Leukemia Cutis

Leukemic skin infiltration, or leukemia cutis, occurs in up to 13% of patients with AML during the course of the disease, most commonly in those with a monocytic component. Skin lesions are often nodular and violaceous (Fig. 75.3), are painless, and may be widespread or localized. Widespread lesions are distinguished from other exanthems by being raised and palpable. Diagnosis is confirmed by biopsy. Skin lesions may precede the diagnosis of AML, or may occur concurrently with AML or as an extramedullary relapse. They are radiosensitive, but patients should usually be treated with systemic chemotherapy.¹⁷¹ Benign skin lesions associated with AML include Sweet syndrome¹⁷² and pyoderma gangrenosum.¹⁷³ These are painful and are responsive to corticosteroids. These diagnoses are also confirmed by skin biopsy. Leukemia cutis is frequently associated with involvement of other extramedullary sites, including the central nervous system (CNS).¹⁷¹ Gum infiltration is also characteristic of acute monocytic leukemia (Fig. 75.4).

Myeloid Sarcoma

Myeloid sarcoma, or granulocytic sarcoma, myeloblastoma, or chloroma is an extramedullary tumor that occurs in 2% to 14% of cases of AML.^{174, 175} and¹⁷⁶ The term chloroma derives from a green appearance due to expression of MPO. The tumors are usually localized, frequently in bone, periosteum, soft tissues, lymph nodes, or skin. Common sites are the orbit and the paranasal sinuses, but other sites reported include the gastrointestinal tract, genitourinary tract, breast, cervix, salivary glands, mediastinum, pleura, peritoneum, and bile duct.¹⁷⁵ Myeloid sarcomas may occur at diagnosis of

AML, may precede the diagnosis, or occur as an extramedullary relapse. They have also been seen in association with MDSs or MPNs and usually predict transformation to acute leukemia.^{174, 175} and ¹⁷⁶ The diagnosis is suggested by presence of eosinophilic myelocytes in hematoxylin and eosin-stained biopsy sections. Imprint preparations can be helpful. The diagnosis can be made if Auer rods are detected or if myeloid origin is confirmed by cytochemical or immunohistochemical methods. Although granulocytic sarcomas are radiosensitive, systemic chemotherapy is warranted in most cases.¹⁷⁷



FIGURE 75.3. Leukemia cutis manifesting as subcutaneous nodules. (Courtesy of Dr. Michael Smith, Division of Dermatology, Vanderbilt University Medical Center.)



FIGURE 75.4. Swollen and spongy gums in a patient with acute leukemia. (Courtesy of Dr. Stuart Salmon, Division of Hematology/Oncology, Vanderbilt University Medical Center.)

Central Nervous System Leukemia

The incidence of CNS disease at diagnosis of AML is difficult to determine because lumbar puncture is not generally performed.¹⁷⁸ Meningeal disease has been reported to develop in up to 16% of adults with AML.¹⁷⁸ The increased use of high-dose cytarabine (HiDAC), which crosses the blood-brain barrier, lessens the risk of CNS leukemia in AML, as evidenced by a 2.2% incidence in a review of 410 patients from a single institution.¹⁷⁹ CNS disease is associated with hyperleukocytosis and the AMoL variants.¹⁸⁰ It is often asymptomatic, but may be associated with headache, nausea, and/or cranial nerve palsies, particularly V and VII. Ocular involvement may result in blindness and suggests meningeal involvement. Intracerebral masses were reported in FAB M4Eo in association with *inv(16)(p13q22)* and M5 subtypes,¹⁸¹ but also appear to be less common with increased use of HiDAC. Prophylactic central nervous system (CNS) therapy is not given routinely to adult patients with AML, but some clinicians advocate prophylaxis in patients with AMoL or with presenting white cell counts greater than 100,000 cells/mm³. Diagnostic lumbar puncture with prophylactic intrathecal chemotherapy may also be advocated prior to hematopoietic stem cell transplantation.

Other Organ System Involvement by Acute Myeloid Leukemia

Other organ systems may be involved. Cardiac abnormalities are usually related to electrolyte imbalances, particularly hypokalemia, but may result from direct involvement of the conduction system or infiltration of vessel walls.¹⁷⁵ Pulmonary symptoms occur in patients with leukostasis, infections related to neutropenia, or hemorrhage. Gastrointestinal symptoms also include infections, particularly perirectal abscesses and typhlitis, which is a necrotizing colitis related to leukemia infiltration of the bowel wall. Management of typhlitis is supportive, including antibiotics and nasogastric suction, but surgical intervention is sometimes unavoidable.¹⁸² Obstructive jaundice has occurred secondary to myeloid sarcoma.

Hypocellular Acute Myeloid Leukemia

Hypocellular AML occurs in 5% to 10% of patients with AML and is defined by the presence of AML in a hypocellular bone marrow, with the definition of hypocellularity varying between 5% and 40%.¹⁸³ Hypocellular AML is typically seen in older patients, and should be distinguished from MDSs and aplastic anemia. Howe et al.

P.1583

demonstrated a CR rate of 73% in a series of 29 patients with hypocellular AML.¹⁸⁴ Although hypocellularity alone should not exclude a patient from receiving chemotherapy, caution should be exercised in treating these patients, and transplantation strategies should be considered.

LABORATORY FINDINGS

Presenting blood counts vary widely among patients with AML.¹⁸⁵ The leukocyte count is elevated in more than half of patients, but is greater than 100,000 cells/mm³ in less than 20%. Blasts are usually present in the peripheral smear or in a buffy coat smear. Auer rods and Phi bodies are considered pathognomonic of AML. Phi bodies are fusiform or spindle-shaped rods similar to Auer rods that require special stains for hydroperoxidases.¹⁸⁶

Cytopenias result from hematopoietic failure and contribute to symptoms and signs. Anemia is common in AML and is predominantly normochromic and normocytic. Reticulocytopenia is generally present, but nucleated red blood cells may be seen. Neutropenia is present in most AML patients. A normal neutrophil count is more common in patients with monocytic variants of AML. Giant lysosomes are rarely noted in neutrophils of patients with AML; their presence has been called a pseudo-Chédiak-Higashi syndrome.¹⁸⁷ Thrombocytopenia is usually present and may be severe at diagnosis. Thrombocytosis is rarely identified, and is characteristic of AML with abnormalities of the long arm of chromosome 3, involving the EVI1 gene.

DIC is more common in AML than in ALL, and is most common in APL (Chapter 78). DIC is seen at presentation in nearly all patients with APL, and its incidence in AML other than APL is in the 10% to 30% range.¹⁸⁸ The cause of DIC is thought to be the release of tissue factor-like procoagulants from the azurophilic granules within the leukemia cells. DIC is manifested clinically by bruising and, when severe, by bleeding from multiple sites. Laboratory findings include thrombocytopenia, hypofibrinogenemia, elevated fibrin split products, and deficiency of coagulation factors, including factor V and factor VIII.¹⁸⁹ Other mechanisms, such as excessive fibrinolysis and secretion of interleukin (IL)-1 by AML cells, may contribute to bleeding.¹⁹⁰

Hyperuricemia is noted in up to 50% of patients with AML and can also be associated with tumor lysis, although the latter is more common in ALL.¹⁹¹ Hydration and administration of allopurinol and/or recombinant urate oxidase (rasburicase) for markedly elevated uric acid levels or elevated uric acid levels with renal insufficiency, can prevent complications of tumor lysis, which may occur during induction chemotherapy, most often in the setting of hyperleukocytosis.

Serum lactate dehydrogenase (LDH) levels may be elevated, particularly in monocytic (FAB M4/M5) subtypes, but to a lesser degree than is observed in ALL.

Levels of lysozyme are elevated, particularly in variants of AML with a predominant monocytic component (FAB M4/M5). Excess lysozyme (muramidase) may cause proximal renal tubular damage, which results in hypokalemia. Other factors that can contribute to hypokalemia in AML include potassium uptake by rapidly proliferating cells, as well as medications, particularly diuretics and the antifungal antibiotic amphoterecin. Hyperkalemia can occur in association with hyperuricemia and tumor lysis. With improved agents to treat hyperuricemia, hyperphosphatemia with or without hypocalcemia is the most common abnormality associated with renal failure during induction therapy. Patients with AML may have hypocalcemia,¹⁹² but hypercalcemia is very rare.¹⁹³

Hyperleukocytosis, arbitrarily defined as a blood blast count greater than 100,000/mm³, occurs most commonly in monocytic (FAB M4/5) AML and in AML with fms-like tyrosine kinase 3 internal tandem duplication (FLT3-ITD).^{174,194} Hyperleukocytosis is a medical emergency because it is associated with leukostasis in the lungs and the CNS,¹⁹⁵ causing respiratory failure and intracerebral hemorrhage,^{180,196, 197} and¹⁹⁸ which are usually rapidly fatal. Pulmonary leukostasis is manifested by dyspnea, tachypnea, rales, interstitial infiltrates, and respiratory failure.^{195,199} CNS leukostasis manifests as headaches, blurred vision, somnolence, obtundation, ischemic stroke, and intracerebral hemorrhage.²⁰⁰ Spurious laboratory data associated with hyperleukocytosis include a falsely elevated platelet count because blast fragments are counted as platelets, pseudohypoxemia caused by oxygen consumption by leukemia cells, pseudohypoglycemia caused by glucose consumption by leukemia cells, hypophosphatemia, and falsely prolonged coagulation tests due to low plasma volume.^{201, 202} and²⁰³ Artfactual lowering of the pO₂ and glucose may be prevented by placing blood samples on ice and performing the tests without delay.¹⁷⁴

To decrease the risk of leukostasis in patients with hyperleukocytosis, the white blood cell count must be rapidly lowered. Therapeutic measures include leukapheresis, administration of large doses of hydroxyurea, and immediate initiation of induction chemotherapy.^{174,198,204} Red cell transfusions should be minimized initially to avoid overcorrection of the

hemoglobin level, because this may produce an increase in blood viscosity that can worsen leukostasis. A hemoglobin goal of 8 g/dl, but not higher, is generally appropriate. In contrast, platelet transfusions are needed to decrease the risk of hemorrhage, because the platelet count may be overestimated, as discussed above. In addition, leukapheresis exacerbates thrombocytopenia and patients may also have DIC. An initial platelet count goal of 50,000/mm³ is generally reasonable. No controlled clinical trials have defined the optimal management of hyperleukocytosis, but retrospective data support the use of leukapheresis.²⁰⁵ Leukapheresis is indicated urgently if symptoms of leukostasis are present.¹⁹⁶ Moreover, leukapheresis should be considered early to decrease the risk of leukostasis in patients with hyperleukocytosis, as the onset of leukostasis may be abrupt, and, once initiated, it may be fulminant and irreversible.¹⁷⁴ Studies suggest that leukapheresis is associated with decreased early mortality and improved complete remission (CR) rates, but not with improved survival.^{197,198} Because leukapheresis is only a temporary measure to decrease the risk of leukostasis, hydroxyurea should also be administered, and chemotherapy should be initiated as rapidly as possible.¹⁷⁴

BIOLOGIC FEATURES

Heterogeneity

AML is a complex and extremely heterogeneous neoplasm in all respects, including cytologic features, stage of differentiation, antigen expression, cytogenetic findings, gene mutations, gene expression, activation of signal transduction pathways, and response to treatment. Significant advances have been made in our understanding of the complex biology of AML, including identification and characterization of multiple interdependent pathogenetic phenomena and pathways. Increasingly sophisticated research techniques are being applied toward elucidating the complex biology of AML and developing more effective therapies.

Aberrant Immunophenotypes

In the majority of cases of AML, leukemia cells have immunophenotypes that distinguish them from myeloid progenitor cells found in normal marrow. Compared to normal bone marrow myeloid cell populations, AML cells exhibit asynchronous myeloid antigen expression, antigen overexpression, loss of antigen expression and co-expression of nonmyeloid antigens.⁹ These findings are consistent with aberrant differentiation rather than arrest of normal differentiation. The ability to distinguish AML cells from normal marrow cells based on aberrant immunophenotypes has

P.1584

formed the basis for flow cytometric analysis of AML in peripheral blood or marrows of patients with AML, as well as for detection of residual disease by flow cytometry.^{206, 207} and ²⁰⁸ Immunophenotypes remain abnormal at relapse, but commonly exhibit gain or loss of one or more antigens and/or changes in antigen density.^{11,209}

Leukemogenesis

Leukemogenesis in AML is a heterogeneous, multistep process that results in maturation arrest, altered proliferation, and impaired apoptosis, mainly through genetic dysregulation. A "two-hit" model of leukemogenesis has been proposed for AML.²¹⁰ In this model, AML is the consequence of at least two classes of mutations. Class I mutations (e.g., BCR-ABL, K-RAS, N-RAS, KIT, FLT3) confer a proliferative and/or survival advantage, whereas Class II mutations (e.g., CBFβ-MYH11, AML1-ETO, TEL-AML1, and PML-RARα fusion genes) result in impaired cellular differentiation and apoptosis. Fusion genes such as AML1-ETO and CBFβ-MYH11, which are involved in the specific structural chromosomal abnormalities t(8;21) and inv(16), respectively, in AML, impair differentiation and apoptosis, but are insufficient to cause AML by themselves.^{211,212} A second class of genetic changes, such as mutations in the receptor tyrosine kinases FLT3,²¹³ KIT,^{214,215} or N-RAS,²¹³ which deregulate proliferation, are required for development of AML. The limitations of this hypothesis include: (1) lack of identifiable mutations in class I and class II in all cases of AML, (2) frequent epigenetic changes in AML, and (3) unexplained role of newly discovered alterations in metabolic pathways and enzymes such as isocitrate dehydrogenase (IDH) in AML pathogenesis.

Recent whole-genome sequencing of bone marrow and skin, paired with skin, from patients with AML evolving from MDS revealed persistence of an antecedent founding clone containing approximately 200 to 650 somatic mutations, accompanied by outgrowth or emergence of at least one subclone with several new mutations.²¹⁶

Clonality

The clonal nature of AML is confirmed by the presence of clonal cytogenetic abnormalities in the majority of cases,¹² and has also been demonstrated by analysis of G6PD isoenzymes²¹⁷ and of restriction fragment length polymorphisms (RFLP).²¹⁸ Clonal abnormalities may be demonstrated in either a single cell line or in more than one cell line (such as

myeloid and erythroid or myeloid and megakaryocytic), indicating that leukemic transformation can occur in either restricted-lineage or multipotential stem cells.^{217,219} Whole genome sequencing demonstrated that irrespective of blast count, more than 80% of bone marrow cells in MDS and s-AML are clonal.²¹⁶

Deep sequencing of genomes from AML patients at initial diagnosis and at relapse suggested two major clonal evolution patterns at AML relapse: (1) gain of new mutations by the founding clone in the primary tumor, or (2) expansion of a subclone of the founding clone surviving initial chemotherapy, with gain of additional mutations. Thus AML relapse is associated with new mutations and clonal evolution, perhaps due to the influence of chemotherapy on the founding clone.²²⁰

Leukemia Stem Cells

It is generally accepted that AML relapse is caused by survival and persistence of rare chemotherapy-resistant leukemia stem cells (LSC).²²¹ Transplantation of AML cells into immune-deficient mice demonstrated that LSCs are present at a frequency of one in 250,000 cells in the peripheral blood of AML patients, are usually enriched in the CD34⁺CD38⁻ cell fraction,²²² and lack expression of CD71 and human lymphocyte antigen (HLA)-DR,²²³ but express CD123.²²⁴ These cells are primarily in the G0 phase of the cell cycle.²²⁵ They are also characterized by activation of the transcription factor nuclear factor- κ B (NF- κ B), which is not activated in normal hematopoietic stem cells.²²⁶ Finally, they express multiple multidrug resistance proteins, including P-glycoprotein (Pgp; MDR1; ABCB1) and breast cancer resistance protein (BCRP; MXR; ABCG2), as do normal hematopoietic stem cells.^{227,228}

Substantial basic and translational research has been performed to better understand the biology of LSCs and ultimately to target them therapeutically.²²⁹ LSCs cannot be distinguished from normal hematopoietic stem cells (HSCs) based on the CD34⁺CD38⁻ phenotype,²³⁰ but intermediate levels of aldehyde dehydrogenase (ALDH) enzyme activity can distinguish CD34⁺CD38⁻ LSCs, capable of engrafting immunodeficient mice, from normal HSCs, which showed higher ALDH activity, and presence of CD34⁺CD38⁻ALDH intermediate leukemic cells in complete remission after induction chemotherapy was associated with subsequent relapse.²³¹ Moreover, using bioinformatic analysis, 42 and 121 genes were identified as LSC-related and HSC-related signatures, respectively, and 44 genes were found in both signatures and were designated as core-enriched HSC-LSC genes. When LSC- and HSC-related gene signatures were examined in 160 patients with cytogenetically normal AML, both signatures correlated negatively with overall survival even in patients with the prognostically favorable FLT3 wildtype and NPM-1 (nucleophosmin-1) mutant status.²³⁰

Hematopoietic Growth Factor Effects

The use of culture systems with phytohemagglutinin (PHA)-conditioned medium from peripheral blood leukocytes in the 1980s allowed growth of clonogenic cells in 80% to 90% of cases of AML,²³² likely because of the presence of hematopoietic growth factors. Leukemia cells, like normal cells, generally require growth factors for survival and proliferation. AML cells express receptors for a number of hematopoietic growth factors, including granulocyte-macrophage colony-stimulating factor (GM-CSF), granulocyte colony-stimulating factor (G-CSF), interleukins 1, 3, 4, 6, and 9, Steel factor (KIT ligand), thrombopoietin (MPL ligand), and FLT3 ligand (FLT3L).^{233, 234, 235} and ²³⁶ Growth factors predominantly cause proliferation, but may also inhibit apoptosis²³⁵ and induce differentiation.²³⁷ Growth factors may be produced by stromal cells or by AML cells themselves, resulting in paracrine or autocrine stimulation, respectively.^{238,239} Patients whose AML cells exhibit autonomous growth in vitro have an inferior response to treatment,^{240,241} and autonomous growth of AML cells is associated with other adverse disease characteristics, including unfavorable cytogenetic risk group,²⁴² multidrug resistance²⁴³ and expression of antiapoptotic proteins.²⁴⁴

Proliferative Characteristics

The proliferative characteristics of AML cells, including the percentage of S-phase cells, the duration of S-phase, and the total cell cycle time, are highly variable,^{245, 246} and ²⁴⁷ and proliferation may be either slower or faster than that of normal myeloid cells. AML with a high or a low proliferative rate responds less well to chemotherapy than AML with an intermediate proliferative rate.²⁴⁵ A high proliferative rate may be associated with marrow aplasia after chemotherapy, but rapid regrowth of leukemia,²⁴⁶ whereas nonproliferative AML cells may be chemoresistant.²⁴⁸ S-phase and total cell cycle times are longer in relapsed than in newly diagnosed AML.²⁴⁵

Resistance to Apoptosis

Resistance to apoptosis contributes to both leukemogenesis and drug resistance in AML.²⁴⁹ Apoptosis occurs by two pathways,

both of which result in caspase activation: (1) receptor-mediated, involving the tumor necrosis factor (TNF) family of death receptors, and (2) mitochondrial-mediated, regulated by the BCL-2 family of proteins.²⁴⁹ Chemotherapy kills malignant cells through activation of mitochondrial-mediated apoptosis, and altered apoptotic pathways are a mechanism of resistance to chemotherapy. AML cells overexpress BCL-2 and other antiapoptotic proteins, including BCL-x(L), MCL-1, XIAP, and survivin,^{250,251} which may be up-regulated by the effects of stromal cells²⁵⁰ and cytokines.²⁵² Permeabilization of the mitochondrial outer membrane is blocked by higher levels of the antiapoptotic proteins BCL-2, BCL-x(L), and MCL-1, and facilitated by the proapoptotic proteins BAX or BAD. High BCL-2-to-BAX protein ratios in AML cells are associated with lower complete remission rates and shorter overall survival.²⁵³ Expression of APAF-1, an important protein in the apoptosis machinery, is commonly silenced by methylation in AML cells, and may be restored by treatment with DNA methyltransferase inhibitors.²⁵⁴ Expression of the multidrug resistance protein P-glycoprotein (ABCB1) may also inhibit AML cell apoptosis by a mechanism independent of drug efflux.²⁵⁵

Signal Transduction Pathway Activation

Activation of signal transduction pathways may result from mutations in gene encoding growth factor receptors such as FLT3, KIT, or RAS. In addition, aberrant activation of the PI3K/Akt/mammalian target of rapamycin (mTOR) signaling pathway is implicated in leukemogenesis in AML,^{256, 257, 258} and²⁵⁹ in the absence of consistent gene mutations. mTOR is constitutively activated in most AML cases,^{256, 257} and²⁵⁸ but not in normal hematopoietic stem cells,²⁵⁷ and P13K/Akt/mTOR pathway activation is associated with compromised apoptotic response mechanisms^{260, 261} and²⁶² and resistance to chemotherapy.^{256,258, 259, 260} and²⁶¹ Thus PI3K/AKT/mTOR inhibitors have the potential to be both effective and selective in AML.^{263,264} Multiple signal transduction pathways may be activated in AML and the number of pathways activated is associated with a progressively worse prognosis.²⁶⁵

Microenvironment

AML bone marrow exhibits increased microvessel density, compared to normal marrow,^{266, 267} and²⁶⁸ and AML cells express vascular endothelial growth factor (VEGF), mRNA, and protein,²⁶⁶ and may also express aberrant VEGF receptors.²⁶⁹ VEGF can act via multiple paracrine,²⁷⁰ as well as autocrine,²⁶⁹ mechanisms to contribute to AML cell expansion and survival in the bone marrow microenvironment.^{271,272} VEGF secretion is strongly correlated with expression of FLT3 and of FLT3 ligand.²⁷³ Inhibition of FLT3 signaling with a small molecule FLT3 inhibitor, an antibody that blocks FLT3 ligand binding or FLT3 receptor siRNA decreases VEGF secretion. FLT3 is likely to induce VEGF secretion through the MAPK (mitogenactivated protein kinase) pathway via its activation of ERK1/2 (extracellular-signal regulated kinase-1 and -2) phosphorylation, rather than through AKT (protein kinase B) or STAT5 (signal transducer and activator of transcription-5),²⁷³ suggesting novel treatment strategies.²⁷⁴

The chemokine stromal cell-derived factor-1 (SDF-1) regulates homing and engraftment of leukemia cells in the bone marrow microenvironment and stromal niche. SDF-1 and its receptor CXCR-4 (fusin, LESTR) are expressed by AML cells and promote AML cell survival²⁷⁵ and stroma-mediated chemoresistance. CXCR-4 represents a novel therapeutic target²⁷⁶ for AML, and CXCR4 inhibitors have been tested in combination with chemotherapy in preclinical and clinical studies, with the goal of inducing mobilization of AML cells into the circulation, with promising results.²⁷⁷

CYTOGENETIC AND MOLECULAR FINDINGS

Cytogenetics

Acquired chromosome abnormalities are present in AML cells in most patients and diverse recurrent abnormalities are strongly predictive of treatment outcomes. Cytogenetic abnormalities were first described in AML in the 1960s, and were found to be present in approximately one half of AML patients in the 1970s with development of chromosome banding techniques (Chapter 3). With technical improvements, recent series have reported abnormal karyotypes in 55% to 78% of adults with AML.^{32,278} Approximately 55% of patients with AML have a single cytogenetic abnormality, including 15% to 20% with gain or loss of a single chromosome as the only change; the remaining 45% have two or more changes. The most common recurring cytogenetic abnormalities in AML include t(15;17), t(8;21), inv(16), +8, +21, del(5q), -7, 11q23 translocations, and 12p11-13 abnormalities.^{32,278}

Correlation of cytogenetics and clinicopathologic data has led to the recognition of distinct subtypes of AML and has helped to identify prognostic groups (Table 75.5).^{32,278} Techniques such as PCR, FISH, and CGH have allowed characterization of cytogenetic abnormalities at the molecular level, demonstrating frequent involvement of oncogenes and tumor-suppressor genes (Chapter 72).

The best described subtypes of AML are defined by recurring structural chromosomal abnormalities, which primarily consist of balanced translocations, occur more commonly in younger patients, tend to correlate with morphology, and are predictive of treatment outcomes. These include t(8;21), inv(16) or t(16;16), and t(15;17) and their variants. AML with t(8;21) tends to have blasts with maturation, often with azurophilic granules and occasionally with very large granules (pseudo-Chédiak-Higashi granules).²⁴ AML with inv(16) or t(16;16) is usually associated with monocytic differentiation and abnormal marrow eosinophils.^{24,181} APL with t(15;17) and its variants is suggested by the presence of hypergranular promyelocytes in association with disseminated intravascular coagulopathy (DIC), but may also be present in a variant microgranular (hypogranular) subtype (Chapter 78). Other cytogenetic abnormalities associated with morphology in AML include 11q23 translocations with monoblastic features;^{24,279} t(6;9) with marrow basophilia;²⁸⁰; abnormalities of 3q21-26 with abnormal platelets and thrombocytosis²⁸¹ and t(9;22), 14q32, or 11q23 with mixed lineage antigen expression.^{282,283} t(8;21), inv(16) and t(15;17) are associated with favorable responses to chemotherapy, and 11q23 translocations, t(6;9), 3q21-26 abnormalities and t(9;22) with adverse treatment outcomes. AML with 11q23 abnormalities is associated with a high complete remission rate but short disease-free and overall survival, whereas the other unfavorable abnormalities are associated with low complete remission rates as well as short disease-free and overall survival.

11q23 translocations are common in t-AML arising following topoisomerase II therapy,^{99,122} but they also occur de novo, and are associated with monocytic differentiation. 11q23 translocations are characterized molecularly by rearrangement of the MLL gene at 11q23. The frequency of MLL rearrangements is sevenfold higher (5.3% vs. 0.8%) in patients younger than 60 years of age. The molecular pathogenesis of MLL gene rearrangements probably involves aberrant nonhomologous end joining of DNA double strand breaks. The normal MLL protein is proteolytically cleaved and functions as a transcriptional repressor or activator. Chimeric proteins that are generated from MLL rearrangements include the N-terminal region of MLL, which is involved in protein-protein interactions and transcriptional repression, and their leukemogenic effects appear to occur via activation of clustered

P.1586

P.1587

homeobox (HOX) genes.²⁸⁴ More than 40 different partner genes for MLL have been identified.²⁴ In t(9;11), t(10;11), and t(11;19), the amino terminus of the MLL gene is fused to one of three homologous genes, AF9, AF10, or ENL, from chromosomes 9q22, 10p12, and 19p13, respectively.²⁸⁵ Survival of patients with de novo t(9;11) has varied among studies, with some groups placing it in an intermediate prognostic group whereas others have reported it as unfavorable.^{29,278,286} De novo AML with t(6;11) (q27;q13) has a very poor prognosis.²⁸⁷ Additional cytogenetic aberrations have been shown to modify the outcome of pediatric 11q23/MLL-rearranged AML.²⁸⁸ AML patients with MLL gene rearrangement may have a better outcome with more intensive treatment regimens.

TABLE 75.5 SELECTED PRIMARY CHROMOSOME ABERRATIONS IN ACUTE MYELOID LEUKEMIA

Type of Rearrangement	Genes Involved	Hematologic Clinical Features	Prognosis
t(1;3)(p36;q21)	<i>MEL1</i>	Preceded by MDS, M1, M4, dysmegakaryopoiesis	Poor
t(1;7)(q10;q10)		Preceded by MDS, M1, M4, genotoxic exposure	Poor
t(1;11)(p32;q23)	<i>AF1P, MLL</i>	M0, M5	Poor
t(1;11)(q21;q23)	<i>AF1Q, MLL</i>	M4, M5, infants	Poor
t(1;22)(p13;q13)	<i>RBM15, MKL1</i>	M7, thrombocytopenia, hepatosplenomegaly, bone marrow fibrosis	Poor
inv(3)(q21;q26);t(3;3)(q21;q26)	<i>EVII, RPN1</i>	Preceded by MDS, M1, M4, M6, abnormal dysmegakaryopoiesis,	Poor

		thrombocytosis	
t(3;5)(q25, 1;q35)	<i>MLF1, NPM</i>	M6, megakaryocytosis, Sweet syndrome	Intermediate to poor
t(3;12)(q26;p13)	<i>MDS1, EVII-TEL</i>	Preceded by MDS, dysmegakaryopoiesis	Poor
t(3;21)(q26;q22)	<i>EVII, MDS1, or EAP; AML1</i>	No FAB preference, genotoxic exposure	Poor
+4		M1, M2, M4; subcutaneous tumors	Poor
-5/del(5q)		No FAB preference, genotoxic exposure	Poor
t(5;17)(q35;q12)	<i>NPM, RAR-α</i>	M3	Poor
t(6;9)(p23;q34)	<i>DEK, CAN</i>	Preceded by MDS; M2 and M4, bone marrow basophilia	Poor
t(6;11)(q27;q23)	<i>AF6, MLL</i>	M4 and M5; localized infections	Poor
-7/del(7q)		No FAB preference; genotoxic exposure; prior MDS	Poor
t(7;11)(p15;p15)	<i>HOXA9, NuP98</i>	M2 with Auer rods	Intermediate
+8		M2, M4, and M5; can be preceded by MDS; no impact on prognosis when associated with good-risk cytogenetics	Intermediate to poor
inv(8)(p11q13)	<i>MOZ TIF2</i>	M5, acute mixed-lineage leukemia, erythrophagocytosis	Poor
t(8;16)(p11;q13)	<i>MOZ, CBP</i>	M5, erythrophagocytosis, DIC; mainly children	Poor
t(8;21)(q22;q22)	<i>ETO, AML1</i>	M2 with Auer rods, eosinophilia, myeloblastoma	Good
t(8;22)(p11;q13)	<i>MOZ, P300</i>	M5, can be therapy-related	Poor
t(9;11)(p21-22;q23)	<i>AF9, MLL</i>	M5	Intermediate
t(9;22)(q34;q11)	<i>ABL, BCR</i>	M1 and M2; biphenotypic, rare	Poor
t(10;11)(p11-15;q13-23)	<i>AF10, MLL</i>	M5	Intermediate to poor
t(10;16)(q22;p13)	<i>MORF, CBP</i>	M5, can be therapy-related	Poor
+11	<i>MLL</i>	M1, M2	Poor
t/del(11q23)	<i>MLL</i>	M5, biphenotypic, genotoxic exposure	Poor
t(11;16)(q23;p13)	<i>MLL, CBP</i>	M4, M5, infants	Poor
t(11;17)(q23;q25)	<i>MLL, AF17</i>	M2, M4, and M5	Poor
t(11;17)(q23;p21)	<i>PLZF, RAR-α</i>	M3	Intermediate
t(11;19)(q23;p13)	<i>MLL, ENL, ELL</i>	M4 and M5; biphenotypic	Poor

t/del(12p)		No FAB preference, genotoxic exposure	Poor
i(12)(p10)		Concurrent germ-cell tumors	Poor
t(12;22)(p13;q11)	<i>TEL, MNI</i>	Preceded by MDS, M1, M4, M7	Poor
+13		No FAB preference	Poor
t(15;17)(q22;q11)	<i>PML, RAR-α</i>	M3, M3v, DIC, Auer rods	Intermediate to poor
inv(16)(p13;q22), t(16;16),	<i>MYH11, CBF-β</i>	M4Eo, central nervous system disease	Good
(p13;q22), del(16)(q22)	<i>FUS, ERG</i>	No FAB preference	Poor
t(16;21)(p11;q22)			
i(17)(q10)		Preceded by MDS, no FAB preference	Poor
del (20q)		No FAB preference	Poor
+21		No FAB preference, MDS	Intermediate
+22		M4, can be associated with inv16; MDS	Intermediate

DIC, disseminated intravascular coagulation; FAB, French/Am British; MDS, myelodysplasia.

Note: See Chapter 72 for description of the genes and Mitelman F, Johansson B, Mertens F, eds., Mitelman database of chromosome aberrations in cancer.

<http://cgap.nci.nih.gov/chromosomes/mitelman>.

Structural abnormalities involving the long arms of chromosomes 5 and/or 7, monosomy 5 and/or 7, and complex karyotypes, defined by the presence of three or more unrelated numerical and/or structural abnormalities, are frequently seen in AML arising from prior MDS and in t-MDS/t-AML associated with alkylating agent therapy.^{100,122} These abnormalities, whether in de novo AML or t-AML, are associated with low complete remission rates and short disease-free and overall survival. Other numerical chromosomal abnormalities associated with poor treatment outcome include +11, +13, and +21.

The monosomal karyotype (MK), recently defined by the presence of at least two autosomal monosomies or a single autosomal monosomy in combination with at least one structural abnormality, is associated with a particularly dismal prognosis, with a 4% \pm 1% 4-year overall survival, whereas the 4-year OS of patients with complex, but nonmonosomal, karyotypes was 26% \pm 2%. In a subsequent Southwest Oncology Group study of 1,344 adult AML patients, MK was present in 13%, increased in incidence with age, being present in 4% of patients age 30 or younger, but 20% of those over age 60, comprised 40% of the unfavorable cytogenetic risk category, and was associated with a complete remission rate of only 18% and only 3% 4-year survival.²⁸⁹ Transplantation resulted in limited improvement in outcome, with 25% 4-year OS in patients transplanted at the Fred Hutchinson Cancer Research Center.²⁹⁰ Thus transplant is indicated when feasible, but improvement in outcome is modest.

Molecular Abnormalities

AML is characterized by recurrent gene mutations that confer constitutive or aberrant signaling through one or more pathways in the complex signaling network that regulates normal hematopoiesis. The therapeutic implications of targeting different signaling pathways have begun to be exploited in recent years, with several promising small molecules and biologic agents in development (see "Therapy" section). Moreover, prognosis in AML is increasingly able to be assessed by evaluating molecular markers including frequently detected gene mutations.²⁹¹ This can be particularly useful in dissecting the prognosis of AML with a normal karyotype.^{49,292} In addition, overexpression of specific genes is associated with unfavorable treatment outcomes. Assays for gene mutations are more readily standardized and more widely applicable than assays measuring gene expression levels. The number of gene abnormalities described in AML continues to increase.

FLT3 is a receptor tyrosine kinase that is expressed on hematopoietic progenitor cells and is activated by binding of FLT3 ligand (FL), stimulating proliferation.²¹⁰ FL binds to the receptor and induces dimerization, tyrosine kinase activation, and

receptor autophosphorylation, followed by initiation of the phosphorylation of downstream signaling proteins. FLT3 is expressed on AML cells in most cases of AML, and is mutated in 20% to 34% of patients with AML^{35,36,37,293,294} resulting in constitutive activation.^{210,293} FLT3 mutations can be detected by genomic PCR amplification and gel electrophoresis. The most common mutation is a small in-frame internal tandem duplication (ITD) in the FLT3 gene that results in duplication of an amino acid sequence within the juxtamembrane domain of the receptor, which disrupts the autoinhibitory activity of the juxtamembrane domain, resulting in constitutive tyrosine kinase activation (Fig. 75.5). Point mutations in the DNA sequence encoding the FLT3 activation loop, predominantly in the aspartic acid (D) residue at amino acid position 835, occur less frequently.³⁶

FLT3 mutations activate similar transduction pathways as binding of FLT3 ligand to the wildtype receptor, including signal transducer and activator of transcription (STAT) 5 and the RAS/MAPK and PI3K/Akt pathways.^{293,295, 296} and ²⁹⁷ Other effects include myeloid maturation arrest by virtue of suppression of the C/EBP α and PU.1 transcription factors,²⁹⁸ and antiapoptotic effects by virtue of phosphorylation of the proapoptotic protein BAD,^{298,299} resulting in inactivation of its proapoptotic function.

FLT3 mutations are associated with higher peripheral blast counts, normal karyotype and FAB M5 disease. Presence of FLT3-ITD does not affect CR rate, but predicts high relapse rate and poor survival and is useful in stratifying patients with AML with a normal karyotype into poor risk groups.^{35,37,293,300,301,302} FLT3 point mutations are less prognostically unfavorable than FLT3-ITD.³⁰³ FLT3-ITDs are of less prognostic significance in AML patients over age 70 years,^{300, 304} likely because they occur in different patient populations than expression of MDR1/Pgp,³⁰⁵ which is a strong adverse prognostic factor in older adult AML patients,³⁰⁶ and because the prognosis of all AML patients over 70 years is poor.³⁰⁷ Prognosis of patients with FLT3-ITD is further worsened by absence of the wildtype allele,³⁸ higher ITD to wildtype allelic ratio, larger size of the ITD³⁰⁰ or presence of the ITD in CD34+CD33-precursors.³⁰⁸ The role of transplantation

P.1588

in overcoming the adverse prognosis associated with FLT3-ITD is under investigation (see "Stem Cell Transplantation" section). Several FLT3 inhibitors are currently being evaluated in clinical trials in AML (see "Therapy" section).

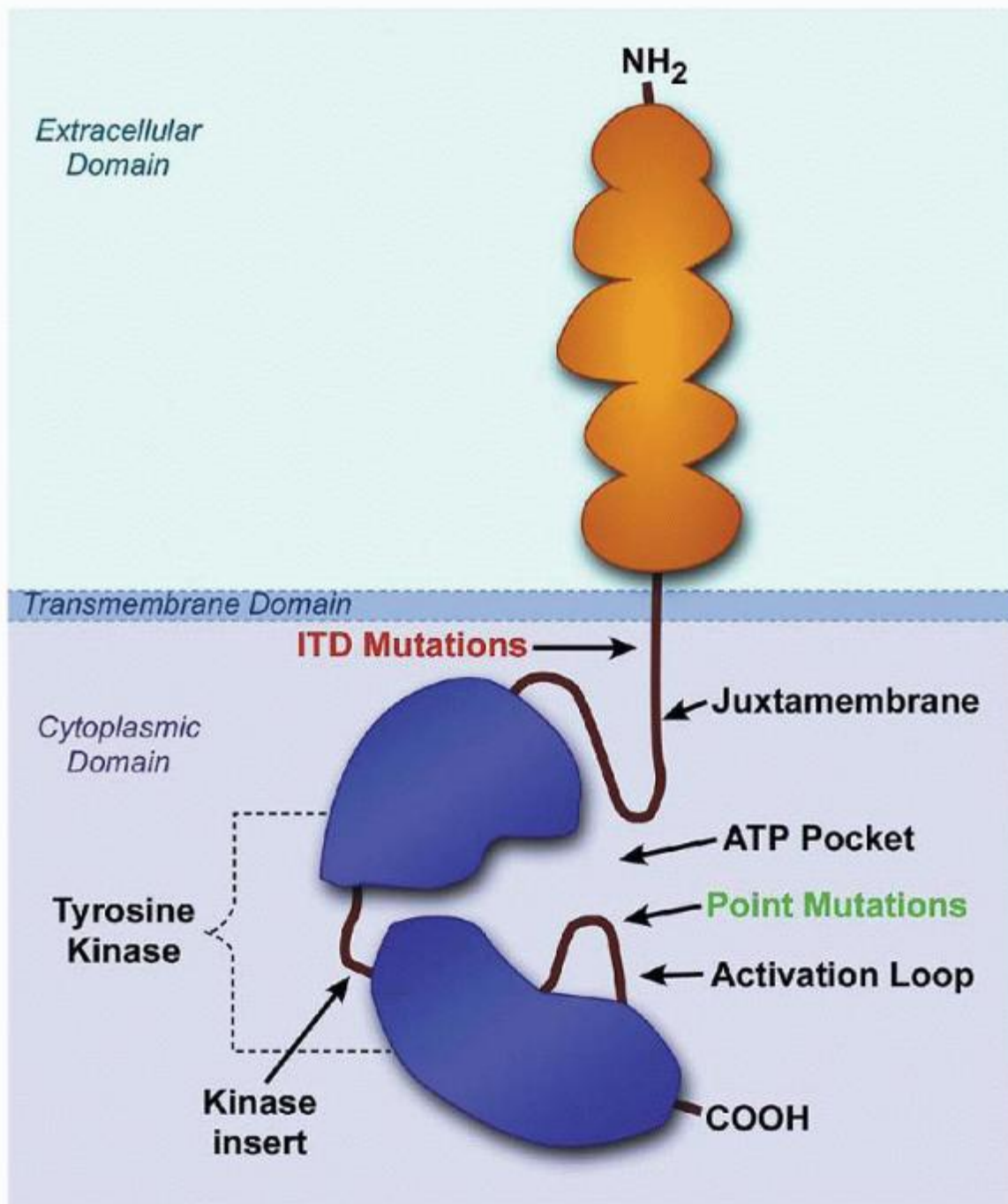

FIGURE 75.5. Simplified diagram of the FLT3 receptor: it contains 993 amino acids and consists of an extracellular ligand-binding domain with five immunoglobulinlike domains, a single transmembrane domain, and a cytoplasmic domain, which is comprised of a juxtamembrane domain followed by the tyrosine kinase domain. Internal tandem duplications (ITD) in the juxtamembrane domain and point mutations at aspartate 835 within the activation loop constitutively activate FLT3. (Drawing by Tim Gilfilen, Medical Art Group, Vanderbilt University.)

Recently several groups have focused on the important role of the FLT3 ligand (FL) in AML with FLT3-ITD. FL expression increases significantly during induction and consolidation chemotherapy, and AML blasts remain highly responsive to FL at relapse, suggesting a potential role of FL in promoting relapse.³⁰⁹ A treatment strategy involving induction chemotherapy, stem cell transplantation, FLT3 inhibitors, and monoclonal antibodies against FL has therefore been proposed for AML with FLT3-ITD.³¹⁰

Mutations of exon 12 of the nucleophosmin (NPM or NPM1) gene are the most common single gene mutations in AML, present in up to half of AML cases with normal karyotypes.^{39,41,311} Nucleophosmin is a nucleocytoplasmic shuttling protein that regulates the p53 tumor suppressor pathway, and NPM1 mutations in AML cells result in cytoplasmic localization of the protein, which can be demonstrated by immunohistochemistry.³¹² NPM1 mutations are found at diagnosis and remain stable throughout the disease course. These mutations are typically found in AML with a normal karyotype,^{39, 40} and^{41,42,312,313} and are associated with prolonged event-free and overall survival.⁴² Co-occurrence of NPM1 with FLT3-ITD mutations, but not with other mutations, negates their favorable prognosis,^{39, 40} and^{41,45,302,314} (Fig. 75.6). The mechanistic role of NPM1 in the pathogenesis of AML has not been fully elucidated. Perhaps due to favorable prognosis of NPM1-mutated AML, targeted therapies have not been investigated. Mutant NPM1 transcript levels have been validated as a residual disease marker, with cumulative incidence of relapse after 4 years after double induction therapy 6.5% in patients who achieved RQ-PCR negativity compared with 53% in RQ-PCR-positive patients ($P < 0.001$); and with much better overall survival (90% vs. 51%; $P = 0.001$) in RQ-PCR-negative patients.³¹⁵

Mutations in the CEBPA (CCAAT/enhancer binding protein alpha) gene,³¹⁶ encoding a transcription factor that is essential for myeloid differentiation, are also a favorable prognostic factor in AML. These mutations are present in approximately 10% of AML patients overall and 15% of those with a normal karyotype,^{46,48} and are correlated with a distinct DNA methylation profile. Mutations at the CEBPA C-terminus generate dysfunctional proteins, and frameshift mutations in the CEBPA N-terminus create a dominant negative shorter protein. Biallelic CEBPA mutations in AML are associated with better prognosis than for unmutated or monoallelic mutated AML.^{50,317,318}

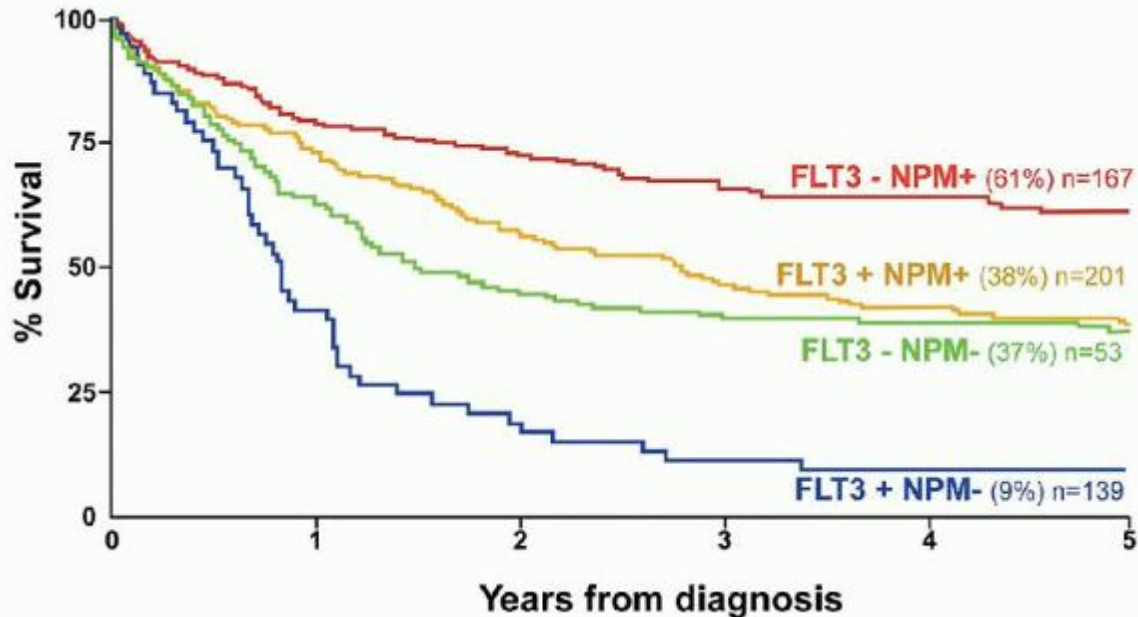

FIGURE 75.6. Clinical outcome in 550 AML patients with a normal karyotype according to FLT3/ITD and NPM1 mutant status. Both markers were prognostically significant predictors of survival ($p < 0.0001$), and together identified three prognostic groups: good (FLT3/ITD- NPM1+), intermediate (FLT3/ITD- NPM1- or FLT3/ITD+ NPM1+), and poor (FLT3/ITD+ NPM1-). (With permission from Gale RE, Green C, Allen C, et al. The impact of FLT3 internal tandem duplication mutant level, number, size, and interaction with NPM1 mutations in a large cohort of young adult patients with acute myeloid leukemia. *Blood* 2008;111:2776-2784.)

Partial tandem duplication of the MLL gene (MLL-PTD), which is the gene at 11q23 that is involved in 11q23 chromosome translocations, was the first molecular abnormality to be identified in cytogenetically normal AML and to be associated with short disease-free survival,^{319, 320} and³²¹ although outcomes are better with recent regimens incorporating more intensive post-remission therapies.³²²

Overexpression of ERG (ets-related gene) adversely affects outcome in AML with a normal karyotype and can be detected in AML with complex karyotypes that have a cryptic amplification of chromosome 21.³²³

When expression of the BAALC (brain and acute leukemia, cytoplasmic) gene is dichotomized into high and low levels, high expression is associated with a higher rate of primary resistant disease and is an adverse prognostic factor for

disease-free survival, cumulative incidence of relapse, event-free survival, and overall survival in AML with a normal karyotype, and predicts adverse prognosis independently from FLT3 mutations.³²⁴ High BAALC expression is also highly predictive of shorter disease-free and overall survival in normal-karyotype AML without FLT3 or CEBPA mutations.⁴⁹ High BAALC expression is associated with FLT3-ITD, absent FLT3-TKD, wildtype NPM1, mutated CEBPA, MLL-PTD, and high ERG expression, but high BAALC expression independently predicted lower complete remission rates when adjusting for ERG expression and age, and shorter survival when adjusting for FLT3-ITD, NPM1, CEBPA, and white blood cell count.³²⁵

Overexpression of the EVI1 (ectotropic viral integration site 1) gene on chromosome 3q26.2 has an incidence of approximately 11% and is seen not only in AML involving 3q26, including inv(3) and t(3;3), but also with other unfavorable karyotypes (e.g., -7/7q- and 11q23 abnormalities) and is associated with a poor prognosis.^{326,327,328} EVI1 is not overexpressed in AML with favorable-risk karyotypes or with NPM1 mutations. Stem cell transplantation in first complete remission has a favorable impact on relapse-free survival of patients with AML overexpressing EVI1 (20% to 40% versus 0%).

RAS mutations occur in 10% to 44% of AML, but rarely with FLT3 mutations, and have not consistently predicted outcome.^{36,329,300} Activation of the RAS/Raf/MEK/ERK pathway has also been demonstrated in AML, promoting AML cell survival and inhibiting apoptosis.^{330,331}

TP53 mutations have a frequency of 10% in de novo AML, but much higher frequency (40% to 50%) in t-AML. They have been associated with abnormalities of chromosomes 5 and/or 7 and with worse overall survival in older patients.³⁰⁰ TP53 mutations, or TP53 mutations and 17p-loss of heterozygosity combined, also have independent negative prognostic effects on survival in AML.³³²

Mutations in the WT1 (Wilms tumor 1) gene occur in 5% to 10% of AML patients, with equal distribution in cytogenetically normal and abnormal AML groups.²⁹¹ There are reports of both positive³³³ and negative³³⁴ prognostic effects of WT1 gene mutation in AML. WT1 mutation in AML was found to be associated with overexpression of CD96, a leukemia stem cell-specific marker, and of genes involved in regulation of gene expression (e.g., MLL, PML, and SNRPN) and in proliferative and metabolic processes (e.g., INSR, IRS2, and PRKAA1).³³⁵

The RUNX1 gene, located on chromosome 21 at band q22.12, encodes a transcription factor that is involved in benign and malignant hematopoiesis. The t(8;21) translocation, which is common in AML, results in a RUNX1 and ETO fusion protein. RUNX1 mutations are identified in 5.6% to 13.2% of AML patients, and are more common in older patients and in men. They are associated with lower lactic dehydrogenase, FAB M0/M1 subtypes, and expression of HLA-DR and CD34, and with lack of CD33, CD15, CD19, and CD56 expression. RUNX1 mutation is a poor prognostic factor, with resistance to chemotherapy and inferior event-free survival, relapse-free survival, and overall survival.^{336,337,338}

P.1589

The additional sex comblike 1 (ASXL1) gene encodes an enhancer of trithorax and polycomb proteins, which functions as a transcriptional activator or repressor in different cells. ASXL1 mutations are present in AML and were found to be five times more common in older (≥ 60 years) patients (16.2%) than those younger than 60 years (3.2%; $P < 0.001$), and to be associated with wildtype NPM1, absence of FLT3-internal tandem duplication and mutated CEBPA, and with inferior complete remission rate and disease-free, overall, and event-free survival in older patients.³³⁹

TET hydroxylase enzymes are involved in DNA hypomethylation and demethylation by α -ketoglutarate-dependent conversion of 5-methylcytosine to 5-hydroxymethylcytosine (alcohol moiety), followed by further oxidation to 5-formylcytosine (aldehyde moiety) and to 5-carboxylcytosine (acid moiety), Figure 75.7.^{340, 341} and ³⁴² Mutations in the 10 to 11 translocation 2 (TET2) gene were identified with frequencies of 22% of myelomonocytic leukemia, 24% in secondary AML, 19% in MDSs, and 12% in MPNs.³⁴³ Heterozygous TET2 mutations were found in 7.6% of younger adult patients with AML and were not associated with favorable or unfavorable response to chemotherapy or with overall survival.³⁴⁴

Chromatin conformation can be affected at the DNA level by addition of a methyl group to the C-5 position of cytosine. Cytosine methylation occurs when the cytosine (C) is followed by a guanosine (G) in CpG pairs (p indicates phosphodiester bond). When CpG dinucleotides in the genome cluster together, they form CpG islands, which are located in proximity to gene promoter regions or in other intergenic areas. DNA methylation is catalyzed by the DNA methyltransferase (DNMT) family of enzymes which transfer a methyl group from S-adenosyl methionine to DNA. Hypermethylation of CpG islands in the promoters of tumor-suppressor genes is common in many cancers.

In 2010, Ley et al. found that 22% of 281 de novo AML cases had mutations in DNMT3A that could affect translation.³⁴⁵ These mutations were seen predominantly in patients with intermediate-risk cytogenetic profiles, and not in patients with favorable-risk profiles. The precise effects of these mutations have not yet been elucidated. FLT3, NPM1, and IDH1 mutations were significantly enriched in samples with DNMT3A mutations. DNMT3A mutations were independently associated with poor prognosis. DNMT3A mutations were associated with significantly shorter median overall survival (12.3 months vs. 41.1 months, $p < 0.001$).

Several subsequent studies have shown that DNMT3A mutations are frequent (approximately 20%) in older patients with normal karyotype AML and are associated with higher WBC and platelet counts, and concurrent mutations in the NPM1, FLT3, and IDH1 or IDH2 genes, and that they independently predict a higher relapse rate and shorter overall survival, but are not associated with a lower CR rate.^{346, 347} and ^{348,349}

Mutations in isocitrate dehydrogenase genes, IDH1 and IDH2 (mIDH), are present in 10% to 15% of de novo AML,⁵⁴ are most common in normal karyotype AML, and are an unfavorable prognostic factor according to most, but not all, studies.^{350,351,352,353,354}

Although wildtype IDH in cytosol and mitochondria catalyzes the conversion of isocitrate to α -ketoglutarate (α -KG) with the production of NADPH, altered amino acids in mIDH1 (R132) and mIDH2 (R140 or R172) reside in the catalytic pocket and result in a neoenzymatic activity, converting α -KG to 2-hydroxyglutarate (2HG), with the consumption of NADPH.^{355,356,357} The primary source for α -KG for these cells is glutamine, which is first converted to glutamate by glutaminase and subsequently to α -KG (Fig. 75.8).³⁵⁸

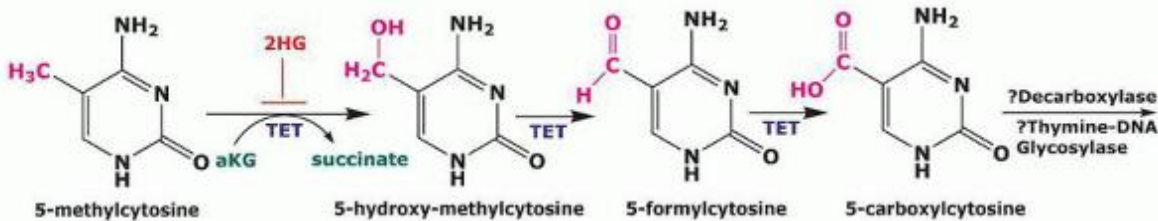

FIGURE 75.7. DNA demethylation reactions mediated by the effect of TET enzymes and 2-HG. 5-methylcytosine in DNA is partially converted to 5-hydroxymethylcytosine by the TET (10 to 11 translocation) dioxygenases. In DNA 5-hydroxymethylcytosines are oxidized to aldehyde (5-formylcytosine) and acid (5-carboxylcytosine) by TET enzymes. TET enzymes use α -KG as co-enzyme. 2-HG, produced by IDH mutant enzyme, inhibit these reactions mediated by TET enzymes. The ultimate outcome is aberrant hypermethylation of DNA. (Drawing by Ashkan Emadi, University of Maryland Greenebaum Cancer Center.)

IDH1 and IDH2 mutations in AML associate with specific cytosine methylation, and aberrant DNA hypermethylation is the dominant feature of IDH1/2-mutant AMLs.³⁵⁹ 2HG, as the unique product of IDH-mutant enzymes, is a competitive inhibitor of multiple α -KG-dependent histone demethylases, prolyl hydroxylases, and TET hydroxylases (Fig. 75.7).^{360,361} Expression of mutant IDH1/2 and loss of TET2 increase expression of stem cell markers and impair myeloid differentiation.³⁵⁹

KIT is a receptor tyrosine kinase, as is FLT3. KIT mutations have been described in approximately a third of cases of AML with t(8;21) or inv(16) in adults and their presence is associated with short disease-free survival in this otherwise prognostically favorable cytogenetic subset.^{214,362,363,364,366} KIT mutations have been incorporated into the European LeukemiaNet prognostic classification.⁵¹ KIT overexpression is also described in t(8;21) or inv(16) cases without KIT mutations.²¹⁴ KIT inhibitors are beginning to be tested in conjunction with chemotherapy in t(8;21) or inv(16) AML.

Patterns of microRNA expression are beginning to be described in AML, with potential prognostic significance;^{55,56,57} microRNA expression may also be a future therapeutic target.

CLASSIFICATION OF ACUTE MYELOID LEUKEMIA

Morphologic Subtypes

The FAB classification identified eight subtypes of AML based on morphology and cytochemical staining, with immunophenotypic data in some instances (Chapter 73).⁶ Four types (M0, M1, M2, M3) are predominantly granulocytic and differ according to the extent of maturation. M4 is both granulocytic and monocytic, with at least 20% monocytic cells, whereas M5 is predominantly monocytic (at least 80% monocytic cells). M6 shows primarily erythroid differentiation with dysplastic features including megaloblastic changes, and M7 is acute megakaryocytic leukemia (AMgL) identified by

the presence of megakaryocyte antigens demonstrated by flow cytometry or immunohistochemistry, or of platelet peroxidase or a demarcation membrane system on ultrastructural studies. Problems with the FAB classification include interobserver variability, lack of definitive criteria for some cases of AML, and poor correlation with survival. In addition, correlations with immunophenotype, cytogenetic findings, and molecular abnormalities were not fully defined. Morphologic subtypes not precisely defined by the FAB include hypocellular AML and mixed lineage acute leukemia.³⁶⁷ Eosinophilic leukemia, basophilic

P.1590

leukemia, and mast cell leukemia are rare, overlap with myeloproliferative disorders, and are also not recognized by the FAB classification. The WHO classification recognizes chronic eosinophilic leukemia with the overlapping hypereosinophilic syndrome, and acute basophilic leukemia and the spectrum of mast cell disease, including mast cell leukemia.²⁴

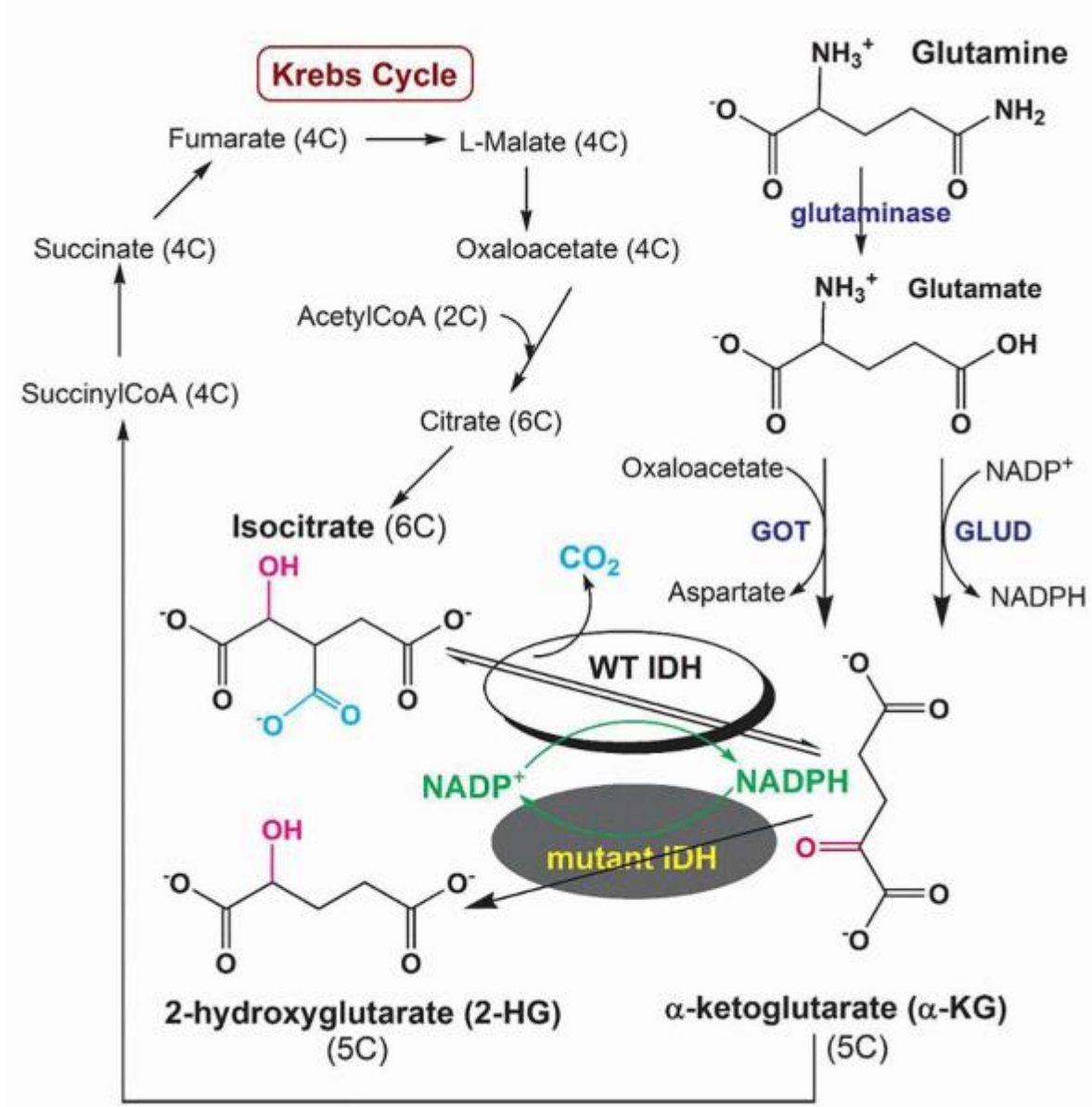

FIGURE 75.8. Chemical reactions that link glutamine to IDH enzymes. In normal cells, IDH catalyzes loss of one carboxyl (CO₂, light blue) group from isocitrate and oxidizes its hydroxyl group (OH, pink) to ketone. The product is α-KG. Under certain conditions, this reaction can be reversible. In cells with mutant IDH, α-KG cannot be converted to isocitrate, instead it is converted to a new molecule 2-HG, and as a result, α-KG is siphoned by the mutant enzyme. Glutamine is the primary source for α-KG, which is replenished via conversion of glutamine to glutamate by glutaminase. Glutamate can be

converted to α -KG either by transamination or by oxidation processes. GOT, glutamate oxaloacetate transaminase; GLUD, glutamate dehydrogenase. (Drawing by Ashkan Emadi, University of Maryland Greenebaum Cancer Center.)

World Health Organization Classification

The WHO classification of acute leukemias and MDS evolved from the FAB classification, which is based on morphology, to also include clinical, immunophenotypic, and cytogenetic features.^{1,3,24} The WHO recognizes five major categories: (a) AML with recurrent genetic abnormalities; (b) AML with multilineage dysplasia; (c) AML and MDS, therapy-related; (d) AML not otherwise categorized; and (e) acute leukemia of ambiguous lineage (Table 75.6). Additionally, the WHO classification defines AML by presence of 20% or more blasts, thus including cases with 20% to 30% blasts, which had been categorized as the refractory anemia with excess blasts in transformation subtype of MDS in the FAB classification. This change was made based on evidence that survival of patients with marrows with 20% or more blasts is similar to that of patients with marrows with 30% or more blasts.³⁶⁸ In addition, in the WHO classification presence of recurrent cytogenetic abnormalities that are characteristic of AML, including (8;21)(q22;q22), inv(16)(p13;q22) or t(16;16)(p13q22), t(15;17)(q22;q12), or translocations or structural abnormalities involving 11q23 establishes the diagnosis of AML, even if the bone marrow contains less than 20% blasts.

AML with recurrent genetic abnormalities includes AML with t(8;21)(q22;q22), inv(16)(p13;q22), or t(16;16)(p13q22), t(15;17)(q22;q12), or translocations or structural abnormalities involving 11q23. t(8;21) and inv(16) or t(16;16) typically occur in younger patients, have a relatively favorable response to therapy, and define the favorable category in cytogenetic classifications of AML. AML patients with 11q23 translocations include two clinical subgroups in particular: AML in infants and therapy-related leukemia, usually occurring after treatment with DNA topoisomerase II inhibitors. AML with recurrent genetic abnormalities is discussed in the "Clinicopathologic Syndromes" section in the context of the FAB morphologic subtype with which the abnormalities correlate and is also discussed in the "Cytogenetic Classification" section.

AML with multilineage dysplasia must have dysplasia in 50% or more of cells of at least two lineages. It is more common in older patients, frequently exhibits aberrant expression of CD56, CD7, or both, and is associated with unfavorable cytogenetic findings, including -7/del(7q), -5/del(5q), +8, +9, +11, del(11q), del(12p), -18, +19, del(20q) +21, and, less often, translocations involving 3q21 and 3q26 and t(1;7)(q10;p10). Abnormalities in the 3q26 region may be associated with increased platelet production. AML with multilineage dysplasia has a poor response to therapy.

AML not otherwise categorized includes AML that does not fulfill criteria for the other groups and essentially reflects the morphologic and cytochemical features and degree of maturation used in the FAB classification, with the exception that AML is defined by 20% (rather than 30%) or more blasts in the marrow. The abnormal promyelocytes in APL and the promonocytes in AML with monocytic differentiation are considered blast equivalents. In addition, AML not otherwise categorized includes acute basophilic leukemia, acute panmyelosis with myelofibrosis, and myeloid sarcoma.

Acute leukemia of ambiguous lineage is diagnosed when blasts lack sufficient lineage-specific antigen expression to classify them as myeloid or lymphoid and is discussed in the "Immunophenotypic Classification" section.

Immunophenotypic Classification

The nonlymphoid derivation of AML is confirmed by the presence of antigens expressed during myelomonocytic differentiation,

P.1591

including CD13 (My7), CD14 (Mo2), CD15 (My1, LeuM1), CD33 (My9), CD117 (KIT), and MPO; erythroid antigens (glycophorin A, CD71); and megakaryocytic antigens, including CD41 (platelet glycoprotein IIb/IIIa), CD42b (platelet glycoprotein Ib), CD61 (platelet glycoprotein IIIa), and factor VIII antigen.³⁶⁹ The stem cell marker CD34 (My10, HPCA-1) is present on blasts in 40% to 65% of cases of AML.^{370,371} Surface markers in most cases have not correlated well with the FAB classification or with prognosis.³⁷² More than 90% of cases of AML express CD33 or CD13, 80% to 90% express HLA-DR, and less than 25% express CD15; CD11b and CD14 are more variably expressed and tend to be present in monocytic (M4/M5) subtypes.⁵¹ Some antigens have also been associated with morphologic and cytogenetic subsets: CD2 with M4Eo with 16q22 rearrangements;³⁷³ absence of HLA-DR (major histocompatibility complex class II) and of CD34 with M3 [t(15;17)]; and presence of CD19 and CD56 with M2 with t(8;21).^{10,374}

TABLE 75.6 CLASSIFICATION OF ACUTE MYELOID LEUKEMIA

Acute Myeloid Leukemia with Recurrent Genetic Abnormalities

Acute myeloid leukemia with t(8;21)(q22;q22), (*RUNX1—RUNX1T1;AML1/ETO*)

Acute myeloid leukemia with abnormal bone marrow eosinophils inv(16)(p13q22) or t(16;16)(p13;q22), (*CBFβ/MYH11*)

Acute promyelocytic leukemia, AML with t(15;17)(q22;q12), (*PML/RARα*) and variants

Acute myeloid leukemia with t(9;11)(p22;q23), (*MLLT3-MLL*)

Acute myeloid leukemia with t(6;9)(p23;q34), (*DEK-NUP214*)

Acute myeloid leukemia with inv(3)(q21q26.2) or t(3;3)(q21;q26.2), (*RPNI-EVII*)

Acute myeloid leukemia (megakaryoblastic) with t(1;22)(p13;q13), (*RBM15-MKLI*)

Provisional entity: AML with mutated *NPM1*

Provisional entity: AML with mutated *CEBPA*

Acute Myeloid Leukemia with Multilineage Dysplasia

Following a myelodysplastic syndrome or myelodysplastic syndrome/myeloproliferative disorder

Without antecedent myelodysplastic syndrome

Acute Myeloid Leukemia and Myelodysplastic Syndromes, Therapy-Related

Alkylating agent-related Topoisomerase type II inhibitor-related (some may be lymphoid)

Other types

Acute Myeloid Leukemia Not Otherwise Categorized

Acute myeloid leukemia minimally differentiated

Acute myeloid leukemia without maturation

Acute myeloid leukemia with maturation

Acute myelomonocytic leukemia

Acute monoblastic and monocytic leukemia

Acute erythroid leukemia

Acute megakaryoblastic leukemia

Acute basophilic leukemia

Acute panmyelosis with myelofibrosis

Myeloid sarcoma

Acute Leukemia of Ambiguous Lineage

The morphologic associations and prognostic significance of surface markers have been variable; antigen expression should be interpreted only in the context of other clinicopathologic features. CD34 is expressed more often in less differentiated subtypes (M0, M1; M5, poorly differentiated) in many series,³⁷⁵ it has also been described as more common in monocytic (M4/M5) than in granulocytic (M1, M2, M3) subtypes.³⁷⁶ CD34 is generally a poor prognostic marker, particularly when observed in older patients, after MDS, or in association with expression of the multidrug resistance gene P-glycoprotein (Pgp; MDR-1; ABCB1),^{375,377} but CD34 is also expressed in FAB M2 AML with the t(8;21) chromosomal translocation³⁷⁸ and in FAB M4Eo with inv(16),³⁷⁶ both of which have a favorable prognosis.

Lineage-specific antigen expression in the WHO classification is demonstrated in Table 75.7. Lymphoid antigens are expressed on blasts in 10% to 30% of cases of AML, and their expression has often been implicated as having prognostic significance, but their presence should be interpreted in the context of all available information.³⁷⁹ Expression of CD19 (B-cell) is associated with a good prognosis when present in AML with t(8;21)²⁸³ and a poor outcome when co-expressed with CD34 in the absence of favorable cytogenetics findings. CD7 (T-cell) is present in 15% to 20% of cases of adult AML and has

been associated with a poor prognosis, usually with less differentiated subtypes (M0/M1) and expression of CD34, Pgp, or TdT.^{380,381} CD56, a cell-surface glycoprotein identical to the neural cell adhesion molecule, is more commonly observed in patients with AMoL, t(8;21), and trisomy 8, and with expression of CD11b, CD14, and CD19,³⁸² and has been associated with shorter disease-free survival in favorable AML subtypes.³⁸³

Acute leukemias of ambiguous lineage are divided into three groups. Undifferentiated acute leukemias, the first group, lack morphologic or immunologic differentiating features. The blasts often express HLA-DR, CD34, and CD38 and may express TdT and CD7. Bilineage acute leukemia, the second group, has two

P.1592

populations of blasts expressing distinct lineage markers of myeloid or lymphoid origin or, less frequently, B- and T-cell lineage. In the third group, biphenotypic acute leukemia, blasts co-express myeloid and lymphoid (B- or T-cell) antigens. Blasts very rarely express myeloid, B-, and T-cell antigens. Rearrangements of the T-cell receptor or the immunoglobulin chain genes are usually absent in AML with lymphoid antigen expression, although they have been described, usually in association with karyotypic abnormalities such as t(9;22), 11q23, or 14q32 translocations.^{384, 385} and ³⁸⁶ Up to 20% of patients with acute leukemia may have biphenotypic or mixed lineage features as detected by immunologic and molecular genetic techniques, but less than 4% of cases are unclassifiable.²⁴

TABLE 75.7 LINEAGE-SPECIFIC ANTIGEN EXPRESSION IN THE WHO CLASSIFICATION

Myeloid	MPO (by flow cytometry, immunohistochemistry or cytochemistry) <i>or</i> monocytic differentiation (at least two of the following: NSE, CD11c, CD14, CD64, lysozyme)
T-lymphoid	Cytoplasmic CD3 (flow cytometry with antibodies to CD3 epsilon chain; immunohistochemistry using polyclonal anti-CD3 antibody may detect CD3 zeta chain, which is not T-cell-specific) <i>or</i> surface CD3 (rare in mixed phenotype acute leukemias)
B-lymphoid	Strong CD19 with at least 1 of the following strongly expressed: CD79a, cytoplasmic CD22, CD10, <i>or</i> weak CD19 with at least two of the following strongly expressed: CD79a, cytoplasmic CD22, CD10

Cytogenetic Classification

Cytogenetic findings are the strongest predictors of AML treatment outcomes. AML has been divided into favorable, intermediate, and unfavorable subgroups based on cytogenetic findings in large series from multiple cooperative groups, with remarkably consistent findings. Cytogenetic classification of AML is discussed in the section, "Prognosis."

Molecular Classification

Cytogenetically normal AML is subdivided based on the presence of diverse mutations, which are detailed above and further discussed in the section, "Prognosis."

European LeukemiaNet Classification

In a 2010 publication, the European LeukemiaNet proposed a classification of AML that integrated cytogenetic and molecular data to define favorable, intermediate-I, intermediate-II, and unfavorable genetic groups.⁵¹ This classification is being widely adopted, and the significance of additional and newly discovered molecular abnormalities is being described in the context of this classification.

CLINICOPATHOLOGIC SYNDROMES

The WHO classification recognizes four major categories of AML defined by specific genetic abnormalities, with multilineage dysplasia, therapy-related, and a not otherwise categorized group that retains the morphology-based FAB classification. In addition, acute leukemia of ambiguous lineage is included. Clinicopathologic syndromes of AML are discussed below.

Minimally Differentiated Acute Myeloid Leukemia (AML M0)

Criteria for FAB M0 were developed in 1991.^{6,387} Immunophenotyping confirms the myeloid nature of blasts in M0, because morphology and cytochemistry are inconclusive. Blasts in M0 AML are agranular and lack Auer rods. By definition, the diagnosis of AML M0 requires less than 3% MPO-positive and Sudan black B-positive cells but more than 20% leukemia cells expressing myeloid antigens (CD13, 33, 117).^{6,387} Of note, lymphoid-associated antigens, particularly T-cell type (CD2

and CD7) and TdT (30 to 50%), are commonly expressed in AML M0, but T-lymphoid-specific cytoplasmic CD3 (cyCD3) and B-lymphoid-specific cytoplasmic CD22 and CD79 (cyCD22, cyCD79) are absent.³⁸⁸ M0 is characterized by a higher incidence of karyotypic abnormalities (70 to 75%) than other FAB subtypes.³⁸⁹ AML M0 tends to occur in older patients (>60 years).³⁹⁰ The CR rate and survival in AML M0 are generally poor, consistent with the association with unfavorable karyotypes.^{391, 392} and ³⁹³

Acute Myeloid Leukemia Without Maturation (AML M1)

AML M1 is defined by a predominance (>90%) of myeloblasts without evidence of maturation (<10% promyelocytes or other, more mature, cells). The presence of Auer rods is variable. At least 3% of the blasts are reactive with Sudan black or MPO. The blasts express myeloid antigens. AML M1 makes up 10% to 20% of cases of AML and is more common in adults than in children; the median age is 45 to 50 years.²⁴ Constitutional symptoms are common, and hepatosplenomegaly and lymphadenopathy occur in up to one third of patients.²⁴ No specific cytogenetic marker has been associated with AML M1, but trisomies 11 and 13 have been reported in the immature myeloid leukemias, AML M0 and M1.³⁸⁹

Acute Myeloid Leukemia with Maturation and with t(8;21) (AML M2)

AML M2 is associated with t(8;21)(q22;q22) in 30% to 40% of cytogenetically abnormal cases.²⁴ Approximately 10% of all AML patients present with this syndrome; most are children and young adults. Myeloid sarcoma is common in this syndrome. AML with t(8;21) is typically associated with prominent Auer rods, marrow eosinophilia, and cytoplasmic globules and vacuoles (Fig. 75.9).

P.1593

Immunophenotypic markers include the presence of myeloid antigens, increased expression of the natural killer cell-associated antigen CD56, and, less commonly, the B-cell antigen CD19.³⁹⁴

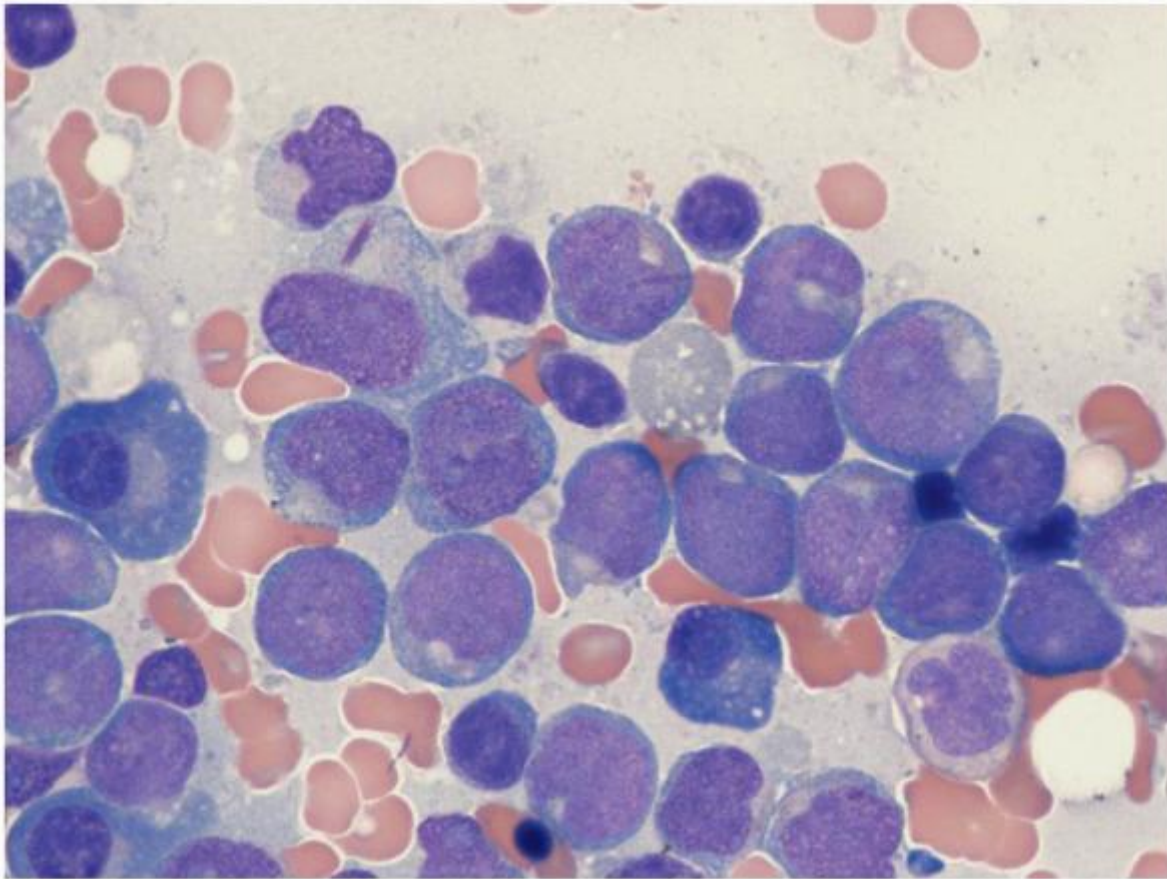

FIGURE 75.9. AML M2 with t(8;21), Wright-stained bone marrow smear. Blasts with maturing myeloid elements. (Courtesy of Dr. Qing Chen, Department of Pathology, University of Maryland.)

The two genes involved in t(8;21) are AML1 (also known as RUNX1, CBF α , and PEBP2 α B) at 21q22 and ETO (also called CDR and MTG8) at 8q22^{395,396} (Chapter 72). They form a fusion gene on the derivative 8 chromosome, which may be detected even in patients in long-term remission, indicating its low value as a marker for minimal residual disease.³⁹⁷ The AML1 gene is also involved in t(3;21)(q26;q22), a rare balanced translocation observed in blast crisis of CML and in t-AML, and in t(12;21) with the TEL gene in ALL.³⁹⁸

The t(8;21) usually occurs in de novo AML and generally predicts a favorable outcome, with a high remission rate (CR rate of 86% to 95%) and long survival (5 years DFS of 57% to 71%), particularly after high-dose cytarabine (HiDAC) consolidation therapy.³⁹⁹ Children and patients with leukocytosis (>20,000 cells/mm³) or with extramedullary disease may have high relapse rates and inferior survival.⁴⁰⁰ Mutations of the growth factor receptor KIT in AML1-ETO AML identify a subgroup of patients with a high white count (median 29,600/mm³), a higher incidence of extramedullary disease (33%), and a poor prognosis.³⁶⁴ Expression of the CD56 antigen on AML cells with t(8;21) is also associated with a shorter disease-free survival (DFS).³⁸³ Because of high survival rates after multiple cycles of HiDAC consolidation, alloSCT is usually reserved for relapse.

Acute Promyelocytic Leukemia (AML M3)

See Chapter 78.

Acute Myelomonocytic Leukemia (AML M4) and Acute Myelomonocytic Leukemia with Eosinophilia (AML M4Eo) and Pericentric Inversion of Chromosome 16

AML M4 and M4Eo is present in approximately 5% to 10% of patients with AML in association with monocytosis and a myeloblastic/monoblastic infiltration of the bone marrow (Fig. 75.10). Organomegaly is common, with splenomegaly in 30% of patients. Hyperleukocytosis (>100,000 cells/mm³) is present in 20% to 25% of patients.²⁴ Extramedullary disease with involvement of skin (scalp), ovaries, testicles, intestine, CNS, and particularly lymphadenopathy occurs in 20% to 30% of patients and may confer a worse prognosis.⁴⁰¹ The immature eosinophils have a monocytoid nucleus and a mixture of eosinophilic and large atypical basophilic granules. Staining with Sudan black, periodic acid-Schiff (PAS), and chloroacetate esterase with nonspecific esterase (double esterase) can identify the neoplastic cell. By flow cytometry, all cases of AML M4Eo express the panmyeloid marker CD13 and the stem cell antigen CD34, but there is variable expression of other myeloid/monocytic markers, including CD11b, CD11c, CD14, and CD33. There is also frequent expression of the T-lymphoid marker CD2, along with HLA-DR.

The syndrome associated with AML M4Eo was first described by Arthur and Bloomfield in 1983 in five patients with a deletion of the long arm of chromosome 16. In subsequent reports, the abnormality has been described in almost all patients as a pericentric inversion of chromosome 16, inv(16)(p13;q22), whereas a minority of patients have a balanced translocation between the two copies of chromosome 16, t(16;16)(p13.1;q22).⁴⁰² The prognosis of patients with t(16;16)(p13;q22) is similar to that of patients with (inv16)(p13;q22).⁴⁰³ Cloning of the 16p and 16q breakpoints has identified the two genes involved: MYH11, which codes for smooth muscle myosin heavy chain, and core-binding factor (CBF) β (also known as PEBP2 β), which codes for the β subunit of CBF, a heterodimeric transcription factor involved in murine leukemogenesis and in T-cell receptor gene expression.^{404,405} CBF β -MYH11 fusion transcripts are detected by RT-PCR in typical AML M4Eo, but also in approximately 10% of patients with AML M4 without eosinophilia.⁴⁰⁶

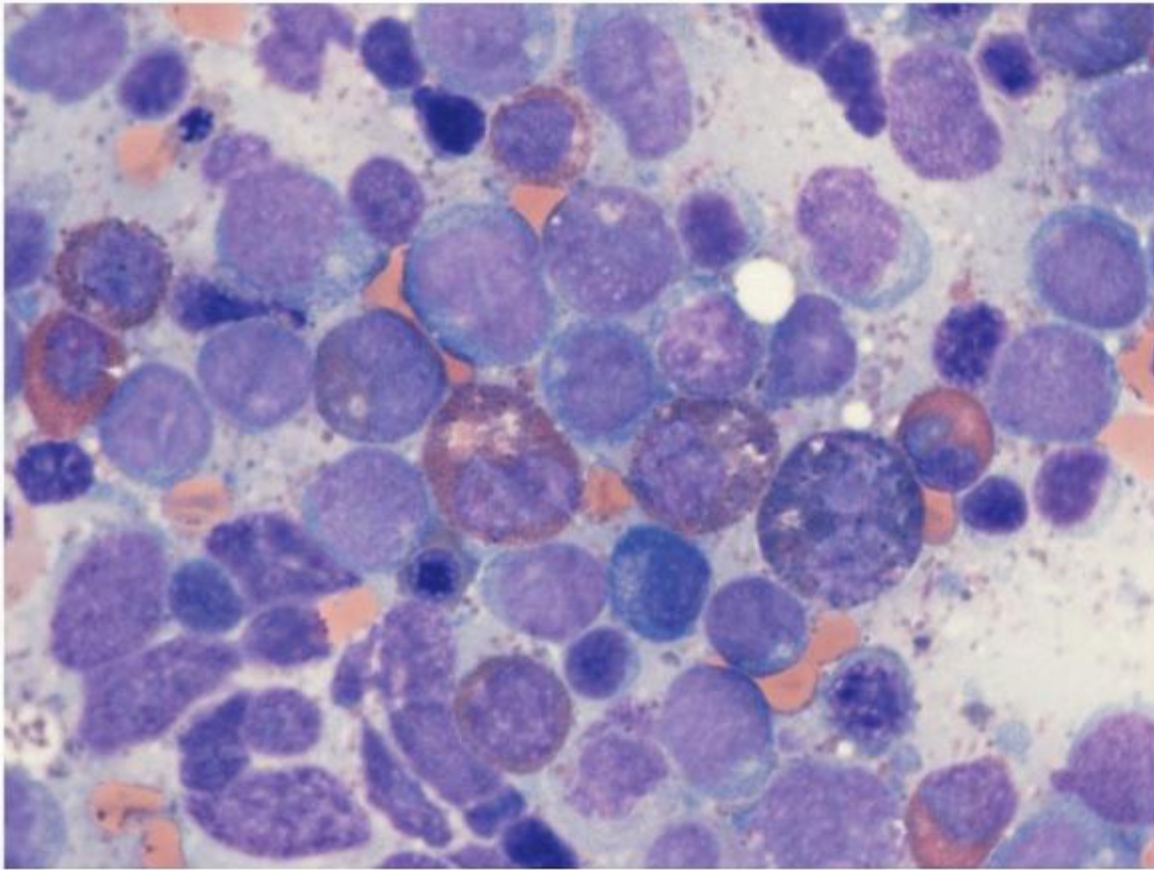

FIGURE 75.10. AML M4Eo with *inv(16)*, Wright-stained bone marrow smear. In addition to myeloblasts and monoblasts, abnormal eosinophils with large basophilic granules are characteristic of this type of AML. (Courtesy of Dr. Qing Chen, Department of Pathology, University of Maryland.)

The 81% to 93% CR rate and 48% to 63% DFS of AML with *inv(16)* or *t(16;16)* to conventional chemotherapy represent a better prognosis than for most other subtypes of AML.^{399,407} Allogeneic transplantation is usually considered only in patients who relapse. AML with inversion 16 previously had a high risk of CNS relapse, but the use of HiDAC as consolidation therapy decreases the incidence of CNS disease and may serve as CNS prophylaxis. Multiple cycles of HiDAC consolidation are associated with better relapse-free survival (RFS) than a single cycle.³⁹⁹ As with AML/ETO, the detection of KIT mutations is associated with an increased relapse rate.³⁶⁶ Minimal residual disease (MRD) can be monitored by quantitative RT-PCR to identify patients at risk for relapse.^{406,408,409} Carefully defined MRD cutpoints for persistent CBF β -MYH11 transcript positivity were shown to be able to distinguish patients with significantly increased risk of relapse.⁴¹⁰

Acute Monocytic Leukemia (AML M5a and M5b) and with 11q23 Abnormalities

AML M5 accounts for 2% to 10% of AML cases. M5 is subdivided into M5a, poorly differentiated (>80% monocytic cells including monoblasts), and M5b, well differentiated (80% monocytic, predominantly promonocytes and monocytes).¹⁷⁸ Patients with M5a tend to be younger (75% <25 years of age) than those with M5b, but both include a wide age range.²⁴ Monocytic precursors are recognized by their fluoride-inhibitable nonspecific esterase positivity and expression of CD14 and CD4 (dim expression) but not CD2. Monoblasts may be recognized by staining with antibodies to lysozyme and to CD68 (KP1).²⁴ There is cytogenetic heterogeneity in AML M5, but common findings include a normal karyotype (49%), 11q23 abnormalities (21%), and trisomy 8 (21%).⁴¹¹ The incidence of 11q23 abnormalities is higher in AML M5a (31% to 33%) than in AML M5b (12% to 16%) and AML M4 (5%); they are found in less than 1% of all other FAB subtypes ($P < 0.0001$).^{278,286,411} Trisomy 8 is more common in M5a than M5b, which has a normal karyotype in 71% of cases.⁴¹¹ FLT3 mutations are more common (29%) in M5b than M5a.⁴¹¹

Extramedullary disease occurs in over 50% of patients with AML M5 and is more common in AML M5 than in other subtypes of AML. It may include cutaneous lesions, gum infiltration,

testicular involvement, and CNS disease.^{412,413} CNS involvement has been reported in 3% to 22% of patients.⁴¹² Leukocytosis is a common finding, present in 10% to 37% of patients. The frequency of DIC is second only to that in APL, and DIC may be exacerbated when therapy begins. Elevated levels of lysozyme are found in more than two thirds of patients and may contribute to renal insufficiency or proteinuria. Results of several studies indicate that AML M5 is associated with poor prognosis, and specifically short disease-free survival.⁴¹² On the other hand, ECOG reported no difference in CR rates for M5 patients (62%) compared to non-M5 patients (60%) and no difference in 3-year overall survival (31% vs. 30%).⁴¹⁴

Erythroleukemia (AML M6)

Erythroleukemia accounts for 2% to 4% of cases of AML and is characterized by a prominent component of erythroblasts. Erythroid/myeloid leukemia (M6a) has 50% or more erythroid precursors in the nucleated population and 20% or more myeloblasts in the nonerythroid population. In the less common pure erythroid leukemia (M6b), 80% of the marrow cells are immature erythroblasts, without a significant percentage of myeloblasts. A third type (M6c) has been characterized by 30% or more nonerythroid blasts and 30% or more pronormoblasts.⁴¹⁵

Morphologic findings in the peripheral smear may include schistocytes, teardrop forms, pincerred red cells, and basophilic stippling.⁴¹⁶ Circulating erythroblasts are observed in one half of patients. The bone marrow is usually hypercellular with megaloblastic changes.⁴¹⁶ Erythroid precursors commonly have multinuclearity (65%), karyorrhexis (53%), morulae (25%), and/or cytoplasmic vacuolization (23%). The PAS reaction may stain abnormal erythroid cells in either a coarse globular (16%) or diffuse (57%) pattern. The most common immunophenotypic markers for erythroleukemia are glycophorin 7 and the transferrin receptor (CD71).

There is a bimodal age distribution for erythroleukemia, with a small peak below 20 years and a broader peak in the seventh decade.⁴¹⁵ In many series approximately one half of cases of erythroleukemia are therapy-related.⁴¹⁶ Cytogenetic abnormalities are found in over 70% of patients, and abnormalities of chromosomes 5 and 7 are common.^{417, 418} and ⁴¹⁹

The prognosis for erythroleukemia is generally poor, with a recent reported overall survival of 8 months,⁴²⁰ but depends upon age, secondary leukemia, cytogenetic abnormalities, and subtype of erythroid leukemia. One report had a CR rate of 62% for de novo erythroleukemia but most series have CR rates in the 10% to 40% range, particularly in secondary erythroleukemia.⁴¹⁵ The CR rate in patients with 5q or 7q abnormalities is approximately 20% and the median survival is 4 months, compared to 18 months in the absence of these abnormalities.⁴²¹ Median survival was inferior in M6b (1.8 months) compared to M6a (18.8 months, $P < 0.002$) and M6c (7 months, $P < 0.01$).⁴²² Allogeneic SCT appears to confer the best long-term survival in erythroleukemia, particularly with unfavorable cytogenetics and/or therapy-related.⁴¹⁵

Acute Megakaryocytic Leukemia (AML M7)

AML M7 was first described in 1931 and was added to the FAB classification in 1985.^{423, 424} and ⁴²⁵ There is a bimodal age distribution, with one peak in infancy and the other in older adults. Megakaryocytic AML represents 0.6% to 1.2% of cases of adult AML, compared to 3% to 10% of childhood AML. The median age for adult AML M7 is 51 to 58 years and there is a male predominance. Morphologically, AML M7 can be confused with the L2 subtype of ALL or with AML M1. Cytoplasmic blebs suggestive of megakaryocyte differentiation may be present on the blasts. The myeloid surface markers CD13 or CD33 may be expressed, and CD34 is often absent. The diagnosis depends on the expression of at least one platelet antigen (CD41, CD42b, CD61, or factor VIII-related antigen) on the leukemia cells. The bone marrow may be difficult to aspirate and over two thirds of patients will have significant fibrosis.

Cytogenetic abnormalities are more frequent (>90%) in AML M7 than in other subtypes of AML.⁴²⁶ They are heterogeneous but differ between children and adults,⁴²⁶ with adults typically having complex karyotypes.

Although data are limited, the clinical presentation of AML M7 is not substantially different from that of other subtypes of AML. Organomegaly is infrequent in adults. Cytopenias are usually present, but approximately 30% of patients have platelet counts above 100,000/ μ l.¹⁷⁸ Platelet function studies usually indicate impaired aggregation responses. Serum LDH levels are often elevated. Osteosclerotic and osteolytic lesions have been demonstrated radiographically.^{178,427}

Prognosis in adult AML M7 is poor.^{423, 424} and ⁴²⁵ The CR rate is 43% to 50% and the median DFS is 6 to 10 months.^{423, 424} and ⁴²⁵ The ECOG series reported an inferior DFS in M7 compared to non-M7 AML (23 vs. 52 weeks, $P < 0.001$), and found M7 AML to be an independent adverse prognostic factor for DFS.⁴²³ Because of the poor prognosis of adult AMGL, early allogeneic SCT should be considered.

Other Clinicopathologic Syndromes

Acute panmyelosis with myelofibrosis (APMF) was first described in 1963 by Lewis and Szur.⁴²⁸ APMF is rare, representing less than 1% of AML, and has replaced acute myelosclerosis or acute myelofibrosis in the WHO classification.⁴²⁸ The median age is 57 to 67 years and there is a male predominance. The onset is sudden and patients have pancytopenia with <5% blasts in the peripheral blood and no to minimal teardrop forms. There is no history of preceding myeloproliferative disorders and there is no, or minimal, splenomegaly. The marrow is hypercellular with various degrees of hyperplasia of the three cell lineages; clusters of late-stage erythroids may be prominent. Dysplastic changes, including hypolobated megakaryocytes with dispersed chromatin, are present. Clusters of immature cells are present, and the degree of marrow fibrosis is variable. If the proliferative process includes predominantly myeloblasts and fibrosis is present, the leukemia should be classified as AML of the appropriate cell types with “myelofibrosis.” The main differential diagnosis is between APMF and AML M7.⁴²⁸ There are fewer blasts in APMF and the blasts rarely express megakaryocytic antigens. Cytogenetic findings are not specific but are often complex and include abnormalities of 5q, 7, and 17p.⁴²⁹ The prognosis of APMF is extremely poor, with a median survival of less than 2 months in some series.^{428,430}

Acute basophilic leukemia is very rare, but is recognized as an independent entity by the WHO classification.⁴³¹ Cutaneous disease, organomegaly, lytic bone lesions, and symptoms of hyperhistaminemia may be present. Blasts have oval, round, or bilobed nuclei and variable numbers of coarse basophilic cytoplasmic granules. The characteristic cytochemical staining is metachromatic positivity with toluidine blue, diffuse acid phosphatase positivity, and, in some cases, block PAS positivity. Blasts often do not stain with Sudan black B, MPO, or nonspecific esterase. Blasts express the panleukocyte antigen CD45, the myeloid antigens CD13, CD33 and CD11b, and usually also CD9 and CD17, CD34, and HLA-DR. Involvement of 12p or t(6;9), which can occur in AML with increased basophils, has been reported.⁴³¹ Some cases may represent blast crisis of CML or de novo Ph+ acute leukemia. Prognosis is uniformly poor.⁴³²

The t(6;9)(p21;q34) is a rare variant of AML (<1%) that was initially described in a young age group (20 to 30 years of age) with basophilia and a poor response to therapy. It is usually of the FAB M2 or M4 subtype.⁴³³ The genes involved are the DEK gene on chromosome 6p23 and the nucleoporin protein, NUP214 (previously CAN) gene on chromosome 9p34.⁴³⁴

P.1595

AML with abnormalities of the long arm of chromosome 3, inv(3)(q21;q26) and t(3;3)(q21;q26), typically presents with a normal platelet count or thrombocytosis.⁴³⁵ The critical gene involved at 3q26 is EVI1 (ecotropic viral integration site 1),^{436,437} and overexpression of EVI1 is found in 9% of AML without 3q26 abnormalities.⁴³⁸ GATA2 (3q21) may also be overexpressed. The inv(3)(q21;q26) syndrome represents 1% to 3% of de novo AML, may also follow MDS, and has a poor prognosis. Abnormal megakaryocytes may be present.⁴³⁹ Other rare balanced rearrangements involving 3q26 include t(3;21)(q26;q22), t(3;12)(q26;p13), and t(2;3)(p15;22;q26).⁴⁴⁰

AML with t(3;5)(q25.1;q35) has been reported in approximately one fourth of patients with erythroleukemia (M6), and the marrow often has trilineage dysplasia and abnormal megakaryocytes. Unlike patients with inv(3), patients with t(3;5) do not have thrombocytosis.⁴⁴¹ The genes involved are NPM on chromosome 5 and myelodysplasia/myeloid leukemia factor 1 (MLF1) on chromosome 3.⁴⁴²

TABLE 75.8 PROGNOSTIC FACTORS IN ACUTE MYELOID LEUKEMIA

Factor	Favorable	Unfavorable
Clinical		
Age	<45 y	<2 y, >60 y
ECOG performance status	0-1	>1
Leukemia	De novo	Antecedent hematologic disorder; myelodysplastic syndrome, myeloproliferative disorder
Infection	Absent	Present
Prior chemotherapy	No	Yes
WBC count	<25,000/mm ³	>100,000/mm ²
Serum LDH	Normal	Elevated

Extramedullary disease	Absent	Present
CNS disease	Absent	Present
Cytoreduction	Rapid	Delayed
Morphology		
Auer rods	Present	Absent
Eosinophils	Present	Absent
Megaloblastic erythroids	Absent	Present
Dysplastic megakaryocytes	Absent	Present
FAB type	M2, M3, M4	M0, M6, M7
Surface/Enzyme Markers		
Myeloid	CD34 ⁻ , CD14 ⁻ , CD13 ⁻	CD34 ⁺
HLA-DR	Absent	Present
TdT	Absent	Present
Lymphoid	CD2 ⁺	CD7 ⁺ , CD56 ⁺ Biphenotypic (two or more lymphoid markers)
MDR-1	Absent	Present
Cytogenetics		
(see Tables 75.4 and 75.6)	t(15;17), t(8;21), inv(16)	-7, del(7q), -5, del(5q), 3q21 and 3q26 abnormalities, complex karyotype
Molecular Markers		
FLT3 mutation	Absent	Present
EVI1 overexpression	Absent	Present
MLL partial tandem duplication	Absent	Present
NPM1 mutation	Present	Absent
CEBP- α mutation	Present	Absent
BAALC overexpression	Absent	Present
VEGF overexpression	Absent	Present

ECOG, Eastern Cooperative Oncology Group; FAB, French-American-British; HLA, human lymphocyte antigen; LDH, lactate dehydrogenase; MDR, multidrug resistance gene.

PROGNOSIS

Prognosis Is Multifactorial

A number of clinical and biologic features, detailed below, predict prognosis in AML, and prognosis is actually determined by interactions between these factors (Table 75.8). As an example,

structural cytogenetic abnormalities involving the genes encoding the core binding factor transcription factor subunits, including t(8;21), inv(16), and t(16;16), define the favorable cytogenetic subgroup of AML, but treatment outcome is significantly worse in older patients with these cytogenetic abnormalities,⁴⁴³ and in patients whose AML cells have mutations of the growth factor receptor KIT.^{364,365,366} As another example, in a Southwest Oncology Group study of older AML patients, secondary AML, unfavorable karyotype and expression of the MDR protein MDR1 (Pgp) were each independently significant associated with lower CR rates, but CR rates ranged from a high of 81% to a low of only 12% depending on how many of these three adverse prognostic factors were present.⁴⁴⁴

Clinical Factors

Age is a powerful prognostic factor, with older adult patients having worse outcomes than younger adults.⁴⁴³ The clinical state of the patient, as reflected in performance status and co-morbid conditions, also affects outcome.⁴⁴⁵ Patients with secondary AML, defined by a preceding bone marrow disorder, including MDS or MPN, or with t-AML, have an inferior response and survival compared to those with de novo AML.^{446,447} Hyperleukocytosis correlates with shorter overall survival⁴⁴⁸ due to both increased induction deaths⁴⁴⁹ and an association with FLT3 mutations.³⁶ Extramedullary disease is unfavorable.⁴⁴⁸ Finally, one report demonstrated lower CR rates and shorter overall survival in African American males, in relation to whites and African American females.⁴⁵⁰

Morphology

Favorable morphologic features include presence of Auer rods (M1-M4) and of eosinophils (M2 and M4Eo), the latter because of the association with the favorable cytogenetic abnormalities t(8;21) in M2 and inv(16) in M4Eo. The eosinophils in M2 show only minor abnormalities such as faint green-blue/yellow granules, whereas in M4Eo they are dysplastic and often have large, irregular deeply purple granules (Figs. 75.6 and 75.9). Morphologic dysplasia is unfavorable,⁴¹⁵ likely by virtue of association with unfavorable karyotypes.⁴⁵¹ In regard to FAB types, patients with M0,³⁹³ M6⁴⁵² and M7^{423,424} generally have lower survival rates. FAB M5 is associated with extramedullary disease and with FLT3 mutations³⁵

Immunophenotype

The effect of surface markers on prognosis is variable and is interdependent with other factors. Although CD34 has been reported as an adverse factor,^{379, 448} in some studies it has had no impact on outcome.^{453,454} CD34 expression is a poor prognostic factor when it is associated with the multidrug resistance gene (MDR1).⁴⁵⁵ CD34 expression is associated with prognostically adverse karyotypes, including abnormalities of chromosome 5 (-5/5q-) and 7,⁴⁵⁴ but it is also expressed in favorable AML subtypes, including AML with t(8;21)^{378, 454} and inv(16).³⁷⁶ The lack of HLA-DR reactivity as observed in APL (M3) has been associated with a good prognosis in some,⁴⁵⁶ but not all,⁴⁵⁷ series, whereas absence of CD33 expression may be unfavorable.⁴⁵³ CD7 expression is prognostically unfavorable.⁴⁵⁸ CD56 expression correlates with extramedullary disease, which is unfavorable.⁴⁴⁸ Both CD19 and CD56 are frequently expressed on AML cells in t(8;21) AML; CD19 does not have prognostic significance, and CD56 is associated with shorter disease-free survival in these patients.³⁸³ Finally, detection of residual or recurrent blasts by multiparameter flow cytometry at diverse time points following therapy predicts adverse outcome.^{206,208,459, 460 and 461}

Multidrug Resistance

Expression of multidrug resistance (MDR) genes has been identified as having adverse prognostic significance in AML.^{377,462,463} The best described MDR gene is MDR1, whose gene product, P-glycoprotein (Pgp), is a 170-Kda cell membrane ATP-binding (ABC) protein (ABCB1) that functions as a drug efflux pump for naturally occurring substances, including anthracyclines, epipodophylotoxins, vinca alkaloids, and taxanes,^{463,464} as well as the calicheamicin moiety of gemtuzumab ozogamicin.⁴⁶⁵ Pgp expression can be detected on the surface of AML cells by flow cytometry using specific antibodies such as MRK16 and can be correlated with functional efflux of substrate fluorescent dyes by AML blasts. Expression of MDR-1/Pgp on blasts is more commonly found in older AML patients, often in conjunction with adverse cytogenetic findings, and is associated with a lower CR rate.³⁷⁷ Moreover, MDR-1/Pgp overexpression and FLT3-ITDs occur largely in different AML patient populations.³⁰⁵

Other transport proteins that mediate cellular drug efflux and appear to mediate drug resistance in AML include the ABC proteins multidrug resistance-associated protein 1 (MRP-1; ABCC1) and breast cancer resistance protein (BRCP; ABCG2).^{377,462,466} MRP-1 has adverse prognostic significance in AML,⁴⁶⁷ especially when co-expressed with MDR-1/Pgp,^{462,468} and BCRP also has adverse prognostic significance.⁴⁶⁹ The major vault protein lung resistance protein (LRP) is not an ABC protein, but rather an intracellular protein that affects cytoplasmic-nuclear drug transport; its expression in AML cells has been associated with adverse treatment outcome in some series.^{463,470}

Cytogenetics

Cytogenetic subgroups identify prognosis better than any other factor in both younger and older adult AML patients,^{28,29,31,32,471,472} and stratification of therapy based on cytogenetic prognostic group has become the standard of care in AML.⁴⁷³ Criteria that subdivide AML patients into favorable, intermediate and unfavorable cytogenetic risk groups vary only minimally among cancer cooperative group studies (Table 75.9). Studies of cytogenetics in AML are important not only in terms of defining prognostic subgroups, but also in terms of defining the features and optimal management of AML with uncommon individual karyotypes.^{278,474} A representative survival curve according to cytogenetic findings is illustrated in Figure 75.11.⁴⁷⁵

APL [t(15;17)] and AML with either of two core binding factor (CBF) abnormalities, t(8;21) and inv(16) or t(16;16), are regarded as favorable types of AML. AML with either of the two CBF abnormalities has both a high CR rate and a high rate of disease-free survival, particularly when treated with high-dose cytarabine-based post-remission regimens.^{399,476} Nevertheless, favorable cytogenetic prognosis may be modified by other factors. For example, when t(8;21) is present in older patients⁴⁴³ or when t(8;21) AML cells express the neural cell adhesion molecule CD56³⁸³ or have mutations of the growth factor receptor KIT,^{364,365} and ³⁶⁶ prognosis is worse. The standard of care for AML with favorable karyotypes is post-remission chemotherapy with high-dose cytarabine, rather than transplantation in remission.⁴⁷³

Unfavorable cytogenetic groups are consistently defined by del(5q)/-5, -7/del(7q) and/or complex karyotypes (defined by either ≥3 or ≥5 unrelated abnormalities), or inv(3)/t(3;3), t(6;9) or t(9;22). There is some variability in additional karyotypes included in unfavorable cytogenetic groups among different cooperative groups^{28,29} and within cooperative groups, when considering induction outcome, cumulative incidence of relapse or overall survival.²⁹ Additional karyotypes predicting adverse outcomes in different series include abnormalities of 9q, 11q, 12p, 17p, 20q, and 21q, +8, and +21. 11q23 abnormalities have adverse significance with regard to survival, except for t(9;11).²⁷⁸ The standard of care for AML with unfavorable karyotypes is

P.1597

allogeneic hematopoietic stem cell transplantation when this option is available, or clinical trials.⁴⁷³

TABLE 75.9 HIERARCHICAL CYTOGENETIC CLASSIFICATION SYSTEMS USED TO DEFINE PROGNOSTIC GROUPS IN ACUTE MYELOID LEUKEMIA

Risk Category	MRC	SWOG/ECOG	CALGB^a	GIMEMA/AM L 10	GERMAN AMLCG
Favorable t(15;17)	t(15;17)	t(8;21)	t(15;17)	t(15;17)	
	t(8;21)	t(8;21) without del(9q) or complex karyotype	inv(16)/t(16;16)	t(8;21)	t(8;21)
	inv(16)/t(16;16)	inv(16)/t(16;16)/del(16q)	del(9q)	inv(16)/t(16;16)	inv(16)/t(16;16)
Intermediate	Normal karyotype	Normal	Normal	Normal	Normal
	del(7q)	-Y	-Y	-Y	Other noncomplex
	+8	+6	del(5q)		
	del(9q)	+8	del(7q)		
	abn(11q23)	del(12p)	t(9;11)		
	+21		+11		
	+22		del(11q)		
All other		abn(12p), +13			

aberrations		del,(20q),+21		
Unfavorable	abn(3q)	inv(3)t/(3;3)	Other	inv(3)/t(3;3)
-5/del(5q)	-5/del(5q)	t(6;9)		-5/del(5q)
-7	t(6;9)	t(6;11)		-7/del(7q)
≥5 aberrations	-7/del(7q)	-7		abn(11q23)
	t(9;22)	+8 sole or with 1 additional aberration		
	abn(9q), abn(11q), abn (17p), abn(20q), abn(21q) ≥3 aberrations	t(11;19) ≥3 aberrations		del(12p) abn(17p)

CALGB, Cancer and Leukemia Group B; GERMAN AMLCG, German AML Cooperative Group; GIMEMA/AML10, Gruppo Italiano Malattie Ematologiche dell'Adulto; MRC, Medical Research Council; SWOG/ECOG, Southwest Oncology Group/Eastern Cooperative Oncology Group.

^aPatients with t(15;17) or t(9;22) were not included in this analysis. Trisomy 8 with core-binding factor or t(9;11) was not adverse; del(5q) was intermediate if sole abnormality (Byrd JC, Mrözek RK, Dodge AJ, et al. Pretreatment cytogenetic abnormalities are predictive of induction success, cumulative incidence of relapse, and overall survival in adult patients with de novo acute myeloid leukemia: results from Cancer and Leukemia Group B (CALGB 8461). Blood 2002;100:4325-4336).

The intermediate-risk cytogenetic group is defined as AML with a normal karyotype or with cytogenetic abnormalities not defined as favorable or unfavorable, although the Southwest Oncology Group classification also includes an "other" group for uncommon abnormalities not specifically listed as favorable.²⁸ Patients with normal karyotypes represent a heterogeneous group that is increasingly able to be further categorized by molecular abnormalities.

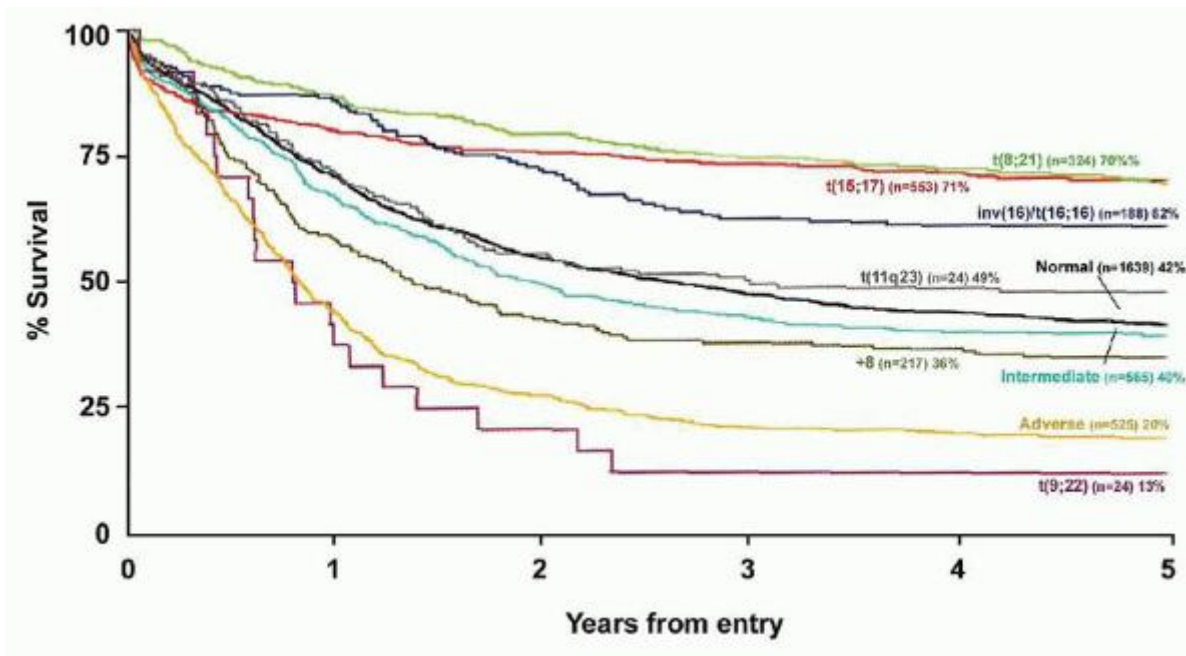

FIGURE 75.11. Overall survival of patients up to 60 years treated in UK Medical Research Council AML 10 and AML 12 trials according to cytogenetics. (With permission from Grimwade D. Impact of cytogenetics on clinical outcome in AML. In: Karp J, ed. Acute myelogenous leukemia. Totawa, NJ: Humana Press, 2007:181.)

Cytogenetic analysis at the time of assessment of response to remission induction therapy is prognostically significant because the relapse rate is higher and both disease-free and overall survival is shorter in patients with persistence of abnormal metaphases following induction chemotherapy.⁴⁷⁷ Cytogenetic risk groups remain prognostically significant following alloSCT for primary refractory AML,⁴⁷⁸ but not for AML in CR.^{479,480}

Molecular

Molecular studies are particularly helpful in subdividing the group of AML patients with a normal karyotype, and in guiding their management.^{49,292} Individual molecular abnormalities and their prognostic significance are detailed above. Prognosis is best determined by combinations of cytogenetic and molecular findings, and this approach was recently formalized by the European LeukemiaNet.⁵¹ The European LeukemiaNet classification is shown in Table 75.10.

Biologic Parameters

Diverse parameters reflecting leukemia biology have been found to have prognostic significance in AML. Increased expression of antiapoptotic proteins such as BCL-2 and/or decreased expression of proapoptotic proteins in AML cells is associated with resistance to chemotherapy and adverse prognosis.^{481, 482, 483} and ⁴⁸⁴ Overexpression of vascular endothelial growth factor (VEGF) and other proteins associated with angiogenesis correlates with increased angiogenesis and has been associated with a worse prognosis in AML.^{485, 486, 487} and ⁴⁸⁸ Expression of the chemokine receptor CXCR-4 on AML cells has also been found to be prognostically unfavorable.^{489,490} Finally, activation of signal transduction pathways in AML cells is associated with a poor prognosis,²⁶⁵ although much remains to be elucidated in this area.

Gene Polymorphisms

Polymorphisms in genes encoding proteins involved in drug detoxification, such as glutathione S-transferases,^{155,491} drug resistance, such as MDR1,⁴⁹² and DNA repair, such as XPA,⁴⁹³ XPD, ERCC1, and XRCC3,¹⁵⁹ have been variably associated with treatment toxicities and treatment outcome. The ultimate goal of these studies is stratification of chemotherapy based on genotypes.

TABLE 75.10 EUROPEAN LEUKEMIANET GENETIC CLASSIFICATION INTEGRATING CYTOGENETIC AND MOLECULAR DATA IN ACUTE MYELOID LEUKEMIA (AML)⁵¹

Genetic Subgroup	Subsets
Favorable	t(8;21)(q22;q22); <i>RUNX1-RUNX1T1</i> inv(16)(p13.1q22) or t(16;16)(p13.1;q22); <i>CBFB-MYH11</i> Mutated <i>NPM1</i> without <i>FLT3-ITD</i> (normal karyotype) Mutated <i>CEBPA</i> (normal karyotype)
Intermediate I	Mutated <i>NPM1</i> and <i>FLT3-ITD</i> (normal karyotype) Wildtype <i>NPM1</i> and <i>FLT3-ITD</i> (normal karyotype) Wildtype <i>NPM1</i> without <i>FLT3-ITD</i> (normal karyotype)
Intermediate II	t(9;11)(p22;q23); <i>MLL3-MLL</i> Cytogenetic abnormalities not classified as favorable or adverse
Adverse	inv(3)(q21q26.2) or t(3;3)(q21;q26.2); <i>RPNI-EVII</i> t(6;9)(p23;q34); <i>DEK-NUP214</i> t(v;11)(v;q23); <i>MLL</i> rearranged -5 or del(5q); -7; abn(17p); complex karyotype

THERAPY

Overview of Treatment

Treatment for AML is divided into two phases, remission induction therapy and post-remission therapy (Fig. 75.12). The goal of induction therapy is attainment of a complete remission, which, except in APL, usually requires a period of marrow aplasia, or a “morphologic leukemia-free state,” following induction chemotherapy. Serial changes in peripheral blood

counts during induction therapy include clearance of blasts from the blood, followed by pancytopenia requiring red blood cell and platelet transfusion support and management of complications of neutropenia, followed by increases in neutrophil and platelet counts and then resolution of anemia in patients with favorable responses to treatment. Table 75.11 outlines the management of AML at diagnosis and during induction therapy.

Post-remission therapy is therapy administered after patients achieve complete remission. Its goal is to prolong complete remission by delaying or preventing recurrence of AML, called relapse, and to maximize the chance of cure. Post-remission therapy may consist of intensification, consolidation, and maintenance therapies. Intensification may include allogeneic or autologous hematopoietic stem cell transplantation, whereas consolidation involves either regimens similar to those used in induction or the use of drugs at higher dosages than in induction; maintenance therapy is less intensive and less myelosuppressive than induction.⁴⁹⁴ Maintenance therapy is standard for ALL and for APL, but not for AML, although new approaches are being tested.⁴⁹⁵

Endpoints of Acute Myeloid Leukemia Treatment

Early assessment of the efficacy of remission induction chemotherapy is by sampling of the bone marrow approximately 14 days following initiation of chemotherapy, during pancytopenia. The morphologic leukemia-free state⁴ desired at this time-point is defined by the presence of less than 5% blasts in an aspirate sample with marrow spicules and with a count of at least 200 nucleated cells and absence of blasts with Auer rods. A bone

P.1599

marrow biopsy performed at the same time allows more bone marrow tissue to be examined and allows identification of clusters of blasts. Patients with clear residual AML at the time of early assessment are unlikely to go on to achieve remission, and additional or alternative therapy should be considered. Persistent detection of cells with the phenotype of the patient's pre-treatment leukemia cells by flow cytometry in marrow that is morphologically leukemia-free is viewed as persistence of leukemia, although therapeutic decisions about re-induction therapy in clinical trials have generally not been based on flow cytometry findings. If presence of residual leukemia is questionable, a bone marrow aspirate and biopsy should be repeated a week later. A morphologic leukemia-free state also requires absence of extramedullary disease.

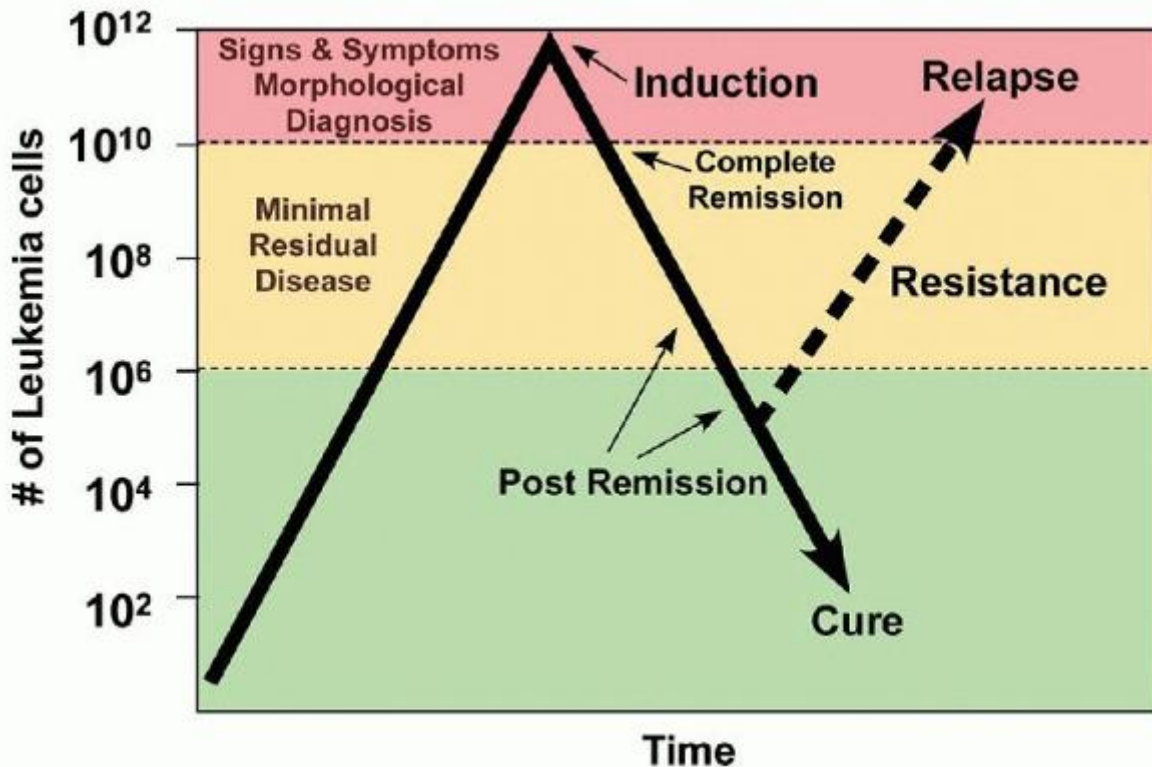

FIGURE 75.12. Phases of therapy. The diagnosis of acute myeloid leukemia can be made when the leukemia cell number is

$>10^{10}$. Induction therapy achieves a clinical complete remission and is followed by post-remission therapy with a goal of cure. If cells develop mechanisms of resistance, relapse occurs.

Patients are then assessed for response to induction therapy at the time of blood count recovery. The definition of complete remission has evolved.⁴ The term complete remission generally refers to morphologic complete remission, defined by red blood cell transfusion independence, an absolute neutrophil count of more than 1,000/ μ l and a platelet count of 100,000/ μ l or greater and the presence of less than 5% blasts in a bone marrow aspirate sample with marrow spicules and with a count of at least 200 nucleated cells, absence of blasts with Auer rods, and absence of extramedullary leukemia. The currently recommended International Working Group (IWG) criteria do not include requirements with regard to bone marrow biopsy cellularity or duration of response, but persistent detection of AML cells with the phenotype of the patient's pre-treatment leukemia cells by flow cytometry in marrow that is morphologically leukemia-free is considered persistence of leukemia.⁴

TABLE 75.11 MANAGEMENT OF ACUTE MYELOID LEUKEMIA AT DIAGNOSIS

Patient History

Review preceding myelodysplasia, prior diagnosis of cancer, previous chemotherapy, occupational exposure, family history, number of full siblings.

Physical Examination

Assess performance status.

Screen for infection: dental, nasopharyngeal, lung, perirectal.

Search for extramedullary disease: skin, neurologic, adenopathy, organomegaly, testicular.

Baseline Laboratory

Complete blood count with differential; type and screen.

Bone marrow examination: include cytogenetic analysis and save sample for molecular diagnostics if applicable.

Screen electrolytes, liver and renal function, tumor lysis parameters.

Screen for DIC.

Viral serologies, particularly HSV, CMV, hepatitis, and HIV.

HLA-A, -B, -DR type.

Chest radiograph: rule out pneumonia, leukostasis, mediastinal mass.

Cardiac status: ejection fraction by echocardiogram or MUGA.

Supportive Care

Transfusions: platelets, packed red blood cells (unless hyperleukocytosis), cryoprecipitate with or without fresh-frozen plasma in DIC.

Central line placement.

Hydration.

Allopurinol. Rasburicase (after checking G6PD).

Treat ongoing infections.

Infection prophylaxis: acyclovir (if HSV-positive), antifungal agents (fluconazole or voriconazole), antibacterial agents (usually to cover Gram-negative and Gram-positive organisms).

If hyperleukocytosis, hydroxyurea, and leukapheresis, uncertain role of CNS radiation.

Therapy

Induction chemotherapy cytarabine and anthracycline; possible role of etoposide or mitoxantrone;

possible role for high-dose cytarabine.

Monitor for DIC and tumor lysis, infection, drug toxicities.

APL, acute promyelocytic leukemia; CMV, cytomegalovirus; CNS, central nervous system; DIC, disseminated intravascular coagulation; HIV, human immunodeficiency virus; HLA, human lymphocyte antigen; HSV, herpes simplex virus; MUGA, multiple uptake gated acquisition scan.

Cytogenetic complete remission (CRc) has been proposed as a separate category of CR, indicating reversion to a normal marrow karyotype at CR in patients with an abnormal karyotype at presentation of AML.⁴ Persistence of abnormal metaphases in morphologically normal marrows of patients following recovery from induction chemotherapy is associated with shorter survival in AML patients.⁴⁷⁷ It is important to specify how many metaphases were examined.

Molecular complete remission (CRm) is also relevant in some subtypes of AML.⁴ Quantitative reverse transcriptase polymerase chain reaction (RT-PCR) may detect residual disease in AML cases with fusion genes resulting from chromosomal translocations [e.g., PML-RAR α in t(15;17), AML1/ETO fusion in t(8;21), CBF β -MYH11 fusion in inv(16), and others]. The prognostic significance of CRm achievement is clearly established for APL^{496,497} and CRm is recognized as a therapeutic objective in APL, whereas the significance of CRm in the other subsets of AML is still controversial, particularly in AML with t(8;21), a prognostically favorable subtype of AML in which AML1/ETO transcripts may continue to be detected in patients in long-term morphologic complete remission.⁴⁹⁸ It is important to establish and specify the sensitivities of assays used in assessing CRm.

Another category of response to induction chemotherapy is morphologic complete remission with incomplete blood count recovery (CRI), defined by fulfillment of all of the criteria for CR except for residual neutropenia (<1,000/ μ l) or thrombocytopenia (< 100,000/ μ l).⁴ This category of response was particularly evident in clinical trials of gemtuzumab ozogamicin,⁴⁹⁹ in which patients commonly met all criteria for complete remission except for platelet count recovery. The term CRp was used to indicate complete remission with incomplete platelet recovery following gemtuzumab ozogamicin treatment,⁴⁹⁹ but CRI is a broader term also incorporating incomplete neutrophil recovery, but not both. Survival of patients with CRp appears to be better than for those with treatment failure due to resistant disease, but not as good as those with morphologic CR. In a retrospective study of more than 6,000 patients with AML treated on ECOG, SWOG, and MD Anderson Cancer Center clinical trials, patients who achieved CR had longer relapse-free survival than patients who achieved CRp, after adjustment for covariates, whereas achieving CRp had a positive impact on survival, compared with resistant disease.⁵⁰⁰ Moreover, favorable pre-treatment prognostic factors predicted a higher likelihood of achieving a CR rather than CRp.⁵⁰⁰

Partial remission is defined by attainment of the blood count criteria for complete remission, and a decrease of at least 50% in the percentage of blasts in the bone marrow aspirate, to 5% to 25%, or less than 5% blasts in the marrow with presence of Auer rods.⁴

Remission induction treatment failure can be divided into at least three categories⁴ (Table 75.12). Patients who survive at least 7 days after completion of treatment and have persistent AML in marrow and/or blood are said to have treatment failure due to resistant disease. Patients who survive at least 7 days after completion of treatment and die while cytopenic and with a post-treatment bone marrow within 7 days of death demonstrating aplasia or hypoplasia are said to have treatment failure due to

P.1600

complications of aplasia. Finally, patients with treatment failure of indeterminate cause include those who die less than 7 days after completion of treatment, those who die 7 or more days after completion of treatment whose blood did not show persistent leukemia and whose marrow was not examined post-treatment, and those who die without completing treatment.

TABLE 75.12 TYPES OF FAILURE IN THERAPY OF ACUTE MYELOID LEUKEMIA

Drug Resistance

No response based on persistence of blasts and absence of hypocellularity (usually day 14)

Hypocellular or partial marrow with subsequent regrowth of leukemia

Complications of Aplasia

Hypoplastic death (within 4 wk)

Regeneration failure: marrow remains hypocellular for >4 wk

Indeterminate Cause

Death within 2-3 wk of initiating therapy (marrow either negative or not tested)

Hematologic Remission but Persistent Disease

Myelodysplasia, extramedullary disease; cytogenetic, flow cytometric, or molecular disease

Remission Induction Therapy

Table 75.13 outlines active agents in AML and includes their cell cycle specificity, major toxicities, response rates, and clinical uses. Cytarabine and anthracyclines have been the subject of most intense study. Cytarabine is incorporated into DNA during DNA synthesis and is only effective in cells in the S-phase of the cell cycle. Anthracyclines are not cell cycle-specific and appear to be the most active single agents. Synergy exists between agents with different mechanisms of action, and combination chemotherapy produces better results in AML. Particular considerations with regard to choice of treatment in older AML patients are discussed below, as is AML diagnosed during pregnancy.

Conventional Induction Therapy

The most common induction chemotherapy regimens in AML involve the use of cytarabine (ara-C) and an anthracycline. Cytarabine is usually administered as a continuous infusion of 100 to 200 mg/m²/day for 7 days, with an anthracycline given by intravenous push daily on the first 3 days of ara-C therapy, a combination called "7 + 3." Studies performed by CALGB in the 1980s established the efficacy of this regimen for newly diagnosed AML and since then has been the most commonly used induction regimen for treatment of adult patients with AML.^{501, 502, 503} and ⁵⁰⁴

Continuous infusion of ara-C at a dosage of 100 mg/m² has been shown to be superior to pulse doses of 100 mg/m² every 12 hours.⁵⁰¹ "7 + 3" has been shown to be superior to the same drugs given over 5 days and 2 days (5 + 2), respectively,⁵⁰¹ and appears equivalent to "10 + 3."⁵⁰³ Increasing the ara-C dose in "7 + 3" from 100 mg/m²/day to 200 mg/m²/day or prolonging the infusion to 10 days, in combination with daunorubicin, increased the toxicity with no to minimal improvement in efficacy.^{503, 504} and ⁵⁰⁵

The addition of oral thioguanine 100 mg/m² twice on days 1 to 7 (7+ 3 + 7) did not improve the results. The anthracycline most commonly used in 7 + 3 is daunorubicin, and its dose has ranged between 30 and 90 mg/m² in different studies. In early studies, daunorubicin 45 mg/m² daily was compared to 30 mg/m² daily in the 7 + 3 regimen, and resulted in higher CR rates in patients younger than age 60 years.⁵⁰² A single course of 7 + 3 ara-C and daunorubicin (45 mg/m²) therapy produces a CR rate in the range of 40% to 50%. When a second course of ara-C and daunorubicin (either 5 + 2 or 7 + 3) is administered to patients with morphologic evidence of persistent leukemia in the bone marrow on day 14, the overall CR rate increases to 50% to 85%. Higher response rates (70% to 85%) are seen in patients under 60 years of age with de novo AML.

Two recent phase 3 randomized clinical trials from the United States and South Korea have confirmed the clinical benefit of daunorubicin dose intensification (90 mg/m² vs. 45 mg/m²) in the context of the 7 + 3 regimen in patients younger than 60 years of age with previously untreated AML.^{506,507} In the US study, 90 mg/m² daunorubicin, as compared with 45 mg/m² of the drug, resulted in a significantly higher CR rate (70.6% vs. 57.3%) and, most important, better overall survival (median, 23.7 vs. 15.7 months). The rates of serious adverse events including heart failure and other cardiac toxicities were similar between the two groups.⁵⁰⁶ In the study conducted in South Korea,⁵⁰⁷ the CR rates were also significantly higher (82.5% vs. 72.0%) in the group who received 90 mg/m² daunorubicin compared to the group receiving 45 mg/m² group. With approximately 4.5 years of median follow-up, both overall survival (46.8% vs. 34.6%) and event-free survival (40.8% vs. 28.4%), were significantly better in the 90 mg/m² arm, compared to the 45 mg/m² arm. The advantage of higher-dose daunorubicin was observed in patients with an intermediate-risk cytogenetics but not in those with an unfavorable karyotype or a high-risk molecular profile. The toxicities were similar in the two groups.

Another clinical trial tested the potential benefit of high-dose daunorubicin in older patients receiving intensive chemotherapy.⁵⁰⁸ Newly diagnosed AML patients 60 years of age and older received the 7 + 3 regimen, consisting of cytarabine 200 mg/m² and daunorubicin either 45 mg/m² or 90 mg/m², followed by a second cycle of 1,000 mg/m² cytarabine every 12 hours for 6 days. Complete remission rates (64% vs. 54%) and rates of complete remission after the first cycle of induction treatment (52% vs. 35%) were significantly higher in the group who received 90 mg/m² daunorubicin, compared to the 45 mg/m² group. There was no significant difference between the two groups in 30-day

mortality rates, hematologic toxicities or moderate, severe, or life-threatening adverse events. The OS rates were similar between the two groups. Patients 60 to 65 years of age had higher rates of CR (73% vs. 51%), EFS (29% vs. 14%), and OS (38% vs. 23%) in the 90 mg/m² group as compared with the patients in the same age group who received 45 mg/m² daunorubicin, however, a difference was not seen in those over 65 years, with the exception of the favorable cytogenetic group, who benefited from daunorubicin dose intensification regardless of age.

Modifications of Standard Induction Therapy

The anthracycline idarubicin and the anthracenedione mitoxantrone have been used instead of daunorubicin in 7 + 3. In three randomized trials, idarubicin, given as 12 mg/m² daily for 3 days with ara-C, tended to produce a higher CR rate than daunorubicin and ara-C, more often required only one cycle to induce remission, and was associated with a better survival in some trials.^{509, 510} and ⁵¹¹ The long-term follow-up of the aforementioned three randomized studies suggested better OS for idarubicin compared with daunorubicin in only one study.⁵¹² However, superiority of idarubicin (10 to 12 mg/m²) over daunorubicin (45 to 60 mg/m²) in the achievement of CR when used in the 7 + 3 regimen was confirmed in a meta-analysis.⁵¹³ In a randomized trial in AML patients between 50 to 70 years, idarubicin produced a higher CR rate than high-dose daunorubicin (80 mg/m²/day for 3 days).⁵¹⁴

P.1601

P.1602

Substitution of idarubicin with either fludarabine or topotecan in combination with ara-C for treatment of newly diagnosed AML, refractory anemia with excess blasts in transformation (RAEB-t), or RAEB resulted in lower CR rates and shorter EFS and OS.⁵¹⁵

TABLE 75.13 STANDARD SINGLE AGENTS IN ACUTE MYELOID LEUKEMIA

Class of Agent	Route of Delivery	Cell-Cycle Specificity	Mechanism of Action	Plasma Half-Life (h)	Main Route of Excretion	Response Rate (%)	Major Toxicities Other Than Myelosuppression	Comments
Cytarabine Pyrimidine analog	IV, SC	S	Active form ara-CTP inhibits DNA polymerase and is incorporated in DNA (S phase).	1-2	Renal	15-35	Cerebellar, gastrointestinal, hepatic, skin and	Antileukemic effect is dose-dependent. Cerebellar toxicity occurs in patients >50 y receiving high doses (3 g/m ²).
Daunorubicin, doxorubicin, idarubicin, epirubicin	IV	NS	Inhibits DNA replication by intercalation of base pairs; inhibits	15-30	Hepatic	40-50	Cardiac, gastrointestinal	Cumulative, dose-dependent cardiomyopathy in patients receiving >500 mg/m ² for

				topoisomerase II.				daunorubicin. (cardiomyopathy uncommon <290 mg/m ²). Increased gastrointestinal toxicity with doxorubicin (idarubicin has longer half-life and probably better efficacy).
6-Thioguanine	Purine analog	PO, IV	S	Ribonucleotide forms incorporated into DNA, leading to strand breaks.	6-12	Renal, 10 hepatic	Hepatic, gastrointestinal	Synergistic with cytarabine; unlikely to add to combination of cytarabine and anthracycline.
Mitoxantrone	Anthracenedione	IV	NS	Intercalates into DNA; induces topoisomerase II-mediated damage.	25-50	Hepatic > renal	Cardiac, gastrointestinal	Probably less cardiotoxic than anthracycline antibiotics.
VP-16 (etoposide)	Epipodophyllotoxin	IV, PO	S	Forms complex with DNA and topoisomerase II, leading to strand breaks (G2 phase).	6-12	Renal > hepatic	Gastrointestinal, hepatic, stomatitis	Effects are dose- and schedule-dependent. Oral dose usually twice IV dose. Efficacious in acute monocytic leukemia of infancy. Etoposide phosphate is a water-soluble

Amsacrine (m-AMSA)	Acridine derivative	IV	S	Intercalates into DNA, produces strand breaks (G2 phase).	7-8	Hepatic > renal	30-50	Cardiac, including QT prolongation; gastrointestinal	prodrug of etoposide. Most effective when combined with high-dose cytarabine.
5-azacytidine, decitabine	Pyrimidine analogs	IV, SC	S	Phosphorylated form incorporates into RNA and DNA.	3-6	Renal	10-20	Gastrointestinal, hepatic, skin, neurologic	No cross-resistance with cytarabine; limited by neurologic toxicities. Approved agents for MDS.
Carboplatin	Platinum analog	IV	NS	Covalent binding to DNA.	0.2-40	Renal	20-28	Gastrointestinal	Less nephrotoxicity, ototoxicity, and emesis than cisplatin, but more myelosuppression.
Fludarabine, cladribine, pentostatin, clofarabine	Purine analogs	IV	NS	Inhibit DNA polymerase, incorporate into DNA and RNA, nicotinamide adenine dinucleotide depletion.	Biphasic: α , <30 min; β , 6-20 h	Hepatic > renal	5-25	Neurotoxicity, pulmonary (fludarabine); immunosuppression (T-cell depletion)	Synergism with cytarabine, can potentiate the accumulation of ara-CTP if given before cytarabine. SC and PO under development.

IV, intravenous; MDS, myelodysplasia; NS, nonspecific; PO, orally; S, specific; SC, subcutaneous.

Historically, mitoxantrone has been used more often to treat relapsed AML, and it may have less cardiotoxicity than the anthracyclines.⁵¹⁶ A randomized trial of daunorubicin, idarubicin, and mitoxantrone with standard-dose ara-C as induction therapy in older AML patients showed no differences in clinical outcome.⁵¹⁷

Daunorubicin (50 mg/m²) on days 1 to 3 plus ara-C (25 mg/m² bolus followed by 160 mg/m² as a continuous infusion daily for 5 days) and 6-thioguanine (100 mg/m² orally every 12 h daily for 5 days) (DAT) was compared with amsacrine (190

mg/m², IV on days 1 to 3) plus ara-C and 6-thioguanine at the similar doses (AAT) in a trial involving approximately 100 adult patients with de novo AML. Patients who achieved CR received two courses of the same chemotherapy regimen as consolidation therapy. Stratified by age, CR rate and OS were better in the AAT group compared to the DAT group.

Other studies have tested the addition of a third agent to the 7 + 3 regimen. The addition of etoposide to 7 + 3 at 75 mg/m²/day for 7 days (7 + 3 + 7) did not improve CR rates and was associated with more mucositis, but it did improve median remission duration (12 months for 7 + 3 vs. 18 months for 7 + 3 + 7). Overall survival was similar between the two groups.⁵¹⁸ A three-drug induction regimen known as ADE, consisting of ara-C 100 mg/m²/day for 7 days and both daunorubicin 90 mg/m² and etoposide 100 mg/m² daily for 3 days, was tested by CALGB in previously untreated de novo AML patients less than 60 years, without excess cardiotoxicity, and with a complete remission rate of 75% and a median disease-free survival of 1.34 years and median overall survival of 1.86 years.⁵¹⁹ Moreover, ADE consisting of ara-C 100 mg/m²/day for 7 days and both daunorubicin 60 mg/m² and etoposide 100 mg/m² daily for 3 days was used in previously untreated older AML patients, with rates of CR, nonresponse, and death of 46%, 34%, and 20% with median disease-free survival of 7 months; these results were not superior to historical results.⁵²⁰

Because Pgp overexpression and function in AML cells are strongly associated with adverse treatment outcome, clinical trials of Pgp modulators, or noncytotoxic competitive inhibitors of drug transport by Pgp, were undertaken in AML. Addition of PSC-833, a cyclosporin derivative which is a potent Pgp inhibitor, to induction regimens containing the Pgp substrates daunorubicin or mitoxantrone and etoposide did not show clinical benefit,^{521,522} nor did addition of zosuquidar, another potent Pgp inhibitor.⁵²³ In contrast, addition of cyclosporin A to chemotherapy was beneficial in some trials.^{524,525} Cyclosporin A blocks drug transport by multiple MDR proteins known to be expressed in AML.⁵²⁶

High-dose Cytarabine

The antileukemic effect of cytarabine depends on dosage and schedule. Cytarabine is effective at both high and standard dosages. Although at plasma concentrations greater than 10 μM, which are achieved with high-dose ara-C (2 to 3 g/m² daily), the drug diffuses freely into cells,⁵²⁷ at concentrations less than 1 μM, which are achieved with 100 to 200 mg/m² daily, ara-C influx into cells is strongly correlated with the number of nucleoside transporters per leukemic blast.⁵²⁸ High-dose cytarabine (HiDAC) (1 to 3 g/m² every 12 to 24 hours, for 4 to 12 doses), with or without either an anthracycline, mitoxantrone, or etoposide, is particularly effective as intensification therapy or as therapy for relapsed disease.^{529, 530} and⁵³¹ HiDAC crosses the blood-brain barrier and can help prevent CNS leukemia, but cerebellar toxicity may develop, particularly in patients 50 years of age or older.⁵³² Lengthening the duration of administration from 1 hour to 3 hours or decreasing the dose from 3 g/m² to 1.5 g/m² may lessen the risk of cerebellar toxicity and is common practice in patients over 50 years of age. Patients receiving HiDAC must be tested for cerebellar toxicity before each dose, and subsequent doses of HiDAC must be withheld if cerebellar toxicity is documented or suspected; the ara-C dose must then be decreased, and HiDAC also cannot be administered as part of any subsequent therapy. Conjunctivitis and a painful, blistering erythematous rash involving the palms and soles are common side effects following HiDAC. Administration of corticosteroid eyedrops may prevent conjunctivitis, which is caused by secretion of cytarabine administered at high doses into tears.

Although HiDAC has most often been given as consolidation therapy or for relapsed disease, high CR rates (up to 90%) were observed when HiDAC was given during induction in some studies in the early 1990s.⁵³³ In a randomized trial by the Australian Leukemia Study Group in newly diagnosed AML patients less than 60 years old,⁵³⁴ the CR rate was similar with HiDAC (6 g/m² per day) and standard-dose (100 to 200 mg/m² daily administered as a 7-day continuous infusion) ara-C-based remission induction and post-remission therapy, but HiDAC was associated with a significantly longer estimated median remission duration (45 vs. 12 months) and higher percentage of 5-year relapse-free survival (48% vs. 25%), but also with greater hematologic and nonhematologic toxicities. Another randomized trial of high-dose (4 g/m² per day) versus standard-dose ara-C in newly diagnosed AML patients less than 65 years old by the Southwest Oncology Group⁵³⁵ demonstrated slightly better relapse-free survival (33% vs. 21% at 4 years for patients less than age 50 and 21% vs. 9% for ages 50 to 64 years), but a significantly higher risk of fatal toxicity with high-dose ara-C. The efficacy of HiDAC, as part of a double induction strategy, was tested against standard-dose ara-C in a large randomized trial.⁵³⁶ Two courses of standard-dose cytarabine, daunorubicin, and 6-thioguanine (TAD) were compared with one course of TAD followed by high-dose cytarabine (3 g/m² every 12 hours for 6 doses) with mitoxantrone (HAM) starting on day 21 regardless of the presence or absence of leukemic blasts in the bone marrow. CR rates (65% vs. 71%) and survival were similar between the two groups. Recently, another randomized clinical trial in more than 800 AML patients younger than 60 years tested the efficacy and toxicity of different doses of cytarabine in the setting of a double-induction chemotherapy regimen.⁵³⁷ Patients were randomly assigned to receive either intermediate doses of cytarabine (200 mg/m² for cycle 1 followed by 1 g/m² twice daily for cycle 2) or HiDAC (1 g/m² twice daily for cycle 1 followed by 2 g/m² twice daily for cycle 2), with idarubicin in cycle

1 and amsacrine in cycle 2 in all patients. If patients achieved a CR, they received consolidation therapy that did not contain cytarabine. This trial showed no efficacy advantage for HiDAC when compared to intermediate-dose cytarabine. The rates of CR (80% vs. 82%), CR after the first cycle 1 (60% vs. 66%), 30-day mortality (10% in both groups), event-free survival (34% vs. 35%), and overall survival (40% vs. 42%) at 5 years were similar for intermediate dose and HiDAC, respectively.⁵³⁷ Patients in the HiDAC group experienced higher rates of grade 3 and grade 4 toxicities (51% vs. 61%) in cycle 1, and prolonged hospitalization, and delayed neutrophil and platelet recovery in cycle 2. On the basis of these data, the use of HiDAC for induction chemotherapy for newly diagnosed AML is not generally recommended, unless in special circumstances.

Other Nucleoside Analogues

Nucleoside analogues including cladribine (2-CdA), fludarabine, clofarabine, gemcitabine, pentostatin, troxacitabine, and sapacitabine have also been tested in AML.^{538, 539, 540} and ^{541,542,543}

Fludarabine has been extensively studied in AML because of pre-clinical⁵⁴⁴ and clinical data demonstrating that its administration prior to ara-C sensitizes leukemic blasts to ara-C by enhancing ara-CTP formation.⁵⁴⁵ The observation that administration of

P.1603

G-CSF with fludarabine further enhanced this effect⁵⁴⁶ led to the design of a regimen consisting of fludarabine with high-dose cytarabine and G-CSF (FLAG).^{547, 548} and ⁵⁴⁹ Derivative regimens incorporating idarubicin with (FLAG-IDA)^{550,551} or without G-CSF (FLAI)⁵⁵² are also active in AML.

Clofarabine is a second-generation nucleoside analog that has activity in AML by itself or when administered prior to ara-C.^{553,554} In a phase II trial in hematologic malignancies, an overall response rate of 48% was reported; AML patients with a short first CR (≤ 1 year) had a response rate of 18%, compared to 87% in those with a longer first CR.⁵⁵³ Clofarabine combined with ara-C produced a response rate of 60% and a CR rate of 52% in untreated AML, and a response rate of 38% and a CR rate of 22% in relapsed AML.^{554,555} In two single-arm studies, single-agent intravenous clofarabine (30 mg/m² daily for 5 days) demonstrated a CR + CRi rate of approximately 46% to 48%, with CR rates of 32% to 38% in high-risk older patients, including those with an unfavorable karyotype.^{556,557}

Recently, a 652-patient Polish Adult Leukemia Group (PALG) randomized multicenter trial in patients age 60 years or younger with AML demonstrated that cladribine, but not fludarabine, added to 7 + 3 induction chemotherapy prolonged survival.⁵⁴² Patients received 7 + 3 alone (AraC 200 mg/m² on days 1 to 7 as a continuous infusion plus daunorubicin 60 mg/m² daily infusion on days 1 to 3) or 7 + 3 plus a 3-h infusion of cladribine (5 mg/m² daily on days 1 to 5), or 7 + 3 plus a 30-min infusion of fludarabine (25 mg/m² daily on days 1 to 5). Consolidation chemotherapy included high-dose cytarabine and stem cell transplantation or 2 years maintenance chemotherapy, based on relapse risk. Both the CR rates (68% vs. 56% vs. 59%) and 3-year overall survival rates (45% vs. 33% vs. 35%) were significantly improved by addition of cladribine to the 7 + 3 regimen, compared to 7 + 3 alone and 7 + 3 + fludarabine, respectively. Toxicity was not significantly different in the three arms. Patients with an unfavorable karyotype also benefited from 7 + 3 + cladribine.

Hematopoietic Growth Factors

A variety of purified cytokines has been investigated as modifiers of cytopenias and of leukemia growth in vitro and in vivo. The best studied are the myeloid hematopoietic growth factors GM-CSF and G-CSF. Due to in vitro data demonstrating proliferative effects on AML blasts and based on clinical trial data outlined below, routine use of the myeloid growth factors in AML is not recommended.

Despite concerns about proliferative effects of myeloid CSFs on AML cell growth, studies were initiated in the 1990s to determine their clinical efficacy in AML. Two studies evaluated Escherichia coli-derived G-CSF in patients with relapsed or refractory leukemia and yeast-derived GM-CSF in older patients with de novo AML. Both reports indicated that the CSFs could be administered safely, with a statistically significant reduction in the duration of neutropenia and in early deaths, and trends toward an improvement in the CR rate, but not in survival.^{558,559}

Subsequently, a number of phase III trials of GM-CSF and G-CSF consistently showed more rapid neutrophil recovery, which usually results in fewer infections and shorter hospitalizations, but no improvement in CR rates, relapse rates, or overall survival.^{560, 561, 562, 563, 564, 565, 566} and ⁵⁶⁷ Two randomized trials evaluating the role of G-CSF after consolidation therapy showed decreases in the duration of severe neutropenia and a decreased rate of infection, but no effect on CR duration or OS.^{566,568}

There were also attempts to exploit the proliferative effect of myeloid growth factors on leukemia cells to recruit AML cells into S-phase in order to increase chemosensitivity to ara-C, an S-phase-specific agent. In these clinical trials, G-CSF or GM-CSF was administered prior to and/or during chemotherapy, so-called "growth factor priming." These clinical trials have generally not demonstrated clinical benefit,^{517,563,569, 570} and⁵⁷¹ with some exceptions.^{572,573} One possible reason is that, although G-CSF administered to untreated AML patients prior to chemotherapy did increase the percentage of blasts in S-phase, this percentage remained low.⁵⁷⁴ Hematopoietic growth factor priming is not recommended, outside of clinical trials.⁵⁷⁵

Post-remission Therapy

In the absence of post-remission therapy, the probability of cure is approximately zero⁵⁷⁶ with all patients relapsing within a median of 6 months, so post-remission therapy is essential, with the goals of decreasing and attempting to eliminate residual disease, delaying relapse and increasing the likelihood of cure.

Although additional therapy clearly is required beyond induction therapy, utilizing drugs at similar doses to those used in induction therapy, with or without maintenance therapy, has not had a major impact on survival in AML. With a CR rate of 60% to 75%, 15% to 25% of adults could be expected to have prolonged survival after consolidation or maintenance therapy administered through 1980.

Studies involving the use of HiDAC at different dosages and schedules as post-remission therapy suggested that survival in AML could be improved by dose escalation (Table 75.14).^{577,578,579,580} Wolff et al. reported the efficacy of HiDAC/daunomycin intensification in AML, with a projected 49% survival that was age-dependent (83%, 50%, and 23% for age groups 25 or less, 26 to 45, and more than 45 years, respectively).⁵⁷⁹

Randomized trials were performed to confirm the value of HiDAC consolidation.^{581,582,583} In an ECOG trial of 143 patients in first CR after daunorubicin, cytarabine, and 6-thioguanine, patients were randomly assigned to 24 months of low-dose maintenance therapy or one course of HiDAC (3 g/m² every 12 hours for 6 days) plus amsacrine.⁵⁸² Although HiDAC caused more toxic deaths, the 4-year DFS in patients less than 60 years of age was 28%, compared to 15% for those receiving maintenance therapy. In contrast the Leukemia Group for the Swiss Society for Cancer randomly assigned 137 patients in first CR after ara-C, daunorubicin, etoposide, and AMSA to standard-dose ara-C at 100 mg/m²/day for 7 days or HiDAC at 3 g/m² every 12 hours for 6 days and found no difference in DFS.⁵⁸⁴

In a landmark clinical trial, the CALGB randomly assigned 596 patients in first CR after 7 + 3 to one of three different ara-C dose schedules: HiDAC at 3 g/m² over 3 hours every 12 hours on days 1, 3, and 5 (6 doses); intermediate-dose ara-C at 400 mg/m²/day for 5 days by continuous infusion; or lower-dose ara-C at 100 mg/m² for 5 days by continuous infusion.⁵⁸³ The estimated probabilities of remaining in CR at 4 years for patients less than 61 years of age were 44%, 29%, and 24% for the three treatments, respectively (Fig. 75.13, P = 0.002), but there were no differences among the arms in patients over the age of 60, with a probability of 16% or less of remaining in CR. These results clearly show that consolidation with HiDAC improves DFS in younger patients in first CR. Multiple cycles may be required to obtain the maximum benefit of HiDAC consolidation.^{535,583}

The efficacy of HiDAC consolidation therapy also varies by cytogenetic group. In an analysis of cytogenetic correlates in the CALGB three-arm consolidation study referred to above,⁵⁸³ Bloomfield et al. found that the impact of HiDAC consolidation was greatest in the favorable cytogenetic group, with 78% of patients remaining in remission at 5 years, compared to 40% of those with a normal karyotype, and 21% of those with other abnormalities.⁵⁸⁵ The favorable impact of repetitive cycles of HiDAC in AML with the favorable karyotypes t(8;21) and inv(16) was confirmed in series focusing on patients with those abnormalities.⁴⁷⁶ In addition, patients less than 60 years old with a normal karyotype had 5-year disease-free survival rates of 41% and 45% following four cycles of HiDAC or ara-C 400 mg/m² consolidation or one cycle of

P.1604

HiDAC/etoposide followed by autologous hematopoietic stem cell transplantation.⁵⁸⁶ Of note, these studies antedated the availability of molecular data.

TABLE 75.14 TRIALS EVALUATING HIGH-DOSE CYTARABINE (HiDAC) IN POST-REMISSION THERAPY

Source	Post-remission	Duration (mo)	CR No. of Patients (%) in	Median Age (y)	Median Duration of Follow-up (y)	Median Duration of CR (y)	Complete Response (%)	Toxic Death (%)
--------	----------------	---------------	---------------------------	----------------	----------------------------------	---------------------------	-----------------------	-----------------

		Remission	-Up (mo)	(mo) ³	in Continuous Remission after 24 mo (%)				
Uncontrolled	Regimen	n	n	n	n				
Vaughan ⁵⁶⁴	Ara-C, DNR, ara-c	Ara-C, DNR, 3	76	25	35	35	30	44	4
Preisler ⁴⁹⁸	7 + 3 or 10 + 3	Ara-C, Dox, Amsa, or HiDAC	58	123	55	20	22	47	5
Tricot ⁵⁶⁵	10 + 3	HiDAC, ara-C, DNR	72	44	36	14	Not reached	62	9
Champlin ⁵⁶³	DAT	HiDAC, DNR, Ara-C, DNR	63	70	47	55	23	40	6
Wolff ⁵⁶⁶	7 + 3 or 10 + 3	HiDAC, DNR	87	38	42	36	49	5	
Harousseau ⁵⁶⁷	Z/ara-C	Ara-C/DNR; HiDAC/Amsa, BCNU, ara-C, cyclo etoposide	76	57	44	60	43	40	12
Controlled									
Cassileth ⁵⁷⁰	DAT	HiDAC/Amsa	99				N/A	28	12
			68		44	48		(p = 0.047)	
		Ara-C, 6-TG	94				N/A	15	0
Mayer ⁵⁷¹	3 + 7	HiDAC	187	43			44	5	
		Ara-C, 400 mg/m ²	64	206	49	37	N/A	29	6
		Ara-C, 100 mg/m ²	203		48			24	
								(p = 0.002)	1

ara-C, cytarabine; Armsa, amsacrine; BCNU, carmustine; CR, complete remission; cyclo, cyclophosphamide; DNR, daunorubicin; Dox, doxorubicin; N/A, not available, 6-TG, 6-thioguanine;

Z, zorubicin. CR duration data for controlled studies presented for patients <60 years of age.

A recent, large (n = 781) prospective randomized trial from Japan compared four courses of conventional multiagent chemotherapy to three courses of HiDAC (2 g/m² twice daily for 5 days) alone as post-remission therapy for AML in adult patients younger than 65 years in first complete remission.⁵⁸⁷ Five-year DFS (43% vs. 39%) and 5-year OS (58% vs. 56%) were similar for the HiDAC group and the multiagent chemotherapy, respectively. In patients with favorable cytogenetic risk, 5-year DFS (57% vs. 39%) and 5-year OS (75% vs. 66%) were significantly better in the HiDAC group compared with the multiagent chemotherapy group. The frequency of infections was higher in the HiDAC group. Another recent clinical trial (n = 237) from France compared HiDAC with timed-sequential chemotherapy in patients 15 to 50 years of age with AML in first remission.⁵⁸⁸ No significant difference was reported between the two arms with respect to 5-year EFS, cumulative incidence of relapse, or treatment-related mortality. Finally, a clinical trial (n = 933) from Germany compared two HiDAC regimens (36 g/m² vs. 12 g/m²) as a first consolidation in untreated AML patients age 15 to 60 years.⁵⁸⁹ In the intention-to-treat analysis, there were no significant differences in the 5-year OS (30% vs. 33%) or DFS (37% vs. 38%).

Data with regard to administration of hematopoietic growth factors after post-remission therapy are similar to those on administration after induction. Two randomized trials evaluating the role of G-CSF after consolidation therapy both showed decreases in the duration of severe neutropenia and a decreased rate of infection, but no effect on complete response duration or overall survival.^{566,568}

In summary, for younger adults with favorable cytogenetic and molecular findings, HiDAC intensification alone (four cycles using CALGB doses and schedule) is often considered the best treatment choice. For younger adults with intermediate-prognosis cytogenetic and molecular findings, reasonable choices include HiDAC consolidation alone (four cycles using CALGB doses and schedule), or allogeneic transplantation. For older patients with good performance status and who have an available donor and meet age and health criteria, allogeneic transplantation should be considered, and a modified HiDAC regimen can be used for those without transplant options or opting not to pursue transplant. Because there is no post-remission chemotherapy regimen established as superior to others in older patients, participation in a clinical trial is recommended. For all patients who have adverse prognostic features including, in particular, prognostically unfavorable karyotypes or molecular findings (see section "Prognosis") and who have an available donor and meet age and health criteria, allogeneic hematopoietic SCT is the treatment of choice in first remission (see "Stem Cell Transplant" section).

In contrast to the approach in ALL, maintenance chemotherapy does not play an important role in AML. Randomized trials showed that maintenance therapy may prolong initial remissions,^{200,590} but has no benefit in improving the cure rate of AML.^{591,592} Moreover, maintenance chemotherapy appears unwarranted in AML if post-remission therapy is of adequate intensity.^{591,592} Novel approaches to maintenance therapy are being explored,⁴⁹⁵ but their ultimate benefit is unknown.

P.1605

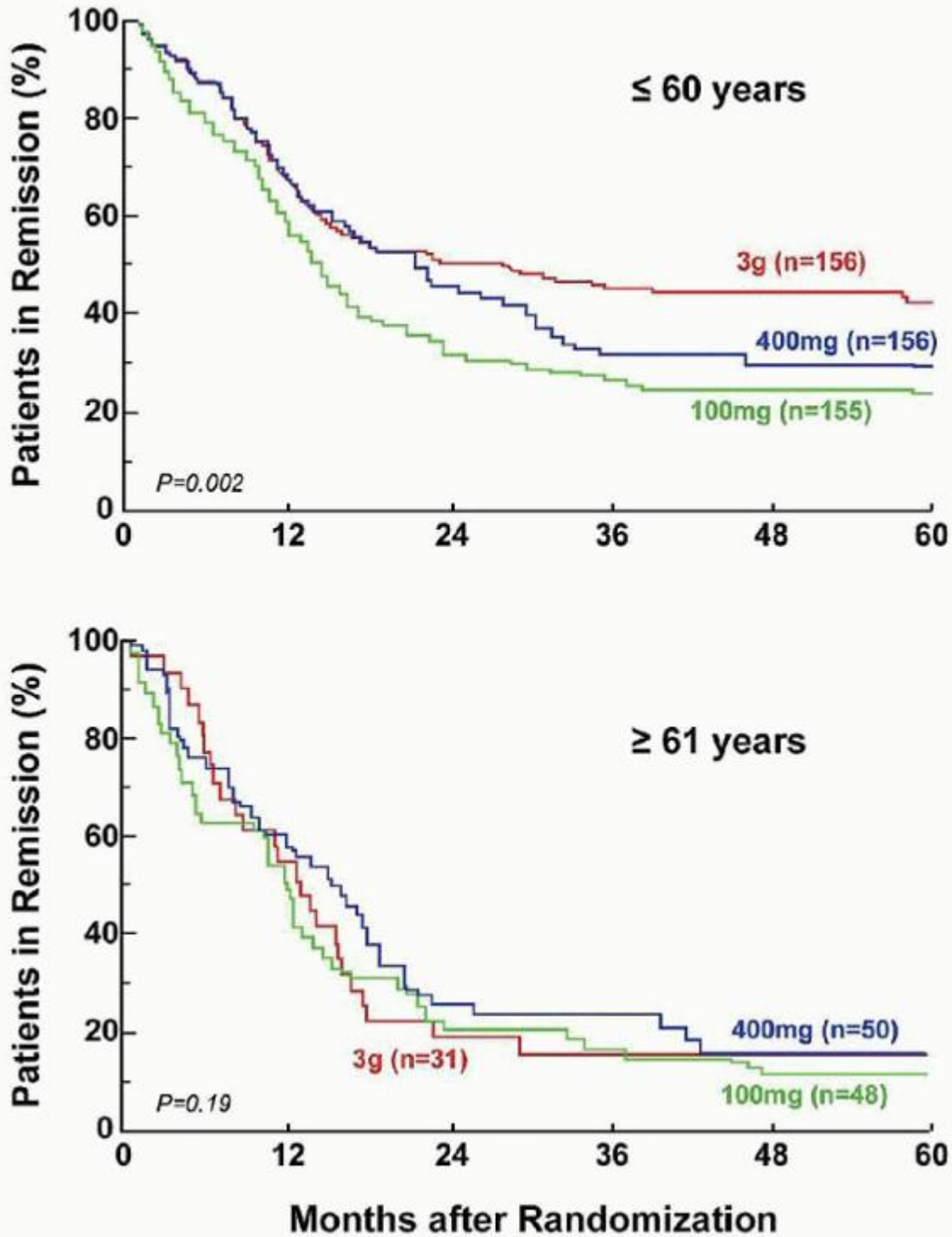

FIGURE 75.13. Effect of different doses of cytarabine on disease-free survival, patients 60 years of age or younger (A), and patients >60 years of age (B). Only patients who underwent randomization are included. The p values are for the differences among the three treatment groups. Median follow-up was 52 months. (With permission from Mayer R, Davis RB, Schiffer CA, et al. Intensive postremission chemotherapy in adults with acute myeloid leukemia. *N Engl J M* 1994;331:896-903.)

Novel Agents

New agents with novel mechanisms of actions are being investigated for the treatment of AML. Table 75.15 shows some of these agents with their chemical structures. Also see the section on “Other Nucleoside Analogs.”

Several pre-clinical and early-phase clinical trials have been conducted to test the potential antileukemic activity of novel agents that target molecular mutations, epigenetic gene silencing, and aberrant signal transduction. Targets include, but are not limited to, the FLT3-ITD mutation, the epigenome (DNA methylation and histone acetylation), kinases (Pim, aurora, RAS/RAF/MAP), metabolic pathways (PI3K/AKT/mTOR), cellular reduction/oxidation (redox) states, mitochondria and reactive oxygen species, the WNT/ β -catenin signaling pathway, Hedgehog signaling, TP53, angiogenesis, ubiquitin-proteasome pathways, cell surface farnesylation, and anti- and proapoptotic proteins such as MCL-1, BCL-2, and BAX.

DNA methylation may contribute to leukemogenesis by silencing tumor suppressor genes, and the DNA methyltransferase inhibitors azacitidine and decitabine inhibit DNA methylation and have had activity in phase I-II trials in patients with AML as well as MDS, as do histone deacetylase inhibitors such as phenylbutyrate, valproic acid, depsipeptide, suberoylanilide hydroxamic acid (SAHA), and MS-275.^{593, 594, 595, 596, 597} and⁵⁹⁸ DNA methyltransferase inhibitors are being evaluated as initial therapy for AML in older adults.^{599, 600, 601, 602} and⁶⁰³

FLT3 Inhibitors

Because of the importance of FLT3-ITD resulting in constitutive FLT3 signaling as an adverse prognostic factor in AML, as outlined above, inhibitors of FLT3 signaling have been developed and are being tested in clinical trials in AML (Fig. 75.14). FLT3 inhibitors that have been tested include midostaurin,⁶⁰⁴ lestaurtinib,⁶⁰⁵ sorafenib,⁶⁰⁶ sunitinib,⁶⁰⁷ tandutinib,⁶⁰⁸ and AC220.⁶⁰⁹ CEP-701 (lestaurtinib) is an orally administered indolocarbazole derivative that is cytotoxic to AML blasts with FLT3-ITD in vitro⁶¹⁰ and in vivo⁶¹¹ and has clinical activity in AML.^{612, 613} It was tested in combination with chemotherapy, with the design of the combination regimen based on pre-clinical data,⁶¹⁴ but unfortunately no clinical benefit was seen.⁶⁰⁵ Clinical trials of other agents are recently completed or in progress. Resistance to FLT3 inhibitors may occur by activation of other signaling pathways⁶¹⁵ or by progressive up-regulation of FLT3 ligand.³⁰⁹ FLT3 inhibitors also have in vitro activity in AML without FLT3 mutations.⁶¹³

Gemtuzumab Ozogamicin

In early studies in AML, unconjugated monoclonal antibodies targeting CD14, CD15, and CD33 produced low response rates (<10%).^{616, 617} Consequently, investigators turned to conjugated antibody therapy, with CD33 being the best studied target, as it is present on AML cells in 90% of cases²⁰⁹ and is expressed on normal hematopoietic cells but not on normal hematopoietic stem cells. The best studied anti-CD33 antibody conjugate is gemtuzumab ozogamicin (Mylotarg), which uses a recombinant humanized anti-CD33 monoclonal antibody to deliver calicheamicin, an antibiotic that binds to the minor grooves of DNA, causing double-strand breaks and apoptosis.⁶¹⁸ Calicheamicin is a substrate for Pgp-mediated efflux.⁶¹⁹

When two 9 mg/m² gemtuzumab ozogamicin doses were given over 4 h 14 days apart to patients with CD33⁺ AML in untreated first relapse in phase II trials, the overall response rate was 26%, including 13% CR, and 13% CRp.^{620, 621} Response rates did not differ based on age or length of first remission. The median overall survival was 4.9 months for all patients and 12.6 months for responders. Severe myelosuppression was uniformly present, reflecting expression of CD33 on mature myeloid cells, but sepsis (17%) and pneumonia (8%) were relatively uncommon.⁶²¹

Gemtuzumab ozogamicin was subsequently also tested as frontline therapy. A 33%/5% CR/CRp rate was seen in AML patients 61 to 75 years of age who were not candidates for standard chemotherapy, but toxicity was excessive in patients older than 75 years.⁶²² In a randomized trial, the addition of gemtuzumab ozogamicin to different induction and consolidation chemotherapy regimens resulted in no difference in CR rate or survival,⁶²³ but survival benefit was demonstrated for patients with favorable-risk cytogenetic findings.

Gemtuzumab ozogamicin was approved by the United States Food and Drug Administration in May, 2000 under the accelerated approval regulations for the treatment of patients 60 years of age or older with CD33-positive AML in first relapse. Post-marketing reports of fatal anaphylaxis, tumor lysis, adult respiratory distress syndrome (ARDS), and hepatic veno-occlusive disease (VOD) required labeling revisions and the initiation of a surveillance program.⁶²⁰ Tumor lysis and ARDS were primarily observed in patients with leukocyte counts above 30,000/ml. VOD was also observed.^{620, 624}

Under accelerated approval, additional clinical trials after approval are required to confirm the drug's benefit. If those trials fail to confirm clinical benefit to patients, the FDA can withdraw the drug from the market. For gemtuzumab ozogamicin, a confirmatory clinical trial was designed and begun in 2004 to determine whether adding gemtuzumab ozogamicin to standard chemotherapy would improve survival of patients with AML. The trial was stopped early when no

clinical benefit was observed, and after a greater number of deaths occurred in patients who received gemtuzumab ozogamicin compared with those who received chemotherapy alone. Gemtuzumab ozogamicin was withdrawn from the P.1606

P.1607

P.1608

market in June, 2010. Nevertheless other subsequently published studies have shown benefit.⁶²⁵

TABLE 75.15 NEW AGENTS IN DEVELOPEMENT FOR TREATMENT OF ACUTE MYELOID LEUKEMIA

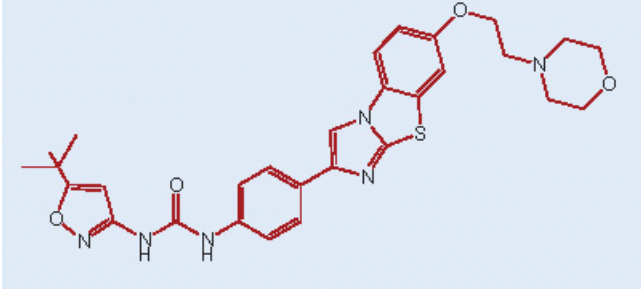
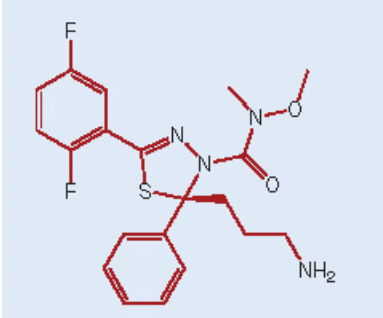
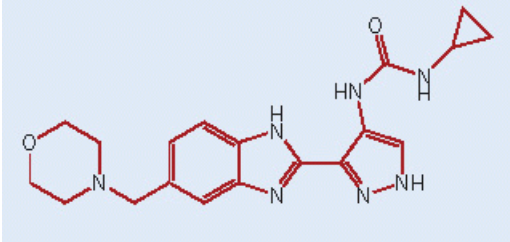
Compound	Chemical Structure	Mechanism of Action
AC-220		Flt3 kinase inhibitor
Aflibercept	Fusion Protein	Angiogenesis inhibitor, VEGF antagonist
ARRY-520		Kinesin spindle protein inhibitor, cell cycle inhibitor, mitotic inhibitor
AT-9283		Aurora kinase inhibitor, Janus kinase 2 inhibitor, cell cycle inhibitor, mitotic inhibitor

Azacitidine

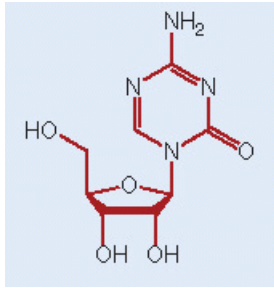

DNA methyltransferase inhibitor

AZD-1152

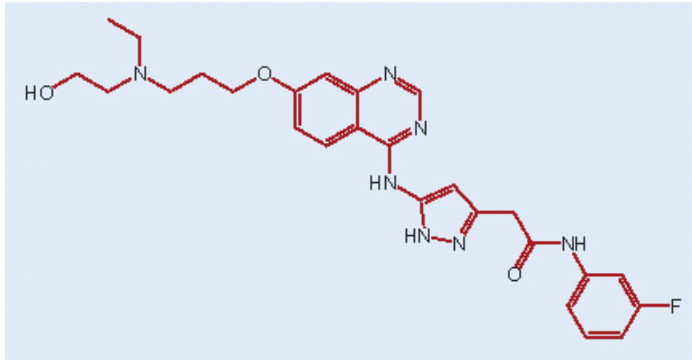

Aurora kinase inhibitor

Belinostat

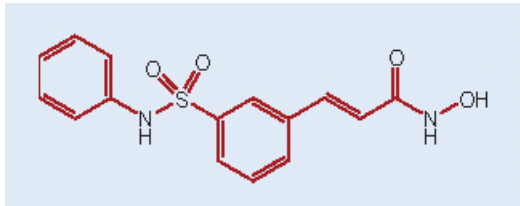

Histone deacetylase inhibitor

Bortezomib

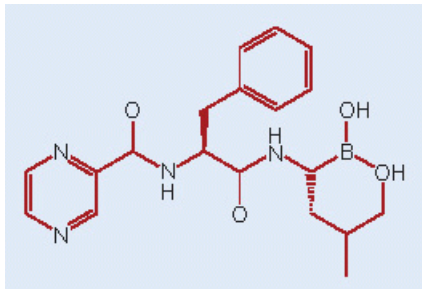

Proteasome inhibitor, transcription factor NF-κB inhibitor

CP-4055 (Elacyt)

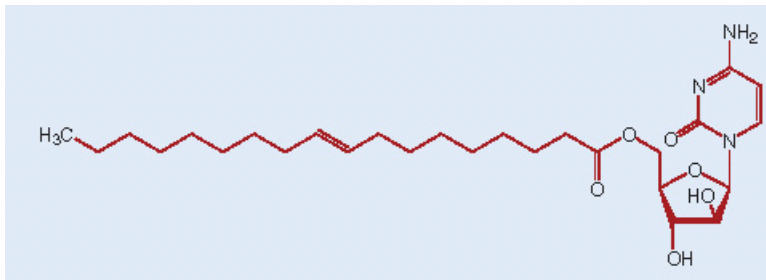

Antimetabolite, DNA/RNA synthesis inhibitor ara-C-5'-elaidic acid ester

CSL-360

Monoclonal antibody

Monoclonal antibody against leukemia stem cells

Decitabine

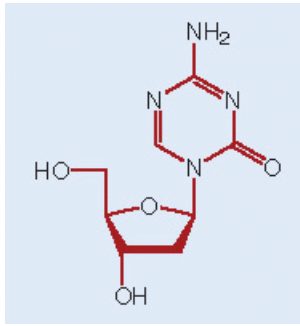

DNA methyltransferase inhibitor

17-DMAG

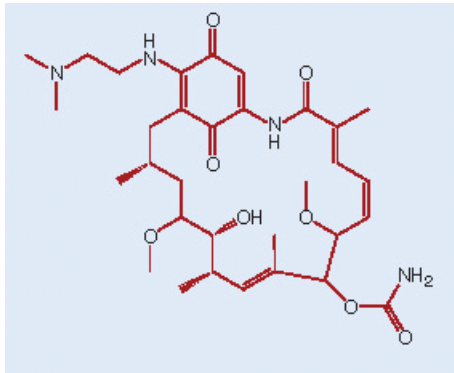

Hsp90 inhibitor

Entinostat

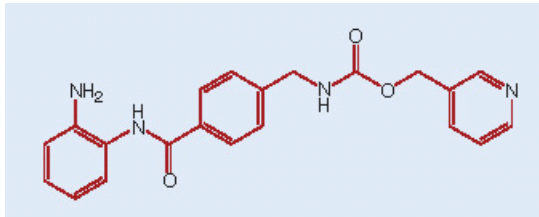

Histone deacetylase inhibitor

Everolimus

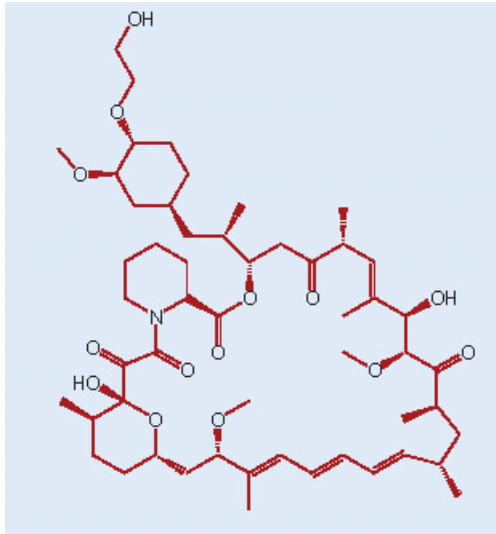

mTOR inhibitor,
angiogenesis inhibitor

Flavopiridol



Cyclin-dependent kinase (Cdk) inhibitor

Lenalidomide

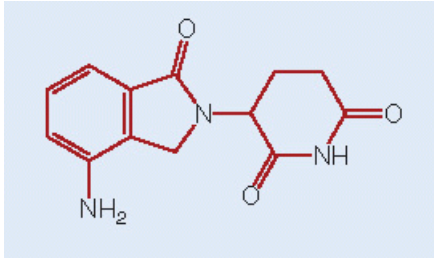

Immunomodulation,
angiogenesis inhibition,
tumor necrosis factor α
antagonist

Lintuzumab Monoclonal antibody

Monoclonal antibody
against CD33

Midostaurin

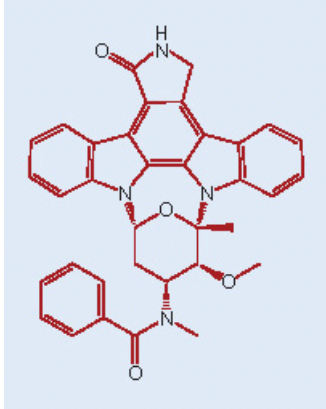

Protein kinase C inhibitor,
Flt-3 kinase inhibitor, cell
cycle inhibitor

Mocetinostat

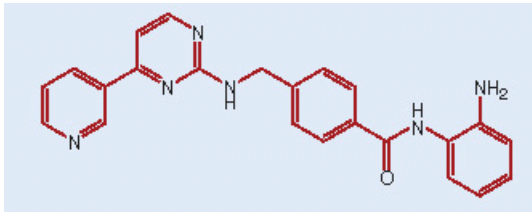

Histone deacetylase
inhibitor

Obatoclax
mesylate

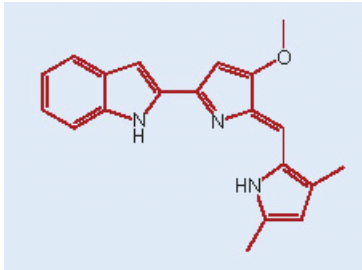

Mcl-1 antagonist, Bcl2
antagonist

Sapacitabine

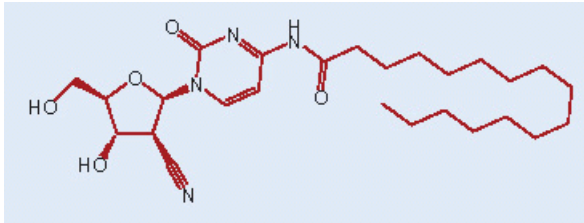

Antimetabolite, DNA
synthesis inhibitor

Sirolimus

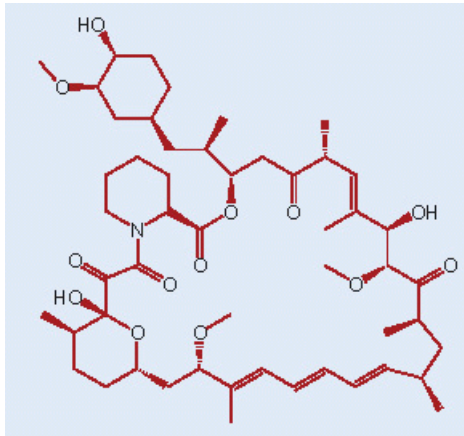

mTOR inhibitor,
angiogenesis inhibitor

Sorafenib

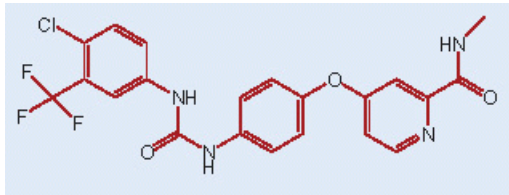

Flt-3 kinase inhibitor, RET
tyrosine kinase inhibitor, B-
raf kinase inhibitor, EGF
receptor kinase, inhibitor,
PDGF receptor kinase
inhibitor, angiogenesis
inhibitor

Sunitinib

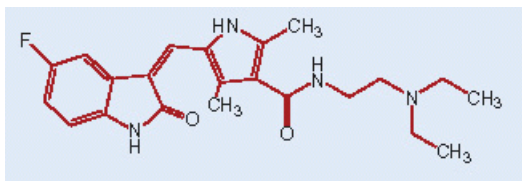

Flt-3 kinase inhibitor, c-kit
inhibitor, EGF receptor
kinase inhibitor, PDGF
receptor kinase inhibitor

Temsirolimus

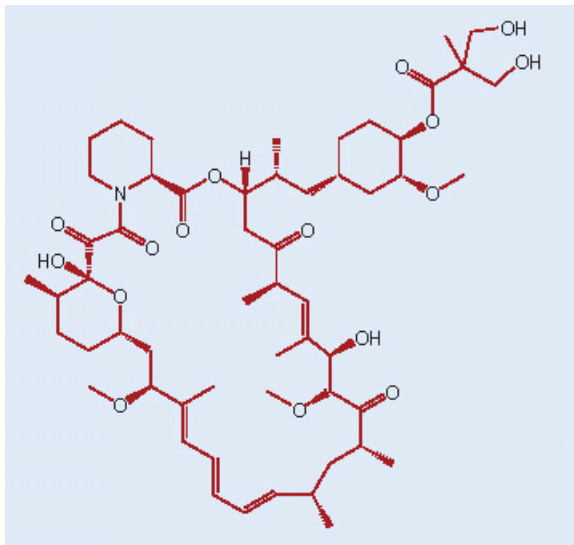

mTOR kinase inhibitor

Tandutinib



Flt-3 kinase inhibitor, c-kit
inhibitor, PDGF receptor
kinase inhibitor

Tipifarnib

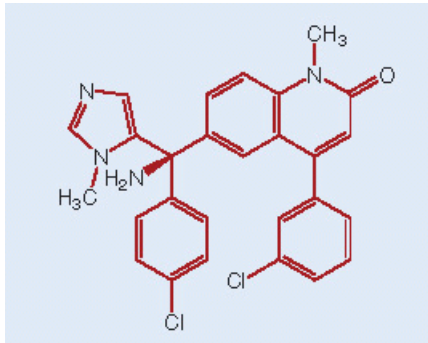

Farnesyltransferase inhibitor

Voreloxin

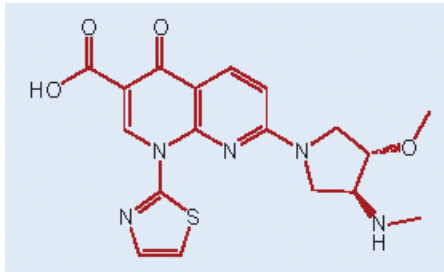

DNA Topoisomerase II inhibitor, DNA-dependent protein kinase inhibitor

Vorinostat (SAHA)

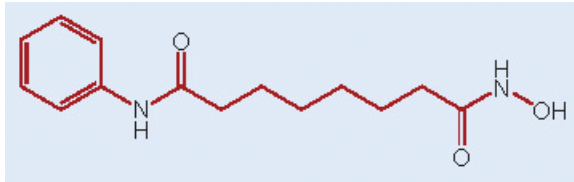

Histone deacetylase inhibitor

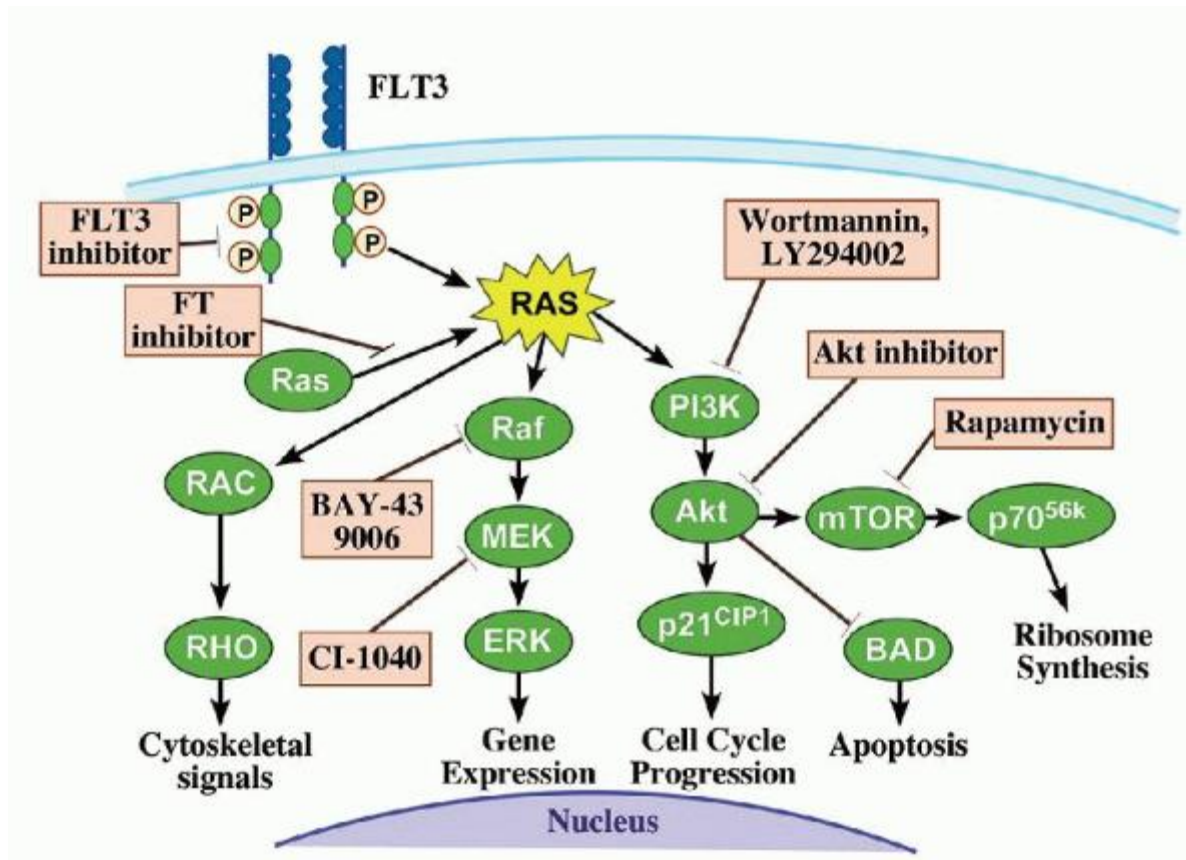

FIGURE 75.14. Signal transduction pathways downstream to FLT 3 and other tyrosine kinase receptors include Ras/Raf/MEK and PI3K/Akt. FT, farnesyl transferase. (See text for description of targets and inhibitors.) (Drawing by Tim

Gilfilen, Medical Art Group, Vanderbilt University.)

Other Novel Agents in Acute Myeloid Leukemia

Lenalidomide has antiangiogenic effects and other effects on the marrow microenvironment, has been approved for MDS with 5q-, and is under investigation in AML.^{626,627} Angiogenesis is targeted by several other novel agents: SU5416 (Semaxinib) in an example of a small molecule receptor tyrosine kinase inhibitor directed at the vascular endothelial growth factor pathway; early trials with SU5416 indicate activity in AML.⁶²⁸ The anti-VEGF monoclonal antibody bevacizumab also has activity in AML.⁶²⁹ Bortezomib (Velcade) is a small molecule proteasome inhibitor that has activity in vitro in AML and is in clinical trials.⁶³⁰ Tipifarnib (Zarnestra) is an orally administered nonpeptidomimetic enzyme-specific inhibitor of farnesyl protein transferase, an enzyme that promotes RAS processing and transduction of proliferative signals.^{626,631} Inhibitors of mammalian target of rapamycin (mTOR) signaling have activity in AML.^{632,633} Heat shock protein 90 (Hsp 90) is a molecular chaperone involved in signaling pathways for cellular proliferation and survival, and a small molecule inhibitor of Hsp 90, the benzoquinone antibiotic 17-allylamino-17-demethoxygeldanamycin (17-AAG), suppresses the chaperone function of Hsp 90.⁶³⁴

Immunotherapy

Immunotherapeutic interventions are being explored in the setting of minimal residual disease following post-remission therapy in AML. Post-consolidation immunotherapy with interleukin-2 and histamine dihydrochloride, both administered subcutaneously, significantly improved 3-year leukemia-free survival.⁶³⁵ In addition, diverse novel vaccines and vaccine strategies are being developed and are beginning to be tested clinically in AML.^{636,637} The ideal vaccine strategy is to identify leukemia-associated antigens that are absent in hematopoietic stem cells or normal tissues and can elicit a cytotoxic T-cell response.⁶³⁷ The ability of AML blasts to differentiate into dendritic cells that can present target antigens is a method of vaccination under investigation.⁶³⁶ Peptide vaccination trials in AML have targeted different epitopes of the Wilms' tumor gene 1, the proteinase 3-derived epitope peptide, and the receptor for hyaluronic acid mediated motility (RHAMM/CD 168)-derived epitope R3. Other AML targets include preferentially expressed antigen of melanoma (PRAME), G250/CA9, BCL2, laminin receptor 1 (LamR1), and telomerase reverse transcriptase (hTERT).⁶³⁷ WT1 has been the target in recent promising clinical trials.^{638,639}

Therapy of Acute Myeloid Leukemia in Older Patients

Older patients with AML, usually defined as those 60 years of age and greater, have a worse outcome than younger patients.⁴⁴³ Reasons include differences in performance status and comorbidities, but also in biology, including cytogenetics and other parameters associated with drug resistance.⁶⁴⁰ The biology of AML may differ in older patients, with the malignant cell originating in an earlier stem cell than in younger patients.²¹⁷ Prior MDS and t-AML are more common. Unfavorable cytogenetic findings are more common in the elderly, whereas the favorable abnormalities are less common. Increased expression of the MDR1 protein on AML blasts is more common in older patients.^{377,463} In addition, older patients are more likely to have defects in the MSH2 protein which is involved in DNA repair and is associated with microsatellite instability and TP53 mutations.⁵⁹⁵

Although the overall prognosis of AML patients over 60 years of age is poor, CR rates approaching those of younger patients can be observed, so chemotherapy should not be withheld on the basis of age alone. Patients with favorable and intermediate karyotypes and with good performance status may respond well to chemotherapy,⁴⁴³ and CR rates with chemotherapy in older patients are usually in the 35% to 60% range. Unfortunately, however, median remission duration is less than one year in older patients regardless of post-remission chemotherapy regimen. Therefore, for older patients who achieve complete remission, reduced-intensity allogeneic hematopoietic stem cell transplantation should be strongly considered. In general, because of poor long-term DFS with chemotherapy (5% to 15%), it is important to discuss the poor prognosis with patients and families, to enroll patients on clinical trials, and to implement low-intensity therapies for patients unlikely to benefit from intensive chemotherapy. For older patients unlikely to benefit from chemotherapy because of disease- and/or patient-related factors, a number of novel agents and approaches are being pursued in clinical trials and as standard therapies. These currently include the DNA methyltransferase inhibitors decitabine and azacitidine, the nucleoside analogs clofarabine and sapacitabine, the immunomodulatory agent lenalidomide, and the farnesyl transferase inhibitor tipifarnib. Some of these agents, such as the DNA methyltransferase inhibitors, may be administered in the outpatient setting.

In summary, for older AML patients, the critical decision is whether to administer intensive induction chemotherapy. This decision should not be solely based on age, but also on performance status, co-morbidities, and AML risk profile including primarily cytogenetics.^{307,443} It has been shown to be feasible to wait for and use cytogenetic results in choosing initial treatment for older AML patients.⁶⁴¹ In older patients who achieve complete remission, the option of reduced-intensity

allogeneic hematopoietic stem cell transplantation should be considered.⁶⁴² Older patients with poor performance status, advanced age, and unfavorable-risk AML should optimally be treated on clinical trials of novel therapies.

Acute Myeloid Leukemia in Pregnancy

Although development of AML during pregnancy is rare, occurring in less than 1 in 10,000 pregnancies, it represents a major quandary in patient management.^{643, 644} and ⁶⁴⁵ Transmission of leukemia from mother to fetus is extremely unusual.^{646,647} Diagnosis of AML is less common in the first trimester than in the second or third trimesters, occurring in 14% in a series of 59 patients.⁶⁴⁸ Teratogenic effects of chemotherapy are more common in the

P.1609

first trimester and appear to be minimal in the second or third trimester.^{645,649,650} Options in the first trimester include therapeutic abortion and supportive therapy until the second trimester. Chemotherapy with intensive supportive care can result in a successful outcome for the fetus and the mother with leukemia in the second or third trimester^{644,645,650,651} usually without a need to terminate pregnancy. Fetuses exposed to antileukemia therapy in utero may have slight fetal growth retardation as well as transient myelosuppression if treatment is given near delivery, but generally have normal growth and development in childhood.^{652,653} The choice of induction chemotherapy is similar to that in nonpregnant patients. In addition to close monitoring of the mother and the fetus, delivery should optimally occur during a noncytopenic period.⁶⁵⁴

Relapsed and Refractory Acute Myeloid Leukemia

Approximately half of younger patients and a large majority (>85%) of older patients will either not achieve a complete remission or will relapse. The percentage of patients who have refractory AML (i.e., never obtain a complete remission) is at least 20%, but varies depending upon age, cytogenetics, and other prognostic factors. The definition of refractory AML includes patients who do not achieve complete remission with induction chemotherapy, those with a short (less than 6 to 12 months) first complete remission and patients who have relapsed twice or more.⁶⁵⁵ Prognostically relevant variables at first relapse include length of relapse-free interval after first complete remission, cytogenetics at diagnosis, age at relapse, and whether stem cell transplantation was performed previously.⁶⁵⁶ All patients with relapsed or refractory AML are candidates for clinical trials with novel therapies (see "Therapy" section).

AlloSCT is superior to chemotherapy for patients with relapsed or refractory disease, but many patients do not have a donor, or are too old or too ill for alloSCT (see "Stem Cell Transplantation" section). Although patients with a matched related donor can be offered an alloSCT in early relapse, there is an advantage and sometimes a necessity to receive additional chemotherapy to lessen the leukemia burden before a transplant, particularly if there is a delay in obtaining an alternative (i.e., unrelated) donor or if a nonmyeloablative approach is utilized (see "Stem Cell Transplantation" section). Autologous SCT is also an alternative for patients in second remission, but it is probably inferior to alloSCT and is not universally recommended.

Second remissions can be obtained in 30% to 80% of patients who had an initial first remission, are generally shorter in duration than first remissions, and are achieved more readily in patients with initial remissions longer than one year or with favorable cytogenetics.^{657, 658} and ⁶⁵⁹ Second CR was achieved in 55% to 60% of patients with initial CR > 1 year, compared to 33% to 46% with CR < 1 year.^{655, 658} Second CR was obtained in 80% to 88% of patients with favorable cytogenetics, 18% to 49% with intermediate, and 0% to 30% with poor risk.^{657,660}

To date, there is no standard regimen for induction of a second CR. Dose escalation and use of noncross-resistant regimens have been helpful in inducing second remissions. Cytarabine has been used in doses ranging from 500 mg/m² to 3 g/m² every 12 to 24 h for 3 to 6 days, alone or in combination with other agents, including anthracyclines, etoposide, clofarabine, fludarabine, gemtuzumab ozogamicin, irinotecan, L-asparaginase, mitoxantrone, and topotecan.^{661, 662, 663, 664, 665, 666, 667, 668, 669, 670} and ⁶⁷¹ HiDAC alone resulted in a CR rate of 40%, compared to 56% in patients receiving HiDAC with an anthracycline,⁶⁶¹ but two large randomized trials have not shown a benefit to adding a second agent to cytarabine.^{531,672}

A liposomal formulation of ara-C and daunorubicin with specific molar ratio (CPX-351) has shown promising activity in in vitro and in vivo studies.^{673,674} Preliminary results from a randomized trial (n = 126) showed no significant differences in CR/CRi rates for CPX-351 compared to other salvage chemotherapy (51% vs. 41%), but there were 2 months overall survival advantage for AML patients with unfavorable prognostic risk disease who received CPX-351 compared to other therapies (6.6 months vs. 4.2 months).

Reversal of drug resistance may be accomplished through the use of drugs that compete with chemotherapy agents for binding sites on p-glycoprotein. A randomized trial comparing cyclosporine A with chemotherapy versus chemotherapy

alone in poor-risk AML favored the cyclosporine A arm;⁵²⁴ however, trials evaluating the cyclosporine D derivative PSC-833 (valsopodar) and zosuquidar, a third-generation MDR modifier with less effect on pharmacokinetics of chemotherapy drugs, in initial therapy have been disappointing, as discussed above.^{521,522}

The DNA methyltransferase inhibitors azacitidine and decitabine have been used for the treatment of relapsed or refractory AML with generation of anecdotal evidence to support their use in this setting.^{675,676,677}

Single-agent clofarabine resulted in 30% CR rate in a phase 2 single-arm clinical trial in patients with relapsed or refractory leukemias.⁵⁵³ A combination of clofarabine with ara-C generated a response rate of 38% in another single arm study.⁵⁵⁴ A phase 3 prospective randomized trial (n = 320) in patients older than 55 years of age with relapsed/refractory AML compared the combination of clofarabine plus ara-C (clofarabine at 40 mg/m²/day × 5 days, ara-C 1 g/m²/day × 5 days) versus ara-C alone.⁶⁷⁸ Overall survival as the primary endpoint was not different between the two arms (6.6 months for the combination vs. 6.4 months in the ara-C arm), but CR rate (41% for the combination vs. 16% for ara-C alone, P = 0.001) was higher with the combination regimen.

Novel molecules as single agents are warranted and have been commonly used in the context of phase I and II clinical trials in relapsed patients who have short first remissions or have failed an initial salvage regimen (see “Therapy” section).

STEM CELL TRANSPLANTATION

AML has replaced CML as the most common disease to be treated with alloSCT due to the success of tyrosine kinase inhibitors in treating CML. AlloSCT is thought to have excellent efficacy in treatment of AML due to both the effect of high-dose chemotherapy with or without whole body irradiation utilized in the conditioning regimen and the immunologic graft-versus-leukemia (GVL) effect.⁶⁷⁹ AlloSCT is associated with the lowest relapse rates and can be effective in chemotherapy-refractory acute leukemia. Patient age, disease status, cytogenetics, prior therapy, co-morbidities, performance status, timing, and type of transplant determine its outcome.

AlloSCT is recommended for AML in second remission, but its benefit needs to be assessed against its risk for patients in first remission. Randomized trials in the 1990s comparing alloSCT to autoSCT and chemotherapy produced mixed results; there tended to be better disease-free survival with allogeneic SCT, but no improvement in overall survival^{680,681} (Figs. 75.15 and 75.16). Primary problems with alloSCT have been lack of suitable donors and a high early mortality caused by organ toxicity, infections, and graft-versus-host disease (GVHD).

The landscape of SCT is constantly changing (Chapters 104 and 105), and overall survival after allografts is gradually improving.^{682, 683} and ⁶⁸⁴ Major improvements in alloSCT have included: (1) high-resolution DNA typing for HLA matching; (2) improved prevention and treatment of GVHD; (3) improved supportive care, including molecular monitoring of CMV and use of pre-emptive antiviral therapy and improved antifungal therapy; (4) the development of reduced-intensity (nonmyeloablative) conditioning regimens;

P.1610

and (5) the use of co-morbidity indices to predict prognosis and to select patients and type of transplant.^{685, 686} and ⁶⁸⁷ The donor pool is expanding with the increased availability of unrelated donors and umbilical cord transplants in adults and with innovative immunosuppression to allow HLA-mismatched donors.^{688, 689, 690} and ⁶⁹¹ The HLA-haploidentical 2 or 3-loci mismatched related donor is an important and viable alternative stem cell source for patients who do not have matched donors, and it has been used in many transplant centers with outcomes that appear not to be inferior to transplantation from matched unrelated donors.⁶⁹²

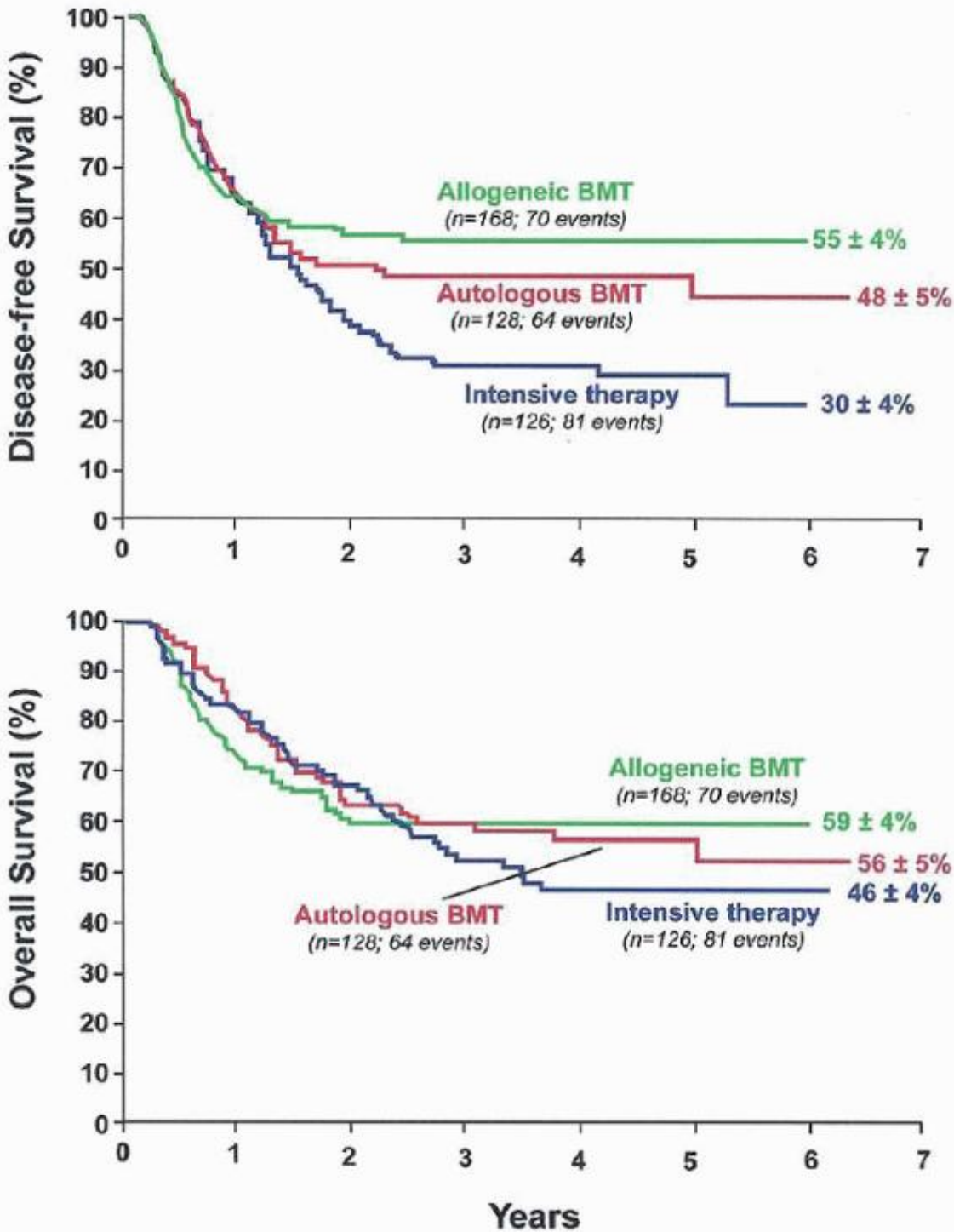

FIGURE 75.15. Impact of different post-remission therapies on survival. A: Disease-free survival (DFS). Allogeneic bone marrow transplantation (BMT) has the best DFS, versus randomization between autologous BMT and intensive chemotherapy ($p = 0.05$). B: Overall survival (OS): There were no differences in OS among the three. (With permission from Zittoun RA, Mandelli F, Willemze R, et al. Autologous or allogeneic bone marrow transplantation compared with intensive chemotherapy in acute myelogenous leukemia. *N Engl J Med* 1995;332:217-223.)

Age is no longer an absolute contraindication to alloSCT with the use of nonmyeloablative conditioning regimens (Fig. 75.17),⁶⁸⁵ which allow older patients and those with comorbid illnesses to undergo alloSCT with low early mortality, albeit with a higher relapse rate. Because nonmyeloablative SCT has less antileukemic effect, it relies on the graft-versus-

leukemia (GVL) effect. Transplant-related mortality with nonmyeloablative conditioning regimens is reduced to the 10% to 20% range, but the relapse rates of 30% to 65% are higher than for myeloablative SCT. Overall survival appears to be equivalent following reduced-intensity and myeloablative conditioning regimens in patients in remission or with low tumor burden.^{693,694} The 3-year DFS for AML utilizing reduced intensity conditioning has been 30% to 66%.⁶⁹⁵

AutoSCT is associated with lower transplant-related mortality than alloSCT, but with higher relapse rates. In vitro purging with cyclophosphamide derivatives or by positive stem cell selection has been associated with a lower relapse rate, but the role of purging remains controversial because it can delay engraftment and it has not been validated in a large randomized trial.⁶⁹⁶ A randomized trial comparing alloSCT to autoSCT in first CR, the EORTC-GIMEMA AML-10 trial, favored the allo (donor) arm over the auto (no donor) arm, but only in patients with poor-risk cytogenetics.⁶⁹⁷ Other reports have favored autoSCT over alloSCT.^{698,699} In a retrospective comparison of autoSCT and matched unrelated donor (MUD) SCT, the 3-year survival probabilities were: 57% \pm 4 versus 44% \pm 7 (P = 0.002) in CR1 and 46% \pm 7 versus 33% \pm 5 in CR2 (P = 0.006).⁶⁹⁹ However, cytogenetic data were unavailable for most patients and it is likely that alloSCT would have had better outcomes than autoSCT in patients with poor-risk cytogenetics. Due to a leukemia-free stem cell source and a lower relapse rate, alloSCT from a matched related donor (MRD) tends to be preferred over autoSCT.

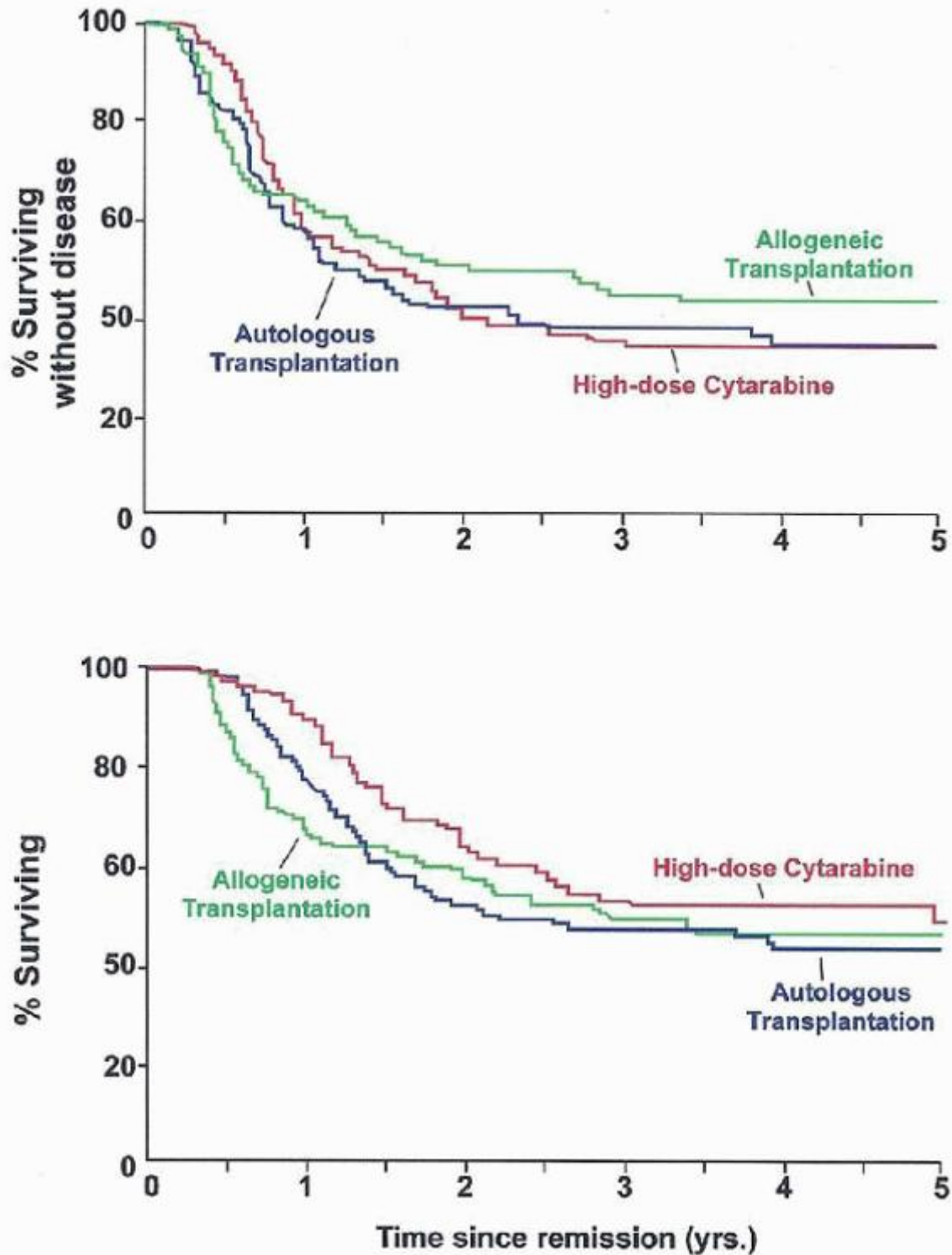

FIGURE 75.16. A: Disease-free survival according to post-remission therapy was not statistically significant at 4 years: autologous bone marrow transplantation (autoBMT), 35.6%; allogeneic bone marrow transplantation (alloBMT), 43.6%; high-dose cytarabine, 35.6%. B: Overall survival at 4 years was better for high-dose cytarabine, 52 ± 9%, than for either alloBMT, 46 ± 10% (p = 0.04) or auto BMT, 43 ± 9% (p = 0.05). (With permission from Cassileth PA, Harrington DP, Appelbaum FR, et al. Chemotherapy compared with autologous or allogeneic bone marrow transplantation in the management of acute myeloid leukemia in first remission. *N Engl J Med* 1998;339:1649-1656.)

Transplant in first CR is generally not recommended for patients with favorable-risk cytogenetics, including t(8;21) and inv(16), but gene mutations may identify patients with good-risk cytogenetics who are unlikely to be cured by chemotherapy and should be considered for early transplantation. KIT mutations are associated with an inferior survival for favorable-risk core-binding factor AML.^{364,365,366}

FLT3 mutations, particularly of the internal tandem duplication (ITD) type, are the most important adverse prognostic factor in cytogenetically normal AML. A retrospective, single-institution study suggested that performing alloSCT in early first complete remission could improve long-term outcomes for FLT3/ITD AML,⁷⁰⁰ with 4 years overall survival for the 31 FLT3/ITD patients comparable to the 102 patients with WT FLT3. Patients with normal karyotype and FLT3 mutations also appear to benefit from autoSCT.⁷⁰¹ In addition, patients with a normal karyotype who had NPM-1 mutations and did not have FLT3-ITD did not

P.1611

benefit from alloSCT, whereas those with other combinations of the mutations did benefit in a retrospective evaluation.⁴⁵

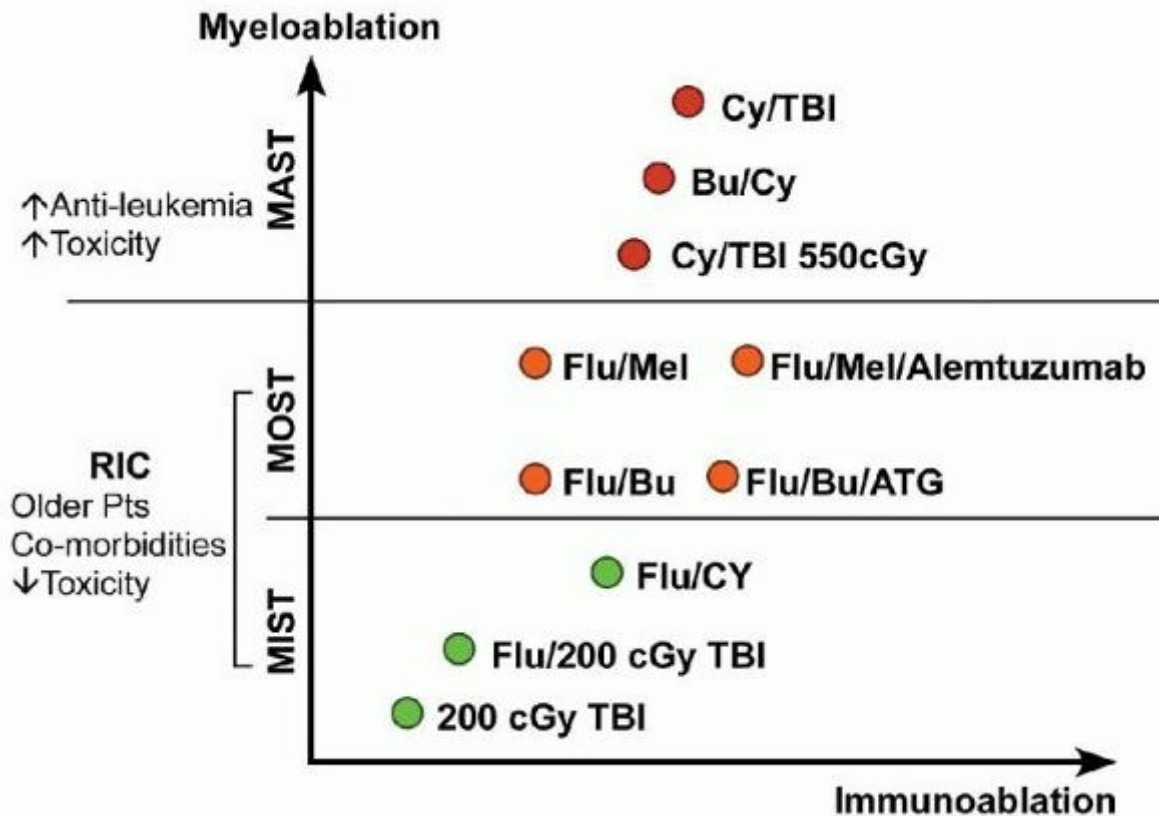

FIGURE 75.17. Diagram showing intensity of different regimens. The horizontal axis indicates the degree of immunoablation, and the vertical axis that of myeloablation. ATG, antithymocyte globulin; Bu, busulfan; CY, cyclophosphamide; Flu, fludarabine; MAST, myeloablative SCT; Mel, melphalan; MIST, minimal-intensity SCT; MOST, moderate-intensity SCT; RIC, reduced-intensity stem cell transplantation (SCT); TBI, total-body irradiation. (Adapted from Kassim AA, Chinratanalab W, Ferrara JLM, Mineishi S. Reduced-intensity allogeneic hematopoietic stem cell transplantation for acute leukemias: “what is the best recipe?” Bone Marrow Transplant 2005;36:565-574.)

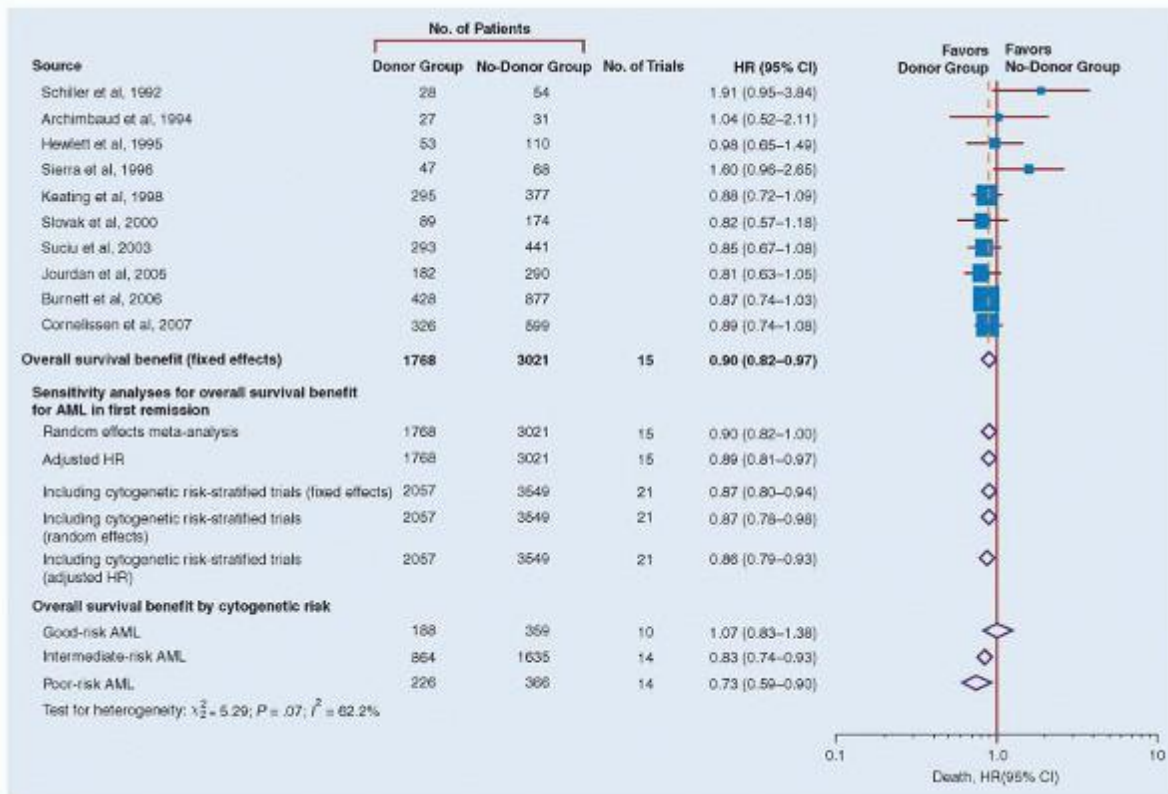

FIGURE 75.18. Overall survival benefit of allogeneic SCT for AML in first complete remission. Black rectangles indicate summary effects estimates (hazard ratios [HRs]) for individual study reports. Sizes of data markers are proportional to the study weights. Error bars indicate 95% confidence intervals (CIs). AML indicates acute myeloid leukemia. (From Koreth J, Schlenk R, Kopecky KJ, Honda S, Sierra J, Djulbegovic BJ, Wadleigh M, DeAngelo DJ, Stone RM, Sakamaki H, Appelbaum FR, Döhner H, Antin JH, Soiffer RJ, Cutler C. Allogeneic stem cell transplantation for acute myeloid leukemia in first complete remission: systematic review and meta-analysis of prospective clinical trials. JAMA 2009;301(22):2349-2361.)

The role of SCT in the treatment of AML has been investigated in several prospective clinical trials.^{680,681,697,702, 703} and ⁷⁰⁴ In four major prospective trials, involving approximately 2,700 AML patients in first CR, only 71% of eligible patients received alloSCT, and only 47% of the remainder were randomized.⁷⁰² Intent-to-treat analyses comparing survival between donor versus no-donor are recommended to assess the impact of alloSCT in prospective trials. In three large prospective trials, EORTC-GIMEMA favored the donor arm for poor-risk cytogenetics, the MRC 10 favored the donor arm for intermediate-risk cytogenetics, and the HOVON-SAKK favored the donor arm for both risk groups.^{697,702,704} A systematic review and meta-analysis of clinical trials involving more than 3,500 patients with AML in first complete remission including prospective biologic assignment reported a significant survival advantage of alloSCT compared to non-alloSCT in the treatment of AML patients with intermediate and unfavorable cytogenetics, but not with favorable cytogenetics (Fig. 75.18).⁷⁰⁵

Although there is general agreement that alloSCT offers the best option for preventing relapse in patients with AML with intermediate- or poor-risk cytogenetics, its overall impact on survival and the optimal timing and method of SCT (related vs. unrelated; myeloablative vs. reduced intensity) remain unresolved issues. In most trials utilizing alloSCT in first CR for patients

P.1612

without favorable cytogenetics, 5-year DFS is 45% to 75% using an MRD.^{706,707} There has been a significant decline in transplant-related mortality to less than 10% for patients in first CR in some reports due to a decrease in deaths from GVHD, infections, and organ toxicity; this decline in transplant-related mortality has led to improved survival in first remission patients but not in patients in relapse or second remission⁷⁰⁸ (Fig. 75.19).

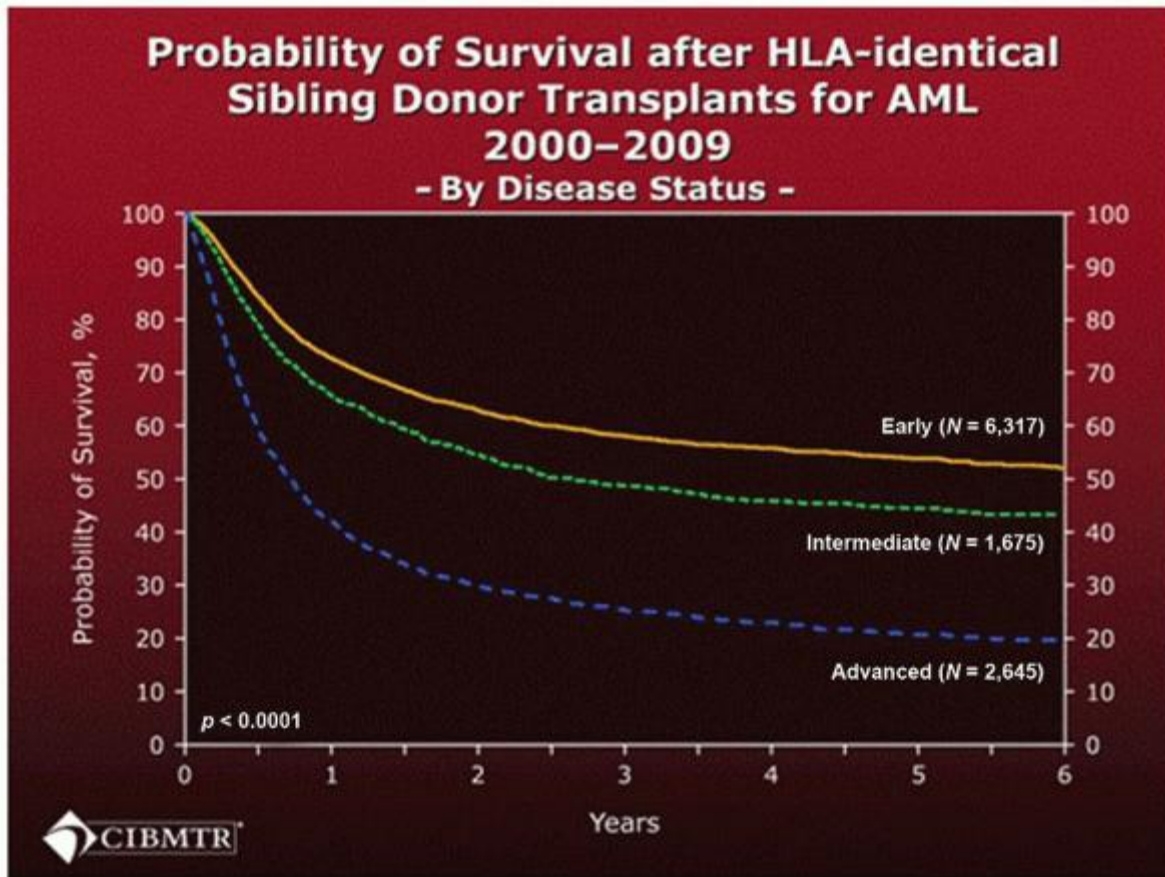

FIGURE 75.19. Probability of survival in adults (age ≥ 18 years) after HLA-identical sibling transplants for AML, 2000-2009, by disease status. (From the Center for International Blood and Marrow Transplant Research (CIBMTR), Pasquini MC, Wang Z. Current use and outcome of hematopoietic stem cell transplantation: CIBMTR Summary Slides, 2010. Available at: <http://www.cibmtr.org>.)

Despite improvements in HLA matching and supportive care, results of transplants from unrelated donors are usually inferior to those from matched siblings in first CR.⁷⁰⁹ In contrast, recent reports have indicated equivalent survival for sibling and unrelated transplants for AML, particularly for patients in early relapse or second CR, for whom DFS is in the 20% to 40% range (Fig. 75.20).⁷¹⁰ Fortunately approximately one third of patients who fail induction therapy but achieve remission with subsequent therapy and proceed to alloSCT can have prolonged DFS.⁷¹¹ For patients with refractory or advanced AML, the salvage rate is 5% to 30%.^{478,712}

Patients with acute GVHD (grades II-IV) or chronic GVHD and patients transplanted from unrelated donors have had lower relapse rates than patients without GVHD or transplanted from matched related donors, respectively.⁷¹³ However, GVHD and the therapy of GVHD can be debilitating or fatal, especially for the older patient. There are ongoing trials with different nonmyeloablative regimens and different immunosuppressive agents to control GVHD without losing GVL.^{714,715}

FUTURE DIRECTIONS

Further studies will identify and characterize additional gene mutations, epigenetic changes, patterns of microRNA expression, and aberrant signal transduction that will serve to further refine prognostic subsets and provide new therapeutic targets. Refined approaches to transplantation will increase its safety and efficacy, and its applicability in older patients, who are in great need of more effective therapies to prolong disease-free and overall survival. Novel immunotherapeutic approaches may also favorably affect outcomes in the future. The detection of residual disease is an ongoing area of study that should come into increasing use in the management of AML, and measurable minimal residual disease may serve as a target for innovative therapies.

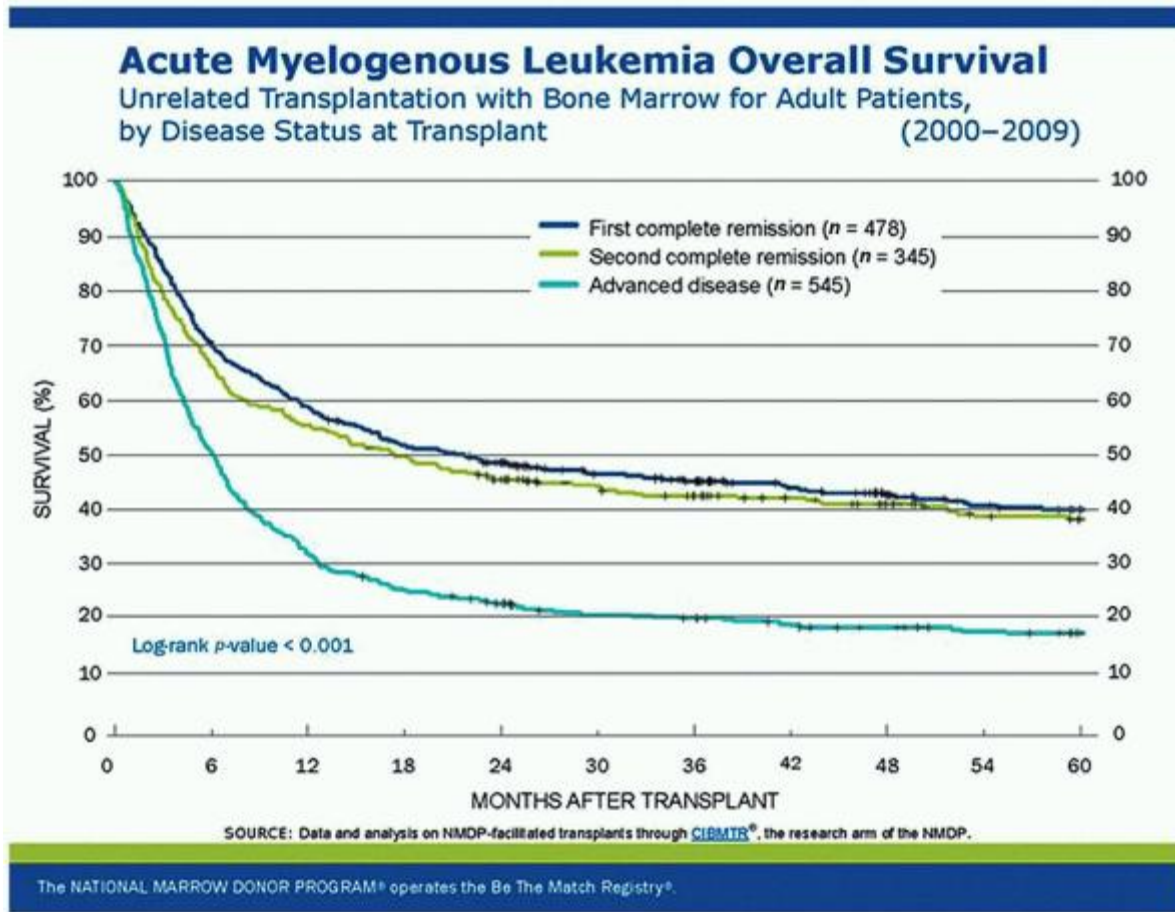

FIGURE 75.20. Survival of adult (age ≥ 18 years) unrelated bone marrow transplants with myeloablative preparative regimens for AML by disease status, 2000–2009. Five-year survivals were approximately 40% in first and second CRs, and less than 20% for advanced disease. Survival is significantly increased for transplants in CR1 or CR2 compared to transplants for patients with more advanced disease. (From the National Marrow Donor Program.)

REFERENCES

- Vardiman JW, Harris NL, Brunning RD. The World Health Organization (WHO) classification of the myeloid neoplasms. *Blood* 2002;100(7):2292-2302.
- Vardiman JW, Thiele J, Arber DA, et al. The 2008 revision of the World Health Organization (WHO) classification of myeloid neoplasms and acute leukemia: rationale and important changes. *Blood* 2009;114(5):937-951.
- Vardiman JW. The World Health Organization (WHO) classification of tumors of the hematopoietic and lymphoid tissues: an overview with emphasis on the myeloid neoplasms. *Chem Biol Interact* 2010;184(1-2):16-20.
- Cheson BD, Bennett JM, Kopecky KJ, et al. Revised recommendations of the International Working Group for Diagnosis, Standardization of Response Criteria, Treatment Outcomes, and Reporting Standards for Therapeutic Trials in Acute Myeloid Leukemia. *J Clin Oncol* 2003;21(24):4642-4649.
- Todd WM. Acute myeloid leukemia and related conditions. *Hematol Oncol Clin North Am* 2002;16(2):301-319.
- Bennett JM, Catovsky D, Daniel MT, et al. Proposal for the recognition of minimally differentiated acute myeloid leukaemia (AML-MO). *Br J Haematol* 1991;78(3):325-329.
- Stasi R, Del Poeta G, Venditti A, et al. Lineage identification of acute leukemias: relevance of immunologic and ultrastructural techniques. *Hematol Pathol* 1995;9(2):79-94.
- Khalidi HS, Medeiros LJ, Chang KL, Brynes RK, Slovak ML, Arber DA. The immunophenotype of adult acute myeloid leukemia: high frequency of lymphoid antigen expression and comparison of immunophenotype, French-American-British classification, and karyotypic abnormalities. *Am J Clin Pathol* 1998;109(2):211-220.

9. Terstappen LW, Safford M, Konemann S, et al. Flow cytometric characterization of acute myeloid leukemia. Part II. Phenotypic heterogeneity at diagnosis. *Leukemia* 1992;6(1):70-80.
10. Reading CL, Estey EH, Huh YO, et al. Expression of unusual immunophenotype combinations in acute myelogenous leukemia. *Blood* 1993;81(11):3083-3090.
11. Buccisano F, Maurillo L, Del Principe MI, et al. Prognostic and therapeutic implications of minimal residual disease detection in acute myeloid leukemia. *Blood* 2012;119(2):332-341.
12. Yunis JJ, Bloomfield CD, Ensrud K. All patients with acute nonlymphocytic leukemia may have a chromosomal defect. *N Engl J Med* 1981;305(3): 135-139.
13. Grimwade D, Hills RK, Moorman AV, et al. Refinement of cytogenetic classification in acute myeloid leukemia: determination of prognostic significance of rare recurring chromosomal abnormalities among 5876 younger adult patients treated in the United Kingdom Medical Research Council trials. *Blood* 2010;116(3):354-365.
14. Pffirmann M, Ehninger G, Thiede C, et al. Prediction of post-remission survival in acute myeloid leukaemia: a post-hoc analysis of the AML96 trial. *Lancet Oncol* 2012;13(2):207-214.
15. Virchow RLK. Wiesses Blut. *N Notiz Geb Natur u Heilk* 1845;36:151-156.
16. Virchow R. Wiesses Blut und Milztumoren. II. *Med Z* 1847;16:9-15.
17. Naegli O. Ueber rotes knoxhenmark and myeloblasten. *Dtsch Med Wochenschr* 1900;26:287.
18. Reschad H, Schilling-Torgau V. Ueber eine neue leukamie durch echte uebergangsformen (splenozyten-leukamie) and ihre bedeutung fur die selbstandigkeit dieser zellen. *Munch Med Wochenschr* 1913.
19. DiGuglielmo G. Ricerche di hematologia: I. Una casa di eritroleucemia. *Folia Med* 1917;13.
20. Von Boros J, Karenyi A. Uber einem fall von akuter megakaryoblastenleukamie, zugleich einige bemerkungen zum problem der akuten leukamie. *Z Klin Med* 1931;118.
21. Hilstad LK. Acute promyelocytic leukemia. *Acta Med Scand* 1947;159.
22. Bennett JM, Catovsky D, Daniel MT, et al. Proposals for the classification of the acute leukaemias. French-American-British (FAB) co-operative group. *Br J Haematol* 1976;33(4):451-458.
23. Head DR. Proposed changes in the definitions of acute myeloid leukemia and myelodysplastic syndrome: are they helpful? *Curr Opin Oncol* 2002;14(1):19-23.
24. Brunning RD, Vardiman J, Matutes E. Acute Myeloid Leukemia. In: Jaffe E, Harris N, Stein H, Vardiman J, editors. *World Health Organization Classification of Tumours Pathology and Genetics Tumours of Haematopoietic and Lymphoid Tissues*. Lyon, France: IARC Press, 2001:75-107.
25. Rowley JD. Identificaton of a translocation with quinacrine fluorescence in a patient with acute leukemia. *Ann Genet* 1973;16(2):109-112.
26. Rowley JD, Golomb HM, Dougherty C. 15/17 translocation, a consistent chromosomal change in acute promyelocytic leukaemia. *Lancet* 1977;1(8010):549-550.
27. Grimwade D, Walker H, Oliver F, et al. The importance of diagnostic cytogenetics on outcome in AML: analysis of 1,612 patients entered into the MRC AML 10 trial. The Medical Research Council Adult and Children's Leukaemia Working Parties. *Blood* 1998;92(7):2322-2333.
28. Slovak ML, Kopecky KJ, Cassileth PA, et al. Karyotypic analysis predicts outcome of preremission and postremission therapy in adult acute myeloid leukemia: a Southwest Oncology Group/Eastern Cooperative Oncology Group study. *Blood* 2000;96(13):4075-4083.
29. Byrd JC, Mrozek K, Dodge RK, et al. Pretreatment cytogenetic abnormalities are predictive of induction success, cumulative incidence of relapse, and overall survival in adult patients with de novo acute myeloid leukemia: results from Cancer and Leukemia Group B (CALGB 8461). *Blood* 2002;100(13):4325-4336.
30. Wheatley K, Brookes CL, Howman AJ, et al. Prognostic factor analysis of the survival of elderly patients with AML in the MRC AML11 and LRF AML14 trials. *Br J Haematol* 2009;145(5):598-605.

31. Frohling S, Schlenk RF, Kayser S, et al. Cytogenetics and age are major determinants of outcome in intensively treated acute myeloid leukemia patients older than 60 years: results from AMLSG trial AML HD98-B. *Blood* 2006;108(10):3280-3288.
32. Grimwade D, Walker H, Harrison G, et al. The predictive value of hierarchical cytogenetic classification in older adults with acute myeloid leukemia (AML): analysis of 1065 patients entered into the United Kingdom Medical Research Council AML11 trial. *Blood* 2001;98(5):1312-1320.
33. Cancer, Leukemia Group B, Farag SS, et al. Pretreatment cytogenetics add to other prognostic factors predicting complete remission and long-term outcome in patients 60 years of age or older with acute myeloid leukemia: results from Cancer and Leukemia Group B 8461. *Blood* 2006;108(1):63-73.
34. Buchner T, Berdel WE, Haferlach C, et al. Age-related risk profile and chemotherapy dose response in acute myeloid leukemia: a study by the German Acute Myeloid Leukemia Cooperative Group. *J Clin Oncol* 2009;27(1):61-69.
35. Thiede C, Steudel C, Mohr B, et al. Analysis of FLT3-activating mutations in 979 patients with acute myelogenous leukemia: association with FAB subtypes and identification of subgroups with poor prognosis. *Blood* 2002;99(12):4326-4335.
- P.1613
36. Frohling S, Schlenk RF, Breitruck J, et al. Prognostic significance of activating FLT3 mutations in younger adults (16 to 60 years) with acute myeloid leukemia and normal cytogenetics: a study of the AML Study Group Ulm. *Blood* 2002;100(13):4372-4380.
37. Kottaridis PD, Gale RE, Frew ME, et al. The presence of a FLT3 internal tandem duplication in patients with acute myeloid leukemia (AML) adds important prognostic information to cytogenetic risk group and response to the first cycle of chemotherapy: analysis of 854 patients from the United Kingdom Medical Research Council AML 10 and 12 trials. *Blood* 2001;98(6):1752-1759.
38. Whitman SP, Archer KJ, Feng L, et al. Absence of the wild-type allele predicts poor prognosis in adult de novo acute myeloid leukemia with normal cytogenetics and the internal tandem duplication of FLT3: a Cancer and Leukemia Group B study. *Cancer Res* 2001;61(19):7233-7239.
39. Dohner K, Schlenk RF, Habdank M, et al. Mutant nucleophosmin (NPM1) predicts favorable prognosis in younger adults with acute myeloid leukemia and normal cytogenetics: interaction with other gene mutations. *Blood* 2005;106(12):3740-3746.
40. Verhaak RG, Goudswaard CS, van Putten W, et al. Mutations in nucleophosmin (NPM1) in acute myeloid leukemia (AML): association with other gene abnormalities and previously established gene expression signatures and their favorable prognostic significance. *Blood* 2005;106(12):3747-3754.
41. Schnittger S, Schoch C, Kern W, et al. Nucleophosmin gene mutations are predictors of favorable prognosis in acute myelogenous leukemia with a normal karyotype. *Blood* 2005;106(12):3733-3739.
42. Thiede C, Koch S, Creutzig E, et al. Prevalence and prognostic impact of NPM1 mutations in 1485 adult patients with acute myeloid leukemia (AML). *Blood* 2006;107(10):4011-4020.
43. Schlenk RF, Dohner K, Kneba M, et al. Gene mutations and response to treatment with all-trans retinoic acid in elderly patients with acute myeloid leukemia. Results from the AMLSG Trial AML HD98B. *Haematologica* 2009;94(1):54-60.
44. Becker H, Marcucci G, Maharry K, et al. Favorable prognostic impact of NPM1 mutations in older patients with cytogenetically normal de novo acute myeloid leukemia and associated gene- and microRNA-expression signatures: a Cancer and Leukemia Group B study. *J Clin Oncol* 2010;28(4):596-604.
45. Schlenk RF, Dohner K, Krauter J, et al. Mutations and treatment outcome in cytogenetically normal acute myeloid leukemia. *N Engl J Med* 2008;358(18):1909-1918.
46. Preudhomme C, Sagot C, Boissel N, et al. Favorable prognostic significance of CEBPA mutations in patients with de novo acute myeloid leukemia: a study from the Acute Leukemia French Association (ALFA). *Blood* 2002;100(8):2717-2723.
47. Barjesteh van Waalwijk van Doorn-Khosrovani S, Erpelinck C, Meijer J, et al. Biallelic mutations in the CEBPA gene and low CEBPA expression levels as prognostic markers in intermediate-risk AML. *Hematol J* 2003;4(1):31-40.

48. Frohling S, Schlenk RF, Stolze I, et al. CEBPA mutations in younger adults with acute myeloid leukemia and normal cytogenetics: prognostic relevance and analysis of cooperating mutations. *J Clin Oncol* 2004;22(4):624-633.
49. Bienz M, Ludwig M, Leibundgut EO, et al. Risk assessment in patients with acute myeloid leukemia and a normal karyotype. *Clin Cancer Res* 2005;11(4):1416-1424.
50. Marcucci G, Maharry K, Radmacher MD, et al. Prognostic significance of, and gene and microRNA expression signatures associated with, CEBPA mutations in cytogenetically normal acute myeloid leukemia with high-risk molecular features: a Cancer and Leukemia Group B Study. *J Clin Oncol* 2008;26(31):5078-5087.
51. Dohner H, Estey EH, Amadori S, et al. Diagnosis and management of acute myeloid leukemia in adults: recommendations from an international expert panel, on behalf of the European LeukemiaNet. *Blood* 2010;115(3): 453-474.
52. Rollig C, Bornhauser M, Thiede C, et al. Long-term prognosis of acute myeloid leukemia according to the new genetic risk classification of the European LeukemiaNet recommendations: evaluation of the proposed reporting system. *J Clin Oncol* 2011;29(20):2758-2765.
53. Ley TJ, Mardis ER, Ding L, et al. DNA sequencing of a cytogenetically normal acute myeloid leukaemia genome. *Nature* 2008;456(7218):66-72.
54. Mardis ER, Ding L, Dooling DJ, et al. Recurring mutations found by sequencing an acute myeloid leukemia genome. *N Engl J Med* 2009;361(11): 1058-1066.
55. Li Z, Lu J, Sun M, et al. Distinct microRNA expression profiles in acute myeloid leukemia with common translocations. *Proc Natl Acad Sci U S A* 2008;105(40):15535-15540.
56. Garzon R, Volinia S, Liu CG, et al. MicroRNA signatures associated with cytogenetics and prognosis in acute myeloid leukemia. *Blood* 2008;111(6): 3183-3189.
57. Wieser R, Scheideler M, Hackl H, et al. microRNAs in acute myeloid leukemia: expression patterns, correlations with genetic and clinical parameters, and prognostic significance. *Genes Chromosomes Cancer* 2010;49(3):193-203.
58. Howlader N, Noone AM, Krapcho M, et al. SEER Cancer statistics review, 1975-2009 (Vintage 2009 Populations), National Cancer Institute. Bethesda, MD. http://seercancer.gov/csr/1975_2009_pops09/2012; based on November 2011 SEER data submission, posted to the SEER web site, 2012.
59. National Cancer Institute. SEER Data in AML. http://seercancer.gov/csr/1975_2009_pops09/results_single/sect_01_table01pdf.2012, Accessed November 1, 2012.
60. Linet MS, Devesa SS. Epidemiology of leukemia: overview and patterns of occurrence. In: Henderson ES, Lister TA, Greaves MF, editors. *Leukemia*. Philadelphia: W.B. Saunders; 2002:131-151.
61. Howe HL, Wu X, Ries LA, et al. Annual report to the nation on the status of cancer, 1975-2003, featuring cancer among U.S. Hispanic/Latino populations. *Cancer* 2006;107(8):1711-1742.
62. National Cancer Institute. SEER Data in AML. http://seercancer.gov/csr/1975_2009_pops09/results_single/sect_01_table11_2pgspdf.2012, Accessed November 1, 2012.
63. Sandler DP, Ross JA. Epidemiology of acute leukemia in children and adults. *Semin Oncol* 1997;24(1):3-16.
64. National Cancer Institute. SEER Data in AML. http://seercancer.gov/csr/1975_2009_pops09/results_single/sect_01_table13_2pgspdf.2012, Accessed November 1, 2012.
65. Deschler B, Lubbert M. Acute myeloid leukemia: epidemiology and etiology. *Cancer* 2006;107(9):2099-2107.
66. Strom SS, Oum R, Elhor Gbito KY, Garcia-Manero G, Yamamura Y. De novo acute myeloid leukemia risk factors: a Texas case-control study. *Cancer* 2012;118(18):4589-4596.
67. Terry PD, Shore DL, Rauscher GH, Sandler DP. Occupation, hobbies, and acute leukemia in adults. *Leuk Res* 2005;29(10):1117-1130.
68. Guenel P, Imbernon E, Chevalier A, Crinquand-Calastreng A, Goldberg M. Leukemia in relation to occupational exposures to benzene and other agents: a case-control study nested in a cohort of gas and electric utility workers. *Am J Ind Med* 2002;42(2):87-97.

69. Costantini AS, Miligi L, Kriebel D, et al. A multicenter case-control study in Italy on hematolymphopoietic neoplasms and occupation. *Epidemiology* 2001;12(1):78-87.
70. Kolstad HA, Lyng E, Olsen J, Breum N. Incidence of lymphohematopoietic malignancies among styrene-exposed workers of the reinforced plastics industry. *Scand J Work Environ Health* 1994;20(4):272-278.
71. Adegoke OJ, Blair A, Shu XO, et al. Occupational history and exposure and the risk of adult leukemia in Shanghai. *Ann Epidemiol* 2003;13(7):485-494.
72. Richardson S, Zittoun R, Bastuji-Garin S, et al. Occupational risk factors for acute leukaemia: a case-control study. *Int J Epidemiol* 1992;21(6): 1063-1073.
73. Vigliani EC. Leukemia associated with benzene exposure. *Ann N Y Acad Sci* 1976;271:143-151.
74. Pyatt D. Benzene and hematopoietic malignancies. *Clin Occup Environ Med* 2004;4(3):529-555,vii.
75. Glass DC, Gray CN, Jolley DJ, et al. Leukemia risk associated with low-level benzene exposure. *Epidemiology* 2003;14(5):569-577.
76. Yin SN, Li GL, Tain FD, et al. Leukaemia in benzene workers: a retrospective cohort study. *Br J Ind Med* 1987;44(2):124-128.
77. Hayes RB, Yin SN, Dosemeci M, et al. Benzene and the dose-related incidence of hematologic neoplasms in China. Chinese Academy of Preventive Medicine—National Cancer Institute Benzene Study Group. *J Natl Cancer Inst* 1997;89(14):1065-1071.
78. Khalade A, Jaakkola MS, Pukkala E, Jaakkola JJ. Exposure to benzene at work and the risk of leukemia: a systematic review and meta-analysis. *Environ Health* 2010;9:31.
79. Zhang L, Lan Q, Guo W, et al. Chromosome-wide aneuploidy study (CWAS) in workers exposed to an established leukemogen, benzene. *Carcinogenesis* 2011;32(4):605-612.
80. Pierce DA, Shimizu Y, Preston DL, Vaeth M, Mabuchi K. Studies of the mortality of atomic bomb survivors. Report 12, Part I. Cancer: 1950-1990. *Radiat Res* 1996;146(1):1-27.
81. Folley JH, Borges W, Yamawaki T. Incidence of leukemia in survivors of the atomic bomb in Hiroshima and Nagasaki, Japan. *Am J Med* 1952;13(3): 311-321.
82. Richardson D, Sugiyama H, Nishi N, et al. Ionizing radiation and leukemia mortality among Japanese Atomic Bomb Survivors, 1950-2000. *Radiat Res* 2009;172(3):368-382.
83. Boice JD Jr, Holm LE. Radiation risk estimates for leukemia and thyroid cancer among Russian emergency workers at Chernobyl. *Radiat Environ Biophys* 1997;36(3):213-214.
84. Littlefield LG, McFee AF, Salomaa SI, et al. Do recorded doses overestimate true doses received by Chernobyl cleanup workers? Results of cytogenetic analyses of Estonian workers by fluorescence in situ hybridization. *Radiat Res* 1998;150(2):237-249.
85. Gluzman D, Imamura N, Sklyarenko L, Nadgornaya V, Zavelevich M, Machilo V. Malignant diseases of hematopoietic and lymphoid tissues in Chernobyl clean-up workers. *Hematol J* 2005;5(7):565-571.
86. Garfinkel L, Boffetta P. Association between smoking and leukemia in two American Cancer Society prospective studies. *Cancer* 1990;65(10): 2356-2360.
87. Brownson RC, Novotny TE, Perry MC. Cigarette smoking and adult leukemia. A meta-analysis. *Arch Intern Med* 1993;153(4):469-475.
88. Sandler DP, Shore DL, Anderson JR, et al. Cigarette smoking and risk of acute leukemia: associations with morphology and cytogenetic abnormalities in bone marrow. *J Natl Cancer Inst* 1993;85(24):1994-2003.
89. Pasqualetti P, Festuccia V, Acitelli P, Collacciani A, Giusti A, Casale R. Tobacco smoking and risk of haematological malignancies in adults: a case-control study. *Br J Haematol* 1997;97(3):659-662.
90. Bjork J, Albin M, Mauritzson N, Stromberg U, Johansson B, Hagmar L. Smoking and acute myeloid leukemia: associations with morphology and karyotypic patterns and evaluation of dose-response relations. *Leuk Res* 2001;25(10):865-872.

91. Pogoda JM, Preston-Martin S, Nichols PW, Ross RK. Smoking and risk of acute myeloid leukemia: results from a Los Angeles County case-control study. *Am J Epidemiol* 2002;155(6):546-553.
92. Bjork J, Johansson B, Broberg K, Albin M. Smoking as a risk factor for myelodysplastic syndromes and acute myeloid leukemia and its relation to cytogenetic findings: a case-control study. *Leuk Res* 2009;33(6):788-791.
93. Doll R. Cancers weakly related to smoking. *Br Med Bull* 1996;52(1):35-49.
94. Severson RK, Davis S, Heuser L, Daling JR, Thomas DB. Cigarette smoking and acute nonlymphocytic leukemia. *Am J Epidemiol* 1990;132(3):418-422.
95. Kasim K, Levallois P, Abdous B, Auger P, Johnson KC. Lifestyle factors and the risk of adult leukemia in Canada. *Cancer Causes Control* 2005;16(5):489-500.
96. Samanic C, Gridley G, Chow WH, Lubin J, Hoover RN, Fraumeni JF Jr. Obesity and cancer risk among white and black United States veterans. *Cancer Causes Control* 2004;15(1):35-43.
97. Ross JA, Parker E, Blair CK, Cerhan JR, Folsom AR. Body mass index and risk of leukemia in older women. *Cancer Epidemiol Biomarkers Prev* 2004;13 (11 Pt 1):1810-1813.
98. Rauscher GH, Shore D, Sandler DP. Hair dye use and risk of adult acute leukemia. *Am J Epidemiol* 2004;160(1):19-25.
99. Karp JE, Smith MA. The molecular pathogenesis of treatment-induced (secondary) leukemias: foundations for treatment and prevention. *Semin Oncol* 1997;24(1):103-113.
100. Larson RA, Le Beau MM. Therapy-related myeloid leukaemia: a model for leukemogenesis in humans. *Chem Biol Interact* 2005;153-154:187-195.
101. Smith SM, Le Beau MM, Huo D, et al. Clinical-cytogenetic associations in 306 patients with therapy-related myelodysplasia and myeloid leukemia: the university of Chicago series. *Blood* 2003;102(1):43-52.
102. Smith PG, Doll R. Mortality among patients with ankylosing spondylitis after a single treatment course with x rays. *Br Med J (Clin Res Ed)* 1982;284(6314):449-460.
103. Inskip PD, Kleinerman RA, Stovall M, et al. Leukemia, lymphoma, and multiple myeloma after pelvic radiotherapy for benign disease. *Radiat Res* 1993;135(1):108-124.
104. Ron E, Modan B, Boice JD Jr. Mortality after radiotherapy for ringworm of the scalp. *Am J Epidemiol* 1988;127(4):713-725.
105. Griem ML, Kleinerman RA, Boice JD Jr, Stovall M, Shefner D, Lubin JH. Cancer following radiotherapy for peptic ulcer. *J Natl Cancer Inst* 1994;86(11):842-849.
106. Olney HJ, Mitelman F, Johansson B, Mrozek K, Berger R, Rowley JD. Unique balanced chromosome abnormalities in treatment-related myelodysplastic syndromes and acute myeloid leukemia: report from an international workshop. *Genes Chromosomes Cancer* 2002;33(4):413-423.
107. Andersen MK, Pedersen-Bjergaard J. Therapy-related MDS and AML in acute promyelocytic leukemia. *Blood* 2002;100(5):1928-1929;author reply 9.
108. Quesnel B, Kantarjian H, Bjergaard JP, et al. Therapy-related acute myeloid leukemia with t(8;21), inv(16), and t(8;16): a report on 25 cases and review of the literature. *J Clin Oncol* 1993;11(12):2370-2379.
109. Gustafson SA, Lin P, Chen SS, et al. Therapy-related acute myeloid leukemia with t(8;21) (q22;q22) shares many features with de novo acute myeloid leukemia with t(8;21)(q22;q22) but does not have a favorable outcome. *Am J Clin Pathol* 2009;131(5):647-655.
110. Seedhouse C, Faulkner R, Ashraf N, Das-Gupta E, Russell N. Polymorphisms in genes involved in homologous recombination repair interact to increase the risk of developing acute myeloid leukemia. *Clin Cancer Res* 2004;10(8):2675-2680.
111. Jawad M, Seedhouse CH, Russell N, Plumb M. Polymorphisms in human homeobox HLX1 and DNA repair RAD51 genes increase the risk of therapy-related acute myeloid leukemia. *Blood* 2006;108(12):3916-3918.
112. Worrillow LJ, Travis LB, Smith AG, et al. An intron splice acceptor polymorphism in hMSH2 and risk of leukemia after treatment with chemotherapeutic alkylating agents. *Clin Cancer Res* 2003;9(8):3012-3020.

113. Pedersen-Bjergaard J, Specht L, Larsen SO, et al. Risk of therapy-related leukaemia and preleukaemia after Hodgkin's disease. Relation to age, cumulative dose of alkylating agents, and time from chemotherapy. *Lancet* 1987;2(8550):83-88.
114. Green DM, Hyland A, Barcos MP, et al. Second malignant neoplasms after treatment for Hodgkin's disease in childhood or adolescence. *J Clin Oncol* 2000;18(7):1492-1499.
115. Swerdlow AJ, Barber JA, Hudson GV, et al. Risk of second malignancy after Hodgkin's disease in a collaborative British cohort: the relation to age at treatment. *J Clin Oncol* 2000;18(3):498-509.
116. Chaplain G, Milan C, Sgro C, Carli PM, Bonithon-Kopp C. Increased risk of acute leukemia after adjuvant chemotherapy for breast cancer: a population-based study. *J Clin Oncol* 2000;18(15):2836-2842.
117. Bergsagel DE, Bailey AJ, Langley GR, MacDonald RN, White DF, Miller AB. The chemotherapy on plasma-cell myeloma and the incidence of acute leukemia. *N Engl J Med* 1979;301(14):743-748.
118. Greene MH, Boice JD Jr, Greer BE, Blessing JA, Dembo AJ. Acute nonlymphocytic leukemia after therapy with alkylating agents for ovarian cancer: a study of five randomized clinical trials. *N Engl J Med* 1982;307(23): 1416-1421.
119. van Leeuwen FE, Somers R, Taal BG, et al. Increased risk of lung cancer, non-Hodgkin's lymphoma, and leukemia following Hodgkin's disease. *J Clin Oncol* 1989;7(8):1046-1058.
120. Henry-Amar M, Dietrich PY. Acute leukemia after the treatment of Hodgkin's disease. *Hematol Oncol Clin North Am* 1993;7(2):369-387.
121. Micallef IN, Lillington DM, Apostolidis J, et al. Therapy-related myelodysplasia and secondary acute myelogenous leukemia after high-dose therapy with autologous hematopoietic progenitor-cell support for lymphoid malignancies. *J Clin Oncol* 2000;18(5):947-955.
122. Pedersen-Bjergaard J, Christiansen DH, Andersen MK, Skovby F. Causality of myelodysplasia and acute myeloid leukemia and their genetic abnormalities. *Leukemia* 2002;16(11):2177-2184.
123. Wolden SL, Lamborn KR, Cleary SF, Tate DJ, Donaldson SS. Second cancers following pediatric Hodgkin's disease. *J Clin Oncol* 1998;16(2):536-544.
124. Pedersen-Bjergaard J, Philip P. Two different classes of therapy-related and de-novo acute myeloid leukemia? *Cancer Genet Cytogenet* 1991;55(1): 119-124.
125. Johnson DH, Porter LL, List AF, Hande KR, Hainsworth JD, Greco FA. Acute nonlymphocytic leukemia after treatment of small cell lung cancer. *Am J Med* 1986;81(6):962-968.
126. Ratain MJ, Kaminer LS, Bitran JD, et al. Acute nonlymphocytic leukemia following etoposide and cisplatin combination chemotherapy for advanced non-small-cell carcinoma of the lung. *Blood* 1987;70(5):1412-1417.
127. Whitlock JA, Greer JP, Lukens JN. Epipodophyllotoxin-related leukemia. Identification of a new subset of secondary leukemia. *Cancer* 1991;68(3): 600-604.
128. Pui CH, Behm FG, Raimondi SC, et al. Secondary acute myeloid leukemia in children treated for acute lymphoid leukemia. *N Engl J Med* 1989;321(3):136-142.
129. Weh HJ, Hossfeld DK. 12p-chromosome in patients with acute myelocytic leukemia or myelodysplastic syndromes following exposure to mutagenic agents. *Cancer Genet Cytogenet* 1986;19(3-4):355-356.
130. Fenaux P, Jouet JP, Bauters F, Lai JL, Lepelley P. Translocation t(9;11) (p21;q23) with acute myelomonocytic leukemia after chemotherapy for osteosarcoma: good response to antileukemic drugs. *J Clin Oncol* 1987;5(8): 1304-1305.
131. Smith RE, Bryant J, DeCillis A, Anderson S, National Surgical Adjuvant B, Bowel Project E. Acute myeloid leukemia and myelodysplastic syndrome after doxorubicin-cyclophosphamide adjuvant therapy for operable breast cancer: the National Surgical Adjuvant Breast and Bowel Project Experience. *J Clin Oncol* 2003;21(7):1195-1204.
132. Le Deley MC, Suzan F, Cutuli B, et al. Anthracyclines, mitoxantrone, radiotherapy, and granulocyte colony-stimulating factor: risk factors for leukemia and myelodysplastic syndrome after breast cancer. *J Clin Oncol* 2007;25(3):292-300.
133. Hershman D, Neugut AI, Jacobson JS, et al. Acute myeloid leukemia or myelodysplastic syndrome following use of granulocyte colony-stimulating factors during breast cancer adjuvant chemotherapy. *J Natl Cancer Inst* 2007;99(3):196-205.
134. Boice JD Jr, Bigbee WL, Mumma MT, Blot WJ. Cancer mortality in counties near two former nuclear materials processing facilities in Pennsylvania, 1950-1995. *Health Phys* 2003;85(6):691-700.

135. Boice JD Jr, Bigbee WL, Mumma MT, Blot WJ. Cancer incidence in municipalities near two former nuclear materials processing facilities in Pennsylvania. *Health Phys* 2003;85(6):678-690.
136. Curtis RE, Boice JD Jr, Stovall M, et al. Risk of leukemia after chemotherapy and radiation treatment for breast cancer. *N Engl J Med* 1992;326(26): 1745-1751.
137. Morrison VA, Rai KR, Peterson BL, et al. Therapy-related myeloid leukemias are observed in patients with chronic lymphocytic leukemia after treatment with fludarabine and chlorambucil: results of an intergroup study, Cancer and Leukemia Group B 9011. *J Clin Oncol* 2002;20(18):3878-3884.
138. Carney DA, Westerman DA, Tam CS, et al. Therapy-related myelodysplastic syndrome and acute myeloid leukemia following fludarabine combination chemotherapy. *Leukemia* 2010;24(12):2056-2062.
139. Leleu X, Soumerai J, Roccaro A, et al. Increased incidence of transformation and myelodysplasia/acute leukemia in patients with Waldenstrom macroglobulinemia treated with nucleoside analogs. *J Clin Oncol* 2009;27(2): 250-255.
140. Kwong YL. Azathioprine: association with therapy-related myelodysplastic syndrome and acute myeloid leukemia. *J Rheumatol* 2010;37(3):485-490.
141. Bo J, Schroder H, Kristinsson J, et al. Possible carcinogenic effect of 6-mercaptopurine on bone marrow stem cells: relation to thiopurine metabolism. *Cancer* 1999;86(6):1080-1086.
142. Arana-Yi C, Block AW, Sait SN, Ford LA, Barcos M, Baer MR. Therapy-related myelodysplastic syndrome and acute myeloid leukemia following treatment of acute myeloid leukemia: possible role of cytarabine. *Leuk Res* 2008;32(7):1043-1048.
143. Montesinos P, Gonzalez JD, Gonzalez J, et al. Therapy-related myeloid neoplasms in patients with acute promyelocytic leukemia treated with all-trans-retinoic Acid and anthracycline-based chemotherapy. *J Clin Oncol* 2010;28(24):3872-3879.
144. Boice JD Jr, Blettner M, Kleinerman RA, et al. Radiation dose and leukemia risk in patients treated for cancer of the cervix. *J Natl Cancer Inst* 1987;79(6):1295-1311.
145. Curtis RE, Boice JD Jr, Stovall M, et al. Relationship of leukemia risk to radiation dose following cancer of the uterine corpus. *J Natl Cancer Inst* 1994;86(17):1315-1324.
146. Kaldor JM, Day NE, Pettersson F, et al. Leukemia following chemotherapy for ovarian cancer. *N Engl J Med* 1990;322(1):1-6.
147. Kaldor JM, Day NE, Clarke EA, et al. Leukemia following Hodgkin's disease. *N Engl J Med* 1990;322(1):7-13.
148. Nardi V, Winkfield KM, Ok CY, et al. Acute myeloid leukemia and myelodysplastic syndromes after radiation therapy are similar to de novo disease and differ from other therapy-related myeloid neoplasms. *J Clin Oncol* 2012;30(19):2340-2347.
149. Sawka AM, Thabane L, Parlea L, et al. Second primary malignancy risk after radioactive iodine treatment for thyroid cancer: a systematic review and meta-analysis. *Thyroid* 2009;19(5):451-457.
150. Iyer NG, Morris LG, Tuttle RM, Shaha AR, Ganly I. Rising incidence of second cancers in patients with low-risk (T1N0) thyroid cancer who receive radioactive iodine therapy. *Cancer* 2011;117(19):4439-4446.
151. Andersson M, Carstensen B, Visfeldt J. Leukemia and other related hematological disorders among Danish patients exposed to Thorotrast. *Radiat Res* 1993;134(2):224-233.
152. Schwartz CL, Cohen HJ. Preleukemic syndromes and other syndromes predisposing to leukemia. *Pediatr Clin North Am* 1988;35(4):853-871.
153. Ellis NA, Groden J, Ye TZ, et al. The Bloom's syndrome gene product is homologous to RecQ helicases. *Cell* 1995;83(4):655-666.
154. Das P, Shaik AP, Bammidi VK. Meta-analysis study of glutathione-S-transferases (GSTM1, GSTP1, and GSTT1) gene polymorphisms and risk of acute myeloid leukemia. *Leuk Lymphoma* 2009;50(8):1345-1351.
155. Voso MT, D'Alo F, Putzulu R, et al. Negative prognostic value of glutathione S-transferase (GSTM1 and GSTT1) deletions in adult acute myeloid leukemia. *Blood* 2002;100(8):2703-2707.
156. Voso MT, Hohaus S, Guidi F, et al. Prognostic role of glutathione S-transferase polymorphisms in acute myeloid leukemia. *Leukemia* 2008;22(9): 1685-1691.

157. Seedhouse C, Bainton R, Lewis M, Harding A, Russell N, Das-Gupta E. The genotype distribution of the XRCC1 gene indicates a role for base excision repair in the development of therapy-related acute myeloblastic leukemia. *Blood* 2002;100(10):3761-3766.
158. Smith AG, Worrillow LJ, Allan JM. A common genetic variant in XPD associates with risk of 5q- and 7q-deleted acute myeloid leukemia. *Blood* 2007;109(3):1233-1236.
159. Kuptsova N, Kopecky KJ, Godwin J, et al. Polymorphisms in DNA repair genes and therapeutic outcomes of AML patients from SWOG clinical trials. *Blood* 2007;109(9):3936-3944.
160. Kutler DI, Singh B, Satagopan J, et al. A 20-year perspective on the International Fanconi Anemia Registry (IFAR). *Blood* 2003;101(4):1249-1256.
161. Michaud J, Wu F, Osato M, et al. In vitro analyses of known and novel RUNX1/AML1 mutations in dominant familial platelet disorder with predisposition to acute myelogenous leukemia: implications for mechanisms of pathogenesis. *Blood* 2002;99(4):1364-1372.
162. Smith ML, Cavenagh JD, Lister TA, Fitzgibbon J. Mutation of CEBPA in familial acute myeloid leukemia. *N Engl J Med* 2004;351(23):2403-2407.
163. Minelli A, Maserati E, Rossi G, et al. Familial platelet disorder with propensity to acute myelogenous leukemia: genetic heterogeneity and progression to leukemia via acquisition of clonal chromosome anomalies. *Genes Chromosomes Cancer* 2004;40(3):165-171.
164. Dale DC, Bolyard AA, Schwinger BG, et al. The Severe Chronic Neutropenia International Registry: 10-Year Follow-up Report. *Support Cancer Ther* 2006;3(4):220-231.
165. Shwachman H, Diamond LK, Oski FA, Khaw KT. The Syndrome of Pancreatic Insufficiency and Bone Marrow Dysfunction. *J Pediatr* 1964;65:645-663.
166. Taylor GM, Birch JM. The hereditary basis of human leukemia. In: Henderson ES, Lister TA, Greaves MF, editors. *Leukemia*. Philadelphia: W.B. Saunders; 1996:210-245.
167. Banerjee A, Shannon KM. Leukemic transformation in patients with severe congenital neutropenia. *J Pediatr Hematol Oncol* 2001;23(8):487-495.
168. Hunter MG, Avalos BR. Granulocyte colony-stimulating factor receptor mutations in severe congenital neutropenia transforming to acute myelogenous leukemia confer resistance to apoptosis and enhance cell survival. *Blood* 2000;95(6):2132-2137.
169. Li FP, Fraumeni JF Jr. Soft-tissue sarcomas, breast cancer, and other neoplasms. A familial syndrome? *Ann Intern Med* 1969;71(4):747-752.
170. Malkin D, Li FP, Strong LC, et al. Germ line p53 mutations in a familial syndrome of breast cancer, sarcomas, and other neoplasms. *Science* 1990;250(4985):1233-1238.
171. Baer MR, Barcos M, Farrell H, Raza A, Preisler HD. Acute myelogenous leukemia with leukemia cutis. Eighteen cases seen between 1969 and 1986. *Cancer* 1989;63(11):2192-2200.
172. Cohen PR, Talpaz M, Kurzrock R. Malignancy-associated Sweet's syndrome: review of the world literature. *J Clin Oncol* 1988;6(12):1887-1897.
173. Schwaegerle SM, Bergfeld WF, Senitzer D, Tidrick RT. Pyoderma gangrenosum: a review. *J Am Acad Dermatol* 1988;18(3):559-568.
174. Baer MR. Management of unusual presentations of acute leukemia. *Hematol Oncol Clin North Am* 1993;7(1):275-292.
175. Wiernik PH. *Extramedullary manifestations of adult leukemia*. London: BC Decker; 2001.
176. Pileri SA, Ascani S, Cox MC, et al. Myeloid sarcoma: clinico-pathologic, phenotypic and cytogenetic analysis of 92 adult patients. *Leukemia* 2007;21(2):340-350.
177. Byrd JC, Edenfield WJ, Shields DJ, Dawson NA. Extramedullary myeloid cell tumors in acute nonlymphocytic leukemia: a clinical review. *J Clin Oncol* 1995;13(7):1800-1816.
178. Peterson BA, Brunning RD, Bloomfield CD, et al. Central nervous system involvement in acute nonlymphocytic leukemia. A prospective study of adults in remission. *Am J Med* 1987;83(3):464-470.

179. Castagnola C, Nozza A, Corso A, Bernasconi C. The value of combination therapy in adult acute myeloid leukemia with central nervous system involvement. *Haematologica* 1997;82(5):577-580.
180. Cassileth PA, Sylvester LS, Bennett JM, Begg CB. High peripheral blast count in adult acute myelogenous leukemia is a primary risk factor for CNS leukemia. *J Clin Oncol* 1988;6(3):495-498.
181. Holmes R, Keating MJ, Cork A, et al. A unique pattern of central nervous system leukemia in acute myelomonocytic leukemia associated with inv(16) (p13q22). *Blood* 1985;65(5):1071-1078.
182. Keidan RD, Fanning J, Gatenby RA, Weese JL. Recurrent typhlitis. A disease resulting from aggressive chemotherapy. *Dis Colon Rectum* 1989;32(3): 206-209.
183. Hoelzer D, Ganser A, Heimpel H. "Atypical" leukemias: preleukemia, smoldering leukemia and hypoplastic leukemia. *Recent Results Cancer Res* 1984;93:69-101.
184. Howe RB, Bloomfield CD, McKenna RW. Hypocellular acute leukemia. *Am J Med* 1982;72(3):391-395.
185. Boggs DR, Wintrobe MM, Cartwright GE. The acute leukemias. Analysis of 322 cases and review of the literature. *Medicine (Baltimore)* 1962;41: 163-225.
186. Hanker JS, Laszlo J, Moore JO. The light microscopic demonstration of hydroperoxidase-positive Phi bodies and rods in leukocytes in acute myeloid leukemia. *Histochemistry* 1978;58(4):241-252.
187. Tulliez M, Vernant JP, Breton-Gorius J, Imbert M, Sultan C. Pseudo-Chediak-Higashi anomaly in a case of acute myeloid leukemia: electron microscopic studies. *Blood* 1979;54(4):863-871.
188. Yanada M, Matsushita T, Suzuki M, et al. Disseminated intravascular coagulation in acute leukemia: clinical and laboratory features at presentation. *Eur J Haematol* 2006;77(4):282-287.
189. Ribeiro RC, Pui CH. The clinical and biological correlates of coagulopathy in children with acute leukemia. *J Clin Oncol* 1986;4(8):1212-1218.
190. Bennett B, Booth NA, Croll A, Dawson AA. The bleeding disorder in acute promyelocytic leukaemia: fibrinolysis due to u-PA rather than defibrination. *Br J Haematol* 1989;71(4):511-217.
191. O'Regan S, Carson S, Chesney RW, Drummond KN. Electrolyte and acid-base disturbances in the management of leukemia. *Blood* 1977;49(3):345-353.
192. Schenkein DP, O'Neill WC, Shapiro J, Miller KB. Accelerated bone formation causing profound hypocalcemia in acute leukemia. *Ann Intern Med* 1986;105(3):375-378.
193. Gewirtz AM, Stewart AF, Vignery A, Hoffman R. Hypercalcaemia complicating acute myelogenous leukaemia: a syndrome of multiple aetiologies. *Br J Haematol* 1983;54(1):133-141.
194. Bunin NJ, Pui CH. Differing complications of hyperleukocytosis in children with acute lymphoblastic or acute nonlymphoblastic leukemia. *J Clin Oncol* 1985;3(12):1590-1595.
195. McKee LC Jr, Collins RD. Intravascular leukocyte thrombi and aggregates as a cause of morbidity and mortality in leukemia. *Medicine (Baltimore)* 1974;53(6):463-478.
196. Lester TJ, Johnson JW, Cuttner J. Pulmonary leukostasis as the single worst prognostic factor in patients with acute myelocytic leukemia and hyperleukocytosis. *Am J Med* 1985;79(1):43-48.
197. Giles FJ, Shen Y, Kantarjian HM, et al. Leukapheresis reduces early mortality in patients with acute myeloid leukemia with high white cell counts but does not improve long- term survival. *Leuk Lymphoma* 2001; 42(1-2):67-73.
198. Thiebaut A, Thomas X, Belhabri A, Anglaret B, Archimbaud E. Impact of pre-induction therapy leukapheresis on treatment outcome in adult acute myelogenous leukemia presenting with hyperleukocytosis. *Ann Hematol* 2000;79(9):501-506.
199. Creutzig U, Ritter J, Budde M, Sutor A, Schellong G. Early deaths due to hemorrhage and leukostasis in childhood acute myelogenous leukemia. Associations with hyperleukocytosis and acute monocytic leukemia. *Cancer* 1987;60(12):3071-3079.
200. Cassileth PA, Harrington DP, Hines JD, et al. Maintenance chemotherapy prolongs remission duration in adult acute nonlymphocytic leukemia. *J Clin Oncol* 1988;6(4):583-587.
201. Fox MJ, Brody JS, Weintraub LR. Leukocyte larceny: a cause of spurious hypoxemia. *Am J Med* 1979;67(5):742-746.

202. Field JB, Williams HE. Artfactual hypoglycemia associated with leukemia. *N Engl J Med* 1961;265:946-948.
203. Hess CE, Nichols AB, Hunt WB, Suratt PM. Pseudohypoxemia secondary to leukemia and thrombocytosis. *N Engl J Med* 1979;301(7):361-363.
204. Lichtman MA, Rowe JM. Hyperleukocytic leukemias: rheological, clinical, and therapeutic considerations. *Blood* 1982;60(2):279-283.
205. Bug G, Anargyrou K, Tonn T, et al. Impact of leukapheresis on early death rate in adult acute myeloid leukemia presenting with hyperleukocytosis. *Transfusion* 2007;47(10):1843-1850.
206. Venditti A, Buccisano F, Del Poeta G, et al. Level of minimal residual disease after consolidation therapy predicts outcome in acute myeloid leukemia. *Blood* 2000;96(12):3948-3952.
207. San Miguel JF, Vidriales MB, Lopez-Berges C, et al. Early immunophenotypical evaluation of minimal residual disease in acute myeloid leukemia identifies different patient risk groups and may contribute to postinduction treatment stratification. *Blood* 2001;98(6):1746-1751.
208. Kern W, Voskova D, Schoch C, Hiddemann W, Schnittger S, Haferlach T. Determination of relapse risk based on assessment of minimal residual disease during complete remission by multiparameter flow cytometry in unselected patients with acute myeloid leukemia. *Blood* 2004;104(10):3078-3085.
209. Baer MR, Stewart CC, Dodge RK, et al. High frequency of immunophenotype changes in acute myeloid leukemia at relapse: implications for residual disease detection (Cancer and Leukemia Group B Study 8361). *Blood* 2001;97(11):3574-3580.
210. Gilliland DG, Griffin JD. The roles of FLT3 in hematopoiesis and leukemia. *Blood* 2002;100(5):1532-1542.
211. Castilla LH, Garrett L, Adya N, et al. The fusion gene Cbfb-MYH11 blocks myeloid differentiation and predisposes mice to acute myelomonocytic leukaemia. *Nat Genet* 1999;23(2):144-146.
212. Yuan Y, Zhou L, Miyamoto T, et al. AML1-ETO expression is directly involved in the development of acute myeloid leukemia in the presence of additional mutations. *Proc Natl Acad Sci U S A* 2001;98(18):10398-10403.
213. Schessl C, Rawat VP, Cusan M, et al. The AML1-ETO fusion gene and the FLT3 length mutation collaborate in inducing acute leukemia in mice. *J Clin Invest* 2005;115(8):2159-2168.
214. Wang YY, Zhou GB, Yin T, et al. AML1-ETO and C-KIT mutation/overexpression in t(8;21) leukemia: implication in stepwise leukemogenesis and response to Gleevec. *Proc Natl Acad Sci U S A* 2005;102(4):1104-1109.
215. Wang YY, Zhao LJ, Wu CF, et al. C-KIT mutation cooperates with full-length AML1-ETO to induce acute myeloid leukemia in mice. *Proc Natl Acad Sci U S A* 2011;108(6):2450-2455.
216. Walter MJ, Shen D, Ding L, et al. Clonal architecture of secondary acute myeloid leukemia. *N Engl J Med* 2012;366(12):1090-1098.
217. Fialkow PJ, Singer JW, Raskind WH, et al. Clonal development, stem-cell differentiation, and clinical remissions in acute nonlymphocytic leukemia. *N Engl J Med* 1987;317(8):468-473.
218. Fearon ER, Winkelstein JA, Civin CI, Pardoll DM, Vogelstein B. Carrier detection in X-linked agammaglobulinemia by analysis of X-chromosome inactivation. *N Engl J Med* 1987;316(8):427-431.
219. Keinanen M, Griffin JD, Bloomfield CD, Machnicki J, de la Chapelle A. Clonal chromosomal abnormalities showing multiple-cell-lineage involvement in acute myeloid leukemia. *N Engl J Med* 1988;318(18):1153-1158.
- P.1614
220. Ding L, Ley TJ, Larson DE, et al. Clonal evolution in relapsed acute myeloid leukaemia revealed by whole-genome sequencing. *Nature* 2012;481(7382): 506-510.
221. Felipe Rico J, Hassane DC, Guzman ML. Acute myelogenous leukemia stem cells: from Bench to Bedside. *Cancer Lett* 2012.
222. Lapidot T, Sirard C, Vormoor J, et al. A cell initiating human acute myeloid leukaemia after transplantation into SCID mice. *Nature* 1994;367(6464): 645-648.

223. Blair A, Hogge DE, Sutherland HJ. Most acute myeloid leukemia progenitor cells with long-term proliferative ability in vitro and in vivo have the phenotype CD34(+)/CD71(-)/HLA-DR. *Blood* 1998;92(11):4325-4335.
224. Jordan CT, Upchurch D, Szilvassy SJ, et al. The interleukin-3 receptor alpha chain is a unique marker for human acute myelogenous leukemia stem cells. *Leukemia* 2000;14(10):1777-1784.
225. Guan Y, Gerhard B, Hogge DE. Detection, isolation, and stimulation of quiescent primitive leukemic progenitor cells from patients with acute myeloid leukemia (AML). *Blood* 2003;101(8):3142-3149.
226. Guzman ML, Neering SJ, Upchurch D, et al. Nuclear factor-kappaB is constitutively activated in primitive human acute myelogenous leukemia cells. *Blood* 2001;98(8):2301-2307.
227. Raaijmakers MH, de Grouw EP, Heuver LH, et al. Breast cancer resistance protein in drug resistance of primitive CD34+38- cells in acute myeloid leukemia. *Clin Cancer Res* 2005;11(6):2436-2444.
228. Raaijmakers MH, de Grouw EP, van der Reijden BA, de Witte TJ, Jansen JH, Raymakers RA. ABCB1 modulation does not circumvent drug extrusion from primitive leukemic progenitor cells and may preferentially target residual normal cells in acute myelogenous leukemia. *Clin Cancer Res* 2006;12 (11 Pt 1):3452-3458.
229. Emadi A. Stem cells: the good, the bad, and the ugly. *Sci Transl Med* 2011;3(102):ec157.
230. Eppert K, Takenaka K, Lechman ER, et al. Stem cell gene expression programs influence clinical outcome in human leukemia. *Nat Med* 2011;17(9):1086-1093.
231. Gerber JM, Smith BD, Ngwang B, et al. A clinically relevant population of leukemic CD34(+)/CD38(-) cells in acute myeloid leukemia. *Blood* 2012;119(15):3571-3577.
232. Marie JP, Zittoun R, Thevenin D, Mathieu M, Viguie F. In vitro culture of clonogenic leukaemic cells in acute myeloid leukaemia: growth pattern and drug sensitivity. *Br J Haematol* 1983;55(3):427-437.
233. Kelleher C, Miyauchi J, Wong G, Clark S, Minden MD, McCulloch EA. Synergism between recombinant growth factors, GM-CSF and G-CSF, acting on the blast cells of acute myeloblastic leukemia. *Blood* 1987;69(5):1498-1503.
234. Lemoli RM, Fortuna A, Tafuri A, et al. Interleukin-9 stimulates the proliferation of human myeloid leukemic cells. *Blood* 1996;87(9):3852-3859.
235. Lisovsky M, Estrov Z, Zhang X, et al. Flt3 ligand stimulates proliferation and inhibits apoptosis of acute myeloid leukemia cells: regulation of Bcl-2 and Bax. *Blood* 1996;88(10):3987-3997.
236. Corazza F, Hermans C, D'Hondt S, et al. Circulating thrombopoietin as an in vivo growth factor for blast cells in acute myeloid leukemia. *Blood* 2006;107(6):2525-2530.
237. Souza LM, Boone TC, Gabilove J, et al. Recombinant human granulocyte colony-stimulating factor: effects on normal and leukemic myeloid cells. *Science* 1986;232(4746):61-65.
238. Rodriguez-Cimadevilla JC, Beauchemin V, Villeneuve L, Letendre F, Shaw A, Hoang T. Coordinate secretion of interleukin-1 beta and granulocyte-macrophage colony-stimulating factor by the blast cells of acute myeloblastic leukemia: role of interleukin-1 as an endogenous inducer. *Blood* 1990;76(8):1481-1489.
239. Bradbury D, Rogers S, Reilly IA, Kozlowski R, Russell NH. Role of autocrine and paracrine production of granulocyte-macrophage colony-stimulating factor and interleukin-1 beta in the autonomous growth of acute myeloblastic leukaemia cells—studies using purified CD34-positive cells. *Leukemia* 1992;6(6):562-566.
240. Lowenberg B, van Putten WL, Touw IP, Delwel R, Santini V. Autonomous proliferation of leukemic cells in vitro as a determinant of prognosis in adult acute myeloid leukemia. *N Engl J Med* 1993;328(9):614-619.
241. Hunter AE, Rogers SY, Roberts IA, Barrett AJ, Russell N. Autonomous growth of blast cells is associated with reduced survival in acute myeloblastic leukemia. *Blood* 1993;82(3):899-903.
242. Ohler L, Berer A, Aletaha D, et al. Cytogenetic risk groups in acute myeloblastic leukaemia differ greatly in their semi-solid colony growth. *Br J Haematol* 2001;113(1):120-125.
243. del Canizo MC, Brufau A, Almeida J, et al. In vitro growth in acute myeloblastic leukaemia: relationship with other clinico-biological characteristics of the disease. *Br J Haematol* 1998;103(1):137-142.
244. Pallis M, Zhu YM, Russell NH. Bcl-x(L) is heterogeneously expressed by acute myeloblastic leukaemia cells and is associated with autonomous growth in vitro and with P-glycoprotein expression. *Leukemia* 1997;11(7):945-949.

245. Raza A, Maheshwari Y, Preisler HD. Differences in cell cycle characteristics among patients with acute nonlymphocytic leukemia. *Blood* 1987;69(6): 1647-1653.
246. Raza A, Preisler HD, Day R, et al. Direct relationship between remission duration in acute myeloid leukemia and cell cycle kinetics: a leukemia intergroup study. *Blood* 1990;76(11):2191-2197.
247. Brons PP, Haanen C, Boezeman JB, et al. Proliferation patterns in acute myeloid leukemia: leukemic clonogenic growth and in vivo cell cycle kinetics. *Ann Hematol* 1993;66(5):225-233.
248. Smeets ME, Raymakers RA, Vierwinden G, et al. Idarubicin DNA intercalation is reduced by MRP1 and not Pgp. *Leukemia* 1999;13(9):1390-1398.
249. Schimmer AD, Hedley DW, Penn LZ, Minden MD. Receptor- and mitochondrial-mediated apoptosis in acute leukemia: a translational view. *Blood* 2001;98(13):3541-3553.
250. Konopleva M, Zhao S, Hu W, et al. The anti-apoptotic genes Bcl-X(L) and Bcl-2 are over-expressed and contribute to chemoresistance of non-proliferating leukaemic CD34+ cells. *Br J Haematol* 2002;118(2):521-534.
251. Carter BZ, Milella M, Tsao T, et al. Regulation and targeting of antiapoptotic XIAP in acute myeloid leukemia. *Leukemia* 2003;17(11):2081-2089.
252. Turzanski J, Grundy M, Russell NH, Pallis M. Interleukin-1beta maintains an apoptosis-resistant phenotype in the blast cells of acute myeloid leukaemia via multiple pathways. *Leukemia* 2004;18(10):1662-1670.
253. Del Poeta G, Bruno A, Del Principe MI, et al. Deregulation of the mitochondrial apoptotic machinery and development of molecular targeted drugs in acute myeloid leukemia. *Curr Cancer Drug Targets* 2008;8(3):207-222.
254. Furukawa Y, Sutheesophon K, Wada T, Nishimura M, Saito Y, Ishii H. Methylation silencing of the Apaf-1 gene in acute leukemia. *Mol Cancer Res* 2005;3(6):325-334.
255. Pallis M, Russell N. P-glycoprotein plays a drug-efflux-independent role in augmenting cell survival in acute myeloblastic leukemia and is associated with modulation of a sphingomyelin-ceramide apoptotic pathway. *Blood* 2000;95(9):2897-2904.
256. Xu Q, Simpson SE, Scialla TJ, Bagg A, Carroll M. Survival of acute myeloid leukemia cells requires PI3 kinase activation. *Blood* 2003;102(3):972-980.
257. Recher C, Beyne-Rauzy O, Demur C, et al. Antileukemic activity of rapamycin in acute myeloid leukemia. *Blood* 2005;105(6):2527-2534.
258. Xu Q, Thompson JE, Carroll M. mTOR regulates cell survival after etoposide treatment in primary AML cells. *Blood* 2005;106(13):4261-4268.
259. Grandage VL, Gale RE, Linch DC, Khwaja A. PI3-kinase/Akt is constitutively active in primary acute myeloid leukaemia cells and regulates survival and chemoresistance via NF-kappaB, Mapkinase and p53 pathways. *Leukemia* 2005;19(4):586-594.
260. Martelli AM, Tazzari PL, Tabellini G, et al. A new selective AKT pharmacological inhibitor reduces resistance to chemotherapeutic drugs, TRAIL, all-trans-retinoic acid, and ionizing radiation of human leukemia cells. *Leukemia* 2003;17(9):1794-1805.
261. Neri LM, Borgatti P, Tazzari PL, et al. The phosphoinositide 3-kinase/AKT1 pathway involvement in drug and all-trans-retinoic acid resistance of leukemia cells. *Mol Cancer Res* 2003;1(3):234-246.
262. Zhao S, Konopleva M, Cabreira-Hansen M, et al. Inhibition of phosphatidylinositol 3-kinase dephosphorylates BAD and promotes apoptosis in myeloid leukemias. *Leukemia* 2004;18(2):267-275.
263. Martelli AM, Evangelisti C, Chiarini F, Grimaldi C, Manzoli L, McCubrey JA. Targeting the PI3K/AKT/mTOR signaling network in acute myelogenous leukemia. *Expert Opin Investig Drugs* 2009;18(9):1333-1349.
264. Martelli AM, Chiarini F, Evangelisti C, et al. Two hits are better than one: targeting both phosphatidylinositol 3-kinase and mammalian target of rapamycin as a therapeutic strategy for acute leukemia treatment. *Oncotarget* 2012;3(4):371-394.
265. Kornblau SM, Womble M, Qiu YH, et al. Simultaneous activation of multiple signal transduction pathways confers poor prognosis in acute myelogenous leukemia. *Blood* 2006;108(7):2358-2365.

266. Hussong JW, Rodgers GM, Shami PJ. Evidence of increased angiogenesis in patients with acute myeloid leukemia. *Blood* 2000;95(1):309-313.
267. Padro T, Ruiz S, Bieker R, et al. Increased angiogenesis in the bone marrow of patients with acute myeloid leukemia. *Blood* 2000;95(8):2637-2644.
268. de Bont ES, Rosati S, Jacobs S, Kamps WA, Vellenga E. Increased bone marrow vascularization in patients with acute myeloid leukaemia: a possible role for vascular endothelial growth factor. *Br J Haematol* 2001;113(2):296-304.
269. Padro T, Bieker R, Ruiz S, et al. Overexpression of vascular endothelial growth factor (VEGF) and its cellular receptor KDR (VEGFR-2) in the bone marrow of patients with acute myeloid leukemia. *Leukemia* 2002;16(7):1302-1310.
270. Fiedler W, Graeven U, Ergun S, et al. Vascular endothelial growth factor, a possible paracrine growth factor in human acute myeloid leukemia. *Blood* 1997;89(6):1870-1875.
271. Dias S, Hattori K, Heissig B, et al. Inhibition of both paracrine and autocrine VEGF/ VEGFR-2 signaling pathways is essential to induce long-term remission of xenotransplanted human leukemias. *Proc Natl Acad Sci U S A* 2001;98(19):10857-10862.
272. Dias S, Shmelkov SV, Lam G, Rafii S. VEGF(165) promotes survival of leukemic cells by Hsp90-mediated induction of Bcl-2 expression and apoptosis inhibition. *Blood* 2002;99(7):2532-2540.
273. Markovic A, MacKenzie KL, Lock RB. Induction of vascular endothelial growth factor secretion by childhood acute lymphoblastic leukemia cells via the FLT-3 signaling pathway. *Mol Cancer Ther* 2012;11(1):183-193.
274. Emadi A. Leukemia: the master vampire. *Sci Transl Med* 2011;3(110):ec189.
275. Tavor S, Petit I, Porozov S, et al. CXCR4 regulates migration and development of human acute myelogenous leukemia stem cells in transplanted NOD/SCID mice. *Cancer Res* 2004;64(8):2817-2824.
276. Zeng Z, Samudio IJ, Munsell M, et al. Inhibition of CXCR4 with the novel RCP168 peptide overcomes stroma-mediated chemoresistance in chronic and acute leukemias. *Mol Cancer Ther* 2006;5(12):3113-3121.
277. Tavor S, Petit I. Can inhibition of the SDF-1/CXCR4 axis eradicate acute leukemia? *Semin Cancer Biol* 2010;20(3):178-185.
278. Mrozek K, Heinonen K, Lawrence D, et al. Adult patients with de novo acute myeloid leukemia and t(9; 11)(p22; q23) have a superior outcome to patients with other translocations involving band 11q23: a Cancer and Leukemia Group B study. *Blood* 1997;90(11):4532-4538.
279. Mirro J, Kitchingman G, Williams D, et al. Clinical and laboratory characteristics of acute leukemia with the 4;11 translocation. *Blood* 1986;67(3):689-697.
280. Berger R, Bernheim A, Le Coniat M, et al. Abnormalities of the short arm of chromosome 12 in acute nonlymphocytic leukemia and dysmyelopoietic syndrome. *Cancer Genet Cytogenet* 1986;19(3-4):281-289.
281. Bloomfield CD, Garson OM, Volin L, Knuutila S, de la Chapelle A. t(1;3) (p36;q21) in acute nonlymphocytic leukemia: a new cytogenetic-clinicopathologic association. *Blood* 1985;66(6):1409-1413.
282. Ball ED, Davis RB, Griffin JD, et al. Prognostic value of lymphocyte surface markers in acute myeloid leukemia. *Blood* 1991;77(10):2242-2250.
283. Solary E, Casasnovas RO, Campos L, et al. Surface markers in adult acute myeloblastic leukemia: correlation of CD19+, CD34+ and CD14+/DR—phenotypes with shorter survival. Groupe d'Etude Immunologique des Leucemies (GEIL). *Leukemia* 1992;6(5):393-399.
284. Harper DP, Aplan PD. Chromosomal rearrangements leading to MLL gene fusions: clinical and biological aspects. *Cancer Res* 2008;68(24): 10024-10027.
285. Nakamura T, Alder H, Gu Y, et al. Genes on chromosomes 4, 9, and 19 involved in 11q23 abnormalities in acute leukemia share sequence homology and/or common motifs. *Proc Natl Acad Sci U S A* 1993;90(10):4631-4635.
286. Schoch C, Schnittger S, Klaus M, Kern W, Hiddemann W, Haferlach T. AML with 11q23/MLL abnormalities as defined by the WHO classification: incidence, partner chromosomes, FAB subtype, age distribution, and prognostic impact in an unselected series of 1897 cytogenetically analyzed AML cases. *Blood* 2003;102(7):2395-2402.
287. Blum W, Mrozek K, Ruppert AS, et al. Adult de novo acute myeloid leukemia with t(6;11)(q27;q23): results from Cancer and Leukemia Group B Study 8461 and review of the literature. *Cancer* 2004;101(6):1420-1427.

288. Coenen EA, Raimondi SC, Harbott J, et al. Prognostic significance of additional cytogenetic aberrations in 733 de novo pediatric 11q23/MLL-rearranged AML patients: results of an international study. *Blood* 2011;117(26):7102-7111.
289. Medeiros BC, Othus M, Fang M, Roulston D, Appelbaum FR. Prognostic impact of monosomal karyotype in young adult and elderly acute myeloid leukemia: the Southwest Oncology Group (SWOG) experience. *Blood* 2010;116(13):2224-2228.
290. Fang M, Storer B, Estey E, et al. Outcome of patients with acute myeloid leukemia with monosomal karyotype who undergo hematopoietic cell transplantation. *Blood* 2011;118(6):1490-1494.
291. Shen Y, Zhu YM, Fan X, et al. Gene mutation patterns and their prognostic impact in a cohort of 1185 patients with acute myeloid leukemia. *Blood* 2011;118(20):5593-5603.
292. Mrozek K, Marcucci G, Paschka P, Whitman SP, Bloomfield CD. Clinical relevance of mutations and gene-expression changes in adult acute myeloid leukemia with normal cytogenetics: are we ready for a prognostically prioritized molecular classification? *Blood* 2007;109(2):431-448.
293. Kiyoi H, Ohno R, Ueda R, Saito H, Naoe T. Mechanism of constitutive activation of FLT3 with internal tandem duplication in the juxtamembrane domain. *Oncogene* 2002;21(16):2555-2563.
294. Stirewalt DL, Kopecky KJ, Meshinchi S, et al. Size of FLT3 internal tandem duplication has prognostic significance in patients with acute myeloid leukemia. *Blood* 2006;107(9):3724-3726.
295. Mizuki M, Fenski R, Halfter H, et al. Flt3 mutations from patients with acute myeloid leukemia induce transformation of 32D cells mediated by the Ras and STAT5 pathways. *Blood* 2000;96(12):3907-3914.
296. Spiekermann K, Bagrintseva K, Schwab R, Schmieja K, Hiddemann W. Overexpression and constitutive activation of FLT3 induces STAT5 activation in primary acute myeloid leukemia blast cells. *Clin Cancer Res* 2003;9(6):2140-2150.
297. Brandts CH, Sargin B, Rode M, et al. Constitutive activation of Akt by Flt3 internal tandem duplications is necessary for increased survival, proliferation, and myeloid transformation. *Cancer Res* 2005;65(21):9643-9650.
298. Zheng R, Friedman AD, Levis M, Li L, Weir EG, Small D. Internal tandem duplication mutation of FLT3 blocks myeloid differentiation through suppression of C/EBPalpha expression. *Blood* 2004;103(5):1883-1890.
299. Kim KT, Levis M, Small D. Constitutively activated FLT3 phosphorylates BAD partially through pim-1. *Br J Haematol* 2006;134(5):500-509.
300. Stirewalt DL, Kopecky KJ, Meshinchi S, et al. FLT3, RAS, and TP53 mutations in elderly patients with acute myeloid leukemia. *Blood* 2001;97(11): 3589-3595.
301. Boissel N, Cayuela JM, Preudhomme C, et al. Prognostic significance of FLT3 internal tandem repeat in patients with de novo acute myeloid leukemia treated with reinforced courses of chemotherapy. *Leukemia* 2002;16(9):1699-1704.
302. Gale RE, Green C, Allen C, et al. The impact of FLT3 internal tandem duplication mutant level, number, size, and interaction with NPM1 mutations in a large cohort of young adult patients with acute myeloid leukemia. *Blood* 2008;111(5):2776-2784.
303. Mead AJ, Linch DC, Hills RK, Wheatley K, Burnett AK, Gale RE. FLT3 tyrosine kinase domain mutations are biologically distinct from and have a significantly more favorable prognosis than FLT3 internal tandem duplications in patients with acute myeloid leukemia. *Blood* 2007.
304. Beran M, Luthra R, Kantarjian H, Estey E. FLT3 mutation and response to intensive chemotherapy in young adult and elderly patients with normal karyotype. *Leuk Res* 2004;28(6):547-550.
305. Marzac C, Teyssandier I, Calendini O, et al. Flt3 internal tandem duplication and P-glycoprotein functionality in 171 patients with acute myeloid leukemia. *Clin Cancer Res* 2006;12(23):7018-7024.
306. Whitman SP, Maharry K, Radmacher MD, et al. FLT3 internal tandem duplication associates with adverse outcome and gene- and microRNA-expression signatures in patients 60 years of age or older with primary cytogenetically normal acute myeloid leukemia: a Cancer and Leukemia Group B study. *Blood* 2010;116(18):3622-3626.
307. Kantarjian H, Ravandi F, O'Brien S, et al. Intensive chemotherapy does not benefit most older patients (age 70 years or older) with acute myeloid leukemia. *Blood* 2010;116(22):4422-4429.
308. Pollard JA, Alonzo TA, Gerbing RB, et al. FLT3 internal tandem duplication in CD34+/CD33- precursors predicts poor outcome in acute myeloid leukemia. *Blood* 2006;108(8):2764-2769.

309. Sato T, Yang X, Knapper S, et al. FLT3 ligand impedes the efficacy of FLT3 inhibitors in vitro and in vivo. *Blood* 2011;117(12):3286-3293.
310. Levis M. FLT3/ITD AML and the law of unintended consequences. *Blood* 2011;117(26):6987-6990.
311. Boissel N, Renneville A, Biggio V, et al. Prevalence, clinical profile, and prognosis of NPM mutations in AML with normal karyotype. *Blood* 2005;106(10):3618-3620.
312. Falini B, Mecucci C, Tiacci E, et al. Cytoplasmic nucleophosmin in acute myelogenous leukemia with a normal karyotype. *N Engl J Med* 2005;352(3):254-266.
313. Suzuki T, Kiyoi H, Ozeki K, et al. Clinical characteristics and prognostic implications of NPM1 mutations in acute myeloid leukemia. *Blood* 2005;106(8):2854-2861.
314. Haferlach C, Mecucci C, Schnittger S, et al. AML with mutated NPM1 carrying a normal or aberrant karyotype show overlapping biologic, pathologic, immunophenotypic, and prognostic features. *Blood* 2009;114(14): 3024-3032.
315. Kronke J, Schlenk RF, Jensen KO, et al. Monitoring of minimal residual disease in NPM1-mutated acute myeloid leukemia: a study from the German-Austrian acute myeloid leukemia study group. *J Clin Oncol* 2011;29(19):2709-2716.
316. Pabst T, Mueller BU, Zhang P, et al. Dominant-negative mutations of CEBPA, encoding CCAAT/enhancer binding protein-alpha (C/EBPalpha), in acute myeloid leukemia. *Nat Genet* 2001;27(3):263-270.
317. Green CL, Koo KK, Hills RK, Burnett AK, Linch DC, Gale RE. Prognostic significance of CEBPA mutations in a large cohort of younger adult patients with acute myeloid leukemia: impact of double CEBPA mutations and the interaction with FLT3 and NPM1 mutations. *J Clin Oncol* 2010;28(16): 2739-2747.
318. Dufour A, Schneider F, Metzeler KH, et al. Acute myeloid leukemia with biallelic CEBPA gene mutations and normal karyotype represents a distinct genetic entity associated with a favorable clinical outcome. *J Clin Oncol* 2010;28(4):570-577.
319. Caligiuri MA, Strout MP, Lawrence D, et al. Rearrangement of ALL1 (MLL) in acute myeloid leukemia with normal cytogenetics. *Cancer Res* 1998;58(1): 55-59.
320. Schnittger S, Kinkelin U, Schoch C, et al. Screening for MLL tandem duplication in 387 unselected patients with AML identify a prognostically unfavorable subset of AML. *Leukemia* 2000;14(5):796-804.
321. Dohner K, Tobis K, Ulrich R, et al. Prognostic significance of partial tandem duplications of the MLL gene in adult patients 16 to 60 years old with acute myeloid leukemia and normal cytogenetics: a study of the Acute Myeloid Leukemia Study Group Ulm. *J Clin Oncol* 2002;20(15):3254-3261.
322. Whitman SP, Ruppert AS, Marcucci G, et al. Long-term disease-free survivors with cytogenetically normal acute myeloid leukemia and MLL partial tandem duplication: a Cancer and Leukemia Group B study. *Blood* 2007;109(12):5164-5167.
323. Marcucci G, Baldus CD, Ruppert AS, et al. Overexpression of the ETS-related gene, ERG, predicts a worse outcome in acute myeloid leukemia with normal karyotype: a Cancer and Leukemia Group B study. *J Clin Oncol* 2005;23(36):9234-9242.
324. Baldus CD, Thiede C, Soucek S, Bloomfield CD, Thiel E, Ehninger G. BAALC expression and FLT3 internal tandem duplication mutations in acute myeloid leukemia patients with normal cytogenetics: prognostic implications. *J Clin Oncol* 2006;24(5):790-797.
325. Langer C, Radmacher MD, Ruppert AS, et al. High BAALC expression associates with other molecular prognostic markers, poor outcome, and a distinct gene-expression signature in cytogenetically normal patients younger than 60 years with acute myeloid leukemia: a Cancer and Leukemia Group B (CALGB) study. *Blood* 2008;111(11):5371-5379.
326. Barjesteh van Waalwijk van Doorn-Khosrovani S, Erpelinck C, van Putten WL, et al. High EVI1 expression predicts poor survival in acute myeloid leukemia: a study of 319 de novo AML patients. *Blood* 2003;101(3):837-845.
327. Lugthart S, van Drunen E, van Norden Y, et al. High EVI1 levels predict adverse outcome in acute myeloid leukemia: prevalence of EVI1 over-expression and chromosome 3q26 abnormalities underestimated. *Blood* 2008;111(8):4329-4337.
328. Groschel S, Lugthart S, Schlenk RF, et al. High EVI1 expression predicts outcome in younger adult patients with acute myeloid leukemia and is associated with distinct cytogenetic abnormalities. *J Clin Oncol* 2010;28(12): 2101-2107.

329. Bacher U, Haferlach T, Schoch C, Kern W, Schnittger S. Implications of NRAS mutations in AML: a study of 2502 patients. *Blood* 2006;107(10):3847-3853.
330. Milella M, Estrov Z, Kornblau SM, et al. Synergistic induction of apoptosis by simultaneous disruption of the Bcl-2 and MEK/MAPK pathways in acute myelogenous leukemia. *Blood* 2002;99(9):3461-3464.
331. Lunghi P, Tabilio A, Dall'Aglio PP, et al. Downmodulation of ERK activity inhibits the proliferation and induces the apoptosis of primary acute myelogenous leukemia blasts. *Leukemia* 2003;17(9):1783-1793.
332. Parkin B, Erba H, Ouillette P, et al. Acquired genomic copy number aberrations and survival in adult acute myelogenous leukemia. *Blood* 2010;116(23):4958-4967.
333. Miglino M, Colombo N, Pica G, et al. WT1 overexpression at diagnosis may predict favorable outcome in patients with de novo non-M3 acute myeloid leukemia. *Leuk Lymphoma* 2011;52(10):1961-1969.
334. Virappane P, Gale R, Hills R, et al. Mutation of the Wilms' tumor 1 gene is a poor prognostic factor associated with chemotherapy resistance in normal karyotype acute myeloid leukemia: the United Kingdom Medical Research Council Adult Leukaemia Working Party. *J Clin Oncol* 2008;26(33): 5429-5435.
335. Becker H, Marcucci G, Maharry K, et al. Mutations of the Wilms tumor 1 gene (WT1) in older patients with primary cytogenetically normal acute myeloid leukemia: a Cancer and Leukemia Group B study. *Blood* 2010;116(5):788-792.
336. Tang JL, Hou HA, Chen CY, et al. AML1/RUNX1 mutations in 470 adult patients with de novo acute myeloid leukemia: prognostic implication and interaction with other gene alterations. *Blood* 2009;114(26):5352-5361.
337. Gaidzik VI, Bullinger L, Schlenk RF, et al. RUNX1 mutations in acute myeloid leukemia: results from a comprehensive genetic and clinical analysis from the AML study group. *J Clin Oncol* 2011;29(10):1364-1372.
338. Mendler JH, Maharry K, Radmacher MD, et al. RUNX1 Mutations Are Associated With Poor Outcome in Younger and Older Patients With Cytogenetically Normal Acute Myeloid Leukemia and With Distinct Gene and MicroRNA Expression Signatures. *J Clin Oncol* 2012.
339. Metzeler KH, Becker H, Maharry K, et al. ASXL1 mutations identify a high-risk subgroup of older patients with primary cytogenetically normal AML within the ELN Favorable genetic category. *Blood* 2011;118(26):6920-6929.
340. Ito S, Shen L, Dai Q, et al. Tet proteins can convert 5-methylcytosine to 5-formylcytosine and 5-carboxylcytosine. *Science* 2011;333(6047):1300-1303.
341. He YF, Li BZ, Li Z, et al. Tet-mediated formation of 5-carboxylcytosine and its excision by TDG in mammalian DNA. *Science* 2011;333(6047):1303-1307.
342. Ko M, Huang Y, Jankowska AM, et al. Impaired hydroxylation of 5-methylcytosine in myeloid cancers with mutant TET2. *Nature* 2010;468(7325):839-843.
343. Delhommeau F, Dupont S, Della Valle V, et al. Mutation in TET2 in myeloid cancers. *N Engl J Med* 2009;360(22):2289-2301.
344. Gaidzik VI, Paschka P, Spath D, et al. TET2 mutations in acute myeloid leukemia (AML): results from a comprehensive genetic and clinical analysis of the AML study group. *J Clin Oncol* 2012;30(12):1350-1357.
345. Ley TJ, Ding L, Walter MJ, et al. DNMT3A mutations in acute myeloid leukemia. *N Engl J Med* 2010;363(25):2424-2433.
346. Thol F, Damm F, Ludeking A, et al. Incidence and prognostic influence of DNMT3A mutations in acute myeloid leukemia. *J Clin Oncol* 2011;29(21):2889-2896.
347. Hou HA, Kuo YY, Liu CY, et al. DNMT3A mutations in acute myeloid leukemia: stability during disease evolution and clinical implications. *Blood* 2012;119(2):559-568.
348. Markova J, Michkova P, Burckova K, et al. Prognostic impact of DNMT3A mutations in patients with intermediate cytogenetic risk profile acute myeloid leukemia. *Eur J Haematol* 2012;88(2):128-135.
349. Renneville A, Boissel N, Nibourel O, et al. Prognostic significance of DNA methyltransferase 3A mutations in cytogenetically normal acute myeloid leukemia: a study by the Acute Leukemia French Association. *Leukemia* 2012;26(6):1247-1254.

350. Marcucci G, Maharry K, Wu YZ, et al. IDH1 and IDH2 gene mutations identify novel molecular subsets within de novo cytogenetically normal acute myeloid leukemia: a Cancer and Leukemia Group B study. *J Clin Oncol* 2010;28(14):2348-2355.
351. Paschka P, Schlenk RF, Gaidzik VI, et al. IDH1 and IDH2 mutations are frequent genetic alterations in acute myeloid leukemia and confer adverse prognosis in cytogenetically normal acute myeloid leukemia with NPM1 mutation without FLT3 internal tandem duplication. *J Clin Oncol* 2010;28(22):3636-3643.
352. Abbas S, Lugthart S, Kavelaars FG, et al. Acquired mutations in the genes encoding IDH1 and IDH2 both are recurrent aberrations in acute myeloid leukemia: prevalence and prognostic value. *Blood* 2010;116(12):2122-2126.
353. Zou Y, Zeng Y, Zhang DF, Zou SH, Cheng YF, Yao YG. IDH1 and IDH2 mutations are frequent in Chinese patients with acute myeloid leukemia but rare in other types of hematological disorders. *Biochem Biophys Res Commun* 2010;402(2):378-383.
354. Patel JP, Gonen M, Figueroa ME, et al. Prognostic relevance of integrated genetic profiling in acute myeloid leukemia. *N Engl J Med* 2012;366(12):1079-1089.
355. Dang L, White DW, Gross S, et al. Cancer-associated IDH1 mutations produce 2-hydroxyglutarate. *Nature* 2009;462(7274):739-744.
356. Chou WC, Hou HA, Chen CY, et al. Distinct clinical and biologic characteristics in adult acute myeloid leukemia bearing the isocitrate dehydrogenase 1 mutation. *Blood* 2010;115(14):2749-2754.
357. Ward PS, Patel J, Wise DR, et al. The common feature of leukemia-associated IDH1 and IDH2 mutations is a neomorphic enzyme activity converting alpha-ketoglutarate to 2-hydroxyglutarate. *Cancer Cell* 2010;17(3):225-234.
358. Gross S, Cairns RA, Minden MD, et al. Cancer-associated metabolite 2-hydroxyglutarate accumulates in acute myelogenous leukemia with isocitrate dehydrogenase 1 and 2 mutations. *J Exp Med* 2010;207(2):339-344.
359. Figueroa ME, Abdel-Wahab O, Lu C, et al. Leukemic IDH1 and IDH2 mutations result in a hypermethylation phenotype, disrupt TET2 function, and impair hematopoietic differentiation. *Cancer Cell* 2010;18(6):553-567.
360. Chowdhury R, Yeoh KK, Tian YM, et al. The oncometabolite 2-hydroxyglutarate inhibits histone lysine demethylases. *EMBO Rep* 2011;12(5):463-469.
361. Emadi A. At the crossroads: tumor metabolism and epigenetics. *Sci Transl Med* 2011;3(82):ec68.
362. Kohl TM, Schnittger S, Ellwart JW, Hiddemann W, Spiekermann K. KIT exon 8 mutations associated with core-binding factor (CBF)-acute myeloid leukemia (AML) cause hyperactivation of the receptor in response to stem cell factor. *Blood* 2005;105(8):3319-3321.
363. Cammenga J, Horn S, Bergholz U, et al. Extracellular KIT receptor mutants, commonly found in core binding factor AML, are constitutively active and respond to imatinib mesylate. *Blood* 2005;106(12):3958-3961.
364. Schnittger S, Kohl TM, Haferlach T, et al. KIT-D816 mutations in AML1-ETO-positive AML are associated with impaired event-free and overall survival. *Blood* 2006;107(5):1791-1799.
365. Cairoli R, Beghini A, Grillo G, et al. Prognostic impact of c-KIT mutations in core binding factor leukemias: an Italian retrospective study. *Blood* 2006;107(9):3463-3468.
366. Paschka P, Marcucci G, Ruppert AS, et al. Adverse prognostic significance of KIT mutations in adult acute myeloid leukemia with inv(16) and t(8;21): a Cancer and Leukemia Group B Study. *J Clin Oncol* 2006;24(24):3904-3911.
367. Legrand O, Perrot JY, Simonin G, et al. Adult biphenotypic acute leukaemia: an entity with poor prognosis which is related to unfavourable cytogenetics and P-glycoprotein over-expression. *Br J Haematol* 1998;100(1):147-155.
368. Estey E, Thall P, Beran M, Kantarjian H, Pierce S, Keating M. Effect of diagnosis (refractory anemia with excess blasts, refractory anemia with excess blasts in transformation, or acute myeloid leukemia [AML]) on outcome of AML-type chemotherapy. *Blood* 1997;90(8):2969-2977.
369. Jennings CD, Foon KA. Flow cytometry: recent advances in diagnosis and monitoring of leukemia. *Cancer Invest* 1997;15(4):384-399.
370. Borowitz MJ, Gockerman JP, Moore JO, et al. Clinicopathologic and cytogenetic features of CD34 (My 10)-positive acute nonlymphocytic leukemia. *Am J Clin Pathol* 1989;91(3):265-270.

371. Greaves MF, Brown J, Molgaard HV, et al. Molecular features of CD34: a hemopoietic progenitor cell-associated molecule. *Leukemia* 1992;6 (Suppl 1):31-36.
372. Kaleem Z, Crawford E, Pathan MH, et al. Flow cytometric analysis of acute leukemias. Diagnostic utility and critical analysis of data. *Arch Pathol Lab Med* 2003;127(1):42-48.
373. Paietta E, Wiernik PH, Andersen J, Bennett J, Yunis J. Acute myeloid leukemia M4 with inv(16) (p13q22) exhibits a specific immunophenotype with CD2 expression. *Blood* 1993;82(8):2595.
374. Kita K, Nakase K, Miwa H, et al. Phenotypical characteristics of acute myelocytic leukemia associated with the t(8;21)(q22;q22) chromosomal abnormality: frequent expression of immature B-cell antigen CD19 together with stem cell antigen CD34. *Blood* 1992;80(2):470-477.
375. Geller RB, Zahurak M, Hurwitz CA, et al. Prognostic importance of immunophenotyping in adults with acute myelocytic leukaemia: the significance of the stem-cell glycoprotein CD34 (My10). *Br J Haematol* 1990;76(3):340-347.
376. Adriaansen HJ, te Boekhorst PA, Hagemeyer AM, van der Schoot CE, Delwel HR, van Dongen JJ. Acute myeloid leukemia M4 with bone marrow eosinophilia (M4Eo) and inv(16)(p13q22) exhibits a specific immunophenotype with CD2 expression. *Blood* 1993;81(11):3043-3051.
377. Leith CP, Kopecky KJ, Chen IM, et al. Frequency and clinical significance of the expression of the multidrug resistance proteins MDR1/P-glycoprotein, MRP1, and LRP in acute myeloid leukemia: a Southwest Oncology Group study. *Blood* 1999;94(3):1086-1099.
378. Porwit-MacDonald A, Janossy G, Ivory K, et al. Leukemia-associated changes identified by quantitative flow cytometry. IV. CD34 overexpression in acute myelogenous leukemia M2 with t(8;21). *Blood* 1996;87(3):1162-1169.
379. Lee EJ, Yang J, Leavitt RD, et al. The significance of CD34 and TdT determinations in patients with untreated de novo acute myeloid leukemia. *Leukemia* 1992;6(11):1203-1209.
380. Jensen AW, Hokland M, Jorgensen H, Justesen J, Ellegaard J, Hokland P. Solitary expression of CD7 among T-cell antigens in acute myeloid leukemia: identification of a group of patients with similar T-cell receptor beta and delta rearrangements and course of disease suggestive of poor prognosis. *Blood* 1991;78(5):1292-1300.
381. Kita K, Miwa H, Nakase K, et al. Clinical importance of CD7 expression in acute myelocytic leukemia. The Japan Cooperative Group of Leukemia/Lymphoma. *Blood* 1993;81(9):2399-2405.
382. Seymour JF, Pierce SA, Kantarjian HM, Keating MJ, Estey EH. Investigation of karyotypic, morphologic and clinical features in patients with acute myeloid leukemia blast cells expressing the neural cell adhesion molecule (CD56). *Leukemia* 1994;8(5):823-826.
383. Baer MR, Stewart CC, Lawrence D, et al. Expression of the neural cell adhesion molecule CD56 is associated with short remission duration and survival in acute myeloid leukemia with t(8;21)(q22;q22). *Blood* 1997;90(4): 1643-1648.
384. Hamaguchi H, Nakamura Y, Nagata K, et al. Philadelphia-chromosome-positive, monosomy 7 biphenotypic acute mixed lineage leukemia in adults: a pluripotent stem cell disorder. *Leukemia* 1993;7(11):1752-1758.
385. Buccheri V, Matutes E, Dyer MJ, Catovsky D. Lineage commitment in biphenotypic acute leukemia. *Leukemia* 1993;7(6):919-927.
386. Kawakubo K, Ohyashiki K, Ohyashiki JH, et al. Acute myeloid leukemia with concomitant expression of T-/B-lymphoid antigens and immunogenotypic alterations exhibiting t(7;12)(q32;q24). *Leukemia* 1993;7(6):909-911.
387. Venditti A, Del Poeta G, Stasi R, et al. Minimally differentiated acute myeloid leukaemia (AML-M0): cytochemical, immunophenotypic and cytogenetic analysis of 19 cases. *Br J Haematol* 1994;88(4):784-793.
388. Kaleem Z, White G. Diagnostic criteria for minimally differentiated acute myeloid leukemia (AML-M0). Evaluation and a proposal. *Am J Clin Pathol* 2001;115(6):876-884.
389. Klaus M, Haferlach T, Schnittger S, Kern W, Hiddemann W, Schoch C. Cytogenetic profile in de novo acute myeloid leukemia with FAB subtypes M0, M1, and M2: a study based on 652 cases analyzed with morphology, cytogenetics, and fluorescence in situ hybridization. *Cancer Genet Cytogenet* 2004;155(1):47-56.
390. Stasi R, Del Poeta G, Venditti A, et al. Analysis of treatment failure in patients with minimally differentiated acute myeloid leukemia (AML-M0). *Blood* 1994;83(6):1619-1625.

391. Venditti A, Del Poeta G, Buccisano F, et al. Minimally differentiated acute myeloid leukemia (AML-M0): comparison of 25 cases with other French-American-British subtypes. *Blood* 1997;89(2):621-629.
392. Cuneo A, Ferrant A, Michaux JL, et al. Cytogenetic profile of minimally differentiated (FAB M0) acute myeloid leukemia: correlation with clinicobiologic findings. *Blood* 1995;85(12):3688-3694.
393. Amadori S, Venditti A, Del Poeta G, et al. Minimally differentiated acute myeloid leukemia (AML-M0): a distinct clinico-biologic entity with poor prognosis. *Ann Hematol* 1996;72(4):208-215.
394. Hurwitz CA, Raimondi SC, Head D, et al. Distinctive immunophenotypic features of t(8;21)(q22;q22) acute myeloblastic leukemia in children. *Blood* 1992;80(12):3182-3188.
395. Nisson PE, Watkins PC, Sacchi N. Transcriptionally active chimeric gene derived from the fusion of the AML1 gene and a novel gene on chromosome 8 in t(8;21) leukemic cells. *Cancer Genet Cytogenet* 1992;63(2):81-88.
396. Peterson LF, Zhang DE. The 8;21 translocation in leukemogenesis. *Oncogene* 2004;23(24):4255-4262.
397. Nucifora G, Birn DJ, Erickson P, et al. Detection of DNA rearrangements in the AML1 and ETO loci and of an AML1/ETO fusion mRNA in patients with t(8;21) acute myeloid leukemia. *Blood* 1993;81(4):883-888.
398. Rubin CM, Larson RA, Anastasi J, et al. t(3;21)(q26;q22): a recurring chromosomal abnormality in therapy-related myelodysplastic syndrome and acute myeloid leukemia. *Blood* 1990;76(12):2594-2598.
399. Byrd JC, Dodge RK, Carroll A, et al. Patients with t(8;21)(q22;q22) and acute myeloid leukemia have superior failure-free and overall survival when repetitive cycles of high-dose cytarabine are administered. *J Clin Oncol* 1999;17(12):3767-3775.
400. Byrd JC, Weiss RB, Arthur DC, et al. Extramedullary leukemia adversely affects hematologic complete remission rate and overall survival in patients with t(8;21)(q22;q22): results from Cancer and Leukemia Group B 8461. *J Clin Oncol* 1997;15(2):466-475.
401. Billstrom R, Ahlgren T, Bekassy AN, et al. Acute myeloid leukemia with inv(16)(p13q22): involvement of cervical lymph nodes and tonsils is common and may be a negative prognostic sign. *Am J Hematol* 2002;71(1):15-19.
402. Le Beau MM, Larson RA, Bitter MA, Vardiman JW, Golomb HM, Rowley JD. Association of an inversion of chromosome 16 with abnormal marrow eosinophils in acute myelomonocytic leukemia. A unique cytogenetic-clinicopathological association. *N Engl J Med* 1983;309(11):630-636.
403. Eghtedar A, Borthakur G, Ravandi F, et al. Characteristics of translocation (16;16)(p13;q22) acute myeloid leukemia. *Am J Hematol* 2012;87(3): 317-318.
404. Liu PP, Hajra A, Wijmenga C, Collins FS. Molecular pathogenesis of the chromosome 16 inversion in the M4Eo subtype of acute myeloid leukemia. *Blood* 1995;85(9):2289-2302.
405. Poirel H, Radford-Weiss I, Rack K, et al. Detection of the chromosome 16 CBF beta-MYH11 fusion transcript in myelomonocytic leukemias. *Blood* 1995;85(5):1313-1322.
406. Buonamici S, Ottaviani E, Testoni N, et al. Real-time quantitation of minimal residual disease in inv(16)-positive acute myeloid leukemia may indicate risk for clinical relapse and may identify patients in a curable state. *Blood* 2002;99(2):443-449.
407. Delaunay J, Vey N, Leblanc T, et al. Prognosis of inv(16)/t(16;16) acute myeloid leukemia (AML): a survey of 110 cases from the French AML Intergroup. *Blood* 2003;102(2):462-469.
408. Perea G, Lasa A, Aventin A, et al. Prognostic value of minimal residual disease (MRD) in acute myeloid leukemia (AML) with favorable cytogenetics [t(8;21) and inv(16)]. *Leukemia* 2006;20(1):87-94.
409. Stentoft J, Hokland P, Ostergaard M, Hasle H, Nyvold CG. Minimal residual core binding factor AMLs by real time quantitative PCR—initial response to chemotherapy predicts event free survival and close monitoring of peripheral blood unravels the kinetics of relapse. *Leuk Res* 2006;30(4):389-395.
410. Corbacioglu A, Scholl C, Schlenk RF, et al. Prognostic impact of minimal residual disease in CBFβ-MYH11-positive acute myeloid leukemia. *J Clin Oncol* 2010;28(23):3724-3729.
411. Haferlach T, Schoch C, Schnittger S, Kern W, Löffler H, Hiddemann W. Distinct genetic patterns can be identified in acute monoblastic and acute monocytic leukaemia (FAB AML M5a and M5b): a study of 124 patients. *Br J Haematol* 2002;118(2):426-431.

412. Scott CS, Stark AN, Limbert HJ, Master PS, Head C, Roberts BE. Diagnostic and prognostic factors in acute monocytic leukaemia: an analysis of 51 cases. *Br J Haematol* 1988;69(2):247-252.
413. Fung H, Shepherd JD, Naiman SC, et al. Acute monocytic leukemia: a single institution experience. *Leuk Lymphoma* 1995;19(3-4):259-265.
414. Tallman MS, Kim HT, Paietta E, et al. Acute monocytic leukemia (French-American-British classification M5) does not have a worse prognosis than other subtypes of acute myeloid leukemia: a report from the Eastern Cooperative Oncology Group. *J Clin Oncol* 2004;22(7):1276-1286.
415. Park S, Picard F, Dreyfus F. Erythroleukemia: a need for a new definition. *Leukemia* 2002;16(8):1399-1401.
416. Domingo-Claros A, Larriba I, Rozman M, et al. Acute erythroid neoplastic proliferations. A biological study based on 62 patients. *Haematologica* 2002;87(2):148-153.
417. Rowley JD, Alimena G, Garson OM, Hagemeyer A, Mitelman F, Prigogina EL. A collaborative study of the relationship of the morphological type of acute nonlymphocytic leukemia with patient age and karyotype. *Blood* 1982;59(5):1013-1022.
418. Rowley JD. Chromosome abnormalities in human acute nonlymphocytic leukemia: relationship to age, sex, and exposure to mutagens. *Natl Cancer Inst Monogr* 1982;60:17-23.
419. Stamberg J. Chromosome abnormalities in erythroleukemia. *Cancer* 1987;60(11):2649-2653.
420. Hasserjian RP, Zuo Z, Garcia C, et al. Acute erythroid leukemia: a re-assessment using criteria refined in the 2008 WHO classification. *Blood* 2010;115(10):1985-1992.
421. Olopade OI, Thangavelu M, Larson RA, et al. Clinical, morphologic, and cytogenetic characteristics of 26 patients with acute erythroblastic leukemia. *Blood* 1992;80(11):2873-2882.
422. Kowal-Vern A, Mazzella FM, Cotelingam JD, Shrit MA, Rector JT, Schumacher HR. Diagnosis and characterization of acute erythroleukemia subsets by determining the percentages of myeloblasts and proerythroblasts in 69 cases. *Am J Hematol* 2000;65(1):5-13.
423. Tallman MS, Neuberger D, Bennett JM, et al. Acute megakaryocytic leukemia: the Eastern Cooperative Oncology Group experience. *Blood* 2000;96(7): 2405-2411.
424. Oki Y, Kantarjian HM, Zhou X, et al. Adult acute megakaryocytic leukemia: an analysis of 37 patients treated at M.D. Anderson Cancer Center. *Blood* 2006;107(3):880-884.
425. Pagano L, Pulsoni A, Vignetti M, et al. Acute megakaryoblastic leukemia: experience of GIMEMA trials. *Leukemia* 2002;16(9):1622-1626.
426. Dastugue N, Lafage-Pochitaloff M, Pages MP, et al. Cytogenetic profile of childhood and adult megakaryoblastic leukemia (M7): a study of the Groupe Francais de Cyto-genetique Hematologique (GFCH). *Blood* 2002;100(2): 618-626.
427. Dharmasena F, Wickham N, McHugh PJ, Catovsky D, Galton DA. Osteolytic tumors in acute megakaryoblastic leukemia. *Cancer* 1986;58(10):2273-2277.
428. Orazi A, O'Malley DP, Jiang J, et al. Acute panmyelosis with myelofibrosis: an entity distinct from acute megakaryoblastic leukemia. *Mod Pathol* 2005;18(5):603-614.
429. Thiele J, Kvasnicka HM, Zerhusen G, et al. Acute panmyelosis with myelofibrosis: a clinicopathological study on 46 patients including histochemistry of bone marrow biopsies and follow-up. *Ann Hematol* 2004;83(8):513-521.
430. Suvajdzic N, Marisavljevic D, Kraguljac N, et al. Acute panmyelosis with myelofibrosis: clinical, immunophenotypic and cytogenetic study of twelve cases. *Leuk Lymphoma* 2004;45(9):1873-1879.
431. Giagounidis AA, Hildebrandt B, Heinsch M, Germing U, Aivado M, Aul C. Acute basophilic leukemia. *Eur J Haematol* 2001;67(2):72-76.
432. Peterson LC, Parkin JL, Arthur DC, Brunning RD. Acute basophilic leukemia. A clinical, morphologic, and cytogenetic study of eight cases. *Am J Clin Pathol* 1991;96(2):160-170.
433. Soekarman D, von Lindern M, Daenen S, et al. The translocation (6;9) (p23;q34) shows consistent rearrangement of two genes and defines a myeloproliferative disorder with specific clinical features. *Blood* 1992;79(11):2990-2997.

434. Ageberg M, Drott K, Olofsson T, Gullberg U, Lindmark A. Identification of a novel and myeloid specific role of the leukemia-associated fusion protein DEK-NUP214 leading to increased protein synthesis. *Genes Chromosomes Cancer* 2008;47(4):276-287.
435. Jotterand Bellomo M, Parlier V, Muhlematter D, Grob JP, Beris P. Three new cases of chromosome 3 rearrangement in bands q21 and q26 with abnormal thrombopoiesis bring further evidence to the existence of a 3q21q26 syndrome. *Cancer Genet Cytogenet* 1992;59(2):138-160.
436. Fichelson S, Dreyfus F, Berger R, et al. Evi-1 expression in leukemic patients with rearrangements of the 3q25-q28 chromosomal region. *Leukemia* 1992;6(2):93-99.
437. Levy ER, Parganas E, Morishita K, et al. DNA rearrangements proximal to the EVI1 locus associated with the 3q21q26 syndrome. *Blood* 1994;83(5):1348-1354.
438. Lahortiga I, Vazquez I, Agirre X, et al. Molecular heterogeneity in AML/MDS patients with 3q21q26 rearrangements. *Genes Chromosomes Cancer* 2004;40(3):179-189.
439. Sulak LE, Clare CN, Morale BA, Hansen KL, Montiel MM. Biphenotypic acute leukemia in adults. *Am J Clin Pathol* 1990;94(1):54-58.
440. Trubia M, Albano F, Cavazzini F, et al. Characterization of a recurrent trans-location t(2;3)(p15-22;q26) occurring in acute myeloid leukaemia. *Leukemia* 2006;20(1):48-54.
441. Mijovic A, Novak A, Medenica L. Sweet's syndrome associated with inversion of chromosome 3q in a patient with refractory anemia. *Eur J Haematol* 1992;49(3):156-157.
442. Yoneda-Kato N, Look AT, Kirstein MN, et al. The t(3;5)(q25.1;q34) of myelodysplastic syndrome and acute myeloid leukemia produces a novel fusion gene, NPM-MLF1. *Oncogene* 1996;12(2):265-275.
443. Appelbaum FR, Gundacker H, Head DR, et al. Age and acute myeloid leukemia. *Blood* 2006;107(9):3481-3485.
444. Leith CP, Kopecky KJ, Godwin J, et al. Acute myeloid leukemia in the elderly: assessment of multidrug resistance (MDR1) and cytogenetics distinguishes biologic subgroups with remarkably distinct responses to standard chemotherapy. A Southwest Oncology Group study. *Blood* 1997;89(9):3323-3329.
445. Kantarjian H, O'Brien S, Cortes J, et al. Results of intensive chemotherapy in 998 patients age 65 years or older with acute myeloid leukemia or high-risk myelodysplastic syndrome: predictive prognostic models for outcome. *Cancer* 2006;106(5):1090-1098.
446. Hoyle CF, de Bastos M, Wheatley K, et al. AML associated with previous cytotoxic therapy, MDS or myeloproliferative disorders: results from the MRC's 9th AML trial. *Br J Haematol* 1989;72(1):45-53.
447. Kayser S, Dohner K, Krauter J, et al. The impact of therapy-related acute myeloid leukemia (AML) on outcome in 2853 adult patients with newly diagnosed AML. *Blood* 2011;117(7):2137-2145.
448. Chang H, Brandwein J, Yi QL, Chun K, Patterson B, Brien B. Extramedullary infiltrates of AML are associated with CD56 expression, 11q23 abnormalities and inferior clinical outcome. *Leuk Res* 2004;28(10):1007-1011.
449. Greenwood MJ, Seftel MD, Richardson C, et al. Leukocyte count as a predictor of death during remission induction in acute myeloid leukemia. *Leuk Lymphoma* 2006;47(7):1245-1252.
450. Sekeres MA, Peterson B, Dodge RK, et al. Differences in prognostic factors and outcomes in African Americans and whites with acute myeloid leukemia. *Blood* 2004;103(11):4036-4042.
451. Haferlach T, Schoch C, Loffler H, et al. Morphologic dysplasia in de novo acute myeloid leukemia (AML) is related to unfavorable cytogenetics but has no independent prognostic relevance under the conditions of intensive induction therapy: results of a multiparameter analysis from the German AML Cooperative Group studies. *J Clin Oncol* 2003;21(2):256-265.
452. Colita A, Belhabri A, Chelghoum Y, Charrin C, Fiere D, Thomas X. Prognostic factors and treatment effects on survival in acute myeloid leukemia of M6 subtype: a retrospective study of 54 cases. *Ann Oncol* 2001;12(4):451-455.
453. de Nully Brown P, Jurlander J, Pedersen-Bjergaard J, Victor MA, Geisler CH. The prognostic significance of chromosomal analysis and immunophenotyping in 117 patients with de novo acute myeloid leukemia. *Leuk Res* 1997;21(10):985-995.

454. Fruchart C, Lenormand B, Bastard C, et al. Correlation between CD34 expression and chromosomal abnormalities but not clinical outcome in acute myeloid leukemia. *Am J Hematol* 1996;53(3):175-980.
455. Lamy T, Goasguen JE, Mordelet E, et al. P-glycoprotein (P-170) and CD34 expression in adult acute myeloid leukemia (AML). *Leukemia* 1994;8(11):1879-1883.
456. Chang H, Salma F, Yi QL, Patterson B, Brien B, Minden MD. Prognostic relevance of immunophenotyping in 379 patients with acute myeloid leukemia. *Leuk Res* 2004;28(1):43-48.
457. Wetzler M, McElwain BK, Stewart CC, et al. HLA-DR antigen-negative acute myeloid leukemia. *Leukemia* 2003;17(4):707-715.
458. Del Poeta G, Stasi R, Venditti A, et al. Prognostic value of cell marker analysis in de novo acute myeloid leukemia. *Leukemia* 1994;8(3):388-394.
459. Feller N, van der Pol MA, van Stijn A, et al. MRD parameters using immunophenotypic detection methods are highly reliable in predicting survival in acute myeloid leukaemia. *Leukemia* 2004;18(8):1380-1390.
460. Buccisano F, Maurillo L, Gattei V, et al. The kinetics of reduction of minimal residual disease impacts on duration of response and survival of patients with acute myeloid leukemia. *Leukemia* 2006;20(10):1783-1789.
461. Gianfaldoni G, Mannelli F, Baccini M, Antonioli E, Leoni F, Bosi A. Clearance of leukaemic blasts from peripheral blood during standard induction treatment predicts the bone marrow response in acute myeloid leukaemia: a pilot study. *Br J Haematol* 2006;134(1):54-57.
462. van der Kolk DM, de Vries EG, van Putten WJ, et al. P-glycoprotein and mul-tidrug resistance protein activities in relation to treatment outcome in acute myeloid leukemia. *Clin Cancer Res* 2000;6(8):3205-3214.
463. List AF. Role of multidrug resistance and its pharmacological modulation in acute myeloid leukemia. *Leukemia* 1996;10(6):937-942.
464. Murren JR. Modulating multidrug resistance: can we target this therapy? *Clin Cancer Res* 2002;8(3):633-635.
465. Naito K, Takeshita A, Shigeno K, et al. Calicheamicin-conjugated humanized anti-CD33 monoclonal antibody (gemtuzumab zogamicin, CMA-676) shows cytotoxic effect on CD33-positive leukemia cell lines, but is inactive on P-glycoprotein-expressing sublines. *Leukemia* 2000;14(8):1436-1443.
466. van den Heuvel-Eibrink MM, Wiemer EA, de Boevere MJ, et al. MDR1 gene-related clonal selection and P-glycoprotein function and expression in relapsed or refractory acute myeloid leukemia. *Blood* 2001;97(11): 3605-3611.
467. Schaich M, Soucek S, Thiede C, Ehninger G, Illmer T. MDR1 and MRP1 gene expression are independent predictors for treatment outcome in adult acute myeloid leukaemia. *Br J Haematol* 2005;128(3):324-332.
468. Legrand O, Simonin G, Beauchamp-Nicoud A, Zittoun R, Marie JP. Simultaneous activity of MRP1 and Pgp is correlated with in vitro resistance to daunorubicin and with in vivo resistance in adult acute myeloid leukemia. *Blood* 1999;94(3):1046-1056.
469. Benderra Z, Faussat AM, Sayada L, et al. MRP3, BCRP, and P-glycoprotein activities are prognostic factors in adult acute myeloid leukemia. *Clin Cancer Res* 2005;11(21):7764-7772.
470. Filipits M, Pohl G, Stranzl T, et al. Expression of the lung resistance protein predicts poor outcome in de novo acute myeloid leukemia. *Blood* 1998;91(5):1508-1513.
471. Farag SS, Archer KJ, Mrozek K, et al. Pretreatment cytogenetics add to other prognostic factors predicting complete remission and long-term outcome in patients 60 years of age or older with acute myeloid leukemia: results from Cancer and Leukemia Group B 8461. *Blood* 2006;108(1):63-73.
472. van der Holt B, Breems DA, Berna Beverloo H, et al. Various distinctive cytogenetic abnormalities in patients with acute myeloid leukaemia aged 60 years and older express adverse prognostic value: results from a prospective clinical trial. *Br J Haematol* 2007;136(1):96-105.
473. O'Donnell MR, Abboud CN, Altman J, et al. Acute myeloid leukemia. *J Natl Compr Canc Netw* 2012;10(8):984-1021.
474. Slovak ML, Gundacker H, Bloomfield CD, et al. A retrospective study of 69 patients with t(6;9)(p23;q34) AML emphasizes the need for a prospective, multicenter initiative for rare "poor prognosis" myeloid malignancies. *Leukemia* 2006;20(7):1295-1297.

475. Grimwade D. Impact of cytogenetics on clinical outcome in AML. In: Karp J, ed. Acute myelogenous leukemia. Totowa, NJ. Humana Press, 2007:181.
476. Byrd JC, Ruppert AS, Mrozek K, et al. Repetitive cycles of high-dose cytarabine benefit patients with acute myeloid leukemia and inv(16)(p13q22) or t(16;16)(p13;q22): results from CALGB 8461. *J Clin Oncol* 2004;22(6): 1087-1094.
477. Marcucci G, Mrozek K, Ruppert AS, et al. Abnormal cytogenetics at date of morphologic complete remission predicts short overall and disease-free survival, and higher relapse rate in adult acute myeloid leukemia: results from Cancer and Leukemia Group B study 8461. *J Clin Oncol* 2004;22(12): 2410-2418.
478. Fung HC, Stein A, Slovak M, et al. A long-term follow-up report on allogeneic stem cell transplantation for patients with primary refractory acute myelogenous leukemia: impact of cytogenetic characteristics on transplantation outcome. *Biol Blood Marrow Transplant* 2003;9(12):766-771.
479. Chalandon Y, Barnett MJ, Horsman DE, et al. Influence of cytogenetic abnormalities on outcome after allogeneic bone marrow transplantation for acute myeloid leukemia in first complete remission. *Biol Blood Marrow Transplant* 2002;8(8):435-443.
480. Tallman MS, Dewald GW, Gandham S, et al. Impact of cytogenetics on outcome of matched unrelated donor hematopoietic stem cell transplantation for acute myeloid leukemia in first or second complete remission. *Blood* 2007.
481. Del Poeta G, Venditti A, Del Principe MI, et al. Amount of spontaneous apoptosis detected by Bax/Bcl-2 ratio predicts outcome in acute myeloid leukemia (AML). *Blood* 2003;101(6):2125-2131.
482. Kornblau SM, Thall PF, Estrov Z, et al. The prognostic impact of BCL2 protein expression in acute myelogenous leukemia varies with cytogenetics. *Clin Cancer Res* 1999;5(7):1758-1766.
483. Hess CJ, Berkhof J, Denkers F, et al. Activated intrinsic apoptosis pathway is a key related prognostic parameter in acute myeloid leukemia. *J Clin Oncol* 2007;25(10):1209-1215.
484. Oto OA, Paydas S, Tanriverdi K, Seydaoglu G, Yavuz S, Disel U. Survivin and EPR-1 expression in acute leukemias: prognostic significance and review of the literature. *Leuk Res* 2007;31(11):1495-1501.
485. Aguayo A, Kantarjian HM, Estey EH, et al. Plasma vascular endothelial growth factor levels have prognostic significance in patients with acute myeloid leukemia but not in patients with myelodysplastic syndromes. *Cancer* 2002;95(9):1923-1930.
486. Hu Q, Dey AL, Yang Y, et al. Soluble vascular endothelial growth factor receptor 1, and not receptor 2, is an independent prognostic factor in acute myeloid leukemia and myelodysplastic syndromes. *Cancer* 2004;100(9):1884-1891.
487. Loges S, Heil G, Bruweleit M, et al. Analysis of concerted expression of angiogenic growth factors in acute myeloid leukemia: expression of angiopoietin-2 represents an independent prognostic factor for overall survival. *J Clin Oncol* 2005;23(6):1109-1117.
488. Kreuter M, Woelke K, Bieker R, et al. Correlation of neuropilin-1 overexpression to survival in acute myeloid leukemia. *Leukemia* 2006;20(11):1950-1954.
489. Rombouts EJ, Pavic B, Lowenberg B, Ploemacher RE. Relation between CXCR-4 expression, Flt3 mutations, and unfavorable prognosis of adult acute myeloid leukemia. *Blood* 2004;104(2):550-557.
490. Spoo AC, Lubbert M, Wierda WG, Burger JA. CXCR4 is a prognostic marker in acute myelogenous leukemia. *Blood* 2007;109(2):786-791.
491. Naoe T, Tagawa Y, Kiyoi H, et al. Prognostic significance of the null genotype of glutathione S-transferase-T1 in patients with acute myeloid leukemia: increased early death after chemotherapy. *Leukemia* 2002;16(2):203-208.
492. Illmer T, Schuler US, Thiede C, et al. MDR1 gene polymorphisms affect therapy outcome in acute myeloid leukemia patients. *Cancer Res* 2002;62(17): 4955-4962.
493. Monzo M, Brunet S, Urbano-Ispizua A, et al. Genomic polymorphisms provide prognostic information in intermediate-risk acute myeloblastic leukemia. *Blood* 2006;107(12):4871-4879.
494. Bloomfield CD. Post-remission therapy in acute myeloid leukemia. *J Clin Oncol* 1985;3(12):1570-1572.
495. Baer MR. Is there a role for maintenance therapy in acute myeloid leukaemia? *Best Pract Res Clin Haematol* 2009;22(4):517-521.

496. Diverio D, Rossi V, Avvisati G, et al. Early detection of relapse by prospective reverse transcriptase-polymerase chain reaction analysis of the PML/RARalpha fusion gene in patients with acute promyelocytic leukemia enrolled in the GIMEMA-AIEOP multicenter "AIDA" trial. GIMEMA-AIEOP Multicenter "AIDA" Trial. *Blood* 1998;92(3):784-789.
497. Jurcic JG, Nimer SD, Scheinberg DA, DeBlasio T, Warrell RP Jr, Miller WH Jr. Prognostic significance of minimal residual disease detection and PML/RARalpha isoform type: long-term follow-up in acute promyelocytic leukemia. *Blood* 2001;98(9):2651-2656.
498. Jurlander J, Caligiuri MA, Ruutu T, et al. Persistence of the AML1/ETO fusion transcript in patients treated with allogeneic bone marrow transplantation for t(8;21) leukemia. *Blood* 1996;88(6):2183-2191.
499. Sievers EL, Larson RA, Stadtmauer EA, et al. Efficacy and safety of gemtuzumab ozogamicin in patients with CD33-positive acute myeloid leukemia in first relapse. *J Clin Oncol* 2001;19(13):3244-3254.
500. Walter RB, Kantarjian HM, Huang X, et al. Effect of complete remission and responses less than complete remission on survival in acute myeloid leukemia: a combined Eastern Cooperative Oncology Group, Southwest Oncology Group, and M. D. Anderson Cancer Center Study. *J Clin Oncol* 2010;28(10):1766-1771.
501. Rai KR, Holland JF, Glidewell OJ, et al. Treatment of acute myelocytic leukemia: a study by cancer and leukemia group B. *Blood* 1981;58(6):1203-1212.
502. Yates J, Glidewell O, Wiernik P, et al. Cytosine arabinoside with daunorubicin or adriamycin for therapy of acute myelocytic leukemia: a CALGB study. *Blood* 1982;60(2):454-462.
503. Preisler H, Davis RB, Kirshner J, et al. Comparison of three remission induction regimens and two postinduction strategies for the treatment of acute nonlymphocytic leukemia: a cancer and leukemia group B study. *Blood* 1987;69(5):1441-1449.
504. Dillman RO, Davis RB, Green MR, et al. A comparative study of two different doses of cytarabine for acute myeloid leukemia: a phase III trial of Cancer and Leukemia Group B. *Blood* 1991;78(10):2520-2526.
505. Rowe JM, Tallman MS. Intensifying induction therapy in acute myeloid leukemia: has a new standard of care emerged? *Blood* 1997;90(6):2121-2126.
506. Fernandez HF, Sun Z, Yao X, et al. Anthracycline dose intensification in acute myeloid leukemia. *N Engl J Med* 2009;361(13):1249-1259.
507. Lee JH, Joo YD, Kim H, et al. A randomized trial comparing standard versus high-dose daunorubicin induction in patients with acute myeloid leukemia. *Blood* 2011;118(14):3832-3841.
508. Lowenberg B, Ossenkoppele GJ, van Putten W, et al. High-dose daunorubicin in older patients with acute myeloid leukemia. *N Engl J Med* 2009;361(13):1235-1248.
509. Wiernik PH, Banks PL, Case DC Jr, et al. Cytarabine plus idarubicin or daunorubicin as induction and consolidation therapy for previously untreated adult patients with acute myeloid leukemia. *Blood* 1992;79(2):313-319.
510. Vogler WR, Velez-Garcia E, Weiner RS, et al. A phase III trial comparing idarubicin and daunorubicin in combination with cytarabine in acute myelogenous leukemia: a Southeastern Cancer Study Group study. *J Clin Oncol* 1992;10(7):1103-1111.
511. Berman E, Heller G, Santorsa J, et al. Results of a randomized trial comparing idarubicin and cytosine arabinoside with daunorubicin and cytosine arabinoside in adult patients with newly diagnosed acute myelogenous leukemia. *Blood* 1991;77(8):1666-1674.
512. Berman E, Wiernik P, Vogler R, Velez-Garcia E, Bartolucci A, Whaley FS. Long-term follow-up of three randomized trials comparing idarubicin and daunorubicin as induction therapies for patients with untreated acute myeloid leukemia. *Cancer* 1997;80(11 Suppl):2181-2185.
513. A systematic collaborative overview of randomized trials comparing idarubicin with daunorubicin (or other anthracyclines) as induction therapy for acute myeloid leukaemia. AML Collaborative Group. *Br J Haematol* 1998;103(1):100-109.
514. Gardin C, Turlure P, Fagot T, et al. Postremission treatment of elderly patients with acute myeloid leukemia in first complete remission after intensive induction chemotherapy: results of the multicenter randomized Acute Leukemia French Association (ALFA) 9803 trial. *Blood* 2007;109(12):5129-5135.

515. Estey EH, Thall PF, Cortes JE, et al. Comparison of idarubicin + ara-C-, fludarabine + ara-C-, and topotecan + ara-C-based regimens in treatment of newly diagnosed acute myeloid leukemia, refractory anemia with excess blasts in transformation, or refractory anemia with excess blasts. *Blood* 2001;98(13):3575-3583.
516. Lowenberg B, Suciú S, Archimbaud E, et al. Mitoxantrone versus daunorubicin in induction-consolidation chemotherapy—the value of low-dose cytarabine for maintenance of remission, and an assessment of prognostic factors in acute myeloid leukemia in the elderly: final report. European organization for the research and treatment of cancer and the Dutch-Belgian Hemato-Oncology Cooperative Hovon Group. *J Clin Oncol* 1998;16(3):872-881.
517. Rowe JM, Neuberg D, FriedenberG W, et al. A phase 3 study of three induction regimens and of priming with GM-CSF in older adults with acute myeloid leukemia: a trial by the Eastern Cooperative Oncology Group. *Blood* 2004;103(2):479-485.
518. Bishop JF, Lowenthal RM, Joshua D, et al. Etoposide in acute nonlymphocytic leukemia. Australian Leukemia Study Group. *Blood* 1990;75(1):27-32.
519. Kolitz JE, George SL, Marcucci G, et al. P-glycoprotein inhibition using valspodar (PSC-833) does not improve outcomes for patients younger than age 60 years with newly diagnosed acute myeloid leukemia: Cancer and Leukemia Group B study 19808. *Blood* 2010;116(9):1413-1421.
520. Baer MR, George SL, Sanford BL, et al. Escalation of daunorubicin and addition of etoposide in the ADE regimen in acute myeloid leukemia patients aged 60 years and older: Cancer and Leukemia Group B Study 9720. *Leukemia* 2011;25(5):800-807.
521. Baer MR, George SL, Dodge RK, et al. Phase 3 study of the multidrug resistance modulator PSC-833 in previously untreated patients 60 years of age and older with acute myeloid leukemia: Cancer and Leukemia Group B Study 9720. *Blood* 2002;100(4):1224-1232.
522. Greenberg PL, Lee SJ, Advani R, et al. Mitoxantrone, etoposide, and cytarabine with or without valspodar in patients with relapsed or refractory acute myeloid leukemia and high-risk myelodysplastic syndrome: a phase III trial (E2995). *J Clin Oncol* 2004;22(6):1078-1086.
523. Cripe LD, Uno H, Paietta EM, et al. Zosuquidar, a novel modulator of P-glycoprotein, does not improve the outcome of older patients with newly diagnosed acute myeloid leukemia: a randomized, placebo-controlled trial of the Eastern Cooperative Oncology Group 3999. *Blood* 2010;116(20):4077-4085.
524. List AF, Kopecky KJ, Willman CL, et al. Benefit of cyclosporine modulation of drug resistance in patients with poor-risk acute myeloid leukemia: a Southwest Oncology Group study. *Blood* 2001;98(12):3212-3220.
525. Matsouka P, Pagoni M, Zikos P, et al. Addition of cyclosporin-A to chemotherapy in secondary (post-MDS) AML in the elderly. A multicenter randomized trial of the Leukemia Working Group of the Hellenic Society of Hematology. *Ann Hematol* 2006;85(4):250-256.
526. Qadir M, O'Loughlin KL, Fricke SM, et al. Cyclosporin A is a broad-spectrum multidrug resistance modulator. *Clin Cancer Res* 2005;11(6):2320-2326.
527. Capizzi RL, Yang JL, Cheng E, et al. Alteration of the pharmacokinetics of high-dose ara-C by its metabolite, high ara-U in patients with acute leukemia. *J Clin Oncol* 1983;1(12):763-771.
528. Sundaram M, Yao SY, Ingram JC, et al. Topology of a human equilibrative, nitrobenzylthioinosine (NBMPR)-sensitive nucleoside transporter (hENT1) implicated in the cellular uptake of adenosine and anti-cancer drugs. *J Biol Chem* 2001;276(48):45270-45275.
529. Heil G, Mitrou PS, Hoelzer D, et al. High-dose cytosine arabinoside and daunorubicin postremission therapy in adults with de novo acute myeloid leukemia. Long-term follow-up of a prospective multicenter trial. *Ann Hematol* 1995;71(5):219-225.
530. Whitlock JA, Wells RJ, Hord JD, et al. High-dose cytosine arabinoside and etoposide: an effective regimen without anthracyclines for refractory childhood acute non-lymphocytic leukemia. *Leukemia* 1997;11(2):185-189.
531. Karanes C, Kopecky KJ, Head DR, et al. A phase III comparison of high dose ARA-C (HIDAC) versus HIDAC plus mitoxantrone in the treatment of first relapsed or refractory acute myeloid leukemia Southwest Oncology Group Study. *Leuk Res* 1999;23(9):787-794.

532. Herzig RH, Herzig GP, Wolff SN, Hines JD, Fay JW, Phillips GL. Central nervous system effects of high-dose cytosine arabinoside. *Semin Oncol* 1987;14(2 Suppl 1):21-24.
533. Phillips GL, Reece DE, Shepherd JD, et al. High-dose cytarabine and daunorubicin induction and postremission chemotherapy for the treatment of acute myelogenous leukemia in adults. *Blood* 1991;77(7):1429-1435.
534. Bishop JF, Matthews JP, Young GA, et al. A randomized study of high-dose cytarabine in induction in acute myeloid leukemia. *Blood* 1996;87(5): 1710-1717.
535. Weick JK, Kopecky KJ, Appelbaum FR, et al. A randomized investigation of high-dose versus standard-dose cytosine arabinoside with daunorubicin in patients with previously untreated acute myeloid leukemia: a Southwest Oncology Group study. *Blood* 1996;88(8):2841-2851.
536. Buchner T, Hiddemann W, Wormann B, et al. Double induction strategy for acute myeloid leukemia: the effect of high-dose cytarabine with mitoxantrone instead of standard-dose cytarabine with daunorubicin and 6-thioguanine: a randomized trial by the German AML Cooperative Group. *Blood* 1999;93(12):4116-4124.
537. Lowenberg B, Pabst T, Vellenga E, et al. Cytarabine dose for acute myeloid leukemia. *N Engl J Med* 2011;364(11):1027-1036.
538. Rizzieri DA, Bass AJ, Rosner GL, et al. Phase I evaluation of prolonged-infusion gemcitabine with mitoxantrone for relapsed or refractory acute leukemia. *J Clin Oncol* 2002;20(3):674-679.
539. Faderl S, Ravandi F, Huang X, et al. A randomized study of clofarabine versus clofarabine plus low-dose cytarabine as front-line therapy for patients aged 60 years and older with acute myeloid leukemia and high-risk myelodysplastic syndrome. *Blood* 2008;112(5):1638-1645.
540. Fong CY, Grigoriadis G, Hocking J, et al. Fludarabine, cytarabine, granulocyte-colony stimulating factor and amsacrine: an effective salvage therapy option for acute myeloid leukemia at first relapse. *Leuk Lymphoma* 2012.
541. Inaba H, Stewart CF, Crews KR, et al. Combination of cladribine plus topotecan for recurrent or refractory pediatric acute myeloid leukemia. *Cancer* 2010;116(1):98-105.
542. Holowiecki J, Grosicki S, Giebel S, et al. Cladribine, but not Fludarabine, added to Daunorubicin and Cytarabine during induction prolongs survival of patients with acute myeloid leukemia: a multicenter, randomized phase III study. *J Clin Oncol* 2012.
543. Hills RK, Burnett AK. Applicability of a "Pick a Winner" trial design to acute myeloid leukemia. *Blood* 2011;118(9):2389-2394.
544. Gandhi V, Estey E, Keating MJ, Plunkett W. Biochemical modulation of arabinosylcytosine for therapy of leukemias. *Leuk Lymphoma* 1993;10(Suppl): 109-114.
545. Gandhi V, Estey E, Keating MJ, Plunkett W. Fludarabine potentiates metabolism of cytarabine in patients with acute myelogenous leukemia during therapy. *J Clin Oncol* 1993;11(1):116-124.
546. Gandhi V, Estey E, Du M, Nowak B, Keating MJ, Plunkett W. Modulation of the cellular metabolism of cytarabine and fludarabine by granulocytecolony-stimulating factor during therapy of acute myelogenous leukemia. *Clin Cancer Res* 1995;1(2):169-178.
547. Estey E, Thall P, Andreeff M, et al. Use of granulocyte colony-stimulating factor before, during, and after fludarabine plus cytarabine induction therapy of newly diagnosed acute myelogenous leukemia or myelodysplastic syndromes: comparison with fludarabine plus cytarabine without granulocyte colony-stimulating factor. *J Clin Oncol* 1994;12(4):671-678.
548. Nokes TJ, Johnson S, Harvey D, Goldstone AH. FLAG is a useful regimen for poor prognosis adult myeloid leukaemias and myelodysplastic syndromes. *Leuk Lymphoma* 1997;27(1-2):93-101.
549. Ossenkoppele GJ, Graveland WJ, Sonneveld P, et al. The value of fludarabine in addition to ARA-C and G-CSF in the treatment of patients with high-risk myelodysplastic syndromes and AML in elderly patients. *Blood* 2004;103(8):2908-2913.
550. de la Rubia J, Regadera A, Martin G, et al. FLAG-IDA regimen (fludarabine, cytarabine, idarubicin and G-CSF) in the treatment of patients with high-risk myeloid malignancies. *Leuk Res* 2002;26(8):725-730.

551. Virchis A, Koh M, Rankin P, et al. Fludarabine, cytosine arabinoside, granulocyte-colony stimulating factor with or without idarubicin in the treatment of high risk acute leukaemia or myelodysplastic syndromes. *Br J Haematol* 2004;124(1): 26-32.
552. Russo D, Malagola M, de Vivo A, et al. Multicentre phase III trial on fludarabine, cytarabine (Ara-C), and idarubicin versus idarubicin, Ara-C and etoposide for induction treatment of younger, newly diagnosed acute myeloid leukaemia patients. *Br J Haematol* 2005;131(2):172-179.
553. Kantarjian H, Gandhi V, Cortes J, et al. Phase 2 clinical and pharmacologic study of clofarabine in patients with refractory or relapsed acute leukemia. *Blood* 2003;102(7):2379-2386.
554. Faderl S, Gandhi V, O'Brien S, et al. Results of a phase 1-2 study of clofarabine in combination with cytarabine (ara-C) in relapsed and refractory acute leukemias. *Blood* 2005;105(3):940-947.
555. Faderl S, Verstovsek S, Cortes J, et al. Clofarabine and cytarabine combination as induction therapy for acute myeloid leukemia (AML) in patients 50 years of age or older. *Blood* 2006;108(1):45-51.
556. Kantarjian HM, Erba HP, Claxton D, et al. Phase II study of clofarabine monotherapy in previously untreated older adults with acute myeloid leukemia and unfavorable prognostic factors. *J Clin Oncol* 2010;28(4):549-555.
557. Burnett AK, Russell NH, Kell J, et al. European development of clofarabine as treatment for older patients with acute myeloid leukemia considered unsuitable for intensive chemotherapy. *J Clin Oncol* 2010;28(14):2389-2395.
558. Ohno R, Tomonaga M, Kobayashi T, et al. Effect of granulocyte colony-stimulating factor after intensive induction therapy in relapsed or refractory acute leukemia. *N Engl J Med* 1990;323(13):871-877.
559. Buchner T, Hiddemann W, Koenigsmann M, et al. Recombinant human granulocyte-macrophage colony-stimulating factor after chemotherapy in patients with acute myeloid leukemia at higher age or after relapse. *Blood* 1991;78(5):1190-1197.
560. Stone RM, Berg DT, George SL, et al. Granulocyte-macrophage colony-stimulating factor after initial chemotherapy for elderly patients with primary acute myelogenous leukemia. *Cancer and Leukemia Group B. N Engl J Med* 1995;332(25):1671-1677.
561. Zittoun R, Suci S, Mandelli F, et al. Granulocyte-macrophage colony-stimulating factor associated with induction treatment of acute myelogenous leukemia: a randomized trial by the european organization for research and treatment of cancer leukemia cooperative group. *J Clin Oncol* 1996;14(7):2150-2159.
562. Lowenberg B, Boogaerts MA, Daenen SM, et al. Value of different modalities of granulocyte-macrophage colony-stimulating factor applied during or after induction therapy of acute myeloid leukemia. *J Clin Oncol* 1997;15(12): 3496-3506.
563. Lowenberg B, Suci S, Archimbaud E, et al. Use of recombinant GM-CSF during and after remission induction chemotherapy in patients aged 61 years and older with acute myeloid leukemia: final report of AML-11, a phase III randomized study of the leukemia cooperative group of european organisation for the research and treatment of cancer and the Dutch Belgian Hemato-Oncology cooperative group. *Blood* 1997;90(8):2952-2961.
564. Rowe JM, Andersen JW, Mazza JJ, et al. A randomized placebo-controlled phase III study of granulocyte-macrophage colony-stimulating factor in adult patients (> 55 to 70 years of age) with acute myelogenous leukemia: a study of the Eastern Cooperative Oncology Group (E1490). *Blood* 1995;86(2): 457-462.
565. Dombret H, Chastang C, Fenaux P, et al. A controlled study of recombinant human granulocyte colony-stimulating factor in elderly patients after treatment for acute myelogenous leukemia. *AML cooperative study group. N Engl J Med* 1995;332(25):1678-1683.
566. Heil G, Hoelzer D, Sanz MA, et al. A randomized, double-blind, placebo-controlled, phase III study of filgrastim in remission induction and consolidation therapy for adults with de novo acute myeloid leukemia. *The international acute myeloid leukemia study group. Blood* 1997;90(12):4710-4718.
567. Godwin JE, Kopecky KJ, Head DR, et al. A double-blind placebo-controlled trial of granulocyte colony-stimulating factor in elderly patients with previously untreated acute myeloid leukemia: a Southwest Oncology Group study (9031). *Blood* 1998;91(10):3607-3615.

568. Harousseau JL, Witz B, Lioure B, et al. Granulocyte colony-stimulating factor after intensive consolidation chemotherapy in acute myeloid leukemia: results of a randomized trial of the Groupe Ouest-Est Leucemies Aigues Myeloblastiques. *J Clin Oncol* 2000;18(4):780-787.
569. Thomas X, Fenaux P, Dombret H, et al. Granulocyte-macrophage colony-stimulating factor (GM-CSF) to increase efficacy of intensive sequential chemotherapy with etoposide, mitoxantrone and cytarabine (EMA) in previously treated acute myeloid leukemia: a multicenter randomized placebo-controlled trial (EMA91 Trial). *Leukemia* 1999;13(8):1214-1220.
570. Amadori S, Suci S, Jehn U, et al. Use of glycosylated recombinant human G-CSF (lenograstim) during and/or after induction chemotherapy in patients 61 years of age and older with acute myeloid leukemia: final results of AML-13, a randomized phase-3 study. *Blood* 2005;106(1):27-34.
571. Thomas X, Raffoux E, Botton S, et al. Effect of priming with granulocyte-macrophage colony-stimulating factor in younger adults with newly diagnosed acute myeloid leukemia: a trial by the Acute Leukemia French Association (ALFA) group. *Leukemia* 2007;21(3):453-461.
572. Witz F, Sadoun A, Perrin MC, et al. A placebo-controlled study of recombinant human granulocyte-macrophage colony-stimulating factor administered during and after induction treatment for de novo acute myelogenous leukemia in elderly patients. *Groupe Ouest Est Leucemies Aigues Myeloblastiques (GOELAM)*. *Blood* 1998;91(8):2722-2730.
573. Lowenberg B, van Putten W, Theobald M, et al. Effect of priming with granulocyte colony-stimulating factor on the outcome of chemotherapy for acute myeloid leukemia. *N Engl J Med* 2003;349(8):743-752.
574. Baer MR, Bernstein SH, Brunetto VL, et al. Biological effects of recombinant human granulocyte colony-stimulating factor in patients with untreated acute myeloid leukemia. *Blood* 1996;87(4):1484-1494.
575. Smith TJ, Khatcheressian J, Lyman GH, et al. 2006 update of recommendations for the use of white blood cell growth factors: an evidence-based clinical practice guideline. *J Clin Oncol* 2006;24(19):3187-3205.
576. Cassileth PA, Begg CB, Bennett JM, et al. A randomized study of the efficacy of consolidation therapy in adult acute nonlymphocytic leukemia. *Blood* 1984;63(4):843-847.
577. Champlin R, Gajewski J, Nimer S, et al. Postremission chemotherapy for adults with acute myelogenous leukemia: improved survival with high-dose cytarabine and daunorubicin consolidation treatment. *J Clin Oncol* 1990;8(7):1199-1206.
578. Vaughan WP, Karp JE, Burke PJ. Two-cycle timed-sequential chemotherapy for adult acute nonlymphocytic leukemia. *Blood* 1984;64(5):975-980.
579. Wolff SN, Herzig RH, Fay JW, et al. High-dose cytarabine and daunorubicin as consolidation therapy for acute myeloid leukemia in first remission: long-term follow-up and results. *J Clin Oncol* 1989;7(9):1260-1267.
580. Harousseau JL, Milpied N, Briere J, et al. Double intensive consolidation chemotherapy in adult acute myeloid leukemia. *J Clin Oncol* 1991;9(8):1432-1437.
581. Cassileth PA, Andersen JW, Bennett JM, et al. Escalating the intensity of post-remission therapy improves the outcome in acute myeloid leukemia: the ECOG experience. *The Eastern Cooperative Oncology Group*. *Leukemia* 1992;6(Suppl 2):116-119.
582. Cassileth PA, Lynch E, Hines JD, et al. Varying intensity of post-remission therapy in acute myeloid leukemia. *Blood* 1992;79(8):1924-1930.
583. Mayer RJ, Davis RB, Schiffer CA, et al. Intensive post-remission chemotherapy in adults with acute myeloid leukemia. *Cancer and Leukemia Group B*. *N Engl J Med* 1994;331(14):896-903.
584. Fopp M, Fey MF, Bacchi M, et al. Post-remission therapy of adult acute myeloid leukaemia: one cycle of high-dose versus standard-dose cytarabine. *Leukaemia Project Group of the Swiss Group for Clinical Cancer Research (SAKK)*. *Ann Oncol* 1997;8(3):251-257.
585. Bloomfield CD, Lawrence D, Byrd JC, et al. Frequency of prolonged remission duration after high-dose cytarabine intensification in acute myeloid leukemia varies by cytogenetic subtype. *Cancer Res* 1998;58(18):4173-4179.
586. Farag SS, Ruppert AS, Mrozek K, et al. Outcome of induction and post-remission therapy in younger adults with acute myeloid leukemia with normal karyotype: a cancer and leukemia group B study. *J Clin Oncol* 2005;23(3):482-493.

587. Miyawaki S, Ohtake S, Fujisawa S, et al. A randomized comparison of 4 courses of standard-dose multiagent chemotherapy versus 3 courses of high-dose cytarabine alone in postremission therapy for acute myeloid leukemia in adults: the JALSG AML201 Study. *Blood* 2011;117(8):2366-2372.
588. Thomas X, Elhamri M, Raffoux E, et al. Comparison of high-dose cytarabine and timed-sequential chemotherapy as consolidation for younger adults with AML in first remission: the ALFA-9802 study. *Blood* 2011;118(7):1754-1762.
- P.1615
589. Schaich M, Rollig C, Soucek S, et al. Cytarabine dose of 36 g/m² compared with 12 g/m² within first consolidation in acute myeloid leukemia: results of patients enrolled onto the prospective randomized AML96 study. *J Clin Oncol* 2011;29(19):2696-2702.
590. Dutcher JP, Wiernik PH, Markus S, Weinberg V, Schiffer CA, Harwood KV. Intensive maintenance therapy improves survival in adult acute nonlymphocytic leukemia: an eight-year follow-up. *Leukemia* 1988;2(7):413-419.
591. Volger WR, Weiner RS, Moore JO, Omura GA, Bartolucci AA, Stagg M. Long-term follow-up of a randomized post-induction therapy trial in acute myelogenous leukemia (a Southeastern Cancer Study Group trial). *Leukemia* 1995;9(9):1456-1460.
592. Sauter C, Berchtold W, Fopp M, et al. Acute myelogenous leukaemia: maintenance chemotherapy after early consolidation treatment does not prolong survival. *Lancet* 1984;1(8373):379-382.
593. Giles FJ. Troxacitabine-based therapy of refractory leukemia. *Expert Rev Anticancer Ther* 2002;2(3):261-266.
594. Lubbert M. DNA methylation inhibitors in the treatment of leukemias, myelodysplastic syndromes and hemoglobinopathies: clinical results and possible mechanisms of action. *Curr Top Microbiol Immunol* 2000;249:135-164.
595. Zhu WG, Lakshmanan RR, Beal MD, Otterson GA. DNA methyltransferase inhibition enhances apoptosis induced by histone deacetylase inhibitors. *Cancer Res* 2001;61(4):1327-1333.
596. Silverman LR, Demakos EP, Peterson BL, et al. Randomized controlled trial of azacitidine in patients with the myelodysplastic syndrome: a study of the cancer and leukemia group B. *J Clin Oncol* 2002;20(10):2429-2440.
597. Wijermans P, Lubbert M, Verhoef G, et al. Low-dose 5-aza-2'-deoxycytidine, a DNA hypomethylating agent, for the treatment of high-risk myelodysplastic syndrome: a multicenter phase II study in elderly patients. *J Clin Oncol* 2000;18(5):956-962.
598. Gojo I, Jiemjit A, Trepel JB, et al. Phase 1 and pharmacologic study of MS-275, a histone deacetylase inhibitor, in adults with refractory and relapsed acute leukemias. *Blood* 2007;109(7):2781-2790.
599. Silverman LR, McKenzie DR, Peterson BL, et al. Further analysis of trials with azacitidine in patients with myelodysplastic syndrome: studies 8421, 8921, and 9221 by the Cancer and Leukemia Group B. *J Clin Oncol* 2006;24(24):3895-3903.
600. Fenaux P, Mufti GJ, Hellstrom-Lindberg E, et al. Azacitidine prolongs overall survival compared with conventional care regimens in elderly patients with low bone marrow blast count acute myeloid leukemia. *J Clin Oncol* 2010;28(4):562-569.
601. Cashen AF, Schiller GJ, O'Donnell MR, DiPersio JF. Multicenter, phase II study of decitabine for the first-line treatment of older patients with acute myeloid leukemia. *J Clin Oncol* 2010;28(4):556-561.
602. Blum W, Garzon R, Klisovic RB, et al. Clinical response and miR-29b predictive significance in older AML patients treated with a 10-day schedule of decitabine. *Proc Natl Acad Sci U S A* 2010;107(16):7473-7478.
603. Kantarjian HM, Thomas XG, Dmoszynska A, et al. Multicenter, randomized, open-label, phase III trial of decitabine versus patient choice, with physician advice, of either supportive care or low-dose cytarabine for the treatment of older patients with newly diagnosed acute myeloid leukemia. *J Clin Oncol* 2012;30(21):2670-2677.
604. Stone RM, DeAngelo DJ, Klimek V, et al. Patients with acute myeloid leukemia and an activating mutation in FLT3 respond to a small-molecule FLT3 tyrosine kinase inhibitor, PKC412. *Blood* 2005;105(1):54-60.
605. Levis M, Ravandi F, Wang ES, et al. Results from a randomized trial of salvage chemotherapy followed by lestaurtinib for patients with FLT3 mutant AML in first relapse. *Blood* 2011;117(12):3294-3301.

606. Zhang W, Konopleva M, Shi YX, et al. Mutant FLT3: a direct target of sorafenib in acute myelogenous leukemia. *J Natl Cancer Inst* 2008;100(3):184-198.
607. Fiedler W, Serve H, Dohner H, et al. A phase 1 study of SU11248 in the treatment of patients with refractory or resistant acute myeloid leukemia (AML) or not amenable to conventional therapy for the disease. *Blood* 2005;105(3):986-993.
608. DeAngelo DJ, Stone RM, Heaney ML, et al. Phase 1 clinical results with tandutinib (MLN518), a novel FLT3 antagonist, in patients with acute myelogenous leukemia or high-risk myelodysplastic syndrome: safety, pharmacokinetics, and pharmacodynamics. *Blood* 2006;108(12):3674-3681.
609. Zarrinkar PP, Gunawardane RN, Cramer MD, et al. AC220 is a uniquely potent and selective inhibitor of FLT3 for the treatment of acute myeloid leukemia (AML). *Blood* 2009;114(14):2984-2992.
610. Levis M, Tse KF, Smith BD, Garrett E, Small D. A FLT3 tyrosine kinase inhibitor is selectively cytotoxic to acute myeloid leukemia blasts harboring FLT3 internal tandem duplication mutations. *Blood* 2001;98(3):885-887.
611. Levis M, Allebach J, Tse KF, et al. A FLT3-targeted tyrosine kinase inhibitor is cytotoxic to leukemia cells in vitro and in vivo. *Blood* 2002;99(11): 3885-3891.
612. Smith BD, Levis M, Beran M, et al. Single-agent CEP-701, a novel FLT3 inhibitor, shows biologic and clinical activity in patients with relapsed or refractory acute myeloid leukemia. *Blood* 2004;103(10):3669-3676.
613. Knapper S, Mills KI, Gilkes AF, Austin SJ, Walsh V, Burnett AK. The effects of lestaurtinib (CEP701) and PKC412 on primary AML blasts: the induction of cytotoxicity varies with dependence on FLT3 signaling in both FLT3-mutated and wild-type cases. *Blood* 2006;108(10):3494-3503.
614. Levis M, Pham R, Smith BD, Small D. In vitro studies of a FLT3 inhibitor combined with chemotherapy: sequence of administration is important to achieve synergistic cytotoxic effects. *Blood* 2004;104(4):1145-1150.
615. Piloto O, Wright M, Brown P, Kim KT, Levis M, Small D. Prolonged exposure to FLT3 inhibitors leads to resistance via activation of parallel signaling pathways. *Blood* 2007;109(4):1643-1652.
616. Caron PC, Jurcic JG, Scott AM, et al. A phase 1B trial of humanized monoclonal antibody M195 (anti-CD33) in myeloid leukemia: specific targeting without immunogenicity. *Blood* 1994;83(7):1760-1768.
617. Scheinberg DA, Lovett D, Divgi CR, et al. A phase I trial of monoclonal antibody M195 in acute myelogenous leukemia: specific bone marrow targeting and internalization of radionuclide. *J Clin Oncol* 1991;9(3):478-490.
618. van Der Velden VH, te Marvelde JG, Hoogeveen PG, et al. Targeting of the CD33-calicheamicin immunoconjugate Mylotarg (CMA-676) in acute myeloid leukemia: in vivo and in vitro saturation and internalization by leukemic and normal myeloid cells. *Blood* 2001;97(10):3197-3204.
619. Walter RB, Raden BW, Hong TC, Flowers DA, Bernstein ID, Linenberger ML. Multidrug resistance protein attenuates gemtuzumab ozogamicin-induced cytotoxicity in acute myeloid leukemia cells. *Blood* 2003;102(4):1466-1473.
620. Bross PF, Beitz J, Chen G, et al. Approval summary: gemtuzumab ozogamicin in relapsed acute myeloid leukemia. *Clin Cancer Res* 2001;7(6):1490-1496.
621. Larson RA, Sievers EL, Stadtmauer EA, et al. Final report of the efficacy and safety of gemtuzumab ozogamicin (Mylotarg) in patients with CD33-positive acute myeloid leukemia in first recurrence. *Cancer* 2005;104(7):1442-1452.
622. Amadori S, Suci S, Stasi R, et al. Gemtuzumab ozogamicin (Mylotarg) as single-agent treatment for frail patients 61 years of age and older with acute myeloid leukemia: final results of AML-15B, a phase 2 study of the European Organisation for Research and Treatment of Cancer and Gruppo Italiano Malattie Ematologiche dell'Adulto Leukemia Groups. *Leukemia* 2005;19(10):1768-1773.
623. Burnett AK, Hills RK, Milligan D, et al. Identification of patients with acute myeloblastic leukemia who benefit from the addition of gemtuzumab ozogamicin: results of the MRC AML15 trial. *J Clin Oncol* 2011;29(4):369-377.
624. Tack DK, Letendre L, Kamath PS, Tefferi A. Development of hepatic venoocclusive disease after Mylotarg infusion for relapsed acute myeloid leukemia. *Bone Marrow Transplant* 2001;28(9):895-897.
625. Castaigne S, Pautas C, Terre C, et al. Effect of gemtuzumab ozogamicin on survival of adult patients with de-novo acute myeloid leukaemia (ALFA-0701): a randomised, open-label, phase 3 study. *Lancet* 2012;379(9825):1508-1516.

626. Lancet JE, Gojo I, Gotlib J, et al. A phase 2 study of the farnesyltransferase inhibitor tipifarnib in poor-risk and elderly patients with previously untreated acute myelogenous leukemia. *Blood* 2007;109(4):1387-1394.
627. Fehniger TA, Uy GL, Trinkaus K, et al. A phase 2 study of high-dose lenalidomide as initial therapy for older patients with acute myeloid leukemia. *Blood* 2011;117(6):1828-1833.
628. Mesters RM, Padro T, Bieker R, et al. Stable remission after administration of the receptor tyrosine kinase inhibitor SU5416 in a patient with refractory acute myeloid leukemia. *Blood* 2001;98(1):241-243.
629. Karp JE, Gojo I, Pili R, et al. Targeting vascular endothelial growth factor for relapsed and refractory adult acute myelogenous leukemias: therapy with sequential 1-beta-d-arabinofuranosylcytosine, mitoxantrone, and bevacizumab. *Clin Cancer Res* 2004;10(11):3577-3585.
630. Stapnes C, Doskeland AP, Hatfield K, et al. The proteasome inhibitors bortezomib and PR-171 have antiproliferative and proapoptotic effects on primary human acute myeloid leukaemia cells. *Br J Haematol* 2007;136(6):814-828.
631. Karp JE, Vener TI, Raponi M, et al. Multi-institutional phase 2 clinical and pharmacogenomic trial of tipifarnib plus etoposide for elderly adults with newly diagnosed acute myelogenous leukemia. *Blood* 2012;119(1):55-63.
632. Perl AE, Kasner MT, Tsai DE, et al. A phase I study of the mammalian target of rapamycin inhibitor sirolimus and MEC chemotherapy in relapsed and refractory acute myelogenous leukemia. *Clin Cancer Res* 2009;15(21): 6732-6739.
633. Amadori S, Stasi R, Martelli AM, et al. Temsirolimus, an mTOR inhibitor, in combination with lower-dose clofarabine as salvage therapy for older patients with acute myeloid leukaemia: results of a phase II GIMEMA study (AML-1107). *Br J Haematol* 2012;156(2):205-212.
634. Lancet JE, Gojo I, Burton M, et al. Phase I study of the heat shock protein 90 inhibitor alvespimycin (KOS-1022, 17-DMAG) administered intravenously twice weekly to patients with acute myeloid leukemia. *Leukemia* 2010;24(4):699-705.
635. Brune M, Castaigne S, Catalano J, et al. Improved leukemia-free survival after postconsolidation immunotherapy with histamine dihydrochloride and interleukin-2 in acute myeloid leukemia: results of a randomized phase 3 trial. *Blood* 2006;108(1):88-96.
636. Houtenbos I, Westers TM, Ossenkoppele GJ, van de Loosdrecht AA. Feasibility of clinical dendritic cell vaccination in acute myeloid leukemia. *Immunobiology* 2006;211(6-8):677-685.
637. Greiner J, Dohner H, Schmitt M. Cancer vaccines for patients with acute myeloid leukemia—definition of leukemia-associated antigens and current clinical protocols targeting these antigens. *Haematologica* 2006;91(12): 1653-1661.
638. Keilholz U, Letsch A, Busse A, et al. A clinical and immunologic phase 2 trial of Wilms tumor gene product 1 (WT1) peptide vaccination in patients with AML and MDS. *Blood* 2009;113(26):6541-6548.
639. Van Tendeloo VF, Van de Velde A, Van Driessche A, et al. Induction of complete and molecular remissions in acute myeloid leukemia by Wilms' tumor 1 antigen-targeted dendritic cell vaccination. *Proc Natl Acad Sci U S A* 2010;107(31):13824-13829.
640. Lowenberg B. Managing therapy in older adult patients with acute myeloid leukemia. *Semin Hematol* 2001;38(3 Suppl 6):10-16.
641. Sekeres MA, Elson P, Kalaycio ME, et al. Time from diagnosis to treatment initiation predicts survival in younger, but not older, acute myeloid leukemia patients. *Blood* 2009;113(1):28-36.
642. McClune BL, Weisdorf DJ, Pedersen TL, et al. Effect of age on outcome of reduced-intensity hematopoietic cell transplantation for older patients with acute myeloid leukemia in first complete remission or with myelodysplastic syndrome. *J Clin Oncol* 2010;28(11):1878-1887.
643. Juarez S, Cuadrado Pastor JM, Feliu J, Gonzalez Baron M, Ordonez A, Montero JM. Association of leukemia and pregnancy: clinical and obstetric aspects. *Am J Clin Oncol* 1988;11(2):159-165.
644. Reynoso EE, Shepherd FA, Messner HA, Farquharson HA, Garvey MB, Baker MA. Acute leukemia during pregnancy: the Toronto leukemia study group experience with long-term follow-up of children exposed in utero to chemotherapeutic agents. *J Clin Oncol* 1987;5(7):1098-1106.
645. Brell J, Kalaycio M. Leukemia in pregnancy. *Semin Oncol* 2000;27(6): 667-677.
646. Dildy GA 3rd, Moise KJ Jr, Carpenter RJ Jr, Klima T. Maternal malignancy metastatic to the products of conception: a review. *Obstet Gynecol Surv* 1989;44(7):535-540.

647. Honore LH, Brown LB. Intervillous placental metastasis with maternal myeloid leukemia. *Arch Pathol Lab Med* 1990;114(5):450.
648. Feliu J, Juarez S, Ordonez A, Garcia-Paredes ML, Gonzalez-Baron M, Montero JM. Acute leukemia and pregnancy. *Cancer* 1988;61(3):580-584.
649. Doll DC, Ringenberg QS, Yarbrow JW. Antineoplastic agents and pregnancy. *Semin Oncol* 1989;16(5):337-346.
650. Greenlund LJ, Letendre L, Tefferi A. Acute leukemia during pregnancy: a single institutional experience with 17 cases. *Leuk Lymphoma* 2001;41(5-6):571-577.
651. Chelghoum Y, Vey N, Raffoux E, et al. Acute leukemia during pregnancy: a report on 37 patients and a review of the literature. *Cancer* 2005;104(1): 110-117.
652. Aviles A, Diaz-Maqueo JC, Talavera A, Guzman R, Garcia EL. Growth and development of children of mothers treated with chemotherapy during pregnancy: current status of 43 children. *Am J Hematol* 1991;36(4):243-248.
653. Resnik R. Cancer during pregnancy. *N Engl J Med* 1999;341(2):120-121.
654. Shapira T, Pereg D, Lishner M. How I treat acute and chronic leukemia in pregnancy. *Blood Rev* 2008;22(5):247-259.
655. Hiddemann W, Schleyer E, Uhrmeister C, et al. High-dose versus intermediate-dose cytosine arabinoside in combination with mitoxantrone for the treatment of relapsed and refractory acute myeloid leukemia—preliminary clinical and pharmacological data of a randomized comparison. *Cancer Treat Rev* 1990;17(2-3):279-285.
656. Breems DA, Van Putten WL, Huijgens PC, et al. Prognostic index for adult patients with acute myeloid leukemia in first relapse. *J Clin Oncol* 2005;23(9):1969-1978.
657. Weltermann A, Fonatsch C, Haas OA, et al. Impact of cytogenetics on the prognosis of adults with de novo AML in first relapse. *Leukemia* 2004;18(2):293-302.
658. Thalhammer F, Geissler K, Jager U, et al. Duration of second complete remission in patients with acute myeloid leukemia treated with chemotherapy: a retrospective single-center study. *Ann Hematol* 1996;72(4):216-222.
659. Kern W, Haferlach T, Schnittger S, Ludwig WD, Hiddemann W, Schoch C. Karyotype instability between diagnosis and relapse in 117 patients with acute myeloid leukemia: implications for resistance against therapy. *Leukemia* 2002;16(10):2084-2091.
660. Kern W, Haferlach T, Schoch C, et al. Early blast clearance by remission induction therapy is a major independent prognostic factor for both achievement of complete remission and long-term outcome in acute myeloid leukemia: data from the German AML Cooperative Group (AMLCG) 1992 Trial. *Blood* 2003;101(1):64-70.
661. Herzig RH, Lazarus HM, Wolff SN, Phillips GL, Herzig GP. High-dose cytosine arabinoside therapy with and without anthracycline antibiotics for remission reinduction of acute nonlymphoblastic leukemia. *J Clin Oncol* 1985;3(7): 992-997.
662. Evans C, Winkelstein A, Rosenfeld CS, Zeigler ZR, Shaddock RK. High-dose cytosine arabinoside and L-asparaginase therapy for poor-risk adult acute nonlymphocytic leukemia. A retrospective study. *Cancer* 1990;65(12):2624-2630.
663. Capizzi RL, Davis R, Powell B, et al. Synergy between high-dose cytarabine and asparaginase in the treatment of adults with refractory and relapsed acute myelogenous leukemia—a Cancer and Leukemia Group B Study. *J Clin Oncol* 1988;6(3):499-508.
664. Carella AM, Cascavilla N, Greco MM, et al. Treatment of “poor risk” acute myeloid leukemia with fludarabine, cytarabine and G-CSF (flag regimen): a single center study. *Leuk Lymphoma* 2001;40(3-4):295-303.
665. Tedeschi A, Montillo M, Strocchi E, et al. High-dose idarubicin in combination with Ara-C in patients with relapsed or refractory acute lymphoblastic leukemia: a pharmacokinetic and clinical study. *Cancer Chemother Pharmacol* 2007;59(6):771-779.
666. Schimmer AD, Estey EH, Borthakur G, et al. Phase I/II trial of AEG35156 X-linked inhibitor of apoptosis protein antisense oligonucleotide combined with idarubicin and cytarabine in patients with relapsed or primary refractory acute myeloid leukemia. *J Clin Oncol* 2009;27(28):4741-4746.
667. Stone RM, Moser B, Sanford B, et al. High dose cytarabine plus gemtuzumab ozogamicin for patients with relapsed or refractory acute myeloid leukemia: Cancer and Leukemia Group B study 19902. *Leuk Res* 2011;35(3):329-333.

668. Prebet T, Etienne A, Devillier R, et al. Improved outcome of patients with low- and intermediate-risk cytogenetics acute myeloid leukemia (AML) in first relapse with gemtuzumab and cytarabine versus cytarabine: results of a retrospective comparative study. *Cancer* 2011;117(5):974-981.
669. Tse E, Leung AY, Sim J, et al. Clofarabine and high-dose cytosine arabinoside in the treatment of refractory or relapsed acute myeloid leukaemia. *Ann Hematol* 2011;90(11):1277-1281.
670. Larson SM, Campbell NP, Huo D, et al. High dose cytarabine and mitoxantrone: an effective induction regimen for high-risk acute myeloid leukemia (AML). *Leuk Lymphoma* 2012;53(3):445-450.
671. Becker PS, Kantarjian HM, Appelbaum FR, et al. Retrospective comparison of clofarabine versus fludarabine in combination with high dose cytarabine with or without granulocyte colony-stimulating factor as salvage therapies for acute myeloid leukemia. *Haematologica* 2012.
672. Vogler WR, McCarley DL, Stagg M, et al. A phase III trial of high-dose cytosine arabinoside with or without etoposide in relapsed and refractory acute myelogenous leukemia. A Southeastern Cancer Study Group trial. *Leukemia* 1994;8(11):1847-1853.
673. Lim WS, Tardi PG, Xie X, et al. Schedule- and dose-dependency of CPX-351, a synergistic fixed ratio cytarabine:daunorubicin formulation, in consolidation treatment against human leukemia xenografts. *Leuk Lymphoma* 2010;51(8):1536-1542.
674. Lim WS, Tardi PG, Dos Santos N, et al. Leukemia-selective uptake and cytotoxicity of CPX-351, a synergistic fixed-ratio cytarabine:daunorubicin formulation, in bone marrow xenografts. *Leuk Res* 2010;34(9):1214-1223.
675. Graef T, Kuendgen A, Fenk R, Zohren F, Haas R, Kobbe G. Successful treatment of relapsed AML after allogeneic stem cell transplantation with azacitidine. *Leuk Res* 2007;31(2):257-259.
676. Chowdhury S, Seropian S, Marks PW. Decitabine combined with fractionated gemtuzumab ozogamicin therapy in patients with relapsed or refractory acute myeloid leukemia. *Am J Hematol* 2009;84(9):599-600.
677. Platzbecker U, Wermke M, Radke J, et al. Azacitidine for treatment of imminent relapse in MDS or AML patients after allogeneic HSCT: results of the RELAZA trial. *Leukemia* 2012;26(3):381-389.
678. Faderl S, Wetzler M, Rizzieri D, Schiller G, Jagasia M. Clofarabine plus cytarabine compared to cytarabine alone in older patients with relapsed or refractory (R/R) acute myelogenous leukemia (AML): results from the phase III CLASSIC 1 trial. *J Clin Oncol* 2011;29(Suppl):Abstr 6503.
679. Horowitz MM, Gale RP, Sondel PM, et al. Graft-versus-leukemia reactions after bone marrow transplantation. *Blood* 1990;75(3):555-562.
680. Zittoun RA, Mandelli F, Willemze R, et al. Autologous or allogeneic bone marrow transplantation compared with intensive chemotherapy in acute myelogenous leukemia. European Organization for Research and Treatment of Cancer (EORTC) and the Gruppo Italiano Malattie Ematologiche Maligne dell'Adulto (GIMEMA) Leukemia Cooperative Groups. *N Engl J Med* 1995;332(4):217-223.
681. Cassileth PA, Harrington DP, Appelbaum FR, et al. Chemotherapy compared with autologous or allogeneic bone marrow transplantation in the management of acute myeloid leukemia in first remission. *N Engl J Med* 1998;339(23):1649-1656.
682. Kumar L. Leukemia: management of relapse after allogeneic bone marrow transplantation. *J Clin Oncol* 1994;12(8):1710-1717.
683. Giralt S, Anagnostopoulos A, Shahjahan M, Champlin R. Nonablative stem cell transplantation for older patients with acute leukemias and myelodysplastic syndromes. *Semin Hematol* 2002;39(1):57-62.
684. McSweeney PA, Niederwieser D, Shizuru JA, et al. Hematopoietic cell transplantation in older patients with hematologic malignancies: replacing high-dose cytotoxic therapy with graft-versus-tumor effects. *Blood* 2001;97(11):3390-3400.
685. Kassim AA, Chinratanalab W, Ferrara JL, Mineishi S. Reduced-intensity allogeneic hematopoietic stem cell transplantation for acute leukemias: "what is the best recipe?". *Bone Marrow Transplant* 2005;36(7):565-574.
686. Alamo J, Shahjahan M, Lazarus HM, de Lima M, Giralt SA. Comorbidity indices in hematopoietic stem cell transplantation: a new report card. *Bone Marrow Transplant* 2005;36(6):475-479.

687. Sorror ML, Maris MB, Storb R, et al. Hematopoietic cell transplantation (HCT)-specific comorbidity index: a new tool for risk assessment before allogeneic HCT. *Blood* 2005;106(8):2912-2919.
688. Appelbaum FR. Hematopoietic cell transplantation from unrelated donors for treatment of patients with acute myeloid leukemia in first complete remission. *Best Pract Res Clin Haematol* 2007;20(1):67-75.
689. Brunstein CG, Barker JN, Weisdorf DJ, et al. Umbilical cord blood transplantation after nonmyeloablative conditioning: impact on transplantation outcomes in 110 adults with hematologic disease. *Blood* 2007;110(8):3064-3070.
690. Brunstein CG, Baker KS, Wagner JE. Umbilical cord blood transplantation for myeloid malignancies. *Curr Opin Hematol* 2007;14(2):162-169.
691. Zuckerman T, Rowe JM. Alternative donor transplantation in acute myeloid leukemia: which source and when? *Curr Opin Hematol* 2007;14(2):152-161.
692. Reisner Y, Hagin D, Martelli MF. Haploidentical hematopoietic transplantation: current status and future perspectives. *Blood* 2011;118(23):6006-6017.
693. Aoudjhane M, Labopin M, Gorin NC, et al. Comparative outcome of reduced intensity and myeloablative conditioning regimen in HLA identical sibling allogeneic haematopoietic stem cell transplantation for patients older than 50 years of age with acute myeloblastic leukaemia: a retrospective survey from the Acute Leukemia Working Party (ALWP) of the European group for Blood and Marrow Transplantation (EBMT). *Leukemia* 2005;19(12):2304-2312.
694. Alyea EP, Kim HT, Ho V, et al. Comparative outcome of nonmyeloablative and myeloablative allogeneic hematopoietic cell transplantation for patients older than 50 years of age. *Blood* 2005;105(4):1810-1814.
695. Cornelissen JJ, Lowenberg B. Role of allogeneic stem cell transplantation in current treatment of acute myeloid leukemia. *Hematology Am Soc Hematol Educ Program* 2005:151-155.
696. Miller CB, Rowlings PA, Zhang MJ, et al. The effect of graft purging with 4-hydroperoxycyclophosphamide in autologous bone marrow transplantation for acute myelogenous leukemia. *Exp Hematol* 2001;29(11):1336-1346.
697. Suci S, Mandelli F, de Witte T, et al. Allogeneic compared with autologous stem cell transplantation in the treatment of patients younger than 46 years with acute myeloid leukemia (AML) in first complete remission (CR1): an intention-to-treat analysis of the EORTC/GIMEMAAML-10 trial. *Blood* 2003;102(4):1232-1240.
698. Thomas X, Le Q, Botton S, et al. Autologous or allogeneic stem cell transplantation as post-remission therapy in refractory or relapsed acute myeloid leukemia after highly intensive chemotherapy. *Leuk Lymphoma* 2005;46(7):1007-1016.
699. Lazarus HM, Perez WS, Klein JP, et al. Autotransplantation versus HLA-matched unrelated donor transplantation for acute myeloid leukaemia: a retrospective analysis from the Center for international blood and marrow transplant research. *Br J Haematol* 2006;132(6):755-769.
700. DeZern AE, Sung A, Kim S, et al. Role of allogeneic transplantation for FLT3/ITD acute myeloid leukemia: outcomes from 133 consecutive newly diagnosed patients from a single institution. *Biol Blood Marrow Transplant* 2011;17(9):1404-1409.
701. Yoshimoto G, Nagafuji K, Miyamoto T, et al. FLT3 mutations in normal karyotype acute myeloid leukemia in first complete remission treated with autologous peripheral blood stem cell transplantation. *Bone Marrow Transplant* 2005;36(11):977-983.
702. Burnett AK, Wheatley K, Goldstone AH, et al. The value of allogeneic bone marrow transplant in patients with acute myeloid leukaemia at differing risk of relapse: results of the UK MRC AML 10 trial. *Br J Haematol* 2002;118(2):385-400.
703. Harousseau JL, Cahn JY, Pignon B, et al. Comparison of autologous bone marrow transplantation and intensive chemotherapy as postremission therapy in adult acute myeloid leukemia. The Groupe Ouest Est Leucemies Aigues Myeloblastiques (GOELAM). *Blood* 1997;90(8):2978-2986.
704. Cornelissen JJ, van Putten WL, Verdonck LF, et al. Results of a HOVON/SAKK donor versus no-donor analysis of myeloablative HLA-identical sibling stem cell transplantation in first remission acute myeloid leukemia in young and middle-aged adults: benefits for whom? *Blood* 2007;109(9):3658-3666.
705. Koreth J, Schlenk R, Kopecky KJ, et al. Allogeneic stem cell transplantation for acute myeloid leukemia in first complete remission: systematic review and meta-analysis of prospective clinical trials. *JAMA* 2009;301(22):2349-2361.

706. McGlave PB, Haake RJ, Bostrom BC, et al. Allogeneic bone marrow transplantation for acute nonlymphocytic leukemia in first remission. *Blood* 1988;72(5):1512-1517.
707. Blume KG, Forman SJ, O'Donnell MR, et al. Total body irradiation and high-dose etoposide: a new preparatory regimen for bone marrow transplantation in patients with advanced hematologic malignancies. *Blood* 1987;69(4):1015-1020.
708. Bacigalupo A, Sormani MP, Lamparelli T, et al. Reducing transplant-related mortality after allogeneic hematopoietic stem cell transplantation. *Haematologica* 2004;89(10):1238-1247.
709. Sierra J, Storer B, Hansen JA, et al. Unrelated donor marrow transplantation for acute myeloid leukemia: an update of the Seattle experience. *Bone Marrow Transplant* 2000;26(4):397-404.
710. Moore J, Nivison-Smith I, Goh K, et al. Equivalent survival for sibling and unrelated donor allogeneic stem cell transplantation for acute myelogenous leukemia. *Biol Blood Marrow Transplant* 2007;13(5):601-607.
711. Cook G, Clark RE, Crawley C, et al. The outcome of sibling and unrelated donor allogeneic stem cell transplantation in adult patients with acute myeloid leukemia in first remission who were initially refractory to first induction chemotherapy. *Biol Blood Marrow Transplant* 2006;12(3):293-300.
712. Brown RA, Wolff SN, Fay JW, et al. High-dose etoposide, cyclophosphamide, and total body irradiation with allogeneic bone marrow transplantation for patients with acute myeloid leukemia in untreated first relapse: a study by the North American Marrow Transplant Group. *Blood* 1995;85(5): 1391-1395.
713. Martino R, Perez-Simon JA, Moreno E, et al. Reduced-intensity conditioning allogeneic blood stem cell transplantation with fludarabine and oral busulfan with or without pharmacokinetically targeted busulfan dosing in patients with myeloid leukemia ineligible for conventional conditioning. *Biol Blood Marrow Transplant* 2005;11(6):437-447.
714. Deeg HJ, Storer BE, Boeckh M, et al. Reduced incidence of acute and chronic graft-versus-host disease with the addition of thymoglobulin to a targeted busulfan/cyclophosphamide regimen. *Biol Blood Marrow Transplant* 2006;12(5):573-584.
715. van Besien K, Artz A, Smith S, et al. Fludarabine, melphalan, and alemtuzumab conditioning in adults with standard-risk advanced acute myeloid leukemia and myelodysplastic syndrome. *J Clin Oncol* 2005;23(24):5728-5738.

Chapter 76 Acute Lymphoblastic Leukemia in Children

> Table of Contents > Part VII - Hematologic Malignancies > Section 2 - The Acute Leukemias > Chapter 76 - Acute Lymphoblastic Leukemia in Children

Chapter 76

Acute Lymphoblastic Leukemia in Children

Elizabeth A. Raetz

Mignon Lee-Chuen Loh

Maureen M. O'Brien

James A. Whitlock

Acute lymphoblastic leukemia (ALL) is the most common childhood malignancy, accounting for approximately 20% of all cancers and 75% of all leukemias among patients younger than 20 years of age.¹ Approximately 2,500 to 3,500 new cases of ALL are diagnosed in children each year in the United States with an incidence of 31.9 cases per one million person-years. Although most patients are younger than 5 years old, ALL occurs in an age-, gender-, ethnically, and socioeconomically diverse population.

Both in the clinic and in the laboratory, the vast heterogeneity of ALL is apparent. Patients may present with greater disease burden with symptoms of leukemic proliferation demonstrated, for example, by bone pain, lymphadenopathy, respiratory distress from a mediastinal mass, or abdominal discomfort secondary to organomegaly, or with no evident disease burden after a more insidious onset of symptoms related to marrow failure, such as, fatigue from anemia, fever from neutropenia, and bruising or bleeding from thrombocytopenia. Although most cases may be classified as B-precursor or T-cell ALL, great diversity is seen in the various combinations of B-, T-, and myeloid-associated membrane markers

expressed by leukemia cells. Great diversity is also seen in the broad array of known cytogenetic and molecular abnormalities.^{2,3}

ALL remained a fatal childhood disease until effective presymptomatic central nervous system (CNS) therapy was developed in the 1960s. Although combination chemotherapy provided frequent remissions (disappearance of microscopically detectable leukemia in the bone marrow with recovery of adequate marrow function), the subsequent appearance of leukemia cells in the CNS was common, and marrow relapse followed despite further treatment.

Over the following decades, better postinduction intensification has improved the 5-year event-free survival (EFS) from 50% to nearly 90% for children younger than 15 years of age (Fig. 76.1) and allowed replacement of craniospinal radiation for most patients with intrathecal therapy.^{4,5} Unlike other childhood cancers for which curative therapy is available, outcomes are best with prolonged treatment extending 2 to 3 years or more. Treatment is tailored to risk of relapse; patients at higher risk of relapse, as defined by specific clinical and biologic features, receive more aggressive treatment, whereas patients at lower risk of relapse obtain excellent outcomes with less morbid treatment. Initial response to induction therapy, assessed by multiparameter flow cytometry or PCR-based technology, now supplements presenting clinical features and cytogenetics for treatment allocation. Despite continued improvements in prognostication, treatment remains the most important prognostic factor.

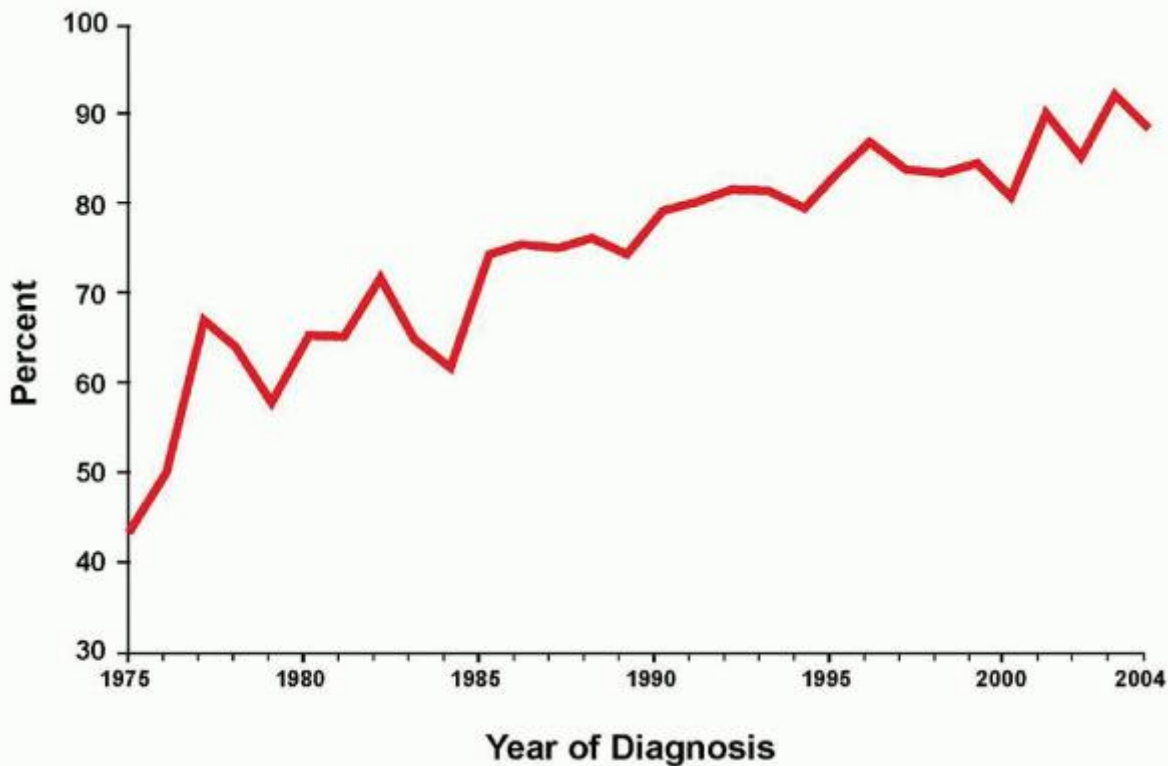

FIGURE 76.1. Five-year relative survival rates by year of diagnosis for acute lymphoblastic leukemia (ALL) (all races, both sexes, age <20 years, 1975 to 2004, SEER Cancer Statistics).

Because the incidence of ALL is higher than other childhood cancers, the incidence of relapsed ALL is similar to the incidence of newly diagnosed pediatric cancers such as acute myeloid leukemia (AML) and Hodgkin lymphoma despite excellent initial cure rates. Outcomes after relapse, particularly marrow relapse, remain poor despite substantial success in inducing remission and the increasing application of allogeneic hematopoietic stem cell transplantation (HSCT). The majority of patients who relapse will ultimately die of their leukemia.

The diagnosis and characterization of ALL are discussed in Chapter 73. Cytogenetics are discussed in Chapter 3 and molecular genetics are discussed in Chapter 72. This chapter is concerned with the clinical characteristics, treatment, and late sequelae of childhood ALL. Therapy of Burkitt leukemia is addressed in Chapter 89.

PRESENTING CLINICAL FEATURES

Although it affects all age groups, the highest incidence of B-precursor ALL in children is between the ages of 1 and 5 years, with a peak incidence between 3 and 4 years (Fig. 76.2) where favorable cytogenetic patterns such as trisomies (trisomy 4 and 10)

P.1617

and translocation t(12;21) are most common.⁶ This early peak is not seen in African Americans, and as a result, ALL is more common in children of Caucasian descent.⁷ Children of Hispanic ethnicity have the highest incidence of ALL, and emerging data suggest that genetic polymorphisms may contribute to both the increased risk of ALL for Hispanic children as well as inferior outcomes.⁸ Overall, ALL is slightly more common in males compared to females (1.3:1 ratio). Patients with T-cell ALL tend to be older (median age 9 years) and more commonly are male (75%).⁹

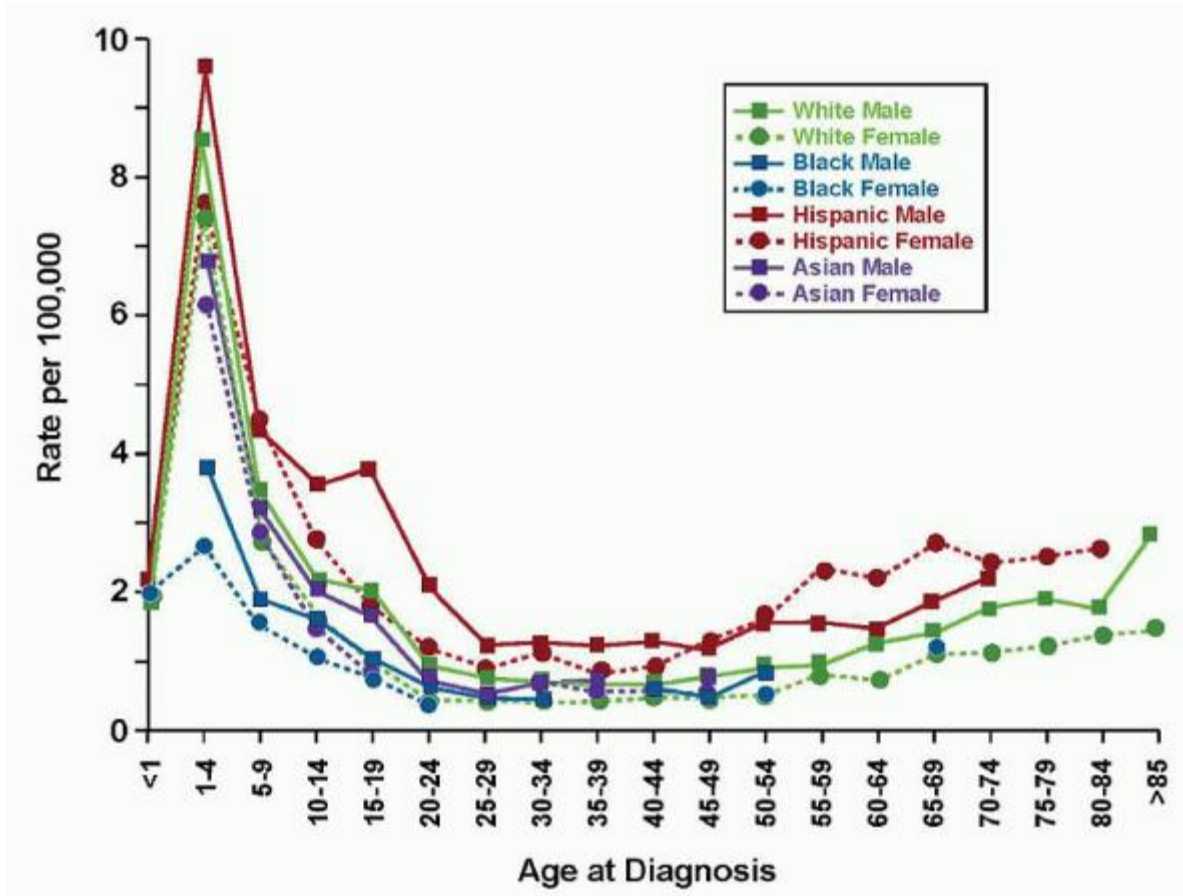

FIGURE 76.2. Age-specific incidence rates of ALL according to race and gender (SEER Cancer Statistics, 2000 to 2009).

TABLE 76.1 FREQUENCY OF CLINICAL AND LABORATORY FINDINGS AT DIAGNOSIS IN 178 CHILDREN AND ADULTS WITH ACUTE LYMPHOBLASTIC LEUKEMIA

Clinical Features	Percentage	Laboratory Features	Percentage
Symptoms	—	White blood cells ($\times 10^9/L$)	—
Fatigue	92	<10	40
Bone or joint pain	79	10-49	34
Fever without infection	71	50-99	15
Weight loss	66	≥ 100	11
Abnormal masses	62	Neutrophils ($\times 10^9/L$)	—
Purpura	51	<1	73

Other hemorrhage	27	1-2	9
Infection	17	>2	18
Physical findings	—	Packed cell volume (L/L)	—
Splenomegaly	86	<30	65
Lymphadenopathy	76	>30	35
Hepatomegaly	74	Platelets ($\times 10^9/L$)	—
Sternal tenderness	69	<50	62
Purpura	50	50-150	30
Fundic hemorrhage	14	>150	8

From Boggs DR, Wintrobe MM, Cartwright GE. The acute leukemias. *Medicine* 1962;41:163.

Symptoms and signs are a consequence of bone marrow failure or the infiltration of medullary or extramedullary sites by leukemia (Table 76.1). The onset of symptoms may be insidious and slowly progressive over weeks to months, or acute and explosive. In general, the more indolent the onset of symptoms, the better the outcome.¹⁰ Fatigue, lethargy, persistent fever, bruising or bleeding, and bone pain are the most common presenting complaints. Fatigue and lethargy correlate with the severity of anemia. No infectious basis for fever is found in many cases, especially if the neutrophil count exceeds $0.2 \times 10^9/L$, but infection

P.1618

must be presumed and treated with broad-spectrum parenteral antibiotics.¹¹ Fever usually resolves promptly after the institution of antibiotics and chemotherapy.¹² Thrombocytopenia may cause bruising and bleeding. Approximately 2% of children present with marrow findings consistent with aplastic anemia, followed by overt leukemia within weeks to months.¹³

Bone pain is a frequent complaint and may result from marrow expansion, bone erosion, or leukemic involvement of the periosteum. Young children, in particular, may present with gait disturbances or a refusal to walk. Vertebral compression fractures may complicate generalized osteoporosis, leading to back pain. Prominent skeletal symptoms occur primarily in children with no lymphadenopathy, organomegaly, or leukocytosis, and as a result, the diagnosis of leukemia often is delayed.^{14, 15} and ¹⁶ Less commonly, bone pain is caused by recurring episodes of bone marrow necrosis.^{17, 18} and ¹⁹ Marrow necrosis is also typically associated with a small leukemic burden and an aleukemic blood picture. In approximately 5% of patients with ALL, bone or joint pain may be the only presenting symptoms and patients may be referred for rheumatology evaluation for concern of juvenile rheumatoid arthritis (JRA). Diagnosis in these patients may be delayed, and differentiation of ALL from JRA is critical to avoid pretreatment with corticosteroids which might have a negative impact on subsequent diagnosis and risk stratification.²⁰

Physical findings may include pallor, petechiae or purpura, mucous membrane bleeding, and fever. Extramedullary leukemic spread may be manifest by lymphadenopathy which is present in approximately 50% of patients, as well as splenomegaly and hepatomegaly which are frequently noted on imaging or examination but rarely cause symptoms.²¹ Skin involvement is rare; when it occurs, it presents as cutaneous nodules and is associated with a pre-B-cell phenotype.²²

Approximately 60% of patients with acute T lymphoblastic leukemia (T-ALL) have enlarged anterior mediastinal lymphadenopathy at the time of diagnosis, which is rarely seen in children with B-precursor ALL. The presence of mediastinal mass at diagnosis does not have prognostic significance.²³ The mediastinal mass may be asymptomatic and detected only on chest x-ray, or may cause cough and dyspnea, particularly on lying flat, or with facial swelling and plethora due to vascular compression with superior vena cava syndrome. Identification of clinically significant mediastinal adenopathy is critical prior to sedation for diagnostic procedures such as bone marrow aspiration.

Microscopic leukemic infiltration of the testes in males is common at presentation and requires no specific treatment. Testicular biopsy is discouraged at presentation as a routine part of staging, as it is likely to be positive, even in patients with a normal testicular examination. Overt testicular involvement with leukemia (2% to 3% of patients) presents as painlessly enlarged or irregular testes, and carries no adverse prognosis in the modern treatment era when treated with appropriately intense therapy.^{24,25}

CNS involvement by leukemia occurs in approximately 2% to 3% of patients at diagnosis and is more common in patients with T-ALL. Most patients with CNS involvement are asymptomatic and only diagnosed by lumbar puncture. Rarely, symptoms include headaches, vomiting, or cranial nerve palsies.²⁶

PRESENTING LABORATORY AND RADIOGRAPHIC FEATURES

The white blood cell (WBC) count is elevated in 60% of patients (see Table 76.1). Neutropenia is frequent. Although leukemic blasts are obvious in smears of patients with high WBC counts, they may be absent or found only after thorough review of blood smears from patients with decreased leukocyte counts. A WBC count in excess of $50 \times 10^9/L$ is frequently associated with prominent lymphadenopathy, hepatosplenomegaly, and T-cell immunophenotype. A WBC count in excess of $200 \times 10^9/L$ is termed hyperleukocytosis. Unlike the situation in AML, hyperleukocytosis rarely is complicated by intracerebral hemorrhages or pulmonary insufficiency.²⁷ Although thrombocytopenia is common, patients with ALL do not present with isolated thrombocytopenia without other abnormal laboratory tests and/or physical findings.²⁸

A large leukemic cell burden with a high rate of cell turnover may produce tumor lysis syndrome, that is, multiple metabolic disturbances, the most prominent of which is elevation of the serum uric acid level, which in turn may lead to urate nephropathy. Acute renal failure resulting from urate nephropathy may rarely be a presenting feature, but more commonly follows initiation of antileukemic treatment.²⁹ Kidney function may be further diminished by leukemic infiltration of the kidney or extrarenal obstruction by enlarged lymph nodes. Increased cell destruction causes hyperphosphatemia and secondary hypocalcemia, which may lead to the precipitation of calcium phosphate in renal tubules and consequent acute renal failure, and hyperkalemia, leading in turn to cardiac arrhythmias or asystole.^{30,31} The availability of recombinant uricase, which breaks down uric acid, has improved the treatment of tumor lysis syndrome. The management of these metabolic complications is discussed in Chapter 69. Serum levels of lactic dehydrogenase (LDH) are increased because of an increased turnover of leukemic cells, but have no physiologic consequences and need not be repetitively monitored.

Although occurring less frequently than in AML, coagulopathies may lead to either hemorrhagic or thrombotic complications.³² Most often coagulopathy follows asparaginase administration and thrombosis is believed mediated by acquired antithrombin III deficiency leading to increased thrombin generation.^{33,34} The data for attempts to prevent thromboses with administration of antithrombin III concentrates remain less than compelling.

Radiographic examination of the chest demonstrates an anterior mediastinal mass in 5% to 10% of newly diagnosed patients with ALL, most commonly in patients with T-cell disease. The thymic mass may be associated with pleural effusions, which are frequently malignant and yield diagnostic cells upon thoracentesis. A large mediastinal mass represents a medical emergency, requiring careful monitoring and prompt initiation of chemotherapy, and complicating routine sedation or anesthesia. Skeletal lesions can be radiographically demonstrated in more than 50% of patients.³⁵ The most common abnormalities include transverse metaphyseal radiolucent lines adjacent to the zone of provisional calcification at the end of long bones, generalized rarefaction of bones, cortical and trabecular osteolytic lesions, and periosteal new bone formation.

Bone marrow aspiration is the standard method of establishing a diagnosis, and provides cells for morphologic, histochemical, immunophenotypic, cytogenetic, and molecular analysis. In bone marrow aspiration, careful attention is provided toward minimizing pain and fear for the patient and family, with the routine utilization of conscious sedation or general anesthesia. In ALL, the marrow is typically hypercellular with replacement of fat spaces and normal marrow elements by leukemic cells. In contrast to AML, residual myeloid and erythroid precursors appear morphologically normal. Megakaryocytes are decreased or absent. Bone marrow lymphoblasts are more homogeneous with respect to both morphologic and biologic characteristics than those in the blood. When marrow aspiration is unsuccessful due to increased cell density, a biopsy should be performed. As other diagnostic modalities such as flow cytometry can replace marrow morphology, examination of peripheral blasts, when present in sufficient quantity, may replace marrow aspiration or biopsy when aspiration is unsuccessful or clinically risky.

Lumbar puncture provides evidence of overt CNS involvement in approximately 3% of children with ALL at diagnosis.

P.1619

Cyocentrifugation (cytospin) of cerebrospinal fluid (CSF) enhances diagnostic sensitivity by concentrating low numbers of cells. Involvement is classified as CNS 1 (no blasts on cytospin), CNS 2 (blasts on cytospin but CSF WBC < 5 cells/ μ l), and CNS 3 (blasts on cytospin with WBC \geq 5 cells/ μ l).^{36,37} Recent reports suggest adverse significance for CNS 2 status or a traumatic initial lumbar puncture with blasts in some series.^{37,38} As a result, it is recommended that the platelet count be elevated to $>100 \times 10^9/L$ by transfusion prior to the diagnostic lumbar puncture to minimize risk of a traumatic tap, and

that the procedure be performed by the most highly skilled practitioner with the patient under general anesthesia. Cranial nerve findings in the absence of CSF blasts are highly suggestive of CNS leukemia.

RISK STRATIFICATION

As therapy remains the single most important factor to influence outcome, the relative prognostic significance of characteristics at diagnosis (Table 76.2) varies for the different treatment strategies delivered by national and international investigators. Consequently, evolving combinations of clinical, laboratory, and response variables have been used to guide therapeutic intensity over the years by those who conduct clinical trials for childhood ALL, overall with increasingly successful results. Indeed, the Children's Oncology Group (COG) recently reported that sequential outcomes of over 21,000 patients (age 0 to 22 years) enrolled on COG trials between 1990 and 2005 culminated in survival rates of 90.4% for those children treated between 2000 and 2005 (Fig. 76.3).⁵ Concomitantly, studies conducted on long-term survivors of childhood cancer reveal that up to 62% of patients suffer from at least one chronic condition and 27% suffer from a grade 3 or 4 condition.³⁹ The goal of modern risk stratification, then, is to cure patients while minimizing acute and late toxicity, otherwise known as maximizing the therapeutic benefit.

Differences among the risk classification criteria used to deliver varied intensities of therapy by disparate groups have made accurate comparisons of outcomes difficult, if not impossible. To overcome this obstacle, an international workshop held in Rome in 1985³⁶ and a subsequent consensus workshop, sponsored by the United States National Cancer Institute in 1993, led to the development of common risk-based criteria.⁴⁰ In 1993, the NCI-Rome risk criteria were agreed upon by leaders among the major clinical consortia in an attempt to analyze different datasets using two of the most powerful predictors of outcome across all studies for B-lineage ALL: age and presenting WBC count at diagnosis. The standard-risk group (NCI-SR) includes those patients with B-precursor ALL ages 1 to 9 years with a WBC count less than $50 \times 10^9/L$. In 1995, NCI-SR patients were estimated to have EFS rates of approximately 80% and the remaining high-risk (NCI-HR) patients were estimated to have EFS of approximately 65%.

TABLE 76.2 PROGNOSTIC FACTORS IN ACUTE LYMPHOBLASTIC LEUKEMIA

Determinants	Favorable	Unfavorable
White blood cell counts	$<10 \times 10^9/L$	$>200 \times 10^9/L$
Age	1-10 y	<1, >10 y
Gender	Female	Male
Node, liver, spleen enlargement	Absent	Massive
Testicular enlargement	Absent	Present
Central nervous system leukemia	Absent	Overt (blasts + pleocytosis)
FAB morphologic features	L1	L2
Immunophenotype	Pre-B or T	Early T-cell precursor
Ploidy	Hyperdiploidy >50	Hypodiploidy <44
Genetic markers (examples)		
B lineage	Trisomies 4 and 10 t(12;21) (p13;q22) (<i>ETV6-RUNX1</i>)	iAMP 21 <i>IKZF1</i> deletions/mutations t(4;11) (q21;q23) (<i>MLL-AFF1</i>)
T lineage	t(1;14) (p32;q11) (<i>TAL1-TRD@</i>) t(10;14) (q24;q11) (<i>TLX1-TRA@/TRD@</i>) t(11;14) (p15;q11) (<i>LMO2-TRA@/TRD@</i>)	t(10;11) (p13;q14) (<i>PICALM-MLLT10</i>) t(5;14) (q35;q32) (<i>TLX3-BCL11B</i>) t(7;7) or inv7 (p15q34) (<i>HOXA-TRB@</i>)

t(11;19) (q23;p13) (*MLL-ENL*)

Time to remission	<8 d	>28 d
Minimal residual disease (day 28-56)	<10 ⁻⁴	>10 ⁻⁴

In the current era, approximately 85% of children with ALL will present with B-lineage disease and the remainder will present with T-lineage ALL. Two thirds of patients with B-lineage ALL present with NCI-SR features. Notably, the constellation of age and WBC count cannot reliably be used to predict outcome for patients with T-cell ALL, likely reflecting the different genomic and subsequent biochemical landscape of these malignancies. However, the unique biologic features of T-cell disease, the failure of prognostic factors effective in precursor B-cell ALL to predict outcome in T-cell ALL,⁴¹ the differing patterns of MRD between B- and T-lineage disease,⁴² and the advent of T-cell-specific therapies^{43,44} all argue for the separate stratification of T-cell ALL in classification and treatment, an approach that has been adopted by many cooperative childhood leukemia groups.

In addition, genomic factors appear to be increasingly relevant for older adolescents and young adults with B-lineage ALL, and recent discoveries may affect not only prognosis but therapy. Finally, for patients less than 1 year of age with B-lineage ALL, the most important adverse prognostic factor remains the presence or absence of a rearrangement (not deletion) in the mixed lineage leukemia (MLL) gene, which is most commonly seen in infants less than 3 months of age.

P.1620

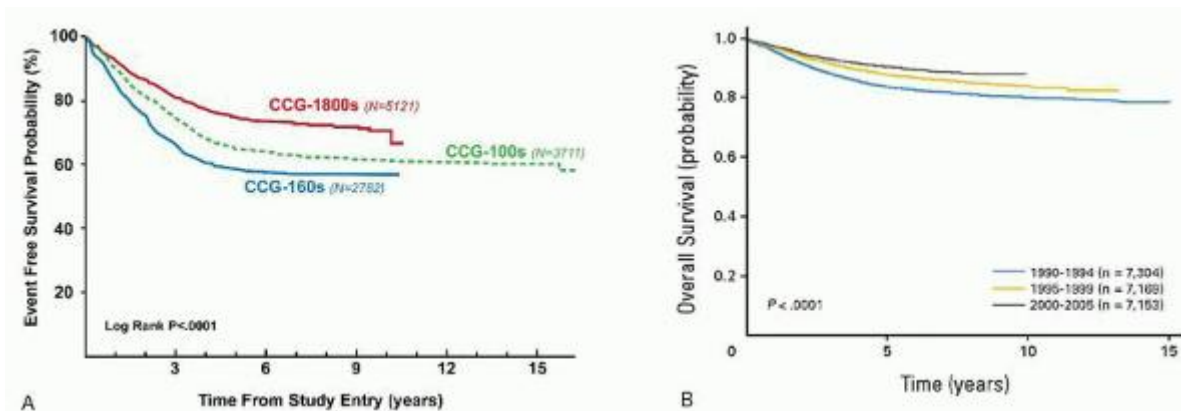

FIGURE 76.3. Survival by treatment era for patients enrolled in Children's Oncology Group trials. A: Earlier trials of Children's Cancer Group: CCG-160s, 1978 to 1983; CCG-100s, 1983 to 1988; CCG-1800s, 1989 to 1985. B: Overall survival probability by treatment era for patients enrolled onto Children's Oncology Group trials in 1990-1994, 1995-1999, and 2000-2005. (With permission from Hunger SP, Lu X, Devidas M, et al. Improved Survival for Children and Adolescents With Acute Lymphoblastic Leukemia Between 1990 and 2005: A Report From the Children's Oncology Group. *J Clin Oncol* 2012; 30:1663-1669.)

The successful intensification of therapy for high-risk ALL has weakened the power of many historically used adverse predictive factors (Fig. 76.4). Although the NCI-Rome criteria represented a major advance in risk classification of childhood ALL, these criteria did not adequately take into account more current biologic features, such as molecular genetic alterations, that likely contribute to the age and presenting WBC count. In addition other powerful predictors of outcome include early response to therapy, as measured by either flow cytometric or polymerase chain reaction methodologies to detect minimal residual disease (MRD). In particular, the strongest predictor of outcome for B-lineage disease across all studies in multivariable analyses is the presence or absence of MRD at the end of the first or second phase of therapy. Indeed, many of the large international consortia have devised complex algorithms to direct therapy, the separate components of which will be presented and then reintegrated into current risk stratification schemes used by the major consortia groups.

Molecular Genetic Alterations Contributing to Modern Risk Stratification

The prognostic significance of various genetic features of leukemic blasts has long been known (Fig. 76.5). In particular, very high risk features for relapse include the presence of the BCR/ABL, or Philadelphia chromosome (3% of B-lineage patients), extreme hypodiploidy (less than 44 chromosomes or a DNA index of less than 0.81; 3% of B-lineage patients), and intrachromosomal amplification of 21 (iAMP21; 1% to 3% of B-lineage patients).^{45,46,47,48,49,50} Recent analyses of 610 patients with Ph-positive ALL who did not receive tyrosine kinase inhibitor (TKI) therapy and who were treated between 1995 and 2005 revealed improved 7-year overall survival in contrast to those who were treated between 1986 and 1996 (OS $44.9 \pm 2.2\%$ vs. $36.0 \pm 2.0\%$, $P = 0.017$).⁴⁶ Therapeutic benefit was seen with the use of maximally intensive, myeloablative HSCT. However, the addition of continuous imatinib, a TKI to the backbone of dose-intensive chemotherapy in COG AALL0031 demonstrated for the first time that adding a targeted agent could provide a survival benefit for a disease that was otherwise only optimally treated using HSCT.^{45,51} (See Philadelphia chromosome-positive ALL in “Unique Patient Subgroups.”)

Similar improvements in outcome have not been established for patients diagnosed with hypodiploid ALL. Identified through either characteristic karyotype findings or DNA indices, rare cases of near-haploid ALL may escape detection due to the presence of a double hypodiploid clone, leading to “masked” near haploidy or hypodiploidy. However, in these cases, one clue may be the retention of two or four copies of chromosome 21, as this chromosome is never lost in a true hypodiploid genome. Experienced cytogenetic review can aid in the identification of these cases. Recent discoveries in the molecular genetics of hypodiploid ALL reveal a high frequency of genes regulating the RAS pathway (NF1, NRAS, KRAS, PTPN11, FLT3, and PAG1), IKZF3 (encoding the lymphoid transcription factor), and a histone gene cluster at 6p22 in near haploid ALL (<32 chromosomes), and a similarly high proportion of TP53, RB, and IKZF2 mutations in low hypodiploid ALL (32 to 39 chromosomes).⁵² Currently, although no specific targeted agents are known directly to inhibit the various perturbed pathways listed above, additional work is being performed in preclinical models in order to further identify optimal therapeutic strategies.

Intrachromosomal amplification of a region on chromosome 21 has also been associated with poor prognosis by several groups, with EFS rates below 60%.^{48,49,50} The detection of iAMP21 is relatively easy to distinguish using fluorescence-in-situ hybridization assays which are frequently performed to detect the ETV6/RUNX1 fusion gene. In these cases, not only is the favorable ETV6/RUNX1 fusion absent, but ≥ 5 RUNX1 (4 or more on a derivative chromosome) signals are present, signifying this amplification.

Although the poor outcomes of infants harboring MLL translocations have long been established,⁵³ the outcomes for older patients have been controversial. Recent data from the COG on the outcomes of 155 patients older than 1 year (2.2% of the entire population studied) reveal that the majority of these patients present with NCI-HR features (4.3% of NCI-HR vs. 1.1% of NCI-SR patients). More than half of the MLL rearrangements were t(4;11), and the majority of the remainder were t(11;17) (16%), t(3;11) or t(11;19) (13% each). Although MLL-rearranged patients did poorly overall compared with non-MLL-rearranged patients, the presence of an MLL rearrangement was not statistically significant in a multivariable model. Instead, among MLL-rearranged patients who had a rapid response to induction therapy, EFS rates approached 81.1%, considerably better than anticipated. It should be noted, however, that in these clinical trials (AALL0331 and AALL0232), patients with MLL rearrangements were treated with maximally intensive augmented BFM therapy, thus illustrating the concept of “treating” away adverse prognostic factors.

Likewise, several leukemic blast genetic factors have been shown to be strong predictors of favorable outcomes among many consortia, including the ETV6/RUNX1 (formerly TEL/AML1) translocation and the presence of trisomy 4 and 10. Fortunately, these are some of the most common genetic features that occur in childhood ALL, with ETV6/RUNX1 occurring in approximately

P.1621

25% and trisomy 4 and 10 occurring in approximately 18% of any risk childhood ALL. Some groups do risk stratify based on the presence of either or both of these factors; however, a multivariate analysis performed on >2,000 COG 9900 patients revealed that double trisomy of 4 and 10 retained independent significance whereas ETV6/RUNX1 did not. However, among patients with these genetic features and a rapid response to induction therapy within the first week, more than 98% were long-term survivors, leading COG investigators to incorporate response with leukemia-specific genetic factors in their current approaches to risk stratification.

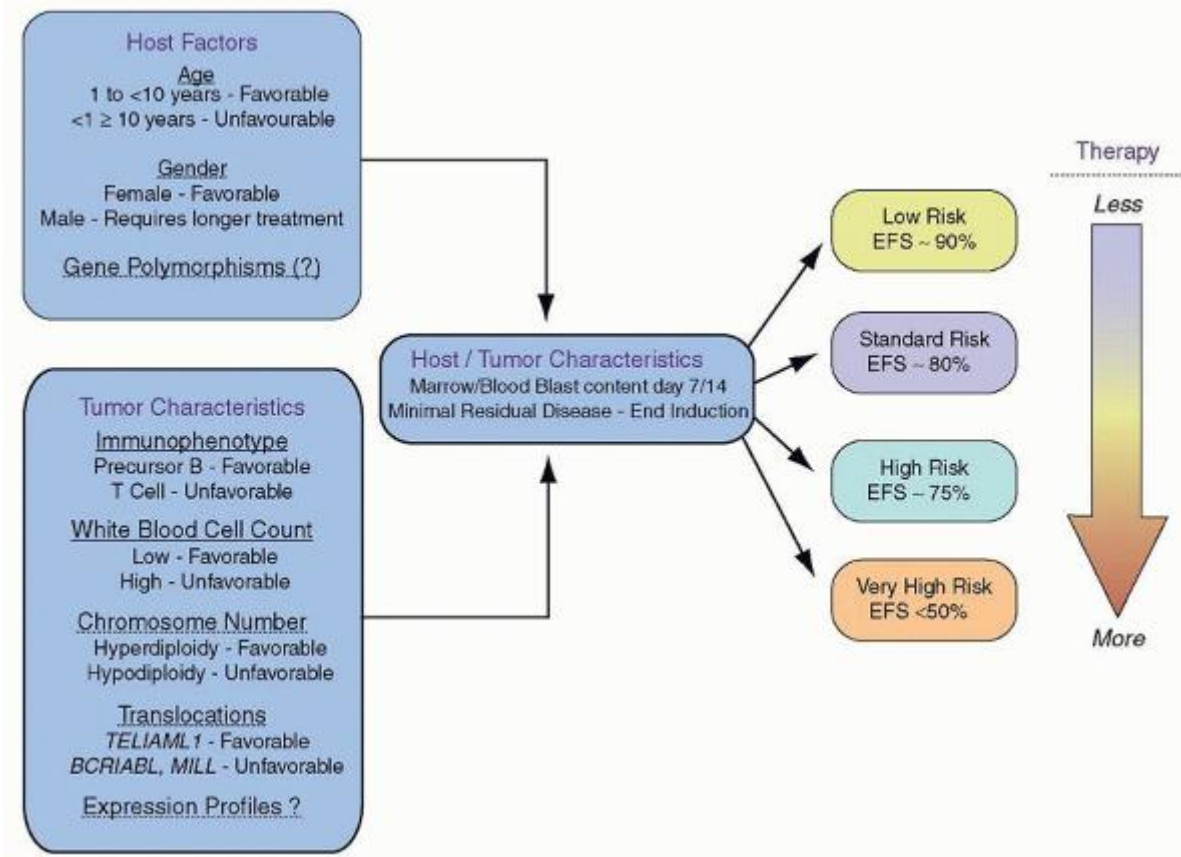

FIGURE 76.4. Risk-group stratification in childhood ALL in 2005. A combination of clinical and biological features along with treatment response was used to select therapy. Children in lower-risk groups received less intensive therapy than those in higher-risk groups. (With permission from Carroll WL, Raetz EA. Building better therapy for children with acute lymphoblastic leukemia. *Cancer Cell* 2005;7:289-291.)

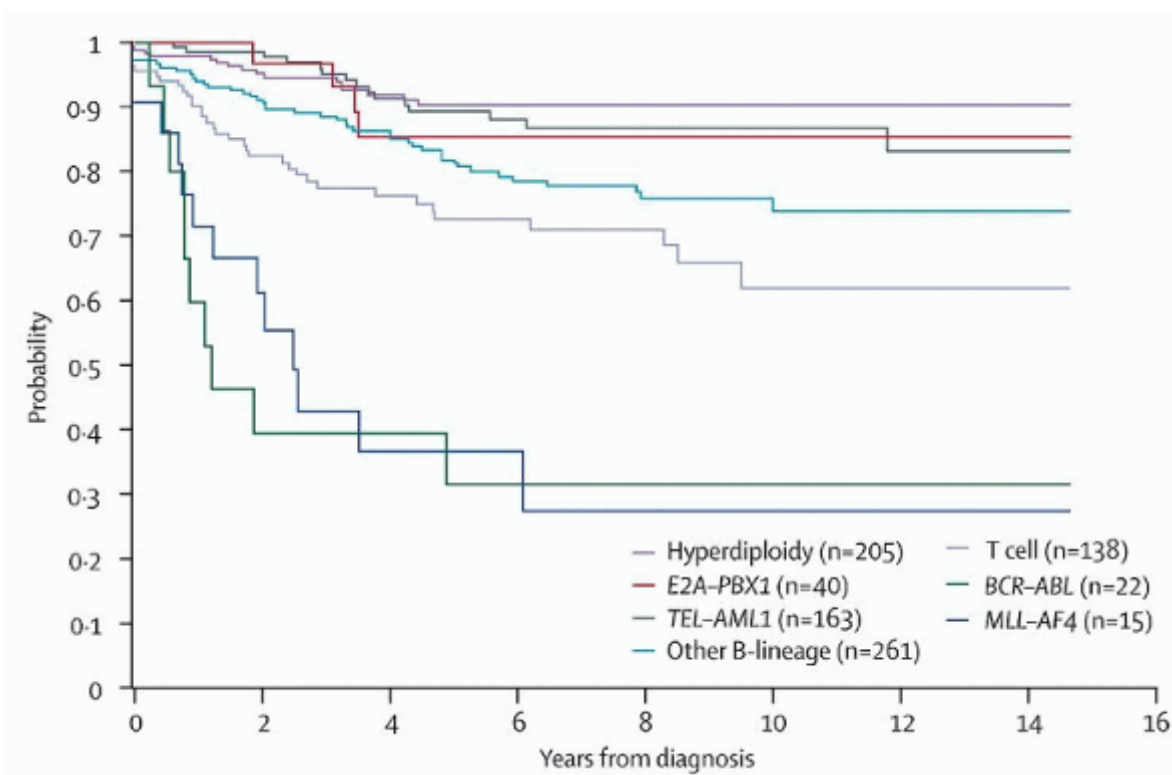

FIGURE 76.5. Kaplan-Meier event-free survival according to biologic subtypes. (With permission from Pui CH, Robison L, Look TA. Acute lymphoblastic leukemia. *Lancet* 2008;371:1030-1043.)

Additional genetic factors that may affect risk stratification and therapy in the future, and are thus beyond the scope of this chapter include those patients who have been recently identified to display a Ph-like gene expression profile (GEP) without harboring BCR/ABL (15% of NCI HR patients). These patients frequently harbor genomic rearrangements in CRLF2 with subsequent overexpression of the TSLP receptor, JAK family mutations, or novel kinase fusion genes. It is important to note that the Ph-like GEP is an independently poor prognostic factor in multivariable analyses when analyzed among NCI HR patients treated on AALL0232, and thus supports identifying alternative approaches, similar to the TKI+ chemotherapy approach used for Ph+ ALL, to maximize outcomes for these patients.^{53a}

Response to Induction and Minimal Residual Disease

Response to induction has long been valued as a predictor of outcome. In 1983, investigators in the Berlin-Frankfurt-Münster (BFM) group evaluated the use of a 7-day prophase of prednisone and a single dose of intrathecal methotrexate to determine which patients should receive more intensive therapy. Prednisone poor responders (PPR), or those who had more than 1,000 circulating blasts day 8 of therapy, comprised 10% of their population and had an outcome that was 50% as good as the prednisone good responders (PGR). In subsequent protocols beginning in 1986, therapeutic questions were asked of the PPR versus PGR group, and this continues currently. In parallel efforts, the legacy

P.1622

Children's Cancer Group (CCG) also determined that delivering augmented therapy to those NCI HR patients with a poor bone marrow morphology response (day 7 M2 (5% to 25% blasts by morphology) or M3 (>25% blasts by morphology) improved their outcome.⁵⁴

The technological ability of measuring response to induction using residual blasts grew out of these initial observations. The ability to detect small numbers of leukemic cells in peripheral blood or bone marrow samples from patients in clinical remission by highly sensitive methods such as the polymerase chain reaction^{55,56,57,58,59} or multiparametric flow cytometry^{60,61,62} has enabled the monitoring of MRD, with the possibility of intensifying therapy for patients at higher risk of relapse. A number of studies have demonstrated the ability to identify impending relapse in subsets of patients, based on correlation of detection of MRD during or following completion of therapy.^{55, 56, 57} and ^{58,63} Although variations in the sensitivity and specificity of the methods used to detect and to quantify MRD, as well as questions raised by the

unexpected finding of persistent genetic abnormalities related to the leukemic clone in patients in apparent sustained remissions^{58,64,65} initially delayed the implementation of MRD assessment in patient management, recent studies using improved methodologies have shown that detection of MRD by either multiparametric flow cytometry analysis of leukemia-associated antigens^{66,67,68} or polymerase chain reaction detection of leukemia-specific immunoglobulin and T-cell receptor rearrangements^{61,69, 70} and ^{71,72} definitively correlates with outcome. Indeed, the presence of MRD early in the treatment of ALL patients is highly prognostic of outcome and currently is a key variable to determine the intensity of postinduction therapy for many groups. In the COG 9900 series of clinical trials, end induction bone marrow MRD and day 8 peripheral blood MRD were the most powerful predictors of outcome in a multivariable analysis.⁶⁸ It should be noted, however, that MRD is not the sole predictor of outcome in this model; NCI risk group and genetic factors also remain prognostic, thus justifying the current approach that the COG is using in determining risk stratification. Other groups, including the St. Jude Children's Research Group (SJCRH) and the Dana-Farber Cancer Institute (DFCI) incorporate measurements of MRD at the end of induction to intensify patients for additional therapy. Despite MRD being the most powerful predictor of outcome, up to 50% of children who relapse do not have evidence of disease using these sensitive methodologies, implying that additional features, such as critical genetic lesions, affect outcome.

TABLE 76.3 OVERVIEW OF THE AALL08B1 CLASSIFICATION SYSTEM FOR B-PRECURSOR ALL

Risk Group (% pts)	Low (15%)	Average ^a (36%)				High ^b (25%)		Very High (25%)		
Projected 5-year EFS	>95%	90-95%				88-90%		<80%		
NCI risk group	SR	SR	SR	SR	SR	HR (<13 years)	HR	HR (≥13 years)	SR or HR	
Favorable genetics ^c	Yes	Yes	No	Yes	No	Any	No	Any	Any	Any
Unfavorable Characteristics ^d	No	No	No	No	No	No	No	No	No	Yes
Day 8 PB MRD	<0.01%	≥0.01%	<1%	Any	≥1%	Any	Any	Any	Any	Any
Day 29 BM MRD	<0.01%	<0.01%	<0.01%	≥0.01%	<0.01%	<0.01%	≥0.01%	≥0.01%	<0.01%	Any

BM bone marrow; HR, high risk; MRD, minimal residual disease; PB, peripheral blood; SR, standard risk.

^a NCI SR patients who are CNS2 may be included in an average risk, but will not be eligible for the low risk arm.

^b All patients with testicular leukemia will be assigned as HR at start Induction, but may change to VHR if Day 29 MRD ≥0.01% or unfavorable characteristics are present.

^c “Yes” is defined as the presence of double trisomy 4 and 10 or *ETV6-RUNX1* fusion.

^d Consists of patients with CNS3, hypodiploidy (<44 chromosomes and/or DNA index <0.81), iAMP21, Induction failure (m3 marrow Day 29), or *MLL* rearrangement (not *MLL* deletion). *BCR-ABL1* positive patients are eligible for a separate Ph+ ALL study.

Adapted with permission from Hunger SP, Loh ML, Whitlock JA, et al. Review Children's Oncology Group's 2013 blueprint for research: acute lymphoblastic leukemia. *Pediatr Blood Cancer* 2013;60: 957-963.

The clinical use of MRD at the end of the first phase of therapy (traditionally deemed “induction”) or the second phase of therapy (“consolidation”) remains somewhat consortium dependent. In T-cell ALL, the prognostic significance of MRD

appears in at least one report to be more powerful at the end of the second phase of therapy than at the end of the first phase.⁷³

Finally, outcomes for the small number (<3%) of pediatric patients who fail to attain remission following induction therapy, although predictably poorer than other patients, are not as dismal as might be expected.⁷⁴ An intergroup study of 1,041 patients who failed induction reported a 10-year survival of 32±1%. Age ≥10 years, T-cell leukemia, the presence of 11q23 rearrangement, and ≥25% blasts at end of induction had a poor outcome. However, children <6 years of age with precursor B-ALL and without adverse genetics had a 10-year survival at 72±5% when treated with chemotherapy only. Patients with T-cell leukemia had improved survival with allogeneic HSCT.

Current Approaches to Staging/Stratification

Based on the collective information above, the COG has developed a risk-stratification system that incorporates key clinical features including National Cancer Institute (NCI) risk group⁷⁵ [Standard Risk (SR): age 1 to 9.99 years and initial WBC count <50 × 10⁹/L; High Risk (HR): age 10+ years and/or initial WBC ≥50 × 10⁹/L], immunophenotype, presence/absence of central nervous system or testicular leukemia, presence/absence of specific sentinel genetic lesions [good risk: ETV6-RUNX1 fusion or hyperdiploidy with trisomies of chromosomes 4 and 10; poor risk: MLL-rearrangements (MLL-R), hypodiploidy, intrachromosomal amplification of chromosome 21 (iAMP21), Philadelphia chromosome positive (Ph+) ALL], and early minimal residual disease response for risk stratification and treatment allocation.^{51,68,76} The current risk stratification system (AALL08B1) builds on that developed for the first generation COG ALL trials (AALL03B1) with key differences being changing the MRD threshold used to define poor response from ≥0.1% (AALL03B1) to ≥0.01% (AALL08B1), and incorporating day 8 peripheral blood [and day 29 bone marrow (BM)] MRD measurements while eliminating day 8/15 BM morphology⁷⁷ (Table 76.3).

P.1623

TREATMENT

Over successive decades dating back to the 1950s, there has been continued progress in treating children, adolescents, and young adults with newly diagnosed ALL and overall 5-year survival rates now reach 90%.⁵ Table 76.4 outlines outcomes from recent trials conducted internationally.^{78,79,80,81} The mainstay of treatment is a 2- to 3-year schedule of multiagent chemotherapy generally divided into induction, intensification, and maintenance phases of treatment. An essential component of treatment is presymptomatic CNS therapy and this is accomplished with intrathecal and systemic chemotherapy with the growing trend of limiting the use of cranial irradiation. In recent years improvements in ALL therapy have resulted from further refinements in risk allocation with the successful application of MRD testing and improvements in supportive care. Outcomes have continued to improve as treatment with standard agents is optimized and new targeted therapies are introduced, such as TKIs for the treatment of Ph+ ALL. Ongoing studies by several groups are seeking to further refine elements of ALL therapy including corticosteroid formulation and dosing during induction, frequency of vincristine/steroid pulses in maintenance, the optimal use of asparaginase and methotrexate (MTX) during the intensification phase of treatment, and further reductions in the use of cranial irradiation. The definition of additional high-risk features from emerging genomic discoveries also offers promise for continued improvements in risk stratification in the future. Challenges still remain, however, for several high-risk subgroups, which include the age spectrum of infant and adolescent and young adult (AYA) ALL as well as children with unfavorable blast cytogenetics, induction failures, Down syndrome, T-ALL, and relapsed ALL. As the number of childhood ALL survivors is increasing, several initiatives are also underway to better understand, prevent, and treat sequelae from ALL therapy.

ALL therapy is generally divided into phases, namely, induction, intensification, and maintenance. The goal of induction is hematologic remission, the eradication of all microscopically detectable leukemia with recovery of peripheral neutrophils and platelets. Remission induction in ALL is aided by the availability of three very active drugs with minimal myelotoxicity: vincristine, a glucocorticoid (usually prednisone or dexamethasone), and L-asparaginase [native or “PEGylated” (modified with polyethylene glycol)]. The goal of intensification, or consolidation, is presymptomatic CNS treatment and improvement in the quality of marrow remission. Postinduction intensification has been a productive strategy for enhancing cure rates over the past 30 years. Persistence of detectable MRD after several weeks of intensification is a poor prognostic sign.^{71,73,84} The goal of maintenance is the preservation of remission. Childhood ALL is unique in its requirement for prolonged (2 to 3 years) therapy of only modest intensity.

TABLE 76.4 TREATMENT RESULTS FROM SELECTED TRIALS IN CHILDREN WITH ALL

Study Group	Years of Study	Patient Numbers	Age Range in Years	% T-ALL	5-Year Outcome	
					EFS (% ± SE)	OS (% ± SE)
AIEOP-95 ⁷⁸	1995-2000	1,743	0-18	11	75.9 (1.0)	85.5 (0.8)
BFM-95 ⁷⁹	1995-1999	2,169	0-18	13	79.6 (0.9)	87.0 (0.7)
COG ⁵	2000-2005	7,153	0-21	7	NA	90.4(0.5)
DCOG-9 ⁸²	1997-2004	859	1-18	11	80.6 (1.4)	86.4 (1.2)
UKALL 97/99 ⁸³	1999-2002	938	1-18	11	80.0 (1.3)	88.0 (1.1)
DFCI-00-01 ⁸⁰	2000-2004	492	1-18	11	80.0 (2.0)	91.0 (1.0)
NOPHO-2000 ⁸¹	2002-2007	1,023	1-15	11	79.4 (1.5)	89.1 (1.1)
SJCRH 15 ⁴	2000-2007	498	1-18	15	85.6 (2.9)	93.5 (1.9)

AIEOP, Associazione Italiana di Ematologia ed Oncologia Pediatrica; BFM, Berlin-Frankfurt-Münster; DCOG, Dutch Childhood Oncology Group; DFCI, Dana-Farber Cancer Institute consortium; EFS indicates event-free survival; NA, not available; NOPHO, Nordic Society of Pediatric Hematology and Oncology; SJCRH, St Jude Children's Research Hospital; and UKALL, United Kingdom Medical Research Council Working Party on Childhood Leukaemia.

Adapted from Pui CH, Mullighan CG, Evans WE, et al. Pediatric acute lymphoblastic leukemia: where are we going and how do we get there? *Blood* 2012;120:1165-1174.

Outcome is usually described in terms of overall survival (OS), EFS, or disease-free survival (DFS). Overall survival is simply the cumulative percentage of living patients, with or without intervening leukemic relapse or second malignant neoplasm. EFS is the cumulative fraction or percentage of patients surviving from time of diagnosis with no intervening adverse event such as failure to achieve remission, death, relapse, or second malignant neoplasm. DFS includes only patients who achieve remission, excluding remission deaths and remission failures, and describes the cumulative fraction or percentage of patients surviving with no intervening adverse event such as remission death, relapse, or second malignant neoplasm. As cure rates have increased, attention has broadened to include late sequelae of therapy that may have a lasting impact on quality of life, such as neurotoxicity, osteonecrosis, anthracycline cardiotoxicity, and secondary malignant neoplasms.⁸⁵

Primary Treatment

Remission Induction

The goal of induction therapy is to rapidly eliminate all leukemia cells using agents with different mechanisms of action. Although the majority of children with ALL will achieve remission with vincristine and a corticosteroid alone, the addition of asparaginase and/or an anthracycline raises the remission induction rate to 98% to 99%.⁸⁶ Current practice utilizes 3 to 5 systemic agents in induction over 4 to 6 weeks. The COG and other groups treat children with NCI standard risk ALL with a 3-drug (vincristine, dexamethasone, PEG-asparaginase) induction and reserve the addition of an anthracycline for NCI high risk and T-ALL patients, however, other groups use 4 to 5 drug induction regimens for all patients.^{4,79,83,87, 88} and ⁸⁹ A 3-drug induction for SR ALL has proven very effective, provided children receive later intensification of therapy.⁹⁰ With contemporary supportive care measures, induction death rates from toxicity are typically 1% to 2%.

Corticosteroids are the mainstay of induction regimens and prednisone (PRED) or dexamethasone (DEX) are most commonly

P.1624

used. Advantages of DEX include better CNS penetration and greater in vitro activity against ALL blasts, and DEX has been used with increasing frequency in recent trials.⁹¹ Compared to historical controls who received PRED, the Dutch ALL VI trial showed 80% versus 66% 3-year EFS advantage for DEX for standard-risk patients.⁹² The CCG-1922 study examined the same question in a randomized trial for children with NCI standard risk features and DEX reduced the CNS relapse rate and also was associated with superior EFS at 4 years (88% vs. 81%).⁹³ A similar advantage for DEX was observed in the MRC

ALL-97-99 trial.⁹⁴ Based on these results, presently within the COG, DEX is used as the induction steroid as part of a 3-drug induction containing vincristine and PEG-asparaginase for children with standard risk precursor B-cell ALL.

Corticosteroid formulation and dosing have also been studied in NCI high-risk precursor B-cell ALL. The recently completed COG AALL0232 trial compared PRED 60 mg/m²/day for 28 days to DEX 10 mg/m²/day for 14 days during induction in patients ages 1 to 30 years and high-dose methotrexate (HD MTX) versus escalating methotrexate plus asparaginase without leucovorin rescue (MTX-ASNase) during interim maintenance. Due to higher than expected rates of osteonecrosis (ON) among 10+ year olds on the DEX arm, the study was amended to restrict the steroid randomization to children <10 years of age. For the patients <10 years, DEX during induction had superior EFS compared to PRED, when combined with high-dose methotrexate during interim maintenance.⁹⁵ No benefit of DEX over PRED during induction, however, was observed among patients 10+ years of age and DEX was associated with a much higher risk of ON in the older age group. Based on these results, presently within the COG, DEX is used as the induction steroid for children <10 years of age and high-risk B-cell precursor (BCP) ALL and PRED is used for children and adolescents 10+ years of age within the context of a 4-drug induction also containing daunomycin. Benefits of DEX during induction have also been observed in T-ALL with good initial prednisone responses, where when compared to PRED, DEX during induction was associated with threefold reduction in the incidence of relapse in the AIEOP-BFM 2000 trial.⁹⁶

Some studies, however, have not shown a benefit of DEX compared to PRED.^{92,97} A possible explanation for these differences could be related to the DEX to PRED ratio. Studies using a ratio of 1:5 to 1:7 have shown a benefit for DEX whereas those using a DEX to PRED ratio exceeding 1:7 have shown similar outcomes with both formulations.⁹¹ Important concerns have been raised about higher toxicity rates associated with DEX,⁹⁸ especially when it is combined with an anthracycline^{99,100} however, in the recently completed UKALL 2003 study, DEX at a dose of 6 mg/m²/day × 28 days was well tolerated within the context of a 4-drug induction.¹⁰¹

L-asparaginase is another common element of most induction regimens for ALL that has been used to treat children with ALL since the 1970s. When native L-asparaginase was combined with vincristine and prednisone in early studies, remission induction rates exceeded 90%.¹⁰² Although not considered an essential amino acid, exogenous asparagine is required by lymphoblasts in vivo. Asparaginase, which deaminates asparagine to form aspartate, is unique among anticancer drugs in that it requires neither activation nor intracellular uptake.

Three different formulations of asparaginase have mainly been used to date: native *Escherichia coli* L-asparaginase, polyethylene glycol conjugated *Escherichia coli* L-asparaginase (PEG-asparaginase), and *Erwinia chrysanthemi* L-asparaginase¹⁰³ and newer formulations are in clinical development. PEG-asparaginase is now used most often in children with ALL and advantages of this formulation include its long half-life, which allows less frequent dosing and reduced immunogenicity.^{104,105} PEG-asparaginase during induction was also associated with more rapid early blast clearance on days 7 and 14 when compared to native *Escherichia coli* L-asparaginase.¹⁰⁴ For individuals who develop hypersensitivity to PEG-asparaginase, *Erwinia chrysanthemi* L-asparaginase is recommended as an alternative, although its half-life is much shorter than that of PEG-asparaginase (0.65 ± 0.13 vs. 5.73 ± 3.24 days),¹⁰³ so more frequent administration is required.¹⁰⁶

Although some patients can be re-treated successfully with PEG-asparaginase with premedication after mild allergic reactions, this is generally not recommended because it can mask the presence of neutralizing antibodies, which reduce asparaginase activity.¹⁰⁷ Historically, asparaginase preparations were all administered intramuscularly due to concerns about the risk for anaphylaxis; however, PEG-asparaginase is now routinely administered intravenously and this has been well tolerated and not associated with greater toxicities.¹⁰⁸

Response and Outcome

The rapidity of response to chemotherapy during induction, whether measured by routine morphologic assessment or by flow-cytometry-based or molecular MRD techniques, is a robust predictor of outcome as it takes into account all aspects of the treatment as well as the unique biologic features of the host and the disease. In any clinical or cytogenetic patient subset, slower initial response to treatment, whether it be the persistence of peripheral blood blasts following intrathecal MTX and a week of prednisone, or marrow blasts >5% by light microscopy after 1 or 2 weeks of multiagent induction therapy, or persistence of marrow blasts by multiparameter flow cytometry or PCR on completion of 4 weeks of induction therapy, predicts an inferior outcome compared to more rapid initial responses^{61,68,84,109, 110, 111, 112} and¹¹³ End-induction bone marrow MRD was shown to be the most important prognostic variable in multivariate analysis for precursor B-cell ALL in recently completed COG protocols,⁶⁸ and peripheral blood MRD 1 week after initiation of therapy is now replacing bone marrow aspirates for early response determination in the newest COG ALL protocols.

Since the benefit of intensifying postinduction therapy for slow early morphologic responses or persistent MRD has been demonstrated,^{4,54} response-based treatment allocation is a common feature of most contemporary ALL protocols. Within

the COG, all children with precursor B-cell who have end induction (day 29) MRD >0.01% using flow-cytometry-based assays are designated very high risk and receive intensified augmented BFM-based therapy postinduction and similar strategies are used by other groups. Failure to achieve marrow remission, that is, marrow blasts <5% by microscopy, portends a poor outcome. About two thirds of patients with induction failure eventually achieve remission, and of these, about one third are cured.⁷⁴ Somewhat better outcomes may be obtained for some patient subsets with induction failures, such as patients with T-ALL, with HSCT in first remission, whereas as others with low-risk features fare just as well with chemotherapy alone.^{74,114,115}

Presymptomatic Central Nervous System Therapy

Presymptomatic treatment of the CNS has been established as an essential component of effective ALL therapy for decades. Between 1967 and 1968, in Study Total V, Pinkel et al. at St. Jude Children's Research Hospital treated 31 children with no evidence of CNS leukemia at diagnosis with 24 Gy cranial irradiation and intrathecal methotrexate. Only three patients had a subsequent CNS relapse, and more than half of patients were long-term disease-free survivors. Between 1968 and 1971, in Study Total VI, Pinkel et al. compared 24 Gy cranial-spinal irradiation with no CNS-directed intrathecal methotrexate and confirmed the results of Total V. In Study Total VII, similar benefit was shown for 24 Gy cranial-spinal irradiation and 24 Gy cranial irradiation

P.1625

with intrathecal methotrexate. In striking contrast to all previous experience, one half of patients remained long-term disease-free survivors.^{116,117}

Since this time, efforts have been underway worldwide to define optimal CNS preventative therapy. Current CNS treatment modalities include cranial or craniospinal irradiation, systemic chemotherapy (e.g., dexamethasone, methotrexate and asparaginase), and intrathecal chemotherapy with any combination of 1 to 3 agents. As concerns about the long-term sequelae from radiation therapy have increased, there has been a growing trend to reduce both the dose and the number of children who receive this treatment modality, such that cranial radiation therapy (CRT) is often reserved for just those at highest risk for CNS relapse, for example, children with T-ALL and high-risk features, those with slow initial responses, or CNS leukemia (CNS3) at diagnosis. Some groups have eliminated CRT altogether for all children with ALL without any decline in outcomes, using regimens with triple intrathecal chemotherapy, dexamethasone, and intermediate- or high-dose methotrexate.^{4,82}

Historically within the COG, the CCG 161 trial showed that intrathecal therapy extended through the 2- to 3-year duration of systemic therapy could replace cranial irradiation and limited intrathecal therapy for lower-risk patients, age 2 to 10 years with WBC <10 × 10⁹/L.¹¹⁸ The CCG 105 trial extended this observation to intermediate-risk children between the ages of 1 and 9 with WBC between 10 and 50 × 10⁹/L, but only when patients received intensified systemic therapy.¹¹⁹ With only less intensive, "standard" systemic therapy, cranial irradiation and limited intrathecal therapy were superior to extended intrathecal methotrexate with no irradiation. In CCG 1882, higher-risk patients, either >10 years of age or with WBC >50 × 10⁹/L, with a rapid initial response to induction therapy, received either 18 Gy cranial irradiation and extended intrathecal methotrexate or additional intrathecal methotrexate with no whole-brain irradiation. All received intensive systemic therapy. The cumulative incidence of isolated CNS relapse was 3.6% for patients not receiving cranial irradiation and 2.3% for patients receiving cranial irradiation.⁵⁴ However, patients receiving additional intrathecal methotrexate had numerically fewer bone marrow relapses, and DFS was similar. Thus, in the presence of effective systemic therapy, cranial irradiation could also be replaced with aggressive intrathecal methotrexate for this largely precursor B-cell ALL population.⁵⁴ When this approach was extended to T-cell ALL patients in CCG 1961, isolated CNS relapse comprised two thirds of initial relapses in the superior "stronger" intensification arms.¹²⁰ An ongoing COG trial has modified the dose of prophylactic radiation in T-ALL according to risk groups: none for low-risk, 12 Gy for intermediate-risk, and 18 Gy for high-risk disease and future reductions in radiation therapy in T-ALL are planned within the COG with optimization of systemic chemotherapy and IT therapy, so that is envisioned that cranial irradiation will be used only for the 10% to 15% or fewer children with T-ALL and high-risk features or CNS disease in the future.

Triple intrathecal therapy with cytarabine, methotrexate, and hydrocortisone (ITT) has also been compared to single-agent IT MTX for prevention of CNS leukemia. Matloub et al. reported a randomized comparison of ITT and single-agent methotrexate therapy with more than 2,000 randomized patients.¹²¹ Although ITT halved the CNS relapse rate, EFS was similar at 5 years, and survival was actually significantly worse because of inferior salvage after bone marrow relapse, which occurred disproportionately in the ITT arm.

In a recent meta-analysis of patients treated on 47 trials with different comparisons of presymptomatic CNS therapy, effective systemic and protracted intrathecal chemotherapy was shown to yield comparable outcomes to that of CRT.¹²² The addition of IV methotrexate was shown to provide additional benefit, reducing rates of both CNS and non-CNS relapse. Although historically CRT provided a benefit with less intensive systemic regimens and few doses of IT therapy, the benefit has not been observed with more contemporary regimens. Furthermore, several comparisons of different doses of cranial radiation showed no benefit from higher doses of CRT.

Traumatic lumbar punctures (>10 RBCs/ μ l) with blasts (TLP+) have been associated with inferior outcomes.^{123,124} Therefore it is important that all possible measures be taken to reduce the risk of bleeding with the initial diagnostic lumbar puncture. The presence of blasts in the CSF but fewer than 5 WBC/ μ l (CNS2) has been linked to a higher risk of CNS relapse by some, but not all, groups.³⁷ Some groups have intensified CNS-directed therapy for CNS2 status and/or traumatic lumbar punctures; however, the COG historically has not and this will allow the prognostic significance of CNS status to be examined within the context of improved systemic chemotherapy on current protocols.

Postinduction Intensification

Postinduction intensification is essential for all patients with ALL; however, there is not a consensus on an optimal regimen or duration of therapy.⁸⁶ Intensification with methotrexate has been a strategy that has been commonly employed and the optimal dose, formulation, and schedule of methotrexate have been studied by several groups internationally over the past decades.^{125, 126, 127, 128, 129, 130, 131, 132, 133, 134, 135, 136, 137} and¹³⁸ The recently completed COG study, CCG-1991, showed a benefit for escalating IV methotrexate without leucovorin rescue compared to oral methotrexate during interim maintenance in standard risk precursor B-cell ALL. The COG recently completed a phase III trial for newly diagnosed NCI high-risk precursor B-cell ALL, which demonstrated the benefit of high-dose MTX (HD-MTX), compared to escalating MTX and asparaginase without leucovorin rescue in this group.¹³⁹ This HD-MTX schedule has been used widely in frontline ALL for many years by groups worldwide.^{140,141} HD-MTX has also been commonly used in children with T-ALL¹⁴² and comparison of HD-MTX versus escalating MTX and asparaginase during interim maintenance is also presently underway within the COG in pediatric patients with newly diagnosed T-ALL. Individualized MTX dosing has been pursued by investigators at SJCRH in an effort to achieve optimal steady-state plasma concentrations and minimize toxicity.⁸⁶ Acute neurologic toxicity has been acceptable and studies are underway to examine late neuropsychological outcomes in patients who receive more intensive systemic MTX therapy.

Asparaginase is another essential element of most ALL intensification regimens and there is extensive clinical experience supporting its use in B- and T-lineage ALL. Since the 1970s, the Dana-Farber Cancer Institute and ALL Consortium has included 20 to 30 consecutive weeks of asparaginase during postinduction consolidation therapy and has demonstrated that this treatment significantly improves long-term EFS.¹⁴³

The DFCI 91-01 showed superior outcomes for patients receiving at least 26 weeks of continuous asparaginase therapy compared to those who received less with 5-year EFS 90% versus 73%, $P = 0.01$, respectively.¹⁴⁴ A similar advantage in disease-free survival was observed in the International BFM Study Group when children with standard-risk ALL were randomized to receive 20 weekly doses of asparaginase.¹⁴⁵ DFCI studies have also compared different asparaginase formulations and the 95-01 trial showed an outcome benefit for weekly native *E. Coli* asparaginase when compared to weekly Erwinia asparaginase, postinduction, perhaps secondary to the shorter half-life of the latter drug.¹⁴⁶ A trial comparing IV PEG-asparaginase with native *E. Coli* asparaginase was recently completed with analyses of the toxicity profiles and outcomes underway.⁸⁹ Children with low-risk B-lineage ALL (ETV6-RUNX1 translocations or triple trisomies present with rapid early responses) were randomized to receive 4 additional doses of PEG-asparaginase postinduction in the COG

P.1626

AALL0331 trial based on in vitro data showing blasts with these features are more sensitive to asparaginase. Analyses of the outcomes of these patients are underway.

Current lines of investigation in optimizing asparaginase therapy include developing measures to detect the presence of neutralizing antibodies that reduce drug activity ("silent inactivation"), further studies to determine the most effective dose and schedule, and measures to reduce the incidence of dose limiting toxicities, the most common of which are hypersensitivity reactions.^{147,148}

Most contemporary ALL protocols also include a delayed intensification phase based on BFM therapy and this has been shown to be beneficial for all patient subgroups. In 1970, investigators from the BFM group introduced a 3-month intensive induction/early intensification phase called Protocol I, which followed a VPLD induction with a segment including

cyclophosphamide, cytosine arabinoside, and 6-MP.¹⁴⁹ In 1976, a second intensification phase, Protocol II, was added that included a reinduction segment of vincristine, dexamethasone, l-asparaginase, and doxorubicin followed by a segment including cyclophosphamide, cytosine arabinoside, and 6-thioguanine. Outcomes improved compared to historical controls, and advantages were most striking for higher-risk patients. EFS was similar whether Protocol II followed immediately after Protocol I or after 2 months' delay. Morbidity was less when intensification was delayed.¹⁵⁰ In the United States, Protocol II was termed "delayed intensification," and a series of studies conducted in the 1980s and early 1990s established the benefit of delayed intensification therapy for both SR and HR subgroups of patients (Fig. 76.6).^{90,149,151, 152, 153} and ¹⁵⁴

A further CCG modification of this therapy, the "augmented regimen," posited that more resistant cells responsible for relapse might need a stronger and more prolonged postinduction intensification. The augmented regimen provided two applications of delayed intensification and four 2-week courses of nonmyelosuppressive vincristine and l-asparaginase during the periods of myelosuppression that invariably follow the cyclophosphamide, cytosine arabinoside, and thiopurine pulses in consolidation (Protocol Ib) and reconsolidation (Protocol IIb). Two courses of five Capizzi I pulses^{155,156} of vincristine, parenteral methotrexate, and l-asparaginase replace the two 2-month courses of oral 6-MP and MTX between consolidation and delayed intensification #1 and between delayed intensification #1 and delayed intensification #2. High-risk patients treated on the CCG-1882 trial with a poor initial response to therapy (i.e., >25% marrow blasts on day 7) were randomized to receive standard or augmented BFM therapy. At 5 years, DFS was 75% for the augmented regimen and 55% for standard intensive therapy (Fig. 76.7).⁵⁴

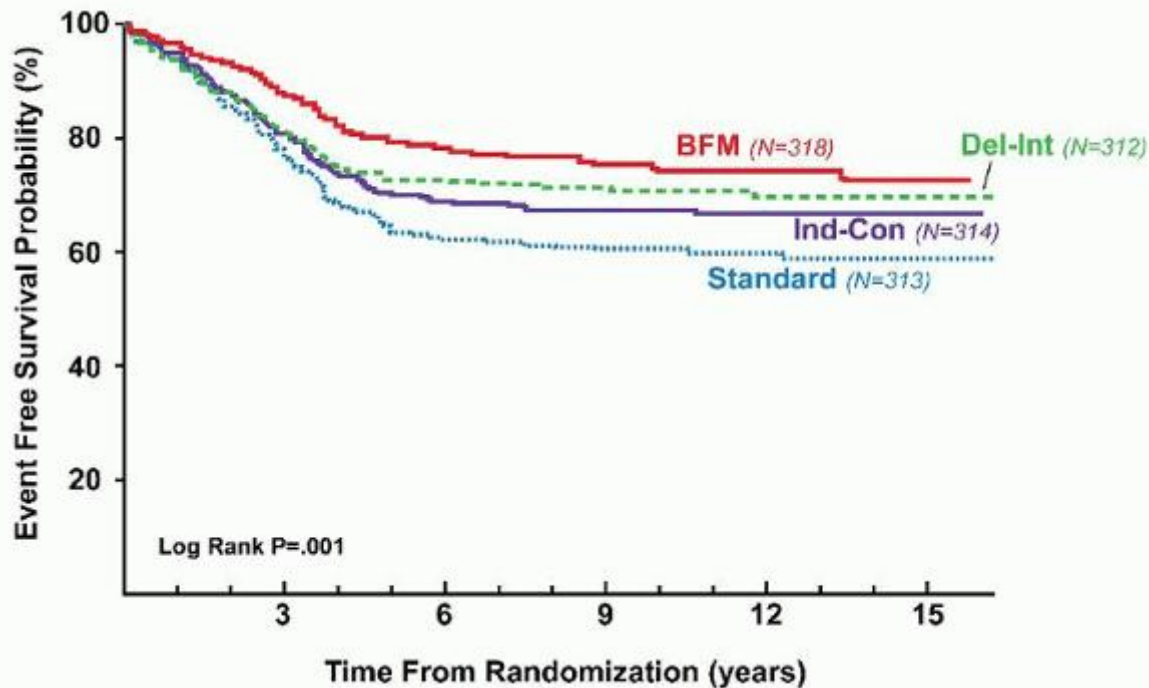

FIGURE 76.6. Impact of intensive induction/consolidation (Ind-Con) and delayed intensification (Del-Int) on event-free survival of children with average-risk acute lymphoblastic leukemia. BFM, both intensive induction consolidation and delayed intensification based on the Berlin-Frankfurt-Münster 76/79 study; standard, neither intensive induction consolidation nor delayed intensification. (Children's Cancer Group-105 study; chair Dr. David G. Tubergen.) (Courtesy of Dr. Harland N. Sather and the Children's Cancer Group, Arcadia, CA.)

In order to assess individual components of intensification approaches, CCG-1961 utilized a 2 × 2 factorial design to compare standard versus augmented BFM-based postinduction therapy as well as standard (1 IM and 1 DI phase) versus increased duration (2 IM and 2 DI phases) in patients with rapid initial responses. Augmented therapy improved 5-year EFS (81% vs. 72%, $P < 0.001$; Fig. 76.8) and survival (89% vs. 83%, $P = 0.003$).¹²⁰ However, longer intensification with a second IM and DI produced no benefit over standard duration with a single IM and DI in rapid responders. The authors suggested there is a window of opportunity to eradicate resistant clones with intensification, but additional intensification was not successful because of drug-resistant disease. A second DI phase also provided no benefit to SR patients who were rapid responders on the CCG 1991 trial⁸⁸ and the recently completed COG AALL0331 trial for standard-risk precursor B-cell

ALL is testing whether augmented BFM-based consolidation is beneficial in this population. Replacing oral MTX, 6-MP, vincristine, and DEX during interim maintenance with vincristine and escalating intravenous MTX improved EFS in CCG 1991.⁸⁸ (Fig. 76.9)

Maintenance Therapy

Daily oral 6-MP and weekly oral or parenteral MTX, with or without pulses of steroid and vincristine, with an extended periodic intrathecal therapy comprise the most common maintenance or continuation regimens. Oral 6-thioguanine (TG) is a more potent thiopurine than mercaptopurine,^{157,158} which has provided the rationale for prior randomized trials comparing the efficacy of MP and TG. The MRC ALL97 trial concluded that TG caused excess toxicity without overall benefit.¹⁵⁹ Children were randomly assigned to either TG or MP during interim maintenance and maintenance therapy and after a median follow-up of 6 years, no differences in EFS or OS were observed. TG conferred a lower risk of isolated CNS disease, however, this was offset by hepatic toxicity. The CCG-1952 trial showed an improvement in EFS in children with standard risk ALL who received TG, however, there was no increase in overall survival and TG-induced veno-occlusive disease of the liver precluded prolonged administration of TG during maintenance.¹⁶⁰ A recent meta-analysis of randomized

P.1627

trials comparing thiopurines also showed that TG did not improve overall EFS, although it may be beneficial in some subsets of patients.¹⁶¹ Given these data, and hepatic toxicity that has been observed with TG, it is now standard practice to use daily oral MP in maintenance.

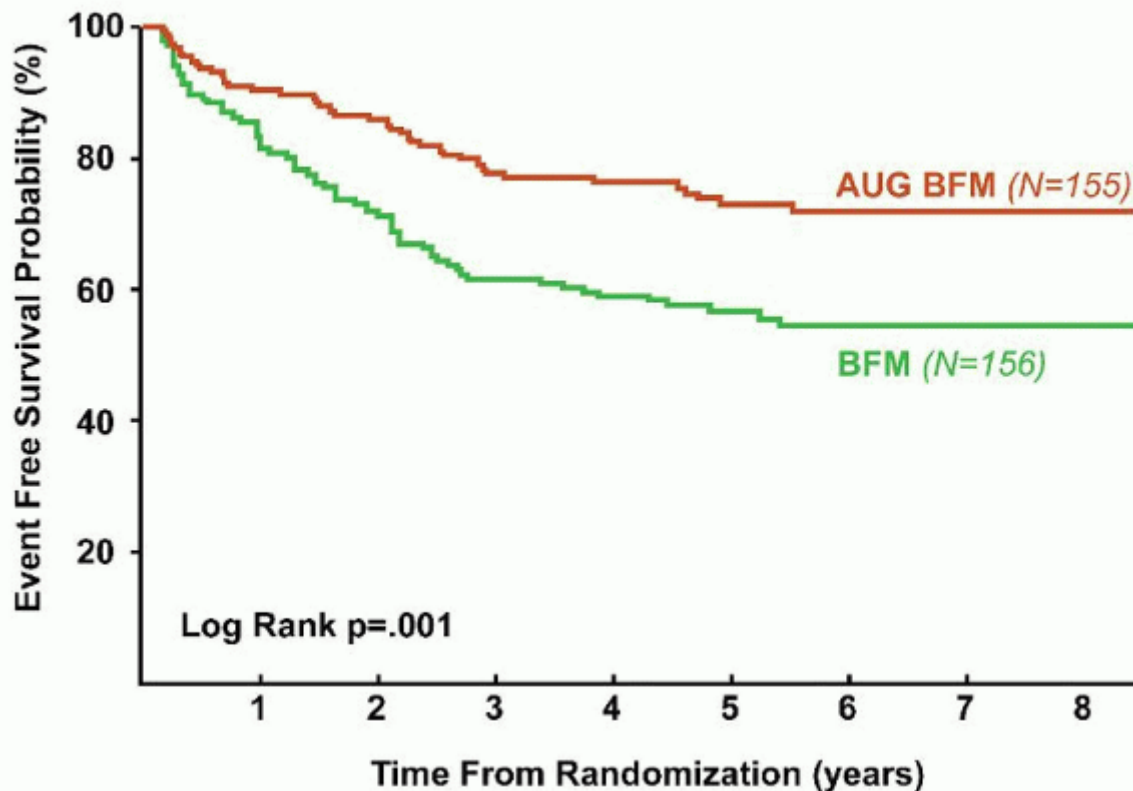

FIGURE 76.7. Benefit of longer and stronger postinduction intensification (augmented BFM) therapy on event-free survival for high-risk ALL and a poor day 7 marrow response. BFM 76/79, standard postinduction intensification (Children's Cancer Group—1882, Chair James B. Nachman). Nachman JB, Sather HN, Sensel MG, et al. Augmented postinduction therapy for children with high-risk acute lymphoblastic leukemia and a slow response to initial therapy. *N Engl J Med* 1998; 338:1663-1671. (Courtesy of Harland N, Sather H, and the Children's Cancer Group.)

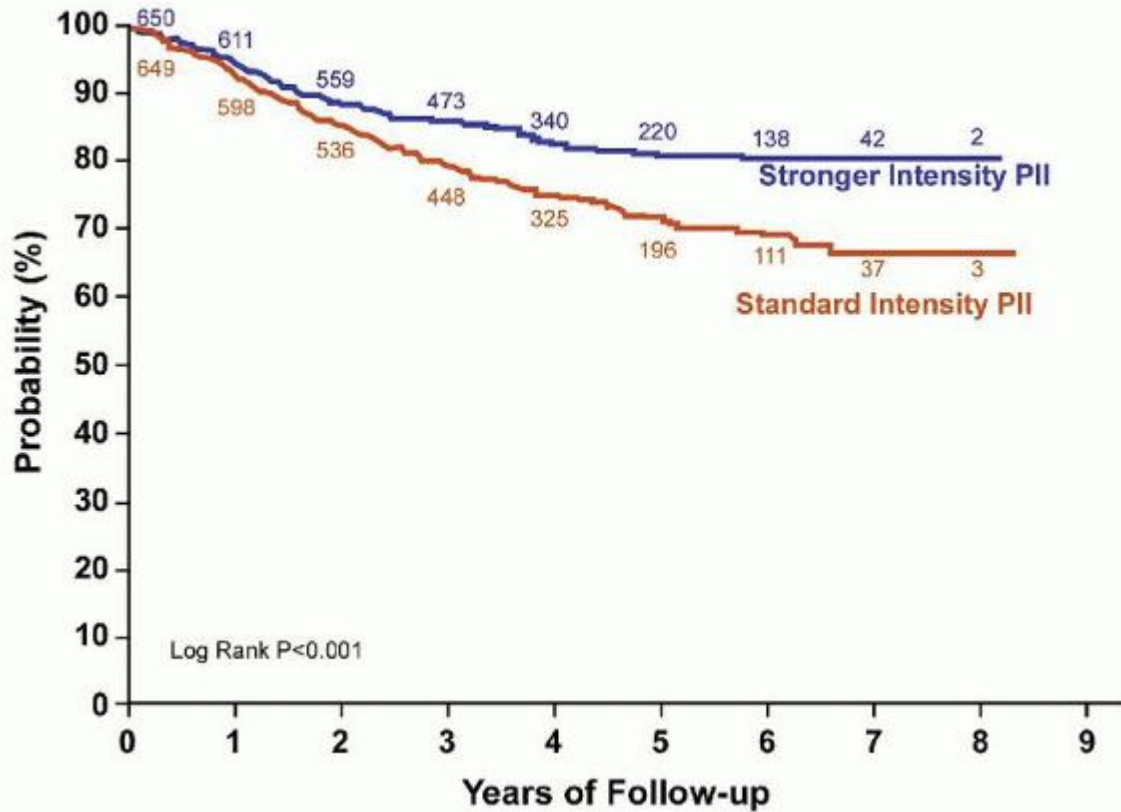

FIGURE 76.8. Event-free survival in patients with high-risk ALL according to the type of postinduction intensification (PII) chemotherapy (CCG-1961). (With permission from Seibel NL, Steinherz PG, Sather HN, et al. Early postinduction intensification therapy improves survival for children and adolescents with high-risk acute lymphoblastic leukemia: a report from the Children's Oncology Group. *Blood* 2008;111:2548-2555.)

Interpatient variations in MP absorption are well known.¹⁶² An association between levels of erythrocyte TG nucleotides and freedom from relapse has been shown.¹⁶³ This observation encouraged attempts to improve outcome by enhancing intracellular TG nucleotide accumulation. Strategies include replacement of oral MP by parenteral MP^{93,164} or by oral or parenteral TG.^{157,158} Tailoring doses of 6-MP and methotrexate has been associated with improved outcomes and ascertaining the genetic polymorphism status of thiopurine methyltransferase helps in that regard.⁸⁶ A number of randomized outcome comparisons have been undertaken. Thus far, intravenous 6-MP has provided no clinical advantage over oral MP in any study.^{93,164}

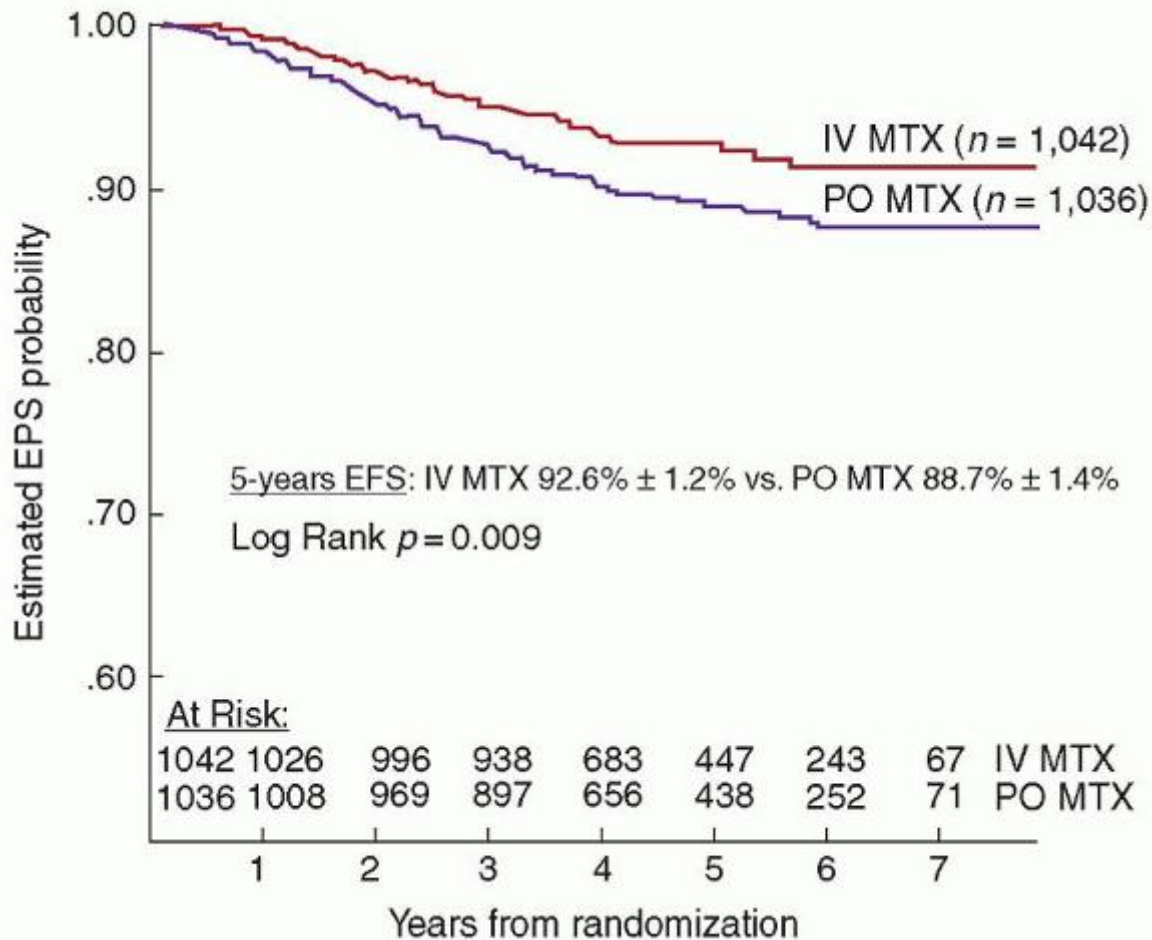

FIGURE 76.9. Event-free survival for standard-risk ALL comparing intravenous methotrexate (IV MTX) to oral (PO) MTX in CCG-1991. (With permission from Matloub Y, Bostrom BC, Hunger SP, et al. Escalating intravenous methotrexate improves event-free survival in children with standard-risk acute lymphoblastic leukemia: a report from the Children's Oncology Group. *Blood* 2011;118:243-251.)

Most maintenance therapy is continued until children receive a minimum of 2 years of therapy from the time remission is achieved. Although in some groups, such as the COG, treatment for boys is 1 year longer than girls, in most other groups, the duration of maintenance therapy is the same among both genders. Inferior outcomes have been noted when the treatment duration has been shortened to 18 months; however, no benefit to extending maintenance therapy beyond 3 years has been observed. Despite effective postinduction intensification, the BFM Group found that 18 months of treatment was inferior to 24 months (83% vs. 77%).¹⁴⁹ The Childhood ALL Collaborative Group compiled 16 randomized trials that compared shorter and longer therapy in a meta-analysis that included 3,861 patients.¹⁶⁵ Longer therapy provided a small but statistically significant 3.3 percentage-point improvement in EFS and a statistically not significant 0.8 percentage-point improvement in survival. An advantage for longer therapy was found in the 24- versus 18-month and 36- versus 24-month comparisons, but not in the 60- versus 36-month comparisons. Longer therapy provided statistically significant reductions in bone marrow relapse (26%) and testicular relapse (36%), but patients on longer therapy were more likely to die in remission (2.7% vs. 1.2%). Contrary to popular memory, boys and girls derived a similar small benefit from longer therapy. Of course, this type of analysis cannot determine the value of duration of continuation therapy in regimens not studied, but cross-study consistency lends weight to its conclusions. The debate continues as to whether more effective postinduction intensification will allow briefer maintenance therapy or, conversely, will add value to longer therapy as more patients are brought to 24 months in remission. Optimal duration of therapy may differ among subsets, being more important in standard-risk patients and less important in older or T-cell patients.

Vincristine and corticosteroid pulses are a component of maintenance therapy in many ALL protocols; however, the benefit of these pulses is controversial within the context of contemporary, more intensive therapy. Furthermore, there has been growing concern about the potential toxicities of pulse therapy including ON, mood disturbances adversely

affecting quality of life, obesity, and peripheral neuropathy. Although studies from earlier treatment eras have shown a benefit for vincristine/corticosteroid pulses in maintenance,¹¹⁸ a more recent review involving more than 5,000 children with ALL has called the benefit of pulse therapy into question with current regimens where early therapy has been intensified.¹⁶⁶ In a recent multicenter randomized trial in children treated with a BFM-based regimen for intermediate risk ALL, no benefit for the addition of 6 pulses of vincristine and dexamethasone during maintenance therapy was observed.¹⁶⁷ Among younger children, when pulses are used in maintenance therapy, DEX is preferred over PRED due to the outcome benefits that have been reported.^{93,94} PRED is used during maintenance among older patients in some groups due to the concerns for a heightened risk of ON with DEX.¹⁶⁸ The COG is currently investigating the use of less frequent vincristine/corticosteroid pulses (every 12 weeks vs. every 4 weeks) during maintenance in children with standard risk ALL on the AALL0932 protocol.

Variations in the common continuation therapy program are found in the DFCl studies,^{169, 170} and¹⁷¹ the NY I and NY II protocols,^{172,173} and Brazilian¹⁷⁴ and Japanese studies.¹³⁴ The Japanese Children's Cancer and Leukemia Study Group compared MP 175 mg/m²/day days 0 to 4 and intravenous methotrexate 225 mg/m² day 14 with daily oral MP 50 mg/m² and weekly oral methotrexate 20 mg/m². All patients received vincristine and prednisone pulses every 4 weeks and intrathecal methotrexate every 12 weeks. The 5-year EFS was 73% for the intermittent alternating regimen and 50% for the conventional regimen. The conventional regimen had more infections and late marrow, CNS,

P.1628

and testicular relapses.¹³⁴ The Brazilian Childhood Cooperative Group protocol ALL-99 compared standard daily versus intermittent dosing of methotrexate and MP in children with low-risk ALL and found less toxicity with the intermittent schedule and significant improvement in EFS among boys with the intermittent regimen (85.7% ± 4.3% vs. 74.9% ± 4.6%; P = 0.027).¹⁷⁴

Unique Patient Subgroups

Philadelphia Chromosome Positive (Ph+) ALL

Prior to the advent of TKI therapy, outcomes for children, adolescents, and young adults with Ph+ ALL were poor with fewer than half of patients surviving^{46,175} despite intensive treatment strategies that often included allogeneic stem cell transplant (SCT) in CR1. The COG AALL0031 study introduced imatinib in combination with an intensive chemotherapy platform and the regimen was well tolerated and patients treated with continuous imatinib (340 mg/m²/day) therapy had a 3-year EFS of 80% versus 35% (P < 0.0001) for historical controls treated in the pre-TKI era.⁴⁵ The COG successor trial, AALL0622, replaced imatinib with the more potent TKI, dasatinib (60 mg/m²/day), and further established the safety of combining a TKI with an intensive chemotherapy platform.¹⁷⁶ In efforts to facilitate the study of small ALL subsets, a transatlantic collaboration is now underway with the European EsPhALL group investigating dasatinib in combination with chemotherapy (COG AALL1122). The results of these more recent trials with dasatinib remain to be determined; however, if the promising results achieved with imatinib are observed, SCT may have a more limited role for patients with Ph+ ALL in the future and TKI therapy in combination chemotherapy may be applicable to other high-risk subsets with altered kinase signaling.

T-ALL

T-cell lymphoid malignancies have distinct biochemical, immunologic, and clinical features that distinguish them from B lymphoid malignancies. Historically, the diagnosis of T-ALL portended a worse prognosis than precursor B-cell ALL; however, over the past three decades, the introduction of intensive, high-dose, multiagent pulse chemotherapy has improved the EFS for patients with T-ALL such that outcomes are now comparable to those of children with high-risk B-lineage ALL.^{146,177} Intensive therapy is important for all patients with T-ALL as children with NCI standard risk T-ALL have had inferior outcomes when they were treated with standard risk therapy on the CCG 1952 study.¹⁷⁸ Based on these findings, it is now standard practice for children with both NCI SR and HR T-ALL to receive more intensified treatment with a 4-drug induction and augmented postinduction therapy.

The role of high-dose methotrexate (HD-MTX) has been evaluated in T-ALL and in the recently completed POG9404 study patients were randomized to receive HD-MTX (5 g/m² at weeks 4, 7, 10, and 13) within the context of a regimen containing intensive asparaginase, doxorubicin, and cranial irradiation. Patients who received HD-MTX had 5-year and 10-year EFS that was significantly better than those who did not receive HD-MTX (5 years: 79.5% ± 3.4%, 10 years: 77.3% ± 5.3%) versus no HD-MTX (5 years: 67.5% ± 3.9%, 10 years: 66.0% ± 6.6%; P = 0.047).¹⁴²

Another agent, which has been studied in children with T-ALL, is nelarabine, a prodrug of Ara-G, which is uniquely cytotoxic to T-lymphoblasts. Based on its differential effect in T-ALL blasts and promising results in early phase trials for refractory/relapsed disease, nelarabine was added to traditional chemotherapy in children with T-ALL and high-risk features. Combination therapy was acceptably tolerated⁴⁴ and this therapy is now being tested in the randomized phase III COG trial AALL0434 in pediatric patients with newly diagnosed intermediate- and high-risk T-ALL.

The overall outcomes for pediatric patients with T-ALL have improved; however, there are subsets of patients who have not fared well, such as those with the persistence of MRD at day 78 (time point 2) of therapy.⁷³ A recently described immunophenotype in T-ALL is the “early thymocyte precursor (ETP),” where T-cells retain stem cell-like features. The ETP phenotype has been associated with inferior responses to induction therapy and outcomes; children with this T-ALL phenotype might be candidates for novel therapy in the future.¹⁷⁹

Adolescents and Young Adults with Acute Lymphoblastic Leukemia

Although improvements in outcome for adolescents and young adults, 16+ years of age, with ALL have been observed, they still lag behind those in younger children. AYAs had a fourfold higher relative risk of death from their disease compared to younger children in recent generations of COG ALL protocols.⁵ Treatment approaches for this group of patients have varied as they seek care at both adult and pediatric centers. Several clinical trials have demonstrated that treatment with pediatric protocols, which utilize high cumulative doses of vincristine, corticosteroids, and asparaginase, particularly during periods of myelosuppression, significantly improves outcomes in this population.^{5,180,181, 182 and 183}

In examining AYA outcomes on recently completed pediatric trials, where enrollment commonly spans into young adulthood, the 5-year EFS of AYA patients (ages 16 to 21 years) who achieved rapid initial responses to therapy was 81.8% (SE 5.4%) on augmented arms of the recently completed COG study, CCG-1961 for National Cancer Institute (NCI) high-risk (HR) ALL.¹⁸² Similarly, SJCRH evaluated the outcomes of older adolescents (ages 15-18) on four recent ALL studies (XIIIA, XIIB, XIV, and XV), and the 5-year EFS for AYA patients on study XV was 86.4% ± 5.2% compared to 87.4% ± 1.7% in younger patients (P = 0.61).¹⁸³

In addition to examining the outcomes for AYA patients on pediatric treatment protocols, several retrospective comparisons of AYA outcomes on pediatric versus adult protocols have been undertaken and the vast majority have found a significant advantage for a pediatric approach.^{184, 185 and 186,187} The largest of these studies was a retrospective comparison of 124 patients ages 16 to 20 years enrolled on Cancer and Acute Leukemia Group B (CALGB) ALL trials from 1988 to 2001, to 197 patients ages 16 to 20 years enrolled on COG ALL studies from 1989 to 1995.¹⁸⁷ Both cooperative groups utilized BFM-based chemotherapy regimens. The rates of CR were similar; however, 7-year EFS was significantly better for the patients treated on COG studies (63%, CI 55% to 72%) compared to those treated on CALGB trials (34%, CI 24% to 44%; P < 0.001). Several adult centers have utilized pediatric regimens, including a collaborative cooperative group clinical trial involving CALGB, the Eastern Cooperative Oncology Group and Southwest Oncology Group (C-10403; NCT00558519), which was recently completed. Patients with newly diagnosed ALL, ages 16 to 39 years are treated according to the standard arm of the recently completed COG study AALL0232 in the study and this will provide additional insight into outcomes for this unique subset of patients. Current COG frontline ALL trials also accrue AYAs up to 30 years of age.

Infants with Acute Lymphoblastic Leukemia

Infants 12 months of age or younger may present with a constellation of features that portend an unfavorable outcome and this group of patients routinely receives separate treatment regimens that are tailored to their unique features. They are more likely to have hyperleukocytosis, massive hepatosplenomegaly, CNS involvement, chromosomal rearrangements involving MLL, and a slow response to induction therapy.⁵⁶ Historically, infants with

P.1629

ALL have inferior outcomes with 4-year EFS rates of 47% on the largest recent trial.¹⁸⁸ Infants with ALL are susceptible to toxicity, especially those <90 days of age at diagnosis. To address these challenges, many groups have recommended that infants with ALL now receive an induction regimen tailored for age with enhanced and aggressive supportive care measures. The FLT3 tyrosine kinase has been shown to be highly expressed in MLL-rearranged infant ALL¹⁸⁹ and the addition of the FLT3 inhibitor lestaurtinib, is also being studied in combination with chemotherapy in an ongoing COG trial.¹⁹⁰ The role of allo-HSCT has been debated for infants with ALL as larger analyses have not shown an overall benefit for this strategy but recent data indicate that it may prove beneficial for a subgroup of patients.^{188,191,192}

Children with Down Syndrome and Acute Lymphoblastic Leukemia

Down syndrome is the most common genetic risk factor for childhood ALL.¹⁹³ Children in whom ALL is associated with Down syndrome have a significantly lower rate of remission, a higher mortality rate during the induction phase, and a poorer long-term survival rate in many studies^{194, 195, 196, 197} and^{198,199} in contrast to children with AML and Down syndrome.²⁰⁰ The adverse influence of Down syndrome may be explained in part by a greater incidence of toxicity related to intensive treatment,^{195,197,201} in part by the absence of favorable biologic features such as the ETV6-RUNX1 fusion and hyperdiploidy, as well as a particularly high incidence of Janus kinase (JAK2) mutations and increased expression of the cytokine receptor CRLF2.^{193,202,203,204,205} Intensification of therapy abrogates the adverse affect of Down syndrome in some studies, but it is attended by greater serious toxicity.^{201,206} Given the unique toxicity profile in children with Down syndrome in ALL, the COG has modified therapy and implemented aggressive supportive care for this unique subset of patients.²⁰⁷

Treatment after Relapse

Despite the advances made with intensive and risk-stratified treatment regimens for childhood ALL, approximately 20% of patients will relapse. Most relapses occur during treatment or within the first 2 years off therapy, although late relapses have been reported many years after diagnosis. Because of the high incidence of ALL among pediatric malignancies, the number of children with relapsed acute leukemia equals or exceeds the incidence of most other pediatric tumors.²⁰⁸ In contrast to the success of frontline ALL therapy, outcomes for children with relapsed disease remain suboptimal. Although many patients achieve subsequent remission, long-term survival rates for patients with first marrow relapse of ALL range from 20% to 40%, even with the use of intensive chemotherapy and allogeneic stem cell transplantation.^{209,210,211} Analysis of outcomes for patients who relapsed after treatment on frontline CCG studies did not show any differences in survival after relapse for patients treated on CCG trials between 1983 and 1989 and those treated from 1988 to 2002.²¹² As a result, despite the fact that 80% of children with ALL will be cured with frontline therapy, more children die from ALL than are diagnosed with non-Hodgkin lymphoma, Wilms tumor, Hodgkin lymphoma, CNS primitive neuroectodermal tumor, AML, and rhabdomyosarcoma.²¹³

Population-based data from the Nordic consortium capturing 100% of children age 1 to 15 years diagnosed with ALL from 1981 to 2001 found that 854 of 3,356 children (25%) had a first relapse.²¹⁴ 776 patients (90.8%) achieved second remission of whom 29% underwent allogeneic HSCT with overall survival 46% at 10 years, and 71% received ongoing chemotherapy with OS 39% at 10 years. The toxic death rate in CR2 was 19% and 50% of patients experienced a second relapse, demonstrating that lack of disease control is the major cause of failure despite achievement of second remission. Of 274 patients with a second relapse of ALL, 72% achieved a third remission although long-term survival was dismal (12% at 20 years). A retrospective review of 313 children with relapsed ALL treated at institutions in the TACL (Therapeutic Advances in Childhood Leukemia) consortium from 1995 to 2004 found that patients with a second marrow relapse had a complete remission rate of only 44% with 15% 5-year disease-free survival.²¹⁵

Multiple childhood cancer cooperative groups have evaluated cohorts of patients with relapsed ALL to identify prognostic factors for outcome after relapse. On CCG trials from 1983 to 1989, the strongest predictor of prolonged survival after relapse was an initial time to first relapse ≥ 36 months.²¹⁶ More recently, Nguyen and colleagues reported the outcomes of 9,585 patients with newly diagnosed ALL treated on CCG protocols from 1988 to 2002, of whom 1,961 relapsed (20.5%).²¹² The most common sites of relapse were isolated bone marrow (57%), isolated CNS (20.9%), concurrent marrow and extramedullary (13.5%), isolated testicular (5.3), and other extramedullary (3.1%). Rare extramedullary sites include isolated leukemic infiltration of the lymph nodes, eyes, and bone.^{216, 217} and²¹⁸ Clinical features at the time of initial ALL diagnosis that correlated with increased risk of relapse included age < 1 year or ≥ 10 years, male gender, initial WBC $> 100 \times 10^9/L$, African American or Hispanic ethnicity and slow early response to induction therapy. Features associated with survival after relapse include site of relapse, with 5-year OS 59% for those with isolated CNS relapse compared to 24% for isolated marrow relapse and 39% for concurrent marrow and extramedullary relapse. Time to relapse, or duration of first remission, is also a critical feature, with patients with early (< 18 months from initial diagnosis) or intermediate (18 to 36 months) relapses faring more poorly than those with late relapse > 36 months from initial diagnosis. Among patients with marrow relapse within 36 months from initial diagnosis, long-term survival is rare (below 10%) despite intensive chemotherapy and use of HSCT.²⁰⁸ Indeed, among patients treated on CCG protocols, 5-year survival for isolated early marrow relapse was 11.5% compared to 18.4% for intermediate, and 43.5% for patients with late marrow relapse. Notably, patients with late isolated extramedullary relapse fared the best, with 5-year survival 78% (isolated CNS), 60% (isolated testicular), and 85% (isolated other extramedullary \pm CNS).²¹² Other factors that were significant predictors of survival postrelapse included T-cell immunophenotypes, age < 1 year or > 10 years at the time of initial diagnosis, history of CNS disease, NCI high-risk features at the time of initial diagnosis, and male gender.

Other groups have confirmed the importance of time to relapse and site of relapse^{211,219} as well as T-cell immunophenotype. (220) As a result, cooperative group trials for first relapse of ALL risk stratify patients based on these features, allocating patients with favorable features (e.g., late isolated CNS relapse of pre-B ALL) to chemotherapy and CNS radiation, whereas those with unfavorable features are planned to undergo allogeneic HSCT in second remission. The evaluation of minimal residual disease (MRD) following reinduction chemotherapy for relapse has been found to influence prognosis, with those patients with negative (<0.01%) or low-level MRD (<0.1%) having improved outcomes. On the COG AALL01P2 trial of a combination chemotherapy regimen for first marrow relapse, 96% of the pre-B patients with late relapses achieved CR2 after the first block of treatment, although 51% of those had MRD > 0.01%. For those with early marrow relapse of pre-B ALL, the CR2 rate was 68% with 75% of those achieving remission having MRD > 0.01%. The presence of MRD > 0.01% at the end of reinduction block 1 was predictive of 12-month EFS for both early and late relapses. Outcome for the small subgroup of patients with relapsed T-ALL was dismal with 5 of 7 failing to achieve CR2 and no survivors beyond 10 months from relapse.²²¹ Other investigators have demonstrated the prognostic significance

P.1630

of MRD prior to HSCT,²²² and it is currently being incorporated into risk classification schemes in clinical trials for relapsed disease.^{223,224,225}

Most risk stratification strategies for relapsed ALL do not incorporate cytogenetic features that do not represent currently druggable targets (e.g., hypodiploidy, MLL rearrangement, ETV6-RUNX1 fusion). Some patients with ETV6-RUNX1 translocations with late bone marrow relapses have been found to have novel deletions of the nontranslocated ETV6 gene at the time of relapse compared to original diagnosis, suggesting that some of these “relapses” are actually second de novo leukemias that might be treated with conventional frontline chemotherapy.^{226,227} In addition, novel molecular predictors of inferior outcome after relapse are emerging, including IKZF1 deletion and alteration of TP53, which in the future may further refine risk stratification.²²⁸

Treatment of Marrow Relapse

Treatment of relapse begins with an attempt to obtain a second remission. This is usually successful with agents similar to those used at initial presentation, more so in late than in early relapse. In pediatric series, remission induction rates range from 71% to 97%.^{209,221,224,229, 230, 231} and ²³² Retreatment of the CNS appears critical even in isolated bone marrow relapse.²³³ Postinduction therapy is generally pursued, ranging from conventional chemotherapy intensification and maintenance to marrow ablative therapy and stem cell rescue (see below). Outcomes improve with an increasing duration of first remission,^{216,217} with protocol as opposed to ad hoc therapy,²¹⁹ and less certainly with increasing intensity of otherwise somewhat effective therapy.^{229,234} A substantial number of patients with an initial relapse after 3 years achieve long-term DFS with chemotherapy without bone marrow transplant.^{211,229,235}

Treatment of Isolated Extramedullary Relapse

Isolated extramedullary relapses are rarely truly isolated to the apparent site of involvement. PCR-based assays may show the presence of marrow cells sharing the clonotypic immunoglobulin or T-receptor rearrangement found in the leukemic blasts at presentation.^{236, 237} and ²³⁸ The principal clinical challenge of isolated extramedullary relapse is prevention of subsequent marrow relapse. Local control of CNS or testicular sites can usually be obtained and maintained with chemotherapy and radiation therapy. Thus, isolated extramedullary relapse usually represents a failure of systemic therapy, not only local therapy.

Isolated CNS Relapse

CNS disease may present with signs of increased intracranial pressure, such as headache or vomiting (especially morning vomiting). Because all patients receive maintenance intrathecal therapy, most CNS relapses occurring during treatment are discovered incidentally. CNS relapses tend to occur between 1 and 3 years after diagnosis.

CNS blasts may be cleared with weekly or twice-weekly intrathecal therapy. Three-agent methotrexate, hydrocortisone, and cytosine arabinoside therapy was no more effective than two-agent methotrexate and hydrocortisone therapy in one trial.²³⁹ Cranial irradiation and intrathecal maintenance therapy were less effective in maintaining CNS remission than craniospinal irradiation.²⁴⁰ Patients undergo systemic reinduction therapy and cranial or craniospinal irradiation is administered 1 month²⁴¹ to 6 months^{229,242,243} from relapse. Radiation may be delayed in order to preserve marrow reserve for aggressive systemic therapy.²⁴⁴ The dose of cranial irradiation is generally 18 to 24 Gy. The spinal dose is 6 to 15 Gy.^{229,242,243} Overall, at least 50% of patients may achieve long-term DFS after CNS relapse; time to relapse is prognostic.²⁴⁴ The bone marrow is the principal site of treatment failure.²⁴⁵

In the past, most children received cranial irradiation as part of their initial presymptomatic CNS therapy and treatment after CNS relapse represented a second radiation exposure and higher cumulative dose. Mulhern et al. found an average of more than 10 points decline in full-scale IQ compared to population norms in 40 children 6 years after CNS relapse. Eight children were labeled mentally retarded and were receiving special education assistance. Younger children and those with seizures or structural brain abnormalities had the poorest cognitive outcomes.²⁴⁶ Winick et al. studied 120 patients with isolated CNS relapse of whom 14 had received prior cranial irradiation. Of these, 17% had signs or symptoms of leukoencephalopathy, presenting with seizure in 85% and ataxia, memory loss, and motor and cranial nerve deficits in others. Of children with prior cranial irradiation, 27% had significant neurotoxicity compared to 15% of children who did not ($P = 0.33$). Twelve patients had progressive neurologic deterioration despite the cessation of intrathecal therapy. Eight had mild stable symptoms and of these, four had learning disabilities.²⁴¹ Prevention of subsequent relapse and preservation of neurocognitive function remain dual challenges for patients with CNS relapse.

Isolated Testicular Relapse

Testicular leukemia presents with unilateral or bilateral painless testicular enlargement. At least half of cases occur more than 3 years from diagnosis. Outcomes appear better for patients with overt disease after completion of therapy than for patients with overt disease while still on therapy.²⁴⁷ In two trials, about 10% of boys had occult testicular relapse on elective biopsy at 3 years from diagnosis. However, no advantage could be shown for early diagnosis and 25 of 839 boys with negative initial biopsies had subsequent testicular relapse.^{248,249}

CCG reported a series of patients with overt isolated testicular relapse (ITR) on or shortly after initial therapy. Patients received salvage chemotherapy as per the NY I¹⁷³ or CCG BFM-based¹⁵¹ regimens and bilateral testicular irradiation. Among 57 boys, the 5-year EFS was 43%.²⁵¹ This result is similar to that obtained in a POG series with somewhat different chemotherapy.²⁵² For patients with an earlier or later overt testicular relapse, POG investigators obtained 4-year EFS of 53% or 84%.²⁵³ In adults, testicular irradiation doses greater than 4 to 6 Gy may result in persistent azoospermia. Even scatter from spinal irradiation may cause elevation of FSH or decreased testicular volume in some patients. Leydig cell function is generally spared. However, testicular irradiation doses greater than 20 Gy may compromise Leydig cell function in children, resulting in elevated LH, decreased testosterone, and delayed puberty.²⁵⁴ Doses greater than 20 Gy are generally used in the treatment of testicular relapse. The use of intensified systemic chemotherapy to allow elimination of radiation therapy in selected low-risk ITR patients is under investigation by COG.

Bone Marrow Transplantation

The potential benefit of allogeneic bone marrow transplantation (BMT) likely derives less from the opportunity for marrow ablative therapy, that is, high-dose chemotherapy with or without total body irradiation, and more from the immunologic benefits of graft-versus-leukemia effect. As the majority of children with relapsed ALL who need a donor for allogeneic transplant will not have a matched sibling donor (MSD), other stem cell sources such as matched unrelated marrow (MUD)^{255, 256} and ²⁵⁷ or peripheral blood or cord blood stem cells,^{258,259} and related but partially mismatched marrow, peripheral blood, or cord blood stem cells²⁶⁰ are increasingly utilized. With continued improvements in tissue typing, management of acute graft-versus-host disease and other supportive care measures, the outcomes of such alternative donor transplants now approximate those from matched related donors.²⁶¹

P.1631

Definition of the role of BMT in childhood ALL has been an ongoing challenge. Interpretation of reported BMT outcomes is complicated by the preponderance of small series, selection bias, waiting-time bias, and lack of adequate controls. Even in aggregate, small series may not be representative of the total experience. Small numbers quickly erode statistical power and obscure possibly important differences. Selection biases complicate comparisons; in "treatment-received" reports, patients who relapse before a BMT is performed are excluded from the treatment-received experience, but are included in the control group receiving chemotherapy. Patients deemed clinically unfit for BMT because of organ dysfunction or deep-seated infection are excluded from the BMT arm, but may be included in the chemotherapy control. Various statistical techniques can adjust for waiting-time bias but selection bias proves more challenging; therefore, an intent-to-treat analysis is the least biased. Interpretation of BMT results is also complicated by differences in therapy before BMT, in marrow ablative therapy, in graft-versus-host disease prophylaxis, and in supportive care. The superiority of a particular transplant regimen over a particular chemotherapy regimen does not imply that the same or a second transplant regimen will necessarily be superior to a second chemotherapy regimen.

For children in second marrow remission, a case-control analysis of International Bone Marrow Transplant Registry data suggested that matched BMT is superior to chemotherapy for both early and late marrow relapse. The 5-year DFS was estimated at 40% for BMT patients and 17% for matched chemotherapy patients, excluding patients who failed to achieve or maintained remission long enough to have received a transplant had they had a donor (Fig. 76.10). Comparisons of BMT and chemotherapy outcomes for initial remissions before 18 months, at 18 to 36 months, and at 36 months or later were 29% versus 14%, 41% versus 7%, and 53% versus 32%, respectively.²⁶² A matched-pairs analysis of patients treated with chemotherapy or unrelated donor transplantation was undertaken by the BFM group. Patients treated with HSCT had an EFS of 42% compared to an EFS of only 17% for those treated with chemotherapy; the poorer outcome in the chemotherapy group was primarily attributable to the dismal outcome of those with high-risk features such as early relapse.²²⁰

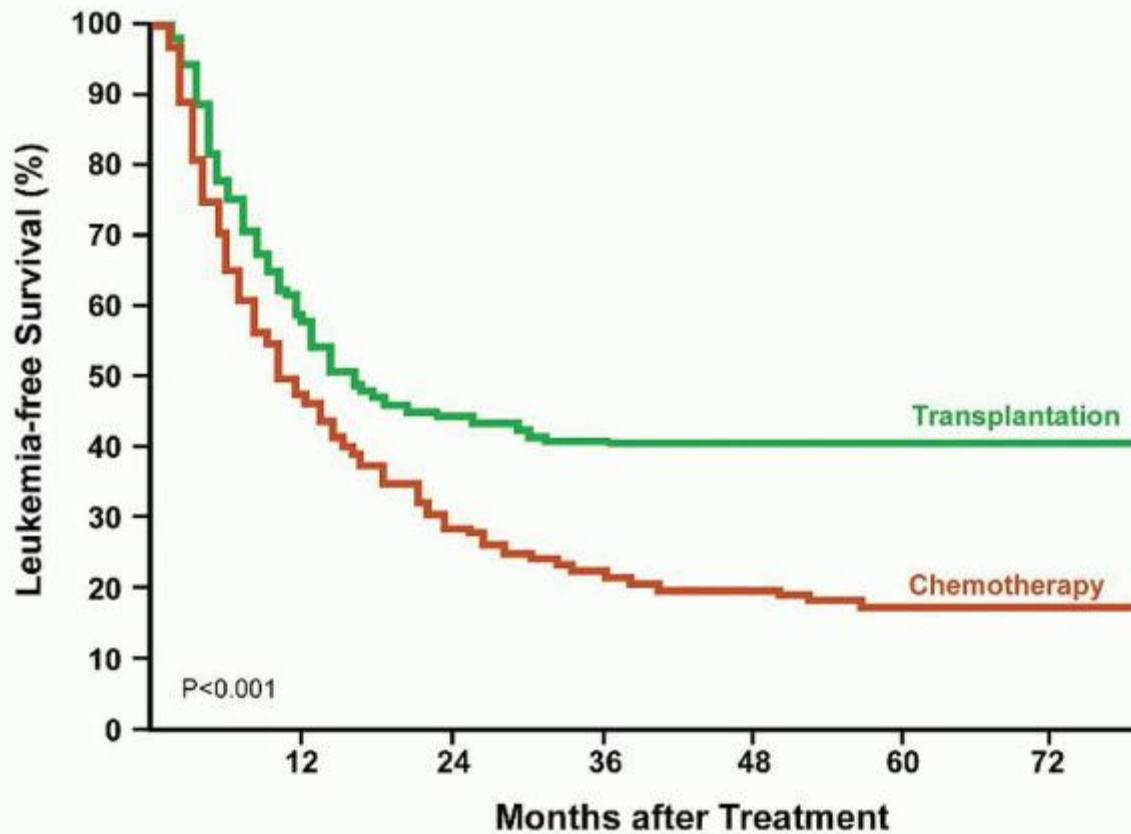

FIGURE 76.10. Probability of leukemia-free survival in matched cohorts ($n = 255$ in each) of children receiving chemotherapy or undergoing sibling donor transplantation for relapsed ALL. (With permission from Barret AJ, Horowitz MM, Pollock BH, et al. Bone marrow transplants from HLA-identical siblings as compared with chemotherapy for children with acute lymphoblastic leukemia in second remission. *N Eng J Med* 1994;331:1253-1258.)

In a rare prospective trial, Wheeler and coworkers in the British MRC designated 473 of 3,676 children diagnosed between 1985 and 1997 as “very high (VH) risk” on the basis of presenting clinical and cytogenetic features. Of 288 patients with tissue typing, 99 had a MSD and 76 underwent BMT in first remission. Of 189 patients with no MSD, 25 underwent BMT from a MUD, contrary to protocol. At 10 years, the adjusted EFS was 45% for 101 children receiving first remission BMT versus 39% for 351 children receiving chemotherapy. In contrast, the 10-year EFS was 50% for children without MSD compared to 40% for children with MSD.²⁶³ They concluded that first remission BMT has not improved EFS for VH-risk ALL.

Gaynon et al. undertook a prospective randomized trial (CCG 1941) for children with ALL and early marrow relapse.²⁰⁹ Of 215 patients enrolled, 165 achieved remission (77%). Forty-two refused postinduction allocation. Fifty-one patients had matched related donors, of which 40 underwent BMT in second remission; 8 died from TRM (20%) and 19 relapsed. Seventy-two patients had no matched related donor and were allocated to alternative donor BMT or chemotherapy. Of 37 patients allocated to alternative donor BMT, 20 underwent BMT in second remission; 8 died from TRM (40%) and 6 relapsed. Of 35 patients allocated to chemotherapy, 10 patients underwent alternative donor BMT; 4 died from TRM and 3 relapsed. Twenty-five patients received only chemotherapy; 2 died from TRM and 16 relapsed. The 2-year EFS for MSD

BMT and alternative BMT was 40% and 23%. By intent-to-treat from the end of induction, the 3-year DFS were not significant: 29%, 18%, and 28% for matched related BMT, alternative BMT, and chemotherapy, respectively. Censoring the chemotherapy patients who underwent BMT, the DFS is 36%.

The British MRC has undertaken three prospective trials in patients after relapse. Wheeler et al. studied 489 children who relapsed from the UKALL X trial. Harrison et al. studied 256 relapsed children enrolled on the UKALL R1 trial.²⁶⁴ In adjusted comparisons, BMT improved 5-year EFS from 26% to 41% in UKALL X ($P = 0.05$). The 5-year EFS was only 3% for patients with marrow relapse prior to 2 years, whatever therapy was pursued. The 5-year EFS was 66% for late extramedullary relapse. On the UKALL R1 study, 67 children had MSD BMT and 139 had no MSD. Sixty-three of 67 patients with MSDs underwent BMT. Contrary to protocol, 41/139 patients with no MSD underwent MUD BMT, of which 6 patients died from TRM (15%). Within the

P.1632

power of the comparison, no statistically significant difference was apparent in intent-to-treat comparisons of patients with MSD versus patients with no MSD or in adjusted treatment-received comparisons of patients undergoing BMT versus patients receiving chemotherapy. The UK ALL-R3 randomized 219 children with first relapse of ALL to receive either idarubicin or mitoxantrone during reinduction therapy; all high-risk patients, and those standard-risk patients with MRD levels ($\geq 10^{-4}$ cells) after 3 courses of reinduction therapy, underwent allogeneic SCT, whereas standard-risk patients with less end-induction MRD received continuation chemotherapy. Estimated 3-year progression-free survival was significantly better in the mitoxantrone group (64.6% ; 95% CI 54.2-73.2) than in the idarubicin group (35.9%; CI 25.9-45.9), despite no obvious difference in end-induction MRD results between the two groups.²²⁴

Further refinements in improving BMT outcomes may come from reducing pretransplant levels of disease with either standard or novel agents, better conditioning, less TRM, and enhancement of the graft-versus-leukemia effect. Although data clearly link end-induction or pretransplant levels of MRD to outcome,^{221,222} no data have been published demonstrating that further therapy in those patients with detectable disease prior to HSCT will improve outcomes; an alternative explanation is that detectable MRD prior to HSCT may reflect adverse biologic features resistant to currently available therapies. Clinical trials are underway or planned that will address this important issue.

The optimal choice of conditioning regimen is also unclear; although the use of regimens utilizing total-body irradiation (TBI) may be superior to busulfan-based regimens in ALL.^{265,266} Concerns about the long-term complications of TBI in children have led to plans for an international trial randomizing TBI-based and non-TBI-based regimens in relapsed childhood ALL. The identification of those elements comprising an optimal TBI-based regimen (cytosine arabinoside, cyclophosphamide, or etoposide) are similarly unclear.^{267,268} Reduced graft-versus-host disease prophylaxis²⁶⁹ or rapid withdrawal of GVHD prophylaxis following HSCT in the setting of increasing mixed chimerism^{270,271} may enhance graft-versus-leukemia effect and improve outcomes.

Future progress in further improving the outcome of children with newly diagnosed high-risk or relapsed ALL will come from the incorporation of promising new therapies into treatment regimens, either through empiric testing or through the identification of critical signaling pathways that are amenable to therapeutic targeting (Table 76.5).⁵¹ Newer cytotoxic chemotherapy agents that have shown promising results in relapse and are being evaluated or planned for evaluation in high-risk subsets of ALL include clofarabine,^{272,273} nelarabine,⁴³ and bortezomib.^{274,275} Among the many other therapies in early development for lymphoid malignancies, the most promising appear to be the immunoconjugates moxetumomab,²⁷⁶ inotuzumab,²⁷⁷ and blinatumomab. The latter agent, the first of a novel class of agents known as bispecific T-cell engagers (BiTEs), is a single-chain bispecific antibody construct with specificity for CD19 and CD3 which has shown impressive activity in adults with CD19+ non-Hodgkin lymphomas and ALL.^{278,279} Similar activity has been seen in a small number of children,²⁸⁰ and prospective pediatric trials of this agent are underway.

OUTCOMES

Quality of Life

With steady improvements in survival over successive decades, growing attention and focus have been devoted to the short- and long-term effects of ALL therapy and their impact on quality of life. In a recent analysis of 10-year event-free survivors of childhood ALL, 95% were long-term survivors 30 years from achievement of first complete remission, a rate very similar to the general US population.⁸⁵ Although ALL survivors are 3.7 times more likely to report a significant chronic medical condition compared to their siblings and they have poorer self-reported health status, remarkably, 92% of survivors who did not develop a relapse or receive irradiation did not report any severe chronic medication condition after therapy.²⁸¹ In an analysis of more than 800 patients who received treatment on SJCRH protocols and attained at least 10-

year EFS, quality of life among nonirradiated survivors was very good with rates of health insurance coverage, marriage, and employment that were similar to the age- and sex-adjusted national averages.⁸⁵ Many therapeutic trials for childhood ALL now include prospective assessments of common toxicities as well as underlying host factors that contribute to the risk of experiencing side effects from ALL therapy and this is envisioned to facilitate prevention of late effects from treatment more effectively in the future.

Neuropsychological Sequelae

Cognitive outcomes of children who receive ALL therapy have been an area of active investigation as the side effects of CNS-directed therapy have become increasingly recognized.²⁸² Risk factors for the impairment in neurocognitive functioning have included younger age (<5 years), female gender, more intensive treatment, and cranial irradiation.^{283, 284, 285, 286, 287, 288, 289, 290} and ²⁹¹ Historically, cranial irradiation, especially when administered to children <3 years of age and at the higher doses used in earlier generation treatment protocols, has been linked to later cognitive impairment as well as a decline in neuropsychological functioning, such as visual-motor integration, processing speed, attention, short-term memory, and executive functioning (organization and planning).^{285,287,292, 293} and ^{294,295} In recent years, there has been a growing trend to reduce the number of children who receive cranial irradiation and this has prompted assessments of the cognitive and neuropsychological outcomes in children treated with systemic and intrathecal chemotherapy alone. The impact of parenteral methotrexate and intrathecal chemotherapy and other agents such as corticosteroids has been somewhat challenging to define. Factors such as the assessment tools used, heterogeneity in populations tested and the treatment regimens delivered, differences in time points during treatment when testing was undertaken, also contribute to the complexity in defining the risk, and furthermore, the clinical impact of numerical differences in test scores can be difficult to define.

There have been relatively few large prospective studies of children with ALL who have received common treatment and undergone uniform neurocognitive assessments. Comparisons of neurocognitive outcomes in children treated with regimens containing cranial irradiation versus chemotherapy alone have generally suggested better outcomes when radiation is omitted^{289,294,295,296} but not all studies have shown a significant difference.^{292,297,298} Most studies of outcomes following treatment with chemotherapy without cranial irradiation have reported favorable cognitive and intellectual outcomes; however, some meaningful deficits in neurocognitive function with difficulties in attention, working memory, processing speed, mathematics, and visual-motor integration have been reported.^{283,286,299,300,301}

A recently completed study assessing cognitive outcomes 2½ years following remission induction in 243 children who were enrolled on the St. Jude Total Therapy Study XV, which omitted cranial irradiation for all patients, showed that children who received ALL therapy in comparison to a normative group, had a higher likelihood of below-average performance on sustained attention in approximately 40% of patients.³⁰² Those treated on this protocol, however, did well on global measure of cognitive ability without evidence of impairment on measures of intellectual functioning, academic abilities, learning, or memory. More intensive therapy and younger age portended a higher risk for impairment; however, gender was not a significant risk factor in

P.1633

this study. Prospective longitudinal studies of large numbers of children who receive contemporary chemotherapy regimens will be helpful in further defining risk factors for adverse neurologic sequelae and the natural history of deficits over time. Monitoring and intervention for neuropsychological effects of therapy is an essential element of ALL survivorship care.

TABLE 76.5 NOVEL AGENTS FOR THERAPY OF ACUTE LYMPHOBLASTIC LEUKEMIA

Agent	Comment
Monoclonal Antibodies	
Blinatumomab	Bispecific antibodies (BiTE) that direct CD3 ⁺ T-cell against CD19 ⁺ B-ALL
Rituximab	Utilized in adult B-cell lymphoma and Burkitt lymphoma/leukemia; under investigation in CD 20 ⁺ precursor B-ALL
Epratuzumab	Under investigation for relapsed CD22 ⁺ precursor B-ALL; probable synergy with other antibodies

Inotuzumab ozogamicin	Humanized anti-CD22 antibody conjugated to calicheamicin
Alemtuzumab	Anecdotal responses in CD52 ⁺ ALL; under investigation to eradicate minimal residual disease and in patients who have multiple relapses

Antimetabolites

Clofarabine	Nucleoside analogue; inhibits ribonucleotide reductase and DNA polymerase. Approved for relapsed childhood ALL; CR of 20-24% and overall response of 30-47%
Nelarabine	Pro-drug of ara-G; inhibits purine nucleoside phosphorylase. Approved for third-line treatment for T-ALL; CR rate of 27-35% with a higher rate (46%) in first relapse and lower rate (21%) with CNS disease
Forodesine	Inhibits purine nucleoside phosphorylase. Preliminary data indicate similar activity to nelarabine in T-cell malignancies and with less neurotoxicity

Tyrosine Kinase Inhibitors (TKI)

Imatinib	Utilized with chemotherapy for Ph+ ALL
Nilotinib	
Dasatinib	
Bosutinib	
Ponatinib	
MK-0457	

Fms-like Tyrosine Kinase Inhibitors (FLT-3) Inhibitors

Lestaurtinib	Small molecule inhibitors; <i>FLT3</i> mutations occur in MLL+ acute leukemias, KIT (CD117) + T-ALL, and hyperdiploid ALL. Lestaurtinib is in phase I trial as inhibitor of JAK2 in ALL
Midostaurin	
Tandutinib	
Sunitinib	

Farnesyltransferase Inhibitors

Tipifarnib	Inhibition of farnesylation of multiple proteins, including the RAS/RAF pathway, which affects cell survival. Preliminary data indicate activity in T-ALL
Lonafarnib	

Proteasome Inhibitors

Bortezomib	Inhibits ubiquitin proteasome pathway and blocks nuclear factor κB. Leukemia cells become more sensitive to chemotherapy by inducing phosphorylation of BCL 2 and BCLX and inhibiting MAPK signaling
Carfilzomib	

γ Secretase Inhibitors

MK-0752	Mutations of <i>NOTCH 1</i> occur in ~50% of T-ALL; loss of PTEN (phosphatase and tensin homologue) gene may lead to resistance to NOTCH 1 inhibition and require inhibition of PI3K/AKT pathway
---------	--

Histone Deacetylase Inhibitors

Depsipeptide	Synergistic with DNA methyl transferase inhibitors; can induce differentiation and apoptosis by upregulating cyclin-dependent kinase inhibitor A (P21) and down-regulating cyclin D1 and D2
Vorinostat	
AN-9	

Folate acid antagonist

Pemetrexed	Folic acid. Modest activity in phase I trials; likely synergistic with other agents
Talotrexin	

Mammalian Target of Rapamycin (mTOR) Inhibitors

Sirolimus	Signal transduction inhibitors; induce cell-cycle arrest so that cells may be less susceptible to cell-cycle specific agents
Temsirolimus	

Everolimus

Deforolimus (AP-23573)

Secondary Malignant Neoplasms

Cancer survivors treated with radiation therapy and/or chemotherapy are at some increased risk for developing a second malignant neoplasm (SMN), although this risk is low in ALL survivors and estimated to be 1.18% at 10 years with contemporary risk-based therapy in a cohort of 8,831 children treated on COG protocols from 1983 to 1995.³⁰³ Similarly, in an analysis of 5,006 children treated on BFM ALL protocols from 1979 to 1995, the cumulative risk of SMNs at 15 years was 1.2% in nonirradiated children versus 3.5% among those who had received prior irradiation.³⁰⁴ Investigators at SJCRH followed a cohort of ALL survivors for a more extended period of time (median follow-up of 18.7 years) and found that the incidence of SMNs continues to increase over 30 years.³⁰⁵ Although the majority of late-occurring

P.1634

SMNs are low-grade tumors such as basal cell carcinoma and meningioma, aggressive tumors occur as well and exceed the incidence in the general population, highlighting the need for life-long follow-up of childhood ALL survivors. Reported risk factors for SMNs are female gender, prior cranial irradiation, primary disease recurrence, and treatment at a younger age.^{303,304}

The majority of the SMNs that occur in survivors of childhood ALL are secondary high- and low-grade brain tumors among children who received prior cranial irradiation.²⁸¹ This risk approaches 0.5% at 10 years, which is a tenfold increased risk compared to the general population, and the latency period can exceed 10 years.³⁰³ A higher than anticipated incidence of secondary brain tumors was observed on SJCRH studies where intensive antimetabolite therapy was given before and during radiation and this was linked to mutations in the thiopurine methyltransferase gene, which resulted in defective thiopurine catabolism.³⁰⁶ This suggests that other components of therapy, as well as underlying genetic characteristics of patients may also be associated with the risk for SMNs.

There is also a risk of chemotherapy-related myelodysplasia (t-MDS) and AML, linked to exposures to epipodophyllotoxin therapy. The cumulative incidence of secondary AML/MDS among children treated on COG protocols was 0.2%.³⁰³ A higher incidence of 3.8% at 6 years has been reported after treatment on protocols with greater epipodophyllotoxin exposure.³⁰⁷ These SMNs are characterized by latency periods of <10 years.

Osteonecrosis

Osteonecrosis (ON, avascular necrosis of bone) has been recognized with increasing frequency in the greater number of surviving older children and adults with ALL after chemotherapy or after BMT (Fig. 76.11). Osteonecrosis and decreased bone mineral density are well-known side effects of glucocorticoids and ON has emerged as one of the greatest causes of treatment-related morbidity in survivors of ALL therapy, particularly the adolescents.^{168,308,309} Symptomatic ON has been reported to occur in up to 20% of children and adolescents with ALL and its pathogenesis is thought to involve ischemia

due to intravascular thrombi and extravascular lipid deposition as well as compromised intramedullary blood flow due to increased intraosseous lipocyte size. Adolescent age (10 to 20 years) and exposure to dexamethasone have been shown to be some of the greatest risk factors for this complication. New evidence is also emerging to suggest that ON may be associated with inherited genomic variation.³¹⁰ Pain is the common initial symptom of ON and the hips and knees are the most commonly affected joints. In severe cases, ON results in joint collapse and may require total joint replacement. In a recent report of results from the COG-1961 study for treatment of newly diagnosed NCI high-risk ALL, the use of alternate-week dexamethasone during delayed intensification significantly reduced the incidence of ON compared to continuous dosing schedules with incidence rates of 8.7% versus 17%, $P = 0.0005$, respectively.³⁰⁸

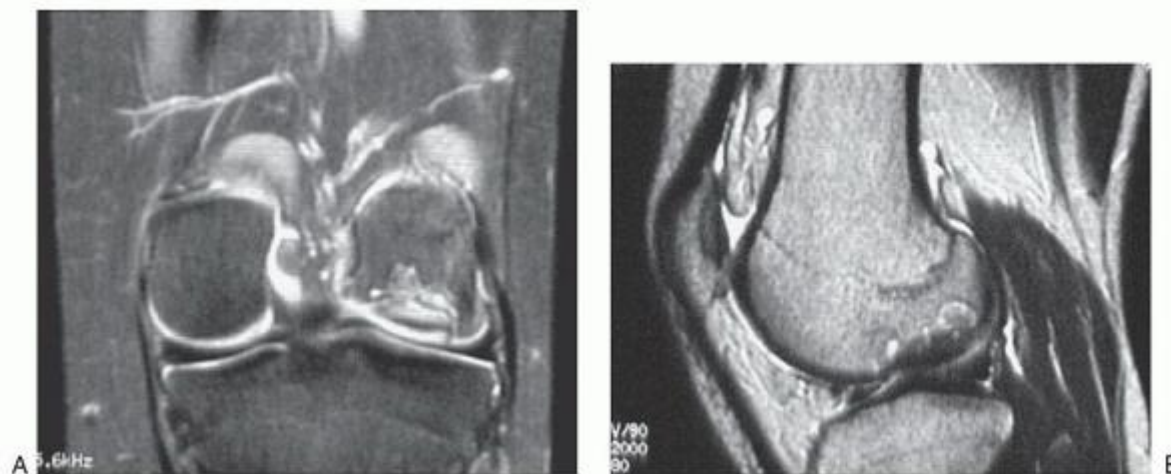

FIGURE 76.11. Coronal (A) and sagittal (B) T2 images from a magnetic resonance imaging scan demonstrating corticosteroid-induced avascular necrosis of the right medial femoral condyle in a 15-year-old white girl. (Courtesy of Dr. Leonard A. Mattano, Michigan State University, Kalamazoo Center for Medical Studies.)

Cardiac Toxicity

Anthracyclines are commonly used in the treatment of ALL in adults and children and there is a risk of cardiotoxicity associated with their use, especially in doses that exceed 300 mg/m^2 .³¹¹ Cumulative doses of anthracycline have been shown to be the most important predictor of abnormal cardiac function^{312,313} and females have also been reported to be at higher risk³¹³ as well as children with a younger age at exposure.³¹⁴ Reported frequencies of anthracycline-induced clinical heart failure have varied from 0% to 16%.³¹⁵ Because most ALL protocols have far less cumulative exposure, overt congestive heart failure is now infrequent, although abnormalities in cardiac indices have been reported even with lower anthracycline exposures and the natural history of these findings is being tracked.³¹⁶ Lipschultz et al. reported that 17% of patients who had received only 45 mg/m^2 of doxorubicin had slightly elevated age-adjusted left ventricular load, as measured by end-systolic wall stress.³¹²

Measures to prevent cardiotoxicity have been investigated and some groups have used the cardioprotectant dexrazoxane.³¹⁴ In a randomized study, children with ALL who received dexrazoxane with doxorubicin were less likely to have cardiac injury, as reflected by elevations in troponin T and N-terminal pro-brain natriuretic peptide (NT-proBNP; cardiomyopathy biomarker).^{317,318} The potential impact of dexrazoxane on the antitumor effect of anthracyclines and the risk of SMN as well as the association between cardiac biomarkers and long-term cardiac outcomes are areas of ongoing investigation.

Endocrinologic Late Effects

Survivors of ALL are also at risk for a spectrum of endocrinologic late effects. These include impairment in growth, thyroid function, gonadal function, bone health, and adrenal function.³¹⁹ There is growing recognition that survivors are at risk for obesity and metabolic syndrome possibly related to steroid exposure and insulin resistance.^{320,321,322, 323} and³²⁴ Screening for endocrinologic sequelae is

P.1635

essential both during and following therapy as many treatment-related side effects can be improved by medical, environmental, and dietary interventions.

SUMMARY

The steady progress in pediatric ALL has served as a model of incremental improvements in therapy through clinical trials. Prognostic risk stratification is shifting from clinical factors to a combination of clinical, immunophenotype, and molecular genetic data. Early identification of minimal residual disease is also now incorporated into therapeutic strategies. Pharmacogenomics may lead to individualization of therapy. Novel agents that are directed at molecular targets are under investigation to improve outcomes. The goal of therapy in ALL is to continue to maximize and maintain remission while minimizing long-term complications.

REFERENCES

1. Linabery AM, Ross JA. Trends in childhood cancer incidence in the U.S. (1992-2004). *Cancer* 2008;112:416-432.
2. Pui CH, Relling MV, Downing JR. Acute lymphoblastic leukemia. *N Engl J Med* 2004;350:1535-1548.
3. Mullighan CG, Goorha S, Radtke I, et al. Genome-wide analysis of genetic alterations in acute lymphoblastic leukaemia. *Nature* 2007;446:758-764.
4. Pui CH, Campana D, Pei D, et al. Treating childhood acute lymphoblastic leukemia without cranial irradiation. *N Engl J Med* 2009;360:2730-2741.
5. Hunger SP, Lu X, Devidas M, et al. Improved survival for children and adolescents with acute lymphoblastic leukemia between 1990 and 2005: a report from the children's oncology group. *J Clin Oncol* 2012;30:1663-1669.
6. Dores GM, Devesa SS, Curtis RE, et al. Acute leukemia incidence and patient survival among children and adults in the United States, 2001-2007. *Blood* 2012;119:34-43.
7. Macdougall LG. Acute childhood leukemia in Johannesburg: ethnic differences in incidence, cell type, and survival. *Am J Pediatr Hematol Oncol* 1986;8:43-51.
8. Xu H, Cheng C, Devidas M, et al. ARID5B genetic polymorphisms contribute to racial disparities in the incidence and treatment outcome of childhood acute lymphoblastic leukemia. *J Clin Oncol* 2012;30:751-757.
9. Crist W, Pullen J, Boyett J, et al. Acute lymphoid leukemia in adolescents: clinical and biologic features predict a poor prognosis - a Pediatric Oncology Group study. *J Clin Oncol* 1988;6:34-43.
10. Simone JV, Verzosa MS, Rudy JA. Initial features and prognosis in 363 children with acute lymphocytic leukemia. *Cancer* 1975;36:2099-2108.
11. Peng LH, Keng TC, Sinniah D. Fever in children with acute lymphocytic leukemia. *Cancer* 1981;47:583-587.
12. Freeman AI, Pantazopoulos N, DeCastro L, et al. Infections in children with acute leukemia. *Med Pediatr Oncol* 1975;1:67-73.
13. Breatnach F, Chessells JM, Greaves MF. The aplastic presentation of childhood leukaemia: a feature of common-ALL. *Br J Haematol* 1981;49:387-393.
14. Blatt J, Martini SL, PENCHANSKY L. Characteristics of acute lymphoblastic leukemia in children with osteopenia and vertebral compression fractures. *J Pediatr* 1984;105:280-282.
15. Jonsson OG, Sartain P, Ducore JM, et al. Bone pain as an initial symptom of childhood acute lymphoblastic leukemia: association with nearly normal hematologic indexes. *J Pediatr* 1990;117:233-237.
16. Ribeiro RC, Pui C-H, Schell MJ. Vertebral compression fractures as a presenting feature of acute lymphoblastic leukemia in children. *Cancer* 1988;61: 589-592.
17. Bevilacqua G, Abadessa A, Consolini R, et al. Bone marrow necrosis foreshadowing acute lymphoid leukemia. *Am J Pediatr Hematol Oncol* 1985;7: 228-233.
18. Niebrugge DL, Benjamin DR. Bone marrow necrosis preceding acute lymphoblastic leukemia in childhood. *Cancer* 1983;52:2162-2164.
19. Pui C-H, Stass S, Green A. Bone marrow necrosis in children with malignant disease. *Cancer* 1985;56:1522-1525.
20. Marwaha RK, Kulkarni KP, Bansal D, et al. Acute lymphoblastic leukemia masquerading as juvenile rheumatoid arthritis: diagnostic pitfall and association with survival. *Ann Hematol* 2010;89:249-254.
21. Ojala AE, Lanning FP, Paakko E, et al. Osteonecrosis in children treated for acute lymphoblastic leukemia: a magnetic resonance imaging study after treatment. *Med Pediatr Oncol* 1997;29:260-265.

22. Link MP, Roper M, Dorfman RF, et al. Cutaneous lymphoblastic lymphoma with pre-B markers. *Blood* 1983;61:838-841.
23. Arico M, Basso G, Mandelli F, et al. Good steroid response in vivo predicts a favorable outcome in children with T-cell acute lymphoblastic leukemia. The Associazione Italiana Ematologia Oncologia Pediatrica (AIEOP). *Cancer* 1995;75:1684-1693.
24. Hijiya N, Liu W, Sandlund JT, et al. Overt testicular disease at diagnosis of childhood acute lymphoblastic leukemia: lack of therapeutic role of local irradiation. *Leukemia* 2005;19:1399-1403.
25. Sirvent N, Suci S, Bertrand Y, et al. Overt testicular disease (OTD) at diagnosis is not associated with a poor prognosis in childhood acute lymphoblastic leukemia: results of the EORTC CLG Study 58881. *Pediatr Blood Cancer* 2007;49:344-348.
26. Ingram LC, Fairclough DL, Furman WL, et al. Cranial nerve palsy in childhood acute lymphoblastic leukemia and non-Hodgkin's lymphoma. *Cancer* 1991;67:2262-2268.
27. Bunin NJ, Pui C-H. Differing complications of hyperleukocytosis in children with acute lymphoblastic or acute nonlymphoblastic leukemia. *J Clin Oncol* 1985;3:1590-1595.
28. Dubansky AS, Boyett JM, Faletta J. Isolated thrombocytopenia in children with acute lymphoblastic leukemia: a rare event in a Pediatric Oncology Group Study. *Pediatrics* 1989;84:1068-1071.
29. Jones DP, Stapleton FB, Kalwinsky D, et al. Renal dysfunction and hyperuricemia at presentation and relapse of acute lymphoblastic leukemia. *Med Pediatr Oncol* 1990;18:283-286.
30. Zusman J, Brown DM, Nesbit ME. Hyperphosphatemia, hyperphosphaturia and hypocalcemia in acute leukemia. *N Engl J Med* 1973;289:1335-1340.
31. Cairo MS, Bishop M. Tumour lysis syndrome: new therapeutic strategies and classification. *Br J Haematol* 2004;127:3-11.
32. Mitchell LG, Andrew M, Hanna K, et al. A prospective cohort study determining the prevalence of thrombotic events in children with acute lymphoblastic leukemia and a central venous line who are treated with L-asparaginase: results of the Prophylactic Antithrombin Replacement in Kids with Acute Lymphoblastic Leukemia Treated with Asparaginase (PARKAA) Study. *Cancer* 2003;97:508-516.
33. Abshire TC, Gold SH, Odom LF, et al. The coagulopathy of childhood leukemia: thrombin activation or primary fibrinolysis? *Cancer* 1990;66:716-721.
34. Mitchell L, Hoogendoorn H, Giles A, et al. Increased endogenous thrombin generation in children with acute lymphoblastic leukemia: risk of thrombotic complications in L'Asparaginase-induced antithrombin III deficiency. *Blood* 1994;83:386-391.
35. Rosenfield NS. *The radiology of childhood leukemia and its therapy*. St. Louis: Warren H. Green, 1982.
36. Mastrangelo R, Poplack D, Bleyer A, et al. Report and recommendations of the Rome workshop concerning poor-prognosis acute lymphoblastic leukemia in children: biologic bases for staging, stratification, and treatment. *Med Pediatr Oncol* 1986;14:191-194.
37. Mahmoud HH, Rivera GK, Hancock ML, et al. Low leukocyte counts with blast cells in cerebrospinal fluid of children with newly diagnosed acute lymphoblastic leukemia. *N Engl J Med* 1993;329:314-319.
38. Pui CH. Toward optimal central nervous system-directed treatment in childhood acute lymphoblastic leukemia. *J Clin Oncol* 2003;21:179-181.
39. Oeffinger KC, Mertens AC, Sklar CA, et al. Chronic health conditions in adult survivors of childhood cancer. *N Engl J Med* 2006;355:1572-1582.
40. Carroll WL, Raetz EA. Building better therapy for children with acute lymphoblastic leukemia. *Cancer Cell* 2005;7:289-291.
41. Pullen J, Shuster JJ, Link M, et al. Significance of commonly used prognostic factors differs for children with T cell acute lymphocytic leukemia (ALL), as compared to those with B-precursor ALL. A Pediatric Oncology Group study. *Leukemia* 1999;13:1696-1707.
42. Willemse MJ, Seriu T, Hettlinger K, et al. Detection of minimal residual disease identifies differences in treatment response between T-ALL and precursor B-ALL. *Blood* 2002;99:4386-4393.

43. Berg SL, Blaney SM, Devidas M, et al. Phase II study of nelarabine (compound 506U78) in children and young adults with refractory T-cell malignancies: a report from the Children's Oncology Group. *J Clin Oncol* 2005;23:3376-3382.
44. Dunsmore KP, Devidas M, Linda SB, et al. Pilot study of nelarabine in combination with intensive chemotherapy in high-risk T-cell acute lymphoblastic leukemia: a report from the Children's Oncology Group. *J Clin Oncol* 2012;30:2753-2759.
45. Schultz KR, Bowman WP, Aledo A, et al. Improved early event-free survival with imatinib in Philadelphia chromosome-positive acute lymphoblastic leukemia: a children's oncology group study. *J Clin Oncol* 2009;27:5175-5181.
46. Arico M, Schrappe M, Hunger SP, et al. Clinical outcome of children with newly diagnosed Philadelphia chromosome-positive acute lymphoblastic leukemia treated between 1995 and 2005. *J Clin Oncol* 2010;28:4755-4761.
47. Nachman JB, Heerema NA, Sather H, et al. Outcome of treatment in children with hypodiploid acute lymphoblastic leukemia. *Blood* 2007;110:1112-1115.
48. Robinson HM, Broadfield ZJ, Cheung KL, et al. Amplification of AML1 in acute lymphoblastic leukemia is associated with a poor outcome. *Leukemia* 2003;17:2249-2250.
49. Attarbaschi A, Mann G, Panzer-Grumayer R, et al. Minimal residual disease values discriminate between low and high relapse risk in children with B-cell precursor acute lymphoblastic leukemia and an intrachromosomal amplification of chromosome 21: the Austrian and German acute lymphoblastic leukemia Berlin-Frankfurt-Munster (ALL-BFM) trials. *J Clin Oncol* 2008;26:3046-3050.
50. Moorman AV, Richards SM, Robinson HM, et al. Prognosis of children with acute lymphoblastic leukemia (ALL) and intrachromosomal amplification of chromosome 21 (iAMP21). *Blood* 2007;109:2327-2330.
51. Hunger SP, Raetz EA, Loh ML, et al. Improving outcomes for high-risk ALL: translating new discoveries into clinical care. *Pediatr Blood Cancer* 2011;56:984-993.
52. Holmfeldt L, Wei L, Diaz-Flores E, et al. The genomic landscape of hypodiploid acute lymphoblastic leukemia. *Nat Genet* 2013;45:242-252.
53. Pui CH, Chessells JM, Camitta B, et al. Clinical heterogeneity in childhood acute lymphoblastic leukemia with 11q23 rearrangements. *Leukemia* 2003;17:700-706.
- 53a. Loh ML, Harvey RC, Mullighan CG, et al. A BCR-ABL1-Like Gene Expression Profile Confers a Poor Prognosis In Patients with High-Risk Acute Lymphoblastic Leukemia (HR-ALL): A Report From Children's Oncology Group (COG) AALL0232. *Blood* 2011;118:743.
54. Nachman JB, Sather HN, Sensel MG, et al. Augmented post-induction therapy for children with high-risk acute lymphoblastic leukemia and a slow response to initial therapy. *N Engl J Med* 1998;338:1663-1671.
55. Neale GAM, Menarguez J, Kitchingman GR, et al. Detection of minimal residual disease in T-cell acute lymphoblastic leukemia using polymerase chain reaction predicts impending relapse. *Blood* 1991;78:739-747.
56. Wasserman R, Galali N, Ito Y, et al. Residual disease at the end of induction therapy as a predictor of relapse during therapy in childhood B-lineage acute lymphoblastic leukemia. *J Clin Oncol* 1992;10:1879-1888.
57. Nizet Y, Daele SV, Lewalle P, et al. Long-term follow-up of residual disease in acute lymphoblastic leukemia patients in complete remission using clonogenic IgH probes and the polymerase chain reaction. *Blood* 1993;82:1618-1625.
58. Roberts WR, Estrov Z, Ouspenskaia MV, et al. Measurement of residual leukemia during remission in childhood acute lymphoblastic leukemia. *N Engl J Med* 1997;336:317-323.
59. Mayer SP, Giamelli J, Sandoval C, et al. Quantification of leukemia clone-specific antigen gene rearrangements by a single-step PCR and fluorescence-based detection method. *Leukemia* 1999;13:1843-1852.
60. Campana D, Pui C-H. Detection of minimal residual disease in acute leukemia: methodologic advances and clinical significance. *Blood* 1995;85: 1416-1434.
61. van Dongen JJ, Seriu T, Panzer-Grumayer ER, et al. Prognostic value of minimal residual disease in acute lymphoblastic leukaemia in childhood. *Lancet* 1998;352:1731-1738.
62. Campana D, Coustan-Smith E. Minimal residual disease studies by flow cytometry in acute leukemia. *Acta Haematol* 2004;112:8-15.

63. Dibenedetto SP, Nigro LL, Mayer SP, et al. Detectable molecular residual disease at the beginning of maintenance therapy indicates poor outcome in children with T-cell acute lymphoblastic leukemia. *Blood* 1997;90:1226-1232.
64. Negrin RS, Blume KG. The use of the polymerase chain reaction for the detection of minimal residual malignant disease. *Blood* 1991;78:255-258.
65. Ito Y, Wasserman R, Galili N, et al. Molecular residual disease status at the end of chemotherapy fails to predict subsequent relapse in children with B-lineage acute lymphoblastic leukemia. *J Clin Oncol* 1993;11:546-553.
66. Coustan-Smith E, Sancho J, Hancock ML, et al. Clinical importance of minimal residual disease in childhood acute lymphoblastic leukemia. *Blood* 2000;96:2691-2696.
67. Bjorklund E, Mazur J, Soderhall S, et al. Flow cytometric follow-up of minimal residual disease in bone marrow gives prognostic information in children with acute lymphoblastic leukemia. *Leukemia* 2003;17:138-148.
68. Borowitz MJ, Devidas M, Hunger SP, et al. Clinical significance of minimal residual disease in childhood acute lymphoblastic leukemia and its relationship to other prognostic factors: a Children's Oncology Group study. *Blood* 2008;111:5477-5485.
69. Jacquy C, Delepaut B, Daele SV, et al. A prospective study of minimal residual disease in childhood B-lineage acute lymphoblastic leukaemia: MRD level at the end of induction is a strong predictive factor of relapse. *Br J Haematol* 1997;98:140-146.
70. Cavé H, Bosch JvdWt, Suciú S, et al. Clinical significance of minimal residual disease in childhood acute lymphoblastic leukemia. *N Engl J Med* 1998;339:591-598.
71. Marshall GM, Haber M, Kwan E, et al. Importance of minimal residual disease testing during the second year of therapy for children with acute lymphoblastic leukemia. *J Clin Oncol* 2003;21:704-709.
72. Flohr T, Schrauder A, Cazzaniga G, et al. Minimal residual disease-directed risk stratification using real-time quantitative PCR analysis of immunoglobulin and T-cell receptor gene rearrangements in the international multicenter trial AIEOP-BFM ALL 2000 for childhood acute lymphoblastic leukemia. *Leukemia* 2008;22:771-782.
73. Schrappe M, Valsecchi MG, Bartram CR, et al. Late MRD response determines relapse risk overall and in subsets of childhood T-cell ALL: results of the AIEOP-BFM-ALL 2000 study. *Blood* 2011;118:2077-2084.
74. Schrappe M, Hunger SP, Pui CH, et al. Outcomes after induction failure in childhood acute lymphoblastic leukemia. *N Engl J Med* 2012;366:1371-1381.
75. Smith M, Arthur D, Camitta B, et al. Uniform approach to risk classification and treatment assignment for children with acute lymphoblastic leukemia. *J Clin Oncol* 1996;14:18-24.
76. Schultz KR, Pullen DJ, Sather HN, et al. Risk- and response-based classification of childhood B-precursor acute lymphoblastic leukemia: a combined analysis of prognostic markers from the Pediatric Oncology Group (POG) and Children's Cancer Group (CCG). *Blood* 2007;109:926-935.
77. Hunger SP, Loh ML, Whitlock JA, et al. Children's Oncology Group's 2013 blueprint for research: acute lymphoblastic leukemia. *Pediatr Blood Cancer* 2013;60:957-963.
78. Conter V, Arico M, Basso G, et al. Long-term results of the Italian Association of Pediatric Hematology and Oncology (AIEOP) Studies 82, 87, 88, 91 and 95 for childhood acute lymphoblastic leukemia. *Leukemia* 2010;24:255-264.
79. Moricke A, Zimmermann M, Reiter A, et al. Long-term results of five consecutive trials in childhood acute lymphoblastic leukemia performed by the ALL-BFM study group from 1981 to 2000. *Leukemia* 2010;24:265-284.
80. Vrooman LM, Neuberg DS, Stevenson KE, et al. Dexamethasone and individualized asparaginase dosing are each associated with superior event-free survival in childhood acute lymphoblastic leukemia: results from DFCI-ALL consortium protocol 00-01. *Blood* 2009;114:321.
81. Schmiegelow K, Forestier E, Hellebostad M, et al. Long-term results of NOPHO ALL-92 and ALL-2000 studies of childhood acute lymphoblastic leukemia. *Leukemia* 2010;24:345-354.
82. Veerman AJ, Kamps WA, van den Berg H, et al. Dexamethasone-based therapy for childhood acute lymphoblastic leukaemia: results of the prospective Dutch Childhood Oncology Group (DCOG) protocol ALL-9 (1997-2004). *Lancet Oncol* 2009;10:957-966.

83. Mitchell C, Richards S, Harrison CJ, et al. Long-term follow-up of the United Kingdom medical research council protocols for childhood acute lymphoblastic leukaemia, 1980-2001. *Leukemia* 2010;24:406-418.
84. Conter V, Bartram CR, Valsecchi MG, et al. Molecular response to treatment redefines all prognostic factors in children and adolescents with B-cell precursor acute lymphoblastic leukemia: results in 3184 patients of the AIEOP-BFM ALL 2000 study. *Blood* 2010;115:3206-3214.
85. Pui CH, Cheng C, Leung W, et al. Extended follow-up of long-term survivors of childhood acute lymphoblastic leukemia. *N Engl J Med* 2003;349:640-649.
86. Pui CH, Mullighan CG, Evans WE, et al. Pediatric acute lymphoblastic leukemia: where are we going and how do we get there? *Blood* 2012;120: 1165-1174.
87. Kamps WA, van der Pal-de Bruin KM, Veerman AJ, et al. Long-term results of Dutch Childhood Oncology Group studies for children with acute lymphoblastic leukemia from 1984 to 2004. *Leukemia* 2010;24:309-319.
88. Matloub Y, Bostrom BC, Hunger SP, et al. Escalating intravenous methotrexate improves event-free survival in children with standard-risk acute lymphoblastic leukemia: a report from the Children's Oncology Group. *Blood* 2011;118:243-251.
89. Silverman LB, Stevenson KE, O'Brien, JE, et al. Long-term results of Dana-Farber Cancer Institute ALL Consortium protocols for children with newly diagnosed acute lymphoblastic leukemia (1985-2000). *Leukemia* 2010;24:320-334.
90. Gaynon PS, Angiolillo AL, Carroll WL, et al. Long-term results of the children's cancer group studies for childhood acute lymphoblastic leukemia 1983-2002: a Children's Oncology Group Report. *Leukemia* 2010;24:285-297.
91. Inaba H, Pui CH. Glucocorticoid use in acute lymphoblastic leukaemia. *Lancet Oncol* 2010;11:1096-1106.
92. De Moerloose B, Suciú S, Bertrand Y, et al. Improved outcome with pulses of vincristine and corticosteroids in continuation therapy of children with average risk acute lymphoblastic leukemia (ALL) and lymphoblastic non-Hodgkin lymphoma (NHL): report of the EORTC randomized phase 3 trial 58951. *Blood* 2010;116:36-44.
93. Bostrom BC, Sensel MR, Sather HN, et al. Dexamethasone versus prednisone and daily oral versus weekly intravenous mercaptopurine for patients with standard-risk acute lymphoblastic leukemia: a report from the Children's Cancer Group. *Blood* 2003;101:3809-3817.
94. Mitchell CD, Richards SM, Kinsey SE, et al. Benefit of dexamethasone compared with prednisolone for childhood acute lymphoblastic leukaemia: results of the UK Medical Research Council ALL97 randomized trial. *Br J Haematol* 2005;129:734-745.
95. Winick NJ, Salzer WL, Devidas M, et al. Dexamethasone (DEX) versus prednisone (PRED) during induction for children with high-risk acute lymphoblastic leukemia (HR-ALL): a report from the Children's Oncology Group Study AALL0232. *ASCO Meeting Abstracts* 2011;29:9504.
96. Schrappe M, Zimmermann M, Moricke A, et al. Dexamethasone in induction can eliminate one third of all relapses in childhood acute lymphoblastic leukemia (ALL): results of an international randomized trial in 3655 patients (Trial AIEOP-BFM ALL 2000). *Blood* 2008;112:7.
97. Igarashi S, Manabe A, Ohara A, et al. No advantage of dexamethasone over prednisolone for the outcome of standard- and intermediate-risk childhood acute lymphoblastic leukemia in the Tokyo Children's Cancer Study Group L95-14 protocol. *J Clin Oncol* 2005;23:6489-6498.
98. Teuffel O, Kuster SP, Hunger SP, et al. Dexamethasone versus prednisone for induction therapy in childhood acute lymphoblastic leukemia: a systematic review and meta-analysis. *Leukemia* 2011;25:1232-1238.
99. Belgaumi AF, Al-Bakrah M, Al-Mahr M, et al. Dexamethasone-associated toxicity during induction chemotherapy for childhood acute lymphoblastic leukemia is augmented by concurrent use of daunomycin. *Cancer* 2003;97:2898-2903.
100. Hurwitz CA, Silverman LB, Schorin MA, et al. Substituting dexamethasone for prednisone complicates remission induction in children with acute lymphoblastic leukemia. *Cancer* 2000;88:1964-1969.
101. Vora A, Wade R, Mitchell CD. Improved outcome for children and young adults with t-cell acute lymphoblastic leukemia (all): results of the united kingdom medical research council (mrc) trial ukall 2003. *Blood* 2008;112:908 (abstract).
102. Ortega JA, Nesbit ME Jr, Donaldson MH, et al. L-Asparaginase, vincristine, and prednisone for induction of first remission in acute lymphocytic leukemia. *Cancer Res* 1977;37:535-540.

103. Asselin BL, Whitin JC, Coppola DJ, et al. Comparative pharmacokinetic studies of three asparaginase preparations. *J Clin Oncol* 1993;11:1780-1786.
104. Avramis VI, Sencer S, Periclou AP, et al. A randomized comparison of native *Escherichia coli* asparaginase and polyethylene glycol conjugated asparaginase for treatment of children with newly diagnosed standard-risk acute lymphoblastic leukemia: a Children's Cancer Group study. *Blood* 2002;99:1986-1994.
105. Panetta JC, Gajjar A, Hijiya N, et al. Comparison of native *E. coli* and PEG asparaginase pharmacokinetics and pharmacodynamics in pediatric acute lymphoblastic leukemia. *Clin Pharmacol Ther* 2009;86:651-658.
106. Pieters R, Hunger SP, Boos J, et al. L-asparaginase treatment in acute lymphoblastic leukemia: a focus on *Erwinia* asparaginase. *Cancer* 2011;117:238-249.
107. Panosyan EH, Seibel NL, Martin-Aragon S, et al. Asparaginase antibody and asparaginase activity in children with higher-risk acute lymphoblastic leukemia: Children's Cancer Group Study CCG-1961. *J Pediatr Hematol Oncol* 2004;26:217-226.
108. Silverman LB, Supko JG, Stevenson KE, et al. Intravenous PEG-asparaginase during remission induction in children and adolescents with newly diagnosed acute lymphoblastic leukemia. *Blood* 2010;115:1351-1353.
109. Basso G, Veltroni M, Valsecchi MG, et al. Risk of relapse of childhood acute lymphoblastic leukemia is predicted by flow cytometric measurement of residual disease on day 15 bone marrow. *J Clin Oncol* 2009;27:5168-5174.
110. Coustan-Smith E, Sancho J, Behm FG, et al. Prognostic importance of measuring early clearance of leukemic cells by flow cytometry in childhood acute lymphoblastic leukemia. *Blood* 2002;100:52-58.
111. Gaynon PS, Desai AA, Bostrom BC, et al. Early response to therapy and outcome in childhood acute lymphoblastic leukemia: a review. *Cancer* 1997;80:1717-1726.
112. Zhou J, Goldwasser MA, Li A, et al. Quantitative analysis of minimal residual disease predicts relapse in children with B-lineage acute lymphoblastic leukemia in DFCI ALL Consortium Protocol 95-01. *Blood* 2007;110:1607-1611.
113. Vora AJ, Goulden N, Mitchell CD, et al. UKALL 2003, A randomised trial investigating treatment intensification for children and young adults with minimal residual disease defined high risk acute lymphoblastic leukaemia. *Blood* 2012;120:136.
114. Oudot C, Auclerc MF, Levy V, et al. Prognostic factors for leukemic induction failure in children with acute lymphoblastic leukemia and outcome after salvage therapy: the FRALLE 93 study. *J Clin Oncol* 2008;26:1496-1503.
115. Silverman LB, Gelber RD, Young ML, et al. Induction failure in acute lymphoblastic leukemia of childhood. *Cancer* 1999;85:1395-1404.
116. Simone J, Aur RJ, Hustu HO, et al. "Total therapy" studies of acute lymphocytic leukemia in children. Current results and prospects for cure. *Cancer* 1972;30:1488-1494.
117. Simone JV, Aur RJ, Hustu HO, et al. Combined modality therapy of acute lymphocytic leukemia. *Cancer* 1975;35:25-35.
118. Bleyer WA, Sather HN, Nickerson HJ, et al. Monthly pulses of vincristine and prednisone prevent bone marrow and testicular relapse in low-risk childhood acute lymphoblastic leukemia: a report of the CCG-161 study by the Children's Cancer Study Group. *J Clin Oncol* 1991;9:1012-1021.
119. Tubergen DG, Gilchrist GS, O'Brien, RT, et al. Improved outcome with delayed intensification for children with acute lymphoblastic leukemia and intermediate presenting features: a Children's Cancer Group phase III trial. *J Clin Oncol* 1993;11:527-537.
120. Seibel NL, Steinherz PG, Sather HN, et al. Early postinduction intensification therapy improves survival for children and adolescents with high-risk acute lymphoblastic leukemia: a report from the Children's Oncology Group. *Blood* 2008;111:2548-2555.
121. Matloub Y, Lindemulder S, Gaynon PS, et al. Intrathecal triple therapy decreases central nervous system relapse but fails to improve event-free survival when compared with intrathecal methotrexate: results of the Children's Cancer Group (CCG) 1952 study for standard-risk acute lymphoblastic leukemia, reported by the Children's Oncology Group. *Blood* 2006;108:1165-1173.
122. Richards S, Pui CH, Gayon P, et al. Systematic review and meta-analysis of randomized trials of central nervous system directed therapy for childhood acute lymphoblastic leukemia. *Pediatr Blood Cancer* 2013;60:185-195.

123. Burger B, Zimmermann M, Mann G, et al. Diagnostic cerebrospinal fluid examination in children with acute lymphoblastic leukemia: significance of low leukocyte counts with blasts or traumatic lumbar puncture. *J Clin Oncol* 2003;21:184-188.
124. Gajjar A, Harrison PL, Sandlund JT, et al. Traumatic lumbar puncture at diagnosis adversely affects outcome in childhood acute lymphoblastic leukemia. *Blood* 2000;96:3381-3384.
125. Freeman AI, Weinberg V, Brecher ML, et al. Comparison of intermediate-dose methotrexate with cranial irradiation for the post-induction treatment of acute lymphocytic leukemia in children. *N Engl J Med* 1983;308:477-484.
126. Brecher ML, Weinberg V, Boyett JM, et al. Intermediate dose methotrexate in childhood acute lymphoblastic leukemia resulting in decreased incidence of testicular relapse. *Cancer* 1986;58:1024-1028.
127. Janka GE, Winkler K, Juergens H, et al. Early intensification therapy in high-risk childhood acute lymphocytic leukemia: lack of benefit from high-dose methotrexate. *Haematol Blood Transfus* 1987;30:456-460.
128. Abromowitch M, Ochs J, Pui CH, et al. Efficacy of high-dose methotrexate in childhood acute lymphocytic leukemia: analysis by contemporary risk classifications. *Blood* 1988;71:866-869.
129. Abromowitch M, Ochs J, Pui CH, et al. High-dose methotrexate improves clinical outcome in children with acute lymphoblastic leukemia: St. Jude Total Therapy Study X. *Med Pediatr Oncol* 1988;16:297-303.
130. Schrappe M, Reiter A, Sauter S, et al. [Concept and interim result of the ALL-BFM 90 therapy study in treatment of acute lymphoblastic leukemia in children and adolescents: the significance of initial therapy response in blood and bone marrow]. *Klin Padiatr* 1994;206:208-221.
131. Lange BJ, Blatt J, Sather HN, et al. Randomized comparison of moderate-dose methotrexate infusions to oral methotrexate in children with intermediate risk acute lymphoblastic leukemia: a Children's Cancer Group study. *Med Pediatr Oncol* 1996;27:15-20.
132. Nathan PC, Whitcomb T, Wolters PL, et al. Very high-dose methotrexate (33.6 g/m²) as central nervous system preventive therapy for childhood acute lymphoblastic leukemia: results of National Cancer Institute/Children's Cancer Group trials CCG-191P, CCG-134P and CCG-144P. *Leuk Lymphoma* 2006;47:2488-2504.
133. Wehinger H, Gutjahr P, Hofweber K, et al. Which is the best methotrexate schedule for maintenance therapy of childhood ALL? A randomized study. *Klin Padiatr* 1982;194:214-218.
134. Koizumi S, Fujimoto T, Takeda T, et al. Comparison of intermittent or continuous methotrexate plus 6-mercaptopurine in regimens for standard-risk acute lymphoblastic leukemia in childhood (JCCLSG-S811). The Japanese Children's Cancer and Leukemia Study Group. *Cancer* 1988;61:1292-1300.
135. Reiter A, Schrappe M, Ludwig W, et al. Chemotherapy in 998 unselected childhood acute lymphoblastic leukemia patients. Results and conclusions of the multicenter trial ALL-BFM 86. *Blood* 1994;84:3122-3133.
136. Jurgens H, Janka G, Ibrahim M, et al. Prognostic significance of exposure to intermediate-dose methotrexate in children with standard risk ALL: the COALL 82/85 experience. *Haematol Blood Transfus* 1992;34:338-342.
137. Winick N, Shuster JJ, Bowman WP, et al. Intensive oral methotrexate protects against lymphoid marrow relapse in childhood B-precursor acute lymphoblastic leukemia. *J Clin Oncol* 1996;14:2803-2811.
138. Mahoney DH Jr, Shuster J, Nitschke R, et al. Intermediate-dose intravenous methotrexate with intravenous mercaptopurine is superior to repetitive low-dose oral methotrexate with intravenous mercaptopurine for children with lower-risk B-lineage acute lymphoblastic leukemia: a Pediatric Oncology Group phase III trial. *J Clin Oncol* 1998;16:246-254.
139. Larsen EC, Salzer WL, Devidas M, et al. Comparison of high-dose methotrexate (HD-MTX) with Capizzi methotrexate plus asparaginase (C-MTX/ASNase) in children and young adults with high-risk acute lymphoblastic leukemia (HR-ALL): a report from the Children's Oncology Group Study AALL0232. *ASCO Meeting Abstracts* 2011;29:3.
140. Pui CH, Pei D, Sandlund JT, et al. Long-term results of St Jude Total Therapy Studies 11, 12, 13A, 13B, and 14 for childhood acute lymphoblastic leukemia. *Leukemia* 2010;24:371-382.
141. Schrappe M, Reiter A, Zimmermann M, et al. Long-term results of four consecutive trials in childhood ALL performed by the ALL-BFM study group from 1981 to 1995. Berlin-Frankfurt-Munster. *Leukemia* 2000;14:2205-2222.

142. Asselin BL, Devidas M, Wang C, et al. Effectiveness of high-dose methotrexate in T-cell lymphoblastic leukemia and advanced-stage lymphoblastic lymphoma: a randomized study by the Children's Oncology Group (POG 9404). *Blood* 2011;118:874-883.
143. Sallan SE, Hitchcock-Bryan S, Gelber R, et al. Influence of intensive asparaginase in the treatment of childhood non-T-cell acute lymphoblastic leukemia. *Cancer Res* 1983;43:5601-5607.
144. Silverman LB, Gelber RD, Dalton VK, et al. Improved outcome for children with acute lymphoblastic leukemia: results of Dana-Farber Consortium Protocol 91-01. *Blood* 2001;97:1211-1218.
145. Pession A, Valsecchi MG, Masera G, et al. Long-term results of a randomized trial on extended use of high dose L-asparaginase for standard risk childhood acute lymphoblastic leukemia. *J Clin Oncol* 2005;23:7161-7167.
146. Moghrabi A, Levy DE, Asselin B, et al. Results of the Dana-Farber Cancer Institute ALL Consortium Protocol 95-01 for children with acute lymphoblastic leukemia. *Blood* 2007;109:896-904.
147. Asselin BL. L-asparaginase for treatment of childhood acute lymphoblastic leukemia: what have we learned? *Pediatr Blood Cancer* 2011;57:357-358.
148. Raetz EA, Salzer WL. Tolerability and efficacy of L-asparaginase therapy in pediatric patients with acute lymphoblastic leukemia. *J Pediatr Hematol Oncol* 2010;32:554-563.
149. Riehm H, Gadner H, Henze G, et al. Results and significance of six randomized trials in four consecutive ALL-BFM studies. *Haematol Blood Transfus* 1990;33:439-450.
150. Henze G, Langermann HJ, Ritter J, et al. Treatment strategy for different risk groups in childhood acute lymphoblastic leukemia: a report from the BFM Study Group. *Haematol Blood Transfus* 1981;26:87-93.
151. Gaynon PS, Bleyer WA, Steinherz PG, et al. Modified BFM therapy for children with previously untreated acute lymphoblastic leukemia and unfavorable prognostic features. Report of Children's Cancer Study Group Study CCG-193P. *Am J Pediatr Hematol Oncol* 1988;10:42-50.
152. Gaynon PS, Steinherz PG, Bleyer WA, et al. Improved therapy for children with acute lymphoblastic leukemia and unfavorable presenting features: a follow-up report of the Children's Cancer Group Study CCG-106. *J Clin Oncol* 1993;11:2234-2242.
153. Steinherz PG, Gaynon PS, Breneman JC, et al. Treatment of patients with acute lymphoblastic leukemia with bulky extramedullary disease and T-cell phenotype or other poor prognostic features: randomized controlled trial from the Children's Cancer Group. *Cancer* 1998;82:600-612.
154. Hutchinson RJ, Gaynon PS, Sather H, et al. Intensification of therapy for children with lower-risk acute lymphoblastic leukemia: long-term follow-up of patients treated on Children's Cancer Group Trial 1881. *J Clin Oncol* 2003;21:1790-1797.
155. Capizzi R, Castro O, Aspnes G, et al. Treatment of acute lymphocytic leukemia (ALL) with intermittent high dose methotrexate (MTX) and asparaginase (A'ASE). *Proc Am Soc Clin Oncol Am Asso Cancer Res* 1974;15:182.
156. Baum E, Nachman J, Ramsay N, et al. Prolonged second remissions in childhood acute lymphocytic leukemia: a report from the Children's Cancer Study Group. *Med Pediatr Oncol* 1983;11:1-7.
157. Adamson PC, Poplack DG, Balis FM. The cytotoxicity of thioguanine vs mercaptopurine in acute lymphoblastic leukemia. *Leuk Res* 1994;18:805-810.
158. Lennard L, Davies HA, Lilleyman JS. Is 6-thioguanine more appropriate than 6-mercaptopurine for children with acute lymphoblastic leukaemia? *Br J Cancer* 1993;68:186-190.
159. Vora A, Mitchell CD, Lennard L, et al. Toxicity and efficacy of 6-thioguanine versus 6-mercaptopurine in childhood lymphoblastic leukaemia: a randomised trial. *Lancet* 2006;368:1339-1348.
160. Stork LC, Matloub Y, Broxson E, et al. Oral 6-mercaptopurine versus oral 6-thioguanine and veno-occlusive disease in children with standard-risk acute lymphoblastic leukemia: report of the Children's Oncology Group CCG-1952 clinical trial. *Blood* 2010;115:2740-2748.

P.1636

161. Escherich G, Richards S, Stork LC, et al. Meta-analysis of randomised trials comparing thiopurines in childhood acute lymphoblastic leukaemia. *Leukemia* 2011;25:953-959.
162. Zimm S, Collins JM, Riccardi R, et al. Variable bioavailability of oral mercaptopurine. Is maintenance chemotherapy in acute lymphoblastic leukemia being optimally delivered? *N Engl J Med* 1983;308:1005-1009.
163. Lilleyman JS, Lennard L. Mercaptopurine metabolism and risk of relapse in childhood lymphoblastic leukaemia. *Lancet* 1994;343:1188-1190.
164. Camitta B, Leventhal B, Lauer S, et al. Intermediate-dose intravenous methotrexate and mercaptopurine therapy for non-T, non-B acute lymphocytic leukemia of childhood: a Pediatric Oncology Group study. *J Clin Oncol* 1989;7:1539-1544.
165. Duration and intensity of maintenance chemotherapy in acute lymphoblastic leukaemia: overview of 42 trials involving 12 000 randomised children. *Lancet* 1996;347:1783-1788.
166. Eden T, Pieters R, Richards S. Systematic review of the addition of vincristine plus steroid pulses in maintenance treatment for childhood acute lymphoblastic leukaemia - an individual patient data meta-analysis involving 5,659 children. *Br J Haematol* 2010;149:722-733.
167. Conter V, Valsecchi MG, Silvestri D, et al. Pulses of vincristine and dexamethasone in addition to intensive chemotherapy for children with intermediate-risk acute lymphoblastic leukaemia: a multicentre randomised trial. *Lancet* 2007;369:123-131.
168. Mattano LA Jr, Sather HN, Trigg ME, et al. Osteonecrosis as a complication of treating acute lymphoblastic leukemia in children: a report from the Children's Cancer Group. *J Clin Oncol* 2000;18:3262-3272.
169. Clavell LA, Gelber RD, Cohen HJ, et al. Four-agent induction and intensive asparaginase therapy for treatment of childhood acute lymphoblastic leukemia. *N Engl J Med* 1986;315:657-663.
170. Silverman LB, Declerck L, Gelber RD, et al. Results of Dana-Farber Cancer Institute Consortium protocols for children with newly diagnosed acute lymphoblastic leukemia (1981-1995). *Leukemia* 2000;14:2247-2256.
171. Schorin M, Blattner S, Gelber R, et al. Treatment of childhood acute lymphoblastic leukemia: results of Dana-Farber Cancer Institute/Children's Hospital Acute Lymphoblastic Leukemia Consortium Protocol 85-01. *J Clin Oncol* 1994;12:740-747.
172. Steinherz PG, Gaynon P, Miller DR, et al. Improved disease-free survival of children with acute lymphoblastic leukemia at high risk for early relapse with the New York regimen, a new intensive therapy protocol. *J Clin Oncol* 1986;4:744-752.
173. Steinherz PG, Redner A, Steinherz L, et al. Development of a new intensive therapy for acute lymphoblastic leukemia in children at increased risk of early relapse. The Memorial Sloan-Kettering-New York-II protocol. *Cancer* 1993;72:3120-3130.
174. Brandalise SR, Pinheiro VR, Aguiar SS, et al. Benefits of the intermittent use of 6-mercaptopurine and methotrexate in maintenance treatment for low-risk acute lymphoblastic leukemia in children: randomized trial from the Brazilian Childhood Cooperative Group—protocol ALL-99. *J Clin Oncol* 2010;28:1911-1918.
175. Arico M, Valsecchi MG, Camitta B, et al. Outcome of treatment in children with Philadelphia chromosome-positive acute lymphoblastic leukemia. *N Engl J Med* 2000;342:998-1006.
176. Slayton WB, Schultz KR, Jones T, et al. Continuous dose dasatinib is safe and feasible in combination with intensive chemotherapy in pediatric philadelphia chromosome positive acute lymphoblastic leukemia (Ph+ ALL): Children's Oncology Group (COG) trial AALL0622. *Blood* 2012;120:137.
177. Goldberg JM, Silverman LB, Levy DE, et al. Childhood T-cell acute lymphoblastic leukemia: the Dana-Farber Cancer Institute acute lymphoblastic leukemia consortium experience. *J Clin Oncol* 2003;21:3616-3622.
178. Matloub Y, Asselin BL, Stork LC, et al. Outcome of children with T-cell acute lymphoblastic leukemia (T-ALL) and standard risk (SR) features: results of CCG-1952, CCG-1991 and POG 9404. *Blood* 2004;104:680.
179. Coustan-Smith E, Mullighan CG, Onciu M, et al. Early T-cell precursor leukaemia: a subtype of very high-risk acute lymphoblastic leukaemia. *Lancet Oncol* 2009;10:147-156.
180. Barry E, DeAngelo DJ, Neuberg D, et al. Favorable outcome for adolescents with acute lymphoblastic leukemia treated on Dana-Farber Cancer Institute Acute Lymphoblastic Leukemia Consortium Protocols. *J Clin Oncol* 2007;25:813-819.

181. McNeer JL, Raetz EA. Acute lymphoblastic leukemia in young adults: which treatment? *Curr Opin Oncol* 2012;24:487-494.
182. Nachman JB, La MK, Hunger SP, et al. Young adults with acute lymphoblastic leukemia have an excellent outcome with chemotherapy alone and benefit from intensive postinduction treatment: a report from the children's oncology group. *J Clin Oncol* 2009;27:5189-5194.
183. Pui CH, Pei D, Campana D, et al. Improved prognosis for older adolescents with acute lymphoblastic leukemia. *J Clin Oncol* 2011;29:386-391.
184. Boissel N, Auclerc MF, Lheritier V, et al. Should adolescents with acute lymphoblastic leukemia be treated as old children or young adults? Comparison of the French FRALLE-93 and LALA-94 trials. *J Clin Oncol* 2003;21:774-780.
185. Hallbook H, Gustafsson G, Smedmyr B, et al. Treatment outcome in young adults and children +10 years of age with acute lymphoblastic leukemia in Sweden: a comparison between a pediatric protocol and an adult protocol. *Cancer* 2006;107:1551-1561.
186. Ramanujachar R, Richards S, Hann I, et al. Adolescents with acute lymphoblastic leukaemia: outcome on UK national paediatric (ALL97) and adult (UKALLXII/E2993) trials. *Pediatr Blood Cancer* 2007;48:254-261.
187. Stock W, La M, Sanford B, et al. What determines the outcomes for adolescents and young adults with acute lymphoblastic leukemia treated on cooperative group protocols? A comparison of Children's Cancer Group and Cancer and Leukemia Group B studies. *Blood* 2008;112:1646-1654.
188. Pieters R, Schrappe M, De Lorenzo P, et al. A treatment protocol for infants younger than 1 year with acute lymphoblastic leukaemia (Interfant-99): an observational study and a multicentre randomised trial. *Lancet* 2007;370:240-250.
189. Armstrong SA, Staunton JE, Silverman LB, et al. MLL translocations specify a distinct gene expression profile that distinguishes a unique leukemia. *Nat Genet* 2002;30:41-47.
190. Brown P, Levis M, McIntyre E, et al. Combinations of the FLT3 inhibitor CEP-701 and chemotherapy synergistically kill infant and childhood MLL-rearranged ALL cells in a sequence-dependent manner. *Leukemia* 2006;20:1368-1376.
191. Dreyer ZE, Dinndorf PA, Camitta B, et al. Analysis of the role of hematopoietic stem-cell transplantation in infants with acute lymphoblastic leukemia in first remission and MLL gene rearrangements: a report from the Children's Oncology Group. *J Clin Oncol* 2011;29:214-222.
192. Mann G, Attarbaschi A, Schrappe M, et al. Improved outcome with hematopoietic stem cell transplantation in a poor prognostic subgroup of infants with mixed-lineage-leukemia (MLL)-rearranged acute lymphoblastic leukemia: results from the Interfant-99 Study. *Blood* 2010;116:2644-2650.
193. Whitlock JA. Down syndrome and acute lymphoblastic leukaemia. *Br J Haematol* 2006;135:595-602.
194. Robison LL, Nesbit ME, Sather HN, et al. Down syndrome and acute leukemia in children: a 10-year retrospective study from Children's Cancer Study Group. *J Pediatr* 1984;105:235-242.
195. Kalwinsky DK, Raimondi SC, Bunin NJ, et al. Clinical and biological characteristics of acute lymphocytic leukemia in children with Down syndrome. *Am J Med Genet Suppl* 1990;7:267-271.
196. Levitt GA, Stiller CA, Chessells JM. Prognosis of Down's syndrome with acute leukemia. *Arch Dis Child* 1990;65:212-216.
197. Dördelmann M, Schrappe M, Reiter A, et al. Down's syndrome in childhood acute lymphoblastic leukemia: clinical characteristics and treatment outcome in four consecutive BFM trials. *Leukemia* 1998;12:645-651.
198. Chessells JM, Harrison G, Richards SM. Down's syndrome and acute lymphoblastic leukaemia: clinical features and response to treatment. *Arch Dis Child* 2001;85:321-325.
199. Whitlock JA, Sather HN, Gaynon P, et al. Clinical characteristics and outcome of children with Down syndrome and acute lymphoblastic leukemia: a Children's Cancer Group study. *Blood* 2005;106:4043-4049.
200. Ravindranath Y, Abella E, Krischer JP, et al. Acute myeloid leukemia (AML) in Down's syndrome is highly responsive to chemotherapy: experience on Pediatric Oncology Group AML Study 8498. *Blood* 1992;80:2210-2214.
201. Pui C-H, Raimondi SC, Borowitz MJ, et al. Immunophenotypes and karyotypes of leukemic cells in children with Down syndrome and acute lymphoblastic leukemia. *J Clin Oncol* 1993;11:1361-1367.

202. Forestier E, Izraeli S, Beverloo B, et al. Cytogenetic features of acute lymphoblastic and myeloid leukemias in pediatric patients with Down syndrome: an iBFM-SG study. *Blood* 2008;111:1575-1583.
203. Hertzberg L, Vendramini E, Ganmore I, et al. Down syndrome acute lymphoblastic leukemia, a highly heterogeneous disease in which aberrant expression of CRLF2 is associated with mutated JAK2: a report from the International BFM Study Group. *Blood* 2010;115:1006-1017.
204. Maloney KW, Carroll WL, Carroll AJ, et al. Down syndrome childhood acute lymphoblastic leukemia has a unique spectrum of sentinel cytogenetic lesions that influences treatment outcome: a report from the Children's Oncology Group. *Blood* 2010;116:1045-1050.
205. Mullighan CG, Collins-Underwood JR, Phillips LA, et al. Rearrangement of CRLF2 in B-progenitor- and Down syndrome-associated acute lymphoblastic leukemia. *Nat Genet* 2009;41:1243-1246.
206. Ragab AH, Abdel-Mageed A, Shuster JJ, et al. Clinical characteristics and treatment outcome of children with acute lymphocytic leukemia and Down's syndrome: a Pediatric Oncology Group study. *Cancer* 1991;67:1057-1063.
207. Maloney KW, Larsen E, Mattano L, et al. Improved toxic mortality rates for children with down syndrome acute lymphoblastic leukemia (DS-ALLI) treated on on children's oncology group (COG) trials for standard risk (SR;AALL0331) but not high risk (HR, AALL0232) ALL. *Pediatr Blood Cancer* 2011;56:900.
208. Gaynon PS. Childhood acute lymphoblastic leukaemia and relapse. *Br J Haematol* 2005;131:579-587.
209. Gaynon PS, Harris RE, Altman AJ, et al. Bone marrow transplantation versus prolonged intensive chemotherapy for children with acute lymphoblastic leukemia and an initial bone marrow relapse within 12 months of the completion of primary therapy: Children's Oncology Group study CCG-1941. *J Clin Oncol* 2006;24:3150-3156.
210. Bailey LC, Lange BJ, Rheingold SR, et al. Bone-marrow relapse in paediatric acute lymphoblastic leukaemia. *Lancet Oncol* 2008;9:873-883.
211. Einsiedel HG, von Stackelberg A, Hartmann R, et al. Long-term outcome in children with relapsed ALL by risk-stratified salvage therapy: results of trial acute lymphoblastic leukemia-relapse study of the Berlin-Frankfurt-Munster Group 87. *J Clin Oncol* 2005;23:7942-7950.
212. Nguyen K, Devidas M, Cheng SC, et al. Factors influencing survival after relapse from acute lymphoblastic leukemia: a Children's Oncology Group study. *Leukemia* 2008;22:2142-2150.
213. Gurney JG, Severson RK, Davis S, et al. Incidence of cancer in children in the United States. Sex-, race-, and 1-year age-specific rates by histologic type. *Cancer* 1995;75:2186-2195.
214. Saarinen-Pihkala UM, Heilmann C, Winiarski J, et al. Pathways through relapses and deaths of children with acute lymphoblastic leukemia: role of allogeneic stem-cell transplantation in nordic data. *J Clin Oncol* 2006;24:5750-5762.
215. Ko RH, Ji L, Barnette P, et al. Outcome of patients treated for relapsed or refractory acute lymphoblastic leukemia: a therapeutic advances in childhood leukemia consortium study. *J Clin Oncol* 2010;28:648-654.
216. Gaynon PS, Qu RP, Chappell RJ, et al. Survival after relapse in childhood acute lymphoblastic leukemia: impact of site and time to first relapse—the Children's Cancer Group Experience. *Cancer* 1998;82:1387-1395.
217. Chessells JM. Relapsed lymphoblastic leukaemia in children: a continuing challenge. *Br J Haematol* 1998;102:423-438.
218. Bunin NJ, Pui CH, Hustu HO, et al. Unusual extramedullary relapses in children with acute lymphoblastic leukemia. *J Pediatr* 1986;109:665-668.
219. Lawson SE, Harrison G, Richards S, et al. The UK experience in treating relapsed childhood acute lymphoblastic leukaemia: a report on the medical research council UKALLR1 study. *Br J Haematol* 2000;108:531-543.
220. Borgmann A, von Stackelberg A, Hartmann R, et al. Unrelated donor stem cell transplantation compared with chemotherapy for children with acute lymphoblastic leukemia in a second remission: a matched-pair analysis. *Blood* 2003;101:3835-3839.
221. Raetz EA, Borowitz MJ, Devidas M, et al. Reinduction platform for children with first marrow relapse of acute lymphoblastic leukemia: a Children's Oncology Group Study. *J Clin Oncol* 2008;26:3971-3978.
222. Bader P, Kreyenberg H, Henze GH, et al. Prognostic value of minimal residual disease quantification before allogeneic stem-cell transplantation in relapsed childhood acute lymphoblastic leukemia: the ALL-REZ BFM Study Group. *J Clin Oncol* 2009;27:377-384.

223. Paganin M, Zecca M, Fabbri G, et al. Minimal residual disease is an important predictive factor of outcome in children with relapsed 'high-risk' acute lymphoblastic leukemia. *Leukemia* 2008;22:2193-2200.
224. Parker C, Waters R, Leighton C, et al. Effect of mitoxantrone on outcome of children with first relapse of acute lymphoblastic leukaemia (ALL R3): an open-label randomised trial. *Lancet* 2010;376:2009-2017.
225. Coustan-Smith E, Song G, Clark C, et al. New markers for minimal residual disease detection in acute lymphoblastic leukemia. *Blood* 2011;117: 6267-6276.
226. Forestier E, Heyman M, Andersen MK, et al. Outcome of ETV6/RUNX1-positive childhood acute lymphoblastic leukaemia in the NOPHO-ALL-1992 protocol: frequent late relapses but good overall survival. *Br J Haematol* 2008;140:665-672.
227. Ford AM, Fasching K, Panzer-Grumayer ER, et al. Origins of "late" relapse in childhood acute lymphoblastic leukemia with TEL-AML1 fusion genes. *Blood* 2001;98:558-564.
228. Krentz S, Hof J, Mendioroz A, et al. Prognostic value of genetic alterations in children with first bone marrow relapse of childhood B-cell precursor acute lymphoblastic leukemia. *Leukemia* 2013;27:295-304.
229. Henze G, Fengler R, Hartmann R, et al. Six-year experience with a comprehensive approach to the treatment of recurrent childhood acute lymphoblastic leukemia (ALL-REZ BFM 85). A relapse study of the BFM group. *Blood* 1991;78:1166-1172.
230. Chessells JM, Leiper AD, Richards SM. A second course of treatment for childhood acute lymphoblastic leukaemia: long-term follow-up is needed to assess results. *Br J Haematol* 1994;86:48-54.
231. Feig SA, Ames MM, Sather HN, et al. Comparison of idarubicin to daunomycin in a randomized multidrug treatment of childhood acute lymphoblastic leukemia at first bone marrow relapse: a report from the Children's Cancer Group. *Med Pediatr Oncol* 1996;27:505-514.
232. Leahey AM, Bunin NJ, Belasco JB, et al. Novel multiagent chemotherapy for bone marrow relapse of pediatric acute lymphoblastic leukemia. *Med Pediatr Oncol* 2000;34:313-318.
233. Buhner C, Hartmann R, Fengler R, et al. Importance of effective central nervous system therapy in isolated bone marrow relapse of childhood acute lymphoblastic leukemia. BFM (Berlin-Frankfurt-Munster) Relapse Study Group. *Blood* 1994;83:3468-3472.
234. Wheeler K, Leiper AD, Jannoun L, et al. Medical cost of curing childhood acute lymphoblastic leukaemia. *Br Med J (Clin Res Ed)* 1988;296:162-166.
235. Rivera GK, Hudson MM, Liu Q, et al. Effectiveness of intensified rotational combination chemotherapy for late hematologic relapse of childhood acute lymphoblastic leukemia. *Blood* 1996;88:831-837.
236. Goulden N, Langlands K, Steward C, et al. PCR assessment of bone marrow status in 'isolated' extramedullary relapse of childhood B-precursor acute lymphoblastic leukaemia. *Br J Haematol* 1994;87:282-285.
237. Neale GA, Pui CH, Mahmoud HH, et al. Molecular evidence for minimal residual bone marrow disease in children with 'isolated' extra-medullary relapse of T-cell acute lymphoblastic leukemia. *Leukemia* 1994;8:768-775.
238. Murray JC, Gmoser DJ, Barnes DA, et al. Isolated bone relapse during hematologic remission in childhood acute lymphoblastic leukemia: report of a metatarsal relapse and review of the literature. *Med Pediatr Oncol* 1994;23:153-157.
239. Sullivan MP, Moon TE, Trueworthy R, et al. Combination intrathecal therapy for meningeal leukemia: two versus three drugs. *Blood* 1977;50:471-479.
240. Land VJ, Thomas PR, Boyett JM, et al. Comparison of maintenance treatment regimens for first central nervous system relapse in children with acute lymphocytic leukemia. a Pediatric Oncology Group study. *Cancer* 1985;56:81-87.
241. Winick NJ, Smith SD, Shuster J, et al. Treatment of CNS relapse in children with acute lymphoblastic leukemia: a Pediatric Oncology Group study. *J Clin Oncol* 1993;11:271-278.
242. Ritchey AK, Pollock BH, Lauer SJ, et al. Improved survival of children with isolated CNS relapse of acute lymphoblastic leukemia: a pediatric oncology group study. *J Clin Oncol* 1999;17:3745-3752.
243. Ribeiro RC, Rivera GK, Hudson M, et al. An intensive re-treatment protocol for children with an isolated CNS relapse of acute lymphoblastic leukemia. *J Clin Oncol* 1995;13:333-338.

244. Barredo JC, Devidas M, Lauer SJ, et al. Isolated CNS relapse of acute lymphoblastic leukemia treated with intensive systemic chemotherapy and delayed CNS radiation: a pediatric oncology group study. *J Clin Oncol* 2006;24: 3142-3149.
245. Uderzo C, Grazia Zurlo M, Adamoli L, et al. Treatment of isolated testicular relapse in childhood acute lymphoblastic leukemia: an Italian multicenter study. *Associazione Italiana Ematologia ed Oncologia Pediatrica. J Clin Oncol* 1990;8:672-677.
246. Mulhern RK, Ochs J, Fairclough D, et al. Intellectual and academic achievement status after CNS relapse: a retrospective analysis of 40 children treated for acute lymphoblastic leukemia. *J Clin Oncol* 1987;5:933-940.
247. Russo A, Schiliro G. The enigma of testicular leukemia: a critical review. *Med Pediatr Oncol* 1986;14:300-305.
248. Miller DR, Leikin SL, Albo VC, et al. The prognostic value of testicular biopsy in childhood acute lymphoblastic leukemia: a report from the Childrens Cancer Study Group. *J Clin Oncol* 1990;8:57-66.
249. Nachman J, Palmer NF, Sather HN, et al. Open-wedge testicular biopsy in childhood acute lymphoblastic leukemia after two years of maintenance therapy: diagnostic accuracy and influence on outcome—a report from Children's Cancer Study Group. *Blood* 1990;75:1051-1055.
250. Gaynon PS, Steinherz PG, Bleyer WA, et al. Intensive therapy for children with acute lymphoblastic leukaemia and unfavourable presenting features. Early conclusions of study CCG-106 by the Childrens Cancer Study Group. *Lancet* 1988;2:921-924.
251. Finklestein JZ, Miller DR, Feusner J, et al. Treatment of overt isolated testicular relapse in children on therapy for acute lymphoblastic leukemia. A report from the Childrens Cancer Group. *Cancer* 1994;73:219-223.
252. Buchanan GR, Boyett JM, Pollock BH, et al. Improved treatment results in boys with overt testicular relapse during or shortly after initial therapy for acute lymphoblastic leukemia. A Pediatric Oncology group study. *Cancer* 1991;68:48-55.
253. Wofford MM, Smith SD, Shuster JJ, et al. Treatment of occult or late overt testicular relapse in children with acute lymphoblastic leukemia: a Pediatric Oncology Group study. *J Clin Oncol* 1992;10:624-630.
254. Sklar CA, Robison LL, Nesbit ME, et al. Effects of radiation on testicular function in long-term survivors of childhood acute lymphoblastic leukemia: a report from the Children Cancer Study Group. *J Clin Oncol* 1990;8:1981-1987.
255. Kernan NA, Bartsch G, Ash RC, et al. Analysis of 462 transplantations from unrelated donors facilitated by the National Marrow Donor Program. *N Engl J Med* 1993;328:593-602.
256. Balduzzi A, Gooley T, Anasetti C, et al. Unrelated donor marrow transplantation in children. *Blood* 1995;86:3247-3256.
257. Casper J, Camitta B, Truitt R, et al. Unrelated bone marrow donor transplants for children with leukemia or myelodysplasia. *Blood* 1995;85:2354-2363.
258. Kurtzberg J, Laughlin M, Graham ML, et al. Placental blood as a source of hematopoietic stem cells for transplantation into unrelated recipients. *N Engl J Med* 1996;335:157-166.
259. Kurtzberg J, Martin P, Chao N, et al. Unrelated placental blood in marrow transplantation. *Stem Cells* 2000;18:153-154.
260. Handgretinger R, Klingebiel T, Lang P, et al. Megadose transplantation of purified peripheral blood CD34(+) progenitor cells from HLA-mismatched parental donors in children. *Bone Marrow Transplant* 2001;27:777-783.
261. Smith AR, Baker KS, Defor TE, et al. Hematopoietic cell transplantation for children with acute lymphoblastic leukemia in second complete remission: similar outcomes in recipients of unrelated marrow and umbilical cord blood versus marrow from HLA matched sibling donors. *Biol Blood Marrow Transplant* 2009;15:1086-1093.
262. Barrett AJ, Horowitz MM, Pollock BH, et al. Bone marrow transplants from HLA-identical siblings as compared with chemotherapy for children with acute lymphoblastic leukemia in a second remission. *N Engl J Med* 1994;331:1253-1258.
263. Wheeler KA, Richards SM, Bailey CC, et al. Bone marrow transplantation versus chemotherapy in the treatment of very high-risk childhood acute lymphoblastic leukemia in first remission: results from Medical Research Council UKALL X and XI. *Blood* 2000;96:2412-2418.
264. Harrison G, Richards S, Lawson S, et al. Comparison of allogeneic transplant versus chemotherapy for relapsed childhood acute lymphoblastic leukaemia in the MRC UKALL R1 trial. MRC Childhood Leukaemia Working Party. *Ann Oncol* 2000;11:999-1006.

265. Davies SM, Ramsay NK, Klein JP, et al. Comparison of preparative regimens in transplants for children with acute lymphoblastic leukemia. *J Clin Oncol* 2000;18:340-347.
266. Bunin N, Aplenc R, Kamani N, et al. Randomized trial of busulfan vs total body irradiation containing conditioning regimens for children with acute lymphoblastic leukemia: a Pediatric Blood and Marrow Transplant Consortium study. *Bone Marrow Transplant* 2003;32:543-548.
267. Weisdorf DJ, Woods WG, Nesbit ME Jr, et al. Allogeneic bone marrow transplantation for acute lymphoblastic leukaemia: risk factors and clinical outcome. *Br J Haematol* 1994;86:62-69.
268. Dopfer R, Henze G, Bender-Gotze C, et al. Allogeneic bone marrow transplantation for childhood acute lymphoblastic leukemia in second remission after intensive primary and relapse therapy according to the BFM- and CoALLprotocols: results of the German Cooperative Study. *Blood* 1991;78:2780-2784.
269. Locatelli F, Zecca M, Rondelli R, et al. Graft versus host disease prophylaxis with low-dose cyclosporine-A reduces the risk of relapse in children with acute leukemia given HLA-identical sibling bone marrow transplantation: results of a randomized trial. *Blood* 2000;95:1572-1579.
270. Bader P, Kreyenberg H, Hoelle W, et al. Increasing mixed chimerism is an important prognostic factor for unfavorable outcome in children with acute lymphoblastic leukemia after allogeneic stem-cell transplantation: possible role for pre-emptive immunotherapy? *J Clin Oncol* 2004;22:1696-1705.
271. Horn B, Soni S, Khan S, et al. Feasibility study of preemptive withdrawal of immunosuppression based on chimerism testing in children undergoing myeloablative allogeneic transplantation for hematologic malignancies. *Bone Marrow Transplant* 2009;43:469-476.
272. Hijiya N, Gaynon P, Barry E, et al. A multi-center phase I study of clofarabine, etoposide and cyclophosphamide in combination in pediatric patients with refractory or relapsed acute leukemia. *Leukemia* 2009;23:2259-2264.
273. Hijiya N, Thomson B, Isakoff MS, et al. Phase 2 trial of clofarabine in combination with etoposide and cyclophosphamide in pediatric patients with refractory or relapsed acute lymphoblastic leukemia. *Blood* 2011;118:6043-6049.
274. Messinger Y, Gaynon P, Raetz E, et al. Phase I study of bortezomib combined with chemotherapy in children with relapsed childhood acute lymphoblastic leukemia (ALL): a report from the therapeutic advances in childhood leukemia (TACL) consortium. *Pediatr Blood Cancer* 2010;55:254-259.
275. Messinger YH, Gaynon PS, Sposto R, et al. Bortezomib with chemotherapy is highly active in advanced B-precursor acute lymphoblastic leukemia: Therapeutic Advances in Childhood Leukemia & Lymphoma (TACL) Study. *Blood* 2012;120:285-290.
276. Kreitman RJ, Pastan I. Antibody fusion proteins: anti-CD22 recombinant immunotoxin moxetumomab pasudotox. *Clin Cancer Res* 2011;17:6398-6405.
277. Kantarjian H, Thomas D, Jorgensen J, et al. Inotuzumab ozogamicin, an anti-CD22-calecheamicin conjugate, for refractory and relapsed acute lymphocytic leukaemia: a phase 2 study. *Lancet Oncol* 2012;13:403-411.
278. Topp MS, Kufer P, Gokbuget N, et al. Targeted therapy with the T-cellengaging antibody blinatumomab of chemotherapy-refractory minimal residual disease in B-lineage acute lymphoblastic leukemia patients results in high response rate and prolonged leukemia-free survival. *J Clin Oncol* 2011;29:2493-2498.
279. Topp MS, Gokbuget N, Zugmaier G, et al. Long-term follow-up of hematologic relapse-free survival in a phase 2 study of blinatumomab in patients with MRD in B-lineage ALL. *Blood* 2012;120:5185-5187.
280. Handgretinger R, Zugmaier G, Henze G, et al. Complete remission after blinatumomab-induced donor T-cell activation in three pediatric patients with post-transplant relapsed acute lymphoblastic leukemia. *Leukemia* 2011;25:181-184.
281. Mody R, Li S, Dover DC, et al. Twenty-five-year follow-up among survivors of childhood acute lymphoblastic leukemia: a report from the Childhood Cancer Survivor Study. *Blood* 2008;111:5515-5523.
282. Campbell LK, Scaduto M, Sharp W, et al. A meta-analysis of the neurocognitive sequelae of treatment for childhood acute lymphocytic leukemia. *Pediatr Blood Cancer* 2007;49:65-73.
283. Buizer AI, de Sonnevile LM, van den Heuvel-Eibrink MM, et al. Chemotherapy and attentional dysfunction in survivors of childhood acute lymphoblastic leukemia: effect of treatment intensity. *Pediatr Blood Cancer* 2005;45: 281-290.

284. Copeland DR, Fletcher JM, Pfefferbaum-Levine B, et al. Neuropsychological sequelae of childhood cancer in long-term survivors. *Pediatrics* 1985;75: 745-753.
285. Cousens P, Waters B, Said J, et al. Cognitive effects of cranial irradiation in leukaemia: a survey and meta-analysis. *J Child Psychol Psychiatry* 1988;29:839-852.
286. Jain N, Brouwers P, Okcu MF, et al. Sex-specific attention problems in long-term survivors of pediatric acute lymphoblastic leukemia. *Cancer* 2009;115:4238-4245.
287. Jankovic M, Brouwers P, Valsecchi MG, et al. Association of 1800 cGy cranial irradiation with intellectual function in children with acute lymphoblastic leukaemia. ISPACC. International Study Group on Psychosocial Aspects of Childhood Cancer. *Lancet* 1994;344:224-227.
288. Robison LL, Nesbit ME Jr, Sather HN, et al. Factors associated with IQ scores in long-term survivors of childhood acute lymphoblastic leukemia. *Am J Pediatr Hematol Oncol* 1984;6:115-121.
289. Smibert E, Anderson V, Godber T, et al. Risk factors for intellectual and educational sequelae of cranial irradiation in childhood acute lymphoblastic leukaemia. *Br J Cancer* 1996;73:825-830.
290. Waber DP, Gioia G, Paccia J, et al. Sex differences in cognitive processing in children treated with CNS prophylaxis for acute lymphoblastic leukemia. *J Pediatr Psychol* 1990;15:105-122.
291. Waber DP, Urion DK, Tarbell NJ, et al. Late effects of central nervous system treatment of acute lymphoblastic leukemia in childhood are sex-dependent. *Dev Med Child Neurol* 1990;32:238-248.
292. Mulhern RK, Fairclough D, Ochs J. A prospective comparison of neuropsychologic performance of children surviving leukemia who received 18-Gy, 24-Gy, or no cranial irradiation. *J Clin Oncol* 1991;9:1348-1356.
293. Rowland JH, Glidewell OJ, Sibley RF, et al. Effects of different forms of central nervous system prophylaxis on neuropsychologic function in childhood leukemia. *J Clin Oncol* 1984;2:1327-1335.
294. Schatz J, Kramer JH, Ablin A, et al. Processing speed, working memory, and IQ: a developmental model of cognitive deficits following cranial radiation therapy. *Neuropsychology* 2000;14:189-200.
295. Langer T, Martus P, Ottensmeier H, et al. CNS late-effects after ALL therapy in childhood. Part III: neuropsychological performance in long-term survivors of childhood ALL: impairments of concentration, attention, and memory. *Med Pediatr Oncol* 2002;38:320-328.
296. Spiegler BJ, Kennedy K, Maze R, et al. Comparison of long-term neurocognitive outcomes in young children with acute lymphoblastic leukemia treated with cranial radiation or high-dose or very high-dose intravenous methotrexate. *J Clin Oncol* 2006;24:3858-3864.
297. Ochs J, Mulhern R, Fairclough D, et al. Comparison of neuropsychologic functioning and clinical indicators of neurotoxicity in long-term survivors of childhood leukemia given cranial radiation or parenteral methotrexate: a prospective study. *J Clin Oncol* 1991;9:145-151.
298. Waber DP, Turek J, Catania L, et al. Neuropsychological outcomes from a randomized trial of triple intrathecal chemotherapy compared with 18 Gy cranial radiation as CNS treatment in acute lymphoblastic leukemia: findings from Dana-Farber Cancer Institute ALL Consortium Protocol 95-01. *J Clin Oncol* 2007;25:4914-4921.
299. Ashford J, Schoffstall C, Reddick WE, et al. Attention and working memory abilities in children treated for acute lymphoblastic leukemia. *Cancer* 2010;116:4638-4645.
300. Buizer AI, De Sonneville LM, van den Heuvel-Eibrink MM, et al. Visuomotor control in survivors of childhood acute lymphoblastic leukemia treated with chemotherapy only. *J Int Neuropsychol Soc* 2005;11:554-565.
301. Janzen LA, Spiegler BJ. Neurodevelopmental sequelae of pediatric acute lymphoblastic leukemia and its treatment. *Dev Disabil Res Rev* 2008;14:185-195.
302. Conklin HM, Krull KR, Reddick WE, et al. Cognitive outcomes following contemporary treatment without cranial irradiation for childhood acute lymphoblastic leukemia. *J Natl Cancer Inst* 2012;104:1386-1395.
303. Bhatia S, Sather HN, Pabustan OB, et al. Low incidence of second neoplasms among children diagnosed with acute lymphoblastic leukemia after 1983. *Blood* 2002;99:4257-4264.

304. Loning L, Zimmermann M, Reiter A, et al. Secondary neoplasms subsequent to Berlin-Frankfurt-Munster therapy of acute lymphoblastic leukemia in childhood: significantly lower risk without cranial radiotherapy. *Blood* 2000;95:2770-2775.
305. Hijiya N, Hudson MM, Lensing S, et al. Cumulative incidence of secondary neoplasms as a first event after childhood acute lymphoblastic leukemia. *JAMA* 2007;297:1207-1215.
306. Relling MV, Rubnitz JE, Rivera GK, et al. High incidence of secondary brain tumours after radiotherapy and antimetabolites. *Lancet* 1999;354:34-39.
307. Pui CH, Behm FG, Raimondi SC, et al. Secondary acute myeloid leukemia in children treated for acute lymphoid leukemia. *N Engl J Med* 1989;321: 136-142.
308. Mattano LA Jr, Devidas M, Nachman JB, et al. Effect of alternate-week versus continuous dexamethasone scheduling on the risk of osteonecrosis in paediatric patients with acute lymphoblastic leukaemia: results from the CCG-1961 randomised cohort trial. *Lancet Oncol* 2012;13:906-915.
309. Patel B, Richards SM, Rowe JM, et al. High incidence of avascular necrosis in adolescents with acute lymphoblastic leukaemia: a UKALL XII analysis. *Leukemia* 2008;22:308-312.
310. Kawedia JD, Kaste SC, Pei D, et al. Pharmacokinetic, pharmacodynamic, and pharmacogenetic determinants of osteonecrosis in children with acute lymphoblastic leukemia. *Blood* 2011;117:2340-2347;quiz 2556.
311. Kremer LC, van Dalen EC, Offringa M, et al. Anthracycline-induced clinical heart failure in a cohort of 607 children: long-term follow-up study. *J Clin Oncol* 2001;19:191-196.
312. Lipshultz SE, Colan SD, Gelber RD, et al. Late cardiac effects of doxorubicin therapy for acute lymphoblastic leukemia in childhood. *N Engl J Med* 1991;324:808-815.
313. Lipshultz SE, Lipsitz SR, Mone SM, et al. Female sex and drug dose as risk factors for late cardiotoxic effects of doxorubicin therapy for childhood cancer. *N Engl J Med* 1995;332:1738-1743.
314. Harake D, Franco VI, Henkel JM, et al. Cardiotoxicity in childhood cancer survivors: strategies for prevention and management. *Future Cardiol* 2012;8:647-670.
315. Kremer LC, van Dalen EC, Offringa M, et al. Frequency and risk factors of anthracycline-induced clinical heart failure in children: a systematic review. *Ann Oncol* 2002;13:503-512.
316. Lipshultz SE, Lipsitz SR, Sallan SE, et al. Chronic progressive cardiac dysfunction years after doxorubicin therapy for childhood acute lymphoblastic leukemia. *J Clin Oncol* 2005;23:2629-2636.
317. Lipshultz SE, Miller TL, Scully RE, et al. Changes in cardiac biomarkers during doxorubicin treatment of pediatric patients with high-risk acute lymphoblastic leukemia: associations with long-term echocardiographic outcomes. *J Clin Oncol* 2012;30:1042-1049.
318. Lipshultz SE, Rifai N, Dalton VM, et al. The effect of dexrazoxane on myocardial injury in doxorubicin-treated children with acute lymphoblastic leukemia. *N Engl J Med* 2004;351:145-153.
319. Steffens M, Beauloye V, Brichard B, et al. Endocrine and metabolic disorders in young adult survivors of childhood acute lymphoblastic leukaemia (ALL) or non-Hodgkin lymphoma (NHL). *Clin Endocrinol (Oxf)* 2008;69:819-827.
320. Asner S, Ammann RA, Ozsahin H, et al. Obesity in long-term survivors of childhood acute lymphoblastic leukemia. *Pediatr Blood Cancer* 2008;51: 118-122.
321. Chow EJ, Pihoker C, Friedman DL, et al. Glucocorticoids and insulin resistance in children with acute lymphoblastic leukemia. *Pediatr Blood Cancer* 2013;60:621-626.
322. Gurney JG, Ness KK, Sibley SD, et al. Metabolic syndrome and growth hormone deficiency in adult survivors of childhood acute lymphoblastic leukemia. *Cancer* 2006;107:1303-1312.
323. Oeffinger KC, Adams-Huet B, Victor RG, et al. Insulin resistance and risk factors for cardiovascular disease in young adult survivors of childhood acute lymphoblastic leukemia. *J Clin Oncol* 2009;27:3698-3704.
324. Oeffinger KC, Mertens AC, Sklar CA, et al. Obesity in adult survivors of childhood acute lymphoblastic leukemia: a report from the Childhood Cancer Survivor Study. *J Clin Oncol* 2003;21:1359-1365.

Chapter 77 Acute Myelogenous Leukemia in Children

> Table of Contents > Part VII - Hematologic Malignancies > Section 2 - The Acute Leukemias > Chapter 77 - Acute Myelogenous Leukemia in Children

Chapter 77

Acute Myelogenous Leukemia in Children

Robert J. Arceci

HISTORICAL BACKGROUND

Acute myelogenous leukemia (AML) represents a heterogeneous group of hematologic malignancies arising from the transformation and expansion of an early myeloid stem or progenitor cell. The term leukemia originated with Virchow, who, in 1845, recognized a clinical entity characterized by too many white blood cells (WBCs), leading him to name the condition white blood, or leukemia.¹ Of some historical interest is that Dr.

John Hughes Bennett's report of a case of leukemia preceded Virchow's description by ~6 weeks.¹ However, Bennett had concluded that the condition was secondary to an infection and referred to it as pyemia. The term myelogenous, or myeloid, derives from the terms myelos, meaning marrow and genesis, meaning birth.

The original cases of Virchow and Bennett probably represented what we now know to be either chronic lymphocytic or myelogenous leukemia. The first likely case of acute leukemia was reported by Friedreich and was believed to be lymphocytic.² It would take the identification of the myeloblast as a precursor cell for granulocytes by Naegeli in 1900 to set the stage for the description of the first cases of AML or what was originally termed acute nonlymphocytic leukemia.³ Even during the first half of the 20th century, reports describing different types of myeloid leukemia made it clear that this was not one but a variety of distinct disorders, all deriving from a bone marrow precursor myeloblast. Initially, cases of monocytic leukemia were described, followed by myelomonocytic leukemia.^{3,4} Cases of erythroleukemia, megakaryoblastic leukemia, and acute promyelocytic leukemia (APL) were subsequently described in 1917, 1931, and 1957, respectively.^{5, 6} and ⁷ During the mid-1970s, the French/American/British (FAB) classification system was developed and defined the major categories of AML as M1 through M7.⁸ More recently, the World Health Organization (WHO) provided a new classification system that utilizes genetic, immunophenotypic, biologic, and clinical features in addition to morphology.⁹

The description and classification of AML moved more rapidly than the development of effective treatments. During the mid-1800s, Virchow used diet therapies, ferric iodide, and application of abdominal and foot baths.¹ In 1865, Lissauer used arsenic (Fowler solution) to treat patients with leukemia, but with little success.¹ Radiation therapy was used in the late 1800s, mostly as a form of palliation for chronic leukemias.¹ In 1938, Forkner stated, "Although leukemia is a fatal disease much can be done to add to the comfort, and promote the general health of sufferers from the chronic forms of the disease. Unfortunately acute leukemia does not respond satisfactorily to any form of treatment."¹ In 1948, Farber demonstrated that the use of the antimetabolite aminopterin could produce transient remissions in children with acute lymphocytic leukemia (ALL).¹⁰ The pioneering work resulted in the National Cancer Institute developing screening programs for other possible antitumor therapies during the 1950s. During the 1960s, several chemotherapeutic agents, particularly cytarabine and anthracyclines, were developed and used in the treatment of AML. During the 1970s, clinical trials demonstrated that combining these two agents would result in long-term remissions for 10% to 15% of patients with AML. The subsequent introduction of more intensive remission induction regimens and post-remission therapy increased the need for more rigorous supportive care measures, and the development of bone marrow transplantation led to current cure rates of about 50%.^{11,12}

EPIDEMIOLOGY

Approximately 6,500 children <20 years of age develop acute leukemia annually in the United States, and AML represents approximately 15%, resulting in approximately 600 new cases/year.¹³ The remaining cases of acute leukemia in children and adolescents are lymphoblastic leukemia. Essentially the opposite ratios exist for adults, with AML accounting for about 80% of acute leukemia and lymphoblastic the remaining 20%. With the exception of a peak in incidence of AML in infants, the incidence of AML is relatively constant until early adolescence following which it continues to rise slowly through young adulthood and beyond 50 years of age the incidence rises dramatically.¹⁴

Some variation in the incidence of AML in children has been reported among different racial and ethnic groups. For example, black children have an incidence of 5.8 cases/million, compared to 4.8 cases/million in white children.^{15,16}

Children and young adults of Hispanic background have the highest annual incidence at 9 cases per million with the major subtype being APL.^{17, 18, 19} and ²⁰ The annual incidence of AML in children from Japan, Australia, and Zimbabwe has been reported as 8, 8, and 11 per million.²¹ The increasing incidence of secondary leukemia, resulting from chemotherapy and treatment for other malignancies, is a problem of increasing significance in pediatrics.^{22, 23, 24, 25, 26, 27} and ²⁸

CELLULAR AND MOLECULAR ORIGINS OF ACUTE MYELOGENOUS LEUKEMIA: HEMATOPOIETIC HIERARCHIES

The determination of the AML stem cell is not solely of biologic interest but has profound significance for understanding the causes of leukemia and potentially the development of curative therapies. This section discusses the cellular and molecular determinants of AML.

Normal hematopoiesis occurs through a series of complex changes that facilitate multipotential hematopoietic stem cells to both expand and differentiate into various mature blood cell types. Because AML is derived from an abnormal immature hematopoietic precursor cell, these leukemias also have the capacity to expand and to show characteristics of limited differentiation. Thus, myeloid leukemias retain many of the molecular and cellular phenotypic characteristics of their normal hematopoietic origins, providing the means to distinguish subtypes of the disease and define potential leukemic stem cell compartments. For example, although most myeloid leukemia cells often express growth, survival, and differentiation receptors for specific cytokines such as KIT, FLT3, and granulocyte-macrophage colony-stimulating factor receptor, some subtypes also express more lineage-specific surface receptors, such as those for granulocyte colony-stimulating factor (G-CSF) and erythropoietin. The same is true for the expression of differentiation markers that characterize various myeloid lineages such as megakaryoblastic, erythroid, or monocytic. These diverse phenotypic characteristics of different subtypes suggest significant heterogeneity of both the genetic changes and the cell of origin in AML.

Some of the earliest biologic tools used to define the cellular compartment in which leukemic stem cells arise included the use of X-linked glucose 6-phosphate dehydrogenase isoenzyme analysis in female patients with chronic myelogenous leukemia

P.1638

(CML) and then AML.^{29,30} Subsequently, karyotypic abnormalities were examined in the maturing colony-forming units to evaluate which lineage (colony-forming unit stem, colony-forming unit granulocyte-macrophage, colony-forming unit megakaryocyte, colony-forming unit granulocyte, colony-forming unit eosinophil, etc.) contained the aberrant chromosomal marker.³¹ These studies revealed that although CML arises in a very early pluripotential hematopoietic cell, there are cases of AML that arise in more mature pluri- and unipotential progenitor cells.³¹

By depleting samples of AML with antibodies directed against lineage-specific surface antigens, a very small percentage of lineage-negative (Lin⁻) cells were isolated that had the capacity to generate AML at a higher percentage than more mature leukemic cells when transferred to immunodeficient mice. These leukemogenic CD34⁺ CD38⁻ Lin⁻ cells (termed self-renewing leukemia-initiating cells) were in most cases rare, having a frequency of as few as 0.2 to 200/106 mononuclear cells.^{32,33, 34, 35} Of further significance was that the frequency of the self-renewing leukemia-initiating cell did not correlate with age, sex, or FAB classification, with the exception of some cases of APL.³³ In the case of APL, a significant percentage of cases appeared to be derived from a more committed progenitor cell.^{33,36} Subsequent investigations identified both CD34⁺ and CD34⁻ lineage-negative self-renewing leukemia-initiating cell populations that were present at extremely low frequency, demonstrating that the AML stem cell is in many cases derived from a very immature hematopoietic precursor cell.³⁷

When these results are placed into the context of the hematopoietic differentiation schema, the conclusion can be made that there must be primary genetic changes that occur in a very primitive self-renewing stem cell and that the nature of those genetic changes in part determines the subtype of AML. For example, a t(8;21) abnormality may lead to M1 AML with minimal differentiation, whereas an inv(16) abnormality may result in an M4Eo subtype. The initiating events may primarily affect the ability of the leukemic stem cell to differentiate but retain the ability to self-replicate.^{38,39} Subsequent genetic changes, such as mutation pathways regulating apoptosis, cell survival, and proliferation, may further change the phenotype of the leukemia as well as provide the proliferative potential for the leukemia. These might be considered "driver" and "modifier" mutations, respectively. Mutations that do not affect the phenotype may be considered "passenger" mutations. This latter type of genetic change involves mostly secondary mutations that affect the function of growth and survival factor receptors, such as FLT3 or KIT. By themselves, most single mutations are insufficient to cause leukemia. However, when present together in the same cell, they can cooperate and lead to the development of AML. A slightly different alternative way of understanding the etiology of AML in the context of gene mutations is to consider

genetic changes such as AML-ETO translocation as a Type I mutation and FLT3-ITD or KIT point mutations as Type II mutations that in combination result in the proliferation of progenitors with limited and aberrant differentiation.⁴⁰

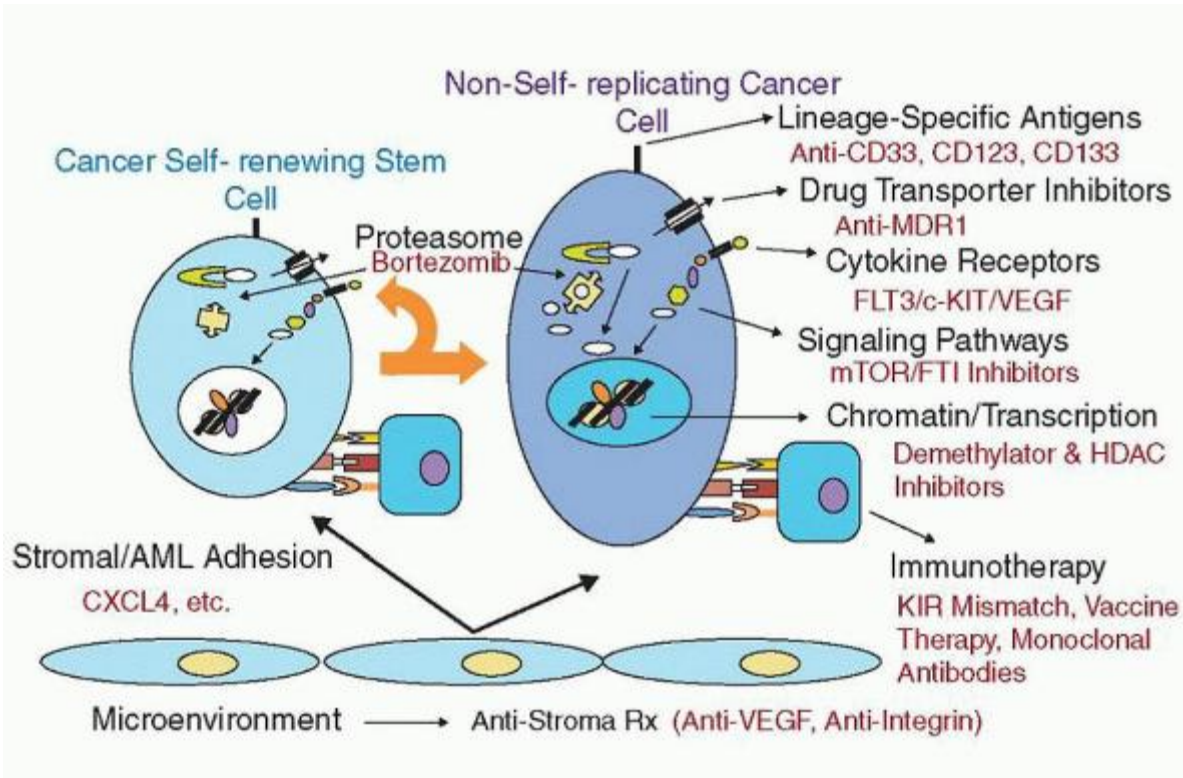

FIGURE 77.1. Therapeutic targets being tested in acute myelogenous leukemia (AML). The schema shows different pathways and/or approaches that have been or are being tested in clinical trials, including those that may affect the leukemia-initiating cell.

Genome-wide sequencing has confirmed the above models but also revealed many additional subkaryotypic abnormalities including gene mutations encoding classes of proteins involved in epigenetic patterning^{41, 42, 43} and RNA splicing.^{44, 45} Such studies have also helped to define the heterogeneity of AML and its clonal evolution during treatment.^{46, 47} Of interest, although many of the same mutations observed in older adults with AML have been found in children with AML, there is a growing body of evidence that shows significant differences also exist.^{48, 49} and ⁵⁰

These results have important implications not only for understanding the etiology and pathogenesis of AML but also for the development of more effective treatments (Fig. 77.1). The causes of generating genetic mutations contributing to AML involve both inherited and environmental factors. In pediatrics, the former class of factors is particularly important.

PREDISPOSING FACTORS AND PATHOPHYSIOLOGY

Inherited Predisposition Syndromes

Abnormal Chromosomal Number

Trisomy 21, or Down syndrome (DS), represents the most common inherited condition that predisposes to the development of leukemia. The overall risk of developing leukemia has been estimated to be about 14-fold above that of the general population.^{51, 52} Although older children with DS have a similar frequency of ALL and AML, within the first 3 years of life, AML, and particularly acute megakaryoblastic leukemia (AMKL), predominates.⁵²

Patients with DS also have an increased predisposition to develop a condition known as preleukemia or transient myeloproliferative disorder (TMD). Approximately 10% of newborns with DS develop TMD. Although clinically indistinguishable from congenital leukemia (Fig. 77.2), TMD, as the name suggests, is usually self-resolving. It is importantly to note that even children who are mosaic for trisomy 21 but phenotypically normal share the increased risk of developing TMD and subsequent leukemia. Approximately 20% to 30% of children whose TMD resolves still develop AMKL.

The close association of trisomy 21 with TMD and AMKL suggests that predisposing genetic events exist. RUNX1 (AML1),

P.1639

which is located on chromosome 21 and known to be involved in some subtypes of AML, has been implicated etiologically, but no definitive evidence has yet demonstrated a specific mutation or gene dosage effect leading to AML. However, other investigations have demonstrated the interesting finding that TMD and AMKL are both characterized by mutations of the GATA1 gene that result in the introduction of a premature stop codon, truncating GATA1 before the amino-terminal activation domain and reducing its transcriptional activation ability.^{53,54} The same GATA1 mutation has been observed in the blasts from TMD as well as in AMKL.^{53, 54, 55} and⁵⁶ These results argue strongly that mutations in the GATA1 hematopoietic transcription factor are an early event in the development of TMD and AMKL in children with DS. It remains unclear why a majority of children with DS and TMD show regression of their disease.

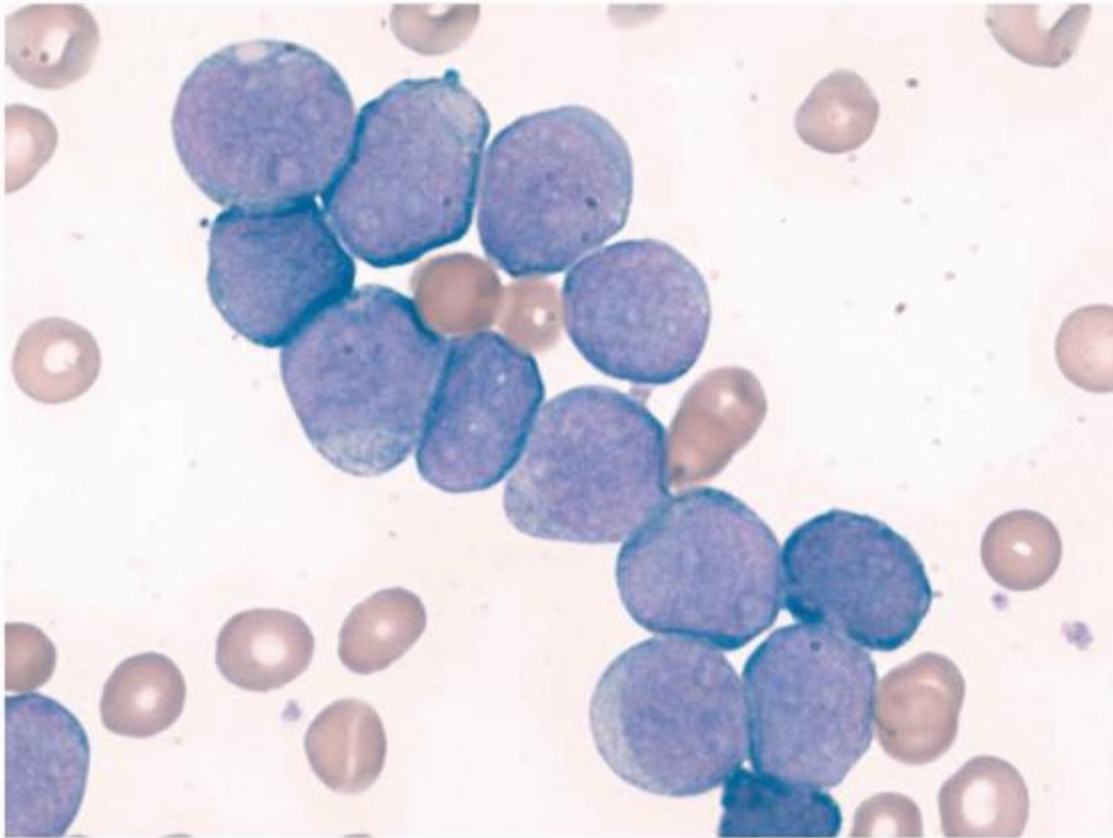

FIGURE 77.2. Photomicrograph of a peripheral blood smear from a patient with Down syndrome and transient myeloproliferative disease.

An increased risk of developing AML in patients with Klinefelter syndrome (XXY) and Turner syndrome (XO) has also been reported, but the numbers of such cases are quite low.^{57,58}

Inherited Marrow Failure and Chromosome Instability Syndromes

There are several inherited syndromes characterized by progressive marrow failure and cytopenias with a high frequency of AML. Fanconi anemia (FA) is an autosomal recessive inherited disorder with common congenital abnormalities including skeletal abnormalities, short stature, microcephaly, cardiac abnormalities, genitourinary tract abnormalities, café-au-lait spots, and mental retardation. Patients with FA have an estimated 15,000 times greater risk than the general population for developing AML and an actuarial risk of myelodysplastic syndrome (MDS) or AML of approximately 52% by 40 years of age.^{59,60} There are multiple gene defects that give rise to FA and affect distinct but functionally related proteins that regulate DNA repair; the mutations result in a hypersensitivity to genotoxic agents such as mitomycin C or diepoxybutane and chromosomal instability.⁶¹ Somatic mutations in several of the FA genes have also been observed in AML outside the setting of FA, thus further strengthening the link of these genes with predisposition for AML.^{62,63}

Severe congenital neutropenia (Kostmann syndrome) represents an important inherited cytopenia of the granulocytic lineage with an increased risk of MDS/AML that increases with age.⁶⁴ Introduction of G-CSF for the treatment of patients with Kostmann syndrome has been linked to the development of AML. However, it is possible that patients on G-CSF may survive for longer periods, raising the possibility that the development of AML is secondary to an intrinsically increased risk of leukemia in patients with Kostmann syndrome or a combination of this predisposition and G-CSF stimulation. Mutations in the elastase gene have been associated with both cyclic neutropenias and Kostmann syndrome.^{65,66} The detection of somatic activating mutations of the G-CSF receptor has been observed before the development of overt AML in patients with Kostmann syndrome.^{67,68} Thus, when a rising WBC count is observed in a patient with Kostmann syndrome who was previously stable on G-CSF, one should consider that autoactivating mutations of G-CSF have occurred and that the patient has developed AML.

Shwachman-Diamond syndrome, inherited in an autosomal recessive fashion, is characterized by pancreatic insufficiency, skeletal abnormalities, neutropenia, and an increased incidence of MDS and AML.^{63,69,70} Diamond-Blackfan anemia (DBA) is another inherited syndrome characterized by congenital anemia, skeletal and urogenital abnormalities, and an increased risk of developing MDS and AML.⁶⁰ An association of mutations and/or deletions in both small and large ribosomal subunit proteinencoding genes has established DBA as a ribosomopathy. In addition to showing an increased frequency of AML, patients with DBA also appear to have a predisposition to other cancers, making DBA a true cancer-predisposition syndrome.

Neurofibromatosis Type I (NF1) is caused by mutations in the neurofibromin gene, encoding a RAS-inactivating GTPase, and closely associated with an increased incidence of juvenile myelomonocytic leukemia (JMML) and AML.^{71,72} Noonan syndrome, caused by mutations in the PTPN11 gene, which encodes a SHP-2 tyrosine phosphatase, also has an increased predisposition to JMML.^{73,74} Mutations in CBL, encoding an E3 ubiquitin ligase, have been reported to be associated with a dominant inheritance and predisposition to JMML.^{75,76} and ⁷⁷ Patients with Li-Fraumeni syndrome and Bloom syndrome, involved defects in TP53 and the BLM helicase gene, respectively, have also been reported to have a propensity to develop leukemia, including AML.^{60,78,79,80} and ⁸¹

Additional inherited AML predisposition syndromes include congenital amegakaryocytic thrombocytopenia (defects in the CFFA2 gene and thrombopoietin receptor gene, c-mpl), autosomal dominant macrothrombocytopenia (Fechtner syndrome, MYH9 gene), familial platelet disorder with propensity to myeloid malignancy (FPD/AML, and germline mutations in the RUNX1/CEPB-alpha gene).^{60,69,82,83,84,85,86} and ⁸⁷ Other DNA repair/chromosome instability syndromes that can lead to leukemia, although more commonly ALL, include Bloom syndrome, secondary to an inherited defect in the blm helicase gene, ataxia telangiectasia, due to defects in the ATM gene, and Li-Fraumeni syndrome, due to inherited mutations in TP53.^{60,78,79,80,81}

Twins and Familial Cases

The increased frequency of both AML and ALL in siblings of patients with leukemia has been recognized since the early 1920s. The risk for identical twins is high when leukemia first develops during infancy; in most cases, transmission has been shown to be the result of transplacental transfer. Transmission rates have been reported to be 20% to 30%, although other investigators have concluded transmission rates may approach 100%.^{88,89} and ⁹⁰ There is also a high concordance of timing of the onset of leukemia. Molecular studies have demonstrated that identical molecular defects characterized the leukemia in both twins.^{88,91,92} and ⁹³

Clinical follow-up is therefore essential in identical twins when one of them is diagnosed with acute leukemia. These normal twins should be followed approximately every 1 to 2 months until approximately 2 years of age with physical examinations and peripheral blood cell counts. Bone marrow examinations should only be done when clinically indicated. The risk of developing acute leukemia for nonidentical twins has been estimated

P.1640

to be a two- to fourfold increase until about 6 years of age, after which the risk becomes similar to that of the general population. Nontwin familial cases of AML are rare and often associated with constitutional translocations, such as t(7;20) and t(3;6) or monosomy 7.^{94,95} and ⁹⁶

Acquired Predisposition

A variety of acquired AML predisposition disorders exist. For example, patients with severe aplastic anemia (SAA) treated with immunosuppressive agents, such as cyclosporin A and antithymocyte globulin (ATG) or cyclophosphamide, as well as with recombinant human G-CSF have been reported to have up to a 20% risk of developing MDS or AML.^{97,98} and ⁹⁹

Paroxysmal nocturnal hemoglobinuria is also associated with an increased risk of developing MDS and AML although less frequently than SAA.¹⁰⁰ Although AML arising in patients with MDS is a relatively common event in adults, MDS is rare in children and may differ in biologic and clinical characteristics from that observed in adults.¹⁰¹ Acquired monosomy 7 may predispose individuals to developing MDS and AML.¹⁰² The acquisition of predisposing conditions or chromosomal abnormalities is often linked to environmental exposures.

Environmental Factors

A wide variety of genotoxic environmental exposures can predispose individuals to AML. For example, in the period after the dropping of atomic bombs on Nagasaki and Hiroshima during World War II, an approximately 20-fold increase in myeloid leukemia was documented, with a peak incidence between 6 and 8 years.^{103, 104, 105} and ¹⁰⁶ The absence of a documented increase in leukemia in children exposed prenatally to the radiation of the atomic bombs has been reported¹⁰⁷ and may be consistent with the absence of definitive evidence that prenatal exposure to x-rays increases leukemia risk.¹⁰⁸ There remains no convincing evidence that ultrasound or the effects of living near high-voltage power lines predisposes individuals to leukemia, although reports differ in their conclusions.^{109, 110} and ¹¹¹

Prenatal exposure to chemical genotoxic agents has been reported to increase postnatal incidence of myeloid leukemia. For example, maternal alcohol consumption has been associated with an increased risk of AML in offspring.¹¹² A significant association of dose-response of prenatal alcohol consumption and the development of AML in offspring was documented.¹¹³ However, not all reports have concluded such strong associations.^{112,114} There has been an association of maternal ingestion of topoisomerase II inhibitors and the development of AML with malignant lymphoblastic lymphoma rearrangements in offspring.^{115, 116, 117} and ¹¹⁸ Parental smoking of tobacco or marijuana has also been associated with an increased incidence of AML in offspring although there are reports with dissenting conclusions.^{119, 120} and ¹²¹ Some reports have linked cigarette smoking in adults to an increased incidence of AML, making antismoking preventive counseling important, particularly during teenage years.¹²²

Exposure of individuals to environmentally derived genotoxic agents is quite substantial, and several specific examples of such exposures have been shown to be etiologically related to the development of AML. Such exposures include petroleum products, benzene, pesticides, and herbicides,^{123, 124, 125, 126} and ¹²⁷ although these studies have not focused on children. Interestingly, in some instances, such as with organophosphate pesticides, children may be at greater risk for accumulating higher levels of the chemicals.¹²⁸

An increasingly worrisome group of patients are those who develop AML as a result of chemotherapeutic exposures for treatment of their primary cancer or even nonmalignant conditions. For example, exposure to alkylating agents, commonly used to treat patients with brain tumors, lymphomas, and other solid tumors, results in an increased incidence of secondary AML, with a peak incidence at 4 to 5 years but with an at-risk period extending 12 years.^{129, 130} and ¹³¹ Exposure to topoisomerase I inhibitors, including anthracyclines, and topoisomerase II inhibitors, including epipodophyllotoxins such as etoposide, is also etiologically linked to the development of AML.^{132, 133, 134} and ¹³⁵ Whereas cumulative dose and schedule of drug delivery may play important roles in the development of AML¹³⁶ nearly any exposures to such genotoxic agents can result in secondary AML, as demonstrated in a child initially treated for neuroblastoma.^{137,138} The development of secondary AML in patients treated first for primary cancers may be one of the most compelling reasons to develop alternative and less genotoxic approaches to therapy.

PRESENTATION

The clinical presentation of AML varies greatly with systemic symptoms and severity of illness usually being a result of leukemia cells' replacement of normal hematopoietic progenitors in the bone marrow as well as their infiltration into various organs. Approximately 1012 leukemia cells have been estimated to be present at the time of diagnosis. The leukemic blasts can invade extramedullary sites, such as soft tissues, skin (leukemia cutis), gingiva, orbit, and brain. Patients typically present with signs and symptoms of neutropenia, anemia, and thrombocytopenia. On occasion, other systems may be involved at presentation, as in the case of coagulopathy seen most commonly in APL, spinal cord compression from chloromas, or end-organ damage due to hyperleukocytosis.

The total WBC count may be low, normal, or high depending upon the number of circulating leukemic cells. The absolute neutrophil count is often less than $0.5 \times 10^9/L$ and is associated with an increased risk of infections, often life threatening. Blood cultures and broad-spectrum intravenous antibiotic coverage are indicated in any newly diagnosed patient with leukemia and fever. Anemia results in fatigue, lethargy, decreased exercise tolerance, headache, and pallor. Although uncommon at the time of presentation, congestive heart failure (CHF) may occur, particularly with severe anemia, which is usually normocytic and normochromic although evidence of red cell fragmentation may be seen in cases presenting with disseminated intravascular coagulation (DIC); the transfusion of packed red blood cells should usually be done slowly

to prevent precipitating or worsening CHF. Thrombocytopenia often leads to bruising and petechiae, and occasionally overt hemorrhage into the gastrointestinal track, lungs, or central nervous system (CNS). Approximately 50% of patients have hepatosplenomegaly and lymphadenopathy. Gingival hyperplasia and leukemia cutis are less frequent but particularly characteristic of myeloid leukemia with monocytic differentiation.

Patients may also present with anemia, which gives rise to fatigue, pallor, and, in extreme cases, hemodynamic instability. The anemia is typically normocytic and normochromic, although evidence of red cell fragmentation may be seen in severe cases of DIC. The median hemoglobin is ~70 g/L, with a range of 25 to 140 g/L.

Nearly 75% of patients present with a platelet count $<100 \times 10^9/L$.¹⁷⁹ Thrombocytopenia may cause petechiae, purpura, mucosal bleeding, and, rarely, CNS and pulmonary hemorrhage. Thrombocytopenia is exacerbated by coagulopathy, especially in the M3 and M5 AML subtypes. Although the mechanism for DIC is not known in M5 AML, there is convincing evidence that expression of annexin II, a receptor for fibrinolytic proteins, facilitates plasminogen activation by associating plasminogen and its activator, tissue plasminogen activator, at the APL (M3) leukemic blast cell surface.¹⁸⁰

Patients with peripheral blast counts $>200 \times 10^9/L$ are at risk for CNS stroke due to hyperviscosity, and benefit from leukopheresis to drop the blast count rapidly.¹⁸¹ Similarly, pulmonary insufficiency may occur in patients with very high leukemia blast

P.1641

counts. Approximately 5% of patients with AML have CNS disease at diagnosis, and a smaller percentage presents with CNS chloromas.¹⁸² These patients may have headaches, cranial nerve palsies, focal neurologic deficits, and, rarely, seizures.

DIFFERENTIAL DIAGNOSIS

Whereas the diagnosis of AML is generally straightforward, the differential diagnosis is broad, including both malignant and nonmalignant conditions. Juvenile rheumatoid arthritis, infectious mononucleosis, aplastic anemia, congenital and acquired cytopenias, and the transient myeloproliferative syndrome of DS infants may all mimic AML. AML may be mistaken for MDS or chronic leukemias, including CML, chronic myelomonocytic leukemia, and JMML. Undifferentiated leukemia or FAB L2 ALL may be morphologically difficult to distinguish from megakaryoblastic AML. Metastatic rhabdomyosarcoma or neuroblastoma in the bone marrow may appear as megakaryoblastic or monoblastic AML, especially in the neonate.

The diagnosis of AML is typically made on bone marrow aspirate examination, with special stains, flow cytometry, and cytogenetics providing additional data. On occasion, definitive diagnosis is difficult either because of technical difficulties in obtaining an adequate specimen or because of conflicting data. Repeat marrow aspirate and biopsy may provide a specimen adequate for diagnosis. Touch preparations of the bone marrow biopsy may be used in cases in which bone marrow aspiration is difficult. Increasingly, a diagnosis can be made from peripheral blood using multiparameter flow cytometry, although in some instances significant differences in antigen expression may exist on leukemic blasts in the bone marrow compared to the peripheral blood.

TABLE 77.1 COMPARISON OF KEY CHARACTERISTICS OF ACUTE MYELOGENOUS LEUKEMIA (AML) IN PEDIATRIC VERSUS ADULT PATIENTS

Characteristic	Pediatric ≤ 21 y	Adults >21 and $<55-60$ y
Cytogenetics	Higher frequency favorable risk cytogenetics	Greater percent of unfavorable cytogenetics and drug resistant markers
Antecedent AML predisposing disorders	Rare (some inherited predisposition)	Common (MDS, MPN, and therapy-related)
Subtype	More M4/M5, DS, TMD	Less M4/M5, no DS or TMD
Extramedullary disease	More CNS disease/leukemia cutis	Uncommon except in monocytic lineage
Induction	ADE	“7&3” standard

Remission rates (after 2 courses)	85-90%	60-80%
CNS Prophylaxis	Yes	Not routine
HSCT	Only for high-risk patients	For some intermediate- and most high-risk patients
APL Treatment	ATRA at 25 mg/m ²	ATRA at 45 mg/m ²
Gene mutations		
<i>FLT3-ITD</i>	10-20%	20-50%
<i>KIT</i>	25% in t(8;21)	17% in CBF
<i>N-RAS</i>	20%	10%
<i>PTPN11</i>	5-21% (infants)	Rare
<i>WT1</i>	13% (CN-AML)	10% (Normal karyotype)
<i>NPM1</i>	5-10% (14-22% in CN-AML)	35% (53% in CN-AML)
<i>CEBPA</i>	5% (14% in CN-AML)	10% in CN-AML
<i>IDH1 or 2</i>	16%	2-3%
<i>TET2</i>	Rare	16%
<i>DNMT3A</i>	Rare	20%
Overall survival	Approximately 60-65%	Approximately 40%
Late complications	Growth, endocrine, cardiac, neurocognitive, secondary malignancies	Secondary malignancies

ADE, ARAC, daunomycin and etoposide; CN-AML, cytogenetically normal AML; CNS, central nervous system; DS, down syndrome; MDS, myelodysplastic syndrome; MPN, myeloproliferative neoplasm; TMD, transient myeloproliferative disorder. Adapted from^{214, 422} and¹⁴⁹.

ACUTE MYELOGENOUS LEUKEMIA SUBTYPES

Both FAB and WHO classification systems are used by clinicians treating pediatric AML patients. Generally, both classification systems apply equally well to pediatric and adult patients. However, some important differences exist. FAB subtypes M0, M1, and M2 correspond to AML that is minimally differentiated, without maturation, and with maturation, respectively, are more common in older rather than younger children, with frequencies in children 10 to 15 years of age very similar to reported adult frequencies.^{139,140} On the other hand, FAB subtypes M5 (acute monocytic leukemia) and M7 (AMKL) are significantly more common in younger children.^{139,141} Likewise, the increased frequency of M7 AML in young patients is mostly due to the high rate of the M7 subtype in patients with DS.¹⁴² Younger children are less likely to have t(8;21) and t(15;17) but more frequently have chromosome abnormalities involving 11q23. M0 AML is defined as AML without morphologic signs of differentiation and by expression of CD13, CD33, and CD117 (c-KIT) and myeloperoxidase by flow cytometry or electron microscopy (Table 77.1).

P.1642

THERAPY FOR PATIENTS WITH NEWLY DIAGNOSED ACUTE MYELOGENOUS LEUKEMIA

Background

Pediatric AML protocols begin with a remission-induction regimen, followed by a course of consolidation therapy, and, subsequently, intensification courses that may include hematopoietic stem cell transplantation (HSCT). This relatively brief

but intensive approach has yielded an approximately 60% to 70% chance of overall survival across different cooperative group protocols.^{143, 144, 145, 146, 147, 148} and ¹⁴⁹ Although there is general agreement that pediatric AML therapy should be based on the use of anthracyclines and cytarabine, pediatric cooperative groups differ in their induction regimens and the use of HSCT transplant in the post-remission period. The major pediatric cooperative groups are also presently evaluating various risk-stratification methods as well as the use of novel agents.

Induction Therapy

The primary goal is to achieve a remission of disease, which is currently defined in the United States as peripheral blood count recovery with a normal or slightly hypocellular marrow with fewer than 5% leukemic blasts and no evidence of extramedullary disease. An increasingly important additional marker is the eradication of detectable minimal residual disease (MRD).

The first significant successful remission-induction regimen for patients with AML included 7 days of continuous infusion Ara-C at 100 mg/m²/day and 3 initial days of an anthracycline, such as daunorubicin, at 45 mg/m² to 60 mg/m² per day. This regimen resulted in remission rates of between 60% to 70% in children and young adults.^{150,151} However, several approaches have been utilized to improve on these remission rates, including altering the schedule and doses of Ara-C and anthracyclines, as well as the introduction of additional agents. Furthermore, supportive care measures, such as the preemptive use of broad-spectrum antibiotics and/or blood product transfusions, have proven to reduce significantly remission induction mortality and thus have improved remission rates.

Despite the different approaches taken by the cooperative groups, several important conclusions can be made. First, remission quality, now defined as negative MRD at the end of induction, modifies relapse risk, and more intensive induction regimens may provide deeper (i.e., nondetectable MRD) remissions with lower relapse rates and improved OS. The issue of induction intensification was nicely demonstrated in the Children's Cancer Group (CCG)-2,891 study, in which the intensively timed DCTER (dexamethasone, cytarabine, thioguanine, etoposide, and rubidomycin) arm had a similar morphologic induction success rate compared to the standard timing regimen, but the relapse rate for the intensively timed arm was lower regardless of post-induction therapy.¹⁴⁶ However, more intensive induction regimens also carry greater treatment-related morbidity and mortality that can diminish the net benefit of such intensive therapy. In general, each trial using a very intensive induction regimen has noted an initial toxic death rate of approximately 15%, which decreases to usually less than 5% with acquired treatment experience.^{152,153}

This high induction mortality rate has been reduced in several studies by mandated supportive care guidelines (see the section "Supportive Care"). Although escalating the economic cost of AML therapy, these supportive care guidelines are critical for improved outcomes. In the CCG, these guidelines mandated early initiation of broad-spectrum antibiotics, including vancomycin at the first febrile episode, early initiation of treatment doses of antifungal agents after 3 days of persistent fevers, hospitalization until granulocyte recovery, strict hand washing, and use of high-efficiency particulateair - filtered rooms whenever possible. Institution of these guidelines lowered toxic mortality to ~5% across cooperative group trials.¹⁹³

Various trials have also tried to answer additional remission induction questions, including (1) determining the optimal dose and schedule of cytarabine, 2) determining the optimal anthracycline and dose, and (3) determining what agents can be added to the cytarabine and anthracycline backbone to improve outcomes. Although dose intensification of cytarabine has not been demonstrated to improve remission induction rates, higher doses appear to confer lower rates of leukemia relapse in adults in patients with core-binding factor AML.^{151,154} Becton et al. reported the POG 9421 trial that randomized patients to standard versus high-dose cytarabine in induction therapy. No statistically significant differences in remission induction rate or EFS were observed; patients randomized to high-dose cytarabine had an increased risk of bacteremia/sepsis that approached, but did not reach, statistical significance (28% vs. 22%, P = 0.1).¹⁵⁵ A second pediatric study has also demonstrated no benefit for high-dose cytarabine over standard-dose cytarabine when used during induction therapy.¹⁴⁸

Debate continues over the optimal anthracycline choice in induction. The Berlin-Frankfurt-Munster (BFM) group showed evidence that idarubicin was superior to daunomycin in induction,^{156,157} and a meta-analysis by the Medical Research Council (MRC)/Institute for Cancer Research of randomized idarubicin/daunomycin comparisons suggested that idarubicin is superior.¹⁵⁸ The CCG-2941 and COG-2961 trials showed that idarubicin was too toxic to be used in sequential courses of intensively timed IdDCTER therapy.^{153,159,160}

The MRC AML-12 trial randomized daunorubicin, ARAC, and thioguanine (ADE) versus mitoxantrone, ARAC, etoposide (MAE) in combination with cytarabine and etoposide. Although the MAE regimen showed a decrease in the relapse rate

compared to the ADE-treated group, the increased risk of treatment-related mortality led to no overall benefit in DFS or OS. These results were similar in children and adults.^{161,162}

Whereas the addition of other agents to the “7 and 3” backbone has helped increase induction rates from 70% to 85%, no randomized trial has demonstrated the superiority of a particular agent, or combination of agents, over any other combination. Specifically, the MRC-10 trial tested 6-thioguanine versus etoposide with daunomycin and cytarabine and found no statistically significant difference between the two induction regimens.¹⁴⁵ In an attempt to introduce a novel, noncross-resistant agent into induction therapy, the COG AAML03P1 trial demonstrated that gemtuzumab ozogamicin (GO) can be safely added to a backbone of cytarabine, daunorubicin, and etoposide, resulting in a remission rate of 83.5% after 1 cycle of therapy.^{147,163} Results of the randomized trial using GO have not been reported at the time of this writing. However, the randomized study from the MRC has demonstrated no change in remission rates with the addition of GO, but an OS advantage particularly for patients with core-binding factor AML.¹⁶⁴ No advantage was observed in a Nordic Society of Pediatric Hematology and Oncology (NOPHO) trial randomizing GO in the post-remission setting.¹⁶⁵

In summary, current pediatric AML induction regimens successfully induce remission in approximately 85% of patients using a variety of induction strategies. The improvements in induction remission rates have come primarily from intensification of therapy, either by adding additional agents to the “7 and 3” backbone or from dose intensification. Although successful, it appears unlikely that further dose escalation or intensification will significantly improve remission rates. Thus, a central remission induction question now centers on the selection and safe integration of other novel agents aside from GO, in order to increase antileukemic activity with less toxicity than conventional chemotherapy.

P.1643

Post-remission Therapy

Once a complete remission has been achieved, including negative MRD status, additional therapy is required to avoid disease relapse. Various combinations and numbers of courses of therapy have been tested.

Dose and Duration

Although agreement exists on the role of cytarabine-based intensification therapy, especially for core-binding factor myeloid leukemias in which additional courses of cytarabine appear to decrease relapse risk significantly, the optimal number of cycles of intensification chemotherapy is not known.^{146, 166, 167} The published pediatric AML trials have used either 2 or 3 courses of consolidation therapy, for a total of 4 or 5 courses of therapy.^{168, 169} and ¹⁷⁰ The MRC AML-10 trial randomized patients to either auto-HSCT transplant or no further therapy and demonstrated a decreased relapse risk in patients receiving auto-HSCT. However, the addition of auto-HSCT was associated with significant morbidity and mortality, thus abrogating any OS advantage.¹⁶⁹ The CCG-2961 trial gave patients a total of 3 courses of chemotherapy with a resulting overall survival of 57% following changes in supportive care recommendations.¹⁷¹ The MRC AML-12 trial randomized patients to a total of 4 versus 5 courses of chemotherapy with an OS of 81% versus 78%, respectively, at 5 years ($P = 0.5$). However, the survival for patients with very high risk AML was significantly less than for patients with intermediate and favorable risk AML; thus, any attempts to test 4 versus 3 courses of therapy should likely be done in the latter groups.¹⁶²

With the exception of patients with APL, the use of maintenance therapy with relatively low dose chemotherapy has been currently abandoned with the exception of BFM studies, which in part base this choice on the results of BFM-87, in which a maintenance phase was beneficial to a low-risk group of patients who did not receive HSCT. However, when only randomized patients were analyzed, no significant difference in outcome was observed, and no significant difference was observed.¹⁷² Other cooperative groups, however, have shown that maintenance therapy is associated with a decrease in both EFS and OS when compared to shorter, more intensive regimens, with relapsed disease being more resistant to subsequent therapies.^{173, 174, 175}

Hematopoietic Stem Cell Transplantation

Sustained improvements in chemotherapeutic regimens and supportive care have continued to reduce the need for patients to receive allogeneic HSCT. Furthermore, several studies have shown equivalent overall survival when compared to chemotherapy; most co-operative groups have thus omitted autologous HSCT from consideration in order potentially to avoid greater short- and long-term toxicities.^{145, 168, 176, 177} However, with equivalency of overall outcome between autologous HSCT and chemotherapy, one might also conclude that either approach would be a reasonable, evidenced-based recommendation.¹⁷⁸ In addition, alternative approaches to transplantation, such as the use of nonablative or

intensity-reduced allogeneic or haplo-identical HSCT, remain experimental and need prospective testing in comparison to more conventional approaches.

Pediatric cooperative groups generally agree that intensive cytarabine-based post-remission induction therapy is required to minimize relapse risk. The role of allogeneic HSCT has continued to evolve. This has in large part been due to the advances in chemotherapy-based treatments for patients who might have previously been considered candidates for allogeneic HSCT. Key questions are whether allogeneic HSCT provides an overall improvement in survival and quality of life compared to chemotherapy-only treatment approaches. In order to answer these questions, it has been necessary to define risk groups more carefully in terms of outcome and potential for benefit from HSCT. In addition, whereas most trials have analyzed outcomes on whether patients did or did not have an HLA-matched donor, the improving success being obtained using matched unrelated donor HSCT has led to outcome analysis based on availability of the best HLA-matched donor.¹⁶²

Many trials have shown that allogeneic HSCT results in an improved disease-free survival compared to chemotherapy or autologous HSCT.^{162, 168, 177, 179, 180, 181} However, HSCT has not usually resulted in an improved event-free or overall survival, reflecting the associated increased treatment-related mortality. Such results suggest that HSCT may benefit some groups more than others. Several studies have attempted to define such subgroups more precisely.

The availability of an HLA-matched donor was used to analyze outcome in the MRC AML 10 trial.¹⁸² There was no statistically significant difference in overall survival between those children with (68%) or without (59%) a donor at 10 years, even though there was a significant difference in relapse rate (30% with donors vs. 45% without donors). Based on the MRC cytogenetic and response-based risk stratification, overall survival at 5 years from the time of relapse was 57%, 14%, and 8% for good, standard, and poor risk groups, respectively; this led to the conclusion that allogeneic HSCT should be done in good risk AML in CR2. Although outcomes from MRC AML 10 also suggested that allo-HSCT in first remission as improved for patients with intermediate- and high-risk AML, combined data from the MRC AML 10 and 12 trials showed no statistically significant benefit for these groups of patients compared to chemotherapy alone.¹⁸² BFM trials and POG 8,821 and 9,421 studies showed comparable results although in the POG trials did not do a detailed subgroup stratification.^{155, 183, 184}

In contrast, analysis of post-remission treatment of 1,464 children less than age 21 years on 5 consecutive CCG trials from 1979 to 1996 has shown an advantage to those patients assigned a HSCT in terms of overall survival ($P = 0.026$), disease-free survival ($P = 0.005$), and relapse rate ($P < 0.001$).¹⁸⁵ Subgroup analysis demonstrated that HSCT was associated with improved survival for patients with WBC greater than 50,000/ μL and for those with normal karyotype, but was not beneficial for patients with AML characterized by good-risk cytogenetics, such as $\text{inv}(16)$ or $\text{t}(8;21)$. In support of such data, a report from the CCG 2961 trial showed no statistically significant advantage of having a HSCT donor in terms of OS or DFS in the subgroup of patients with $\text{inv}(16)$ or $\text{t}(8;21)$ chromosomal translocations.¹⁷¹ A detailed analysis of the effect of donor availability on patients with standard and poor risk features was not reported although no advantage of having a HSCT matched family member donor was observed compared to chemotherapy for the entire study population. Overall, these results appear to be consistent with those reported from pediatric MRC AML trials.

A more detailed analysis of the MRC AML 12 outcomes has reported no advantage of HSCT for patients in the good and intermediate groups, but a statistically significant advantage for relapse-free survival and overall survival for a subset of patients with high-risk AML; for example, in the 12% of patients defined as having poor-risk AML, HSCT was associated with an overall survival of 41% compared to 10% for those who received only chemotherapy ($P = 0.001$).¹⁶²

Whether patients with other subtypes of AML might also benefit from receiving an allogeneic HSCT remains controversial. A high FLT3-ITD mutant to normal allele frequency has been uniformly associated with a poor prognosis when patients are treated with standard chemotherapeutic regimens alone.^{186, 187, 188} A significant question is whether more allogeneic HSCT is able to improve outcomes in patients with a high allelic ratio FLT3-ITD AML.

Some studies have strongly suggested an advantage of HSCT for patients with a high mutant allele frequency of FLT3-ITD.
P.1644

mutations.^{188, 189, 190} and ¹⁹¹ Data from the CCG 2941 and 2961 trials showed a borderline significant difference in relapse for patients with FLT3-ITD positive AML who received a allogeneic matched sibling donor HSCT ($27\% \pm 27\%$) compared to those treated with only chemotherapy ($65\% \pm 15\%$, $p = 0.05$). However, overall survival at 4 years from the end of the second course of treatment was not significantly different ($64\% \pm 29\%$ for those with FLT3-ITD AML who received an allogeneic HSCT and $48\% \pm 17\%$ for those treated with chemotherapy [$p = 0.4$]).^{188, 192} The MRC AML 10 and 12 trials concluded that there was no strong evidence that FLT3 status should be considered as to whether to perform a HSCT

based on their analysis of 1,135 young adult patients.¹⁹³ Because OS was not significantly improved by having a donor in patients with FLT3-ITD positive or negative AML, it was concluded that allogeneic HSCT is not able to overcome the intrinsic chemoresistance or radiation resistance of FLT3-ITD positive AML. Thus, whether allogeneic HSCT can improve outcomes for patients with FLT3-ITD remains an open question. Nevertheless, most ongoing clinical trials for children and young adults assign allogeneic HSCT for patients with AML characterized by a high mutant FLT3-ITD to normal allelic ratio, often in the context of additional targeted therapy directed toward inhibition of the mutant receptor.

Current strategies for determining which patients should receive matched or single mismatched family donor or alternative donor HSCT are thus based on risk assessment and stratification. Patients with AML characterized by alternations in core binding or transcription factors (e.g., t(8;21), inv(16), biallelic CEBPA mutations) have an approximately 80% overall survival with chemotherapy alone and, thus, HSCT is recommended only in CR2. Similarly, children and young adults with APL have an overall survival of 75% to 90%, depending on risk group, with chemotherapy plus all-trans-retinoic acid (ATRA) and, more recently, arsenic.^{194, 195} Thus, HSCT is not usually recommended in CR1 for these patients, but instead following CR2, in which case allogeneic, and in some instances autologous, HSCT result in an approximately 70% overall survival.^{195, 196} and ¹⁹⁷

MLL-rearranged AML represents an extremely heterogeneous group of leukemias associated with variable outcomes. For example, an international trial has reported that survival is 100%, 63%, 27%, and 22% for patients with the t(1;11), the t(9;11), the t(4;11), and the t(6;11), respectively.¹⁹⁸ Because of the wide variability of outcomes along with small numbers of patients with MLL subtypes as well as no prospective definitive data that demonstrate HSCG improves outcome in this group of patients, most cooperative group clinical trials have not used allogeneic HSCT in CR1.¹⁷⁸ An intention-to-treat analysis of the AML-BFM 98 study has suggested an improved OS with allogeneic MSD HSCT for patients with 11q23 (MLL) rearrangements.¹⁹⁹

AML characterized by a normal karyotype represents a large percentage of cases, however, it is also proving to be a molecularly heterogeneous group. For example, nucleophosmin member 1 (NPM1) mutations are associated with an improved outcome, although not necessarily in the presence of high mutant FLT3-ITD to normal allelic ratio is somewhat controversial.^{200,201} AML with CEBPA mutations is usually associated with normal karyotype AML and improved overall survival, thus making HSCT undesirable in CR1.⁵⁰ Point mutations involving KIT, RAS, or WT1 (Wilms tumor 1) have not yet been definitively shown to improve outcome although some data exist linking them to a poorer prognosis.^{202,203} Furthermore, patients with AML having high-risk cytogenetics, such as monosomy 7 or del(5q)- and -5, are recommended to have HSCT in CR1 (Table 77.2).

The Children's Oncology Group (COG) frontline AML clinical trial AAML1031 uses allogeneic HSCT in first remission only for patients with predicted high risk of treatment failure based on unfavorable cytogenetic, molecular characteristics and elevated end-of-induction MRD levels.²⁰⁴ In contrast, the AML-BFM 2004 clinical trial restricted allogeneic HSCT to patients in second CR and to refractory AML, based on results from their AML-BFM 98 study showing no improvement in DFS or OS for high-risk patients receiving allogeneic HSCT.²⁰⁵ Although the optimal timing for allogeneic HSCT has not been determined, most cooperative groups recommend doing HSCT following the second or third course of chemotherapy, based in part due to the time involved in obtaining HLA typing. The use of matched unrelated donors (MUD), haploidentical donors, single- or double-cord blood donor, or nonablative approaches for HSCT in CR1 are not as clearly established as MSD HSCT, but are increasingly used to provide potential curative treatment for patients with recurrent AML (Table 77.3).^{206,207}

TABLE 77.2 RISK GROUPS DEFINED BY CYTOGENETIC AND MOLECULAR ALTERATIONS

Favorable

t(8;21)

inv16

t(15;17)

t(1;11)

CEBPA biallelic mutation

GATA1 (DS)

Intermediate

Normal karyotype**Other Cytogenetic Abnormalities of Neither Favorable or Unfavorable Type**

7q-

Unfavorable

-7

-5/del5

inv(3), t(3;3)

t(6;9)

t(7;12)

t(4;11), t(6;11), t(5;11), t(10;11)

t(9;22)

t(1;22) in non-DS

High *FLT3*-ITD/*wild-type* allelic ratio***WT1/FLT3*-ITD****Complex karyotype****TABLE 77.3 CHILDREN'S ONCOLOGY GROUP (COG) RISK CLASSIFICATION FOR AAML1031 TRIAL****Low Risk (~70-75% of Patients with Predicted OS of 70-75%)**

Presence of favorable cytogenetics involving inv(16) or t(8;21), mutations of *CEBPA*, *NPM1*, and with any MRD status at the end of first induction course

OR

Standard risk cytogenetics and negative MRD at end of first induction course

High Risk (~25-30% of Patients with OS < 35%)

Presence of poor prognosis cytogenetic changes such as monosomy 7, del(5q), with any MRD status at end of first induction course

OR

High *FLT3*-ITD to *wild-type* allelic ratio with any MRD status at end of first induction course

OR

Standard risk cytogenetics and positive MRD at end of first induction course

Note: In this schema, patients without minimal residual disease (MRD) or noninformative cytogenetic/molecular studies are classified as having low-risk disease

P.1645

Summary of Therapy for Patients with Newly Diagnosed Acute Myelogenous Leukemia

Despite some differences in their approaches, most pediatric cooperative groups share a common treatment strategy based on anthracyclines and cytarabine and risk stratified use of HSCT.^{173, 174, 183, 184, 208, 209, 210} and ^{211, 212, 213, 214} Overall survival at 5 years for children with AML is in the 55% to 65% range, with some patients doing significantly better and others worse. As more children and adolescents are long-term survivors, increased attention is also now being paid to survivorship issues.

THERAPY FOR PATIENTS WITH RELAPSED/REFRACTORY DISEASE

Despite AML treatment intensification, recurrent and/or refractory disease remain the major causes of treatment failure. Re-induction regimens typically use high-dose cytarabine, even if prior therapy has included substantial cytarabine exposure. With the addition of agents such as mitoxantrone, etoposide, fludarabine, cladribine, or clofarabine to cytarabine, approximately 50% to 70% of patients with relapsed or refractory patients achieve CR, depending on the time of their relapse relative to their therapy.^{215, 216, 217} and ^{218, 219, 220} There is evidence that the combination of fludarabine, idarubicin, and cytarabine (FLAG-Ida) has a high remission-induction rate, which may be of longer duration. However, the toxicity associated with this regimen is also substantial.^{218,220,221} The combination of mitoxantrone and high-dose cytarabine used in the CCG-2951 study achieved a 76% overall remission rate.²²² Several adult trials have demonstrated that GO may be safely combined with several chemotherapy regimens for AML re-induction therapy. The COG AAML00P2 trial demonstrated that GO could be safely combined with either cytarabine/mitoxantrone or with cytarabine/L-asparaginase. However, exposure to GO, particularly at single-agent doses, <3 months prior to HSCT increases the risk of severe veno-occlusive disease during HSCT.^{223, 224} and ²²⁵

Patients with refractory or relapsed AML will usually require an allogeneic HSCT from either a related or an unrelated donor to achieve a long-term cure.^{206,226} Conditioning regimens are quite variable and randomized, and prospective trials rare. Because many investigators are reluctant to give conditioning regimens that include total-body irradiation to young children, the balance between risks and benefits of total-body irradiation-containing regimens for relapsed AML is largely based on retrospective comparative reports. Donor sources have included MUD, HLA-matched and -mismatched cord blood (single or double) donors, haploidentical donors as well as KIR-mismatched unrelated or haploidentical donors.²²⁷

Although the use of cord blood units and haploidentical grafts makes alternative donors available for almost every patient, both of these stem cell sources have disadvantages over fully MUD. Cord blood grafts may have less of a graft-versus-leukemia effect, and the small number of stem cells can delay engraftment or increase graft failure. Haploidentical grafts may be associated with higher rates of graft-versus-host disease, as well as higher rates of viral infections and post-transplant lymphoproliferative disease as a result of the intensive immunosuppressive transplant regimens used.²²⁸

Despite the increased risks of toxicity, infectious complications, and graft-versus-host disease associated with the allogeneic transplant typically used for relapsed or refractory AML, between 20% and 50% of patients may achieve long-term survival.^{229,230} Cure is significantly affected by the duration of first CR, with shorter CR-1 (e.g., <6 months off therapy or while on therapy) being associated with lower overall survival.²³¹ Leukemia karyotype may also modify the probability of achieving CR with relapsed and/or refractory AML.²³² Overall, patients with AML characterized by such high-risk features have a 3-year survival of <20%, whereas patients with initial CR lasting >1 year may have a 30% to 40% 3-year survival. However, the rate of cure for patients with typical core binding factor AML, such as t(8;21), have an excellent survival rate following relapse following CR2 and allogeneic HSCT.

SUPPORTIVE CARE

Current AML treatments are among the most intensive used in children with cancer, and cause a wide variety of severe complications. AML treatment-related morbidity and mortality significantly affect OS of patients, both through treatment delays and deaths due to toxicity. Thus, patients with AML should be cared for by physicians and nurses experienced in AML therapy in institutions with appropriate laboratory, radiology, blood banking, and surgical services.

Standardization of supportive care, as shown by Riley et al., may reduce treatment-related mortality by 50%.¹⁵² AML supportive care guidelines typically focus on infection prophylaxis and treatment, although hematologic support is also critical. Fever and neutropenia in patients with AML constitute a medical emergency. After obtaining blood cultures, broad-spectrum antibiotic therapy should be instituted rapidly. Coverage for penicillin-resistant *Streptococcus viridans* and Gram-negative organisms should be given, and anaerobic coverage should be added if clinically indicated. Local microbial resistance patterns should dictate selection of initial antibiotics, although broad-spectrum antibiotics are typically included in the initial antibiotic selection. Patients should remain on broad-spectrum coverage until their neutropenia shows signs of resolution. Vancomycin use may be limited to 24 to 48 hours until a resistant *S. viridans* infection has been excluded. Although patients with AML are at risk for a wide range of bacterial infections, Gram-negative organisms occur frequently at diagnosis, and α -hemolytic streptococcus is often seen after intensive consolidation regimens.²³³

Empiric antifungal therapy should begin if fever persists for >3 to 5 days after initiation of antibiotic therapy or with recurrent fever. Amphotericin B has been the first-line choice for antifungal coverage, although recently voriconazole and caspofungin have been shown to be effective agents associated with fewer toxicities.²³⁴ Selection of the appropriate antifungal agent is guided by culture results, which may require biopsy, radiographic findings of lesions difficult to biopsy, and the side-effect profiles of the various antifungal agents. Note that strict hand-washing guidelines, mandated

hospitalization until neutrophil recovery, and use of high-efficiency particulate-air-filtered rooms whenever possible all significantly decrease the incidence, morbidity, and mortality of infections in pediatric AML patients.

Multiple studies, including the recently reported BFM 98 trial, have demonstrated that G-CSF may decrease the length of neutropenia and the length of hospital stay, but it does not appear to alter severe toxicity or infection rates.^{235, 236} and ²³⁷ Unlike studies in adults, G-CSF treatment in patients with hypercellular day 7 bone marrows on CCG-2891 had a statistically significantly improved remission rate and OS, although the introduction of G-CSF in this study was not randomized.²³⁸

Prophylaxis against opportunistic infections is also an important supportive care issue. Although *Pneumocystis jiroveci* is rare in pediatric patients with AML, prophylaxis with trimethoprim-sulfamethoxazole is often given. *S. viridans* sepsis may be prevented by penicillin prophylaxis in centers where *S. viridans* remains penicillin-sensitive. Penicillin resistance, however, is becoming more frequently detected. High-efficiency particulateair -filtration has been shown to diminish *Aspergillus* infection in marrow transplant patients and likely benefits AML patients who

P.1646

experience prolonged periods of neutropenia and immunosuppression.²³⁹ In addition to management of infectious complications, the pre-emptive use of blood products has also been shown to play a critical role in the successful treatment of patients with AML.^{240,241}

LATE EFFECTS OF THERAPY

Although intensive AML protocols cure a substantial fraction of children with AML, the late effects of these therapies can be significant. Several investigators have reported on AML late effects, but population-based follow-up studies of recent intensive therapies are lacking and remain a critically needed area of research.^{242, 243} and ²⁴⁴ Leung et al., reporting on 77 patients surviving more than 10 years from diagnosis, observed that increasing radiation dose as well as younger age at diagnosis and timing of radiation therapy were risk factors for growth delay, infertility, academic difficulties, cataracts, and hypothyroidism. Patients receiving total-body irradiation had lower cumulative anthracycline doses (204 mg/m² vs. 335 mg/m²) but did not have a lower rate of cardiomyopathy, suggesting an interaction of radiation and anthracyclines.²⁴⁴ An analysis of a cohort of infants with leukemia treated by chemotherapy and then HSCT indicated that 59% had growth hormone deficiency, 35% had hypothyroidism, 24% had osteochondromas, 24% had decreased bone mineral density, and 59% had dyslipidemias.²⁴⁵ Temming et al. reported on results from the United Kingdom that there was a 13.7% and 17.4% prevalence of early and late cardiotoxicity in children survivors of AML treated with chemotherapy.²⁴⁶ Patients who survive AML therapy also have a significantly increased rate of secondary malignancies.²⁴⁷ However, primary disease relapse and therapy-related morbidity decrease EFS significantly more than secondary AML.

A population-based study involving children treated on NOPHO clinical trials demonstrated overall equivalent usage of health care services compared to their siblings, although there was a significant increase in use of prescription medications, especially for asthma in the leukemia survivors.²⁴⁸ A Childhood Cancer Survivor Study (CCSS) analysis of 272 5-year survivors of AML showed excellent resiliency and health in this group with significant concerns relating to secondary malignant neoplasms (the majority of which were in the setting of radiation exposure) as well as lower socioeconomic achievement compared to siblings. In addition, half of the survivors reported at least one chronic medical problem and were considered at increased risk for a severe or life-threatening condition compared to their siblings.²⁴⁹

MANAGEMENT OF PATIENTS WITH DOWN SYNDROME

The majority of leukemias in children with DS are lymphoid, although DS children comprise 10% of pediatric AML patients and thus represent the most frequently associated genetic disorder associated with the development of AML.²⁵⁰ Furthermore, there is an up to twentyfold risk of developing leukemia in children with DS or mosaicism for Trisomy 21. Approximately 5% of newborns with DS experience transient myeloproliferative disease (TMD).²⁵⁰ Although TMD will usually spontaneously resolve over the course of several weeks to months, about 10% to 20% of these infants will go on to develop AML, mostly of the megakaryoblastic subtype (AMKL). The leukemic blasts in TMD and DS AMKL express exon 2 mutations of GATA-1 and originate from fetal liver hematopoietic precursors.²⁵¹ These disorders may be associated with hydrops fetalis as well as liver cirrhosis.

Because of the spontaneous remissions observed in DS patients with TMD, close observation is usually the first approach to management. However, when life-threatening signs and symptoms occur, often a result of hyperleukocytosis and organomegaly, treatment approaches can include exchange transfusion and/or low-dose cytarabine arabinoside at 1 to 1.5 mg/kg IV for 5 to 7 days.^{250 252}

The favorable outcome for young children with DS and AML treated with less intensive chemotherapy regimens has been observed since the 1990s.^{253, 254, 255, 256, 257} and ^{258, 259} However, age at the time of diagnosis is an important prognostic factor in children with DS and AML with children greater than 4 years of age having a significantly worse 4-year EFS of 28% compared to the greater than 85% for younger patients.^{250, 259, 260, 261} Older patients with DS and AML are often now treated on conventional AML protocols, albeit with mixed results. Significant improvements in therapy are needed for this group of patients. However, because of the excellent prognosis of younger patients with DS and AML, the goal of trials continues to be directed toward reducing the intensity of therapy, and, particularly, anthracycline exposure.²⁶²

MANAGEMENT OF PATIENTS WITH NON-DOWN SYNDROME INHERITED SYNDROMES

Patients with inherited syndromes, such as those characterized by DNA repair defects, usually are not able to tolerate the effects of chemotherapy or radiation treatment as well as other children with AML. For example, patients with FA require substantial dose reductions in chemotherapeutic drugs as well as bone marrow transplantation regimens, but such patients can sometimes be cured of their AML. However, chemotherapy to cytoreduce leukemia burden followed by reduced-intensity regimens are therefore recommended for such patients.^{263, 264, 265, 266, 267, 268} and ²⁶⁹ Patients with other familial cancer predisposition syndromes, such as those with germline CEBPA mutations, or Kostmann syndrome, who develop AML, can also be effectively treated with allogeneic HSCT.^{270, 271} and ²⁷²

MANAGEMENT OF INFANTS WITH ACUTE MYELOGENOUS LEUKEMIA

Congenital leukemia is defined as that which occurs in the first month of life. Approximately two thirds of patients present with leukemia cutis, giving a "blueberry muffin" baby appearance that may also be seen in metastatic neuroblastoma or rhabdomyosarcoma and histiocytosis (Fig. 77.3). Hepatosplenomegaly is also typically present, but lymphadenopathy less so; CNS involvement is present in 50% of cases that included performance of a lumbar puncture. The WBC count is typically elevated, and the majority of reported congenital myeloid leukemias have been of the M5 subtype. A majority of congenital AML cases have abnormal cytogenetic findings, with approximately one fourth of cases having 11q23 abnormalities.^{273, 274} AML in infants (usually considered as being less than 12 months of age) is also characterized by a high predominance of MLL rearrangements.²⁷⁵

Although spontaneous remissions have been reported in neonates with AML,²⁷⁶ OS tends to be poor, with an OS of 24% at 2 years in the most comprehensive review.^{273, 274} For these neonates and infants, conventional approaches to therapy using AML regimens used in older children are typically used, but with dose adjustments.²⁷⁵ This is in part due to the immaturity of organs as well as the immune system, resulting in significant treatment-related toxicities, including death.^{275, 277} For instance, the AML-BFM studies have suggested the dose reduction of cytarabine arabinoside because of the reduced clearance in children under the age of 2 years.²⁷⁸ With such intensive, although in part modified, AML-directed regimens, the survival for infants can be similar to that reported in older children, i.e., in the 65% to 75%

P.1647

range for 5-year overall survival.^{153, 162, 275} The role of transplantation in infants remains unclear.



FIGURE 77.3. Leukemia cutis in an infant with congenital leukemia. (From Arceci R, Weinstein H. Neoplasia in the neonate and young infant. In Avery GB, ed. Neonatology: pathophysiology and management of the newborn. Philadelphia, PA: JB

Lippincott, 2005, with permission.)

MANAGEMENT OF ACUTE PROMYELOCYTIC LEUKEMIA

Before the introduction of differentiation targeted therapy, APL had a significantly poor outcome (Chapter 74). The use of ATRA, directed against the fusion proteins characteristically involving the retinoic acid receptor alpha (RARA) formed as a result of the usual t(15;17) chromosomal translocation, reversed this scenario.^{279,280} Overall survival at 5 years is now in the 75% to 90% range depending upon the presence of different risk factors when patients are treated with combination regimens that include ATRA and chemotherapy.^{195, 281, 282,283, 284,285, 286,287} Other RARA fusion proteins occur less frequently and display varying sensitivity to ATRA.

The therapy for APL is essentially identical for pediatric and adult patients. Thus, pediatric patients have usually been enrolled in various adult APL cooperative group trials. This has resulted in pediatric patients being exposed to significant amounts of anthracyclines as well as higher doses of ATRA. For instance, a conventional dose ATRA at 45 mg/m² is usually employed in adult trials, and results in a 90% or greater CR rate when used alone or in combination with chemotherapy. This type of treatment in children has been associated with increased toxicities, such as pseudotumor cerebri and "APL differentiation syndrome," which can occur in up to 25% of patients and is characterized by fever, respiratory distress, pulmonary infiltrates, pleural/pericardial effusions, fluid overload, hypotension, and acute renal failure. A dose of 25 mg/m² of ATRA appears to be equally effective and is thus recommended in most pediatric trials.^{194, 195, 288, 289, 290, 291} and ²⁹² The recognition of this syndrome and early treatment with corticosteroids and temporary cessation of ATRA is critical. The effective use of prophylactic corticosteroids has been reported for patients with presenting WBC counts of > 5,000/ μ l.²⁹³

In addition, the high doses (usually in the 400 to 750 mg/m²) of anthracyclines commonly used to treat patients with APL can have particularly significant adverse consequences to cardiac function in children.¹⁹⁵ Thus, an ongoing goal for pediatric trials (and some adult trials) has been to reduce overall anthracycline exposure. The introduction of arsenic trioxide (ATO) as a single agent in APL that has results in CR rates of up to 85% in patients with relapsed disease, has provided a potential alternative to anthracycline.^{294, 295, 296} and ²⁹⁷ In addition, several studies have shown excellent to superior results when testing ATO in combination with chemotherapy along with ATRA.^{298, 299,300, 301} The use of ATRA for induction therapy followed by 6 months of maintenance with arsenic has been reported to achieve a 3-year overall survival of 86%.³⁰² The combined use of ATRA, arsenic, and immunotargeted therapy with anti-CD33-calicheamicin monoclonal antibody (gemtuzumab ozogamicin or GO) has also been reported.^{303,304}

The recently completed COG trial replaced a course of anthracycline-containing chemotherapy with arsenic, thereby reducing anthracycline exposure to 355 mg/m² of daunorubicin equivalents for standard-risk patients with negative MRD at the end of induction and to 455 mg/m² for high-risk patients and standard-risk patients who have MRD after the third treatment course. Of note, this trial also used high-dose AraC during consolidation based on positive results from a randomized trial in adults.³⁰⁵

Unlike other subtypes of AML, maintenance therapy with ATRA plus antimetabolites has also proven to provide improved outcomes for patients with APL, although subsequent data in a randomized trial in adults has suggested that such maintenance therapy may not be required for a subset of patients with good-risk APL.³⁰⁶ Reducing or omitting maintenance therapy in subsets of pediatric patients with APL has not been reported.

The use of intrathecal (IT) chemotherapy as prophylaxis in patients with APL remains unclear. Some studies have suggested that the incidence of CNS relapse is higher in patients treated with ATRA or with high risk APL, however, definitive data demonstrating that IT prophylaxis reduces extramedullary relapse have not been reported.^{307,308} Overall, the incidence of extramedullary relapse in patients with APL is about 3% to 5%.³⁰⁹ Most pediatric trials continue to include some IT prophylaxis.

An important issue, however, is that lumbar puncture may not be safe at the time of presentation because of underlying coagulopathy, thus further complicating the timing of CSF sampling and IT prophylaxis. Another important consideration in treating patients with APL is to evaluate their initial risk status. Patients who present with APL and a WBC >10⁹/L are considered in most studies to have high-risk disease and are usually treated with more intense regimens. The presence of FLT3-ITD mutation might predict early death in pediatric patients with APL³¹⁰ and a low FLT3-ITD to normal FLT3 allele ratio has been reported to be associated with an improved prognosis in APL.³¹¹ Nevertheless, patients with high-risk APL make up a large percentage of the approximately 15% to 20% of patients with APL who experience relapse of their leukemia. The detection of early (molecular) relapse in adults has also proven to be advantageous.^{312,313, 314} Treatment goals in this situation are to obtain a second CR,

which can usually be achieved with single-agent ATO or in combination with chemotherapy and ATRA. Post-remission therapy is required to improve overall outcome. For example, in one report, 50% of patients who received an additional course of therapy with ATO were alive at 2 years compared to 78% who underwent either allogeneic or autologous HSCT.³¹⁵ Thus, some type of HSCT as consolidation therapy for patients with relapsed APL is usually recommended. A study from the European APL Group reported that the 7-year OS for adults was significantly better for those who received autologous HSCT compared to those receiving an allogeneic HSCT (60% vs. 52%, respectively; $p = 0.04$); this difference was in large part due to the increased treatment-related toxicity with allogeneic HSCT.¹⁹⁶ Another important consideration, however, is whether there is any bone marrow, molecular evidence of the APL at the time of stem cell harvest for autologous HSCT. Meloni et al. reported that all patients whose autologous graft was positive by RT-PCR for RARA fusion transcript relapsed within 9 months of autologous HSCT.³¹⁶ Thus, autologous HSCT may be beneficial for patients who achieve a molecular remission before graft harvest. For instance, Thirugnanam et al. have reported a 5-year EFS of about 83% for patients who received an autologous HSCT compared to 35% for those who received only maintenance therapy after achieving a second CR.¹⁹⁷ For patients where residual disease persists, allogeneic HSCT may be a more advantageous treatment strategy.^{195, 317}

A significant and unresolved challenge in both children and adults with APL is the prevention of early death due to hemorrhagic complications, which can occur in about 3% of patients.^{318, 319} The pathogenesis of the underlying coagulopathy in APL is complex, involving the release of activators of both coagulation and fibrinolysis by the leukemic cells.^{320, 321} Early detection and initiation of antileukemic treatment along with aggressive supportive care measures to control the coagulopathy are essential.^{322, 323}

GRANULOCYTIC SARCOMA

Granulocytic sarcoma, myeloid sarcoma, extramedullary AML, and chloroma all refer to AML presenting as a solid tumor from the localized proliferation of malignant myeloblasts. These may occur anywhere in the body, but are most commonly seen in skin, bones, or paraspinal/epidural sites. Chloromas may be present in up to about 5% of cases and are most frequently associated with AML characterized by the t(8;21) chromosomal translocation, but also can be seen in other subtypes, especially in infants with myelomonocytic or monocytic AML.³²⁴ Patients may also present, albeit it rarely, with a chloroma and no detectable bone marrow or other systemic involvement.^{324, 325} Biopsy of a chloroma with special immunohistochemical staining for myeloid markers, FISH, and cytogenetics for AML-related alterations as well as flow immunophenotyping should be done as such lesions can be confused with lymphomas or bone and soft tissue sarcomas.

The management of patients presenting with chloromas should be similar to that of patients with AML as defined by conventional risk groups. A CCG study reported that EFS and local recurrence rates were similar for patients treated with chemotherapy alone compared to chemotherapy plus radiation to the chloroma(s).³²⁶ Radiation therapy may thus be reserved in cases where a chloroma does not respond to intensive AML-directed chemotherapy.^{324, 326}

BIPHENOTYPIC LEUKEMIA

Biphenotypic, bilineage, bilineal, or mixed phenotype acute leukemia refer to leukemias which co-express proteins that are characteristically restricted during differentiation to either the lymphoid or myeloid lineage. The WHO classification has referred to these leukemias as having ambiguous lineage, with biphenotypic referring to one population of leukemic blasts that co-express myeloid and lymphoid antigens and bilineage referring to two distinct populations of leukemic blasts of different lineages. Usually more than one lineage marker from the opposite lineage is considered to be necessary to call the leukemia biphenotypic, as the aberrant expression of lymphoid-associated or myeloid-associated antigens may be present on 10% to 20% of AML and 20% to 40% of AML, respectively, and generally have not been shown to have prognostic significance.³²⁷

The optimal treatment of children with mixed lineage leukemia has not been determined. A recommendation that has resulted in reasonable outcomes is to direct treatment toward the dominant phenotype present. Thus, if a leukemia primarily demonstrates a lymphoid phenotype, then ALL directed therapy can be used to start induction therapy.^{328, 329, 330} Although these leukemias are often considered to arise from earlier progenitors and thus difficult to cure with chemotherapy alone, HSCT may not be required in a significant number of cases.³³¹

SECONDARY OR THERAPY-RELATED ACUTE MYELOGENOUS LEUKEMIA

Therapy-related AML (TR-AML) is most commonly related to exposure to specific chemotherapeutic agents, such as alkylating agents or topoisomerase inhibitors, as well as radiation.^{22, 332} The goal of treatment should be to achieve a CR and then proceed to allogeneic HSCT with the best available donor, including haploidentical donors. In addition to genotoxic exposures, there may also be predisposing genetic or susceptibilities, such as polymorphisms in drug

detoxification and DNA repair enzymes.^{333, 334, 335, 336} and ³³⁷ Depending on the level of exposures and predisposing factors, estimates of between 0.4% and 2% risk for developing TR-AML exists for patients undergoing treatment for solid tumors.^{247,338,339}

Complete remission rates and overall survival are usually lower for patients with TR-AML compared those with de novo AML.^{332,340,341} A high nonrelapse mortality has also been reported for this group of patients undergoing HSCT.³³⁴ Adverse or high-risk cytogenetic abnormalities and molecular alterations are more frequently observed in TR-AML.^{22,332} Re-induction regimens should ideally include chemotherapeutic agents which patients have not been exposed to previously to reduce the risk of cross-resistance of the leukemia, although this is not always possible. However, novel agents and regimens available through clinical trials should be strongly considered if available. The relatively poor outcome for such patients increases the importance of determining more effective and less toxic treatments for patients with first malignancies.

PROGNOSTIC FACTORS

One of the greatest challenges in the treatment of patients with AML has been the identification of risk factors that could be used to more precisely direct treatment. Such risk or prognostic factors include those of the host and the disease as well as the treatment that is used (Fig. 77.4). Our limited ability to identify and act on such factors has relegated AML treatment to a population-based approach. However, there has been a continuous effort to improve this through a variety of methodologies and observations, leading to the hope that future therapeutic approaches can be more individualized.

Host Factors

Of the host factors, patient age, race, and specific constitutional abnormalities are most strongly correlated with outcome. In general, patient age is inversely related to treatment outcome. This

P.1649

relationship was clearly demonstrated in the MRC AML-10 trial and was confirmed in MRC AML-12, in which infants, despite worse toxicity, had higher survival rates than older children.^{226,342} The CCG-2891 trial has also demonstrated a benefit of young age¹⁴⁶ although age has not been found to be an independent risk factor in AML-BFM trials.^{275,343} These differences may in part be due to treatment effects (Table 77.4).

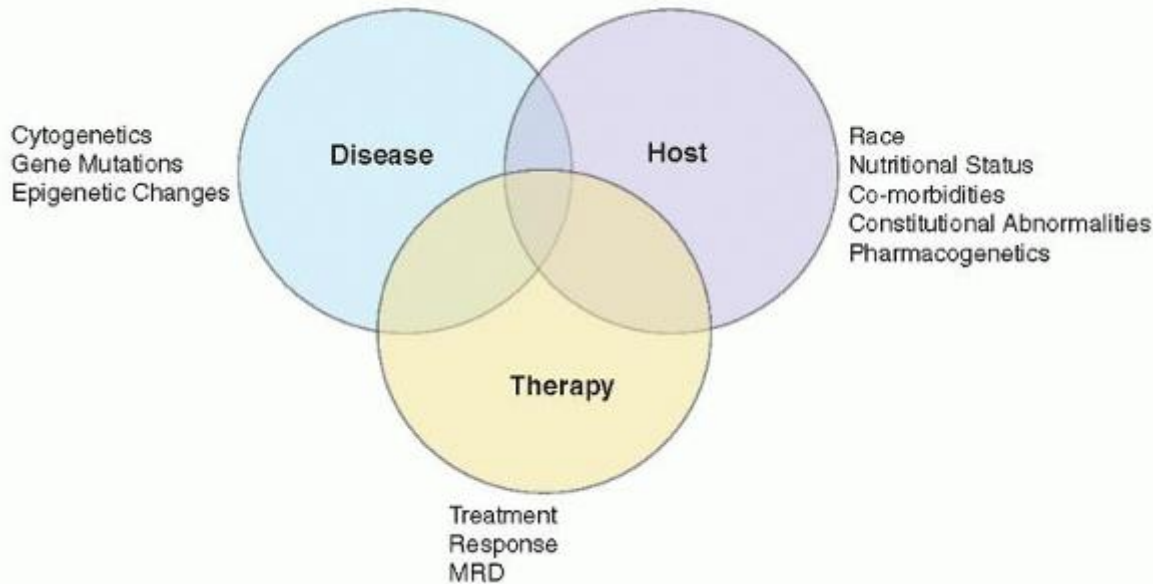

FIGURE 77.4. Relationship of prognostic factors in pediatric acute myelogenous leukemia. See text for details. FAB, French/American/British classification; MRD, minimal residual disease; PCR, polymerase chain reaction; WBC, white blood cell.

TABLE 77.4 TREATMENT OUTCOMES FROM SELECTED PEDIATRIC GROUP TRIALS

Study	Years	Number of Patients ^a	Early Death (%)	CR Rate (%)	CR Evaluation Number of Courses	5-Y		S 5-Y		SE Reference
						EF %	SE %	OS	SE	
POG 8821	1988-1993	511	3.9	77	2	31	2	40	2	184
CCG 2891	1989-1995	750	4.0	77	2	34	3	45	3	173
MRC-AML 10	1988-1995	303	4	93	4	49		58		182
PINDA-92	1992-1998	151	21	74	NS	36		37		423
LAME-91	1991-1998	247	6	91	2	48	4	62	4	424
TCCSG M91-13/M96-14	1991-1998	192	4	88	NS	56		62		425
BFM-93	1993-1998	427	7	82	4	50	2	57	2	183
CCG 2961	1996-1999	901	6	83	2	42	3	52	4	153
EORTC-CLG 58921	1993-2000	166	1	84	2	49	4	62	4	211
GATLA-AML90	1993-2000	179	20	70	NS	31	4	41	4	426
AIEOP LAM-92	1992-2001	160	6	89	2	54	4	60	4	210
NOPHO-AML 93	1993-2001	223	2	92	3	50	3	66	3	213
POG 9241	1995-1999	622	3	90	2	36	2	54	2	155
MRC-AML 12	1995-2002	504	4	92	4	54		63		161,182,427
AML99	2000-2002	260	2	94	2	61	3	75	3	428
BFM-98	1998-2004	430	3	88	4	51	3	61	2	429
SJCRH AML02 ^b	2002-2008	230	1	94	2	63	4	71	4	148
COG AAML03P1 ^b	2003-2005	350	3	83	2	53	6	66	5	147
NOPHO-AML 2004 ^c	2004-2007	120	2	80	1	53		77		165

BFM-AML 2004	2004- 2009	422	2	NS	NS	54	3	72	3	430,431
-----------------	---------------	-----	---	----	----	----	---	----	---	---------

Results are reported for only those trials that had 150 patients and information provided for each of the column headings. All numbers and percentages were rounded to the lowest value if less than 0.5 and to the next upper integer if ≥ 0.5 .

^a Ages include patients from 0 up to and including age 15 years: BFM-98 included patients from 0 to less than 17 years of age; number of patients excludes patients with Down syndrome; CCG-2961 included patients from 0 to 21 years of age.

^b SJCRH AML02 and the COG AAML03P1 have EFS and OS at 3-year follow-up; COG AAML03P1 enrolled patients ≥ 1 month and ≤ 21 years of age.

^c This reported results for two groups of patients who received identical induction therapy but randomized to receive or not receive post-remission gemtuzumab ozogamicin. Numbers in tables represent average of the reported values for each group.

AIEOP LAM, Associazione Italiana di Ematologia ed Oncologia Pediatrica Leucemia Acuta Meiloide; BFM, Berlin-Frankfurt-Munster; CCG, Children's Cancer Group; COG, Children's Oncology Group; CR, complete remission; EFS, Event-free survival; EORTC-CLG, European Organization for Research and Treatment of Cancer Children's Leukemia Group; GATLA-AML, Argentine Group for the Treatment of Acute Leukemia; LAME, Leucemie Aigue Myeloblastique Enfant; MRC-AML, United Kingdom's Medical Research Council Acute Myelogenous Leukemia Study; NOPHO-AML, Nordic Society of Pediatric Hematology and Oncology—Acute Myeloid Leukemia; NS, not specified; OS, overall survival; PINDA, National Program for Antineoplastic Drugs for Children; POG, Pediatric Oncology Group; SJCRH, St. Jude Children's Research Hospital; TCCSG, Tokyo Children's Cancer Study Group.

Adapted from Pui CH, Carroll WL, Meshinchi S, et al. Biology, risk stratification, and therapy of pediatric acute leukemias: an update. *J Clin Oncol* 2011.

Although patient gender is not usually included in risk models, females generally have marginally better outcomes than males. In CCG studies, race has consistently been a predictor of outcome, specifically with blacks having a poorer outcome than whites,³⁴⁴ although this has not been observed in other studies.^{345, 346} The importance of body weight has also been underscored by a report from the CCG-2961 study, in which there was a twofold greater risk of treatment-related toxic deaths associated with patients who were ≤ 10 th percentile or >95 th percentile.³⁴⁷

Whereas the pharmacogenetic basis of treatment response is poorly understood, homozygous deletions of the GST theta gene, a detoxifying phase II enzyme, have been reported to be associated with decreased survival (52% vs. 40%; $P = 0.05$).³⁴⁸ This difference in survival is due to an excess of toxicity in patients who are GST theta null (24% vs. 12%; $P = 0.05$).

Patients with constitutional abnormalities also have altered risk of treatment response. Most notably, patients with trisomy 21 who are less than 4 years of age may experience more therapy-related toxicity with conventional, dose-intensive AML regimens, but have higher survival rates than patients with a

P.1650

normal constitutional karyotype when less intensive regimens are used.^{250,260} Patients with other constitutional abnormalities, particularly FA, have increased toxicity with standard AML therapy. The underlying ineffective hematopoiesis leading to cytopenias limits their ability to recover normal hematopoiesis after AML therapy. As a result, these patients are generally excluded from standard AML protocols.

Disease-associated Factors—Clinical

Several characteristics of leukemia are also associated with outcome, including initial WBC count, FAB morphology, and cytogenetics. Like age, initial WBC blast count is inversely related to outcome. An initial WBC count $< 20 \times 10^9/L$ is

associated with a favorable prognosis, whereas an initial WBC count $>100 \times 10^9/L$ has been associated with an unfavorable prognosis in both the MRC and BFM trials. In the CCG-2891 study, patients with a WBC count $>330 \times 10^9/L$ had an unfavorable prognosis, with an EFS of 7%, due to early death, induction failure, and relapse.¹⁴⁶ However, in the BFM trials, very high leukemia blast counts at diagnosis were not associated with a worse DFS, but with increased risk of early death and decreased induction remission.³⁴⁹ High leukemia blast counts are now known to be associated with biologic factors, such as FLT3-ITD mutations.

CNS involvement, which occurs in about 5% to 10% of children with AML, has not been shown to result in decreased remission rates or survival, although there may be an increase of isolated CNS relapse.^{350,351} Of note, of patients with chloromatous disease, those with orbital involvement have been reported to have an improved outcome.³⁵²

Morphologic classification schemes, such as the FAB classification, were once used to assign risk to subtypes of AML, however, this has been replaced by a more current WHO classification based on underlying biology.

Whereas the FAB group has been associated with treatment outcome, different studies have found different associations. The BFM group reported that patients with FAB M1-M4 had improved survival over patients with either M0 or M5-7.³⁰⁹ However, in both MRC-10 and CCG-2891, the M5 FAB subtype was associated with favorable prognosis. FAB M7 in non-trisomy 21 patients has been associated with poor survival in CCG studies.

The cytogenetics karyotype of the leukemia blasts is a robust predictor of outcome. Patients with t(15;17), t(8;21), and inv(16) fare better than patients with other cytogenetic findings. Patients with monosomy 7 or 5 do poorly, as do patients with complex karyotypes, although the concomitant presence of monosomy 7 or 5 with complex karyotypes has made it difficult to discriminate between the contributions of other chromosomal changes. For example, FAB subtypes M1/M2 have been historically associated with a favorable prognosis but have a higher representation of favorable-risk cytogenetic changes. One exception may be with APL, where the early morphologic recognition and initiation of treatment can have important clinical consequences.

Disease-associated Characteristics—Cytogenetics/Molecular

The detection of recurrent chromosomal rearrangements in AML has been used to decide on probable risk of treatment failure since the 1990s. Chromosomal translocations involving core-binding transcription factors have been associated with a favorable prognosis, such as the t(8;21)(q22;q22) and inv(16) (p13.1q22), account for about 14% and 8% of pediatric AML, respectively. Although these core-binding factor leukemias are often considered together as a single group, there are important differences. For instance, the AML-BFM group has reported that reduction of intensity of treatment by omitting a high-dose ARA-C and mitoxantrone course during induction led to a decreased EFS and OS for patients with AML with t(8;21) but not inv(16).³⁵³ AML characterized by t(8;21) is also associated in about 20% of cases with the occurrence of chloromas and expression of CD19 and CD56 antigens.^{354,355} The inv(16) translocation is associated with the FAB o morphologic subtype.

The t(15;17)(q22;q21) translocation resulting in the PML-RARA gene fusion, occurs in about 5% to 10% of pediatric AML, and, as discussed above, is associated with greater than 75% overall survival using APL-directed therapies. APL with t(11;17), which involves the PLZF instead of the PML gene, has been associated with decreased sensitivity to ATRA.³⁵⁶

Rearrangements of the MLL gene at chromosome band 11q23 occur in 15% to 20% of pediatric AML, making them the most commonly observed cytogenetic abnormality.^{357,358} The specific types of fusion gene generated from MLL rearrangements appear to have different impacts on outcomes. For example, patients with AML having a t(1;11)(q21;q23) have an extremely favorable prognosis whereas those with t(4;11), t(10;11), and t(6;11) have poor outcomes.³⁵⁹ Patients with t(9;11) AML have been reported to have a favorable prognosis³⁶⁰ however, subsequent studies have established this translocation to be associated with an intermediate prognostic category.³⁵⁹ When combined with the core-binding factor leukemias, including APL, MLL rearranged AML represents approximately 50% of pediatric AML, which is significantly different from the cytogenetic distribution observed in adults with AML.³⁶¹

Several large studies have defined other chromosomal abnormalities as being associated with unfavorable outcomes. Monosomy 7 or abnormalities of 7q, when recurrent genetic changes are excluded,³⁶² represents about 3% of pediatric AML. Of note, AML with del(7q) has been reported to have a better prognosis (5-year OS of 51%) compared to monosomy 7 (5-year OS of 30%).^{357,358,363} Studies from the MRC and BFM AML groups have reported that abnormalities of chromosome 12p, often associated with 12p13 rearrangements that involve the ETV6 gene, are associated with an unfavorable prognosis.^{357,358} Other poor prognostic cytogenetic changes include t(6;11), t(10;11), t(7;12) t(6;9), 5(5;11), and -17/abn(17p).³⁶⁴ The t(1;22)(p13;q13) translocation, often associated with megakaryoblastic leukemia in infants less than 12 months of age, was historically considered a poor prognostic feature, but intensive chemotherapy regimens have led to improved outcomes for these patients.^{365,366} Rearrangements involving the 3q26 locus that includes the EVI1 gene,

including t(3;3)(q21;26), have been reported to be a poor prognostic factor in adults but are extremely rare in children.³⁶⁷ However, increased expression of EVI1 in children with MLL-rearranged leukemia, monosomy 7 or megakaryoblastic morphology, has been reported to predict an intermediate or unfavorable prognosis.^{368, 369} and ³⁷⁰ Chromosomal 5q- portends a poor prognosis in adults but is exceedingly rare in childhood AML. Complex karyotypes, usually defined as the presence of three or more chromosome abnormalities in the absence of one of the WHO-noted recurring chromosomal translocations or inversions, are generally associated with unfavorable outcomes regardless of whether good prognosis changes are observed.^{357,358}

As cytogenetic abnormalities in AML tend to correlate with patient age, with, for example, MLL-rearrangements being common in infants and core-binding factor leukemias more common in older patients,³⁴³ a similar correlation holds for molecularly defined prognostic factors. In addition, approximately 20% of children with AML have essentially normal cytogenetics and thus cannot be stratified into risk groups based on such criteria. Molecular studies have helped to determine patients further with more or less favorable AML in this group.

Internal tandem duplications in the juxtamembrane region of the FLT3 tyrosine kinase receptor, called FLT3-ITD mutations, occur in approximately 15% of children, about 25% or

P.1651

greater in adults, and infrequently in very young children.³⁷¹ High mutant to normal allelic ratios have been shown to predict a poor prognosis across several large studies in children and adults.^{187, 371, 372, 373, 374} Mutations may also occur in the kinase domain of FLT3, but these have not been shown to portend an adverse prognosis.^{187, 371, 372, 375} FLT3 mutations have also been reported to be present in up to 40% of children and adults with APL, and appear to be associated with the microgranular variant, hyperleukocytosis, and early death in children.^{310, 376, 377} and ³⁷⁸ Mutations in the KIT tyrosine kinase receptor occur in up to 25% of patients with core-binding factor AML and have been reported in some studies to define a higher risk subgroup,^{379, 380} but this was not observed in a subsequent COG report.³⁸¹

Mutations in the NPM1, a component of nuclear to cytoplasmic transport complexes, tend to increase chemosensitivity and are associated with improved outcomes with 5-year EFS of about 70%.^{200,201} Notably, when NPM1 mutations occur in the presence of FLT3-ITD mutations, they do not appear to ameliorate an unfavorable prognosis.³⁷⁴

CEBPA mutations occur in approximately 6% of pediatric AML and are usually associated with normal karyotype AML and favorable prognosis.^{50, 374, 382, 383, 384} Biallelic mutations of CEBPA define a distinct subtype of AML with a favorable prognosis.^{383, 385}

Mutations in the WT1 gene occur in about 10% of pediatric AML and are usually associated with normal karyotypes, but can be associated with FLT3-ITD in approximately 40% of cases.^{202,203,386, 387} WT1 mutations are independently associated, however, with poor 5-year OS of about 20%,^{203,374} although this poor outcome was not observed in a COG trial.²⁰³ Interestingly, WT1 single-nucleotide polymorphism (SNP) of rs16754 in exon 7 has been reported to be present on a major allele in 28% of patients and to be associated with an improved 5-year OS of 62% compared to 44% for AML not containing the SNP; in addition, high WT1 expression was associated with poor outcome in patients without the rs16754 SNP but not in those with the SNP.³⁸⁷ However, this has not been seen in all studies.³⁸⁶

NRAS and KRAS mutations have been reported in 10% to 15% and 3% of pediatric AML, and up to 20% in adult AML.^{374, 388, 389, 390} NRAS mutations have been strongly associated with NPM1 mutations in patients with excellent prognosis, although an independent impact of NRAS on remission rates or OS was not observed.³⁹⁰

Regulators of epigenetic patterning have been observed more commonly in adult compared to pediatric AML. For instance, whereas mutations of TET2 on chromosome 4q24 have been reported in about 12% of adult AML (about 23% in normal cytogenetic AML) and to portend a poor prognosis,^{391, 392} and ³⁹³ these mutations occur in only about 6% of pediatric AML and may be, however, similarly associated with poorer prognosis.^{48,394,395, 396} Mutations of the IDH1 (isocitrate dehydrogenase) gene interestingly produce a gain-of-function activity that in turn results in increased levels of 2-hydroxyglutarate and aberrantly hypermethylated promoter CpG sites.^{397, 398} and ³⁹⁹ Although IDH1 mutations have been reported in about 8% of young adults with AML, and often associated with the presence of NPM1 mutations, they appear to occur in up to 10% of pediatric AML.^{49,400,401} Poor outcome has been associated with IDH1 mutations in adults, but this has not been demonstrated in multivariate analyses from pediatric trials.^{49,400,401} A minor SNP at rs11554137 associated with IDH1, found in about 10% of pediatric patients with AML, could also not be correlated with outcome.⁴⁰² Although mutations of the DNA methyltransferase encoding gene, DNMT3A, may occur in up to 20% of adult AML and have been associated with poor prognosis,^{41,403, 404, 405} and ⁴⁰⁶ such mutations are exceedingly rare in pediatric AML.^{48, 407,408}

The robust prognostic cytogenetic and molecular characteristics that have been and continue to be identified have resulted in most clinical features, such as age, WBC at diagnosis, and morphologic classification, not to be significant in multivariate analyses. Figure 77.5 summarizes cytogenetic abnormalities and gene mutations in pediatric AML. However, despite the acknowledgment of the increasing heterogeneity of AML based on genetic, RNA expression, and epigenetic patterns, a complete understanding of what predicts response or resistance to therapy is lacking. To this end, increasingly sensitive assays to measure in vivo response to treatment have been developed to help predict outcomes in combination with the cytogenetic and molecular features.

Conventional morphologic assessment of early response to therapy is predictive of outcome, however, the application of flow-cytometric immunophenotyping or molecular methods have demonstrated substantially better sensitivity and predictability.^{409,410,411} Although several reports have shown that increasing levels of t(8;21) or inv(16) transcripts portend relapse,^{412,413} and ⁴¹⁴ polymerase chain-reaction-based approaches to detect MRD have also been employed but are limited by the heterogeneous nature of chromosomal changes.^{415,416} Detection of the t(15;17) fusion gene on consecutive testing during remission is associated with a high risk of relapse, although this assay is not very informative at the end of induction therapy as the majority of patients will still have detectable fusion transcripts at that time.^{417,418} and ⁴¹⁹

MRC AML studies have demonstrated that 94% of children with AML have informative immunophenotypes that could identify AML blasts from normal hematopoietic progenitors. The 3-year RFS for those patients with MRD less than 0.1% at the end of induction was 64% compared to 14% for those with MRD values of greater than 0.5%. Note that MRD assessment retained its significance in a multivariate analysis that included such factors as age, WBC, cytogenetics, and FLT3-ITD status.⁴²⁰ A study from SJCRH demonstrated MRD by flow cytometry that MRD values at the end of induction of 1% or higher was the most significant adverse prognostic factor for EFS and OS.¹⁴⁸ Using four-color multiparameter flow cytometry, COG reported from the AAML0531 study that an MRD value at the end of induction greater than 0.1% predicted a DFS at 3 years of 34% compared to 60% for patients without detectable MRD. It is important to note that a significant impact of MRD was absent in patients with favorable cytogenetics and in those with high-risk characteristics.²⁰⁴ Although these results would suggest limited utility of MRD detection except in intermediate risk AML, they have been used to devise a risk stratification strategy for the ongoing COG AAML1031 trial for newly diagnosed patients with AML. Thus, by combining cytogenetic, molecular, and MRD assessments, two risk stratification groups are being used to direct treatment. Low-risk AML, representing 73% of patients with a predicted OS of about 73%, includes mutations involving CBF, CEBPA, and NPM and no MRD at the end of induction. High-risk AML, representing 27% of patients and with a predicted survival of less than 35%, includes adverse cytogenetic changes such as monosomy 7, del(5q), -5, high FLT3-ITD to wild-type allelic ratio, or positive MRD at the end of induction. Patients with low-risk disease will not be recommended for HSCT in first remission, whereas those in the high-risk group will be recommended for transplant in CR1 with the best available donor. Those patients with AML having FLT3-ITD receive both pre- and post-HSCT inhibitor (sorafenib). Other cooperative groups continue to evolve risk stratification schema by refining favorable, intermediate, and high-risk AML groups. In pediatric AML, usually only those with high-risk disease are recommended for allogeneic HSCT.

FUTURE THERAPEUTIC CHALLENGES

Although chemotherapy dose intensification with or without bone marrow transplantation has significantly improved the outcome of patients with AML, the associated morbidity and mortality

P.1652

P.1653

preclude similar approaches from being pursued in the future. Instead, future therapeutic advances need to deliver greater leukemic cell killing but without additional collateral toxicity to normal tissues. These advances have been focused on developing targeted therapies directed toward specific molecular pathways that lead to increased leukemic cell survival, proliferation, and drug resistance. Some of these targets may be prognostic factors, but this is certainly not a requirement, as some key pathways that drive leukemia may not necessarily be predictive of outcome in the context of conventional chemotherapeutic approaches.

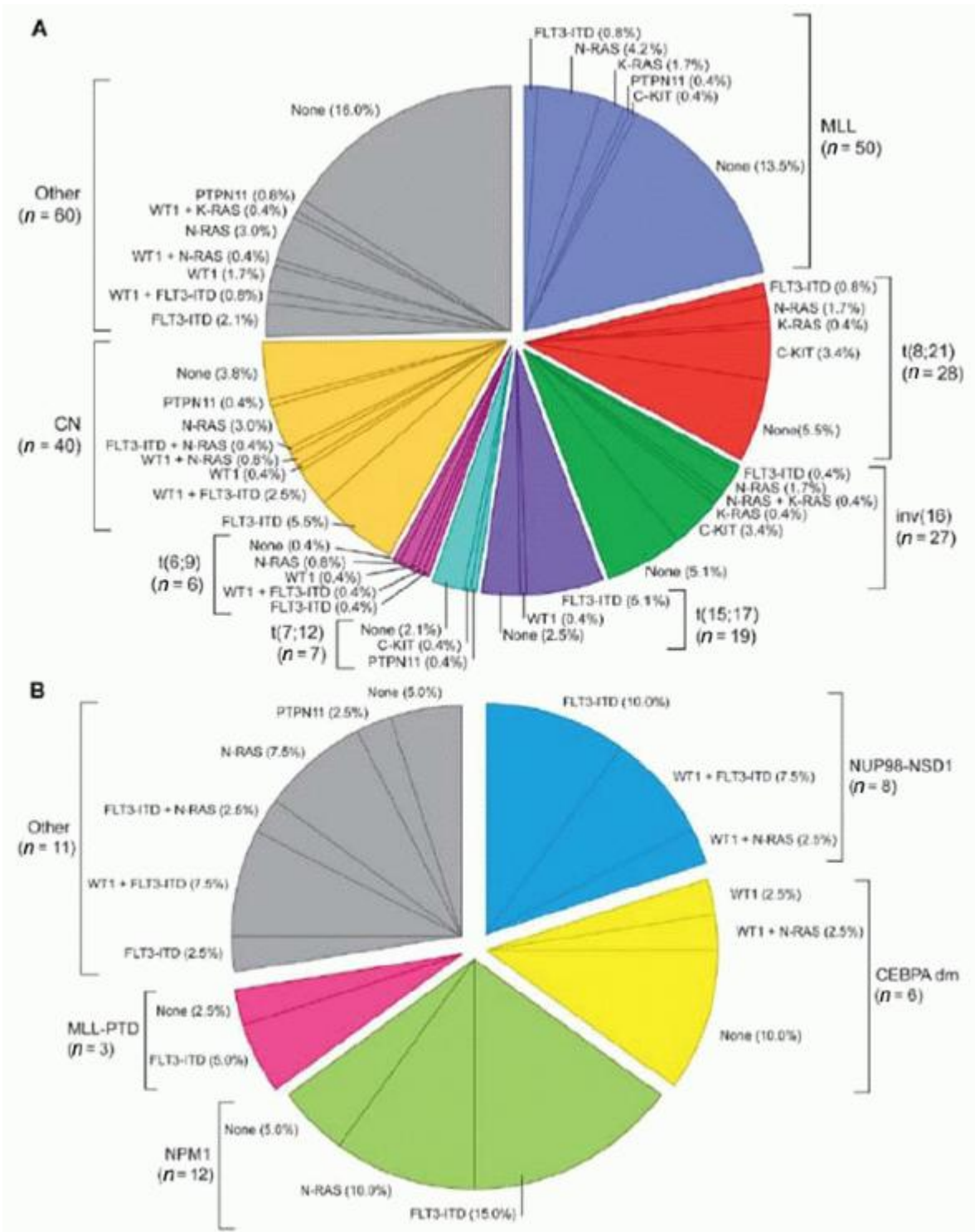

FIGURE 77.5. Pie chart representations of cytogenetic abnormalities and gene mutations alone and in combination in pediatric acute myelogenous leukemia (AML). A: Data shown for all subtypes. B: Detailed data apply to only cytogenetically normal (CN) AML. The data are based on 237 pediatric patients with de novo AML. The different pie slices indicate the percentage of patients whose AML had one or more mutations as noted. With permission from Creutzig et al.,¹⁴⁹ Hollink et al.,⁴²¹ and Balgobind et al.³⁷⁴

In part because of the tremendous advances in understanding the genetic defects and their molecular consequences in AML, there are many potential therapeutic targets that are being explored. However, the continuously increasing plethora of molecular data make it particularly challenging to distinguish mutations and pathways that drive leukemic development and behavior which in turn will become increasingly important in the future development of targeted therapies.

Ideally, molecularly targeted therapies should be leukemia-specific. Examples of this approach include strategies targeting the unique fusion proteins that result from distinctive chromosomal translocations or the use of agents that would specifically exploit a mutation in a cytokine receptor such as FLT3-ITD or KIT. Other therapies directed at chromatin remodeling and reprogramming gene expression involve inhibitors of DNA methyltransferases as well as histone modifying enzymes.

Additional approaches would be to target pathways or molecular targets that were shared by tumor cells and some normal cells but on which leukemic cells are more dependent in terms of their survival and proliferation. Such strategies might include the antisense inhibition of antiapoptotic pathways dependent on BCL2 expression, the inhibition of activated RAS and its downstream pathways, and immunotargeted therapy using immunoconjugates or chimeric antibody receptors.

Both specific and selective targeted therapies are currently being tested in both adult and pediatric patients with AML. However, recent data have demonstrated that even molecularly targeted therapies are not often as specific as initial results would suggest and that leukemia resistance commonly develops or is already present at the initiation of treatment, which leads in turn to the selection of resistant leukemic clones, including leukemia-initiating cells (also referred to as leukemia stem cells).

Although targeted therapies hold significant hope for improved antileukemic activity and for potentially sparing normal tissues from damage, there are clearly significant hurdles to overcome, including how to define first the key leukemia-driving molecular pathways, as well as understanding how to optimize the use of such agents in combinations that will address cellular responses and feedback mechanisms of resistance.

REFERENCES

1. Gunz FW. The dread leukemias and the lymphomas: their nature and their prospects. In: Wintrobe MM, ed. *Blood, pure and eloquent*. New York, NY: McGraw-Hill Book Company, 1980:511-548.
2. Friedreich N. Ein neue fall von leukamie. *Virchows Arch Path Anat* 1857;12:37.
3. Naegli O. Ueber rotes knochenmark und myeloblasten. *Dtsch Med Wochenschr* 1900;26:287.
4. Reschad H, Schilling-Torgau V. Ueber eine neue leukamie durch echte uebergangsformen (splenozyten-leukamie) und ihre bedeutung fur die selbstandigkeit dieser zellen. *Munch Med Wochenschr* 1913;60:1981.
5. DiGuglielmo G. Ricerche di hematologia: I. Una casa di eritroleucemia. *Folia Med* 1917;13:386.
6. Hilstad LK. Acute promyelocytic leukemia. *Acta Med Scand* 1957;159:189.
7. Von Boros J, Karenyi A. Uber einem fall von akuter megakaryoblastenleukamie: zugleich einige bemerkungen zum problem der akuten leukamie. *Z Klin Med* 1931;118:697.
8. Bennett JM, Catovsky D, Daniel MT, et al. Proposals for the classification of the acute leukaemias. French-American-British (FAB) co-operative group. *Br J Haematol* 1976;33(4):451-458.
9. WHO classification of tumours of haematopoietic and lymphoid tissues. In: Swerdlow SH, et al., eds. Albany, NY: WHO Publications Center, Albany NY, 2008:31-145.
10. Farber S, Diamond LK, Mercer RD, et al. Temporary remissions in acute leukemia in children produced by folic acid antagonist, 4-aminopteroyl-glutamic acid (Aminopterin). *N Engl J Med* 1948;238:787-793.
11. Arceci RJ. Progress and controversies in the treatment of pediatric acute myelogenous leukemia. *Curr Opin Hematol* 2002;9(4):353-360.
12. Clark JJ, Smith FO, Arceci RJ. Update in childhood acute myeloid leukemia: recent developments in the molecular basis of disease and novel therapies. *Curr Opin Hematol* 2003;10(1):31-39.
13. Ries L, Melbert D, Krapcho M, et al. SEER cancer statistics review, 1975-2004. Bethesda, MD: National Cancer Institute, 2007.
14. Juliusson G, Antunovic P, Derolf A, et al. Age and acute myeloid leukemia: real world data on decision to treat and outcomes from the Swedish Acute Leukemia Registry. *Blood* 2009;113(18):4179-4187.
15. Bhatia S, Neglia JP. Epidemiology of childhood acute myelogenous leukemia. *J Pediatr Hematol Oncol* 1995;17(2):94-100.

16. Gurney JG, Severson RK, Davis S, et al. Incidence of cancer in children in the United States. Sex, race, and 1 year age-specific rates by histologic type. *Cancer* 1995;75:2186-2195.
17. Douer D, Preston-Martin S, Chang E, et al. High frequency of acute promyelocytic leukemia among Latinos with acute myeloid leukemia. *Blood* 1996;87(1): 308-313.
18. Glazer ER, Perkins CI, Young JL Jr, et al. Cancer among Hispanic children in California, 1988-1994: comparison with non-Hispanic white children. *Cancer* 1999;86(6):1070-1079.
19. Robison LL, Ross JA. Epidemiology of leukaemias and lymphomas in childhood. In: Chessels J, Hann I, eds. *Bailliere's clinical paediatrics*. London: W.B. Saunders Co., 1995:639-657.
20. Ross JA, Davies SM, Potter JD. Epidemiology of childhood leukemia, with a focus on infants. *Epidemiol Rev* 1994;16:243-272.
21. Stiller CA. Epidemiology and genetics of childhood cancer. *Oncogene* 2004;23(38):6429-6444.
22. Barnard DR, Woods WG. Treatment-related myelodysplastic syndrome/acute myeloid leukemia in survivors of childhood cancer—an update. *Leuk Lymphoma* 2005;46(5):651-663.
23. Verma D, O'Brien S, Thomas D, et al. Therapy-related acute myelogenous leukemia and myelodysplastic syndrome in patients with acute lymphoblastic leukemia treated with the hyperfractionated cyclophosphamide, vincristine, doxorubicin, and dexamethasone regimens. *Cancer* 2009;115(1):101-106.
24. Le Deley MC, Leblanc T, Shamsaldin A, et al. Risk of secondary leukemia after a solid tumor in childhood according to the dose of epipodophyllotoxins and anthracyclines: a case-control study by the Societe Francaise d'Oncologie Pediatrique. *J Clin Oncol* 2003;21(6):1074-1081.
25. Howe R, Micallef IN, Inwards DJ, et al. Secondary myelodysplastic syndrome and acute myelogenous leukemia are significant complications following autologous stem cell transplantation for lymphoma. *Bone Marrow Transplant* 2003;32(3):317-324.
26. Sandoval C, Pui CH, Bowman LC, et al. Secondary acute myeloid leukemia in children previously treated with alkylating agents, intercalating topoisomerase II inhibitors, and irradiation. *J Clin Oncol* 1993;11(6):1039-1045.
27. Vrooman LM, Neuberger DS, Stevenson KE, et al. The low incidence of secondary acute myelogenous leukaemia in children and adolescents treated with dexrazoxane for acute lymphoblastic leukaemia: a report from the Dana-Farber Cancer Institute ALL Consortium. *Eur J Cancer* 2011;47(9):1373-1379.
28. Gombos DS, Hungerford J, Abramson DH, et al. Secondary acute myelogenous leukemia in patients with retinoblastoma: is chemotherapy a factor? *Ophthalmology* 2007;114(7):1378-1383.
29. Fialkow PJ. Stem cell origin of human myeloid blood cell neoplasms. *Verh Dtsch Ges Pathol* 1990;74:43-47.
30. Fialkow PJ, Gartler SM, Yoshida A. Clonal origin of chronic myelocytic leukemia in man. *Proc Natl Acad Sci U S A* 1967;58:1468.
31. Sabbath KD, Ball ED, Larcom P, et al. Heterogeneity of clonogenic cells in acute myeloblastic leukemia. *J Clin Invest* 1985;75(2):746-753.
32. Bonnet D. Normal and leukaemic stem cells. *Br J Haematol* 2005;130(4): 469-479.
33. Bonnet D, Dick JE. Human acute myeloid leukemia is organized as a hierarchy that originates from a primitive hematopoietic cell. *Nat Med* 1997;3(7):730-737.
34. Lapidot T, Sirard C, Vormoor J, et al. A cell initiating human acute myeloid leukaemia after transplantation into SCID mice. *Nature* 1994;367(6464): 645-648.
35. Sirard C, Lapidot T, Vormoor J, et al. Normal and leukemic SCID-repopulating cells (SRC) coexist in the bone marrow and peripheral blood from CML patients in chronic phase, whereas leukemic SRC are detected in blast crisis. *Blood* 1996;87(4):1539-1548.
36. Turhan AG, Lemoine FM, Debert C, et al. Highly purified primitive hematopoietic stem cells are PML-RARA negative and generate nonclonal progenitors in acute promyelocytic leukemia. *Blood* 1995;85(8):2154-2161.
37. Terpstra W, Prins A, Ploemacher RE, et al. Long-term leukemia-initiating capacity of a CD34-subpopulation of acute myeloid leukemia. *Blood* 1996;87(6):2187-2194.

38. Castilla LH, Garrett L, Adya N, et al. The fusion gene Cbfb-MYH11 blocks myeloid differentiation and predisposes mice to acute myelomonocytic leukaemia. *Nat Genet* 1999;23(2):144-146.
39. Castilla LH, Perrat P, Martinez NJ, et al. Identification of genes that synergize with Cbfb-MYH11 in the pathogenesis of acute myeloid leukemia. *Proc Natl Acad Sci U S A* 2004;101(14):4924-4929.
40. Gilliland DG, Jordan CT, Felix CA. The molecular basis of leukemia. *Hematology (Am Soc Hematol Educ Program)* 2004;2004:80-97.
41. Ley TJ, Ding L, Walter MJ, et al. DNMT3A mutations in acute myeloid leukemia. *N Engl J Med* 2010;363(25):2424-2433.
42. Ley TJ, Mardis ER, Ding L, et al. DNA sequencing of a cytogenetically normal acute myeloid leukaemia genome. *Nature* 2008;456(7218):66-72.
43. Mardis ER, Ding L, Dooling DJ, et al. Recurring mutations found by sequencing an acute myeloid leukemia genome. *N Engl J Med* 2009;361(11):1058-1066.
44. Graubert TA, Shen D, Ding L, et al. Recurrent mutations in the U2AF1 splicing factor in myelodysplastic syndromes. *Nat Genet* 2012;44(1):53-57.
45. Makishima H, Visconte V, Sakaguchi H, et al. Mutations in the spliceosome machinery, a novel and ubiquitous pathway in leukemogenesis. *Blood* 2012;119(14):3203-3210.
46. Walter MJ, Shen D, Ding L, et al. Clonal architecture of secondary acute myeloid leukemia. *N Engl J Med* 2012;366(12):1090-1098.
47. Ding L, Ley TJ, Larson DE, et al. Clonal evolution in relapsed acute myeloid leukaemia revealed by whole-genome sequencing. *Nature* 2012;481(7382): 506-510.
48. Ho PA, Kutny MA, Alonzo TA, et al. Leukemic mutations in the methylation-associated genes DNMT3A and IDH2 are rare events in pediatric AML: a report from the Children's Oncology Group. *Pediatr Blood Cancer* 2011;57(2):204-209.
49. Ho PA, Alonzo TA, Kopecky KJ, et al. Molecular alterations of the IDH1 gene in AML: a Children's Oncology Group and Southwest Oncology Group study. *Leukemia* 2010;24(5):909-913.
50. Ho PA, Alonzo TA, Gerbing RB, et al. Prevalence and prognostic implications of CEBPA mutations in pediatric acute myeloid leukemia (AML): a report from the Children's Oncology Group. *Blood* 2009;113(26):6558-6566.
51. Robison LL. Down syndrome and leukemia. *Leukemia* 1992;6(Suppl 1):5-7.
52. Ross JA, Spector LG, Robison LL, et al. Epidemiology of leukemia in children with Down syndrome. *Pediatr Blood Cancer* 2005;44(1):8-12.
53. Wechsler J, Greene M, McDevitt MA, et al. Acquired mutations in GATA1 in the megakaryoblastic leukemia of Down syndrome. *Nat Genet* 2002;32(1): 148-152.
54. Groet J, McElwaine S, Spinelli M, et al. Acquired mutations in GATA1 in neonates with Down's syndrome with transient myeloid disorder. *Lancet* 2003;361(9369):1617-1620.
55. Hitzler J, Zipursky A. GATA 1 mutations as clonal markers of minimal residual disease in acute megakaryoblastic leukemia of Down syndrome—a new tool with significant potential applications. *Leuk Res* 2005;29(11):1239-1240.
56. Rainis L, Bercovich D, Strehl S, et al. Mutations in exon 2 of GATA1 are early events in megakaryocytic malignancies associated with trisomy 21. *Blood* 2003;102(3):981-986.
57. Geraedts JP, Ford CE, Briet E, et al. Klinefelter syndrome: predisposition to acute non-lymphocytic leukaemia? *Lancet* 1980;1(8177):1092.
58. Wertelecki W, Shapiro JR. 45, XO Turner's syndrome and leukaemia. *Lancet* 1970;1(7650):789-790.
59. Alter BP, Greene MH, Velazquez I, et al. Cancer in Fanconi anemia. *Blood* 2003;101(5):2072.
60. Alter BP, Giri N, Savage SA, et al. Malignancies and survival patterns in the National Cancer Institute inherited bone marrow failure syndromes cohort study. *Br J Haematol* 2010;150(2):179-188.
61. Auerbach AD. Fanconi anemia and its diagnosis. *Mutat Res* 2009;668 (1-2):4-10.
62. Alter BP. Diagnosis, genetics, and management of inherited bone marrow failure syndromes. *Hematology (Am Soc Hematol Educ Program)*, 2007:29-39.

63. Shimamura A. Inherited bone marrow failure syndromes: molecular features. *Hematology (Am Soc Hematol Educ Program)* 2006;63-71.
64. Zeidler C, Schwitzer B, Welte K. Congenital neutropenias. *Rev Clin Exp Hematol* 2003;7(1):72-83.
65. Horwitz M, Benson KF, Duan Z, et al. Role of neutrophil elastase in bone marrow failure syndromes: molecular genetic revival of the chalone hypothesis. *Curr Opin Hematol* 2003;10(1):49-54.
66. Steele JM, Sung L, Klaassen R, et al. Disease progression in recently diagnosed patients with inherited marrow failure syndromes: a Canadian Inherited Marrow Failure Registry (CIMFR) report. *Pediatr Blood Cancer* 2006;47(7):918-925.
67. Hunter MG, Avalos BR. Granulocyte colony-stimulating factor receptor mutations in severe congenital neutropenia transforming to acute myelogenous leukemia confer resistance to apoptosis and enhance cell survival. *Blood* 2000;95(6):2132-2137.
68. Jeha S, Chan KW, Aprikyan AG, et al. Spontaneous remission of granulocyte colony-stimulating factor-associated leukemia in a child with severe congenital neutropenia. *Blood* 2000;96(10):3647-3649.
69. Tamary H, Nishri D, Yacovich J, et al. Frequency and natural history of inherited bone marrow failure syndromes: the Israeli Inherited Bone Marrow Failure Registry. *Haematologica* 2010;95(8):1300-1307.
70. Tamary H, Alter BP. Current diagnosis of inherited bone marrow failure syndromes. *Pediatr Hematol Oncol* 2007;24(2):87-99.
71. Lauchle JO, Braun BS, Loh ML, et al. Inherited predispositions and hyperactive Ras in myeloid leukemogenesis. *Pediatr Blood Cancer* 2006;46(5):579-585.
72. de Vries AC, Zwaan CM, van den Heuvel-Eibrink MM. Molecular basis of juvenile myelomonocytic leukemia. *Haematologica* 2010;95(2):179-182.
73. Tartaglia M, Niemeyer CM, Fragale A, et al. Somatic mutations in PTPN11 in juvenile myelomonocytic leukemia, myelodysplastic syndromes and acute myeloid leukemia. *Nat Genet* 2003;34(2):148-150.
74. Loh ML, Vattikuti S, Schubert S, et al. Mutations in PTPN11 implicate the SHP-2 phosphatase in leukemogenesis. *Blood* 2004;103(6):2325-2331.
75. Shiba N, Kato M, Park MJ, et al. CBL mutations in juvenile myelomonocytic leukemia and pediatric myelodysplastic syndrome. *Leukemia* 2010;24(5):1090-1092.
76. Muramatsu H, Makishima H, Jankowska AM, et al. Mutations of an E3 ubiquitin ligase c-Cbl but not TET2 mutations are pathogenic in juvenile myelomonocytic leukemia. *Blood* 2010;115(10):1969-1975.
77. Niemeyer CM, Kang MW, Shin DH, et al. Germline CBL mutations cause developmental abnormalities and predispose to juvenile myelomonocytic leukemia. *Nat Genet* 2010;42(9):794-800.
78. Horwitz M. The genetics of familial leukemia. *Leukemia* 1997;11(8): 1347-1359.
79. Poppe B, Van Limbergen H, Van Roy N, et al. Chromosomal aberrations in Bloom syndrome patients with myeloid malignancies. *Cancer Genet Cytogenet* 2001;128(1):39-42.
80. Lynch HT, Weisenburger DD, Quinn-Laquer B, et al. Family with acute myelocytic leukemia, breast, ovarian, and gastrointestinal cancer. *Cancer Genet Cytogenet* 2002;137(1):8-14.
81. Alter BP. Bone marrow failure syndromes in children. *Pediatr Clin North Am* 2002;49(5):973-988.
82. Geddis AE. Congenital amegakaryocytic thrombocytopenia and thrombocytopenia with absent radii. *Hematol Oncol Clin North Am* 2009;23(2):321-331.
83. Owen C, Barnett M, Fitzgibbon J. Familial myelodysplasia and acute myeloid leukaemia—a review. *Br J Haematol* 2008;140(2):123-132.
84. Owen CJ, Toze CL, Koochin A, et al. Five new pedigrees with inherited RUNX1 mutations causing familial platelet disorder with propensity to myeloid malignancy. *Blood* 2008;112(12):4639-4645.
85. Matheny CJ, Speck ME, Cushing PR, et al. Disease mutations in RUNX1 and RUNX2 create nonfunctional, dominant-negative, or hypomorphic alleles. *Embo J* 2007;26(4):1163-1175.
86. Rheingold SR. Acute myeloid leukemia in a child with hereditary thrombocytopenia. *Pediatr Blood Cancer* 2007;48(1):105-107.

87. Walker LC, Stevens J, Campbell H, et al. A novel inherited mutation of the transcription factor RUNX1 causes thrombocytopenia and may predispose to acute myeloid leukaemia. *Br J Haematol* 2002;117(4):878-881.
88. Greaves MF, Maia AT, Wiemels JL, et al. Leukemia in twins: lessons in natural history. *Blood* 2003;102(7):2321-2333.
89. Greaves M. Pre-natal origins of childhood leukemia. *Rev Clin Exp Hematol* 2003;7(3):233-245.
90. Wiemels J. Chromosomal translocations in childhood leukemia: natural history, mechanisms, and epidemiology. *J Natl Cancer Inst Monogr* 2008(39):87-90.
91. Richkind KE, Loew T, Meisner L, et al. Identical cytogenetic clones and clonal evolution in pediatric monozygotic twins with acute myeloid leukemia: presymptomatic disease detection by interphase fluorescence in situ hybridization and review of the literature. *J Pediatr Hematol Oncol* 1998;20(3):264-267.
92. Wiemels JL, Cazzaniga G, Daniotti M, et al. Prenatal origin of acute lymphoblastic leukaemia in children. *Lancet* 1999;354(9189):1499-1503.
93. Kurita S, Kamei Y, Ota K. Genetic studies on familial leukemia. *Cancer* 1974;34:1098.
94. Markkanen A, Ruutu T, Rasi V, et al. Constitutional translocation t(3;6) (p14;p11) in a family with hematologic malignancies. *Cancer Genet Cytogenet* 1987;25(1):87-95.
95. Minelli A, Maserati E, Giudici G, et al. Familial partial monosomy 7 and myelodysplasia: different parental origin of the monosomy 7 suggests action of a mutator gene. *Cancer Genet Cytogenet* 2001;124(2):147-151.
96. Riccardi VM, Humbert JR, Peakman D. Acute leukemia associated with trisomy 8 mosaicism and a familial translocation 46,XY,t(7;20)(p13;p12). *Am J Med Genet* 1978;2(1):15-21.
97. Nouri AM, Dorey E, Davis CL, et al. Generation of cytotoxic T lymphocytes from peripheral blood of leukaemic patients. *Cancer Immunol Immunother* 1993;37(1):47-53.
98. Ohara A, Kojima S, Hamajima N, et al. Myelodysplastic syndrome and acute myelogenous leukemia as a late clonal complication in children with acquired aplastic anemia. *Blood* 1997;90(3):1009-1013.
99. Shannon KM, Turhan AG, Chang SS, et al. Familial bone marrow monosomy 7. Evidence that the predisposing locus is not on the long arm of chromosome 7. *J Clin Invest* 1989;84(3):984-989.
100. Bagby GC, Meyers G. Myelodysplasia and acute leukemia as late complications of marrow failure: future prospects for leukemia prevention. *Hematol Oncol Clin North Am* 2009;23(2):361-376.
101. Luna-Fineman S, Shannon KM, Atwater SK, et al. Myelodysplastic and myeloproliferative disorders of childhood: a study of 167 patients. *Blood* 1999;93(2):459-466.
102. Maris JM, Wiersma SR, Mahgoub N, et al. Monosomy 7 myelodysplastic syndrome and other second malignant neoplasms in children with neurofibromatosis type 1. *Cancer* 1997;79(7):1438-1446.
103. Ichimaru M, Ishimaru T, Belsky JL. Incidence of leukemia in atomic bomb survivors belonging to a fixed cohort in Hiroshima and Nagasaki. 1950-1971: radiation dose, years after exposure, age at exposure, and type of leukemia. *J Radiat Res* 1978;19:262.
104. Ichimaru M, Tomonaga M, Amenomori T, et al. Atomic bomb and leukemia. *J Radiat Res (Tokyo)* 1991;32(Suppl 2):14-19.
105. Kato H, Schull WJ. Studies of the mortality of A-bomb survivors: Mortality, 1950-1978: part I. Cancer mortality. *Radiat Res* 1982;90:395.
106. Shimizu Y, Schull WI, Kato H. Cancer risk among atomic bomb survivors: the RERF life span study. *JAMA* 1990;264:601.
107. Jablon S, Kato H. Childhood cancer in relation to prenatal exposure to atomic-bomb radiation. *Lancet* 1970;2(7681):1000-1003.
108. Wakeford R, Little MP. Childhood cancer after low-level intrauterine exposure to radiation. *J Radiol Prot* 2002;22(3A):A123-A127.
109. Kavet R, Zaffanella LE, Daigle JP, et al. The possible role of contact current in cancer risk associated with residential magnetic fields *Bioelectromagnetics* 2000;21(7):538-553.

110. Kleinerman RA, Kaune WT, Hatch EE, et al. Are children living near high-voltage power lines at increased risk of acute lymphoblastic leukemia? *Am J Epidemiol* 2000;151(5):512-515.
111. Linet MS, Hatch EE, Kleinerman RA, et al. Residential exposure to magnetic fields and acute lymphoblastic leukemia in children. *N Engl J Med* 1997;337(1):1-7.
112. Menegaux F, Ripert M, Hemon D, et al. Maternal alcohol and coffee drinking, parental smoking and childhood leukaemia: a French population-based case-control study. *Paediatr Perinat Epidemiol* 2007;21(4):293-299.
113. Shu XO, Ross JA, Pendergrass TW, et al. Parental alcohol consumption, cigarette smoking, and risk of infant leukemia: a Children's Cancer Group study. *J Natl Cancer Inst* 1996;88(1):24-31.
114. Menegaux F, Steffen C, Bellec S, et al. Maternal coffee and alcohol consumption during pregnancy, parental smoking and risk of childhood acute leukaemia. *Cancer Detect Prev* 2005;29(6):487-493.
115. Alexander FE, Patheal SL, Biondi A, et al. Transplacental chemical exposure and risk of infant leukemia with MLL gene fusion. *Cancer Res* 2001;61(6): 2542-2546.
116. Ross JA. Dietary flavonoids and the MLL gene: a pathway to infant leukemia? *Proc Natl Acad Sci U S A* 2000;97(9):4411-4413.
117. Ross JA, Potter JD, Reaman GH, et al. Maternal exposure to potential inhibitors of DNA topoisomerase II and infant leukemia (United States): a report from the Children's Cancer Group. *Cancer Causes Control* 1996;7(6):581-590.
118. Strick R, Strissel PL, Borgers S, et al. Dietary bioflavonoids induce cleavage in the MLL gene and may contribute to infant leukemia. *Proc Natl Acad Sci U S A* 2000;97(9):4790-4795.
119. Robison LL, Buckley JD, Daigle AE, et al. Maternal drug use and risk of childhood nonlymphoblastic leukemia among offspring. An epidemiologic investigation implicating marijuana (a report from the Children's Cancer Study Group). *Cancer* 1989;63(10):1904-1911.
120. Brondum J, Shu XO, Steinbuch M, et al. Parental cigarette smoking and the risk of acute leukemia in children. *Cancer* 1999;85(6):1380-1388.
121. Chang JS, Selvin S, Metayer C, et al. Parental smoking and the risk of childhood leukemia. *Am J Epidemiol* 2006;163(12):1091-1100.
122. Pogoda JM, Preston-Martin S, Nichols PW, et al. Smoking and risk of acute myeloid leukemia: results from a Los Angeles County case-control study. *Am J Epidemiol* 2002;155(6):546-553.
123. Korte JE, Hertz-Picciotto I, Schulz MR, et al. The contribution of benzene to smoking-induced leukemia. *Environ Health Perspect* 2000;108(4):333-339.
124. Linet MS, Bailey PE. Benzene, leukemia, and the Supreme Court. *J Public Health Policy* 1981;2(2):116-135.
125. McBride ML. Childhood cancer and environmental contaminants. *Can J Public Health* 1998;89(Suppl 1):S53-S62, S58-S68.
126. Yin SN, Hayes RB, Linet MS, et al. A cohort study of cancer among benzene-exposed workers in China: overall results. *Am J Ind Med* 1996;29(3):227-235.
127. Yin SN, Hayes RB, Linet MS, et al. An expanded cohort study of cancer among benzene-exposed workers in China. Benzene Study Group. *Environ Health Perspect* 1996;104(Suppl 6):1339-1341.
128. Mills PK, Zahm SH. Organophosphate pesticide residues in urine of farm-workers and their children in Fresno County, California. *Am J Ind Med* 2001;40(5):571-577.
129. Baehring JM, Marks PW. Treatment-related myelodysplasia in patients with primary brain tumors. *Neuro-oncology* 2012;14(5):529-540.
130. Haupt R, Fears TR, Rosso P, et al. Increased risk of secondary leukemia after single-agent treatment with etoposide for Langerhans' cell histiocytosis. *Pediatr Hematol Oncol* 1994;11(5):499-507.
131. Schneider DT, Hilgenfeld E, Schwabe D, et al. Acute myelogenous leukemia after treatment for malignant germ cell tumors in children. *J Clin Oncol* 1999;17(10):3226-3233.

132. Duffner PK, Krischer JP, Horowitz ME, et al. Second malignancies in young children with primary brain tumors following treatment with prolonged post-operative chemotherapy and delayed irradiation: a Pediatric Oncology Group study. *Ann Neurol* 1998;44(3):313-316.
133. Stine KC, Saylor RL, Sawyer JR, et al. Secondary acute myelogenous leukemia following safe exposure to etoposide. *J Clin Oncol* 1997;15(4):1583-1586.
134. Ogami A, Morimoto A, Hibi S, et al. Secondary acute promyelocytic leukemia following chemotherapy for non-Hodgkin's lymphoma in a child. *J Pediatr Hematol Oncol* 2004;26(7):427-430.
135. Schiavetti A, Varrasso G, Maurizi P, et al. Two secondary leukemias among 15 children given oral etoposide. *Med Pediatr Oncol* 2001;37(2):148-149.
136. Pui CH, Ribeiro RC, Hancock ML, et al. Acute myeloid leukemia in children treated with epipodophyllotoxins for acute lymphoblastic leukemia. *N Engl J Med* 1991;325(24):1682-1687.
137. Megonigal MD, Cheung NK, Rappaport EF, et al. Detection of leukemia-associated MLL-GAS7 translocation early during chemotherapy with DNA topoisomerase II inhibitors. *Proc Natl Acad Sci U S A* 2000;97(6):2814-2819.
138. Pegram LD, Megonigal MD, Lange BJ, et al. t(3;11) translocation in treatment-related acute myeloid leukemia fuses MLL with the GMPS (GUANOSINE 5' MONOPHOSPHATE SYNTHETASE) gene. *Blood* 2000;96(13):4360-4362.
139. Webb DK, Harrison G, Stevens RF, et al. Relationships between age at diagnosis, clinical features, and outcome of therapy in children treated in the Medical Research Council AML 10 and 12 trials for acute myeloid leukemia. *Blood* 2001;98(6):1714-1720.
140. Haferlach T, Schoch C, Loffler H, et al. Morphologic dysplasia in de novo acute myeloid leukemia (AML) is related to unfavorable cytogenetics but has no independent prognostic relevance under the conditions of intensive induction therapy: results of a multiparameter analysis from the German AML Cooperative Group studies. *J Clin Oncol* 2003;21(2):256-265.
141. Horibe K, Tsukimoto I, Ohno R. Clinicopathologic characteristics of leukemia in Japanese children and young adults. *Leukemia* 2001;15(8):1256-1261.
142. Raimondi SC, Chang MN, Ravindranath Y, et al. Chromosomal abnormalities in 478 children with acute myeloid leukemia: clinical characteristics and treatment outcome in a cooperative pediatric oncology group study-POG 8821. *Blood* 1999;94(11):3707-3716.
143. Kaspers GJ. Pediatric acute myeloid leukemia. *Expert Rev Anticancer Ther* 2012;12(3):405-413.
144. Creutzig U, Ritter J, Zimmermann M, et al. Improved treatment results in high-risk pediatric acute myeloid leukemia patients after intensification with high-dose cytarabine and mitoxantrone: results of Study Acute Myeloid Leukemia-Berlin-Frankfurt-Munster 93. *J Clin Oncol* 2001;19(10): 2705-2713.
145. Hann IM, Stevens RF, Goldstone AH, et al. Randomized comparison of DAT versus ADE as induction chemotherapy in children and younger adults with acute myeloid leukemia. Results of the Medical Research Council's 10th AML trial (MRC AML10). Adult and childhood leukaemia working parties of the medical research council. *Blood* 1997;89(7):2311-2318.
146. Woods WG, Kobrinsky N, Buckley JD, et al. Timed-sequential induction therapy improves postremission outcome in acute myeloid leukemia: a report from the Children's Cancer Group. *Blood* 1996;87(12):4979-4989.
147. Cooper TM, Franklin J, Gerbing RB, et al. AAML03P1, a pilot study of the safety of gemtuzumab ozogamicin in combination with chemotherapy for newly diagnosed childhood acute myeloid leukemia: a report from the Children's Oncology Group. *Cancer* 2012;118(3):761-769.
148. Rubnitz JE, Inaba H, Dahl G, et al. Minimal residual disease-directed therapy for childhood acute myeloid leukaemia: results of the AML02 multicentre trial. *Lancet Oncol* 2010;11(6):543-552.
149. Creutzig U, van den Heuvel-Eibrink MM, Gibson B, et al. Diagnosis and management of acute myeloid leukemia in children and adolescents: recommendations from an international expert panel. *Blood* 2012;120(16):3187-3205.
150. Bishop JF, Matthews JP, Young GA, et al. A randomized study of high-dose cytarabine in induction in acute myeloid leukemia. *Blood* 1996;87(5):1710-1717.
151. Weick JK, Kopecky KJ, Appelbaum FR, et al. A randomized investigation of high-dose versus standard-dose cytosine arabinoside with daunorubicin in patients with previously untreated acute myeloid leukemia: a Southwest Oncology Group study. *Blood* 1996;88(8):2841-2851.

152. Riley LC, Hann IM, Wheatley K, et al. Treatment-related deaths during induction and first remission of acute myeloid leukaemia in children treated on the Tenth Medical Research Council acute myeloid leukaemia trial (MRC AML10). The MCR childhood leukaemia working party. *Br J Haematol* 1999;106(2):436-444.
153. Lange BJ, Smith FO, Feusner J, et al. Outcomes in CCG-2961, a children's oncology group phase 3 trial for untreated pediatric acute myeloid leukemia: a report from the children's oncology group. *Blood* 2008;111(3):1044-1053.
154. Lowenthal RM, Bradstock KF, Matthews JP, et al. A phase I/II study of intensive dose escalation of cytarabine in combination with idarubicin and etoposide in induction and consolidation treatment of adult acute myeloid leukemia. Australian Leukaemia Study Group (ALSG). *Leuk Lymphoma* 1999;34(5-6):501-510.
155. Becton D, Dahl GV, Ravindranath Y, et al. Randomized use of cyclosporin A (CsA) to modulate P-glycoprotein in children with AML in remission: pediatric oncology group study 9421. *Blood* 2006;107(4):1315-1324.
156. Creutzig U, Berthold F, Boos J, et al. Improved treatment results in children with AML: results of study AML-BFM 93. *Klin Padiatr* 2001;213(4):175-185.
157. Creutzig U, Ritter J, Zimmermann M, et al. Idarubicin improves blast cell clearance during induction therapy in children with AML: results of study AML-BFM 93. AML-BFM Study Group. *Leukemia* 2001;15(3):348-354.
158. Wheatley K. Meta-analysis of randomized trials of idarubicin (IDAR) or metozantrone (Mito) versus daunorubicin (DNR) as induction therapy for acute myeloid leukaemia (AML). *Blood* 1995;86:43A.
159. Sievers EL. Targeted therapy of acute myeloid leukemia with monoclonal antibodies and immunoconjugates. *Cancer Chemother Pharmacol* 2000;46(Suppl):S18-S22.
160. Lange BJ, Dinndorf P, Smith FO, et al. Pilot study of idarubicin-based intensive-timing induction therapy for children with previously untreated acute myeloid leukemia: children's cancer group study 2941. *J Clin Oncol* 2004;22(1):150-156.
161. Gibson BE, Webb DK, Howman AJ, et al. Results of a randomized trial in children with Acute Myeloid Leukaemia: medical research council AML12 trial. *Br J Haematol* 2011;155(3):366-376.
162. Burnett AK, Hills RK, Milligan DW, et al. Attempts to optimize induction and consolidation treatment in acute myeloid leukemia: results of the MRC AML12 trial. *J Clin Oncol* 2010;28(4):586-595.
163. Cooper TM, Franklin J, Gerbing RB, et al. A pilot study of the safety and efficacy of Gemtuzumab Ozogamicin in combination with chemotherapy for newly diagnosed childhood acute myeloid leukemia: a report from the Children's Oncology Group. *Pediatric Blood Cancer* 2012;118:761-769.
164. Burnett AK, Hills RK, Milligan D, et al. Identification of patients with acute myeloblastic leukemia who benefit from the addition of gemtuzumab ozogamicin: results of the MRC AML15 trial. *J Clin Oncol* 2011;29(4):369-377.
165. Hasle H, Abrahamsson J, Forestier E, et al. Gemtuzumab ozogamicin as post-consolidation therapy does not prevent relapse in children with AML: results from NOPHO-AML 2004. *Blood* 2012;120(5):978-984.
166. Bloomfield CD, Lawrence D, Byrd JC, et al. Frequency of prolonged remission duration after high-dose cytarabine intensification in acute myeloid leukemia varies by cytogenetic subtype. *Cancer Res* 1998;58(18):4173-4179.
167. Grimwade D, Walker H, Oliver F, et al. The importance of diagnostic cytogenetics on outcome in AML: analysis of 1,612 patients entered into the MRC AML 10 trial. The medical research council adult and children's leukaemia working parties. *Blood* 1998;92(7):2322-2333.
168. Woods WG, Neudorf S, Gold S, et al. A comparison of allogeneic bone marrow transplantation, autologous bone marrow transplantation, and aggressive chemotherapy in children with acute myeloid leukemia in remission: a report from the Children's cancer group. *Blood* 2001;97(1):56-62.
169. Burnett AK, Goldstone AH, Stevens RM, et al. Randomised comparison of addition of autologous bone-marrow transplantation to intensive chemotherapy for acute myeloid leukaemia in first remission: results of MRC AML 10 trial. UK medical research council adult and children's leukaemia working parties. *Lancet* 1998;351(9104):700-708.
170. Byrd JC, Dodge RK, Carroll A, et al. Patients with t(8;21)(q22;q22) and acute myeloid leukemia have superior failure-free and overall survival when repetitive cycles of high-dose cytarabine are administered. *J Clin Oncol* 1999;17(12):3767-3775.
171. Lange BJ, Smith FO, Feusner J, et al. Outcomes in CCG-2961, a Children's Oncology Group phase 3 trial for untreated pediatric acute myeloid leukemia (AML): a report from the Children's Oncology Group. *Blood* 2008;111:1044-1053.

172. Creutzig U, Bender-Gotze C, Klingebiel T, et al. Comparison of chemotherapy alone with allogeneic bone marrow transplantation in first full remission in children with acute myeloid leukemia in the AML-BFM-83 and AML-BFM-87 studies—matched pair analysis. *Klin Padiatr* 1992;204(4):246-252.
173. Smith FO, Alonzo TA, Gerbing RB, et al. Long-term results of children with acute myeloid leukemia: a report of three consecutive Phase III trials by the Children's Cancer Group: CCG 251, CCG 213 and CCG 2891. *Leukemia* 2005;19(12):2054-2062.
174. Perel Y, Auvrignon A, Leblanc T, et al. Treatment of childhood acute myeloblastic leukemia: dose intensification improves outcome and maintenance therapy is of no benefit—multicenter studies of the French LAME (Leucemie Aigue Myeloblastique Enfant) Cooperative Group. *Leukemia* 2005;19(12):2082-2089.
175. Perel Y, Auvrignon A, Leblanc T, et al. Impact of addition of maintenance therapy to intensive induction and consolidation chemotherapy for childhood acute myeloblastic leukemia: results of a prospective randomized trial, LAME 89/91. *Leucemie Aigue Myeloide Enfant. J Clin Oncol* 2002;20(12):2774-2782.
176. Woods WG, Kobrinsky N, Buckley J, et al. Intensively timed induction therapy followed by autologous or allogeneic bone marrow transplantation for children with acute myeloid leukemia or myelodysplastic syndrome: a Children's Cancer Group pilot study. *J Clin Oncol* 1993;11(8):1448-1457.
177. Ravindranath Y, Yeager AM, Chang MN, et al. Autologous bone marrow transplantation versus intensive consolidation chemotherapy for acute myeloid leukemia in childhood. Pediatric Oncology Group. *N Engl J Med* 1996;334(22):1428-1434.
178. Oliansky DM, Appelbaum F, Cassileth PA, et al. The role of cytotoxic therapy with hematopoietic stem cell transplantation in the therapy of acute myelogenous leukemia in adults: an evidence-based review. *Biol Blood Marrow Transplant* 2008;14(2):137-180.
179. Burnett AK, Wheatley K, Goldstone AH, et al. The value of allogeneic bone marrow transplant in patients with acute myeloid leukaemia at differing risk of relapse: results of the UK MRC AML 10 trial. *Br J Haematol* 2002;118(2):385-400.
180. Chen AR, Alonzo TA, Woods WG, et al. Current controversies: which patients with acute myeloid leukaemia should receive a bone marrow transplantation? —an American view. *Br J Haematol* 2002;118(2):378-384.
181. Oliansky DM, Rizzo JD, Aplan PD, et al. The role of cytotoxic therapy with hematopoietic stem cell transplantation in the therapy of acute myeloid leukemia in children: an evidence-based review. *Biol Blood Marrow Transplant* 2007;13(1):1-25.
182. Gibson BE, Wheatley K, Hann IM, et al. Treatment strategy and long-term results in paediatric patients treated in consecutive UK AML trials. *Leukemia* 2005;19(12):2130-2138.
183. Creutzig U, Zimmermann M, Ritter J, et al. Treatment strategies and long-term results in paediatric patients treated in four consecutive AML-BFM trials. *Leukemia* 2005;19(12):2030-2042.
184. Ravindranath Y, Chang M, Steuber CP, et al. Pediatric Oncology Group (POG) studies of acute myeloid leukemia (AML): a review of four consecutive childhood AML trials conducted between 1981 and 2000. *Leukemia* 2005;19(12):2101-2116.
185. Alonzo TA, Wells RJ, Woods WG, et al. Postremission therapy for children with acute myeloid leukemia: the children's cancer group experience in the transplant era. *Leukemia* 2005;19(6):965-970.
186. Meshinchi S, Arceci RJ. Prognostic factors and risk-based therapy in pediatric acute myeloid leukemia. *Oncologist* 2007;12(3):341-355.
187. Zwaan CM, Meshinchi S, Radich JP, et al. FLT3 internal tandem duplication in 234 children with acute myeloid leukemia: prognostic significance and relation to cellular drug resistance. *Blood* 2003;102(7):2387-2394.
188. Meshinchi S, Alonzo TA, Gerbing R, et al. FLT3 internal tandem duplication is a prognostic factor for poor outcome in pediatric AML; a CCG-1961 study [abstract]. *Blood* 2003;102(11):335a.
189. Bornhauser M, Illmer T, Schaich M, et al. Improved outcome after stem-cell transplantation in FLT3/ITD-positive AML. *Blood* 2007;109(5):2264-2265, author reply 2265.
190. Doubek M, Muzik J, Sotzkowski T, et al. Is FLT3 internal tandem duplication significant indicator for allogeneic transplantation in acute myeloid leukemia? An analysis of patients from the Czech Acute Leukemia Clinical Register (ALERT). *Neoplasma* 2007;54(1):89-94.

191. Yoshimoto G, Nagafuji K, Miyamoto T, et al. FLT3 mutations in normal karyotype acute myeloid leukemia in first complete remission treated with autologous peripheral blood stem cell transplantation. *Bone Marrow Transplant* 2005;36(11):977-983.
192. Meshinchi S, Arceci RJ, Sanders JE, et al. Role of allogeneic stem cell transplantation in FLT3/ITD-positive AML. *Blood* 2006;108(1):400-401.
193. Gale RE, Hills R, Kottaridis PD, et al. No evidence that FLT3 status should be considered as an indicator for transplantation in acute myeloid leukemia (AML): an analysis of 1135 patients, excluding acute promyelocytic leukemia, from the UK MRC AML10 and 12 trials. *Blood* 2005;106(10): 3658-3665.
194. Ortega JJ, Madero L, Martin G, et al. Treatment with all-trans retinoic acid and anthracycline monochemotherapy for children with acute promyelocytic leukemia: a multicenter study by the PETHEMA Group. *J Clin Oncol* 2005;23(30):7632-7640.
195. Bally C, Fadlallah J, Leverger G, et al. Outcome of acute promyelocytic leukemia (APL) in children and adolescents: an analysis in two consecutive trials of the European APL Group. *J Clin Oncol* 2012;30(14):1641-1646.
- P.1654
196. de Botton S, Fawaz A, Chevret S, et al. Autologous and allogeneic stem-cell transplantation as salvage treatment of acute promyelocytic leukemia initially treated with all-trans-retinoic acid: a retrospective analysis of the European acute promyelocytic leukemia group. *J Clin Oncol* 2005;23(1):120-126.
197. Thirugnanam R, George B, Chendamarai E, et al. Comparison of clinical outcomes of patients with relapsed acute promyelocytic leukemia induced with arsenic trioxide and consolidated with either an autologous stem cell transplant or an arsenic trioxide-based regimen. *Biol Blood Marrow Transplant* 2009;15(11):1479-1484.
198. Balgobind BV, Raimondi SC, Harbott J, et al. Novel prognostic subgroups in childhood 11q23/MLL-rearranged acute myeloid leukemia: results of an international retrospective study. *Blood* 2009;114(12):2489-2496.
199. Klusmann JH, Reinhardt D, Zimmermann M, et al. The role of matched sibling donor allogeneic stem cell transplantation in pediatric high-risk acute myeloid leukemia: results from the AML-BFM 98 study. *Haematologica* 2012;97(1):21-29.
200. Hollink IH, Zwaan CM, Zimmermann M, et al. Favorable prognostic impact of NPM1 gene mutations in childhood acute myeloid leukemia, with emphasis on cytogenetically normal AML. *Leukemia* 2009;23(2):262-270.
201. Brown P, McIntyre E, Rau R, et al. The incidence and clinical significance of nucleophosmin mutations in childhood AML. *Blood* 2007;110(3):979-985.
202. Hollink IH, van den Heuvel-Eibrink MM, Zimmermann M, et al. Clinical relevance of Wilms tumor 1 gene mutations in childhood acute myeloid leukemia. *Blood* 2009;113(23):5951-5960.
203. Ho PA, Zeng R, Alonzo TA, et al. Prevalence and prognostic implications of WT1 mutations in pediatric acute myeloid leukemia (AML): a report from the Children's Oncology Group. *Blood* 2010;116(5):702-710.
204. Loken MR, Alonzo TA, Pardo L, et al. Residual disease detected by multidimensional flow cytometry signifies high relapse risk in patients with de novo acute myeloid leukemia: a report from Children's Oncology Group. *Blood* 2012;120(8):1581-1588.
205. Niewerth D, Creutzig U, Bierings MB, et al. A review on allogeneic stem cell transplantation for newly diagnosed pediatric acute myeloid leukemia. *Blood* 2010;116(13):2205-2214.
206. Beier R, Albert MH, Bader P, et al. Allo-SCT using BU, CY and melphalan for children with AML in second CR. *Bone Marrow Transplant* 2012;Sept:1-6.
207. Lee JH, Yoon HS, Song JS, et al. Unrelated hematopoietic stem cell transplantation for children with acute leukemia: experience at a single institution. *J Korean Med Sci* 2009;24(5):904-909.
208. Kardos G, Zwaan CM, Kaspers GJ, et al. Treatment strategy and results in children treated on three Dutch Childhood Oncology Group acute myeloid leukemia trials. *Leukemia* 2005;19(12):2063-2071.

209. Ribeiro RC, Razzouk BI, Pounds S, et al. Successive clinical trials for childhood acute myeloid leukemia at St Jude Children's Research Hospital, from 1980 to 2000. *Leukemia* 2005;19(12):2125-2129.
210. Pession A, Rondelli R, Basso G, et al. Treatment and long-term results in children with acute myeloid leukaemia treated according to the AIEOP AML protocols. *Leukemia* 2005;19(12):2043-2053.
211. Entz-Werle N, Suciu S, van der Werff ten Bosch J, et al. Results of 58872 and 58921 trials in acute myeloblastic leukemia and relative value of chemotherapy vs allogeneic bone marrow transplantation in first complete remission: the EORTC Children Leukemia Group report. *Leukemia* 2005;19(12): 2072-2081.
212. Dluzniewska A, Balwierz W, Armata J, et al. Twenty years of Polish experience with three consecutive protocols for treatment of childhood acute myelogenous leukemia. *Leukemia* 2005;19(12):2117-2124.
213. Lie SO, Abrahamsson J, Clausen N, et al. Long-term results in children with AML: NOPHO-AML Study Group—report of three consecutive trials. *Leukemia* 2005;19(12):2090-2100.
214. Pui CH, Carroll WL, Meshinchi S, et al. Biology, risk stratification, and therapy of pediatric acute leukemias: an update. *J Clin Oncol* 2012;29:551-565.
215. Leahey A, Kelly K, Rorke LB, et al. A phase I/II study of idarubicin (Ida) with continuous infusion fludarabine (F-ara-A) and cytarabine (ara-C) for refractory or recurrent pediatric acute myeloid leukemia (AML). *J Pediatr Hematol Oncol* 1997;19(4):304-308.
216. Martinelli G, Testoni N, Zuffa E, et al. FLANG (fludarabine + cytosine arabinoside + novantrone + G-CSF) induces partial remission in lymphoid blast transformation of Ph+chronic myelogenous leukaemia. *Leuk Lymphoma* 1996;22(1-2):173-176.
217. Thomas MB, Koller C, Yang Y, et al. Comparison of fludarabine-containing salvage chemotherapy regimens for relapsed/refractory acute myelogenous leukemia. *Leukemia* 2003;17(5):990-993.
218. Fleischhack G, Graf N, Hasan C, et al. IDA-FLAG (idarubicin, fludarabine, high dosage cytarabine and G-CSF)—an effective therapy regimen in treatment of recurrent acute myelocytic leukemia in children and adolescents. Initial results of a pilot study. *Klin Padiatr* 1996;208(4):229-235.
219. Miano M, Pistorio A, Putti MC, et al. Clofarabine, cyclophosphamide and etoposide for the treatment of relapsed or resistant acute leukemia in pediatric patients. *Leuk Lymphoma* 2012;53(9):1693-1698.
220. Quarello P, Berger M, Rivetti E, et al. FLAG-liposomal doxorubicin (Myocet) regimen for refractory or relapsed acute leukemia pediatric patients. *J Pediatr Hematol/Oncol* 2012;34(3):208-216.
221. Parker JE, Pagliuca A, Mijovic A, et al. Fludarabine, cytarabine, G-CSF and idarubicin (FLAG-IDA) for the treatment of poor-risk myelodysplastic syndromes and acute myeloid leukaemia. *Br J Haematol* 1997;99(4): 939-944.
222. Wells RJ, Adams MT, Alonzo TA, et al. Mitoxantrone and cytarabine induction, high-dose cytarabine, and etoposide intensification for pediatric patients with relapsed or refractory acute myeloid leukemia: Children's Cancer Group Study 2951. *J Clin Oncol* 2003;21(15):2940-2947.
223. Arceci RJ, Sande J, Lange B, et al. Safety and efficacy of gemtuzumab ozogamicin in pediatric patients with advanced CD33+ acute myeloid leukemia. *Blood* 2005;106(4):1183-1188.
224. Reinhardt D, Diekamp S, Fleischhack G, et al. Gemtuzumab ozogamicin (Mylotarg) in children with refractory or relapsed acute myeloid leukemia. *Onkologie* 2004;27(3):269-272.
225. Zwaan CM, Reinhardt D, Zimmerman M, et al. Salvage treatment for children with refractory first or second relapse of acute myeloid leukaemia with gemtuzumab ozogamicin: results of a phase II study. *Br J Haematol* 2010;148(5):768-776.
226. Webb DK, Wheatley K, Harrison G, et al. Outcome for children with relapsed acute myeloid leukaemia following initial therapy in the Medical Research Council (MRC) AML 10 trial. MRC Childhood Leukaemia Working Party. *Leukemia* 1999;13(1):25-31.
227. Handgretinger R, Schumm M, Lang P, et al. Transplantation of megadoses of purified haploidentical stem cells. *Ann N Y Acad Sci* 1999;872:351-361, discussion 361-352.
228. Peters C, Matthes-Martin S, Fritsch G, et al. Transplantation of highly purified peripheral blood CD34+ cells from HLA-mismatched parental donors in 14 children: evaluation of early monitoring of engraftment. *Leukemia* 1999;13(12):2070-2078.

229. Davies SM, Ruggieri L, DeFor T, et al. Evaluation of KIR ligand incompatibility in mismatched unrelated donor hematopoietic transplants. Killer immunoglobulin-like receptor. *Blood* 2002;100(10):3825-3827.
230. Davies SM, Wagner JE, DeFor T, et al. Unrelated donor bone marrow transplantation for children and adolescents with aplastic anaemia or myelodysplasia. *Br J Haematol* 1997;96(4):749-756.
231. Estey EH. Treatment of relapsed and refractory acute myelogenous leukemia. *Leukemia* 2000;14(3):476-479.
232. Tavernier E, Le QH, Elhamri M, et al. Salvage therapy in refractory acute myeloid leukemia: prediction of outcome based on analysis of prognostic factors. *Leuk Res* 2003;27(3):205-214.
233. Gamis AS, Howells WB, DeSwarte-Wallace J, et al. Alpha hemolytic streptococcal infection during intensive treatment for acute myeloid leukemia: a report from the Children's cancer group study CCG-2891. *J Clin Oncol* 2000;18(9):1845-1855.
234. Lehrnbecher T, Phillips R, Alexander S, et al. Guideline for the management of fever and neutropenia in children with cancer and/or undergoing hematopoietic stem-cell transplantation. *J Clin Oncol* 2012;30:4427-4438.
235. Dombret H, Sutton L, Duarte M, et al. Combined therapy with all-trans-retinoic acid and high-dose chemotherapy in patients with hyperleukocytic acute promyelocytic leukemia and severe visceral hemorrhage. *Leukemia* 1992;6(12):1237-1242.
236. Estey E, Thall P, Andreeff M, et al. Use of granulocyte colony-stimulating factor before, during, and after fludarabine plus cytarabine induction therapy of newly diagnosed acute myelogenous leukemia or myelodysplastic syndromes: comparison with fludarabine plus cytarabine without granulocyte colony-stimulating factor [see comments]. *J Clin Oncol* 1994;12(4):671-678.
237. Heil G, Hoelzer D, Sanz MA, et al. A randomized, double-blind, placebo-controlled, phase III study of filgrastim in remission induction and consolidation therapy for adults with de novo acute myeloid leukemia. The International Acute Myeloid Leukemia Study Group. *Blood* 1997;90(12):4710-4718.
238. Alonzo TA, Kobrinisky NL, Aledo A, et al. Impact of granulocyte colony-stimulating factor use during induction for acute myelogenous leukemia in children: a report from the Children's Cancer Group. *J Pediatr Hematol Oncol* 2002;24(8):627-635.
239. Sherertz RJ, Belani A, Kramer BS, et al. Impact of air filtration on nosocomial *Aspergillus* infections. Unique risk of bone marrow transplant recipients. *Am J Med* 1987;83(4):709-718.
240. Rebutta P, Finazzi G, Marangoni F, et al. The threshold for prophylactic platelet transfusions in adults with acute myeloid leukemia. Gruppo Italiano Malattie Ematologiche Maligne dell'Adulto. *N Engl J Med* 1997;337(26):1870-1875.
241. Hebert PC. Anemia and red cell transfusion in critical care. Transfusion requirements in critical care investigators and the Canadian critical care trials group. *Minerva Anestesiol* 1999;65(5):293-304.
242. Liesner RJ, Leiper AD, Hann IM, et al. Late effects of intensive treatment for acute myeloid leukemia and myelodysplasia in childhood. *J Clin Oncol* 1994;12(5):916-924.
243. Leahey AM, Teunissen H, Friedman DL, et al. Late effects of chemotherapy compared to bone marrow transplantation in the treatment of pediatric acute myeloid leukemia and myelodysplasia. *Med Pediatr Oncol* 1999;32(3):163-169.
244. Leung W, Hudson MM, Strickland DK, et al. Late effects of treatment in survivors of childhood acute myeloid leukemia. *J Clin Oncol* 2000;18(18):3273-3279.
245. Perkins JL, Kunin-Batson AS, Youngren NM, et al. Long-term follow-up of children who underwent hematopoietic cell transplant (HCT) for AML or ALL at less than 3 years of age. *Pediatr Blood Cancer* 2007;49(7):958-963.
246. Temming P, Qureshi A, Hardt J, et al. Prevalence and predictors of anthracycline cardiotoxicity in children treated for acute myeloid leukaemia: retrospective cohort study in a single centre in the United Kingdom. *Pediatr Blood Cancer* 2011;56(4):625-630.
247. Leone G, Fianchi L, Voso MT. Therapy-related myeloid neoplasms. *Curr Opin Oncol* 2011;23(6):672-680.
248. Molgaard-Hansen L, Glosli H, Jahnukainen K, et al. Quality of health in survivors of childhood acute myeloid leukemia treated with chemotherapy only: a NOPHO-AML study. *Pediatr Blood Cancer* 2011;57(7):1222-1229.

249. Mulrooney DA, Dover DC, Li S, et al. Twenty years of follow-up among survivors of childhood and young adult acute myeloid leukemia: a report from the Childhood Cancer Survivor Study. *Cancer* 2008;112(9):2071-2079.
250. Gamis AS. Acute myeloid leukemia and Down syndrome evolution of modern therapy—state of the art review. *Pediatr Blood Cancer* 2005;44(1):13-20.
251. Li Z, Godinho FJ, Klusmann JH, et al. Developmental stage-selective effect of somatically mutated leukemogenic transcription factor GATA1. *Nat Genet* 2005;37(6):613-619.
252. Klusmann JH, Creutzig U, Zimmermann M, et al. Treatment and prognostic impact of transient leukemia in neonates with Down syndrome. *Blood* 2008;111(6):2991-2998.
253. Ravindranath Y, Abella E, Krischer JP, et al. Acute myeloid leukemia (AML) in Down's syndrome is highly responsive to chemotherapy: experience on Pediatric Oncology Group AML Study 8498. *Blood* 1992;80(9):2210-2214.
254. Stevens RF, Hann IM, Wheatley K, et al. Marked improvements in outcome with chemotherapy alone in paediatric acute myeloid leukemia: results of the United Kingdom Medical Research Council's 10th AML trial. MRC Childhood Leukaemia Working Party. *Br J Haematol* 1998;101(1):130-140.
255. Craze JL, Harrison G, Wheatley K, et al. Improved outcome of acute myeloid leukaemia in Down's syndrome. *Arch Dis Child* 1999;81(1):32-37.
256. Creutzig U, Ritter J, Vormoor J, et al. Myelodysplasia and acute myelogenous leukemia in Down's syndrome. A report of 40 children of the AML-BFM Study Group. *Leukemia* 1996;10(11):1677-1686.
257. Kojima S, Kato K, Matsuyama T, et al. Favorable treatment outcome in children with acute myeloid leukemia and Down syndrome. *Blood* 1993;81(11):3164.
258. Lie SO, Jonmundsson G, Mellander L, et al. A population-based study of 272 children with acute myeloid leukaemia treated on two consecutive protocols with different intensity: best outcome in girls, infants, and children with Down's syndrome. Nordic Society of Paediatric Haematology and Oncology (NOPHO). *Br J Haematol* 1996;94(1):82-88.
259. Gamis AS, Woods WG, Alonzo TA, et al. Increased age at diagnosis has a significantly negative effect on outcome in children with Down syndrome and acute myeloid leukemia: a report from the Children's Cancer Group Study 2891. *J Clin Oncol* 2003;21(18):3415-3422.
260. Gamis AS, Alonzo TA, Gerbing RB, et al. Natural history of transient myeloproliferative disorder clinically diagnosed in Down syndrome neonates: a report from the Children's Oncology Group Study A2971. *Blood* 2011;118(26):6752-6759, quiz 6996.
261. Creutzig U, Reinhardt D, Diekamp S, et al. AML patients with Down syndrome have a high cure rate with AML-BFM therapy with reduced dose intensity. *Leukemia* 2005;19(8):1355-1360.
262. O'Brien MM, Taub JW, Chang MN, et al. Cardiomyopathy in children with Down syndrome treated for acute myeloid leukemia: a report from the Children's Oncology Group Study POG 9421. *J Clin Oncol* 2008;26(3): 414-420.
263. Davies SM, Khan S, Wagner JE, et al. Unrelated donor bone marrow transplantation for Fanconi anemia. *Bone Marrow Transplant* 1996;17(1):43-47.
264. Gluckman E, Auerbach AD, Horowitz MM, et al. Bone marrow transplantation for Fanconi anemia. *Blood* 1995;86(7):2856-2862.
265. Gluckman E, Wagner JE. Hematopoietic stem cell transplantation in childhood inherited bone marrow failure syndrome. *Bone Marrow Transplant* 2008;41(2):127-132.
266. Guardiola P, Pasquini R, Dokal I, et al. Outcome of 69 allogeneic stem cell transplantations for Fanconi anemia using HLA-matched unrelated donors: a study on behalf of the European Group for Blood and Marrow Transplantation. *Blood* 2000;95(2):422-429.
267. Ruggeri A, de Latour RP, Rocha V, et al. Double cord blood transplantation in patients with high risk bone marrow failure syndromes. *Br J Haematol* 2008;143(3):404-408.
268. Zanis-Neto J, Flowers ME, Medeiros CR, et al. Low-dose cyclophosphamide conditioning for hematopoietic cell transplantation from HLA-matched related donors in patients with Fanconi anaemia. *Br J Haematol* 2005;130(1):99-106.
269. Zanis-Neto J, Ribeiro RC, Medeiros C, et al. Bone marrow transplantation for patients with Fanconi anemia: a study of 24 cases from a single institution. *Bone Marrow Transplant* 1995;15(2):293-298.

270. Stelljes M, Corbacioglu A, Schlenk RF, et al. Allogeneic stem cell transplant to eliminate germline mutations in the gene for CCAAT-enhancer-binding protein alpha from hematopoietic cells in a family with AML. *Leukemia* 2011;25(7):1209-1210.
271. Fukano R, Nagatoshi Y, Shinkoda Y, et al. Unrelated bone marrow transplantation using a reduced-intensity conditioning regimen for the treatment of Kostmann syndrome. *Bone Marrow Transplant* 2006;38(9):635-636.
272. Myers SN, Zeevi A, Zorich GP, et al. Successful engraftment following unrelated donor transplant in an alloimmunized patient with Kostmann syndrome. *Pediatr Blood Cancer* 2005;44(5):508-510.
273. Ishii E, Oda M, Kinugawa N, et al. Features and outcome of neonatal leukemia in Japan: experience of the Japan infant leukemia study group. *Pediatr Blood Cancer* 2006;47(3):268-272.
274. Bresters D, Reus AC, Veerman AJ, et al. Congenital leukaemia: the Dutch experience and review of the literature. *Br J Haematol* 2002;117(3):513-524.
275. Creutzig U, Zimmermann M, Bourquin JP, et al. Favorable outcome in infants with AML after intensive first- and second-line treatment: an AML-BFM study group report. *Leukemia* 2012;26(4):654-661.
276. Grundy RG, Martinez A, Kempinski H, et al. Spontaneous remission of congenital leukemia: a case for conservative treatment. *J Pediatr Hematol Oncol* 2000;22(3):252-255.
277. Hutson JR, Weitzman S, Schechter T, et al. Pharmacokinetic and pharmacogenetic determinants and considerations in chemotherapy selection and dosing in infants. *Expert Opin Drug Metab Toxicol* 2012;8(6):709-722.
278. Periclou AP, Avramis VI. NONMEM population pharmacokinetic studies of cytosine arabinoside after high-dose and after loading bolus followed by continuous infusion of the drug in pediatric patients with leukemias. *Cancer Chemother Pharmacol* 1996;39(1-2):42-50.
279. Huang ME, Ye YC, Chen SR, et al. All-trans retinoic acid with or without low dose cytosine arabinoside in acute promyelocytic leukemia. Report of 6 cases. *Chin Med J* 1987;100(12):949-953.
280. Huang ME, Ye YC, Chen SR, et al. Use of all-trans retinoic acid in the treatment of acute promyelocytic leukemia. *Blood* 1988;72(2):567-572.
281. Tallman MS. Updates on the treatment of acute promyelocytic leukemia. *Clin Adv Hematol Oncol* 2010;8(2):89-90.
282. Avvisati G, Lo-Coco F, Paoloni FP, et al. AIDA 0493 protocol for newly diagnosed acute promyelocytic leukemia: very long-term results and role of maintenance. *Blood* 2011;117(18):4716-4725.
283. Mandelli F, Diverio D, Avvisati G, et al. Molecular remission in PML/RAR alpha-positive acute promyelocytic leukemia by combined all-trans retinoic acid and idarubicin (AIDA) therapy. Gruppo Italiano-Malattie Ematologiche Maligne dell'Adulto and Associazione Italiana di Ematologia ed Oncologia Pediatrica Cooperative Groups. *Blood* 1997;90(3):1014-1021.
284. Sanz MA, Martin G, Rayon C, et al. A modified AIDA protocol with anthracycline-based consolidation results in high antileukemic efficacy and reduced toxicity in newly diagnosed PML/RARalpha-positive acute promyelocytic leukemia. PETHEMA group. *Blood* 1999;94(9):3015-3021.
285. Sanz MA, Montesinos P, Rayon C, et al. Risk-adapted treatment of acute promyelocytic leukemia based on all-trans retinoic acid and anthracycline with addition of cytarabine in consolidation therapy for high-risk patients: further improvements in treatment outcome. *Blood* 2010;115(25):5137-5146.
286. Tallman M, Douer D, Gore S, et al. Treatment of patients with acute promyelocytic leukemia: a consensus statement on risk-adapted approaches to therapy. *Clin Lymphoma Myeloma Leuk* 2010;10(Suppl 3):S122-S126.
287. Li EQ, Xu L, Zhang ZQ, et al. Retrospective analysis of 119 cases of pediatric acute promyelocytic leukemia: comparisons of four treatment regimens. *Exp Ther Med* 2012;4(1):93-98.
288. Castaigne S, Lefebvre P, Chomienne C, et al. Effectiveness and pharmacokinetics of low-dose all-trans retinoic acid (25 mg/m²) in acute promyelocytic leukemia. *Blood* 1993;82(12):3560-3563.
289. Mann G, Reinhardt D, Ritter J, et al. Treatment with all-trans retinoic acid in acute promyelocytic leukemia reduces early deaths in children. *Ann Hematol* 2001;80(7):417-422.
290. de Botton S, Coiteux V, Chevret S, et al. Outcome of childhood acute promyelocytic leukemia with all-trans-retinoic acid and chemotherapy. *J Clin Oncol* 2004;22(8):1404-1412.

291. Testi AM, Moleti ML, Del Giudice I, et al. Acute promyelocytic leukemia (APL) in children: results of the AIDA Italian protocol. *Blood* 2000;96:467a.
292. Testi AM, Biondi A, Lo Coco F, et al. GIMEMA-AIEOPAIDA protocol for the treatment of newly diagnosed acute promyelocytic leukemia (APL) in children. *Blood* 2005;106(2):447-453.
293. Wiley JS, Firkin FC. Reduction of pulmonary toxicity by prednisolone prophylaxis during all-trans retinoic acid treatment of acute promyelocytic leukemia. Australian Leukaemia Study Group. *Leukemia* 1995;9(5):774-778.
294. Shen ZX, Chen GQ, Ni JH, et al. Use of arsenic trioxide (As₂O₃) in the treatment of acute promyelocytic leukemia (APL): II. Clinical efficacy and pharmacokinetics in relapsed patients. *Blood* 1997;89(9):3354-3360.
295. Shen Y, Shen ZX, Yan H, et al. Studies on the clinical efficacy and pharmacokinetics of low-dose arsenic trioxide in the treatment of relapsed acute promyelocytic leukemia: a comparison with conventional dosage. *Leukemia* 2001;15(5):735-741.
296. Soignet SL, Maslak P, Wang ZG, et al. Complete remission after treatment of acute promyelocytic leukemia with arsenic trioxide. *N Engl J Med* 1998;339(19):1341-1348.
297. Zhou J, Zhang Y, Li J, et al. Single-agent arsenic trioxide in the treatment of children with newly diagnosed acute promyelocytic leukemia. *Blood* 2010;115(9):1697-1702.
298. Gore SD, Gojo I, Sekeres MA, et al. Single cycle of arsenic trioxide-based consolidation chemotherapy spares anthracycline exposure in the primary management of acute promyelocytic leukemia. *J Clin Oncol* 2010;28(6):1047-1053.
299. Powell BL. Effect of consolidation with arsenic trioxide (As₂O₃) on event-free survival (EFS) and overall survival (OS) among patients with newly diagnosed acute promyelocytic leukemia (APL): North American Intergroup Protocol C9710. *J Clin Oncol* 2007;25:15.
300. Powell BL, Moser B, Stock W, et al. Arsenic trioxide improves event-free and overall survival for adults with acute promyelocytic leukemia: North American Leukemia Intergroup Study C9710. *Blood* 2010;116(19):3751-3757.
301. Iland HJ, Bradstock K, Supple SG, et al. All-trans-retinoic acid, idarubicin, and IV arsenic trioxide as initial therapy in acute promyelocytic leukemia (APML4). *Blood* 2012;120(8):1570-1580, quiz 1752.
302. Mathews V, George B, Lakshmi KM, et al. Single-agent arsenic trioxide in the treatment of newly diagnosed acute promyelocytic leukemia: durable remissions with minimal toxicity. *Blood* 2006;107(7):2627-2632.
303. Ravandi F, Estey E, Jones D, et al. Effective treatment of acute promyelocytic leukemia with all-trans-retinoic acid, arsenic trioxide, and gemtuzumab ozogamicin. *J Clin Oncol* 2009;27(4):504-510.
304. Estey EH, Giles FJ, Beran M, et al. Experience with gemtuzumab ozogamycin ("mylotarg") and all-trans retinoic acid in untreated acute promyelocytic leukemia. *Blood* 2002;99(11):4222-4224.
305. Ades L, Chevret S, Raffoux E, et al. Is cytarabine useful in the treatment of acute promyelocytic leukemia? Results of a randomized trial from the European Acute Promyelocytic Leukemia Group. *J Clin Oncol* 2006;24(36):5703-5710.
306. Asou N, Kishimoto Y, Kiyoi H, et al. A randomized study with or without intensified maintenance chemotherapy in patients with acute promyelocytic leukemia who have become negative for PML-RAR α transcript after consolidation therapy: the Japan Adult Leukemia Study Group (JALSG) APL97 study. *Blood* 2007;110(1):59-66.
307. de Botton S, Sanz MA, Chevret S, et al. Extramedullary relapse in acute promyelocytic leukemia treated with all-trans retinoic acid and chemotherapy. *Leukemia* 2006;20(1):35-41.
308. Ravandi F. Prophylactic intrathecal chemotherapy in acute promyelocytic leukemia (APL). *Leukemia* 2004;18(4):879-880.
309. Albano F, Specchia G. Extramedullary disease in acute promyelocytic leukemia: two-in-one disease. *Mediterr J Hematol Infect Dis* 2011;3(1):e2011066.
310. Kutny MA, Moser BK, Laumann K, et al. FLT3 mutation status is a predictor of early death in pediatric acute promyelocytic leukemia: a report from the Children's Oncology Group. *Pediatr Blood Cancer* 2012;59(4):662-667.
311. Schnittger S, Bacher U, Haferlach C, et al. Clinical impact of FLT3 mutation load in acute promyelocytic leukemia with t(15;17)/PML-RARA. *Haematologica* 2011;96(12):1799-1807.
312. Lo-Coco F, Ammatuna E. Front line clinical trials and minimal residual disease monitoring in acute promyelocytic leukemia. *Curr Top Microbiol Immunol* 2007;313:145-156.

313. Lo-Coco F, Breccia M, Diverio D. The importance of molecular monitoring in acute promyelocytic leukaemia. *Best Pract Res Clin Haematol* 2003;16(3):503-520.
314. Grimwade D, Jovanovic JV, Hills RK, et al. Prospective minimal residual disease monitoring to predict relapse of acute promyelocytic leukemia and to direct pre-emptive arsenic trioxide therapy. *J Clin Oncol* 2009;27(22):3650-3658.
315. Douer D, Hu W, Giralt S, et al. Arsenic trioxide (trisenox) therapy for acute promyelocytic leukemia in the setting of hematopoietic stem cell transplantation. *Oncologist* 2003;8(2):132-140.
316. Meloni G, Diverio D, Vignetti M, et al. Autologous bone marrow transplantation for acute promyelocytic leukemia in second remission: prognostic relevance of pretransplant minimal residual disease assessment by reverse-transcription polymerase chain reaction of the PML/RAR alpha fusion gene. *Blood* 1997;90(3):1321-1325.
317. Ramadan SM, Di Veroli A, Camboni A, et al. Allogeneic stem cell transplantation for advanced acute promyelocytic leukemia in the ATRA and ATO era. *Haematologica* 2012;97(11):1731-1735.
318. Fenaux P, Chastang C, Chevret S, et al. A randomized comparison of all transretinoic acid (ATRA) followed by chemotherapy and ATRA plus chemotherapy and the role of maintenance therapy in newly diagnosed acute promyelocytic leukemia. The European APL Group. *Blood* 1999;94(4):1192-1200.
319. Choudhry A, DeLoughery TG. Bleeding and thrombosis in acute promyelocytic leukemia. *Am J Hematol* 2012;87(6):596-603.
320. Breen KA, Grimwade D, Hunt BJ. The pathogenesis and management of the coagulopathy of acute promyelocytic leukaemia. *Br J Haematol* 2012;156(1):24-36.
321. Sanz MA, Montesinos P. Open issues on bleeding and thrombosis in acute promyelocytic leukemia. *Thromb Res* 2010;125(Suppl 2):S51-S54.
322. Yanada M, Matsushita T, Asou N, et al. Severe hemorrhagic complications during remission induction therapy for acute promyelocytic leukemia: incidence, risk factors, and influence on outcome. *Eur J Haematol* 2007;78(3):213-219.
323. Tallman MS, Abutalib SA, Altman JK. The double hazard of thrombophilia and bleeding in acute promyelocytic leukemia. *Semin Thromb Hemost* 2007;33(4):330-338.
324. Reinhardt D, Creutzig U. Isolated myelosarcoma in children—update and review. *Leuk Lymphoma* 2002;43(3):565-574.
325. Landis DM, Aboulafia DM. Granulocytic sarcoma: an unusual complication of aleukemic myeloid leukemia causing spinal cord compression. A case report and literature review. *Leuk Lymphoma* 2003;44(10):1753-1760.
326. Dusenbery KE, Howells WB, Arthur DC, et al. Extramedullary leukemia in children with newly diagnosed acute myeloid leukemia: a report from the Children's Cancer Group. *J Pediatr Hematol Oncol* 2003;25(10):760-768.
327. Smith FO, Lampkin BC, Versteeg C, et al. Expression of lymphoid-associated cell surface antigens by childhood acute myeloid leukemia cells lacks prognostic significance. *Blood* 1992;79(9):2415-2422.
328. Al-Seraihy AS, Owaidah TM, Ayas M, et al. Clinical characteristics and outcome of children with biphenotypic acute leukemia. *Haematologica* 2009;94(12):1682-1690.
329. Mejstrikova E, Volejnikova J, Fronkova E, et al. Prognosis of children with mixed phenotype acute leukemia treated on the basis of consistent immunophenotypic criteria. *Haematologica* 2010;95(6):928-935.
330. Gerr H, Zimmermann M, Schrappe M, et al. Acute leukaemias of ambiguous lineage in children: characterization, prognosis and therapy recommendations. *Br J Haematol* 2010;149(1):84-92.
331. Rubnitz JE, Onciu M, Pounds S, et al. Acute mixed lineage leukemia in children: the experience of St Jude Children's Research Hospital. *Blood* 2009;113(21):5083-5089.
332. Larson RA. Etiology and management of therapy-related myeloid leukemia. *Hematology (Am Soc Hematol Educ Program)* 2007:453-459.
333. Leone G, Pagano L, Ben-Yehuda D, et al. Therapy-related leukemia and myelodysplasia: susceptibility and incidence. *Haematologica* 2007;92(10):1389-1398.
334. Woodard P, Barfield R, Hale G, et al. Outcome of hematopoietic stem cell transplantation for pediatric patients with therapy-related acute myeloid leukemia or myelodysplastic syndrome. *Pediatr Blood Cancer* 2006;47(7):931-935.

335. Bolufer P, Collado M, Barragan E, et al. Profile of polymorphisms of drug-metabolising enzymes and the risk of therapy-related leukaemia. *Br J Haematol* 2007;136(4):590-596.
336. Ezoë S. Secondary leukemia associated with the anti-cancer agent, etoposide, a topoisomerase II inhibitor. *Int J Environ Res Public Health* 2012;9(7):2444-2453.
337. Ding Y, Sun CL, Li L, et al. Genetic susceptibility to therapy-related leukemia after Hodgkin lymphoma or non-Hodgkin lymphoma: role of drug metabolism, apoptosis and DNA repair. *Blood Cancer J* 2012;2(3):e58.
338. Bhatia S, Krailo MD, Chen Z, et al. Therapy-related myelodysplasia and acute myeloid leukemia after Ewing sarcoma and primitive neuroectodermal tumor of bone: a report from the Children's Oncology Group. *Blood* 2007;109(1):46-51.
339. Schmiegelow K. Epidemiology of therapy-related myeloid neoplasms after treatment for pediatric acute lymphoblastic leukemia in the nordic countries. *Mediterr J Hematol Infect Dis* 2011;3(1):e2011020.
340. Aguilera DG, Vaklavas C, Tsimberidou AM, et al. Pediatric therapy-related myelodysplastic syndrome/acute myeloid leukemia: the MD Anderson Cancer Center experience. *J Pediatr Hematol/Oncol* 2009;31(11):803-811.
341. Yokoyama H, Mori S, Kobayashi Y, et al. Hematopoietic stem cell transplantation for therapy-related myelodysplastic syndrome and acute leukemia: a single-center analysis of 47 patients. *Int J Hematol* 2010;92(2):334-341.
342. Wheatley K, Burnett AK, Goldstone AH, et al. A simple, robust, validated and highly predictive index for the determination of risk-directed therapy in acute myeloid leukaemia derived from the MRC AML 10 trial. United Kingdom Medical Research Council's Adult and Childhood Leukaemia Working Parties. *Br J Haematol* 1999;107(1):69-79.
343. Creutzig U, Buchner T, Sauerland MC, et al. Significance of age in acute myeloid leukemia patients younger than 30 years: a common analysis of the pediatric trials AML-BFM 93/98 and the adult trials AMLCG 92/99 and AMLSG HD93/98A. *Cancer* 2008;112(3):562-571.
344. Aplenc R, Alonzo TA, Gerbing RB, et al. Ethnicity and survival in childhood acute myeloid leukemia: a report from the Children's Oncology Group. *Blood* 2006;108(1):74-80.
345. Rubnitz JE, Lensing S, Razzouk BI, et al. Effect of race on outcome of white and black children with acute myeloid leukemia: the St. Jude experience. *Pediatr Blood Cancer* 2007;48(1):10-15.
346. Brady AK, Fu AZ, Earl M, et al. Race and intensity of post-remission therapy in acute myeloid leukemia. *Leuk Res* 2011;35(3):346-350.
347. Lange BJ, Gerbing RB, Feusner J, et al. Mortality in overweight and underweight children with acute myeloid leukemia. *JAMA* 2005;293(2):203-211.
348. Davies SM, Robison LL, Buckley JD, et al. Glutathione S-transferase polymorphisms in children with myeloid leukemia: a Children's Cancer Group study. *Cancer Epidemiol Biomarkers Prev* 2000;9(6):563-566.
349. Creutzig U, Zimmermann M, Ritter J, et al. Definition of a standard-risk group in children with AML. *Br J Haematol* 1999;104(3):630-639.
350. Abbott BL, Rubnitz JE, Tong X, et al. Clinical significance of central nervous system involvement at diagnosis of pediatric acute myeloid leukemia: a single institution's experience. *Leukemia* 2003;17(11):2090-2096.
351. Johnston DL, Alonzo TA, Gerbing RB, et al. The presence of central nervous system disease at diagnosis in pediatric acute myeloid leukemia does not affect survival: a Children's Oncology Group study. *Pediatr Blood Cancer* 2010;55(3):414-420.
352. Johnston DL, Alonzo TA, Gerbing RB, et al. Superior outcome of pediatric acute myeloid leukemia patients with orbital and CNS myeloid sarcoma: a report from the Children's Oncology Group. *Pediatr Blood Cancer* 2012;58(4):519-524.
353. Creutzig U, Zimmermann M, Bourquin JP, et al. Second induction with high-dose cytarabine and mitoxantrone: different impact on pediatric AML patients with t(8;21) and with inv(16). *Blood* 2011;118(20):5409-5415.
354. Brown LM, Daeschner CD, Timms J, et al. Granulocytic sarcoma in childhood acute myelogenous leukemia. *Pediatr Neurol* 1989;5(3):173-178.
355. Hurwitz CA, Raimondi SC, Head D, et al. Distinctive immunophenotypic features of t(8;21)(q22;q22) acute myeloblastic leukemia in children. *Blood* 1992;80(12):3182-3188.
356. Licht JD, Chomienne C, Goy A, et al. Clinical and molecular characterization of a rare syndrome of acute promyelocytic leukemia associated with translocation (11;17). *Blood* 1995;85(4):1083-1094.

357. Harrison CJ, Hills RK, Moorman AV, et al. Cytogenetics of childhood acute myeloid leukemia: United Kingdom Medical Research Council Treatment trials AML 10 and 12. *J Clin Oncol* 2010;28(16):2674-2681.
358. von Neuhoff C, Reinhardt D, Sander A, et al. Prognostic impact of specific chromosomal aberrations in a large group of pediatric patients with acute myeloid leukemia treated uniformly according to trial AML-BFM 98. *J Clin Oncol* 2010;28(16):2682-2689.
359. Balgobind BV, Zwaan CM, Pieters R, et al. The heterogeneity of pediatric MLL-rearranged acute myeloid leukemia. *Leukemia* 2011;25(8):1239-1248.
360. Rubnitz JE, Raimondi SC, Tong X, et al. Favorable impact of the t(9;11) in childhood acute myeloid leukemia. *J Clin Oncol* 2002;20(9):2302-2309.
361. Grimwade D, Tallman MS. Should minimal residual disease monitoring be the standard of care for all patients with acute promyelocytic leukemia? *Leuk Res* 2011;35(1):3-7.
362. Swerdlow SH, Campo E, Harris NL, et al. WHO Classification of tumors of haematopoietic and lymphoid tissues. Lyon, France: International Agency for Research on Cancer, 2008.
363. Hasle H, Alonzo TA, Auvrignon A, et al. Monosomy 7 and deletion 7q in children and adolescents with acute myeloid leukemia: an international retrospective study. *Blood* 2007;109(11):4641-4647.
364. Grimwade D, Hills RK, Moorman AV, et al. Refinement of cytogenetic classification in acute myeloid leukemia: determination of prognostic significance of rare recurring chromosomal abnormalities among 5876 younger adult patients treated in the United Kingdom Medical Research Council trials. *Blood* 2010;116(3):354-365.
365. Carroll A, Civin C, Schneider N, et al. The t(1;22) (p13;q13) is nonrandom and restricted to infants with acute megakaryoblastic leukemia: a Pediatric Oncology Group Study. *Blood* 1991;78(3):748-752.
366. Mercher T, Busson-Le Coniat M, Nguyen Khac F, et al. Recurrence of OTTMAL fusion in t(1;22) of infant AML-M7. *Genes Chromosomes Cancer* 2002;33(1):22-28.
367. Levy ER, Parganas E, Morishita K, et al. DNA rearrangements proximal to the EVI1 locus associated with the 3q21q26 syndrome. *Blood* 1994;83(5):1348-1354.
368. Lugthart S, Groschel S, Beverloo HB, et al. Clinical, molecular, and prognostic significance of WHO type inv(3)(q21q26.2)/t(3;3)(q21;q26.2) and various other 3q abnormalities in acute myeloid leukemia. *J Clin Oncol* 2010;28(24):3890-3898.
369. Balgobind BV, Lugthart S, Hollink IH, et al. EVI1 overexpression in distinct subtypes of pediatric acute myeloid leukemia. *Leukemia* 2010;24(5):942-949.
370. Shackelford D, Kenific C, Blusztajn A, et al. Targeted degradation of the AML1/MDS1/EVI1 oncoprotein by arsenic trioxide. *Cancer Res* 2006;66(23): 11360-11369.
371. Meshinchi S, Woods WG, Stirewalt DL, et al. Prevalence and prognostic significance of FLT3 internal tandem duplication in pediatric acute myeloid leukemia. *Blood* 2001;97(1):89-94.
372. Meshinchi S, Stirewalt DL, Alonzo TA, et al. Structural and numerical variation of FLT3/ITD in pediatric AML. *Blood* 2008;111(10):4930-4933.
373. Pollard JA, Alonzo TA, Gerbing RB, et al. FLT3 internal tandem duplication in CD34+/CD33- precursors predicts poor outcome in acute myeloid leukemia. *Blood* 2006;108(8):2764-2769.
374. Balgobind BV, Hollink IH, Arentsen-Peters ST, et al. Integrative analysis of type-I and type-II aberrations underscores the genetic heterogeneity of pediatric acute myeloid leukemia. *Haematologica* 2011;96(10):1478-1487.
375. Schnittger S, Schoch C, Dugas M, et al. Analysis of FLT3 length mutations in 1003 patients with acute myeloid leukemia: correlation to cytogenetics, FAB subtype, and prognosis in the AMLCG study and usefulness as a marker for the detection of minimal residual disease. *Blood* 2002;100(1):59-66.
376. Arrigoni P, Beretta C, Silvestri D, et al. FLT3 internal tandem duplication in childhood acute myeloid leukaemia: association with hyperleucocytosis in acute promyelocytic leukaemia. *Br J Haematol* 2003;120(1):89-92.
377. Noguera NI, Breccia M, Divona M, et al. Alterations of the FLT3 gene in acute promyelocytic leukemia: association with diagnostic characteristics and analysis of clinical outcome in patients treated with the Italian AIDA protocol. *Leukemia* 2002;16(11):2185-2189.

378. Shih LY, Kuo MC, Liang DC, et al. Internal tandem duplication and Asp835 mutations of the FMS-like tyrosine kinase 3 (FLT3) gene in acute promyelocytic leukemia. *Cancer* 2003;98(6):1206-1216.
379. Schnittger S, Kohl TM, Haferlach T, et al. KIT-D816 mutations in AML1-ETOpositive AML are associated with impaired event-free and overall survival. *Blood* 2006;107(5):1791-1799.
380. Shimada A, Taki T, Tabuchi K, et al. KIT mutations, and not FLT3 internal tandem duplication, are strongly associated with a poor prognosis in pediatric acute myeloid leukemia with t(8;21): a study of the Japanese Childhood AML Cooperative Study Group. *Blood* 2006;107(5):1806-1809.
381. Pollard JA, Alonzo TA, Gerbing RB, et al. Prevalence and prognostic significance of KIT mutations in pediatric patients with core binding factor AML enrolled on serial pediatric cooperative trials for de novo AML. *Blood* 2010;115(12):2372-2379.
382. Liang DC, Shih LY, Huang CF, et al. CEBPalpha mutations in childhood acute myeloid leukemia. *Leukemia* 2005;19(3):410-414.
383. Taskesen E, Bullinger L, Corbacioglu A, et al. Prognostic impact, concurrent genetic mutations and gene expression features of AML with CEBPA mutations in a cohort of 1182 cytogenetically normal AML: further evidence for CEBPA double mutant AML as a distinctive disease entity. *Blood* 2011;117:2469-2475.

P.1655

384. Hollink IH, van den Heuvel-Eibrink MM, Arentsen-Peters ST, et al. Characterization of CEBPA mutations and promoter hypermethylation in pediatric acute myeloid leukemia. *Haematologica* 2011;96(3):384-392.
385. Wouters BJ, Lowenberg B, Erpelinck-Verschueren CA, et al. Double CEBPA mutations, but not single CEBPA mutations, define a subgroup of acute myeloid leukemia with a distinctive gene expression profile that is uniquely associated with a favorable outcome. *Blood* 2009;113(13):3088-3091.
386. Hollink IH, van den Heuvel-Eibrink MM, Zimmermann M, et al. No prognostic impact of the WT1 gene single nucleotide polymorphism rs16754 in pediatric acute myeloid leukemia. *J Clin Oncol* 2010;28(28):e523-e526, author reply e527-e528.
387. Ho PA, Kuhn J, Gerbing RB, et al. WT1 synonymous single nucleotide polymorphism rs16754 correlates with higher mRNA expression and predicts significantly improved outcome in favorable-risk pediatric acute myeloid leukemia: a report from the children's oncology group. *J Clin Oncol* 2011;29(6):704-711.
388. Farr C, Gill R, Katz F, et al. Analysis of ras gene mutations in childhood myeloid leukaemia. *Br J Haematol* 1991;77(3):323-327.
389. Meshinchi S, Stirewalt DL, Alonzo TA, et al. Activating mutations of RTK/ras signal transduction pathway in pediatric acute myeloid leukemia. *Blood* 2003;102(4):1474-1479.
390. Berman JN, Gerbing RB, Alonzo TA, et al. Prevalence and clinical implications of NRAS mutations in childhood AML: a report from the Children's Oncology Group. *Leukemia* 2011;25(6):1039-1042.
391. Ko M, Huang Y, Jankowska AM, et al. Impaired hydroxylation of 5-methylcytosine in myeloid cancers with mutant TET2. *Nature* 2010;468(7325):839-843.
392. Chou WC, Chou SC, Liu CY, et al. TET2 mutation is an unfavorable prognostic factor in acute myeloid leukemia patients with intermediate-risk cytogenetics. *Blood* 2011;118(14):3803-3810.
393. Metzeler KH, Maharry K, Radmacher MD, et al. TET2 mutations improve the new European Leukemia Net risk classification of acute myeloid leukemia: a Cancer and Leukemia Group B study. *J Clin Oncol* 2011;29(10):1373-1381.
394. Kuhn MW, Radtke I, Bullinger L, et al. High-resolution genomic profiling of adult and pediatric core-binding factor acute myeloid leukemia reveals new recurrent genomic alterations. *Blood* 2012;119(10):e67-e75.
395. Kutny MA, Alonzo TA, Gerbing RB, et al. TET mutations are associated with poor outcome in pediatric AML: a report from the Children's Oncology Group. *Blood (ASH Annual Meeting Abstracts)* 2011;118:569.
396. Langemeijer SM, Jansen JH, Hooijer J, et al. TET2 mutations in childhood leukemia. *Leukemia* 2011;25(1):189-192.

397. Gross S, Cairns RA, Minden MD, et al. Cancer-associated metabolite 2-hydroxyglutarate accumulates in acute myelogenous leukemia with isocitrate dehydrogenase 1 and 2 mutations. *J Exp Med* 2010;207(2):339-344.
398. Lu C, Ward PS, Kapoor GS, et al. IDH mutation impairs histone demethylation and results in a block to cell differentiation. *Nature* 2012;483(7390):474-478.
399. Figueroa ME, Lugthart S, Li Y, et al. DNA methylation signatures identify biologically distinct subtypes in acute myeloid leukemia. *Cancer Cell* 2010;17(1):13-27.
400. Green CL, Evans CM, Hills RK, et al. The prognostic significance of IDH1 mutations in younger adult patients with acute myeloid leukemia is dependent on FLT3/ITD status. *Blood* 2010;116(15):2779-2782.
401. Damm F, Heuser M, Morgan M, et al. Integrative prognostic risk score in acute myeloid leukemia with normal karyotype. *Blood* 2011;117(17): 4561-4568.
402. Ho PA, Kopecky KJ, Alonzo TA, et al. Prognostic implications of the IDH1 synonymous SNP rs11554137 in pediatric and adult AML: a report from the Children's Oncology Group and SWOG. *Blood* 2011;118(17):4561-4566.
403. Hou HA, Kuo YY, Liu CY, et al. DNMT3A mutations in acute myeloid leukemia: stability during disease evolution and clinical implications. *Blood* 2012;119(2):559-568.
404. Marcucci G, Metzeler KH, Schwind S, et al. Age-related prognostic impact of different types of DNMT3A mutations in adults with primary cytogenetically normal acute myeloid leukemia. *J Clin Oncol* 2012;30(7):742-750.
405. Renneville A, Boissel N, Nibourel O, et al. Prognostic significance of DNA methyltransferase 3A mutations in cytogenetically normal acute myeloid leukemia: a study by the Acute Leukemia French Association. *Leukemia* 2012;26(6):1247-1254.
406. Shah MY, Licht JD. DNMT3A mutations in acute myeloid leukemia. *Nat Genet* 2011;43(4):289-290.
407. Hama A, Muramatsu H, Makishima H, et al. Molecular lesions in childhood and adult acute megakaryoblastic leukaemia. *Br J Haematol* 2012;156(3):316-325.
408. Hollink IH, Feng Q, Danen-van Oorschot AA, et al. Low frequency of DNMT3A mutations in pediatric AML, and the identification of the OCI-AML3 cell line as an in vitro model. *Leukemia* 2012;26(2):371-373.
409. Sievers EL, Lange BJ, Alonzo TA, et al. Immunophenotypic evidence of leukemia after induction therapy predicts relapse: results from a prospective Children's Cancer Group study of 252 patients with acute myeloid leukemia. *Blood* 2003;101(9):3398-3406.
410. Coustan-Smith E, Ribeiro RC, Rubnitz JE, et al. Clinical significance of residual disease during treatment in childhood acute myeloid leukaemia. *Br J Haematol* 2003;123(2):243-252.
411. Rizzari C, Cazzaniga G, Coliva T, et al. Predictive factors of relapse and survival in childhood acute myeloid leukemia: role of minimal residual disease. *Expert Rev Anticancer Ther* 2011;11(9):1391-1401.
412. Yin JA, Frost L. Monitoring AML1-ETO and CBFbeta-MYH11 transcripts in acute myeloid leukemia. *Curr Oncol Rep* 2003;5(5):399-404.
413. Guerrasio A, Pilatrin C, De Micheli D, et al. Assessment of minimal residual disease (MRD) in CBFbeta/MYH11-positive acute myeloid leukemias by qualitative and quantitative RT-PCR amplification of fusion transcripts. *Leukemia* 2002;16(6):1176-1181.
414. Buonamici S, Ottaviani E, Testoni N, et al. Real-time quantitation of minimal residual disease in inv(16)-positive acute myeloid leukemia may indicate risk for clinical relapse and may identify patients in a curable state. *Blood* 2002;99(2):443-449.
415. Inaba H, Coustan-Smith E, Cao X, et al. Comparative analysis of different approaches to measure treatment response in acute myeloid leukemia. *J Clin Oncol* 2012;30(29):3625-3632.
416. Garces-Eisele J. Molecular biology strategies to detect residual disease. *Hematology* 2012;17(Suppl 1):S66-S68.
417. Diverio D, Pandolfi PP, Rossi V, et al. Monitoring of treatment outcome in acute promyelocytic leukemia by RT-PCR. *Leukemia* 1994;8(7):1105-1107.
418. Grimwade D, Lo Coco F. Acute promyelocytic leukemia: a model for the role of molecular diagnosis and residual disease monitoring in directing treatment approach in acute myeloid leukemia. *Leukemia* 2002;16(10):1959-1973.

419. Grimwade D. The significance of minimal residual disease in patients with t(15;17). *Best practice & research. Clin Haematol* 2002;15(1):137-158.
420. van der Velden VH, van der Sluijs-Geling A, Gibson BE, et al. Clinical significance of flow cytometric minimal residual disease detection in pediatric acute myeloid leukemia patients treated according to the DCOG ANLL97/MRC AML12 protocol. *Leukemia* 2010;24(9):1599-1606.
421. Hollink IH, van den Heuvel-Eibrink MM, Arentsen-Peters ST, et al. NUP98/NSD1 characterizes a novel poor prognostic group in acute myeloid leukemia with a distinct HOX gene expression pattern. *Blood* 2011;118(13):3645-3656.
422. Arceci RJ, Meshinchi S, Rosenblat TL, et al. Childhood, adolescent and young adult acute myeloid leukemias. In: Cairo MS, Perkins SL, eds. *Hematological malignancies in children, adolescents and young adults*. Singapore: World Scientific Publishing, 2012:237-266.
423. Quintana J, Advis P, Becker A, et al. Acute myelogenous leukemia in Chile PINDA protocols 87 and 92 results. *Leukemia* 2005;19(12):2143-2146.
424. Perel JM, McCarthy C, Walker O, et al. Clinical significance of development of Philadelphia-chromosome negative clones in patients with chronic myeloid leukemia treated with imatinib mesylate. *Haematologica* 2005;90(Suppl):ECR25.
425. Tomizawa D, Tabuchi K, Kinoshita A, et al. Repetitive cycles of high-dose cytarabine are effective for childhood acute myeloid leukemia: long-term outcome of the children with AML treated on two consecutive trials of Tokyo Children's Cancer Study Group. *Pediatr Blood Cancer* 2007;49(2):127-132.
426. Armendariz H, Barbieri MA, Freigeiro D, et al. Treatment strategy and long-term results in pediatric patients treated in two consecutive AML-GATLA trials. *Leukemia* 2005;19(12):2139-2142.
427. Burnett AK, Hills RK, Green C, et al. The impact on outcome of the addition of all-trans retinoic acid to intensive chemotherapy in younger patients with nonacute promyelocytic acute myeloid leukemia: overall results and results in genotypic subgroups defined by mutations in NPM1, FLT3, and CEBPA. *Blood* 2010;115(5):948-956.
428. Tsukimoto I, Tawa A, Horibe K, et al. Risk-stratified therapy and the intensive use of cytarabine improves the outcome in childhood acute myeloid leukemia: the AML99 trial from the Japanese Childhood AML Cooperative Study Group. *J Clin Oncol* 2009;27(24):4007-4013.
429. Creutzig U, Reinhardt D, Zimmermann M. Prognostic relevance of risk groups in the pediatric AML-BFM trials 93 and 98. *Ann Hematol* 2004;83 (Suppl 1):S112-S116.
430. von Neuhoff C, Sander A, Bradtke J, et al. New aspects for future stratifications in paediatric AML: outcome according to cytogenetics of 386 patients enrolled in study AML-BFM 2004. *Blood (ASH Annual Meeting Abstracts)* 2010;116:Abstract 2741.
431. Creutzig U, Zimmermann M, Dworzak M, et al. Study AML-BFM 2004: improved survival in childhood acute myeloid leukemia without increased toxicity. *ASH (ASH Annual Meeting Abstracts)* 2010;116:Abstract 181.

Chapter 78 Acute Promyelocytic Leukemia

> Table of Contents > Part VII - Hematologic Malignancies > Section 2 - The Acute Leukemias > Chapter 78 - Acute Promyelocytic Leukemia

Chapter 78

Acute Promyelocytic Leukemia

Jeffrey E. Lancet

Peter Maslak

Steven L. Soignet

Acute myelogenous leukemia (AML) is a malignant disorder of the bone marrow where a maturational arrest in blood cell progenitors results in failure of normal hematopoiesis. Acute promyelocytic leukemia (APL) is a subtype of AML with a defined clinical course and a biology that is distinct from the other forms of AML. Morphologically, the most common form of APL can have a characteristic appearance as the bone marrow is effaced by heavily granulated cells with folded, twisted nuclei. Biologically, the cytogenetic changes define the syndrome and the molecular consequences of the chromosomal changes found in APL play a critical role in leukemogenesis. Clinically, patients typically display symptoms

associated with cytopenias. The hemorrhagic complications are, however, often out of proportion to the degree of thrombocytopenia reflecting the underlying biologic properties of the transformed promyelocyte. Historically, recognition of this form of AML as a separate entity was important for the clinician, not because the chemotherapy used as treatment differed substantially from the other subtypes of AML, but because the relative common occurrence of life-threatening coagulopathy mandated special supportive maneuvers including the use of low-dose heparin and aggressive blood product support. Yet, despite prompt diagnosis and attention to potential complications associated with the institution of therapy, peri-induction mortality was often significantly higher than in other forms of AML. Some older series reported a treatment-related death rate approaching 50%.^{1, 2} and ³ Hence, APL became a primary example of the most feared features associated with an acute leukemia: a fulminant disorder that struck primarily young people, had devastating effects on an individual's life, and resulted in death for a large number of patients during the early phases of therapy.

The last two decades have seen a fundamental shift from this paradigm, with APL now recognized as one of the most curable forms of acute leukemia. In part, this change has been accomplished because specific supportive care practices have been developed and refined. The most dramatic events, however, have been the introduction of targeted therapy with all-trans retinoic acid (ATRA) and, subsequently, arsenic trioxide (ATO). Laboratory investigations into the mechanism of the differentiating/apoptotic effects of these agents have led to an understanding of the basic biology of APL, making the disease a model for the development of new therapies with possible applications across the entire field of cancer medicine.

EPIDEMIOLOGY

AML is, in itself, a rare disease. In 2012, approximately 13,780 new cases of AML in the United States will be diagnosed.⁴ There is a moderately higher incidence in males than in females, and the median age is 66 years. APL comprises approximately 7% to 8% of adult AML cases, with a median age of 47 years.⁵ An increased incidence has been reported in Hispanic populations, although some recent reports have disputed this finding.⁶ One group has reported an association with obesity.⁷ Although relatively uncommon in children, clustering of cases in pediatric populations has been described, raising the issue of possible environmental exposure.⁸ APL generally is not preceded by a myelodysplastic syndrome. The disease may, however, result as a consequence of prior therapy (particularly with topoisomerase-II inhibitors) for an unrelated malignancy, with a median interval from primary disorder to APL of approximately 25 months.^{9,10} In such cases, the clinical characteristics are determined by the karyotype, and these patients do as well as individuals who present with de novo disease. This is in marked contrast to other secondary myeloid leukemias that result from exposure to radiation, topoisomerase therapy, or alkylating agents, in which the prognosis is significantly worse.

CLINICAL PRESENTATION

As with any acute leukemia, the symptoms associated with APL may be relatively nonspecific. Most patients complain of fatigue with a significant decrease in their previous level of activity. The manifestations of hemorrhage are often the most dramatic findings in the physical examination. There may be prominent petechiae or extensive ecchymotic involvement of the skin. Visual changes may result from retinal hemorrhages and subconjunctival hemorrhage may follow episodes of coughing or vomiting. Overt hemorrhage from the gums, nose, mouth, or other bodily orifices can occur.

Frank infiltration of extramedullary sites (i.e., skin, central nervous system [CNS], gums) is rare in the newly diagnosed patients, although such findings have been described in patients who relapse following therapy.^{11,12}

LABORATORY ANALYSIS

The clinical laboratory plays an important role in the diagnosis of APL and serves to focus nonspecific complaints and signs toward a hematologic origin. A complete blood count is among the first laboratory tests obtained and is almost always abnormal. Cytopenias, of all three lineages, are the most common findings. The white blood cell count may be elevated in 10% to 30% of patients and has been associated with a morphologic variant of APL (see below).^{3, 13,14,15,16,17} Early recognition of this entity is important as such patients have historically had a higher incidence of peri-induction morbidity/mortality, which may be attenuated with more aggressive management, based upon more recent studies.¹⁸

Quantitative abnormalities mandate that the peripheral smear be reviewed by an experienced morphologist. The peripheral blood often contains heavily granulated cells that are characteristic of the disease, but these are more likely to be found in the bone marrow. Direct examination of the blood smear also serves to verify any abnormalities and avoids spurious values such as thrombocytopenia secondary to platelet clumping. In addition, many of the standard "Coulter counter" instruments that rely solely on changes in electric impedance to generate blood cell differentials are unable to differentiate the heavily granulated promyelocytes from granulocytes, causing a false reading on the machine-generated differential. Some of the newer blood analyzers rely on a combination of light scatter and flow cytochemistry (detecting myeloperoxidase [MPO] content) to differentiate between peripheral blood cell types. The high MPO content of the

abnormal promyelocytes produces a characteristic scatter plot (Fig. 78.1), which can aid in the confirmation of the diagnosis.^{19,20} This finding is particularly useful in identifying patients with the microgranular variant because the cytochemical properties of the cell are unchanged and detected by flow cytometry, whereas the morphology may be problematic.

P.1657

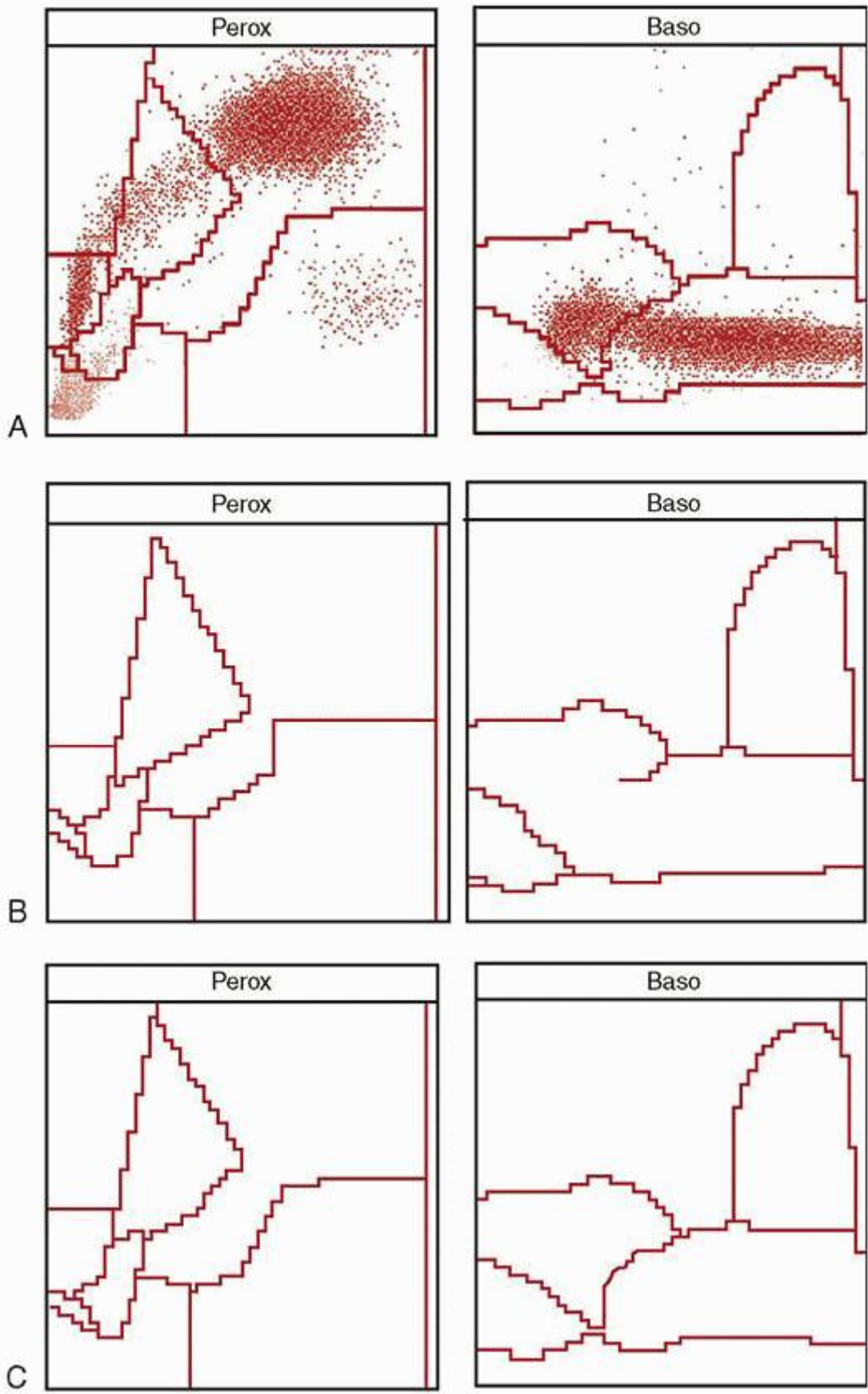

FIGURE 78.1. Representative cytograms from an automated blood analyzer that plots cell volume (y-axis) versus peroxidase (Perox) activity (x-axis) to generate a blood cell differential. A: Normal cytogram shows a cluster of cells in the

upper right of the peroxidase channel (left panel) typical for granulocytes. B: Untreated acute promyelocytic leukemia. The granulocyte cluster is now shifted to the extreme right, reflecting the high myeloperoxidase content of the abnormal promyelocytes. This pattern is characteristic of acute promyelocytic leukemia and is preserved in the microgranular variant. C: Treated acute promyelocytic leukemia. The same patient shown in B approximately 35 days after receiving all-trans retinoic acid, idarubicin, and cytarabine. The normal pattern has been restored. Baso, basophile channel; perox, peroxidase channel.

The other blood tests obtained at the time of diagnosis generally serve to screen for complications that can be associated with the leukemia. Serum electrolyte abnormalities need to be corrected, particularly prior to the institution of cytotoxic chemotherapy.²¹ Adequate renal function is extremely important as aggressive blood product replacement can be anticipated in this disorder and the management of extreme fluid overload may complicate care.

Coagulation Studies

Because the recognition and management of coagulopathy is of the utmost importance in treating patients with APL, the initial laboratory evaluation may include a platelet count, prothrombin time (PT), activated partial thromboplastin time (PTT), D-dimer or fibrin split products, and fibrinogen.²² This disease-related coagulopathy, typically bleeding diathesis, represents a major source of morbidity, and despite the effective antileukemia therapy presently available, it remains the leading cause of peri-induction mortality,^{23, 24} and ²⁵ with early hemorrhagic death rates generally ranging from 5% to 11%.^{23,25, 26} and ²⁷ Although less common than hemorrhage, thrombotic complications have been reported in up to 10% of patients at the time of diagnosis.²⁸ The mechanism underlying the coagulopathy is complex and has been the subject of intensive investigation. Historically, the coagulopathy had been ascribed to disseminated intravascular coagulation (DIC), which resulted as the abnormal promyelocytes lysed and liberated the procoagulant contents of their granules.²⁹ Evidence for DIC as the underlying mechanism has been provided by finding that APL cells release increased levels of tissue factor.^{30, 31} Tissue factor may serve to promote interaction between factor VII and other circulating procoagulants resulting in a widespread generation of thrombin. The coagulopathy can occur in the absence of chemotherapy as the neoplastic cells undergo autolysis, and it is found in approximately 80% of APL patients at the time of diagnosis. The coagulopathy may be exacerbated by the institution of chemotherapy, which results in the massive lysis of abnormal promyelocytes amplifying the already existing activation of the coagulation pathway. Both the PT and PTT are abnormally elevated, and the fibrinogen is low, reflecting an ongoing consumption. In addition, a number of other coagulation parameters such as the thrombin time and the level of fibrin split products are elevated, reflecting widespread disruption of the normal coagulation cascade. It is important to note that a fibrinogen in the low range of normal is still cause for concern given that it is an acute-phase reactant and ordinarily would be elevated in an ill patient. Serial measurements (approximately 6 to 12 hours apart) often reveal the developing hypofibrinogenemia indicative of consumption and help guide replacement therapy with blood products.

More recently, other explanations for the bleeding diathesis have attributed important roles for hyperfibrinolysis as well as nonspecific proteolysis.³² An ongoing unchecked fibrinolytic process will also result in a low fibrinogen producing a clinical picture where hemorrhage is the primary sequela. Evidence for this hypothesis has been provided by the finding that low plasma levels of plasminogen, α 2-plasmin inhibitor, and plasminogenactivator inhibitor 1 are found in fibrinolytic states and are also found in APL. In addition, annexin II, a cell-surface receptor for plasminogen and tissue plasminogen activator, is expressed at abnormally high levels on APL cells but not on blasts from other forms of acute leukemia.^{33,34} The increased expression of annexin II may lead to overproduction of plasmin, which results in dysregulated fibrinolysis. The potential for hemorrhage is further amplified by the depletion of the main inhibitor of plasmin, α 2-plasmin inhibitor, which is consumed in an effort to counter the increased production of plasmin. The clinical manifestations of the coagulopathy are controlled and some of the coagulation parameters progressively improve within days following the institution of therapy with either ATRA or ATO.^{24,33}

Morphology, Cytochemistry, and Immunophenotype

Examination of the bone marrow aspirate and biopsy are the standard tests by which the diagnosis of acute leukemia is made. The morphologic features of the cells in the blood and the bone marrow may be different, underscoring the importance of sampling the bone marrow. The various morphologic subtypes of APL and their defining features are summarized in Table 78.1.^{14,16,17,35,36} Characteristic examples of the morphology are provided in Figure 78.2. In the classic hypergranular variety of APL, the bone marrow aspirate is generally hypercellular and the abnormal promyelocytes constitute the predominant population. Blasts may be increased, but their number alone may not meet the minimal criteria by which classification systems

such as the French-American-British (FAB) and World Health Organization define AML. The malignant promyelocytes need to be considered as part of the total blast count to establish a diagnosis of AML. Malignant promyelocytes may be slightly larger than their normal counterpart. Such cells are heavily granulated: the granules often obscure the nucleus, making the nucleocytoplasmic border somewhat indistinct. In addition, the nucleus may be folded or bilobed. The cytoplasm often contains vacuoles, and distinctive Auer rods are frequently visible. Auer rods are coalesced primary granules and may be abundant. Multiple Auer rods clustered together within a single cell resemble a bundle of sticks or twigs, and such cells have been labeled faggot cells (after the French term for bundle of sticks). Globular cytoplasmic inclusions (pseudo-Chédiak-Higashi inclusions) have also been described. The term flaming promyelocyte has been coined to describe cells that appear to be “breaking apart,” taking on a vibrant reddishpurple hue with the apparent liberation of granules into the surrounding cellular matrix.

TABLE 78.1
MORPHOLOGIC SUBTYPES OF ACUTE PROMYELOCYTIC LEUKEMIA

	Hypergranular (Classic M₃)	Microgranular (M₃V)	Promyelocytic Leukemia Hyperbasophilic	Zinc Finger/Retinoic Acid Receptor-α (M₃r)
Nucleus	Folded, lobulated; granules obscure borders	Irregular, folded	High nucleocytoplasmic ratio	Regular round/ovoid: condensed chromatin pattern; Pelger-like cells
Cytoplasm	Prominent azurophilic granules	Fine small granules; “dusky” appearance	Granules sparse; strongly basophilic; cytoplasmic “budding” noted	Granularity intermediate between M ₃ and M ₂
Auer rods	Frequent; faggot cells	Rare	Not seen	Rare; faggot cells absent

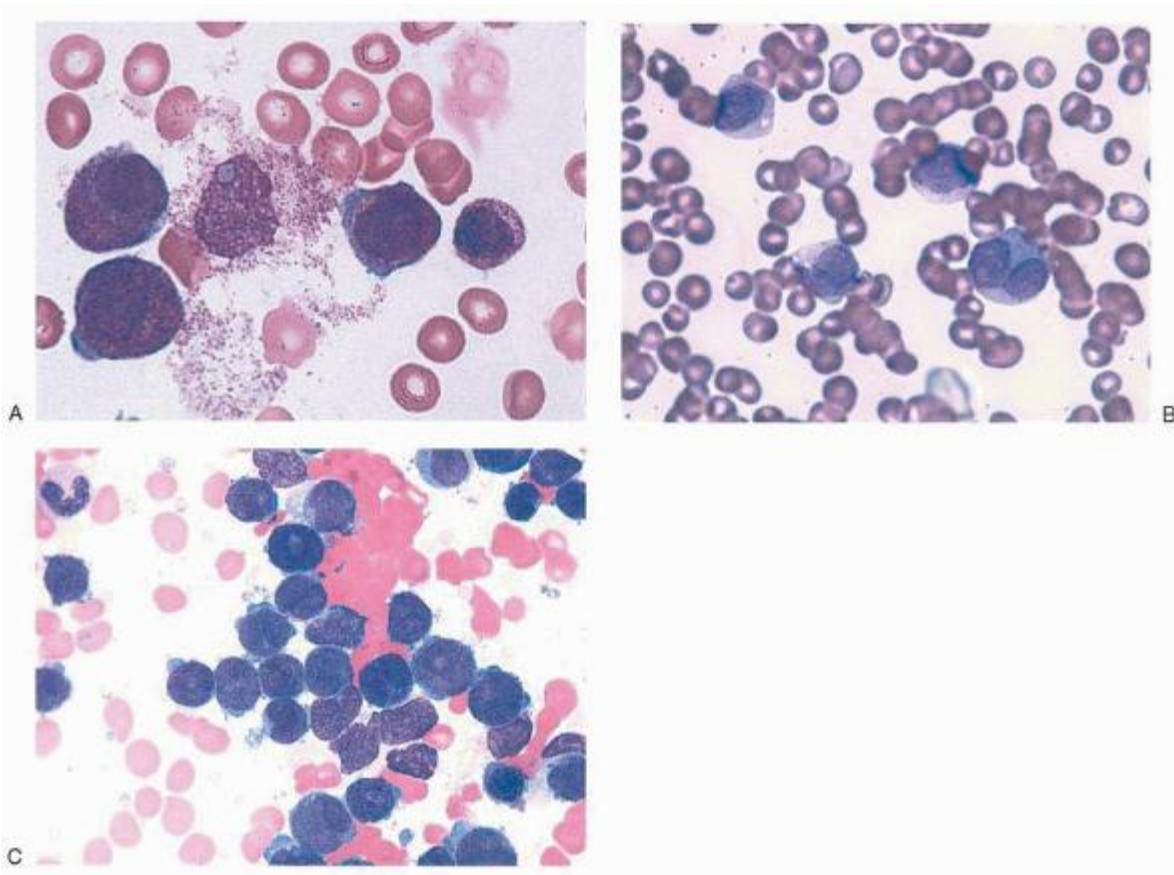

FIGURE 78.2. Morphologic subtypes of acute promyelocytic leukemia. A: “Classic” M₃ is characterized by heavily

granulated promyelocytes with abundant Auer rods. B: Microgranular variant (M_3v) has fine granulation with bilobed folded nucleus. C: Hyperbasophilic variant has few granules, intense basophilia, and small cytoplasmic projections or "buds" reminiscent of micromegakaryocytes (100 \times , MacNeal Tetrachrome).

Identification of the microgranular variant (M_3v) according to the FAB classification system) may be more problematic.^{14,16} This entity generally constitutes about 20% to 30% of APL cases. It was first recognized because it shared some clinical features as well as the typical t(15;17) with the hypergranular form of APL. The granules in the microgranular variant are less prominent, are somewhat dispersed, and may be difficult to visualize using light microscopy. Instead, the granulation may be fine and the cells may appear "dusky" or "hazy." The shape of the nucleus, which has a characteristic bilobed, folded appearance, is often the key in identifying this disorder. Auer rods may be present but are generally less plentiful than the hypergranular variety. Another clue to

P.1659

diagnosis is the finding of a few of the more typical hypergranulated forms in the bone marrow. Although diminished in number, their presence helps distinguish this disorder from leukemias of monocytic origin. The peripheral white blood cell count may be higher than the classic variety, and any hypergranulated promyelocytes are less likely to be found in the peripheral blood. The characteristic cytogram found via flow cytochemistry (Fig. 78.1B) will be preserved in the microgranular variant, providing useful rapid confirmation of the diagnosis before the cytogenetic or molecular results are available.¹⁷

A third morphologic form of APL, the hyperbasophilic variant, has been described.¹⁷ This is a relatively uncommon form of APL that some experts group within the M_3v category. However, the morphologic features are distinct enough to warrant separate consideration. The cells in this disorder have few, if any, granules. Instead, the cytoplasm is deeply basophilic and may be noted to have small blebs, buds, or projections, making the appearance reminiscent of micromegakaryocytes. The nucleus tends to occupy most of the cell and has an irregular lobulated appearance. Both the microgranular and hyperbasophilic variants can be mistaken for an acute monocytic leukemia. A variant form of AML associated with CD56 expression and natural killer (NK) cell lineage has been confused with M_3v but lacks the defining t(15,17) cytogenetic abnormality.³⁷ More recently, a European consensus group has described distinctive morphologic features of APL variants associated with the promyelocytic leukemia zinc finger gene (PLZF)/retinoic acid receptor- α (RAR α) fusion products (see below) and have proposed a new morphologic category, M_3r . These leukemias exhibit cells that lack a folded or bilobed nucleus but instead have a regular round or oval appearance. An increased number of Pelger-like cells reminiscent of those found in a myelodysplastic syndrome can also be seen. Auer rods are generally rare and the cytoplasmic granularity is intermediate between M_3 and M_2 varieties of AML.³⁶

Although not diagnostic for APL, cytochemistry and immunophenotyping may help characterize APL. The cytochemical properties of the abnormal promyelocytes are consistent with a diagnosis of AML.^{14,16,17,35,38} The hypergranular variety stains intensely with Sudan black, MPO, or chloroacetate esterase. The microgranular variant retains this staining pattern, although the degree of positivity may be less intense. As discussed above, the high MPO content of abnormal promyelocytes may be detected in the peripheral blood using modern blood analyzers. Less useful is the observation that nonspecific esterase activity has been noted in some abnormal promyelocytes, further confusing the differentiation between acute monocytic leukemia and some forms of APL.³⁹ These reactions are weaker than those found in monocytes, and some forms of the isoenzymes found in monocytes are absent in the abnormal promyelocytes. Metachromatic staining with toluidine blue has been reported in cases of APL with basophilic differentiation.

Immunophenotyping is also useful in confirming the diagnosis of APL.^{38,40} Promyelocytes are partially differentiated cells that are reflected in the immunophenotype. The cells express the early myeloid marker CD33 but lack human leukocyte antigen (HLA)-DR, a marker often associated with some earlier progenitor cells. It is important to emphasize that this immunophenotypic profile is characteristic but not diagnostic of APL. Up to 20% of other types of AML may express CD33 but not HLA-DR. The marker CD9 is expressed in APL but not in other AML subtypes.⁴¹ Unfortunately, this finding is not clinically useful as few screening panels used for diagnosis contain CD9 as part of the initial workup. The stem cell marker C34 is generally not expressed, whereas the myeloid lineage marker CD13 is occasionally observed and possibly associated with the development of retinoic acid syndrome (RAS).⁴² The T-cell marker CD7 is negative, as are the myelomonocytic markers CD11b and CD14. CD11b is also an indicator of myeloid maturation and, along with CD16, a surface marker found on granulocytes, can be induced with differentiation therapy. The aberrant expression of the T-cell marker CD2 has been correlated with the microgranular variant, as well as a shorter duration of remission.⁴³ Reports of a correlation with the short form of the promyelocytic leukemia (PML)/RAR α fusion transcripts have been mixed.^{44,45,46,47} Expression of the P-

glycoprotein associated with the MDR phenotype is generally not found in APL. The NK marker CD56 has been reported in true APL (as opposed to NK-AML) and has been associated with a poor prognosis.^{48,49}

Differential Diagnosis

As discussed above, the morphologic appearance of APL can be quite striking, given the characteristic appearance of the most common variety, the hypergranular form. The differential diagnosis of APL includes reactive disorders of the bone marrow as well as other subtypes of acute leukemia. Recovery from an insult producing relative aplasia can result in increased myeloid activity with a left shift in the myeloid series. Therapy with the myeloid growth factors, granulocyte colony-stimulating factor or granulocyte-macrophage colony-stimulating factor, can result in a hypercellular bone marrow with prominent toxic granulations. Maturation, however, is preserved, and Auer rods are not found. Other marrow elements such as erythroid and megakaryocytic precursors are present, although the relative number appears somewhat diminished. Chronic myelogenous leukemia may appear with a hypercellular marrow containing a predominant myeloid component that appears heavily granulated. In this disorder, all stages of maturation are present and accompanied by increased eosinophils and/or basophils. Acute myeloid leukemia with maturation (FAB M2) may contain blasts as well as cells that contain too many granules to be considered blasts but are not mature enough to be classified as promyelocytes. Auer rods are also found in this AML subtype, but these usually occur as single structures and not as clusters. Faggot cells are generally not found. Abnormal promyelocytes can be seen, but these cells do not constitute the predominant population in the bone marrow. A monocytic component may be present in <20% of the nonerythroid elements. The microgranular and hyperbasophilic variants may be mistaken for monocytic leukemia because of the deeply staining cytoplasm, lack of granules, and folded convoluted nuclei. Other rare forms of leukemia such as mast cell leukemia or basophilic leukemia may, at first, be confused with APL, but lack characteristic features such as Auer rods and the nuclear folding pattern and present with granules that can be readily distinguished from those of the promyelocyte using conventional histochemical stains.

Cytogenetics and Molecular Biology

Despite the minor variations in phenotype discussed above, APL as a clinical syndrome is defined by its cytogenetics. The balanced translocation between chromosomes 15 and 17 characterizes over 95% of cases of APL.^{50,51} The breakpoints for the translocation usually occur at q22 loci on chromosome 15 and q21 on chromosome 17. The t(15;17) is generally detected by conventional cytogenetic techniques and provides definitive evidence of the diagnosis of APL. The molecular consequence of this translocation results in a fusion of a portion of the gene for the RAR α on chromosome 17 to part of the PML gene on chromosome 15.^{50,52,53} and ⁵⁴ Although the break within the RAR gene is invariable within the second intron of the gene, the point of rearrangement within the PML gene can occur at two major breakpoints, resulting in three isoforms of the transcript. Breakpoints within PML intron 3 (bcr3) generally yield a shorter messenger RNA transcript, whereas breakpoints within intron 6 (bcr1) result in the long form of the transcript.⁴⁶ Breakpoints within intron 6 of PML can also occur at a second site (bcr2) and result in a transcript

P.1660

of variable length. The site of the breakpoint has been reported to have prognostic implications as newly diagnosed patients with the short isoform appear to have a shorter disease-free survival (DFS) and overall survival (OS) compared with the long isoform in some series.^{42,46,55} Other authors have correlated the isoform with various other prognostic factors but discount an independent effect on outcome.⁵⁶ In all cases, the chimeric gene products that result from this translocation have fundamental implications for the cell and are thought to be causative in producing the malignant phenotype. Variations of this translocation exist, and in some instances have profound clinical implications.

Although the t(15;17) is the defining cytogenetic abnormality in APL, other additional chromosomal abnormalities can be found in 30% to 40% of patients with APL.^{57,58} The most common among these are trisomy 8 and isochromosome 17. Additional chromosomal abnormalities do not have a negative impact on the overall prognosis.^{58,59} Complex translocations involving other chromosomes in addition to 15 and 17 can occur. Masked translocations, where pieces of chromosome 15 and 17 are transposed but escape detection by conventional techniques, have been reported.^{60,61} In most of these cases, the molecular abnormality, either the PML-RAR α or the reciprocal RAR α -PML transcript, can be detected. Expression of the fusion gene product ultimately results in the clinical syndrome identified with APL despite the lack of gross chromosomal changes.

Variant translocations also exist and are rare as clinical entities but are instructive in helping define the biology of APL. The most common variants involve translocations between chromosome 17 and either chromosome 5 or 11.^{62,63,64,65} These variant translocations retain the same break within the RAR α intron but differ in the molecular partner gene (X gene),

which may account for some of the differences regarding their functional effects on the cell. The individual variants are summarized in Table 78.2. The structural changes within these genes may affect the normal function of the wildtype product, resulting in the phenotypic abnormality, which is expressed as the leukemia. Most notable among the variants is the t(11;17) (q23q21) because this entity is resistant to the differentiation effects of ATRA. This chromosomal translocation results in a fusion of the RAR gene with PLZF. PLZF is similar to PML in that it has profound implications for the cell with regard to regulation of transcription of target genes resulting in differentiation. However, PLZF is distinctly different from PML in that properties of this gene product interact differently with retinoic acid, rendering it ineffective.⁶⁶ This form of APL also has a poor response to standard chemotherapy, underscoring the multiple differences in biology between these two entities.

TABLE 78.2
ACUTE PROMYELOCYTIC LEUKEMIA: CHROMOSOMAL TRANSLOCATIONS AND FUSION PRODUCTS

Translocation	Frequency (%)	Molecular Fusion Product (X-<i>RARα</i>)	Function “X” Gene	Retinoid Sensitive	Chemotherapy Sensitive
(15;17) (q22,q21)	95	<i>PML-RARα</i>	Transcriptional factor	+	+
(11;17) (q23,q21)	<5	<i>PLZF-RARα</i>	Developmental/differentiation control	-	-
(5;17) (q35,q21)	<1	<i>NPM-RARα</i>	Ribonucleoprotein maturation and transport	+	+
(11;17) (q13,q21)	<1	<i>NuMA-RARα</i>	Structural role in mitosis, apoptosis, and interphase nuclear matrix	±	±
(17;17) (q11,q21)	<1	<i>STAT 5b-RARα</i>	Signal transduction, transcriptional factor	-	?

+, sensitive; -, not sensitive; ±, may be sensitive; *NPM*, nucleophosmin; *NuMA*, nuclear mitotic apparatus; *PLZF*, promyelocytic leukemia zinc finger; *PML*, promyelocytic leukemia; *RARα*, retinoic acid receptor- α ; *STAT 5b*, signal transducer and activator of transcription 5b; “X,” *RARα* partner gene.

In addition to variant chromosome translocations in APL, it has been discovered that APL commonly harbors co-existing mutations that may have biologic and clinical impact. To date, internal tandem duplication (ITD) mutations of the *fms*-like tyrosine kinase 3 (*FLT3*) gene are the most frequent concurrent mutational events in APL, occurring at a frequency of 21% to 32%.^{67,68,69,70} Constitutive activation of the *FLT3* receptor via this mutation is known to confer a proliferative and survival advantage to AML blasts.^{71,72} In non-M3 AML, this mutation occurs at a similar frequency and is generally associated with worse DFS and OS than occurs in *FLT3*-ITD wildtype AML.^{74,75} The adverse effect of this mutation in APL is less clear, with most series suggesting that the mere presence of an *FLT3*-ITD mutation does not independently affect survival, although it does associate with other known adverse factors, such as elevated WBC. However, quantitatively higher expression levels of *FLT3*-ITD and longer transcript length may have a negative impact on DFS.^{68,70} Given the recent influx of clinically available pharmacologic inhibitors of *FLT3*, such inhibitors may eventually become incorporated into standard therapy for selected patients with APL whose disease harbors a *FLT3* mutation.

Based on experimental data generated in cell lines, transgenic mice, and correlations with clinical treatment data, a model for leukemogenesis in APL has been developed (Fig. 78.3).^{73,74,75,76,77} On the most basic level, this hypothesis states that APL results from transcriptional dysregulation of differentiation produced by the *PML-RARα* gene product. In the normal cell, *RARα* plays an important role in modulating myeloid differentiation by virtue of its ability to recruit various nuclear co-repressors such as SMRT/N-CoR and mSin3. These transcription co-repressors, in turn, bind various histone deacetylases, affecting chromatin conformation and resulting in repression of transcription of target genes fundamental to the differentiation process. Under physiologic conditions, binding of retinoic acid causes dissociation of the co-repressor complex, recruits transcriptional activators, and “opens” the chromatin, facilitating the transcription of the various target genes and allowing normal maturation. The *PML-RARα* fusion protein has an increased affinity for the N-

CoR co-repressor complex such that physiologic doses of RA $<(10^{-8} \text{ M})$ fail to produce a dissociation of the complex, resulting in continued transcriptional repression and a maturational block. Instead, supraphysiologic doses achieved by the administration of ATRA are required to recapitulate the behavior of the wildtype receptor. In the PLZF-RAR α variant, there is a second binding site for the co-repressor proteins within the PLZF portion of the fusion protein

P.1661

that is not sensitive to retinoic acid. Hence, even supraphysiologic doses are unable to free the co-repressor complex and permit the conformational changes in the histones necessary for permitting differentiation to occur. This may be an explanation for the clinical resistance of t(11;17) to ATRA and has led investigators to explore compounds such as histone deacetylase inhibitors that bypass co-repressor binding as defined by the activity of RARs and directly effect transcriptional activation.

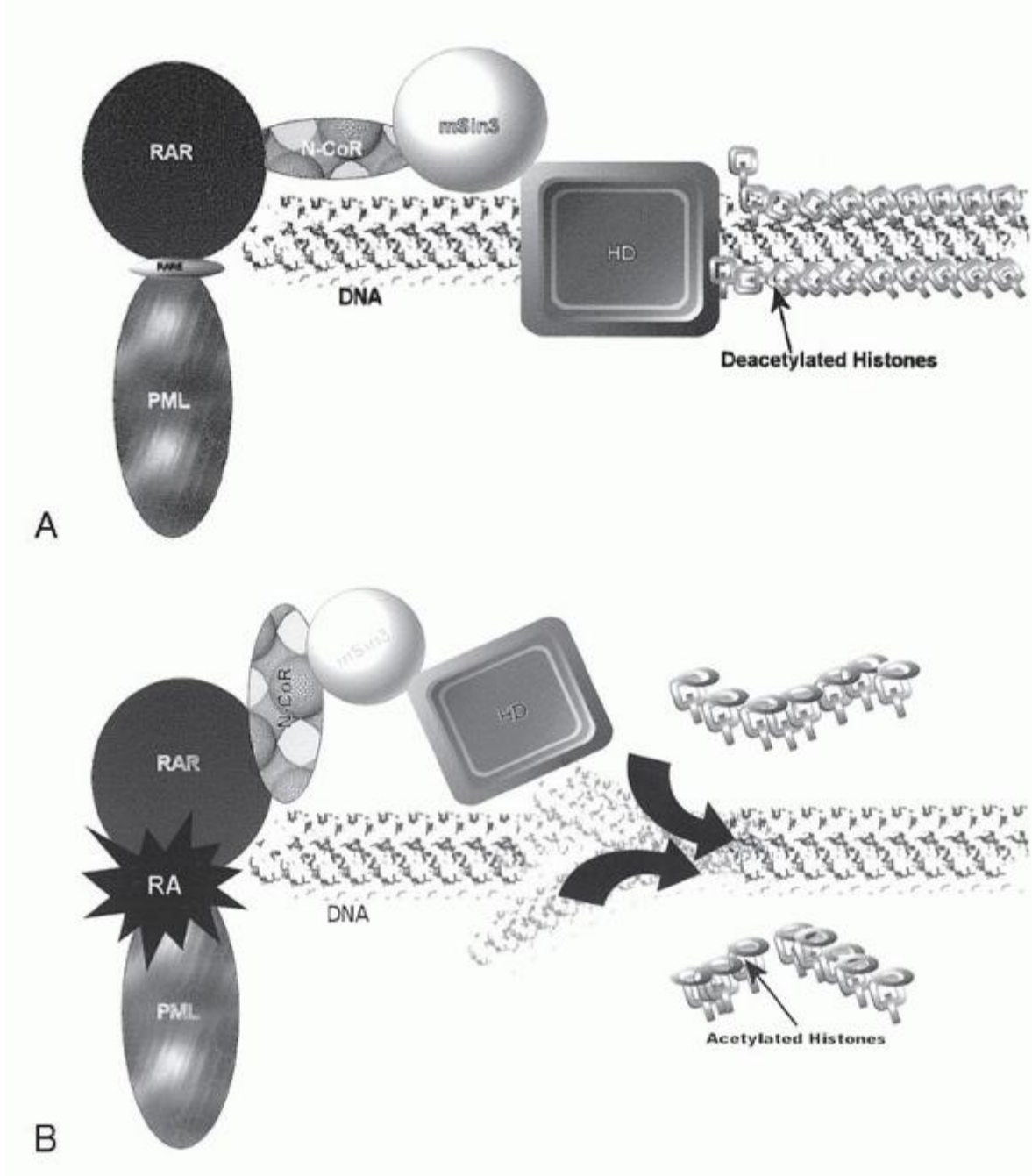

FIGURE 78.3. Model of transcriptional dysregulation in acute promyelocytic leukemia. A: Aberrant retinoic acid receptor- α

(RAR α)/promyelocytic leukemia (PML) fusion product recruits histone deacetylase complex (N-CoR/mSin3/HD), resulting in widespread histone deacetylation, which, in turn, effectively blocks the transcription of downstream genes critical for myeloid maturation. B: Binding of pharmacologic doses of retinoic acid (RA) causes a dissociation of the co-repressor complex, resulting in histone acetylation and providing an "open" conformation to the chromatin, which facilitates transcription of downstream target genes, resulting in myeloid maturation. HD, histone deacetylase(s).

Although the model of transcriptional repression through chromatin remodeling may rest on the interaction of the aberrant RAR α fusion protein with key regulatory genetic elements, the primary partners in the molecular fusion proteins, namely PML and PLZF, are important in leukemogenesis and may also serve to amplify dysregulation of transcription.^{66,73} PML does not directly bind DNA but has been found to regulate transcription through interaction with a number of transcription factors and repressors.^{78,79,80} In the normal cell, PML is localized in discrete subnuclear structures called PML oncogenic domains or PML nuclear bodies (PNBs). These PNBs may functionally regulate transcription by either binding various transcription activators/repressors or sequestering them from circulating in the nucleoplasm, thereby preventing any interaction with other regulatory elements, or by providing an environment where the various regulatory factors can interact or be modified. This function, in turn, may affect fundamental cellular processes such as growth, senescence, and apoptosis. PML-RAR disrupts the organization and function of the PNBs and displaces PML, forming a microspeckled pattern in the nucleus. Treatment with RA causes the PNBs to reorganize and presumably restores not only the structure, but also the functional activity.

Less is known regarding the function of PLZF. It also modulates transcriptional repression through multiple interactions with SMRT/N-CoR/mSin3/HDAC complexes and may localize in structures similar to the PNBs. Some of the mediators with which PLZF interacts are insensitive to modulation by RA, and these properties are retained in the PLZF-RAR fusion product, resulting in clinical ATRA resistance.

In addition to providing an understanding of the underlying biology of leukemia with possible application to cancer as a whole, the molecular genetics of APL also provide a useful tool for the clinician in confirming the diagnosis and planning therapy. As discussed above, the vast majority of APL is characterized by the t(15;17), resulting in a PML-RAR fusion product. These genetic changes are specific for APL and, using the modern molecular technique, reverse transcriptase-polymerase chain reaction (RT-PCR), are easily detectable.^{81,82,83} RT-PCR has become a standard tool in the management of APL. It is now readily available in commercial laboratories, and there is usually a rapid turnaround time. RT-PCR is useful in confirming the diagnosis of APL, particularly in cases where morphology is problematic. In addition, this unique molecular "signature" can be used to monitor response and test for minimal residual disease (MRD).^{55,81,82,83,84,85,86} This ability to have an effective method for detecting MRD is in sharp contrast to the other forms of AML, where response is assessed primarily through morphologic examination of the bone marrow and blood. Therefore, in APL, the concept of remission can be redefined to include a molecular response. Molecular relapse can be detected before it is clinically apparent, and this information can be used to guide therapy. An effective treatment regimen will render the RT-PCR assay for PML-RAR negative. The conversion from a negative result to positive that is reproducible on two sequential assays is predictive of clinical relapse. Some groups have reported highly successful results treating the disease in molecular relapse prior to the occurrence of the full-blown clinical syndrome.⁸⁷ This has led to the standard recommendation that patients with APL be serially monitored via RT-PCR for PML-RAR every 3 months during the first 2 years after remission is achieved, when the risk of relapse is the greatest.⁵⁵ It is important to note, however, that there are different forms of PCR analysis with different sensitivities, and the clinical results have only been validated with RT-PCR assays having relatively low sensitivities. More recently, the low relapse rate following modern treatment regimens has caused some investigators to question the need for a monitoring strategy, instead reserving such strict monitoring to those defined as having poor-risk disease. The role of real-time quantitative PCR (RQ-PCR) as part of any monitoring strategy has yet to be defined and is currently under investigation.

THERAPY OF ACUTE PROMYELOCYTIC LEUKEMIA

General Principles of Management

Although therapy for APL is highly successful, early death remains an important problem, accounting for at least 50% of the total 3-year mortality rates in this disease, a figure that has not changed substantively over the past 15 to 20 years.⁸⁸ As mentioned earlier, the primary early life-threatening complication of APL is hemorrhage.^{23, 24} and ²⁵ Hence, successful management of the patient with APL includes first recognizing the disorder (Table 78.3), and then anticipating the known complications and instituting therapy early enough to limit toxicity, the main challenge being effective support of the patient through the 3 to 5 weeks necessary to achieve remission.

Stabilizing the patient requires interpretation of the history, clinical presentation, and initial laboratory data to correctly diagnose the underlying condition as APL. Many patients present to medical attention with fever, and inasmuch as infection in the setting of neutropenia can be rapidly fatal, empiric antibiotics

P.1662

are promptly started following an initial attempt at identifying a source of infection.⁸⁹ This empiric antibiotic coverage can be altered based on the sensitivities of any organism isolated from the various cultures. Continued fever despite broad-spectrum antibiotics may require empiric therapy with an antifungal such as an azole, amphotericin preparation, or an echinocandin.

TABLE 78.3 KEY STEPS IN DIAGNOSING ACUTE PROMYELOCYTIC LEUKEMIA

Test	Turnover Time
Examine the peripheral blood smear	Minutes to hours
<ul style="list-style-type: none"> • WBC count often low • Thrombocytopenia often present • High peroxidase channel on automated flow cytochemistry (i.e., ADVIA) • <i>Pitfall</i>: Few white cells in the peripheral smear; characteristic cells may not be present 	
Determine morphologic appearance of the bone marrow	Hours to days
<ul style="list-style-type: none"> • Hypercellular aspirate • Most common form: Hypergranulated promyelocytes • Auer rods present and abundant • <i>Pitfalls</i>: Morphologic variants can be confused with monocytic leukemia; hypergranulated forms confused with AML with maturation (FAB M₂) 	
Demonstrate characteristic karyotype/molecular abnormality	
• FISH for <i>PML/RARα</i>	Day
• RT-PCR for <i>PML/RARα</i>	Days
• Karyotype for t(15;17)	Days to weeks
• <i>Pitfalls</i> : Only karyotype may detect cytogenetic variants	

AML, acute myelogenous leukemia; FAB, French-American-British; FISH, fluorescence in situ hybridization; *PML*, promyelocytic leukemia; *RARα*, retinoic acid receptor- α ; RT-PCR, reverse transcriptase-polymerase chain reaction; WBC, white blood cell.

Approximately 80% of patients with APL present with coagulopathy in addition to thrombocytopenia. As discussed above, laboratory tests useful as indicators of coagulopathy include the platelet count, PT, PTT, and fibrinogen levels. Other coagulation parameters such as thrombin time, the ethanol gelation test, and the protamine sulfate test may also be obtained, but add little to the clinical decision making in addition to confirming the presence of a coagulopathy. An increased risk of hemorrhage has been associated with elevated WBC, hypofibrinogenemia, and elevated serum creatinine, but not platelet count.^{22,90,91}

Although definitive management of this coagulopathy requires treating the underlying leukemia, the initial therapy for the coagulopathy, prior to the onset of the stabilizing effect seen with the retinoid, is primarily supportive and based on aggressive platelet and blood product support. Frequent monitoring is the cornerstone of this management strategy. Intervention may be based on a worsening trend in a laboratory value such as the fibrinogen level. Platelets may be transfused multiple times a day to maintain a platelet count above $50 \times 10^9/L$ and cryoprecipitate or fresh frozen plasma

(FFP) should be administered to maintain fibrinogen levels above 100 mg/dl.²² Failure to achieve thresholds of platelets above $30 \times 10^9/L$ and fibrinogen above 150 mg/dl may increase the risk of hemorrhagic events.⁹¹

The use of low-dose heparin as management of coagulopathy in APL is controversial, never having been addressed in a prospective randomized trial. Although the rationale for such a strategy was, at best, unclear, some early studies reported a decreased rate of morbidity/mortality when heparin was used prophylactically when compared with historical controls with no heparin.⁹² However, in a retrospective analysis of the larger GIMEMA series, no differences in early hemorrhagic death were observed between patients receiving low-dose heparin, antifibrinolytic therapy, or supportive care.⁹⁰ In addition, the introduction of retinoic acid has changed the clinical scenario because this therapy does not cause an immediate, massive cell lysis and does not worsen the coagulopathy. Instead, the clinical coagulopathy typically abates after about 5 to 8 days of therapy, perhaps rendering further study and discussion of prophylactic low-dose anticoagulation irrelevant.

Despite aggressive blood product support and the early administration of either ATRA or arsenic, patients can and do experience catastrophic hemorrhage or thrombosis. In these instances, it may be appropriate after discussion with the patient's health care proxy to institute life support measures in an effort to stabilize the patient while continuing to administer the leukemia therapy. Hemorrhage in the lung may require mechanical ventilation to support the airways, whereas a limited CNS hemorrhage may require measures to reduce intracranial pressure. The use of the antifibrinolytic ϵ -aminocaproic acid has been advocated by some for use with CNS bleeding to inhibit fibrinolysis and help stabilize any clot formation.⁹³ Underlying such heroic measures is the recognition that APL is ultimately a curable disease in the modern era. Primary resistance to either ATRA or ATO is rare, and most of the patients who fail these therapies do so because they are unable to be supported through the acute phases of the illness.

Assessment of Response

The traditional therapy for AML has relied on the strategy of using cytotoxic chemotherapy to induce bone marrow aplasia and clear the bone marrow of the malignant clone, allowing subsequent regrowth of normal progenitor cells with the restoration of normal hematopoiesis. A standard method for assessing whether aplasia has been achieved is to perform a bone marrow examination on approximately day 14 of therapy. The finding of persistent blasts on this day 14 bone marrow may prompt re-treatment with a second course of induction therapy.

This paradigm does not apply to APL. The day 14 bone marrow following the initial course of induction chemotherapy may reveal persistent abnormal promyelocytes, yet the patients are able to achieve remission at week 4 or 5 without further chemotherapy.⁹⁴ Therefore, the finding of these abnormal promyelocytes should not automatically trigger a second course of chemotherapy. The pattern of response of APL to standard induction therapy is atypical and once again underscores that this disease is biologically distinct from other forms of AML. Some have interpreted these findings to mean that standard chemotherapy has a differentiating effect on the abnormal promyelocytes, whereas still others have cited a differential effect of cytotoxic therapy on the replicating abnormal progenitors with relative sparing of the quiescent, partially differentiated promyelocytes.

The introduction of ATRA and ATO as agents that accomplish remission by inducing differentiation/apoptosis have further modified the ways in which response is determined. The standard definitions of complete remission (CR) established by National Cancer Institute consensus criteria still remain useful.⁹⁵ With the widespread availability of RT-PCR, the definition of CR has been further refined to include molecular remission. Often, the first sign that a patient is responding to therapy is the resolution of the coagulopathy with progressive improvement in the various coagulation parameters.⁹⁶ The transfusion requirements for platelets may decrease and FFP may no longer be needed to maintain the fibrinogen level. Leukocytosis, which can occur with either ATRA or ATO, may represent evidence of a biologic response of the abnormal clone to therapy. Peripheral blood leukocytes undergo progressive morphologic changes, which include

P.1663

nuclear condensation and lobulation accompanied by cytoplasmic vacuolization (Fig. 78.4).⁹⁶ Granulocytic forms with persistent azurophilic granules may appear and have been labeled "intermediate" cells as they retain features of promyelocytes but display some morphologic characteristics of neutrophils.⁹⁷ These cells may also display an intermediate immunophenotype with the co-expression of CD33, a marker associated with immature myeloid cells, and CD16 or CD11b cell-surface markers, which are found on granulocytes and maturing myeloid elements.⁸⁴ Various sources have also described the occurrence of polymorphonuclear leukocytes with Auer rods, another anomalous finding resulting from differentiation of the abnormal clone. Techniques such as fluorescence in situ hybridization and premature chromosomal

condensation have been used to verify that morphologically maturing cells are derived from the original malignant clone.⁹⁸

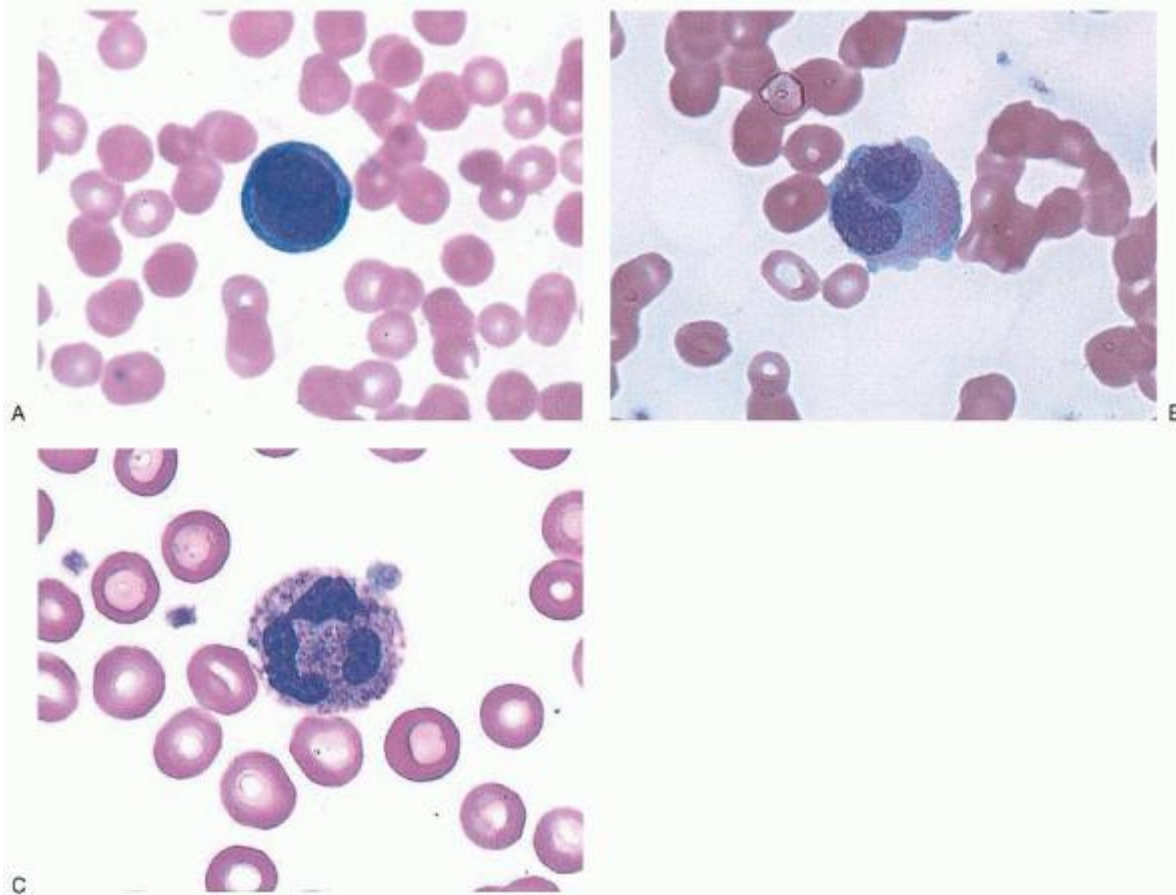

FIGURE 78.4. Morphologic progression during all-trans retinoic acid (ATRA) therapy. A: Abnormal promyelocyte in the peripheral blood prior to therapy. This patient has a hyperbasophilic variant; cells are deeply basophilic with a folded nucleus. B: Approximately day 14 of ATRA therapy; intermediate cells pictured. These cells share characteristics of the abnormal promyelocytes and the mature granulocytes. The nucleus is starting to become lobulated. The cytoplasm has lightened and specific granules have started to appear. C: Approximately day 30 of ATRA therapy. Most circulating myeloid cells largely resemble mature granulocytes. Some minor differences may persist, however.

Although there may be a variety of clinical and morphologic changes that occur with therapy, the process of achieving CR is gradual. After about 4 to 6 weeks of treatment, the standard definition of CR should apply: adequate cellularity as determined by bone marrow biopsy and normal maturation of all cell lines with <5% blasts. No cells with Auer rods should be visualized. Restoration of normal hematopoiesis should be evidenced by a peripheral blood neutrophil count $\geq 1.5 \times 10^9/L$, and the platelet count should be $>100 \times 10^9/L$. In order to meet criteria for CR, these findings should be present for at least 4 weeks.⁹⁵

Despite fulfilling the morphologic criteria for CR, approximately 85% to 90% of patients treated with ATRA alone and 15% to 25% of relapsed patients treated with ATO alone still have molecular evidence of disease as detected by RT-PCR.^{55,99,100,101} The addition of chemotherapy to ATRA increases the proportion of patients who become negative for molecular evidence of the disease.^{102,103} Repeated cycles of ATO may be needed to achieve this molecular remission.¹⁰¹ Given the relative importance of the RT-PCR assay results, some experts have recommended that the bone marrow be sampled and examined for both morphologic and molecular evidence of remission at least every 3 months for the first 2 years post-remission.⁵⁵ More recently, RT-PCR of the peripheral blood has been substituted for the bone-marrow-based assay, but such a practice has yet to be clinically validated. Patients whose RT-PCR result converts from a negative to positive should have the bone marrow examination repeated within 1 month to verify this result. Patients tend to relapse within 6 months of completing therapy, so it may be important to continue monitoring during this critical time. Despite

relatively intensive molecular monitoring, some patients relapse with overt clinical disease, raising questions regarding the predictive nature of the test as well as the sensitivity and the standardization of the assay.^{104,105}

Current Therapy

Although APL was recognized as a distinct subtype of AML in 1957¹⁰⁶ until the early 1990s this disease was managed with standard therapy used for all subtypes of AML, consisting of a combination of an anthracycline and cytosine arabinoside. Using this approach, investigators reported CR rates in the 50% to 60% range, but with improvement in the management of infections and the APL-related coagulopathy, CR rates increased to as high

P.1664

as 80%.^{90,107,108} The likely reasons for failure of this treatment included mortality related to sepsis, catastrophic hemorrhage, or, less frequently, primary drug resistance.^{109,110} However, despite this high CR rate, long-term DFS in patients with APL was approximately 30% to 40%.^{3,111,112} Subsequently, the incorporation of ATRA as part of induction therapy in newly diagnosed APL and the use of ATO in relapsed disease have markedly improved the outcome of patients with this disease. See Table 78.4 for representative therapies for APL. A randomized trial has shown that ATO consolidation therapy improves survival in newly diagnosed patients with APL.¹¹³

Chemotherapy

Anthracyclines are one of the most important cytotoxic agents used in treating all subtypes of AML. Several studies have specifically demonstrated the sensitivity of APL to this class of agents.^{3,112} However, whether there is a clinical advantage of one anthracycline compared to another remains controversial. Prospective randomized trials have not convincingly or consistently shown an advantage of either daunorubicin or idarubicin in the treatment of AML,^{114,115} and specifically, no prospective randomized trial has compared these agents in the treatment of APL. Currently, both daunorubicin and idarubicin are used in clinical practice for treatment of APL.

TABLE 78.4
REPRESENTATIVE THERAPIES IN NEWLY DIAGNOSED ACUTE PROMYELOCYTIC LEUKEMIA

Study	Primary Therapy	N	CR	EFS or DFS	Relapse Rate
Marty et al. ¹¹² 1984	Daunorubicin	83	64%		
Avvisati et al. ¹¹⁶ 1990	Idarubicin	131	76%		
Warrell et al. ¹²⁷ 1994	ATRA followed by chemotherapy	49	85%		
Sanz et al. ¹¹⁹ 1999	Idarubicin and ATRA (elimination of cytarabine)	123	89%	2-y DFS	92% ± 3%
Avvisati et al. ¹³³ 2011	Idarubicin and ATRA (elimination of cytarabine)	82	89%	12-y EFS	69%
Tallman et al. ²⁷ 1997 (randomized)	ATRA followed by chemotherapy	172	72%	3-y DFS	
	vs. chemotherapy	—	—	67%	
		174	69%	—	
			(NS)	32%	
				(<i>p</i> < 0.001)	
Burnett et al. ¹⁴⁹ 1999 (randomized)	ATRA × 5 d followed by chemotherapy	119	70%	DFS	
	vs.	—	—	—	36%

	ATRA daily until CR + chemotherapy	12087%	72%	20%
		($p < 0.001$)	($p = 0.07$)	($p = 0.04$)
Ades et al. ¹³⁰ 2010 (randomized)	ATRA followed by chemotherapy		10-y EFS	10-y CIR
		12293%	64%	22%
	vs.	— —	—	—
	ATRA + chemotherapy	18496%	76%	13%
		(NS)	($p = 0.019$)	($p = 0.087$)
Powell et al. ¹¹³ 2010 (randomized)	ATRA + chemotherapy		3-y EFS	
		237	63%	
	vs.	— —	—	—
	ATRA + chemotherapy followed by ATO consolidation	244	80%	
			$p < 0.0001$	

ATRA, all-*trans* retinoic acid; ATO, arsenic trioxide; CR, complete remission; DFS, disease-free survival; EFS, event-free survival.

Although cytosine arabinoside is the backbone of treatment for AML in general, the importance of this drug in the treatment of APL specifically remains indistinct. In APL patients, monotherapy using either daunorubicin or idarubicin achieves a CR rate in the 55% to 88% range.^{112,116,117} A retrospective analysis of 62 patients with APL treated with either single-agent daunorubicin or in combination with cytosine arabinoside for induction therapy showed no difference in CR rates.¹¹⁷ Similarly, in a randomized Italian Cooperative Group (GIMEMA) prospective study in untreated APL patients comparing idarubicin to the combination of idarubicin plus cytosine arabinoside, no difference in CR rate or event-free survival (EFS) was observed.¹¹⁶ Longer term follow-up of this GIMEMA study revealed that EFS at 7 years was superior in the idarubicin-only arm.¹¹⁸ Considering the exquisite sensitivity of APL to anthracyclines, dose-intense single-agent anthracycline, particularly idarubicin, may be more beneficial than and a less toxic alternative to standard combination therapy as suggested by a study¹¹⁹ conducted by the Spanish Programa para el Tratamiento de Hemopatias Malignas (PETHEMA) group.

All-Trans Retinoic-Based Strategies

The introduction of ATRA into the treatment strategy of APL fundamentally changed the management and outcome of this disease. The first series of patients treated with ATRA was reported

P.1665

by Huang et al. in 1987.¹²⁰ By the mid-1990s more than 3,000 APL patients worldwide had been treated with ATRA, with published data showing a median CR response >85%.^{96,98,120,121,122} Although doses of ATRA up to 100 mg/m² have been used in various studies, no particular dose-effect correlation has emerged. Most clinical experience has been obtained with a dose of 45 mg/m²/day administered as a single daily dose or in two equally divided doses and given approximately 12 hours apart. In a multicenter study conducted in APL patients by Castaigne et al.¹²³ a dose of 25 mg/m²/day of ATRA revealed similar results in terms of CR rates and pharmacokinetic parameters compared to ATRA at 45 mg/m²/day. The incidence of hyperleukocytosis and RAS, however, was also the same. In contrast, a small study conducted at the Shanghai Institute of Hematology reported achieving a clinical CR in 24 of 26 (92%) newly diagnosed APL patients with daily oral ATRA of 15 to 20 mg/m²/day with no reported events of RAS.¹²⁴ However, no prospective randomized trials have been conducted to establish the long-term therapeutic effects of a lower dose of ATRA, and therefore doses <45 mg/m²/day should not be used routinely as standard of care.

The clinical response to ATRA is correlated with the presence of the 15;17 chromosomal translocation assessed by conventional cytogenetics or by RT-PCR.^{81,82,85} This translocation involves the molecular rearrangement of RAR α , which appears to be the link to the clinical responsiveness to ATRA. Some patients with equivocal cellular morphology and normal karyotypes have shown typical rearrangements of RAR α by molecular testing, and these patients are clinically responsive to ATRA.^{81,83} However, patients who are negative by RT-PCR for PML/RAR α and/or do not exhibit the karyotypic t(15;17) do not respond to ATRA.^{63,81} Therefore, it is critical to note that patients with acute leukemia with cytogenetic or molecular findings other than the common t(15;17) or PML/RAR α that is distinctly found in APL, respectively, do not respond to ATRA and should be immediately treated with standard antileukemic therapy.

In the initial phase II studies with ATRA in APL, two important clinical observations became evident. The first was that up to one half of the patients developed what is now known as RAS, which in the preliminary experience often proved to be fatal. Gradually, a number of treatment strategies emerged that improved the associated morbidity/mortality of this syndrome. Currently, as the result of vigilant monitoring and the initiation of high-dose dexamethasone with the first presenting sign or symptom (discussed below), few patients die as a result of RAS. The second observation was that remissions induced and maintained solely by ATRA are brief in duration, with few patients remaining in remission >1 year.^{125,126,127} Subsequently, both randomized^{27,121} and nonrandomized^{127,128} studies revealed that by combining standard induction therapy (anthracycline based) with ATRA, followed by consolidation treatments, remissions were not only durable, but also superior to those achieved by chemotherapy alone.

In the initial trials incorporating ATRA in the treatment of APL, the drug was given as a single agent until CR was achieved; then patients were consolidated with chemotherapy. However, the optimal schedule and duration of ATRA therapy needed to be determined for best clinical outcome. In the U.S. Intergroup Study,²⁷ 346 newly diagnosed APL patients were randomized to receive either ATRA or daunorubicin plus cytosine arabinoside for remission induction. Patients who obtained a CR received two cycles of consolidation chemotherapy. Patients who remained in remission after completing consolidation therapy were randomized to either observation only or maintenance treatment with ATRA. Therefore, the majority of patients on this trial received ATRA, either as induction therapy, maintenance, or both. There was no significant difference in the CR rate between the ATRA (72%) and chemotherapy (69%) induction groups, however, the 3-year DFS was statistically improved in the ATRA-treated patients compared to those treated with standard antileukemic therapy (72% vs. 32%, $P < 0.001$). This trial clearly showed the benefit of ATRA in the management of APL, particularly when ATRA was incorporated in the induction therapy. The group of patients who received no ATRA had a 3-year DFS of only 18%, which was consistent with the historical survival rate of APL patients.

The European APL group addressed the issue of scheduling of the ATRA/chemotherapy by prospectively randomizing 413 untreated APL patients between concurrent ATRA plus chemotherapy (daunorubicin and cytosine arabinoside) and sequential ATRA followed by the same chemotherapy. Following one to two courses of consolidation, patients were then randomized to receive either 2 years of maintenance chemotherapy consisting of ATRA alone, methotrexate plus 6-mercaptopurine (6-MP), ATRA plus methotrexate and 6-MP, or no maintenance chemotherapy (observation only).¹²⁹ The proportion of patients achieving a CR in these two induction groups was no different, with an overall CR rate of 92%. However, the EFS at 2 years was estimated at 84% in the concurrent ATRA plus chemotherapy group versus 77% in the ATRA followed by chemotherapy group ($P = 0.1$). Longer term follow-up from this trial confirmed statistically significant superior EFS and cumulative incidence of relapse (CIR) at 10 years in the patients assigned to concurrent ATRA plus chemotherapy.¹³⁰ One possible advantage from the concurrent ATRA plus chemotherapy treatment approach appears to be a significant (approximately 50%) reduction in the incidence of the potentially fatal RAS.^{131,132}

Other groups have advocated for anthracycline dose intensity during ATRA-based induction therapy. Both the GIMEMA group and the Spanish Cooperative Group (PETHEMA) have completed trials in APL utilizing induction therapy with daily ATRA plus idarubicin on days 2, 4, 6, and 8.^{119,133} Although these trials differed in their consolidation (with respect to use of cytarabine) and maintenance regimens, both demonstrated impressively high CR rates (>90%) and long-term DFS rates of >70% beyond 5 years. Using this same regimen, the GIMEMA group also reported a CR rate of 96% ($n = 107$) in children (younger than 18 years old) with untreated APL, resulting in an OS and EFS of 89% and 76%, respectively, with more than 10 years of follow-up.¹³⁴ Hence, dose-intensive anthracycline chemotherapy (without cytarabine) in combination with ATRA during induction results in highly successful outcomes that are comparable with regimens that incorporate cytarabine into induction.

The French-Belgian-Swiss APL 2000 study in non-high-risk APL compared outcomes between patients assigned to induction therapy consisting of daunorubicin plus ATRA versus daunorubicin plus cytarabine plus ATRA, followed by consolidation that included high-dose cytarabine in the patients assigned to the cytarabine arm during induction.¹⁰² In this trial, both DFS and OS were superior in the cytarabine-treated patients. A lower cumulative dose of anthracycline in this

trial than in the GIMEMA and PETHEMA trials was postulated as an explanation for the superiority in the cytarabine arm. In addition, it was not clear whether the use of high-dose cytarabine during consolidation in the patients randomized to cytarabine induction could have been responsible for better outcomes. In an attempt to address these questions, a joint analysis of the LPA 99 (PETHEMA) and APL 2000 (French-Belgian-Swiss) trials was performed.¹³⁵ This analysis revealed that the DFS and OS benefits of cytarabine during induction were limited to patients with high-risk disease ($WBC \geq 10 \times 10^9/L$) at diagnosis. Based upon the available data to date, then, inclusion of cytarabine within induction and consolidation regimens for patients with high-risk APL appears justified, recognizing the limitations of direct comparisons between trials.

Duration of All-Trans Retinoic Acid

Currently, ATRA is recommended as part of the induction regimen and as maintenance therapy, which is initiated after P.1666

the completion of consolidation chemotherapy. There is no benefit to continuous treatment with oral ATRA once patients have achieved a CR. Generally, patients who relapse while taking ATRA, or shortly after discontinuing ATRA, fail to respond to further treatment with standard-dose or high-dose ATRA therapy.^{120,127} It would be particularly unusual for patients with a molecular diagnosis of APL who are retinoid-naïve to be resistant to ATRA. Given the limited duration of remission with ATRA as a single oral agent, acquired resistance to ATRA could theoretically result from genetic or epigenetic events.¹³⁶ Acquired resistance in HL-60, a retinoid-sensitive leukemic cell line, has been associated with point mutations in the RAR α fusion gene.^{137,138} Initial analysis from clinical specimens collected from patients prior to treatment with ATRA and at the time of relapse did not reveal additional mutations in PML/RAR- α .¹³⁹ More recently, mutations in the high-affinity ATRA binding site of clinical specimens have been identified,¹⁴⁰ with an incidence of up to 40% in the relapsed setting following ATRA-based therapy.^{141,142} Interestingly, proximate ATRA selection pressure is not thought to be the sole or main determinant for the emergence of dominant PML-RAR α mutant subclones, and these subclones are predisposed to further mutations that result in a survival advantage.¹⁴²

It appears that multiple mechanisms are likely involved in the development of resistance. Continuous daily treatment with ATRA is associated with a marked decrease in plasma drug concentrations occurring as early as 1 to 2 weeks of initiation of therapy.¹⁴³ The mechanisms by which this occurs include induction of cytochrome P450 catabolic enzymes, increased expression of oxidative co-factors, and/or up-regulation of cellular retinoic acid binding proteins.^{143,144} These biologic mechanisms function cooperatively to modulate intracellular retinoid concentrations. Therefore, it is conceivable that prolonged administration of ATRA could result in the development of clinical resistance due to an inability to sustain effective concentrations in vivo that would be required to achieve cytodifferentiation.

Post-remission Consolidation Therapy

As reviewed above, treatment of APL with ATRA alone or in combination with chemotherapy yields a complete clinical remission rate as high as 85% to 95%. However, MRD detected by a positive RT-PCR for the PML/RAR α transcript is present in 80% to 90% and 50% of patients following induction therapy with ATRA alone⁵⁵ and ATRA plus chemotherapy,^{26,119} respectively. Invariably, patients with positive cytogenetics for t(15;17) or MRD determined by RT-PCR will clinically relapse.^{81,82,83,84,85,86} The percentage of patients with MRD is significantly reduced by the administration of post-remission chemotherapy, which correlates with a higher proportion of patients cured of this disease.^{81,86,119} The Memorial Sloan-Kettering group performed serial PCR analysis on the bone marrows of patients with untreated APL who received ATRA induction followed by consolidation treatment with chemotherapy, RA, and biologic agents;⁵⁵ 85% had MRD detectable by RT-PCR after ATRA induction, and only (10%) had detectable MRD after completing three cycles of consolidation therapy. Consistent with these results, other groups have reported molecular remission rates $\geq 90\%$ after two to three cycles of anthracycline-based consolidation therapy.^{26,102,133,145,146,147} More recently, a prospective trial assessing MRD kinetics during the entire treatment course using RQ-PCR in 70 patients newly diagnosed with APL was conducted.¹⁴⁸ At a median follow-up of 44 months, of those who achieved a CR, nine patients had clinical relapse. The greatest predictor of relapse (85.7% vs. 7.3%, $P < 0.001$) and DFS (14.3% vs. 91.2%, $P < 0.001$) was an MRD level of $>10^{-3}$ after the first consolidation treatment. Thus, the use of prospective MRD monitoring using quantitative PCR could become a critical component in risk-adaptive and long-term treatment strategies to obtain the best clinical outcome.

Although several groups have incorporated high-dose cytosine arabinoside as part of the consolidation strategy,^{27,102,135,149,150} the overall benefit of dose-intense cytosine arabinoside in either induction or consolidation remains unclear. Schlenk et al.¹⁵¹ evaluated high-dose cytarabine in combination with mitoxantrone as consolidation therapy. In this study 82 newly diagnosed APL patients received induction therapy according to the AIDA protocol (ATRA, idarubicin) followed by one cycle of idarubicin, cytarabine, etoposide and two cycles of HAM (cytarabine 3 g/m² every 12 hours days 1

to 3; mitoxantrone 10 mg/m² on days 2 and 3). Ten patients died from early/hypoplastic death; 72 (88%) achieved a CR; and 71 of these patients received at least one cycle of HAM. After 46 months, relapse-free survival (RFS) and OS were 83% and 82%, respectively. As discussed, recent data from a French-Belgian-Swiss trial, where patients with high-risk APL (WBC ≥ 10 × 10⁹/L) received standard-dose cytarabine during induction and dose-intensive cytarabine during consolidation, demonstrated an excellent 2-year EFS of 89% along with superior outcomes compared to high-risk patients treated with non-cytarabine-containing regimens.^{102,135} More recently, the PETHEMA group launched a trial (LPA2005) that incorporated high-dose cytarabine into consolidation therapy for high-risk patients, demonstrating a decreased CIR and marginally improved DFS compared with their previous trial (LPA99) in which cytarabine was not utilized during consolidation.¹⁴⁶ Similarly, the GIMEMA group also introduced a risk-adapted approach for high-risk patients in the AIDA2000 study, utilizing high-dose cytarabine during the first course of consolidation.¹⁴⁵ Once again, CIR and DFS were improved in high-risk patients treated with high-dose cytarabine compared with patients in the previous study (AIDA0493) that did not utilize high-dose cytarabine during consolidation. Taken together, these findings suggest a role for high-dose cytarabine during consolidation for patients with high-risk APL, but the overall topic remains somewhat confounded by a lack of randomized trials to address this issue.

Historically, most groups have used a combination of ATRA and chemotherapy (anthracycline-based) for remission induction, followed by two to three cycles of consolidation chemotherapy that lacks ATRA inclusion, with the goal of eliminating MRD. As previously noted, results of this approach have been extremely effective, with a high likelihood of cure. In an attempt to further improve outcomes, the PETHEMA groups LPA99 trial used a risk-adaptive approach, adding ATRA to consolidation in the patients with intermediate and high-risk disease, along with increased doses of anthracyclines, and evaluated relapse rates in comparison to patients treated on the previous LPA96 trial, where risk-adapted addition of ATRA and anthracyclines did not occur (Table 78.5). Compared to patients treated with the LPA96 regimen, the risk-adapted approach utilized during consolidation in the LPA99 trial demonstrated an overall reduction in the relapse rate from 20.1% to 8.7% (P = 0.004), most notably in the intermediate-risk group, where the reduction was from 14.0%

P.1667

to 2.5% (P = 0.006). This approach also translated into apparent improved DFS and OS.²⁶ Long-term follow-up of this trial confirmed continued DFS benefits with such risk-adapted therapy at 5 years and beyond.¹⁴⁷

**TABLE 78.5
PREDICTIVE MODEL FOR RELAPSE-FREE SURVIVAL**

Risk	WBC Count	Platelet Count
Low	≤10 × 10 ⁹ /L	>40 × 10 ⁹ /L
Intermediate	≤10 × 10 ⁹ /L	≤40 × 10 ⁹ /L
High	>10 × 10 ⁹ /L	

WBC, white blood cell.

Sanz MA, Lo Coco F, Martín G, et al. Definition of relapse risk and role of non-anthracycline drugs for consolidation in patients with acute promyelocytic leukemia: a joint study of the PETHEMA and GIMEMA cooperative groups. *Blood* 2000;96:1247-1253.

Maintenance Therapy

Traditionally, maintenance therapy has not been a standard component of the state of the art management of AML. However, in APL, there are several small studies that have suggested a possible benefit of maintenance chemotherapy. In an early trial conducted at MD Anderson, 39 of 70 patients with APL who received 6-MP and methotrexate as maintenance therapy had a nearly twofold (56% vs. 30%; P < 0.01) higher sustained 3-year remission rate compared to those patients who did not receive maintenance.¹⁵² Subsequently, results of two randomized trials^{27,129} and one nonrandomized¹¹⁹ trial have shown a reduction in the risk of relapse in patients treated with either ATRA and/or chemotherapy as maintenance. In the European APL 93 trial,¹²⁹ the largest of these three studies, 289 patients, after completing their consolidation therapy, were randomized to no maintenance or to maintenance with either ATRA (45 mg/m²/day for 15 days every 3 months), continuous low-dose chemotherapy with 6-MP (90 mg/m²/day) plus methotrexate (50 mg/m² given weekly), or both ATRA and continuous low-dose chemotherapy after completion of their

consolidation therapy. The 2-year relapse incidence was 13% compared to 25% in patients who received versus those who did not receive ATRA, respectively ($P = 0.02$), and 11% compared to 27% in patients who received versus those who did not receive chemotherapy as maintenance, respectively ($P = 0.0002$). However, the relapse rate (6 out of 74 patients, 8%) was lowest in the subgroup that was randomized to both ATRA and low-dose chemotherapy. In addition, there was an improvement in OS ($P = 0.01$) in those patients who received chemotherapy maintenance, and a similar trend in those patients who received ATRA maintenance ($P = 0.22$). Interestingly, high-risk patients (presenting with WBC counts $>5,000$ and older than 60 years) who received both ATRA and low-dose chemotherapy seemed to benefit the most from such therapy. In contrast to these results, the GIMEMA Cooperative Group (AIDA 0493), which randomized patients in molecular CR to the same maintenance therapy used in the European APL 93 study, failed to demonstrate a long-term benefit of any maintenance regimen.¹³³ Similarly, the Japan Adult Leukemia Study Group APL97 study failed to demonstrate a benefit to maintenance chemotherapy, although ATRA was not included in the maintenance chemotherapy regimen in this trial.¹⁵³ Finally, in a recent update to the CALGB9710 US Intergroup Trial, there was no difference in DFS or OS in patients randomized to maintenance therapy with ATRA monotherapy versus those randomized to maintenance with ATRA plus low-dose oral chemotherapy.¹⁵⁴ Although the exact role of maintenance therapy remains to be defined, particularly with respect to its optimal schedule, most current protocols include this maintenance approach in their overall therapeutic strategy.

Most important in the management of APL is that patients in remission should be monitored routinely for evidence of MRD by RT-PCR. The experience to date shows that patients who remain positive after the completion of consolidation therapy, or those who convert from negative to positive (molecular relapse), will inevitably relapse.^{69,70,71} Such patients should receive additional therapy; in particular, allogeneic bone marrow or stem cell transplantation should be considered.

Adverse Effects of Retinoic Acid

The toxicity profile of ATRA is comparable to other retinoids. APL patients, however, are uniquely prone to the development of a hyperleukocytosis and a reaction known as RAS.^{155,156} RAS is characterized by fever, respiratory distress, radiographic pulmonary infiltrates, pleural or pericardial effusions, weight gain due to fluid overload, episodic hypotension, and acute renal failure. In the setting of ATRA monotherapy, RAS has an incidence of 20% to 30%.^{123,126,156} The clinical diagnosis can be challenging because this patient population is at risk to develop pneumonia, sepsis, and congestive heart failure because of the disease and due to complications of cytotoxic chemotherapy. The first sign or symptom of RAS has been reported to occur anytime within the first few days to weeks of initiating ATRA therapy.¹³⁹ It is interesting that there have been reports of this adverse event occurring in patients who were maintained on ATRA and whose marrow was recovering post-myelosuppressive doses of chemotherapy.¹⁵⁵ Although hyperleukocytosis is frequently observed preceding RAS, the reaction may occur with a normal leukocyte count in up to one third of cases.^{42,26,156} In addition, there are conflicting reports as to whether an elevated pre-treatment leukocyte count is associated with an increased risk for subsequent development of RAS.^{155,157} Overall, there have been no clearly established independent prognostic factors for the development of RAS. Fatality from RAS has been correlated with the pre-treatment factors of hypalbuminemia and ECOG performance status.²³

Clinically, RAS gives the impression of a "capillary leak syndrome." Postmortem examination performed on patients who have died with progressive hypoxemia and multiorgan failure revealed extensive infiltration of maturing myeloid cells into lung, skin, kidney, liver, and lymph nodes.¹⁵⁶ The cause of RAS is unknown, although several mechanisms have been proposed, including the release of vasoactive cytokines, increased expression of adhesion molecules on myeloid cell surfaces, and attainment of migratory capabilities by the malignant promyelocytes as they undergo differentiation.^{42,156} ATRA increases the expression of the surface integrin intracellular adhesion molecule-1 in certain cell lines. Of clinical importance, this effect can be blocked by treatment with dexamethasone.¹⁵⁸ Development of this reaction is also correlated with expression of CD13 (aminopeptidase N),⁴² which has been associated with a poor outcome in patients with acute myeloid leukemia. These observations suggest a link to the clinical experience of extravascular adhesion and migration of differentiating cells in this reaction.

The progression of RAS can be terminated by early intervention with a short course of high-dose dexamethasone (10 mg twice a day for 3 days), and as a result the mortality from this adverse event has decreased significantly.¹³² The importance, however, of the immediate recognition and appropriate interventions cannot be overemphasized. The development of any unexplained signs or symptoms, particularly fluid retention, sporadic fevers, and pulmonary infiltrates, should prompt immediate dexamethasone treatment. Once fully established, the management of RAS has proved especially difficult and often results in significant morbidity and, frequently, death. Therefore, the benefits of empiric steroid therapy far outweigh the risk of complications associated with inappropriate use in leukemic patients with

infections. In a nonrandomized prospective study, the Australian Study Group treated patients with prophylaxis corticosteroids (prednisone 75 mg/day) and reported a lower incidence of pulmonary toxicity and RAS.¹⁵⁹ Most groups have not adopted this as a standard approach given the risks/benefits of corticosteroids but instead administer dexamethasone at the earliest appearance of any of the signs or symptoms suggestive of RAS.

Although APL has generally been associated with leukopenia at the time of presentation, leukocytosis ($\geq 10 \times 10^9/L$) frequently occurs in APL patients treated with ATRA alone. In general, it was recognized that patients who developed leukocytosis while receiving ATRA fared as well as patients who developed RAS. In addition, it has been suggested that the development of leukocytosis and RAS is associated with a higher risk of extramedullary relapse (EMR).¹⁶⁰ The prevention and/or management of leukocytosis involves using full-dose chemotherapy along with ATRA. The

P.1668

concurrent administration of these agents also appears to result in a lower incidence of RAS. With ATRA alone, the incidence of RAS is approximately 25%; when given concurrently with chemotherapy, the GIMEMA Trial, the Japanese Adult Leukemia Study Group, and the European APL study reported an incidence of 10%, 6%, and 15%, respectively.^{27,119,129}

Management of Relapsed Acute Promyelocytic Leukemia

Despite the significant improvement in CR and survival rates observed since the incorporation of ATRA in the treatment of APL,^{27,98,161} 15% to 20% of these patients relapse and are often resistant to further treatment with ATRA.^{98,121} Some patients, however, who have relapsed >6 months after completing their last ATRA therapy have achieved a second CR when retreated with ATRA.¹⁰⁹ This relative "reversal of resistance" may in part be related to the metabolism of ATRA. The plasma levels of ATRA have been shown to decline over time in pharmacokinetics studies where ATRA was given continuously, in part, as a result of autoinduction as discussed earlier. Clinically, this could result in a subtherapeutic plasma level and thereby give the appearance of drug resistance. The up-regulation of the respective metabolic enzymes reverses after a defined period from discontinuation of therapy.^{162,163} Therefore, when re-instituting therapy with standard doses of ATRA, the therapeutic levels needed clinically to induce myeloid differentiation are once again obtained.

Patients who achieve a second CR irrespective of agent(s) used will need additional curative therapy. Salvage therapy often entails high doses of cytotoxic chemotherapy followed by either autologous or allogeneic transplantation. Such an approach carries a risk of significant morbidity and mortality and may not be appropriate for some patients, an important consideration in treating very young or elderly patients. Also, an allograft is contingent on finding an HLA-identical donor for these patients, which occurs only for a subset of the patients.

Since the inclusion of ATRA as part of standard first-line therapy, there have been limited clinical data available reviewing the role of dose-intense chemotherapy followed by transplantation in relapsed patients. In the European APL 91 trial¹²⁹ and the Italian GIMEMA Group study,¹⁶⁴ 4 of 5 patients and 6 of 15 patients in second CR, respectively, who underwent allografts obtained a prolonged CR. Thomas et al.¹⁶⁵ reported treating 50 patients with APL in first relapse with single-agent ATRA until CR followed by sequential EMA chemotherapy (etoposide 200 mg/m²/day for 3 days, mitoxantrone 12 mg/m²/day for 3 days, and cytosine arabinoside 500 mg/m²/day for two sequences of 3 days). Forty-five (90%) patients achieved a second CR; 37 of these 45 patients had ATRA as part of their first remission regimen when newly diagnosed. While in second CR, 11 patients underwent HLA-identical allogeneic transplant and had a median DFS of 8.2 months; 22 patients underwent autologous transplants and had a 3-year DFS rate of 77%. These results suggest that autologous transplantation effectively cures a large proportion of these patients in first relapse at the risk of significant but acceptable toxicity. For patients undergoing an autologous transplantation in second CR, an important consideration is the RT-PCR status for PML/RAR α , which is indicative of MRD. In a small series, Meloni et al.¹⁶⁶ reported that all 7 patients whose graft was positive for PML/RAR α relapsed within 9 months post transplant, and six of eight patients with PCR-negative disease remained in molecular remission at a median of 28 months. Relapse rates are lower with allogeneic transplant, but the treatment-related mortality tends to offset any advantage.¹⁶⁷

Arsenic Trioxide

Based on initial reports from China,^{168,169} a pilot trial using daily infusions of ATO in 12 patients with relapsed APL was conducted in 1997 at Memorial Sloan-Kettering Cancer Center that demonstrated a 92% (11 out of 12 patients) CR rate.¹⁷⁰ Subsequently, in a confirmatory US multicenter study,¹⁰¹ 40 patients received a daily 1-hour infusion of 0.15 mg/kg of ATO until the elimination of visible leukemic cells in the bone marrow. The CR rate was 85% and median times to bone marrow leukemic blast clearance and CR were 35 days and 59 days, respectively. In addition, 78% of these patients achieved PML-

RAR α transcript negativity by RT-PCR by the completion of their consolidation therapy. Eighteen patients subsequently received one to four cycles of ATO maintenance on a different protocol, and 12 patients ultimately underwent allogeneic (n = 9) or autologous (n = 3) transplant while in CR. When the data from the 12 patients treated in the original single institution study¹⁴⁹ of ATO are combined with results from these 40 patients, combined analysis of the 52 patients in the Memorial Sloan-Kettering and the US multicenter studies revealed a Kaplan-Meier 18-month estimate of OS and RFS of 66% and 50%, respectively.¹⁰¹ Subsequently, other groups have treated relapse/refractory APL with ATO using a dose and schedule similar to the US Multicenter Study and have reported comparable outcomes in terms of hematologic and molecular remission rates.^{99,100} As a result of the high efficacy and safety profile observed, ATO is used as standard therapy in patients with two or more relapses and is now more frequently used in patients after a first relapse, particularly in those patients whose first CR lasted <12 months, and including molecular relapse. The best subsequent treatment strategy (i.e., maintenance ATO vs. autologous transplant vs. allogeneic transplant), remains to be determined.

Since receiving Food and Drug Administration approval in September 2000, ATO has also been shown to be effective when used as a single agent or in combination with ATRA in newly diagnosed APL.^{171,172,173,174,175} Representative studies are shown in Table 78.6. Shen¹⁷⁴ et al. randomized 61 newly diagnosed APL patients into three treatment groups: ATRA, ATO, or the combination of the two. CR was achieved in $\geq 90\%$ in all groups, and median time to CR was the shortest (25.5 days) in the combination arm. Other clinical benefits in the combination arm included faster recovery of platelet count and normalization of coagulation and fibrinolysis parameters, as well as faster decrement in PML/RAR α transcripts, as measured by RQ-PCR. It is important to note that relapse occurred in 7 of the 37 (19%) patients treated with monotherapy at a median of 18 months, compared with relapsed none of the 20 patients in the combination group (P < 0.05). These favorable clinical benefits with the combination of ATRA and ATO were also reported by other investigators.¹⁷⁵ As a single agent for untreated APL, ATO appears to produce a durable long-term benefit, with actuarial 5-year EFS and OS rates of 69% and 74%, respectively.¹⁷⁶

Considering the efficacy and safety of ATRA and ATO as single agents in APL, the group at MD Anderson evaluated the combination of these two agents as an alternative to ATRA plus chemotherapy in untreated APL.^{171,177} Using a treatment strategy based upon risk categorization at diagnosis, 56 low-risk (presenting WBC count < $10 \times 10^9/L$) and 26 high-risk patients (WBC > $10 \times 10^9/L$) received ATRA (45 mg/m² daily) and ATO (0.15 mg/kg daily, beginning day 10 of ATRA, and later modified to begin on day 1) for induction therapy. In addition to the ATO and ATRA, high-risk patients received chemotherapy (gemtuzumab ozogamicin) on day 1 of induction. Patients achieving a CR then received only ATO plus ATRA as consolidation therapy unless they were molecularly positive for PML-RAR α 3 months from the CR date or had molecular relapse, and then chemotherapy (gemtuzumab ozogamicin) was given in combination with ATO and ATRA during consolidation. The overall CR rate was 92% (95% in low risk, 81% in high risk). At a median follow-up of 99 weeks, the estimated EFS and OS were >80%. Both EFS and OS were superior in the low-risk group compared with the high-risk group. It was concluded that the combination of ATRA and ATO could be used as an alternative to

P.1669

chemotherapy in low-risk untreated APL. Further study of ATRA plus ATO plus gemtuzumab ozogamicin in high-risk groups is the subject of an ongoing US Southwest Oncology Group trial.

TABLE 78.6
REPRESENTATIVE STUDIES OF ARSENIC TRIOXIDE (ATO) IN ACUTE PROMYELOCYTIC LEUKEMIA

Study	Disease Status	Therapy	N	CR	Molecular Response (RT-PCR Negative)	Survival
Shen et al. ¹⁶⁸ 1997	Relapse	ATO (10 mg/d)	10	9 (90%)	—	—
Soignet et al. ¹⁷⁰ 1998	Relapse/refractory	ATO (0.06-0.20 mg/kg/d)	12	11 (92%)	8/11 (72%)	—
Soignet et al. ¹⁰¹ 2001	Relapse/refractory	ATO (0.15 mg/kg/d)	40	34 (85%)	78%	18 mo KM estimates

						OS 66%
						EFS 50%
Shigeno et al. ¹⁰⁰ 2005	Relapsed/refractory ATI (0.15 mg/kg/d)	34	31 (91%)	72%		2-y OS 56%
Shen et al. ¹⁷⁴ 2004 Randomized	Untreated				Quantitative RT-PCR (median reduction fold after CR)	Median follow-up of 18 mo DFS
	ATRA (25 mg/m ² /d)	20	19 (95%)	6.7		13 mo
	ATO (0.16 mg/kg/d)	20	18 (90%)	32.1		16 mo
	ATRA + ATO	21	20 (95%)	118.9		20 mo
Wang et al. ¹⁷⁵ 2004	Untreated					
	ATRA (20 mg TID)	36	31 (83.3%)			
	ATO (10 mg/d)	40	36 (90%)	—		—
	ATRA (10 mg TID) plus ATO (10 mg/d)	80	74 (92.5%)			
Mathews et al. ¹⁷³ 2006	Untreated					
	ATO (10 mg/d)	72	86%			3-y KM estimates
				—		EFS 74.9%
						DFS 87.2%
						OS 86.1%
Ghavamzadeh et al. ¹⁷² 2006	Untreated					
	ATO (0.25 mg/kg/d)	11	95 (86%)	92%	(44 of 48 tested)	1-y DFS 88.3%
						2-y DFS 63.7%
						1-y OS 95.5%
						3-y OS 87.6%
Ravandi et al. ¹⁷⁷ 2009	Untreated					
	Low risk (WBC < 10 × 10 ⁹ L):	56	53 (95%)		Negative PCR: 49/49 (100%) at 6 mo post-CR	
	ATO (0.15 mg/kg/d)+ ATRA					

(45 mg/m²/d)41/43 (95%) at 12
mo post-CRHigh risk WBC > 26 21(86%)
10 × 10⁹ L):ATO (0.15
mg/kg/d) + ATRA
(45 mg/m²/d) + GO
(9 mg/m² on day 1)36/37 (97%) at 24
mo post-CR

ATRA, all-*trans* retinoic acid; DFS, disease-free survival; EFS, event-free survival; GO, gemtuzumab ozogamicin; KM, Kaplan-Meier; OS, overall survival; RT-PCR, reverse transcriptase-polymerase chain reaction; TID, three times per day; WBC, white blood cell.

The CALGB group has also evaluated the role of ATO during consolidation therapy in APL.¹¹³ In this trial, patients with newly diagnosed APL were randomized, following ATRA-based induction, to 2 cycles of ATO versus no ATO consolidation (followed thereafter by 2 cycles of ATRA plus daunorubicin late consolidation in each arm). This study demonstrated significant improvement in EFS in the ATO-treated patients compared with controls, along with a trend toward improved OS in this group, indicating a role for ATO earlier in therapy, prior to relapse. It should be pointed out, however, that differences exist between the US and non-ATO European induction regimens (especially with respect to anthracycline dose intensity), such that the precise overall role of ATO in untreated APL remains undefined.

Finally, and most recently, the Italian-German Cooperative Groups tested ATRA + ATO versus ATRA + idarubicin in newly diagnosed APL, revealing a non-inferior 2 year event-free survival amongst ATRA + ATO treated patients. These data demonstrated, for the first time, that an “all biologic” regimen provides similar or superior outcomes compared to a regimen inclusive of traditional cytotoxic chemotherapy, an observation that may ultimately change the standard of care in APL.^{177a}

The most common adverse events observed with ATO in the US multicenter study included leukocytosis (>10 × 10⁹/L) P.1670

during induction therapy, mild hyperglycemia, and fatigue. Also, 10 patients developed signs and/or symptoms suggestive of RAS and were effectively treated with dexamethasone. A potentially life-threatening side effect was QT prolongation on electrocardiogram, which was observed in 63% of patients. Although all of these patients were asymptomatic, including one patient who developed a brief episode of torsades de pointes, other investigators have reported sudden cardiac death^{178,179} associated with ATO therapy in APL patients. Therefore, close monitoring including aggressive management of electrolytes, particularly potassium and magnesium, is undertaken in conjunction with ATO therapy. Both intravenous and oral supplements are liberally provided to maintain the serum potassium > 4 mEq/L and the magnesium level > 1.8 mg/dl. In addition, every effort should be made to limit the concomitant use of other agents known to prolong QT intervals or induce ventricular arrhythmias. Following these management guidelines, in a post-marketing safety update on over 2,200 patients treated with ATO, including 437 patients with APL, no torsade de pointes nor deaths due to ATO (Trisenox)-associated arrhythmia have been reported.¹⁸⁰

Liposomal All-Trans Retinoic Acid and Gemtuzumab Ozogamicin

Other agents that have shown benefit in patients with relapsed APL include liposomal ATRA and gemtuzumab ozogamicin (Mylotarg). Douer et al.¹⁸¹ conducted a trial using a liposomal formulation of ATRA and administered it intravenously in 69 patients with newly diagnosed (32 patients) or relapsed (35 patients) APL, and in 2 patients who failed oral ATRA. A CR was achieved in 62% of previously untreated patients and in 70% of those patients in first relapse who were ATRA naive or off oral ATRA for ≥1 year. In those patients who were in first relapse and off oral ATRA for <1 year or in their second or greater relapse, 20% achieved a CR. In a study reported by Tsimberidou et al.,¹⁸² single-agent Lipo-ATRA (liposomal ATRA) was used in untreated APL for induction and for consolidation in those patients who achieved a CR. Molecular disease was monitored by RT-PCR for PML-RARα every 3 months from the time of CR, with idarubicin added to those patients who were positive for molecular disease. A CR was obtained in 79% of patients. Of 26 responders 10 who never received chemotherapy remained in first CR at a median of 6.4 years. However, the proportion of patients responding in these

studies may be no different than expected in the same population treated with oral ATRA. However, the durability of remissions achieved with single-agent Lipo-ATRA have not been reported with oral ATRA. This agent warrants further exploration in the treatment of APL and clearly is important in a patient population in which oral ATRA is not ideal, such as patients who are not able to tolerate or absorb the oral formulation.

Gemtuzumab ozogamicin is an engineered human anti-CD33 antibody linked with the potent antitumor antibiotic calicheamicin. This agent binds to the CD33 antigen that is found on the surface of leukemic cells in more than 80% of patients with AML, and virtually in 100% with APL. The binding of CD33 by gemtuzumab results in the internalization and hydrolytic release of calicheamicin, which belongs to the anthracycline class of drug. Pre-clinical studies have shown this agent to be effective against ATRA- and ATO-resistant APL cells.¹⁸³ Clinical remissions have been observed with gemtuzumab, including a clinical and molecular remission in a patient with multiple relapsed APL.¹⁸⁴ In a study of patients with molecular (not hematologic relapse,¹⁸⁵ 16 patients received gemtuzumab at 6 mg/m². There were 14 patients (87%) who achieved a molecular remission after receiving one to three doses, which was sustained for a median of 15 months (range, 7 to 31 months) in 3 patients. This drug was withdrawn from the US market in 2010, and is not commercially available for any indication, although its primary role in APL remains to be determined.

Special Issues

Management of the Elderly Patient

As APL typically manifests in younger patients, the therapeutic experience in older adults (age > 60) is more limited. In large cooperative group studies, older patients comprise between 5% and 20% of the overall study population.^{113,133,135,146} In general, older patients with AML demonstrate poorer tolerance for cytotoxic induction therapy,^{186,187,188} so the same concerns logically exist for the elderly APL patient, in whom cytotoxic therapy is planned.

Both the PETHEMA and the GIMEMA cooperative groups have comprehensively analyzed their experience with older adults in APL^{103,189} in their therapeutic trials (LPA96/99 and 0493, respectively). In both groups, early mortality was more frequently encountered in patients older than 70, initial CR rates were >80%, and 3-year DFS rates were >70%. In the GIMEMA trials, OS at 6 years was 56%.¹⁸⁹ The GIMEMA group recently published the results of its modified APL treatment regimen for patients older than 60, utilizing induction with ATRA + idarubicin, followed by a single course of consolidation with idarubicin + cytarabine, followed thereafter with ATRA maintenance.¹⁹⁰ This regimen produced 5-year OS and DFS rates of 76% and 65%, respectively. The use of ATRA + ATO during induction, based upon the MD Anderson experience, resulted in similar rates of OS among older and younger individuals, suggesting that a regimen free of cytotoxic chemotherapy could be better suited for older patients.¹⁷⁷ Hence, although APL occurs infrequently in older individuals, outcomes are favorable, indicating the importance of pursuing aggressive therapy, with evolution toward reduction or omission of cytotoxic chemotherapeutic agents.

Extramedullary Disease and Relapse

Extramedullary disease (EMD) occurs in approximately 5% to 10% of adult patients with AML, most commonly in the myelomonocytic and monocytic subtypes.¹⁹¹ Historically, the incidence of EMD in patients with APL has been considered rare.^{192,193} However, since the early 1990s there have been numerous reported cases in patients with APL at the time of relapse, mostly involving the skin and CNS.^{160,192,194,195,196} In the Italian GIMEMA group study, 13 of 97 patients with relapsed APL had EMD, and in the European APL 93 trial 3 of 75 relapsed patients had documented EMD. Using a competing-risk method to analyze the incidence, presenting features, and risk factors of EMR in 740 patients with APL treated with ATRA and chemotherapy, it was concluded that EMR occurs more frequently in patients with increased WBC counts (>10,000/mm³) and carries a poor prognosis.¹⁹⁴ It appears that CNS involvement is more common than either skin or organ infiltration. In a series of 21 reported cases of EMR, 14 cases involved the CNS.¹¹ The same group also analyzed the incidence of EMD involvement in their series of APL patients who were treated with either chemotherapy alone or with AIDA regimen and subsequently relapsed.¹¹ Accounting for all relapses, there were no conclusive data to support a higher incidence of EMD in patients treated with ATRA. However, the proportion of patients with EMD who had CNS involvement was significantly higher in the group that received ATRA as part of their induction therapy compared to those who received only chemotherapy. One explanation for this observation is that ATRA therapy induces the expression of adhesion molecules such as CD11c, CD13, and CD56 in the malignant promyelocytes and that may facilitate CNS infiltration.^{48,197,198} There was no comparative difference in the incidence of other sites of EMD. Of note, 14 of the 16 patients in the AIDA trial with EMD found at relapse also had hematologic or molecular evidence of disease. Treatment for CNS relapse requires systemic re-induction along with four to six cycles of intrathecal methotrexate or

cytosine arabinoside. Some patients may benefit from additional cranial-spinal radiation. It is reasonable to consider CNS prophylaxis, particularly in those patients who present with high WBC counts. However, CNS prophylaxis with either intrathecal chemotherapy alone or combined with cranial irradiation has not been shown to improve DFS in adults with AML in general. This is likely because the majority of the patients have systemic relapse in addition to CNS or EMD.

SUMMARY

APL is a highly curable disease and represents a model for modern cancer therapy. It is unique in that the identification of the specific genotype that is used for diagnosis, monitoring MRD, and detection of early relapse has also resulted in a greater understanding of the fundamental biology of this disease, which serves as a template for the development of targeted therapies. APL is the first known disease that is clinically sensitive to differentiation therapy, and as a result, the paradigm for the treatment of leukemia has been irrevocably altered. As medicine moves through the era of genomics, proteomics, and rationale drug design, the models of pathogenesis based on interactions between both genetic and epigenetic factors may be instrumental in the understanding and treatment of other forms of malignancy.

REFERENCES

1. Drapkin RL, Gee TS, Dowling MD, et al. Prophylactic heparin therapy in acute promyelocytic leukemia. *Cancer* 1978;41:2484-2490.
2. Gralnick HR, Bagley J, Abrell E. Heparin treatment for the hemorrhagic diathesis of acute promyelocytic leukemia. *Am J Med* 1972;52:167-174.
3. Kantarjian HM, Keating MJ, Walters RS, et al. Acute promyelocytic leukemia: M.D. Anderson hospital experience. *Am J Med* 1986;80:789-797.
4. Howlader N, Noone A, Krapcho M, et al, eds. SEER cancer statistics review, 1975-2009 (Vintage 2009 Populations) Bethesda, MD: National Cancer Institute, 2012.
5. Dores GaM, Devesa SS, Curtis RE, Linet MS, Morton LM. Acute leukemia incidence and patient survival among children and adults in the United States, 2001-2007. *Blood* 2012;119:34-43.
6. Matasar MJ, Ritchie EK, Consedine N, Magai C, Neugut AI. Incidence rates of acute promyelocytic leukemia among Hispanics, blacks, Asians, and non-Hispanic whites in the United States. *Eur J Cancer Prev* 2006;15:367-370.
7. Estey E, Thall P, Kantarjian H, Pierce S, Kornblau S, Keating M. Association between increased body mass index and a diagnosis of acute promyelocytic leukemia in patients with acute myeloid leukemia. *Leukemia* 1997; 11:1661-1664.
8. Gilbert RD, Karabus CD, Mills AE. Acute promyelocytic leukemia. A childhood cluster. *Cancer* 1987;59:933-935.
9. Beaumont M, Sanz M, Carli PM, et al. Therapy-related acute promyelocytic leukemia. *J Clin Oncol* 2003;21:2123-2137.
10. Pollicardo N, O'Brien S, Estey E. Secondary acute promyelocytic leukemia. Characteristics and prognosis of 14 patients from a single institution. *Leukemia* 1996;10:27-31.
11. Specchia G, Lo Coco F, Vignetti M, et al. Extramedullary involvement at relapse in acute promyelocytic leukemia patients treated or not with all-trans retinoic acid: a report by the Gruppo Italiano Malattie Ematologiche dell'Adulto. *J Clin Oncol* 2001;19:4023-4028.
12. Weiss MA, Warrell RP. Two cases of extramedullary acute promyelocytic leukemia. Cytogenetics, molecular biology, and phenotypic and clinical studies. *Cancer* 1994;74:1882-1886.
13. Asou N, Adachi K, Tamura J, et al. Analysis of prognostic factors in newly diagnosed acute promyelocytic leukemia treated with all-trans retinoic acid and chemotherapy. Japan Adult Leukemia Study Group. *J Clin Oncol* 1998;16:78-85.
14. Bennett JM, Catovsky D, Daniel MT, et al. A variant form of hypergranular promyelocytic leukaemia (M3). *Br J Haematol* 1980;44:169-170.
15. Cunningham I, Gee T, Reich L, Kempin S, Naval A, Clarkson B. Acute promyelocytic leukemia: treatment results during a decade at Memorial Hospital. *Blood* 1989;73:1116-1122.
16. Golomb H, Rowley J, Vardiman J, Testa J, Butler A. "Microgranular" acute promyelocytic leukemia: a distinct clinical, ultrastructural, and cytogenetic entity. *Blood* 1980;55:253-259.
17. McKenna RW, Parkin J, Bloomfield CD, Dorothy Sundberg R, Brunning RD. Acute promyelocytic leukaemia: a study of 39 cases with identification of a hyperbasophilic microgranular variant. *Br J Haematol* 1982;50:201-214.

18. Kelaidi C, Chevret S, De Botton Sp, et al. Improved outcome of acute promyelocytic leukemia with high WBC counts over the last 15 years: the European APL group experience. *J Clin Oncol* 2009;27:2668-2676.
19. Drewinko B, Bollinger P, Brailas C, et al. Flow cytochemical patterns of white blood cells in human haematopoietic malignancies. *Br J Haematol* 1987;66:27-36.
20. Krause JR, Stolc V, Kaplan SS, PENCHANSKY L. Microgranular promyelocytic leukemia: a multiparameter examination. *Am J Hematol* 1989;30:158-163.
21. O'Regan S, Carson S, Chesney R, Drummond K. Electrolyte and acid-base disturbances in the management of leukemia. *Blood* 1977;49:345-353.
22. Tallman MS, Brenner B, Serna Jdl, et al. Meeting report. *Leuk Res* 2005;29:347-351.
23. de la Serna J, Montesinos P, Vellenga E, et al. Causes and prognostic factors of remission induction failure in patients with acute promyelocytic leukemia treated with all-trans retinoic acid and idarubicin. *Blood* 2008;111: 3395-3402.
24. Di Bona E, Avvisati G, Castaman G, et al. Early haemorrhagic morbidity and mortality during remission induction with or without all-trans retinoic acid in acute promyelocytic leukaemia. *Br J Haematol* 2000;108:689-695.
25. Lehmann S, Ravn A, Carlsson L, et al. Continuing high early death rate in acute promyelocytic leukemia: a population-based report from the Swedish Adult Acute Leukemia Registry. *Leukemia* 2011;25:1128-1134.
26. Sanz MA, Martín G, González M, et al. Risk-adapted treatment of acute promyelocytic leukemia with all-trans-retinoic acid and anthracycline monochemotherapy: a multicenter study by the PETHEMA group. *Blood* 2004;103:1237-1243.
27. Tallman MS, Andersen JW, Schiffer CA, et al. All-trans-retinoic acid in acute promyelocytic leukemia. *N Engl J Med* 1997;337:1021-1028.
28. De Stefano V, Sorà F, Rossi E, et al. The risk of thrombosis in patients with acute leukemia: occurrence of thrombosis at diagnosis and during treatment. *J Thromb Haemost* 2005;3:1985-1992.
29. Gralnick HR, Abrell E. Studies of the procoagulant and fibrinolytic activity of promyelocytes in acute promyelocytic leukaemia. *Br J Haematol* 1973;24:89-99.
30. Gouault-Heilmann M, Chardon E, Sultan C, Josso F. The procoagulant factor of leukaemic promyelocytes: demonstration of immunologic cross reactivity with human brain tissue factor. *Br J Haematol* 1975;30:151-158.
31. Zhu J, Guo WM, Yao YY, et al. Tissue factors on acute promyelocytic leukemia and endothelial cells are differently regulated by retinoic acid, arsenic trioxide and chemotherapeutic agents. *Leukemia* 1999;13:1062-1070.
32. Dombret H, Scrobohaci ML, Daniel MT, et al. In vivo thrombin and plasmin activities in patients with acute promyelocytic leukemia (APL): effect of all-trans retinoic acid (ATRA) therapy. *Leukemia* 1995;9:19-24.
33. Liu Y, Wang Z, Jiang M, et al. The expression of annexin II and its role in the fibrinolytic activity in acute promyelocytic leukemia. *Leuk Res* 2011;35: 879-884.
34. Menell JS, Cesarman GM, Jacovina AT, McLaughlin MA, Lev EA, Hajjar KA. Annexin II and Bleeding in Acute Promyelocytic Leukemia. *N Engl J Med* 1999;340:994-1004.
35. Bennett JM, Catovsky D, Daniel MT, et al. Proposals for the Classification of the Acute Leukaemias French-American-British (FAB) Co-operative Group. *Br J Haematol* 1976;33:451-458.
36. Sainy D, Liso V, Cantù-Rajoldi A, et al. A new morphologic classification system for acute promyelocytic leukemia distinguishes cases with underlying PLZF/RARA gene rearrangements. *Blood* 2000;96:1287-1296.
37. Scott A, Head D, Kopecky K, et al. HLA-DR-, CD33+, CD56+, CD16- myeloid/natural killer cell acute leukemia: a previously unrecognized form of acute leukemia potentially misdiagnosed as French-American-British acute myeloid leukemia-M3 [see comments]. *Blood* 1994;84:244-255.
38. Gupta AD, Sapre RS, Shah AS, Advani SH, Nair CN. Cytochemical and immunophenotypic heterogeneity in acute promyelocytic leukemia. *Acta Haematol* 1989;81:5-9.
39. Matsuo T, Jain NC, Bennett JM. Nonspecific esterase of acute promyelocytic leukemia (M3). *Am J Hematol* 1988;29:148-151.
40. Paietta E, Andersen J, Gallagher R, et al. The immunophenotype of acute promyelocytic leukemia (APL): an ECOG study. *Leukemia* 1994;8:1108-1112.

41. Erber WN, Asbahr H, Rule SA, Scott CS. Unique immunophenotype of acute promyelocytic leukaemia as defined by CD9 and CD68 antibodies. *Br J Haematol* 1994;88:101-104.
42. Vahdat L, Maslak P, Miller WJ, et al. Early mortality and the retinoic acid syndrome in acute promyelocytic leukemia: impact of leukocytosis, low-dose chemotherapy, PMN/RAR-alpha isoform, and CD13 expression in patients treated with all-trans retinoic acid. *Blood* 1994;84:3843-3849.
43. Lin P, Hao S, Medeiros LJ, et al. Expression of CD2 in acute promyelocytic leukemia correlates with short form of PML-RARalpha transcripts and poorer prognosis. *Am J Clin Pathol* 2004;121:402-407.
44. Biondi A, Luciano A, Bassan R, et al. CD2 expression in acute promyelocytic leukemia is associated with microgranular morphology (FAB M3v) but not with any PML gene breakpoint. *Leukemia* 1995;9:1461-1466.
45. Claxton D, Reading C, Nagarajan L, et al. Correlation of CD2 expression with PML gene breakpoints in patients with acute promyelocytic leukemia [see comments]. *Blood* 1992;80:582-586.
46. Guglielmi C, Paola Martelli M, Diverio D, et al. Immunophenotype of adult and childhood acute promyelocytic leukaemia: correlation with morphology, type of PML gene breakpoint and clinical outcome. A cooperative Italian study on 196 cases. *Br J Haematol* 1998;102:1035-1041.
47. Maslak P, Miller WJ, Heller G, Scheinberg D, Dmitrovsky E, Warrell RJ. CD2 expression and PML/RAR-alpha transcripts in acute promyelocytic leukemia [letter; comment] [see comments]. *Blood* 1993;81:1666.
48. Ferrara F, Morabito F, Martino B, et al. CD56 Expression is an indicator of poor clinical outcome in patients with acute promyelocytic leukemia treated with simultaneous all-trans-retinoic acid and chemotherapy. *J Clin Oncol* 2000;18:1295-1300.
49. Murray CK, Estey E, Paietta E, et al. CD56 Expression in acute promyelocytic leukemia: a possible indicator of poor treatment outcome? *J Clin Oncol* 1999;17:293.
50. Larson RA, Kondo K, Vardiman JW, Butler AE, Golomb HM, Rowley JD. Evidence for a 15; 17 translocation in every patient with acute promyelocytic leukemia. *Am J Medicine* 1984;76:827-841.
51. Rowley JD, Golomb HM, Dougherty C. 15/17 translocation, a consistent chromosomal change in acute promyelocytic leukaemia. *Lancet* 1977;1: 549-550.
52. de Thé H, Chomienne C, Lanotte M, Degos L, Dejean A. The t(15;17) translocation of acute promyelocytic leukaemia fuses the retinoic acid receptor alpha gene to a novel transcribed locus. *Nature* 1990;347:558-561.
53. de Thé H, Lavau C, Marchio A, Chomienne C, Degos L, Dejean A. The PML-RAR ± fusion mRNA generated by the t(15;17) translocation in acute promyelocytic leukemia encodes a functionally altered RAR. *Cell* 1991;66:675-684.
54. Kakizuka A, Miller WH, Umesono K, et al. Chromosomal translocation t(15;17) in human acute promyelocytic leukemia fuses RAR ± with a novel putative transcription factor, PML. *Cell* 1991;66:663-674.
55. Jurcic JG, Nimer SD, Scheinberg DA, DeBlasio T, Warrell RP, Miller WH. Prognostic significance of minimal residual disease detection and PML/RAR-α isoform type: long-term follow-up in acute promyelocytic leukemia. *Blood* 2001;98:2651-2656.
56. Gallagher RE, Willman CL, Slack JL, et al. Association of PML-RARα fusion mRNA type with pretreatment hematologic characteristics but not treatment outcome in acute promyelocytic leukemia: an intergroup molecular study. *Blood* 1997;90:1656-1663.
57. Johansson B, Mertens F, Mitelman F. Secondary chromosomal abnormalities in acute leukemias. *Leukemia* 1994;8:953-962.
58. Slack JL, Arthur DC, Lawrence D, et al. Secondary cytogenetic changes in acute promyelocytic leukemia-prognostic importance in patients treated with chemotherapy alone and association with the intron 3 breakpoint of the PML gene: a Cancer and Leukemia Group B study. *J Clin Oncol* 1997;15: 1786-1795.
59. Schoch C, Haase D, Haferlach T, et al. Incidence and implication of additional chromosome aberrations in acute promyelocytic leukaemia with translocation t(15;17)(q22;q21): a report on 50 patients. *Br J Haematol* 1996;94:493-500.
60. Grimwade D, Biondi A, Mozziconacci M-J, et al. Characterization of acute promyelocytic leukemia cases lacking the classic t(15;17): results of the European working party. *Blood* 2000;96:1297-1308.

61. Grimwade D, Gorman P, Duprez E, et al. Characterization of cryptic rearrangements and variant translocations in acute promyelocytic leukemia. *Blood* 1997;90:4876-4885.
62. Chen Z, Brand NJ, Chen A, et al. Fusion between a novel Kruppel-like zinc finger gene and the retinoic acid receptor-alpha locus due to a variant t(11;17) translocation associated with acute promyelocytic leukaemia. *EMBO J* 1993;12:1161-1167.
63. Licht J, Chomienne C, Goy A, et al. Clinical and molecular characterization of a rare syndrome of acute promyelocytic leukemia associated with translocation (11;17). *Blood* 1995;85:1083-1094.
64. Redner RL, Chen JD, Rush EA, Li H, Pollock SL. The t(5;17) acute promyelocytic leukemia fusion protein NPM-RAR interacts with co-repressor and co-activator proteins and exhibits both positive and negative transcriptional properties. *Blood* 2000;95:2683-2690.
65. Wells RA, Catzavelos C, Kamel-Reid S. Fusion of retinoic acid receptor alpha to NuMA, the nuclear mitotic apparatus protein, by a variant translocation in acute promyelocytic leukaemia. *Nat Genet* 1997;17:109-113.
66. He LZ, Guidez F, Tribioli C, et al. Distinct interactions of PML-RARalpha and PLZF-RARalpha with co-repressors determine differential responses to RA in APL. *Nat Genet* 1998;18:126-135.
67. Barragan E, Montesinos P, Camos M, et al. Prognostic value of FLT3 mutations in patients with acute promyelocytic leukemia treated with all-trans retinoic acid and anthracycline monochemotherapy. *Haematologica* 2011;96:1470-1477.
68. Chillon MC, Santamaria C, Garcia-Sanz R, et al. Long FLT3 internal tandem duplications and reduced PML-RARalpha expression at diagnosis characterize a high-risk subgroup of acute promyelocytic leukemia patients. *Haematologica* 2011;95:745-751.
69. Gale RE, Hills R, Pizzey AR, et al. Relationship between FLT3 mutation status, biologic characteristics, and response to targeted therapy in acute promyelocytic leukemia. *Blood* 2005;106:3768-3776.
70. Schnittger S, Bacher U, Haferlach C, Kern W, Alpermann T, Haferlach T. Clinical impact of FLT3 mutation load in acute promyelocytic leukemia with t(15;17)/PML-RARA. *Haematologica* 2011;96:1799-1807.
71. Choudhary C, Schwable J, Brandts C, et al. AML-associated Flt3 kinase domain mutations show signal transduction differences compared with Flt3 ITD mutations. *Blood* 2005;106:265-273.
72. Grundler R, Miething C, Thiede C, Peschel C, Duyster J. FLT3-ITD and tyrosine kinase domain mutants induce 2 distinct phenotypes in a murine bone marrow transplantation model. *Blood* 2005;105:4792-4799.
73. Guidez F, Ivins S, Zhu J, Söderström M, Waxman S, Zelent A. Reduced Retinoic Acid-Sensitivities of Nuclear Receptor Corepressor Binding to PML- and PLZF-RAR α Underlie Molecular Pathogenesis and Treatment of Acute Promyelocytic Leukemia. *Blood* 1998;91:2634-2642.
74. Heinzl T, Lavinsky RM, Mullen TM, et al. A complex containing N-CoR, mSin3 and histone deacetylase mediates transcriptional repression. *Nature* 1997;387:43-48.
75. Hong SH, David G, Wong CW, Dejean A, Privalsky ML. SMRT corepressor interacts with PLZF and with the PML-retinoic acid receptor alpha (RARalpha) and PLZF-RARalpha oncoproteins associated with acute promyelocytic leukemia. *Proc Natl Acad Sci U S A* 1997;94:9028-9033.
76. Lin RJ, Nagy L, Inoue S, Shao W, Miller WH Jr, Evans RM. Role of the histone deacetylase complex in acute promyelocytic leukaemia. *Nature* 1998;391:811-814.
77. Utley RT, Ikeda K, Grant PA, et al. Transcriptional activators direct histone acetyltransferase complexes to nucleosomes. *Nature* 1998;394:498-502.
78. Rego EM, Wang ZG, Peruzzi D, He LZ, Cordon-Cardo C, Pandolfi PP. Role of promyelocytic leukemia (PML) protein in tumor suppression. *J Exp Med* 2001;193:521-529.
79. Wang ZG, Delva L, Gaboli M, et al. Role of PML in cell growth and the retinoic acid pathway. *Science* 1998;279:1547-1551.
80. Wang ZG, Ruggero D, Ronchetti S, et al. PML is essential for multiple apoptotic pathways. *Nat Genet* 1998;20:266-272.
81. Lo Coco F, Diverio D, Pandolfi PP, et al. Molecular evaluation of residual disease as a predictor of relapse in acute promyelocytic leukaemia. *Lancet* 1992;340:1437-1438.

82. Miller WH Jr, Kakizuka A, Frankel SR, et al. Reverse transcription polymerase chain reaction for the rearranged retinoic acid receptor alpha clarifies diagnosis and detects minimal residual disease in acute promyelocytic leukemia. *Proc Natl Acad Sci U S A* 1992;89:2694-2698.
83. Miller WJ, Levine K, DeBlasio A, Frankel S, Dmitrovsky E, Warrell RJ. Detection of minimal residual disease in acute promyelocytic leukemia by a reverse transcription polymerase chain reaction assay for the PML/RAR-alpha fusion mRNA. *Blood* 1993;82:1689-1694.
84. Breccia M, Diverio D, Noguera NI, et al. Clinico-biological features and outcome of acute promyelocytic leukemia patients with persistent polymerase chain reaction-detectable disease after the AIDA front-line induction and consolidation therapy. *Haematologica* 2004;89:29-33.
85. Diverio D, Rossi V, Avvisati G, et al. Early detection of relapse by prospective reverse transcriptase-polymerase chain reaction analysis of the PML/RAR α fusion gene in patients with acute promyelocytic leukemia enrolled in the GIMEMA-AIEOP multicenter "AIDA" trial. *Blood* 1998;92:784-789.
86. Grimwade D, Howe K, Langabeer S, Burnett A, Goldstone A, Solomon E. Minimal residual disease detection in acute promyelocytic leukemia by reverse-transcriptase PCR: evaluation of PML-RAR alpha and RAR alpha-PML assessment in patients who ultimately relapse. *Leukemia* 1996;10:61-66.
87. Coco FL, Diverio D, Avvisati G, et al. Therapy of molecular relapse in acute promyelocytic leukemia. *Blood* 1999;94:2225-2229.
88. Park JH, Qiao B, Panageas KS, et al. Early death rate in acute promyelocytic leukemia remains high despite all-trans retinoic acid. *Blood* 2011;118:1248-1254.
89. Hughes WT, Armstrong D, Bodey GP, et al. 2002 guidelines for the use of antimicrobial agents in neutropenic patients with cancer. *Clin Infect Dis* 2002;34:730-751.
90. Rodeghiero F, Avvisati G, Castaman G, Barbui T, Mandelli F. Early deaths and anti-hemorrhagic treatments in acute promyelocytic leukemia. A GIMEMA retrospective study in 268 consecutive patients. *Blood* 1990;75:2112-2117.
91. Yanada M, Matsushita T, Asou N, et al. Severe hemorrhagic complications during remission induction therapy for acute promyelocytic leukemia: incidence, risk factors, and influence on outcome. *Eur J Haematol* 2007;78:213-219.
92. Tallman M, Kwaan H. Reassessing the hemostatic disorder associated with acute promyelocytic leukemia [see comments]. *Blood* 1992;79:543-553.
93. Schwartz BS, Williams EC, Conlan MG, Mosher DF. Epsilon-aminocaproic acid in the treatment of patients with acute promyelocytic leukemia and acquired alpha-2-plasmin inhibitor deficiency. *Ann Intern Med* 1986;105:873-877.
94. Stone R, Maguire M, Goldberg M, Antin J, Rosenthal D, Mayer R. Complete remission in acute promyelocytic leukemia despite persistence of abnormal bone marrow promyelocytes during induction therapy: experience in 34 patients. *Blood* 1988;71:690-696.
95. Cheson BD, Cassileth PA, Head DR, et al. Report of the National Cancer Institute-sponsored workshop on definitions of diagnosis and response in acute myeloid leukemia. *J Clin Oncol* 1990;8:813-819.
96. Huang M, Ye Y, Chen S, et al. Use of all-trans retinoic acid in the treatment of acute promyelocytic leukemia. *Blood* 1988;72:567-572.
97. Miyauchi J, Ohyashiki K, Inatomi Y, Toyama K. Neutrophil secondary-granule deficiency as a hallmark of all-trans retinoic acid-induced differentiation of acute promyelocytic leukemia Cells. *Blood* 1997;90:803-813.
98. Warrell RP Jr, Frankel SR, Miller WH Jr, et al. Differentiation therapy of acute promyelocytic leukemia with tretinoin (all-trans-retinoic acid). *N Engl J Med* 1991;324:1385-1393.
99. Carosino I, Latagliata R, Avvisati G, et al. Arsenic trioxide in the treatment of advanced acute promyelocytic leukemia. *Haematologica* 2004;89:615-617.
100. Shigeno K, Naito K, Sahara N, et al. Arsenic trioxide therapy in relapsed or refractory Japanese patients with acute promyelocytic leukemia: updated outcomes of the phase II study and postremission therapies. *Int J Hematol* 2005;82:224-229.
101. Soignet SL, Frankel SR, Douer D, et al. United States Multicenter Study of arsenic trioxide in relapsed acute promyelocytic leukemia. *J Clin Oncol* 2001;19:3852-3860.

102. Ades L, Chevret S, Raffoux E, et al. Is cytarabine useful in the treatment of acute promyelocytic leukemia? Results of a randomized trial from the European Acute Promyelocytic Leukemia Group. *J Clin Oncol* 2006;24:5703-5710.

P.1672

103. Sanz MA, Vellenga E, Rayon C, et al. All-trans retinoic acid and anthracycline monochemotherapy for the treatment of elderly patients with acute promyelocytic leukemia. *Blood* 2004;104:3490-3493.

104. Bolufer P, Barragan E, Sanz MA, et al. Preliminary experience in external quality control of RT-PCR PML-RAR alpha detection in promyelocytic leukemia. *Leukemia* 1998;12:2024-2028.

105. Cassinat B, Zassadowski F, Balitrand N, et al. Quantitation of minimal residual disease in acute promyelocytic leukemia patients with t(15;17) translocation using real-time RT-PCR. *Leukemia* 2000;14:324-328.

106. Hillestad LK. Acute promyelocytic leukemia. *Acta Med Scand* 1957;159: 189-194.

107. Fenaux P, Pollet JP, Vandenbossche-Simon L, et al. Treatment of acute promyelocytic leukemia: a report of 70 cases. *Leuk Lymphoma* 1991;4:239-248.

108. Warrell RP, de The H, Wang Z-Y, Degos L. Acute promyelocytic leukemia. *N Engl J Med* 1993;329:177-189.

109. Fenaux P, Chomienne C, Degos L. All-trans retinoic acid and chemotherapy in the treatment of acute promyelocytic leukemia. *Semin Hematol* 2001;38: 13-25.

110. Sanz MA, Jarque I, Martin G, et al. Acute promyelocytic leukemia. Therapy results and prognostic factors. *Cancer* 1988;61:7-13.

111. Bennett B, Booth NA, Croll A, Dawson AA. The bleeding disorder in acute promyelocytic leukaemia: fibrinolysis due to u-PA rather than defibrination. *Br J Haematol* 1989;71:511-517.

112. Marty M, Ganem G, Fischer J, et al. Acute promyelocytic leukemia: retrospective study of 119 patients treated with daunorubicin. *Nouv Rev Fr Hematol* 1984;26:371-378.

113. Powell BL, Moser B, Stock W, et al. Arsenic trioxide improves event-free and overall survival for adults with acute promyelocytic leukemia: North American Leukemia Intergroup Study C9710. *Blood* 2010;116: 3751-3757.

114. Berman E, Wiernik P, Vogler R, Velez-Garcia E, Bartolucci A, Whaley FS. Long-term follow-up of three randomized trials comparing idarubicin and daunorubicin as induction therapies for patients with untreated acute myeloid leukemia. *Cancer* 1997;80:2181-2185.

115. O'Brien TA, Russell SJ, Vowels MR, et al. Results of consecutive trials for children newly diagnosed with acute myeloid leukemia from the Australian and New Zealand Children's Cancer Study Group. *Blood* 2002;100:2708-2716.

116. Avvisati G, Mandelli F, Petti MC, et al. Idarubicin (4-demethoxydaunorubicin) as single agent for remission induction of previously untreated acute promyelocytic leukemia: a pilot study of the Italian cooperative group GIMEMA. *Eur J Haematol* 1990;44:257-260.

117. Petti MC, Avvisati G, Amadori S, et al. Acute promyelocytic leukemia: clinical aspects and results of treatment in 62 patients. *Haematologica* 1987; 72:151-155.

118. Avvisati G, Petti MC, Lo-Coco F, et al. Induction therapy with idarubicin alone significantly influences event-free survival duration in patients with newly diagnosed hypergranular acute promyelocytic leukemia: final results of the GIMEMA randomized study LAP 0389 with 7 years of minimal follow-up. *Blood* 2002;100:3141-3146.

119. Sanz MA, Martin G, Rayón C, et al. A modified AIDA protocol with anthracycline-based consolidation results in high antileukemic efficacy and reduced toxicity in newly diagnosed PML/RAR α -positive acute promyelocytic leukemia. *Blood* 1999;94:3015-3021.

120. Huang ME, Ye YC, Chen SR, et al. All-trans retinoic acid with or without low dose cytosine arabinoside in acute promyelocytic leukemia. Report of 6 cases. *Chin Med J* 1987;100:949-953.

121. Fenaux P, Le Deley M, Castaigne S, et al. Effect of all transretinoic acid in newly diagnosed acute promyelocytic leukemia. Results of a multicenter randomized trial. European APL 91 Group. *Blood* 1993;82:3241-3249.

122. Lo Coco F, Avvisati G, Diverio D, et al. Molecular evaluation of response to all-trans-retinoic acid therapy in patients with acute promyelocytic leukemia. *Blood* 1991;77:1657-1659.
123. Castaigne S, Lefebvre P, Chomienne C, et al. Effectiveness and pharmacokinetics of low-dose all-trans retinoic acid (25 mg/m²) in acute promyelocytic leukemia. *Blood* 1993;82:3560-3563.
124. Chen GQ, Shen ZX, Wu F, et al. Pharmacokinetics and efficacy of low-dose all-trans retinoic acid in the treatment of acute promyelocytic leukemia. *Leukemia* 1996;10:825-828.
125. Castaigne S, Chomienne C, Daniel M, et al. All-trans retinoic acid as a differentiation therapy for acute promyelocytic leukemia. I. Clinical results [see comments]. *Blood* 1990;76:1704-1709.
126. Frankel SR, Eardley A, Heller G, et al. All-trans retinoic acid for acute promyelocytic leukemia. Results of the New York study. *Ann Intern Med* 1994;120:278-286.
127. Warrell RP Jr, Maslak P, Eardley A, Heller G, Miller WH Jr, Frankel SR. Treatment of acute promyelocytic leukemia with all-trans retinoic acid: an update of the New York experience. *Leukemia* 1994;8:929-933.
128. Kanamaru A, Takemoto Y, Tanimoto M, et al. All-trans retinoic acid for the treatment of newly diagnosed acute promyelocytic leukemia. Japan Adult Leukemia Study Group [see comments]. *Blood* 1995;85:1202-1206.
129. Fenaux P, Chastang C, Chevret S, et al. A randomized comparison of all transretinoic acid (ATRA) followed by chemotherapy and ATRA plus chemotherapy and the role of maintenance therapy in newly diagnosed acute promyelocytic leukemia. *Blood* 1999;94:1192-1200.
130. Ades L, Guerci A, Raffoux E, et al. Very long-term outcome of acute promyelocytic leukemia after treatment with all-trans retinoic acid and chemotherapy: the European APL Group experience. *Blood* 2010;115:1690-1696.
131. de Botton S, Chevret S, Coiteux V, et al. Early onset of chemotherapy can reduce the incidence of ATRA syndrome in newly diagnosed acute promyelocytic leukemia (APL) with low white blood cell counts: results from APL 93 trial. *Leukemia* 2003;17:339-342.
132. Tallman MS, Nabhan C, Feusner JH, Rowe JM. Acute promyelocytic leukemia: evolving therapeutic strategies. *Blood* 2002;99:759-767.
133. Avvisati G, Lo-Coco F, Paoloni FP, et al. AIDA 0493 protocol for newly diagnosed acute promyelocytic leukemia: very long-term results and role of maintenance. *Blood* 2011;117:4716-4725.
134. Testi AM, Biondi A, Lo Coco F, et al. GIMEMA-AIEOPAIDA protocol for the treatment of newly diagnosed acute promyelocytic leukemia (APL) in children. *Blood* 2005;106:447-453.
135. Adès L, Sanz MA, Chevret S, et al. Treatment of newly diagnosed acute promyelocytic leukemia (APL): a comparison of French-Belgian-Swiss and PETHEMA results. *Blood* 2008;111:1078-1084.
136. Warrell RP Jr. Retinoid resistance in acute promyelocytic leukemia: new mechanisms, strategies, and implications: *Blood*. 1993;82(7):1949-1953.
137. Li Y, Said F, Gallagher R. Retinoic acid-resistant HL-60 cells exclusively contain mutant retinoic acid receptor-alpha. *Blood* 1994;83:3298-3302.
138. Robertson K, Emami B, Collins S. Retinoic acid-resistant HL-60R cells harbor a point mutation in the retinoic acid receptor ligand-binding domain that confers dominant negative activity. *Blood* 1992;80:1885-1889.
139. Warrell RP Jr. Pathogenesis and management of acute promyelocytic leukemia. *Annu Rev Med* 1996;47:555-565.
140. Marasca R, Zucchini P, Galimberti S, et al. Missense mutations in the PML/RARalpha ligand binding domain in ATRA-resistant As(2)O(3) sensitive relapsed acute promyelocytic leukemia. *Haematologica* 1999;84:963-968.
141. Gallagher RE, Moser BK, Racevskis J, et al. Treatment-influenced associations of PML-RARalpha mutations, FLT3 mutations and additional chromosome abnormalities in relapse acute promyelocytic leukemia. *Blood* 2012.
142. Gallagher RE, Schachter-Tokarz EL, Zhou DC, et al. Relapse of acute promyelocytic leukemia with PML-RARalpha mutant subclones independent of proximate all-trans retinoic acid selection pressure. *Leukemia* 2006;20:556-562.
143. Muindi J, Frankel SR, Miller WH Jr, et al. Continuous treatment with all-trans retinoic acid causes a progressive reduction in plasma drug concentrations: implications for relapse and retinoid "resistance" in patients with acute promyelocytic leukemia. *Blood* 1992;79:299-303.

144. Muindi JF, Scher HI, Rigas JR, Warrell RP Jr, Young CW. Elevated plasma lipid peroxide content correlates with rapid plasma clearance of all-trans-retinoic acid in patients with advanced cancer. *Cancer Res* 1994;54:2125-2128.
145. Lo-Coco F, Avvisati G, Vignetti M, et al. Front-line treatment of acute promyelocytic leukemia with AIDA induction followed by risk-adapted consolidation for adults younger than 61 years: results of the AIDA-2000 trial of the GIMEMA Group. *Blood* 2010;116:3171-3179.
146. Sanz MA, Montesinos P, Rayon C, et al. Risk-adapted treatment of acute promyelocytic leukemia based on all-trans retinoic acid and anthracycline with addition of cytarabine in consolidation therapy for high-risk patients: further improvements in treatment outcome. *Blood* 2010;115:5137-5146.
147. Sanz MA, Montesinos P, Vellenga E, et al. Risk-adapted treatment of acute promyelocytic leukemia with all-trans retinoic acid and anthracycline mono-chemotherapy: long-term outcome of the LPA 99 multicenter study by the PETHEMA Group. *Blood* 2008;112:3130-3134.
148. Lee S, Kim YJ, Eom KS, et al. The significance of minimal residual disease kinetics in adults with newly diagnosed PML-RARalpha-positive acute promyelocytic leukemia: results of a prospective trial. *Haematologica* 2006;91:671-674.
149. Burnett AK, Grimwade D, Solomon E, Wheatley K, Goldstone AH. Presenting white blood cell count and kinetics of molecular remission predict prognosis in acute promyelocytic leukemia treated with all-trans retinoic acid: result of the randomized MRC trial. *Blood* 1999;93:4131-4143.
150. Lengfelder E, Reichert A, Schoch C, et al. Double induction strategy including high dose cytarabine in combination with all-trans retinoic acid: effects in patients with newly diagnosed acute promyelocytic leukemia. German AML Cooperative Group. *Leukemia* 2000;14:1362-1370.
151. Schlenk RF, Germing U, Hartmann F, et al. High-dose cytarabine and mitoxantrone in consolidation therapy for acute promyelocytic leukemia. *Leukemia* 2005;19:978-983.
152. Kantarjian HM, Keating MJ, Walters RS, Smith TL, McCredie KB, Freireich EJ. Role of maintenance chemotherapy in acute promyelocytic leukemia. *Cancer* 1987;59:1258-1263.
153. Asou N, Kishimoto Y, Kiyoi H, et al. A randomized study with or without intensified maintenance chemotherapy in patients with acute promyelocytic leukemia who have become negative for PML-RARalpha transcript after consolidation therapy: the Japan Adult Leukemia Study Group (JALSG) APL97 study. *Blood* 2007;110:59-66.
154. Powell BL, Moser BK, Stock W, et al. Adding mercaptopurine and methotrexate to alternate week atra maintenance therapy does not improve the outcome for adults with acute promyelocytic leukemia (apl) in first remission: results from North American Leukemia Intergroup Trial C9710. *ASH Annu Meeting Abstr* 2011;118:258.
155. De Botton S, Dombret H, Sanz M, et al. Incidence, clinical features, and outcome of alltrans-retinoic acid syndrome in 413 cases of newly diagnosed acute promyelocytic leukemia. *Blood* 1998;92:2712-2718.
156. Frankel SR, Eardley A, Lauwers G, Weiss M, Warrell JRP. The "retinoic acid syndrome" in acute promyelocytic leukemia. *Ann Intern Med* 1992; 117:292-296.
157. Montesinos P, Bergua JM, Vellenga E, et al. Differentiation syndrome in patients with acute promyelocytic leukemia treated with all-trans retinoic acid and anthracycline chemotherapy: characteristics, outcome, and prognostic factors. *Blood* 2009;113:775-783.
158. Zhang Z, Tarone G, Turner DC. Expression of integrin alpha 1 beta 1 is regulated by nerve growth factor and dexamethasone in PC12 cells. Functional consequences for adhesion and neurite outgrowth. *J Biol Chem* 1993;268:5557-5565.
159. Wiley JS, Firkin FC. Reduction of pulmonary toxicity by prednisolone prophylaxis during all-trans retinoic acid treatment of acute promyelocytic leukemia. Australian Leukaemia Study Group. *Leukemia* 1995;9:774-778.
160. Ko BS, Tang JL, Chen YC, et al. Extramedullary relapse after all-trans retinoic acid treatment in acute promyelocytic leukemia—the occurrence of retinoic acid syndrome is a risk factor. *Leukemia* 1999;13:1406-1408.
161. Soignet S, Fleischauer A, Polyak T, Heller G, Warrell RP Jr. All-trans retinoic acid significantly increases 5 years survival in patients with acute promyelocytic leukemia: long-term follow-up of the New York study. *Cancer Chemother Pharmacol* 1997;40:S25-S29.
162. Adamson PC, Bailey J, Pluda J, et al. Pharmacokinetics of all-trans-retinoic acid administered on an intermittent schedule. *J Clin Oncol* 1995;13: 1238-1241.

163. Delva L, Cornic M, Balitrand N, et al. Resistance to all-trans retinoic acid (ATRA) therapy in relapsing acute promyelocytic leukemia: study of in vitro ATRA sensitivity and cellular retinoic acid binding protein levels in leukemic cells [see comments]. *Blood* 1993;82:2175-2181.
164. Mandelli F, Diverio D, Avvisati G, et al. Molecular remission in PML/RAR alpha-positive acute promyelocytic leukemia by combined all-trans retinoic acid and idarubicin (AIDA) therapy. Gruppo Italiano-Malattie Ematologiche Maligne dell'Adulto and Associazione Italiana di Ematologia ed Oncologia Pediatrica Cooperative Groups. *Blood* 1997;90:1014-1021.
165. Thomas X, Dombret H, Cordonnier C, et al. Treatment of relapsing acute promyelocytic leukemia by all-trans retinoic acid therapy followed by timed sequential chemotherapy and stem cell transplantation. APL Study Group. *Acute promyelocytic leukemia*. *Leukemia* 2000;14:1006-1013.
166. Meloni G, Diverio D, Vignetti M, et al. Autologous bone marrow transplantation for acute promyelocytic leukemia in second remission: prognostic relevance of pretransplant minimal residual disease assessment by reverse-transcription polymerase chain reaction of the PML/RAR α fusion gene. *Blood* 1997;90:1321-1325.
167. Kharfan-Dabaja MA, Abou Mourad YR, Fernandez HF, Pasquini MC, Santos ES. Hematopoietic cell transplantation in acute promyelocytic leukemia: a comprehensive review. *Biol Blood Marrow Transplant* 2007;13:997-1004.
168. Shen Z-X, Chen G-Q, Ni J-H, et al. Use of Arsenic Trioxide (As₂O₃) in the treatment of acute promyelocytic leukemia (APL): II. Clinical efficacy and pharmacokinetics in relapsed patients. *Blood* 1997;89:3354-3360.
169. Zhang P, Wang S, Hu L, et al. Arsenic Trioxide treated 72 cases of acute promyelocytic leukemia. *Chinese J Hematol* 1996;2:58-60.
170. Soignet SL, Maslak P, Wang Z-G, et al. Complete remission after treatment of acute promyelocytic leukemia with Arsenic Trioxide. *N Engl J Med* 1998;339:1341-1348.
171. Estey E, Garcia-Manero G, Ferrajoli A, et al. Use of all-trans retinoic acid plus arsenic trioxide as an alternative to chemotherapy in untreated acute promyelocytic leukemia. *Blood* 2006;107:3469-3473.
172. Ghavamzadeh A, Alimoghaddam K, Ghaffari SH, et al. Treatment of acute promyelocytic leukemia with arsenic trioxide without ATRA and/or chemotherapy. *Ann Oncol* 2006;17:131-134.
173. Mathews V, George B, Lakshmi KM, et al. Single-agent arsenic trioxide in the treatment of newly diagnosed acute promyelocytic leukemia: durable remissions with minimal toxicity. *Blood* 2006;107:2627-2632.
174. Shen Z-X, Shi Z-Z, Fang J, et al. All-trans retinoic acid/As₂O₃ combination yields a high quality remission and survival in newly diagnosed acute promyelocytic leukemia. *Proc Natl Acad Sci U S A* 2004;101:5328-5335.
175. Wang G, Li W, Cui J, et al. An efficient therapeutic approach to patients with acute promyelocytic leukemia using a combination of arsenic trioxide with low-dose all-trans retinoic acid. *Hematol Oncol* 2004;22:63-71.
176. Mathews V, George B, Chendamarai E, et al. Single-agent arsenic trioxide in the treatment of newly diagnosed acute promyelocytic leukemia: long-term follow-up data. *J Clin Oncol* 2010;28:3866-3871.
177. Ravandi F, Estey E, Jones D, et al. Effective treatment of acute promyelocytic leukemia with all-trans-retinoic acid, arsenic trioxide, and gemtuzumab ozogamicin. *J Clin Oncol* 2009;27:504-510.
- 177a. Lo-Coco F, Avvisati G, Orlando SM, et al. ATRA and Arsenic Trioxide (ATO) Versus ATRA and Idarubicin (AIDA) for Newly Diagnosed, Non High-Risk Acute Promyelocytic Leukemia (APL): Results of the Phase III, Prospective, Randomized, Intergroup APL0406 Study by the Italian-German Cooperative Groups Gimema-SAL-AMLSG. *ASH Annual Meeting Abstracts* 2012;120:6.
178. Unnikrishnan D, Dutcher JP, Varshneya N, et al. Torsades de pointes in 3 patients with leukemia treated with arsenic trioxide. *Blood* 2001;97:1514-1516.
179. Westervelt P, Brown RA, Adkins DR, et al. Sudden death among patients with acute promyelocytic leukemia treated with arsenic trioxide. *Blood* 2001;98:266-271.
180. Singer J, Kirkhar B, Frank K, et al. Safety experience with trisenox (arsenic trioxide). *Blood* 2003;102:502b (abstract 5767).
181. Douer D, Estey E, Santillana S, et al. Treatment of newly diagnosed and relapsed acute promyelocytic leukemia with intravenous liposomal all-transretinoic acid. *Blood* 2001;97:73-80.

182. Tsimberidou AM, Tirado-Gomez M, Andreeff M, et al. Single-agent liposomal all-trans retinoic acid can cure some patients with untreated acute promyelocytic leukemia: an update of The University of Texas M. D. Anderson Cancer Center Series. *Leuk Lymphoma* 2006;47:1062-1068.
183. Takeshita A, Shinjo K, Naito K, et al. Efficacy of gemtuzumab ozogamicin on ATRA- and arsenic-resistant acute promyelocytic leukemia (APL) cells. *Leukemia* 2005;19:1306-1311.
184. Petti MC, Pinazzi MB, Diverio D, et al. Prolonged molecular remission in advanced acute promyelocytic leukaemia after treatment with gemtuzumab ozogamicin (Mylotarg CMA-676). *Br J Haematol* 2001;115:63-65.
185. Lo-Coco F, Cimino G, Breccia M, et al. Gemtuzumab ozogamicin (Mylotarg) as a single agent for molecularly relapsed acute promyelocytic leukemia. *Blood* 2004;104:1995-1999.
186. Appelbaum FR, Gundacker H, Head DR, et al. Age and acute myeloid leukemia. *Blood* 2006;107:3481-3485.
187. Juliusson G, Antunovic P, Derolf A, et al. Age and acute myeloid leukemia: real world data on decision to treat and outcomes from the Swedish Acute Leukemia Registry. *Blood* 2009;113:4179-4187.
188. Kantarjian H, O'Brien S, Cortes J, et al. Results of intensive chemotherapy in 998 patients age 65 years or older with acute myeloid leukemia or high-risk myelodysplastic syndrome: Predictive prognostic models for outcome. *Cancer* 2006;106:1090-1098.
189. Mandelli F, Latagliata R, Avvisati G, et al. Treatment of elderly patients (> or = 60 years) with newly diagnosed acute promyelocytic leukemia. Results of the Italian multicenter group GIMEMA with ATRA and idarubicin (AIDA) protocols. *Leukemia* 2003;17:1085-1090.
190. Latagliata R, Breccia M, Fazi P, et al. GIMEMA AIDA 0493 amended protocol for elderly patients with acute promyelocytic leukaemia. Long-term results and prognostic factors. *Br J Haematol* 2011;154:564-568.
191. Baer MR, Barcos M, Farrell H, Raza A, Preisler HD. Acute myelogenous leukemia with leukemia cutis. Eighteen cases seen between 1969 and 1986. *Cancer* 1989;63:2192-2200.
192. Liso V, Specchia G, Pogliani EM, et al. Extramedullary involvement in patients with acute promyelocytic leukemia: a report of seven cases. *Cancer* 1998;83:1522-1528.
193. Marra R, Stori S, Pagano L, et al. Central nervous system acute promyelocytic leukaemia: a report of three cases. *Haematologia (Budap)* 1989; 22:195-199.
194. de Botton S, Sanz MA, Chevret S, et al. Extramedullary relapse in acute promyelocytic leukemia treated with all-trans retinoic acid and chemotherapy. *Leukemia* 2006;20:35-41.
195. Menendez A, Gonzalez A, Cabrera H, et al. Clinical spectrum of extramedullary acute promyelocytic leukemia. *Eur J Haematol* 2000;64:201-203.
196. Weiss MA, Warrell RP Jr. Two cases of extramedullary acute promyelocytic leukemia. Cytogenetics, molecular biology, and phenotypic and clinical studies. *Cancer* 1994;74:1882-1886.
197. Di Noto R, Lo Pardo C, Schiavone EM, et al. All-trans retinoic acid (ATRA) and the regulation of adhesion molecules in acute myeloid leukemia. *Leuk Lymphoma* 1996;21:201-209.
198. Evans GD, Grimwade DJ. Extramedullary disease in acute promyelocytic leukemia. *Leuk Lymphoma* 1999;33:219-229.

Chapter 79 The Myelodysplastic Syndromes

> Table of Contents > Part VII - Hematologic Malignancies > Section 2 - The Acute Leukemias > Chapter 79 - The Myelodysplastic Syndromes

Chapter 79

The Myelodysplastic Syndromes

Guillermo Garcia-Manero

ABSTRACT

The myelodysplastic syndromes (MDS) are a very complex group of myeloid disorders characterized by peripheral blood cytopenias and morphologic evidence of dysplasia in bone marrow hematopoietic cellular elements. Over the last decade, significant progress has been made in the understanding of MDS. This includes the discovery of multiple molecular

alterations, resulting in better classifications, the development of new prognostic scores, and newer forms of therapy. Despite these advances, most patients with MDS will succumb either to complications of the disease itself, such as infections or bleeding, or from transformation to acute myelogenous leukemia. In this chapter, I will provide a summary of current knowledge of MDS, including basic epidemiologic and molecular data, prognostic scores, and therapy, including stem cell transplantation.

INTRODUCTION

The myelodysplastic syndromes (MDS) are a very heterogeneous group of myeloid malignancies that result in bone marrow failure and peripheral blood cytopenias.¹ MDS is diagnosed based on the presence of dysplastic features in the bone marrow. Diagnosis is often supported by the presence of cytogenetic alterations and, more recently, genetic mutations. The natural history of patients with MDS is also very heterogeneous, with a small subgroup of patients surviving for long periods of time with minimal intervention and other patients with very poor prognosis that succumb early to the disease either from complications of infections or bleeding or from transformation to acute myelogenous leukemia (AML).^{2,3} Over the last 15 years, the field of MDS has transformed from a rarely studied condition, often considered to be a preleukemia, to the focus of the work of multiple investigators around the world. These efforts have resulted in significant improvements in our understanding of MDS as well as in our ability to treat patients with this group of disorders. Here I will summarize this progress and provide concepts for future work in this area.

Clinical Presentation and Complications of Myelodysplastic Syndrome

The clinical presentation of most patients with MDS is not specific. At the present time, most patients with MDS are diagnosed after a routine examination of peripheral blood. MDS is suspected based on the presence of one or more peripheral blood cytopenias. Although there is no formal data to prove this point, it is my experience that it is uncommon to diagnose patients with MDS because of critically symptomatic anemia, bleeding, or neutropenic fever.⁴ That said, symptoms of anemia, thrombocytopenia, fever, other constitutional symptoms, or unexplained infectious processes can lead to a diagnosis of MDS. The presence of more than one cytopenia should prompt a diagnostic bone marrow evaluation, as will be discussed below. Because the initial clinical differential diagnosis of MDS is broad and includes potentially clinically significant conditions, it is important to perform a thorough evaluation to rule out other conditions that may exclude a diagnosis of MDS or may contribute to the severity of the disease. Common examples include iron deficiency anemia from gastrointestinal sources, hemolysis, and immunemediated cytopenias. Inflammatory clinical syndromes, that can be seen, for instance, in the context of connective tissue disorders,⁵ are also important to be investigated in patients with suggestive clinical manifestations. Drug-induced cytopenias are not uncommon and need to be excluded.⁶ It is also important to realize that all these conditions can overlap. Patients with MDS can have gastrointestinal blood losses that may present with normal to mildly increased red cell volumes. A fraction of patients with MDS may also have evidence of a concomitant hemolytic process. Finally, the diagnosis of MDS should be confirmed after performing a diagnostic test that always includes evaluation of the morphology of a bone marrow specimen.

The natural history of patients with MDS has not been studied in detail. In the earlier phases of the disease it is likely that most of the complications are derived from persistent anemia, thrombocytopenia, and neutropenia. Also, a fraction of patients will progress to either higher-risk MDS or AML. The natural history of patients with higher-risk MDS is probably not different from that of patients with AML. We performed an analysis of the cause of death of patients with lower-risk MDS.³ In this study, we retrospectively analyzed the cause of death in a cohort of 273 deceased patients with lower-risk MDS that presented to MDACC from 1980 to 2004. Patients had received supportive care only. The cause of death was MDS-related in 230 of 273 patients (84%) with the most common events being infection (38%), transformation to AML (15%), and hemorrhage (13%)³ (Fig. 79.1).

Diagnostic Evaluation

A diagnosis of MDS is based on evidence of the presence of dysplastic features on examination of a bone marrow aspirate. At the present time, most investigators use criteria proposed by the World Health Organization (WHO).⁷ This classification has by and large replaced the prior French-American-British system (FAB) that was commonly used before.⁸ By FAB criteria, patients with up to 30% blasts were considered to have MDS. This percentage was decreased to 20% by the WHO classification. It should be noted that WHO should not strictly be used to make treatment decisions, as several of the drugs used in MDS, including decitabine⁹ and azacitidine,¹⁰ were approved based on FAB criteria. WHO classification includes the percentage of blasts in both the bone marrow and peripheral blood, the number of dysplastic lineages, and the presence of ring sideroblasts. It is recommended that 500 nucleated bone marrow cells and 200 from peripheral blood be evaluated. Dysplasia should be present in more than 10% of cells evaluated for each specific lineage. Erythroid dysplasia can affect both the nucleus and the cytoplasm, including the presence of sideroblasts, cellular vacuolization, and

PAS positivity. Dysgranulopoiesis can be represented by alterations in size, nuclear hypolobation, or irregular hypersegmentation. Dysmegakaryopoiesis is often represented by the presence of micromegakaryocytes, hypolobation, or multinucleation. Examination of a bone marrow biopsy specimen, in conjunction with bone marrow aspirate, helps in evaluating bone marrow cellularity and the presence of significant fibrosis, and in making a diagnosis of hypoplastic MDS versus aplastic anemia.¹¹

Based on morphologic criteria, MDS is subclassified into 10 categories (Table 79.1). Bone marrow and peripheral blood findings are also summarized in Table 79.1. A photomicrograph of a representative case of MDS is shown in Figure 79.2. Although morphology is fundamental for diagnosis, and morphologic subsets have different natural histories, morphology by itself is insufficient to make prognostic predictions or to select therapy. Because the diagnosis of MDS can be subjective, several investigators have noted a significant degree of discrepancy in the diagnosis of

P.1674

patients with MDS.¹² In a series of 915 patients with MDS referred to a tertiary care center, discordance in diagnosis using very strict criteria was documented in 12% of patients. A majority of patients were reclassified as having higher-risk disease by the International Prognostic Scoring System (IPSS).² This has obvious implications, as most patients with higher-risk disease will be candidates for some form of therapy. Therefore, it is fundamental for the clinician to have proper documentation of the final morphologic diagnosis both for proper prediction of survival and for therapy selection.

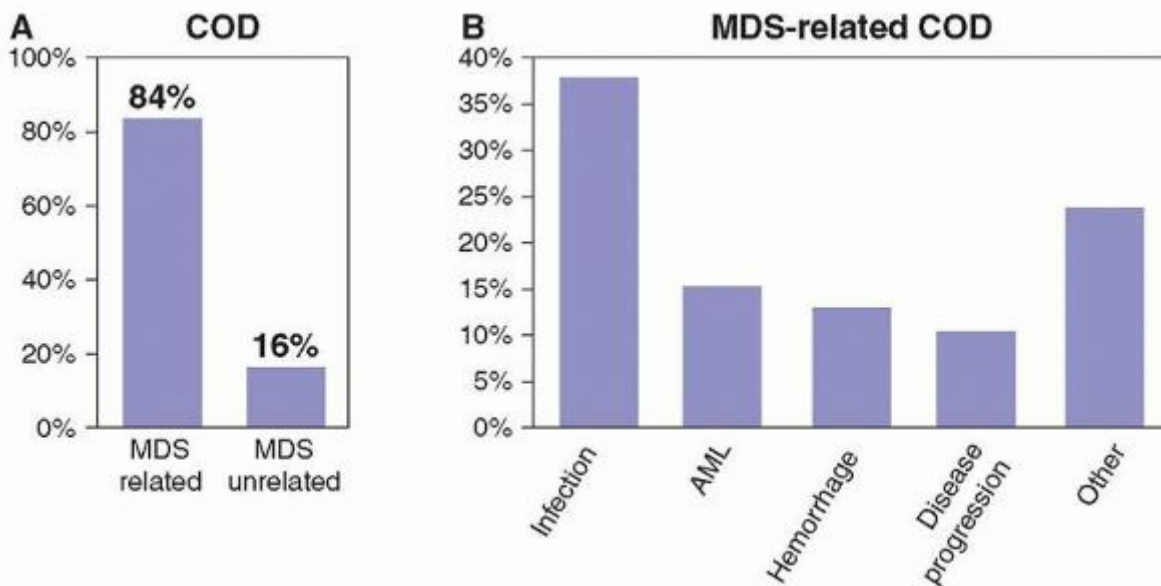

FIGURE 79.1. Cause of death in patients with myelodysplastic syndromes (MDS). A retrospective analysis was performed to determine the cause of death in patients with MDS. As shown in panel A, most patients succumb to causes intrinsic to the disease. B, The most common causes of death are infectious complications, transformation to AML, and bleeding. Adapted from Dayyani F, Conley AP, Strom SS, et al. Cause of death in patients with lowerrisk myelodysplastic syndrome. *Cancer* 2010;116:2174-2179.

TABLE 79.1 WORLD HEALTH ORGANIZATION (WHO) CLASSIFICATION OF MYELODYSPLASTIC SYNDROME (MDS)

Disease	Blood Findings	Bone Marrow Findings
Refractory cytopenias with unilineage dysplasia (RCUD)	Unicytopenia or bicytopenia	Unilineage dysplasia: ≥10% of the cells in one myeloid lineage
Refractory anemia (RA); Refractory neutropenia (RN)	No or rare blasts (<1%)	<5% blasts

Refractory thrombocytopenia (RT)		<15% of erythroid precursors are ring sideroblasts
Refractory anemia with ring sideroblasts (RARS)	Anemia No blasts	≥15% of erythroid precursors are ring sideroblasts Erythroid dysplasia only <5% blasts
Refractory cytopenia with multilineage dysplasia (RCMD)	Cytopenia(s) No or rare blasts (<1%) No Auer rods <1 × 10 ⁹ /L monocytes	Dysplasia in ≥ 10% of the cells in ≥ two myeloid lineages (neutrophil and/or erythroid precursors and/or megakaryocytes) <5% blasts in marrow No Auer rods ±15% ring sideroblasts
Refractory anemia with excess blasts-1 (RAEB-1)	Cytopenia(s) <5% blasts No Auer rods <1 × 10 ⁹ /L monocytes	Unilineage or multilineage dysplasia 5%-9% blasts No Auer rods
Refractory anemia with excess blasts-2 (RAEB-2)	Cytopenia(s) 5%-19% blasts Auer rods ± ³ <1 × 10 ⁹ /L monocytes	Unilineage or multilineage dysplasia 10%-19% blasts Auer rods ± ³
Myelodysplastic syndrome—unclassified (MDS-U)	Cytopenias ≤1% blasts	Unequivocal dysplasia in less than 10% of cells in one or more myeloid cell lines when accompanied by a cytogenetic abnormality considered as presumptive evidence for a diagnosis of MDS (see Table 5.04) <5% blasts
MDS associated with isolated del(5q)	Anemia Usually normal or increased platelet count No or rare blasts (<1%)	Normal to increased megakaryocytes with hypolobated nuclei <5% blasts Isolated del(5q) cytogenetic abnormality No Auer rods

A number of diagnostic tools can help the hematopathologist confirm the diagnosis of MDS and classify the disease. The most important assay, which is mandatory in the evaluation of a patient with MDS, is cytogenetic analysis. There is no specific cytogenetic pattern diagnostic of MDS. Typically, 20 metaphases are required for optimal analysis. That said, it is not uncommon to obtain fewer cells in patients with MDS. The presence of cytogenetic alterations can have both a diagnostic and a prognostic value. For instance, in patients with profound marrow hypocellularity, the presence of

P.1675

a cytogenetic alteration will allow the differentiation of hypoplastic MDS from aplastic anemia.¹¹ Finally, and more

significantly, specific cytogenetic alterations have different prognostic values. A number of cytogenetic classifications have been proposed in patients with MDS. The most recent one is a 5-subgroup classification that forms the basis of the Revised International Prognostic Scoring System (IPSS-R).^{13,14} This cytogenetic scoring system is summarized in Figure 79.3. It is of interest as it further delineates rare cytogenetic alterations with favorable prognostic impact, such as alterations of chromosome 11, and also further defines the weight of alterations of chromosome 7 or complex karyotypes such as those with 3 or more abnormalities. Finally, the presence of specific cytogenetic alterations may help in the selection of specific forms of therapy. A classic example is the presence of deletions of chromosome 5 in patients with the so-called 5q-syndrome.¹⁵ Other alterations, such as chromosome 7 alterations or complex karyotypes may aid the clinician in selecting different forms of therapy with different intensities, such as hypomethylating agents.¹⁰ This is discussed later. A number of groups have proposed the use of fluorescence in situ hybridization (FISH) techniques to aid in the clinical work-up of patients with MDS.¹⁶ At the M.D. Anderson Cancer Center (MDACC), we do not routinely use FISH in MDS because it evaluates only a limited number of chromosomes, and the sensitivity and specificity of the different probes used is not fully understood or standardized. The frequency of cytogenetic alterations depends on risk. For instance, patients in the lower-risk categories by IPSS are diploid in over 50% of cases.¹⁷ This figure increases in patients with more advanced forms of the disease,¹⁸ and over 70% of patients with therapy-related MDS will have a cytogenetic alteration.¹⁹

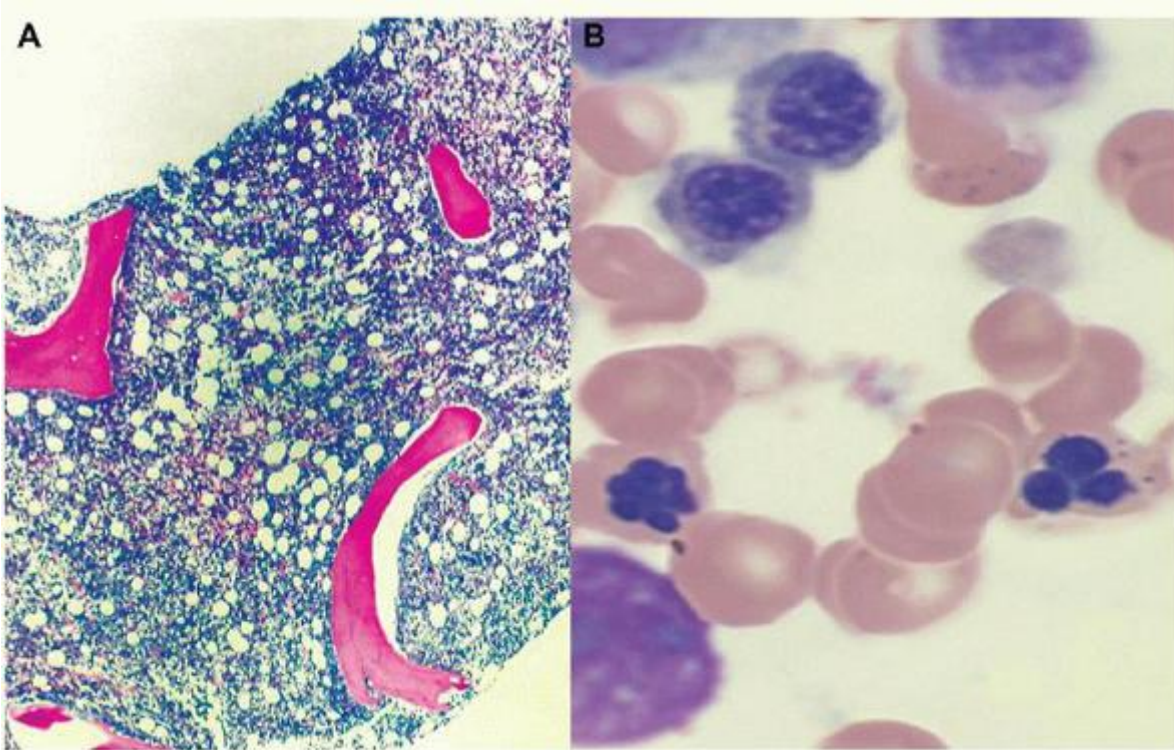

FIGURE 79.2. Representative example of morphologic alteration in MDS. Panel A shows a view of a bone marrow biopsy with almost complete replacement of marrow space with cellular element. Panel B shows a higher magnification of bone marrow aspirate, demonstrating nucleated red cell and micromegakaryocytes characteristic of this disease.

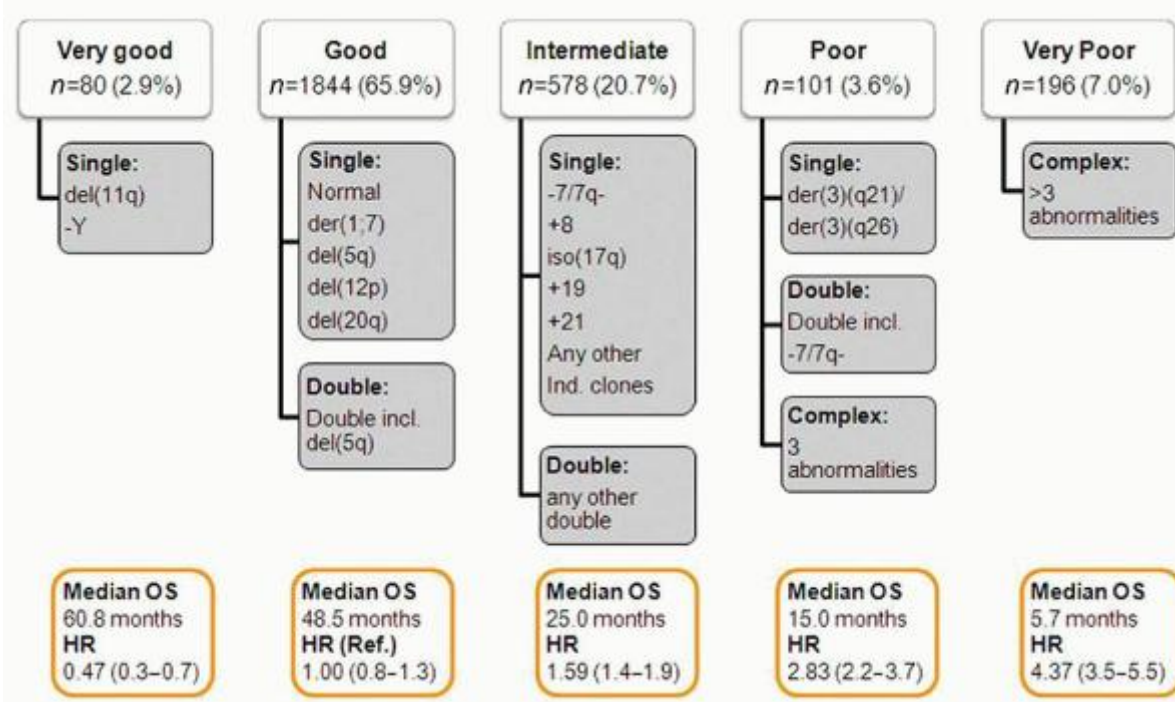

FIGURE 79.3. New 5-subgroup cytogenetic classification of myelodysplastic syndromes (MDS). This new cytogenetic classification divides patients into 5 categories based on their characteristics. Impact on survival is shown for each subset at the bottom of each subgroup. Adapted from Schanz J, et al.¹⁴ J Clin Oncol 2012;30:820-829.

Flow cytometry can help in the confirmation of a diagnosis of MDS, and specific phenotypes may have prognostic value.²⁰ At the present time, there is no flow cytometry panel that is diagnostic of MDS, and flow cytometry cannot replace morphologic examination.²¹ It is not uncommon that clinicians may try to quantitate the percentage of blasts by annotating the number of CD34⁺ cells. Although the number of CD34⁺ cells has been proposed to have prognostic value,^{20,22} it is not an appropriate tool to estimate percentage of blasts and it should be considered only complementary.

Newer genomic technologies are currently being developed that allow the analysis of multiple genetic events in MDS and other

P.1676

cancers. These include next-generation gene sequencing²³ and analysis of single nucleotide polymorphisms.²⁴ Although these assays are of great interest, they are not currently integrated into clinical practice.

Specific Diagnostic Subgroups of Myelodysplastic Syndrome-Related Syndromes: Chronic Myelomonocytic Leukemia and Overlap Myelodysplastic Myeloproliferative Syndromes

Chronic myelomonocytic leukemia (CMML) is considered a distinct clinical entity by the WHO classification and is grouped in the subset of patients with myelodysplastic myeloproliferative neoplasms. This group also includes BCR/ABL negative chronic myelogenous leukemia (CML), MDS/MPN unclassified, juvenile myelomonocytic leukemia, and potentially refractory anemia with ring sideroblasts and thrombocytosis (RARS-T). Traditionally, CMML has been considered 1 subtype of MDS. IPSS² included patients with CMML if the white cell count was less than $12 \times 10^3/L$. From a practical and therapeutic perspective, most clinicians still consider CMML as a subtype of MDS. The natural history of patients with CMML is distinct from that of patients with classic MDS. Patients tend to have higher frequency of B symptoms and extramedullary manifestations of the disease. Tissue infiltration causing hepatic or renal dysfunction is not uncommon. Diagnosis is established by the presence of persistent monocytosis ($>1 \times 10^9/L$) in the peripheral blood without evidence of BCR/ABL fusion genes or PDGFR alterations. Blasts, that include promonocytes, should be less than 20% and dysplasia is routine, although often less pronounced than in other MDS categories. CMML is further divided into CMML-1 and CMML-2 based on the percentage of bone marrow and peripheral blood blasts (CMML-1 is less than 10% bone marrow blasts or less than 5% in peripheral blood; whereas CMML-2 will include cases with more blasts). Cells usually express markers of myelomonocytic differentiation that include CD33 and CD13. Cytogenetic alterations occur as in other cases of MDS, and

the presence of RAS mutations can be observed in up to 40% of patients.²⁵ Another group of disorders are the MDS/MPN unclassified (MDS/MPN-U) disorders. These are of particular interest at this time because of the advent of agents that inhibit JAK2,²⁶ a common molecular alteration in MPN that may explain the proliferative feature of the disease. Although the natural history of patients with MDS/MPN-U is not fully understood, it appears that specific subsets of patients such as those with RARS-T may have a more benign prognosis.²⁷

EPIDEMIOLOGY AND ETIOLOGY

Because of the heterogeneity of MDS and a prior concept that MDS was a preleukemic condition of unclear significance affecting older individuals, there are no robust mature registries of MDS, at least in the US. A number of studies have tried to delineate the incidence and prevalence of MDS. Data from the North American Association of Central Cancer Registries (NAACCR) and the Surveillance, Epidemiology and End Results (SEER) program indicate that the average annual age-adjusted incidence rate of MDS for 2001 through 2003 was 3.3 per 100,000. This translates to approximately 9,700 patients with MDS in the US per year. Of interest, incidence rates increased per year in that analysis. Of importance, only a minority of patients were reported to registries by physicians' offices.²⁸ After this initial study, several other groups have reported higher incidence rates in MDS. For instance, investigators using a claims-based algorithm have reported the incidence of MDS being close to 75 individuals per 100,000 in people over 60 years of age.^{29,30} More recently, Cogle et al. constructed 4 claims-based algorithms to assess MDS incidence and applied them to the 2000 to 2008 SEER-Medicare database.³⁰ Using this approach, the annual incidence of MDS in the US was projected to be 75 per 100,000 persons 65 years or older, much higher than previously estimated. MDS is a disease of aging. The incidence of the disease sharply increases in patients older than 60 years of age, and the median age is 70 years.²⁸ As the age of the population increases, it is expected that MDS may become a major medical problem, at least in developed countries.

The cause of MDS is not known, but there is strong data that suggest that MDS can also be the result of toxic exposure of bone marrow stem cells. A prototypical example is cases secondary to exposure to prior chemotherapy or radiation therapy, i.e., therapy-related (t)-MDS.^{19,31} Therapy-related MDS often is characterized by complex karyotypes and can occur in younger patients. Depending on the type of chemotherapy exposure, different patterns of disease evolution and cytogenetic abnormalities can be documented.³¹ The prognosis of patients with t-MDS is very poor, but it is unclear if this is the result of characteristics intrinsic to the disease or because a large majority of these patients have very complex karyotypes that are associated with poor prognosis. For instance, in therapy-related AML (t-AML), it has been shown that common functional p53-pathway variants such as the MDM2 SNP309 and the TP53 codon 72 polymorphism may be associated with an increased risk of developing t-AML.³² This data is of significance as it suggests that predisposing molecular features are involved in the development of therapy-related myeloid malignancies.³³ At MDACC, we evaluated the characteristics of patients with t-MDS. We studied 281 patients with MDS that had received prior chemotherapy and/or radiotherapy for prior malignancy. Multivariate Cox regression analysis identified 7 factors that independently predicted short survival in t-MDS: age \geq 65 years (HR = 1.63), ECOG performance status 2 to 4 (HR = 1.86), poor cytogenetics (-7 and/or complex; HR = 2.47), WHO MDS subtype (RARS or RAEB-1/2; HR = 1.92), hemoglobin (<11 g/dl; HR = 2.24), platelets ($<50 \times 10^9$ /dl; HR = 2.01), and transfusion dependency (HR = 1.59). These risk factors were used to create a prognostic model that segregated patients into three groups with distinct median overall survival: good (0 to 2 risk factors; 34 months), intermediate (3 to 4 risk factors; 12 months), and poor (5 to 7 risk factors; 5 months) ($p < 0.001$); and 1-year leukemia-free survival (96%, 84%, and 72%, respectively, $p = 0.003$). This model also identified distinct survival groups according to t-MDS therapy.

A number of epidemiologic studies have suggested that environmental factors play a role in the development of MDS. Recently, a pooled analysis studied the effects of benzene exposure in oil workers. Exposure to benzene was associated with MDS. High benzene exposure (>3 ppm) was associated with a risk of MDS (OR = 6.32, 95% CI = 1.32 to 30.2). Of interest, no association was observed with AML.³⁴ In a hospital-based case-control study of 354 adult de novo MDS cases and 452 controls, a family history of hematopoietic cancer (odds ratio [OR] = 1.92), smoking (OR = 1.65), and exposure to agricultural chemicals (OR = 4.55) or solvents (OR = 2.05) were associated with MDS risk. For patients with lower-risk disease (RA/RARS) only smoking (OR = 2.23) and agricultural chemical exposure (OR = 5.68) were identified. For patients with higher-risk disease (RAEB/RAEBT), a family history of hematopoietic cancer (OR = 2.10), smoking (OR = 1.52), and exposure to agricultural chemicals (OR = 3.79) or solvents (OR = 2.71) were independent risk factors. Drinking wine reduced risk for all FAB types by almost 50% (OR = 0.54). A joint effect between smoking and chemical exposure was observed, with the highest risk among smokers exposed to solvents/agricultural chemicals (OR = 3.22).³⁵

Finally, a number of genetic syndromes associated with bone marrow failure were recently associated with the development

of MDS.³⁶ Of importance, several of these disorders are ribosomopathies characterized by altered ribosome biogenesis and function.³⁷ Syndromes in this category include Diamond-Blackfan anemia, Schwachman-Diamond syndrome, dyskeratosis congenita, cartilage hair hypoplasia, and Treacher Collins syndrome.³⁷ Haploinsufficiency in ribosomal genes, such as RPS14, are also implicated in the pathogenesis of the 5q-syndrome, thus providing further linkage between these conditions.³⁸ Patients with Fanconi anemia are also at increased risk of developing MDS.³⁹ Mutations in Runx1 have been described in MDS of patients with Fanconi anemia.⁴⁰

A number of rare familial syndromes have been reported. For instance, germline mutations in Runx1 have been shown to occur in families characterized by thrombocytopenia and increased risk of developing MDS and AML.⁴¹ Mutations are more common in the DNA binding domain or N-terminus of the gene. The median incidence of MDS/AML among carriers of RUNX1 mutation was 35%.⁴² It should be noted that not all family members with the mutation had low platelet counts.⁴² It should also be noted that allogeneic stem cell transplantation (SCT) was associated with a high rate of complications.⁴² Therefore SCT cannot be recommended in all patients at risk. Because mutational analysis of Runx1 is not commonly performed in clinical practice, it is possible that there are more individuals and families affected by this type of familial syndrome. Younger patients with thrombocytopenia or MDS should be screened for Runx1 mutations. Germline mutations in GATA-2 have also been involved in a familial syndrome of MDS/AML, MonoMAC, and lymphedema.⁴³ MonoMAC is an autosomal dominant syndrome associated with monocytopenia; B and NK cell lymphopenia; and mycobacterial, fungal, and viral infections. This syndrome is also associated with pulmonary alveolar proteinosis.⁴⁴

Molecular Pathogenesis

The cause of MDS is not known but remains strongly linked to senescence. Over the last 5 years we have gained significant knowledge in both genetic and epigenetic alterations that characterize MDS. This information is of great significance and is going to aid not only in understanding the molecular bases of MDS but also in developing molecularly based classifications of MDS, as well as in developing new targeted interventions for patients with MDS.

The molecular analysis of MDS has been revolutionized by the advent of powerful new sequencing techniques. Using these technologies, several groups have reported a large number of genetic mutations in patients with MDS.^{23,45} A list is shown in Table 79.2. The most frequent events are genes involved in control of gene splicing^{46, 47} and⁴⁸ and epigenetic regulators⁴⁹ such as TET2^{45,50} or ASXL1^{45,51} or EZH2.^{45,52} At the present time, it is not known why splicing mutations are so prevalent in MDS and what the downstream effects of these mutations are. The mutations on epigenetic regulators are of special interest. TET2 mutations were first identified in myeloid leukemia but their functional relevance or clinical impact was unknown.^{50,53} The presence of mutations in the TET family was rapidly confirmed by several groups.⁵³ TET2 is located on chromosome 4q24 and has been shown to have a role in the control of DNA hydroxymethylation.^{54,55} Therefore it is likely that patients with mutations in TET2 will have abnormal DNA methylation patterns that could broadly impact gene expression patterns in MDS. It has been shown that TET2 has a role in the homeostasis of hematopoietic stem cells.^{56,57} Although the prognostic impact of TET2 is not clear at this time, data from several groups has suggested that the presence of TET2 mutations may be associated with response to azacitidine.⁵⁸ EZH2 is located on chromosome 7 and is a member of the Polycomb group family. It is a histone 3 k27 methylase and therefore is also involved in the control of epigenetic gene repression. In contrast with EZH2 mutations described in lymphoma⁵⁹ that are activating, EZH2 mutations in MDS inactivate the gene. Mutations in EZH2 are associated with a poor prognosis, particularly in patients with lower-risk MDS.⁶⁰ Although the analysis of current genetic data in MDS is in flux, it is becoming apparent that specific molecular pathways may separate different subsets of patients. For instance, in the analysis of Bejar et al.,⁴⁵ patients could be separated into 2 major subgroups: those with p53 mutations and complex cytogenetics, and those without p53 mutations⁴⁵ (Fig. 79.4). These results should be considered as preliminary, as it is likely that ongoing studies using whole genome sequencing technologies will uncover additional mutations that will provide a deeper insight into the biology of MDS.

TABLE 79.2 REPORTED FREQUENCY OF GENETIC LESIONS IN MDS

Gene	%	Location	Function
<i>SF3B1</i>	28	2q33	Splicing factor
<i>TET2</i>	21	4q24	Control of cytosine hydroxymethylation
<i>ASXL1</i>	14	20q11	Epigenetic regulator
<i>SRSF2</i>	12	17q25	Splicing factor

<i>RUNX1</i>	9 21q22	Transcription factor
<i>TP53</i>	8 17p13	Transcription factor
<i>U2AF1</i>	7 21q22	Splicing factor
<i>EZH2</i>	6 7q36	Polycomb group protein
<i>NRAS</i>	4 1p13	Signal transduction
<i>JAK2</i>	3 9p24	Tyrosine kinase
<i>ETV6</i>	3 12p13	Transcription factor
<i>CBL</i>	2 11q23	Signal transduction
<i>IDH2</i>	2 15q26	Cell metabolism, epigenetic regulation
<i>NPM1</i>	2 5q35	Phosphoprotein
<i>IDH1</i>	1 2q33	As IDH1
<i>KRAS</i>	<112p12	Signal transduction
<i>GNAS</i>	<120q13	G protein
<i>PTPN11</i>	<112q24	Protein phosphatase
<i>BRAF</i>	<17q34	Raf kinase
<i>PTEN</i>	<110q23	Phosphatase
<i>CDKN2A</i>	<19q121	Cell cycle control

Together with genetic alterations, epigenetic lesions, in particular aberrant DNA methylation of promoter CpG islands, have been reported in MDS. Aberrant DNA methylation is common both in AML⁶¹ and MDS.⁶² This observation has promoted significant interest in the use of hypomethylating agents in MDS, which is discussed below. Although aberrant DNA methylation is common in MDS, whether specific methylation patterns are associated with response to these agents or with overall outcome is not fully understood. In a study by Shen et al.⁶² patients with higher methylation scores had worse survival. Further studies correlating methylation and hydroxymethylation patterns with genetic alterations are needed in MDS and other leukemias to clarify these important concepts.

Prognostic Classifications

A number of clinical and variable characteristics are associated with prognosis in MDS. These include percentage of marrow blasts captured by the FAB classification, cytogenetics (discussed above), age, molecular alterations, presence of bone

P.1678

fibrosis, number of marrow CD34⁺ cells, LDH, ferritin, and beta 2 microglobulin, to name a few. Prognostic stratification has an important role in MDS. One can consider this as a static concept helping the clinician predict survival and risk of transformation at the time of initial presentation without including the impact of any therapy. Other systems may allow prognostic calculation in a dynamic fashion by permitting sequential application during the life of the patient. And finally prognostic models may incorporate calculations of the impact of responses and or survival and response durations for a specific form of therapy. A number of classifications exist that fulfill one or more of these criteria. Until 2012, the standard prognostic classification system for patients with MDS was the IPSS.² This model was developed in 1997 by Greenberg et al. and included a cohort of 880 patients that had not received prior therapy. This model has been the basis of most clinical research performed in the field over the last 20 years and therefore is of significant importance. Because IPSS is based on FAB morphologic criteria, in particular the percentage of marrow blasts up to 30%, and most currently approved drugs use either IPSS or FAB for their approval, IPSS still is of significant practical importance. IPSS is summarized in Table 79.3. IPSS has several limitations, the most important being that it underestimates the importance of the severity of cytopenias and it places too much weight on the percentage of blasts at the expense of cytogenetic alterations. Because of these limitations, a number of newer classifications have been developed by several groups. Examples include the

WHO-based prognostic scoring system (WPSS) system⁶³ and the Global MD Anderson Cancer (MDACC) model.¹⁸ That said, neither of these latter two models have been formally accepted

P.1679

by all groups. Because of this, a very large international effort was initiated approximately 4 years ago to develop a new international MDS scoring system. This system is known as IPSS-R,¹³ or revised IPSS, and was recently published.¹³ IPSS-R is summarized in Table 79.4. The major differences between IPSS and IPSS-R is that the latter includes the new 5-subgroup cytogenetic classification discussed above and different cut-offs of cytopenias and percentages of marrow blasts, paralleled by 5 prognostic categories. IPSS-R has not been formally evaluated in a prospective fashion and has not yet been tested in patients receiving active therapy. Also, IPSS-R does not include molecular data and therefore is likely to be revised in the near future once large-scale mutational analyses are incorporated into routine clinical practice.

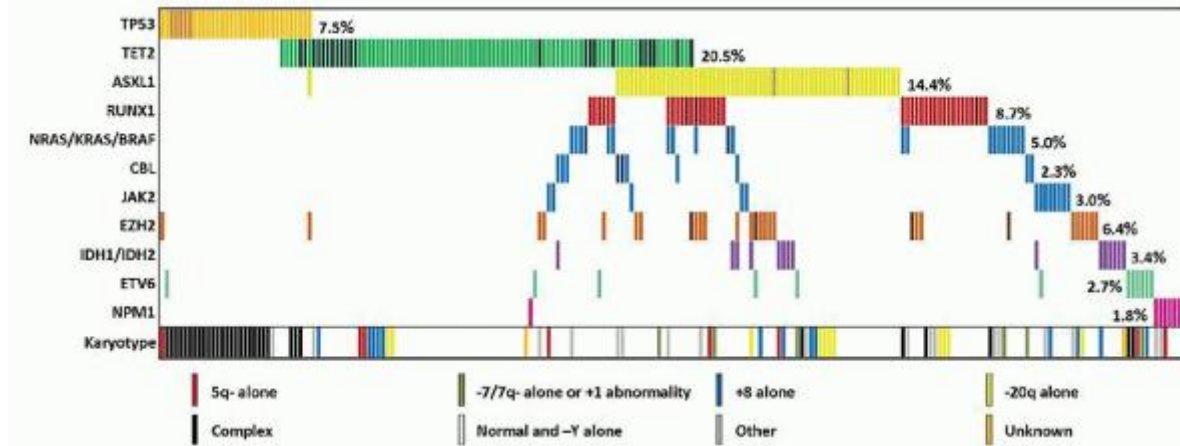

FIGURE 79.4. Distribution of mutations in myelodysplastic syndromes (MDS). Bejar et al. performed an analysis of mutation status in a cohort of 439 patients with MDS. Each row represents a gene, and at the bottom, the cytogenetic characteristics for each patient. Each column represents a patient. Adapted from Bejar R, Stevenson K, Abdel-Wahab O, et al. Clinical effect of point mutations in myelodysplastic syndromes. N Engl J Med 2011;364:2496-2506.

TABLE 79.3 THE INTERNATIONAL PROGNOSTIC SCORING SYSTEM

A: IPSS score is the sum of the three listed prognostic factors

Score	0	0.5	1	1.5	2
BM blasts (%)	<5	5-10	—	11-20	21-30
Karyotype*	Good	Intermediate	Poor		
Cytopenias	0/1	2/3			

* Good: normal, -Y, del(5q), del(20q); Poor: complex (≥3 abnormalities) or chromosome 7 anomalies; Intermediate: other abnormalities
 Cytopenias defined as hemoglobin concentration < 10 g/dl, neutrophils < 1.5 × 10⁹/L, and platelets < 100 × 10⁹/L

B: Prognosis determined by IPSS score

Risk group	IPSS score	Median survival (years)			
		≤60 y	>60 y	≤70 y	>70 y
Low	0	11.84.8	9	3.9	
Intermediate-1	0.5-1.0	5.22.7	4.4	2.4	
Intermediate-2	1.5-2.0	1.81.1	1.3	1.2	
High	≥ 2.5	0.30.5	0.4	0.4	

Adapted from Greenberg P, Cox C, LeBeau MM, et al. International scoring system for evaluating prognosis in myelodysplastic syndromes. *Blood* 1997;89:2079-2088.

Identification of Patients with “Lower-risk Disease” and Poor Prognosis

Until recently, most investigators have recommended two types of approaches to patients with MDS. Patients in the higher-risk categories, characterized by excess blasts, were recommended therapies similar to those used in AML in an attempt to induce remissions and prolong survival. In contrast, patients with lower-risk disease, low percentage of blasts or cytopenias, have been proposed to undergo interventions to minimize transfusion needs and improve quality of life. Over the last few years, work from several groups has indicated that the prognosis of this group of patients can be very heterogeneous. For instance, the Düsseldorf group reported that the presence of specific cytogenetic alterations, such as those involving chromosomes 5 and 7, were associated with independent poor prognosis with equal or more weight than, for instance, excess blasts.^{64,65} Based on this and clinical experience suggesting that prognosis of patients with low or int-1 disease by IPSS was very heterogeneous, a prognostic model was developed for this group of patients.¹⁷ For this study, 856 patients with low and intermediate-1-risk MDS were analyzed. Patients were grouped with diploid and 5q as favorable cytogenetics and all others as unfavorable. The final model included age, unfavorable cytogenetics, platelet count, hemoglobin, and percent of marrow blasts. The survival outcome for each score point is listed in Table 79.5. Based on this, patients could be divided into 3 subgroups. Patients with category 1 (n = 182, 21%) (score 0 to 2 points) had a median survival of 80.3 months (95% CI 68-NA), and a 4-year survival rate of 65% (95% CI 55 to 76). Patients in category 2 (score 3 or 4 points) (n = 408, 48%) had a median survival of 26.6 months (95% CI 22 to 32), and a 4-year survival rate of 33% (95% CI 27 to 40). Patients in category 3 (score 5 to 7 points) (n = 265, 31%) had a median survival of 14.2 months (95% CI 13 to 18), and a 4-year survival rate of 7% (95% CI 3 to 14). The proposed model was able to further stratify patients in either IPSS low or intermediate-1 into 3 risk groups (p < 0.0001 for both low-risk and intermediate-1). The IPSS scoring did not segregate patients with low or intermediate-1 risk within each of the 3 risk categories identified by this analysis. Two other factors were studied but not included in the multivariate analysis, ferritin and β2-microglobulin, because data was available only in a fraction of the patients. Only 10% of patients eventually transformed to AML. By univariate analysis, IPSS intermediate-1 versus low-risk (p = 0.005), increased percentage of marrow blasts (p < 0.001), infection at presentation (p = 0.001), and chromosome 7 abnormalities (p = 0.01) were associated with a significant higher-risk of AML progression. Only a higher percentage of marrow blasts, chromosome 7 anomalies, and infection at referral remained in the final multivariate model and were associated with an increased risk of AML transformation (p = 0.01 for all three of them). When the results of the lower-risk MDS model were presented, they had not been validated by any group nor was there a hypothesis of why different patients with low-risk features would have different prognoses. Recently, Bejar et al. performed a retrospective analysis of 288 patients with lower-risk MDs and confirmed the lower-risk model.⁶⁰ More importantly, these investigators analyzed the mutational status of 22 genes in these patients. Mutations were identified in 71% of cases. Mutations of EZH2, RUNX1, TP53, and ASXL1 were associated with shorter overall survival, independent of the prognostic score. The conclusion of the study was that combining the lower-risk MDACC model with EZH2 mutation analysis resulted in the identification of close to a third of patients with a worse-than-expected prognosis. The distribution of mutations and risk category is shown in Figure 79.5. This study has important future implications because it opens the door for molecular stratification of patients with earlier stages of the disease.

TABLE 79.4 THE REVISED NEW INTERNATIONAL PROGNOSTIC SCORING SYSTEM (IPSS) SCORE

Prognostic variable	0	0.5	1	1.5	2	3	4
Cytogenetics	Very good	—	Good	—	Intermediate	Poor	Very poor
BM blast, %	≤2	—	>2%-<5%	—	5%-10%	>10%	—
Hemoglobin	≥10	—	8-<10	<8	—	—	—
Platelets	≥100	50-<100	<50	—	—	—	—
ANC	≥0.8	<0.8	—	—	—	—	—

IPSS-R Prognostic Risk Categories/Scores

Risk category	Risk score
Very low	≤1.5
Low	>1.5-3

Intermediate	>3-4.5
High	>4.5-6
Very high	>6

—, Indicates not applicable.

Adapted from Greenberg PL, Tuechler H, Schanz J, et al. Revised International Prognostic Scoring System for myelodysplastic syndromes. *Blood* 2012;120:2454-2465.

P.1680

TABLE 79.5 M.D. ANDERSON CANCER CENTER (MDACC) MYELODYSPLASTIC SYNDROME (MDS) LOWER-RISK PROGNOSTIC MODEL

Characteristics	Points		
Unfavorable cytogenetics	1		
Age ≥ 60 y	2		
Hemoglobin < 10 (g/dl)	1		
Platelets			
<50 × 10 ⁹ /L	2		
50-200 × 10 ⁹ /L	1		
Bone Marrow Blasts ≥ 4%	1		
Score	Median Survival	4-y OS (%)	
0		NR	78
1		83	82
2		51	51
3		36	40
4		22	27
5		14	9
6		16	7
7		9	N/A

Characteristics were selected from multivariate analysis model in patients with lower-risk MDS. Each characteristic is associated with a number of points. Score is calculated by adding all points. Each score allows calculation of median survival (in months) and probability of survival at 4 years.

Adapted from Garcia-Manero G, Shan J, Faderl S, et al. A prognostic score for patients with lower-risk myelodysplastic syndrome. *Leukemia* 2008;22:538-543.

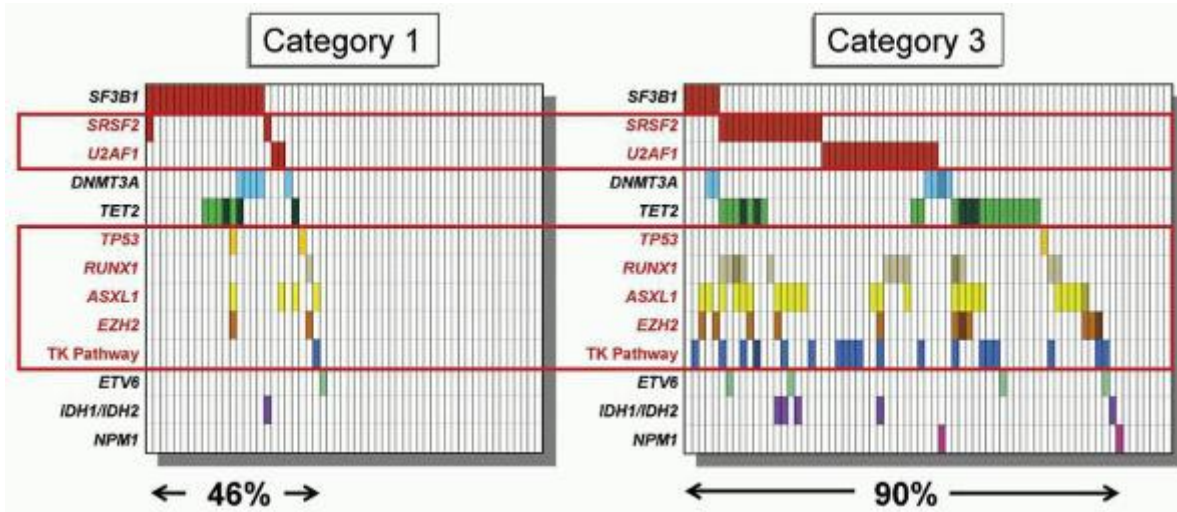

FIGURE 79.5. Distribution of mutational events in lower-risk myelodysplastic syndromes (MDS). Patients were divided based on the MDACC lower-risk score into different categories.¹⁷ Then analysis of distribution of mutations was retrospectively performed using data from Bejar et al.⁶⁰. *J Clin Oncol* 2012;30: 3376-3382. As shown in the figure, patients in the lower-risk category 1 had fewer molecular events than those in the poorer risk subset of category 3.

Impact of Comorbidities

Patients with MDS tend to be older and to be affected by comorbidities expected due to age or known history of exposures. Therefore it is important to incorporate information regarding how comorbidities affect the natural history of MDS and how they affect therapeutic decisions in MDS. A number of studies have addressed this issue using different systems. Wang et al. conducted a population-based study of older persons with MDS that suggested lower survival in those with comorbid ailments, particularly those with congestive heart failure (CHF) and chronic obstructive pulmonary disease.⁶⁶ Moreover, previous studies have shown CHF, pulmonary and liver failure, infections, hemorrhage, and solid tumors as main causes of non-leukemic death in MDS.^{3,67,68} At MDACC, we used the ACE-27 comorbidity score to address this issue.⁶⁹

The ACE-27 was developed by Piccirillo et al. and was derived from adult cancer patients.⁷⁰ In our analysis, 600 patients with MDS were included. Approximately half of the patients had a baseline IPSS classification of low or intermediate-1. The distribution of comorbidities is shown in Figure 79.6. Baseline ACE-27 comorbidity scores were as follows: none, 137 patients (22.8%); mild, 254 (42.3%); moderate, 127 (21.2%); and severe, 82 (13.7%). Approximately 55% of the patients were diagnosed with disorder of the cardiovascular system, with hypertension being the most common comorbidity (37.0%), followed by coronary artery bypass graft (14.3%). History of prior malignancy was reported in 168 (28.0%) patients. Ninety-seven (16.2%) patients had diabetes mellitus. Median survival according to the ACE-27 scores was: 31.8 months for no comorbidity, 16.8 months for mild comorbidity, 15.2 months for moderate comorbidity, and 9.7 months for severe comorbidity ($p < 0.0001$). A prior history of malignancy and cardiovascular disease were associated with worst survival. Older age, advanced IPSS, and leukemic transformation were associated with a greater risk of death, while having undergone SCT was associated with longer survival. Comorbidity did not have a significant effect on survival for patients in the low-risk category,

P.1681

whereas patients in the intermediate-1 and -2 groups ($p = 0.001$) and high-risk category ($p = 0.04$) had significantly worse survival with increasing ACE-27 scores. Comorbidities significantly decreased survival in those younger than 65 years ($p < 0.0001$), but had no significant effect in those older than 65. We conducted a multivariate analysis using the Cox Proportional Hazards model. Included in the final model are: age, IPSS, and ACE-27 comorbidity scores. The final prognostic model for the overall survival was thus developed as low (score 0 to 1), intermediate (score 2 to 4), and high (score 5 to 8). The model predicted survival on the entire patient group. Patients in the low-risk category had a median survival of 43.0 months versus 23.0 months and 9.0 months for those in the intermediate-risk and high-risk groups, respectively ($p < 0.001$).⁶⁹

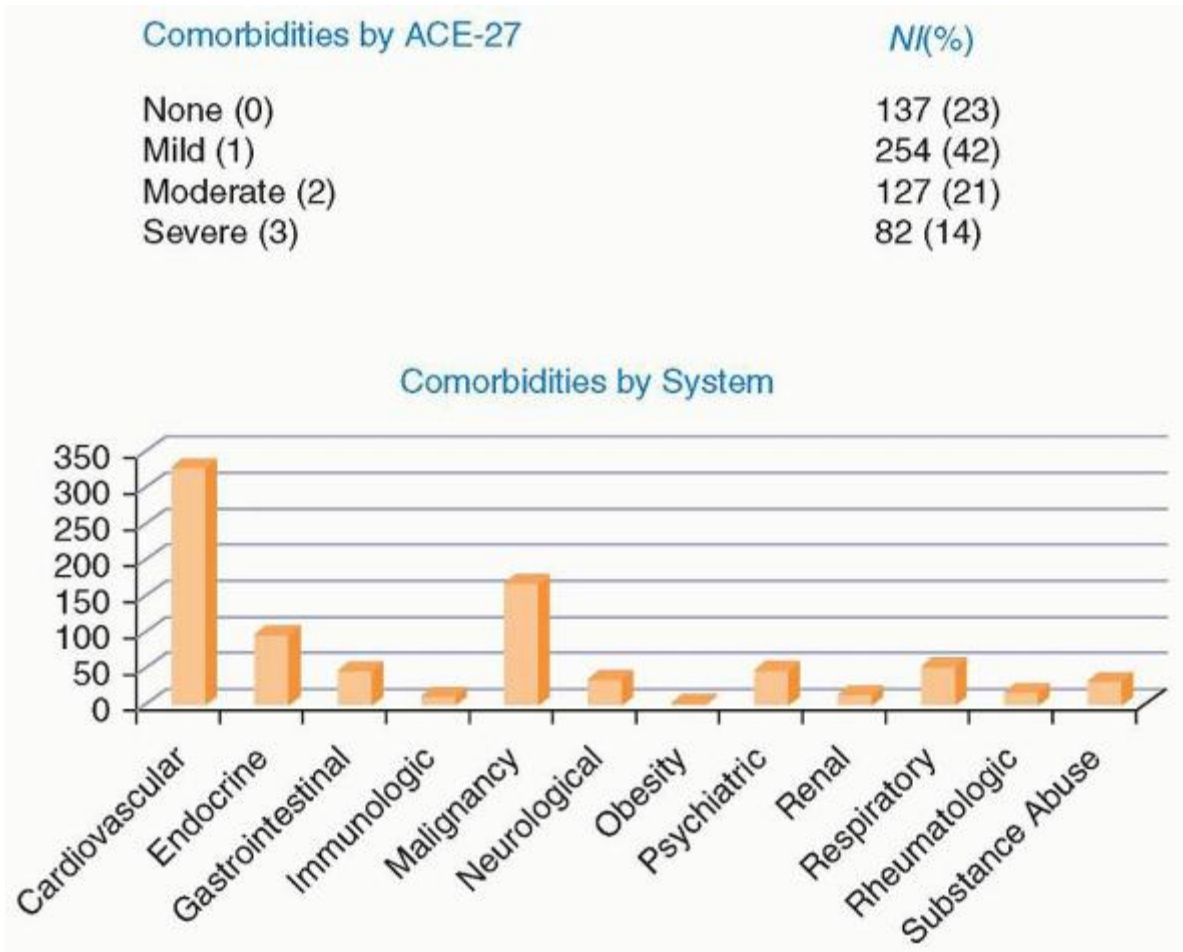

FIGURE 79.6. Distribution of comorbidities in myelodysplastic syndromes (MDS) using ACE-27 score. Adapted from Naqvi K, et al.⁶⁹ J Clin Oncol in press 2011;29:2240-2246.

THERAPEUTIC APPROACHES FOR PATIENTS WITH MYELOYDYSPLASTIC SYNDROME

In practical terms, therapy for patients with MDS is divided into approaches for patients with lower-risk disease and those with higher-risk disease. Although investigators may use different criteria, it is accepted that lower-risk disease includes patients with low and int-1 disease and those with higher-risk disease, int-2 or high, by IPSS.² The role of IPSS-R in therapy has not been confirmed at this time.¹³ In the US, clinicians use guidelines set by NCCN for decision making when selecting therapy.⁷¹ A summary of therapies for patients with MDS is shown in Figure 79.7.

Therapy for Patients with Lower-risk Myelodysplastic Syndrome

Most clinicians believe that the role of therapy in lower-risk MDS should focus on improving symptoms and minimizing transfusion needs, whereas the potential impact on survival remains unproven. We believe in the need to develop curative approaches for patients with lower-risk MDS in the context of clinical trials.

Supportive Care for Patients with Lower-risk Myelodysplastic Syndrome

Supportive care is an integral part of the care for patients with both lower- and higher-risk MDS. In general, we refer to supportive care measures as those that mitigate complications of cytopenias, such as severe anemia, thrombocytopenia, and risk of infections. Indeed, an analysis of cause of death in patients with lower-risk MDS has indicated that the most frequent events associated with death were infectious and bleeding complications.³ Based on this, three major approaches are considered as supportive care measures in MDS. These include transfusions of red cells and/or platelets, the use of prophylactic antibiotics, and the use of growth factors. Because there is some controversy as to whether this last approach may have a primary effect on the natural history of patients with MDS, we will discuss that below. Finally and more recently, a debate has evolved around the topic of iron chelation in red cell transfusion-dependent patients. This is also discussed in a separate section below.

There are different practices for both red cell and platelet transfusions. In most centers in the US, patients receive red cell transfusions if hemoglobin is less than 8 g/dl or if the patient has symptomatic anemia. Platelets are transfused if the platelet count is less than 10 k/ μ l or if the patient has active bleeding. These parameters can change based on geographical distribution and practice patterns. Over the years, there has also been a question about the need for irradiated blood products, in particular for patients that could be potential candidates for stem cell transplantation. This is not the standard practice at MDACC. Finally, some centers also provide support with white cell transfusions as an early intervention for patients with neutropenic fever or resistant infections. These are considered experimental at this point.

P.1682

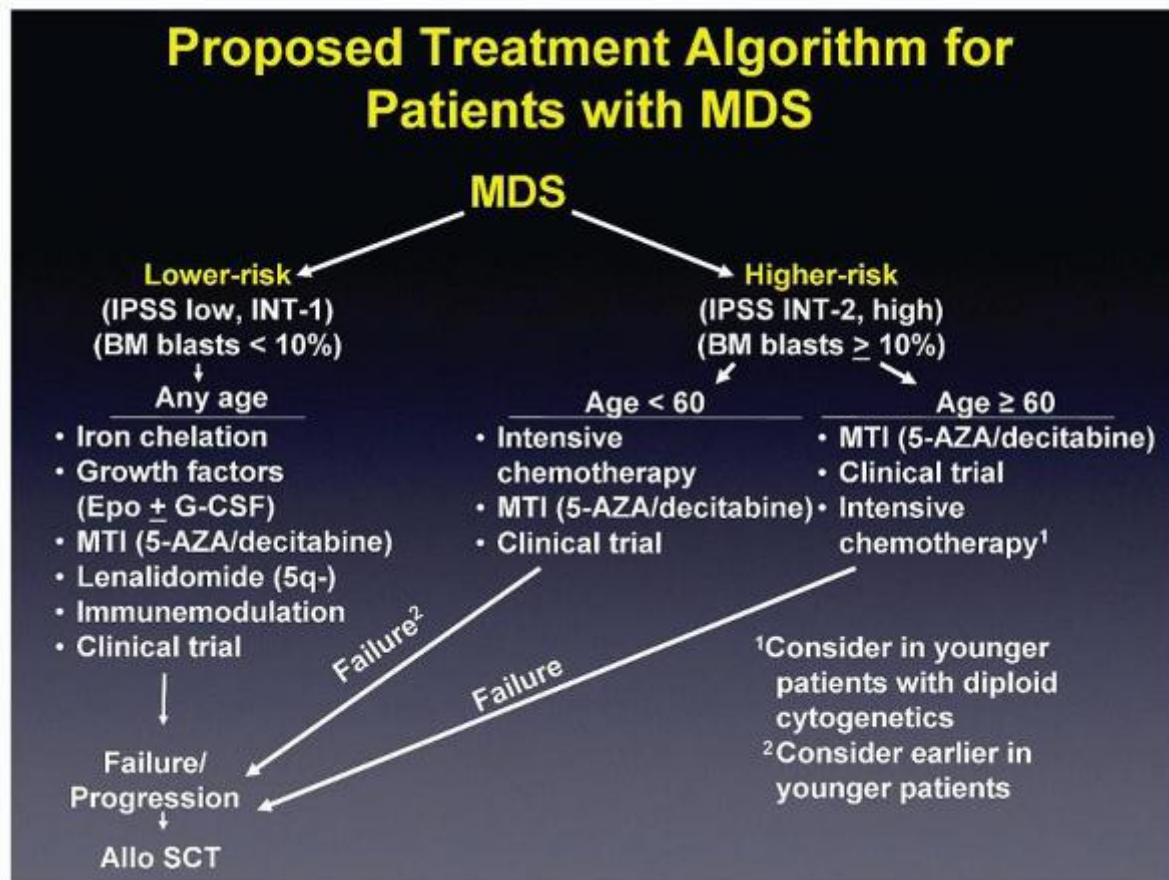

FIGURE 79.7. A treatment algorithm for patients with myelodysplastic syndromes (MDS). GM-CSF, granulocyte-macrophage colony-stimulating factor; IPSS, International Prognostic Scoring System.

The role of prophylactic antibiotics is also questionable. Many centers, including MDACC, use a triple combination of antibacterial, antiviral, and antifungal agents in patients with MDS and significant neutropenia or who are receiving active therapy with a cytotoxic agent. There is no systematic data on the use of this approach, and criticism may stem from the potential development of multidrug resistance.

The Role of Growth Factor Support in Myelodysplastic Syndrome

In 2012, growth factor stimulation may include all 3 hematopoietic lineages, including neutrophils, erythrocytes, and megakaryocytes. Although growth factor support is commonly used in MDS, there is no prospective study that has proven that their use is associated with improvements in the survival of patients with MDS. Patients with isolated neutropenia are uncommon in MDS, and although there are no large series focusing on this subset of patients, it is my impression that their natural history is benign. That said, recent series have associated outcomes in MDS with degrees of neutropenia.⁷² In general, the use of prophylactic myeloid growth factors, such as granulocyte colony-stimulating factor (G-CSF) or granulocyte-macrophage colony-stimulating factor (GM-CSF), is not recommended in these patients. It should be noted

that the use of these agents is important in patients that are experiencing complications from neutropenia exacerbated by agents used for primary therapy such as lenalidomide or hypomethylating agents that are associated with such an effect. When used in this context, growth factors are commonly used for a short period of time until complications resolve.

Recently, 2 new growth factors for platelet generation have been developed and approved for patients with immune-mediated thrombocytopenia. These agents, romiplostim⁷³ and eltrombopag,⁷⁴ are thrombomimetic agents that stimulate TPO receptors. Results in MDS are controversial.⁷⁵ Interim analysis of a large study with romiplostim in patients with low or intermediate-1 MDS with significant thrombocytopenia suggests that patients treated with this agent had a higher risk of developing AML and marrow fibrosis. Whether this was the result of the natural history of the disease or a true leukemogenic effect of the drug is unknown at this time. There is less experience with eltrombopag in MDS.⁷⁴ With the current information that we have, we cannot routinely recommend the use of these compounds for patients with MDS. Current investigations with these agents have focused on their use as an adjunct to other therapies in MDS, such as of the azanucleosides, decitabine or azacitidine.^{76,77} Recently, in the United States, strict FDA guidelines have limited the use of these agents to patients with significant immune thrombocytopenia and preclude use of them in patients with MDS.

Erythroid stimulating agents (ESA) are commonly used in patients with anemia and lower-risk MDS. These guidelines were developed after reports of a potential association between ESA administration and the development of secondary solid malignancies.⁷⁵ That said, it is important to realize that there is no prospective data indicating that ESA use has any significant survival benefit in patients with MDS. The Nordic group pioneered the use of these agents in MDS.⁷⁵ Although it is clear that its use is associated with erythroid responses in close to a third of patients, the effect of ESA on survival remains unclear. Of interest, in the latest analysis by this group, a cohort of patients that was treated with epoetin alpha and G-CSF in consecutive clinical trials was compared to a historical group in an Italian database that was not. Only the subset of patients that were minimally transfusion-dependent experienced erythroid responses that translated into a survival advantage and reduced risk of AML compared to the control cohort, matched for prognostic features.⁷⁸ Although ESAs remain the most widely utilized agent for management of anemia in MDS, the potential impact on its natural history is limited.

The Role of Iron Chelation in Myelodysplastic Syndrome

Because anemia is a common feature of patients with MDS that results in the need for red cell transfusions, it is not uncommon that patients with MDS may develop significant evidence of iron

P.1683

overload. A number of groups have suggested that excess iron deposition in the hepatic parenchyma and myocardium are associated with significant morbidity and mortality in patients with MDS.⁷⁹ Other groups have challenged that assertion.¹⁷ It is clear that patients who require systematic red cell transfusions are at increased risk of dying from complications of MDS, whether these are derived from end-organ damage to tissues or because this represents a subset of patients with more aggressive natural histories. Based on these concepts, a number of iron chelating agents have been developed not only for MDS, but for other hematologic conditions. For instance, at the present time, an oral chelating agent known as deferasirox is currently approved in Europe and the USA for patients with evidence of iron overload and lower-risk MDS. This was an accelerated approval that awaits validation in a large ongoing phase III trial. In general, iron chelating agents have been shown to decrease ferritin levels in transfusion-dependent patients and to have a manageable toxicity profile.⁸⁰ Some studies have also suggested a potential impact on survival.⁸¹ Finally, it should be mentioned that these agents may have other potential effects on MDS that include modifying the risk of both bacterial and fungal infections, stimulation of effective hematopoiesis,⁸² and delaying transformation to AML. These have not been systematically studied, but could be of significant clinical benefit. Finally, a number of groups have reported that the use of iron chelating agents are associated with significant clinical improvements in patients undergoing stem cell transplantation.⁸³

Lenalidomide

Lenalidomide is a derivative of thalidomide with immune modulatory activity that has been shown to have significant activity in patients with lower-risk MDS and anemia. Initial studies with thalidomide indicated that this agent had modest but measurable activity in patients with MDS and resulted in the development of several more potent derivatives.⁸⁴ Lenalidomide is an oral immunomodulatory agent. In the initial study, List et al. documented that this agent was safe up to doses of 25 mg daily and that a particular subset of patients with an interstitial deletion of chromosome 5q experienced a high frequency of red blood cell transfusion independence and cytogenetic response with the use of this compound.^{15,85} This was confirmed in a subsequent multicenter study that focused on patients with lower-risk MDS, transfusion-dependent anemia, and an alteration of chromosome 5.⁸⁶ Characteristics associated with response were a history of less

than 4 units of red cell transfusions and platelet counts over 100 k/ μ l. These responses were durable with a median duration exceeding 2 years. Because this compound has a very acceptable toxicity profile, the drug was approved in the US for the treatment of lower-risk, del(5q) MDS patients with transfusion-dependent anemia. Furthermore, nearly 50% of the patients achieved a complete cytogenetic response after 6 months of treatment. A subsequent dose-comparative study in Europe randomized transfusion-dependent patients with lower-risk del(5q) MDS to either lenalidomide 5 mg daily (n = 69), 10 mg daily for 21 days every 28 days (n = 69), and placebo (n = 67). Crossover to lenalidomide or a higher dose was allowed after 16 weeks for nonresponders. RBC-transfusion independence for more than 26 weeks was achieved in 56% of patients treated with 10 mg of lenalidomide, compared to 41% and 6% of patients receiving 5mg of lenalidomide or placebo, respectively. Median duration of RBC-TI was not reached (median follow-up, 1.55 years), with 60% to 67% of responses ongoing in patients. Of importance, cytogenetic response rates were 41.5% (10 mg) versus 17.4% (5 mg; p = 0.066). For the lenalidomide groups combined, 3-year overall survival and AML risk were 56% and 25%, respectively, indicating that the 10 mg dose is the preferred dose of lenalidomide, that yields higher rates of both RBC-transfusion independence and cytogenetic response.

Lenalidomide has also been studied in patients with lower-risk MDS, but without a chromosome 5 alteration.⁸⁷ A phase 2 multicenter trial of lenalidomide was performed in transfusion-dependent patients with low- or int-1-risk MDS without deletion 5q. Eligible patients had 50,000/mm³ or more platelets and required 2 units or more RBCs within the previous 8 weeks. In summary, 214 patients received 10 mg of oral lenalidomide daily or 10 mg on days 1 to 21 of a 28-day cycle. The drug was well tolerated. Using an intention-to-treat analysis, 56 patients (26%) achieved transfusion independence (TI) after a median of 4.8 weeks of treatment with a median duration of TI of 41.0 weeks. A 50% or greater reduction in transfusion requirement occurred in 37 additional patients, yielding a 43% overall rate of hematologic improvement. Although less active than in patients with del(5q) MDS, a large randomized study is evaluating the clinical activity of lenalidomide in patients without chromosome 5 alterations.

Recent investigations have provided further insight into the karyotype-specific mechanism of action of lenalidomide in patients with del(5q) MDS. Haploinsufficiency for 2 dualspecificity phosphatases encoded within the proximal CDR on chromosome 5q accounts for the differential sensitivity of del(5q) progenitors. Lenalidomide directly inhibits cell division cycle 25 C (Cdc25C) and is an indirect inhibitor of the catalytic subunit alpha isoform of the protein phosphatase 2A (PP2A α), both coregulators of the G2-M checkpoint.⁸⁸ Moreover, lenalidomide also acts to stabilize MDM2, thereby accelerating p53 degradation and permitting cycling of del(5q) before arrest at the G2/M juncture.⁸⁹ Ebert et al. reported data that a gene expression signature could be used to predict response to this agent in nondel(5q) MDS.⁹⁰ Recently, a group has shown the activity of this compound at the stem cell level.⁹¹

Antithymocyte Globulin

A fraction of patients with MDS have a significant inflammatory component, and it is possible that they have underlying autoimmune alterations. Patients with so-called hypoplastic MDS, whose pathogenesis may overlap with aplastic anemia, are an example of this.¹¹ Hypoplastic MDS is defined as bone marrow cellularity of less than 30% to 20%, depending on the age of the patient, with evidence of dysplastic features or a clonal cytogenetic alteration.¹¹ A group at the NIH has pioneered the use of ATG in patients with MDS.⁹² Whether combining this agent with other immunosuppressive agents, such as cyclosporine and/or steroids, is beneficial, is unclear at this time. A recent randomized study in patients with aplastic anemia has suggested that a horse-derived ATG is superior to the one generated from rabbits.⁹³ The group at the NIH has also developed criteria that allow for a prediction of the response to ATG-based therapy.⁹⁴ These include age, an HLA-DR15 class II phenotype, and duration of red blood cell transfusion dependence. Both Kings College in London and MDACC have reported that the most important predictors for response to ATG-based therapy are age and presence of bone marrow hypocellularity.⁹⁵ Data from all the studies has indicated that younger patients with hypoplastic MDS benefit from stem cell transplantation and that the prognosis of older patients with hypoplastic MDS is very poor, despite the use of these agents. Also, it has been reported that the ratio of CD4⁺ to CD8⁺ cells can be used to predict response to ATG.⁹⁶ Until recently there was no salvage therapy for patients that had failed ATG therapy and were not candidates for a stem cell transplant. Recently, the group at NIH has also shown data that the use of eltrombopag may be associated with trilineage response in aplastic anemia patients that failed ATG.⁹⁷ This data is of significant importance and needs to be studied in the MDS population. Finally, several groups have also studied the potential role of alemtuzumab as therapy for aplastic anemia and hypoplastic MDS.⁹⁸ The actual activity and safety of this compound is not clear at this point.

P.1684

The Use of Hypomethylating Agents in Lower-risk Myelodysplastic Syndrome

The hypomethylating agents are the standard of care for patients with high-risk MDS. Initial clinical studies in the US performed well before the development of WHO criteria for MDS included patients with all FAB categories. Therefore the approval of these agents in the US, in particular for azacitidine, is for all subsets of patients with MDS.⁹⁹ There is relatively little systematic analysis of what is the most effective and safest schedule of this class of compounds in lower-risk MDS. In a randomized phase II study by a group of community oncologists, it was observed that shorter versus longer schedules of azacitidine (5 versus 7 days) were less myelosuppressive and were potentially associated with an increased rate of hematologic responses in a largely lower-risk patient population.¹⁰⁰ A multicenter Phase II randomized trial investigated the activity of two very low dose schedules of decitabine in patients with low and intermediate-1 MDS. In this study, known as DACO-26, decitabine administered at a dose of 15 mg/m² subcutaneous daily for 3 days on a 28-day schedule was compared to decitabine given at the same dose and route weekly × 3, also on a 28-day schedule. Although the final analysis of this study did not show the superiority of one arm versus the other, treatment of patients with lower-risk MDS with this very low dose schedule of decitabine was associated with trilineage responses of over 60% in this group of patients.¹⁰¹ These lower dose schedules were associated with manageable myelosuppression and no mortality. Based on this concept, a number of investigators have developed oral derivatives of the hypomethylating agents. In principle, nucleoside analogs are difficult to absorb because they are catabolized by cytidine deaminase. That said, both an oral formulation of decitabine and one of azacitidine are in development. Oral azacitidine was first investigated in a Phase 0 trial that demonstrated that the drug could be absorbed by patients with leukemia.¹⁰² These positive results led to the design and completion of a Phase I study of oral azacitidine for patients with MDS.¹⁰³ In this study, 41 individuals were treated with doses of oral azacitidine up to 600 mg on a 7-day schedule. An expansion of this study also evaluated more extended schedules for 14 to 21 days with the drug administered once or twice a day at doses of 200 to 300 mg. The results of this study were of interest because it was shown that oral azacitidine was associated with an overall response rate of 35% in previously treated patients and 73% in previously untreated patients. Responses were durable and the drug was very well tolerated. Furthermore, using large-scale DNA methylation analysis platforms, it was shown that oral azacitidine could induce significant induction of promoter DNA hypomethylation. What was interesting from this study was the observation that the pharmacokinetic profile of oral azacitidine was significantly lower than that of the parenteral route of administration. Mean relative oral bioavailability ranged from 6.3% to 20%. These results are interesting in view of a recent report by the Baylin group that studied the effect in animal systems of very low exposure to hypomethylating agents.¹⁰⁴ Planned studies with oral azacitidine include a Phase III trial for patients with lower-risk disease and significant thrombocytopenia starting in 2013.

The Role of Allogeneic Stem Cell Transplantation in Lower-risk Myelodysplastic Syndrome

SCT is curative in a fraction of patients with MDS.^{105,106} The questions remain as to who is the best candidate for transplant and when to perform it. Patients with lower-risk MDS are in general characterized by a low percentage of blasts in their bone marrows. In principle this makes them perfect candidates for upfront transplantation, as they do not require debulking preparative chemotherapy prior to stem cell transplantation (SCT). Unfortunately, SCT is associated with significant early mortality that depends on the age of the patient and donor, as well as the degree of matching. Mortality in the first 100 days can range from 10% to 40% depending on the series and the center's expertise. Because most patients with lower-risk MDS are expected to live more than 100 days, initial results evaluating the role of SCT in lower-risk MDS have suggested that early transplantation is not indicated.¹⁰⁷ In a recent collaborative study using datasets from IBMTR and several cohorts of older patients with lower-risk MDS that had received either supportive care, hypomethylating agents, or reduced intensity transplantation, it was shown using a Markov model that transplantation was associated with lower survival. These results are in line with the initial report of Cutler et al.¹⁰⁷ and indicate that transplantation should be delayed as much as possible in this group of patients.

Therapy for Patients with Higher-risk Myelodysplastic Syndrome

Over the last decade we have experienced significant advances in the therapy of patients with higher-risk MDS. Prior to that, the only treatment modalities were induction therapy or salvage stem cell transplantation. The results of these approaches were disappointing, particularly in older patients and in those with complex cytogenetics.¹⁰⁸

Hypomethylating Agents in High-risk Myelodysplastic Syndrome

Hypomethylating agents are the standard of care in a large majority of patients with higher-risk MDS.¹⁰⁸ They have also transformed our capacity to treat patients with MDS and have increased interest in this disease. The initial significant study with azacitidine is known as CALGB-9221.⁹⁹ This study, which I consider seminal in the field, was led by Dr. Lewis Silverman and randomized patients with MDS by FAB classification (including up to 30% blasts) to either supportive care

or a 7-day schedule of azacitidine at the dose of 75 mg/m² via subcutaneous route. The study had a crossover design in which patients that had not benefited in 1 arm could then be treated in the other arm. The drug was very well tolerated, with virtually no induction mortality. Treatment with azacitidine was associated with significant clinical activity, including a complete remission rate of 7% and an overall response rate of 60%. Of interest, patients that crossed from the supportive care arm to the azacitidine arm had similar rates of response, confirming the activity of the drug. Crossover designs do not allow one to evaluate the impact on survival, and therefore this study was not powered to show the drug's effect on survival. That said, survival in the azacitidine group was close to 20 months. The investigators performed a landmark analysis at 6 months in patients, with or without crossover, that suggested a survival advantage with azacitidine therapy. CALGB-9221 also included a quality of life analysis.¹⁰⁹ The report of this study suggested that patients treated with azacitidine had a better quality of life. All this data served as the basis for approval of this compound in the US. Subsequent analysis of this cohort of patients has also provided significant information regarding the clinical use of azacitidine in MDS. It is now known that responses may require multiple cycles of therapy administration and that in the initial cycles of therapy it is not uncommon to observe significant myelosuppression. Proper supportive care and continuation of therapy, despite cytopenias, are associated with improved outcomes. Because of the lack of survival data with CALGB-9221, European regulators recommended a noncrossover design as an approval strategy for azacitidine in Europe. This study, known as AZA-001, was a randomized trial of azacitidine using the

P.1685

same schedule as in CALGB-9221 versus treatment with either low-dose cytarabine, AML induction therapy, or supportive care based on physician preference.¹⁰ Patients were stratified by FAB and IPSS. The primary endpoint was overall survival. Efficacy analyses were by intention-to-treat for all patients assigned to receive treatment. In total, 358 patients were randomly assigned to receive azacitidine (n = 179) or conventional care regimens (n = 179). Four patients in the azacitidine and 14 in the conventional care groups received no study drugs but were included in the intention-to-treat efficacy analysis. After a median follow-up of 21.1 months, median overall survival was 24.5 months (9.9 not reached) for the azacitidine group versus 15.0 months (5.6 to 24.1) for the conventional care group (hazard ratio 0.58; 95% CI 0.43 to 0.77; stratified log-rank p = 0.0001). At 2 years, on the basis of Kaplan-Meier estimates, 50.8% (95% CI 42.1 to 58.8) of patients in the azacitidine group were alive compared with 26.2% (18.7 to 34.3) in the conventional care group (p < 0.0001). Of interest, response rates were also different among different treatment modalities. Although response rates were higher with intensive chemotherapy, used mainly in younger patients, these did not translate into a clear survival benefit. As with CALGB-9221, the toxicity profile of azacitidine was acceptable with minimal induction mortality. Additional analysis of AZA-001 have also provided significant clues for the clinical management of patients with MDS. First, the median number of cycles with azacitidine in this group of patients was 9. It is believed that the duration of therapy is crucial for the survival advantage documented with this drug. Second, in a post hoc analysis, investigators studied the impact of age and AML blasts by WHO category (20% to 30% blasts) in patients treated with AZA-001. The results indicated that older individuals benefited significantly from therapy and that excess blasts was not a negative predictor of response.¹¹⁰ Finally, by multivariate analysis, it was shown in AZA-001 that presence of adverse cytogenetic features, such as deletion of chromosome 7, were positively associated with azacitidine therapy when compared to other therapy. That said, it is important to emphasize that outcomes were better in diploid patients. The NCCN guidelines recommend azacitidine as frontline therapy in most patients with higher-risk MDS.¹¹¹

In parallel with azacitidine, decitabine (5-aza-2'-deoxycytidine) is another hypomethylating agent that has been extensively studied in MDS. In an initial randomized non-crossover study, decitabine administration was found to be safe in this group of patients and to have significant clinical activity with an overall response rate of 17%.⁹ In this initial study, the drug was administered over 4 hours 3 times a day on a 3-day schedule every 6 weeks. In parallel, a daily schedule for 5 to 10 days was investigated at MDACC.¹¹² This study suggested that a 5-day schedule at a dose of 20 mg/m² was potentially an optimal way to administer decitabine. This was further studied in a 3-arm randomized Bayesian study comparing different doses and schedules of decitabine.¹¹³ The results with the 5-day schedule indicated a complete remission rate of over 30% and overall response rate of 73%.¹¹⁴ These results were further confirmed with the ADOPT trial, a multicenter single-arm study that served as the basis for the approval of the 5-day schedule of decitabine in the US.¹¹⁵ As with AZA-001, a survival study with decitabine was performed in Europe.¹¹⁶ Unfortunately, this study failed to show a survival advantage with decitabine. The reason for this effect is likely due to the design of the study, in which the drug was administered using the initial 3-day schedule every 6 weeks and treatment was capped at 8 months, a fact that resulted in a median number of 4 cycles of decitabine administration. These factors likely negatively influenced the results of this trial. It should be noted that recently decitabine was approved in Europe for the treatment of older patients with AML because of its toxicity profile and modest survival effect in this population.¹¹⁷

There are no comparative studies of azacitidine versus decitabine, and therefore it is not possible to make a recommendation in terms of frontline therapy, although most treating physicians nowadays use azacitidine in frontline therapy of patients with higher-risk MDS because of its reported survival benefit.

Biomarkers of Response to Hypomethylatingbased Therapy in Myelodysplastic Syndrome

It is obvious from the data above that only a fraction of patients have significant benefit from the use of either decitabine or azacitidine. Because patients require several months of therapy to determine any potential clinical benefit, it would be very important to have access to a potential biomarker of response to this class of agents. Because hypomethylating agents dynamically modify in a transient fashion both global and gene-specific methylation patterns, a number of groups have analyzed the relationship between specific methylation patterns and changes in methylation patterns with response to hypomethylating agents. At the present time, there is no evidence that the specific methylation patterns are associated with a distinct response to these agents.^{62,118} A number of groups have reported on specific molecular biomarkers of response to these compounds. For instance, levels of micro-RNA29b, which targets DNMT1, have been reported to be associated with response to decitabine.¹¹⁹ These results, although functionally relevant, have not been reproduced by other groups.¹²⁰ A number of mutational events, such as mutations in TET2, have been associated with response, but not survival, to azacitidine.¹²¹ This observation is of great importance because TET2 is involved in the control of hydroxy DNA methylation. Prospective studies are still needed to prove this association.

Finally, the French group has developed a very simple model to predict outcomes with azacitidine.¹²² These investigators analyzed 282 patients treated in France with azacitidine outside clinical trials and identified the following characteristics associated with outcome: previous low-dose cytosine arabinoside treatment, bone marrow blasts >15% (p = 0.004), and abnormal karyotypes (p = 0.03) were independent predictors of lower response rates. Complex karyotypes predicted shorter responses (p = 0.0003). Performance status, intermediate- and poor-risk cytogenetics, presence of circulating blasts, and red blood cell transfusion dependency also independently predicted poorer overall survival (OS). A prognostic score based on those factors was developed (Table 79.6).

Improving Results with Hypomethylating Agents

Although the hypomethylating agents have resulted in very significant improvements for our patients with MDS, it is obvious that most patients will lose response (discussed below) and that new alternatives are needed. One approach is to develop combination strategies with azacitidine or decitabine and a second agent. Over the last decade, a number of groups reported on the activity of the combination of a hypomethylating agent with a histone deacetylase inhibitor (HDACi).¹²³ These were based on initial observations by Baylin et al. that clearly demonstrated that these agents are highly synergistic in vitro.¹²⁴ This resulted in studies combining either azacitidine or decitabine with agents such as valproic acid,^{125,126} vorinostat,¹²⁷ MGCD0103,¹²⁸ and panabinstat.¹²⁹ Pilot data from these studies in general indicated that response rates were higher than expected with the combination and that the responses were faster. Unfortunately, no randomized study has proven this observation. An initial randomized trial performed at MDACC with valproic acid and decitabine failed to show an improvement. More recently, ECOG reported results of a combination of azacitidine with a carbamate derivative HDACi known as SD275 that also failed to show an advantage to the combination.

P.1686

TABLE 79.6 PROGNOSTIC FACTORS OF OVERALL SURVIVAL

Characteristics	Multivariate analysis	
	HR (95% CI)	P
ECOG PS		<0.0001
0-1	1	
≥2	2.0 [1.4-2.9]	
Cytogenic risk		<0.0001
Favorable	1	
Intermediate	1.4 [0.8-2.3]	0.23

Unfavorable	3.0 [2.0-4.3]	<0.0001
Transfusion dependence		<0.0001
≥ 4 RBC units/8 wk	1.9 [1.4-2.6]	
0-3 RBC units/8 wk	1	
PB blasts		<0.0001
Present	2.0 [1.5-2.7]	
Absent	1	

Prognostic score for overall survival. The score was computed (for each patient) based on the presence of PS ≥ 2 (1 point), presence of circulating blasts (1 point), RBC TD ≥ 4 RBC units/8 weeks (1 point), and intermediate- and high-risk cytogenetics (1 and 2 points, respectively). Low score = 0 points, intermediate score = 1-, and high score = 4 to 5 points. Adapted from Itzykson R, et al.¹²² Blood 2011;117:403-411.

In parallel with this effort, Sekkeres et al. developed pilot studies of the combination of azacitidine with lenalidomide.¹³⁰ Although the rationale and mechanism of action of this combination is unknown at this time, it is clear from the data reported that this combination has significant clinical activity. The optimal dose of lenalidomide in combination is not known at this time and studies have used doses ranging from 10 mg/day to 75 mg/day. Currently, a US intergroup trial is comparing azacitidine versus the combinations with either lenalidomide or vorinostat.

Finally, other ways to optimize the use of these agents is by selecting a specific group of patients according to their patient characteristics, as per the French model, or based on specific genotypic characteristics.

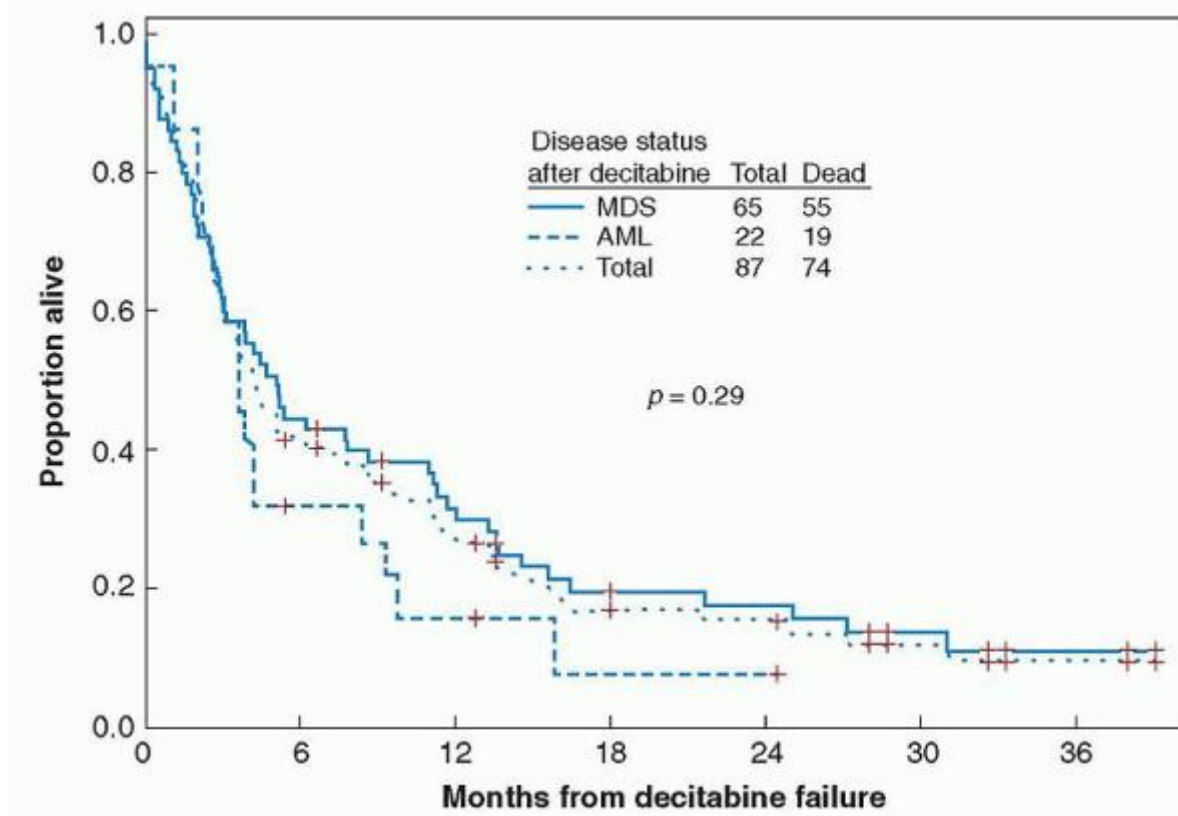

FIGURE 79.8. Survival of patients with myelodysplastic syndromes (MDS) that have failed a hypomethylating agent. Adapted from Jabbour E, et al.¹³¹ Cancer 2010;116:3830-3834.

Failure of Hypomethylating Agent

It is now recognized that most patients treated with hypomethylating agents that benefit from drug administration will eventually lose response to these agents. The outcome of this group of patients is extremely poor, with survivals that range from 4 to 6 months after failure (Fig. 79.8).^{131,132} The mechanisms of failure at the present time are unknown and are likely due to a combination of factors, ranging from pharmacologic resistance to genetic evolution. This is an important area of research at this point. Because the mechanisms of resistance are not understood it has been difficult to target this problem. A number of chemotherapy agents are being investigated for patients with both higher- and lower-risk hypomethylating failure. These include kinase inhibitors, such as ON1910; more traditional cytotoxic agents, such as clofarabine and sapacitabine; and the p38MAPK inhibitor ARRY614, particularly in patients with lower-risk disease.¹³³

The Role of Stem Cell Transplantation in Higher-risk Myelodysplastic Syndrome

SCT is curative in a significant fraction of patients with higher-risk MDS. Data from the Fred Hutchinson Cancer Center has reported long term survival rates of over 30% in selected patients.¹³⁴ Confirming this data, an analysis by IBMTR using Markov decision analysis indicated also that survival is improved with transplant in patients with higher-risk MDS. That said, transplant was associated with early risk of mortality in this patient population. Furthermore, most centers recommend against proceeding with transplant in patients with active disease. Therefore, it has become evident that initial bridge therapies are needed to take the patient successfully through transplantation. One common approach is the use of AML induction therapies that have more recently been replaced by the incorporation of hypomethylating agents prior to transplant. A number of groups have shown both in vivo and in vitro that hypomethylating agents have effects on specific subsets of T cell regulatory compartments that may result in increased graft-versus-leukemia effect and control of GVHD.¹³⁵ A number of trials are testing this concept.

P.1687

It is also now clear that early successful transplantation does not eradicate the possibility of relapse posttransplant. With the advent of less toxic reduced intensity transplant treatment modalities, death post-SCT is more commonly associated with relapsed disease than with acute or chronic GVHD. It is of interest that a number of groups have reported now that poor prognostic cytogenetic features are also associated with dismal outcomes posttransplant. Deeg et al. have also reported on the impact of the new five-subset cytogenetic classification on outcomes on patients with MDS receiving SCT.¹³⁶ Because of the problem of relapse posttransplant, a number of groups have investigated the role of "maintenance" approaches posttransplant. DeLima et al. pioneered the use of low-dose azacitidine in patients with myeloid leukemias at very high risk of relapse posttransplant.¹³⁷ These initial studies are now being further tested in randomized clinical trials, including a planned trial of oral azacitidine post-SCT. Also recently, German investigators have reported on the potential activity of lenalidomide in the posttransplant setting.

CONCLUSION

Over the last decade, we have witnessed significant improvements in our abilities to diagnose, classify, and understand MDS. At the present time, a significant effort is being developed by multiple investigators to better understand specific molecular subsets of patients. These data will also help develop rationale targeted interventions that will result in the improvement of outcomes with current available agents and stem cell transplantation. Finally, we also expect that detailed genomic analysis of MDS will result in the identification of new prognostic and therapeutic targets.

REFERENCES

1. Tefferi A, Vardiman JW. Myelodysplastic syndromes. *N Engl J Med* 2009;361:1872-1885.
2. Greenberg P, Cox C, LeBeau MM, et al. International scoring system for evaluating prognosis in myelodysplastic syndromes. *Blood* 1997;89:2079-2088.
3. Dayyani F, Conley AP, Strom SS, et al. Cause of death in patients with lower-risk myelodysplastic syndrome. *Cancer* 2010;116:2174-2179.
4. Foran JM, Shammo JM. Clinical presentation, diagnosis, and prognosis of myelodysplastic syndromes. *Am J Med* 2012;125:S6-S13.
5. George SW, Newman ED. Seronegative inflammatory arthritis in the myelodysplastic syndromes. *Semin Arthritis Rheum* 1992;21:345-354.
6. Sachs B, Erdmann S, Borchardt I, et al. Drug-induced allergic cytopenia: in vitro confirmation by the lymphocyte transformation test. *Arch Intern Med* 2000;160:2218-2219.

7. Swerdlow S, Campos E, Harris N, et al. Therapy-related myeloid neoplasms, in Swerdlow S, Campos E, Harris N, et al., eds. WHO classification of tumours of haematopoietic and lymphoid tissues. Lyon: International Agency for Research on Cancer, 2008:127.
8. Bennett JM, Catovsky D, Daniel MT, et al. Proposals for the classification of the myelodysplastic syndromes. *Br J Haematol* 1982;51:189-199.
9. Kantarjian H, Issa JP, Rosenfeld CS, et al. Decitabine improves patient outcomes in myelodysplastic syndromes: results of a phase III randomized study. *Cancer* 2006;106:1794-1803.
10. Fenaux P, Mufti GJ, Hellstrom-Lindberg E, et al. Efficacy of azacitidine compared with that of conventional care regimens in the treatment of higher-risk myelodysplastic syndromes: a randomised, open-label, phase III study. *Lancet Oncol* 2009;10:223-232.
11. Tong W-G, Kadia T, Borthakur G, et al. Prognostic factors and survival in patients with hypocellular myelodysplastic syndrome: development of a disease specific prognostic score. *Blood* 2009;114:3819.
12. Naqvi K, Jabbour E, Bueso-Ramos C, et al. Implications of discrepancy in morphologic diagnosis of myelodysplastic syndrome between referral and tertiary care centers. *Blood* 2011;118:4690-4693.
13. Greenberg PL, Tuechler H, Schanz J, et al. Revised international prognostic scoring system for myelodysplastic syndromes. *Blood* 2012;120:2454-2465.
14. Schanz J, Tuechler H, Sole F, et al. New comprehensive cytogenetic scoring system for primary myelodysplastic syndromes (MDS) and oligoblastic acute myeloid leukemia after MDS derived from an international database merge. *J Clin Oncol* 2012;30:820-829.
15. List A, Dewald G, Bennett J, et al. Lenalidomide in the myelodysplastic syndrome with chromosome 5q deletion. *N Engl J Med* 2006;355:1456-1465.
16. Jiang H, Xue Y, Wang Q, et al. The utility of fluorescence in situ hybridization analysis in diagnosing myelodysplastic syndromes is limited to cases with karyotype failure. *Leuk Res* 2012;36:448-452.
17. Garcia-Manero G, Shan J, Faderl S, et al. A prognostic score for patients with lower risk myelodysplastic syndrome. *Leukemia* 2008;22:538-543.
18. Kantarjian H, O'Brien S, Ravandi F, et al. Proposal for a new risk model in myelodysplastic syndrome that accounts for events not considered in the original International Prognostic Scoring System. *Cancer* 2008;113:1351-1361.
19. Qian Z, Joslin JM, Tennant TR, et al. Cytogenetic and genetic pathways in therapy-related acute myeloid leukemia. *Chem Biol Interact* 2010;184:50-57.
20. Della Porta MG, Malcovati L, Boveri E, et al. Clinical relevance of bone marrow fibrosis and CD34-positive cell clusters in primary myelodysplastic syndromes. *J Clin Oncol* 2009;27:754-762.
21. Tang G, Jorgensen JL, Zhou Y, et al. Multi-color CD34(+) progenitor-focused flow cytometric assay in evaluation of myelodysplastic syndromes in patients with post cancer therapy cytopenia. *Leuk Res* 2012;36:974-981.
22. van de Loosdrecht AA, Ireland R, Kern W, et al. Rationale for the clinical application of flow cytometry in patients with myelodysplastic syndromes: position paper of an international consortium and the European LeukemiaNet Working Group. *Leuk Lymphoma* 2013;54:472-475.
23. Bejar R, Levine R, Ebert BL. Unraveling the molecular pathophysiology of myelodysplastic syndromes. *J Clin Oncol* 2011;29:504-515.
24. Maciejewski JP, Mufti GJ. Whole genome scanning as a cytogenetic tool in hematologic malignancies. *Blood* 2008;112:965-974.
25. Kohlmann A, Klein HU, Weissmann S, et al. The Interlaboratory ROBustness of Next-generation sequencing (IRON) study: a deep sequencing investigation of TET2, CBL and KRAS mutations by an international consortium involving 10 laboratories. *Leukemia* 2011;25:1840-1848.
26. Verstovsek S, Mesa RA, Gotlib J, et al. A double-blind, placebo-controlled trial of ruxolitinib for myelofibrosis. *N Engl J Med* 2012;366:799-807.

27. Szpurka H, Tiu R, Murugesan G, et al. Refractory anemia with ringed sideroblasts associated with marked thrombocytosis (RARS-T), another myeloproliferative condition characterized by JAK2 V617F mutation. *Blood* 2006;108:2173-2181.
28. Rollison DE, Howlader N, Smith MT, et al. Epidemiology of myelodysplastic syndromes and chronic myeloproliferative disorders in the United States, 2001-2004, using data from the NAACCR and SEER programs. *Blood* 2008;112:45-52.
29. Goldberg SL, Chen E, Corral M, et al. Incidence and clinical complications of myelodysplastic syndromes among United States Medicare beneficiaries. *J Clin Oncol* 2011;28:2847-2852.
30. Cogle CR, Craig BM, Rollison DE, et al. Incidence of the myelodysplastic syndromes using a novel claims-based algorithm: high number of uncaptured cases by cancer registries. *Blood* 2011;117:7121-7125.
31. Smith SM, Le Beau MM, Huo D, et al. Clinical-cytogenetic associations in 306 patients with therapy-related myelodysplasia and myeloid leukemia: the University of Chicago series. *Blood* 2003;102:43-52.
32. Ellis NA, Huo D, Yildiz O, et al. MDM2 SNP309 and TP53 Arg72Pro interact to alter therapy-related acute myeloid leukemia susceptibility. *Blood* 2008;112:741-749.
33. Godley LA, Larson RA. Therapy-related myeloid leukemia. *Semin Oncol* 2008;35:418-429.
34. Schnatter AR, Glass DC, Tang G, et al. Myelodysplastic syndrome and benzene exposure among petroleum workers: an international pooled analysis. *J Natl Cancer Inst* 2012;104:1724-1737.
35. Strom SS, Gu Y, Gruschkus SK, et al. Risk factors of myelodysplastic syndromes: a case-control study. *Leukemia* 2005;19:1912-1918.
36. Bagby GC, Meyers G. Myelodysplasia and acute leukemia as late complications of marrow failure: future prospects for leukemia prevention. *Hematol Oncol Clin North Am* 2009;23:361-376.
37. Narla A, Ebert BL. Ribosomopathies: human disorders of ribosome dysfunction. *Blood* 2010;115:3196-3205.
38. Ebert BL, Pretz J, Bosco J, et al. Identification of RPS14 as a 5q-syndrome gene by RNA interference screen. *Nature* 2008;451:335-339.
39. Cioc AM, Wagner JE, MacMillan ML, et al. Diagnosis of myelodysplastic syndrome among a cohort of 119 patients with fanconi anemia: morphologic and cytogenetic characteristics. *Am J Clin Pathol* 2010;133:92-100.
40. Quentin S, Cuccuini W, Ceccaldi R, et al. Myelodysplasia and leukemia of Fanconi anemia are associated with a specific pattern of genomic abnormalities that includes cryptic RUNX1/AML1 lesions. *Blood* 2011;117: e161-e170.
41. Song WJ, Sullivan MG, Legare RD, et al. Haploinsufficiency of CBFA2 causes familial thrombocytopenia with propensity to develop acute myelogenous leukaemia. *Nat Genet* 1999;23:166-175.
42. Owen CJ, Toze CL, Koochin A, et al. Five new pedigrees with inherited RUNX1 mutations causing familial platelet disorder with propensity to myeloid malignancy. *Blood* 2008;112:4639-4645.
43. Kazenwadel J, Secker GA, Liu YJ, et al. Loss-of-function germline GATA2 mutations in patients with MDS/AML or MonoMAC syndrome and primary lymphedema reveal a key role for GATA2 in the lymphatic vasculature. *Blood* 2012;119:1283-1291.
44. Hsu AP, Sampaio EP, Khan J, et al. Mutations in GATA2 are associated with the autosomal dominant and sporadic monocytopenia and mycobacterial infection (MonoMAC) syndrome. *Blood* 2011;118:2653-2655.
45. Bejar R, Stevenson K, Abdel-Wahab O, et al. Clinical effect of point mutations in myelodysplastic syndromes. *N Engl J Med* 2011;364:2496-2506.
46. Graubert TA, Shen D, Ding L, et al. Recurrent mutations in the U2AF1 splicing factor in myelodysplastic syndromes. *Nat Genet* 2011;44:53-57.
47. Damm F, Kosmider O, Gelsi-Boyer V, et al. Mutations affecting mRNA splicing define distinct clinical phenotypes and correlate with patient outcome in myelodysplastic syndromes. *Blood* 2012;119:3211-3218.
48. Malcovati L, Papaemmanuil E, Bowen DT, et al. Clinical significance of SF3B1 mutations in myelodysplastic syndromes and myelodysplastic/myeloproliferative neoplasms. *Blood* 2011;118:6239-6246.
49. Abdel-Wahab O, Patel J, Levine RL. Clinical implications of novel mutations in epigenetic modifiers in AML. *Hematol Oncol Clin North Am* 2011;25:1119-1133.

50. Delhommeau F, Dupont S, Della Valle V, et al. Mutation in TET2 in myeloid cancers. *N Engl J Med* 2009;360:2289-2301.
51. Gelsi-Boyer V, Trouplin V, Adelaide J, et al. Mutations of polycomb-associated gene ASXL1 in myelodysplastic syndromes and chronic myelomonocytic leukaemia. *Br J Haematol* 2010;151:365-375.
52. Nikoloski G, Langemeijer SM, Kuiper RP, et al. Somatic mutations of the histone methyltransferase gene EZH2 in myelodysplastic syndromes. *Nat Genet* 2010;42:665-667.
53. Abdel-Wahab O, Mullally A, Hedvat C, et al. Genetic characterization of TET1, TET2, and TET3 alterations in myeloid malignancies. *Blood* 2009;114: 144-147.
54. Ito S, D'Alessio AC, Taranova OV, et al. Role of Tet proteins in 5mC to 5hmC conversion, ES-cell self-renewal and inner cell mass specification. *Nature* 2011;466:1129-1133.
55. Ko M, Huang Y, Jankowska AM, et al. Impaired hydroxylation of 5-methylcytosine in myeloid cancers with mutant TET2. *Nature* 2011;468:839-843.
56. Ko M, Bandukwala HS, An J, et al. Ten-Eleven-Translocation 2 (TET2) negatively regulates homeostasis and differentiation of hematopoietic stem cells in mice. *Proc Natl Acad Sci U S A* 2011;108:14566-14571.
57. Moran-Crusio K, Reavie L, Shih A, et al. Tet2 loss leads to increased hematopoietic stem cell self-renewal and myeloid transformation. *Cancer Cell* 2011;20:11-24.
58. Itzykson R, Kosmider O, Cluzeau T, et al. Impact of TET2 mutations on response rate to azacitidine in myelodysplastic syndromes and low blast count acute myeloid leukemias. *Leukemia* 2011;25:1147-1152.
59. Morin RD, Johnson NA, Severson TM, et al. Somatic mutations altering EZH2 (Tyr641) in follicular and diffuse large B-cell lymphomas of germinal-center origin. *Nat Genet* 2010;42:181-185.
60. Bejar R, Stevenson KE, Caughey BA, et al. Validation of a prognostic model and the impact of mutations in patients with lower-risk myelodysplastic syndromes. *J Clin Oncol* 2012;30:3376-3382.
61. Toyota M, Kopecky KJ, Toyota MO, et al. Methylation profiling in acute myeloid leukemia. *Blood* 2001;97:2823-2829.
62. Shen L, Kantarjian H, Guo Y, et al. DNA methylation predicts survival and response to therapy in patients with myelodysplastic syndromes. *J Clin Oncol* 2010;28:605-613.
63. Malcovati L, Germing U, Kuendgen A, et al. Time-dependent prognostic scoring system for predicting survival and leukemic evolution in myelodysplastic syndromes. *J Clin Oncol* 2007;25:3503-3510.
64. Haase D, Germing U, Schanz J, et al. New and comprehensive cytogenetic prognostication and categorization in MDS. *Blood* 2006;108:abstract 248.
65. Schanz J, Steidl C, Fonatsch C, et al. Coalesced multicentric analysis of 2,351 patients with myelodysplastic syndromes indicates an underestimation of poor-risk cytogenetics of myelodysplastic syndromes in the International Prognostic Scoring System. *J Clin Oncol* in press 2011.
66. Wang R, Gross CP, Halene S, et al. Comorbidities and survival in a large cohort of patients with newly diagnosed myelodysplastic syndromes. *Leuk Res* 2009;33:1594-1598.
67. Malcovati L, Porta MG, Pascutto C, et al. Prognostic factors and life expectancy in myelodysplastic syndromes classified according to WHO criteria: a basis for clinical decision making. *J Clin Oncol* 2005;23:7594-7603.
68. Della Porta MG, Malcovati L. Clinical relevance of extra-hematologic comorbidity in the management of patients with myelodysplastic syndrome. *Haematologica* 2009;94:602-606.
69. Naqvi K, Garcia-Manero G, Sardesai S, et al. Association of comorbidities with overall survival in myelodysplastic syndrome: development of a prognostic model. *J Clin Oncol* 2011;29:2240-2246.
70. Piccirillo J, Costas I, Claybour P, et al. The measurement of comorbidity by cancer registries. *J Registry Manage.* 2003;30:8-14.
71. Greenberg PL, Attar E, Bennett JM, et al. NCCN clinical practice guidelines in oncology: myelodysplastic syndromes. *J Natl Compr Canc Netw* 2011;9:30-56.
72. Cordoba I, Gonzalez-Porras JR, Such E, et al. The degree of neutropenia has a prognostic impact in low risk myelodysplastic syndrome. *Leuk Res* 2012;36:287-292.

73. Kantarjian H, Fenaux P, Sekeres MA, et al. Safety and efficacy of romiplostim in patients with lower-risk myelodysplastic syndrome and thrombocytopenia. *J Clin Oncol* 2010;28:437-444.
74. Will B, Kawahara M, Luciano JP, et al. Effect of the nonpeptide thrombopoietin receptor agonist eltrombopag on bone marrow cells from patients with acute myeloid leukemia and myelodysplastic syndrome. *Blood* 2009;114:3899-3908.
75. Steensma DP. Hematopoietic growth factors in myelodysplastic syndromes. *Semin Oncol* 2011;38:635-647.
76. Kantarjian HM, Giles FJ, Greenberg PL, et al. Phase 2 study of romiplostim in patients with low- or intermediate-risk myelodysplastic syndrome receiving azacitidine therapy. *Blood* 2010;116:3163-3170.
77. Greenberg PL, Garcia-Manero G, Moore M, et al. A randomized controlled trial of romiplostim in patients with low- or intermediate-risk myelodysplastic syndrome (MDS) receiving decitabine. *Leuk Lymphoma* 2012.
78. Jadersten M, Malcovati L, Dybedal I, et al. Erythropoietin and granulocyte-colony stimulating factor treatment associated with improved survival in myelodysplastic syndrome. *J Clin Oncol* 2008;26:3607-3613.
79. Cazzola M, Malcovati L. Myelodysplastic syndromes—coping with ineffective hematopoiesis. *N Engl J Med* 2005;352:536-538.
80. List AF, Baer MR, Steensma DP, et al. Deferasirox reduces serum ferritin and labile plasma iron in RBC transfusion-dependent patients with myelodysplastic syndrome. *J Clin Oncol* 2012;30:2134-2139.
81. Rose C, Brechignac S, Vassilief D, et al. Positive impact of iron chelation therapy (CT) on survival in regularly transfused MDS patients. A prospective analysis by the GFM. *Blood* 2007;110:249.
82. Guariglia R, Martorelli MC, Villani O, et al. Positive effects on hematopoiesis in patients with myelodysplastic syndrome receiving deferasirox as oral iron chelation therapy: a brief review. *Leuk Res* 2011;35:566-570.
83. Armand P, Sainvil MM, Kim HT, et al. Pre-transplantation iron chelation in patients with MDS or acute leukemia and iron overload undergoing myeloablative allo-SCT. *Bone Marrow Transplant* 2013;48:146-147.
84. Raza A, Lisak L, Little L, et al. Thalidomide as a single agent or in combination with topotecan, pentoxifylline and/or enbrel in myelodysplastic syndromes (MDS). *Blood* 2000;96:146A.
85. List A, Kurtin S, Roe DJ, et al. Efficacy of lenalidomide in myelodysplastic syndromes. *N Engl J Med* 2005;352:549-557.
86. Fenaux P, Giagounidis A, Selleslag D, et al. A randomized phase 3 study of lenalidomide versus placebo in RBC transfusion-dependent patients with low-/intermediate-1-risk myelodysplastic syndromes with del5q. *Blood* 2011;118:3765-3776.
87. Raza A, Reeves JA, Feldman EJ, et al. Phase 2 study of lenalidomide in transfusion-dependent, low-risk, and intermediate-1 risk myelodysplastic syndromes with karyotypes other than deletion 5q. *Blood* 2008;111:86-93.
88. Wei S, Chen X, Rocha K, et al. A critical role for phosphatase haplo deficiency in the selective suppression of deletion 5q MDS by lenalidomide. *Proc Natl Acad Sci U S A* 2009;106:12974-12979.
89. Ebert BL. Molecular dissection of the 5q deletion in myelodysplastic syndrome. *Semin Oncol* 2011;38:621-626.
90. Ebert BL, Galili N, Tamayo P, et al. An erythroid differentiation signature predicts response to lenalidomide in myelodysplastic syndrome. *PLoS Med* 2008;5:e35.
91. Tehranchi R, Woll PS, Anderson K, et al. Persistent malignant stem cells in del(5q) myelodysplasia in remission. *N Engl J Med* 2010;363:1025-1037.
92. Sloand EM, Wu CO, Greenberg P, et al. Factors affecting response and survival in patients with myelodysplasia treated with immunosuppressive therapy. *J Clin Oncol* 2008;26:2505-2511.
93. Scheinberg P, Nunez O, Weinstein B, et al. Horse versus rabbit antithymocyte globulin in acquired aplastic anemia. *N Engl J Med* 2011;365:430-438.
94. Sauntharajah Y, Nakamura R, Wesley R, et al. A simple method to predict response to immunosuppressive therapy in patients with myelodysplastic syndrome. *Blood* 2003;102:3025-3027.
95. Lim ZY, Killick S, Germing U, et al. Low IPSS score and bone marrow hypocellularity in MDS patients predict hematological responses to antithymocyte globulin. *Leukemia* 2007;21:1436-1441.
96. Zou JX, Rollison DE, Boulware D, et al. Altered naive and memory CD4+ T-cell homeostasis and immunosenescence characterize younger patients with myelodysplastic syndrome. *Leukemia* 2009;23:1288-1296.

97. Olnes MJ, Scheinberg P, Calvo KR, et al. Eltrombopag and improved hematopoiesis in refractory aplastic anemia. *N Engl J Med* 2012;367:11-19.
98. Scheinberg P, Nunez O, Weinstein B, et al. Activity of alemtuzumab mono-therapy in treatment-naive, relapsed, and refractory severe acquired aplastic anemia. *Blood* 2012;119:345-354.
99. Silverman LR, Demakos EP, Peterson BL, et al. Randomized controlled trial of azacitidine in patients with the myelodysplastic syndrome: a study of the cancer and leukemia group B. *J Clin Oncol* 2002;20:2429-2440.
100. Lyons RM, Cosgriff TM, Modi SS, et al. Hematologic response to three alternative dosing schedules of azacitidine in patients with myelodysplastic syndromes. *J Clin Oncol* 2009;27:1850-1856.
101. Garcia-Manero G. Myelodysplastic syndromes: 2011 update on diagnosis, risk-stratification, and management. *Am J Hematol* 2011;86:490-498.
102. Garcia-Manero G, Stoltz ML, Ward MR, et al. A pilot pharmacokinetic study of oral azacitidine. *Leukemia* 2008;22:1680-1684.
103. Garcia-Manero G, Gore SD, Cogle C, et al. Phase I study of oral azacitidine in myelodysplastic syndromes, chronic myelomonocytic leukemia, and acute myeloid leukemia. *J Clin Oncol* 2011;29:2521-2527.
104. Tsai HC, Li H, Van Neste L, et al. Transient low doses of DNA-demethylating agents exert durable antitumor effects on hematological and epithelial tumor cells. *Cancer Cell* 2012;21:430-446.
105. Platzbecker U, Schetelig J, Finke J, et al. Allogeneic hematopoietic cell transplantation in patients age 60-70 years with de novo high-risk myelodysplastic syndrome or secondary acute myelogenous leukemia: comparison with patients lacking donors who received azacitidine. *Biol Blood Marrow Transplant* 2012;18:1415-1421.
106. Chang C, Storer BE, Scott BL, et al. Hematopoietic cell transplantation in patients with myelodysplastic syndrome or acute myeloid leukemia arising from myelodysplastic syndrome: similar outcomes in patients with de novo disease and disease following prior therapy or antecedent hematologic disorders. *Blood* 2007;110:1379-1387.
107. Cutler CS, Lee SJ, Greenberg P, et al. A decision analysis of allogeneic bone marrow transplantation for the myelodysplastic syndromes: delayed transplantation for low-risk myelodysplasia is associated with improved outcome. *Blood* 2004;104:579-585.
108. Garcia-Manero G, Fenaux P. Hypomethylating agents and other novel strategies in myelodysplastic syndromes. *J Clin Oncol* 2011;29:516-523.
109. Kornblith AB, Herndon JE 2nd, Silverman LR, et al. Impact of azacytidine on the quality of life of patients with myelodysplastic syndrome treated in a randomized phase III trial: a Cancer and Leukemia Group B study. *J Clin Oncol* 2002;20:2441-2452.
110. Fenaux P, Mufti GJ, Hellstrom-Lindberg E, et al. Azacitidine prolongs overall survival compared with conventional care regimens in elderly patients with low bone marrow blast count acute myeloid leukemia. *J Clin Oncol* 2010;28:562-569.
111. Greenberg PL, Attar E, Bennett JM, et al. Myelodysplastic syndromes. *J Natl Compr Canc Netw* 2011;9:30-56.
112. Issa JP, Garcia-Manero G, Giles FJ, et al. Phase 1 study of low-dose prolonged exposure schedules of the hypomethylating agent 5-aza-2'-deoxycytidine (decitabine) in hematopoietic malignancies. *Blood* 2004;103:1635-1640.
113. Kantarjian H, O'Brien S, Giles F, et al. Decitabine low dose schedule (100 mg/m²/course) in myelodysplastic syndrome. Comparison of 3 different dose schedules. *Blood* 2005;106:708a.
114. Kantarjian H, Oki Y, Garcia-Manero G, et al. Results of a randomized study of 3 schedules of low-dose decitabine in higher-risk myelodysplastic syndrome and chronic myelomonocytic leukemia. *Blood* 2007;109:52-57.
115. Steensma DP, Baer MR, Slack JL, et al. Multicenter study of decitabine administered daily for 5 days every 4 weeks to adults with myelodysplastic syndromes: the Alternative Dosing for Outpatient Treatment (ADOPT) Trial. *J Clin Oncol* 2009;27:3842-3848.
116. Lubbert M, Suci S, Baila L, et al. Low-dose decitabine versus best supportive care in elderly patients with intermediate- or high-risk myelodysplastic syndrome (MDS) ineligible for intensive chemotherapy: final results of the randomized phase III study of the European Organisation for Research and Treatment of Cancer Leukemia Group and the German MDS Study Group. *J Clin Oncol* 2011;29:1987-1996.

117. Kantarjian HM, Thomas XG, Dmoszynska A, et al. Multicenter, randomized, open-label, phase III trial of decitabine versus patient choice, with physician advice, of either supportive care or low-dose cytarabine for the treatment of older patients with newly diagnosed acute myeloid leukemia. *J Clin Oncol* 2012;30:2670-2677.
118. Fandy TE, Herman JG, Kerns P, et al. Early epigenetic changes and DNA damage do not predict clinical response in an overlapping schedule of 5-azacytidine and entinostat in patients with myeloid malignancies. *Blood* 2009;114:2764-2773.
119. Blum W, Garzon R, Klisovic RB, et al. Clinical response and miR-29b predictive significance in older AML patients treated with a 10-day schedule of decitabine. *Proc Natl Acad Sci U S A* 2010;107:7473-7478.
120. Yang H, Fang Z, Wei Y, et al. Levels of miR-29b do not predict for response in patients with acute myelogenous leukemia treated with the combination of 5-azacytidine, valproic acid, and ATRA. *Am J Hematol* 2011;86:237-238.
121. Itzykson R, Kosmider O, Cluzeau T, et al. Presence of TET2 mutation predicts a higher response rate to azacitidine in MDS and AML post MDS. *Blood* 2010:abstract 439.
122. Itzykson R, Thepot S, Quesnel B, et al. Prognostic factors for response and overall survival in 282 patients with higher-risk myelodysplastic syndromes treated with azacitidine. *Blood* 2011;117:403-411.
123. Garcia-Manero G, Gore SD. Future directions for the use of hypomethylating agents. *Semin Hematol* 2005;42:S50-S59.
124. Cameron EE, Bachman KE, Myohanen S, et al. Synergy of demethylation and histone deacetylase inhibition in the re-expression of genes silenced in cancer. *Nat Genet* 1999;21:103-107.
125. Garcia-Manero G, Kantarjian HM, Sanchez-Gonzalez B, et al. Phase 1/2 study of the combination of 5-aza-2'-deoxycytidine with valproic acid in patients with leukemia. *Blood* 2006;108:3271-3279.
126. Soriano A, Braiteh F, Garcia-Manero G, et al. Combination of 5-azacitidine and valproic acid in advanced solid cancers: a phase 1 study. *Proc ASCO* 2007;25:3547.
127. Garcia-Manero G, Yang H, Bueso-Ramos C, et al. Phase 1 study of the histone deacetylase inhibitor vorinostat (suberoylanilide hydroxamic acid [SAHA]) in patients with advanced leukemias and myelodysplastic syndromes. *Blood* 2008;111:1060-1066.
128. Garcia-Manero G, Assouline S, Cortes J, et al. Phase 1 study of the oral isotype specific histone deacetylase inhibitor MGCD0103 in leukemia. *Blood* 2008;112:981-989.
129. Giles F, Fischer T, Cortes J, et al. A phase I study of intravenous LBH589, a novel cinnamic hydroxamic acid analogue histone deacetylase inhibitor, in patients with refractory hematologic malignancies. *Clin Cancer Res* 2006;12:4628-4635.
130. Sekeres MA, List AF, Cuthbertson D, et al. Phase I combination trial of lenalidomide and azacitidine in patients with higher-risk myelodysplastic syndromes. *J Clin Oncol* 2010;28:2253-2258.
131. Jabbour E, Garcia-Manero G, Batty N, et al. Outcome of patients with myelodysplastic syndrome after failure of decitabine therapy. *Cancer* 2010;116:3830-3834.
132. Prebet T, Gore SD, Esterni B, et al. Outcome of high-risk myelodysplastic syndrome after azacitidine treatment failure. *J Clin Oncol* 2011;29: 3322-3327.
133. Prebet T, Thepot S, Gore SD, et al. Outcome of patients with low risk myelodysplasia after azacitidine treatment failure. *Haematologica* 2013;98:e18-19.
134. Deeg HJ, Bartenstein M. Allogeneic hematopoietic cell transplantation for myelodysplastic syndrome: current status. *Arch Immunol Ther Exp (Warsz)* 2012;60:31-41.
135. Sanchez-Abarca LI, Gutierrez-Cosio S, Santamaria C, et al. Immunomodulatory effect of 5-azacytidine (5-azaC): potential role in the transplantation setting. *Blood* 2010;115:107-121.
136. Deeg HJ, Scott BL, Fang M, et al. Five-group cytogenetic risk classification, monosomal karyotype, and outcome after hematopoietic cell transplantation for MDS or acute leukemia evolving from MDS. *Blood* 2012;120:1398-1408.
137. de Lima M, Giral S, Thall PF, et al. Maintenance therapy with low-dose azacitidine after allogeneic hematopoietic stem cell transplantation for recurrent acute myelogenous leukemia or myelodysplastic syndrome: a dose and schedule finding study. *Cancer* 2010;116:5420-5431.

Section 3 - Myeloproliferative Disorders

Chapter 80 Pathology of the Myeloproliferative Neoplasms

> Table of Contents > Part VII - Hematologic Malignancies > Section 3 - Myeloproliferative Disorders > Chapter 80 - Pathology of the Myeloproliferative Neoplasms

Chapter 80

Pathology of the Myeloproliferative Neoplasms

Luke R. Shier

Tracy I. George

The myeloproliferative neoplasms include both chronic myeloproliferative disorders and overlap myelodysplastic/myeloproliferative syndromes. This chapter reviews the pathology of the myeloproliferative diseases, including pertinent clinical, laboratory, histologic, cytogenetic, and molecular genetic findings necessary for the classification of these disorders. Both myeloproliferative neoplasms (MPNs) and overlap myelodysplastic/myeloproliferative neoplasms (MDS/MPNs) are clonal neoplasms with typical increased marrow cellularity, maturation of cell lineages, and organomegaly. The MPNs also share effective hematopoiesis and varying amounts of marrow fibrosis, but generally differ by which myeloid cell lineage dominates hematopoiesis. The MDS/MPNs overlap myeloproliferative and myelodysplastic disorders, with varying degrees of effective hematopoiesis and myelodysplasia. A common theme of aberrant activation of tyrosine kinase signaling pathways has emerged among the myeloproliferative diseases^{1, 2} and ^{3,4,5}. Not only has this helped further our understanding of these complex disorders, but also identification of aberrant kinase signaling cascades has led to targeted small molecule tyrosine kinase inhibitors (TKIs), such as imatinib, being used successfully in the treatment of certain diseases. Thus, the diagnosis and classification of the MPNs and overlap disorders requires correlation of morphology with clinical, hematologic, and molecular genetic findings⁶. An abbreviated overview of select myeloid neoplasms including the myeloproliferative diseases (Table 80.1) correlates each disease with its corresponding identified aberrant tyrosine kinase or related gene involved in the pathogenesis of the disorder and corresponding molecular genetic findings. In categorizing these disorders, separation of the MPNs from the overlap MDS/MPNs is recognized by the presence of myelodysplasia in the latter syndromes. Of the MPNs, there are the four common disorders, recognized as chronic myelogenous leukemia (CML), with its characteristic 9;22 translocation and BCR-ABL1 fusion protein, and three non-CML MPNs: polycythemia vera (PV), essential thrombocythemia (ET), and primary myelofibrosis (PMF). These common non-CML MPNs (PV, ET, PMF) share a high incidence of the acquired point mutation (V617F) in the JAK2 kinase^{7, 8, 9} and ¹⁰, a cytoplasmic tyrosine kinase important in hematopoietic proliferation. This mutation is associated with constitutive Jak-STAT activation in cell lines and MPN-like disorders in mouse models^{3,11}, and occurs in stem cells in humans with polycythemia vera predisposing toward erythroid hyperplasia^{12,13}. Other JAK2 mutations have also been described in patients with PV¹⁴. Given the importance of JAK2 V617F, the 2008 revision of the World Health Organization (WHO) classification system now includes this mutation in the diagnostic criteria for the common non-CML MPNs^{15,16,17}.

The MPNs also include a number of uncommon or atypical disorders. These uncommon MPNs include chronic eosinophilic leukemia not otherwise specified (CEL), systemic mastocytosis (SM), and chronic neutrophilic leukemia (CNL). Several atypical MPNs and MDS-MPNs with eosinophilia are now also recognized as sharing tyrosine kinase abnormalities, such as FIP1L1-PDGFR α in disorders previously considered to be CEL and SM with eosinophilia, ETV6-PDGFR β in cases with features of chronic myelomonocytic leukemia (CMML) with eosinophilia or atypical chronic myeloid leukemia (aCML), and FGFR1 rearrangements seen in a number of hematologic neoplasms (formerly classified as the 8p11 myeloproliferative syndrome). These disorders are now classified as myeloid neoplasms with eosinophilia and abnormalities of PDGFR α , PDGFR β , or FGFR1¹⁸ rather than as subtypes of other MPNs. The presence of these genetic abnormalities is not merely academic, as patients with PDGFR α or PDGFR β rearrangements have shown responsiveness to TKIs. For example, MPNs with eosinophilia and FIP1L1-PDGFR α can contain proliferations of CD25 positive mast cells that are sensitive to imatinib, whereas SM with KIT D816V mutations (and dense proliferations of CD25 positive mast cells) is resistant to the same drug^{19,20}. The latter patients may respond to second-generation TKIs initially developed for imatinib-resistant CML patients or FLT3 inhibitors developed for patients with acute myeloid leukemia, as these drugs have activity against multiple

tyrosine kinases^{21,22}. The development of new tyrosine kinase pathway-targeted small molecule inhibitors is likely to accelerate further the molecular classification of myeloproliferative neoplasms.

The overlap MDS/MPNs, according to the WHO classification, have traditionally included chronic myelomonocytic leukemia (CMML), juvenile myelomonocytic leukemia (JMML), and atypical CML (aCML). A provisional entity, refractory anemia with ringed sideroblasts and thrombocytosis (RARS-T), also fits within this overlap group, sharing features of dysplasia and MPN. These overlap syndromes also share tyrosine kinase pathways, including JAK2 and MPL W515K/L mutations in RARS-T. As with all classification schemes, not every patient's findings are amenable to these guidelines, and it is preferred to term these "unclassifiable" until further information clarifies the disorder.

MYELOPROLIFERATIVE NEOPLASMS

The traditional classification of the common MPNs is based on which cell line is most proliferative (i.e., granulocytic, erythroid, and megakaryocytic) and the amount of marrow fibrosis, combined with clinical, laboratory, and cytogenetic/molecular genetic features (Table 80.2). As a consequence of excess cell proliferation with effective maturation, there is resulting leukocytosis, erythrocytosis, and/or thrombocytosis. Subsequent hepatosplenomegaly follows due to sequestration of excess cells, extramedullary hematopoiesis, or infiltration by neoplastic cells. Although this initial dysregulated proliferation may manifest as an indolent disorder, these clonal stem cell disorders all have the potential for evolution. This manifests as either a stepwise increase in fibrosis to an end-stage myelofibrosis or as an increase in blasts, transforming

P.1689

through an accelerated phase (10% to 19% blasts) to overt acute leukemia (20% or more blasts). The MPNs differ in the incidence of this evolution and transformation.

TABLE 80.1 MYELOID NEOPLASMS WITH ASSOCIATED TYROSINE KINASES AND GENETIC ABNORMALITIES

Myeloproliferative Neoplasms

CML	<i>ABL1</i>	t(9;22)(q34;q11); <i>BCR/ABL1</i>
Non-CML MPN		
PV	<i>JAK2</i>	<i>JAK2</i> V617F, <i>JAK2</i> exon 12
ET	<i>JAK2</i> , <i>MPL</i>	<i>JAK2</i> V617F, <i>MPL</i> W151L/K
PMF	<i>JAK2</i> , <i>MPL</i>	<i>JAK2</i> V617F, <i>MPL</i> W151L/K
Uncommon non-CML MPNs and other myeloid neoplasms		
Myeloid neoplasms with eosinophilia	<i>PDGFRA</i>	del(4q12); <i>FIP1L1-PDGFR</i> A
	<i>PDGFRB</i>	t(5;12); <i>ETV6-PDGFR</i> B
	<i>FGFR1</i>	8p11 abnormalities
SM	<i>KIT</i>	<i>KIT</i> D816V

Myelodysplastic/Myeloproliferative Syndromes

JMML	<i>RAS</i> , <i>NF1</i> , <i>PTPN11</i>
RARS-T	<i>JAK2</i> <i>JAK2</i> V617F

CML, chronic myelogenous leukemia; ET, essential thrombocythemia; JMML, juvenile myelomonocytic leukemia; MPN, myeloproliferative neoplasm; PMF, primary myelofibrosis; PV, polycythemia vera; RARS-T, refractory anemia with ring sideroblasts and thrombocytosis; SM, systemic mastocytosis.

Chronic Myelogenous Leukemia

Chronic myelogenous leukemia, BCR-ABL1 positive (CML)^{23,24,25}, is the most common of the MPNs and can occur at any age, although it is uncommon in children. The average age at diagnosis is 50 to 60 years old with a slightly increased male-to-female ratio. CML is defined by the presence of the Philadelphia chromosome or molecular genetic evidence of the

BCR-ABL1 fusion. In contrast to the t(9;22) of acute leukemias, which usually demonstrate the p190 BCR-ABL1 fusion protein, CML almost always demonstrates the p210 fusion protein of this translocation. The rare p230 fusion protein is typical of the rare neutrophilic form of CML, which is discussed later. CML is primarily a proliferation of granulocytic cells, although multiple cell lines demonstrate the Philadelphia chromosome. This expansion of myeloid cells typically involves the blood, bone marrow, spleen, and liver. Extramedullary involvement may be seen during the blast phase of the disease. The typical clinical course of CML is an indolent chronic phase followed by either blast crisis or progression to an accelerated phase with subsequent blast crisis.

TABLE 80.2 SELECT MOLECULAR GENETIC, MORPHOLOGIC, LABORATORY, AND CLINICAL FINDINGS IN THE COMMON MYELOPROLIFERATIVE NEOPLASMS

Disease	Molecular Findings	Blood Smear	Bone Marrow	Fibrosis	Splenomegaly	Other
CML	<i>BCR-ABL1</i>	Leukocytosis with immature granulocytes, basophilia	Marked myeloid hyperplasia with prominence of neutrophils and myelocytes	Variable	++	
PV	<i>JAK2</i> V617F <i>JAK2</i> exon 12	Normo- or hypochromic anemia, may have thrombocytosis and mild basophilia	Panmyelosis ± erythroid hyperplasia, atypical megakaryocytic hyperplasia	Increased in spent phase	++	Low EPO
PMF	<i>JAK2</i> V617F <i>MPL</i> W151L/K	Leukoerythroblastic with dacrocytes, giant and bizarre platelets	Panmyelosis with atypical megakaryocytic hyperplasia, dysplastic and bizarre megakaryocytes	Marked fibrotic phase	+++	
ET	<i>JAK2</i> V617F <i>MPL</i> W151L/K	Thrombocytosis, often with abnormal platelets and megakaryocytic nuclei	Atypical megakaryocytic hyperplasia with large/giant forms	Minimal	-/+	

CML, chronic myelogenous leukemia; EPO, erythropoietin; ET, essential thrombocythemia; PV, polycythemia vera; PMF, primary myelofibrosis.

Table adapted with permission from George TI, Arber DA. Pathology of the myeloproliferative diseases. *Hematol Oncol Clin North Am* 2003;17:1101-1127, Copyright © Elsevier.

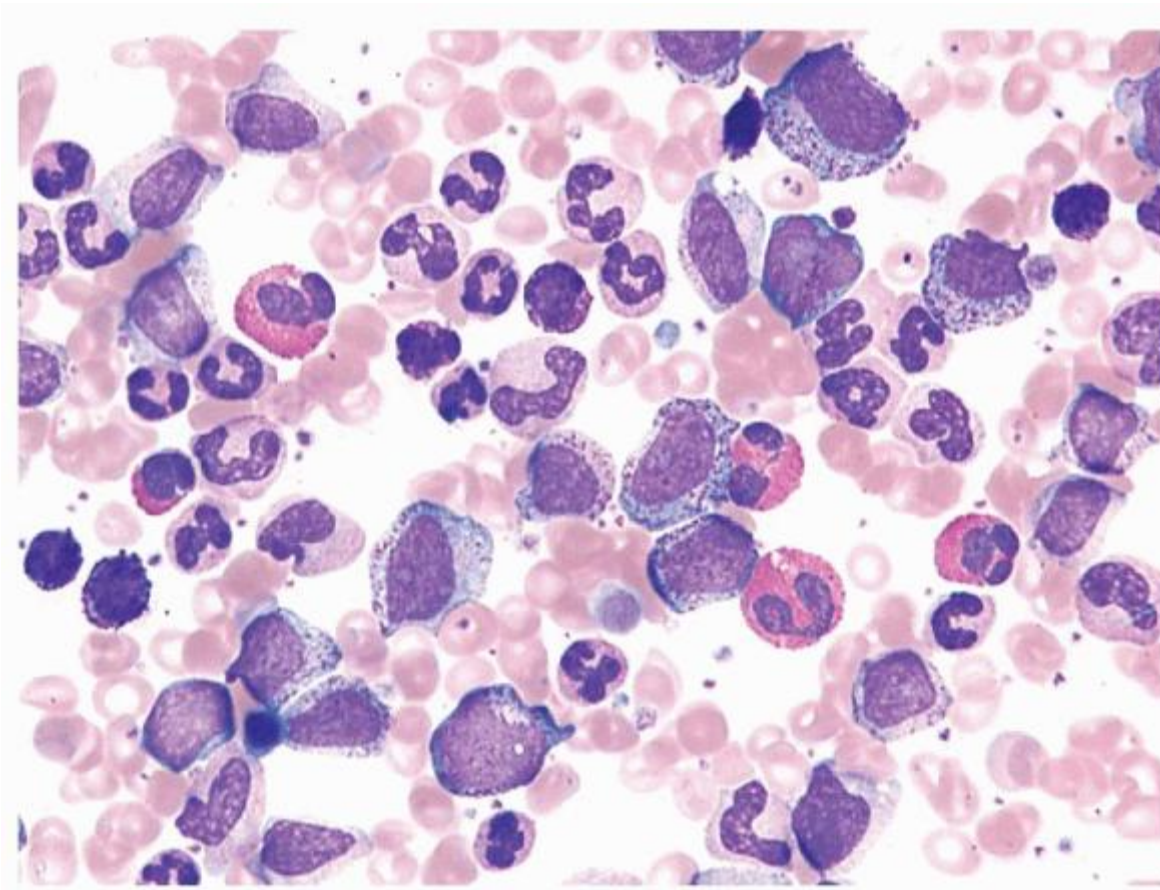

FIGURE 80.1. Chronic myelogenous leukemia. The peripheral blood demonstrates neutrophilia with prominent left shift, eosinophilia, and basophilia. Typically numerous myelocytes and segmented neutrophils predominate. Wright-Giemsa, 500 \times .

The peripheral blood findings are those of a leukocytosis with granulocytes at all stages of maturation (Fig. 80.1). Segmented neutrophils may show abnormal nuclear segmentation. Myelocytes

P.1690

and metamyelocytes are present in high numbers in the peripheral blood with concomitant basophilia and often eosinophilia. Abnormal basophils with “washed-out” granules may be identified. Platelets are usually elevated. An absolute monocytosis may also be present. The bone marrow is markedly hypercellular with cellularity approaching 100% in most untreated cases (Fig. 80.2). The myeloid-to-erythroid ratio of the bone marrow is increased, often >10:1. An atypical megakaryocytic hyperplasia is present, with clustering of megakaryocytes, which are small and contain hypolobated nuclei. Some degree of reticulin fibrosis is usually demonstrated in these cases, and marked increases in reticulin and collagen marrow fibrosis are associated with accelerated phase and decreased survival²⁶. Pseudo-Gaucher histiocytes are common in CML, reportedly present in 37% to 70% of cases²⁷. These histiocytes have abundant fibrillar birefringent cytoplasm, and their presence has been associated with an improved survival²⁶. Leukemoid reactions, in patients with infectious or other reactive conditions, may demonstrate similar features to CML. These reactive proliferations, however, do not usually show the basophilia, degree of marrow cellularity, or megakaryocyte clustering characteristic of CML. However, cytogenetic or molecular genetic studies are indicated if the differential diagnosis includes CML.

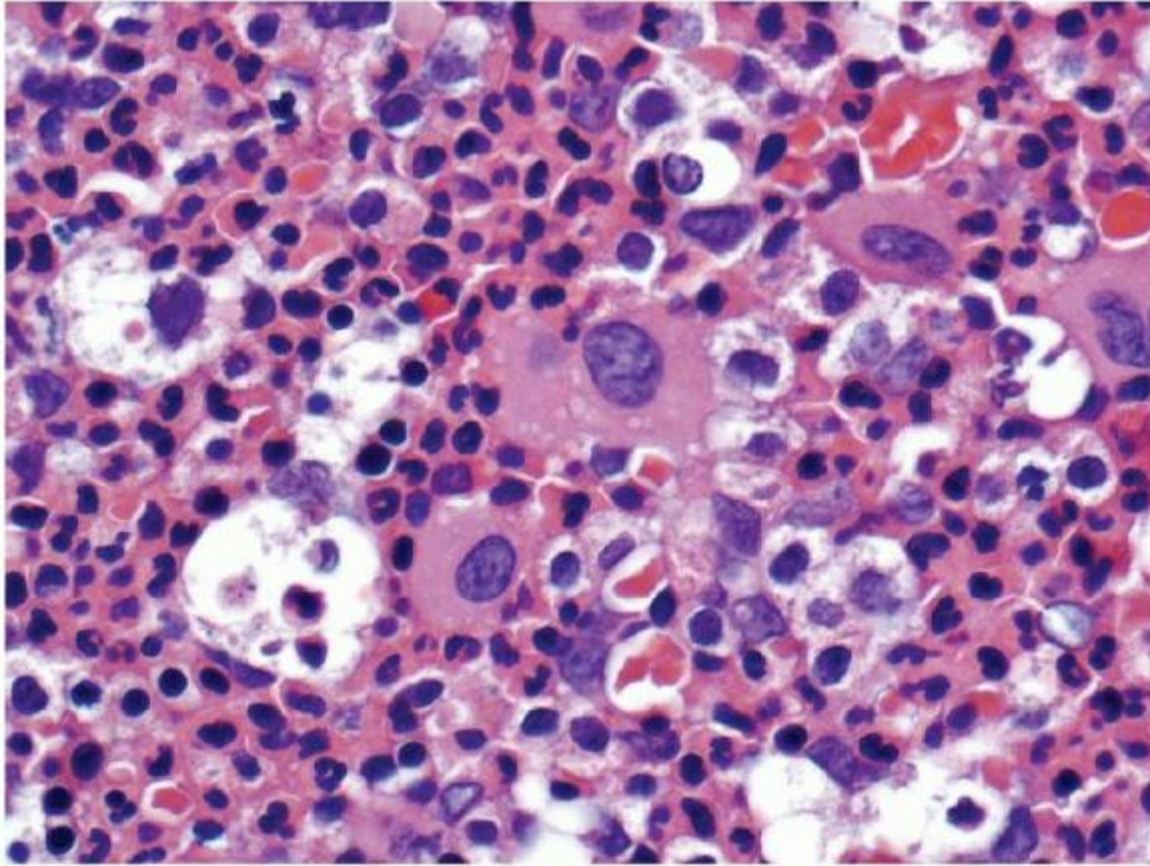

FIGURE 80.2. Chronic myelogenous leukemia (CML). The bone marrow biopsy is hypercellular with myeloid and megakaryocytic hyperplasia. Note the clusters of small hypolobated megakaryocytes typical of CML. Hematoxylin and eosin, 500 \times .

Chronic myelogenous leukemia usually presents in chronic phase, which is essentially defined by the lack of features of accelerated phase or blast crisis. Marrow blasts are usually <5%, but may range up to 9%. The natural course of the disease is progression from chronic phase to a more aggressive phase of the disease within 3 to 5 years. Any one of a variety of parameters defines the accelerated phase of CML, but the criteria are inconsistent in the literature^{28,29}. WHO criteria (Table 80.3) require the presence of either 10% to 19% blasts in the peripheral blood or bone marrow, the acquisition of additional chromosomal abnormalities, elevations of basophils to 20% or more of blood cells, persistent thrombocytopenia (<100 $\times 10^9/L$), or either of the following that do not respond to conventional therapies: platelet elevations of >1,000 $\times 10^9/L$ or increasing splenomegaly associated with an increasing white blood cell (WBC) count³⁰. In addition, megakaryocytic proliferation in sheets and clusters associated with marked fibrosis and/or marked granulocytic dysplasia has also been described as suggestive of an accelerated phase³¹. Blast phase, or blast crisis, of CML is defined by the presence of 20% or more blasts in the peripheral blood or bone marrow (Fig. 80.3)³⁰. Large clusters of blasts on the bone marrow biopsy are also sufficient for a diagnosis of blast phase³¹. The development of extramedullary myeloid tumors (myeloid or granulocytic sarcomas, chloromas) is also sufficient for blast phase using the WHO criteria. Cytogenetic clonal evolution, which may be present at the time of transformation to either the accelerated phase or blast phase, typically includes an extra Philadelphia chromosome, trisomy 8, or i(17q)^{25,32,33}.

TABLE 80.3 WHO CRITERIA FOR ACCELERATED PHASE OF CHRONIC MYELOGENOUS LEUKEMIA^a

- Blasts 10-19% in blood or marrow
- Peripheral blood basophilia $\geq 20\%$
- Cytogenetic clonal evolution
- Persistent thrombocytopenia (<100 $\times 10^9/L$)

Persistent thrombocytosis ($>1,000 \times 10^9/L$) unresponsive to therapy

Increasing splenomegaly and/or increasing WBC count unresponsive to therapy

WBC, white blood cell; WHO, World Health Organization.

^aThe diagnosis requires one or more of the listed criteria.

Detection of the t(9;22)(q34;q11) by karyotype analysis, fluorescent in situ hybridization (FISH), or reverse transcriptase polymerase chain reaction (RT-PCR) is essential for the diagnosis of CML. Detection of this abnormality confirms the clonal or neoplastic nature of the proliferation and excludes reactive conditions and other MPNs that may mimic CML. Immunophenotyping studies add little in the chronic phase of CML, but are helpful in defining the blast cell population of accelerated and blast phases of this disease^{34,35}. The majority of blast crisis cases will express myeloid-associated antigens without lymphoid markers and are easily classified as myeloid blast crisis by immunophenotyping studies; however, some myeloid blast crisis cases may be myeloperoxidase negative by cytochemistry. Although most blast transformations of CML are proliferations of myeloblasts, approximately one third of cases are lymphoid blast crises (Fig. 80.4). The vast majority of lymphoid blast crisis cases are of precursor B-cell lineage, but rare T-cell blast crisis cases occur. Lymphoid blast crisis is reported to have a better prognosis than myeloid blast crisis, and lymphoid blast crisis has traditionally been defined as a blast cell proliferation that is terminal deoxynucleotidyl transferase (TdT) positive. More detailed immunophenotyping of these cases

P.1691

usually demonstrates expression of other precursor B-cell markers, such as CD19 and CD10, but expression of myeloid-associated antigens, such as CD13 and CD33, is also common. Cases with a lymphoid immunophenotype lacking myeloperoxidase, irrespective of the expression of other myeloid antigens, have an improved survival³⁵ and are probably best classified as lymphoid blast crises. A small proportion of CML blast crises are mixed phenotype, which must be distinguished from de novo mixed phenotype acute leukemia (MPAL), a subset of which also has the BCR-ABL1 gene rearrangement.

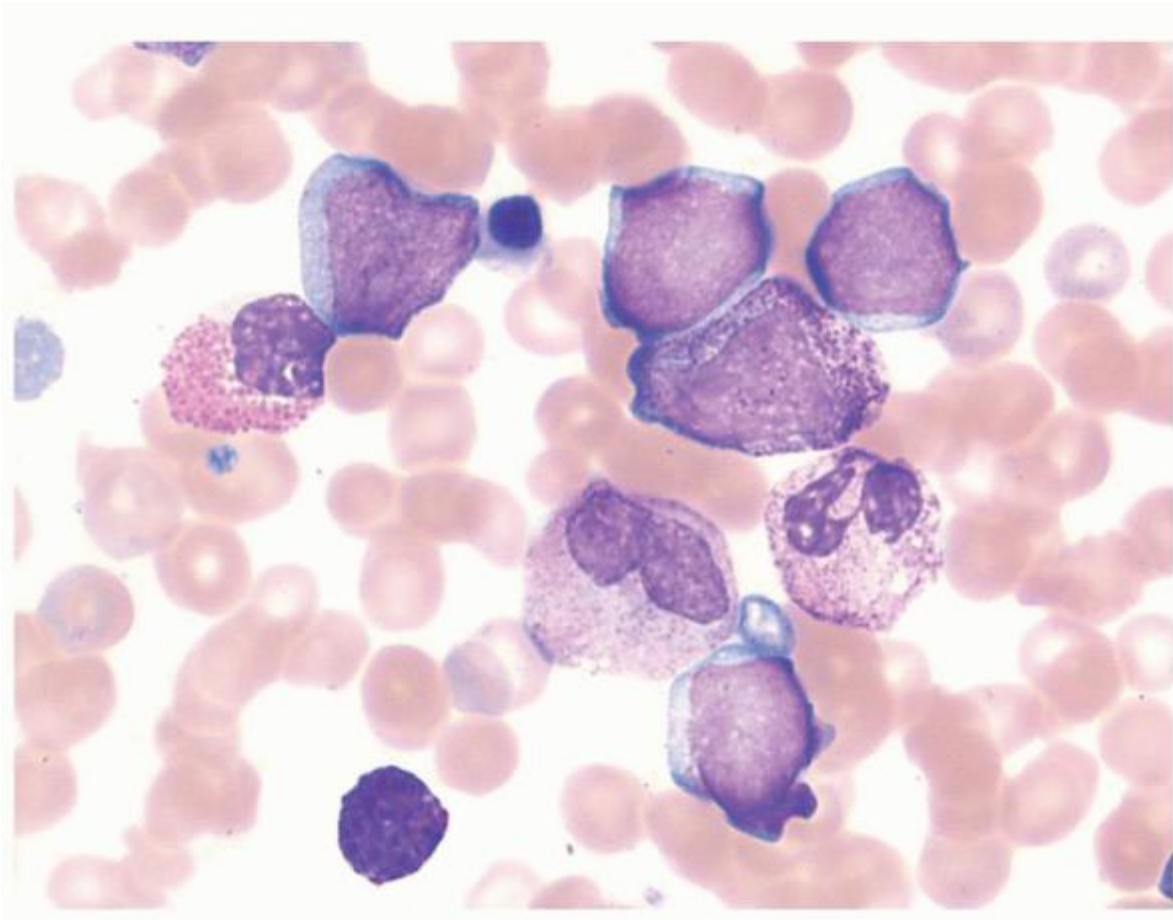

FIGURE 80.3. Myeloid blast crisis of chronic myelogenous leukemia (CML). Peripheral blood smear showing numerous agranular blasts on a background of neutrophils, immature granulocytes, eosinophils, and basophils. When blasts are the dominant cell present, the background changes of CML may be subtle or obscured. Wright-Giemsa, 1,000 \times .

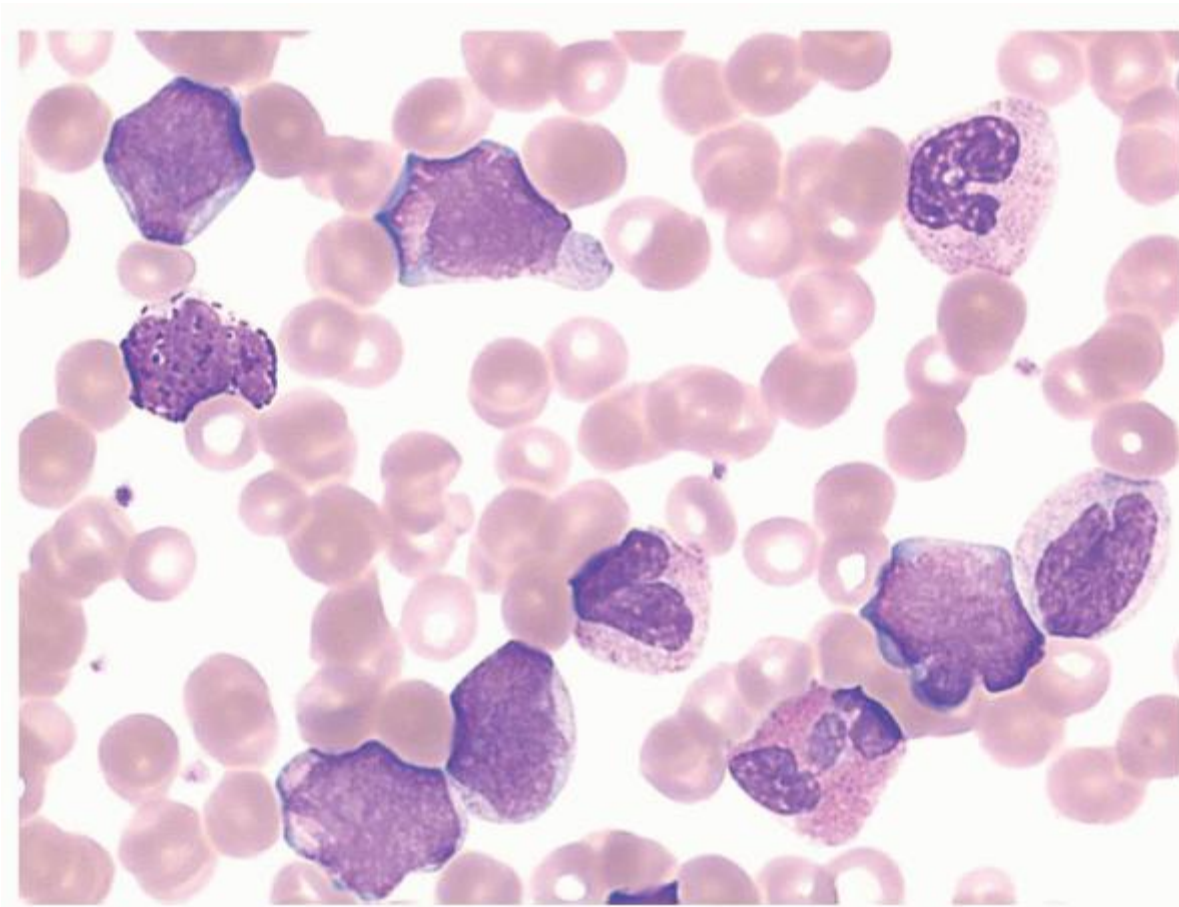

FIGURE 80.4. Lymphoid blast crisis of chronic myelogenous leukemia (CML). Peripheral blood smear shows intermediate-sized blasts with high nuclear-to-cytoplasmic ratios, a very small amount of basophilic cytoplasm, irregular and clefted nuclear contours, and immature chromatin. The background shows features of CML. Flow cytometry demonstrated a B-lymphoblastic immunophenotype. Wright-Giemsa, 1,000 \times .

Typically, patients with all phases of CML are treated with a TKI, imatinib, which directly blocks the effects of the BCR-ABL1 fusion protein³⁶. Imatinib results in a clinical, morphologic, and at least partial cytogenetic remission in most patients, with reduction in marrow cellularity, normalization of the myeloid-to-erythroid ratio, and normalization of megakaryocyte number and morphology^{37,38,39,40,41}. The peripheral blood is the first to respond to imatinib therapy with a normalization of the white blood cell and platelet counts, a decrease in basophils, and normal-appearing platelets occurring after about 2 months of therapy. During therapy, the hemoglobin level tends to decrease slightly, and a subset of patients may develop neutropenia or thrombocytopenia. Bone marrow hypercellularity gradually decreases and by 8 to 11 months the marrow is normocellular or hypocellular with a normal or decreased myeloid-to-erythroid ratio in most patients. Even in chronic phase, bone marrow blasts and megakaryocytes decrease, and the number of hypolobated megakaryocytes and the presence of megakaryocyte clustering become less common as the marrow cellularity decreases. This therapy has also been reported to gradually eliminate the marrow fibrosis that is prominent in some cases of CML^{37,38,42}. Patients with accelerated or blast phases of CML show similar changes with rapid decreases in peripheral blood and bone marrow blast cell counts³⁷. Two thirds of patients treated in chronic phase tolerate imatinib therapy well and experience an excellent and sustained remission^{40,41}. More recently, the development of second-generation TKIs (dasatinib, nilotinib) have proven effective in many patients who fail or are not tolerant of imatinib, and these may become effective alternatives for front line therapy^{43,44} and⁴⁵. Whereas TKIs are now well established as front line therapy, stem cell transplantation (SCT) remains an effective curative option although the risks are not insignificant. SCT is therefore now employed as salvage therapy⁴⁶.

Neutrophilic-chronic myelogenous leukemia appears to be a less aggressive variant of CML in which the t(9;22) codes for a 230-kD BCR-ABL1 fusion protein⁴⁷. This disease is associated with a proliferation of more mature granulocytes, usually at the segmented neutrophil stage of development. These patients have less severe clinical symptoms and are slower to

progress to a blastic stage. This CML variant has been shown in one study to have low levels of p230 BCR-ABL1 messenger RNA and undetectable protein product, which may explain the milder phenotype in these patients⁴⁸.

Philadelphia chromosome-negative CML is not recognized in the 2008 WHO classification and such a diagnosis should be made with caution. Cryptic BCR-ABL1 translocations may occur that cannot be identified by routine karyotype analysis. When this is suspected, molecular genetic studies, such as FISH or RT-PCR analysis, are indicated. When these studies are negative, other diagnostic considerations must be entertained. Review of cytogenetic and molecular genetic Philadelphia chromosome-negative CML cases has resulted in most being reclassified as chronic myelomonocytic leukemia or atypical CML (described below)⁴⁹.

Polycythemia Vera

Polycythemia vera is a clonal proliferation, usually occurring in elderly patients with a male predominance, that presents as an expansion of the red blood cell mass^{50,51,52}. This expansion is secondary to increased red cell production from dysregulated erythropoiesis. An acquired JAK2 V617F mutation in exon 14 is detected in 95% to 97% of patients with PV^{53,54}, with exon 12 mutations accounting for most JAK2 V617F negative cases^{14,55}. The WHO 2008 criteria for PV now include JAK2 or functionally similar mutations as a major criterion for diagnosis (Table 80.4)^{15,17}. These mutations produce a PV-like disease in mice^{14,55} and involve a stem cell in humans predisposing toward erythroid differentiation⁸. Typically, the spleen is enlarged and erythropoietin levels are decreased in this disease⁵⁶. The presence of a JAK2 mutation allows for the exclusion of a reactive erythrocytosis, but is not diagnostic for PV, as JAK2 mutations occur in approximately one half of patients with ET and PMF, as well as involving atypical MPNs and overlap MDS/MPNs at lower levels^{53,57,58}.

TABLE 80.4 WHO CRITERIA FOR THE DIAGNOSIS OF POLYCYTHEMIA VERA^a

Major Criteria

- Hemoglobin >18.5 g/dl in men, >16.5 g/dl in women or evidence of increased red cell volume^b
- Presence of *JAK2* mutation

Minor Criteria

- Hypercellular bone marrow biopsy with panmyelosis with prominent erythroid, granulocytic, and megakaryocytic hyperplasia
- Low serum erythropoietin level
- Endogenous erythroid colony formation in vitro

WHO, World Health Organization.

^aDiagnosis requires the presence of both major criteria and one minor criterion or the presence of the first major criterion and two minor criteria. The *JAK2* mutation refers to the *JAK2V617F* or other functionally similar *JAK2* mutation.

^bHemoglobin or hematocrit >99% of method-specific range for age, sex, and altitude of residence or hemoglobin >17 g/dl in men, >15 g/dl in women if associated with a sustained increase of at least 2 g/dl from an individual's baseline value that cannot be attributed to correction of iron deficiency.

From Swerdlow SH, Campo E, Harris NL, et al. World Health Organization Classification of Tumours of Haematopoietic and Lymphoid Tissues. IARC, Lyon, 2008.

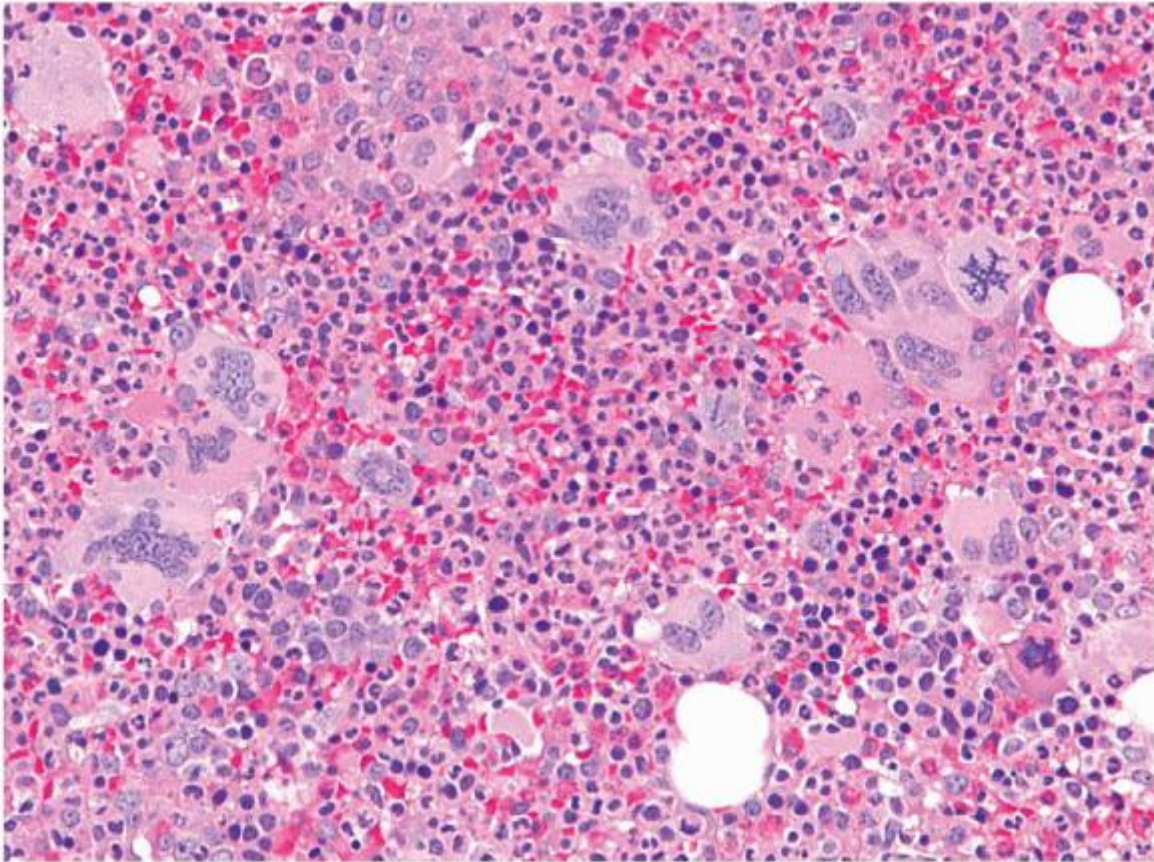

FIGURE 80.5. Polycythemia vera. The bone marrow biopsy from a patient with polycythemia vera is hypercellular, with panmyelosis, an increased number of erythroid precursors, and large atypical megakaryocytes in loose clusters. Hematoxylin and eosin, 200 \times .

Two morphologic phases of PV are well described⁵⁹. The proliferative or erythrocytotic phase typically shows elevations of red blood cells, white blood cells, and platelets. Slight elevations in the peripheral blood basophil count may be present, but are not as elevated as is usually seen in CML. A neutrophilia with left-shifted granulocytes is commonly seen. Platelet counts can exceed $600 \times 10^9/L$, which may cause confusion with essential thrombocythemia. It is not uncommon for patients to have associated iron deficiency with microcytic red blood cells; absent stainable iron on marrow examination is typical⁵⁹. The bone marrow is usually moderately hypercellular with trilineage proliferation (Fig. 80.5). In contrast to the other MPNs, however, the erythroid series is relatively increased. Loose clusters of pleomorphic megakaryocytes are prominent, with very small and giant megakaryocytes adjacent to each other. Marrow fibrosis may be minimal in this stage of the disease^{60,61}. Reactive lymphoid aggregates are also common⁶². The spent phase or post-polycythemic phase of PV is associated with marked marrow fibrosis and shows peripheral blood and bone marrow changes that are similar or identical to those seen in primary myelofibrosis with leukoerythroblastic peripheral blood changes, splenomegaly, and marrow fibrosis (Fig. 80.6). Differentiation between these two diseases may not be possible without a history of the earlier phase of PV (Fig. 80.7). Approximately 10% of PV patients will transform to acute myeloid leukemia within 15 years and up to half will develop acute leukemia over 20 years (Fig. 80.8)⁶³. Rare cases of myelodysplastic transformation are also reported in the literature, which appear to be treatment related⁶⁴.

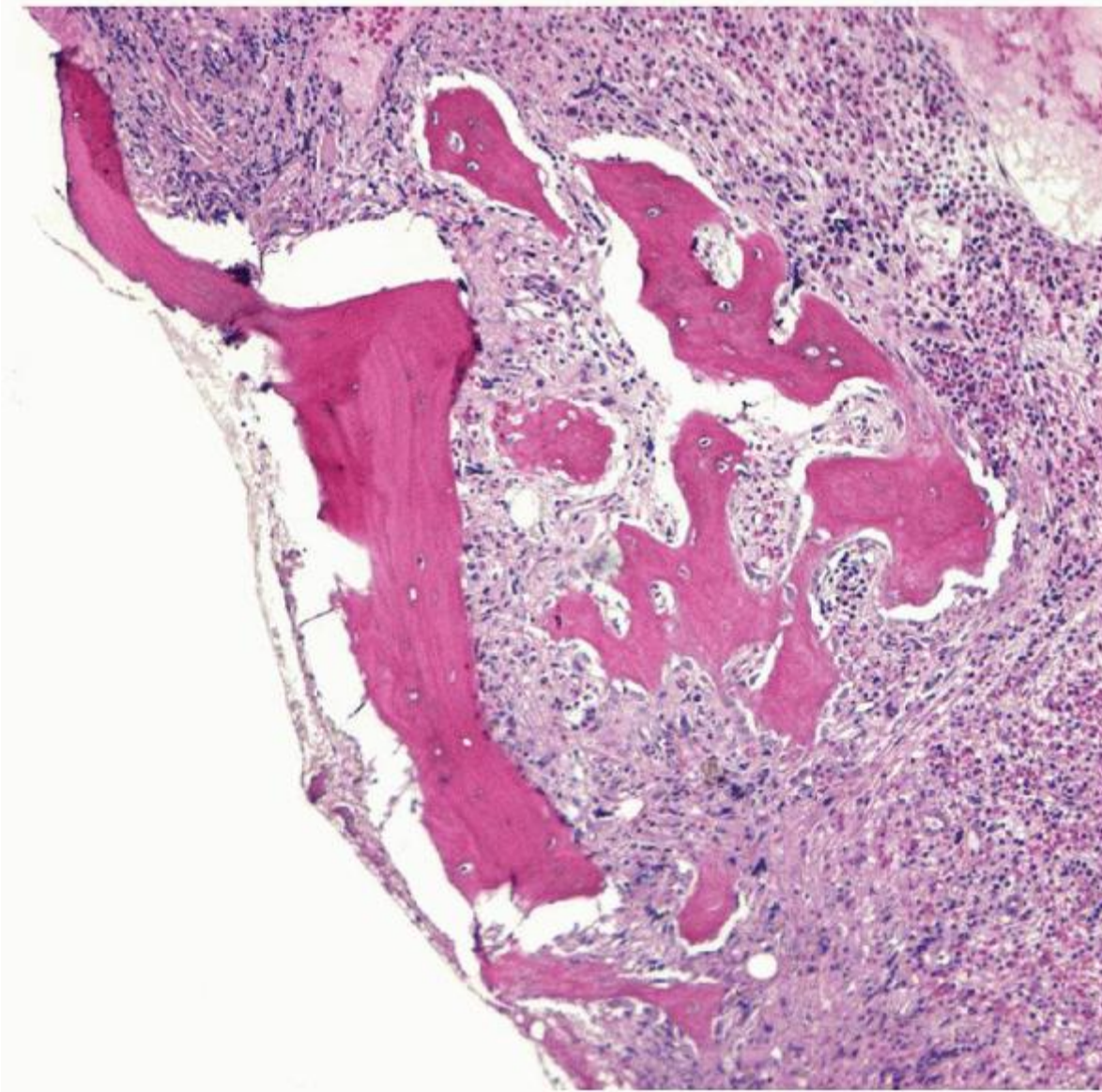

FIGURE 80.6. Post-polycythemic phase of polycythemia vera. Bone marrow biopsy showing increased fibrosis and osteosclerosis. Hematoxylin and eosin, 400 \times .

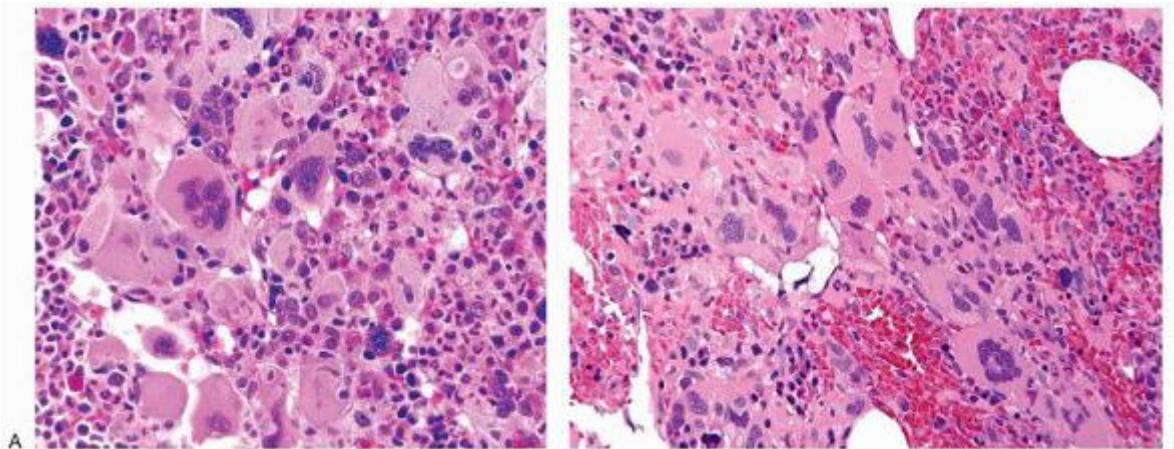

FIGURE 80.7. The post-polycythemic phase of polycythemia vera shows bone marrow changes (A) indistinguishable from

those of the fibrotic stage of primary myelofibrosis (B). Both bone marrow biopsies are hypercellular with atypical megakaryocyte clustering, including hyperchromatic enlarged megakaryocytes amidst a fibrotic background. Hematoxylin and eosin, 400 \times .

Evaluation of red cell mass (RCM), which previously was recommended for the diagnosis of PV, has now largely been supplanted by JAK2 testing, bone marrow histology, and serum erythropoietin levels⁶⁵. However, given the overlap in features between PV and other MPNs, some cases may only be resolved by RCM studies, although these studies have their own challenges⁶⁵. An absolute erythrocytosis is the feature that separates

P.1693

PV from other MPNs, and RCM may be decreased in PV patients with concurrent iron deficiency; thus, studies may have to be repeated after iron therapy. Reactive or secondary polycythemias must also be excluded and these may be related to smoking, lung and renal disease, erythropoietin-producing tumors, congenital conditions causing erythropoietin overproduction, and exogenous administration of erythropoietin. Although many of these secondary polycythemias will lack JAK2 mutations, not all idiopathic erythrocytoses that meet neither criterion for PV or secondary polycythemia are well understood⁶⁶. Some of these idiopathic erythrocytoses represent recently described exon 12 or 14 JAK2 mutations, whereas others are still being investigated^{14,55}. Studies have emphasized the value of bone marrow histology in distinguishing between early-stage PV and reactive polycythemias. The atypical megakaryocytic hyperplasia of PV is not seen in secondary polycythemias. These reactive conditions tend to show only a borderline increase in cellularity, with an altered interstitial compartment containing increased deposition of cellular debris within histiocytic cells, hemosiderin-laden macrophages, and perivascular plasmacytosis^{60,61}.

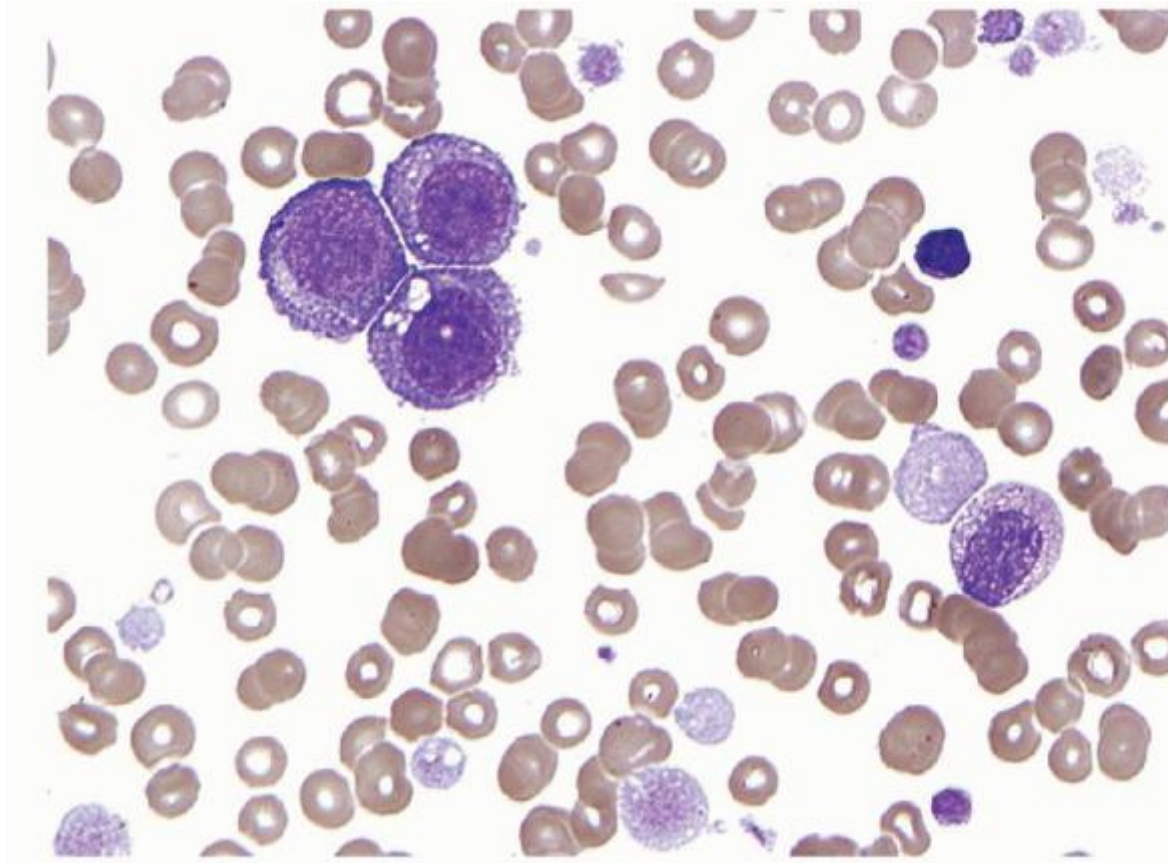

FIGURE 80.8. Transformation of polycythemia vera. Peripheral blood smear shows numerous giant platelets, including hypogranular forms, a myelocyte, a lymphocyte, and a cluster of three blasts. Wright-Giemsa, 600 \times .

Other karyotypic abnormalities may be detected in up to half of cases of PV, with chromosome 20q deletions being the most common^{67,68}. These abnormalities, however, are not specific for PV⁶⁹. Various point mutations occur in association with polycythemias, particularly in the congenital or familial forms⁷⁰. Clonogenic stem cell assays are a minor diagnostic criterion used in the diagnosis of PV. Progenitor cells from patients with PV are hypersensitive to several growth factors,

and in vitro detection of endogenous erythroid colonies occurs in PV. Although the predictive value of clonogenic stem cell assays in certain defined settings may be high (97%)⁷¹, their availability is limited and these assays are difficult to standardize. Thus, these assays are now infrequently used in the routine diagnosis of PV⁷².

Primary Myelofibrosis

Primary myelofibrosis, also known as chronic idiopathic myelofibrosis, myelofibrosis with myeloid metaplasia, and agnogenic myeloid metaplasia, occurs in elderly patients and usually presents with a leukoerythroblastic peripheral blood smear, massive splenomegaly, and marrow fibrosis^{73,74}. The peripheral blood changes include the presence of large teardrop-shaped red blood cells (dacryocytes), a granulocyte left-shift that often includes rare myeloblasts, and thrombocytosis with giant platelets that are larger than a red blood cell (Fig. 80.9). Basophilia may be present and bare megakaryocyte nuclei are often seen in the blood and bone marrow. Although spleen enlargement occurs with many myeloproliferative neoplasms, the splenomegaly of PMF is striking, and may cause severe discomfort and wasting syndromes. The bone marrow may be hypercellular, particularly early in the disease when marrow fibrosis is less prominent, in the prefibrotic phase of PMF. The myeloid-to-erythroid ratio is slightly increased and megakaryocytes are increased. Atypical megakaryocyte clustering is prominent, with clusters of medium-sized to giant megakaryocytes often adjacent to sinuses and bony trabeculae. The megakaryocytes are atypical with hyperchromatic megakaryocytic nuclei and coarse lobulations^{75, 76, 77} and ⁷⁸. The differential diagnosis between the prefibrotic stage of PMF and ET can be quite difficult, but abnormal megakaryopoiesis is most helpful in establishing the diagnosis of PMF, although other features including bone marrow cellularity (increased markedly in the cellular phase of PMF) and left-shifted myeloid hyperplasia (usual in PMF) are also useful^{79, 80, 81} and ^{82,83,84}. Most patients are diagnosed in the fibrotic stage and show marked marrow fibrosis (Fig. 80.10), which may include collagen fibrosis. Interestingly, this accompanying fibrosis is reactive, whereas clonal studies have shown that the trilineage hematopoietic proliferation is monoclonal⁸⁵. Clusters of atypical megakaryocytes remain prominent in association with the fibrosis, and megakaryocyte clusters in sinusoids may be evident. The sinuses are often dilated with intrasinusoidal hematopoiesis. Sclerosis of bone trabeculae also occurs in many patients with broad irregular trabeculae, which can occupy much of the marrow biopsy (Fig. 80.10D). Lymphoid aggregates, of predominantly T-cells, occur commonly in association with PMF.

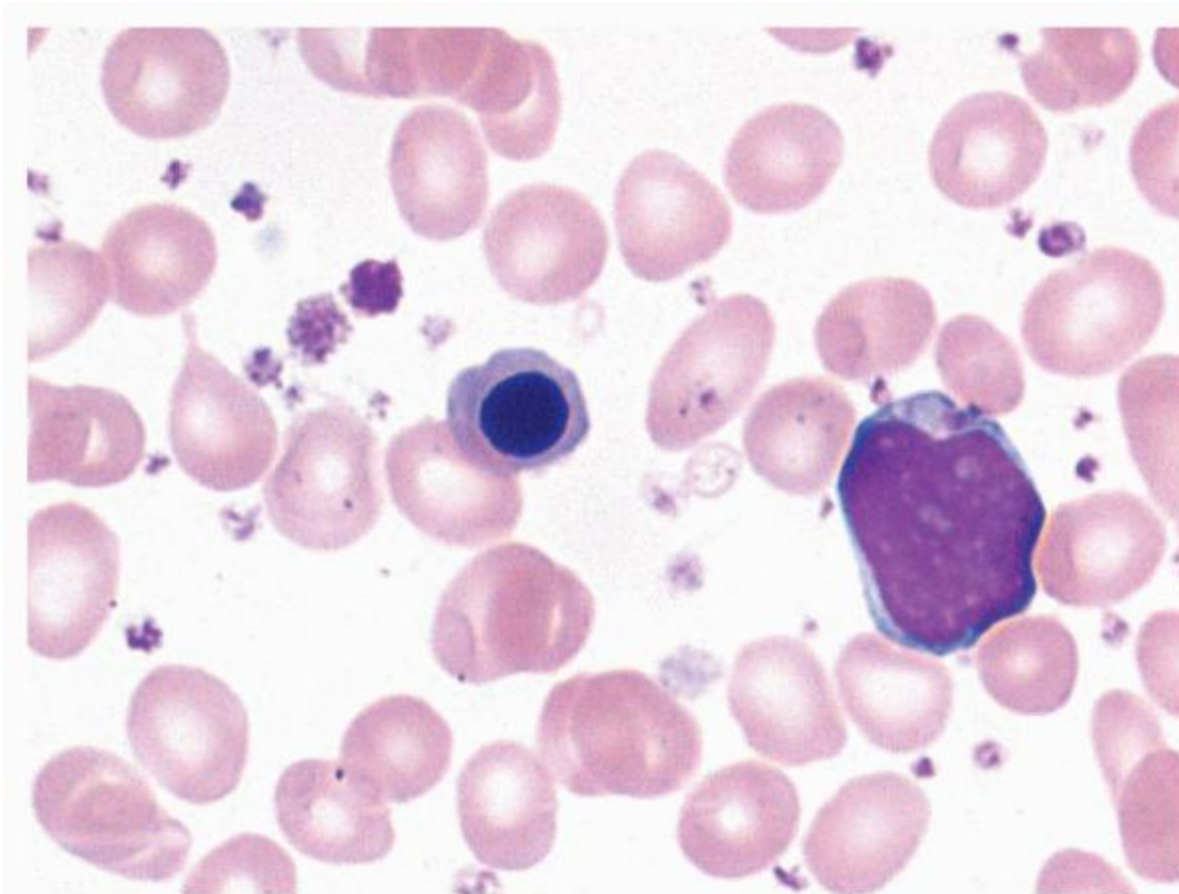

FIGURE 80.9. Primary myelofibrosis. The peripheral blood changes of myelofibrosis show the characteristic findings of leukoerythroblastosis with rare blasts, nucleated red blood cells, large platelets, and teardrop-shaped red cells (dacrocytes). Wright-Giemsa, 1,000 \times .

Ancillary studies are required to exclude the Philadelphia chromosome of CML, and approximately one half of PMF patients will have an acquired JAK2 mutation⁵³. An MPL mutation, MPL W515L, has also been described in a subset of patients with PMF; some of these patients lacked the JAK2 mutation whereas others occurred concurrently^{86,87}. Studies report that 35% to 61% of patients will demonstrate a cytogenetic abnormality, with deletions of chromosomal arms 20q and 13q most common, as well as der(6)t(1;6) (q21-23;p21.3)^{74,88, 89, 90} and ⁹¹. Other ancillary studies are of limited utility with the exception of immunophenotyping of blasts in cases that undergo blastic transformation.

The Italian criteria for myelofibrosis focused on the fibrotic phase of the disease, requiring diffuse fibrosis of the marrow, among other features⁹². The 2008 WHO criteria for PMF require three major and two of four minor criteria¹⁵. The first major criterion addresses bone marrow histology and allows diagnosis in either the fibrotic or prefibrotic phase by focusing on

P.1694

characteristic megakaryocytic proliferation and atypia accompanied either by significant fibrosis or a hypercellular marrow with granulocytic proliferation. The two additional required major criteria are the demonstration of the JAK2 V617F mutation or a similar clonal marker (such as MPL W515K/L), and the exclusion of other MPNs, MDS, and BCR-ABL1-positive CML (Table 80.5). Two of four minor criteria must also be met, including (a) leukoerythroblastosis, (b) elevated serum lactate dehydrogenase levels, (c) anemia, or (d) splenomegaly. As described above, the megakaryocytic atypia is quite marked with loose to tight clusters of megakaryocytes, including a wide variation in size with hyperchromatic, irregularly folded or bulbous nuclei, as well as abnormal nuclear-to-cytoplasmic ratios^{78,93}.

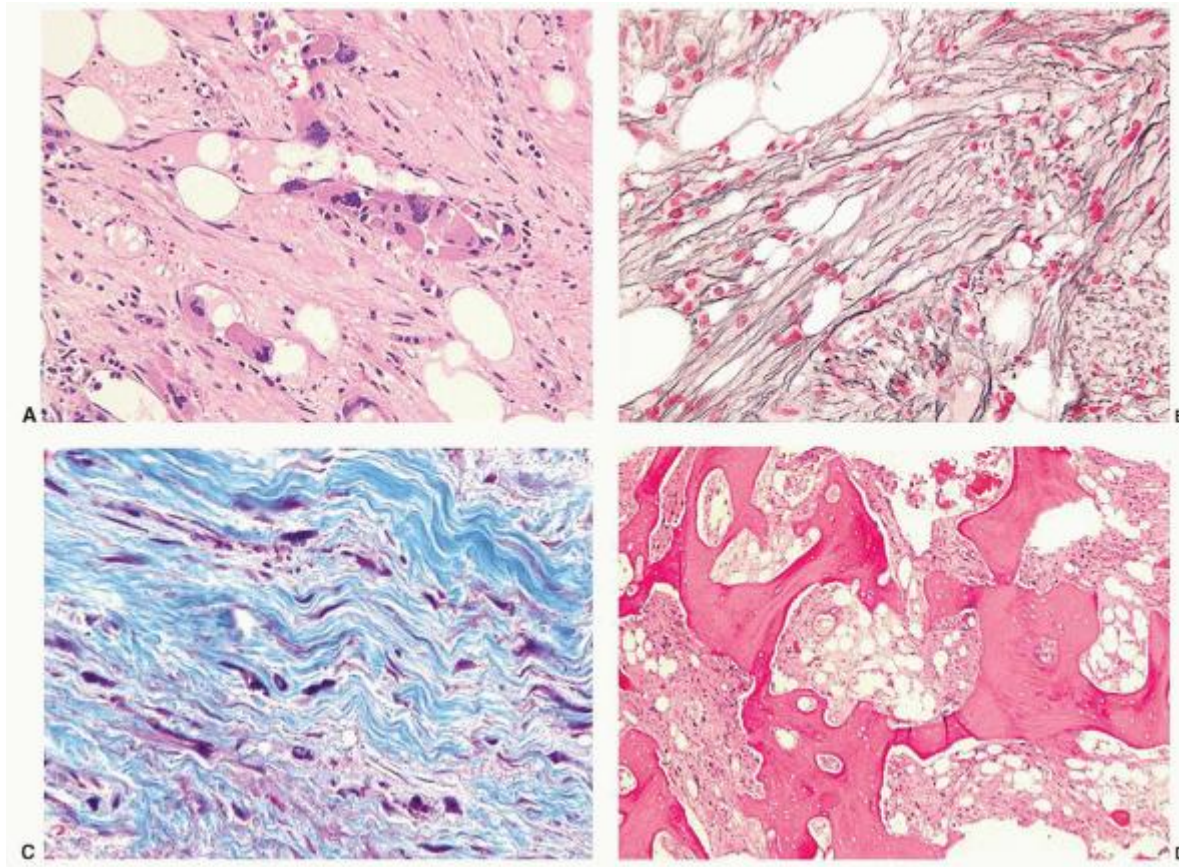

FIGURE 80.10. Bone marrow changes of fibrotic phase primary myelofibrosis. Fibrosis and intrasinusoidal clusters of atypical megakaryocytes are evident in (A). Hematoxylin and eosin, 200 \times . Diffusely increased coarse reticulin fibrosis is shown in (B). Reticulin stain, 500 \times . Coarse collagen fibrils are demonstrated in (C). Masson trichrome, 500 \times . Late-stage osteosclerotic changes are noted in (D), Hematoxylin and eosin, 50 \times .

Median survival for patients with PMF varies from 17.5 to 1.8 years for low- to high-risk subgroups⁹⁴, using the Dynamic International Prognostic Scoring System (DIPSS)-plus with the following eight risk factors: age > 65 years, constitutional symptoms, RBC transfusion need, hemoglobin <10 g/dL, leukocyte count >25 × 10⁹/L, circulating blasts ≥1%, platelet count <100 × 10⁹/L, and an unfavorable karyotype⁹⁵. The most frequent causes of death are complications of marrow failure (22%), including anemia, infection, and hemorrhage; transformation to AML (15%); and complications related to massive splenomegaly (11%)⁸⁸. At present, there are few therapeutic options for PMF⁹⁶. Allogeneic SCT provides a chance for cure, but the morbidity and mortality in PMF can be significant⁹⁷.

Essential Thrombocythemia

Essential thrombocythemia is a bone marrow proliferation characterized primarily by an elevation in peripheral blood platelets, usually over 1,000 × 10⁹/L. The 2008 WHO classification specifies four criteria for diagnosis: a sustained platelet count ≥450 × 10⁹/L; bone marrow biopsy showing megakaryocyte proliferation with enlarged mature megakaryocytes and with no significant increase or left shift of granulopoiesis or erythropoiesis; the exclusion of PV, PMF, CML, MDS, or another myeloid neoplasm; and either the presence of JAK2 V617F or another clonal marker or the exclusion of reactive thrombocytosis (Table 80.6)⁹⁸. Causes of reactive thrombocytosis include iron deficiency, splenectomy, surgery, infection, inflammation, connective tissue disease, metastatic cancer, and lymphoproliferative diseases. JAK2 mutations are found in ~50% of patients with ET, and the MPL W515K/L in 3%, with both mutations found in a few patients^{58,99}.

ET probably represents two different diseases, one clonal and one reactive, even using the listed criteria¹⁰⁰. Patients with the nonclonal form of the disease may include those with abnormalities of the thrombopoietin gene, and appear to be at a decreased

P.1695

risk of developing thrombosis^{100,101}. Both types show similar peripheral blood and bone marrow features.

TABLE 80.5 WHO CRITERIA FOR PRIMARY MYELOFIBROSIS^A

Major Criteria

- Atypical megakaryocytic hyperplasia, often accompanied by reticulin and/or collagen fibrosis or in the absence of fibrosis, megakaryocytic atypia and marrow hypercellularity with granulocytic hyperplasia and erythroid hypoplasia
- Exclusion of WHO criteria for PV, CML, MDS, or other MPNs
- *JAK2* V617F mutation or other clonal marker or if no clonal marker, exclusion of marrow fibrosis secondary to inflammatory or other neoplastic disorders

Minor Criteria

- Leukoerythroblastic peripheral blood smear
- Elevated serum lactate dehydrogenase level
- Anemia
- Splenomegaly

CML, chronic myelogenous leukemia; MDS, myelodysplastic syndrome; MPN, myeloproliferative neoplasm; PV, polycythemia vera; WHO, World Health Organization.

^ADiagnosis requires all major criteria and two minor criteria. From Swerdlow SH, Campo E, Harris NL, et al. World Health Organization Classification of Tumours of Haematopoietic and Lymphoid Tissues. IARC, Lyon, 2008.

The thrombocytosis in ET is usually accompanied by abnormal large platelets. If leukocytosis is present, it is usually mild without the prominent left-shift or associated increase in basophils seen in CML. The marrow is normocellular to moderately hypercellular with increased numbers of megakaryocytes occurring in loose clusters or distributed throughout the marrow (Fig. 80.11). The megakaryocytes tend to be large with abundant cytoplasm and multilobated nuclei¹⁰², and they are larger than those seen in reactive conditions and CML⁸⁰. The myeloid-to-erythroid ratio is near normal and marrow fibrosis is absent or minimal.

The most frequent significant complications of ET are thrombosis and hemorrhage¹⁰³. In high-risk patients, these complications are significantly reduced with low-dose aspirin and hydroxyurea therapy^{104,105}. Transformation to acute leukemia or progression to overt myelofibrosis are uncommon^{106,107}, provided the diagnosis is made with careful adherence to 2008 WHO criteria in order to differentiate ET from early PMF⁸³. Therapy-related AML and MDS, commonly associated with 17p deletions, may occur in ET patients treated with hydroxyurea and/or other chemotherapy¹⁰⁶, but the risk is greater in patients previously treated with radiophosphorus or alkylating agents. When compared with anagrelide, a medication with no known mutagenic potential, hydroxyurea showed no increased risk of leukemogenesis¹⁰⁴. To date there are no convincing data demonstrating that the rate of leukemic transformation in ET is attributable to hydroxyurea.

TABLE 80.6 WHO CRITERIA FOR ESSENTIAL THROMBOCYTHEMIA^a

- Sustained platelet count $\geq 450 \times 10^9/L$
- Bone marrow biopsy showing proliferation of enlarged mature megakaryocytes, without significant increase or left-shift of granulopoiesis or erythropoiesis
- Exclusion of WHO criteria for PV, CIMF, CML, MDS, or other myeloid neoplasm
- *JAK2* mutation or other clonal marker, or if no clonal marker, then exclusion of reactive thrombocytosis

CML, chronic myelogenous leukemia; MDS, myelodysplastic syndrome; PV, polycythemia vera; PMF, primary myelofibrosis; WHO, World Health Organization.

^aAll criteria must be met for diagnosis.

From Swerdlow SH, Campo E, Harris NL, et al. World Health Organization Classification of Tumours of Haematopoietic and Lymphoid Tissues. IARC, Lyon, 2008.

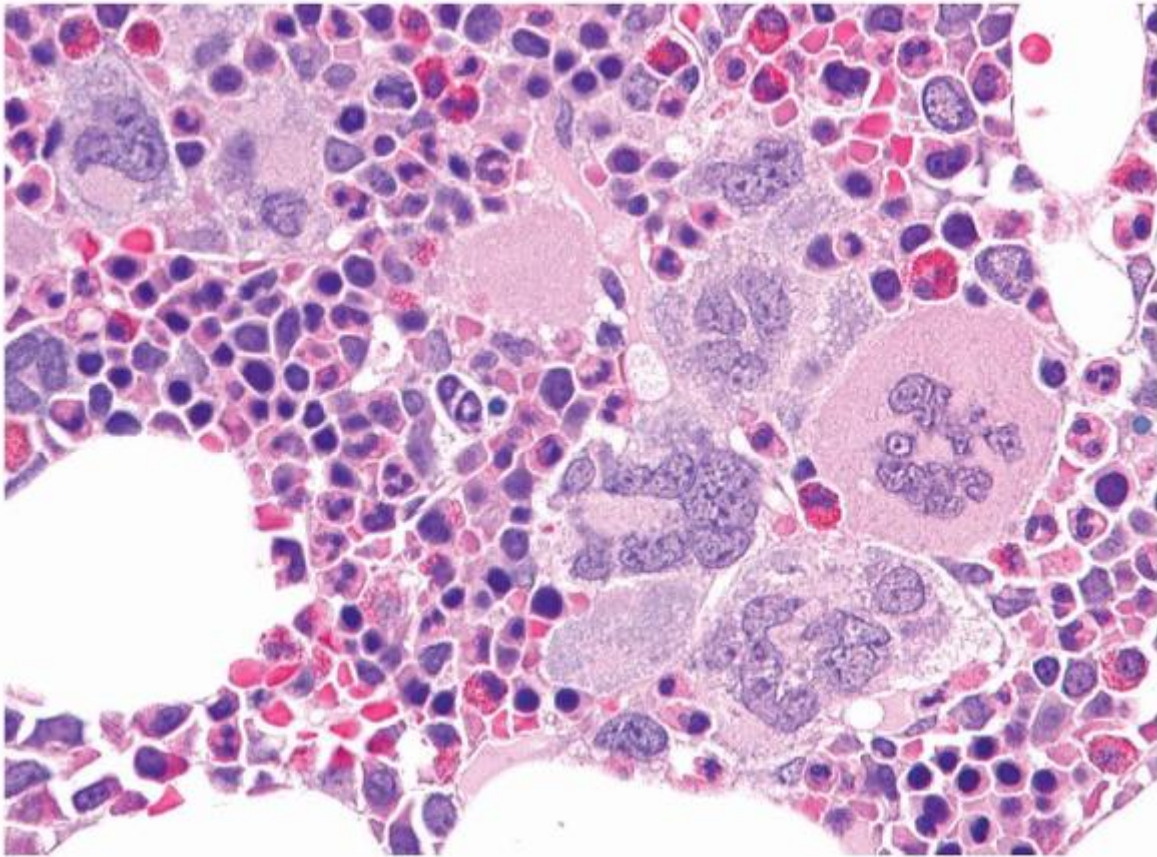

FIGURE 80.11. Essential thrombocythemia. Bone marrow biopsy is mildly hypercellular with atypical megakaryocyte clustering. The megakaryocytes are enlarged with abundant cytoplasm and distinct nuclear lobations. Hematoxylin and eosin, 500 \times .

There is considerable overlap between ET and PMF^{73,80,108}. In one retrospective study of 120 patients¹⁰⁸, of a group of 43 "true" ET, only 1 developed an increase in reticulin fibrosis on subsequent serial bone marrow biopsies; this group also showed an 80% probability to lack splenomegaly. Serial bone marrow biopsies on the other patients identified prefibrotic PMF, with 65 of 77 patients in this group evolving into overt myelofibrosis/osteosclerosis. Survival analysis confirmed the better prognosis of the ET group compared to the PMF group. Thus, in the gray area of ET and the early or cellular phase of PMF, bone marrow morphology plays an important role in discriminating between these two entities, and sequential biopsies may allow for definitive classification in difficult cases. Reactive causes of megakaryocyte hyperplasia and thrombocytosis also must be excluded. RCM studies may be necessary to exclude cases of PV with associated thrombocytosis that might mimic ET. Whereas the presence of the JAK2 V617F mutation will not distinguish among the non-CML MPNs presenting with thrombocytosis, the presence of this mutation will exclude reactive thrombocytosis¹⁰⁹.

The value of other ancillary studies in ET is similar to CML. The detection of clonal cytogenetic abnormalities is useful in determining that the morphologic changes represent a neoplastic rather than a reactive process. Although the vast majority of cases do not demonstrate cytogenetic abnormalities, abnormalities such as del(20q), trisomy 8, and many others have been reported in ET¹¹⁰. Rare Philadelphia chromosome-positive or Philadelphia-negative BCR-ABL1-positive ET cases are described in the literature. These appear to have a higher frequency of blast transformation than other types of ET, and most authors consider such cases to be unusual variants of CML¹¹¹. However, both the development of a new BCR-ABL1 clone in patients with a pre-existing JAK2 positive MPN, and the development of a JAK2 V617F clone in patients with CML have also been reported¹¹².

Rarely, there are patients who present with features of ET with ringed sideroblasts, now considered a provisional entity in the WHO classification, best considered under overlap MDS/MPN, unclassifiable^{113, 114} and ¹¹⁵.

Chronic Eosinophilic Leukemia

Chronic eosinophilic leukemia, not otherwise specified is a clonal myeloproliferative neoplasm in which the predominant finding is an eosinophilic proliferation in the blood and marrow (Fig. 80.12).

P.1696

The peripheral blood shows a sustained proliferation of eosinophils $\geq 1.5 \times 10^9/L$ and the bone marrow is hypercellular with proliferation of eosinophil precursors. Other myeloid neoplasms with eosinophilia [CML, AML with inv(16)/t(16;16), and neoplasms involving PDGFRA/B or FGFR1] are excluded. Causes of reactive physiologic eosinophilia, including allergic disease, collagen vascular disease, medication hypersensitivity, pulmonary eosinophilic disease, adrenal insufficiency, parasite infections, other nonmyeloid malignancies, or an aberrant or clonal T-cell population should also be excluded. The latter refers to lymphocyte-variant hypereosinophilia, in which a clonal T-cell population produces cytokines resulting in a reactive eosinophilia^{116,117}. The 2008 WHO diagnostic criteria now also require either a clonal cytogenetic or molecular abnormality, or an elevation in blasts >2% in the blood or >5% in the marrow (but less than 20%)¹¹⁸. It should be noted that some cases without clonal cytogenetic abnormalities have demonstrated clonality by analysis of X-chromosome inactivation patterns¹¹⁹.

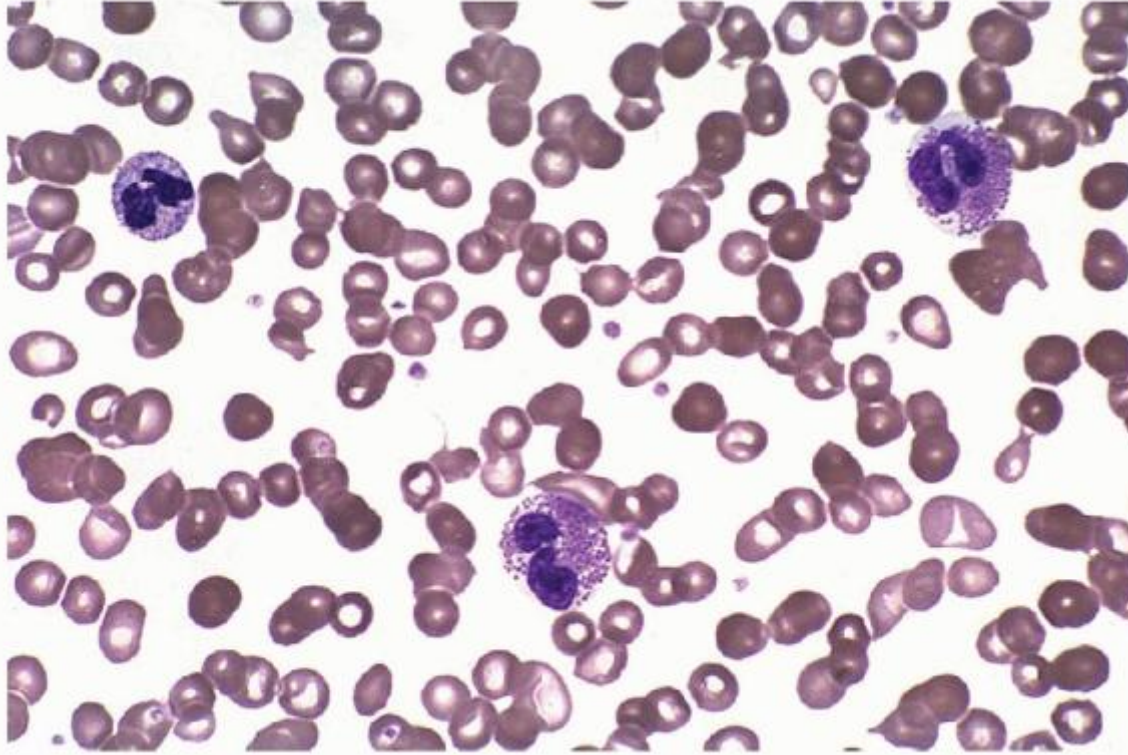

FIGURE 80.12. Chronic eosinophilic leukemia, NOS. Peripheral blood smear showing increased numbers of normal-appearing eosinophils. Wright-Giemsa, 600 \times .

The diagnosis of idiopathic hypereosinophilic syndrome (HES) is recommended for those cases without any evidence of either a primary myeloproliferative or secondary eosinophilia. Idiopathic HES is defined as eosinophilia $\geq 1.5 \times 10^9/L$ for 6 or more months without an identifiable cause, with evidence of organ damage. This definition was originally based on criteria of Chusid et al.¹²⁰. The requirement for eosinophilia to persist for a minimum of 6 months need not be strictly adhered to if there is concern for end organ damage. Patients with idiopathic HES may subsequently develop a myeloid malignancy or acquire a clonal abnormality. Eosinophilic tissue damage may affect any organ system, including skin, pulmonary, gastrointestinal, and cardiac¹²¹, presumably related to release of eosinophil granule contents. In the absence of organ damage, the term idiopathic hypereosinophilia is more appropriate.

A variety of clonal cytogenetic abnormalities is reported in CEL, including PDGFRA/B rearrangements^{19,122,123,124}. The presence of a PDGFRA/B rearrangement should be noted in the diagnosis, as these are now classified as neoplasms with eosinophilia and abnormalities of PDGFRA, PDGFRB, or FGFR1. Patients with a PDGFRA/B rearrangement have a high likelihood of responding to imatinib, but a subset of FIP1L1-PDGFRB-negative CEL patients will also respond¹⁹, which argues for a trial of TKI therapy in these patients as well¹²¹.

The diagnostic algorithm for hypereosinophilia should include a bone marrow examination with cytogenetic studies and screening for the FIP1L1-PDGFRB fusion gene for those patients whose workup is negative for secondary causes of eosinophilia¹²¹. As standard cytogenetics will not detect this fusion gene, this must be accomplished by either FISH or RT-PCR¹²⁵.

TABLE 80.7 WHO CLASSIFICATION OF MASTOCYTOSIS

Cutaneous mastocytosis

Urticaria pigmentosa/maculopapular cutaneous mastocytosis

Diffuse cutaneous mastocytosis

Solitary mastocytoma of skin

Indolent systemic mastocytosis

Systemic mastocytosis with associated clonal, hematologic non-mast-cell lineage disease

Aggressive systemic mastocytosis

Mast cell leukemia

Mast cell sarcoma

Extracutaneous mastocytoma

WHO, World Health Organization.

From Swerdlow SH, Campo E, Harris NL, et al. World Health Organization Classification of Tumours of Haematopoietic and Lymphoid Tissues. IARC, Lyon, 2008.

Systemic Mastocytosis

Mastocytosis includes a variety of disorders that are characterized by the presence of mast cell aggregates in tissue sections, ranging from isolated indolent proliferations to aggressive systemic disorders^{126,127}. The WHO classification of mastocytosis (Table 80.7) separates cutaneous from systemic forms for the disease¹²⁸. Subclassification of systemic mastocytosis subtypes requires correlation with clinical, laboratory, and molecular features (Table 80.8). In tissue or bone marrow biopsy sections, mast cells can range from aggregates of round cells with fine granular pink abundant cytoplasm to more spindled cells with associated fibrosis. Mast cells are often accompanied by eosinophils and small lymphocytes, even plasma cells, and may be overlooked due to these cellular components. On bone marrow aspirate smears, mast cells are most easily identified in the central portion of marrow particles as round or spindled cells with fine basophilic granules that obscure the nucleus. Nuclei may be round to oval in shape, with irregular nuclear contours yielding “dumbbell-shaped” forms. Spindled and more atypical mast cell features tend to correlate with the more aggressive clinical syndromes, but morphology alone is not adequate for classification.

A diagnosis of systemic mastocytosis requires detection of multiple dense mast cell aggregates in tissue sections (major criterion) and one minor criterion or, in the absence of tissue section aggregates, identification of three minor criteria (Table 80.8). Further

P.1697

subclassification of systemic mastocytosis requires correlation with clinical, morphologic, and laboratory findings designated as “B” or “C” findings (Table 80.9)¹²⁸. Indolent systemic mastocytosis, the most common form of systemic mast cell disease, meets criteria for systemic mastocytosis without B or C findings and no evidence of another hematologic malignancy. Skin lesions are usually present. Systemic mastocytosis with associated clonal, hematologic nonmast cell lineage disease is defined just as the name states and occurs in approximately one third of systemic mast cell disease patients. Typically the associated clonal, hematologic disease is a myeloid malignancy. MDS, MPNs, MDS/MPN, AML, and CEL have all been described as associated myeloid malignancies. Associated lymphoid malignancies may also occur, including multiple myeloma, chronic lymphocytic leukemia, acute lymphoblastic leukemia, and hairy cell leukemia. It is the associated hematologic malignancy that determines the prognosis of these patients. In rare cases, mast cell disease is not identified at initial diagnosis but becomes apparent later in the disease. Aggressive systemic mastocytosis includes criteria for systemic mastocytosis and includes one or more of the C findings (Table 80.9), which indicates organ dysfunction secondary to mast cell infiltration. These patients have a very short survival of weeks to months. A variant termed lymphadenopathic mastocytosis with eosinophilia will present with lymphadenopathy and eosinophilia, but those cases with a PDGFRA rearrangement are excluded. Finally, mast cell leukemia is a type of systemic mastocytosis with diffuse marrow infiltration with 20% or more mast cells in the bone marrow aspirate smear¹²⁹. This is an aggressive disease with similar prognosis as found in aggressive systemic mastocytosis.

TABLE 80.8 WHO CRITERIA FOR SYSTEMIC MASTOCYTOSIS^a

Major Criterion

Multifocal, dense mast cell infiltrates (≥ 15 cells) in tissue sections confirmed by tryptase or other special stains

Minor Criteria

- $>25\%$ spindled, immature, or atypical mast cells in tissue sections or bone marrow aspirate

smears

- Detection of *KIT* D816V mutation
- Expression of CD117 with CD25 and/or CD2
- Serum total tryptase persistently >20 ng/ml (unless associated with a clonal myeloid disorder)

WHO, World Health Organization.

From Swerdlow SH, Campo E, Harris NL, et al. World Health Organization Classification of Tumours of Haematopoietic and Lymphoid Tissues. IARC, Lyon, 2008.

^aDiagnosis requires major and one minor or three minor criteria.

TABLE 80.9 WHO B AND C FINDINGS IN SYSTEMIC MASTOCYTOSIS

B Findings

- >30% of bone marrow mast cells in focal dense aggregates and/or serum total tryptase level >200 ng/ml
- Signs of dysplasia or myeloproliferation in non-mast-cell lineage, but insufficient criteria for a definitive diagnosis of a hematopoietic neoplasm by WHO, with normal or only slightly abnormal blood counts
- Hepatomegaly without liver function impairment, and/or palpable splenomegaly without hypersplenism, and/or palpable or visceral lymphadenopathy

C Findings

- Bone marrow dysfunction manifested by 1+ cytopenias (ANC <1.0 × 10⁹/L, Hgb <10 g/dl, or PLT <100 × 10⁹/L) without non-mast-cell hematopoietic malignancy
- Palpable hepatomegaly with impairment of liver function, ascites, and/or portal hypertension
- Skeletal involvement with large-sized osteolysis and/or pathologic fractures
- Palpable splenomegaly with hypersplenism
- Malabsorption with weight loss due to gastrointestinal mast cell infiltrates

ANC, absolute neutrophil count; Hgb, hemoglobin; PLT, platelet count; WHO, World Health Organization.

From Swerdlow SH, Campo E, Harris NL, et al. World Health Organization Classification of Tumours of Haematopoietic and Lymphoid Tissues. IARC, Lyon, 2008.

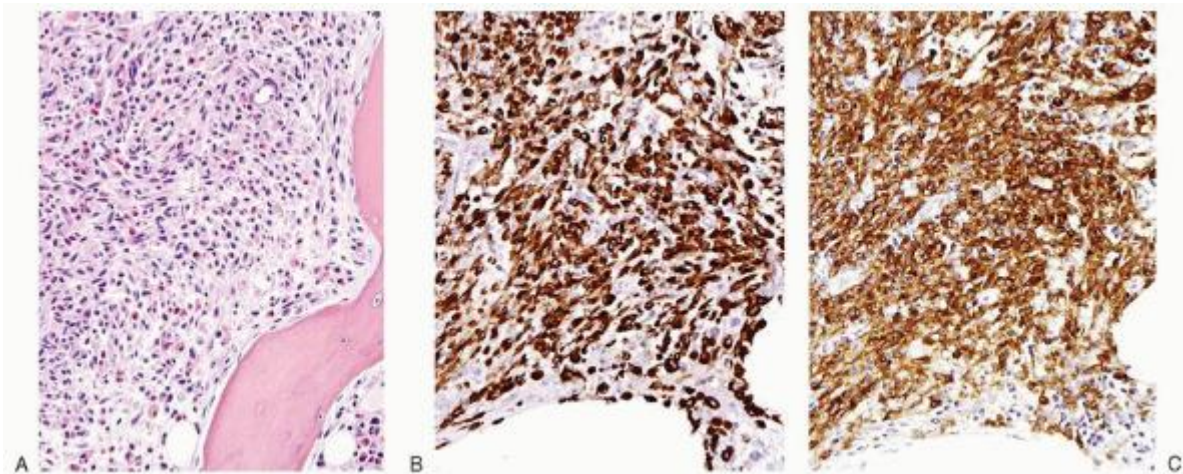

FIGURE 80.13. Aggressive systemic mastocytosis. Bone marrow biopsy shows a paratrabeular nodule of spindled mast

cells admixed with scattered eosinophils (A). Mast cells are highlighted by tryptase (B) and CD25 (C). Hematoxylin and eosin, 200×.

Special stains, including toluidine blue and chloracetate esterase, will mark normal mast cells, but more specific immunophenotypic markers now exist. Mast cells express CD33, CD43, CD68, CD117, and tryptase, with tryptase being the most lineage-specific of these markers¹³⁰. Neoplastic mast cells express CD25 and/or CD2, detectable either by immunohistochemistry or flow cytometry¹³¹. A typical immunohistochemical panel of CD25, CD117, and tryptase is recommended for most cases to confirm cell lineage and aberrant immunophenotype. In the bone marrow, immunohistochemistry can be performed on the core biopsy and will show paratrabecular aggregates of mast cells with associated fibrosis in systemic mastocytosis (Fig. 80.13). Because bone marrow aspirates may yield hemodilute samples due to the fibrosis with fewer mast cells for analysis, flow cytometry immunophenotyping may require a higher number of events for adequate immunophenotypic characterization of mast cells present¹³².

The most common genetic abnormality in mastocytosis is a point mutation of the tyrosine kinase receptor gene KIT resulting in a substitution of valine for aspartate at codon 816 of exon 17, Asp816Val, or D816V^{128,133,134,135}. D816V is found in over 90% of patients with systemic mastocytosis^{128,134,135}. Other mutations include tyrosine or phenylalanine substitutions for aspartate at codon 816 and lysine for glutamic acid at codon 839¹³⁶. KIT mutations, including D816V, are not specific for mastocytosis and have been reported in other diseases^{137,138}.

A proliferation of mast cells with eosinophilia that is associated with the FIP1L1-PDGFR α fusion gene^{139,140}, is now classified with myeloid and lymphoid neoplasms with eosinophilia and abnormalities of PDGFR α , PDGFR β , or FGFR1, discussed below.

P.1698

Chronic Neutrophilic Leukemia

Chronic neutrophilic leukemia is a rare myeloproliferative disorder that requires the exclusion of reactive leukocytoses and other MPNs^{141, 142} and ^{143,144,145,146}. WHO 2008 diagnostic criteria are: peripheral blood leukocytosis $\geq 25 \times 10^9/L$ with neutrophils and band forms comprising $>80\%$, immature granulocytes $<10\%$, and myeloblasts $<1\%$ of white blood cells; bone marrow myeloid hyperplasia with normal maturation, no increase in blasts, and normal or left shifted megakaryocytes; hepatosplenomegaly; no Philadelphia chromosome or BCR-ABL1; no rearrangement of PDGFR α , PDGFR β , or FGFR1; no evidence of another myeloproliferative neoplasm (PV, PMF, ET); no evidence of MDS or an MDS/MPN; and either the exclusion of a physiologic neutrophilia (infection, inflammation, underlying malignancy) or molecular or cytogenetic evidence of clonality within myeloid cells¹⁴⁶. Peripheral blood neutrophils may appear toxic but without dysplasia, and there is no monocytosis, eosinophilia, or basophilia. The platelet count may be normal, but thrombocytopenia develops with progressive splenomegaly. The marrow shows no evidence of dysplasia or significant reticulin fibrosis.

Patients usually are asymptomatic at diagnosis, but do have splenomegaly. Some authors have questioned whether CNL is a distinct clinical entity¹⁴⁷. The etiology of CNL is unknown, but up to 20% to 30% of cases have been reported as associated with an underlying neoplasm, most typically plasma cell dyscrasias, although it is unclear whether all of these cases are truly clonal proliferations^{148, 149, 150, 151} and ¹⁵². Cytogenetics are abnormal in $\sim 20\%$ of patients and have included trisomy 9, deletion of 11q, deletion of 20q, and trisomy 21¹⁵³. Prognosis is variable and reports of transformation to acute leukemia are documented^{142,154,155}.

MYELOID AND LYMPHOID NEOPLASMS WITH EOSINOPHILIA AND ABNORMALITIES OF PDGFR α , PDGFR β , OR FGFR1

This new category is comprised of rare myeloproliferative as well as lymphoid neoplasms that share eosinophilia and recently recognized acquired genetic mutations within a specific group of genes resulting in an aberrant tyrosine kinase within a pluripotent hematopoietic stem cell^{18,117}. The genes involved are the platelet-derived growth factor receptor alpha (PDGFR α) on chromosome 4q12, platelet-derived growth factor receptor beta (PDGFR β) at 5q31~33, and fibroblast growth factor receptor 1 (FGFR1) at 8p11~13. The associated diseases may present with features of an MPN (CEL or SM), MDS/MPN (CMML), AML, T-lymphoblastic leukemia/lymphoma, or more rarely B-lymphoblastic leukemia/lymphoma. The clinical significance in recognizing these rare but distinct entities is that diseases with rearrangements of PDGFR α /B are responsive to TKIs. It is hoped that similar targeted therapy for rearrangements of FGFR1 will be developed.

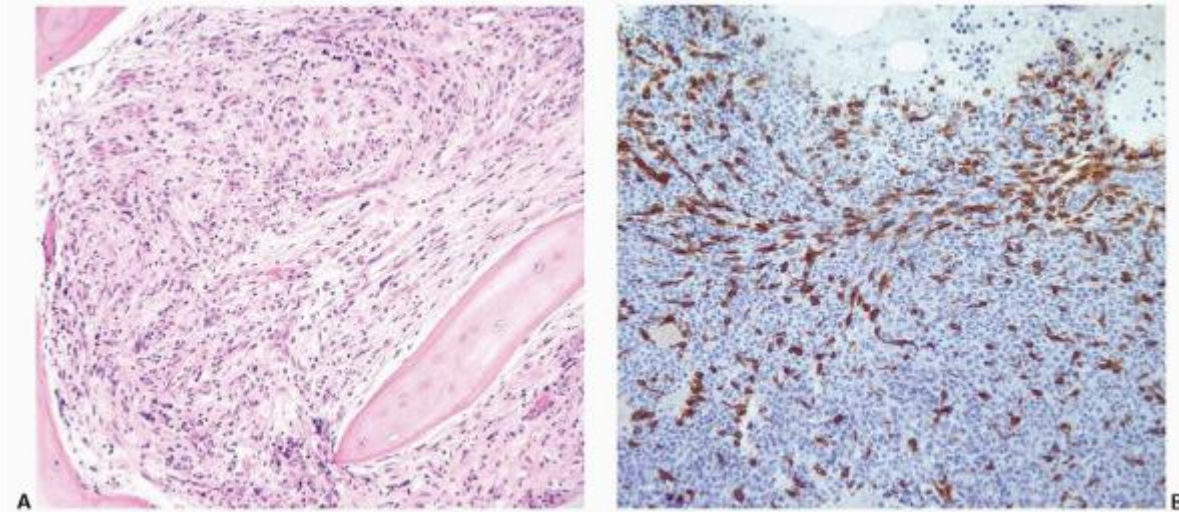

FIGURE 80.14. Chronic eosinophilic leukemia with PDGFRA. The bone marrow biopsy is striking for marked fibrosis that accompanies a hypercellular marrow with eosinophilia (A). Hematoxylin and eosin, 200 \times . A loose infiltrate of mast cells is seen using immunohistochemistry directed against CD117, which was not readily visible on hematoxylin and eosin stained sections of the bone marrow biopsy (B). CD117, 200 \times .

Myeloid and Lymphoid Neoplasms with PDGFRA Rearrangement

The most common PDGFRA rearrangement is FIP1L1-PDGFRB, formed by a cryptic deletion at 4q12. This fusion gene has been identified in a subset of patients with CEL and also in patients with features similar to systemic mastocytosis with eosinophilia, but has also been described in AML and T-lymphoblastic lymphoma.

Patients are young men with eosinophilia and a subset may present with elevated serum tryptase levels¹³⁹. A prevalence of 14% of the FIP1L1-PDGFRB fusion gene has been reported in patients with primarily eosinophilia¹⁵⁶. Morphologic findings are those of a hypercellular marrow with a myeloid hyperplasia and marked eosinophilia; fibrosis is typically present (Fig. 80.14). Although in some cases there is no abnormal mast cell infiltrate¹⁵⁶, in other cases tryptase or CD117 immunostaining typically identifies loose, ill-defined mast cell aggregates that are difficult to appreciate on hematoxylin and eosin sections (Fig. 80.14)¹³⁹, which does not technically meet WHO criteria for mastocytosis. Mast cells show a similar aberrant immunophenotype with CD25 coexpression and demonstrate the CHIC2 deletion, a marker for the FIP1L1-PDGFRB fusion gene¹⁴⁰, but do not have the KIT D816V mutation. Recognition and awareness of this FIP1L1-PDGFRB myeloid neoplasm involving eosinophilia and mast cell proliferations but lacking KIT mutations should avoid misclassification as CEL or SM^{117,121}. The importance of the FIP1L1-PDGFRB translocation is underscored by its

P.1699

responsiveness to imatinib with rapid and complete hematologic remissions^{19,157, 158} and^{159,160,161}.

Myeloid Neoplasms with PDGFRB Rearrangement

The most common PDGFRB rearrangement is t(5;12)(q33;p13) with production of the fusion oncogene, ETV6-PDGFRB, resulting in constitutive activation of the kinase domain of PDGFRB^{122,123,124}. Translocations involving other fusion partners for PDGFRB have also been described¹⁶². The disease associated with ETV6-PDGFRB presents with features suggestive of CMML with eosinophilia (Fig. 80.15). The variant translocations have been associated with features of CMML, CEL, and chronic basophilic leukemia, as well as a Ph-negative MPN resembling CML or aCML. Not all cases have an associated eosinophilia. Isolated cases with features of juvenile myelomonocytic leukemia (JMML) or transformed AML have been reported. The chronic myeloid neoplasms with PDGFRB rearrangements appear to be aggressive, with a high risk of acute transformation. Similar to rearrangements of PDGFRA, diseases with rearrangements of PDGFRB are sensitive to TKI therapy.

Myeloid and Lymphoid Neoplasms with FGFR1 Abnormalities

Hematologic neoplasms associated with rearrangements of the fibroblast growth factor receptor-1 (FGFR1) gene of chromosome band 8q11 are heterogeneous and may manifest as T-lymphoblastic lymphoma, myeloid, lymphoblastic, or mixed lineage acute leukemia, or less commonly B-lymphoblastic lymphoma or CEL^{163, 164, 165} and¹⁶⁶. Those cases

presenting with features of CEL have an increased risk of transformation to acute myeloid leukemia or myeloid sarcoma. Regardless of the presenting neoplasm, patients usually have eosinophilia in the blood, marrow, or both. The FGFR1 gene most commonly fuses with the ZMYM2 gene of 13q12 for a t(8;13)(q11;q12), but other translocations may occur^{167,168}. Unlike the neoplasms involving PDGFRA/B, neoplasms with FGFR1 rearrangements are not responsive to currently available TKIs.

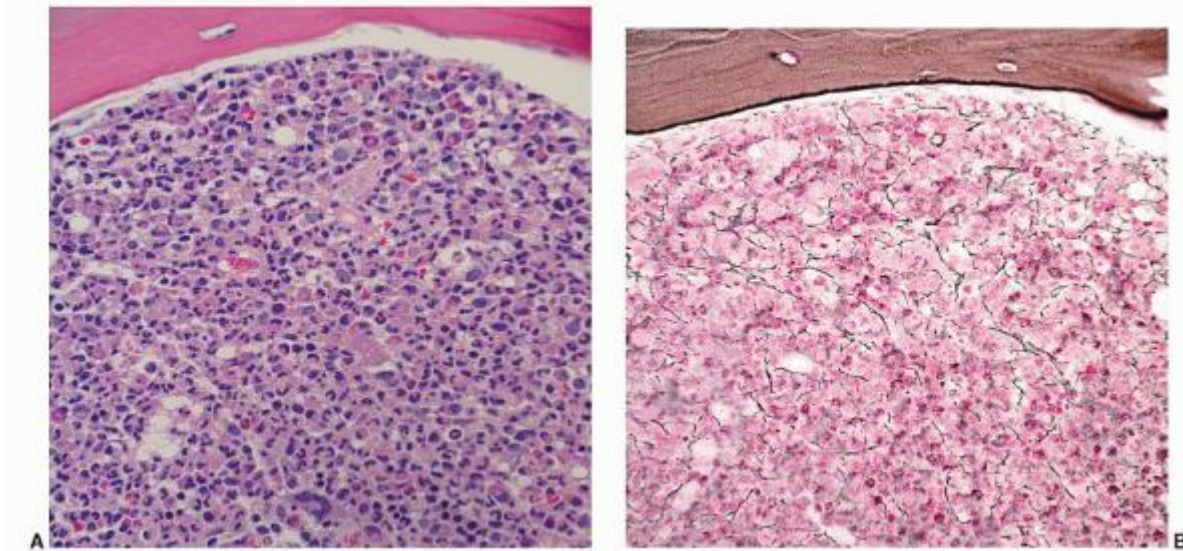

FIGURE 80.15. Myeloid neoplasm with eosinophilia with PDGFRB. The bone marrow biopsy is hypercellular with a granulocytic hyperplasia and marrow eosinophilia (A). Hematoxylin and eosin, 400 \times . Increased coarse reticulin fibrosis is present (B). Reticulin stain, 400 \times .

MYELODYSPLASTIC/MYELOPROLIFERATIVE NEOPLASMS

Some proliferations have features of both an MPN and MDS^{145,169}. These disorders may present with cytopenias and dysplastic changes of any cell line, similar to the myelodysplastic syndromes, as well as leukocytosis, hypercellular marrow with fibrosis, and organomegaly, features more commonly associated with myeloproliferative disorders. The presence of fibrosis alone in a case that is otherwise typical of myelodysplasia is not sufficient to use this category. In addition, patients with a long history of MPN who subsequently develop dysplasia are not classified in this group. The three best delineated overlap MDS/MPNs are chronic myelomonocytic leukemia (CMML), atypical chronic myeloid leukemia (aCML), and juvenile myelomonocytic leukemia (JMML). Features that are helpful in differentiating the chronic phase of CML from atypical CML and chronic myelomonocytic leukemia in adults are listed in Table 80.10.

Chronic Myelomonocytic Leukemia

Chronic myelomonocytic leukemia was originally defined as a myelodysplastic syndrome in the French-American-British (FAB) classification, but is now best classified as a mixed MDS/MPN using the WHO classification^{16,170}. Patients often have both dysplastic changes and elevated white blood cell counts with splenomegaly. The disease was originally divided into myelodysplastic and myeloproliferative subtypes based on a white blood cell count level of $13 \times 10^9/L$ (i.e., $<13 \times 10^9/L$ myelodysplastic type, $\geq 13 \times 10^9/L$ myeloproliferative type) using recommendations by the FAB group¹⁷¹, but clinical studies that stratified patients according to the WBC count failed to show prognostic or biologic differences using this scheme^{172,173,174,175}.

The diagnosis of CMML requires the presence of $>1 \times 10^9/L$ of monocytes in the peripheral blood (Table 80.11). The monocytes may be abnormal in appearance¹⁷⁶. Promonocytes, with more immature nuclear chromatin, may be present in the blood, but monoblasts are usually rare to absent. Much controversy surrounds the definition of a promonocyte, and distinguishing

P.1700

a promonocyte from a monoblast or a mature monocyte can be difficult, even in the most experienced of laboratories. A recent consensus guideline defines morphologic criteria to help standardize the differentiation of monoblasts and promonocytes from immature and mature monocytes¹⁷⁷. The peripheral blood in CMML (Fig. 80.16) may demonstrate

cytopenias and dysplastic changes more typical of the myelodysplastic syndromes, or dysplastic changes may be minimal. A subset of patients presents with eosinophilia of $>1.5 \times 10^9/L$ and is associated with $t(5;12)(q31;p12)$ ^{122,124,178,179}. This CMML-like disorder with eosinophilia variant is now classified with the myeloid and lymphoid neoplasms with eosinophilia and abnormalities of *PDGFRA*, *PDGFRB*, or *FGFR1*. Although an elevated peripheral blood monocyte count is necessary for the diagnosis of CMML, such a diagnosis should never be made without examination of the bone marrow. Some acute myeloid leukemias with monocytic blasts may show peripheral blood changes similar to CMML due to maturation of the blast cell population in the peripheral blood. The bone marrow of CMML is usually hypercellular and may demonstrate monocytic or granulocytic hyperplasia (Fig. 80.17). When granulocytic hyperplasia is prominent, it may be difficult to distinguish the abnormal monocyte population from myelocytes. Erythroid precursors and megakaryocytes may demonstrate prominent dysplastic changes, but often these cell types are normal in appearance. Ringed sideroblasts are present in increased numbers in some cases. Blasts and promonocytes may be elevated up to 19%. When bone marrow blasts and promonocytes are $\geq 20\%$, such cases are now diagnosed as acute myeloid leukemias. Cases where blasts are $<5\%$ in the blood and $<10\%$ in the marrow are designated CMML-1, whereas cases with 5% to 19% blasts in the blood or 10% to 19% in the marrow are diagnosed as CMML-2. Multiple studies have shown that increased blasts correlate with poor prognosis^{174,180, 181, 182} and ¹⁸³. Variable marrow fibrosis may also be seen in nearly 30% of cases¹⁸⁴.

TABLE 80.10 THE DIFFERENTIAL DIAGNOSIS OF CHRONIC-PHASE CML, ATYPICAL CML, AND CMML IN ADULTS

Feature	CML	Atypical CML	CMML
<i>BCR/ABL1</i>	+	-	-
WBC	+++	++	+
Basophils ^a	$\geq 2\%$	$<2\%$	$<2\%$
Monocytes ^a	$<3\%$	3-10%	Usually $>10\%$
Immature granulocytes ^a	$>20\%$	10-20%	$<10\%$
Granulocyte dysplasia	-	++	+
Marrow erythroid hyperplasia	-	-	+

CML, chronic myelogenous leukemia, chronic phase, CMML, chronic myelomonocytic leukemia; WBC, white blood cell count. Only CML is distinguished by the presence of the Philadelphia chromosome or *BCR/ABL1*. CML typically has a higher WBC count than either CMML or atypical CML, with occasional WBC counts of $>200 \times 10^9/L$. A prominent basophilia is also more characteristic of CML, although a mild basophilia may occur in either atypical CML or CMML. A marked monocytosis is more typical of CMML than either CML or atypical CML. CML also shows a marked left-shift in granulocytes on the peripheral blood smear compared to atypical CML or CMML; however, increased circulating blasts may occur in atypical CML compared with CML or CMML. Atypical CML also shows the most prominent granulocytic dysplasia. Finally, a bone marrow erythroid hyperplasia occurs more often in CMML than in *de novo* CML or atypical CML.

^a Refers to peripheral blood.

Table adapted with permission from George TI, Arber DA. Pathology of the myeloproliferative diseases. Hematol Oncol Clin North Am 2003;17:1101-1127. Copyright © Elsevier.

TABLE 80.11 WHO CRITERIA FOR CHRONIC MYELOMONOCYTIC LEUKEMIA

- Persistent peripheral blood monocytes $>1.0 \times 10^9/L$
 - Blasts + promonocytes $<20\%$ in blood and marrow
 - Absence of Philadelphia chromosome or *BCR-ABL1* fusion gene
 - No rearrangement of *PDGFRA* or *PDGFRB*
 - Dysplasia in one or more myeloid lineages^a
- WHO, World Health Organization.

^a If minimal to absent myelodysplasia, the diagnosis also requires either of the following criteria: acquired, clonal cytogenetic abnormality; or persistent monocytosis at least 3 mo and exclusion of all other causes of monocytosis.

From Swerdlow SH, Campo E, Harris NL, et al. World Health Organization Classification of Tumours of Haematopoietic and Lymphoid Tissues. IARC, Lyon, 2008.

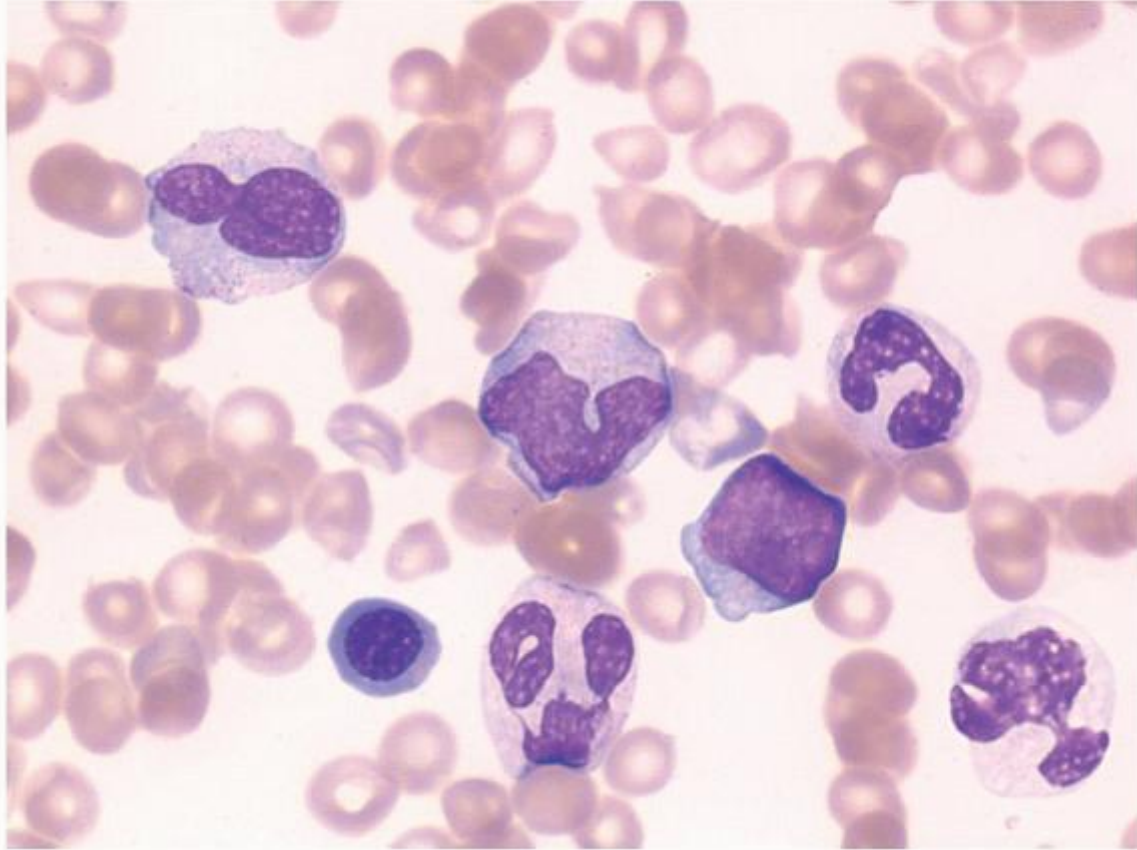

FIGURE 80.16. Chronic myelomonocytic leukemia. Peripheral blood smear with monocytes demonstrating abundant pale cytoplasm containing fine granulation, and folded nuclei with delicate chromatin and small nucleoli. Dysplastic hypogranular neutrophils, a single blast, and a nucleated red cell are also present. Wright-Giemsa, 1000 \times .

Ancillary studies are helpful in the differential diagnosis of CMML. Cytochemistry for nonspecific esterase on the peripheral blood and bone marrow confirms the presence of an increase in monocytes and can help differentiate abnormal monocytes of CMML from myelocytes in CML and aCML. Flow cytometry may

P.1701

be helpful in excluding acute myeloid leukemia, but enumeration of blasts (including monoblasts and promonocytes) must be based on morphology rather than flow cytometry. Cytogenetic and molecular genetic studies, particularly the absence of the Philadelphia chromosome or BCR-ABL1, are required to exclude CML. Approximately 20% to 40% of CMML will have detectable clonal abnormalities^{185, 186} and ¹⁸⁷. The most frequent recurring cytogenetic abnormalities include trisomy 8, monosomy 7/deletion (7q), structural abnormalities of 12p, and i(17q). Isochromosome 17q has been identified as a possible distinct subtype of mixed MDS/MPN, which is addressed below¹⁸⁸. JAK2 mutations have been detected in ~3% of patients⁵⁷.

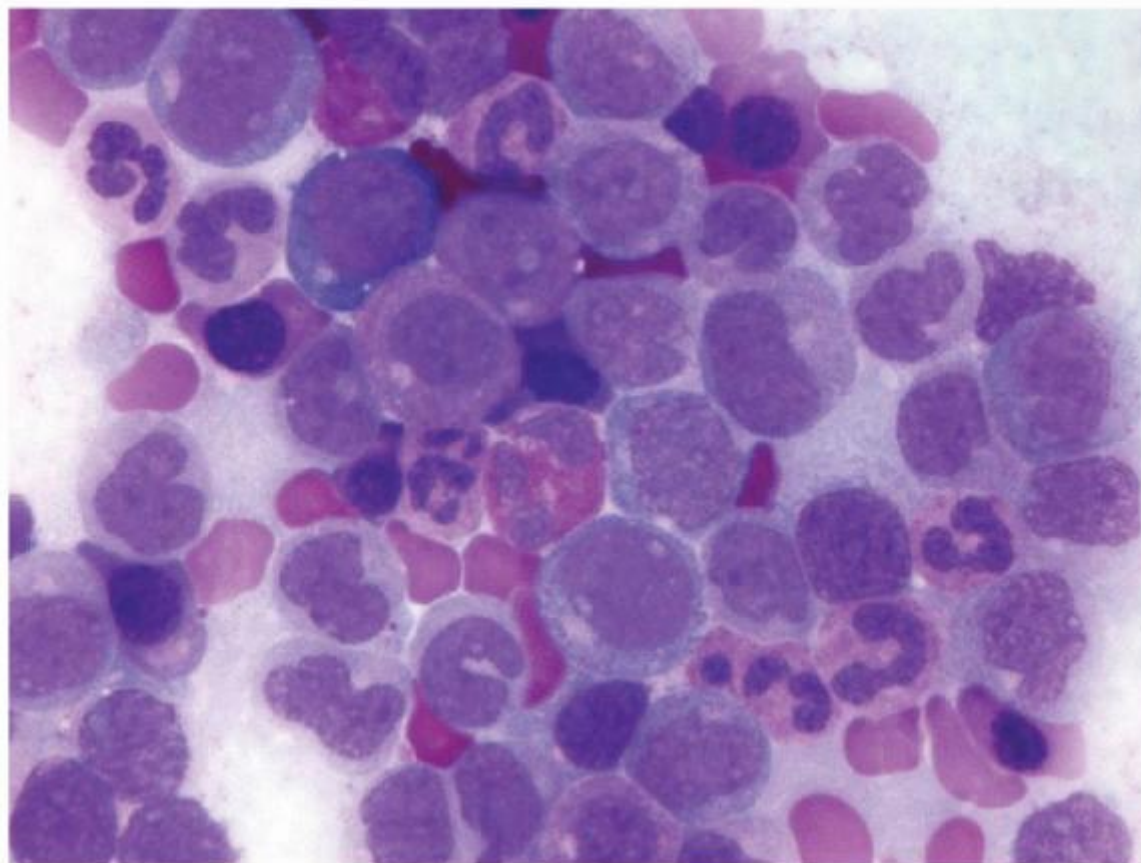

FIGURE 80.17. Chronic myelomonocytic leukemia. Bone marrow aspirate shows a monocytic and left-shifted myeloid hyperplasia. Wright-Giemsa, 1,000 \times .

Mutations of RAS are detected in approximately one third of CMML cases¹⁸⁹. Although detection of RAS mutations is not typically used for the diagnosis of CMML, abnormalities involving the RAS pathway are thought to be involved in the pathogenesis of this disorder and other MPNs, including CML¹⁹⁰.

The differential diagnosis between BCR-ABL1 negative atypical chronic myeloid leukemia (aCML) and CMML may be difficult, but is critical given the worse prognosis of patients with aCML when compared to CMML. CMML may be distinguished from aCML by peripheral blood features¹⁷¹, but some overlap with aCML may occur (Table 80.12). Monocytes are slightly elevated in aCML, but do not usually exceed 10%, whereas monocytes in CMML are usually >10%. Also, the degree of granulocyte dysplasia in CMML is not as pronounced as is usually seen in aCML. Atypical CML demonstrates an increase in immature granulocytes, including blasts, promyelocytes, and myelocytes, of up to 20% in the peripheral blood; these cell types are almost always below 10% in the blood of patients with CMML.

Atypical Chronic Myeloid Leukemia, BCR-ABL1 Negative

Atypical chronic myeloid leukemia is a misnomer with no relation to CML^{171,191}. Whenever this diagnosis is considered, CML should be excluded by standard cytogenetics karyotype and PCR or FISH for BCR-ABL1, as should rearrangements of PDGFRA/B. This rare MDS/MPN affects elderly patients with an apparent male predominance. Patients have some features of usual CML with splenomegaly, an elevated white blood cell count of predominantly granulocytic cells, anemia, and normal or decreased platelets. However, aCML patients are usually older and may have an initial presentation more typical of myelodysplasia with leukopenia and evolution into aCML¹⁹². The white blood cells are left-shifted with immature granulocytes, including blasts, promyelocytes, and myelocytes, representing 10% to 20% of cells (Fig. 80.18). Monocytes are usually <10% of peripheral blood cells. The bone marrow is hypercellular, with an elevated myeloid-to-erythroid ratio, and marrow fibrosis may be prominent. In contrast to usual CML, basophilia is not prominent, usually <2% of peripheral white blood cells. The myeloid-to-erythroid ratio is usually <10:1 and there is no evidence of the Philadelphia chromosome by either routine karyotype or molecular genetic studies for the BCR-ABL1 fusion product. Whereas some abnormalities of granulocyte nuclear lobation may be seen in CML, aCML usually has more typical dysplastic changes that may involve all

cell lines. Granulocytes may show pseudo-Pelger-Huet changes and cytoplasmic hypogranularity. Dyserythropoiesis and megakaryocyte dysplasia are common and megakaryocytes may be reduced in number with associated thrombocytopenia. Atypical CML appears to be a more aggressive disease than usual CML, with progression occurring within 2 years^{192, 193, 194, 195} and ¹⁹⁶. Patients may develop acute leukemia or bone marrow failure secondary to marked fibrosis. Cytogenetic and molecular genetic studies are essential in the diagnosis of aCML, to exclude t(9;22) or BCR-ABL1 of usual-type CML. There is no defining cytogenetic abnormality known at this time for aCML, although +8, +13, del(12p), del(20)(q11), and i(17q) have been reported^{193, 194} and ^{195,197}. In addition, rare cases with features of aCML containing t(5;10) (q33;q22) have been described in which the fusion gene PDGFRB-CCDC6 is expressed^{198, 199} and ²⁰⁰, but would now be considered cases of myeloid neoplasms with PDGFRB rearrangement. In addition, three cases have been shown to have t(4;22)(q12;q11)²⁰¹. RAS mutations have also been described¹⁹⁰. Other ancillary studies, particularly immunophenotyping studies, are usually not helpful unless an elevation in blasts is present.

TABLE 80.12 WHO CRITERIA FOR JUVENILE MYELOMONOCYTIC LEUKEMIA

Required Criteria

Peripheral blood monocytes $>1.0 \times 10^9/L$

Blasts + promonocytes $<20\%$ in blood and marrow

Absence of Philadelphia chromosome or *BCR/ABL1* fusion gene

Optional Criteria^a

Increased hemoglobin F for age

Immature granulocytes in peripheral blood

WBC count $>10 \times 10^9/L$

Clonal chromosomal abnormality (i.e., includes monosomy 7)

GM-CSF hypersensitivity of myeloid progenitors in vitro

GM-CSF, granulocyte-macrophage colony-stimulating factor; WBC, white blood cell.

^aDiagnosis requires all major criteria plus two or more of the optional criteria. Diagnostic criteria originally from Neimeyer CM, Fenu S, Hasle H, et al. Response to: Differentiating Juvenile Myelomonocytic Leukemia from Infectious Disease. *Blood* 1998;91:365-367. Reprinted with permission.

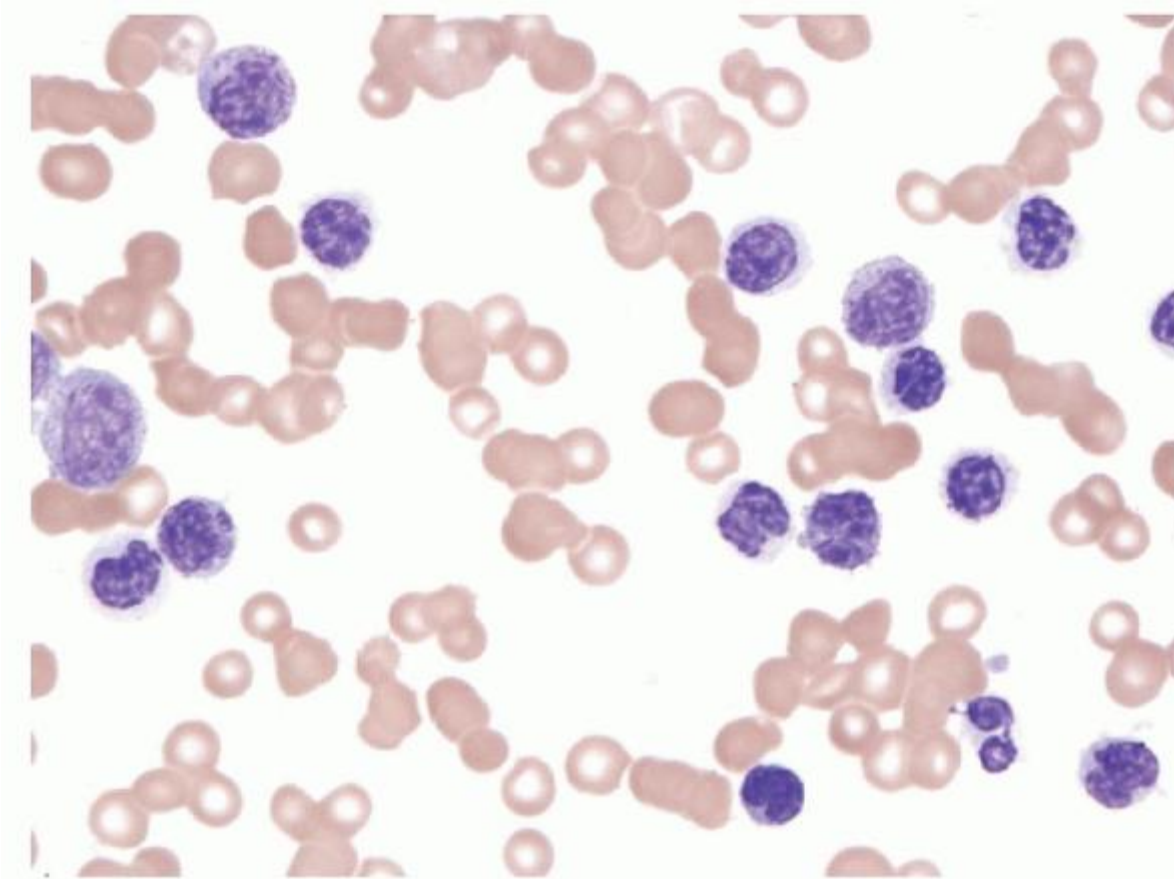

FIGURE 80.18. Atypical chronic myeloid leukemia. The peripheral blood smear shows leukocytosis and marked thrombocytopenia. Granulocytes are left-shifted and dysplastic with hypolobated nuclei and hypogranular cytoplasm. Wright-Giemsa, 600 \times .

Juvenile Myelomonocytic Leukemia

Juvenile myelomonocytic leukemia²⁰² is a childhood mixed MDS/MPN that includes childhood leukemias previously classified as CMML, juvenile CML, and infantile monosomy 7 syndrome. JMML, although rare^{203, 204} and²⁰⁵, is the most common MDS/MPN of children^{206,207,208,209,210}. Children with JMML are more often boys and develop the disease by age 4 years in the vast majority of cases. The children usually have elevations of fetal hemoglobin. Skin lesions often precede the diagnosis, and these children present with an elevated white blood cell count, composed of granulocytes and monocytes, which may be identical to CMML of adults (Fig. 80.19).

P.1702

Thrombocytopenia is also often present and organomegaly is common. Dysplastic changes and marrow hypercellularity are typical (Fig. 80.20), similar to adult CMML. Overlap with features of adult aCML also occurs and the criteria for aCML and CMML are probably not appropriate in children²¹¹. JMML must also be differentiated from infection, which can present with similar clinical and morphologic findings²¹². Criteria (Table 80.12) for the diagnosis of JMML describe typical clinical findings of hepatosplenomegaly, lymphadenopathy, pallor, fever, and skin rash^{202,213}. Laboratory criteria include the absence of t(9;22), monocytosis of $>1 \times 10^9/L$, and $<20\%$ bone marrow blast cells. Exclusion of rearrangements of PDGFRA/B is not within current 2008 WHO criteria, but it should be noted that an isolated case of JMML with PDGFRB has been reported²¹⁴. Infantile monosomy 7 syndrome is clinically similar to JMML and probably represents a subgroup of JMML patients²¹⁵; one notable laboratory difference is that patients with monosomy 7 have normal or modestly elevated hemoglobin F²¹⁰. Cytogenetic abnormalities other than monosomy 7, which may occur with any of the myelodysplastic syndromes, are not specific for JMML. Similar to adult CMML, RAS mutations occur in approximately 20% of cases of JMML²¹⁶. There is also an association between JMML and neurofibromatosis type 1, as well as with Noonan syndrome, leading to a markedly increased risk of developing JMML^{208,217}. Abnormalities of the NF1 gene lead to loss of

neurofibromin, a guanosine triphosphatase (GTPase)-activating protein for RAS, resulting in deregulation of the normal RAS signaling pathways, with subsequent selective hypersensitivity of myeloid progenitor cells to granulocyte-macrophage colony-stimulating factor (GM-CSF)^{218,219}. The increased prevalence of JMML in Noonan syndrome is linked to abnormalities in the PTPN11 gene, a gene that encodes SHP-2, required for RAS-dependent functions; these mutations also induce hypersensitivity of myeloid progenitors to GM-CSF²²⁰. Given the aggressive clinical course of JMML with current treatment regimens^{206,207,210,221}, work has focused on targeting the RAS pathway, which may result in new therapies^{222,223}.

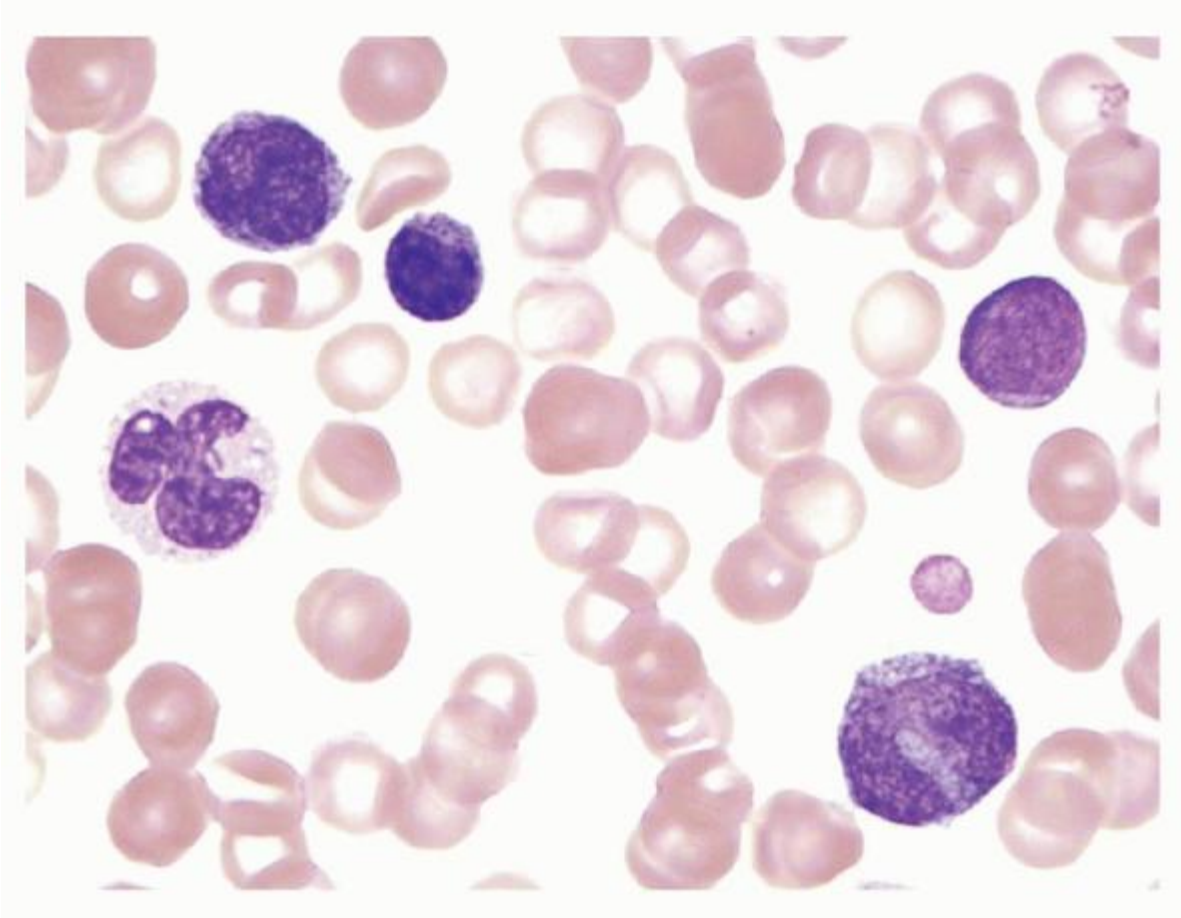

FIGURE 80.19. Juvenile myelomonocytic leukemia. Peripheral blood smear shows left-shifted leukocytosis and dysplastic monocytosis. A small blast is above a sparsely granulated lone platelet adjacent to a monocyte. Two dysplastic monocytes on the upper left contrast with a lymphocyte. Wright-Giemsa, 1,000 \times . (Reprinted with permission from Tkachuk DC, Hirschmann JV, eds. Wintrobe's atlas of clinical hematology. Philadelphia, PA: Lippincott Williams & Wilkins, 2007. Fig. 4.52.)

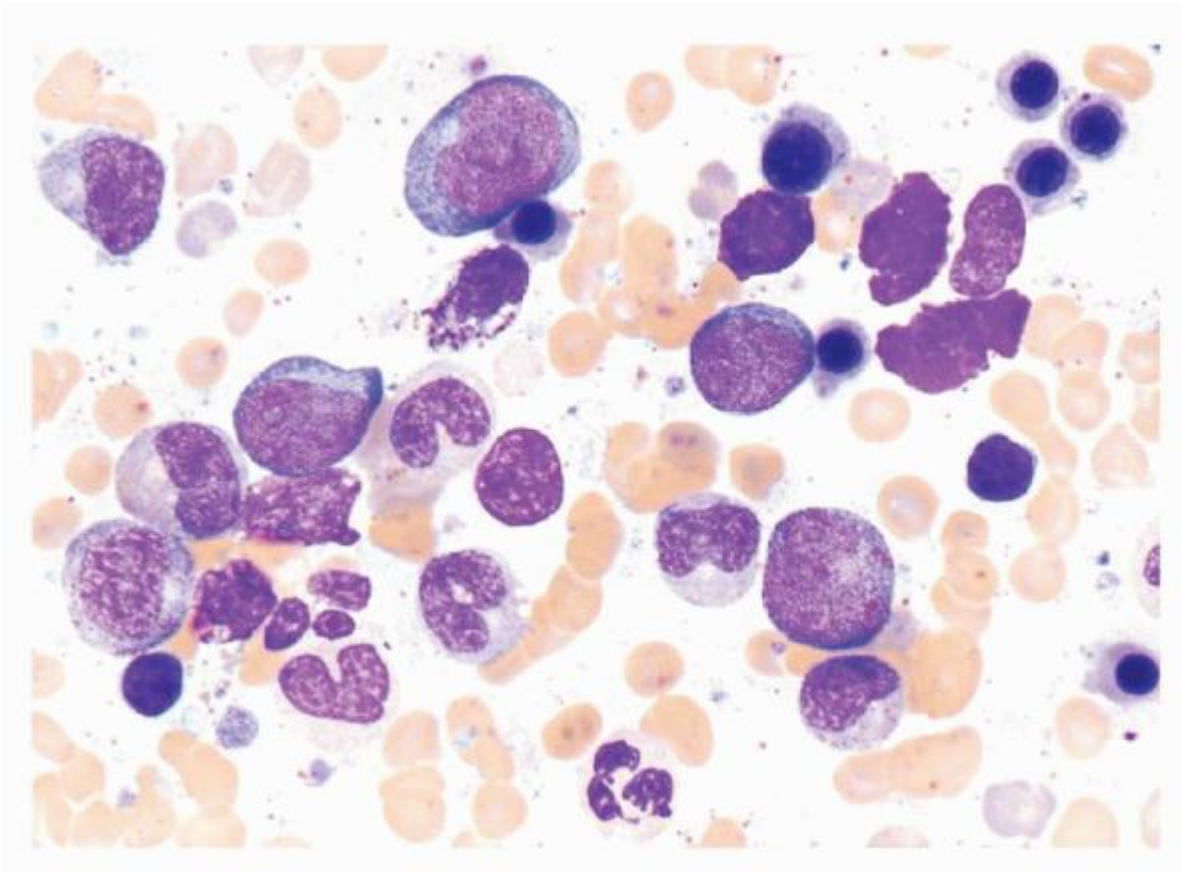

FIGURE 80.20. Juvenile myelomonocytic leukemia. Bone marrow aspirate shows numerous erythroid precursors and left-shifted immature myeloid cells with dysplasia. Wright-Giemsa, 600 \times .

Myelodysplastic/Myeloproliferative Neoplasm, Unclassifiable

Some cases with features of both MDS and MPN do not fit well into any of the previously mentioned categories. Many of these cases have typical features of myelodysplasia, as well as an atypical finding more suggestive of a myeloproliferative disorder, such as marked marrow fibrosis and hypercellularity or organomegaly. Such cases may be termed myelodysplastic/myeloproliferative disease, unclassifiable, with a comment describing the atypical findings. One such syndrome is refractory anemia with ring sideroblasts (RARS) associated with marked thrombocytosis^{113, 114} and^{115,169,224}. These cases have no sex predilection or specific cytogenetic abnormality and must be differentiated from the 5q syndrome. The bone marrow contains >15% ringed sideroblasts with an accompanying atypical megakaryocytic proliferation; megakaryocytes often resemble those seen in essential thrombocythemia (Fig. 80.21). The platelet counts are >600 $\times 10^9/L$. An analysis of 38 such patients showed a heterogeneous spectrum of diseases based on bone marrow findings and cytologic features, including ET, PMF, and MDS²²⁵. JAK2 mutations are found in a majority of cases of RARS-T²²⁶. Also recently described is a mixed MDS/MPN associated with isochromosome 17q that occurs in adults with a male predominance associated with severe hyposegmentation of neutrophil nuclei, monocytosis, and a high rate of transformation to acute myeloid leukemia¹⁸⁸. Abnormalities

P.1703

of chromosome 3q21q26 are also associated with MDS or AML patients, accompanied by thrombocytosis with micromegakaryocytes on bone marrow histology^{227, 228, 229, 230, 231} and²³². These cases usually have a poor prognosis, and should not be placed in the unclassifiable mixed MDS/MPN category. Rather, they should be classified into the appropriate MDS or AML category.

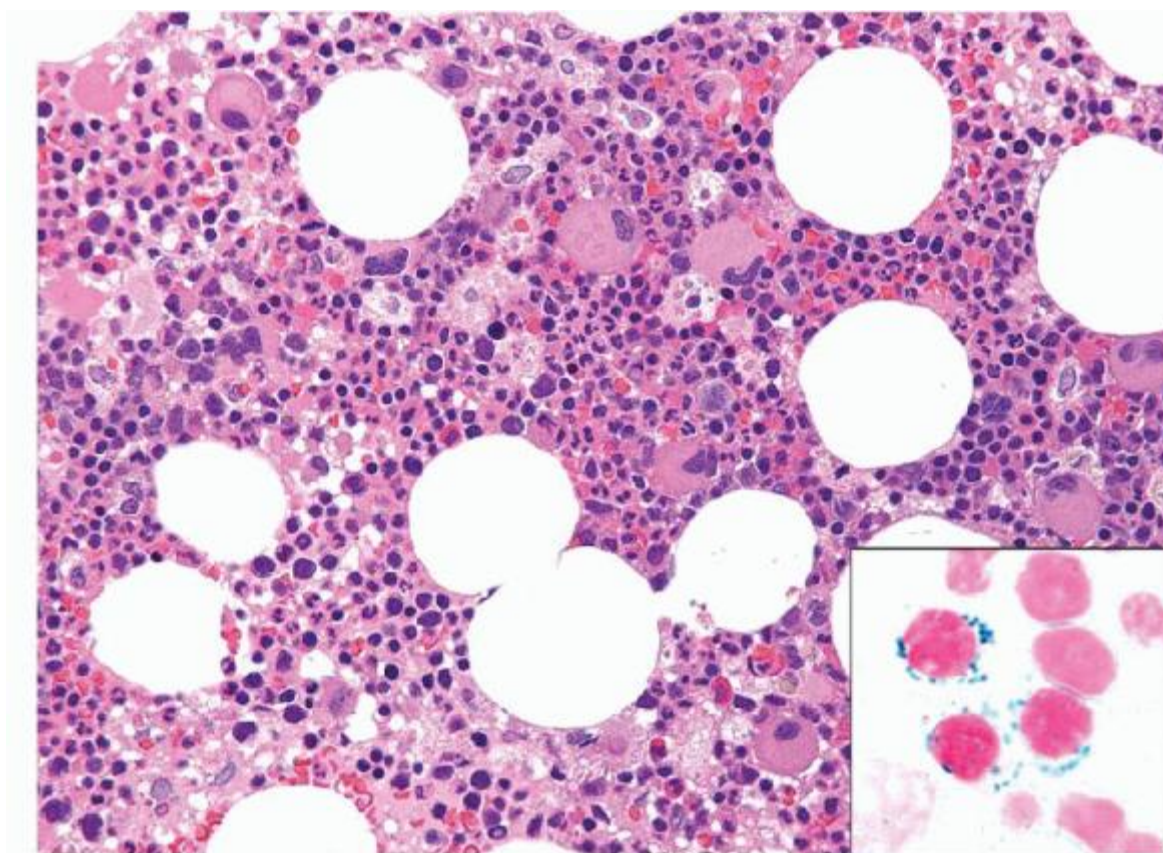

FIGURE 80.21. Refractory anemia with ring sideroblasts and thrombocytosis. The bone marrow biopsy shows dysplastic megakaryocytes, small hypolobated forms, and micromegakaryocytes, in a hypercellular marrow, with inset demonstrating numerous ringed sideroblasts. Hematoxylin and eosin, 400 \times . Prussian blue stain, 1,000 \times .

CONCLUSION

The classification of myeloid neoplasms now includes MPN; neoplasms with eosinophilia and abnormalities of PDGFRA/B or FGFR1, MDS/MPN, MDS; and acute myeloid leukemias. MPN and MDS/MPN, both clonal stem cell diseases, share myeloproliferative features including typically hypercellular marrows, cell lineage maturation, and organomegaly. The MPNs generally differ by which myeloid cell lineage dominates hematopoiesis, and the main players include CML, PV, ET, and PMF. The new category of myeloid and lymphoid neoplasms with eosinophilia and abnormalities of PDGFRA/B or FGFR1 represents another significant step forward in the molecular classification of neoplastic diseases. This category is also highly clinically relevant, due to the responsiveness of the PDGFRA/B associated neoplasms to TKI therapy. The overlap MDS/MPNs also show dysplastic features and variable amounts of effective hematopoiesis; these disorders include CMML, JMML, and aCML. Given the mix of morphology among these diseases, correlation with clinical, hematologic, and cytogenetic/molecular genetic findings is imperative for precise classification.

REFERENCES

1. Deininger MW, Goldman JM, Melo JV. The molecular biology of chronic myeloid leukemia. *Blood* 2000;96:3343.
2. Shannon K, Van Etten RA. JAKing up hematopoietic proliferation. *Cancer Cell* 2005;7:291-293.
3. Levine RL, Gilliland DG. JAK-2 mutations and their relevance to myeloproliferative disease. *Curr Opin Hematol*. 2007;14:43-47.
4. Kota J, Caceres N, Constantinescu SN. Aberrant signal transduction pathways in myeloproliferative neoplasms. *Leukemia* 2008;22:1828-1840.
5. Vainchenker W, Delhommeau F, Constantinescu SN, Bernard OA. New mutations and pathogenesis of myeloproliferative neoplasms. *Blood* 2011;118:1723-1735.
6. George TI, Arber DA. Pathology of the myeloproliferative diseases. *Hematol Oncol Clin North Am* 2003;17:1101-1127.

7. Levine RL, Wadleigh M, Cools J, et al. Activating mutation in the tyrosine kinase JAK2 in polycythemia vera, essential thrombocythemia, and myeloid metaplasia with myelofibrosis. *Cancer Cell* 2005;7:387-397.
8. Baxter EJ, Scott LM, Campbell PJ, et al. Acquired mutation of the tyrosine kinase JAK2 in human myeloproliferative disorders. *Lancet* 2005;365:1054-1061.
9. James C, Ugo V, Le Couedic JP, et al. A unique clonal JAK2 mutation leading to constitutive signalling causes polycythaemia vera. *Nature* 2005;434:1144-1148.
10. Kralovics R, Passamonti F, Buser AS, et al. A gain-of-function mutation of JAK2 in myeloproliferative disorders. *N Engl J Med* 2005;352:1779-1790.
11. Oh ST, Gotlib J. JAK2 V617F and beyond: role of genetics and aberrant signaling in the pathogenesis of myeloproliferative neoplasms. *Expert Rev Hematol.* 2010;3:323-337.
12. Jamieson CH, Gotlib J, Durocher JA, et al. The JAK2 V617F mutation occurs in hematopoietic stem cells in polycythemia vera and predisposes toward erythroid differentiation. *Proc Natl Acad Sci U S A* 2006;103:6224-6229.
13. Chen E, Beer PA, Godfrey AL, et al. Distinct clinical phenotypes associated with JAK2V617F reflect differential STAT1 signaling. *Cancer Cell* 2010;18:524-535.
14. Scott LM, Tong W, Levine RL, et al. JAK2 exon 12 mutations in polycythemia vera and idiopathic erythrocytosis. *N Engl J Med* 2007;356:459-468.
15. Swerdlow SH, Campo E, Harris NL, et al., eds. WHO classification of tumours of haematopoietic and lymphoid tissues. Lyon, France: IARC Press, 2008.
16. Tefferi A, Thiele J, Vardiman JW. The 2008 World Health Organization classification system for myeloproliferative neoplasms: order out of chaos. *Cancer* 2009;115:3842-3847.
17. Tefferi A, Vardiman JW. Classification and diagnosis of myeloproliferative neoplasms: the 2008 World Health Organization criteria and point-of-care diagnostic algorithms. *Leukemia* 2008;22:14-22.
18. Bain BJ, Gilliland DG, Horny H-P, et al. Myeloid and lymphoid neoplasms with eosinophilia and abnormalities of PDGFRA, PDGFRB, or FGFR1. In: Swerdlow SH, Campo E, Harris NL, et al., eds. WHO classification of tumours of haematopoietic and lymphoid tissues. Lyon, France: IARC Press, 2008:68-73.
19. Cools J, DeAngelo DJ, Gotlib J, et al. A tyrosine kinase created by fusion of the PDGFRA and FIP1L1 genes as a therapeutic target of imatinib in idiopathic hypereosinophilic syndrome. *N Engl J Med* 2003;348(13):1201-1214.
20. Ma Y, Zeng S, Metcalfe DD, et al. The c-KIT mutation causing human mastocytosis is resistant to STI571 and other KIT kinase inhibitors; kinases with enzymatic site mutations show different inhibitor sensitivity profiles than wild-type kinases and those with regulatory-type mutations. *Blood* 2002;99:1741-1744.
21. Verstovsek S, Tefferi A, Cortes J, et al. Phase II study of dasatinib in Philadelphia chromosome-negative acute and chronic myeloid diseases, including systemic mastocytosis. *Clin Cancer Res* 2008;14(12):3906-3915.
22. Gotlib J, Berube C, Growney JD, et al. Activity of the tyrosine kinase inhibitor PKC412 in a patient with mast cell leukemia with the D816V KIT mutation. *Blood* 2005;106(8):2865-2870.
23. Alvarez RH, Kantarjian H, Cortes JE. The biology of chronic myelogenous leukemia: implications for imatinib therapy. *Semin Hematol* 2007;44:S4-S14.
24. Sawyers CL. Chronic myeloid leukemia. *N Engl J Med* 1999;340:1330-1340.
25. Faderl S, Talpaz M, Estrov Z, et al. The biology of chronic myeloid leukemia. *N Engl J Med* 1999;341:164-172.
26. Thiele J, Kvasnicka HM, Titius BR, et al. Histological features of prognostic significance in CML-an immunohistochemical and morphometric study (multivariate regression analysis) on trephine biopsies of the bone marrow. *Ann Hematol* 1993;66:291-302.
27. Busche G, Majewski H, Schlue J, et al. Frequency of pseudo-Gaucher cells in diagnostic bone marrow biopsies from patients with Ph-positive chronic myeloid leukaemia. *Virchows Arch* 1997;430:139-148.
28. Arlin ZA, Silver RT, Bennett JM. Blastic phase of chronic myeloid leukemia (bCMML): a proposal for standardization of diagnostic and response criteria. *Leukemia* 1990;4:755-757.

29. Ross DW, Brunning RD, Kantarjian HM, et al. A proposed staging system for chronic myeloid leukemia. *Cancer* 1993;71:3788-3791.
30. Vardiman JW, Melo JV, Baccarani M, Thiele J. Chronic myelogenous leukemia, BCR-ABL1 positive. In: Swerdlow SH, Campo E, Harris NL, et al., eds. WHO classification of tumours of haematopoietic and lymphoid tissues. Lyon, France: IARC Press, 2008:32-37.
31. Brunning RD, McKenna RW. Tumors of the bone marrow. Washington, DC: Armed Forces Institute of Pathology, 1994.
32. Mitelman F, Levan G, Nilsson PG, et al. Non-random karyotypic evolution in chronic myeloid leukemia. *Int J Cancer* 1976;18:24-30.
33. Mitelman F. The cytogenetic scenario of chronic myeloid leukemia. *Leuk Lymphoma* 1993;11(Suppl 1):11-15.
34. Khalidi HS, Brynes RK, Medeiros LJ, et al. The immunophenotype of blast transformation of chronic myelogenous leukemia: a high frequency of mixed lineage phenotype in "lymphoid" blasts and a comparison of morphologic, immunophenotypic, and molecular findings. *Mod Pathol* 1998;11:1211-1221.
35. Cervantes F, Villamor N, Esteve J, et al. 'Lymphoid' blast crisis of chronic myeloid leukaemia is associated with distinct clinicohaematological features. *Br J Haematol* 1998;100:123-128.
36. Kantarjian H, Sawyers C, Hochhaus A, et al. Hematologic and cytogenetic responses to imatinib mesylate in chronic myelogenous leukemia. *N Engl J Med* 2002;346:645-652.
37. Hasserjian RP, Boecklin F, Parker S, et al. ST1571 (imatinib mesylate) reduces bone marrow cellularity and normalizes morphologic features irrespective of cytogenetic response. *Am J Clin Pathol* 2002;117:360-367.
38. Brazier RM, Launder TM, Druker BJ, et al. Hematopathologic and cytogenetic findings in imatinib mesylate-treated chronic myelogenous leukemia patients: 14 months' experience. *Blood* 2002;100:435-441.
39. Druker BJ, Guilhot F, O'Brien SG, et al. Five-year follow-up of patients receiving imatinib for chronic myeloid leukemia. *N Engl J Med* 2006;355:2408-2417.
40. Gambacorti-Passerini C, Antolini L, Mahon FX, et al. Multicenter independent assessment of outcomes in chronic myeloid leukemia patients treated with imatinib. *J Natl Cancer Inst* 2011;103:553-561.
41. Palandri F, Castagnetti F, Alimena G, et al. The long-term durability of cytogenetic responses in patients with accelerated phase chronic myeloid leukemia treated with imatinib 600 mg: the GIMEMA CML Working Party experience after a 7-year follow-up. *Haematologica* 2009;94:205-212.
42. Beham-Schmid C, Apfelbeck U, Sill H, et al. Treatment of chronic myelogenous leukemia with the tyrosine kinase inhibitor ST1571 results in marked regression of bone marrow fibrosis. *Blood* 2002;99:381-383.
43. Ibrahim AR, Clark RE, Holyoake TL, et al. Second-generation tyrosine kinase inhibitors improve the survival of patients with chronic myeloid leukemia in whom imatinib therapy has failed. *Haematologica* 2011;96:1779-1782.
44. Saglio G, Kantarjian H, Holyoake T, et al. Proceedings of the third global workshop on chronic myeloid leukemia. *Clin Lymphoma Myeloma Leuk* 2010;10:443-451.
45. Cervantes F, Mauro M. Practical management of patients with chronic myeloid leukemia. *Cancer* 2011;117:4343-4354.
46. Radich J. Stem cell transplant for chronic myeloid leukemia in the imatinib era. *Semin Hematol* 2010;47:354-361.
47. Pane F, Frigeri F, Sindona M, et al. Neutrophilic-chronic myeloid leukemia: a distinct disease with a specific molecular marker (BCR/ABL with C3/A2 junction). *Blood* 1996;88:2410-2414.
48. Verstovsek S, Lin H, Kantarjian H, et al. Neutrophilic-chronic myeloid leukemia: low levels of p230 BCR/ABL mRNA and undetectable BCR/ABL protein may predict an indolent course. *Cancer* 2002;94:2416-2425.
49. Wiedemann LM, Karhi KK, Shivji MK, et al. The correlation of breakpoint cluster region rearrangement and p210 *bcr/abl* expression with morphological analysis of Ph-negative chronic myeloid leukemia and other myeloproliferative diseases. *Blood* 1988;71:349-355.
50. Michiels JJ, De Raeve H, Berneman Z, et al. The 2001 World Health Organization and updated European clinical and pathological criteria for the diagnosis, classification, and staging of the Philadelphia chromosome-negative chronic myeloproliferative disorders. *Semin Thromb Hemost* 2006;32:307-340.

51. Polycythemia vera: the natural history of 1213 patients followed for 20 years. Gruppo Italiano Studio Policitemia. *Ann Intern Med* 1995;123:656-664.
52. Tefferi A, Spivak JL. Polycythemia vera: scientific advances and current practice. *Semin Hematol* 2005;42:206-220.
53. Tefferi A, Gilliland DG. The JAK2V617F tyrosine kinase mutation in myeloproliferative disorders: status report and immediate implications for disease classification and diagnosis. *Mayo Clin Proc* 2005;80:947-958.
54. Pardanani A, Lasho TL, Finke C, et al. Prevalence and clinicopathologic correlates of JAK2 exon 12 mutations in JAK2V617F-negative polycythemia vera. *Leukemia* 2007;21:1960-1963.
55. Scott LM. The JAK2 exon 12 mutations: a comprehensive review. *Am J Hematol*. 2011;86:668-676.
56. Johansson P, Safai-Kutti S, Lindstedt G, et al. Red cell mass, spleen size and plasma erythropoietin in polycythaemia vera and apparent polycythaemia. *Acta Haematol* 2002;108:1-7.
57. Steensma DP, Dewald GW, Lasho TL, et al. The JAK2 V617F activating tyrosine kinase mutation is an infrequent event in both "atypical" myeloproliferative disorders and myelodysplastic syndromes. *Blood* 2005;106:1207-1209.
58. Jones AV, Kreil S, Zoi K, et al. Widespread occurrence of the JAK2 V617F mutation in chronic myeloproliferative disorders. *Blood* 2005;106:2162-2168.
59. Ellis JT, Peterson P, Geller SA, et al. Studies of the bone marrow in polycythemia vera and the evolution of myelofibrosis and second hematologic malignancies. *Semin Hematol* 1986;23:144-155.
60. Thiele J, Kvasnicka HM, Zankovich R, et al. The value of bone marrow histology in differentiating between early stage polycythemia vera and secondary (reactive) polycythemia. *Haematologica* 2001;86:368-374.
61. Thiele J, Kvasnicka HM, Muehlhausen K, et al. Polycythemia rubra vera versus secondary polycythemia. A clinicopathological evaluation of distinctive features in 199 patients. *Pathol Res Pract* 2001;197:77-84.
62. Thiele J, Zirbes TK, Kvasnicka HM, et al. Focal lymphoid aggregates (nodules) in bone marrow biopsies: differentiation between benign hyperplasia and malignant lymphoma—a practical guideline. *J Clin Pathol* 1999;52:294-300.
63. Murphy S. Diagnostic criteria and prognosis in polycythemia vera and essential thrombocythemia. *Semin Hematol* 1999;36:9-13.
64. Najean Y, Deschamps A, Dresch C, et al. Acute leukemia and myelodysplasia in polycythemia vera. A clinical study with long-term follow-up. *Cancer* 1988;61:89-95.
65. Tefferi A. The rise and fall of red cell mass measurement in polycythemia vera. *Curr Hematol Rep* 2005;4:213-217.
66. Finazzi G, Gregg XT, Barbui T, et al. Idiopathic erythrocytosis and other non-clonal polycythemia. *Best Pract Res Clin Haematol* 2006;19:471-482.
67. Diez-Martin JL, Graham DL, Pettitt RM, et al. Chromosome studies in 104 patients with polycythemia vera. *Mayo Clin Proc* 1991;66:287-299.
68. Asimakopoulos FA, Gilbert JG, Aldred MA, et al. Interstitial deletion constitutes the major mechanism for loss of heterozygosity on chromosome 20q in polycythemia vera. *Blood* 1996;88:2690-2698.
69. Asimakopoulos FA, Green AR. Deletions of chromosome 20q and the pathogenesis of myeloproliferative disorders. *Br J Haematol* 1996;95:219-226.
70. Prchal JF, Prchal JT. Molecular basis for polycythemia. *Curr Opin Hematol* 1999;6:100-109.
71. Zwicky C, Theiler L, Zbaren K, et al. The predictive value of clonogenic stem cell assays for the diagnosis of polycythaemia vera. *Br J Haematol* 2002;117:598-604.
72. Streiff MB, Smith B, Spivak JL. The diagnosis and management of polycythemia vera in the era since the Polycythemia Vera Study Group: a survey of American Society of Hematology members' practice patterns. *Blood* 2002;99:1144-1149.
73. Thiele J, Kvasnicka HM, Werden C, et al. Idiopathic primary osteo-myelofibrosis: a clinico-pathological study on 208 patients with special emphasis on evolution of disease features, differentiation from essential thrombocythemia and variables of prognostic impact. *Leuk Lymphoma* 1996;22:303-317.
74. Tefferi A. Myelofibrosis with myeloid metaplasia. *N Engl J Med* 2000;342:1255-1265.
75. Michiels JJ, Thiele J. Clinical and pathological criteria for the diagnosis of essential thrombocythemia, polycythemia vera, and idiopathic myelofibrosis (agnogenic myeloid metaplasia). *Int J Hematol* 2002;76:133-145.

76. Thiele J, Kvasnicka HM, Zankovich R, et al. Early-stage idiopathic (primary) myelofibrosis—current issues of diagnostic features. *Leuk Lymphoma* 2002;43:1035-1041.
77. Thiele J, Kvasnicka HM, Zankovich R, et al. Clinical and morphological criteria for the diagnosis of prefibrotic idiopathic (primary) myelofibrosis. *Ann Hematol* 2001;80:160-165.
78. Thiele J, Kvasnicka HM. Hematopathologic findings in chronic idiopathic myelofibrosis. *Semin Oncol* 2005;32:380-394.
79. Thiele J, Kvasnicka HM, Boeltken B, et al. Initial (prefibrotic) stages of idiopathic (primary) myelofibrosis (IMF)—a clinicopathological study. *Leukemia* 1999;13:1741-1748.
80. Thiele J, Kvasnicka HM, Diehl V, et al. Clinicopathological diagnosis and differential criteria of thrombocythemias in various myeloproliferative disorders by histopathology, histochemistry and immunostaining from bone marrow biopsies. *Leuk Lymphoma* 1999;33:207-218.
81. Thiele J, Kvasnicka HM, Zankovich R, et al. Relevance of bone marrow features in the differential diagnosis between essential thrombocythemia and early stage idiopathic myelofibrosis. *Haematologica* 2000;85:1126-1134.
82. Thiele J, Kvasnicka HM. Clinicopathological criteria for differential diagnosis of thrombocythemias in various myeloproliferative disorders. *Semin Thromb Hemost* 2006;32:219-230.
83. Barbui T, Thiele J, Passamonti F, et al. Survival and disease progression in essential thrombocythemia are significantly influenced by accurate morphologic diagnosis: an international study. *J Clin Oncol* 2011;29:3179-3184.
84. Thiele J, Kvasnicka HM, Müllauer L, et al. Essential thrombocythemia versus early primary myelofibrosis: a multicenter study to validate the WHO classification. *Blood* 2011;117:5710-5718.
85. Jacobson RJ, Salo A, Fialkow PJ. Agnogenic myeloid metaplasia: a clonal proliferation of hematopoietic stem cells with secondary myelofibrosis. *Blood* 1978;51:189-194.
86. Lasho TL, Pardanani A, McClure RF, et al. Concurrent MPL515 and JAK2V 617F mutations in myelofibrosis: chronology of clonal emergence and changes in mutant allele burden over time. *Br J Haematol* 2006;135:683-687.
87. Pardanani AD, Levine RL, Lasho T, et al. MPL515 mutations in myeloproliferative and other myeloid disorders: a study of 1182 patients. *Blood* 2006;108:3472-3476.
88. Dupriez B, Morel P, Demory JL, et al. Prognostic factors in agnogenic myeloid metaplasia: a report on 195 cases with a new scoring system. *Blood* 1996;88:1013-1018.
89. Dingli D, Grand FH, Mahaffey V, et al. Der(6)t(1;6)(q21-23;p21.3): a specific cytogenetic abnormality in myelofibrosis with myeloid metaplasia. *Br J Haematol* 2005;130:229-232.
90. Reilly JT, Snowden JA, Spearing RL, et al. Cytogenetic abnormalities and their prognostic significance in idiopathic myelofibrosis: a study of 106 cases. *Br J Haematol* 1997;98:96-102.
91. Tefferi A, Meyer RG, Wyatt WA, et al. Comparison of peripheral blood inter-phase cytogenetics with bone marrow karyotype analysis in myelofibrosis with myeloid metaplasia. *Br J Haematol* 2001;115:316-319.
92. Barosi G, Ambrosetti A, Finelli C, et al. The Italian consensus conference on diagnostic criteria for myelofibrosis with myeloid metaplasia. *Br J Haematol* 1999;104:730-737.
93. Thiele J, Kvasnicka HM, Vardiman J. Bone marrow histopathology in the diagnosis of chronic myeloproliferative disorders: a forgotten pearl. *Best Pract Res Clin Haematol* 2006;19:413-437.
94. Tefferi A, Lasho TL, Jimma T, et al. One thousand patients with primary myelofibrosis: the mayo clinic experience. *Mayo Clin Proc* 2012;87:25-33.
95. Gangat N, Caramazza D, Vaidya R, et al. DIPSS plus: a refined Dynamic International Prognostic Scoring System for primary myelofibrosis that incorporates prognostic information from karyotype, platelet count, and transfusion status. *J Clin Oncol* 2011;29:392-397.
96. Tefferi A. How I treat myelofibrosis. *Blood* 2011;117:3494-3504.
97. Ballen KK, Shrestha S, Sobocinski KA, et al. Outcome of transplantation for myelofibrosis. *Biol Blood Marrow Transplant* 2010;16:358-367.
98. Thiele J, Kvasnicka HM, Orazi A, et al. Essential thrombocythaemia. In: Swerdlow SH, Campo E, Harris NL, et al., eds. *WHO classification of tumours of haematopoietic and lymphoid tissues*. Lyon, France: IARC Press, 2008:48-50.

99. Vannucchi AM, Antonioli E, Guglielmelli P, et al. Characteristics and clinical correlates of MPL 515W>L/K mutation in essential thrombocythemia. *Blood* 2008;112:844-847.
100. Harrison CN, Gale RE, Machin SJ, et al. A large proportion of patients with a diagnosis of essential thrombocythemia do not have a clonal disorder and may be at lower risk of thrombotic complications. *Blood* 1999;93: 417-424.
101. Nimer SD. Essential thrombocythemia: another "heterogeneous disease" better understood? *Blood* 1999;93:415-416.
102. Thiele J, Schneider G, Hoepfner B, et al. Histomorphometry of bone marrow biopsies in chronic myeloproliferative disorders with associated thrombocytosis —features of significance for the diagnosis of primary (essential) thrombocythaemia. *Virchows Arch A Pathol Anat Histopathol* 1988;413: 407-417.
103. Besses C, Cervantes F, Pereira A, et al. Major vascular complications in essential thrombocythemia: a study of the predictive factors in a series of 148 patients. *Leukemia* 1999;13:150-154.
104. Harrison CN, Campbell PJ, Buck G, et al. Hydroxyurea compared with anagrelide in high-risk essential thrombocythemia. *N Engl J Med* 2005;353:33-45.
105. Cortelazzo S, Finazzi G, Ruggeri M, et al. Hydroxyurea for patients with essential thrombocythemia and a high risk of thrombosis. *N Engl J Med* 1995;332:1132-1136.
106. Sterkers Y, Preudhomme C, Lai JL, et al. Acute myeloid leukemia and myelodysplastic syndromes following essential thrombocythemia treated with hydroxyurea: high proportion of cases with 17p deletion. *Blood* 1998;91:616-622.
107. Mesa RA, Silverstein MN, Jacobsen SJ, et al. Population-based incidence and survival figures in essential thrombocythemia and agnogenic myeloid metaplasia: an Olmsted County Study, 1976-1995. *Am J Hematol* 1999;61:10-15.
108. Thiele J, Kvasnicka HM, Schmitt-Graeff A, et al. Follow-up examinations including sequential bone marrow biopsies in essential thrombocythemia (ET): a retrospective clinicopathological study of 120 patients. *Am J Hematol* 2002;70:283-291.
109. Tefferi A, Pardanani A. Mutation screening for JAK2V617F: when to order the test and how to interpret the results. *Leuk Res* 2006;30:739-744.
110. Steensma DP, Tefferi A. Cytogenetic and molecular genetic aspects of essential thrombocythemia. *Acta Haematol* 2002;108:55-65.
111. Aviram A, Blickstein D, Stark P, et al. Significance of BCR-ABL transcripts in bone marrow aspirates of Philadelphia-negative essential thrombocythemia patients. *Leuk Lymphoma* 1999;33:77-82.
112. Hussein K, Bock O, Theophile K, et al. Chronic myeloproliferative diseases with concurrent BCR-ABL junction and JAK2V617F mutation. *Leukemia* 2008;1059-1062.
113. Case records of the Massachusetts General Hospital. Weekly clinicopathological exercises. Case 17-1992. Repeated bouts of hematochezia in an 80-year-old hypertensive man. *N Engl J Med* 1992;326:1137-1146.
114. Gupta R, Abdalla SH, Bain BJ. Thrombocytosis with sideroblastic erythropoiesis: a mixed myeloproliferative myelodysplastic syndrome. *Leuk Lymphoma* 1999;34:615-619.
115. Koike T, Uesugi Y, Toba K, et al. 5q-syndrome presenting as essential thrombocythemia: myelodysplastic syndrome or chronic myeloproliferative disorders? *Leukemia* 1995;9:517-518.
116. Roufousse F, Cogan E, Goldman M. Recent advances in pathogenesis and management of hypereosinophilic syndromes. *Allergy* 2004;59:673-689.
117. Gotlib J. World Health Organization-defined eosinophilic disorders: 2011 update on diagnosis, risk stratification, and management. *Am J Hematol*. 2011;86(8):677-688.
118. Bain BJ, Gilliland DG, Vardiman JW, et al. Chronic eosinophilic leukemia, not otherwise specified. In: Swerdlow SH, Campo E, Harris NL, et al., eds. WHO classification of tumours of haematopoietic and lymphoid tissues. Lyon, France: IARC Press, 2008:51-53.
119. Chang HW, Leong KH, Koh DR, et al. Clonality of isolated eosinophils in the hypereosinophilic syndrome. *Blood* 1999;93:1651-1657.
120. Chusid MJ, Dale DC, West BC, et al. The hypereosinophilic syndrome: analysis of fourteen cases with review of the literature. *Medicine (Baltimore)* 1975;54:1-27.

121. Gotlib J, Cools J, Malone JM 3rd, et al. The FIP1L1-PDGFRalpha fusion tyrosine kinase in hypereosinophilic syndrome and chronic eosinophilic leukemia: implications for diagnosis, classification, and management. *Blood* 2004;103:2879-2891.
122. Baranger L, Szapiro N, Gardais J, et al. Translocation t(5;12)(q31-q33;p12-p13): a non-random translocation associated with a myeloid disorder with eosinophilia. *Br J Haematol* 1994;88:343-347.
123. Berkowicz M, Rosner E, Rechavi G, et al. Atypical chronic myelomonocytic leukemia with eosinophilia and translocation (5;12). A new association. *Cancer Genet Cytogenet* 1991;51:277-278.
124. Golub TR, Barker GF, Lovett M, et al. Fusion of PDGF receptor beta to a novel ets-like gene, tel, in chronic myelomonocytic leukemia with t(5;12) chromosomal translocation. *Cell* 1994;77:307-316.
125. Cools J, Stover EH, Gilliland DG. Detection of the FIP1L1-PDGFRalpha fusion in idiopathic hypereosinophilic syndrome and chronic eosinophilic leukemia. *Methods Mol Med* 2006;125:177-187.
126. George TI, Horny HP. Systemic mastocytosis. *Surg Path Clinics* 2010;3(4):1185-1202.
127. George TI. Mastocytosis. *Current Cancer Therapy Reviews* 2012;8(1):35-43.
128. Horny H-P, Metcalfe DD, Bennett JM, et al. Mastocytosis. In: Swerdlow SH, Campo E, Harris NL, et al., eds. WHO classification of tumours of haematopoietic and lymphoid tissues. Lyon, France: IARC Press, 2008:54-63.
129. Arredondo AR, Gotlib J, Shier L, et al. Myelomastocytic leukemia versus mast cell leukemia versus systemic mastocytosis associated with acute myeloid leukemia: a diagnostic challenge. *Am J Hematol* 2010;85(8):600-606
130. Horny HP, Sillaber C, Menke D, et al. Diagnostic value of immunostaining for tryptase in patients with mastocytosis. *Am J Surg Pathol* 1998;22:1132-1140.
131. Sotlar K, Horny HP, Simonitsch I, et al. CD25 indicates the neoplastic phenotype of mast cells: a novel immunohistochemical marker for the diagnosis of systemic mastocytosis (SM) in routinely processed bone marrow biopsy specimens. *Am J Surg Pathol* 2004;28:1319-1325.
132. Escribano L, Diaz-Agustin B, Lopez, et al. Immunophenotypic analysis of mast cells in mastocytosis: when and how to do it. Proposals of the Spanish network on mastocytosis (REMA). *Cytometry Part B (Clinical Cytometry)* 2004;58B:1-8.
133. Longley BJ, Tyrrell L, Lu S. Somatic c-KIT activating mutation in urticaria pigmentosa and aggressive mastocytosis: establishment of clonality in a human mast cell neoplasm. *Nat Genet* 1996;12:312-314.
134. Nagata H, Worobec AS, Oh CK. Identification of a point mutation in the catalytic domain of the protooncogene c-kit in peripheral blood mononuclear cells of patients who have mastocytosis with an associated hematologic disorder. *Proc Natl Acad Sci U S A* 1995;92:10560-10564.
135. Furitsu T, Tsujimura T, Tono T. Identification of mutations in the coding sequence of the proto-oncogene c-kit in a human mast cell leukemia cell line causing ligand-independent activation of c-kit product. *J Clin Invest* 1993;92:1736-1744.
136. Tefferi A, Gilliland DG. Oncogenes in myeloproliferative disorders. *Cell Cycle* 2007;6:550-566.
137. Lasota J, Miettinen M. Clinical significance of oncogenic KIT and PDGFRA mutations in gastrointestinal stromal tumours. *Histopathology* 2008;53(3): 245-266.
138. Beghini A, Ripamonti CB, Cairoli R, et al. KIT activating mutations: incidence in adult and pediatric acute myeloid leukemia, and identification of an internal tandem duplication. *Haematologica* 2004;89(8): 920-925.
139. Klion AD, Noel P, Akin C, et al. Elevated serum tryptase levels identify a subset of patients with a myeloproliferative variant of idiopathic hypereosinophilic syndrome associated with tissue fibrosis, poor prognosis, and imatinib responsiveness. *Blood* 2003;101:4660-4666.
140. Pardanani A, Ketterling RP, Brockman SR, et al. CHIC2 deletion, a surrogate for FIP1L1-PDGFRalpha fusion, occurs in systemic mastocytosis associated with eosinophilia and predicts response to imatinib mesylate therapy. *Blood* 2003;102:3093-3096.
141. You W, Weisbrodt IM. Chronic neutrophilic leukemia. Report of two cases and review of the literature. *Am J Clin Pathol* 1979;72:233-242.
142. Zittoun R, Rea D, Ngoc LH, et al. Chronic neutrophilic leukemia. A study of four cases. *Ann Hematol* 1994;68:55-60.
143. Elliott MA, Dewald GW, Tefferi A, et al. Chronic neutrophilic leukemia (CNL): a clinical, pathologic and cytogenetic study. *Leukemia* 2001;15:35-40.

144. Elliott MA, Hanson CA, Dewald GW, et al. WHO-defined chronic neutrophilic leukemia: a long-term analysis of 12 cases and a critical review of the literature. *Leukemia* 2005;19:313-317.
145. Tefferi A, Elliott MA, Pardanani A. Atypical myeloproliferative disorders: diagnosis and management. *Mayo Clin Proc* 2006;81(4):553-563.
146. Bain BJ, Brunning RD, Vardiman JW, et al. Chronic neutrophilic leukemia. In: Swerdlow SH, Campo E, Harris NL, et al., eds. WHO classification of tumours of haematopoietic and lymphoid tissues. Lyon, France: IARC Press, 2008:38-39.
147. Reilly JT. Chronic neutrophilic leukaemia: a distinct clinical entity? *Br J Haematol* 2002;116:10-18.
148. Tursz T, Flandrin G, Brouet JC, et al. (Coexistence of a myeloma and a granulocytic leukemia in the absence of any treatment. Study of 4 cases). *Nouv Rev Fr Hematol* 1974;14:693-704.
149. Cehreli C, Undar B, Akkoc N, et al. Coexistence of chronic neutrophilic leukemia with light chain myeloma. *Acta Haematol* 1994;91:32-34.
150. Standen GR, Jasani B, Wagstaff M, et al. Chronic neutrophilic leukemia and multiple myeloma. An association with lambda light chain expression. *Cancer* 1990;66:162-166.
151. Dincol G, Nalcaci M, Dogan O, et al. Coexistence of chronic neutrophilic leukemia with multiple myeloma. *Leuk Lymphoma* 2002;43:649-651.
152. Rovira M, Cervantes F, Nomdedeu B, et al. Chronic neutrophilic leukaemia preceding for seven years the development of multiple myeloma. *Acta Haematol* 1990;83:94-95.
153. Bench AJ, Nacheva EP, Champion KM, et al. Molecular genetics and cytogenetics of myeloproliferative disorders. *Baillieres Clin Haematol* 1998;11:819-848.
154. Hasle H, Olesen G, Kerndrup G, et al. Chronic neutrophil leukaemia in adolescence and young adulthood. *Br J Haematol* 1996;94:628-630.
155. Katsuki K, Shinohara K, Takeda K, et al. Chronic neutrophilic leukemia with acute myeloblastic transformation. *Jpn J Clin Oncol* 2000;30:362-365.
156. Pardanani A, Brockman SR, Paternoster SF, et al. FIP1L1-PDGFR α fusion: prevalence and clinicopathologic correlates in 89 consecutive patients with moderate to severe eosinophilia. *Blood* 2004;104:3038-3045.
157. Schaller JL, Burkland GA. Case report: rapid and complete control of idiopathic hypereosinophilia with imatinib mesylate. *MedGenMed* 2001;3:9.
158. Gleich GJ, Leiferman KM, Pardanani A, et al. Treatment of hypereosinophilic syndrome with imatinib mesilate. *Lancet* 2002;359:1577-1578.
159. Ault P, Cortes J, Koller C, et al. Response of idiopathic hypereosinophilic syndrome to treatment with imatinib mesylate. *Leuk Res* 2002;26:881-884.
160. Pardanani A, Reeder T, Porrata LF, et al. Imatinib therapy for hypereosinophilic syndrome and other eosinophilic disorders. *Blood* 2003;101:3391-3397.
161. Cortes J, Ault P, Koller C, et al. Efficacy of imatinib mesylate in the treatment of idiopathic hypereosinophilic syndrome. *Blood* 2003;101:4714-4716.

P.1704

162. Bain BJ, Fletcher SH. Chronic eosinophilic leukemias and the myeloproliferative variant of the hypereosinophilic syndrome. *Allergy Clin North Am* 2007;27:377-388.
163. Macdonald D, Aguiar RC, Mason PJ, et al. A new myeloproliferative disorder associated with chromosomal translocations involving 8p11: a review. *Leukemia* 1995;9:1628-1630.
164. Abruzzo LV, Jaffe ES, Cotelingam JD, et al. T-cell lymphoblastic lymphoma with eosinophilia associated with subsequent myeloid malignancy. *Am J Surg Pathol* 1992;16:236-245.
165. Macdonald D, Reiter A, Cross NC. The 8p11 myeloproliferative syndrome: a distinct clinical entity caused by constitutive activation of FGFR1. *Acta Haematol* 2002;107:101-107.

166. Walz C, Chase A, Schoch C, et al. The t(8;17)(p11;q23) in the 8p11 myeloproliferative syndrome fuses MYO18A to FGFR1. *Leukemia* 2005;19:1005-1009.
167. Reiter A, Sohal J, Kulkarni S, et al. Consistent fusion of ZNF198 to the fibroblast growth factor receptor-1 in the t(8;13)(p11;q12) myeloproliferative syndrome. *Blood* 1998;92:1735-1742.
168. Xiao S, Nalabolu SR, Aster JC, et al. FGFR1 is fused with a novel zinc-finger gene, ZNF198, in the t(8;13) leukaemia/lymphoma syndrome. *Nat Genet* 1998;18:84-87.
169. Neuwirtova R, Mocikova K, Musilova J, et al. Mixed myelodysplastic and myeloproliferative syndromes. *Leuk Res* 1996;20:717-726.
170. Orazi A, Bennett JM, Germing U, et al. Chronic myelomonocytic leukemia. In: Swerdlow SH, Campo E, Harris NL, et al., eds. WHO classification of tumours of haematopoietic and lymphoid tissues. Lyon, France: IARC Press, 2008:76-79.
171. Bennett JM, Catovsky D, Daniel MT, et al. The chronic myeloid leukaemias: guidelines for distinguishing chronic granulocytic, atypical chronic myeloid, and chronic myelomonocytic leukaemia. Proposals by the French-American-British Cooperative Leukaemia Group. *Br J Haematol* 1994;87:746-754.
172. Germing U, Gattermann N, Minning H, et al. Problems in the classification of CMML—dysplastic versus proliferative type. *Leuk Res* 1998;22:871-878.
173. Voglova J, Chrobak L, Neuwirtova R, et al. Myelodysplastic and myeloproliferative type of chronic myelomonocytic leukemia—distinct subgroups or two stages of the same disease? *Leuk Res* 2001;25:493-499.
174. Onida F, Kantarjian HM, Smith TL, et al. Prognostic factors and scoring systems in chronic myelomonocytic leukemia: a retrospective analysis of 213 patients. *Blood* 2002;99:840-849.
175. Gonzalez-Medina I, Bueno J, Torrequebrada A, et al. Two groups of chronic myelomonocytic leukaemia: myelodysplastic and myeloproliferative. Prognostic implications in a series of a single center. *Leuk Res* 2002;26:821-824.
176. Kouides PA, Bennett JM. Morphology and classification of the myelodysplastic syndromes and their pathologic variants. *Semin Hematol* 1996;33:95-110.
177. Goasguen JE, Bennett JM, Bain BJ, et al. Morphological evaluation of monocytes and their precursors. *Haematologica* 2009;94:994-997
178. Sawyers CL, Denny CT. Chronic myelomonocytic leukemia: Tel-a-kinase what Ets all about. *Cell* 1994;77:171-173.
179. Gilliland DG. Molecular genetics of human leukemia. *Leukemia* 1998;12(Suppl 1):S7-S12.
180. Fenaux P, Beuscart R, Lai JL, et al. Prognostic factors in adult chronic myelomonocytic leukemia: an analysis of 107 cases. *J Clin Oncol* 1988;6:1417-1424.
181. Chronic myelomonocytic leukemia: single entity or heterogeneous disorder? A prospective multicenter study of 100 patients. Groupe Francais de Cytogenetique Hematologique. *Cancer Genet Cytogenet* 1991;55:57-65.
182. Storniolo AM, Moloney WC, Rosenthal DS, et al. Chronic myelomonocytic leukemia. *Leukemia* 1990;4:766-770.
183. Tefferi A, Hoagland HC, Therneau TM, et al. Chronic myelomonocytic leukemia: natural history and prognostic determinants. *Mayo Clin Proc* 1989;64:1246-1254.
184. Maschek H, Georgii A, Kaloutsi V, et al. Myelofibrosis in primary myelodysplastic syndromes: a retrospective study of 352 patients. *Eur J Haematol* 1992;48:208-214.
185. Toyama K, Ohyashiki K, Yoshida Y, et al. Clinical implications of chromosomal abnormalities in 401 patients with myelodysplastic syndromes: a multicentric study in Japan. *Leukemia* 1993;7:499-508.
186. Haase D, Fonatsch C, Freund M, et al. Cytogenetic findings in 179 patients with myelodysplastic syndromes. *Ann Hematol* 1995;70:171-187.
187. Fenaux P, Morel P, Lai JL. Cytogenetics of myelodysplastic syndromes. *Semin Hematol* 1996;33:127-138.
188. McClure RF, Dewald GW, Hoyer JD, et al. Isolated isochromosome 17q: a distinct type of mixed myeloproliferative disorder/myelodysplastic syndrome with an aggressive clinical course. *Br J Haematol* 1999;106:445-454.
189. Willman CL. Molecular genetic features of myelodysplastic syndromes (MDS). *Leukemia* 1998;12(Suppl 1):S2-S6.
190. Cogswell PC, Morgan R, Dunn M, et al. Mutations of the ras protooncogenes in chronic myelogenous leukemia: a high frequency of ras mutations in bcr/abl rearrangement-negative chronic myelogenous leukemia. *Blood* 1989;74:2629-2633.

191. Dobrovic A, Morley AA, Seshadri R, et al. Molecular diagnosis of Philadelphia negative CML using the polymerase chain reaction and DNA analysis: clinical features and course of M-bcr negative and M-bcr positive CML. *Leukemia* 1991;5:187-190.
192. Oscier DG. Atypical chronic myeloid leukaemia, a distinct clinical entity related to the myelodysplastic syndrome? *Br J Haematol* 1996;92:582-586.
193. Hernandez JM, del Canizo MC, Cuneo A, et al. Clinical, hematological and cytogenetic characteristics of atypical chronic myeloid leukemia. *Ann Oncol* 2000;11:441-444.
194. Costello R, Sainty D, Lafage-Pochitaloff M, et al. Clinical and biological aspects of Philadelphia-negative/BCR-negative chronic myeloid leukemia. *Leuk Lymphoma* 1997;25:225-232.
195. Martiat P, Michaux JL, Rodhain J. Philadelphia-negative (Ph-) chronic myeloid leukemia (CML): comparison with Ph+ CML and chronic myelomonocytic leukemia. *The Groupe Francais de Cytogenetique Hematologique. Blood* 1991;78:205-211.
196. Shepherd PC, Ganesan TS, Galton DA. Haematological classification of the chronic myeloid leukaemias. *Baillieres Clin Haematol* 1987;1:887-906.
197. Oscier D. Atypical chronic myeloid leukemias. *Pathol Biol (Paris)* 1997;45:587-593.
198. Schwaller J, Anastasiadou E, Cain D, et al. H4(D10S170), a gene frequently rearranged in papillary thyroid carcinoma, is fused to the platelet-derived growth factor receptor beta gene in atypical chronic myeloid leukemia with t(5;10)(q33;q22). *Blood* 2001;97:3910-3918.
199. Siena S, Sammarelli G, Grimoldi MG, et al. New reciprocal translocation t(5;10)(q33;q22) associated with atypical chronic myeloid leukemia. *Haematologica* 1999;84:369-372.
200. Kulkarni S, Heath C, Parker S, et al. Fusion of H4/D10S170 to the platelet-derived growth factor receptor beta in BCR-ABL-negative myeloproliferative disorders with a t(5;10)(q33;q21). *Cancer Res* 2000;60:3592-3598.
201. Baxter EJ, Hochhaus A, Bolufer P, et al. The t(4;22)(q12;q11) in atypical chronic myeloid leukaemia fuses BCR to PDGFRA. *Hum Mol Genet* 2002;11:1391-1397.
202. Niemeyer CM, Fenu S, Hasle H, et al. Differentiating juvenile myelomonocytic leukemia from infectious disease (response). *Blood* 1998;91:365-367.
203. Jackson GH, Carey PJ, Cant AJ, et al. Myelodysplastic syndromes in children. *Br J Haematol* 1993;84:185-186.
204. Hasle H, Kerndrup G, Jacobsen BB. Childhood myelodysplastic syndrome in Denmark: incidence and predisposing conditions. *Leukemia* 1995;9:1569-1572.
205. Hasle H, Wadsworth LD, Massing BG, et al. A population-based study of childhood myelodysplastic syndrome in British Columbia, Canada. *Br J Haematol* 1999;106:1027-1032.
206. Sasaki H, Manabe A, Kojima S, et al. Myelodysplastic syndrome in childhood: a retrospective study of 189 patients in Japan. *Leukemia* 2001;15:1713-1720.
207. Hasle H, Arico M, Basso G, et al. Myelodysplastic syndrome, juvenile myelomonocytic leukemia, and acute myeloid leukemia associated with complete or partial monosomy 7. *European Working Group on MDS in Childhood (EWOGMDS). Leukemia* 1999;13:376-385.
208. Luna-Fineman S, Shannon KM, Atwater SK, et al. Myelodysplastic and myeloproliferative disorders of childhood: a study of 167 patients. *Blood* 1999;93:459-466.
209. Arico M, Biondi A, Pui CH. Juvenile myelomonocytic leukemia. *Blood* 1997;90:479-488.
210. Niemeyer CM, Arico M, Basso G, et al. Chronic myelomonocytic leukemia in childhood: a retrospective analysis of 110 cases. *European Working Group on Myelodysplastic Syndromes in Childhood (EWOG-MDS). Blood* 1997;89:3534-3543.
211. Hasle H, Kerndrup G. Atypical chronic myeloid leukaemia and chronic myelomonocytic leukaemia in children. *Br J Haematol* 1995;89:428-429.
212. Pinkel D. Differentiating juvenile myelomonocytic leukemia from infectious disease. *Blood* 1998;91:365-367.
213. Emanuel PD. Myelodysplasia and myeloproliferative disorders in childhood: an update. *Br J Haematol* 1999;105:852-863.

214. Morerio C, Acquila M, Rosanda C, et al. HCMOGT-1 is a novel fusion partner to PDGFRB in juvenile myelomonocytic leukemia with t(5;17)(q33;p11.2). *Cancer Res* 2004;64:2649-2651.
215. Luna-Fineman S, Shannon KM, Lange BJ. Childhood monosomy 7: epidemiology, biology, and mechanistic implications. *Blood* 1995;85:1985-1999.
216. Flotho C, Valcamonica S, Mach-Pascual S, et al. RAS mutations and clonality analysis in children with juvenile myelomonocytic leukemia (JMML). *Leukemia* 1999;13:32-37.
217. Tartaglia M, Niemeyer CM, Fragale A, et al. Somatic mutations in PTPN11 in juvenile myelomonocytic leukemia, myelodysplastic syndromes and acute myeloid leukemia. *Nat Genet* 2003;34:148-150.
218. Largaespada DA, Brannan CI, Jenkins NA, et al. Nf1 deficiency causes Ras-mediated granulocyte/macrophage colony stimulating factor hypersensitivity and chronic myeloid leukaemia. *Nat Genet* 1996;12:137-143.
219. Bollag G, Clapp DW, Shih S, et al. Loss of NF1 results in activation of the Ras signaling pathway and leads to aberrant growth in haematopoietic cells. *Nat Genet* 1996;12:144-148.
220. Loh ML, Vattikuti S, Schubert S, et al. Mutations in PTPN11 implicate the SHP-2 phosphatase in leukemogenesis. *Blood* 2004;103:2325-2331.
221. Woods WG, Barnard DR, Alonzo TA, et al. Prospective study of 90 children requiring treatment for juvenile myelomonocytic leukemia or myelodysplastic syndrome: a report from the Children's Cancer Group. *J Clin Oncol* 2002;20:434-440.
222. Iversen PO, Emanuel PD, Sioud M. Targeting Raf-1 gene expression by a DNA enzyme inhibits juvenile myelomonocytic leukemia cell growth. *Blood* 2002;99:4147-4153.
223. Emanuel PD, Snyder RC, Wiley T, et al. Inhibition of juvenile myelomonocytic leukemia cell growth in vitro by farnesyltransferase inhibitors. *Blood* 2000;95:639-645.
224. Streeter RR, Presant CA, Reinhard E. Prognostic significance of thrombocytosis in idiopathic sideroblastic anemia. *Blood* 1977;50:427-432.
225. Schmitt-Graeff A, Thiele J, Zuk I, et al. Essential thrombocythemia with ringed sideroblasts: a heterogeneous spectrum of diseases, but not a distinct entity. *Haematologica* 2002;87:392-399.
226. Szpurka H, Tiu R, Murugesan G, et al. Refractory anemia with ringed sideroblasts associated with marked thrombocytosis (RARS-T), another myeloproliferative condition characterized by JAK2 V617F mutation. *Blood* 2006;108:2173-2181.
227. Norrby A, Ridell B, Swolin B, et al. Rearrangement of chromosome no. 3 in a case of preleukemia with thrombocytosis. *Cancer Genet Cytogenet* 1982;5:257-263.
228. Carroll AJ, Poon MC, Robinson NC, et al. Sideroblastic anemia associated with thrombocytosis and a chromosome 3 abnormality. *Cancer Genet Cytogenet* 1986;22:183-187.
229. Jotterand Bellomo M, Parlier V, Muhlematter D, et al. Three new cases of chromosome 3 rearrangement in bands q21 and q26 with abnormal thrombopoiesis bring further evidence to the existence of a 3q21q26 syndrome. *Cancer Genet Cytogenet* 1992;59:138-160.
230. Grigg AP, Gascoyne RD, Phillips GL, et al. Clinical, haematological and cytogenetic features in 24 patients with structural rearrangements of the Q arm of chromosome 3. *Br J Haematol* 1993;83:158-165.
231. Fonatsch C, Gudat H, Lengfelder E, et al. Correlation of cytogenetic findings with clinical features in 18 patients with inv(3)(q21q26) or t(3;3)(q21;q26). *Leukemia* 1994;8:1318-1326.
232. Secker-Walker LM, Mehta A, Bain B. Abnormalities of 3q21 and 3q26 in myeloid malignancy: a United Kingdom Cancer Cytogenetic Group study. *Br J Haematol* 1995;91:490-501.

Chapter 81 Chronic Myeloid Leukemia

> Table of Contents > Part VII - Hematologic Malignancies > Section 3 - Myeloproliferative Disorders > Chapter 81 - Chronic Myeloid Leukemia

Chapter 81

Chronic Myeloid Leukemia

Michael W.N. Deininger

HISTORICAL PERSPECTIVE

Chronic myeloid leukemia (CML), although a rare disease, has disproportionately influenced hematology/oncology and modern medicine. Reports of what was probably CML date back to the middle of the 19th century. In 1845, John Hughes Bennett, an Edinburgh pathologist, described a "Case of Hypertrophy of the Spleen and Liver in which Death Took Place from Suppuration of the Blood."¹ It was only a few weeks later when Rudolf Virchow of Berlin reported on a very similar case in an article titled, "Weisses Blut" (white blood).² It is likely that both patients involved indeed suffered from CML and presented with its most typical clinical features: leukocytosis and splenomegaly. Whereas Bennett believed that the new disease represented an infection, Virchow recognized the neoplastic nature of the process and coined the term "leukemia," from the Greek words "λευκον αιμα," which mean "white blood." The ensuing academic dispute was eventually settled cordially: Virchow acknowledged Bennett's priority of discovery and Bennett that leukemia is a neoplastic rather than infectious process. Ironically, both were actually preceded by Alfred Donné of Paris, Bennett's previous mentor, whose description of leukemia in his 1844 *Cours de Microscopie* had lacked sufficient detail and visibility to attract attention.³ The next leap forward came in 1872, when Ernst Neumann established the bone marrow as the origin of leukemia and of blood cells in general.⁴ The following 100 years saw progress in understanding leukemia, with perhaps the most notable advance being the recognition of myeloid versus lymphoid disease. In 1951, William Dameshek posited that CML belongs to a larger group of related disorders characterized by increased numbers of differentiated blood cells as the result of enhanced proliferation of the bone marrow, which he accordingly named myeloproliferative disorders.⁵

A fundamental experimental breakthrough by Philadelphia cytogeneticists Peter Nowell and David Hungerford followed in 1960. They observed an abnormally small G-group chromosome in metaphase spreads from several patients with CML.⁶ This first consistent karyotypic abnormality associated with cancer settled the debate as to whether DNA or proteins transmitted the neoplastic phenotype to the next generation of cells. The discovery team anticipated that this minute chromosome in CML might represent the first in a long list of cancer chromosomes, and thus referred to it as the Ph¹ chromosome (now more commonly known as Ph). The presence of Ph in all CML cells was indicative of their clonal origin from a single parental cell. Formal proof for this notion was lacking until Fred Fialkow demonstrated X-chromosome inactivation in CML neutrophils by uniform glucose-6-phosphate dehydrogenase (G6PD) isoenzyme expression.⁷

In 1973, Janet Rowley recognized that Ph was not just a shortened chromosome 22, but was in fact the product of a reciprocal translocation between chromosomes 9 and 22.⁸ Over the following 25 years, the molecular anatomy and consequences of t(9;22) were revealed with increasing resolution. Work from several laboratories identified the genes juxtaposed by t(9;22) to form a fusion gene on Ph.^{9,10} The chromosome 9 partner was found to be ABL1 (formerly ABL), the human homolog of v-abl oncogene of the Abelson murine leukemia virus (A-MuLV).¹¹ On the derivative chromosome 22, ABL1 sequences consistently translocated to the same genetic region, which became known as the "breakpoint cluster region" (BCR), a name that was subsequently used to describe the new gene fused upstream of ABL1. The next critical set of discoveries was that BCR-ABL1, similar to murine v-Abl, is a constitutively active tyrosine kinase and that kinase activity is required for cellular transformation.¹² Lastly, retroviral expression of BCR-ABL1 in murine bone marrow cells was found to induce a CML-like disease in mice, another milestone in the history of cancer research.¹³

Therapy developed slowly. Arsenicals, in use for cancer treatment since ancient times, were the only CML therapy available in the 19th century, usually in the form of Fowler's solution, which contained potassium arsenite. The German physician Heinrich Lissauer is credited with the first publication on the remarkable efficacy of Fowler's solution in a patient with leukemia.¹⁴ In an 1882 *Lancet* paper, Conan Doyle, the author of the Sherlock Holmes detective stories, published on a patient with the clinical presentation of CML who achieved a partial response to arsenic.¹⁵ In the 1920s, splenic irradiation was used for symptomatic relief and remained the mainstay of therapy for the first half of the 20th century. In 1959, busulfan was introduced as the first drug that reliably controlled white blood cell counts in CML and, 10 years later, hydroxyurea premiered as the first intervention that significantly prolonged survival.^{16,17} Despite these advances, a cure remained elusive until the late 1970s, when the disappearance of the Ph⁺ clone in CML patients treated with allogeneic stem cell transplantation was reported.¹⁸ In the early 1980s, interferon- α (IFN) became the standard drug therapy. This agent induced complete cytogenetic responses (CCyRs) and long-term survival in 10% to 20% of patients.¹⁹

In 1992, Alexander Levitzki proposed inhibiting ABL1 with small molecules called tyrphostins as a potentially useful approach to treat leukemias driven by ABL1 oncogenes.²⁰ At about the same time, Alois Matter, Jürg Zimmermann, and Nick Lydon at Ciba-Geigy had synthesized a compound called GCP57148B,²¹ now known as imatinib, that inhibited ABL1

and a restricted set of other tyrosine kinases at submicromolar concentrations. Clinical trials led by Brian Druker from Oregon Health & Science University, very much in the face of skepticism by the manufacturer, rapidly established imatinib's unprecedented activity in patients with CML and revolutionized CML therapy.^{22,23,24} Dasatinib and nilotinib, tyrosine kinase inhibitors (TKIs) with increased activity against BCR-ABL1, were initially developed to overcome imatinib resistance, but have since gained approval for frontline therapy.^{25,26} However, once CML has progressed beyond the chronic phase, allogeneic stem cell transplant is still the recommendation for all eligible patients. There is compelling evidence that CML stem cells are not dependent on BCR-ABL1 kinase activity, implying that treatment must continue indefinitely in order to prevent recurrence of active leukemia. Current research efforts focus on improving the poor prognosis of advanced CML, controlling TKI resistance, and developing strategies to eradicate CML stem cells.

PATHOPHYSIOLOGY

It is thought that CML originates from a single hematopoietic cell that has acquired Ph. In contrast to an acute myeloid leukemia (AML)-associated fusion gene such as MOZ-TIF2, BCR-ABL1 does not confer self-renewal capacity, implying that the initial translocation event must occur in a multipotent hematopoietic stem cell already endowed with this critical property.²⁷ BCR-ABL1 is detected in cells of all hematopoietic lineages.²⁸ For unknown reasons, the BCR-ABL1-induced cellular expansion predominantly

P.1706

targets the myeloid progenitor cell compartment, giving rise to the clinical phenotype, whereas many newly diagnosed patients have mostly Ph⁻ stem cells.^{29,30} As a consequence, the hierarchical organization of hematopoiesis is maintained during the chronic phase, and a substantial number of Ph⁻ stem cells are available to reconstitute the system when CML hematopoiesis is therapeutically suppressed. Both factors are important for the response to TKIs. The salient biologic features of CML cells are as follows: increased proliferation, resistance to apoptosis, perturbed interaction with bone marrow stromal cells, and genetic instability.³¹

BCR-ABL1 Translocation and Fusion Gene

Ph is the result of a reciprocal translocation between the long arms of chromosomes 9 and 22 [t(9;22)(q34;q11)].⁸ As a result of this translocation, genetic sequences from the ABL1 gene on 9q34 are fused downstream of the BCR gene on 22q11 (Fig. 81.1A,B). With rare exceptions, breaks in chromosome 22 localize to one of three BCRs and determine the portions of BCR retained in the BCR-ABL1 fusion mRNA and protein. In contrast, the chromosome 9 breaks can occur over a large genetic region, 5' of ABL1 exon 1b, 3' of ABL1 exon 1a, or most commonly between the two alternative first ABL1 exons. Rare exceptions aside, splicing consistently leads to fusion mRNAs that encompass ABL1 exons 2 to 11 (Fig. 81.2C).³² Breakpoints in the minor BCR (m-BCR) give rise to an e1a2 fusion mRNA and p190^{BCR-ABL}, which is found in 2/3 of Ph⁺ acute lymphoblastic leukemia (ALL) cases. The very rare p190^{BCR-ABL} positive CML is associated with monocytosis and exhibits a more aggressive clinical course.^{33,34} In an overwhelming majority of CML patients, the break occurs in the major BCR (M-BCR), generating e13a2 or e14a2 fusion mRNAs (formerly referred to as b2a2 and b3a2) and a p210^{BCR-ABL} fusion protein. p230^{BCR-ABL}, the largest of the fusion proteins, corresponds to a break in the micro-BCR (μ-BCR), an e19a2 fusion mRNA, and is associated with neutrophilic predominance and possibly less aggressive disease.³⁵ In addition to the major types of BCR-ABL1 fusion mRNAs, there are a number of rare variants whose main clinical significance is that they can give rise to misleading reverse transcription polymerase chain reaction (RT-PCR) results.^{36, 37} and ³⁸ Approximately two-thirds of CML cases also express the reciprocal ABL1-BCR mRNA, but there is no evidence that this influences disease biology or prognosis.^{39,40}

BCR and ABL1 Proteins and Their Contribution to Cellular Transformation

BCR is an ubiquitously expressed 160 kD cytoplasmic protein with several functional domains (Fig. 81.2A). The N-terminus contains a coiled-coil motif that allows for dimerization, which is critical for activation of ABL1 kinase in the BCR-ABL1 fusion protein.⁴¹ Further 3' there are: a serine/threonine kinase motif whose only recognized substrate is Bap-1, a member of the 14-3-3 family of proteins,⁴² and dbl-like and pleckstrin-homology (PH) domains that stimulate the exchange of GTP for GDP on Rho guanine exchange factors.⁴³ The C-terminus contains a putative site for calcium-dependent lipid binding (CaLB) and a GTPase activating function (RAC-GAP). The latter regulates activity of RAC, a small GTPase of the RAS superfamily that regulates actin polymerization and an NADPH oxidase in phagocytic cells.^{44,45} Despite these diverse functions, Bcr null mice are viable and fertile and the only recognizable defect is an increased oxidative burst in neutrophils, suggesting redundancy of signaling pathways.⁴⁶ BCR can be phosphorylated on several tyrosine residues, most importantly tyrosine 177, which binds GRB2, an adapter molecule involved in activation of the RAS pathway in CML

cells.^{47,48,49} The Rho-GEF and RAC-GAP functions of BCR that are retained in p210BCR-ABL but missing from p190^{BCR-ABL} are thought to attenuate the disease and cause a phenotypic shift from lymphoid to myeloid

P.1707

leukemia.^{43,50,51} It is possible that this reflects the fact that hematopoietic stem cells are susceptible to transformation by p210^{BCR-ABL}, and p190^{BCR-ABL} targets pre-B-cells.⁵² It has been suggested that BCR may negatively regulate BCR-ABL1-induced leukemogenesis.⁵³ However, the fact that incidence and biology of p190^{BCR-ABL}-induced leukemia are identical in Bcr^{-/-} mice compared to wildtype mice indicates that BCR is not essential for Ph⁺ leukemia.⁵⁴

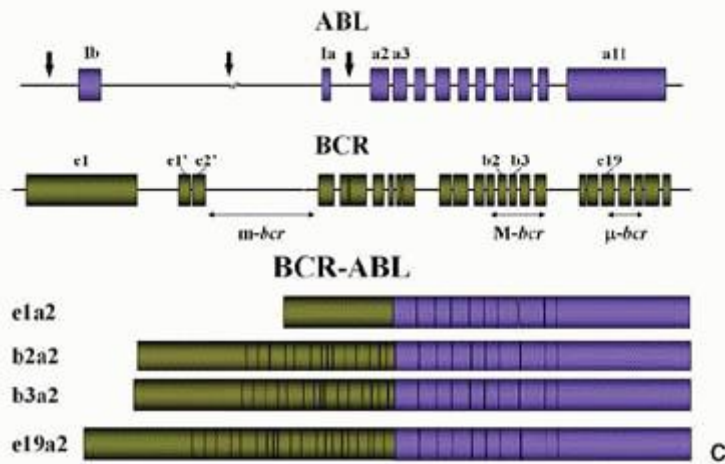
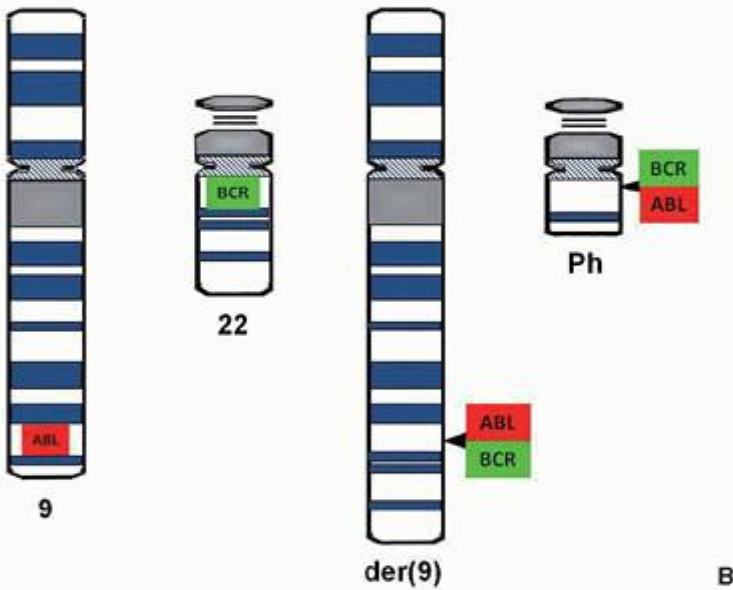
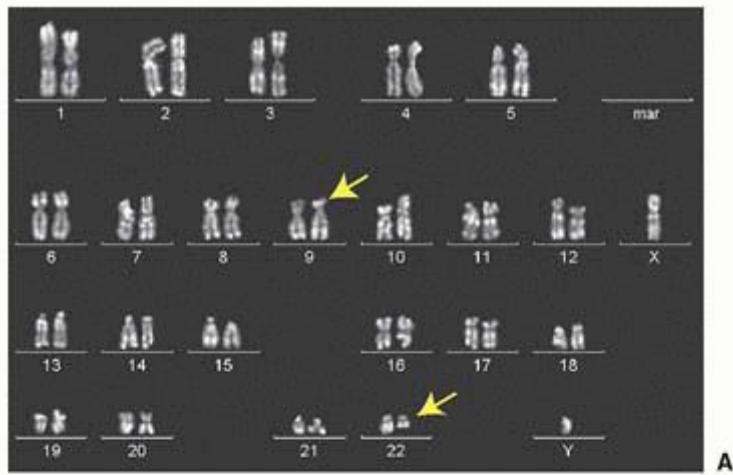

FIGURE 81.1. A: Metaphase karyogram of a newly diagnosed man with CML. The yellow arrows indicate the derivative chromosome 9 and the Philadelphia chromosome (Ph). B: Schematic of chromosomes 9, 22 and the derivatives resulting

from t(9;22)(q34;q11). C: Molecular anatomy of the BCR-ABL1 fusion gene. The upper panel shows the ABL1 gene, which contains 11 exons, including two alternative first exons. Arrows indicate the breakpoints at the genomic level. The middle panel depicts the BCR gene with the three breakpoint cluster regions (BCRs). Breaks in the minor BCR (m-BCR) give rise to p190^{BCR-ABL}, which is typical of Ph⁺ ALL, whereas breaks in the major BCR (M-BCR) generate p210^{BCR-ABL}, typical of CML and also found in 1/3 of Ph⁺ ALL patients. Lastly, breaks in the micro-BCR (μ -BCR) lead to p230^{BCR-ABL}, which is associated with neutrophilia. The lower panel shows the structure of the corresponding mRNAs. Note that BCR exons b2 and b3 are now commonly referred to as exons e13 and e14, respectively.

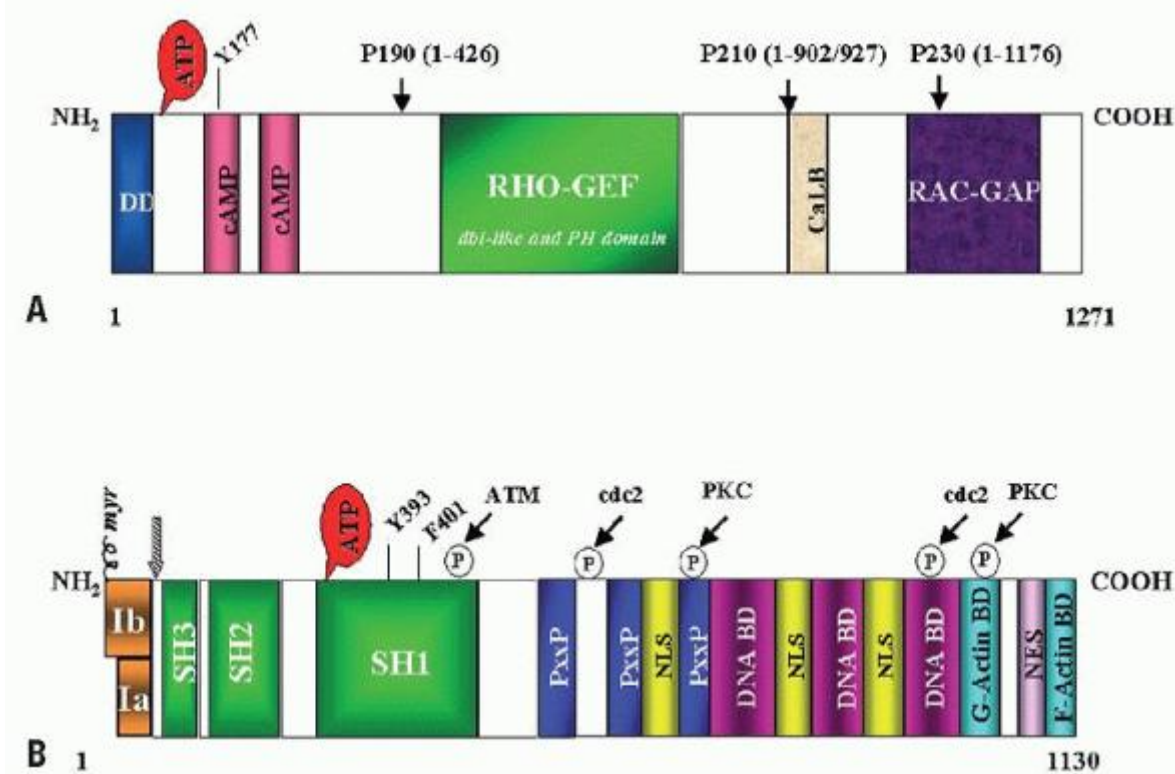

FIGURE 81.2. A: Structure of the BCR protein. Note the dimerization domain (DD) and the two cAMP kinase homologous domains at the N-terminus. Y177 is the autophosphorylation site crucial for binding to GRB2. The center of the molecule contains a region homologous to Rho guanine nucleotide exchange factors (Rho-GEF) as well as dbl-like and pleckstrin-homology (PH) domains. Toward the C-terminus, a putative site for calcium-dependent lipid binding (CaLB) and a domain with activating function for RAC-GTPase (RAC-GAP) are found. Arrowheads indicate the position of the breakpoints in the BCR-ABL1 fusion proteins. B: Structure of the ABL1 protein. The type Ia isoform is slightly shorter than type Ib, which contains a myristoylation (myr) site for attachment to the plasma membrane. Note the three SRC-homology (SH) domains situated toward the NH₂ terminus. Y393 is the major site of autophosphorylation within the kinase domain, and phenylalanine 401 (F401) is highly conserved in PTKs containing SH3 domains. The middle of the protein is dominated by proline-rich regions (PxxP) capable of binding to SH3 domains and also harbors one of three nuclear localization signals (NLS). The C-terminus contains DNA binding as well as G- and F-actin binding domains. Phosphorylation sites by ATM, cdc2, and PKC are shown. The arrowhead indicates the position of the breakpoint in the BCR-ABL1 fusion protein.

ABL1, the human homolog of the v-abl oncogene of the A-MuLV,⁵⁵ encodes a nonreceptor tyrosine kinase.⁵⁶ The 145-kDa ABL1 protein is ubiquitously expressed and exhibits two isoforms arising from alternative splicing of the first exon.⁵⁷ The N-terminal region contains three SRC-homology domains (SH1 to SH3). SH1 carries the tyrosine kinase function, whereas the SH2 and SH3 domains engage in protein-protein interactions (Fig. 81.2B).⁵⁸ In addition, proline-rich sequences in the center of ABL1 interact with SH3 domains of other proteins such as Crk.^{59,60} The C-terminus contains nuclear localization, DNA binding,⁶¹ and actin-binding motifs.⁶² Diverse functions have been attributed to ABL1, which include negative regulation of cell cycle and proliferation,^{63,64} response to genotoxic stress,^{65,66,67,68,69} and integrin signaling.⁷⁰ The emerging picture is complex and perhaps ABL1 could best be characterized as a cellular module that integrates signals from various extra- and intracellular sources to influence decisions in regard to cell cycle and apoptosis. It must be stressed, however, that many results are based primarily on in vitro studies in fibroblasts, not hematopoietic cells. Unfortunately, the generation of Abl1 null mice failed to shed light on the physiologic function of ABL1. These mice have a severe phenotype,

including high perinatal mortality, runting, and skeletal and immune system defects.^{71,72} Mice null for Abl1 and the Abl-related gene (formerly Arg, now Abl2) are embryonically lethal due to absence of neurulation.⁷³ The latter observation raised considerable concerns about the potential side effects of ABL inhibitors that were fortunately not confirmed clinically.

Constitutive Kinase Activation in the BCR-ABL1 Fusion Protein

In contrast to ABL1, a tightly regulated nuclear kinase, BCR-ABL1 is constitutively active and localized in the cytoplasm. The mechanism by which the replacement of the ABL1 N-terminus with BCR sequences leads to kinase activation has been probed by mutagenesis and X-ray crystallography.⁷⁴ A critical feature is the coiled-coil domain of BCR that promotes dimerization, which allows for an initial transphosphorylation event, followed by autophosphorylation of additional tyrosine residues to activate the kinase fully.⁷⁵ Moreover, the N-terminal "cap" region of ABL1, when myristoylated, binds a hydrophobic pocket at the base of the kinase domain, thereby forming a latch that maintains ABL1 in an inactive state.^{76, 77} and ⁷⁸ Replacement of the cap by BCR sequences abolishes this negative regulation. Unexpectedly, recent studies have shown that certain residues within the SH2 domain participate in the regulation of kinase activity, an indication of the complexity of kinase regulation.⁷⁹ Lastly, trans-acting binding partners such as the ABL1 interacting proteins have been implicated as physiologic inhibitors whose down-regulation upon disease progression may contribute to BCR-ABL1 activation.^{80,81}

Signaling Pathways in BCR-ABL1 Transformed Cells

Two decades of intense research have identified multiple BCR-ABL1 substrates, binding partners, and downstream signaling molecules involved in the process of cellular transformation (Fig. 81.3). Much effort has been directed at linking these pathways to the specific pathologic features that characterize CML cells, such as increased proliferation or genetic instability leading to disease progression. A comprehensive review of the multiple pathways implicated in BCR-ABL1 transformation is beyond the scope of this chapter. Studies of mice with homozygous deletions of signaling proteins have identified very few pathway components with a truly essential function, speaking to the extensive redundancy of the transformation network.

Phosphatidylinositol-3 Kinase

In BCR-ABL1-expressing cells, phosphatidylinositol-3 kinase (PI3K) is activated by at least two different mechanisms. The first requires autophosphorylation of BCR-ABL1 tyrosine 177 (Y177), which generates a docking site for the GRB2 adapter protein, which in turn recruits GAB2, another adapter, into a complex that activates PI3K.^{82,83} Consistent with a critical role for the Y177/GRB2/GAB2 axis, mutation of tyrosine 177 to phenylalanine or lack of GAB2 abrogates myeloid leukemia in murine models.⁸³ Alternatively, PI3K can be activated by complex formation between the p85 regulatory subunit of PI3K, CBL, and CRKL, which bind to the SH2 and proline-rich domains of BCR-ABL1.⁸⁴ The main downstream outlet of PI3K is the serine-threonine kinase AKT, a major conduit for oncogenic signals in different cancer types. In CML cells, AKT enhances survival by suppressing activity of the forkhead O transcription factors (FOXO), as well as phosphorylation and inactivation of proapoptotic proteins such as BAD.^{85,86,87} Additionally, PI3K promotes proteasomal degradation of p27, a cyclin-dependent kinase inhibitor, through up-regulation of SKP2, the F-Box recognition protein of SCF/SKP2 E3 ubiquitin ligase. Accordingly, absence of SKP2 from leukemia cells prolongs survival in a murine CML model.⁸⁸ Furthermore, AKT activates mTOR, which phosphorylates ribosomal proteins p70S6 kinase (S6K) and 4E-BP1. S6K activation promotes cell growth and proliferation by yet undefined mechanisms. However, phosphorylation by mTOR has been shown to inactivate 4EBP-1, thereby activating the translation initiation factor eIF4E to enhance protein synthesis.^{89,90}

P.1708

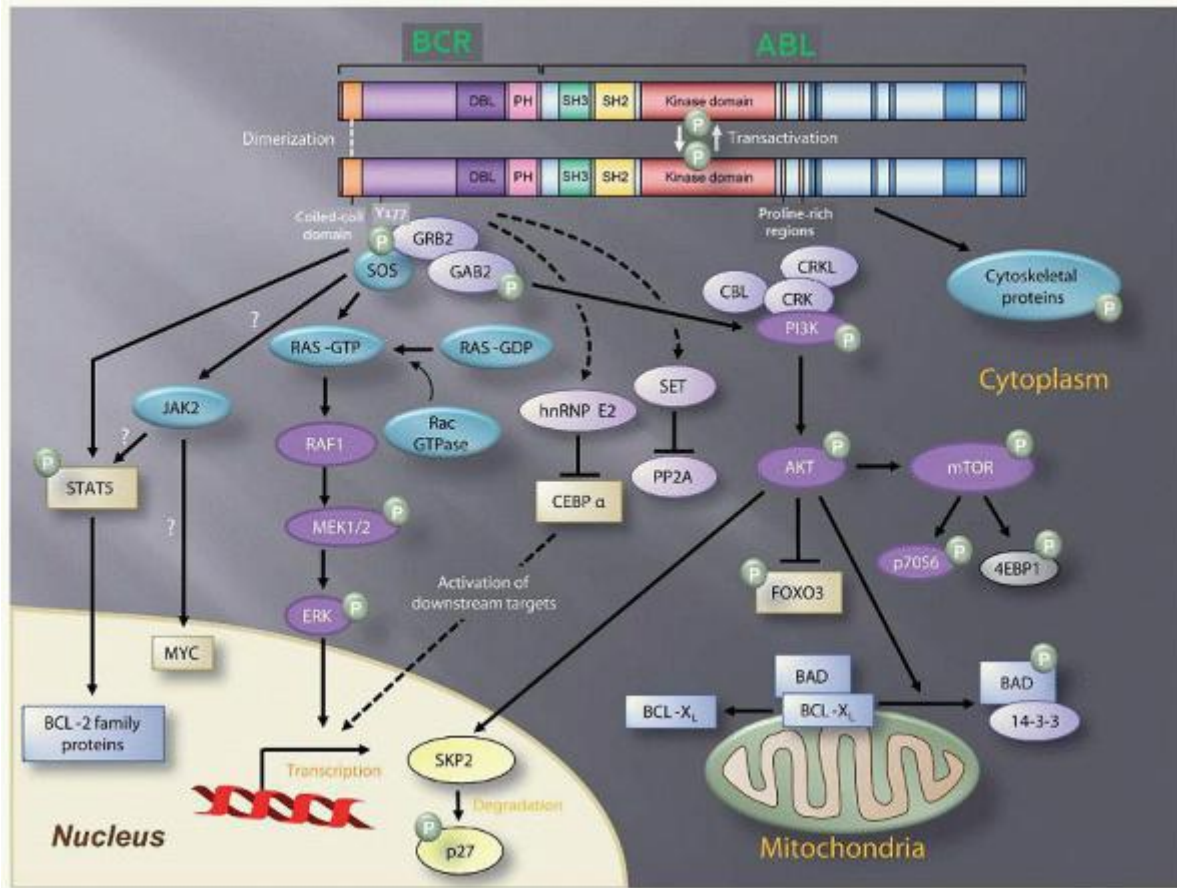

FIGURE 81.3. Simplified representation of molecular signaling pathways activated in chronic myeloid leukemia (CML) cells. Autophosphorylation generates docking sites on BCR-ABL1 that facilitate interaction with intermediary proteins such as GRB2. CRKL and CBL are also direct substrates of BCR-ABL1 that are part of a multimeric complex. Additionally, BCR-ABL-dependent signaling complexes activate multiple pathways, which modulate the function of critical proteins (blue) that inhibit apoptosis, enhance proliferation, perturb adhesion and migration, and impart genomic instability. For details see text.

RAS/Mitogen-activated Protein Kinase Pathways

Phosphorylation of tyrosine 177 with recruitment of GRB2 and SOS promotes exchange of GTP for GDP on RAS.^{82,91} In its GTP-bound form, RAS activates the serine-threonine kinase RAF-1,^{92,93} which subsequently activates mitogen-activated protein kinase (MAPK). Other small GTPases such as RAC1/2 have also been implicated in BCR-ABL1 signaling.⁹⁴ Lack of RAC1/2 has been shown to delay BCR-ABL1 leukemia in a murine model.⁹⁵

Janus Kinase/Signal Transducer and Activator of Transcription Pathway

The transcription factor signal transducer and activator of transcription 5 (STAT5) is constitutively tyrosine-phosphorylated in CML cells. Initial experiments in mice failed to demonstrate a critical role for STAT5.⁹⁶ However, it was subsequently established that the mice used in this study were not null for Stat5, but expressed an N-terminally deleted protein with partially retained function. Although STAT5 is not required for the initiation of CML, there is convincing evidence that it plays a rate-limiting role in leukemogenesis.^{97,98} In fact, absence of only STAT5A or overexpression of a dominant-negative STAT5 mutant in the bone marrow attenuates CML.⁹⁹ The principal consequence of STAT5 activation is inhibition of apoptosis by enhancing transcription of antiapoptotic proteins such as MCL-1 and BCL-X_L.¹⁰⁰ BCR-ABL1 may activate STAT5 through direct phosphorylation or indirectly by promoting phosphorylation by HCK or Janus kinase 2 (JAK2).^{101,102} There is controversy about the role of JAK2 in BCR-ABL1-induced leukemia. Previous studies had suggested that JAK2 plays an important if not essential role,¹⁰³ but a recent report using conditional knockout technology showed that murine CML does not require JAK2.¹⁰⁴

Cytoskeletal Proteins

BCR-ABL1 phosphorylates several proteins involved in adhesion and migration, including focal adhesion kinase (FAK), CRKL, paxillin, p130CAS, and HEF1.^{105, 106, 107, 108, 109} and ¹¹⁰ Although details remain to be elucidated, it is thought that this may explain why integrin-mediated adhesion of CML progenitors to bone marrow stroma and extracellular matrix is defective. Alternatively, integrin functions may be compromised through activation of RAS or BCR-ABL1 binding to F-actin.^{82,111} Given that adhesion to integrins inhibits proliferation of hematopoietic progenitors, the defect in integrin function may contribute to the premature circulation as well as the abnormal proliferation of Ph⁺ progenitor cells.¹¹²

P.1709

DNA Damage Surveillance and Repair Pathways

The fact that untreated CML-CP invariably progresses to blast phase CML (CML-BP) is testimony to the profound dysregulation of DNA repair in CML. A central finding is the two- to sixfold increase in reactive oxygen species (ROS) in CML CD34+ cells compared with normal controls, which is particularly pronounced in CML-BP cells.^{113,114,115} ROS generate oxidized bases and double-strand breaks (DSB). It was estimated that CML cells may contain up to eight times more oxidized bases and DSBs than normal cells.¹¹⁶ Although PI3K activation is primarily responsible for ROS production,¹¹⁷ an additional mechanism operational in lymphoid blast phase cells is activation of activation-induced cytidine deaminase (AID), which promotes point mutations.¹¹⁸ The consequences of increased DNA damage are greatly aggravated by the impairment of DNA damage surveillance and repair. Multiple mechanisms have been implicated, and many but not all of these mechanisms are BCR-ABL1-dependent. For example, BCR-ABL1 has been shown to impair the intra-S-phase cell cycle checkpoint through suppression of checkpoint kinase 1 (CHK1), either by inhibition of the nuclear protein kinase ATR¹¹⁹ or down-regulation of BRCA1, a substrate of ataxia telangiectasia mutated (ATM).¹²⁰ Nonhomologous end-joining (NHEJ) and homologous recombination (HR), critical DSB repair pathways, are also deregulated in CML. For example, the catalytic subunit of DNA-dependent protein kinase (DNA-PKcs) is down-regulated in CD34+ CML progenitors, leading to error-prone NHEJ.¹²¹ Furthermore, BCR-ABL1 up-regulates RAD51.¹²² As a result, DSB repair upon challenge with cytotoxic agents and induced ROS is shifted toward a rapid but low fidelity pathway, thus promoting chronic oxidative DNA damage. Lastly, telomere length is correlated with time to disease progression.¹²³ Whether TKIs themselves may cause DNA damage is controversial. Imatinib was reported to induce centrosome abnormalities in vitro.¹²⁴ Given that the overall risk of cancer is not increased in patients on long-term imatinib,¹²⁵ the significance of these findings is not clear. Furthermore, the fact that clonal cytogenetic abnormalities in Ph-negative cells (CCA/Ph⁻) appear in some CML patients with a cytogenetic response to TKI therapy is consistent in principle with genomic instability prior to acquisition of Ph.¹²⁶ Indeed, some patients with CCA/Ph⁻ have progressed to MDS or AML, especially those with monosomy 7.¹²⁷ However, the overall prognosis of patients with CCA/Ph⁻ is identical to that of other CML patients with a comparable cytogenetic response, which argues against genomic instability predating Ph.¹²⁸ The mechanistic underpinning of genomic instability in CML is of considerable complexity.^{115,116}

A wealth of data on BCR-ABL1 signaling has been amassed, yet a complete picture is still elusive. As conventional approaches have typically focused on single pathways, efforts are now underway to establish a more comprehensive picture of BCR-ABL1 signaling complexes by quantitative genomics.¹²⁹ These data suggest that cellular processes in CML rely on integrated networks rather than single pathways, which co-operate to realize the leukemogenic potential of BCR-ABL1 fully.

Transformation to Accelerated and Blastic Phase

It could be argued that the key objective in CML therapy is the prevention of transformation to blastic phase (BP), an acute leukemia with either myeloid (M-BP) or pre-B-cell phenotype (L-BP). A host of genetic alterations has been associated with transformation to accelerated phase (AP)/BP. CCA/Ph⁺ is present in 70% to 80% of cases and includes a number of nonrandom abnormalities, the most common of which are +8 (34% of cases with CCA/Ph⁺), +Ph (30%), i(17q) (20%), +19 (13%), -Y (8% of males), +21 (7%), +17 (5%), and monosomy 7 (5%). These frequent chromosomal changes are sometimes referred to as major route abnormalities,¹³⁰ although this is not a universally accepted definition. Many other cytogenetic abnormalities have been described in smaller subsets of patients and multiple different mutations have been detected at the molecular level. For example, in M-BP, inactivating mutations of p53 and RUNX1 occur in 20% to 30% and 38% of cases, respectively, whereas L-BP is characterized by inactivating mutations in CDKN2A/B (50%) or IKZF1 (55%) (reviewed in Ref. 116).

BCR-ABL1 expression and activity increase with progression to BP. In some patients, rising BCR-ABL1 mRNA levels are associated with duplication of Ph, but in the majority of cases this seems to result from enhanced transcription due to as

yet unknown mechanisms.¹³¹ Increased BCR-ABL1 promotes expression of SET, which in turn inhibits PP2A, a tumor suppressor phosphatase that dephosphorylates BCR-ABL1 and other important substrates by activating SHP-1.¹³² Thus, reduced PP2A activity will increase BCR-ABL1 activity and further enhance the signal in a positive feedback loop. Consistent with the importance of this pathway, reduced SHP-1 activity has been associated with resistance to TKIs.¹³³ In addition to SET-mediated inhibition of PP2A, cancerous inhibitor of PP2A (CIP2A) was also shown to inhibit this phosphatase, and high CIP2A activity predicts a high risk of transformation to BP.¹³⁴

The central feature of blastic transformation is the loss of terminal differentiation capacity. Based on the paradigm that AML requires at least two types of mutations, one driving proliferation and one blocking differentiation, it follows that the BP in CML should be associated with inactivating mutations in myeloid differentiation genes.¹³⁵ Consistent with this, some patients acquire AML-type translocations such as CBF β -MYH11 at the time of transformation, but these are rare.¹³⁶ In the majority of patients, myeloid differentiation is impaired due to suppression of CAAT enhancer binding protein α (C/EBP α), which occurs as a result of increased BCR-ABL1 expression and activity.¹³⁷ Mechanistically, this is due to enhanced expression of the RNA-binding protein heterogeneous nuclear ribonucleoprotein E2 (hnRNP-E2), which inhibits C/EBP α translation.¹³⁷ Down-regulation of miR-328 is also required for this to occur, as miR-328 would otherwise bind hnRNP-E2, thereby blocking its activity.¹³⁸ Repression of other myeloid transcription factors such as C/EBP β and overexpression of EVI-1 have also been implicated in blastic transformation.^{139,140,141} In addition to the loss of differentiation capacity, the organization of leukemic hematopoiesis seems to change upon transformation, as granulocyte-macrophage progenitor cells acquire self-renewal capacity, possibly by activation of nuclear β -catenin, undermining the hierarchical structure of CML-CP hematopoiesis.¹⁴² Various mechanisms have been implicated in β -catenin activation, including stabilization by BCR-ABL1 tyrosine phosphorylation and inactivation of glycogen synthase kinase β by missplicing.^{143,144} Unsurprisingly, CML-BP responses to therapy are usually short-lived.

CLINICAL FEATURES

Epidemiology

With an annual incidence of 1.3 to 1.6/10⁵ population, CML accounts for 15% to 20% of cases of leukemia in adults. Males are more commonly affected, but there is no geographic, ethnic, or familial predisposition. The only well-established risk factor is exposure to ionizing radiation, evident by the increased CML incidence in survivors of the atomic bomb explosions in Japan; patients who were treated with radiotherapy or exposed to thorotrast, an α -emitting contrast medium used in the 1930s,^{145, 146} and ¹⁴⁷ have an increased CML risk as well. From 2004 to 2009, the median age at diagnosis in the United States was 64 years.¹⁴⁸ The prevalence of CML is increasing due to reduced mortality.¹⁴⁹ For the United States, estimates

P.1710

are 70,000 in 2010, 144,000 in 2030, and 181,000 in 2050, when prevalence will approach a plateau.¹⁵⁰

Clinical Presentation

Signs and Symptoms

CML may present with fatigue, weight loss, fever, night sweats, bone pain, abdominal pain, and fullness.¹⁵¹ Rare patients with excessively high white blood cell counts have symptoms related to leukostasis, such as priapism and neurologic deficits. Physical exam may reveal splenomegaly and sometimes hepatomegaly, although involvement of other extramedullary sites is uncommon. None of these signs or symptoms is typical or even pathognomonic for CML, and the clinical presentation has changed considerably due to earlier diagnosis. In the United States and other developed countries, the majority of patients are diagnosed incidentally, when an abnormal complete blood count obtained for an unrelated reason leads to a diagnostic work-up.

Disease Phases

CML evolves in stages termed chronic phase (CML-CP), accelerated phase (CML-AP), and blastic phase (CML-BP). In the Western world, most patients present in CML-CP, whereas more advanced disease at diagnosis is common in developing countries. CML-CP is characterized by left-shifted granulocytosis with maintained terminal differentiation, frequently accompanied by basophilia and sometimes eosinophilia. Thrombocytosis and mild anemia are also common. Dysplasia is not a feature of CML and raises the question of alternative diagnoses, such as atypical CML.¹⁵² Bone marrow aspirate and histology are hypercellular for age, but demonstrate complete cellular maturation (Fig. 81.4A). A fairly typical finding is micromegakaryocytes, which are small monolobated megakaryocytes. Mild reticulin fibrosis may be present, but severe reticulin fibrosis is uncommon and may be associated with poorer outcomes.¹⁵³ Without effective therapy, CML-CP

inexorably progresses to CML-BP, which can exhibit a pre-B-lymphoid (25%), myeloid (70%), or indeterminate (5%) phenotype (Fig. 81.4B).¹⁵⁴ CML-BP can develop rapidly or over a period of time through the intermediary stage of CML-AP. A variety of clinical and laboratory features has been used to define CML-AP, making comparison of results between different studies difficult. Today, the criteria used in the clinical trials leading to approval of imatinib are widely accepted (Table 81.1).¹⁵⁵ The exception is clonal cytogenetic evolution, i.e., the presence of additional cytogenetic abnormalities in the Ph⁺ cell clone (CCA/Ph⁺). Although there is agreement that CCA/Ph⁺ on treatment is diagnostic of CML-AP and therapy failure,¹⁵⁶ this is not universally accepted for newly diagnosed patients. Recent studies showed that these patients have inferior outcomes even in the absence of any other features of CML-AP, raising the question of whether the criteria should be changed.¹⁵⁷ A blast count of $\geq 30\%$ in the blood or bone marrow or extramedullary blastic leukemic infiltrates (chloroma) in tissues other than liver or spleen define CML-BP. Gene expression profiling has revealed that CML-AP and CML-BP are closely related to each other, suggesting that CML is a two-phase rather than a three-phase disease.¹⁵⁸ In the future, molecular markers and response to treatment may replace conventional diagnostic criteria used to define the phases of CML.¹⁵⁹

Risk Scores

Several prognostication systems have been developed to sub-classify CML-CP. The oldest, developed by Joseph Sokal, uses a formula based on age, blast count in the blood, platelet count, and spleen size (in cm below the left costal margin). Scores of <0.8 , 0.8 to 1.2 , and >1.2 define low, intermediate, and high risk.¹⁶⁰ Although the Sokal score was derived from a cohort of patients treated with busulfan-based chemotherapy, it has been applied successfully to risk-stratify patients treated with IFN or TKIs.^{161,162} Subsequently, Hasford developed a score optimized for patients on IFN.¹⁶³ Recently, a third prognostication system (EUTOS score) optimized for patients on imatinib was reported.¹⁶⁴

P.1711

The EUTOS score is simple, relying on basophils and spleen size only, but has not been universally confirmed in independent studies.¹⁶⁵ As with the definitions of disease phases, it is likely that molecular markers will eventually replace clinical risk scores.¹⁵⁹

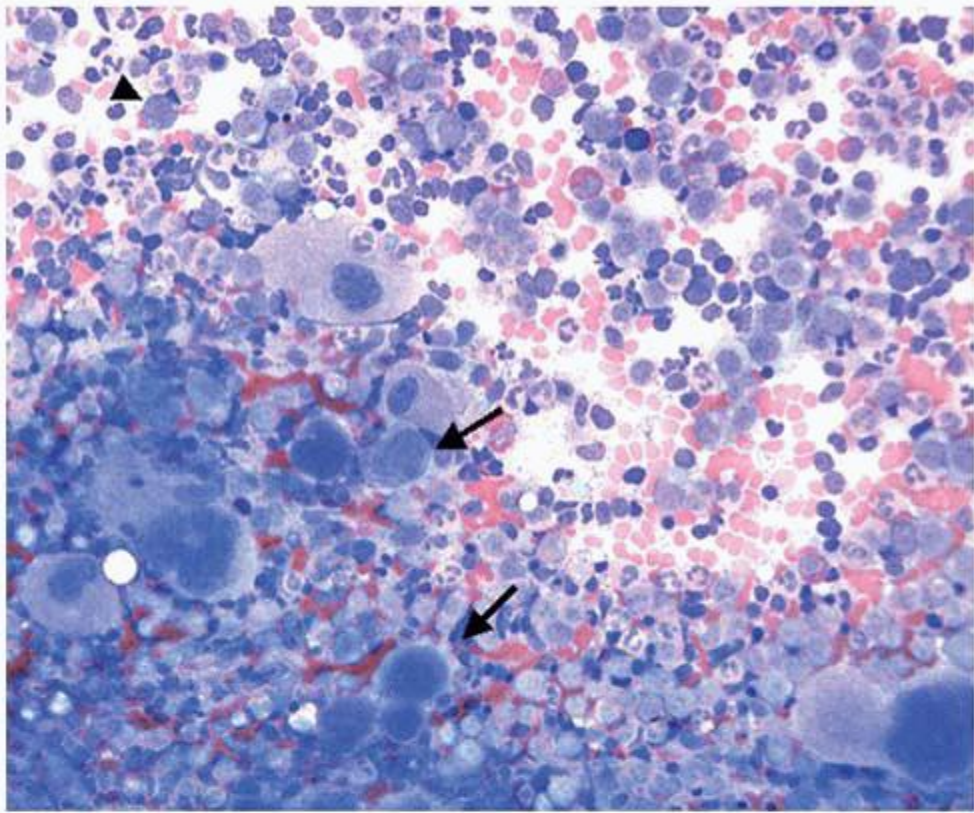

A

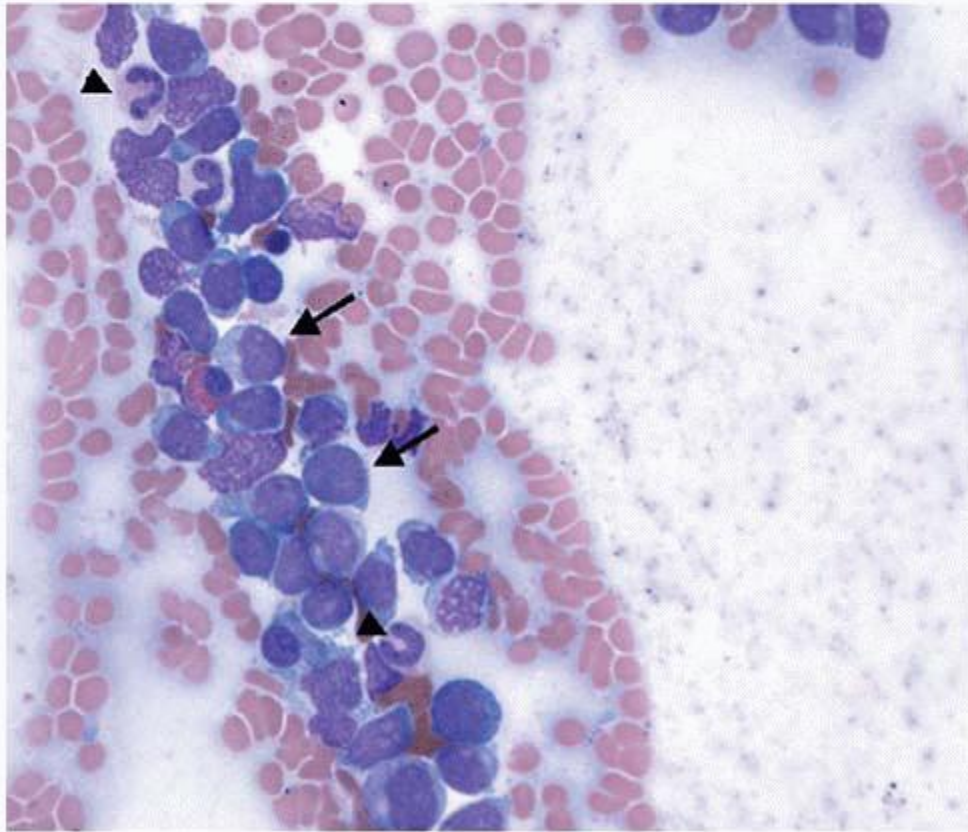

B

FIGURE 81.4. A: Bone marrow aspirate in chronic phase chronic myeloid leukemia (CML) (magnification $\times 20$). Note the hypercellularity and the predominance of granulopoiesis. Maturation is preserved, with only occasional blasts

(arrowhead). Numerous megakaryocytes, many of them small with hypolobulated nuclei (micromegakaryocytes), form sheets and clusters (arrows). B: Bone marrow aspirate in a patient with blastic phase. Most of the cells are immature blasts (arrows), with only occasional cells still exhibiting differentiation (arrowheads). Courtesy of Dr. Marc Loriaux, Department of Pathology, Oregon Health & Science University, USA.

TABLE 81.1 DEFINITION OF ACCELERATED PHASE^a

Blast count at least 15% to less than 30% in blood or marrow

Blasts plus promyelocytes of 15-30% in blood or marrow

Basophil count at least 20% in the blood

Platelet count less than $100 \times 10^9/L$, unrelated to therapy

^aAt least one criterion must be satisfied.

DIAGNOSIS AND INITIAL WORK-UP

Clinical Evaluation

A complete history and physical exam are mandatory. Constitutional symptoms raise concerns about more aggressive disease. Spleen size (in cm below the left costal margin in the mid-clavicular line) must be documented. Despite its inaccuracy, this simple clinical test has remained a significant component of all CML risk scores.^{160,163,164} Imaging studies such as abdominal ultrasound or computed tomography are not indicated unless there is suspicion of additional abdominal pathology. In the absence of an algorithm to convert imaging-based measurements of spleen size into clinical measurements, these data cannot be used to calculate risk scores. Extramedullary disease other than hepatosplenomegaly is uncommon at presentation, and if suspected must be verified histologically. An immature cellular infiltrate (chloroma) indicates blastic transformation, but if there is differentiation it can be difficult to distinguish between true extramedullary disease and an inflammatory process that recruits CML cells.

Laboratory Tests

Complete Blood Count

A complete blood count (CBC) with manual white blood cell differential count is usually the first diagnostic step or the first abnormal finding in an otherwise asymptomatic patient. The diagnosis of CML is suspected based on the morphology of a Wright- or Giemsa-stained blood smear. Typical features of CML include left-shifted granulopoiesis that may encompass the full spectrum of granulocytic precursors including blasts and promyelocytes, basophilia, and sometimes eosinophilia and thrombocytosis. Some automated cell counters do not provide the percentage of promyelocytes, which is required to determine the phase of disease, and in such cases a manual count is necessary. All risk scores to stratify CML-CP are based on pre-therapeutic values; therefore, it is important to document the counts before any therapy is initiated. Flow cytometry is indicated only if AP/BP is suspected. Problems can arise in cases of discrepancies between morphologic and immunophenotypic blast counts, which are usually based on CD34 expression. In our practice, morphologic blast counts take precedence over flow cytometry, but there is currently no universally accepted rule.

Bone Marrow Aspirate and Biopsy

Bone marrow morphology studies at diagnosis are essential to establish disease phase. Unfortunately, more and more patients do not have a bone marrow biopsy at diagnosis, and in some of these, AP/BP will be overlooked and result in undertreatment. Whether all patients should have a biopsy is debatable, and practice varies considerably from country to country. We routinely perform a biopsy at diagnosis to identify the occasional patient with nests of blasts undetected by cytology. This is particularly important in patients with an aggressive presentation and those with inadequate aspirates or dry taps. As for peripheral blood, flow cytometry is not typically indicated.

Bone Marrow Karyotyping

Metaphase karyotyping of bone marrow cells using G- or R-banding must be performed at diagnosis. In 95% of CML patients, the BCR-ABL1 fusion gene will be evident as Ph, sometimes as part of complex translocations involving additional chromosomes. These complex translocations do not seem to affect the outcome of patients on TKI therapy, and they must not be confused with clonal cytogenetic abnormalities in Ph⁺ cells (CCA/Ph⁺, also referred to as clonal cytogenetic evolution).¹⁵⁷ As a rule, a minimum of 20 metaphase spreads is analyzed. Rare patients have a silent Ph that is not identified by karyotyping; in these patients, molecular testing is required to establish the diagnosis of CML. Another

important piece of information from karyotyping is CCA/Ph⁺, because these patients have inferior progression-free and overall survival on TKI therapy, even in the absence of other features suggestive of AP.¹⁵⁷

Fluorescence In Situ Hybridization

Fluorescence in situ hybridization (FISH) uses fluorescent DNA probes to label BCR and ABL1 genetic regions adjacent to the translocation breakpoints, typically red fluorescence to label ABL1 and green fluorescence to label BCR (Fig. 81.5). Most FISH systems identify both BCR-ABL1 (on Ph) and ABL1-BCR fusion signals (on the derivative chromosome 9), and have low false-positive and -negative rates.¹⁶⁶ FISH is usually performed on interphase nuclei. Advantages of FISH compared to conventional karyotyping include higher sensitivity (200 to 500 nuclei are routinely analyzed) and the fact that no metaphases are needed, which is important in view of the 5% to 20% failure rate of metaphase karyotyping. In cases of silent Ph, FISH is an excellent tool to establish the diagnosis of CML. On the other hand, FISH does not detect CCA/Ph⁺. Modern FISH probes identify deletions in ABL1 adjacent to the translocation breakpoint. These deletions (and similar deletions in BCR) confer an adverse prognosis to patients treated with IFN and second-line imatinib, but their negative impact is overcome by frontline TKI therapy.^{167, 168} and ¹⁶⁹ All in all, FISH at diagnosis does not add actionable information for patients with Ph by standard karyotyping and its routine use in addition to conventional karyotyping is not justified.

Reverse Transcription Polymerase Chain Reaction

The main use of qualitative PCR is to identify a BCR-ABL1 fusion mRNA in patients with suspected CML who are Ph⁻ by metaphase karyotyping. As such, this technique provides the same information as FISH. If qualitative RT-PCR is used to ascertain the presence of a BCR-ABL1 translocation, it is important to make sure that the assay detects all types of BCR-ABL1 transcripts, including rare atypical transcripts.¹⁷⁰ Quantitative PCR (qPCR) assays will detect most types of BCR-ABL1 mRNA transcripts, but depending on test design will miss e1a2 and atypical transcripts. Thus, qPCR is not indicated to establish the diagnosis of CML, although it is used routinely to monitor patients on therapy. A detailed

P.1712

discussion of qPCR for BCR-ABL1 is provided in the section “Monitoring Response.”

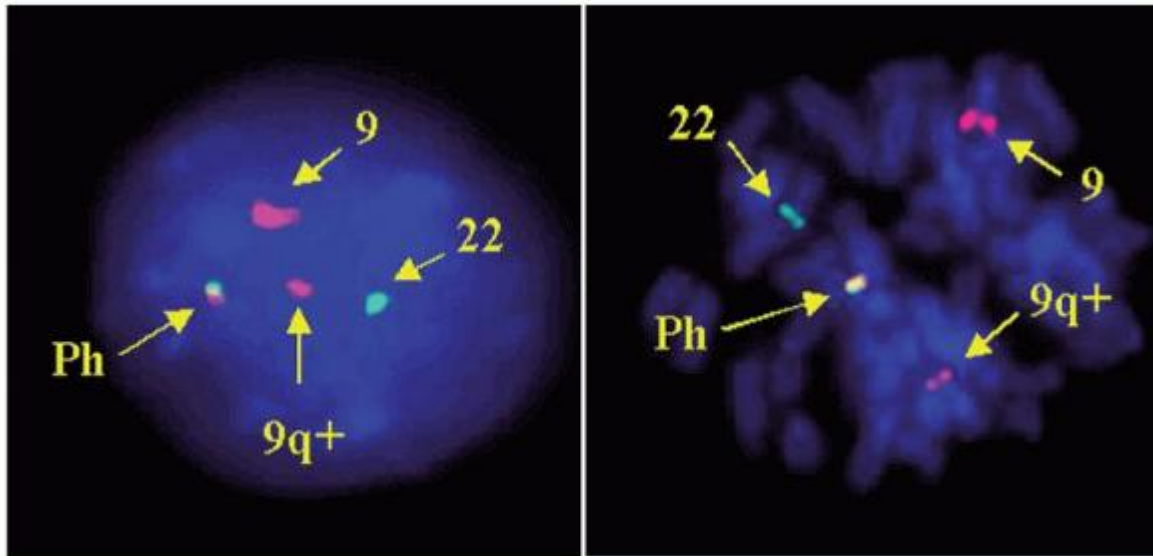

FIGURE 81.5. Fluorescence in situ hybridization (FISH). The left panel shows an interphase nucleus, the right panel a metaphase. FISH was done with the LSI BCR/ABL ES probe (Vysis, Downer's Grove, IL, US) that detects the BCR-ABL1 fusion (yellow) as well as signal on the derivative chromosomes 9 (red) and 22 (green). Courtesy of Christel Mueller, Department of Hematology, University of Leipzig, Germany.

Differential Diagnosis

MPNs such as atypical CML, chronic myelomonocytic leukemia (CMML), chronic neutrophilic leukemia, MPN associated with rearrangements within the platelet-derived growth factor receptors (PDGFRs) or fibroblast growth factor receptor 3 (FGFR3) can be indistinguishable from CML on morphologic and clinical grounds alone. Conversely, some CML patients

present with a disease that resembles essential thrombocythemia (ET) or primary myelofibrosis.¹⁵² Given the profound therapeutic implications, it is mandatory to ascertain the presence or absence of BCR-ABL1 in every patient with MPN. Once Ph or BCR-ABL1 has been demonstrated, the diagnosis is CML, irrespective of the particular MPN morphology. Tests such as the leukocyte alkaline phosphatase (LAP) score (low in CML, high in leukemoid reactions) or vitamin B12 levels (high in CML) have been superseded by molecular tests and are of historical interest only. CML may present in lymphoid or myeloid BP and these cases can be extremely difficult to distinguish from de novo Ph⁺ ALL or Ph⁺ AML, a rare and sometimes disputed entity. Residual left-shifted but maturing granulocytic precursors, basophilia, and splenomegaly point to a prior CML-CP. A BCR breakpoint in the m-BCR with e1a2 BCR-ABL1 transcript establishes a diagnosis of Ph⁺ ALL for all practical purposes.

MONITORING RESPONSE TO THERAPY

Once treatment is initiated, response is measured by clinical, hematologic, cytogenetic, and eventually molecular parameters. These different levels of response reflect the decrease of leukemia burden (Fig. 81.6).

Complete Hematologic Response

Complete hematologic response (CHR) requires the normalization of white blood cell and platelet counts as well as the white blood cell differential. Normalization of hemoglobin is not part of the CHR definition. Additionally, all CML-related clinical symptoms must have resolved and the spleen should not be palpable. The latter requirement is stringent and precise; however, bulky splenomegaly is often slow to resolve and the significance of persistent minimal splenomegaly in patients who meet all other CHR criteria is unknown. The term “major hematologic response” is sometimes used to describe response in patients with AP/BP who clear blasts from the blood and have less than 5% of blasts in the bone marrow without reconstitution of peripheral blood counts.

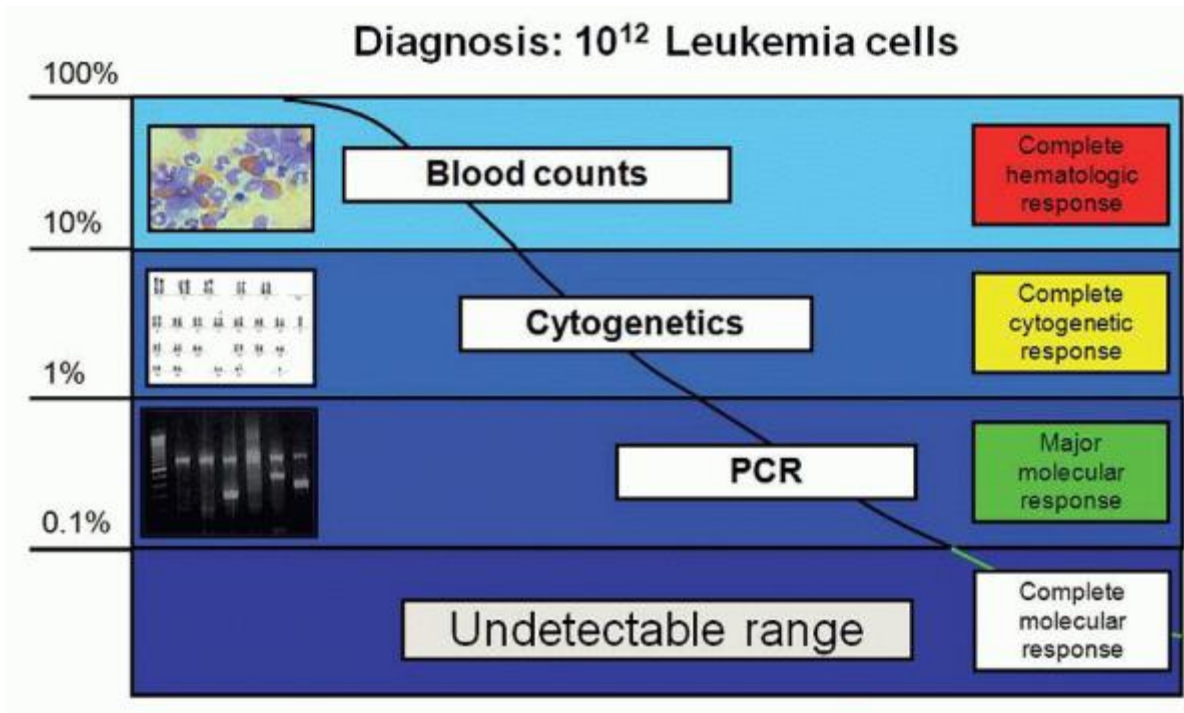

FIGURE 81.6. Reduction of leukemia burden with increasing depth of response. Estimates are that at least 10¹² chronic myeloid leukemia (CML) cells may be present at diagnosis. Complete hematologic response (CHR) is the first therapeutic objective. A complete cytogenetic response (CCyR) is equivalent to approximately 2-log reduction of disease burden and a major molecular response (MMR) to 3-log reduction, compared with a standardized baseline (not to the individual patient's initial disease burden). Further decreases can lead to a state where even the most sensitive tests fail to detect residual leukemia, which is commonly referred to as a complete molecular response (CMR). PCR, polymerase chain reaction

Cytogenetic Response

At least 20 metaphases must be karyotyped to assess cytogenetic response. A partial cytogenetic response (PCyR) is present if 35% or less of these metaphases are Ph⁺, and a CCyR if all are Ph⁻. The 35% definition of PCyR reflects the lower

bound of the 95% confidence interval around 50% Ph⁺ metaphases based on analysis of 20 metaphases. CCyR and PCyR combined are referred to as major cytogenetic response (MCyR). Some studies also report minor (36% to 65% Ph⁺) and minimal (66% to 95% Ph⁺) cytogenetic response, but these response levels have limited clinical significance. Given the efficacy of TKI therapy and the availability of quantitative RT-PCR (qPCR), CCyR may become the only cytogenetic response level used in the future.

Molecular Response

qPCR is widely used for monitoring of patients on TKI therapy or after allogeneic stem cell transplantation. The use of numerous technologies has created a confusing landscape, which has led to efforts aimed at establishing minimal requirements for test performance. Unfortunately, harmonization of BCR-ABL1 testing in the United States is lagging behind other developed countries.¹⁷¹ An exhaustive discussion of qPCR monitoring is beyond the scope of this chapter and the reader is referred to comprehensive reviews of the subject,¹⁷² but a few critical points deserve to be mentioned here. (i) Compared with metaphase karyotyping and FISH, qPCR has a vastly greater dynamic range, which may span up to 5 logs. However, this sensitivity is reached only if the sample is of optimal quality. Thus, reliable laboratories report the sensitivity reached for a given sample to enable correct interpretation of results. (ii) Not all housekeeping genes are equally suitable as control genes for normalization of RNA input; acceptable choices include ABL1, BCR, GUS, and G6PD.¹⁷² β -actin is not suitable due to high-level expression that may conceal degradation of the sample. (iii) In clinical practice it is often necessary to decide whether a rise of BCR-ABL1 mRNA is significant and should trigger a more extensive work-up. The most important factor is the quality of the test, which determines the extent of intertest variation and, as such, the optimal compromise between sensitivity

P.1713

and specificity.¹⁷³ Current recommendation is that a fivefold rise in transcript level be regarded as significant.¹⁷² In excellent laboratories this may decrease to twofold,¹⁷⁴ whereas in poor laboratories even tenfold rises may not be dependable. For the clinician, it is important to know the performance of the laboratory to ascertain correct interpretation of test results. (iv) qPCR is more reproducible at high levels of BCR-ABL1 than at low levels. Thus, it is good clinical practice to repeat the test in the case of rising BCR-ABL1 mRNA levels before rushing to far-reaching conclusions, particularly if the changes occur at a low level. (v) A major breakthrough was the introduction of the international scale (IS), which allows for the expression of values from different laboratories and different assays on a uniform scale. To express their individual values on the IS, laboratories obtain a series of standards to calculate a lab-specific conversion factor.^{175, 176} and ¹⁷⁷ Key anchoring points of the IS are: (1) 100%, which is equivalent to the average BCR-ABL1 mRNA expression of a cohort of patients treated on the International Randomized Study of Interferon and STI571 (IRIS) study¹⁷⁸ and (2) a level of 0.1% IS, corresponding to a 3-log reduction compared with this baseline and referred to as a major molecular response (MMR). Achievement of MMR on TKI therapy is an important milestone that portends a good prognosis. Further reductions of BCR-ABL1 mRNA by 4 or 4.5 logs are referred to as MR⁴ or MR^{4.5}, respectively. It is extremely important to be aware that the fold reductions of BCR-ABL1 expressed on IS refer to a standardized baseline, not to the patient's individual baseline, thus representing an absolute measurement of leukemia burden. Residual leukemia levels will be underestimated if the patient-specific baseline is used in patients with high levels of BCR-ABL1 mRNA at diagnosis. Inasmuch as this correlates with more advanced disease, this is exactly the group of patients where overestimating response may have dire consequences.¹³¹ Equally important, IS values are directly comparable between different laboratories, enabling continuity. (vi) A complete molecular response (CMR) is present if BCR-ABL1 mRNA is undetectable by qPCR. However, in contrast to MMR, which is an absolute value due to its anchoring to a standardized baseline, a universal definition of CMR is impossible, as it depends on the sensitivity of the assay, which may increase with advances of technology.

Regrettably, major commercial laboratories in the United States have been slow to adopt the IS. Results from these laboratories are not interpretable with respect to the key clinical trials that define current practice standards. In fact, results expressed on some obscure percentage scale can be mistaken for IS results, potentially giving the patient false reassurance about her or his response to TKIs.

BCR-ABL1 Mutation Testing

BCR-ABL1 mutations are an important mechanism of TKI resistance. The current recommendation is to test for mutations in patients with evidence of resistance. The National Comprehensive Cancer Network (NCCN) guidelines and European Leukemia Net (ELN) recommendations advocate for mutation analysis at baseline in patients with AP/BP, but in the absence of prospective studies that modified therapy based on these results, it seems hard to justify this practice.¹⁷⁹

Similarly, the benefit of mutation surveillance in high-risk patients remains to be determined prospectively. Direct sequencing of BCR-ABL1 amplicons identifies mutant alleles with a sensitivity of 20% to 30% and is currently recommended as the technology of choice.¹⁷² In contrast, detection of BCR-ABL1 kinase domain mutations by very sensitive assays such as allele-specific PCR does not predict failure and is not useful clinically.¹⁸⁰ The optimum may be in the middle: techniques such as high performance liquid chromatography and Sequenom MassARRAY® may have the right sensitivity to avoid too many false-positive results.^{181,182} However, it will still be necessary to evaluate these approaches in prospective interventional studies.

THERAPY

Cytotoxic Agents and Interferon- α

Busulfan, an alkylating agent with considerable hematopoietic stem cell toxicity, was the first drug that effectively controlled white blood cell and platelet counts, but is rarely used today except as part of conditioning regimens in allogeneic stem cell transplantation.¹⁶ Chronic busulfan exposure is associated with pulmonary fibrosis, and proper dosing can be challenging due to prolonged cytopenias. Hydroxyurea, a ribonucleotide reductase inhibitor, is indicated as an effective method for lowering white blood cell counts until the diagnosis of CML is confirmed. Because, at conventional doses, hydroxyurea acts predominantly on the more mature progenitor cells, cytopenias are usually short-lived and therapy is easily adjusted based on CBCs. IFN was the first drug therapy that induced durable cytogenetic responses, albeit only in a small minority of patients and for reasons that remain incompletely understood. Combinations with cytarabine, which has single agent activity in CML, were the standard of care in the 1990s.^{183,184}

Tyrosine Kinase Inhibitors

TKIs are the standard of care for newly diagnosed CML patients in all disease phases. The three approved TKIs—imatinib, dasatinib, and nilotinib—are made distinct by their potency, activity against BCR-ABL1 mutants (discussed in detail below), spectrum of activity against kinases other than BCR-ABL1, and side effect profiles (Table 81.2). Today's treatment algorithms are based on the results of a series of clinical trials, starting with a phase 1 imatinib study initiated in 1998 (Table 81.3).

Imatinib

A phase 1 trial of imatinib in CML patients who had failed conventional therapy demonstrated activity in all disease phases. It is important to note that cytogenetic responses were seen, particularly in CML-CP.^{23,24} No maximum tolerated dose was identified. Based on the cytogenetic responses, an initial dose of 400 mg daily was selected for phase 2 studies in CP, AP, and BP. These trials confirmed or exceeded the phase 1 results and led to approval of imatinib for patients who had failed prior IFN due to resistance or intolerance.^{185,186, 187} and ¹⁸⁸ CML-CP responses were mostly durable, but there was a high failure rate in advanced CML, which led to an increase of the starting dose to 600 mg imatinib daily. Approval for frontline use in newly diagnosed patients followed in 2003 based on the results of the IRIS study, which compared imatinib 400 mg daily versus a combination of IFN and cytarabine. This trial showed imatinib to be vastly superior in all major endpoints, but most importantly in progression-free survival.¹⁸⁹ Crossover was permitted for resistance or intolerance and occurred almost exclusively in patients failing IFN. The fact that many of these patients were effectively salvaged by imatinib may explain why no difference in overall survival between the two experimental arms was observed.¹⁹⁰ Subsequent phase 3 studies of imatinib in newly diagnosed CML-CP patients mainly addressed the question of the optimal dose and the role of combinations with IFN and cytarabine. Single-arm studies in comparison with historical controls had suggested higher rates of CCyR and MMR for 800 mg imatinib daily, commonly referred to as high-dose imatinib.^{191,192} However, this was not confirmed in two prospective randomized studies. The Tyrosine Kinase Inhibitor Optimization and Selectivity Study (TOPS) trial compared 400 versus 800 mg imatinib daily in newly diagnosed patients irrespective of Sokal risk, and an Italian study compared the identical doses in high Sokal risk patients. Both studies failed in their primary endpoint, improved MMR or CCyR at 12 months at the higher dose.^{193,194} Recently, the German CML IV study reported superior rates of MMR at 12 months for

P.1714

800 mg imatinib daily (59% vs. 44%, $P < 0.001$).¹⁹⁵ Interestingly, in this study, imatinib dosing was more flexible and was maximized based on the individual patient's tolerability, resulting in a median dose of 627 mg imatinib daily. Similarly, the French SPIRIT study reported higher MMR rates at 12 months (49% vs. 38%) for patients treated with 600 versus 400 mg imatinib daily.¹⁹⁶ Thus, the optimal dose of imatinib may be approximately 600 mg daily, equal to the recommended dose for AP/BC.

TABLE 81.2 TYROSINE KINASE INHIBITORS APPROVED FOR THE TREATMENT OF CHRONIC MYELOID LEUKEMIA

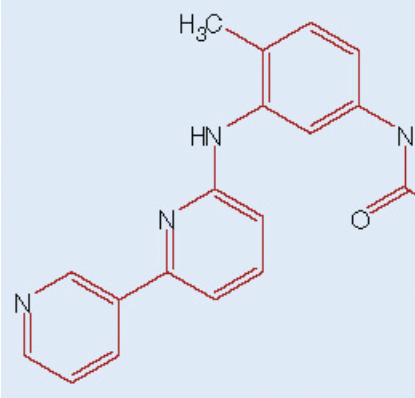
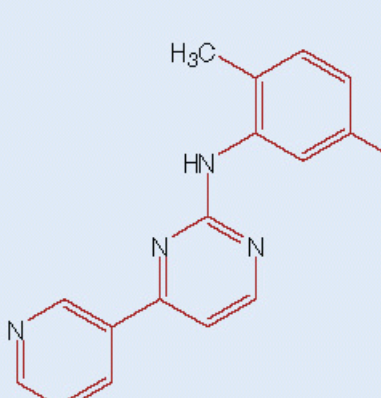
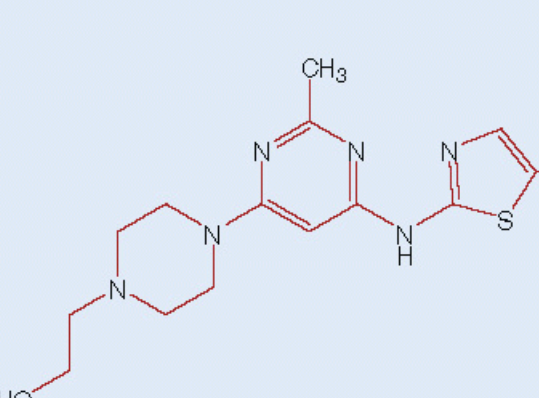
Inhibitor	Imatinib	Nilotinib	Dasatinib
			
Binding mode	Inactive conformation (type II)	Inactive conformation (type II)	Active conformation (type I)
IC₅₀ native BCR-ABL-expressing cells (nM)	260	13	0.8
IC₅₀ ABL substrate phosphorylation (nM)	280	15	0.6
Additonal targets	KIT, PDGFRA/B, CSF1R, LCKKIT, PDGFRA/B		SRC family and multiple other kinases
Dose	400 mg once daily (CML-CP) 600 mg once daily (CML-AP, CML-BP)	300 mg twice daily (CML-CP, newly diagnosed) 400 mg twice daily (CML-CP, CML-BP resistant to imatinib)	140 mg once daily (CML-AP, CML-BP resistant to imatinib)
Adverse events in newly diagnosed patients irrespective	Fluid retention 62 (3) - Superficial edema 60 (2) - Other fluid retention reactions 7 (1) Nausea 50 (1) Muscle cramps 49 (2)	Rash 33 (2) Pruritus 29 (1) Nausea 31 (1) Diarrhea 22 (3) Constipation 21 (<1) Vomiting 21 (<1)	Fluid retention 23 (1) Pleural effusion 12 (<1) Superficial localized edema 10 (0) Generalized edema 3 (0) Congestions 2 (<1)

tive of relation to drug (only grades 3 and 4)	Musculoskeletal pain 47 (5)	Abdominal pain 11 (1)	Pericardial effusion 2 (<1)
	Diarrhea 45 (3)	Headache 31 (3)	Pulmonary hypertension 1 (0)
	Rash 40 (3)	Fatigue 28 (1)	Pulmonary edema <1(0)
	Fatigue 39 (2)	Pyrexia 14 (1)	Diarrhea 18 (<1)
	Headache 37 (<1)	Asthenia 14 (0)	Headache 12 (0)
	Joint pain 31 (3)	Edema, peripheral 11 (0)	Musculoskeletal pain 12 (0)
	Abdominal pain 37 (4)	Arthralgia 18 (2)	Rash 11 (0)
	Nasopharyngitis 31 (0)	Myalgia 14 (2)	Nausea 9 (0)
	Hemorrhage 29 (2)	Pain in extremity 13 (1)	Fatigue 8 (<1)
	- GI hemorrhage 2 (<1)	Bone pain 11 (<1)	Myalgia 6 (0)
	- CNS hemorrhage 0.2 (0)	Muscle spasms 11 (<1)	Hemorrhage 6 (1)
	Myalgia 24 (2)	Back pain 10 (<1)	GI bleeding 2 (1)
	Vomiting 23(2)	Cough 17 (<1)	Other bleeding 5 (0)
	Dyspepsia 19 (0)	Dyspnea 11 (1)	Vomiting 5 (0)
	Cough 20 (<1)	Nasopharyngitis 16 (<1)	Muscle inflammation 4 (0)
	Pharyngolaryngeal pain 18 (<1)		
	Upper respiratory tract infection 21 (<1)		
	Dizziness 19 (<1)		
	Pyrexia 18 (<1)		
	Weight gain 16 (2)		
	Insomnia 15 (0)		
	Depression 15 (<1)		
	Influenza 14 (<1)		
	Bone pain 11 (2)		
	Constipation 11 (<1)		

CML, chronic myeloid leukemia; CML-AP, CML-accelerated phase; CML-BP; CML-blastic phase; CML-CP, CML-chronic phase; CNS, central nervous system; GI, gastrointestinal; PDGFR, platelet-derived growth factor receptors.

Dasatinib

An initial phase I study on CML patients in all disease phases who had failed imatinib due to resistance or intolerance revealed considerable activity upon treatment with dasatinib.¹⁹⁷ This study was followed by a series of phase 2 trials that tested dasatinib in larger cohorts of patients in the different disease phases, and two dose optimization studies that tested 100 versus 140 mg daily administered as a single dose or in two separate doses.^{198, 199} and ^{200,201,202} From these studies, 100 mg dasatinib once daily for CML-CP, and 140 mg once daily for AP and BP, emerged as the recommended doses. Dasatinib was subsequently compared with imatinib 400 mg in a phase 3 study (DASatinib versus Imatinib Study In treatment-Naive CML patients, DASISION) in newly diagnosed CML-CP patients and proved superior in the primary endpoint, CCyR at 12 months, as well as several secondary endpoints, including MMR at 12 months.²⁰² Progression events were reduced, but the difference did not reach statistical significance, and no difference in overall survival was observed. Based

P.1715

on the DASISION trial, dasatinib was approved for use in newly diagnosed CML patients.

TABLE 81.3 TREATMENT RESULTS

Trial	N	Treatment mg/d	CCyR	MMR	CMR	PFS	OS
<i>IRIS</i> (18 mo)	553	IM 400	74% (estimated at 18 mo)	57%	NR	96.6% (12 mo) 92.1% (18 mo)	97.2% (18 mo)
<i>IRIS</i> (60 mo)	553	IM 400	87% (estimated at 60) mo)			83% EFS (60 mo)	89%
<i>TOPS</i> (12 mo)	157	IM 400	66% ^a	46% ^o		95% (18 mo)(P = 0.63)	
	319	IM 800	70% ^a	54% ^o		97.4% (18 mo)(P = 0.63)	
<i>ENESTnd</i> (24 mo)	282	NIL 600	63%	51%	16% ^b	98.0%	97.4%
	281	NIL 800	56%	44%	16% ^b	97.7%	97.8%
	283	IM 400	46%	25%	4% ^b	95.2%	96.3%
<i>DASISION</i> (24 mo)	260	IM 400	74%	46%		92.1%	95.2%
	259	DAS 100	80%	64%		93.7%	95.3%
<i>SPIRIT</i> (12 mo)	159	IM 400	58%	43%	9%		
	160	IM 600	65%	53%	8%		
	158	IM 400 + ARAC	70%	54%	8%		
	159	IM 400 + IFN	66%	64%	16%		
<i>CML IV</i> (24 mo)	306	IM 400	74%	63%	31%	94% (36 mo)	95% (36 mo)
	328	IM 800	82%	76%	43%	94% (36 mo)	95% (36 mo)
	336	IM 400 + IFN	77%	63%	30 %	94% (36 mo)	95% (36 mo)

CCyR, complete cytogenetic response; CMR, complete molecular remission OR undetectable residual disease; IFN, interferon; MMR, major molecular response; OS, overall survival; PFS, progression-free survival.

^a Cumulative incidence of CCyR by timepoint, 12 months. MMR in evaluable patients at timepoint, 12 months.

^b CMR at any time (ITT).

Nilotinib

An initial phase 1 study tested nilotinib in a cohort of CML and Ph⁺ ALL patients who had failed imatinib due to resistance or intolerance. Considerable activity was seen in CP and AP, although results in BP were less impressive.²⁰³ Subsequent phase 2 studies led to approval of nilotinib 400 mg twice daily for patients with CML-CP and CML-AP who had failed prior imatinib therapy.^{204,205} The recently published results of CML-BP are comparable to those of dasatinib, but nilotinib is not currently approved for this indication.²⁰⁶ Nilotinib (300 or 400 mg twice daily) was then compared to imatinib in the Evaluating Nilotinib Efficacy and Safety in Clinical Trials-Newly Diagnosed (ENESTnd) study, with MMR at 12 months as the major endpoint.²⁰⁷ This study showed both experimental arms superior to the standard arm. Note that progression-free survival was improved with nilotinib. The results of the ENESTnd study led to approval of nilotinib (300 mg twice daily) for frontline therapy in newly diagnosed patients with CML-CP.

Drug Combinations

Imatinib has been tested in combination with multiple cytotoxic agents and signal transduction inhibitors, mostly in the setting of resistance. In the frontline setting, data are limited to combinations with cytarabine and IFN. In the SPIRIT study, 400 mg imatinib daily was compared with 600 mg daily as well as 400 mg daily combined with pegylated IFN or cytarabine, with MMR at 12 months as the major endpoint.¹⁹⁶ Patients in the IFN/imatinib arm had significantly higher rates of MMR than all other arms of the study (57% vs. 38% at 12 months for the comparison with imatinib 400 mg daily). These data were confirmed by a smaller Scandinavian study.²⁰⁸ Thus far, no differences in overall and progression-free survival were seen, and IFN/imatinib combinations should be considered experimental.

APPROACH TO THE NEWLY DIAGNOSED CHRONIC-PHASE PATIENT

Selection of Frontline Tyrosine Kinase Inhibitor

Once staging and risk assessment are complete, the question is how to choose among the three approved TKIs. Selection is influenced by several considerations, not all of which are strictly medical. As of 2012, there is no significant difference in overall survival between patients treated with imatinib versus dasatinib or nilotinib. However, key molecular endpoints such as MMR and CMR are achieved faster with the two newer TKIs. It seems likely that with more follow-up a relatively small but significant advantage in overall survival will become apparent. This gain must be balanced against the long and very impressive safety record of imatinib.¹²⁵ The risk/benefit assessment would change dramatically in favor of the dasatinib or nilotinib if there were a substantial increase in the numbers of patients who can discontinue therapy altogether, an outcome as much desirable as uncertain. An important factor to consider is the risk score. Although molecular responses with dasatinib or nilotinib are superior across all risk categories, progression to AP/BP is very rare in low-risk patients treated with imatinib. Conversely, high-risk patients may benefit disproportionately from dasatinib or nilotinib. Lastly, the patient's past medical history is critical for TKI selection. Diabetes, pancreatitis, and QT prolongation are contraindications for nilotinib,²⁰³ and a history of pleural effusions, heart failure, or gastrointestinal bleeding argues against dasatinib.¹⁹⁷ Peripheral edema is frequently aggravated by imatinib.²⁰⁹ However, in many cases, there are no firm contraindications against any one of the three TKIs, and it can be a matter of trial and error to identify the drug with the optimal tolerability in a given patient. In some patients, compatibility with lifestyle may favor once-daily dosing to optimize regimen adherence. Lastly, medication cost will play an increasing role. Dasatinib and nilotinib are more expensive than imatinib, and this difference will probably increase dramatically when generic imatinib preparations become available (expected in 2015).

P.1716

Optimizing drug therapy for newly diagnosed patients in a general way will require a CML management strategy rather than a single drug approach. Important questions will have to be answered in well-designed prospective studies. For example, can second-generation TKIs be used as an induction therapy, followed in good responders by low-cost maintenance imatinib? Or could patients be started on imatinib and switch to a second-generation TKI if an early response assessment reveals an unsatisfactory response?

Monitoring Patients on Therapy

Regardless of the TKI selected for initial therapy, weekly CBCs are indicated until blood counts are stable, at which point intervals are extended. Cytopenias are common during the initial phase of treatment and may require dose interruption and/or reduction. In most cases cytopenias are transient, reflecting therapeutic effects on leukemic hematopoiesis, when residual normal hematopoiesis is still suppressed. Algorithms have been proposed to optimize dose intensity, while avoiding prolonged myelosuppression.²¹⁰ In addition, complete metabolic profiles (including lipase in the case of nilotinib) must be done periodically to monitor for liver and pancreatic toxicity as well as electrolyte imbalances. Repeat bone marrow biopsies are indicated until CCyR is achieved, typically at 3, 6, and 12 months. qPCR is the monitoring strategy of

choice for patients who attained CCyR. The current recommendation is to perform qPCR every three months. Once stable MMR or even CMR has been achieved, these intervals can be extended to 6 months.¹⁵⁶ Although no exact data are available, it is likely that many rises of BCR-ABL1 levels in patients with well-controlled CML reflect non-adherence. FISH for BCR-ABL1 on peripheral blood interphases should be used only if there is no access to reliable qPCR. An expert panel convened by the ELN has recommended milestones of response on TKI therapy, which have been widely accepted internationally, although minor differences remain compared to the NCCN guidelines.¹⁸⁶ The ELN milestones are defined timepoints in which responses are classified as optimal, suboptimal, and failure (Table 81.4). In addition, there are so-called warning signs that may trigger clinical actions such as an increased density of surveillance. In their latest version, the ELN recommendations for newly diagnosed CML-CP patients were still based on imatinib as frontline therapy; with the approval of dasatinib and nilotinib, and the maturation of the ENESTnd and DASISION studies, they will need to be adjusted.

TABLE 81.4 EVALUATION OF OVERALL RESPONSE TO IMATINIB FRONTLINE IN EARLY CHRONIC PHASE

Evaluation Time, Months	Response			Warnings
	Optimal	Suboptimal	Failure	
Baseline	NA	NA	NA	High risk; CCA/Ph ⁺ ^a
3	CHR and at least minor CgR (Ph ⁺ ≤ 65%)	No CgR (Ph ⁺ > 95%)	Less than CHR	NA
6	At least PCgR (Ph ⁺ ≤ 35%)	Less than PCgR (Ph ⁺ > 35%)	No CgR (Ph ⁺ > 95%)	NA
12	CCgR	PCgR (Ph ⁺ 1-35%)	Less than PCgR (Ph ⁺ > 35%)	Less than MMR ^b
18	MMR ^b	Less than MMR ^b	Less than CCgR	NA
Any time during treatment	Stable or improving MMR ^b	Loss of MMR ^b ; mutations ^c	Loss of CHR; loss of CCgR; mutations ^d ; CCA/Ph ⁺	Increase in <i>BCR-ABL1</i> transcript level; CCA/Ph ⁺

CCA, clonal chromosome abnormalities; CCgR, complete cytogenetic response; CgR, cytogenetic response; CHR, complete hematologic response; MMR, major molecular response; NA, not applicable; PCgR, partial cytogenetic response; Ph⁺, Philadelphia chromosome positive; Ph⁻, Philadelphia chromosome negative.

^a CCA/Ph⁺ is a warning factor at diagnosis, although its occurrence during treatment (i.e., clonal progression) is a marker of treatment failure. Two consecutive cytogenetic tests are required and must show the same CCA in at least two Ph⁺ cells.

^b MMR indicates a ratio of *BCR-ABL1* to *ABL1* or other housekeeping genes of ≤ 0.1% on the international scale.

^c BCR-ABL1 kinase domain mutations still sensitive to imatinib.

^d BCR-ABL1 kinase domain mutations poorly sensitive to imatinib.

^e The significance of the increase may vary by a factor of 2 to 10, depending on the laboratories.

Adapted from Baccarani M, Cortes J, Pane F, et al. Chronic myeloid leukemia: an update of concepts

and management recommendations of European LeukemiaNet. *J Clin Oncol* 2009;27:6041-6051.

APPROACH TO THE PATIENT PRESENTING IN ACCELERATED PHASE/BLASTIC PHASE

As presentation of CML in AP or BP is uncommon in the developed world, there are limited data for this group of patients. However, second-generation TKIs are preferred over imatinib. In the salvage setting, dasatinib has shown slightly higher response rates and more durable responses in CML-AP and is currently the only second-generation TKI approved for CML-BP. In the case of blastic transformation, dasatinib is usually combined with AML- or ALL-type multiagent chemotherapy, although this is not typically the case for AP.¹⁵⁴ All patients with AP/BP should be considered for an allogeneic stem cell transplant, with TKI therapy used to restore a second chronic phase and bridge the time to transplant. Therefore, HLA typing and a transplant consultation are essential parts of the initial work-up for patients who present in AP/BP. Whether to proceed to allografting in an AP/BP patient who attained a very good response to TKI can pose an extremely challenging clinical decision and it is wise to discuss this eventuality prior to starting TKI therapy. Transplant risk, co-morbidities, and the patient's personal preferences are critical factors.

RESISTANCE TO TYROSINE KINASE INHIBITORS

TKI resistance is grouped into primary and secondary (acquired) resistance. At a mechanistic level, resistance can be classified as BCR-ABL1-dependent or BCR-ABL1-independent. In

P.1717

BCR-ABL1-dependent resistance, there is reactivation of BCR-ABL1 kinase, which implies that responses may be recaptured if BCR-ABL1 inhibition is restored. In BCR-ABL1-independent resistance, alternative growth and survival pathways substitute for BCR-ABL1 kinase activity.²¹¹

BCR-ABL1 Kinase Domain Mutations

The best characterized mechanism of TKI resistance is point mutations in the BCR-ABL1 kinase domain that impair drug binding.²¹² Solving the crystal structure of ABL1 in complex with an imatinib analog was instrumental to understanding how kinase domain mutations cause resistance.²¹³ In contrast to expectations, imatinib was found to bind an inactive conformation of ABL1, with the activation loop of the kinase in a closed position. Additionally, there was extensive downward displacement of the ATP binding loop. Mutations in the kinase domain can cause resistance by steric hindrance or elimination of hydrogen bonds, most impressive in the T315I mutation at the gatekeeper position. A different type of mutation affects the ATP binding loop, preventing the rearrangements required for optimal drug binding. Examples include Q252H, Y253(H/F), and E255(K/V). Lastly, mutations in the activation loop such as H396P stabilize an open conformation, to which imatinib cannot bind.²¹⁴ Although imatinib is vulnerable to a broad range of mutations, the spectrum is much more limited for nilotinib and dasatinib, reflecting their greater potency and, in the case of dasatinib, less stringent binding requirements.²¹⁵ Clinical resistance mutations are precisely predicted by *in vitro* assays, which enable the development of pre-emptive strategies to overcome this type of resistance.^{216,217,218} Biochemical and cell proliferation data have been used to rank kinase domain mutations according to the degree of TKI resistance they confer (Table 81.5).²¹⁹ Although these data are based on *in vitro* studies, they tend to correlate with clinical responses.^{220,221} However, correlations are not as tight as one might suspect, suggesting that additional mechanisms govern clinical resistance. The exception to this rule is the T315I mutation that confers complete resistance to all approved TKIs, both *in vitro* and *in vivo*. For several other mutants, the difference in sensitivity is sufficient to support the use of dasatinib over nilotinib or vice versa (Table 81.5). An in-depth discussion of the many reported mutations and their sensitivity profiles is beyond the scope of this chapter and the reader is referred to detailed reviews of this subject.^{219,222}

Activation of Alternative Signaling Pathways

In contrast to kinase domain mutations, BCR-ABL1 kinase-independent resistance is less well understood and seems to involve multiple different mechanisms. For example, activation of SRC family kinases, MAP kinase, STAT5, SYK, and PI3K have all been associated with TKI resistance despite sustained inhibition of BCR-ABL1.^{223,224,225, 226} and ²²⁷ Extrinsic factors such as cytokines may also play a role.^{228,229} Targeting these diverse pathways is therapeutically challenging.

APPROACH TO THE PATIENT WITH TYROSINE KINASE INHIBITOR RESISTANCE

Failure to achieve therapeutic milestones or a loss of response from a given level suggests TKI resistance, and should trigger a careful evaluation. The first call of order is to assess medication adherence through a thorough history. Drug level testing, widely available only for imatinib, is not useful, as patients have been found to make up for skipped doses during the last few days prior to the office visit.²³⁰ Moreover, drug interactions should be considered, especially in patients on

multiple co-medications. It is particularly important to include herbal preparations and other over-the-counter remedies, for example, St. John's Wort, which can drastically lower imatinib plasma concentrations.²³¹ A realistic view, however, is that drug interactions are almost impossible to predict in patients on polypharmacotherapy, and the situation is even more complicated in cases of impaired renal or hepatic function. If nonadherence or drug interactions seem unlikely, a complete resistance work-up that includes a physical exam, CBC, bone marrow aspirate and biopsy, bone marrow metaphase karyotyping, and BCR-ABL1 mutation analysis is indicated. TKI resistance defines a high-risk situation and should be approached as a diagnosis with significant clinical implications. Key pieces of information derived from this work-up are disease phase, BCR-ABL1 mutation status, and karyotype, including CCA/Ph⁺.

TABLE 81.5 SENSITIVITY OF BCR-ABL1 KINASE DOMAIN MUTANTS TO ABL KINASE INHIBITORS**Ba/F3 Cellular Proliferation IC₅₀ Values**

	Imatinib (nM)	Nilotinib (nM)	Dasatinib (nM)	
Native	Bcr-Abl		260	130.8
M244V	2,000		38	1.3
G250E	1,350		48	1.8
Q252H	1,325		70	3.4
Y253F	3,475		125	1.4
Y253H	>6,400		450	1.3
E255K	5,200		200	5.6
E255V	>6,400		430	11
V299L	540 ^a		nd	18 ^a
F311L	480		23	1.3
T315A	971		61	125 ^a
T315I	>6,400		>2,000	>200
F317L	1,050		50	7.4
F317V	350 ^a		nd	53 ^a
M351T	880		15	1.1
E355G	2,300 ^b		nd	1.8 ^c
F359V	1,825		175	2.2
V379I	1,630		51	0.8
L387M	1,000		49	2
H396P	850		41	0.6
H396R	1,750		41	1.3
	Sensitive	Intermediate sensitivity	Insensitive	

Imatinib: sensitive ($\leq 1,000$ nM), intermediate ($\leq 3,000$ nM), insensitive ($> 3,000$ nM).

Nilotinib: sensitive (≤ 50 nM), intermediate (≤ 500 nM), insensitive (> 500 nM). Dasatinib: sensitive (≤ 3 nM), intermediate (≤ 60 nM), insensitive (> 60 nM).

^a IC₅₀ values from Burgess MR, Skaggs BJ, Shah NP, Lee FY, Sawyers CL. Comparative analysis of two clinically active BCR-ABL kinase inhibitors reveals the role of conformation-specific binding in resistance. Proc Natl Acad Sci U S A. 2005;102(9):3395-400.

^b IC₅₀ value from Shah NP, Nicoll JM, Nagar B, et al. Multiple BCR-ABL kinase domain mutations confer polyclonal resistance to the tyrosine kinase inhibitor imatinib (STI571) in chronic phase and blast crisis chronic myeloid leukemia. *Cancer Cell*. 2002;2(2):117-25.

^c IC₅₀ value estimated from Shah N, Tran C, Lee FY, et al. Overriding imatinib resistance with a novel ABL kinase inhibitor. *Science* 2004;305:399-401.

Adapted from O'Hare T, Eide CA, Deininger MW. Bcr-Abl kinase domain mutations, drug resistance, and the road to a cure for chronic myeloid leukemia. *Blood* 2007;110:2242-2249.

Patients with resistance to imatinib can be managed with a second-line TKI alone as long as they are in chronic phase and do not have the T315I mutation. The selection of dasatinib versus

P.1718

nilotinib is based on past medical history to avoid specific side effects and the type of BCR-ABL1 mutation (if present). It is good clinical practice to have the patient evaluated or re-evaluated by a transplant center. Analogous to newly diagnosed patients, patients on second-line TKIs must be assessed at regular intervals to determine whether their response meets expectations. One study showed that only 7% of patients who failed to achieve a minor cytogenetic response ($\leq 65\%$ Ph⁺ metaphases) at 3 months were in MCyR at 12 months, whereas MCyR at 12 months predicted progression-free and overall survival.²³² Patients who fail frontline or second-line dasatinib or nilotinib are at very high risk, even if still in CP, and have limited drug treatment options. Switching from nilotinib to dasatinib or vice versa is effective only in some patients, and responses are not generally durable.²³³ Thus, experimental agents and/or allogeneic stem cell transplant must be considered.

It is likely that this therapeutic space will soon become more nuanced with the advent of third-line TKIs, particularly ponatinib, a highly potent BCR-ABL1 TKI with activity against all reported single mutants, including T315I.²³⁴ Ponatinib showed considerable activity in a phase 1 study of patients with failure to respond to dasatinib and/or nilotinib or the T315I mutation, and a large phase 2 study (PACE trial) confirmed the results.^{235,236} Ponatinib is currently under consideration for regulatory approval and may replace dasatinib and nilotinib for second-line therapy. Patients who progress to AP/BP on imatinib are managed with the appropriate second-line TKI, and in the case of BP typically combined with chemotherapy. All eligible patients in this category should be offered an allogeneic stem cell transplant, with the second-line TKI used as a bridge.

DISCONTINUATION OF TYROSINE KINASE INHIBITOR THERAPY

Several studies have reported on patients who discontinued imatinib, typically after achieving CMR and maintaining it for 1 to 2 years.^{237,238} The recurrence rate of molecularly detectable leukemia in these patients was approximately 60%, and 40% maintained responses without TKI treatment, sometimes with intermittent low-level positivity by qPCR. It is interesting that almost all recurrences occurred within 6 months, consistent with two distinct patient populations. High Sokal risk at diagnosis and a shorter duration of therapy were associated with recurrence. Patients with recurrence universally responded to re-treatment, suggesting this approach is safe as long as patients are monitored closely. These results have raised hopes that imatinib may be curative in a subset of patients.²³⁹ Larger studies are underway, including patients with CMR on dasatinib or nilotinib. Although these data are clearly very encouraging, they do not at this point support a change of clinical practice. This is particularly important in the United States, where high-quality molecular monitoring is not widely offered. Individual decisions to discontinue therapy may be made in the case of unacceptable side effects and after careful consideration of all alternatives. Otherwise, discontinuation should be regarded as experimental and should only be considered within a clinical study.

ALLOGENEIC STEM CELL TRANSPLANTATION

Allogeneic hematopoietic stem cell transplantation was the first treatment modality that restored Ph⁻ hematopoiesis and induced durable responses.¹⁸ CML is more susceptible to immunotherapy in an allogeneic setting than most other hematologic cancers. Donor leukocyte infusions (DLIs) were first used in CML patients and demonstrated not only the effectiveness of this approach, but also substantiated the existence of a graft-versus-leukemia effect.²⁴⁰ Prior to the introduction of imatinib, allografting was recommended to all eligible patients, and even today it is still regarded as the only therapy with curative potential. Only one study prospectively compared allotransplant versus drug therapy. Newly diagnosed patients with CML-CP were biologically randomized to a matched sibling transplant versus IFN-based drug

therapy, the best nontransplant treatment available when the trial was initiated.²⁴¹ Patients managed with drug therapy had superior survival, with the biggest difference observed in low-risk patients. After approximately 8 years the survival curves crossed, suggesting that transplant would be superior in the long run if IFN were the alternative. However, given the efficacy of TKIs in the frontline setting, and that early transplant-related mortality is clearly higher than the risk of early disease progression, allotransplant is no longer justifiable in newly diagnosed patients with CML-CP, except in unusual circumstances.¹⁵⁶

Risk scores for allografting in CML were developed by the European Group for Blood and Marrow Transplantation (EBMT) in the pre-imatinib era and identified disease duration of >12 months, more advanced disease, higher age, unrelated donor type, and the combination of a male recipient with a female donor as adverse prognostic factors (Table 81.6).²⁴² Disease phase had the greatest impact on outcome. Although somewhat historical, the EBMT score is still useful for prognostication. There is consensus that allotransplant should be offered to all patients with progression to AP/BP. Good transplant risk patients who fail imatinib and all patients who fail dasatinib or nilotinib in chronic phase should also be considered, provided they are medically fit to undergo the procedure. Fortunately there is no evidence that imatinib or other TKIs prior to allografting negatively affect the outcome. On the contrary, for unknown reasons, imatinib prior to allotransplant seems to reduce the risk of chronic graft-versus-host disease and possibly relapse risk.^{243, 244} and ²⁴⁵ Recent results from the German CML study group re-assert the importance of transplanting patients while they are still in chronic phase: 3-year overall survival was 91% for patients transplanted in CP after failing imatinib versus 59% for patients transplanted in AP/BP.²⁴⁶ There is an emerging consensus that bone marrow is preferred over peripheral blood stem cells (PBSCs) in patients with CML-CP, where graft-versus-host disease is a greater concern than disease control.²⁴⁷ This assessment is different for patients with transformation to AP/BP, even if they have achieved a second chronic phase. High relapse risk patients should receive a TKI post-transplant; BCR-ABL1 mutation analysis at the time of resistance will help match the optimal TKI to individual patients. Given the high median age at the time of diagnosis, many patients will be eligible only for reduced intensity conditioning regimens. An in-depth discussion of the various conditioning regimens, selection of bone marrow versus PBSCs, and post-transplant immunosuppression is presented elsewhere.

TABLE 81.6 ALLO-HEMATOPOIETIC STEM CELL TRANSPLANTATION RISK FACTORS AND EUROPEAN GROUP FOR BLOOD AND MARROW TRANSPLANTATION RISK SCORE

Risk Factor	Score and Description
Disease phase	0 if CP; 1 if AP; 2 if BP
Age	0 if <20 y; 1 if 20-40 y; 2 if >40 y
Interval from diagnosis	0 if ≤ 1 y; 1 if >1 y
Donor type	0 if HLA-identical sibling; 1 in any other instance
Donor-recipient sex match	1 if female donor and male recipient; 0 for any other match

Note: The EBMT risk score was based on 3,142 patients treated with alloHSCT between 1989 and 1997, prior to the introduction of tyrosine kinase inhibitors. For low-risk patients (i.e., risk score of 0 to 2), the transplantation-related mortality was 31% in the original cohort; however, in a more recent cohort of patients who underwent transplantation between 2000 and 2003, transplantation-related mortality was reduced to 17%. For the patients with a risk score of 3 to 4, transplantation-related mortality was approximately 50%, and it was approximately 70% for the patients with a risk score of 5 to 6.⁹³

AP, accelerated phase; BP, blast phase; CP, chronic phase.

Adapted from Gratwohl A, Hermans J, Goldman JM, et al. Risk assessment for patients with chronic myeloid leukaemia before allogeneic blood or marrow transplantation. Chronic Leukemia Working Party of the European Group for Blood and Marrow Transplantation. *Lancet* 1998;352:1087-1092.

P.1719

Transformation to BP is rare in the age of TKIs, but the prognosis for patients crossing this threshold remains dismal. Understanding the mechanisms of resistance to advanced TKIs such as ponatinib will be critical for developing effective therapeutic strategies. Although ponatinib blocks all single BCR-ABL1 mutants, responses in BP are rarely maintained regardless of BCR-ABL1 mutational status. In vitro studies have shown that compound mutations, i.e., the presence of two point mutations in the same BCR-ABL1 molecule, can confer high-level ponatinib resistance and the same may occur in vivo.²³⁴ Patients without detectable kinase domain mutations apparently develop truly BCR-ABL1 kinase-independent leukemia. As with refractory AML, it seems that we are approaching a ceiling on what can be achieved by concentrating on the leukemia cells, and future research must take into account the protective effects of the microenvironment.

At the other end of the disease spectrum, the majority of patients responding to TKIs continue to harbor residual leukemia cells, evident either as low-level qPCR positivity or as recurrence in the case of TKI discontinuation, a state often referred to as disease persistence. Ex vivo studies on cells from patients in CMR have identified Ph⁺ cells both in progenitor and primitive long-term culture-initiating cells, and the frequency of leukemia stem cells in the CD34⁺CD38⁻ fraction was estimated at 0.59% ± 0.1% based on xenograft studies in immunodeficient mice.^{248,249} There is convincing evidence that persistent CML cells are not (or are not solely) dependent on BCR-ABL1 kinase activity for their survival.^{250,251} Several pathways have been implicated in mediating survival despite inhibition of BCR-ABL1 activity, including Wnt/β-catenin, PML, Hedgehog, Alox5, BCL6, and PP2A, among others.^{252,253,254,255,256,257,258,259} The microenvironment may play a key role in activating these pathways, providing a sanctuary to residual CML cells. Significant efforts are being directed toward identifying therapeutic targets to eradicate residual leukemia. The biggest challenge is that many potential targets have important roles in normal hematopoiesis or development in general, limiting the therapeutic windows of targeted therapies. On the other hand, some patients treated with imatinib maintain CMR or MMR in the absence of continued therapy, and it will be important to understand the biology of these responses. One potential mechanism is that the CML clone, once reduced to very low levels by TKI treatment, is controlled by the immune system; alternatively, clonal extinction may be possible in some patients with biologically low-risk disease.²³⁹ Whether this equals a cure may be a question of defining “cure” in the context of CML. Given that elimination of all leukemia cells cannot be proven, we may define “cure” as a risk of active CML that is not different from that in the general population. Long follow-up is needed to ascertain this point, and late relapses after allogeneic transplantation speak to the resilience of the Ph⁺ cell clone.²⁶⁰ More work is needed to truly turn CML into a problem of the past.

Acknowledgments

This work was supported by HL082978-01, CA04963920A2, Leukemia and Lymphoma Society grant 7036-01, and a Scholarship in Clinical Research of the Leukemia and Lymphoma Society. I am grateful to Kimberly Snow, University of Utah, for excellent editorial assistance and to Drs. Thomas O'Hare and Anna M. Eiring, University of Utah Huntsman Cancer Institute, for their critical feedback and encouragement.

REFERENCES

1. Bennett JH. Case of hypertrophy of the spleen and liver in which death took place from suppuration of the blood. *Edinburgh Med Surg J* 1845;64: 413-423.
2. Virchow R. Weisses Blut. *Frorieps Notizen* 1845;36:151-156.
3. Donne A. *Cours de Microscopie*: Bailliere. 1844;10-12.
4. Neumann E. Ein Fall von Leukmie mit Erkrankung des Knochenmarks. *Arch der Heilkunde* 1870.
5. Dameshek W. Some speculations on the myeloproliferative syndromes. *Blood* 1951;6:372-375.
6. Nowell P, Hungerford D. A minute chromosome in human chronic granulocytic leukemia. *Science* 1960;132:1497.
7. Fialkow PJ, Gartler SM, Yoshida A. Clonal origin of chronic myelocytic leukemia in man. *Proc Natl Acad Sci U S A* 1967;58:1468-1471.
8. Rowley JD. A new consistent chromosomal abnormality in chronic myelogenous leukaemia identified by quinacrine fluorescence and Giemsa staining. *Nature* 1973;243:290-293.
9. Groffen J, Stephenson JR, Heisterkamp N, et al. Philadelphia chromosomal breakpoints are clustered within a limited region, bcr, on chromosome 22. *Cell* 1984;36:93-99.
10. Bartram CR, de Klein A, Hagemeijer A, et al. Translocation of c-abl oncogene correlates with the presence of a Philadelphia chromosome in chronic myelocytic leukaemia. *Nature* 1983;306:277-280.

11. Abelson HT, Rabstein LS. Lymphosarcoma: virus-induced thymic-independent disease in mice. *Cancer Res* 1970;30:2213-2222.
12. Lugo TG, Pendergast AM, Muller AJ, et al. Tyrosine kinase activity and transformation potency of bcr-abl oncogene products. *Science* 1990;247: 1079-1082.
13. Daley GQ, Van Etten RA, Baltimore D. Induction of chronic myelogenous leukemia in mice by the P210bcr/abl gene of the Philadelphia chromosome. *Science* 1990;247:824-830.
14. Lissauer H. Zwei Faelle von Leucaemie. *Berl Klin Wochenschr* 1865;2: 403-405.
15. Cowan Doyle A. Notes on a Case of Leucocythaemia. *Lancet* 1882;119:490.
16. Hehlmann R, Heimpel H, Hasford J, et al. Randomized comparison of interferon-alpha with busulfan and hydroxyurea in chronic myelogenous leukemia. The German CML Study Group. *Blood* 1994;84:4064-4077.
17. Djaldetti M, Padeh B, Pinkhas J, et al. Prolonged remission in chronic myeloid leukemia after one course of busulfan. *Blood* 1966;27:103-109.
18. Fefer A, Cheever MA, Thomas ED, et al. Disappearance of Ph1-positive cells in four patients with chronic granulocytic leukemia after chemotherapy, irradiation and marrow transplantation from an identical twin. *N Engl J Med* 1979;300:333-337.
19. Talpaz M, Kantarjian H, Kurzrock R, et al. Interferon-alpha produces sustained cytogenetic responses in chronic myelogenous leukemia. Philadelphia chromosome-positive patients. *Ann Intern Med* 1991;114:532-538.
20. Gazit A, Yaish P, Gilon C, et al. Tyrphostins I: synthesis and biological activity of protein tyrosine kinase inhibitors. *J Med Chem* 1989;32:2344-2352.
21. Buchdunger E, Zimmermann J, Mett H, et al. Selective inhibition of the platelet-derived growth factor signal transduction pathway by a protein-tyrosine kinase inhibitor of the 2-phenylaminopyrimidine class. *Proc Natl Acad Sci U S A* 1995;92:2558-2562.
22. Druker BJ, Tamura S, Buchdunger E, et al. Effects of a selective inhibitor of the Abl tyrosine kinase on the growth of Bcr-Abl positive cells. *Nat Med* 1996;2:561-566.
23. Druker BJ, Sawyers CL, Kantarjian H, et al. Activity of a specific inhibitor of the BCR-ABL tyrosine kinase in the blast crisis of chronic myeloid leukemia and acute lymphoblastic leukemia with the Philadelphia chromosome. *N Engl J Med* 2001;344:1038-1042.
24. Druker BJ, Talpaz M, Resta DJ, et al. Efficacy and safety of a specific inhibitor of the BCR-ABL tyrosine kinase in chronic myeloid leukemia. *N Engl J Med* 2001;344:1031-1037.
25. Shah N, Tran C, Lee FY, et al. Overriding imatinib resistance with a novel ABL kinase inhibitor. *Science* 2004;305:399-401.
26. Weisberg E, Manley PW, Breitenstein W, et al. Characterization of AMN107, a selective inhibitor of native and mutant Bcr-Abl. *Cancer Cell* 2005;7:129-141.
27. Huntly BJ, Shigematsu H, Deguchi K, et al. MOZ-TIF2, but not BCR-ABL, confers properties of leukemic stem cells to committed murine hematopoietic progenitors. *Cancer Cell* 2004;6:587-596.
28. Takahashi N, Miura I, Saitoh K, et al. Lineage involvement of stem cells bearing the Philadelphia chromosome in chronic myeloid leukemia in the chronic phase as shown by a combination of fluorescence-activated cell sorting and fluorescence in situ hybridization. *Blood* 1998;92:4758-4763.
29. Marley SB, Deininger MW, Davidson RJ, et al. The tyrosine kinase inhibitor STI571, like interferon-alpha, preferentially reduces the capacity for amplification of granulocyte- macrophage progenitors from patients with chronic myeloid leukemia. *Exp Hematol* 2000;28:551-557.
30. Petzer AL, Eaves CJ, Lansdorp PM, et al. Characterization of primitive sub-population of normal and leukemic cells present in the blood of patients with newly diagnosed as well as established chronic myeloid leukemia. *Blood* 1996;88:2162-2171.
31. Deininger MW, Goldman JM, Melo JV. The molecular biology of chronic myeloid leukemia. *Blood* 2000;96:3343-3356.
32. Melo JV. The diversity of BCR-ABL fusion proteins and their relationship to leukemia phenotype. *Blood* 1996;88:2375-2384.

33. Verma D, Kantarjian HM, Jones D, et al. Chronic myeloid leukemia (CML) with P190 BCR-ABL: analysis of characteristics, outcomes, and prognostic significance. *Blood* 2009;114:2232-2235.
34. Melo JV, Myint H, Galton DA, et al. P190BCR-ABL chronic myeloid leukaemia: the missing link with chronic myelomonocytic leukaemia? *Leukemia* 1994;8:208-211.
35. Pane F, Frigeri F, Sindona M, et al. Neutrophilic chronic myeloid leukemia: a distinct disease with a specific molecular marker (BCR/ABL with C3/A2 junction). *Blood* 1996;88:2410-2414.
36. Demehri S, Paschka P, Schultheis B, et al. e8a2 BCR-ABL: more frequent than other atypical BCR-ABL variants? *Leukemia* 2005;19:681-684.
37. Hochhaus A, Reiter A, Skladny H, et al. A novel BCR-ABL fusion gene (e6a2) in a patient with Philadelphia chromosome-negative chronic myelogenous leukemia. *Blood* 1996;88:2236-2240.
38. Al Ali HK, Leiblein S, Kovacs I, et al. CML with an e1a3 BCR-ABL fusion: rare, benign, and a potential diagnostic pitfall. *Blood* 2002;100:1092-1093.
39. Melo JV, Gordon DE, Cross NC, et al. The ABL-BCR fusion gene is expressed in chronic myeloid leukemia. *Blood* 1993;81:158-165.
40. Huntly BJ, Bench AJ, Delabesse E, et al. Derivative chromosome 9 deletions in chronic myeloid leukemia: poor prognosis is not associated with loss of ABL-BCR expression, elevated BCR-ABL levels, or karyotypic instability. *Blood* 2002;99:4547-4553.
41. McWhirter JR, Galasso DL, Wang JY. A coiled-coil oligomerization domain of Bcr is essential for the transforming function of Bcr-Abl oncoproteins. *Mol Cell Biol* 1993;13:7587-7595.
42. Maru Y, Witte ON. The BCR gene encodes a novel serine/threonine kinase activity within a single exon. *Cell* 1991;67:459-468.
43. Harnois T, Constantin B, Rioux A, et al. Differential interaction and activation of Rho family GTPases by p210bcr-abl and p190bcr-abl. *Oncogene* 2003;22:6445-6454.
44. Diekmann D, Brill S, Garrett MD, et al. Bcr encodes a GTPase-activating protein for p21rac. *Nature* 1991;351:400-402.
45. Diekmann D, Nobes CD, Burbelo PD, et al. Rac GTPase interacts with GAPs and target proteins through multiple effector sites. *EMBO J* 1995;14: 5297-5305.
46. Voncken JW, van Schaick H, Kaartinen V, et al. Increased neutrophil respiratory burst in bcr-null mutants. *Cell* 1995;80:719-728.
47. Liu J, Campbell M, Guo JQ, et al. BCR-ABL tyrosine kinase is autophosphorylated or transphosphorylates P160 BCR on tyrosine predominantly within the first BCR exon. *Oncogene* 1993;8:101-109.
48. Liu J, Wu Y, Ma GZ, et al. Inhibition of Bcr serine kinase by tyrosine phosphorylation. *Mol Cell Biol* 1996;16:998-1005.
49. Ma G, Lu D, Wu Y, et al. Bcr phosphorylated on tyrosine 177 binds Grb2. *Oncogene* 1997;14:2367-2372.
50. Kin Y, Li G, Shibuya M, et al. The Dbl homology domain of BCR is not a simple spacer in P210BCR-ABL of the Philadelphia chromosome. *J Biol Chem* 2001;276:39462-39468.
51. Demehri S, O'Hare T, Eide CA, et al. The function of the pleckstrin homology domain in BCR-ABL-mediated leukemogenesis. *Leukemia* 2010;24:226-229.
52. Castor A, Nilsson L, Astrand-Grundstrom I, et al. Distinct patterns of hematopoietic stem cell involvement in acute lymphoblastic leukemia. *Nat Med* 2005;11:630-637.
53. Wu Y, Ma G, Lu D, et al. Bcr: a negative regulator of the Bcr-Abl oncoprotein. *Oncogene* 1999;18:4416-4424.
54. Voncken JW, Kaartinen V, Groffen J, et al. Bcr/Abl associated leukemogenesis in bcr null mutant mice. *Oncogene* 1998;16:2029-2032.
55. Rabstein LS, Gazdar AF, Chopra HC, et al. Early morphological changes associated with infection by a murine nonthymic lymphatic tumor virus. *J Natl Cancer Inst* 1971;46:481-491.
56. Konopka JB, Watanabe SM, Witte ON. An alteration of the human c-abl protein in K562 leukemia cells unmasks associated tyrosine kinase activity. *Cell* 1984;37:1035-1042.

57. Bernardis A, Rubin CM, Westbrook CA, et al. The first intron in the human c-abl gene is at least 200 kilobases long and is a target for translocations in chronic myelogenous leukemia. *Mol Cell Biol* 1987;7:3231-3236.
58. Laneuville P. Abl tyrosine protein kinase. *Semin Immunol* 1995;7:255-266.
59. Feller SM, Ren R, Hanafusa H, et al. SH2 and SH3 domains as molecular adhesives: the interactions of Crk and Abl. *Trends Biochem Sci* 1994;19: 453-458.
60. Feller SM, Knudsen B, Hanafusa H. c-Abl kinase regulates the protein binding activity of c-Crk. *EMBO J* 1994;13:2341-2351.
61. Kipreos ET, Wang JY. Cell cycle-regulated binding of c-Abl tyrosine kinase to DNA. *Science* 1992;256:382-385.
62. McWhirter JR, Wang JY. An actin-binding function contributes to transformation by the Bcr-Abl oncoprotein of Philadelphia chromosome-positive human leukemias. *EMBO J* 1993;12:1533-1546.
63. Kipreos ET, Wang JY. Differential phosphorylation of c-Abl in cell cycle determined by cdc2 kinase and phosphatase activity. *Science* 1990;248:217-220.
64. Sawyers CL, McLaughlin J, Goga A, et al. The nuclear tyrosine kinase c-Abl negatively regulates cell growth. *Cell* 1994;77:121-131.
65. Baskaran R, Wood LD, Whitaker LL, et al. Ataxia telangiectasia mutant protein activates c-Abl tyrosine kinase in response to ionizing radiation. *Nature* 1997;387:516-519.
66. Yuan ZM, Utsugisawa T, Huang Y, et al. Inhibition of phosphatidylinositol 3-kinase by c-Abl in the genotoxic stress response. *J Biol Chem* 1997;272:23485-23488.
67. Kharbanda S, Pandey P, Jin S, et al. Functional interaction between DNA-PK and c-Abl in response to DNA damage. *Nature* 1997;386:732-735.
68. Yuan ZM, Huang Y, Ishiko T, et al. Regulation of Rad51 function by c-Abl in response to DNA damage. *J Biol Chem* 1998;273:3799-3802.
69. Yuan ZM, Utsugisawa T, Ishiko T, et al. Activation of protein kinase C delta by the c-Abl tyrosine kinase in response to ionizing radiation. *Oncogene* 1998;16:1643-1648.
70. Lewis JM, Baskaran R, Taagepera S, et al. Integrin regulation of c-Abl tyrosine kinase activity and cytoplasmic-nuclear transport. *Proc Natl Acad Sci U S A* 1996;93:15174-15179.
71. Schwartzberg PL, Stall AM, Hardin JD, et al. Mice homozygous for the ablm1 mutation show poor viability and depletion of selected B and T cell populations. *Cell* 1991;65:1165-1175.
72. Tybulewicz VL, Crawford CE, Jackson PK, et al. Neonatal lethality and lymphopenia in mice with a homozygous disruption of the c-abl proto-oncogene. *Cell* 1991;65:1153-1163.
73. Koleske AJ, Gifford AM, Scott ML, et al. Essential roles for the Abl and Arg tyrosine kinases in neurulation. *Neuron* 1998;21:1259-1272.
74. Zhao X, Ghaffari S, Lodish H, et al. Structure of the Bcr-Abl oncoprotein oligomerization domain. *Nat Struct Biol* 2002;9:117-120.
75. Smith KM, Yacobi R, Van Etten RA. Autoinhibition of Bcr-Abl through its SH3 domain. *Mol Cell* 2003;12:27-37.
76. Pluk H, Dorey K, Superti-Furga G. Autoinhibition of c-Abl. *Cell* 2002;108: 247-259.
77. Nagar B, Hantschel O, Young MA, et al. Structural basis for the autoinhibition of c-Abl tyrosine kinase. *Cell* 2003;112:859-871.
78. Hantschel O, Nagar B, Guettler S, et al. A myristoyl/phosphotyrosine switch regulates c-Abl. *Cell* 2003;112:845-857.
79. Grebien F, Hantschel O, Wojcik J, et al. Targeting the SH2-kinase interface in Bcr-Abl inhibits leukemogenesis. *Cell* 2011;147:306-319.
80. Dai Z, Pendergast AM. Abi-2, a novel SH3-containing protein interacts with the c-Abl tyrosine kinase and modulates c-Abl transforming activity. *Genes Dev* 1995;9:2569-2582.
81. Dai Z, Quackenbush RC, Courtney KD, et al. Oncogenic Abl and Src tyrosine kinases elicit the ubiquitin-dependent degradation of target proteins through a Ras- independent pathway. *Genes Dev* 1998;12:1415-1424.

82. Chu S, Li L, Singh H, et al. BCR-tyrosine 177 plays an essential role in Ras and Akt activation and in human hematopoietic progenitor transformation in chronic myelogenous leukemia. *Cancer Res* 2007;67:7045-7053.
83. Sattler M, Mohi MG, Pride YB, et al. Critical role for Gab2 in transformation by BCR/ABL. *Cancer Cell* 2002;1:479-492.
84. Gaston I, Johnson KJ, Oda T, et al. Coexistence of phosphotyrosine-dependent and -independent interactions between Cbl and Bcr-Abl. *Exp Hematol* 2004;32:113-121.
85. Komatsu N, Watanabe T, Uchida M, et al. A member of Forkhead transcription factor FKHL1 is a downstream effector of STI571-induced cell cycle arrest in BCR-ABL-expressing cells. *J Biol Chem* 2003;278:6411-6419.
86. Atfi A, Abecassis L, Bourgeade MF. Bcr-Abl activates the AKT/Fox O3 signalling pathway to restrict transforming growth factor-beta-mediated cytostatic signals. *EMBO Rep* 2005;6:985-991.

P.1720

87. Neshat MS, Raitano AB, Wang HG, et al. The survival function of the Bcr-Abl oncogene is mediated by Bad-dependent and -independent pathways: roles for phosphatidylinositol 3-kinase and Raf. *Mol Cell Biol* 2000;20:1179-1186.
88. Agarwal A, Bumm TG, Corbin AS, et al. Absence of SKP2 expression attenuates BCR-ABL-induced myeloproliferative disease. *Blood* 2008;112: 1960-1970.
89. Markova B, Albers C, Breitenbuecher F, et al. Novel pathway in Bcr-Abl signal transduction involves Akt-independent, PLC-gamma1-driven activation of mTOR/p70S6-kinase pathway. *Oncogene* 2010;29:739-751.
90. Ly C, Arechiga AF, Melo JV, et al. Bcr-Abl kinase modulates the translation regulators ribosomal protein S6 and 4E-BP1 in chronic myelogenous leukemia cells via the mammalian target of rapamycin. *Cancer Res* 2003;63: 5716-5722.
91. Kardinal C, Konkol B, Lin H, et al. Chronic myelogenous leukemia blast cell proliferation is inhibited by peptides that disrupt Grb2-SoS complexes. *Blood* 2001;98:1773-1781.
92. Marais R, Light Y, Paterson HF, et al. Ras recruits Raf-1 to the plasma membrane for activation by tyrosine phosphorylation. *EMBO J* 1995;14: 3136-3145.
93. Salomoni P, Wasik MA, Riedel RF, et al. Expression of constitutively active Raf-1 in the mitochondria restores antiapoptotic and leukemogenic potential of a transformation-deficient BCR/ABL mutant. *J Exp Med* 1998;187: 1995-2007.
94. Thomas EK, Cancelas JA, Zheng Y, et al. Rac GTPases as key regulators of p210-BCR-ABL-dependent leukemogenesis. *Leukemia* 2008;22:898-904.
95. Thomas EK, Cancelas JA, Chae HD, et al. Rac guanosine triphosphatases represent integrating molecular therapeutic targets for BCR-ABL-induced myeloproliferative disease. *Cancer Cell* 2007;12:467-478.
96. Sexl V, Piekorz R, Moriggl R, et al. Stat5a/b contribute to interleukin 7-induced B-cell precursor expansion, but abl- and bcr/abl-induced transformation are independent of stat5. *Blood* 2000;96:2277-2283.
97. Walz C, Ahmed W, Lazarides K, et al. Essential role for Stat5a/b in myeloproliferative neoplasms induced by BCR-ABL1 and JAK2(V617F) in mice. *Blood* 2012;119:3550-3560.
98. Hoelbl A, Schuster C, Kovacic B, et al. Stat5 is indispensable for the maintenance of bcr/abl-positive leukaemia. *EMBO Mol Med* 2010;2:98-110.
99. Ye D, Wolff N, Li L, et al. STAT5 signaling is required for the efficient induction and maintenance of CML in mice. *Blood* 2006;107:4917-4925.
100. Klejman A, Schreiner SJ, Nieborowska-Skorska M, et al. The Src family kinase Hck couples BCR/ABL to STAT5 activation in myeloid leukemia cells. *EMBO J* 2002;21:5766-5774.
101. Frank DA, Varticovski L. BCR/abl leads to the constitutive activation of Stat proteins, and shares an epitope with tyrosine phosphorylated Stats. *Leukemia* 1996;10:1724-1730.
102. Ilaria RL, Jr., Van Etten RA. P210 and P190(BCR/ABL) induce the tyrosine phosphorylation and DNA binding activity of multiple specific STAT family members. *J Biol Chem* 1996;271:31704-31710.
103. Samanta AK, Lin H, Sun T, et al. Janus kinase 2: a critical target in chronic myelogenous leukemia. *Cancer Res* 2006;66:6468-6472.

104. Hantschel O, Warsch W, Eckelhart E, et al. BCR-ABL uncouples canonical JAK2-STAT5 signaling in chronic myeloid leukemia. *Nat Chem Biol* 2012;8:285-293.
105. Gotoh A, Miyazawa K, Ohyashiki K, et al. Tyrosine phosphorylation and activation of focal adhesion kinase (p125FAK) by BCR-ABL oncoprotein. *Exp Hematol* 1995;23:1153-1159.
106. Salgia R, Li JL, Lo SH, et al. Molecular cloning of human paxillin, a focal adhesion protein phosphorylated by P210BCR/ABL. *J Biol Chem* 1995;270: 5039-5047.
107. Salgia R, Pisick E, Sattler M, et al. p130CAS forms a signaling complex with the adapter protein CRKL in hematopoietic cells transformed by the BCR/ABL oncogene. *J Biol Chem* 1996;271:25198-25203.
108. Sattler M, Salgia R, Shrikhande G, et al. Differential signaling after beta1 integrin ligation is mediated through binding of CRKL to p120(CBL) and p110(HEF1). *J Biol Chem* 1997;272:14320-14326.
109. Uemura N, Griffin JD. The adapter protein Crkl links Cbl to C3G after integrin ligation and enhances cell migration. *J Biol Chem* 1999;274:37525-37532.
110. Oda T, Heaney C, Hagopian JR, et al. Crkl is the major tyrosine-phosphorylated protein in neutrophils from patients with chronic myelogenous leukemia. *J Biol Chem* 1994;269:22925-22928.
111. Verfaillie CM, Hurley R, Zhao RC, et al. Pathophysiology of CML: do defects in integrin function contribute to the premature circulation and massive expansion of the BCR/ABL positive clone? *J Lab Clin Med* 1997;129:584-591.
112. Ramaraj P, Singh H, Niu N, et al. Effect of mutational inactivation of tyrosine kinase activity on BCR/ABL-induced abnormalities in cell growth and adhesion in human hematopoietic progenitors. *Cancer Res* 2004;64:5322-5331.
113. Cramer K, Nieborowska-Skorska M, Koptyra M, et al. BCR/ABL and other kinases from chronic myeloproliferative disorders stimulate single-strand annealing, an unfaithful DNA double-strand break repair. *Cancer Res* 2008;68:6884-6888.
114. Nowicki MO, Falinski R, Koptyra M, et al. BCR/ABL oncogenic kinase promotes unfaithful repair of the reactive oxygen species-dependent DNA double-strand breaks. *Blood* 2004;104:3746-3753.
115. Koptyra M, Falinski R, Nowicki MO, et al. BCR/ABL kinase induces selfmutagenesis via reactive oxygen species to encode imatinib resistance. *Blood* 2006;108:319-327.
116. Perrotti D, Jamieson C, Goldman J, et al. Chronic myeloid leukemia: mechanisms of blastic transformation. *J Clin Invest* 2010;120:2254-2264.
117. Sattler M, Verma S, Shrikhande G, et al. The BCR/ABL tyrosine kinase induces production of reactive oxygen species in hematopoietic cells. *J Biol Chem* 2000;275:24273-24278.
118. Feldhahn N, Henke N, Melchior K, et al. Activation-induced cytidine deaminase acts as a mutator in BCR-ABL1-transformed acute lymphoblastic leukemia cells. *J Exp Med* 2007;204:1157-1166.
119. Melo JV, Barnes DJ. Chronic myeloid leukaemia as a model of disease evolution in human cancer. *Nat Rev Cancer* 2007;7:441-453.
120. Risch HA, McLaughlin JR, Cole DE, et al. Population BRCA1 and BRCA2 mutation frequencies and cancer penetrances: a kin-cohort study in Ontario, Canada. *J Natl Cancer Inst* 2006;98:1694-1706.
121. Deutsch E, Dugray A, AbdulKarim B, et al. BCR-ABL down-regulates the DNA repair protein DNA-PKcs. *Blood* 2001;97:2084-2090.
122. Slupianek A, Hoser G, Majsterek I, et al. Fusion tyrosine kinases induce drug resistance by stimulation of homology-dependent recombination repair, prolongation of G(2)/M phase, and protection from apoptosis. *Mol Cell Biol* 2002;22:4189-4201.
123. Brummendorf TH, Holyoake TL, Rufer N, et al. Prognostic implications of differences in telomere length between normal and malignant cells from patients with chronic myeloid leukemia measured by flow cytometry. *Blood* 2000;95:1883-1890.
124. Fabarius A, Giehl M, Frank O, et al. Induction of centrosome and chromosome aberrations by imatinib in vitro. *Leukemia* 2005;19:1573-1578.
125. Gambacorti-Passerini C, Antolini L, Mahon FX, et al. Multicenter independent assessment of outcomes in chronic myeloid leukemia patients treated with imatinib. *J Natl Cancer Inst* 2011;103:553-561.

126. Bumm T, Muller C, Al Ali HK, et al. Emergence of clonal cytogenetic abnormalities in Ph- cells in some CML patients in cytogenetic remission to imatinib but restoration of polyclonal hematopoiesis in the majority. *Blood* 2003;101:1941-1949.
127. Karimata K, Masuko M, Ushiki T, et al. Myelodysplastic syndrome with Ph negative monosomy 7 chromosome following transient bone marrow dysplasia during imatinib treatment for chronic myeloid leukemia. *Intern Med* 2011;50:481-485.
128. Deininger MW, Cortes J, Paquette R, et al. The prognosis for patients with chronic myeloid leukemia who have clonal cytogenetic abnormalities in philadelphia chromosome-negative cells. *Cancer* 2007;110:1509-1519.
129. Brehme M, Hantschel O, Colinge J, et al. Charting the molecular network of the drug target Bcr-Abl. *Proc Natl Acad Sci U S A* 2009;106:7414-7419.
130. Johansson B, Fioretos T, Mitelman F. Cytogenetic and molecular genetic evolution of chronic myeloid leukemia. *Acta Haematol* 2002;107:76-94.
131. Elmaagacli AH, Beelen DW, Opalka B, et al. The amount of BCR-ABL fusion transcripts detected by the real-time quantitative polymerase chain reaction method in patients with Philadelphia chromosome positive chronic myeloid leukemia correlates with the disease stage. *Ann Hematol* 2000;79:424-431.
132. Neviani P, Santhanam R, Trotta R, et al. The tumor suppressor PP2A is functionally inactivated in blast crisis CML through the inhibitory activity of the BCR/ABL-regulated SET protein. *Cancer Cell* 2005;8:355-368.
133. Esposito N, Colavita I, Quintarelli C, et al. SHP-1 expression accounts for resistance to imatinib treatment in Philadelphia chromosome-positive cells derived from patients with chronic myeloid leukemia. *Blood* 2011;118:3634-3644.
134. Lucas CM, Harris RJ, Giannoudis A, et al. Cancerous inhibitor of PP2A (CIP2A) at diagnosis of chronic myeloid leukemia is a critical determinant of disease progression. *Blood* 2011;117:6660-6668.
135. Deguchi K, Gilliland DG. Cooperativity between mutations in tyrosine kinases and in hematopoietic transcription factors in AML. *Leukemia* 2002;16: 740-744.
136. Wu Y, Slovak ML, Snyder DS, et al. Coexistence of inversion 16 and the Philadelphia chromosome in acute and chronic myeloid leukemias: report of six cases and review of literature. *Am J Clin Pathol* 2006;125:260-266.
137. Perrotti D, Cesi V, Trotta R, et al. BCR-ABL suppresses C/EBPalpha expression through inhibitory action of hnRNP E2. *Nat Genet* 2002;30:48-58.
138. Eiring AM, Harb JG, Neviani P, et al. miR-328 functions as an RNA decoy to modulate hnRNP E2 regulation of mRNA translation in leukemic blasts. *Cell* 2010;140:652-665.
139. Guerzoni C, Bardini M, Mariani SA, et al. Inducible activation of CEBPB, a gene negatively regulated by BCR/ABL, inhibits proliferation and promotes differentiation of BCR/ABL-expressing cells. *Blood* 2006;107:4080-4089.
140. Cuenco GM, Ren R. Both AML1 and EVI1 oncogenic components are required for the cooperation of AML1/MDS1/EVI1 with BCR/ABL in the induction of acute myelogenous leukemia in mice. *Oncogene* 2004;23:569-579.
141. De Weer A, Poppe B, Cauwelier B, et al. EVI1 activation in blast crisis CML due to juxtaposition to the rare 17q22 partner region as part of a 4-way variant translocation t(9;22). *BMC Cancer* 2008;8:193.
142. Jamieson CH, Ailles LE, Dylla SJ, et al. Granulocyte-macrophage progenitors as candidate leukemic stem cells in blast-crisis CML. *N Engl J Med* 2004;351:657-667.
143. Coluccia AM, Vacca A, Dunach M, et al. Bcr-Abl stabilizes beta-catenin in chronic myeloid leukemia through its tyrosine phosphorylation. *EMBO J* 2007;26:1456-1466.
144. Abrahamsson AE, Geron I, Gotlib J, et al. Glycogen synthase kinase 3beta missplicing contributes to leukemia stem cell generation. *Proc Natl Acad Sci U S A* 2009;106:3925-3929.
145. Tanaka K, Takechi M, Hong J, et al. 9;22 translocation and bcr rearrangements in chronic myelocytic leukemia patients among atomic bomb survivors. *J Radiat Res (Tokyo)* 1989;30:352-358.
146. Corso A, Lazzarino M, Morra E, et al. Chronic myelogenous leukemia and exposure to ionizing radiation—a retrospective study of 443 patients. *Ann Hematol* 1995;70:79-82.
147. Van Kaick G, Wesch H, Luhrs H, et al. Neoplastic diseases induced by chronic alpha-irradiation—epidemiological, biophysical and clinical results of the German Thorotrast Study. *J Radiat Res (Tokyo)* 1991;32(Suppl 2):20-33.

148. SEER. <http://seer.cancer.gov/statfacts/html/cm1.html>. Accessed July 8, 2012.
149. Corm S, Roche L, Micol JB, et al. Changes in the dynamics of the excess mortality rate in chronic phase-chronic myeloid leukemia over 1990-2007: a population study. *Blood* 2011;118:4331-4337.
150. Huang X, Cortes J, Kantarjian H. Estimations of the increasing prevalence and plateau prevalence of chronic myeloid leukemia in the era of tyrosine kinase inhibitor therapy. *Cancer* 2012;118:3123-3127.
151. Sawyers CL. Chronic myeloid leukemia. *N Engl J Med* 1999;340:1330-1340.
152. Vardiman JW, Melo JV, Baccarani M, et al. Myeloproliferative neoplasms. In: Swerdlow SH, Campo E, Harris NL, et al., eds. Lyon: WHO Press, 2008:31-65.
153. Thiele J, Kvasnicka HM, Schmitt-Graeff A, et al. Bone marrow features and clinical findings in chronic myeloid leukemia—a comparative, multicenter, immunohistological and morphometric study on 614 patients. *Leuk Lymphoma* 2000;36:295-308.
154. Hehlmann R. How I treat CML blast crisis. *Blood* 2012;120:737-747.
155. Kantarjian HM, Talpaz M. Definition of the accelerated phase of chronic myelogenous leukemia. *J Clin Oncol* 1988;6:180-182.
156. Baccarani M, Cortes J, Pane F, et al. Chronic myeloid leukemia: an update of concepts and management recommendations of European LeukemiaNet. *J Clin Oncol* 2009;27:6041-6051.
157. Fabarius A, Leitner A, Hochhaus A, et al. Impact of additional cytogenetic aberrations at diagnosis on prognosis of CML: long-term observation of 1151 patients from the randomized CML Study IV. *Blood* 2011;118:6760-6768.
158. Radich JP, Dai H, Mao M, et al. Gene expression changes associated with progression and response in chronic myeloid leukemia. *Proc Natl Acad Sci U S A* 2006;103:2794-2799.
159. Mitchell B, Deininger M. Techniques for risk stratification of newly diagnosed patients with chronic myeloid leukemia. *Leuk Lymphoma* 2011;52 (Suppl 1):4-11.
160. Sokal JE, Cox EB, Baccarani M, et al. Prognostic discrimination in “good-risk” chronic granulocytic leukemia. *Blood* 1984;63:789-799.
161. Bonifazi F, de Vivo A, Rosti G, et al. Chronic myeloid leukemia and interferon-alpha: a study of complete cytogenetic responders. *Blood* 2001;98: 3074-3081.
162. Druker BJ, Guilhot F, O'Brien SG, et al. Five-year follow-up of patients receiving imatinib for chronic myeloid leukemia. *N Engl J Med* 2006;355: 2408-2417.
163. Hasford J, Pffirmann M, Hehlmann R, et al. A new prognostic score for survival of patients with chronic myeloid leukemia treated with interferon alfa. Writing Committee for the Collaborative CML Prognostic Factors Project Group. *J Natl Cancer Inst* 1998;90:850-858.
164. Hasford J, Baccarani M, Hoffmann V, et al. Predicting complete cytogenetic response and subsequent progression-free survival in 2060 patients with CML on imatinib treatment: the EUTOS score. *Blood* 2011;118:686-692.
165. Jabbour E, Cortes J, Nazha A, et al. EUTOS score is not predictive for survival and outcome in patients with early chronic phase chronic myeloid leukemia treated with tyrosine kinase inhibitors: a single institution experience. *Blood* 2012;119:4524-4526.
166. Sinclair PB, Green AR, Grace C, et al. Improved sensitivity of BCR-ABL detection: a triple-probe three-color fluorescence in situ hybridization system. *Blood* 1997;90:1395-1402.
167. Huntly BJ, Guilhot F, Reid AG, et al. Imatinib improves but may not fully reverse the poor prognosis of patients with CML with derivative chromosome 9 deletions. *Blood* 2003;102:2205-2212.
168. Sinclair PB, Nacheva EP, Leversha M, et al. Large deletions at the t(9;22) breakpoint are common and may identify a poor-prognosis subgroup of patients with chronic myeloid leukemia. *Blood* 2000;95:738-743.
169. Quintas-Cardama A, Kantarjian H, Talpaz M, et al. Imatinib mesylate therapy may overcome the poor prognostic significance of deletions of derivative chromosome 9 in patients with chronic myelogenous leukemia. *Blood* 2005;105:2281-2286.

170. Cross NC, Melo JV, Feng L, et al. An optimized multiplex polymerase chain reaction (PCR) for detection of BCR-ABL fusion mRNAs in haematological disorders. *Leukemia* 1994;8:186-189.
171. Muller MC, Cross NC, Erben P, et al. Harmonization of molecular monitoring of CML therapy in Europe. *Leukemia* 2009;23:1957-1963.
172. Hughes T, Deininger M, Hochhaus A, et al. Monitoring CML patients responding to treatment with tyrosine kinase inhibitors: review and recommendations for harmonizing current methodology for detecting BCR-ABL transcripts and kinase domain mutations and for expressing results. *Blood* 2006;108:28-37.
173. Press RD, Willis SG, Laudadio J, et al. Determining the rise in BCR-ABL RNA that optimally predicts a kinase domain mutation in patients with chronic myeloid leukemia on imatinib. *Blood* 2009;114:2598-2605.
174. Branford S, Rudzki Z, Parkinson I, et al. Real-time quantitative PCR analysis can be used as a primary screen to identify patients with CML treated with imatinib who have BCR-ABL kinase domain mutations. *Blood* 2004;104:2926-2932.
175. Muller MC, Saglio G, Lin F, et al. An international study to standardize the detection and quantitation of BCR-ABL transcripts from stabilized peripheral blood preparations by quantitative RT-PCR. *Haematologica* 2007;92:970-973.
176. White HE, Matejtschuk P, Rigsby P, et al. Establishment of the first World Health Organization International Genetic Reference Panel for quantitation of BCR-ABL mRNA. *Blood* 2010;116:e111-e117.
177. Branford S, Fletcher L, Cross NC, et al. Desirable performance characteristics for BCR-ABL measurement on an international reporting scale to allow consistent interpretation of individual patient response and comparison of response rates between clinical trials. *Blood* 2008;112:3330-3338.
178. Hughes TP, Kaeda J, Branford S, et al. Frequency of major molecular responses to imatinib or interferon alfa plus cytarabine in newly diagnosed chronic myeloid leukemia. *N Engl J Med* 2003;349:1423-1432.
179. Soverini S, Hochhaus A, Nicolini FE, et al. BCR-ABL kinase domain mutation analysis in chronic myeloid leukemia patients treated with tyrosine kinase inhibitors: recommendations from an expert panel on behalf of European LeukemiaNet. *Blood* 2011;118:1208-1215.
180. Willis SG, Lange T, Demehri S, et al. High-sensitivity detection of BCR-ABL kinase domain mutations in imatinib-naive patients: correlation with clonal cytogenetic evolution but not response to therapy. *Blood* 2005;106:2128-2137.
181. Ernst T, Erben P, Muller MC, et al. Dynamics of BCR-ABL mutated clones prior to hematologic or cytogenetic resistance to imatinib. *Haematologica* 2008;93:186-192.
182. Parker WT, Ho M, Scott HS, et al. Poor response to second-line kinase inhibitors in chronic myeloid leukemia patients with multiple low-level mutations, irrespective of their resistance profile. *Blood* 2012;119:2234-2238.
183. Guilhot F, Chastang C, Michallet M, et al. Interferon alfa-2b combined with cytarabine versus interferon alone in chronic myelogenous leukemia. French Chronic Myeloid Leukemia Study Group. *N Engl J Med* 1997;337:223-229.
184. Baccarani M, Rosti G, de Vivo A, et al. A randomized study of interferon-alpha versus interferon-alpha and low-dose arabinosyl cytosine in chronic myeloid leukemia. *Blood* 2002;99:1527-1535.
185. Kantarjian H, Sawyers C, Hochhaus A, et al. Hematologic and cytogenetic responses to imatinib mesylate in chronic myelogenous leukemia. *N Engl J Med* 2002;346:645-652.
186. Talpaz M, Silver RT, Druker BJ, et al. Imatinib induces durable hematologic and cytogenetic responses in patients with accelerated phase chronic myeloid leukemia: results of a phase 2 study. *Blood* 2002;99:1928-1937.
187. Sawyers CL, Hochhaus A, Feldman E, et al. Imatinib induces hematologic and cytogenetic responses in patients with chronic myelogenous leukemia in myeloid blast crisis: results of a phase II study. *Blood* 2002;99:3530-3539.
188. Ottmann OG, Druker BJ, Sawyers CL, et al. A phase 2 study of imatinib in patients with relapsed or refractory Philadelphia chromosome-positive acute lymphoid leukemias. *Blood* 2002;100:1965-1971.
189. O'Brien SG, Deininger MW. Imatinib in patients with newly diagnosed chronic-phase chronic myeloid leukemia. *Semin Hematol* 2003;40:26-30.
190. Guilhot F, Druker B, Larson RA, et al. High rates of durable response are achieved with imatinib after treatment with interferon alpha plus cytarabine: results from the International Randomized Study of Interferon and STI571 (IRIS) trial. *Haematologica* 2009;94:1669-1675.

191. Kantarjian H, Talpaz M, O'Brien S, et al. High-dose imatinib mesylate therapy in newly diagnosed Philadelphia chromosome-positive chronic phase chronic myeloid leukemia. *Blood* 2004;103:2873-2878.
192. Cortes J, Giles F, O'Brien S, et al. Result of high-dose imatinib mesylate in patients with Philadelphia chromosome—positive chronic myeloid leukemia after failure of interferon-alpha. *Blood* 2003;102:83-86.
193. Cortes JE, Baccarani M, Guilhot F, et al. Phase III, randomized, open-label study of daily imatinib mesylate 400 mg versus 800 mg in patients with newly diagnosed, previously untreated chronic myeloid leukemia in chronic phase using molecular end points: tyrosine kinase inhibitor optimization and selectivity study. *J Clin Oncol* 2010;28:424-430.
194. Castagnetti F, Palandri F, Amabile M, et al. Results of high-dose imatinib mesylate in intermediate Sokal risk chronic myeloid leukemia patients in early chronic phase: a phase 2 trial of the GIMEMA CML Working Party. *Blood* 2009;113:3428-3434.
195. Hehlmann R, Lauseker M, Jung-Munkwitz S, et al. Tolerability-adapted imatinib 800 mg/d versus 400 mg/d versus 400 mg/d plus interferon- α in newly diagnosed chronic myeloid leukemia. *J Clin Oncol* 2011;29: 1634-1642.
196. Preudhomme C, Guilhot J, Nicolini FE, et al. Imatinib plus peginterferon alfa-2a in chronic myeloid leukemia. *N Engl J Med* 2010;363:2511-2521.
197. Talpaz M, Shah NP, Kantarjian H, et al. Dasatinib in imatinib-resistant Philadelphia chromosome-positive leukemias. *N Engl J Med* 2006;354: 2531-2541.
198. Hochhaus A, Kantarjian HM, Baccarani M, et al. Dasatinib induces notable hematologic and cytogenetic responses in chronic phase chronic myeloid leukemia after failure of imatinib therapy. *Blood* 2007;109:2303-2309.
199. Cortes J, Rousselot P, Kim DW, et al. Dasatinib induces complete hematologic and cytogenetic responses in patients with imatinib-resistant or -intolerant chronic myeloid leukemia in blast crisis. *Blood* 2007;109:3207-3213.
200. Guilhot F, Apperley J, Kim DW, et al. Dasatinib induces significant hematologic and cytogenetic responses in patients with imatinib-resistant or -intolerant chronic myeloid leukemia in accelerated phase. *Blood* 2007;109:4143-4150.
201. Shah NP, Kantarjian HM, Kim DW, et al. Intermittent target inhibition with dasatinib 100 mg once daily preserves efficacy and improves tolerability in imatinib-resistant and -intolerant chronic-phase chronic myeloid leukemia. *J Clin Oncol* 2008;26:3204-3212.
202. Kantarjian H, Cortes J, Kim DW, et al. Phase 3 study of dasatinib 140 mg once daily versus 70 mg twice daily in patients with chronic myeloid leukemia in accelerated phase resistant or intolerant to imatinib: 15-month median follow-up. *Blood* 2009;113:6322-6329.
203. Kantarjian H, Giles F, Wunderle L, et al. Nilotinib in imatinib-resistant CML and Philadelphia chromosome-positive ALL. *N Engl J Med* 2006;354: 2542-2551.
204. Le CP, Ottmann OG, Giles F, et al. Nilotinib (formerly AMN107), a highly selective BCR-ABL tyrosine kinase inhibitor, is active in patients with imatinib-resistant or -intolerant accelerated-phase chronic myelogenous leukemia. *Blood* 2008;111:1834-1839.
205. Kantarjian HM, Giles F, Gattermann N, et al. Nilotinib (formerly AMN107), a highly selective BCR-ABL tyrosine kinase inhibitor, is effective in patients with Philadelphia chromosome-positive chronic myelogenous leukemia in chronic phase following imatinib resistance and intolerance. *Blood* 2007;110:3540-3546.
206. Giles FJ, Kantarjian HM, le Coutre PD, et al. Nilotinib is effective in imatinib-resistant or -intolerant patients with chronic myeloid leukemia in blastic phase. *Leukemia* 2012;26:959-962.
207. Saglio G, Kim DW, Issaragrisil S, et al. Nilotinib versus imatinib for newly diagnosed chronic myeloid leukemia. *N Engl J Med* 2010;362:2251-2259.
208. Simonsson B, Gedde-Dahl T, Markevarn B, et al. Combination of pegylated IFN-alpha2b with imatinib increases molecular response rates in patients with low- or intermediate-risk chronic myeloid leukemia. *Blood* 2011;118: 3228-3235.
209. O'Brien SG, Guilhot F, Larson RA, et al. Imatinib compared with interferon and low-dose cytarabine for newly diagnosed chronic-phase chronic myeloid leukemia. *N Engl J Med* 2003;348:994-1004.
210. Deininger MW, O'Brien SG, Ford JM, et al. Practical management of patients with chronic myeloid leukemia receiving imatinib. *J Clin Oncol* 2003;21:1637-1647.

211. La Rosee P, Deininger MW. Resistance to imatinib: mutations and beyond. *Semin Hematol* 2010;47:335-343.
212. Gorre ME, Mohammed M, Ellwood K, et al. Clinical resistance to STI-571 cancer therapy caused by BCR-ABL gene mutation or amplification. *Science* 2001;293:876-880.
213. Schindler T, Bornmann W, Pellicena P, et al. Structural mechanism for STI-571 inhibition of abelson tyrosine kinase. *Science* 2000;289:1938-1942.
214. Deininger M, Buchdunger E, Druker. The development of imatinib as a therapeutic agent for chronic myeloid leukemia. *Blood* 2005;105:2640-2653.
215. Tokarski JS, Newitt JA, Chang CY, et al. The structure of dasatinib (BMS-354825) bound to activated ABL kinase domain elucidates its inhibitory activity against imatinib-resistant ABL mutants. *Cancer Res* 2006;66:5790-5797.
216. Bradeen HA, Eide CA, O'Hare T, et al. Comparison of imatinib mesylate, dasatinib (BMS-354825), and nilotinib (AMN107) in an N-ethyl-N-nitrosourea (ENU)-based mutagenesis screen: high efficacy of drug combinations. *Blood* 2006;108:2332-2338.
217. Azam M, Latek RR, Daley GQ. Mechanisms of autoinhibition and STI-571/imatinib resistance revealed by mutagenesis of BCR-ABL. *Cell* 2003;112: 831-843.
218. von Bubnoff N, Veach DR, van der KH, et al. A cell-based screen for resistance of Bcr-Abl-positive leukemia identifies the mutation pattern for PD166326, an alternative Abl kinase inhibitor. *Blood* 2005;105:1652-1659.
219. O'Hare T, Eide CA, Deininger MW. Bcr-Abl kinase domain mutations, drug resistance, and the road to a cure for chronic myeloid leukemia. *Blood* 2007;110:2242-2249.
220. Muller MC, Cortes JE, Kim DW, et al. Dasatinib treatment of chronic-phase chronic myeloid leukemia: analysis of responses according to preexisting BCR-ABL mutations. *Blood* 2009;114:4944-4953.
221. Hughes T, Saglio G, Branford S, et al. Impact of baseline BCR-ABL mutations on response to nilotinib in patients with chronic myeloid leukemia in chronic phase. *J Clin Oncol* 2009;27:4204-4210.
222. Apperley JF. Part I: mechanisms of resistance to imatinib in chronic myeloid leukaemia. *Lancet Oncol* 2007;8:1018-1029.
223. Donato NJ, Wu JY, Stapley J, et al. BCR-ABL independence and LYN kinase overexpression in chronic myelogenous leukemia cells selected for resistance to STI571. *Blood* 2003;101:690-698.
224. Warsch W, Kollmann K, Eckelhart E, et al. High STAT5 levels mediate imatinib resistance and indicate disease progression in chronic myeloid leukemia. *Blood* 2011;117:3409-3420.
225. Burchert A, Wang Y, Cai D, et al. Compensatory PI3-kinase/Akt/mTor activation regulates imatinib resistance development. *Leukemia* 2005;19: 1774-1782.
226. Aceves-Luquero CI, Agarwal A, Callejas-Valera JL, et al. ERK2, but not ERK1, mediates acquired and "de novo" resistance to imatinib mesylate: implication for CML therapy. *PLoS One* 2009;4:e6124.
227. Gioia R, Leroy C, Drullion C, et al. Quantitative phosphoproteomics revealed interplay between Syk and Lyn in the resistance to nilotinib in chronic myeloid leukemia cells. *Blood* 2011;118:2211-2221.
228. Wang Y, Cai D, Brendel C, et al. Adaptive secretion of granulocyte-macrophage colony-stimulating factor (GM-CSF) mediates imatinib and nilotinib resistance in BCR/ABL+ progenitors via JAK-2/STAT-5 pathway activation. *Blood* 2007;109:2147-2155.
229. Weisberg E, Wright RD, McMillin DW, et al. Stromal-mediated protection of tyrosine kinase inhibitor-treated BCR-ABL-expressing leukemia cells. *Mol Cancer Ther* 2008;7:1121-1129.
230. Marin D, Bazeos A, Mahon FX, et al. Adherence is the critical factor for achieving molecular responses in patients with chronic myeloid leukemia who achieve complete cytogenetic responses on imatinib. *J Clin Oncol* 2010;28:2381-2388.
231. Frye RF, Fitzgerald SM, Lagattuta TF, et al. Effect of St John's wort on imatinib mesylate pharmacokinetics. *Clin Pharmacol Ther* 2004;76:323-329.
232. Tam CS, Kantarjian H, Garcia-Manero G, et al. Failure to achieve a major cytogenetic response by 12 months defines inadequate response in patients receiving nilotinib or dasatinib as second or subsequent line therapy for chronic myeloid leukemia. *Blood* 2008;112:516-518.

233. Garg RJ, Kantarjian H, O'Brien S, et al. The use of nilotinib or dasatinib after failure to 2 prior tyrosine kinase inhibitors: long-term follow-up. *Blood* 2009;114:4361-4368.
234. O'Hare T, Shakespeare WC, Zhu X, et al. AP24534, a pan-BCR-ABL inhibitor for chronic myeloid leukemia, potently inhibits the T315I mutant and overcomes mutation-based resistance. *Cancer Cell* 2009;16:401-412.
235. Cortes J, Talpaz M, Bixby D, et al. A phase 1 trial of oral ponatinib (AP24534) in patients with refractory chronic myelogenous leukemia (CML) and other hematologic malignancies: Emerging safety and clinical response findings. *ASH Annual Meeting Abstracts*. *Blood* 2010;116:210.
236. Cortes JE, Kim D-W, Pinilla-Ibarz J, et al. Initial findings from the PACE trial: a pivotal phase 2 study of ponatinib in patients with CML and Ph+ ALL resistant or intolerant to dasatinib or nilotinib, or with the T315I mutation. *ASH Annual Meeting Abstracts*. *Blood* 2011;118:109.
237. Mahon FX, Rea D, Guilhot J, et al. Discontinuation of imatinib in patients with chronic myeloid leukaemia who have maintained complete molecular remission for at least 2 years: the prospective, multicentre Stop Imatinib (STIM) trial. *Lancet Oncol* 2010;11:1029-1035.
238. Rousselot P, Huguet F, Rea D, et al. Imatinib mesylate discontinuation in patients with chronic myelogenous leukemia in complete molecular remission for more than 2 years. *Blood* 2007;109:58-60.
239. Deininger M. Hematology: curing CML with imatinib—a dream come true? *Nat Rev Clin Oncol* 2011;8:127-128.
240. Kolb HJ, Mittermuller J, Clemm C, et al. Donor leukocyte transfusions for treatment of recurrent chronic myelogenous leukemia in marrow transplant patients. *Blood* 1990;76:2462-2465.
241. Hehlmann R, Berger U, Pfirrmann M, et al. Drug treatment is superior to allografting as first-line therapy in chronic myeloid leukemia. *Blood* 2007;109:4686-4692.
242. Gratwohl A, Hermans J, Goldman JM, et al. Risk assessment for patients with chronic myeloid leukaemia before allogeneic blood or marrow transplantation. *Chronic Leukemia Working Party of the European Group for Blood and Marrow Transplantation*. *Lancet* 1998;352:1087-1092.
243. Deininger M, Schleuning M, Greinix H, et al. The effect of prior exposure to imatinib on transplant-related mortality. *Haematologica* 2006;91:452-459.
244. Oehler VG, Gooley T, Snyder DS, et al. The effects of imatinib mesylate treatment before allogeneic transplantation for chronic myeloid leukemia. *Blood* 2007;109:1782-1789.
245. Lee SJ, Kukreja M, Wang T, et al. Impact of prior imatinib mesylate on the outcome of hematopoietic cell transplantation for chronic myeloid leukemia. *Blood* 2008;112:3500-3507.
246. Saussele S, Lauseker M, Gratwohl A, et al. Allogeneic hematopoietic stem cell transplantation (allo SCT) for chronic myeloid leukemia in the imatinib era: evaluation of its impact within a subgroup of the randomized German CML Study IV. *Blood* 2010;115:1880-1885.
247. Zhang H, Chen J, Que W. Allogeneic peripheral blood stem cell and bone marrow transplantation for hematologic malignancies: meta-analysis of randomized controlled trials. *Leuk Res* 2012;36:431-437.
248. Chu S, McDonald T, Lin A, et al. Persistence of leukemia stem cells in chronic myelogenous leukemia patients in prolonged remission with imatinib treatment. *Blood* 2011;118:5565-5572.
249. Chomel JC, Bonnet ML, Sorel N, et al. Leukemic stem cell persistence in chronic myeloid leukemia patients with sustained undetectable molecular residual disease. *Blood* 2011;118:3657-3660.
- P.1721
250. Corbin AS, Agarwal A, Loriaux M, et al. Human chronic myeloid leukemia stem cells are insensitive to imatinib despite inhibition of BCR-ABL activity. *J Clin Invest* 2011;121:396-409.
251. Hamilton A, Helgason GV, Schemionek M, et al. Chronic myeloid leukemia stem cells are not dependent on Bcr-Abl kinase activity for their survival. *Blood* 2012;119:1501-1510.
252. Zhao C, Chen A, Jamieson CH, et al. Hedgehog signalling is essential for maintenance of cancer stem cells in myeloid leukaemia. *Nature* 2009;458:776-779.

253. Zhao C, Blum J, Chen A, et al. Loss of beta-catenin impairs the renewal of normal and CML stem cells in vivo. *Cancer Cell* 2007;12:528-541.
254. Dierks C, Beigi R, Guo GR, et al. Expansion of Bcr-Abl-positive leukemic stem cells is dependent on Hedgehog pathway activation. *Cancer Cell* 2008;14:238-249.
255. Ito K, Bernardi R, Morotti A, et al. PML targeting eradicates quiescent leukaemia-initiating cells. *Nature* 2008;453:1072-1078.
256. Hurtz C, Hatzi K, Cerchiotti L, et al. BCL6-mediated repression of p53 is critical for leukemia stem cell survival in chronic myeloid leukemia. *J Exp Med* 2011;208:2163-2174.
257. Chen Y, Hu Y, Zhang H, et al. Loss of the Alox5 gene impairs leukemia stem cells and prevents chronic myeloid leukemia. *Nat Genet* 2009;41: 783-792.
258. Perrotti D, Neviani P. Protein phosphatase 2A (PP2A), a drugable tumor suppressor in Ph1(+) leukemias. *Cancer Metastasis Rev* 2008;27:159-168.
259. Traer E, Mackenzie R, Snead J, et al. Blockade of JAK2-mediated extrinsic survival signals restores sensitivity of CML cells to ABL inhibitors. *Leukemia* 2012;26:1140-1143.
260. Goldman JM, Majhail NS, Klein JP, et al. Relapse and late mortality in 5-year survivors of myeloablative allogeneic hematopoietic cell transplantation for chronic myeloid leukemia in first chronic phase. *J Clin Oncol* 2010;28: 1888-1895.

Chapter 82 Polycythemia Vera

> Table of Contents > Part VII - Hematologic Malignancies > Section 3 - Myeloproliferative Disorders > Chapter 82 - Polycythemia Vera

Chapter 82

Polycythemia Vera

Robert T. Means, Jr.

DEFINITION AND HISTORY

Polycythemia vera (PV), also called polycythemia rubra vera, is a chronic clonal myeloproliferative disorder characterized by a striking absolute increase in the number of red blood cells and in the total blood volume, and usually by leukocytosis, thrombocytosis, and splenomegaly. The bone marrow is typically hypercellular and exhibits hyperplasia of myeloid, erythroid, and megakaryocyte lineages.

In 1892, Vaquez described persistent polycythemia, as distinguished from relative and transient forms, in a man whom he believed to have a congenital cardiac lesion even though no auscultatory signs were noted. At autopsy, a year after the patient was first examined, his heart was found to be normal.¹ In 1903 and 1908, Osler recognized that various reports of polycythemia in the literature represented a single disorder and further clarified the clinical picture of the disease,^{2, 3} and Türk, in 1904, called attention to the occurrence of leukocytosis as well as to immature forms of cells of the red and white series, suggesting a hyperplastic disorder of blood formation involving the marrow as a tissue and not merely erythrocytes.⁵ Thus, the general clinical picture of the disease was established in the earliest publications.⁶

Synonyms for PV used in the older literature include erythremia, splenomegalic polycythemia, Vaquez disease, Osler disease, polycythemia with chronic cyanosis, myelopathic polycythemia, erythrocytosis megalosplenica, and cryptogenic polycythemia.

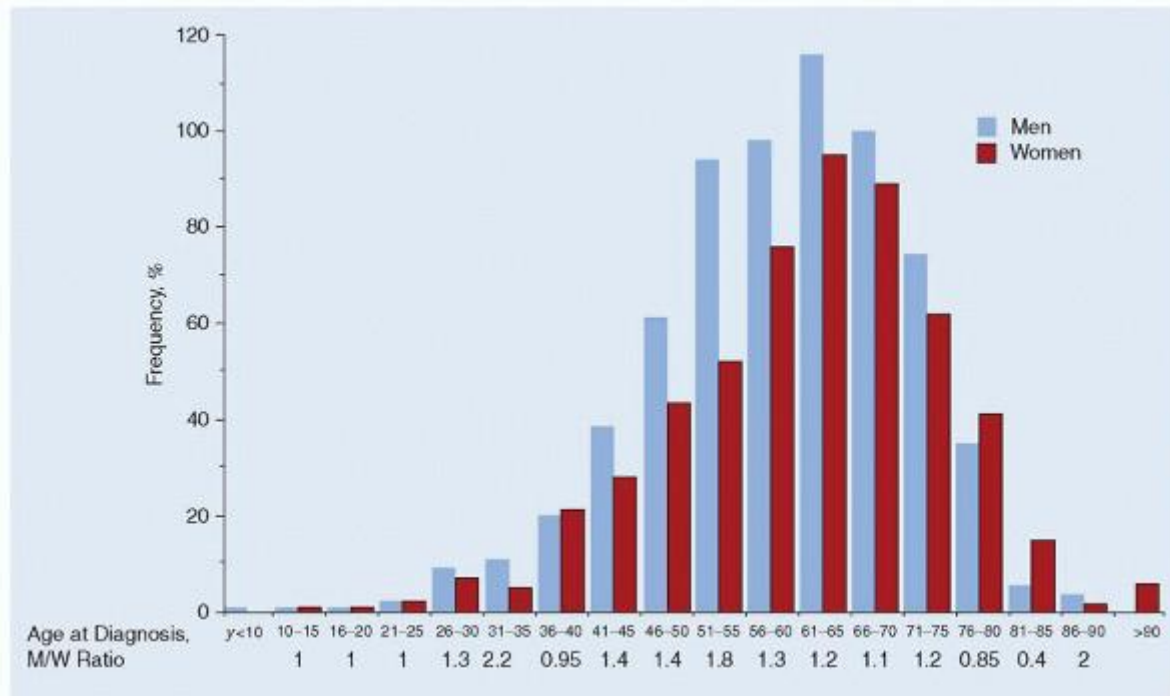

FIGURE 82.1 Frequency of diagnosis of polycythemia vera according to age and sex. Age at diagnosis of polycythemia vera for 671 men (55%) and 542 women (45%). M/W, ratio of men to women for diagnosis of polycythemia vera in each 5-year group. (From Gruppo Italiano Studio Policitemia. Polycythemia vera: the natural history of 1213 patients followed for 20 years. *Ann Intern Med* 1995;123:656-664, with permission.)

EPIDEMIOLOGY

The age- and sex-adjusted incidence rate of PV was 1.9 per 100,000 person-years in Olmstead County, Minnesota, during the years 1935 to 1989,⁷ and 2.6 per 100,000 person-years in Malmo, Sweden, during 1980 to 1984.⁸ PV appears to be somewhat more common in men than in women, with reported male-to-female ratios ranging from 1.2 to 2.2 in various studies.^{7,9,10} and ¹¹ PV in younger patients reportedly shows less marked male predominance.¹⁰ Some⁸ but not all⁷ studies have suggested that the incidence of PV is increasing over time. The frequency of PV according to age and sex is shown in Figure 82.1.

PV tends to be a disease of older individuals, with peak incidence observed at 60 to 80 years of age,^{10,11} with maximum incidence exceeding 20 per 100,000 person-years.⁷ The mean age at diagnosis has increased steadily since the 1920s.^{11,12,13,14} and ¹⁵ Cases of PV have also been reported in patients younger than the age of 40 years.^{16,17}

Racial and ethnic factors influence the incidence of PV. PV is significantly less common in African Americans than Americans of European ancestry.^{9,13,18} A number of investigators (beginning with Türk) have reported that the incidence of PV is higher in individuals of Jewish origin.^{9,13,19,20} Ashkenazi Jews in Northern Israel exhibit a higher incidence of PV than do their neighbors of Arab or Sephardic Jewish origins.¹⁹

Familial occurrence of PV has been reported by 6% of patients enrolled in the protocols of the Polycythemia Vera Study Group (PVSG) and in intermittent sporadic cases.^{21,22,23,24} and ^{25,26,27}

P.1723

It was previously claimed that PV affected primarily those of slender body habitus, but there is little evidence to support this statement.¹³

CLINICAL FEATURES

The symptoms and signs of PV can be attributed in large part to the expanded total blood volume and to the slowing of the blood flow as a result of increased blood viscosity, as discussed in Chapter 44. At the time of diagnosis, it becomes apparent that the disorder has been present for a long time in most cases. Patients may complain of headache, dizziness, tinnitus, visual disturbances, dyspnea, lassitude, or weakness. Although the color of the skin often is acknowledged to

have been abnormal for a long time, this complaint alone rarely brings the patient to the physician. Skin and mucous membrane hemorrhages are not uncommon; these, or a sense of weight or swelling in the abdomen owing to enlargement of the spleen, may be the initial symptoms. The lack of specificity of symptoms may in fact contribute to the delay in diagnosis. On the other hand, some patients have no complaints whatsoever, and polycythemia is discovered incidentally. Table 82.1 lists the frequency of common symptoms and physical findings in patients with PV.

Skin and Mucous Membranes

The color of the face is not cyanotic but is rather "ruddy," as might be produced by severe sunburn or a profound blush. The face also often appears swollen. This "rubor" may be so intense that it produces a startling appearance. The face, particularly the lips, cheeks, tip of the nose, ears, and neck, show this color (Fig. 82.2), but the skin of the trunk usually is not particularly affected. The distal portions of the extremities exhibit these changes more than the proximal portions and may be more truly cyanotic. The skin capillaries are distended, and the capillary loops are enlarged. The degree of red or blue coloration depends on the state of dilation of the peripheral vascular network and on the speed of circulation through these areas, because these factors determine the quantity of reduced hemoglobin present.²⁸ This is responsible for the frequent description in earlier reports that PV produced "cyanosis." These findings are not unique to PV, but are also observed in patients with an elevated hematocrit from secondary erythrocytosis.

TABLE 82.1 PHYSICAL FINDINGS AND SYMPTOMS IN POLYCYTHEMIA VERA

Physical Findings	Frequency (%)
Splenomegaly	70
Skin plethora	67
Conjunctival plethora	59
Engorged vessels in the optic fluid	46
Hepatomegaly	40
Systolic blood pressure > 140 mm Hg	72
Diastolic blood pressure > 90 mm Hg	32
Symptoms	
Headache	48
Weakness	47
Pruritus	43
Dizziness	43
Diaphoresis	33
Visual disturbances	31
Weight loss	29
Paresthesias	29
Dyspnea	26
Joint symptoms	26
Epigastric discomfort	24

Data from Berlin NI. Diagnosis and classification of the polycythemias. *Semin Haematol* 1975;12:339-351.



FIGURE 82.2 Photograph of a drawing (original in color) of one of Osler's original patients.

Ecchymoses and purpura of various sizes are common as the disease progresses. Red or dark-violet spots or brownish pigmentation of the skin may be found, and a great variety of skin lesions²⁹ have been observed, including dry skin, eczema, acneiform or urticarial changes, acne rosacea, acne urticata,³⁰ urticaria pigmentosa,^{31, 32, 33} and³⁴ and neutrophilic dermatosis (Sweet syndrome).^{35, 36, 37} and³⁸ The eyes may appear bloodshot. The mucous membranes may be a deep raspberry-red, and epistaxis and/or gingival bleeding may occur.

A common complaint is aquagenic pruritus, intense itching after exposure to water (most typically in a bath or shower). This may be the initial presentation of PV and is reported in up to 60% of PV patients younger than the age of 40 years.^{17,39,40} The itching may be so troublesome that bathing with hot or even warm water is avoided. The reaction is less frequent after the use of cold water. This complaint tends to disappear as the polycythemia is treated, but may require specific intervention. Reddening, swelling, and pain in the digits (erythromelalgia) may occur and are typically associated with extreme platelet elevations.^{41,42}

Cardiovascular System

Cardiac symptoms are not particularly prominent, and cardiac hypertrophy is typically absent. The circulatory minute volume is reduced, and the velocity of blood flow is greatly lowered,⁴³ but the cardiac output and work are normal.^{44,45} Electrocardiograms may show prolonged QT duration.⁴⁶ When echocardiographic abnormalities are observed, they are typically associated with previous thromboembolic events and consequent pulmonary hypertension.^{47,48} PV occurs in the population generally considered to be at highest risk for myocardial infarction, so whether PV increases this risk, and if it does, to what degree, is unclear.⁴⁹ Increased blood viscosity related to polycythemia, however, may contribute to symptoms in patients with atherosclerotic

P.1724

cardiovascular disease.^{50,51} Thrombotic events, in both the arterial and venous circulations, are common in patients with PV. Nineteen percent of the 1,213 patients followed by the Gruppo Italiano Studio Policitemia (GISP) experienced a thrombotic event. Of these, 50.5% of nonfatal thrombotic events were documented as having occurred in the arterial circulation and 38.5% in the venous circulation. More than 80% of fatal thromboses were arterial.¹⁰ Other abnormalities of the venous system include varicosities and phlebitis.⁵² Venous thrombosis is more common in women.⁵³ Moderate or significant thickening of the peripheral arteries is found in patients with PV, and coronary thrombosis, claudication without occlusion, arterial occlusion with gangrene, acroparesthesia, Raynaud phenomenon, and thromboangiitis obliterans have been described.^{54,55}

As noted in Table 82.1 and in other studies,⁵⁶ hypertension is relatively common in patients with PV. It is unclear whether this reflects the increased incidence of hypertension in the middle-aged and elderly or is a consequence of increased blood viscosity. Certainly, improvement of blood viscosity by reduction of the red cell volume aids in the control of blood pressure.

Gastrointestinal System

In addition to nonspecific gastrointestinal symptoms experienced by everyone at some time, such as feelings of fullness, thirst, gas pains, and constipation, patients with PV have an increased frequency of peptic ulcer, gastrointestinal bleeding, or thrombosis of mesenteric vessels. When compared with dyspeptic controls, PV patients had a three- to fourfold greater frequency of upper gastrointestinal erosions or ulcers.^{57,58} The relationship of blood basophil concentration, histamine content, gastric acid secretion, and dyspepsia on peptic ulceration has also been examined in a small group of patients with PV.⁵⁹ No convincing correlations were demonstrated. The frequency of *Helicobacter pylori* infection is increased in PV patients.⁵⁸

Massive hemorrhage from varices in the esophagus, stomach, or bowel may be observed.^{60, 61} and ⁶² Thrombosis in the mesenteric veins and arteries may be mistaken for peritonitis or the perforation of an ulcer. Hepatomegaly is common (Table 82.1), and cirrhosis has also been reported.⁶³ Mosse syndrome is a term applied by some to the co-existence of cirrhosis and PV.⁶⁴ Budd-Chiari syndrome also occurs,^{65,66,67} particularly in patients with a concurrent hypercoagulable state.^{68, 69, 70} and ⁷¹

Splenomegaly

Palpable splenomegaly occurs in more than two thirds of PV patients (Table 82.1).^{12,72} The size of the spleen varies greatly between individual patients and occasionally may extend to the pelvic brim.⁷³ It is usually hard and smooth. Patients may experience pain in the splenic region, and after infarction a friction rub can be heard in this area. The general assumption is that polycythemia antedates the enlargement of the spleen and that engorgement of this organ with blood and extramedullary hematopoiesis are the major contributors to splenomegaly. Splenomegaly appreciated only by radiographic techniques was considered a minor diagnostic criterion in most pre-2007 diagnostic schemes for PV.^{74,75} Experience suggests that most practitioners regard it as the equivalent of splenomegaly observed on physical examination.

Respiratory System

Dyspnea on severe exertion is common, and hoarseness is not unusual. Chest radiographs often reveal prominent vascular markings. Before the establishment of the PVSG diagnostic criteria, which require a reasonably normal arterial oxygen saturation for the diagnosis of PV, it was noted that the vast majority of patients with PV had normal arterial oxygen saturation, even when the hemoglobin levels were high, indicating that the high viscosity of the blood does not prevent normal blood oxygenation; oxygen dissociation studies were also normal.^{76, 77, 78} and ⁷⁹ High diffusing capacities, which were reduced after phlebotomy, were also noted in a number of patients with PV.⁸⁰ In another study, hypoxia, as evidenced by a low arterial oxygen tension and saturation, was observed in the absence of demonstrable co-existent

cardiorespiratory disease.⁸¹ In these individuals, ventilation-perfusion ratios were altered, and the diffusing capacity was low. The authors postulated that these findings might be the result of an alteration of the pulmonary vasculature caused by unrecognized thromboembolism. Pulmonary hypertension is reported in patients with PV and other myeloproliferative disorders.^{48,82}

Genitourinary System

Vesical, vaginal, and uterine bleeding have been reported, as has nontraumatic perirenal hematoma.^{83, 84, 85} and ⁸⁶ When hypertension is noted, albuminuria and signs of renal disease may be found.

Neuromuscular System

Headache is the most common neurologic symptom⁸⁷ but lassitude, vertigo and giddiness, transitory syncope, insomnia, weakness, and a sensation of fullness in the head and numbness and tingling in the fingers (less often in the feet) are also common.

Visual disturbances are common and include transitory dimness of vision, or even temporary blindness, scotomas, specks and bright points in front of the field of vision, diplopia, and temporary paralysis of one of the eye muscles. On examination of the eye grounds, the vessels may be engorged, tortuous, and irregular in diameter; the veins may be dark purple, and the retina deeply colored. Papilledema and embolism of the central retinal artery have been reported.⁸⁸

The cerebrospinal fluid pressure may be increased.⁸⁹ Ringing and roaring in the ears are exceedingly common when the hematocrit is significantly elevated. Ménière syndrome and chorea⁹⁰ have also been reported.

Vascular lesions of the brain constitute the most serious complication of PV.^{91, 92, 93} and ⁹⁴ A variety of neurologic syndromes, ranging from hemiparesis to seizures to alteration of cerebral function, have been reported in patients with PV. All such symptoms and signs presumably are secondary to increased blood volume and/or decreased blood flow. Investigators have shown clearly that cerebral blood flow is greatly diminished at hematocrit levels between 0.53 and 0.62,⁹⁵ and that elevated hematocrit is a risk factor for cerebrovascular accidents.^{96,97} Central nervous system vascular events represented 30% of the nonfatal thrombotic events and 10.3% of deaths observed in the GISP study.¹⁰

Pain in the limbs may be troublesome and severe. It has been attributed to pressure on the bone by swollen, hyperplastic bone marrow. Unusual paresthesias may be encountered, but anatomic evidence of spinal cord changes has not typically been found at autopsy.

BLOOD AND LABORATORY FINDINGS

Hematologic Findings

Erythrocytes

Hemoglobin concentration typically is in the range of 18 to 24 g/dl. Red cell counts of 7 to $10 \times 10^{12}/L$ are common when patients with this disease are first evaluated, and values as high as 12 and even $15 \times 10^{12}/L$ have been recorded.⁹⁸ The individual erythrocytes usually appear normal. Slight anisocytosis may be evident, but poikilocytosis is unusual.

Polychromatophilia and,

P.1725

occasionally, basophilic stippling may be found. An occasional normoblast may be observed in the blood smear, and, in the presence of a relatively normal or definitely increased red cell count, should arouse suspicion of PV. The reticulocyte percentage is not significantly increased. After hemorrhage, however, the reticulocytes may be increased, and a number of other immature forms of the red cell series may be encountered. If bleeding occurs repeatedly, iron-deficient erythropoiesis may develop. This raises an interesting semantic point: these patients are iron deficient in that iron stores are absent, but the total body iron content, including the iron present as hemoglobin in red cells, may be normal. Increased resistance to osmotic lysis has been reported for PV erythrocytes.⁹⁹

Leukocytes

Leukocyte counts of $25.0 \times 10^9/L$ are not uncommon and values in the $50.0 \times 10^9/L$ range are occasionally seen.¹⁰⁰ The myeloid leukocytes are both relatively and absolutely increased, metamyelocytes are increased in number, and 1% or 2% of myelocytes, sometimes more, are found. Myeloblasts usually are not observed. Basophil, eosinophil, or monocyte concentrations may be increased and provide a marker of an underlying myeloproliferative disorder. Leukocytes from patients with PV exhibit increased metabolic activity.¹⁰¹ A total leukocyte count greater than 12.5 to $15.0 \times 10^9/L$ is a risk factor for thrombosis.¹⁰²

Neither Vaquez nor Osler appreciated the significance of the leukocytosis with a “shift to the left” in the myeloid series of leukocytes that often is present in this disease initially described by them. Türk, in 1904, called attention to this significant finding, which suggested that the whole bone marrow, rather than the erythropoietic tissue alone, was hyperactive. The leukocyte counts were $>10.0 \times 10^9/L$ in 50% of Osler's patients. In larger series, leukocytosis is seen in more than 80% of patients, and counts greater than $12.0 \times 10^9/L$ in approximately 40%.^{12,100}

Platelets

The platelet count frequently is increased, usually in the 500 to $1,000 \times 10^9/L$ range, but counts as high as $3,000$ and even $6,000 \times 10^9/L$ have been reported.¹⁰³ Bleeding time and conventional coagulation parameters usually are normal, but the clot may retract poorly. An artifactual elevation of protime and activated partial thromboplastin time may be observed in patients with erythrocytosis. The standard citrated tube used for coagulation studies contains a fixed quantity of anticoagulant for a fixed volume of blood. In polycythemia, there is a relative reduction of plasma, meaning that there will be excess anticoagulant for the volume of plasma. Functional assays of coagulation factors will thus be prolonged. This prolongation has no clinical significance other than provoking panic on the part of the individual reviewing the laboratory results. The leukocyte and platelet counts are not always increased above normal in patients with otherwise typical disease. Normal values were found in 20% of the patients in one series.¹⁵

Morphologic and qualitative functional platelet abnormalities often are detectable. Platelets may appear to be abnormally large, and even bizarre-shaped, and megakaryocyte fragments sometimes are seen in the blood smear. The hemorrhagic complications of this disease suggest that a hemostatic defect may be present, although physical distention of the vascular bed undoubtedly contributes to bleeding when it occurs. Platelet function defects reported in PV include shortened platelet survival in patients with erythromelalgia,¹⁰⁴ altered von Willebrand factor multimers¹⁰⁵ and acquired von Willebrand syndrome,¹⁰⁶ deficient platelet-aggregating factor-induced aggregation,¹⁰⁷ increased platelet thromboxane production,¹⁰⁸ and platelet factor 3 deficiency.¹⁰⁹ Plasminogen activator inhibitor-1 levels have been reported to be both elevated¹⁰⁹ and decreased¹¹⁰ in patients with PV. Platelet glycoprotein IIIa expression has also been reported to be decreased in PV patients.¹¹¹

Total Blood Volume

The total blood volume characteristically is increased. The enormous increase in blood volume, which distends even the smaller vessels of the whole body, no doubt accounts for many of the symptoms of this disease. In a group of 30 patients in whom the hematocrit was 0.55 or greater, the total red cell volume, measured by the radioactive phosphorus (³²P)-labeled red cell method, was 38.8 to 91.9 ml/kg body weight as compared with the normal average of 29.9 ml/kg.¹¹² In two thirds of this patient group, the plasma volumes were below the lower limits of normal, and in none was the plasma volume above normal. Similar observations have been made using the chromium isotope method.¹¹ Because of variations in plasma volume, the packed cell volume (or hematocrit) gives only a rough indication of the size of the red cell mass.

In the early phases of PV, the red cell volume may not be elevated into this range. It has been proposed that a red cell volume $> 125\%$ of predicted is an appropriate criterion for polycythemia.¹¹³ In other circumstances, blood loss may result in “autophlebotomy”; that is, the patient becomes iron deficient, and the hemoglobin, hematocrit, and red cell volume fall into the normal range.

Erythrocyte Kinetics

Erythrokinetic studies have shown active hemoglobin production, but otherwise, findings have been diverse. Erythrocyte survival may be normal¹¹⁴ or shortened,¹¹⁵ and splenic sequestration may or may not be present. As measured by the ¹⁵N-glycine method, the rate of hemoglobin production was approximately two times the normal rate. The plasma iron turnover rate was also increased.¹¹⁵ This value was not reduced to normal by oxygen administration, as occurs when polycythemia is caused by anoxia.

Increased serum bilirubin⁹⁹ and increased urine and stool urobilinogen¹¹⁶ levels have been demonstrated in some patients with PV, but when adjusted for the increase in the total amount of hemoglobin that must be degraded, fecal urobilinogen values rarely are increased above expected values and may be somewhat reduced.

Neutrophil Kinetics

Studies of neutrophil kinetics in patients with PV in whom neutrophil counts ranged from normal to $23.9 \times 10^9/L$ showed a blood neutrophil pool that ranged from normal to 12 times normal, with increased margination and a normal or slightly prolonged half disappearance time. The blood neutrophil turnover rate (effective neutrophil production) usually was increased and varied from normal to five times normal mean values.¹¹⁷ Increased polymorphonuclear leukocyte activation is also observed in PV patients, and is associated with evidence of endothelial damage.¹¹⁸

Platelet Kinetics

Studies of platelet kinetics in five patients with PV in whom the platelet concentration was increased revealed effective production rates that ranged from 2 to 13 times normal. The marrow megakaryocyte mass was increased in all five patients studied.¹¹⁹

Fibrinogen Turnover

Results of studies involving three patients with erythremia indicated that fibrinogen was consumed in the course of chronic disseminated intravascular coagulation¹²⁰; similar findings were

P.1726

observed in several patients with erythrocytosis secondary to pulmonary insufficiency. No correlations between fibrinolytic parameters and thrombotic complications of PV have been reported.¹²¹

Other Laboratory Findings

The viscosity of the blood may be five to eight times greater than normal.^{98,122} The specific gravity is 1.075 to 1.080, compared with the normal range of 1.055 to 1.065. The degree of abnormality varies with the relative quantity of red corpuscles. The viscosity and specific gravity of the serum were actually less than normal. The erythrocyte sedimentation rate of polycythemic blood is low.¹²³ The urine may be normal, but albuminuria is found occasionally, and, less often, casts are present.¹⁰⁰ The increased urobilinogenuria noted in some of the patients has been mentioned. Studies of renal hemodynamics suggested that glomerular filtration, despite the decreased fraction of plasma in the blood, is kept at almost normal values by an increase in renal blood flow and in the proportion of plasma filtered.¹²⁴ The amount of uric acid in the serum may be normal or increased. Hyperuricemia was present in 70% of 127 patients in one series¹²⁵ and in 55% of 325 patients¹¹ in another series. Values ranged from 2.8 to 11.7 mg/dl (average, 6.6 mg).¹¹ Secondary gout occurs in 5% or more of these patients,^{13,17,125, 126} and¹²⁷ and symptoms often are atypical.⁹⁸ The occurrence of hyperuricemia in association with PV is attributable to overproduction of uric acid.^{126,128} A vitamin B₁₂-binding protein, which may be an altered form of transcobalamin I (Chapter 36), has been found in the plasma of patients with PV and in a variety of conditions involving leukocytosis.^{129,130} The presence of this protein may explain the observation that, whereas serum B₁₂ content may be within the normal range or only moderately elevated, the capacity of the serum to bind additional vitamin B₁₂ added in vitro (unsaturated B₁₂-binding capacity, UB₁₂BC) is increased. Plasma homocysteine levels in polycythemic patients are higher than nonpolycythemic subjects but still in the normal range.¹³¹ The leukocyte alkaline phosphatase score is normal or elevated in 80% to 100% of PV patients.^{113,125}

Serum erythropoietin concentration is typically low in PV and may be elevated in secondary polycythemia. An elevated erythropoietin level in a polycythemic patient with reduced arterial oxygen saturation would be evidence against PV. Birgegard and Wide have proposed that PV can be distinguished from secondary polycythemia by the erythropoietin response to phlebotomy: the erythropoietin concentration rises after phlebotomy in secondary erythrocytosis but remains unchanged in PV.¹³² A decreased serum erythropoietin concentration is a minor criterion for the diagnosis of PV in the WHO criteria, and a clinical criterion in the European Clinical and Pathological (ECP) criteria.^{74,113,133}

Spurious hyperkalemia has been noted when platelets are greatly increased in number.¹³⁴ Hyperhistaminemia and hyperhistaminuria were reported in patients with PV compared with normal controls and secondary polycythemia subjects, but did not correlate with the pruritus often present.¹³⁵ The basal metabolic rate may be increased moderately.¹³⁶ Gastric acidity ranges from absent to increased.

Patients with PV and thrombosis exhibit a greater frequency of procoagulant abnormalities in antithrombin III, protein C, protein S, and resistance to activated protein C than do PV patients without thrombosis.¹³⁷ Studies of prothrombin and factor V gene polymorphisms with a thrombotic diathesis showed no increased incidence of these abnormalities in PV patients.¹³⁸ However, polymorphisms of the PI^{A2} allele of platelet glycoprotein IIIa were associated with increased arterial thrombosis in PV and essential thrombocythemia patients.¹³⁸

Bone Marrow

For most of the last 40 or 50 years, bone marrow examination was not one of the criteria included in the PVSG standard for the diagnosis of PV.¹¹ The value of bone marrow examination in the differentiation of PV from other myeloproliferative disorders, from secondary polycythemia, from spurious polycythemia, or from the normal state was debated. Some investigators believed it to be an invaluable aid for making this differentiation;^{139,140} others regard it as an important diagnostic tool but not one that is capable of definitively establishing the diagnosis.¹² However, both currently accepted

diagnostic requirements for PV, the World Health Organization (WHO) criteria and the ECP criteria, formally include bone marrow examination.^{133,141}

The marrow typically is hypercellular^{142,143} (Fig. 82.3), but normal cellularity is noted at the time of diagnosis in approximately 13% of cases.¹⁴⁴ Hyperplasia involves all of the marrow elements and displaces marrow fat. Cellularity can be estimated with considerable accuracy by low-power examination of clot sections and needle or trephine biopsies. In several series, the mean cellularity of the marrow was 80% to 90% compared to approximately 30% in normal subjects and 40% in patients with secondary erythrocytosis.^{139,140,145} As mentioned, a few patients with untreated PV may have normal marrow cellularity.^{144,145} Thus, the lack of hypercellularity does not exclude the diagnosis but should make it suspect.

An increase in megakaryocyte number and size is well documented in association with PV and was reported in 95% of 175 cases. When the number of megakaryocytes was expressed in terms of fat-free marrow, however, the megakaryocyte hyperplasia was proportional to overall marrow cellularity.¹⁴⁴ The ratio of the different cell types in the marrow is not strikingly different from normal. Clumps of pronormoblasts and basophilic erythroblasts are seen,¹⁴³ and the percentage of nucleated red cells may be moderately elevated.¹⁴⁶ Myelocyte and myeloblast numbers may be greater than normal, and an increase in eosinophils¹⁴⁷ and basophils may be found.¹⁴⁶

Iron pigment is absent from the marrow in more than 90% of patients, even when phlebotomy has not been performed.^{147,148} Increased marrow iron stores have been suggested as a morphologic hallmark favoring a secondary form of erythrocytosis over PV.^{145,146} An increase in marrow reticulin levels and/or fibrosis has often been reported, but an increase was observed in only 11% to 15% of patients studied early in the course of

P.1727

their disease.^{144,145} The increase in reticulin correlates with the degree of marrow cellularity.¹⁴⁵ It is slowly progressive but no increase occurs in association with a particular form of treatment or with the duration of the disease.¹⁴⁴ Marrow vascularity may be increased in PV and other myeloproliferative disorders.¹⁴⁶

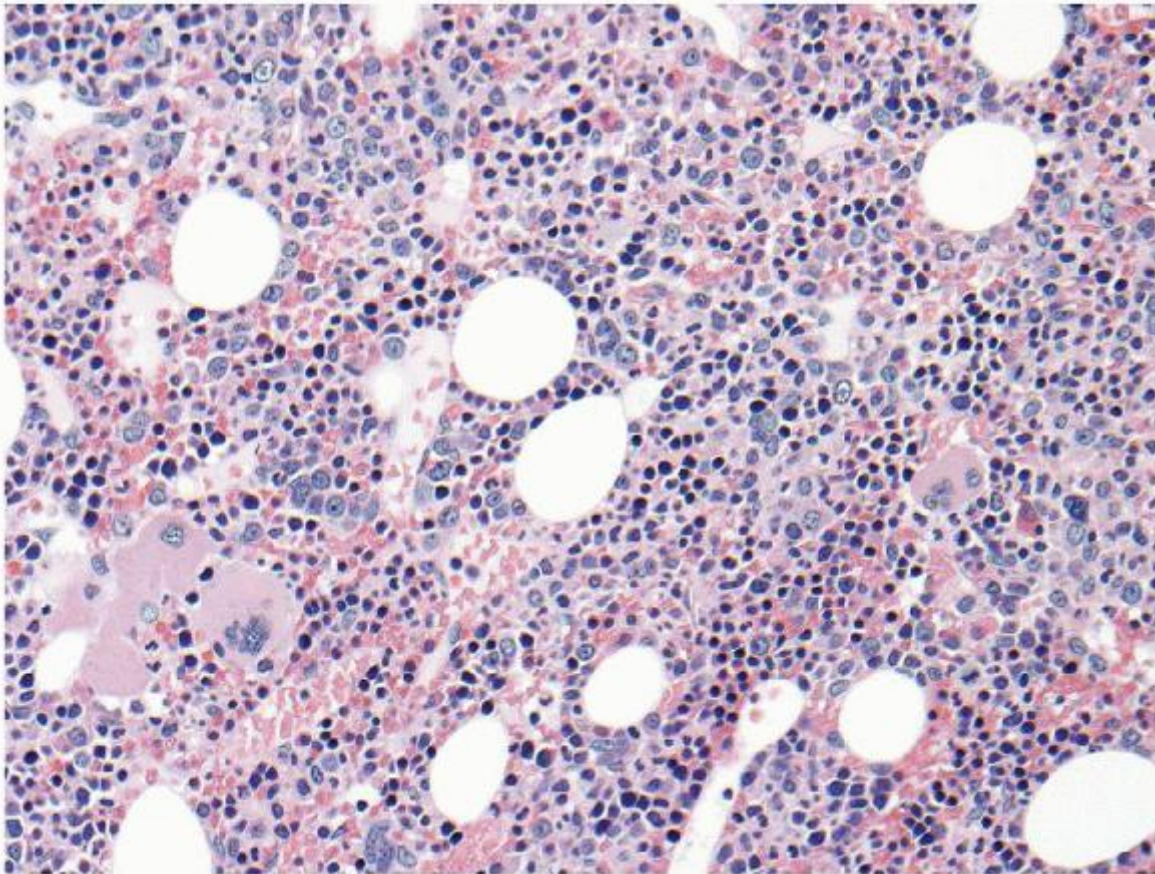

FIGURE 82.3 Bone marrow biopsy from a patient with polycythemia vera, showing hypercellularity and hyperplasia of myeloid, erythroid, and megakaryocyte series (1,000×).

Cytogenetics

In early studies of cytogenetic abnormalities associated with PV, aneuploidy was noted in some patients; however, many subjects had been treated previously and modern banding techniques were not used.¹⁴⁹ In more modern studies, cytogenetic abnormalities were observed in 20% to 43% of patients.^{150, 151} and ¹⁵² The frequency of chromosomal abnormalities varied with the clinical picture. Results from two series are presented in Table 82.2.^{151,152} Fewer than 20% of patients studied at diagnosis had a cytogenetic abnormality. Patients evaluated during a clinical course not associated with progression had cytogenetic abnormalities in 25% to 35% of cases. However, patients who progressed to either myeloid metaplasia, myelofibrosis, or acute leukemia/myelodysplastic syndrome had abnormal cytogenetics in 75% to 100% of evaluations. The greater frequency of cytogenetic abnormalities in patients progressing to myelofibrosis in one of these series may reflect the greater utilization of ³²P therapy and alkylating agents among those patients.¹⁵² The cytogenetic abnormalities most commonly observed were trisomy 8, trisomy 9, and deletions of Y, 5q, 6q, 7q, 11q, 13q, and 20q.¹⁵¹ Although cytogenetics do not predict outcome, they appear to be correlated with disease stage and duration. Specific evaluation for trisomy 8, trisomy 9, and 20q- by fluorescent in situ hybridization may be a useful adjunct to conventional cytogenetics.¹⁵³

PATHOGENESIS

The cause of PV is unknown. The early suggestion that this disease was the compensatory result of anoxemia of the bone marrow was based on the presence of capillary thickening and subintimal and adventitial fibrosis of small vessels in the bone marrow.¹⁵⁴ Direct measurements of bone marrow oxygen saturation, however, gave normal values,¹⁵⁵ and the lack of elevated serum or urinary erythropoietin levels^{156,157} is also contrary to this hypothesis.

Clonality

In view of the increased production and turnover of erythrocytes, neutrophils, and platelets as well as the hypercellular marrow, hematopoiesis in PV is abnormal at a multipotent progenitor or stem cell level. Evidence supporting this hypothesis was provided by a study of two black female patients with PV who were heterozygous for X-linked glucose-6-phosphate dehydrogenase deficiency.¹⁵⁸ In these patients, tissues not affected by PV (skin fibroblasts and lymphocytes) possessed both A- and B-type glucose-6-phosphate dehydrogenase isozymes, as expected. Red blood cells, granulocytes, and platelets contained only one isozyme (type A), however, thus demonstrating a probable clonal origin of this disorder at a pluripotent hematopoietic progenitor level. In one other patient, most B lymphocytes were also from the disease clone,¹⁵⁹ indicating involvement of an earlier hematopoietic progenitor that had differentiation potential for the lymphoid as well as the myeloid, erythroid, and megakaryocytic series.

TABLE 82.2 FREQUENCY OF ABNORMAL CYTOGENETICS BY POLYCYTHEMIA VERA DISEASE STAGE IN TWO SERIES

Reference	Patient Number	Frequency (Expressed as Percentage of Patients)				
		At Diagnosis	Polycythemia Vera	Myelofibrosis	Myeloid Metaplasia	Acute Leukemia/Myelodysplasia
146	64	17	32	85	75	75
145	37	14	25	40	78	100

Hematopoietic Progenitor Studies

The number of erythroid progenitors (burst-forming units-erythroid [BFUs-E] and colony-forming units-erythroid [CFUs-E]) detected in PV patients has been variously reported as either similar to that observed in normal persons or increased.^{160,161} It has also been suggested that there is an increase in cycling of primitive BFUs-E, and that CFUs-E (typically observed only in marrow) are to be found in the peripheral blood of patients with PV.^{162,163}

A hallmark of PV (and other myeloproliferative disorders as well) is erythroid progenitor colony formation in vitro without the addition of exogenous erythropoietin, the phenomenon called endogenous erythroid colonies (EECs) or sometimes erythropoietin-independent colony formation.^{164,165} This phenomenon has been observed with progenitors cultured from the marrow or the blood^{162,163,166, 167, 168} and ¹⁶⁹ of PV patients. This can be a consequence of true erythropoietin independence or of exquisite sensitivity to erythropoietin, which would permit a response to the extremely small quantities of erythropoietin present in the serum used in culture media. A variety of investigators, using either serum-free medium or neutralizing antibodies to erythropoietin in serum-containing medium, have provided data suggesting that

EECs are a consequence of enhanced sensitivity to erythropoietin.^{168,170,171,172} Another group subsequently reported studies suggesting that EECs are a consequence of an altered response pattern induced by hypersensitivity to interleukin-3.¹⁷³ Studies using antibodies capable of blocking the erythropoietin receptor suggest that BFUs-E fall into two categories: those that exhibit a normal response to erythropoietin and those that are truly erythropoietin independent.¹⁷⁴

In addition to interleukin-3 and erythropoietin, erythroid progenitors from PV patients have been reported to exhibit hypersensitivity to granulocyte-macrophage colony-stimulating factor, interleukin-1, stem cell factor, and insulinlike growth factor-1.^{175, 176, 177, 178, 179} and¹⁸⁰

Hematopoietic Growth Factor Signal Transduction

The reported hypersensitivity of erythroid progenitors to erythropoietin in PV prompted evaluation of the erythropoietin receptor in this disease. The normal human erythropoietin receptor, although the product of a single gene, is detected on CFU-E as a high- and low-affinity receptor.^{181,182} In CFU-E

P.1728

generated from PV patients, only the low-affinity receptor is present.¹⁸³ This differs from the finding in normal individuals, patients with hemolysis, or patients with secondary erythrocytosis. Studies of the erythropoietin receptor gene in PV have typically shown no mutations,^{184,185} suggesting that the detection of only the low-affinity receptor class is the result of an alteration in post-translational processing. Normal erythroid progenitors have been reported to express both a full-length erythropoietin receptor and a nonfunctional truncated version, which is believed to act as a dominant negative regulator of erythropoietin signal transduction. Expression of the truncated variant is reportedly decreased in PV patients, suggesting a mechanism for erythropoietin hypersensitivity.¹⁸⁶

The thrombopoietin receptor (Mpl) has been reported to be markedly decreased or absent on the platelets of PV patients and also of some individuals with myelofibrosis.¹⁸⁷ These individuals exhibit decreased thrombopoietin-induced tyrosine phosphorylation.¹⁸⁷ This decrease in phosphorylation appears to result from aberrant signaling through an abnormal Mpl characterized by decreased glycosylation.^{188,189} It has been suggested that this abnormality in Mpl expression and function is both a marker for PV and, through suppression of apoptosis, a potential pathophysiologic contributor.¹⁸⁸ Other investigators have questioned the usefulness of Mpl as a diagnostic marker of PV, as marked heterogeneity in its expression was observed in their laboratory, resulting in overlap with normal individuals.¹⁹⁰

The characteristic behavior of hematopoietic progenitors in PV may also reflect constitutive or deregulated activation of antiapoptotic mechanisms. Various investigators studying PV have reported constitutive activation of STAT3¹⁹¹; deregulation of the antiapoptotic protein Bcl-x^{192,193}; decreased expression of SHP-1 phosphatase, a negative regulator of hematopoietic growth factor-induced mitogenesis¹⁹⁴; increased protein tyrosine phosphatase activity¹⁹⁵; decreased sensitivity of protein kinase C to the effects of inhibitors¹⁹⁶; decreased expression of the tumor suppressor gene H19¹⁹⁷; and increased expression of FLIPshort, a cellular inhibitor of death-receptor-induced apoptosis.¹⁹⁸ Activation of STAT5 and/or Bcl-xL in erythroid progenitors leads to erythropoietin-independent colony formation.¹⁹⁹

CD177 (PRV-1) is a gene of the urokinase plasminogen activator receptor superfamily, which is highly expressed in granulocytes from PV patients but not from patients with other chronic myeloproliferative disorders or from normal individuals.²⁰⁰ Polymerase chain-reaction-based techniques for detecting PRV-1 have been developed, and appear to be highly sensitive and specific for PV.²⁰¹ PRV-1 expression is highly correlated with expression of the JAK2 V617F mutation (discussed below).²⁰²

JAK2

The observation that patients with myeloproliferative disorders frequently have a gain-of-function mutation on the short arm of chromosome 9, in which the valine at position 617 of the Janus kinase 2 gene is replaced by phenylalanine (JAK2 V617F),²⁰³ has had significant impact on the approach to the diagnosis of PV and on investigation into its pathogenesis. This mutation results in constitutive activation of tyrosine kinase signaling through the JAK/STAT pathways. JAK2 V617F has been reported to be present in up to 96% of PV patients at diagnosis,²⁰⁴ and correlates strongly with the PVSG and 2001 WHO criteria for the diagnosis of PV.²⁰⁵ However, it is not pathognomonic for PV, inasmuch as a significant proportion of patients with essential thrombocytosis and myelofibrosis also have the JAK2 V617F mutation.²⁰⁴ PV patients who lack the JAK2 V617F mutation often have mutations in exon 12 of the JAK2 gene.^{206,207,208,209}

Although mice expressing JAK2 V617F have a clinical phenotype resembling a myeloproliferative disorder,²¹⁰ JAK2 mutations do not appear to be the initiating event in the molecular cascade leading to PV, but rather appear to be a relatively late event.^{211,212} The specific phenotype seen with JAK2 V617F mutations is effected by concurrent expression of

other genes (TET2,²¹³ PRV1,²¹⁴ and IDH1 or IDH2²¹⁵) and by the JAK2 haplotype.²¹⁶ JAK2 V617F expression correlates with the expression of erythrocyte adhesion molecules such as laminin α_5 and Lu/BCAM.^{217,218}

DIAGNOSIS

In order to standardize the diagnostic basis of PV so that all patients included in their protocols had clear-cut and inarguable PV, the PVSG developed a set of criteria that were useful clinically and conceptually (Table 82.3).¹¹ The diagnosis of PV required the presence of all three major criteria (M) or the first two major criteria and two minor criteria (m). The first major criterion provided confirmation that the patient has actual polycythemia, as indicated by an elevated red cell mass. The second major criterion ruled out the most common etiology of secondary polycythemia, severe arterial hypoxemia, by demonstrating a normal or only moderately reduced arterial oxygen saturation. The third requirement, evidence of a myeloproliferative syndrome, was met either by the third major criterion, splenomegaly appreciable on physical examination, or by two of the four minor criteria. Over the years, a number of alternate major and minor criteria developed^{113,219} (Table 82.3).

PVSG's goal was to establish exclusive criteria. Although most PV patients meet the PVSG criteria, some do not. The current (2007) WHO criteria and the ECP diagnostic criteria for the diagnosis of PV were developed to address the perceived deficiencies of the PVSG criteria (Table 82.4). The ECP criteria are strongly oriented toward morphologic and molecular diagnostic criteria, and separate PV into overt PV (having a high red cell mass) and early PV.^{74,133} For purposes of research or publication, the 2007 WHO and/or ECP criteria have largely replaced the PVSG criteria, although not without some controversy.²²⁰ The WHO and ECP criteria may be less applicable to childhood PV.²²¹

The diagnostic approach to erythrocytosis is outlined in Chapter 44 and Tables 44.3 and 44.4. In essence, a patient with polycythemia should undergo testing for JAK2 V617F. If positive, the patient presumably has PV, although a low erythropoietin concentration or a characteristic bone marrow examination is required for confirmation. If JAK2 V617F is not present, then one must decide if features are suggestive of PV (essentially, the criteria listed in Table 82.3), or if one should proceed to identify an etiology of secondary polycythemia. Some clinical situations, such as distinguishing JAK2 V617F-positive essential thrombocytosis with concurrent secondary polycythemia from PV, may be challenging to sort out.

In JAK2 V617F-negative patients, testing for alternate JAK2 mutations can be considered. It has been suggested that JAK2 exon 12 mutations identify a specific subset of PV characterized by "pure" erythrocytosis, with few or no abnormalities in the white blood cell or platelet lineages.^{206,222}

NATURAL HISTORY

The clinical picture of PV is characterized by the complications of polycythemia-induced hyperviscosity, expanded blood volume, and thrombosis. The occurrence of these complications is significantly affected by therapy and is discussed under specific therapeutic modalities.

Two other significant complications that may be observed late in the course of PV are the development of myeloid metaplasia with myelofibrosis and acute leukemia. In perhaps 25% of patients with PV, a progressive reduction in erythrocyte survival, decreased erythropoiesis, and myelofibrosis develop.²²³

P.1729

Extramedullary hematopoiesis takes place in the spleen and liver. A rising leukocyte count with increased immature myeloid forms accompanies these changes. In addition, the teardrop and nucleated red cells characteristic of myelofibrosis and myeloid metaplasia appear in the blood. The spleen may enlarge dramatically. A picture simulating that of acute myeloblastic leukemia develops in approximately one third of these patients.²²³ Others develop progressive anemia and thrombocytopenia and die of a variety of intercurrent complications in the "spent" or "burnt-out" phase of myeloid metaplasia.²²⁴ It has been suggested that post-polycythemia myeloid metaplasia syndrome was related to the use of ³²P therapy,²²⁴ although it clearly occurs in patients who have never received this therapy. In still other patients,^{10,223} an acute leukemia-like picture develops without preceding evidence of myeloid metaplasia or myelofibrosis. It has been suggested that the small number of patients who have cytogenetic abnormalities at diagnosis are those who will eventually develop leukemia, but this is not observed in all series.^{151,152,223} The effect of therapy on the development of leukemia is discussed in the "Chemotherapy" section that follows.

TABLE 82.3 POLYCYTHEMIA VERA STUDY GROUP DIAGNOSTIC CRITERIA: SIGNIFICANCE AND PROPOSED ALTERNATIVES/ADDITIONS

Significance	Original Criteria	Alternative/Additional Criteria
---------------------	--------------------------	--

M1. Identifies actual polycythemia vs. spurious polycythemia	M1. Increased RCM Male >36 ml/mg Female >32 ml/kg	M1. RCM > 125% of predicted
M2. Rules out most common etiology of secondary polycythemia	M2. Arterial O ₂ saturation > 92%	M2. Serum erythropoietin concentration not elevated
M3. Evidence of a myeloproliferative state	M3. Clinical splenomegaly or two of the following: m1. Thrombocytosis > 400,000/ μ l m2. Leukocytosis > 12,000/ μ l m3. Leukocyte alkaline phosphatase activity > 100 (no fever or infection) m4. Serum B ₁₂ (>900 pg/ml) or unsaturated B ₁₂ binding capacity (>2,200 pg/ml)	M3. (Additional minor criteria) Splenomegaly apparent only on scans Hypercellular marrow with trilineage hyperplasia Characteristic hematopoietic colony response to growth factors Evidence of clonal marrow cell population PRV-1 gene expression in granulocytes Decreased Mpl expression on platelets

RCM, red cell mass.

A number of other diseases have been reported in association with PV. It is unclear whether these represent coincidence or an actual pathophysiologic relationship. These include hyperthyroidism,²²⁵ neurofibromatosis (von Recklinghausen disease),²²⁶ chronic lymphocytic leukemia,²²⁷ lymphoma, multiple myeloma,²²⁸ as well as development of a marrow picture resembling aplastic anemia²²⁹ or pernicious anemia.^{230,231}

The median survival of untreated PV patients is reported to be 18 months²³²; in a more contemporaneous series of treated patients, median survival is greater than 15 years.¹⁰ Overall survival of PV patients appears decreased compared to age- and sex-matched controls.²³³ Table 82.5 gives the causes of death from three large series of PV patients.^{10,234,235} Thrombotic and cardiovascular events are the leading cause of death, followed by acute leukemia and other malignancies, hemorrhage, and myelofibrosis/myeloid metaplasia, which represented 2% to 4% of patients. The most important predictors of cardiovascular events are age older than 65 and a history of thrombosis.²³⁵ The JAK2 V617F allele burden appears to identify patients at higher risk for major vascular events and evolution to myelofibrosis, inasmuch as it also identifies patients more likely to have marked leukocytosis,²³⁶ which may be the basis for the increased risk.^{237,238}

TREATMENT

The object of therapy in PV is to produce a reduction in the red cell mass by methods that (a) permit the longest survival; (b) are associated with fewest significant complications, allowing the patient maximum quality of life; and (c) are least expensive and inconvenient for the patient.

Phlebotomy

Phlebotomy offers prompt and effective reduction of the red cell mass and blood volume to normal values. Many patients can be maintained in an essentially normal state by phlebotomy together with a few simple adjuvants, when necessary, to control hyperuricemia or pruritus. The advantages of phlebotomy are that it is inexpensive, requires extremely limited technical support, and allows rapid control of symptoms. Criticisms of phlebotomy are the potential problem of venous access in elderly patients, that it does not address leukocytosis or thrombocytosis, and that erythropoiesis is stimulated by the blood loss.¹⁵⁶ This last point is only a transient concern; the goal of phlebotomy is to induce a state of iron deficiency that will itself suppress erythropoiesis.

The PVSG took patients who had been phlebotomized to maintain a normal hematocrit (≤ 0.45) and then randomized patients to phlebotomy to maintain the hematocrit in this range, to therapy with ^{32}P , or to therapy with chlorambucil.²³⁹ Median survival from study entry until death was 9.1 years for patients in the chlorambucil arm, 10.9 years for ^{32}P -treated patients, and 12.6 years for phlebotomized patients ($P = 0.008$). The survival differences did not become apparent until after 7 years into the study, indicating that the development of late events (principally leukemia) was responsible for these differences.²³⁹ Acute leukemia developed in 1.5% of phlebotomy patients, 14.2% of chlorambucil patients, and 9.6% of ^{32}P patients. This complication was more frequent in patients with the “spent phase” of PV. Myelofibrosis was observed in 8.6%, 7.1%, and 7.7% of the phlebotomy, chlorambucil, and ^{32}P patients, respectively.²³⁹

The apparent advantage of phlebotomy was undercut by an increased risk of thrombosis. Thrombosis-free cumulative survival was significantly worse in the phlebotomy arm ($P = 0.015$). This increased risk was predominantly limited to the first 3 years of therapy.²³⁹ Advanced age and history of previous thrombosis contributed to the relative risk of thrombosis in this and other studies.^{10,234}

P.1730

TABLE 82.4 2007 WORLD HEALTH ORGANIZATION AND EUROPEAN CLINICAL AND PATHOLOGICAL CRITERIA FOR DIAGNOSIS OF POLYCYTHEMIA VERA^{74, 133}

Who	Ecp
Major Criteria	Pathologic Criteria
A1. Hb > 18.5 g/dl male/16.5 g/dl female; or other evidence of increased RCM	P1. Marrow morphology
A2. Presence of <i>JAK2</i> V617F or other functionally similar mutation	P2. Bone marrow EEC formation
Minor Criteria	P3. <i>JAK2</i> V617F mutation
B1. Marrow morphology	Clinical Criteria
B2. Serum erythropoietin below reference range for normal 0.43-0.46 female	C1. Increased RCM (same as WHO A1)
B3. EEC colony formation in vitro	C2. Hematocrit 0.45-0.51 male
Marrow morphology: hypercellular marrow with trilineage hyperplasia; clustering of pleomorphic megakaryocytes; absent stainable iron; no major inflammatory features	C3. Low serum erythropoietin
	C4. Persistent thrombocytosis
	Grade I: 400,000-1,500,000/ μl ;
	Grade II: >1,500,000/ μl
	C5. Palpable splenomegaly or radiologic splenomegaly > 12 cm
	C6. Granulocytosis > 10,000/ μl ; or leukocytosis > 12,000/ μl ; or increased LAP score; or increased PRV-1 expression, in absence of fever or infection
	C7. Platelet-mediated microvascular disease or thrombosis
	C8. Typical PV signs/symptoms of hypervolemia
	C9. Pruritus, fatigue, upper abdominal discomfort

<p>Diagnosis</p> <p>A1 + A2 + any one from B</p> <p>A1 + any two from B</p>	<p>C10. Absence of secondary erythrocytosis</p> <p>Diagnosis</p> <p>P1 + P2 + P3 = PV</p> <p>P1 + P2 + P3 + C1 = overt PV</p> <p>P1 + P2 + P3 + C2 + any</p> <p>(C3-C10) = early PV</p>
---	---

ECP, European Clinical and Pathological; EEC, endogenous erythroid colony formation; Hb, hemoglobin; LAP, leukocyte alkaline phosphatase; PV, polycythemia vera; RCM, red cell mass; WHO, World Health Organization.

Phlebotomy and Antiplatelet Agents

In an effort to reduce the thrombotic risk that impairs the otherwise excellent response to phlebotomy, the PVSG randomized patients to phlebotomy with aspirin, 300 mg three times daily, and dipyridamole, 75 mg three times daily, versus ³²P. The study was stopped early because of excessive thrombosis, hemorrhage, and death in the phlebotomy/aspirin/dipyridamole arm.²³⁹ A subsequent study, however, found that total aspirin doses of 325 mg/day or less and phlebotomy resulted in no hemorrhagic or thrombotic complications in 69 patient-years of follow-up.²⁴⁰ However, this latter study contained a preponderance of patients with known disease duration longer than 3 years; as discussed above, the thrombotic risk occurs predominantly in the first 3 years after diagnosis. A small placebo-controlled study performed by the GISP using an aspirin dose of 40 mg/day (112 patients followed for 1 year) reported similar results.²⁴¹ The European Collaborative for Low Dose Aspirin in Polycythemia Vera study randomized 518 patients to aspirin 100 mg/day or placebo, and followed them for at least a year. Median duration since the diagnosis of PV was <5 years. Patients in the aspirin group had no increased bleeding incidence and had a decrease of combined endpoint including nonfatal stroke, nonfatal myocardial infarction, pulmonary embolism, and major venous thrombosis. However, there was no impact on cardiovascular mortality or overall mortality.²⁴² This study supports the safety of administering low-dose aspirin; its efficacy may have been underestimated, because optimum control of the hematocrit appears not to have been obtained in most patients (median hematocrit 0.48).²⁴² In a large retrospective study, patients treated with antithrombotic agents such as aspirin, phlebotomy to keep the hematocrit < 0.48, and who did not receive alkylating agents, had survival that did not differ from that of healthy age-matched controls.²⁴³

TABLE 82.5 CAUSES OF DEATH IN POLYCYTHEMIA VERA PATIENTS

Cause of Death	PVSG (%)	GISP (%)	ECLAP (%)
Thrombosis/thromboembolism	31	29.7	26
Acute myeloid leukemia	19	14.6	12.5
Other malignancy	15	15.5	20
Hemorrhage	6	2.6	4
Myelofibrosis/myeloid metaplasia	4	2.6	0.5
Other	25	35.0	37

ECLAP, European Collaborative on Low-Dose Aspirin in Polycythemia Vera²³⁵; GISP, Gruppo Italiano Studio Policitemia¹⁰; PVSG, Polycythemia Vera Study Group.²³⁴

The goal of phlebotomy should be to maintain the hematocrit in the normal range (0.42 to 0.44 for men, 0.39 to 0.42 for women). This reflects a slight reduction in the previous upper limit target for men: the Cyto-reductive Therapy in Polycythemia Vera (CYTO-PV) Collaborative Group has recently reported that patients treated with a hematocrit goal of less than 0.45 had significantly lower cardiovascular mortality and fewer major thrombotic events than patients in the 0.45 to 0.50 hematocrit ranged. Patients with hematocrits < 0.45 obtained their target with phlebotomy with or without cyto-reductive drugs as needed.²⁴⁴ In elderly patients, patients with known cardiovascular disease, or hospitalized patients with severe symptoms, phlebotomy should be initiated cautiously, either using frequent small-volume phlebotomy (100 to 150 ml every day or on alternate days) or in larger (500 ml) volumes using fluid replacement so that the patient remains isovolemic.²⁴⁵ The hazards of excessively aggressive initial phlebotomy have been well described.²⁴⁶ After the hematocrit

falls to <0.55, or more than 750 to 1,000 ml of blood have been removed, phlebotomy of 250 to 500 ml can generally be carried out safely at weekly or less frequent intervals, as clinically indicated. Some advocate the administration of iron during phlebotomy to prevent the “symptoms” of iron deficiency. In many ways, this defeats the long-term purpose of phlebotomy, which is to establish a state of iron deficiency that will restrict red cell production. It has also been demonstrated that iron-deficient PV patients have no significant symptoms compared with other PV patients.²⁴⁷

P.1731

Chemotherapy

Alkylating Agents

Many chemotherapeutic agents have been used for the treatment of PV. Many agents fell into disuse through a poor toxicity-to-efficacy ratio and are noted here for historical interest: these include nitrogen mustard,²⁴⁸ melphalan,²⁴⁹ triethylene melamine,²⁵⁰ pyrimethamine,²⁵¹ and Vercyte (a neutral piperazine compound).²⁵² Busulfan,²⁵³ pipobroman,²⁵⁴ and chlorambucil²⁵⁵ are alkylating agents that were widely used in PV in the modern era, but the increased frequency of leukemia observed with alkylating agents led to a discontinuation of their first-line use.^{234,256,257} They may have some utility in selected high-risk cases resistant to other modalities.

Hydroxyurea

The nonalkylating myelosuppressive agent hydroxyurea is the chemotherapeutic agent most widely used in PV at present.^{258,259} Its efficacy in controlling erythrocyte, leukocyte, and platelet counts in PV has been clearly demonstrated.^{260,261} Thrombotic complications are less common than are observed in patients treated with phlebotomy only.²³⁹ Hydroxyurea permits rapid reduction of leukocyte and platelet counts; supplemental phlebotomy may occasionally be necessary to reduce the red cell mass.²³⁹ As a rule, neutropenia or thrombocytopenia corrects rapidly after cessation or reduction of hydroxyurea dose; for the same reason, however, missing a few days of therapy may be associated with recurrence of leukocytosis or thrombocytosis.

The incidence of leukemia in patients treated long term with hydroxyurea appears to be low and similar to that observed in patients treated with phlebotomy alone.^{239,256,262,263} However, a study in which older PV patients initially treated with ³²P were randomized to maintenance with hydroxyurea or observation with phlebotomy showed a higher incidence of leukemia in the hydroxyurea arm. This suggests that there may be at least some leukemogenic potential with this agent.²⁶⁴ A higher JAK2 V617F allele burden has been reported to predict sensitivity to hydroxyurea.²⁶⁵ Response to hydroxyurea has been associated with a decline in JAK2 V617F expression by some^{266,267} but not all²⁶⁸ investigators. The usual starting dose of hydroxyurea is 500 mg either once or twice daily and is adjusted according to clinical requirements. The development of leg ulcers, particularly over the malleoli of the ankles, is an idiosyncratic adverse effect requiring immediate drug cessation.^{269, 270} and ²⁷¹

Interferon

Recombinant human interferon- α is an agent that has also demonstrated efficacy in PV.^{272, 273} and ²⁷⁴ In at least one study, interferon was more efficacious than phlebotomy.²⁷⁴ Another group found that only a subset of patients was responsive to interferon.²⁷³ In general, interferon appears to control leukocytosis and thrombocytosis and to reduce or eliminate the need for phlebotomy in a significant proportion of patients.^{275,276,277} It also appears to improve pruritus.^{275,276,278} Reversal of marrow fibrosis has been reported in some, although not all, studies.^{275,279} Pegylated interferon- α may decrease the expression of JAK2 V617F, suggesting that it induces responses at a molecular level, rather than simply controlling abnormal blood counts.²⁸⁰ The precise role of interferon in PV, whether as therapy of first or later choice, remains to be firmly established, as does its optimum dose schedule.²⁵⁹ Many hematologists use interferon as first-line therapy in younger patients, particularly women of childbearing years.

Anagrelide

Anagrelide is a platelet-aggregating agent that is useful in the control of thrombocytosis refractory to hydroxyurea or interferon in myeloproliferative disorders such as PV.²⁸¹ A large study of anagrelide and low-dose aspirin compared to hydroxyurea and low-dose aspirin in essential thrombocytosis patients at high risk for vascular events found that control of platelet counts was equivalent, but patients in the anagrelide arm had a higher rate of arterial thrombosis, serious hemorrhage, and transformation to myelofibrosis, but a lower rate of venous thrombosis.²⁸² These findings, although not directly referring to PV, suggest that anagrelide should stay a second-line agent for thrombocytosis.

Imatinib Mesylate

Imatinib mesylate has been reported to decrease blood counts, splenomegaly, and need for phlebotomy in small series of PV patients.^{283, 284} and ²⁸⁵ This presumably reflects effects mediated through c-kit. Other studies of imatinib in PV have been less encouraging.²⁸⁶ Imatinib may be most useful in younger PV patients with normal or near-normal platelet counts.²⁸⁷

Anti-JAK2 Agents

Given the significant role of JAK2 V617F in the pathogenesis and diagnosis of PV, agents directed against JAK2 would appear to be promising additions to the therapeutic armamentarium. At present, such agents appear to be beneficial in symptoms of post-PV myelofibrosis or for splenomegaly, but not for molecular improvement.²⁸⁸ Therapy targeted against JAK2 may benefit refractory pruritus in PV patients.⁴⁰

Radioactive Phosphorus

Whole-body or regional external beam irradiation is not especially useful in PV.²⁸⁹ However, administration of ³²P was first- or second-line therapy for many years. It fell into disfavor because of the increased incidence of acute leukemia (10% to 15%), developing 7 or more years after treatment.^{225,239,290} However, it may be useful in carefully selected high-risk elderly patients with limited life expectancy. In such patients, ³²P is effective and easily tolerated therapy that can induce satisfactory clinical and hematologic remissions that may last years.^{291,292} Survival after treatment is reported to be 10 to 14.5 years.^{100,290,293}

³²P is provided as a dibasic sodium salt and administered intravenously.^{292,294} It passes to tissues like bone that have a high phosphorus content and metabolize phosphorus rapidly. Its uptake by rapidly dividing cells is greater than that by normal cells. Because the physical half-life of this isotope is 14.3 days, steady irradiation of tissue takes place for several weeks.²⁹⁴ The fall in the red cell count usually does not begin until 30 to 60 days from the time ³²P is given.

A usual dose is 3 to 5 mCi of ³²P intravenously, or 2.3 mCi/m.^{221,295} No additional ³²P is given for 3 months to avoid cumulative effects. If the hematocrit rises above 0.44 in the interval, phlebotomy should be performed. If, after 3 months, the need for phlebotomy persists and leukopenia and thrombocytopenia are not present, a second injection of 1 to 4 mCi may be given. Examinations are repeated at 3-month intervals. Some patients do not require a second injection or further phlebotomies for 6 to 18 months or longer. A small minority, reportedly 10% of patients, need a third injection. After this third injection, no further injections are given for at least 12 to 18 months.²⁹⁶

An analysis of 300 courses administered to 139 patients showed that an average of 6.7 mCi had been given during the first 6 months of treatment.¹⁰⁰ Most of these patients were re-treated

P.1732

within intervals of 6 to 10 months. In another series of 241 patients,²⁹⁷ the average dose required to produce remissions was 5.7 mCi in patients without leukocytosis or myeloid immaturity and as much as 8.3 mCi in others. The range of dose required was 3 to 21 mCi.

As outlined above, the benefits of ³²P may exceed the potential risks in a very small number of carefully selected elderly symptomatic patients who are resistant to, or intolerant of, other modalities. Obviously a full explanation of the associated risks and benefit is required prior to treatment.

Other Modalities

Splenectomy is useful only as a palliative measure in the late stages of the disease, when the spleen becomes massive and causes early satiety and weight loss, severe anemia, or thrombocytopenia.²²² Hematopoietic stem cell transplantation has been reported in 10 PV patients who had progressed to myelofibrosis or myelodysplastic syndrome/acute leukemia.²⁹⁸ Five of these patients had a complete response. There is also one report of a successful bone marrow transplant in an adolescent with PV.²⁹⁹

Special Topics

Pruritus

It has been reported that pruritus, upper gastrointestinal distress, and the urticarial manifestations of PV correlate with increased levels of whole blood histamine, which in turn is roughly related to the basophil leukocyte count³⁰⁰ (although other studies have questioned this model³⁰¹). These clinical manifestations were controlled by the administration of a potent antihistaminic agent, cyproheptadine (4 mg three or four times per day), in 12 of 18 patients so treated.³⁰⁰

Cimetidine,³⁰² serotonin release inhibitors,⁴⁰ and hydroxyurea⁴⁰ have been useful in approximately 40% of patients with pruritus. Interferon has been used in intractable cases.²⁷⁷ Anecdotal experience suggests that aspirin (80 to 325 mg/day) also relieves pruritus in certain patients. Experimental agents showing efficacy against pruritus include JAK2 inhibitors and mammalian target of rapamycin (mTOR) inhibitors.⁴⁰ As noted earlier, the most effective management of pruritus is establishing good hematologic control of PV.

Hyperuricemia

Because of the excessive urinary load of uric acid excreted by patients with myeloproliferative disorders,³⁰³ urate may be precipitated in the kidneys, leading to stone formation or nephropathy. An effective means of reducing uric acid production in patients with PV, other than by myelosuppression, is by the use of allopurinol, 300 mg/day.²⁷⁸ This agent is most useful during the short periods at the initiation of cytoreductive therapy when cell turnover is likely to be high and the avoidance of uric acid deposition is a major concern.

Surgery

Patients with poorly controlled PV are at increased risk for complications of elective surgery. In a series of 54 PV patients, a complication rate of 83% (46% morbidity, 37% mortality) was observed in poorly controlled patients, compared to a complication rate of 21% (16% morbidity, 5% mortality) in well-controlled patients.³⁰⁴ Fewer and less serious complications were observed in patients who had had stable, well-controlled counts for more than 4 months.³⁰⁴ It is recommended that PV patients undergoing elective surgery be in good hematologic control for at least 4 months. In more urgent surgery, control should be obtained as quickly as possible using phlebotomy with volume replacement, hydroxyurea, and cytapheeresis if necessary, and should be maintained as long as possible pre- and post operatively.

Summary and Recommendations for Treatment

Although treatment with any of a variety of approaches is effective and prolongs survival, no modality is clearly the best for everyone. The following recommendations represent a reasonable approach. More detailed recommendations have been published elsewhere.^{259,305,306,307}

Most newly diagnosed patients should undergo phlebotomy to obtain symptomatic control of polycythemia. The rate and volume of phlebotomy are dictated by the patient's clinical status, as out-lined in the section on phlebotomy above. The hematocrit should be reduced to the upper normal range (<0.45 for men, 0.39 to 0.42 for women).

The long-term therapy chosen to control PV varies according to the patient's clinical status. Young patients (younger than 50 years) with no history of thrombosis and without severe thrombocytosis ($>1,000 \times 10^9/L$) can probably be managed best with phlebotomy alone, with a target hematocrit as above. The addition of aspirin, 325 mg/day or less, may be beneficial. Patients with a history of thrombosis who are older than 65 to 70 years should be treated with myelosuppressive agents.²⁵⁸ Patients with severe thrombocytosis are considered by many hematologists to be in this category, as well. Patients between the ages of 50 and 65 to 70 years with no history of thrombosis or severe thrombocytosis can be managed with myelosuppressive agents or phlebotomy, although the latter modality may increase their risk for thrombotic events.

The current myelosuppressive agent of first choice is hydroxyurea. Although the additional risk of leukemia with long-term hydroxyurea therapy appears to be small, it is probably not zero.^{234,308} Interferon is clearly an effective agent in PV and should be considered a possible alternative to hydroxyurea. It may be particularly useful in younger patients and women of childbearing years. Imatinib may be useful in young patients with normal platelet counts. ³²P may be beneficial in a small number of very carefully selected symptomatic elderly patients refractory to or intolerant of other approaches, in whom the potential leukemic risks are outweighed by limitations imposed by other clinical conditions.

REFERENCES

1. Vaquez H. Sur une forme speciale de cyanose s'accompanant d'hyperglobulie excessive et persistante. C R Soc Biol (Paris) 1892;4:384.
2. Osler W. Chronic cyanosis with polycythemia and enlarged spleen; a new clinical entity. Am J Med Sci 1903;126:187-201.
3. Osler W. Erythremia (polycythemia with cyanosis, Maladie de Vaquez). Lancet 1908;1:143-146.
4. Osler W. Splenic polycythaemia with cyanosis. Proc R Soc Med 1908;1(Clin Sect):41-43.
5. Turk W. Beitrage zur Kenntniss des symptomensbildes Polyzythmie mit Milztumor und Zyanose. Wien Med Wochenschr 1904;17:153-160.

6. Means RT. Perspective: Osler's 1903 paper on polycythemia vera. *Am J Med Sci* 2008;335(6):418-419.
7. Ania BJ, Suman VJ, Sobell JL, Codd MB, Silverstein MN, Melton LJ 3rd. Trends in the incidence of polycythemia vera among Olmstead County, Minnesota, residents, 1935-1989. *Am J Hematol* 1994;47:89-93.
8. Berglund S, Zettervall O. Incidence of polycythemia vera in a defined population. *Eur J Haematol* 1992;48:20-26.
9. Modan B. An epidemiological study of polycythemia vera. *Blood* 1965;26(5):657-667.
10. Policitemia GIS. Polycythemia vera: the natural history of 1213 patients followed for 20 years. *Ann Intern Med* 1995;123(9):656-664.
11. Berlin NI. Diagnosis and classification of the polycythemias. *Semin Hematol* 1975;12(4):339-351.
12. Calabresi P, Meyer OO. Polycythemia vera. I. Clinical and laboratory manifestations. *Ann Intern Med* 1959;50(5):1182-1202.
13. Damon A, Holub DA. Host factors in polycythemia vera. *Ann Intern Med* 1958;49(1):43-60.
14. Osgood EE. Polycythemia vera: age relationships and survival. *Blood* 1965;26:243-256.
15. Szur L, Lewis SM, Goolden AW. Polycythaemia vera and its treatment with radioactive phosphorus. A review of 90 cases. *Q J Med* 1959;28:397-424.
16. Danish EH, Rasch CA, Harris JW. Polycythemia vera in childhood: case report and review of the literature. *Am J Hematol* 1980;9(4):421-428.
17. Najean Y, Mugnier P, Dresch C, Rain JD. Polycythemia vera in young people: an analysis of 58 cases diagnosed before 40 years. *Br J Haematol* 1987;67:285-291.
18. Wasi P, Block M. Polycythemia vera in a Negro woman. *Arch Intern Med* 1961;107:260-263.
19. Chaiter Y, Brenner B, Aghai E, Tatarsky I. High incidence of myeloproliferative disorders in Ashkenazi Jews in northern Israel. *Leuk Lymphoma* 1992;7:251-255.
20. Modan B, Kallner H, Zemer D, Yoran C. A note on the increased risk of polycythemia vera in Jews. *Blood* 1971;37(2):172-176.
21. Brubaker LH, Wasserman LR, Goldberg JD, et al. Increased prevalence of polycythemia vera in parents of patients on Polycythemia Vera Study Group protocols. *Am J Hematol* 1984;16(4):367-373.
22. Hoffman R, Wasserman LR. Natural history and management of polycythemia vera. *Adv Intern Med* 1979;24:255-285.
23. Inaba T, Shimazaki C, Hirai H, et al. Familial polycythemia vera in father and daughter. *Am J Hematol* 1996;51(2):172.
24. Manoharan A, Garson OM. Familial polycythaemia vera: a study of 3 sisters. *Scand J Haematol* 1976;17(1):10-16.
25. Miller RL, Purvis JD 3rd, Weick JK. Familial polycythemia vera. *Cleve Clin J Med* 1989;56(8):813-818.
26. Hemminki K, Jiang Y. Familial polycythemia vera: results from the Swedish Family-Cancer Database. *Leukemia* 2001;15(8):1313-1315.
27. Hussein K, Bock O, Ballmaier M, et al. Familial polycythemia vera with nongermline JAK2(V617F) mutation sparing the abnormal and clonal granulopoiesis. *Leukemia* 2007;21(12):2566-2568.
28. Lundsgaard C. Erythroslis, or false cyanosis. *J Exp Med* 1919;30(3):295-298.
29. Bluefarb SM. Cutaneous manifestations of polycythemia vera. *Q Bull Northwest Univ Med Sch* 1955;29(1):8-17.
30. Baxter DL, Lockwood JH. Acne urticata polycythemica; report of a case. *Arch Dermatol* 1958;78(3):325-329.
31. Bowdler AJ, Tullett GL. Urticaria pigmentosa and polycythaemia vera: a case report. *Br Med J* 1960;1(5170):396-397.
32. Diamond JH, Gross L. Urticaria pigmentosa complicated by polycythemia vera. Report of a case. *Blood* 1966;27(2):253-257.
33. Handler G, Isenberg L, Greaves MW. Concurrence of urticaria pigmentosa and polycythaemia rubra vera. *Clin Exp Dermatol* 1981;6(1): 43-46.
34. Farrell AM, Sabroe RA, Bunker CB. Urticarial vasculitis associated with polycythaemia rubra vera. *Clin Exp Dermatol* 1996;21(4):302-304.

35. Furukawa T, Takahashi M, Shimada H, Moriyama Y, Shibata A, Katsumi S. Polycythaemia vera with Sweet's syndrome. *Clin Lab Haematol* 1989;11(1): 67-70.
36. Cox NH, Leggat H. Sweet's syndrome associated with polycythemia rubra vera. *J Am Acad Dermatol* 1990;23(6 Pt 1):1171-1172.
37. Wong GA, Guerin DM, Parslew R. Sweet's syndrome and polycythaemia rubra vera. *Clin Exp Dermatol* 2000;25(4):296-298.
38. Gomez Vazquez M, Sanchez-Aguilar D, Peteiro C, Toribio J. Sweet's syndrome and polycythaemia vera. *J Eur Acad Dermatol Venereol* 2005;19(3):382-383.
39. Abdel-Naser MB, Gollnick H, Orfanos CE. Aquagenic pruritus as a presenting symptom of polycythemia vera. *Dermatology* 1993;187(2):130-133.
40. Saini KS, Patnaik MM, Tefferi A. Polycythemia vera-associated pruritus and its management. *Eur J Clin Invest* 2010;40(9):828-834.
41. van Genderen PJJ, Michiels JJ. Erythromelalgic, thrombotic, and haemorrhagic manifestations of thrombocythaemia. *Presse Med* 1994;23:73-77.
42. Michiels JJ, Berneman Z, Schroyens W, et al. Platelet-mediated erythromelalgic, cerebral, ocular and coronary microvascular ischemic and thrombotic manifestations in patients with essential thrombocythemia and polycythemia vera: a distinct aspirin-responsive and coumadin-resistant arterial thrombophilia. *Platelets* 2006;17(8):528-544.
43. Blumgart HL, Gargill SL, Gilligan DR. Studies on the velocity of blood flow: XV. The velocity of blood flow and other aspects of the circulation in patients with "primary" and secondary anemia and in to patients with polycythemia vera. *J Clin Invest* 1931;9(4):679-692.
44. Murray JF, Gold P, Johnson BL Jr. The circulatory effects of hematocrit variations in normovolemic and hypervolemic dogs. *J Clin Invest* 1963;42:1150-1159.
45. Weber PM, Pollycove M, Bacaner MB, Lawrence JH. Cardiac output in polycythemia vera. *J Lab Clin Med* 1969;73(5):753-762.
46. Kayrak M, Acar K, Gul EE, et al. Electrocardiographic findings in patients with polycythemia vera. *Int J Med Sci* 2012;9(1):93-102.
47. Dingli D, Utz JP, Krowka MJ, Oberg AL, Tefferi A. Unexplained pulmonary hypertension in chronic myeloproliferative disorders. *Chest* 2001;120(3):801-808.
48. Reisner SA, Rinkevich D, Markiewicz W, Tatarsky I, Brenner B. Cardiac involvement in patients with myeloproliferative disorders. *Am J Med* 1992;93:498-504.
49. Venegoni P, Cyprus G. Polycythemia and the heart. A review. *Tex Heart Inst J* 1994;21(3):198-201.
50. Venegoni P, Schroth G. Myocardial infarction and polycythemia vera: how should we treat it? *Cathet Cardiovasc Diagn* 1994;32:259-261.
51. Piccirillo G, Fimongari FL, Valdivia JL, Marigliano V. Effects of phlebotomy on a patient with secondary polycythemia and angina pectoris. *Int J Cardiol* 1994;44:175-177.
52. Muller GL. Experimental bone marrow reactions: III. Polycythemia, normoblastosis, and erythrocytic hyperplasia of the bone marrow produced by gum shellac. *J Exp Med* 1927;45(5):753-770.
53. Landolfi R, Di Gennaro L, Nicolazzi MA, Giarretta I, Marfisi R, Marchioli R. Polycythemia vera: gender-related phenotypic differences. *Intern Emerg Med* 2012;7:509-515.
54. Cucuianu A, Stoia M, Farcas A, et al. Arterial stenosis and atherothrombotic events in polycythemia vera and essential thrombocythemia. *Rom J Intern Med* 2006;44(4):397-406.
55. Varma S, Sharma A, Malhotra P, Kumari S, Jain S, Varma N. Thrombotic complications of polycythemia vera. *Hematology* 2008;13(6):319-323.
56. Hilden M, Leth A, Hilden T. High haemoglobin values during medical treatment of hypertension. *Br Med J* 1968;3(5611):163-165.
57. Videbaek A. Polycythaemia vera. Course and prognosis. *Acta Med Scand* 1950;138(3):179-187.

58. Torgano G, Mandelli C, Massaro P, et al. Gastroduodenal lesions in polycythaemia vera: frequency and role of *Helicobacter pylori*. *Br J Haematol* 2002;117(1):198-202.
59. Gray AG, Boughton BJ, Burt DS, Struthers GR. Basophils, histamine and gastric acid secretin in chronic myeloproliferative disorders. *Br J Haematol* 1982;51(1):117-123.
60. Alford FP, Myers KA, Syme J. Portal hypertension and bleeding varices due to thrombosis in the portal venous system complicating polycythaemia vera. *Med J Aust* 1968;2(2):64-66.
61. Scherl ND, Klein R. Portal thrombosis, bleeding varices and mesenteric infarction in a patient with polycythemia vera. *Am J Gastroenterol* 1970;53(2):164-168.
62. Baniel J, Ziv Y, Wolloch Y. Segmental portal hypertension and polycythemia vera. *Isr J Med Sci* 1989;25(4):202-204.
63. Ameredes HT, Joyce JM, Fecher A, Landreneau R, Keenan R, Jackson T. Scintigraphic diagnosis of pleuroperitoneal communication in cirrhosis secondary to polycythemia vera. *Clin Nucl Med* 2003;28(4):332-333.
64. Chiba S. Mosse's syndrome (polycythemia rubra vera). *Nihon Rinsho Spring* 1977;35(Suppl 1):952-953.
65. Karti SS, Yilmaz M, Kosucu P, et al. Early medical treatment is life saving in acute Budd-Chiari due to polycythemia vera. *Hepatogastroenterology* 2003;50(50):512-514.
66. Buzas C, Sparchez Z, Cucuianu A, Manole S, Lupescu I, Acalovschi M. Budd-Chiari syndrome secondary to polycythemia vera. A case report. *J Gastrointest Liver Dis* 2009;18(3):363-366.
67. Cario H, McMullin MF, Pahl HL. Clinical and hematological presentation of children and adolescents with polycythemia vera. *Ann Hematol* 2009;88(8):713-719.
68. Brown RN, Pidgeon JW, Johnson HA. The Budd-Chiari syndrome complicating a case of polycythemia vera. *Calif Med* 1955;83(1):37-39.
69. Breccia M, Morano SG, D'Andrea M, Russo E, D'Elia GM, Alimena G. Budd-Chiari syndrome as the first manifestation of polycythemia vera in young women with inherited thrombophilic state: an aggressive form of myeloproliferative disorder requiring multidisciplinary management. *Eur J Haematol* 2005;75(5):396-400.
70. Akyildiz M, Karasu Z, Dheir H, Osmanoglu N, Akay S, Ilter T. Fulminant Budd-Chiari syndrome associated with polycythemia rubra vera and factor V Leiden mutation. *Eur J Intern Med* 2006;17(1):66-67.
71. Akoum R, Mahfoud D, Ghaoui A, et al. Budd-Chiari syndrome and heparin-induced thrombocytopenia in polycythemia vera: successful treatment with repeated TIPS and interferon alpha. *J Cancer Res Ther* 2009;5(4):305-308.
72. Huber H, Lewis SM, Szur L. The influence of anaemia, polycythaemia and splenomegaly on the relationship between venous haematocrit and red-cell volume. *Br J Haematol* 1964;10:567-575.
73. Dameshek W, Henstell HH. The diagnosis of polycythemia. *Ann Intern Med* 1940;13(8):1360-1387.
P.1733
74. Michiels JJ, De RH, Berneman Z, et al. The 2001 World Health Organization and updated European clinical and pathological criteria for the diagnosis, classification, and staging of the Philadelphia chromosome-negative chronic myeloproliferative disorders. *Semin Thromb Hemost* 2006;32(4 Pt 2):307-340.
75. Strieff MB, Smith B, Spivak JL. The diagnosis and management of polycythemia vera in the era since the Polycythemia Vera Study Group: a survey of American Society of Hematology members' practice patterns. *Blood* 2002;99:1144-1149.
76. Wasserman LR, Dobson RL, Lawrence JH. Blood oxygen studies in patients with polycythemia and in normal subjects. *J Clin Invest* 1949;28(1):60-65.
77. Cassels DE, Morse M. The arterial blood gases, the oxygen dissociation curve, and the acid-base balance in polycythemia vera. *J Clin Invest* 1953;32(1):52-59.
78. Fisher JM, Bedell GN, Seebohm PM. Differentiation of polycythemia vera and secondary polycythemia by arterial oxygen saturation and pulmonary function tests. *J Lab Clin Med* 1957;50(3):455-463.
79. Bader RA, Bader ME, Duberstein JL. Polycythemia vera and arterial oxygen saturation. *Am J Med* 1963;34:435-439.

80. Herbert SJ, Weill H, Stuckey WJ, Urner C, Gonzales E, Ziskind MM. Pulmonary diffusing capacity in polycythemic states before and after phlebotomy. *Dis Chest* 1965;48(4):408-415.
81. Lertzman M, Frome BM, Israels LG, Cherniack RM. Hypoxia in polycythemia vera. *Ann Intern Med* 1964;60:409-417.
82. Nand S, Orfei E. Pulmonary hypertension in polycythemia vera. *Am J Hematol* 1994;47(3):242-244.
83. Doering P, Wenker H. Kidney function and intra-renal hemodynamics in polycythemia rubra vera. *Klin Wochenschr* 1956;34(37-38):1028-1032.
84. Plomley RF, Sullivan JR, Whitworth JA, Kincaid-Smith PS, Fairley KF, Brown RW. Polycythemia vera and glomerulonephritis. *Aust N Z J Med* 1983;13(2):125-129.
85. Biggs B, Anderton JL. Reno-vascular disease in polycythaemia rubra vera. *Postgrad Med J* 1983;59(692):382-383.
86. Kanauchi M, Dohi K, Shiiki H, Fujii Y, Ishikawa H. Henoch-Schonlein purpura nephritis associated with polycythemia vera. *Intern Med* 1994;33(1):36-40.
87. Newton LK. Neurologic complications of polycythemia and their impact on therapy. *Oncology (Williston Park)* 1990;4(3):59-64; discussion 64-56.
88. Ahn BY, Choi KD, Choi YJ, Jea SY, Lee JE. Isolated monocular visual loss as an initial manifestation of polycythemia vera. *J Neurol Sci* 2007;258(1-2):151-153.
89. Kremer M, Lambert CD, Lawton N. Progressive neurological deficits in primary polycythaemia. *Br Med J* 1972;3(5820):216-218.
90. Kumar H, Masiowski P, Jog M. Chorea in the elderly with mutation positive polycythemia vera: a case report. *Can J Neurol Sci* 2009;36(3):370-372.
91. Blood AM. Polycythemia vera: analysis of forty-one cases with special emphasis on neurologic and psychiatric manifestations. *Miss Doct* 1950;28(1):6-8.
92. Hilzenrat N, Zilberman D, Sikuler E. Isolated cerebellar infarction as a presenting symptom of polycythemia vera. *Acta Haematol* 1992;88(4):204-206.
93. Segura T, Serena J, Teruel J, Davalos A. Cerebral embolism in a patient with polycythemia rubra vera. *Eur J Neurol* 2000;7(1):87-90.
94. Koennecke HC, Bernarding J. Diffusion-weighted magnetic resonance imaging in two patients with polycythemia rubra vera and early ischemic stroke. *Eur J Neurol* 2001;8(3):273-277.
95. Thomas DJ, Marshall J, Ross Russell RW, et al. Cerebral blood-flow in polycythemia. *Lancet* 1977;2:161-163.
96. Jaillard AS, Hommel M, Mazetti P. Prevalence of stroke at high altitude (3380 m) in Cuzco, a town of Peru. A population-based study. *Stroke* 1995;26: 562-568.
97. Niazi GA, Awada A, al Rajeh S, Larbi E. Hematological values and their assessment as risk factors in Saudi patients with stroke. *Acta Neurol Scand* 1994;89:439-445.
98. Harrop GA. Polycythemia. *Medicine* 1928;7(3):291-344.
99. Minot GR, Buckman TE. Erythremia (polycythemia rubra vera). *Am J Med Sci* 1923;166(4):469-488.
100. Lawrence JH, Berlin NI, Huff RL. The nature and treatment of polycythemia; studies on 263 patients. *Medicine (Baltimore)* 1953;32(3):323-388.
101. Cooper MR, DeChatelet LR, McCall CE, Spurr CL. The activated phagocyte of polycythemia vera. *Blood* 1972;40(3):366-374.
102. De Stefano V, Za T, Rossi E, et al. Leukocytosis is a risk factor for recurrent arterial thrombosis in young patients with polycythemia vera and essential thrombocythemia. *Am J Hematol* 2010;85(2):97-100.
103. Kessler CM, Klein HG, Havlik RJ. Uncontrolled thrombocytosis in chronic myeloproliferative disorders. *Br J Haematol* 1982;50(1):157-167.
104. van Genderen RJ, Michiels JJ, van Strik R, Lindemans J, van Vliet HH. Platelet consumption in thrombocythemia complicated by erythromelalgia: reversal by aspirin. *Thromb Haemost* 1995;73:210-214.

105. Castaman G, Lattuada A, Ruggeri M, Tosetto A, Manucci PM, Rodeghiero F. Platelet von Willebrand factor abnormalities in myeloproliferative syndromes. *Am J Hematol* 1995;49:289-293.
106. LeBlanc K, Berg A, Palmblad J, Samuelsson J. Stimulus-specific defect in platelet aggregation in polycythemia vera. *Eur J Haematol* 1994;53(3):145-149.
107. Landolfi R, Ciabattini G, Patrignani P, et al. Increased thromboxane biosynthesis in patients with polycythemia vera: evidence for aspirin suppressible platelet activation in vivo. *Blood* 1992;80:1965-1971.
108. Abraham JP, Ulutin ON, Johnson SA, Caldwell MJ. A study of the defects in the blood coagulation mechanisms in polycythemia vera. *Am J Clin Pathol* 1961;36:7-15.
109. Cancelas JA, Garcia-Avello A, Garcia-Frade LJ. High levels of plasminogen activator inhibitor 1 (PAI-1) in polycythemia vera and essential thrombocythemia are associated with thrombosis. *Thromb Res* 1994;75:513-520.
110. FriedenberG WR, Roberts RC, David DE. Relationship of thrombohemorrhagic complications to endothelial cell function in patients with chronic myeloproliferative disorders. *Am J Hematol* 1992;40:283-289.
111. Le Blanc K, Berg A, Palmblad J, Samuelsson J. Defective platelet aggregation in polycythaemia vera is not caused by impaired calcium signaling, phospholipase D activation or decreased amounts of focal adhesion proteins. *Eur J Haematol* 2000;65(5):322-330.
112. Berlin NI, Lawrence JH, Gartland J. Blood volume in polycythemia as determined by P32 labeled red blood cells. *Am J Med* 1950;9(6):747-751.
113. Pearson TC, Messinezy M. The diagnostic criteria of polycythemia rubra vera. *Leuk Lymphoma* 1996;22(Suppl 1):87-93.
114. London IM, Shemin D, et al. Heme synthesis and red blood cell dynamics in normal humans and in subjects with polycythemia vera, sickle-cell anemia, and pernicious anemia. *J Biol Chem* 1949;179(1):463-484.
115. Huff RL, Hennessy TG, Austin RE, Garcia JF, Roberts BM, Lawrence JH. Plasma and red cell iron turnover in normal subjects and in patients having various hematopoietic disorders. *J Clin Invest* 1950;29(8):1041-1052.
116. Seaton DA. A comparison of direct and indirect methods in the diagnosis of haemolysis. *Scott Med J* 1964;9:197-200.
117. Athens JW, Haab OP, Raab SO, et al. Leukokinetic studies. XI. Blood granulocyte kinetics in polycythemia vera, infection, and myelofibrosis. *J Clin Invest* 1965;44:778-788.
118. Falanga A, Marchetti M, Evangelista V, et al. Polymorphonuclear leukocyte activation and hemostasis in patients with essential thrombocythemia and polycythemia vera. *Blood* 2000;96:4261-4266.
119. Harker LA, Finch CA. ThrombokinetiCs in man. *J Clin Invest* 1969;48(6): 963-974.
120. Tytgat GN, Collen D, Vermynlen J. Metabolism and distribution of fibrinogen. II. Fibrinogen turnover in polycythaemia, thrombocytosis, haemophilia A, congenital afibrinogenaemia and during streptokinase therapy. *Br J Haematol* 1972;22(6):701-717.
121. Lugassy G, Filin I. Study of fibrinolytic parameters in different types of polycythemia. *Am J Hematol* 1999;60:196-199.
122. Hershko C, Carmeli D. The effect of packed cell volume, hemoglobin content and red cell count on whole blood viscosity. *Acta Haematol* 1970;44(3):142-154.
123. Streichman S, Avdi N, Joffe G, Matathias L, Tatarsky I. Some characteristics of circulating erythrocytes in polycythaemia vera: common features with normal young and foetal red blood cells. *Scand J Haematol* 1986;36(1): 33-38.
124. De Wardener HE, McSwiney RR, Miles BE. Renal haemodynamics in primary polycythaemia. *Lancet* 1951;2(6675):204-205.
125. Perkins J, Israuels MC, Wilkinson JF. Polycythaemia vera: clinical studies on a series of 127 patients managed without radiation therapy. *Q J Med* 1964;33:499-518.
126. Gutman AB, Kupfer S, Sharney L, Weissmann B, Yu TF. On the biosynthesis of uric acid from glycine-N15 in primary and secondary polycythemia. *Am J Med* 1956;21(6):901-917.
127. Gutman AB, Weissmann B, Yu TF. The concept of secondary gout; relation to purine metabolism in polycythemia and myeloid metaplasia. *Trans Assoc Am Physicians* 1956;69:229-238.
128. Shelburne SA, Hanzal RF. The endogenous uric acid metabolism in polycythemia vera. *J Clin Invest* 1932;11:865-866.

129. Carmel R. Vitamin B₁₂-binding protein abnormality in subjects without myeloproliferative disease. II. The presence of a third vitamin B₁₂-binding protein in serum. *Br J Haematol* 1972;22(1):53-62.
130. Hall CA, Finkler AE. Vitamin B₁₂-binding protein in polycythemia vera plasma. *J Lab Clin Med* 1969;73(1):60-69.
131. Gisslinger H, Rodeghiero F, Ruggeri M, et al. Homocysteine levels in polycythaemia vera and essential thrombocythaemia. *Br J Haematol* 1999;105(2):551-555.
132. Birgegard G, Wide L. Serum erythropoietin in the diagnosis of polycythemia and after phlebotomy treatment. *Br J Haematol* 1992;81:603-606.
133. Tefferi A, Thiele J, Orazi A, et al. Proposals and rationale for revision of the World Health Organization diagnostic criteria for polycythemia vera, essential thrombocythemia, and primary myelofibrosis: recommendations from an ad hoc international expert panel. *Blood* 2007;110: 1092-1097.
134. Fukasawa H, Furuya R, Kato A, et al. Pseudohyperkalemia occurring in a patient with chronic renal failure and polycythemia vera without severe leukocytosis or thrombocytosis. *Clin Nephrol* 2002;58(6):451-454.
135. Westin J, Granerus G, Weinfeld A, Wetterquist H. Histamine metabolism in polycythaemia vera. *Scand J Haematol* 1975;15(1):45-57.
136. Bliss TL. Basal metabolism in polycythemia vera. *Ann Intern Med* 1929;2(11):1155-1161.
137. Bucalossi A, Marotta G, Bigazzi C, Galieni P, Dispensa E. Reduction of anti-thrombin III, protein C, and protein S levels and activated protein C resistance in polycythemia vera and essential thrombocythemia patients with thrombosis. *Am J Hematol* 1996;52(1):14-20.
138. Afshar-Kharghan V, Lopez JA, Gray LA, et al. Hemostatic gene polymorphisms and the prevalence of thrombotic complications in polycythemia vera and essential thrombocythemia. *Blood Coagul Fibrinolysis* 2004; 15(1):21-24.
139. Lundin PM, Ridell B, Weinfeld A. The significance of bone marrow morphology for the diagnosis of polycythaemia vera. *Scand J Haematol* 1972;9(3):271-282.
140. Block M, Jacobson LO, Bethard W. Bone marrow in the diagnosis and treatment of polycythemia vera. *Proc Inst Med Chic* 1952;19(4):84-85.
141. Michiels JJ, Bernema Z, Van Bockstaele D, De Raeve H, Schroyens W. Current diagnostic criteria for the chronic myeloproliferative disorders (MPD) essential thrombocythemia (ET), polycythemia vera (PV) and chronic idiopathic myelofibrosis (CIMF). *Pathol Biol (Paris)* 2007;55(2):92-104.
142. Ellis JT, Silver RT, Coleman M, Geller SA. The bone marrow in polycythemia vera. *Semin Hematol* 1975;12(4):433-444.
143. Ellis JT, Peterson P, Geller SA, Rappaport H. Studies of the bone marrow in polycythemia vera and the evolution of myelofibrosis and second hematologic malignancies. *Semin Hematol* 1986;23(2):144-155.
144. Wasserman LR, Lawrence JH, Berlin NI, Dobson RL, Estren S. The bone marrow picture in polycythemia vera before and after treatment with radioactive phosphorus. *Acta Med Scand* 1952;143(6):442-449.
145. Thiele J, Kvasnicka HM, Zoankovich R, Diehl V. The value of bone marrow histology in differentiating between early stage polycythemia vera and secondary (reactive) polycythemias. *Haematologica* 2001;86(4):368-374.
146. Lundberg LG, Lerner R, Sundelin P, Rogers R, Folkman J, Palmblad J. Bone marrow in polycythemia vera, chronic myelocytic leukemia, and myelofibrosis has an increased vascularity. *Am J Pathol* 2000;157(1):15-19.
147. Kurnick JE, Ward HP, Block MH. Bone marrow sections in the differential diagnosis of polycythemia. *Arch Pathol* 1972;94(6):489-499.
148. Thiele J, Kvasnicka HM, Muehlhausen K, Walter S, Zankovich R, Diehl V. Polycythemia rubra vera versus secondary polycythemias. A clinicopathological evaluation of distinctive features in 199 patients. *Pathol Res Pract* 2001;197(2):77-84.
149. Wurster-Hill D, Whang-Peng J, McIntyre OR, et al. Cytogenetic studies in polycythemia vera. *Semin Hematol* 1976;13(1):13-32.
150. Berger R, Bernheim A, LeConiat M, et al. Chromosome studies in polycythemia vera patients. *Cancer Genet Cytogenet* 1984;12:217-223.
151. Diez-Martin JL, Graham DL, Pettitt RM, Dewald GW. Chromosome studies in 104 patients with polycythemia vera. *Mayo Clin Proc* 1991;66(3):287-299.

152. Swolin B, Weinfeld A, Westin J. A prospective long-term cytogenetic study in polycythemia vera in relation to treatment and clinical course. *Blood* 1988;72:386-395.
153. Westwood NB, Gruszka-Westwood AM, Pearson CE, et al. The incidences of trisomy 8, trisomy 9 and D20S108 deletion in polycythaemia vera: an analysis of blood granulocytes using interphase fluorescence in situ hybridization. *Br J Haematol* 2000;110:839-846.
154. Reznikoff P. Polycythemia. *Bull N Y Acad Med* 1939;15(5):311-321.
155. Berk L, Burchenal JH, et al. Oxygen saturation of sternal marrow blood with special reference to pathogenesis of polycythemia vera. *Proc Soc Exp Biol Med* 1948;69(2):316-320.
156. Adamson JW. The erythropoietin-hematocrit relationship in normal and polycythemic man: implications of marrow regulation. *Blood* 1968;32(4):597-609.
157. Alexanian R. Correlations between erythropoietin production and excretion. *J Lab Clin Med* 1969;74(4):614-622.
158. Adamson JW, Fialkow PJ, Murphy S, Prchal JF, Steinmann L. Polycythemia vera: stem-cell and probable clonal origin of the disease. *N Engl J Med* 1976;295:913-916.
159. Raskind WH, Jacobson R, Murphy S, Adamson JW, Fialkow PJ. Evidence for the involvement of B lymphoid cells in polycythemia vera and essential thrombocythemia. *J Clin Invest* 1985;75(4):1388-1390.
160. Eridani S, Batten E, Sawyer B. Erythropoietic activity in primary proliferative polycythemia (letter). *Br J Haematol* 1983;55:557.
161. Eaves AC, Eaves CJ. Erythropoiesis in culture. *Clin Haematol* 1984;13:371-391.
162. Eaves AC, Henkelmann DH, Eaves CJ. Abnormal erythropoiesis in the myeloproliferative disorders: an analysis of underlying cellular and humoral mechanisms. *Exp Hematol* 1980;8(Suppl 8):235-247.
163. Cashman J, Henkelmann D, Humphries K, Eaves C, Eaves A. Individual BFU-E in polycythemia vera produce both erythropoietin dependent and independent progeny. *Blood* 1983;61:876-884.
164. Reid CDL, Fidler J, Kirk A. Endogenous erythroid colonies (EEC) in polycythaemia and their relationship to diagnosis and the response to treatment. *Br J Haematol* 1988;68:395-400.
165. Reid CDL. The significance of endogenous erythroid colonies in haematological disorders. *Blood Rev* 1987;1:133-140.
166. Eaves CJ, Eaves AC. Erythropoietin dose-response curves for three classes of erythroid progenitors in normal human marrow and in polycythemia vera. *Blood* 1978;52:1196-1210.
167. Prchal JF, Axelrad AA. Letter: bone-marrow responses in polycythemia vera. *N Engl J Med* 1974;290(24):1382.
168. Golde DW, Bersch N, Cline MJ. Polycythemia vera: hormonal modulation of erythropoiesis in vitro. *Blood* 1977;49(3):399-405.
169. Mladenovic J, Adamson JW. Characteristics of circulating erythroid colony-forming cells in normal and polycythaemic man. *Br J Haematol* 1982;51: 377-384.
170. Zanjani ED, Lutton JD, Hoffman R, Wasserman LR. Erythroid colony formation by polycythemia vera bone marrow in vitro. Dependence on erythropoietin. *J Clin Invest* 1977;59(5):841-848.
171. Prchal JF, Adamson JW, Murphy M, Steinmann L, Fialkow PJ. Polycythemia vera. The in vitro response of normal and abnormal stem cell lines to erythropoietin. *J Clin Invest* 1978;61:1044-1047.
172. Casadevall N, Vainchecker W, LaCombe C, et al. Erythroid progenitors in polycythemia vera: demonstration of their hypersensitivity to erythropoietin using serum free cultures. *Blood* 1982;59:447-451.
173. Dai CH, Krantz SB, Means RT, Horn ST, Gilbert HS. Polycythemia vera blood burst-forming units-erythroid are hypersensitive to interleukin-3. *J Clin Invest* 1991;87:391-396.
174. Fisher MJ, Prchal JF, Prchal JT, D'Andrea AD. Anti-erythropoietin (EPO) receptor monoclonal antibodies distinguish EPO-dependent and EPO-independent erythroid progenitors in polycythemia vera. *Blood* 1994;84:1982-1991.
175. Dai CH, Krantz SB, Dessypris EN, Means RT, Horn ST, Gilbert HS. Polycythemia vera. II. Hypersensitivity of bone marrow erythroid, granulocyte-macrophage, and megakaryocyte progenitor cells to interleukin- 3 and granulocyte-macrophage colony stimulating factor. *Blood* 1992;80:891-899.

176. Muller EW, de Wolf J, Hendriks DW, Esselink MT, Halie MR, Vellenga E. Recombinant human mast cell growth factor supports erythroid colony formation in polycythemia vera in the presence and absence of erythropoietin and serum. *Exp Hematol* 1993;21:1353-1357.
177. de Wolf JT, Hendriks DW, Esselink MT, Halie MR, Vellenga E. The effects of IL-1 and IL-4 on the Epo-independent erythroid progenitor in polycythaemia vera. *Br J Haematol* 1994;88(2):242-246.
178. Mirza AM, Ezzat S, Axelrad AA. Insulin-like growth factor binding protein-1 is elevated in patients with polycythemia vera and stimulates erythroid burst formation in vitro. *Blood* 1997;89:1862-1869.
179. Michl P, Spoettl G, Engelhardt D, Weber MM. Alterations of the insulin-like growth factor system in patients with polycythemia vera. *Mol Cell Endocrinol* 2001;181:189-197.
180. Dai CH, Krantz SB, Zsebo KM. Human burst-forming units-erythroid need direct interaction with stem cell factor for further development. *Blood* 1991;78:2493-2497.
181. Sawada K, Krantz SB, Sawyer ST, Civin CI. Quantitation of specific binding of erythropoietin to human erythroid colony-forming cells. *J Cell Physiol* 1988;137:337-345.
182. Sawyer ST, Penta K. Erythropoietin cell biology. *Hematol Oncol Clin North Am* 1994;8:895-911.
183. Means RT, Krantz SB, Sawyer ST, Gilbert HS. Erythropoietin receptors in polycythemia vera. *J Clin Investig* 1989;84:1340-1344.
184. Kralovics R, Indrak K, Stopka T, Berman BW, Prchal JF, Prchal JT. Two new EPO receptor mutations: truncated EPO receptors are most frequently associated with primary familial and congenital polycythemia. *Blood* 1997;90:2057-2061.
185. Hess G, Rose P, Gamm H, Papadileris S, Huber C, Seliger B. Molecular analysis of the erythropoietin receptor system in patients with polycythaemia vera. *Br J Haematol* 1994;88(4):794-802.
186. Chiba S, Takahashi T, Takeshita K, et al. Selective expression of mRNA coding for the truncated form of erythropoietin receptor in hematopoietic cells and its decrease in patients with polycythemia vera. *Blood* 1997;90:97-104.
187. Moliterno AR, Hankins WD, Spivak JL. Impaired expression of the thrombopoietin receptor by platelets from patients with polycythemia vera. *N Engl J Med* 1998;338:572-580.
188. Moliterno AR, Spivak JL. Posttranslational processing of the thrombopoietin receptor is impaired in polycythemia vera. *Blood* 1999;94:2555-2561.
189. Moliterno AR, Williams DM, Spivak JL. Enhanced in vitro viability of polycythemia vera CD34+ cells is associated with abnormal thrombopoietin receptor expression and aberrant signal transduction (abstract). *Blood* 2001;98(Suppl):1961a.
190. Le Blanc K, Andersson P, Samuelsson J. Marked heterogeneity in protein levels and functional integrity of the thrombopoietin receptor c-mpl in polycythaemia vera. *Br J Haematol* 2000;108:80-85.
191. Roder S, Steimle C, Meinhardt G, Pahl HL. STAT3 is constitutively active in some patients with Polycythemia rubra vera. *Exp Hematol* 2001;29: 694-702.
192. Silva M, Richard C, Benito A, Sanz C, Olalla I, Fernandez-Luna JL. Expression of Bcl-x in erythroid precursor cells from patients with polycythemia vera. *N Engl J Med* 1998;338:564-571.
193. Zeuner A, Pedini F, Francescangeli F, et al. Activity of the BH3 mimetic ABT-737 on polycythemia vera erythroid precursor cells. *Blood* 2009;113(7): 1522-1525.
194. Wickrema A, Chen F, Namin F, et al. Defective expression of the SHP-1 phosphatase in polycythemia vera. *Exp Hematol* 1999;27:1124-1132.
195. Sui X, Krantz SB, Zhao Z. Identification of increased protein tyrosine phosphatase activity in polycythemia vera erythroid progenitor cells. *Blood* 1997;90:651-657.
196. Kawada E, Tamura J, Kubota K, Murakami H, Naruse T, Tsuchiya J. Possible involvement of protein kinase C in the aberrant regulation of erythropoiesis in polycythemia vera. *Leuk Res* 1997;21:101-105.
197. Nunez C, Bashein AM, Brunet CL, et al. Expression of the imprinted tumour-suppressor gene H19 is tightly regulated during normal haematopoiesis and is reduced in haematopoietic precursors of patients with the myeloproliferative disease polycythaemia vera. *J Pathol* 2000;190:61-68.

198. Zeuner A, Pedini F, Signore M, et al. Increased death receptor resistance and FLIPshort expression in polycythemia vera erythroid precursor cells. *Blood* 2006;107(9):3495-3502.
199. Garcon L, Rivat C, James C, et al. Constitutive activation of STAT5 and Bcl-xL overexpression can induce endogenous erythroid colony formation in human primary cells. *Blood* 2006;108(5):1551-1554.
200. Temerinac S, Klippel S, Strunck E, et al. Cloning of PRV-1, a novel member of the uPAR receptor superfamily, which is overexpressed in polycythemia rubra vera. *Blood* 2000;95:2569-2576.
201. Klippel S, Strunck E, Temerinac S, et al. Quantification of PRV-1 mRNA distinguishes polycythemia vera from secondary erythrocytosis. *Blood* 2003;102(10):3569-3574.
202. Tefferi A, Sirhan S, Lasho TL, et al. Concomitant neutrophil JAK2 mutation screening and PRV-1 expression analysis in myeloproliferative disorders and secondary polycythaemia. *Br J Haematol* 2005;131(2):166-171.
203. Kralovics R, Passamonti F, Buser AS, et al. A gain-of-function mutation of JAK2 in myeloproliferative disorders. *N Engl J Med* 2005;352(17): 1779-1790.
204. Lippert E, Boissinot M, Kralovics R, et al. The JAK2-V617F mutation is frequently present at diagnosis in patients with essential thrombocythemia and polycythemia vera. *Blood* 2006;108:1865-1867.
205. Ganly P, Hanrahan V, Baker B, Romeril K. Identification of JAK2(V617F) in patients with polycythemia is highly correlated with conventional criteria for diagnosis of polycythemia vera. *Am J Hematol* 2007;82:80-82.
206. Scott LM, Tong W, Levine RL, et al. JAK2 exon 12 mutations in polycythemia vera and idiopathic erythrocytosis. *N Engl J Med* 2007;356(5):459-468.
207. Kouroupi E, Zoi K, Parquet N, et al. Mutations in exon 12 of JAK2 are mainly found in JAK2 V617F-negative polycythaemia vera patients. *Br J Haematol* 2008;142(4):676-679.
208. Rothlisberger B, Huber A, Bargetzi M, Mendez A, Heizmann M. JAK2 exon 12 mutation in JAK2V617F-negative polycythemia vera. *Leuk Lymphoma* 2008;49(3):586-588.
209. Schnittger S, Bacher U, Haferlach C, et al. Detection of JAK2 exon 12 mutations in 15 patients with JAK2V617F negative polycythemia vera. *Haematologica* 2009;94(3):414-418.
210. Zaleskas VM, Krause DS, Lazarides K, et al. Molecular pathogenesis and therapy of polycythemia induced in mice by JAK2 V617F. *PLoS One* 2006;1:e18.
211. Nussenzweig RH, Swierczek SI, Jelinek J, et al. Polycythemia vera is not initiated by JAK2V617F mutation. *Exp Hematol* 2007;35(1):32-38.
212. Kralovics R, Teo SS, Li S, et al. Acquisition of the V617F mutation of JAK2 is a late genetic event in a subset of patients with myeloproliferative disorders. *Blood* 2006;108(4):1377-1380.
213. Swierczek SI, Yoon D, Bellanne-Chantelot C, et al. Extent of hematopoietic involvement by TET2 mutations in JAK2V(6)(1)(7)F polycythemia vera. *Haematologica* 2011;96(5):775-778.
214. Mnjoyan Z, Yoon D, Li J, Delhommeau F, fshar-Kharghan V. The effect of the JAK2 V617F mutation on PRV-1 expression. *Haematologica* 2006;91(3):411-412.
215. Tefferi A, Lasho TL, Abdel-Wahab O, et al. IDH1 and IDH2 mutation studies in 1473 patients with chronic-, fibrotic- or blast-phase essential thrombocythemia, polycythemia vera or myelofibrosis. *Leukemia* 2010;24(7):1302-1309.
216. Jones AV, Campbell PJ, Beer PA, et al. The JAK2 46/1 haplotype predisposes to MPL mutated myeloproliferative neoplasms. *Blood* 2010: blood-2009.
217. Wautier MP, El NW, Gane P, et al. Increased adhesion to endothelial cells of erythrocytes from patients with polycythemia vera is mediated by laminin alpha5 chain and Lu/BCAM. *Blood* 2007;110(3):894-901.
218. Colin Y, Rahuel C, Wautier MP, et al. Red cell and endothelial Lu/BCAM beyond sickle cell disease. *Transfus Clin Biol* 2008;15:402-405.
219. Westwood N, Dudley JM, Sawyer B, Messinezy M, Pearson TC. Primary polycythaemia: diagnosis by non-conventional positive criteria. *Eur J Haematol* 1993;51:228-232.
220. Spivak JL, Silver RT. The revised World Health Organization diagnostic criteria for polycythemia vera, essential thrombocytosis, and primary myelofibrosis: an alternative proposal. *Blood* 2008;112(2):231-239.

221. Teofili L, Giona F, Martini M, et al. The revised WHO diagnostic criteria for Ph-negative myeloproliferative diseases are not appropriate for the diagnostic screening of childhood polycythemia vera and essential thrombocythemia. *Blood* 2007;110(9):3384-3386.
222. Pardanani A, Lasho TL, Finke C, Hanson CA, Tefferi A. Prevalence and clinicopathologic correlates of JAK2 exon 12 mutations in JAK2V617F-negative polycythemia vera. *Leukemia* 2007;21:1960-1963.
223. Lawrence JH, Winchell HS, Donald WG. Leukemia in polycythemia vera. Relationship to splenic myeloid metaplasia and therapeutic radiation dose. *Ann Intern Med* 1969;70(4):763-771.
224. Silverstein MN. The evolution into and the treatment of late stage polycythemia vera. *Semin Hematol* 1976;13(1):79-84.
225. Small P, Lerman S. Hyperthyroidism and polycythemia vera with chronic urticaria and angioedema. *Ann Allergy* 1981;46(5):256-259.
226. Van Baren N, Issa A, Delannoy A. Von Recklinghausen neurofibromatosis and hematologic malignancies: 2 case reports in adulthood. *Acta Clin Belg* 1993;48:164-170.
227. Bethard WF, Block MH, Robson M. Coexistent chronic lymphatic leukemia and polycythemia vera; morphologic and clinical studies with particular reference to unusual iron metabolism. *Blood* 1953;8(10):934-943.
228. Heinle EW Jr, Sarasti HO, Garcia D, Kenny JJ, Westerman MP. Polycythemia vera associated with lymphomatous diseases and myeloma. *Arch Intern Med* 1966;118(4):351-355.
229. Bouscary D, Jondeau K, Viguie F, et al. Aplastic anemia responsive to cyclosporine complicating the evolution of polycythemia vera. *Leuk Lymphoma* 1999; 33:607-611.
230. Skouby AP. The occurrence of pernicious anemia and polycythemia in the same patient. *Acta Med Scand* 1952;141(4):244-248.
231. Hinz CF Jr. Fatal polycythemia following pernicious anemia treated with vitamin B12. *Ann Intern Med* 1957;47(3):544-552.
232. Chievitz E, Thiede T. Complications and causes of death in polycythaemia vera. *Acta Med Scand* 1962;172:513-523.
233. Passamonti F, Rumi E, Pungolino E, et al. Life expectancy and prognostic factors for survival in patients with polycythemia vera and essential thrombocythemia. *Am J Med* 2004;117(10):755-761.
234. Wasserman LR, Balcerzak SP, Berk PD, et al. Influence of therapy on causes of death in polycythemia vera. *Trans Assoc Am Physicians* 1981;94:30-38.
235. Marchioli R, Finazzi G, Landolfi R, et al. Vascular and neoplastic risk in a large cohort of patients with polycythemia vera. *J Clin Oncol* 2005;23(10): 2224-2232.
236. Landolfi R, Di Gennaro L, Barbui T, et al. Leukocytosis as a major thrombotic risk factor in patients with polycythemia vera. *Blood* 2007;109(6):2446-2452.
237. Alvarez-Larran A, Bellosillo B, Martinez-Aviles L, et al. Postpolycythaemic myelofibrosis: frequency and risk factors for this complication in 116 patients. *Br J Haematol* 2009;146(5):504-509.
238. Vannucchi AM, Antonioli E, Guglielmelli P, et al. Prospective identification of high-risk polycythemia vera patients based on JAK2(V617F) allele burden. *Leukemia* 2007;21(9):1952-1959.
239. Berk PD, Wasserman LR, Fruchtman SM, Goldberg JD. Treatment of polycythemia vera: a summary of trials conducted by the Polycythemia Vera Study Group. In: Wasserman LR, ed. *Polycythemia vera and the myeloproliferative disorders*. Philadelphia, PA: WB Saunders, 1995:166-194.
240. Gilbert HS, Hanna MM. Low-dose aspirin/low-hematocrit regimen: a safe and efficacious treatment for polycythemia vera (abstract). *Blood* 1986; 68(Suppl 1):223a.
241. Gruppo Italiano Studio P. Low-dose aspirin in polycythaemia vera: a pilot study. *Br J Haematol* 1997;97:453-456.
242. Landolfi R, Marchioli R, Kutti J, et al. Efficacy and safety of low-dose aspirin in polycythemia vera. *N Engl J Med* 2004;350:114-124.

243. Crisa E, Venturino E, Passera R, et al. A retrospective study on 226 polycythemia vera patients: impact of median hematocrit value on clinical outcomes and survival improvement with anti-thrombotic prophylaxis and non-alkylating drugs. *Ann Hematol* 2010;89(7):691-699.
244. Marchioli R, Finazzi G, Specchia G, et al. Cardiovascular events and intensity of treatment in polycythemia vera. *N Engl J Med* 2013;368:22-33.
245. Gardner FH. Treatment of polycythemia vera (P. vera). *Semin Hematol* 1966;3:220-225.
246. Kiraly JF, Feldmann JE, Wheby MS. Hazards of phlebotomy in polycythemic patients with cardiovascular disease. *J Am Med Assoc* 1976;236: 2080-2081.
247. Rector WG Jr, Fortuin NJ, Conley CL. Non-hematologic effects of chronic iron deficiency. A study of patients with polycythemia vera treated solely by phlebotomy. *Medicine (Baltimore)* 1982;61:382-389.
248. Spurr CL, Smith TR, et al. A clinical study of the use of nitrogen mustard therapy in polycythemia vera. *J Lab Clin Med* 1950;35(2):252-264.
249. Logue GL, Gutterman JU, McGinn TG, Laszlo J, Rundles RW. Melphalan therapy of polycythemia vera. *Blood* 1970;36(1):70-86.
250. Rosenthal N, Rosenthal RL. Treatment of polycythemia vera with triethylene melamine; summary of thirty cases. *Arch Intern Med* 1952;90(3):379-388.
251. Frost JW, Jones R Jr, Jonsson U. Pyrimethamine in the treatment of polycythemia vera. *South Med J* 1958;51(10):1260-1265.
252. Monto RW, Tenpas A, Battle JD Jr, Rohn RJ, Louis J, Louis NB. A-8103 in polycythemia. *JAMA* 1964;190:833-836.
253. Brodsky I. Busulphan treatment of polycythaemia vera. *Br J Haematol* 1982;52(1):1-6.
254. Najman A, Stachowiak J, Parlier Y, Gorin NC, Duhamel G. Pipobroman therapy of polycythemia vera. *Blood* 1982;59(5):890-894.
255. Varela JE, Kremenichuzky S, Fraga A, Etcheverry MA, Figueiras H. Evaluation of haemopoiesis and comparative study of ³²P and chlorambucil therapy by means of radiotracers in polycythemia vera. *Minerva Nucl* 1965;9(5):275-280.
256. Finazzi G, Caruso V, Marchioli R, et al. Acute leukemia in polycythemia vera: an analysis of 1638 patients enrolled in a prospective observational study. *Blood* 2005;105(7):2664-2670.
257. Berk PD, Goldberg JD, Silverstein MN, et al. Increased incidence of acute leukemia in polycythemia vera associated with chlorambucil therapy. *N Engl J Med* 1981;304(8):441-447.
258. Finazzi G. Risk stratification, staging, and treatment of patients with polycythemia vera: Italian and European collaboration on low-dose aspirin in polycythemia data. *Semin Thromb Hemost* 2006;32(3):276-282.
259. Passamonti F. How I treat polycythemia vera. *Blood* 2012;120(2):275-284.
260. Kaplan ME, Mack K, Goldberg JD, Donovan PB, Berk PD, Wasserman LR. Long-term management of polycythemia vera with hydroxyurea: a progress report. *Semin Hematol* 1986;23(3):167-171.
261. Donovan PB, Kaplan ME, Goldberg JD, et al. Treatment of polycythemia vera with hydroxyurea. *Am J Hematol* 1984;17(4):329-334.
262. Nand S, Stock W, Godwin J, Fisher SG. Leukemogenic risk of hydroxyurea therapy in polycythemia vera, essential thrombocythemia, and myeloid metaplasia with myelofibrosis. *Am J Hematol* 1996;52(1):42-46.
263. West WO. Hydroxyurea in the treatment of polycythemia vera: a prospective study of 100 patients over 20 years. *South Med J* 1987;80:323-327.
264. Najean Y, Rain JD. Treatment of polycythemia vera: use of ³²P alone or in combination with maintenance therapy using hydroxyurea in 461 patients greater than 65 years of age. *Blood* 1997;89:2319-2327.
265. Sirhan S, Lasho TL, Hanson CA, Mesa RA, Pardanani A, Tefferi A. The presence of JAK2V617F in primary myelofibrosis or its allele burden in polycythemia vera predicts chemosensitivity to hydroxyurea. *Am J Hematol* 2008;83(5):363-365.
266. Besses C, Alvarez-Larrán A, Martínez-Avilés L, et al. Modulation of JAK2 V617F allele burden dynamics by hydroxycarbamide in polycythaemia vera and essential thrombocythaemia patients. *Br J Haematol* 2011;152(4): 413-419.

267. Girodon F, Schaeffer C, Cleyrat C, et al. Frequent reduction or absence of detection of the JAK2-mutated clone in JAK2V617F-positive patients within the first years of hydroxyurea therapy. *Haematologica* 2008;93(11): 1723-1727.
268. Antonioli E, Carobbio A, Pieri L, et al. Hydroxyurea does not appreciably reduce JAK2 V617F allele burden in patients with polycythemia vera or essential thrombocythemia. *Haematologica* 2010;95(8):1435-1438.
269. Haniffa MA, Speight EL. Painful leg ulcers and a rash in a patient with polycythaemia rubra vera. Diagnosis: hydroxyurea-induced leg ulceration and dermatomyositis-like skin changes. *Clin Exp Dermatol* 2006;31(5):733-734.
270. Hoff NP, Akanay-Diesel S, Pippirs U, Schulte KW, Hanneken S. Cutaneous side effects of hydroxyurea treatment for polycythemia vera. *Hautarzt* 2009;60(10):783-787.
271. Khaled A, El Guellali N, Aissaoui L, et al. Hydroxyurea induced-leg ulcer in polycythemia vera. *Tunis Med* 2011;89(3):292-294.
272. Silver RT. A new treatment for polycythemia vera: recombinant interferon alfa. *Blood* 1990;76:664-665.
273. Foa P, Massaro P, Ribera S, et al. Role of interferon alpha-2a in the treatment of polycythemia vera. *Am J Hematol* 1995;48(1):55-57.
274. Sacchi S, Leoni P, Riccardi A, et al. A prospective comparison between treatment with phlebotomy alone and with interferon-alpha in patients with polycythemia vera. *Ann Hematol* 1994;68:247-250.
275. Lengfelder E, Berger U, Hehlmann R. Interferon alpha in the treatment of polycythemia vera. *Ann Hematol* 2000;79:103-109.
276. Elliott MA, Tefferi A. Interferon-alpha therapy in polycythemia vera and essential thrombocythemia. *Semin Thromb Hemost* 1997;23:463-472.
277. Heis N, Rintelen C, Gisslinger B, Knobl P, Lechner K, Gisslinger H. The effect of interferon alpha on myeloproliferation and vascular complications in polycythemia vera. *Eur J Haematol* 1999;62:27-31.
278. Finelli C, Gugliotta L, Gamberi B, Vianelli N, Visani G, Tura S. Relief of intractable pruritus in polycythemia vera with recombinant interferon alpha. *Am J Hematol* 1993;43:316-318.
279. Kreft A, Nolde C, Busche G, Buhr T, Kreipe H, Georgii A. Polycythaemia vera: bone marrow histopathology under treatment with interferon, hydroxyurea and busulphan. *Eur J Haematol* 2000;64:32-41.
280. Kiladjian JJ, Cassinat B, Turlure P, Cambier N, Roussel M, Bellucci S. High molecular response rate of polycythemia vera patients treated with pegylated interferon alpha-2a. *Blood* 2006;108:2037-2040.
281. Anagrelide Study G. Anagrelide, a therapy for thrombocythemic states: experience in 577 patients. *Am J Med* 1992;92:69-76.
282. Harrison CN, Campbell PJ, Buck G, et al. Hydroxyurea compared with anagrelide in high-risk essential thrombocythemia. *N Engl J Med* 2005;353(1):33-45.
283. Silver RT. Imatinib mesylate (Gleevec(TM)) reduces phlebotomy requirements in polycythemia vera. *Leukemia* 2003;17(6):1186-1187.
284. Jones CM, Dickinson TM. Polycythemia vera responds to imatinib mesylate. *Am J Med Sci* 2003;325(3):149-152.
285. Jones CM, Dickinson TM, Salvado A. Phase II open label trial of imatinib in polycythemia rubra vera. *Int J Hematol* 2008;88(5):489-494.
286. Nussenzweig RH, Cortes J, Sever M, et al. Imatinib mesylate therapy for polycythemia vera: final result of a phase II study initiated in 2001. *Int J Hematol* 2009;90(1):58-63.
287. Silver RT, Bourla MH, Vandris K, et al. Treatment of polycythemia vera with imatinib mesylate. *Leuk Res* 2012;36(2):156-162.
288. Barosi G, Rosti V. Novel strategies for patients with chronic myeloproliferative disorders. *Curr Opin Hematol* 2009;16(2):129-134.
289. Pack GT, Craver LF. Radiation therapy of polycythemia vera. *Am J Med Sci* 1930;180(5):609-617.
290. Tubiana M, Flamant R, Attie E, Hayat M. A study of hematological complications occurring in patients with polycythemia vera treated with 32-P (based on a series of 296 patients). *Blood* 1968;32(4):536-548.

291. Lawrence JH. The control of polycythemia by marrow inhibition; a 10-year study of 172 patients. *J Am Med Assoc* 1949;141(1):13-18.
292. Harman JB, Hart PL, Ledlie EM. Treatment of polycythaemia with radioactive phosphorus. *Br Med J* 1955;1(4919):930-934.
293. Harman JB, Ledlie EM. Survival of polycythaemia vera patients treated with radioactive phosphorus. *Br Med J* 1967;2(5545):146-148.
294. Friedell HL, Storaasli JP. The therapeutic application of radioactive phosphorus with special reference to the treatment of primary polycythemia and chronic myeloid leukemia. *J Clin Invest* 1949;28(6 Pt 1):1308-1323.
295. Wasserman LR. The management of polycythaemia vera. *Br J Haematol* 1971;21(4):371-376.
296. Reinhard EH, Moore CV, et al. Radioactive phosphorus as a therapeutic agent; a review of the literature and analysis of the results of treatment of 155 patients with various blood dyscrasias, lymphomas, and other malignant neoplastic diseases. *J Lab Clin Med* 1946;31:107-218.
297. Stroebel CF, Hall BE, Pease GL. Evaluation of radiophosphorus therapy in primary polycythemia. *J Am Med Assoc* 1951;146(14):1301-1307.
298. Jurado M, Deeg H, Gooley T, et al. Haemopoietic stem cell transplantation for advanced polycythaemia vera or essential thrombocythaemia. *Br J Haematol* 2001;112:392-396.
299. Stobart K, Rogers PC. Allogeneic bone marrow transplantation for an adolescent with polycythemia vera. *Bone Marrow Transplant* 1994;13:337-339.
300. Gilbert HS, Warner RR, Wasserman LR. A study of histamine in myeloproliferative disease. *Blood* 1966;28(6):795-806.
301. Buchanan JG, Ameratunga RV, Hawkins RC. Polycythemia vera and water-induced pruritus: evidence against mast cell involvement. *Pathology* 1994;26:43-45.
302. Weick JK, Donovan PB, Najean Y, et al. The use of cimetidine for the treatment of pruritus in polycythemia vera. *Arch Intern Med* 1982;142(2):241-242.
303. Yue TF, Gutman AB. Effect of allopurinol (4-hydroxypyrazolo-(3,4-D)pyrimidine) on serum and urinary uric acid in primary and secondary gout. *Am J Med* 1964;37:885-898.
304. Wasserman LR, Gilbert HS. Surgery in polycythemia vera. *N Engl J Med* 1963;269:1226-1230.
305. Fruchtman SM, Wasserman LR. Therapeutic recommendations for polycythemia vera. In: Wasserman LR, ed. *Polycythemia vera and the myeloproliferative syndromes*. Philadelphia, PA: WB Saunders, 1995:337-350.
306. Finazzi G, Barbui T. How I treat patients with polycythemia vera. *Blood* 2007;109(12):5104-5111.
307. Barbui T, Finazzi MC, Finazzi G. Front-line therapy in polycythemia vera and essential thrombocythemia. *Blood Rev* 2012;26:205-211.
308. Weinfield A, Swolin B, Westin J. Acute leukaemia after hydroxyurea therapy in polycythemia vera and allied disorders: prospective study of efficacy and leukaemogenicity with therapeutic implications. *Eur J Haematol* 1994;52:134-139.

Chapter 83 Myelofibrosis

> Table of Contents > Part VII - Hematologic Malignancies > Section 3 - Myeloproliferative Disorders > Chapter 83 - Myelofibrosis

Chapter 83

Myelofibrosis

Rami Komrokji

Eric Padron

Srdan Verstovsek

DEFINITION

Myelofibrosis (MF) is a rare, serious myeloid malignancy classified as one of the Philadelphia chromosome negative [Ph(-)] myeloproliferative neoplasms (MPNs).¹

MF is subdivided into primary MF (PMF) and secondary MF.² Secondary MF may arise from polycythemia vera (PV) or essential thrombocythemia (ET).³

Terms frequently used synonymously with PMF include chronic idiopathic myelofibrosis ([CIMF; World Health Organization [(WHO)], agnogenic myeloid metaplasia, MF with myeloid metaplasia, and idiopathic MF.^{4,5}

The International Working Group for Myelofibrosis Research and Treatment (IWG-MRT) has defined MF as either PMF (de novo presenting disease), or post-PV or ET MF (MF transformation from prior PV or ET). Furthermore, patients with transformation to acute leukemia are referred to as PMF in blast phase (PMF-BP) or post-PV/ET MF in blast phase.⁵

The hallmark of MF neoplasm is an increase in mature blood cells, which arise from clonal expansion driven by genetic mutations in pluripotent cells of the bone marrow compartment. The response to this malignant myeloproliferative process is the secretion of multiple profibrogenic, -angiogenic, and -inflammatory cytokines that eventually results in polyclonal bone marrow fibrosis. MF is typically associated with progressive splenomegaly and in many cases with hepatomegaly, which can lead to other complications such as portal hypertension or splenic infarcts, cytopenias, and an increased likelihood of transforming to a blast phase.^{6,7}

HISTORICAL PERSPECTIVE

1879First report of PMF was by Heuck.⁸

1935Secondary myelofibrosis (post-PV MF) was described by Hirsch.⁹

1951Dameshek coined the classification of PMF as a myeloproliferative disorder (MPD).¹⁰

1960The Philadelphia chromosome abnormality t(9;22)(q32;q13) was described in chronic myeloid leukemia (CML) by Nowell and Hungerford.¹¹

1978PMF was characterized as a stem-cell-derived clonal myeloproliferative disorder associated with reactive MF by Fialkow's group.¹²

1992The JAK-STAT pathway was described.¹³

2005Several groups described a novel gain-of-function mutation in the gene encoding Janus kinase (JAK) 2. The mutation is a single nucleotide change, which results in a valine to phenylalanine substitution at codon 617 (*JAK2* V617F) in over 90% of patients with PV and ~50% of those with either PMF or ET.^{14,15,16 and 17}

2006A mutation in the myeloproliferative leukemia virus gene (*MPL*) for the thrombopoietin receptor was described in ~5% of patients with PMF.¹⁸ The mutation was a substitution of tryptophan to leucine at position 515 in the *MPL* gene sequence, *MPL* W515L. The “W” and “L” are the shorthand way to indicate which change occurred and resulted in the gene becoming abnormally active.¹⁹

2008The WHO classification changed the term from MPD to MPN.³

2009Other novel mutations were described for PMF in other genes, including ten-eleven-translocation 2 (*TET2*), additional sex-combslike 1 (*ASXL1*), Casitas B-lineage lymphoma (*CBL*), isocitrate dehydrogenase (*IDH*) 1 and 2, and IKAROS family zinc finger-1 (*IKZF1*). These mutations occur in 0% to 17% of MPNs and are more common in chronic (*TET2*, *ASXL1*, *CBL*) or juvenile (*CBL*) myelomonocytic leukemia, myelodysplastic syndromes (MDS) (*TET2*, *ASXL1*), and secondary acute myeloid leukemia, including the blast phase of MPN.²⁰

2011The FDA approved the first JAK2 inhibitor, ruxolitinib, for treatment of intermediate- or high-risk PMF or secondary MF.

EPIDEMIOLOGY

PMF is a rare disease. The annual incidence of MF has been estimated to be 0.41 to 1.46 cases per 100,000 individuals.^{21,22} The prevalence of MF in the United States has been estimated as 16,000 to 18,500 patients. MF is slightly more common

in males and more common in older patients.²¹ The median age of patients at the time of diagnosis is 67 years.²¹ Among the Philadelphia chromosome negative MPNs (e.g., MF, PV, ET), MF is the most symptomatic and carries the worst prognosis.

A higher incidence of PMF and related MPN has been suggested for persons of Jewish Ashkenazi ancestry.²³ Benzene, industrial solvents, and radiation exposure have been reported to be associated with increased risk of PMF.^{24, 25} and ²⁶

PATHOGENESIS

Current understanding suggests that PMF occurs secondary to acquired mutations that target the hematopoietic stem cell.^{1,12,27} As a result, ineffective hematopoiesis and proliferation of dysfunctional megakaryocytes are commonly seen in MF. The hallmark of the disease pathologically is bone marrow reticulin and collagen fibrosis, ineffective extramedullary hematopoiesis (EMH), and deregulated cytokine production.

The disease-initiating mutations remain unknown. Cytogenetic abnormalities originating on the progenitor cell level are well described in MF. In general, approximately half of patients with PMF display cytogenetic abnormalities that include del(20)(q11;q13), del(13)(q12;q22), trisomy 8, trisomy 9, del(12)(p11;p13), monosomy or deletions chromosome 7, and partial trisomy 1q. None of these abnormalities is specific to PMF, although the presence of either del(13)(q12;q22) or der(6)t(1;6)(q21-23;p21-23) is strongly suggestive of PMF diagnosis. Molecular cytogenetics using FISH did not reveal additional karyotypically occult cytogenetic lesions, but comparative genomic hybridization (CGH) studies have disclosed gains of chromosome 9p as the most frequent abnormality occurring in 50% of patients.^{28,29, 30} and ³¹

Deregulation of the Janus kinase-signal transducer and activator of transcription (JAK-STAT) pathway is the key contributor to the clinical phenotype of the disease regardless of the presence or absence of the JAK2 V617F mutation. The mutation described is not a disease initiating abnormality. The JAK-STAT pathway plays a pivotal role in the differentiation and development of hematopoietic cells and the functioning of the immune system.³² The JAK family comprises JAK1, JAK2, JAK3, and TYK2.³³ Cytokines and growth factors activate the extracellular portion of their cognate receptors,^{33,34} which promote the recruitment of JAK proteins to associate closely with the intracellular portion of these receptors and the activation of

P.1735

the JAK proteins via phosphorylation (Fig. 83.1). Phosphorylation of JAK proteins, in turn, leads to the phosphorylation and activation of several intracellular downstream signaling proteins, such as STAT proteins.³⁵ Phosphorylated STATs translocate to the nucleus and act as inducible nuclear transcription factors, which lead to transcriptional modulation and eventual expression of cellular, molecular, and (patho) physiologic actions that were promoted by the initial signal (ligand).

The dysregulation of the JAK-STAT signaling pathway in hematopoietic progenitor cells has been implicated in the pathogenesis of MF. JAK-STAT signaling in the pathogenesis of MF also relates to its role in mediating signaling from proinflammatory cytokines. These cytokines are elevated in environments of myeloproliferative disease and contribute to the debilitating symptoms of MPNs.³⁶ Somatic mutations that contribute to this dysregulated JAK-STAT activity include gain-of-function mutations directly in JAK2, or upstream signaling mutations such as the mutation of the thrombopoietin receptor (MPL W515L),¹⁸ and loss of JAK regulation by mutations in the gene for the lymphocyte-specific adaptor protein (LNK exon 2 mutations).³⁷ Mutations in JAK2 that lead to the constitutive activation of the JAK-STAT pathway, namely the JAK2 V617F^{14, 15} and ¹⁶ and JAK2 exon 12 mutations, have been identified, although this latter mutation was primarily identified in patients with PV.³⁸ JAK2 V617F is the most common mutation occurring in a large proportion (50% to 60%) of patients with PMF.^{14,15} With JAK2 activating mutations, the pathway becomes cytokine- and growth-factor-independent; therefore, even in the absence of these ligands, the intracellular signaling proteins are constitutively active. Clonal expansion leads to an increased JAK2 V617F allele burden and homozygosity influencing disease phenotype and differentiation of PV and ET.

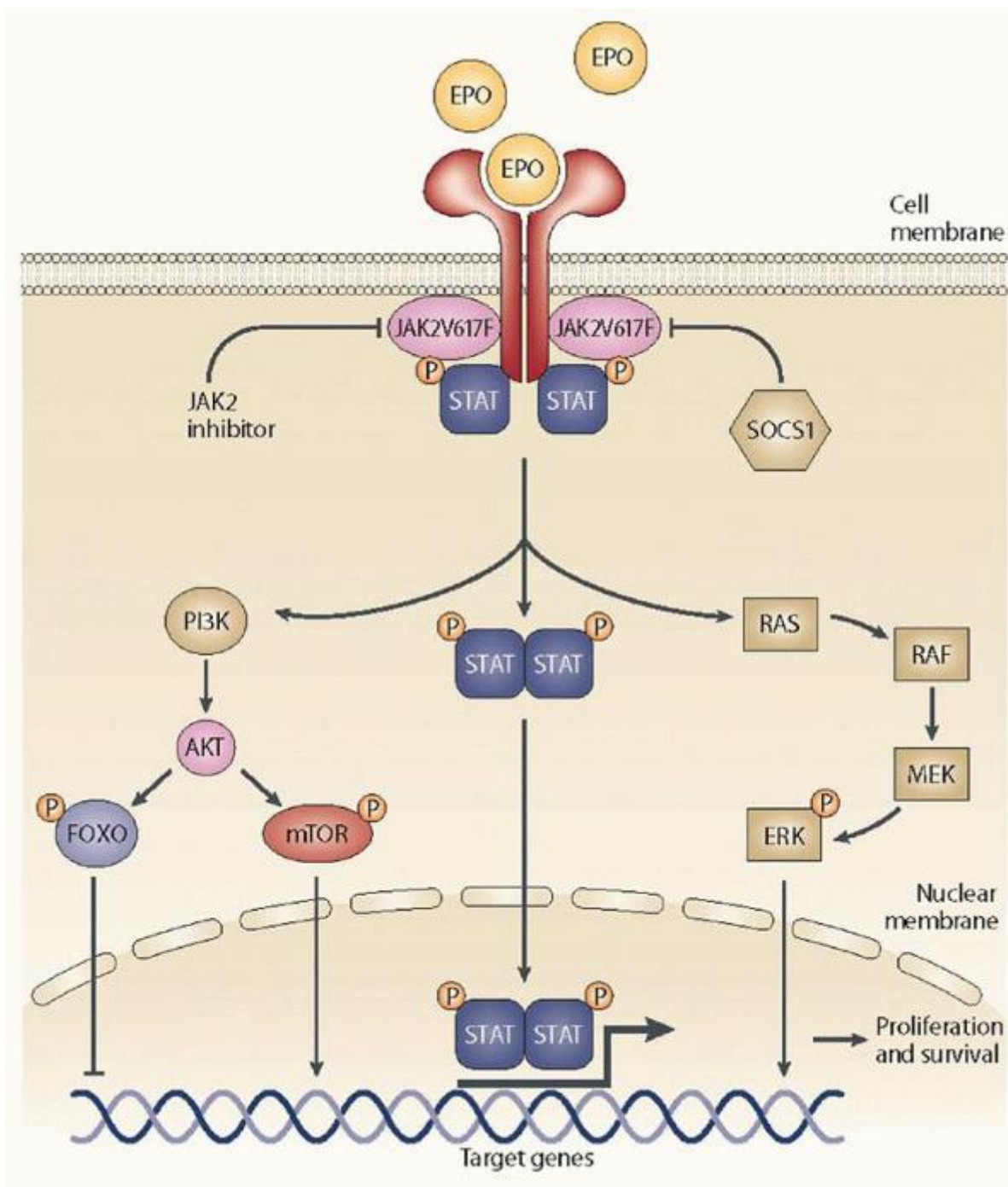

FIGURE 83.1. The JAK-STAT signaling pathway. Cytokines and growth factors bind to the extracellular receptor and induce a series of intracellular changes: (1) JAK proteins associate with the intracellular portion of the receptor and are phosphorylated; (2) phosphorylated-JAK proteins in turn phosphorylate STAT proteins, which then phosphorylate other downstream proteins; and (3) phosphorylated-STAT translocates into the nucleus and promotes the transcription of genes. Other proteins also regulate this signaling pathway, such as SOCS1, which prevents activation of this pathway. (With permission from Quintas-Cardama A, Kantarjian H, Cortes J, et al. Janus kinase inhibitors for the treatment of myeloproliferative neoplasias and beyond. *Nat Rev Drug Discov* 2011;10:127-140.)

Megakaryocyte-derived transforming growth factor- β 1 (TGF- β 1) has been identified as the primary cytokine that mediates many of the bone marrow stromal changes (i.e., collagen fibrosis, osteosclerosis, angiogenesis) in PMF.^{39,40} In mice, the PMF phenotype has been induced either by systemic overexpression of thrombopoietin (TPO^{high} mice) or by megakaryocyte lineage-restricted underexpression of the transcription factor GATA-1 (GATA-1^{low} mice). In both instances, the megakaryocytes display abnormal distribution of P-selectin that is believed to promote a pathologic

interaction between megakaryocytes and neutrophils, resulting in the release of both fibrogenic and angiogenic cytokines including TGF- β , platelet-derived growth factor (PDGF), basic fibroblast growth factor (bFGF), vascular endothelial growth factor (VEGF), tissue inhibitors of matrix metalloproteinases, and neutrophil-derived elastase and other proteases.^{41, 42}

P.1736

Another characteristic feature in PMF that accompanies the aberrant bone marrow stromal reaction involves peripheral blood expansion of both CD34-positive myeloid progenitors and endothelial cells.^{43,44} Current consensus implicates both circulating progenitor cell trapping and abnormal cytokine stimulation of embryonic hematopoietic sites as mechanisms of hepatosplenic EMH in PMF.^{45,46} Such a contention is supported by the high concordance between bone marrow and splenic tissue cytogenetic findings in PMF.⁴⁷

Disease progression to blast phase (acute myeloid leukemia [AML]) is probably driven by additional clonal evolution and acquired mutations (see section "Disease Course").

CLINICAL FEATURES

Splenomegaly is a well-established clinical feature of MF with 85% or more of MF patients presenting with palpable splenomegaly at the time of diagnosis. One third of patients will have marked splenomegaly (Fig. 83.2) and 50% of patients will also have hepatomegaly.^{48,49} Spleen-related symptoms include abdominal discomfort, early satiety, and pain under the left ribs. Portal hypertension and variceal bleeding can be morbid complications of splenomegaly. Some patients may experience severe pain secondary to splenic infarcts.⁵⁰

Constitutional symptoms are common and often debilitating. Disease burden due to those symptoms often interfere with daily quality of life. These symptoms include fatigue, pruritus, night sweats, fever and bone/muscle pain, and cachexia. Presence of those symptoms is associated with worse outcome.

Cytopenias can dominate the course of the disease especially at the advanced stages. Two thirds of patients may have anemia at diagnosis and 20% are transfusion-dependent.^{51,52} Thrombocytopenia may be present in 21% to 37% and leukopenia in 7% to 22%.⁵³

Some patients present with leukocytosis (41% to 49% incidence), and/or thrombocytosis (13% to 31%). Furthermore, >10% of patients may present with extreme thrombocytosis (platelet count $>1,000 \times 10^9/L$), whereas >20% present with marked leukocytosis (leukocyte count $>20 \times 10^9/L$).⁵³ Patients with MF are also at risk for developing thrombohemorrhagic complications secondary to leukocytosis and/or thrombocytosis.⁵⁴

Other potential symptoms and complications include ascites, portal hypertension, lymphadenopathy, pleural effusions, and nerve or cord compression secondary to EMH.⁵⁵

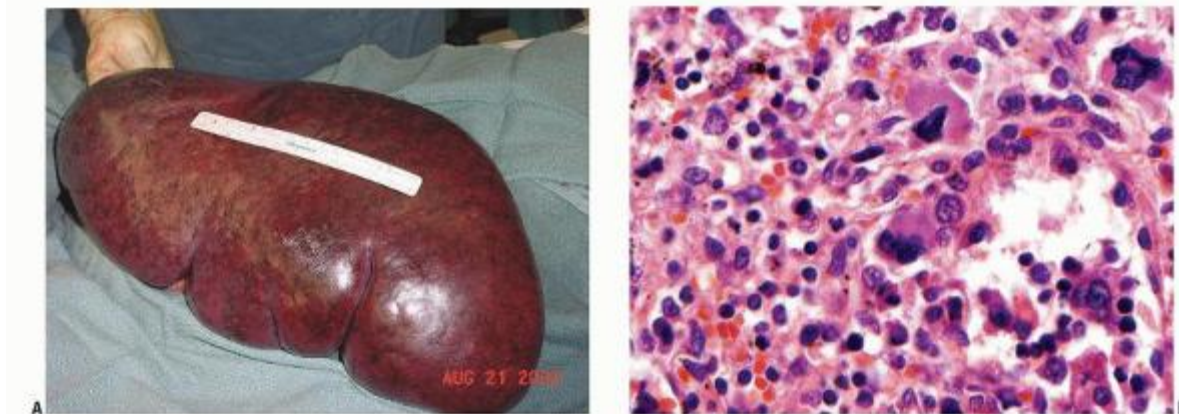

FIGURE 83.2. Splenomegaly due to extramedullary hematopoiesis in a patient with myelofibrosis. A: Massive splenomegaly. B: Chronic idiopathic myelofibrosis in the spleen. The red pulp shows extensive involvement by maturing myeloid and erythroid cells, as well as atypical megakaryocytes. Some of this abnormal extramedullary hematopoiesis is in a sinus at the lower right side of the figure.

Characteristic laboratory findings in MF may include peripheral blood leukoerythroblastosis, dacryocytosis, teardrop-shaped red blood cells (see Fig. 80.9), circulating immature myeloid cells, increased serum lactate dehydrogenase,

increased vitamin B12 levels, and hyperuricemia. The characteristic bone marrow aspirate and biopsy findings may be limited by the inability to collect an adequate bone marrow aspirate (so-called dry tap). The clustering of atypical megakaryocytes, which may often be mistaken as dysplasia by an inexperienced pathologist, is a pathologic hallmark of myeloproliferative syndromes.⁵⁶ Reticulin staining demonstrates an increased deposition of reticulin fibers. Collagen fibrosis can be appreciated and may be more disease-specific compared to reticulin staining. In some early cases of MF, the bone marrow could only be hypercellular with no evidence of fibrosis.⁷ Figure 83.3 illustrates typical bone marrow findings in MF. Circulating levels of CD34⁺, hematopoietic stem cells and progenitors are high in patients with MF compared with healthy patients as well as patients with other Philadelphia chromosome negative MPNs.⁴²

DIAGNOSIS

The differential diagnosis of MF should include bone marrow fibrosis associated with nonneoplastic and neoplastic conditions (Table 83.1) including but not limited to chronic myeloid leukemia (CML), MDS, chronic myelomonocytic leukemia (CMML), lymphoma, or AML. Presence of JAK2 or MPL mutation is a reliable screen to rule out reactive bone marrow fibrosis or a nonmyeloid malignancy. The diagnosis of PMF is facilitated using the WHO criteria, whereas post-PV or post-EF MF diagnosis is based on the IWG-MRT criteria (Table 83.2).^{3,57}

PMF is typically characterized by the presence of morphologically bizarre megakaryocytes in clusters. However, it is important to note that the presence of apparent reticulin fibrosis is not essential for the diagnosis of PMF. Accordingly, there are two histologic variants of PMF: fibrotic and cellular (prefibrotic) phases.⁵⁸ Reticulin fibrosis is either absent or minimal in cellular-phase PMF, and it is thus possible to confuse cellular-phase PMF with ET. However, bone marrow is markedly hypercellular, with both granulocytic and megakaryocytic proliferation in PMF, as opposed to often normocellular bone marrow with only megakaryocytic hyperplasia in ET. Further distinction is facilitated by the appreciation of subtle differences in megakaryocyte

P.1737

morphology; PMF megakaryocytes display defective maturation with prominent “cloudlike” hyperchromatic nuclei, whereas ET megakaryocytes appear mature although large in size, with well-lobulated (i.e., staghornlike) nuclei.⁵⁹ Other distinguishing features between cellular-phase PMF and ET include the presence of myelophthisis and/or increased LDH in the former but not the latter. One distinct WHO category of AML (i.e., acute MF) can sometimes be confused with PMF. Patients with fibrotic AML, either AML M7 or other AML subtype, usually present with severe constitutional symptoms, pancytopenia, mild or no splenomegaly, and feature an increase in blood and bone marrow blasts that might not necessarily fulfill the required threshold for AML diagnosis.

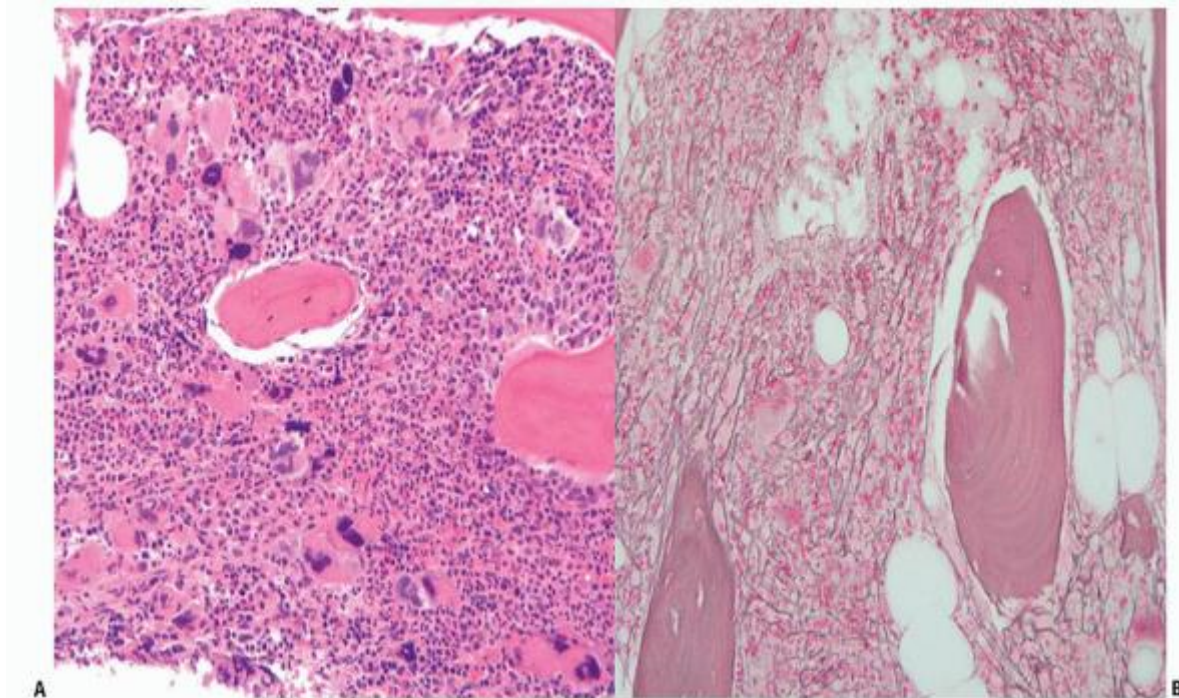

FIGURE 83.3. Bone marrow in myelofibrosis. A: Hypercellular bone marrow biopsy with megakaryocytic atypia. B: Reticulin stain demonstrating presence of myelofibrosis.

TABLE 83.1 DIFFERENTIAL DIAGNOSIS FOR BONE MARROW FIBROSIS

Hematologic Disorders		Non-hematologic Disorders
Myeloid Disorders	Lymphoid Disorders	
Primary myelofibrosis	Hairy cell leukemia	Metastatic cancer
Chronic myeloid leukemia	Hodgkin lymphoma	Autoimmune myelofibrosis
Myelodysplastic syndrome	Non-Hodgkin lymphoma	Systemic lupus erythematosus
Chronic myelomonocytic leukemia	Multiple myeloma	Kala-Azar (leishmaniasis)
Chronic eosinophilic leukemia		Tuberculosis
Systemic mastocytosis		Paget disease
Acute megakaryocytic leukemia		HIV infection
Other acute myeloid leukemias		Vitamin D-deficient rickets
Acute lymphocytic leukemia		Renal osteodystrophy
Acute myelofibrosis		Hyperparathyroidism
Malignant histiocytosis		Gray platelet syndrome
		Familial infantile myelofibrosis
		Idiopathic pulmonary hypertension

TABLE 83.2 WHO CRITERIA FOR DIAGNOSIS OF PRIMARY AND POST-ET/PV MYELOFIBROSIS

WHO Criteria: Primary MF	IWG Criteria: Post-ET MF and Post-PV MF
Major Criteria (All Required)	Major Criteria (All Required)
<ul style="list-style-type: none"> • Megakaryocyte proliferation and atypia <ul style="list-style-type: none"> ○ Reticulin or collagen fibrosis • Does not meet criteria for other myeloid disorders (e.g., PV, CML, MDS) • Clonal marker (e.g., <i>MPLW515K/L</i>, <i>JAK2V617F</i>) or no evidence for secondary marrow fibrosis 	<ul style="list-style-type: none"> • Previous diagnosis of ET or PV • Grade 2-3 bone marrow fibrosis (on 0-3 scale) or Grade 3-4 bone marrow fibrosis (on 0-4 scale)
Minor Criteria (Must Meet 2)	Minor Criteria (Must Meet 2)
<ul style="list-style-type: none"> • Increase in serum LDH • Palpable splenomegaly • Leukoerythroblastosis • Anemia 	<ul style="list-style-type: none"> • ≥ 5 cm increase in palpable splenomegaly or new splenomegaly • Leukoerythroblastosis • One or more constitutional symptoms • Increase in serum LDH (Post-ET MF only) • Anemia with Hgb ≥ 2 mg/ml decrease from baseline (post-ET MF only) • Anemia or sustained loss of requirement for either cytoreductive treatment or phlebotomy (post-PV MF only)

IWG, International Working Group; Post-ET MF, post-essential thrombocythemia myelofibrosis; Post-PV MF, post polycythemia vera myelofibrosis; WHO, World Health Organization.

P.1738

DISEASE COURSE

MF is a progressive disease. Patients develop progressive splenomegaly and its related complications, and suffer from debilitating disease burden symptoms such as cachexia, bone pain, and/or profound fatigue. Cytopenias can worsen during the course of the disease with more patients becoming red blood cell transfusion dependent and developing thrombocytopenia and neutropenia. The rate of secondary AML transformation (or better termed blast phase-PMF) is 10% to 15%. Blast phase-PMF is very difficult to manage, and response to intensive chemotherapy is poor.⁶⁰ The major causes of death in PMF include infections (26% to 29%), bleeding (11% to 22%), heart failure (7% to 15%), liver failure (3% to 8%), and portal hypertension (6%).^{61,62}

RISK STRATIFICATION AND PROGNOSIS

MF is a progressive hematologic disease and its prognosis is dependent on several factors. The International Prognostic Scoring System (IPSS) estimates survival from the time of diagnosis using the following risk factors: (1) age 65 years or older; (2) anemia (hemoglobin <10 g/dl); (3) presence of constitutional symptoms; (4) leukocytosis (white blood cell count $>25 \times 10^9/L$); and (5) circulating blasts of at least 1%.⁶³ Patients presenting with more than two of the aforementioned prognostic factors of MF have a median survival of less than 3 years, whereas patients without any of the factors have a median survival of more than 10 years. The presence of 0, 1, 2, and ≥ 3 factors using IPSS define low, intermediate-1, intermediate 2, and high-risk disease, respectively.

Patient karyotype abnormality is also prognostic of survival. In a retrospective review of 200 MF patients, in comparison with trisomy 8 or a complex karyotype, patients with sole 13q deletion, 20q deletion, or trisomy 9 had an improved survival and no leukemia transformation.⁶⁴ In a study of 433 patients with PMF, a high-risk cytogenetic profile was when patients had a complex karyotype or sole or two abnormalities that included +8, -7/7q, i(17q), -5/5q-, 12p-, or 11q23 rearrangement, and a low-risk profile was when patients had normal karyotype, or sole abnormalities not present in the high-risk group, including +9, 13q-, 20q-, or chromosome 1 translocations/duplications.⁶⁵ The 5-year survival rates were 8% and 51%, respectively (Fig. 83.4). In a study of 793 patients, 62 (8%) displayed an unfavorable karyotype by way of complex cytogenetics (n = 41) or sole trisomy 8 (n = 21).⁶⁶ The presence of monosomal karyotype in 41% of the patients with complex cytogenetics had an extremely poor prognosis with a 2-year leukemia transformation rate of 29.4% and a median survival of only 6 months.

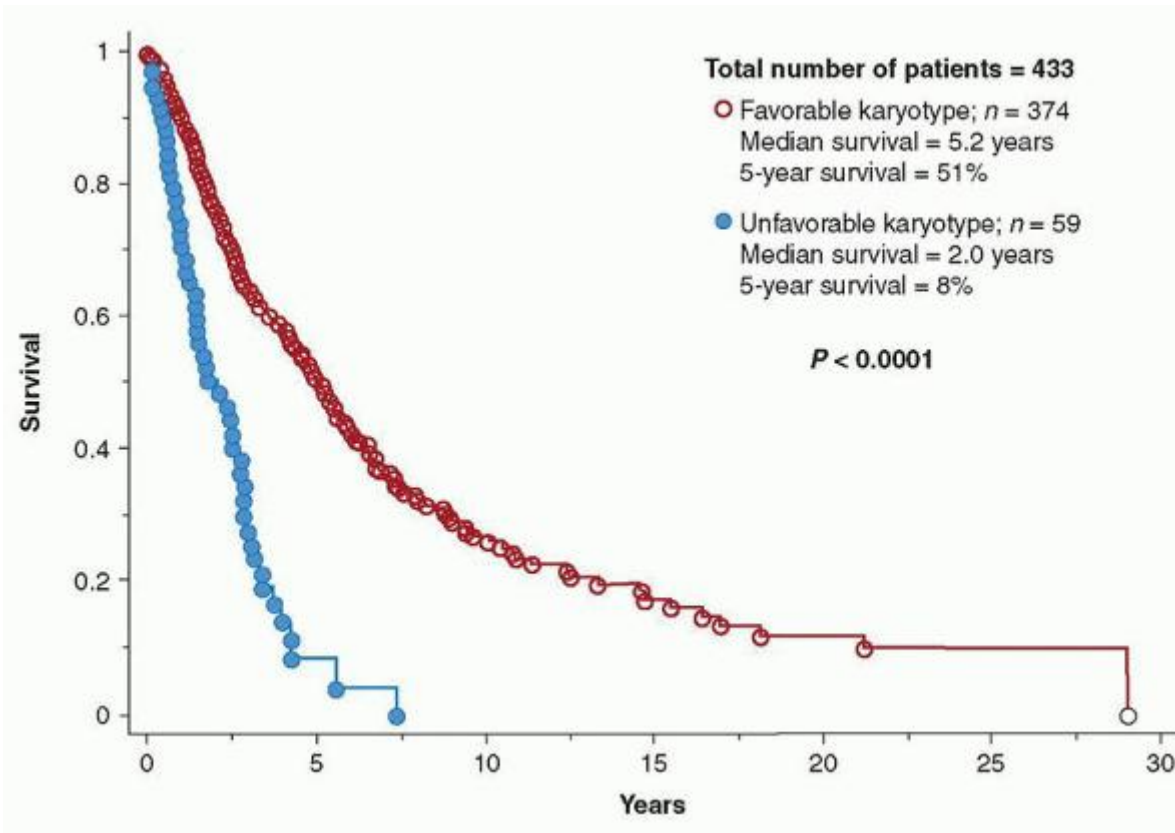

FIGURE 83.4. Survival data of patients with primary myelofibrosis stratified by two-tiered cytogenetic-risk categorization: unfavorable (complex karyotype or sole or two abnormalities that include +8, -7/7q-, i(17q), inv(3), -5/5q-, 12p-, or 11q23 rearrangement) and favorable (all others including normal karyotype). (With permission from Caramazza D, Begna KH, Gangat N, et al. Refined cytogenetic-risk categorization for overall and leukemia-free survival in primary myelofibrosis: a single center study of 433 patients. *Leukemia* 2011;25:82-88.)

In an update to the IPSS, the Dynamic IPSS (DIPSS) was modified using the same prognostic factors from IPSS.⁶⁷ Unlike the IPSS, the DIPSS may be used at any time-point in disease to estimate survival; opposed to IPSS, in DIPSS the development of disease-related anemia carries two points. Most recently, the DIPSS was updated to the DIPSS-plus, which incorporates three more prognostic factors including red blood cell transfusion need, platelet count $<100 \times 10^9/L$, and unfavorable karyotype (Fig. 83.5).⁶⁸ Table 83.3 summarizes risk stratification models in MF.

In addition to the prognostic factors in IPSS and DIPSS-plus, increased interleukin-8 (IL-8), IL-10, IL-15, or IL-2 receptor have also been associated with reduced overall survival and leukemia-free survival.⁶⁹

The ability to prognosticate and stratify severity of disease is critical in effectively counseling patients regarding expected outcome and to define the most appropriate treatment strategies. Risk stratification allows the clinician to identify high-risk patients who may benefit from intensive therapy such as allogeneic stem cell transplant where benefit outweighs the risk. Lower risk MF patients or MF patients who are not transplant candidates are managed based on the presence of constitutional symptoms, symptomatic splenomegaly, or severe cytopenias.

Response Criteria and Assessment Tools

The International Working Group for Myelofibrosis Research and Treatment (IWG-MRT) developed criteria for response to therapy in MF, modeled after other criteria, such as the IWG criteria for MDS.⁷⁰ Treatment responses are categorized as complete remission (CR), partial remission (PR), or clinical improvement. Recently

P.1739

revised response criteria by the IWG and European Leukemia Net (ELN) have been proposed (Table 83.4).^{70,71} The criteria for “clinical improvement” incorporate reduction in spleen size and improvements in anemia, platelet count, and

neutrophil count. The CR and PR as surrogate markers of survival have not been validated, and it would be difficult to achieve CR or PR with currently available therapy apart from allogeneic hematopoietic cell transplantation (alloHCT).

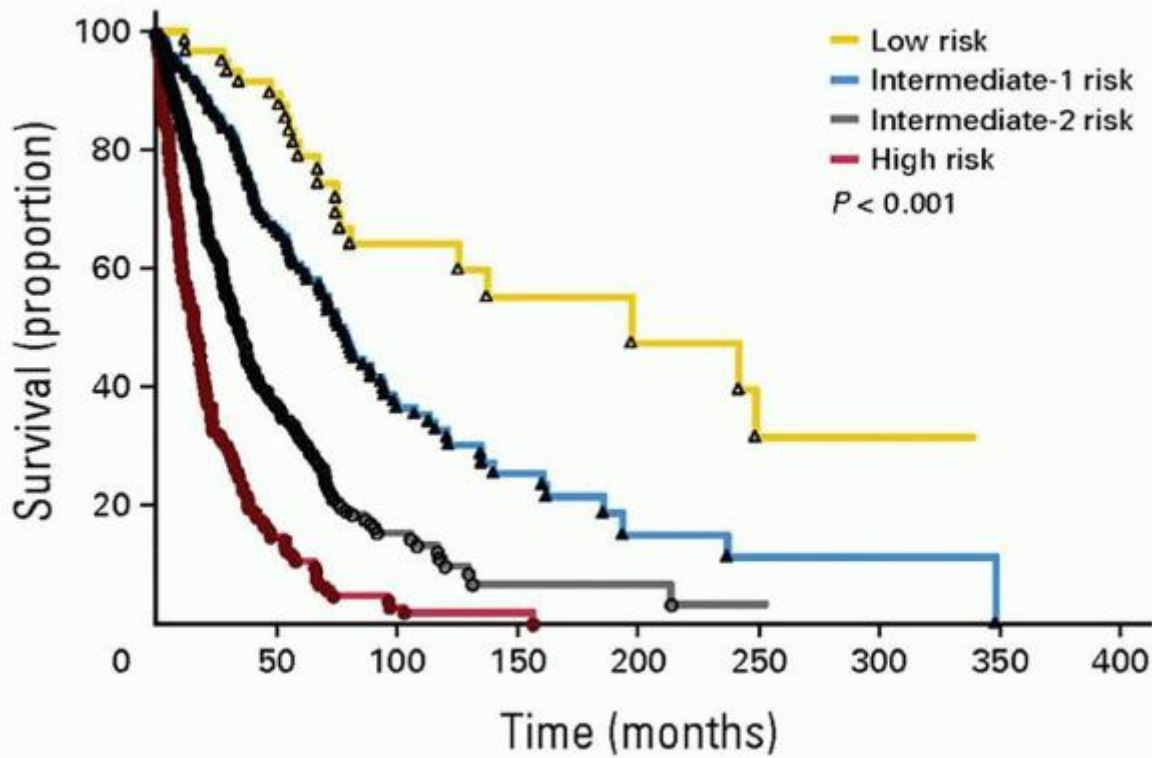

FIGURE 83.5. Survival data of 793 patients with primary myelofibrosis evaluated at time of their first Mayo Clinic referral and stratified by their Dynamic International Prognostic Scoring System (DIPSS) + karyotype + platelet count + transfusion status prognostic scores. Low risk, zero adverse points; n = 66; median survival, 185 months. Intermediate-1 risk, one adverse point; n = 174; median survival, 78 months. Intermediate-2 risk, two or three adverse points, n = 360; median survival, 35 months. High risk, four to six adverse points; n = 193; median survival, 16 months. (With permission from Gangat N, Caramazza, D, Vaidya R, et al. DIPSS plus: a refined Dynamic International Prognostic Scoring System for primary myelofibrosis that incorporates prognostic information from karyotype, platelet count, and transfusion status. J Clin Oncol 2011;29:392-397.)

Some clinical trials define spleen response as a $\geq 50\%$ reduction in splenic size (length) as assessed by palpation (consistent with IWG-MRT criteria) or $\geq 35\%$ reduction when assessed by imaging (corresponding to an approximate $\geq 50\%$ reduction in palpable spleen length, as shown in the Phase I/II trial of ruxolitinib).³⁶ Evaluating changes in spleen size by palpation, however, may not be as objective as evaluating changes in spleen size by MRI. In a Phase II study evaluating the JAK inhibitor pacritinib (formerly known as SB1518), a 50% reduction in spleen size as assessed by palpation correlated with a 25% reduction in spleen size as assessed by MRI.⁷² Thus, use of objective measurements such as MRI or CT to evaluate changes in spleen size may be more useful in evaluating response to therapy, especially in clinical trials. In practice, physical examination or ultrasound remain the most common tools utilized for spleen size assessment.

TABLE 83.3 RISK STRATIFICATION MODELS IN MYELOFIBROSIS

Risk Factor	IPSS	DIPSS	DIPSS plus
Age >65	X	X	X
Constitutional symptoms	X	X	X
Anemia (Hgb <10 g/dl)	X	X	X
WBC >25 × 10 ⁹ /L	X	X	X

Circulating myeloblasts $\geq 1\%$	X	X	X
RBC transfusion dependence			X
Unfavorable karyotype, complex karyotype, or sole or 2 abnormalities that include +8, -7/7q-, i(17q), inv(3), -5/5q-, 12p-, or 11q23 rearrangement			X
Platelets $< 100 \times 10^9 /L$			X
Points	1 each	1 each except anemia = 2	1 each
Risk Groups (sum points)	0 = Low 1 = Intermediate-1 2 = Intermediate-2 ≥ 3 = High risk	0 = Low 1-2 = Intermediate-1 3-4 = Intermediate-2 5-6 = High risk	0 = Low 1 = Intermediate-1 2-3 = Intermediate-2 ≥ 4 = High risk
Median Overall Survival	Low: 11.3 y Int-1: 7.9 y Int-2: 4 y High 2.3 y	Low: NR Int-1 14.2 y Int-2: 4 y High 1.5 y	Low: 15.4 Int-1 6.5 y Int-2: 2.9 y High 1.3 y

DIPSS, dynamic IPSS; IPSS, International Prognostic Scoring System; NR, not reached.

P.1740

TABLE 83.4 REVISED INTERNATIONAL WORKING GROUP FOR MYELOPROLIFERATIVE NEOPLASMS RESEARCH AND TREATMENT (IWG-MRT) AND EUROPEAN LEUKEMIA NET (ELN) RESPONSE CRITERIA FOR MYELOFIBROSIS

Response Categories	Required Criteria (For All Response Categories, Benefit Must Last for ≥ 12 Weeks in Order to Qualify as a Response)
Complete Remission (CR)	<i>Bone marrow:</i> ^a Age-adjusted normocellularity; $< 5\%$ blasts; \leq Grade 1 myelofibrosis ^b , and <i>Peripheral blood:</i> Hemoglobin ≥ 100 g/L and $<$ UNL; neutrophil count $\geq 1 \times 10^9/L$ and $<$ UNL. Platelet count $\geq 100 \times 10^9/L$ and $<$ UNL; $< 2\%$ immature myeloid cells ^c , and <i>Clinical:</i> Resolution of disease symptoms; spleen and liver not palpable; no evidence of EMH.
Partial Remission (PR)	<i>Peripheral blood:</i> Hemoglobin ≥ 100 g/L and $<$ UNL; Neutrophil count $\geq 1 \times 10^9/L$ and $<$ UNL. Platelet count $\geq 100 \times 10^9/L$ and $<$ UNL; $< 2\%$ immature myeloid cells ^c , and <i>Clinical:</i> Resolution of disease symptoms; spleen and liver not palpable; No evidence of EMH, or <i>Bone marrow:</i> ^a Age-adjusted normocellularity; $< 5\%$ blasts; \leq Grade 1 myelofibrosis ^b , and <i>Peripheral blood:</i> Hemoglobin ≥ 85 but < 100 g/L and $<$ UNL; neutrophil count $\geq 1 \times 10^9/L$ and $<$ UNL; Platelet count ≥ 50 but $< 100 \times 10^9/L$ and $<$ UNL; $< 2\%$ immature myeloid cells ^c , and <i>Clinical:</i> Resolution of disease symptoms; spleen and liver not palpable; no evidence of EMH.
Clinical Improvement (CI)	The achievement of anemia, spleen, or symptoms response without progressive disease or deterioration in anemia ^d .

Anemia Response	<i>Transfusion-independent patients:</i> a ≥ 20 g/L increase in hemoglobin level ^e . <i>Transfusion-dependent patients:</i> becoming transfusion-independent ^f .
Spleen Response^g	A baseline splenomegaly that is palpable at 5-10 cm, below the LCM, becomes not palpable ^h , or A baseline splenomegaly that is palpable at >10 cm, below the LCM, decreases by $\geq 50\%$ ^h A baseline splenomegaly that is palpable at <5 cm, below the LCM, is not eligible for spleen response. A spleen response requires confirmation by MRI or CT showing $\geq 35\%$ spleen volume reduction.
Symptoms Response	A $\geq 50\%$ reduction in the Myeloproliferative Neoplasm Symptom Assessment Form total symptom score (MPN-SAF TSS) ⁱ .
Progressive Disease^j	Appearance of a new splenomegaly that is palpable at least 5 cm below the LCM, or A $\geq 100\%$ increase in palpable distance, below LCM, for baseline splenomegaly of 5 to 10 cm, or A 50% increase in palpable distance, below LCM, for baseline splenomegaly of >10 cm, or Leukemic transformation confirmed by a bone marrow blast count of $\geq 20\%$, or A peripheral blood blast count of $\geq 20\%$ that lasts for at least 2 wk.
Stable Disease	Belonging to none of the above-listed response categories.
Relapse	No longer meeting criteria for at least CI after achieving CR, PR, or CI, or Loss of anemia response persisting for at least 1 mo, or Loss of spleen response persisting for at least 1 mo
Guidelines for Assessing Treatment-induced Cytogenetic and Molecular Changes	
Cytogenetic Remission	At least 10 metaphases must be analyzed for cytogenetic response evaluation, and requires confirmation by repeat testing within 6 mo window. <i>Complete response:</i> eradication of a pre-existing abnormality. <i>Partial response:</i> $\geq 50\%$ reduction in abnormal metaphases. (partial response applies only to patients with at least 10 abnormal metaphases at baseline).
Molecular Remission	Molecular response evaluation must be analyzed in peripheral blood granulocytes, and requires confirmation by repeat testing within 6 mo window. <i>Complete response:</i> eradication of a pre-existing abnormality. <i>Partial response:</i> $\geq 50\%$ decrease in allele burden. (partial response applies only to patients with at least 20% mutant allele burden at baseline).
Cytogenetic/Molecular Relapse	Re-emergence of a pre-existing cytogenetic or molecular abnormality that is confirmed by repeat testing.

CT, computed tomography; EMH, extramedullary hematopoiesis (no evidence of EMH implies the absence of pathology, or imaging study-proven nonhepatosplenic EMH); LCM, left costal margin; MRI, magnetic resonance imaging; UNL, upper normal limit.

^a Baseline and post-treatment bone marrow slides are to be stained at the same time and interpreted at one sitting by a central review process. Cytogenetic and molecular responses are not required for CR assignment.

^b Grading of myelofibrosis is according to the European classification (Thiele K, vannicka HM, Facchetti F, Franco V, van der Walt J, Orazi A. European consensus on grading bone marrow fibrosis and assessment of cellularity. *Haematologica* 2005;90:1128).

^c Immature myeloid cells constitute blasts + promyelocytes + myelocytes + metamyelocytes + nucleated red blood cells. In splenectomized patients, <5% immature myeloid cells is allowed.

^d See [Table 83.1](#) for definitions of anemia response, spleen response, and progressive disease. Deterioration in anemia constitutes the occurrence of new transfusion dependency or a ≥ 20 g/L decrease in hemoglobin level from pre-treatment baseline that lasts for at least 12 weeks.

^e Applicable only to patients with baseline hemoglobin of <100 g/L. In patients not meeting the strict criteria for transfusion-dependency at the time of study enrollment (see below), but have received transfusions within the previous month, the pre-transfusion hemoglobin level should be used as the baseline.

^f Transfusion dependency before study enrollment is defined as transfusions of at least 6 units of packed red blood cells (PRBC), in the 12 weeks prior to study enrollment, for a hemoglobin level of <85 g/L, in the absence of bleeding or treatment-induced anemia. In addition, the most recent transfusion episode must have occurred in the 28 days prior to study enrollment. Response in transfusion-dependent patients requires absence of any PRBC transfusions during any consecutive “rolling” 12-week interval during the treatment phase, capped by a hemoglobin level of ≥ 85 g/L.

^g In splenectomized patients, palpable hepatomegaly is substituted with the same measurement strategy.

^h Spleen or liver responses must be confirmed by imaging studies where a $\geq 35\%$ reduction in spleen volume, as assessed by magnetic resonance imaging (MRI) or computed tomography (CT), is required. Furthermore, a $\geq 35\%$ volume reduction in the spleen or liver, by MRI or CT, constitutes a response regardless of what is reported with physical examination.

ⁱ Symptoms are evaluated by the Myeloproliferative Neoplasm Symptom Assessment Form total symptom score (MPN-SAF TSS).⁹ The MPN-SAF TSS is assessed by the patients themselves and includes fatigue, concentration, early satiety, inactivity, night sweats, itching, bone pain, abdominal discomfort, weight loss, and fevers. Scoring is from 0 (absent/as good as it can be) to 10 (worst imaginable/as bad as it can be) for each item. The MPN-SAF TSS is the summation of all the individual scores (0-to-100 scale). Symptoms response requires $\geq 50\%$ reduction in the MPN-SAF TSS.

^j Progressive disease assignment for splenomegaly requires confirmation by MRI or CT showing a $\geq 25\%$ increase in spleen volume from baseline. Baseline values for both physical examination and imaging studies refer to pre-treatment baseline and not to post-treatment measurements.

Modified from Tefferi A, Cervantes F, Mesa R, et al. Revised response criteria for myelofibrosis: International Working Group-Myeloproliferative Neoplasms Research and Treatment (IWG-MRT) & European LeukemiaNet (ELN) consensus report. *Blood* 2013; doi: 10.1182/blood-2013-03-488098 [Epub ahead of print].

P.1741

The Myelofibrosis Symptom Assessment Form (MFSAF) is a tool specifically developed to evaluate the presence and severity of MF-associated symptoms.⁷³ In a recent version of the MFSAF (v2.0), patients rated the presence and severity of splenomegaly-related symptoms (abdominal discomfort, pain under the ribs on left side, early satiety), systemic symptoms

(night sweats, pruritus, bone/muscle pain), and inactivity using a scale of 0 (symptom not present) to 10 (symptom present and worst imaginable).⁷⁴

Fatigue is a problematic symptom and is pervasive, persistently severe, and almost universally present in MF patients.⁷⁵ Moreover, it interferes with activities of daily living and quality of life (QoL). Tools to evaluate fatigue include the Functional Assessment of Cancer Therapy Fatigue scale (FACT-F), the Brief Fatigue Inventory (BFI), the Cancer Linear Analogue Scale (CLAS), and the Patient Reported Outcomes Measurement Information System (PROMIS) Fatigue scale.^{76,77} The FACT-Lym, which was developed for assessment of symptoms in lymphoma patients, includes an evaluation of constitutional (or “B”) symptoms, such as pruritus, bone/muscle pain, and fatigue.⁷⁸

MANAGEMENT

The first step in disease management is risk stratification. For patients with intermediate-2 or high-risk disease allogeneic stem cell transplant should be considered. If patients are nontransplant candidates or have lower risk disease, treatment is only for symptomatic patients (with constitutional and/or spleen-related symptoms) and those with severe cytopenias. The selection of treatment is based on the particular patient's characteristics. Figure 83.6 summarizes a suggested algorithm for management of PMF.

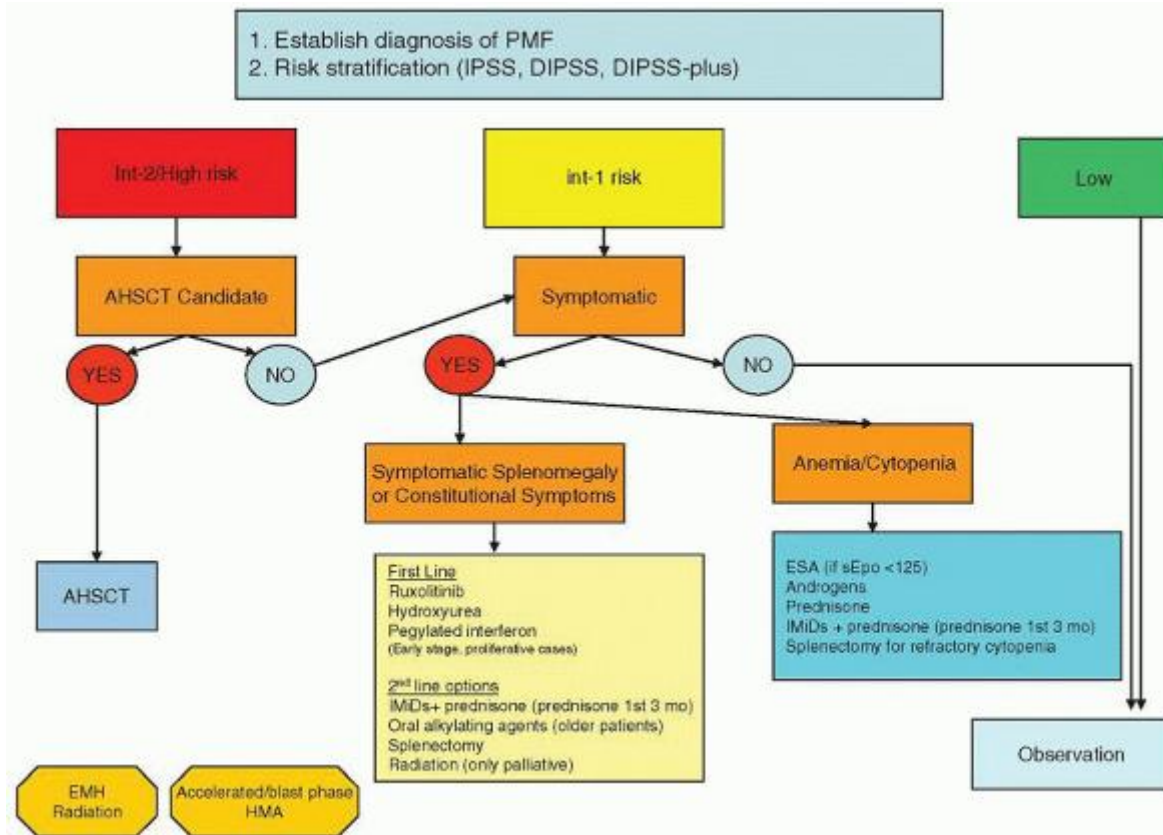

FIGURE 83.6. Suggested algorithm for management of primary myelofibrosis (PMF). AHSCT, allogeneic hematopoietic stem cell transplantation; EMH, extramedullary hematopoiesis; ESA, erythroid stimulating agents; HMA, hypomethylating agents; int, intermediate; ImiDs, immunomodulatory drugs (lenalidomide or thalidomide); sEpo, endogenous serum erythropoietin level.

Treatment of Anemia

Treatment of anemia and resultant RBC transfusion dependency remain an unmet challenge in management of PMF. Options for treatment include erythroid stimulating agents (ESA), steroids, androgens, or immunomodulatory drugs (ImiDs) which include thalidomide and lenalidomide. Transfusion independency had been reported with some of the new JAK-2 inhibitors. Many patients will remain RBC transfusion dependent.

Subcutaneous erythropoietin (Epo) injections (40,000 U weekly) are safe and most suitable for patients with an endogenous serum Epo level <125 U/L. Response rate in such patients is estimated at 50% and might be even higher in

transfusion-independent patients.⁷⁹ The median duration of response is only 1 year, and some patients experience further enlargement of their spleen during treatment with ESA.

Corticosteroid therapy (variable doses of prednisone, between 0.5 and 1.0 mg/kg/day) has been used in the past, with response rates that were higher in female patients (52%) compared to male patients (29%).⁸⁰ Similar response rates (i.e., 30% to 40%) have also been observed with several androgen preparations, including testosterone enanthate (400 to 600 mg intramuscularly, weekly) and oral fluoxymesterone (10 mg/three times a day).⁸⁰ The addition of corticosteroids appears to increase the response rate observed with androgens, whereas the presence of cytogenetic abnormality predicts a lesser response rate.⁸¹ Danazol produces a transient (average 5 months) response rate in PMF that is similar to that seen with other androgen preparations (i.e., ~30% to 40% at a dose of 600 mg/day).⁸²

Thalidomide and lenalidomide were recently added to the therapeutic armamentarium for PMF-associated anemia after each drug was shown to effect an ~20% response rate.^{83,84}

P.1742

Thalidomide is used at low doses (50 mg/day) and in combination with corticosteroids (prednisone, 15 to 30 mg/day for 3 months only)⁸⁵ and lenalidomide is clearly active in the presence of del(5)(q31).^{84,86} A phase II clinical study using lenalidomide 10 mg po daily for 21 days every 28 days (dose adjusted based on platelet count) combined with prednisone for 3 months (30 mg daily first month, 15 mg daily second month, and 15 mg every other day third month) reported a 30% hemoglobin response but not if patients had baseline thrombocytopenia or neutropenia.⁸⁷ Pomalidomide was also reported to be active in anemia treatment in PMF where its use remains currently investigational.⁸⁸ Phase I/II studies 0.5 mg was the recommended dose and durable hemoglobin responses were reported in 25% of patients. A recent phase III placebo controlled study finished accrual results of which are pending. Outside the context of a clinical trial, we use lenalidomide in patients without baseline of thrombocytopenia/neutropenia and thalidomide if those are present.

Treatment of Splenomegaly and/or Constitutional Symptoms

Splenomegaly and its related symptoms, as well as constitutional symptoms, remain the most common indication for treatment. Options for treatment include hydroxyurea, alkylating agents, purine analogues, interferon, IMiDs, JAK-2 inhibitors, splenectomy, and splenic radiation.

Conventional Drug Therapy

Historically, hydroxyurea was considered the first-line therapy for decreasing splenomegaly and the estimated patient response rate is less than 50%.⁴⁸ Limitations with hydroxyurea include lack of sustained improvements, rarity in inducing complete regression of the enlarged spleen, the requirement for high doses to induce a response, and the potential for cytopenias.⁴⁸ Other agents that may alleviate splenomegaly, but have their own risks, include oral alkylating agents such as melphalan (2.5 mg three times a week),⁸⁹ and busulfan (2 to 6 mg/day with close monitoring of blood counts);⁹⁰ or intravenous cladribine (5 mg/m²/day in a 2-hour infusion for 5 consecutive days, repeated for 4 to 6 monthly cycles).⁹¹

Splenomegaly reduction was reported in 33% of patients with low-dose thalidomide combined with a prednisone taper.⁸⁵ Lenalidomide produced similar results in a separate study and was better tolerated in patients with adequate baseline neutrophils and platelets.⁸⁷

TABLE 83.5 CLINICAL TRIALS WITH JAK INHIBITORS

JAK Inhibitor	Study Phase	Targets	Efficacy	Major Adverse Events
Ruxolitinib	Approved Phase III	JAK-2/JAK-1	Spleen response 42% >50% reduction in symptoms in 46%	Anemia Thrombocytopenia
SAR302503 (TG101348)	Phase III	JAK-2/FLT-3	Spleen Response 45% + improvement of disease related symptoms + control of leukocytosis and thrombocytosis	Anemia Thrombocytopenia Diarrhea Hyperlipasemia

Pacritinib (SB1518)	Phase II	JAK-2/FLT-3	Spleen Response 32% by MRI, 44% by physical exam + improvement of disease-related symptoms	GI-related Symptoms
CYT387	Phase II	JAK-1/JAK-2	+ Spleen response (37%) + RBC transfusion independence (68%)	Thrombocytopenia Hyperlipasemia Peripheral neuropathy
LY2784544	Phase I	JAK-2 V617F (mutation)-selective	+ spleen response + symptom improvement + reversal of fibrosis	Tumor lysis

Interferon

For treatment of PMF, α has been evaluated; however, its toxicity prohibits its use in many cases with more than half of the patients discontinuing treatment due to toxicity (e.g., worsening cytopenias).⁹² It had been suggested that interferon may alter the natural history of the disease and reverse fibrosis in vitro.⁹³ Although many clinical studies in PMF have been disappointing,^{94, 95} and ⁹⁶ results of a recent prospective study of 17 low- and intermediate-1 risk patients treated with interferon- α reported that >80% of patients had either response or stable disease (2 patients with complete remission and 7 with partial remission).⁹⁷ Interferon- α may be considered in young lower-risk patients and is the treatment of choice in women of childbearing age contemplating pregnancy. Pegylated interferon may be an appealing choice for further study inasmuch as it is given less frequently (usually once a week) and has a better toxicity profile than standard interferon.^{98,99}

JAK 2 Inhibitors

There are numerous JAK2 inhibitors undergoing evaluation in clinical trials for the management of MF (Table 83.5).^{72,74,100,101,102, 103} and ¹⁰⁴ In November 2011, ruxolitinib was approved by the FDA for treatment of patients with intermediate- (both intermediate-1 and -2) or high-risk MF, including PMF, post-PV MF and post-ET MF marking the first MF disease-specific drug approval and the first in its class.

Ruxolitinib treatment demonstrated efficacy in two large phase III studies in patients with PMF, post-PV MF, and post-ET MF and intermediate-2 or high-risk disease. The COntrolled MyeloFibrosis study with ORal JAK inhibitor Treatment (COMFORT)-I was a double-blind, placebo-controlled phase III clinical study (n = 309) in which patients were randomized (1:1) to ruxolitinib or placebo. Patients randomized to placebo and experiencing worsening symptoms and splenomegaly were allowed to receive ruxolitinib ("crossover"). Significantly more patients in the ruxolitinib arm achieved at least a 35% reduction in spleen volume, as assessed by MRI or CT, versus placebo at week 24 (41.9% vs. 0.7%, P < 0.001). Indeed, a great majority

P.1743

of patients in the ruxolitinib arm had some reduction in spleen volume.⁷⁴ Improvements in MF-associated symptoms were also achieved with ruxolitinib therapy. Symptom burden was assessed with the modified MFSAF v2.0 where 45.9% of patients in the ruxolitinib arm achieved a 50% or greater improvement in total symptom score by week 24 versus 5.3% in the placebo group (P < 0.001). Moreover, patients also experienced improvements in fatigue and QoL. Most patients participating in this trial and receiving ruxolitinib are still on the therapy after 2 years of follow-up. Note that, despite a crossover study design (about three quarters of placebo-treated patients received ruxolitinib upon disease worsening) in the intent-to-treat analysis, those patients randomized to ruxolitinib had improved survival over those initially randomized to placebo.¹⁰⁵

In a separate open-label, randomized phase III study (COMFORT-II; n = 219), patients were randomized (2:1) to ruxolitinib or best available therapy (BAT). This study also allowed a crossover of patients from BAT to ruxolitinib for disease worsening.¹⁰⁰ Significantly more patients in the ruxolitinib arm (28%) achieved at least a 35% reduction in spleen volume versus BAT (0%) (P < 0.001) at week 48. Although most patients in the ruxolitinib arm had a reduction in spleen size, the majority of patients in the BAT arm had worsening splenomegaly. Patients in the ruxolitinib arm experienced improvements in global health status (GHS) and role functioning, as well as individual MF-related symptoms captured by

the QLQ-C30 instrument, whereas those in the BAT arm experienced worsening by most of these measures. FACT-Lym scores also improved with ruxolitinib treatment. Similarly to the COMFORT-1 study, most patients on ruxolitinib are still on the therapy after 2 years of follow-up. A survival advantage of therapy with ruxolitinib versus therapy with BAT (despite a crossover to ruxolitinib) has recently been reported, similar to the results of COMFORT-1.¹⁰⁶

The most common adverse drug effects in COMFORT I and II included thrombocytopenia and anemia. The rate of grade 3 or 4 anemia and thrombocytopenia was greater in ruxolitinib-treated patients versus placebo (45.2% and 12.9% vs. 19.2% and 1.3%, respectively) in COMFORT I. Similarly, in COMFORT II patients treated with ruxolitinib versus best available therapy experienced more grade 3 or 4 anemia and thrombocytopenia (42% and 8% vs. 31% and 7%, respectively). In COMFORT I, the mean hemoglobin level reached a nadir of 95 g/L after approximately 8 to 12 weeks of therapy with an increase by week 24 to a new steady state of 101 g/dl. Nonhematologic adverse drug effects included ecchymosis, dizziness, and headache. Note that MF-related symptoms typically returned after 1 week of ruxolitinib discontinuation, strongly suggesting that close monitoring of patients on the therapy during the first 1 to 2 months (when most of the side effects happen) and proactive dose-modification is very important, in order to deliver therapy in the best possible way and avoid unnecessary interruptions.

The starting dose of ruxolitinib is dependent on the baseline platelet count. For patients with a platelet count greater than $200 \times 10^9/L$, a dose of 20 mg twice daily is indicated and 15 mg twice daily is indicated in patients with a platelet count between $100 \times 10^9/L$ and $200 \times 10^9/L$. There are no contraindications to the use of ruxolitinib, however, experience with its use in patients with platelet count lower than $100 \times 10^9/L$ is limited and subject to investigational trials. It is prudent to use ruxolitinib in such patients at the reduced dose, for example, 5 mg twice a day as the starting dose. A baseline complete blood cell count and at 2 to 4 weeks (more often at the start of the therapy) depending on patient response will help guide therapy. If thrombocytopenia develops, the dosage should be reduced. The dosage may be increased to a maximum of 25 mg twice daily depending on patient response. If no reductions in splenomegaly or symptoms are observed after 6 months, therapy should be discontinued. Ruxolitinib is nonspecific for JAK2 V617F mutation; therefore, it may be useful in all patients with MF.

Splenectomy is associated with significant morbidity and mortality. The perioperative mortality of splenectomy in PMF is between 5% and 10%, and post-splenectomy complications occur in ~50% of patients: surgical-site bleeding, thrombosis, accelerated hepatomegaly, extreme thrombocytosis, and leukocytosis with excess blasts.¹⁰⁷ The indications for splenectomy include symptomatic portal hypertension (e.g., variceal bleeding, ascites), drug-refractory marked splenomegaly that is either painful or is associated with severe cachexia, and frequent red blood cell transfusions or refractory cytopenia.

Radiation provides transient (median response duration of 3 to 6 months) symptomatic relief of mechanical discomfort from hepatosplenomegaly. When it is employed, splenic irradiation is given in a total dose of 0.1 to 0.5 Gy in 5 to 10 fractions and is associated with a >10% mortality rate from consequences of cytopenias.¹⁰⁸ In our practice we restrict use of splenic radiation as a last resort for pure palliation for drug-refractory patients. Radiation therapy is most useful in patients with nonhepatosplenic EMH presenting with mass effect.¹⁰⁹ The thoracic vertebral column is the most frequent site of nonhepatosplenic EMH in PMF; other sites include lymph nodes, the lung, pleura, small bowel, peritoneum, urogenital tract, and heart. When patients are symptomatic, such occurrences are effectively treated with low-dose radiation therapy (0.1 to 1 Gy in 5 to 10 fractions).¹⁰⁹

Primary Myelofibrosis and Risk of Thrombosis

In a cohort of 707 patients, the cumulative rate of fatal and nonfatal cerebrovascular (CV) events was 7.2%, accounting for 1.75 events per 100 patient-years. (2.23 events per 100 patient-years adjusted).¹¹⁰ For nonfatal CV events the cumulative rate was 6.6%; the incidences of myocardial infarction and peripheral arterial thrombosis were lower than those of stroke. There was a remarkably high rate of fatal (9 cases) and nonfatal (22 cases) venous thrombosis. In patients presenting with thrombosis at diagnosis or with a thrombotic history, the incidence of recurrences was 9%. In multivariable analysis, age and JAK2 mutation were the only two risk factors to independently predict risk of thrombosis; and patients who were JAK2 V617F mutated and presented with leukocytosis had the highest incidence of thrombosis (3.9% pt-yr).

Management of Blast-Phase Primary Myelofibrosis

Treatment of the blast phase is typically met with limited success. In a retrospective analysis of 91 cases of blast-phase PMF seen at the Mayo Clinic, 98% of the patients died at a median of 2.6 months (range 0 to 24.2 months) from time of transformation into blast-phase PMF. Aggressive chemotherapy was no better than supportive care, and AML-like induction chemotherapy did not produce complete remission in any patient.⁶⁰ Allogeneic stem cell transplant may offer better long-term outcome in a small subset of patients.¹¹¹ Outside the context of a clinical trial, we use azanucleosides

(azacitidine or decitabine) as an alternative to intensive chemotherapy for patients with accelerated-phase or blast-phase PMF.¹¹²

Allogeneic Hematopoietic Stem Cell Transplantation

AlloHCT remains the only curative option for patients with PMF. The decision and timing to proceed with HCT is a complex issue weighing potential benefits and substantial morbidity and mortality (see Chapter 104 for more details of HCT for P.1744

MF).^{113, 114, 115, 116, 117, 118} The current recommendation is to consider alloHCT worth the risk in patients with PMF whose median survival is expected to be less than 5 years.¹¹⁹ The consensus is to evaluate alloHCT for patients with a good performance status and no major comorbidities who are intermediate-2 or high-risk disease by risk stratification models. However, an argument can be made to allograft selected low and intermediate-1 DIPSS risk patients who have had 5-year survivals following alloHCT over 80% and 60%, respectively, compared to median survivals of 7 and 2.5 years for intermediate-2 and high-risk patients, respectively.¹²⁰

The use of reduced intensity conditioning (RIC) has expanded the availability of alloHCT in diseases such as PMF where the median age is old and comorbidities are frequently present. The nonrelapse mortality is less and the relapse rate is higher but the disease-free survival of patients undergoing RIC tends to be similar to that of patients who receive myeloablative conditioning.¹¹⁶ Alternative donors, particularly matched unrelated, are also allowing more patients to undergo alloHCT and the results were initially inferior but are approaching those seen with matched sibling donors.¹²¹ Umbilical cord and haptoidentical transplants are under investigation for patients with MF.¹²²

The role of splenectomy for PMF prior to alloHCT is controversial. Splenectomized patients may engraft more quickly, but there is the problem of perioperative morbidity and mortality and there are conflicting results about its effect on graft versus host disease (GVHD) and survival. Massive splenomegaly can resolve following alloHCT, including RIC-alloHCT.¹²³ Although splenectomy may be considered for an individual patient, pre-emptive splenectomy is not routinely recommended for patients with PMF undergoing HCT.

The role of JAK2 inhibitors prior to alloHCT in PMF is uncertain, but they could reduce spleen size and improve engraftment and could decrease the levels of inflammatory cytokines which might affect GVHD and prognosis post-alloHCT.¹¹⁶ Clearing of JAK2 V617F in the peripheral blood after alloHCT had a significantly reduced risk of relapse than patients who did not clear the mutation.¹²⁴ Clinical trials are warranted to determine the efficacy of JAK2 inhibition as a bridge to alloHCT, a strategy to delay HCT, or a therapy after HCT.

SUMMARY

PMF is a progressive MPN associated with significant disease burden, including splenomegaly, cytopenias, and constitutional symptoms that have an impact on patient survival and quality of life. Over the past several years, we uncovered important biologic aspects of the disease such as discovery of the JAK-STAT pathway dysregulation and multiple different mutations leading to abnormal genetic and epigenetic regulation in MF. After establishing the diagnosis, risk stratification is the most important next step. Allogeneic stem cell transplant remains the only curative option and should be offered for higher risk patients. Goals of medical therapy are mostly centered around improving splenomegaly, anemia, and very poor quality of life. Treatment options remain limited but the development of JAK inhibitors results in better control of the signs and symptoms of the disease and, therefore, improves patients' outlook. The inhibitors may serve as a building block for combination therapies that would significantly alter the biology of the disease.

Acknowledgment

The authors recognize Ayalew Tefferi for his many contributions to the understanding and therapy of myelofibrosis.

REFERENCES

1. Tefferi A. How I treat myelofibrosis. *Blood* 2011;117:3494-3504.
2. Tefferi A, Vainchenker W. Myeloproliferative neoplasms: molecular pathophysiology, essential clinical understanding, and treatment strategies. *J Clin Oncol* 2011;29:573-582.
3. Tefferi A, Thiele J, Orazi A, et al. Proposals and rationale for revision of the World Health Organization diagnostic criteria for polycythemia vera, essential thrombocythemia, and primary myelofibrosis: recommendations from an ad hoc international expert panel. *Blood* 2007;110:1092-1097.

4. Mesa RA. Navigating the evolving paradigms in the diagnosis and treatment of myeloproliferative disorders. *Hematology Am Soc Hematol Educ Program* 2007;355-362.
5. Mesa RA, Verstovsek S, Cervantes F, et al. Primary myelofibrosis (PMF), post polycythemia vera myelofibrosis (post-PV MF), post essential thrombocythemia myelofibrosis (post-ET MF), blast phase PMF (PMF-BP): Consensus on terminology by the international working group for myelofibrosis research and treatment (IWG-MRT). *Leuk Res* 2007;31:737-740.
6. Pardanani A, Vannucchi AM, Passamonti F, et al. JAK inhibitor therapy for myelofibrosis: critical assessment of value and limitations. *Leukemia* 2011;25:218-225.
7. Tefferi A. Myelofibrosis with myeloid metaplasia. *N Engl J Med* 2000;342:1255-1265.
8. Heuck G. Zwei Falle von Leukemie mit eigenthumlichen Blutresp. Knochenmarksbefund. *Arch Pathol Anat Physiol Virchows* 1879;78:475-496.
9. Hirsch R. Generalized osteosclerosis with chronic polycythemia vera. *Arch Pathol* 1935;19:91-97.
10. Dameshek W. Some speculations on the myeloproliferative syndromes. *Blood* 1951;6:372-375.
11. Nowell PC, Hungerford DA. Chromosome studies on normal and leukemic human leukocytes. *J Natl Cancer Inst* 1960;25:85-109.
12. Jacobson RJ, Salo A, Fialkow PJ. Agnogenic myeloid metaplasia: a clonal proliferation of hematopoietic stem cells with secondary myelofibrosis. *Blood* 1978;51:189-194.
13. Schindler C, Shuai K, Prezioso VR, et al. Interferon-dependent tyrosine phosphorylation of a latent cytoplasmic transcription factor. *Science* 1992;257:809-813.
14. Levine RL, Wadleigh M, Cools J, et al. Activating mutation in the tyrosine kinase JAK2 in polycythemia vera, essential thrombocythemia, and myeloid metaplasia with myelofibrosis. *Cancer Cell* 2005;7:387-397.
15. Baxter EJ, Scott LM, Campbell PJ, et al. Acquired mutation of the tyrosine kinase JAK2 in human myeloproliferative disorders. *Lancet* 2005;365:1054-1061.
16. Kralovics R, Passamonti F, Buser AS, et al. A gain-of-function mutation of JAK2 in myeloproliferative disorders. *N Engl J Med* 2005;352:1779-1790.
17. James C, Ugo V, Le Couedic JP, et al. A unique clonal JAK2 mutation leading to constitutive signalling causes polycythaemia vera. *Nature* 2005;434:1144-1148.
18. Pikman Y, Lee BH, Mercher T, et al. MPLW515L is a novel somatic activating mutation in myelofibrosis with myeloid metaplasia. *PLoS Med* 2006;3:e270.
19. Pardanani AD, Levine RL, Lasho T, et al. MPL515 mutations in myeloproliferative and other myeloid disorders: a study of 1182 patients. *Blood* 2006;108:3472-3476.
20. Tefferi A. Novel mutations and their functional and clinical relevance in myeloproliferative neoplasms: JAK2, MPL, TET2, ASXL1, CBL, IDH and IKZF1. *Leukemia* 2010;24:1128-1138.
21. Rollison DE, Howlader N, Smith MT, et al. Epidemiology of myelodysplastic syndromes and chronic myeloproliferative disorders in the United States, 2001-2004, using data from the NAACCR and SEER programs. *Blood* 2008;112:45-52.
22. Mesa RA, Silverstein MN, Jacobsen SJ, et al. Population-based incidence and survival figures in essential thrombocythemia and agnogenic myeloid metaplasia: an Olmsted County Study, 1976-1995. *Am J Hematol* 1999;61:10-15.
23. Chaiter Y, Brenner B, Aghai E, et al. High incidence of myeloproliferative disorders in Ashkenazi Jews in northern Israel. *Leuk Lymphoma* 1992;7:251-255.
24. Tondel M, Persson B, Carstensen J. Myelofibrosis and benzene exposure. *Occup Med (Lond)* 1995;45:51-52.
25. Honda Y, Delzell E, Cole P. An updated study of mortality among workers at a petroleum manufacturing plant. *J Occup Environ Med* 1995;37:194-200.
26. Anderson RE, Hoshino T, Yamamoto T. Myelofibrosis with Myeloid Metaplasia in Survivors of the Atomic Bomb in Hiroshima. *Ann Intern Med* 1964;60:1-18.
27. Reeder TL, Bailey RJ, Dewald GW, et al. Both B and T lymphocytes may be clonally involved in myelofibrosis with myeloid metaplasia. *Blood* 2003;101:1981-1983.

28. Tefferi A, Mesa RA, Schroeder G, et al. Cytogenetic findings and their clinical relevance in myelofibrosis with myeloid metaplasia. *Br J Haematol* 2001;113:763-771.
29. Dingli D, Grand FH, Mahaffey V, et al. Der(6)t(1;6)(q21-23;p21.3): a specific cytogenetic abnormality in myelofibrosis with myeloid metaplasia. *Br J Haematol* 2005;130:229-232.
30. Tefferi A, Meyer RG, Wyatt WA, et al. Comparison of peripheral blood inter-phase cytogenetics with bone marrow karyotype analysis in myelofibrosis with myeloid metaplasia. *Br J Haematol* 2001;115:316-319.
31. Al-Assar O, Ul-Hassan A, Brown R, et al. Gains on 9p are common genomic aberrations in idiopathic myelofibrosis: a comparative genomic hybridization study. *Br J Haematol* 2005;129:66-71.
32. Pesu M, Laurence A, Kishore N, et al. Therapeutic targeting of Janus kinases. *Immunol Rev* 2008;223:132-142.
33. Quintas-Cardama A, Kantarjian H, Cortes J, et al. Janus kinase inhibitors for the treatment of myeloproliferative neoplasias and beyond. *Nat Rev Drug Discov* 2011;10:127-140.
34. Agrawal M, Garg RJ, Cortes J, et al. Experimental therapeutics for patients with myeloproliferative neoplasias. *Cancer* 2011;117:662-676.
35. O'Sullivan LA, Liongue C, Lewis RS, et al. Cytokine receptor signaling through the Jak-Stat-Socs pathway in disease. *Mol Immunol* 2007;44:2497-2506.
36. Verstovsek S, Kantarjian H, Mesa RA, et al. Safety and efficacy of INCB018424, a JAK1 and JAK2 inhibitor, in myelofibrosis. *N Engl J Med* 2010;363:1117-1127.
37. Vainchenker W, Delhommeau F, Constantinescu SN, et al. New mutations and pathogenesis of myeloproliferative neoplasms. *Blood* 2011;118:1723-1735.
38. Scott LM, Tong W, Levine RL, et al. JAK2 exon 12 mutations in polycythemia vera and idiopathic erythrocytosis. *N Engl J Med* 2007;356:459-468.
39. Chagraoui H, Komura E, Tulliez M, et al. Prominent role of TGF-beta 1 in thrombopoietin-induced myelofibrosis in mice. *Blood* 2002;100:3495-3503.
40. Vannucchi AM, Bianchi L, Cellai C, et al. Development of myelofibrosis in mice genetically impaired for GATA-1 expression (GATA-1(low) mice). *Blood* 2002;100:1123-1132.
41. Schmitt A, Jouault H, Guichard J, et al. Pathologic interaction between megakaryocytes and polymorphonuclear leukocytes in myelofibrosis. *Blood* 2000;96:1342-1347.
42. Xu M, Bruno E, Chao J, et al. Constitutive mobilization of CD34+ cells into the peripheral blood in idiopathic myelofibrosis may be due to the action of a number of proteases. *Blood* 2005;105:4508-4515.
43. Massa M, Rosti V, Ramajoli I, et al. Circulating CD34+, CD133+, and vascular endothelial growth factor receptor 2-positive endothelial progenitor cells in myelofibrosis with myeloid metaplasia. *J Clin Oncol* 2005;23:5688-5695.
44. Barosi G, Viarengo G, Pecci A, et al. Diagnostic and clinical relevance of the number of circulating CD34(+) cells in myelofibrosis with myeloid metaplasia. *Blood* 2001;98:3249-3255.
45. Wolf BC, Neiman RS. Hypothesis: splenic filtration and the pathogenesis of extramedullary hematopoiesis in agnogenic myeloid metaplasia. *Hematol Pathol* 1987;1:77-80.
46. O'Keane JC, Wolf BC, Neiman RS. The pathogenesis of splenic extramedullary hematopoiesis in metastatic carcinoma. *Cancer* 1989;63:1539-1543.
47. Mesa RA, Li CY, Schroeder G, et al. Clinical correlates of splenic histopathology and splenic karyotype in myelofibrosis with myeloid metaplasia. *Blood* 2001;97:3665-3667.
48. Mesa RA. How I treat symptomatic splenomegaly in patients with myelofibrosis. *Blood* 2009;113:5394-5400.
49. Cervantes F, Pereira A, Esteve J, et al. The changing profile of idiopathic myelofibrosis: a comparison of the presenting features of patients diagnosed in two different decades. *Eur J Haematol* 1998;60:101-105.
50. Jaroch MT, Broughan TA, Hermann RE. The natural history of splenic infarction. *Surgery* 1986;100:743-750.
51. Strasser-Weippl K, Steurer M, Kees M, et al. Age and hemoglobin level emerge as most important clinical prognostic parameters in patients with osteomyelofibrosis: introduction of a simplified prognostic score. *Leuk Lymphoma* 2006;47:441-450.

52. Dupriez B, Morel P, Demory JL, et al. Prognostic factors in agnogenic myeloid metaplasia: a report on 195 cases with a new scoring system. *Blood* 1996;88:1013-1018.
53. Kreft A, Weiss M, Wiese B, et al. Chronic idiopathic myelofibrosis: prognostic impact of myelofibrosis and clinical parameters on event-free survival in 122 patients who presented in prefibrotic and fibrotic stages. A retrospective study identifying subgroups of different prognoses by using the RECPAM method. *Ann Hematol* 2003;82:605-611.
54. Vannucchi AM. Management of myelofibrosis. *Hematology Am Soc Hematol Educ Program* 2011;2011:222-230.
55. Abdel-Wahab OI, Levine RL. Primary myelofibrosis: update on definition, pathogenesis, and treatment. *Annu Rev Med* 2009;60:233-245.
56. Tefferi A, Lasho TL, Jimma T, et al. One thousand patients with primary myelofibrosis: the mayo clinic experience. *Mayo Clin Proc* 2012;87:25-33.
57. Barosi G, Mesa RA, Thiele J, et al. Proposed criteria for the diagnosis of post-polycythemia vera and post-essential thrombocythemia myelofibrosis: a consensus statement from the International Working Group for Myelofibrosis Research and Treatment. *Leukemia* 2008;22:437-438.
58. Thiele J, Kvasnicka HM, Tefferi A, et al. Primary myelofibrosis. In: Swerdlow SH, Campo E, Harris NL, et al., eds. *World Health Organization classification of tumors: tumours of haematopoietic and lymphoid tissues*. Lyon, France: International Agency for Research on Cancer, 2008:44-47.
59. Thiele J, Kvasnicka HM. A critical reappraisal of the WHO classification of the chronic myeloproliferative disorders. *Leuk Lymphoma* 2006;47:381-396.
60. Mesa RA, Tefferi A. Survival and outcomes to therapy in leukemic transformation of myelofibrosis with myeloid metaplasia; a single institution experience with 91 patients. *Blood* 2003;102:917a-918a.
61. Cervantes F, Pereira A, Esteve J, et al. Identification of "short-lived" and "long-lived" patients at presentation of idiopathic myelofibrosis. *Br J Haematol* 1997;97:635-640.
62. Okamura T, Kinukawa N, Niho Y, et al. Primary chronic myelofibrosis: clinical and prognostic evaluation in 336 Japanese patients. *Int J Hematol* 2001;73:194-198.
63. Cervantes F, Dupriez B, Pereira A, et al. New prognostic scoring system for primary myelofibrosis based on a study of the International Working Group for Myelofibrosis Research and Treatment. *Blood* 2009;113:2895-2901.
64. Hussein K, Pardanani AD, Van Dyke DL, et al. International Prognostic Scoring System-independent cytogenetic risk categorization in primary myelofibrosis. *Blood* 2010;115:496-499.
65. Caramazza D, Begna KH, Gangat N, et al. Refined cytogenetic-risk categorization for overall and leukemia-free survival in primary myelofibrosis: a single center study of 433 patients. *Leukemia* 2011;25:82-88.
- P.1745
66. Vaidya R, Caramazza D, Begna KH, et al. Monosomal karyotype in primary myelofibrosis is detrimental to both overall and leukemia-free survival. *Blood* 2011;117:5612-5615.
67. Passamonti F, Cervantes F, Vannucchi AM, et al. A dynamic prognostic model to predict survival in primary myelofibrosis: a study by the IWG-MRT (International Working Group for Myeloproliferative Neoplasms Research and Treatment). *Blood* 2010;115:1703-1708.
68. Gangat N, Caramazza D, Vaidya R, et al. DIPSS plus: a refined Dynamic International Prognostic Scoring System for primary myelofibrosis that incorporates prognostic information from karyotype, platelet count, and transfusion status. *J Clin Oncol* 2010;29:392-397.
69. Tefferi A, Vaidya R, Caramazza D, et al. Circulating interleukin (IL)-8, IL-2R, IL-12, and IL-15 levels are independently prognostic in primary myelofibrosis: a comprehensive cytokine profiling study. *J Clin Oncol* 2011;29:1356-1363.
70. Tefferi A, Barosi G, Mesa RA, et al. International Working Group (IWG) consensus criteria for treatment response in myelofibrosis with myeloid metaplasia, for the IWG for Myelofibrosis Research and Treatment (IWG-MRT). *Blood* 2006;108:1497-1503.

71. Barosi G, Bordessoule D, Briere J, et al. Response criteria for myelofibrosis with myeloid metaplasia: results of an initiative of the European Myelofibrosis Network (EUMNET). *Blood* 2005;106:2849-2853.
72. Komrokji RS, Wadleigh M, Seymour JF, et al. Results of a phase 2 study of pacritinib (SB1518), a novel oral JAK2 inhibitor, in patients with primary, post-polycythemia vera, and post-essential thrombocythemia myelofibrosis. *Blood (ASH Annual Meeting Abstracts)* 2011;118:282.
73. Mesa RA, Schwager S, Radia D, et al. The Myelofibrosis Symptom Assessment Form (MFSAF): an evidence-based brief inventory to measure quality of life and symptomatic response to treatment in myelofibrosis. *Leuk Res* 2009;33:1199-1203.
74. Verstovsek S, Mesa RA, Gotlib J, et al. A double-blind, placebo-controlled trial of ruxolitinib for myelofibrosis. *N Engl J Med* 2012;366:799-807.
75. Mesa RA, Niblack J, Wadleigh M, et al. The burden of fatigue and quality of life in myeloproliferative disorders (MPDs): an international Internet-based survey of 1179 MPD patients. *Cancer* 2007;109:68-76.
76. Ahlberg K, Ekman T, Gaston-Johansson F, et al. Assessment and management of cancer-related fatigue in adults. *Lancet* 2003;362:640-650.
77. Cella D, Yount S, Rothrock N, et al. The Patient-Reported Outcomes Measurement Information System (PROMIS): progress of an NIH Roadmap cooperative group during its first two years. *Med Care* 2007;45:S3-S11.
78. Cella D, Webster K, Cashy J, et al. Development of a measure of health-related quality of life for Non-Hodgkin's Lymphoma Clinical Research: The Functional Assessment of Cancer Therapy - Lymphoma (FACT-Lym). *Blood (ASH Annual Meeting Abstracts)* 2005;106:750.
79. Cervantes F, Alvarez-Larran A, Hernandez-Boluda JC, et al. Erythropoietin treatment of the anaemia of myelofibrosis with myeloid metaplasia: results in 20 patients and review of the literature. *Br J Haematol* 2004;127:399-403.
80. Silverstein MN. Agnogenic myeloid metaplasia. 126. Acton, MA: Publishing Sciences Group, 1975.
81. Besa EC, Nowell PC, Geller NL, et al. Analysis of the androgen response of 23 patients with agnogenic myeloid metaplasia: the value of chromosomal studies in predicting response and survival. *Cancer* 1982;49:308-313.
82. Cervantes F, Alvarez-Larran A, Domingo A, et al. Efficacy and tolerability of danazol as a treatment for the anaemia of myelofibrosis with myeloid metaplasia: long-term results in 30 patients. *Br J Haematol* 2005;129:771-775.
83. Elliott MA, Mesa RA, Li CY, et al. Thalidomide treatment in myelofibrosis with myeloid metaplasia. *Br J Haematol* 2002;117:288-296.
84. Tefferi A, Cortes J, Verstovsek S, et al. Lenalidomide therapy in myelofibrosis with myeloid metaplasia. *Blood* 2006;108:1158-1164.
85. Mesa RA, Steensma DP, Pardanani A, et al. A phase 2 trial of combination low-dose thalidomide and prednisone for the treatment of myelofibrosis with myeloid metaplasia. *Blood* 2003;101:2534-2541.
86. Tefferi A, Lasho TL, Mesa RA, et al. Lenalidomide therapy in del(5)(q31)-associated myelofibrosis: cytogenetic and JAK2V617F molecular remissions. *Leukemia* 2007;21:1827-1828.
87. Quintas-Cardama A, Kantarjian HM, Manshouri T, et al. Lenalidomide plus prednisone results in durable clinical, histopathologic, and molecular responses in patients with myelofibrosis. *J Clin Oncol* 2009;27:4760-4766.
88. Tefferi A, Verstovsek S, Barosi G, et al. Pomalidomide is active in the treatment of anemia associated with myelofibrosis. *J Clin Oncol* 2009;27:4563-4569.
89. Petti MC, Latagliata R, Spadea T, et al. Melphalan treatment in patients with myelofibrosis with myeloid metaplasia. *Br J Haematol* 2002;116:576-581.
90. Naqvi T, Baumann MA. Myelofibrosis: response to busulfan after hydroxyurea failure. *Int J Clin Pract* 2002;56:312-313.
91. Tefferi A, Silverstein MN, Li CY. 2-Chlorodeoxyadenosine treatment after splenectomy in patients who have myelofibrosis with myeloid metaplasia. *Br J Haematol* 1997;99:352-357.
92. Kiladjian JJ, Mesa RA, Hoffman R. The renaissance of interferon therapy for the treatment of myeloid malignancies. *Blood* 2011;117:4706-4715.

93. Hasselbalch H. Hypothesis: a possible role for interferon in the treatment of idiopathic myelofibrosis. *Med Hypotheses* 1988;27:345-347.
94. Tefferi A, Elliot MA, Yoon SY, et al. Clinical and bone marrow effects of interferon alfa therapy in myelofibrosis with myeloid metaplasia. *Blood* 2001;97:1896.
95. Barosi G, Liberato LN, Costa A, et al. Cytoreductive effect of recombinant alpha interferon in patients with myelofibrosis with myeloid metaplasia. *Blut* 1989;58:271-274.
96. Gilbert HS. Long term treatment of myeloproliferative disease with interferon-alpha-2b: feasibility and efficacy. *Cancer* 1998;83:1205-1213.
97. Silver RT, Vandris K, Goldman JJ. Recombinant interferon-alpha may retard progression of early primary myelofibrosis: a preliminary report. *Blood* 2011;117:6669-6672.
98. Ianotto JC, Kiladjian JJ, Demory JL, et al. PEG-IFN-alpha-2a therapy in patients with myelofibrosis: a study of the French Groupe d'Etudes des Myelofibroses (GEM) and France Intergroupe des syndromes Myeloproliferatifs (FIM). *Br J Haematol* 2009;146:223-225.
99. Hasselbalch HC, Kiladjian JJ, Silver RT. Interferon alfa in the treatment of Philadelphia-negative chronic myeloproliferative neoplasms. *J Clin Oncol* 2011;29:e564-e565.
100. Harrison C, Kiladjian JJ, Al-Ali HK, et al. JAK inhibition with ruxolitinib versus best available therapy for myelofibrosis. *N Engl J Med* 2012;366:787-798.
101. Pardanani A, Gotlib JR, Jamieson C, et al. Safety and efficacy of TG101348, a selective JAK2 inhibitor, in myelofibrosis. *J Clin Oncol* 2011;29:789-796.
102. Pardanani A, George G, Lasho T, et al. A Phase I/II study of CYT387, an oral JAK-1/2 inhibitor, in myelofibrosis: significant response rates in anemia, splenomegaly, and constitutional symptoms. *Blood (ASH Annual Meeting Abstracts)* 2010;116:460.
103. Verstovsek S, Mesa R, Kloeker-Rhoades S, et al. Phase I study of the JAK2 V617F inhibitor, LY2784544, in patients with myelofibrosis (MF), polycythemia vera (PV), and essential thrombocythemia (ET). *Blood (ASH Annual Meeting Abstracts)* 2011;118
104. Barosi G. Myelofibrosis with myeloid metaplasia: diagnostic definition and prognostic classification for clinical studies and treatment guidelines. *J Clin Oncol* 1999;17:2954-2970.
105. Verstovsek S, Kiladjian JJ, Mesa R, et al. Effect of ruxolitinib on the incidence of splenectomy in patients with myelofibrosis: a retrospective analysis of data from ruxolitinib clinical trials. *Blood (ASH Annual Meeting Abstracts)* 2012;120:2847.
106. Cervantes F, Kiladjian JJ, Niederwieser D, et al. Long-term safety, efficacy, and survival findings from comfort-II, a phase 3 study comparing ruxolitinib with best available therapy (BAT) for the treatment of myelofibrosis (MF). *Blood (ASH Annual Meeting Abstracts)* 2012;120:801.
107. Tefferi A, Mesa RA, Nagorney DM, et al. Splenectomy in myelofibrosis with myeloid metaplasia: a single-institution experience with 223 patients. *Blood* 2000;95:2226-2233.
108. Elliott MA, Chen MG, Silverstein MN, et al. Splenic irradiation for symptomatic splenomegaly associated with myelofibrosis with myeloid metaplasia. *Br J Haematol* 1998;103:505-511.
109. Koch CA, Li CY, Mesa RA, et al. Nonhepatosplenic extramedullary hematopoiesis: associated diseases, pathology, clinical course, and treatment. *Mayo Clin Proc* 2003;78:1223-1233.
110. Barbui T, Carobbio A, Cervantes F, et al. Thrombosis in primary myelofibrosis: incidence and risk factors. *Blood* 2010;115:778-782.
111. Kundranda MN, Tibes R, Mesa RA. Transformation of a chronic myeloproliferative neoplasm to acute myelogenous leukemia: does anything work? *Curr Hematol Malig Rep* 2012;7:78-86.
112. Thepot S, Itzykson R, Seegers V, et al. Treatment of progression of Philadelphia-negative myeloproliferative neoplasms to myelodysplastic syndrome or acute myeloid leukemia by azacitidine: a report on 54 cases on the behalf of the Groupe Francophone des Myelodysplasies (GFM). *Blood* 2010;116:3735-3742.

113. Ballen KK, Shrestha S, Sobocinski KA, et al. Outcome of transplantation for myelofibrosis. *Biol Blood Marrow Transplant* 2010;16:358-367.
114. Bacigalupo A, Soraru M, Dominietto A, et al. Allogeneic hemopoietic SCT for patients with primary myelofibrosis: a predictive transplant score based on transfusion requirement, spleen size and donor type. *Bone Marrow Transplant* 2010;45:458-463.
115. Gupta V, Kroger N, Aschan J, et al. A retrospective comparison of conventional intensity conditioning and reduced-intensity conditioning for allogeneic hematopoietic cell transplantation in myelofibrosis. *Bone Marrow Transplant* 2009;44:317-320.
116. Gupta V, Hari P, Hoffman R. Allogeneic hematopoietic cell transplantation for myelofibrosis in the era of JAK inhibitors. *Blood* 2012;120:1367-1379.
117. McLornan DP, Mead AJ, Jackson G, et al. Allogeneic stem cell transplantation for myelofibrosis in 2012. *Br J Haematol* 2012;157:413-425.
118. Ballen K. How to manage the transplant question in myelofibrosis. *Blood Cancer J* 2012;2:e59.
119. Barbui T, Barosi G, Birgegard G, et al. Philadelphia-negative classical myeloproliferative neoplasms: critical concepts and management recommendations from European LeukemiaNet. *J Clin Oncol* 2011;29:761-770.
120. Scott BL, Gooley TA, Sorrow ML, et al. The Dynamic International Prognostic Scoring System for myelofibrosis predicts outcomes after hematopoietic cell transplantation. *Blood* 2012;119:2657-2664.
121. Kroger N, Zabelina T, Schieder H, et al. Pilot study of reduced-intensity conditioning followed by allogeneic stem cell transplantation from related and unrelated donors in patients with myelofibrosis. *Br J Haematol* 2005;128:690-697.
122. Takagi S, Ota Y, Uchida N, et al. Successful engraftment after reduced-intensity umbilical cord blood transplantation for myelofibrosis. *Blood* 2010;116:649-652.
123. Ciurea SO, Sadegi B, Wilbur A, et al. Effects of extensive splenomegaly in patients with myelofibrosis undergoing a reduced intensity allogeneic stem cell transplantation. *Br J Haematol* 2008;141:80-83.
124. Alchalby H, Badbaran A, Zabelina T, et al. Impact of JAK2V617F mutation status, allele burden, and clearance after allogeneic stem cell transplantation for myelofibrosis. *Blood* 2010;116:3572-3581.

Chapter 84 Eosinophilic Neoplasms and Hypereosinophilic Syndrome

> Table of Contents > Part VII - Hematologic Malignancies > Section 3 - Myeloproliferative Disorders > Chapter 84 - Eosinophilic Neoplasms and Hypereosinophilic Syndrome

Chapter 84

Eosinophilic Neoplasms and Hypereosinophilic Syndrome

Huong (Marie) Nguyen

Jason Gotlib

HISTORICAL BACKGROUND

Paul Ehrlich's use of aniline dyes facilitated identification of the eosinophil as a unique leukocyte in 1879.¹ Reactive eosinophilias and eosinophilia-associated leukemias were recognized in the early to mid-twentieth century. However, a nomenclature for unexplained eosinophilias was not formulated until 1968 when Hardy and Anderson originated the term hypereosinophilic syndrome (HES).² In 1975, Chusid and colleagues generated diagnostic criteria for (idiopathic) hypereosinophilic syndrome based on a small case series of patients: (1) persistent eosinophilia of $1.5 \times 10^9/L$ for more than 6 months; (2) lack of evidence for parasitic, allergic, or other known causes of eosinophilia; and (3) signs and symptoms of organ involvement.³ In the last 20 years, the evaluation of eosinophilic disorders has advanced from its descriptive roots to a more comprehensive approach which relies on a combination of histopathology, cytogenetics, molecular genetics, and immunophenotyping. Table 84.1 lists recent modern nosologic and clinicopathologic landmarks which reflect this evolution in the diagnosis and classification of eosinophilic disorders.

DEFINITION OF EOSINOPHILIA

Although minor differences may exist between laboratories, the upper limit of normal for the percent peripheral blood eosinophils is 5%, with a corresponding absolute eosinophil count (AEC) of approximately $0.5 \times 10^9/L$ ($500/mm^3$).^{4,5} The severity of hypereosinophilia (HE) has been stratified into mild, moderate, or severe (with AECs between the upper range of normal to $1.5 \times 10^9/L$ ($1,500/mm^3$), 1.5 to $5.0 \times 10^9/L$ ($1,500$ to $5,000/mm^3$), or $>5.0 \times 10^9/L$ ($>5,000/mm^3$), respectively). Alternatively, the singular term hypereosinophilia has been used to denote an AEC of $>1.5 \times 10^9/L$ ($>1,500/mm^3$).

TABLE 84.1 MODERN CLASSIFICATION AND CLINICOPATHOLOGIC LANDMARKS IN EOSINOPHILIC DISORDERS

Year	Event
1968	Term “hypereosinophilic syndrome” coined by Hardy and Anderson
1975	Diagnostic criteria for HES established by Chusid and colleagues
1994	Characterization of the first <i>PDGFRB</i> rearrangement (<i>ETV6-PDGFRB</i>), t(5;12)(q31-33;p13)
1994	First description of lymphocyte-variant hypereosinophilia
1998	Identification of rearrangement of the <i>FGFR1</i> gene as the basis for the 8p11 syndrome
2001	WHO diagnostic criteria for HES and CEL
2001-2002	Successful empiric treatment of HES patients with imatinib
2002	Characterization of the first <i>PDGFRA</i> rearrangement (<i>BCR-PDGFR</i>), t(4;22)(q12q11)
2003	Identification of the <i>FIP1L1-PDGFRα</i> fusion as the therapeutic target of imatinib
2003	Identification of <i>FIP1L1-PDGFR</i> using the surrogate test “FISH for the <i>CHIC2</i> deletion”
2008	Revised WHO criteria include the category of “Myeloid and lymphoid neoplasms with eosinophilia and abnormalities of <i>PDGFRA</i> , <i>PDGFRB</i> , or <i>FGFR1</i> ”

CEL, chronic eosinophilic leukemia; *FGFR1*, fibroblast growth factor receptor 1;

FISH, fluorescent *in situ* hybridization; HES, idiopathic hypereosinophilic syndrome; *PDGFRA*; platelet-derived growth factor receptor alpha; *PDGFRB*, platelet-derived growth factor receptor beta; WHO, World Health Organization.

EPIDEMIOLOGY

HES and chronic eosinophilic leukemia (CEL) are very uncommon disorders. Data obtained from the Surveillance, Epidemiology, and End Results (SEER) program during the years 2001 to 2005 revealed an age-adjusted incidence rate of 0.036 per 100,000.⁶ Eosinophilias with recurrent genetic abnormalities (*PDGFRA/B*, *FGFR1*) are yet even more rare, representing approximately 10% cases of initially unexplained eosinophilias in developed countries.⁷ SEER identified a peak age range at diagnosis of 65 to 74 years, with cases uncommonly diagnosed in infants and children. The male to female ratio of HES/CEL is approximately 1.5:1, but *FIP1L1-PDGFR*-positive disease is almost exclusively diagnosed in men, a phenomenon whose biologic basis remains unknown.^{6,7}

EOSINOPHIL PHYSIOLOGY

Eosinophil-committed hematopoietic progenitors are identified within the $CD34^+$ progenitor population as interleukin-5 receptor (*IL5R*)⁺/*CCR3*⁺ cells.^{8,9} Their production is tightly regulated by a network of eosinophilopoietic cytokines. IL-5, interleukin-3 (IL-3), and granulocyte-macrophage colony-stimulating factor are the most relevant to eosinophil physiology, and are primarily responsible for the commitment, proliferation, and differentiation of hematopoietic progenitors into the eosinophil lineage.^{4,10} These factors are elaborated by several cell types including T-lymphocytes, mast cells, and stromal cells, and bind to their respective receptors on eosinophils.¹¹ Migration of eosinophils from the circulation to tissues is mediated via interactions between endothelial cell adhesion molecules such as ICAM-1 and VCAM1 and eosinophil surface integrins (e.g., the $\alpha 1$ and $\beta 2$ integrins VLA-4 and CD18, respectively).¹² Eosinophil migration is influenced by several potent eosinophil chemoattractants including leukotriene $\beta 4$, complement fragment 5a, platelet activating factor, RANTES, and eotaxins, which are ligands for the eosinophil receptor *CCR3*.^{13, 14} and ¹⁵ Although eosinophils serve as an essential component of the immune system's normal homeostatic function, including defense against infection and recruitment in response to allergy and inflammation, the potential for collateral tissue injury exists due to mediators

released from eosinophils undergoing marked or persistent activation. These biologically active molecules are released from intracellular granule compartments and include preformed substances such as major basic protein, eosinophil peroxidase, eosinophil cationic protein, and eosinophilderived neurotoxin.⁴ Eosinophils also contain hydrolytic enzymes such as acid phosphatase, catalase, arylsulfatase, and newly synthesized mediators such as hydrogen peroxide that can contribute to organ damage.⁴

P.1747

MODERN CLASSIFICATION

The most recent iteration of the World Health Organization (WHO) classification of hematolymphoid neoplasms incorporates eosinophilic disorders among the umbrella of myeloid neoplasms (Table 84.2). The WHO classification recognized the unique molecular basis of a subset of certain eosinophilic disorders by establishing the major category entitled, "Myeloid and lymphoid neoplasms with eosinophilia and abnormalities of platelet-derived growth factor receptor alpha (PDGFRA), platelet-derived growth factor receptor beta (PDGFRB), or fibroblast growth factor receptor 1 (FGFR1)" (Table 84.3).¹⁶ The diagnostic entity "chronic eosinophilic leukemia not otherwise specified (CEL-NOS)" is one of eight diseases included within another major WHO category, "Myeloproliferative Neoplasms (MPNs)" (Table 84.3).¹⁷

CEL-NOS is defined by the absence of the Philadelphia chromosome or a rearrangement involving PDGFRA/B or FGFR1, and the exclusion of other WHO-defined acute or chronic primary marrow neoplasms associated with eosinophilia, e.g., acute myeloid leukemia (AML), myelodysplastic syndrome (MDS), MPNs such as chronic

P.1748

myelogenous leukemia (CML) or systemic mastocytosis (SM), and overlap MDS/MPNs. It is also defined by an increase in blood or marrow blasts (<20%), and/or nonspecific cytogenetic abnormalities. The diagnostic criteria of HES formulated by Chusid and colleagues is recapitulated by the WHO, but the original requirement that eosinophilia persist for more than 6 months is no longer consistently embraced. This relates to the faster-paced and more sophisticated evaluation of eosinophilia that is now feasible, and the recognition that early treatment can be critical to mitigating eosinophilia-mediated organ damage. The nosological distinction between "idiopathic hypereosinophilia" and "idiopathic HES" reflects the requirement that organ damage be present in the latter. "Lymphocyte-variant hypereosinophilia" is a provisional diagnosis that is referred to in the WHO classification and should be considered before settling on the diagnosis of idiopathic hypereosinophilia or HES, which are diagnoses of exclusion.¹⁷

TABLE 84.2 2008 WORLD HEALTH ORGANIZATION CLASSIFICATION OF MYELOID MALIGNANCIES

1. Acute myeloid leukemia and related disorders
2. MPNs
 - a. Chronic myelogenous leukemia, *BCR-ABL1* positive
 - b. Chronic neutrophilic leukemia
 - c. Polycythemia vera
 - d. Primary myelofibrosis
 - e. Essential thrombocythemia
 - f. ***Chronic eosinophilic leukemia, not otherwise specified***
 - g. Mastocytosis
 - h. Myeloproliferative neoplasm, unclassifiable
3. MDS
 - a. Refractory cytopenia with unilineage dysplasia
 - b. Refractory anemia

- c. Refractory neutropenia
 - d. Refractory thrombocytopenia
 - e. Refractory anemia with ring sideroblasts
 - f. Refractory cytopenia with multi-lineage dysplasia
 - g. Refractory anemia with excess blasts I
 - h. Refractory anemia with excess blasts II
 - i. MDS with isolated del(5q)
 - j. MDS, unclassifiable
4. MDS/MPN
- a. Chronic myelomonocytic leukemia 1
 - b. Chronic myelomonocytic leukemia 2
 - c. Atypical chronic myeloid leukemia, *BCR-ABL* negative
 - d. Juvenile myelomonocytic leukemia
 - e. MDS/MPN, unclassifiable
 - f. Refractory anemia with ring sideroblasts and thrombocytosis
5. Myeloid and lymphoid neoplasms associated with eosinophilia and abnormalities of *PDGFRA*, *PDGFRB*, or *FGFR1*
- a. Myeloid and lymphoid neoplasms associated with *PDGFRA* rearrangement
 - b. Myeloid neoplasms associated with *PDGFRB* rearrangement
 - c. Myeloid and lymphoid neoplasms associated with *FGFR1* abnormalities

MDS, myelodysplastic syndrome; MPN, myeloproliferative neoplasms.

TABLE 84.3 2008 WORLD HEALTH ORGANIZATION CLASSIFICATION OF EOSINOPHILIC DISORDERS

- 1. Myeloid and lymphoid neoplasms associated with eosinophilia and abnormalities of *PDGFRA*, *PDGFRB*, or *FGFR1***
- 1. Diagnostic criteria of an MPN^a with eosinophilia associated with *FIP1L1-PDGFRB***
 - 1. An MPN with prominent eosinophilia and
 - 2. Presence of an *FIP1L1-PDGFRB* fusion gene^b
 - 2. Diagnostic criteria of MPN associated with *ETV6-PDGFRB* fusion gene or other rearrangement of *PDGFRB***
 - 1. An MPN, often with prominent eosinophilia and sometimes with neutrophilia and monocytosis and
 - 2. Presence of t(5;12)(q31~q33;p13), or a variant translocation^c, or demonstration of an *ETV6-PDGFRB* fusion gene or rearrangement of *PDGFRB*
 - 3. Diagnostic criteria of MPN or acute leukemia associated with *FGFR1* gene rearrangement**
 - 1. An MPN with prominent eosinophilia and sometimes with neutrophilia or monocytosis or AML or precursor T-cell or precursor B-cell lymphoblastic leukemia/lymphoma (usually associated with peripheral blood or bone marrow

eosinophilia) and

2. Presence of t(8;13)(p11;q12) or a variant translocation leading to *FGFR1* rearrangement demonstrated in myeloid cells, lymphoblasts, or both

2. Chronic Eosinophilic Leukemia-NOS

- a. Eosinophilia (eosinophil count $> 1.5 \times 10^9/L$)
- b. No Ph chromosome or *BCR-ABL* fusion gene or other MPNs (PV, ET, PMF, systemic mastocytosis) or MDS/MPN (CMML or atypical CML)
- c. No t(5;12)(q31~q35;p13) or other rearrangement of *PDGFRB*
- d. No *FIP1L1-PDGFRB* fusion gene or other rearrangement of *PDGFRB*
- e. No rearrangement of *FGFR1*
- f. Blast cell count in the peripheral blood and bone marrow is less than 20% and there is no inv(16)(p13q22) or t(16;16)(p13q22) or other feature diagnostic of AML
- g. There is a clonal cytogenetic or molecular genetic abnormality, or blast cells are more than 2% in the peripheral blood or more than 5% in the bone marrow

3. Idiopathic Hypereosinophilic Syndrome

EXCLUSION of the following:

- . Reactive eosinophilia
 - a. Lymphocyte-variant hypereosinophilia (cytokine-producing immunophenotypically aberrant T-cell population)
 - b. Chronic eosinophilic leukemia, NOS
 - c. WHO-defined myeloid malignancies associated with eosinophilia (e.g., MDS, MPNs, MDS/MPNs, or AML)
 - d. Eosinophilia-associated MPNs or AML/ALL with rearrangements of *PDGFRB*, *PDGFRB*, or *FGFR1*
 - e. Absolute eosinophil count of $>1,500/mm^3$ must persist for at least 6 mo and tissue damage must be present. If there is no tissue damage, idiopathic hypereosinophilia is the preferred diagnosis
- ALL, acute lymphoblastic leukemia; AML, acute myeloid leukemia; CML, chronic myelogenous leukemia; CMML, chronic myelomonocytic leukemia; ET, essential thrombocythemia; MDS, myelodysplastic syndrome; MPN, myeloproliferative neoplasms; NOS, not otherwise specified; PMF, primary myelofibrosis; PV, polycythemia vera.

^a Patients presenting with AML or lymphoblastic leukemia/lymphoma with eosinophilia and an *FIP1L1-PDGFRB* fusion gene are also assigned to this category.

^b If appropriate molecular analysis is not available, this diagnosis should be suspected if there is a Ph-negative MPN with the hematologic features of chronic eosinophilic leukemia associated with splenomegaly, a marked elevation of serum vitamin B12, elevation of serum tryptase, and increased bone marrow mast cells.

^c Because t(5;12)(q31~q33;p12) does not always lead to an *ETV6-PDGFRB* fusion gene, molecular confirmation is highly desirable. If molecular analysis is not available, this diagnosis should be suspected if there is a Ph-negative MPN associated with eosinophilia and with a translocation with a 5q31-33 breakpoint.

In 2011, members from the Working Conference on Eosinophil Disorders and Syndromes proposed a new terminology for eosinophilic syndromes.¹⁸ The panel recommended the higher level term “Hypereosinophilia (HE)” for persistent and marked eosinophilia ($AEC > 1.5 \times 10^9/L$). In turn, HE subtypes were divided into a hereditary (familial) variant (HE_{FA}), HE of undetermined significance (HE_{US}), primary (clonal/neoplastic) HE produced by clonal/neoplastic eosinophils (HE_N), and secondary (reactive) HE (HE_R). HEUS was introduced as a novel term in lieu of “idiopathic hypereosinophilia.” Any HE (not just idiopathic) associated with organ damage is referred to as “HES” with specific variants designated by subscripts (e.g., HES_{US} , HES_N , and HES_R). Additional recommendations advanced by the consensus panel are summarized in their report.¹⁸

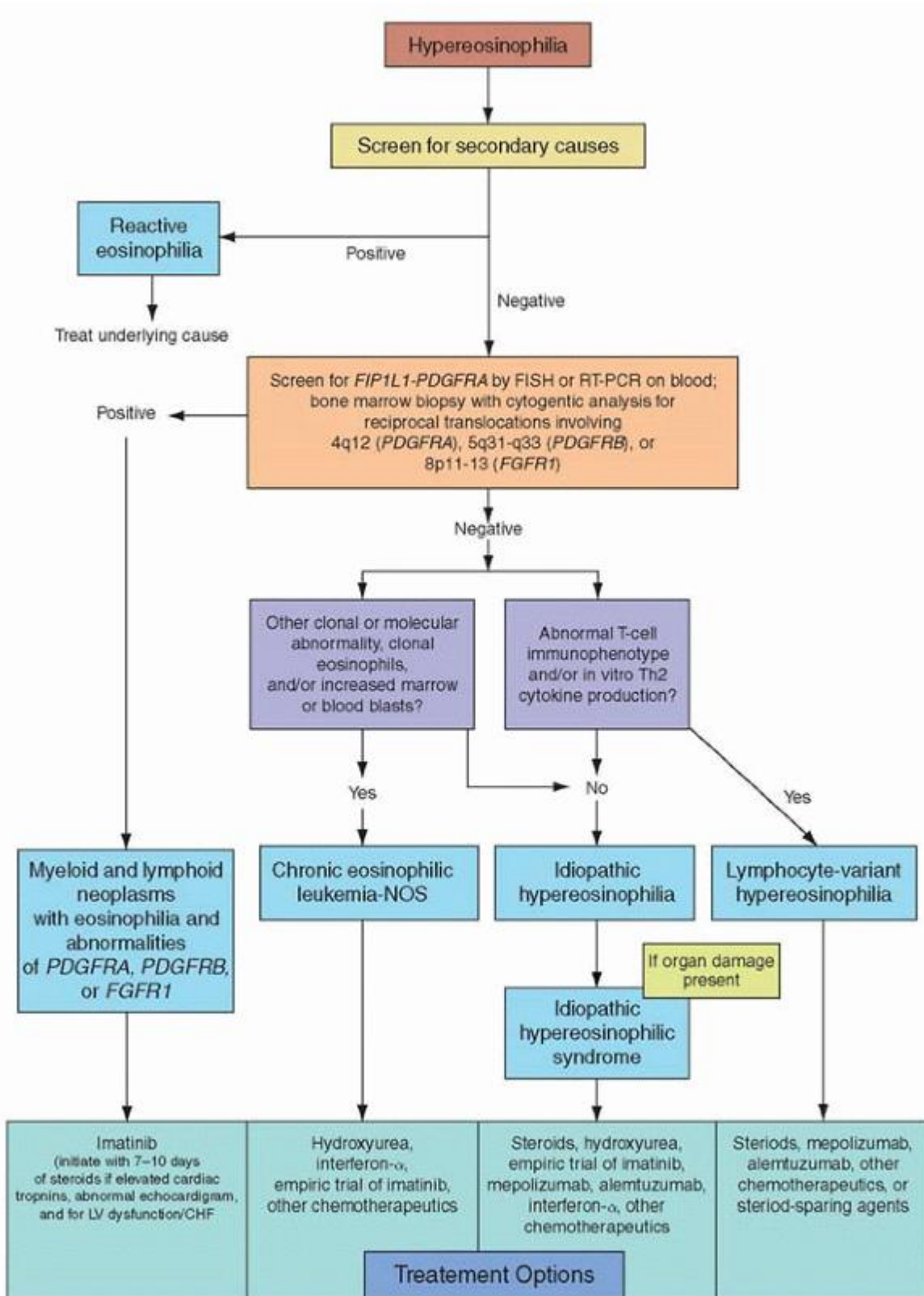

FIGURE 84.1 Algorithm for the diagnosis and treatment of eosinophilic disorders.

DIAGNOSTIC EVALUATION FOR HYPEREOSINOPHILIA

In addition to a hematology consultation, a multi-disciplinary evaluation including allergy/immunology, dermatology, and infectious diseases/tropical medicine may be required to identify the etiology of HE. The workup of HE (Fig. 84.1) should

commence with a thorough evaluation of reactive causes, with particular attention to comorbid health conditions, medications, and travel

P.1749

history/environmental exposures. Helminth infections are the most common cause of HE in developing countries, and hypersensitivity/atopy is the most frequent etiology in industrialized nations. In addition to infection and hypersensitivity conditions, other secondary causes of HE include connective tissue disorders (Churg-Strauss syndrome), granulomatosis with polyangiitis (Wegener's, systemic lupus erythematosus), solid or hematologic malignancies, metabolic disorders (e.g., adrenal insufficiency), eosinophilic pulmonary diseases, and rare entities such as familial eosinophilia,¹⁹ hyper-immunoglobulin (Ig)E syndrome, Omenn syndrome, episodic angioedema and eosinophilia (Gleich's syndrome), and eosinophilia-myalgia syndrome (possibly related to tryptophan ingestion and the historical epidemic of toxic-oil syndrome).^{20, 21}

In addition to a complete blood count with a white blood cell count (WBC) differential to measure the severity of eosinophilia, the initial laboratory workup for reactive causes of HE typically includes stool culture and serial ova and parasite testing, and sometimes serologic testing for specific parasites (e.g., strongyloides antibody). Testing for specific bacteria, fungi, or viruses may also be warranted in selected cases. The use of chest x-ray, electrocardiogram and/or echocardiography, and computed tomography scan of the chest or abdomen/pelvis are similarly guided by the patient's symptoms and physical exam findings. Imaging studies may help discern the basis for eosinophilia, establish the presence or severity of organ damage, and guide the need for tissue biopsy. For eosinophilic lung diseases, pulmonary function testing, bronchoscopy, and serologic tests (e.g., aspergillus IgE to evaluate for allergic bronchopulmonary aspergillosis) may be obtained to further characterize lung involvement.

If secondary causes of eosinophilia are excluded, the work-up should proceed to the evaluation of a primary bone marrow disorder. Bone marrow aspirate and trephine biopsy with cytogenetics and immunophenotyping (with relevant iron and reticulin/trichrome stains) are useful to elucidate WHO-defined clonal myeloid neoplasms associated with eosinophilia such as acute myeloid leukemia, specifically AML with inv(16)(p13;q22) or t(16;16)(p13;q22), CML or other MPNs (e.g., SM), and overlap MDS/MPN disorders such as chronic myelomonocytic leukemia (CMML).¹⁷

Myeloid malignancies primarily defined by eosinophilia include the aforementioned CEL-NOS and the category of PDGFRA/B or FGFR1-rearranged neoplasms. Diagnostic assessment of primary eosinophilia should begin with screening of the peripheral blood for the FIP1L1-PDGFRB gene fusion by interphase or metaphase fluorescence in situ hybridization (FISH).²² Less commonly, reverse-transcriptase polymerase chain reaction (PCR) is used to detect the fusion. FISH probes that hybridize between the FIP1L1 and PDGFRA loci detect the 800-kb interstitial deletion on chromosome 4q12 that results in gene fusion. Because the CHIC2 gene is located in this deleted genetic segment, the test has been referred to as "FISH for the CHIC2 deletion."²³ If FIP1L1-PDGFRB screening is not available, serum tryptase has been used as a surrogate marker for FIP1L1-PDGFRB-positive disease, since increased levels have been associated with the fusion or myeloproliferative forms of HE.²⁴ In contrast to FIP1L1-PDGFRB, which is not detectable by standard karyotyping, rearrangements involving PDGFRB and FGFR1 can be inferred by cytogenetic analysis, represented by the breakpoints 5q31-33 (PDGFRB) and 8p11-12 (FGFR1), respectively.¹⁶ Reciprocal chromosomal translocations involving the breakpoints 9p24 or 13q12 may relate to JAK2 (e.g., PCM1-JAK2) or FLT3 (e.g., ETV6-FLT3) fusions, respectively, and have been associated with eosinophilia.^{25,26} Knowledge of these breakpoints is critical because targeted therapy may have clinical efficacy against these constitutively activated tyrosine kinases. Bone marrow biopsy studies as highlighted above should be performed to complement peripheral blood analyses.

If both secondary and primary causes of eosinophilias are excluded, lymphocyte-variant HE should be considered next in the diagnostic algorithm.²⁷ Patients with lymphocyte-variant HE often have cutaneous signs and symptoms as the primary disease manifestation. Although patients' skin disease can be symptomatic, the natural history of this condition is typically indolent, with rare patients progressing to T-cell lymphoma or Sézary syndrome. Progression has been associated with acquisition of cytogenetic abnormalities (e.g., partial 6q and 10p deletions, trisomy 7) in T cells and with proliferation of lymphocytes with the CD3⁺CD4⁺ phenotype.^{28, 29,30, 31,31} This syndrome represents a mixture of clonal and reactive processes resulting in the expansion of a clone of T-lymphocytes that produce cytokines that drive eosinophilia.^{27, 32, 33} Although these laboratory findings constitute basic elements of this syndrome, neither the WHO nor other consensus panels have established specific diagnostic criteria for this condition.^{16, 17} and ¹⁸ The finding of isolated T-cell clonality by PCR without T-cell immunophenotypic abnormalities or demonstration of Th2 cytokine production is not adequate to make a diagnosis of this variant.³² In an analysis of patients diagnosed with HES, 18/42 (43%) subjects exhibited a clonal T-cell receptor gene rearrangement by PCR.³⁴ However, the biologic relevance of such clonal T-cell populations to

eosinophilia was not established.³⁴ Therefore, whether such patients should still be referred to as HES, or as lymphocyte-variant HE, remains a matter of debate. Laboratory features that suggest this disorder are shown in Table 84.4.

BIOLOGY OF FIP1L1-PDGFR α

FIP1L1-PDGFR α can promote the proliferation and survival of eosinophils through the activation of several signaling pathways such as phosphoinositol 3-kinase (PI3 kinase), ERK1/2, and STAT5.^{22, 35} The exact mechanism by which FIP1L1-PDGFR α preferentially affects eosinophils remains unclear. Recently, it was found that in vitro inhibition of JAK2 in the FIP1L1-PDGFR α -positive EOL-1 cell line, primary FIP1L1-PDGFR α -positive cells, and T674I FIP1L1-PDGFR α -imatinib-resistant cells, by either JAK2-specific short interfering RNA or the tryphostin derivative AG490 (a JAK inhibitor), significantly reduced cellular proliferation and induced cellular apoptosis.³⁶ JAK2 inhibition also reduced PI3 kinase, AKT, and nuclear factor kappa B activity in a dose-dependent manner, and suppressed expression levels of

P.1750

c-myc and survivin.³⁶ The results suggest that JAK2 is activated by FIP1L1-PDGFR α and is required for cellular proliferation, possibly through induction of c-myc and survivin.

TABLE 84.4 LABORATORY FINDINGS IN LYMPHOCYTE-VARIANT HYPEREOSINOPHILIA

1. Cytokine-producing abnormal T-lymphocyte population with aberrant immunophenotype
 - a. Double-negative, immature T cells (e.g., CD3⁺CD4⁻CD8⁻), or
 - b. Absence of CD3 (e.g., CD3⁻CD4⁺), a normal component of the T-cell receptor, or
 - c. Elevated CD5 expression on CD3⁻CD4⁺ cells, or
 - d. Loss of surface CD7 and/or expression of CD27
2. Reactive eosinophilia in response to T-lymphocyte secretion of eosinophilopoietic cytokines
3. Elevated serum IgE levels
4. Lymphocyte production of cytokines (e.g., IL-5, IL-4, IL-13) suggesting Th2 cytokine profile
5. Elevated production of TARC, a chemokine in Th2-mediated diseases

IL, interleukin; TARC, thymus and activation-regulated chemokine; Th2, T cells with helper type 2.

In one murine model, expression of the FIP1L1-PDGFR α fusion in bone marrow cells was not sufficient to cause eosinophilia, but only a general myeloproliferative disease.³⁷ However, in another murine model, expression of FIP1L1-PDGFR α together with overexpression of IL-5, the most potent eosinophilopoietic cytokine, mimicked more typical features of HES, such as tissue infiltration of eosinophils.³⁸ Polymorphic variation at the IL-5 receptor- α (IL5RA) gene revealed an association between a single nucleotide polymorphism in the 5' untranslated region of IL5RA and the eosinophil count/presence of tissue infiltration in FIP1L1-PDGFR α -positive patients.³⁹ These data suggest that FIP1L1-PDGFR α alone is not sufficient to explain the development of HES/CEL, and that additional factors such as IL-5 signaling may also be implicated in the disease phenotype.

The structure of the FIP1L1-PDGFR α fusion protein is similar to the structure of the ETV6-PDGFR α , ZNF198-FGFR1, and BCR-ABL1 proteins, for which homotypic oligomerization mediated by domains within ETV6, ZNF198, or BCR has been reported.^{40, 41} and ⁴² Oligomerization of the corresponding fusion proteins leads to activation of the tyrosine kinase domains, which in turn activate downstream signaling pathways regulating cell proliferation and survival. In contrast, interruption of the juxtamembrane of PDGFR α , either due to mutations or duplications, causes constitutive activation of kinase activity.^{43, 44} This mechanism occurs with internal tandem duplications in FLT3 and mutations of KIT in AML or gastrointestinal stromal tumors.^{45, 46} Fusion of FIP1L1 to the PDGFR α protein yields a constitutively active tyrosine kinase only if the juxtamembrane domain of PDGFR α is partially or completely removed.⁴⁷ The different breakpoints within the PDGFR α gene are tightly clustered, resulting in the removal of part of the juxtamembrane domain and activation of the kinase domain.⁴⁸ In contrast, with many PDGFRB fusions, the juxtamembrane is completely intact, and activation of PDGFRB kinase activity is obtained through oligomerization mediated by the fusion partner.

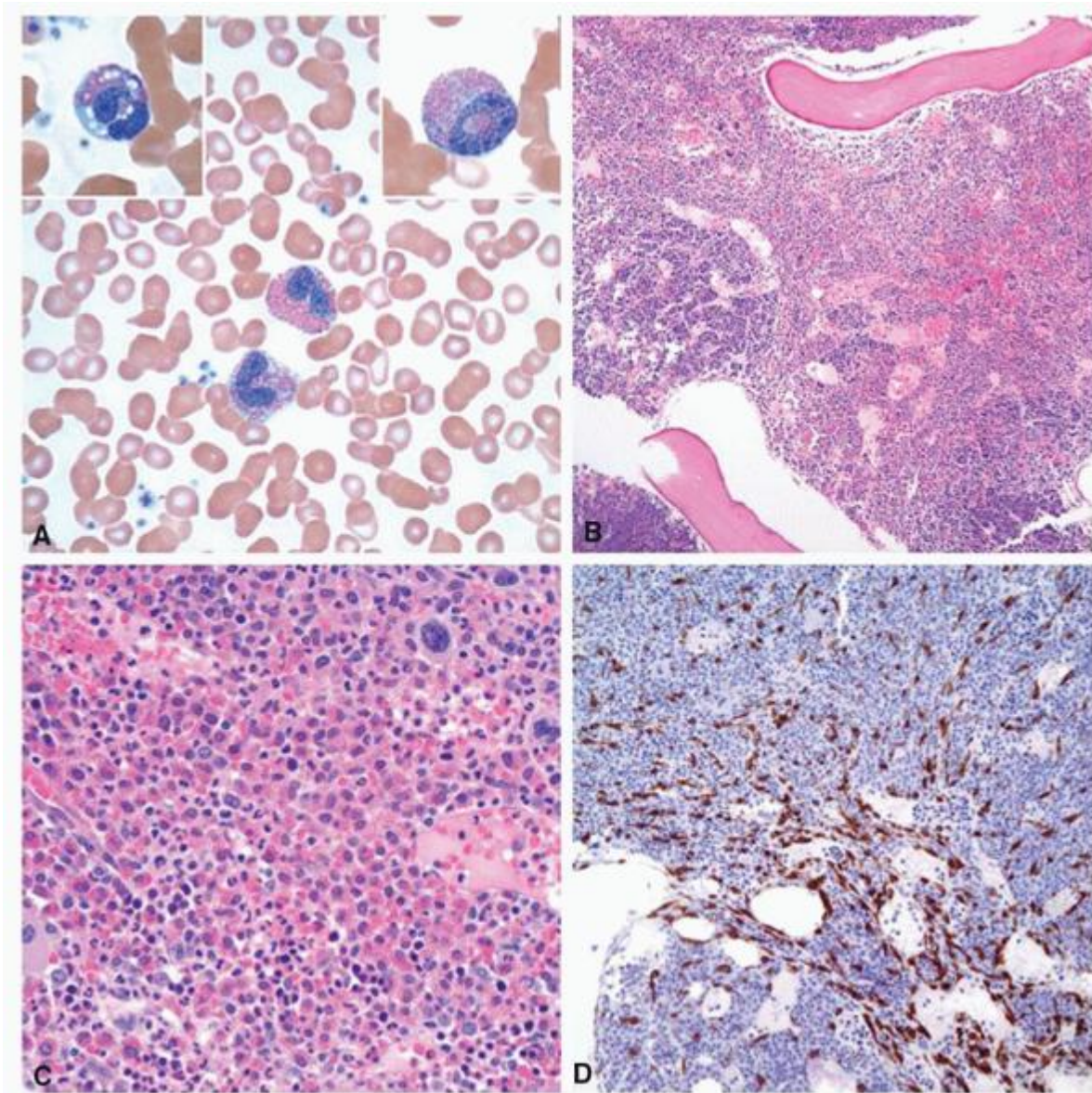

FIGURE 84.2 Histopathology of a FIP1L1—PDGFRA-positive myeloid neoplasm associated with eosinophilia. A peripheral eosinophilia is present with an absolute eosinophil count of $2.48 \times 10^9/L$. Eosinophils include atypical forms with ring nuclei (inset, right), vacuolated cytoplasm (inset, left), as well as irregularly granulated eosinophils (A). Wright-Giemsa, 1,000 \times . The bone marrow biopsy is hypercellular for age with dilated marrow sinuses, a feature associated with marrow fibrosis (B). Hematoxylin and eosin, 100 \times . The bone marrow biopsy shows a myeloid hyperplasia with a marked eosinophilia (C). Hematoxylin and eosin, 400 \times . Loose aggregates of mast cells are present in the bone marrow biopsy as shown by immunohistochemistry, but were not readily visible on hematoxylin and eosin-stained sections (D). CD117, 200 \times . Images provided courtesy of Dr. Tracy George.

In addition to dysregulation of PDGFRA by fusion to FIP1L1 or other partner genes, activating point mutations have been identified in PDGFRA in patients with HE.⁴⁹ Although there was variability in their transforming ability, injection of cells harboring these mutants into mice induced a leukemia-like disease. Imatinib treatment significantly decreased leukemic growth and prolonged survival.⁴⁹

CLINICAL PRESENTATION AND PROGNOSIS

Clinicopathologic Features

Patients with FIP1L1-PDGFRA-associated eosinophilia present with features of an MPN: splenomegaly, hypercellular bone marrows, and clinicopathologic characteristics which overlap with systemic mast cell disease, including increased numbers

of abnormal-appearing bone marrow mast cells, marrow fibrosis, and elevated serum tryptase levels (see Fig. 84.2).^{24,48} Soon after the discovery of the fusion, a debate arose regarding whether FIP1L1-PDGFRB-positive disease represents a subtype of SM rather than a primary eosinophilic neoplasm, because atypical mast cells can be found in the marrows of these patients. In a Mayo Clinic series, the bone marrow biopsies of FIP1L1-PDGFRB-positive patients were described as showing a loose, interstitial pattern of mast cells by tryptase immunostaining compared to the multifocal dense aggregates characteristic of D816V KIT-positive SM.⁵⁰ In some cases, the mast cells exhibited spindle-shaped morphology and aberrant

P.1751

surface expression of CD25, both WHO minor criteria for SM. However, in the revised 2008 WHO classification, this entity was not considered a subtype of SM, but instead was included in the new category "Myeloid and lymphoid neoplasms with eosinophilia and abnormalities of PDGFRA, PDGFRB, or FGFR1."¹⁶ Reliable distinction between KIT D816V-positive SM with eosinophilia and FIP1L1-PDGFRB-positive eosinophilia was demonstrated based on several clinical and laboratory features.⁵¹ In the KIT D816V-positive SM cohort, gastrointestinal symptoms, urticaria pigmentosa, thrombocytosis, median serum tryptase value, and the presence of dense marrow mast cell aggregates were significantly elevated or more frequently represented compared to patients with FIP1L1-PDGFRB-positive disease. Conversely, male sex, cardiac and pulmonary symptoms, median peak AEC, the eosinophil to tryptase ratio, and serum B12 levels were significantly elevated or more frequently represented in the FIP1L1-PDGFRB-positive group. A scoring system that incorporated these findings was devised that could reliably predict these two diagnostic entities.

Although FIP1L1-PDGFRB-positivity is almost always associated with the phenotype of a chronic MPN, the fusion may be rarely found in AMLs or T-cell leukemias/lymphomas associated with eosinophilia.⁵² In addition to the FIP1L1-PDGFRB fusion gene, >5 PDGFRA fusion genes, as well as >20 different PDGFRB genes, have been described in MPNs with eosinophilia (Fig. 84.3). Among 56,709 cytogenetically defined cases at the Mayo Clinic, only 25 (0.04%) exhibited the t(5;12) breakpoint.⁵³ The classic variant t(5;12)(q33;p13), likely representing the ETV6-PDGFRB gene fusion, was present in only 4 of these cases.⁵³ Despite the rare frequency (<<1%) of PDGFRB-rearrangements in cytogenetically defined cases with features of CMML and other myeloid neoplasms (e.g., atypical CML, juvenile myelomonocytic leukemia, chronic basophilic leukemia, MDS/MPN-unclassifiable),⁵³ their recognition is critical given their responsiveness to imatinib. However, not all 5q31-33 breakpoints represent the PDGFRB gene. For example, IL-3 (on chromosome 5q31) is fused to the Ig heavy chain gene (chromosome 14q32) in a subset of eosinophilia-associated B-cell acute lymphoblastic leukemias (ALLs).⁵⁴ In addition, in cases of MDS/AML with associated eosinophilia and a t(5;12)(q31;p13) translocation, an ETV6-ACSF2 gene fusion was identified.⁵⁵ Finally, more than 10 fusion partners of FGFR1 have been described in the context of stem cell leukemia/lymphoma (Fig. 84.3).

Clinical Presentation

In two retrospective series of HES, eosinophilia was an incidental finding in 6% to 12% of patients with HE.^{54,55} In a study of 188 patients, the mean peak eosinophil count was $6.6 \times 10^9/L$ (range of 1.5 to $400 \times 10^9/L$).⁵⁵ Primary marrow eosinophilias, also referred to as "myeloproliferative variants of eosinophilia," may be characterized by blood or bone marrow neutrophilia, basophilia, and myeloid immaturity. Eosinophil morphology can be normal or abnormal in marrow-derived eosinophilias and cannot be used as a distinguishing feature between reactive and primary eosinophilias. Marrow findings of Charcot-Leyden crystals, increased blasts, and fibrosis are found in a spectrum of eosinophilic myeloid neoplasms and are not unique to CEL-NOS or myeloid neoplasms with eosinophilia and rearrangements of PDGFRA/B or FGFR1.^{16,17}

Common non-hematologic signs and symptoms of HES include (in descending frequency) weakness and fatigue (26%), cough (24%), dyspnea (16%), myalgias or angioedema (14%), rash or fever (12%), and rhinitis (10%).⁵⁶ In follow-up of patients with sustained eosinophilia, skin involvement was the most frequent clinical manifestation (69% of patients), followed by pulmonary (44%) and gastrointestinal (38%) findings.⁵⁷ Cardiac sequelae (unrelated to hypertension, atherosclerosis, or rheumatic disease) was eventually identified in 20% of patients at follow-up (only 6% at the time of initial presentation).⁵⁷ Table 84.5 shows the frequency and type of organ system involvement from 3 historical studies.^{56,58,60}

Prognosis

Older case series identify cardiac disease as the primary etiology of premature death. A review of 57 HES cases published through 1973 reported a median survival of 9 months, and the 3-year survival was only 12%.³ Patients usually presented with advanced disease, with congestive heart failure accounting for 65% of deaths at autopsy. In addition to cardiac

involvement, peripheral blood blasts or a WBC count greater than $100 \times 10^9/L$ were poor prognostic factors.³ A later report of 40 HES patients cited a 5-year survival rate of 80%, decreasing to 42% at 15 years.⁵⁸ Factors predictive of a worse outcome included the presence of an MPN, corticosteroid-refractory HE, cardiac disease, male sex, and the height of eosinophilia.⁵⁸

The historical, shortened life expectancy related to heart damage provides a useful example of the consequences of eosinophil-mediated tissue injury. It is typically a step-wise process resulting from local infiltration and release of toxic mediators.^{56,60} Damage to the endocardium can lead to local deposition of platelet thrombi, and subsequently to larger mural thrombi and increased risk of thromboembolic disease. With time, fibrous thickening of the endocardial lining and leaflets of the mitral and tricuspid valves can result in a restrictive cardiomyopathy and valvular insufficiency.^{61,62} Advances in cardiac surgery have reduced morbidity and mortality related to eosinophil-mediated heart damage.

In WHO-defined myeloid malignancies, the prognostic importance of associated eosinophilia has only been studied in a few diseases. In a series of 123 patients with SM, eosinophilia was prevalent in 34% of cases, but was prognostically neutral and not affected by exclusion of FIP1L1-PDGFR α -positive cases.⁶³ In a study of 1,008 patients with de novo MDS, eosinophilia (and basophilia) predicted a significantly reduced survival without having a significant impact on leukemia-free survival.⁶⁴ A retrospective analysis of 288 individuals with newly diagnosed MDS revealed that significantly higher numbers of patients with eosinophilia or basophilia (compared to patients with neither) had chromosomal abnormalities carrying an intermediate or poor prognosis.⁶⁵ In addition, the overall survival rate was significantly lower and a higher rate of evolution to AML was observed.⁶⁵

TREATMENT

FIP1L1-PDGFR α -Positive Neoplasms

At the turn of the 21st century, no unique and recurrent clonal marker had been linked to eosinophilic neoplasms despite an ever-growing list of nonspecific chromosomal abnormalities (e.g., trisomy 8) having been catalogued.⁶⁶ In 2001, Schaller and Burkland described a male patient with HES who was resistant or intolerant to prior therapies including corticosteroids, hydroxyurea, and interferon- α .⁶⁷ The patient was treated with imatinib at least partly based on the rationale that the myeloproliferative features of HES could share a similar pathobiology to CML. After several days of imatinib therapy of 100 mg daily, the patient achieved a rapid and complete hematologic remission with resolution of peripheral blood eosinophilia just after 1 month of treatment. Shortly thereafter, a few case series established that imatinib at doses ranging from 100 to 400 mg daily could elicit rapid and complete hematologic responses in patients with heavily pretreated refractory/relapsed HES or CEL.^{67,68} In the landmark report published in 2003, the fusion tyrosine kinase FIP1L1-PDGFR α was ultimately identified as the therapeutic target of imatinib in responsive patients.²² At the same time, the

P.1752

FIP1L1-PDGFR α fusion was discovered in the imatinib-sensitive EOL-1 cell line by another group of investigators.⁶⁹

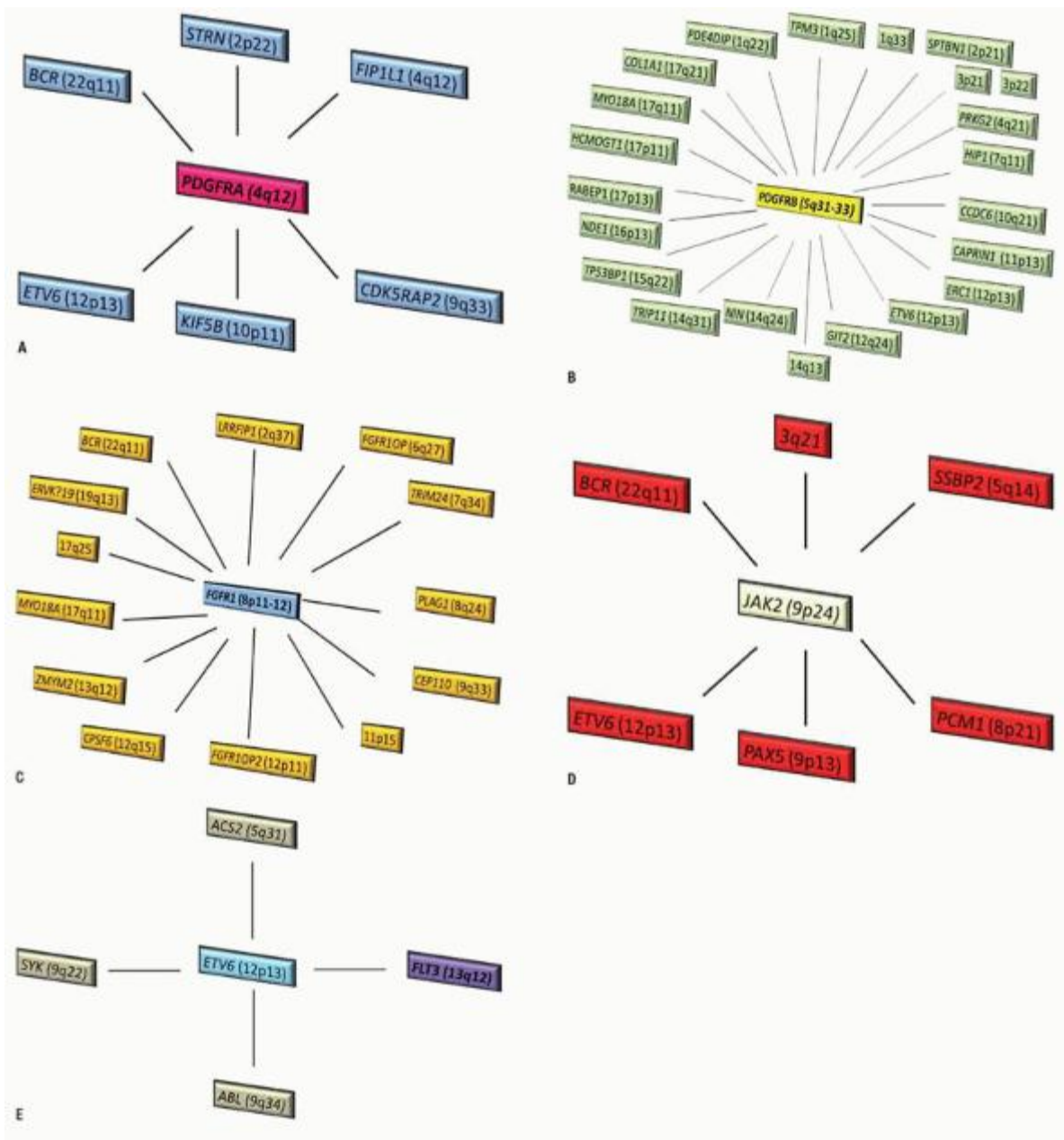

FIGURE 84.3 Fusion genes and translocations associated with eosinophilia and rearranged PDGFRA/B, FGFR1, JAK2, ETV6, and FLT3. Adapted from the Atlas of Genetics and Cytogenetics in Oncology and Haematology. <http://AtlasGeneticsOncology.org>

Similar to the experience with CML, imatinib has transformed the prognosis of patients with the FIP1L1-PDGFR A abnormality. In addition to rapid hematologic remissions, molecular remissions can be achieved in the majority of patients with doses in the range of 100 to 300-400 mg daily.^{22,67,68} Although maintenance doses of 100 to 200 mg weekly may preserve ongoing molecular remissions in some patients, the optimal dose for maintaining response has not been defined.⁷⁰ Because of its good tolerability and safety profile, ongoing therapy with a starting dose of 100 to 400 mg is commonly utilized.

The long-term experience with imatinib-treated FIP1L1-PDGFR A-positive myeloid neoplasms is very favorable. In an Italian prospective study of 27 patients followed for a median period of 25 months (range 15 to 60 months), patients were initially dosed at 100 mg daily and increased to 400 mg daily.⁷¹ Complete hematologic remission was achieved in all patients within 1 month, and all patients became PCR-negative for FIP1L1-PDGFR A after a median of 3 months (range 1 to P.1753

10 months). Patients continuing imatinib remained PCR-negative during a median follow-up period of 19 months (range 6 to 56+ months). Another European study prospectively assessed the natural history of molecular responses to imatinib doses of 100 to 400 mg daily.⁷² Among 11 patients with high pretreatment transcript levels, all achieved a 3-log reduction in transcript levels by 1 year of therapy, and 9 of 11 patients achieved a molecular remission.

TABLE 84.5 ORGAN MANIFESTATIONS OF EOSINOPHILIC NEOPLASMS/HYPEREOSINOPHILIC SYNDROMES

Organ System	Cumulative Frequency from Three Studies (%)^a	Examples of Organ-Specific Manifestations
Hematologic	100	Leukocytosis with eosinophilia; neutrophilia, basophilia, myeloid immaturity, immature and/or dysplastic eosinophils; anemia, thrombocytopenia or thrombocytosis, increased marrow blasts, myelofibrosis.
Cardiovascular	58	Cardiomyopathy, congestive heart failure, constrictive pericarditis, myocarditis, mural thrombi, valvular dysfunction, endomyocardial fibrosis, myocardial infarction, pericardial effusion, deep venous thrombosis, superficial thrombophlebitis
Dermatologic	56	Angioedema, urticaria, papules/nodules, dermatitis, plaques, (aquagenic) pruritus, erythroderma, mucosal ulcers, vesicobullous lesions, microthrombi, vasculitis, Wells syndrome
Neurologic	54	Thromboembolic stroke, peripheral neuropathy, encephalopathy, dementia, epilepsy, cerebellar disease, eosinophilic meningitis, vertigo, paresthesia, change in mentation, aphasia, visual disturbances
Pulmonary	49	Pulmonary infiltrates, effusions, fibrosis, emboli, nodules/focal ground glass attenuation, acute respiratory distress syndrome, asthma, sinusitis, rhinitis, cough, dyspnea, recurrent upper respiratory tract infection
Spleen	43	Splenomegaly, hypersplenism, infarct
Liver/gallbladder	30	Hepatomegaly, focal or diffuse hepatic lesions on imaging, chronic active hepatitis, hepatic necrosis, Budd-Chiari syndrome, sclerosing cholangitis, cholecystitis, cholestasis
Ocular	23	Microthrombi, choroidal infarcts, retinal arteritis, episcleritis, keratoconjunctivitis sicca, Adie syndrome (pupillotonia)
Gastrointestinal	23	Ascites, diarrhea, gastritis, colitis, pancreatitis, abdominal pain, vomiting
Musculoskeletal/rheumatologic	—	Arthritis/arthralgias, effusions, bursitis, synovitis, Raynaud phenomena, digital necrosis,

polymyositis/myopathy, myalgias

Renal

—Acute renal failure with Charcot-Leyden crystalluria, nephrotic syndrome, immunotactoid glomerulopathy, crescentic glomerulonephritis

^aData from Fauci et al.,⁵⁶ Lefebvre et al.,⁵⁸ and Spry et al.⁵⁹ From Gotlib J, Cools J, Malone JM III. The FIP1L1-PDGFRα fusion tyrosine kinase in hypereosinophilic syndrome and chronic eosinophilic leukemia: implications for diagnosis, classification, and management. *Blood* 2004;103:2879-2891. © The American Society of Hematology.

Despite in-depth and durable molecular remissions, discontinuation of imatinib usually leads to disease relapse. In a dose de-escalation trial of imatinib in five patients who had achieved a stable hematologic and molecular remission at 300 to 400 mg daily for at least 1 year, molecular relapse was observed in all patients after 2 to 5 months of either imatinib dose reduction or discontinuation.⁷³ Molecular remissions were reestablished with reinitiation of imatinib in all patients at a dose range of 100 to 400 mg daily. In a cohort of patients evaluated by the Mayo Clinic, hematologic relapse occurred only several weeks after discontinuation of imatinib in four patients.⁷⁴ These data indicate that imatinib does not cure FIP1L1-PDGFRα-positive disease and argue for ongoing imatinib therapy to suppress the abnormal clone.

As with CML, FIP1L1-PDGFRα-positive patients can develop resistance to imatinib, mostly involving the T674I mutation within the ATP-binding domain of PDGFRα.^{22,75,76,77} T674I PDGFRα is analogous to the T315I ABL1 mutation in CML, which confers panresistance to the tyrosine kinase inhibitors imatinib, dasatinib, and nilotinib. However, unlike CML, this secondary resistance is much less common (less than 10 cases in the literature) and is almost exclusively observed during advanced phases of the disease. In one study, it was found that the PDGFRα kinase domain contains a limited number of residues where exchanges critically interfere with the binding of—and inhibition by—available PDGFR kinase inhibitors.⁷⁸ This may be one explanation for the low frequency of imatinib resistance in these patients.

Options for second-line treatment for T674I imatinib resistance are limited. One patient with the FIP1L1-PDGFRα T674I mutation in blast crisis responded briefly to sorafenib, but this was followed by rapid emergence of a panresistant FIP1L1-PDGFRα D842V mutant.⁷⁷ Other reports have demonstrated either in vitro or in vivo activity of sorafenib, midostaurin (PKC412), or nilotinib against the T674I mutant.^{37,79,80,81} The ability of alternative tyrosine kinase inhibitors to elicit durable clinical remissions (despite in vitro data demonstrating inhibitory activity against mutated fusions) has been disappointing.⁸² To date, the only report of primary resistance to imatinib in chronic phase FIP1L1-PDGFRα-positive disease has been attributed to the identification of two novel mutations, PDGFRα S601P and L629P.⁸³

In patients with rearrangements of PDGFRB or PDGFRα variants other than FIP1L1-PDGFRα, case reports and series indicate that imatinib, usually at doses of 400 mg daily, can elicit durable hematologic and cytogenetic remissions.⁸⁴ FISH and conventional karyotyping can gauge cytogenetic responses to imatinib in PDGFRB-rearranged cases.

Though well-tolerated, with a safety profile similar to imatinib used in CML, several cases have been reported in which FIP1L1-PDGFRα-positive patients treated with imatinib experienced cardiogenic shock.^{85,86} It is therefore recommended that for patients with known cardiac disease or elevated troponin levels (possibly related to eosinophil-mediated damage of cardiac tissue), prophylactic steroids should be given for 7 to 10 days at the time of imatinib initiation.

The poor-prognosis FGFR1-rearranged neoplasms remain a therapeutic challenge. Patients with these stem cell neoplasms P.1754

exhibit an aggressive course usually terminating in AML in 1 to 2 years.¹⁶ Intensive chemotherapy with AML-type inductions or ALL-based regimens such as hyper-cyclophosphamide, vincristine, doxorubicin, and dexamethasone, followed by early allogeneic stem cell transplantation is recommended for patients with FGFR-1-rearranged disease. The data for small molecule inhibitors targeting constitutively activated FGFR1 is thus far limited, but several agents are in development. In one report, midostaurin (PKC412) inhibited the dysregulated ZNF198-FGFR1 fusion in vitro, and elicited a hematologic and cytogenetic response in a patient with this molecular abnormality.⁸⁷ For patients with JAK2 or FLT3 rearrangements, there may be a role for small molecule inhibitors of FLT3⁸⁸ and JAK2, but their use remains investigational.

Treatment of Patients with Hypereosinophilic Syndrome and Chronic Eosinophilic Leukemia, Not Otherwise Specified

Corticosteroids (e.g., prednisone 1 mg/kg) are recommended as first-line treatment for HES. Steroids have potent antieosinophil activity and can produce rapid reductions in eosinophil count. In a retrospective analysis of 188 patients,⁵⁷ 141 HES patients on corticosteroids as first-line monotherapy achieved a complete remission (CR) or partial remission (PR) after 1 month, with duration of therapy ranging from 2 to 20 years and a median maintenance dose of 10 mg/day.⁵⁷ As symptoms improve and eosinophil counts normalize, a steroid taper can be instituted, particularly given the long-term treatment side effects of steroids.

Hydroxyurea at 500 to 1,000 mg daily is also an effective first-line option for HES, with the understanding that, like corticosteroids, hydroxyurea is palliative and does not change the natural course of the disease. Hydroxyurea can be used as monotherapy or in combination with corticosteroids. In the same retrospective study, 64 HES patients (34%) received hydroxyurea monotherapy, with 13 (72%) achieving CR or PR.⁵⁷ One should note that for CEL-NOS and steroid-refractory idiopathic HES, hydroxyurea has been used as a first-line treatment.

IFN- α has been used effectively to induce hematologic and cytogenetic remissions in patients with HES and CEL-NOS who are either refractory to steroids or hydroxyurea, or administered in addition to corticosteroids as a steroid-sparing agent.^{89, 90, 91, 92, 93} and ^{94, 95} Of the 188 patients in a retrospective study, 46 were treated with IFN- α in combination with steroids, with response rates ranging from 50% to 75%, respectively.⁵⁷ IFN- α remissions have been associated with improvement in clinical symptoms as well as occasional improvement or reversion of end-organ injury, including hepatosplenomegaly and cardiac and thromboembolic complications.^{89, 90, 91, 92, 93} and ^{94, 95} The optimal starting or maintenance dose of IFN- α has not been well defined, but the initial dose required to control eosinophil counts often exceeds the doses required to sustain a remission. Initiation of therapy at 1 million units by subcutaneous injection three times weekly (tiw) and gradual escalation of the dose to 3 to 4 million units tiw or higher may be required to control the eosinophil count. Treatment of four HES patients with PEG-IFN- α -2b among a larger cohort of BCR-ABL1-negative MPN patients resulted in one complete and one partial response, but side effects required that the initial study dose be reduced from 3 to 2 $\mu\text{g}/\text{kg}/\text{week}$.⁹⁶ A lower starting dose of 90 $\mu\text{g}/\text{kg}$ weekly (e.g., 1 to 1.5 $\mu\text{g}/\text{kg}$ weekly) is better tolerated based on the experience of PEG-IFN- α -2a (Pegasy) in the MPNs polycythemia vera and essential thrombocythemia.^{97, 98} Side effects of short- and longeracting formulations of IFN- α are usually dose-dependent and can include fatigue and flu-like symptoms, transaminitis, cytopenias, depression, hypothyroidism, and peripheral neuropathy. IFN- α is considered safe for use in pregnancy.

Second- and third-line agents for the treatment of HES have included vincristine, cyclophosphamide, etoposide, 2-chlorodeoxyadenosine alone or in combination with cytarabine, and cyclosporin-A.^{99, 100, 101, 102, 103, 104, 105, 106, 107} and ¹⁰⁸ Imatinib has been used empirically in PDGFRA/B-rearrangement-negative patients (e.g., with HES or CEL-NOS). At doses of 400 mg or higher,¹⁰⁹ partial hematologic responses are sometimes observed, but are more often transient and may reflect drug-related myelosuppression.

Similar to HES, patients with lymphocyte-variant HE are initially treated with corticosteroids. Refractory or relapsed disease may be considered for treatment with IFN- α or steroid-sparing immunosuppressive agents. Hydroxyurea and imatinib are less likely to demonstrate efficacy in this form of HE. Elevated serum IgE and thymus and activation-regulated chemokine levels have been associated with responsiveness to steroids.⁵⁷

Antibody Approaches

Other treatment options for HES have included the anti-CD52 monoclonal antibody, alemtuzumab, based on the expression of the CD52 antigen on eosinophils. In patients with HES who were refractory to other therapies, infusion of alemtuzumab one to three times weekly produced a hematologic remission in 10 of 11 patients (91%), but responses were not sustained when alemtuzumab was discontinued.¹¹⁰ Other antibody treatment approaches to HES include the use of mepolizumab, an anti-IL-5, humanized monoclonal antibody that inhibits binding of IL-5 to the alpha chain of the IL5R found on eosinophils.¹¹¹ Mepolizumab has been evaluated in a large, randomized, double-blinded, placebo-controlled trial of 85 HES patients (e.g., FIP1L1-PDGFR α -negative patients).¹¹² Patients were randomized to intravenous mepolizumab 750 mg or placebo every 4 weeks for 36 weeks. No adverse events were significantly more frequent with mepolizumab compared to placebo. A significantly higher proportion of mepolizumab-treated HES patients versus placebo were able to achieve the primary efficacy endpoint of a daily prednisone dose of <10 mg daily for at least 8 consecutive weeks. Therefore, mepolizumab has a potential role as a steroid-sparing agent for these patients. Mepolizumab has not yet been approved by the FDA, but is currently available on a compassionate use basis (ClinicalTrials.gov Identifier NCT00244686) for individuals with life-threatening HES who have failed prior therapies.

Allogeneic stem cell transplant has been attempted for patients with aggressive disease with anecdotal benefit. Disease-free survival ranging from 8 months to 5 years has been reported,^{113, 114, 115, 116, 117} with one patient relapsing at 40

months.¹¹⁸ Allogeneic transplantation using nonmyeloablative conditioning regimens have been reported in three patients, with remission duration of 3 to 12 months at the time of reported follow-up.^{119,120} In one patient who underwent an allogeneic stem cell transplantation from an HLA-matched sibling, the patient was disease free at 3 years and there was no evidence of the FIP1L1-PDGFR α fusion which was present at diagnosis.¹²¹ Despite success in selected cases, the role of transplantation in HES is not well established.

Although less commonly used today, cardiac surgery has extended the life of patients with late-stage cardiac disease manifested by endomyocardial fibrosis, mural thrombosis, and valvular insufficiency.^{56,60} Mitral and/or tricuspid valve repair or replacement^{61,122,123, 124,125} and endomyocardectomy for latest-age fibrotic heart disease^{61,126} can improve cardiac function. Bioprosthetic devices are preferred over their mechanical counterparts because of the reduced frequency of valve thrombosis. Anticoagulants and antiplatelet agents have shown variable success in preventing recurrent thromboembolism.^{127, 128,129}

SUMMARY

Recognition of molecularly defined eosinophilias, whose pathobiology is linked to dysregulated tyrosine kinases, has transformed the classification and treatment of these diseases. The sensitivity

P.1755

of PDGFR α /B-rearranged eosinophilic neoplasms to imatinib has reversed the course of these historically poor-prognosis diseases. In addition to small molecule inhibitors, antibody approaches (e.g., mepolizumab, alemtuzumab) and pegylated IFN offer therapeutic options beyond corticosteroids and cytotoxic chemotherapy. Despite these advances, the pathogenesis of HES, CEL-NOS, and lymphocyte-variant HE remains obscure. Translational research approaches which incorporate next generation sequencing technologies and functional assays to interrogate eosinophil biology (e.g., phospho-specific flow cytometry) should help facilitate the identification of therapeutic targets in these conditions.

REFERENCES

1. Perkins WH. Beitrage zur Kenntnis der granulierten Bindegewebszellen und der eosinophilen Leukocythen. *Archiv Anat Physiol Physiol Abteil (Leipzig)* 1879;166-169.
2. Hardy WR, Anderson RE. The hypereosinophilic syndrome. *Ann Intern Med* 1968;68:1220-1229.
3. Chusid MJ, Dale DC, West BC, et al. The hypereosinophilic syndrome. Analysis of fourteen cases with review of the literature. *Medicine* 1975;54:1-27.
4. Rothenberg ME. Eosinophilia. *New Engl J Med* 1998;338:1592-1600.
5. Brigden M, Graydon C. Eosinophilia detected by automated blood cell counting in ambulatory North American outpatients. Incidence and clinical significance. *Arch Pathol Lab Med* 1997;121:963-967.
6. Crane MM, Chang CM, Kobayashi MG, et al. Incidence of myeloproliferative hypereosinophilic syndrome in the United States and an estimate of all hypereosinophilic syndrome incidence. *J Allergy Clin Immunol* 2010;126:179-181.
7. Gotlib J. World Health Organization -defined eosinophilic disorders: 2011 update on diagnosis, risk stratification, and management. *Am J Hematol* 2011;86:677-688.
8. Gauvreau GM, Ellis AK, Denburg JA. Haemopoietic processes in allergic disease: eosinophil/basophil development. *Clin Exp Allergy* 2009;39:1297-1306.
9. Lamkhioed B, Abdelilah SG, Hamid Q, et al. The CCR3 receptor is involved in eosinophil differentiation and is up-regulated by Th2 cytokines in CD34+ progenitor cells. *J Immunol* 2003;170:537-547.
10. Sanderson CJ. Interleukin-5, eosinophils, and disease. *Blood* 1992;79: 3101-3109.
11. Hogan SP, Rosenberg HF, Moqbel R, et al. Eosinophils: biological properties and role in health and disease. *Clin Exp Allergy* 2008;38:709-750.
12. Schleimer RP, Sterbinsky SA, Kaiser J, et al. IL-4 induces adherence of human eosinophils and basophils but not neutrophils to endothelium: association with expression of VCAM-1. *J Immunol* 1992;148:1086-1092.
13. Wardlaw AJ, Moqbel R, Cromwell O, et al. Platelet-activating factor: a potent chemotactic and chemokinetic factor for human eosinophils. *J Clin Invest* 1986;78:1701-1706.

14. Forssman U, Uguccioni M, Loetscher P, et al. Eotaxin-2, a novel CC chemokine that is selective for the chemokine receptor CCR3, and acts like eotaxin on human eosinophil and basophil leukocytes. *J Exp Med* 1997;185:2171-2176.
15. Kameyoshi Y, Dorschner A, Mallet AI, et al. Cytokine RANTES released by thrombin-stimulated platelets is a potent attractant for human eosinophils. *J Exp Med* 1992;176:587-592.
16. Bain BJ, Gilliland DG, Horny H-P, et al. Myeloid and lymphoid neoplasms with eosinophilia and abnormalities of PDGFRA, PDGFRB, or FGFR1. In: Swerdlow S, Harris NL, Stein H, Jaffe ES, Theile J, Vardiman JW, eds. World health organization classification of tumours. Pathology and genetics of tumours of haematopoietic and lymphoid tissues. Lyon, France: IARC Press, 2008:68-73.
17. Bain BJ, Gilliland DG, Horny H-P, et al. Chronic eosinophilic leukaemia, not otherwise specified. In: Swerdlow S, Harris NL, Stein H, Jaffe ES, Theile J, Vardiman JW, eds. World Health Organization classification of tumours. Pathology and genetics of tumours of haematopoietic and lymphoid tissues. Lyon, France: IARC Press, 2008:51-53.
18. Valent P, Klion D, Horny HP, et al. Contemporary consensus proposal on criteria and classification of eosinophilic disorders and related syndromes. *J Allergy Clin Immunol.* 2012;130(3):607-612.
19. Klion AD, Law MA, Riemenschneider W, et al. Familial eosinophilia: a benign disorder? *Blood* 2004;103:4050-4055.
20. Amor B, Rajzbaum G, Poiraudou S, et al. Eosinophilia-myalgia linked with L-tryptophan. *Lancet* 1990;335:420-421.
21. Kilbourne EM, Rigau-Perez JG, Heath CW Jr, et al. Clinical epidemiology of toxic-oil syndrome. Manifestations of a new illness. *N Engl J Med* 1983;209:1408-1414.
22. Cools J, DeAngelo DJ, Gotlib J, et al. A tyrosine kinase created by fusion of the PDGFRA and FIP1L1 genes as a therapeutic target of imatinib in idiopathic hypereosinophilic syndrome. *N Engl J Med* 2003;348:1201-1214.
23. Pardanani A, Ketterling RP, Brockman SR, et al. CHIC2 deletion, a surrogate for FIP1L1-PDGFR fusion, occurs in systemic mastocytosis associated with eosinophilia and predicts response to imatinib mesylate therapy. *Blood* 2003;102:3093-3096.
24. Klion AD, Noel P, Akin C, et al. Elevated serum tryptase levels identify a subset of patients with a myeloproliferative variant of idiopathic hypereosinophilic syndrome associated with tissue fibrosis, poor prognosis, and imatinib responsiveness. *Blood* 2003;101:4660-4666.
25. Reiter A, Walz C, Watmore A, et al. The t(8;9)(p22;p24) is a recurrent abnormality in chronic and acute leukemia that fuses PCM1 to JAK2. *Cancer Res* 2005;65:2662-2667.
26. Vu HA, Xinh PT, Masusa M, et al. FLT3 is fused to ETV6 in a myeloproliferative disorder with hypereosinophilia and a t(12;13)(p13;q12) translocation. *Leukemia* 2006;20:1414-1421.
27. Roufousse F, Cogan E, Goldman M. Recent advances in pathogenesis and management of hypereosinophilic syndromes. *Allergy* 2004;59:673-689.
28. Bank I, Amariglio N, Reshef A, et al. The hypereosinophilic syndrome associated with CD4+CD3-helper type 2 (Th2) lymphocytes. *Leuk Lymphoma* 2001;42:123-133.
29. Simon HU, Plotz SG, Dummer R, Blaser K. Abnormal clones of T cells producing interleukin-5 in idiopathic hypereosinophilia. *N Engl J Med* 1999;341:1112-1120.
30. Brugnani D, Airo P, Tosoni C, et al. CD3-CD4+ cells with a Th2-like pattern of cytokine production in the peripheral blood of a patient with cutaneous T cell lymphoma. *Leukemia* 1997;11:1983-1985.
31. Roumier AS, Gardel N, Lai JL, et al. Hypereosinophilia with abnormal T cells, trisomy 7, and elevated TARC serum level. *Haematologica* 2003;88:ECR24.
32. Roufousse F. Hypereosinophilic syndrome variants: diagnostic and therapeutic considerations. *Haematologica* 2009;94:1188-1193.
33. Cogan E, Schandene L, Crusiaux A, et al. Brief report: clonal proliferation of type 2 helper T cells in a man with the hypereosinophilic syndrome. *N Engl J Med* 1994;330:535-538.
34. Helbig G, Wieczorkiewicz A, Dziaczkowska-Suszek J, et al. T-cell abnormalities are present at high frequencies at high frequencies in patients with hypereosinophilic syndrome. *Haematologica* 2009;94:1236-1241.
35. Buitenhuis M, Verhagen LP, Cools J, et al. Molecular mechanisms underlying FIP1L1-PDGFR-mediated myeloproliferation. *Cancer Res* 2007;67: 3759-3766.

36. Li B, Zhang G, Li C, et al. Identification of JAK2 as a mediator of FIP1L1-PDGFR α -induced eosinophil growth and function in CEL. *PLoS One* 2012;7(4):e34912. Epub 2012 Apr 16.
37. Cools J, Stover EH, Boulton CL, et al. PKC412 overcomes resistance to imatinib in a murine model of FIP1L1-PDGFR α -induced myeloproliferative disease. *Cancer Cell* 2003;3:459-469.
38. Yamada Y, Rothenberg ME, Lee AW, et al. The FIP1L1-PDGFR α fusion gene cooperates with IL-5 to induce murine hypereosinophilic syndrome (HES)/chronic eosinophilic leukemia (CEL)-like disease. *Blood* 2006;107: 4071-4079.
39. Burgstaller S, Kreil S, Waghorn K, et al. The severity of FIP1L1-PDGFR α -positive chronic eosinophilic leukaemia is associated with polymorphic variation at the IL5RA locus. *Leukemia* 2007;21:2428-2432.
40. Golub TR, Goga A, Barker GF, et al. Oligomerization of the ABL tyrosine kinase by the Ets protein TEL in human leukemia. *Mol Cell Biol* 1996;16:4107-4116.
41. Xiao S, McCarthy JG, Aster JC, et al. ZNF198-FGFR1 transforming activity depends on a novel proline-rich ZNF198 oligomerization domain. *Blood* 2000;96:699-704.
42. McWhirter JR, Galasso DL, Wang JY. A coiled-coil oligomerization domain of Bcr is essential for the transforming function of Bcr-Abl oncoproteins. *Mol Cell Biol* 1993;13:7587-7595.
43. Chan PM, Ilangumaran S, La RJ, et al. Autoinhibition of the kit receptor tyrosine kinase by the cytosolic juxtamembrane region. *Mol Cell Biol* 2003;23:3067-3078.
44. Griffith J, Black J, Faerman C, et al. The structural basis for autoinhibition of FLT3 by the juxtamembrane domain. *Mol Cell* 2004;13:169-178.
45. Gilliland DG, Griffin JD. The roles of FLT3 in hematopoiesis and leukemia. *Blood* 2002;100:1532-1542.
46. Heinrich MC, Corless CL, Demetri GD, et al. Kinase mutations and imatinib response in patients with metastatic gastrointestinal stromal tumor. *J Clin Oncol* 2003;21:4342-4349.
47. Stover EH, Chen J, Folens C, et al. Activation of FIP1L1-PDGFR α requires disruption of the juxtamembrane domain of PDGFR α and is FIP1L1-independent. *Proc Natl Acad Sci U S A* 2006;103:8078-8083.
48. Gotlib J, Cools J, Malone JM, et al. The FIP1L1-PDGFR α fusion tyrosine kinase in hypereosinophilic syndrome and chronic eosinophilic leukemia: implications for diagnosis, classification, and management. *Blood* 2004;103: 2879-2891.
49. Elling C, Erben P, Walz C, et al. Novel imatinib-sensitive PDGFR α -activating point mutations in hypereosinophilic syndrome induce growth factor independence and leukemia-like disease. *Blood* 2011;117(10):2935-2943.
50. Pardanani A, Brockman SR, Paternoster SF, et al. FIP1L1-PDGFR α fusion: prevalence and clinicopathologic correlates in 89 consecutive patients with moderate to severe eosinophilia. *Blood* 2004;104:3038-3045.
51. Maric I, Robyn J, Metcalfe DD, et al. KIT D816V-associated systemic mastocytosis with eosinophilia and FIP1L1/PDGFR α -associated chronic eosinophilic leukemia are distinct entities. *J Allergy Clin Immunol* 2007;120:680-687.
52. Metzgeroth G, Walz C, Score J, et al. Recurrent finding of the FIP1L1-PDGFR α fusion gene in eosinophilia-associated acute myeloid leukemia and lymphoblastic T-cell lymphoma. *Leukemia* 2007;21:1183-1188.
53. Greipp PT, Dewald GW, Tefferi A. Prevalence, breakpoint distribution, and clinical correlates of t(5;12). *Cancer Genet Cytogenet* 2004;153:170-172.
54. Meeker TC, Hardy D, Willman C, et al. Activation of the interleukin-3 gene by chromosome translocation in acute lymphoblastic leukemia with eosinophilia. *Blood* 1990;76:285-289.
55. Yagasaki F, Jinnai I, Yoshida S, et al. Fusion of TEL/ETV6 to a novel ACS2 in myelodysplastic syndrome and acute myelogenous leukemia with t(5;12) (q31;p13). *Genes Chromosomes Cancer* 1999;26:192-202.
56. Fauci AS, Harley JB, Roberts WC, et al. The idiopathic hypereosinophilic syndrome. Clinical, pathophysiologic, and therapeutic considerations. *Ann Intern Med* 1982;97:78-92.
57. Ogbogu PU, Bochner BS, Butterfield JH, et al. Hypereosinophilic syndromes: a multicenter, retrospective analysis of clinical characteristics and response to therapy. *J Allergy Clin Immunol* 2009;124:1319-1325.
58. Lefebvre C, Bletry O, Degoulet P, et al. Prognostic factors of hypereosinophilic syndrome. Study of 40 cases. *Ann Med Interne (Paris)* 1989;140:253-257.

59. Spry CJ, Davies J, Tai PC, et al. Clinical features of fifteen patients with the hypereosinophilic syndrome. *Q J Med* 1983;52:1-22.
60. Weller PF, Bublely GJ. The idiopathic hypereosinophilic syndrome. *Blood* 1994;83:2759-2779.
61. Tanino M, Kitamura K, Ohta G, et al. Hypereosinophilic syndrome with extensive myocardial involvement and mitral valve thrombus instead of mural thrombi. *Acta Pathol Jpn* 1983;33:1233-1242.
62. Radford DJ, Garlick RB, Pohlner PG. Multiple valvular replacement for hypereosinophilic syndrome. *Cardiol Young* 2002;12:67-70.
63. Pardanani A, Lim KH, Lasho TL, et al. Prognostically relevant breakdown of 123 patients with systemic mastocytosis associated with other myeloid malignancies. *Blood* 2009;114:3769-3772.
64. Wimazal F, Germing U, Kundi M, et al. Evaluation of the prognostic significance of eosinophilia and basophilia in a larger cohort of patients with myelodysplastic syndromes. *Cancer* 2010;116:2372-2381.
65. Matsushima T, Handa H, Yokohama A, et al. Prevalence and clinical characteristics of myelodysplastic syndrome with bone marrow eosinophilia or basophilia. *Blood* 2003;101:3386-3390.
66. Gotlib J. Molecular classification and pathogenesis of eosinophilic disorders: 2005 update. *Acta Haematol* 2005;114:7-25.
67. Schaller JL, Burkland GA. Case report: rapid and complete control of idiopathic hypereosinophilia with imatinib mesylate. *Med Gen Med* 2001;3:9.
68. Gleich GJ, Leiferman KM, Pardanani A, et al. Treatment of hypereosinophilic syndrome with imatinib mesylate. *Lancet* 2002;359:1577-1578.
69. Ault P, Cortes J, Koller C, et al. Response of idiopathic hypereosinophilic syndrome to treatment with imatinib mesylate. *Leuk Res* 2002;26:881-884.
70. Griffin JH, Leung J, Bruner RJ, et al. Discovery of a fusion kinase in EOL-1 cells and idiopathic hypereosinophilic syndrome. *Proc Natl Acad Sci U S A* 2003;100:7830-7835.
- P.1756
71. Helbig G, Stella-Hołowiecka B, Majewski M, et al. A single weekly dose of imatinib is sufficient to induce and maintain remission of chronic eosinophilic leukaemia in FIP1L1-PDGFRα-expressing patients. *Br J Haematol* 2008;141(2):200-204.
72. Baccarani M, Cilloni D, Rondoni M, et al. The efficacy of imatinib mesylate in patients with FIP1L1-PDGFRα-positive hypereosinophilic syndrome. Results of a multicenter prospective study. *Haematologica* 2007;92: 1173-1179.
73. Jovanovic JV, Score J, Waghorn K, et al. Low-dose imatinib mesylate leads to rapid induction of major molecular responses and achievement of complete molecular remission in FIP1L1-PDGFRα-positive chronic eosinophilic leukemia. *Blood* 2007;109:4635-4640.
74. Klion AD, Robyn J, Maric I, et al. Relapse following discontinuation of imatinib mesylate therapy for FIP1L1/PDGFRα-positive chronic eosinophilic leukemia: implications for optimal dosing. *Blood* 2007;110:3552-3556.
75. Pardanani A, Ketterling RP, Li CY, et al. FIP1L1-PDGFRα in eosinophilic disorders: prevalence in routine clinical practice, long-term experience with imatinib therapy, and a critical review of the literature. *Leuk Res* 2006;30:965-970.
76. Von Bubnoff N, Sandherr M, Schlimok G, et al. Myeloid blast crisis evolving during imatinib treatment of an FIP1L1-PDGFRα-positive chronic myeloproliferative disease with prominent eosinophilia. *Leukemia* 2004;19: 286-287.
77. Ohnishi H, Kandabashi K, Maeda Y, et al. Chronic eosinophilic leukaemia with FIP1L1-PDGFRα fusion and T6741 mutation that evolved from Langerhans cell histiocytosis with eosinophilia after chemotherapy. *Br J Haematol* 2006;134:547-549.
78. Lierman E, Michaux L, Beullens E, et al. FIP1L1-PDGFRα D842V, a novel panresistant mutant, emerging after treatment of FIP1L1-PDGFRα T674I eosinophilic leukemia with single agent sorafenib. *Leukemia* 2009;23: 845-851.

79. von Bubnoff N, Gorantla SP, Engh RA, et al. The low frequency of clinical resistance to PDGFR inhibitors in myeloid neoplasms with abnormalities of PDGFRA might be related to the limited repertoire of possible PDGFRA kinase domain mutations in vitro. *Oncogene* 2011;30:933-943.
80. Lierman E, Folens C, Stover EH, et al. Sorafenib is a potent inhibitor of FIP1L1-PDGFRalpha and the imatinib-resistant FIP1L1-PDGFRalpha T674I mutant. *Blood* 2006;108:1374-1376.
81. Stover EH, Chen J, Lee BH, et al. The small molecule tyrosine kinase inhibitor AMN107 inhibits TEL-PDGFRbeta and FIP1L1-PDGFRalpha in vitro and in vivo. *Blood* 2005;106:3206-3213.
82. von Bubnoff N, Gorantla SP, Thone S, et al. The FIP1L1-PDGFR T674I mutation can be inhibited by the tyrosine kinase inhibitor AMN107 (nilotinib). *Blood* 2006;107:4970-4971.
83. Metzgeroth G, Erben P, Martin H, et al. Limited clinical activity of nilotinib and sorafenib in FIP1L1-PDGFR positive chronic eosinophilic leukemia with imatinib-resistant T674I mutation. *Leukemia* 2012;26:162-164.
84. Salemi S, Yousefi S, Simon D, et al. A novel FIP1L1-PDGFR mutant destabilizing the inactive conformation of the kinase domain in chronic eosinophilic leukemia/hypereosinophilic syndrome. *Allergy* 2009;64:913-918.
85. Cross DM, Cross NC, Burgstaller S, et al. Durable responses to imatinib in patients with PDGFRB fusion gene-positive and BCR-ABL-negative chronic myeloproliferative disorders. *Blood* 2007;109:61-64.
86. Pardananani A, Reeder T, Porrata L, et al. Imatinib therapy for hypereosinophilic syndrome and other eosinophilic disorders. *Blood* 2003;101:3391-3397.
87. Pitini V, Arrigo C, Azzarello D, et al. Serum concentration of cardiac troponin T in patients with hypereosinophilic syndrome treated with imatinib is predictive of adverse outcomes. *Blood* 2003;102:3456-3457.
88. Chen J, DeAngelo DJ, Kutok JL, et al. PKC412 inhibits the zinc finger 198-fibroblast growth factor receptor 1 fusion tyrosine kinase and is active in treatment of stem cell myeloproliferative disorder. *Proc Natl Acad Sci U S A* 2004;101:14479-14484.
89. Walz C, Erben P, Ritter M, et al. Response of ETV6-FLT3-positive myeloid/lymphoid neoplasm with eosinophilia to inhibitors of FMS-like tyrosine kinase 3. *Blood* 2011;118:2239-2242.
90. Quiquandon I, Claisse JF, Capiod JC, et al. Alpha-interferon and hypereosinophilic syndrome with trisomy 8: karyotypic remission. *Blood* 1995;85: 2284-2285.
91. Luciano L, Catalano L, Sarrantonio C, et al. α IFN-induced hematologic and cytogenetic remission in chronic eosinophilic leukemia with t(1;5). *Haematologica* 1999;84:651-653.
92. Yamada O, Kitahara K, Imamura K, et al. Clinical and cytogenetic remission induced by interferon- α in a patient with chronic eosinophilic leukemia associated with a unique t(3;9;5) translocation. *Am J Hematol* 1998;58:137-141.
93. Malbrain ML, Van den Bergh H, Zachee P. Further evidence for the clonal nature of the idiopathic hypereosinophilic syndrome: complete haematological and cytogenetic remission induced by interferon-alpha in a case with a unique chromosomal abnormality. *Br J Haematol* 1996;92:176-183.
94. Butterfield JH, Gleich GJ. Response of six patients with idiopathic hypereosinophilic syndrome to interferon alpha. *J Allergy Clin Immunol* 1994;94: 1318-1326.
95. Ceretelli S, Capochiani E, Petrini M. Interferon-alpha in the idiopathic hypereosinophilic syndrome: consideration of five cases. *Ann Hematol* 1998;77:161-164.
96. Yoon TY, Ahn GB, Chang SH. Complete remission of hypereosinophilic syndrome after interferon-alpha therapy: report of a case and literature review. *J Dermatol* 2000;27:110-115.
97. Jabbour E, Kantarjian H, Cortes J, et al. PEG-IFN-a-2b therapy in BCR-ABL-negative myeloproliferative disorders. Final result of a phase 2 study. *Cancer* 2007;110:2012-2018.
98. Kiladjian JJ, Cassinat B, Chevret S, et al. Pegylated interferon-alpha-2a induces complete hematologic and molecular responses with low toxicity in polycythemia vera. *Blood* 2008;112:3065-3072.
99. Quintas-Cardama A, Kantarjian H, Manshour T, et al. Pegylated interferonalpha-2a yields high rates of hematologic and molecular response in patients with advanced essential thrombocythemia and polycythemia vera. *J Clin Oncol* 2009;27:5418-5424.
100. Chusid MJ, Dale DC. Eosinophilic leukemia. Remission with vincristine and hydroxyurea. *Am J Med* 1975;59:297-300.

101. Cofrancesco E, Cortellaro M, Pogliani E, et al. Response to vincristine treatment in a case of idiopathic hypereosinophilic syndrome with multiple clinical manifestations. *Acta Haematol* 1984;72:21-25.
102. Sakamoto K, Erdreich-Epstein A, deClerck Y, et al. Prolonged clinical response to vincristine treatment in two patients with hypereosinophilic syndrome. *Am J Pediatr Hematol Oncol* 1992;14:348-351.
103. Lee JH, Lee JW, Jang CS, et al. Successful cyclophosphamide therapy in recurrent eosinophilic colitis associated with hypereosinophilic syndrome. *Yonsei Med J* 2002;43:267-270.
104. Smit AJ, van Essen LH, de Vries EG. Successful long-term control of idiopathic hypereosinophilic syndrome with etoposide. *Cancer* 1991;67:2826-2827.
105. Bourrat E, Lebbe C, Calvo F. Etoposide for treating the hypereosinophilic syndrome. *Ann Intern Med* 1994;121:899-900.
106. Ueno NT, Zhao S, Robertson LE, et al. 2-chlorodeoxyadenosine therapy for idiopathic hypereosinophilic syndrome. *Leukemia* 1997;11:1386-1390.
107. Jabbour E, Verstovsek S, Giles F, et al. 2-chlorodeoxyadenosine and cytarabine combination therapy for idiopathic hypereosinophilic syndrome. *Cancer* 2005;104:541-546.
108. Zabel P, Schlaak M. Cyclosporine for hypereosinophilic syndrome. *Ann Hematol* 1991;62:230-231.
109. Nadarajah S, Krafchik B, Roifman C, et al. Treatment of hypereosinophilic syndrome in a child using cyclosporine: implication for a primary T-cell abnormality. *Pediatrics* 1997;99:630-633.
110. Butterfield JH. Success of short-term, higher-dose imatinib mesylate to induce clinical response in FIP1L1-PDGFRalpha-negative hypereosinophilic syndrome. *Leuk Res* 2009;33:1127-1129.
111. Verstovsek S, Tefferi A, Kantarjian H, et al. Alemtuzumab therapy for hypereosinophilic syndrome and chronic eosinophilic leukemia. *Clin Cancer Res* 2009;15:368-373.
112. Hart TK, Cook RM, Zia-Amirhosseini P, et al. Preclinical efficacy and safety of mepolizumab (SB-240563), a humanized monoclonal antibody to IL-5, in cynomolgus monkeys. *J Allergy Clin Immunol* 2001;108:250-257.
113. Rothenberg ME, Klion AD, Roufosse FE, et al. Treatment of patients with the hypereosinophilic syndrome with mepolizumab. *New Engl J Med* 2008;358:1215-1228.
114. Vazquez L, Caballero D, Canizo CD, et al. Allogeneic peripheral blood cell transplantation for hypereosinophilic syndrome with myelofibrosis. *Bone Marrow Transplant* 2000;25:217-218.
115. Chockalingam A, Jalil A, Shadduck RK, Lister J. Allogeneic peripheral blood stem cell transplantation for hypereosinophilic syndrome with severe cardiac dysfunction. *Bone Marrow Transplant* 1999;23:1093-1094.
116. Basara N, Markova J, Schmetzer B, et al. Chronic eosinophilic leukemia: successful treatment with an unrelated bone marrow transplantation. *Leuk Lymphoma* 1998;32:189-193.
117. Sigmund DA, Flessa HC. Hypereosinophilic syndrome: successful allogeneic bone marrow transplantation. *Bone Marrow Transplant* 1995;15:647-648.
118. Esteva-Lorenzo FJ, Meehan KR, Spitzer TR, et al. Allogeneic bone marrow transplantation in a patient with hypereosinophilic syndrome. *Am J Hematol* 1996;51:164-165.
119. Sadoun A, Lacotte L, Delwail V, et al. Allogeneic bone marrow transplantation for hypereosinophilic syndrome with advanced myelofibrosis. *Bone Marrow Transplant* 1997;19:741-743.
120. Juvonen E, Volin L, Kopenen A, et al. Allogeneic blood stem cell transplantation following non-myeloablative conditioning for hypereosinophilic syndrome. *Bone Marrow Transplant* 2002;29:457-458.
121. Ueno NT, Anagnostopoulos A, Rondon G, et al. Successful non-myeloablative allogeneic transplantation for treatment of idiopathic hypereosinophilic syndrome. *Br J Haematol* 2002;119:131-134.
122. Halaburda K, Prejzner W, Szatkowski D, et al. Allogeneic bone marrow transplantation for hypereosinophilic syndrome: long-term follow-up with eradication of FIP1L1-PDGFR fusion transcript. *Bone Marrow Transplant* 2006;319-320.
123. Harley JB, McIntosh XL, Kirklin JJ, et al. Atrioventricular valve replacement in the idiopathic hypereosinophilic syndrome. *Am J Med* 1982;73:77-81.

124. Hendren WG, Jones EL, Smith MD. Aortic and mitral valve replacement in idiopathic hypereosinophilic syndrome. *Ann Thorac Surg* 1988;46: 570-571.
125. Cameron J, Radford DJ, Howell J, et al. Hypereosinophilic heart disease. *Med J Aust* 1985;143:408-410.
126. Weyman AE, Rankin R, King H. Loeffler's endocarditis presenting as mitral and tricuspid stenosis. *Am J Cardiol* 1977;40:438-444.
127. Chandra M, Pettigrew RI, Eley JW, et al. Cine-MRI-aided endomyocardectomy in idiopathic hypereosinophilic syndrome. *Ann Thorac Surg* 1996;62: 1856-1858.
128. Moore PM, Harley JB, Fauci AS. Neurologic dysfunction in the idiopathic hypereosinophilic syndrome. *Ann Intern Med* 1985;102:109-114.
129. Johnston AM, Woodcock BE. Acute aortic thrombosis despite anticoagulant therapy in idiopathic hypereosinophilic syndrome. *J R Soc Med* 1998;91: 492-493.

Chapter 85 Systemic Mastocytosis

> Table of Contents > Part VII - Hematologic Malignancies > Section 3 - Myeloproliferative Disorders > Chapter 85 - Systemic Mastocytosis

Chapter 85

Systemic Mastocytosis

Dean D. Metcalfe

HISTORICAL BACKGROUND

Mastocytosis is a heterogeneous disease characterized by the abnormal growth and accumulation of mast cells in one or more organs. The first case of mastocytosis was reported in 1869 by Nettleship and Tay under the heading of “rare forms of urticaria.” Cutaneous lesions were described as “brown cutaneous lesions that wheal after scratching”¹ and were termed urticaria pigmentosa (UP) 1 year after this initial description.² The association between mast cells and mastocytosis was made in 1887, when Unna found that UP lesions were characterized by an increased number of mast cells in the dermis.³

Subsequent appreciation of the full clinical spectrum of these disorders has identified variants of mastocytosis that involve mast cell infiltration of visceral organs, and these forms of disease have collectively been termed systemic mastocytosis (SM).⁴ It is now accepted that SM may present with or without skin lesions and may show an indolent or aggressive clinical course, in some cases complicated by concomitant emergence of a clonal non-mast cell lineage disorder, such as one of the myeloproliferative disorders or myelodysplastic syndromes. This has led to further classification of mastocytosis based on hematologic findings, molecular markers, and serum levels of biomarkers like tryptase and the cluster designation (CD) markers such as CD25, thereby grouping patients into better-defined clinical categories, which have been adopted by the World Health Organization (WHO).⁵

PATHOPHYSIOLOGY

The current understanding of the etiology of mastocytosis has evolved from concentrated research efforts in the 1990s that linked two key factors controlling mast cell growth and activity—stem cell factor (SCF) and the SCF receptor, KIT, and disruption of the normal function of KIT through activating mutations.⁶

Mastocytosis is thus recognized in the majority of cases to represent a clonal disorder of a pluripotent hematopoietic progenitor cell with the most common mutation consisting of an activating mutation at codon 816 in KIT.^{6, 7, 8} and⁹ This precursor is believed to be more primitive than precursors committed to either the neutrophil/macrophage or erythroid cell lineages, with the affected clone showing variable expansion in these lineages in the peripheral blood of patients with SM.¹⁰ Thus, mastocytosis in such cases represents a somatic cell disorder that is confined to hematopoietic lineages. Although T and B cells of such mastocytosis patients carry a codon 816 mutation (such as D816V), unlike mast cells, these cells do not express surface KIT when mature, and thus may be less susceptible to the biologic effects of constitutively activated KIT.

Early research efforts in the area of mast cell biology concentrated on identifying the key biochemical pathways and mediators that accounted for the clinical sequelae seen in physiologic processes due to mast cell activation, including anaphylaxis and allergic diseases. Subsequent work by Kitamura et al.^{11,12} focused on murine models of mast cell

deficiency via studies on mice that exhibited abnormal Kit (W/W^v mice)¹¹ and laid the foundation for suggesting the pathophysiologic basis of human mastocytosis as compromising dysfunction at the c-kit-SCF axis.¹² Two predominant hypotheses thus emerged regarding the etiology of mastocytosis: (a) mastocytosis as a result of local overproduction of soluble SCF and (b) mastocytosis as a result of mutations in KIT and downstream signaling molecules that lead to cell proliferation. Over time, with the lack of evidence of overproduction of SCF in tissues¹³ and with the identification of the D816V mutation in KIT in patients with mastocytosis,⁶ the second hypothesis rose to prominence.

Human mast cells normally reside in tissues associated with epithelial surfaces, blood vessels, nerves, and glands, and are derived from CD34⁺ pluripotential progenitor cells.^{14,15} Except for a population of mast cells that reside in the bone marrow, mast cells complete maturation in peripheral tissues. During this maturation, mast cells downregulate CD34, but continue to express cell-surface CD117.^{14,15,16} Under normal physiologic conditions, mast cells and mast cell progenitors do not or only minimally express CD2, CD25, or CD35 on their cell surface. This expression pattern, however, is altered in most patients with mastocytosis.¹⁷

The KIT mutation D816V or another similar activating mutation in KIT is found in the majority of adults with SM. However, this single mutation cannot alone explain the multiple variants of mastocytosis. In one hypothesis, c-kit D816V would play an important and possibly causative role in indolent mastocytosis, where the pathologic hallmark is mast cell differentiation and clustering without signs of substantial proliferation. More advanced cases of mastocytosis would then require additional genetic defects not specific to mastocytosis; for example, a mutation in TET2 or NRAS¹⁸ that would contribute to the excessive proliferation of mast cell progenitors.

Human mast cells are heterogeneous in terms of morphologic, biochemical, and functional characteristics. These differences correlate with differences in their anatomic locations and, when perturbed in function, associate with specific clinical signs and symptoms. Clinical sequelae of mastocytosis are thus not only the result of organ infiltration, but also the result of mast cell mediator release from spontaneous or induced mechanisms.

Mast cells are deemed to be long-lived cells, though it appears that at least some mast cells may proliferate locally in tissues in response to inflammatory or repair processes. In tissue sections, mast cells typically appear as either round or elongated cells, usually with a nonsegmented nucleus with moderate condensation of nuclear chromatin, and contain prominent cytoplasmic granules and lipid bodies. The cytoplasmic granules of mast cells contain heparin and chondroitin sulfate proteoglycans covalently linked to a protein core. Under appropriate conditions, the proteoglycan complexes stain metachromatically with basic dyes.

Human mast cells are characterized primarily as either mucosal or connective tissue mast cells, the former being located at mucosal locations, such as the lamina propria of the gastrointestinal (GI) tract, and containing a specific tryptase (thus a "T-type" mast cell). The latter are more commonly found near the epithelial surface of the skin and respiratory, GI, and genitourinary tracts and containing both tryptase and a chymotryptase (CT mast cells).¹⁹ Human mast cell granules also contain such biologically active molecules as tumor necrosis factor- α , histamine, acid hydrolases, cathepsin G, and carboxypeptidase.²⁰ They are activated by a number of stimuli that are both Fc ϵ RI dependent and Fc ϵ RI independent. After activation, mast cells immediately release granule-associated mediators and generate lipid-derived substances that induce immediate allergic responses. Together, these mediators are deemed responsible for many of the clinical sequelae of the immediate hypersensitivity reaction, including pruritus, flushing, palpitations, and lightheadedness, also commonly reported in patients with mastocytosis.

P.1758

Major lipid mediators produced on appropriate activation via immunoglobulin E (IgE) or non-IgE stimuli include prostaglandin D₂ and leukotriene C₄.³¹ Mast cell activation is followed hours later by the synthesis and release of additional chemokines and cytokines, which then contribute to chronic inflammation. Growth factors and cytokines reported to be synthesized and released from mast cells include basic fibroblast growth factor, nerve growth factor, tumor necrosis factor, granulocyte-macrophage colony-stimulating factor, vascular endothelial growth factor, interleukin-1 (IL-1), IL-2, IL-3, IL-4, IL-5, IL-6, IL-8, IL-9, IL-10, IL-13, and IL-16.^{19,21}

Studies performed in rodents, nonhuman primates, and humans have shown that many aspects of mast cell development are critically regulated by SCF, produced by such cells as endothelial cells, fibroblasts, and mast cells.^{19,21,22} SCF has been shown to work in concert with other growth factors, such as IL-3, IL-4, IL-5, IL-6, IL-9, and nerve growth factor, to induce optimal mast cell precursor proliferation and survival.^{14,15,20} SCF has also been reported to be present in the lesional skin of patients with UP²³ but was not identified in blister fluids¹³ and has been reported within neoplastic mast cells.²⁴ SCF

augments mast cell mediator release in response to stimulation by IgE and antigen.²² Cells bearing mutated KIT on their surface have been shown to have an increased chemotactic response toward SCF.²⁵ SCF may influence the aggregation of mast cells leading to mast cell lesions as found in SM within marrow.

The binding of SCF to KIT induces dimerization, with activation of intrinsic tyrosine kinase activity and phosphorylation of the receptor. This in turn leads to exposure of specific recognition motifs for intracellular binding proteins containing Src homology (SH2) domains such as phospholipase C γ -1, phosphatidylinositol-3' kinase, mitogen-activated kinase, and Ras protein.^{20,26} Activating or gain-of-function mutations in KIT are associated with constitutive tyrosine kinase activation and ligand-independent autophosphorylation of KIT, thereby giving affected mast cells a survival advantage over wild-type cells.^{20,27,28,29}

The D816V mutation was first reported in patients with mastocytosis in the peripheral blood mononuclear cells (PBMCs) of adult patients with mastocytosis with an associated hematologic disorder and in patients with persistent mastocytosis and extensive disease,^{6,7,29} but codon 816 mutations (D816Y and D816H) have been shown to be present in UP lesions of adults and in a subset of pediatric patients with more severe mastocytosis.^{6,7,30} An E839K mutation has been reported in skin lesions of some pediatric patients with mastocytosis.³¹ Exceedingly rare KIT mutations, which are reported to be present in less than 1% of patients with mastocytosis, include R815K, D820G, V533D, V559A, del419, K509I, and A533D.^{32,33} KIT-dependent downstream signaling events including the JAK-STAT pathway may magnify the consequences of mutations in KIT.³² In addition to D817V, the V560G mutation within the juxtamembrane domain of KIT was detected in the human mast cell leukemia (MCL) cell line HMC-1,³⁴ the E839K-dominant inactivating mutation in several reported cases of pediatric mastocytosis, and the rare germline mutation F522C.^{27,35} Thus far, somewhat different mutation patterns appear to be emerging for adult- versus pediatric-onset mastocytosis, which may explain the differences in presentation and clinical course for these two different patient populations.

Irrespective of effects on KIT, inhibition of mast cell apoptosis through other biologic pathways may also contribute to the pathogenesis of mastocytosis. A subset of SM patients with associated eosinophilia and increased serum tryptase levels has been described; these patients carry the Fip1-like-1-platelet-derived growth factor receptor- α (FIP1L1-PDGFR α) fusion oncogene in pluripotent hematopoietic progenitor cells, which results from an approximately 800-kb interstitial deletion of chromosome 4q12.³⁶ Similarly, a rare case of SM and chronic basophilic leukemia was found secondary to a PRKG2-PDGFRB fusion.³⁷ A polymorphism in the gene for the IL-4 receptor α -chain has been shown to be associated with less extensive mast cell involvement, with disease usually localized to the skin.³⁸ In addition, the bone marrow cells of patients with mastocytosis have been found to constitutively express the antiapoptotic proteins Bcl-XL and Bcl-2,³⁹ which may explain the long survival of these cells and perhaps their resistance to chemotherapy-induced apoptosis.

Additional studies using gene expression analysis of bone marrow mononuclear cells derived from patients with indolent SM revealed that, compared with healthy controls, patients with mastocytosis displayed a highly consistent profile with 168 genes that were significantly up- or downregulated in patient samples.⁴⁰ Further analysis using such microarray technology will be useful to identify candidate genes distinguishing patient groups showing divergent clinical behavior.

Consistent with the progressive genetic instability that is often described in other human tumors, increased chromosomal abnormalities unrelated to the KIT locus have been detected in patients with more malignant forms of mastocytosis, and new abnormalities may appear in a subset of such patients on disease progression.⁴¹ No recurrent patterns of chromosomal changes have been consistently reported in patients with SM. The implications of these findings are that, at least in some patients with mastocytosis, the etiology of their disease may encompass a broader chromosomal problem of genetic instability. For instance, tumor mast cell lines express persistently high telomerase activity throughout the cell cycle which does not appear to be dependent on intracellular signals or cell replication, in contrast to normal human progenitor mast cells that experience transient induction of telomerase activity that is dependent on growth factor-mediated signals such as SCF-, IL-3-, and IL-6-mediated p38 mitogen-activated kinase and phosphatidylinositol-3' kinase.⁴²

CLINICAL FEATURES

The clinical manifestations of mastocytosis are diverse and may be divided into those that are systemic or localized.^{20,31,33} Systemic effects of this disorder result from the release of significant amounts of mast cell mediators into the circulation. Clinical signs and symptoms that comprise systemic mediator release are those reported with anaphylaxis and include flushing, pruritus, hypotension, syncope, palpitations, and tachycardia. GI symptoms are commonly associated with mastocytosis and include nausea, vomiting, abdominal cramping, bloating, and/or diarrhea. Peptic ulcer disease, which appears to reflect at least partially increased gastric acid secretion due to hyperhistaminemia, may occur in up to 50% of patients with systemic disease.⁴³ Malabsorption, though less common, tends to be mild and may occur in those with progressive disease. Local sequelae of mastocytosis are largely due to the effects of mast cell collections at specific organ

sites and may result in severe end-organ dysfunction due to infiltration of normal tissue with mast cells and subsequent fibrosis (e.g., end-stage liver disease due to fibrosis and bone marrow failure).

For some patients, in particular those with advanced disease or with an associated hematologic disorder, the most bothersome complaints include severe and nonspecific constitutional symptoms of fatigue, weakness, anorexia, weight loss, low-grade fevers, night sweats, musculoskeletal pain, headaches, depression, altered attention span, irritability, and even subtle cognitive deficits such as mild memory loss. Some of these symptoms are attributable to ongoing chronic disease, whereas others may in part be a result of the central nervous system effects of mast cell mediators.

Attacks in some individuals are precipitated by stimuli such as heat, cold, pressure, alcohol, medications (e.g., opiates, non-steroidal antiinflammatory agents, and estrogens), radiocontrast agents, and venoms. Reactions may be more severe in such patients (e.g., anaphylaxis after hymenoptera stings) because of an expanded mast cell population.^{21,44} Patients with aggressive disease also often present with lymphadenopathy, splenomegaly,

P.1759

or hepatomegaly that may or may not be symptomatic. One of the most difficult clinical scenarios of mastocytosis from a management perspective is the treatment of severe musculoskeletal pain and/or pathologic fractures due to the osteoporosis that results from release of mast cell mediators and/or an expanding marrow compartment with active proliferation of mast cells. Besides local disruption of normal bone architecture, mast cell infiltration of bone may cause bone loss due to the secretion of heparin, IL-6, proteases, and mediators, and from their paracrine effects on osteoclast function.

The most frequently involved organs in SM are the skin, bone marrow, lymph nodes, spleen, liver, and GI tract. The lungs are usually spared in mastocytosis. Atopy (e.g., eczema, allergic rhinitis) and airway hyperreactivity (e.g., asthma) are not generally features of this disease.

Mastocytosis is one of eight subcategories of myeloproliferative neoplasms in the 2008 WHO classification of tumors of hematopoietic and lymphoid tissues.⁵ The criteria for the diagnosis of cutaneous and SM adopted by the WHO are provided in Table 85.1. The diagnosis of SM requires that one major and one minor criterion or three minor criteria be present. WHO Criteria for variants of SM are provided in Table 85.2.

The prognosis of patients with adult mastocytosis is dependent on the extent of disease and presence of an associated hematologic disorder. Patients with ISM tend to remain within this category of disease, although a subset will progress to more aggressive forms of disease such as SM-AHNMD (associated non-mast cell lineage clonal hematologic disorder with systemic mastocytosis). For children with isolated UP, at least 50% of cases are reported to resolve by adulthood.⁴⁵

Patients with SM-AHNMD have a course

P.1760

that depends largely on the prognosis of the specific hematologic disorder and response to aggressive therapy.²⁰ The mean survival time for patients with MCL is usually less than 12 months, although the prognosis is improving with the use of newer tyrosine kinase inhibitors. The survival time with aggressive systemic mastocytosis (ASM) is 2 to 4 years with aggressive management. Variables strongly associated with poor survival in adult patients include advanced age, weight loss, anemia, thrombocytopenia, hypoalbuminemia, and excess bone marrow blasts.⁴⁶

TABLE 85.1 WORLD HEALTH ORGANIZATION DIAGNOSTIC CRITERIA FOR CUTANEOUS AND SYSTEMIC MASTOCYTOSIS

Cutaneous mastocytosis (CM)

Typical clinical findings of urticaria pigmentosa (UP)/maculopapular cutaneous mastocytosis (MPCM), diffuse cutaneous mastocytosis (DCM), or solitary mastocytoma, and typical infiltrates of mast cells in a multifocal or diffuse pattern on skin biopsy.

Systemic mastocytosis (SM)

The diagnosis of SM is made if one major and one minor criterion are present, or if three minor criteria are met.

Major criterion

Multifocal, dense infiltrates of mast cells (15 or more in aggregates) detected in sections of bone

marrow and/or another extracutaneous organ, and confirmed by tryptase immunohistochemistry or other special stains.

Minor criteria

- In biopsy sections of bone marrow or other extracutaneous organs, more than 25% of the mast cells in the infiltrate are spindle-shaped or have atypical morphology, or, of all mast cells in bone marrow aspirate smears, more than 25% are immature or atypical mast cells.
- Detection of an activating point mutation at codon 816 of *KIT* in bone marrow, blood, or another extracutaneous organ.
- Mast cells in bone marrow, blood, or another extracutaneous organ express CD117 with CD2 and/or CD25.
- Serum total tryptase persistently greater than 20 ng/ml in the absence of an associated clonal myeloid disorder.

WHO, World Health Organization.

TABLE 85.2 WORLD HEALTH ORGANIZATION CRITERIA FOR VARIANTS OF SYSTEMIC MASTOCYTOSIS

Indolent systemic mastocytosis (ISM)

Meets criteria for SM (see [Table 88.1](#)). No “C” findings (see below). No evidence of an associated non-mast cell lineage clonal hematologic disorder (AHNMD). In this variant, the mast cell burden is low and skin lesions are usually present.

- Bone marrow mastocytosis

As above for ISM with bone marrow involvement, but no skin lesions.

- Smoldering systemic mastocytosis

As above for ISM, but with two or more “B” findings and no “C” findings.

Systemic mastocytosis with associated clonal, hematologic non-mast cell lineage disease (SM-AHNMD)

Meets criteria for SM and criteria for an associated, clonal hematologic non-mast cell lineage disorder, AHNMD (MDS, MPN, AML, lymphoma, or other hematologic neoplasm that meets the criteria for a distinct entity in the WHO classification).

Aggressive systemic mastocytosis (ASM)

Meets criteria for SM with one or more “C” findings. No evidence of mast cell leukemia. Usually without skin lesions.

- Lymphadenopathic mastocytosis with eosinophilia

Progressive lymphadenopathy with peripheral blood eosinophilia, often with extensive bone involvement, and hepatosplenomegaly, but usually without skin lesions. Cases with rearrangement of *PDGFRA* are excluded.

Mast cell leukemia (MCL)

Meets criteria for SM. Bone marrow biopsy shows a diffuse infiltration by atypical, immature mast cells. Bone marrow aspirate smears show 20% or more mast cells. Mast cells account for 10% or more of peripheral white blood cells. Variant: leukemic mast cell leukemia as above, but less than 10% of white blood cells are mast cells. Usually without skin lesions.

Mast cell sarcoma (MCS)

Unifocal mast cell tumor. No evidence of SM. Destructive growth pattern. High-grade cytology.

Extracutaneous mastocytoma

Unifocal mast cell tumor. No evidence of SM. No skin lesions. Non-destructive growth pattern. Low-grade cytology

“B” findings

1. Bone marrow biopsy showing greater than 30% infiltration by mast cells (focal, dense aggregates) and/or serum total tryptase level greater than 200 ng/ml.
2. Signs of dysplasia or myeloproliferation in non-mast cell lineages, but insufficient criteria for definitive diagnosis of a hematopoietic neoplasm with normal or slightly abnormal blood counts.
3. Hepatomegaly without impairment of liver function, and/or palpable splenomegaly without hypersplenism, and/or lymphadenopathy.

“C” findings

1. Bone marrow dysfunction manifested by one or more cytopenia (ANC $<1.0 \times 10^9/L$, Hb <10 g/dl, or platelets $<100 \times 10^9/L$), but no obvious non-mast cell hematopoietic malignancy.
2. Palpable hepatomegaly with impairment of liver function, ascites, and/or portal hypertension.
3. Skeletal involvement with large osteolytic lesions and/or pathologic fractures.
4. Palpable splenomegaly with hypersplenism.
5. Malabsorption with weight loss due to GI mast cell infiltrates.

“WHO, World Health Organization.

Cutaneous Mastocytosis

Cutaneous mastocytosis is composed of three distinct clinical variants: UP/maculopapular cutaneous mastocytosis, solitary mastocytoma, and diffuse-erythrodermic disease, also known as diffuse cutaneous mastocytosis (DCM) (Table 85.1). UP is further subcategorized into four subvariants: Typical UP, a plaque form, a nodular form, and telangiectasia macularis eruptiva perstans (TMEP).⁵

The classic lesions of cutaneous mast cell disease are UP, which consist of reddish-brown macules, papules, or plaques that urticate (i.e., form a wheal and erythema with a distinct border when stroked [a positive Darier sign]). However, in a number of patients, cutaneous lesions are lacking, and other organs, particularly the bone marrow, when biopsied, support the diagnosis of SM.

UP lesions tend to occur in a generalized distribution, most commonly occurring over the trunk and generally sparing the face, scalp, palms, and soles. When abundant, they may form a cobblestone appearance. There appears to be no sex predilection or familial pattern of cutaneous disease, though mastocytosis of one form or another has been described in families, including several sets of twins.⁴⁵

Histologically, UP lesions are composed of a collection of mast cells within the papillary dermis with variable extension throughout the reticular dermis and into the subcutaneous fat. An increase in dermal mast cells ≥ 10 times that of normal skin, in the absence of other pathology, is highly suggestive of UP.^{45,47} Petechiae, ecchymoses, and telangiectasias may be present in or adjacent to UP lesions. Blister formation and hemorrhage may occur, particularly in infants and young children. This complication is presumed to occur due to high local levels of mediators released from mast cells, but why this younger age group is more adversely affected is unknown. After age 10 years, vesicles do not generally occur, and UP lesions tend to be smaller and more numerous. Onset of UP lesions tends to follow a biphasic curve, with one peak at 2.5 months of age and another at 26.5 years.⁴⁷ Of pediatric patients in whom UP occurs, approximately half lose these lesions by adolescence. The remaining patients generally have lighter macular lesions at previously involved sites. Pruritus is the most common symptom that accompanies UP. Approximately 15% to 30% of pediatric patients whose skin lesions persist into adulthood progress to develop SM.⁴⁸

Although UP in adults may persist indefinitely, a subset of patients, estimated from 7% to 19% in published series, experience fading or resolution of cutaneous lesions over time.⁴⁹ Regression of UP in patients with indolent SM (ISM) appears to parallel a decrease in disease severity in terms of constitutional symptoms, although bone marrow findings of ISM remain. In contrast, disappearance of lesions in patients with an associated hematologic disorder may herald progression of disease, with more severe bone marrow pathology noted on follow-up biopsies. The absence or presence of the Asp816Val mutation in PBMCs did not predict the course of UP. Disease progression in patients with SM-AHNMD is therefore better monitored with serum tryptase levels and bone marrow biopsy findings than with changes in the number, distribution, or intensity of skin lesions.

DCM is a less frequent cutaneous manifestation and generally presents before the age of 3 years. It is characterized by a diffuse mast cell infiltration of the dermis and thus the entire skin is generally involved. DCM presents as a yellow-red-brown discoloration with a peau d'orange appearance, or as a generalized erythroderma in which severe edema gives the skin a doughy appearance. Additionally, yellow-cream-colored papules have been described that resemble xanthomas and pseudoxanthoma elasticum.⁴⁷ Only rarely does skin appear superficially normal in DCM. Dermatographism and formation of hemorrhagic blisters may occur. GI manifestations, such as diarrhea, flushing, and hypotension, may be associated, and such patients have an increased risk for more serious clinical sequelae such as shock, significant GI bleeding, and death. DCM may resolve spontaneously by age 5 to 15 months, but when persistent, the skin may remain thickened and doughy and recalcitrant to treatment. Solitary mastocytomas are considered a variant of cutaneous mastocytosis that may present at birth or more commonly within the first 3 months of age, with spontaneous involution during childhood.^{45,47} They are only rarely described in adults. They present as macules, plaques, or nodules and are formed by dermal collections of mast cells without cellular atypia. They are most commonly seen on the extremities and may involve the palms or soles. When systemic symptoms are present, they most commonly involve flushing.

TMEP is a rare form of cutaneous mastocytosis (<1% of cases) that is thought to usually be limited to the skin and only reported in adults. Select cases with concomitant splenomegaly, increased mast cells in the bone marrow, and abnormal skeletal radiographs suggest that this form of cutaneous disease may have systemic features.^{47,50} The characteristic skin lesion in TMEP is a telangiectatic, red macule on a tan-brown background. Individual lesions are 2 to 6 mm in diameter and are without sharply defined borders. Pruritus, purpura, and blister formation are not generally associated with TMEP, though lesions may become edematous when rubbed. Occasionally, these lesions are found to coexist with UP.

Indolent Systemic Mastocytosis

ISM is characterized by mast cell involvement at various organ sites, although significant organ dysfunction (C findings) is usually absent, and prognosis in these patients is generally good. In most cases, clonal mast cells express CD2 and/or CD25 surface markers and contain the D816V mutation. The bone marrow is the most common site of extracutaneous mastocytosis, with the vast majority of adult patients with indolent disease demonstrating bone marrow mast cell infiltration.^{51,52,53,54} The criteria for diagnosis of ISM are provided in Table 85.2.⁵

Characteristic bone marrow lesions of SM consist of focal dense, mixed, diffuse dense, or diffuse interstitial aggregates of mast cells, with differing histopathologic patterns of mast cell infiltration of the bone marrow related to differing prognoses and subtype of mastocytosis.⁶ Focal infiltrates are frequently observed in paratrabeular and perivascular areas and may be associated with adjacent lymphoid or eosinophil aggregates, or both.⁵⁵ Mast cells in these patients show characteristic cytologic abnormalities, including cytoplasmic surface projections, eccentric oval nuclei, and a hypogranulated cytoplasm (atypical mast cell type I).⁵ A representative bone marrow aspirate from a patient with ISM with characteristic morphologic features compared with a control bone marrow aspirate is shown in Figure 85.1. Clonal mast cells generally express CD2 or CD25, or both, on their cell surface, and the D816V mutation.^{5,17,52} The bone marrow lesions of SM may contain a mixed population of B and T cells, in addition to mast cells identified by antitryptase staining. The histopathology of these lymphoid aggregates is similar to benign lymphoid aggregates associated with reactive bone marrow and not lymphoproliferative disease, the latter being uncommon in patients with adult-onset ISM. In bone marrow extensively involved by mast cell infiltration, the bony trabeculae may be moderately to markedly thickened.

P.1761

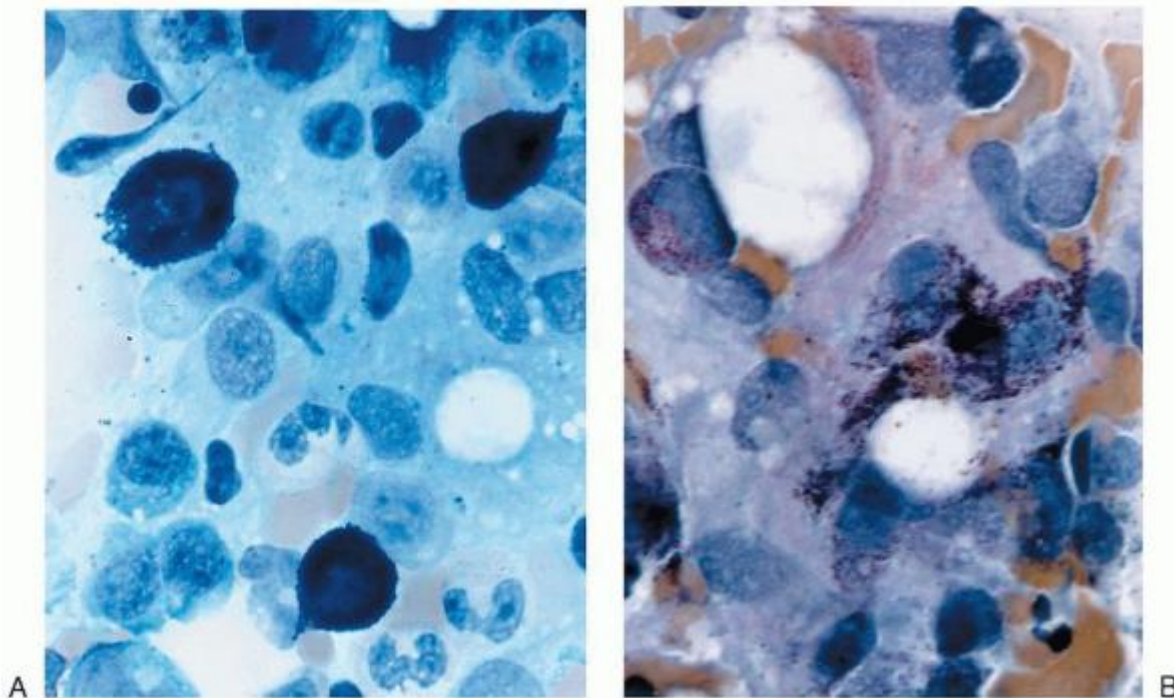

FIGURE 85.1. Morphologic features of mast cells from normal versus mastocytosis bone marrow aspirate. Panel A shows staining of a control bone marrow aspirate from an individual with aplastic anemia using toluidine blue stain (magnification, 40×). Panel B shows a hematoxylin and eosin stain of a bone marrow aspirate acquired from a patient with indolent systemic mastocytosis and illustrates representative spindle-shaped mast cells with an eccentric nucleus (magnification, 40×).

A number of hematologic abnormalities have been reported in patients with SM, including cytopenias (e.g., anemia, thrombocytopenia, leukopenia, and lymphopenia) and increased blood cell counts (e.g., leukocytosis, eosinophilia, basophilia, monocytosis, lymphocytosis, and thrombocytosis).⁵³ Hematologic abnormalities in children with mastocytosis are unusual, with a normochromic normocytic anemia being the most common finding.³¹ Prolonged bleeding times have been reported in infants with mastocytosis due to abnormal thrombin clotting times. In published reports of rare pediatric mastocytosis patients who have developed an associated hematologic malignancy, these were most frequently acute myeloid leukemias and acute lymphoblastic leukemias.³¹

Isolated bone marrow mastocytosis is a rare subvariant of ISM that is distinctive in lacking cutaneous and multiorgan involvement.⁵ The tryptase level in this group of patients is usually >20 ng/ml. These patients generally require no specific therapy, but ISM must be differentiated from ASM or MCL, in which skin lesions are also absent.

Smoldering mastocytosis is another subvariant of ISM.⁵⁴ Unlike typical ISM, these patients manifest two or more B findings (but no C findings) and have a higher mast cell burden (e.g., bone marrow infiltration grade >30% [dense infiltrates] and serum tryptase >200 ng/ml) with extension of a clonal disease process to several myeloid lineages. Although these patients have no overt myeloproliferative or myelodysplastic disease, they are at higher risk for progression to more aggressive forms of mastocytosis and carry a worse prognosis than those with indolent disease. Bone marrow lesions typically contain dense focal and diffuse mast cell infiltrates, and mast cells detected in such lesions may be immature. Markers of a poorer prognosis seen in this subvariant include a hypercellular bone marrow, hepatosplenomegaly or lymphadenopathy, and presence of a KIT mutation in PBMCs.

In contrast to adults with SM, definitive marrow involvement in children is much less common. In a study of 17 children with cutaneous or disseminated mastocytosis, only ten patients had small focal mast cell lesions on bone marrow biopsy, and only five demonstrated increased mast cells on bone marrow aspirate.⁵⁵ A follow-up of 15 of these patients 20 years later revealed that 10 patients had complete clinical regression of disease, while 5 patients had major or partial disease regression.⁵⁶ Those experiencing complete disease progression had no evidence of systemic disease on initial bone marrow examination.

Lymphadenopathy is present in a subset of patients with mastocytosis and is more commonly seen in those with an associated hematologic disorder. Peripheral adenopathy has been reported to be present in 26% of patients and central lymphadenopathy in 19% of patients at the time of diagnosis of SM.⁵⁷ Hyperplasia of lymph nodes is the result of infiltration with mast cells, and in approximately one-half of cases is associated with aggregates of eosinophils. Infiltrates are more commonly observed in the paracortex, follicles, medullary cords, and sinuses. Other histopathologic findings may include extramedullary hematopoiesis, small blood vessel proliferation in paracortical areas, and collagen fibrosis.⁵⁸

The presence of lymphadenopathy by itself does not signal aggressive disease. However, patients who present with progressive lymphadenopathy, with or without hepatosplenomegaly, and especially if accompanied by peripheral blood abnormalities, should be closely monitored for evolution into a more aggressive systemic disorder. This latter patient population may be more likely to harbor mutations in KIT.

Splenomegaly due to splenic infiltration with mast cells is likewise a frequent finding in systemic disease and has also been reported to occur in the absence of demonstrable mast cell infiltration on biopsy.⁵⁹ A review of pathologic features of 16 spleens from patients with mastocytosis showed a paratrabecular distribution of mast cell infiltrates in 15 of 16 spleens. In addition, parafollicular, follicular, and diffuse infiltrates were noted in ten (64%), two (4%), and one (7%) patients, respectively.⁵⁷ Varying degrees of trabecular and capsular fibrosis and eosinophilic hematopoiesis and plasmacytosis were seen, and 71% of all biopsies revealed extramedullary hematopoiesis. The prognostic significance of splenomegaly is seen with markedly increased splenic weights (>700 g) that have been reported to correlate with SM-AHNMD or ASM⁵⁹ and may be a contributing factor to the hematologic abnormalities seen in such patients.

Mast cell infiltration of the liver is a common finding in SM, although severe liver disease and hepatomegaly are relatively uncommon except, again, in patients with more aggressive forms of disease. In a study of 41 patients with mastocytosis, liver disease was reported in 61%.⁶⁰ Approximately one-half of the patients with liver disease in this series exhibited elevated liver function tests, either an elevated alkaline phosphatase, 5' nucleotidase, or γ -glutamyl transpeptidase. Mast cell infiltration has been described to show two distinct patterns: diffuse infiltration

P.1762

involving the cords and sinuses in the red pulp and focal infiltration in the white pulp of the liver. Hepatomegaly, infiltration of the liver by mast cells on liver biopsy, and hepatic fibrosis correlate with elevated levels of serum alkaline phosphatase. These findings are more commonly seen in patients with aggressive disease, ascites, or portal hypertension. As confirmed on liver biopsy, portal fibrosis and venopathy with subsequent veno-occlusive disease appear to be a result of vascular obstruction by mast cell infiltrates.⁶⁰ Fibrosis, including that which affects the liver, often accompanies mast cell proliferation and may be due to mast cell release of such proinflammatory mediators as transforming growth factor- β .

GI symptoms reported in SM include abdominal pain, cramping, nausea, vomiting, diarrhea, and peptic ulcer disease. Malabsorption syndrome due to mucosal mast cell infiltration is less commonly observed.^{43,61} One prospective study revealed that 6 of 16 patients with SM had a significantly elevated basal acid secretion, with concomitantly low gastrin levels.⁴³ These data were found to be consistent with the hypothesis that histamine secreted by mast cells contributes to gastric hypersecretion. Subsequent studies have shown that biopsy of gastric tissues in mastocytosis patients with acid hypersecretion symptoms did not always demonstrate increased mast cell infiltrates, thereby suggesting that the hyperhistaminemia observed in such patients may be due to oversecretion by all mast cells and not to an increased mast cell burden in the gastric tissues. GI disease is much less common in children, although GI bleeding is a potential complication with severe disease,⁴⁵ and abdominal cramping and diarrhea have also been reported.

Musculoskeletal pain in patients with SM has been well documented, although of uncertain etiology unless associated with osteopenia or osteoporosis, with more aggravated cases of osteoporosis leading to pathologic fractures.^{62,63,64} In some cases, osteoporosis or pathologic fractures, or both, may be the initial manifestation of mastocytosis.

In the evaluation of skeletal disease in mastocytosis, bone scans may show focal or diffuse abnormalities, and the latter have been associated with more aggressive disease and a worse prognosis. The most commonly reported abnormalities are diffuse, poorly demarcated, sclerotic, and lucent areas involving the axial skeleton.⁶³ In addition to bone loss, patients with mastocytosis may also exhibit concomitant abnormal bone formation, resulting in osteosclerosis.

Occasionally, patients in whom bone involvement by mastocytosis is not seen on routine diagnostic evaluation and symptoms are not found to be attributable to any known cause may nonetheless report myalgias and arthralgias, often in concert with constitutional symptoms of fatigue, general weakness, and depression. Management of this patient subset may be particularly challenging and may require behavior modification practices as well as therapeutic intervention utilizing both non-narcotic and narcotic analgesics for adequate pain relief.

Systemic Mastocytosis with an Associated Hematologic Clonal Non-mast Cell Lineage Disorder

A subset of patients with SM either present with, or develop over time, a defined hematologic disease in association with mastocytosis. These patients are categorized as SM-AHNMD.^{5,53,64,65} Among 138 consecutive reported cases with SM-AHNMD, 89% had an associated myeloid neoplasm: myeloproliferative neoplasm (45%), chronic myelomonocytic leukemia (29%), myelodysplastic syndrome (23%), and acute leukemia (3%).⁶⁶ Also rarely observed are myeloma or lymphoma.^{5,53,64,65} In all such patients, WHO criteria to diagnose an AHNMD as well as ISM criteria may be applied with specific reference to the associated diagnostic entity.^{6,66} Management of these patients involves targeting the underlying non-mast cell hematologic disorder either via close observation for stable disease, chemotherapy for progressive disease, or bone marrow (stem cell) transplantation in suitable candidates. The prognosis for such patients is dictated by the course of the associated non-mast cell lineage disorder.

Bone marrow findings that are more common with SM-AHNMD and have been associated with the D816V KIT mutation include a hypercellular bone marrow, dysplasia of myeloid or erythroid cell lineages, and an increased megakaryocyte number or megakaryocyte atypia. Fibrosis may be seen and is more frequent in patients with an associated hematologic disorder. Mast cells with bilobed nuclei, if seen on biopsy, portend a poor prognosis.

An imatinib-sensitive, FIP1L1-PDGFR α fusion oncogene-positive subset of SM patients with associated eosinophilia and increased serum tryptase levels has been described. Such patients display clinical and histologic features of a myeloproliferative disorder but lack the pathognomonic clusters of atypical mast cells in the bone marrow on routine hematoxylin and eosin staining.^{36,67} This syndrome has been variably classified as a unique subtype of SM, as a "myeloproliferative variant" of hypereosinophilic syndrome, as a chronic eosinophilic leukemia, or as a myelomastocytic overlap syndrome. However, the WHO classification⁵ now places these cases, with PDGFRA/PDGFRB-rearranged myeloproliferative neoplasm with an increase in mast cells in the bone marrow, under myeloid of lymphoid neoplasms with eosinophilia and abnormalities of PDGFRA, PDGFRB or FGFR1. It is thus recommended that all suspected mastocytosis cases with hypereosinophilia undergo screening for the FIP1L1-PDGFR α fusion by either fluorescence in situ hybridization or reverse transcriptase-polymerase chain reaction. Similarly, an imatinib-sensitive PRKG2-PDGFRB fusion has been identified in a patient presenting with increased numbers of mast cells and peripheral basophilia.³⁷ Such cases would now be considered within the category of myeloid neoplasms with PDGFRB rearrangements.

Aggressive Systemic Mastocytosis

ASM is a unique variant of mastocytosis characterized by abnormal myelopoiesis with mixed focal and diffuse mast cell infiltration of the bone marrow. These cells may be atypical and may be associated with other peripheral blood abnormalities (initially often presenting with eosinophilia), hepatosplenomegaly, osteopenia and pathologic fractures, and life-threatening organ impairment.^{5,68} A subset of cases appears to be associated with a prior history of malignant germ cell tumors.⁶⁹ This disease has been described in many respects as resembling a "lymphoma-like" illness with progressive infiltration of organs with mast cell infiltrates. Cutaneous involvement is usually absent.

In some patients, bone marrow aspirates may reveal significant numbers of mast cells with bi- or multilobed nuclei (high-grade morphology). Metachromatic blasts may also be detected. The peripheral blood smear may show cytopenias, leukocytosis, eosinophilia, or monocytosis.⁷⁰ Laboratory test abnormalities are frequently observed in such patients, with elevations in liver function, serum calcium, and alkaline phosphatase tests and prolonged prothrombin and partial thromboplastin time. As a result of impaired hepatic function and a propensity for spontaneous mast cell degranulation, ASM patients with more advanced disease may be at high risk for spontaneous hemorrhage during periods of mast cell activation. Serum tryptase levels may be high and demonstrate wide fluctuations due to spontaneous mast cell degranulation.

Mast Cell Leukemia

MCL is a rare variant of mastocytosis, with a grave prognosis and poorly understood pathophysiology.^{5,66,71} MCL is defined by the presence of mast cells as $\geq 10\%$ of circulating peripheral white

P.1763

blood cells. The bone marrow typically shows a dense and diffuse infiltration ($\geq 20\%$) with mast cells that display an immature, blastlike morphology with bi- or multilobed nuclei. Many of these mast cells express CD2 or CD25, or both.^{5,72} The KIT mutation D816V may be detected. Other peripheral blood abnormalities may be observed and include leukocytosis, anemia, and/or thrombocytopenia.⁷² In general, such patients manifest bone marrow and peripheral blood abnormalities that are insufficient to fulfill WHO criteria for SM-AHNMD.⁵ In the aleukemic variant of MCL, mast cells

account for <10% of peripheral white blood cells, and patients develop pancytopenia.⁵ Similar to aggressive mastocytosis, MCL patients are prone to bleeding diatheses, with or without signs of consumption or hyperfibrinolysis.

Mast Cell Sarcoma

Mast cell sarcoma (MCS) is a rare and ill-defined malignant mast cell neoplasm composed of immature cells with a high nucleus-to-cytoplasm ratio, nucleoli, and a hypogranulated cytoplasm. It carries a highly unfavorable prognosis. The cellular atypia described in MCS is comparable to the high-grade cytologic abnormalities found in MCL. It is characterized by local, destructive, sarcoma-like growth, with transformation to generalized involvement of multiple organ sites in its terminal phase. Cases described in the literature have included MCS of the larynx, the ascending colon, and an intracranial site.^{73,74,75} This disorder may terminate as MCL, with no known effective life-prolonging or curative treatments.

Extracutaneous Mastocytoma

Extracutaneous mastocytoma is another rare variant of mast cell disease, with most cases reported in the literature occurring in the lungs.⁷⁶ They are generally considered benign because of their low-grade histology consisting of mature mast cells, and lack of progression to aggressive disease or MCL. Because they may present similarly to MCS, they must be differentiated from the latter.

Monoclonal Mast Cell Activation Syndrome

Monoclonal mast cell activation syndrome (MMAS) is a term adopted by a consensus conference to be applied to patients who are found to have one or two minor diagnostic criteria for mastocytosis but lack the full diagnostic criteria for systemic disease.³³ Patients with such findings have been identified within groups of patients diagnosed with idiopathic anaphylaxis and patients with anaphylaxis to stinging insects.^{44,77,78} Most of these patients have a tryptase level below 20 ng/ml. The suggestion has been made that these studies may be identifying patients with an advancing clonal mast cell disorder that may one day meet the diagnostic criteria for SM.

For now such patients are treated under guidelines for the treatment of anaphylaxis. Follow-up at yearly intervals is recommended. The follow-up examination should include a physical exam to rule out evolving organomegaly or lymphadenopathy, a serum tryptase level to determine if there is indirect evidence of an expanding mast cell compartment, and a CBC with differential and platelet count to help rule out an evolving hematologic disorder.

Mast Cell Activation Syndrome

The term mast cell activation syndrome (MCAS) is now applied as a diagnosis for individuals who present with episodic allergic-like signs and symptoms such as flushing, urticaria, diarrhea, and wheezing involving two or more organ systems; and where an extensive medical evaluation has failed to identify an etiology. The assumption is that individuals to whom this diagnosis is applied are having episodes due to the release of mediators associated with hyperreactivity of mast cells that then activate spontaneously.

Diagnostic criteria have been proposed to separate this possibility from other causes of such clinical findings. These additional criteria include response to anti-mediator therapy and an elevation in a validated urinary or serum marker of mast cell activation such as serum tryptase with an episode.^{79,80} Primary (clonal) and other clinical disorders associated with mast cell activation, as well as other conditions associated with vasoactive mediator release must be eliminated as possible causes of the clinical findings. Clonal disorders to be considered include mastocytosis and MMAS. Other disorders associated with mast cell activation including allergic diseases, mast cell activation associated with chronic inflammatory or neoplastic disorders, and chronic autoimmune urticaria must be eliminated as diagnostic possibilities. Conditions such as carcinoid syndrome must also be sought and rejected. Once the diagnostic criteria are met, therapy is symptomatic. Care must be maintained lest one of the diagnoses eliminated during the initial evaluation reaches the level of diagnosis.

LABORATORY FINDINGS

The diagnosis of mastocytosis is based on the finding of confluent clusters of mast cells in affected organ sites or diffuse infiltration with replacement of normal tissue by mast cells, coupled with clinical signs and symptoms and laboratory tests that are consistent with mast cell disease.⁵ Bone marrow biopsy in pediatric-onset cutaneous disease is generally not recommended unless there is evidence of systemic disease, such as unexplained peripheral blood abnormalities, hepatosplenomegaly, or lymphadenopathy.⁵⁵ In patients with elevated serum total tryptase,⁵ a bone marrow biopsy and aspiration should be considered, particularly in adults. The consideration to obtain tissue biopsy specimens from the liver, spleen, GI tract, or lymph nodes should be based on a high suspicion of disease involvement and likelihood of yielding clinically useful information. Slight increases in mast cell numbers in target tissues (up to fourfold) are not diagnostic, as they may reflect normal variation or inflammatory or reactive processes.

Examination of the bone marrow in patients with suspected mastocytosis includes both an inspection of the bone marrow biopsy and the aspirate. Immunohistochemical staining of the bone marrow biopsy with antibody directed to mast cell tryptase is the method of choice to visualize mast cells,^{5,81,82} as shown in Figure 85.2. In most patients with SM, tryptase-positive infiltrates are composed of spindle-shaped mast cells. In these patients, SM can be diagnosed without additional tests, provided that major and minor SM criteria are met. In the case of patients with tryptase-positive round cell infiltrates (designated TROCI-bm) where the infiltrates comprise >95% round cells and <5% spindle-shaped cells, application of additional immunohistochemistry markers to confirm the diagnosis of SM should be applied if possible (e.g., 2D7 or BB1), since basophils and sometimes blast cells also express tryptase.³³ The coexpression of CD2 and/or CD25 in CD117 (KIT)-positive mast cells by flow cytometry of bone marrow aspirates or by immunohistochemical analysis of bone marrow biopsies is generally accepted to be the most sensitive and specific method to support the diagnosis of SM in bone marrow.^{21,33,52} The cellular composition of lymphoid collections is evaluated by using lineage-specific antibodies against CD3 and CD20, respectively,²⁴ as seen in Figure 85.3. Other approaches commonly used include reticulin staining to detect fibrosis and Masson trichrome staining to evaluate the extent of collagen deposition.

The finding of clusters of confluent mast cells on bone marrow aspirate is consistent with SM; however, not all patients demonstrate this finding. Therefore, underestimation of the degree of mast cell infiltration through examination of an aspirate may be more common than appreciated, with aspirates compromised because of underlying marrow fibrosis and a resultant inability to obtain adequate marrow aspirate or spicules at fibrotic marrow

P.1764

sites. Surrogate disease markers in mastocytosis include serum or plasma tryptase levels, serum histamine, urinary histamine metabolites, soluble CD117, soluble CD25, and CD2.⁸³

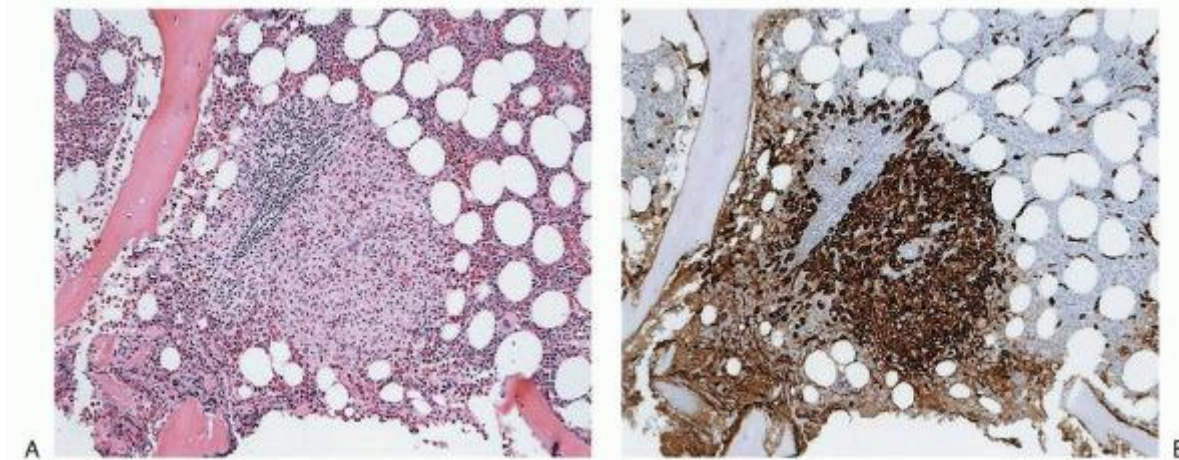

FIGURE 85.2. Bone marrow histopathology showing focal mast cell infiltrates in a bone marrow biopsy taken from a patient with indolent systemic mastocytosis. Panel A shows staining of a representative mast cell lesion with hematoxylin and eosin stain (magnification, 10×) and panel B shows staining of the same section with antitryptase antibody (magnification, 10×).

Serum mast cell tryptase is the most commonly used surrogate marker for SM and is quantified using a commercial enzyme-linked immunosorbent assay. It has both high sensitivity and high specificity.^{83,84} A total tryptase >20 ng/ml is suggestive of mastocytosis and has been included as a minor criterion in the diagnosis of SM.^{5,33} Normal baseline levels in healthy individuals are generally ≤ 12 ng/ml. Tryptase levels ≤ 20 ng/ml have been

P.1765

detected in patients with cutaneous mastocytosis and in those with limited systemic disease.⁸¹ In general, higher tryptase values increase the likelihood of multiorgan involvement. Thus, the tryptase level is an important parameter in evaluating patients with suspected mastocytosis and is useful in assessing disease severity and monitoring disease activity.

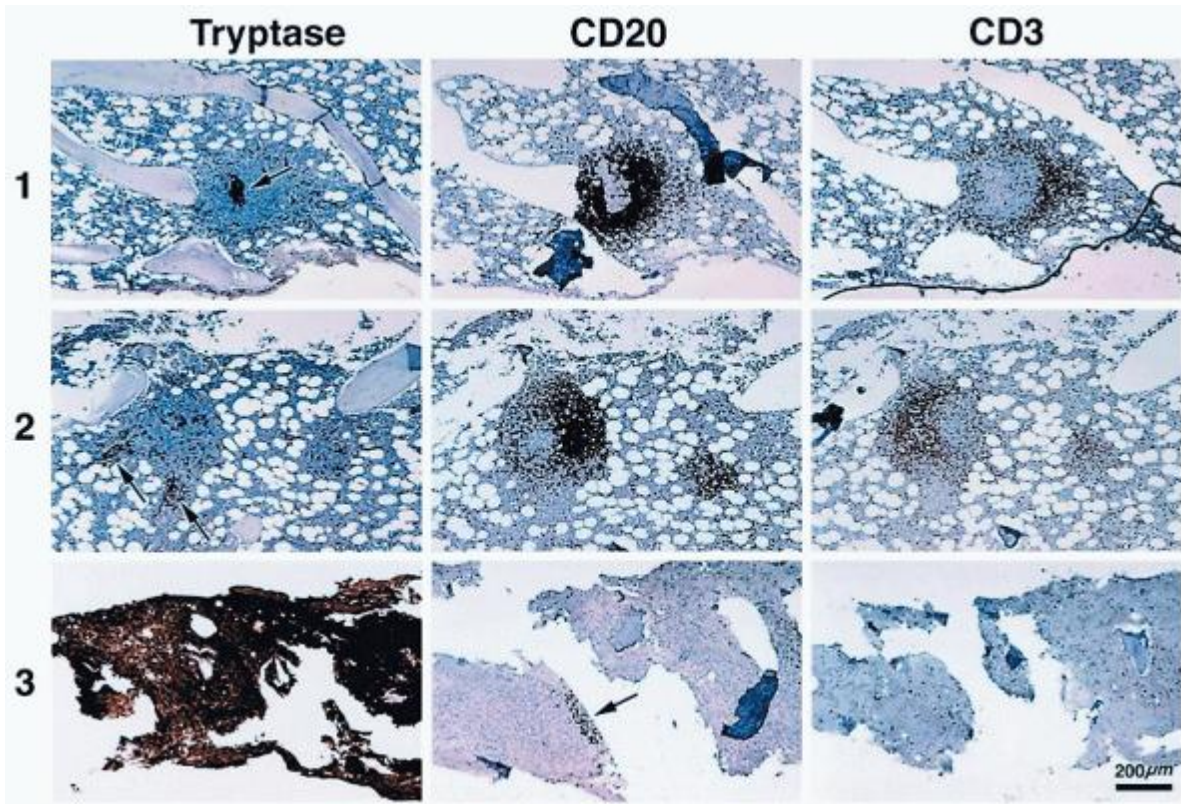

FIGURE 85.3. Immunohistochemical staining of lymphoid aggregates in two patients with a focal (1 and 2) and one patient with a diffuse (3) increase in mast cells. Antibodies are shown on top of each column. Nodular lesions shown in 1 and 2 contain a central core of mast cells (arrows) surrounded by B cells (CD20) and a peripheral rim of T cells (CD3). Diffuse mast cell infiltrates (3) are seen in association with a small B cell collection (arrow) and scattered single T cells. The bar represents 200 μm . (From Akin C, Jaffe ES, Raffeld M, et al. An immunohistochemical study of the bone marrow lesions of systemic mastocytosis. *Am J Clin Pathol* 2002;118:242-247, by permission of Dr. Cem Akin and the American Journal of Clinical Pathology.)

Other mast cell mediators that are surrogate disease markers for mastocytosis include serum histamine and 24-hour urine sampling for the urinary histamine metabolites, N-methylhistamine, and methylimidazole acetic acid. These tests are less commonly used with the availability of a commercial tryptase assay. A comparison of serum tryptase to urine N-methylhistamine in patients with suspected mastocytosis indicated that serum tryptase (using the UniCAP fluorezyme immunoassay) was able to better identify patients with an increased number of mast cell aggregates.⁸⁵ Other disadvantages of using blood and urinary histamine levels for diagnosis and prognostication of patients with mastocytosis are the variability of histamine levels among healthy individuals and patients, difficulty in assay standardization, and the problem of false-positive results due to presumed synthesis of histamine by bacteria in the urinary tract. Other variables that can alter results of histamine assays are prior ingestion of foods rich in histamine and improper storage of the urine sample. Because basophils also contain histamine, hematologic disorders presenting with basophilia or allergic events that lead to basophil and mast cell activation result in elevated histamine levels.

Various metabolites of arachidonic acid are also elevated in patients with mastocytosis. These include urinary PGD-M or 9 α , 11 β -dihydroxy-15-oxo-2,2,18,19-tetranorprost-5-ene-1,20-dioic acid, as well as plasma thromboxane B2 and its metabolites. Because the source of prostaglandins and thromboxanes in mastocytosis is not exclusively limited to mast cells, reliance on assays that measure these metabolites is unlikely to be sufficiently specific for diagnostic purposes. However, if measured, elevations in one or more mast cell mediators raise the suspicion of mastocytosis and warrant further diagnostic evaluation.

Identification of genetic markers of mastocytosis, such as point mutations in KIT, helps support the diagnosis of mastocytosis. The identification of the D816V mutation fulfills a minor diagnostic criterion in the diagnosis of mastocytosis. Such mutations are more easily identified in patients with more severe disease due to the relative clonal expansion of cells derived from the neoplastic progenitor. Such mutations may be helpful in following disease progression by assessing the relative intensity of the reverse transcriptase-polymerase chain reaction complementary DNA bands over

the patient's course. Analysis for KIT mutations are best performed on bone marrow and, specifically, on sorted malignant mast cells so as to increase sensitivity. Inability to identify the presence of a point mutation at codon 816 in KIT does not eliminate the possibility that cells bearing this mutation are present, as the malignant clone may have not expanded to sufficient cell numbers to allow for detection of the mutation in KIT.²¹ In patients with coexisting eosinophilia, peripheral blood should be examined for the presence of the FIP1L1/PDGFR α fusion gene. Several techniques to detect KIT mutations have been reported, but current recommendations for the most sensitive assays include RT-PCR-positive restriction fragment length polymorphism testing, peptide nucleic acid-mediated PCR, or allele-specific PCR.³³ When employing KIT mutations as a diagnostic criterion for SM, it is important to be aware that such mutations are also detectable in some patients with germ cell tumors or other non-mast cell tumors with or without coexisting SM.³³ Plasma IL-6 levels may correlate with disease severity, in particular the extent of bone marrow pathology and presence of a non-mast cell hematologic disorder, but are not currently recommended for diagnosis or routine monitoring of patients.^{13,86}

Additional surrogate markers that may also be useful in assessing more severe forms of mastocytosis, such as SM-AHNMD, and in following disease severity are the soluble receptors CD117 (KIT) and CD25 (the α -chain of the IL-2 receptor).⁸⁷ These receptors are expressed in both membrane-bound and soluble forms, with the latter being a result of proteolytic cleavage. Soluble forms of these receptors are more readily detectable in the circulation in patients with an increased mast cell burden and correlate with disease severity and bone marrow pathology. Soluble CD117 levels are also found to be elevated in some patients with acute myeloid leukemias and advanced myelodysplastic syndromes. Elevated CD25 levels may be seen in patients with hairy cell leukemia, solid tumors, and a number of infectious and autoimmune diseases. A comparison of the plasma CD117 and tryptase levels for various categories of mastocytosis revealed that tryptase levels were more sensitive indicators of early disease, whereas elevated plasma CD117 levels demonstrated a stronger correlation with advanced disease.⁸⁷

A dual-energy X-ray absorptiometry scan should be employed to monitor osteoporosis in those with mastocytosis. Sites commonly measured include the lumbar spine and hip. The diagnosis is established according to WHO criteria defining osteopenia.³³ A physical examination, serum tryptase determination, and complete blood count should be recommended at yearly intervals in patients with stable ISM.^{21,33}

DIFFERENTIAL DIAGNOSIS

The differential diagnostic list of disorders for mastocytosis consists of those diseases that have a similar clinical presentation. These include hereditary or acquired angioedema, idiopathic flushing or anaphylaxis, carcinoid tumor, pheochromocytoma, and idiopathic capillary leak syndrome. Pheochromocytoma should be considered when episodic hypertension is a predominant clinical manifestation. Unexplained gastroduodenal disease should include evaluation for Zollinger-Ellison gastrinoma. Helicobacter pylori infection should be considered in all patients with gastric ulcers, even in those patients diagnosed with mastocytosis.

DCM should be included in the differential diagnosis of neonatal blister disorders such as pemphigoid. Extensive bullae with crusting may be the first presentation in an infant who later develops DCM.

A number of non-mast cell hematologic disorders, such as the myeloproliferative disorders (e.g., chronic myelogenous leukemia) or lymphoma of the bone marrow, may present with an increased number of mast cells and, in some cases, immature mast cells on bone marrow biopsy, though circumscribed lesions are generally lacking in these disorders and WHO criteria for diagnosis of primary mast cell disease are not met.^{88,89} Diseases with bone marrow lesions on biopsy that appear similar to SM on gross analysis include primary myelofibrosis, angioimmunoblastic lymphadenopathy, eosinophilic fibrohistiocytoma, and "myelomastocytic leukemia."^{88,90} Close evaluation of histopathologic specimens differentiates these disorders from mastocytosis in part on the basis of a general absence of mast cell infiltrates. Myelofibrosis can resemble mastocytosis when fibrosis is extensive and the marrow is diffusely infiltrated with an increased number of mast cells. The distinguishing feature between these two disorders is the greater absolute number of mast cells on bone marrow biopsy in mastocytosis. Although differentiation of mastocytosis from angioimmunoblastic lymphadenopathy may be made on the basis of the presence of plasma cells and immunoblasts in the latter and absence of neovascularity in mastocytosis, differentiation of mastocytosis from fibrohistiocytoma is more difficult. Large histiocytic cells noted in eosinophilic fibrohistiocytic lesions have a similar appearance to the large mast cells seen in many mast cell lesions.⁹¹

Conditions with secondary changes in mast cell numbers have been observed at sites of pathology in a number of autoimmune

P.1766

disorders, including systemic lupus erythematosus, rheumatoid arthritis, psoriatic arthritis, and scleroderma; with chronic

liver or renal disease; and with a variety of infectious diseases, although in such cases, these increases are nominal.²⁰ On resolution of the infection, mast cell numbers generally return to normal. At sites of allergic inflammation, increases of mast cells up to fourfold over normal have been described.

MANAGEMENT

Treatment of all categories of mastocytosis involves control of symptoms by blocking the action of mast cell mediators, though several new therapeutic strategies may hold promise for more severe forms of the disease by targeting mast cell growth and development.^{92,93,94} Because of the heterogeneous nature of disease manifestations in this group of disorders, therapy should be individualized to each patient's clinical presentation and prognosis. Aggressive forms of therapy are not indicated in patients with indolent mastocytosis, as this disease category has a favorable prognosis. A summary of treatment approaches for mastocytosis is provided in Table 85.3.

The treatment for most categories of mastocytosis includes H₁ and H₂ antihistamine blockade for prophylaxis of hypotensive episodes, for control of cutaneous manifestations such as pruritus and flushing, and for gastric hypersecretion. Corticosteroids are used for control of malabsorption and ascites and for prevention or amelioration of anaphylaxis.^{20,92,95,96} Nonsedating antihistamines have utility when patient sedation is a key concern and are now considered the agents of choice for pruritus and urticaria. Alternative approaches include administration of a nonsedating antihistamine during the day, with supplementation of one of the potent sedating antihistamines at bedtime for added symptom relief.

Addition of an H₂ antihistamine may be beneficial in cases in which insufficient symptom control is afforded by use of an H₁ antihistamine alone.^{92,96} Aspirin has been used in some patients to treat flushing, tachycardia, and syncope. However, aspirin must be used with caution, as it may cause vascular collapse in some patients with mastocytosis and may also exacerbate peptic ulcer disease. Neither chemotherapy nor splenectomy appears to have any role in the treatment of cutaneous or indolent forms of mastocytosis.

For cutaneous manifestations of mastocytosis, other therapies may be beneficial in addition to antihistamines.⁹² UP and DCM have been shown to be responsive to corticosteroids^{97,98} and oral methoxypsoralen therapy with long-wave ultraviolet radiation; psoralen and ultraviolet A light has been used for both UP and DCM.^{99,100,101} Indeed, some patients report a decrease in the number or intensity of cutaneous lesions after repeated exposure to natural sunlight.¹⁰² Photochemotherapy, however, should only be used in instances of extensive cutaneous disease unresponsive to other therapy. TMEP, a rare variant of cutaneous disease, is somewhat more complicated in that lesions are chronic and tend to be unresponsive to currently available therapies. Neither corticosteroids nor psoralen and ultraviolet A light have been shown to afford significant improvement in TMEP, and improvement is transient in UP and DCM.¹⁰² A limited body of literature indicates that laser therapy may have some utility in the treatment of TMEP.⁹² In children with mastocytomas with associated severe systemic symptoms due to mast cell mediator release, surgical excision of the mastocytoma may be considered.⁴⁵ An alternative approach used involves injection of the mastocytoma with corticosteroids to induce involution.¹⁰³ There are also now considerations of alternative approaches to the treatment of cutaneous mastocytosis not yet validated, including the use of topical pimecrolimus, an immunomodulating agent used in the treatment of eczema.¹⁰⁴

TABLE 85.3 SUGGESTED THERAPY FOR MASTOCYTOSIS

FOR ALL VARIANTS: Hypotensive/anaphylaxis

Epinephrine (intramuscular [e.g., Epi-Pen])

More severe, frequent episodes: consider prophylaxis with H₁ and H₂ antihistamines ± corticosteroids

Cutaneous disease

Antihistamines: H₁ ± H₂

Corticosteroids

Psoralen and ultraviolet A light: consider for recalcitrant disease

Laser therapy: consider for telangiectasia macularis eruptiva perstans

Gastrointestinal disease

Peptic ulcer disease/gastroesophageal reflux: H₂ antihistamines, omeprazole

Abdominal cramping: cromolyn sodium

Diarrhea: anticholinergics, cromolyn sodium, omeprazole

Malabsorption: corticosteroids

Ascites: corticosteroids, consider a portacaval shunt

Bone disease

Calcium supplementation ± vitamin D

Bisphosphonates

Consider estrogen therapy for postmenopausal women, testosterone replacement in men with low testosterone levels

Consider interferon- α 2b in patients with severe bone disease and severe musculoskeletal pain

Radiotherapy: palliative therapy for severe, localized bone pain

INDOLENT SYSTEMIC MASTOCYTOSIS

No cytoreductive treatment

SMOLDERING SYSTEMIC MASTOCYTOSIS

In severe selected cases with disease progression consider interferon- α , cladribine, and tyrosine kinase inhibitors

SYSTEMIC MASTOCYTOSIS WITH AN ASSOCIATED NON-MAST CELL LINEAGE DISEASE

If indicated, treatment of the associated non-mast cell hematologic disorder

Interferon- α

Cladribine

Consider a tyrosine kinase inhibitor

AGGRESSIVE SYSTEMIC MASTOCYTOSIS

Interferon- α

Cladribine

Consider a tyrosine kinase inhibitor and/or combination therapy

Consider bone marrow transplantation

Consider splenectomy if patient has an enlarged spleen and/or cytopenias and if chemotherapy is to be considered

MAST CELL LEUKEMIA

Consider interferon- α or cladribine or a tyrosine kinase inhibitor

Combined chemotherapy

Consider phase 1 or phase 2 investigational research studies, including bone marrow transplantation

Management of GI symptoms should address the type and severity of symptoms. H₂ antihistamines are specifically used to treat gastric hypersecretion and peptic ulcer disease associated with mastocytosis. Proton pump inhibitors (e.g., omeprazole) may be effective in decreasing diarrhea in addition to controlling gastric acid hypersecretion.¹⁰²

Antileukotrienes are effective in some patients in helping control symptoms of flushing, diarrhea, and abdominal cramping. Anticholinergics and orally administered cromolyn sodium may also be useful for control of diarrhea.¹⁰⁵

Intestinal absorption of cromolyn is limited ($\leq 1\%$), and a number

P.1767

of weeks of therapy may be needed before clinical benefits are seen. The recommended adult dosage is 200 mg four times daily, and doses ranging from 60 mg daily to 100 mg four times daily have been used in children.^{45,92} In addition to its efficacy in treating GI symptoms, cromolyn has been reported to decrease musculoskeletal pain and headaches and improve cognitive abilities.⁹² Its purported mechanism of action is in decreasing mast cell degranulation. As such, its use would not be expected to alter the natural course of the disease.

Malabsorption is generally managed with corticosteroids.⁹² In adults, oral prednisone (40 to 60 mg/day) usually results in a decrease in malabsorption over 10 to 20 days, after which steroids can usually be tapered to as low as 15 to 20 mg every other day. A more difficult treatment dilemma, ascites, has been shown to improve with systemic corticosteroids.⁹² Again, in adults, treatment with prednisone, 40 to 60 mg/day, with tapering to an every-other-day dose, usually results in a decrease in ascites. A subgroup of patients with mastocytosis who develop ascites may also develop portal hypertension, which may be exceedingly difficult to manage and indicates a poor prognosis.¹⁰⁶ At least one patient with portal hypertension was reported to have been successfully managed with a portacaval shunt.¹⁰⁷

Epinephrine is used to treat acute episodes of hypotension.⁹² Treatment of refractory hypotension and shock requires fluid resuscitative measures along with additional pharmacologic intervention.

Osteoporosis in those with mastocytosis may be underdetected and, hence, undertreated. Recommended approaches to treatment include calcium supplementation, vitamin D, and use of bisphosphonates.^{33,92} Narcotic analgesics should be used with care, as these, particularly at high doses or in susceptible patients, have been suspected of potentiating mast cell degranulation. Radiotherapy may have a palliative role in decreasing bone pain in isolated areas.¹⁰⁸ In severe cases or patients with drug intolerance, an intravenous bisphosphonate or low-dose interferon- α 2b may be appropriate, as the literature indicates that interferon- α 2b may have some efficacy in decreasing musculoskeletal pain and improving bone mineralization in patients with extensive bony involvement.⁹² Patients with osteolysis and pathologic fractures are candidates for cytoreductive drugs (plus a bisphosphonate). The decision to initiate treatment with interferon- α 2b therapy should take into consideration side effects such as fever, malaise, nausea, and hypothyroidism, along with the small but well-described risk for anaphylaxis. Patients with mastocytosis who ultimately require joint replacement due to extensive bone loss generally tolerate these procedures well; however, such procedures do not obviate further decline in bone mass.¹⁰⁹

Neither chemotherapy, cytoreductive therapy such as cladribine (see below), nor splenectomy have any role in the treatment of indolent mastocytosis. Smoldering SM patients with rapid progression of B findings or new C findings may be an exception to this general rule.¹⁰² Therapeutic options for patients with SM-AHNMD, ASM, and MCL are at the present time based on treating associated medical conditions and, when associated, the underlying hematologic disorder.^{20,110,111,112,113,114,115}

Interferon- α with or without steroids is often employed as first-line cytoreductive therapy in more aggressive forms of SM.^{110,115} The optimal dose and duration of therapy are unclear and results are mixed. In general, interferon- α treatment appears to diminish skin findings and symptoms, decrease mast cell infiltration of the marrow, lessen osteoporosis, and ameliorate cytopenias.¹¹¹ The time to response may approach a year, and relapse after discontinuing interferon- α is common.¹¹⁵ Furthermore, its use is complicated by flu-like symptoms, fever, hypothyroidism, and cytopenias.⁹² One group commonly starts with 1 to 3 million units subcutaneously three times per week, followed by gradual escalation to 3 to 5 million units 3 to 5 times per week.¹¹⁵ Prednisone is commonly used from the start and tapered as possible. Duration of therapy is determined by the response and absence of significant side effects.

Cladribine (2-chlorodeoxyadenosine, 2CdA), a purine nucleoside analog, has been reported to reduce neoplastic mast cell burden and induce clinical remissions in patients with more aggressive forms of mastocytosis.^{112,115} Cladribine is a reasonable therapeutic approach in treating those with aggressive forms of mastocytosis who need a rapid reduction in mast cell burden, or have interferon- α -resistant advanced disease or interferon intolerance. Potential toxicities include myelosuppression, lymphopenia, and opportunistic infections. Prophylactic glucocorticoids, antihistamines, and antibiotics are recommended.

Peripheral stem cell or bone marrow transplantation has the potential of allowing long-term engraftment of healthy bone marrow progenitors along with provision for a graft-versus-leukemia effect. Allogeneic nonmyeloablative bone marrow transplantation from human leukocyte antigen-identical sibling donors has been shown to cause less transplant-related mortality when compared to myeloablative transplantation.¹¹⁶ Here, too, limited published data are available, but overall results to date have been disappointing even when a graft versus mast cell state was induced.^{113,116,117,118,119} The current

thinking with regard to transplantation is that effective prior cytoreductive therapy may be necessary to achieve long-term disease control and cure.

In SM-AHNMD patients with significant cytopenias and splenomegaly, splenectomy may result in some amelioration of the cytopenias and thereby reduce a patient's transfusion requirement or risk of bleeding or infection.¹²⁰ Such patients might also be better able to tolerate chemotherapy, as suggested by a study in which patients with more aggressive forms of mastocytosis who underwent splenectomy had a mean survival time of 34 months compared to 26 months in those who did not undergo splenectomy.¹²⁰

Tyrosine kinase inhibitors are under investigation as a therapeutic class that could be used to interfere with mast cell proliferation and survival. Imatinib mesylate in vitro inhibits the phosphorylation of wild-type KIT, and F522C and V560G mutants. It is ineffective at inhibiting KIT bearing the common D816V mutation.^{121,122,123} Major toxicities include diarrhea and peripheral edema. Interstitial pneumonitis appears to be a rare side effect. These data underscore the importance of performing a mutational analysis of KIT prior to initiating therapy with imatinib.

Future directions for treatment of mastocytosis involve the second generation tyrosine kinase inhibitors including midostaurin (PKC412), dasatinib, and nilotinib. Midostaurin has activity against the D816Y and D816V KIT mutants.^{124,125,126} In a phase-2 study, midostaurin was orally administered to patients with mastocytosis variants including SM-CMML, SM-MDS, SM-MDS/MPN-U, and MCL.¹²⁷ There was a major response rate of 38%, which included improvement of hemoglobin and platelet counts, improvement of liver function abnormalities, and improvement of ascites. Side effects included nausea, vomiting, diarrhea, and fatigue. Treatment had to be discontinued in 69% of the patients. Additional studies are needed to clarify the advantage of midostaurin vs. 2-CdA or interferon- α . Dasatinib also has activity against KIT mutants including D816V.¹²⁶ In one study, dasatinib was given to patients with ISM, ASM, and SM-AHMD.¹²⁸ Twenty-seven percent experienced symptomatic improvement, but significant toxicities were observed in 58%. It is not clear which patient group will obtain the most benefit. Nilotinib has a target profile similar to imatinib. A phase II trial evaluated nilotinib in 60 patients with SM. An overall response was observed in 12 patients.^{94,129} The clinical trials evaluating tyrosine kinase inhibitors have been relatively disappointing as judged by achieving complete remission, in part due to multiple off-target effects and the fact that neoplastic mast cells acquire additional KIT-independent mutations that contribute to mast cell proliferation.⁹⁴ This has led to an ongoing search for more specific inhibitors of KIT¹³⁰ and raises the possibility that combination therapy directed at multiple targets may be required.

P.1768

Irrespective of the intricacies of treating this diverse group of disorders, an important component of management of all categories of mastocytosis is patient avoidance of triggering factors such as alcohol and nonsteroidal antiinflammatory agents in sensitive patients; pressure, friction, or extremes of temperature; and agents to which the patient is specifically allergic.^{77,78,92} As with other syndromes in which patients may be at risk for severe type I hypersensitivity reactions, patients with mastocytosis should carry epinephrine-filled syringes and be skilled in self-administration. In situations where surgery under general anesthesia is necessary, patients with mastocytosis should undergo appropriate prophylaxis with H₁ and H₂ antihistamines, as medications used in general anesthesia are known to variably induce mast cell degranulation. Pharmacologic agents that should be avoided if possible include β -adrenergic agents and α -adrenergic and cholinergic receptor antagonists. Serum tryptase levels should be obtained and blood coagulation parameters monitored perioperatively and during anesthesia if a suspected mast cell degranulation event occurs.¹³¹

DEVELOPMENT OF CLINICAL RESPONSE CRITERIA TO ASSESS EFFICACY TO THERAPY

Despite the emergence of novel pharmaceutical agents for the treatment of mastocytosis, assessment of response to therapy using uniform criteria that are objective, reproducible, and mastocytosis variant-specific remains the subject of discussion. Response criteria developed by consensus have been published.³³ These criteria or modified versions have been used in clinical trials. Clinical evidence of organ damage forms the basis of judging the level of response and determining where additional criteria, including changes in mast cell burden and serum tryptase levels, are employed to subcategorize levels of major response. More recently, attempts have been made to make response criteria more clinically relevant using disease-related symptoms, organomegaly, organopathy, and bone marrow findings.^{132,134} It is hoped that further consensus and the resulting algorithms and recommendations that arise will greatly facilitate the management of patients in clinical practice, provide better guidelines for selection of appropriate categories of mastocytosis for evaluation in clinical trials, and ultimately allow for individualized and molecularly tailored therapy of patients with mastocytosis, based on their genotype and phenotype.

WEBSITES

The following websites provide updated information on mastocytosis: www.niaid.nih.gov/factsheets/masto.htm, www.mastocytosis.com, and www.rarediseases.org.

REFERENCES

1. Nettleship E, Tay W. Rare forms of urticaria. *BMJ* 1869;2:323-330.
2. Sanger A. An anomalous mottled rash, accompanied by pruritus, factious urticaria and pigmentation, "urticaria pigmentosa." *Trans Clin Soc Lond* 1878;11:161-163.
3. Unna PG. Beitrage zur anatomic und pathogenese der urticaria simplex und pigmentosa. *Mschr Prakt Dermatol Suppl Dermatol Stud* 1887;3:9.
4. Ellis JM. Urticaria pigmentosa. A report of a case with autopsy. *AMA Arch Pathol* 1949;48:426-429.
5. Horny HP, Akin C, Metcalfe DD, et al. Mastocytosis. In: Swerdlow SH, Campo E, Harris NL, et al., eds. *World Health Organization classification of tumours of haematopoietic and lymphoid tissues*. Lyon: IARC Press, 2008:54-63.
6. Nagata H, Worobec AS, Oh CK, et al. Identification of a point mutation in the catalytic domain of the protooncogene c-kit in peripheral blood mononuclear cells of patients who have mastocytosis with an associated hematologic disorder. *Proc Natl Acad Sci U S A* 1995;92:10560-10564.
7. Longley BJ, Tyrrell L, Lu SZ, et al. Somatic c-KIT activating mutation in urticaria pigmentosa and aggressive mastocytosis: establishment of clonality in a human mast cell neoplasm. *Nat Genet* 1996;12:312-314.
8. Yavuz AS, Lipsky PE, Yavuz S, et al. Evidence for the involvement of a hematopoietic progenitor cell in systemic mastocytosis from single-cell analysis of mutations in the c-kit gene. *Blood* 2002;100:661-665.
9. Taylor ML, Sehgal D, Raffeld M, et al. Demonstration that mast cells, T cells, and B cells bearing the activating mutation D816V occur in clusters within the marrow of patients with mastocytosis. *J Mol Diag* 2004;6:335-342.
10. Akin C, Kirshenbaum AS, Semere T, et al. Analysis of the surface expression of the c-kit Asp816Val activating mutation in T cells, B cells, and myelomonocytic cells in patients with mastocytosis. *Exp Hematol* 2000;28:140-147.
11. Kitamura Y, Go S, Hatanaka S. Decrease in mast cells in W/W^v mice and their increase by bone marrow transplantation. *Blood* 1978;52:447-452.
12. Sonoda T, Kitamura Y, Haku Y, et al. Mast cell precursors in various hematopoietic colonies of mice produced in vivo and in vitro. *Br J Hematol* 1983;53:611-620.
13. Brockow KC, Akin C, Huber M, et al. Levels of mast cell growth factors in plasma and in suction blister fluid in adults with mastocytosis: correlation with dermal mast cell numbers and mast cell tryptase. *J Allergy Clin Immunol* 2002;109:82-88.
14. Kirshenbaum AS, Goff JP, Kessler SW, et al. Effects of IL-3 and stem cell factor on the appearance of human basophils and mast cells from CD34⁺ pluripotent progenitor cells. *J Immunol* 1992;148:772-777.
15. Kirshenbaum AS, Goff JP, Semere T, et al. Demonstration that human mast cells arise from a progenitor cell population that is CD34⁺, c-kit⁺, and expresses aminopeptidase N (CD13). *Blood* 1999;94:2333-2342.
16. Kirshenbaum AS, Kessler SW, Goff JP, et al. Demonstration of the origin of human mast cells from CD34⁺ bone marrow progenitor cells. *J Immunol* 1991;146:1410-1415.
17. Escribano L, Orfao A, Diaz-Augustin B, et al. Indolent systemic mast cell disease in adults: immunophenotypic characterization of bone marrow mast cells and its diagnostic implication. *Blood* 1998;91:2731-2736.
18. Wilson TM, Maric MI, Simakova O, et al. Clonal analysis of NRAS activating mutations in KIT-D816V systemic mastocytosis. *Haematologica* 2011;96:459-463.
19. Schwartz LB. Diagnostic value of tryptase in anaphylaxis and mastocytosis. *Immunol Allergy Clin North Am* 2006;26:451-463.
20. Metcalfe DD. Mast cells and mastocytosis. *Blood* 2008;112:946-956.
21. Metz M, Brockow K, Metcalfe DD, et al. Mast cells, basophils and mastocytosis. In: Rich RR, Fleisher TA, Shearer WT, et al., eds. *Clinical immunology: principles and practice*, 4th ed. Elsevier, London, in press.

22. Gilfillan AM, Peavy RD, Metcalfe DD. Amplification mechanisms for the enhancement of antigen mediated mast cell activation. *Immunol Res* 2009;43:15-24.
23. Longley BJ Jr, Morganroth GS, Tyrrell L, et al. Altered metabolism of mast-cell growth factor (c-kit ligand) in cutaneous mastocytosis. *N Engl J Med* 1993;328:1302-1307.
24. Akin C, Jaffe ES, Raffeld M, et al. An immunohistochemical study of the bone marrow lesions of systemic mastocytosis. *Am J Clin Pathol* 2002;118: 242-247.
25. Taylor ML, Dastyh J, Sehgal D, et al. The Kit-activating mutation D816V enhances stem cell factor-dependent chemotaxis. *Blood* 2001;28:140-147.
26. Lee YN, Brandal S, Noel P, et al. KIT signaling regulates MITF expression through microRNAs in normal and malignant mast cell proliferation. *Blood* 2011;117:3629-3640.
27. Miettinen M, Lasota J. KIT (CD117): a review on expression in normal and neoplastic tissues, and mutations and their clinicopathologic correlation. *Appl Immunohistochem Mol Morphol* 2005;13:205-220.
28. Furitsu T, Tsujimura T, Tono T, et al. Identification of mutations in the coding sequence of the proto-oncogene c-kit in a human mast cell leukemia cell line causing ligand-independent activation of c-kit product. *J Clin Invest* 1993;92:1736-1744.
29. Feger F, Ribadue Dumas A, Leriche L, et al. Kit and c-kit mutations in mastocytosis: a short overview with special reference to novel molecular and diagnostic concepts. *Int Arch Allergy Immunol* 2002;127:110-114.
30. Longley BJ Jr, Metcalfe DD, Tharp M, et al. Activating and dominant inactivation c-KIT catalytic domain mutations in distinct clinical forms of human mastocytosis. *Proc Natl Acad Sci U S A* 1999;96:1609-1614.
31. Carter MC, Metcalfe DD. Pediatric mastocytosis. *Arch Dis Child* 2002;86: 315-319.
32. Lasho T, Tefferi A, Pardanani A, Inhibition of JAK-STAT signaling by TG101348: a novel mechanism for inhibition of KITD816V-dependent growth in mast cell leukemia cells. *Leukemia* 2010;24:1378-1380.
33. Valent P, Akin C, Escribano L, et al. Standards and standardization in mastocytosis: consensus statement on diagnostics, treatment recommendations and response criteria. *Eur J Clin Invest* 2007;37:435-453.
34. Furitsu T, Tsujimura T, Tono T, et al. Identification of mutations in the coding sequence of the proto-oncogene c-kit in a human mast cell leukemia cell line causing ligand-independent activation of c-kit product. *J Clin Invest* 1993;92:1736-1744.
35. Yanagihori H, Oyama N, Nakamura K, et al. c-kit Mutations in patients with childhood-onset mastocytosis and genotype-phenotype correlation. *J Mol Diag* 2005;7:252-257.
36. Cools J, DeAngelo DJ, Gotlib J, et al. A tyrosine kinase created by fusion of the PDGFRA and FIP1L1 genes as a therapeutic target of imatinib in idiopathic hypereosinophilic syndrome. *N Engl J Med* 2003;348:1201-1214.
37. Lahortiga I, Akin C, Cools J, et al. Activity of imatinib in systemic mastocytosis with chronic basophilic leukemia and PRKG2-PDGFRB fusion. *Haematologica* 2008;93:49-56.
38. Daley T, Metcalfe DD, Akin C. Association of the Q576R polymorphism in the interleukin-4 receptor alpha chain with indolent mastocytosis limited to the skin. *Blood* 2001;98:880-882.
39. Mekori YA, Gilfillan AM, Akin C, et al. Human mast cell apoptosis is regulated through Bcl-2 and Bcl-XL. *J Clin Immunol* 2001;21:171-174.
40. D'Ambrosio C, Akin C, Wu Y, et al. Gene expression analysis in mastocytosis reveals a highly consistent profile with candidate molecular markers. *J Allergy Clin Immunol* 2003;112:1162-1170.
41. Gupt R, Bain BJ, Knight CL. Cytogenetic and molecular genetic abnormalities in systemic mastocytosis. *Acta Haematol* 2002;107:123-128.
42. Chaves-Dias C, Hundley TR, Gilfillan AM, et al. Induction of telomerase activity during development of human mast cells from peripheral blood CD34+ cells: comparisons with tumor mast cell lines. *J Immunol* 2001;166: 6647-6656.
43. Cherner JA, Jensen RT, Dubois A, et al. Gastrointestinal dysfunction in systemic mastocytosis. *Gastroenterology* 1988;95:657-667
44. Rueff F, Placzek M, Przybilla B. Mastocytosis and hymenoptera allergy. *Curr Opin Allergy Clin Immunol* 2006;6:284-288.
45. Castells M, Metcalfe DD, Escribano L. Diagnosis and treatment of cutaneous mastocytosis in children: practical recommendations. *Amer J Clin Dermatol* 2011;12:259-270.

46. Lim KH, Tefferi A, Lasho TL, et al. Systemic mastocytosis in 342 consecutive adults: survival studies and prognostic factors. *Blood* 2009;113:5727-5736.
47. Soter NA. Mastocytosis and the skin. *Hematol Oncol Clin North Am* 2000;14:537-555.
48. Caplan R. The natural course of urticaria pigmentosa. *Arch Dermatol* 1963;87:146-157.
49. Brockow K, Scott LM, Worobec AS, et al. Regression of urticaria pigmentosa in adult patients with systemic mastocytosis. *Arch Dermatol* 2002;138: 785-790.
50. Sarkany RP, Monk BE, Handfield-Jones SE. Telangiectasia macularis eruptiva perstans: a case report and review of the literature. *Clin Exp Dermatol* 1998;23:38-39.
51. Horny HP, Valent P. Histopathological and immunohistochemical aspects of mastocytosis. *Int Arch Allergy Immunol* 2002;127:115-117.
52. Akin C, Valent P, Escribano L. Urticaria pigmentosa and mastocytosis: the role of immunophenotyping in diagnosis and determining response to treatment. *Curr Allergy Asthma Rep* 2006;6:282-288.
53. Lawrence JB, Friedman BS, Travis WD, et al. Hematologic manifestations of systemic mast cell disease: a prospective study of laboratory and morphologic features and their relation to prognosis. *Am J Med* 1991;91:612-624.
54. Valent P, Akin C, Sperr WR, et al. Smouldering mastocytosis: a new type of systemic mastocytosis with slow progression. *Int Arch Allergy Immunol* 2002;127:137-139.
- P.1769
55. Kettlehut BV, Parker RI, Travis WD, et al. Hematopathology of the bone marrow in pediatric cutaneous mastocytosis. A study of 17 patients. *Am J Clin Pathol* 1989;91:558-562.
56. Uzzaman A, Maric I, Noel P, et al. Pediatric-onset mastocytosis: a long term clinical follow-up and correlation with bone marrow histopathology. *Pediatr Blood Cancer* 2009;53:629-634.
57. Travis WD, Li CY. Pathology of the lymph node and spleen in systemic mast cell disease. *Mod Pathol* 1988;1:4-14.
58. Horny HP, Kaiserling E, Rarwaresch MR, et al. Lymph node findings in generalized mastocytosis. *Histopathology* 1992;21:439-446.
59. Horny HP, Ruck MT, Kaiserling E. Spleen findings in generalized mastocytosis. A clinicopathologic study. *Cancer* 1992;70:459-468.
60. Mican JM, DiBisceglie AM, Fong TL, et al. Hepatic involvement in mastocytosis: clinicopathologic correlations in 41 cases. *Hepatology* 1995;22: 1163-1170.
61. Jensen RT. Gastrointestinal abnormalities and involvement in systemic mastocytosis. *Hematol Oncol Clin North Am* 2000;14:579-623.
62. Chen CC, Andrich MP, Metcalfe DD, et al. A retrospective analysis of bone scan abnormalities in mastocytosis: correlation with disease category and prognosis. *J Nuclear Med* 1994;35:1471-1475.
63. Horan RF, Austen KF. Systemic mastocytosis: retrospective review of a decade's clinical experience at the Brigham and Women's Hospital. *J Invest Dermatol* 1991;96:55-135.
64. Travis WD, Li CY, Yam LT, et al. Significance of systemic mast cell disease with associated hematologic disorders. *Cancer* 1988;62:965-972.
65. Sperr WR, Horny HP, Lechner K, et al. Clinical and biological diversity of leukemias occurring in patients with mastocytosis. *Leuk Lymphoma* 2000;37:473-486.
66. Pardanani A, Lim K-H, Lasho TL, et al. Prognostically relevant breakdown of 123 patients with systemic mastocytosis associated with other myeloid malignancies. *Blood* 2009;114:3769-3772.
67. Tefferi A, Elliott MA, Pardanani A. Atypical myeloproliferative disorders: diagnosis and management. *Mayo Clin Proc* 2006;81:553-563.
68. Valent P, Akin C, Sperr WR, et al. Aggressive systemic mastocytosis and related mast cell disorders: current treatment options and proposed response criteria. *Leuk Res* 2003;27:635-641.

69. Travis WD, Li CY, Bergstralh EJ. Solid and hematologic malignancies in 60 patients with systemic mast cell disease. *Arch Pathol Lab Med* 1989;113: 365-368.
70. Valent P. Biology, classification and treatment of human mastocytosis. *Wien Klin Wschr* 1996;108:385-397.
71. Travis WD, Li CY, Hoagland HC, et al. Mast cell leukemia. Report of a case and review of the literature. *Mayo Clin Proc* 1986;61:957-966.
72. Sperr WR, Escribano L, Jordan JH, et al. Morphologic properties of neoplastic mast cells: delineation of stages of maturation and implication for cytological grading of mastocytosis. *Leuk Res* 2001;25:529-536.
73. Horny HP, Parwaresch MR, Kaiserling E, et al. Mast cell sarcoma of the larynx. *J Clin Pathol* 1986;39:596-602.
74. Kojima M, Nakamura S, Itoh H, et al. Mast cell sarcoma with tissue eosinophilia arising in the ascending colon. *Mod Pathol* 1999;12:739-743.
75. Guenther PP, Huebner A, Sobottka SB, et al. Intracranial mast cell sarcoma. *J Pediatr Hematol Oncol* 2001;23:134-138.
76. Kudo H, Morinaga S, Shimosata Y, et al. Solitary mast cell tumor of the lung. *Cancer* 1988;61:2089-2094.
77. Bonadonna P, Perbellini O, Passalacqua G, et al. Clonal mast cell disorders in patients with systemic reactions to Hymenoptera stings and increased serum tryptase levels. *J Allergy Clin Immunol* 2009;123:680-686.
78. Akin C, Scott LH, Kocabas CN, et al. Demonstration of an aberrant mast cell population with clonal markers in a subset of patients with "idiopathic" anaphylaxis. *Blood* 2007;110:2331-2333.
79. Akin C, Valent P, Metcalfe DD. Mast cell activation syndrome: proposed diagnostic criteria. *J Allergy Clin Immunol* 2012;126:1099-1104.
80. Valent P, Akin C, Arock M, et al. Definitions, criteria, and global classification of mast cell disorders with special reference to mast cell activation syndromes: a consensus proposal. *Int Arch Allergy Immunol* 2011;157:215-225.
81. Schwartz LB. Clinical utility of tryptase levels in systemic mastocytosis and associated hematologic disorders. *Leuk Res* 2001;25:553-562.
82. Li CY. Diagnosis of mastocytosis: value of cytochemistry and immunohistochemistry. *Leuk Res* 2001;25:537-541.
83. Akin C, Metcalfe DD. Surrogate markers of disease in mastocytosis. *Int Arch Allergy Immunol* 2002;127:133-136.
84. Sperr WR, Jordan JH, Fiegl M, et al. Serum tryptase levels in patients with mastocytosis: correlation with mast cell burden and implication for defining the category of disease. *Int Arch Allergy Immunol* 2002;128:136-141.
85. van Toorenenbergen AW, Oranje AP. Comparison of serum tryptase and urine N-methylhistamine in patients with suspected mastocytosis. *Clin Chim Acta* 2005;359:72-77.
86. Brockow K, Akin C, Huber M, et al. IL-6 levels predict disease variant and extent of organ involvement in patients with mastocytosis. *Clin Immunol* 2005;115:216-223.
87. Akin C, Schwartz LB, Kitoh T, et al. Soluble stem cell factor receptor (CD117) and IL-2 receptor alpha chain (CD25) levels in the plasma of patients with mastocytosis: relationships to disease severity and bone marrow pathology. *Blood* 2000;96:1267-1273.
88. Valent P, Sperr WR, Samarapoompichit P, et al. Myelomastocytic overlap syndromes: biology, criteria, and relationship to mastocytosis. *Leuk Res* 2001;25:595-602.
89. Dunphy CH. Evaluation of mast cells in myeloproliferative disorders and myelodysplastic syndromes. *Arch Pathol Lab Med* 2005;129:219-222.
90. Sperr WR, Drach J, Hauswirth AW, et al. Myelomastocytic leukemia: evidence for the origin of mast cells from the leukemic clone and eradication by allogeneic stem cell transplantation. *Clin Cancer Res* 2005;11:6787-6792.
91. Te Velde J, Vismans FJFE, Leenheers-Binnendijk L, et al. The eosinophilic fibrohistiocytic lesion of the bone marrow: a mastocellular lesion in bone disease. *Virchows Arch Pathol Anat* 1978;377:279-285.
92. Worobec AS. Treatment of systemic mast cell disorders. *Hematol Oncol Clin North Am* 2000;14:659-687.
93. Lim KH, Pardini A, Butterfield JH, et al. Cytoreductive therapy in 108 adults with systemic mastocytosis: outcome analysis and response prediction during treatment with interferon-alpha, hydroxyurea, imatinib mesylate or 2-chlorodeoxyadenosine. *Am J Hematol* 2009;85:790-794.

94. Ustun C, DeRemer DL, Akin C. Tyrosine kinase inhibitors in the treatment of systemic mastocytosis. *Leuk Res* 2011;35:1143-1152.
95. Frieri M, Alling DW, Metcalfe DD. Comparison of the therapeutic efficacy of cromolyn sodium with that of combined chlorpheniramine and cimetidine in systemic mastocytosis. *Am J Med* 1985;78:9-14.
96. Escribano L, Akin C, Castells M, et al. Current options in the treatment of mast cell mediator-related symptoms in mastocytosis. *Inflamm Allergy Drug Targets* 2006;5:61-77.
97. Tebbe B, Stavropoulos PG, Krasagakis K, et al. Cutaneous mastocytosis in adults. Evaluation of 14 patients with respect to systemic disease manifestations. *Dermatology* 1998;197:101-108.
98. Higgins EM, Humphreys S, Duivivier AW. Urticaria pigmentosa-response to topical steroids. *Clin Exp Dermatol* 1994;19:438-440.
99. Mackey S, Pride HB, Tyler WB. Diffuse cutaneous mastocytosis: treatment with oral psoralen plus UV-A. *Arch Dermatol* 1996;132:1429-1430.
100. Stege H, Schopf E, Ruzicka T, et al. High-dose UVA1 for urticaria pigmentosa. *Lancet* 1996;347:64.
101. Godt O, Proksch E, Streit V, et al. Short- and long-term effectiveness of oral and bath PUVA therapy in urticaria pigmentosa and systemic mastocytosis. *Dermatology* 1997;195:35-39.
102. Wilson TM, Metcalfe DD, Robyn J. Treatment of systemic mastocytosis. *Immunol Allergy Clin North Am* 2006;26:549-573.
103. Allison MA, Schmidt CP. Urticaria pigmentosa. *Int J Dermatol* 1997;36: 321-325.
104. Correia O, Duarte AF, Quirino, P, et al. Cutaneous mastocytosis: two pediatric cases treated with topical pimecrolimus. *Dermatol Online* 2010;16:8.
105. Achord JL, Langford H. The effect of cimetidine and propantheline on the symptoms of a patient with systemic mastocytosis. *Am J Med* 1980;69: 610-614.
106. Fonga-Djimi HS, Gottrand F, Bonneville M, et al. A fatal case of portal hypertension complicating systemic mastocytosis in an adolescent. *Eur J Pediatr* 1995;154:819-821.
107. Bonnet P, Smadja C, Szekely AM. Intractable ascites in systemic mastocytosis treated by portal diversion. *Dig Dis Sci* 1987;32:209-213.
108. Johnstone PAS, Mican JM, Metcalfe DD, et al. Radiotherapy of refractory bone pain due to systemic mast cell disease. *Am J Clin Oncol* 1994;17:328-330.
109. Moret H, Plihal E, Saudan Y. Case report of bone mastocytosis: total hip arthroplasty for osteoarthritis and open reduction for condylar fracture of the knee. *Clin Rheumatol* 1994;13:616-623.
110. Cassasus P, Caillat-Vigneron N, Martin A, et al. Treatment of adult systemic mastocytosis with interferon alpha: results of a multi-centre phase trial on 20 patients. *Br J Haematol* 2002;119:1090-1097.
111. Lehmann T, Beyeler C, Lammle B, et al. Case report: severe osteoporosis due to systemic mast cell disease: successful treatment with interferon alpha-2b. *Br J Rheumatol* 1996;35:898-900.
112. Tefferi A, Chin-Yang L, Butterfield JH, et al. Treatment of systemic mast cell disease with cladribine. *N Engl J Med* 2001;344:307-309.
113. Hennessy B, Giles F, Cortes J, et al. Management of patients with systemic mastocytosis: review of M.D. Anderson Cancer Center experience. *Am J Hematol* 2004;77:209-214.
114. Valent P, Ghannadan M, Akin C, et al. On the way to targeted therapy of mast cell neoplasms: identification of molecular targets in neoplastic mast cells and evaluation of arising treatment concepts. *Eur J Clin Invest* 2004;34: 41-52.
115. Pardanani A. Systemic mastocytosis in adults: 2012 update on diagnosis, risk stratification, and management. *Am J Hematol* 2012;87:402-411.
116. Nakamura R, Chakrabati S, Akin C, et al. A pilot study of nonmyeloablative allogeneic hematopoietic stem cell transplantation for advanced systemic mastocytosis. *Bone Marrow Transplant* 2006;37:353-358.
117. Przepiorka D, Giralt S, Khouri I, et al. Allogeneic marrow transplantation for myeloproliferative disorders other than chronic myelogenous leukemia: review of forty cases. *Am J Hematol* 1998;57:24-28.

118. Ronnov-Jessen D, Lovgreen Nielsen P, Horn T. Persistence of systemic mastocytosis after allogeneic bone marrow transplantation in spite of complete remission of the associated myelodysplastic syndrome. *Bone Marrow Transplant* 1991;8:413-415.
119. Van Hoof A, Criel A, Louwagie A, et al. Cutaneous mastocytosis after autologous bone marrow transplantation. *Bone Marrow Transplant* 1991;8: 151-153.
120. Friedman B, Darling G, Norton J, et al. Splenectomy in the management of systemic mast cell disease. *Surgery* 1990;107:94-100.
121. Ma Y, Zeng S, Metcalfe DD, et al. The c-kit mutation causing human mastocytosis is resistant to STI571 and other kit kinase inhibitors; kinases with enzymatic site mutations show different inhibitor sensitivity profiles than wild-type kinases and those with regulatory-type mutations. *Blood* 2002;99:1741-1744.
122. Ueda S, Ikeda H, Mizuki M, et al. Constitutive activation of c-kit by the juxtamembrane but not the catalytic domain mutations is inhibited selectively by tyrosine kinase inhibitors STI571 and AG1296. *Int J Hematol* 2002;76: 427-435.
123. Akin C, Fumo G, Yavuz AS, et al. A novel form of mastocytosis associated with a transmembrane c-kit mutation and response to imatinib. *Blood* 2004;103:3222-3225.
124. Gleixner KV, Mayerhofer M, Aichberger KJ, et al. PKC412 inhibits in vitro growth of neoplastic human mast cells expressing the D816V-mutated variant of KIT: comparison with AMN107, imatinib, and cladribine (2CdA) and evaluation of cooperative drug effects. *Blood* 2006;107:752-759.
125. Gotlib J, Berube C, Growney JD, et al. Activity of the tyrosine kinase inhibitor PKC412 in a patient with mast cell leukemia with the D816V KIT mutation. *Blood* 2005;106:2865-2870.
126. Shah NP, Lee FY, Luo R. Dasatinib (BMS-354825) inhibits KITD816V, an imatinib-resistant activating mutation that triggers neoplastic growth in the majority of patients with systemic mastocytosis. *Blood* 2006;108:286-291.
127. Gotlib J, DeAngelo DJ, George TI, et al. KIT inhibitor midostaurin exhibits a high rate of clinically meaningful and durable responses in advanced systemic mastocytosis: report of a fully accrued phase II trial. *ASH Annual Meeting Abstracts*. *Blood* 2012;116:316..
128. Verstovsek S, Tefferi A, Cortes J, et al. Phase II study of dasatinib in Philadelphia chromosome-negative acute and chronic myeloid diseases including systemic mastocytosis. *Cancer Res* 2008;14:3906-3915.
129. Hochhaus A, Ottmann OG, Lauber S, et al. A phase II study of nilotinib, a novel inhibitor of c-kit, PDGFR, and Bcr-Abl, administered to patients with systemic mastocytosis. *Blood* 2006;108: abstract 2703.
130. Bai Y, Bandara G, Chan EC, et al. Targeting the KIT switch control pocket: a novel mechanism to inhibit neoplastic mast cell proliferation and mast cell activation. *Leuk Res* 2012, in press.
131. Carter MC, Uzzaman A, Scott LM, et al. Pediatric mastocytosis: routine anesthetic management for a complex disease. *Anesth Analg* 2008;107:422-427
132. Pardanani A. Systemic mastocytosis in adults: 2012 Update on diagnosis, risk stratification, and management. *Am J Hematol* 2012;87:401-411.
133. Pardanani A, Tefferi A. A critical reappraisal of treatment response criteria in systemic mastocytosis and a proposal for revisions. *Eur J Haematol* 2010;84:371-378.

Section 4 - Lymphoproliferative Disorders

Chapter 86 Diagnosis and Classification of Lymphomas

> Table of Contents > Part VII - Hematologic Malignancies > Section 4 - Lymphoproliferative Disorders > Chapter 86 - Diagnosis and Classification of Lymphomas

Chapter 86

Diagnosis and Classification of Lymphomas

William R. Macon

Paul J. Kurtin

Ahmet Dogan

SPECIMEN EVALUATION

Tissue Sampling and Processing

Precise assessment of hematopathologic specimens depends, in large part, on adequate sampling and proper handling of tissues, both of which may be influenced significantly by clinicians. Therefore, effective communication between the clinician and the pathologist is imperative for obtaining pertinent patient history and the proper specimen. The largest lymph node or mass lesion generally provides the most useful material for accurate diagnosis and should undergo surgical biopsy. Fresh tissue, moistened in a balanced solution, such as normal saline, should be sent intact to the surgical pathology laboratory without delay to maximize the immunophenotypic, genotypic, and karyotypic studies that are available and to minimize irreversible tissue artifacts. Frozen sections should be discouraged on small specimens, as lymphoid hyperplasias may appear indistinguishable from lymphomas, and freezing permanently distorts the tissue. Touch imprints are generally satisfactory for initial evaluation and for directing specimen work-up.

Needle biopsy and aspiration cytology is playing an expanded role in the primary diagnosis and monitoring of patients with malignant lymphomas. The major advantages of these techniques include: (a) their relatively noninvasive nature and (b) the rapidity with which the cytology can be reviewed (minutes) and the aspirated cells immunophenotyped (2 to 3 hours by flow cytometry). With computed tomography guidance, lesions in the mediastinum and retroperitoneum or in any highly vascular organ or tissue can be sampled with minimal morbidity. Technical advances in flow cytometry and molecular biology continue to reduce the amount of tissue required to provide immunophenotypic and genetic data.

Just as with lymph node and bone marrow biopsies, however, optimal information can be obtained only by close coordination between the clinician, the person performing the aspirate (radiologist or pathologist), and the hematopathologist providing ancillary diagnostic services. If the material is put into fixative, it cannot be used for flow cytometric phenotypic analysis or standard karyotypic studies.

The limitations of fine-needle aspiration (FNA) include: (a) the possibility of missing focal lesions, (b) the difficulty in making a primary diagnosis of malignant lymphoma in which the tumor cells are a minor population (e.g., Hodgkin lymphoma [HL] and T cell/histiocyte-rich large B-cell lymphoma [THRLBCL]), and (c) the difficulty in precisely classifying many reactive processes in which architectural features are of prominent diagnostic importance. For example, in patients with mediastinal masses, it may be impossible to distinguish between normal thymus, thymoma, and T lymphoblastic lymphoma by the cytology of the lymphoid population. Furthermore, immunophenotypic studies may identify a common thymocyte phenotype that can be dominant in all three. Despite these limitations, FNA coupled with flow cytometry and fluorescence in situ hybridization (FISH) will play a major role in the diagnosis of many non-Hodgkin lymphomas (NHLs) in the future.

Morphologic Examination

Morphologic examination starts at low magnification to evaluate tissue architecture and patterns of infiltration. Lymphomas may cause partial or complete destruction of the normal architectural features of the lymph node. Growth patterns are generally described as nodular or diffuse. Lymphomas are often distributed within specific anatomic compartments of the lymph node, such as follicle (germinal) centers, follicle mantles, or the paracortical and medullary areas. The low magnification pattern of neoplastic cell distribution within the lymph node suggests the type of lymphoma present (Fig. 86.1). High magnification is then used to examine cytologic features, such as the neoplastic cell types (e.g., small cleaved cells [centrocytes], large transformed cells [centroblasts or immunoblasts], and plasmacytoid lymphocytes or plasma cells), because this information helps establish the classification and grade of the tumor. In some lymphomas, the composition of the reactive cell constituents also may be of prognostic significance.

Immunophenotypic and Genotypic Analysis

Immunophenotypic analysis uses antibodies of variable specificity to detect cellular antigens (surface, cytoplasmic, or nuclear) in cell suspensions (flow cytometry) or in frozen or paraffin-embedded tissue sections (Table 86.1). These studies are often invaluable, because they help in distinguishing subtle lymphomatous infiltrates from reactive hyperplasias, can demonstrate the lineage of the neoplastic cell (e.g., B cell, T cell, and natural killer [NK] cell), can provide data necessary for precise classification of some

P.1771

P.1772

lymphomas (e.g., mantle cell lymphoma vs. small lymphocytic lymphoma [SLL]) (Table 86.2), can identify important nonlineage-related markers (e.g., CD15, CD30, and CD56), and can determine the proliferative rate of lymphomas. Immunoglobulin (Ig) light chain restriction is evidence of B-cell clonality, whereas aberrant B-cell or T-cell phenotypes infer clonality.^{1,2} As small monotypic (light chain-restricted) B-cell or genotypically clonal B-cell or T-cell populations may be seen in reactive processes, correlation of these studies with the morphologic features is essential to prevent misdiagnosis and clinical confusion.^{3,4} and ⁵

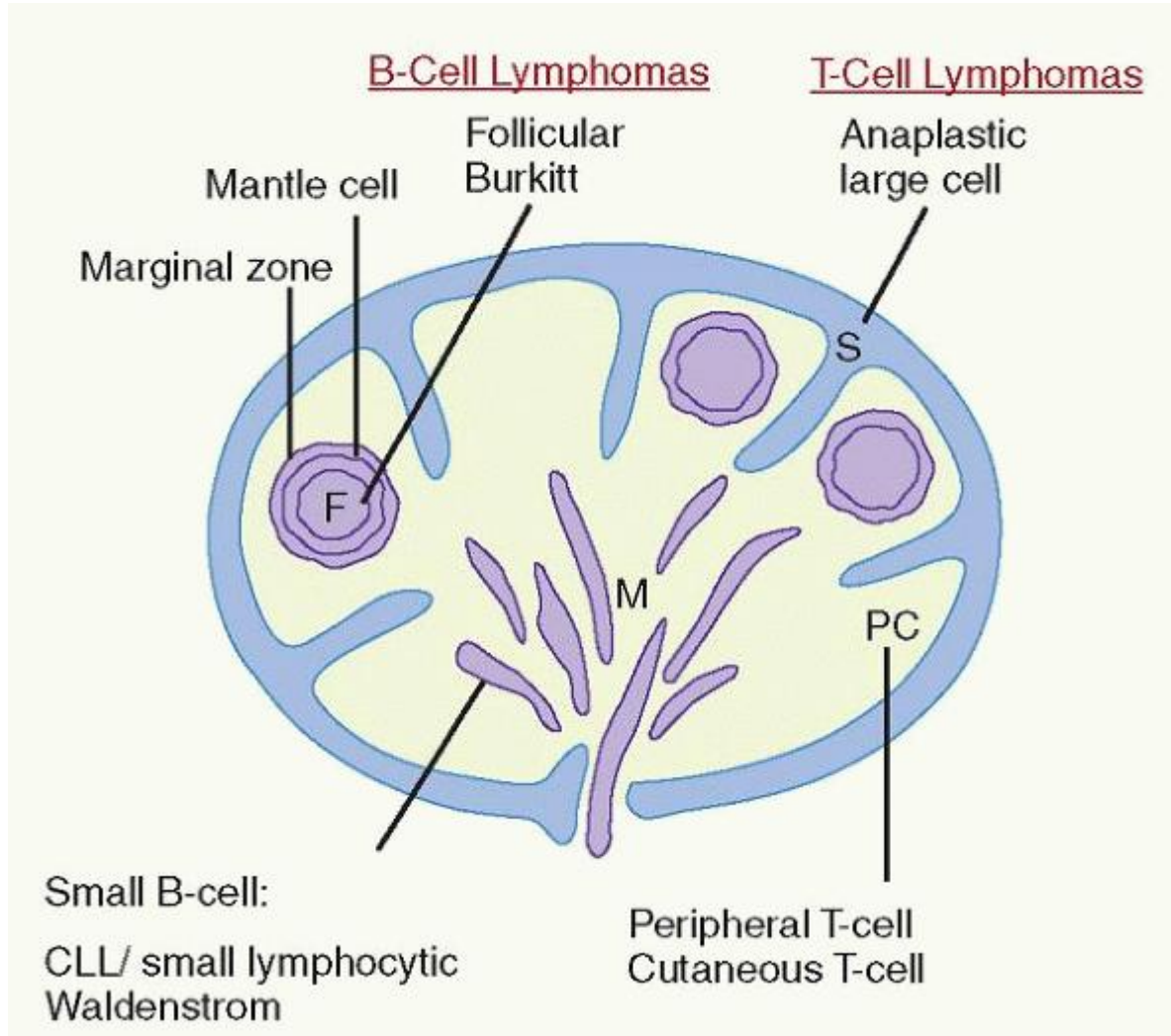

FIGURE 86.1. Sites of origin of malignant lymphomas in a lymph node according to anatomic and functional compartments of the immune system. CLL, chronic lymphocytic leukemia; F, follicles with germinal centers; M, medullary cords; PC, paracortex, or interfollicular areas; S, sinuses. (Adapted from Mann RB, et al. Malignant lymphomas: a conceptual understanding of morphologic diversity. *Am J Pathol* 1979;94:1.)

TABLE 86.1 IMMUNOPHENOTYPIC MARKERS USED IN DIAGNOSIS OF MALIGNANT LYMPHOMAS

Antibody Designation	Reactivity	Examples of Lymphoid Neoplasms
CD1a	Thymocytes, dendritic cells, and epidermal Langerhans cells	T lymphoblastic leukemia/lymphoma and Langerhans cell histiocytosis
CD2	T cells and natural killer cells	T-cell and natural killer cell lymphomas

CD3	T cells	T-cell lymphomas
CD4	Helper and inducer T cells, monocytes, and macrophages	T-cell lymphomas and diffuse large B-cell lymphoma with ALK expression (rare)
CD5	T-cells and B-cell subset	T-cell lymphomas, chronic lymphocytic leukemia/small lymphocytic lymphoma, and mantle cell lymphoma
CD7	T cells and natural killer cells	T-cell and natural killer cell lymphomas
CD8	Cytotoxic and suppressor cells T cells and natural killer cells	Cytotoxic T-cell lymphomas and natural killer cell lymphomas
CD10	Precursor B cells, B-cell subset (follicle center cells), and follicle center T-helper cells	B and some T lymphoblastic leukemias/lymphomas, follicular lymphoma, some diffuse large B-cell lymphomas, Burkitt lymphoma, and angioimmunoblastic T-cell lymphoma
CD15	Granulocytes, monocytes, Reed-Sternberg cells, activated lymphocytes, and some epithelial cells	Classical Hodgkin lymphomas
CD19	B cells	B-cell lymphomas
CD20	B cells	B-cell lymphomas and nodular lymphocyte predominant Hodgkin lymphoma
CD21	B-cell subset and follicular dendritic cells	Follicular dendritic cell sarcoma and follicular dendritic cell meshworks in angioimmunoblastic T-cell lymphoma
CD22	B-cell subset	Some B-cell lymphomas and hairy cell leukemia
CD23	Activated B cells, mantle B cells, and follicular dendritic cells	Chronic lymphocytic leukemia/small lymphocytic lymphoma and follicular dendritic cell meshworks in angioimmunoblastic T-cell lymphoma
CD25	Activated T- and B cells and activated macrophages	Adult T-cell leukemia/lymphoma, anaplastic large cell lymphoma, and hairy cell leukemia
CD30	Activated T- and B cells and Reed-Sternberg cells	Classical Hodgkin lymphomas, anaplastic large cell lymphoma, some peripheral T-cell lymphomas, NOS, and some large B-cell lymphomas
CD38	Plasma cells, thymocytes, and activated T cells	Plasma cell neoplasms, B-cell lymphomas with plasmacytic differentiation, and some chronic lymphocytic leukemias/small lymphocytic lymphomas
CD43	T cells, B cell subset, granulocytes, and monocytes and macrophages	T-cell lymphomas, chronic lymphocytic leukemia/small lymphocytic lymphoma, mantle cell lymphoma, some marginal zone B-cell lymphomas, and Burkitt lymphoma
CD45	Leukocytes	Non-Hodgkin lymphomas and nodular lymphocyte predominant Hodgkin lymphoma

CD45RA	B cells, T-cell subset, granulocytes, and monocytes	B-cell lymphomas and some T-cell lymphomas
CD45RB	B cells, T-cell subset, granulocytes, and monocytes and macrophages	B-cell lymphomas and some T-cell lymphomas
CD45RO	T cells, B-cell subset, granulocytes, and monocytes and macrophages	Most T-cell lymphomas and some diffuse large B-cell lymphomas
CD56	Natural killer cells and T-cell subset	Natural killer cell lymphomas, some cytotoxic T-cell lymphomas, and plasma cell neoplasms
CD57	Natural killer cells and T-cell subset	Natural killer cell lymphomas, some cytotoxic T-cell lymphomas, and diffuse large B-cell lymphoma with ALK expression (rare)
CD68	Monocytes and macrophages	Histiocytic sarcomas and reactive histiocytes in many lymphomas
CD79a	B cells	Most B-cell lymphomas and plasma cell neoplasms
CD103	Intestinal intraepithelial T cells	Enteropathy-associated T-cell lymphoma and hairy cell leukemia
CD138	Plasma cells	Plasma cell neoplasms and some B-cell lymphomas with plasmacytic differentiation
CD246 (ALK)	Neoplastic cells in anaplastic large cell lymphoma	Most anaplastic large cell lymphomas and diffuse large B-cell lymphoma with ALK expression (rare)
Bcl-2	B-cell subset and T cells	Follicular lymphoma and most other B-cell and T-cell lymphomas
Bcl-6	Follicle center B cells	Follicular lymphoma and some diffuse large B-cell lymphomas
Clusterin	Follicular dendritic cells	Follicular dendritic cell sarcoma, anaplastic large cell lymphoma, and follicular dendritic cell meshworks in angioimmunoblastic T-cell lymphoma
CXCL13	Follicle center T-helper cells	Angioimmunoblastic T-cell lymphoma and nodular lymphocyte predominant Hodgkin lymphoma
Cyclin D1	Neoplastic mantle cells	Mantle cell lymphoma, hairy cell leukemia, and some plasma cell neoplasms
Epithelial membrane antigen	Epithelial cells and plasma cells	Anaplastic large cell lymphoma, nodular lymphocyte predominant Hodgkin lymphoma, plasmablastic lymphoma, and plasma cell neoplasms
Fascin	Follicular dendritic cells, histiocytes, Reed-Sternberg cells, and Epstein-Barr virus-infected immunoblasts	Classical Hodgkin lymphoma, Epstein-Barr virus-positive B-cell and T-cell lymphomas, follicular dendritic cell sarcoma
FoxP3	CD4 ⁺ /CD25 ⁺ regulatory T cells	Adult T-cell leukemia/lymphoma
Granzyme A,	Natural killer cells and activated	Natural killer cell and activated cytotoxic T-cell

B, and M	cytotoxic T cells	lymphomas
IgA, IgD, IgE, IgG, and IgM	Immunoglobulin heavy chains	B-cell lymphomas and plasma cell neoplasms
Kappa and Lambda	Immunoglobulin light chains	B-cell lymphomas and plasma cell neoplasms
Ki-67/mib-1	Nuclear proliferation antigens	
MUM-1	B cells in terminal phase of differentiation, plasma cells, activated T cells, and Reed-Sternberg cells	Lymphoplasmacytic lymphoma, some diffuse large B-cell lymphomas, plasma cell neoplasms, some T-cell lymphomas, and Hodgkin lymphomas
PAX-5	B cells and Reed-Sternberg cells	B-cell lymphomas and Hodgkin lymphomas
T-cell receptor α/β	α/β T cells	Most T-cell lymphomas
T-cell receptor γ/δ	γ/δ T cells	Few T-cell lymphomas
TdT	Lymphoblasts and some myeloblasts	B and T lymphoblastic leukemias/lymphomas
TIA-1	Natural killer cells and cytotoxic T cells	Natural killer cell and cytotoxic T-cell lymphomas

TABLE 86.2 PATHOLOGIC FEATURES IN THE DIFFERENTIAL DIAGNOSIS OF SMALL B-CELL LYMPHOMAS

Lymphoma Type	Growth Pattern	Cytology	Immunophenotype			Surface Ig	Genetics
			CD5	CD10	CD23		
Follicular lymphoma	Nodular (follicular)	Lymphocytes with irregular cleaved nuclei (centrocytes) and admixed large cells (centroblasts)	-	+	-	Bright	t(14;18)(q32;q21) in >85%
Chronic lymphocytic leukemia/small lymphocytic lymphoma	Diffuse with proliferation centers	Small lymphocytes with round nuclei and scant cytoplasm	+	-	+	Weak IgM and IgG > IgA	Trisomy 12 > 20% to 30%
Lymphoplasmacytic lymphoma	Diffuse or interfollicular	Small lymphocytes, plasma cells, and plasmacytoid lymphocytes	-	-	-	Moderate IgM	MYD88 L265P mutation
Mantle cell lymphoma	Diffuse or vaguely nodular	Small lymphocytes with irregular nuclei, scant cytoplasm, and few admixed large cells	+	-	-	Moderate IgM and IgD; Lambda > kappa	t(11;14)(q13;q32)
Nodal marginal zone	Interfollicular and	Small lymphocytes with round, folded	-	-	-	Moderate	None

B-cell lymphoma	perisinusoidal	nuclei and abundant cytoplasm ± plasma cells				IgM	
Splenic marginal zone B-cell lymphoma	Nodular	Biphasic: inner core of small lymphocytes with irregular nuclei and scant cytoplasm; outer core of medium-size lymphocytes with round nuclei and abundant clear cytoplasm +/- plasma cells	-	-	-	IgM +/- IgD	Del 7q
Extranodal marginal zone B-cell lymphoma of mucosa-associated lymphoid tissue	Diffuse	Small lymphocytes with round, folded nuclei and abundant cytoplasm ± plasma cells	-	-	-	IgM	Trisomy 3 or t(11;18) (q21; q21)

Ig, immunoglobulin; +, positive; -, negative.

P.1773

Each of the major immunologic techniques has its strengths and liabilities. Flow cytometry permits rapid analysis of large numbers of cells for virtually any surface or cytoplasmic antigen. Flow cytometry is the primary tool used for phenotyping most NHLs and leukemias and is a very sensitive and specific technique for detecting residual disease.^{6,7,8,9} Studies for coexpression of more than one marker are easily accomplished (e.g., CD5 on CD19+ B cells). Flow cytometry also allows correlation of phenotypic characteristics with cell cycle kinetics and other biologic features of cells. Data storage in list mode permits retrospective off-line multiparameter analysis of lymphocyte subpopulations. However, for most analyses, flow cytometry requires viable cell populations. The quality of the information produced by flow cytometry is directly related to the quality of the communication between the flow cytometrist and the pathologist. The basic question is, "Is the cell population of interest to the pathologist the same cell population analyzed by flow cytometry?"

Immunohistochemical studies on paraffin-embedded tissue permit direct visualization of antigens on the cell of interest. Leukocyte common antigen (CD45) is a reliable marker for identifying most hematopoietic or lymphoid neoplasms but can be negative in acute leukemias, plasma cell neoplasms, anaplastic large cell lymphoma (ALCL), and classical HLs.^{10,11} Two markers that work well in paraffin, such as CD20 (pan-B cell) and CD3 (pan-T cell), are adequate to categorize most NHLs as to their B-cell or T-cell lineage.^{12,13} Detection of light chain restriction is most easily achieved in B-cell lymphomas that have abundant cytoplasmic Ig (most lymphomas with plasmacytic differentiation and many large B-cell lymphomas). The major liability of paraffin immunohistochemistry is the loss of some lymphocyte antigens during tissue processing. However, the explosion of fixation-sensitive markers for lymphoma-associated antigens (e.g., CD2, CD4, CD5, CD8, CD10, CD23, cyclin D1, and anaplastic lymphoma kinase [ALK]) has allowed precise classification of most lymphomas in paraffin-embedded tissue, obviating the need to rebiopsy to obtain fresh tissue for flow cytometry and cytogenetics.¹⁴

Genotypic analysis using the Southern blot technique provides a sensitive, but time-consuming and expensive, means of detecting clonal lymphoproliferations and their lineage. Polymerase chain reaction (PCR) is more sensitive than Southern blot for detecting clonality and also can be performed more rapidly. PCR is particularly helpful for establishing B-cell or T-cell clonality in lymphoproliferations present in paraffin-embedded small biopsies, such as those obtained by endoscopy.¹⁵ These methods are most useful when immunophenotypic studies are inconclusive and are the only practical way of proving B-cell or T-cell clonality. Southern blot and PCR also can demonstrate significant chromosomal abnormalities (e.g.,

CCND1, BCL2, and MYC gene rearrangements) and viral nucleic acids that may be involved in lymphomagenesis (e.g., Epstein-Barr virus [EBV], human T-cell lymphotropic virus type 1 [HTLV-1], and human herpes virus 8). PCR also is proving valuable in the detection of minimal amounts of residual disease in treated patients.

More recently, FISH applied to paraffin-embedded tissue has allowed detection of critical translocations in NHLs with sensitivity that is much greater than classic cytogenetics on fresh tissue or PCR on fresh or fixed tissue.^{16,17,18} FISH can be performed on very small specimens (e.g., smears and touch imprints) and may be completed in less than 24 hours. FISH added to flow cytometry is greatly increasing the opportunity for making rapid primary diagnoses of NHLs on FNA material.^{19,20}

In the coming 5 years, it is expected that next-generation whole genome/exome/transcriptome sequencing technologies will alter the way lymphomas are diagnosed, classified, risk stratified, and treated. Already a number of detailed genetic analyses have been published for diffuse large B-cell lymphoma (DLBCL), mantle cell lymphoma, Burkitt lymphoma, hairy cell leukemia, chronic lymphocytic leukemia (CLL), splenic marginal zone lymphoma, and ALCL. These studies have highlighted a marked heterogeneity within histologically defined lymphoma subtypes, but also have identified a range of genetic abnormalities shared between different tumor types. Translation of these findings to meaningful diagnostic, prognostic, predictive, and therapeutic tests and strategies will be the main challenge for the near future.

Classification of Non-Hodgkin Lymphomas

For the clinician, pathologist, and basic scientist working in lymphoid neoplasia, the classification of NHLs is a persistent, confusing, and controversial problem. Several competing classification schemes have evolved, all with their supporters and detractors. In the 1950s, Rappaport developed a classification system based on growth pattern (nodular or diffuse) and cytology of lymphocytes (well differentiated, poorly differentiated, undifferentiated, or histiocytic).^{21,22} This scheme enjoyed enormous popularity because of its simplicity and reproducibility, but was superseded by classification schemes that reflected advances in cellular immunology.

In the early 1970s, Lukes and Collins,²³ in the United States, and Lennert,²⁴ in Kiel, Germany, proposed NHL classifications that related morphology to lymphocyte lineage. Both recognized follicular structures as a histologic correlate of B-cell differentiation. Each subdivided follicular lymphomas by the cytologic appearance of the predominant follicle center cell type: small and large cleaved cells in the Lukes-Collins classification (centrocytes in Kiel classification) and small and large noncleaved (transformed) cells in the Lukes-Collins classification (centroblasts in Kiel classification). For NHLs with diffuse growth patterns, immunophenotypic studies facilitated and, in many cases, were essential for precise classification.^{25,26}

In 1982, the Working Formulation (WF) was introduced in an attempt to provide a morphologic classification scheme with prognostic relevance.²⁷ Although the WF was an improvement over the earlier Rappaport classification, it had the same limitations as all purely morphologic classification schemes, separating biologically closely related lymphomas and grouping together biologically unrelated entities. All consideration regarding immunophenotype was excluded, so that the WF did not foster recognition of new entities.

In 1994, the Revised European American Lymphoma (REAL) classification was proposed and listed well-defined, "real disease entities recognized and diagnosed in daily practice".²⁸ More recently, the World Health Organization (WHO) classification²⁹ built on the REAL classification and corrected some of its deficiencies. The WHO classification has many strongpoints and is comprehensive, and its most recent edition includes virtually all lymphoid malignancies described at the time of its publication in 2008 (Table 86.3).³⁰ It defines diseases by four features: morphology, immunophenotype, genetics, and clinical information. Accordingly, the major diagnostic criteria for each of the major groups of NHL and HL are presented in the following discussion.

B-CELL LYMPHOMAS

B-Cell Lymphoblastic Leukemia/Lymphoma

Lymphoblastic lymphoma is a malignant lymphoma of precursor lymphocytes. Approximately 10% of lymphoblastic lymphomas are of B-cell lineage.³⁰ They are distinguished from extramedullary acute lymphoblastic leukemia (ALL) by (a) the absence of peripheral blood involvement at presentation, (b) absence or only patchy marrow involvement (<25%) by blast cells, and (c) a clinical picture dominated by extramedullary tumor. Although they

P.1774

may occur at any age, the majority of these rare lymphomas have been described in children and young adults. These

neoplasms present frequently in extranodal sites such as bone and soft tissue or as skin tumors of the scalp and face.^{31,32,33,34} They almost never present as mediastinal masses.

TABLE 86.3 WORLD HEALTH ORGANIZATION CLASSIFICATION OF MALIGNANT LYMPHOMAS

B-cell Neoplasms	T-cell and NK-cell Neoplasms
Precursor B-cell neoplasm	Precursor T-cell neoplasm
B lymphoblastic leukemia/lymphoma	T lymphoblastic leukemia/lymphoma
Mature B-cell lymphomas	Mature T cell and NK cell lymphomas
Follicular lymphoma	Peripheral T-cell lymphoma, NOS
Chronic lymphocytic leukemia/small lymphocytic lymphoma	Angioimmunoblastic T-cell lymphoma
Lymphoplasmacytic lymphoma	Anaplastic large cell lymphoma
Mantle cell lymphoma	Adult T-cell leukemia/lymphoma
Nodal marginal zone B-cell lymphoma	Hepatosplenic T-cell lymphoma
Splenic marginal zone B-cell lymphoma	Subcutaneous panniculitis-like T-cell lymphoma
Extranodal marginal zone B-cell lymphoma of mucosa-associated lymphoid tissue	Enteropathy-associated T-cell lymphoma
Diffuse large B-cell lymphoma, NOS	Mycosis fungoides/Sézary syndrome
T-cell/histiocyte-rich large B-cell lymphoma	Extranodal NK/T-cell lymphoma, nasal type
Primary mediastinal (thymic) large B-cell lymphoma	
Primary diffuse large B-cell lymphoma of the CNS	
Epstein-Barr virus-positive diffuse large B-cell lymphoma of the elderly	
Rare large B-cell lymphoma types: DLBCL associated with chronic inflammation; lymphomatoid granulomatosis; intravascular large B-cell lymphoma; ALK-positive large B-cell lymphoma; plasmablastic lymphoma; large B-cell lymphoma arising in HHV-8-associated multicentric Castleman disease; primary effusion lymphoma	
Burkitt lymphoma	
Hodgkin lymphomas	

Classical Hodgkin lymphoma

Mixed cellularity Hodgkin lymphoma

Lymphocyte-rich classical Hodgkin lymphoma

Nodular sclerosis Hodgkin lymphoma

Lymphocyte depleted Hodgkin lymphoma

Nodular lymphocyte predominant Hodgkin lymphoma

ALK, anaplastic lymphoma kinase; CNS, central nervous system; DLBCL, diffuse large B-cell lymphoma; HHV, human herpes virus; NK, natural killer; NOS, not otherwise specified.

Histologically, they exhibit a diffuse growth pattern with frequent mitoses and a “starry sky” appearance. Linear capsular infiltration and interfollicular involvement is characteristic in lymph nodes. Cytologically, the tumor cells are small to intermediate in size with irregular nuclear borders, dispersed chromatin, small nucleoli, and scant cytoplasm.³³

Most B lymphoblastic lymphomas are CD19, CD79a, CD10, and terminal deoxynucleotidyl transferase (TdT) positive with undetectable cytoplasmic Ig and variable expression of CD45 (weak to absent) and CD20.^{33,34} Only a few surface Ig-positive cases have been described.³⁵ Lymphoblastic lymphomas in tissue sections may be difficult to distinguish from nonhematopoietic small cell undifferentiated tumors, such as Ewing sarcoma, rhabdomyosarcoma, and neuroblastoma, as well as T lymphoblastic lymphoma and blastoid variants of mantle cell lymphoma. Therefore, immunohistochemical studies are essential for diagnosis.^{36,37}

Studies of the genetics of B lymphoblastic lymphoma are limited. The blasts show clonal Ig gene rearrangements without somatic mutation consistent with a pregerminal center cell of origin.³⁸ It appears that hyperdiploidy or the presence of many of the translocations seen in pediatric ALL, such as t(9;22), t(1;19), and t(4;11), are uncommon. Chromosome 21 additions, including trisomy and tetrasomy, have been described.³⁴

Follicular Lymphoma

The WHO classification of follicular lymphomas requires at least a partial follicular growth pattern (Fig. 86.2A). It excludes lymphomas, such as extranodal marginal zone B-cell lymphomas of mucosa-associated lymphoid tissue (MALT lymphomas) and mantle cell lymphomas, which also may have a nodular growth pattern. The incidence of follicular lymphomas is second only to DLBCL in the United States and Western Europe. These usually indolent lymphomas commonly present as painless lymphadenopathy in middle-aged or elderly adults. They commonly involve the bone marrow early.³⁰ Follicular lymphomas in young children and some extranodal follicular lymphomas (e.g., skin and gastrointestinal tract) tend to be more localized at presentation than nodal follicular lymphomas in adults.^{39,40,41,42}

Background

The follicle center is the major site of B-lymphocyte differentiation and proliferation.^{43,44} It may also serve as the site of lymphomagenesis of most B-cell lymphomas and HLs.⁴⁵ B-lymphocytes move into the follicle after they first encounter protein antigen in the paracortex, to begin a series of steps that ultimately produces plasma cells with high-affinity Ig and memory B cells. Morphologically, the follicular center reflects this biologic transformation by frequent mitoses and by its range of cell types, including cleaved cells (or centrocytes) and large noncleaved cells (or centroblasts). Differentiation results in the Ig heavy chain class switching from IgM to IgG, IgA, or IgE, and in enhanced Ig synthesis. Proliferation produces the clonal expansion that is the basis of immunologic memory and an effective humoral immune response.^{43,44}

Somatic mutation in the Ig genes occurring during proliferation is followed by selection of B cells with surface Ig of higher affinity for antigen. Successful interaction of B cells with antigenbearing follicular dendritic cells triggers B-cell expression of BCL2 protein that saves the B cell from apoptotic cell death.⁴⁶ Tingible body macrophages mark the passing via apoptosis of B cells not selected for survival. Somatic mutation may serve to identify those neoplasms that have arisen from B cells that have been exposed to antigen in the environment of the follicle, such as follicular lymphomas and multiple myeloma, versus those that have not, such as most mantle cell lymphomas. Most B-cell NHLs and HLs have extensive somatic mutations.^{45,47,48} Somatic mutation of non-Ig genes, such as BCL6, may participate in lymphomagenesis.⁴⁹ The recognition of the contribution of somatic mutation, receptor editing, and class switching in lymphomagenesis supports a major role for the follicle in neoplastic transformation.^{45,50,51}

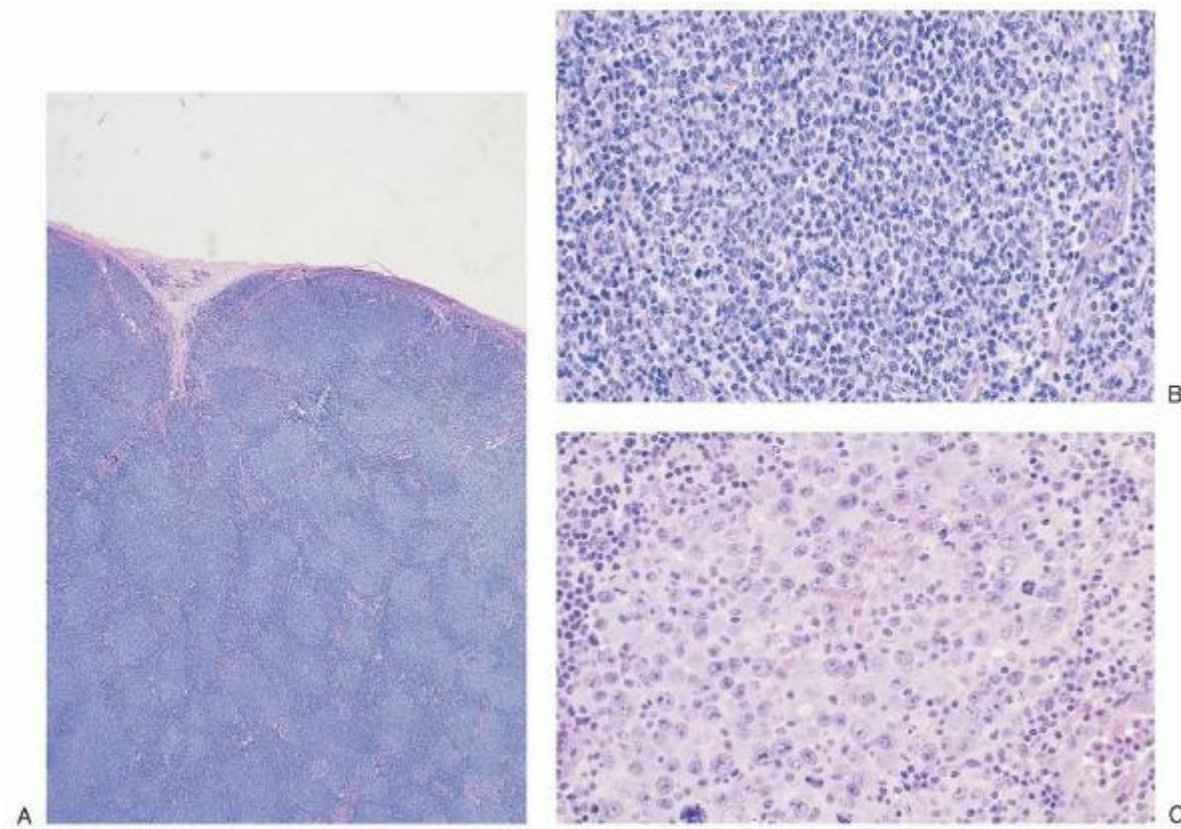

FIGURE 86.2. Lymph node: follicular lymphoma. A: Low magnification demonstrates effacement of architecture by a follicular proliferation producing a nodular pattern. B: In a higher magnification, the follicles are composed almost entirely of centrocytes (follicular lymphoma, grade 1), whereas, in (C), from another patient, the follicles are dominated by centroblasts (follicular lymphoma, grade 3).

Grading

A major problem area within follicular lymphoma is grading. Virtually all follicular lymphomas are composed of a mixture of centrocytes and centroblasts. Numerous studies have correlated the number of centroblasts with prognosis. Most studies agree that follicular lymphomas composed predominantly of centrocytes have a more indolent course than those composed predominantly of centroblasts.^{52, 53} and ⁵⁴ The most popular scheme for subclassification of follicular lymphoma is a modified version of that proposed by Berard, which bases categorization on numbers of centroblasts per standardized high magnification field (HMF) with fewer than six per HMF classified as grade 1 follicular lymphoma, 6 to 15 per HMF as grade 2, and greater than 15 per HMF as grade 3.⁵⁵ In all of these schemes of grading, there is substantial subjectivity and often disappointing interinstitutional reproducibility.^{56,57}

Morphology

Follicular lymphomas are recognized at low magnification by the effacement of nodal architecture by follicles that crowd one another and fill the cortex and the medulla (Fig. 86.2A). Tingible body macrophages are not seen in contrast to reactive follicles. Mantle zones are usually thin or absent.⁵⁸ Occasional patients, usually with limited stage disease, have partial nodal involvement amidst residual reactive lymphoid follicles.⁵⁹ A small number of follicular lymphomas show differentiation to marginal zone-like cells with a “halo-like” distribution around neoplastic follicles. These marginal zone cells, although often CD10 and BCL2 protein negative, are genetically identical to the neoplastic cells of the follicles.⁶⁰ On high magnification, low-grade (WHO grades 1 and 2) follicular lymphomas are composed of a relatively homogeneous population of centrocytes (smaller than, or the same size as a macrophage nucleus) with twisted nuclei, condensed chromatin, and inapparent nucleoli (Fig. 86.2B). Centrocytes frequently infiltrate the interfollicular areas and capsule. A variable number of centroblasts with oval to round nuclei (greater in size than a macrophage nucleus), dispersed chromatin, and one to three nucleoli that often abut the nuclear membrane also are present. Grade 3 follicular

lymphomas, which by definition have an increased number of centroblasts (Fig. 86.2C), have been provisionally subcategorized into 3a and 3b, with the former having a mix of centrocytes and centroblasts, and the latter consisting exclusively of centroblasts.⁶¹ Areas of diffuse growth composed predominately of centrocytes do not appear to affect prognosis.⁵² Low-grade follicular lymphomas with a purely diffuse growth pattern are uncommon and may be difficult to separate morphologically from mantle cell lymphoma without immunophenotypic or cytogenetic studies. Recently, an early phase of follicular lymphoma restricted to the B-cell follicles without altering the lymph node architecture has been recognized.^{62,63} These are often referred to as “follicular lymphoma in situ,” and are identified in lymph nodes removed for other reasons. These lesions appear to have an indolent course with a very low rate of progression to clinically significant follicular lymphoma.

Follicular lymphomas composed mostly of large centrocytes (large cleaved cell lymphoma) are not recognized as a separate entity in the WHO classification. Large centrocytes differ from small centrocytes not only in nuclear size (larger than macrophage nucleus), but also in chromatin pattern, which is more open with occasional small nucleoli. The nuclei are elongated and twisted like small centrocytes. Because of the abundant cytoplasm of tumor cells, the follicles appear pale. A minority of follicular

P.1776

lymphomas of large centrocytes exhibit a predominantly diffuse growth pattern. Several studies suggest that these lymphomas have a course similar to that of low-grade follicular lymphomas composed predominantly of small centrocytes.⁶⁴

Follicular lymphomas, particularly those arising in the retroperitoneum, have a propensity for extranodal growth and interfollicular sclerosis.⁶⁵ Occasionally, follicular lymphomas present with massive nodal necrosis. Immunopositivity for CD20 and clonal Ig gene rearrangements can sometimes be demonstrated in these necrotic lymph nodes without morphologically viable lymphocytes.^{66,67} A small number of follicular lymphomas contain plasma cells that may be polytypic or monotypic with the same Ig heavy chain and light chain as the follicle center cells.⁶⁸ Rarely, accumulations of intracytoplasmic Ig give cells in follicular lymphomas a signet ring cell-like appearance.⁶⁹ A leukemic phase may be present in as much as 10% of patients with low-grade follicular lymphomas. Circulating cells show nuclear irregularity and are immunophenotypically distinct from neoplastic cells of B-cell CLL/SLL or mantle cell lymphoma. Neoplastic transformation to a DLBCL occurs in approximately one-half of cases.^{70,71,72,73} Pathology reports should emphasize areas of diffuse growth of large cells, as they are sufficient for regarding the tumor as higher grade regardless of the grade of the tumor in any residual follicles.⁷⁴ More recently, a rare form of transformation in which the tumor cells have a blast-like morphology has been recognized. These blastoid variants of follicular lymphoma are aggressive clinically.⁷⁵ Another aggressive variant of follicular lymphoma has a low-grade histologic appearance with a high proliferation index on Ki-67 staining.⁷⁶ Rare clinicopathological variants of follicular lymphoma include so-called pediatric-type follicular lymphoma⁷⁷ and extranodal follicular lymphomas arising in the duodenum, skin, thyroid gland, and genitourinary tract. The pediatric-type follicular lymphoma is characterized by presentation in children and young adults, large cell cytology, lack of BCL2 gene rearrangement, limited stage disease, and indolent clinical behavior. Similarly, primary extranodal follicular lymphomas tend to have a more indolent behavior irrespective of the large cell component.

Immunophenotype

Follicular lymphomas generally express bright surface Ig fluorescence, but a small number of large cell follicular lymphomas are surface Ig negative.¹ Most follicular lymphomas are CD10⁺ (WHO grades 1 and 2), as are more than one-half of grade 3 lymphomas.⁷⁸ Most follicular lymphomas are BCL6 positive as well. Follicular lymphomas are almost always CD5⁻, but rare CD5⁺/CD10⁺ cases have been described that often exhibit atypical histopathology such as floral variants or patterns that may be confused with progressive transformation of germinal centers.^{79,80} Expression of BCL2 protein may be helpful in differentiating some follicular lymphoid hyperplasia from follicular lymphoma; however, overexpression of BCL2 protein does not help differentiate follicular lymphomas from other NHLs.⁸¹ Overexpression of p53, detected by immunohistochemistry, may identify patients with increased risk for transformation.^{82,83} Low-grade follicular lymphomas differ from most other small B-cell lymphomas in having a significant admixture of T cells, and some authors have suggested that large numbers of T cells indicate a favorable prognostic feature.⁸⁴ Immunohistochemical and gene expression data have correlated features of the tumor microenvironment such as number of infiltrating macrophages and composition of T-cell subsets with prognosis in follicular lymphomas.^{85, 86, 87} and ⁸⁸

Genetics

More than 85% of nodal follicular lymphomas and 25% to 30% of DLBCLs have a t(14;18) (q32;q21) chromosomal abnormality. These numbers are lower in children and in patients with extranodal presentations. Molecular genetic studies and FISH may identify additional cases not recognized by conventional cytogenetics.^{89,90,91} Abnormalities of chromosomes 3q27, 5, 7, 12, and 13q are more common in a higher grade (WHO grade 3) or in transformation of follicular lymphoma. Abnormalities of chromosome 8q24 are associated with blastoid variants of follicular lymphoma.^{92,93} Recently a subset of follicular lymphomas occurring young adults and children (so-called pediatric follicular lymphoma) has been shown to have translocations involving the IRF4 gene.⁹⁴ The pattern of somatic mutation in follicular lymphomas suggests a role for antigen selection in their clonal evolution.^{47,48}

Chronic Lymphocytic Leukemia/Small Lymphocytic Lymphoma

B-cell CLL/SLL is a neoplasm of small round B cells that usually have scant surface Ig and a CD5⁺/CD23⁺ phenotype. SLL is the term used to describe the disease when lymph node involvement is the dominant feature. Usually, these lymphomas present in elderly patients with a leukemic phase and generalized lymphadenopathy on routine physical examination. Bone marrow involvement is often extensive. Occasionally, patients present with bacterial infection related to hypogammaglobulinemia or with signs and symptoms secondary to anemia or thrombocytopenia that may have an autoimmune basis. CLL may occur in familial clusters with a decreasing age of onset from generation to generation.⁹⁵

Lymph node architecture is totally effaced with loss of lymphoid follicles and obliteration of sinuses by an infiltrate of monomorphic small round lymphocytes with condensed chromatin and scant cytoplasm. Growth centers or proliferation centers (collections of intermediate-size round lymphocytes with open chromatin and small nucleoli called paraimmunoblasts) are dispersed throughout the lymph node and are thought to represent foci of cell proliferation (Fig. 86.3).⁹⁶ Morphologic features that correlate with a worse prognosis include prominent proliferation centers in lymph nodes or increased numbers (>10%) of prolymphocytes (intermediate-size lymphocytes with prominent central nucleoli) in the blood.^{97,98} A clinically aggressive paraimmunoblastic variant of SLL has been described in which cells resembling those in growth centers predominate throughout the node.⁹⁹

Richter syndrome, which is the evolution of CLL/SLL to a large cell lymphoma, occurs in less than 5% of patients and may arise as transformation of the neoplastic small B cell or as an unrelated B-cell clone.^{100,101,102} Less commonly, B-cell SLL may transform to prolymphocytic leukemia.¹⁰³ Rarely, HL complicates B-cell SLL.¹⁰⁴ Of interest is a description of 13 cases of B-cell SLL with Reed-Sternberg (RS)-like cells that contained EBV RNA as detected by in situ hybridization; three of these patients developed disseminated HL.¹⁰⁵ The diagnosis of concurrent HL in a lymph node with CLL/SLL requires both RS cells and a polymorphic reactive cell background.

On immunologic typing studies, neoplastic lymphocytes have weak or scant monotypic surface Ig, which usually is IgM associated with IgD. Neoplastic lymphocytes coexpress the nominal T-cell antigen CD5 with B-cell markers CD19, CD20 (weak); CD21, CD11c (weak); and CD23. The tumor cells are negative for FMC7, CD10, and cyclin D1. Phenotypically, SLL and CLL are identical.¹⁰⁶ Admixed T cells are usually few in number. CD23 expression and FMC7 and cyclin D1 negativity are helpful in the phenotypic separation of CLL/SLL from mantle cell lymphoma, another CD5⁺ small B-cell neoplasm.¹⁰⁷ With the increased use of flow cytometry, small populations of circulating light chain-restricted B cells with a CLL/SLL phenotype are being detected in asymptomatic patients with no clinical features of neoplasia.¹⁰⁸

Classic cytogenetic studies demonstrate specific chromosomal abnormalities in more than one-third of patients with CLL/SLL, with FISH detecting abnormalities of chromosomes 11, 12, 13,

P.1777

and 17 in almost two-thirds of patients. Deletion of 13q is the most frequent abnormality and correlates with a stable clinical course in older patients. Trisomy 12, ATM deletions (11q), and TP53 deletions (17p) are associated with progressive disease.^{109,110} Molecular genetic studies divide CLL/SLL into two major groups based on the presence or absence of somatic mutation. The absence of somatic mutation is associated with a more aggressive clinical course and correlates with an increased expression of CD38 and the tyrosine kinase, ZAP-70.^{111,112,113,114,115} Risk stratification in CLL/SLL has therefore become an increasingly complex and controversial exercise with no clear consensus as to the relative roles of cytogenetics, molecular genetics for somatic mutation status, and use of surrogate markers such as CD38 and ZAP-70.^{116,117}

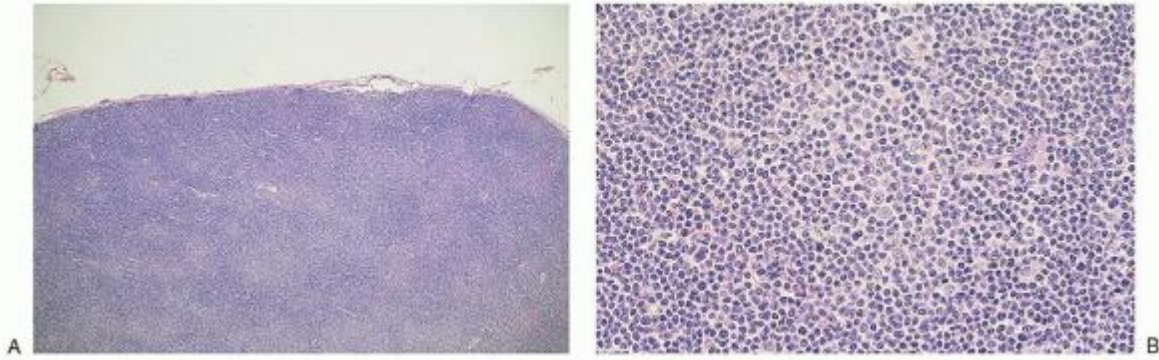

FIGURE 86.3. Lymph node: chronic lymphocytic leukemia/small lymphocytic lymphoma. A: Low magnification shows diffuse alteration of architecture, with pale areas corresponding to proliferation centers. B: A higher power of a proliferation center that is composed of intermediate-sized cells with small nucleoli that are surrounded by small round lymphocytes.

Lymphoplasmacytic Lymphoma

Lymphoplasmacytic lymphomas (LPLs) are uncommon B cell neoplasms composed of small lymphocytes, plasmacytoid lymphocytes, plasma cells, and variable numbers of large lymphocytes. These lymphomas, like CLL/SLL, often have marrow involvement and a leukemic phase. They are often associated with high levels of an IgM paraprotein (Waldenström macroglobulinemia) or type II cryoglobulinemia.^{118,119} Some patients have antecedent systemic or localized abnormal immune reactions, such as Sjögren syndrome.¹²⁰ Many patients have hepatitis C infection.¹²¹ LPL must be differentiated from other small B-cell lymphomas that frequently exhibit plasmacytic differentiation, including nodal and extranodal marginal zone B-cell lymphomas.

LPLs are morphologically diverse and may cause diffuse or partial alteration of lymph node architecture. Many have an interfollicular distribution and abundant macrophages that may impart a mottled low magnification appearance, resembling HL. On high magnification, small lymphocytes are admixed with variable numbers of plasma cells, plasmacytoid lymphocytes, and admixed large lymphocytes. Other features indicating plasmacytic differentiation include Dutcher bodies (cytoplasmic Ig inclusions that appear to be intranuclear) and extracellular periodic acid-Schiff-positive material. Mast cells and hemosiderin-laden macrophages are often present. These lymphomas may transform to large cell lymphomas.^{122, 123} and ¹²⁴ These higher grade lymphomas usually produce the same Ig heavy chains and light chains as the original tumor.

Plasmacytoid lymphocytes and plasma cells contain abundant intracellular Ig, which usually is monotypic IgM without IgD and can be detected using paraffin immunoperoxidase reactions. In cell suspension studies, neoplastic lymphocytes usually express more surface Ig than is usually seen in CLL/SLL.¹²⁴ Tumor cells express pan-B-cell markers CD19 and CD20 and are usually CD5⁻ and CD10⁻.^{125,126} As the tumor cells are actively secreting Ig, many patients have high levels of monoclonal IgM producing hyperviscosity (Waldenström macroglobulinemia). The IgM may have rheumatoid factor activity or function as cryoglobulin, or both.¹¹⁸ Less commonly, these neoplasms may be associated with production of other Ig heavy chain classes.¹²⁷

LPLs lack translocations involving the Ig heavy chain gene locus but most have a 3p22.2 abnormality resulting in the somatic mutation MYD88 L265P, particularly in patients with Waldenström macroglobulinemia.^{128,129} This variant is present in few cases of other B-cell neoplasms that have features similar to LPL. Somatic mutations of Ig genes are commonly found in Waldenström macroglobulinemia.^{130,131}

Mantle Cell Lymphoma

Mantle cell lymphoma is a B-cell lymphoma typically composed of small lymphocytes with irregular nuclear outlines that have a CD5⁺ and CD23⁻ phenotype and overexpress cyclin D1. These lymphomas are usually widespread at diagnosis with generalized adenopathy and extensive bone marrow involvement. They may involve extranodal sites, such as the Waldeyer ring, or present as lymphomatous polyposis of the lower gastrointestinal tract.^{132,133,134} A few have a leukemic phase mimicking CLL, prolymphocytic leukemia, or acute leukemia (blastoid variants of mantle cell lymphoma).¹³⁵ Recognition of mantle cell lymphoma is clinically important, as these lymphomas pursue a more aggressive clinical course than other small B-cell lymphomas.^{136,137}

Mantle cell lymphomas are composed of small lymphocytes with irregular nuclear contours. Mitotic activity is often brisk, and large lymphocytes are usually few in number except in the pleomorphic form of the blastoid variant, in which they predominate. Mantle cell lymphomas usually have a diffuse growth pattern (Fig. 86.4A,B) or surround reactive germinal centers in a mantle zone pattern. Extension of the lymphoma into the capsule and perinodal fat is common.^{132,133,138} The blastoid variant of mantle cell lymphoma is characterized by nuclei with increased size, dispersed chromatin, small nucleoli, frequent mitoses, and an aggressive clinical course. There is now molecular genetic evidence that at least some blastoid variants of mantle cell lymphoma are morphologic transformations of typical mantle cell lymphoma.¹³⁹ The differential diagnosis of blastoid transformation of mantle cell lymphoma includes acute leukemia involving lymph nodes and lymphoblastic lymphoma.^{37,140}

The neoplastic cell shares immunophenotypic features with normal mantle zone lymphocytes, including moderate amounts of surface IgM, usually with IgD. Neoplastic cells are generally CD5⁺ and CD10⁻, but a subset of mantle cell lymphomas has CD5⁻ tumor cells.¹⁴¹ Mantle cell lymphomas usually mark with

P.1778

antibodies to pan-B-cell antigens CD19, CD20, and CD22. CD23 is negative or sometimes partially expressed, and FMC7 is positive in contrast to the tumor cells of CLL/SLL.^{107,142} Overexpression of cyclin D1 is almost universal in mantle cell lymphoma¹⁴³ (Fig. 86.4C), is not seen in follicular lymphoid hyperplasia, and is uncommon in other small B-cell malignancies, with the exception of plasmacytic neoplasms and hairy cell leukemia.¹⁴⁴ Recent gene expression studies have identified SOX11 expression as another specific marker for mantle cell lymphoma.¹⁴⁵ Rare "in situ" mantle cell lymphomas have been recognized in which cyclin D1-positive cells fill unexpanded mantle zones without distortion of nodal architecture.¹⁴⁶ The clinical significance of these cases is unclear at this time. High Ki-67 expression is associated with a poor prognosis.^{147,148}

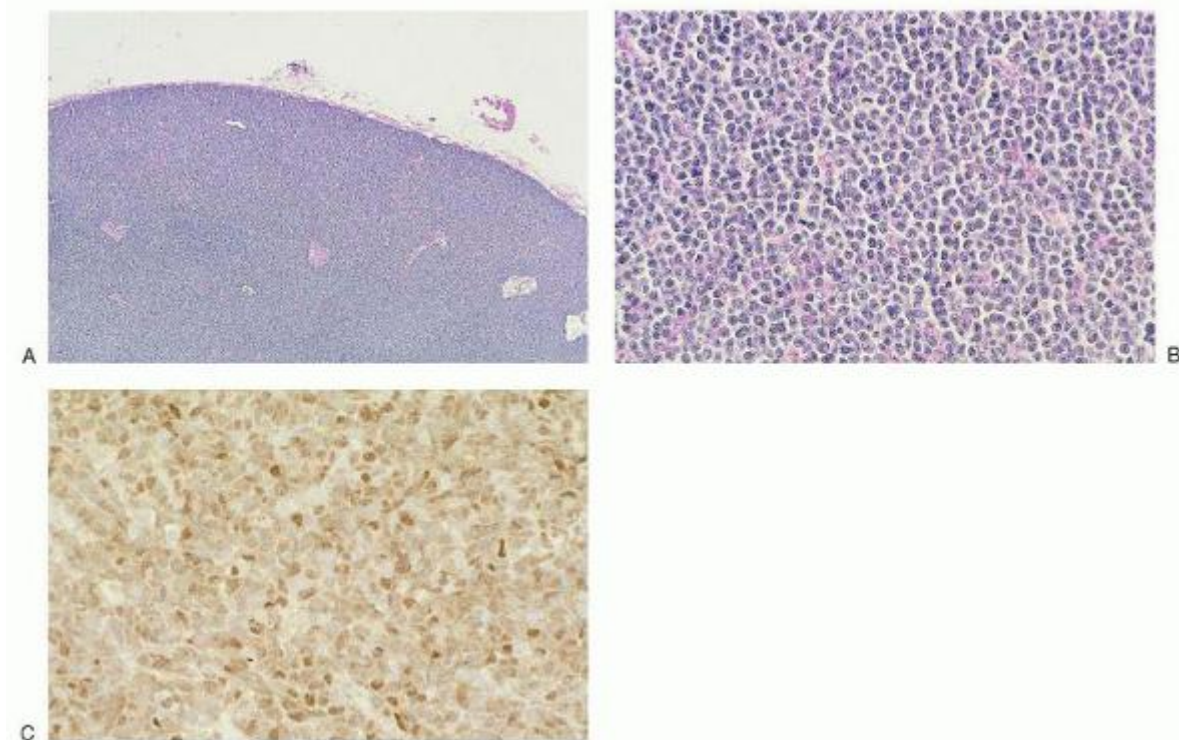

FIGURE 86.4. Lymph node: mantle cell lymphoma. A: Low magnification shows diffuse architectural effacement, which, on higher magnification in (B), is composed of sheets of small irregular lymphocytes with few large cells. C: Small lymphocytes exhibit nuclear staining for cyclin D1.

On classic cytogenetics, most cases of mantle cell lymphoma show evidence of t(11;14) (q13;q32) involving the cyclin D1 gene (CCND1).^{149,150} FISH analysis of paraffin-embedded tissue extends the sensitivity of t(11;14) detection to greater than 90% and does not require fresh or frozen tissue.¹⁶ Rare cyclin D1-negative mantle cell lymphomas exhibit a gene expression profile similar to cyclin D1-positive tumors including expression of SOX11.¹⁵¹ The former cases show

overexpression of cyclin D2 or cyclin D3 without translocations involving these genes. Almost one-third of patients with mantle cell lymphoma have somatic mutation of their Ig heavy chain genes. The presence of somatic mutation is associated with nonnodal disease, lack of SOX11 expression, and a more indolent clinical course.^{152,153,154}

Nodal Marginal Zone B-cell Lymphoma

Nodal marginal zone B-cell lymphomas represent a rare, clinically and biologically heterogeneous entity.^{155, 156} and ¹⁵⁷ The diagnosis often rests on exclusion of other possible lymphomas, in particular, nodal involvement by splenic marginal zone B-cell lymphoma (SMZL) and extranodal marginal zone B-cell lymphoma of MALT lymphoma. Clinically, these lymphomas appear more aggressive than other marginal zone lymphomas.¹⁵⁸ They have a tendency to early relapse, and a small minority transform to large cell lymphoma.¹⁵⁷

Nodal marginal zone lymphomas characteristically involve the interfollicular areas of lymph nodes and are composed predominantly of "monocytoid" small- and medium-sized lymphocytes of uniform size with distinct cell membranes that surround an abundant amount of pale cytoplasm. Nuclei are bland and oval to coffee bean in shape. In some cases, plasma cells are prominent.^{159,160} Admixed large lymphocytes are present, and mitotic activity is variable.¹⁵⁵

Nodal marginal zone B-cell lymphomas express pan-B-cell antigens (CD19, CD20, and CD79a) and monotypic Ig (IgM without IgD) and are typically negative for CD5, CD10, and cyclin D1. A variable number are positive for BCL2 protein and CD43.^{155,156}

Genetic studies are limited and have not identified any common cytogenetic abnormalities. Somatic mutation is usually, but not always, present in the Ig genes.¹⁵⁶

Splenic Marginal Zone B-cell Lymphoma

SMZL is a rare disease accounting for approximately 1% of all lymphomas and approximately 20% of lymphoproliferative disorders in diagnostic splenectomy specimens.^{161,162} SMZL is a small B-cell lymphoma of the white pulp of the spleen that often involves the splenic hilar lymph nodes, bone marrow, and peripheral blood.¹⁶³ The patients typically present with splenomegaly, B symptoms (fever, weight loss, and night sweats), abdominal pain, and cytopenias.^{164,165} A low level of monoclonal paraprotein can be detected in approximately one-half of the patients.^{166,167}

P.1779

The spleen is massively enlarged, weighing well over 1,000 g in most cases. Microscopically, the most striking feature is a nodular infiltrate centered on the preexisting white pulp lymphoid follicles.¹⁶⁸ The tumor has a biphasic pattern with an inner core of small lymphocytes and an outer margin of medium-sized lymphocytes. The inner central zone of small lymphocytes resembles normal mantle zone cells with scant cytoplasm and small irregular nuclei, clumped chromatin, and indistinct nucleoli. The lymphocytes occupying the marginal zone appear similar to normal splenic marginal zone lymphocytes. These have well-defined clear cytoplasm and round/oval nuclei with a more open chromatin pattern and indistinct nucleoli. Variable numbers of large lymphocytes with prominent nucleoli are also present in the marginal zone. Occasionally, plasmacytic differentiation within the marginal zone or in the center of the nodules can be observed. Bone marrow involvement is nodular or interstitial and frequently intrasinusoidal. Tumor cells in peripheral blood often have short villous projections.^{163,166} This cytologic appearance is the reason why some cases of SMZL were called splenic lymphoma with villous lymphocytes. Transformation to large B-cell lymphoma is seen in as many as 15% of cases.¹⁶⁹

Neoplastic cells are CD45, CD20, and BCL2 protein positive with monotypic IgM, with or without IgD. Tumor cells are negative for CD10, CD21, CD43, and cyclin D1, and in most cases, for CD5.^{163,164,168} Unlike hairy cell leukemia, they are usually CD11c, CD103, and DBA.44 negative.

Allelic loss of 7q21-32 is seen in slightly less than one-half of patients.¹⁷⁰ Chromosomal translocations that are seen in other small B-cell lymphomas involving CCND1, BCL2, and MALT1 are not present. On molecular genetic studies, approximately one-half of cases show somatic mutation, and one-half have unmutated Ig genes.¹⁷¹ The latter group more frequently has deletions and allelic loss of 7q31-32 and may have a worse prognosis.

Recently, a primary low-grade B-cell splenic lymphoma showing morphologic features distinct from splenic marginal lymphoma has been described. This entity is often referred to as "splenic diffuse red pulp small B-cell lymphoma." It is characterized by diffuse red pulp involvement in the spleen, intrasinusoidal involvement in the bone marrow, more frequent expression of IgG and DBA.44 by immunohistochemistry, bright expression of CD11c and CD22 by flow cytometry, and an indolent clinical behavior.^{172,173}

Extranodal Marginal Zone B-cell Lymphoma of Mucosa-associated Lymphoid Tissue

Extranodal marginal zone B-cell lymphoma of MALT lymphoma is the third most common type of NHL, accounting for approximately 6% to 8% of all NHLs in the Western hemisphere.¹⁷⁴ Although MALT lymphomas are clinically indolent, the disease is typically chronic, requiring long-term clinical surveillance and, often, repeated biopsies.^{175,176}

Most MALT lymphomas arise in mucosal sites devoid of organized lymphoid structures. Development of MALT lymphoma is often preceded by a chronic inflammatory process that leads to acquisition of lymphoid tissue.^{177,178, 179, 180, 181, 182, 183, 184, 185, 186} and ¹⁸⁷ This forms the background for the emergence of the lymphoma. The examples of chronic inflammatory processes that are associated with MALT lymphoma development are listed in Table 86.4.

The infectious process not only creates the microenvironment for development of the tumor but also the microenvironment necessary to sustain the tumor progression. Eradication of the infectious etiology has been shown to lead to remission in gastric, orbital, and cutaneous MALT lymphomas and is recognized as the first line of therapy, particularly for gastric MALT lymphoma.

MALT lymphomas are cytologically low-grade lymphoid neoplasms and are thought to arise from the marginal zone B-cell compartment of the mucosal lymphoid follicles.¹⁸⁸ The cytologic features and the architecture of the tumor often mimic the features of normal mucosal organized lymphoid tissues such as intestinal Peyer's patches. For this reason, many of the cases have been mistakenly diagnosed as pseudo-lymphomas before the application of clonality and genetic studies. MALT lymphomas tend to remain localized at the site of origin for many years. When they disseminate they tend to go to other mucosal sites, a phenomenon thought to be a result of homing programming. Transformation to large cell lymphoma occurs in a minority of cases.¹⁷⁶

TABLE 86.4 RISK FACTORS FOR EXTRANODAL MARGINAL ZONE B-CELL LYMPHOMAS OF MUCOSA-ASSOCIATED LYMPHOID TISSUE (MALT LYMPHOMAS)

Site	Risk Factor	Reference
Stomach	<i>Helicobacter pylori</i>	177,178
Intestine	<i>Campylobacter jejuni</i>	179,180
Orbit	<i>Chlamydia psittaci</i>	181,182
Salivary gland	Hepatitis C virus, autoimmunity (Sjögren syndrome)	183
Thyroid	Autoimmunity (Hashimoto's thyroiditis)	184
Skin	<i>Borrelia burgdorferi</i>	185,186 and 187

The lymphoma cells assume varied cytologic appearances, often within individual specimens. Characteristic are the centrocyte-like cells, small to medium-sized lymphocytes with irregular nuclei. Alternatively, the neoplastic cells may have a monocytoid appearance with abundant pale cytoplasm and distinct cell borders. The tumor cells also may resemble mature small lymphocytes. Scattered large cells are usually dispersed throughout the lymphoma. Variable numbers of plasma cells are frequently present, often adjacent to epithelium. In approximately one-third of cases the plasma cells are part of the neoplastic clone and may show atypical features such as Dutcher bodies. Regardless of the neoplastic cells' appearance, they produce a diffuse infiltrate that invades epithelial structures, producing lymphoepithelial lesions (Fig. 86.5A,B) and subsequent epithelial disruption.¹⁸⁹ Reactive lymphoid follicles are generally present, and the neoplastic lymphocytes may infiltrate and colonize them.¹⁹⁰

MALT lymphomas express B-cell antigens (CD19 and CD20) and monotypic surface Ig (usually IgM without IgD). They may be CD43⁺ but usually lack other antigens expressed by small B-cell lymphomas, such as CD5, CD10, CD23, and cyclin D1. Cytoplasmic Ig is present in cases exhibiting plasmacytic differentiation.¹⁹⁰ These lymphomas demonstrate clonal Ig gene rearrangements and show extensive somatic mutations characteristic of post-germinal center B cells.

The three major chromosomal translocations seen in MALT lymphomas are t(11;18)(q22;q21)/BIRC3 (API2)-MALT1, t(14;18) (q32;q21)/IGH@-MALT1, and t(1;14)(p22;q32)/IGH-BCL10.^{175,176} Remarkably, these appear to promote lymphoma development by a common mechanism. This concordance results from the roles of both the adapter protein BCL10 and the caspase-like protein MALT1 in antigen receptor-mediated activation of nuclear factor kappa B (NFκB), a transcription factor that regulates the expression of genes involved in lymphocyte proliferation and survival.^{191,192} Importantly, MALT lymphomas do not carry t(11;14)(q13;q32)/IGH@-CCND1 or t(14;18)(q32;q21)/IGH@-BCL2 chromosomal abnormalities typical of mantle cell lymphoma or follicular lymphoma, respectively.

T(11;18) identifies gastric MALT lymphomas that (a) present with advanced-stage disease, (b) do not respond to *Helicobacter pylori* eradication, and (c) are unlikely to transform to large cell lymphoma.^{193,194}

P.1780

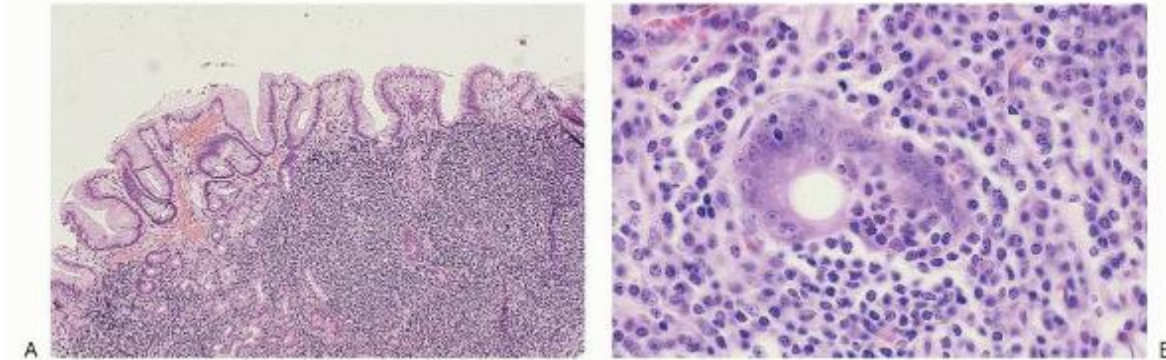

FIGURE 86.5. Stomach: extranodal marginal zone B cell lymphoma of mucosa-associated lymphoid tissue. A: The submucosa contains a diffuse infiltrate of small lymphocytes. B: Centrocyte-like cells with moderate amounts of clear cytoplasm invade gastric glands, producing lymphoepithelial lesions.

Diffuse Large B-cell Lymphoma

DLBCLs are a morphologically, phenotypically, and genetically heterogeneous group of mature B-cell malignancies unified by the presence of large (nuclear size greater than the macrophage nuclei) neoplastic B cells. Comprising 30% to 40% of all lymphomas, they are the most common lymphoma type in the United States and Europe.^{174,195} A greater appreciation for their complexity has followed from recent clinical, pathologic, and biologic studies, so that the most recent WHO classification recognizes 13 subtypes/DLBCL clinical entities.³⁰ The more common DLBCL entities are discussed below.

Diffuse Large B-cell Lymphoma, Not Otherwise Specified

DLBCL, not otherwise specified (NOS), occurs in all age groups, with an incidence that increases with age, and with a slight male predominance.^{196,197} Though most DLBCL, NOS cases arise *de novo*, risk factors for DLBCL, NOS include immunosuppression and prior low-grade B cell lymphoma. The most common presentation is as a bulky mass of lymph nodes, but up to 40% of cases arise in extranodal sites, including spleen or bone marrow. Staging bone marrows are involved in approximately 10% to 25% of cases. The pattern of bone marrow involvement may be concordant or discordant—constituted by a lower grade lymphoma. The former is associated with an adverse outcome; the latter with response to initial therapy similar to the cases without bone marrow involvement, but with increased risk for late recurrence.¹⁹⁸

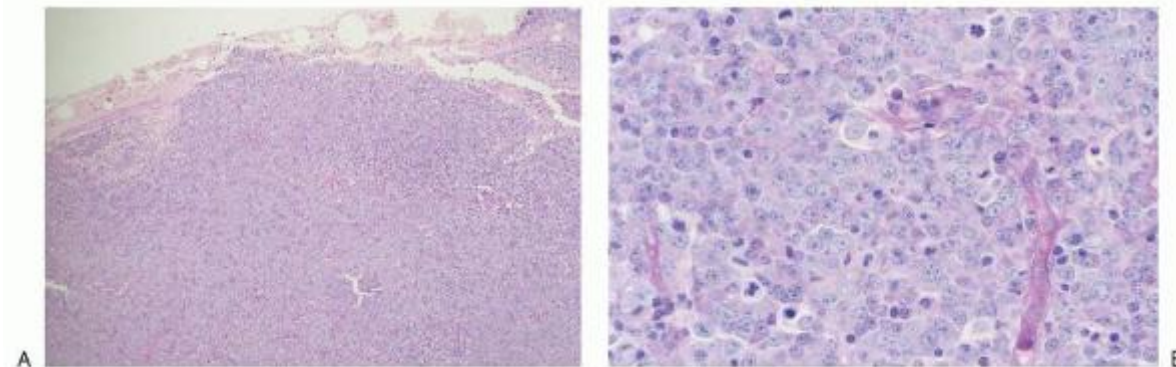

FIGURE 86.6. Lymph node: diffuse large B cell lymphoma. A: On low magnification, a neoplastic large lymphocyte population diffusely effaces lymph node architecture. B: On high magnification, round nuclei, partially clumped chromatin, small nucleoli and modest amounts of pale cytoplasm characterize the tumor cells. Note the apoptotic bodies and mitotic figures.

Morphology

Regardless of the anatomic site involved by DLBCL, NOS, the basic pathologic features are similar. The large neoplastic lymphoid cells grow in a purely diffuse pattern and efface the underlying tissue architecture (Fig. 86.6). Tingible body macrophages, apoptotic bodies, mitotic figures, and zones of necrosis and/or fibrosis variably accompany the neoplastic cells. Three cytologic variants are recognized by the WHO: centroblastic, immunoblastic (Fig. 86.7), and anaplastic.¹⁹⁷ Rounded nuclei, dispersed chromatin, multiple small nucleoli, and modestly abundant basophilic cytoplasm characterize centroblastic DLBCL. These cells resemble the centroblasts of normal germinal centers. Round nuclei, with dispersed or marginated chromatin, prominent single centrally located nucleoli, and abundant cytoplasm usually eccentrically distributed relative to the nucleus are the cytologic features of immunoblastic DLBCL. Patients whose DLBCL contains 90% of cells with immunoblastic cytology may have an adverse outcome.^{196,199} A pleomorphic cell population that includes multinucleated tumor giant cells constitutes anaplastic DLBCL. The designation “anaplastic” for a DLBCL is a cytologic descriptive term that should not be confused with anaplastic large cell lymphoma, now considered a separate lymphoma entity comprised of neoplastic T cells. Occasional DLBCL have further cytologic diversity that includes signet ring cells, cells with multilobate nuclei, or spindle-shaped cells.

P.1781

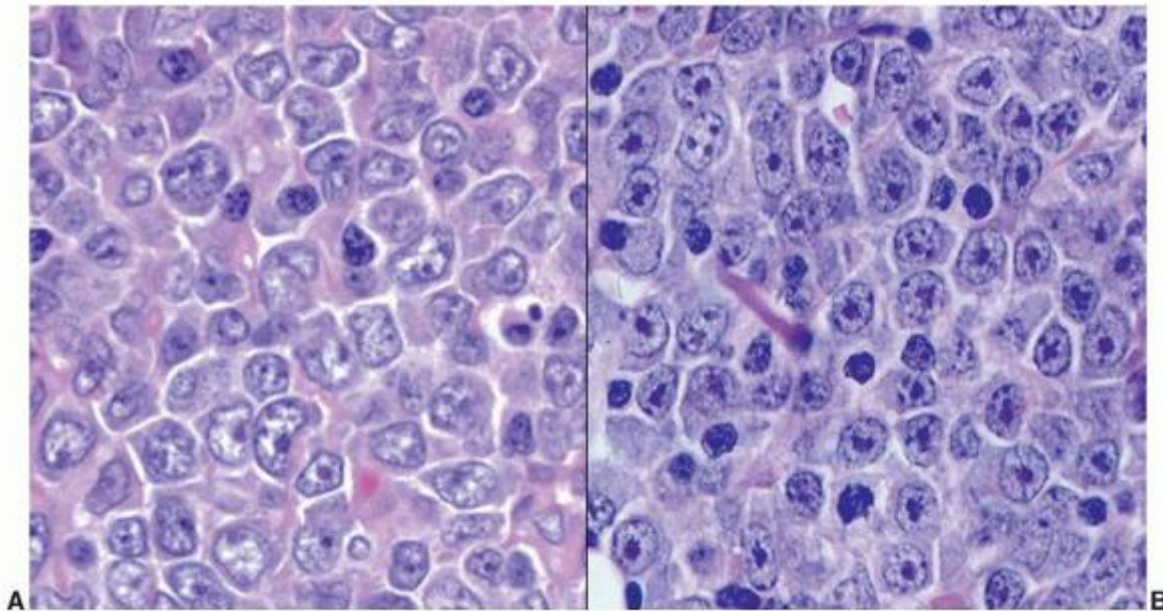

FIGURE 86.7. Lymph node: cytologic variability in diffuse large B cell lymphoma. A: Centroblastic. B: Immunoblastic.

Immunophenotype

DLBCL cells express CD45 and a variety of pan-B-cell antigens, including CD19, CD20, CD22, CD79a, and PAX-5 in almost every case.²⁰⁰ Ninety percent express light chain restricted surface Ig. Following rituximab (R) therapy, CD20 may be lost from the tumor cells,²⁰¹ in which case B-cell lineage is defined by expression of one or more of the other B-cell antigens. Variable subsets of DLBCL express CD10, BCL6, GCET1, LMO2,²⁰² BCL2, IRF4 (MUM1), and FoxP1.²⁰³ The pattern of expression of these latter markers by immunohistochemistry variably correlates with germinal center (CD10, BCL6, GCET1, LMO2) or nongerminal center (IRF4 and FoxP1) B-cell derivation of the DLBCL as defined by gene expression profiling (Fig. 86.8). Germinal center B cell (GCB)-derived DLBCL are thought to have a better prognosis than non-GCB DLBCL, and so

P.1782

for practical purposes, several immunohistochemistry algorithms, Choi,²⁰⁴ Hans,²⁰⁵ Muris,²⁰⁶ Nyman,²⁰⁷ and Talley,²⁰⁸ have been proposed by which GCB and non-GCB are assigned. All have been shown to predict prognosis of R-CHOP-treated DLBCL patients in some, but not all studies. Therefore, phenotyping to assign a DLBCL to the GCB vs. non-GCB subtype for the purpose of selecting optimal therapy has been inconsistently applied to routine practice. Approximately 5% of DLBCL

cases express CD5.^{200,209} These cases are distinguished from the blastoid variant of mantle cell lymphoma because they are cyclin D1⁺. They tend to occur in older patients, are more frequent in women than in men, and tend to be disseminated at the time of diagnosis.²⁰⁹ They are biologically distinct by genetic and gene expression profiling studies,^{210,211} but are not recognized as a separate entity in the WHO classification. One other marker of interest in DLBCL is Ki-67, a marker of cells in cycle. The fraction of Ki-67⁺ cells in a tumor is a general indicator of its proliferative rate. Ki-67 positivity ranges from 30% to nearly 100% in DLBCL cases, and it too, if expressed in greater than 90% of the cells, has been suggested as an adverse prognostic indicator in DLBCL.²¹²

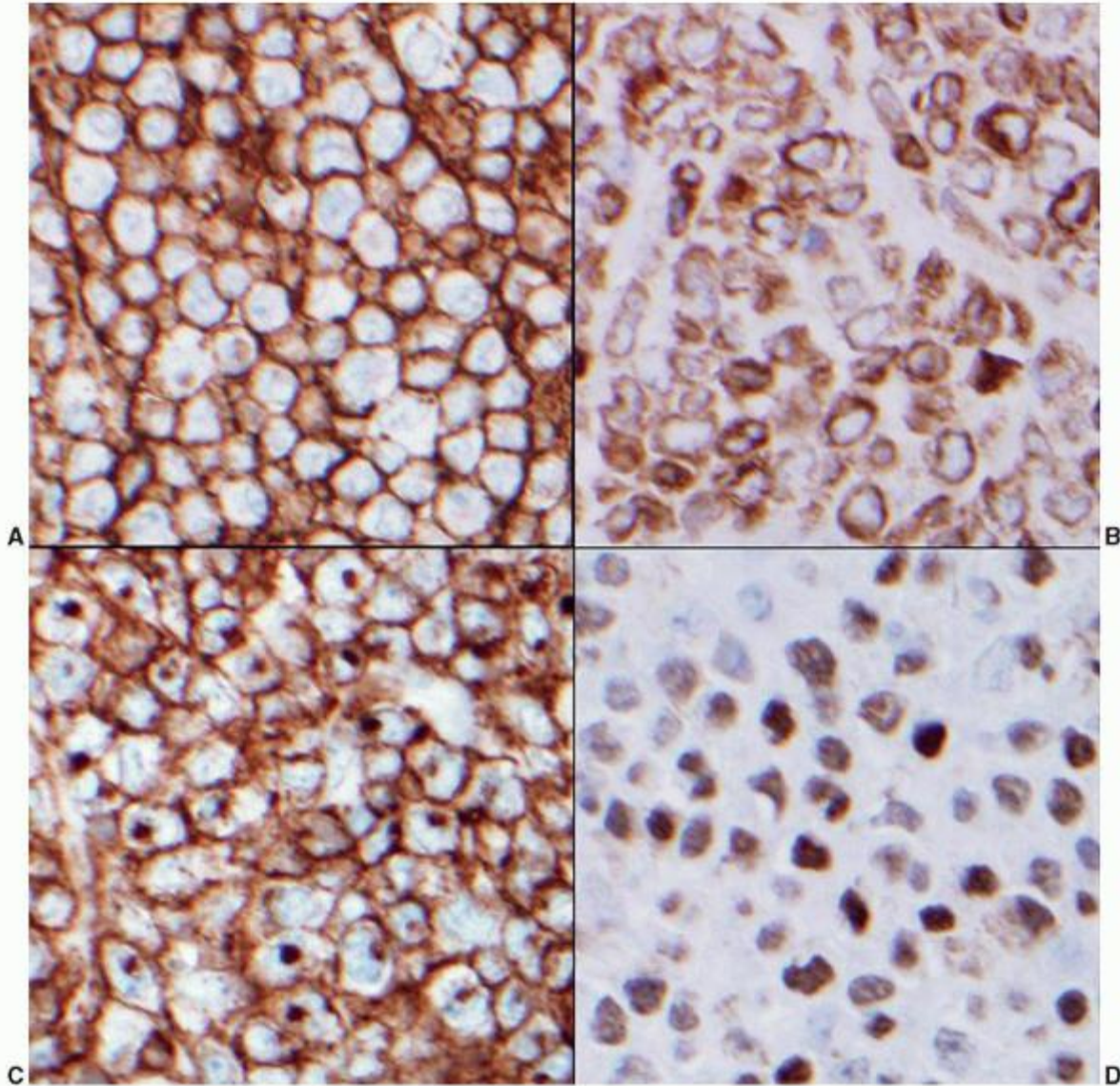

FIGURE 86.8. Lymph node: germinal center B cell lymphoma phenotype. By the criteria of the Hans algorithm this DLBCL has a germinal center phenotype. Using immunohistochemistry on paraffin sections the neoplastic cells express: A: CD20, B: bcl-2, C: CD10, and D: bcl-6.

Genetics

There is no single genetic abnormality that typifies DLBCL. Rather, a complex karyotype with genetic imbalances occurs in two-thirds of cases.²¹³ In decreasing frequency, subsets of DLBCL cases have recurrent translocations involving BCL6 (3q27), BCL2 (18q21), and MYC (8q24) usually, but not always, to Ig heavy or light chain gene loci. BCL6 and BCL2 translocations do not predict prognosis in DLBCL patients but MYC translocations do.²¹⁴ FAS and BCL6²¹⁵ hypermutation are relatively common in DLBCL cases as are amplifications of REL²¹⁶ and BCL2. Finally, particularly in DLBCL that arises from a lower grade lymphoma, p53 deletion or point mutations are also observed.²¹⁷ Together these mutations are pathogenetic by promoting entry of the neoplastic cells into the cell cycle, inhibition of apoptosis, promoting genetic

instability, and/or producing maturation arrest in the neoplastic cells. Finally, there is a subset of cases of morphologically typical DLBCL that usually express CD10 and BCL2 that contain translocations involving both MYC and BCL2.²¹⁸ Colloquially termed “double-hit” lymphomas, these tumors have a particularly aggressive clinical course and are resistant to most chemotherapy regimens.^{219,220,221,222} By convention, they are typically categorized among “B-cell lymphoma, unclassifiable, with features intermediate between DLBCL and Burkitt lymphoma”.²²³

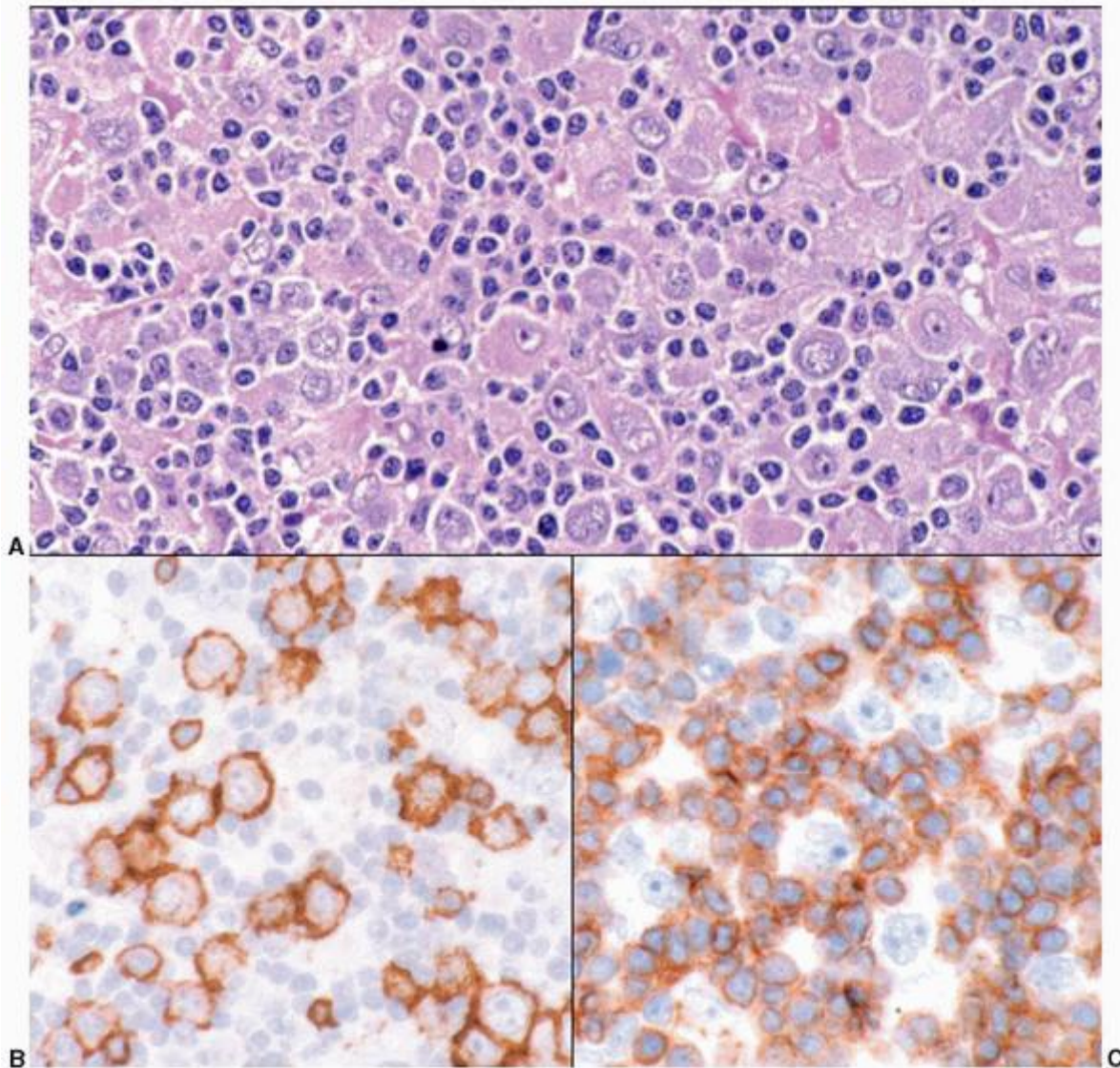

FIGURE 86.9. Lymph node: T-cell/histiocyte-rich large B-cell lymphoma. A: A mixture of small lymphocytes and histiocytes dominates the morphology. Occasional large neoplastic cells with rounded to lobulated nuclei, delicate chromatin, small nucleoli, and pale cytoplasm are present. Immunoperoxidase stains for (B) CD20 highlight the neoplastic cells and for (C) CD3 demonstrate staining in the nonneoplastic T-cells.

T-cell/Histiocyte-rich Large B-cell Lymphoma

The typical patient with THRLBCL presents with systemic symptoms and widespread disease involving lymph nodes and bone marrow with or without hepatosplenic involvement. THRLBCL occurs at a younger median age than DLBCL, NOS and has a decided male predominance.^{224,225, 226, 227} and ²²⁸

Morphology

In lymph nodes a heterogeneous cell population diffusely effaces the architecture. Small lymphocytes and histiocytes in varying proportions dominate the histologic picture. In contrast, the neoplastic cells are in the minority and are singly

distributed without clustering together or forming sheets. Centroblast-like, immunoblast-like, or pleomorphic cytologic features typify the neoplastic cells in most cases (Fig. 86.9). Because the reactive elements

P.1783

dominate the histologic picture, the challenge in these cases is to recognize THRLBCL as lymphoma rather than a reactive process. In some cases the neoplastic cells have characteristics similar to LP cells of nodular lymphocyte predominant Hodgkin lymphoma (NLPHL); in others they resemble diagnostic RS cells of classical Hodgkin lymphoma (CHL). In these cases the diagnostic challenge is to distinguish THRLBCL from HL. The phenotype of both the neoplastic cells and the reacting cell populations usually resolves the differential diagnostic problems.

Immunophenotype

The large neoplastic cells express CD45 and pan-B cell antigens (CD19, CD20, CD22, and PAX-5), are usually positive for BCL6, and variably express BCL2. They typically lack expression of classical Hodgkin cell-associated markers such as CD15 and CD30. The small background lymphocytes are CD3⁺ T cells and the histiocytes express CD68 and CD163. Virtually no small non-neoplastic CD20⁺ or IgD⁺ lymphocytes accompany the large cells and the lesions are devoid of both CD57/CD279 (PD-1) rosettes surrounding the neoplastic B cells and CD21⁺ follicular dendritic cell meshworks. These latter are immunoarchitectural features that help to distinguish THRLBCL from NLPHL.²²⁹

Genetics

Genetics are nondistinctive. But, as expected, these tumors have a gene expression profile enriched for a T cell/histiocytic host response.²³⁰

Primary Mediastinal (Thymic) Large B-cell Lymphoma

Primary mediastinal large B-cell lymphoma (PMBCL) is a biologically, clinically, and pathologically distinct lymphoma type²³¹ thought to arise from a peculiar subset of intrathymic B cells.^{232,233} The tumor originates in the thymus, and grows into a mediastinal mass that produces symptoms as it enlarges and infiltrates and compresses local structures such as lung, pericardium, and superior vena cava. Women are affected more commonly than men and PMBCL typically occurs at a younger age (median, 35 years) than DLBCL, NOS.^{234,235}

Morphology

A diffusely growing population of medium to large lymphoid cells effaces the architecture of the underlying thymus and infiltrates into adjacent anatomic sites. The tumor cells are variably accompanied by a richly vascular fibrous stroma that frequently circumscribes clusters of neoplastic cells. This can be a cause of diagnostic difficulty, because fibrosis itself and/or compression artifact introduced when biopsying a firm mass, can obscure the tumor cells. PMBCL is cytologically characterized by case-to-case variability. Some examples are composed of cells resembling centroblasts; others contain a prominent population of immunoblast-like neoplastic cells. Cells with multilobulated nuclei and varying amounts of clear cytoplasm or with features of RS or Hodgkin cells can constitute the neoplasm in some cases. This cytologic diversity is not of prognostic significance, but pathologists must appreciate it as part of the possible spectrum observed in PMBCL. A nonneoplastic population of T cells and histiocytes often accompanies, and together with fibrosis can also potentially obscure, the neoplastic cells. Finally, residual thymic Hassall's corpuscles can be found in some cases.

Immunophenotype

The tumor cells express CD45, CD19, CD20, PAX5, and the transcription factors OCT2 and BOB1.²³¹ They are frequently positive for CD23,²³⁶ BCL6, and IRF4 (MUM1), and either lack or show only variable immunoreactivity for CD30. They are typically negative for surface and cytoplasmic Ig and for CD15. Stains for keratin highlight the residual thymic epithelial elements.

Genetics

Gains in chromosomes 9p24 (75% of cases)²³⁷ and the REL²³⁸ locus on 2p (50% of cases) typify PMBCL, which unlike other DLBCL cases only rarely harbors BCL2 or BCL6 translocations.

Other Considerations

In gene expression profiling studies, PMBCL cases are more similar to cases of nodular sclerosis Hodgkin lymphoma (NSHL) than to DLBCL, NOS.^{239,240,241,242} Both tumor types contain similar genetic abnormalities and have activation of the NFκB pathway, altered JAK/STAT signaling, and aberrant activation of the PI3K/AKT pathway. Thus it is no surprise that morphologic and clinical overlap between PMBCL and NSHL occurs. In most cases sufficient sampling, careful microscopic

observations, and application of immunohistochemical stains can readily distinguish these two from one another. However, in rare instances, PMBCL cannot be distinguished from NSHL. Recognition of this phenomenon has led the WHO to acknowledge a lymphoma category termed "B cell lymphoma, unclassifiable, with features intermediate between DLBCL and CHL,"²⁴³ or, colloquially, "gray zone lymphoma."²⁴⁴ The actual diagnostic criteria for use of this term are incompletely defined. It should be applied rarely and only for those cases where an abundant tissue sample has been comprehensively evaluated by morphology and phenotype and the distinction between PMBCL and CHL is still impossible.

Primary Diffuse Large B-cell Lymphoma of the Central Nervous System

This tumor is defined as a neoplasm of large B cells exclusively involving the brain parenchyma or the eye (retina, vitreous, but not the soft tissues of the orbit).²⁴⁵ Secondary brain involvement by systemic lymphoma, exclusive meningeal involvement, or a history of immunodeficiency/immunosuppression excludes the diagnosis of primary central nervous system lymphoma (PCNSL). The lymphomas may be unifocal (75%) or multifocal (25%) in the brain. Of patients who present with intraocular involvement, intraparenchymal brain involvement eventually develops in the majority, and about 20% of patients who present with intracerebral disease will develop intraocular involvement. Most patients with PCNSL are elderly. There is a slight male predominance.^{246, 247 and 248}

Morphology

PCNSLs preferentially involve perivascular spaces with varying degrees of infiltration into the brain parenchyma. The neoplastic cells usually have cytologic features of centroblasts or immunoblasts or a combination of both. Reactive astrocytes, activated microglial cells, and histiocytes complete the histologic picture. Preoperative corticosteroid therapy to reduce intracerebral edema prior to biopsy can cause intralesional necrosis or regression of the neoplasm. Sometimes tumor cell ghosts can be recognized within the necrotic areas suggesting the diagnosis, but in some cases steroid therapy leaves behind only a mixture of small T-lymphocytes and histiocytes or sheets of foamy macrophages. Necrosis in a large B cell lymphoma involving the central nervous system (CNS) is also relatively common in cases that are associated with EBV or with immunosuppression. Thus necrotic areas in a large cell lymphoma involving the CNS should raise the question of prior corticosteroid therapy, underlying immunosuppression, or an association of the lesion with EBV, and the diagnosis/classification of the tumor adjusted accordingly.²⁴⁵

Immunophenotype

PCNSL cells are CD19⁺ and CD20⁺. They almost always express IRF4 and are positive for BCL6 in a substantial subset of the cases. Because they typically lack immunoreactivity for CD10 and are positive for IRF4, only a small subset of PCNSL have a GCB

P.1784

phenotype using the GCB versus non-GCB immunohistochemistrybased classifier algorithms.²⁴⁹

Genetics

Complex karyotypes are common in PCNSL cases. BCL6 translocations occur in 15% to 45% of cases with both IGH@ and non-Ig gene partners. Translocations involving MYC and BCL2 are rare in this lymphoma type.^{247,250}

Epstein-Barr Virus-Positive Diffuse Large B-cell Lymphoma of the Elderly

EBV-positive DLBCL of the elderly has only recently been formally recognized as a distinct entity.²⁵¹ By definition, it occurs in adults greater than 50 years of age who have no identifiable underlying cause for immunosuppression/immunodeficiency. It is presumed that age-related immune senescence allows latently infected EBV⁺ B cells to escape from immune surveillance and proliferate to form these tumors. In this regard they are pathogenetically analogous to EBV-related posttransplant lymphoproliferative disorders in which iatrogenic immunosuppression allows for EBV⁺ B cell proliferation to occur. EBV-positive DLBCL of the elderly increases in frequency with age, has a male predominance, and typically involves extranodal sites.^{252,253}

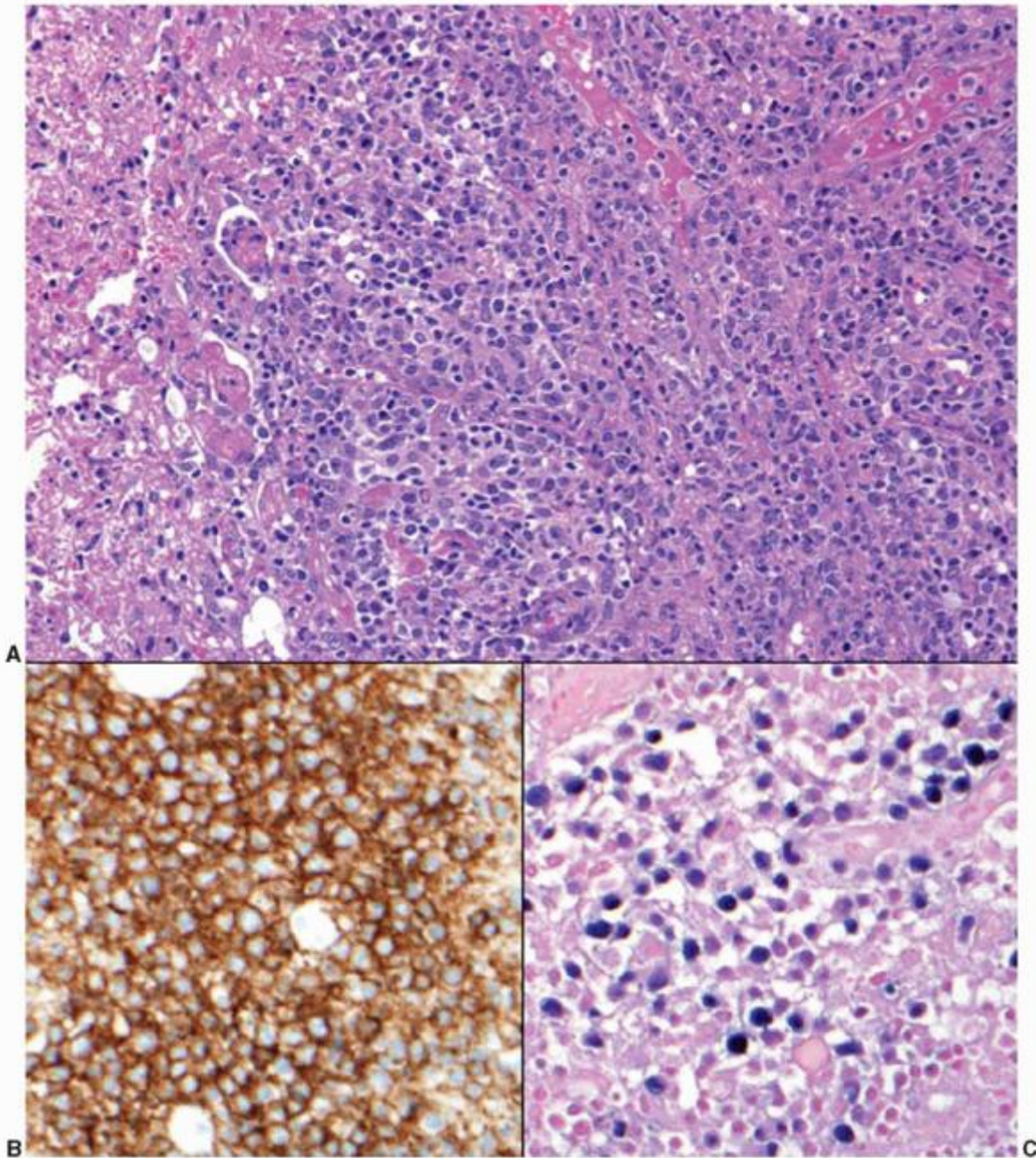

FIGURE 86.10. Soft tissue: EBV-positive DLBCL of the elderly. A: The tumor diffusely effaces tissue architecture and is associated with necrosis (left). The neoplastic cells are medium size and large with hyperchromatic, irregular nuclei. They are positive for (B) CD20 by immunohistochemistry and for (C) EBV by in situ hybridization.

Morphology

A diffusely growing cell population that not infrequently is associated with necrosis effaces the architecture of the underlying tissue.²⁵⁴ Many cases are composed of a relatively monomorphic population of large lymphoid cells (“large cell lymphoma subtype”) resembling centroblasts and immunoblasts with varying proportions of RS-like cells. The most abnormal-appearing neoplastic cells frequently surround the areas of necrosis (Fig. 86.10A). Other cases, termed “polymorphous subtype” contain a tumor cell population of large immunoblasts, plasma cells, and cells with transition features between plasma cells and immunoblasts. They are often variably mixed with small lymphocytes and histiocytes. While it is no longer thought that “large cell lymphoma” and “polymorphous” subtypes of EBV-positive DLBCL of the elderly carry prognostic significance, pathologists must recognize them as part of the morphologic spectrum of this tumor and therefore it is useful to maintain this distinction.²⁵⁵

Immunophenotype

The neoplastic cells in the large cell lymphoma subtype of EBV-positive DLBCL of the elderly usually express CD45, CD19, CD20, PAX5, and IRF4 (Fig. 86.10B). They are usually negative for CD10. The greater the number of neoplastic plasmacytoid and plasma cells contained in the tumor, the less frequently CD20 is expressed

P.1785

by the tumor and the more frequently IRF4⁺ and CD138⁺ cells constitute the tumor cell population. The ease with which light chain-restricted cytoplasmic Ig expression can be demonstrated also increases with increasing plasma cell differentiation in these tumors. By definition, the tumor cells are positive for EBV, most sensitively detected by in situ hybridization with probes that recognize EBV-encoded RNA (EBER) (Fig. 86.10C). By immunohistochemistry, the neoplasms express EBV latent membrane protein (LMP)-1 in 94% of cases and Epstein-Barr nuclear antigen 2 in 28% of cases.²⁵²

Genetics

Insufficient numbers of cases have been studied to comment on recurring genetic abnormalities in these tumors.

Other Considerations

EBV-positive DLBCL of the elderly has most recently been recognized as the most malignant end of a spectrum of EBV-related lymphoproliferative disorders occurring in adults. While it is outside the scope of this chapter to comment on the more benign entities, EBV reactivation with reactive lymphoid hyperplasia, EBV-associated polymorphous extranodal lymphoproliferations including mucocutaneous ulcer,²⁵⁶ and polymorphous nodal EBV-associated lymphoproliferations all are within the differential diagnosis of EBV-positive DLBCL of the elderly.²⁵⁷ The differential diagnosis of EBV-related lesions in adults also includes posttransplant lymphoproliferative disorders and EBV-related lymphoproliferations that occur following immunomodulatory therapy for autoimmune diseases. They are morphologically and phenotypically similar to EBV-positive DLBCL of the elderly. Except in the situation of pathologically and clinically overt DLBCL, consideration of the patient's history and following the clinical evolution of the lesion are important so that aggressive therapy is not prematurely instituted in EBV-associated lymphoproliferative disorders in adults.

Rare Large B-cell Lymphoma Types

Some rare large B-cell lymphoma types have been described in the WHO classification³⁰ and are shown in Table 86.5 and illustrated in Figure 86.11.

Burkitt Lymphoma

Burkitt lymphoma is a high-grade B-cell lymphoma composed of medium-sized, rapidly dividing lymphocytes. These lymphomas usually affect children and young adults and often present at extranodal sites. Less commonly, they have a leukemic phase. Three clinical forms are recognized: (a) endemic, which classically presents as jaw or facial masses in young boys

P.1786

in equatorial Africa; (b) sporadic, which may present at any age with frequent abdominal involvement; and (c) epidemic (immunodeficiency-associated), such as in patients who are human immunodeficiency virus (HIV)-positive. All subtypes are characterized by chromosomal rearrangements involving the MYC oncogene that lead to its inappropriate expression in B cells. The three forms have variable association with EBV infection, 100% in endemic Burkitt lymphomas and 20% to 40% in sporadic and immunodeficiency-associated Burkitt lymphomas.^{30,279, 280} and ²⁸¹

TABLE 86.5 RARE LARGE B-CELL LYMPHOMA TYPES

Rare Large B-cell Lymphoma

Type	Clinical Features	Morphology	Phenotype	Genetics
DLBCL associated with chronic inflammation ^{258,}	<ul style="list-style-type: none"> Elderly patients M:F = 12:1 	<ul style="list-style-type: none"> Similar to DLBCL, NOS 	<ul style="list-style-type: none"> Most: CD19⁺, CD20⁺, 	<ul style="list-style-type: none"> Complex clonal karyotype

259,260 and 261

- Arises in sites associated with longstanding (>10 y) chronic inflammation (e.g., lung/pleura in tuberculosis patients or near prosthetic/chronically inflamed joints)
- PAX-5+
- Some: CD20⁻, IRF-4⁺, CD138⁺
- Rare: B cells aberrant T cell antigen expression
- EBER+ almost all

Lymphomatoid granulomatosis²
62,263,264

- Predominantly adults
- M:F = 2:1
- May be immunodeficiency related
- Typically extranodal: lung (90%)—prototypic site, kidney, brain, liver, skin, others
- Angiocentric, angiodestructive lympho-histiocytic infiltrates associated with necrotic zones (“granulomatosis”)
- Varying proportion of large abnormal lymphocytes resembling centroblasts and immunoblasts and small lymphocytes
- Large lymphoid cells: CD19⁺, CD20[±], EBER+
- Small lymphocytes: CD3⁺ T cells enriched in Tia-1 positive cytolytic lymphocytes
- Non-distinctive

Intravascular large B-cell lymphoma^{265,266,267}

- Predominantly adults
- M:F = 1:1
- Protean clinical manifestations
- Anatomic sites: disseminated, bone marrow,
- Large neoplastic lymphoid cells resembling centroblasts or immunoblasts
- Neoplastic cells confined to blood vessel lumens
- Minimal or no extravascular infiltrates
- CD19⁺, CD20⁺
- CD5⁺ in 38%, CD10⁺ in 13%, remainder are IRF-4+
- Insufficient studied cases

	<p>brain, lung, skin, kidney, others, but only rarely detectable in peripheral blood</p> <ul style="list-style-type: none"> • Hemophagocytic syndrome (more common in Asian cases) 			
<p>ALK-positive large B-cell lymphoma^{268,269,270,271}</p>	<ul style="list-style-type: none"> • Very rare • Predominantly adults, but described in children • M:F = 3:1 • Anatomic sites: lymph nodes most common, isolated cases reported in extranodal locations 	<ul style="list-style-type: none"> • Preferentially involves lymph node sinuses • Cytologic features similar to immunoblasts/plasmablasts 	<ul style="list-style-type: none"> • CD138⁺, IRF-4⁺ • CD20⁻ (most cases) • ALK⁺ (entity defining phenotype) • Cytoplasmic Ig light chain restriction and expression of IgH, usually IgA 	<ul style="list-style-type: none"> • t(2:17)(p23;q23); involves <i>ALK</i> and <i>CLTC</i> genes (most cases) • t(2:5)(p23;q35) involves <i>ALK</i> and <i>NPM</i> genes • Other rare translocations/insertions involving <i>ALK</i>
<p>Plasmablastic lymphoma^{272,273,274}</p>	<ul style="list-style-type: none"> • Predominantly adults • Male predominance • Underlying immunodeficiency in almost all (HIV, immunomodulatory 	<ul style="list-style-type: none"> • Diffuse sheets of cells with plasmablastic cytology (round nuclei, marginated chromatin, distinct central nucleoli, eccentrically distributed cytoplasm with a perinuclear hof) variably mixed with more “mature” 	<ul style="list-style-type: none"> • CD138⁺, CD38⁺, IRF-4⁺ • CD20 and PAX-5- to minimally positive • Cytoplasmic Ig 	<ul style="list-style-type: none"> • Complex karyotype • <i>MYC@</i> translocation usually with <i>IGH@</i>, i.e., t(8:14)(q24;q32) in 50%

	<p>therapy for autoimmune diseases, organ transplant, immune senescence in elderly)</p> <ul style="list-style-type: none"> • MUST exclude multiple myeloma in EBV negative cases • Anatomic sites: extranodal (oral cavity, nasopharynx, orbit, skin, gastrointestinal, others) 	<p>plasma cells</p>	<p>light chain restriction and expression of IgH, usually IgG</p> <ul style="list-style-type: none"> • EBER+ (almost all, if negative, consider myeloma) 	
<p>Large B-cell lymphoma arising in HHV8-associated multicentric Castleman disease²⁷⁵</p>	<ul style="list-style-type: none"> • HIV+ adults • Baseline clinical features of HHV-8-associated multicentric Castleman disease • Severe immunodeficiency associated with asymmetric lymph node enlargement and/or splenomegaly • Also associated with 	<ul style="list-style-type: none"> • Background of Castleman disease (regressively transformed germinal centers and interfollicular plasma cell sheets • Progression from isolated immunoblast/plasma blast-like cells in follicular mantles (polyclonal) to aggregates of these cells (emergence of monoclonal proliferation) to sheets of overtly neoplastic large lymphoid cells that diffusely efface tissue architecture 	<ul style="list-style-type: none"> • CD20±, CD138⁻, IRF-4+ • Cytoplasmic Ig light chain restriction (almost always λ) and expression of IgH, almost always IgM • HHV-8+ (entity defining phenotype) • EBER- 	<ul style="list-style-type: none"> • Insufficient studied cases

<p>PEL^{276,277,278}</p>	<p>concurrent Kaposi sarcoma</p> <ul style="list-style-type: none"> • Epidemiology linked to cause for immunosuppression (found in almost all cases): young gay HIV+ males, solid organ transplant recipients, elderly patients with immune related immunosenescence, often from Mediterranean countries with high HHV-8 prevalence • Pleural, pericardial and abdominal cavities, minimal organ infiltration, rare lymph node or extranodal cases (“solid PEL”) 	<ul style="list-style-type: none"> • Immunoblastic/plasmablastic cytology, often with pleomorphic tumor giant cells and abundant apoptotic bodies in cytocentrifuge preparations or cell blocks made from involved fluids • Preferentially involve sinuses in rare cases involving lymph nodes 	<ul style="list-style-type: none"> • CD45+, CD19⁻, CD20⁻, CD79a⁻ • Surface and cytoplasmic immunoglobulin negative • Variable expression of CD38, CD138, and IRF-4 • HHV-8+ and EBER+ (disease defining phenotype, present in almost all cases) 	<ul style="list-style-type: none"> • Complex clonal karyotype
----------------------------------	--	--	--	--

ALK, anaplastic lymphoma kinase; DLBCL, diffuse large B-cell lymphoma; EBER, Epstein-Barr virus-encoded RNA; HHV, human herpes virus; NK, natural killer; NOS, not otherwise specified; PEL, primary effusion lymphoma.

Burkitt lymphomas typically have a diffuse growth pattern that is dominated on low magnification by the “starry sky” produced by tingible body macrophages (Fig. 86.12A). Tumor cells may home into residual follicles and often have a cohesive appearance at the interface of tumor and soft tissue. Nuclear size is equivalent to that of endothelial cells or macrophages. The nuclei are round to oval with small nucleoli and a moderate amount of amphophilic cytoplasm. Mitoses are frequent (Fig. 86.12B). On Wright-stained touch imprints, the neoplastic cells show remarkable nuclear homogeneity and the presence of characteristic vacuolated, basophilic cytoplasm.

Immunophenotypically, these lymphomas express pan-B cell antigens, are CD10⁺ and BCL6⁺, and are negative for BCL2.³⁰ They have monotypic surface Ig (usually IgM) and are TdT⁺, indicating a mature B cell phenotype. Ki-67/mib-1 staining shows greater than 95% of tumor cells are positive, which is consistent with a high growth fraction.

These tumors have reciprocal translocations involving the MYC oncogene mapped to chromosome 8q24, which is usually juxtaposed to the IGH@ gene on chromosome 14q32. The translocation less commonly involves the κ-light chain (IGK@; chromosome 2p12) or λ-light chain (IGL@; chromosome 22q11) genes.²⁸² In endemic Burkitt lymphoma, the translocation breakpoints are located far upstream 5′ to MYC and in the joining region of IGH@.²⁸³ In the sporadic form, the breakpoints are immediately 5′ to MYC and in the switch region of IGH@. In the immunodeficiency-associated cases, the breakpoints involve the first exon or intron of MYC and the switch region of IGH@. Therefore, different mechanisms may generate the chromosomal breakpoints in the various forms of this lymphoma.²⁸⁴ All forms show the presence of somatic mutation, which is ongoing in some cases of epidemic Burkitt lymphoma.^{285,286}

Pediatric Burkitt lymphomas, whether endemic or sporadic, appear to be a more homogeneous entity than adult Burkitt lymphomas in terms of morphology, immunophenotype, and cytogenetics.^{219,286,287} Furthermore, there may be considerable overlap in the pathologic features of some adult Burkitt lymphomas and DLBCLs, which makes accurate distinction problematic, resulting in the previously discussed WHO classification category “B cell lymphoma, unclassifiable, with features intermediate between DLBCL and Burkitt lymphoma.”²²³ Gene expression profiling may provide a more precise biologic definition of Burkitt lymphoma,^{288,289} but this technique is not currently useful for daily clinical practice.

P.1787

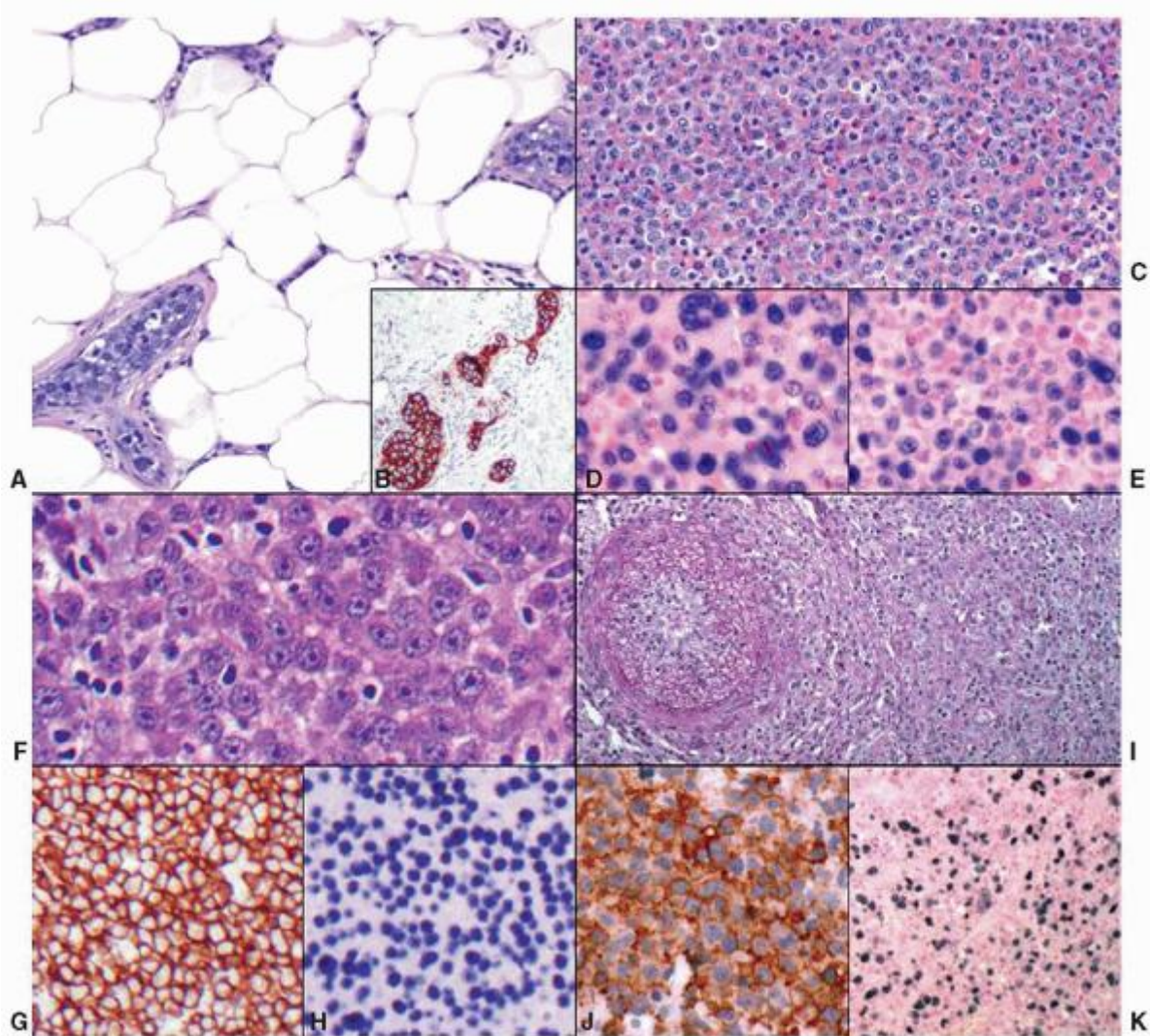

FIGURE 86.11. Various tissue sites: uncommon types of DLBCL. A and B: Intravascular large B cell lymphoma. A: Large neoplastic cells fill vascular spaces in the subcutis and are positive for (B) CD20. C, D, and E: Primary effusion lymphoma. C: The cell block prepared from pleural fluid contains pleomorphic tumor cells characteristic for this entity. By in situ hybridization they are positive for (D) EBER and (E) HHV-8. F, G, and H: Plasmablastic lymphoma. F: Note the round nuclei, margined chromatin, prominent nucleoli, and eccentric cytoplasm of the plasmablasts. They express (G) CD138 and are positive for (H) EBER. I, J and K: Lymphomatoid granulomatosis. I: In this periodic acid-Schiff-stained section, the angiocentric, angioinvasive growth pattern is highlighted. The tumor cells express (J) CD20 and are (K) EBER positive.

T-CELL AND NATURAL KILLER-CELL LYMPHOMAS

T-cell and NK-cell lymphomas may be grouped together, because their normal counterparts apparently arise from a common progenitor cell that expresses CD3 ϵ and is unable to develop into B cells.²⁹⁰ Furthermore, some lymphomas from these two lymphoid lineages have considerable morphologic, immunologic, and clinical overlap. Overall, T and NK cell lymphomas are less common than B-cell malignancies, as they comprise approximately 10% of NHLs in the United States and Western Europe.³⁰

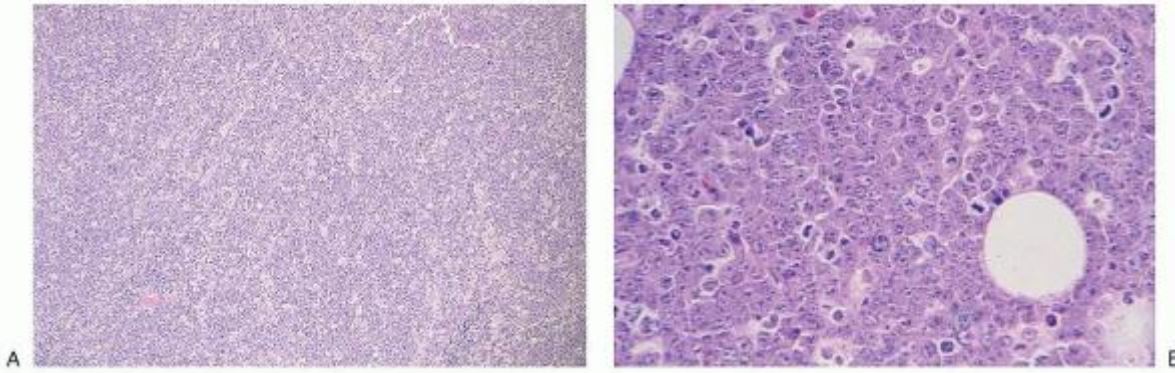

FIGURE 86.12. Lymph node: Burkitt lymphoma. A: The architecture is effaced by a diffuse infiltrate with a “starry sky” appearance. B: High magnification shows a monotonous population of small noncleaved lymphocytes with round to oval nuclei and variable cytoplasm. Mitotic figures are frequent. Numerous tingible body macrophages are present.

The WHO classification divides T-cell and NK-cell neoplasms into precursor and mature categories.³⁰ The mature (peripheral) T-cell and NK-cell neoplasms are subdivided into those that are leukemic, cutaneous and extranodal, and nodal in origin. Most peripheral T-cell lymphomas (PTCLs) are postthymic malignancies that express TCR α/β chains and are apparently derived from the adaptive (antigen-specific receptor-based) immune system (e.g., PTCL, NOS, angioimmunoblastic T-cell lymphoma

P.1788

[AITL], and systemic ALCL).²⁹¹ They generally arise in peripheral lymphoid organs from naïve, effector (regulatory [CD4⁺] and cytotoxic [CD8⁺]) or memory T cells.²⁹² NK cell lymphomas and a small number of PTCLs that may be extrathymically-derived are related to the innate (non-MHC-restricted) immune system.²⁹¹ The PTCLs in this group (e.g., hepatosplenic T-cell lymphoma [HSTCL], subcutaneous panniculitis-like T-cell lymphoma, and enteropathy-associated T-cell lymphoma [EATL]) tend to arise in mucosal or cutaneous sites, and often express TCR γ/δ chains, NK-cell-associated antigens, and cytotoxic granule-associated proteins, including granzyme M.^{293,294,295}

Precursor and peripheral T- and NK-cell lymphomas are discussed in the following sections. T lymphoblastic leukemia (T-ALL) (Chapters 73, 74, and 76), T-cell prolymphocytic leukemia and T-cell large granular lymphocytic leukemia (Chapters 88 and 90) and mycosis fungoides (Chapter 92) are discussed elsewhere in this text.

T Lymphoblastic Leukemia/Lymphoma

T lymphoblastic leukemia/lymphoma is a highly aggressive malignancy of immature (precursor) T cells that generally presents in children and young adults. The lymphomatous form of the disease typically presents as an anterior mediastinal mass, often accompanied by supradiaphragmatic lymphadenopathy. These lymphomas efface the thymic and nodal architecture in a diffuse pattern, and infiltrate the capsule and adjacent soft tissue. Numerous tingible body macrophages impart a “starry sky” appearance similar to Burkitt lymphoma (Fig. 86.13A). Monomorphic neoplastic lymphocytes are small to intermediate in size, contain scant cytoplasm, and have round to convoluted nuclei (Fig. 86.13B). The chromatin is dispersed and blast-like, and nucleoli are usually indistinct. Mitotic figures are abundant. These morphologic features are indistinguishable from disseminated T-ALL²⁹⁶ and the infrequent B-cell lymphoblastic lymphomas that were discussed previously.

T lymphoblastic lymphomas express diverse T-cell antigens, but most are CD3⁺ and CD7⁺. Some lesions correspond to early (CD1⁻, cytoplasmic CD3⁺, CD4⁻, and CD8⁻), common (CD1⁺, cytoplasmic CD3⁺, CD4⁺, and CD8⁺), or late (CD1⁻, surface CD3⁺, CD4⁺, or CD8⁺) thymocytes.²⁹⁷ Cytoplasmic CD3 expression is the most specific early marker of a T-cell phenotype and is also present in T-ALL.^{298,299} TdT is present in T lymphoblastic lymphomas, and 25% of these lymphomas are CD10⁺. HLA-DR expression is absent in almost all cases unlike B-ALL and most non-lymphoid leukemias. CD34 expression is also uncommon in T lymphoblastic lymphomas. Occasional T lymphoblastic lymphomas express NK-cell-associated antigens (e.g., CD16, CD56, or CD57).³⁰⁰

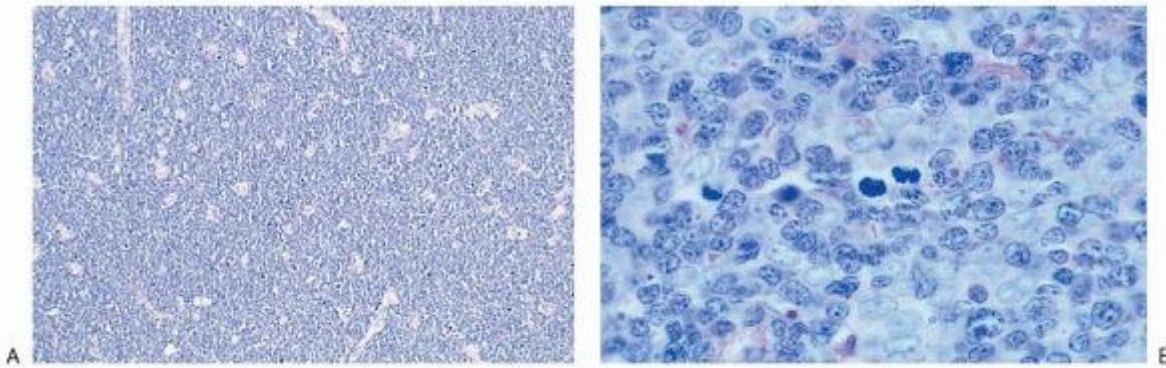

FIGURE 86.13. Lymph node: T lymphoblastic lymphoma. A: The nodal architecture is completely effaced by a diffuse lymphoid infiltrate. The interspersed macrophages help impart a “starry sky” appearance. B: The neoplastic cells are intermediate in size and have delicate chromatin characteristic of blasts, indistinct nucleoli, and scant cytoplasm. Frequent mitoses are present (center).

Because T lymphoblastic lymphoma and T-ALL have considerable overlap of morphologic, immunologic, and clinical features, it may be impossible to distinguish between the two for individual precursor T-cell neoplasms. Extensive mediastinal and peripheral lymph node involvement with limited bone marrow and peripheral blood disease favors a diagnosis of T lymphoblastic lymphoma, whereas the presence of greater than 25% T-cell lymphoblasts in the marrow is considered T-ALL.³⁰

Peripheral T-cell Lymphoma, Not Otherwise Specified

Several specific types of PTCLs are recognized by the WHO classification, as discussed separately in the following sections. However, nearly one-third of PTCLs do not fit a distinctive type and are regarded as PTCL, NOS. These lymphomas are heterogeneous, but usually present in adults who have disseminated disease accompanied by B symptoms and poor performance status. There is generally a diffuse growth pattern, but rare cases may appear nodular.^{301,302} A variety of the following morphologic features may also be seen: neoplastic lymphocytes of varying size that often have clear cytoplasm; large tumor cells that may have hyperlobated nuclei, may be multinucleate, or may resemble RS cells; frequent reactive epithelioid histiocytes; delicate connective tissue bands that segregate cells into clusters; and hypervascularity.³⁰¹ These lesions have diverse and often aberrant T cell phenotypes.³⁰³ Most express α/β TCRs and demonstrate TCR gene rearrangements.^{304,305} Tumors with a cytotoxic lymphocyte phenotype or that are EBV⁺ appear to have a worse prognosis than other lymphomas in this category.^{306,307} A recurrent t(5;9) (q31-q32;q22) chromosomal abnormality that fuses ITK to SYK has been identified in a very small number of PTCL, NOS that tend to have follicular involvement.³⁰⁸ Rare cases of cytotoxic PTCL, NOS, with skin and bone marrow involvement, have a t(6;14) (p25;q11.2) that fuses IRF4 to the TCR-alpha (TRA@) locus.³⁰⁹ Otherwise, recurrent chromosomal translocations in PTCL, NOS have not been described. Gene expression profiling may determine different molecular subgroups or therapeutic targets among PTCL, NOS, but the impact of the nonneoplastic cell constituents on the results of such studies must be considered.^{310,311}

T-zone Lymphoma

T-zone lymphoma is recognized as a morphologic variant among the PTCL, NOS in the WHO classification.³⁰ The characteristic histopathologic feature is an interfollicular growth of primarily

P.1789

small neoplastic T cells with clear cytoplasm that are associated with prominent high endothelial venules and spared secondary lymphoid follicles.

Lymphoepithelioid Cell Lymphoma

Lymphoepithelioid cell (Lennert) lymphoma^{312, 313} and³¹⁴ is also considered a morphologic variant among PTCL, NOS in the WHO classification.³⁰ The most striking histologic feature is the numerous clusters of epithelioid histiocytes that are relatively evenly dispersed throughout tissues obliterated by a lymphomatous infiltrate composed primarily of small neoplastic T cells. This moderately aggressive lymphoma must be distinguished from some cases of HL, B-cell lymphomas, and other PTCLs that are also accompanied by a high content of epithelioid histiocytes.^{123,315, 316} and³¹⁷ Misinterpretation as a reactive process may occur when attention is focused on the histiocytes rather than on the lymphoid infiltrate that

destroys tissue architecture. When localized, Lennert lymphoma tends to involve the head and neck region, particularly cervical lymph nodes and sometimes the Waldeyer ring.

Follicular T-cell Lymphoma

Follicular T-cell lymphoma is another variant of PTCL, NOS that is recognized in the WHO classification.³⁰ It is characterized by intrafollicular aggregates of T cells with clear cytoplasm that have a follicular T-follicular helper (T_{FH}) cell phenotype.³¹⁸ The resulting expansion of the lymphoid follicles may mimic follicular lymphoma or, sometimes, NLPHL. A $t(5;9)(q31-q32;q22)$ is present in some cases.³⁰⁸

Angioimmunoblastic T-cell Lymphoma

AITL was first described in the 1970s as a clinical syndrome characterized by generalized lymphadenopathy, hepatosplenomegaly, anemia, and hypergammaglobulinemia.^{319,320} The lymph node histology showed a number of distinctive features, including partial effacement of the architecture by a polymorphic inflammatory cell infiltrate, including large lymphocytes (immunoblasts), and marked vascular proliferation. Based on these histologic appearances, the disease was called a variety of terms, including immunoblastic lymphadenopathy, lymphogranulomatosis X, and angioimmunoblastic lymphadenopathy with dysproteinemia (AILD). The latter term for this clinical syndrome was accepted by most investigators.³¹⁹

AILD was initially thought to be an atypical lymphoid hyperplasia, a premalignant lesion with a tendency to develop into a lymphoma, rather than as a frank neoplasm from the onset. With the advent of immunophenotyping and molecular techniques, it became apparent that most cases of AILD contained monoclonal T-cell populations as well as clonal cytogenetic abnormalities, strongly suggesting that most of the cases were neoplastic from the onset.³²⁰ It was included in the updated Kiel classification of lymphomas as T-cell lymphoma of AILD-type. Since then, the WHO classification has dropped the term AILD-like TCL and opted for the term AITL to stress the neoplastic nature of this disease.

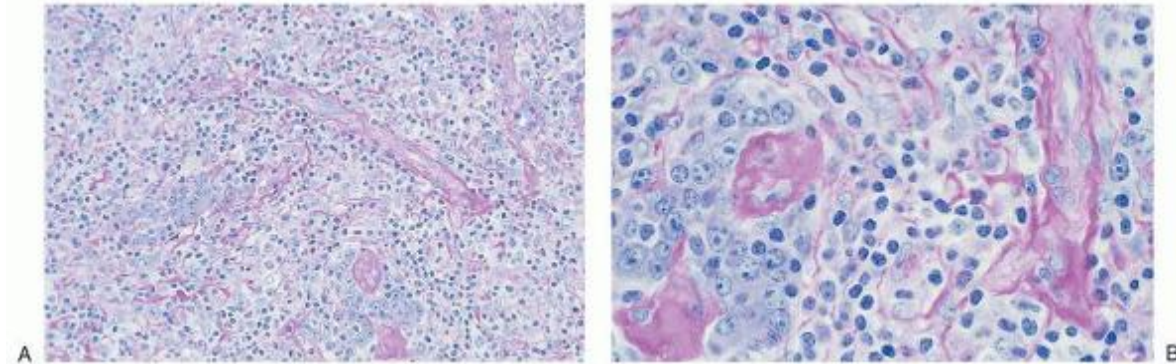

FIGURE 86.14. Lymph node: angioimmunoblastic T-cell lymphoma. A: There is a diffuse lymphoproliferation that is associated with prominent periodic acid-Schiff-staining blood vessels. B: Perivascular clusters of “clear cell” immunoblasts (left) are admixed with small lymphocytes and periodic acid-Schiff-staining blood vessels.

Morphology

AITL is characterized by partial effacement of the lymph node architecture by a polymorphic inflammatory cell infiltrate predominantly within the paracortical areas (Fig. 86.14A). In the original descriptions of AITL, absence of hyperplastic B-cell follicles was considered to be a characteristic feature. It is now recognized that the architectural changes in AITL fall into three overlapping patterns.^{321,322} In pattern I (15% of the cases), there is partial preservation of the lymph node architecture. Hyperplastic B-cell follicles with poorly developed mantle zones and ill-defined borders are easily identifiable in the cortex of the lymph node. These merge into the expanded paracortex, containing a polymorphic infiltrate of small lymphocytes, immunoblasts, plasma cells, macrophages, and eosinophils within a prominent vascular network. Pattern II (25% of the cases) is characterized by loss of normal architecture except for the presence of occasional depleted follicles with concentrically arranged follicular dendritic cells. In some cases, follicular dendritic cell proliferation extending beyond the follicles can be identified. The rest of the lymph node shows a polymorphic inflammatory cell infiltrate with increased numbers of immunoblasts and vascular proliferation similar to that described for pattern I. In pattern III (60% of the cases), the normal architecture is completely effaced and no B-cell follicles can be identified. Prominent irregular proliferation of follicular dendritic cells can be seen in hematoxylin and eosin (H&E)-stained sections in some cases, and this is accompanied by extensive vascular proliferation and a polymorphic inflammatory cell infiltrate similar to that seen in patterns I and II. Approximately one-half of the cases contain perivascular collections of atypical medium-large

lymphoid cells with clear or pale cytoplasm (Fig. 86.14B), whereas in other cases cytologic features of malignancy may not be apparent. In a few cases where consecutive biopsies from the same patient have been reviewed, there appears to be a transition from pattern 1 to pattern 3 as the tumor progresses. This suggests that pattern 3 cases represent advanced disease.³²²

P.1790

Although generalized lymphadenopathy is the main presenting sign, many of the patients have evidence of extranodal involvement at the time of diagnosis. The most frequently involved extranodal sites include the bone marrow, spleen, skin, and lungs. The histologic appearances in these sites are usually nonspecific but mimic some of the features described in the lymph node including increased vascularity and a polymorphic inflammatory cell infiltrate.^{323, 324} and ³²⁵ Cytologic features of malignancy can rarely be identified and tumor involvement can be shown only by immunohistochemistry and molecular clonality analysis. Therefore, the initial diagnosis of AITL rests on histologic examination of the lymph node.

Immunophenotype

Immunohistochemistry shows the expansion of the interfollicular areas by a diffuse infiltrate of CD3⁺ T cells. In most cases CD4⁺ T cells dominate, but there is usually an intermixed population of CD8⁺ cells. B-cell markers CD20 and CD79a highlight the residual follicle center and mantle zone B cells as well as many of the immunoblasts in the interfollicular areas. In some instances these can be numerous, mimicking a large B-cell lymphoma or classical HL, though they are typically polytypic for Ig light chain expression. One of the most important immunophenotypic features in AITL is the expansion of the follicular dendritic cell meshwork that typically surrounds the paracortical small vessels. Although this is sometimes visible on H&E-stained sections, it is best demonstrated by staining for follicular dendritic cell markers such as CD21.^{326,327,328}

Until recently, the assessment of immunophenotype of the AITL cells was difficult, since the neoplastic cells in many cases were not readily identifiable and no specific markers were available to highlight the tumor cells. However, recent phenotyping and gene expression profiling studies have shown that the neoplastic cells of AITL express a number of T_{FH} cell markers, including CD10, CXCL13, and CD279 (PD-1), which suggests AITL may be derived from intrafollicular T cells.^{318,322,329} T_{FH} cell markers are not expressed by normal peripheral T cells except for a minority of follicle center T cells. The expression of CD10, CXCL13, and CD279 on neoplastic T cells appears highly specific for AITL, as most other PTCLs are negative for these antigens. Although it is not yet known whether CD10 is expressed by all tumor cells or only by a subset of the tumor cells, the availability of specific markers for AITL has helped understand the biology of this disease. Initially, the tumor cells account for only a small fraction of the whole infiltrate (pattern 1). The cells are intimately related to the residual reactive B-cell follicles and the expanded follicular dendritic cell meshwork, some being located within the follicle centers and others surrounding the follicles. As the tumor progresses (patterns 2 and 3) the neoplastic cells spill into the interfollicular area but retain the intimate association with the follicular dendritic cell meshwork. This suggests that the follicular dendritic cell microenvironment may be important in tumor growth. Interestingly, follicular dendritic cells also express CXCL13, a chemokine critical for B-cell entry into follicle centers. In T-cell lymphomas, CXCL13 shows a very similar expression pattern as CD10 and can be utilized as a diagnostic marker for AITL.^{330,331, 332} and ³³³ The neoplastic T cells in extranodal dissemination may retain expression of CD10 and this may be helpful for diagnosis.³³⁴

Virtually all cases of AITL contain increased numbers of EBV-infected cells with immunoblastic or RS cell-like morphology. Double immunolabeling suggests that these are B cells, and convincing evidence for infection of T cells is lacking.

The overwhelming evidence suggests that there is a monoclonal T-cell population in the vast majority of AITLs. Interestingly, the presence of a B-cell clone can also be demonstrated in a subset of cases.³²⁰ These are thought to be expanded EBV-infected B-cell clones possibly secondary to underlying immunodeficiency/immune activation.

Anaplastic Large Cell Lymphoma

ALCL is typically characterized by an infiltrate of highly pleomorphic large lymphocytes that express strong reactivity with antibodies directed against CD30, a T-cell activation-associated antigen.^{335,336} The entity initially included all lymphomas composed of large cells and uniformly expressing CD30 (Ki-1). However, the current WHO classification restricts the entity to those cases showing either a T-cell lineage or a null phenotype and excludes CD30⁺ large B-cell lymphomas.

As defined by the WHO classification primary, ALCL comprises three different clinicopathologic entities sharing similar morphology and immunophenotype but showing distinct clinical features. These are (1) systemic ALCL, ALK-positive³³⁷; (2)

systemic ALCL, ALK-negative³³⁸; and (3) cutaneous ALCL, which is grouped among cases classified as “primary cutaneous CD30-positive T-cell lymphoproliferative disorders.”³³⁹

Anaplastic Lymphoma Kinase-Positive Anaplastic Large Cell Lymphoma

Primary systemic ALCL, ALK-positive is a moderately aggressive tumor that generally presents in young patients who have peripheral lymphadenopathy and extranodal disease that often includes the skin.^{340,341} The lymphoma preferentially infiltrates nodal sinuses (Fig. 86.15A) and extends into the paracortical region, often sparing secondary lymphoid follicles. The neoplastic large cells seem cohesive and usually have great variability in nuclear appearance, including some that are horseshoe- or doughnut-shaped (“hallmark” cells) (Fig. 86.15B) or are multinucleate with a resemblance to RS cells of HL.³⁴² These features of the tumor cells are characteristic of the common variant of ALCL with pleomorphic cytology. The common variant, comprising approximately 70% of ALCL, also includes cases with monomorphic cytologic features in which the nuclei are round rather than pleomorphic. The chromatin pattern is dispersed (blast-like), and there are often prominent nucleoli. The cytoplasm is abundant, and the mitotic rate is often brisk. The common variant of ALCL may be misdiagnosed as metastatic carcinoma or malignant histiocytosis because of the pleomorphic cytologic features of the tumor cells.^{335,336} Small cell and lymphohistiocytic variants have been described, each comprising approximately 10% of ALCL.^{343,344} The latter two variants may be misdiagnosed as an inflammatory process.

The tumor cells in ALCL are always CD30⁺, may express pan-T-cell antigens such as CD2 and CD3 and, frequently, cytotoxic granule-associated proteins.^{345,346} Most cases express ALK oncoprotein, most frequently due to a t(2;5) (p23;q35.1) chromosomal abnormality.^{347,348} This translocation fuses the ALK gene on chromosome 2 and the nucleophosmin (NPM1) gene on chromosome 5.³⁴⁹ The fusion protein can be detected with a cytoplasmic and nuclear ALK staining pattern by immunohistochemistry.³⁵⁰ Approximately 70% to 80% of ALK-positive ALCL have cytoplasmic and nuclear staining, whereas the remainder have cytoplasmic staining only, indicating variant translocations involving ALK and partner genes other than NPM1. Variant ALK gene translocations include t(1;2)(q21.3;p23), which fuses the tropomyosin 3 (TPM3) gene on chromosome 1 and ALK; t(2;3) (p23;q12.2), which involves the TRK-fused gene (TFG) on chromosome 3 and ALK; inv(2)(p23q35), which involves the ATIC gene (encoding for 5-aminoimidazole-4-carboxamide-ribonucleotide) on chromosome 2 and ALK; and t(2;17)(p23;q11-qter), which fuses the clathrin heavy chain (CLTC) gene on chromosome 17 and ALK.^{351, 352, 353} and ³⁵⁴

P.1791

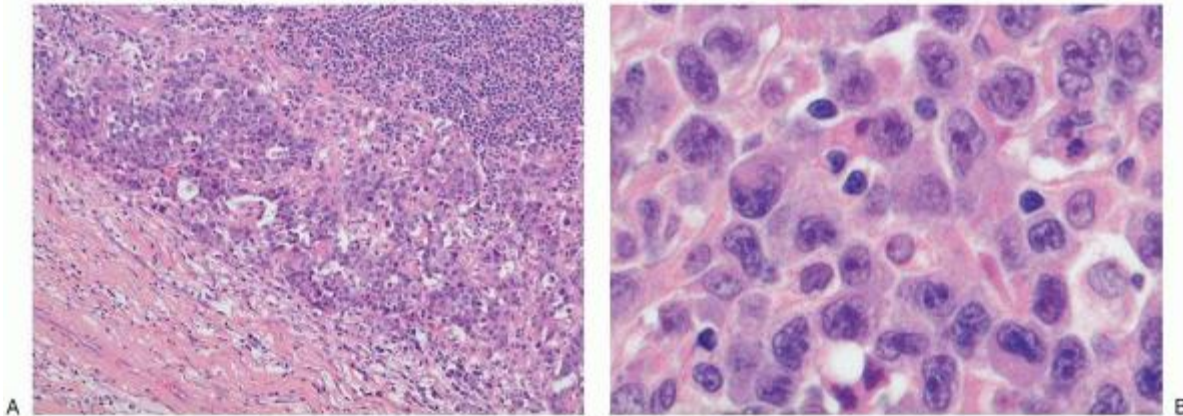

FIGURE 86.15. Lymph node: anaplastic large cell lymphoma. A: Tumor cell infiltrates with a cohesive appearance fill the sinuses, mimicking a metastatic carcinoma. B: The lymphoma is composed of pleomorphic large lymphocytes, some of which have the horseshoe- or bean-shaped nuclei that are characteristic of “hallmark” cells of anaplastic large cell lymphoma.

Anaplastic Lymphoma Kinase-Negative Anaplastic Large Cell Lymphoma

Systemic ALCLs lacking ALK expression are morphologically and immunophenotypically very similar to ALK-positive ALCLs but they lack genetic abnormalities involving ALK and ALK protein expression. ALK-negative ALCLs also appear genetically distinct from ALK-positive ALCLs by comparative genomic hybridization and microarray gene expression profiling.^{355, 356} and ³⁵⁷ Furthermore, the patients are typically older and, clinically, have a worse prognosis compared to ALK-positive

ALCLs.^{358,359} Therefore, whether or not ALK-negative ALCLs should be regarded as ALCLs or grouped among PTCLs, unspecified is controversial. However, this debate does not appear to need an answer at this time because ALK-negative ALCL and PTCL, NOS share a similar poor prognosis.³⁶⁰ The first recurrent translocation, t(6;7)(pter-q22.33;q32.3), among ALK-negative ALCLs, was recently described, which results in fusion of DUSP22 and FRA7H.³⁶¹

Primary Cutaneous Anaplastic Large Cell Lymphoma

Primary cutaneous ALCL typically occurs in adults who have localized disease at the time of diagnosis.^{339,340} This form of ALCL is often indolent and may be an extension of lymphomatoid papulosis (LyP) type A. The tumor cells generally resemble those of the common variant of primary systemic ALCL and express T-cell antigens. Primary cutaneous ALCL is usually epithelial membrane antigen negative and lacks t(2;5) and ALK expression, suggesting it has a different pathogenetic mechanism than that of primary systemic ALK-positive ALCL.^{339,340,348} A significant subset of primary cutaneous ALCLs have IRF4 translocations, an abnormality rarely seen in LyP, mycosis fungoides, and systemic ALCL.³⁶²

Other Considerations

ALCLs have been reported in seroma fluid or in capsules associated with silicone or saline breast implants.^{363,364} The absolute risk of developing ALCL adjacent to breast implants is exceedingly low, and the tumors show no propensity for producing solid tumors or systemic disease despite being consistently ALK-negative. This clonal proliferation has an indolent clinical behavior similar to primary cutaneous ALCL.

CD30⁺ T-cell lymphoproliferations confined to the mucosa in the head and neck may have morphologic and immunophenotypic features resembling ALK-negative ALCL, but the clinical course is indolent like primary cutaneous CD30-positive T-cell lymphoproliferative disorders.³⁶⁵

Adult T-cell Leukemia/Lymphoma

Adult T-cell leukemia/lymphoma (ATLL) is a peripheral T-cell neoplasm caused by HTLV-1, and it is most prevalent where the retrovirus is endemic (southwestern Japan, central Africa, and the Caribbean basin). However, the incidence of the disease appears to be increasing in nonendemic areas due to spreading by carriers of the virus.³⁶⁶ There is a long latency period for HTLV-1, and the lifetime risk of developing ATLL is <5% among those infected. ATLL occurs in adults and has four clinical subtypes: acute, chronic, lymphomatous, and smoldering.^{367,368,369} Bone marrow infiltrates are interstitial or diffuse and may be less impressive than the degree of peripheral blood involvement. Circulating tumor cells have hyperlobate nuclei, sometimes with a cloverleaf shape. Lymph nodes are generally effaced by a diffuse infiltrate of pleomorphic lymphocytes of variable size, an appearance that may be difficult to distinguish from some PTCL, NOS by morphology alone.³⁷⁰ Cutaneous infiltrates may be difficult to distinguish from mycosis fungoides, because ATLL can have epidermotropism with formation of Pautrier's microabscesses.³⁶⁷ The neoplastic cells express T-cell antigens but often lack CD7. Most cases are CD4⁺, express the activation marker CD25 (interleukin-2 receptor) and are positive for FoxP3, a phenotype characteristic of regulatory T cells.³⁷¹ ATLL exhibits TCR gene rearrangements and clonal integration of HTLV-1 genomes.³⁶⁹ The virally-encoded protein, Tax, activates numerous transcription factors and represses cell cycle-active proteins, resulting in persistent clonal proliferation of virally-infected cells.

Hepatosplenic T-cell Lymphoma

HSTCL, a rare extranodal lymphoma comprising <1% of NHLs, probably arises from the cytotoxic γ/δ and α/β T cells of the splenic red pulp.³⁷² Despite the few descriptions of HSTCLs,^{373,374,375,376} a fairly typical clinicopathologic picture has emerged for these neoplasms. Most cases involve young, adult men who present with B symptoms, massive hepatosplenomegaly, no lymphadenopathy, moderate anemia, and marked thrombocytopenia. Approximately

P.1792

20% of HSTCLs arise in the setting of prolonged antigenic stimulation or chronic immunosuppression, such as following solid organ transplantation or treatment of inflammatory bowel disease.^{375,377} The disease is aggressive, and most patients die within 2 years, even if a remission is achieved initially with therapy.

This lymphoma preferentially infiltrates the cords and sinuses of the splenic red pulp, hepatic sinusoids, and bone marrow sinuses. A leukemic phase may develop as the disease progresses. Tumor cells are generally small to intermediate in size, but some cases may have a predominance of large cells. There are condensed chromatin, indistinct nucleoli, and scant eosinophilic cytoplasm. Circulating tumor cells are generally agranular, but cytoplasmic granules have been detected by electron microscopy in some cases.³⁷⁸ There may be an associated hemophagocytosis by benign histiocytes.³⁷⁸ The characteristic phenotype is CD2⁺, CD3⁺, CD4⁻, CD5⁻, CD7⁺, and CD8⁻. Most reported cases express TCR γ/δ chains, but a

subset has TCR α/β chains.³⁷⁶ The TCR γ/δ cases are derived preferentially from the V δ 1 subset of γ/δ T cells.³⁷⁹ NK-cell-associated antigens, such as CD16 and CD56, are often detected.^{336,374,378} The pattern of cytotoxic granule-associated protein expression, TIA-1+, granzyme M+, granzyme B-, and perforin-, is consistent with nonactivated cytotoxic T cells of the innate immune system.^{295,374,375,376,378} HSTCLs also express killer cell Ig-like receptors (KIRs) consistent with a derivation from memory T cells, and their exhibiting multiple KIR isoforms (CD158a, CD158b, and CD158e) is unique among cytotoxic T-cell lymphomas.³⁸⁰ TCR gene rearrangements are observed. Karyotypic studies often show isochromosome 7q that may be accompanied by trisomy 8 and loss of a sex chromosome.^{374,375,376,378,381} HSTCL has a distinct molecular signature when compared with gene expression profiling of other T-cell lymphomas.³⁸²

Subcutaneous Panniculitis-like T-cell Lymphoma

Subcutaneous panniculitis-like T-cell lymphoma usually presents as multiple erythematous subcutaneous nodules of variable size (0.5 to 12.0 cm) on the extremities or trunk, or both, of adults.^{383,384,385,386} This moderately aggressive lymphoma tends to remain localized to the subcutis throughout the clinical course that may be complicated by a severe, and often fatal, hemophagocytic syndrome.

The lymphoma primarily involves the subcutaneous adipose tissue, where there is a lobular panniculitic infiltrate of pleomorphic lymphocytes of variable size. There may be tumor in the deep dermis, but the upper dermis and epidermis are spared. Karyorrhexis and fat necrosis are always present, as are benign histiocytes that often exhibit phagocytosis of nuclear debris or red blood cells. The lymphoma cells express a T-cell phenotype that may be aberrant. Only cases with α/β TCRs are accepted in this disease category.³⁸⁶ Lymphomas that have a subcutaneous panniculitis-like growth pattern but express γ/δ TCRs are included in the cutaneous γ/δ T-cell lymphoma group among the primary cutaneous PTCL, unspecified category.³⁸⁶ Subcutaneous panniculitis-like T-cell lymphomas often express CD8, contain cytotoxic granule-associated proteins, and may express NK-cell-associated antigens.^{385,386} TCR gene rearrangements have been identified.^{385,386}

Enteropathy-associated T-cell Lymphoma

EATL is a tumor of the intraepithelial lymphocytes most frequently arising as a complication of celiac disease, which is often not clinically evident.^{387,388} Most patients are middle-aged to elderly; it is unusual for these lymphomas to present before 40 years of age. The most common presenting symptoms are abdominal pain and weight loss. Diarrhea is present less often but is not infrequent. There may be signs of acute obstruction or spontaneous perforation. The disease has an aggressive course, with most patients dying within a few years of diagnosis.

It is now realized that the pathology of the tumor shows a spectrum.^{389,390,391} At one end of the spectrum, the lymphoma is limited to the intraepithelial lymphocyte population (intraepithelial EATL). No tumor mass or cytologic features of malignancy are seen, but there is often aberrant loss of CD8 expression and a monoclonal T-cell population by molecular analysis. These patients frequently present with refractory celiac disease and demonstrate serologic findings of celiac disease. Some of these cases are complicated by multiple ulcers in the small intestinal mucosa (ulcerative jejunitis). Tumors cannot be identified by histology in the ulcer bases, which contain a mixed inflammatory cell infiltrate. TCR gene rearrangements can be demonstrated, however.³⁹² At the other end of the spectrum, the lymphoma presents as single or multiple tumor masses along the small intestine, most frequently in the jejunum. Histologically, the tumor cells are usually intermediate to large in size with oval to pleomorphic nuclei (type I EATL). There is generally abundant clear to eosinophilic cytoplasm, and azurophilic cytoplasmic granules are occasionally observed on touch imprints of the tumor. Mitotic activity is usually brisk. The phenotype is variable but is often CD2⁺, CD3⁺, CD4⁺, CD5⁻, CD7⁺, CD8⁷⁺, TCR α/β positive, and TCR γ/δ negative. Some cases may be CD30⁺ and must be distinguished from ALCL. A unique subset of EATL, which often lacks clinical features of celiac disease, is composed of small- to medium-sized lymphoid cells (Type II EATL). These tumors, in addition to pan-T-cell markers, coexpress CD8 and CD56.

Many cases demonstrate TCR β -chain (TRB@) gene rearrangements. Comparative genomic hybridization has shown chromosomal imbalances in 87% of EATLs with gains at chromosome 9q being the most frequent by far.³⁹³

Virtually all cases presenting with a tumor mass contain clonally-linked intraepithelial low-grade lymphoma in the distant small intestinal mucosa, suggesting that the large cell lymphoma has arisen from an underlying intraepithelial lymphoma. This intraepithelial component is a very helpful hint in establishing the nature of a large cell lymphoma in the intestinal tract.

Extranodal Natural Killer/T-cell Lymphoma Nasal Type

Nasal NK/T-cell lymphomas occur in the nasopharyngeal or sinonasal areas and include cases with morphologic features described previously as polymorphic reticulosis and lethal midline granuloma. These lymphomas are often angiocentric,

angioinvasive, and angiodestructive lesions composed of a polymorphic infiltrate of small lymphocytes and immunoblasts with significant cytologic atypia.^{394,395} The lymphoid infiltrate often occludes vessels producing areas of ischemic necrosis. The clinical course is typically aggressive and prognosis is poor. These lymphomas are observed most frequently in East Asia and among the native American populations of Mexico, Central America, and South America. They are rare in the United States and Europe. Any age group can be affected.

Recent studies have shown these lymphomas are true NK-cell lymphomas or cytotoxic PTCLs. Most cases express NK-cell-associated antigens, particularly CD56, and some contain azurophilic cytoplasmic granules on Romanowsky-type-stained smears or cytotoxic granule-associated proteins recognized by immunohistochemistry.^{394,395, 396} and ³⁹⁷ The true NK-cell lymphomas lack TCR gene rearrangements, whereas the few well-defined T-cell cases demonstrate TCR gene rearrangements or transcripts.^{394,395, 396, 397} and ³⁹⁸ Most of these lymphomas are EBV-associated.^{395,397, 398} and ³⁹⁹ Extranodal NK/T-cell lymphoma, nasal type has a distinct molecular signature when compared with gene expression profiling of PTCL, NOS.⁴⁰⁰

Nonnasal NK/T-cell lymphomas may be called extranodal NK/T-cell lymphoma, nasal type, because they share many of the P.1793

features of the more commonly occurring NK/T-cell lymphomas in the nasal region.⁴⁰¹ Skin, soft tissue, gastrointestinal tract, and testis are the most frequent nonnasal extranodal sites involved by NK/T-cell lymphomas.^{402, 403} and ⁴⁰⁴ Some cutaneous and subcutaneous NK/T-cell lymphomas may represent secondary spread from nasal NK/T-cell lymphomas. Cutaneous cases are generally true NK-cell lymphomas. Most express CD56, and azurophilic cytoplasmic granules are often present. There is also a high degree of association with EBV, particularly those of apparent, true NK-cell origin.^{404,405}

HODGKIN LYMPHOMAS

Although HL has distinct clinical manifestations that help to define the disease, its simplest pathology definition is a neoplasm of RS cells and RS cell variants (collectively termed Hodgkin cells) that are associated with an inflammatory response that often dominates the morphologic picture. This histopathologic definition formulated by Jackson and Parker and further refined by Lukes, Butler, and Hicks, has formed the basis for reproducible diagnosis of this disease for many years. However, based on advances in the understanding of the biology of Hodgkin cells, the WHO modified the defining features of HL to include phenotypic criteria.⁴⁰⁶ Thus, HL was subdivided into 2 major categories: lymphocyte predominant HL and classical HL. LPHL is rather homogeneous, both histopathologically and clinically. However, there is heterogeneity in the histopathology and clinical features of CHL and so the WHO classification continues to recognize as subtypes of CHL mixed cellularity (MC), lymphocyte-rich (LR), nodular sclerosis (NS), and lymphocyte-depleted (LD) types. Aside from the modification to include phenotype in the definition of CHL, the subtypes of CHL are recognized using the same basic criteria as those proffered in the Rye modification of the Lukes, Butler, and Hicks HL classification scheme.^{407,408} Although the prognostic significance of the histologic type of CHL has not been proven to be independent of clinical stage, the diagnostic importance of this classification scheme is not diminished. To the contrary, it is very useful to pathologists, helping them to recognize the histologic diversity of HL, and to managing clinicians, helping them to predict the likelihood of advanced-stage disease. In general, LPHL and NSHL correlate with low stage disease; LDHL with advanced-stage disease; and MCHL presents an intermediate risk for widespread disease.⁴⁰⁹

Classical Hodgkin Lymphoma

The histopathologic features of CHL include architectural effacement of the involved tissue by a mixed cell infiltrate that includes RS cells, large neoplastic cells with some, but not all of the features of RS cells (termed Hodgkin cells or RS cell variants), and inflammatory cells, including varying numbers of small lymphocytes, macrophages, plasma cells, eosinophils, neutrophils, and fibroblasts.^{406,407,410} HL is an unusual neoplasm because the RS cells and Hodgkin cells are in the minority, and the inflammatory host response constitutes most of the cellular infiltrates. RS cells are characteristically described as large cells, 20 to 50 μm in diameter, with bilobed, multilobed, or multiple nuclei (Fig. 86.16). Each nucleus or nuclear lobe has a thick nuclear membrane with vesicular chromatin. Typically, large inclusion-like nucleoli surrounded by a perinucleolar halo are present. The cytoplasm is abundant, eosinophilic to amphophilic and homogeneous throughout. By current WHO lymphoma classification criteria, CHL is not only cytologically defined, it is also phenotypically defined. Immunohistochemistry performed on paraffin sections of the tumor is the preferred modality to phenotype cases of HL. The RS cells and variants in CHL express CD30 and PAX5, they often express CD15 and they are negative for CD45 (Fig. 86.17). Variable immunoreactivity for CD20 is present in a subset of cases. Hodgkin cells do not express CD3.

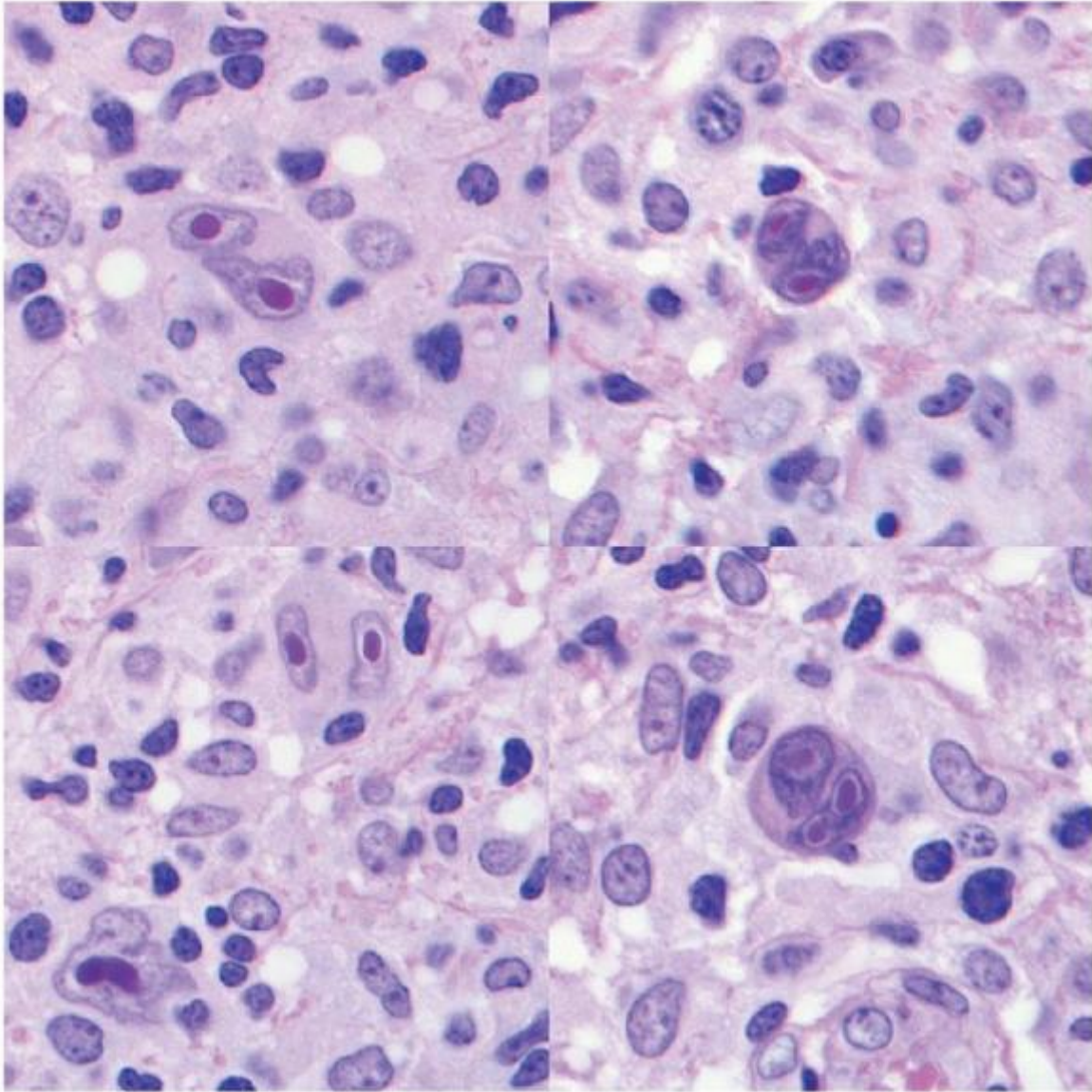

FIGURE 86.16. Lymph node: classical Hodgkin lymphoma. This composite photograph highlights the features of diagnostic Reed-Sternberg cells: multiple or bilobed nuclei, prominent inclusion-like nucleoli, and abundant eosinophilic cytoplasm.

Although the presence and phenotype of RS cells constitute defining features of CHL, cells that are cytologically (and phenotypically) identical to RS cells can be seen in reactive conditions, such as infectious mononucleosis^{411,412} and in other NHLs. Therefore, tissue architectural effacement and the inflammatory cells that accompany the Hodgkin cells are also critical criteria for the diagnosis of HL. Careful attention to the inflammatory cells, particularly the lymphocytes, helps the pathologist to distinguish HLs from NHLs containing RS-like cells. In the former, there is a dimorphism between the Hodgkin cells and the small bland appearing lymphocytes. NHLs with RS-like cells often contain a population of medium-size lymphocytes with cytologic features, including nuclear irregularities and pleomorphism. The presence of the prominent host response in HL also complicates separation of HL from benign, inflammatory processes. Granulomas containing multinucleated giant cells with or without central necrosis, abundant neutrophils, numerous eosinophils, granulation tissue, collagen deposition, and vascular proliferation are the hallmarks of the host immune response to a variety of infectious agents or can be seen in allergic reactions and autoimmune diseases. Tissues involved by CHL can contain these same features. Once the essential diagnostic features of HL are recognized CHL is subclassified based upon the presence or absence of particular types of RS cell variants and upon the varying proportions of reacting host inflammatory cells and fibrosis.

Mixed Cellularity Hodgkin Lymphoma

Mixed cellularity Hodgkin lymphoma (MCHL) is probably best thought of as the prototype of CHL because it contains all of the essential diagnostic features of this disorder.⁴¹³ In the most characteristic cases RS cells, RS cell variants, and an admixture of lymphocytes, plasma cells, eosinophils, and macrophages diffusely efface lymph node architecture (Fig. 86.18). RS cells are typically quite numerous. There may be a delicate collagen fibrosis between the cells, but collagen bands that thicken the lymph

P.1794

node capsule and define the borders of nodules are not present. In addition, lacunar cells and LP variants of RS cells are not identified. Within this basic morphologic framework, MCHL can span a considerable histologic spectrum based on the relative numbers of Hodgkin cells and the different types and proportions of reacting cells present in the cellular infiltrates.

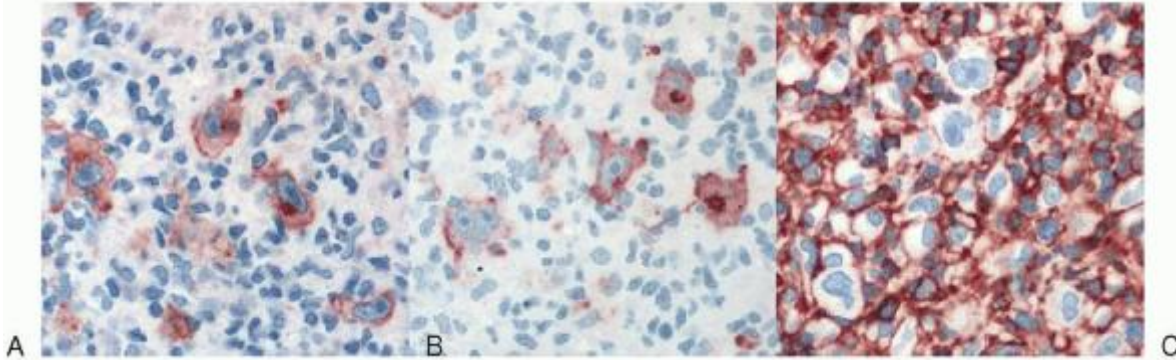

FIGURE 86.17. Lymph node: phenotypic features of Reed-Sternberg cells in classical Hodgkin lymphoma. A: The large Hodgkin cells are positive for CD30 and B: CD15, C: but are negative for CD45 in immunoperoxidase stains performed on paraffin sections of this involved lymph node.

In some lymph nodes, the diagnostic infiltrates of HL occur between reactive germinal centers. This pattern was termed "interfollicular Hodgkin's disease".⁴¹⁴ In lymph nodes containing interfollicular HL, the reactive follicles predominate. In most cases, they are constituted by centroblasts, centrocytes, tingible body macrophages, and frequent mitotic figures. However, in a small number of cases, regressive transformation of germinal centers identical to the follicular changes in hyaline vascular type Castleman disease are present. The areas diagnostic of HL occur between the follicles and contain varying numbers of RS cells, small lymphocytes, macrophages, eosinophils, and plasma cells. Interfollicular HL does not constitute a specific subtype of CHL; rather it represents early, partial lymph node involvement by MC or NS type. There are no reported distinctive clinical features of interfollicular HL.

Lymphocyte-rich Classical Hodgkin Lymphoma

Once CHL and LPHL were defined phenotypically, it was recognized that there were HLs containing Hodgkin cells that were phenotypically identical to those in classical types of HL, but whose reaction was composed almost exclusively of small lymphocytes. These cases would have been diagnosed as LPHL prior to the WHO lymphoma classification, but in deference to the phenotype are now termed "lymphocyte-rich classical Hodgkin lymphoma."^{415,416,417} Their clinical features more closely resemble MCHL than LPHL. LRHL grows in either a nodular or diffuse pattern. There are relatively sparse RS cells and Hodgkin cells; almost all of the remaining cells in the infiltrates are small lymphocytes (Fig. 86.19). RS cells and variants in LRHL express the same antigens as their counterparts in other types of CHL. Small non-neoplastic T- and B-lymphocytes comprise almost all of the rest of the cells in this disease. The differential diagnosis includes LPHL^{227,418,419,} and⁴²⁰ and⁴²¹ distinguished by the phenotype of the Hodgkin cells (see below) and T-cell/histiocyte-rich large B-cell lymphomas.^{227,418,419,}

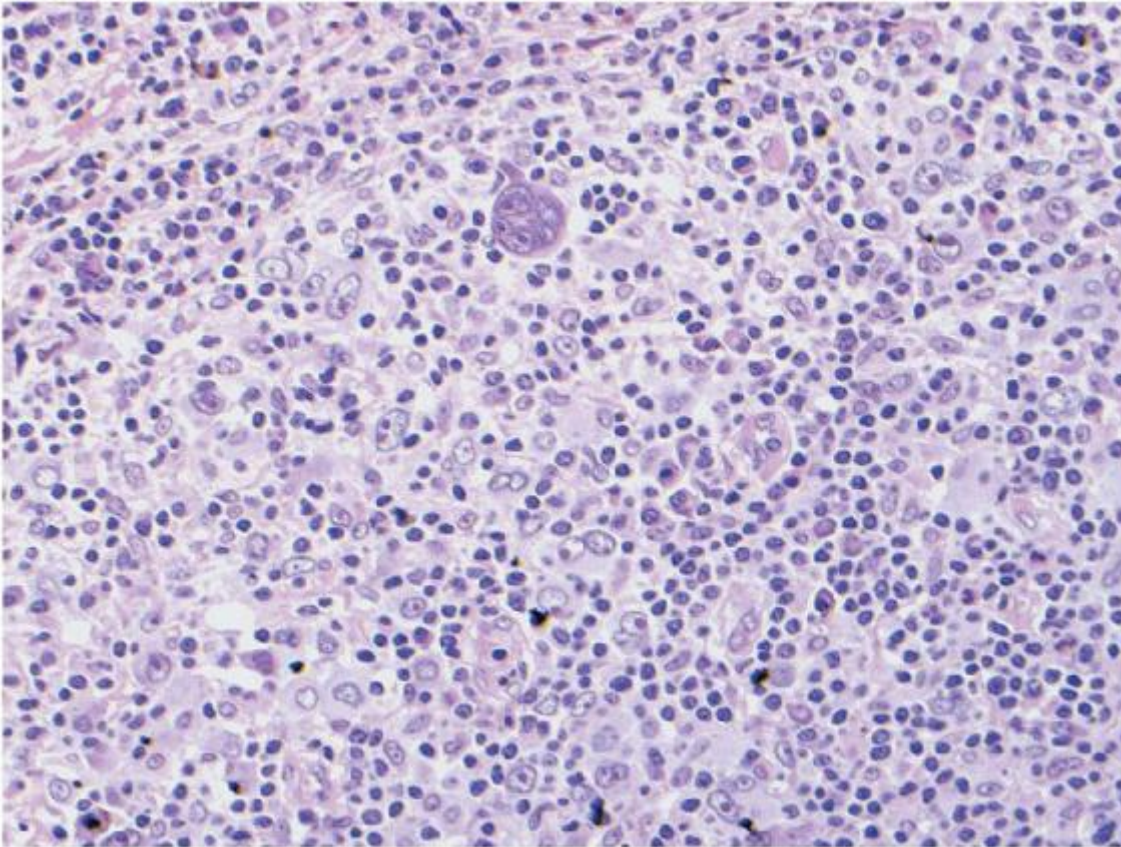

FIGURE 86.18. Lymph node: mixed cellularity Hodgkin lymphoma. There are many large Hodgkin cells, a diagnostic Reed-Sternberg cell (upper center), and a background population of small lymphocytes, histiocytes, plasma cells, and eosinophils.

Nodular Sclerosis Hodgkin Lymphoma

NSHL is the most common histologic type of HL encountered in the United States and it is the most reproducibly diagnosed. In addition to meeting the general criteria of HL (phenotypically characteristic RS cells and the appropriate inflammatory cellularity), two additional criteria define this subtype: collagen band formation and lacunar cells (Fig. 86.20).⁴²² Within this basic definitional framework there is a broad spectrum of possible histologic appearances of NSHL, depending on the relative contributions of RS cells and lacunar cells, the degree of collagen sclerosis, the proportions of the various inflammatory cells and the presence and extent of necrosis.

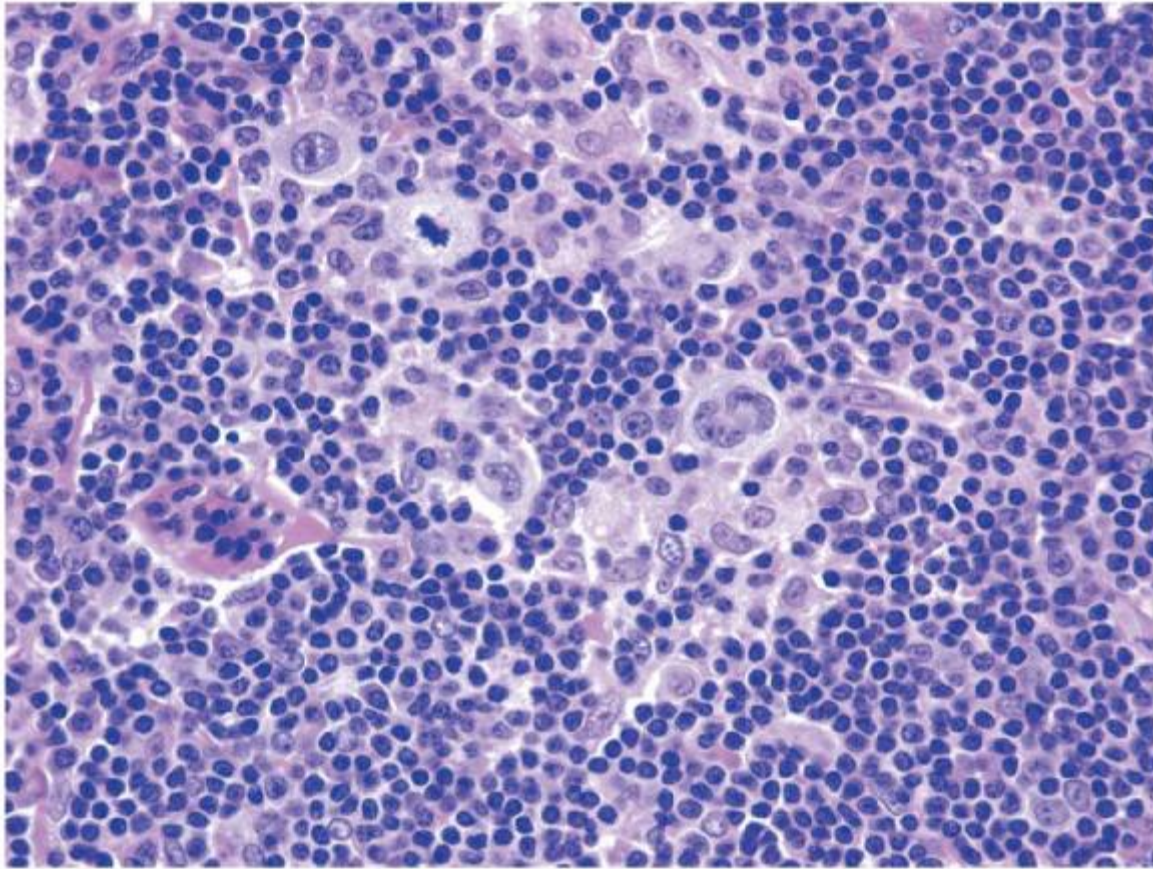

FIGURE 86.19. Lymph node: lymphocyte-rich classical Hodgkin lymphoma. Few Hodgkin and Reed-Sternberg cells are present in a background composed almost exclusively of small lymphocytes and histiocytes.

P.1795

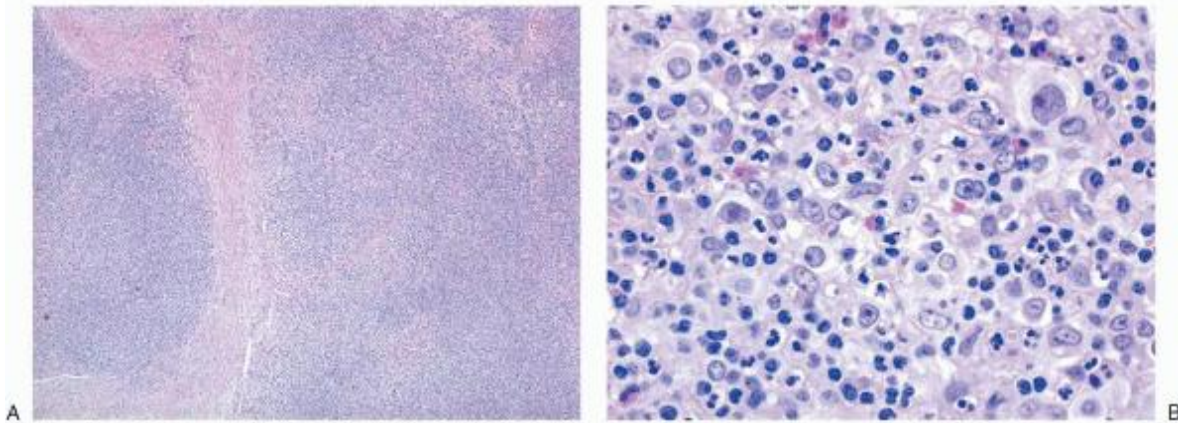

FIGURE 86.20. Lymph node: nodular sclerosis Hodgkin lymphoma. A: Collagen band formation is illustrated, circumscribing the mixed cell infiltrates into nodules. B: This photograph demonstrates the cytologic features of lacunar cells (upper right). Note also the background population of small lymphocytes, neutrophils, eosinophils, and plasma cells.

Lacunar cells have distinctive nuclear and cytoplasmic features.^{407,410} The nuclei are hyperlobated with delicate chromatin and small nucleoli. The cytoplasm is abundant and pale, staining to clear with sharply demarcated peripheral margins. It is in B5 or Zenker's fixed tissue sections where the distinctive cytologic features of lacunar cells are best appreciated.

However, in formalin-fixed tissue sections, lacunar cells stand out because their cytoplasm retracts from the adjacent cells, forming the lacunae from which these cells derive their name. Lacunar cells may be very numerous, forming large aggregates or clusters or they may be individually distributed. The earliest manifestation of NSHL in lymph nodes is the appearance of lacunar cells in the corticomedullary junction without collagen deposition, a phenomenon termed cellular phase of NSHL by some authors.

Collagen band formation, the second diagnostic criteria of NSHL, begins in the lymph node capsule and extends into the cortex. The degree of sclerosis varies from collagen bands that completely circumscribe the cellular nodules to obliterating sclerosis in which the majority of the lymph node is replaced by collagen.

In an attempt to define prognostic subgroups of patients with NSHL, histologic grading schemes have been devised, most notably, those proposed by the British National Lymphoma Investigation (BNLI).⁴²³ By the BNLI criteria, the cellular composition of the nodules determines the histologic grade. Any one of the following indicated higher grade (grade II): replacement of the cellular nodules by bland looking fibroblasts and histiocytes with little pleomorphism and few RS cells and lacunar variants; nodules composed of uniform sheets of lacunar cells (the "syncytial variant" of NSHL); and nodules composed of numerous lacunar cells that include pleomorphic giant cells. NSHL that lack these features are designated grade I. In the studies of the BNLI and others, stage-matched, similarly treated patients with grade II NSHL have a worse survival than their counterparts with grade I NSHL. The WHO does not require grading of NSHL cases because not all studies have replicated survival differences based of BNLI grade.^{424, 425} and ⁴²⁶

Lymphocyte-depleted Hodgkin Lymphoma

Lymphocyte-depleted Hodgkin lymphoma (LDHL) is the least common type of HL.⁴²⁷ Although the Rye conference on HL contracted the original histologically defined categories of diffuse fibrosis and reticular types of HL into LDHL, maintaining the separation is most useful to pathologists who must recognize the histologic variability of LDHL.⁴⁰⁸ The term lymphocyte-depleted is also somewhat imprecise, because it implies that this type of HL is defined solely by the absence of lymphocytes rather than by the presence of numerous RS cells and variants or by the presence of a peculiar type of collagen fibrosis. Therefore, for the purposes of this discussion the distinction of reticular and diffuse fibrosis variants of LDHL will be maintained.^{407,428,429}

The reticular variant of LDHL has two basic morphologic expressions. In each there is diffuse architectural effacement of the lymph node, absence of distinct nodularity, absence of birefringent collagen bands, diminished numbers of lymphocytes, and a cytologic composition dominated by RS cells. In each, granular interstitial material can be present between the cellular elements, and areas of necrosis can be prominent. Numerous typical RS cells with large nucleoli numerically predominate the cellular infiltrates in one manifestation of the reticular variant of LDHL. In the other, the frequent RS cells are extremely pleomorphic, almost sarcomatoid appearing. Because the reticular variant of LDHL has histologic features that overlap considerably with other NHLs and with other pleomorphic malignancies, the definition of reticular variant of LDHL requires that the neoplastic cells exhibit the distinctive phenotype of RS cells. LDHL, reticular variant, can be particularly difficult to distinguish from ALCL.

In the diffuse fibrosis variant of LDHL nonbirefringent collagen admixed with relatively few RS cells and variants accompanied by a rather minimal inflammatory cellularity, particularly poor in lymphocytes effaces the lymph node architecture (Fig. 86.21). In early stages, the lymph node is usually small with a depleted appearance and with fibrosis that appears amorphous and compact and that is deposited in the reticular framework of the lymph node, sparing the lymph node sinuses and capsule. At the opposite end of the diffuse fibrosis spectrum, almost the entire lymph node is replaced by compact, hyalinized, disorderly collagen. In these late stages, RS cells and variants are quite infrequent. Unless this latter feature is appreciated, the diagnosis of LDHL can be missed entirely.

Immunophenotypic Features of Classical Hodgkin Lymphoma

Phenotypic, cytogenetic, molecular genetic, and cell culture experiments indicate that Hodgkin cells are activated post-germinal center B-lymphocytes. They are uniformly positive for CD30^{406,430,431} and PAX5.⁴³² They express CD15 in 75% to 80% of cases⁴³³ and are negative for CD45.¹⁰ They variably express other pan-B-cell

P.1796

antigens, such as CD19, CD20, and CD79a. However, strong uniform positivity for any of these markers by the entire Hodgkin cell population in CHL is not characteristic and should suggest an alternative diagnosis. Hodgkin cells typically lack staining for Ig. The biologic bases for this finding include "crippling" point mutations in the Ig genes or diminished expression of Ig transcription factors (OCT2, BOB1, PU.1).^{434,435,436}

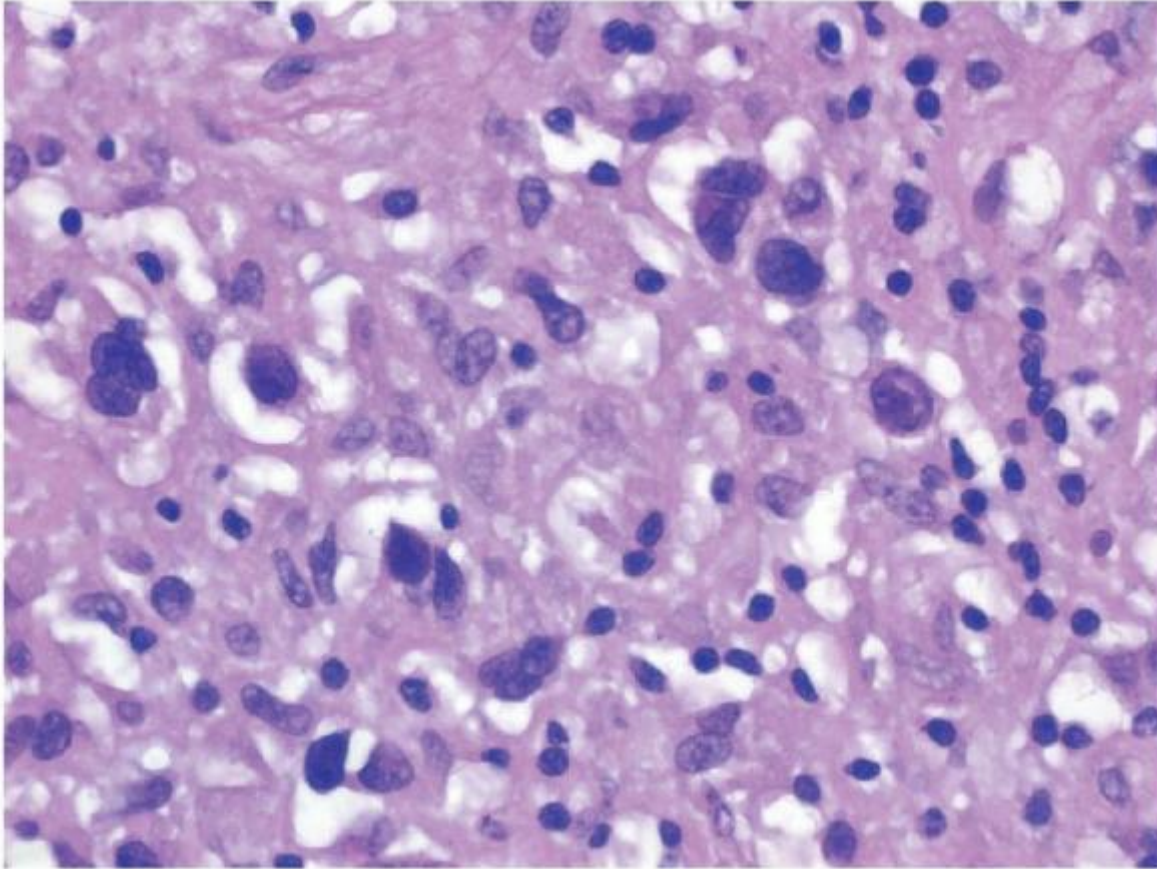

FIGURE 86.21. Lymph node: Lymphocyte-depleted Hodgkin lymphoma, diffuse fibrosis variant. Hodgkin cells and a few small lymphocytes are present amid the disorganized collagen.

Epstein-Barr Virus and Classical Hodgkin Lymphoma

Several lines of evidence suggest that HL is related to EBV.⁴³⁷ Epidemiologic studies show that there is an increased incidence of HL in people who have had infectious mononucleosis.^{438,439} Conversely people with HL have higher antibody titers to EBV than age-matched control patients.⁴⁴⁰ In addition, there are great morphologic and phenotypic similarities between RS-like cells in the tissue reaction to EBV and actual RS cells in HLs.⁴⁴¹

The most useful technique to study HL tissues for the presence of EBV has been in situ hybridization using probes that recognize EBER. The frequency of HLs positive for EBV using this technique varies. In Western countries, RS cells are EBV⁺ in up to 50% of cases, with the highest frequency detected in MCHL.^{442, 443} and ^{444,445} The incidence of EBV positivity in RS cells from tissue samples obtained from patients from underdeveloped countries is much higher; in some nations it approaches 100%.^{444,446, 447, 448, 449, 450} and ⁴⁵¹ EBV has also been found in Hodgkin cells in most HLs that complicate HIV infections.^{452,453} The RS cells in EBV+ HLs express EBV LMP-1 and in many instances LMP-2A, but these cells lack the EBV proteins EBNA-2, glycoprotein 350/250, viral capsid antigen, and early membrane antigen.^{454, 455, 456, 457} and ⁴⁵⁸ These findings are consistent with a type II latency pattern. When considering only nonimmunosuppressed patients, the data regarding the significance of EBV positivity for HL clinical outcome is somewhat contradictory.^{459, 460} and ⁴⁶¹ But in general, Hodgkin cell positivity for EBV suggests a favorable outcome in children and young adults, but predicts for an adverse outcome in older adults (greater than 50 years old).

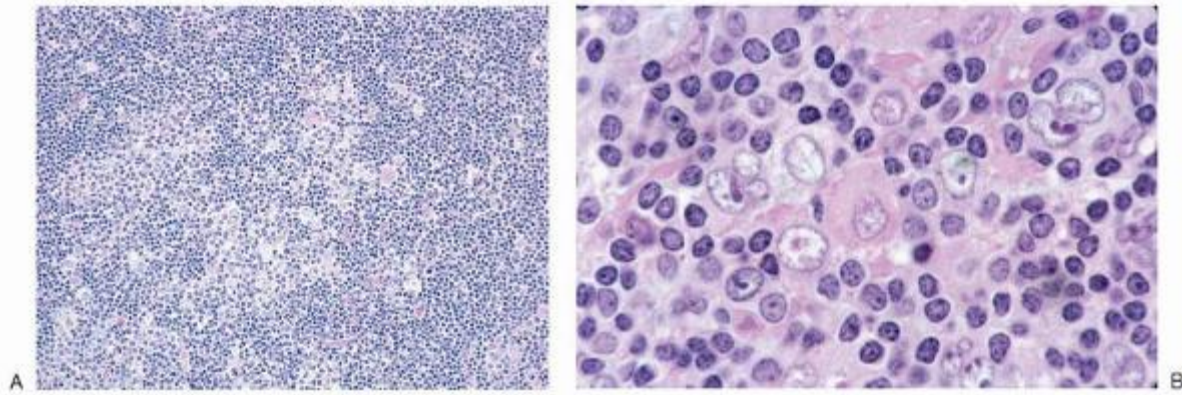

FIGURE 86.22. Lymph node: nodular lymphocyte-predominant Hodgkin lymphoma. A: This photograph was taken from one of the nodules. It shows the few LP Reed-Sternberg cell variants together with abundant small lymphocytes and few histiocytes. B: This high-power field shows typical LP cells with their lobulated nuclei, delicate chromatin, small nucleoli, and pale staining cytoplasm.

Nodular Lymphocyte Predominant Hodgkin Lymphoma

The WHO classification requires both morphologic and phenotypic criteria for the diagnosis of NLPHL.⁴⁶² In addition, since the description of diffusely growing large B-cell lymphomas with a background rich in nonneoplastic T cells and/or histiocytes (T-cell/histiocyte-rich large B-cell lymphomas), the boundary between diffuse LPHL and THRLBCL has been blurred. Therefore, in the WHO classification, nodular LPHL is the defined entity with some reservations expressed about the feasibility of separating de novo diffuse LPHL from THRLBCL.^{4,462}

The morphologic features of LPHL include the presence of RS cell variants, colloquially termed “LP cells,” and a host response rich in lymphocytes and macrophages.^{410,463} LP cells are large and have distinctly indented or lobulated nuclei (“popcorn cells”), delicate chromatin, small nucleoli, and moderately abundant wispy pale staining cytoplasm.

In prototypic cases, nodular LPHL variably effaces the lymph node architecture by small lymphocytes, macrophages, and LP cells growing in a macronodular pattern (Fig. 86.22). The nodules are usually larger than reactive lymphoid follicles and vary in number in any given lymph node. In early involvement, only a few nodules are present in the lymph node cortex, accompanied by follicular lymphoid hyperplasia and progressively transformed germinal centers (PTGCs). In the most histologically advanced cases, the nodules coalesce, becoming confluent, such that almost all the tumor grows in a diffuse pattern with only focal nodularity.

P.1797

The latter can be so minimal that wide sampling of the lymph node or application of immunohistochemistry is required to find the nodular areas. The cytologic composition of the nodules varies from case to case. Usually small lymphocytes, similar to mantle zone B cells, comprise the majority of the cellularity of the nodule. Epithelioid macrophages can be present within the nodules, distributed singly or in small clusters, or they can satellite around the nodules in a wreath-like arrangement. LP cells, a diagnostic requirement for this HL type, are present. The numbers of LP cells can vary greatly from one nodule to the next, ranging from one or two per nodule to near-confluent aggregates. Diagnostic RS cells are extremely rare. If there are any more than one or two cells that have the features of RS cells in cases thought to represent nodular LPHL, the diagnosis of CHL should be entertained. In contrast to CHL, plasma cells, eosinophils, and fibrosis are conspicuous by their absence in nodular LPHL. Finally, a careful search usually uncovers the presence of intranodular follicular dendritic cells. Based on morphology and immunohistochemistry the Stanford group reported six patterns of nodular LPHL: “classic” (B-cell-rich) nodular, serpiginous/interconnected nodular, nodular with prominent extra-nodular LP cells, T-cell-rich nodular, diffuse with a T-cell-rich background (T-cell-rich B-cell lymphoma [TCRBCL]-like), and a (diffuse) B-cell-rich pattern.⁴⁶⁴ This variability highlights the complexity of the histopathology and immunoarchitecture of this disease.

Progressive transformation of germinal centers^{465,466} is an unusual reactive pattern that often accompanies the infiltrates of nodular LPHL. PTGCs are larger than usual germinal centers. They have a “darker” appearance because they are composed of a large proportion of small lymphocytes indistinguishable from mantle zone lymphocytes. Although small lymphocytes predominate, all PTGC contain single and clustered germinal center cells, scattered tingible body

macrophages, and expanded follicular dendritic cell meshworks. In contrast to the nodules of nodular LPHL, PTGC do not tend toward confluence, do not efface lymph node architecture, and do not contain LP cells. The germinal center B cells of PTGC exhibit Ig gene somatic hypermutation with intranodular clonal expansion. However, the Ig gene rearrangements found in different nodules of PTGC are dissimilar. This feature distinguishes PTGC from the nodules in LPHL in which the LP cells of different nodules within the same lymph node are clonally-related to one another.⁴⁶⁷ PTGC can be present in reactive lymph node specimens from patients prior to the development of LPHL, concurrent with LPHL, or following LPHL, suggesting a relationship between these two conditions.^{466,468,469} However, PTGC occur much more frequently as a reactive process accompanying follicular lymphoid hyperplasia. Their presence does not de facto indicate the presence of nodular LPHL, nor do they necessarily predict for subsequent development of LPHL.⁴⁷⁰

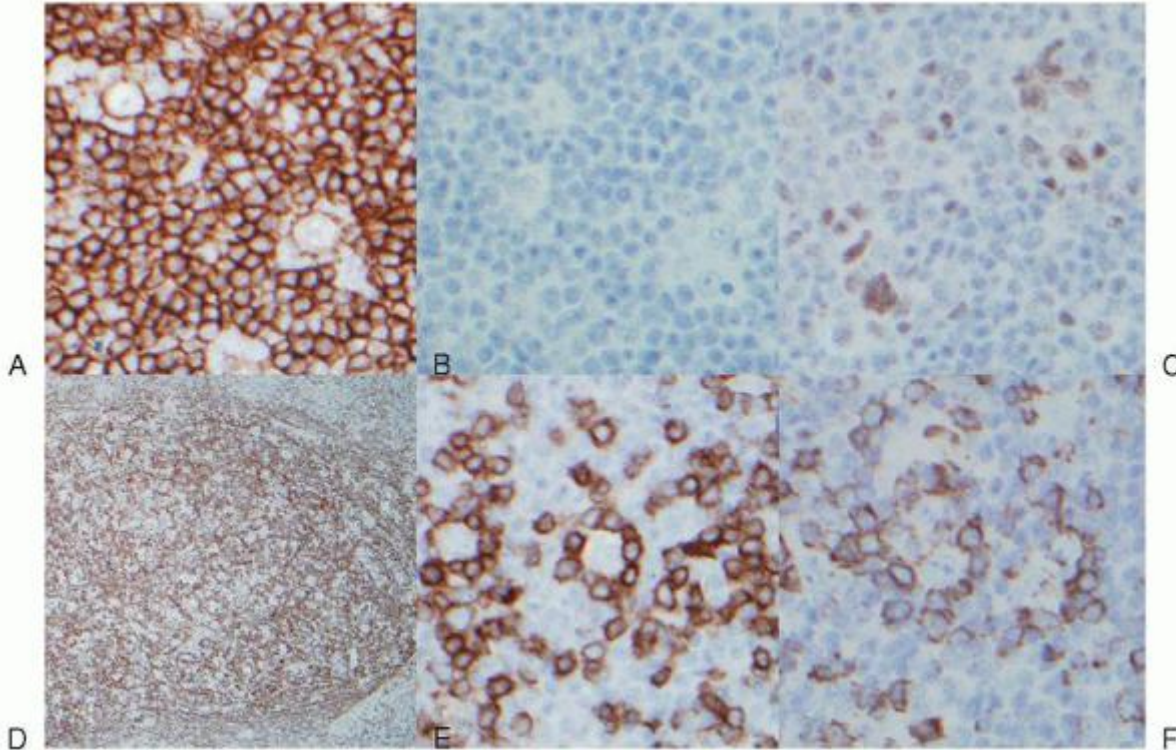

FIGURE 86.23. Lymph node: immunoarchitecture of nodular lymphocyte-predominant Hodgkin lymphoma. A: The LP cells and most of the background small lymphocytes are strongly positive for CD20. B: The LP cells and small lymphocytes are CD30-negative. C: The LP cells show nuclear bcl-6 positivity. D: CD21-positive follicular dendritic cells form a meshwork that defines the nodules in this disorder. E: Small lymphocytes in the immediate vicinity of the LP cells, some forming rosettes around tumor cells, are CD3-positive and F: CD57-positive T-cells.

Immunophenotypic Features of Lymphocyte Predominant Hodgkin Lymphoma

Unlike Hodgkin cells in other types of HL, LP cells have a distinctive and consistent phenotype, indicating GCB lineage (Fig. 86.23). They are consistently positive for pan-B-cell antigens, such as CD19, CD20, CD22, CD79a, PAX5,^{463,471,472,473,474,475} and J chain.⁴⁷⁶ The neoplastic cells in LPHL are also positive for Ig light chains when optimized paraffin section immunohistochemistry is used. Kappa light chain expressing cases greatly outnumber lambda light chain expressing cases.⁴⁷⁷ While the heavy chain type expressed by LP cells is usually IgG, a subset of cases with unique histologic and clinical attributes contains LP cells positive for IgD.⁴⁷⁸ These cases typically occur in young males. BCL6, a zincfinger protein normally expressed by follicle center B-lymphocytes is also localized to the nuclei of LP cells.⁴⁷⁹ LP cells strongly express B-lymphocyte transcription factors OCT2 and BOB1. In contrast to other types of HL, the LP cells are frequently positive for CD45. By definition, they lack staining for CD30 and CD15, and in a subset of cases, they express epithelial membrane antigen.⁴⁷¹

In most cases of nodular LPHL, the majority of the small lymphocytes accompanying the intranodular LP cells are polytypic IgD and IgM expressing B cells. The small lymphocytes that are immediately adjacent to the LP cells ("rosetting" around the LP cells) also have a distinctive phenotype.^{480, 481} and ⁴⁸² They are CD2, CD3, CD4, CD57, CXCL13, BCL6, and CD279 (PD-1) positive.⁴⁸³ This unusual cell population has the phenotype of transiently activated germinal center T cells. Finally,

expanded mesh works of CD21⁺ follicular dendritic cells form the immunoarchitectural background of the nodules of LPHL. In combination, the phenotypic attributes of LP cells coupled with the immunoarchitecture of the reactive cell populations is highly characteristic for LPHL.

P.1798

Involvement of Extranodal Sites by Hodgkin Lymphoma

Once a diagnosis of HL has been definitively established based on characteristic morphologic and immunophenotypic criteria in the initial biopsy specimen, the criteria for involvement of other sites are relaxed. In any involved anatomic site, Hodgkin cells, including diagnostic RS cells, do not occur as isolated cells but always carry with them the host immune reaction. So, in staging samples, Hodgkin cells together with the appropriate inflammatory background are all that is required to diagnose involvement by HL. Diagnostic RS cells need not be present and phenotyping does not have to be performed, as long as the infiltrates have features within the morphologic spectrum of HL.

Spleen, liver, and bone marrow are the most frequent sites of extranodal involvement by HL. In the spleen, it is very unusual to find HL in random histologic sections. Sectioning at two-millimeter intervals and careful gross examination allow one to identify the small white nodules of potential HL and to sample them for histologic examination. If it is difficult to cut the fresh spleen thin enough, resectioning and reexamining the gross anatomy of the spleen following a brief period of fixation optimizes the probability of identifying HL. Because the number of nodules of splenic involvement by HL is of prognostic significance⁴⁸⁴ (greater than five confers a greater risk for recurrence following initial therapy), this should be recorded. In the liver, HL most frequently involves the periportal areas.^{485,486} It should be remembered that hepatic involvement by HL is almost never encountered in the absence of splenic involvement. Finally, sarcoid-type granulomas can be encountered in any tissue sample obtained from a patient with HL.^{487,488} By themselves, they do not indicate the presence of HL in the tissues in which they are found and should not advance the stage of the disease. However, because sarcoid-type granulomas are potentially part of the inflammatory background of HL, Hodgkin cells must be searched for whenever these granulomas are observed.

Bone marrow involvement by HL in general is quite infrequent, seen in no more than 5% to 10% of cases at diagnosis. However, the frequency of bone marrow involvement varies with the histologic type of HL. In LPHL, encountering a bone marrow positive for HL is very rare.^{489,490} Intertrabecular and paratrabecular aggregates of small lymphocytes admixed with macrophages and occasional LP cells typify bone marrow involvement by LPHL. The LP cells can be present on only one or two levels of the biopsy specimen and therefore step sectioning any lymphoid aggregates in the bone marrow from patients with LPHL may be necessary to find the LP cells and confirm bone marrow involvement.

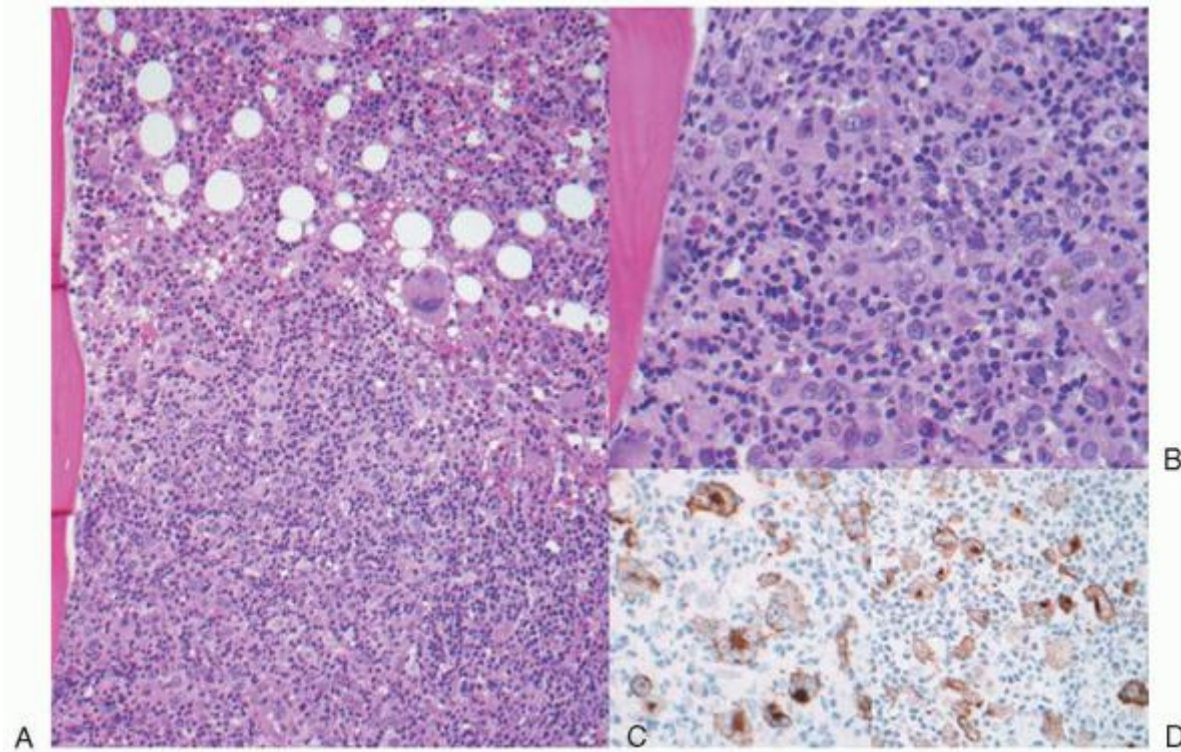

FIGURE 86.24. Bone marrow: classical Hodgkin lymphoma. A: The bone marrow is focally replaced by Hodgkin lymphoma. B: Small lymphocytes, macrophages, and Hodgkin cells (but no diagnostic Reed-Sternberg cells) are present in the infiltrates. Using paraffin section immunohistochemistry, the Hodgkin cells expressed C: CD30 and D: CD15.

In CHL, the bone marrow is positive in 5%, 10%, and greater than 50% of patients with NSHL, MCHL, and LDHL, respectively.^{491,492,493} In all, the histologic pattern of bone marrow involvement is similar, such that the type of CHL cannot be specified from the bone marrow findings alone. There are intertrabecular or paratrabecular aggregates of mixed cell composition including lymphocytes, macrophages, eosinophils, and plasma cells, together with a few RS cells or Hodgkin cells (Fig. 86.24). The areas of involvement can be quite hypocellular appearing, are usually associated with fibrosis, and often have stellate borders. In some cases, histiocytes predominate, simulating granulomatous infiltrates. In others, the fibrosis and eosinophilic infiltrates simulate systemic mastocytosis. In patients with HL who are HIV-infected, or in patients with LDHL⁴⁹² who present with fever of undetermined origin and minimal peripheral adenopathy, the bone marrow often becomes the primary site from which a diagnosis of HL is established. In these instances, one must find diagnostic RS cells. Because bone marrow involvement by PTCL and THRLBCL can closely simulate HL, it is also essential to perform phenotypic studies on paraffin section of the bone marrow specimen to confirm that the RS cells and variants are CD15⁺, CD30⁺, PAX5⁺, and CD45⁻ before rendering a definitive diagnosis of classical HL on the basis of the bone marrow alone. Finally, the noninvolved bone marrow from patients with HL can show trilineage hyperplasia, eosinophil hyperplasia, benign lymphoid aggregates, and noncaseating granulomas, all due to the generalized host response to HL. In the absence of RS cells and/or variants, these features do not indicate bone marrow involvement by HL. Flow cytometry and cytogenetic analysis play no role in assessing the bone marrow for involvement by HL.

P.1799

REFERENCES

1. Picker LJ, Weiss LM, Medeiros LJ, et al. Immunophenotypic criteria for the diagnosis of non-Hodgkin's lymphoma. *Am J Pathol* 1987;128:181-201.
2. Jamal S, Picker LJ, Aquino DB, et al. Immunophenotypic analysis of peripheral T-cell neoplasms. *Am J Clin Pathol* 2001;116:512-526.

3. Palutke M, Schnitzer B, Mirchandani I, et al. Increased numbers of lymphocytes with single class surface immunoglobulins in reactive hyperplasia of lymphoid tissue. *Am J Clin Pathol* 1982;78:316-323.
4. Chamberlain WD, Falta MT, Kotzin BL. Functional subsets within clonally expanded CD8+ memory T cells in elderly humans. *Clin Immunol* 2000;94(3):160-172.
5. Fishleder A, Tubbs R, Hesse B, et al. Uniform detection of immunoglobulin gene rearrangement in benign lymphoepithelial lesions. *N Engl J Med* 1987;316:1118-1121.
6. Kaleem Z. Flow cytometric analysis of lymphomas. Current status and usefulness. *Arch Pathol Lab Med* 2006;130:1850-1858.
7. Jorgensen JL. State of the Art Symposium: flow cytometry in the diagnosis of lymphoproliferative disorders by fine-needle aspiration. *Cancer* 2005;105:443-451.
8. Dey P, Amir T, Al Jassar A, et al. Combined applications of fine needle aspiration cytology and flow cytometric immunophenotyping for diagnosis and classification of non-Hodgkin lymphoma. *Cyto J* 2006;3:24.
9. Sánchez ML, Almeida J, Vidriales B, et al. Incidence of phenotypic aberrations in a series of 467 patients with B chronic lymphoproliferative disorders: basis for the design of specific four-color stainings to be used for minimal residual disease investigation. *Leukemia* 2002;16:1460-1469.
10. Kurtin PJ, Pinkus GS. Leukocyte common antigen—a diagnostic discriminant between hematopoietic and nonhematopoietic neoplasms in paraffin sections using monoclonal antibodies: correlation with immunologic studies and ultrastructural localization. *Hum Pathol* 1985;16:353-365.
11. Weiss LM, Arber DA, Chang KL. CD45. A review. *Appl Immunohistochem Mol Morphol* 1993;1:166-181.
12. Kurtin PJ, Roche PC. Immunoperoxidase staining of non-Hodgkin's lymphomas for T-cell lineage associated antigens in paraffin sections. *Am J Surg Pathol* 1993;17:898-904.
13. Chadburn A, Knowles DM. Paraffin-resistant antigens detectable by antibodies L26 and polyclonal CD3 predict the B- or T-cell lineage of 95% of diffuse aggressive non-Hodgkin's lymphomas. *Am J Clin Pathol* 1994;102:284-291.
14. Kurtin PJ, Hobday KS, Ziesmer S, et al. Demonstration of distinct antigenic profiles of small B-cell lymphomas by paraffin section immunohistochemistry. *Am J Clin Pathol* 199;112:319-329.
15. Sukpanichnant S, Vnencak-Jones CL, McCurley TL. Determination of B-cell clonality in paraffin-embedded endoscopic biopsy specimens of abnormal lymphocytic infiltrates and gastrointestinal lymphoma by polymerase chain reaction. *Am J Clin Pathol* 1994;102:299-305.
16. Remstein ED, Kurtin PJ, Buño I, et al. Diagnostic utility of fluorescence in situ hybridization in mantle-cell lymphoma. *Br J Haematol* 2000;110:856-862.
17. Cataldo KA, Jalal SM, Law ME, et al. Detection of t(2;5) in anaplastic large cell lymphoma: comparison of immunohistochemical studies, FISH, and RT-PCR in paraffin-embedded tissue. *Am J Surg Pathol* 1999;23:1386-1392.
18. Paternoster SF, Brockman SR, McClure RF, et al. A new method to extract nuclei from paraffin-embedded tissue to study lymphomas using interphase fluorescence in situ hybridization. *Am J Pathol* 2002;160:1967-1972.
19. Safley AM, Buckley PJ, Creager AJ, et al. The value of fluorescence in situ hybridization and polymerase chain reaction in the diagnosis of B-cell non-Hodgkin lymphoma by fine-needle aspiration. *Arch Pathol Lab Med* 2004;128:1395-1403.
20. Buno I, Nava P, Alvarez-Doval A, et al. Lymphoma associated chromosomal abnormalities can easily be detected by FISH on tissue imprints. An under-used diagnostic alternative. *J Clin Pathol* 2005;58:629-633.
21. Rappaport H, Winter WJ, Hicks EB. Follicular lymphoma: a re-evaluation of its position in the scheme of malignant lymphoma, based on a survey of 253 cases. *Cancer* 1956;9:792-821.
22. Rappaport H. Tumors of the hematopoietic system. Atlas of tumor pathology, Section 3, Fascicle 8. Washington, DC: US Armed Forces Institute of Pathology, 1966.
23. Lukes RJ, Collins RD. Immunologic characterization of human malignant lymphomas. *Cancer* 1974;34:1488-1503.
24. Lennert K, Mohri N, Stein H, et al. The histopathology of malignant lymphoma. *Br J Haematol* 1975;31(Suppl):193-203.
25. Bloomfield CD, Gajl-Peczalska KJ, Frizzera G, et al. Clinical utility of lymphocyte surface markers combined with the Lukes-Collins histologic classification in adult lymphoma. *N Engl J Med* 1979;301:512-518.

26. Schuurman HJ, van Baarlen J, Huppel W, et al. Immunophenotyping of non-Hodgkin's lymphoma. Lack of correlation between immunophenotype and cell morphology. *Am J Pathol* 1987;129:140-151.
27. Non-Hodgkin's lymphoma pathologic classification project. National Cancer Institute sponsored study of classifications of non-Hodgkin's lymphomas: summary and description of a working formulation for clinical usage. *Cancer* 1982;49:2112-2135.
28. Harris NL, Jaffe ES, Stein H, et al. A revised European-American classification of lymphoid neoplasms: a proposal from the International Lymphoma Study Group. *Blood* 1994;84:1361-1392.
29. Jaffe ES, Harris NL, Stein H, et al., eds. World Health Organization classification of tumours. Pathology and genetics of tumours of haematopoietic and lymphoid tissues. Lyon: IARC Press, 2001.
30. Swerdlow SH, Campo E, Harris NL, et al, eds. World Health Organization classification of tumours. WHO classification of tumours of haematopoietic and lymphoid tissues, 4th ed. Lyon: IARC Press, 2008.
31. Sander CA, Medeiros LJ, Abruzzo LV, et al. Lymphoblastic lymphoma presenting in cutaneous sites. *J Am Acad Dermatol* 1991;25:1023-1031.
32. Irvani S, Singleton TP, Ross CW, et al. Precursor B lymphoblastic lymphoma presenting as lytic bone lesions. *Am J Clin Pathol* 1999;112:836-843.
33. Lin P, Jones D, Dorfman DM, et al. Precursor B-cell lymphoblastic lymphoma: a predominantly extranodal tumor with low propensity for leukemic involvement. *Am J Surg Pathol* 2000;24:1480-1490.
34. Maitra A, McKenna RW, Weinberg AG, et al. Precursor B-cell lymphoblastic lymphoma. A study of nine cases lacking blood and bone marrow involvement and review of the literature. *Am J Clin Pathol* 2001;115:868-875.
35. Stroup R, Sheibani K, Misset J-L, et al. Surface immunoglobulin-positive lymphoblastic lymphoma. A report of three cases. *Cancer* 1990;65:2559-2563.
36. Ozdemirli M, Fanburg-Smith JC, Hartmann DP, et al. Differentiating lymphoblastic lymphoma and Ewing's sarcoma: lymphocyte markers and gene rearrangement. *Mod Pathol* 2001;14:1175-1182.
37. Cheng A-L, Su I-J, Tien H-F, et al. Characteristic clinicopathologic features of adult B-cell lymphoblastic lymphoma with special emphasis on differential diagnosis with an atypical form probably of blastic lymphocytic lymphoma of intermediate differentiation origin. *Cancer* 1994;73:706-710.
38. Hojo H, Sasaki Y, Nakamura N, et al. Absence of somatic hypermutation of immunoglobulin heavy chain variable region genes in precursor B-lymphoblastic lymphoma: a study of four cases in childhood and adolescence. *Am J Clin Pathol* 2001;116:673-682.
39. Lorscheid RB, Shay-Seymore D, Moore J, et al. Clinicopathologic analysis of follicular lymphoma occurring in children. *Blood* 2002;99:1959-1964.
40. Goodlad JR, Krajewski AS, Batstone PJ, et al. Primary cutaneous follicular lymphoma: a clinicopathologic and molecular study of 16 cases in support of a distinct entity. *Am J Surg Pathol* 2002;26:733-741.
41. Shia J, Teruya-Feldstein J, Pan D, et al. Primary follicular lymphoma of the gastrointestinal tract. A clinical and pathologic study of 26 cases. *Am J Surg Pathol* 2002;26:216-224.
42. Goodlad JR, MacPerson S, Jackson R, et al. Extranodal follicular lymphoma: a clinicopathological and genetic analysis of 15 cases arising at non-cutaneous extranodal sites. *Histopathology* 2004;22:268-276.
43. Liu Y-J, Johnson GD, Gordon J, et al. Germinal centers in T-cell-dependent antibody responses. *Immunol Today* 1992;13:17-21.
44. Liu Y-J, Banchereau J. The paths and molecular controls of peripheral B-cell development. *Immunologist* 1996;4:55-66.
45. Kuppers R, Klein U, Hansmann ML, et al. Cellular origin of human B-cell lymphomas. *N Engl J Med* 1999;341:1520-1529.
46. Korsmeyer SJ. Bcl-2 initiates a new category of oncogenes: regulators of cell death. *Blood* 1992;80:879-886.
47. Bahler DW, Levy R. Clonal evolution of a follicular lymphoma: evidence for antigen selection. *Proc Natl Acad Sci U S A* 1992;89:6770-6774.
48. Zhu D, Hawkins RE, Hamblin TJ, et al. Clonal history of a human follicular lymphoma as revealed in the immunoglobulin variable region genes. *Br J Haematol* 1994;86:505-512.

49. Stamatopoulos K, Kosmas C, Belessi C, et al. Molecular insights into the immunopathogenesis of follicular lymphoma. *Immunol Today* 2000;21:298-305.
50. Brauninger A, Hansmann ML, Strickler JG, et al. Identification of common germinal-center B-cell precursors in two patients with both Hodgkin's disease and non-Hodgkin's lymphoma. *N Engl J Med* 1999;340:1239-1247.
51. Kuppers R, Dalla-Favers R. Mechanisms of chromosomal translocations in B-cell lymphomas. *Oncogene* 2001;20:5580-5594.
52. Stein RS, Cousar J, Flexner JM, et al. Malignant lymphomas of follicular center cell origin in man. III. Prognostic features. *Cancer* 1979;44:2236-2243.
53. Martin AR, Weisenburger DD, Chan WC, et al. Prognostic value of cellular proliferation and histologic grade in follicular lymphoma. *Blood* 1995;85:3671-3678.
54. Bartlett NL, Rizeqi M, Dorfman RF, et al. Follicular large-cell lymphoma: intermediate or low grade? *J Clin Oncol* 1994;12:1349-1357.
55. Nathwani BN, Metter GE, Miller TP, et al. What should be the morphologic criteria for the subdivision of follicular lymphomas? *Blood* 1986;68:837-845.
56. Coiffier B, Bastion Y, Berger F, et al. Prognostic factors in follicular lymphomas. *Semin Oncol* 1993;20:89-95.
57. Metter GE, Nathwani BN, Burke JS, et al. Morphological subclassification of follicular lymphoma: variability of diagnoses among hematopathologists, a collaborative study between the repository center and pathology panel for lymphoma clinical studies. *J Clin Oncol* 1985;3:25-38.
58. Weisenburger DD, Chan WC. Lymphomas of follicles. Mantle cell and follicle center cell lymphomas. *Am J Clin Pathol* 1993;99:409-420.
59. Adam P, Katzenberger T, Eifert M, et al. Presence of preserved reactive germinal centers in follicular lymphoma is a strong histopathologic indicator of limited disease stage. *Am J Surg Pathol* 2005;29:1661-1664.
60. Yegappan S, Schnitzer B, Hsi ED. Follicular lymphoma with marginal zone differentiation: microdissection demonstrates the t(14;18) in both the follicular and marginal zone components. *Mod Pathol* 2001;14:191-196.
61. Ott G, Katzenberger T, Lohr A, et al. Cytomorphologic, immunohistochemical, and cytogenetic profiles of follicular lymphoma: 2 types of follicular lymphoma grade 3. *Blood* 2002;99(10):3806-3812.
62. Cong P, Raffeld M, Teruya-Feldstein J, et al. In situ localization of follicular lymphoma: description and analysis by laser capture microdissection. *Blood* 2002;99:3376-3382.
63. Jegalian AG, Eberle FC, Park SD, et al. Follicular lymphoma in situ: clinical implications and comparisons with partial involvement by follicular lymphoma. *Blood* 2011;118:2976-2984.
64. Stein RS, Greer JP, Flexner JM, et al. Large-cell lymphomas: clinical and prognostic features. *J Clin Oncol* 1990;8:1370-1379.
65. Waldron JA, Newcomer LN, Katz ME, et al. Sclerosing variants of follicular center cell lymphomas presenting in the retroperitoneum. *Cancer* 1983;52:712-720.
66. Cleary KR, Osborne BM, Butler JJ. Lymph node infarction foreshadowing malignant lymphoma. *Am J Surg Pathol* 1982;6:435-442.
67. Laszewski MJ, Belding PJ, Feddersen RM, et al. Clonal immunoglobulin gene rearrangement in infarcted lymph node syndrome. *Am J Clin Pathol* 1991;96:116-120.
68. Keith TA, Cousar JB, Glick AD, et al. Plasmacytic differentiation in follicular center cell (FCC) lymphomas. *Am J Clin Pathol* 1985;84:283-290.
69. Kim H, Dorfman RF, Rappaport H. Signet ring cell lymphoma: a rare morphologic and functional expression of nodular (follicular) lymphoma. *Am J Surg Pathol* 1978;2:119-131.
70. Yuen AR, Kamel OW, Halpern J, et al. Long-term survival after histologic transformation of low-grade follicular lymphoma. *J Clin Oncol* 1995;13:1726-1733.
71. Cullen MH, Lister TA, Brearley RL, et al. Histological transformation of non-Hodgkin's lymphoma. A prospective study. *Cancer* 1979;44:645-651.

72. Hubbard SM, Chabner BA, DeVita VT Jr, et al. Histologic progression in non-Hodgkin's lymphoma. *Blood* 1982;258-264.
73. Horning SJ, Rosenberg SA. The natural history of initially untreated low-grade non-Hodgkin's lymphomas. *N Engl J Med* 1984;311:1471-1475.
74. Hans CP, Weisenburger DD, Vose JM, et al. A significant diffuse component predicts for inferior survival in grade 3 follicular lymphoma, but cytological subtypes do not predict survival. *Blood* 2003;101:2363-2367.
75. Natkunam Y, Warnke RA, Zehnder JL, et al. Blastic/blastoid transformation of follicular lymphoma: immunohistologic and molecular analyses of five cases. *Am J Surg Pathol* 2000;24:525-534.
76. Wang SA, Wang L, Hochberg EP, et al. Low histologic grade follicular lymphoma with high proliferation index: morphologic and clinical features. *Am J Surg Pathol* 2002;29:1490-1496.
77. Louissaint A, Ackerman AM, Dias-Santagata D, et al. Pediatric-type nodal follicular lymphoma: an indolent clonal proliferation in children and adults, with high proliferation index and no BCL2 rearrangement. *Blood*. 2012 Jul 31 [Epub]. PubMed PMID:22855608.
78. Eshoa C, Perkins S, Kampalath B, et al. Decreased CD10 expression in grade III and in interfollicular infiltrates of follicular lymphomas. *Am J Clin Pathol* 2001;115:862-867.
79. Tiesinga JJ, Wu CD, Inghirami G. CD5+ follicle center lymphoma. Immunophenotyping detects a unique subset of "floral" follicular lymphoma. *Am J Clin Pathol* 2002;114:912-921.
80. Barekman CL, Aguilera NS, Abbondanzo SL. Low-grade B-cell lymphoma with co-expression of both CD5 and CD10. A report of 3 cases. *Arch Pathol Lab Med* 2001;125:951-953.
81. Gaulard P, d'Agay M-F, Peuchmaur M, et al. Expression of the bcl-2 gene product in follicular lymphoma. *Am J Pathol* 1991;140:1089-1095.
82. Sander CQ, Yano T, Clark HM, et al. p53 mutation is associated with progression in follicular lymphomas. *Blood* 1993;82:1994-2004.
83. Nguyen PL, Zukerberg LR, Benedict WF, et al. Immunohistochemical detection of p53, bcl-2 and retinoblastoma proteins in follicular lymphoma. *Am J Clin Pathol* 1996;105:538-543.
84. Swerdlow SH, Murray LJ, Habeshaw JA, et al. B- and T-cell subsets in follicular centroblastic/centrocytic (cleaved follicular center cell) lymphoma: an immunohistologic analysis of 26 lymph nodes and three spleens. *Hum Pathol* 1985;16:339-352.
85. Dave SS, Wright G, Tan B, et al. Prediction of survival in follicular lymphoma based on molecular features of tumor-infiltrating immune cells. *N Engl J Med* 2004;351:2159-2169.
86. Farinha P, Masoudi H, Skinnider B, et al. Analysis of multiple biomarkers shows that lymphoma-associated macrophage (LAM) content is an independent predictor of survival in follicular lymphoma (FL). *Blood* 2005;106: 2169-2174.
87. Carreras J, Lopez-Guillermo A, Fox BC, et al. High numbers of tumor-infiltrating FOXP3-positive regulatory T cells are associated with improved overall survival in follicular lymphoma. *Blood* 2006;108:2957-2964.
88. Glas AM, Knoop L, Delahaye L, et al. Gene-expression and immunohistochemical study of specific T-cell subsets and accessory cell types in the transformation and prognosis of follicular lymphoma. *J Clin Oncol* 2007;25:390-398.
89. Yunis JJ, Frizzera G, Oken MM, et al. Multiple recurrent genomic defects in follicular lymphoma. A possible model for cancer. *N Engl J Med* 1987;316:79-84.
90. Weiss LM, Warnke RA, Sklar J, et al. Molecular analysis of the t(14;18) chromosomal translocation in malignant lymphomas. *N Engl J Med* 1987;317:1185-1189.
91. Streubel B, Scheucher B, Valencak J, et al. Molecular cytogenetic evidence of t(14;18)(IGH;BCL2) in a substantial proportion of primary cutaneous follicle center lymphomas. *Am J Surg Pathol* 2006;30:529-536.
92. Mohamed AN, Palutke M, Eisenberg L, et al. Chromosomal analyses of 52 cases of follicular lymphoma with t(14;18), including blastic/blastoid variant. *Cancer Genet Cytogenet* 2002;126:45-51.
93. Martinez-Climent JA, Alizadeh AA, Segraves R, et al. Transformation of follicular lymphoma to diffuse large cell lymphoma is associated with a heterogeneous set of DNA copy number and gene expression alterations. *Blood* 2003;101:3109-3117.

94. Salaverria I, Philipp C, Oschlies I, et al. Molecular mechanisms in malignant lymphomas network project of the Deutsche Krebshilfe: German High-Grade Lymphoma Study Group: Berlin-Frankfort-Münster-NHL trial group. Translocations activating IRF4 identify a subtype of germinal center-derived B-cell lymphoma affecting predominantly children and young adults. *Blood* 2011;118(1):139-147. 2011 Apr 12 [Epub]. PubMed PMID:21487109.
95. Aoun P, Zhou G, Chan WC, et al. Familial B-cell chronic lymphocytic leukemia. Analysis of cytogenetic abnormalities, immunophenotypic profiles, and immunoglobulin heavy chain gene usage. *Am J Clin Pathol* 2007;127:31-38.
96. Müller-Hermelink HK, Montserrat E, Catovsky D, et al. Chronic lymphocytic leukemia/small lymphocytic lymphoma. In: Swerdlow SH, Campo E, Harris NL, et al., eds. World Health Organization classification of tumours. WHO classification of tumours of haematopoietic and lymphoid tissues, 4th ed. Lyon: IARC Press, 2008:180-182.
97. Ciccone M, Agostinelli C, Rigolin GM, et al. Proliferation centers in chronic lymphocytic leukemia: correlation with cytogenetics and clinicobiological features in consecutive patients analyzed on tissue microarrays. *Leukemia* 2012;26:499-508.
98. Ben-Ezra J, Burke JS, Schwartz WG, et al. Small lymphocytic lymphoma: a clinicopathologic analysis of 268 cases. *Blood* 1989;73:579-587.
99. Pugh WC, Manning JT, Butler JJ. Paraimmunoblastic variant of small lymphocytic lymphoma/leukemia. *Am J Surg Pathol* 1988;12:907-917.
100. Nakamura N, Abe M. Richter syndrome in B-cell chronic lymphocytic leukemia. *Pathol Int* 2003;53:195-203.
101. Robertson LE, Pugh W, O'Brien S, et al. Richter's syndrome: a report on 39 patients. *J Clin Oncol* 1993;11:1985-1989.
102. Timar B, Fulop Z, Csernus B, et al. Relationship between the mutational status of VH genes and pathogenesis of diffuse large B-cell lymphoma in Richter's syndrome. *Leukemia* 2004;18:326-330.
103. Ghani AM, Krause JR, Brody JP. Polymphocytic transformation of chronic lymphocytic leukemia: a report of three cases and review of the literature. *Cancer* 1986;57:75-80.
104. Choi H, Keller RH. Coexistence of chronic lymphocytic leukemia and Hodgkin's disease. *Cancer* 1981;48:48-57.
105. Momose H, Jaffe ES, Shin SS, et al. Chronic lymphocytic leukemia/small lymphocytic lymphoma with Reed-Sternberg-like cells and possible transformation to Hodgkin's disease. *Am J Surg Pathol* 1992;16:859-867.
106. Batata A, Shen B. Relationship between chronic lymphocytic leukemia and small lymphocytic lymphoma. *Cancer* 1992;70:625-632.
107. Kilo MN, Dorfman DM. The utility of flow cytometric immunophenotypic analysis in the distinction of small lymphocytic lymphoma/chronic lymphocytic leukemia from mantle cell lymphoma. *Am J Clin Pathol* 1996;105:451-457.
108. Rawstron AC, Green MJ, Kuzmicki A, et al. Monoclonal B lymphocytes with the characteristic of "indolent" chronic lymphocytic leukemia are present in 3.5% of adults with normal blood counts. *Blood* 2002;100:635-639.
109. Wiktor A, Van Dyke DL. Combined cytogenetics testing and fluorescence in situ hybridization analysis in the study of chronic lymphocytic leukemia and multiple myeloma. *Cancer Genet Cytogenet* 2004;153:73-76.
110. Ripollés L, Ortega M, Ortuño F, et al. Genetics abnormalities and clinical outcome in chronic lymphocytic leukemia. *Cancer Genet Cytogenet* 2006;171:57-64.
111. Damle RN, Wasil T, Fais F, et al. Ig V gene mutation status and CD38 expression as novel prognostic indicators in chronic lymphocytic leukemia. *Blood* 1999;6:1840-1847.
112. Oscier DG, Gardiner AC, Mould SJ, et al. Multivariate analysis of prognostic factors in CLL: clinical stage, IGVH gene mutational status, and loss or mutation of the p53 gene are independent prognostic factors. *Blood* 2002;100:1177-1184.
113. Krober A, Seiler T, Benner A, et al. V(H) mutation status, CD38 expression level, genomic aberrations, and survival in chronic lymphocytic leukemia. *Blood* 2002;100:1410-1416.
114. Hamblin TJ, Davis Z, Gardiner A, et al. Unmutated Ig V(H) genes are associated with a more aggressive form of chronic lymphocytic leukemia. *Blood* 1999;94:1848-1854.
115. Chen YH, Peterson LC, Dittmann D, et al. Comparative analysis of flow cytometric techniques in assessment of ZAP-70 expression in relation to IgVH mutational status in chronic lymphocytic leukemia. *Am J Clin Pathol* 2007;127:182-191.
116. Seiler T, Döhner H, Stilgenbauer S. Risk stratification in chronic lymphocytic leukemia. *Semin Oncol* 2006;33:186-194.

117. Grever MR, Lucas DM, Dewald GW, et al. Comprehensive assessment of genetic and molecular features predicting outcome in patients with chronic lymphocytic leukemia: results from the US Intergroup Phase III Trial E2997. *J Clin Oncol* 2007;25:799-804.
118. Raje N, Ferry JA. Case records of the Massachusetts General Hospital (Case 27-2001) *N Engl J Med* 2001;345:682-687.
119. Kyrtsolis MC, Vassilakopoulos TP, Angelopoulou MK, et al. Waldenström's macroglobulinemia: clinical course and prognostic factors in 60 patients. Experience from a single hematology unit. *Ann Hematol* 2001;80: 722-727.
120. McCurley TL, Collins RD, Ball E, et al. Nodal and extranodal lymphoproliferative disorders in Sjögren's syndrome: a clinical and immunopathologic study. *Hum Pathol* 1990;21:482-492.
121. Silvestri F, Pipan C, Barillari G, et al. Prevalence of hepatitis C virus infection in patients with lymphoproliferative disorders. *Blood* 1996;87:4296-4301.
122. Harris NL, Bhan AK. B-cell neoplasms of the lymphocytic, lymphoplasmacytoid, and plasma cell types: immunohistologic analysis and clinical correlation. *Hum Pathol* 1985;16:829-837.
123. Patsouris E, Noël H, Lennert K. Lymphoplasmacytic/lymphoplasmacytoid immunocytoma with a high content of epithelioid cells. *Am J Surg Pathol* 1990;14:660-670.
124. Andriko JA, Swerdlow SH, Aguilera NI, et al. Is lymphoplasmacytic lymphoma/immunocytoma a distinct entity? A clinicopathologic study of 20 cases. *Am J Surg Pathol* 2001;25:742-751.
125. Lin P, Medeiros LJ. Lymphoplasmacytic lymphoma/Waldenström macroglobulinemia. An evolving concept. *Adv Ana Pathol* 2005;12:246-255.
126. Hunter ZR, Branagan AR, Manning R, et al. CD5, CD10, and CD23 expression in Waldenström's macroglobulinemia. *Clin Lymphoma* 2005;5:246-249.
127. Levine AM, Lichtenstein A, Gresik MV, et al. Clinical and immunologic spectrum of plasmacytoid lymphocytic lymphoma without serum monoclonal IgM. *Br J Haematol* 1980;46:225-233.
128. Treon SP, Xu L, Yang G, et al. MYD88 L265P somatic mutation in Waldenström's macroglobulinemia. *N Engl J Med* 2012;367:826-833.
129. Gachard N, Parrens M, Soubeyran I, et al. IGHV gene features and MYD88 L265P mutation separate the three marginal zone lymphomas entities and Waldenström macroglobulinemia/lymphoplasmacytic lymphomas. *Leukemia*. 2012 Sep 4 [Epub]. PubMed PMID:22944768.
130. Aoki H, Takishita M, Kosaka M, et al. Frequent somatic mutations in V and/or JH segments of Ig gene in Waldenström's macroglobulinemia and chronic lymphocytic leukemia with Richter's syndrome but not in common CLL. *Blood* 1995;85:1913-1919.
131. Sahota SS, Forconi F, Ottensmeier CH, et al. Typical Waldenström macroglobulinemia is derived from a B-cell arrested after cessation of somatic mutation but prior to isotype switch events. *Blood* 2002;100:1505-1507.
132. Banks PM, Chan J, Cleary ML, et al. Mantle cell lymphoma: a proposal for unification of morphologic, immunologic, and molecular data. *Am J Surg Pathol* 1992;16:637-640.
133. Raffeld M, Sander CA, Yano T, et al. Mantle cell lymphoma: an update. *Leuk Lymphoma* 1992;8:161-166.
134. Kodama T, Ohshima K, Nomura K, et al. Lymphomatous polyposis of the gastrointestinal tract, including mantle cell lymphoma, follicular lymphoma and mucosa-associated lymphoid tissue lymphoma. *Histopathology* 2005;47: 467-478.
135. Schlette E, Lai R, Onciu M, et al. Leukemic mantle cell lymphoma: clinical and pathologic spectrum of twenty-three cases. *Mod Pathol* 2001;14:1133-1140.
136. Weisenburger DD, Armitage JO. Mantle cell lymphoma—an entity comes of age. *Blood* 1996;87:4483-4494.
137. Yatabe Y, Suzuki R, Tobinai K, et al. Significance of cyclin D1 overexpression for the diagnosis of mantle cell lymphoma: a clinicopathologic comparison of cyclin D1-positive MCL and cyclin D1-negative MCL-like B-cell lymphoma. *Blood* 2000;95:2253-2261.
138. Yatabe Y, Suzuki R, Matsuno Y, et al. Morphological spectrum of cyclin D1-positive mantle cell lymphoma: study of 168 cases. *Pathol Int* 2001;51:747-761.

139. Yin CC, Medeiros LJ, Cromwell CC, et al. Sequence analysis proves clonal identity in five patients with typical and blastoid mantle cell lymphoma. *Mod Pathol* 2007;20:1-7.
140. Bernard M, Gressin R, Lefrere F, et al. Blastic variant of mantle cell lymphoma: a rare but highly aggressive subtype. *Leukemia* 2001;15:1785-1791.
141. Liu Z, Dong HY, Gorczyca W, et al. CD5- mantle cell lymphoma. *Am J Clin Pathol* 2002;118:216-224.
142. Sanchez ML, Almeida J, Vidrales B, et al. Incidence of phenotypic aberrations in a series of 467 patients with B chronic lymphoproliferative disorders: basis for the design of specific four-color stainings to be used for minimal residual disease investigation. *Leukemia* 2002;16(8):1460-1469.
143. Zukerberg LR, Yang WI, Arnold A, et al. Cyclin D1 expression in non-Hodgkin's lymphomas. Detection by immunohistochemistry. *Am J Clin Pathol* 1995;103:756-760.
144. Swerdlow SH, Zukerberg LR, Yang W-I, et al. The morphologic spectrum of non-Hodgkin's lymphomas with BCL-1/Cyclin D1 gene rearrangements. *Am J Surg Pathol* 1996;20:627-640.
145. Mozos A, Royo C, Hartmann E, et al. SOX11 expression is highly specific for mantle cell lymphoma and identifies the cyclin D1-negative subtype. *Haematologica* 2009;94:1555-1562.
146. Richard P, Vassallo J, Valmary S, et al. "In situ-like" mantle cell lymphoma: a report of two cases. *J Clin Pathol* 2006;59:995-996.
147. Rätty R, Franssila K, Joensuu H, et al. Ki-67 expression level, histological subtype, and the International Prognostic Index as outcome predictors in mantle cell lymphoma. *Eur J Haematol* 2002;69:11-20.
148. Tiemann M, Schrader C, Klapper W, et al. Histopathology, cell proliferation indices and clinical outcome in 304 patients with mantle cell lymphoma (MCL): a clinicopathological study from the European MCL Network. *Br J Haematol* 2005;131:29-38.
149. Williams ME, Zukerberg LR, Harris NL, et al. Mantle cell/centrocytic lymphoma: molecular and phenotypic analysis including analysis of the bcl-1 major translocation cluster by PCR. *Curr Top Microbiol Immunol* 1995;194: 341-346.
150. Segal GH, Masih AS, Fox AC, et al. CD5-expressing B-cell non-Hodgkin's lymphomas with bcl-1 gene rearrangement have a relatively homogeneous immunophenotype and are associated with an overall poor prognosis. *Blood* 1995;85:1570-1579.
151. Fu K, Weisenburger DD, Greiner TC, et al. Cyclin D1-negative mantle cell lymphoma: a clinicopathologic study based on gene expression profiling. *Blood* 2005;106:4315-4321.
152. Nodit L, Bahler DW, Jacobs SA, et al. Indolent mantle cell lymphoma with nodal involvement and mutated immunoglobulin heavy chain genes. *Hum Pathol* 2003;34:1030-1034.
153. Orchard J, Garand R, Davis Z, et al. A subset of t(11;14) lymphoma with mantle cell features displays mutated IgV_H genes and includes patients with good prognosis, nonnodal disease. *Blood* 2003;101:4975-4981.
154. Navarro A, Clot G, Rovo C, et al. Molecular subsets of mantle cell lymphoma defined by the IGHV mutational status and SOX11 expression have distinct biological and clinical features. *Cancer Res.* 2012 Aug 20 [Epub]. PubMed PMID:22915760.
155. Traverse-Glehen A, Felman P, Callet-Bauchu E, et al. A clinicopathological study of nodal marginal zone B-cell lymphoma. A report on 21 cases. *Histopathology* 2006;48:162-173.
156. Camacho FI, Algara P, Mollejo M, et al. Nodal marginal zone lymphoma: a heterogeneous tumor: a comprehensive analysis of a series of 27 cases. *Am J Surg Pathol* 2003;27:762-771.
157. Nathwani BN, Drachenberg MR, Hernandez AM, et al. Nodal monocytoid B-cell lymphoma (nodal marginal-zone B-cell lymphoma). *Semin Hematol* 1999;36:128-138.
158. Berger F, Felman P, Thieblemont C, et al. Non-MALT marginal zone B-cell lymphomas: a description of clinical presentation and outcome in 124 patients. *Blood* 2000;95:1950-1956.
159. Davis GG, York JC, Glick AD, et al. Plasmacytic differentiation in parafollicular (monocytoid) B-cell lymphoma. A study of 12 cases. *Am J Surg Pathol* 1992;16:1066-1074.
160. Berger F, Traverse-Glehen A, Felman P, et al. Clinicopathologic features of Waldenström's macroglobulinemia and marginal zone lymphoma: are they distinct or the same entity? *Clin Lymphoma* 2005;5:220-224.

161. Dogan A, Isaacson PG. Splenic marginal zone lymphoma. *Semin Diagn Pathol* 2003;20:121-127.
162. Mollejo M, Camacho FI, Algara P, et al. Nodal and splenic marginal zone B cell lymphomas. *Hematol Oncol* 2005;23:108-118.
163. Isaacson PG, Matutes E, Burke M, et al. The histopathology of splenic lymphoma with villous lymphocytes. *Blood* 1994;84:3828-3834.
164. Hammer RD, Glick AD, Greer JP, et al. Splenic marginal zone lymphoma: a distinct B-cell neoplasm. *Am J Surg Pathol* 1996;20:613-626.
165. Chacon JJ, Mollejo M, Munoz E, et al. Splenic marginal zone lymphoma: clinical characteristics and prognostic factors in a series of 60 patients. *Blood* 2002;100:1648-1654.
166. Melo JV, Robinson DS, Gregory C, et al. Splenic B cell lymphoma with "villous" lymphocytes in the peripheral blood: a disorder distinct from hairy cell leukemia. *Leukemia* 1987;1:294-298.
167. Mulligan SP, Matutes E, Dearden C, et al. Splenic lymphoma with villous lymphocytes: natural history and response to therapy in 50 cases. *Br J Haematol* 1991;78:206-209.
168. Schmid C, Kirkham N, Diss T, et al. Splenic marginal zone lymphoma. *Am J Surg Pathol* 1992;16:455-466.
169. Camacho FI, Mollejo M, Mateo MS, et al. Progression to large B-cell lymphoma in splenic marginal zone lymphoma: a description of a series of 12 cases. *Am J Surg Pathol* 2001;25:1268-1276.
170. Mateo M, Mollejo M, Villuendas R, et al. 7q31-32 allelic loss is a frequent finding in splenic marginal zone lymphoma. *Am J Pathol* 1999;154:1583-1589.
171. Algara P, Mateo MS, Sanchez-Beato M, et al. Analysis of the IgV(H) somatic mutations in splenic marginal zone lymphoma defines a group of unmutated cases with frequent 7q deletion and adverse clinical course. *Blood* 2002;99:1299-1304.
172. Traverse-Glehan A, Baseggio L, Bauchu EC, et al. Splenic red pulp lymphoma with numerous basophilic villous lymphocytes: a distinct clinicopathologic and molecular entity? *Blood* 2008;111:2253-2260.
173. Kanellis G, Mollejo M, Montes-Moreno S, et al. Splenic diffuse red pulp small B-cell lymphoma: revision of a series of cases reveals characteristic clinicopathologic features. *Haematologica* 2010;95:1122-1129.
174. A clinical evaluation of the International Lymphoma Study Group classification of non-Hodgkin's lymphoma. The Non-Hodgkin's Lymphoma Classification Project. *Blood* 1997;89:3909-3918.
175. Isaacson PG, Du MQ. MALT lymphoma: from morphology to molecules. *Nat Rev Cancer* 2004;4:644-653.
176. Bacon CM, Du MQ, Dogan A. Mucosa-associated lymphoid tissue (MALT) lymphoma: a practical guide for pathologists. *J Clin Pathol* 2007;60: 361-372.
177. Wotherspoon AC, Ortiz-Hidalgo C, Falzon MR, et al. Helicobacter pylori-associated gastritis and primary B-cell gastric lymphoma. *Lancet* 1991;338: 1175-1176.
178. Parsonnet J, Hansen S, Rodriguez L, et al. Helicobacter pylori infection and gastric lymphoma. *N Engl J Med* 1994;330:1267-1271.
179. Baginsky L, Diss T, Ye H, et al. Campylobacter jejuni infection in intestinal lymphoma: a strong association with immunoproliferative small intestinal disease. *Blood* 2004;104(Part 1):384a.
180. Lecuit M, Abachin E, Martin A, et al. Immunoproliferative small intestinal disease associated with Campylobacter jejuni. *N Engl J Med* 2004;350: 239-248.
181. Ferreri AJ, Guidoboni M, Ponzoni M, et al. Evidence for an association between Chlamydia psittaci and ocular adnexal lymphomas. *J Natl Cancer Inst* 2004;96:586-594.
182. Ferreri AJ, Ponzoni M, Guidoboni M, et al. Regression of ocular adnexal lymphoma after Chlamydia psittaci-eradicating antibiotic therapy. *J Clin Oncol* 2005;23:5067-5073.
183. Ambrosetti A, Zanotti R, Pattaro C, et al. Most cases of primary salivary mucosa-associated lymphoid tissue lymphoma are associated either with Sjögren syndrome or hepatitis C virus infection. *Br J Haematol* 2004;126:43-49.
184. Hyjek E, Smith WJ, Isaacson PG. Primary B-cell lymphoma of salivary glands and its relationship to myoepithelial sialadenitis. *Hum Pathol* 1988;19: 766-776.

185. Goodlad JR, Davidson MM, Hollowood K, et al. Primary cutaneous B-cell lymphoma and *Borrelia burgdorferi* infection in patients from the Highlands of Scotland. *Am J Surg Pathol* 2000;24:1279-1285.
186. Cerroni L, Zochling N, Putz B, et al. Infection by *Borrelia burgdorferi* and cutaneous B-cell lymphoma. *J Cutan Pathol* 1997;24:457-461.
187. Roggero E, Zucca E, Mainetti C, et al. Eradication of *Borrelia burgdorferi* infection in primary marginal zone B-cell lymphoma of the skin. *Hum Pathol* 2000;31:263-268.
188. Isaacson PG, Spencer J. Malignant lymphoma of mucosa-associated lymphoid tissue. *Histopathology* 1987;11:445-462.
189. Papadaki L, Wotherspoon AC, Isaacson PG. The lymphoepithelial lesion of gastric low-grade B-cell lymphoma of mucosa-associated lymphoid tissue (MALT): an ultrastructural study. *Histopathology* 1992;21:415-421.
190. Isaacson PG, Wotherspoon AC, Diss T, et al. Follicular colonization in B-cell lymphoma of mucosa-associated lymphoid tissue. *Am J Surg Pathol* 1991;15:819-828.
191. Thome M. CARMA1, BCL-10 and MALT1 in lymphocyte development and activation. *Nat Rev Immunol* 2004;4:348-359.
192. Lin X, Wang D. The roles of CARMA1, Bcl10, and MALT1 in antigen receptor signaling. *Semin Immunol* 2004;16:429-435.
193. Liu H, Ye H, Ruskone-Fourmesttraux A, et al. T(11;18) is a marker for all stage gastric MALT lymphomas that will not respond to *H. pylori* eradication. *Gastroenterology* 2002;122:1286-1294.
194. Liu H, Ruskon-Fourmesttraux A, Lavergne-Slove A, et al. Resistance of t(11;18) positive gastric mucosa-associated lymphoid tissue lymphoma to *Helicobacter pylori* eradication therapy. *Lancet* 2001;357:39-40.
195. Jaffe E, Stein H, Swerdlow S, et al. B-cell lymphoma, unclassifiable, with features intermediate between diffuse large B-cell lymphoma and classical Hodgkin lymphoma. In: Swerdlow SH, Campo E, Harris NL, et al., eds. World Health Organization classification of tumours. WHO classification of tumours of haematopoietic and lymphoid tissues, 4th ed. Lyon: IARC Press, 2008:267-268.
196. Diebold J, Anderson JR, Armitage JO, et al. Diffuse large B-cell lymphoma: a clinicopathologic analysis of 444 cases classified according to the updated Kiel classification. *Leuk Lymphoma* 2002;43:97-104.
197. Stein H, Warnke R, Chan W, et al. Diffuse large B-cell lymphoma, not otherwise specified. In: Swerdlow SH, Campo E, Harris NL, et al., eds. World Health Organization classification of tumours. WHO classification of tumours of haematopoietic and lymphoid tissues, 4th ed. Lyon: IARC Press, 2008: 233-237.
198. Kremer M, Spitzer M, Mandl-Weber S, et al. Discordant bone marrow involvement in diffuse large B cell lymphoma: comparative molecular analysis reveals a heterogeneous group of disorders. *Lab Invest* 2003;83:107-114.
199. Ott G, Ziepert M, Klapper W, et al. Immunoblastic morphology but not the immunohistochemical GCB/nonGCB classifier predicts outcome in diffuse large B cell lymphoma in the RICOVER-60 trial of the DSHNHL. *Blood* 2010;116:4916-4925.
200. de Leval L, Harris NL. Variability in immunophenotype in diffuse large B cell lymphoma and its clinical relevance. *Histopathology* 2003;43:509-528.
201. Davis TA, Czerwinski DK, Levy R. Therapy of B cell lymphoma with anti-CD20 antibodies can result in the loss of CD20 antigen expression. *Clin Cancer Res* 1999;5:611-615.
202. Natkunam Y, Farinha P, Hsi ED, et al. LMO2 protein expression predicts survival in patients with diffuse large B cell lymphoma treated with anthracycline-based chemotherapy with and without rituximab. *J Clin Oncol* 2008;26:447-454.
203. Banham AH, Connors JM, Brown PJ, et al. Expression of the FOXP1 transcription factor is strongly associated with inferior survival in patients with diffuse large B cell lymphoma. *Clin Cancer Res* 2005;11:1065-1072.
204. Choi WW, Weisenburger DD, Greiner TC, et al. A new immunostain algorithm classifies diffuse large B cell lymphoma into molecular subtypes with high accuracy. *Clin Cancer Res* 2009;15:5494-5502.
205. Hans CP, Weisenburger DD, Greiner TC, et al. Confirmation of the molecular classification of diffuse large B cell lymphoma by immunohistochemistry using a tissue microarray. *Blood* 2004;103:275-282.

206. Muris JF, Meijer CJLM, Vos W, et al. Immunohistochemical profiling based on Bcl-2, CD10 and MUM1 expression improves risk stratification in patients with primary nodal diffuse large B cell lymphoma. *J Pathol* 2006;208: 714-723.
207. Nyman H, Adde M, Karjalainen-Lindsberg ML, et al. Prognostic impact of immunohistochemically defined germinal center phenotype in diffuse large B-cell lymphoma patients treated with immunochemotherapy. *Blood* 2007;109:4930-4935.
208. Meyer PN, Fu K, Greiner TC, et al. Immunohistochemical methods for predicting cell of origin and survival in patients with diffuse large B-cell lymphoma treated with rituximab. *J Clin Oncol* 2011;29:200-207.
209. Yamaguchi M, Seto M, Okamoto M, et al. De novo CD5+ diffuse large B-cell lymphoma: a clinicopathologic study of 109 patients. *Blood* 2002;99: 815-821.
210. Kobayashi T, Yamaguchi M, Kim S, et al. Microarray reveals differences in both tumors and vascular specific gene expression in de novo CD5+ and CD5- diffuse large B-cell lymphomas. *Cancer Res* 2003;63:60-66.
211. Tagawa H, Tsuzuki S, Suzuki R, et al. Genome-wide array-based comparative genomic hybridization of diffuse large B-cell lymphoma: comparison between CD5-positive and CD5-negative cases. *Cancer Res* 2004;64:5948-5955.
212. Lossos IS, Morgensztern D. Prognostic biomarkers in diffuse large B-cell lymphoma. *J Clin Oncol* 2006;24:995-1007.
213. Chaganti RS, Nanjangud G, Schmidt H, et al. Recurring chromosomal abnormalities in non-Hodgkin's lymphoma: biologic and clinical significance. *Semin Hematol* 2000;37:396-411.
214. Savage KJ, Johnson NA, Ben-Neriah S, et al. MYC gene rearrangements are associated with a poor prognosis in diffuse large B-cell lymphoma patients treated with R-CHOP chemotherapy. *Blood* 2009;114:3533-3537.
215. Iqbal J, Greiner TC, Patel K, et al. Distinctive patterns of BCL6 molecular alterations and their functional consequences in different subgroups of diffuse large B-cell lymphoma. *Leukemia* 2007;21:2332-2343.
216. Houldsworth J, Olshen AB, Cattoretti G, et al. Relationship between REL amplification, REL function, and clinical and biologic features in diffuse large B-cell lymphomas. *Blood* 2004;103:1862-1868.
217. Young KH, Leroy K, Moller MB, et al. Structural profiles of TP53 gene mutations predict clinical outcome in diffuse large B-cell lymphoma: an international collaborative study. *Blood* 2008;112:3088-3098.
218. Kanungo A, Medeiros LJ, Abruzzo LV, et al. Lymphoid neoplasms associated with concurrent t(14;18) and 8q24/c-MYC translocation generally have a poor prognosis. *Mod Pathol* 2006;19:25-33.
219. McClure RF, Remstein ED, Macon WR, et al. Adult B-cell lymphomas with Burkitt-like morphology are phenotypically and genotypically heterogeneous with aggressive clinical behavior. *Am J Surg Pathol* 2005;29:1652-1660.
220. Aukema SM, Siebert R, Schuurin E, et al. Double-hit B-cell lymphomas. *Blood* 2011;117:2319-2331.
221. Green TM, Young KH, Visco C, et al. Immunohistochemical double-hit score is a strong predictor of outcome in patients with diffuse large B-cell lymphoma treated with rituximab plus cyclophosphamide, doxorubicin, vincristine, and prednisone. *J Clin Oncol*. 2012 Sep 4 [Epub]. PubMed PMID:22665537.
222. Johnson NA, Savage KJ, Ludkovski O, et al. Lymphomas with concurrent BCL2 and MYC translocations: the critical factors associated with survival. *Blood* 2009;114:2273-2279.
223. Kluin P, Harris N, Stein H, et al. B-cell lymphoma, unclassifiable, with features intermediate between diffuse large B-cell lymphoma and Burkitt lymphoma. In: Swerdlow SH, Campo E, Harris NL, et al., eds. *World Health Organization classification of tumours. WHO classification of tumours of haematopoietic and lymphoid tissues*, 4th ed. Lyon: IARC Press, 2008:265-266.
224. Achten R, Verhoef G, Vanuystel I, et al. Histiocyte-rich, T-cell-rich B-cell lymphoma: a distinct diffuse large B-cell lymphoma subtype showing characteristic morphologic and immunophenotypic features. *Histopathology* 2002;40:31-45.
225. De Wolf-Peters C, Delabie J, Campo E, et al. T-cell/histiocyte-rich large B-cell lymphoma. In: Swerdlow SH, Campo E, Harris NL, et al., eds. *World Health Organization classification of tumours. WHO classification of tumours of haematopoietic and lymphoid tissues*, 4th ed. Lyon: IARC Press, 2008:238-239.
226. Lim MS, Beaty M, Sorbara L, et al. T-cell/histiocyte-rich large B-cell lymphoma: a heterogeneous entity with derivation from germinal center B-cells. *Am J Surg Pathol* 2002;26:1458-1466.
227. Macon WR, Williams ME, Greer JP, et al. T-cell-rich B-cell lymphomas. A clinicopathologic study of 19 cases. *Am J Surg Pathol* 1992;16:351-363.

228. Rudiger T, Ott G, Ott MM, et al. Differential diagnosis between classic Hodgkin's lymphoma, T-cell-rich B-cell lymphoma, and paraganuloma by paraffin immunohistochemistry. *Am J Surg Pathol* 1998;22:1184-1191.
229. Nam-Cha SH, Roncador G, Sanchez-Verde L, et al. PD-1, a follicular T-cell marker useful for recognizing nodular lymphocyte-predominant Hodgkin lymphoma. *Am J Surg Pathol* 2008;32:1252-1257.
230. Monti S, Savage KJ, Kutok JL, et al. Molecular profiling of diffuse large B-cell lymphoma identifies robust subtypes including one characterized by host inflammatory response. *Blood* 2005;105:1851-1861.
231. Gaulard P, Harris NP, Pileri SA, et al. Primary mediastinal (thymic) large B-cell lymphoma. In: Swerdlow SH, Campo E, Harris NL, et al., eds. World Health Organization classification of tumours. WHO classification of tumours of haematopoietic and lymphoid tissues, 4th ed. Lyon: IARC Press, 2008: 250-251.
232. Addis BJ, Isaacson PG. Large cell lymphoma of the mediastinum: a B-cell tumour of probable thymic origin. *Histopathology* 1986;10:379-390.
233. Isaacson PG, Norton AJ, Addis BJ. The human thymus contains a novel population of B lymphocytes. *Lancet* 1987;2:1488-4891.
234. Cazals-Hatem D, Lepage E, Brice P, et al. Primary mediastinal large B-cell lymphoma. A clinicopathologic study of 141 cases compared with 916 nonmediastinal large B-cell lymphomas, a GELA ("Groupe d'Etude des Lymphomes de l'Adulte") study. *Am J Surg Pathol* 1996;20:877-888.
235. Jacobson JO, Aisenberg AC, Lamarre L, et al. Mediastinal large cell lymphoma. An uncommon subset of adult lymphoma curable with combined modality therapy. *Cancer* 1988;62:1893-1898.
236. Calaminici M, Piper K, Lee AM, et al. CD23 expression in mediastinal large B-cell lymphomas. *Histopathology* 2004;45:619-624.
237. Joos S, Otano-Joos MI, Ziegler S, et al. Primary mediastinal (thymic) B-cell lymphoma is characterized by gains of chromosomal material including 9p and amplification of the REL gene. *Blood* 1996;87:1571-1578.
238. Wessendorf S, Barth TF, Viardot A, et al. Further delineation of chromosomal consensus regions in primary mediastinal B-cell lymphomas: an analysis of 37 tumor samples using high-resolution genomic profiling (array-CGH). *Leukemia* 2007;21:2463-2469.
239. Guiter C, Dusanter-Fourt I, Copie-Bergman C, et al. Constitutive STAT6 activation in primary mediastinal large B-cell lymphoma. *Blood* 2004;104:543-549.
240. Renne C, Willenbrock K, Martin-Subero JI, et al. High expression of several tyrosine kinases and activation of the PI3K/AKT pathway in mediastinal large B-cell lymphoma reveals further similarities to Hodgkin lymphoma. *Leukemia* 2007;21:780-787.
241. Rosenwald A, Wright G, Leroy K, et al. Molecular diagnosis of primary mediastinal B-cell lymphoma identifies a clinically favorable subgroup of diffuse large B-cell lymphoma related to Hodgkin lymphoma. *J Exp Med* 2003;198:851-862.
242. Savage KJ, Monti S, Kutok, et al. The molecular signature of mediastinal large B-cell lymphoma differs from that of other diffuse large B-cell lymphomas and shares features with classical Hodgkin lymphoma. *Blood* 2003;102:3871-3879.
243. Jaffe E, Harris N, Stein H, Campo E, Pileri S, Swerdlow S. Introduction and overview of the classification of the lymphoid neoplasms. In: Swerdlow SH, Campo E, Harris NL, et al., eds. World Health Organization classification of tumours. WHO classification of tumours of haematopoietic and lymphoid tissues, 4th ed. Lyon: IARC Press, 2008:158-166.
244. Traverse-Glehen A, Pittaluga S, Gaulard P, et al. Mediastinal gray zone lymphoma: the missing link between classic Hodgkin's lymphoma and mediastinal large B-cell lymphoma. *Am J Surg Pathol* 2005;29:1411-1421.
245. Kluin P, Deckert M, Ferry J. Primary diffuse large B-cell lymphoma of the CNS. In: Swerdlow SH, Campo E, Harris NL, et al., eds. World Health Organization classification of tumours. WHO classification of tumours of haematopoietic and lymphoid tissues, 4th ed. Lyon: IARC Press, 2008:240-241.
246. Batchelor T, Loeffler JS. Primary CNS lymphoma. *J Clin Oncol* 2006;24: 1281-1288.
247. Montesinos-Rongen M, Siebert R, Deckert M. Primary lymphoma of the central nervous system: just DLBCL or not? *Blood* 2009;113:7-10.
248. Tomlinson FH, Kurtin PJ, Suman VJ, et al. Primary intracerebral malignant lymphoma: a clinicopathological study of 89 patients. *J Neurosurg* 1995;82:558-566.

249. Camilleri-Broet S, Criniere E, Broet P, et al. A uniform activated B-cell-like immunophenotype might explain the poor prognosis of primary central nervous system lymphomas: analysis of 83 cases. *Blood* 2006;107:190-196.
250. Cady FM, O'Neill BP, Law ME, et al. Del(6)(q22) and BCL6 rearrangements in primary CNS lymphoma are indicators of an aggressive clinical course. *J Clin Oncol* 2008;26:4814-4819.
251. Nakamura S, Jaffe E, Swerdlow S. EBV positive diffuse large B-cell lymphoma of the elderly. In: Swerdlow SH, Campo E, Harris NL, et al., eds. World Health Organization classification of tumours. WHO classification of tumours of haematopoietic and lymphoid tissues, 4th ed. Lyon: IARC Press, 2008: 243-244.
252. Asano N, Yamamoto K, Tamaru J, et al. Age-related Epstein-Barr virus (EBV)-associated B-cell lymphoproliferative disorders: comparison with EBV-positive classic Hodgkin lymphoma in elderly patients. *Blood* 2009;113: 2629-2636.
253. Shimoyama Y, Oyama T, Asano N, et al. Senile Epstein-Barr virus-associated B-cell lymphoproliferative disorders: a mini review. *J Clin Exp Hematop* 2006;46:1-4.
254. Oyama T, Ichimura K, Suzuki R, et al. Senile EBV+ B-cell lymphoproliferative disorders: a clinicopathologic study of 22 patients. *Am J Surg Pathol* 2003;27:16-26.
255. Oyama T, Yamamoto K, Asano N, et al. Age-related EBV-associated B-cell lymphoproliferative disorders constitute a distinct clinicopathologic group: a study of 96 patients. *Clin Cancer Res* 2007;13:5124-5132.
256. Dojcinov SD, Venkataraman G, Raffeld M, et al. EBV positive mucocutaneous ulcer—a study of 26 cases associated with various sources of immunosuppression. *Am J Surg Pathol* 2010;34:405-417.
257. Dojcinov SD, Venkataraman G, Pittaluga S, et al. Age-related EBV-associated lymphoproliferative disorders in the Western population: a spectrum of reactive lymphoid hyperplasia and lymphoma. *Blood* 2011;117:4726-4735.
258. Chan J, Aozasa K, Gaulard P. DLBCL associated with chronic inflammation. In: Swerdlow SH, Campo E, Harris NL, et al., eds. World Health Organization classification of tumours. WHO classification of tumours of haematopoietic and lymphoid tissues, 4th ed. Lyon: IARC Press, 2008:245-246.
259. Nakatsuka S, Yao M, Hoshida Y, et al. Pyothorax-associated lymphoma: a review of 106 cases. *J Clin Oncol* 2002;20:4255-4260.
260. Petitjean B, Jardin F, Joly B, et al. Pyothorax-associated lymphoma: a peculiar clinicopathologic entity derived from B-cells at late stage of differentiation and with occasional aberrant dual B- and T-cell phenotype. *Am J Surg Pathol* 2002;26:724-732.
261. Cheuk W, Chan AC, Chan JK, et al. Metallic implant-associated lymphoma: a distinct subgroup of large B-cell lymphoma related to pyothorax-associated lymphoma? *Am J Surg Pathol* 2005;29:832-836.
262. Guinee D Jr, Jaffe E, Kingma D, et al. Pulmonary lymphomatoid granulomatosis. Evidence for a proliferation of Epstein-Barr virus infected B-lymphocytes with a prominent T-cell component and vasculitis. *Am J Surg Pathol* 1994;18:753-764.
263. Myers JL, Kurtin PJ, Katzenstein AL, et al. Lymphomatoid granulomatosis. Evidence of immunophenotypic diversity and relationship to Epstein-Barr virus infection. *Am J Surg Pathol* 1995;19:1300-1312.
264. Pittaluga S, Wilson W, Jaffe E. Lymphomatoid granulomatosis. In: Swerdlow SH, Campo E, Harris NL, et al., eds. World Health Organization classification of tumours. WHO classification of tumours of haematopoietic and lymphoid tissues, 4th ed. Lyon: IARC Press, 2008:247-249.
265. Murase T, Nakamura S, Kawauchi K, et al. An Asian variant of intravascular large B-cell lymphoma: clinical, pathological and cytogenetic approaches to diffuse large B-cell lymphoma associated with haemophagocytic syndrome. *Br J Haematol* 2000;111:826-834.
266. Nakamura S, Ponzoni M, Campo E. Intravascular large B-cell lymphoma. In: Swerdlow SH, Campo E, Harris NL, et al., eds. World Health Organization classification of tumours. WHO classification of tumours of haematopoietic and lymphoid tissues, 4th ed. Lyon: IARC Press, 2008:252-253.
267. Ponzoni M, Ferreri AJ, Campo E, et al. Definition, diagnosis, and management of intravascular large B-cell lymphoma: proposals and perspectives from an international consensus meeting. *J Clin Oncol* 2007;25:3168-3173.
268. Delsol G, Campo E, Gascoyne R. ALK-positive large B-cell lymphoma. In: Swerdlow SH, Campo E, Harris NL, et al., eds. World Health Organization classification of tumours. WHO classification of tumours of haematopoietic and lymphoid tissues, 4th ed. Lyon: IARC Press, 2008:254-255.

269. Delsol G, Lamant L, Mariame B, et al. A new subtype of large B-cell lymphoma expressing the ALK kinase and lacking the 2; 5 translocation. *Blood* 1997;89:1483-1490.
270. Gascoyne RD, Lamant L, Martin-Subero JI, et al. ALK-positive diffuse large B-cell lymphoma is associated with Clathrin-ALK rearrangements: report of 6 cases. *Blood* 2003;102:2568-2573.
271. Onciu M, Behm FG, Downing JR, et al. ALK-positive plasmablastic B-cell lymphoma with expression of the NPM-ALK fusion transcript: report of 2 cases. *Blood* 2003;102:2642-2644.
272. Colomo L, Loong F, Rives S, et al. Diffuse large B-cell lymphomas with plasmablastic differentiation represent a heterogeneous group of disease entities. *Am J Surg Pathol* 2004;28:736-747.
273. Delecluse HJ, Anagnostopoulos I, Dallenbach F, et al. Plasmablastic lymphomas of the oral cavity: a new entity associated with the human immunodeficiency virus infection. *Blood* 1997;89:1413-1420.
274. Stein H, Harris N, Campo E. Plasmablastic lymphoma. In: Swerdlow SH, Campo E, Harris NL, et al., eds. *World Health Organization classification of tumours. WHO classification of tumours of haematopoietic and lymphoid tissues*, 4th ed. Lyon: IARC Press, 2008:256-257.
275. Isaacson P, Campo E, Harris N. Large B-cell lymphoma arising in HHV8-associated multicentric Castleman disease. In: Swerdlow SH, Campo E, Harris NL, et al., eds. *World Health Organization classification of tumours. WHO classification of tumours of haematopoietic and lymphoid tissues*, 4th ed. Lyon: IARC Press, 2008:258-259.
276. Ansari MQ, Dawson DB, Nador R, et al. Primary body cavity-based AIDS-related lymphomas. *Am J Clin Pathol* 1996;105:221-229.
277. Cesarman E, Chang Y, Moore PS, et al. Kaposi's sarcoma-associated herpes-virus-like DNA sequences in AIDS-related body-cavity-based lymphomas. *N Engl J Med* 1995;332:1186-1191.
278. Cesarman E, Nador RG, Aozasa K, et al. Kaposi's sarcoma-associated herpes-virus in non-AIDS related lymphomas occurring in body cavities. *Am J Pathol* 1996;149:53-57.
279. Raphael M, Gentilhomme O, Tulliez M, et al. Histopathologic features of high-grade non-Hodgkin's lymphomas in acquired immunodeficiency syndrome. *Arch Pathol Lab Med* 1991;115:15-20.
280. Magrath IT. African Burkitt's lymphoma. *Am J Pediatr Hematol Oncol* 1991;13(2):222-246.
281. Sandlund JT, Downing JR, Crist WM. Non-Hodgkin's lymphoma in childhood. *N Engl J Med* 1996;334:1238-1248. P.1800
282. Kornblau SM, Goodacre A, Cabanillas F. Chromosomal abnormalities in adult non-endemic Burkitt's lymphoma and leukemia: 22 new reports and a review of 148 cases from the literature. *Hematol Oncol* 1991;9:63-78.
283. Shiramizu B, Barriga F, Neequaye J, et al. Patterns of chromosomal breakpoint locations in Burkitt's lymphoma: relevance to geography and Epstein-Barr virus association. *Blood* 1991;77:1516-1526.
284. Haralambieva E, Boerma E-J, van Imhoff GW, et al. Clinical, immunophenotypic, and genetic analysis of adult lymphomas with morphologic features of Burkitt lymphoma. *Am J Surg Pathol* 2005;29:1086-1094.
285. Chapman CJ, Mockridge CI, Rowe M, et al. Analysis of VH genes used by neoplastic B-cells in endemic Burkitt's lymphoma shows somatic hypermutation and intraclonal heterogeneity. *Blood* 1995;85:2176-2181.
286. Hecht JL, Aster JC. Molecular biology of Burkitt's lymphoma. *J Clin Oncol* 2000;18(21):3707-3721.
287. Barth TFE, Müller S, Pawlita M, et al. Homogeneous immunophenotype and paucity of secondary genomic aberrations are distinctive features of endemic but not of sporadic Burkitt's lymphoma and diffuse large B-cell lymphoma with MYC rearrangement. *J Pathol* 2004;203:940-945.
288. Hummel M, Bentink S, Berger H, et al. A biologic definition of Burkitt's lymphoma from transcriptional and genomic profiling. *N Engl J Med* 2006;354:2419-2430.
289. Dave SS, Fu K, Wright GW, et al. Molecular diagnosis of Burkitt's lymphoma. *N Engl J Med* 2006;354:2431-2442.
290. Spits H, Lanier LL, Phillips JH. Development of human T and natural killer cells. *Blood* 1995;85:2654-2670.
291. Jaffe ES. Pathobiology of peripheral T-cell lymphomas. *Hematology Am Soc Hematol Educ Program* 2006:317-322.

292. Geissinger E, Bonzheim I, Krenács L, et al. Nodal peripheral T-cell lymphomas correspond to distinct mature T-cell populations *J Pathol* 2006;210: 172-180.
293. Macon WR, Williams ME, Greer JP, et al. Natural killer-like T cell lymphomas: aggressive lymphomas of T-large granular lymphocytes. *Blood* 1996;87:1474-1483.
294. Felgar RE, Macon WR, Kinney MC, et al. TIA-1 expression in lymphoid neoplasms: identification of subsets with cytotoxic T lymphocyte or natural killer cell differentiation. *Am J Pathol* 1997;150:1893-1900.
295. Krenacs L, Smyth MJ, Bagdi E, et al. The serine protease granzyme M is preferentially expressed in NK-cell, $\gamma\delta$ T-cell, and intestinal T-cell lymphomas: evidence of origin from lymphocytes involved in innate immunity. *Blood* 2003;101:3590-3593.
296. Nathwani BN, Diamond LW, Winberg CD. Lymphoblastic lymphoma: a clinicopathologic study of 95 patients. *Cancer* 1981;48:2347-2357.
297. Bernard A, Boumsell L, Reinherz L, et al. Cell surface characterization of malignant T cells from lymphoblastic lymphoma using monoclonal antibodies: evidence for phenotypic differences between malignant T cells from patients with acute lymphoblastic leukemia and lymphoblastic lymphoma. *Blood* 1981;57:1105-1110.
298. Mori N, Oka K, Yoda Y, et al. Leu-4 (CD3) antigen expression in the neoplastic cells from T-ALL and T-lymphoblastic lymphoma. *Am J Clin Pathol* 1988;90:244-249.
299. Weiss L, Bindl J, Picozzi V, et al. Lymphoblastic lymphoma: an immunophenotype study of 26 cases with comparison to T cell acute lymphoblastic leukemia. *Blood* 1986;67:474-478.
300. Sheibani K, Winberg C, Burke J. Lymphoblastic lymphoma expressing natural killer cell-associated antigens: a clinicopathologic study of six cases. *Leuk Res* 1987;11:371-377.
301. Waldron JA, Leech JH, Glick AD, et al. Malignant lymphoma of peripheral T-lymphocyte origin: immunologic, pathologic, and clinical features in six patients. *Cancer* 1977;40:1604-1617.
302. Macon WR, William ME, Greer JP, et al. Paracortical nodular T-cell lymphoma: identification of an unusual variant of T-cell lymphoma. *Am J Surg Pathol* 1996;19:297-303.
303. Hastrup N, Ralfkiaer E, Pallesen G. Aberrant phenotypes in peripheral T cell lymphomas. *J Clin Pathol* 1989;42:398-402.
304. Gaulard P, Bourquelot P, Kanavaros P. Expression of the alpha/beta and gamma/delta T-cell receptors in 57 cases of peripheral T-cell lymphomas: identification of a subset of γ/δ T-cell lymphomas. *Am J Pathol* 1990;137: 617-628.
305. Brüggemann M, White H, Gaulard P, et al. Powerful strategy for polymerase chain reaction-based clonality assessment in T-cell malignancies. Report of the BIOMED-2 Concerted Action BHM4 CT98-3936. *Leukemia* 2007;21: 215-221.
306. Asano N, Suzuki R, Kagami Y, et al. Clinicopathologic and prognostic significance of cytotoxic molecule expression in nodal peripheral T-cell lymphoma, unspecified. *Am J Surg Pathol* 2005;29:1284-1293.
307. Dupuis J, Emile J-F, Mounier N, et al. Prognostic significance of Epstein-Barr virus in nodal peripheral T-cell lymphoma, unspecified: a Groupe d'Etude des Lymphomes de l'Adulte (GELA) study. *Blood* 2006;108:4163-4169.
308. Streubel B, Vinatzer U, Willheim M, et al. Novel t(5;9) (q33;q22) fuses ITK to SYK in unspecified peripheral T-cell lymphoma. *Leukemia* 2006;20:313-318.
309. Feldman AL, Law M, Remstein ED, et al. Recurrent translocations involving the IRF4 oncogene locus in peripheral T-cell lymphomas. *Leukemia* 2009;23:574-580.
310. Ballester B, Ramuz O, Gisselbrecht C, et al. Gene expression profiling identifies molecular subgroups among nodal peripheral T-cell lymphomas. *Oncogene* 2006;25:1560-1570.
311. Piccaluga PP, Agostinelli C, Califano A, et al. Gene expression analysis of peripheral T cell lymphoma, unspecified, reveals distinct profiles and new potential therapeutic targets. *J Clin Invest* 2007;117:823-834.
312. Burke JS, Butler JJ. Malignant lymphoma with a high content of epithelioid histiocytes (Lennert's lymphoma). *Am J Clin Pathol* 1976;66:1-9.
313. Kim H, Jacobs C, Warnke R, et al. Malignant lymphoma with a high content of epithelioid histiocytes: a distinct clinicopathologic entity and a form of so-called "Lennert's lymphoma." *Cancer* 1978;41:620-635.

314. Patsouris E, Nöel H, Lennert K. Histological and immunohistological findings in lymphoepithelioid cell lymphoma (Lennert's lymphoma). *Am J Surg Pathol* 1988;12:341-350.
315. Patsouris E, Nöel H, Lennert K. Angioimmunoblastic lymphadenopathy-type of T-cell lymphoma with a high content of epithelioid cells. Histopathology and comparison with lymphoepithelioid cell lymphoma. *Am J Surg Pathol* 1989;13:262-275.
316. Patsouris E, Nöel H, Lennert K. Cytohistologic and immunohistochemical findings in Hodgkin's disease, mixed cellularity type, with a high content of epithelioid cells. *Am J Surg Pathol* 1989;13:1014-1022.
317. Kojima M, Nakamura S, Motoori T, et al. Centroblastic and centroblasticcentrocytic lymphomas associated with prominent epithelioid granulomatous response without plasma cell differentiation: a clinicopathologic study of 12 cases. *Hum Pathol* 1996;27:660-667.
318. de Leval L, Savilo E, Longtine J, et al. Peripheral T-cell lymphoma with follicular involvement and a CD4+/bcl-6+ phenotype. *Am J Surg Pathol* 2001;25:395-400.
319. Frizzera G, Moran E, Rappaport H. Angio-immunoblastic lymphadenopathy with dysproteinemia. *Lancet* 1974;1:1070-1073.
320. Dogan A, Attygalle AD, Kyriakou C. Angioimmunoblastic T-cell lymphoma. *Br J Haematol* 2003;121:681-691.
321. Ree HJ, Kadin ME, Kikuchi M, et al. Angioimmunoblastic lymphoma (AILDtype T-cell lymphoma) with hyperplastic germinal centers. *Am J Surg Pathol* 1998;22:643-655.
322. Attygalle A, Al-Jehani R, Diss TC, et al. Neoplastic T-cells in angioimmunoblastic T-cell lymphoma express CD10. *Blood* 2002;99:627-633.
323. Seehafer JR, Goldberg NC, Dicken CH, et al. Cutaneous manifestations of angioimmunoblastic lymphadenopathy. *Arch Dermatol* 1980;116:41-45.
324. Grogg KL, Morice WG, Macon WR. Spectrum of bone marrow findings in patients with angioimmunoblastic T-cell lymphoma. *Br J Haematol* 2007 (in press).
325. Brown HA, Macon WR, Kurtin PJ, et al. Cutaneous involvement by angioimmunoblastic T-cell lymphoma with remarkable heterogeneous Epstein-Barr virus expression. *J Cutan Pathol* 2001;28:432-438.
326. Leung CY, Ho FC, Srivastava G, et al. Usefulness of follicular dendritic cell pattern in classification of peripheral T-cell lymphomas. *Histopathology* 1993;23:433-437.
327. Jones D, Jorgensen JL, Shahsafaei A, et al. Characteristic proliferations of reticular and dendritic cells in angioimmunoblastic lymphoma. *Am J Surg Pathol* 1998;22:956-964.
328. Bagdi E, Krenacs L, Krenacs T, et al. Follicular dendritic cells in reactive and neoplastic lymphoid tissues: a reevaluation of staining patterns of CD21, CD23, and CD35 antibodies in paraffin sections after wet heat-induced epitope retrieval. *Appl Immunohistochem Mol Morphol* 2001;9:117-124.
329. Ree HJ, Kadin ME, Kikuchi M, et al. Bcl-6 expression in reactive follicular hyperplasia, follicular lymphoma, and angioimmunoblastic T-cell lymphoma with hyperplastic germinal centers: heterogeneity of intrafollicular T-cells and their altered distribution in the pathogenesis of angioimmunoblastic T-cell lymphoma. *Hum Pathol* 1999;30:403-411.
330. Grogg KL, Attygalle AD, Macon WR, et al. Angioimmunoblastic T-cell lymphoma: a neoplasm of germinal-center T-helper cells? *Blood* 2005;106: 1501-1502.
331. Grogg KL, Attygalle AD, Macon WR, et al. Expression of CXCL13, a chemokine highly upregulated in germinal center T-helper cells, distinguishes angioimmunoblastic T-cell lymphoma from peripheral T-cell lymphoma, unspecified. *Mod Pathol* 2006;19:1101-1107.
332. Dupuis J, Boye K, Martin N, et al. Expression of CXCL13 by neoplastic cells in angioimmunoblastic T-cell lymphoma (AITL): a new diagnostic marker providing evidence that AITL derives from follicular helper T cells. *Am J Surg Pathol* 2006;30:490-494.
333. de Leval L, Rickman DS, Thielen C, et al. The gene expression profile of nodal peripheral T-cell lymphoma demonstrates a molecular link between angioimmunoblastic T-cell lymphoma (AITL) and follicular helper T-cells (TFH). *Blood* 2007;109:4952-4963.

334. Attygalle AD, Diss TC, Munson P, et al. CD10 expression in extranodal dissemination of angioimmunoblastic T-cell lymphoma. *Am J Surg Pathol* 2004;28:54-61.
335. Stein H, Mason D, Gerdes J, et al. The expression of the Hodgkin's disease associated antigen Ki-1 in reactive and neoplastic lymphoid tissue: evidence that Reed-Stenberg cells and histiocytic malignancies are derived from activated lymphoid cells. *Blood* 1985;66:848-858.
336. Stein H, Foss HD, Durkop H, et al. CD30(+) anaplastic large cell lymphoma: a review of its histopathologic, genetic, and clinical features. *Blood* 2000;96:3681-3695.
337. Delsol G, Falini B, Müller-Hermelink HK, et al. Anaplastic large cell lymphoma (ALCL), ALK-positive. In: Swerdlow SH, Campo E, Harris NL, et al., eds. World Health Organization classification of tumours. WHO classification of tumours of haematopoietic and lymphoid tissues, 4th ed. Lyon: IARC Press, 2008:312-316.
338. Mason DY, Harris NL, Delsol G, et al. Anaplastic large cell lymphoma, ALKnegative. In: Swerdlow SH, Campo E, Harris NL, et al., eds. World Health Organization classification of tumours. WHO classification of tumours of haematopoietic and lymphoid tissues, 4th ed. Lyon: IARC Press, 2008:317-319.
339. Ralfkiaer E, Willemze R, Paulli M, et al. Primary cutaneous CD30-positive T-cell lymphoproliferative disorders. In: Swerdlow SH, Campo E, Harris NL, et al., eds. World Health Organization classification of tumours. WHO classification of tumours of haematopoietic and lymphoid tissues, 4th ed. Lyon: IARC Press, 2008:300-301.
340. de Bruin P, Beljaards R, van Heerde P, et al. Differences in clinical behavior and immunophenotype between primary cutaneous and primary nodal anaplastic large cell lymphoma of T-cell or null cell phenotype. *Histopathology* 1993;23:127-135.
341. Kadin ME, Sako D, Berliner N, et al. Childhood Ki-1 lymphoma presenting with skin lesions and peripheral lymphadenopathy. *Blood* 1986;68: 1042-1049.
342. Chott A, Kaserer K, Augustin I. Ki-1 positive large cell lymphoma: a clinicopathologic study of 41 cases. *Am J Surg Pathol* 1990;14:439-448.
343. Kinney M, Collins R, Greer J, et al. A small-cell-predominant variant of primary Ki-1 (CD30)+ T-cell lymphoma. *Am J Surg Pathol* 1993;17:859-868.
344. Pileri S, Falini B, Delsol G, et al. Lymphohistiocytic T-cell lymphoma (anaplastic large cell lymphoma CD30+/Ki-1+) with a high content of reactive histiocytes. *Histopathology* 1998;16:383-391.
345. Krenacs L, Wellman A, Sorbara L, et al. Cytotoxic cell antigen expression in anaplastic large cell lymphomas of T- and null-cell type and Hodgkin's disease: evidence for a distinct cellular origin. *Blood* 1997;89:980-989.
346. Felgar RE, Salhany KE, Macon WR, et al. The expression of TIA-1+ cytologic-type granules and other cytolytic lymphocyte-associated markers in CD30+ anaplastic large cell lymphomas (ALCL): correlation with morphology, immunophenotype, ultrastructure and clinical features. *Hum Pathol* 1999;30:228-236.
347. LeBeau MM, Bitter MA, Larson RA, et al. The t(2;5)(p23;q35): a recurring chromosomal abnormality in Ki-1-positive anaplastic large cell lymphoma. *Leukemia* 1989;3:866-870.
348. DeCoteau JF, Butmarc JR, Kinney MC, et al. The t(2;5) chromosomal translocation is not a common feature of primary cutaneous CD30+ lymphoproliferative disorders: comparison with anaplastic large-cell lymphoma of nodal origin. *Blood* 1996;87:3437-3441.
349. Morris SW, Kirstein MN, Valentine MB, et al. Fusion of a kinase gene, ALK, to a nucleolar protein gene, NPM, in non-Hodgkin's lymphoma. *Science* 1994;263:1281-1284.
350. Pulford K, Lamant L, Morris SW, et al. Detection of anaplastic lymphoma kinase (ALK) and nucleolar protein nucleoplasmin (NPM)-ALK proteins in normal and neoplastic cells with the monoclonal antibody ALK1. *Blood* 1997;89:1394-1404.
351. Lamant L, Dastugue N, Pulford K, et al. A new fusion gene TPM3-ALK in anaplastic large cell lymphoma created by a (1;2)(q25;p23) translocation. *Blood* 1999;93:3088-3095.
352. Hernández L, Piniyol M, Hernández S, et al. TRK-fused gene (TFG) is a new partner of ALK in anaplastic large cell lymphoma producing two structurally different TFG-ALK translocations. *Blood* 1999;94:3265-3268.

353. Ma Z, Cools J, Marynen P, et al. Inv(2)(p23q35) in anaplastic large-cell lymphoma induces constitutive anaplastic lymphoma kinase (ALK) tyrosine kinase activation by fusion to ATIC, an enzyme involved in purine nucleotide biosynthesis. *Blood* 2000;95:2144-2149.
354. Touriol C, Greenland C, Lamant L, et al. Further demonstration of the diversity of chromosomal changes involving 2p23 in ALK-positive lymphoma: 2 cases expressing ALK kinase fused to CLTCL (clathrin chain polypeptidlike). *Blood* 2000;95:3204-3207.
355. Zettl A, Rüdiger T, Konrad M-A, et al. Genomic profiling of peripheral T-cell lymphoma, unspecified, and anaplastic large T-cell lymphoma delineates novel recurrent chromosomal alterations. *Am J Pathol* 2004;164:1837-1848.
356. Thompson MA, Stumph J, Henrickson SE, et al. Differential gene expression in anaplastic lymphoma kinase-positive and anaplastic lymphoma kinase-negative anaplastic large cell lymphomas. *Hum Pathol* 2005;36:494-504.
357. Lamant L, de Reyniès A, Duplantier M-M, et al. Gene-expression profiling of systemic anaplastic large-cell lymphoma reveals differences based on ALK status and two distinct morphologic ALK+ subtypes. *Blood* 2007;109:2156-2164.
358. Falini B, Pileri S, Zinzani PL, et al. ALK+ lymphoma: clinico-pathological findings and outcome. *Blood* 1999;93:2697-2706.
359. Gascoyne RD, Aoun P, Wu D, et al. Prognostic significance of anaplastic lymphoma kinase (ALK) protein expression in adults with anaplastic large cell lymphoma. *Blood* 1999;93:3913-3921.
360. ten Berge RL, de Bruin PC, Oudejans JJ, et al. ALK-negative anaplastic large-cell lymphoma demonstrates similar poor prognosis to peripheral T-cell lymphoma, unspecified. *Histopathology* 2003;43:462-469.
361. Feldman AL, Dogan A, Smith DI, et al. Discovery of recurrent (6;7) (p25.3;q32.3) translocations in ALK-negative anaplastic large cell lymphomas by massively parallel genomic sequencing. *Blood* 2011;117:915-919.
362. Wada DA, Law ME, Hsi ED, et al. Specificity of IRF4 translocations for primary cutaneous anaplastic large cell lymphoma: a multicenter study of 204 skin biopsies. *Mod Pathol* 2011;24:596-605.
363. Roden AC, Macon WR, Keeney GL, et al. Seroma-associated primary anaplastic large-cell lymphoma adjacent to breast implants: an indolent T-cell lymphoproliferative disorder. *Mod Pathol* 2008;21:455-463.
364. de Jong D, Vasmel WL, de Boer JP, et al. Anaplastic large-cell lymphoma in women with breast implants. *JAMA* 2008;300:2030-2035.
365. Sciallis AP, Law ME, Inwards DJ, et al. Mucosal CD30-positive T-cell lymphoproliferations of the head and neck show a similar clinicopathologic spectrum to cutaneous CD30-positive T-cell lymphoproliferative disorders. *Mod Pathol* 2012;25:983-992.
366. Chihara D, Ito H, Katanoda K, et al. Increase in incidence of adult T-cell leukemia/lymphoma in non-endemic areas of Japan and the United States. *Cancer Sci* 2012. doi:10.1111/j.1349-7006.2012.02373.x. 2012 Jun 28 [Epub].
367. Jaffe E, Blattner W, Blayney D, et al. The pathologic spectrum of adult T-cell leukemia/lymphoma in the United States. *Am J Pathol* 1984;8:263-275.
368. Shimoyama M. Diagnostic criteria and classification of clinical subtypes of adult T-cell leukaemia-lymphoma. *Br J Haematol* 1991;79:428-437.
369. Yoshida M, Seiki M, Yamaguchi K, et al. Monoclonal integration of human T-cell leukemia provirus in all primary tumors of adult T-cell leukemia suggests causative role of human T-cell leukemia virus in the disease. *Proc Natl Acad Sci U S A* 1984;81:2534-2537.
370. Suchi T, Lennert K, Tu L-Y. Histopathology and immunohistochemistry of peripheral T-cell lymphomas: a proposal for their classification. *J Clin Pathol* 1987;40:995-1015.
371. Karube K, Ohshima K, Tsuchiya T, et al. Expression of FoxP3, a key molecule in CD4+ CD25+ regulatory T-cells, in adult T-cell leukaemia/lymphoma cells. *Br J Haematol* 2004;126:81-84.
372. Falini B, Flenghi L, Pileri S, et al. Distribution of T-cells bearing different forms of the T-cell receptor γ/δ in normal and pathological human tissue. *J Immunol* 1989;143:2480-2488.
373. Farcet J-P, Gaulard P, Marolleau J-P, et al. Hepatosplenic T-cell lymphoma: sinusal/sinusoidal localization of malignant cells expressing the T-cell receptor $\gamma\delta$. *Blood* 1990;75:2213-2219.

374. Cooke CB, Krenacs L, Stetler-Stevenson M, et al. Hepatosplenic T-cell lymphoma: a distinct clinicopathologic entity of cytotoxic $\gamma\delta$ T-cell origin. *Blood* 1996;88:4265-4274.
375. Belhadj K, Reyes F, Farcet J-P, et al. Hepatosplenic $\gamma\delta$ T-cell lymphoma is a rare clinicopathologic entity with poor outcome: report on a series of 21 patients. *Blood* 2003;102:4261-4269.
376. Macon WR, Levy NB, Kurtin PJ, et al. Hepatosplenic $\alpha\beta$ T-cell lymphomas. A report of 14 cases and comparison with hepatosplenic $\gamma\sigma$ T-cell lymphomas. *Am J Surg Pathol* 2000;25:285-296.
377. Shale M, Kanfer E, Pannaccione R, et al. Hepatosplenic T cell lymphoma in inflammatory bowel disease. *Gut* 2008;57:1639-1641.
378. Salhany KE, Feldman M, Peritt D, et al. Hepatosplenic $\gamma\delta$ T-cell lymphoma: ultrastructural, immunophenotypic and functional evidence for cytotoxic T lymphocyte (CTL) differentiation. *Hum Pathol* 1997;28:674-685.
379. Przybylski GK, Wu H, Macon WR, et al. Hepatosplenic and subcutaneous panniculitis-like γ/σ T cell lymphomas are derived from different $\gamma\delta$ subsets of γ/σ T lymphocytes. *J Mol Diagn* 2000;2:11-19.
380. Morice WG, Macon WR, Dogan A, et al. NK-cell-associated receptor expression in hepatosplenic T-cell lymphoma, insights into pathogenesis. *Leukemia* 2006;20:883-886.
381. Wang C-C, Tien H-F, Lin M-T, et al. Consistent presence of isochromosome 7q in hepatosplenic T γ/δ lymphoma: a new cytogenetic-clinicopathologic entity. *Genes Chromosomes Cancer* 1995;12:161-164.
382. Travert M, Huang Y, de Leval L, et al. Molecular features of hepatosplenic T-cell lymphoma unravels potential novel therapeutic targets. *Blood* 2012;119:5795-5806.
383. Gonzales CL, Medeiros LJ, Braziel RM, et al. T-cell lymphoma involving subcutaneous tissue: a clinicopathologic entity commonly associated with hemophagocytic syndrome. *Am J Surg Pathol* 1991;15:17-27.
384. Mehregan DA, Su WPD, Kurtin PJ. Subcutaneous T-cell lymphoma: a clinical, histopathologic, and immunohistochemical study of six cases. *J Cutan Pathol* 1994;21:110-117.
385. Salhany KE, Macon WR, Choi JK, et al. Subcutaneous panniculitis-like T-cell lymphoma: clinicopathologic, immunophenotypic, and genotypic analysis of alpha/beta and gamma/delta subtypes. *Am J Surg Pathol* 1998;22:881-893.
386. Willemze R, Jansen PM, Cerroni L, et al. Subcutaneous panniculitis-like T-cell lymphoma: definition, classification, and prognostic factors: an EORTC Cutaneous Lymphoma Group Study of 83 cases. *Blood* 2008;111:838-845.
387. Isaacson P, Wright DH. Intestinal lymphoma associated with malabsorption. *Lancet* 1978;1:67-70.
388. Egan LJ, Walsh SV, Stevens FM, et al. Celiac-associated lymphoma. A single institution experience of 30 cases in the combination chemotherapy era. *J Clin Gastroenterol* 1995;21:123-129.
389. Bagdi E, Diss TC, Munson P, et al. Mucosal intra-epithelial lymphocytes in enteropathy-associated T-cell lymphoma, ulcerative jejunitis, and refractory celiac disease constitute a neoplastic population. *Blood* 1999;94:260-264.
390. Cellier C, Delabesse E, Helmer C, et al. Refractory sprue, coeliac disease, and enteropathy-associated T-cell lymphoma. French Coeliac Disease Study Group. *Lancet* 2000;356:203-208.
391. Isaacson PG. Relation between cryptic intestinal lymphoma and refractory sprue. *Lancet* 2000;356:178-179.
392. Ashton-Key M, Diss TC, Pan L, et al. Molecular analysis of T-cell clonality in ulcerative jejunitis and enteropathy-associated T-cell lymphoma. *Am J Pathol* 1997;151:493-498.
393. Zettl A, Ott G, Makulik A, et al. Chromosomal gains at 9q characterize enteropathy-type T-cell lymphoma. *Am J Pathol* 2002;161:1635-1645.
394. Suzumiya J, Takeshita M, Kimura N, et al. Expression of adult and fetal natural killer cell markers in sinonasal lymphomas. *Blood* 1994;83:2255-2260.
395. Van Gorp J, De Bruin PC, Sie-Go DMDS, et al. Nasal T-cell lymphoma: a clinicopathologic and immunophenotypic analysis of 13 cases. *Histopathology* 1995;27:139-148.
396. Chiang AKS, Srivastava G, Lau PWF, et al. Differences in T-cell-receptor gene rearrangement and transcription in nasal lymphomas of natural killer and T-cell types: implications on cellular origin. *Hum Pathol* 1996;27:701-707.

397. Pongpruttipan T, Sukpanichnant S, Assanasen T, et al. Extranodal NK/T-cell lymphoma, nasal type, includes cases of natural killer cell and $\alpha\beta$, $\gamma\delta$, and $\alpha\beta/\gamma\delta$ T-cell origin: a comprehensive clinicopathologic and phenotypic study. *Am J Surg Pathol* 2012;36:481-499.
398. Petrella T, Delfau-Larue M-H, Caillot D, et al. Nasopharyngeal lymphomas: further evidence for a natural killer cell origin. *Hum Pathol* 1996;27:827-833.
399. Chan JKC, Yip TTC, Tsang WYW, et al. Detection of Epstein-Barr viral RNA in malignant lymphomas of the upper aerodigestive tract. *Am J Surg Pathol* 1994;18:938-946.
400. Huang Y, de Reyniès A, de Leval L, et al. Gene expression profiling identifies emerging oncogenic pathways operating in extranodal NK/T-cell lymphoma, nasal type. *Blood* 2010;115:1226-1237.
401. Jaffe ES, Chan JKC, Su I-J, et al. Report of the workshop on nasal and related extranodal angiocentric T/natural killer cell lymphomas. Definitions, differential diagnosis and epidemiology. *Am J Surg Pathol* 1996;20:103-111.
402. Wong KF, Chan JKC, Ng CS, et al. CD56 (NKH-1)-positive hematolymphoid malignancies: an aggressive neoplasm featuring frequent cutaneous/mucosal involvement, cytoplasmic azurophilic granules, and angiocentricity. *Hum Pathol* 1992;23:798-804.
403. Nakamura S, Suchi T, Koshikawa T, et al. Clinicopathologic study of CD56 (NCAM)-positive angiocentric lymphoma occurring in sites other than the upper and lower respiratory tract. *Am J Surg Pathol* 1995;19:284-296.
404. Totonchi KF, Engel G, Weisenberg E, et al. Testicular natural killer/T-cell lymphoma, nasal type, of true natural killer-cell origin. *Arch Pathol Lab Med* 2002;126:1527-1529.
405. Tsang WYW, Chan JKC, Yip TTC, et al. In situ localization of Epstein-Barr virus encoded RNA in non-nasal/nasopharyngeal CD56-positive and CD56-negative T-cell lymphomas. *Hum Pathol* 1994;25:758-765.
406. Stein H, Delsol G, Pileri S, et al. Classical Hodgkin lymphoma, introduction. In: Swerdlow SH, Campo E, Harris NL, et al., eds. *World Health Organization classification of tumours. WHO classification of tumours of haematopoietic and lymphoid tissues*, 4th ed. Lyon: IARC Press, 2008:326-329.
407. Lukes R, Craver L, Hall T, et al. Report of the nomenclature committee. *Cancer Res* 1966;26:1311-1326.
408. Lukes R, Butler J. The pathology and nomenclature of Hodgkin's disease. *Cancer Res* 1966;26:1063-1081.
409. Keller AR, Kaplan HS, Lukes RJ, et al. Correlation of histopathology with other prognostic indicators in Hodgkin's disease. *Cancer* 1968;22:487-499.
410. Lukes RJ. Criteria for involvement of lymph node, bone marrow, spleen, and liver in Hodgkin's disease. *Cancer Res* 1971;31:1755-1767.
411. Reynolds DJ, Banks PM, Gulley ML. New characterization of infectious mononucleosis and a phenotypic comparison with Hodgkin's disease. *Am J Pathol* 1995;146:379-388.
412. Tindle B, Parker J, Lukes R. "Reed-Sternberg cells" in infectious mononucleosis? *Am J Clin Pathol* 1972;58:607-617.
413. Weiss LM, von Wasielewski R, Delsol G, et al. Mixed cellularity classical Hodgkin lymphoma. In: Swerdlow SH, Campo E, Harris NL, et al., eds. *World Health Organization classification of tumours. WHO classification of tumours of haematopoietic and lymphoid tissues*, 4th ed. Lyon: IARC Press, 2008:331.
414. Doggett RS, Colby TV, Dorfman RF. Interfollicular Hodgkin's disease. *Am J Surg Pathol* 1983;7:145-149.
415. Anagnostopoulos I, Isaacson PG, Stein H. Lymphocyte-rich classical Hodgkin lymphoma. In: Swerdlow SH, Campo E, Harris NL, et al., eds. *World Health Organization classification of tumours. WHO classification of tumours of haematopoietic and lymphoid tissues*, 4th ed. Lyon: IARC Press, 2008:332-333.
416. Shimabukuro-Vornhagen A, Haverkamp H, Engert A, et al. Lymphocyte-rich classical Hodgkin's lymphoma: clinical presentation and treatment outcome in 100 patients treated within German Hodgkin's Study Group trials. *J Clin Oncol* 2005;23:5739-5745.
417. von Wasielewski R, Werner M, Fischer R, et al. Lymphocyte-predominant Hodgkin's disease. An immunohistochemical analysis of 208 reviewed Hodgkin's disease cases from the German Hodgkin Study group. *Am J Pathol* 1997;150:793-803.
418. Chittal SM, Brousset P, Voigt JJ, et al. Large B-cell lymphoma rich in T-cells and simulating Hodgkin's disease. *Histopathology* 1991;19:211-220.

419. Ng CS, Chan JKC, Hui PK, et al. Large B-cell lymphomas with a high content of reactive T-cells. *Hum Pathol* 1989;20:1145-54.
420. Ramsay AD, Smith WJ, Isaacson PG. T-cell-rich B-cell lymphoma. *Am J Surg Pathol* 1988;12:433-443.
421. Rodriguez J, Pugh WC, Cabanilla F. T-cell-rich B-cell lymphoma. *Blood* 1993;82:1586-1589.
422. Stein H, von Wasielewski R, Poppema S, et al. Nodular sclerosis classical Hodgkin lymphoma. In: Swerdlow SH, Campo E, Harris NL, et al., eds. World Health Organization classification of tumours. WHO classification of tumours of haematopoietic and lymphoid tissues, 4th ed. Lyon: IARC Press, 2008:330.
423. Bennett M, Tu A, Hudson G. Analysis of Grade I Hodgkin's disease. *Clin Radiol* 1981;32:491-498.
424. Hess JL, Bodis S, Pinkus G, et al. Histopathologic grading of nodular sclerosis Hodgkin's disease: lack of prognostic significance in 254 surgically staged patients. *Cancer* 1994;74:708-714.
425. MacLennan KA, Bennett MH, Tu A, et al. Relationship of histopathologic features to survival and relapse in nodular sclerosing Hodgkin's disease. A study of 1659 patients. *Cancer* 1989;64:1686-1693.
426. Masih A, Weisenburger D, Vose J, et al. Histologic grade does not predict prognosis in optimally treated, advanced-stage nodular sclerosing Hodgkin's disease. *Cancer* 1992;69:228-232.
427. Benkharroch D, Stein H, Peh S-C. Lymphocyte-depleted classical Hodgkin lymphoma. In: Swerdlow SH, Campo E, Harris NL, et al., eds. World Health Organization classification of tumours. WHO classification of tumours of haematopoietic and lymphoid tissues, 4th ed. Lyon: IARC Press, 2008:334.
428. Lukes RJ, Butler JJ, Hicks EB. Natural history of Hodgkin's disease as related to its pathologic picture. *Cancer* 1966;19:317-1344.
429. Neiman R, Rosen P, Lukes R. Lymphocyte-depletion Hodgkin's disease. A clinicopathologic study. *N Engl J Med* 1973;288:751-755.
430. Hall PA, D'Ardenne AJ, Stansfield AG. Paraffin section immunohistochemistry. II. Hodgkin's disease and large cell anaplastic (Ki-1) lymphoma. *Histopathology* 1988;13:161-169.
431. Hsu SM, Yang K, Jaffe ES. Phenotypic expression of Hodgkin's and Reed-Sternberg cells in Hodgkin's disease. *Am J Pathol* 1985;118:209-217.
432. Foss HD, Reusch R, Demel G, et al. Frequent expression of the B-cell-specific activator protein in Reed-Sternberg cells of classical Hodgkin's disease provides further evidence for its B-cell origin. *Blood* 1999;94:3108-3113.
433. Arber DA, Weiss LM. CD15: a review. *Appl Immunohistochem* 1993;1:17-30.
434. Garcia-Cosio M, Santon A, Martin P, et al. Analysis of transcription factor OCT.1, OCT.2 and BOB.1 expression using tissue arrays in classical Hodgkin's lymphoma. *Mod Pathol* 2004;17:1531-1538.
435. Kanzler H, Küppers R, Hansmann ML, et al. Hodgkin and Reed-Sternberg cells in Hodgkin's disease represent the outgrowth of a dominant tumor clone derived from (crippled) germinal center B-cells. *J Exp Med* 1996;184: 1495-1505.
436. Marafioti T, Hummel M, Foss HD, et al. Hodgkin and Reed-Sternberg cells represent an expansion of a single clone originating from a germinal center B-cell with functional immunoglobulin gene rearrangements but defective immunoglobulin transcription. *Blood* 2000;95:1443-1450.
437. Gandhi MK, Tellam JT, Khanna R. Epstein-Barr virus-associated Hodgkin's lymphoma. *Br J of Haematol* 2004;125:267-281.
438. Mueller N. Epidemiologic studies assessing the role of Epstein-Barr virus in Hodgkin's disease. *Yale J Biol Med* 1987;60:321-332.
439. Rosdahl N, Larsen SO, Clemmesen J. Hodgkin's disease in patients with previous infectious mononucleosis: 30 years' experience. *Br Med J* 1974;2:253-256.
440. Mueller N, Evans A, Harris ML, et al. Hodgkin's disease and Epstein-Barr virus. Altered antibody pattern before diagnosis. *N Engl J Med* 1989;320:689-695.
441. Reynolds DJ, Banks PM, Gulley ML. New characterization of infectious mononucleosis and a phenotypic comparison with Hodgkin's disease. *Am J Pathol* 1995;146:379-388.

442. Weiss LM. Gene analysis and Epstein-Barr viral genome studies of Hodgkin's disease. *Int Rev Exp Pathol* 1992;33:165-184.
443. Hummel M, Anagnostopoulos J, Dallenbach F, et al. EBV infection patterns in Hodgkin's disease and normal lymphoid tissue: expression and cellular localization of EBV gene products. *Br J Haematol* 1992;82:689-694.
444. Khan G, Norton AJ, Slavin G. Epstein-Barr virus in Hodgkin disease. Relation to age and subtype. *Cancer* 1993;71:3124-3129.
445. Weiss LM, Chen YY, Liu XF, et al. Epstein-Barr virus and Hodgkin's disease. A correlative in situ hybridization and polymerase chain reaction study. *Am J Pathol* 1991;139:1259-1265.
446. Ambinder RF, Browning PJ, Lorenzana I, et al. Epstein-Barr virus and childhood Hodgkin's disease in Honduras and the United States. *Blood* 1993;81:462-467.
447. Chang KL, Albuja PF, Chen YY, et al. High prevalence of Epstein-Barr virus in the Reed-Sternberg cells of Hodgkin's disease occurring in Peru. *Blood* 1993;81:496-501.
448. Huh J, Park C, Juhng S, et al. A pathologic study of Hodgkin's disease in Korea and its association with the Epstein-Barr virus infection. *Cancer* 1996;77:949-955.
449. Leoncini L, Spina D, Nyong'o A, et al. Neoplastic cells of Hodgkin's disease show differences in EBV expression between Kenya and Italy. *Int J Cancer* 1996;65:781-784.
450. Weinreb M, Day PJR, Niggli F, et al. The consistent association between Epstein-Barr virus and Hodgkin's disease in children in Kenya. *Blood* 1996;87:3828-3836.
451. Zarate-Osorno A, Roman LN, Kingma DW, et al. Hodgkin's disease in Mexico. Prevalence of Epstein-Barr virus sequences and correlations with histologic subtype. *Cancer* 1994;75:1360-1366.
452. Herndier BG, Sanchez HL, Chang KL, et al. High prevalence of Epstein-Barr virus in the Reed-Sternberg cells of HIV-associated Hodgkin's disease. *Am J Pathol* 1993;142:1073-1079.
453. Uccini S, Monardo F, Stoppacciaro A, et al. High frequency of Epstein-Barr virus genome detection in Hodgkin's disease of HIV-positive patients. *Int J Cancer* 1990;46:581-585.
454. Deacon EM, Pallesen G, Niedobitek G, et al. Epstein-Barr virus and Hodgkin's disease: transcriptional analysis of virus latency in the malignant cells. *J Exp Med* 1993;177:339-349.
455. Herbst H, Steinbrecher E, Niedobitek G, et al. Distribution and phenotype of Epstein-Barr virus-harboring cells in Hodgkin's disease. *Blood* 1992;80: 484-491.
456. Isaacson PG, Schmid C, Pan L, et al. Epstein-Barr virus latent membrane protein expression by Hodgkin and Reed-Sternberg-like cells in acute infectious mononucleosis. *J Pathol* 1992;167:267-271.
457. Niedobitek G, Kremmer E, Herbst H, et al. Immunohistochemical detection of the Epstein-Barr virus-encoded latent membrane protein 2A in Hodgkin's disease and infectious mononucleosis. *Blood* 1997;90:1664-1672.
458. Pallesen G, Sandvej K, Hamilton-Dutoit SJ, et al. Activation of Epstein-Barr virus replication in Hodgkin and Reed-Sternberg cells. *Blood* 1991;78: 1162-1165.
459. Jarrett RF, Stark GL, White J, et al. Impact of tumor Epstein-Barr virus status on presenting features and outcome in age-defined subgroups of patients with classic Hodgkin lymphoma: a population-based study. *Blood* 2005;106:2444-2451.
460. Keegan TH, Glaser SL, Clarke CA, et al. Epstein-Barr virus as a marker of survival after Hodgkin's lymphoma: a population-based study. *J Clin Oncol* 2005;23:7604-7613.
461. Krugmann J, Tzankov A, Gschwendtner A, et al. Longer failure-free survival interval of Epstein-Barr virus-associated classical Hodgkin's lymphoma: a single-institution study. *Mod Pathol* 2003;16:566-573.
462. Poppema S, Delsol G, Pileri SA, et al. Nodular lymphocyte predominant Hodgkin lymphoma. In: Swerdlow SH, Campo E, Harris NL, et al., eds. *World Health Organization classification of tumours. WHO classification of tumours of haematopoietic and lymphoid tissues*, 4th ed. Lyon: IARC Press, 2008:323-325.
463. Poppema S, Timens W, Visser L. Nodular lymphocyte predominance type of Hodgkin's disease is a B-cell lymphoma. *Adv Exp Med Biol* 1985;186: 963-969.

464. Fan Z, Natkunam Y, Bair E, et al. Characterization of variant patterns of nodular lymphocyte predominant Hodgkin lymphoma with immunohistologic and clinical correlation. *Am J Surg Pathol* 2003;27:1346-1356.
465. Burns BF, Colby TV, Dorfman RF. Differential diagnostic features of nodular L & H Hodgkin's disease, including progressive transformation of germinal centers. *Am J Surg Pathol* 1984;8:253-261.
466. Poppema S, Kaiserling E, Lennert K. Hodgkin's disease with lymphocytic predominance, nodular type (nodular paraganuloma) and progressively transformed germinal centres—a cytohistological study. *Histopathology* 1979;3:295-308.
467. Brauning A, Yang W, Wacker HH, et al. B-cell development in progressively transformed germinal centers: similarities and differences compared with classical germinal centers and lymphocyte-predominant Hodgkin disease. *Blood* 2001;97:714-719.
468. Hansmann ML, Fellbaum C, Hui PK, et al. Progressive transformation of germinal centers with and without association to Hodgkin's disease. *Am J Clin Pathol* 1990;93:219-226.
469. Osborne BM, Butler JJ. Clinical implication of progressive transformation of germinal centers. *Am J Surg Pathol* 1984;8:725-733.
470. Ferry JA, Zukerberg LR, Harris WL. Florid progressive transformation of germinal centers: a syndrome affecting young men without early progression to nodular lymphocyte predominance Hodgkin's disease. *Am J Surg Pathol* 1992;16:252-258.
471. Bishop PW, Harris M, Smith AP, et al. Immunophenotypic study of lymphocyte predominance Hodgkin's disease. *Histopathology* 1991;18:19-24.
472. Coles RB, Cartun RW, Pastuszak WT. Hodgkin's disease, lymphocyte-predominant type: immunoreactivity with B-cell antibodies. *Mod Pathol* 1988;1:274-278.
473. Korkolopoulou P, Cordell J, Jones M, et al. The expression of the B-cell marker Mb-1 (CD79a) in Hodgkin's disease. *Histopathology* 1994;24:511-515.
474. Pinkus GS, Said JW. Hodgkin's disease, lymphocyte predominance type, nodular—a distinct entity? Unique staining profile for L & H variants of Reed-Sternberg cells defined by monoclonal antibodies to leukocyte common antigen, granulocyte-specific antigen, and B-cell-specific antigen. *Am J Pathol* 1985;133:211-217.
475. Pinkus GS, Said JW. Hodgkin's disease, lymphocyte predominance type, nodular—further evidence for a B-cell derivation. L & H variants of Reed-Sternberg cells express L26, a pan B cell marker. *Am J Pathol* 1988;133: 211-217.
476. Stein H, Hansmann ML, Lennert K, et al. Reed-Sternberg and Hodgkin cells in lymphocyte-predominant Hodgkin's disease of nodular subtype contain J chain. *Am J Clin Pathol* 1986;86:292-297.
477. Schmid C, Sargeant C, Isaacson PG. L and H cells of nodular lymphocyte predominant Hodgkin's disease show immunoglobulin light-chain restriction. *Am J Pathol* 1991;139:1281-1289.
478. Prakash S, Fountaine T, Raffeld M, et al. IgD positive L&H cells identify a unique subset of nodular lymphocyte predominant Hodgkin lymphoma. *Am J Surg Pathol* 2006;30:585-592.
479. Flenghi L, Bigerna B, Bizzotti M, et al. Monoclonal antibodies PG-B6a and PG-B6p recognize, respectively, a highly conserved and a formol-resistant epitope on the human BCL-6 protein amino-terminal region. *Am J Pathol* 1996;148:1543-1555.
480. Falini B, Bigerna B, Pasqualucci L, et al. Distinctive expression pattern of the BCL-6 protein in nodular lymphocyte predominance Hodgkin's disease. *Blood* 1996;87:465-471.
481. Hansmann ML, Fellbaum C, Hui PK, et al. Correlation of content of B cells and Leu7-positive cells with subtype and stage in lymphocyte predominance type Hodgkin's disease. *J Cancer Res Clin Oncol* 1988;114:405-410.
482. Poppema S. The nature of the lymphocytes surrounding Reed-Sternberg cells in nodular lymphocyte predominance and in other types of Hodgkin's disease. *Am J Pathol* 1989;135:351-357.
483. Lin P, Medeiros LJ, Wilder RB, et al. The activation profile of tumour-associated reactive T-cells differs in the nodular and diffuse patterns of lymphocyte predominant Hodgkin's disease. *Histopathology* 2004;44:561-569.
484. Hoppe R, Rosenberg S, Kaplan H, et al. Prognostic factors in pathological stage IIIA Hodgkin's disease. *Cancer* 1980;46:1240-1246.

485. Bagley C, Roth J, Thomas L, et al. Liver biopsy in Hodgkin's disease: clinicopathologic correlations in 127 patients. *Ann Intern Med* 1972;76:219-225.
486. Dich N, Goodman Z, Klein M. Hepatic involvement in Hodgkin's disease: clues to histologic diagnosis. *Cancer* 1989;64:2121-2126.
487. Kadin M, Donaldson S, Dorfman R. Isolated granulomas in Hodgkin's disease. *N Engl J Med* 1970;283:859-861.
488. Sacks E, Donaldson S, Gordon J, et al. Epithelioid granulomas associated with Hodgkin's disease: clinical correlations in 55 previously untreated patients. *Cancer* 1978;41:562-567.
489. Chang K, Kamel O, Arber D, et al. Pathologic features of nodular lymphocyte predominance Hodgkin's disease in extranodal sites. *Am J Surg Pathol* 1995;19:1313-1324.
490. Siebert J, Stuckey J, Kurtin P, et al. Extranodal lymphocyte predominance Hodgkin's disease. Clinical and pathologic features. *Am J Clin Pathol* 1995;103:485-491.
491. Bartl R, Frisch B, Burkhardt R, et al. Assessment of bone marrow histology in Hodgkin's disease: correlation with clinical factors. *Br J Haematol* 1982;51:345-360.
492. Kinney M, Greer J, Stein R, et al. Lymphocyte-depletion Hodgkin's disease. Histopathologic diagnosis of marrow involvement. *Am J Surg Pathol* 1986;10:219-226.
493. Munker R, Hasenclever D, Brosteanu O, et al. Bone marrow involvement in Hodgkin's disease: an analysis of 135 consecutive cases. *J Clin Oncol* 1995;13:403-409.

Chapter 87 Molecular Genetic Aspects of Non-Hodgkin Lymphomas

> Table of Contents > Part VII - Hematologic Malignancies > Section 4 - Lymphoproliferative Disorders > Chapter 87 - Molecular Genetic Aspects of Non-Hodgkin Lymphomas

Chapter 87

Molecular Genetic Aspects of Non-Hodgkin Lymphomas

Annette S. Kim

INTRODUCTION

The non-Hodgkin lymphomas (NHLs) are a diverse group of mature lymphoid neoplasms with a wide range of cellular morphologies, histologic presentations, clinical presentations, cells of origin, etiologies, and responses to therapy. Due to the protean manifestations, NHLs remain a significant diagnostic challenge for hematopathologists. In fact, using morphology alone, the interpathologist consensus is 41% to 93%, depending on the diagnosis.¹ This lack of consensus is especially true of the T-cell lymphomas which are even more varied in presentation than their B-cell counterparts. Incorporation of clinical history and immunophenotyping can improve the consensus, but pathognomonic diagnostic clues are often missing.

The NHLs represent 4% of all cancers with an overall annual incidence of 19.6/100,000 in the United States (Fig. 87.1), making it the seventh most common cancer in both males and females.^{2,3,4} Despite their relatively high frequency in clinical practice, the NHLs have defied numerous attempts to classify them. Early classification schemes relied heavily upon morphology. However, as the classification of acute leukemias moved to emphasize the cell of origin, so too did lymphoma classifications attempt to identify a cell of origin and stage of maturation. Most recently, leukemia classification schemes have advanced beyond morphologic or immunophenotypic criteria to molecular genetic criteria for the subclassification of acute leukemias. Not only are leukemias defined by their genetic translocations, but rapidly molecular mutations, invisible on the metaphase cytogenetic level of resolution, are defining diagnostic and prognostic categories.

In fact, the researchers of the NHLs were pioneers in the discovery of molecular genetic underpinnings of hematolymphoid malignancies. The first reciprocal translocations that caused tumorigenesis were identified in Burkitt lymphoma (BL), translocations involving the MYC oncogene.⁵ These were followed by the discovery of the t(14;18) in follicular lymphoma (FL).⁶ However, after an initial flurry of activity, the NHLs have lagged behind their leukemia counterparts in the identification of the molecular genetic causes of neoplasia. The most recent 2008 World Health Organization classification scheme still largely relies upon cell of origin as the primary discriminator of the B-cell NHLs,^{4,7,8}

and T-cell lymphomas are even less well understood in general, with many of the classifications defined by the site of the tumor. Molecular changes in NHLs, although often associated with a given type of lymphoma, do not solely characterize that entity.^{4,9} For example, 10% to 15% of FLs lack the hallmark t(14;18),¹⁰ whereas t(14;18) can be seen in some types of de novo diffuse large B-cell lymphoma (DLBCL) without a preceding history of FL. Other molecular genetic changes are often more phenomenologic, rather than pathognomonic, of the particular type of lymphoma and only further highlight the molecular heterogeneity of these neoplasms.

However, other molecular aberrations are likely as yet unrecognized and new efforts in next generation sequencing (NGS) and mutational analysis in general are slowly elucidating new markers of disease. It is possible, however, that disease classification in the future of NHL will not be defined by single molecular aberrations, but by pathway dysregulation. Therefore, more global methods of assessing molecular genetic aberrations may become more prominent in the diagnosis and prognosis on NHLs in the years to come.

OVERVIEW OF METHODOLOGIES

Commonly Used Techniques

One of the mainstays of molecular testing in lymphoid malignancies is the use of clonality testing. These methods are based upon the unique rearrangement of either the B-cell receptor (BCR), composed of an immunoglobulin (Ig) heavy chain and one of two light chains, or the T-cell receptor (TCR), heterodimers of either α/β subunits or γ/δ subunits. However, there are other recurrent reciprocal translocations that can also be assessed by polymerase chain reaction (PCR), quantitative real-time polymerase chain reaction (q-PCR), fluorescent in situ hybridization (FISH), or metaphase cytogenetics (MC). The latter two methodologies can also identify other structural or numeric aberrations as well. These other methodologies, often in conjunction with clonality testing, are useful diagnostically as well as potentially for the measurement of minimal residual disease (MRD) during therapy monitoring. Gene naming conventions throughout the chapter follow the nomenclature recommendations set forth by the HUGO Gene Nomenclature Committee.¹¹

Clonality Testing

Immunoglobulin Gene Rearrangements

The expression of Ig is one of the defining characteristics of all mature B-cells. At the earliest stages of B-cell ontogeny, recombination of the Ig heavy chain (IGH@) can be detected, well before the expression of the complete heterotetrameric product composed of two heavy chains and two light chains on the surface of the B-cell, where the light chain can be either kappa or lambda (Fig. 87.2). Although the individual Ig genes are located at disparate locations in the genome—the IGH@ locus on chromosome 14q32, the kappa locus (IGK@) at 2p11, and the lambda locus (IGL@) at 22q11—the genes are all structured in a similar fashion to enable the unique somatic recombination of germline gene segments that create the antigen specificity of the final Ig protein heterotetramer. During this recombination process, individual variable regions (V regions), joining regions (J regions), and constant regions (C regions) are selected which form the body of the final Ig chain and contribute to the antigen specificity. In addition, the IGH@ locus also contains diversity regions (D regions), for a final VDJC rearrangement (versus VJC for the light chains).¹²

Each gene segment is marked for potential recombination by a recombination signal sequence (RSS) which is acted upon by the recombination-activating genes 1 and 2 to create double-stranded DNA breaks that are recombined through nonhomologous end-joining, with assistance from the DNA-bending proteins, HMG1 and HMG2. The D-J recombination is the first rearrangement of the IGH@ locus, followed by V-DJ and VDJ-C. At each recombination site, these double-stranded breaks can be further modified by being filled in with palindromic nucleotide insertions (P nucleotides), removal of one to two nucleotides through a random exonuclease activity, or further varied by the addition of N nucleotides that are not present in the germline sequence through terminal deoxynucleotidyl transferase. These actions also contribute to the diversity of the Igs. The cut and modified ends of the coding sequence are then also repaired by nonhomologous end-joining.¹²

P.1802

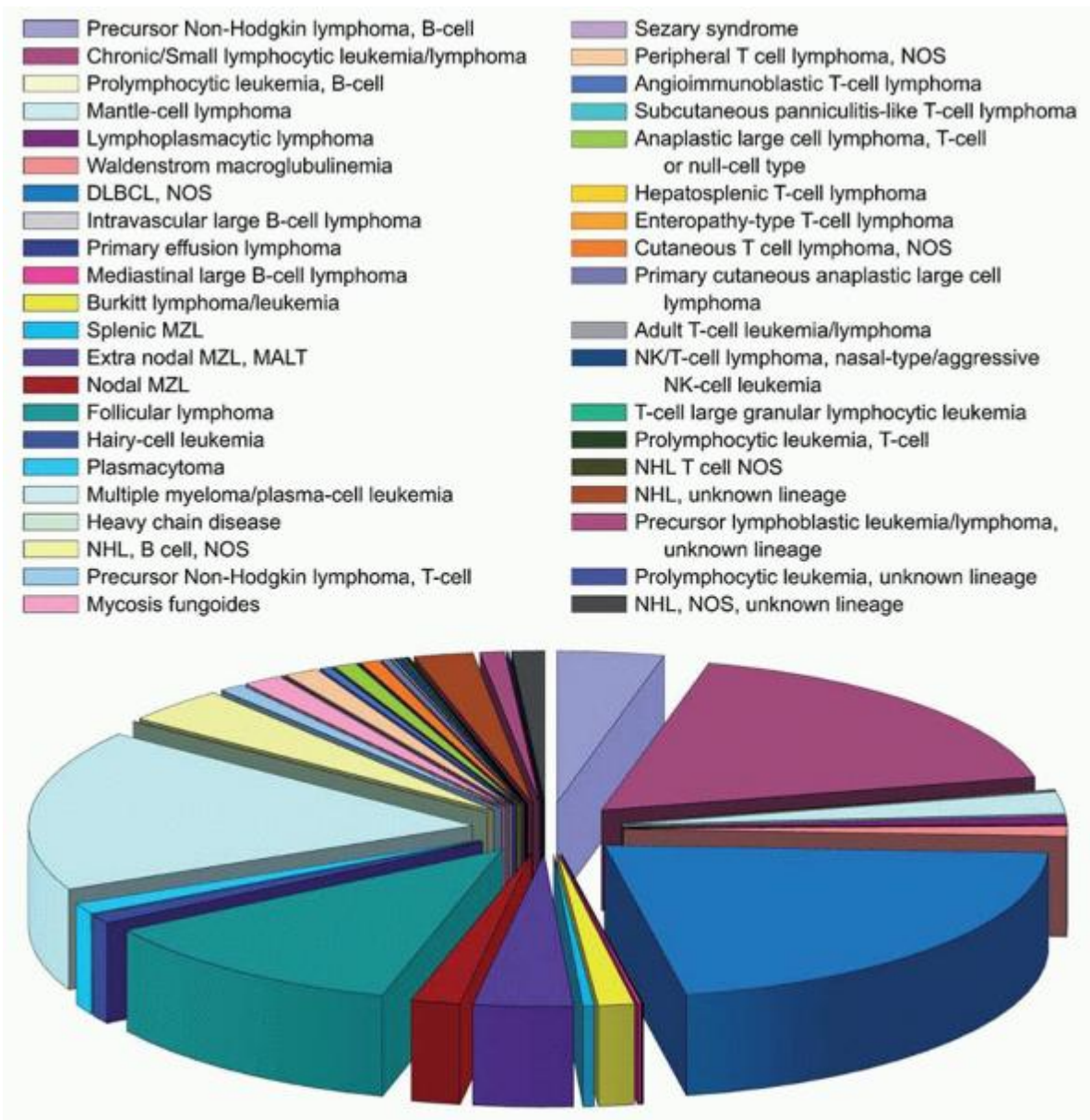

FIGURE 87.1. Surveillance epidemiology and end result (SEER) data for the relative incidence of non-Hodgkin lymphomas. See Reference 3.

The variable regions of all the Ig proteins form a canonical beta-sheet structure which necessarily means that the majority of amino acids are paradoxically highly conserved.¹³ These conserved regions are termed the framework regions, FR1-3 (Fig. 87.3). Between these framework regions are the truly variable complementary determining regions (CDRs1-3) which encode sequences of approximately 10 amino acids that project from the tips of the beta-sheet as fingers reaching out to contact antigen. Therefore, although the IGH@ gene contains up to 200 different V regions (approximately 80 of which are widely used in human biology),¹² consensus primers can be constructed against the V regions that will permit the amplification of the gene across the VDJ recombination sites by PCR. Due to the variability of the encompassed CDRs as well as the diversity created by the random exonuclease activity and N nucleotide addition, physiologic B-cells should each have a distinctively sized PCR product, and

P.1803

clonal populations should have identical PCR products. This forms the basis of the Ig gene rearrangement studies by PCR. Southern blot (SB) methods, which look for the unique rearrangements on unamplified DNA, have been considered the

gold standard for gene rearrangement studies, but have fallen into disuse with the ease of PCR-based methods and now next generation sequencing.

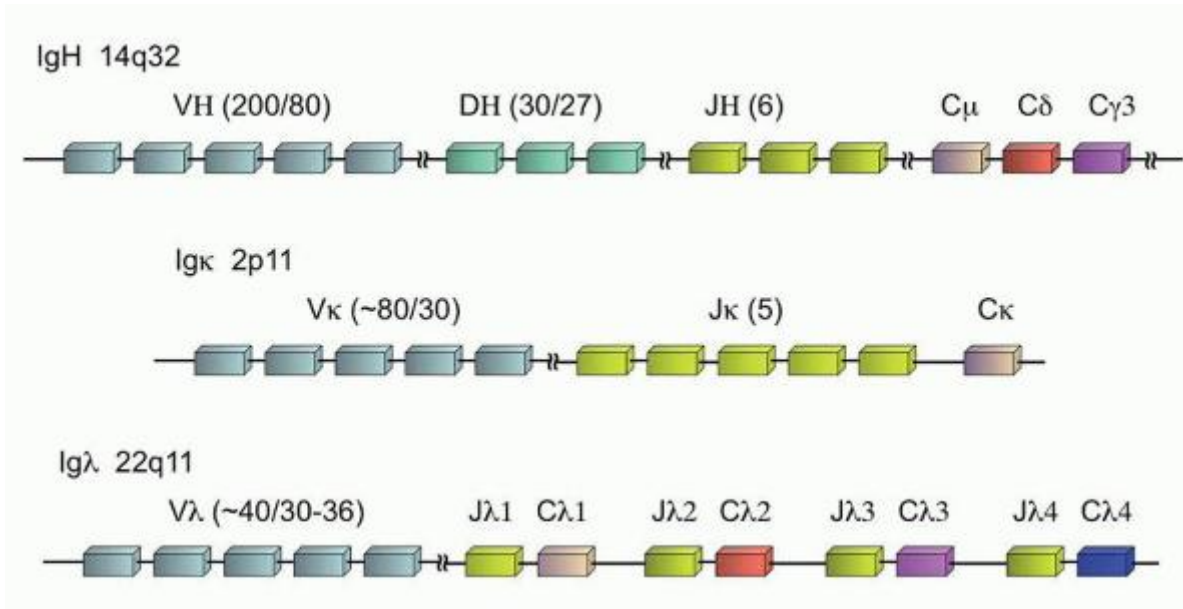

FIGURE 87.2. Immunoglobulin genes and their chromosomal organization. The number of subunits of each type (V, D, or J) is noted in parentheses as follows: total number of subunits/number of subunits in physiologic use.

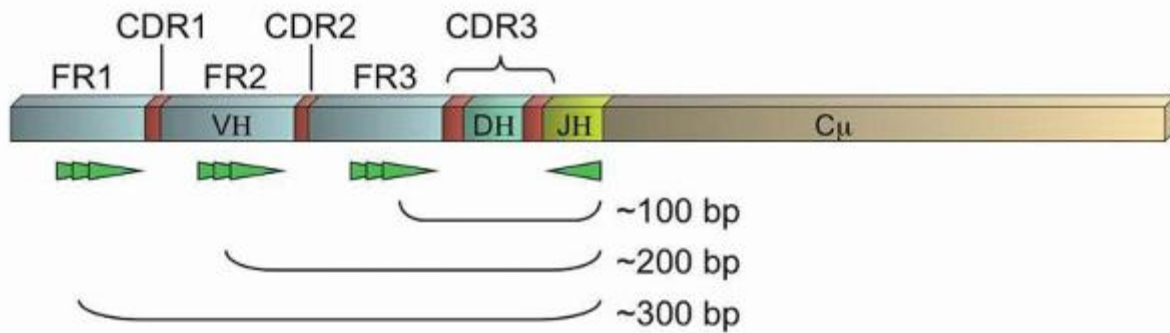

FIGURE 87.3. Schematic of an immunoglobulin gene rearrangement. Shown are the framework regions (FR1-3, light blue), complementary determining regions (CDRs, red; note CDR3 is composed of the DH region and the flanking variable junctions created by random exonuclease activity and N and P nucleotide insertions), and representations of potential locations of primers in the FRs noted (bright green). General sizes of polymerase chain reaction (PCR) products are indicated.

PCR primers may be constructed against any of the three framework regions. Although more variability is theoretically captured by using FR1 primers, the PCR products are longer and therefore more difficult to obtain using standard methods (Fig. 87.3). Therefore, many labs use only FR3 primers (coupled with J region primers), or a combination of FR3 and FR2 primers. However, somatic hypermutation (SHM), a process that occurs physiologically in the germinal centers of lymphoid tissues when a B-cell is exposed to antigen, can cause sequence changes in both the CDRs and the FRs.^{7,13} This normal physiologic process can prevent the binding of individual primers should a mutation occur in the targeted “consensus” sequence. Thus, SHM limits the clinical sensitivity of limited sets of primers to detect clonal populations of B-cells (e.g., some clones may not be detected by PCR due to failure of the consensus primers to bind to that clone's specific sequence). However, several commercial kits are now available that utilize multiplexed sets of primers against all the FRs, in the hopes that at least one primer will have an intact unmutated sequence to permit amplification of the unique PCR product.^{14,15,16,17} In addition, primers against IGK@ and IGL@ can also be utilized, although the PCR products do not form a well-dispersed Gaussian distribution as in the case of the IGH@ assay, complicating their interpretation.¹⁶

Table 87.1 shows the range of clinical detection rates (clinical sensitivity) of multiplexed IGH@ PCR assays compiled from several published papers.^{14,15,17} These data clearly demonstrate the high clinical detection rates for neoplasms of pre-

germinal center B-cells (pre-GCB). However, the gene rearrangement assays have a lower clinical sensitivity for neoplasms of post-GCB-cells and particularly of germinal center lesions, during which active SHM may be ongoing, resulting in very low detection rates.^{7,18} IGK@ or IGL@ assays can be used if the IGH@ assay fails to detect a clonal rearrangement for a known neoplastic B-cell process. Therefore, combinations of primers of all three frameworks of IGH@ and for IGK@ are required to ensure reasonable clinical sensitivity across all B-cell neoplasms.^{14,15,17} On the other hand, the detection of an apparently clonal population does not equate with neoplasia, as pseudoclonality can be seen in reactive conditions with a strong reaction to a particular antigen, or in cases of a limited B-cell repertoire.

Analytical sensitivity of the IGH@ PCR assay depends upon the number of polyclonal background B-cells. In cases of limited background B-cells, the neoplastic clone can be detected at 1 cell in 100 nonneoplastic (and non-B lineage) cells, or approximately 1%. However, in cases of significant numbers of background polyclonal B-cells, the detection of a clonal peak rising above the Gaussian distribution of background B-cell rearrangements can be as low as roughly 5% analytical sensitivity (Fig. 87.4). The analytical sensitivity can be increased by the design of allele-specific oligonucleotide primers. However, this technique requires sequencing of the patient's specific clonal Ig rearrangement. With the advent of rapid sequencing methods, this may become more practical in the future. However, recently next generation sequencing itself has been developed as a method to determine clonality and to monitor MRD.^{18a}

T-cell Gene Rearrangements

The TCR is a heterodimer of two proteins that form the functional receptor, either $\alpha\beta$ or $\gamma\delta$. During T-cell ontogeny, the γ (TRG@) and δ (TRD@) genes rearrange first, so that the $\gamma\delta$ receptor is the first to be expressed. Subsequently the α (TRA@) and β (TRB@) genes rearrange, and ultimately 85% to 98% of mature peripheral T-cells express the $\alpha\beta$ receptor.^{19,20} It is interesting that the location of these genes is such that the δ locus is actually embedded within the α gene on chromosome 14q11 (Fig. 87.5). Thus, in the vast majority of the cases, the subsequent rearrangement of the α gene results in excision of the δ gene from the cell's DNA, and any previously rearranged sequences are lost. However, the β and γ loci, although both on chromosome 7, are distinct (7q34 and 7p15, respectively), and the rearrangement of the γ loci is retained, even if the cell ultimately expresses the $\alpha\beta$ T-cell receptor.

Like the immunoglobulin genes, the TCR genes are composed of V, D (β and δ genes only), J, and C regions (Fig. 87.5). However, unlike the immunoglobulin genes, there are no specific framework regions, and therefore consensus primers are difficult to design for the various V regions. Therefore, with the exception of homology between a few of the V regions, separate V region primers are required to assess all physiologically

P.1804

relevant TCR gene rearrangements. Due to the location of the α gene within the δ gene which limits its utility, the limited number of γ gene V regions (only V γ 1-11 are physiologically relevant of the 15 V γ segments),²¹ and the homology between the V γ segments 1 to 8 which allows the use of a common primer for those segments, typically TRG@ is the common target of most clinical assays, with or without the addition of TRB@ assessment as well.

TABLE 87.1 CLINICAL SENSITIVITIES OF THE IMMUNOGLOBULIN GENE REARRANGEMENT STUDIES^{14,15,17}

Method	MCL	CLL	FL	DLBCL	MZL
IGH@ FR1	100	95-100	30-73	50-68	48-73
IGH@ FR2	98-100	91-100	30-76	58-61	66-85
IGH@ FR3	96-100	93-100	13-52	50	62-68
IGH@ FR1-3	100	100	37-84	79-88	86-88
IGK@	75-94	96-100	60-63	58-61	62-68
IGK@de	50-75	61-67	57-59	46-58	48-54
all IGK@	100	100	80-84	75-80	69-83
IGL@	44-75	30-44	21-23	8-28	28-29
IGH@ FR1-3 and all IGK@	100	100	100	96-98	95-100

CLL, chronic lymphocytic leukemia; DLBCL, diffuse large B-cell lymphoma; FL, follicular

lymphoma; IGH@, immunoglobulin heavy chain; IGK@, immunoglobulin kappa locus; IGL@, immunoglobulin lambda locus; MCL, mantle cell lymphoma; MZL, Marginal Zone Lymphoma

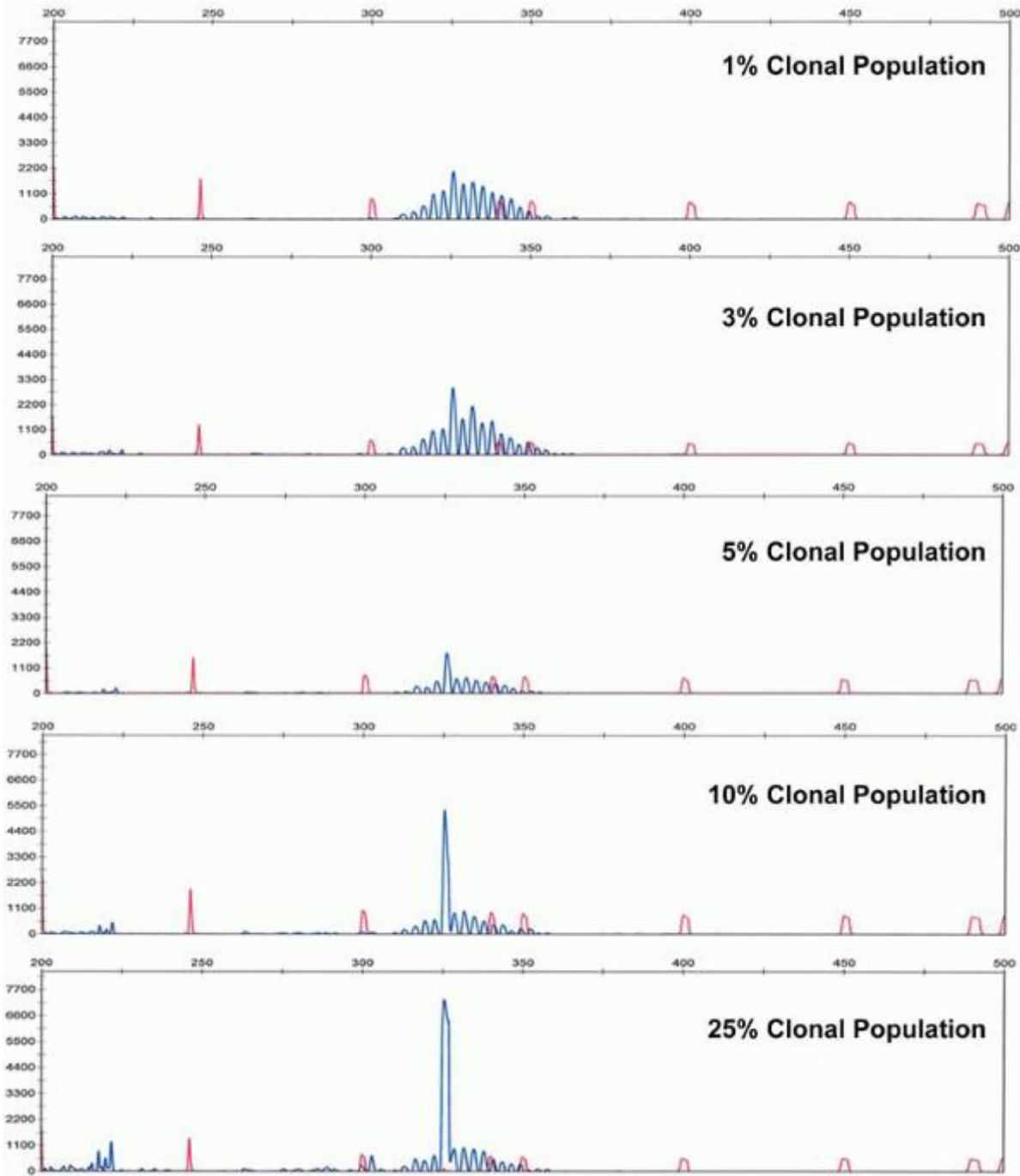

FIGURE 87.4. Analytical sensitivity of immunoglobulin gene rearrangement studies as illustrated by dilutions of a clonal population into a polyclonal background.

P.1805

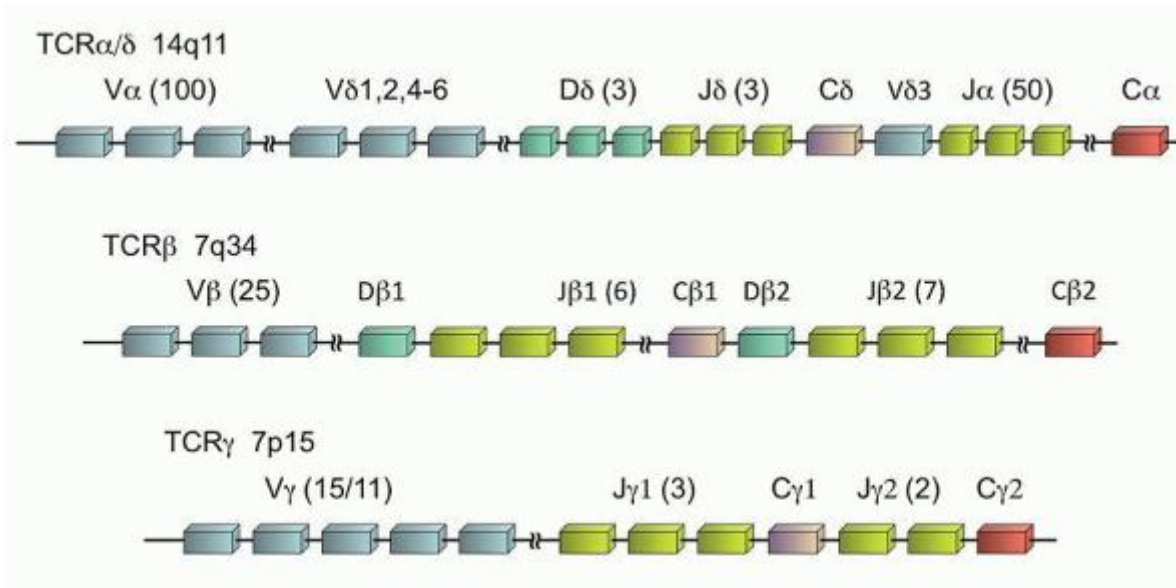

FIGURE 87.5. T-cell receptor genes. The number of subunits of each type (V, D, or J) is noted in parentheses as follows: total number of subunits/number of subunits in physiologic use.

The clinical sensitivity of the TRG@ assay is higher than for the corresponding Ig assay due to the absence of SHM of the TCR. However, the assay still does not detect 100% of all neoplastic rearrangements due to other acquired mutations, and the true clinical sensitivity is approximately 89% to 94%.^{15,17,22} In cases of a known neoplastic T-cell process, TRB@ assay can also be used to look for a clonal marker of disease. The analytical sensitivity of the TCR clonality assays is similar to that of the immunoglobulin assays, although for biologic reasons limited T-cell repertoires can often lead to pseudo-clonality or oligoclonality in certain tissues (such as skin), making it easy to overcall or undercall TCR clonality results. Therefore, the presence of an apparently clonal population does not equate with neoplasia, and the absence of a clonal population does not exclude a neoplastic process. Next generation sequencing methods have also been developed for diagnostic and MRD purposes for the assessment of T cell clonality.^{18a}

Southern Blot

As alluded to earlier, SB is the gold standard, albeit outdated, method for all clonality testing and has been used to test for various translocations or other chromosomal aberrations as well. First introduced in 1975, this technique uses unamplified genomic DNA from the sample which is fragmented using restriction enzymes.²³ These cleavage products are separated by size via agarose gel electrophoresis and then transferred or "blotted" to a nitrocellulose membrane. The membrane is then treated with typically radiolabeled probes that are complementary to a particular sequence of interest. The radiolabel provides signal amplification at the final detection stage that affords an analytical sensitivity of approximately 2% to 3% tumor cells of the sample cellularity.

This method is extremely time consuming, labor intensive, and requires numerous precautions for the handling and disposal of radioactivity. For these reasons, SB has been replaced in most clinical laboratories by methods based upon PCR.

Polymerase Chain Reaction

PCR is a commonly used method for template amplification due to its ease, versatility, and analytical sensitivity. The achievable levels of amplification are such that as few as 1 neoplastic cell can be detected out of 10^5 to 10^7 cells (0.001% to 0.00001% analytical sensitivity). Amplification also permits the use of this assay in small sample volumes. In addition, if the size of the amplicon (product of the PCR reaction) is small, even partially sheared DNA, such as that obtained from formalin fixed paraffin-embedded tissue, is adequate for the assay. The high sensitivity of the assay also makes it ideal for the detection of MRD.

In this assay, forward and reverse primers (typically 15 to 25 bp in length) are generated against the target region. These primers may be specific for a mutated versus a wild-type sequence or may flank the area of interest (especially flanking areas of small insertions or deletions, or flanking a translocation site). Using a specific temperature-resistant polymerase (Taq polymerase) that allows repeated cycles of strand melting (separation of double-stranded DNA), primer annealing, and polymerase-mediated extension of the primers based upon the target sequence, the targeted region in DNA can be

doubled per cycle. If compatible conditions can be designed for multiple sets of primers, the PCR assay can be multiplexed. The template can consist of genomic DNA, or mRNA that has been reverse transcribed into clonal DNA (cDNA).

PCR products, or amplicons, can be detected in several different ways. Qualitative detection methods include agarose gel electrophoresis and capillary electrophoresis, both of which allow the separation of amplicons by size. In the latter method, fluorescently tagged primers are used, which allows separation of the amplicons along the capillary tube and detection using a fluorescent camera as the separated products exit the tube. By using multiple different fluorophores on each primer set, even multiplexed assays can be analyzed by this method.

Quantitative detection methods can also be used, typically involving some version of quantitative real-time PCR (q-PCR). In this technique, fluorescence is directly proportional to the amount of amplicon generated. This fluorescence can be generated after the amplification is completed by the intercalation of a fluorescent dye, such as SYBR green, or can be continuously generated during each cycle of amplification by the release of fluorescence during the extension step (e.g., Taqman probes). Using pre-made dilutions of the desired amplicon to generate a standard curve, direct quantitation of the amount of the target in the sample can be made.

Fluorescent In Situ Hybridization

FISH is another molecular method of interrogating genomic aberrations. FISH utilizes longer probes than PCR (typically 200 to 400 bp in length) which bind in a complementary sequencespecific fashion to the intact chromatin of interphase cells.²⁴ FISH is commonly used to identify balanced translocations, and can also identify copy number variations (CNVs) of large segments of chromatin. In the former case, by using probes directed against the translocation partners, each labeled with a different fluorophores, the presence of a translocation is marked by fusion of the two signals (Fig. 87.6). FISH can also be used in cases where the translocation partner is unknown by the use of breakapart probes, probes located adjacent to each other on either side of the putative breakpoint in the one known translocation partner,

P.1806

which appear as a fused signal when the gene is intact, and separate signals when a translocation occurs.

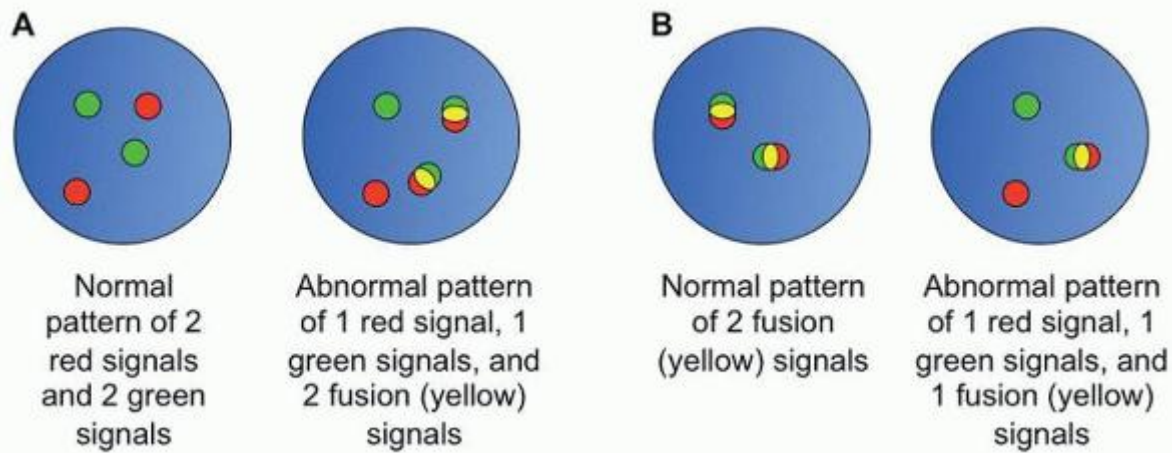

FIGURE 87.6. Examples of FISH patterns. A: Schematic of dual color dual fusion fluorescent in situ hybridization (FISH) probes. B: Schematic of breakapart FISH probes.

This method, like that of PCR methods, is necessarily targeted and therefore biased by the subjective nature of which probes are selected for study (Table 87.2). Unlike PCR, FISH has low resolution of the sites of aberrancy, in the range of 2 to 5 kb (kilobase pairs).²⁴ The analytical sensitivity depends upon the nature of the probes utilized in the assay and the number of interphases assessed. However, typical analytical sensitivities range from 1% to 5% for 200 interphase cells evaluated. Nevertheless, FISH remains a mainstay in the identification of genetic aberrances in lymphoid lesions due to the variety of breakpoints and translocation partners in these malignancies which often limit the use of the highly targeted PCR methods.

Metaphase Cytogenetics

Conventional karyotyping, based upon metaphase cytogenetics (MC), is a mainstay in hematopathology due to its unbiased and uniform genomewide coverage (Table 87.2). Due to the requirement to culture the cells in order to obtain metaphase spreads and the time-consuming microscopy to generate the karyotypes, the method takes typically at least 2 days. In addition, terminally differentiated cells, such as mature lymphocytes and plasma cells, do not readily undergo mitosis, and therefore standard methods often fail to identify the neoplastic karyotype of most lymphoid neoplasms.^{25,26}

TABLE 87.2 CHARACTERISTICS OF DIFFERENT GENOMEWIDE STUDIES

Method	Resolution	Genome Coverage	Sensitivity	Detection of UPD and CN LOH	Detection of Balanced Translocations	Detection of Unbalanced Translocations	Utility in Screening New Lesions	Distinguish Individual Clones	Utilize Interphase DNA	Distinguish Somatic Versus Germline Aberrations
aCGH	5-6 kb	Uniform	2-30%	No	No	Yes	Yes	No	Yes	Yes
aSNP	25-50 kb	Not Uniform	2-30%	Yes	No	No	Yes	No	Yes	No
Conventional karyotyping	5-10 Mb	Uniform	10% ^a	No	Yes	Yes	Yes	Yes	No	No/Yes
FISH	2-5 kb	Targeted	1-5%	No	Yes	No	No	Yes	Yes	No/Yes
PCR	Potentially single nucleotide aberrations	Targeted	Variable, potentially as low as 0.00001%	No	Possible	Possible	Yes	No	Yes	Possible
NGS	Potentially single nucleotide aberrations	uniform or targeted	5-10%	Possible	Possible	Possible	Yes	No	Yes	Possible

aCGH, array comparative genomic hybridization; aSNP, array single nucleotide polymorphisms; CN LOH, copy neutral loss of heterozygosity; FISH, fluorescent in situ hybridization; NGS, next generation sequencing; PCR, polymerase chain reaction; UPD, uniparental disomy.

^a Clonality is typically defined as involving at least 2 of 20 metaphases.²⁸ For PCR and NGS methods, depending on the design of the assay/experiment, different questions may be answered. For instance, if normal and tumor tissues are examined for a particular mutation, somatic versus germline mutational

status can be ascertained by PCR.

Portions adapted from Reference 27.

The resolution of MC is low, 5 to 10 Mb (megabase pairs).²⁷ In addition, due to the need to construct the individual karyotypes manually, even with the aid of computers, typically only 20 metaphases are examined, and the analytical sensitivity is therefore only approximately 10% (for balanced translocations, 2 of 20 metaphases must demonstrate the same abnormality for it to be considered a clonal change, and 3 metaphases must demonstrate the same CNV for it to be considered clonal).²⁸ Thus, this methodology is of limited utility in MRD testing and often is not helpful for lymphoid neoplasms with routine culture conditions.

Other Techniques

Somatic Hypermutation

SHM testing can be used both to identify clonal rearrangements of the IGH@ gene and to calculate the percent of nucleotides that have undergone SHM in the V regions of IGH@. This assay has been used to understand the biology of many B-cell neoplasms. However, its main clinical utility has been in the determination of the mutational status in chronic lymphocytic leukemia/small

P.1807

lymphocytic lymphoma (CLL/SLL). Typically a cutoff of 98% homology to germline is used to determine the mutational status, with greater than 98% homology corresponding to the unmutated designation, which carries a poor prognosis in CLL, and less than or equal to 98% homology describing a somatically hypermutated state, which is associated with a better prognosis in CLL.^{29,30}

PCR using typically FR1 primers or leader primers (primers located in the leader region upstream from FR1) are used in conjunction with partner J_H primers. PCR can be performed on either genomic DNA (gDNA) or cDNA. Many laboratories report both results which typically are very similar, although each input type has its distinct advantages. Utilization of gDNA is the easiest to perform inasmuch as it involves the isolation of the more stable DNA from the samples (compared to labile RNA required for the preparation of cDNA) and avoids a requisite reverse transcription step. However, cDNA is better for the identification of function rearrangements as well as double in-frame small insertions and deletions (indels). In addition, it is better at defining the Ig isotype. After PCR, the amplicons can then be directly sequenced using labeled sequencing primers by capillary electrophoresis, or can be cloned into a plasmid and then sequenced following colony expansion and plasmid extraction. The latter method is required if there is significant background amplification (background polyclonal B-cells), but is quite time consuming and labor intensive.

Array Comparative Genomic Hybridization and Array Single Nucleotide Polymorphism

CGH was initially developed as a method to identify CNVs in patient tissues. The methodology is based upon the differential labeling of patient and control DNA, followed by competitively hybridizing those labeled samples to metaphase spreads. Areas of deletions would be seen as regions with a predominance of the control DNA fluorophore, whereas areas of duplications show a predominance of the patient DNA fluorophore. Due to the limitations of metaphase spreads, the array format was developed to contain an array of probes that span the genome (Fig. 87.7). The probes for array comparative genomic hybridization (aCGH) can be obtained from bacterial artificial chromosome (BAC)-derived sequences, cDNA, or from oligonucleotides. Using this method, CNVs and unbalanced translocations can be interrogated uniformly throughout the genome at a resolution as low as 5 to 6 kb (kilobase pairs) in some cases (Table 87.2).^{27,31,32} The analytical sensitivity varies from 2% to 30% sensitivity.

By contrast, aSNP (array single nucleotide polymorphisms) is a single-color experiment that hybridizes labeled patient DNA or amplicons to an array composed of probes that are sequence-specific to interrogate individual SNPs. Because these are designed to target specific SNPs at their nonrandom genomic locations, the genome coverage is not uniform and this method is not useful in identifying balanced translocations or in distinguishing germline from somatic changes.^{27,32} However, aSNP is especially useful in the identification of copy neutral loss of heterozygosity and uniparental disomy that are not assessed by aCGH. Analytical sensitivities are similar to those for aCGH. To leverage the advantages of both aSNP and aCGH, many commercial platforms are now available that combine the two array methods.

Due to the challenges of obtaining metaphases in lymphoid neoplasms, aCGH was rapidly applied to the study of chronic lymphocytic leukemia (CLL), for which disease aCGH can identify clonal abnormalities in 100% of cases.²⁶ For comparison

with FISH and metaphase cytogenetics, other studies have demonstrated the ability of aCGH to detect abnormalities in 12% of normal karyotype CLL cases²⁶ and in 21% of cases where no aberration was detected by FISH.³³

Metaphases are also difficult to obtain in plasma cell neoplasms, leading to the prominent role of FISH in the diagnosis and prognosis of myeloma. However, because FISH is targeted, it cannot provide an unbiased genomewide assessment as can be achieved by aCGH. Gutierrez et al. found CNVs by aCGH in 69% of myeloma patients and that those patients had significantly decreased overall survival.³⁴ The prognostic significance of other specific loci, which include gains of 1q and 7q, have also been studied using aCGH.^{35,36} The latter study also highlighted the utility of this method in paraffin-embedded tissue.

Next Generation Sequencing

Whole genome sequencing (WGS) provides the theoretically optimal combination of uniform unbiased genomewide coverage with nucleotide-level resolution for the discovery of acquired genetic aberrations in oncology (Table 87.2). The caveats, of course, center upon the cost and analysis of the potentially terabytes of data accumulated by a single WGS analysis. Prior to 2005, nearly all DNA sequencing was performed using some variant of Sanger sequencing, a method by which sequencing was achieved by chain termination first described in 1977.³⁷ These Sanger-based methods typically required large quantities of input DNA since the DNA needed to serve as the template for at least as many polymerase extension reactions as nucleotides to be sequenced. The polymerase products are separated by size to determine the sequence. This traditional sequencing is plagued by poor quality of the initial 15 to 40 bases of the sequence, and read lengths are limited to 500 to 1,000 bases.³⁸

All NGS methodologies are based on read-through sequence determination, or sequence by synthesis, rather than chain-termination technology, and the sequencing is conducted in a massively parallel fashion (Fig. 87.8).^{38,39} Sheared DNA, the

P.1808

template, is immobilized in spatially fixed and arrayed positions by a variety of means and then iteratively interrogated by the repeated addition of each of the 4 nucleotides. Several methods of detection are utilized by the various commercial platforms. Illumina and Helicos BioSciences both use dye-labeled nucleotides which are reversible chain terminators; i.e., after detection of addition of a labeled nucleotide, the chain termination is chemically reversed before the next nucleotide is added (Fig. 87.7). Roche's pyrosequencing-based technology and Ion Torrent's semiconductor-based platform are both based upon the detection of the release of pyrophosphate or H⁺ ion, respectively, which are chemically produced each time a nucleotide is added by the polymerase. Applied Biosystem's SOLiD™ platform uses a library of probes which encompasses all combinations of a dinucleotide sequence that are iteratively added through ligation to the growing strand.

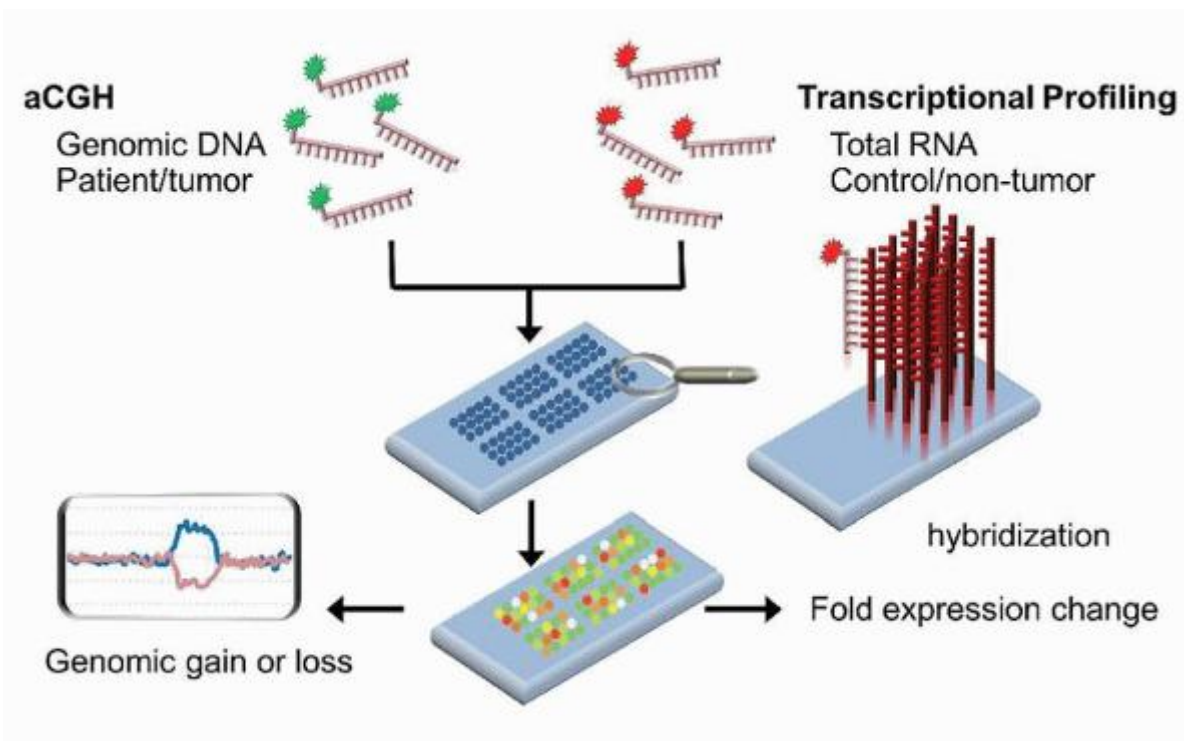

FIGURE 87.7. Schematic of array comparative hybridization (aCGH) and transcriptional profiling using a dual-channel platform. Patient and control genomic DNA (aCGH) or RNA (transcriptional profiling) are differentially labeled with fluorophores, then stoichiometrically mixed and allowed to hybridize to probes fixed to a solid surface. The relative amounts of fluorescence at each feature is measured to gain information about gains or losses in the patient sample compared to control (aCGH) or about over- or underexpression of genes (transcriptional profiling).

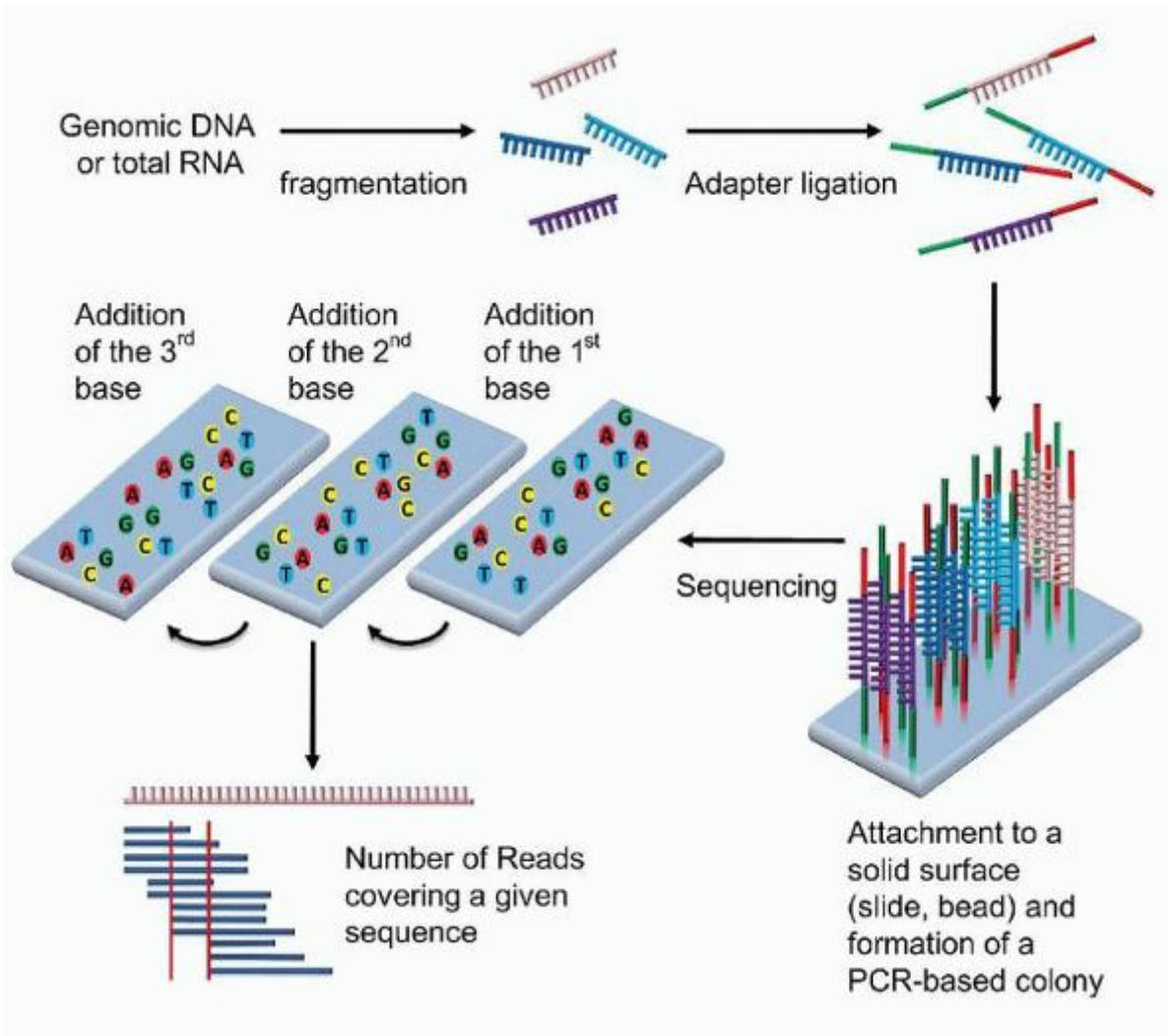

FIGURE 87.8. Schematic of next generation sequencing using dye-labeled nucleotides which act as reversible chain terminators. The DNA is first sheared and modified with adaptors. These adaptors can be used to immobilize the DNA fragments and serve as primers for polymerase chain reaction (PCR) amplification and for sequencing using the reversible chain terminators. The sequence of each fragment is determined, followed by the computational alignment of the fragments to construct the genomic sequence.

Although the first human genome project took approximately 13 years and cost nearly 3 billion dollars to complete through Sanger-based methods, the advent of NGS has dramatically changed the landscape.⁴⁰ Today, a full genome can be sequenced at a cost of \$1 to \$5000 and take less than a day.³⁸ The read length for NGS is significantly shorter than for Sanger sequencing, often 30 to 400 bp. Therefore, the ability to map these sequences back to the genome requires significant overlap of the reads, from tens to even millions of reads per nucleotide. The higher number of reads are required to detect even small insertions and deletions or translocations. The analytical sensitivity for typical NGS can approach 5% tumor cells in a background of nonneoplastic cells.⁴¹ However, newer deep sequencing methods have been adapted for MRD testing. Using very high read depths, sensitivities of 0.0001% can be achieved.^{18a}

WGS can encompass vast amounts of data, however. For example the roughly 3 Gb (gigabase pairs) of the human genome at only 30 reads per nucleotide results in 90 Gb of data. However, by targeting the sequencing to a smaller portion of the genome, the data generated can be significantly decreased. Therefore, methods have been developed to conduct whole exome sequencing (WES), targeted WES, transcriptome sequencing (RNA-seq), sequencing of DNA methylation sites (bisulfite seq), mirnome sequencing (miRNA-seq), sequencing of immunoprecipitated DNA (ChIP-seq), and many others.³⁸ Targeting 500 kb at 100 reads generates only 50 Mb of data. Many of these targeted platforms can essentially perform expression profiling by sequencing.

Transcriptional Profiling

Initially developed in the 1980s, transcriptional profiling was the first omic technology to see widespread utilization. This methodology enables the assessment of the transcriptome, the sum of expressed genes reflected in the mRNA population of the cell(s). Since the 1990s, a number of high-density commercial microarray platforms, in addition to the numerous academic methods, have been available, differing in their amplification methods, types of probes, probe content, probe design, probe adherence technologies, and labeling and hybridization methods.⁴² The two main types of DNA microarrays that have dominated the field involved probes made from either cDNA libraries or oligonucleotides, although the majority of the commercial platforms now use oligonucleotide probes. Transcriptional profiling can be performed as either a single-channel or a dual-channel experiment (Fig. 87.7).

This methodology does not capture the protein expression of various genes and any post-translational modifications. In addition, when the mRNA levels are varied between two samples, it is impossible to determine in a single timepoint comparison whether the differences are due to primary changes at the DNA mutational level, primary changes at the transcriptional level, or secondary changes at the transcriptional level resulting from the true disease-causing aberration. Therefore, the results are largely phenomenologic until extensive research is conducted to deconvolute the true disease-causing aberrancy. In addition, the methodology has limited analytical sensitivity for small fold changes, and limited clinical sensitivity if the reference samples are not chosen wisely. This methodology may be falling into disuse with the advent of NGS.

Nonetheless, transcriptional profiling has led to significant discoveries in lymphoid malignancies. One main utility has been in the definition of prognostic subgroups. For example, its use in the study of SHM status in CLL led to the identification of ZAP70 expression as an independent poor prognostic marker.⁴³ Similarly, in DLBCL, transcriptional profiling has identified three widely used prognostic subgroups: GCB-like with better prognosis, and activated B-cell (ABC) and type 3 DLBCL, which does not

P.1809

express either set of genes at a high level, the latter two subgroups with poorer prognosis.⁴⁴

Gene expression profiling studies have also been useful in clarifying the biologic relationships between various hematolymphoid neoplasms. Studies have demonstrated, for example, the similarities at the transcriptional level between primary mediastinal large B-cell lymphoma (PMBL) and classical Hodgkin lymphoma (cHL)-derived cell lines,⁴⁵ or between anaplastic large cell lymphoma (ALCL) and cHL.⁴⁶

MicroRNAs, Epigenetic Changes

MicroRNAs

Both plants and animals have evolved microRNAs (miRNAs), single-stranded RNAs of ~21 nucleotides, as a mechanism for translational regulation. These miRNAs are encoded in the genome and are transcribed by DNA polymerase II. Following processing in both the nucleus and cytoplasm, the mature miRNA, mediated by the RNA-induced silencing complex, binds in a complementary fashion to the 3'untranslated regions (3'-UTR) of target mRNAs to cause translational repression.

Physiologically, miRNAs play a key role in the development and identity of different cell types.^{47,48} The pattern of transcription of miRNAs during ontogeny is tightly regulated.^{49,50} Additionally, miRNAs expression patterns are also associated with specific cell types at a given stage of development. For example, differentiation of the hematopoietic lineages involves carefully co-ordinated changes of expressed miRNAs.^{51,52} In addition, to their roles in differentiation, whether at the organism or cellular level, miRNAs are important in cell identity.⁵³ Thus, miRNAs, individually or in profiles, can be markers of tissue type.

Due to their roles in cell identity and differentiation, miRNAs have been investigated in numerous tumor types. Interestingly, the location of all miRNAs in the human genome is nonrandom. It has been demonstrated that miRNAs are concentrated by a factor of nine in genomic fragile sites and others that are commonly altered in cancer.⁴⁸ Thus, over one-half of 186 miRNAs evaluated in one study were located at cancer-associated genomic regions, such as regions of loss of heterozygosity, common breakpoints and areas of amplification. These findings suggest that aberrant miRNA expression might be a common pathway in oncogenesis.

For example, the commonly deleted region in CLL (13q14) contains two miRNAs, miR-15a and miR-16-1.^{56,54,55} These are consequently down-regulated in CLL, resulting in overexpression of their target mRNAs, BCL2 and MCL1, and an overall antiapoptotic effect.⁵⁶ By contrast, miR-155 has been identified as up-regulated in a number of B-cell lymphomas. First identified in cases of childhood BL, expression of the pre-miRNA for miR-155 was found to be up-regulated in BL, DLBCL (associated with the ABC subtype), CLL, and marginal zone lymphoma.^{57, 58} and ^{59,60,61} The miRNA polycistron miR-17-92,

located at 13q31, is also implicated in lymphomas such DLBCL, FL, mantle cell lymphoma (MCL), and primary cutaneous B-cell lymphoma, among others.⁶²

Using miRNA RT-PCR, microarrays, and NGS methods, miRNA expression patterns have been interrogated and represent an unfolding field of lymphoma research. The future may see these miRNAs as the target of diagnostic, prognostic, or even therapy monitoring assays.

Epigenetics

Epigenetics involves the heritable alterations in gene expression that are not caused by actual changes in the genomic sequence. Epigenetic changes occur through one of two main pathways. Methylation of the 5-position of cytosines, particularly in CpG rich sites such as CpG islands, shores, and shelves, results in transcriptional repression. CpG islands are defined as regions >500 bp in length with a CG percentage >55% and an observed to expected CpG ratio of >65%.^{63,64} Alternatively, post-translational modification of the amino acids of histones via methylation or acetylation can result in heritable changes in histone structure and therefore the accessibility of the DNA to transcription. DNA methylation has been the better-examined epigenetic mechanism of the two, and methylome studies can be conducted via NGS, methylation arrays, and targeted methylation methods.

All methods to interrogate methylation status depend upon one of three main techniques.^{65,66,67} Isoschizomer restriction enzyme based methods rely upon the selective cleavage of either methylated or unmethylated sequences by specific restriction enzymes. A second method uses the chemistry of bisulfite to convert unmethylated cytosine to uracil, thereby causing a sequence change in unmethylated CpG sites but not in methylated sites. These differences can then be identified via sequencing or sequence specific hybridization methods. Lastly, proteins that selectively bind to methylated CpG sites, whether the naturally occurring methylation binding protein or antibodies generated against CpG sites, can be used to pull down methylated fragments of DNA. All three techniques can be used to prepare samples for sequencing, arrays, or more targeted methods.

RECURRENT MOLECULAR ABERRANCIES IN B-CELL AND T-CELL NEOPLASMS

Tables 87.3 and 87.4 list many of the common reciprocal translocations found in B-cell and T-cell malignancies, respectively. Of note, many of the reciprocal translocations involve one of the immunoglobulin genes in the case of B-cell lymphomas (most commonly IGH@ on chromosome 14q32). A smaller proportion of T-cell lymphomas involve the TCR α/δ locus on chromosome 14q11. The ensuing text highlights some of the better known translocations, and discusses selected other molecular aberrancies identified in specific lymphoid neoplasms.

Mature Neoplasms of B-cells

Burkitt Lymphoma

BL is a highly aggressive B-cell neoplasm that can have a lymphomatous, leukemic, or combined presentation, although these forms are not biologically distinct. However, there are three subtypes of BL that appear to have different epidemiologic and molecular bases, while related by their common dependence upon MYC dysregulation.⁴ The endemic variant of BL is prevalent in equatorial Africa, tending to occur in young children between the ages of 4 and 7, with involvement of the mandible, maxilla, other facial bones, and abdomen.⁵ There is an association of this form of BL with Epstein-Barr virus (EBV) which is also endemic to that geographic region, and approximately 95% of endemic BL contains clonal EBV DNA. Sporadic BL is found predominantly in adolescents and young adults of Western countries, and is the most common form of childhood lymphoma in the United States. In these cases, the disease is predominately abdominal with less frequent association with EBV in 5% to 30% of cases.^{4,9,68} Immunodeficiency-associated BL is the third biologic subtype, where the most common association is with human immunodeficiency virus (HIV), although this form of BL can be seen secondary to other causes of immunodeficiency, both primary and secondary in nature. In approximately 25% to 40% of cases, there is an association with clonal EBV as well.^{69,70}

Translocations of the MYC gene characterize BL as well as a subset of aggressive DLBCLs, many of which are currently best classified as B-cell lymphoma, unclassifiable, with features intermediate between DLBCL and BL. Thus, although essentially all BLs have some form of a MYC translocation, a MYC translocation is not specific to BL.

P.1810

TABLE 87.3 COMMON CHROMOSOMAL TRANSLOCATIONS IN B-CELL NHL

Translocation	Product	Disease Association
t(1;14)(p22;q32)	<i>BCL10</i> overexpression (<i>IGH@</i>)	MALT ^a
t(1;14)(q21;q32)	<i>BCL9</i> overexpression (<i>IGH@</i>)	B-LBL and others
t(1;14)(q21;q32)	<i>FCRL4/5</i> overexpression (<i>IGH@</i>)	Myeloma (<5%)
t(1;14)(q22;q32)	<i>MUC1</i> overexpression (<i>IGH@</i>)	DLBCL
t(1;22)(q23;q11)	<i>FCGR2B</i> overexpression (<i>IGL@</i>)	Transformed FL
t(2;7)(p12;q21-q22)	<i>CDK6</i>	SMZL
t(2;14)(p16.1;q32)	<i>BCL11A</i> overexpression (<i>IGH@</i>)	CLL, DLBCL
t(3;14)(q27;q32)/t(3;v)(q27;v)	<i>BCL6</i> overexpression (<i>IGH@</i> or <i>IGK@/IGL@</i>)	DLBCL (5-10%) and others
t(3;14)(p14;q32)	<i>FOXP1</i> overexpression(<i>IGH@</i>)	MALT
t(4;14)(p16;q32)	<i>WHSC1 (MMSET)/FGFR3</i> overexpression (<i>IGH@</i>)	Myeloma (20-25%)
t(5;14)(q23-q31;q32)	<i>IL3</i> overexpression (<i>IGH@</i>)	B-LBL
t(6;14)(p25-p23;q32)	<i>IRF4</i> overexpression (<i>IGH@</i>)	Myeloma (~20%)
t(6;14)(p21;q32)	<i>CCND3</i> overexpression (<i>IGH@</i>)	Myeloma (<5%), DLBCL, SMZL, MZL
t(6;14)(p22;q32)	<i>ID4</i> overexpression (<i>IGH@</i>)	B-LBL (<1%)
t(8;14)(q24;q32)/t(8;v)(q24;v)	<i>MYC</i> overexpression (<i>IGH@</i> or <i>IGK@/IGL@</i>)	BL (>98%), DLBCL ^a , FL ^a , PLL, myeloma
t(8;14)(q11;q32)	<i>CEBPD</i> overexpression (<i>IGH@</i>)	B-LBL (<1%)
t(9;14)(p13;q32)	<i>PAX5</i> overexpression (<i>IGH@</i>)	LPL (1-2%), other neoplasms with plasmacytic differentiation, DLBCL
t(10;14)(q24;q32)	<i>NFKB2</i> overexpression (<i>IGH@</i>)	DLBCL
t(11;14)(q13;q32)	<i>CCND1</i> overexpression (<i>IGH@</i>)	MCL (>95%), PLL, SMZL, myeloma ^b (20-25%)
t(11;14)(q23;q32)	<i>PAFAH1B2</i> overexpression (<i>IGH@</i>)	PMBCL
t(11;14)(q23;q32)	<i>DDX6</i> overexpression (<i>IGH@</i>)	DLBCL
t(11;18)(q22;q21)	<i>BIRC3-MALT1</i> fusion	MALT ^a
t(12;14)(q23;q32)	<i>CHST11</i> overexpression (<i>IGH@</i>)	DLBCL, CLL (rare)
t(12;14)(q24;q32)	<i>BCL7A</i>	BL, myeloma
t(12;15)(q32;q11-13)	<i>NBEAP1?</i>	DLBCL
t(12;22)(p13;q11)	<i>CCND2</i>	CLL
t(14;16)(q32;q22-q23)	<i>MAF</i> overexpression (<i>IGH@</i>)	Myeloma (20-25%)
t(14;18)(q32;q21)	<i>BCL2</i> overexpression (<i>IGH@</i>)	FL (~80%), DLBCL (~20%)
t(14;18)(q32;q21)	<i>MALT1</i> overexpression (<i>IGH@</i>)	MALT

t(14;19)(q32;q13)	<i>BCL3</i> overexpression (<i>IGH@</i>)	CLL
t(14;19)(q32;q13)	<i>CEBPA</i> overexpression (<i>IGH@</i>)	B-LBL (<1%)
t(14;20)(q32;q11-q13)	<i>MAFB</i> overexpression (<i>IGH@</i>)	Myeloma

B-LBL, B lymphoblastic leukemia/lymphoma; BL, Burkitt lymphoma; CLL, chronic lymphocytic leukemia; DLBCL, diffuse large B-cell lymphoma; FL, follicular lymphoma; LPL, lymphoplasmacytic lymphoma; MALT, mucosa-associated lymphoid tissue; MCL, mantle cell lymphoma; PLL, prolymphocytic leukemia; PMBCL, primary mediastinal large B-cell lymphoma; SMZL, splenic marginal zone lymphoma

^a Indicates adverse prognostic significance in addition to diagnostic role.

^b Indicates favorable prognostic significance in addition to diagnostic role.

The most common translocation partner of *MYC*, located at 8q24, is the *IGH@* locus on chromosome 14q32. This t(8;14)(q24;q32) can be identified in 80% of all BL and results in the overexpression of *MYC*.^{71,72} The remaining cases of BL place *MYC* under the regulation, not of the heavy chain locus, but under one of the light chains, with a kappa light chain partner in a t(2;8)(p11;q24) and with lambda in t(8;22)(q24;q11).^{73,74} The *MYC* gene is composed of three exons, the first noncoding, and the remaining two coding. *MYC* encodes for a transcription factor involved in both cell proliferation as well as apoptosis (Fig. 87.9). Dysregulated function of *MYC* results in increased cell cycling through its inhibition of p21 and p27 as well its promotion of CDK2 and CDK4.⁷⁵ This is manifest pathologically by the numerous mitoses in BL as well as the extremely high proliferation rate, with Ki-67 expression typically >99%. In addition, *MYC* is proapoptotic, correlating with the numerous apoptotic bodies that create the classic “starry sky” histologic appearance of these tumors.

Although all cases of BL contain a translocation of *MYC*, the different subtypes of BL are molecularly distinct as well.^{76,77,78,79} All the translocations with immunoglobulin genes result in the transcription of the full *MYC* coding sequences. However, the breakpoints of *MYC* and immunoglobulin genes vary among the BL subtypes. In endemic BL, the *MYC* breakpoint is located approximately 300 kb upstream from exon 1. This breakpoint translocates the full *MYC* gene to the *J_H* region of *IGH@*. By contrast, the *MYC* breakpoint in sporadic BL can occur 5' to exon 1 or within intron 1, still translocating the full *MYC* coding region in either scenario to the one of the C regions of *IGH@* (C_μ, C_γ, and C_α have all been documented). In the translocations involving either *IGK@* or *IGL@*, the *MYC* gene typically remains on chromosome 8, with the breakpoint 3' to the third and final coding exon to which the *IGK@* or *IGL@* locus is affixed at either a V or J segment. These differing molecular breakpoints may be related to differences in the stages of B-cell development during which the

P.1811

oncogenic change occurs. The sporadic cases may develop during class switching, whereas endemic cases may occur during SHM.⁹

TABLE 87.4 COMMON CHROMOSOMAL TRANSLOCATIONS IN T-CELL NON-HODGKIN LYMPHOMA

Translocation	Product	Disease Association
t(1;14)(p32;q11)/t(1;7)(p32;q34)	<i>TALI</i> overexpression (<i>TRD@/TRB@</i>)	T-LBL (3%)
t(1;7)(p34;q34)	<i>LCK</i> overexpression(<i>TRB@</i>)	T-LBL (1%)
t(2;5)(p23;q35)	<i>ALK/NPM1</i> fusion	ALCL ^a 84% of ALK+ cases
t(5;14)(q35;q11)	<i>TLX3</i> overexpression (<i>TRD@</i>)	T-LBL (1%)
t(6;7)(q22-q23;q32-36)	<i>MYB</i> overexpression (<i>TRB@</i>)	T-LBL (1%)
t(7;7)(q34;p15)/inv(7)(q35p15)	<i>HOXA</i> cluster overexpression (<i>TRB@</i>)	T-LBL (5%)
t(7;9)(q34;q32)	<i>TAL2</i> overexpression (<i>TRB@</i>)	T-LBL (1%)

t(7;9)(q34;q34)	<i>NOTCH1</i> overexpression (<i>TRB</i> @)	T-LBL (1%)
t(7;12)(q34;p13)	<i>CCND2</i> overexpression (<i>TRB</i> @)	T-LBL (1%)
t(7;19)(q34;p13)	<i>LYL1</i> overexpression (<i>TRB</i> @)	T-LBL (1%)
iso(7q)	product unknown	HSTL ^b >80%
t(8;13)(p12;q11-q12)	<i>FGFR1/ZMYM2</i> fusion	Myeloproliferative neoplasm associated with T-LBL
t(8;14)(q24;q11)	<i>MYC</i> overexpression (<i>TRD</i> @/ <i>TRA</i> @)	T-LBL (1%)
t(10;14)(q24;q11)/t(7;10)(q34;q11)	<i>TLX1</i> overexpression (<i>TRD</i> @/ <i>TRB</i> @)	T-LBL (10-30%)
t(11;14)(p13;q11)/t(7;11)(q34;p13)	<i>LMO2</i> overexpression (<i>TRD</i> @/ <i>TRB</i> @)	T-LBL (3%)
t(11;14)(p15;q11)	<i>LMO1</i> overexpression (<i>TRD</i> @)	T-LBL (2%)
t(14;14)(q11;q32)/inv14(q11q32)	<i>TCL1</i> overexpression (<i>TRD</i> @/ <i>TRA</i> @)	T-PLL (70-75%), T-LBL (<1%)
t(X;14)(q28;q11)	<i>MTCPI</i> overexpression (<i>TRD</i> @/ <i>TRA</i> @)	T-PLL (~5%)

ALCL, anaplastic large cell lymphoma; HSTL, hepatosplenic T-cell lymphoma; T-LBL, T-cell lymphoblastic leukemia/lymphoma; T-PLL, T-prolymphocytic leukemia

^a Indicates favorable prognostic significance in addition to diagnostic role.

^b Indicates adverse prognostic significance in addition to its diagnostic role when extra copies of 7q are identified.

As a result of the wide range of potential breakpoints in both the *MYC* gene and the immunoglobulin genes, PCR-based assays for *MYC* translocations are not practical, although primers have been generated against specific *MYC* breakpoints.⁸⁰ Rather, FISH is the optimal means for detection of *MYC* translocations at diagnosis. Specific probes against both *MYC* and *IGH*@ can be used to assess for the t(8;14)(q24;q32). However these probes will be less sensitive for the variant light chain rearrangements. Therefore, *MYC* breakpart probes provide greater sensitivity for any *MYC* rearrangement, regardless of the immunoglobulin partner.⁸¹

In addition to BL, 5% to 16% of DLBCLs may contain a *MYC* translocation^{82,226} and *MYC* translocations are seen in 35% to 50% of B-cell lymphoma, unclassifiable, with features intermediate between DLBCL and BL.⁴ Therefore, the presence of a *MYC* translocation alone does not define BL in the absence of the appropriate morphologic and immunophenotypic features. In cases where either the morphology or the immunophenotype is not classic for BL, additional FISH studies are recommended to rule out a double- or even triple-hit lymphoma.^{83,84} These include FISH assessment for the *BCL2-IGH*@ translocation t(14;18)(q32;q21) as well as for rearrangements of *BCL6* on chromosome 3q27. In addition, use of *MYC* breakpart probes are critical in these cases as the translocation partner in some cases may involve nonimmunoglobulin-related genes.⁴

Gene expression profiling studies have clearly supported the distinction of BL from DLBCL and the category formerly known as atypical BL (many of which are currently classified as B-cell lymphoma, unclassifiable, with features intermediate between DLBCL and BL).^{85,86} These studies have also highlighted the overexpression of T-cell leukemia 1 (*TCL1*) in BL which appears to be dependent upon the presence of EBV. Other studies have identified significant overexpression of miR-155.^{57,59} In fact, the combinatorial decreases of several miRNAs, including miR-34b, may help explain the overexpression of *MYC* in those cases that appear to lack a *MYC* rearrangement (up to 10% of BL in some studies).^{86,87,88} Another

mechanism to account for these rare cases may be mutations in the MYC gene, although most of these are found in addition to a MYC translocation and may enhance the tumorigenicity of the MYC dysregulation.⁸⁹

Guidelines for Molecular Testing in Burkitt Lymphoma

FISH confirmation of a MYC rearrangement is recommended at diagnosis of BL. However, FISH is not a sensitive marker of MRD. Due to the extensive SHM of BL as a neoplasm of GCBs, PCR-based immunoglobulin gene rearrangement studies have very poor clinical sensitivity, and, in the absence of allele-specific primers, PCR for immunoglobulin gene rearrangements is not superior to FISH in terms of analytical sensitivity. PCR directed against the MYC rearrangement itself sees little practical use due to the low clinical sensitivity. NGS may provide a good means for MRD testing. Therefore, FISH remains the optimal diagnostic test, and there is a limited role for any testing for MRD other than potentially NGS. As mentioned earlier, in cases that do not have the classic morphologic or immunophenotypic profile of BL, additional FISH studies for BCL2 and BCL6 gene rearrangements are also recommended.

Diagnosis

MRD

FISH for MYC

Consider NGS for Ig gene rearrangement studies

Consider FISH for BCL2 and BCL6

Consider NGS for Ig gene rearrangement studies

Follicular Lymphoma

FL accounts for approximately 20% of all lymphomas, and is the second most common B-cell lymphoma, especially prevalent in Western nations.⁴ FL is predominantly a disease of adults and subclassifications are based upon the histologic grade and degree of nodularity. Notable subtypes include primary cutaneous FL, pediatric FL, and FL of specific extranodal sites such as the duodenum or testes.

A BCL2 translocation can be found in approximately 85% to 90% of cases of FL as well as in 20% to 25% of de novo DLBCLs (not transformed from a known prior FL), occasional cases of CLL, and rarely in other lymphomas.^{10,90,91,92} Therefore, although the BCL2 rearrangement is the canonical cytogenetic abnormality associated with FL, it is not pathognomonic for this entity.

P.1812

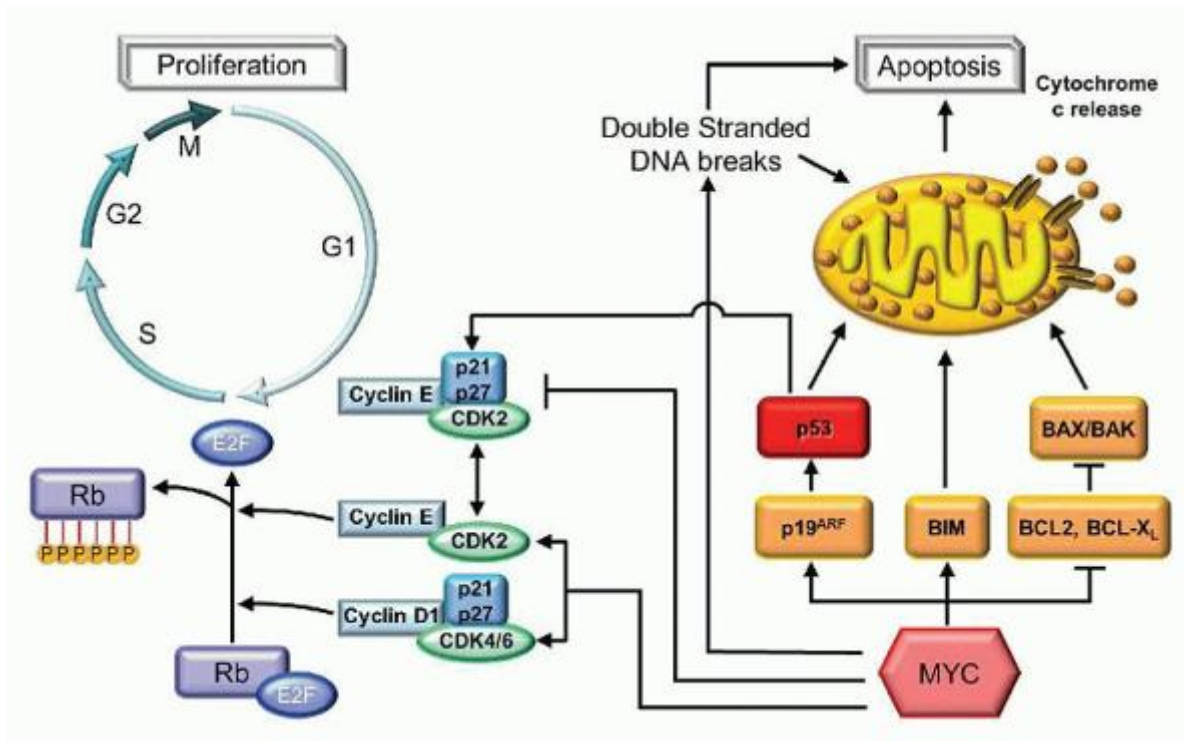

FIGURE 87.9. Apoptosis and proliferation pathways illustrating some of the roles of cyclin D1, MYC, and BCL2. Cyclin D1 associates with the cyclin-dependent kinases, CDK4 and CDK6, to form a complex that hyperphosphorylates the retinoblastoma protein (Rb). When phosphorylated, Rb is unable to sequester and inhibit the function of E2F1 in promoting entry into S phase and promoting cell cycling. MYC inhibits p21 and p27, inhibitors of the cyclin-dependent kinases, and promotes the expression of CDK2 and CDK4. MYC also inhibits several antiapoptotic proteins, such as BCL2. BCL2 forms a heterodimer with BAX, thereby preventing the formation of proapoptotic BAX/BAK homodimers. MYC also promotes the p19ARF activation of p53-mediated apoptosis and cell cycle arrest through p21 and p27.

The t(14;18)(q32,q21) is involved in the pathogenesis of FL, placing the BCL2 gene on 18q21 under the regulation of the IGH@ gene locus at 14q32. The translocation, which appears to be directed by the RSS-mediated VDJ rearrangement process, results in the overexpression of BCL2 which can be determined by immunohistochemical staining (IHC) except in cases when a mutation in BCL2, superimposed on the rearrangement, prevents the antibody from binding.⁹³ BCL2 is a mitochondrial membrane-bound protein that plays a critical role in the prevention of apoptosis (Fig. 87.9). BCL2 forms a heterodimer with BAX, thereby preventing the formation of proapoptotic BAX or BAK homodimers.^{94,95} For GCBs, which should undergo apoptosis in the absence of appropriate nonself antigen stimulation, the overexpression of BCL2 results in the failure of the neoplastic cells to apoptose. This pathogenesis explains the rather indolent behavior of this lymphoma in the absence of additional hits that create a more proliferative drive.

Because FL is a neoplasm of GCBs, ongoing SHM limits the utility of immunoglobulin gene rearrangement molecular assays. Indeed, these assays have a notoriously low clinical sensitivity for FL using a single set of IGH@ FR3 primers, ranging from 13% to 52%.^{14,15,17} This corresponds to the extremely high average frequency of mutations in FL, of 11.6% for IgG clones, 9.9% for IgA clones, and 7.8% for IgM clones.⁹⁶ V_H contains an overall of 11.0% mutations in essentially 100% of cases of FL, where V_K contains a mean mutation rate of only 0.5% in only 33% of cases.⁹⁷ Therefore, the addition of IGK@ primers greatly enhances the clinical sensitivity of the assay for FLs. The IGK@ locus tends to harbor fewer mutations, 4.7% according to one study.⁹⁸ Therefore, by combining multiple immunoglobulin primers against both IGH@ and IGK@, a clonal rearrangement can be identified.^{14,15,17,97} However, without the development of allele-specific primers, any background B-cells can decrease the sensitivity of the detection of the clone to 1% to 5%.

BCL-2, chromosome 18q21

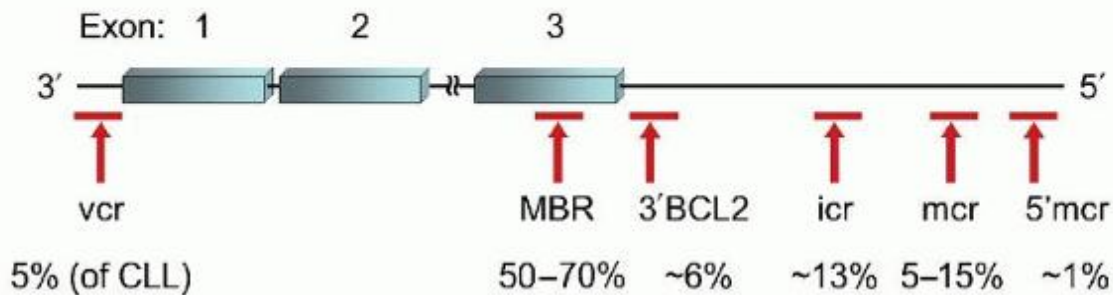

FIGURE 87.10. Location of breakpoint clusters in the BCL2 gene and their relative frequencies in follicular lymphoma and other B-cell neoplasms. MBR, major breakpoint region; mcr, minor cluster region; icr, intermediate cluster region; vcr, variable cluster region.^{99,100}

However, within the BCL2 locus there are several clusters of breakpoints spread out over the entire length of the coding gene and extending to more than 30 kb downstream from the final exon 3 (Fig. 87.10).^{99,100} The majority of the potential breakpoint clusters involve translocation of the full coding sequence of BCL2 to chromosome 14. The major breakpoint region (MBR) is located within the 3'-UTR of exon 3 and accounts for 50% to 70% of potential breakpoints in BCL2. The minor cluster region (mcr) is located 20 to 30 kb farther downstream of exon 3, accounting for 5% to 15% of cases. The most common laboratory practice is to design primers for the MBR and mcr regions separately, using partner primers in the J_H subunit. These two sets of primers are able to detect approximately 70% to 85% of potential rearrangements.¹⁰ However, there are several additional sites within the BCL2 locus that can also be involved in rearrangements with immunoglobulin.^{99,100} The intermediate cluster region (icr) may actually be more prevalent in neoplasms than the mcr, accounting for approximately 13% of translocations. The icr is located between the MBR and the mcr as is the 3' BCL2 cluster which accounts for 6% of cases. The 5' mcr is the farthest downstream breakpoint region, but only accounts for approximately 1% of cases. Lastly, the variable cluster region (vcr) is located 5' to the first exon but is found predominantly

in the rare cases of CLL which harbor a t(14;18) as well as rare cases of FL. The vcr is the only one of the breakpoint regions that occasionally can be involved in translocations involving either IGH@ or IGL@ instead of IGH@. Unlike in BL, there is no definitive evidence that the location of the breakpoint plays a particular role in prognosis or disease biology.¹⁰⁰

Given the only 70% to 85% clinical sensitivity of most clinical PCR-based assays for t(14;18)(q32;q21), FISH for the rearrangement does play a role in those cases where the diagnosis is not definitive and the molecular testing fails to identify the translocation.¹⁰¹ The clinical sensitivity of FISH is significantly higher (100% correlation with SB) due to the far longer probes used in this method which are not dependent upon the specific site of the break. However, due to the limited analytical sensitivity of FISH compared to PCR-based methods, FISH is less useful in monitoring patients for MRD. For cases in which there is morphologic concern for a more high-grade process (foci of grade 3B or concomitant DLBCL), FISH for MYC and BCL6 rearrangements may also be helpful to identify transformation to a double- or triple-hit lymphoma.^{83,84}

Even with the more clinically sensitive FISH studies, still approximately 10% of FLs will be negative for a t(14;18). Approximately 5% to 15% of FL cases may have translocations

P.1813

involving BCL6 instead, often associated with more aggressive lesions with increased large cells.^{102,103,104,105} In addition, the FL variants such as primary cutaneous FL and pediatric FL are also typically t(14;18)-negative.⁴ Higher grade FL is also associated with a higher incidence of t(14;18)-negativity.¹⁰⁶ These t(14;18)-negative FLs have been associated with down-regulation of miR-16, miR-26a, miR-101, miR-29c, and miR-138, supporting a later germinal center cell of origin.¹⁰⁷

Studies on the prognostic significance of t(14;18) testing results have demonstrated that the achievement of PCR-negativity after induction chemotherapy did not significantly effect progression-free survival.¹⁰⁸ However, there is a significantly better survival in those patients who were PCR-negative in the bone marrow at diagnosis and for those who achieved PCR-negativity in the bone marrow after maintenance rituximab chemotherapy.^{108,109} Thus, there is a role for molecular testing of t(14;18) in prognostication, although the role in MRD testing may be limited to after long-term maintenance therapy.

The use of molecular testing for BCL2-IGH@ rearrangements for MRD monitoring carries one significant caveat. Using highly sensitive nested PCR methods or RT-PCR, t(14;18) may be found in up to 50% of normal individuals, the incidence increasing with age.¹¹⁰ At this time, there is no indication that these t(14;18)-positive individuals are at any higher risk of developing FL. This phenomenon may serve as the basis for those individuals who enjoy prolonged complete remission while remaining PCR-positive.¹¹¹

The presence of t(14;18) in normal individuals suggests that overexpression of BCL2 alone is not tumorigenic. Indeed, careful cytogenetic examination of FL by karyotype, aCGH, or aSNP can identify additional aberrations in up to 97% of FLs, including loss of 1p, 6q, 10q, 13q, and 17p as well as gains of 1q, 2p, 7, 8, 12q, 18q, and X.^{112,113} Even in those cases without a CNV, copy neutral loss of heterozygosity can occur.¹¹⁴ Cytogenetic abnormalities tend to accumulate with transformation of FL to DLBCL, and deletions or mutations of TP53 located on 17p13, deletions of 6q or 9p are particularly associated with poor prognosis.^{115,116} Losses or copy number neutral LOH of 1p36, at which site TP73 and TNFRSF14 are located, have been associated predominantly with diffuse FL.^{117,118} In addition, acquisition of a MYC translocation may also be associated with transformation.⁴

Gene expression profiling studies in FL have identified two separate prognostic groups distinguished by their tumor microenvironment. Whereas a prominent T-cell signature is associated with better prognosis, a dominant macrophage signature is associated with poor outcomes.¹¹⁹ Given the impracticality of diagnostic transcriptional profiling for all patients at this time, immunohistochemical surrogates have been sought including the quantitation of CD68⁺ macrophages and the histologic localization and number of FoxP3⁺ Treg cells, but the interpretation of these studies remains somewhat controversial.¹¹⁷ Other studies have examined markers of microvascular density,¹²⁰ other antiapoptotic proteins in the BCL2 family,^{121,122} BCL2/BAK ratios,¹²³ and CCNB1 expression¹²⁴ in FL for prognosis and diagnosis.

MiRNA profiling has identified expression profiles that distinguish FL from nonneoplastic cases as well as DLBCL, and can even discriminate between transformed and nontransformed FL.¹²⁵ Methylation studies have identified global hypermethylation in FL including the methylation of the promoters of CDKN2B (p15) and CDKN2A (p16).¹²⁶ It is interesting that this global hypermethylation occurs with the concomitant overexpression of the methyltransferase EZH2 in FL.¹²⁷ However, in those 7% to 22% of cases of FLs with a mutation in EZH2 identified by NGS there is paradoxically reduced transferase activity.^{128,129}

In fact, genes involved in epigenetic regulation are commonly mutated in FL. MLL2, a histone methyltransferase, contains somatic mutations in 89% of FL whereas MEF2B, a gene that interacts with CREBBP and EP300 to acetylate histones, is mutated in 13.4% of FL.¹³⁰ As mentioned earlier, EZH2 mutations are common in B-cell lymphomas of germinal center origin, with the exception of BL.¹²⁹ Many of the genes that are affected by somatic mutation are similar to those found in cases of DLBCL as well, suggesting a common oncogenic pathway revolving around epigenetic dysregulation.

Guidelines for Molecular Testing in Follicular Lymphoma

At diagnosis, PCR or SB for the t(14;18) is recommended to establish the sensitivity of the assay for that patient's specific rearrangement. If positive, this marker can then be used to monitor MRD in this patient for prognostic import after maintenance therapy. Due to the extensive SHM of BL as a neoplasm of GCBs, PCR-based immunoglobulin gene rearrangement studies have very poor clinical sensitivity, and, in the absence of allele-specific primers, PCR for immunoglobulin gene rearrangements is not superior to FISH in terms of analytical sensitivity, and is vastly inferior to PCR for t(14;18) or NGS deep sequencing methods. Therefore, if the molecular assay for the BCL2-IGH@ translocation fails to detect the patient's clonal rearrangement, then FISH for t(14;18) may be necessary if the diagnosis is cannot be made morphologically. If there is morphologic evidence for a more high-grade process disease, then FISH for MYC and BCL6 may also be appropriate.

Diagnosis	MRD
PCR or SB for <i>BCL2-IGH@</i>	PCR for <i>BCL2-IGH@</i> after maintenance
Consider FISH for <i>BCL2</i>	Consider NGS for Ig gene rearrangement studies
Consider FISH for <i>MYC</i> and <i>BCL6</i> if aggressive	
Consider NGS for Ig gene rearrangement studies	

Mantle Cell Lymphoma

MCL accounts for 5% to 6% of NHLs, occurring predominantly in males over the age of 55 years (male:female ratio of 4:1).^{4,131} MCL is typically thought of as an aggressive disease that is often widespread at diagnosis, although more indolent cases, often with a more leukemic presentation, can have longer survival times (average 79 months rather than 36 to 60 months for typical cases).^{132,133} Other morphologic variants, such as the pleomorphic or blastoid variants, tend to have poorer outcomes.⁴

The hallmark cytogenetic aberration in MCL is the CCND1-IGH@ translocation that can be found in 90% to 99% of all cases of MCL.^{134,135} In addition, this rearrangement can also be seen in 20% to 25% of plasma cell myelomas, and some cases of CLL or prolymphocytic leukemia (PLL), and splenic marginal zone lymphomas.^{136,137, 138} and ^{139,140} This translocation results in the overexpression of cyclin D1 which can be assessed via IHC, with greater than 90% sensitivity for the translocation.¹⁴⁰ However, overexpression of cyclinD1 is also associated with the above lymphoid neoplasms as well as in the proliferation centers of typical CLL and in some cases of hairy cell leukemia (HCL) that do not harbor the translocation.^{141,142}

The t(11;14)(q13;q32) in MCL juxtaposes the CCND1 gene on 11q13 which encodes for cyclin D1 with J_H subunit of the IGH@ locus on 14q32. As in the cases of MYC and BCL2, the majority of the translocations place the entire coding region of CCND1 under regulation of the IGH@ locus, resulting in overexpression of the full cyclin D1 protein. As in FL, the translocation with the J_H subunit is directed by the RSS. Cyclin D1 associates with the cyclin-dependent kinases, CDK4 and CDK6, to form a complex

P.1814

that hyperphosphorylates the retinoblastoma protein (Rb).¹⁴³ When phosphorylated, Rb is unable to sequester and inhibit the function of E2F1 in promoting entry into S phase and promoting cell cycling (Fig. 87.9). This increased proliferation is marked by Ki-67 IHC staining, with higher levels of Ki-67 portending a more aggressive disease (cut-offs vary from >40% to >60%).^{144,145}

CCND1, chromosome 11q13

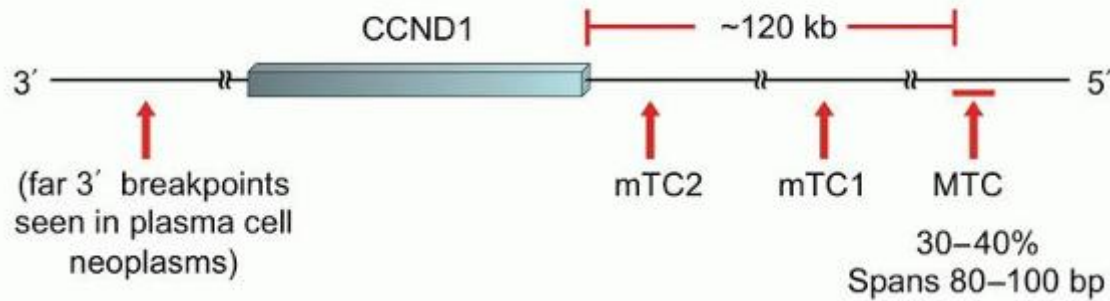

FIGURE 87.11. Location of breakpoint regions in the CCND1 gene and the frequency of the most common breakpoint in mantle cell lymphoma. MTC: major translocation cluster, mTC: minor translocation clusters 1 and 2.^{99,146}

The majority of the CCND1 breakpoints occur upstream or centromeric to the coding sequence (Fig. 87.11). However, these breakpoint regions are spread out across approximately 120 kb.^{99,146} Although there are three main regions of breakpoints, these are not tightly clustered. The major translocation cluster (MTC) spans an 80 to 100 bp region located the farthest upstream from the CCND1 gene, accounting for 30% to 40% of translocations. This region was formerly known as the B-cell lymphoma/leukemia 1 region (BCL1), prior to the recognition that the gene responsible for the biology of MCL was actually the downstream CCND1 gene. The minor translocation clusters (mTC1 and mTC2) lie closer to the CCND1 coding sequence. In addition, occasional breakpoints 3' to the coding sequence can be seen, especially in plasma cell myeloma. In addition to the translocations, deletions or point mutations in the 3'-UTR of CCND1 mRNA have been identified in 5% to 10% of patients which result in increased stability of the transcript, potentially due to inability of miR-16-1 to target the mRNA. The resultant increased half-life of the transcript is associated with increased proliferative rate and poor survival.^{147,148} By contrast, recently discovered 5'-UTR and first exon mutations in CCND1 appear to be bystander mutations without prognostic significance.¹⁴⁹

The wide distribution of these breakpoints explains the poor clinical sensitivity of PCR-based molecular assays for the t(11;14). The majority of PCR assays are designed to target just the MTC, resulting in a 30% to 40% clinical sensitivity, and due to variability within the J_H subunit as well, product sizes can span 143 to 934 bp.¹⁴⁶ By contrast, FISH, with its large probes, has nearly 100% sensitivity for the rearrangement.^{135,140} However, given the greater than 90% correlation with IHC, in most cases IHC alone is required to make the diagnosis, with the caveat that other benign and neoplastic entities can have some cyclin D1 expression without harboring the t(11;14).

FISH and IHC, however, are not sufficiently sensitive for the detection of MRD. However, a clonal immunoglobulin gene rearrangement can be identified in the majority of cases of MCL (approaching 100% in some studies with a single set of FR3 primers).^{14,15,17} The high clinical sensitivity of this test is due to the pre-germinal center naive B-cell origin of this neoplasm. In the majority of cases, the clonal cell population has not undergone any SHM. More detailed analysis, however, reveals that 26% of cases of MCL do indeed exceed the 2% nonhomology with germline used to define SHM, with an average mutation rate of 1.51% for the 32 cases examined.¹⁵⁰

For the development of a true MRD test, however, the analytical sensitivity must be below the 1% to 5% range achievable by either FISH, IHC, or immunoglobulin gene rearrangements using standard primers. Using allele-specific primers, the utility of RT-PCR for IGH@ VDJ rearrangement assays (peripheral blood either MRD positive or negative) has been demonstrated in the prediction of progression-free survival.¹⁵¹ These methods, however, have not yet achieved widespread clinical utilization.

Approximately 1% to 10% of cases of MCL are t(11;14)-negative, involving variant translocations. These are divided among cyclin D1 overexpression by rearrangement with the light chains as well as overexpression of cyclin D2 or D3 with the immunoglobulins: t(2;11)(p11;q13) (CCND1-IGK@), t(11;22)(q13;q11) (CCND1-IGL@), t(12;14)(p13;q32) (CCND2-IGH@), t(2;12)(p11;p13) (CCND2-IGK@), t(12;22)(p13;q21) (CCND2-IGL@), and t(6;14)(p21;q32) (CCND3-IGH@).¹³⁵ These cases may be difficult to diagnose using cyclin D1 FISH, although breakapart of the CCND1 signal may be seen with the light chain variants and breakapart of the IGH@ locus may be seen with either CCND2 or CCND3 recombinations with IGH@. Strong expression of SOX11 by IHC has been identified in 90% of MCLs, including the t(11;14)-negative cases.^{152,153} Expression of this transcription factor is negative in nearly all other mature B- and T-cell lymphoma, with the exception of

some cases of BL, T-prolymphocytic leukemia (T-PLL), and lymphoblastic neoplasms. However, to date this immunohistochemical stain is not widely employed in histology laboratories.

MCL is also commonly associated with other genetic aberrations. The most common secondary abnormality is loss or mutation of the ATM gene, with inactivating mutations identified in 40% to 75% of cases and deletions of 11q22-23 in 21% to 59% of cases.⁴ Mutations of TP53 seen in approximately 7% to 20% of cases of MCL and deletions of the 17p13-pter are seen in 21% to 45% of cases.^{4,154,155} Decreased function of either ATM or p53 affects the ability of MCL cells to respond appropriately to DNA damage, enabling the accumulation of additional genetic changes. Approximately 20% to 30% of MCL have deletions of the INK4α/ARF locus (CDKN2A) which encodes for both p14 and p16 in alternate reading frames.^{156, 157} and ^{158,159} The latter protein is an inhibitor of both CDK4 and CDK6; therefore its deletion facilitates cell cycling in conjunction with cyclin D1 overexpression. The p14ARF protein inhibits MDM2/HDM2 which negatively regulates p53. Thus, deletion of p14 results in decreased p53 function as a tumor suppressor and regulator of DNA damage.

Other common aberrations identified by karyotyping or aCGH include gains of 3q, 7p, 8q (MYC), 12q (CDK4), 12, 15q, and 18q (BCL2) and losses of 1p, 6q, 8p, 9p (CDKN2A), 9q, 10p (BMI1), 11q, 13q, and 17p (TP53) (SB validated candidate genes in parentheses).¹³⁵ Many of these changes are aberrations commonly associated with CLL, such as del(11q23), del(17p13), +12, del(13q14), and may suggest some commonality in pathogenic pathways. Blastoid and pleomorphic MCL may harbor tetraploid cytogenetics as well as gains of 3q, 7p, and 12q, and losses of 9p21 (CDKN2A) and 17p (TP53).¹³⁵ By contrast, indolent cases of MCL often have t(11;14) as the sole abnormality.¹³⁵

Gene expression profiling on a large series of MCL patients has identified a characteristic signature of 20 genes which, not surprisingly, are associated with proliferation.¹⁵⁹ When this gene set was pared down to a minimal set of 5 genes (RAN, MYC, TNFRSF10B, POLE2, and SLC29A2), the profile by RT-PCR was able to predict survival.¹⁶⁰ Methylation profiling has been helpful in distinguishing MCL from CLL, identifying a MCL methylation profile demonstrating hypermethylation of developmental genes, in particular homeobox genes.^{161,162} miRNA profiling has also identified several candidate miRNAs which might serve as adverse prognostic markers, such as down-regulation of miR-29 and up-regulation of miR-17-5p/miR-20a.^{163,164}

NGS has recently confirmed mutations of TP53 (7% to 20%), ATM (20% to 33%), and CHEK2 (anecdotal)^{135,154,155,165, 166} and ¹⁶⁷ but also discovered a 12% prevalence of NOTCH1 mutations in MCL associated with decreased overall survival.¹⁴⁹ These mutations are truncation mutations or small frameshift indels in the PEST domain that result in decreased ubiquitination and increased

P.1815

NOTCH1 activity. These mutations are similar in frequency and location to those seen in CLL, and differ from the more prevalent and widespread NOTCH1 mutations in precursor T lymphoblastic leukemia.

Diagnosis

MRD

IHC for CyclinD1, Ki-67, p53

Consider PCR or NGS for Ig gene rearrangement studies

Consider PCR or NGS for Ig gene rearrangement studies

Consider FISH for variant translocations or 17p13

Consider IHC for SOX11

Guidelines for Molecular Testing in Mantle Cell Lymphoma

At diagnosis, IHC for cyclin D1 overexpression is required. Further testing by FISH is only required for the rare cyclin D1-negative cases. IHC for SOX11 can also be considered in those cases (limited availability at this time). There are no good MRD markers for MCL, in the absence of allele-specific primers for patient-defined immunoglobulin gene rearrangements. Additional prognostic information may be gleaned from loss of the TP53 locus, and NOTCH1 mutational testing may be relevant in the future.

Extranodal Marginal Zone Lymphoma (Mucosa-associated Lymphoid Tissue Lymphoma)

Extranodal marginal zone lymphomas comprise 7% to 8% of all B-cell lymphomas and are the most common NHL of extranodal site.⁴ This neoplasm is not to be confused with splenic marginal zone lymphoma or nodal marginal zone

lymphoma, as these entities lack the characteristic reciprocal translocations found in the lymphomas of the mucosa-associated lymphoid tissue (MALT). It is interesting that these lymphomas are not traditionally found in normal physiologic sites of MALT, but rather in sites exposed to chronic inflammation that acquire a significant lymphoid infiltrate.⁹ This chronic inflammation is often associated with specific infectious agents or autoimmune disease, and these instigating etiologies segregate by the sites of the MALT lymphomas (Table 87.5).^{168,169}

Four recurrent reciprocal translocations are identified in MALT lymphomas: t(11;18)(q22;q21), t(1;14)(p22;q32), t(14;18)(q32;q21), and t(3;14)(p14.1;q32). The first three of these translocations all involve overexpression or fusion of components within the NF-κB pathway, resulting in overstimulation of the pathway and overexpression of NF-κB-dependent genes involved in antiapoptosis and cellular proliferation (Fig. 87.12).¹⁶⁸ Typically, stimulation of the BCR (Ig complex) induces the interaction of BCL10 and MALT1 which promotes dimerization of MALT1. This complex in turn causes oligomerization of the TNF receptor-associated factor 6 (TRAF6). This activation of TRAF6 results in promotion of IKKγ-mediated phosphorylation of Iκ-B. Phosphorylated Iκ-B is then targeted for degradation, releasing NF-κB, which translocates to the nucleus and promotes transcription of genes involved in lymphocyte survival and proliferation. The various NF-κB pathway-related translocations cause induction of this pathway independent of stimulation through the BCR.

TABLE 87.5 TRANSLOCATIONS IN EXTRANODAL MARGINAL ZONE LYMPHOMAS, THEIR FREQUENCY BY SITE, AND THEIR ASSOCIATION WITH CHRONIC INFLAMMATORY AGENTS/DISORDERS^{168,169}

Translocation	t(11;18)(q22;q21)	t(1;14)(p22;q32)	t(14;18)(q32;q21)	t(3;14)(q14.1;q32)	Potential Agent
Product	BIRC3-MALT1 Fusion (%)	Overexpression of BCL10 (%)	Overexpression of MALT1 (%)	Overexpression of FOXP1 (%)	
Locations:					
Stomach	22	3			<i>Helicobacter pylori</i>
Intestine	15	10			<i>Campylobacter jejuni</i>
Lung	42	7			<i>Chlamydia psittaci</i>
Ocular adnexa			13	20	<i>C. psittaci</i>
Salivary glands			5		<i>Sjogren's disease</i>
Thyroid				50	<i>Hashimoto's disease</i>
Skin			14	10	<i>Borrelia burgdorferi</i>

The t(11;18)(q22;q21) creates a fusion product between BIRC3 (API2) on 11q22 and MALT1 on 18q21 and is the most common recurrent translocation in MALT lymphomas.^{170,171} Although BIRC3 contains some independent antiapoptotic activity, more importantly for MALT lymphomas it also contains a dimerization domain. This fusion therefore results in MALT1 units that can dimerize independent of the BCR, thereby creating constitutive, antigen-independent stimulation of the NF-κB pathway. All of the translocation sites in BIRC3 (at least 4 known) are localized downstream from the BIR domains in the gene, resulting in full BIR domain activity in the fusion protein.¹⁷² These domains mark BIRC3 as a member of the inhibitors of apoptosis (IAP) family of proteins that inhibit the caspases. However, these domains are also capable of homophilic interactions, causing dimerization. Over 90% of the translocation sites in BIRC3 occur at a single site, just 5' to its CARD domain, so designing primers against this most common breakpoint region is possible. Unfortunately, the MALT1 breakpoint regions are spread over 300 bp throughout the middle portion of the gene, leaving the carboxyl terminus of the MALT1 gene fused to BIRC3.¹⁷² Nevertheless, PCR-based assays have been designed for this lesion, which, depending on the primers, have variable but overall moderate clinical sensitivity. FISH probes, which easily span the

possible breakpoint sites, provide higher clinical sensitivity for this translocation which has significant therapeutic relevance (vide infra).¹⁷³

The t(1;14)(p22;q32) results in the overexpression of the BCL10 gene on 1p22 through its relocation under the IGH@ enhancer. The resultant increased concentration of BCL10 in the cytoplasm results in its forced association with MALT1 and activation of the NF-κB pathway. Interestingly, the interaction of BCL10 with MALT1 appears to help localize BCL10 to the cytoplasm,

P.1816

and overexpression of BCL10 results in excess unbound BCL10 and consequent nuclear expression of BCL10 in cells with this translocation. The formation of BIRC3-MALT1 fusion in cases harboring the t(11;18) likewise frees BCL10 from the cytoplasm and results in nuclear expression of BCL10. This can be seen immunohistochemically, and may prove to be a good surrogate for these translocations.^{172,174,175} Currently, there is limited offering of FISH or any molecular assay for this translocation, although IGH@-breakpart probes can be used to identify the translocation, albeit not its partner.

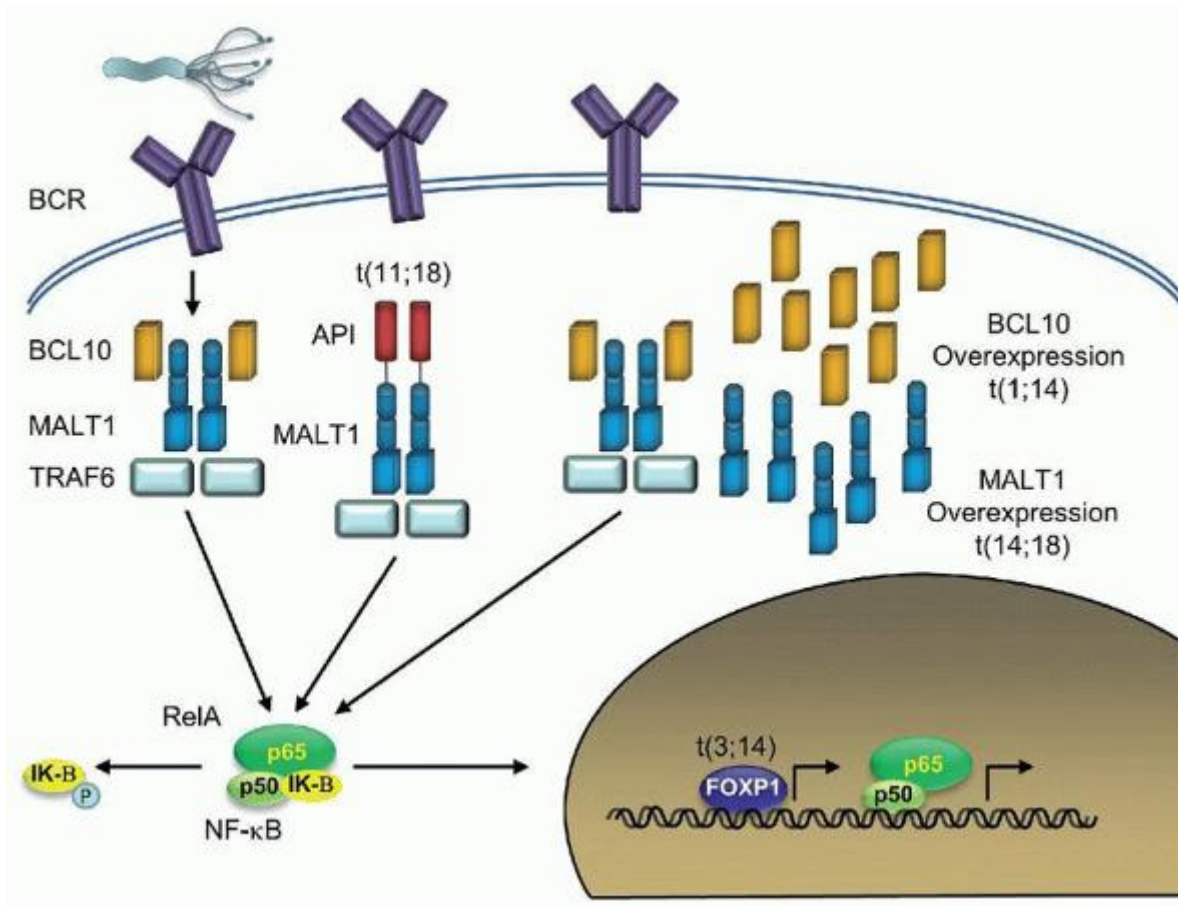

FIGURE 87.12. Biology of translocations common in extranodal marginal zone lymphomas. On the far left: *Helicobacter pylori* stimulation of the B-cell receptor (BCR) induces the interaction of BCL10 and MALT1, promoting dimerization of MALT1 and downstream oligomerization of TRAF6. This activation of TRAF6 results in promotion of IKKγ-mediated phosphorylation of IκB (IKKγ not shown). Phosphorylated IκB is then targeted for degradation, releasing NF-κB, which translocates to the nucleus and transcriptionally activates genes involved in lymphocyte survival and proliferation. The t(11;18) induces BCR-independent dimerization of MALT1 and activation of the pathway. The t(1;14) induces BCL10 overexpression and promotes dimerization of MALT1 as does overexpression of MALT1 itself via a t(14;18). Lastly the t(3;14) induces a FOXP1 transcriptional program that must be related to the NF-κB program.¹⁶⁸

The t(14;18)(q32;q21) seen in approximately 10% of MALT lymphomas contains the identical karyotypic breakpoints to those seen in FL.¹⁷⁶ However, with increased resolution, the BCL2 gene is in reality located 5 Mb telomeric to the MALT1 gene.¹⁷⁷ As in FL and MCL, this translocation juxtaposes the IGH@ partner, in this case MALT1, with the IGH@ enhancer through a RSS-guided rearrangement to the J_H subunit of IGH@.¹⁷⁶ The resultant overexpression of MALT1 protein results

in elevated cytoplasmic concentrations of the protein, which stochastically force enough proximity to induce TRAF6 oligomerization and NF-κB activation. The majority of MALT1 breakpoints appear to occur within an 87 bp region which may permit the development of a PCR-based assay for this translocation. However, due to the relatively low frequency of this translocation in MALT lymphoma, clinical development has not been widespread. Rather, FISH probes for these loci are commonly available.

Finally, the t(3;14)(p14.1;q32) involves the overexpression of the FOXP1 gene on 3p14 due to its relocation to the IGH@ gene locus.¹⁷⁸ FOXP1 encodes a transcriptional repressor in the Forkhead family which is critical for B-cell development and whose overexpression is implicated in several B-cell lymphomas in addition to MALT lymphomas, including DLBCL, FL, and cutaneous B-cell lymphomas. Although FOXP1 can be interrogated by IHC, this antibody is not commonly used in clinical laboratories, nor are directed FISH probes or PCR-based assays. IGH@-breakapart probes can be used to identify the translocation, albeit not its partner.

These translocations are associated with specific sites and etiologies of MALT lymphomas.¹⁶⁸ The t(11;18) and t(1;14) are most common in gastric, intestinal, and lung MALT lymphomas with the t(11;18) being especially prevalent in the gastric and lung neoplasms. By contrast, the t(14;18) and t(3;14) occur in the ocular adnexa and skin, with the t(14;18) also rarely found in the salivary gland lymphomas and the t(3;14) commonly found in the thyroid lesions. Each of these different sites has a distinct source of chronic inflammation that has been associated with MALT lymphomas in these sites, although exactly how the particular instigating agent causes specific reciprocal translocations remains to be understood. However, it is known that although early gastric MALT lymphomas are dependent upon Helicobacter pylori stimulation of the B-cell, once the neoplasm acquires a t(11;18), it becomes independent of the bacterium. Thus, whereas antibiotics successfully treat up to 75% of gastric MALT lymphomas, the cases with t(11;18) are refractory to antibiotic therapy.¹⁷⁹

Inasmuch as MALT lymphomas are derived from post-germinal center marginal zone B-cells, they tend to have significant SHM. Thus, immunoglobulin gene rearrangement studies identify clonal rearrangements in only 62% to 68% of cases using a single set of FR3 primers.^{14,15,17} However, when a clonal population can be identified, it can be a valuable test both for diagnostic purposes as well as for monitoring for MRD. Distinguishing reactive lymphoid hyperplasia from MALT lymphoma in sites of chronic inflammation can be histologically challenging; in these cases, Ig gene rearrangement studies, when positive, can be helpful. However, these results must be interpreted with caution, as inflammatory lesions can demonstrate pseudoclonality due a limited repertoire of B-cells responding to a given antigen. Similarly, a negative result may be due to SHM and does not preclude a neoplasm.

MALT lymphomas, as well as other marginal zone lymphomas, can demonstrate ancillary cytogenetic changes, in particular trisomies of 3, 7, 12, and 18.¹⁸⁰ In addition, with transformation to DLBCL, additional aberrations may accumulate in TP53, CDKN2B (p15), CDKN2A (p16), RB1, and MYC.¹⁶⁸ The accumulation of genetic changes is also reflected in the accumulation of miRNA expression changes from controls, to gastritis, to MALT

P.1817

lymphoma, to DLBCL.^{181,182} Note that in the transformation to DLBCL, gastric MALT lymphomas appear to acquire a signature of 27 down-regulated miRNAs that are all transcriptionally repressed by MYC, and MYC overexpression was found in 80% of the DLBCLs, but only 20% of the low grade MALT lymphomas. In particular miR-34a down-regulation caused overexpression of its target, FOXP1, in DLBCL but not in MALT lymphoma.¹⁸³ A similar gradation of accumulated changes is seen in the increase in the CpG island methylator phenotype from 0% in controls, 62% in MALT lymphomas, and 93% of DLBCLs.¹⁸⁴

Diagnosis

Consider FISH for various translocations

Consider PCR or NGS for Ig gene rearrangement studies

MRD

Consider PCR or NGS for Ig gene rearrangement studies

Guidelines for Molecular Testing in Extranodal Marginal Zone Lymphoma

No specific molecular testing is required to make the diagnosis of a MALT lymphoma. However, FISH for t(11;18) may have therapeutic implications for the patient at diagnosis. In addition, assessment of whether a clonal population can be detected by Ig gene rearrangement studies at diagnosis may be helpful both in distinguishing a reactive process for neoplasia and in the identification of a molecular marker of disease for therapy monitoring.

Chronic Lymphocytic Leukemia/Small Lymphocytic Lymphoma

Accounting for only 6.7% of NHLs, CLL/SLL is nonetheless the most common adult chronic leukemia in Western countries.^{4,9} The majority of these cases are leukemic (CLL), with the isolated lymphomatous presentation of SLL uncommon. Although considered to be overall an indolent disease, there is wide variability in clinical outcomes, with some patients enjoying survival measured in decades, and others succumbing to disease or disease-associated sequelae within just a few years. A minority of cases can progress to more aggressive disease, including DLBCL (Richter's transformation, 2% to 8%), Hodgkin lymphoma (<1%), and prolymphocytic leukemia (PLL).⁴

Genetic aberrations are found in the vast majority of cases of CLL, although the identification of these changes varies widely upon the methodology. Conventional MC identifies abnormalities in only approximately 40% of cases.¹⁸⁵ However, FISH can detect cytogenetic changes in about 80% of CLL cases.¹⁸⁶ Typical FISH panels interrogate four common chromosomal aberrancies: deletions of 13q14, 11q22-23, and 17p13 as well as trisomy of chromosome 12. Array CGH methods have the potential to identify even more aberrations, and some institutions routinely perform aCGH for CLL, although most of the published studies still use FISH as the gold standard for comparison.^{187,188}

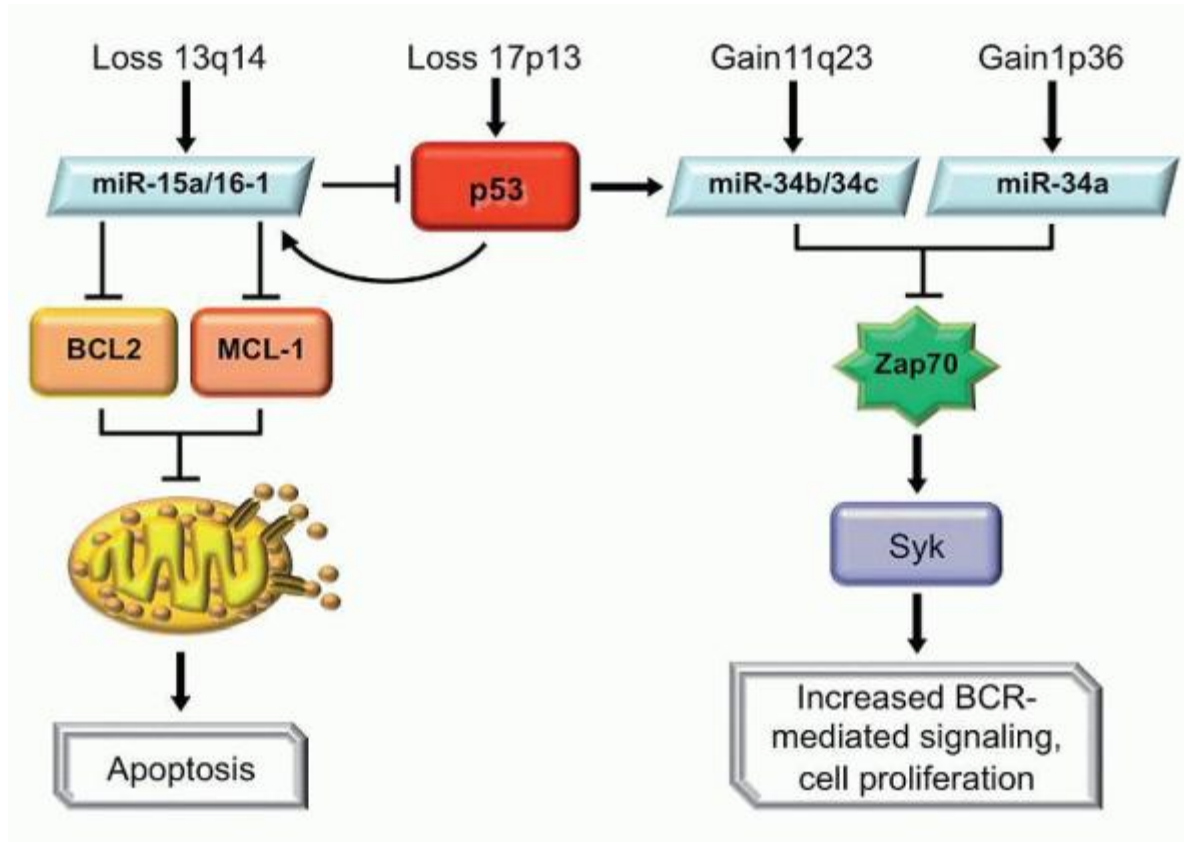

FIGURE 87.13. Chronic lymphocytic leukemia (CLL) biology. Loss of 13q14 causes decreased miR15a/16-1, resulting in decreased apoptosis. Trisomy 11 results in increased miR-34b/34c, with resultant decreased ZAP 70 and decreased B-cell receptor (BCR) signaling. However, loss of 17q13 results in increased ZAP 70 and increased BCR-mediated signaling with decreased apoptosis.

Deletions of 13q14 are the most common recurrent abnormality in CLL and account for 50% to 60% of cases.¹⁸⁶ Patients can show either homozygous or heterozygous losses of 13q14, both associated with favorable prognosis. The locus affected by this deletion appears to contain two miRNAs, miR-15a and miR-16-1, and deletion of these miRNAs are common in familial cases of CLL as well.^{54,55} These miRNAs have been demonstrated to target and translationally repress a number of genes involved in apoptosis, including BCL2, MCL1, and TP53, therefore the loss of these miRNAs results in increased expression of the antiapoptotic genes BCL2 and MCL1 (Fig. 87.13). Although TP53 is proapoptotic, its role in CLL may be more complex than previously understood. The protein product of TP53, p53, also promotes transcription of two other miRNAs, miR-34b and miR-34c, both of which target the mRNA of ZAP70.¹⁸⁹ Thus in 13q14-deleted CLLs, there is increased p53 expression, increased miR-34b and miR-34c, and decreased ZAP70 protein. ZAP70 has independently been determined to portend a poor prognosis.⁴³

Deletions of 11q22-23 are identified in approximately 17% of cases of CLL.¹⁹⁰ This locus contains a number of important genes in the pathogenesis of CLL. ATM is located in this deleted region at 11q22.3. As noted earlier, ATM phosphorylates p53, resulting in its protection from ubiquitination and degradation by MDM2. The active p53 then can induce cell cycle arrest followed by either apoptosis or DNA repair. Therefore, loss of the ATM locus is tantamount to decreased function of p53. In addition, miRNAs, miR-34b and miR-34c, are located at 11q23.1 and are also deleted with ATM. The deletion of these miRNAs results in increased ZAP70 protein, the poor prognostic marker.^{43,189} Deletions of 11q22-23 are therefore consistent with a poor prognosis. Recent studies have suggested the importance of adding alkylating agents such as cyclophosphamide to regimens used to treat patients with deletion 11q22-23.¹⁹¹

Deletions of 17p13 involve the loss of the TP53 locus, and are found in approximately 8% of cases of CLL, also associated with a poor prognosis.¹⁹⁰ By itself, deletion of the tumor suppressor gene is typically associated across malignancies with negative prognosis. In CLL, it has been demonstrated that loss of p53 can also result in decreased miR-34b and miR-34c transcription and

P.1818

therefore increased ZAP70 expression.¹⁸⁹ The identification of del(17p) is a critical predictor of fludarabine-resistance. Because fludarabine forms the backbone of most chemoimmunotherapy regimens for CLL, FISH for TP53 provides therapeutically important information, and may prompt the use of alemtuzumab instead of fludarabine.¹⁹²

Trisomy 12 is found in approximately 20% of cases of CLL, and can be associated with more atypical morphologic features such as irregular nuclear contours and less condensed chromatin as well as increased CD11c expression.^{4,190,193} Trisomy 12 is considered to be an intermediate risk factor in CLL but can be associated with specific other abnormalities that may modify its prognostic import.

Although it has subsequently been shown to be an independent poor prognostic marker, the importance of ZAP70 expression was originally identified as a surrogate marker for SHM status through gene expression profiling studies.^{43,194,195} CLL cases are nearly divided evenly in their mutational status, approximately 40% to 50% SHM-negative and 50% to 60% SHM-positive.^{29,30} The discovery of SHM in CLL caused a revolution in the thinking of the biologic origin of CLL. These same gene expression profiling studies also determined that CLL is a neoplasm of memory B-cells, approximately 50% of which pass through the germinal center thereby acquiring SHM in a T-cell dependent fashion, whereas the remaining memory B-cells are part of our innate immune system and become memory B-cells without traversing the germinal center in a T-cell independent manner.^{194, 195} and ¹⁹⁶ These latter cases therefore do not acquire SHM. Prognostically, the SHM-positive cases of CLL have longer overall survival (median 293 months for low stage disease), and SHM-negative cases portend a poor prognosis (median survival 95 months for low stage disease).^{30,197} Despite the presence of SHM in roughly half the cases of CLL, nonetheless, Ig gene rearrangement studies have a universally high level of detection of clonal rearrangements using standard framework primers.^{14,15,17}

The V_H repertoire utilized in CLL is biased, implying a common set of antigens or superantigens in the pathogenesis of CLL that have yet to be identified.¹⁹⁸ and ^{199,200,201} In some cases, certain Ig genes appear to be preferentially used in unmutated rearrangements (V_H1-69, V_K1-33, V_L3-21) whereas others are associated with SHM-positive cases (V_H4-34, V_K3-7, V_L3-23, V_L2-30, V_L2-8).^{200,201} Within these gene regions even the specific amino acid changes that occur in these regions in those cases exhibiting SHM involve stereotyped changes, providing further evidence of selection for specific pathogenic antigens.²⁰⁰ Certain of the stereotypes are associated with poor prognosis regardless of mutational status. The most well documented of these is V_H3-21, although V_H3-48 and V_H3-53 have been discussed in this context as well.^{197,202,203,204} Other B-cell Ig gene stereotypes have been associated with better prognosis, including V_H4-34 and V_H2-30.²⁰⁰ Monoclonal B-cell lymphocytosis appears to utilize V_H4-59/61 preferentially, although it has a similar array of cytogenetic changes as CLL.²⁰⁵

SLL, although derived from the same cell of origin as CLL, demonstrates slightly different prognostic markers. SLL is associated with a lower rate of SHM than CLL (26% of cases compared to 40% of cases).²⁰⁶ The prevalence of trisomy 12 and V_H3-21 is also significantly increased in SLL compared to CLL.²⁰⁷

Disease progression and transformation in CLL appears to be associated with an accumulation of genetic changes, particularly deletion of 6q21-q24.^{186,208} Therefore, at relapse or progressive disease, the number and nature of cytogenetic aberrancies can differ from diagnosis. Acquisition of reciprocal translocations, even those commonly associated with other B-cell lymphomas such as rearrangements of BCL2, MYC, and BCL3, can be seen at disease progression.^{90,92,209, 210, 211} and ²¹² Many of these involve the light chain Ig loci in addition to IGH@.

The accumulation of mutations during disease progression has been documented by NGS as well. NGS has confirmed mutation rates for TP53 (15%) and ATM (9%).²¹³ In addition, several new mutations have been identified that may play key

roles in CLL pathogenesis. Mutations in NOTCH1 have been identified in 4% to 12% of CLLs, associated with decreased overall survival.^{213,214,215,216} The majority of these cases contain a two-nucleotide deletion in the PEST domain. Similar to those identified in MCL, these deletions are expected to result in decreased ubiquitination and increased NOTCH1 activity. The prevalence of NOTCH1 mutations increases with Richter transformation (from 8.3% to 31.0%) as well as with chemorefractoriness (20.8%).²¹⁵ NOTCH1 can directly stimulate MYC transcription, and mutations of NOTCH1 appear to be mutually exclusive with MYC activation, suggesting that the MYC oncogenic pathway can be accessed by either mechanism in CLL. NOTCH1 mutation or MYC activation can coexist with decreased p53 function, perhaps to counteract the role of MYC in apoptosis, especially in cases of fludarabine-refractory CLL or Richter's transformation.^{215,217,218} NOTCH1 mutations are associated with trisomy 12 and unmutated Ig status.^{214,215,218}

NGS has also identified several other genes that are mutated in CLL.^{213,214,215,216} MYD88 mutations, occurring in 10% of cases, predominantly involve missense mutations occurring at only three sites within a 40 bp region of the gene.²¹³ These patients tend to be younger with disease presenting at a more advanced clinical state, and are highly associated with SHM and del(13q). FBXW7 mutations (4% of cases), as well as NOTCH1 mutations, are associated with trisomy 12. TP53 mutations (15% of cases) often occur in conjunction with del(17p), to result in biallelic loss of function. Lastly, SF3B1 was identified as one of the most common mutations in CLL, occurring with a frequency of 15% of all CLL cases.²¹⁹ This gene functions in the catalytic core of the SF3b complex of the spliceosome. The majority of the mutations are a single K700E mutation (mutational hotspots also include codons 662 and 666) which is believed to be a gain-of-function mutation causing aberrant splicing in these patients. This mutation is commonly associated with del(11q) or mutations in the ATM gene, and found in predominantly unmutated cases of CLL. It is interesting that SF3B1 mutations and TP53 aberrations appear to be mutually exclusive in fludarabine-refractory cases, suggesting some overlap in their roles in chemorefractoriness, although perhaps SF3B1 and ATM aberrations are synergistic. SF3B1 mutations have also been identified in the myeloid neoplasm, myelodysplastic syndrome, suggesting interesting hypotheses about the relationship between myeloid and T-cells developmentally as well as the role of aberrant splicing in general oncogenesis.^{220, 221, 222, 223} and²²⁴

Guidelines for Molecular Testing in Chronic Lymphocytic Leukemia

Although no molecular testing is required to make a diagnosis of CLL, molecular cytogenetic aberrations may play an important role in prognostication and also in the selection of chemoimmunotherapy regimens. These include FISH or aCGH for the recurrent abnormalities and SHM testing. In addition, assessment of a clonal population at diagnosis may be helpful in the identification of a molecular marker of disease for therapy monitoring. Several of the novel markers identified by NGS, such as NOTCH1 and SF3B1 have highly localized mutations for which very sensitive PCR methods can easily be developed in addition to NGS. These may be used prognostically at diagnosis, and possibly for monitoring MRD, although no studies exist exploring this role for molecular studies at this time.

Diffuse Large B-cell Lymphoma

DLBCL, not otherwise specified, is the most common adult lymphoma, comprising approximately 30% to 40% of cases of NHL.⁴ This is a heterogeneous category of disease for which there is varied clinical presentation, response to therapy, and molecular

P.1819

aberrancies. These features have made the study of DLBCL challenging, and molecular discoveries have lagged behind some of the more homogeneous lymphoma entities. Nevertheless, gene rearrangements can be identified by FISH using breakapart probes in approximately 65% of cases of DLBCL, split among those involving BCL6 (45% of cases), BCL2 (21% of cases), BCL10 (18% of cases), and MYC (16% of cases).^{225,226}

Diagnosis

FISH or aCGH

MRD

Consider PCR or NGS for Ig gene rearrangement studies

SHM testing

Consider PCR or NGS for Ig gene rearrangement studies

Future: novel markers by PCR or NGS

BCL6 gene rearrangements involve the translocation of the entire coding region of BCL6 on chromosome 3q27 to its partner chromosome. At least 20 such partners have been described, including both Ig and non-Ig genes, mandating the requirement for breakapart FISH probes against BCL6.²²⁷ These translocations place the BCL6 coding sequencing downstream of the heterologous promoter sequences of the partner chromosome, resulting in overexpression of BCL6.²²⁸ The breakpoints in the BCL6 are predominantly located in the MBR which consists of the 5' flanking region, the first noncoding exon, and part of the first intron. An alternative breakpoint region (ABR), found in 17% of BCL6 translocations, is located 240 to 280 kb 5' to the MBR and requires a separate FISH probe to identify these rearrangements.²²⁹ Most FISH studies only use the single MBR-directed breakapart probes, thereby decreasing their clinical sensitivity,^{229,230,231,232} but newer FISH assays cover both breakpoints. BCL6 translocations are associated primarily with germinal center histogenic origin, and confer an advantageous prognosis, although they can be seen in nongermlinal center DLBCLs as well where they appear to be associated with poor outcome.²³³

BCL6 encodes a POZ (Poxvirus zinc finger) domain, that is involved in both homodimerization and heterodimerization with other POZ-containing proteins, as well as a DNA recognition sequence. BCL6 is a germinal center-specific transcriptional repressor, regulating genes such as PRDM1 (BLIMP1) and CDKN1B, TP53, ATR, and BCL2.^{7,234} PRDM1 is another transcriptional factor that regulates the transition from the GCB stage to the plasma cell stage of differentiation through inhibition of MYC expression, preventing further proliferation. CDKN1B encodes for p27, a cell cycle inhibitor. ATR and TP53 are involved in DNA damage repair and cell cycle arrest, whereas BCL2 inhibits apoptosis. Therefore overexpression of BCL6 blocks plasmacytic differentiation, promotes proliferation, and inhibits apoptosis. BCL6 inhibition has therefore become an active area for the development of new therapeutics.^{235, 236, 237} and ²³⁸

By locking the neoplastic B-cells in the germinal center stage of maturation, BCL6 translocations permit ongoing SHM. BCL6 is itself a target of this SHM both physiologically and in DLBCL. The mutations are clustered in the MBR and are seen in approximately 25% to 45% of cases of DLBCL, often multiple or biallelic.^{226,239,240} These mutations are found in both rearranged and wild-type alleles and, interestingly, the SHM occurs even when the translocation partner is not one of the Ig genes.²⁴¹ These mutations can affect the BCL6 binding sites in exon 1, preventing the normal negative feedback inhibition of BCL6 and accounting for a second cause of BCL6 overexpression.²⁴¹

The BCL2 rearrangement found in 20% to 30% of DLBCLs is the identical hallmark t(14;18)(q32;q21) of FL.^{4,91} In many cases these are de novo DLBCLs, without transformation from a preceding or concomitant FL. As in FL, this translocation is associated with a germinal center origin of the lymphomas. However, BCL2 overexpression due to chromosomal gains at this locus can be associated with more ABC -type DLBCLs.²²⁵

BCL10 overexpression as a result of reciprocal translocations appear to be unrelated to any associated MALT lymphoma in most cases, and are associated with a poor prognosis.²²⁶

Lastly, MYC translocations are found in up to 16% of cases of DLBCL (most studies suggest 5% to 10%).^{225,226} MYC rearrangements are found in de novo DLBCL, as a secondary acquired genetic change during the process of transformation from a low-grade lymphoma, and in the recently described category B-cell lymphoma unclassifiable, with features intermediate between DLBCL and BL.⁹ In all three cases, the MYC translocation carries a poor prognosis²⁴² and may be a component of double- or triple-hit lymphomas, which carry especially dire prognoses.^{243,244} Double-hit lymphomas harboring both MYC and BCL2 can be identified by FISH and recent studies suggest that IHC for these two markers may also be prognostically important.²⁴⁴

Gene expression profiling studies have distinguished three separate biologic subtypes of DLBCL.^{60,245} The germinal center B-cell-like DLBCLs (GCB DLBCLs) were characterized by expression of genes such as MME (CD10), BCL6, and MYBL1 (A-MYB). These cases had a 5-year overall survival of 60%.^{60,246} By contrast, the ABC-like subtype of DLBCL expressed genes that are induced by mitogenic stimulation, such as BCL2, IRF4 (which encodes for MUM1), and CCND2. The ABC lymphomas had only a 35% 5-year median overall survival.^{60,246} In addition, a third category of DLBCL, termed the "type 3" category did not molecularly cluster with either the GCB or ABC groups.⁶⁰

Due to the cost and impracticality of performing gene expression profiling for routine diagnosis, a flurry of research has been devoted to the identification of IHC surrogates for the GCB and ABC categories. From the three marker algorithms involving CD10/BCL6/MUM1^{247,248} or BCL2/CD10/MUM1,²⁴⁹ to the five marker algorithms such as GCET1/CD10/BCL6/MUM1/FOXP1 or GCET1/CD10/MUM1/FOXP1/LMO2,^{250,251} all have shown excellent correlation to the gene expression profiles in their own institutions, but show only moderate correlation in the hands of an outside institution.^{90,247, 248, 249, 250} and ^{251,252,253} In addition, most studies have shown that the addition of rituximab to current chemotherapy regimens so improves the outcomes of the ABC group as to eliminate all prognostic differences between the groups, although this is still a contested area.^{252,254,255} Accordingly, the initial excitement for IHC surrogates has

somewhat abated, and many no longer attempt to subclassify DLBCL into GCB or ABC, preferring instead to rely upon Ki-67 and MYC dysregulation.

Both gene and miRNA expression profiling have identified important markers of response to anthracycline-based chemotherapy. Earlier studies by gene expression profiling detailed the 5-year survival rates of the GCB, ABC, and type 3 subgroups of DLBCL in the pre-rituximab era (60%, 35%, and 39%, respectively).^{91,246} However, more recent miRNA studies using standard rituximab-containing therapy identified miRNA signatures that correlate with the cell of origin (GCB versus ABC), as well as a completely distinct set of miRNAs which correlated with outcome.²⁵⁶ This study cast further doubt upon the prognostic relevance of the ABC and GCB determinations in the rituximab era. It is interesting that two of the miRNAs overexpressed in the GCB DLBCLs, miR-151 and miR-28, are predicted to down-regulate

P.1820

FOXP1 (a marker expressed in the ABC subtype) whereas miR-451, a miRNA in the ABC signature is predicted to down-regulate CD10 (a germinal center marker).²⁵⁶

Diagnosis

MRD

Consider FISH for *BCL2*, *BCL6*, or *MYC*

Consider PCR or SB for *BCL2-IGH@*

Consider PCR for *BCL2-IGH@*

Consider PCR or NGS for Ig gene rearrangement studies

Consider PCR or NGS for Ig gene rearrangement studies

Both genomic deletions and promoter methylation have been found to account for decreased expression of CDKN2A which encodes p14 and p16.^{257,258} As mentioned previously, these proteins play important roles in promoting cell cycling and in inhibiting p53 function. Other mutations identified by NGS (WES) in DLBCL have included expected deletions of CDKN2A and CDKN2B as well as mutations in PRDM1, TNFAIP3, CARD11, CD79B, and MYD88.²⁵⁹ Many of these genes are important in the NF-κB pathway which has been shown to underlie the ABC subtype of DLBCL. In addition, mutations were found in CREBBP, EZH2 (6% to 14% of samples), and MLL (11% to 24% of samples) which are involved in the epigenetic regulation.^{129,130,259}

Guidelines for Molecular Testing in Diffuse Large B-cell Lymphoma

There are no molecular tests required for the diagnosis of DLBCL. If the t(14;18) is present, this rearrangement can provide a good marker for MRD. Ig gene rearrangements have only a moderate level of clinical sensitivity for DLBCL, and, in the absence of primers, have moderate analytical sensitivity. FISH may be helpful in the identification of double- or triple-hit lymphomas, although currently probes for BCL10 are uncommon.

Hairy Cell Leukemia

HCL is a rare leukemic mature B-cell neoplasm which affects middle aged to older adults with a strong male:female bias (5:1).⁴ Until recently, no consistent or specific cytogenetic abnormalities had been identified in HCL, although gains in chromosome 5 (20%) and losses of the long arm of chromosome 7 (10%) had been identified.^{260, 261} and ²⁶² The cell of origin is believed to be a late post-germinal center memory B-cell, since more than 85% of cases demonstrate significant SHM.^{4,263} Unlike many of the other B-cell lymphomas which develop reciprocal translocations during RSS-guided VDJ rearrangement, reciprocal translocations are rare in HCL. This is further supported by the balanced genomic profile of HCL by aSNP.²⁶⁴ Instead, many cases of HCL appear to have multiple clonally related Ig-isotypes, suggesting that the defect lies in the class switching process.²⁶⁵ Gene expression profiling has likewise failed to determine a pathogenic pathway in HCL. These studies instead demonstrate a molecular signature that matches the morphologic and clinical characteristics of the disease, with prominent signatures generated by adhesion molecules, homing molecules, and molecules involved in marrow fibrosis.²⁶⁶

Diagnosis

MRD

Consider *BRAF* V600E testing

Consider *BRAF* V600E testing

Consider PCR or NGS for Ig gene rearrangements

Consider PCR or NGS for Ig gene rearrangements









Translocation	Fusion Partners	Staining Pattern	Frequency
t(2;5)(p23;q35)	 NPM ALK	Nuclear, diffuse cytoplasmic	84%
t(1;2)(q25;p23)	 TPM3 ALK	Diffuse cytoplasmic	13%
inv(2)(p23q35)	 AT1C ALK	Diffuse cytoplasmic	1%
t(2;3)(p23;q21)	 TFG ALK	Diffuse cytoplasmic	<1%
t(2;17)(p23;q23)	 CLTC ALK	Granular cytoplasmic	<1%
t(2;X)(p23;q11-12)	 MSN ALK	Membrane	<1%
t(2;22)(p23;q11.2)	 MYH9 ALK	Diffuse cytoplasmic	<1%
t(2;19)(p23;q13.1)	 TPM4 ALK	Diffuse cytoplasmic	<1%
t(2;17)(p23;q25)	 ALO17 ALK	Diffuse cytoplasmic	<1%

FIGURE 87.14. Anaplastic large cell lymphoma. The various translocations of ALK with its myriad partners is demonstrated with cytogenetic translocations and immunohistochemical pattern of ALK described. Adapted from Swerdlow SH, International Agency for Research on Cancer, World Health Organization. WHO classification of tumours of haematopoietic and lymphoid tissues, 4th ed. Lyon, France: International Agency for Research on Cancer, 2008.

However, the advent of NGS has permitted the identification of point mutations in HCL. Of those identified, the V600E mutation in BRAF has been proven in several studies to be 100% sensitive for HCL, and highly specific as well, with no mutation identified in cases that can be morphologic mimics such as splenic marginal zone lymphoma and unclassifiable splenic B-cell lymphoma/leukemia.^{267,268} This mutation is most commonly found as a heterozygous somatic mutation, but in rare cases can be homozygous. This mutation has been found to activate the MAPK pathway, a pathway previously identified as important in HCL. Dysregulation of this pathway results in constitutive transcription of cyclin D1 and down-regulation of p27, both of which conspire to cause increased cellular proliferation, and explain the expression of cyclin D1 by IHC in HCL without any evidence of the t(11;14). Highly sensitive PCR-based BRAF assays have already been developed for melanoma, and may be helpful in the diagnosis and almost certainly in the future monitoring of patients with HCL.^{269,270}

Guidelines for Molecular Testing in Hairy Cell Leukemia

Molecular testing is generally not needed for the diagnosis of HCL when morphology and immunophenotype are definitive. Therefore the V600E BRAF mutation is likely not required at diagnosis, although it may be helpful in distinguishing HCL from some of its morphologic mimics. Sensitive PCR-based methods for the detection of the mutation should be helpful in monitoring MRD status in these patients, although no studies to date have examined BRAF mutations in the MRD setting of HCL. Due to the high rates of SHM, Ig gene rearrangement studies are not recommended and are less sensitive than BRAF testing for MRD.

P.1821

Mature Neoplasms of T-cells

Anaplastic Large Cell Lymphoma, Anaplastic Lymphoma Kinase-positive

Anaplastic Lymphoma Kinase (ALK)-positive ALCLs comprise roughly 3% of all adult NHLs (12% of T-cell NHLs), but as much as 20% of childhood lymphomas.^{3,4} Incidence peaks in the second decade of life, and cases in elderly adults are rare. These lymphomas are highly chemosensitive, although aggressive, and the overall 5-year survival approaches 80%, up to 90% in

patients with low prognostic indices. By contrast, incidence of ALK-negative ALCLs peaks in the sixth decade of life, and survival is considerably less than in the ALK-positive cases (36% 5-year survival). For these reasons, these two forms of ALCL are classified separately, and, despite their similarity in morphology and CD30 expression that initially grouped them together as ALCLs, they have very different epidemiology and clinical outcomes.

These two entities also differ significantly in what is known of their molecular underpinnings, although both have clonally rearranged T-cell genes: 76% of ALK-positive ALCLs, 89% of ALK-negative ALCLs. Together, 79% of all ALCLs can be detected by a combination of TRG@ and TRB@ sets of commercial primers.²² Although the ALK-negative cases have only rare recurrent cytogenetic aberrations, the ALK-positive cases of ALCL have well-documented driving reciprocal translocations involving the ALK locus on chromosome 2p23 and a limited set of partner chromosomes. ALK encodes for a transmembrane tyrosine kinase protein which is found in neural cells, but has no appreciable expression in normal hematopoietic cells.²⁷¹ The breakpoints in ALK are located near this transmembrane domain and result in the full expression of the tyrosine kinase domain in the fusion product in all cases. The most common partner is the NPM1 gene on chromosome 5q35.1, found in 84% of ALK-positive cases, resulting in a t(2;5) (p23;q35.1) (Fig. 87.14).^{4,272} NPM1 encodes for nucleophosmin, a protein that shuttles ribonucleoproteins from the nucleus to the cytoplasm and is involved in preribosomal assembly.²⁷³ As a result, the fusion protein is also found in both locations, and IHC stains targeting the normally cytoplasmic C-terminus of ALK show both nuclear and cytoplasmic staining.⁴ The fusion attaches the N-terminus of NPM containing an oligomerization domain to ALK, resulting in constitutive activation of ALK kinase activity. This kinase activity activates numerous pathways involved in growth and cell survival, including AKT/PI3K/mTOR, Jak/STAT, JUN, and MYC pathways.²⁷⁴ The dependence of the ALCL cells upon the fusion protein has made the fusion and its downstream collaborators a target for the development of novel therapeutics.^{275,276}

In addition to the t(2;5)(p23;q35.1), several other translocations of ALK are summarized in Fig. 87.14.⁴ In each case, the partner chromosome contains an oligomerization domain and in most cases there is a single breakpoint region involved. The physiologic localization of the partner protein is mimicked in the fusion protein, resulting in characteristic patterns on ALK IHC.

Although the t(2;5)(p23;q35.1) can be identified by a number of molecular techniques, including PCR, reverse transcription PCR, SB, and FISH, the most prevalent method in clinical use is FISH, inasmuch as it has the best clinical sensitivity for the variant rearrangements.^{277,278,279} In addition, CGH studies have determined that 58% of ALK-positive ALCLs may carry additional aberrations such as gains of 17p and 17q24-qter and losses of 4q13-q21 and 11q14.²⁸⁰ These aberrations were not associated with any particular prognostic import. Here too, ALK-negative cases of ALCL demonstrate a different pattern of imbalances (gains of 1q, 6p21, 3p, and losses of 16pter, 6q13q21 a15, and 17p13) in 65% of cases which further supports their biologic separation.^{280,281}

Gene expression profiling studies of ALCLs have identified a profile of activated T-cells involving the JAK3/STAT3 pathway (IL26, IL31RA, IL9), molecules that characterize Th17-cells (IL17A, IL17F, RORC), as well as overexpression of ALK, albeit with down-regulation of a number of other molecules which typically characterize T-cells.^{282,283,284} In fact the profiles of both ALK-positive and ALK-negative ALCLs resemble the signature obtained from cHL, with overexpression of members of the NF- κ B pathway, and in fact, the cHL cell lines more closely resemble ALK-positive ALCL than other B-cell lymphomas, despite the differences in their cells of origin.^{46,282,285} Both ALK-positive and ALK-negative cases also form a common ALCL signature that is distinct from that of other T-cell lymphomas, supporting their continued separation from peripheral T-cell lymphoma, not otherwise specified (PTCL, NOS).²⁸⁴ However, distinct signatures separate the ALCLs by ALK status as well, with ALK-positive tumors overexpressing the cyclin, CCND3, as well other signal transduction molecules (SYK, LYN, CDC37) and ALK-negative lymphomas demonstrating decreased expression of p19INK4D, a cell cycle inhibitor, and underexpression of homeobox transcription factors, HOXC6 and HOXA4.²⁸⁶

Recently studies on miRNAs in ALK-positive ALCLs have identified both miR-135b and miR-29a as regulated by the expression of the NPM1-ALK fusion. The resultant up-regulation of miR-135b blocks IL-17 production by ALCL cells, suppressing a Th2 phenotype and inducing a Th17 phenotype.²⁸⁷ These results are compatible with the gene expression profiling studies that also find a prominent Th17 signature.²⁸³ NPM-ALK mediated down-regulation of miR-29a may result in the downstream overexpression of MCL1 and inhibition of apoptosis.²⁸⁸ In the miR-29a study, the authors propose that the down-regulation of miR-29a is due to methylation of the miRNA promoter. Similarly, the NPM1-ALK fusion has also been implicated in the methylation of the IL2RG gene promoter directly through STAT3 regulation of DNA methyl transferases and indirectly through repression of miR-21 expression.²⁸⁹ Comparisons with ALK-negative ALCLs have been made through miRNA profiling, and identified several miRNAs up-regulated in the ALK-positive cases (miR-866-3p, miR-20b, miR-20a, miR-17, and miR-106a) and miR-155 which was highly up-regulated in the ALK-negative cases.²⁷⁴

Lastly, a recurrent t(6;7)(p25.3;q32.2) has recently been identified in ALK-negative ALCL via NGS methods.²⁹⁰ This reciprocal translocation places the DUSP22 phosphatase gene or the IRF4 gene (encoding MUM1) on chromosome 6p25.3 adjacent to chromosome 7q32.3, near the FRA7H fragile genomic site and miR-29, and is the first balanced translocation identified in this diagnostic entity. Using FISH probes against these loci, 20% to 45% of cases of ALK-negative ALCL (both systemic and primary cutaneous) were shown to have this rearrangement, approximately two-thirds with DUSP22, whereas only rare PTCLs were positive and with no other cutaneous T-cell lymphomas.^{275,290} DUSP22 and IRF4 are located within 40 kb of each other. Translocations of IRF4 do not appear to affect MUM1 expression; however, DUSP22-containing rearrangements result in a decrease of DUSP22 expression, which has been shown to have tumor suppressor activity in some other T-cell neoplasms, as well as overexpression of miR-29.²⁹⁰

Guidelines for Molecular Testing in Anaplastic Large Cell Lymphoma

Beyond IHC, no particular molecular studies are required for the diagnosis of ALCL. TCR gene rearrangement studies may be helpful for the identification of a molecular marker to monitor response to therapy (MRD testing), although the test only has analytical sensitivity of approximately 1% to 5%. If TCR studies fail to detect a reliable marker of disease, FISH for the t(2;5) may be helpful for ALK-positive cases, although the analytical sensitivity for this assay is not superior to the molecular studies. As the probes for the DUSP22/IRF4 and FRA7H loci become available, this may become a useful discriminator between ALK-negative ALCL and PTCL, NOS, permitting better prognostication.²⁹¹

P.1822

Diagnosis

Consider PCR or NGS for TCR gene rearrangement studies

Consider FISH for t(2;5)

Consider FISH for t(6;7) as it becomes available

Peripheral T-cell Lymphoma, Not Otherwise Specified

PTCL, NOS, is a diagnosis of exclusion, accounting for approximately 26% of T-cell NHLs.²⁹² This category encompasses a wide range of neoplasms of T-cells that fail to fall clearly into the other defined categories of T-cell lymphomas. Many of these lymphomas are defined by site, rather than by the biology of the cell of origin. As a result, there is a wide range of clinical, epidemiologic, and pathologic findings. In addition, there are few cytogenetic changes specifically associated with PTCL, but rather a panoply of nonspecific changes. Essentially all cases of PTCL, NOS, contain clonally rearranged TCR genes that can be detected by a combination of TRG@ and TRB@ commercial primers.²²

Discrimination between ALK-positive ALCL, ALK-negative ALCL, and PTCL, NOS, has been the focus of much research in an attempt to define different cells of origin, aspiring to the success seen in the B-cell lymphomas. The diagnostic dilemma is particularly challenging between ALK-negative ALCL and PTCL, NOS, with high expression of CD30. The distinction between these two entities is clinically relevant inasmuch as prognostically the ALK-negative ALCLs fare better than the PTCLs (74% 5-year overall survival for cases with a low prognostic index, IPI 0-1, versus 52% to 56% for similar IPI PTCL groups, respectively).^{291,292}

Cytogenetic studies have identified a wide spectrum of changes in these latter two entities (ALK-positive ALCL detailed in the previous section) which point to slightly different patterns of aberrations, albeit with some overlap. Both disease categories share common gains of 1q and 3p and losses of 13q.²⁸¹ As mentioned in the previous section, ALK-negative ALCL also demonstrate losses of 16pter, 6q13q21, 15, and 17p13 whereas PTCL, NOS, showed losses of 6q22q24, 9p21-pter, 10p13pter, 10q23-24, and 12q21-q22 as well as additional gains of 7q22q31, 5p, 11q13, and 12p13.^{281,293,294} None of the specific aberrations appear to have discrete impacts on overall survival although general cytogenetic complexity does correspond to poorer overall survival.

SNP arrays have identified candidate genes at the site of recurrent losses in PTCL at chromosome 9p21.3, encompassing CDKN2A and CDKN2B, loci that encode for key proteins in regulating cell cycling and apoptosis, p14/p16 and p15, respectively.²⁹⁵ In addition, the recurrent gain at 7p22 contains the apoptosis-related gene CARD11 (CARMA1), corresponding to overexpression of the corresponding mRNA. Prognostically, gains at chromosomes 2 and 5 are associated with poor clinical outcomes in PTCL.²⁹⁵

MRD

Consider PCR or NGS for TCR gene rearrangement studies

Gene expression profiling has been perhaps the most useful in discerning differences in biology of different T-cell lymphomas. However, due to its heterogeneity, PTCL, NOS, not surprisingly has been difficult to associate with a clear defining transcriptional signature, often interspersed among the other subtypes of T-cell lymphomas.²⁹⁶ The most successful profiling experiments have been able to assign profiles to PTCL, NOS, which most closely resemble activated CD4⁺ or CD8⁺ T cells.²⁹⁷ Transcriptional profiling has identified one discrete subset of PTCL, NOS, which expresses a signature characteristic of cytotoxic T-cells and is associated with a poor prognosis. Although not all these tumors are CD8⁺ (in fact, 55% were CD4⁺), they expressed two key transcription factors found in CD8⁺ T-cells, T-bet (TBX21) and eomesodermin, as well as their target genes (CXCR3, IL2RB, CCL3, IFNG). These cells also expressed typical cytotoxic molecules and even killer cell immunoglobulin-like receptor family members and other NK-cell markers.²⁸³

A single recurrent translocation has been found in a particular histologic subtype of PTCL accounting for 18% of PTCL, NOS.^{298,299} The t(5;9)(q31-q32;q22) represents one of the few recurrent translocations in PTCL, NOS, and appears to be specific, inasmuch as it is not found in angioimmunoblastic T-cell lymphoma (AITL) or ALK-negative ALCL.²⁹⁹ This rearrangement fuses the inducible T-cell kinase (ITK) with the spleen tyrosine kinase (SYK). ITK is activated through the TCR. SYK is integral in the function of both the BCR and the TCR, playing the predominant role in B-cells whereas ZAP-70 plays an analogous role in T-cells.³⁰⁰ The fusion results in loss of the ITK kinase domain and autoinhibitory SH2 and SH3 domains (with retention of the pleckstrin homology domain and proline-rich region) and their replacement by the kinase domain of SYK, which may prove to be a reasonable target for kinase inhibitors such as fostamatinib.²⁷⁵ These lymphomas demonstrate a characteristic histologic pattern of lymphoid follicles ("follicular pattern" PTCL) which immunophenotypically marks a neoplasm of follicular helper T-cells. This raises the possibility that this neoplasm may be more closely related to AITL than to other cases of PTCL, NOS, although the t(5;9) has yet to be identified in AITL.

Although the ITK-SYK translocation is limited to follicular pattern PTCL, approximately 95% of all peripheral T-cell lymphomas demonstrate overexpression of SYK by IHC, whereas nonneoplastic T-cells are negative. The kinase in these lymphomas is phosphorylated and therefore in an activated state, suggesting the possibility of SYK inhibition in the treatment of PTCL.^{275,301} Similarly, overexpression of PDGFRA has been identified in 85% to 90% of PTCLs by gene expression profiling studies and RT-PCR without any genomic imbalances involving the 4q11-q13 locus, providing another potential molecular target for treatment.^{275,297,302}

Rare cases of a IRF4-TRA@ fusion in PTCL have also been noted, resulting from a t(6;14)(p25;q11.2). These cases appear to be associated with a cytotoxic T-cell phenotype and involve the bone marrow and skin without concomitant lymphadenopathy.³⁰³

Recently, mutations in TET2 and DNMT3A, commonly associated with acute myeloid leukemias (AML), have also been identified in PTCL.^{304,305, 306, 307} and ³⁰⁸ Both genes involve epigenetic regulation of transcription through CpG methylation. TET2 is involved in the oxidation of the 5-methyl group of 5-methylcytosine, believed to be the first step in demethylation. DNMT3A is a DNA methyltransferase, although the role of DNMT3A mutations in global methylation status is unclear. TET2 mutations have been found in 12% of nodal and extranodal T-cell lymphomas (compared to only 2% of B-cell lymphomas) and are not found in the leukemic or disseminated T-cell neoplasms such as T-PLL, T-cell large granular lymphocytic leukemia, or adult T-cell leukemia/lymphoma.³⁰⁸ TET2 mutations are often found in conjunction with mutations in DNMT3A as well.³⁰⁴

Guidelines for Molecular Testing in Peripheral T-cell Lymphoma

TCR gene rearrangement studies may be helpful for the identification of a molecular marker to monitor response to therapy (MRD testing), although the test only has analytical sensitivity of approximately 1% to 5%. In addition, SYK and PDGFR α overexpression by IHC may become therapeutically relevant in the future as may molecular testing for mutations in TET2 and DNMT3A. Because TET2 mutations are spread throughout the gene and the common R882 site in DNMT3A does not account for all mutations in that gene either, these targets for molecular testing will be less useful as markers of MRD.

Angioimmunoblastic T-cell Lymphoma

AITL is an EBV-associated T-cell lymphoma associated with a wide range of systemic symptomatology.^{4,275} It is one of the more common subtypes of peripheral T-cell lymphomas, accounting

P.1823

for 15% to 20% of cases, although it comprises only 1% to 2% of all NHLs.⁴ Patients typically present in their sixth or seventh decade. Systemic symptoms include hepatosplenomegaly, lymphadenopathy, polyclonal

hypergammaglobulinemia, rash, pruritus, cold agglutinin disease associated with hemolytic anemia, positive rheumatoid factor, the presence of antismooth muscle antibodies, and immunodeficiency. Interestingly, although this lymphoma is associated with EBV, only the background B-cells in this lymphoma are EBV-positive. The EBV-driven B-cells can undergo a resultant immunoblastic proliferation and often can demonstrate a clonal/pseudoclonal Ig gene rearrangement. The T-cells, by contrast, are EBV-negative. AITL is one of the few T-cell lymphomas for which the cell of origin is well established to be a CD4⁺ follicular helper T-cell. Clonally rearranged TCR genes are identified in 95% of cases of AITL using commercial primers.²²

Diagnosis

Consider PCR or NGS for TCR gene rearrangement studies

Consider IHC for SYK and PDGFR α

Future: novel markers by PCR or NGS

Early attempts at establishing a gene expression profile of AITL were plagued by the numerous contaminating B-cells, dendritic cells, and endothelial cells in this lymphoma.^{296,309,310} However, recent studies have confirmed a signature of follicular helper T-cells in AITL, with expression of CXCL13, CXCR5, BCL6, PDCD1, CD40LG, and NFATC1.^{283,311} These studies have defined the characteristic protein profile of the neoplastic cells in AITL through the use of a range of IHC markers and in situ hybridization for EBV RNA. In addition, a signature of immunosuppressive cytokines and their receptors was also notable (TNF- β 1, TNF- β 2, IL-10R α , IL-10-R β).²⁸³ A prognostic signature was also obtained for AITL by gene expression profiling. Cases with a poor prognosis (1.05 years median overall survival versus 3.06 years, $P < 0.001$) demonstrate high expression levels of PDGFR α and PDGFR β , suggesting the potential for tyrosine kinase inhibitors in treating this disorder.^{275,283}

Until recently little was known about any recurrent genetic aberrations in AITL. aCGH studies identify gains of 22q, 19 and 11q11-q14 (11q13) and losses of 13q.²⁹³ The gain of 11q13 is shared by both AITL and PTCL, NOS, and may involve either CCND1 or GSTP1, a gene often co-amplified with CCND1 encoding for a glutathione transferase. aSNP studies show general copy number or LOH findings very similar to those of PTCL, NOS. Specifically in AITL, gains of 13q22.3 may involve MYCBP2, a gene that encodes a MYC binding protein with putative ubiquitin ligase activity that may regulate MYC-mediated transcription. These gains are associated with poor prognosis in these patients.²⁹⁵

Diagnosis

Consider PCR or NGS for TCR gene rearrangement studies

Consider *IDH2* testing

MRD

Consider PCR or NGS for TCR gene rearrangement studies

MRD

Consider PCR or NGS for TCR gene rearrangement studies

Consider *IDH2* testing

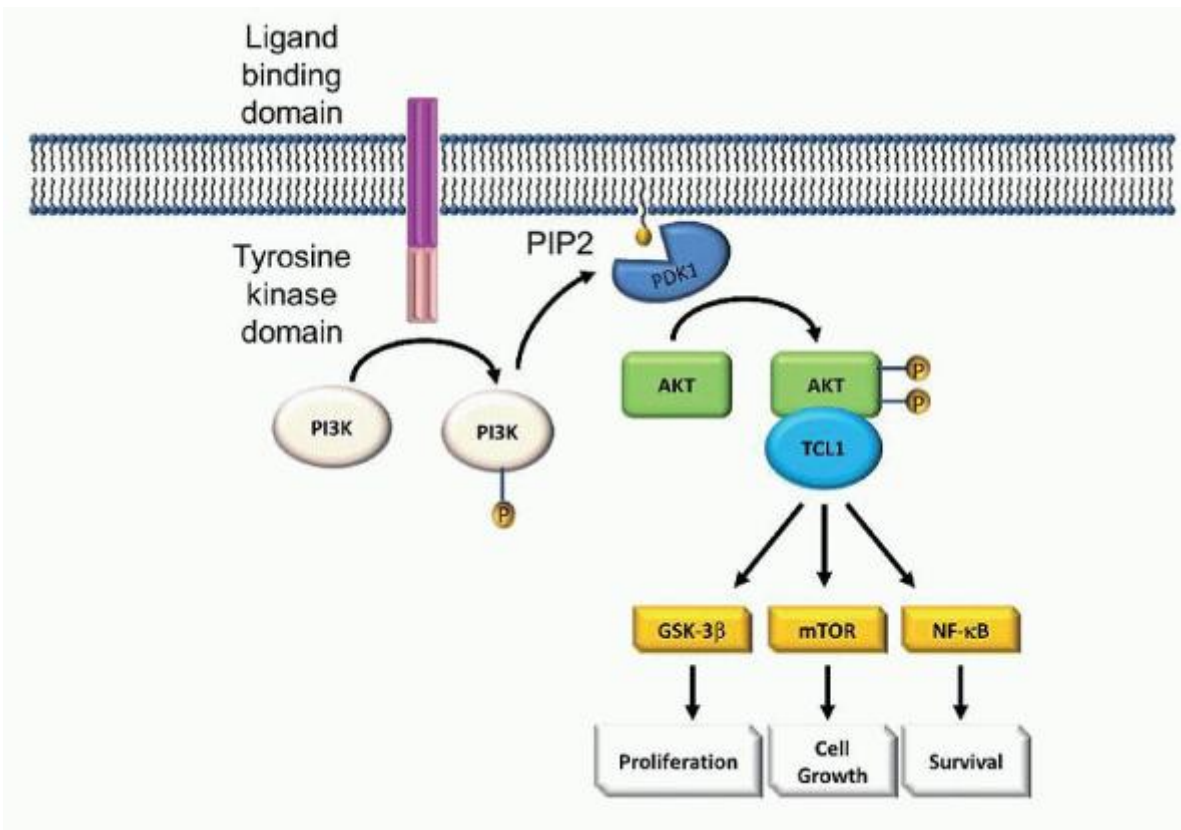

FIGURE 87.15. Biology of TCL-1. Receptor tyrosine kinases activate PI3K through phosphorylation which in turn catalyzes the formation of phosphatidylinositol-3,4-bisphosphate (PIP₂) and phosphatidylinositol-3,4,5-trisphosphate (PIP₃). These molecules localize PDK1 to the membrane which then phosphorylates AKT. The interaction of TCL1 with activated AKT further enhances the phosphorylation of downstream AKT target substrates.

Recently, mutations in TET2, DNMT3A, and IDH2 have been identified at a high prevalence in AITL. All three genes are involved in the DNA methylation. The roles of TET2 and DNMT3A in the regulation of DNA methylation have been described above. TET2 mutations have been found in up to 33% of cases of AITL, located throughout the gene on chromosome 10.308 It is common for TET2 mutations to occur in conjunction with DNMT3A mutations, implying some synergism.³⁰⁴ IDH2, located on chromosome 15q21-qter, encodes for a mitochondrial NADP(+)-dependent isocitrate dehydrogenase which physiologically plays a role in the citric acid cycle, converting isocitrate to α -ketoglutarate. The mutant enzyme is believed to catalyze the production of (R)-2-hydroxyglutarate which may inhibit the function of TET2 and Jumonji histone demethylases, thereby affecting epigenetic regulation of the cell.^{312, 313, 314} and ³¹⁵ IDH2 mutations (predominantly R172, with fewer R140) were identified in approximately 45% of all cases of AITL.³¹⁶ Identical mutations are also seen in gliomas and AMLs.^{314,317} Unlike in these other disease types, mutations in IDH1 are not identified and there is no suggestion of any prognostic import of the identification of this mutation at this time. Likewise, TET2 and DNMT3A mutations are also common in AML and other myeloid neoplasms. The coincident finding of similar sets of mutations in myeloid and T-cell neoplasms may be a result of the established relationship of these lineages,^{220,224} and may point to possible common pathways on tumorigenesis. These mutations may also provide targets for novel therapeutics in AITL and MRD monitoring, although to date no studies have been conducted to investigate their use in MRD testing. IDH2 provides the greatest potential for MRD testing inasmuch as a single mutation at R172 accounts for 15/16 cases examined, allowing for high clinical sensitivity and the development of highly sensitive allele-specific PCR assays.

P.1824

Guidelines for Molecular Testing in Angioimmunoblastic Lymphoma

TCR gene rearrangement studies may be helpful for the identification of a molecular marker to monitor response to therapy (MRD testing), although the test only has analytical sensitivity of approximately 1% to 5%. Future testing

modalities may also include use of the IDH2 R172 or R140 mutations in diagnosis and monitoring of MRD for AITL. In addition, assessment of PDGFR expression may be prognostically helpful, although a clinically useful testing modality has not yet been identified.

T-prolymphocytic Leukemia

T-PLL is a rare aggressive T-cell neoplasm found in adults. Involvement is predominantly of the peripheral blood and bone marrow, with frequent infiltration of the lymph nodes and occasionally of the skin (20% of cases).⁴ This neoplasm is not known to be virally driven, although it occurs with increased frequency in patient with ataxia-telangiectasia due to mutations in the ATM gene.³¹⁸ Clonal rearrangements of the TCR genes are detectable in essentially all cases of T-PLL using commercial primers against TCRG and TCRB.²²

Although the cell of origin is poorly understood, T-PLL is easily distinguished from other T-cell neoplasms by the presence of hallmark translocations and inversions involving the oncogenes TCL1A, TCL1B, or MTCP1 with the TRA@ gene. These rearrangements are found in greater than 90% of cases of T-PLL.³¹⁹ TCL1A and TCL1B are located on chromosome 14q32, resulting in inv(14)(q11;q32.1) or t(14;14)(q11;q32.1). Less frequently, translocations can involve the homologous MTCP1 locus in chromosome Xq28 in a t(X;14)(q28;q11). Overexpression of the genes fused to the TRA@ locus at the J/D segment is the result in all these aberrations. This overexpression is independent of the orientation relative to the TRA@ enhancer, due to the presence of TCL1A and TCL1B in opposite orientations within a 120 kb region which separates the two breakpoint clusters common at 14q32.1.³¹⁸ Less commonly, rearrangements of TCL1 can involve TRB@ as well.³²⁰

TCL1A and TCL1B encode for a cytoplasmic protein that is typically expressed in early double-negative T-cell progenitors and most B-cells, but not in mature T-cells. However, its overexpression in T-PLL, a mature T-cell neoplasm, appears to be oncogenic, functioning through activation of the AKT pathway (Fig. 87.15).³¹⁸ In addition, recently ATM has been identified as a TCL1-interaction protein, leading to activation of the NF-κB pathway.³²¹

Various profiling methods (aCGH, aSNP, and gene expression profiling) have identified other common secondary cytogenetic aberrations in T-PLL, which can lead to quite complex karyotypes.^{322,323} These changes include large regions of gains in 6p and 8q, as well as losses of 6q, 8p, 10p, 11q, and 22q. These loci correspond to genes found to be over- or underexpressed by gene expression profiling which involved pathways in lymphomagenesis, cell cycle regulation, apoptosis, and DNA repair.³²² In particular, SMARCB1, a gene involved in chromatin remodeling and checkpoint control, may be recurrently lost on 22q11.23.³²⁴

Guidelines for Molecular Testing in T-prolymphocytic Leukemia

TCR gene rearrangement studies may be helpful for the identification of a molecular marker to monitor response to therapy (MRD testing), although the test only has analytical sensitivity of approximately 1% to 5%. Likewise, FISH for inv(14) or t(14;14) suffers from a similar lack of analytical sensitivity.

Diagnosis

MRD

Consider PCR or NGS for TCR gene rearrangement studies

Consider PCR or NGS for TCR gene rearrangement studies

FISH for inv(14) or t(14;14)

Consider FISH for inv(14) or t(14;14)

REFERENCES

1. A clinical evaluation of the International Lymphoma Study Group classification of non-Hodgkin's lymphoma. The Non-Hodgkin's Lymphoma Classification Project. *Blood* 1997;89(11):3909-3918.
2. Cancer Facts & Figures 2012. American Cancer Society. 2012(Atlanta).
3. Howlader N, Noone AM, Krapcho M, et al., eds. SEER Cancer Statistics Review, 1975-2009 (Vintage 2009 Populations).
4. Swerdlow SH, International Agency for Research on Cancer, World Health Organization. WHO classification of tumours of haematopoietic and lymphoid tissues, 4th ed. Lyon, France: International Agency for Research on Cancer, 2008.
5. Burkitt DP. A sarcoma involving the jaws in African children. *Br J Surg* 1958;46(197):218-223.
6. Tsujimoto Y, Finger LR, Yunis J, Nowell PC, Croce CM. Cloning of the chromosome breakpoint of neoplastic B cells with the t(14;18) chromosome translocation. *Science* 1984;226(4678):1097-1099.
7. Klein U, Dalla-Favera R. Germinal centres: role in B-cell physiology and malignancy. *Nat Rev Immunol* 2008;8(1):22-33.

8. Shaffer AL, Rosenwald A, Staudt LM. Lymphoid malignancies: the dark side of B-cell differentiation. *Nat Rev Immunol* 2002;2(12):920-932.
9. Roullet M, Bagg A. The basis and rational use of molecular genetic testing in mature B-cell lymphomas. *Adv Anat Pathol* 2010;17(5):333-358.
10. Aster JC, Longtine JA. Detection of BCL2 rearrangements in follicular lymphoma. *Am J Pathol* 2002;160(3):759-763.
11. Available at www.genenames.org.
12. Schroeder HW Jr, Cavacini L. Structure and function of immunoglobulins. *J Allergy Clin Immunol* 2010;125(2 Suppl 2):S41-52.
13. Abbas AK, Lichtman AH, Pillai S. Cellular and molecular immunology, 7th ed. Philadelphia, PA: Elsevier/Saunders, 2012.
14. Evans PA, Pott C, Groenen PJ, et al. Significantly improved PCR-based clonality testing in B-cell malignancies by use of multiple immunoglobulin gene targets. Report of the BIOMED-2 Concerted Action BHM4-CT98-3936. *Leukemia* 2007;21(2):207-214.
15. Liu H, Bench AJ, Bacon CM, et al. A practical strategy for the routine use of BIOMED-2 PCR assays for detection of B- and T-cell clonality in diagnostic haematopathology. *Br J Haematol* 2007;138(1):31-43.
16. van Dongen JJ, Langerak AW, Bruggemann M, et al. Design and standardization of PCR primers and protocols for detection of clonal immunoglobulin and T-cell receptor gene recombinations in suspect lymphoproliferations: report of the BIOMED-2 Concerted Action BMH4-CT98-3936. *Leukemia* 2003;17(12):2257-2317.
17. van Krieken JH, Langerak AW, Macintyre EA, et al. Improved reliability of lymphoma diagnostics via PCR-based clonality testing: report of the BIOMED-2 Concerted Action BHM4-CT98-3936. *Leukemia* 2007;21(2):201-206.
18. Alencar AJ, Malumbres R, Kozloski GA, et al. MicroRNAs are independent predictors of outcome in diffuse large B-cell lymphoma patients treated with R-CHOP. *Clin Cancer Res* 2011;17(12):4125-4135.
- 18a. Faram M, Zheng J, Moorhead M, et al. Deep-sequencing for minimal residual disease detection in acute lymphoblastic leukemia. *Blood* 2012;120(26): 5173-5180.
19. van Dongen JJ, Comans-Bitter WM, Wolvers-Tettero IL, Borst J. Development of human T lymphocytes and their thymus-dependency. *Thymus* 1990; 16(3-4):207-234.
20. Winoto A, Baltimore D. Separate lineages of T cells expressing the alpha beta and gamma delta receptors. *Nature* 1989;338(6214):430-432.
21. Lefranc MP. IMGT databases, web resources and tools for immunoglobulin and T cell receptor sequence analysis, <http://imgt.cines.fr>. *Leukemia* 2003;17(1):260-266.
22. Bruggemann M, White H, Gaulard P, et al. Powerful strategy for polymerase chain reaction-based clonality assessment in T-cell malignancies Report of the BIOMED-2 Concerted Action BHM4 CT98-3936. *Leukemia* 2007;21(2):215-221.
23. Southern EM. Detection of specific sequences among DNA fragments separated by gel electrophoresis. *J Mol Biol* 1975;98(3):503-517.
24. Trask BJ. Fluorescence in situ hybridization: applications in cytogenetics and gene mapping. *Trends Genet* 1991;7(5):149-154.
25. Gutierrez NC, Garcia JL, Hernandez JM, et al. Prognostic and biologic significance of chromosomal imbalances assessed by comparative genomic hybridization in multiple myeloma. *Blood* 2004;104(9):2661-2666.
26. Schwaenen C, Nessling M, Wessendorf S, et al. Automated array-based genomic profiling in chronic lymphocytic leukemia: development of a clinical tool and discovery of recurrent genomic alterations. *Proc Natl Acad Sci U S A* 2004;101(4):1039-1044.
27. Maciejewski JP, Tiu RV, O'Keefe C. Application of array-based whole genome scanning technologies as a cytogenetic tool in haematological malignancies. *Br J Haematol* 2009;146(5):479-488.
28. ISCN rules for listing chromosomal rearrangements. *Curr Protoc Hum Genet* 1998:A.4C.1-A.4C.55.
29. Damle RN, Wasil T, Fais F, et al. Ig V gene mutation status and CD38 expression as novel prognostic indicators in chronic lymphocytic leukemia. *Blood* 1999;94(6):1840-1847.

30. Hamblin TJ, Davis Z, Gardiner A, Oscier DG, Stevenson FK. Unmutated Ig V(H) genes are associated with a more aggressive form of chronic lymphocytic leukemia. *Blood* 1999;94(6):1848-1854.
31. de Ravel TJ, Devriendt K, Fryns JP, Vermeesch JR. What's new in karyotyping? The move towards array comparative genomic hybridisation (CGH). *Eur J Pediatr* 2007;166(7):637-643.
32. Maciejewski JP, Mufti GJ. Whole genome scanning as a cytogenetic tool in hematologic malignancies. *Blood* 2008;112(4):965-974.
33. Gunn SR, Mohammed MS, Gorre ME, et al. Whole-genome scanning by array comparative genomic hybridization as a clinical tool for risk assessment in chronic lymphocytic leukemia. *J Mol Diagn* 2008;10(5): 442-451.
34. Gutierrez NC, Garcia JL, Hernandez JM, et al. Prognostic and biologic significance of chromosomal imbalances assessed by comparative genomic hybridization in multiple myeloma. *Blood* 2004;104(9):2661-2666.
35. Balcarkova J, Urbankova H, Scudla V, et al. Gain of chromosome arm 1q in patients in relapse and progression of multiple myeloma. *Cancer Genet Cytogenet* 2009;192(2):68-72.
36. Lennon PA, Zhuang Y, Pierson D, et al. Bacterial artificial chromosome array-based comparative genomic hybridization using paired formalin-fixed, paraffin-embedded and fresh frozen tissue specimens in multiple myeloma. *Cancer* 2009;115(2):345-354.
37. Sanger F, Nicklen S, Coulson AR. DNA sequencing with chain-terminating inhibitors. *Proc Natl Acad Sci U S A* 1977;74(12):5463-5467.
38. Rizzo JM, Buck MJ. Key Principles and clinical applications of “next-generation” DNA sequencing. *Cancer Prev Res (Phila)* 2012;5(7):887-900.
39. Metzker ML. Sequencing technologies - the next generation. *Nat Rev Genet* 2010;11(1):31-46.
40. Available from: http://www.ornl.gov/sci/techresources/Human_Genome/project/whydoe.shtml.
41. Lea NC, Abdallah A, Kizilors A, et al. Kings Health Partners 17 gene amplicon panel for next generation sequencing one stop mutational assessment in myeloid malignancies. *Blood* 2011;118(21):Abstract #748.
42. Mandruzzato S. Technological platforms for microarray gene expression profiling. In: Mocellin S, Rossi CR, eds. *Microarray technology and cancer gene profiling*. New York, NY: Landes Bioscience and Springer Science+Business Media, LLC, 2007:12-18.
43. Crespo M, Bosch F, Villamor N, et al. ZAP-70 expression as a surrogate for immunoglobulin-variable-region mutations in chronic lymphocytic leukemia. *N Engl J Med* 2003;348(18):1764-1775.
44. Rosenwald A, Staudt LM. Gene expression profiling of diffuse large B-cell lymphoma. *Leuk Lymphoma* 2003;44(Suppl 3):S41-S47.
45. Savage KJ, Monti S, Kutok JL, et al. The molecular signature of mediastinal large B-cell lymphoma differs from that of other diffuse large B-cell lymphomas and shares features with classical Hodgkin lymphoma. *Blood* 2003;102(12):3871-3879.
46. Willenbrock K, Kuppers R, Renne C, et al. Common features and differences in the transcriptome of large cell anaplastic lymphoma and classical Hodgkin's lymphoma. *Haematologica* 2006;91(5):596-604.
47. Alvarez-Garcia I, Miska EA. MicroRNA functions in animal development and human disease. *Development* 2005;132(21):4653-4662.
48. Sevignani C, Calin GA, Siracusa LD, Croce CM. Mammalian microRNAs: a small world for fine-tuning gene expression. *Mamm Genome* 2006;17(3): 189-202.
49. Krichevsky AM, King KS, Donahue CP, Khrapko K, Kosik KS. A microRNA array reveals extensive regulation of microRNAs during brain development. *RNA* 2003;9(10):1274-1281.
50. Miska EA, Alvarez-Saavedra E, Townsend M, et al. Microarray analysis of microRNA expression in the developing mammalian brain. *Genome Biol* 2004;5(9):R68.
51. Havelange V, Garzon R. MicroRNAs: emerging key regulators of hematopoiesis. *Am J Hematol* 2010;85(12):935-942.
52. Garzon R, Croce CM. MicroRNAs in normal and malignant hematopoiesis. *Curr Opin Hematol* 2008;15(4):352-358.

53. Lim LP, Lau NC, Garrett-Engele P, et al. Microarray analysis shows that some microRNAs downregulate large numbers of target mRNAs. *Nature* 2005;433(7027):769-773.
54. Calin GA, Dumitru CD, Shimizu M, et al. Frequent deletions and down-regulation of micro- RNA genes miR15 and miR16 at 13q14 in chronic lymphocytic leukemia. *Proc Natl Acad Sci U S A* 2002;99(24):15524-15529.
55. Calin GA, Ferracin M, Cimmino A, et al. A MicroRNA signature associated with prognosis and progression in chronic lymphocytic leukemia. *N Engl J Med* 2005;353(17):1793-1801.
56. Calin GA, Pekarsky Y, Croce CM. The role of microRNA and other non-coding RNA in the pathogenesis of chronic lymphocytic leukemia. *Best Pract Res Clin Haematol* 2007;20(3):425-437.
57. Metzler M, Wilda M, Busch K, Viehmann S, Borkhardt A. High expression of precursor microRNA-155/BIC RNA in children with Burkitt lymphoma. *Genes Chromosomes Cancer* 2004;39(2):167-169.
58. Jiang J, Lee EJ, Schmittgen TD. Increased expression of microRNA-155 in Epstein-Barr virus transformed lymphoblastoid cell lines. *Genes Chromosomes Cancer* 2006;45(1):103-106.
59. Eis PS, Tam W, Sun L, et al. Accumulation of miR-155 and BIC RNA in human B cell lymphomas. *Proc Natl Acad Sci U S A* 2005;102(10):3627-3632.
60. Alizadeh AA, Eisen MB, Davis RE, et al. Distinct types of diffuse large B-cell lymphoma identified by gene expression profiling. *Nature* 2000;403(6769):503-511.
61. Kuppers R, Klein U, Schwering I, et al. Identification of Hodgkin and Reed-Sternberg cell-specific genes by gene expression profiling. *J Clin Invest* 2003;111(4):529-537.
62. He L, Thomson JM, Hemann MT, et al. A microRNA polycistron as a potential human oncogene. *Nature* 2005;435(7043):828-833.
63. Gardiner-Garden M, Frommer M. CpG islands in vertebrate genomes. *J Mol Biol* 1987;196(2):261-282.
64. Takai D, Jones PA. Comprehensive analysis of CpG islands in human chromosomes 21 and 22. *Proc Natl Acad Sci U S A* 2002;99(6):3740-3745.
65. Ammerpohl O, Martin-Subero JI, Richter J, Vater I, Siebert R. Hunting for the 5th base: techniques for analyzing DNA methylation. *Biochim Biophys Acta* 2009;1790(9):847-862.
66. Chang JW, Huang TH, Wang YC. Emerging methods for analysis of the cancer methylome. *Pharmacogenomics* 2008;9(12):1869-1878.
67. Huang YW, Huang TH, Wang LS. Profiling DNA methylomes from microarray to genome-scale sequencing. *Technol Cancer Res Treat* 2010;9(2): 139-147.
68. Jarrett RF. Viruses and lymphoma/leukaemia. *J Pathol* 2006;208(2):176-186.
69. Hamilton-Dutoit SJ, Raphael M, Audouin J, et al. In situ demonstration of Epstein-Barr virus small RNAs (EBER 1) in acquired immunodeficiency syndrome-related lymphomas: correlation with tumor morphology and primary site. *Blood* 1993;82(2):619-624.
70. Raphael M, Gentilhomme O, Tulliez M, Byron PA, Diebold J. Histopathologic features of high-grade non-Hodgkin's lymphomas in acquired immunodeficiency syndrome. The French Study Group of Pathology for Human Immunodeficiency Virus-Associated Tumors. *Arch Pathol Lab Med* 1991;115(1):15-20.
71. Dalla-Favera R, Bregni M, Erikson J, Patterson D, Gallo RC, Croce CM. Human c-myc onc gene is located on the region of chromosome 8 that is translocated in Burkitt lymphoma cells. *Proc Natl Acad Sci U S A* 1982;79(24):7824-7827.
72. Taub R, Kirsch I, Morton C, et al. Translocation of the c-myc gene into the immunoglobulin heavy chain locus in human Burkitt lymphoma and murine plasmacytoma cells. *Proc Natl Acad Sci U S A* 1982;79(24):7837-7841.
73. Erikson J, Nishikura K, ar-Rushdi A, et al. Translocation of an immunoglobulin kappa locus to a region 3' of an unrearranged c-myc oncogene enhances c-myc transcription. *Proc Natl Acad Sci U S A* 1983;80(24):7581-7585.
74. Hollis GF, Mitchell KF, Battey J, et al. A variant translocation places the lambda immunoglobulin genes 3' to the c-myc oncogene in Burkitt's lymphoma. *Nature* 1984;307(5953):752-755.
75. Pelengaris S, Khan M, Evan G. c-MYC: more than just a matter of life and death. *Nat Rev Cancer* 2002;2(10):764-776.

76. Barriga F, Kiwanuka J, Alvarez-Mon M, et al. Significance of chromosome 8 breakpoint location in Burkitt's lymphoma: correlation with geographical origin and association with Epstein-Barr virus. *Curr Top Microbiol Immunol* 1988;141:128-137.
77. Gutierrez MI, Bhatia K, Barriga F, et al. Molecular epidemiology of Burkitt's lymphoma from South America: differences in breakpoint location and Epstein-Barr virus association from tumors in other world regions. *Blood* 1992;79(12):3261-3266.
78. Pelicci PG, Knowles DM 2nd, Magrath I, Dalla-Favera R. Chromosomal breakpoints and structural alterations of the c-myc locus differ in endemic and sporadic forms of Burkitt lymphoma. *Proc Natl Acad Sci U S A* 1986;83(9):2984-2988.
79. Shiramizu B, Barriga F, Neequaye J, et al. Patterns of chromosomal breakpoint locations in Burkitt's lymphoma: relevance to geography and Epstein-Barr virus association. *Blood* 1991;77(7):1516-1526.
80. Shiramizu B, Magrath I. Localization of breakpoints by polymerase chain reactions in Burkitt's lymphoma with 8;14 translocations. *Blood* 1990;75(9):1848-1852.
81. Haralambieva E, Banham AH, Bastard C, et al. Detection by the fluorescence in situ hybridization technique of MYC translocations in paraffin-embedded lymphoma biopsy samples. *Br J Haematol* 2003;121(1):49-56.
- P.1825
82. Lossos IS. Molecular pathogenesis of diffuse large B-cell lymphoma. *J Clin Oncol* 2005;23(26):6351-6357.
83. Aukema SM, Siebert R, Schuurin E, et al. Double-hit B-cell lymphomas. *Blood* 2011;117(8):2319-2331.
84. Li S, Lin P, Fayad LE, et al. B-cell lymphomas with MYC/8q24 rearrangements and IGH@BCL2/t(14;18)(q32;q21): an aggressive disease with heterogeneous histology, germinal center B-cell immunophenotype and poor outcome. *Mod Pathol* 2012;25(1):145-156.
85. Dave SS, Fu K, Wright GW, et al. Molecular diagnosis of Burkitt's lymphoma. *N Engl J Med* 2006;354(23):2431-2442.
86. Hummel M, Bentink S, Berger H, et al. A biologic definition of Burkitt's lymphoma from transcriptional and genomic profiling. *N Engl J Med* 2006;354(23):2419-2430.
87. Bueno MJ, Gomez de Cedron M, Gomez-Lopez G, et al. Combinatorial effects of microRNAs to suppress the Myc oncogenic pathway. *Blood* 2011;117(23):6255-6266.
88. Haralambieva E, Boerma EJ, van Imhoff GW, et al. Clinical, immunophenotypic, and genetic analysis of adult lymphomas with morphologic features of Burkitt lymphoma. *Am J Surg Pathol* 2005;29(8):1086-1094.
89. Zajac-Kaye M, Gelmann EP, Levens D. A point mutation in the c-myc locus of a Burkitt lymphoma abolishes binding of a nuclear protein. *Science* 1988;240(4860):1776-1780.
90. Baseggio L, Geay MO, Gazzo S, et al. In non-follicular lymphoproliferative disorders, IGH/BCL2-fusion is not restricted to chronic lymphocytic leukaemia. *Br J Haematol* 2012;158(4):489-498.
91. Huang JZ, Sanger WG, Greiner TC, et al. The t(14;18) defines a unique subset of diffuse large B-cell lymphoma with a germinal center B-cell gene expression profile. *Blood* 2002;99(7):2285-2290.
92. Weiss LM, Warnke RA, Sklar J, Cleary ML. Molecular analysis of the t(14;18) chromosomal translocation in malignant lymphomas. *N Engl J Med* 1987;317(19):1185-1189.
93. Tanaka S, Louie DC, Kant JA, Reed JC. Frequent incidence of somatic mutations in translocated BCL2 oncogenes of non-Hodgkin's lymphomas. *Blood* 1992; 79(1):229-237.
94. Cheng EH, Wei MC, Weiler S, et al. BCL-2, BCL-X(L) sequester BH3 domain-only molecules preventing BAX- and BAK-mediated mitochondrial apoptosis. *Mol Cell* 2001;8(3):705-711.
95. Yin XM, Oltvai ZN, Korsmeyer SJ. BH1 and BH2 domains of Bcl-2 are required for inhibition of apoptosis and heterodimerization with Bax. *Nature* 1994;369(6478):321-323.
96. Aarts WM, Bende RJ, Steenbergen EJ, et al. Variable heavy chain gene analysis of follicular lymphomas: correlation between heavy chain isotype expression and somatic mutation load. *Blood* 2000;95(9):2922-2929.

97. Payne K, Wright P, Grant JW, et al. BIOMED-2 PCR assays for IGK gene rearrangements are essential for B-cell clonality analysis in follicular lymphoma. *Br J Haematol* 2011;155(1):84-92.
98. Stamatopoulos K, Kosmas C, Papadaki T, et al. Follicular lymphoma immunoglobulin kappa light chains are affected by the antigen selection process, but to a lesser degree than their partner heavy chains. *Br J Haematol* 1997;96(1):132-146.
99. Vega F, Medeiros JL, Luthra R. Taqman PCR in the detection and quantification of chromosomal translocations in follicular lymphoma, mantle cell lymphoma and chronic myeloid leukemia: Taqman real-time PCR assay. *Internet J Pathol* 2002;2(1).
100. Weinberg OK, Ai WZ, Mariappan MR, Shum C, Levy R, Arber DA. "Minor" BCL2 breakpoints in follicular lymphoma: frequency and correlation with grade and disease presentation in 236 cases. *J Mol Diagn* 2007;9(4):530-537.
101. Vaandrager JW, Schuurin E, Raap T, Philippo K, Kleiverda K, Kluin P. Interphase FISH detection of BCL2 rearrangement in follicular lymphoma using breakpoint-flanking probes. *Genes Chromosomes Cancer* 2000;27(1):85-94.
102. Guo Y, Karube K, Kawano R, et al. Bcl2-negative follicular lymphomas frequently have Bcl6 translocation and/or Bcl6 or p53 expression. *Pathol Int* 2007;57(3):148-152.
103. Guo Y, Karube K, Kawano R, et al. Low-grade follicular lymphoma with t(14;18) presents a homogeneous disease entity otherwise the rest comprises minor groups of heterogeneous disease entities with Bcl2 amplification, Bcl6 translocation or other gene aberrances. *Leukemia* 2005;19(6):1058-1063.
104. Karube K, Guo Y, Suzumiya J, et al. CD10-MUM1+ follicular lymphoma lacks BCL2 gene translocation and shows characteristic biologic and clinical features. *Blood* 2007;109(7):3076-3079.
105. Katzenberger T, Ott G, Klein T, Kalla J, Muller-Hermelink HK, Ott MM. Cytogenetic alterations affecting BCL6 are predominantly found in follicular lymphomas grade 3B with a diffuse large B-cell component. *Am J Pathol* 2004;165(2):481-490.
106. Ott G, Katzenberger T, Lohr A, et al. Cytomorphologic, immunohistochemical, and cytogenetic profiles of follicular lymphoma: 2 types of follicular lymphoma grade 3. *Blood* 2002;99(10):3806-3812.
107. Leich E, Zamo A, Horn H, et al. MicroRNA profiles of t(14;18)-negative follicular lymphoma support a late germinal center B-cell phenotype. *Blood* 2011;118(20):5550-5558.
108. van Oers MH, Tonnissen E, Van Glabbeke M, et al. BCL-2/IgH polymerase chain reaction status at the end of induction treatment is not predictive for progression-free survival in relapsed/resistant follicular lymphoma: results of a prospective randomized EORTC 20981 phase III intergroup study. *J Clin Oncol* 2010;28(13):2246-2252.
109. Rambaldi A, Carlotti E, Oldani E, et al. Quantitative PCR of bone marrow BCL2/IgH+ cells at diagnosis predicts treatment response and long-term outcome in follicular non-Hodgkin lymphoma. *Blood* 2005;105(9):3428-3433.
110. Schmitt C, Balogh B, Grundt A, et al. The bcl-2/IgH rearrangement in a population of 204 healthy individuals: occurrence, age and gender distribution, breakpoints, and detection method validity. *Leuk Res* 2006;30(6):745-750.
111. Finke J, Slanina J, Lange W, Dolken G. Persistence of circulating t(14;18)-positive cells in long-term remission after radiation therapy for localized-stage follicular lymphoma. *J Clin Oncol* 1993;11(9):1668-1673.
112. Horsman DE, Connors JM, Pantzar T, Gascoyne RD. Analysis of secondary chromosomal alterations in 165 cases of follicular lymphoma with t(14;18). *Genes Chromosomes Cancer* 2001;30(4):375-382.
113. Viardot A, Barth TF, Moller P, Dohner H, Bentz M. Cytogenetic evolution of follicular lymphoma. *Semin Cancer Biol* 2003;13(3):183-190.
114. Cheung KJ, Rogic S, Ben-Neriah S, et al. SNP analysis of minimally evolved t(14;18)(q32;q21)-positive follicular lymphomas reveals a common copy-neutral loss of heterozygosity pattern. *Cytogenet Genome Res* 2012;136(1):38-43.
115. d'Amore F, Chan E, Iqbal J, et al. Clonal evolution in t(14;18)-positive follicular lymphoma, evidence for multiple common pathways, and frequent parallel clonal evolution. *Clin Cancer Res* 2008;14(22):7180-7187.
116. Schwaenen C, Viardot A, Berger H, et al. Microarray-based genomic profiling reveals novel genomic aberrations in follicular lymphoma which associate with patient survival and gene expression status. *Genes Chromosomes Cancer* 2009;48(1):39-54.
117. Leich E, Ott G, Rosenwald A. Pathology, pathogenesis and molecular genetics of follicular NHL. *Best Pract Res Clin Haematol* 2011;24(2):95-109.

118. Cheung KJ, Johnson NA, Affleck JG, et al. Acquired TNFRSF14 mutations in follicular lymphoma are associated with worse prognosis. *Cancer Res* 2010;70(22):9166-9174.
119. Dave SS, Wright G, Tan B, et al. Prediction of survival in follicular lymphoma based on molecular features of tumor-infiltrating immune cells. *N Engl J Med* 2004;351(21):2159-2169.
120. Clear AJ, Lee AM, Calaminici M, et al. Increased angiogenic sprouting in poor prognosis FL is associated with elevated numbers of CD163+ macrophages within the immediate sprouting microenvironment. *Blood* 2010;115(24):5053-5056.
121. Michels J, Foria V, Mead B, et al. Immunohistochemical analysis of the antiapoptotic Mcl-1 and Bcl-2 proteins in follicular lymphoma. *Br J Haematol* 2006;132(6):743-746.
122. Zhao WL, Daneshpouy ME, Mounier N, et al. Prognostic significance of bcl-xL gene expression and apoptotic cell counts in follicular lymphoma. *Blood* 2004;103(2):695-697.
123. Gulmann C, Espina V, Petricoin E 3rd, et al. Proteomic analysis of apoptotic pathways reveals prognostic factors in follicular lymphoma. *Clin Cancer Res* 2005;11(16):5847-5855.
124. Bjorck E, Ek S, Landgren O, et al. High expression of cyclin B1 predicts a favorable outcome in patients with follicular lymphoma. *Blood* 2005;105(7):2908-2915.
125. Lawrie CH, Chi J, Taylor S, et al. Expression of microRNAs in diffuse large B cell lymphoma is associated with immunophenotype, survival and transformation from follicular lymphoma. *J Cell Mol Med* 2009;13(7):1248-1260.
126. Baur AS, Shaw P, Burri N, Delacretaz F, Bosman FT, Chaubert P. Frequent methylation silencing of p15(INK4b) (MTS2) and p16(INK4a) (MTS1) in B-cell and T-cell lymphomas. *Blood* 1999;94(5):1773-1781.
127. Martin-Subero JI, Ammerpohl O, Bibikova M, et al. A comprehensive microarray-based DNA methylation study of 367 hematological neoplasms. *PLoS One* 2009;4(9):e6986.
128. Morin RD, Johnson NA, Severson TM, et al. Somatic mutations altering EZH2 (Tyr641) in follicular and diffuse large B-cell lymphomas of germinal-center origin. *Nat Genet* 2010;42(2):181-185.
129. Ryan RJ, Nitta M, Borger D, et al. EZH2 codon 641 mutations are common in BCL2-rearranged germinal center B cell lymphomas. *PLoS One* 2011;6(12):e28585.
130. Morin RD, Mendez-Lago M, Mungall AJ, et al. Frequent mutation of histonemodifying genes in non-Hodgkin lymphoma. *Nature* 2011;476(7360):298-303.
131. Swerdlow SH, Williams ME. From centrocytic to mantle cell lymphoma: a clinicopathologic and molecular review of 3 decades. *Hum Pathol* 2002;33(1):7-20.
132. Ondrejka SL, Lai R, Smith SD, Hsi ED. Indolent mantle cell leukemia: a clinicopathological variant characterized by isolated lymphocytosis, interstitial bone marrow involvement, kappa light chain restriction, and good prognosis. *Haematologica* 2011;96(8):1121-1127.
133. Orchard J, Garand R, Davis Z, et al. A subset of t(11;14) lymphoma with mantle cell features displays mutated IgVH genes and includes patients with good prognosis, nonnodal disease. *Blood* 2003;101(12):4975-4981.
134. Fu K, Weisenburger DD, Greiner TC, et al. Cyclin D1-negative mantle cell lymphoma: a clinicopathologic study based on gene expression profiling. *Blood* 2005;106(13):4315-4321.
135. Royo C, Salaverria I, Hartmann EM, Rosenwald A, Campo E, Bea S. The complex landscape of genetic alterations in mantle cell lymphoma. *Semin Cancer Biol* 2011;21(5):322-334.
136. Brito-Babapulle V, Ellis J, Matutes E, et al. Translocation t(11;14)(q13;q32) in chronic lymphoid disorders. *Genes Chromosomes Cancer* 1992;5(2):158-165.
137. Fiedler W, Weh HJ, Hossfeld DK. Comparison of chromosome analysis and BCL-1 rearrangement in a series of patients with multiple myeloma. *Br J Haematol* 1992;81(1):58-61.
138. Ronchetti D, Finelli P, Richelda R, et al. Molecular analysis of 11q13 breakpoints in multiple myeloma. *Blood* 1999;93(4):1330-1337.
139. Vandenbergh E, De Wolf Peeters C, Wlodarska I, et al. Chromosome 11q rearrangements in B non Hodgkin's lymphoma. *Br J Haematol* 1992;81(2):212-217.

140. Belaud-Rotureau MA, Parrens M, Dubus P, Garroste JC, de Mascarel A, Merlio JP. A comparative analysis of FISH, RT-PCR, PCR, and immunohistochemistry for the diagnosis of mantle cell lymphomas. *Mod Pathol* 2002;15(5):517-525.
141. Miranda RN, Briggs RC, Kinney MC, Veno PA, Hammer RD, Cousar JB. Immunohistochemical detection of cyclin D1 using optimized conditions is highly specific for mantle cell lymphoma and hairy cell leukemia. *Mod Pathol* 2000;13(12):1308-1314.
142. Zukerberg LR, Yang WI, Arnold A, Harris NL. Cyclin D1 expression in non-Hodgkin's lymphomas. Detection by immunohistochemistry. *Am J Clin Pathol* 1995;103(6):756-760.
143. Diehl JA. Cycling to cancer with cyclin D1. *Cancer Biol Ther* 2002;1(3):226-231.
144. Katzenberger T, Petzoldt C, Holler S, et al. The Ki67 proliferation index is a quantitative indicator of clinical risk in mantle cell lymphoma. *Blood* 2006;107(8):3407.
145. Tiemann M, Schrader C, Klapper W, et al. Histopathology, cell proliferation indices and clinical outcome in 304 patients with mantle cell lymphoma (MCL): a clinicopathological study from the European MCL Network. *Br J Haematol* 2005;131(1):29-38.
146. Wickham CL, Harries LW, Sarsfield P, Joyner MV, Ellard S. Large variation in t(11;14)(q13;q32) and t(14;18)(q32;q21) translocation product size is confirmed by sequence analysis of PCR products. *Clin Lab Haematol* 2006;28(4):248-253.
147. Chen RW, Bemis LT, Amato CM, et al. Truncation in CCND1 mRNA alters miR-16-1 regulation in mantle cell lymphoma. *Blood* 2008;112(3):822-829.
148. Wiestner A, Tehrani M, Chiorazzi M, et al. Point mutations and genomic deletions in CCND1 create stable truncated cyclin D1 mRNAs that are associated with increased proliferation rate and shorter survival. *Blood* 2007;109(11):4599-4606.
149. Kridel R, Meissner B, Rogic S, et al. Whole transcriptome sequencing reveals recurrent NOTCH1 mutations in mantle cell lymphoma. *Blood* 2012;119(9):1963-1971.
150. Schraders M, Oeschger S, Kluin PM, et al. Hypermutation in mantle cell lymphoma does not indicate a clinical or biological subentity. *Mod Pathol* 2009;22(3):416-425.
151. Gimenez E, Chauvet M, Rabin L, et al. Cloned IGH VDJ targets as tools for personalized minimal residual disease monitoring in mature lymphoid malignancies; a feasibility study in mantle cell lymphoma by the Groupe Ouest Est d'Etude des Leucemies et Autres Maladies du Sang. *Br J Haematol* 2012;158(2):186-197.
152. Chen YH, Gao J, Fan G, Peterson LC. Nuclear expression of sox11 is highly associated with mantle cell lymphoma but is independent of t(11;14)(q13;q32) in non-mantle cell B-cell neoplasms. *Mod Pathol* 2010;23(1):105-112.
153. Mozos A, Royo C, Hartmann E, et al. SOX11 expression is highly specific for mantle cell lymphoma and identifies the cyclin D1-negative subtype. *Haematologica* 2009;94(11):1555-1562.
154. Greiner TC, Moynihan MJ, Chan WC, et al. p53 mutations in mantle cell lymphoma are associated with variant cytology and predict a poor prognosis. *Blood* 1996;87(10):4302-4310.
155. Hernandez L, Fest T, Cazorla M, et al. p53 gene mutations and protein overexpression are associated with aggressive variants of mantle cell lymphomas. *Blood* 1996;87(8):3351-3359.
156. Dreyling MH, Bullinger L, Ott G, et al. Alterations of the cyclin D1/p16-pRB pathway in mantle cell lymphoma. *Cancer Res* 1997;57(20):4608-4614.
157. Pinyol M, Cobo F, Bea S, et al. p16(INK4a) gene inactivation by deletions, mutations, and hypermethylation is associated with transformed and aggressive variants of non-Hodgkin's lymphomas. *Blood* 1998;91(8): 2977-2984.
158. Pinyol M, Hernandez L, Cazorla M, et al. Deletions and loss of expression of p16INK4a and p21Waf1 genes are associated with aggressive variants of mantle cell lymphomas. *Blood* 1997;89(1):272-280.
159. Rosenwald A, Wright G, Wiestner A, et al. The proliferation gene expression signature is a quantitative integrator of oncogenic events that predicts survival in mantle cell lymphoma. *Cancer Cell* 2003;3(2):185-197.
160. Hartmann E, Fernandez V, Moreno V, et al. Five-gene model to predict survival in mantle-cell lymphoma using frozen or formalin-fixed, paraffin-embedded tissue. *J Clin Oncol* 2008;26(30):4966-4972.
161. Halldorsdottir AM, Kanduri M, Marincevic M, et al. Mantle cell lymphoma displays a homogenous methylation profile: a comparative analysis with chronic lymphocytic leukemia. *Am J Hematol* 2012;87(4):361-367.

162. Leshchenko VV, Kuo PY, Shaknovich R, et al. Genomewide DNA methylation analysis reveals novel targets for drug development in mantle cell lymphoma. *Blood* 2010;116(7):1025-1034.
163. Navarro A, Bea S, Fernandez V, et al. MicroRNA expression, chromosomal alterations, and immunoglobulin variable heavy chain hypermutations in Mantle cell lymphomas. *Cancer Res* 2009;69(17):7071-7078.
164. Zhao JJ, Lin J, Lwin T, et al. microRNA expression profile and identification of miR-29 as a prognostic marker and pathogenetic factor by targeting CDK6 in mantle cell lymphoma. *Blood* 2010;115(13):2630-2639.
165. Hangaishi A, Ogawa S, Qiao Y, et al. Mutations of Chk2 in primary hematopoietic neoplasms. *Blood* 2002;99(8):3075-3077.
166. Tort F, Hernandez S, Bea S, et al. CHK2-decreased protein expression and infrequent genetic alterations mainly occur in aggressive types of non-Hodgkin lymphomas. *Blood* 2002;100(13):4602-4608.
167. Camacho E, Hernandez L, Hernandez S, et al. ATM gene inactivation in mantle cell lymphoma mainly occurs by truncating mutations and missense mutations involving the phosphatidylinositol-3 kinase domain and is associated with increasing numbers of chromosomal imbalances. *Blood* 2002;99(1):238-244.
168. Farinha P, Gascoyne RD. Molecular pathogenesis of mucosa-associated lymphoid tissue lymphoma. *J Clin Oncol* 2005;23(26):6370-6378.
169. Aigelsreiter A, Gerlza T, Deutsch AJ, et al. Chlamydia psittaci Infection in non-gastrointestinal extranodal MALT lymphomas and their precursor lesions. *Am J Clin Pathol* 2011;135(1):70-75.
170. Auer IA, Gascoyne RD, Connors JM, et al. t(11;18)(q21;q21) is the most common translocation in MALT lymphomas. *Ann Oncol* 1997;8(10):979-985.
171. Ott G, Katzenberger T, Greiner A, et al. The t(11;18)(q21;q21) chromosome translocation is a frequent and specific aberration in low-grade but not high-grade malignant non-Hodgkin's lymphomas of the mucosa-associated lymphoid tissue (MALT-) type. *Cancer Res* 1997;57(18):3944-3948.
172. Liu H, Ye H, Dogan A, et al. T(11;18)(q21;q21) is associated with advanced mucosa-associated lymphoid tissue lymphoma that expresses nuclear BCL10. *Blood* 2001;98(4):1182-1187.
173. Dierlamm J, Baens M, Stefanova-Ouzounova M, et al. Detection of t(11;18) (q21;q21) by interphase fluorescence in situ hybridization using API2 and MLT specific probes. *Blood* 2000;96(6):2215-2218.
174. Nakagawa M, Seto M, Hosokawa Y. Molecular pathogenesis of MALT lymphoma: two signaling pathways underlying the antiapoptotic effect of API2-MALT1 fusion protein. *Leukemia* 2006;20(6):929-936.
175. Ye H, Dogan A, Karran L, et al. BCL10 expression in normal and neoplastic lymphoid tissue. Nuclear localization in MALT lymphoma. *Am J Pathol* 2000;157(4):1147-1154.
176. Murga Penas EM, Callet-Bauchu E, Ye H, et al. The t(14;18)(q32;q21)/IGHMALT1 translocation in MALT lymphomas contains templated nucleotide insertions and a major breakpoint region similar to follicular and mantle cell lymphoma. *Blood* 2010;115(11):2214-2219.
177. Sagaert X, De Wolf-Peeters C, Noels H, Baens M. The pathogenesis of MALT lymphomas: where do we stand? *Leukemia* 2007;21(3):389-396.
178. Streubel B, Vinatzer U, Lamprecht A, Raderer M, Chott A. T(3;14)(p14.1;q32) involving IGH and FOXP1 is a novel recurrent chromosomal aberration in MALT lymphoma. *Leukemia* 2005;19(4):652-658.
179. Liu H, Ye H, Ruskone-Fourmesttraux A, et al. T(11;18) is a marker for all stage gastric MALT lymphomas that will not respond to H. pylori eradication. *Gastroenterology* 2002;122(5):1286-1294.
180. Dierlamm J, Pittaluga S, Wlodarska I, et al. Marginal zone B-cell lymphomas of different sites share similar cytogenetic and morphologic features. *Blood* 1996;87(1):299-307.
181. Craig VJ, Cogliatti SB, Rehrauer H, Wundisch T, Muller A. Epigenetic silencing of microRNA-203 dysregulates ABL1 expression and drives Helicobacter-associated gastric lymphomagenesis. *Cancer Res* 2011;71(10):3616-3624.
182. Thorns C, Kuba J, Bernard V, et al. Deregulation of a distinct set of microRNAs is associated with transformation of gastritis into MALT lymphoma. *Virchows Arch* 2012;460(4):371-377.
183. Craig VJ, Cogliatti SB, Imig J, et al. Myc-mediated repression of microRNA-34a promotes high-grade transformation of B-cell lymphoma by dysregulation of FoxP1. *Blood* 2011;117(23):6227-6236.

184. Kondo T, Oka T, Sato H, et al. Accumulation of aberrant CpG hypermethylation by *Helicobacter pylori* infection promotes development and progression of gastric MALT lymphoma. *Int J Oncol* 2009;35(3):547-557.
185. Dohner H, Stilgenbauer S, Dohner K, Bentz M, Lichter P. Chromosome aberrations in B-cell chronic lymphocytic leukemia: reassessment based on molecular cytogenetic analysis. *J Mol Med (Berl)* 1999;77(2):266-281.
186. Dohner H, Stilgenbauer S, Benner A, et al. Genomic aberrations and survival in chronic lymphocytic leukemia. *N Engl J Med* 2000;343(26):1910-1916.
187. O'Malley DP, Giudice C, Chang AS, et al. Comparison of array comparative genomic hybridization (aCGH) to FISH and cytogenetics in prognostic evaluation of chronic lymphocytic leukemia. *Int J Lab Hematol* 2011;33(3):238-244.
188. Sargent R, Jones D, Abruzzo LV, et al. Customized oligonucleotide array-based comparative genomic hybridization as a clinical assay for genomic profiling of chronic lymphocytic leukemia. *J Mol Diagn* 2009;11(1):25-34.
189. Fabbri M, Bottoni A, Shimizu M, et al. Association of a microRNA/TP53 feedback circuitry with pathogenesis and outcome of B-cell chronic lymphocytic leukemia. *JAMA* 2011;305(1):59-67.
190. Grever MR, Lucas DM, Dewald GW, et al. Comprehensive assessment of genetic and molecular features predicting outcome in patients with chronic lymphocytic leukemia: results from the US Intergroup Phase III Trial E2997. *J Clin Oncol* 2007;25(7):799-804.
191. Ding W, Ferrajoli A. Evidence-based mini-review: the role of alkylating agents in the initial treatment of chronic lymphocytic leukemia patients with the 11q deletion. *Hematology Am Soc Hematol Educ Program* 2010;2010:90-92.
192. Badoux XC, Keating MJ, Wierda WG. What is the best frontline therapy for patients with CLL and 17p deletion? *Curr Hematol Malig Rep* 2011;6(1):36-46.
193. Matutes E, Oscier D, Garcia-Marco J, et al. Trisomy 12 defines a group of CLL with atypical morphology: correlation between cytogenetic, clinical and laboratory features in 544 patients. *Br J Haematol* 1996;92(2):382-388.
194. Klein U, Tu Y, Stolovitzky GA, et al. Gene expression profiling of B cell chronic lymphocytic leukemia reveals a homogeneous phenotype related to memory B cells. *J Exp Med* 2001;194(11):1625-1638.
195. Rosenwald A, Alizadeh AA, Widhopf G, et al. Relation of gene expression phenotype to immunoglobulin mutation genotype in B cell chronic lymphocytic leukemia. *J Exp Med* 2001;194(11):1639-1647.
196. Chiorazzi N, Ferrarini M. Cellular origin(s) of chronic lymphocytic leukemia: cautionary notes and additional considerations and possibilities. *Blood* 2011;117(6):1781-1791.
197. Lin KI, Tam CS, Keating MJ, et al. Relevance of the immunoglobulin VH somatic mutation status in patients with chronic lymphocytic leukemia treated with fludarabine, cyclophosphamide, and rituximab (FCR) or related chemoimmunotherapy regimens. *Blood* 2009;113(14):3168-3171.
198. Ghia EM, Jain S, Widhopf GF 2nd, et al. Use of IGHV3-21 in chronic lymphocytic leukemia is associated with high-risk disease and reflects antigen-driven, post-germinal center leukemogenic selection. *Blood* 2008;111(10): 5101-5108.
199. Mauere K, Zahrieh D, Gorgun G, et al. Immunoglobulin gene segment usage, location and immunogenicity in mutated and unmutated chronic lymphocytic leukaemia. *Br J Haematol* 2005;129(4):499-510.
200. Murray F, Darzentas N, Hadzidimitriou A, et al. Stereotyped patterns of somatic hypermutation in subsets of patients with chronic lymphocytic leukemia: implications for the role of antigen selection in leukemogenesis. *Blood* 2008;111(3):1524-1533.
201. Stamatopoulos K, Belessi C, Moreno C, et al. Over 20% of patients with chronic lymphocytic leukemia carry stereotyped receptors: pathogenetic implications and clinical correlations. *Blood* 2007;109(1):259-270.
202. Falt S, Merup M, Tobin G, et al. Distinctive gene expression pattern in VH3-21 utilizing B-cell chronic lymphocytic leukemia. *Blood* 2005;106(2):681-689.
203. Thorselius M, Krober A, Murray F, et al. Strikingly homologous immunoglobulin gene rearrangements and poor outcome in VH3-21-using chronic lymphocytic leukemia patients independent of geographic origin and mutational status. *Blood* 2006;107(7):2889-2894.
204. Tobin G, Thunberg U, Johnson A, et al. Chronic lymphocytic leukemias utilizing the VH3-21 gene display highly restricted Vlambda2-14 gene use and homologous CDR3s: implicating recognition of a common antigen epitope. *Blood* 2003;101(12):4952-4957.

205. Fazi C, Scarfo L, Pecciarini L, et al. General population low-count CLL-like MBL persists over time without clinical progression, although carrying the same cytogenetic abnormalities of CLL. *Blood* 2011;118(25):6618-6625.
206. Yeung CC, Powers ML, Nguyen TD, et al. Relevance of IgVH gene somatic hypermutation and interphase cytogenetics in lymphomatous presentation of chronic lymphocytic leukemia/small lymphocytic lymphoma. *Int J Surg Pathol* 2011;19(5):563-569.
207. Daudignon A, Poulain S, Morel P, et al. Increased trisomy 12 frequency and a biased IgVH 3-21 gene usage characterize small lymphocytic lymphoma. *Leuk Res* 2010;34(5):580-584.
208. Finn WG, Kay NE, Kroft SH, Church S, Peterson LC. Secondary abnormalities of chromosome 6q in B-cell chronic lymphocytic leukemia: a sequential study of karyotypic instability in 51 patients. *Am J Hematol* 1998;59(3):223-229.
209. Huh YO, Lin KI, Vega F, et al. MYC translocation in chronic lymphocytic leukaemia is associated with increased prolymphocytes and a poor prognosis. *Br J Haematol* 2008;142(1):36-44.
210. McKeithan TW, Rowley JD, Shows TB, Diaz MO. Cloning of the chromosome translocation breakpoint junction of the t(14;19) in chronic lymphocytic leukemia. *Proc Natl Acad Sci U S A* 1987;84(24):9257-9260.
211. Reddy K, Satyadev R, Bouman D, Hibbard MK, Lu G, Paolo R. Burkitt t(8;14) (q24;q32) and cryptic deletion in a CLL patient: report of a case and review of literature. *Cancer Genet Cytogenet* 2006;166(1):12-21.
212. Sen F, Lai R, Albitar M. Chronic lymphocytic leukemia with t(14;18) and trisomy 12. *Arch Pathol Lab Med* 2002;126(12):1543-1546.
213. Wang L, Lawrence MS, Wan Y, et al. SF3B1 and other novel cancer genes in chronic lymphocytic leukemia. *N Engl J Med* 2011;365(26):2497-2506.
214. Balatti V, Bottoni A, Palamarchuk A, et al. NOTCH1 mutations in CLL associated with trisomy 12. *Blood* 2012;119(2):329-331.
215. Fabbri G, Rasi S, Rossi D, et al. Analysis of the chronic lymphocytic leukemia coding genome: role of NOTCH1 mutational activation. *J Exp Med* 2011;208(7):1389-1401.
216. Puente XS, Pinyol M, Quesada V, et al. Whole-genome sequencing identifies recurrent mutations in chronic lymphocytic leukaemia. *Nature* 2011;475(7354):101-105.
217. Eischen CM, Weber JD, Roussel MF, Sherr CJ, Cleveland JL. Disruption of the ARF-Mdm2-p53 tumor suppressor pathway in Myc-induced lymphomagenesis. *Genes Dev* 1999;13(20):2658-2669.
218. Rossi D, Rasi S, Fabbri G, et al. Mutations of NOTCH1 are an independent predictor of survival in chronic lymphocytic leukemia. *Blood* 2012;119(2): 521-529.
219. Rossi D, Brusca A, Spina V, et al. Mutations of the SF3B1 splicing factor in chronic lymphocytic leukemia: association with progression and fludarabine refractoriness. *Blood* 2011;118(26):6904-6908.
220. Bell JJ, Bhandoola A. The earliest thymic progenitors for T cells possess myeloid lineage potential. *Nature* 2008;452(7188):764-767.
221. Malcovati L, Papaemmanuil E, Bowen DT, et al. Clinical significance of SF3B1 mutations in myelodysplastic syndromes and myelodysplastic/myeloproliferative neoplasms. *Blood* 2011;118(24):6239-6246.
222. Papaemmanuil E, Cazzola M, Boulton J, et al. Somatic SF3B1 mutation in myelodysplasia with ring sideroblasts. *N Engl J Med* 2011;365(15): 1384-1395.
223. Patnaik MM, Lasho TL, Hodnefield JM, et al. SF3B1 mutations are prevalent in myelodysplastic syndromes with ring sideroblasts but do not hold independent prognostic value. *Blood* 2012;119(2):569-572.
224. Wada H, Masuda K, Satoh R, et al. Adult T-cell progenitors retain myeloid potential. *Nature* 2008;452(7188):768-772.
225. Kramer MH, Hermans J, Wijburg E, et al. Clinical relevance of BCL2, BCL6, and MYC rearrangements in diffuse large B-cell lymphoma. *Blood* 1998;92(9):3152-3162.
226. Tibiletti MG, Martin V, Bernasconi B, et al. BCL2, BCL6, MYC, MALT 1, and BCL10 rearrangements in nodal diffuse large B-cell lymphomas: a multicenter evaluation of a new set of fluorescent in situ hybridization probes and correlation with clinical outcome. *Hum Pathol* 2009;40(5):645-652.

227. Akasaka H, Akasaka T, Kurata M, et al. Molecular anatomy of BCL6 translocations revealed by long-distance polymerase chain reaction-based assays. *Cancer Res* 2000;60(9):2335-2341.
228. Ye BH, Chaganti S, Chang CC, et al. Chromosomal translocations cause deregulated BCL6 expression by promoter substitution in B cell lymphoma. *EMBO J* 1995;14(24):6209-6217.
229. Iqbal J, Greiner TC, Patel K, et al. Distinctive patterns of BCL6 molecular alterations and their functional consequences in different subgroups of diffuse large B-cell lymphoma. *Leukemia* 2007;21(11):2332-2343.
230. Bosga-Bouwer AG, Haralambieva E, Booman M, et al. BCL6 alternative trans-location breakpoint cluster region associated with follicular lymphoma grade 3B. *Genes Chromosomes Cancer* 2005;44(3):301-304.
231. Gu K, Fu K, Jain S, et al. t(14;18)-negative follicular lymphomas are associated with a high frequency of BCL6 rearrangement at the alternative breakpoint region. *Mod Pathol* 2009;22(9):1251-1257.
232. Ueda C, Nishikori M, Kitawaki T, Uchiyama T, Ohno H. Coexistent rearrangements of c-MYC, BCL2, and BCL6 genes in a diffuse large B-cell lymphoma. *Int J Hematol* 2004;79(1):52-54.
233. Barrans SL, O'Connor SJ, Evans PA, et al. Rearrangement of the BCL6 locus at 3q27 is an independent poor prognostic factor in nodal diffuse large B-cell lymphoma. *Br J Haematol* 2002;117(2):322-332.
234. Shaffer AL, Yu X, He Y, Boldrick J, Chan EP, Staudt LM. BCL-6 represses genes that function in lymphocyte differentiation, inflammation, and cell cycle control. *Immunity* 2000;13(2):199-212.
235. Cerchiatti LC, Ghetu AF, Zhu X, et al. A small-molecule inhibitor of BCL6 kills DLBCL cells in vitro and in vivo. *Cancer Cell* 2010;17(4):400-411.
236. Cerchiatti LC, Yang SN, Shaknovich R, et al. A peptomimetic inhibitor of BCL6 with potent antilymphoma effects in vitro and in vivo. *Blood* 2009;113(15):3397-3405.
237. Tzankov A, Schneider A, Hoeller S, Dirnhofer S. Prognostic importance of BCL6 rearrangements in diffuse large B-cell lymphoma with respect to Bcl6 protein levels and primary lymphoma site. *Hum Pathol* 2009;40(7):1055-1056; author reply 6.
238. Wagner SD, Ahearne M, Ko Ferrigno P. The role of BCL6 in lymphomas and routes to therapy. *Br J Haematol* 2011;152(1):3-12.
239. Pasqualucci L, Migliazza A, Fracchiolla N, et al. BCL-6 mutations in normal germinal center B cells: evidence of somatic hypermutation acting outside Ig loci. *Proc Natl Acad Sci U S A* 1998;95(20):11816-11821.
240. Shen HM, Peters A, Baron B, Zhu X, Storb U. Mutation of BCL-6 gene in normal B cells by the process of somatic hypermutation of Ig genes. *Science* 1998;280(5370):1750-1752.
241. Migliazza A, Martinotti S, Chen W, et al. Frequent somatic hypermutation of the 5' noncoding region of the BCL6 gene in B-cell lymphoma. *Proc Natl Acad Sci U S A* 1995;92(26):12520-12524.
242. Barrans S, Crouch S, Smith A, et al. Rearrangement of MYC is associated with poor prognosis in patients with diffuse large B-cell lymphoma treated in the era of rituximab. *J Clin Oncol* 2010;28(20):3360-3365.
243. Akyurek N, Uner A, Benekli M, Barista I. Prognostic significance of MYC, BCL2, and BCL6 rearrangements in patients with diffuse large B-cell lymphoma treated with cyclophosphamide, doxorubicin, vincristine, and prednisone plus rituximab. *Cancer* 2012;118(17):4173-4183.
244. Green TM, Young KH, Visco C, et al. Immunohistochemical double-hit score is a strong predictor of outcome in patients with diffuse large B-cell lymphoma treated with rituximab plus cyclophosphamide, doxorubicin, vincristine, and prednisone. *J Clin Oncol* 2012;30(28):3460-3467.
245. Shipp MA, Ross KN, Tamayo P, et al. Diffuse large B-cell lymphoma outcome prediction by gene-expression profiling and supervised machine learning. *Nat Med* 2002;8(1):68-74.
246. Rosenwald A, Wright G, Chan WC, et al. The use of molecular profiling to predict survival after chemotherapy for diffuse large-B-cell lymphoma. *N Engl J Med* 2002;346(25):1937-1947.
247. Colomo L, Lopez-Guillermo A, Perales M, et al. Clinical impact of the differentiation profile assessed by immunophenotyping in patients with diffuse large B-cell lymphoma. *Blood* 2003;101(1):78-84.
248. Hans CP, Weisenburger DD, Greiner TC, et al. Confirmation of the molecular classification of diffuse large B-cell lymphoma by immunohistochemistry using a tissue microarray. *Blood* 2004;103(1):275-282.

249. Muris JJ, Meijer CJ, Vos W, et al. Immunohistochemical profiling based on Bcl-2, CD10 and MUM1 expression improves risk stratification in patients with primary nodal diffuse large B cell lymphoma. *J Pathol* 2006;208(5):714-723.
250. Choi WW, Weisenburger DD, Greiner TC, et al. A new immunostain algorithm classifies diffuse large B-cell lymphoma into molecular subtypes with high accuracy. *Clin Cancer Res* 2009;15(17):5494-5502.
251. Meyer PN, Fu K, Greiner TC, et al. Immunohistochemical methods for predicting cell of origin and survival in patients with diffuse large B-cell lymphoma treated with rituximab. *J Clin Oncol* 2011;29(2):200-207.
252. Gutierrez-Garcia G, Cardesa-Salzmann T, Climent F, et al. Gene-expression profiling and not immunophenotypic algorithms predicts prognosis in patients with diffuse large B-cell lymphoma treated with immunochemotherapy. *Blood* 2011;117(18):4836-4843.
253. Ott G, Ziepert M, Klapper W, et al. Immunoblastic morphology but not the immunohistochemical GCB/nonGCB classifier predicts outcome in diffuse large B-cell lymphoma in the RICOVER-60 trial of the DSHNHL. *Blood* 2010;116(23):4916-4925.
254. Salles G, de Jong D, Xie W, et al. Prognostic significance of immunohistochemical biomarkers in diffuse large B-cell lymphoma: a study from the Lunenburg Lymphoma Biomarker Consortium. *Blood* 2011;117(26): 7070-7078.
255. Visco C, Li Y, Xu-Monette ZY, et al. Comprehensive gene expression profiling and immunohistochemical studies support application of immunophenotypic algorithm for molecular subtype classification in diffuse large B-cell lymphoma: a report from the International DLBCL Rituximab-CHOP Consortium Program Study. *Leukemia* 2012;26(9):2103-2113.
256. Montes-Moreno S, Martinez N, Sanchez-Espiridion B, et al. miRNA expression in diffuse large B-cell lymphoma treated with chemoimmunotherapy. *Blood* 2011;118(4):1034-1040.
257. Guney S, Bertrand P, Jardin F, et al. Molecular characterization of 9p21 deletions shows a minimal common deleted region removing CDKN2A exon 1 and CDKN2B exon 2 in diffuse large B-cell lymphomas. *Genes Chromosomes Cancer* 2011;50(9):715-725.
258. Guney S, Jardin F, Bertrand P, et al. Several mechanisms lead to the inactivation of the CDKN2A (P16), P14ARF, or CDKN2B (P15) genes in the GCB and ABC molecular DLBCL subtypes. *Genes Chromosomes Cancer* 2012;51(9): 858-867.
259. Pasqualucci L, Trifonov V, Fabbri G, et al. Analysis of the coding genome of diffuse large B-cell lymphoma. *Nat Genet* 2011;43(9):830-837.
260. Andersen CL, Gruszka-Westwood A, Ostergaard M, et al. A narrow deletion of 7q is common to HCL, and SMZL, but not CLL. *Eur J Haematol* 2004;72(6):390-402.
261. Cawley JC. The pathophysiology of the hairy cell. *Hematol Oncol Clin North Am* 2006;20(5):1011-1021.
262. Wu X, Ivanova G, Merup M, et al. Molecular analysis of the human chromosome 5q13.3 region in patients with hairy cell leukemia and identification of tumor suppressor gene candidates. *Genomics* 1999;60(2):161-171.
263. Arons E, Roth L, Sapolsky J, Suntum T, Stetler-Stevenson M, Kreitman RJ. Evidence of canonical somatic hypermutation in hairy cell leukemia. *Blood* 2011;117(18):4844-4851.
264. Forconi F, Poretti G, Kwee I, et al. High density genome-wide DNA profiling reveals a remarkably stable profile in hairy cell leukaemia. *Br J Haematol* 2008;141(5):622-630.
265. Forconi F, Sozzi E, Rossi D, et al. Selective influences in the expressed immunoglobulin heavy and light chain gene repertoire in hairy cell leukemia. *Haematologica* 2008;93(5):697-705.
266. Basso K, Liso A, Tiacci E, et al. Gene expression profiling of hairy cell leukemia reveals a phenotype related to memory B cells with altered expression of chemokine and adhesion receptors. *J Exp Med* 2004;199(1):59-68.
267. Blombery PA, Wong SQ, Hewitt CA, et al. Detection of BRAF mutations in patients with hairy cell leukemia and related lymphoproliferative disorders. *Haematologica* 2012;97(5):780-783.
268. Tiacci E, Trifonov V, Schiavoni G, et al. BRAF mutations in hairy-cell leukemia. *N Engl J Med* 2011;364(24):2305-2315.
269. Brose MS, Volpe P, Feldman M, et al. BRAF and RAS mutations in human lung cancer and melanoma. *Cancer Res* 2002;62(23):6997-7000.
270. Li WQ, Kawakami K, Ruskiewicz A, Bennett G, Moore J, Iacopetta B. BRAF mutations are associated with distinctive clinical, pathological and molecular features of colorectal cancer independently of microsatellite instability status. *Mol Cancer* 2006;5:2.

271. Falini B, Mason DY. Proteins encoded by genes involved in chromosomal alterations in lymphoma and leukemia: clinical value of their detection by immunocytochemistry. *Blood* 2002;99(2):409-426.
272. Morris SW, Kirstein MN, Valentine MB, et al. Fusion of a kinase gene, ALK, to a nucleolar protein gene, NPM, in non-Hodgkin's lymphoma. *Science* 1994;263(5151):1281-1284.
273. Chan WY, Liu QR, Borjigin J, et al. Characterization of the cDNA encoding human nucleophosmin and studies of its role in normal and abnormal growth. *Biochemistry* 1989;28(3):1033-1039.
274. Merkel O, Hamacher F, Laimer D, et al. Identification of differential and functionally active miRNAs in both anaplastic lymphoma kinase (ALK)+ and ALK- anaplastic large-cell lymphoma. *Proc Natl Acad Sci U S A* 2010;107(37):16228-16233. P.1826
275. Bisig B, Gaulard P, de Leval L. New biomarkers in T-cell lymphomas. *Best Pract Res Clin Haematol* 2012;25(1):13-28.
276. Merkel O, Hamacher F, Sifft E, Kenner L, Greil R. Novel therapeutic options in anaplastic large cell lymphoma: molecular targets and immunological tools. *Mol Cancer Ther* 2011;10(7):1127-1136.
277. Mathew P, Sanger WG, Weisenburger DD, et al. Detection of the t(2;5) (p23;q35) and NPM-ALK fusion in non-Hodgkin's lymphoma by two-color fluorescence in situ hybridization. *Blood* 1997;89(5):1678-1685.
278. Sarris AH, Luthra R, Papadimitracopoulou V, et al. Amplification of genomic DNA demonstrates the presence of the t(2;5) (p23;q35) in anaplastic large cell lymphoma, but not in other non-Hodgkin's lymphomas, Hodgkin's disease, or lymphomatoid papulosis. *Blood* 1996;88(5):1771-1779.
279. Wellmann A, Otsuki T, Vogelbruch M, Clark HM, Jaffe ES, Raffeld M. Analysis of the t(2;5)(p23;q35) translocation by reverse transcription-polymerase chain reaction in CD30+ anaplastic large-cell lymphomas, in other non-Hodgkin's lymphomas of T-cell phenotype, and in Hodgkin's disease. *Blood* 1995;86(6):2321-2328.
280. Salaverria I, Bea S, Lopez-Guillermo A, et al. Genomic profiling reveals different genetic aberrations in systemic ALK-positive and ALK-negative anaplastic large cell lymphomas. *Br J Haematol* 2008;140(5):516-526.
281. Nelson M, Horsman DE, Weisenburger DD, et al. Cytogenetic abnormalities and clinical correlations in peripheral T-cell lymphoma. *Br J Haematol* 2008;141(4):461-469.
282. Eckerle S, Brune V, Doring C, et al. Gene expression profiling of isolated tumour cells from anaplastic large cell lymphomas: insights into its cellular origin, pathogenesis and relation to Hodgkin lymphoma. *Leukemia* 2009;23(11):2129-2138.
283. Iqbal J, Weisenburger DD, Greiner TC, et al. Molecular signatures to improve diagnosis in peripheral T-cell lymphoma and prognostication in angioimmunoblastic T-cell lymphoma. *Blood* 2010;115(5):1026-1036.
284. Piva R, Agnelli L, Pellegrino E, et al. Gene expression profiling uncovers molecular classifiers for the recognition of anaplastic large-cell lymphoma within peripheral T-cell neoplasms. *J Clin Oncol* 2010;28(9):1583-1590.
285. Lamant L, de Reynies A, Duplantier MM, et al. Gene-expression profiling of systemic anaplastic large-cell lymphoma reveals differences based on ALK status and two distinct morphologic ALK+ subtypes. *Blood* 2007;109(5): 2156-2164.
286. Thompson MA, Stumph J, Henrickson SE, et al. Differential gene expression in anaplastic lymphoma kinase-positive and anaplastic lymphoma kinase-negative anaplastic large cell lymphomas. *Hum Pathol* 2005;36(5): 494-504.
287. Matsuyama H, Suzuki HI, Nishimori H, et al. miR-135b mediates NPM-ALK-driven oncogenicity and renders IL-17-producing immunophenotype to anaplastic large cell lymphoma. *Blood* 2011;118(26):6881-6892.
288. Desjobert C, Renalier MH, Bergalet J, et al. MiR-29a down-regulation in ALK-positive anaplastic large cell lymphomas contributes to apoptosis blockade through MCL-1 overexpression. *Blood* 2011;117(24):6627-6637.
289. Zhang Q, Wang HY, Liu X, Bhutani G, Kantekure K, Wasik M. IL-2R common gamma-chain is epigenetically silenced by nucleophosmin-anaplastic lymphoma kinase (NPM-ALK) and acts as a tumor suppressor by targeting NPM-ALK. *Proc Natl Acad Sci U S A* 2011;108(29):11977-11982.
290. Feldman AL, Dogan A, Smith DI, et al. Discovery of recurrent t(6;7) (p25.3;q32.3) translocations in ALK-negative anaplastic large cell lymphomas by massively parallel genomic sequencing. *Blood* 2011;117(3):915-919.

291. Savage KJ, Harris NL, Vose JM, et al. ALK- anaplastic large-cell lymphoma is clinically and immunophenotypically different from both ALK+ ALCL and peripheral T-cell lymphoma, not otherwise specified: report from the International Peripheral T-Cell Lymphoma Project. *Blood* 2008;111(12): 5496-5504.
292. Foss FM, Zinzani PL, Vose JM, Gascoyne RD, Rosen ST, Tobinai K. Peripheral T-cell lymphoma. *Blood* 2011;117(25):6756-6767.
293. Thorns C, Bastian B, Pinkel D, et al. Chromosomal aberrations in angioimmunoblastic T-cell lymphoma and peripheral T-cell lymphoma unspecified: a matrix-based CGH approach. *Genes Chromosomes Cancer* 2007;46(1):37-44.
294. Zettl A, Rudiger T, Konrad MA, et al. Genomic profiling of peripheral T-cell lymphoma, unspecified, and anaplastic large T-cell lymphoma delineates novel recurrent chromosomal alterations. *Am J Pathol* 2004;164(5): 1837-1848.
295. Fujiwara SI, Yamashita Y, Nakamura N, et al. High-resolution analysis of chromosome copy number alterations in angioimmunoblastic T-cell lymphoma and peripheral T-cell lymphoma, unspecified, with single nucleotide polymorphism-typing microarrays. *Leukemia* 2008;22(10):1891-1898.
296. Ballester B, Ramuz O, Gisselbrecht C, et al. Gene expression profiling identifies molecular subgroups among nodal peripheral T-cell lymphomas. *Oncogene* 2006;25(10):1560-1570.
297. Piccaluga PP, Agostinelli C, Califano A, et al. Gene expression analysis of peripheral T cell lymphoma, unspecified, reveals distinct profiles and new potential therapeutic targets. *J Clin Invest* 2007;117(3):823-834.
298. Huang Y, Moreau A, Dupuis J, et al. Peripheral T-cell lymphomas with a follicular growth pattern are derived from follicular helper T cells (TFH) and may show overlapping features with angioimmunoblastic T-cell lymphomas. *Am J Surg Pathol* 2009;33(5):682-690.
299. Streubel B, Vinatzer U, Willheim M, Raderer M, Chott A. Novel t(5;9)(q33;q22) fuses ITK to SYK in unspecified peripheral T-cell lymphoma. *Leukemia* 2006;20(2):313-318.
300. Mulloy JC. Peripheral T cell lymphoma: new model + new insight. *J Exp Med* 2010;207(5):911-913.
301. Feldman AL, Sun DX, Law ME, et al. Overexpression of Syk tyrosine kinase in peripheral T-cell lymphomas. *Leukemia* 2008;22(6):1139-1143.
302. Piccaluga PP, Agostinelli C, Zinzani PL, Baccarani M, Dalla Favera R, Pileri SA. Expression of platelet-derived growth factor receptor alpha in peripheral T-cell lymphoma not otherwise specified. *Lancet Oncol* 2005;6(6):440.
303. Feldman AL, Law M, Remstein ED, et al. Recurrent translocations involving the IRF4 oncogene locus in peripheral T-cell lymphomas. *Leukemia* 2009;23(3):574-580.
304. Couronne L, Bastard C, Bernard OA. TET2 and DNMT3A mutations in human T-cell lymphoma. *N Engl J Med* 2012;366(1):95-96.
305. Gaidzik VI, Paschka P, Spath D, et al. TET2 mutations in acute myeloid leukemia (AML): results from a comprehensive genetic and clinical analysis of the AML study group. *J Clin Oncol* 2012;30(12):1350-1357.
306. Ley TJ, Ding L, Walter MJ, et al. DNMT3A mutations in acute myeloid leukemia. *N Engl J Med* 2010;363(25):2424-2433.
307. Metzeler KH, Maharry K, Radmacher MD, et al. TET2 mutations improve the new European LeukemiaNet risk classification of acute myeloid leukemia: a Cancer and Leukemia Group B study. *J Clin Oncol* 2011;29(10): 1373-1381.
308. Quivoron C, Couronne L, Della Valle V, et al. TET2 inactivation results in pleiotropic hematopoietic abnormalities in mouse and is a recurrent event during human lymphomagenesis. *Cancer Cell* 2011;20(1):25-38.
309. Cuadros M, Dave SS, Jaffe ES, et al. Identification of a proliferation signature related to survival in nodal peripheral T-cell lymphomas. *J Clin Oncol* 2007;25(22):3321-3329.
310. Miyazaki K, Yamaguchi M, Imai H, et al. Gene expression profiling of peripheral T-cell lymphoma including gammadelta T-cell lymphoma. *Blood* 2009;113(5):1071-1074.
311. de Leval L, Rickman DS, Thielen C, et al. The gene expression profile of nodal peripheral T-cell lymphoma demonstrates a molecular link between angioimmunoblastic T-cell lymphoma (AITL) and follicular helper T (TFH) cells. *Blood* 2007;109(11):4952-4963.
312. Dang L, White DW, Gross S, et al. Cancer-associated IDH1 mutations produce 2-hydroxyglutarate. *Nature* 2010;465(7300):966.

313. Deneberg S, Guardiola P, Lennartsson A, et al. Prognostic DNA methylation patterns in cytogenetically normal acute myeloid leukemia are predefined by stem cell chromatin marks. *Blood* 2011;118(20):5573-5582.
314. Marcucci G, Maharry K, Wu YZ, et al. IDH1 and IDH2 gene mutations identify novel molecular subsets within de novo cytogenetically normal acute myeloid leukemia: a Cancer and Leukemia Group B study. *J Clin Oncol* 2010;28(14):2348-2355.
315. Ward PS, Cross JR, Lu C, et al. Identification of additional IDH mutations associated with oncometabolite R(-)-2-hydroxyglutarate production. *Oncogene* 2012;31(19):2491-2498.
316. Cairns RA, Iqbal J, Lemonnier F, et al. IDH2 mutations are frequent in angioimmunoblastic T-cell lymphoma. *Blood* 2012;119(8):1901-1903.
317. Yan H, Parsons DW, Jin G, et al. IDH1 and IDH2 mutations in gliomas. *N Engl J Med* 2009;360(8):765-773.
318. Pekarsky Y, Hallas C, Croce CM. Molecular basis of mature T-cell leukemia. *JAMA* 2001;286(18):2308-2314.
319. de Leval L, Gaulard P. Tricky and terrible T-cell tumors: these are thrilling times for testing: molecular pathology of peripheral T-cell lymphomas. *Hematology Am Soc Hematol Educ Program* 2011;2011:336-343.
320. Virgilio L, Isobe M, Narducci MG, et al. Chromosome walking on the TCL1 locus involved in T-cell neoplasia. *Proc Natl Acad Sci U S A* 1993;90(20): 9275-9279.
321. Gaudio E, Spizzo R, Paduano F, et al. Tcl1 interacts with Atm and enhances NF-kappaB activation in hematologic malignancies. *Blood* 2012;119(1): 180-187.
322. Durig J, Bug S, Klein-Hitpass L, et al. Combined single nucleotide polymorphism-based genomic mapping and global gene expression profiling identifies novel chromosomal imbalances, mechanisms and candidate genes important in the pathogenesis of T-cell prolymphocytic leukemia with inv(14)(q11q32). *Leukemia* 2007;21(10):2153-2163.
323. Urbankova H, Holzerova M, Balcarkova J, et al. Array comparative genomic hybridization in the detection of chromosomal abnormalities in T-cell prolymphocytic leukemia. *Cancer Genet Cytogenet* 2010;202(1):58-62.
324. Bug S, Durig J, Oyen F, et al. Recurrent loss, but lack of mutations, of the SMARCB1 tumor suppressor gene in T-cell prolymphocytic leukemia with TCL1A-TCRAD juxtaposition. *Cancer Genet Cytogenet* 2009;192(1):44-47.

Chapter 88 Non-Hodgkin Lymphoma in Adults

> Table of Contents > Part VII - Hematologic Malignancies > Section 4 - Lymphoproliferative Disorders > Chapter 88 - Non-Hodgkin Lymphoma in Adults

Chapter 88

Non-Hodgkin Lymphoma in Adults

John P. Greer

Nishitha M. Reddy

Michael E. Williams

HISTORICAL PERSPECTIVE

Thomas Hodgkin was the first to recognize that lymphadenopathy could occur as a primary disorder rather than secondary to infection or carcinoma in his 1832 paper entitled, "On Some Morbid Appearances of the Absorbent Glands and Spleen."¹ Since Hodgkin's initial description, there have been four historical phases in the study of non-Hodgkin lymphoma (NHL): (1) clinical features, 1832 to 1900; (2) histopathology, 1900 to 1972; (3) immunopathology, 1972 to the present; and (4) molecular genetics, 1982 to the present. These phases naturally overlap and all contribute to the understanding of NHL.²

From 1863 to 1865, Virchow introduced the terms aleukemia and lymphosarcoma to distinguish lymphoproliferative diseases from leukemia³ and in 1871, Billroth used the term malignant lymphoma for a vague collection of primary lymphoid disorders.⁴ In 1893, Kundrat proposed that the term lymphosarcoma was more specific than the term originally used by Virchow and should be reserved for the sarcomatous tumors of lymph nodes.⁵

At the turn of the last century, Sternberg⁶ and Reed⁷ identified the giant cells characteristic of Hodgkin lymphoma (HL) and introduced histopathology as a method for diagnosis and classification of lymphoma. Brill⁸ and Symmers⁹ described

follicular lymphoma (FL) in the 1920s and indicated it was a malignant, albeit indolent, disorder. Ewing (1914), Oberling (1928), and Roulet (1930) used the term reticulum cell sarcoma which came to be used for large cell lymphoma and was distinct from lymphosarcoma, mainly composed of small lymphocytes.¹⁰ In 1941, Gall and Mallory developed a classification scheme on NHL that had both clinical and histopathologic significance.¹¹ The histopathologic phase of NHL culminated in the 1956 classic work of Rappaport who developed a morphologic classification which stratified cases according to the pattern of growth with nodular replacing follicular and contrasting with diffuse.¹² There were four categories of lymphoma: well differentiated lymphocytic, poorly differentiated lymphocytic, mixed lymphocytic and histocytic, and histocytic.

In 1967, Good and Finstad discussed the relationship of B and T cells to lymphoid neoplasia, and Dameshek introduced the concepts that lymphomas were aberrations of immunologically competent cells and that transformation of lymphocytes to “blast” forms (immunoblasts) could occur secondary to antigenic stimulation.⁴ In 1972, the immunologic origin of lymphoid neoplasia was confirmed by the presence of monotypic immunoglobulin (Ig) on the cell surface (B cell) or by sheep erythrocyte rosette formation with neoplastic cells (T cell).^{13, 14} Lymphoblastic lymphoma (LBL) was determined to originate from thymocytes by Smith in 1973.¹⁵ Barcos and Lukes described the clinicopathologic features of “convoluted lymphocytic lymphoma” of thymic origin and used the term LBL, which was later preferred by Nathwani because of similarities to blasts of T cell acute lymphoblastic leukemia (ALL).^{14, 16}

In 1974, Lennert in Kiel, Germany, and Lukes and Collins in the United States classified NHL on the basis of the cell of origin within the immune system (Fig. 88.1).^{17, 18} Subsequently, monoclonal antibodies to lymphocyte differentiation antigens have been able to detect sequential stages in the development of B and T cells and to identify subtypes of NHL. Recurrent cytogenetic translocations involving the IG gene locus on chromosome 14 were identified in Burkitt lymphoma (BL) in 1976 and in FL in 1979.^{19, 20} In the 1980s, the lymphoid origin of NHL was confirmed at the molecular level with the identification of specific IG gene and T cell receptor (TCR) gene rearrangements in B and T cell lymphomas, respectively.^{21, 22}

In 1982, a Working Formulation (WF) of NHL separated diseases according to histologic grade and made correlations with survival; however, the WF lumped disparate diseases together by basing the diagnosis on morphology without utilizing immunophenotyping or molecular genetic techniques. The laboratories of Leder and Croce in 1982 identified MYC as the gene translocated from chromosome 8 to the IG genes in BL.^{20, 23, 24} Subsequently, the genes defining FL, BCL2/IGH, and mantle cell lymphoma, CCND1/IGH, were described.^{23, 24} Recurrent translocations were less commonly seen in T cell lymphomas, but novel genes were translocated with the loci of T cell receptor genes in T-LBL/ALL. In 1989, a proportion of T-anaplastic large cell lymphomas (ALCL) were found to have t(2;5) (p23-, q35);²⁵ and in 1994, Morris identified the genes, ALK/NPM, involved in the translocation.²⁶

Issacson and Stein formed an international group of pathologists, International Lymphoma Study Group (ILSG), to develop a consensus about diagnosis and terminology of lymphoid neoplasms.² In 1994, a Revised European-American Lymphoma (REAL) classification was proposed to identify specific types of lymphomas of B and T cell origin.²⁷ The REAL classification dropped the grading schema of lymphomas and developed a diagnosis by identifying clinical features, morphology, immunophenotype, and genetic data when available. An International Lymphoma Classification Project organized by Armitage affirmed the clinical utility and the reproducibility of the REAL classification.²⁸ The World Health Organization (WHO) has adopted the diagnostic principles of the REAL classification, and the WHO classification is utilized as the schema for diagnosis of all hematopoietic neoplasms.

EPIDEMIOLOGY

There is a worldwide epidemic of NHL that varies according to gender, race, and geography. The rise in NHL has been faster than that of all other malignancies except lung cancer in women, melanoma, and prostate cancer.²⁹ The age-adjusted incidence of NHL in the United States increased from 11.1 per 100,000 people in 1975 to 19.3 in 2002; there has been a plateau in the incidence with 19.6 in 2009. There were approximately 484,000 people (250,000 men and 232,000 women) alive in 2009 with a history of NHL. More than 70,000 new cases will be diagnosed and nearly 19,000 will die of NHL in the United States (US) in 2012.³⁰ Worldwide, 356,000 new cases of NHL occurred in 2008 and over 191,000 deaths were due to NHL.³¹

Part of the increase was attributed to the development of NHL in patients with the acquired immunodeficiency syndrome (AIDS); however, there are a large number of other possible contributing factors to the epidemic (Table 88.1). Improvement in disease detection and cancer registration have likely played a role. Even before the AIDS crisis, there was a steady increase of 3% to 4% per year from the 1970s up until the early 1990s, when there was even a drop-off in some subgroups of patients (Fig. 88.2). Part of the drop-off is attributed to the introduction of highly active anti-retroviral

therapy (HAART) for AIDS patients.³² The consensus is that the increase in NHL remains unexplained by either the AIDS crisis or improvements in diagnosis.

P.1828

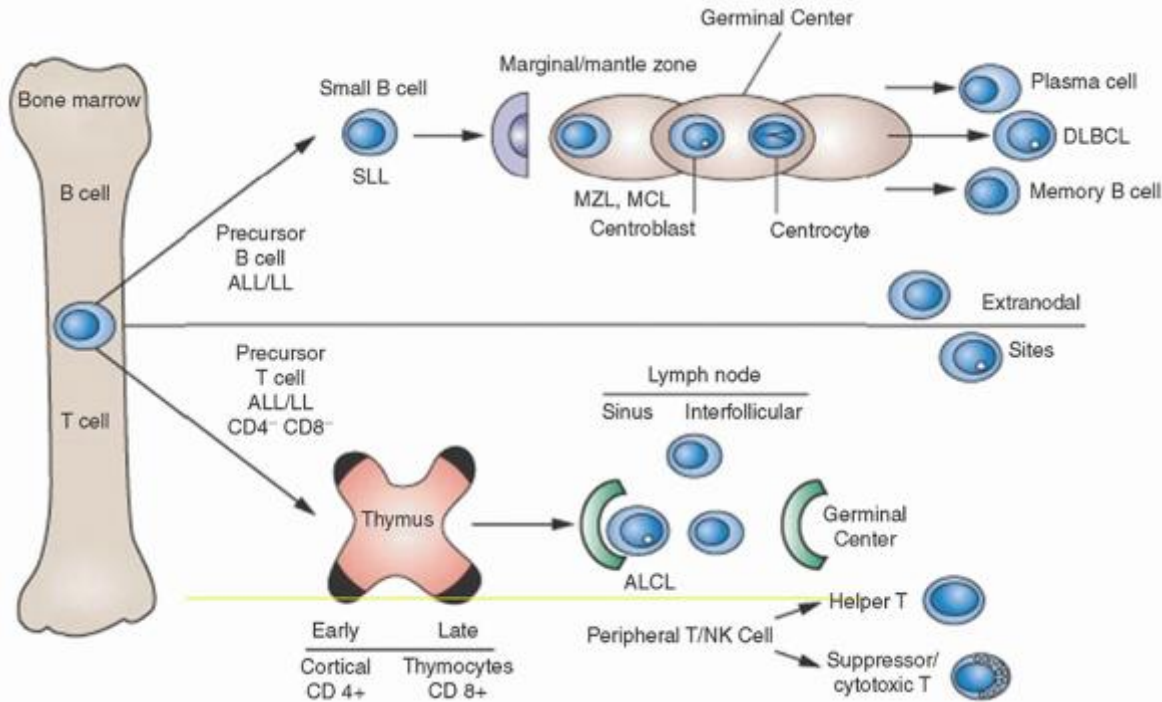

FIGURE 88.1. Cellular origins of non-Hodgkin lymphoma by B and T cell differentiation pathways. B and T cells originate in the marrow, where they are antigen independent. The follicular center is a normal site of antigen-dependent B cells which go through different stages: (a) proliferation of centroblasts (large noncleaved cells), (b) selection of centrocytes (small cleaved cells) or cell death via apoptosis, (c) differentiation into postgerminal center memory B lymphocytes or plasma cells, often in association with increased antigen affinity and an immunoglobulin isotope switch. The T cells depend upon the thymus for early differentiation before becoming peripheral T cells. The most immature T cell precursors are negative for both CD4 and CD8. Thymocytes can become committed to either the gamma-delta or alpha-beta lineage. As thymocytes within the alpha-beta lineage mature they gain CD4 and then CD8 to become double positive thymocytes. Normal thymocytes downregulate the expression of CD4 or CD8 to become mature peripheral T cells, which are subdivided into helper (CD4⁺) and suppressor/cytotoxic (CD8⁺) subsets. Corresponding lymphomas are based on stage of cellular differentiation and site(s) of nodal and/or extranodal origin. BCL, precursor B cell lymphoblastic lymphoma; SLL, small lymphocytic lymphoma; MZL, marginal zone lymphoma (MALT types, postgerminal center); MCL, mantle cell lymphoma (pre-germinal center); FL, follicular lymphoma; DLBCL, diffuse large B cell lymphoma; TCL, precursor T cell lymphoblastic lymphoma; ALCL, anaplastic large cell lymphoma (sinus involvement). Peripheral T/NK lymphomas tend to involve the interfollicular zone of lymph nodes or specific extranodal sites.

TABLE 88.1 EPIDEMIOLOGIC FACTORS THAT ARE ASSOCIATED WITH AN INCREASED RISK OF NON-HODGKIN LYMPHOMA

Immunodeficiency

 Congenital

 Acquired

Infectious agents

Male gender

Increasing age

Family history of non-Hodgkin lymphoma

Prior cancer history

Drug Exposure:

 Immunosuppressive agents

 Antiepileptic medication

Occupational History

Exposure to: herbicides

 pesticides

 wood dust

 epoxy glue

 solvents

Other possible etiologic factors

 Hair dye use

 Nutritional factors

 Blood transfusion

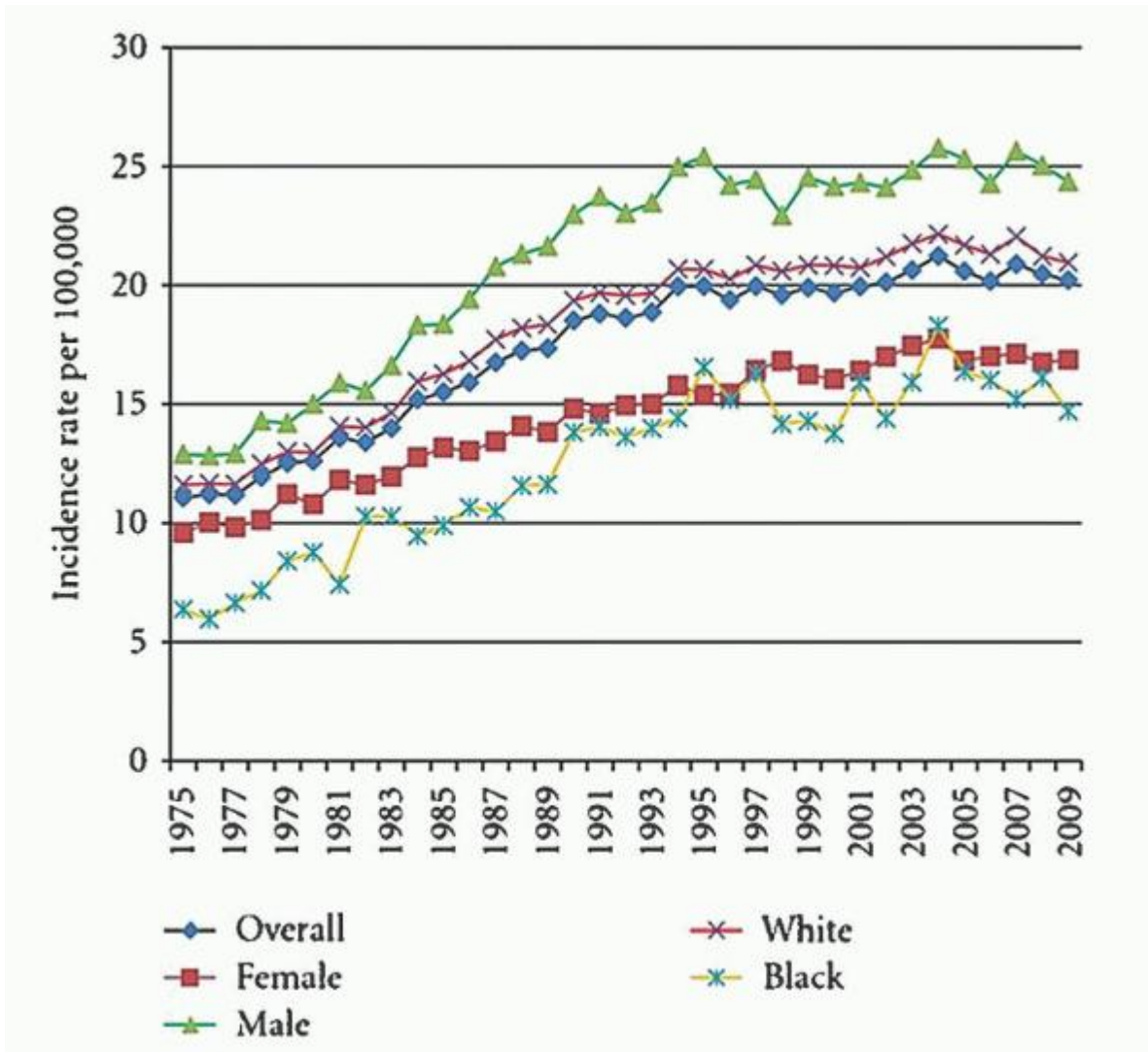

FIGURE 88.2. Temporal trends in the age-adjusted incidence rates of NHL in the United States (SEER data, 1979 to 2009). P.1829

Age, Race, and Sex Differences

The frequency of various lymphoid neoplasms is age-dependent, has a variable worldwide distribution, and is more common in males than females. Lymphomas represent approximately 10% of all childhood cancers in developed countries and are third in relative frequency behind acute leukemias and brain tumors. They are more common in adults than in children and have a steady increase in incidence from childhood through age 80 years (Fig. 88.3).³³ They are the fifth most common cancer in the United States and represent 4% of all cancers. The mean age at diagnosis is 45 to 55 years and the median age for 2005 to 2009 was 66 years. The annual incidence rate of NHL in 2005 to 2009 was 40% higher for males (23.8 per 100,000) than females (16.3 per 100,000). The median age of death was 75 years of age. The highest age-adjusted mortality in 2009 was in white males (8.7 per 100,000) and the lowest mortality has been in Asian/Pacific Islander females (3.4 per 100,000).³³ The incidence and mortality rates for NHL vary worldwide, with North America having the highest (Fig. 88.4).

A comparison of NHL in children and adults is outlined in Table 88.2. Lymphomas involving peripheral lymph nodes are usually of B cell origin in North America and Europe and are more common in adults than in children, who often present with gastrointestinal involvement (BL) or mediastinal widening (usually lymphoblastic lymphoma of T cell origin). The histologic appearance of NHL is more variable in adults, who frequently have low grade follicular or diffuse patterns in

which the majority of malignant cells are small, dormant lymphocytes; children predominantly have high-grade diffuse patterns in which the malignant cells have a “blastic” or transformed appearance and a high mitotic rate. A possible explanation of the differences between childhood and adult NHL is that most childhood lymphomas arise from early cells that are antigen-independent, whereas many adult lymphomas arise from fully differentiated cells and are antigen-dependent.

Extranodal presentation of NHL occurs in 15% to 25% of adult patients in the United States, is higher in Europe, and is up to 40% to 50% in Asia.³⁴ Clinicopathologic features of the epidemic of NHL include a faster rise in extranodal than nodal disease, an increase in diffuse pattern over nodular, and in aggressive NHL than in indolent disease.³⁵ NHL of the brain has risen 4 times as rapidly as other extranodal sites and is partly due to AIDS, but the upward trend began before the AIDS crisis and continues to rise in immunocompetent hosts of all ages and in both genders.³⁶ The most common extranodal sites are the gastrointestinal tract and nasopharynx; other common sites include brain, skin, bone, thyroid, salivary glands, and testis.

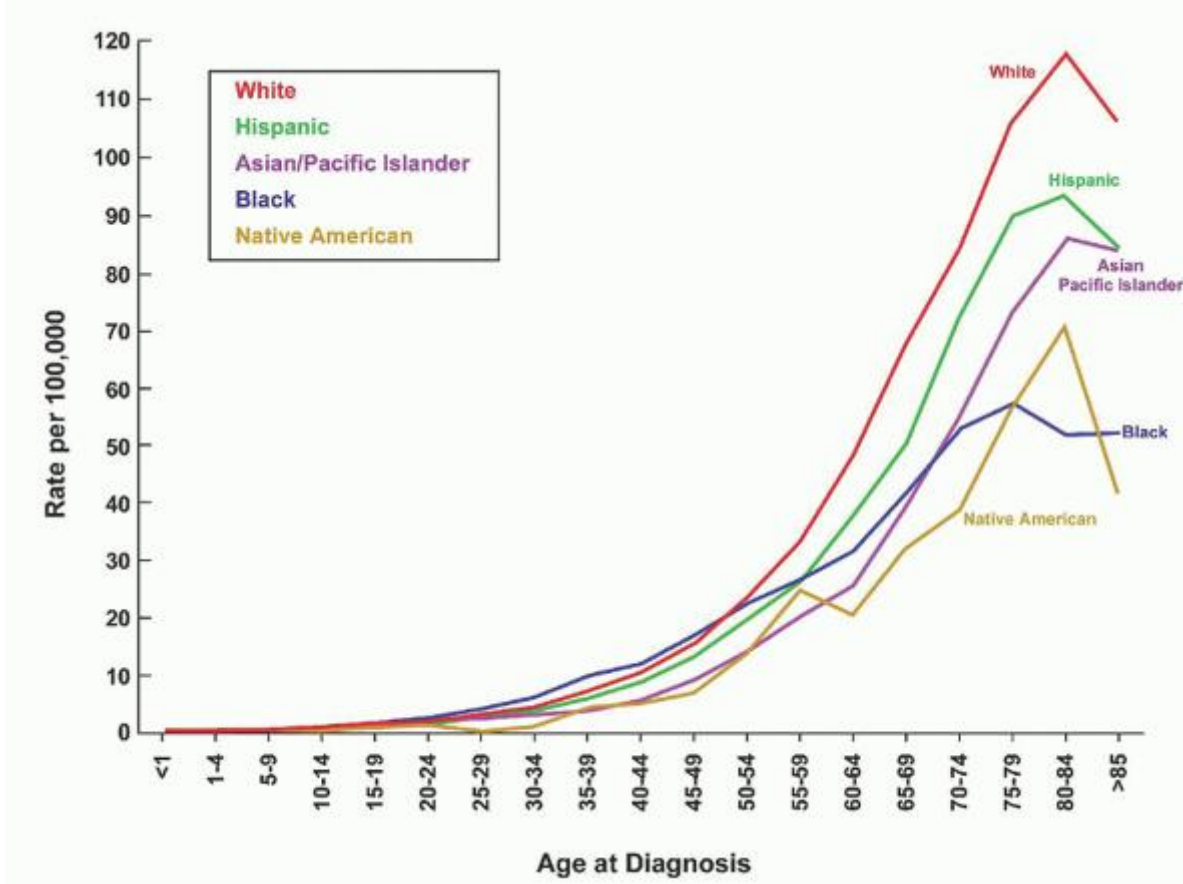

FIGURE 88.3. Age-specific incidence rates of NHL according to race (SEER data, 1979 to 2009).

Familial aggregation of NHL plays a small role in the epidemic and accounts for a 1.5- to 4-fold increased risk for NHL in close relatives of patients with lymphoma or other hematopoietic neoplasm.³⁷ Aggregation has been reported to be stronger for siblings and male relatives.^{38, 39} Anticipation (earlier age of onset in subsequent generations) has been reported in NHL;⁴⁰ however, others have disputed the finding by suggesting that the studies do not account for the increasing incidence of NHL.⁴¹

There is an increased risk for both NHL and HL in families with an autoimmune lymphoproliferative syndrome (ALPS, also known as the Canale-Smith syndrome), which is characterized by chronic lymphadenopathy, splenomegaly, autoimmune features, and expanded T cells, negative for CD4 and CD8.⁴² Both NHL and HL, particularly nodular lymphocyte-predominant, may occur decades after recognition of the syndrome and are associated with germline FAS mutations and defective lymphocyte apoptosis. Somatic FAS mutations and CASP10 germline mutations are other subtypes of ALPS.⁴³

A prior history of cancer, Jewish ancestry, and small size families have been suggested as risk factors for lymphoma.⁴⁴ In families with a diagnosis of NHL, there are reports indicating an increased risk for melanoma and other cancers, including

pancreas and stomach.³⁸ Patients who have both a family history of hematologic cancer and occupational exposures to certain substances (e.g., gasoline or benzene) appear to have an increased risk for NHL.⁴⁵

Infectious Agents

Infectious diseases have contributed to understanding the mechanisms of lymphomagenesis. The role infections play in specific lymphomas vary according to host factors, environment,

P.1830

and geography.⁴⁶ There are at least two mechanisms in which infections contribute to lymphomagenesis. The best described is direct lymphocyte transformation by microbial agents. Lymphotropic viruses include Epstein-Barr virus (EBV), human T-leukemia virus-1 (HTLV-1), and human herpes virus 8 (HHV8). An alternative mechanism is an agent, such as *Helicobacter pylori* (*H. pylori*), infecting host tissues and eliciting a lymphoproliferation response that remains dependent upon the presence of the agent, or antigen. The former does not usually respond to antimicrobial therapy, while the latter does. There are an expanding number of infections associated with specific types of NHL (Table 88.3).

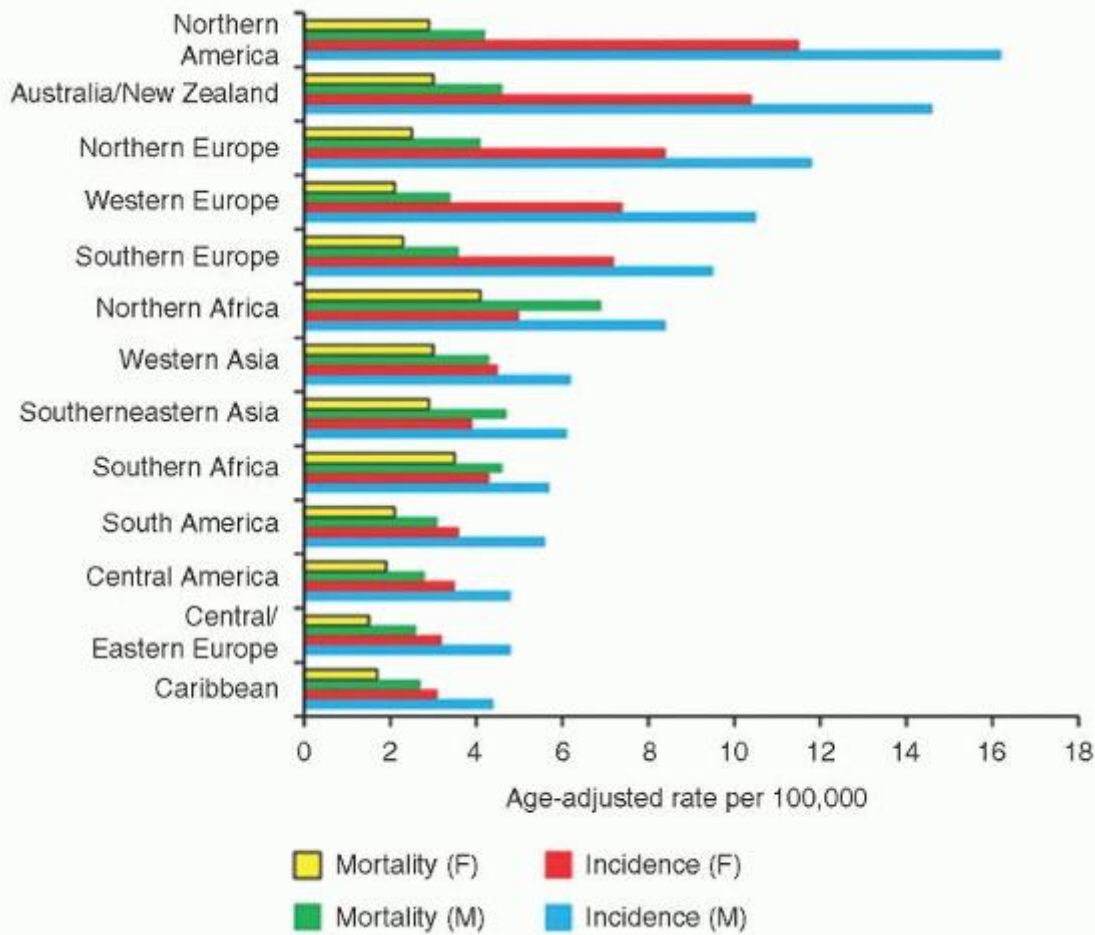

FIGURE 88.4. Age-adjusted incidence and mortality rates of NHL in selected world regions. From International Agency for Research on Cancer GLOBOCAN 2008 data, from Bassig BA, Lan Q, Rothman N, et al. Current understanding of life-style and environmental factors and risk of non-Hodgkin lymphoma: an epidemiological update. J Cancer Epidemiol 2012: 978930, with permission.

The complex interplay of environmental and host factors in the pathogenesis of lymphoma was recognized through Dennis Burkitt's description in 1958 of an aggressive tumor of young children that was characterized by frequent jaw and abdominal involvement (Fig. 88.5A). Using careful epidemiologic surveys, Burkitt identified a tumor belt across equatorial Africa that was associated with temperature, rainfall, and elevation (Fig. 88.5B).^{47, 48} Subsequently, the geographic distribution of this neoplasm was shown to correlate with that of endemic malaria. In 1964, Epstein, Achong, and Barr found viral particles in tumor cell lines derived from Burkitt's patients.¹⁰ A direct causative role for the virus was

subsequently questioned by its infrequency in BL occurring outside Africa; however, the EBV was shown to be trophic for B cells, to induce B cell proliferation and differentiation, and to be the etiologic agent for infectious mononucleosis. In 1965, Burkitt was the first to discover that the lymphoma could be cured with chemotherapy.⁴⁹

TABLE 88.2 CLINICOPATHOLOGIC DIFFERENCES BETWEEN CHILDHOOD AND ADULT NON-HODGKIN LYMPHOMAS

	Children	Adults
Incidence	Rare	Common
Median Age	10-15 years	55-70 years
Presentation	Extranodal > nodal	Nodal > extranodal
Most Common	B cell: Burkitt	B cell: Diffuse large cell (DLBCL)
Histologic	Diffuse large cell	Follicular
Diagnoses	T cell: Lymphoblastic ALK + anaplastic large cell	T cell: Peripheral T cell, not otherwise specified Anaplastic large cell Angioimmunoblastic
Immunophenotype	60-70% B cell	85-90% B cell (United States, Europe); 20-35% T/NK cell (Asia)
Paraprotein	None	Rare (<5%)
Clinical Course	Aggressive	Variable—often indolent
Curability	70-95%	<30%, except 40% to 70% in aggressive subtypes, particularly DLBCL

TABLE 88.3 INFECTIONS AND ASSOCIATIONS WITH LYMPHOMA

Agent	Lymphoma Type(s)
Epstein-Barr virus (EBV)	Burkitt lymphoma (Africa) Posttransplant lymphoproliferative disorders Acquired immunodeficiency syndrome-related lymphoma (central nervous system, others) Natural killer/T cell nasal lymphoma Hodgkin lymphoma Diffuse large B cell lymphoma of the elderly
Human T-lymphotropic virus I (HTLV-1)	Adult T cell leukemia/lymphoma
Human herpes virus 8/Kaposi sarcoma-associated herpes virus	Primary effusion lymphoma Plasmablastic lymphoma
<i>Helicobacter pylori</i>	Gastric MALToma ^a
Hepatitis B virus	Diffuse large B cell lymphoma
Hepatitis C virus	Splenic marginal zone lymphoma; other B cell lymphomas
<i>Campylobacter jejuni</i>	Immunoproliferative small intestinal disease ^a
<i>Borrelia burgdorferi</i>	Primary cutaneous B cell lymphoma ^a
<i>Chlamydia psittaci</i>	Ocular adnexal lymphoma ^a

^aExtranodal marginal zone lymphoma, MALT-type.

The identification of a 14q+ cytogenetic abnormality in BL by Manalov and Manalova⁵⁰ in 1971 led to the description of the 8;14 chromosomal translocation by Zech¹⁹ in 1976. Subsequent molecular genetic studies showed that this translocation juxtaposed the MYC oncogene on chromosome 8 to the IG heavy chain gene sequences on chromosome 14.⁵¹ These observations suggest that the 8;14 translocation of endemic Burkitt NHL arises in a state of EBV-induced polyclonal B cell proliferation in the setting of immunodeficiency associated with chronic malaria.⁵² Support for this theory has been derived by the role of EBV in lymphoproliferation in other immunodeficient conditions. EBV has also been implicated in posttransplant lymphomas, AIDS-related lymphomas (mostly central nervous system [CNS] and variably with systemic), some T/NK lymphomas, particularly nasal; some HL, and several lymphomas that developed after chronic infectious mononucleosis.^{53, 54, 55}

Shortly after immunologic classifications for NHL were proposed, adult T cell leukemia/lymphoma (ATL) was described in Japan by Takatsuki and Uchiyama in 1977.⁵⁶ The clinical course of ATL was variable, but the majority of patients presented with an acute form, which was characterized by lymphadenopathy, organomegaly, skin lesions, hypercalcemia, and an elevated white count with multilobated lymphocytes, referred to as "cloverleaf" or "flower" cells (see Fig. 88.21D), and a rapidly fatal course. In 1980 to 1982, Poiesz et al. in Gallo's lab in the United States and

P.1831

Yoshida et al. in Hinuma's lab in Japan independently discovered an unique retrovirus, HTLV-1, as the etiologic agent of ATL.^{57, 58} HTLV-1 was shown to be endemic to certain geographic areas: southwestern Japan, in which 6% to 20% of the population is seropositive for HTLV-1; the Caribbean Islands, New Guinea, parts of Central Africa and South America, parts of West Africa, the Middle East and Melanesia (Fig. 88.6).^{59, 60}

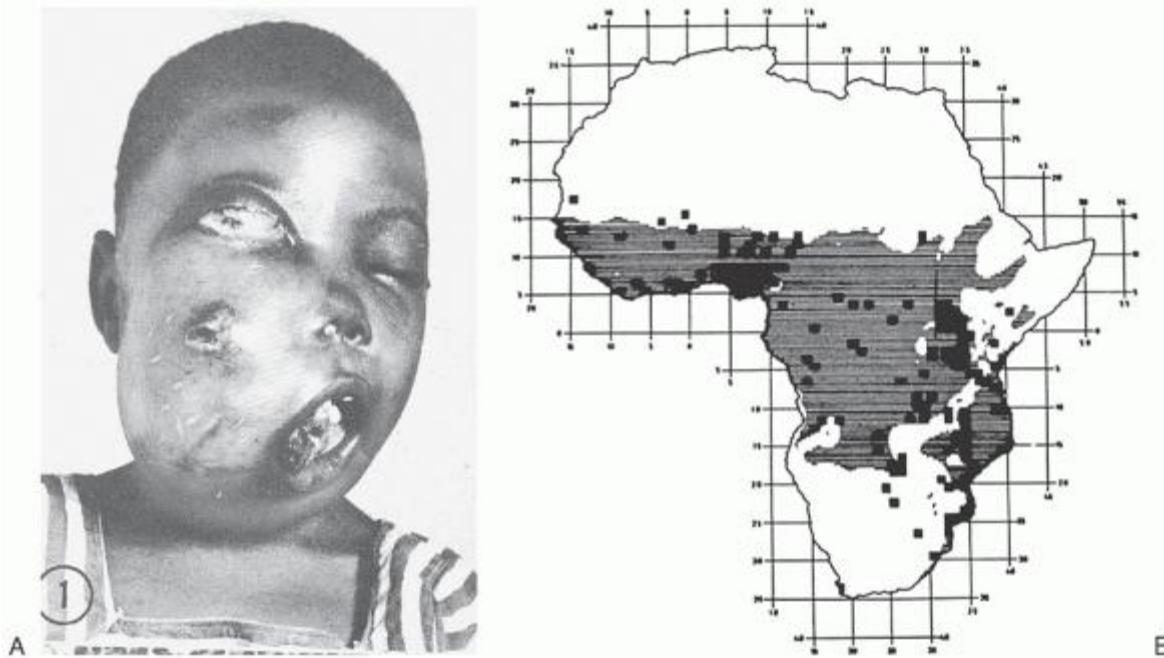

FIGURE 88.5. A: Burkitt lymphoma involving mandible, maxilla, and orbit. From O'Connor GT. Significant aspects of childhood lymphomas in Africa. *Cancer Res* 1963;23:1514-1527. B: Lymphoma belt of Africa: Burkitt lymphoma occurred only in areas below 3,000 feet (above sea level), with mean temperature above 15.6°C, and with annual rainfall over 50 cm. Shaded area, where Burkitt lymphoma would be expected to occur; black squares, sites of cases identified by Burkitt. From Haddow AJ. An improved map for study of Burkitt lymphoma syndrome in Africa. *E Afr Med J* 1963;40:429-432.

HTLV-1 is an RNA-containing delta retrovirus that infects mature T cells, usually CD3⁺, CD4⁺, and HLA-DR⁺. The molecular pathogenesis revolves around TAX, a potent HTLV-1 transcription activator protein, and HTLV-1 basic ZIP factor, HBZ (Fig. 88.7).⁵⁹ T cell dysregulation may initially involve an autocrine interleukin (IL)-2 loop as well as paracrine effects from other cellular genes and cytokines. The TAX protein is prominent during the initial infection by increasing the expression of viral genes through viral long terminal repeats (LTRs) and by stimulating the transcription of cellular genes through signaling pathways of nuclear factor Kappa B (NFκB), serum response factor (SRF), cyclic AMP response element binding protein (CREB), and activated protein 1 (AP1).⁵⁹ The TAX protein induces proliferation and inhibits apoptosis of HTLV-1 cells

through induction of I κ B-alpha degradation, which activates the NF κ B pathway, which in turn promotes expression of cell-cycle regulators (cyclin D2 and CDK6) and leads to increased activation of PI3-kinase signaling.⁶¹ TAX deregulates the expression of cytokines (IL-2 and IL-15) and antiapoptotic genes, upregulates vascular cell adhesion molecules, activates osteoclasts, and alters interferon signaling, all of which contribute to the pathogenesis of ATL.

HBZ is transcribed from the 3'-LTR and is the only gene which is conserved and unmethylated in all ATL cases, while the TAX gene is often inactivated by epigenetic changes or the loss of 5'-LTR.⁶² Unlike TAX, which activates both the classical and alternative NF κ B pathways and suppresses TGF- β signaling, HBZ suppresses the classical pathway without inhibiting alternative NF κ B signaling and promotes TGF- β signaling, which leads to upregulation of forkhead box P3 (FOXP3) protein. By enhancing TGF- β and increasing FOXP3 expression, HBZ allows infected T cells to convert to Tregs, which contribute to viral persistence and leukemogenesis. HBZ promotes T cell proliferation in its RNA form by the regulation of E2F transcription factor 1 pathway; the HBZ protein interacts with CREB-2 and suppresses TAX-mediated viral transcription.^{62, 63} Initially, the T lymphoproliferation is polyclonal and controlled by host defense mechanisms;⁶⁴ however, as TAX expression diminishes, an oligoclonal or monoclonal T cell proliferation that is IL-2-independent emerges, resulting in the clinical manifestations of ATL. HTLV-1 contributes to a multistep process of worsening genetic instability characterized by mutation of TP53, deletion of tumor suppressor genes CDKN2B/p15 and CDKN2A/p16, and DNA methylation.⁵⁹

HTLV-I can be transmitted by blood transfusions, needle sharing, sexual intercourse, and from mother to child through breast milk or through the placenta. Over 20 million people worldwide are estimated to be infected with HTLV-1, and over 90% will remain asymptomatic carriers.⁶⁰ The virus can have a prolonged latency period of decades before clinical syndromes appear^{64, 65} (see section on "Mature T/NK Leukemias"). Where the virus is endemic, ATL occurs at a rate of 20 to 86 cases per 100,000 population per year, with a lifetime risk of approximately 1% to 6% for those persons seropositive for HTLV-I antibodies.⁶⁴ In Japan, males are 3 times more likely to develop ATLL than females, with a peak age around 60 years, while in the Caribbean there is no gender difference and the peak age is 40 years.⁶⁶

HTLV-I infection induces the production of antibodies to various viral core proteins which can be used as serologic markers of infection.⁶⁷ The diagnosis is usually suggested by a screening enzyme-linked immunoabsorbent assay and confirmed by Western blot. Because of slow replication, seroconversion may take up to 2 years in HTLV-I infection compared to the 3 to 6 months for HIV. PCR utilizes primers and probes of the Pol (polymerase or reverse transcripter) and TAX (transactivator) regions and is the most sensitive and specific assay for detecting HTLV-I. HTLV-I can lead to other diseases, including myelopathy/tropical spastic paraparesis, uveitis, bronchopneumopathy, and arthropathy.^{60, 67}

Other viruses have been implicated in lymphoid neoplasia and include HTLV-II, herpes virus (HHV-6), HHV-8, (Kaposi's sarcoma-associated herpes virus [KSHV]), and hepatitis B and C. HTLV-2 was isolated in 1982 by Kalyanaraman et al. from a

P.1832

P.1833

patient with an unusual T cell variant of hairy cell leukemia.⁶⁸ It has subsequently been isolated only rarely in lymphoid neoplasia and in HTLV-I negative tropical spastic paraparesis, but it is prevalent in intravenous drug abusers.⁶⁹ Two other related viruses, HTLV-3 and HTLV-4, were reported in 2005 in Central Africa but have not been linked to human disease.⁷⁰ Salahuddin et al. identified HHV-6 in B lymphocytes from 6 patients with various lymphoproliferative disorders;⁷¹ it was identified subsequently as the etiologic agent for exanthem subitum (roseola infantum) and as a cause for pneumonia in immunocompromised hosts.⁷² A role for HTLV-2 or HHV6 in lymphoproliferation has not been detected. KSHV, also referred to as HHV-8, has been identified in AIDS-related body-cavity based B cell lymphomas and multicentric Castleman disease and has been associated with EBV genome in the absence of MYC rearrangement.^{73, 74} Theoretically, KSHV acts synergistically with EBV to transform B cells and causes a unique clinical presentation.

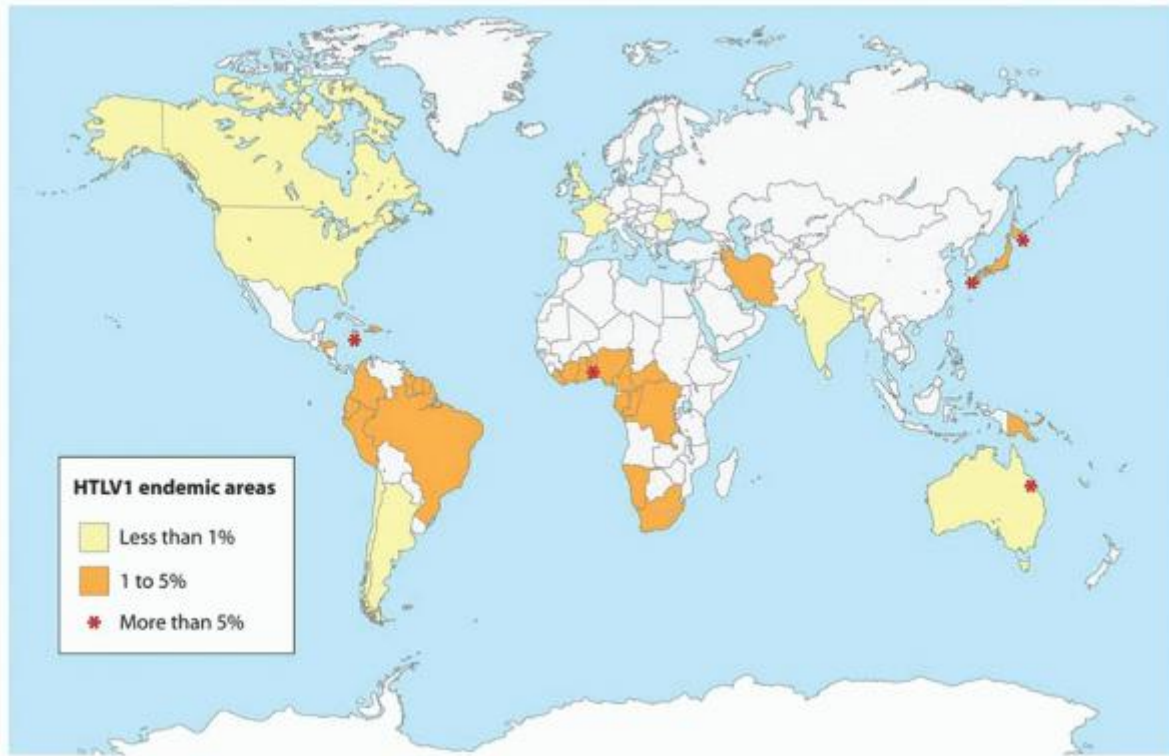

FIGURE 88.6. Geographic distribution of HTLV-1 in countries where the disease is endemic. The stars emphasize high-prevalence areas. The country boundaries shown in the map are not coincidental with the areas of endemicity, reflecting the cluster nature of HTLV infection. From Goncalves DU, Proietti FA, Ribas JG, et al. Epidemiology, treatment, and prevention of human T cell leukemia virus type 1-associated diseases. Clin Microbiol Rev 2010;23:577-589, with permission.

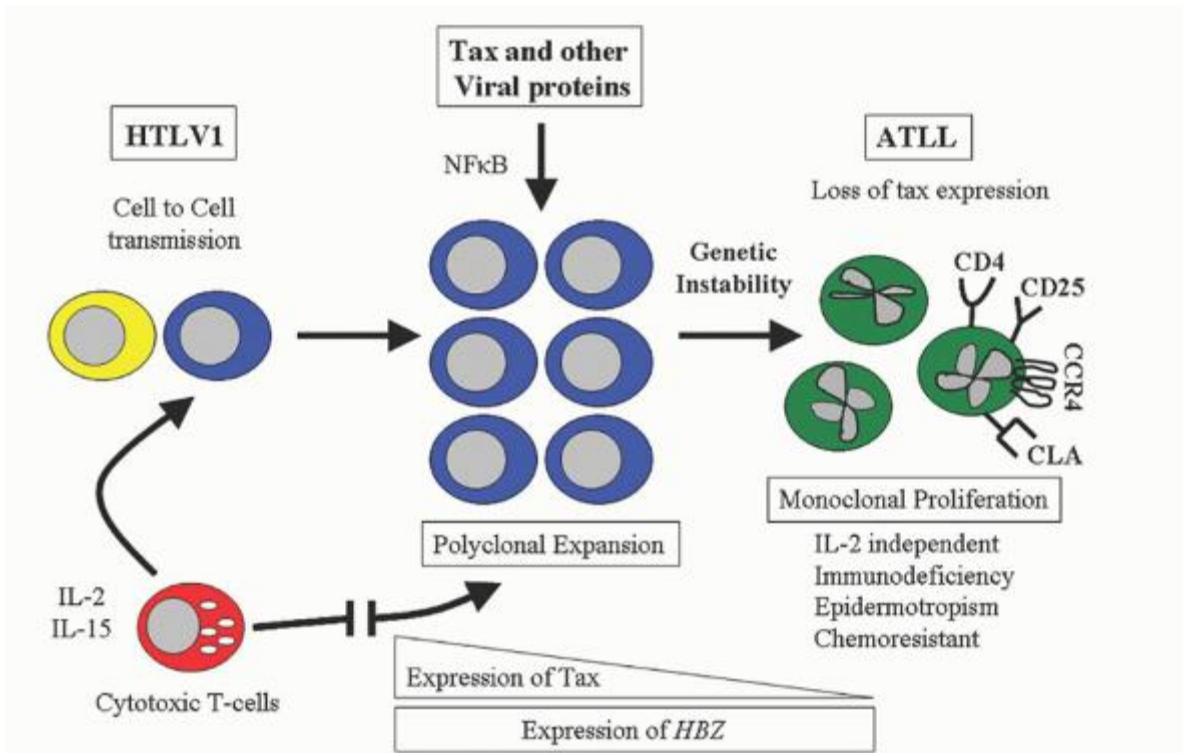

FIGURE 88.7. Course of HTLV-1 infection. After infection of a mature T helper cell, there is a long latency period (decades) which can be controlled by cytotoxic T cells and an autocrine IL-2 loop. Clonal proliferation is promoted by pleiotropic

actions of Tax and other viral proteins that inhibit apoptosis and induce IκBα, which activates the NFκB pathway. HBZ promotes T cell proliferation and the HBZ protein suppresses TAX-mediated viral transcription. As TAX expression is lost, there is the emergence of a monoclonal T cell population that is independent of IL-2. CC chemokine receptor 4 (CCR4) and cutaneous lymphocyte antigen (CLA) on ATL cells interact with endothelial cells in the skin and contribute to epidermotropism. ATL follows a multistep process of worsening genetic instability and is subdivided into clinical syndromes characterized by immunodeficiency and chemoresistance.

There is conflicting data regarding the risk of NHL in patients infected with hepatitis B (HBV) and C (HCV), but the association appears valid, particularly in endemic areas. Meta-analyses have reported a 2- to 3- and a 2- to 4-fold risk of developing NHL in HBV and HCV-infected patients, respectively.^{75, 76, 77, 78} The incubation time for lymphoma to occur in patients infected with hepatitis is estimated to be as long as 15 years.⁷⁹ DLBCL is the most common subtype associated with HBV.⁷⁵ Besides the association of HBV with NHL, cytotoxic therapy with or without rituximab can lead to HBV reactivation, resulting in hepatitis and even liver failure.^{78, 80} Screening HBV status prior to chemotherapy and prophylaxis with antiviral therapy for positive patients can decrease the rate of reactivation.⁸¹

The causative fraction of NHL by HCV varies widely according to country, but is estimated to be as high as 10% where HCV is endemic, such as Egypt, Italy, and South Korea.⁸² Chronic HCV infection is often (40% to 90%) present in patients with type II mixed cryoglobulinemia (MC); and 5% to 10% of MC patients have or will develop a B cell lymphoma (see Chapter 101).^{83, 84, 85} Early studies stating that indolent B cell lymphomas, lymphoplasmacytic and marginal zone, were the most common subtypes associated with HCV have not been confirmed, but they were reported mainly in patients with MC who do have an increased risk for indolent lymphomas.^{76, 86} Spleen involvement is more common in DLBCL with HCV (34% vs. 13%); some of the DLBCL have undergone transformation from an indolent NHL.⁸⁷ Rearrangement of either IGH or the BCL2 genes occurs in up to three-fourths of patients with HCV and MC and can regress with antiviral therapy.⁸⁸ Complete responses to antiviral therapy, primarily peg-interferon and ribavirin, occur in 60% to 75% of patients with HCV-positive lymphomas.^{89, 90, 91} Adding rituximab to antiviral therapy is well tolerated and improves responses.^{92, 93} Proposed mechanisms of HCV's role in lymphomagenesis include chronic antigenic stimulation, activation of B cells by an HCV E2 protein, and direct infection of B cells, a combination of which could lead to genetic aberrations.^{76, 85}

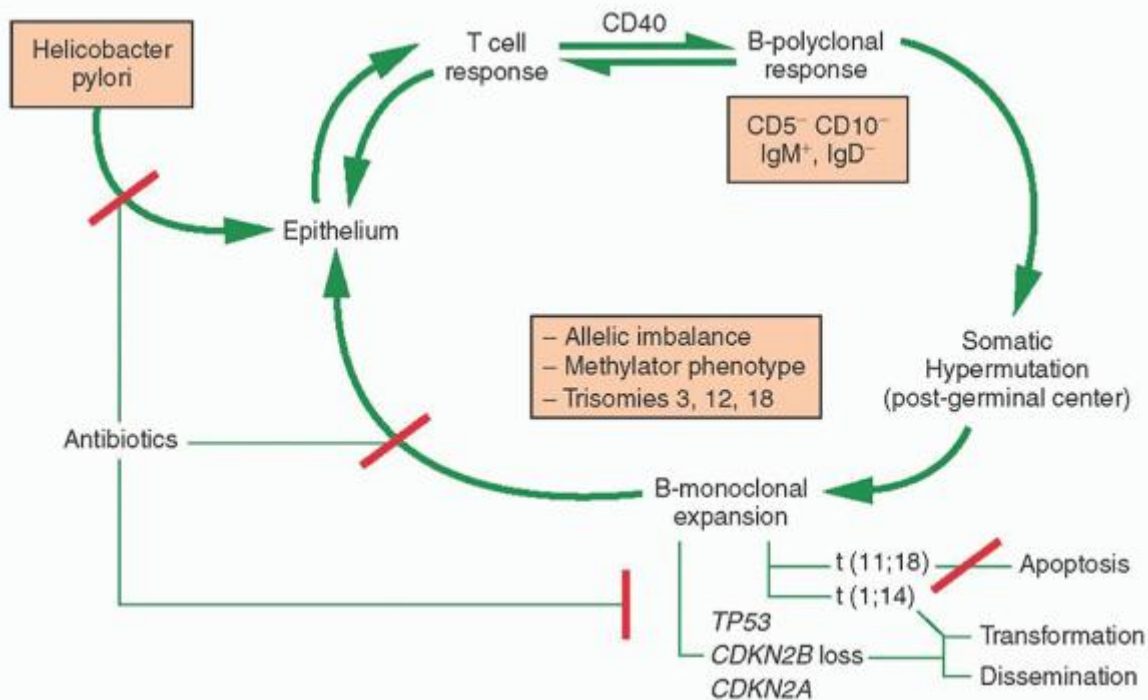

FIGURE 88.8. MALToma of the stomach: model for lymphomagenesis. *Helicobacter pylori* infects the epithelial cells and there is recruitment of both T and B cells. Contact-dependent T cell help is mediated by CD40 and CD40 ligand interaction. B cells undergo a T cell-dependent polyclonal response which can develop into a postgerminal center monoclonal B cell lymphoma. Three-fourths of gastric MALTomas have allelic imbalance, methylator phenotype, and/or trisomies and respond to antibiotics that eradicate *Helicobacter pylori*. Alternatively, there can be clonal evolution that involves a specific translocation (i.e., t[11;18] or t[11;14]) and/or a loss of tumor suppressor genes (i.e., TP53, CDKN2B/p15,

CDKN2A/p16), which are associated with dissemination of disease. The t(11;18) rarely is associated with transformation while the t(11;14) may progress to a diffuse large B cell lymphoma.

H. pylori is a gram-negative rod which was discovered by Warren and Marshall in 1983 and was shown to be associated with peptic ulcer disease, gastric carcinoma, and NHL.^{94, 95, 96} Gastric lymphoma was found to have a high frequency in certain parts of Europe, such as the Veneto region of Italy, and was usually an indolent B cell lymphoma of mucosa-associated lymphoid tissue (MALToma), a term proposed by Isaacson and Wright.^{97, 98} Parsonett recognized that *H. pylori* infection preceded the development of lymphoma,⁹⁹ and Wotherspoon reported in 1993 that antibiotic treatment for *H. pylori* caused regression of the lymphoma in over two-thirds of patients.¹⁰⁰ Over one-half of *H. pylori* large B cell gastric lymphoma will also respond to antibiotics.¹⁰¹

MALToma of the stomach serves as a model for lymphomagenesis secondary to antigenic stimulation (Fig. 88.8).¹⁰² Both B and T cells are recruited to the gastric mucosa following *H. pylori* infection. Proliferation of B cells are dependent upon reactive T cells.¹⁰³ There is a continuous spectrum of pathologic lesions during the transition from gastritis to low grade MALToma to the less frequent large B cell.¹⁰² PCR may be helpful in identifying a malignant B cell clone which may persist after histologic regression following antibiotic therapy.¹⁰⁴ Somatic hypermutation is characteristic of the B cell clone of MALToma and, along with the observation of plasmacytic differentiation, indicates a post germinal center origin. Translocation-positive gastric MALTomas lead to activation of the NFκB pathway which causes overexpression

P.1834

of BCL2, blocks apoptosis of B cells, and leads to antibiotic resistance, while translocation-negative cases involve inflammatory and immune responses, which maintain B and T cell interaction and respond to *H. pylori* eradication.¹⁰⁵ The oncoprotein of the CAGA gene has been shown to be directly delivered into B cells by *H. pylori*, and it likely contributes to lymphomagenesis.¹⁰⁶

The most common genetic abnormality in gastric MALToma is the t(11;18)(q21;q21) which is present in one-quarter to one-third of cases, and up to one-half of *H. pylori* negative cases.^{107, 108} The genes involved at t(11;18) are an apoptosis inhibitor-2 gene (API2) and a novel 18q gene, MALT, and are more likely to result in disseminated disease but less likely to undergo histologic transformation than other genetic abnormalities.¹⁰⁹ The t(14;18) in MALToma involves IGH/MALT2 and may coexist with trisomies 3, 12, or 18; occurs in 5% gastric MALTomas; and is more common in nongastrointestinal sites.¹⁰⁸ The t(1;14)(p22;q32) and t(1;2)(p22;q12) involve the BCL10 gene^{102, 110} and are present in 1% to 3% of gastric MALTomas.^{102, 108, 110} BCL1 and BCL2 gene rearrangements are usually not present in MALTomas, and BCL-6 has rarely (1% to 2%) been reported.^{102, 111} There is controversy whether the B cell clones remain dependent upon antigen stimulation or expand through autonomous (antigen-independent) growth. Loss of tumor suppressor genes and amplification of 3q27 have been associated with histologic progression and dissemination of MALTomas.^{109, 112}

Other infections associated with specific MALTomas include *Borrelia burgdorferi* with primary cutaneous B cell lymphoma, *Chlamydia psittaci* with ocular adnexal MALTomas, and *Campylobacter jejuni* with immunoproliferative small intestinal disease (also called alpha heavy chain disease or Mediterranean lymphoma).^{46, 113} Their frequency varies according to endemic geography and have been found more commonly in Europe than in North America or Asia. The ability to diagnose the association depends upon either immunohistochemistry using a monoclonal antibody detecting the agent or, preferably, targeted polymerase chain reaction (PCR) that detects the DNA of the infectious agent. When the infections are present in these MALTomas, the lymphomas will regress in the majority of patients treated with antibiotics.^{114, 115}

Environmental Factors

Environmental associations implicated in the pathogenesis of NHL include not only infections, but also drug exposure and toxic chemical exposure. Immunosuppressive agents contribute to lymphomagenesis through interaction with EBV, particularly in organ transplants. Phenytoin and carbamazepine have been associated with both pseudolymphoma and malignant lymphoma, with the former condition presenting with fever, rash, and adenopathy that regress after drug withdrawal.¹¹⁶ Methotrexate and the tumor necrosis factor (TNF) alpha inhibitors (adalimumab, certolizumab, etanercept, golimumab, and infliximab) have been associated with an increased risk of lymphoma in some but not all studies in rheumatoid arthritis, which itself may have an increased risk (see section on "Preliminary Conditions").¹¹⁷ In a meta-analysis of randomized controlled studies, there was a trend for an increased risk of B-NHL in patients receiving anti-TNF therapy, but it did not reach statistical significance.¹¹⁸ Hepatosplenic T cell lymphoma has been reported in patients with Crohn disease receiving anti-TNF therapy usually with other immunomodulators.¹¹⁹ Although epidemiologic studies are flawed by methodologic weaknesses, other drugs possibly associated with NHL include analgesics, antibiotics, steroids,

digitalis, estrogen, and tranquilizers.^{44, 120, 121, 122} A Danish study found no increased risk of NHL in women using postmenopausal hormone replacement.¹²³

Occupational exposures have been suggested as factors in the epidemic, but studies are often flawed because of small numbers and being retrospective. An increased risk of NHL has been reported among people employed in agriculture, forestry, fishing, construction, motor vehicles, telephone communication, and leather Industries.^{124, 125} Specific jobs at risk include plant and poultry farmers, butchers, gardeners, painters and plasterers, car repair and gasoline station workers, carpenters, brick and stone masons, plumbers, welders and solderers, roofers, and teachers. The associations tend to increase with longer duration of employment, and studies have correlated specific jobs with histologic types.¹²⁵

Chemicals that have been implicated in the epidemic include organochlorines and phenoxyacetic acids that are commonly found in pesticides and herbicides.^{126, 127, 128, 129} A number of organochlorine compounds have been banned in the United States, including dichlorodiphenyl-trichloroethane (DDT, used from 1939 to 1972), polychlorinated biphenyls (PCBs, 1929 to 1977), and chlordane (1947 to 1988); however, studies have correlated the presence of these and similar chemicals in carpet dust and in adipose tissue with a higher risk of developing NHL. An excess risk for NHL has also been suggested for exposure to organic solvents, such as benzene, xylene, toluene and trichloroethylene, fertilizers, epoxy glues, and wood dust.¹³⁰ Variations in immune genes or DNA repair genes may affect an individual's risk of developing NHL after exposure to solvents,^{131, 132} which may also directly impair cell-mediated immunity.

Hair dyes, ultraviolet light (UV), and nutritional factors have been implicated in some epidemiologic studies and negated in others.^{133, 134, 135, 136} Hair dye is more likely to be a factor in women than in men because of greater use in women. There has been an increased risk for NHL in women who used hair dyes before 1980, but not among women after 1980, probably related to removal of carcinogenic compounds.^{136, 137}

Several studies noted an increase in NHL among patients with melanoma or squamous cell skin cancer and suggested a role for UV suppressing the immune system;¹³³ however, there was no correlation between NHL mortality and increased UV light exposure in the southern United States or in Scandinavia.^{134, 138} Additionally, a reduced risk of NHL has been reported with higher sun exposure.^{138, 139} A hypothesis is that reduced risk in midlatitudes arises from vitamin D production with UVB light, while an increased risk arises from immunosuppression by more UVA light in higher latitudes.¹⁴⁰ Other studies have found no protective effect of UV radiation and no association between vitamin D and NHL risk.^{141, 142}

Nutritional factors, including milk, butter, liver, meat, coffee, and cola consumption, have been identified as possible risk factors.^{143, 144, 145, 146, 147} A high-meat diet and a high intake of fat from animal sources have been associated with an increased risk of NHL; there was a decreased risk with increased ingestion of fruits.¹³⁵ Other studies have reported a lower risk for NHL with higher intakes of vegetables, lutein and zeaxanthin, and zinc.¹⁴⁸ Milk consumption has had conflicting reports.^{135, 147} Obesity and lack of exercise have been suggested as contributing to the epidemic in some studies and refuted in others.^{147, 149, 150}

Blood transfusion has been implicated as contributing to the increased incidence of NHL.^{151, 152, 153} The use of blood products beginning in the 1950s has coincided with the epidemic. Transmission of infectious agents through blood transfusion could suppress the immune system, and make a patient susceptible to the development of lymphoma. Blood transfusion has been associated with all types of histologies, but a meta-analysis found a higher risk for CLL/SLL.^{152, 153} While cohort studies have supported the connection between blood transfusion and lymphoma, case-control studies have not consistently confirmed the association.^{151, 153, 154}

A number of other factors have been mentioned as possibly contributing to the epidemic, including ionizing radiation, electromagnetic fields, alcohol, tobacco, and chronic fatigue syndrome, but the data is weak to support an association of any of these factors

P.1835

with an increased risk of NHL.^{155, 156, 157, 158} The epidemiology of NHL continues under investigation and requires carefully designed studies with large cohorts and prolonged follow-up to determine the validity of an association between a factor and NHL. InterLymph, an international consortium of NHL studies, is providing large databases to assess the impact of environmental risk factors.¹⁵⁹

PRELYMPHOMATOUS CONDITIONS

The mechanism of developing lymphomas has been best studied in those occurring in immunodeficiency states. These disorders can be subdivided into congenital, or primary, immunodeficiencies, and acquired, or secondary,

immunodeficiencies (Table 88.4). Common components to all these disorders are defects in immunoregulation, particularly in T cell immunity, resulting in decreased cytokines, and uncontrolled B cell growth in lymphoid tissue, often in association with the EBV genome. Since 1973, cases of malignant disease in children with immunodeficiency have been recorded by immunodeficiency cancer registries, and NHL constitutes the majority of the cases.^{160, 161} The median age of onset is 7 years and there is a predominance of males over females, due in part to the contribution of X-linked disorders.¹⁶⁰ The importance of EBV in the pathogenesis of lymphoproliferation in immunodeficiency was suggested by Purtilo et al. in 1974, when they described an X-linked disorder in which 6 boys in a single family died of infectious mononucleosis, agammaglobulinemia, or malignant lymphoma.¹⁶² The role of EBV in lymphomas developing in patients with immunodeficiencies is addressed in Chapters 62, 63 and 64.

Organ Transplants

In the early 1980s, a range of lymphoproliferative lesions was described that occurred in patients receiving chronic immunosuppressive therapy after solid organ transplantation. The clinical and pathologic spectrum of diseases included primary infectious mononucleosis, polymorphic B cell hyperplasia, and intermediate-to high-grade B cell lymphomas in which necrosis, cytologic atypia, monotypic Ig expression, and cytogenetic abnormalities are harbingers of neoplastic transformation and aggressive behavior.¹⁶³ Serologic and molecular studies linked many of these lymphoproliferations to primary or secondary EBV infection.¹⁶⁴ The risk of developing lymphoproliferation after transplantation is dependent upon age, EBV status, type of transplant, and amount of immunosuppression.¹⁶⁵ A lower chance occurs in older as opposed to younger age, sibling over cadaver donor, and single over multiple transplants. Early reports from Stanford University indicated that up to 40% of patients surviving cardiac transplantation developed a malignant lymphoma.¹⁶⁶ With less immunosuppression, the incidence is 1% to 15% after solid organ transplants, which is a 30- to 60-fold increase in lymphomas compared to the general population.^{167, 168} The diagnosis and management of posttransplant lymphoproliferative disease (PTLD) is described in Chapter 62.

TABLE 88.4 PRELYMPHOMATOUS CONDITIONS

Congenital	Acquired
Ataxia telangiectasia	Immunodeficiency
Wiskott-Aldrich syndrome	Organ transplants Acquired immunodeficiency syndrome
Severe combined immunodeficiency	
Common variable immunodeficiency	Autoimmune disorders Sjögren syndrome
Hyper IgM syndrome	Hashimoto thyroiditis
Hyper IgE syndrome	Rheumatoid arthritis Systemic lupus erythematosus
X-linked hypogammaglobulinemia	Inflammatory bowel disease
X-linked lymphoproliferative syndrome	Castleman disease Hodgkin lymphoma
Autoimmune lymphoproliferative syndrome	Lymphomatoid granulomatosis Predisposition to T cell lymphoma Nontropical sprue Angioimmunoblastic lymphadenopathy Lymphomatoid papulosis

Acquired Immunodeficiency Syndrome

AIDS was recognized as a disease in 1981 and the first case of lymphoma in an AIDS patient was reported in 1982.¹⁶⁹ This was followed by a series of 90 homosexual patients with NHL reported by Ziegler et al. in 1984.¹⁷⁰ In 1985, the diagnosis of

NHL in association with positive serologic evidence for human immunodeficiency virus (HIV) became a criterion for the diagnosis of AIDS.¹⁷¹ In Ziegler's series, presenting features included generalized adenopathy and opportunistic infections in one-third of patients.¹⁷⁰ Extranodal sites of disease and advanced stage occur in three-fourths of patients with AIDS-related lymphoma (ARL). The most common extranodal sites are the meninges, gastrointestinal tract, bone marrow, liver, and lung/pleura; unusual sites include rectum, oral cavity, heart/pericardium, common bile duct, and skin.¹⁷² NHLs in AIDS patients are usually of B cell origin and include diffuse large B cell (DLBCL: immunoblastic, or large transformed) and BL. Unique presentations of ARL include plasmablastic lymphoma of the oral cavity¹⁷³ and primary effusion lymphoma.⁷³ Differences in the histology of ARL have not impacted survival;¹⁷⁴ however, they are likely to become more important with improved survival in AIDS.

The prevalence of NHL in AIDS is 3% to 6%, and before the era of highly active antiretroviral therapy (HAART) there were projected increased risks over time.¹⁷⁵ The risk of lymphoma is increased 60- to 650-fold among HIV-infected patients compared to the general population and is associated with older age, severe immunodeficiency (defined by CD4 count and HIV viral load), and prolonged HIV infection.^{176, 177} Since the introduction of HAART in 1996, epidemiologic studies in developed countries are reporting an increase in ARL as the first AIDS-defining illness but decreased overall incidence in ARL, particularly in primary CNS NHL and in DLBCL (immunoblastic) histology.^{172, 177, 178, 179} Additionally, survival for ARL has improved.^{177, 180} Prognostic factors and therapy of ARL are addressed in Chapter 64.

Autoimmune and Other Immunologic Disorders

Chronic inflammation, immune hyperactivity, and/or immunosuppression are elements of autoimmune disorders that predispose patients to lymphoma.^{98, 181, 182} Many of these lymphomas arise in extranodal sites where there is sparse lymphoid tissue; they are usually localized, low grade B cell lymphomas arising from mucosa-associated lymphoid tissue (MALT). Isaacson and Wright initially recognized MALTomas in the gastrointestinal tract and indicated they were a subset of immunoproliferative small intestinal disease, or Mediterranean lymphoma; however, they subsequently identified similar lymphomas occurring in the lung and salivary gland.¹⁸³ Multiple other extranodal sites have been involved with MALTomas and include thyroid gland, thymus, breast, conjunctiva, gallbladder, skin, cervix, larynx, and trachea. Although the term MALToma is misleading due to the fact that not all of the lesions arise in mucosal tissue, two common features are chronic inflammation and the presence of glandular epithelium that is destroyed by progressive lymphocytic infiltration.

P.1836

Lymphomas associated with Sjögren syndrome (SS) and Hashimoto thyroiditis (HT) are of B cell origin and tend to occur in elderly females. The presumed pathogenesis of lymphomas in these patients is associated with chronic antigenic stimulation causing polyclonal B cell growth with eventual development of a monoclonal B cell lymphoma. Bunim and Talal reported the first association of lymphoma and SS in 1963,¹⁸⁴ and Kassan et al. subsequently reported a greater than 40-fold risk for lymphomas in these patients.¹⁸⁵ Approximately 5% of patients with primary SS will develop lymphoma.^{186, 187}

The histologic lesion of SS is a myoepithelial sialoadenitis (MESA) characterized by lymphoid infiltration of the salivary gland along with acinar atrophy and proliferation of ductal cells to form myoepithelial islands.¹⁸⁸ Although the initial clinical course of SS usually is benign, clonally rearranged IG genes can be detected in the biopsy of MESA.¹⁸⁹ Furthermore, the finding of light chain restriction in minor salivary glands of the lip by in situ hybridization techniques correlates with development of lymphoma.¹⁹⁰ These findings suggest, as in many other prelymphomatous conditions, that the "benign" lesion actually represents either a monoclonal population of unknown significance or malignant lymphoma in situ. B-lymphocyte activator of the TNF-family (BAFF) is overexpressed in SS salivary glands, induces BCL-2 which impairs apoptosis, and likely contributes to lymphomagenesis.¹⁹¹ Overt lymphoma tends to occur in those lesions with extensive, confluent areas of monotypic B cell proliferation, and the lymphomas most commonly seen are marginal zone, lymphoplasmacytic, or DLBCL types.

Lindsay and Dailey described an association between lymphoma of the thyroid and HT in 1957.¹⁹² Subsequent studies indicate that over 75% of thyroid lymphomas are preceded by HT, made evident by thyroiditis in the nonlymphomatous portion of the pathologic specimens and by antithyroid antibodies in most patients.¹⁹³ There is a 60- to 80-fold increase in thyroid lymphoma after thyroiditis, but the lifetime risk is only 1% to 2%.¹⁹⁴ Unlike the lesion of SS, which has IG gene rearrangement, the lesion of HT does not usually have a clonal population of cells identified by DNA analysis;¹⁹⁵ however, similar IGH bands have been detected in a minority of HT patients and subsequent thyroid lymphoma, supporting the

hypothesis of clonal evolution of NHL from HT.¹⁹⁶ Most thyroid lymphomas express surface IgG rather than the IgM characteristic of follicular center cell (FCC) lymphomas, suggesting that thyroid lymphomas involve B cell progenitors with the ability to differentiate further from IgM to IgG production.¹⁹⁷

Lymphomas have been reported in patients with other autoimmune disorders, including rheumatoid arthritis (RA), systemic lupus erythematosus (SLE), scleroderma, inflammatory bowel disease, and dermatomyositis; however, the increased incidence in these disorders are complicated by the use of immunosuppressive therapy and by possible methodologic flaws in the epidemiologic studies.¹⁹⁸ The increased risk for lymphoma in RA varies from 2- to 15-fold and is higher in patients with more severe disease or with Felty syndrome.¹⁹⁹ A large study reported an increased NHL risk (2.9[1.7 to 4.9]) in RA patients treated with any biologic agent and a greater risk with anti-TNF agents than methotrexate.²⁰⁰ A meta-analysis of randomized clinical trials in RA reported no increased risk of malignancy with biologic therapy, but did find an increased risk for NHL of 2.1 (0.55 to 8.4) in patients receiving anti-TNF therapy compared with controls.²⁰¹ A wide spectrum of lesions have been described in RA patients, ranging from lesions that resemble posttransplant polymorphous lymphoproliferation to large B cell lymphomas, the most common type, HL, and, rarely, PTCL.^{198, 202} EBV may be present in tumor cells, and the lymphoproliferations may regress with discontinuation of immunosuppression.^{202, 203} T-large granular lymphocyte leukemia is often associated with rheumatoid arthritis and neutropenia.²⁰⁴ The risk of NHL in SLE is increased 3- to 4-fold and DLBCL is the most common type.²⁰⁵

Castleman disease (CD) (giant lymph node hyperplasia, angiofollicular lymph node hyperplasia) was first recognized in the 1920s and was further described as a clinicopathologic entity in 1954.^{206, 207} It has two types of clinical presentations (localized and multicentric) and three types of histologic subtypes (hyaline vascular, plasma cell, and mixed).^{208, 209} The hyaline vascular type is the most common subtype and presents as localized adenopathy, often in the mediastinum. It can be amenable to surgical resection; and although it was initially reported to be radioresistant, it has been successfully treated with radiation as well.²¹⁰

The plasma cell variant is associated with systemic symptoms, anemia of chronic disease, hypergammaglobulinemia, and a variety of unusual syndromes, including myasthenia gravis, nephrotic syndrome, peripheral neuropathy, amyloidosis, and temporal arteritis.²¹¹ A plasmablastic subvariant is associated with HIV infection. Increased expression of the gene coding for IL-6 has been identified in CD, and retroviral transduction of the gene into mice has reproduced histology and symptoms.²¹² Moreover, antibodies to IL-6 or its receptor have ameliorated the disease.²¹³ The plasma cell variant tends to be either a local form, more commonly occurring in a young adult and amenable to local therapy, or a multicentric form occurring in an older adult or in an HIV-infected patient with diffuse adenopathy and a variable, but often fatal, clinical course in which 20% to 30% of patients develop either Kaposi sarcoma or B cell lymphoma.^{211, 214, 215} Immunophenotyping and IG gene rearrangements of the plasma cell variant in CD indicate that patients usually have polyclonal lesions,²¹⁶ however, monoclonal IG gene rearrangements have been identified in patients with the multicentric form and in patients developing B cell lymphoma.²¹⁷ KSHV (HHV8) has been identified in HIV-associated multicentric CD cases and levels of KSHV DNA correlate with symptomatic disease.^{215, 218} KSHV positive plasmablasts have lambda light chain restriction, are localized to the mantle zone of germinal centers, and can coalesce to form microscopic lymphomas.²¹⁹ The lymphomas have had a variable histologic pattern but they are usually of B cell origin with mantle cell the most common subtype and have a poor prognosis.²²⁰ Plasmablastic lymphoma and primary effusion lymphoma have also been reported.⁷⁴ There is no standard of treatment for multicentric CD, and anecdotal cases have utilized rituximab, interferon, thalidomide, tocilizumab (anti-IL6), antiviral therapy, and chemotherapy with variable success.^{207, 215, 221, 222}

NHL may follow HL, with prior therapy and the cell-mediated immune defect characteristic of HL serving as possible contributing factors. Krikorian et al. reported 6 cases from Stanford University of intermediate- to high-grade lymphoma developing after HL.²²³ In subsequent series, authors estimated that 1% to 5% of patients with HL will develop NHL;²²⁴ some studies have indicated a greater risk in the nodular variant of lymphocyte predominant HL (LPHL), which has a unique CD20⁺ B cell immunophenotype.^{225, 226} The large B cell lymphomas associated with LPHL generally are regarded as a progression of LPHL rather than as secondary neoplasms. Single cell analysis of the lymphocytic and histiocytic cells of LPHL have proven a clonal relation to large B cell lymphoma developing in the same patient.²²⁷ There are rare patients with intermediate clinical and pathological features between DLBCL and classical HL that have been referred to as "mediastinal gray zone lymphoma," or "large B cell lymphoma with Hodgkin-like features."²²⁸ Most NHL that occur after all subtypes of HL are of B cell origin,^{225, 229} but those of T cell immunophenotype have followed HL as well.²³⁰ The EBV genome has been found in some cases of NHL developing after HL.²³¹

T cell lymphomas commonly do not occur in the setting of immunodeficiencies, with the exception of ataxia telangiectasia; however, some disorders appear to predispose to PTCL, and up to one-tenth of lymphomas in organ

transplants are of T cell origin. PTLD of T cell origin tend to occur late and have a poor prognosis.²³² Hepatosplenic $\gamma\delta$ T cell lymphoma can occur late

P.1837

after solid organ transplantation and in patients with Crohn disease, the majority of whom were on anti-TNF therapy.¹¹⁹,²³³ PTCL comprise only 3% of all AIDS lymphomas.²³⁴ Patients with gluten-sensitive enteropathy or celiac disease have an increased incidence of intestinal T cell lymphoma.²³⁵ Although Isaacson et al. initially reported that these lymphomas were variants of malignant histiocytosis, subsequent studies with gene rearrangement techniques indicated a T cell origin and they are referred to as enteropathy-associated T cell lymphoma (EATL).²³⁶ Primary anaplastic large cell lymphoma has been reported after breast implant surgery.²³⁷

Skin disorders may also evolve into a malignant CTCL (Chapter 92). Clonality, as evidenced by TCR gene rearrangements, has been detected in some patients with lymphomatoid papulosis²³⁸ as well as in those with other cutaneous T cell processes of uncertain malignant potential, such as pityriasis lichenoides et varioliformis acuta,²³⁹ granulomatous slack skin disease,²⁴⁰ and pagetoid reticulosis.²⁴¹ The latter two disorders are considered variants of mycosis fungoides.

CLINICAL FEATURES AT PRESENTATION

The majority of patients with NHL present with painless adenopathy, more commonly in the cervical or supraclavicular regions;²⁴² however, extranodal disease can be detected at presentation in up to 40% of patients and varies depending upon immune status and geographic differences. Systemic symptoms occur in less than 25% of patients in most large series.²⁴²,²⁴³ When present, however, they usually are associated with advanced stages of disease and a poor prognosis. Significant cytopenias are rare unless marrow involvement is extensive or there are associated immune mediated cytopenias, hypersplenism, or rarely, hemophagocytosis. Leukemia presentations in NHL are rare and variably impact prognosis.²⁴⁴,²⁴⁵

The gastrointestinal tract is the most common extranodal site at presentation and is involved in 5% to 20% of adults with NHL.²⁴⁶ The stomach is most frequently involved followed by the small intestine, the colon, and the esophagus. Approximately 90% of primary gastrointestinal lymphomas are of B cell origin. Certain subtypes have a site predilection: MALToma in the stomach, Burkitt (non-African) in the terminal ileum; mantle cell in the terminal ileum, jejunum, and colon; T cell (EATL) in the jejunum; follicular in the duodenum.

Gastrointestinal symptoms are often nonspecific with vague abdominal pain the most common presenting symptom. Epigastric pain, dyspepsia, nausea and, less often, early satiety, suggest stomach involvement. Frank bleeding occurs in less than 30% of patients with gastrointestinal lymphomas, and usually is from either a gastric (melanotic stool) or large bowel source.²⁴⁷ Patients with rectal involvement usually present with hematochezia or a change in bowel habits.²⁴⁸ Obstruction, specifically intussusception, or perforation are associated with aggressive small bowel lymphomas, particularly BL and EATL. Mantle cell lymphoma presents with gastrointestinal symptoms in 20% to 30% of patients, and multiple polyposis may be found on colonoscopy (Fig. 88.9). Lymphomatous polyposis of the gastrointestinal tract is not restricted to MCL and has also been detected in FL and MALToma.²⁴⁶,²⁴⁹ Although the mucosa may appear normal, abnormal histology in the gastrointestinal tract is found in over 80% of MCL patients.²⁵⁰ Dysphagia, airway obstruction, and eustachian tube blockage with or without cervical adenopathy are symptoms suggesting Waldeyer's ring involvement. Epistaxis and nasal obstruction usually with facial edema are common signs of involvement of nasal lymphomas.

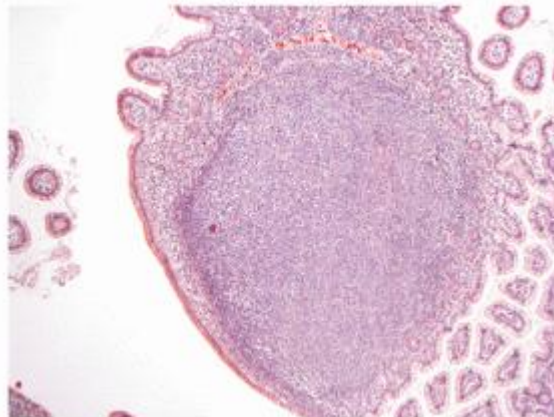

FIGURE 88.9. Mantle cell lymphoma. A: Intestine involved by multiple lymphomatous polyposis. Multiple small nodules extensively involve the bowel mucosa. Image provided by Dr. Lawrence Weiss, City of Hope National Medical Center. B: Aggregates of small B cells from multiple nodules just beneath the mucosa express CD5 and cyclin D1. Image provided by Dr. Dan Arber, Stanford University, Palo Alto, CA.

Hepatosplenomegaly is a common feature of advanced indolent B cell lymphoma, including small B lymphocytic lymphoma, and splenic marginal zone lymphoma (SZML), and can be the predominant clinical feature of hepatosplenic T cell lymphoma. Subclinical secondary involvement of the liver has been reported in 26% to 40% of NHL, while primary hepatic lymphoma (PHL) is extremely rare, representing 0.05% of extranodal lymphoma.^{251, 252} Primary splenic lymphoma is similarly rare, and splenectomy may be considered for diagnosis and therapy.²⁵³ Primary NHL of the liver usually is a large B cell type, can be associated with hepatitis C (40% to 60%), and can arise in immunodeficient hosts. Presenting features include right upper quadrant pain, anorexia, nausea, coagulopathy, and elevated liver enzymes without significant jaundice.^{251, 252, 254} Hypercalcemia is present in 40% of patients. Hypodense, nonenhancing (possible rim enhancement) masses on CT imaging are characteristic of primary liver NHL. Solitary masses occur in approximately two-thirds, multiple masses in one-third, and diffuse infiltration is unusual.^{251, 254} Obstructive jaundice can occur in NHL secondary to periportal lymphadenopathy or to primary lymphoma of the bile duct or pancreas. Rarely, liver involvement with NHL may present with hepatic failure.²⁵⁵

The skin is another common extranodal presentation of NHL, and the most common primary cutaneous type is the cerebriform T cell of mycosis fungoides/Sezary syndrome (Chapter 92). While mycosis fungoides tends to be confined to the skin with characteristic stages, B cell lymphomas involving the skin represent only 15% to 25% of primary cutaneous lymphoma and usually present

P.1838

as nodules involving head, neck, or trunk.^{256, 257} The major types of primary cutaneous B cell lymphomas and their distinguishing immunotypes include marginal zone (MALT-type) (CD20+, CD5⁻, CD10⁻), primary cutaneous follicular lymphoma (PCFL) (CD20⁺, CD10⁺), and primary cutaneous large B cell lymphoma (PCBCL) (CD20⁺; usually CD10⁻). Other T cell lymphomas with unique skin involvement include anaplastic large cell lymphoma (ALCL), which can be a primary cutaneous type or a systemic disease;²⁵⁸ subcutaneous panniculitis-like PTCL, $\alpha\beta$ subtype; and 3 provisional entities, cutaneous $\gamma\delta$ T cell lymphoma (TCL), aggressive epidermotropic CD8⁺ cytotoxic TCL, and primary cutaneous CD4⁺ small/medium-sized pleomorphic TCL.

Neurologic symptoms and signs, including headache, confusion, lethargy, dysphasia, hemiparesis, seizures, and cranial nerve palsies, and rarely, multifocal leucoencephalopathy, may be presenting features of CNS involvement.²⁵⁹ Cognitive and personality changes are more common in primary CNS lymphoma (PCNSL) due to a predilection for involvement in the frontal lobes, corpus callosum, and periventricular areas. Approximately 90% of PCNSL are DLBCL; the remainder are indolent B cell lymphomas, BLs, and peripheral T cell lymphomas.^{259, 260}

The detection of a single lesion on MRI favors PCNSL, but multifocal lesions can occur in approximately one-third of normal hosts and formerly more frequently in AIDS patients (Fig. 88.10). The differential in AIDS patients with intracranial mass lesions includes not only CNS lymphoma, but also toxoplasmosis, progressive multifocal leucoencephalopathy, and other opportunistic infections. CT scanning of CNS lymphoma usually identifies a contrast enhancing lesion or lesions with a mass effect and edema which may have ring enhancement, a common finding in toxoplasmosis. The definitive diagnostic procedure is CT-guided stereotactic biopsy.²⁶¹ Positron emission tomography (PET) scanning may distinguish lymphoma and toxoplasmosis and obviate the need for biopsy in some AIDS patients.²⁶²

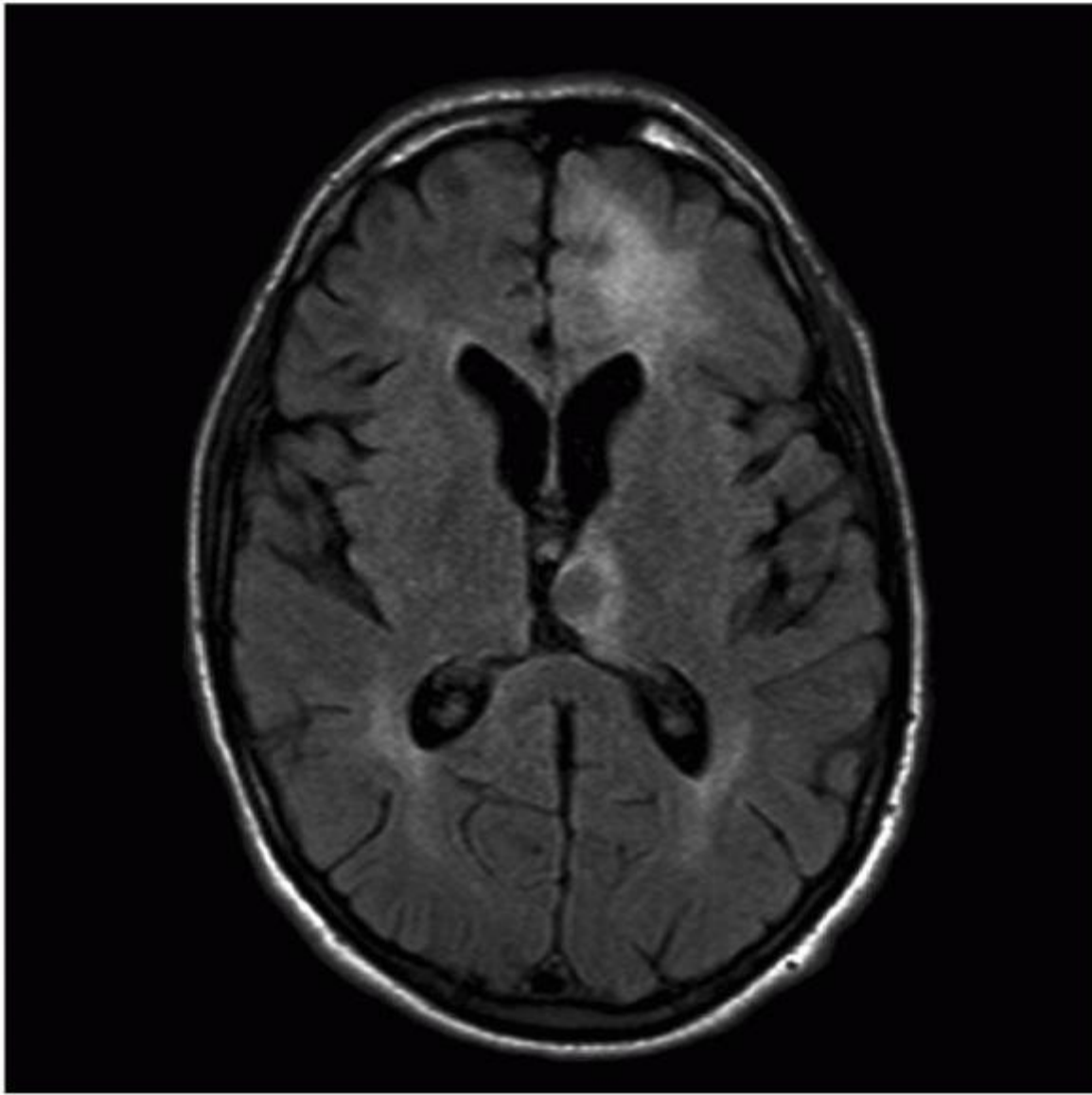

FIGURE 88.10. Primary CNS lymphoma. This FLAIR sequence MRI demonstrates a small periventricular mass lesion in the left thalamus. The lesion displays a signal intensity that is isointense compared with normal gray matter structures. This feature is consistent with a highly cellular lesion, a finding that suggests lymphoma but is not specific for that diagnosis. In addition, there are multiple areas of high signal intensity with ill-defined borders, most pronounced in the left frontal region. This appearance is also nonspecific, reflecting increased water content or decreased myelin in those regions, as may occur with any cause of inflammation. It is consistent with a multifocal, widely infiltrative process, and supportive of the diagnosis of lymphoma. Description provided by Dr. Paul Moots, Vanderbilt University, Nashville, TN.

Lymphomatous meningeal infiltration may be detected in up to 15% of patients with parenchymal PCNSL or may occur as an early or late complication in patients with specific sites of disease, including nasopharynx through local extension, testicular, or extensive marrow involvement.²⁶³ The histologies involving the spinal fluid are usually aggressive and include Burkitt, lymphoblastic, and DLBCL. Primary leptomeningeal lymphoma is when there is no systemic lymphoma or parenchymal disease and occurs in 7% of presentations with CNS disease.²⁶³ Neurolymphomatosis is a rare syndrome characterized by a clinical neuropathy with variable pain and is due to lymphomatous infiltration of peripheral nerve(s), nerve root or plexus, or cranial nerves.²⁶⁴ Intravascular B cell lymphoma usually has subcutaneous skin lesions, but can present with a wide variety of neurological symptoms, including neuropathies, myopathy, dementia, and stroke.²⁶⁵

Because of the risk of leptomeningeal disease in PCNSL, ARL, Burkitt, lymphoblastic, and DLBCL with the specific sites noted above, the CSF should be examined by cytology and flow cytometry, and prophylaxis should be considered in these

patients. Elevated LDH and more than one extranodal site have been associated with CNS disease in patients with intermediate to high-grade histologies.²⁶⁶

Symptoms of spinal cord compression may include back pain, paresthesias, weakness, and incontinence, and requires emergent recognition and therapy. Compression occurs through extension of a paravertebral mass or direct involvement of a vertebral body. MRI of the entire spine is recommended to exclude multiple sites of involvement. The thoracic spine is the most common area, followed by lumbar and then cervical.²⁶⁷

Primary ocular lymphoma is part of the spectrum of CNS lymphoma, usually with DLBCL histology; and is defined by infiltration by lymphoma cells in the visual tract, retina, vitreous, or optic nerve head. Approximately 5% to 15% of PCNSL have ocular involvement at diagnosis while CNS involvement may follow isolated ocular lymphoma in 50% to 80% of patients.²⁵⁹ Ocular symptoms include blurred vision and loss of visual acuity, or "floaters," but patients can be asymptomatic. Slit lamp examination is recommended for patients with CNS or ocular lymphoma. The external eye usually is normal, and the diagnosis can be confused with uveitis, vitritis, or glaucoma.²⁶⁸

Lymphomas of the extraocular space are more common than ocular lymphomas and can arise in the superficial conjunctiva or eyelids or deeper in the lacrimal gland or retrobulbar tissues.^{269, 270} Blurred vision, ptosis, chemosis, epiphora, and proptosis can occur depending upon the orbital site involved. Most orbital lymphomas are of B cell origin and are low grade, particularly in the conjunctiva or eyelids, but can be a large B cell lymphoma in the lacrimal gland or retrobulbar area. Bilateral involvement occurs in 10% to 15% of patients, mostly in conjunctival forms. CNS involvement rarely occurs, and the risk of distant spread is less with conjunctival lesions.

Other symptoms and signs depend on unusual extranodal presentations. Bone pain is uncommon unless the lymphoma has a leukemic component or the patient has extranodal bone lymphoma, which accounts for 3% to 5% of extranodal NHL.²⁷¹ The long bones are most commonly affected and there may be soft tissue swelling.²⁷² The lesions may be lytic, sclerotic, or mixed with periosteal erosion, and are best evaluated by MRI. Genitourinary presentations include renal mass, ureteral obstruction, testicular mass, ovarian mass, and vaginal bleeding. The most common cause of a testicular mass in an elderly male is NHL. Primary breast lymphoma is rare, accounts for 0.04% to 0.5% of all malignant breast tumors, and has a bimodal presentation. Breast lymphoma in young women is associated with pregnancy and lactation and often has diffuse involvement of both breasts.²⁷³ Older women tend to have discrete masses with unilateral involvement. Large B cell lymphoma is the most common type of the above extranodal NHL.

P.1839

Lung and heart are rarely involved in NHL, but patients commonly present with cardiopulmonary symptoms. Cough, dyspnea, and chest pain usually of a short duration of a few weeks may be the presenting symptoms of mediastinal nodal involvement. The superior vena caval syndrome can occur with either T-lymphoblastic lymphoma or large B cell lymphoma of the mediastinum. Pleural effusions require cytology and immunophenotyping by flow cytometry to determine if there is lymphomatous involvement. The most common primary lung lymphoma is a MALToma, a small B cell bronchus-associated lymphoid tissue (BALT) lymphoma which more commonly presents as localized opacities.^{274, 275} Bronchoscopy may reveal bronchial narrowing and biopsy can identify submucosal involvement. Open thoracotomy or video-assisted thoracoscopy is required in the majority of cases because bronchoscopy is diagnostic in approximately one-third of patients.²⁷⁵ Primary lymphoma of the pleura has been associated with chronic tuberculosis pyothorax or empyema.²⁷⁶ Primary cardiac lymphoma is extremely rare, usually occurs as a large B cell NHL in an immunocompromised host, and may present with heart failure, pericardial effusion, or arrhythmia, including heart block.²⁷⁷

NHL occasionally will present with metabolic and endocrine problems, which tend to be more prominent following introduction of therapy, particularly in the setting of a large tumor volume or aggressive histologies. Hypercalcemia, hyperuricemic renal failure, and severe hypoglycemia are unusual metabolic presentations. Hypercalcemia is present in approximately one-fifth of patients with ATL at diagnosis and occurs in up to 70% during the course of the illness.⁵⁹ A few cases of primary adrenal lymphoma have been reported and the initial presentation is usually due to the mass effect.²⁷⁸ Rarely, adrenal insufficiency may be the initial presentation of NHL and is rapidly fatal if unrecognized.²⁷⁹

STAGING

The Ann Arbor staging classification (Table 88.5) developed for HL in 1971 has been the standard scheme for NHL;²⁸⁰ however, it does not account for tumor burden and does not correlate well with prognosis. Other staging systems have been developed for NHL, particularly in children (Chapter 89), specific pathologies, and extranodal sites of disease,

including gastrointestinal (Table 88.5). Prognosis and therapy depend not only on stage, but also on the pathologic features of the lymphoma and by a variety of clinical parameters which reflect tumor bulk and kinetics (e.g., size of mass, LDH level, number of extranodal sites).^{281, 282}

The International Prognostic Index (IPI) (Table 88.5) was developed to correlate clinical parameters with prognosis and appears more useful than the Ann Arbor staging system in predicting survival.²⁸³ When the REAL classification was under evaluation for clinical utility, an early report indicated that a high IPI did not predict an adverse outcome for ALCL; however, subsequent studies have indicated that the IPI correlates with prognosis for all histologies.^{284, 285} There are situations where the IPI may be less useful, such as large B cell lymphoma of the mediastinum, for which prognosis depends upon the extent of local disease.

P.1840

Modification in clinical prognostic indices have been made for different types of NHL and biologic parameters can further subdivide groups (see section on "Prognostic Factors").

TABLE 88.5 STAGING OF NON-HODGKIN LYMPHOMA

Staging System	Stage	Definition
Ann Arbor	I	Involvement of a single lymph node region or of a single extranodal organ or site (I _E)
	II	Involvement of two or more node regions on the same side of the diaphragm, or localized involvement of an extranodal site or organ (II _E) and one or more lymph node regions on the same side of the diaphragm
	III	Involvement of lymph node regions on both sides of the diaphragm which may also be accompanied by localized involvement of an extranodal organ or site (III _E) or spleen (III _S) or both (III _{SE})
	IV	Diffuse or disseminated involvement of one or more distant extranodal organs with or without associated lymph node involvement
	B symptoms	Fever >38°C, night sweats, and/or weight loss >10% of body weight in the 6 months preceding admission are defined as systemic symptoms

Staging
Modification

The E designation is used when extranodal lymphoid malignancies arise in tissues separate from, but near, the major lymphatic aggregates. Stage IV refers to disease that is diffusely spread throughout an extranodal site, such as the liver. If pathologic proof of involvement of one or more extralymphatic sites has been documented, the symbol for the site of involvement, followed by a plus sign (+), is listed. Sites are identified by the following notation: H, Liver; S, spleen; L, Lung; P, pleura; M, bone marrow; O, bone; D, skin. Current practice assigns a clinical stage (CS) based on the findings of the clinical evaluation and a pathologic stage (PS) based on the findings made as a result of invasive procedures beyond the initial biopsy

**International
Prognostic
Index**

Adverse Factor	Risk Group	Number of Factors
Performance status $\geq 2^*$	Low	0, 1
LDH > normal*	Low-intermediate	2
Extranodal sites ≥ 2	High-intermediate	3
Stage III/IV disease*	High	4.5
Age > 60		
Age-adjusted factors*		

Follicular Lymphoma International Prognostic Index (FLIPI)

Adverse Factor	Risk Group	Number of Factors
Age > 60 years	Low	0,1
Stage III/IV	Intermediate	2
Hemoglobin <120 g/L	High	≥ 3
Number of nodal areas >4		
LDH > normal		

FLIPI2: Adverse Factor

β -2
 Microglobulin elevated
 Age >60 y
 Bone marrow positive for lymphoma
 Anemia, hemoglobin < 120 g/L
 One or more nodes > 6 cm

Proposed Staging System for Gastrointestinal Non-Hodgkin Lymphoma^a

Stage	Description
Stage I	Tumor confined to gastrointestinal tract without serosal penetration Single primary site
Stage II	Tumor extending into abdomen from primary site—nodal involvement

	II ₁ Local (gastric/mesenteric)
	II ₂ Distant (para-aortic/para-caval)
Stage II _E	Penetration of serosa to involve adjacent “structures”; enumerate actual site of involvement, such as Stage II _E (large intestine)
	Perforation/peritonitis
Stage IV	Disseminated extranodal involvement or a gastrointestinal tract lesion with supradiaphragmatic nodal involvement

^a From Rohatiner A. Report on a workshop convened to discuss the pathological and staging classifications of gastrointestinal tract lymphoma. *Ann Oncol* 1994;5:397-400.

Table 88.6 outlines the clinical evaluation and staging studies to consider when evaluating patients with NHL. Bone marrow evaluation detects disease in 20% to 40% of all patients with NHL and from 50% to 70% of patients with indolent lymphomas.²⁸⁶ Flow cytometry (FC) can increase the overall percent involvement; but morphology can be positive when FC is negative, as well as vice versa.²⁸⁷ Immunoperoxidase techniques may identify isolated tumor cells not visualized on routine hematoxylin and eosin stains. Because NHL can have focal involvement, there may be a slight advantage in performing bilateral posterior iliac crest biopsies.²⁸⁸ MRI is a sensitive technique to identify marrow involvement in patients whose biopsies have been negative.²⁸⁹ Molecular studies, particularly PCR, are more sensitive than morphology and further increase the percentage of marrow involvement; however, there is an ongoing debate about the impact of molecular markers on prognosis in NHL.²⁹⁰

Positron emission tomography (PET) using 18F-fluorodeoxyglucose (18F-FDG) has replaced 67-gallium (67Ga) scintigraphy as a nuclear medicine imaging technique to diagnose disseminated disease and to assess response (see section on “Functional Imaging in Prognostic Factors”). Patients with a tumor that remains 18F-FDG avid during therapy are more likely to develop progressive disease than those patients with lesions that become FDG negative.²⁹¹ 18F-FDG uptake varies according to histology and proliferative activity, with less uptake in the indolent lymphomas than in the aggressive lymphomas. Although there is increasing reliance on PET scans, there is no substitute for tissue diagnosis to confirm the presence of disease.

TABLE 88.6 STAGING STUDIES IN NON-HODGKIN LYMPHOMA

Complete history and physical examination, inquiring about B symptoms, HIV risk, infections, autoimmune diseases, immunosuppressive therapy

Complete blood count, including leukocyte count with differential, platelet count

Chemistry profile, particularly lactate dehydrogenase: also alkaline phosphatase, uric acid, creatinine, calcium, and albumin

Computerized tomography of chest, abdomen, pelvis and neck

Bone marrow aspiration and biopsy - cytogenetics [+fluorescent *in situ* hybridization (FISH) in specific lymphomas: *BCL2*, *BCL1*, *MYC*, *ALK*, others] and consider molecular tests and gene rearrangement studies in selected patients

Lumbar puncture with cytology in selected patients: all patients with Burkitt and lymphoblastic lymphomas; patients with non-Hodgkin lymphoma in certain sites: nasopharynx, epidural space, testes, and large cell with marrow involvement; HIV+ patients

Gastrointestinal endoscopy for patients with Waldeyer ring involvement or abdominal symptoms

Cytologic assessment of third space fluids (pleura, peritoneum)

Immunophenotype of pathology specimen (cytogenetics/gene rearrangement data in selected patients)

Immunophenotype of pathology specimen (cytogenetics/gene rearrangement data in selected patients)

Selected radiologic procedures as clinically appropriate (e.g. PET scan, MRI, ultrasound, bone scan)

Other blood evaluations: levels of β_2 -microglobulin and cytokines (IL-2 receptor, tumor necrosis

factor)

P.1841

PROGNOSTIC FACTORS

The broad spectrum of NHL is reflected by a highly variable prognosis among and within individual subtypes of the disease. Recent advances in clinical scoring systems, molecular and immunophenotypic markers, and functional imaging techniques such as PET scans have improved the ability to predict therapeutic response and clinical outcome for individual patients. Table 88.7 outlines clinical, laboratory, and biologic features that affect prognosis in NHL. Prognostic biomarkers specific to individual NHL subtypes are also discussed with these entities in this chapter. An important aim of ongoing studies of prognostic markers is to identify approaches for rational and effective risk-adapted therapy that takes into account the marked heterogeneity within individual NHL entities and among patients with otherwise histologically identical diseases.

Histologic Type

The WHO classification separates disorders into B, T, and NK cell neoplasms, with the B and T cell lymphomas further subdivided into precursor versus mature subtypes. The B cell lymphomas represent about 85% of NHL in Western countries, whereas T-cell subtypes are more prevalent in Asia. B cell NHL are clinically stratified as indolent (e.g., follicular, marginal zone, and small lymphocytic) versus aggressive (e.g., DLBCL, mantle cell, and Burkitt) subtypes. Patients with follicular grade 1 to 2 lymphoma typically experience prolonged survival despite a continuous rate of relapse, while FL grade IIIa may have prolonged disease-free survival following anthracycline-based induction therapy.^{292, 293} Discordant lymphoma is encountered when DLBCL presents with a coexisting indolent lymphoma in the marrow or lymph node; in most cases this represents an aggressive component that has transformed from a preexisting indolent B cell clone. These patients show lower rates of complete response and freedom from progression than de novo DLBCL, although the overall survival (OS) does not differ.²⁹⁴ Concordant involvement of the marrow has an inferior OS compared to DLBCL with discordant involvement or a negative marrow.²⁹⁵

Since the initial recognition of T cell lymphomas in the 1970s, there has been controversy about the effect of recognizing the cell of origin on prognosis. Large, prospective trials have indicated a worse prognosis for PTCL than for DLBCL except for ALCL of Tcell origin, which has a survival equivalent or superior to DLBCL (Fig. 88.11).^{296, 297} Within B and T cell lymphoma subtypes there are clinical, immunophenotypic, and genetic markers that further predict prognosis. Randomized pediatric trials for the most aggressive lymphomas (Burkitt and T-lymphoblastic) have identified the effects of pathology and different therapies on outcome.²⁹⁸ The improved response and survival with anti-CD20 monoclonal antibody plus chemotherapy compared to chemotherapy alone in DLBCL is additional evidence supporting the importance of recognizing the cell of origin.²⁹⁹

TABLE 88.7 CLINICAL AND PATHOLOGIC FEATURES THAT AFFECT TREATMENT OUTCOME IN NON-HODGKIN LYMPHOMA**Clinical Features**

Stage (I/II vs. III/IV)

Age (≤ 60 vs. > 60 years)Performance status (ECOG 0, 1 vs. ≥ 2)**B symptoms**Mass size (< 10 cm vs. ≥ 10 cm)Number of extranodal sites (< 2 vs. ≥ 2)

Bone marrow involvement

Functional imaging (PET)

Treatment courses to CR (≤ 3 vs. > 3)**Laboratory Parameters**

Lactate dehydrogenase

 β_2 - Microglobulin

Biologic Characteristics

Histology

Lineage (B cell vs. T cell)

Proliferative rate

Tumor-infiltrating T lymphocyte response

Lymphocyte-associated macrophage content

Karyotype

Genotype

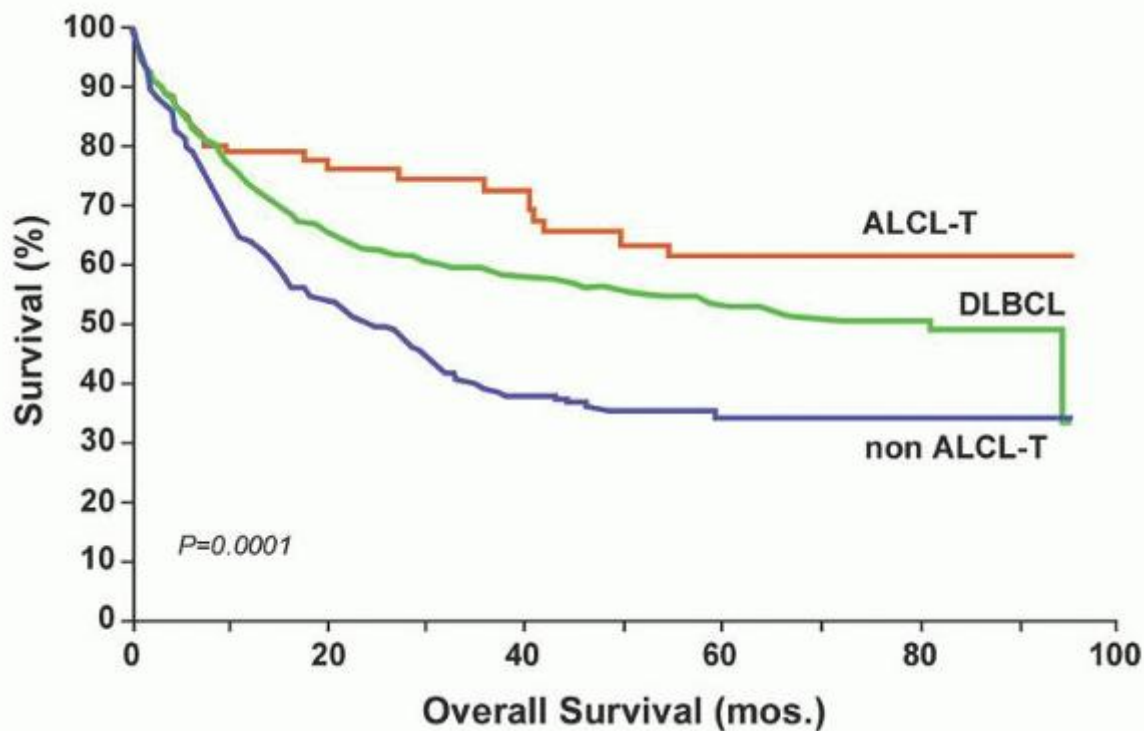

FIGURE 88.11. Overall survival of 228 PTCL (non-ALCL) and 60 T-ALCL compared with 1,595 DLBCL patients. From Gisselbrecht C, Gaulard P, LePage E, et al. Prognostic significance of T cell phenotype in aggressive non-Hodgkin's lymphoma. *Blood* 1998;92:76-82, with permission.

Clinical Scoring Systems

The International Prognostic Index (IPI) score has utility in predicting survival for DLBCL based on readily available clinical and laboratory parameters (Table 88.5).³⁰⁰ Revisions to the IPI have been based on the improved outcomes observed for patients treated with the R-CHOP immunochemotherapy regimen incorporating rituximab as opposed to earlier chemotherapy-only regimens.³⁰¹ Whereas the original IPI identified 4 prognostic subgroups, the revised IPI found that patients could be stratified into 3 groups, defined as very good (0 risk factors) (10% of patients, 4-year overall survival [OS] 94%), good (1 or 2 factors) (45% of patients, 4-year OS 79%), and poor (≥ 3 factors) (45% of patients, 4-year OS 55%) (Fig. 88.12).

As a component of the IPI, serum LDH represents a surrogate quantitative measure for tumor burden. Other serologic markers, particularly β_2 microglobulin (β_2m), have been identified as prognostic factors. β_2m is a low-molecular-weight polypeptide noncovalently linked to the heavy chain of Class I histocompatibility antigens that is shed with cell turnover.³⁰² Combined with serum LDH, β_2m provides a reliable serologic system for predicting freedom from relapse and

survival in large cell lymphoma.³⁰³ Patients at low risk for disease recurrence have normal levels of both markers, whereas elevations in levels of both LDH and β -2m (>3.0 mg/L) predict shortened remission and survival.³⁰³ The IPI also is predictive in FL, but its discriminatory value is limited because most patients fall into low- or low-intermediate-risk groups. A scoring system designated the FLIPI stratifies patients into low-, intermediate-, or high-risk groups based on the number of nodal groups involved, age, Ann Arbor stage, hemoglobin level, and LDH (Table 88.5).³⁰⁴ The FLIPI has been validated as a useful prognostic tool, and provides a means of comparing relative patient risk distribution among clinical trials. The FLIPI2 scoring system (Table 88.5)

P.1842

is more relevant to current patients, however, as it is based on initial therapy with rituximab-containing regimens (Fig. 88.13). The acronym "BABA6" can be used for the 5 FLIPI2 markers: Beta-2 microglobulin $>$ normal, Anemia with hemoglobin <120 g/L, Bone marrow positive for lymphoma, Age > 60 years, and one or more nodal masses ≥ 6 cm in diameter. Five- and ten-year overall survival rates had a strong inverse correlation with low-, intermediate-, and high-risk FLIPI2 scores.³⁰⁵

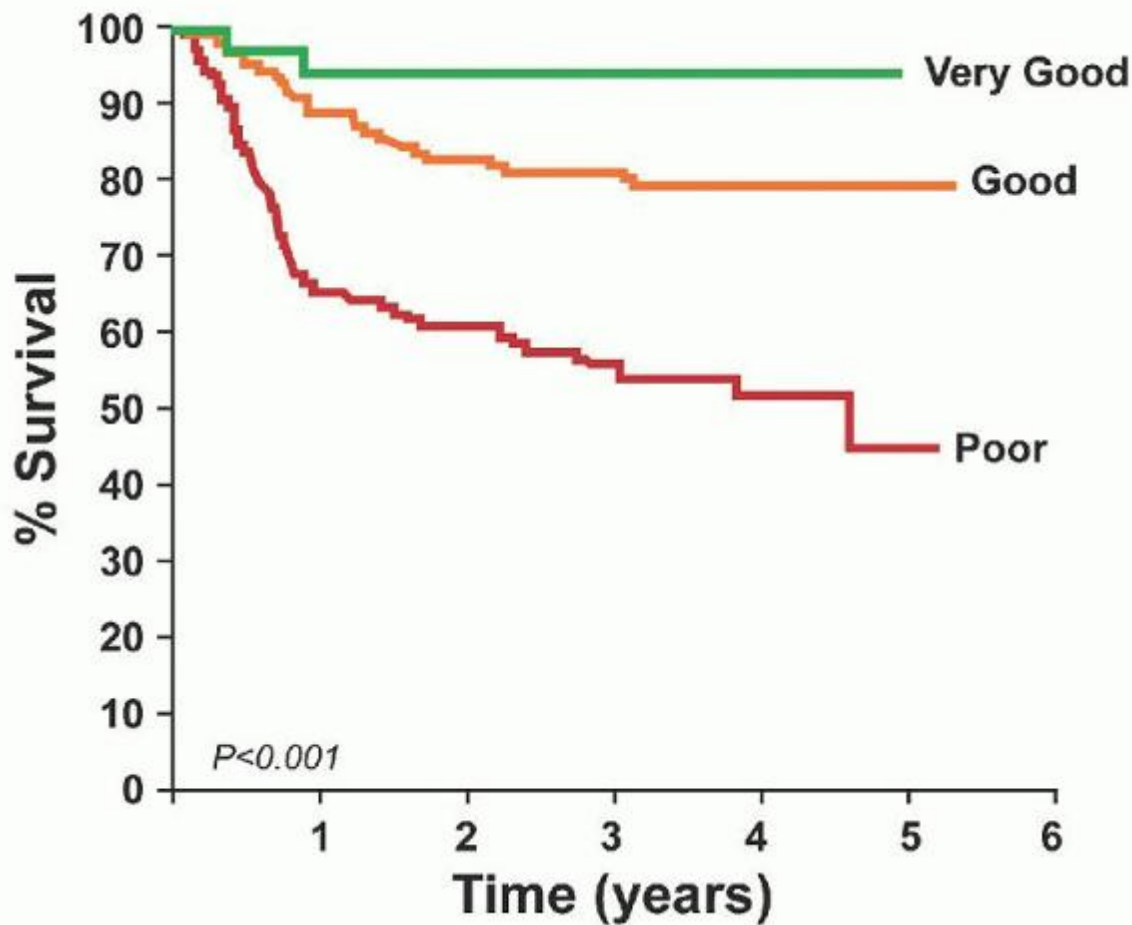

FIGURE 88.12. Progression-free survival according to the revised International Prognostic Index. From Sehn LH, Berry B, Chhanabhai M, et al. The revised International Prognostic Index (R-IPI) is a better predictor of outcome than the standard IPI for patients with diffuse large B cell lymphoma treated with R-CHOP. *Blood* 2007;109:1857-1861, with permission.

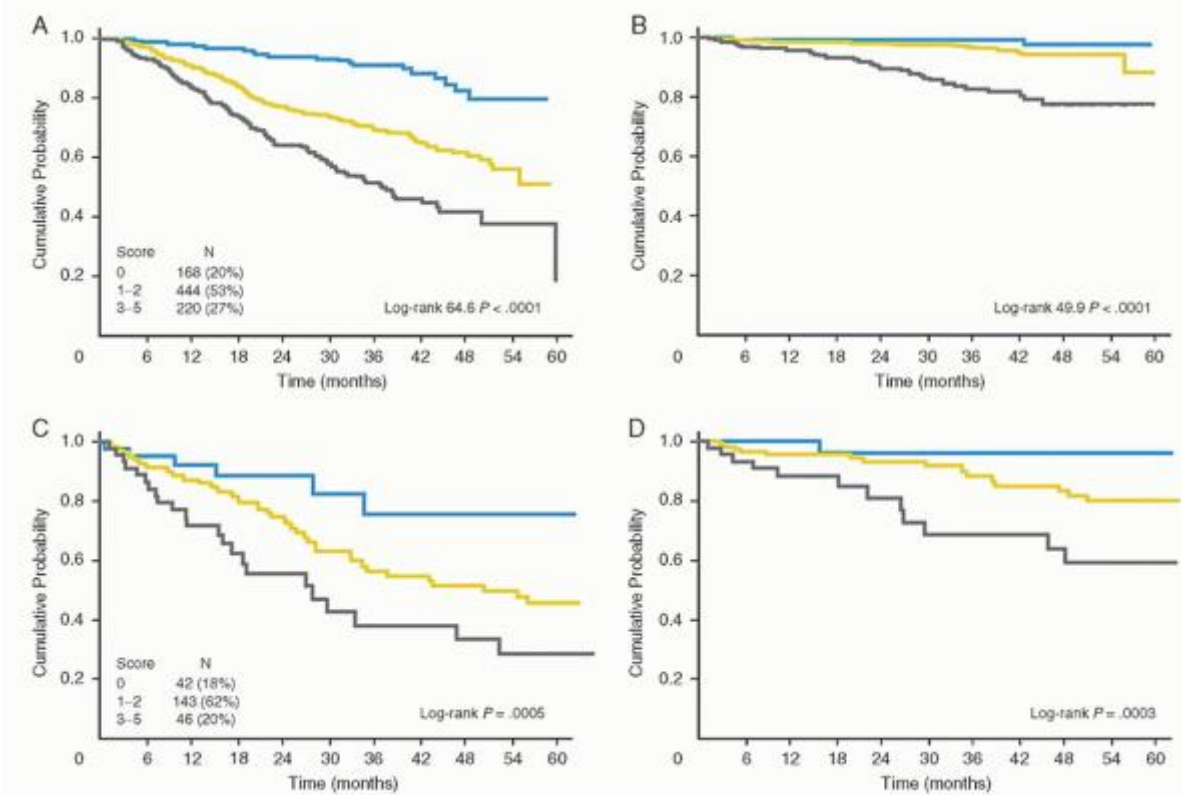

FIGURE 88.13. Progression-free survival and overall survival according to the Follicular Lymphoma International Index 2. A and B are the PFS and OS for the training sample (832 patients) and C and D are for the validation sample (231 patients). FLIPI2: low risk (blue line), score 0; intermediate risk (yellow line), score 1-2; high risk (grey line), score 3-5. From Federico M, Bellei M, Marcheselli L, et al. Follicular lymphoma international prognostic index 2: A new prognostic index for follicular lymphoma developed by the International Follicular Lymphoma Prognostic Factor Project. *J Clin Oncol* 2009;27:4555-4562, with permission.

A mantle cell lymphoma IPI (MIPI) score has also been validated that utilizes the clinical parameters of age, LDH, white blood cell count, and performance status, and has been further refined to include the proliferation marker Ki-67.³⁰⁶ Similarly, a prognostic index for PTCL (PIT) includes 4 variables: bone marrow involvement, age, performance status, and LDH.³⁰⁷

Immunophenotypic and Molecular Markers

Advances in the molecular and cellular biology of lymphoma have contributed to better understanding of tumor-specific variables that affect clinical behavior and therapeutic response. Cell kinetics (low-growth vs. high-growth fraction), tumor microenvironment (e.g., monocyte/macrophage vs. T cell predominance), and cell adhesion molecules are biologic parameters that contribute to lymphomagenesis and may correlate with prognosis. In DLBCL and mantle cell lymphoma, a high proliferative fraction as defined by expression of the nuclear proliferation antigen Ki-67 (MIB1; >30% to 60% of malignant cells) has identified patients at risk for early relapse and short survival.^{306, 308, 309}

Correlations between acquired molecular abnormalities and specific lymphoma entities are a central part of the WHO classification and the understanding of lymphomagenesis. Immunophenotyping further identifies protein expression patterns that correlate with specific cytogenetic abnormalities and with prognosis (Table 88.8). Examples include nuclear cyclin D1 expression with the t(11;14)(q13;q32) of mantle cell lymphoma, and anaplastic lymphoma kinase (ALK) expression with

P.1843

the t(2;5) and its variants in ALCL.³¹⁰ BCL-6 expression has been associated with an improved outcome in DLBCL, but its absence may be less deleterious in the rituximab era.³¹¹

TABLE 88.8 PROGNOSTIC BIOMARKERS BY IMMUNOHISTOCHEMISTRY IN AGGRESSIVE LYMPHOMA

Biomarker	Pathway/Function	Correlation	Reference
ALK	Proliferation (tyrosine kinase)	Improved survival if positive in T-ALCL	310, 561, 562
BCL-2	Apoptosis	Decreased survival in activated B-cell-like (ABC) expressing BCL-2	506
Ki-67	Proliferation	Expression associated with increased proliferative rate and decreased survival in MCL, PTCL, and DLBCL	306, 309
FOX P1	Transcription factor	Poor survival in cases with strong expression (DLBCL)	317, 521
BCL-6	Transcriptional repressor, marker of germinal center origin	Improved response and survival in BCL-6 positive DLBCL	311
CD10+; or CD10-, BCL-6+, MUM1-	Markers for Germinal center B-like (GCB) subtype	Improved survival vs. non-GCB (DLBCL)	315, 316
CD10-, BCL-6-; or CD10-, BCL-6+, MUM1+	Markers for non-GCB subtypes	Decreased survival vs. GCB (DLBCL)	315, 316
MYC plus BCL-2	Proliferation and apoptosis	Double hit DLBCL, poor prognosis	319, 320
TP53 ⁺ , CDKN1A-	Proliferation and apoptosis	TP53 mutation, poor prognosis DLBCL and PTCL	517, 586

ALCL, anaplastic large cell lymphoma;DLBCL, diffuse large B cell lymphoma; MCL, mantle cell lymphoma;PTCL, peripheral T cell lymphoma.

Gene expression profiling using cDNA microarrays has been a powerful tool for dissecting pathogenetically relevant mutations and therapeutically targetable pathways in lymphomas. For example, DLBCL may be stratified into prognostic subtypes based upon molecular profile.^{323, 324} These include primary mediastinal Bcell lymphoma (PMBL), germinal center Bcell-like (GCB), activated Bcell-like (ABC), and a fourth type with a microarray signature distinct from the other types. PMBL and GCB have better prognoses than the others in patients treated with CHOP-like chemotherapy (Fig. 88.14).³²⁵ Since molecular profiling is not currently practical for routine clinical use, efforts have been made to use immunophenotypic expression patterns to stratify DLBCL into GCB or non-GCB subtypes. One of these systems, the Hans algorithm, uses immunostains for CD10, BCL-6, and MUM1, with good correlation with gene expression profile analysis.^{317, 318}

A modification, the Choi algorithm, also uses these markers plus GCET1 and FOXP1 to stratify patients into GCB vs. ABC DLBCL, again with good correlation with patient overall survival.³¹⁵ To further enhance this scoring system, the Choi algorithm was integrated with immunohistochemical staining for a marker of the DLBCL tumor microenvironment and stromal-1 signature (SPARC: secreted protein, acidic, and rich in cysteine), a good prognostic marker when expressed;and markers of angiogenesis and microvessel density within the tumor stroma, a poor prognostic marker when increased. The resulting "biologic prognostic model" assigned 1 point each for each adverse prognostic marker; those patients with 0 or 1 marker designated "low-risk" and those ≥ 2 as intermediate- or high-risk.³²⁶ All patients had de novo DLBCL treated with R-CHOP or R-CHOP-like regimens in this multicenter study. A highly significant correlation was found for improved event-free and overall survival for those in the low-risk group.

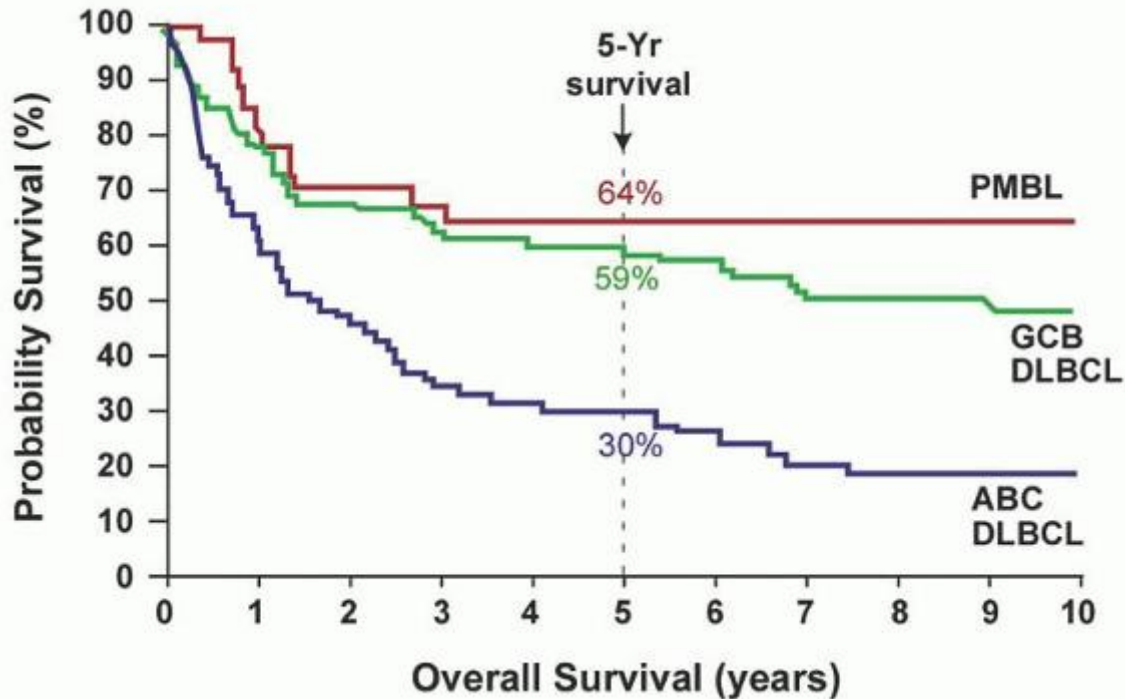

FIGURE 88.14. Gene expression arrays can stratify diffuse large B cell lymphoma (DLBCL) into at least three subtypes, primary mediastinal B cell lymphoma (PMBL), germinal center B cell (GCB), and activated B cell-like (ABC). This Kaplan-Meier curve indicates differing survival among the groups. From Rosenwald A, Wright G, Leroy K, et al. Molecular diagnosis of primary mediastinal B cell lymphoma identifies a clinically favorable subgroup of diffuse large B cell lymphoma related to Hodgkin lymphoma. *J Exp Med* 2003;198:851-862, with permission.

About 5% to 8% of DLBCL carry translocations in the MYC oncogene, often with coexisting BCL2 and/or BCL6 translocations (“doublehit” or “triplehit”). MYC protein expression identifies MYC deregulation not detected by FISH; and coexpression with BCL-2 is present in 21% to 29% of DLBCL.^{319, 320} Double hit DLBCL has a poor outcome with standard R-CHOP chemotherapy; as such, testing for these markers using immunohistochemistry or FISH analysis and applying alternative treatment strategies for these patients is now being assessed.^{327, 328}

Whereas molecular and phenotypic features of the tumor cells themselves have prognostic relevance in DLBCL, gene expression profiling in FLs revealed prognostic subsets correlating with survival based on the type of tumor-infiltrating immune cells.³²⁹ FL patients with a predominant T cell signature had improved outcome versus those patients with an immune response signature reflecting a predominant monocyte/macrophage infiltrate. An immunophenotypic correlate was shown by analysis of lymphoma-associated macrophage (LAM) content, wherein FL patients with >15 LAM per high-power field had inferior survival compared to those with fewer LAM.³³⁰ Similarly, a high number of regulatory T cells in the tumor microenvironment as assessed by FOXP3 expression was associated with improved survival.^{331, 332}

It should be recognized that prognostic markers for treatment response and patient outcome are defined within the context of specific regimens and thus may become irrelevant when newer therapeutics are applied. As such, it is essential to revalidate these markers with new regimens and targeted therapies.

P.1844

Treatment-associated Parameters

The ability to deliver a prescribed treatment regimen is a recognized prerequisite to optimal patient outcome in any area of oncology. Treatment delays, dose reductions, or eliminating one or more agents during a patient's therapy—i.e., a reduction in dose-intensity or dose-density—may lead to a lower likelihood of achieving durable remission or cure. While tumor-associated features correlate with outcome, as described above, patient-associated variability in pharmacokinetics may have an important impact even with strict adherence to a treatment regimen. The dose-adjusted R-EPOCH regimen

(rituximab, continuous-infusion etoposide, doxorubicin, and vincristine plus cyclophosphamide and prednisone) was designed to address potential underdosing by integrating scheduled incremental dose increases based upon interim neutrophil counts between cycles for treatment of DLBCL.³³³ Phase II studies have shown improved progression-free survival as compared with historic R-CHOP data; a U.S. Intergroup trial led by CALGB is directly comparing DA-R-EPOCH with R-CHOP. This study is also correlating GCB vs. non-GCB DLBCL subtype with the treatment regimen and patient outcome. Looking forward, it is anticipated that methods for pharmacogenomic assessment and dose-optimized delivery of chemotherapy and targeted agents will become available to improve treatment response and to decrease treatment-associated toxicities.

Functional Imaging

The use of 18F-FDG-PET scans has improved the sensitivity for initial staging and posttreatment restaging of NHL.³³⁴ Assessment of treatment response by anatomic staging with routine CT scans, especially in aggressive lymphomas, reveals that many patients have measurable residual abnormalities. The significance of such findings is often problematic as to whether they represent fibrous tissue only versus residual lymphoma, and biopsy of these residual masses may be inconclusive or falsely negative due to sampling error or necrosis. Properly performed and interpreted PET scans have a high discriminatory value in identifying residual lymphoma in patients with incomplete therapeutic response. Several studies have correlated posttreatment PET positivity with relapse and poor survival, and prospective clinical trials are ongoing to assess the use of PET imaging to stratify patients for early institution of dose-intensive therapy.³³⁵

TABLE 88.9 2007 RESPONSE CRITERIA FOR NON-HODGKIN LYMPHOMA

Response Category	Definition	Nodal Masses	Spleen/Liver	Bone Marrow
Complete response	Disappearance of all evidence of disease	a) FDG-avid or PET positive prior to therapy becomes negative; a post treatment mass of any size is permitted if PET negative b) If variably FDG-avid or PET positive, all lymph nodes should regress to normal size on CT	Not palpable; nodules disappear	Infiltrate cleared on repeat biopsy; if indeterminate by morphology, immunohistochemistry should be negative
Partial Response	Regression of measurable disease and no new sites	a) $\geq 50\%$ decrease in SPD of up to 6 largest masses; no increase in size of other nodes b) One or more persistently FDG-avid or PET positive sites c) Regression on CT if variably FDG-avid or PET negative	$\geq 50\%$ decrease in SPD of nodules; no increase in size of liver or spleen Irrelevant if positive prior to therapy and partial response at other sites	
Stable Disease	Failure to attain CR/PR, but does not meet criteria for progressive disease	a) FDG-avid or PET positive at prior sites of disease and no new sites on PET or CT b) Variably FDG-avid or PET negative; no change in size of previous lesions		

		on CT	
Relapsed or Progressive Disease	Any new lesion or increase by $\geq 50\%$ of previously involved sites from nadir	Appearance of a new lesion(s) > 1.5 cm in any axis, $\geq 50\%$ increase in SPD of more than one node, or $\geq 50\%$ increase in longest diameter of a previously identified node > 1 cm in short axis. Lesions PET positive if FDG-avid lymphoma or PET positive prior to therapy	>50% increase from nadir in the involvement SPD of any previous lesions New or recurrent

CT, computed tomography; FDG (18F)fluorodeoxyglucose; PET, positron emission tomography; PR, partial remission; SPD, sum of the product of the diameters.

Adapted from Cheson BD, Pfistner B, Juweid ME, et al. Revised response criteria for malignant lymphoma. *J Clin Oncol* 2007;25:579-586.

The use of interim PET imaging following two to three cycles of chemotherapy has shown a strong correlation with outcome in HL; however, interim PET in DLBCL remains controversial. Interim 18-FDG-PET/CT failed to predict outcome in diffuse large Bcell lymphoma patients treated at diagnosis with rituximab-CHOP.^{336, 337} Retrospective data in mantle cell lymphoma suggested an improved outcome for negative posttreatment PET/CT but not for interim scans.³³⁸ Pre- and postinduction PET/CT imaging was performed in 122 patients with FL who took part in a prospective clinical trial of rituximab-chemotherapy followed by maintenance rituximab versus observation.³³⁹ Patients remaining PET-positive after induction therapy had significantly inferior progression-free survival and increased risk of death compared to PET-negative individuals. Interestingly, response by traditional posttreatment restaging including CT scans did not correlate with outcome.

Response criteria for NHL now include recommendations for incorporation of functional imaging by PET in patients with DLBCL and HL (Table 88.9).³⁴⁰ In addition, guidelines for standardization and interpretation of PET scans have been recommended for use in clinical trials and in prospective registries assessing treatment outcomes and prognosis.³⁴¹

THERAPEUTIC PRINCIPLES

Therapy follows assessment of the patient, pathology, and stage of disease. The ability of the patient to tolerate therapy is dependent upon age, performance status, and, if present, immunodeficiency due to a prelymphomatous condition. How advanced age

P.1845

adversely affects outcome in therapy is controversial, but comorbid illnesses and biologic differences of lymphomas can contribute to higher mortality in the elderly. Treatment-related toxicities are greater in elderly patients, but deaths from unrelated causes are also increased.^{342, 343} Biologic differences of NHL between young and old patients are implicated by a greater lymphomarelated mortality in some series of elderly patients compared with younger cohorts³⁴⁴ (see section on "Therapy in the Elderly").

The type of therapy is based on pathology. One of the clinical disadvantages of the WHO/REAL classifications was deleting the WF grading system. Clinical schemas have been proposed to recognize the biologic behavior along with the cell of origin of the lymphoid neoplasm (Table 88.10).

The intensity of therapy is based on pathology and stage of disease. Advanced stage, tumor bulk as reflected by size (usually greater than 10 cm) and LDH, and number of extranodal sites of involvement were recognized early as independent prognostic determinants in NHL and contribute to the IPI. The IPI has correlated clinical features into prognostic groups for both indolent and aggressive lymphomas.^{345, 346}

TABLE 88.10 CLINICAL SCHEMA FOR LYMPHOID NEOPLASMS

B Cell Lineage**T/NK Cell Lineage**

Indolent Lymphomas/Leukemia

Chronic lymphocytic leukemia/small lymphocytic lymphoma

Lymphoplasmacytic lymphoma/Waldenström macroglobulinemia

Follicular lymphoma (grade I/II)

Marginal zone B cell lymphoma

Splenic marginal zone lymphoma

Extranodal (MALT-B cell lymphoma)

Nodal (monocytoid)

Large granular lymphocytic leukemia, T and NK cell types

Mycosis fungoides/Sezary syndrome

Primary cutaneous anaplastic large cell

Smoldering and chronic adult T cell leukemia/lymphoma (HTLV1⁺)

Aggressive Lymphomas

Mantle cell lymphoma (can be indolent)

Follicular (large cell)-grade III

Diffuse large B cell lymphoma

Primary mediastinal large B cell lymphoma

Large B cell lymphoma with intermediate features between DLBCL and Hodgkin lymphoma

Prolymphocytic leukemia (can be indolent)

Peripheral T cell lymphoma, not otherwise specified

Anaplastic large cell lymphoma (ALK +/ALK-)

Angioimmunoblastic lymphoma

Enteropathy-associated T cell lymphoma

Nasal type NK/T cell lymphoma

Hepatosplenic $\gamma\delta$ T cell lymphomaSubcutaneous panniculitis-like T cell lymphoma, $\alpha\beta$ (can be indolent)

Highly Aggressive Lymphomas/Acute Leukemias

Precursor B-lymphoblastic lymphoma/leukemia

Burkitt lymphoma/B cell acute leukemia Large B cell lymphoma with intermediate features between DLBCL and Burkitt lymphoma

Precursor T-lymphoblastic lymphoma/leukemia

Adult T cell lymphoma/leukemia (HTLV-1+) (lymphoma and acute leukemia subtypes)

Natural killer cell leukemia

ALK, anaplastic lymphoma kinase; DLBCL, diffuse large B cell lymphoma ; HTLV-1, human T-leukemia virus-1; NK, natural killer.

After therapy is instituted, response formerly was assessed according to standardized criteria developed in 1999;³⁴⁷ however, new criteria based on PET scans, immunohistochemistry and flow cytometry are now being used³⁴⁰ (Table 88.9). Previously, nodal masses should be ≤ 1.5 cm to be considered normal but should be ≤ 1.0 cm if initially clinically abnormal in the 1.0 to 1.5 cm range.³⁴⁷ A common problem particularly in large cell NHL is a residual mass after therapy. A designation of unconfirmed complete response (CRu) was given if there was a greater than 75% reduction in tumor size after therapy; but the criteria utilizing PET scans eliminates the CRu category.³⁴⁰ Persistently positive PET scans after therapy suggest residual disease, but biopsy should be performed if a therapeutic decision is going to be made. The end points of clinical trials should be well defined, and their importance may vary according to type of lymphoma. For

example, PFS is more important in aggressive lymphomas than in indolent lymphomas, for which OS or time to next treatment may be more relevant. The problem with the latter endpoint is that guidelines for initiation of treatment need to be standardized as well.

INDOLENT LYMPHOMAS

Indolent lymphomas are characterized by a long median survival and by a slow but continuous decline in survival. They are usually advanced stage at presentation; respond to therapy, but relapse; over time, may transform to a more aggressive course; and rarely, spontaneously regress. With the availability of new chemotherapy agents and the advent of immunotherapy, the therapeutic options for indolent lymphomas are increasing in number and prognosis is improving (Table 88.11). While the expansion of therapies represents a major advancement, the decisions of when to initiate therapy and what type of therapy to select are often controversial and confusing for the individual patient.

Indolent B cell lymphomas include FL, small lymphocytic lymphoma, lymphoplasmacytoid lymphoma, and marginal zone lymphoma. Indolent T/NK cell lymphomas are less common and are less well recognized, other than mycosis fungoides (Chapter 92).

P.1846

T/NK lymphomas/leukemias which can have an indolent phase include large granular T/NK leukemia, smoldering and chronic HTLV-1+ ATL, T-prolymphocytic leukemia, and, more controversially, some types of PTCL. FLs formerly included follicular small cleaved (FSCL), mixed (FML), and large cell (FLCL), and roughly correlated with cytologic grades 1, 2, and 3, respectively. Cytologic grading of FL is under scrutiny due to poor reproducibility among pathologists.

TABLE 88.11 THERAPEUTIC OPTIONS FOR INDOLENT LYMPHOMA

Watchful waiting

Local radiation for limited stage disease

Chemotherapy

Alkylating agent

Nucleoside analogue

Bendamustine

Combination chemotherapy

Immunotherapy

Unconjugated monoclonal antibody

Radioimmunotherapy

Interferons

Cellular

Vaccines

Combined modality

Chemotherapy and immunotherapy

Chemotherapy and radiation

Transplantation

Autologous ± purging

Allogeneic:

Myeloablative

Nonmyeloablative

Selected therapies

Antibiotics in selected MALTomas

Splenectomy

FL (grades I and II) is the second most common NHL behind DLBCL and is the most common indolent lymphoma in North America and Europe, usually comprising 25% to 35% of lymphomas, compared to 5% to 12% in Asia and developing countries.^{348, 349, 350} Most patients present with asymptomatic lymphadenopathy; B symptoms occur in approximately one-fourth of patients.²⁹² The disease occurs primarily in the elderly (median age, 55 to 65 years), has a near equal male:female ratio, and usually is disseminated at diagnosis (stage III/IV \geq 70%).^{292, 351, 352} Marrow involvement occurs in 30% to 60% of FL.^{351, 352, 353} Evaluating the marrow or blood for the BCL-2 translocation will often identify occult disease and can upstage patients by molecular criteria.^{354, 355}

Prior to the recognition of different types of lymphomas by immunophenotyping and the prevalence of BCL-2 translocation in FL, extensive descriptions were made about pathologic differences among FLs. The degree of nodularity was associated with a better prognosis in grade I FL, but it was not of major significance without near complete absence of follicles, as in diffuse small cleaved cell lymphoma (DSCL).³⁵¹ With present-day immunophenotyping, most DSCL are more aggressive diseases than FL and include mantle cell NHL and PTCL. FL immunophenotyping is characterized by the presence of CD10⁺, CD20⁺, BCL2⁺, CD23^{+/−}, CD43[−], CD5[−], CCND1[−], and BCL6⁺.

Cytologic grading further subclassifies FL into grades 1 to 3. Histologic grades 1 and 2 are treated as indolent disease, while grade 3b is usually excluded from clinical trials involving FL due to its similar behavior to that of intermediate-grade lymphoma. Identification of BCL2 translocations and Ki-67 may add to the prognosis of FL. Approximately 70% of patients have translocations at the major breakpoint region (MBR) located in the untranslated region 3' of the last exon of the BCL2 gene, and 10% to 15% of patients have translocations in the minor cluster region (mcr) which is 30 kb downstream of the BCL2 gene.³⁴⁸ Lopez-Guillermo correlated survival with BCL2 rearrangements: the 3-year failure-free survival (FFS) for mcr, MBR, and germline cases were 95%, 76%, and 57%, respectively (P < 0.001).³⁵⁶ The impact of persistence of BCL2 rearrangement in FL after therapy is controversial, because there is data indicating its presence adversely affects clinical progression after therapy and, alternatively, other series indicate that it has no effect on long-term survival.^{355, 357} Patients with low grade and a high proliferation index (Ki-67 > 30%) appear to have clinically aggressive behavior.^{358, 359} Median survivals for FL were static in the range of 8 to 12 years for several decades, but are now improving due, in part, to monoclonal antibody therapy and better supportive care.^{351, 352, 360, 361}

The microenvironment and gene expression profiling in FL are likely to add prognostic information and potential therapeutic targets. There has been conflicting data about the presence of tumor-associated CD68⁺ macrophages (TAM) and T-reg cells, with initial reports indicating a poor prognosis for the former and a favorable prognosis for the latter. Subsequent studies have not confirmed these findings.^{330, 332, 364} Gene profiling identified a favorable "immune response 1" signature encoding T cells (CD7, CD8B1, ITK, LEF1, and STAT4) and macrophages. (ACTN1 and TNFSF3B) and an unfavorable "immune response 2" signature of genes in macrophages and/or dendritic cells (TLR5, FCGR1A, SEPT10, CCR1, LGMN, and C3AR1). Future studies will incorporate genetic, molecular, and biologic data into prognostic models which will influence the selection of therapy.

Small B lymphocytic lymphoma (SLL) comprises 3% to 10% of all NHL and is part of the spectrum of diffuse small B cell lymphomas which includes lymphoplasmacytoid lymphoma, marginal zone lymphomas, and mantle cell lymphoma (Chapter 86).^{365, 366} There is extensive clinical overlap with chronic lymphocytic leukemia (CLL) (Chapter 90), although there is more prominent lymphadenopathy and less lymphocytosis in SLL than in CLL.^{367, 368, 369, 370} The WHO considers SLL and CLL different clinical presentations of the same disease. An initial lymphocyte count greater than $5 \times 10^9/L$ is considered diagnostic of CLL. Over time, 10% to 20% of patients develop a lymphocytosis consistent with CLL. SLL represents 4% to 6% of NHL in the West, is a disease of the elderly (median age, 55 to 65 years), and has a male:female ratio of approximately 2:1.^{367, 368} Patients usually present with generalized adenopathy, and marrow involvement is found in most patients (70% to 80%). Median survivals have been variable from a low of 4 to 6 years to 10+ years, may depend upon prognostic factors and the criteria utilized to separate SLL from CLL, but are similarly improving in the rituximab era.³⁷¹ Deletion at chromosome 6q is the most common cytogenetic abnormality in SLL, but has had no effect on prognosis,³⁷² whereas del(17p) and del(11q) are associated with poorer prognosis.³⁷³ Both unmutated genes as opposed to hypermutated genes and expression of CD38 or ZAP 70 have been associated with a worse prognosis in CLL.³⁷⁴ Between 2% and 8% of SLL and CLL evolve into an aggressive large cell process known as Richter syndrome, which is characterized by bulky retroperitoneal adenopathy, rising LDH, and survival usually less than 1 year.^{375, 376} Prognosis is better if transformation occurs in previously untreated patients.³⁷⁰

Lymphoplasmacytic lymphoma (LPL) largely overlaps with Waldenström macroglobulinemia (WM) (Chapter 100). LPL represents 1% to 2% of NHL, usually occurs in the elderly (median age 60 to 70 years), and presents with lymphadenopathy (15% to 20%), splenomegaly (10% to 20%), and marrow involvement in most patients.^{377, 378} A paraprotein is found in 29% to 50% of patients, with IgM the most prevalent type, and can contribute to hyperviscosity (6% to 20%), neuropathy, and glomerular disease.³⁷⁷ A positive Coombs' test, cold agglutinin disease, cryoglobulinemia, autoimmune diseases, and positive hepatitis C serology can be associated with LPL and WM.^{379, 380} Mutation of the myeloid differentiation primary response gene⁸⁸ (MYC88) is nearly universal in WM and can be useful in differentiating it from other disorders.³⁸¹ Translocation (9;14) involving the paired box gene PAX5 can be detected in LPL, but its frequency and significance are a matter of debate.³⁷⁸ Deletion of 6q is the most common cytogenetic abnormality but it is not specific for LPL/WM.³⁷⁸ Median survivals have been variable, usually in the 7- to 10-year range, and are worse with advanced age, cytopenias, organomegaly, elevated B2 M, and hypoalbuminemia.^{378, 382, 383}

Marginal zone B cell lymphomas (MZL) usually account for between 5% and 7% of all NHL and include extranodal MALToma, nodal based disease, and SMZL.³⁸⁴ Extranodal MALTomas represent the most common MZL (50% to 70%) and are discussed in the section "Management of Extranodal Lymphomas". Nodal MZL occurs in the elderly (median age, 59 to 65 years) and preferentially in women (up to 2:1 female:male ratio), may present with localized lymphadenopathy, and has less marrow involvement (28% to 45%) than other indolent lymphomas.^{371, 384, 385, 386} Cytopenias or a paraprotein (10%) are rarely present. The most frequent cytogenetic abnormalities are gains in chromosomes 3 and 18q23.³⁸⁷ Median survival has been variable due to limited numbers of patients but has been recorded in the 9- to 12-year range.³⁷¹

SMZL occurs in the elderly (median age, 61 to 70 years), has a slight female predominance, and usually presents because of symptoms of splenomegaly.^{384, 388, 389} Cytopenias are common (46% to 60%); peripheral adenopathy is rare (10% to 15%); and marrow involvement is usually detected (73% to 100%).^{390, 391}

P.1847

A paraprotein may be present and is usually IgM. Despite disseminated disease, splenectomy can alleviate symptoms and improve cytopenias.^{389, 390} Median survival has been recorded to be 10.5 years, but is shorter in the presence of a paraprotein, elevated β -2m, or lymphocytosis ($>9 \times 10^9/L$).^{391, 392} A simple prognostic scoring system is based on 3 factors: hemoglobin <120 g/L, LDH level greater than normal, and albumin <35 g/L. The 5-year cause-specific survival was subdivided into 3 groups: 88% for no adverse factor, 73% (one factor), and 50% (two or more factors).³⁸⁸ Complete or partial trisomy 3 is the most frequent (~85%) cytogenetic abnormality.³⁹³ The abnormality characteristic of SMZL is a deletion or translocation of chromosome 7q32, present in 40% of patients.³⁸⁴ Adverse cytogenetics include del(17p), del(8p), and del(7q) with unmutated genes.^{394, 395}

Special Clinicopathologic Features

Clinicopathologic features unique to indolent lymphomas are histologic transformation (HT) and spontaneous regression. The forerunner and counterpart of HT is the Richter syndrome of CLL/SLL.^{375, 376, 396, 397} HT of indolent lymphomas usually is associated clinically with increasing adenopathy and LDH levels. All of the indolent lymphomas can undergo transformation, but the most common lymphoma to do so is grade I FL; the transformation is characterized pathologically by a loss of a follicular pattern and an increase in the number of large noncleaved cells.^{397, 398, 399, 400} Predictive factors for HT of FL have included no prior CR, hypoalbuminemia, an elevated B2m (>3 mg/L), and a high FLIPI score at diagnosis.^{396, 401} The median time from initial diagnosis to HT is 4 to 6 years.^{398, 399, 400} Historically, the incidence of HT is uncertain, but has been estimated to be between 10% and 70% of indolent lymphomas. Discrepancies among studies are related to methodological differences, including the definition of transformation.³⁹⁷ The risk of HT in FL is estimated at 2% to 4% per year, and it appears to increase over time, but some series have suggested a plateau at 20 years (Fig. 88.15A).^{401, 402, 403} Autopsy series of nodular lymphomas have identified diffuse morphologic changes, usually with increased large cells, in more than two-thirds of patients.⁴⁰⁴ HT may involve the expression of additional cytogenetic abnormalities and oncogenes.^{405, 406, 407} The disease course usually progresses rapidly after HT, with median survival usually less than 1 year and ranges from 2.5 to 22 months (Fig. 88.15B).^{398, 401, 403} Patients with limited stage disease, low FLIPI, and no prior chemotherapy at the time of histologic transformation are more likely to have prolonged survival.^{397, 400, 403}

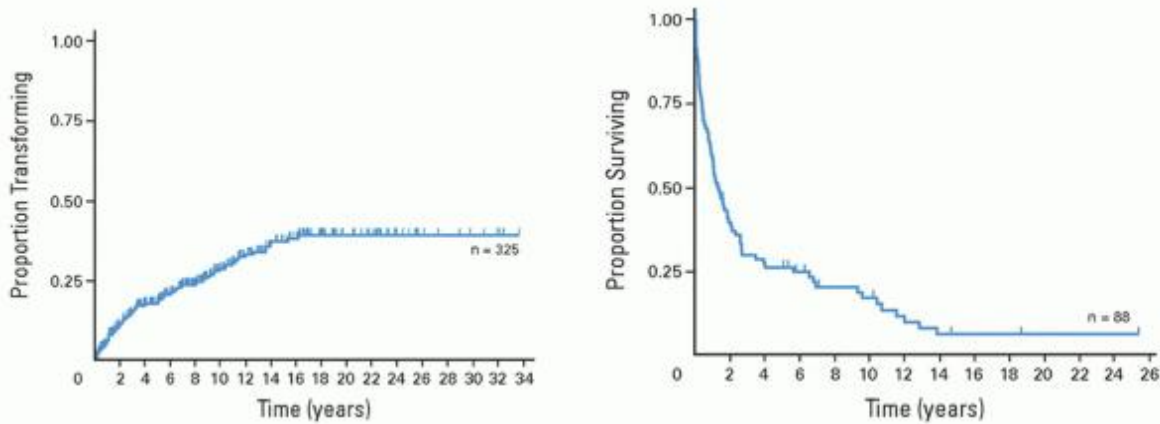

FIGURE 88.15. Histologic transformation of follicular lymphoma. A: Cumulative incidence of transformation. B: Survival (median = 1.2 years) in patients after transformation. From Montoto S, Davies AJ, Matthews J, et al. Risk and clinical implications of transformation of follicular lymphoma to diffuse large B cell lymphoma. *J Clin Oncol* 2007;25:2426-2433, with permission.

Spontaneous regression has occurred in the indolent lymphomas, but its exact incidence is uncertain. Horning and Rosenberg reported regression in 19 (23%) of 83 untreated FL patients, including complete regression in 6 patients.⁴⁰² Spontaneous regression occurs in approximately one-fourth of primary cutaneous ALCL (see section on “ALCL”). Spontaneous remission in DLCL has rarely been observed.⁴⁰⁸

Additional clinicopathologic terms that are often misnomers are discordant histology, composite lymphoma, and gray zone lymphoma. Discordant histology refers to identifying different histologic grades of lymphoma in the same patient. The most commonly identified discordant histology is a peripheral node with predominantly large cells and a marrow with small cleaved cells (see section on “Prognostic Factors”).^{295, 409} Composite lymphoma has been used to describe a mixture of histologic grades but probably should be restricted to lymphomas that have two distinct histopathologic types, i.e., two distinct diseases, preferably with both immunophenotypic and molecular genetic differences.⁴¹⁰ Gray zone lymphomas are intermediate between two diseases with DLBCL having overlap features with either Hodgkin or BL.^{228, 411}

Stages I and II Indolent Lymphoma

Limited stage disease in indolent lymphomas is infrequent and may be as low as 6%, as reported by the National Cancer Institute (NCI) series of pathologically staged patients;⁴¹² most series that involve clinical staging report between 10% and 20% of patients with limited stage disease.^{351, 413} Immunophenotyping and molecular genetic studies may identify more advanced stage disease as well as predict the clinical course, but their impact on therapeutic decisions is controversial. Radiation therapy has achieved disease-free survival (DFS) in 31% to 85% of limited stage FL patients with follow-up over 10 years, including reports from Stanford University of relapse-free survival (RFS) of 44% and 37% at 10 and 20 years, and from Dana Farber Cancer Institute of freedom from treatment failure (FFTF) of 47% and 43% at 10 and 15 years.^{414, 415} The median survival in the latter study involving predominantly stage I FL (only grades 1 and 2) was 19 years.⁴¹⁵ While these reports suggest that some limited stage patients may be curable, there is not a clear plateau on the survival curves. Most relapses have occurred outside the radiation field. The best results have been in young patients (less than 50 years), with stage I and nonbulky disease (less than 2.5 cm).⁴¹³ Observation alone can be considered in patients with clinically insignificant disease and has no adverse effect on prognosis even

P.1848

in the rituximab era.^{416, 417} In a study that evaluated the role of reduced field of radiation (involved regional field or involved nodal radiation therapy), the 10-year PFS and OS were 49% and 66%, respectively. By reducing the field of radiation, there was no difference in the recurrence rate.⁴¹⁸

Rituximab (anti-CD20 monoclonal antibody) (see section on “Immunotherapy”) was initially approved for relapsed indolent lymphomas with response rates in the 50% range, but is now being used as front-line single agent therapy with response rates of 47% to 76%.^{419, 420} The rationale for its use in limited stage patients includes its efficacy with low tumor burden, better PFS with molecular responses, and the fact that most limited stage patients actually have advanced stage disease.⁴²¹

Stages III and IV Indolent Lymphoma

Many investigators advocate initial “watchful waiting” for asymptomatic patients with advanced stage indolent lymphomas, because of a continual risk of relapse; early chemotherapy has not improved overall survival (OS).^{422, 423} Although stages III and IV usually are considered together, stage III has a tendency toward better survival than stage IV.^{351, 413} Among the most controversial aspects in the management of indolent lymphomas are the initiation of therapy and the selection of type of therapy (Table 88.11). The choices of therapy are multiple and vary widely from no initial therapy, rituximab alone, to various chemotherapy agents (single or in combination) with or without monoclonal antibody therapy, to radioimmunotherapy, and to transplantation.^{422, 424}

The number of choices are increasing but there is general agreement that once a decision has been made to start therapy, combination chemotherapy with rituximab offers the best response.^{350, 425} Clinical features which usually warrant therapy include B symptoms, bulky lymphadenopathy, nodal encroachment on vital organs, massive organomegaly, cytopenias, or transformation.^{363, 422, 426, 427} Age of the patient, histologic grade, performance status, comorbid illnesses, patient preference, and physician training and bias influence therapeutic decisions. A number of clinical scoring systems, including the FLIPI and subsequent modifications have been devised not only to predict prognosis, but also to select patients for therapy (see section on “Prognostic Factors”). Because indolent lymphomas usually have long median survivals, prolonged follow-up is required and randomized trials are needed to determine optimal therapy.

Watchful waiting can be psychologically difficult for both patient and physician, but remains a valid approach based on initial observations and randomized trials before the availability of rituximab. There are 3 randomized trials that compared watchful waiting to some form of initial therapy.^{423, 428, 429} The NCI group used an aggressive combined modality regimen ProMACE (prednisone, methotrexate, Adriamycin [doxorubicin], cyclophosphamide, and etoposide) and MOPP (mustard, Oncovin [vincristine], procarbazine, and prednisone) plus total lymphoid irradiation; the French used interferon or prednimustine; and the British used chlorambucil. There was no difference in overall survival between observation and therapy in all these reports. In the latter study, the median follow-up was 16 years; and the median length of time until chemotherapy was started in the observation group was 31 months. The actuarial chance of not requiring chemotherapy at 10 years was 19%.⁴²⁹ In a phase III trial evaluating the role of immediate treatment with rituximab versus watchful waiting for advanced stage disease, the median PFS was significantly longer in patients receiving rituximab therapy (NR vs. 24 months; $P < 0.001$); but there was no difference in OS.⁴³⁰

There is no standard of care treatment recommendation for upfront therapy of FL. Rituximab is uniformly incorporated with chemotherapy at the time of treatment initiation. Multiple randomized trials comparing chemotherapy plus rituximab to chemotherapy alone have shown improved response rates and PFS with the rituximab arm.⁴²⁵ Due to the lack of randomized trials, disparate therapeutic approaches have been adopted worldwide. The most commonly used regimens for advanced indolent lymphoma, particularly FL, were formerly alkylator based and included single agents, chlorambucil or cyclophosphamide, with or without prednisone; and CVP (cyclophosphamide, vincristine, prednisone);⁴³¹ however, the addition of doxorubicin in R-CHOP is the most commonly used regimen. Nucleoside analogs, bendamustine, and mitoxantrone are all being used in different upfront regimens as well. In a multicenter longitudinal study by the National LymphoCare in the United States, the initial chemotherapeutic regimen of choice was R-CHOP (55%), followed by R-CVP (23%) and R-fludarabine based (15.5%).⁴³²

Nucleoside analogs are well tolerated, with few gastrointestinal side effects and no alopecia, but cause prolonged decrease in T cell immunity and contribute to immune mediated cytopenias. Responses with single agent nucleoside analogs are 40% to 50% (10% to 20% CR) in previously treated patients, and 60% to 90% (37% to 50% CR) in untreated patients.^{433, 434, 435} Adding rituximab to fludarabine yielded a response rate of 90% with 80% CR.⁴³⁶

Combination of nucleoside analogs with other agents are being used in indolent lymphomas. In phase I and II trials of fludarabine plus cyclophosphamide in untreated indolent lymphomas and SLL/CLL, the response rates have been 92% to 100%, including CR rates of 47% to 89%.^{437, 438} The addition of rituximab to this combination has similarly high response rates and can achieve molecular remission.⁴³⁹ Despite these encouraging results, opportunistic infections are increased with the combination; there may be increased incidence of myelodysplasia; and stem cells may be difficult to collect after its use.

The combination of fludarabine, mitoxantrone (Novantrone) and dexamethasone (FND) has also been established as an effective combination with response rates over 90% (CR 43% to 67%) in both treated and untreated indolent lymphoma.^{440, 441} In previously untreated patients, the 2-year PFS was 63% and OS was 93%.⁴⁴² Steroids may not increase efficacy and have been dropped by some investigators. In a phase III study comparing R-FM vs. R-CVP vs. R-CHOP, the rate of CR was similar in all treatment arms; however, the 3-year time to treatment failure was significantly shorter in the R-

CVP arm compared with R-FM or R-CHOP (46%, 61%, and 64%, respectively). The rate of secondary malignancies was notably higher in the R-FM arm (8%).⁴⁴³

An area of controversy in indolent lymphomas is the use of anthracyclines with initial therapy. Retrospective studies have been equivocal with some showing no significant differences in response and OS^{444, 445} while others show superiority to anthracycline-based regimens over less aggressive therapy.⁴⁴⁶ R-CHOP was established as an effective regimen in a limited number (N = 38) of patients.⁴⁴⁷ The response rate was 100% with 87% CR/Cru, with a median time to progression of 82.3 months; 42% remain in continuous remission (6.4 to 8.8 years). Subsequently, R-CHOP was shown to have a higher response rate and prolonged remission when compared to CHOP alone.⁴²⁵ Both mitoxantrone and doxorubicin contribute to cardiotoxicity, and an argument could be made to restrict their use to FL, with either grade 3 histology, particularly 3b, and/or a high prognostic index score. In a randomized phase III trial by Rummel et al. bendamustine and rituximab (BR) was compared with R-CHOP therapy in patients with low grade lymphomas. The preliminary data favored BR over R-CHOP with a CR rate (40.1% vs. 30.8%, P = 0.03) and PFS (69.5 vs. 31.2 months, P < 0.001).⁴⁴⁸ Other options for therapy in indolent lymphomas include radioimmunotherapy, salvage chemotherapy regimens, novel agents, and transplantation, which are addressed in subsequent sections.

P.1849

Immunotherapy

Immunotherapy for lymphoma includes a broad and expanding number of approaches. These include nonspecific immunostimulation with interferons (now largely of historic interest in lymphoma therapy), passive humoral therapy with antilymphoid monoclonal antibodies, radioimmunotherapy, drug-antibody conjugates, patient-specific anti-idiotype vaccines, and novel approaches to cellular therapy such as chimeric antigen receptor (CAR)-directed T-cells.

Despite modest evidence of biologic activity, IFN has not been widely adopted in standard lymphoma therapy because of its toxicity and the emergence of more active immunotherapeutics. The most widely used agent among these is rituximab, a chimeric IgG anti-CD20 monoclonal antibody consisting of a murine IgG anti-CD20 antigen binding domain coupled with a human IgG light and heavy chain-constant region.⁴²¹ CD20 is a highly useful antigenic target in that it is not expressed on mature plasma cells or on hematopoietic stem cells and does not shed or internalize after binding with antibody. Major mechanisms of response include antibody-dependent cellular cytotoxicity (ADCC) via Ig heavy chain receptors (FcR) on monocytes, T cells, and natural killer cells, as well as complement activation. Rituximab is an integral component as a single agent or in combination with chemotherapy in the treatment of all subtypes of Bcell lymphomas. In a phase I dose-escalation trial, Maloney et al. determined a dosage of 375 mg/m² weekly for 4 doses as the dose for subsequent phase II trials.^{449, 450} In a multicenter trial involving 166 patients with relapsed indolent NHL, McLaughlin et al. reported a 48% response and a median time to progression of 13 months for responders.⁴⁵¹ This study led to rituximab's approval by the U.S. FDA for relapsed indolent NHL in 1997.

Rituximab has response rates of 47% to 76% (up to 20% to 45% CR) as front-line singleagent therapy, depending upon disease burden and Bcell lymphoma subtype. Randomized trials almost uniformly have favored the rituximab-plus-chemotherapy arms over chemotherapy alone for both indolent and diffuse large B-cell lymphomas. Rituximab maintenance therapy following rituximab or rituximab-chemotherapy induction has improved PFS but, in most studies, not overall survival.

A number of novel next-generation antibodies have been developed to better engage hostresponse mechanisms, many being tested on ongoing clinical trials.^{452, 453} These include bispecific molecules that bind both tumor and effector Tcells such as blinatumomab (anti-CD19 plus anti-CD3), or the concomitant use of the effector cell agonist anti-CD137 following rituximab.⁴⁵⁴ Other Tcell immunomodulators such as anti-CTLA-4 and anti-PD-1 are being pursued in both hematologic malignancies and solid tumors.

Radioimmunotherapy includes two agents consisting of a radioisotope (yttrium-90 [90Y] or iodine-131 [131I]) conjugated to a murine anti-CD20 antibody. In a randomized trial comparing 90Y-ibritumomab tiuxetan to rituximab in relapsed/refractory follicular or CD20⁺ transformed NHL, Witzig et al. reported that radioimmunotherapy had a higher response rate (80 vs. 56%, P = 0.002; 30 vs. 16% for CR, P = 0.04). Although there was no difference in median duration of response (14.2 months vs. 12.1 months), durable responses of ≥6 months were statistically more frequent with radioimmunotherapy (64 vs. 47%, P = 0.030). Iodine-131 tositumomab similarly showed response rates of 65% in patients with chemorefractory indolent or transformed NHL, compared to 28% response after their last chemotherapy (P < 0.001).⁴⁵⁵ The median duration of response was 6.5 months for 131I tositumomab, compared to 3.4 months after

chemotherapy ($P < 0.001$).⁴⁵⁵ When used as initial therapy in patients with FL, the response rate was 97%, including 75% CR, and the median PFS was 6.1 years.⁴⁵⁶ Postinduction consolidation therapy with 90Y-ibritumomab tiuxetan significantly improved response durations following complete or partial remission to chemotherapy or rituximab-chemotherapy induction (FIT trial).⁴⁵⁷ RIT is also being investigated as a component of induction therapy or conditioning prior to stem cell transplantation in relapsed Bcell NHL.

Vaccination with anti-idiotype vaccines unique to individual patient lymphomas was pioneered by Levy and colleagues at Stanford University.⁴⁵⁸ Unfortunately, multicenter Phase II-III clinical trials have been largely disappointing, although one anti-idiotype vaccine that showed an improved disease-free survival in FL patients achieving remission with induction chemotherapy has been FDA approved for this indication.⁴⁵⁹

The ability of monoclonal antibodies to target lymphoma cells has made them an appealing vehicle for delivering a cytotoxic agent, analogous to RIT, with a number of such therapeutics in development. A paradigm for this approach is brentuximab vedotin, an anti-CD30 monoclonal conjugated to the mitotic spindle inhibitor monomethyl auristatin E (MMAE). Once bound to a CD30-positive tumor cell such as anaplastic large cell lymphoma (ALCL) or Hodgkin lymphoma Reed-Sternberg cells, the bound CD30 is internalized and the MMAE is released. Response rates of 80% and higher have been achieved in relapsed or refractory patients, some of whom have then been able to proceed to consolidative and potentially curative stem cell transplantation.⁴⁶⁰

Cellular immunotherapy for lymphomas is an important component of allogeneic stem cell transplantation efficacy, albeit with concomitant risk of graft-versus-host disease. A novel approach instead utilizes autologous patient Tcells genetically modified to express a chimeric antigen receptor (CAR) that combines an anti-Bcell antigen such as CD19 with Tcell activators CD3 and CD137. This strategy showed dramatic efficacy and proof of principle in patients with refractory CLL.⁴⁶¹ Additional studies are ongoing in lymphoma using similar constructs, aimed at further enhancing efficacy and safety while overcoming some of the technical challenges inherent in generating CAR-modified T-cells.

A more detailed discussion of immunotherapy is reviewed in Chapter 70.

MANTLE CELL LYMPHOMA

Mantle cell lymphoma (MCL) was referred to as centrocytic, intermediate lymphocytic, and mantle zone lymphoma in earlier classifications and was given its present name in 1992.^{462, 463, 464} MCL represents ~ 5% of NHL in Western populations. It occurs predominantly in the elderly (median age, 60 to 68 years) and with a two- to threefold male predominance.^{465, 466, 467} Most patients present with diffuse lymphadenopathy and splenomegaly.^{465, 466, 467} B symptoms are present in 25% to 50% of patients, and 15% to 30% have or will develop a unique gastrointestinal presentation with multiple lymphomatous polyposis (Fig. 88.9).^{250, 465, 466, 467} Bone marrow involvement is detected in 60% to 90% of patients, and up to 25% will have an overt leukemic phase, although most patients have a small circulating clone detectable by flow cytometry.^{465, 466, 467} Central nervous system involvement has been documented in 9% of patients during the course of the illness, usually as a later event.^{468, 469}

MCL has a characteristic, although not completely unique, phenotype, with most expressing CD5 and negative for CD10 and CD 23, which helps distinguish MCL from follicular and small lymphocytic lymphomas. Virtually all MCL demonstrate the classic cytogenetic marker $t(11;14)(q13;q32)$ by conventional cytogenetic analysis and fluorescence in situ hybridization (FISH).^{470, 471} Expression of nuclear cyclin D1 protein is found in >90% of cases and is considered the most reliable immunophenotypic marker in the diagnosis of MCL,⁴⁷² although variant MCL with cyclin D2 or cyclin D3 expression also occur.^{473, 474} A minimally deleted segment of 11q22-q23 affecting the ATM gene in 50% of MCL suggests that this is an early genetic event along with the

P.1850

BCL-1/CCND1 (cyclin D1) translocation to chromosome 14.⁴⁷⁵ Loss of tumor suppressor genes, including TP53 and CDKN2/p16, appears to occur later and has been associated with an aggressive clinical course.^{476, 477, 478, 479}

Marked clinical and biologic heterogeneity of MCL is now well recognized, with about a quarter of patients having "indolent" disease that may not require immediate therapy. These patients often present with lymphocytosis and splenomegaly, and their symptoms may be confused with CLL if proper flow cytometry and FISH markers are not obtained at diagnosis. Others present with low tumor burden lymphadenopathy and lack systemic symptoms, and watchful waiting for the assessment of the pace of disease has been proposed as initial management in these cases.⁴⁸⁰ Biomarkers of clinically indolent cases include mutated immunoglobulin heavy chain variable genes, lack of nuclear SOX11 expression and TP53 mutation, few if any karyotypic changes aside from the $t(11;14)$, and a characteristic molecular signature.⁴⁸¹

Clinically aggressive MCL typically has high tumor burden, blastoid morphology, and complex cytogenetics in addition to the t(11;14) and/or high Ki-67 expression. Molecular markers that appear both pathogenically and prognostically relevant include the NOTCH1 mutation,⁴⁸² dysregulation of the Hippo tumor suppressor pathway,⁴⁸³ and a unique microRNA signature and expression of miR-29.^{484, 485} The percentage of tumor cells expressing the proliferation marker Ki-67 has been incorporated into the MIPI score to enhance the discrimination of clinical outcomes among low-, intermediate-, and high-risk MCL patients treated with CHOP or R-CHOP regimens (Fig. 88.16).^{306, 486}

Clinical outcomes and survival have improved in recent years as treatment options have expanded, although MCL remains incurable with standard approaches. Most studies show the absence of a plateau on survival curves. Response rates to initial therapy are typically above 80% with a number of chemoimmunotherapy regimens; CRs are usually <50% and median time to treatment failure is about 18 to 24 months. There is no current standard of care for induction treatment, nor for therapeutically sequencing the various active regimens and targeted agents at relapse. Younger patients often receive an intensive regimen with or without autologous stem cell transplantation in first remission, while older patients and those with significant comorbid disease are managed with less aggressive approaches. Romaguera et al. utilized rituximab- hyper-CVAD/MTX-Ara-C (fractionated cyclophosphamide plus vincristine, doxorubicin, and dexamethasone alternating with high-dose methotrexate-cytarabine regimen) in a single-institution phase II trial.⁴⁸⁷ Among 97 previously untreated patients, 87% achieved complete response. With a median 8-year follow-up, patients <65 years old had a time to treatment failure of 46% and OS 68%, whereas older patients were 16% and 33%, respectively. A multicenter trial in 60 patients 70 years or younger confirmed a high CR rate of 72% and a 5-year OS of 61%, as well as high treatment-associated toxicity—only 37% of patients completed the planned course of therapy.⁴⁸⁸ Patients with low- or intermediate-risk MIPI had much improved outcomes as compared to those with high-risk scores. High-dose cytarabine has emerged as an important component of therapy in a large phase III trial by the European MCL Network comparing R-CHOP versus R-CHOP alternating with R-DHAP (dexamethasone, high-dose Ara-C and cisplatin) followed by autologous stem cell transplantation.⁴⁸⁹ Time to treatment failure for the 420 patients was significantly improved with the addition of R-DHAP, although 4-year OS did not differ at about 80% in each arm. This study also showed that achievement of minimal residual disease (MRD)-negativity in the peripheral blood and bone marrow was strongly associated with prolonged disease-free survival.⁴⁹⁰

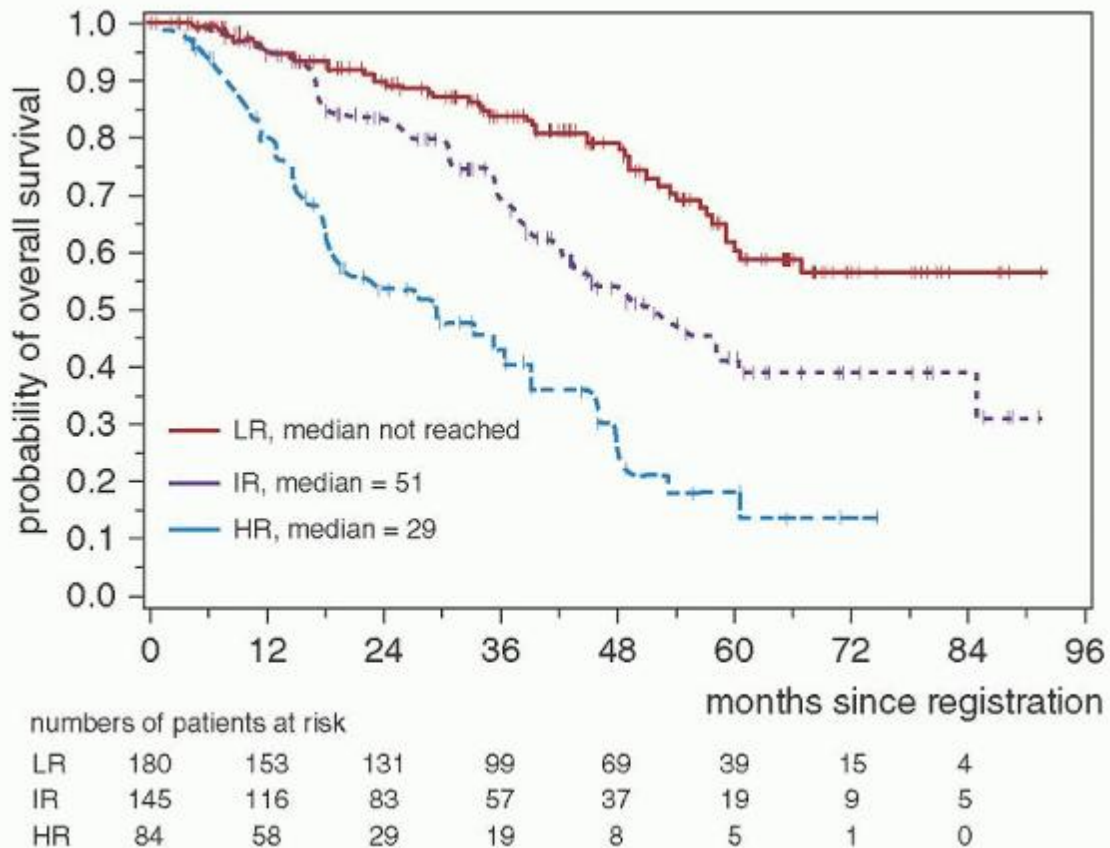

FIGURE 88.16. Overall survival in advanced-stage patients according to the Mantle Cell International Prognostic Index

(MIPI) and Ki67. Low risk (LR) score <5.7 ; intermediate risk (IR) ≥ 5.7 and <6.2 ; high risk (HR) $=6.2$. The combined biologic score is calculated as 0.03535 times age (years) plus 0.6978 (if ECOG > 1) plus 1.367 times \log_{10} (LDH/ULN) plus 0.9393 times \log_{10} (WBC count) plus 0.02142 times Ki-67 (%). From Hoster E, Dreyling M, Klapper W, et al. A new prognostic index (MIPI) for patients with advanced-stage mantle cell lymphoma. *Blood* 2008;111:558-565, with permission.

Bendamustine, a highly active chemotherapeutic in relapsed MCL, was studied as initial therapy in combination with rituximab (BR) and compared with R-CHOP in a phase III trial of nontransplant-eligible patients.⁴⁴⁸ PFS was improved in the BR arm although with a similar continuous rate of relapse. The European MCL Network completed a phase III trial in 560 elderly, nontransplant-eligible patients comparing R-CHOP versus R-FC (fludarabine, cyclophosphamide) followed by a second randomization to interferon- α versus rituximab maintenance therapy.⁴⁹¹ CR rates were similar with the two induction regimens, although toxicity, treatment failure, and 4-year OS were inferior with R-FC. The 4-year OS was significantly improved for R-CHOP followed by maintenance rituximab given once every 2 months until progression as compared with interferon (87% vs. 63%, respectively, $P = 0.005$). MRD-negativity was a strong predictor of improved outcome.⁴⁹⁰ Maintenance rituximab can thus be recommended in this patient population, with confirmatory studies ongoing following BR-based induction and in a U.S. cooperative group trial testing the combination of rituximab plus lenalidomide maintenance.

In younger, fit patients, reinduction followed by related or unrelated allogeneic stem cell transplantation has shown excellent response, with 50% to 60% of patients remaining event-free at 2 years, suggesting a possible graft-versus-lymphoma effect.^{492, 493} While treatment-associated morbidity and mortality remain high, allogeneic transplant consolidation should be considered for selected patients given its potential for durable remission and cure.

A number of treatment options are available for patients with relapsed MCL. The proteasome inhibitor bortezomib provides responses in 33% of relapsed or refractory MCL patients.⁴⁹⁴ As noted, bendamustine is a highly active regimen in the relapse setting, as are several novel targeted agents including the immunomodulatory drug lenalidomide, the mTOR inhibitors temsirolimus and everolimus, and inhibitors of cyclin D1 and cyclin-dependent kinases CDK 4 and -6 (flavopiridol, PD0332991).^{495, 496, 497, 498} Agents targeting the B cell receptor pathway have shown very high response rates in relapsed and refractory MCL. These include the Bruton tyrosine kinase inhibitor ibrutinib and the PI3 kinase inhibitor CAL-101(GS-110)^{499, 500} (see section on "Novel Agents"). It is anticipated that these agents will become integral components of induction and consolidation or maintenance regimens, and will continue to improve outcomes and survival for this challenging lymphoma.

P.1851

AGGRESSIVE LYMPHOMAS

Diffuse Large B Cell Lymphomas

DLBCL is the most common type of adult NHL in North America and Europe, making up 30% to 40% of NHL. DLBCL represents a heterogeneous group of diseases and attempts to subdivide it have been based on morphology, cytogenetics, immunohistochemistry, predominant clinical presentations, and genomic profiles (Table 88.12). Morphologic distinctions in DLBCL can be difficult to reproduce and may not be clinically useful. Morphologic variants include centroblastic, intravascular DLBCL associated with chronic inflammation, EBV-positive DLBCL, immunoblastic (IBL), T cell/histiocyte-rich and anaplastic (see Chapter 86). Although IBL was categorized as high grade in the WF Classification, it is regarded as intermediate-grade in that no apparent differences in survival exist between it and other DLBCL.⁵⁰¹ IBL may need to be distinguished from extramedullary involvement by a plasmablastic variant of plasma cell myeloma.

T cell/histiocyte-rich B cell lymphoma (T/HRBCL) represents 1% to 3% of DLBCL and is a subtype in which the malignant large B cell is the minority cell.^{502, 503, 504} T/HRBCL was first described as T cell-rich B cell lymphoma in 1988 by Ramsay and can be confused with HL, both classical and nodular lymphocyte predominant types, PTCL, and indolent lymphomas.^{503, 504, 505} T/HRBCL occurs at a younger median age than typical DLBCL with most series reporting fourth to fifth decade median ages compared to sixth decade.⁵⁰³ Patients with T/HRBCL have more B symptoms (26% to 62%), splenomegaly (21% to 60%), and marrow involvement (32% to 53%) than traditional DLBCL. Although some series of T/HRBCL have had inferior CR rates compared to DLBCL, there may have been a disproportionate number of patients with a high IPI; and case-controlled series have shown no differences in OS.⁵⁰³ T/HRBCL can be further defined by molecular profiling that identifies a unique cluster of genes involved in host response.^{506, 507}

EBV-positive DLBCL of the elderly is a recent entity which is clinically recognized for its aggressive behavior with frequent extranodal presentation and poor prognosis.⁵⁰⁸ This type of lymphoma is thought to be a result of immunosenescence with aging. The median age at presentation is 75 years. Another form of EBV-positive DLBCL is DLBCL associated with chronic inflammation involving joints or body cavities (pyothorax).^{508, 509}

TABLE 88.12 DIFFUSE LARGE B CELL LYMPHOMA

DLBCL, not otherwise specified

Morphologic: centробlastic, immunoblastic, anaplastic, other

Immunophenotype/gene expression: germinal center-derived, activated B cell, other

Molecular/genetic: *BCL6*, *BCL2*, *MYC*, other

Specified by site

Primary mediastinal large B cell lymphoma

Primary cutaneous large B cell lymphoma, leg-type

Intravascular B cell lymphoma

Other: CNS, testes, bone

Specified by histology or immunophenotype

T cell/histiocyte-rich B cell lymphoma

De novo, CD5⁺ large B cell lymphoma

Anaplastic lymphoma kinase-positive large B cell lymphoma

Associated with EBV and/or KS-HHV8

EBV+ diffuse large B cell lymphoma of the elderly

DLBCL associated with chronic inflammation (e.g., pyothorax)

Plasmablastic lymphoma

Unclassifiable types

LBCL with intermediate features between DLBCL and Hodgkin lymphoma

LBCL with intermediate features between DLBCL and Burkitt lymphoma

DLBCL, diffuse large B cell lymphoma ; EBV, Epstein-Barr virus.

There is no single cytogenetic abnormality which defines DLBCL, but there are a number commonly found with DLBCL, including t(3;14), t(14;18), and t(8;14) and related variants. These cytogenetic abnormalities are commonly found with other types of lymphomas; and when observed in DLBCL, there can be a clinical problem distinguishing transformation from a de novo presentation. BCL6 gene on 3q27 is associated with multiple chromosomal partners; and translocations involving 3q27 are found in 30% to 35% of DLBCL.⁵¹⁰ The prognostic implication of BCL6 abnormalities has been variable, with data indicating a worse survival with nonIG gene BCL6 rearrangements than with IGH/BCL6 translocations of t(3;14).⁵¹¹

The t(14;18) is present in 20% to 25% of DLBCL and may represent transformation from a FL or a true de novo presentation. While BCL2 genetic translocation has not been correlated with survival in de novo DLBCL, BCL2 protein expression has been associated with an inferior survival, specifically in the activated B cell type of DLBCL.³¹⁴ The t(8;14) is usually found in BL and is rare in DLBCL. Double hit lymphomas harbor dual translocations with MYC; t(8;14), and BCL2 ; t(14;18),⁵¹² are refractory to standard chemotherapy regimens, and have a poor prognosis. The synergistic activity of antiapoptosis driven by BCL2 and proliferation by MYC is responsible for the poor outcome with traditional chemotherapy.^{513, 514, 515}

Large B cell lymphoma of the leg is seen in the elderly and has a poorer prognosis than other cutaneous B cell lymphomas.^{516, 517} Intravascular B cell lymphoma was recognized in 1959 and was known as malignant

angioendotheliomatosis.⁵¹⁸ It occurs in the elderly (median age 65 to 70 years) and most commonly affects the skin and central nervous system. Symptoms are usually related to ischemia secondary to occlusion of blood vessels, and approximately one-half of cases are first detected at autopsy.⁵¹⁹

Gray zone lymphoma is an entity applied to tumors that demonstrate morphological and immunophenotypic features between classical HL and DLBCL, especially primary mediastinal large B cell lymphoma (PMLBCL).⁵²⁰ These lymphomas have a poorer outcome than HL or PMLBCL. Unclassifiable B cell lymphomas with features between DLBCL and BL are also included in the WHO classification. These tumors are generally aggressive and respond poorly to standard chemotherapy, though the optimal treatment regimen is not defined.

DLBCL can rarely involve the anaplastic lymphoma kinase (ALK) gene, and most ALK+ DLBCL have a single or complex t(2;17)(p23;q23) involving the ALK gene at chromosome band 2p23 and the clathrin gene at chromosome band 17q23.⁵²¹ ALK+ DLBCL lacks expression of pan-B cell antigens, CD20 and CD79a, but is positive for CD138 and epithelial membrane antigen (EMA). Although data is limited due to the rarity of the disease, ALK+ DLBCL is usually advanced stage and has a poor prognosis.⁵²¹

Mutations in the TP53 gene have been detected in 20% of DLBCL and are associated with a poor prognosis. TP53 expression is detectable by immunohistochemistry in 30% to 40% of DLBCL, does not correlate with the presence of mutations, and has not consistently affected prognosis. However, combining TP53 and its downstream target CDKN1A/P21 (acting as a cyclin-dependent kinase inhibitor) has shown that the TP53+/P21-immunophenotype is a surrogate for TP53 mutations and is associated with poor survival in DLBCL, even with a low-risk IPI.³²¹

Expression of individual antigens assessed by immunophenotyping may help define subsets of DLBCL and may have prognostic value (see section on "Prognostic Factors"). CD10, also known as the common acute lymphoblastic leukemia antigen, is a marker for germinal center derivation and is detected in 20% to 30% of DLBCL. CD10 expression has been associated with improved survival or no effect.⁵²² CD5, an antigen primarily expressed by

P.1852

T cells and a small subset of B cells (B-1 cells), is present on 5% to 10% of DLBCL. CD5⁺ DLBCL has been associated with a high IPI and poor survival in most, but not all studies.⁵²²

As noted in the Prognosis Section, DLBCL can be subdivided by gene expression profiling (GEP) using cDNA or oligonucleotide microarrays into 4 subgroups: germinal center B cell (GCB), activated B cells (ABC), primary mediastinal B cell, and unclassified DLBCL.⁵²³ Comparative genomic hybridization (CGH) has shown differences in genetic imbalances between GCB and ABC DLBCL. GCB is characterized by the gain of 1q, 2p, 7q, and 12q; and ABC has gains of 3q, 18q, and 19q and loss of 6q and 9p21, the latter of which is described with the CDKN2A locus and an aggressive course.⁵²⁴

Tissue microarray (TMA) technology can be performed on formalin-fixed and paraffin-embedded samples and is easier and less expensive than GEP, which requires fresh or optimally cryopreserved samples. TMA can identify protein surrogates for dysregulated genes detected by GEP. Expression of BCL6 and CD10 were associated with a germinal center type and favorable outcome, whereas MUM1, CYCLIN D2, FOX P1, and/or protein kinase C beta (PKC-β) were associated with either the activated B cell or unclassified type and a poor prognosis.^{316, 525}

GEP and TMA are technically difficult studies to perform. Hans et al. proposed a reliable immunohistochemical staining using BCL-6, CD10, and MUM1 which is 80% concordant with that of the DNA-expression analysis.³¹⁷ Choi et al. described a similar approach with additional staining with GCET-1 and FOXP1 that showed a 93% concordance rate.³¹⁵ The clinical utility of these studies are being evaluated in prospective studies (see section on Prognostic Factors).

Current therapy of DLBCL is directed at clinical features, pathology, and stage of disease. As DLBCL represents a group of potentially curable neoplasms, prognostic factors are important to recognize and can influence the type, intensity, and duration of therapy. Selecting the intensity of therapy based upon prognostic factors is referred to as risk stratification and has been applied successfully in pediatrics, in which the curability of all types and stages of NHL is over 80%. The IPI is currently the best prognosticator for survival in DLBCL. Immunohistochemistry can delineate different types of DLBCL, but there is no consensus about the best panel of markers to either subclassify or prognosticate DLBCL. In the rituximab era, the prognosis has improved and the impact of IPI and immunohistochemistry was reassessed and classifies patients into very good, good, or poor risk groups with 94%, 75%, and 55% 4-year OS, respectively.³⁰⁰

Mediastinal (Thymic) Large B Cell Lymphoma

The WHO classification recognizes a distinct large B cell lymphoma postulated to arise from a thymic B cell and that can be confused with lymphoblastic lymphoma, HL, thymomas, and extragonadal germ cell neoplasms.^{526, 527, 528, 529, 530} Older literature referred to this entity as primary sclerosing mediastinal large cell lymphoma. PMLBCL constitute 2% to 3% of NHL and occur predominantly in females (female:male ~2:1) and young adults; three-fourths of cases are less than 35 years old.⁵²⁶ Gains in chromosome 9p24 or 2p15 have been recognized in up to 75% and 50% of patients, respectively.^{530, 531} BCL-2 and BCL-6 gene rearrangements rarely occur; overexpression of the MAL gene is common.⁵³² Interestingly, gene expression analysis has revealed a molecular signature with similarities to classical HL, perhaps reflected in the shared clinical and pathologic features and dysregulation of c-REL/NF-κB pathways.^{533, 534}

Presenting features are usually of short duration, varying from a few weeks to several months, and include chest pain (73%), cough (60%), dyspnea (46%), and superior vena caval obstruction (30% to 57%).^{528, 530} Over two-thirds of patients have large masses (≥ 10cm) (Fig. 88.17). Local extension of the mass into the pericardium, chest wall, or lung is common, while distant involvement of peripheral nodes, marrow, or CNS is infrequent.^{526, 529} The stage of disease is I or II in 80% of patients at diagnosis. Unusual extranodal sites of involvement include kidney, ovaries, and adrenal glands.

Although early reports indicated a poor prognosis despite combination chemotherapy, recent studies have had a good prognosis similar to or better than other DLBCL.^{527, 528, 535} Poor prognostic factors in PMLBCL have been the presence of pleural or pericardial effusion, multiple extranodal sites (≥2) of disease, bulk (≥ 10 cm), high LDH (>3× normal), and a persistently positive gallium or PET scan posttherapy.^{526, 528, 529} The age-adjusted IPI was not found to be predictive in these patients.⁵³⁵ Some of the best treatment results historically included involved field radiation therapy,^{528, 529} but some series have had equally good results without radiation, indicating that the role of radiation remains controversial.^{527, 535} Some centers have favored regimens other than R-CHOP, including R-MACOP-B/VACOP-B regimens and R-EPOCH. The latter was reported to have EFS of 90% in a series of 26 patients, without the use of radiation therapy.^{536, 537} Others have advocated autologous HCT as consolidative therapy among patients with “high-risk” PMLBCL, but there are sparse phase II trials to commend this approach.⁵³⁸

Peripheral T/Natural Killer Cell Lymphomas

The clinical significance and the management of T/natural killer (NK) neoplasms are areas of controversy in part because of the relative infrequency as compared to B cell lymphomas, and the lack of controlled trials evaluating the impact of immunophenotype on prognosis.^{296, 539, 540} PTCL and NK cell neoplasms represent 5% to 15% of all NHL, and there are multiple subtypes so that most represent less than 1% of NHL⁵⁴¹ (Table 88.13). These diseases have a geographic variation with more nodal disease in North America and Europe, including PTCL, unspecified; anaplastic large cell lymphoma (ALCL) and angioimmunoblastic T cell lymphoma (AITL); and more extranodal disease in Asia due to EBV-related nasal NK/T lymphoma and HTLV-1 associated ATL.⁵⁴² The prognosis in most peripheral T/NK neoplasms is poor, with 5-year survival less than 30%.^{539, 540, 542, 543} PTCLs may be associated with paraneoplastic phenomena, including skin rashes, autoimmune hemolytic anemia, hypergammaglobulinemia, eosinophilia, hypercalcemia, vasculitis, hemophagocytosis, and fever of unknown origin, which may obscure the initial diagnosis.

Attempts have been made to separate postthymic T cell neoplasms; however, the so-called low grade T cell lymphomas may have an aggressive course and can undergo histologic transformation similar to that seen in indolent B cell lymphomas.⁵⁴⁴ Cytogenetic differences have been utilized in an attempt to separate PTCL into low- and high-grade categories.⁵⁴⁵ PTCL that have been described with an indolent course include AILT, T-zone lymphoma, and lymphoepithelioid (Lennert) lymphoma;^{544, 546} only AILT is described in the WHO classification as a distinct entity, while the latter two would be referred to as PTCL, unspecified. Lennert lymphoma typically occurs in older patients, often with diffuse adenopathy and involvement of Waldeyer's ring and has a clinical course characterized by recurrent relapses.⁵⁴⁶

Mature T/NK neoplasms do not have the high frequency of translocations involving the T cell receptor genes at 14q11 (alphadelta), 7q34 (beta), and 7p14 (gamma), that the B cell lymphomas do with IG gene receptors, particularly with the IGH. The best described translocation is the t(2;5) (p23;q35) associated with ALCL (vide infra). It produces a fusion gene between the cytoplasmic part of anaplastic lymphoma kinase (ALK), a receptor tyrosine kinase of the insulin receptor subfamily on chromosome 2, and the amino-terminal portion of nucleophosmin (NPM) on chromosome 5.²⁶ A novel t(5;9) translocation involving the IL-2-inducible T cell kinase (ITK) gene on chromosome 5 and the

P.1853

spleen tyrosine kinase (SYK) on chromosome 9 was identified in 5 (17%) PTCL, NOS cases.⁵⁴⁵ Another translocation involving the multiple myeloma gene (MUM1)/ IFN-regulatory factor-4 (IRF4) gene locus with the TRA@ gene, t(6;14) (p25;q11.2) was found in two cases of PTCL, NOS and led to the recognition by FISH screening of non-TCR-related IRF4

translocations in ALK-negative ALCLs. A balanced translocation between DUSP22 phosphatase gene on 6p25.3 and FRA7H on 7q23 was subsequently found in both systemic and cutaneous ALCL.⁵⁴⁷

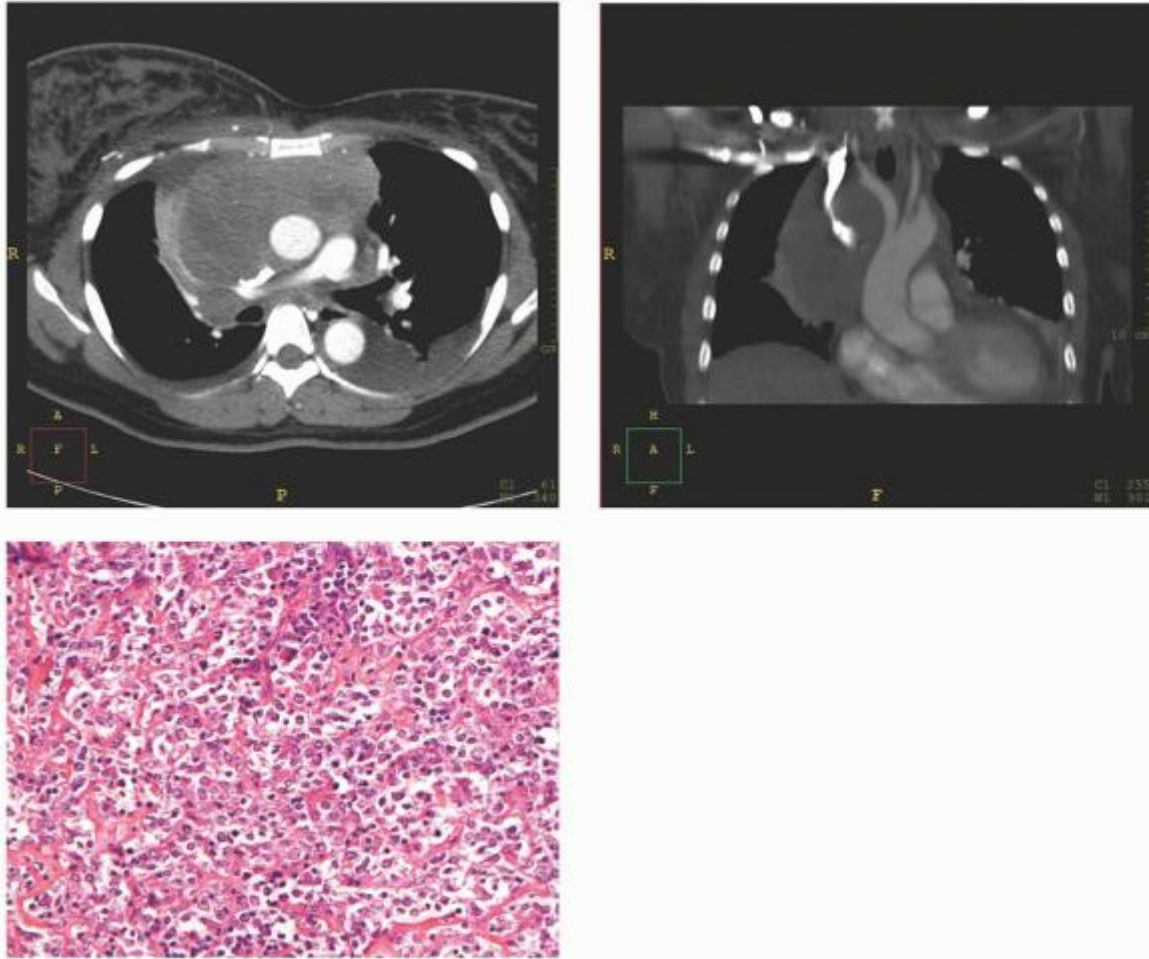

FIGURE 88.17. Large B cell lymphoma of mediastinum: Computerized tomography indicates mass encasing blood vessels in anterior-posterior (A) and sagittal (B) views. Image provided by Dr. Ron Arildsen, Vanderbilt University, Nashville, TN. C: There are aggregates of large B cells with open nuclear chromatin and nucleoli separated by fibrosis. Such fibrosis is characteristic of this lymphoma type. Images provided by Dr. Dan Arbor, Stanford University, Palo Alto, CA.

TABLE 88.13 MATURE (NONCUTANEOUS) T/NK LYMPHOMA/LEUKEMIA

- Nodal
- Peripheral T cell lymphoma, not otherwise specified
- Anaplastic large cell lymphoma
- ALK-positive
- ALK-negative
- Angioimmunoblastic T cell lymphoma
- Extranodal
- Nasal NK/T cell lymphoma
- Localized
- Disseminated (nasal type)

Enteropathy type intestinal T cell lymphoma

Hepatosplenic T cell lymphoma

Subcutaneous panniculitis-like T cell lymphoma, $\alpha\beta$

Leukemia

T-prolymphocytic leukemia

Adult T cell lymphoma/leukemia

Large granular lymphocytic leukemia

Aggressive NK cell leukemia

ALK, anaplastic lymphoma kinase; NK, natural killer.

Although CHOP has been the mainstay of therapy for aggressive lymphomas, its results have been poor for most mature T/NK neoplasms.^{548, 549, 550} The response rates to CHOP have been inferior compared to B cell lymphomas, and there has been no ubiquitous monoclonal antibody similar to rituximab to improve survival. Adding agents to CHOP may slightly improve responses but is limited by increased toxicity. Adding etoposide to CHOP had modest improvement for only young patients, primarily with ALK-positive ALCL, in the combined analysis of trials by the German High-Grade Non-Hodgkin Lymphoma Study Group.⁵⁵¹ Escalating therapy, such as Mega-CHOEP or HyperCVAD, has not improved responses or survival.⁵⁵¹ Addition of alemtuzumab to CHOP led to increased infections so that its use is likely limited.⁵⁵² Using novel non-anthracycline-based regimens such as PEGS (cisplatin, etoposide, gemcitabine, solomedrol) have not improved survival.⁵⁵³

P.1854

How to incorporate newly approved agents such as pralatrexate, an antifolate, and romidepsin, a histone deacetylase inhibitor, into therapy is under investigation in PTCL. The response rate and toxicities in relapsed PTCL for pralatrexate was 29% (11% CR) with 22% mucositis and 18% to 32% cytopenias, and for romidepsin was 38% (18% CR) with 26% grade 3/4 neutropenia.^{554, 555} Because of the overall poor results with CHOP, stem cell transplant, both autologous and allogeneic, has been advocated in first remission in many patients with T/NK neoplasms although there is no randomized trial to prove its superiority.^{556, 557}

The WHO classification separates the mature T/NK neoplasms by site of involvement: nodal, extranodal, leukemic, and cutaneous. In the subsequent section, the focus is primarily on nodal and extranodal diseases followed by a brief description of the leukemias. Cutaneous T cell lymphomas are reviewed in Chapter 92.

Anaplastic Large Cell Lymphoma

Since the original description of Ki-1⁺ (CD30) ALCL by Stein in 1985, a type of ALCL has become a paradigm for the WHO classification for NHL.^{258, 558, 559} The first clinical description of ALCL was in a series by Kadin et al. in 6 children, all of whom had skin lesions.⁵⁶⁰ Subsequent studies recognized a common lymphoma (2% to 8% of NHL) with a wide morphologic spectrum, young median age, peripheral adenopathy with relative sparing of the mediastinum, frequent extranodal disease, and a good prognosis.^{258, 561, 562} In 1989, a proportion of ALCLs were associated with a specific chromosomal translocation;²⁵ and in 1994, Morris identified the genes involved in the t(2;5).²⁶

ALK rearrangements are present in 50% to 70% of CD30⁺ ALCL, and the t(2;5) occurs in approximately three-fourths of these patients.^{258, 563} Cytogenetic variants have been described with t(1;2)(q25;p23) as the most common.⁵⁶³ Immunocytochemical stain for the ALK protein is usually present in both cytoplasm and nuclei of the classic t(2;5)(p23;q35), while only in the cytoplasm of the variants.^{258, 312} Because the variants are of T or null cell origin and occur in a similar age group as the t(2;5), Falini proposed the term "ALKoma" for all patients expressing the ALK protein.³¹²

ALK expression subdivides ALCL into at least 3 clinical subtypes of ALCL: 1) ALK-positive systemic ALCL, 2) ALK-negative systemic ALCL, and 3) primary cutaneous ALCL (also, ALK-negative). ALK-positive ALCL occurs at a younger median age (15 to 30 years) than ALK-negative (45 to 65 years), has a male predominance (male:female = 2-6:1), and usually has advanced stage disease with frequent B symptoms (40% to 75%) and extranodal involvement (50% to 80%).^{258, 312, 313} Skin (21% to 35%) (Fig. 88.18), soft tissue (17%), and bone (8% to 17%) are common extranodal sites, while the gastrointestinal tract and central nervous system are rarely involved.²⁵⁸ Bone marrow involvement in ALK-positive ALCL is identified in 10% to

15% with hematoxylin and eosin stains, but up to 30% if immunohistochemistry stains are used to identify isolated ALCL cells.^{258, 564}

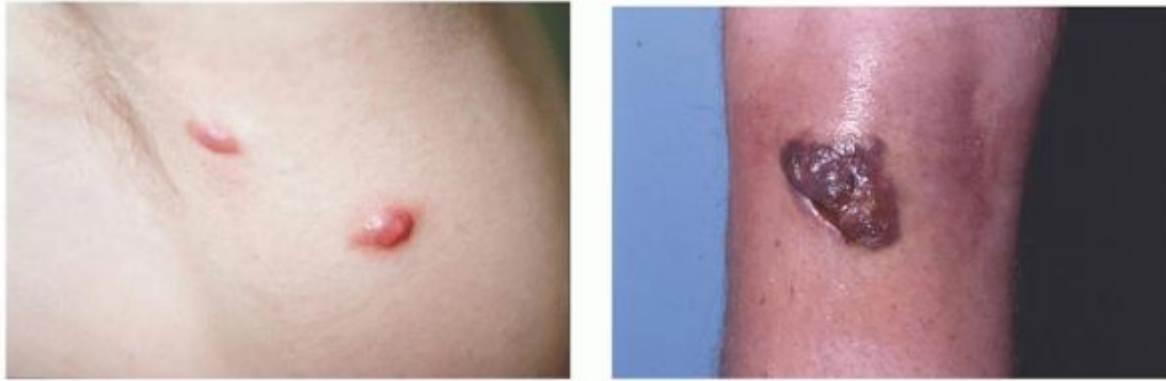

FIGURE 88.18. ALK-1 positive anaplastic large cell lymphoma (ALCL): Skin lesions can vary from nodules (A) in an axilla to ulcerations (B) in a popliteal fossa.

ALK-positive ALCL is more chemosensitive than ALK-negative ALCL with CR rates >75% for ALK-positive and 50% to 75% in ALK-negative.^{312, 313, 565, 566} Better responses have resulted in a twofold or higher increase in survival for ALK-positive ALCL (60% to 93% at 5 years) compared to ALK-negative ALCL (15% to 46%) in retrospective series (Fig. 88.19).^{312, 313, 542, 565, 567, 568, 569} A worse prognosis can be seen in ALK-positive patients with B symptoms, a high IPI, small cell variant histology, and expression of CD56 or survivin (a member of the inhibitor of apoptosis family).^{570, 571}

A problem comparing ALK-positive ALCL to ALK-negative ALCL is the fact that the latter represents a heterogeneous group of diseases. Translocations affecting 6p25.3 which target DUSP22 and/or IFD4 have been identified in a subset of ALK-negative ALCL with predominant skin involvement.⁵⁷² ALK-negative ALCL may be considered as secondary ALCL when it follows mycosis fungoides, lymphomatoid papulosis, or HL.²⁵⁸ Hodgkin-like ALCL is formally a provisional diagnosis of the WHO classification, but is probably a variant of HL.⁵⁷³ ALK-negative ALCL can rarely be of B cell origin, either with an aggressive course or in the setting of AIDS.^{258, 573} Differences in gene expression may further define ALCL with overexpression of genes encoding signal transduction and underexpression of transcription factor genes in ALK-positive compared to ALK-negative ALCL.^{574, 575}

Primary cutaneous ALCL is another ALK-negative ALCL, is part of the spectrum of CD30+ cutaneous lymphoproliferative disease, and clinically overlaps with lymphomatoid papulosis (Chapter 92).^{576, 577} It usually arises in the skin in an older patient (median age ~60 years) as an isolated reddish-violet tumor, which may be ulcerated. Less commonly, it may present as multiple nodules in a circumscribed area, or rarely with disseminated skin lesions. Treatment of localized lesions may be watchful waiting (because approximately one-quarter of patients regress), local excision ± radiation, or radiation alone.^{258, 577} Combination chemotherapy may be warranted with widespread skin disease or localized skin disease with adjacent nodal involvement, but these patients tend to relapse.^{577, 578}

Two proteins provide unique therapeutic targets in ALCL. Brentuximab vedotin (SGN-35; Adcetris, Seattle Genetics, Botnell, WA) is an antibody-drug complex that combines an anti-CD30 antibody with the antimicrotubule agent, monomethylauristatin E. In a phase II trial in 58 patients with relapsed/refractory ALCL, the ORR was 86% with 57% CR. The median duration of objective response was 12.6 months for all patients and 13.2 months for CR patients. Crizotinib (PR-02341066; Xalkori, Pfizer, San Diego, CA)

P.1855

is an oral small-molecule inhibitor of ALK tyrosine kinase that was first used in non-small cell lung cancer with a rearrangement involving ALK in 2% of cases. A phase I trial reported 7 CRs in 8 relapsed pediatric ALK-positive ALCL.⁵⁷⁹ A subsequent report confirmed CRs in adults.⁵⁸⁰ Both agents are being incorporated into phase III trials.⁵⁸¹

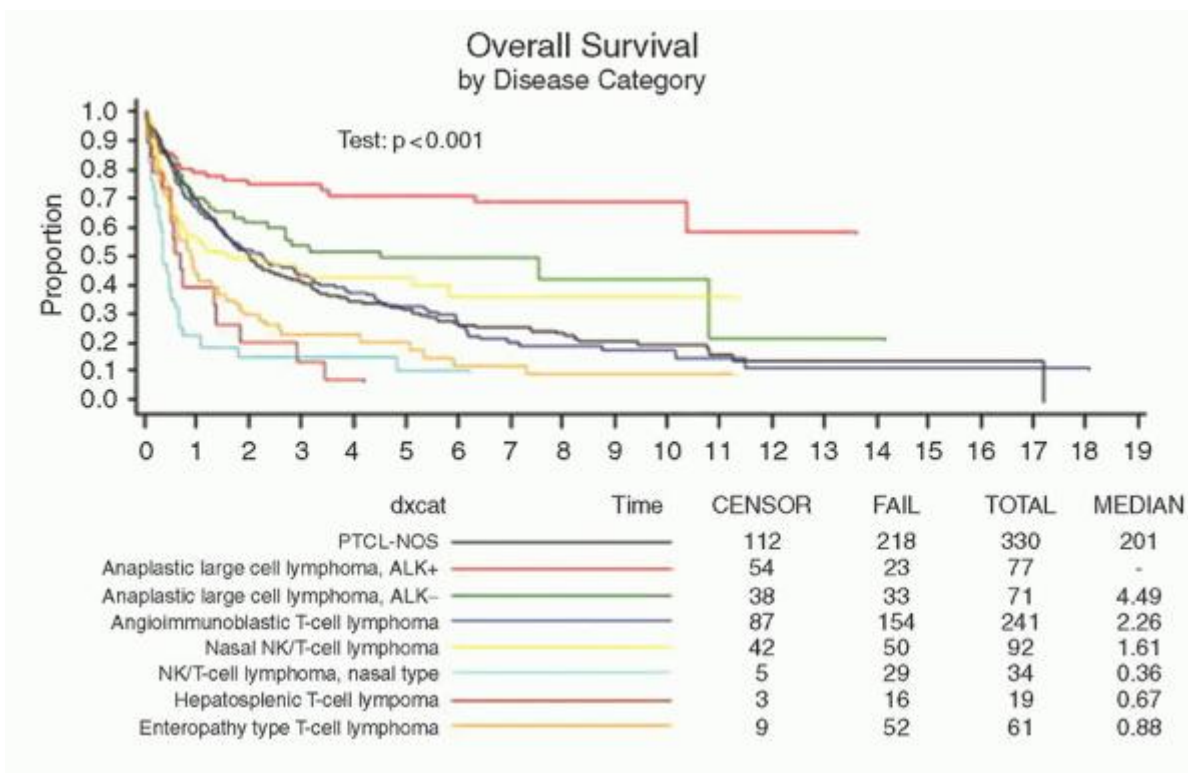

FIGURE 88.19. Overall survival for patients with aggressive peripheral T cell lymphoma by subtype according to the International Peripheral T Cell and NK/T Cell Lymphoma Study. From Armitage JO. The aggressive peripheral T cell lymphomas: 2012 update on diagnosis, risk stratification, and management. *Am J Hematol* 2012;87:511-519, with permission.

Nodal Peripheral T Cell Lymphoma

Problems in management of PTCL include the fact that, unlike B cell NHL, cell size does not correlate with prognosis, and there is sparse data regarding the impact of cytogenetics on diagnosis other than ALK expression in ALCL. The IPI does correlate with prognosis in PTCL-not otherwise specified (NOS), but only the low-risk (0,1) has prolonged survival over 45%.^{346, 5676, 568, 582} A new prognostic model has added bone marrow involvement to some of the IPI factors (age, PS LDH).³⁰⁷ Elevated levels of serological markers, nm23-H1 (involved in regulation of metastasis), IL-2 receptor, and soluble CD44 may enhance the IPI.⁵⁸³

PTCL-NOS represented the largest group (29.5%) in the international T cell Lymphoma Project.⁵⁸² The median age was 60 years with a male predominance. Most patients presented with nodal disease (87%) and had advanced stage (69%); extranodal involvement occurred in 49%. The 5-year OS was 32% and FFS was 20%.

Tumor-specific features under evaluation to assess prognosis include expression of cytotoxic molecules, Ki-67, TP53, chemokine receptors, and gene profiles.⁵⁸⁴ Cytotoxic molecules (CM), TIA-1, and granzyme B in PTCL-NOS, are associated with B symptoms, a higher IPI, an inferior CR rate, and a worse overall survival when compared to a CM-negative group.⁵⁸⁵ The proliferation-associated antigen, Ki67, was additive to IPI factors (age, PS, LDH) in a series of PTCL-NOS.⁵⁸⁶

Immunohistochemistry detection of TP53 overexpression was detected in a minority (29%) of nodal PTCL cases; was associated with Ki-67, BCL-2, and P-glycoprotein; and was a better predictor of poor survival than IPI.³²⁸ Preliminary data indicate chemokine receptor expression that distinguishes subsets of T helper cells, Th1 and Th2, and correlates with histology and prognosis.⁵⁸⁷

Gene expression profiles are under investigation as a method to subdivide PTCL.⁵⁸⁸ Three molecular profiles have been identified in PTCL-NOS: 1) Overexpression of genes with an aggressive course, including CYCLIN D2; 2) genes involved in T cell activation and apoptosis, NFKB1 and BCL-2; and 3) overexpression of genes in the interferon γ /JAK/STAT pathway.⁵⁸⁹ Another study reported that reduced expression of NF- κ B pathway genes had an inferior survival to those with increased NF- κ B expression.⁵⁹⁰ Two different profiles, a large group corresponding to activated CD4⁺ cells and a smaller group of CD8⁺ cells, also subdivided PTCL-NOS.⁵⁹¹

AILT is difficult to diagnose and treat because there may be the presence of both B and T clones, as well as EBV; and it has a variable clinical course with autoimmune features.^{543, 592, 593, 594} AITL was the second most common type (18.5%) in the IPTL usually occurs in the elderly (median age, 57 to 68 years) as a systemic disease with diffuse adenopathy (84% to 100%), B symptoms (52% to 86%), a pruritic rash (38% to 58%), arthritis (16% to 18%), eosinophilia (32% to 50%), and immunologic abnormalities (Coombs' positive hemolytic anemia [32% to 75%], cold agglutinins, cryoglobulinemia, polyclonal hypergammaglobulinemia [50% to 83%], antinuclear antibodies and rheumatoid factors). Most patients have extranodal disease and are advanced stage (68% to 94%).

There is clonal evolution over time in AILT and EBV may participate in lymphomagenesis.⁵⁹⁵ The cell of origin is a T-follicular helper cell (TFH); and there is cytoplasmic expression of the cytokine CXCL13.⁵⁹⁶ TCR gene rearrangements occur early in the course of AILT, indicating a clonal T cell population. Nearly all patients have EBV-positive B cells and approximately one-third have also had IG gene rearrangements.⁵⁹⁷ As with posttransplant lymphoproliferation but unlike other NHL, unrelated or oligoclonal clones are commonly found in AILT. The most common cytogenetic abnormalities are trisomy 3, trisomy 5, and an additional X chromosome, but patients who develop complex aberrant clones and structural abnormalities in the short arm of chromosome 1 progress rapidly.⁵⁹⁸ EBV can be identified in both B cells and T cells of AILT, and it may participate in the occasional B-immunoblastic lymphoma as well as the more common PTCL.^{592, 597, 599} Gene expression profile found overexpression of genes characteristic of TFH cells and genes deregulating vascular endothelial growth factor.^{600, 601}

AILT may spontaneously regress in up to 10% of patients; and it can respond to single agents, including steroids, cyclosporine, methotrexate, interferon, nucleoside analogs, bortezomib, denileukin diftitox, and rituximab. Combination chemotherapy is usually warranted once a diagnosis is made with a CR rate of 50% to 70% following anthracycline-based therapy, but patients have frequent and early relapses or deaths due to infections, with 5-year survival at 10% to 30%.^{543, 593}

P.1856

Extranodal T Cell and Natural Killer-Cell Lymphomas

Hepatosplenic γ/δ T cell lymphoma (HSTL) was first described in 1990 as an aggressive illness with B symptoms and organomegaly in young adult males.^{602, 603} Up to 20% of HSTLs arise in patients with solid organ transplants and Crohn disease.⁵⁴¹ The median age is 25 to 35 years with a male/female ratio of 9:1. Patients have splenomegaly (98%), hepatomegaly (80%), minimal to no lymphadenopathy, anemia (84%) and severe thrombocytopenia (85%).^{233, 604} The bone marrow is involved in 72% of patients and erythrophagocytosis may occur.⁶⁰⁴ Isochrome 7q, often associated with trisomy 8, is a common cytogenetic abnormality.⁶⁰⁵ Most patients are refractory to anthracycline-based therapy or have brief responses and have a median survival less than 1 year.^{233, 549, 604} There is an α/β variant with similar features and prognosis.⁶⁰⁶ A similar gene expression profile involving genes implicated in cytotoxic T and NK cell function is present in both γ/δ and α/β variants.⁶⁰⁷

Subcutaneous panniculitis-like T cell lymphoma (SPTL) presents with subcutaneous nodules, usually on the extremities, and is often associated with systemic symptoms and erythrophagocytosis.^{608, 609, 610} The 2008 WHO classification recognizes only the $\alpha\beta$ subtype as SPTL and distinguishes it from cutaneous $\gamma\delta$ T cell lymphoma, which may have a panniculitis-like presentation.⁶¹¹ The $\alpha\beta$ subtype occurs at a younger median age (36 years) with a female predominance. The skin lesions tend to be self-healing subcutaneous plaques and nodules without ulceration. Disseminated disease and hemophagocytosis (17%) are rare. These patients may be controlled with single agent steroids and/or methotrexate and have a 5-year OS of 82%.⁶¹¹ The $\gamma\delta$ type occurs in an older population (median age, 59 years) with a roughly equal male:female ratio. Skin lesions may involve the epidermis and ulcerate. B symptoms, nodal disease, and hemophagocytosis are associated with a poor prognosis and a 5-year OS of 11% despite combination chemotherapy.⁶¹¹

Enteropathy-associated T cell lymphoma (EATL) has an association with celiac disease but has occurred without it as well.^{612, 613, 614, 615, 616} There are two types of EATL.⁶¹⁶ Type 1 has a large cell or pleomorphic cytology, has chromosome 9q31.3 gain or 16q12.1 deletion, is associated with the HLA-DQ2 haplotype, is strongly associated with celiac disease, and is common in Europe. Type 2 is characterized by monomorphic cells often with CD56 expression, has chromosome 8q24 gain and less commonly 1q and 5q gains, is less associated with sprue, and is found in Asia. The median age is 50 to 64 years and males predominate in most series.^{614, 615} Abdominal pain and weight loss occur in over four-fifths of patients at presentation followed by diarrhea or vomiting in one-third of patients.⁶¹⁴ Small bowel obstruction or perforation is

common, and the diagnosis of EATL is usually made at laparotomy. Prognosis is poor, with median survival of 7.5 months and 1 year failure-free survival less than 20%.^{614, 615, 616}

Nasal and nasal-type NK/T lymphomas are characterized by angiocentric and angiodestructive proliferation; large granular lymphocyte morphology; CD2⁺, CD3⁻, CD16^{+/+}, CD56⁺, CD57⁻ phenotype; and an aggressive course.^{617, 618} Only 10% express surface CD3⁺ and have clonal TCR rearrangement and have a similar course.⁶¹⁸ EBV is consistently detected in tumor cells and elevated levels of EBV DNA in tumor tissue or serum have correlated with a poor prognosis.^{619, 620} NK neoplasms are prevalent in Asia and Latin America. Nasal NK/T lymphoma may present with facial swelling or midfacial destruction and was formerly called lethal midline granuloma or polymorphic reticulosis. The disease occurs more commonly in males with a median age of 50 to 55 years.^{617, 618}



FIGURE 88.20. Nasal NK/T lymphoma: Patient presented with facial edema, proptosis, and dysconjugate gaze (A) and an ulcerated lesion in the hard palate (B).

Nasal NK/T lymphoma is localized stage I/II in 80% of patients at diagnosis but can disseminate early to skin, gastrointestinal tract, testis, orbit, and CNS (Fig. 88.20). Although radiation alone can achieve CR in two-thirds of localized disease, local relapse occurs in half the patients and disseminated disease develops in one-quarter of patients.⁶¹⁷ Combined modality with early radiation and chemotherapy is recommended. Patients with disease confined to the nasal cavity, larynx, pharynx, or oral cavity had 54% 5-year survival compared to 20% ($P = 0.0068$) with more advanced disease.⁶²¹

Nasal-type NK/T cell lymphoma is essentially disseminated nasal disease without obvious nasal involvement.⁶²² Only one-fifth of patients have stage I disease.⁶²² Despite anthracycline therapy, median survival is less than 1 year. L-asparaginase has been shown to be effective as a single agent in patients who failed CHOP.⁶²³ Because of high expression in P-glycoprotein, regimens containing multidrug resistant-independent agents, such

P.1857

as SMILE (steroids, methotrexate, ifosfamide, L-asparaginase, etoposide) have been formulated to treat nasal-type NK/T cell lymphoma.⁶²⁴ Patients with cutaneous only involvement have a better survival.⁶²⁵ A disseminated, leukemic form is usually fatal within weeks.⁶²⁶

Mature T Cell and Natural Killer-Cell Leukemias

The differential diagnosis of CLL in Chapter 90 includes the mature T/NK leukemias. Large granular lymphocyte (LGL) leukemia was associated with chronic neutropenia in 1977, recognized as a clonal disorder in 1985, and classified into T (CD3⁺) and NK (CD3⁻) types in 1993 (Fig. 88.21A).^{204, 627, 628} The median age is 55 to 60 years, and there is an association with rheumatoid arthritis (20%) and autoimmune features.^{204, 629} Lymphocytosis is usually between 2 and $20 \times 10^9/L$ and mild splenomegaly (25% to 50%) may be present, but the usual clinical presentation is neutropenia or anemia. Recurrent infections are usually respiratory or mucocutaneous and occur in 15% to 56% of patients.²⁰⁴ Pure red cell aplasia, autoimmune hemolytic anemia, aplastic anemia, ITP, and MDS may occur in LGL leukemia. LGL cells express high levels of both FAS and FAS ligand, but the cells are resistant to FAS-mediated death due to STAT 3 activation which upregulates an antiapoptotic protein.^{629, 630} LGL leukemia is an indolent disease with median survival over 10 years.²⁰⁴ Immunosuppressant drugs which have been used in LGL leukemia include methotrexate, cyclosporine, prednisone, cyclophosphamide, nucleoside analogs, and alemtuzumab.^{204, 627, 631, 632}

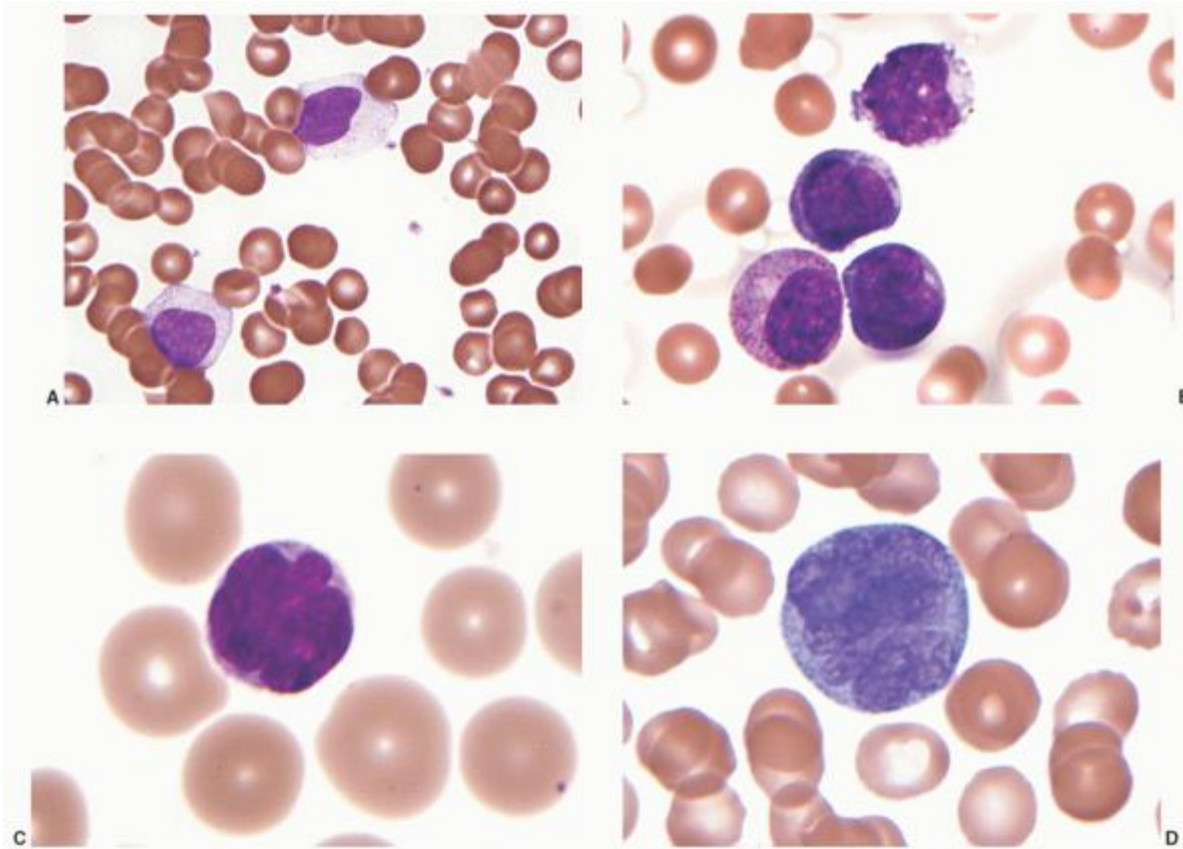

FIGURE 88.21. Mature T/NK leukemias: A: T cell large granular lymphocytic leukemia: The lymphocytes are enlarged with dense nuclear chromatin and abundant cytoplasm with fine azurophilic granules. B: Natural killer/T cell leukemia: Three leukemic cells and one myelocyte are present. The leukemia cells have blastic, fine nuclear chromatin with irregular nuclei and basophilic cytoplasm. Some cases may show cytoplasmic granules. C: T cell prolymphocytic leukemia: The lymphocyte has clumped nuclear chromatin with irregular nuclear contours, sometimes referred to as “knobby cells.” Nucleoli may be inconspicuous, in contrast to B cell prolymphocytic leukemia, which has prominent nucleoli. D: Abnormal T lymphocyte in the peripheral blood of a patient with adult T cell leukemia. The cell is enlarged with a multilobated nucleus. These “flower cells” are usually easily found with this disorder. Images provided by Dr. Dan Arber, Stanford University, Palo Alto, CA.

Aggressive NK leukemia is a rare disorder more common in Asia, is associated with EBV, and represents the leukemic phase of nasal-type NK lymphoma (Fig. 88.21B).⁶³³⁻⁶³⁵ Patients are young (median age, 30 to 40 years) with slight male predominance and present with a fulminant illness characterized by B symptoms, diffuse adenopathy, organomegaly, and circulating LGL cells which can have a blastic appearance.^{634, 635} Patients are chemoresistant and have a median survival of less than 3 months.^{634, 635} Another neoplasm of possible NK cell lineage is myeloid/NK cell precursor acute leukemia.^{636, 637} Blastic plasmacytoid dendritic cell neoplasm, formerly mislabeled as CD4⁺/CD56⁺ hematodermic neoplasm or blastic NK

cell lymphoma, has a predilection for cutaneous involvement and probably should receive therapy for acute myeloid leukemia.⁶³⁸

T-prolymphocytic leukemia (T-PLL) represents approximately 2% of small lymphocytic leukemia in adults (Fig. 88.21C).⁶³⁹,⁶⁴⁰,⁶⁴¹ Median age is 57 to 69 years and the male:female ratio is 1.5:1.⁶⁴²,⁶⁴³ Patients usually have a marked lymphocytosis ($>100 \times 10^9/L$ in 75% of patients), splenomegaly (73%) and lymphadenopathy (53%); and approximately 20% of patients have

P.1858

skin infiltration.⁶³⁹,⁶⁴⁰,⁶⁴² Cell morphology is variable; the nuclei are irregular, include a “knobby” variant, and usually have prominent nucleoli; cytoplasmic protrusions are characteristic. Sixty per cent of patients are CD4⁺/CD8⁻; 25% coexpress CD4⁺/CD8⁺; and 15% are CD4⁻/CD8⁺.⁶³⁹,⁶⁴⁰,⁶⁴²

The most common cytogenetic abnormality occurring in 80% of patients is an inversion of chromosome 14 with break points in q11 and q32; 10% have a reciprocal translocation t(14;14) (q11;q32).⁶³⁹,⁶⁴⁴ These translocations juxtapose the locus of the TCR α/β gene with the TCL1 and TCL1b genes at 14q32.⁶⁴⁵ Deletions at 11q23, the locus for the ATM gene, and at 12p13, and abnormalities of chromosome 8 are other common cytogenetic findings in T-PLL.⁶³⁹,⁶⁴⁶

Response rates in T-PLL are 10% to 48% with few complete remissions utilizing chemotherapy, including CHOP or nucleoside analogs.⁶⁴²,⁶⁴³ Median survival is usually 1 year although up to one-third of patients can have an indolent phase.⁶⁴²,⁶⁴³,⁶⁴⁷ Alemtuzumab (Campath 1H) is the most active single agent in T-PLL with a 74% and 91% response rate in previously treated and untreated patients, respectively.⁶⁴¹,⁶⁴⁸ Preliminary data suggest the best survival occurs in patients treated with intravenous alemtuzumab followed by an allogeneic HCT. Nucleoside analogs, particularly pentostatin, can be effective in slow responders.⁶⁴¹

The clinical course of ATL, which follows infection by HTLV1, is variable and takes 4 basic forms: 1) acute (leukemic) (60%), 2) lymphoma (20%), 3) chronic (20%), and 4) smoldering (5%). The male to female ratio is 1.3-2.2:1, and the median age is 47 to 65 years.⁵⁹ The acute form is characterized by lymphadenopathy, organomegaly, skin lesions, elevated white count with multilobed lymphocytes, often referred to as “cloverleaf” or “flower” cells (Fig. 88.21D), hypercalcemia, elevated lactate dehydrogenase (LDH) level, and usually a rapidly fatal course. The cutaneous lesions have a diverse appearance, including papules, nodules, plaques, tumors, and ulcers. Histologically, dermal invasion predominates, although the lesions of ATL may resemble primary cutaneous T cell lymphoma with epidermotropism and Pautrier's microabscesses. Anemia and thrombocytopenia are infrequent findings because of a low degree of marrow infiltration. Central nervous system involvement may develop in as many as 10% of patients with ATL.⁶⁴⁹

Lymphoma is distinguished by prominent adenopathy without significant peripheral blood involvement. Primary extranodal lymphoma occurs in approximately 5% of lymphomatous presentations and has involved skin, Waldeyer's ring, gastrointestinal tract, sinuses, and pleura.⁶⁵⁰ The chronic type is associated with an increased white blood cell count and occasionally with slight adenopathy and organomegaly. Patients with smoldering ATL have few ATL cells (0.5% to 3%) in the peripheral blood, and may have skin lesions as well as slight adenopathy, organomegaly, and marrow infiltration. Chronic and/or smoldering ATL may evolve into an acute form after many years of indolent disease.⁶⁵¹

No consistent cytogenetic abnormality has been identified in ATL. The most common abnormalities are gains at chromosomes 14q, 7q, and 3p and losses at 6q and 13q.⁶⁵²,⁶⁵³ Aneuploidy, multiple chromosomal breaks, and loss of tumor suppressor genes are associated with an aggressive course.⁶⁵³,⁶⁵⁴

Despite combination chemotherapy, which can yield brief and low responses, median survivals in the acute and lymphomatous forms of ATL are usually less than 1 year.⁵⁹,⁶⁵⁵,⁶⁵⁶,⁶⁵⁷ Chemotherapy with a complex regimen, the LSG15 protocol, is marginally superior to CHOP and has higher response rates in the lymphoma form compared to acute.⁶⁵⁸ Overexpression of MDR (ABCB1) and TP53 contribute to chemoresistance.⁶⁵⁹,⁶⁶⁰ Poor performance status, high LDH, age above 40 years, tumor bulk, and hypercalcemia are adverse prognostic factors.⁶⁵⁵ The chronic and smoldering forms have a longer survival rate regardless of therapy. The major causes of death in ATL are opportunistic pulmonary infections and progressive disease, often in association with hypercalcemia.⁶⁶¹,⁶⁶²

Because of its chemoresistance and its HTLV-1 viral leukemogenesis, ATL has been a unique disease for investigating therapy. Interferon α (IFN) plus zidovudine (AZT) has had a higher response rate (67% to 92%) than chemotherapy regimens in ATLL.⁶⁶³ The current recommendation is to first initiate antiviral therapy for the acute, chronic, and smoldering forms.⁶⁵⁷ Others advocate debulking with chemotherapy followed by antiviral therapy or concomitant treatment, particularly for the lymphoma form. NF- κ B inhibition has been proposed as a therapeutic target in ATL. Arsenic

trioxide synergizes with IFN, has been shown to shut down the NF- κ B pathway, and has been effective in phase II trials.⁶⁶⁴ Conjugated and unconjugated monoclonal antibodies directed at the IL-2 receptor (CD25), CD52 (alemtuzumab), chemokine receptor 4 (KW-0761), and CD2 (Siplizumab) have activity in ATL and are being evaluated in conjunction with other therapy.

Allogeneic hematopoietic cell transplantation (alloHCT) was first reported as a curative option in ATL in 1996. Although the median survival with alloHCT (9.9 months in a review of 586 patients) does not appear superior to other therapy, the 3-year estimated overall survival of 36% suggests HCT may offer the best chance for long-term survival.⁶⁶⁵

Despite the new therapies under investigation in ATL, the ultimate goal is prevention of the disease. Avoiding breast-feeding in mothers infected with HTLV-1 can reduce infection in the newborn by 80%.⁵⁹ Other proposed methods to prevent ATL are antiretroviral therapy and a TAX-targeted vaccine.

THERAPY FOR LOCALIZED LARGE CELL LYMPHOMA

Localized disease is defined by either stage I or II disease which is nonbulky (no tumor mass \geq 10 cm; no mediastinal mass $>$ one-third the chest diameter). Radiation therapy alone has resulted in 20% to 85% cure rates for limited stage large cell lymphomas, with the best results in patients who have stage I disease after undergoing pathologic staging.^{18, 666} With clinical staging, cure rates with radiation alone have usually been less than 50%; therefore, most investigators are advocating chemotherapy, usually CHOP-type regimens, often followed by radiation, with cure rates of 70% to 90%.⁶⁶⁷ Using a stage-modified IPI for localized disease, patients with no adverse risk factors (stage I, age \leq 60, $<$ 2 performance status, normal LDH) have cure rates exceeding 90%.⁶⁶⁸

Clinical trials have addressed the issue of chemotherapy versus combined modality therapy in limited stage large cell lymphoma.⁶⁶⁹ In a SWOG study, patients with localized intermediate-or high-grade NHL were randomized to 3 cycles of CHOP followed by involved field radiation therapy (4,000 to 5,500 cGy) versus 8 cycles of CHOP.⁶⁷⁰ Better PFS (77% versus 64%, $P = 0.03$) and OS (82% versus 72%, $P = 0.02$) were observed in the combined modality arm and there was a trend toward increased toxicity, particularly cardiac, in the chemotherapy-only arm.⁶⁷⁰ A subsequent follow-up report, however, indicates no difference in survival between the two arms.⁶⁷¹ Other concerns of the SWOG study are that 8 cycles of CHOP is probably excessive for localized disease and that radiation will contribute to the risk of long-term toxicities.

An ECOG trial compared low-dose (30 Gy) radiotherapy (RT) with observation in limited stage aggressive lymphoma patients who had achieved CR after CHOP times 8 cycles, and assessed the impact of higher dose (40 Gy) RT in patients in PR.⁶⁷² The DFS at 6 years was significantly greater for CR patients who received RT (76% vs. 56%, $P = 0.05$), but there was no improvement in overall survival. Patients who received RT rarely relapsed in previously irradiated sites. PR patients had a 63% FFS at 6 years, indicating

P.1859

a role for the addition of RT. The efficacy of adding rituximab to CHOP chemotherapy followed by IFRT was evaluated in a SWOG study. The 4-year PFS and OS were 88% and 92%, respectively.⁶⁷³

Other randomized trials in children, as well as adults, have shown no benefit to combined modality over chemotherapy alone in limited stage patients.^{674, 675} A GELA trial compared 4 cycles of CHOP plus RT to 4 cycles of CHOP alone in patients over 60 years of age and found no difference in EFS or OS.⁶⁷⁵ Another GELA randomized trial compared an intensive regimen of ACVBP (doxorubicin, cyclophosphamide, vindesine, bleomycin, and prednisone) to 3 cycles of CHOP followed by involved field RT for patients less than 60 years of age with limited stage disease. Although there was more toxicity in the ACVBP arm, there was superiority in both EFS (82% vs. 74%, $P < 0.001$) and OS (90% vs. 81%, $P = 0.001$) for the intensive regimen over the CHOP plus RT.⁶⁷⁶ The major improvement for ACVBP was in the patients with bulky stage II disease.

Thus, although short course chemotherapy (3 to 4 cycles) followed by RT is an accepted treatment for adults with localized large cell NHL, there is data to support chemotherapy alone for many patients. There may be more local relapses when RT is not used, but there are no differences in survival and there is likely to be fewer long-term toxicities with chemotherapy alone. A potential role for RT could be in patients who have a positive interim or postchemotherapy FDG-PET scan.⁶⁶⁹ In a series of 59 patients (83% with stage I/II disease), the 3-year PFS for patients with negative scans receiving chemotherapy alone ($n = 39$) and with positive scans receiving consolidative involved field RT ($n = 20$) were 97% and 90%, respectively.⁶⁷⁷

CHEMOTHERAPY

In the early 1970s, DeVita introduced a combination chemotherapy regimen, C-MOPP (cyclophosphamide replacing mechlorethamine, vincristine, procarbazine, and prednisone), which produced a CR rate in excess of 40% in patients with diffuse "histiocytic" lymphoma, a neoplasm generally equivalent to DLCL; approximately one-third of these patients were cured.^{678, 679} By the middle 1970s, doxorubicin had been added to cyclophosphamide, vincristine, and prednisone to produce the CHOP regimen, which produced CR rates of 50% to 60% and DFS of 30% to 40%.^{680, 681} CHOP is the most extensively studied and used regimen in the therapy of large cell lymphoma. The addition of rituximab has improved response and survival.⁶⁸² Clinical observations have been that rapid achievement of a CR was associated with a good prognosis^{680, 683} and that relapses after 2 years of DFS were rare. Further follow-up for large cell lymphoma, however, recorded relapses in 6% to 22% of patients after 2 years of CR.^{683, 684}

Subsequent regimens were developed in part on the concepts of Goldie and Coldman, who proposed that tumors develop drug resistance by spontaneous mutation soon after exposure to chemotherapy; and of Hryniuk and Bush, who proposed that increasing dose intensity could overcome drug resistance.^{342, 685, 686, 687, 688, 689, 690, 691, 692} The CR rates of third-generation regimens were 78% to 88% with DFS of 58% to 69% in studies primarily at single institutions.^{686, 692, 693, 694, 695} Many of these newer regimens had considerable toxicity when used initially, and were associated with mortality rates of 5% to 10%; however, the rate of toxic deaths decreased over time with more experience and with better patient selection.⁶⁸⁴ Many of the series in which these regimens were used involved favorable prognostic groups, including patients with limited stage disease and patients with a relatively young median age.

One of the most important clinical trials for lymphoma was performed by an intergroup (SWOG and ECOG) study which compared CHOP with 3 of the newer and reportedly more intensive regimens, m-BACOD (methotrexate, bleomycin, Adriamycin [doxorubicin], cyclophosphamide, Oncovin [vincristine], and dexamethasone), MACOP-B (methotrexate, bleomycin, Adriamycin, cyclophosphamide, Oncovin, and prednisone), and ProMACE-CytaBOM (prednisone, Matulane, Adriamycin, cyclophosphamide, etoposide/cytarabine, bleomycin, Oncovin, methotrexate).⁶⁹⁶ There were no differences in CR, PFS, or OS. The percentage of patients alive without progression at 3 years was 41% in the CHOP and MACOP-B groups and 46% in the m-BACOD and ProMACE-CytaBOM groups (Fig. 88.22). The estimated OS was 52% of the entire group: 50% for both ProMACE-CytaBOM and MACOP-B, 52% for m-BACOD, and 54% for CHOP (P = 0.90). There were also no differences in fatal toxicities among the regimens: CHOP (1%), ProMACE-CytaBOM (3%), m-BACOD (5%), and MACOP-B (6%)(P = 0.09).

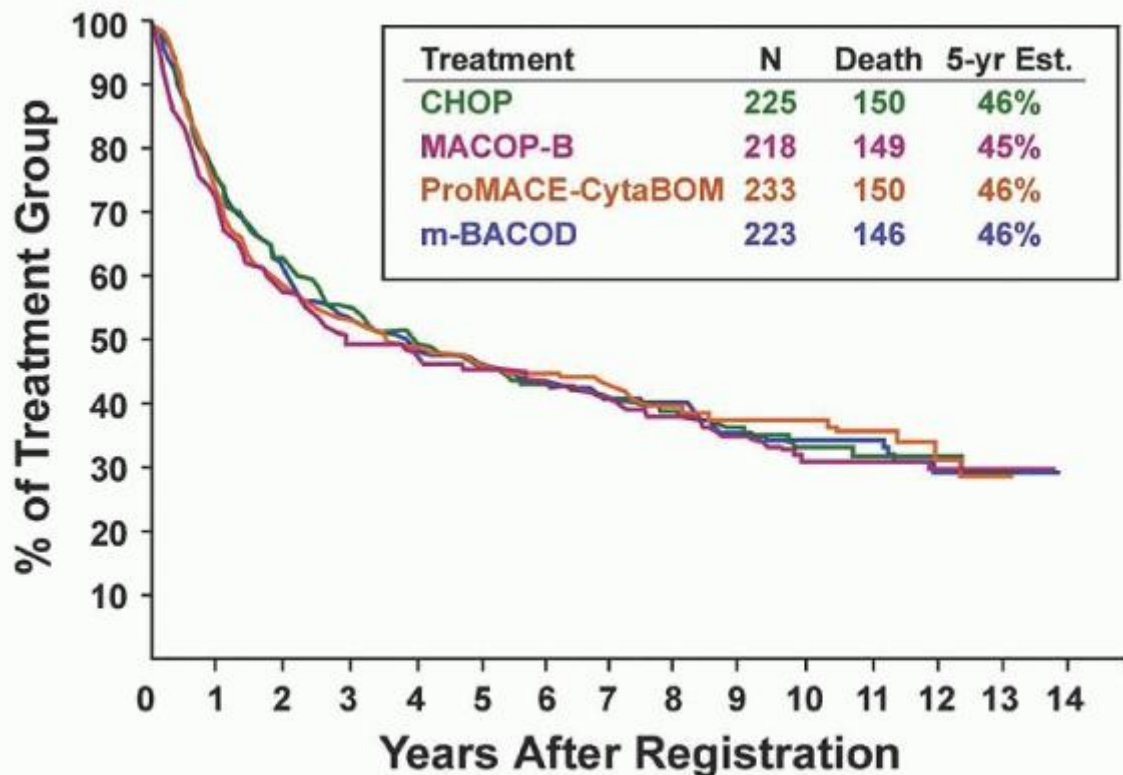

FIGURE 88.22. Intergroup study comparing CHOP, M-BACOD, and ProMACE/CytaBOM in predominantly intermediate

grade Working Formulation (WF) lymphomas. There were no differences observed in time to treatment failure in the four groups. Updated and adapted from Fisher RI, Gaynor ER, Dahlborg S, et al. Comparison of a standard regimen (CHOP) with three intensive chemotherapy regimens for advanced non-Hodgkin's lymphoma. *N Engl J Med* 1993;328:1002-1006, with permission.

While the intergroup study reestablished CHOP as standard therapy for large cell lymphoma, it did not address the issue of dose intensity, and it did not emphasize how poorly these regimens do in patients with adverse prognostic factors. Although the newer regimens supposedly were more dose intensive than CHOP, there are few differences among the regimens with respect to the doses of the most active agents used (i.e., cyclophosphamide and doxorubicin). Although no differences were identified among the regimens in patients with adverse prognostic factors, none of them produced good results. Using these conventional regimens, CR rates of 55% and 44% and 5-year survivals of 43% and 26% were observed in the high-intermediate and high-risk groups, respectively, in the IPI (see section on Prognostic Factors).^{283, 697}

The intergroup trial was met with praise as well as disappointment because it indicated no improvement in survival for nearly two decades after the establishment of CHOP as an effective regimen. The first study to show an improvement in survival was a randomized GELA comparison of CHOP to rituximab plus CHOP (R-CHOP) in elderly patients (age 60 to 80 years) with DLBCL.²⁹⁹ The rate of CR/CRu was higher for R-CHOP compared to CHOP alone (75% versus 63%, $P = 0.005$). The 5-year EFS and OS were significantly higher in the R-CHOP arm: 47% versus 29%, $P < 0.001$; and 58% versus 45%, $P = 0.007$.^{299, 698} The results have held up at 10 years (Fig. 88.23).⁶⁹⁹ A similar intergroup trial reported a 3-year FFS of 53% for R-CHOP and 46% for CHOP ($P = 0.04$).⁷⁰⁰ A second randomization evaluated the role of maintenance rituximab (MR) and resulted in a 2-year FFS of 76% for MR compared to 61% for observation ($P = 0.009$); however, the major improvement was observed in patients who had not

P.1860

received rituximab with CHOP. The 2-year FFS after the second randomization for the 4 arms were: 77%, 79%, 74%, and 45% for R-CHOP, R-CHOP plus MR, CHOP+MR, and CHOP, respectively. Randomized trials in young patients have shown a superiority to the rituximab arm: 79% versus 59% 3-year EFS ($P < 0.0001$).⁷⁰¹ The addition of rituximab to CHOP may partially overcome the adverse prognosis associated with the nongerminal center (ABC) DLBCL.⁷⁰² New prognostic models evaluating biologic markers and/or gene expression are under investigation in the rituximab era, although reproducibility remains a concern.^{326, 703}

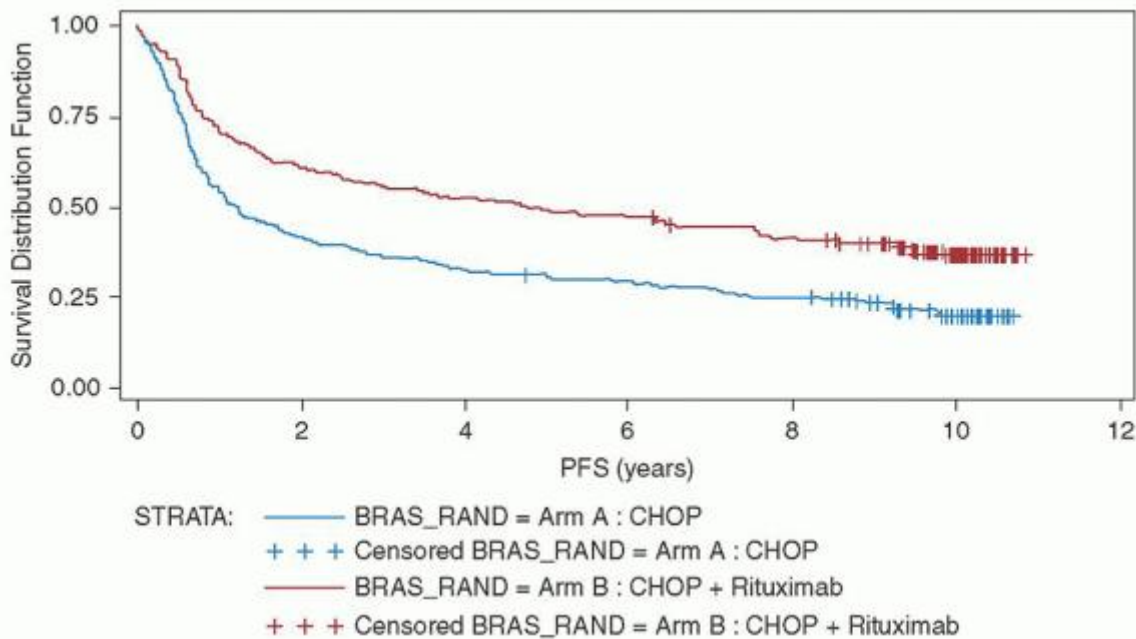

FIGURE 88.23. Progression-free survival (PFS) in elderly patients randomized between CHOP plus rituximab (R-CHOP) and CHOP. The 10-year PFS (median) was 36.5% (4.8 years, 95% CI: 23.7 to 7.6) for R-CHOP versus 20% (1.2 years, 95% CI: 9-1.8) for CHOP ($P < 0.0001$). From Coiffier B, Thieblemont C, Van Den Neste E, et al. Long-term outcome of patients in the LNH-98.5 trial, the first randomized study comparing rituximab-CHOP to standard CHOP chemotherapy in DLBCL patients:

a study by the Groupe d'Etudes des Lymphomes de l'Adulte. Blood 2010;116:2040-2045, with permission.

Strategies to improve response and survival in aggressive lymphomas have included using alternating non-cross-resistant regimens, infusional therapy, additional drugs, shorter intervals, modifiers of multidrug resistant genes, and dose intensification, including HCT. Phase II trials of non-cross-resistant regimens such as alternating triple therapy from M.D. Anderson, appeared to overcome adverse prognostic factors, but they were not compared to CHOP in phase III trials.^{704, 705} Similarly a continuous infusional regimen, EPOCH with dose adjustments (DA-EPOCH) based on an individual's drug clearance, had a CR rate in large B cell NHL of 92%, a 5-year PFS and OS of 70% and 73%, respectively, and overcame the IPI.⁵³⁶ Other phase II trials evaluating infusional therapy with or without modifiers of MDR (verapamil and quinine) have not shown an advantage over historical trials utilizing CHOP therapy.⁷⁰⁶ An intergroup trial is now comparing DA-EPOCH-R to R-CHOP.

German trials have evaluated whether biweekly CHOP (CHOP-14) with or without etoposide (CHOEP) was more effective than the same regimens given on a 21-day cycle. For elderly patients, aged 61 to 75 years, CHOP-14 was superior to CHOP-21 with 43.8% and 53.3% 5-year EFS and OS compared to 32.5% and 40.6%; and the CHOEP regimens were too toxic.⁷⁰⁷ Alternatively, for younger patients, aged 18 to 60 years, the CHOEP regimen had better CR (87.6% versus 79.4%, $P = 0.003$) and 5-year EFS (69.2% versus 57.6%; $P = 0.004$) than CHOP.⁷⁰⁸ There was no statistical advantage of CHOEP-14 over CHOEP-21. These trials were performed without rituximab which, if added, might lessen differences among the regimens. Randomized trials in the United Kingdom and France have compared R-CHOP 14 to R-CHOP 21 and have shown no differences in responses or survivals.^{709, 710}

Dose escalation has been advocated as a means to improve response and survival in aggressive lymphomas, but phase III clinical trials have yet to prove the efficacy of dose intensity. Increased doses of doxorubicin in the BACOP regimen failed to show improvement in response or survival when compared in a randomized trial to standard doses.⁷¹¹ In a small trial of 22 patients treated with high-dose CHOP, the CR rate was 86% with 69% PFS but short follow-up (median of 20 months).⁷¹² In a trial of 70 patients with intermediate- to high-grade lymphoma, a short course (8 weeks), dose intensive therapy, referred to as MEGA, produced an 81% CR rate and 52% 5-year FFS.⁷¹³ Another phase II trial evaluating double dose ProMACE-CytaBOM with growth factor support reported a CR of 69%, PFS of 58%, and OS at 73% at 4 years.⁷¹⁴ A dose-escalated trial known as MegaCHOEP with stem cell transplantation on the third and fourth cycles resulted in FTF of 62.1% and OS of 67.2% at 5 years.⁷¹⁵

In a phase III trial (LNH87-1) that compared a more intensive regimen, ACVBP (Adriamycin [doxorubicin], cyclophosphamide, vindesine, bleomycin, prednisone) to a standard regimen (m-BACOD) in a group of low-risk aggressive lymphoma patients, there were no differences in FFS and OS (65% and 75% in ACVBP, and 61% and 73% in m-BACOD).⁷¹⁶ In a multivariate analysis, ACVBP was associated with a better FFS in the patients with 2 or 3 age-adjusted IPI risk factors.⁷¹⁶ In another randomized trial, ACVBP was superior to CHOP plus RT for limited stage patients.⁶⁷⁶ ACVBP plus rituximab was also superior to R-CHOP in DLBCL patients <60 years with an IPI of 1. Three year EFS was 81% vs. 67% ($P = 0.0035$) and OS was 92% vs. 84% ($P = 0.0071$). Serious adverse events, particularly febrile neutropenia, were more common in R-ACVBP (42%) than in R-CHOP (15%).⁷¹⁷

Some investigators advocate early autologous HCT for selected DLBCL patients with poor prognostic factors, but large randomized trials have failed to consistently show a benefit for early transplantation.^{718, 719, 720, 721, 722, 723} R-CHOP is the standard regimen for DLBCL for adults in the United States. European trials and pediatric studies, however, have indicated a role for more intensive therapy based upon an increasing number of adverse features.^{715, 716, 724} And it is likely that there are patients with such poor survival at diagnosis who should be considered for either dose intensification or early transplantation. Ongoing trials continue to address the issues of dose intensity and transplantation as front-line therapy for aggressive NHL.^{725, 726}

P.1861

SALVAGE CHEMOTHERAPY

Chemotherapy regimens at relapse usually involve agents that are non-cross-resistant with, or at least different from, drugs used in initial therapy. Rituximab is usually added to the regimen as long as the lymphoma remains CD20-positive. For example, ifosfamide, an alkylating agent analog, produced a 29% response rate in phase II trials,⁷²⁷ and has been incorporated into salvage regimens. Investigators at MDACC have developed multiple effective protocols: MIME (methylguazone, ifosfamide, methotrexate, etoposide [VP-16]),⁷²⁸ DHAP (dexamethasone, high-dose cytarabine [ara-C], and cisplatin [Platinol]),⁷²⁹ ESHAP (etoposide, solumedrol [methylprednisone], high-dose cytarabine [ara-C], Platinol

[cisplatin]),⁷³⁰ MINE (mesna, ifosfamide, Novantrone [mitoxantrone], etoposide),⁷³¹ and MINT (mesna, ifosfamide, Novantrone [mitoxantrone], Taxol [paclitaxel]).⁷³² The CR and PR rates for a variety of histologic types were 24% and 36% for MIME; 31% and 24% for DHAP; 37% and 27% for etoposide, solumedrol (methylprednisolone), and high-dose cytarabine (ara-C) with or without cisplatin; and 26% and 20% for MINT. However, most of the responses were of short duration with median times to treatment failure usually less than 1 year. Combining regimens such as MINT-ESHAP or MINE-ESHAP has yielded response rates in the 49% to 69% range, but there are no obvious differences in outcome among the combinations.^{733, 734}

Various doses and schedules of ICE (ifosfamide, carboplatinum, etoposide) have been used in relapsed NHL and to mobilize peripheral blood stem cells prior to transplant.^{735, 736} The response rate to an ICE regimen developed at Memorial Sloan-Kettering Cancer Center was 66%, with 89% of these patients going on to transplantation.⁷³⁵ Patients who achieved a CR to ICE prior to transplantation had a superior OS to patients who had PR (65% versus 30%, $P = 0.003$).⁷³⁵ The addition of rituximab to an ICE regimen improved the CR rate from 27% on a previous study to 53%.⁷³⁷

A phase III trial, the Collaborative Trial in Relapsed Aggressive Lymphoma (CORAL) study, randomized R-ICE versus R-DHAP in patients with refractory or relapsed CD20⁺ DLBCL and found similar response rates (63.5% vs. 62.8%).⁷³⁸ Responding patients failed to mobilize after both regimens and only 50% of patients were able to undergo SCT. There was no difference in 3-year EFS (26% and 35%) or OS (47% and 51%) between the 2 regimens. EFS was adversely affected by initial relapse within 1 year from diagnosis, aIPI of 2 to 3, and prior rituximab treatment.

Based on the premise that prolonged exposure to therapy may be more effective than bolus, EPOCH was developed at the NCI and produced a 24% CR and 50% PR in relapsed/refractory NHL.⁷³⁹ With a median follow-up of 76 months, the OS and EFS were 17.5 and 7 months, respectively. In patients with chemosensitive disease with aggressive histologies, the EFS was 19% at 3 years⁷³⁹ (see section on "DA-EPOCH-R in Chemotherapy"). Investigators at Stanford University developed CEPP(B) (cyclophosphamide, etoposide, procarbazine, prednisone \pm bleomycin), which produced 34% CR and 22% PR in previously treated patients with intermediate- or high-grade histologies.⁷⁴⁰

In general, salvage chemotherapy regimens in DLBCL are utilized as a bridge to transplantations because prolonged survivals without transplant are less than 15%. Single agent therapy is rarely used in intermediate- to high-grade lymphoma except in phase I/II trials or as palliation. Because of significant activity in relapsed disease, some of the agents are being used in combination with other drugs earlier in the course of NHL.

Oxaliplatin, a third-generation platinum drug with no renal toxicity and minimal auditory damage, has a 40% response rate in refractory NHL and is used in salvage regimens.⁷⁴¹ Rituximab, dexamethasone, cytarabine, and oxaliplatin (R-DHAX) had an ORR of 75% (57% CR/CRu) in relapsed NHL, primarily DLBCL and FL.⁷⁴² Combining gemcitabine with oxaliplatin and rituximab (GEMOX-R) led to an ORR of 43% with 34% CR in refractory/relapsing DLBCL.⁷⁴³ Both regimens could be used in elderly patients and the best survivals were in patients who were able to go to transplant.

Doxorubicin-related compounds used as single agents and in combination chemotherapy for relapsed NHL include mitoxantrone,⁷³⁴ amsacrine,⁷⁴⁴ idarubicin,⁷⁴⁵ epirubicin,⁷⁴⁶ aclacinomycin,⁷⁴⁷ esorubicin,⁷⁴⁸ liposomal doxorubicin,⁷⁴⁹ and pixantrone.⁷⁵⁰ No drug has had an advantage over doxorubicin, although mitoxantrone produces less alopecia, mucositis, nausea, emesis, and possibly cardiotoxicity. Liposomal doxorubicin also appears to have less cardiotoxicity. CHOP was superior to CNOP (cyclophosphamide, mitoxantrone, vincristine, prednisone) in a randomized trial in elderly patients;⁷⁵¹ however, an argument has been made that the study did not compare equivalent doses of doxorubicin and mitoxantrone.⁷³⁴ A salvage regimen utilizing mitoxantrone, carboplatin, cytosine arabinoside, and methylprednisolone had a response rate of 70% (26% CR).⁷⁵²

Nucleoside analogs have primarily been used in indolent lymphomas, but gemcitabine, a pyrimidine antimetabolite, has had activity in relapsed aggressive lymphomas (see section on "GEMOX"). A response rate of 20% was observed in predominantly large B cell NHL, and higher responses have been observed in PTCL.^{753, 754} The ORRs in gemcitabine combination regimens with cisplatin and methylprednisolone, and with vinorelbine, have been 79% (21% CR) and 50% (14% CR), respectively.^{755, 756} The ORR of cisplatin, etoposide, gemcitabine, and methylprednisolone (PEGS) in PTCL was 39% (24% CR/CRu) with 2-year OS of 30% and PFS of 12%.⁵⁵³ The authors concluded that PEGS was not clearly superior to results for CHOP likely because of the inherent chemoresistance of PTCL, but PEGS could serve as a comparison for non-CHOP regimens in PTCL.

Vinca alkaloids with less neurotoxicity than vincristine have also been evaluated in NHL. Vincristine sulfate liposomes injection had a 25% ORR (5% CR/CRu) in refractory aggressive NHL with twice the dose intensity of standard vincristine.⁷⁵⁷ Infusional vinorelbine resulted in 25% response with a median PFS of 6 months in responders.⁷⁵⁸ Novel methods of drug

delivery including liposomal formulations, pegylation, different schedules of infusions, and oral formulations may also obtain responses in relapsed NHL.^{757, 759, 760}

Taxanes and camptothecins are agents with activity in solid tumors which are being evaluated in the therapy of NHL. Paclitaxel (Taxol) and docetaxel (Taxotere) are tubulin-binding taxanes which have produced responses in 13% to 23% of heavily treated patients.^{761, 762, 763, 764} Camptothecins, topoisomerase I inhibitors, including hycamptamine (Topotecan), irinotecan (Camptosar), and 9-aminocamptothecin (9-AC) have had responses of 25% to 35%.^{765, 766} Combinations of paclitaxel plus hycamptamine are synergistic, with a response rate of 48% and a median duration of 6 months.⁷⁶⁷

Bortezomib is a proteasome inhibitor that has shown activity in lymphoma, and response rates vary according to histologic subtypes.^{768, 769, 770} The best response rates (33% to 56%) have been reported in MCL, the only type of NHL for which bortezomib is approved. Bortezomib plus CHOP-R is in trials for previously untreated DLBCL and MCL and appears to overcome the poor prognosis of nongerminal DLBCL, possibly through inhibition of the NF-KB pathway.^{494, 769, 770, 771}

Understanding mechanisms of drug resistance is an area of investigation for the development of salvage regimens. Although the multidrug resistance (MDR/ABC1) gene and its gene product, P-glycoprotein, are expressed rarely in lymphomas at diagnosis, MDR expression often is detected in lymphoma cells at relapse. The MDR-inhibiting agents include verapamil, cyclosporine, and its analog valspodar (PSC-833), and their use in conjunction with chemotherapy has been inconsistent in patients with relapsed lymphomas.^{772, 773}

P.1862

NOVEL AGENTS

Relapse due to chemoresistance remains a major obstacle in improving survival for NHL. Targeting B and T cell receptors with monoclonal antibodies, both unconjugated and conjugated, is an ongoing area of investigation (see section on "Immunotherapy"). The PI3K/AKT/mTOR signaling pathway is critical in cancer development, and aberrant activation of the protein tyrosine kinases has led to the development of novel targeted therapy. Drugs under investigation target protein kinases, oncogenic signaling via the mammalian target of rapamycin complex (mTOR), and the tumor microenvironment (immune modulation) (Fig. 88.24).^{774, 775, 776}

B cell receptor (BCR) signaling can lead to activation of spleen tyrosine kinase (SYK) in B cell lymphomas. Fostamatinib, an oral SYK inhibitor, abrogates BCR signaling, inhibits MYC overexpression, and induces apoptosis. In a phase I/II trial of relapsed B-NHL (n = 68), the ORRs were: 22% for DLBCL, 10% for FL, 55% for SLL/CLL, and 11% for MCL.⁷⁷⁷ Side effects included fatigue (41%), diarrhea (41%), cytopenias (24% to 31%), and hypertension (24%).

Ibrutinib (PCI-32765) is an oral, irreversible inhibitor of Bruton tyrosine kinase (BTK) just downstream of SYK; and it inhibits the subsequent pathways, including MAPK, PI3K, and NF-κB signaling.⁷⁷⁸ In 26 elderly (median age, 71 years) CLL patients, 73% achieved a response (65% PR and 8% CR) and an additional 12% had a nodal response with lymphocytosis.⁷⁷⁹ One year PFS was 93%. Diarrhea, nausea, and fatigue were common (grade ≤2) side effects; 10% of patients had > grade 3 cytopenias or infections. In a phase IA study of 56 patients with relapsed B-NHL, the ORR was 62%, including 29% for DLBCL and 78% for MCL.⁷⁸⁰

CAL-101 (GS-1101) is an oral selective inhibitor of PI3K-δ and is active in CLL and other B cell NHL with little toxicity and minimal myelosuppression. In a phase I trial of 55 patients with relapsed B-NHL, PRs occurred in 62% for both indolent NHL and MCL but none in DLBCL.⁷⁸¹ Because CAL-101 inhibits microenvironment signals which can cause drug resistance and enhances cytotoxic agents, it is being investigated in combination regimens.⁷⁸² In 18 patients who received CAL-101 with rituximab or bendamustine, the ORRs were 91% in indolent B-NHL (n = 11) and 71% in CLL.⁷⁸³

Enzastaurin is an oral inhibitor of protein kinase C beta (PKCβ), an essential component of the vascular endothelial growth factor (VEGF) signaling pathway, which has been linked to a poor prognosis in DLBCL.⁷⁸⁴ In a phase II trial of 55 patients with relapsed/refractory DLBCL, 7% had a CR, 22% experienced FFP for ≥ 2 cycles, and 15% had FFP for ≥ 4 cycles.⁷⁸⁵ Toxicities were minimal with 4% grade 3 and there was no grade 3 or 4 neutropenia. In a randomized phase II trial of R-CHOP plus enzastaurin versus R-CHOP in high-intermediate or high IPI DLBCL, the CR rates were 36% vs. 26% and the 1 year PFS was 71% vs. 52% with similar toxicity profiles.⁷⁸⁶

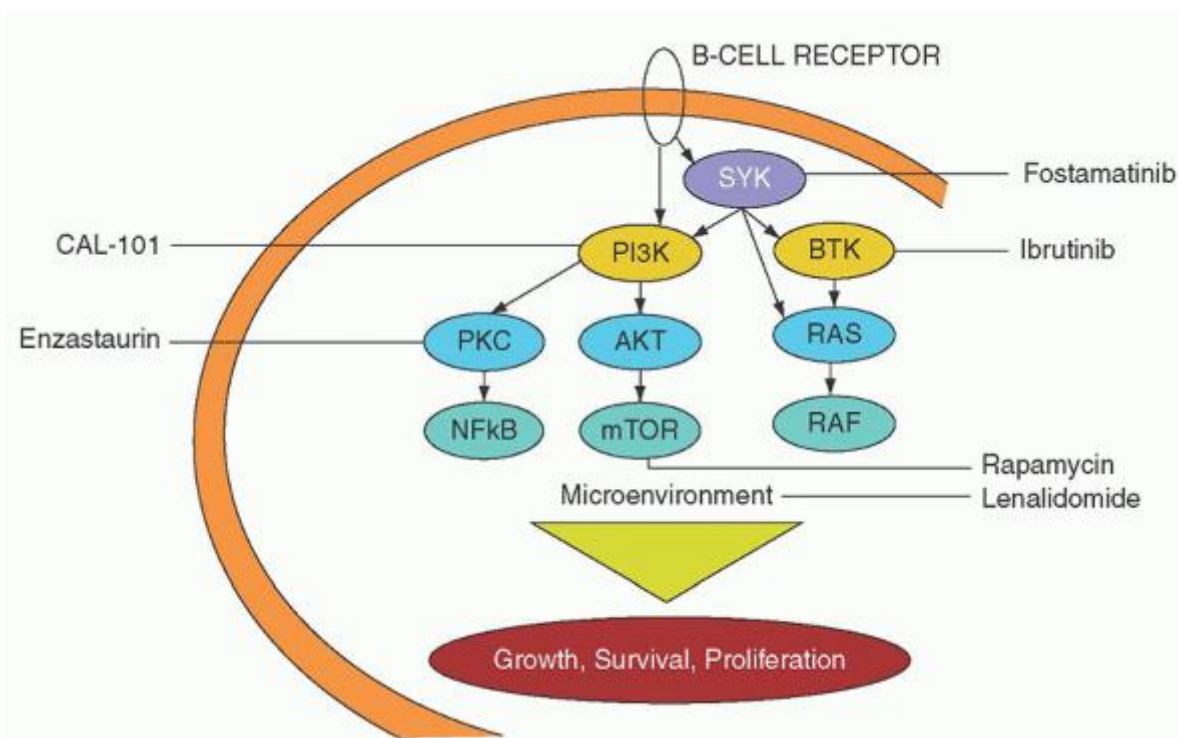

FIGURE 88.24. Targeting B cells: This simplified schematic illustrates relationships between intermediates (see text) in the PI3K/AKT/mTOR pathway and shows points at which selected drugs inhibit B cell growth.

Rapamycin and the rapalogs (temsirolimus, everolimus, and deforolimus) are inhibitors of mTOR kinase, a mediator of growth signaling that follows the PI3K pathway and is activated by mutation or amplification of AKT (protein kinase B).^{774, 787} Temsirolimus has yielded ORR of 22% to 41% in MCL.⁷⁸⁷ In a phase III trial comparing temsirolimus to investigator's choice of therapy in relapsed/refractory MCL, the objective RR was higher for temsirolimus (22% vs. 2%) ($P = 0.0019$); and there was no statistical difference in median OS (12.8 vs. 9.7 months).⁷⁸⁸ The grade 3/4 toxicities were thrombocytopenia (59%), anemia (20%), neutropenia (15%), and asthenia (13%). In a phase II trial of everolimus for relapsed B-NHL, the ORR was 30% with no differences among DLBCL (30%), MCL (32%), and FL (38%).⁷⁸⁹

Immunomodulating drugs (IMiDs) have both immunomodulatory and antiangiogenic properties; they can stimulate T cell responses and dendritic cells to recruit natural killer cells and modify the cytokine microenvironment.⁷⁷⁴ Lenalidomide, an analog of thalidomide, has been extensively evaluated in CLL. Responses of 31% to 47% were observed in relapsed patients and 58% to 65% in previously untreated CLL.⁷⁹⁰ A tumor flare response (painful enlargement of nodes or spleen, fever, and rash) occurs in over half the patients in several series and may be lessened by slow dose escalation and the use of steroids.^{790, 791} Tumor lysis may occur in up to 5% of CLL patients treated with lenalidomide.⁷⁹⁰

Lenalidomide monotherapy has also been used in aggressive lymphomas. An ORR of 35% (12% CR/CRu) was observed in 49 relapsed/refractory B-NHL, including 19% for DLBCL and 53% for MCL.⁷⁹² Grade 4 cytopenias were 8.2%. In an international phase II trial, the ORR was similarly 35% (13% CR): 28% for DLBCL, 42% for MCL, 42% for FL-grade 3, and 45% for transformed lymphoma.⁷⁹³ The PFS was 3.7 months and the median duration of response for responders was 10.6 months. Grade 4 neutropenia and thrombocytopenia occurred in 17% and 6%, respectively. A higher response and improved survival with lenalidomide has been reported for the nongerminal center DLBCL compared to the germinal center type.⁷⁹⁴ An ORR of 30% has been reported in PTCL.⁷⁹⁵

P.1863

All of the above agents and many more are being investigated in combinations with each other, monoclonal antibodies, and chemotherapy. Trials should be designed with specific targets, pre-clinical evidence of synergism, and an awareness of the expense.

HIGHLY AGGRESSIVE LYMPHOMAS

BL and lymphoblastic lymphoma (LBL), usually of immature T cell origin, are rare NHLs in adults, each representing less than 3% of NHLs. Since NHL is more common in adults; the absolute number of highly aggressive lymphomas exceeds that in children. Because children are treated primarily on clinical trials unlike adults, at least in the United States, the main advances learned from pediatrics apply to the therapy of highly aggressive lymphoma in adults (Chapter 89). In brief, short course, dose intensive cyclophosphamide therapy is utilized in BL while therapy for ALL is the main approach to LBL. Both types of highly aggressive NHL require CNS prophylaxis, and have clinical overlap with adult ALL (Chapter 74).

Burkitt Lymphoma

BL has a bimodal peak between 0 and 15 years and a later peak over 60 years.⁷⁹⁶ SEER data indicates the median age is as high as 45 years with 30% over 60 years of age.⁷⁹⁷

BL is characterized by a high proliferative rate (Ki67 approaching 100%), a germinal center phenotype expressing CD10 and BCL6 and weak BCL2, and a MYC/8q24 translocation.⁷⁹⁸ B cell lymphoma unclassified with features intermediate between DLBCL and BL (BLU) tend to have slightly deviant morphology and not quite as high a proliferative rate as BL. MYC translocations occur in 30% to 50% of BLU, but there are usually more complex genetic abnormalities than BL, including "double hits" where there are BCL2 translocations or breakpoints in BCL6.⁵¹⁵

GEP is emerging as a technology to distinguish lymphomas with an intermediate morphology between DLBCL and BL. BL can be distinguished from DLBCL by a high level of MYC target genes, a subgroup of germinal center B genes, and a low level of expression of major-histocompatibility complex Class I genes and NF-κB target genes.⁷⁹⁹ Until GEP becomes more available, detecting MYC translocations by fluorescence in situ hybridization along with a high proliferative index can usually distinguish BL from DLBCL.⁸⁰⁰

In the United States, BL tends to occur in younger adults with more gastrointestinal presentations and less marrow involvement than BLU; but they clinically overlap, have a risk for spontaneous tumor lysis, and have been difficult to cure with conventional chemotherapy for adults. Intraabdominal presentations usually involve the small bowel and intraabdominal nodes and may mimic appendicitis or intussusception.⁸⁰¹ Surgery formerly played a role in staging and debulking disease, but now is reserved for the emergency acute abdomen. Early use of rasburicase and nephrology intervention should be considered in patients with elevated levels of LDH and uric acid. Bone marrow and CNS involvement have been reported in 30% to 38% and 13% to 17% of patients, respectively.⁸⁰¹

Short course, dose intensive regimens have improved results in BL/mature B-ALL.^{727, 802, 803, 804, 805, 806, 807, 808, 809, 810, 811, 812, 813, 814, 815} Results vary in part due to differences in age, stage, number of HIV-positive patients, and intensity of therapy (Table 88.14). In general, the CR rates are in the range of greater than 80% and survival is approximately 50% for the older adult and in the range of 60% to 90% for young adults. CNS prophylaxis previously involved whole brain and occasionally spinal radiation, but can be accomplished by a combination of intravenous and intrathecal drugs (methotrexate and/or cytarabine). Radiation may still be utilized in patients who have documented CNS disease at diagnosis. Growth factors, either G- or GM-CSF, have decreased the length of myelosuppression and are a part of present-day regimens. Rituximab is incorporated into the regimens and appears to have improved outcome, but there are no comparative trials.⁸¹⁰ Relapses are usually confined to the first year after stopping therapy; there is no role for maintenance.

In pediatric and some adult trials, there is a prephase with low-dose cyclophosphamide- vincristin-steroids to debulk and to lessen tumor lysis, followed by intensive therapy stratified according to prognostic factors.⁸⁰³ Prephases are probably unnecessary in most patients, particularly with the use of rasburicase. Patients with limited stage disease often require only 2 to 3 cycles of therapy delivered over 2.5 to 4 months.⁸¹⁶ In a retrospective review of adults treated with the pediatric LMB protocols, the CR rate was 89% with a 3-year OS of 74%.⁸⁰³ The Magrath regimen of CODOX-m/IVAC has been administered to both children and adults and also utilizes risk stratification. The initial reports had a 4-year DFS of 84% but were in a young population with a median age of 25 years.⁷²⁷ Selected older patients are now given the more intensive regimens but tend to have more treatment-related deaths unless modifications are made.⁸¹⁷

Intensity of therapy in HIV patients with NHL was previously reduced due to risk of infections and poor survival; however, in the era of HAART and growth factor support, the CR rate with hyper-CVAD in HIV patients with BL/leukemia has reached 92% with a 2-year survival of 48%.⁸¹⁸ Myelosuppression can still be problematic in HIV patients and dose modifications may be required. There is a randomized trial indicating that rituximab does not improve survival if given with chemotherapy in HIV-related NHL.⁸¹⁹ The lack of improvement in the rituximab arm was attributed to increased infectious deaths in HIV patients with CD4(+) counts less than 50/mm³. Rituximab with concurrent infusional EPOCH achieved a high rate of complete response. At a median follow-up of 5 years the PFS and OS were 84% and 68%,

respectively.⁸²⁰ DA-EPOCH-R is also being used in non-HIV BL/BUL and may be particularly warranted in the elderly due to less toxicity.⁸¹⁵

Advanced stage patients with CNS or marrow involvement previously had survival less than 30% and were considered candidates for early transplantation;⁸²¹ however, with the present-day regimens, DFS is in the 40% to 80% range for BL/B-ALL, obviating the need for early transplantation in most adult patients.⁸²² At relapse, there is no standard therapy, and there is no clear advantage of allogeneic HCT over autologous, even though many centers favor the former.⁸²³ Transplantation is rarely successful for relapsed patients unless they are chemosensitive and in a second CR (see Chapter 104).

Lymphoblastic Lymphoma

T cell LBL is more common than B-LBL in adults, accounting for up to 90% of cases. T-LBL is seen primarily in adolescents and young adults with a predominance of men (2 to 3:1) who have a bimodal distribution (peaks at age 10 to 30 and 60 to 70 years).⁸²⁴ T-LBL presents with a mediastinal mass in 60% to 70% of cases.⁸²⁵ B cell LBL has a slight male predominance, a more even age distribution (median age ~39 years), and rarely has mediastinal or bone marrow involvement. Extranodal sites of disease are common in B-LBL and include skin, bone, and soft tissue.^{826 827}

The immature T cell origin of LBL was confirmed by the presence of the intranuclear enzyme, terminal deoxynucleotidyl transferase (TdT), which is not detected in the mature or peripheral T cell neoplasms. Although LBL expresses less TdT and tends to have a more mature phenotype than T-ALL, considerable overlap exists both biologically and clinically between these entities, and they are unified as precursor T cell lymphoblastic leukemia/lymphoma by the WHO classification.⁸²⁸

Multiple genes have been identified in the translocations associated with T-LBL/ALL. Approximately one-third of patients with T-LBL have translocations involving the loci of T cell receptor

P.1864

P.1865

genes, α and δ at 14q11.2, β at 7q35, and γ at 7p14-5, which produce high levels of transcription factor genes such as HOX11/TLX1, TAL1/SCL, TAL2, and LYL. GEP can subdivide T-LBL into subtypes with differing prognoses.^{829 830 831} Patients with HOX11 have a pattern of gene expression associated with the early cortical thymocyte and have a better prognosis than patients with TAL1 or LYL1 expression, which correlate with late cortical and early pro-T lymphocytes, respectively.⁸³² NOTCH1 is a transmembrane receptor and activating mutations occur in 50% to 60% of patients with childhood T-ALL.⁸³³ FBXW7 is a ubiquitin ligase that triggers ubiquitination and degradation by the proteasome. Inactivating mutations FBXW7 have been reported in 11% to 13% of patients. NOTCH1 and FBXW7 mutational status together identify a favorable group of lymphoblastic lymphoma.⁸³⁵ Rarely, T-LBL is associated with eosinophilia, myeloid malignancy, specific cytogenetic translocations t(8;13) (p11;q12), t(8;9)(p11;q32), or t(6;8)(q27;p11), and is known as 8p11 myeloproliferative disorder.⁸³⁶ Unusual cases of T cell LBL have been associated with prior epipodophyllotoxin chemotherapy and a cytogenetic translocation involving the MLL gene, t(11;19)(q23;p23).⁸³⁷

TABLE 88.14 CHEMOTHERAPY IN ADULTS WITH BURKITT LYMPHOMA

Author, Year	No. Median of Age Pts (Yrs)		HIV (%)	BM(%)	Therapy	Survival			Comments	
						CR (%)	Overall (%)	Limited Advanced (%)		
Lee, 2001 ⁸⁰⁶	54	44	0	80	CALGB 9251	80	52	—	46	Median follow-up 5.1 years; 19 patients excluded by path review
Mead, 2002 ⁸⁰⁷	52	35	0	48	CODOX-M/IVAC	77	73	82	70	Uses Magrath regimen 89-C-41

Rizzieri, 2004 ⁸⁰⁸	92	47	0	63CALGB	74	50-54	67-78	37-39	Study subdivided by IPI: Limited was low and low/intermediate and advanced was high/intermediate and high IPI
Divine, 2005 ⁸⁰⁹	72	33	0	14LMB	65	70	77	69	Some patients underwent autologous stem cell transplant in partial remission
Thomas, 2006 ⁸¹⁰	31	46	0	45R-Hyper CVAD	86	89	100	77	Limited was lymphoma and advanced was leukemia
Hoelzer, 2007 ⁸¹¹	115	36	0	0GMALL (+R)	90	91			Six short alternating intense cycles, preceded by rituximab + two rituximab maintenance cycles
Mead, 2008 ⁸¹²	58	37	0	0dmCODOX-M/IVAC	—	67	82	60	Reduction in high-dose MTX; primary end points were survival
Dunleavy, 2011 ⁸¹⁵	29	35	34	0R-EPOCH	100	100	—	—	Lower toxicity than other regimens
Corazzelli, 2012 ⁸¹³	30	52	0	20RD-CODOX-M/IVAC	93	82	—	—	49% PFS in age > 60 year vs. 93% (<i>P</i> = 0.03). No difference between BL and unclassified B cell lymphoma

BM, bone marrow involved; CALGB, Cancer and Leukemia Group B; CR, complete remission; CODOX, cyclophosphamide, vincristine, doxorubicin, high-dose methotrexate; D, liposomal cytarabine; DFS, disease-free survival; dm, dose-modified; EPOCH, etoposide, prednisone, vincristine, cyclophosphamide, doxorubicin; M, methotrexate; GMALL, German Multicenter ALL; Hyper CVAD, cyclophosphamide, vincristine, Adriamycin (doxorubicin), dexamethasone alternated with high doses of methotrexate and cytarabine; HIV, human immunodeficiency virus; IVAC, ifosfamide, VP-16 (etoposide), Ara-C (cytarabine); LMB, Lymphoma Malins de Burkitt; R, rituximab.

Because LBL is rare in adults, only a few series have addressed therapy and some patients have received early transplantation, which compromises the assessment of the impact of chemotherapy.⁴⁵⁸ Studies in the 1980s indicated a CR rate of 53% to 95% using CHOP-like induction regimens and high CNS relapse (~40%) if CNS prophylaxis was not given.^{838, 839, 840} Using predominantly ALL-like regimens with a maintenance phase lasting 12 to 36 months results in 3- to 5-year survivals of 40% to 72%.^{838, 839, 840} Poor prognostic features included age (> 30 years), bone marrow involvement, elevated white-cell count (>50 × 10⁹/L), CNS disease, elevated LDH, and slow response.^{839, 840} Coleman reported a 5-year

survival of 94% in low-risk patients compared to 19% ($P < 0.001$) with high-risk features, defined by bone marrow or CNS disease or elevated LDH ($>1.5 \times$ normal).⁸⁴⁰ Short course, dose intensive regimens without maintenance have been tried in lymphoblastic lymphoma, but the relapses appear excessive and the numbers are too small to utilize this approach.⁸⁴¹

Controversial management issues for LBL include the optimal type of CNS prophylaxis, the role of radiation to the mediastinum, the type of maintenance therapy, and the role of transplantation. With present-day ALL regimens, the CR rates are 75% to 90%, with prolonged DFS of 40% to 70% of responders (Table 88.15).^{842, 843, 844, 845, 846, 847, 848, 849, 850, 851, 852, 853} An option to consider for young adults is to utilize pediatric-based protocols which have had better EFS when compared to adult ALL protocols.⁸⁵⁴ A retrospective analysis comparing patients irradiated to those not irradiated showed less mediastinal relapse but no difference in FFP or OS.⁸⁵⁵ In the era of intensive ALL regimens, however, routine mediastinal radiation is no longer used in pediatrics and is probably not warranted in most adults. PET imaging may assess residual mediastinal disease, but it has not been well studied in LBL. Because of poor survival with chemotherapy in high-risk patients, there may be a role for early transplantation.⁸⁵¹

TABLE 88.15 CHEMOTHERAPY IN ADULTS WITH LYMPHOBLASTIC LYMPHOMA

Author, Year (Reference)	No. of Patients	Median Age (y)	Regimen	SCT in Overall			Survival by Risk Group	
				CR (%)	1st CR (%)	Survival (%) (at x years)	Low	High ^a
Thomas, 2001 ⁸⁴²		2428	Hyper CVAD	96	0	80 (3)	—	—
Sweetenham, 2001 ⁸⁵⁸		11926	LSA L2/Stanford	57	36 ^b	46 (3)	—	—
Hoelzer, 2002 ⁸⁴⁸		4525	GMALL-89/93	93	0	51 (7)	56	48
Jabbour; 2006 ⁸⁴⁹		2731	LMT-89	74	—	63 (5)	85	30
Song, 2007 ⁸⁵⁰		3426	Hybrid ALL/NHL	66	85 ^c	72 (4)	—	—
Hunault, 2007 ⁸⁵¹		4527	ALL, randomized to auto-SCT	89	44	64 (7)	69	60
Cortelazzo, 2012 ⁸⁵²		3027	ALL ± auto-SCT	62 ^d	47	72 (5)	—	—

ALL, acute lymphoblastic leukemia; CR, complete response; GMALL, German Multicenter Acute Lymphoblastic Leukemia; HyperCVAD, cyclophosphamide, vincristine, doxorubicin, dexamethasone alternated with high-dose methotrexate and cytarabine followed by maintenance; LMT, Lymphoma Malignant T; NHL, non-Hodgkin lymphoma; SCT, stem cell transplant.

^a High risk defined by marrow involvement.

^b Transplant: 12 allo, 31 auto; auto had 55% vs. 24% RFS (3 year) for chemotherapy ($n = 34$) ($P = 0.065$).

^c Transplant: 4 allo, 25 auto.

^d CR rate up to 93% with radiation to 6 pts.

The most significant predictor of survival for patients undergoing HCT is the status of the disease at the time of transplant.^{853, 856, 857, 858, 859} The European Bone Marrow Transplantation Group retrospectively reviewed their experience in 214 patients with LBL who underwent autologous transplantation with 6-year DFS varying according to disease status: 63% in first CR, 31% in second CR, and 15% with resistant disease.⁸⁵³ Trials that evaluate HCT often fail to include intent to

treat analysis and result in a bias favoring the transplant arm. In a randomized trial comparing early autologous HCT to conventional chemotherapy,⁸⁵⁸ there was a trend favoring autoHCT (55% versus 24%, P = 0.065) but there was no improvement in OS.⁸⁵⁸ Only two-thirds of patients eligible for randomization were actually randomized.

The role of allogeneic transplant in LBL in first CR is even more controversial. In an International Bone Marrow Transplant Registry retrospective review of transplants for LBL, there were fewer relapses with allogeneic HCT compared to autologous HCT, but there was no survival advantage due to higher treatment-related mortality.⁸⁵⁹ Recent randomized trials in adult ALL, some of which include LBL, however, are favoring the allogeneic arm.^{860, 861}

Novel agents are being studied in relapsed LBL. Nelarabine, an analog of AraG, had an ORR of 55% in pediatric patients with T-ALL/LBL in first relapse and 27% in second relapse.⁸⁶² An ORR of 46% (36% CR) was reported for adults with relapsed/refractory T-ALL/LBL.⁸⁶³ Clofarabine, a nucleoside analog that

P.1866

inhibits ribonucleotide reductase, had an ORR of 30% (24% CR) in relapsed pediatric ALL and 17% in adult ALL.⁸⁶⁴ Clofarabine combined with cyclophosphamide and/or etoposide had a 31% CR rate in adults with relapsed ALL/LBL, but had 23% treatment-related deaths.⁸⁶⁵ The prevalent NOTCH1 mutations in T-ALL are targets for inhibition, and mutations of NUP214-ABL1, an activated tyrosine kinase in episomal DNA, present in 6% of T-ALL, may respond to tyrosine kinase inhibitors.⁸⁶⁶

MANAGEMENT OF EXTRANODAL LYMPHOMAS

Approximately one-third of NHLs arise from sites other than nodes, spleen, or bone marrow, and have occurred in almost every organ.⁸⁶⁷ There is geographic and ethnic variation for sites and types of extranodal lymphomas.⁸⁶⁸ The gastrointestinal tract accounts for up to one-third of extranodal NHL in the Western hemisphere.^{867, 869} If Waldeyer's ring and tonsils are included, head and neck localizations are the second most common site, accounting for one-fifth of cases. SEER data reports stomach, skin, intestine, and brain to be the most common sites of extranodal disease.³⁵ The sites of extranodal lymphoma reflect the homing mechanisms of lymphocytes and may depend upon antigen-driven lymphoproliferation. Management of extranodal lymphomas does not necessarily follow that of their nodal counterparts.⁸⁷⁰

TABLE 88.16 MANAGEMENT ISSUES FOR EXTRANODAL LYMPHOMAS

Site	Usual Pathology	Clinical Associations	Suggested Therapy ^a
Stomach	B cell MALToma	<i>Helicobacter pylori</i>	Antibiotic trial, serial endoscopy; other therapy if t(11;18), t(1;14), transformation or progressive disease
Intestine	Burkitt	Obstruction	High-dose cyclophosphamide combination chemotherapy ±surgery
Ileum	B cell MALToma	Malabsorption IgA heavy chain, Middle East	Antibiotics, steroids, ± combination chemotherapy
Immunoproliferative small intestinal disease	Peripheral T cell lymphoma	Celiac disease, West	Combination chemotherapy ± surgery; nutrition
Enteropathy-associated T cell lymphoma		Obstruction	
Waldeyer's ring	Large B cell	Other gastrointestinal disease	Combination chemotherapy or combined modality
Paranasal (sinus)	Large B cell	CNS disease	Combined modality, consider CNS prophylaxis
Nasal	Natural killer/T cell lymphoma	Epstein-Barr virus; angiocentric features,	Combined modality, consider CNS prophylaxis

Asia			
Salivary gland	B cell MALToma	Sjögren syndrome	Single agent and/or radiation
Thyroid	Large B cell, B cell MALToma	Hashimoto thyroiditis	Radiation or combined modality, depending on histology and stage
Lung	Small B cell, B cell MALToma		Single agent, surgery, or radiation
Orbital	Small B cell, B cell MALToma		Radiation
Primary CNS	Large B cell	Ocular involvement Leptomeningeal disease AIDS	Steroids, high-dose methotrexate ± radiation
Testis	Large B cell	Contralateral testicular disease, CNS disease, retroperitoneal spread	Orchiectomy, combination chemotherapy, radiation to contralateral testis, CNS prophylaxis
Breast	Large B cell	Pregnancy	Combination chemotherapy ± radiation
Ovary	Burkitt Large B cell	Bilateral disease	Combination chemotherapy
Bone	Large B cell		Combination chemotherapy ± radiation
Cutaneous	Mycosis Fungoides B cell MALTomas, primary cutaneous follicular lymphoma, primary cutaneous large B cell lymphoma		Skin-directed Radiation if stage IE Combined modality (see Chapter 92)

AIDS, acquired immunodeficiency syndrome; CNS, central nervous system; MALToma, lymphoma of mucosa-associated lymphoid tissue.

“Combined modality refers to combination chemotherapy and radiation. Combination chemotherapy refers to doxorubicin-based therapy. Rituximab is added to therapy of most B cell (CD20+) lymphomas.

Site(s) of involvement and histologic type are both important factors in the management of extranodal lymphomas (Table 88.16). It is important to determine whether the disease is localized or disseminated. The Ann Arbor staging system has been used with stage IE, representing localized extranodal lymphoma, and IIE, representing extranodal lymphoma with involvement of adjacent lymph nodes; a subclassification of IIE, which separates involvement into contiguous nodes (II₁E) and noncontiguous nodes (II₂E), has been used in gastric lymphomas; stages III and IV in extranodal lymphomas represent disseminated disease with little advantage in distinguishing the 2 stages. Extranodal lymphomas of the gastrointestinal tract, nasopharynx, and testes are generally more aggressive than those of the lung, orbit, or salivary gland. Therapy, however, depends not only on the site, but also on the histologic characteristics, immunophenotype, epidemiologic factors, size, and stage of the lymphoma.

The stomach accounts for approximately one-half of the gastrointestinal lymphomas; 60% of gastric lymphomas are aggressive, usually DLBCL, sometimes in conjunction with low grade histology, and 40% are indolent, usually of the MALT type. The

P.1867

recognition of MALTomas has led to unique therapeutic options. MALTomas were previously called pseudolymphomas, but the latter term is no longer valid because MALTomas are monoclonal, can be associated with a higher grade histology, and have cytogenetic abnormalities.^{107, 108, 109, 110, 871} Clinically, MALTomas are different from other indolent lymphomas in that they tend to remain localized, rarely disseminate, and respond favorably to local therapy.^{871, 872}

Management of gastric MALToma changed when antibiotic therapy for *H. pylori* resulted in regression of lymphoma.^{873, 874, 875, 876, 877} Ultrasound endoscopy and biopsies assist in determining the extent of disease and depth of invasion, which correlate with spread to regional lymph nodes and response to antibiotics.⁸⁷⁸ CR rates to antibiotics are over 80% when disease is confined to the mucosa and submucosa.⁸⁷⁶ Antibiotics are also curative in over half the patients with *H. pylori* associated gastric large B cell lymphoma, with either a mixed marginal zone/DLBCL or pure DLBCL.¹⁰¹ Infiltration of the muscularis propria or nodal extension and the presence of t(11;18) or t(1;14) predict poor response to antibiotics.^{875, 876, 879} Serial endoscopies are warranted to ensure eradication of *H. pylori* and gradual disappearance of the lymphoma over many months.^{873, 874, 875, 876} Follow-up endoscopy is recommended 2 months after antibiotic therapy and, subsequently, at least twice a year for 2 years.⁸⁷⁸ B cell clonality as detected by PCR may persist after histologic regression, but is of uncertain clinical significance.^{104, 880} If there is *H. pylori* negative or progressive disease, alternative therapies are usually effective and include radiation, rituximab, and/or single agent or combination chemotherapy.^{872, 881, 882}

With the recognition of MALToma and the effectiveness of other therapies, the role of surgery has diminished in the management of gastrointestinal lymphoma. While early studies advocated surgical resection in gastric and other intestinal lymphomas to cure localized disease, debulk, accurately stage, and/or prevent perforation,^{247, 883, 884} recent reports have achieved good results with either combination chemotherapy or combined modality without surgery, particularly for the aggressive histologies.⁸⁶⁹ While a partial or subtotal gastrectomy may be justified in rare cases, more extensive surgery, such as total gastrectomy, should not be routinely performed because of the increased morbidity and the curability with alternative therapies. In a series of 398 patients with localized primary gastric lymphoma (38% MZL and 49% DLBCL) who received radiation and/or chemotherapy, there was no difference in survival at 42 months for those treated with surgery (n = 63; 86% OS) compared to those without surgery (n = 335; 91% OS).⁸⁸⁵

Similar surgical issues pertain to intestinal lymphomas as to gastric lymphomas, particularly if they present with obstruction; however, they usually are less amenable to total resection.⁸⁸⁶ Other B cell tumors which can have unique gastrointestinal presentations are Burkitt in the ileocecal region, which is common in the Middle East,⁸⁸⁷ mantle cell lymphoma, which can present with lymphomatous polyposis,²⁵⁰ and FL in the duodenum.⁸⁸⁸ Immunoproliferative small intestinal disease (IPSID), also called alpha heavy chain disease or Mediterranean lymphoma, can be considered a subtype of B cell MALToma distinguished by its occurrence in older children and young adults (age range, 10 to 35 years) from low socioeconomic groups in the Middle East and North Africa and its association with the synthesis of an IgA heavy chain and *Campylobacter jejuni*.^{114, 889} Although the prognosis is usually considered poor in IPSID, a combination of antibiotics (tetracycline), steroids, and/or anthracycline-based chemotherapy, along with aggressive supportive care with hyperalimentation, can achieve complete remissions in two-thirds of patients, with survivals in over half the patients at 3.5 years.^{889, 890} A unique T cell lymphoma of the small intestine is EATL, which can be associated with celiac disease (type I), may require emergent surgery due to obstruction or perforation, and responds poorly to chemotherapy (see section on "Extranodal Peripheral T Cell Lymphoma").^{612, 891, 892}

Lymphomas involving Waldeyer's ring account for up to one-third of extranodal lymphomas and are second to gastric lymphoma as the most common extranodal site.⁸⁹³ Prognosis depends upon histology, which is usually a DLBCL, size of the tonsillar mass, and stage.⁸⁹⁴ Up to one-half of patients have advanced disease, and simultaneous involvement of the gastrointestinal tract is detected in 10% to 15% of patients with Waldeyer's ring lymphoma.^{895, 896} Because of the usual DLBCL histology and the advanced stage of many patients, chemotherapy plus rituximab, often in combination with radiation, is usually considered the therapy of choice.⁸⁹⁷ With combined modality therapy, 5-year PFS is 70% to 90% for clinical stage IE and 40% to 60% for stage IIE.^{898, 899, 900}

Lymphomas of the nasal cavity and paranasal sinuses often are evaluated in series that include Waldeyer's ring lymphomas, despite differences in presentation, diagnosis, and therapy. The primary lymphoma is often advanced in nasal lymphomas with invasion of adjacent bones and an increased risk for CNS involvement. Although uncommon, cervical

node involvement in nasal lymphomas is associated with a poor prognosis.⁸⁹⁸ Using the American Joint Committee TNM staging for carcinoma of the paranasal sinuses, patients with T 1 to 2 lesions had an 89% 5-year DFS compared to 25% for patients with T 3 to 4 lesions.⁸⁹⁸ DLBCL is the most common histology in the West; but in series from Asia, NK/T cell lymphomas predominate, present with nasal septal perforation or destruction, and are associated with EBV (see section on "Extranodal PTCL").^{617, 901} Concurrent chemoradiotherapy or novel chemotherapy using agents which bypass MDR is advocated for most nasal NK/T cell lymphoma.⁹⁰² The best therapeutic results in nasal lymphomas have tended to be in those series with combined modality therapy.^{901, 903} Adding CNS prophylaxis to combined modality therapy resulted in a 5-year OS of 47% and disease-specific survival of 62%.⁹⁰⁴

Although somewhat variable according to series, the majority of salivary gland lymphomas are indolent (MALToma) and localized, most often to the parotid, and have survivals following radiation therapy alone of 80% to 90% at 5 years and 50% to 70% at 10 years.^{188, 905, 906, 907} Most patients (approximately 80%) with thyroid lymphomas have localized stage IE or IIE disease, and the majority are DLBCL, sometimes with a MALToma component.^{908, 909} Approximately half of the patients have a history of HT.⁹¹⁰ A worse prognosis occurs with penetration of the thyroid capsule, tumor bulk, advanced stage, and intermediate- to high-grade histologic types. Because of the frequency of these factors, many have advocated combined modality therapy for thyroid lymphoma except in the patient with stage I MALToma, who can receive radiation alone.^{909, 910} Five-year OS for DLBCL of the thyroid ranges from 52% to 90%.^{906, 911} Five-year DFS for MALToma of the thyroid following radiation is 88% to 100%.⁹¹²

Most primary pulmonary lymphomas are small B lymphocytic with or without plasmacytic differentiation and are considered a part of the spectrum of MALTomas. Two previously diagnosed entities, pseudolymphoma and lymphocytic interstitial pneumonitis, likely represent MALTomas. Therapy options include rituximab; chemotherapy, either single agent or combination; surgical resection; and radiation. The prognosis is good with 94% OS at 5 years without reaching a median survival at 10 years; and there is no advantage for a specific type of therapy.^{274, 913, 914} Other pulmonary lymphomas are heterogeneous, and therapy depends upon pathology and extent of disease. A favorable prognosis has been reported for DLBCL without bulk disease and normal LDH.⁹¹⁵ Lymphomatoid granulomatosis (LYG) is a rare type of EBV lymphoproliferation of B cells which most commonly presents with lung lesions varying from nodules to necrotic cavitary lesions, and which can have associated CNS and skin lesions.⁹¹⁶ Therapy and prognosis depend upon grading with steroids and

P.1868

interferon used for grades 1/2 and chemotherapy plus rituximab for grade 3 lesions.

Orbital lymphomas usually involve small B lymphocytes with or without plasmacytic differentiation and need to be distinguished from benign lymphoid hyperplasia. Some are associated with *Chlamydia psittaci* and can respond to antibiotics (see section on "Prelymphomatous Conditions"). They tend to be localized (80%+), and 10% to 20% are bilateral. They respond to radiation, with survival of 75% to 95% at 5 years and 70% to 80% at 10 years.^{269, 917, 918} Large B cell lymphomas are less common, tend to involve the lacrimal gland or retro-orbital area, and are treated with (10 to 200) combined modality therapy plus rituximab.^{269, 919}

CNS lymphomas are predominantly DLBCL and are responsive to steroids, radiation, intrathecal or Ommaya reservoir therapy, and systemic chemotherapy which crosses the blood brain barrier.^{920, 921} Standard treatment historically for PCNSL was whole brain radiation therapy (WBRT) alone; and the prognosis was poor with survival less than 6 months in AIDS patients and 1 to 2 years in immunocompetent hosts.^{922, 923} However, recent data utilizing early chemotherapy, particularly high-dose methotrexate or cytosine arabinoside, usually followed by WBRT, have improved results in PCNSL with median survivals from 30 to 60 months.^{920, 924, 925, 926} Severe neurologic toxicity manifested as leukoencephalopathy secondary to radiation is common, particularly in the patient over 60 years of age, and trials with chemotherapy alone and deferred radiation are being conducted.^{266, 927, 928, 929} In a randomized trial of 551 patients with PCNSL, there was no difference in OS when WBRT was omitted from primary chemotherapy.⁹³⁰ Rituximab has poor penetration into the CNS, but it is being used in protocols with PCNSL and its role is yet to be determined.^{920, 931} Alkylating agents with good CNS penetration which are a part of chemotherapy combination include thiotepa, ifosfamide, nitrosoureas, procarbazine, and temozolomide.⁹²⁰ There may be a role for high-dose chemotherapy and autologous transplant for PCNSL in both the relapsed and upfront setting.^{932, 933}

Testicular lymphoma, representing approximately 5% of testicular neoplasms, is the most common testicular tumor beyond the age of 60 years and the most common bilateral testicular tumor.^{934, 935, 936} It is associated with involvement of the contralateral testis in 20% to 35% of patients, and with involvement of the skin, Waldeyer's ring, and CNS, each in

approximately 10% of patients. The predominant histologic type is DLBCL (80% to 90%). In early series, median survivals have been 1 to 2 years, and 5-year survivals have varied from 12% to 48%, depending in part upon the extent of disease.^{934, 935} Because of the poor prognosis and early systemic spread, anthracycline-based chemotherapy and rituximab are warranted, usually with radiation to the involved testis if unresected, as well as to the contralateral testis. Because of the CNS relapse rate of 15% to 31%, CNS prophylaxis should be considered.^{934, 937} In an international phase II trial of 53 patients treated with R-CHOP, usually with CNS prophylaxis and testicular radiation, the 5-year PFS and OS were 74% and 85%, respectively; CNS relapse was 6%.⁹³⁸ Breast lymphomas usually manifest as a rapidly enlarging mass, may be multiple, and involve the opposite breast in 10% to 20% of patients.^{273, 939, 940} The histologic type is variable, but the majority are DLBCL; low grade lesions with MALToma features and an association with lymphocytic lobulitis have been described.⁹⁴¹ Massive bilateral breast involvement with BL has been described in pregnant or lactating women, predominantly from Africa, and is characterized by rapid dissemination with ovarian and CNS disease.²⁷³ After simple biopsy and staging, radiation therapy can be considered for local control of low grade lesions, but combination chemotherapy plus rituximab is warranted for aggressive histologies.

Primary ovarian lymphomas are rare, except in countries where BL is endemic; however, the ovary is the most common site of female genital tract involvement by lymphoma.⁹⁴² Ovarian lymphomas may be associated with bilateral involvement in 20% to 50% of patients and have had a poor prognosis, with 5-year survival of less than 25%. Prognosis depends on the extent of disease and the histologic type. DLBCL is the most common type, followed by FL, all grades, and Burkitt. Combination chemotherapy plus rituximab is warranted in most patients because of aggressive histologies.

Primary bone lymphomas are usually DLBCL (85%+), and approximately one-third have more than one bone involved.²⁷¹ Prognosis depends on the bones involved, with the femur the best and the spine the worst, histologic type, stage, and the presence of soft tissue involvement.^{271, 943} Although combined modality has been recommended for aggressive histologies,^{944, 945} chemotherapy alone has been successful. Because radiologic abnormalities persist after chemotherapy, local radiation is often given to the entire bone with a boost to the tumor bed.⁹⁴⁶ For localized bone lymphoma treated with combined modality, FTF exceeds 80% at 5 years.⁹⁴⁷

Therapy of CTCL and the differential diagnosis of cutaneous lymphomas are addressed in Chapter 92. Local radiation therapy is often adequate for localized (IE) cutaneous MALToma or PCFCL, whereas multiple therapeutic options similar to other indolent lymphomas can be considered for advanced disease. Both the primary cutaneous MALToma, or marginal zone lymphoma (PCMZL), and PCFCL have a good prognosis with 5-year OS exceeding 90%.^{948, 949} The majority of PCMZL have multifocal skin lesions involving the trunk and extremities, and up to 50% will relapse within 5 years of their initial therapy, but will still have a good prognosis (5-year OS>90%).⁹⁴⁸ PCFCLs tend to involve the head and neck and lack BCL-2 expression and the BCL-2 gene rearrangement. Alternatively, BCL-2 expression is often present in PCBCL of the leg as opposed to other sites, is primarily seen in the elderly, and has a poor prognosis (5-year OS 43% to 63%) despite the use of rituximab and combined modality therapy.^{517, 949, 950, 951}

ROLE OF HEMATOPOIETIC CELL TRANSPLANTATION

Transplantation is addressed in Chapters 102 and 104 and has taken an expanded role in the therapy of NHL; its use has been noted in preceding sections on individual diseases. Outcomes depend upon disease state (type of lymphoma, remission status), patient factors (age, performance status), and source of stem cells, either autologous (auto) or allogeneic (allo). In 1978, Appelbaum reported long-term DFS in 3 of 9 patients with relapsed BL who underwent high-dose chemotherapy and autologous marrow transplantation.⁹⁵² Subsequent series reported a 5-year OS rate of 20% to 50% using autoSCT for relapsed NHL.^{953, 954, 956} In the rituximab and RIT era, the OS has improved to 40% to 70%, but is variable depending upon type of lymphoma, prognostic factors, and chemosensitivity.^{957, 958}

Patient selection determines outcome, with the best results achieved in patients who are either in first CR or have minimal residual disease before the transplant and have a good performance status. Transplants in first CR or in patients with indolent histologies are controversial. Patients with predominantly DLBCL who are in a sensitive relapse—i.e., they are responding to additional chemotherapy—have a 30% to 70% salvage rate with autoHCT, compared to 0% to 15% patients who are in a resistant relapse. There is no superior preparative regimen, which may include various chemotherapy agents with or without total body irradiation. Rituximab and/or RIT are being incorporated into preparative regimens to try to decrease relapses.^{957, 959} In a randomized trial comparing BEAM (carmustine, etoposide, cytarabine, and melphalan) plus rituximab vs. BEAM plus conventional tositumomab (Bexxar) followed by autoHCT, there was no difference in PFS, OS, or transplant relapsed mortality (TRM).⁹⁶⁰

AlloHCT has been used less than autoHCT because of higher mortality rates, cost, and/or lack of a donor. It was initially reserved for selected young patients (usually less than 50 years of age) with marrow involvement, highly aggressive lymphomas, or after relapse from an autoHCT. Early (day 100) mortality rates previously were 5% to 25% for autoHCT and 15% to 45% for alloHCT, but are now <5% and 5% to 15%, respectively. Relapse is the main reason for failure after autoHCT; and TRM, either regimen-related toxicity or graft-versus-host disease (GVHD), is the main problem with alloHCT. Donor availability has increased with the expansion of unrelated donor registries, the use of umbilical cord transplantation in adults, and immune suppression to allow the use of mismatched donors.

The development of reduced intensity conditioning (RIC) and nonmyeloablative (NMAC) regimens for alloHCT has led to less early mortality and to use in older patients.⁹⁵⁹ In a CIBMTR report of 396 alloHCT for DLBCL, there was higher 5-year non-relapse mortality (NRM) with myeloablative conditioning (MAC, n = 165) than RIC (n = 143) and NMAC (n = 88) regimens (56% vs. 47% vs. 36%; P = 0.007). Five-year relapse was lower in MAC than in RIC and NMAC (26% vs. 38% vs. 40%; P = 0.031).⁹⁶¹ There were no differences in GVHD 5-year PFS (15% to 25%) and OS (18% to 26%). Similar findings of less NRM and increased relapse were reported by the CIBMTR comparing RIC to MAC for alloHCT patients with relapsed FL.⁹⁶² Chemosensitivity and performance status were better predictors of outcome than intensity of conditioning and have led to a shift in favor of RIC/NMAC for FL. Using a NMAC regimen (fludarabine, cyclophosphamide, and high-dose rituximab), Khouri et al. reported a 5-year OS and PFS rate for FL of 85% and 83%, respectively, with a TRM of 14%; acute GVHD was 11% and chronic GVHD was 60%.⁹⁶³

Unresolved issues of HCT for NHL are the optimal timing and the type of transplant. There is agreement that HCT is warranted in relapsed patients with intermediate-grade histology based on the PARMA trial which randomized patients to transplantation versus chemotherapy (Fig. 88.25).⁹⁵³ Disagreement surrounds which, if any, poor prognostic factors could be used to select patients with NHL for early HCT. While several small series have had DFS over 75% in selected patients with aggressive histologies transplanted in initial PR or first CR,^{954, 955, 956} most studies comparing autoHCT to chemotherapy in first CR or in slow responders have shown no advantage to early transplantation.^{718, 719, 720, 964, 965, 966, 967, 968, 969} Retrospective analysis of trials and an occasional prospective trial indicate a survival advantage for HCT in patients with an age-adjusted IPI that is greater than or equal to 2 (high-intermediate or high);^{719, 968, 970} however, the majority of randomized trials have not supported early transplantation over chemotherapy.^{971, 972} Many centers still offer HCT in first CR for poor prognosis NHL, particularly MCL and PTCL (see sections on these diseases).

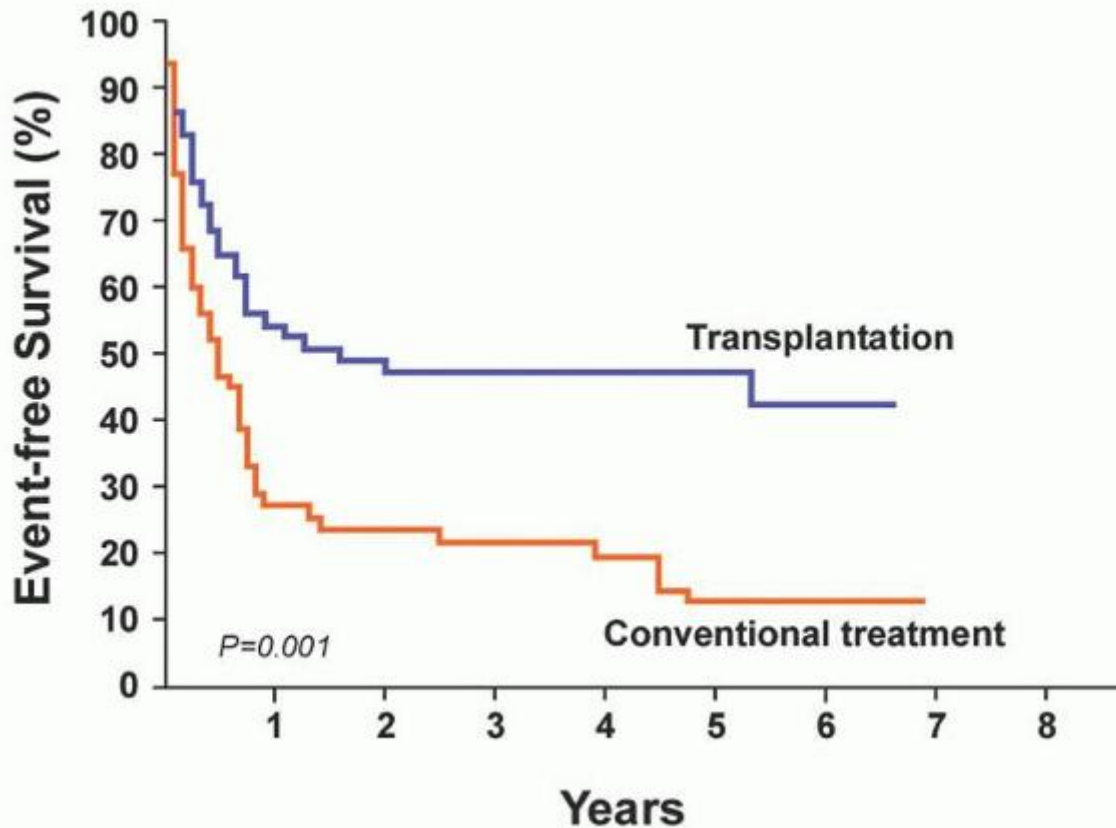

FIGURE 88.25. Kaplan-Meier curves for event-free survival of patients with relapsed intermediate to high grade lymphomas in the transplantation and conventional treatment groups. Data are based on an intention-to-treat analysis. From Philip T, Guglielmi C, Hagenbeck A, et al. Autologous bone marrow transplantation as compared with salvage chemotherapy in relapses of chemotherapy-sensitive non-Hodgkin's lymphoma. *N Engl J Med* 1995;333:1540-1545, with permission.

The use and timing of HCT and the role of purging are controversial in indolent lymphomas. Various techniques have been used for removal of tumor cells and include in vivo and in vitro monoclonal antibodies, metabolites of cytotoxic agents, and physical methods.⁹⁷³ There is evidence that indicates an advantage for successfully purging BCL2-positive clonal B cells in FL patients undergoing autoHCT.⁹⁷⁴ Prognostic models have been developed to select patients with indolent lymphomas for early HCT and include progressive disease within 1 year of initial therapy, extensive marrow involvement, multiple extranodal sites of disease, tumor bulk, transformation, and a high IPI.^{424, 975, 976, 977} Randomized trials comparing chemotherapy to chemotherapy followed by autoHCT are less common in FL than the aggressive histologies, predominantly DLBCL, but similarly have not shown an advantage to early HCT.^{975, 978} Long follow-up and randomized trials are required to determine the role of HCT and purging in indolent lymphomas.^{973, 975}

The optimal transplant strategy and stem cell source remain controversial. Peripheral blood stem cells have replaced bone marrow for autografting because of quicker engraftment, but have not consistently improved survival compared to marrow.⁹⁷⁹ Peripheral blood tends to also be used over marrow for allografts, but is associated with more chronic GVHD. As many as one-half of patients undergoing autologous peripheral stem cell collection mobilize malignant cells.^{979, 980} MDS and secondary AML are an increasingly recognized problem after autografts, with an actuarial incidence of 5% to 10% at 10 years. Prior exposure to radiation, 4 or more chemotherapy regimens, and difficulty harvesting stem cells have been associated with a higher risk of MDS/AML.^{981, 982, 983}

Some investigators have favored allografts because of fewer relapses, a graft-versus-lymphoma effect, a tumor free stem cell source, and less MDS/AML.^{984, 985, 986} The lack of an available donor and the toxicity of allograft transplantation keep the issue of optimal stem cell source unresolved; however, the availability of alternative donors and the use of nonmyeloablative regimens are expanding the role of alloHCT. Because of higher relapse rates in autografts, trials are evaluating pre- and posttransplant immunotherapy and radioimmunotherapy to eradicate minimal residual disease.^{960,}

^{987, 988, 989, 990} An emerging strategy is to utilize an autograft to achieve minimal residual disease followed by a RIC, or NMAC, allograft.^{991, 992}

SPECIAL AREAS

Therapy in the Elderly

Lymphomas steadily increase in number with aging as over half the new cases occur in people over 60 years of age.⁹⁹³ There is an expected increase in lymphomas solely based on the aging population, particularly in developed countries.⁹⁹⁴ The prognosis tends to be poor in the older patient; however, survival has improved for older patients with NHL in 2008 to 2012.⁹⁹⁵ Factors that contribute to poor prognosis in the elderly include poor performance status, reduced vital organ reserve, comorbid diseases, altered absorption or metabolism of drugs, decreased immunologic integrity, and biologic features of the lymphoma. Lymphomas in the elderly have more frequent extranodal presentations and more often have aggressive histologies. Unique presentations with a predilection for the elderly include primary CNS lymphoma,

P.1870

primary cutaneous DLBCL of the leg, EBV-positive DLBCL, and intravascular B cell lymphoma.

Randomized clinical trials comparing different regimens to doxorubicin-based therapy have shown inferior results.^{751, 996, 997, 998, 999} The randomized trials that favored CHOP plus rituximab over CHOP established a new standard for therapy of large B cell lymphoma in the elderly.^{299, 700} Physician biases and reduction of chemotherapy doses may contribute to an inferior prognosis in the elderly.^{1000, 1001} In a SWOG study with CHOP chemotherapy in which the dosage was reduced by 50% in patients over 65 years of age, CR rates declined with advancing age; however, in a small subset of patients over 65 years of age who did receive full doses, the CR rate approximated that of younger patients.¹⁰⁰² A relative dose intensity factor of CHOP-based therapy less than 70% is associated with poor long-term outcomes; however, dose reductions for patients over the age of 70 years (R-70%CHOP) and 80 years (R mini-CHOP) have not markedly compromised response or survival.^{1003, 1004} Elderly patients experience more frequent treatment-related toxicities even with dose reductions and greater utilization of supportive care.^{1005, 1006, 1007, 1008}

Novel regimens have been developed for the elderly patient, not only to lessen toxicity but also to maintain curability or control of NHL.^{1009, 1010, 1011, 1012} For patients who cannot tolerate anthracyclines, there are numerous alternatives, including bendamustine, gemcitabine, and etoposide, among others (see section on "Salvage Regimens"). Growth factors lessen the neutropenia of various regimens and allow the delivery of adequate doses on schedule.¹⁰¹⁰ Age is a continuum, with tolerance to therapy and survival worsening over 70 years of age; however, performance status is the best predictor of treatment-related death.¹⁰¹³ New clinical assessment tools, such as instrumental activities of daily living, may assist in determining a patient's ability to tolerate therapy.¹⁰⁰⁴ AutoHCT in the elderly (patients <70 years) can approach similar outcomes as observed in younger patients.¹⁰¹² With the use of RIC and NMAC regimens, alloHCT is being utilized in the eligible older patient. Elderly patients should not be excluded from clinical trials or curative therapy solely on the basis of age, but dose reductions or alternative drugs may be warranted in selected patients. Palliative care should be offered to those who are too frail or compromised to receive therapy.

Therapy in Pregnancy

Lymphoma is a rare event during pregnancy, but the estimated coincidence of NHL and HL in pregnancy is 1:1,000 to 1:6,000.¹⁰¹⁴ Therapy is based on histologic type and point of gestation at diagnosis.¹⁰¹⁵ Staging studies are limited because of concern for radiation exposure to the fetus. MRI can be used, although it is still recommended to avoid it in the first trimester. Ultrasonography and echocardiograms can provide useful information in the pregnant patient. Most women who develop NHL during pregnancy have aggressive histologies and advanced stage disease.¹⁰¹⁴ There is an unusually high incidence of breast, ovarian, uterine, and cervix involvement attributed to hormonal influences and increased blood flow to these organs.¹⁰¹⁴ Placental involvement is rare, and transmission to the fetus is so uncommon that it is reportable.¹⁰¹⁶

Patients with aggressive lymphomas who present in the first trimester should be considered for a therapeutic abortion unless the lymphoma is localized above the diaphragm and could be treated with involved field radiation plus abdominal shielding.¹⁰¹⁷ Radiation should be avoided until the third trimester, or not used at all, whereas combination chemotherapy can be given successfully in the second or third trimester. Although as a general rule chemotherapy is to be avoided in the first trimester, anthracyclines have been given without untoward effects to mother or fetus.¹⁰¹⁸ Rituximab with chemotherapy has been given to pregnant patients without evident harm to mother or fetus.¹⁰¹⁹ Early delivery (either by induction or caesarean section) can be considered either to avoid myelosuppression of mother and fetus or to initiate intensive chemotherapy. Complete staging should be done after delivery.

The prognosis for mothers has been relatively poor, with DFS of only 40% to 50%, probably because of both the aggressive histologies and the advanced stage.^{1014, 1016, 1017} Although indolent lymphomas constitute a minority of NHL in pregnancy, they generally can be observed until after delivery. If necessary, interferon can be used throughout pregnancy to control indolent hematologic disorders.¹⁰²⁰ Offspring who as fetuses received chemotherapy even in the first trimester have had normal growth and development and no increased risk of cancer.

Long-term Sequelae

The long-term complications of therapy in NHL are not as well described as those in HL, but they appear to be similar and depend on the therapy used, age of the patient, and comorbid illnesses.¹⁰²¹ These problems include endocrine disorders (infertility, hypothyroidism, panhypopituitarism, growth retardation), vital organ toxicity, psychosocial issues, and second neoplasms.^{1022, 1023} Radiation is the main cause of endocrine and neurological toxicities and secondary solid neoplasms.¹⁰²² Cardiotoxicity from anthracyclines is the most common chemotherapy-related toxicity and is usually manifested as congestive heart failure. Factors associated with increased cardiomyopathy include older age (>70 years), previous cardiac disease, hypertension, prior mediastinal radiation, and combination with other chemotherapy agents (e.g., cyclophosphamide). The cumulative incidence of cardiovascular disease in patients with NHL treated with anthracyclines was 12% at 5 years and 22% at 10 years.¹⁰²⁴ Cardiomyopathy can occur many years (15 to 20 years) after completion of therapy.¹⁰²⁵ Although previous studies suggested no increase in second neoplasms after therapy for NHL, the NCI's SEER Program identified an increased risk over time for AML; cancers of the bladder, kidney, and lung; malignant melanoma; and HL.^{1022, 1023} Up to 10% of NHL patients treated with standard chemotherapy regimens or autologous transplantation, particularly using total body irradiation, may develop MDS or AML within 10 years of their initial therapy.^{981, 983}

FUTURE DEVELOPMENTS

Advances in NHL will involve molecular techniques to refine diagnosis, classification, and therapy. The classification of lymphoma will improve with genomic profiling in conjunction with clinical and pathologic factors. The application of PCR to detect minimal residual disease may identify patients who should be followed more closely or receive additional therapy. The success of monoclonal antibody therapy in NHL has been remarkable; and the development of vaccines may be the ultimate goal of immunotherapy (Chapter 70). New agents are targeting both B and T cell receptors and protein signaling pathways critical to lymphomagenesis. The novel agents are synergistic with other chemotherapy and monoclonal antibodies and will require phase III trials to establish their place in the expanding list of treatments for NHL. Continued trials evaluating the role of dose intensification and the use of different types of transplantation are warranted in NHL.

REFERENCES

1. Hodgkin T. On some morbid appearances of the absorbent glands and spleen. *Trans R Med Chir Soc Glasgow* 1832;XVII:68-114.
2. Jaffe ES, Harris NL, Stein H, et al. Classification of lymphoid neoplasms: the microscope as a tool for disease discovery. *Blood* 2008;112:4384-4399.
3. Virchow R. Die Krankhaften Geschwulste dreissig Vorlesungen gehalten wahrend des Wintersemestes 1862-1863 an der Universitat zu Berlin. Berlin: A. Hirschwald, 1863-1867.
4. Robb-Smith AHT, Taylor CR. Lymph node biopsy. New York: Oxford University Press, 1981.
5. Kundrat H. Ueber Lympho-Sarkomatosis. *Wein Klin Wochenschr* 1893;vi: 211-234.
6. Sternberg C. Uber eine eigenartige unter dem Bilde der Pseudoleukamic verlaufende Tuberculose des lymphateschen Apparates. *Ztschr f Heilkd* 1898;xix:21-90.
7. Reed DM. On the pathological changes in Hodgkin's disease, with especial reference to its relation to tuberculosis. *Johns Hopkins Hosp Red* 1902;10: 133-196.
8. Brill NF, Baehr G, Rosenthal N. Generalized giant lymph node hyperplasia of lymph nodes and spleen. A hitherto undescribed type. *JAMA* 1925;84: 668-671.
9. Symmers D. Follicular lymphadenopathy with splenomegaly. A newly recognized disease of the lymphatic system. *Arch Pathol Lab Med* 1927;3:816-820.
10. Epstein MA, Achong BG. Discovery and general biology of the virus. In: Epstein, MA, Achong, BG, eds. *The Epstein-Barr Virus*. Berlin: Springer-Verlag. 1979:1-22.
11. Gall EA, Mallory TB. Malignant lymphoma: A clinico-pathological survey of 618 cases. *Am J Pathol* 1942;18:381-429.

12. Hicks EB, Rappaport H, Winter WJ. Follicular lymphoma: A re-evaluation of its position in the scheme of malignant lymphoma, based on a survey of 253 cases. *Cancer* 1956;9:792-821.
13. Aisenberg AC, Bloch KJ. Immunoglobulins on the surface of neoplastic lymphocytes. *N Engl J Med* 1972;287:272-276.
14. Barcos MP, Lukes RJ. Malignant lymphomas of convoluted lymphocytes: A new entity of possible T-cell type. In: Sinks LF, Godden JO, eds. *Conflicts in childhood cancer: an evaluation of current management*. New York: Alan R. Liss, 1975:147-178.
15. Smith JL, Clein GP, Barker CR, et al. Characterisation of malignant mediastinal lymphoid neoplasm (Sternberg sarcoma) as thymic in origin. *Lancet* 1973;1:74-77.
16. Nathwani BN, Diamond LW, Winberg CD, et al. Lymphoblastic lymphoma: a clinicopathologic study of 95 patients. *Cancer* 1981;48:2347-2357.
17. Lukes RJ, Collins RD. Immunologic characterization of human malignant lymphomas. *Cancer* 1974;34(Suppl):1488-1503.
18. Lester JN, Fuller LM, Conrad FG, et al. The roles of staging laparotomy, chemotherapy, and radiotherapy in the management of localized diffuse large cell lymphoma: a study of 75 patients. *Cancer* 1982;49:1746-1753.
19. Zech L, Haglund U, Nilsson K, et al. Characteristic chromosomal abnormalities in biopsies and lymphoid-cell lines from patients with Burkitt and non-Burkitt lymphomas. *Int J Canc J Int Cancer* 1976;17:47-56.
20. Fukuhara S, Ueshima Y, Shirakawa S, et al. 14q translocations, having a break point at 14q13, in lymphoid malignancy. *Int J Cancer* 1979;24:739-743.
21. Korsmeyer SJ, Hieter PA, Ravetch JV, et al. Developmental hierarchy of immunoglobulin gene rearrangements in human leukemic pre-B-cells. *Proc Natl Acad Sci US A* 1981;78:7096-7100.
22. Waldmann TA, Davis MM, Bongiovanni KF, et al. Rearrangements of genes for the antigen receptor on T cells as markers of lineage and clonality in human lymphoid neoplasms. *N Engl J Med* 1985;313:776-783.
23. Tsujimoto Y, Cossman J, Jaffe E, et al. Involvement of the bcl-2 gene in human follicular lymphoma. *Science* 1985;228:1440-1443.
24. Tsujimoto Y, Yunis J, Onorato-Showe L, et al. Molecular cloning of the chromosomal breakpoint of B-cell lymphomas and leukemias with the t(11;14) chromosome translocation. *Science* 1984;224:1403-1406.
25. Kaneko Y, Frizzera G, Edamura S, et al. A novel translocation, t(2;5)(p23;q35), in childhood phagocytic large T-cell lymphoma mimicking malignant histiocytosis. *Blood* 1989;73:806-813.
26. Morris SW, Kirstein MN, Valentine MB, et al. Fusion of a kinase gene, ALK, to a nucleolar protein gene, NPM, in non-Hodgkin's lymphoma. *Science* 1994;263:1281-1284.
27. Harris NL, Jaffe ES, Stein H, et al. A Revised European-American classification of lymphoid neoplasms: a proposal from the International Lymphoma Study Group. *Blood* 1994;84:1361-1392.
28. A clinical evaluation of the International Lymphoma Study Group classification of non-Hodgkin's lymphoma. The Non-Hodgkin's Lymphoma Classification Project. *Blood* 1997;89:3909-3918.
29. Baris D, Zahm SH. Epidemiology of lymphomas. *Curr Opin Oncol* 2000;12:383-394.
30. Siegel R, Naishadham D, Jemal A. *Cancer Statistics, 2013*. *Ca Cancer J Clin* 2013;63:11-30.
P.1871
31. Bassig BA, Lan Q, Rothman N, et al. Current understanding of lifestyle and environmental factors and risk of non-Hodgkin lymphoma: an epidemiological update. *J Cancer Epidemiol* 2012;2012:978930.
32. Clarke CA, Glaser SL. Changing incidence of non-Hodgkin lymphomas in the United States. *Cancer* 2002;94:2015-2023.
33. Howlader N, Noone AM, Krapcho M, et al.(eds). *SEER Cancer Statistics Review, 1975-2009 (Vintage 2009 Populations)*, National Cancer Institute, Bethesda, MD, <http://seer.cancer.gov/csr/19752009pops09/>, based on November 2011 SEER data submission, posted to the SEER website, April 2012.

34. Gurney KA, Cartwright RA. Increasing incidence and descriptive epidemiology of extranodal non-Hodgkin lymphoma in parts of England and Wales. *Hematol J* 2002;3:95-104.
35. Groves FD, Linet MS, Travis LB, et al. Cancer surveillance series: non-Hodgkin's lymphoma incidence by histologic subtype in the United States from 1978 through 1995. *J Natl Cancer Inst* 2000;92:1240-1251.
36. Olson JE, Janney CA, Rao RD, et al. The continuing increase in the incidence of primary central nervous system non-Hodgkin lymphoma: a surveillance, epidemiology, and end results analysis. *Cancer* 2002;95:1504-1510.
37. Paltiel O, Schmit T, Adler B, et al. The incidence of lymphoma in first-degree relatives of patients with Hodgkin disease and non-Hodgkin lymphoma: results and limitations of a registry-linked study. *Cancer* 2000;88: 2357-2366.
38. Chatterjee N, Hartge P, Cerhan JR, et al. Risk of non-Hodgkin's lymphoma and family history of lymphatic, hematologic, and other cancers. *Cancer Epidemiol Biomark Prevention* 2004;13:1415-1421.
39. Wang SS, Slager SL, Brennan P, et al. Family history of hematopoietic malignancies and risk of non-Hodgkin lymphoma (NHL): a pooled analysis of 10211 cases and 11905 controls from the International Lymphoma Epidemiology Consortium (InterLymph). *Blood* 2007;109:3479-3488.
40. Wiernik PH, Wang SQ, Hu XP, et al. Age of onset evidence for anticipation in familial non-Hodgkin's lymphoma. *Br J Haematol* 2000;108:72-79.
41. Daugherty SE, Pfeiffer RM, Mellemkjaer L, et al. No evidence for anticipation in lymphoproliferative tumors in population-based samples. *Cancer Epidemiol, Biomarkers Prevention* 2005;14:1245-1250.
42. Straus SE, Jaffe ES, Puck JM, et al. The development of lymphomas in families with autoimmune lymphoproliferative syndrome with germline Fas mutations and defective lymphocyte apoptosis. *Blood* 2001;98:194-200.
43. Poppema S, Maggio E, van den Berg A. Development of lymphoma in autoimmune lymphoproliferative syndrome (ALPS) and its relationship to Fas gene mutations. *Leuk Lymphoma* 2004;45:423-431.
44. Bernstein L, Ross RK. Prior medication use and health history as risk factors for non-Hodgkin's lymphoma: preliminary results from a case-control study in Los Angeles County. *Cancer Res* 1992;52:5510s-5515s.
45. Linet MS, Pottern LM. Familial aggregation of hematopoietic malignancies and risk of non-Hodgkin's lymphoma. *Cancer Res* 1992;52:5468s-5473s.
46. Suarez F, Lortholary O, Hermine O, et al. Infection-associated lymphomas derived from marginal zone B cells: a model of antigen-driven lymphoproliferation. *Blood* 2006;107:3034-3044.
47. Burkitt DP. The discovery of Burkitt's lymphoma. *Cancer* 1983;51:1777-1786.
48. Walusansa V, Okuku F, Orem J. Burkitt lymphoma in Uganda, the legacy of Denis Burkitt and an update on the disease status. *Br J Haematol* 2012;156:757-760.
49. Burkitt D, Hutt MS, Wright DH. The African lymphoma: preliminary observations on response to therapy. *Cancer* 1965;18:399-410.
50. Manolov G, Manolova Y. A marker band in one chromosome No. 14 in Burkitt lymphoma. *Hereditas* 1971;69.
51. Dalla-Favera R, Bregni M, Erikson J, et al. Human c-myc onc gene is located on the region of chromosome 8 that is translocated in Burkitt lymphoma cells. *Proc Natl Acad Sci US A* 1982;79:7824-7827.
52. Magrath I. Epidemiology: clues to the pathogenesis of Burkitt lymphoma. *Br J Haematol* 2012;156:744-756.
53. Purtilo DT, Stevenson M. Lymphotropic viruses as etiologic agents of lymphoma. *Hematol/Oncol Clin North Am* 1991;5:901-923.
54. Kanavaros P, Lescs MC, Briere J, et al. Nasal T-cell lymphoma: a clinicopathologic entity associated with peculiar phenotype and with Epstein-Barr virus. *Blood* 1993;81:2688-2695.
55. van Gorp J, Doornwaard H, Verdonck LF, et al. Posttransplant T-cell lymphoma. Report of three cases and a review of the literature. *Cancer* 1994;73:3064-3072.
56. Uchiyama T, Yodoi J, Sagawa K, et al. Adult T-cell leukemia: clinical and hematologic features of 16 cases. *Blood* 1977;50:481-492.
57. Poiesz BJ, Ruscetti FW, Gazdar AF, et al. Detection and isolation of type C retrovirus particles from fresh and cultured lymphocytes of a patient with cutaneous T-cell lymphoma. *Proc Natl Acad Sci USA* 1980;77:7415-7419.

58. Yoshida M, Miyoshi I, Hinuma Y. Isolation and characterization of retrovirus from cell lines of human adult T-cell leukemia and its implication in the disease. *Proc Natl Acad Sci USA* 1982;79:2031-2035.
59. Taylor GP, Matsuoka M. Natural history of adult T-cell leukemia/lymphoma and approaches to therapy. *Oncogene* 2005;24:6047-6057.
60. Goncalves DU, Proietti FA, Ribas JG, et al. Epidemiology, treatment, and prevention of human T-cell leukemia virus type 1-associated diseases. *Clin Microbiol Rev* 2010;23:577-589.
61. Fukuda RI, Tsuchiya K, Suzuki K, et al. HTLV-I Tax regulates the cellular proliferation through the down-regulation of PIP3-phosphatase expressions via the NF-kappaB pathway. *Int J Biochem Mol Biol* 2012;3:95-104.
62. Zhao T, Matsuoka M. HBZ and its roles in HTLV-1 oncogenesis. *Frontiers Microbiol* 2012;3:247.
63. Mesnard JM, Barbeau B, Devaux C. HBZ, a new important player in the mystery of adult T-cell leukemia. *Blood* 2006;108:3979-3982.
64. Mannis A, Hisada M, La Grenade L. Human T-lymphotropic virus type I infection. *Lancet* 1999;353:1951-1958.
65. Blattner WA. Human T-lymphotrophic viruses and diseases of long latency. *Ann Intern Med* 1989;111:4-6.
66. Hisada M, Stuver SO, Okayama A, et al. Persistent paradox of natural history of human T lymphotropic virus type I: parallel analyses of Japanese and Jamaican carriers. *J Infect Dis* 2004;190:1605-1609.
67. Proietti FA, Carneiro-Proietti AB, Catalan-Soares BC, et al. Global epidemiology of HTLV-I infection and associated diseases. *Oncogene* 2005;24:6058-6068.
68. Kalyanaraman VS, Sarngadharan MG, Robert-Guroff M, et al. A new subtype of human T-cell leukemia virus (HTLV-II) associated with a T-cell variant of hairy cell leukemia. *Science* 1982;218:571-573.
69. Rosenblatt JD, Plaeger-Marshall S, Giorgi JV, et al. A clinical, hematologic, and immunologic analysis of 21 HTLV-II-infected intravenous drug users. *Blood* 1990;76:409-417.
70. Mahieux R, Gessain A. The human HTLV-3 and HTLV-4 retroviruses: new members of the HTLV family. *Pathol-Biol* 2009;57:161-166.
71. Salahuddin SZ, Ablashi DV, Markham PD, et al. Isolation of a new virus, HBLV, in patients with lymphoproliferative disorders. *Science* 1986;234:596-601.
72. Yamanishi K, Okuno T, Shiraki K, et al. Identification of human herpesvirus-6 as a causal agent for exanthem subitum. *Lancet* 1988;1:1065-1067.
73. Cesarman E, Chang Y, Moore PS, et al. Kaposi's sarcoma-associated herpes-virus-like DNA sequences in AIDS-related body-cavity-based lymphomas. *N Engl J Med* 1995;332:1186-1191.
74. Oksenhendler E, Boulanger E, Galicier L, et al. High incidence of Kaposi sarcoma-associated herpesvirus-related non-Hodgkin lymphoma in patients with HIV infection and multicentric Castleman disease. *Blood* 2002;99: 2331-2336.
75. Marcucci F, Spada E, Mele A, et al. The association of hepatitis B virus infection with B-cell non-Hodgkin lymphoma—a review. *Am J Blood Res* 2012;2:18-28.
76. Marcucci F, Mele A. Hepatitis viruses and non-Hodgkin lymphoma: epidemiology, mechanisms of tumorigenesis, and therapeutic opportunities. *Blood* 2011;117:1792-1798.
77. Negri E, Little D, Boiocchi M, et al. B-cell non-Hodgkin's lymphoma and hepatitis C virus infection: a systematic review. *Int J Cancer. J Int Cancer* 2004;111:1-8.
78. Nath A, Agarwal R, Malhotra P, et al. Prevalence of hepatitis B virus infection in non-Hodgkin lymphoma: a systematic review and meta-analysis. *Intern Med J* 2010;40:633-641.
79. Duberg AS, Nordstrom M, Torner A, et al. Non-Hodgkin's lymphoma and other nonhepatic malignancies in Swedish patients with hepatitis C virus infection. *Hepatology* 2005;41:652-659.
80. Yeo W, Chan TC, Leung NW, et al. Hepatitis B virus reactivation in lymphoma patients with prior resolved hepatitis B undergoing anticancer therapy with or without rituximab. *J Clin Oncol* 2009;27:605-611.
81. Zurawska U, Hicks LK, Woo G, et al. Hepatitis B virus screening before chemotherapy for lymphoma: a cost-effectiveness analysis. *J Clin Oncol* 2012;30:3167-3173.

82. Dal Maso L, Franceschi S. Hepatitis C virus and risk of lymphoma and other lymphoid neoplasms: a meta-analysis of epidemiologic studies. *Cancer Epidemiol Biomark Prev* 2006;15:2078-2085.
83. Pozzato G, Mazzaro C, Crovatto M, et al. Low-grade malignant lymphoma, hepatitis C virus infection, and mixed cryoglobulinemia. *Blood* 1994;84:3047-3053.
84. Lauletta G, Russi S, Conteduca V, et al. Hepatitis C virus infection and mixed cryoglobulinemia. *Clin Develop Immunol* 2012;2012:502156.
85. Zignego AL, Giannini C, Gragnani L. HCV and lymphoproliferation. *Clin Develop Immunol* 2012;2012:980942.
86. Silvestri F, Barillari G, Fanin R, et al. Impact of hepatitis C virus infection on clinical features, quality of life and survival of patients with lymphoplasmacytoid lymphoma/immunocytoma. *Annal Oncol: Official J Eur Soc Med Oncol/ESMO* 1998;9:499-504.
87. Visco C, Arcaini L, Brusamolino E, et al. Distinctive natural history in hepatitis C virus positive diffuse large B-cell lymphoma: analysis of 156 patients from northern Italy. *Annal Oncol: Official J Eur Soc Med Oncol/ESMO* 2006;17:1434-1440.
88. Zuckerman E, Zuckerman T, Sahar D, et al. The effect of antiviral therapy on t(14;18) translocation and immunoglobulin gene rearrangement in patients with chronic hepatitis C virus infection. *Blood* 2001;97:1555-1559.
89. Saadoun D, Suarez F, Lefrere F, et al. Splenic lymphoma with villous lymphocytes, associated with type II cryoglobulinemia and HCV infection: a new entity? *Blood* 2005;105:74-76.
90. Gisbert JP, Garcia-Buey L, Pajares JM, et al. Systematic review: regression of lymphoproliferative disorders after treatment for hepatitis C infection. *Aliment Pharmacol Ther* 2005;21:653-662.
91. Arcaini L, Merli M, Volpetti S, et al. Indolent B-cell lymphomas associated with HCV infection: clinical and virological features and role of antiviral therapy. *Clin Develop Immunol* 2012;2012:638185.
92. Saadoun D, Resche Rigon M, Sene D, et al. Rituximab plus Peg-interferonalpha/ribavirin compared with Peg-interferon-alpha/ribavirin in hepatitis C-related mixed cryoglobulinemia. *Blood* 2010;116:326-334; quiz 504-505.
93. Dammacco F, Tucci FA, Lauletta G, et al. Pegylated interferon-alpha, ribavirin, and rituximab combined therapy of hepatitis C virus-related mixed cryoglobulinemia: a long-term study. *Blood* 2010;116:343-353.
94. Marshall BJ, Warren JR. Unidentified curved bacilli in the stomach of patients with gastritis and peptic ulceration. *Lancet* 1984;1:1311-1315.
95. Parsonnet J, Friedman GD, Vandersteen DP, et al. *Helicobacter pylori* infection and the risk of gastric carcinoma. *N Engl J Med* 1991;325:1127-1131.
96. Gisbert JP, Calvet X. Review article: common misconceptions in the management of *Helicobacter pylori*-associated gastric MALT-lymphoma. *Aliment Pharmacol Ther* 2011;34:1047-1062.
97. Doglioni C, Wotherspoon AC, Moschini A, et al. High incidence of primary gastric lymphoma in northeastern Italy. *Lancet* 1992;339:834-835.
98. Isaacson P, Wright DH. Malignant lymphoma of mucosa-associated lymphoid tissue. A distinctive type of B-cell lymphoma. *Cancer* 1983;52:1410-1416.
99. Parsonnet J, Hansen S, Rodriguez L, et al. *Helicobacter pylori* infection and gastric lymphoma. *N Engl J Med* 1994;330:1267-1271.
100. Wotherspoon AC, Doglioni C, Diss TC, et al. Regression of primary low-grade B-cell gastric lymphoma of mucosa-associated lymphoid tissue type after eradication of *Helicobacter pylori*. *Lancet* 1993;342:575-577.
101. Kuo SH, Yeh KH, Wu MS, et al. *Helicobacter pylori* eradication therapy is effective in the treatment of early-stage H pylori-positive gastric diffuse large B-cell lymphomas. *Blood* 2012;119:4838-4844; quiz 5057.
102. Zucca E, Bertoni F, Roggero E, et al. The gastric marginal zone B-cell lymphoma of MALT type. *Blood* 2000;96:410-419.
103. Hussell T, Isaacson PG, Crabtree JE, et al. *Helicobacter pylori*-specific tumour-infiltrating T cells provide contact dependent help for the growth of malignant B cells in low-grade gastric lymphoma of mucosa-associated lymphoid tissue. *J Pathol* 1996;178:122-127.

104. Thiede C, Alpen B, Morgner A, et al. Ongoing somatic mutations and clonal expansions after cure of *Helicobacter pylori* infection in gastric mucosa-associated lymphoid tissue B-cell lymphoma. *J Clin Oncol* 1998;16:3822-3831.
105. Hamoudi RA, Appert A, Ye H, et al. Differential expression of NF-kappaB target genes in MALT lymphoma with and without chromosome translocation: insights into molecular mechanism. *Leukemia* 2010;24:1487-1497.
106. Lin WC, Tsai HF, Kuo SH, et al. Translocation of *Helicobacter pylori* CagA into Human B lymphocytes, the origin of mucosa-associated lymphoid tissue lymphoma. *Cancer Res* 2010;70:5740-5748.
107. Ye H, Liu H, Raderer M, et al. High incidence of t(11;18)(q21;q21) in *Helicobacter pylori*-negative gastric MALT lymphoma. *Blood* 2003;101:2547-2550.
108. Owens SR, Smith LB. Molecular Aspects of *H. pylori*-Related MALT Lymphoma. *Pathol Res Int* 2011;2011:193149.
109. Starostik P, Patzner J, Greiner A, et al. Gastric marginal zone B-cell lymphomas of MALT type develop along 2 distinct pathogenetic pathways. *Blood* 2002;99:3-9.
110. Willis TG, Jadayel DM, Du MQ, et al. Bcl10 is involved in t(1;14)(p22;q32) of MALT B cell lymphoma and mutated in multiple tumor types. *Cell* 1999;96:35-45.
111. Ye H, Remstein ED, Bacon CM, et al. Chromosomal translocations involving BCL6 in MALT lymphoma. *Haematologica* 2008;93:145-146.
112. Du M, Peng H, Singh N, et al. The accumulation of p53 abnormalities is associated with progression of mucosa-associated lymphoid tissue lymphoma. *Blood* 1995;86:4587-9453.
113. Ferreri AJ, Ernberg I, Copie-Bergman C. Infectious agents and lymphoma development: molecular and clinical aspects. *J Internal Med* 2009;265:421-438.
114. Lecuit M, Abachin E, Martin A, et al. Immunoproliferative small intestinal disease associated with *Campylobacter jejuni*. *N Engl J Med* 2004;350:239-248.
115. Ferreri AJ, Ponzoni M, Guidoboni M, et al. Regression of ocular adnexal lymphoma after *Chlamydia psittaci*-eradicating antibiotic therapy. *J Clin Oncol* 2005;23:5067-5073.
116. Abbondazo SL, Irey NS, Frizzera G. Dilantin-associated lymphadenopathy. Spectrum of histopathologic patterns. *Am J Surgical Pathol* 1995;19:675-686.
117. Brown SL, Greene MH, Gershon SK, et al. Tumor necrosis factor antagonist therapy and lymphoma development: twenty-six cases reported to the Food and Drug Administration. *Arthritis Rheumatism* 2002;46:3151-3158.
118. Wong AK, Kerkoutian S, Said J, et al. Risk of lymphoma in patients receiving antitumor necrosis factor therapy: a meta-analysis of published randomized controlled studies. *Clin Rheumatol* 2012;31:631-636.
119. Parakkal D, Sifuentes H, Semer R, et al. Hepatosplenic T-cell lymphoma in patients receiving TNF-alpha inhibitor therapy: expanding the groups at risk. *Eur J Gastroenterol Hepatol* 2011;23:1150-1156.
120. Zhang Y, Holford TR, Leaderer B, et al. Prior medical conditions and medication use and risk of non-Hodgkin lymphoma in Connecticut United States women. *Cancer Causes Control : CCC* 2004;15:419-428.
121. Segal GH, Clough JD, Tubbs RR. Autoimmune and iatrogenic causes of lymphadenopathy. *Semin Oncol* 1993;20:611-626.
122. Rasmussen M, Hjalgrim H, Molgaard-Nielsen D, et al. Antibiotic use and risk of non-Hodgkin lymphomas. *Int J Cancer* 2012;131:E1158-E1165.
123. Norgaard M, Poulsen AH, Pedersen L, et al. Use of postmenopausal hormone replacement therapy and risk of non-Hodgkin's lymphoma: a Danish population-based cohort study. *Br J Cancer* 2006;94:1339-1341.
124. Scherr PA, Hutchison GB, Neiman RS. Non-Hodgkin's lymphoma and occupational exposure. *Cancer Res* 1992;52:5503s-5509s.
125. Zheng T, Blair A, Zhang Y, et al. Occupation and risk of non-Hodgkin's lymphoma and chronic lymphocytic leukemia. *J Occup Environ Med* 2002;44:469-474.
126. Colt JS, Davis S, Severson RK, et al. Residential insecticide use and risk of non-Hodgkin's lymphoma. *Cancer Epidemiol Biomarkers Prev* 2006;15: 251-257.

127. Quintana PJ, Delfino RJ, Korrick S, et al. Adipose tissue levels of organochlorine pesticides and polychlorinated biphenyls and risk of non-Hodgkin's lymphoma. *Environ Health Perspect* 2004;112:854-861.
128. Vineis P, Miligi L, Costantini AS. Exposure to solvents and risk of non-Hodgkin lymphoma: clues on putative mechanisms. *Cancer Epidemiol Biomarkers Prev* 2007;16:381-384.
129. Mandel JH, Kelsh MA, Mink PJ, et al. Occupational trichloroethylene exposure and non-Hodgkin's lymphoma: a meta-analysis and review. *Occup Environ Med* 2006;63:597-607.
130. Rego MA, Sousa CS, Kato M, et al. Non-Hodgkin's lymphomas and organic solvents. *J Occup Environ Med* 2002;44:874-881.
131. Deng Q, Zheng T, Lan Q, et al. Occupational solvent exposure, genetic variation in immune genes, and the risk for non-Hodgkin lymphoma. *Eur J Cancer Prev* 2013;22:77-82.
132. Jiao J, Zheng T, Lan Q, et al. Occupational solvent exposure, genetic variation of DNA repair genes, and the risk of non-Hodgkin's lymphoma. *Euro J Cancer Prev* 2012;21:580-584.
133. Hall P, Rosendahl I, Mattsson A, et al. Non-Hodgkin's lymphoma and skin malignancies—shared etiology? *Int J Cancer J Int Cancer* 1995;62:519-522.
134. Hartge P, Devesa SS, Grauman D, et al. Non-Hodgkin's lymphoma and sunlight. *J Natl Cancer Inst* 1996;88:298-300.
135. Chiu BC, Cerhan JR, Folsom AR, et al. Diet and risk of non-Hodgkin lymphoma in older women. *JAMA* 1996;275:1315-1321.
136. Zhang Y, Holford TR, Leaderer B, et al. Hair-coloring product use and risk of non-Hodgkin's lymphoma: a population-based case-control study in Connecticut. *Am J Epidemiol* 2004;159:148-154.
137. Sangrajrang S, Renard H, Kuhaprema T, et al. Personal use of hair dyes—increased risk of non-Hodgkin's lymphoma in Thailand. *Asian Pac J Cancer Prevent: APJCP* 2011;12:2393-2396.
138. Smedby KE, Hjalgrim H, Melbye M, et al. Ultraviolet radiation exposure and risk of malignant lymphomas. *J Natl Cancer Inst* 2005;97:199-209.
139. Freedman DM, Kimlin MG, Hoffbeck RW, et al. Multiple indicators of ambient and personal ultraviolet radiation exposure and risk of non-Hodgkin lymphoma (United States). *J Photochem Photobiol, Biol* 2010;101:321-325.
140. Grant WB. Ultraviolet exposure and non-Hodgkin's lymphoma: beneficial and adverse effects? *Cancer Causes Control* 2012;23:653-655; author reply 7-8.
141. Bertrand KA, Chang ET, Abel GA, et al. Sunlight exposure, vitamin D, and risk of non-Hodgkin lymphoma in the Nurses' Health Study. *Cancer Causes Control* 2011;22:1731-1741.
142. Purdue MP, Freedman DM, Gapstur SM, et al. Circulating 25-hydroxyvitamin D and risk of non-Hodgkin lymphoma: cohort consortium vitamin D pooling project of rarer cancers. *Am J Epidemiol* 2010;172:58-69.
143. Hartge P, Devesa SS, Fraumeni JF Jr. Hodgkin's and non-Hodgkin's lymphomas. In: Doll R, Fraumeni JF Jr, Muir CS, eds. *Cancer surveys. Trends in cancer incidence and mortality, 19-20*. Cold Spring Harbor: Cold Spring Harbor Laboratory Press, 1994: 423-545.
144. Ursin G, Bjelke E, Heuch I, et al. Milk consumption and cancer incidence: a Norwegian prospective study. *Br J Cancer* 1990;61:456-459.
145. Mikhak B, Bracci PM, Gong Z. Intake of vitamins D and A and calcium and risk of non-Hodgkin lymphoma: San Francisco Bay Area population-based case-control study. *Nutr Cancer* 2012;64:674-684.
146. Chang ET, Smedby KE, Zhang SM, et al. Dietary factors and risk of non-hodgkin lymphoma in men and women. *Cancer Epidemiol Biomarkers Prev* 2005;14:512-520.
147. Cross AJ, Lim U. The role of dietary factors in the epidemiology of non-Hodgkin's lymphoma. *Leuk Lymphoma* 2006;47:2477-2487.
148. Kelemen LE, Cerhan JR, Lim U, et al. Vegetables, fruit, and antioxidant-related nutrients and risk of non-Hodgkin lymphoma: a National Cancer Institute-Surveillance, Epidemiology, and End Results population-based case-control study. *Am J Clin Nutr* 2006;83:1401-1410.

149. Cerhan JR, Bernstein L, Severson RK, et al. Anthropometrics, physical activity, related medical conditions, and the risk of non-Hodgkin lymphoma. *Cancer Causes Control* 2005;16:1203-1214.
150. Chang ET, Hjalgrim H, Smedby KE, et al. Body mass index and risk of malignant lymphoma in Scandinavian men and women. *J Natl Cancer Inst* 2005;97:210-218.
151. Vamvakas EC. Allogeneic blood transfusion as a risk factor for the subsequent development of non-Hodgkin's lymphoma. *Transfus Med Rev* 2000;14: 258-268.
152. Cerhan JR, Wallace RB, Dick F, et al. Blood transfusions and risk of non-Hodgkin's lymphoma subtypes and chronic lymphocytic leukemia. *Cancer Epidemiol Biomarkers Prev* 2001;10:361-368.
153. Castillo JJ, Dalia S, Pascual SK. Association between red blood cell transfusions and development of non-Hodgkin lymphoma: a meta-analysis of observational studies. *Blood* 2010;116:2897-2907.
154. Karipidis K, Benke G, Sim M, et al. Occupational exposure to power frequency magnetic fields and risk of non-Hodgkin lymphoma. *Occup Environ Med* 2007;64:25-29.
155. Boice JD, Jr. Radiation and non-Hodgkin's lymphoma. *Cancer Res* 1992;52:5489s-5491s.
156. Chiu BC, Weisenburger DD, Cantor KP, et al. Alcohol consumption, family history of hematolymphoproliferative cancer, and the risk of non-Hodgkin's lymphoma in men. *Ann Epidemiol* 2002;12:309-315.
157. Zahm SH, Weisenburger DD, Holmes FF, et al. Tobacco and non-Hodgkin's lymphoma: combined analysis of three case-control studies (United States). *Cancer Causes Control* 1997;8:159-166.
158. Fernberg P, Odenbro A, Bellocco R, et al. Tobacco use, body mass index and the risk of malignant lymphomas—a nationwide cohort study in Sweden. *Int J Cancer. JInt Cancer* 2006;118:2298-2302.
159. Boffetta P, Armstrong B, Linet M, et al. Consortia in cancer epidemiology: lessons from InterLymph. *Cancer Epidemiol Biomarkers Prev* 2007;16:197-199.
160. Filipovich AH, Heinritz KJ, Robison LL, et al. The Immunodeficiency Cancer Registry. A research resource. *Am J Pediatr Hematol Oncol* 1987;9: 183-184.
161. Schwartz RS. Immunodeficiency, Immunosuppression, and susceptibility to neoplasms. *J Natl Cancer Inst Monogr* 2001;28:5-9.
162. Grierson H, Purtilo DT. Epstein-Barr virus infections in males with the X-linked lymphoproliferative syndrome. *Ann Intern Med* 1987;106:538-545.
163. Nalesnik MA. The diverse pathology of post-transplant lymphoproliferative disorders: the importance of a standardized approach. *Transpl Infect Dis* 2001;3:88-96.
164. Cleary ML, Nalesnik MA, Shearer WT, et al. Clonal analysis of transplant-associated lymphoproliferations based on the structure of the genomic termini of the Epstein-Barr virus. *Blood* 1988;72:349-352.
165. Paya CV, Fung JJ, Nalesnik MA, et al. Epstein-Barr virus-induced posttransplant lymphoproliferative disorders. ASTS/ASTP EBV-PTLD Task Force and The Mayo Clinic Organized International Consensus Development Meeting. *Transplantation* 1999;68:1517-1525.
166. Krikorian JG, Anderson JL, Bieber CP, et al. Malignant neoplasms following cardiac transplantation. *JAMA* 1978;240:639-643.
167. Swerdlow AJ, Higgins CD, Hunt BJ, et al. Risk of lymphoid neoplasia after cardiothoracic transplantation. a cohort study of the relation to Epstein-Barr virus. *Transplantation* 2000;69:897-904.
168. Loren AW, Tsai DE. Post-transplant lymphoproliferative disorder. *Clin Chest Med* 2005;26:631-645, vii.
169. Doll DC, List AF. Burkitt's lymphoma in a homosexual. *Lancet* 1982;1: 1026-1027.
170. Ziegler JL, Beckstead JA, Volberding PA, et al. Non-Hodgkin's lymphoma in 90 homosexual men. Relation to generalized lymphadenopathy and the acquired immunodeficiency syndrome. *N Engl J Med* 1984;311:565-570.
171. Revision of the case definition of acquired immunodeficiency syndrome for national reporting—United States. Centers for Disease Control, Department of Health and Human Services. *Ann Intern Med* 1985;103:402-403.
172. Lim ST, Levine AM. Recent advances in acquired immunodeficiency syndrome (AIDS)-related lymphoma. *CA Cancer J Clin* 2005;55:229-241; 60-61, 64.

173. Delecluse HJ, Anagnostopoulos I, Dallenbach F, et al. Plasmablastic lymphomas of the oral cavity: a new entity associated with the human immunodeficiency virus infection. *Blood* 1997;89:1413-1420.
174. Gabarre J, Raphael M, Lepage E, et al. Human immunodeficiency virus-related lymphoma: relation between clinical features and histologic subtypes. *Am J Med* 2001;111:704-711.
175. Gail MH, Pluda JM, Rabkin CS, et al. Projections of the incidence of non-Hodgkin's lymphoma related to acquired immunodeficiency syndrome. *J Natl Cancer Inst* 1991;83:695-701.
176. Besson C, Goubar A, Gabarre J, et al. Changes in AIDS-related lymphoma since the era of highly active antiretroviral therapy. *Blood* 2001;98: 2339-2344.
177. Vishnu P, Aboulafia DM. AIDS-related non-Hodgkin's lymphoma in the era of highly active antiretroviral therapy. *Adv Hematol* 2012;2012:485943.
178. Diamond C, Taylor TH, Aboumrad T, et al. Changes in acquired immunodeficiency syndrome-related non-Hodgkin lymphoma in the era of highly active antiretroviral therapy: incidence, presentation, treatment, and survival. *Cancer* 2006;106:128-135.
179. Shiels MS, Pfeiffer RM, Hall HI, et al. Proportions of Kaposi sarcoma, selected non-Hodgkin lymphomas, and cervical cancer in the United States occurring in persons with AIDS, 1980-2007. *JAMA* 2011;305:1450-1459.
180. Levine AM. Management of AIDS-related lymphoma. *Curr Opin Oncol* 2008;20:522-528.
181. Franks AL, Slansky JE. Multiple associations between a broad spectrum of autoimmune diseases, chronic inflammatory diseases and cancer. *Anticancer Res* 2012;32:1119-1136.
182. Ekstrom Smedby K, Vajdic CM, Falster M, et al. Autoimmune disorders and risk of non-Hodgkin lymphoma subtypes: a pooled analysis within the InterLymph Consortium. *Blood* 2008;111:4029-4038.
183. Isaacson PG. Lymphomas of mucosa-associated lymphoid tissue (MALT). *Histopathology* 1990;16:617-619.
184. Bunim JJ, Talal N. The association of malignant lymphoma with Sjögren's syndrome. *Trans Assoc Am Phys* 1963;76:45.
185. Kassan SS, Thomas TL, Moutsopoulos HM, et al. Increased risk of lymphoma in sicca syndrome. *Ann Intern Med* 1978;89:888-892.
186. Masaki Y, Sugai S. Lymphoproliferative disorders in Sjögren's syndrome. *Autoimmun Rev* 2004;3:175-182.
187. Kovacs L, Szodoray P, Kiss E. Secondary tumours in Sjögren's syndrome. *Autoimmun Rev* 2010;9:203-206.
188. Schmid U, Helbron D, Lennert K. Primary malignant lymphomas localized in salivary glands. *Histopathology* 1982;6:673-687.
189. Fishleder A, Tubbs R, Hesse B, et al. Uniform detection of immunoglobulin gene rearrangement in benign lymphoepithelial lesions. *N Engl J Med* 1987;316:1118-1121.
190. Speight PM, Jordan R, Colloby P, et al. Early detection of lymphomas in Sjögren's syndrome by in situ hybridisation for kappa and lambda light chain mRNA in labial salivary glands. *Eur J Cancer B Oral Oncol* 1994;30B: 244-247.
191. Groom J, Kalled SL, Cutler AH, et al. Association of BAFF/BLyS overexpression and altered B cell differentiation with Sjögren's syndrome. *J Clin Invest* 2002;109:59-68.
192. Lindsay S, Dailey ME. Malignant lymphoma of the thyroid gland and its relation to Hashimoto disease: A clinical and pathologic study of 8 patients. *J Clin Endocrinol* 1955;15:1332.
193. Aozasa K, Inoue A, Tajima K, et al. Malignant lymphomas of the thyroid gland. Analysis of 79 patients with emphasis on histologic prognostic factors. *Cancer* 1986;58:100-104.
194. Holm LE, Blomgren H, Lowhagen T. Cancer risks in patients with chronic lymphocytic thyroiditis. *N Engl J Med* 1985;312:601-604.
195. Ben-Ezra J, Wu A, Sheibani K. Hashimoto's thyroiditis lacks detectable clonal immunoglobulin and T cell receptor gene rearrangements. *Human Pathol* 1988;19:1444-1448.
196. Moshynska OV, Saxena A. Clonal relationship between Hashimoto thyroiditis and thyroid lymphoma. *J Clin Pathol* 2008;61:438-444.
197. Hyjek E, Isaacson PG. Primary B cell lymphoma of the thyroid and its relationship to Hashimoto's thyroiditis. *Hum Pathol* 1988;19:1315-1326.

198. Bernatsky S, Ramsey-Goldman R, Clarke A. Malignancy and autoimmunity. *Curr Opin Rheumatol* 2006;18:129-134.
199. Baecklund E, Backlin C, Iliadou A, et al. Characteristics of diffuse large B cell lymphomas in rheumatoid arthritis. *Arthritis Rheumat* 2006;54:3774-3781.
200. Wolfe F, Michaud K. Lymphoma in rheumatoid arthritis: the effect of methotrexate and anti-tumor necrosis factor therapy in 18,572 patients. *Arthritis Rheumat* 2004;50:1740-1751.
201. Lopez-Olivo MA, Tayar JH, Martinez-Lopez JA, et al. Risk of malignancies in patients with rheumatoid arthritis treated with biologic therapy: a meta-analysis. *JAMA* 2012;308:898-908.
202. Salloum E, Cooper DL, Howe G, et al. Spontaneous regression of lymphoproliferative disorders in patients treated with methotrexate for rheumatoid arthritis and other rheumatic diseases. *J Clin Oncol* 1996;14:1943-1949.
203. Hoshida Y, Xu JX, Fujita S, et al. Lymphoproliferative disorders in rheumatoid arthritis: clinicopathological analysis of 76 cases in relation to methotrexate medication. *J Rheumatol* 2007;34:322-331.
204. Lamy T, Loughran TP, Jr. How I treat LGL leukemia. *Blood* 2011;117: 2764-2774.
205. Bernatsky S, Boivin JF, Joseph L, et al. An international cohort study of cancer in systemic lupus erythematosus. *Arthritis Rheumat* 2005;52:1481-1490.
206. Castleman B, Iversen L, Menendez VP. Localized mediastinal lymph node hyperplasia resembling thymoma. *Cancer* 1956;9:822-830.
207. El-Osta HE, Kurzrock R. Castleman's disease: from basic mechanisms to molecular therapeutics. *Oncologist* 2011;16:497-511.
208. Keller AR, Hochholzer L, Castleman B. Hyaline-vascular and plasma-cell types of giant lymph node hyperplasia of the mediastinum and other locations. *Cancer* 1972;29:670-683.
209. Herrada J, Cabanillas F, Rice L, et al. The clinical behavior of localized and multicentric Castleman disease. *Ann Intern Med* 1998;128:657-662.
210. Marti S, Pahissa A, Guardia J, et al. Multicentric giant follicular lymph node hyperplasia. Favorable response to radiotherapy. *Cancer* 1983;51:808-810.
211. Peterson BA, Frizzera G. Multicentric Castleman's disease. *Semin Oncol* 1993;20:636-647.
212. Brandt SJ, Bodine DM, Dunbar CE, et al. Dysregulated interleukin 6 expression produces a syndrome resembling Castleman's disease in mice. *J Clin Invest* 1990;86:592-599.
213. Nishimoto N, Sasai M, Shima Y, et al. Improvement in Castleman's disease by humanized anti-interleukin-6 receptor antibody therapy. *Blood* 2000;95:56-61.
214. Frizzera G, Peterson BA, Bayrd ED, et al. A systemic lymphoproliferative disorder with morphologic features of Castleman's disease: clinical findings and clinicopathologic correlations in 15 patients. *J Clin Oncol* 1985;3:1202-1216.
215. Bower M. How I treat HIV-associated multicentric Castleman disease. *Blood* 2010;116:4415-4421.
216. Soulier J, Grollet L, Oksenhendler E, et al. Molecular analysis of clonality in Castleman's disease. *Blood* 1995;86:1131-1138.
217. Hanson CA, Frizzera G, Patton DF, et al. Clonal rearrangement for immunoglobulin and T-cell receptor genes in systemic Castleman's disease. Association with Epstein-Barr virus. *Am J Pathol* 1988;131:84-91.
218. Soulier J, Grollet L, Oksenhendler E, et al. Kaposi's sarcoma-associated herpesvirus-like DNA sequences in multicentric Castleman's disease. *Blood* 1995;86:1276-1280.
219. Dupin N, Diss TL, Kellam P, et al. HHV-8 is associated with a plasmablastic variant of Castleman disease that is linked to HHV-8-positive plasmablastic lymphoma. *Blood* 2000;95:1406-1412.
220. Larroche C, Cacoub P, Soulier J, et al. Castleman's disease and lymphoma: report of eight cases in HIV-negative patients and literature review. *Am J Hematol* 2002;69:119-126.
221. Waterston A, Bower M. Fifty years of multicentric Castleman's disease. *Acta Oncol* 2004;43:698-704.
222. Hoffmann C, Schmid H, Muller M, et al. Improved outcome with rituximab in patients with HIV-associated multicentric Castleman disease. *Blood* 2011;118:3499-3503.

223. Krikorian JG, Burke JS, Rosenberg SA, et al. Occurrence of non-Hodgkin's lymphoma after therapy for Hodgkin's disease. *N Engl J Med* 1979;300: 452-458.
224. Jacquillat C, Khayat D, Desprez-Curely JP, et al. Non-Hodgkin's lymphoma occurring after Hodgkin's disease. Four new cases and a review of the literature. *Cancer* 1984;53:459-462.
225. List AF, Greer JP, Cousar JB, et al. Non-Hodgkin's lymphoma after treatment of Hodgkin's disease: association with Epstein-Barr virus. *Ann Intern Med* 1986;105:668-673.
226. Al-Mansour M, Connors JM, Gascoyne RD, et al. Transformation to aggressive lymphoma in nodular lymphocyte-predominant Hodgkin's lymphoma. *J Clin Oncol* 2010;28:793-799.
227. Ohno T, Huang JZ, Wu G, et al. The tumor cells in nodular lymphocyte-predominant Hodgkin disease are clonally related to the large cell lymphoma occurring in the same individual. Direct demonstration by single cell analysis. *Am J Clin Pathol* 2001;116:506-511.
228. Gualco G, Natkunam Y, Bacchi CE. The spectrum of B-cell lymphoma, unclassifiable, with features intermediate between diffuse large B-cell lymphoma and classical Hodgkin lymphoma: a description of 10 cases. *Modern Pathol Official J US Canad Acad Pathol* 2012;25:661-674.
229. Casey TT, Cousar JB, Mangum M, et al. Monomorphic lymphomas arising in patients with Hodgkin's disease. Correlation of morphologic, immunophenotypic, and molecular genetic findings in 12 cases. *Am J Pathol* 1990;136:81-94.
230. Gowitt GT, Chan WC, Brynes RK, et al. T-cell lymphoma following Hodgkin's disease. *Cancer* 1985;56:1191-1196.
231. Li FP, Gimbrere K, Ritz J, et al. Lymphoma with clonal T-cell receptor gene rearrangement in a 25-year survivor of Hodgkin's disease. *Cancer* 1987;60:2213-2218.
232. Macon WR, Williams ME, Greer JP, et al. Natural killer-like T-cell lymphomas: aggressive lymphomas of T-large granular lymphocytes. *Blood* 1996;87:1474-1483.
233. Belhadj K, Reyes F, Farcet JP, et al. Hepatosplenic gammadelta T-cell lymphoma is a rare clinicopathologic entity with poor outcome: report on a series of 21 patients. *Blood* 2003;102:4261-4269.
234. Arzoo KK, Bu X, Espina BM, et al. T-cell lymphoma in HIV-infected patients. *J Acquir Imm Def Syn* 2004;36:1020-1027.
235. Loughran TP, Jr., Kadin ME, Deeg HJ. T-cell intestinal lymphoma associated with celiac sprue. *Ann Intern Med* 1986;104:44-47.
236. Isaacson PG, O'Connor NT, Spencer J, et al. Malignant histiocytosis of the intestine: a T-cell lymphoma. *Lancet* 1985;2:688-691.
237. Popplewell L, Thomas SH, Huang Q, et al. Primary anaplastic large-cell lymphoma associated with breast implants. *Leuk Lymphoma* 2011;52:1481-1487.
238. Weiss LM, Wood GS, Trela M, et al. Clonal T-cell populations in lymphomatoid papulosis. Evidence of a lymphoproliferative origin for a clinically benign disease. *N Engl J Med* 1986;315:475-479.
239. Weiss LM, Wood GS, Ellisen LW, et al. Clonal T-cell populations in pityriasis lichenoides et varioliformis acuta (MUCHA-Habermann disease). *Am J Pathol* 1987;126:417-421.
240. LeBoit PE, Beckstead JH, Bond B, et al. Granulomatous slack skin: clonal rearrangement of the T-cell receptor beta gene is evidence for the lymphoproliferative nature of a cutaneous elastolytic disorder. *J Invest Dermatol* 1987;89:183-186.
241. Wood GS, Weiss LM, Hu CH, et al. T-cell antigen deficiencies and clonal rearrangements of T-cell receptor genes in pagetoid reticulosis (Woringer-Kolopp disease). *N Engl J Med* 1988;318:164-167.
242. Rosenberg SA, Diamond HD, Jaslowitz B, et al. Lymphosarcoma: A review of 1269 cases. *Medicine* 1961;40:31-84.
243. Jones SE, Fuks Z, Bull M, et al. Non-Hodgkin's lymphomas. IV. Clinicopathologic correlation in 405 cases. *Cancer* 1973;31:806-823.
244. Matutes E, Parry-Jones N, Brito-Babapulle V, et al. The leukemic presentation of mantle-cell lymphoma: disease features and prognostic factors in 58 patients. *Leuk Lymphoma* 2004;45:2007-2015.
245. Tam CS, Prince HM, Westerman D, et al. Leukaemic subtype of marginal zone lymphoma: a presentation of three cases and literature review. *Leuk Lymphoma* 2004;45:705-710.

246. Ghimire P, Wu GY, Zhu L. Primary gastrointestinal lymphoma. *World J Gastroenterol* 2011;17:697-707.
247. List AF, Greer JP, Cousar JC, et al. Non-Hodgkin's lymphoma of the gastrointestinal tract: an analysis of clinical and pathologic features affecting outcome. *J Clin Oncol* 1988;6:1125-1133.
248. Bilsel Y, Balik E, Yamaner S, et al. Clinical and therapeutic considerations of rectal lymphoma: a case report and literature review. *World J Gastroenterol* 2005;11:460-461.
249. Kodama T, Ohshima K, Nomura K, et al. Lymphomatous polyposis of the gastrointestinal tract, including mantle cell lymphoma, follicular lymphoma and mucosa-associated lymphoid tissue lymphoma. *Histopathology* 2005;47:467-478.
250. Romaguera JE, Medeiros LJ, Hagemester FB, et al. Frequency of gastrointestinal involvement and its clinical significance in mantle cell lymphoma. *Cancer* 2003;97:586-591.
251. Salmon JS, Thompson MA, Arildsen RC, et al. Non-Hodgkin's lymphoma involving the liver: clinical and therapeutic considerations. *Clin Lymphoma Myeloma* 2006;6:273-280.
252. Masood A, Kairouz S, Hudhud KH, et al. Primary non-Hodgkin lymphoma of liver. *Curr Oncol* 2009;16:74-77.
253. Milosevic R, Todorovic M, Balint B, et al. Splenectomy with chemotherapy vs surgery alone as initial treatment for splenic marginal zone lymphoma. *World J Gastroenterol* 2009;15:4009-4015.
254. Ohsawa M, Aozasa K, Horiuchi K, et al. Malignant lymphoma of the liver. Report of five cases and review of the literature. *Dig Dis Sci* 1992;37:1105-1109.
255. Thompson DR, Faust TW, Stone MJ, et al. Hepatic failure as the presenting manifestation of malignant lymphoma. *Clin Lymphoma* 2001;2:123-128.
256. Sah A, Barrans SL, Parapia LA, et al. Cutaneous B-cell lymphoma: pathological spectrum and clinical outcome in 51 consecutive patients. *Am J Hematol* 2004;75:195-199.
257. Zackheim HS, Vonderheid EC, Ramsay DL, et al. Relative frequency of various forms of primary cutaneous lymphomas. *Am Acad Dermatol* 2000;43:793-796.
258. Stein H, Foss HD, Durkop H, et al. CD30(+) anaplastic large cell lymphoma: a review of its histopathologic, genetic, and clinical features. *Blood* 2000;96:3681-3695.
259. Batchelor T, Loeffler JS. Primary CNS lymphoma. *J Clin Oncol* 2006;24: 1281-1288.
260. Shenker TN, Blay JY, O'Neill BP, et al. Primary CNS lymphoma of T-cell origin: a descriptive analysis from the international primary CNS lymphoma collaborative group. *J Clin Oncol* 2005;23:2233-2239.
261. Feuerhake F, Baumer C, Cyron D, et al. Primary CNS lymphoma in immunocompetent patients from 1989 to 2001: a retrospective analysis of 164 cases uniformly diagnosed by stereotactic biopsy. *Acta Neurochir (Wien)* 2006;148:831-838; discussion 8.
262. Pierce MA, Johnson MD, Maciunas RJ, et al. Evaluating contrast-enhancing brain lesions in patients with AIDS by using positron emission tomography. *Ann Intern Med* 1995;123:594-598.
263. Shenker TN. Unusual variants of primary central nervous system lymphoma. *Hematol/Oncol Clin N Am* 2005;19:651-664, vi.
264. Baehring JM, Damek D, Martin EC, et al. Neurolymphomatosis. *Neuro-oncol* 2003;5:104-115.
265. Ponzoni M, Ferreri AJ, Campo E, et al. Definition, diagnosis, and management of intravascular large B-cell lymphoma: proposals and perspectives from an international consensus meeting. *J Clin Oncol* 2007;25:3168-3173.
266. Ferreri AJ, Blay JY, Reni M, et al. Prognostic scoring system for primary CNS lymphomas: the International Extranodal Lymphoma Study Group experience. *J Clin Oncol* 2003;21:266-272.
267. Szekely G, Miltenyi Z, Mezey G, et al. Epidural malignant lymphomas of the spine: collected experiences with epidural malignant lymphomas of the spinal canal and their treatment. *Spinal cord* 2008;46:278-281.
268. Corriveau C, Easterbrook M, Payne D. Lymphoma simulating uveitis (masquerade syndrome). *Can J Ophthalmol* 1986;21:144-149.
269. Shenker TN, Connors JM. Primary extranodal non-Hodgkin's lymphomas. In: Canellos, GP, Lister, TA, Young, BD, eds. *The lymphomas*. Philadelphia, PA: Saunders, Elsevier, 2006:325-347.

270. Woolf DK, Ahmed M, Plowman PN. Primary lymphoma of the ocular adnexa (orbital lymphoma) and primary intraocular lymphoma. *Clin Oncol* 2012;24:339-344.
271. Ostrowski ML, Unni KK, Banks PM, et al. Malignant lymphoma of bone. *Cancer* 1986;58:2646-2655.
272. Bacci G, Ferraro A, Casadei R, et al. Primary lymphoma of bone: long term results in patients treated with vincristine-adriamycin-cyclophosphamide and local radiation. *J Chemother* 1991;3:189-193.
273. Hugh JC, Jackson FI, Hanson J, et al. Primary breast lymphoma. An immunohistologic study of 20 new cases. *Cancer* 1990;66:2602-2611.
274. Cordier JF, Chailleux E, Lauque D, et al. Primary pulmonary lymphomas. A clinical study of 70 cases in nonimmunocompromised patients. *Chest* 1993;103:201-208.
275. Kim JH, Lee SH, Park J, et al. Primary pulmonary non-Hodgkin's lymphoma. *Jpn J Clin Oncol* 2004;34:510-514.
276. Aozasa K, Ohsawa M, Iuchi K, et al. Prognostic factors for pleural lymphoma patients. *Jpn J Clin Oncol* 1991;21:417-421.
277. Zaharia L, Gill PS. Primary cardiac lymphoma. *Am J Clin Oncol* 1991;14: 142-145.
278. Choi CH, Durishin M, Garbadawala ST, et al. Non-Hodgkin's lymphoma of the adrenal gland. *Arch Pathol Lab Med* 1990;114:883-885.
279. Kuyama A, Takeuchi M, Munemasa M, et al. Successful treatment of primary adrenal non-Hodgkin's lymphoma associated with adrenal insufficiency. *Leuk Lymphoma* 2000;38:203-205.
280. Carbone PP, Kaplan HS, Musshoff K, et al. Report of the Committee on Hodgkin's disease staging classification. *Cancer Res* 1971;31:1860-1861.
281. Coiffier B, Gisselbrecht C, Vose JM, et al. Prognostic factors in aggressive malignant lymphomas: description and validation of a prognostic index that could identify patients requiring a more intensive therapy. The Groupe d'Etudes des Lymphomes Agressifs. *J Clin Oncol* 1991;9: 211-219.
282. Rodriguez J, Cabanillas F, McLaughlin P, et al. A proposal for a simple staging system for intermediate grade lymphoma and immunoblastic lymphoma based on the 'tumor score'. *Ann Oncol Official J Eur Soc Med Oncol ESMO* 1992;3:711-717.
283. A predictive model for aggressive non-Hodgkin's lymphoma. The International Non-Hodgkin's Lymphoma Prognostic Factors Project. *N Engl J Med* 1993;329:987-994.
284. Armitage JO, Weisenburger DD. New approach to classifying non-Hodgkin's lymphomas: Clinical features of the major histologic subtypes. Non-Hodgkin's Lymphoma Classification Project. *J Clin Oncol* 1998;16:2780-2795.
285. Lopez-Guillermo A, Montserrat E, Bosch F, et al. Applicability of the International Index for aggressive lymphomas to patients with low-grade lymphoma. *J Clin Oncol* 1994;12:1343-1348.
286. Moormeier JA, Williams SF, Golomb HM. The staging of non-Hodgkin's lymphomas. *Semin Oncol* 1990;17:43-50.
287. Duggan PR, Easton D, Luidier J, et al. Bone marrow staging of patients with non-Hodgkin lymphoma by flow cytometry: correlation with morphology. *Cancer* 2000;88:894-899.
288. Collier BS, Chabner BA, Gralnick HR. Frequencies and patterns of bone marrow involvement in non-Hodgkin lymphomas: Observations on the value of bilateral biopsies. *Am J Hematol* 1977;3:105-119.
289. Yasumoto M, Nonomura Y, Yoshimura R, et al. MR detection of iliac bone marrow involvement by malignant lymphoma with various MR sequences including diffusion-weighted echo-planar imaging. *Skeletal Radiol* 2002;31:263-269.
290. Price CG, Meerabux J, Murtagh S, et al. The significance of circulating cells carrying t(14;18) in long remission from follicular lymphoma. *J Clin Oncol* 1991;9:1527-1532.
291. Haioun C, Itti E, Rahmouni A, et al. [18F]fluoro-2-deoxy-D-glucose positron emission tomography (FDG-PET) in aggressive lymphoma: an early prognostic tool for predicting patient outcome. *Blood* 2005;106:1376-1381.
292. Johnson PW, Rohatiner AZ, Whelan JS, et al. Patterns of survival in patients with recurrent follicular lymphoma: a 20-year study from a single center. *J Clin Oncol* 1995;13:140-147.

293. Bartlett NL, Rizeq M, Dorfman RF, et al. Follicular large-cell lymphoma: intermediate or low grade? *J Clin Oncol* 1994;12:1349-1357.
294. Ghesquieres H, Berger F, Felman P, et al. Clinicopathologic characteristics and outcome of diffuse large B-cell lymphomas presenting with an associated low-grade component at diagnosis. *J Clin Oncol* 2006;24:5234-5241.
295. Sehn LH, Scott DW, Chhanabhai M, et al. Impact of concordant and discordant bone marrow involvement on outcome in diffuse large B-cell lymphoma treated with R-CHOP. *J Clin Oncol* 2011;29:1452-1457.
296. Gisselbrecht C, Gaulard P, Lepage E, et al. Prognostic significance of T-cell phenotype in aggressive non-Hodgkin's lymphomas. Groupe d'Etudes des Lymphomes de l'Adulte (GELA). *Blood* 1998;92:76-82.
297. Melnyk A, Rodriguez A, Pugh WC, et al. Evaluation of the Revised European-American Lymphoma classification confirms the clinical relevance of immunophenotype in 560 cases of aggressive non-Hodgkin's lymphoma. *Blood* 1997;89:4514-4520.
298. Anderson JR, Jenkin RD, Wilson JF, et al. Long-term follow-up of patients treated with COMP or LSA2L2 therapy for childhood non-Hodgkin's lymphoma: A report of CCG-551 from the Childrens Cancer Group. *J Clin Oncol* 1993;11:1024-1032.
299. Coiffier B, Lepage E, Briere J, et al. CHOP chemotherapy plus rituximab compared with CHOP alone in elderly patients with diffuse large-B-cell lymphoma. *N Engl J Med* 2002;346:235-242.
300. Sehn LH, Berry B, Chhanabhai M, et al. The revised International Prognostic Index (R-IPI) is a better predictor of outcome than the standard IPI for patients with diffuse large B-cell lymphoma treated with R-CHOP. *Blood* 2007;109:1857-1861.
301. Cresswell P, Springer T, Strominger JL, et al. Immunological identity of the small subunit of HL-A antigens and beta2-microglobulin and its turnover on the cell membrane. *Proc Natl Acad Sci USA* 1974;71:2123-2127.
302. Swan F, Jr., Velasquez WS, Tucker S, et al. A new serologic staging system for large-cell lymphomas based on initial beta 2-microglobulin and lactate dehydrogenase levels. *J Clin Oncol* 1989;7:1518-1527.
303. Pizzolo G, Chilosi M, Semenzato G. The soluble interleukin-2 receptor in haematological disorders. *Br J Haematol* 1987;67:377-380.
304. Solal-Celigny P, Roy P, Colombat P, et al. Follicular lymphoma international prognostic index. *Blood* 2004;104:1258-1265.
305. Federico M, Bellei M, Marcheselli L, et al. Follicular lymphoma international prognostic index 2: a new prognostic index for follicular lymphoma developed by the international follicular lymphoma prognostic factor project. *J Clin Oncol* 2009;27:4555-4562.
306. Determann O, Hoster E, Ott G, et al. Ki-67 predicts outcome in advanced-stage mantle cell lymphoma patients treated with anti-CD20 immunochemotherapy: results from randomized trials of the European MCL Network and the German Low Grade Lymphoma Study Group. *Blood* 2008;111:2385-2387.
307. Gallamini A, Stelitano C, Calvi R, et al. Peripheral T-cell lymphoma unspecified (PTCL-U): a new prognostic model from a retrospective multicentric clinical study. *Blood* 2004;103:2474-2479.
308. Yatabe Y, Suzuki R, Tobinai K, et al. Significance of cyclin D1 overexpression for the diagnosis of mantle cell lymphoma: a clinicopathologic comparison of cyclin D1-positive MCL and cyclin D1-negative MCL-like B-cell lymphoma. *Blood* 2000;95:2253-2261.
309. Miller TP, Grogan TM, Dahlberg S, et al. Prognostic significance of the Ki-67-associated proliferative antigen in aggressive non-Hodgkin's lymphomas: a prospective Southwest Oncology Group trial. *Blood* 1994;83:1460-1466.
310. Kutok JL, Aster JC. Molecular biology of anaplastic lymphoma kinase-positive anaplastic large-cell lymphoma. *J Clin Oncol* 2002;20:3691-3702.
311. Winter JN, Weller EA, Horning SJ, et al. Prognostic significance of Bcl-6 protein expression in DLBCL treated with CHOP or R-CHOP: a prospective correlative study. *Blood* 2006;107:4207-4213.
312. Falini B, Pileri S, Zinzani PL, et al. ALK lymphoma: clinico-pathological findings and outcome. *Blood* 1999;93:2697-2706.

313. Gascoyne RD, Aoun P, Wu D, et al. Prognostic significance of anaplastic lymphoma kinase (ALK) protein expression in adults with anaplastic large cell lymphoma. *Blood* 1999;93:3913-3921.
314. Iqbal J, Neppalli VT, Wright G, et al. BCL2 expression is a prognostic marker for the activated B-cell-like type of diffuse large B-cell lymphoma. *J Clin Oncol* 2006;24:961-968.
315. Choi WW, Weisenburger DD, Greiner TC, et al. A new immunostain algorithm classifies diffuse large B-cell lymphoma into molecular subtypes with high accuracy. *Clin Cancer Res Official J Am Assoc Cancer Res* 2009;15:5494-5502.
316. Barrans SL, Fenton JA, Banham A, et al. Strong expression of FOXP1 identifies a distinct subset of diffuse large B-cell lymphoma (DLBCL) patients with poor outcome. *Blood* 2004;104:2933-2935.
317. Hans CP, Weisenburger DD, Greiner TC, et al. Confirmation of the molecular classification of diffuse large B-cell lymphoma by immunohistochemistry using a tissue microarray. *Blood* 2004;103:275-282.
318. van Imhoff GW, Boerma EJ, van der Holt B, et al. Prognostic impact of germinal center-associated proteins and chromosomal breakpoints in poor-risk diffuse large B-cell lymphoma. *J Clin Oncol* 2006;24:4135-4142.
319. Johnson NA, Slack GW, Savage KJ, et al. Concurrent expression of MYC and BCL2 in diffuse large B-cell lymphoma treated with rituximab plus cyclophosphamide, doxorubicin, vincristine, and prednisone. *J Clin Oncol* 2012;30:3452-3459.
320. Green TM, Young KH, Visco C, et al. Immunohistochemical double-hit score is a strong predictor of outcome in patients with diffuse large B-cell lymphoma treated with rituximab plus cyclophosphamide, doxorubicin, vincristine, and prednisone. *J Clin Oncol* 2012;30:3460-3467.
321. Leroy K, Haioun C, Lepage E, et al. p53 gene mutations are associated with poor survival in low and low-intermediate risk diffuse large B-cell lymphomas. *Ann Oncol Official J Eur Soc Med Oncol/ESMO* 2002;13:1108-1115.
322. Pescarmona E, Pignoloni P, Puopolo M, et al. p53 over-expression identifies a subset of nodal peripheral T-cell lymphomas with a distinctive biological profile and poor clinical outcome. *J Pathol* 2001;195:361-366.
323. Alizadeh AA, Eisen MB, Davis RE, et al. Distinct types of diffuse large B-cell lymphoma identified by gene expression profiling. *Nature* 2000;403: 503-511.
324. Rosenwald A, Wright G, Chan WC, et al. The use of molecular profiling to predict survival after chemotherapy for diffuse large-B-cell lymphoma. *N Engl J Med* 2002;346:1937-1947.
325. Rosenwald A, Wright G, Leroy K, et al. Molecular diagnosis of primary mediastinal B cell lymphoma identifies a clinically favorable subgroup of diffuse large B cell lymphoma related to Hodgkin lymphoma. *J Exp Med* 2003;198:851-862.
326. Perry AM, Cardesa-Salzmann TM, Meyer PN, et al. A new biologic prognostic model based on immunohistochemistry predicts survival in patients with diffuse large B-cell lymphoma. *Blood* 2012;120:2290-2296.
327. Savage KJ, Johnson NA, Ben-Neriah S, et al. MYC gene rearrangements are associated with a poor prognosis in diffuse large B-cell lymphoma patients treated with R-CHOP chemotherapy. *Blood* 2009;114:3533-3537.
328. Gascoyne RD, Rosenwald A, Poppema S, et al. Prognostic biomarkers in malignant lymphomas. *Leuk Lymphoma* 2010;51(Suppl 1):11-19.
329. Dave SS, Wright G, Tan B, et al. Prediction of survival in follicular lymphoma based on molecular features of tumor-infiltrating immune cells. *N Engl J Med* 2004;351:2159-2169.
330. Farinha P, Masoudi H, Skinnider BF, et al. Analysis of multiple biomarkers shows that lymphoma-associated macrophage (LAM) content is an independent predictor of survival in follicular lymphoma (FL). *Blood* 2005;106:2169-2174.
331. Carreras J, Lopez-Guillermo A, Fox BC, et al. High numbers of tumor-infiltrating FOXP3-positive regulatory T cells are associated with improved overall survival in follicular lymphoma. *Blood* 2006;108:2957-2964.
332. Lee AM, Clear AJ, Calaminici M, et al. Number of CD4+ cells and location of forkhead box protein P3-positive cells in diagnostic follicular lymphoma tissue microarrays correlates with outcome. *J Clin Oncol* 2006;24:5052-5059.
333. Wilson WH, Dunleavy K, Pittaluga S, et al. Phase II study of dose-adjusted EPOCH and rituximab in untreated diffuse large B-cell lymphoma with analysis of germinal center and post-germinal center biomarkers. *J Clin Oncol* 2008;26:2717-2724.
334. Cheson BD. Role of functional imaging in the management of lymphoma. *J Clin Oncol* 2011;29:1844-1854.

335. Spaepen K, Stroobants S, Dupont P, et al. Prognostic value of pretransplantation positron emission tomography using fluorine 18-fluorodeoxyglucose in patients with aggressive lymphoma treated with high-dose chemotherapy and stem cell transplantation. *Blood* 2003;102:53-59.
336. Pregno P, Chiappella A, Bello M, et al. Interim 18-FDG-PET/CT failed to predict the outcome in diffuse large B-cell lymphoma patients treated at the diagnosis with rituximab-CHOP. *Blood* 2012;119:2066-2073.
337. Safar V, Dupuis J, Itti E, et al. Interim [18F]fluorodeoxyglucose positron emission tomography scan in diffuse large B-cell lymphoma treated with anthracycline-based chemotherapy plus rituximab. *J Clin Oncol* 2012;30:184-190.
338. Mato AR, Svoboda J, Feldman T, et al. Post-treatment (not interim) positron emission tomography-computed tomography scan status is highly predictive of outcome in mantle cell lymphoma patients treated with R-HyperCVAD. *Cancer* 2012;118:3565-3570.
339. Trotman J, Fournier M, Lamy T, et al. Positron emission tomography-computed tomography (PET-CT) after induction therapy is highly predictive of patient outcome in follicular lymphoma: analysis of PET-CT in a subset of PRIMA trial participants. *J Clin Oncol* 2011;29:3194-3200.
340. Cheson BD, Pfistner B, Juweid ME, et al. Revised response criteria for malignant lymphoma. *J Clin Oncol* 2007;25:579-586.
341. Juweid ME, Stroobants S, Hoekstra OS, et al. Use of positron emission tomography for response assessment of lymphoma: consensus of the Imaging Subcommittee of International Harmonization Project in Lymphoma. *J Clin Oncol* 2007;25:571-578.
342. Vose JM, Armitage JO, Weisenburger DD, et al. The importance of age in survival of patients treated with chemotherapy for aggressive non-Hodgkin's lymphoma. *J Clin Oncol* 1988;6:1838-1844.
343. Fields PA, Linch DC. Treatment of the elderly patient with diffuse large B cell lymphoma. *Br J Haematol* 2012;157:159-170.
344. Solal-Celigny P, Chastang C, Herrera A, et al. Age as the main prognostic factor in adult aggressive non-Hodgkin's lymphoma. *Am J Med* 1987;83:1075-1079.
345. Hermans J, Krol AD, van Groningen K, et al. International Prognostic Index for aggressive non-Hodgkin's lymphoma is valid for all malignancy grades. *Blood* 1995;86:1460-1463.
346. Ansell SM, Habermann TM, Kurtin PJ, et al. Predictive capacity of the International Prognostic Factor Index in patients with peripheral T-cell lymphoma. *J Clin Oncol* 1997;15:2296-2301.
347. Cheson BD, Horning SJ, Coiffier B, et al. Report of an international workshop to standardize response criteria for non-Hodgkin's lymphomas. NCI Sponsored International Working Group. *J Clin Oncol* 1999;17:1244.
348. Biagi JJ, Seymour JF. Insights into the molecular pathogenesis of follicular lymphoma arising from analysis of geographic variation. *Blood* 2002;99:4265-4275.
349. Chang KC, Huang GC, Jones D, et al. Distribution and prognosis of WHO lymphoma subtypes in Taiwan reveals a low incidence of germinal-center derived tumors. *Leuk Lymphoma* 2004;45:1375-1384.
350. Freedman A. Follicular lymphoma: 2012 update on diagnosis and management. *Am J Hematol* 2012;87:988-995.
351. Stein RS, Greer JP, Cousar JB, et al. Malignant lymphomas of follicular centre cell origin in man. VII. Prognostic features in small cleaved cell lymphoma. *Hematol Oncol* 1989;7:381-391.
352. Horning SJ. Natural history of and therapy for the indolent non-Hodgkin's lymphomas. *Semin Oncol* 1993;20:75-88.
353. Arber DA, George TI. Bone marrow biopsy involvement by non-Hodgkin's lymphoma: frequency of lymphoma types, patterns, blood involvement, and discordance with other sites in 450 specimens. *Am J Surg Pathol* 2005;29:1549-1557.
354. Lambrechts AC, Hupkes PE, Dorssers LC, et al. Translocation (14;18)-positive cells are present in the circulation of the majority of patients with localized (stage I and II) follicular non-Hodgkin's lymphoma. *Blood* 1993;82: 2510-2516.
355. Arcaini L, Colombo N, Bernasconi P, et al. Role of the molecular staging and response in the management of follicular lymphoma patients. *Leuk Lymphoma* 2006;47:1018-1022.
356. Lopez-Guillermo A, Cabanillas F, McDonnell TI, et al. Correlation of bcl-2 rearrangement with clinical characteristics and outcome in indolent follicular lymphoma. *Blood* 1999;93:3081-3087.

357. Rambaldi A, Lazzari M, Manzoni C, et al. Monitoring of minimal residual disease after CHOP and rituximab in previously untreated patients with follicular lymphoma. *Blood* 2002;99:856-862.
358. Wang SA, Wang L, Hochberg EP, et al. Low histologic grade follicular lymphoma with high proliferation index: morphologic and clinical features. *Am J Surg Pathol* 2005;29:1490-1496.
359. Koster A, Tromp HA, Raemaekers JM, et al. The prognostic significance of the intra-follicular tumor cell proliferative rate in follicular lymphoma. *Haematologica* 2007;92:184-190.
360. Swenson WT, Wooldridge JE, Lynch CF, et al. Improved survival of follicular lymphoma patients in the United States. *J Clin Oncol* 2005;23:5019-5026.
361. Fisher RI, LeBlanc M, Press OW, et al. New treatment options have changed the survival of patients with follicular lymphoma. *J Clin Oncol* 2005;23:8447-8452.
362. Hoglund M, Sehn L, Connors JM, et al. Identification of cytogenetic subgroups and karyotypic pathways of clonal evolution in follicular lymphomas. *Genes Chromos Cancer* 2004;39:195-204.
363. Solal-Celigny P, Cahu X, Cartron G. Follicular lymphoma prognostic factors in the modern era: what is clinically meaningful? *Int J Hematol* 2010;92:246-254.
364. Taskinen M, Karjalainen-Lindsberg ML, Nyman H, et al. A high tumor-associated macrophage content predicts favorable outcome in follicular lymphoma patients treated with rituximab and cyclophosphamide-doxorubicin-vincristine-prednisone. *Clin Cancer Res Official J Am Assoc Cancer Res* 2007;13:5784-5789.
365. Nola M, Pavletic SZ, Weisenburger DD, et al. Prognostic factors influencing survival in patients with B-cell small lymphocytic lymphoma. *Am J Hematol* 2004;77:31-35.
366. Coelho Siqueira SA, Ferreira Alves VA, Beitler B, et al. Contribution of immunohistochemistry to small B-cell lymphoma classification. *Appl Immunohistochem Mol Morphol* 2006;14:1-6.
367. Ben-Ezra J, Burke JS, Swartz WG, et al. Small lymphocytic lymphoma: a clinicopathologic analysis of 268 cases. *Blood* 1989;73:579-587.
368. Morrison WH, Hoppe RT, Weiss LM, et al. Small lymphocytic lymphoma. *J Clin Oncol* 1989;7:598-606.
369. Gibson SE, Swerdlow SH, Ferry JA, et al. Reassessment of small lymphocytic lymphoma in the era of monoclonal B-cell lymphocytosis. *Haematologica* 2011;96:1144-1152.
370. Gribben JG. How I treat CLL up front. *Blood* 2010;115:187-197.
371. Berger F, Felman P, Thieblemont C, et al. Non-MALT marginal zone B-cell lymphomas: a description of clinical presentation and outcome in 124 patients. *Blood* 2000;95:1950-1956.
372. Offit K, Louie DC, Parsa NZ, et al. Clinical and morphologic features of B-cell small lymphocytic lymphoma with del(6)(q21q23). *Blood* 1994;83:2611-2618.
373. Grever MR, Lucas DM, Dewald GW, et al. Comprehensive assessment of genetic and molecular features predicting outcome in patients with chronic lymphocytic leukemia: results from the US Intergroup Phase III Trial E2997. *J Clin Oncol* 2007;25:799-804.
374. Hamblin TJ, Davis Z, Gardiner A, et al. Unmutated Ig V(H) genes are associated with a more aggressive form of chronic lymphocytic leukemia. *Blood* 1999;94:1848-1854.
375. Richter MN. Generalized reticular cell sarcoma of lymph nodes associated with lymphatic leukemia. *Am J Med* 1928;68:539.
376. Robertson LE, Pugh W, O'Brien S, et al. Richter's syndrome: a report on 39 patients. *J Clin Oncol* 1993;11:1985-1989.
377. Richards MA, Hall PA, Gregory WM, et al. Lymphoplasmacytoid and small cell centrocytic non-Hodgkin's lymphoma—a retrospective analysis from St Bartholomew's Hospital 1972-1986. *Hematol Oncol* 1989;7:19-35.
378. Lin P, Medeiros LJ. Lymphoplasmacytic lymphoma/Waldenström macroglobulinemia: an evolving concept. *Adv Anat Pathol* 2005;12:246-255.
379. Izumi T, Sasaki R, Tsunoda S, et al. B cell malignancy and hepatitis C virus infection. *Leukemia* 1997;11(Suppl 3):516-518.

380. Kristinsson SY, Koshiol J, Bjorkholm M, et al. Immune-related and inflammatory conditions and risk of lymphoplasmacytic lymphoma or Waldenström macroglobulinemia. *J Natl Cancer Inst* 2010;102:557-567.
381. Treon SP, Xu L, Yang G, et al. MYD88 L265P somatic mutation in Waldenström's macroglobulinemia. *N Engl J Med* 2012;367:826-833.
382. Gertz MA. Waldenström's macroglobulinemia: a review of therapy. *Leuk Lymphoma* 2002;43:1517-1526.
383. Dhodapkar MV, Hoering A, Gertz MA, et al. Long-term survival in Waldenström macroglobulinemia: 10-year follow-up of Southwest Oncology Group-directed intergroup trial S9003. *Blood* 2009;113:793-796.
384. Thieblemont C, Davi F, Noguera ME, et al. Non-MALT marginal zone lymphoma. *Curr Opin Hematol* 2011;18:273-279.
385. Nathwani BN, Anderson JR, Armitage JO, et al. Marginal zone B-cell lymphoma: A clinical comparison of nodal and mucosa-associated lymphoid tissue types. Non-Hodgkin's Lymphoma Classification Project. *J Clin Oncol* 1999;17:2486-2492.
386. Thieblemont C. Clinical presentation and management of marginal zone lymphomas. *Hematology (Am Soc Hematol Educ Program)* 2005:307-313.
387. Rinaldi A, Mian M, Chigrinova E, et al. Genome-wide DNA profiling of marginal zone lymphomas identifies subtype-specific lesions with an impact on the clinical outcome. *Blood* 2011;117:1595-604.
388. Arcaini L, Lazzarino M, Colombo N, et al. Splenic marginal zone lymphoma: a prognostic model for clinical use. *Blood* 2006;107:4643-4649.
389. Mollejo M, Camacho FI, Algara P, et al. Nodal and splenic marginal zone B cell lymphomas. *Hematol Oncol* 2005;23:108-118.
390. Chacon JJ, Mollejo M, Munoz E, et al. Splenic marginal zone lymphoma: clinical characteristics and prognostic factors in a series of 60 patients. *Blood* 2002;100:1648-1654.
391. Franco V, Florena AM, Iannitto E. Splenic marginal zone lymphoma. *Blood* 2003;101:2464-2472.
392. Thieblemont C, Felman P, Berger F, et al. Treatment of splenic marginal zone B-cell lymphoma: an analysis of 81 patients. *Clin Lymphoma* 2002;3:41-47.
393. Salido M, Baro C, Oscier D, et al. Cytogenetic aberrations and their prognostic value in a series of 330 splenic marginal zone B-cell lymphomas: a multicenter study of the Splenic B-Cell Lymphoma Group. *Blood* 2010;116: 1479-1488.
394. Algara P, Mateo MS, Sanchez-Beato M, et al. Analysis of the IgV(H) somatic mutations in splenic marginal zone lymphoma defines a group of unmutated cases with frequent 7q deletion and adverse clinical course. *Blood* 2002;99:1299-1304.
395. Baldini L, Guffanti A, Cro L, et al. Poor prognosis in non-villous splenic marginal zone cell lymphoma is associated with p53 mutations. *Br J Haematol* 1997;99:375-378.
396. Freedman AS. Biology and management of histologic transformation of indolent lymphoma. *Hematol/ Edu Prog Am Soc Hematol Am Soc Hematol* 2005:314-320.
397. Lossos IS, Gascoyne RD. Transformation of follicular lymphoma. *Best Pract Res. Clin Haematol* 2011;24:147-163.
398. Oviatt DL, Cousar JB, Collins RD, et al. Malignant lymphomas of follicular center cell origin in humans. V. Incidence, clinical features, and prognostic implications of transformation of small cleaved cell nodular lymphoma. *Cancer* 1984;53:1109-1114.
399. Lee JT, Innes DJ, Jr., Williams ME. Sequential bcl-2 and c-myc oncogene rearrangements associated with the clinical transformation of non-Hodgkin's lymphoma. *J Clin Invest* 1989;84:1454-1459.
400. Yuen AR, Kamel OW, Halpern J, et al. Long-term survival after histologic transformation of low-grade follicular lymphoma. *J Clin Oncol* 1995;13:1726-1733.
401. Bastion Y, Sebban C, Berger F, et al. Incidence, predictive factors, and outcome of lymphoma transformation in follicular lymphoma patients. *J Clin Oncol* 1997;15:1587-1594.
402. Horning SJ, Rosenberg SA. The natural history of initially untreated low-grade non-Hodgkin's lymphomas. *N Engl J Med* 1984;311:1471-1475.

403. Montoto S, Davies AJ, Matthews J, et al. Risk and clinical implications of transformation of follicular lymphoma to diffuse large B-cell lymphoma. *J Clin Oncol* 2007;25:2426-2433.
404. Garvin AJ, Simon RM, Osborne CK, et al. An autopsy study of histologic progression in non-Hodgkin's lymphomas. 192 cases from the National Cancer Institute. *Cancer* 1983;52:393-398.
405. Lossos IS, Alizadeh AA, Diehn M, et al. Transformation of follicular lymphoma to diffuse large-cell lymphoma: alternative patterns with increased or decreased expression of c-myc and its regulated genes. *Proc Natl Acad Sci USA* 2002;99:8886-8891.
406. Sander CA, Yano T, Clark HM, et al. p53 mutation is associated with progression in follicular lymphomas. *Blood* 1993;82:1994-2004.
407. Tilly H, Rossi A, Stamatoullas A, et al. Prognostic value of chromosomal abnormalities in follicular lymphoma. *Blood* 1994;84:1043-1049.
408. Grem JL, Hafez GR, Brandenburg JH, et al. Spontaneous remission in diffuse large cell lymphoma. *Cancer* 1986;57:2042-2044.
409. Chung R, Lai R, Wei P, et al. Concordant but not discordant bone marrow involvement in diffuse large B-cell lymphoma predicts a poor clinical outcome independent of the International Prognostic Index. *Blood* 2007;110:1278-1282.
410. Dargent JL, Lespagnard L, Meiers I, et al. Composite follicular lymphoma and nodular lymphocyte predominance Hodgkin's disease. *Virchows Archiv Int J Pathol* 2005;447:778-780.
411. Hoeller S, Copie-Bergman C. Grey zone lymphomas: lymphomas with intermediate features. *Adv Hematol* 2012;2012:460801.
412. Chabner BA, Johnson RE, Young RC, et al. Sequential nonsurgical and surgical staging of non-Hodgkin's lymphoma. *Cancer* 1978;42:922-925.
413. Gallagher CJ, Gregory WM, Jones AE, et al. Follicular lymphoma: prognostic factors for response and survival. *J Clin Oncol* 1986;4:1470-1480.
414. MacManus MP, Hoppe RT. Is radiotherapy curative for stage I and II low-grade follicular lymphoma? Results of a long-term follow-up study of patients treated at Stanford University. *J Clin Oncol* 1996;14:1282-1290.
415. Guadagnolo BA, Li S, Neuberger D, et al. Long-term outcome and mortality trends in early-stage, Grade 1-2 follicular lymphoma treated with radiation therapy. *Int J Radiat Oncol Biol Phys* 2006;64:928-934.
416. Advani R, Rosenberg SA, Horning SJ. Stage I and II follicular non-Hodgkin's lymphoma: long-term follow-up of no initial therapy. *J Clin Oncol* 2004;22: 1454-1459.
417. Solal-Celigny P, Bellei M, Marcheselli L, et al. Watchful waiting in low-tumor burden follicular lymphoma in the rituximab era: results of an F2-study database. *J Clin Oncol* 2012;30:3848-3853.
418. Campbell BA, Voss N, Woods R, et al. Long-term outcomes for patients with limited stage follicular lymphoma: involved regional radiotherapy versus involved node radiotherapy. *Cancer* 2010;116:3797-3806.
419. Hainsworth JD, Litchy S, Burris HA, 3rd, et al. Rituximab as first-line and maintenance therapy for patients with indolent non-Hodgkin's lymphoma. *J Clin Oncol* 2002;20:4261-4267.
420. Ghielmini M, Schmitz SF, Cogliatti SB, et al. Prolonged treatment with rituximab in patients with follicular lymphoma significantly increases event-free survival and response duration compared with the standard weekly x 4 schedule. *Blood* 2004;103:4416-4423.
421. Buske C, Weigert O, Dreyling M, et al. Current status and perspective of antibody therapy in follicular lymphoma. *Haematologica* 2006;91:104-112.
422. Horning SJ. Treatment approaches to the low-grade lymphomas. *Blood* 1994;83:881-884.
423. Brice P, Bastion Y, Lepage E, et al. Comparison in low-tumor-burden follicular lymphomas between an initial no-treatment policy, prednimustine, or interferon alfa: a randomized study from the Groupe d'Etude des Lymphomes Folliculaires. *Groupe d'Etude des Lymphomes de l'Adulte. J Clin Oncol* 1997;15:1110-1117.
424. Bierman PJ, Vose JM, Anderson JR, et al. High-dose therapy with autologous hematopoietic rescue for follicular low-grade non-Hodgkin's lymphoma. *J Clin Oncol* 1997;15:445-450.

425. Hiddemann W, Buske C, Dreyling M, et al. Treatment strategies in follicular lymphomas: current status and future perspectives. *J Clin Oncol* 2005;23:6394-6399.
426. Rohatiner A, Davies A, Montato S, et al. Follicular lymphoma. In: Canellos, GP, Lister, TA, Young, BD, eds. *The lymphomas*, 2nd ed. Philadelphia, PA: W.B. Saunders Company, 2006:348-373.
427. Federico M, Molica S, Bellei M, et al. Prognostic factors in low-grade non-Hodgkin lymphomas. *Curr Hematol Malignancy Rep* 2009;4:202-210.
428. Young RC, Longo DL, Glatstein E, et al. The treatment of indolent lymphomas: watchful waiting v. aggressive combined modality treatment. *Semin Hematol* 1988;25:11-16.
429. Ardeschna KM, Smith P, Norton A, et al. Long-term effect of a watch and wait policy versus immediate systemic treatment for asymptomatic advanced-stage non-Hodgkin lymphoma: a randomised controlled trial. *Lancet* 2003;362:516-522.
430. Ardeschna KM, Qian W, Smith P, et al. An intergroup randomised trial of rituximab versus a watch and wait strategy in patients with stage II, III, IV, asymptomatic, non-bulky follicular lymphoma (grades 1, 2 and 3a). A preliminary analysis. *Blood (ASH Annual Meeting Abstracts)* 2010;116:6a.
431. Gandhi MK, Marcus RE. Follicular lymphoma: time for a re-think? *Blood Rev* 2005;19:165-178.
432. Friedberg JW, Taylor MD, Cerhan JR, et al. Follicular lymphoma in the United States: first report of the national LymphoCare study. *J Clin Oncol* 2009;27:1202-1208.
433. Piro LD. Cladribine in the treatment of low-grade non-Hodgkin's lymphoma. *Semin Hematol* 1996;33:34-39.
434. Solal-Celigny P, Brice P, Brousse N, et al. Phase II trial of fludarabine monophosphate as first-line treatment in patients with advanced follicular lymphoma: a multicenter study by the Groupe d'Etude des Lymphomes de l'Adulte. *J Clin Oncol* 1996;14:514-519.
435. Klasa RJ, Meyer RM, Shustik C, et al. Randomized phase III study of fludarabine phosphate versus cyclophosphamide, vincristine, and prednisone in patients with recurrent low-grade non-Hodgkin's lymphoma previously treated with an alkylating agent or alkylator-containing regimen. *J Clin Oncol* 2002;20:4649-4654.
436. Czuczman MS, Koryzna A, Mohr A, et al. Rituximab in combination with fludarabine chemotherapy in low-grade or follicular lymphoma. *J Clin Oncol* 2005;23:694-704.
437. Flinn IW, Byrd JC, Morrison C, et al. Fludarabine and cyclophosphamide with filgrastim support in patients with previously untreated indolent lymphoid malignancies. *Blood* 2000;96:71-75.
438. Hochster HS, Oken MM, Winter JN, et al. Phase I study of fludarabine plus cyclophosphamide in patients with previously untreated low-grade lymphoma: results and long-term follow-up—a report from the Eastern Cooperative Oncology Group. *J Clin Oncol* 2000;18:987-994.
439. Tam CS, Wolf M, Prince HM, et al. Fludarabine, cyclophosphamide, and rituximab for the treatment of patients with chronic lymphocytic leukemia or indolent non-Hodgkin lymphoma. *Cancer* 2006;106:2412-2420.
440. McLaughlin P, Hagemester FB, Romaguera JE, et al. Fludarabine, mitoxantrone, and dexamethasone: an effective new regimen for indolent lymphoma. *J Clin Oncol* 1996;14:1262-1268.
441. Zinzani PL, Magagnoli M, Bendandi M, et al. Efficacy of fludarabine and mitoxantrone (FN) combination regimen in untreated indolent non-Hodgkin's lymphomas. *Ann Oncol Official J Eur Soc Med Oncol/ESMO* 2000;11:363-365.
442. Velasquez W, Lew D, Miller TP, et al. SWOG 95-01: A phase II trial of a combination of fludarabine and mitoxantrone (FN) in untreated advanced low grade lymphoma: an effective, well-tolerated therapy (abstract). *Proc Am Soc Clin Oncol* 1999;18:9a.
443. Massimo F, Luminari S, Dondi A, et al. R-CVP versus R-CHOP versus R-FM as first-line therapy for advanced-stage follicular lymphoma: final results of FOLL05 trial from the Fondazione Italiana Linfomi (FIL). *J Clin Oncol (ASCO Meeting Abstracts)* 2012:8006a.
444. Dana BW, Dahlberg S, Nathwani BN, et al. Long-term follow-up of patients with low-grade malignant lymphomas treated with doxorubicin-based chemotherapy or chemoimmunotherapy. *J Clin Oncol* 1993;11:644-651.
445. Peterson BA, Petroni GR, Frizzera G, et al. Prolonged single-agent versus combination chemotherapy in indolent follicular lymphomas: a study of the cancer and leukemia group B. *J Clin Oncol* 2003;21:5-15.

446. Rigacci L, Federico M, Martelli M, et al. The role of anthracyclines in combination chemotherapy for the treatment of follicular lymphoma: retrospective study of the Intergruppo Italiano Linfomi on 761 cases. *Leuk Lymphoma* 2003;44:1911-1917.
447. Czuczman MS, Weaver R, Alkuzweny B, et al. Prolonged clinical and molecular remission in patients with low-grade or follicular non-Hodgkin's lymphoma treated with rituximab plus CHOP chemotherapy: 9-year follow-up. *J Clin Oncol* 2004;22:4711-4716.
448. Rummel M, Niederle N, Maschmeyer G, et al. Bendamustine plus rituximab versus CHOP plus rituximab as first-line treatment for patients with indolent and mantle-cell lymphomas: an open-label, multicentre, randomised, phase 3 non-inferiority trial. *Lancet* 2013;381:1203-1210.
449. Maloney DG, Grillo-Lopez AJ, Bodkin DJ, et al. IDEC-C2B8: results of a phase I multiple-dose trial in patients with relapsed non-Hodgkin's lymphoma. *J Clin Oncol* 1997;15:3266-3274.
450. Davis TA, White CA, Grillo-Lopez AJ, et al. Single-agent monoclonal antibody efficacy in bulky non-Hodgkin's lymphoma: results of a phase II trial of rituximab. *J Clin Oncol* 1999;17:1851-1857.
451. McLaughlin P, Grillo-Lopez AJ, Link BK, et al. Rituximab chimeric anti-CD20 monoclonal antibody therapy for relapsed indolent lymphoma: half of patients respond to a four-dose treatment program. *J Clin Oncol* 1998;16:2825-2833.
452. Brody J, Kohrt H, Marabelle A, et al. Active and passive immunotherapy for lymphoma: proving principles and improving results. *J Clin Oncol* 2011;29:1864-1875.
453. Alduaij W, Illidge TM. The future of anti-CD20 monoclonal antibodies: are we making progress? *Blood* 2011;117:2993-3001.
454. Kohrt HE, Houot R, Goldstein MJ, et al. CD137 stimulation enhances the antilymphoma activity of anti-CD20 antibodies. *Blood* 2011;117:2423-2432.
455. Kaminski MS, Zelenetz AD, Press OW, et al. Pivotal study of iodine I 131 tositumomab for chemotherapy-refractory low-grade or transformed low-grade B-cell non-Hodgkin's lymphomas. *J Clin Oncol* 2001;19:3918-3928.
456. Kaminski MS, Tuck M, Estes J, et al. 131I-tositumomab therapy as initial treatment for follicular lymphoma. *N Engl J Med* 2005;352:441-449.
457. Morschhauser F, Radford J, Van Hoof A, et al. Phase III trial of consolidation therapy with yttrium-90-ibritumomab tiuxetan compared with no additional therapy after first remission in advanced follicular lymphoma. *J Clin Oncol* 2008;26:5156-5164.
458. Dermime S, Aljurf MD. Current advances, problems and prospects for vaccine-based immunotherapy in follicular non-Hodgkin's lymphoma. *Leuk Lymphoma* 2005;46:497-507.
459. Schuster SJ, Neelapu SS, Gause BL, et al. Vaccination with patient-specific tumor-derived antigen in first remission improves disease-free survival in follicular lymphoma. *J Clin Oncol* 2011;29:2787-2794.
460. Younes A, Bartlett NL, Leonard JP, et al. Brentuximab vedotin (SGN-35) for relapsed CD30-positive lymphomas. *N Engl J Med* 2010;363:1812-1821.
461. Porter DL, Levine BL, Kalos M, et al. Chimeric antigen receptor-modified T cells in chronic lymphoid leukemia. *N Engl J Med* 2011;365:725-733.
462. Banks PM, Chan J, Cleary ML, et al. Mantle cell lymphoma. A proposal for unification of morphologic, immunologic, and molecular data. *Am J Surg Pathol* 1992;16:637-640.
463. Weisenburger DD, Armitage JO. Mantle cell lymphoma—an entity comes of age. *Blood* 1996;87:4483-4494.
464. Swerdlow SH, Williams ME. From centrocytic to mantle cell lymphoma: a clinicopathologic and molecular review of 3 decades. *Hum Pathol* 2002;33:7-20.
465. Decaudin D. Mantle cell lymphoma: a biological and therapeutic paradigm. *Leuk Lymphoma* 2002;43:773-781.
466. Andersen NS, Jensen MK, de Nully Brown P, et al. A Danish population-based analysis of 105 mantle cell lymphoma patients: incidences, clinical features, response, survival and prognostic factors. *Eur J Cancer* 2002;38:401-408.
467. Velders GA, Kluin-Nelemans JC, De Boer CJ, et al. Mantle-cell lymphoma: a population-based clinical study. *J Clin Oncol* 1996;14:1269-1274.

468. Gill S, Herbert KE, Prince HM, et al. Mantle cell lymphoma with central nervous system involvement: frequency and clinical features. *Br J Haematol* 2009;147:83-88.
469. Valdez R, Kroft SH, Ross CW, et al. Cerebrospinal fluid involvement in mantle cell lymphoma. *Modern Pathol* 2002;15:1073-1079.
470. Rimokh R, Berger F, Cornillet P, et al. Break in the BCL1 locus is closely associated with intermediate lymphocytic lymphoma subtype. *Genes Chromos Cancer* 1990;2:223-226.
471. Avet-Loiseau H, Garand R, Gaillard F, et al. Detection of t(11;14) using interphase molecular cytogenetics in mantle cell lymphoma and atypical chronic lymphocytic leukemia. *Genes Chromos Cancer* 1998;23:175-182.
472. de Boer CJ, Schuurin E, Dreef E, et al. Cyclin D1 protein analysis in the diagnosis of mantle cell lymphoma. *Blood* 1995;86:2715-2723.
473. Wlodarska I, Dierickx D, Vanhentenrijk V, et al. Translocations targeting CCND2, CCND3, and MYCN do occur in t(11;14)-negative mantle cell lymphomas. *Blood* 2008;111:5683-5690.
474. Fu K, Weisenburger DD, Greiner TC, et al. Cyclin D1-negative mantle cell lymphoma: a clinicopathologic study based on gene expression profiling. *Blood* 2005;106:4315-4321.
475. Stilgenbauer S, Winkler D, Ott G, et al. Molecular characterization of 11q deletions points to a pathogenic role of the ATM gene in mantle cell lymphoma. *Blood* 1999;94:3262-3264.
476. Bea S, Ribas M, Hernandez JM, et al. Increased number of chromosomal imbalances and high-level DNA amplifications in mantle cell lymphoma are associated with blastoid variants. *Blood* 1999;93:4365-4374.
477. Martinez-Climent JA, Vizcarra E, Sanchez D, et al. Loss of a novel tumor suppressor gene locus at chromosome 8p is associated with leukemic mantle cell lymphoma. *Blood* 2001;98:3479-3482.
478. Hernandez L, Fest T, Cazorla M, et al. p53 gene mutations and protein over-expression are associated with aggressive variants of mantle cell lymphomas. *Blood* 1996;87:3351-3359.
479. Dreyling MH, Bullinger L, Ott G, et al. Alterations of the cyclin D1/p16-pRB pathway in mantle cell lymphoma. *Cancer Res* 1997;57:4608-4614.
480. Martin P, Chadburn A, Christos P, et al. Outcome of deferred initial therapy in mantle-cell lymphoma. *J Clin Oncol* 2009;27:1209-1213.
481. Fernandez V, Salamero O, Espinet B, et al. Genomic and gene expression profiling defines indolent forms of mantle cell lymphoma. *Cancer Res* 2010;70:1408-1418.
482. Kridel R, Meissner B, Rogic S, et al. Whole transcriptome sequencing reveals recurrent NOTCH1 mutations in mantle cell lymphoma. *Blood* 2012;119:1963-1971.
483. Hartmann EM, Campo E, Wright G, et al. Pathway discovery in mantle cell lymphoma by integrated analysis of high-resolution gene expression and copy number profiling. *Blood* 2010;116:953-961.
484. Zhao JJ, Lin J, Lwin T, et al. microRNA expression profile and identification of miR-29 as a prognostic marker and pathogenetic factor by targeting CDK6 in mantle cell lymphoma. *Blood* 2010;115:2630-2639.
485. Iqbal J, Shen Y, Liu Y, et al. Genome-wide miRNA profiling of mantle cell lymphoma reveals a distinct subgroup with poor prognosis. *Blood* 2012;119:4939-4948.
486. Hoster E, Dreyling M, Klapper W, et al. A new prognostic index (MIPI) for patients with advanced-stage mantle cell lymphoma. *Blood* 2008;111: 558-565.
487. Romaguera JE, Fayad LE, Feng L, et al. Ten-year follow-up after intense chemoimmunotherapy with rituximab-hyperCVAD alternating with rituximab-high dose methotrexate/cytarabine (R-MA) and without stem cell transplantation in patients with untreated aggressive mantle cell lymphoma. *Br J Haematol* 2010;150:200-208.
488. Merli F, Luminari S, Ilariucci F, et al. Rituximab plus hyper-CVAD alternating with high dose cytarabine and methotrexate for the initial treatment of patients with mantle cell lymphoma, a multicentre trial from Gruppo Italiano Studio Linfomi. *Br J Haematol* 2012;156:346-353.
489. Hermine O, Hoster E, Walewski J, et al. Alternating courses of 3x CHOP and 3x DHAP plus rituximab followed by a high dose ARA-C containing myeloablative regimen and autologous stem cell transplantation (ASCT) is superior to 6 courses CHOP plus rituximab followed by myeloablative radiochemotherapy and ASCT in mantle cell lymphoma: results of the MCL

- Younger Trial of the European Mantle Cell Lymphoma Network (MCL net). *Blood* (ASH Annual Meeting Abstracts) 2010;116:110.
490. Pott C, Hoster E, Delfau-Larue MH, et al. Molecular remission is an independent predictor of clinical outcome in patients with mantle cell lymphoma after combined immunochemotherapy: a European MCL intergroup study. *Blood* 2010;115:3215-3223.
491. Kluin-Nelemans HC, Hoster E, Hermine O, et al. Treatment of older patients with mantle-cell lymphoma. *N Engl J Med* 2012;367:520-531.
492. Maris MB, Sandmaier BM, Storer BE, et al. Allogeneic hematopoietic cell transplantation after fludarabine and 2 Gy total body irradiation for relapsed and refractory mantle cell lymphoma. *Blood* 2004;104:3535-3542.
493. Le Gouill S, Kroger N, Dhedin N, et al. Reduced-intensity conditioning allogeneic stem cell transplantation for relapsed/refractory mantle cell lymphoma: a multicenter experience. *Ann Oncol Official J Eur Soc Med Oncol/ESMO* 2012;23:2695-2703.
494. Fisher RI, Bernstein SH, Kahl BS, et al. Multicenter phase II study of bortezomib in patients with relapsed or refractory mantle cell lymphoma. *J Clin Oncol* 2006;24:4867-4874.
495. Kahl BS, Bartlett NL, Leonard JP, et al. Bendamustine is effective therapy in patients with rituximab-refractory, indolent B-cell non-Hodgkin lymphoma: results from a Multicenter Study. *Cancer* 2010;116:106-114.
496. Habermann TM, Lossos IS, Justice G, et al. Lenalidomide oral monotherapy produces a high response rate in patients with relapsed or refractory mantle cell lymphoma. *Br J Haematol* 2009;145:344-349.
497. Ansell SM, Tang H, Kurtin PJ, et al. Tamsirolimus and rituximab in patients with relapsed or refractory mantle cell lymphoma: a phase 2 study. *Lancet Oncol* 2011;12:361-368.
498. Leonard JP, LaCasce AS, Smith MR, et al. Selective CDK4/6 inhibition with tumor responses by PD0332991 in patients with mantle cell lymphoma. *Blood* 2012;119:4597-4607.
499. Wang L, Martin P, Blum KA, et al. The Bruton's tyrosine kinase inhibitor PCI-32765 is highly active as single-agent therapy in previously-treated mantle cell lymphoma (MCL): preliminary results of a phase II trial. *Blood* (ASH Annual Meeting Abstracts) 2011;118:442a.
500. Kahl BS, Byrd JC, Flinn IW, et al. Clinical safety and activity in a phase 1 study of CAL-101, an isoform-selective inhibitor of phosphatidylinositol 3-kinase P110, in patients with relapsed or refractory non-hodgkin lymphoma. *Blood* (ASH Annual Meeting Abstracts) 2010;116:1777a.
501. Stein RS, Greer JP, Flexner JM, et al. Large-cell lymphomas: clinical and prognostic features. *J Clin Oncol* 1990;8:1370-1379.
502. Aki H, Tuzuner N, Ongoren S, et al. T-cell-rich B-cell lymphoma: a clinicopathologic study of 21 cases and comparison with 43 cases of diffuse large B-cell lymphoma. *Leukemia Res* 2004;28:229-236.
503. Abramson JS. T-cell/histiocyte-rich B-cell lymphoma: biology, diagnosis, and management. *Oncologist* 2006;11:384-392.
504. Tousseyn T, De Wolf-Peeters C. T cell/histiocyte-rich large B-cell lymphoma: an update on its biology and classification. *Virch Arch Int J Pathol* 2011;459:557-563.
505. Ramsay AD, Smith WJ, Isaacson PG. T-cell-rich B-cell lymphoma. *Am J Surg Pathol* 1988;12:433-443.
506. Monti S, Savage KJ, Kutok JL, et al. Molecular profiling of diffuse large B-cell lymphoma identifies robust subtypes including one characterized by host inflammatory response. *Blood* 2005;105:1851-1861.
507. Van Loo P, Tousseyn T, Vanhentenrijk V, et al. T-cell/histiocyte-rich large B-cell lymphoma shows transcriptional features suggestive of a tolerogenic host immune response. *Haematologica* 2010;95:440-448.
508. Oyama T, Yamamoto K, Asano N, et al. Age-related EBV-associated B-cell lymphoproliferative disorders constitute a distinct clinicopathologic group: a study of 96 patients. *Clin Cancer Res Official J Am Assoc Cancer Res* 2007;13:5124-5132.
509. Dojcinov SD, Venkataraman G, Pittaluga S, et al. Age-related EBV-associated lymphoproliferative disorders in the Western population: a spectrum of reactive lymphoid hyperplasia and lymphoma. *Blood* 2011;117:4726-4735.
510. Lo Coco F, Ye BH, Lista F, et al. Rearrangements of the BCL6 gene in diffuse large cell non-Hodgkin's lymphoma. *Blood* 1994;83:1757-1759.

511. Akasaka T, Ueda C, Kurata M, et al. Nonimmunoglobulin (non-Ig)/BCL6 gene fusion in diffuse large B-cell lymphoma results in worse prognosis than Ig/BCL6. *Blood* 2000;96:2907-2909.
512. Kanungo A, Medeiros LJ, Abruzzo LV, et al. Lymphoid neoplasms associated with concurrent t(14;18) and 8q24/c-MYC translocation generally have a poor prognosis. *Modern Pathol Official J USCanad Acad Pathol* 2006;19:25-33.
513. Tomita N, Tokunaka M, Nakamura N, et al. Clinicopathological features of lymphoma/leukemia patients carrying both BCL2 and MYC translocations. *Haematologica* 2009;94:935-943.
514. Johnson NA, Savage KJ, Ludkovski O, et al. Lymphomas with concurrent BCL2 and MYC translocations: the critical factors associated with survival. *Blood* 2009;114:2273-2279.
515. Aukema SM, Siebert R, Schuurin E, et al. Double-hit B-cell lymphomas. *Blood* 2011;117:2319-2331.
516. Pandolfino TL, Siegel RS, Kuzel TM, et al. Primary cutaneous B-cell lymphoma: review and current concepts. *J Clin Oncol* 2000;18:2152-2168.
517. Senff NJ, Hoefnagel JJ, Jansen PM, et al. Reclassification of 300 primary cutaneous B-Cell lymphomas according to the new WHO-EORTC classification for cutaneous lymphomas: comparison with previous classifications and identification of prognostic markers. *J Clin Oncol* 2007;25:1581-1587.
518. DiGiuseppe JA, Nelson WG, Seifter EJ, et al. Intravascular lymphomatosis: a clinicopathologic study of 10 cases and assessment of response to chemotherapy. *J Clin Oncol* 1994;12:2573-2579.
519. Miller DC, Hochberg FH, Harris NL, et al. Pathology with clinical correlations of primary central nervous system non-Hodgkin's lymphoma. The Massachusetts General Hospital experience 1958-1989. *Cancer* 1994; 74:1383-1397.
520. Traverse-Glehen A, Pittaluga S, Gaulard P, et al. Mediastinal gray zone lymphoma: the missing link between classic Hodgkin's lymphoma and mediastinal large B-cell lymphoma. *Am J Surg Pathol* 2005;29:1411-1421.
521. Gascoyne RD, Lamant L, Martin-Subero JI, et al. ALK-positive diffuse large B-cell lymphoma is associated with Clathrin-ALK rearrangements: report of 6 cases. *Blood* 2003;102:2568-2573.
522. Lossos IS, Morgensztern D. Prognostic biomarkers in diffuse large B-cell lymphoma. *J Clin Oncol* 2006;24:995-1007.
523. Sweetenham JW. Diffuse large B-cell lymphoma: risk stratification and management of relapsed disease. *Hematol/Edu Prog Am Soc Hematol Am Soc Hematol* 2005:252-259.
524. Tagawa H, Suguro M, Tsuzuki S, et al. Comparison of genome profiles for identification of distinct subgroups of diffuse large B-cell lymphoma. *Blood* 2005;106:1770-1777.
525. Hans CP, Weisenburger DD, Greiner TC, et al. Expression of PKC-beta or cyclin D2 predicts for inferior survival in diffuse large B-cell lymphoma. *Modern Pathol Official J US Canad Acad Pathol* 2005;18:1377-1384.
526. Aisenberg AC. Primary large cell lymphoma of the mediastinum. *Semin Oncol* 1999;26:251-258.
527. Cazals-Hatem D, Lepage E, Brice P, et al. Primary mediastinal large B-cell lymphoma. A clinicopathologic study of 141 cases compared with 916 nonmediastinal large B-cell lymphomas, a GELA ("Groupe d'Etude des Lymphomes de l'Adulte") study. *Am J Surg Pathol* 1996;20:877-888.
528. Lazzarino M, Orlandi E, Paulli M, et al. Treatment outcome and prognostic factors for primary mediastinal (thymic) B-cell lymphoma: a multicenter study of 106 patients. *J Clin Oncol* 1997;15:1646-1653.
529. van Besien K, Kelta M, Bahaguna P. Primary mediastinal B-cell lymphoma: a review of pathology and management. *J Clin Oncol* 2001;19:1855-1864.
530. Zinzani PL, Piccaluga PP. Primary mediastinal DLBCL: evolving biologic understanding and therapeutic strategies. *Curr Oncol Rep* 2011;13:407-415.
531. Joos S, Otano-Joos MI, Ziegler S, et al. Primary mediastinal (thymic) B-cell lymphoma is characterized by gains of chromosomal material including 9p and amplification of the REL gene. *Blood* 1996;87:1571-1578.
532. Copie-Bergman C, Gaulard P, Maouche-Chretien L, et al. The MAL gene is expressed in primary mediastinal large B-cell lymphoma. *Blood* 1999;94:3567-3575.
533. Savage KJ, Monti S, Kutok JL, et al. The molecular signature of mediastinal large B-cell lymphoma differs from that of other diffuse large B-cell lymphomas and shares features with classical Hodgkin lymphoma. *Blood* 2003;102:3871-3879.

534. Feuerhake F, Kutok JL, Monti S, et al. NFkappaB activity, function, and target-gene signatures in primary mediastinal large B-cell lymphoma and diffuse large B-cell lymphoma subtypes. *Blood* 2005;106:1392-1399.
535. Savage KJ, Al-Rajhi N, Voss N, et al. Favorable outcome of primary mediastinal large B-cell lymphoma in a single institution: the British Columbia experience. *Ann Oncol Official J Eur Soc Med Oncol/ESMO* 2006;17:123-130.
536. Wilson WH, Grossbard ML, Pittaluga S, et al. Dose-adjusted EPOCH chemotherapy for untreated large B-cell lymphomas: a pharmacodynamic approach with high efficacy. *Blood* 2002;99:2685-2693.
537. Wilson WH, Dunleavy K, Pittaluga S, et al. DA-EPOCH-R is highly effective in both BCL-6+ and BCL-6- untreated de novo diffuse large B-cell lymphoma (DLBCL): study update and analysis of survival outcomes for multiple biomarkers. *Blood* 2006;108:65a, abstract 206.
538. Rodriguez J, Conde E, Gutierrez A, et al. Primary mediastinal large cell lymphoma (PMBL): frontline treatment with autologous stem cell transplantation (ASCT). The GEL-TAMO experience. *Hematol Oncol* 2008;26:171-178.
539. Greer JP. Therapy of peripheral T/NK neoplasms. *Hematol/Edu Prog Am Soc Hematol Am Soc Hematol* 2006:331-337.
540. Foss FM, Zinzani PL, Vose JM, et al. Peripheral T-cell lymphoma. *Blood* 2011;117:6756-6767.
541. Jaffe ES. Pathobiology of peripheral T-cell lymphomas. *Hematol/Edu Prog Am Soc Hematol Am Soc Hematol* 2006:317-322.
542. Vose J, Armitage J, Weisenburger D, et al. International peripheral T-cell and natural killer/T-cell lymphoma study: pathology findings and clinical outcomes. *J Clin Oncol* 2008;26:4124-4130.
543. Rizvi MA, Evens AM, Tallman MS, et al. T-cell non-Hodgkin lymphoma. *Blood* 2006;107:1255-1264.
544. Armitage JO, Greer JP, Levine AM, et al. Peripheral T-cell lymphoma. *Cancer* 1989;63:158-163.
545. Schlegelberger B, Himmler A, Godde E, et al. Cytogenetic findings in peripheral T-cell lymphomas as a basis for distinguishing low-grade and high-grade lymphomas. *Blood* 1994;83:505-511.
546. Siegert W, Nerl C, Engelhard M, et al. Peripheral T-cell non-Hodgkin's lymphomas of low malignancy: prospective study of 25 patients with pleomorphic small cell lymphoma, lymphoepitheloid cell (Lennert's) lymphoma and T-zone lymphoma. The Kiel Lymphoma Study Group. *Br J Haematol* 1994;87:529-534.
547. Feldman AL, Law M, Remstein ED, et al. Recurrent translocations involving the IRF4 oncogene locus in peripheral T-cell lymphomas. *Leukemia* 2009;23:574-580.
548. Moskowitz AJ, Lunning MA, Horwitz SM. Should patients with aggressive peripheral T-cell lymphoma all be treated the same?: no... well yes, ... but maybe not for long. *Cancer J* 2012;18:445-449.
549. Armitage JO. The aggressive peripheral T-cell lymphomas: 2012 update on diagnosis, risk stratification, and management. *Am J Hematol* 2012;87:511-519.
550. Savage KJ. Therapies for peripheral T-cell lymphomas. *Hematol/Edu Prog Am Soc Hematol Am Soc Hematol* 2011;2011:515-524.
551. Schmitz N, Trumper L, Ziepert M, et al. Treatment and prognosis of mature T-cell and NK-cell lymphoma: an analysis of patients with T-cell lymphoma treated in studies of the German High-Grade Non-Hodgkin Lymphoma Study Group. *Blood* 2010;116:3418-3425.
552. Gallamini A, Zaja F, Patti C, et al. Alemtuzumab (Campath-1H) and CHOP chemotherapy as first-line treatment of peripheral T-cell lymphoma: results of a GITIL (Gruppo Italiano Terapie Innovative nei Linfomi) prospective multicenter trial. *Blood* 2007;110:2316-2323.
553. Mahadevan D, Unger JM, Spier CM, et al. Phase 2 trial of combined cisplatin, etoposide, gemcitabine, and methylprednisolone (PEGS) in peripheral T-cell non-Hodgkin lymphoma: Southwest Oncology Group Study S0350. *Cancer* 2013;119:317-319.
554. O'Connor OA, Pro B, Pinter-Brown L, et al. Pralatrexate in patients with relapsed or refractory peripheral T-cell lymphoma: results from the pivotal PROPEL study. *J Clin Oncol* 2011;29:1182-1189.
555. Piekarczyk RL, Frye R, Prince HM, et al. Phase 2 trial of romidepsin in patients with peripheral T-cell lymphoma. *Blood* 2011;117:5827-5834.

556. Yared J, Kimball A. The role of high dose chemotherapy and autologous stem-cell transplantation in peripheral T-cell lymphoma: A review of the literature and new perspectives. *Cancer Treat Rev* 2013;39:51-59.
557. d'Amore F, Relander T, Lauritzsen GF, et al. Up-front autologous stem-cell transplantation in peripheral T-cell lymphoma: NLG-T-01. *J Clin Oncol* 2012;30:3093-3099.
558. Stein H, Mason DY, Gerdes J, et al. The expression of the Hodgkin's disease associated antigen Ki-1 in reactive and neoplastic lymphoid tissue: evidence that Reed-Sternberg cells and histiocytic malignancies are derived from activated lymphoid cells. *Blood* 1985;66:848-858.
559. Kinney MC, Higgins RA, Medina EA. Anaplastic large cell lymphoma: twenty-five years of discovery. *Arch Pathol Lab Med* 2011;135:19-43.
560. Kadin ME, Sako D, Berliner N, et al. Childhood Ki-1 lymphoma presenting with skin lesions and peripheral lymphadenopathy. *Blood* 1986;68:1042-1049.
561. Greer JP, Kinney MC, Collins RD, et al. Clinical features of 31 patients with Ki-1 anaplastic large-cell lymphoma. *J Clin Oncol* 1991;9:539-547.
562. Shulman LN, Frisard B, Antin JH, et al. Primary Ki-1 anaplastic large-cell lymphoma in adults: clinical characteristics and therapeutic outcome. *J Clin Oncol* 1993;11:937-942.
563. Duyster J, Bai RY, Morris SW. Translocations involving anaplastic lymphoma kinase (ALK). *Oncogene* 2001;20:5623-5637.
564. Fraga M, Brousset P, Schlaifer D, et al. Bone marrow involvement in anaplastic large cell lymphoma. Immunohistochemical detection of minimal disease and its prognostic significance. *Am J Clin Pathol* 1995;103:82-89.
565. ten Berge RL, de Bruin PC, Oudejans JJ, et al. ALK-negative anaplastic large-cell lymphoma demonstrates similar poor prognosis to peripheral T-cell lymphoma, unspecified. *Histopathology* 2003;43:462-469.
566. Ferreri AJ, Govi S, Pileri SA, et al. Anaplastic large cell lymphoma, ALK-negative. *Critic Rev Oncol/Hematol* 2013;85:206-215.
567. Arrowsmith ER, Macon WR, Kinney MC, et al. Peripheral T-cell lymphomas: clinical features and prognostic factors of 92 cases defined by the Revised European American lymphoma classification. *Leuk Lymphoma* 2003;44: 241-249.
568. Savage KJ, Chhanabhai M, Gascoyne RD, et al. Characterization of peripheral T-cell lymphomas in a single North American institution by the WHO classification. *Ann Oncol Official J Eur Soc Med Oncol/ESMO* 2004;15:1467-1475.
569. Savage KJ, Harris NL, Vose JM, et al. ALK- anaplastic large-cell lymphoma is clinically and immunophenotypically different from both ALK+ ALCL and peripheral T-cell lymphoma, not otherwise specified: report from the International Peripheral T-Cell Lymphoma Project. *Blood* 2008;111:5496-5504.
570. Suzuki R, Kagami Y, Takeuchi K, et al. Prognostic significance of CD56 expression for ALK-positive and ALK-negative anaplastic large-cell lymphoma of T/null cell phenotype. *Blood* 2000;96:2993-3000.
571. Schlette EJ, Medeiros LJ, Goy A, et al. Survivin expression predicts poorer prognosis in anaplastic large-cell lymphoma. *J Clin Oncol* 2004;22:1682-1688.
572. Feldman AL, Dogan A, Smith DI, et al. Discovery of recurrent t(6;7) (p25.3;q32.3) translocations in ALK-negative anaplastic large cell lymphomas by massively parallel genomic sequencing. *Blood* 2011;117:915-919.
573. Jaffe ES. Anaplastic large cell lymphoma: the shifting sands of diagnostic hematopathology. *Modern Pathol Official J USCanad Acad Pathol* 2001; 14:219-228.
574. Thompson MA, Stumph J, Henrickson SE, et al. Differential gene expression in anaplastic lymphoma kinase-positive and anaplastic lymphoma kinase-negative anaplastic large cell lymphomas. *Hum Pathol* 2005;36:494-504.
575. Agnelli L, Mereu E, Pellegrino E, et al. Identification of a 3-gene model as a powerful diagnostic tool for the recognition of ALK-negative anaplastic large-cell lymphoma. *Blood* 2012;120:1274-1281.
576. Kinney MC, Kadin ME. The pathologic and clinical spectrum of anaplastic large cell lymphoma and correlation with ALK gene dysregulation. *Am J Clin Pathol* 1999;111:S56-S67.
577. Rosen ST, Querfeld C. Primary cutaneous T-cell lymphomas. *Hematol/Edu Prog Am Soc Hematol Am Soc Hematol* 2006:323-330.

578. Paulli M, Berti E, Rosso R, et al. CD30/Ki-1-positive lymphoproliferative disorders of the skin—clinicopathologic correlation and statistical analysis of 86 cases: a multicentric study from the European Organization for Research and Treatment of Cancer Cutaneous Lymphoma Project Group. *J Clin Oncol* 1995;13:1343-1354.
579. Mosse YP, Balis FM, Lim MS, et al. Efficacy of crizotinib in children with relapsed/refractory ALK-driven tumors including anaplastic large cell lymphoma and neuroblastoma: a children's oncology group phase I consortium study. *J Clin Oncol* 2012;30:ASCO Annual Meeting Proceedings 9500a.
580. Gambacorti-Passerini C, Messa C, Pogliani EM. Crizotinib in anaplastic large-cell lymphoma. *N Engl J Med* 2011;364:775-776.
581. Foyil KV, Bartlett NL. Brentuximab vedotin and crizotinib in anaplastic large-cell lymphoma. *Cancer J* 2012;18:450-456.
582. Weisenburger DD, Savage KJ, Harris NL, et al. Peripheral T-cell lymphoma, not otherwise specified: a report of 340 cases from the International Peripheral T-cell Lymphoma Project. *Blood* 2011;117:3402-3408.
583. Niitsu N, Okabe-Kado J, Okamoto M, et al. Serum nm23-H1 protein as a prognostic factor in aggressive non-Hodgkin lymphoma. *Blood* 2001;97: 1202-1210.
584. Piccaluga PP, Agostinelli C, Gazzola A, et al. Prognostic markers in peripheral T-cell lymphoma. *Curr Hematol Malignancy Rep* 2010;5:222-228.
585. Asano N, Suzuki R, Kagami Y, et al. Clinicopathologic and prognostic significance of cytotoxic molecule expression in nodal peripheral T-cell lymphoma, unspecified. *Am J Surg Pathol* 2005;29:1284-1293.
586. Went P, Agostinelli C, Gallamini A, et al. Marker expression in peripheral T-cell lymphoma: a proposed clinical-pathologic prognostic score. *J Clin Oncol* 2006;24:2472-2479.
587. Ishida T, Inagaki H, Utsunomiya A, et al. CXC chemokine receptor 3 and CC chemokine receptor 4 expression in T-cell and NK-cell lymphomas with special reference to clinicopathological significance for peripheral T-cell lymphoma, unspecified. *Clin Cancer Res Official J Am Assoc Cancer Res* 2004;10:5494-5500.
588. Costello R, Sanchez C, Le Treut T, et al. Peripheral T-cell lymphoma gene expression profiling and potential therapeutic exploitations. *Br J Haematol* 2010;150:21-27.
589. Ballester B, Ramuz O, Gisselbrecht C, et al. Gene expression profiling identifies molecular subgroups among nodal peripheral T-cell lymphomas. *Oncogene* 2006;25:1560-1570.
590. Martinez-Delgado B, Cuadros M, Honrado E, et al. Differential expression of NF-kappaB pathway genes among peripheral T-cell lymphomas. *Leukemia* 2005;19:2254-2263.
591. Piccaluga PP, Agostinelli C, Califano A, et al. Gene expression analysis of peripheral T cell lymphoma, unspecified, reveals distinct profiles and new potential therapeutic targets. *J Clin Invest* 2007;117:823-834.
592. Federico M, Rudiger T, Bellei M, et al. Clinicopathologic characteristics of angioimmunoblastic T-cell lymphoma: analysis of the international peripheral T-cell lymphoma project. *J Clin Oncol* 2013;31:240-246.
593. Mourad N, Mounier N, Briere J, et al. Clinical, biologic, and pathologic features in 157 patients with angioimmunoblastic T-cell lymphoma treated within the Groupe d'Etude des Lymphomes de l'Adulte (GELA) trials. *Blood* 2008;111:4463-4470.
594. de Leval L, Gisselbrecht C, Gaulard P. Advances in the understanding and management of angioimmunoblastic T-cell lymphoma. *Br J Haematol* 2010;148:673-689.
595. Ohshima K, Takeo H, Kikuchi M, et al. Heterogeneity of Epstein-Barr virus infection in angioimmunoblastic lymphadenopathy type T-cell lymphoma. *Histopathology* 1994;25:569-579.
596. Grogg KL, Attygale AD, Macon WR, et al. Expression of CXCL13, a chemokine highly upregulated in germinal center T-helper cells, distinguishes angioimmunoblastic T-cell lymphoma from peripheral T-cell lymphoma, unspecified. *Modern Pathol Official J US Canad Acad Pathol* 2006;19:1101-1107.
597. Tan BT, Warnke RA, Arber DA. The frequency of B- and T-cell gene rearrangements and epstein-barr virus in T-cell lymphomas: a comparison between angioimmunoblastic T-cell lymphoma and peripheral T-cell lymphoma, unspecified with and without associated B-cell proliferations. *J Mol Diagn* 2006;8:466-475.

598. Schlegelberger B, Zwingers T, Hohenadel K, et al. Significance of cytogenetic findings for the clinical outcome in patients with T-cell lymphoma of angioimmunoblastic lymphadenopathy type. *J Clin Oncol* 1996;14:593-599.
599. Anagnostopoulos I, Hummel M, Finn T, et al. Heterogeneous Epstein-Barr virus infection patterns in peripheral T-cell lymphoma of angioimmunoblastic lymphadenopathy type. *Blood* 1992;80:1804-1812.
600. de Leval L, Rickman DS, Thielen C, et al. The gene expression profile of nodal peripheral T-cell lymphoma demonstrates a molecular link between angioimmunoblastic T-cell lymphoma (AITL) and follicular helper T (TFH) cells. *Blood* 2007;109:4952-4963.
601. Piccaluga PP, Agostinelli C, Califano A, et al. Gene expression analysis of angioimmunoblastic lymphoma indicates derivation from T follicular helper cells and vascular endothelial growth factor deregulation. *Cancer Res* 2007;67:10703-10710.
602. Farcet JP, Gaulard P, Marolleau JP, et al. Hepatosplenic T-cell lymphoma: sinusal/sinusoidal localization of malignant cells expressing the T-cell receptor gamma delta. *Blood* 1990;75:2213-2219.
603. Ferreri AJ, Govi S, Pileri SA. Hepatosplenic gamma-delta T-cell lymphoma. *Critic Rev Oncol/Hematol* 2012;83:283-292.
604. Weidmann E. Hepatosplenic T cell lymphoma. A review on 45 cases since the first report describing the disease as a distinct lymphoma entity in 1990. *Leukemia* 2000;14:991-997.
605. Yao M, Tien HF, Lin MT, et al. Clinical and hematological characteristics of hepatosplenic T gamma/delta lymphoma with isochromosome for long arm of chromosome 7. *Leuk Lymphoma* 1996;22:495-500.
606. Macon WR, Levy NB, Kurtin PJ, et al. Hepatosplenic alphabeta T-cell lymphomas: a report of 14 cases and comparison with hepatosplenic gammadelta T-cell lymphomas. *Am J Surg Pathol* 2001;25:285-296.
607. Travert M, Huang Y, de Leval L, et al. Molecular features of hepatosplenic T-cell lymphoma unravels potential novel therapeutic targets. *Blood* 2012;119:5795-5806.
608. Gonzalez CL, Medeiros LJ, Brazier RM, et al. T-cell lymphoma involving subcutaneous tissue. A clinicopathologic entity commonly associated with hemophagocytic syndrome. *Am J Surg Pathol* 1991;15:17-27.
609. Salhany KE, Macon WR, Choi JK, et al. Subcutaneous panniculitis-like T-cell lymphoma: clinicopathologic, immunophenotypic, and genotypic analysis of alpha/beta and gamma/delta subtypes. *Am J Surg Pathol* 1998;22:881-893.
610. Go RS, Wester SM. Immunophenotypic and molecular features, clinical outcomes, treatments, and prognostic factors associated with subcutaneous panniculitis-like T-cell lymphoma: a systematic analysis of 156 patients reported in the literature. *Cancer* 2004;101:1404-1413.
611. Willemze R, Jansen PM, Cerroni L, et al. Subcutaneous panniculitis-like T-cell lymphoma: definition, classification, and prognostic factors: an EORTC Cutaneous Lymphoma Group Study of 83 cases. *Blood* 2008;111:838-845.
612. Chott A, Dragosics B, Radaszkiewicz T. Peripheral T-cell lymphomas of the intestine. *Am J Pathol* 1992;141:1361-1371.
613. Cellier C, Delabesse E, Helmer C, et al. Refractory sprue, coeliac disease, and enteropathy-associated T-cell lymphoma. French Coeliac Disease Study Group. *Lancet* 2000;356:203-208.
614. Gale J, Simmonds PD, Mead GM, et al. Enteropathy-type intestinal T-cell lymphoma: clinical features and treatment of 31 patients in a single center. *J Clin Oncol* 2000;18:795-803.
615. Al-Toma A, Verbeek W, Hadithi M, et al. Survival in refractory coeliac disease and enteropathy associated T cell lymphoma: retrospective evaluation of single centre experience. *Gut* 2007;56:1373-1378.
616. Delabie J, Holte H, Vose JM, et al. Enteropathy-associated T-cell lymphoma: clinical and histological findings from the international peripheral T-cell lymphoma project. *Blood* 2011;118:148-155.
617. Kim GE, Cho JH, Yang WI, et al. Angiocentric lymphoma of the head and neck: patterns of systemic failure after radiation treatment. *J Clin Oncol* 2000;18:54-63.
618. Liang R, Todd D, Chan TK, et al. Treatment outcome and prognostic factors for primary nasal lymphoma. *J Clin Oncol* 1995;13:666-670.
619. Ishii H, Ogino T, Berger C, et al. Clinical usefulness of serum EBV DNA levels of BamHI W and LMP1 for nasal NK/T-cell lymphoma. *J Med Virol* 2007;79:562-572.

620. Hsieh PP, Tung CL, Chan AB, et al. EBV viral load in tumor tissue is an important prognostic indicator for nasal NK/T-cell lymphoma. *Am J Clin Pathol* 2007;128:579-584.
621. Lee J, Park YH, Kim WS, et al. Extranodal nasal type NK/T-cell lymphoma: elucidating clinical prognostic factors for risk-based stratification of therapy. *Eur J Cancer* 2005;41:1402-1408.
622. Chan JK, Sin VC, Wong KF, et al. Nonnasal lymphoma expressing the natural killer cell marker CD56: a clinicopathologic study of 49 cases of an uncommon aggressive neoplasm. *Blood* 1997;89:4501-4513.
623. Matsumoto Y, Nomura K, Kanda-Akano Y, et al. Successful treatment with Erwinia L-asparaginase for recurrent natural killer/T cell lymphoma. *Leuk Lymphoma* 2003;44:879-882.
624. Yamaguchi M, Suzuki R, Kwong YL, et al. Phase I study of dexamethasone, methotrexate, ifosfamide, L-asparaginase, and etoposide (SMILE) chemotherapy for advanced-stage, relapsed or refractory extranodal natural killer (NK)/T-cell lymphoma and leukemia. *Cancer Sci* 2008;99: 1016-1020.
625. Mraz-Gernhard S, Natkunam Y, Hoppe RT, et al. Natural killer/natural killer-like T-cell lymphoma, CD56+, presenting in the skin: an increasingly recognized entity with an aggressive course. *J Clin Oncol* 2001;19:2179-2188.
626. Kwong YL, Chan AC, Liang R, et al. CD56+ NK lymphomas: clinicopathological features and prognosis. *Br J Haematol* 1997;97:821-829.
627. Sokol L, Loughran TP, Jr. Large granular lymphocyte leukemia. *Oncologist* 2006;11:263-273.
628. Bateau B, Rey J, Hamidou M, et al. Analysis of a French cohort of patients with large granular lymphocyte leukemia: a report on 229 cases. *Haematologica* 2010;95:1534-1541.
629. Lamy T, Liu JH, Landowski TH, et al. Dysregulation of CD95/CD95 ligandapoptotic pathway in CD3(+) large granular lymphocyte leukemia. *Blood* 1998;92:4771-4777.
630. Epling-Burnette PK, Liu JH, Catlett-Falcone R, et al. Inhibition of STAT3 signaling leads to apoptosis of leukemic large granular lymphocytes and decreased Mcl-1 expression. *J Clin Invest* 2001;107:351-362.
631. Loughran TP, Jr., Kidd PG, Starkebaum G. Treatment of large granular lymphocyte leukemia with oral low-dose methotrexate. *Blood* 1994;84: 2164-2170.
632. Sood R, Stewart CC, Aplan PD, et al. Neutropenia associated with T-cell large granular lymphocyte leukemia: long-term response to cyclosporine therapy despite persistence of abnormal cells. *Blood* 1998;91:3372-3378.
633. Sun T, Brody J, Susin M, et al. Aggressive natural killer cell lymphoma/leukemia. A recently recognized clinicopathologic entity. *Am J Surg Pathol* 1993;17:1289-1299.
634. Mori N, Yamashita Y, Tsuzuki T, et al. Lymphomatous features of aggressive NK cell leukaemia/lymphoma with massive necrosis, haemophagocytosis and EB virus infection. *Histopathology* 2000;37:363-371.
635. Chan JKC, Wong KF, Jaffe ES, et al. Aggressive NK-cell leukaemia. In Jaffe, ES, Harris, NL, Stein, H, et al., eds. *Pathology & genetics: tumours of haematopoietic and lymphoid tissues*. Lyon: IARC Press, 2001:190-200.
636. Suzuki R, Yamamoto K, Seto M, et al. CD7+ and CD56+ myeloid/natural killer cell precursor acute leukemia: a distinct hematolymphoid disease entity. *Blood* 1997;90:2417-2428.
637. Ma Y, Chen B, Xu X, et al. Myeloid/natural killer cell precursor acute leukemia with multiple subcutaneous nodules as the initial presentation: a case report and literature review. *Int J Hematol* 2009;90:243-247.
638. Dalle S, Beylot-Barry M, Bagot M, et al. Blastic plasmacytoid dendritic cell neoplasm: is transplantation the treatment of choice? *Br J Dermatol* 2010;162:74-79.
639. Catovsky D, Ralfkiaer E, Muller-Hermelink HK. T-cell prolymphocytic leukaemia. In Jaffe, ES, Harris, NL, Stein, H, et al., eds., *Pathology & genetics: tumours of haematopoietic and lymphoid tissues*. Lyon: IARC Press, 2001: 195-196.
640. Dearden CE. T-cell prolymphocytic leukemia. *Med Oncol* 2006;23:17-22.
641. Dearden C. How I treat prolymphocytic leukemia. *Blood* 2012;120:538-551.
642. Matutes E, Brito-Babapulle V, Swansbury J, et al. Clinical and laboratory features of 78 cases of T-prolymphocytic leukemia. *Blood* 1991;78:3269-3274.
643. Hoyer JD, Ross CW, Li CY, et al. True T-cell chronic lymphocytic leukemia: a morphologic and immunophenotypic study of 25 cases. *Blood* 1995;86: 1163-1169.

644. Maljaei SH, Brito-Babapulle V, Hiorns LR, et al. Abnormalities of chromosomes 8, 11, 14, and X in T-prolymphocytic leukemia studied by fluorescence in situ hybridization. *Cancer Genetics Cytogenet* 1998;103:110-116.
645. Pekarsky Y, Hallas C, Isobe M, et al. Abnormalities at 14q32.1 in T cell malignancies involve two oncogenes. *Proc Natl Acad Sci USA* 1999;96:2949-2951.
646. Stilgenbauer S, Schaffner C, Litterst A, et al. Biallelic mutations in the ATM gene in T-prolymphocytic leukemia. *Nat Med* 1997;3:1155-1159.
647. Garand R, Goasguen J, Brizard A, et al. Indolent course as a relatively frequent presentation in T-prolymphocytic leukaemia. *Groupe Francais d'Hematologie Cellulaire. Br J Haematol* 1998;103:488-494.
648. Dearden CE, Matutes E, Cazin B, et al. High remission rate in T-cell prolymphocytic leukemia with CAMPATH-1H. *Blood* 2001;98:1721-1726.
649. Teshima T, Akashi K, Shibuya T, et al. Central nervous system involvement in adult T-cell leukemia/lymphoma. *Cancer* 1990;65:327-332.
650. Shimamoto Y, Yamaguchi M. HTLV-I induced extranodal lymphomas. *Leuk Lymphoma* 1992;7:37-45.
651. Kinoshita K, Amagasaki T, Ikeda S, et al. Preleukemic state of adult T cell leukemia: abnormal T lymphocytosis induced by human adult T cell leukemia-lymphoma virus. *Blood* 1985;66:120-127.
652. Miyamoto K, Tomita N, Ishii A, et al. Chromosome abnormalities of leukemia cells in adult patients with T-cell leukemia. *J Natl Cancer Inst* 1984;73:353-362.
653. Tsukasaki K, Krebs J, Nagai K, et al. Comparative genomic hybridization analysis in adult T-cell leukemia/lymphoma: correlation with clinical course. *Blood* 2001;97:3875-3881.
654. Itoyama T, Chaganti RS, Yamada Y, et al. Cytogenetic analysis and clinical significance in adult T-cell leukemia/lymphoma: a study of 50 cases from the human T-cell leukemia virus type-1 endemic area, Nagasaki. *Blood* 2001;97:3612-3620.
655. Shimoyama M, Ota K, Kikuchi M, et al. Major prognostic factors of adult patients with advanced T-cell lymphoma/leukemia. *J Clin Oncol* 1988;6:1088-1097.
656. Ishitsuka K, Tamura K. Treatment of adult T-cell leukemia/lymphoma: past, present, and future. *Eur J Haematol* 2008;80:185-196.
657. Bazarbachi A, Suarez F, Fields P, et al. How I treat adult T-cell leukemia/lymphoma. *Blood* 2011;118:1736-1745.
658. Yamada Y, Tomonaga M, Fukuda H, et al. A new G-CSF-supported combination chemotherapy, LSG15, for adult T-cell leukaemia-lymphoma: Japan Clinical Oncology Group Study 9303. *Br J Haematol* 2001;113:375-382.
659. Lau A, Nightingale S, Taylor GP, et al. Enhanced MDR1 gene expression in human T-cell leukemia virus-I-infected patients offers new prospects for therapy. *Blood* 1998;91:2467-2474.
660. Sakashita A, Hattori T, Miller CW, et al. Mutations of the p53 gene in adult T-cell leukemia. *Blood* 1992;79:477-480.
661. Bunn PA, Jr., Schechter GP, Jaffe E, et al. Clinical course of retrovirus-associated adult T-cell lymphoma in the United States. *N Engl J Med* 1983;309:257-264.
662. Sato E. Autopsy findings of adult T cell Lymphoma-leukemia. In: Hanaoka, M, Takatsuki, K, Shimoyama, M, et al., eds. *Adult T cell leukemia and related diseases*. Tokyo: Japan Scientific Societies Press, 1982:28.
663. Bazarbachi A, Plumelle Y, Carlos Ramos J, et al. Meta-analysis on the use of zidovudine and interferon-alfa in adult T-cell leukemia/lymphoma showing improved survival in the leukemic subtypes. *J Clin Oncol* 2010;28:4177-4183.
664. Kchour G, Tarhini M, Kooshyar MM, et al. Phase 2 study of the efficacy and safety of the combination of arsenic trioxide, interferon alpha, and zidovudine in newly diagnosed chronic adult T-cell leukemia/lymphoma (ATL). *Blood* 2009;113:6528-6532.
665. Ishida T, Hishizawa M, Kato K, et al. Allogeneic hematopoietic stem cell transplantation for adult T-cell leukemia-lymphoma with special emphasis on preconditioning regimen: a nationwide retrospective study. *Blood* 2012;120:1734-1741.
666. Ruijs CD, Dekker AW, van Kempen-Harteveld ML, et al. Treatment of localized non-Hodgkin's lymphomas of the head and neck. *Cancer* 1994;74:703-707.

667. Jones SE, Miller TP, Connors JM. Long-term follow-up and analysis for prognostic factors for patients with limited-stage diffuse large-cell lymphoma treated with initial chemotherapy with or without adjuvant radiotherapy. *J Clin Oncol* 1989;7:1186-1191.
668. Shenker TN, Voss N, Fairey R, et al. Brief chemotherapy and involved-region irradiation for limited-stage diffuse large-cell lymphoma: an 18-year experience from the British Columbia Cancer Agency. *J Clin Oncol* 2002;20:197-204.
669. Sehn LH. Chemotherapy alone for localized diffuse large B-cell lymphoma. *Cancer J* 2012;18:421-426.
670. Miller TP, Dahlberg S, Cassady JR, et al. Chemotherapy alone compared with chemotherapy plus radiotherapy for localized intermediate- and high-grade non-Hodgkin's lymphoma. *N Engl J Med* 1998;339:21-26.
671. Miller TP, LeBlanc M, Spier C, et al. CHOP alone compared to CHOP plus radiotherapy for early stage aggressive non-Hodgkin's lymphomas: update of the Southwest Oncology Group (SWOG) randomized trial. *Blood* 2001;98:724a.
672. Horning SJ, Weller E, Kim K, et al. Chemotherapy with or without radiotherapy in limited-stage diffuse aggressive non-Hodgkin's lymphoma: eastern Cooperative Oncology Group study 1484. *J Clin Oncol* 2004;22:3032-3038.
673. Persky DO, Unger JM, Spier CM, et al. Phase II study of rituximab plus three cycles of CHOP and involved-field radiotherapy for patients with limited-stage aggressive B-cell lymphoma: Southwest Oncology Group study 0014. *J Clin Oncol* 2008;26:2258-2263.
674. Link MP, Shuster JJ, Donaldson SS, et al. Treatment of children and young adults with early-stage non-Hodgkin's lymphoma. *N Engl J Med* 1997;337:1259-1266.
675. Bonnet C, Fillet G, Mounier N, et al. CHOP alone compared with CHOP plus radiotherapy for localized aggressive lymphoma in elderly patients: a study by the Groupe d'Etude des Lymphomes de l'Adulte. *J Clin Oncol* 2007;25:787-792.
676. Reyes F, Lepage E, Ganem G, et al. ACVBP versus CHOP plus radiotherapy for localized aggressive lymphoma. *N Engl J Med* 2005;352:1197-1205.
677. Halasz LM, Jacene HA, Catalano PJ, et al. Combined modality treatment for PET-positive non-Hodgkin lymphoma: favorable outcomes of combined modality treatment for patients with non-Hodgkin lymphoma and positive interim or postchemotherapy FDG-PET. *Int J Radiat Oncol Biol Phys* 2012;83:e647-e654.
678. Gaynor ER, Fisher RI. What is the best treatment for diffuse large cell lymphoma? In: Armitage J, Newland A, Keating A, et al, eds. *Haematological oncology*, Great Britain: Cambridge University Press. 1995:119-133.
679. DeVita VT, Jr., Canellos GP, Chabner B, et al. Advanced diffuse histiocytic lymphoma, a potentially curable disease. *Lancet* 1975;1:248-250.
680. Armitage JO, Fyfe MA, Lewis J. Long-term remission durability and functional status of patients treated for diffuse histiocytic lymphoma with the CHOP regimen. *J Clin Oncol* 1984;2:898-902.
681. Jones SE, Grozea PN, Metz EN, et al. Superiority of adriamycin-containing combination chemotherapy in the treatment of diffuse lymphoma: a Southwest Oncology Group study. *Cancer* 1979;43:417-425.
682. Lee L, Crump M, Khor S, et al. Impact of rituximab on treatment outcomes of patients with diffuse large b-cell lymphoma: a population-based analysis. *Br J Haematol* 2012;158:481-488.
683. Haw R, Sawka CA, Franssen E, et al. Significance of a partial or slow response to front-line chemotherapy in the management of intermediate-grade or high-grade non-Hodgkin's lymphoma: a literature review. *J Clin Oncol* 1994;12:1074-1084.
684. Armitage JO, Cheson BD. Interpretation of clinical trials in diffuse large-cell lymphoma. *J Clin Oncol* 1988;6:1335-1347.
685. DeVita VT, Jr., Hubbard SM, Young RC, et al. The role of chemotherapy in diffuse aggressive lymphomas. *Semin Hematol* 1988;25:2-10.
686. Longo DL, DeVita VT, Jr., Duffey PL, et al. Superiority of ProMACE-CytaBOM over ProMACE-MOPP in the treatment of advanced diffuse aggressive lymphoma: results of a prospective randomized trial. *J Clin Oncol* 1991;9:25-38.
687. Gaynor ER, Ultmann JE, Golomb HM, et al. Treatment of diffuse histiocytic lymphoma (DHL) with COMLA (cyclophosphamide, oncovin, methotrexate, leucovorin, cytosine arabinoside): a 10-year experience in a single institution. *J Clin Oncol* 1985;3:1596-1604.

688. Sweet DL, Golomb HM, Ultmann JE, et al. Cyclophosphamide, vincristine, methotrexate with leucovorin rescue, and cytarabine (COMLA) combination sequential chemotherapy for advanced diffuse histiocytic lymphoma. *Ann Intern Med* 1980;92:785-790.
689. Skarin AT, Canellos GP, Rosenthal DS, et al. Improved prognosis of diffuse histiocytic and undifferentiated lymphoma by use of high dose methotrexate alternating with standard agents (M-BACOD). *J Clin Oncol* 1983;1:91-98.
690. Shipp MA, Yeap BY, Harrington DP, et al. The m-BACOD combination chemotherapy regimen in large-cell lymphoma: analysis of the completed trial and comparison with the M-BACOD regimen. *J Clin Oncol* 1990;8:84-93.
691. Fisher RI, DeVita VT, Jr., Hubbard SM, et al. Diffuse aggressive lymphomas: increased survival after alternating flexible sequences of proMACE and MOPP chemotherapy. *Ann Intern Med* 1983;98:304-309.
692. Coleman M, Armitage JO, Gaynor M, et al. The COP-BLAM programs: evolving chemotherapy concepts in large cell lymphoma. *Semin Hematol* 1988;25:23-33.
693. Klimo P, Connors JM. MACOP-B chemotherapy for the treatment of diffuse large-cell lymphoma. *Ann Intern Med* 1985;102:596-602.
694. Boyd DB, Coleman M, Papish SW, et al. COPBLAM III: infusional combination chemotherapy for diffuse large-cell lymphoma. *J Clin Oncol* 1988;6:425-433.
695. Velasquez WS, McLaughlin P, Fuller LM, et al. Intermediate-grade lymphomas treated with cyclophosphamide-doxorubicin-vincristine-prednisone-bleomycin alternated with cyclophosphamide-methotrexate-etoposide-dexamethasone. Application of prognostic models to data analysis. *Cancer* 1994;73:2408-2416.
696. Fisher RI, Gaynor ER, Dahlberg S, et al. Comparison of a standard regimen (CHOP) with three intensive chemotherapy regimens for advanced non-Hodgkin's lymphoma. *N Engl J Med* 1993;328:1002-1006.
697. Shipp MA. Prognostic factors in aggressive non-Hodgkin's lymphoma: who has "high-risk" disease? *Blood* 1994;83:1165-1173.
698. Feugier P, Van Hoof A, Sebban C, et al. Long-term results of the R-CHOP study in the treatment of elderly patients with diffuse large B-cell lymphoma: a study by the Groupe d'Etude des Lymphomes de l'Adulte. *J Clin Oncol* 2005;23:4117-4126.
699. Coiffier B, Thieblemont C, Van Den Neste E, et al. Long-term outcome of patients in the LNH-98.5 trial, the first randomized study comparing rituximab-CHOP to standard CHOP chemotherapy in DLBCL patients: a study by the Groupe d'Etudes des Lymphomes de l'Adulte. *Blood* 2010;116:2040-2045.
700. Habermann TM, Weller EA, Morrison VA, et al. Rituximab-CHOP versus CHOP alone or with maintenance rituximab in older patients with diffuse large B-cell lymphoma. *J Clin Oncol* 2006;24:3121-3127.
701. Pfreundschuh M, Trumper L, Osterborg A, et al. CHOP-like chemotherapy plus rituximab versus CHOP-like chemotherapy alone in young patients with good-prognosis diffuse large-B-cell lymphoma: a randomised controlled trial by the MabThera International Trial (MInT) Group. *Lancet Oncol* 2006;7:379-391.
702. Salles G, de Jong D, Xie W, et al. Prognostic significance of immunohistochemical biomarkers in diffuse large B-cell lymphoma: a study from the Lunenburg Lymphoma Biomarker Consortium. *Blood* 2011;117:7070-7078.
703. Alizadeh AA, Gentles AJ, Alencar AJ, et al. Prediction of survival in diffuse large B-cell lymphoma based on the expression of 2 genes reflecting tumor and microenvironment. *Blood* 2011;118:1350-1358.
704. Cabanillas F, Rodriguez-Diaz Pavon J, Hagemester FB, et al. Alternating triple therapy for the treatment of intermediate grade and immunoblastic lymphoma. *Ann Oncol Official J Eur Soc Med Oncol/ESMO* 1998;9:511-518.
705. Fridrik MA, Hausmaninger H, Linkesch W, et al. CEOP-IMVP-Dexa in the treatment of aggressive lymphomas: an Austrian multicenter trial. *J Clin Oncol* 1996;14:227-232.
706. Gaynor ER, Unger JM, Miller TP, et al. Infusional CHOP chemotherapy (CVAD) with or without chemosensitizers offers no advantage over standard CHOP therapy in the treatment of lymphoma: a Southwest Oncology Group Study. *J Clin Oncol* 2001;19:750-755.
707. Pfreundschuh M, Trumper L, Kloess M, et al. Two-weekly or 3-weekly CHOP chemotherapy with or without etoposide for the treatment of elderly patients with aggressive lymphomas: results of the NHL-B2 trial of the DSHNHL. *Blood* 2004;104:634-641.

708. Pfreundschuh M, Trumper L, Kloess M, et al. Two-weekly or 3-weekly CHOP chemotherapy with or without etoposide for the treatment of young patients with good-prognosis (normal LDH) aggressive lymphomas: results of the NHL-B1 trial of the DSHNHL. *Blood* 2004;104:626-633.
709. Cunningham D, Smith P, Mouncey W, et al. A phase III trial comparing R-CHOP 14 and R-CHOP 21 for the treatment of patients with newly diagnosed diffuse large B-cell non Hodgkin's lymphoma. *J Clin Oncol* 2009;27:ASCO Meeting Abstracts 8506a.
710. Delarue R, Tilly H, Salles G, et al. R-CHOP 14 compared to R-CHOP 21 in elderly patients with diffuse large B cell lymphoma: results of the interim analysis of the LNH03-6B GELA study. *Blood* 2009;114:ASH Annual Meeting Abstracts 406a.
711. Meyer RM, Quirt IC, Skillings JR, et al. Escalated as compared with standard doses of doxorubicin in BACOP therapy for patients with non-Hodgkin's lymphoma. *N Engl J Med* 1993;329:1770-1776.
712. Shipp MA, Neuberg D, Janicek M, et al. High-dose CHOP as initial therapy for patients with poor-prognosis aggressive non-Hodgkin's lymphoma: a dose-finding pilot study. *J Clin Oncol* 1995;13:2916-2923.
713. Waits TM, Greco FA, Greer JP, et al. Effective therapy for poor-prognosis non-Hodgkin's lymphoma with 8 weeks of high-dose-intensity combination chemotherapy. *J Clin Oncol* 1993;11:943-949.
714. Gordon LI, Young M, Weller E, et al. A phase II trial of 200% ProMACECytaBOM in patients with previously untreated aggressive lymphomas: analysis of response, toxicity, and dose intensity. *Blood* 1999;94:3307-3314.
715. Glass B, Kloess M, Bentz M, et al. Dose-escalated CHOP plus etoposide (MegaCHOEP) followed by repeated stem cell transplantation for primary treatment of aggressive high-risk non-Hodgkin lymphoma. *Blood* 2006;107:3058-3064.
716. Tilly H, Mounier N, Lederlin P, et al. Randomized comparison of ACVBP and m-BACOD in the treatment of patients with low-risk aggressive lymphoma: the LNH87-1 study. Groupe d'Etudes des Lymphomes de l'Adulte. *J Clin Oncol* 2000;18:1309-1315.
717. Recher C, Coiffier B, Haioun C, et al. Intensified chemotherapy with ACVBP plus rituximab versus standard CHOP plus rituximab for the treatment of diffuse large B-cell lymphoma (LNH03-2B): an open-label randomised phase 3 trial. *Lancet* 2011;378:1858-1867.
718. Verdonck LF, van Putten WL, Hagenbeek A, et al. Comparison of CHOP chemotherapy with autologous bone marrow transplantation for slowly responding patients with aggressive non-Hodgkin's lymphoma. *N Engl J Med* 1995;332:1045-1051.
- P.1872
719. Haioun C, Lepage E, Gisselbrecht C, et al. Benefit of autologous bone marrow transplantation over sequential chemotherapy in poor-risk aggressive non-Hodgkin's lymphoma: updated results of the prospective study LNH87-2. Groupe d'Etude des Lymphomes de l'Adulte. *J Clin Oncol* 1997;15:1131-1137.
720. Gisselbrecht C, Lepage E, Molina T, et al. Shortened first-line high-dose chemotherapy for patients with poor-prognosis aggressive lymphoma. *J Clin Oncol* 2002;20:2472-2479.
721. Coiffier B, Bryon PA, French M, et al. Intensive chemotherapy in aggressive lymphomas: updated results of LNH-80 protocol and prognostic factors affecting response and survival. *Blood* 1987;70:1394-1399.
722. Coiffier B, Gisselbrecht C, Herbrecht R, et al. LNH-84 regimen: a multicenter study of intensive chemotherapy in 737 patients with aggressive malignant lymphoma. *J Clin Oncol* 1989;7:1018-1026.
723. Oliansky DM, Czuczman M, Fisher RI, et al. The role of cytotoxic therapy with hematopoietic stem cell transplantation in the treatment of diffuse large B cell lymphoma: update of the 2001 evidence-based review. *Biol Blood Marrow Transplant J Am Soc Blood Marrow Transplant* 2011;17:20-47, e30.
724. Fitoussi O, Belhadj K, Mounier N, et al. Survival impact of rituximab combined with ACVBP and upfront consolidation autotransplantation in high-risk diffuse large B-cell lymphoma for GELA. *Haematologica* 2011;96: 1136-1143.
725. Flowers CR, Sinha R, Vose JM. Improving outcomes for patients with diffuse large B-cell lymphoma. *CA Cancer J Clin* 2010;60:393-408.

726. Stiff PJ, Unger JM, Cook J, et al. Randomized phase III U.S./Canadian intergroup trial (SWOG S9704) comparing CHOP {+/-} R for eight cycles to CHOP {+/-} R for six cycles followed by autotransplant for patients with high-intermediate (H-Int) or high IPI grade diffuse aggressive non-Hodgkin lymphoma (NHL). *J Clin Oncol* 2011:ASCO Meeting Abstracts 8001a.
727. Magrath I, Adde M, Shad A, et al. Adults and children with small non-cleavedcell lymphoma have a similar excellent outcome when treated with the same chemotherapy regimen. *J Clin Oncol* 1996;14:925-934.
728. Cabanillas F, Hagemester FB, McLaughlin P, et al. Results of MIME salvage regimen for recurrent or refractory lymphoma. *J Clin Oncol* 1987;5:407-412.
729. Velasquez WS, Cabanillas F, Salvador P, et al. Effective salvage therapy for lymphoma with cisplatin in combination with high-dose Ara-C and dexamethasone (DHAP). *Blood* 1988;71:117-122.
730. Velasquez WS, McLaughlin P, Tucker S, et al. ESHAP—an effective chemotherapy regimen in refractory and relapsing lymphoma: a 4-year follow-up study. *J Clin Oncol* 1994;12:1169-1176.
731. Rodriguez MA, Cabanillas FC, Velasquez W, et al. Results of a salvage treatment program for relapsing lymphoma: MINE consolidated with ESHAP. *J Clin Oncol* 1995;13:1734-1741.
732. Romaguera JE, Rodriguez MA, Hagemester FB, et al. Phase II study of paclitaxel in combination with mitoxantrone and ifosfamide/mesna for patients with relapsed or refractory non-Hodgkin's lymphoma after failure to cytarabine/cisplatin combination. *Invest New Drugs* 1999;17:187-192.
733. Romaguera JE, Hagemester FB, McLaughlin P, et al. Ninety-six-hour paclitaxel infusion with mitoxantrone and ifosfamide/mesna and consolidation with ESHAP for refractory and relapsed non-Hodgkin's lymphoma. *Leuk Lymphoma* 1998;32:97-106.
734. Armitage JO. The role of mitoxantrone in non-Hodgkin's lymphoma. *Oncology (Huntingt)* 2002;16:490-502, 7-8.
735. Moskowitz CH, Bertino JR, Glassman JR, et al. Ifosfamide, carboplatin, and etoposide: a highly effective cytoreduction and peripheral-blood progenitor-cell mobilization regimen for transplant-eligible patients with non-Hodgkin's lymphoma. *J Clin Oncol* 1999;17:3776-3785.
736. Fields KK, Zorsky PE, Hiemenz JW, et al. Ifosfamide, carboplatin, and etoposide: a new regimen with a broad spectrum of activity. *J Clin Oncol* 1994;12:544-552.
737. Kewalramani T, Zelenetz AD, Nimer SD, et al. Rituximab and ICE as second-line therapy before autologous stem cell transplantation for relapsed or primary refractory diffuse large B-cell lymphoma. *Blood* 2004;103:3684-3688.
738. Gisselbrecht C, Glass B, Mounier N, et al. Salvage regimens with autologous transplantation for relapsed large B-cell lymphoma in the rituximab era. *J Clin Oncol* 2010;28:4184-4190.
739. Gutierrez M, Chabner BA, Pearson D, et al. Role of a doxorubicin-containing regimen in relapsed and resistant lymphomas: an 8-year follow-up study of EPOCH. *J Clin Oncol* 2000;18:3633-3642.
740. Chao NJ, Rosenberg SA, Horning SJ. CEPP(B): an effective and well-tolerated regimen in poor-risk, aggressive non-Hodgkin's lymphoma. *Blood* 1990;76:1293-1298.
741. Germann N, Brienza S, Rotarski M, et al. Preliminary results on the activity of oxaliplatin (L-OHP) in refractory/recurrent non-Hodgkin's lymphoma patients. *Ann Oncol Official J Eur Soc Med Oncol/ESMO* 1999;10:351-354.
742. Lignon J, Sibon D, Madelaine I, et al. Rituximab, dexamethasone, cytarabine, and oxaliplatin (R-DHAX) is an effective and safe salvage regimen in relapsed/refractory B-cell non-Hodgkin lymphoma. *Clin Lymphoma Myeloma Leuk* 2010;10:262-269.
743. Lopez A, Gutierrez A, Palacios A, et al. GEMOX-R regimen is a highly effective salvage regimen in patients with refractory/relapsing diffuse large-cell lymphoma: a phase II study. *Eur J Haematol* 2008;80:127-132.
744. Weick JK, Jones SE, Ryan DH. Phase II study of amsacrine (m-AMSA) in advanced lymphomas: a Southwest Oncology Group study. *Cancer Treat Rep* 1983;67:489-492.
745. Cheson BD. New chemotherapeutic agents for non-Hodgkin's lymphomas. *Hematol/Oncol Clin N Am* 1991;5:1027-1051.
746. Zuckerman KS, Case DC, Jr., Gams RA, et al. Chemotherapy of intermediate-and high-grade non-Hodgkin's lymphomas with an intensive epirubicin-containing regimen. *Blood* 1993;82:3564-3573.

747. Warrell RP, Jr., Kempin SJ. Clinical evaluation of a new anthracycline antibiotic, aclacinomycin-A, in patients with advanced malignant lymphoma. *Am J Clin Oncol* 1983;6:81-84.
748. Zagonel V, Tirelli U, Sorio R, et al. 4'-Deoxydoxorubicin (esorubicin) in non-Hodgkin's lymphomas and plasma cell tumors: first evidence of activity. *Haematologica* 1987;72:97-99.
749. Zaja F, Tomadini V, Zaccaria A, et al. CHOP-rituximab with pegylated liposomal doxorubicin for the treatment of elderly patients with diffuse large B-cell lymphoma. *Leuk Lymphoma* 2006;47:2174-2180.
750. Pettengell R, Coiffier B, Narayanan G, et al. Pixantrone dimaleate versus other chemotherapeutic agents as a single-agent salvage treatment in patients with relapsed or refractory aggressive non-Hodgkin lymphoma: a phase 3, multicentre, open-label, randomised trial. *Lancet Oncol* 2012;13: 696-706.
751. Sonneveld P, de Ridder M, van der Lelie H, et al. Comparison of doxorubicin and mitoxantrone in the treatment of elderly patients with advanced diffuse non-Hodgkin's lymphoma using CHOP versus CNOP chemotherapy. *J Clin Oncol* 1995;13:2530-2539.
752. Sora F, Piccirillo N, Chiusolo P, et al. Mitoxantrone, carboplatin, cytosine arabinoside, and methylprednisolone followed by autologous peripheral blood stem cell transplantation: a salvage regimen for patients with refractory or recurrent non-Hodgkin lymphoma. *Cancer* 2006;106:859-866.
753. Fossa A, Santoro A, Hiddemann W, et al. Gemcitabine as a single agent in the treatment of relapsed or refractory aggressive non-Hodgkin's lymphoma. *J Clin Oncol* 1999;17:3786-3792.
754. Zinzani PL, Baliva G, Magagnoli M, et al. Gemcitabine treatment in pretreated cutaneous T-cell lymphoma: experience in 44 patients. *J Clin Oncol* 2000;18:2603-2606.
755. Ng M, Waters J, Cunningham D, et al. Gemcitabine, cisplatin and methylprednisolone (GEM-P) is an effective salvage regimen in patients with relapsed and refractory lymphoma. *Br J Cancer* 2005;92:1352-1357.
756. Papageorgiou ES, Tsigiotis P, Dimopoulos M, et al. Combination chemotherapy with gemcitabine and vinorelbine in the treatment of relapsed or refractory diffuse large B-cell lymphoma: a phase-II trial by the Hellenic Cooperative Oncology Group. *Eur J Haematol* 2005;75:124-129.
757. Rodriguez MA, Pytlik R, Kozak T, et al. Vincristine sulfate liposomes injection (Marqibo) in heavily pretreated patients with refractory aggressive non-Hodgkin lymphoma: report of the pivotal phase 2 study. *Cancer* 2009;115:3475-3482.
758. Sarris AH, Psyrris A, Hagemester F, et al. Infusional vinorelbine in relapsed or refractory lymphomas. *Leuk Lymphoma* 2000;39:291-299.
759. Bass AJ, Gockerman JP, Hammett E, et al. Phase I evaluation of prolonged-infusion gemcitabine with irinotecan for relapsed or refractory leukemia or lymphoma. *J Clin Oncol* 2002;20:2995-3000.
760. Aviles A, Neri N, Castaneda C, et al. Pegylated liposomal doxorubicin in combination chemotherapy in the treatment of previously untreated aggressive diffuse large-B-cell lymphoma. *Med Oncol (Northwood, London, England)* 2002;19:55-58.
761. Younes A, Sarris A, Melnyk A, et al. Three-hour paclitaxel infusion in patients with refractory and relapsed non-Hodgkin's lymphoma. *J Clin Oncol* 1995;13:583-587.
762. Wilson WH, Chabner BA, Bryant G, et al. Phase II study of paclitaxel in relapsed non-Hodgkin's lymphomas. *J Clin Oncol* 1995;13:381-386.
763. Press OW, LeBlanc M, O'Rourke TJ, et al. Phase II trial of paclitaxel by 24-hour continuous infusion for relapsed non-Hodgkin's lymphomas: Southwest Oncology Group trial 9246. *J Clin Oncol* 1998;16:574-578.
764. Budman DR, Petroni GR, Johnson JL, et al. Phase II trial of docetaxel in non-Hodgkin's lymphomas: a study of the Cancer and Leukemia Group B. *J Clin Oncol* 1997;15:3275-3279.
765. Wilson WH, Little R, Pearson D, et al. Phase II and dose-escalation with or without granulocyte colony-stimulating factor study of 9-aminocamptothecin in relapsed and refractory lymphomas. *J Clin Oncol* 1998;16:2345-2351.
766. Sarris AH, Romaguera J, Hagemester FB, et al. Irinotecan in relapsed or refractory non-Hodgkin's lymphoma. *Oncology (Huntingt)* 2001;15:53-56.
767. Younes A, Preti HA, Hagemester FB, et al. Paclitaxel plus topotecan treatment for patients with relapsed or refractory aggressive non-Hodgkin's lymphoma. *Ann Oncol Official J Eur Soc Med Oncol/ESMO* 2001;12:923-927.

768. Goy A, Younes A, McLaughlin P, et al. Phase II study of proteasome inhibitor bortezomib in relapsed or refractory B-cell non-Hodgkin's lymphoma. *J Clin Oncol* 2005;23:667-675.
769. Leonard JP, Furman RR, Coleman M. Proteasome inhibition with bortezomib: a new therapeutic strategy for non-Hodgkin's lymphoma. *Int J Cancer* 2006;119:971-979.
770. Koprivnikar JL, Cheson BD. Bortezomib: a proteasome inhibitor with an evolving role in select subtypes of B-cell non-Hodgkin's lymphoma. *Future Oncol* 2012;8:359-371.
771. Ruan J, Martin P, Furman RR, et al. Bortezomib plus CHOP-rituximab for previously untreated diffuse large B-cell lymphoma and mantle cell lymphoma. *J Clin Oncol* 2011;29:690-697.
772. Miller TP, Grogan TM, Dalton WS, et al. P-glycoprotein expression in malignant lymphoma and reversal of clinical drug resistance with chemotherapy plus high-dose verapamil. *J Clin Oncol* 1991;9:17-24.
773. Sarris AH, Younes A, McLaughlin P, et al. Cyclosporin A does not reverse clinical resistance to paclitaxel in patients with relapsed non-Hodgkin's lymphoma. *J Clin Oncol* 1996;14:233-239.
774. Mounier N, Gisselbrecht C. Relapses, treatments and new drugs. *Best Prac Res Clin Haematol* 2012;25:49-60.
775. Macias-Perez IM, Flinn IW. B-Cell Receptor pathobiology and targeting in NHL. *Curr Oncol Rep* 2012;14:411-418.
776. Foon KA, Takeshita K, Zinzani PL. Novel therapies for aggressive B-cell lymphoma. *Adv Hematol* 2012;2012:302570.
777. Friedberg JW, Sharman J, Sweetenham J, et al. Inhibition of Syk with fostamatinib disodium has significant clinical activity in non-Hodgkin lymphoma and chronic lymphocytic leukemia. *Blood* 2010;115:2578-2585.
778. Herman SE, Gordon AL, Hertlein E, et al. Bruton tyrosine kinase represents a promising therapeutic target for treatment of chronic lymphocytic leukemia and is effectively targeted by PCI-32765. *Blood* 2011;117:6287-6296.
779. Byrd JC, Furman RR, Coutre SE, et al. The Bruton's tyrosine kinase (BTK) inhibitor PCI-32765 (P) in treatment-naive (TN) chronic lymphocytic leukemia (CLL) patients (pts): Interim results of a phase Ib/II study. *J Clin Oncol* 2012:ASCO Meeting Abstracts 6507a.
780. Advani RH, Buggy JJ, Sharman JP, et al. Bruton tyrosine kinase inhibitor ibrutinib (PCI-32765) has significant activity in patients with relapsed/refractory B-cell malignancies. *J Clin Oncol* 2013;31:88-94.
781. Kahl BS, Byrd JC, Flinn IW, et al. Clinical safety and activity in a phase 1 study of CAL-101, an isoform-selective inhibitor of phosphatidylinositol 3-kinase P110, in patients with relapsed or refractory non-Hodgkin lymphoma. *Blood* 2010;116:ASH Annual Meeting Abstracts 1777a.
782. Lannutti B, Meadows SA, Kashishian A, et al. CAL-101, an oral p110 selective phosphatidylinositol-3-kinase (PI3K) inhibitor for the treatment of B cell malignancies inhibits PI3K signaling, cellular viability and protective signals of the microenvironment. *Blood* 2009;114:ASH Annual Meeting Abstracts 286a.
783. Flinn IW, Schreeder MT, Coutre SE, et al. A phase I study of CAL-101, an isoform-selective inhibitor of phosphatidylinositol 3-kinase P110{delta}, in combination with anti-CD20 monoclonal antibody therapy and/or bendamustine in patients with previously treated B-cell malignancies. *J Clin Oncol* 2011:ASCO Meeting Abstracts 3064a.
784. Salven P, Teerenhovi L, Joensuu H. A high pretreatment serum vascular endothelial growth factor concentration is associated with poor outcome in non-Hodgkin's lymphoma. *Blood* 1997;90:3167-3172.
785. Robertson MJ, Kahl BS, Vose JM, et al. Phase II study of enzastaurin, a protein kinase C beta inhibitor, in patients with relapsed or refractory diffuse large B-cell lymphoma. *J Clin Oncol* 2007;25:1741-1746.
786. Hainsworth JD, Arrowsmith E, McCleod M, et al. Randomized phase II study of R-CHOP plus enzastaurin versus R-CHOP in the first-line treatment of patients with intermediate- and high-risk diffuse large B-cell lymphoma (DLBCL): Preliminary analysis. *J Clin Oncol* 2011:ASCO Meeting Abstracts 8016a.
787. Schatz JH. Targeting the PI3K/AKT/mTOR pathway in non-Hodgkin's lymphoma: results, biology, and development strategies. *Curr Oncol Rep* 2011;13:398-406.
788. Hess G, Herbrecht R, Romaguera J, et al. Phase III study to evaluate temsirolimus compared with investigator's choice therapy for the treatment of relapsed or refractory mantle cell lymphoma. *J Clin Oncol* 2009;27:3822-3829.
789. Witzig TE, Reeder CB, LaPlant BR, et al. A phase II trial of the oral mTOR inhibitor everolimus in relapsed aggressive lymphoma. *Leukemia* 2011;25:341-347.

790. Cortelezzi A, Sciume M, Reda G. Lenalidomide in the treatment of chronic lymphocytic leukemia. *Adv Hematol* 2012;2012:393864.
791. Chanan-Khan A, Miller KC, Lawrence D, et al. Tumor flare reaction associated with lenalidomide treatment in patients with chronic lymphocytic leukemia predicts clinical response. *Cancer* 2011;117:2127-2135.
792. Wiernik PH, Lossos IS, Tuscano JM, et al. Lenalidomide monotherapy in relapsed or refractory aggressive non-Hodgkin's lymphoma. *J Clin Oncol* 2008;26:4952-4957.
793. Witzig TE, Vose JM, Zinzani PL, et al. An international phase II trial of single-agent lenalidomide for relapsed or refractory aggressive B-cell non-Hodgkin's lymphoma. *Ann Oncol Official J Eur Soc Med Oncol/ESMO* 2011;22: 1622-1627.
794. Hernandez-Ilizaliturri FJ, Deeb G, Zinzani PL, et al. Higher response to lenalidomide in relapsed/refractory diffuse large B-cell lymphoma in nongerminal center B-cell-like than in germinal center B-cell-like phenotype. *Cancer* 2011;117:5058-5066.
795. Dueck G, Chua N, Prasad A, et al. Interim report of a phase 2 clinical trial of lenalidomide for T-cell non-Hodgkin lymphoma. *Cancer* 2010;116: 4541-4548.
796. Boerma EG, van Imhoff GW, Appel IM, et al. Gender and age-related differences in Burkitt lymphoma—epidemiological and clinical data from The Netherlands. *Eur J Cancer* 2004;40:2781-2787.
797. Kelly JL, Toothaker SR, Ciminello L, et al. Outcomes of patients with Burkitt lymphoma older than age 40 treated with intensive chemotherapeutic regimens. *Clin Lymphoma Myeloma* 2009;9:307-310.
798. Linch DC. Burkitt lymphoma in adults. *Br J Haematol* 2012;156:693-703.
799. Dave SS, Fu K, Wright GW, et al. Molecular diagnosis of Burkitt's lymphoma. *N Engl J Med* 2006;354:2431-2442.
800. Hummel M, Bentink S, Berger H, et al. A biologic definition of Burkitt's lymphoma from transcriptional and genomic profiling. *N Engl J Med* 2006;354:2419-2430.
801. Blum KA, Lozanski G, Byrd JC. Adult Burkitt leukemia and lymphoma. *Blood* 2004;104:3009-3020.
802. McMaster ML, Greer JP, Greco FA, et al. Effective treatment of small-non-cleaved-cell lymphoma with high-intensity, brief-duration chemotherapy. *J Clin Oncol* 1991;9:941-946.
803. Soussain C, Patte C, Ostronoff M, et al. Small noncleaved cell lymphoma and leukemia in adults. A retrospective study of 65 adults treated with the LMB pediatric protocols. *Blood* 1995;85:664-674.
804. Hoelzer D, Ludwig WD, Thiel E, et al. Improved outcome in adult B-cell acute lymphoblastic leukemia. *Blood* 1996;87:495-508.
805. Thomas DA, Cortes J, O'Brien S, et al. Hyper-CVAD program in Burkitt's-type adult acute lymphoblastic leukemia. *J Clin Oncol* 1999;17:2461-2470.
806. Lee EJ, Petroni GR, Schiffer CA, et al. Brief-duration high-intensity chemotherapy for patients with small noncleaved-cell lymphoma or FAB L3 acute lymphocytic leukemia: results of cancer and leukemia group B study 9251. *J Clin Oncol* 2001;19:4014-4022.
807. Mead GM, Sydes MR, Walewski J, et al. An international evaluation of CODOX-M and CODOX-M alternating with IVAC in adult Burkitt's lymphoma: results of United Kingdom Lymphoma Group LY06 study. *Ann Oncol Official J Eur Soc Med Oncol/ESMO* 2002;13:1264-1274.
808. Rizzieri DA, Johnson JL, Niedzwiecki D, et al. Intensive chemotherapy with and without cranial radiation for Burkitt leukemia and lymphoma: final results of Cancer and Leukemia Group B Study 9251. *Cancer* 2004;100: 1438-1448.
809. Divine M, Casassus P, Koscielny S, et al. Burkitt lymphoma in adults: a prospective study of 72 patients treated with an adapted pediatric LMB protocol. *Ann Oncol Official J Eur Soc Med Oncol/ESMO* 2005;16:1928-1935.
810. Thomas DA, Faderl S, O'Brien S, et al. Chemoimmunotherapy with hyper-CVAD plus rituximab for the treatment of adult Burkitt and Burkitt-type lymphoma or acute lymphoblastic leukemia. *Cancer* 2006;106:1569-1580.
811. Hoelzer D, Hiddemann W, Baumann A, et al. High survival rate in adult Burkitt's lymphoma/leukemia and diffuse large B-cell lymphoma with mediastinal involvement. *Blood* 2007;110:ASH Annual Meeting Abstracts 518a.

812. Mead GM, Barrans SL, Qian W, et al. A prospective clinicopathologic study of dose-modified CODOX-M/IVAC in patients with sporadic Burkitt lymphoma defined using cytogenetic and immunophenotypic criteria (MRC/NCRI LY10 trial). *Blood* 2008;112:2248-2260.
813. Corazzelli G, Frigeri F, Russo F, et al. RD-CODOX-M/IVAC with rituximab and intrathecal liposomal cytarabine in adult Burkitt lymphoma and 'unclassifiable' highly aggressive B-cell lymphoma. *Br J Haematol* 2012;156: 234-244.
814. Hoelzer D. Recent results in the treatment of Burkitt lymphomas. *Ann Oncol* 2008;19 Suppl 4, iv83, abstract 008.
815. Dunleavy K, Pittaluga S, Wayne AS, et al. Myc+ aggressive B-cell lymphomas: novel therapy of untreated Burkitt lymphoma and Myc+ diffuse large B-cell lymphoma with DA-EPOCH-R. *Ann Oncol* 2011;22: Suppl 4, iv106, abstract 071.
816. Gerrard M, Cairo MS, Weston C, et al. Excellent survival following two courses of COPAD chemotherapy in children and adolescents with resected localized B-cell non-Hodgkin's lymphoma: results of the FAB/LMB 96 international study. *Br J Haematol* 2008;141:840-847.
817. Lacasce A, Howard O, Lib S, et al. Modified magrath regimens for adults with Burkitt and Burkitt-like lymphomas: preserved efficacy with decreased toxicity. *Leuk Lymphoma* 2004;45:761-767.
818. Cortes J, Thomas D, Rios A, et al. Hyperfractionated cyclophosphamide, vincristine, doxorubicin, and dexamethasone and highly active antiretroviral therapy for patients with acquired immunodeficiency syndrome-related Burkitt lymphoma/leukemia. *Cancer* 2002;94:1492-1499.
819. Kaplan LD, Lee JY, Ambinder RF, et al. Rituximab does not improve clinical outcome in a randomized phase 3 trial of CHOP with or without rituximab in patients with HIV-associated non-Hodgkin lymphoma: AIDS-Malignancies Consortium Trial 010. *Blood* 2005;106:1538-1543.
820. Dunleavy K, Little RF, Pittaluga S, et al. The role of tumor histogenesis, FDG-PET, and short-course EPOCH with dose-dense rituximab (SC-EPOCH-RR) in HIV-associated diffuse large B-cell lymphoma. *Blood* 2010;115:3017-3024.
821. Sweetenham JW, Pearce R, Taghipour G, et al. Adult Burkitt's and Burkitt-like non-Hodgkin's lymphoma—outcome for patients treated with high-dose therapy and autologous stem-cell transplantation in first remission or at relapse: results from the European Group for Blood and Marrow Transplantation. *J Clin Oncol* 1996;14:2465-2472.
822. Fenaux P, Bourhis JH, Ribrag V. Burkitt's acute lymphocytic leukemia (L3ALL) in adults. *Hematol/Oncol Clin N Am* 2001;15:37-50.
823. Ahmed SO, Sureda A, Aljurf M. The role of hematopoietic SCT in adult Burkitt lymphoma. *Bone Marrow Transplant* 2012: advance online publication 30 July 2012; doi: 2010.1038/bmt.2012.2129.
824. Portell CA, Sweetenham JW. Adult lymphoblastic lymphoma. *Cancer J* 2012;18:432-438.
825. Rosen PJ, Feinstein DI, Pattengale PK, et al. Convuluted lymphocytic lymphoma in adults: a clinicopathologic entity. *Ann Intern Med* 1978;89:319-324.
826. Soslow RA, Baergen RN, Warnke RA. B-lineage lymphoblastic lymphoma is a clinicopathologic entity distinct from other histologically similar aggressive lymphomas with blastic morphology. *Cancer* 1999;85:2648-2654.
827. Lin P, Jones D, Dorfman DM, et al. Precursor B-cell lymphoblastic lymphoma: a predominantly extranodal tumor with low propensity for leukemic involvement. *Am J Surg Pathol* 2000;24:1480-1490.
828. Weiss LM, Bindl JM, Picozzi VJ, et al. Lymphoblastic lymphoma: an immunophenotype study of 26 cases with comparison to T cell acute lymphoblastic leukemia. *Blood* 1986;67:474-478.
829. Ferrando AA, Neuberg DS, Staunton J, et al. Gene expression signatures define novel oncogenic pathways in T cell acute lymphoblastic leukemia. *Cancer Cell* 2002;1:75-87.
830. Raetz EA, Perkins SL, Bhojwani D, et al. Gene expression profiling reveals intrinsic differences between T-cell acute lymphoblastic leukemia and T-cell lymphoblastic lymphoma. *Pediatr Blood Cancer* 2006;47:130-140.
831. Baleyrier F, Decouvelaere AV, Bergeron J, et al. T cell receptor genotyping and HOXA/TLX1 expression define three T lymphoblastic lymphoma subsets which might affect clinical outcome. *Clin Cancer Res Official J Am Assoc Cancer Res* 2008;14:692-700.
832. Sweetenham JW. Precursor T-cell lymphoblastic lymphoma. In: Canellos, GP, Lister, TA, Young, BD, eds. *The Lymphomas*. Philadelphia: Saunders Elsevier, 2006:456-463.

833. Breit S, Stanulla M, Flohr T, et al. Activating NOTCH1 mutations predict favorable early treatment response and long-term outcome in childhood precursor T-cell lymphoblastic leukemia. *Blood* 2006;108:1151-1157.
834. Sulis ML, Williams O, Palomero T, et al. NOTCH1 extracellular juxtamembrane expansion mutations in T-ALL. *Blood* 2008;112:733-740.
835. Callens C, Baleyrier F, Lengline E, et al. Clinical impact of NOTCH1 and/or FBXW7 mutations, FLASH deletion, and TCR status in pediatric T-cell lymphoblastic lymphoma. *J Clin Oncol* 2012;30:1966-1973.
836. Aguiar RC, Chase A, Coulthard S, et al. Abnormalities of chromosome band 8p11 in leukemia: two clinical syndromes can be distinguished on the basis of MOZ involvement. *Blood* 1997;90:3130-3135.
837. Thandla S, Alashari M, Green DM, et al. Therapy-related T cell lymphoblastic lymphoma with t(11;19)(q23;p13) and MLL gene rearrangement. *Leukemia* 1999;13:2116-2118.
838. Levine AM, Forman SJ, Meyer PR, et al. Successful therapy of convoluted T-lymphoblastic lymphoma in the adult. *Blood* 1983;61:92-98.
839. Slater DE, Mertelsmann R, Koziner B, et al. Lymphoblastic lymphoma in adults. *J Clin Oncol* 1986;4:57-67.
840. Coleman CN, Picozzi VJ, Jr., Cox RS, et al. Treatment of lymphoblastic lymphoma in adults. *J Clin Oncol* 1986;4:1628-1637.
841. Kobayashi T, Tobinai K, Shimoyama M, et al. Long-term follow-up results of adult patients with acute lymphocytic leukemia or lymphoblastic lymphoma treated with short-term, alternating non-cross-resistant chemotherapy: Japan Clinical Oncology Group Study 8702. Lymphoma Study Group. *Jpn J Clin Oncol* 1999;29:340-348.
842. Thomas D, Kantarjian H, O'Brien S, et al. Outcome with the hyper-CVAD regimen in lymphoblastic lymphoma (LL) (abstract). *Proc Am Soc Clin Oncol* 1999;18:11a.
843. Morel P, Lepage E, Brice P, et al. Prognosis and treatment of lymphoblastic lymphoma in adults: a report on 80 patients. *J Clin Oncol* 1992;10:1078-1085.
844. Colgan JP, Andersen J, Habermann TM, et al. Long-term follow-up of a CHOP-based regimen with maintenance therapy and central nervous system prophylaxis in lymphoblastic non-Hodgkin's lymphoma. *Leuk Lymphoma* 1994;15:291-296.
845. Zinzani PL, Bendandi M, Visani G, et al. Adult lymphoblastic lymphoma: clinical features and prognostic factors in 53 patients. *Leuk Lymphoma* 1996;23:577-582.
846. Kaiser U, Uebelacker I, Havemann K. Non-Hodgkin's lymphoma protocols in the treatment of patients with Burkitt's lymphoma and lymphoblastic lymphoma: a report on 58 patients. *Leuk Lymphoma* 1999;36:101-108.
847. Thomas DA, Kantarjian HM. Lymphoblastic lymphoma. *Hematol/Oncol Clin N Am* 2001;15:51-95, vi.
848. Hoelzer D, Gokbuget N, Digel W, et al. Outcome of adult patients with T-lymphoblastic lymphoma treated according to protocols for acute lymphoblastic leukemia. *Blood* 2002;99:4379-4385.
849. Jabbour E, Koscielny S, Sebban C, et al. High survival rate with the LMT-89 regimen in lymphoblastic lymphoma (LL), but not in T-cell acute lymphoblastic leukemia (T-ALL). *Leukemia* 2006;20:814-819.
850. Song KW, Barnett MJ, Gascoyne RD, et al. Primary therapy for adults with T-cell lymphoblastic lymphoma with hematopoietic stem-cell transplantation results in favorable outcomes. *Ann Oncol Official J Eur Soc Med Oncol/ESMO* 2007;18:535-540.
851. Hunault M, Truchan-Graczyk M, Caillot D, et al. Outcome of adult T-lymphoblastic lymphoma after acute lymphoblastic leukemia-type treatment: a GOELAMS trial. *Haematologica* 2007;92:1623-1630.
852. Cortelazzo S, Intermesoli T, Oldani E, et al. Results of a lymphoblastic leukemia-like chemotherapy program with risk-adapted mediastinal irradiation and stem cell transplantation for adult patients with lymphoblastic lymphoma. *Ann Hematol* 2012;91:73-82.
853. Sweetenham JW, Liberti G, Pearce R, et al. High-dose therapy and autologous bone marrow transplantation for adult patients with lymphoblastic lymphoma: results of the European Group for Bone Marrow Transplantation. *J Clin Oncol* 1994;12:1358-1365.
854. Bleyer WA. Cancer in older adolescents and young adults: epidemiology, diagnosis, treatment, survival, and importance of clinical trials. *Med Pediatr Oncol* 2002;38:1-10.

855. Dabaja BS, Ha CS, Thomas DA, et al. The role of local radiation therapy for mediastinal disease in adults with T-cell lymphoblastic lymphoma. *Cancer* 2002;94:2738-2744.
856. Chopra R, Goldstone AH, Pearce R, et al. Autologous versus allogeneic bone marrow transplantation for non-Hodgkin's lymphoma: a case-controlled analysis of the European Bone Marrow Transplant Group Registry data. *J Clin Oncol* 1992;10:1690-1695.
857. Bouabdallah R, Xerri L, Bardou VJ, et al. Role of induction chemotherapy and bone marrow transplantation in adult lymphoblastic lymphoma: a report on 62 patients from a single center. *Ann Oncol Official J Eur Soc Med Oncol/ESMO* 1998;9:619-625.
858. Sweetenham JW, Santini G, Qian W, et al. High-dose therapy and autologous stem-cell transplantation versus conventional-dose consolidation/maintenance therapy as postremission therapy for adult patients with lymphoblastic lymphoma: results of a randomized trial of the European Group for Blood and Marrow Transplantation and the United Kingdom Lymphoma Group. *J Clin Oncol* 2001;19:2927-2936.
859. Levine JE, Harris RE, Loberiza FR, Jr., et al. A comparison of allogeneic and autologous bone marrow transplantation for lymphoblastic lymphoma. *Blood* 2003;101:2476-2482.
860. Rowe JM, Richards S, Wiernik PH, Canellos, G.P., Dutcher, J.P., Kile, R.A., et al. Allogeneic bone marrow transplantation (BMT) for adults with acute lymphoblastic leukemia (ALL) in first complete remission (CR): Early results from the international ALL trial (MRC UKALL/ECOG E2993). *Blood* 1999;94:732a.
861. Thiebaut A, Vernant JP, Degos L, et al. Adult acute lymphocytic leukemia study testing chemotherapy and autologous and allogeneic transplantation. A follow-up report of the French protocol LALA 87. *Hematol/Oncol Clin N Am* 2000;14:1353-1366, x.
862. Berg SL, Blaney SM, Devidas M, et al. Phase II study of nelarabine (compound 506U78) in children and young adults with refractory T-cell malignancies: a report from the Children's Oncology Group. *J Clin Oncol* 2005;23: 3376-3382.
863. Gokbuget N, Basara N, Baurmann H, et al. High single-drug activity of nelarabine in relapsed T-lymphoblastic leukemia/lymphoma offers curative option with subsequent stem cell transplantation. *Blood* 2011;118:3504-3511.
864. Jeha S, Gandhi V, Chan KW, et al. Clofarabine, a novel nucleoside analog, is active in pediatric patients with advanced leukemia. *Blood* 2004;103:784-789.
865. Barba P, Sampol A, Calbacho M, et al. Clofarabine-based chemotherapy for relapsed/refractory adult acute lymphoblastic leukemia and lymphoblastic lymphoma. The Spanish experience. *Am J Hematol* 2012;87:631-634.
866. De Keersmaecker K, Lahortiga I, Mentens N, et al. In vitro validation of gamma-secretase inhibitors alone or in combination with other anti-cancer drugs for the treatment of T-cell acute lymphoblastic leukemia. *Haematologica* 2008;93:533-542.
867. Cavalli F, Conconi A, Zucca E. Management of lymphoma at extranodal locations. In Magrath, I, Boffetta, P, Potter, M, et al., eds. *The lymphoid neoplasms* 3rd ed. London: Hodder Arnold, 2010:1010-1038.
868. Wu XC, Andrews P, Chen VW, et al. Incidence of extranodal non-Hodgkin lymphomas among whites, blacks, and Asians/Pacific Islanders in the United States: anatomic site and histology differences. *Cancer Epidemiol* 2009;33:337-346.
869. Yoon SS, Coit DG, Portlock CS, et al. The diminishing role of surgery in the treatment of gastric lymphoma. *Ann Surg* 2004;240:28-37.
870. Wright DH. Pathology of extra-nodal non-Hodgkin lymphomas. *Clin Oncol* 2012;24:319-328.
871. Isaacson PG, Spencer J. The biology of low grade MALT lymphoma. *J Clin Pathol* 1995;48:395-397.
872. Pinotti G, Zucca E, Roggero E, et al. Clinical features, treatment and outcome in a series of 93 patients with low-grade gastric MALT lymphoma. *Leuk Lymphoma* 1997;26:527-537.
873. Bayerdorffer E, Neubauer A, Rudolph B, et al. Regression of primary gastric lymphoma of mucosa-associated lymphoid tissue type after cure of *Helicobacter pylori* infection. MALT Lymphoma Study Group. *Lancet* 1995;345:1591-1594.
874. Roggero E, Zucca E, Pinotti G, et al. Eradication of *Helicobacter pylori* infection in primary low-grade gastric lymphoma of mucosa-associated lymphoid tissue. *Ann Intern Med* 1995;122:767-769.

875. Steinbach G, Ford R, Globler G, et al. Antibiotic treatment of gastric lymphoma of mucosa-associated lymphoid tissue. An uncontrolled trial. *Ann Intern Med* 1999;131:88-95.
876. Ruskone-Fourmesttraux A, Lavergne A, Aegerter PH, et al. Predictive factors for regression of gastric MALT lymphoma after anti-*Helicobacter pylori* treatment. *Gut* 2001;48:297-303.
877. Zucca E, Cavalli F. Marginal zone lymphoma. In: Magrath, I, Boffetta, P, Potter, M, et al., eds. *The lymphoid neoplasms* 3rd ed. London: Hodder Arnold, 2010:1158-1172.
878. Cavalli F, Isaacson PG, Gascoyne RD, et al. MALT lymphomas. *Hematology (Am Soc Hematol Educ Program)* 2001;1:241-258.
879. Liu H, Ye H, Ruskone-Fourmesttraux A, et al. T(11;18) is a marker for all stage gastric MALT lymphomas that will not respond to *H. pylori* eradication. *Gastroenterology* 2002;122:1286-1294.
880. Savio A, Franzin G, Wotherspoon AC, et al. Diagnosis and posttreatment follow-up of *Helicobacter pylori*-positive gastric lymphoma of mucosa-associated lymphoid tissue: histology, polymerase chain reaction, or both? *Blood* 1996;87:1255-1260.
881. Hammel P, Haioun C, Chaumette MT, et al. Efficacy of single-agent chemotherapy in low-grade B-cell mucosa-associated lymphoid tissue lymphoma with prominent gastric expression. *J Clin Oncol* 1995;13:2524-2529.
882. Conconi A, Thieblemont C, Martinelli G, et al. An International Extranodal Lymphoma Study group phase II study of rituximab in extranodal marginal zone B-cell lymphomas (MZL) (abstract). *Proc Am Soc Clin Oncol* 2001; 20 (part 1):296a.
883. Schwarz RJ, Conners JM, Schmidt N. Diagnosis and management of stage IE and stage IIE gastric lymphomas. *Am J Surg* 1993;165:561-565.
884. Durr ED, Bonner JA, Strickler JG, et al. Management of stage IE primary gastric lymphoma. *Acta Haematol* 1995;94:59-68.
885. Koch P, Probst A, Berdel WE, et al. Treatment results in localized primary gastric lymphoma: data of patients registered within the German multicenter study (GIT NHL 02/96). *J Clin Oncol* 2005;23:7050-7059.
886. Dragosics B, Bauer P, Radaszkiewicz T. Primary gastrointestinal non-Hodgkin's lymphomas. A retrospective clinicopathologic study of 150 cases. *Cancer* 1985;55:1060-1073.
887. Ladjadj Y, Philip T, Lenoir GM, et al. Abdominal Burkitt-type lymphomas in Algeria. *Br J Cancer* 1984;49:503-512.
888. Sentani K, Maeshima AM, Nomoto J, et al. Follicular lymphoma of the duodenum: a clinicopathologic analysis of 26 cases. *Jpn J Clin Oncol* 2008;38:547-552.
889. Al-Saleem T, Al-Mondhiry H. Immunoproliferative small intestinal disease (IPSID): a model for mature B-cell neoplasms. *Blood* 2005;105:2274-2280.
890. el Saghir NS. Combination chemotherapy with tetracycline and aggressive supportive care for immunoproliferative small-intestinal disease lymphoma. *J Clin Oncol* 1995;13:794-795.
891. O'Farrelly C, Feighery C, O'Briain DS, et al. Humoral response to wheat protein in patients with coeliac disease and enteropathy associated T cell lymphoma. *Br Med J (Clin Res Ed)* 1986;293:908-910.
892. Di Sabatino A, Biagi F, Gobbi PG, et al. How I treat enteropathy-associated T-cell lymphoma. *Blood* 2012;119:2458-2468.
893. Boddie AW, Jr., Mullins JD, West G, et al. Extranodal lymphoma: surgical and other therapeutic alternatives. *Curr Probl Cancer* 1982;6:1-64.
894. Shirato H, Tsujii H, Arimoto T, et al. Early stage head and neck non-Hodgkin's lymphoma. The effect of tumor burden on prognosis. *Cancer* 1986;58:2312-2319.
895. Ree HJ, Rege VB, Knisley RE, et al. Malignant lymphoma of Waldeyer's ring following gastrointestinal lymphoma. *Cancer* 1980;46:1528-1535.
896. Saul SH, Kapadia SB. Primary lymphoma of Waldeyer's ring. Clinicopathologic study of 68 cases. *Cancer* 1985;56:157-166.
897. Uematsu M, Kondo M, Hiramatsu H, et al. Stage IA non-Hodgkin's lymphoma of the Waldeyer's ring. Limited chemotherapy and radiation therapy versus radiation therapy alone. *Acta Oncol* 1993;32:675-678.

898. Robbins KT, Kong JS, Fuller LM, et al. A comparative analysis of lymphomas involving Waldeyer's ring and the nasal cavity and paranasal sinuses. *J Otolaryngol* 1985;14:7-13.
899. Barista I, Tekuzman G, Gullu I, et al. Non-Hodgkin's lymphomas of the tonsil: a retrospective analysis of twenty-eight patients with primary tonsillary lymphoma. *Tumori* 1995;81:234-237.
900. Qi SN, Li YX, Wang H, et al. Diffuse large B-cell lymphoma: clinical characterization and prognosis of Waldeyer ring versus lymph node presentation. *Cancer* 2009;115:4980-4989.
901. Liang R. Diagnosis and management of primary nasal lymphoma of T-cell or NK-cell origin. *Clin Lymphoma* 2000;1:33-37; discussion 8.
902. Kwong YL, Kim WS, Lim ST, et al. SMILE for natural killer/T-cell lymphoma: analysis of safety and efficacy from the Asia Lymphoma Study Group. *Blood* 2012;120:2973-2980.
903. Logsdon MD, Ha CS, Kavadi VS, et al. Lymphoma of the nasal cavity and paranasal sinuses: improved outcome and altered prognostic factors with combined modality therapy. *Cancer* 1997;80:477-488.
904. Laskin JJ, Savage KJ, Voss N, et al. Primary paranasal sinus lymphoma: natural history and improved outcome with central nervous system chemoprophylaxis. *Leuk Lymphoma* 2005;46:1721-1727.
905. Gleeson MJ, Bennett MH, Cawson RA. Lymphomas of salivary glands. *Cancer* 1986;58:699-704.
906. Beasley MJ. Lymphoma of the thyroid and head and neck. *Clin Oncol* 2012;24:345-351.
907. Kojima M, Shimizu K, Nishikawa M, et al. Primary salivary gland lymphoma among Japanese: A clinicopathological study of 30 cases. *Leuk Lymphoma* 2007;48:1793-1798.
908. Skacel M, Ross CW, Hsi ED. A reassessment of primary thyroid lymphoma: high-grade MALT-type lymphoma as a distinct subtype of diffuse large B-cell lymphoma. *Histopathology* 2000;37:10-18.
909. Ha CS, Shadle KM, Medeiros LJ, et al. Localized non-Hodgkin lymphoma involving the thyroid gland. *Cancer* 2001;91:629-635.
910. Kuper-Hommel MJ, Snijder S, Jansen-Heijnen ML, et al. Treatment and survival of patients with thyroid lymphoma: a population-based study with clinical and pathologic reviews. *Clin Lymphoma Myeloma* 2005;6:240-247.
911. Mian M, Gaidano G, Conconi A, et al. High response rate and improvement of long-term survival with combined treatment modalities in patients with poor-risk primary thyroid diffuse large B-cell lymphoma: an International Extranodal Lymphoma Study Group and Intergruppo Italiano Linfomi study. *Leuk Lymphoma* 2011;52:823-832.
912. Goda JS, Gospodarowicz M, Pintilie M, et al. Long-term outcome in localized extranodal mucosa-associated lymphoid tissue lymphomas treated with radiotherapy. *Cancer* 2010;116:3815-3824.
913. Li G, Hansmann ML, Zwingers T, et al. Primary lymphomas of the lung: morphological, immunohistochemical and clinical features. *Histopathology* 1990;16:519-531.
914. Wannesson L, Cavalli F, Zucca E. Primary pulmonary lymphoma: current status. *Clin Lymphoma Myeloma* 2005;6:220-227.
915. Neri N, Jesus Nambo M, Aviles A. Diffuse large B-cell lymphoma primary of lung. *Hematology* 2011;16:110-112.
916. Dunleavy K, Roschewski M, Wilson WH. Lymphomatoid granulomatosis and other Epstein-Barr virus associated lymphoproliferative processes. *Curr Hematol Malignancy Rep* 2012;7:208-215.
917. Pelloski CE, Wilder RB, Ha CS, et al. Clinical stage IEA-IIIEA orbital lymphomas: outcomes in the era of modern staging and treatment. *Radiother Oncol J Eur Soc Therap Radiol Oncol* 2001;59:145-151.
918. Lee SW, Suh CO, Kim GE, et al. Role of radiotherapy for primary orbital lymphoma. *Am J Clin Oncol* 2002;25:261-265.
919. Stacy RC, Jakobiec FA, Herwig MC, et al. Diffuse large B-cell lymphoma of the orbit: clinicopathologic, immunohistochemical, and prognostic features of 20 cases. *Am J Ophthalmol* 2012;154:87-98, e1.
920. Deckert M, Engert A, Bruck W, et al. Modern concepts in the biology, diagnosis, differential diagnosis and treatment of primary central nervous system lymphoma. *Leukemia* 2011;25:1797-1807.
921. Brastianos PK, Batchelor TT. Primary central nervous system lymphoma: overview of current treatment strategies. *Hematol/Oncol Clin N Am* 2012;26:897-916.

922. Nelson DF, Martz KL, Bonner H, et al. Non-Hodgkin's lymphoma of the brain: can high dose, large volume radiation therapy improve survival? Report on a prospective trial by the Radiation Therapy Oncology Group (RTOG): RTOG 8315. *Int J Radiat Oncol Biol Phys* 1992;23:9-17.
923. DeAngelis LM. Current management of primary central nervous system lymphoma. *Oncology (Huntingt)* 1995;9:63-71; discussion, 5-6, 8.
924. Lister A, Abrey LE, Sandlund JT. Central nervous system lymphoma. *Hematology (Am Soc Hematol Educ Program)* 2002;1:283-296.
925. O'Brien P, Roos D, Pratt G, et al. Phase II multicenter study of brief singleagentmethotrexate followed by irradiation in primary CNS lymphoma. *J Clin Oncol* 2000;18:519-526.
926. DeAngelis LM, Seiferheld W, Schold SC, et al. Combination chemotherapy and radiotherapy for primary central nervous system lymphoma: Radiation Therapy Oncology Group Study 93-10. *J Clin Oncol* 2002;20:4643-4648.
927. Hochberg FH, Tabatabai G. Therapy of PCNSL at the Massachusetts General Hospital with high dose methotrexate and deferred radiotherapy. *Ann Hematol* 2001;80(Suppl 3):B111-B112.
928. Batchelor T, Carson K, O'Neill A, et al. Treatment of primary CNS lymphoma with methotrexate and deferred radiotherapy: a report of NABTT 96-07. *J Clin Oncol* 2003;21:1044-1049.
929. Pels H, Schmidt-Wolf IG, Glasmacher A, et al. Primary central nervous system lymphoma: results of a pilot and phase II study of systemic and intraventricular chemotherapy with deferred radiotherapy. *J Clin Oncol* 2003;21:4489-4495.
930. Thiel E, Korfel A, Martus P, et al. High-dose methotrexate with or without whole brain radiotherapy for primary CNS lymphoma (G-PCNSL-SG-1): a phase 3, randomised, non-inferiority trial. *Lancet Oncol* 2010;11:1036-1047.
931. Wong ET, Tishler R, Barron L, et al. Immunochemotherapy with rituximab and temozolomide for central nervous system lymphomas. *Cancer* 2004;101:139-145.
932. Illerhaus G, Marks R, Ihorst G, et al. High-dose chemotherapy with autologous stem-cell transplantation and hyperfractionated radiotherapy as first-line treatment of primary CNS lymphoma. *J Clin Oncol* 2006;24:3865-3870.
933. Colombat P, Lemevel A, Bertrand P, et al. High-dose chemotherapy with autologous stem cell transplantation as first-line therapy for primary CNS lymphoma in patients younger than 60 years: a multicenter phase II study of the GOELAMS group. *Bone Marrow Transplant* 2006;38:417-420.
934. Fonseca R, Habermann TM, Colgan JP, et al. Testicular lymphoma is associated with a high incidence of extranodal recurrence. *Cancer* 2000;88:154-161.
935. Zucca E, Conconi A, Mughal TI, et al. Patterns of outcome and prognostic factors in primary large-cell lymphoma of the testis in a survey by the International Extranodal Lymphoma Study Group. *J Clin Oncol* 2003;21:20-27.
936. Ahmad SS, Idris SF, Follows GA, et al. Primary testicular lymphoma. *Clin Oncol* 2012;24:358-365.
937. Tondini C, Ferreri AJ, Siracusano L, et al. Diffuse large-cell lymphoma of the testis. *J Clin Oncol* 1999;17:2854-2858.
938. Vitolo U, Chiappella A, Ferreri AJ, et al. First-line treatment for primary testicular diffuse large B-cell lymphoma with rituximab-CHOP, CNS prophylaxis, and contralateral testis irradiation: final results of an international phase II trial. *J Clin Oncol* 2011;29:2766-2772.
939. Wong WW, Schild SE, Halyard MY, et al. Primary non-Hodgkin lymphoma of the breast: The Mayo Clinic Experience. *J Surg Oncol* 2002;80:19-25, discussion 6.
940. Gholam D, Bibeau F, El Weshi A, et al. Primary breast lymphoma. *Leuk Lymphoma* 2003;44:1173-1178.
941. Mattia AR, Ferry JA, Harris NL. Breast lymphoma. A B-cell spectrum including the low grade B-cell lymphoma of mucosa associated lymphoid tissue. *Am J Surg Pathol* 1993;17:574-587.
942. Kosari F, Daneshbod Y, Parwaresch R, et al. Lymphomas of the female genital tract: a study of 186 cases and review of the literature. *Am J Surg Pathol* 2005;29:1512-1520.
943. Clayton F, Butler JJ, Ayala AG, et al. Non-Hodgkin's lymphoma in bone. Pathologic and radiologic features with clinical correlates. *Cancer* 1987;60:2494-2501.
944. Bacci G, Picci P, Bertoni F, et al. Primary non-Hodgkin's lymphoma of bone: results in 15 patients treated by radiotherapy combined with systemic chemotherapy. *Cancer Treat Rep* 1982;66:1859-1862.

945. Loeffler JS, Tarbell NJ, Kozakewich H, et al. Primary lymphoma of bone in children: analysis of treatment results with adriamycin, prednisone, Oncovin (APO), and local radiation therapy. *J Clin Oncol* 1986;4:496-501.
946. Lones MA, Perkins SL, Sposto R, et al. Non-Hodgkin's lymphoma arising in bone in children and adolescents is associated with an excellent outcome: a Children's Cancer Group report. *J Clin Oncol* 2002;20:2293-2301.
947. Beal K, Allen L, Yahalom J. Primary bone lymphoma: treatment results and prognostic factors with long-term follow-up of 82 patients. *Cancer* 2006;106:2652-2656.
948. Hoefnagel JJ, Vermeer MH, Jansen PM, et al. Primary cutaneous marginal zone B-cell lymphoma: clinical and therapeutic features in 50 cases. *Arch Dermatol* 2005;141:1139-1145.
949. Sokol L, Naghashpour M, Glass LF. Primary cutaneous B-cell lymphomas: recent advances in diagnosis and management. *Cancer Control J Moffitt Cancer Center* 2012;19:236-244.
950. Geelen FA, Vermeer MH, Meijer CJ, et al. bcl-2 protein expression in primary cutaneous large B-cell lymphoma is site-related. *J Clin Oncol* 1998;16: 2080-2085.
951. Grange F, Beylot-Barry M, Courville P, et al. Primary cutaneous diffuse large B-cell lymphoma, leg type: clinicopathologic features and prognostic analysis in 60 cases. *Arch Dermatol* 2007;143:1144-1150.
952. Appelbaum FR, Deisseroth AB, Graw RG, Jr., et al. Prolonged complete remission following high dose chemotherapy of Burkitt's lymphoma in relapse. *Cancer* 1978;41:1059-1063.
953. Philip T, Guglielmi C, Hagenbeek A, et al. Autologous bone marrow transplantation as compared with salvage chemotherapy in relapses of chemotherapy-sensitive non-Hodgkin's lymphoma. *N Engl J Med* 1995;333:1540-1545.
954. Gulati SC, Shank B, Black P, et al. Autologous bone marrow transplantation for patients with poor-prognosis lymphoma. *J Clin Oncol* 1988;6:1303-1313.
955. Nademanee A, Schmidt GM, O'Donnell MR, et al. High-dose chemoradiotherapy followed by autologous bone marrow transplantation as consolidation therapy during first complete remission in adult patients with poor-risk aggressive lymphoma: a pilot study. *Blood* 1992;80:1130-1134.
956. Freedman AS, Takvorian T, Neuberg D, et al. Autologous bone marrow transplantation in poor-prognosis intermediate-grade and high-grade B-cell non-Hodgkin's lymphoma in first remission: a pilot study. *J Clin Oncol* 1993;11:931-936.
957. Ayala E. Hematopoietic cell transplantation for B-cell lymphoma: an update. *Cancer Control J Moffitt Cancer Center* 2012;19:175-186.
958. Hamadani M. Reappraising the role of autologous transplantation for indolent B-cell lymphomas in the chemoimmunotherapy era: is it still relevant? *Bone Marrow Transplant* 2012;doi: 10.1038/bmt.2012.1182. [Epub ahead of print].
959. Gopal AK, Pagel JM, Rajendran JG, et al. Improving the efficacy of reduced intensity allogeneic transplantation for lymphoma using radioimmunotherapy. *Biol Blood Marrow Transplant* 2006;12:697-702.
960. Vose JM, Bierman PJ, Loberiza FR, et al. Phase II trial of 131-iodine tositumomab with high-dose chemotherapy and autologous stem cell transplantation for relapsed diffuse large B cell lymphoma. *Biol Blood Marrow Transplant J Am Soc Blood Marrow Transplant* 2013;19:123-128.
961. Bacher U, Klyuchnikov E, Le-Rademacher J, et al. Conditioning regimens for allotransplants for diffuse large B-cell lymphoma: myeloablative or reduced intensity? *Blood* 2012;120:4256-4262.
962. Hari P, Carreras J, Zhang MJ, et al. Allogeneic transplants in follicular lymphoma: higher risk of disease progression after reduced-intensity compared to myeloablative conditioning. *Biol Blood Marrow Transplant J Am Soc Blood Marrow Transplant* 2008;14:236-245.
963. Khouri IF, McLaughlin P, Saliba RM, et al. Eight-year experience with allogeneic stem cell transplantation for relapsed follicular lymphoma after nonmyeloablative conditioning with fludarabine, cyclophosphamide, and rituximab. *Blood* 2008;111:5530-5536.
964. Gianni AM, Bregni M, Siena S, et al. High-dose chemotherapy and autologous bone marrow transplantation compared with MACOP-B in aggressive B-cell lymphoma. *N Engl J Med* 1997;336:1290-1297.

965. Santini G, Salvagno L, Leoni P, et al. VACOP-B versus VACOP-B plus autologous bone marrow transplantation for advanced diffuse non-Hodgkin's lymphoma: results of a prospective randomized trial by the non-Hodgkin's Lymphoma Cooperative Study Group. *J Clin Oncol* 1998;16:2796-2802.
966. Kaiser U, Uebelacker I, Abel U, et al. Randomized study to evaluate the use of high-dose therapy as part of primary treatment for "aggressive" lymphoma. *J Clin Oncol* 2002;20:4413-4419.
967. Kluin-Nelemans HC, Zagonel V, Anastasopoulou A, et al. Standard chemotherapy with or without high-dose chemotherapy for aggressive non-Hodgkin's lymphoma: randomized phase III EORTC study. *J Natl Cancer Inst* 2001;93:22-30.
968. Milpied N, Deconinck E, Gaillard F, et al. Initial treatment of aggressive lymphoma with high-dose chemotherapy and autologous stem-cell support. *N Engl J Med* 2004;350:1287-1295.
969. Vitolo U, Liberati AM, Cabras MG, et al. High dose sequential chemotherapy with autologous transplantation versus dose-dense chemotherapy MegaCEOP as first line treatment in poor-prognosis diffuse large cell lymphoma: an "Intergruppo Italiano Linfomi" randomized trial. *Haematologica* 2005;90:793-801.
970. Stiff PJ, Unger JM, Cook J, et al. Randomized phase III U.S./Canadian intergroup trial (SWOG S9704) comparing CHOP {+/-} R for eight cycles to CHOP {+/-} R for six cycles followed by autotransplant for patients with high-intermediate (H-Int) or high IPI grade diffuse aggressive non-Hodgkin lymphoma (NHL). *J Clin Oncol* 2011; ASCO Meeting Abstracts:8001a.
971. Hahn T, Wolff SN, Czuczman M, et al. The role of cytotoxic therapy with hematopoietic stem cell transplantation in the therapy of diffuse large cell B-cell non-Hodgkin's lymphoma: an evidence-based review. *Biol Blood Marrow Transplant J Am Soc Blood Marrow Transplant* 2001;7:308-331.
972. Greb A, Bohlius J, Trelle S, et al. High-dose chemotherapy with autologous stem cell support in first-line treatment of aggressive non-Hodgkin lymphoma—results of a comprehensive meta-analysis. *Cancer Treat Rev* 2007;33:338-346.
973. Williams CD, Goldstone AH, Pearce RM, et al. Purging of bone marrow in autologous bone marrow transplantation for non-Hodgkin's lymphoma: a case-matched comparison with unpurged cases by the European Blood and Marrow Transplant Lymphoma Registry. *J Clin Oncol* 1996;14:2454-2464.
974. Freedman AS, Gribben JG, Neuberg D, et al. High-dose therapy and autologous bone marrow transplantation in patients with follicular lymphoma during first remission. *Blood* 1996;88:2780-2786.
975. Hunault-Berger M, Ifrah N, Solal-Celigny P. Intensive therapies in follicular non-Hodgkin lymphomas. *Blood* 2002;100:1141-1152.
976. Weisdorf DJ, Andersen JW, Glick JH, et al. Survival after relapse of low-grade non-Hodgkin's lymphoma: implications for marrow transplantation. *J Clin Oncol* 1992;10:942-947.
977. Romaguera JE. Can we identify patients with low grade lymphoma for front-line ABMT? *Leuk Lymphoma* 1993;10(Suppl):9-15.
978. Sebban C, Mounier N, Brousse N, et al. Standard chemotherapy with interferon compared with CHOP followed by high-dose therapy with autologous stem cell transplantation in untreated patients with advanced follicular lymphoma: the GELF-94 randomized study from the Groupe d'Etude des Lymphomes de l'Adulte (GELA). *Blood* 2006;108:2540-2544.
979. Vose JM, Sharp G, Chan WC, et al. Autologous transplantation for aggressive non-Hodgkin's lymphoma: results of a randomized trial evaluating graft source and minimal residual disease. *J Clin Oncol* 2002;20:2344-2352.
980. Jacquy C, Soree A, Lambert F, et al. A quantitative study of peripheral blood stem cell contamination in diffuse large-cell non-Hodgkin's lymphoma: one-half of patients significantly mobilize malignant cells. *Br J Haematol* 2000;110:631-637.
981. Kalaycio M, Rybicki L, Pohlman B, et al. Risk factors before autologous stem-cell transplantation for lymphoma predict for secondary myelodysplasia and acute myelogenous leukemia. *J Clin Oncol* 2006;24:3604-3610.
982. Nademanee A, Molina A, Dagens A, et al. Autologous stem-cell transplantation for poor-risk and relapsed intermediate- and high-grade non-Hodgkin's lymphoma. *Clin Lymphoma* 2000;1:46-54.
983. Armitage JO, Carbone PP, Connors JM, et al. Treatment-related myelodysplasia and acute leukemia in non-Hodgkin's lymphoma patients. *J Clin Oncol* 2003;21:897-906.
984. Jones RJ, Ambinder RF, Piantadosi S, et al. Evidence of a graft-versus-lymphoma effect associated with allogeneic bone marrow transplantation. *Blood* 1991; 77:649-653.

985. van Besien KW, Khouri IF, Giral SA, et al. Allogeneic bone marrow transplantation for refractory and recurrent low-grade lymphoma: the case for aggressive management. *J Clin Oncol* 1995;13:1096-1102.
986. Ratanatharathorn V, Uberti J, Karanes C, et al. Prospective comparative trial of autologous versus allogeneic bone marrow transplantation in patients with non-Hodgkin's lymphoma. *Blood* 1994;84:1050-1055.
987. Schenkein DP, Dixon P, Desforges JF, et al. Phase I/II study of cyclophosphamide, carboplatin, and etoposide and autologous hematopoietic stem-cell transplantation with posttransplant interferon alfa-2b for patients with lymphoma and Hodgkin's disease. *J Clin Oncol* 1994;12:2423-2431.
988. Grossbard ML, Gribben JG, Freedman AS, et al. Adjuvant immunotoxin therapy with anti-B4-blocked ricin after autologous bone marrow transplantation for patients with B-cell non-Hodgkin's lymphoma. *Blood* 1993;81: 2263-2271.
989. Rapoport AP, Meisenberg B, Sarkodee-Adoo C, et al. Autotransplantation for advanced lymphoma and Hodgkin's disease followed by post-transplant rituxan/GM-CSF or radiotherapy and consolidation chemotherapy. *Bone marrow transplantation* 2002;29:303-312.
990. Kruger PC, Cooney JP, Turner JH. Iodine-131 rituximab radioimmunotherapy with BEAM conditioning and autologous stem cell transplant salvage therapy for relapsed/refractory aggressive non-hodgkin lymphoma. *Cancer Biother Radiopharmaceut* 2012;27:552-560.
991. Gutman JA, Bearman SI, Nieto Y, et al. Autologous transplantation followed closely by reduced-intensity allogeneic transplantation as consolidative immunotherapy in advanced lymphoma patients: a feasibility study. *Bone Marrow Transplant* 2005;36:443-451.
992. Crocchiolo R, Castagna L, Furst S, et al. Tandem autologous-allo-SCT is feasible in patients with high-risk relapsed non-Hodgkin's lymphoma. *Bone Marrow Transplant* 2013;48:249-252.
993. Thieblemont C, Coiffier B. Lymphoma in older patients. *J Clin Oncol* 2007;25:1916-1923.
994. Connors JM. Management of lymphoid neoplasms in the elderly. In: Magrath, I, ed. *The lymphoid neoplasms*. London: Hodder Arnold, 2010:999-1009.
995. Pulte D, Gondos A, Brenner H. Expected long-term survival of older patients diagnosed with non-Hodgkin lymphoma in 2008-2012. *Cancer Epidemiol* 2012;36:e19-e25.
996. Meyer RM, Browman GP, Samosh ML, et al. Randomized phase II comparison of standard CHOP with weekly CHOP in elderly patients with non-Hodgkin's lymphoma. *J Clin Oncol* 1995;13:2386-2393.
997. Kouroukis CT, Browman GP, Esmail R, et al. Chemotherapy for older patients with newly diagnosed, advanced-stage, aggressive-histology non-Hodgkin lymphoma: a systematic review. *Ann Intern Med* 2002;136:136-143.
998. Bastion Y, Blay JY, Divine M, et al. Elderly patients with aggressive non-Hodgkin's lymphoma: disease presentation, response to treatment, and survival—a Groupe d'Etude des Lymphomes de l'Adulte study on 453 patients older than 69 years. *J Clin Oncol* 1997;15:2945-2953.
999. Tirelli U, Errante D, Van Glabbeke M, et al. CHOP is the standard regimen in patients ≥ 70 years of age with intermediate-grade and high-grade non-Hodgkin's lymphoma: results of a randomized study of the European Organization for Research and Treatment of Cancer Lymphoma Cooperative Study Group. *J Clin Oncol* 1998;16:27-34.
1000. Goss PE. Non-Hodgkin's lymphomas in elderly patients. *Leuk Lymphoma* 1993;10:147-156.
1001. Bertini M, Boccomini C, Calvi R. The Influence of advanced age on the treatment and prognosis of diffuse large-cell lymphoma (DLCL). *Clin Lymphoma* 2001;1:278-284.
1002. Dixon DO, Neilan B, Jones SE, et al. Effect of age on therapeutic outcome in advanced diffuse histiocytic lymphoma: the Southwest Oncology Group experience. *J Clin Oncol* 1986;4:295-305.
1003. Meguro A, Ozaki K, Sato K, et al. Rituximab plus 70% cyclophosphamide, doxorubicin, vincristine and prednisone for Japanese patients with diffuse large B-cell lymphoma aged 70 years and older. *Leuk Lymphoma* 2012;53:43-49.
1004. Peyrade F, Jardin F, Thieblemont C, et al. Attenuated immunochemotherapy regimen (R-miniCHOP) in elderly patients older than 80 years with diffuse large B-cell lymphoma: a multicentre, single-arm, phase 2 trial. *Lancet Oncol* 2011;12:460-468.

1005. Lee KW, Kim DY, Yun T, et al. Doxorubicin-based chemotherapy for diffuse large B-cell lymphoma in elderly patients: comparison of treatment outcomes between young and elderly patients and the significance of doxorubicin dosage. *Cancer* 2003;98:2651-2656.
1006. Pettengell R, Schwenkgenks M, Bosly A. Association of reduced relative dose intensity and survival in lymphoma patients receiving CHOP-21 chemotherapy. *Ann Hematol* 2008;87:429-430.
1007. Hirakawa T, Yamaguchi H, Yokose N, et al. Importance of maintaining the relative dose intensity of CHOP-like regimens combined with rituximab in patients with diffuse large B-cell lymphoma. *Ann Hematol* 2010;89:897-904.
1008. Huntington SF, Talbott MS, Greer JP, et al. Toxicities and outcomes among septuagenarians and octogenarians with diffuse large B-cell lymphoma treated with rituximab, cyclophosphamide, doxorubicin, vincristine and prednisone therapy. *Leuk Lymphoma* 2012;53:1461-1468.
1009. Martino R, Perea G, Caballero MD, et al. Cyclophosphamide, pegylated liposomal doxorubicin (Caelyx), vincristine and prednisone (CCOP) in elderly patients with diffuse large B-cell lymphoma: results from a prospective phase II study. *Haematologica* 2002;87:822-827.
1010. Bertini M, Freilone R, Vitolo U, et al. P-VEBEC: a new 8-weekly schedule with or without rG-CSF for elderly patients with aggressive non-Hodgkin's lymphoma (NHL). *Ann Oncol Official J Eur Soc Med Oncol/ESMO* 1994;5: 895-900.
1011. Gomez H, Mas L, Casanova L, et al. Elderly patients with aggressive non-Hodgkin's lymphoma treated with CHOP chemotherapy plus granulocyte-macrophage colony-stimulating factor: identification of two age subgroups with differing hematologic toxicity. *J Clin Oncol* 1998;16:2352-2358.
1012. Gopal AK, Gooley TA, Golden JB, et al. Efficacy of high-dose therapy and autologous hematopoietic stem cell transplantation for non-Hodgkin's lymphoma in adults 60 years of age and older. *Bone Marrow Transplant* 2001;27:593-599.
1013. Gomez H, Hidalgo M, Casanova L, et al. Risk factors for treatment-related death in elderly patients with aggressive non-Hodgkin's lymphoma: results of a multivariate analysis. *J Clin Oncol* 1998;16:2065-2069.
1014. Pohlman B, Macklis RM. Lymphoma and pregnancy. *Semin Oncol* 2000;27:657-666.
1015. Maghfoor I, Ezzat A. Management of lymphoid neoplasia during pregnancy. In: Magrath, I, ed. *The lymphoid neoplasms*. London: Hodder Arnold, 2010:970-983.
1016. Catlin EA, Roberts JD, Jr., Erana R, et al. Transplacental transmission of natural-killer-cell lymphoma. *N Engl J Med* 1999;341:85-91.
1017. Ward FT, Weiss RB. Lymphoma and pregnancy. *Semin Oncol* 1989;16: 397-409.
1018. Germann N, Goffinet F, Goldwasser F. Anthracyclines during pregnancy: embryo-fetal outcome in 160 patients. *Ann Oncol* 2004;15:146-150.
1019. Herold M, Schnohr S, Bittrich H. Efficacy and safety of a combined rituximab chemotherapy during pregnancy. *J Clin Oncol* 2001;19:3439.
1020. Baer MR, Ozer H, Foon KA. Interferon-alpha therapy during pregnancy in chronic myelogenous leukaemia and hairy cell leukaemia. *Br J Haematol* 1992;81:167-169.
1021. Shankar S, Bhatia S. Late effects of cancer treatment and quality of life. In: Magrath, I, ed. *The lymphoid neoplasms*. London: Hodder Arnold, 2010:1050-1065.
1022. Travis LB, Curtis RE, Boice JD, Jr., et al. Second cancers following non-Hodgkin's lymphoma. *Cancer* 1991;67:2002-2009.
1023. Zarrabi MH. Association of non-Hodgkin's lymphoma and second neoplasms. *Semin Oncol* 1990;17:120-132.
1024. Moser EC, Noordijk EM, van Leeuwen FE, et al. Long-term risk of cardiovascular disease after treatment for aggressive non-Hodgkin lymphoma. *Blood* 2006;107:2912-2919.
1025. Hequet O, Le QH, Moullet I, et al. Subclinical late cardiomyopathy after doxorubicin therapy for lymphoma in adults. *J Clin Oncol* 2004;22:1864-1871.

Chapter 89 Non-Hodgkin Lymphoma in Children

> Table of Contents > Part VII - Hematologic Malignancies > Section 4 - Lymphoproliferative Disorders > Chapter 89 - Non-Hodgkin Lymphoma in Children

Chapter 89

Non-Hodgkin Lymphoma in Children

John T. Sandlund, Jr.

Mihaela Onciu

INTRODUCTION

There have been significant clinical and laboratory advances over the last 25 years in our understanding of the non-Hodgkin lymphomas (NHLs) of childhood. These include the refinement of diagnosis and classification of clinically relevant histologic subtypes, the elucidation of various pathogenic mechanisms, and most importantly, improvements in therapy and supportive care which have resulted in improved event-free and overall survival rates. Increased attention to the reduction and elimination of late effects of therapy such as infertility, cardiotoxicity, and second cancers is another important hallmark of clinical research over recent years. These advances and future directions will be discussed in this chapter.

Malignant lymphomas, which comprise both Hodgkin lymphoma and NHL, are the third most common type of childhood cancer after acute lymphoblastic leukemia (ALL) and brain tumors.^{1, 2, 3, 4, 5, 6, 7} Among children <18 years of age, there is a slight predominance of Hodgkin lymphoma, whereas the reverse is true among those <15 years of age.^{3, 6}

It is important to note the distinction between the NHLs of adults and children.^{8, 9, 10} Children typically present with diffuse extranodal disease in contrast to adults, among whom primary nodal disease is more common. Additionally, the pediatric NHLs are typically high grade tumors,⁹ in contrast to the low- and intermediate-grade tumors which are predominant among adults. Age-related differences in the immune system and associated susceptibility to malignant transformation are possible contributing factors to these observed differences in histologic subtype.⁷

EPIDEMIOLOGY

There are at least 500 cases of newly diagnosed pediatric NHL in the United States each year.^{3, 4, 5} Although there is no clear peak age, the median age in one single institution review was 10 years (range, 7 months to 19 years).¹⁰ This disease occurs uncommonly in very young children (i.e., <3 years of age).^{2, 10} NHL is two to three times more common in boys than in girls, and more common in black children than in white children.^{2, 7} The reasons for these differences have yet to be elucidated.

There are geographical differences with respect to frequency and distribution of histologic subtypes of NHL in children.¹¹ For example, although NHL is very common in equatorial Africa, it is very rare in Japan.¹² Among the NHL cases observed in equatorial Africa, Burkitt lymphoma (BL) is the most common type observed. BL is also the most frequent histologic subtype encountered in northeastern Brazil and in some areas of the Middle East.¹³ In contrast, lymphoblastic lymphoma (LBL) is the predominant histologic subtype in southern India.¹³

BL is also of interest with respect to the geographical (i.e., endemic versus sporadic) variances that exist with respect to both clinical and biologic features.¹⁴ Those tumors, which arise in children from equatorial Africa ("endemic subtype"), are characterized clinically by frequent involvement of jaw, abdomen, paraspinal area, and orbit, and by a younger age at diagnosis.^{14, 15, 16} Those Burkitt tumors which arise in children from Western Europe and the United States ("sporadic subtype"), are in contrast characterized by frequent involvement of the abdomen, nasopharynx, and bone marrow and an older age at diagnosis.^{14, 15, 16} The breakpoint in the c-myc proto-oncogene and in the IG heavy chain (IGH) genes in BLs has also been reported to vary with respect to geography: in sporadic cases the breakpoints tend to occur within the MYC gene and the switch region of IGH gene, as compared to upstream of MYC and the VDJ region of IGH in endemic cases.^{14, 17}

An infectious agent was suspected to play a role in the pathogenesis of BL in equatorial Africa after it was noticed that the malaria belt overlapped with the lymphoma belt. Subsequently, EBV was shown to be associated with BL in this part of the world (i.e., equatorial Africa).^{14, 16} The association of EBV with BL has been shown, however, to vary with geography. EBV association occurs in approximately 85% of endemic cases, in contrast to the 15% association in Western Europe and the United States.^{14, 16} An intermediate degree of EBV association has been observed in other parts of the world, such as

northeastern Brazil.¹⁸ Although the evidence for a direct role for EBV in BL pathogenesis is relatively lacking, the circumstantial evidence is compelling. It was initially hypothesized that EBV, a B-cell mitogen, increases the target pool of cells that would be susceptible to a malignant transformation.¹⁴ This hypothesis is supported by the observation that the expression of the recombination activating gene (RAG) can be induced by EBV, and therefore potentially increases the chance that a chromosomal translocation may occur during IG gene rearrangement.¹⁹

Children with certain immunodeficiency conditions are at increased risk for the development of NHL.^{2, 7} Examples of specific populations at risk include those with congenital immunodeficiency disorders such as ataxia-telangiectasia (A-T),²⁰ X-linked lymphoproliferative syndrome (XLP), and Wiskott-Aldrich syndrome. It is important that these underlying conditions be recognized in children who present with NHL, so that appropriately designed therapy can be delivered. For example, in children with A-T, involved field irradiation and the use of radiomimetics such as bleomycin should be avoided, and the judicious use of x-rays is advised. Children with A-T are also at increased risk for the development of severe late onset hemorrhagic cystitis following the administration of alkylating agents such as cyclophosphamide and ifosfamide; therefore, vigorous hydration and administration of the uroprotectant mesna are recommended whenever these agents are delivered. Boys with XLP are at increased risk for the development of both B-cell lymphomas and fatal infectious mononucleosis, and are potential candidates for allogeneic bone marrow transplantation. Therefore, the diagnosis of XLP should be considered in any boy who presents with a B-cell lymphoma and whose brother has had either B-cell lymphoma or fatal infectious mononucleosis, or in any male who has had two primary B-cell lymphomas. There is also an increased risk for the development of NHL among children with acquired immunodeficiency conditions.²¹ Specific populations at risk include those with the acquired immunodeficiency syndrome (AIDS) and those on immunosuppressive therapy following bone marrow or organ transplantation.

PATHOLOGIC SPECIMEN EVALUATION

Most of the NHLs of childhood are very rapidly growing neoplasms. It is therefore imperative that the diagnosis be established as soon as possible so that appropriate therapy can be started. The diagnosis typically requires a comprehensive characterization of the tumor, including histologic, flow cytometric, cytogenetic,

P.1874

and molecular genetic studies. Ideally, larger fragments of tissue should be obtained by open biopsy of an involved site, but percutaneous image-guided needle biopsy has been increasingly used for diagnosis in the pediatric age group with good results.²² Bilateral bone marrow aspirates and biopsies should be considered before open biopsy, since this may allow the diagnosis to be established without a more invasive open biopsy. In patients who are not candidates for general anesthesia, such as those with a large anterior mediastinal mass, the diagnosis may be established by examination of pleural fluid obtained by thoracentesis or by parasternal core biopsy of the mass using local anesthesia with an anesthesiologist in attendance.²³

CLASSIFICATION

The most recent World Health Organization (WHO) Classification of Tumors of Haematopoietic and Lymphoid Tissues²⁴ designates NHLs, including those predominant in the pediatric age group, according to their clinical, morphologic, immunophenotypic, and genetic features, and also acknowledges difficulties in differentiating some of the clinically significant subtypes of B-cell lymphoma by introducing some borderline ("gray-zone") categories to encompass these issues. Table 89.1 summarizes the pediatric NHLs according to the WHO Classification 2008. Table 89.2 summarizes the main diagnostic immunophenotypic features of the most common subtypes of NHL encountered in this age group.

Lymphoblastic Lymphoma (T and B Lymphoblastic Lymphoma/Leukemia)

ALL and LBL are neoplasms of precursor B-cells or T-cells, characterized by immature (blastic) morphology and immunophenotype. At the pathologic and clinical levels, ALL and LBL appear to represent an overlapping continuum, with the distinction between these two processes being largely quantitative and arbitrary: cases involving at least 25% of the marrow cellularity are managed as ALL, while cases with less or no marrow involvement, are designated as LBL.^{25, 26, 27} More recent studies have identified important differences in gene expression profiles, adhesion molecule expression, and molecular pathways of T-ALL and T-LBL that explain at least partially their distinct dissemination patterns.^{28, 29, 30} T-LBL is the more common subtype and involves most often the mediastinum, lymph nodes, skin, bone, or soft tissues, and less commonly kidney, lung, or orbit. By contrast, the less common B-LBL more often presents in the lymph nodes, skin, bone, soft tissues, or breast, with mediastinal presentation being very uncommon.^{31, 32, 33, 34, 35} The most frequent location of skin lesions in children is the scalp.^{34, 35}

TABLE 89.1 SUBTYPES OF NON-HODGKIN LYMPHOMA ENCOUNTERED IN CHILDREN ACCORDING TO THE WORLD HEALTH ORGANIZATION (WHO) CLASSIFICATION (2008)*Precursor Lymphoid Neoplasms***B lymphoblastic lymphoma/leukemia****T lymphoblastic lymphoma/leukemia***Mature B-cell lymphomas***Burkitt lymphoma****Diffuse large B-cell lymphoma (DLBCL)****Primary mediastinal (thymic) large B-cell lymphoma**

B-cell lymphoma, unclassifiable, with features intermediate between DLBCL and BL

B-cell lymphoma, unclassifiable, with features intermediate between DLBCL and classical Hodgkin lymphoma

Follicular lymphoma. Variant: Pediatric FL

Marginal zone lymphoma (nodal and extranodal/MALT lymphoma). Variant: Pediatric nodal marginal zone lymphoma

*Mature T and NK cell neoplasms***Anaplastic large cell lymphoma, ALK-positive****Peripheral T-cell lymphoma, NOS**

Hepatosplenic T-cell lymphoma

Extranodal NK/T cell lymphoma, nasal type

Subcutaneous panniculitis-like T-cell lymphoma

Primary cutaneous CD30 positive T-cell lymphoproliferative disorders

Mycosis fungoides

Hydroa vacciniforme-like lymphoma^a

The categories highlighted in bold represent entities common in children; the remainder are rare in this age group.

MALT, mucosa-associated lymphoid tissue; NK, natural killer; NOS, Not Otherwise Specified.

^a This type of lymphoma is limited to Asia, South and Central America, and Mexico.

Histologically, B- and T-LBLs show a diffuse growth pattern, with extensive replacement of the underlying normal tissue architecture by sheets of blastic cells. The malignant lymphoblasts are small to intermediate in size, with scant to moderate amounts of basophilic cytoplasm, finely dispersed nuclear chromatin, and small indistinct nucleoli (see Fig. 89.1). In some cases the nuclei may have markedly irregular or convoluted outlines, a feature more common in T-LBL. Mitotic figures may be numerous in some cases, correlating with the presence of a “starry sky” appearance imparted by scattered pale macrophages containing apoptotic nuclear debris. BL should be considered in the differential diagnosis of such cases.

Immunophenotypically, approximately 90% of LBLs are of T lineage and the remaining 10% of B lineage.^{36, 37, 38, 39, 40} Most T-LBLs resemble cortical thymocytes, a feature that may lead to difficulties in the differential diagnosis with thymoma and residual normal thymus in biopsy samples obtained from mediastinal and cervical lesions. They typically express CD1a, CD10, weak CD79a, BCL2, CD99, and the pan-T-cell antigens CD2, CD3 (mostly cytoplasmic), CD5, and CD7, although these markers may under- or overexpressed when compared to their normal counterparts. Similar to thymocytes, T-LBLs are often CD4⁺ and CD8⁺ and usually terminal deoxynucleotidyl transferase (TdT) positive, a marker that can be used to distinguish this neoplastic process from mature T-cell lymphomas.^{41, 46} Other immature T-cell markers, including CD34 and

HLA-DR are also coexpressed in these cases. A more frequent expression of T-cell receptor $\alpha\beta$ than $\gamma\delta$ has been reported in T-cell LBL as compared to precursor T-cell ALL.⁴⁷ Some LBLs may aberrantly express myeloid-associated antigens.^{37, 48, 49} Of note, CD45 expression, often used to differentiate blasts by flow cytometry, ranges from dim (“blast-like”) to strong (“mature lymphocyte-like”) in T-ALL/LBL. A subset of T-LBLs resemble late thymocytes. In these cases TdT expression may be absent. They also express strong surface CD3, lack expression of CD1a, CD10, CD34, and HLA-DR, and are CD4⁺ or CD8⁺, rendering distinction from mature T-NHL very difficult, especially in small needle biopsy samples. The mediastinal localization and blastic cell morphology are very helpful in such cases.

B-LBLs typically resemble normal progenitor B-cells found primarily in the bone marrow and in lower numbers in blood, lymph nodes, and tonsils.^{46, 50, 51} They express CD10, TdT, CD99, the B lineage antigens PAX-5 and CD79a, and may be negative or only weakly positive for the mature B-cell marker CD20. The neoplastic cells most often lack expression of surface Ig and light chain restriction. Most often they express cytoplasmic μ heavy chain without detectable κ or λ Ig light chains.^{38, 52, 53} Rare cases of B-LBL may express surface Ig with light chain restriction, associated with strong CD20 expression and without detectable TdT; in such cases BL should be considered in the differential diagnosis.^{39, 54} Of note, a significant proportion of pediatric B-ALL/LBL lack expression of CD45 (leukocyte common antigen), a marker often used to identify hematopoietic neoplasms in tissue

P.1875

sections. This feature, combined with the frequent expression of CD99 by these neoplasms may lead to an erroneous diagnosis of Ewing sarcoma, another CD99⁺ pediatric neoplasm with blastic morphology, unless other markers (e.g., PAX5, TdT) are included in the diagnostic immunohistochemistry panels.

TABLE 89.2 IMMUNOPHENOTYPIC FEATURES OF THE MOST COMMON PEDIATRIC NON-HODGKIN LYMPHOMAS

	TDT	CD20	CD79a	Ig	CD5	CD3	CD30	CD15	ALK	CTA	MUM1 ^b	BCL2	BCL6
T-LBL	+(-)	-	-(+)	-	+/-	+ ^a	-	-	-	-	-/+	-	+/-
B-LBL	+	-/+	+	-/+b-	-	-	-	-	-	-	-	+/-	-
Burkitt	-	+	+	+	-	-	-	-	-	-	-	-	+
DLBCL	-	+	+	+/-	-/+	-	+/-	-	-/+ ^c	+/-	+/-	+/-	+/-
PMBL	-	+	+	-	-	-	+/-	-	-	-	+/-	-/+	-/+
ALCL, ALK+	-	-	-	-	-/+	-/+	++	-(+)	+	+/-	+	-	+/-
PTCL	-	-	-	-	+/-	+/-	-/+	-	-	-/+	+/-	-/+	-/+
HSL	-	-	-	-	-	+	-	-	-	+	-/+	-	+

+, positive; -, negative; (+) less than 15% of cases positive; +/-, commonly positive but may be negative; -/+, commonly negative but may be positive; (-), less than 15% of cases negative.

ALCL, anaplastic large cell lymphoma; B-LBL, B lymphoblastic lymphoma; CTA, cytotoxic antigen (e.g., TIA-1, perforin); DLBCL, diffuse large B cell lymphoma; FL, follicular lymphoma; HSL; hepatosplenic lymphoma; MUM1, interferon regulatory factor-4 (IRF4); PMBL, mediastinal large B-cell lymphoma; PTCL, peripheral T cell lymphoma; T-LBL, T-lymphoblastic lymphoma.

^a cytoplasmic CD3.

^b cytoplasmic μ heavy chain only.

^c ALK restricted to the ALK+ DLBCL subtype.

Cytogenetic studies of pediatric LBLs are few and include small numbers of patients (Table 89.3).^{55, 56, 57} Additionally, some reports of the cytogenetic or molecular genetics of LBL include cases of ALL with extra-medullary spread. T-LBL and T-ALL share similar chromosomal abnormalities. Chromosome abnormalities of the T cell receptor are relatively common and include chromosome abnormalities at 7q34-36, 7p15, and 14q11.^{56, 57} The t(9;17) translocation appears more

commonly in T-LBL than T-ALL.^{56, 57} These patients often present with a mediastinal mass and have an aggressive disease course. The t(8;13)(p11;q11-14) has been described in rare cases of precursor T-LBL that present with myeloid hyperplasia and eosinophilia.^{58, 59, 60}

The t(10;11) (p13-14;q14-21) is an uncommon but recurring translocation associated with T-ALL, and T-LBL, where it correlates with expression of the γ/δ T-cell receptor by the neoplastic cells.^{61, 62, 63} Cytogenetic abnormalities have not been shown to be of prognostic significance in LBL. At the molecular level, B-LBLs and T-LBLs contain IG (IG) and T-cell receptor gene (TCR) rearrangements, respectively. The latter should not be used for lineage determination, as B-LBLs (like B-ALL) often contain TCR rearrangements, and T-LBLs may also harbor IG gene rearrangements.

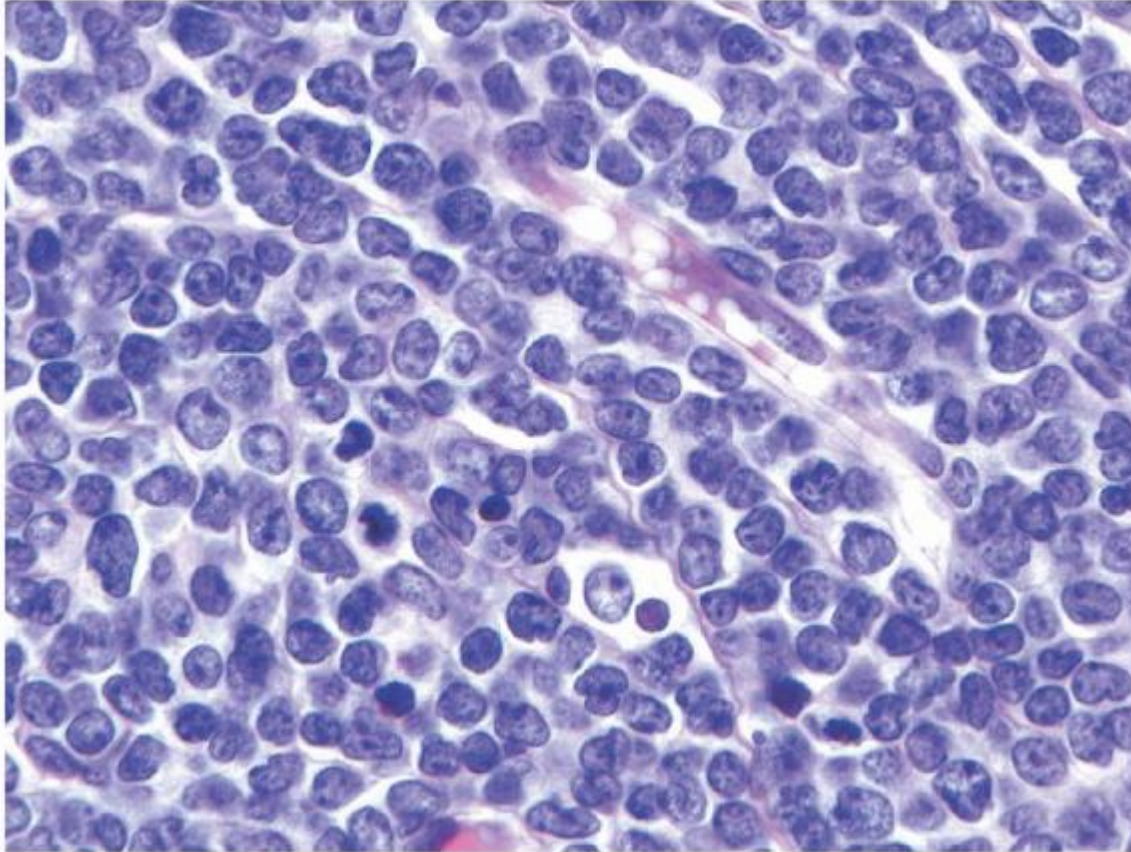

FIGURE 89.1. Lymphoblastic lymphoma. Sheets of small lymphoid cells with fairly uniform chromatin without clearing and scant cytoplasm are present. They show little variation in size and many show mitotic activity.

Burkitt Lymphoma

The WHO Classification replaced “small noncleaved cell lymphoma” of the older NCI Working Formulation with BL (Table 89.1),^{9, 64, 65} and also combined under the same category the ALL-L3 of the French-American-British classification, which corresponded to cases of high-stage BL with leukemic dissemination.

BL is a mature B-cell lymphoma which resembles highly proliferative B-cells present in the follicular germinal center (GC). The biology of this lymphoma is characterized by translocations involving the MYC gene and leading to its overexpression and the typical high proliferation rate. Notably, however, MYC gene rearrangements are not unique to this subtype of mature B-cell lymphoma. Clinically, as described above (see section “Epidemiology”) there are three recognized variants of BL: endemic, sporadic, and immunodeficiency-associated, which appear to correlate with distinct profiles of clinical presentation, association with EBV, molecular lesions, and cytogenetic abnormalities. Histologically, BL may present as one of three patterns with no prognostic significance (classic, atypical, and plasmacytoid), previously recognized as disease variants and currently merged under the unique designation of BL. Regardless of the histologic variant, BL is characterized by a diffuse growth pattern that typically replaces extensively the normal underlying tissue architecture. Occasionally, BL cells may also be seen “colonizing” preexisting GCs adjacent to the main tumor or present in the lymph nodes, draining an area involved by diffuse BL. Frequent mitotic and apoptotic cells are present and reflect this lymphoma's high proliferative rate and apoptotic index,

respectively. Tingible body macrophages interspersed among the neoplastic cells impart a characteristic low-power microscopic "starry sky" appearance. The proliferation index, measured by immunohistochemical nuclear expression for Ki-67, typically approaches 100% of the tumor cells and is a requirement for the diagnosis of BL, regardless of the morphologic subtype, as an acceptable surrogate for the demonstration of MYC gene rearrangements. In the classic BL variant the neoplastic cells are monomorphous, medium-sized ("small noncleaved") with moderate amounts of basophilic cytoplasm (see Fig. 89.2).^{64, 65} The cells have round nuclei, clumped or condensed chromatin with clear parachromatin, and one to three nucleoli. When seen in Wrightstained cytologic preparations, BL cells have a characteristically deeply basophilic cytoplasm with prominent clear cytoplasmic vacuoles. In the atypical variant, the neoplastic cells are more pleomorphic, including large cells with centroblastic appearance and often prominent central nucleoli. The plasmacytoid BL cells, which are seen mostly in association with immunodeficiency, are more monomorphous, predominantly large, with eccentric nucleus, prominent nucleolus, and more abundant, IG-positive cytoplasm. BL cells retrieved from malignant pleural effusions often are larger and more pleomorphic than their tissue or blood counterparts.

TABLE 89.3 CLINICAL AND BIOLOGIC CHARACTERISTICS OF NON-HODGKIN LYMPHOMA IN CHILDREN

Subtype	Proportion of Cases (%) ^a	Phenotype	Primary Site	Translocation	Affected Genes
Burkitt	39	B cell	Abdomen or head and neck	t(8;14)(q24;q32) t(2;8)(p11;q24) t(8;22)(q24;q11)	<i>IGH - MYC</i> <i>IGL - MYC</i> <i>IGK - MYC</i>
Lymphoblastic	28	T-cell ^b	Mediastinum or head and neck	t(1;14)(p32;q11) t(11;14)(p13;q11) t(11;14)(p15;q11) t(10;14)(q24;q11) t(7;19)(q35;p13) t(8;14)(q24;q11) t(1;7)(p34;q34)	<i>TCRαδ - TAL1</i> <i>TCRαδ - LMO2</i> <i>TCRαδ - LMO1</i> <i>TCRαδ - TLX1</i> <i>TCRβ - LYL1</i> <i>TCRαδ - MYC</i> <i>TCRβ - LCK</i>
Large cell ^c	26	B cell, T cell	Mediastinum, abdomen, head and neck, or skin ^d	t(2;5)(p23;q35) ^d	<i>NPM-ALK</i>

Ig, IG; TCR, T cell receptor.

^a Proportion at St. Jude Children's Research Hospital; other histotypes account for approximately 7%.

^b B-cell-progenitor variants have also been described.

^c Includes DLBCL and its variants, ALCL and some types of peripheral T-cell lymphoma.

^d Primarily in T-ALCL.

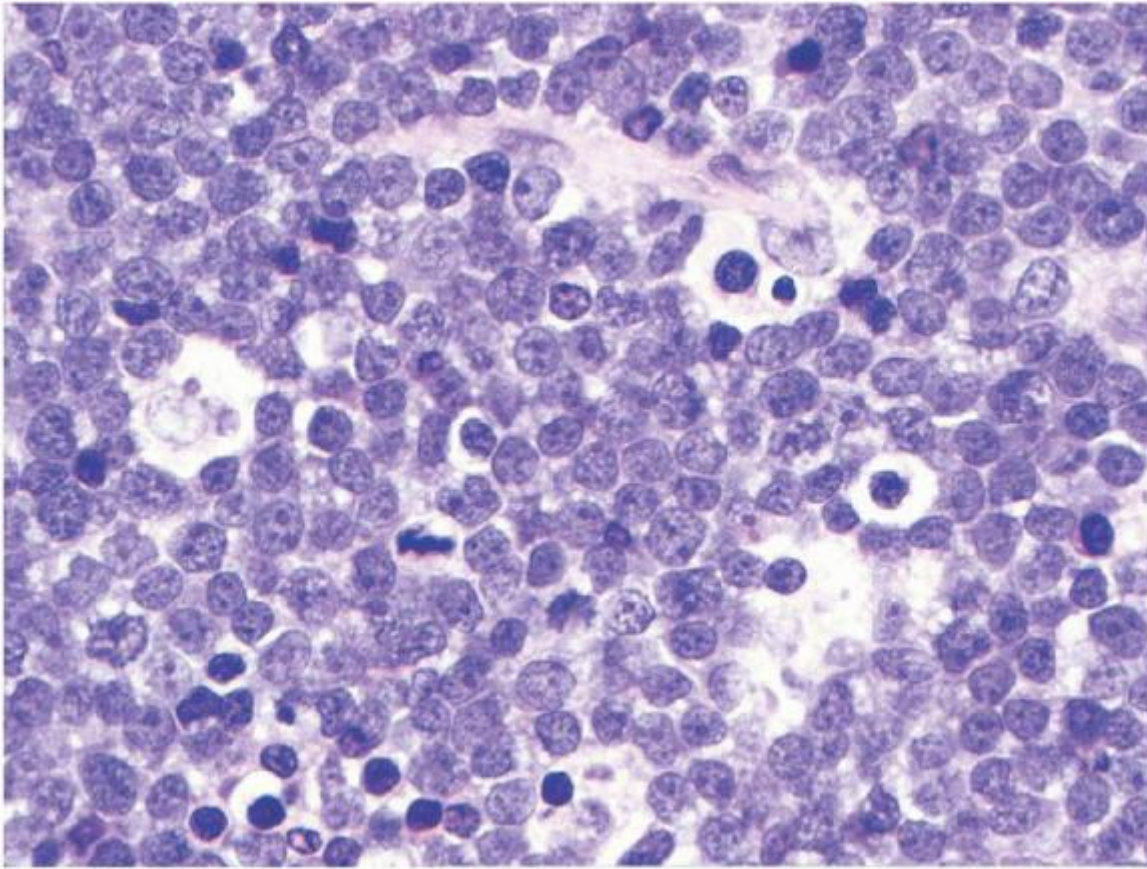

FIGURE 89.2. Burkitt lymphoma. Sheets of medium-sized lymphocytes are present with fine chromatin and multiple nucleoli. In addition, there are scattered large histiocytes containing debris. These histiocytes give the “starry sky” appearance to the histology of BL.

Immunophenotypically, BLs have a mature GC-like profile. They express CD10, CD19, strong uniform CD20, CD22, CD79a, PAX5, BCL-6, and surface IG (IgM, or less commonly IgA or IgG), with IG light chain κ or λ restriction (Table 89.2).⁶⁶ They are typically negative for BCL2, CD34, and TDT. The latter two antigens are useful in the differential diagnosis with B-LBL, which is most often positive for these markers. CD21, the receptor for complement fragment Cd3 and the Epstein-Barr virus, is more frequently detected in the endemic than sporadic form.

Cytogenetically, all cases of BL harbor one of three chromosomal translocations which rearrange the MYC oncogene locus to regions controlled by regulatory components of the IGH or light chain (IGK or IGL) genes, leading to constitutively overexpressed MYC in the neoplastic B-cells (Table 89.3). These translocations include t(8;14)(q24;q32)/MYC-IGH (80% to 90% of the cases), t(2;8)(q11;q32)/IGL-MYC, and t(8;22)(q23;q11)/MYC-IGK. The translocations associated with BL are relatively easily detected by classical cytogenetic methods and more recently by fluorescent in situ hybridization of interphase nuclei.⁶⁷ In addition to these classic translocations, a significant proportion of pediatric BLs also contain other nonspecific but recurrent cytogenetic abnormalities, some of which may correlate with prognosis, at least in cases with high-stage presentation.⁶⁸

Diffuse Large B-cell Lymphoma

Diffuse Large B-Cell Lymphoma (DLBCL) is a mature B-cell neoplasm composed predominantly of large cells (i.e., nuclear size equal to or exceeding that of macrophage nuclei), with a diffuse growth pattern, and with a proliferation index typically less than that required for a diagnosis of BL (typically 90% or less). The neoplastic cells may have a predominantly centroblastic (>80% in children),⁶⁹ immunoblastic (<10% in children),⁶⁹ or anaplastic appearance, defining three morphologic variants with no known prognostic implications (see Fig. 89.3).⁶⁵ Tumors rich in T-lymphocytes and histocytes are defined as a distinct entity in the most recent WHO Classification as T-cell/histiocyte-rich large B-cell lymphoma.

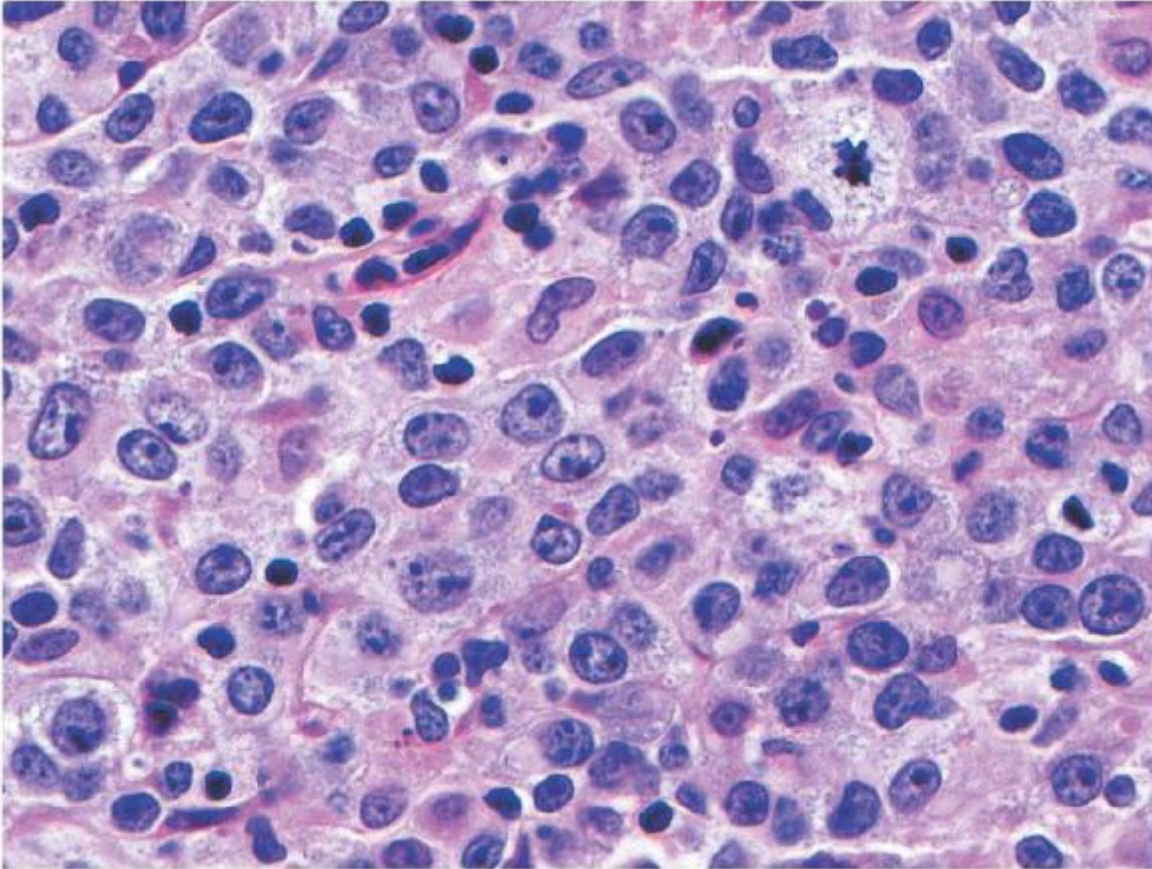

FIGURE 89.3. Diffuse large B cell lymphoma. Sheets of variably sized large cells with prominent nucleoli and chromatin clearing. There is variation in cell size, in contrast to the more uniform cells of BL.

Immunophenotypically, DLBCLs express one or more pan-B-associated markers CD19, CD20, CD22, CD79a, and PAX5. Surface or cytoplasmic IG are expressed by 50% or more cases. Some cases may express CD5, CD10, BCL2, BCL6, IRF4/MUM1, and CD30 (Table 89.3). Gene expression profiling and immunohistochemical studies have defined subgroups with distinct biology in DLBCL. These groups do not currently determine therapy in children. The GC-like group, which is predominant in children⁶⁹ is characterized by a CD10^{+/+}, BCL6^{+/+}, IRF4/MUM1-immunophenotype, while the non-GC subtype is CD10⁻, BCL6^{+/+} and IRF4/MUM1⁺. Rare cases of anaplastic lymphoma kinase (ALK)-expressing DLBCL with plasmablastic features can be found among DLBCL of children.^{70, 71, 72} These have been included under the designation of ALK-positive large B-cell lymphoma in the WHO Classification 2008.²⁴

Cytogenetics of DLBCL often include complex karyotypes with recurrent, but nonspecific abnormalities. While in adults many of the GC-like cases contain the t(14;18) characteristic for follicular lymphoma (FL), this is not the case in pediatrics, perhaps due to the unique biology of FL in this age group (see below).⁶⁹ The rare ALK-positive cases may harbor the t(2;5) or t(2;17), resulting in ALK gene overexpression.^{70, 71, 72}

Primary Mediastinal (Thymic) Large B-cell Lymphoma

Primary mediastinal (thymic) large B-cell lymphoma (PMBL) is an uncommon subtype of diffuse large B-cell lymphoma (<10% of large cell lymphomas in children) thought to arise from noncirculating thymic medullary B-cells.^{65, 73, 74, 75, 76, 77, 78} The latter feature may explain the biologic behavior of this tumor, which never involves the bone marrow (prerequisite feature for a diagnosis of PMBL and exclusion of DLBCL with secondary mediastinal involvement). Patients present with signs and symptoms of a large mediastinal mass, frequently with extension into adjacent structures including lung, pericardium, chest wall, and superior vena cava. Extrathoracic extension at diagnosis is uncommon but with disease progression can include kidneys, brain, soft tissue, skin, and adrenal glands. In the pediatric age group, the presence of extrathoracic disease at presentation is an adverse prognostic feature.⁷⁶

Histologically, PMBL is characterized by a diffuse growth pattern and is composed of tumor cells that may range from medium-sized to large. They may have a centroblast-like appearance, may show lobated, “flower-like” nuclear outlines, or may have an anaplastic, Reed-Sternberg-like appearance. Often, they have abundant pale cytoplasm, with a “clear cell” appearance. The neoplastic cells are typically surrounded by thin to thick, dense fibrotic bands. Small benign-appearing lymphocytes and eosinophils may be present and add to the difficulty in differentiating PMBL from Hodgkin lymphoma.

Immunophenotypically, PMBL cells express CD45 and B-cell-associated antigens PAX5, CD19, CD20, CD22, and CD79a (Table 89.2), characteristically lack IG, and very often show variable degrees of CD30 expression,⁷⁹ as well as CD23 and IRF4/MUM1 positivity. Expression of CD10, BCL-6, and BCL2 is less common. Although not unique to PMBL, the expression of the myelin and lymphocyte protein (MAL) may be useful in differentiating it from other mature B-cell and post-thymic T-cell lymphomas.⁸⁰

Molecular studies uniformly reveal clonal IG gene rearrangements even if IG expression is not demonstrable by immunologic techniques. The lymphoma cells show mutated IG V region genes consistent with post-germinal center B-cells.^{81, 82} Uncommonly, evidence of clonal EBV genome may be present in the tumor cells. The relatively few cytogenetic studies reported show aneuploid tumor cells, often with gains of chromosome 9p or Xq.^{83, 84} The tumor cells may overexpress REL or MAL in a minority of cases.⁸⁵ BCL6, TP53, CDKN2A alterations and MYC rearrangements may be present.^{83, 84, 85, 86, 87}

Unclassifiable Large B-cell Lymphomas

The most recent WHO Classification has recognized the existence of some borderline B-cell lymphomas, where complete morphologic, immunophenotypic, and genetic characterization does not allow a clear distinction between clinically significant categories of aggressive B-cell NHL or between DLBCL and classical Hodgkin lymphoma. This recognition has led to the definition of two heterogeneous disease categories that are not to be applied for cases where sufficient information is not available for a definitive distinction. These rare cases do occur in the pediatric age group and, at the present time, it appears that they are best managed as aggressive B-cell lymphomas in these patients.

B-cell Lymphoma, Unclassifiable, with Features Intermediate between Diffuse Large B-cell Lymphoma and Burkitt Lymphoma

This is a heterogeneous category of mature B-cell lymphomas, often with morphologic features of both DLBCL and BL, but with intermediate biologic features: cases of DLBCL with a gene expression profile similar to BL, many of which harbor dual translocations involving MYC and BCL2 (“double-hit lymphomas”), correlating with a particularly poor outcome; cases of DLBCL with high proliferation rate and immunophenotype resembling BL, but lacking a detectable MYC translocation; or cases with morphology typical for BL, but atypical immunophenotype or genetic features. Some of these cases would have been classified as “Burkitt-like lymphoma” in previous classification systems.

B-cell Lymphoma, Unclassifiable, with Features Intermediate between Diffuse Large B-cell Lymphoma and Classical Hodgkin Lymphoma

This category has been introduced mainly to reflect a distinct group of B-cell lymphomas occurring in the mediastinum and showing features intermediate between PMBL and classical Hodgkin lymphoma (“gray-zone lymphomas”).⁸⁸ However, lymphomas with similar features have also been described in peripheral lymph nodes. Gene expression profiling studies

P.1878

have suggested related molecular signatures for PMBL and classical Hodgkin lymphoma,^{89, 90, 91} offering a possible explanation for these phenotypically intermediate categories, although specific genomic studies of gray-zone lymphomas have not been reported.

Anaplastic Large Cell Lymphoma

Anaplastic large cell lymphomas (ALCLs) are mature T lineage lymphomas characterized by anaplastic morphology (large “hallmark” neoplastic cells with abundant cytoplasm, pleomorphic, often horseshoe-shaped nuclei) and strong uniform expression of CD30. The most recent WHO Classification has recognized two distinct biologic entities sharing these features: ALK-positive ALCL and ALK-negative ALCL. The vast majority of pediatric ALCLs are ALK-positive and therefore, the latter disease subtype will be referred to exclusively in the remainder of this chapter. In children, ALCL tends to involve lymph nodes and extranodal sites including skin, soft tissues, lungs, and bones.⁹² Approximately 20% to 25% of patients have bone marrow involvement at diagnosis that may not be obvious without ancillary studies.⁹³ Histologically, ALK expression by these lymphomas has allowed recognition of a wide spectrum of morphologic variants. These range from

classical (common) cases, where the anaplastic cells predominate, growing in diffuse sheets (see Fig. 89.4) or within sinusoidal lymph node space; to the small cell variant,^{65, 94} where the anaplastic cells are a minor component, admixed with predominantly small neoplastic cells; and the lymphohistiocytic variant,^{95, 96} containing a minority of “hallmark” cells surrounded by a reactive lymphohistiocytic population that forms the bulk of the tumor. The monomorphic variant, more common in children (author's unpublished observation) consists of sheets of monotonous immunoblastic cells with a high mitotic rate and “starry sky” appearance, mimicking BL. Rare cases have a sarcomatoid appearance, consisting of spindled CD3⁺/ALK⁺/CD30⁺ neoplastic cells. Although none of these variants appears to have prognostic implications, the small cell variant appears to be associated more often with systemic dissemination and leukemic peripheral blood involvement at presentation.^{97, 103}

Immunophenotypically, ALCLs express one or more T-cell-associated antigens including CD2, CD3, CD4, CD7, CD43, or CD45RO (Table 89.2).^{65, 104} T-cell antigens CD5 and CD8 are usually negative. Some cases lack demonstrable T-cell antigens but have evidence of TCR gene rearrangements.⁶⁵ Most ALCLs express cytoplasmic cytotoxic cell-associated proteins TIA-1, granzyme B, or perforin. A membranous and Golgi pattern of CD30 expression is characteristic of the neoplastic cells of ALCL.^{105, 107} The most intense reactivity to CD30 antibodies is seen in the large cells, whereas the smaller cells are weakly positive or more often negative. Most ALCLs are positive for the EMA (epithelial membrane antigen) with a pattern similar to CD30.¹⁰⁸ Myeloid-associated antigens (CD13, CD15, CD33) are often expressed by neoplastic cells, especially when analyzed by flow cytometry.¹⁰⁹ Expression of myeloid markers CD13 and CD33 appears to differentiate ALK+ ALCL from ALK- ALCL.¹¹⁰

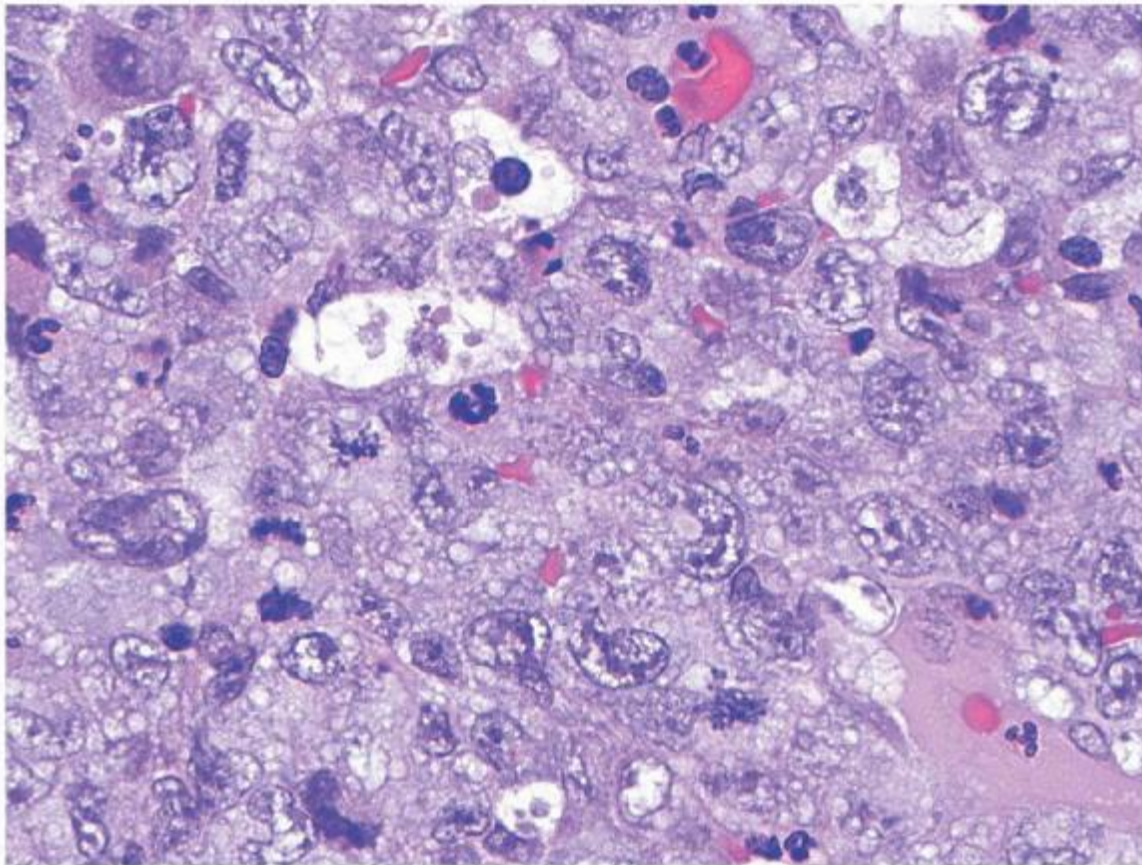

FIGURE 89.4. Anaplastic large cell lymphoma. Heterogeneous population of large lymphocytes is present with clearing of the nuclear chromatin and moderately abundant pink cytoplasm. Some cells have irregular and horseshoe-shaped nuclei (“hallmark” cells).

Cytogenetically, the t(2;5)(p23;q35)/NPM-ALK translocation is demonstrable in over 75% of ALK+ ALCLs (Table 89.3).^{111, 112} Several other translocations involving the ALK gene have been described, including t(1;2)(q25;p23), t(2;3)(p23;q21), inv(2)(p23q35), t(2;22), t(2;17)(p23;q11), and t(2;19)(p23;p13).^{97, 113, 114, 115} All of these translocations lead to cytoplasmic overexpression and activation/phosphorylation of the ALK gene product as a result of dimerization of the gene partner-associated proteins. The NPM-ALK fusion is unique in that it is associated with both nuclear and cytoplasmic expression of

ALK, due to the unique nuclear localization properties of NPM (nucleophosmin). As a result ALCLs associated with this translocation show nuclear and cytoplasmic ALK expression, while all other tumors show cytoplasmic ALK only, allowing immunohistochemical staining for ALK to predict the underlying genetic lesion in these lymphomas.

Of note, ALK expression is not unique to ALCL, but has also been demonstrated in a large subset of inflammatory myofibroblastic tumors, a predominantly pediatric mesenchymal neoplasm that also harbors translocations involving ALK; as well as in other pediatric tumors, where alternative mechanisms of overexpression may be operative.^{116, 117, 118} Therefore, careful immunophenotypic characterization of ALK+ neoplasms should be performed to confirm the diagnosis of ALCL.

Uncommon Pediatric Lymphomas

While the lymphoblastic and large cell lymphomas detailed above represent the vast majority of pediatric NHLs, a small but significant proportion of lymphomas occurring in this age group consists of low-grade B-cell lymphomas and some subtypes of peripheral T-cell lymphoma (see Table 89.1). The diagnosis of these rare lymphomas in children is often delayed or initially interpreted as a reactive process or as one of the more common pediatric lymphomas.

Some of these neoplasms (including FL and marginal zone lymphoma [MZL]) appear to constitute distinct clinicopathologic entities in this age group and will be detailed below. Other rare lymphomas of children and adolescents include hepatosplenic T-cell lymphoma, mycosis fungoides,^{119, 120, 121, 122, 123, 124, 125, 126} panniculitis-like T-cell lymphoma,^{127, 128, 129} HTLV-1-associated leukemia/lymphoma,^{130, 131, 132} and natural killer (NK) lymphoma.^{129, 133, 134, 135} For the most part, the clinical and biologic features of these lymphomas in children resemble their adult counterparts. A detailed presentation of all of these lymphoma subtypes is beyond the scope of this chapter. Only hepatosplenic lymphoma will be discussed below, with an emphasis on the frequent bone marrow involvement at presentation and the importance in differential diagnosis with the more common pediatric leukemias.

Follicular Lymphoma

Follicular lymphoma (FL) is a neoplasm of follicular germinal center B-cells that retains a follicular or nodular growth pattern.

Children may develop FL pathologically and clinically similar to the adult disease, as well as FLs with unique clinicopathologic features, designated by the most recent WHO Classification as pediatric follicular lymphoma (P-FL). P-FL comprises <3% of all pediatric lymphomas,^{2, 136, 139, 140, 141} and usually presents with disease localized to lymph nodes of the head and neck area or

P.1879

testicles.^{140, 142, 143, 144, 145, 146} In striking contrast to adults, transformation to higher grade lymphoma is distinctly uncommon in P-FL, and the patients have prolonged remissions and high event-free survival rates, with or without therapy.^{138, 139, 140}

P-FL is characterized by a follicular growth pattern, often as large, irregular GCs with monotonous, predominantly centroblastic cells, similar to the grade 3 FL seen in adults.^{181, 183, 184, 186} Neoplastic cells of P-FL express CD10, CD19, CD20, CD22, CD79a, and BCL6; may be weakly positive or negative for surface IgM or IgG; and are negative for BCL2.^{65, 140, 141} P-FLs have BCL6 rearrangements but lack the t(14;18)(q32;q21), BCL2 rearrangements and P53 overexpression, despite their apparent high histologic grade (Table 89.3).^{142, 143, 144, 145} This is in contrast to the majority of adult FL, which express BCL-2 and have a t(14;18) that involves rearrangement of BCL2.⁶⁵ The distinction between classic FL and P-FL is important in the pediatric age group. In two separate studies of pediatric nontesticular FL, BCL2 expression was an important determinant of outcome,^{139, 140} with patients with BCL2+ lymphomas presenting with advanced disease stage or disease refractory to therapy; whereas children with BCL2 negative tumors (likely mostly P-FL cases) presented with stage I disease, achieved complete remission, and had no relapses.¹⁴⁰

Marginal Zone B-cell Lymphoma

MZL B-cell lymphoma is rarely diagnosed in the pediatric age group, with only a few reports available to date.^{141, 147, 148} As with adults, MZLs in children and young adults may be nodal or extranodal in their presentation. The extranodal MZLs of mucosa-associated tissue are also referred to as MALT lymphomas. Extranodal sites of presentation include salivary glands, lung, orbit, ocular adnexa, lip, breast, stomach, and sinonasal cavity. Gastric forms are associated with *H. pylori* infection. Nodal MZL is reportedly more frequent in males and presents usually with localized disease. Extranodal MZL also tends to be localized in these young patients and shows a slight male predominance. Most children with MZL do

exceptionally well with treatment. Both nodal and extranodal types demonstrate morphologic and immunophenotypic features similar to their adult counterparts. Morphologically, the marginal zone and interfollicular areas of the lymph node are infiltrated by a mixture of small lymphocytes, centrocyte-like cells, and monocytoid B-cells. A small number of immunoblastic cells may be present. Plasma cells and sometimes significant plasma cell differentiation may be present. Additionally, over two-thirds of pediatric nodal MZLs display disruption of residual normal follicles resembling progressive transformation of GCs, a feature that appears to be unique to MZLs in this age group. Immunophenotypically, the neoplastic cells express CD20, CD79a, IgD, and IgM; but not CD5, CD10, CD43, CD103, and cyclin D1.⁶⁵ Extranodal MZLs must be distinguished from benign marginal zone hyperplasias of tonsils or appendix with λ IG light chain restriction.¹⁴⁹

Hepatosplenic T-cell Lymphoma

Hepatosplenic T-cell lymphoma is an aggressive extranodal malignancy of cytotoxic T-cells usually of $\gamma\delta$ and less commonly $\alpha\beta$ T-cell receptor type.^{65, 150, 151, 152, 153, 154, 155} This rare lymphoma has a peak incidence in adolescents and young adults, with male predominance,^{65, 151} although a female predisposition is reported for $\alpha\beta$ hepatosplenic lymphomas.^{153, 154} A relatively high percentage of cases follow solid organ transplantation or immunosuppressive therapies for other conditions.^{156, 157, 158, 159} Patients typically present with enlarged spleens and livers, but no appreciable lymphadenopathy. Isolated thrombocytopenia is a common presentation. Circulating lymphoma cells are commonly present at diagnosis but may be difficult to distinguish from atypical lymphocytes. A more obvious leukemic phase may develop as the disease progresses.^{153, 154} Cases of $\alpha\beta$ hepatosplenic lymphoma are histologically, cytogenetically, and clinically similar to the $\gamma\delta$ form.¹⁵⁴

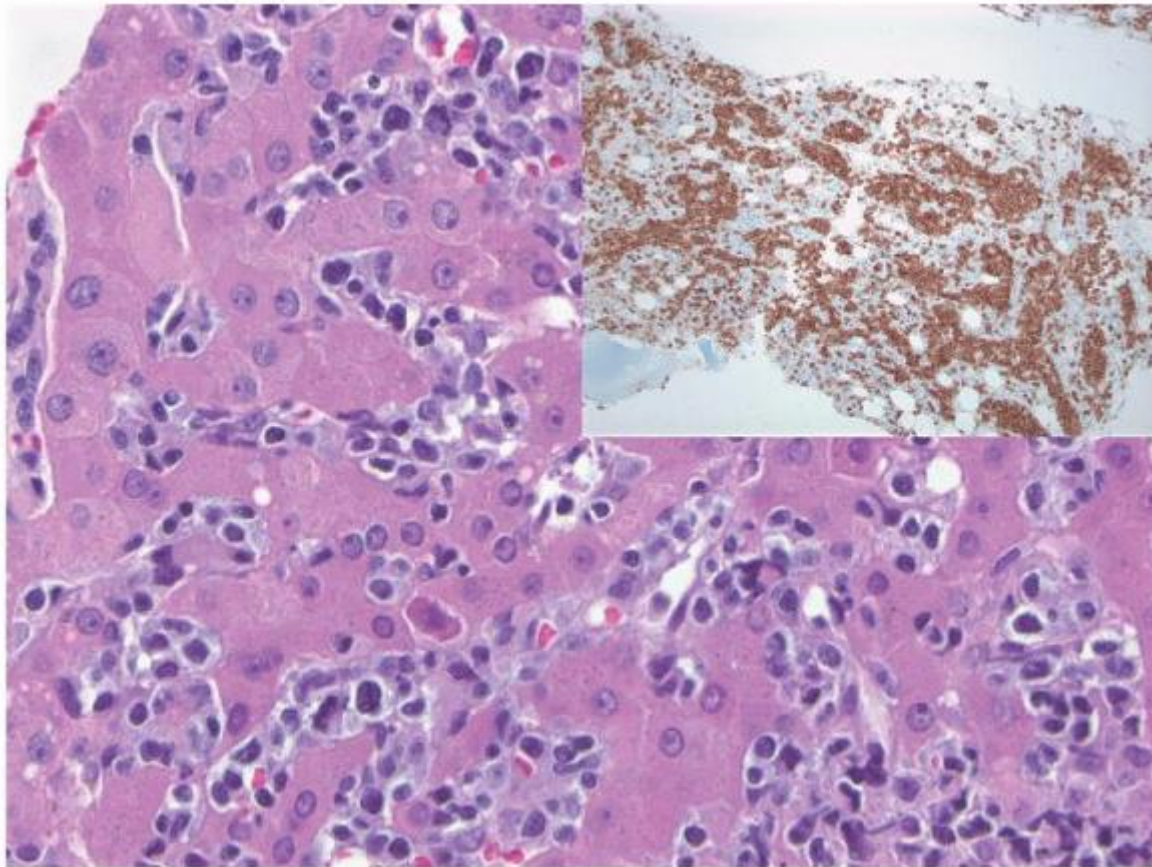

FIGURE 89.5. Hepatosplenic T cell lymphoma. Prominent hepatic sinusoidal infiltration by intermediate to large lymphoid cells with clumped chromatin and occasional nucleoli. Inset: Immunohistochemical staining for CD3 highlights a sinusoidal pattern of bone marrow infiltration.

In liver and spleen samples, the neoplastic cells are medium-sized to large, with scant to moderate amounts of cytoplasm and a predominantly sinusoidal location^{154, 155} (see Fig. 89.5). Azurophilic cytoplasmic granules have been described in a minority of cases. The nuclei may be round or convoluted with condensed chromatin and inconspicuous nucleoli. With disease progression, a blast cell transformation with large cells having prominent nucleoli may occur.^{156, 160, 161} This is the

most frequent lymphoma cell appearance in bone marrow samples from pediatric patients, and therefore it is an important consideration in the differential diagnosis with acute leukemias, especially of myeloid lineage. The bone marrow biopsy samples frequently show a characteristic sinusoidal infiltrate.^{154, 155, 161} Erythrophagocytosis may be evident.^{154, 155, 162, 163} The lymphoma cells have a fairly consistent immunophenotypic expression pattern of CD2⁺, CD3⁺, CD4⁻, CD8[±], CD5⁻, CD7⁺, CD16⁺, and CD56[±] (Table 89.2).^{65, 153, 164} The αβ hepatosplenic lymphomas have a similar immunophenotype except for a slightly more frequent expression of CD57.¹⁵⁴ TCR βδ or less commonly TCR αβ proteins can be detected by flow cytometric analyses.^{150, 155} Cytotoxic granular protein TIA-1 is detected in most cases, whereas granzyme B or perforin are detected in only a minority of cases.^{153, 154, 162, 165, 166}

Cytogenetically, an isochromosome 7q, often with trisomy 8 and other random chromosomal abnormalities, is found in the majority of reported cases.^{154, 158, 160, 161, 167, 168, 169, 170}

CLINICAL FEATURES

The clinical presentation for children with NHL is quite varied (Tables 89.3 and 89.4).^{1, 2, 7} The primary sites of disease, which vary according to histologic subtype, are the primary determinants for the signs and symptoms observed. Children with advanced-stage T-LBL or mediastinal large B-cell lymphoma typically present with a mediastinal mass (Figs. 89.6 and 89.7), whereas children with BL typically present with abdominal disease (usually arising from the terminal ileum and often serving as a trigger point for an intussusception). By way of contrast, children with large cell lymphoma may present with primary involvement of either mediastinum or abdomen.

Those children presenting with an abdominal mass may have associated nausea, vomiting, and abdominal pain. Abdominal distension secondary to obstruction and associated ascites may be present on physical examination. Extension of the mass into the pelvis may result in ureteral compression and hydronephrosis. The presence of an anterior mediastinal mass may result in some

P.1880

degree of respiratory distress, ranging from slight cough to severe respiratory compromise, including arrest.⁷ The respiratory status may also be compromised by the presence of a pleural effusion. A mediastinal mass may obstruct venous return to the heart, resulting in a superior vena cava syndrome.⁷ This syndrome is characterized by swelling in the neck and shoulder region and prominent venous vasculature, a condition which may predispose the patient to the development of a deep venous thrombosis.

TABLE 89.4 STAGES OF NON-HODGKIN'S LYMPHOMA^a

Stage I

A single tumor (extranodal) or involvement of a single anatomical area (nodal), with the exclusion of the mediastinum and abdomen.

Stage II

A single tumor (extranodal) with regional node involvement.

Two or more nodal areas on the same side of the diaphragm.

Two single (extranodal) tumors, with or without regional node involvement on the same side of the diaphragm.

A primary gastrointestinal tract tumor (usually in the ileocecal area), with or without involvement of associated mesenteric nodes, that is completely resectable.

Stage III

Two single tumors (extranodal) on opposite sides of the diaphragm.

Two or more nodal areas above and below the diaphragm.

Any primary intrathoracic tumor (mediastinal, pleural, or thymic).

Extensive primary intraabdominal disease.

Any paraspinous or epidural tumor, whether or not other sites are involved.

Stage IV

Any of the above findings with initial involvement of the central nervous system, bone marrow, or both.

^aBased on the classification proposed by Murphy.

The degree of tumor burden at the time of diagnosis is quite variable. Some children present with isolated lymph node involvement, whereas others may present with more widespread disease (Fig. 89.8). Involvement of the bone marrow may be associated with pancytopenia, pallor, and bruising. Blurred vision, headache, or the presence of a cranial nerve palsy on physical examination may be present when the central nervous system is involved. Skin lesions may be present at the time of diagnosis in approximately 4% of children; however, this is usually associated with the CD30⁺, ALK⁺ anaplastic subtype of large cell lymphoma.^{171, 172} Involvement of bone may be associated with local swelling, pain, or limp. Boys may present with testicular enlargement secondary to tumor infiltration. Involvement of the ovary may be identified on diagnostic imaging studies.



FIGURE 89.6. Computed tomography scan of child with mediastinal lymphoblastic lymphoma.

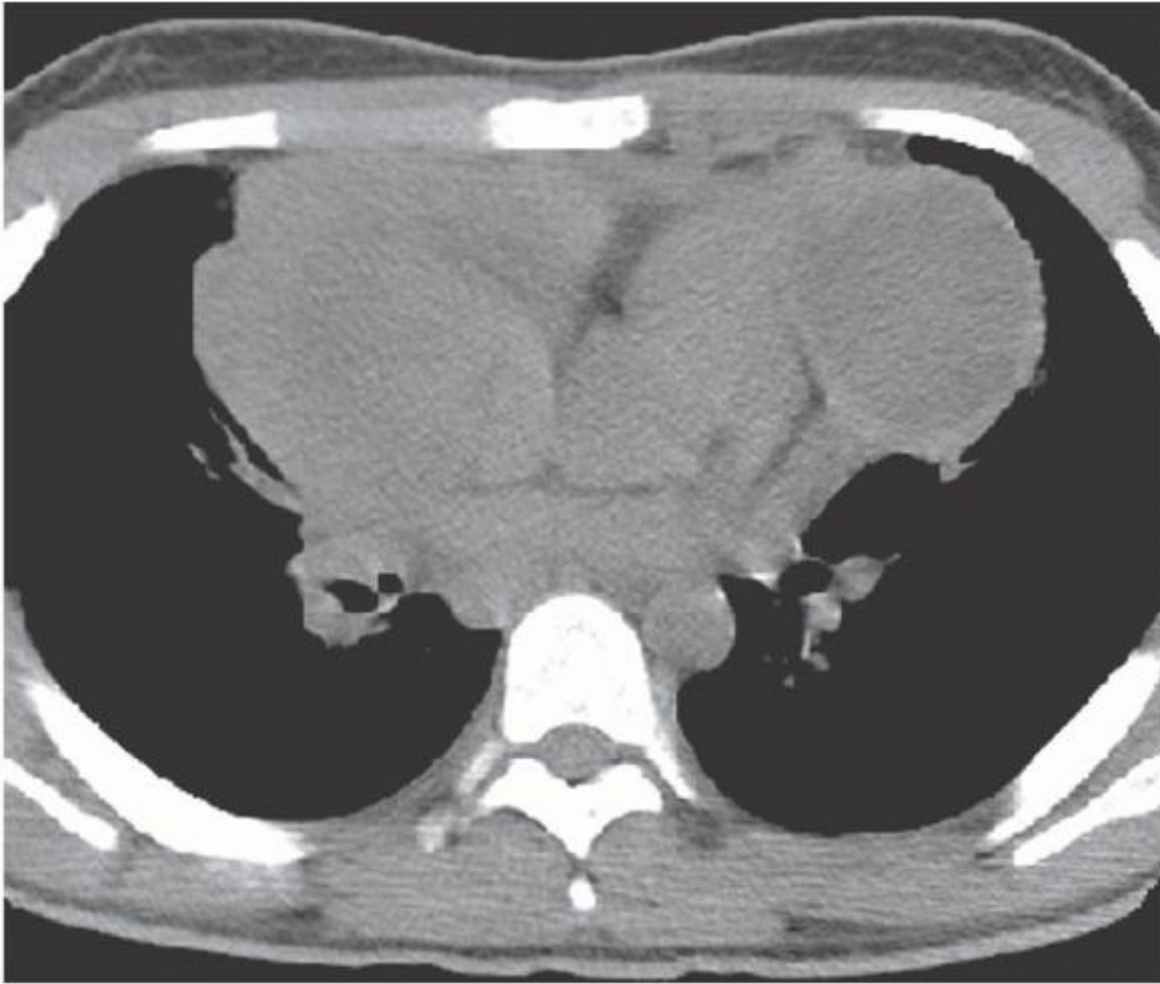

FIGURE 89.7. Computed tomography scan of child with mediastinal large B-cell lymphoma.

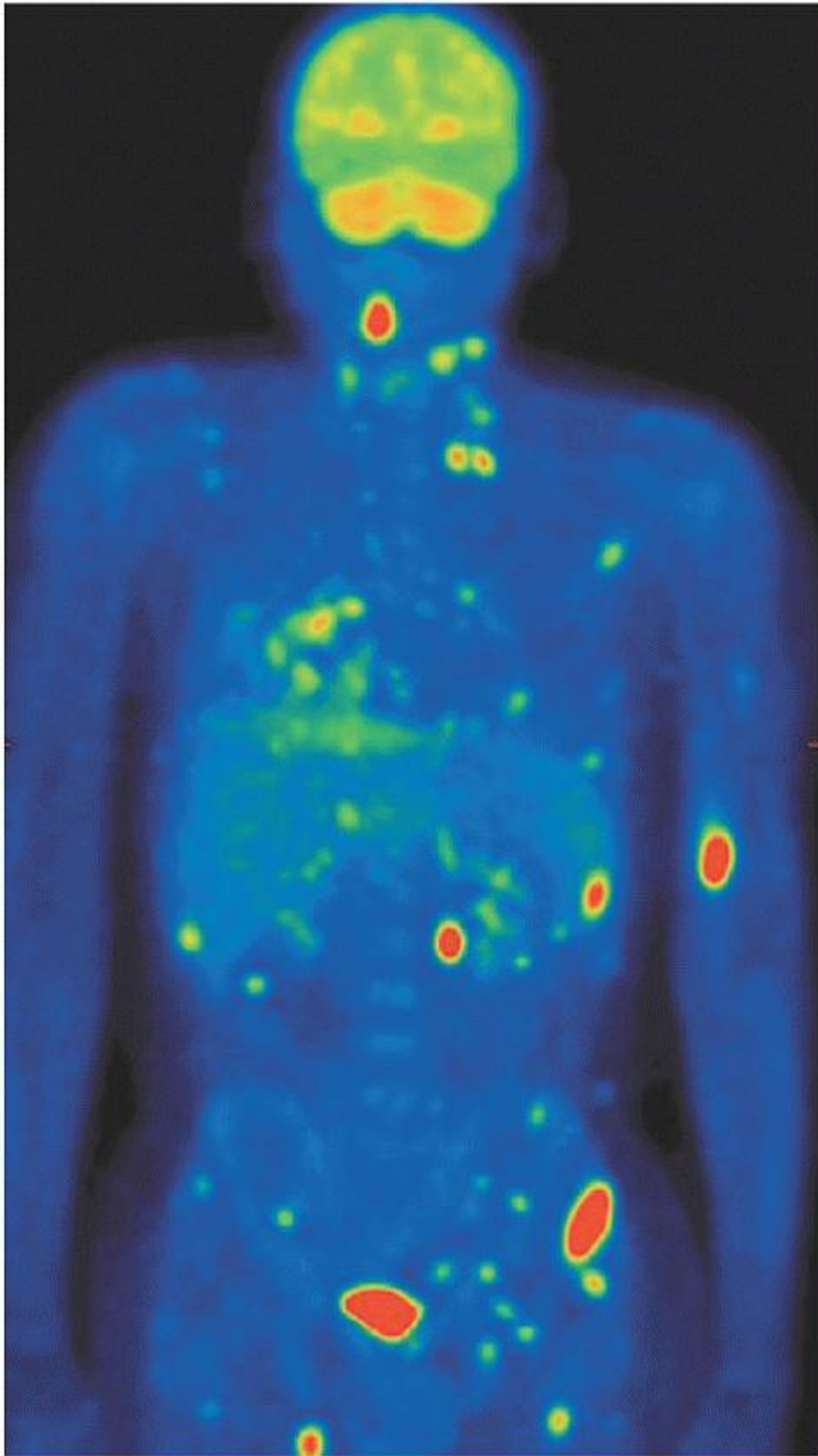

FIGURE 89.8. Positron emission computed tomography scan of child with disseminated anaplastic large cell lymphoma.
P.1881

MANAGEMENT

Initial workup and staging: Modern therapy for the NHLs of childhood is determined by both the histologic diagnosis and the disease stage. It is therefore imperative that an expeditious and comprehensive staging workup be performed after the diagnosis is established. This generally includes: computerized tomography of the neck, chest, abdomen, and pelvis; nuclear imaging; bilateral bone marrow aspirates and biopsies for cell count and differential, flow cytometry if the marrow is overtly involved, cytogenetics, and molecular pathology; lumbar puncture for cerebrospinal fluid cytology.^{2, 7} Over the past⁵ years there has been a change in the type of nuclear imaging studies done in the pediatric NHL staging workup. Historically, gallium and bone scans were considered part of the workup; however, positron emission tomography (PET) is becoming a more widely used staging modality for children with NHL.¹⁷³ Data on how PET compares to conventional gallium and bone scanning is lacking. Uniform criteria for the interpretation of PET findings in children both at diagnosis and in response evaluation are needed. In some large cooperative groups studies, PET is not used at all. Thus, it is important to know what imaging studies are being done for a staging workup when risk-adapted (e.g., stage-adjusted) protocol results are reported. A complete blood count with differential and chemistry panel including serum lactate dehydrogenase (LDH) should also be obtained. Upon completion of the above workup, patients are designated with a disease stage—usually according to the St. Jude system described by Murphy (Table 89.4).⁸ Those with stage I or II are considered to have limited-stage disease, whereas those with stage III or IV are considered to have advanced-stage disease.

Initial management: Upon expeditious completion of the diagnostic and staging workup, appropriate therapeutic options can be implemented. Before chemotherapy is started, however, a number of issues must be considered. Some children are at high risk for tumor lysis syndrome (TLS). This primarily includes children with advanced-stage BL and some children with LBL who have a large tumor burden at diagnosis, which may be reflected by an elevated serum LDH. Some of these children will have metabolic abnormalities with some degree of renal dysfunction at diagnosis, which only worsens once chemotherapy is started (e.g., hyperkalemia, hyperuricemia, hyperphosphatemia, etc.). Therefore, these children should have excellent intravenous access and vigorous hydration before starting chemotherapy. Hyperuricemia has historically been managed using hyperhydration coupled with allopurinol, a xanthine oxidase inhibitor. Uricolytics, such as uricozyme, which cleave uric acid to the more soluble and readily cleared allantoin, have been used for decades. A recombinant form of this drug, rasburicase, has been shown to be very effective and well tolerated with a reduced risk of associated allergic reaction.¹⁷⁴ The advantage of these agents is the precipitous drop in serum uric acid which negates the need for alkalinization, thus facilitating phosphorous excretion. Of note, a study of rasburicase in children at high risk for TLS demonstrated preservation of renal function with no significant associated hyperphosphatemia or hyperkalemia.¹⁷⁴

Therapy: There have been significant improvements in treatment outcome for children with newly diagnosed NHL over the past 25 years.¹ This has been largely accomplished through incremental refinements in sequential multicenter trials which feature both a stage- and histology- or immunophenotype-directed approach to treatment assignment. Two of the initial successful regimens for children with NHL were the multiagent LSA2L2 regimen^{175, 176, 177} designed for children with ALL, and the cyclophosphamide-based COMP regimen.¹⁷⁵ A randomized trial by the Children's Cancer Group (CCG) comparing these two approaches validated a stage- and histology-directed therapeutic approach to pediatric NHL.¹⁷⁵ Specifically, children with limited-stage disease did well regardless of the treatment arm. In contrast, among those with advancedstage disease, those with BL had a better outcome with COMP and those with LBL had a better outcome with LSA2L2; there was no clear therapeutic advantage with either approach for children with advanced-stage large cell lymphoma. Other trials validated and built on these observations.^{96, 178, 215}

Subsequent to the CCG trial comparing LSA2L2 and COMP, the dominant theme of most trials for children with limited-stage disease has been the reduction of treatment-related acute and late effects without compromising treatment outcome.^{180, 182, 183, 198, 201, 202} This has been attempted by shortening the duration of therapy, dose reduction of certain agents, and elimination of involved field irradiation. In the first of two sequential trials performed by the Pediatric Oncology Group (POG),¹⁸³ it was demonstrated that involved field irradiation could safely be eliminated from a 33-week treatment plan that featured three courses of cyclophosphamide, Adriamycin, vincristine, and prednisone (CHOP), followed by a 24-week maintenance phase of 6-mercaptopurine and low-dose methotrexate. In the subsequent trial it was shown that the 24-week maintenance phase could be safely eliminated for children with Burkitt or large cell lymphoma; however, for children with LBL the result was inferior.¹⁸³ Even with the 24-week maintenance phase, one-third of children with LBL experienced a recurrence; however, the majority were successfully salvaged, resulting in a similar overall survival to other histologic subtypes. Other groups have approached limitedstage LBL with a more intensive initial

treatment regimen.¹⁹⁷ For example, the French Society of Paediatric Oncology (SFOP) cooperative group trial treats children with LBL with the same regimen used for those with advanced-stage disease.¹⁹⁷ A somewhat intermediate intensity approach is currently being studied by the Children's Oncology Group (COG), in which patients with limited-stage LBL are receiving a regimen modeled after approaches used for low-risk ALL.

Treatment advances for children with advanced-stage disease have primarily focused on improving histology- and immunophenotype-directed treatment strategies (United States and Europe, respectively). Intensification of therapy, addition of new active agents, and refinement in risk-adapted therapy have all been credited with improvement in outcome.

Burkitt lymphoma: For children with advanced-stage BL, initial improvements in treatment outcome beyond that achieved with COMP were attained by the incorporation of high-dose methotrexate and cytarabine (Table 89.5). Two year event-free survival rates of approximately 80% for children with stage III BL were reported with the Total B regimen which featured 1 gram/m² methotrexate and sequentially escalating doses of continuous infusion cytarabine; for those with bone marrow involvement however, the outcome was inferior (approximately 20%).¹⁸¹ The POG modified the Total B approach in the PG8617 protocol by incorporating high-dose pulses of cytarabine and intensified intrathecal therapy; this resulted in an improved treatment outcome for children with stage IV disease.¹⁸⁵ The optimal duration of therapy was examined in other trials. For example, the French (SFOP)¹⁸⁶ demonstrated that the duration of therapy could be reduced to 4 months; Schwenn et al.¹⁹⁰ reported an excellent result with a 2-month regimen for those with stage III disease. Further advances in therapy were subsequently achieved by dose intensification of cyclophosphamide, methotrexate, and cytarabine and by the incorporation of new active agents (e.g., etoposide). The German Berlin-Frankfurt-Münster (BFM)²⁰¹ and SFOP¹⁸⁰ cooperative groups have reported encouraging results, using risk-directed treatment assignment based on clinical features such as stage, degree of surgical resection, tumor burden, degree of bone marrow involvement, and disease sites. For example, in the SFOP LMB-89 regimen,¹⁸⁰ Group A treatment is restricted to those who completely resected limited-stage disease, whereas Group C, which is the most intensive arm, comprises those who have greater than 70% marrow blasts or central nervous system

P.1882

disease. Group B is intermediate in intensity and is given to those with incompletely resected limited-stage disease, stage III, and those with <70% bone marrow replacement. Approximately 85% of children with advanced-stage B-cell lymphoma are cured with this approach. An international collaborative study (LMB-96) was conducted to determine whether the intensity of LMB-89 therapy could be safely reduced for patients with Group B and C therapy. Among Group B patients it was demonstrated that the avoidance of cyclophosphamide dose escalation in the second course of COPADM and deletion of a maintenance sequence could be safely implemented without compromising the outcome.²¹⁶ Among Group C patients however, reduction in therapy was associated with a poorer outcome.²¹⁷ The BFM cooperative group has also reported excellent results with a regimen that features high-dose methotrexate (5 g/m²), ifosfamide, doxorubicin, etoposide, cytarabine, vincristine, and steroids.²⁰¹ In their most recent trial, it was demonstrated that a 4-hour infusion of methotrexate resulted in a noninferior outcome compared to the 24-hour infusion; however, this was not found to be true for those with advanced-stage disease.²¹⁸ The current BFM study is examining a rituximab window phase to evaluate both activity and toxicity—responses to single agent rituximab were observed in some patients, and the toxicity profile was generally acceptable.²¹⁹

TABLE 89.5 TREATMENT OUTCOME FOR ADVANCED-STAGE BURKITT LYMPHOMA

Protocol	Stage	No. Patients	Event-Free Survival Rate	Reference
POG 8617	IV	34	4 y EFS = 79% ± 9%	185
	B-ALL	47	4 y EFS = 65% ± 8%	
LMB 89 ^a	II	278	5 y EFS = 91% (95%CI,87-180	94%)
	IV	62	5 y EFS = 87% (95%CI,77-	
	B-ALL	102	93%)	
			5 y EFS = 87% (95%CI,79-	

			92%)	
BFM 90	III	169	6 y EFS = 86% ± 3%	201
	IV	24	6 y EFS = 73% ± 10%	
	B-ALL	56	6 y EFS = 74% ± 6%	
LMB 96	III	413	4 y EFS = 89.8%	216
	IV (CNS-)/B-ALL	235	4 y EFS = 79%	217
BFM 95	III	221	3 y EFS = 87%	218
	IV	33	3 y EFS = 81%	
	B-ALL	79	3 y EFS = 79%	

B-ALL, B-cell acute lymphoblastic lymphoma; BFM, Berlin-Frankfurt-Münster; CI, confidence interval; EFS, event-free survival; POG, Pediatric Oncology Group

^a Includes patients with B-cell large cell NHL.

LBL: Strategies to improve the outcome for children with LBL have generally built on the results of the CCG trial, which demonstrated a superior result with an ALL-like treatment approach (i.e., LSA2L2). The incorporation of high-dose methotrexate has been featured in a number of successful treatment regimens (Table 89.6).^{197, 205, 206, 207} For example, the SFOP modified the LSA2L2 regimen by incorporating courses of high-dose methotrexate throughout the maintenance phase of therapy with an excellent treatment result.¹⁹⁷ The BFM cooperative group achieved an outstanding result (i.e., 5-year event-free survival rate of 90%) with an approach which featured a high-dose methotrexate consolidation phase (5 g/m² every other week for a total of 4 courses).²⁰⁵ The improved outcome with higher doses of methotrexate may be the result of higher levels of intracellular methotrexate polyglutamates achieved with dose escalation.²²⁰ The necessity of methotrexate in the treatment regimen has been questioned.²⁰⁷ In a randomized trial performed by the POG, it did not appear that high-dose methotrexate added to the treatment result for children with LBL in the setting of an anthracycline- and asparaginase-rich backbone^{207, 221} however; the result for children with T-ALL entered on this trial was inferior in the arm without high-dose methotrexate.²²¹ The COG recently completed a randomized trial which also examined the need for high-dose methotrexate in children with LBL. In this study, the arm featuring the incorporation of high-dose methotrexate was being compared to an arm which featured the incorporation of extended intrathecal therapy. Preliminary reports suggest no difference in the treatment arms, although the final analysis is pending. Improvements in treatment outcome have also been attributed to other interventions such as the incorporation of a delayed intensification phase²⁰⁵ (i.e., reinduction phase), L-asparaginase,²¹² and new active agents.¹⁹¹ A randomized trial performed by the POG demonstrated a survival advantage for those patients receiving additional doses of L-asparaginase. L-asparaginase is a featured component of the very successful Dana Farber approach. Anthracyclines are also commonly used in successful NHL treatment regimens. For example, they are a featured component in the POG 9404 regimen.^{207, 221} The use of epipodophyllotoxins in the treatment of LBL is more controversial. In this regard, etoposide was a featured agent in the successful NHL13 regimen²²²; however, their use in the POG T3 protocol was found to be associated with an increased rate of secondary AML.²¹²

It has been difficult to identify clinical features among children with LBL that are reliably predictive of outcome—that is, for whom novel or intensified therapy could be planned. However, the use of flow cytometric technology to measure disease extent at diagnosis (minimal disseminated disease, MDD) has identified higher risk patients. A study by Couston-Smith et al. demonstrated that the detection of MDD in the bone marrow of LBL patients at the time of diagnosis was predictive of outcome.²²³ Those with greater than or equal to 1% lymphoblasts in the marrow had a significantly inferior event-free survival compared to those with a lesser amount. Of interest, the level of disease detection in the peripheral blood was comparable to that found in the bone marrow, suggesting that disease response (minimal residual disease, MRD) could be followed with a peripheral blood test instead of bone marrow examination.²²³ This data regarding the prognostic significance of MDD at diagnosis is the basis for two ongoing clinical trials for advanced-stage T-cell LBL in the United States.

TABLE 89.6 TREATMENT OUTCOME FOR ADVANCED-STAGE LYMPHOBLASTIC NON-HODGKIN LYMPHOMA

Protocol	Stage	No. of Patients	Event-Free Survival Rate	Reference
LSA ₂ L ₂ (modified)	III/IV	124	5 y EFS = 64%	175
CCG-551				
BFM 90	III	82	5 y EFS = 90% ± 3%	205
	IV	19	5 y EFS = 95% ± 5%	
X-H SJCRH	III/IV	22	4 y DFS = 73%	191
APO (Dana Farber)	III/IV	21	3 y DFS = 58% ± 23%	271
A-COP + (POG)	III	33	3 y DFS = 54% ± 9%	192
SFOP LMT81	III	33	57 mo EFS = 79% (SE, 4%)	197
	IV/ALL	43	57 mo EFS = 72% (SE, 4%)	
CCG: LSA2L2 (modified)	I-IV	243	5 y EFS = 74%	200
	I-IV	138	5 y EFS = 64%	
vs.				
ADCOMP				
POG8704: no extra Asp	III/IV	83	4 y CCR = 64% (SE, 6%)	212
vs.	III/IV	84	4 y CCR = 78% (SE, 5%)	
extra Asp				
BFM 95	III/IV(CNS-)	156	5 y DFS 88%	252
NHL 13	III/IV	41	5 y EFS = 82.9%	222
POG 9404	III/IV	137	5 y EFS = 84.6%	221

Asp, asparaginase; BFM, Berlin-Frankfurt-Münster; CCG, Children's Cancer Group; CCR, continuous complete remission; DFS, disease-free survival; EFS, event-free survival; POG, Pediatric Oncology Group; SE, standard error.

Large cell lymphoma: Determining the optimal treatment approach for children with advanced-stage large cell lymphoma has been more of a challenge for various reasons. The CCG randomized trial comparing COMP and LSA2L2 did not show an advantage to either approach for children with advanced-stage large cell lymphoma.¹⁷⁵ Further complicating the picture is the fact that historically, children with large cell lymphoma in the United States were treated on the basis of the histologic diagnosis (i.e., uniform therapy for all immunophenotypic subtypes), whereas in Europe, children with large cell lymphoma have been treated primarily according to immunophenotype (e.g., T-cell, B-cell, or CD30⁺ALCL).^{96, 196, 208, 224} With histology-directed therapy, the 5-year event-free survival for children with advanced-stage disease have generally been in the range of 60% to 75%^{175, 178, 179, 188, 208, 210, 211} (Table 89.7). These results have largely been achieved using CHOP-based therapy (cyclophosphamide, Adriamycin, vincristine, and prednisone). During the past 15 years, the investigators in the United States have used an immunophenotype-directed approach for children with large cell lymphoma, in part because of the excellent results achieved in Europe using this strategy. For example, in France (SFOP), children with advanced-stage B-cell large cell lymphoma are treated according to a BL regimen (LMB89) with an excellent result (3-year event-free survival >80%). Most groups are now treating BL and B-cell large cell lymphoma similarly. The PMBL, however, have an inferior outcome with an approximate 70% event-free survival reported with modern therapy.²¹⁶

Preliminary results from protocols featuring dose-adjusted EPOCH-R in adults with PMBL been encouraging^{225, 226, 227} and have recently prompted the development of a protocol examining this approach in children.

TABLE 89.7 TREATMENT OUTCOME FOR ADVANCED-STAGE LARGE CELL NON-HODGKIN LYMPHOMA

Protocol	Stage	No. of Patients	Event-Free Survival Rate	Reference
CHOP	III & IV	21	3 y EFS = 62% ± 11%	178
MACOP-B	III & IV	11	3 y EFS = 55% ± 16%	195
COMP	III & IV	42	5 y EFS = 52%	175
vs.				
LSA ₂ L ₂	III & IV	18	5 y EFS = 43%	
APO	62	III & IV	3 y EFS = 72% ± 6%	209
vs.				
A-COP+	III & IV	58	4 y EFS = 62% ± 7%	

CHOP, cyclophosphamide, Adriamycin, vincristine, and prednisone; EFS, event-free survival.

There are still quite varied approaches used for those children with CD30⁺ ALCL.^{96, 211, 224} In Europe, an immunophenotypedirected approach has been used. In the German BFM trials, children CD30⁺ ALCL have been treated with a B-cell approach (BL like) with an outstanding result (3-year event-free survival rate of approximately 80%).^{196, 224} The United Kingdom Children's Cancer Study Group studied the activity of a B-cell approach (NHL 9002), based on the very successful French LMB-89 B-cell protocol. In this UK study, children with stage II, III, and non-CNS+ stage IV ALCL treated with the Group B arm of the LMB-89 regimen achieved a 55% 5-year event-free survival rate.²¹³ It is unclear why this approach appeared to be inferior to the BFM B-cell approach; however, the BFM approach features more frequent use of alkylators. In SFOP trials, children with CD30⁺ ALCL have been entered on regimens specific for that subtype.⁹⁶ The HM 89 and HM 91 both feature an initial treatment phase (one course of COP followed by two courses of COPADM) based on their very successful B-cell protocol, LMB-89. The maintenance phases, however, were different from LMB-89: the HM 89 protocol

P.1884

featured alternating courses of VEM (etoposide, methotrexate, and cyclophosphamide) and VAD (vincristine, doxorubicin, and decadron), for a total of 8 courses; and the HM 91 regimen featured alternating courses of VEBP (vinblastine, etoposide, bleomycin, and prednisone) and Sequence 1 (vincristine, methotrexate, cyclophosphamide, and doxorubicin) for a total of 8 courses. The 3-year event-free survival for all stages treated with these two regimens was 66% (54% to 76%); however, among stage III and IV patients, the 3-year event-free survival was 55%.

In the United States, a histology-directed approach has historically been used to treat children with large cell lymphoma. The APO regimen is one of the most active regimens, and features an induction phase (doxorubicin, vincristine, prednisone, and intrathecal methotrexate) followed by sequential maintenance phases (doxorubicin, methotrexate, vincristine, prednisone, 6-mercaptopurine, and intrathecal methotrexate).^{193, 210, 211} A POG randomized trial which examined the potential benefit of adding intermediate-dose methotrexate and high-dose cytarabine to the APO regimen found no difference in outcome regardless of immunophenotype.²¹¹ Among the 86 patients with advanced-stage disease, a 4-year event-free survival and overall survival of 71.8% and 88.1%, respectively, were reported.

During the past decade, cooperative group trials in Europe and the United States built on the BFM B-cell and APO strategies, respectively. Both studies are examining the benefit of adding vinblastine, an agent which has activity as a single agent in multiply relapsed ALCL patients.²¹⁵ In the ALCL99 trial (BFM-based), the addition of vinblastine to the BFM backbone did not improve long-term event-free survival.²²⁸ Another observation in this trial was that the infusion of methotrexate could be changed from 1 gram/m² given over 24 hours with IT MTX to a 3-hour infusion of methotrexate at a dosage of 3 g/m² (without IT MTX), without compromising outcome.²²⁹ The shorter infusion was also associated with less toxicity. In this trial, various prognostic factors were examined. Interestingly, stage was not associated with prognosis²³⁰; however, those with a small cell variant or lymphohistiocytic histologic component had a poorer outcome

than children who lacked this subtype.²³¹ Preliminary results from the COG APO trial also indicated that the inclusion of vinblastine did not improve treatment outcome, although the final report is pending.

Relapse: Approximately 20% to 30% of children with NHL will have a treatment failure with frontline therapy as manifested by either recurrent or, less commonly, refractory disease.¹ The prognosis for children with recurrent or refractory NHL has generally been felt to be quite poor. Therefore, most oncologists consider either intensive or novel salvage chemotherapy regimens, followed by an intensification phase including either autologous or allogeneic hematopoietic stem cell transplantation (HSCT) in the majority of cases. However, the role of HSCT in this setting is somewhat controversial.²³²

There are a number of studies which feature HSCT.^{201, 233, 234, 235, 236, 237, 238, 239, 240, 241, 242, 243} For example, some children with BL who had a poor early response to therapy were successfully salvaged with high-dose intensive chemotherapy followed by autologous HSCT in European Cooperative Group trials.^{201, 236, 238, 239, 241} The Spanish Working Party for Bone Marrow Transplantation reported that 58% of the children who had either refractory/recurrent NHL, or high risk in first CR, were event-free survivors following HSCT.²³⁸ SFOP reported that 8 of 24 children with refractory or recurrent NHL were long-term disease-free survivors using HSCT.^{239, 243} In a St. Jude single institution review of 20 children with recurrent or refractory NHL, approximately 45% were survivors following HSCT.²⁴³ Published studies featuring HSCT for pediatric NHL are relatively small in number, and vary with respect to the type of HSCT (autologous versus allogeneic), salvage therapy, preparative regimen, and histologic subtype, making direct comparisons difficult.

The availability of novel and targeted therapies has made the histologic subtype of NHL a crucial factor in determining the appropriate initial salvage therapy, and in some cases the type of HSCT (i.e., allogeneic versus autologous) for those children who experience a failure following primary therapy.

- Various options can be considered for children with recurrent ALCL. Single agent vinblastine has been shown to be active even in children who have experienced multiple relapses. Of interest, some of these patients have experienced extended event-free survival after completing 1 to 2 years of therapy.²⁴⁴ Multiagent chemotherapy regimens have also been reported to be active and include the ICE regimen (ifosfamide, carboplatin, and etoposide)²⁴⁵ and the MIED regimen (methotrexate, ifosfamide, etoposide, and dexamethasone),²⁴⁶ with long-term event-free survival achieved with subsequent auto-HSCT in patients who are chemosensitive going into HSCT. The BFM reported prognostic factors for children with chemosensitive disease that went on to get an auto-HSCT; those with CD3⁺ tumors, or “relapse on therapy” had a poorer outcome.²⁴⁷ The BFM also published very promising results with the use of allo-HSCT for children with high-risk ALCL, suggesting a possible graft-versus-lymphoma effect.²⁴⁸
- One of the most commonly used regimens for children with recurrent CD20 mature B-cell lymphoma (e.g., BL, DLBCL) is the RICE regimen, which includes rituximab, ifosfamide, carboplatin, and etoposide. A COG study demonstrated activity of this regimen in patients with either BL or DLBCL with subsequent event-free survival following either auto-HSCT or allo-HSCT.²⁴⁹ A number of studies have suggested that autologous HSCT is beneficial in the management of children with BL who are poor early responders to initial therapy.^{201, 234, 239} It is less clear which approach is optimal for those children with BL who relapse in the bone marrow, although many would favor an allogeneic approach if a suitable donor is available.
- Children with recurrent T-cell LBL are generally managed with salvage regimens for recurrent T-ALL; if chemosensitive, they are generally managed with allo-HSCT, as auto-HSCT has not been found to be very effective.²⁵⁰

There is a spectrum of preparative regimens which have been studied in children with recurrent or refractory NHL.^{201, 233, 234, 235, 236, 237, 238, 239, 240, 241, 242, 243} Carmustine, etoposide, cytarabine, and melphalan (BEAM); and carmustine, cytarabine, cyclophosphamide, and thioguanine (BACT) are two of the earliest drug combinations used successfully.^{234, 235, 242} SFOP credited their excellent salvage rate in part to the inclusion of high-dose busulfan in the preparative regimen.²³⁹ Gordon et al.²³⁷ reported excellent results for children with recurrent peripheral T-cell lymphoma using a regimen that featured thiotepa. Additional prospective clinical trials which examine HSCT strategies in children with recurrent or refractory NHL are clearly needed; it has been suggested by one group that the potential graft-versus-lymphoma effect of the allogeneic HSCT approach be studied.²⁴¹

LONG-TERM SEQUELAE

Improvements in the cure rate for children with NHL have prompted investigators to more closely examine long-term treatment-related late effects. Areas of concern include second malignancies, second cancers, and fertility. Attempts to

reduce these unwanted sequelae include trials which have eliminated or reduced the doses of certain chemotherapeutic agents or involved field irradiation.

In the first of two sequential randomized trials for limited-stage NHL, the POG demonstrated that involved field irradiation could be safely eliminated without compromising the excellent treatment outcome.¹⁸³ The elimination of involved field irradiation was also shown to be possible without compromising outcomes in a

P.1885

St. Jude study of patients with advanced-stage disease.²⁵¹ Involved field irradiation of primary tumor masses is not used in most current NHL trials. However, cranial irradiation is considered in the management of children with LBL who present with overt involvement of the central nervous system. Historically, the use of cranial irradiation for CNS prophylaxis in children with LBL has been considered controversial; however, studies by the BFM²⁵² and St. Jude²²² have demonstrated that prophylactic cranial irradiation can be safely omitted from the treatment plan without compromising outcomes.

Alkylating agents such as cyclophosphamide and ifosfamide cause a dose-related depletion of germinal cells and tend to be more gonadotoxic in males. Studies suggest that fertility is generally maintained at a cumulative cyclophosphamide dose of $<4 \text{ g/m}^2$, whereas sterility is likely at doses greater than 7.5 g/m^2 .²⁵³ In this regard, various clinical trials have examined the possibility of eliminating or reducing the dose of cyclophosphamide in the treatment of certain NHL subtypes.²⁰⁹ For example, in the LMB-96 trial for children with high-grade mature B-cell lymphomas, it was demonstrated that escalation of the cyclophosphamide dosage in the second course of COPADM could be avoided in Group B patients without compromising the outcome.²¹⁶

Pediatric NHL trials have also been influenced by the desire to avoid or limit anthracycline-related cardiac toxicity. Although adults have been shown to tolerate cumulative Adriamycin doses of 550 mg/m^2 , children treated with lower cumulative doses have been shown to have clinically significant abnormalities in ventricular contractility.²⁵⁴ Factors which have been shown to be predictive of cardiac dysfunction include higher anthracycline dose intensity, cumulative anthracycline dose, female sex, younger age at time of treatment, combined modality therapy which includes mediastinal irradiation, and time interval since completion of therapy.^{255, 256} In addition to trials which attempt to reduce the cumulative dose of anthracyclines,¹⁸⁸ the study of cardioprotectants is also indicated.

FUTURE DIRECTIONS

Although significant progress has been made in the treatment of children with NHL, 25% to 30% continue to have refractory or recurrent disease. Treatment-related late effects are of additional concern. Thus, the continued goal and challenge for the pediatric oncologist is to develop more effective treatment approaches which are not associated with significant late effects. This will require further refinement in risk-adapted treatment planning, which will be made possible by the identification of additional prognostic biologic and clinical factors.

Various strategies may contribute to further improvement in treatment outcome, such as the development of new active agents or new schedules for the delivery of current agents. One of the most promising novel approaches is the use of immunotherapeutic agents such as rituximab for patients with $\text{CD}20^+$ B-cell lymphomas.^{257, 258, 259} In adults, the use of Rituxan has been shown to improve outcome for adults with DLBCL and FL. Pediatric trials which include rituximab for children with $\text{CD}20^+$ B-cell lymphomas are ongoing. The BFM recently reported on the activity and toxicity profile of rituximab given as window therapy before starting conventional therapy.²¹⁹ The COG performed two pilot studies which incorporated rituximab into Groups B and C of LMB-96 based therapy—preliminary results are promising, with final reports pending. Anti-CD30 (SGN30) has been shown to have activity in adults with $\text{CD}30^+$ ALCLs.²⁶⁰ A pediatric trial of SGN30 combined with ICE (ifosfamide, carboplatin, and etoposide) was recently completed, with results forthcoming. An antibody drug conjugate (i.e., SGN35) which links auristatin to anti-CD30 has been shown to be active in $\text{CD}30^+$ ALCL and Hodgkin lymphoma occurring in adults.^{261, 262, 263} Small molecule inhibitors, which have been shown to be active in adults with CML, may have a role in some types of childhood NHL; phase I studies are currently ongoing.^{264, 265} Crizotinib, a small molecule inhibitor of c-MET/ALK, has been shown to be active against ALCL in adults;²⁶⁶ pediatric trials are ongoing. Future plans for the use of targeted therapeutic agents, including immunotherapeutic agents and small molecule inhibitors, include their combination with conventional agents in the management of children with newly diagnosed ALCL.

The continued molecular characterization of chromosomal abnormalities associated with pediatric NHL may prove helpful in refining the classification of clinically relevant histologic subtypes,^{28, 267, 270} evaluating response to therapy, and developing novel therapeutic approaches which target the molecular lesion directly.

REFERENCES

1. Sandlund JT, Downing JR, Crist WM. Non-Hodgkin's lymphoma in childhood. *N Engl J Med* 1996;334:1238-1248.
2. Murphy SB, Fairclough DL, Hutchison RE, et al. Non-Hodgkin's lymphomas of childhood: an analysis of the histology, staging, and response to treatment of 338 cases at a single institution. *J Clin Oncol* 1989;7:186-193.
3. Young JL Jr, Ries LG, Silverberg E, et al. Cancer incidence, survival, and mortality for children younger than age 15 years. *Cancer* 1986;58:598-602.
4. Bleyer WA. The impact of childhood cancer on the United States and the world. *CA Cancer J Clin* 1990;40:355-367.
5. Parker SL, Tong T, Bolden S, et al. Cancer statistics, 1996. *CA Cancer J Clin* 1996;46:5-27.
6. Percy CL, Smith MA, Linet M, et al. Lymphomas and reticuloendothelial neoplasms., In: Ries LAG, Smith MA, Gurney JG, et al., eds. *Cancer incidence and survival among children and adolescents: United States SEER Program 1975-1995*. Bethesda, MD: National Cancer Institute, SEER Program. NIH Pub. No. 99-4649, 1999:35-49.
7. Magrath IT. Malignant non-Hodgkin's lymphomas in children. In: Pizzo PA, Poplack DG, eds. *Principles and practice of pediatric oncology*, 4th ed. Philadelphia: Lippincott Williams & Wilkins, 2002:661-705.
8. Murphy SB. Classification, staging and end results of treatment of childhood non-Hodgkin's lymphomas: dissimilarities from lymphomas in adults. *Semin Oncol* 1980;7:332-339.
9. National Cancer Institute sponsored study of classifications of non-Hodgkin's lymphomas: summary and description of a working formulation for clinical usage. The Non-Hodgkin's Lymphoma Pathologic Classification Project. *Cancer* 1982;49:2112-2135.
10. Hutchison RE, Pui CH, Murphy SB, et al. Non-Hodgkin's lymphoma in children younger than 3 years. *Cancer* 1988;62:1371-1373.
11. Robison L. General principles of the epidemiology of childhood cancer. In: Pizzo PA, Poplack DG, eds. *Principles and practice of pediatric oncology*. Philadelphia: JB Lippincott, 1993:3-10.
12. Molyneux EM, Rochford R, Griffin B, et al. Burkitt's lymphoma. *Lancet* 2012;379:1234-1244.
13. Patte C. Burkitt lymphoma/leukemia in children. In: Magrath I, Bhatia K, Boffetta P, et al., eds. *The lymphoid neoplasms*, 3rd ed. London: Hodder Arnold, 2010:1201-1219.
14. Magrath IT, Bhatia K. Pathogenesis of small noncleaved cell lymphomas (Burkitt's lymphoma). In: Magrath I, ed. *The non-Hodgkin lymphomas*, 2nd ed. London: Arnold, 1997:385.
15. Shad A, Magrath I. Non-Hodgkin's lymphoma. *Pediatr Clin North Am* 1997;44:863-890.
16. Gutierrez MI, Bhatia K, Barriga F, et al. Molecular epidemiology of Burkitt's lymphoma from South America: differences in breakpoint location and Epstein-Barr virus association from tumors in other world regions. *Blood* 1992;79:3261-3266.
17. Boxer LM, Dang CV. Translocations involving c-myc and c-myc function. *Oncogene* 2001;20:5595-5610.
18. Sandlund JT, Fonseca T, Leimig T, et al. Predominance and characteristics of Burkitt lymphoma among children with non-Hodgkin lymphoma in northeastern Brazil. *Leukemia* 1997;11:743-746.
19. Kuhn-Hallek I, Sage DR, Stein L, et al. Expression of recombination activating genes (RAG-1 and RAG-2) in Epstein-Barr virus-bearing B cells. *Blood* 1995;85:1289-1299.
20. Taylor AM, Metcalfe JA, Thick J, et al. Leukemia and lymphoma in ataxia telangiectasia. *Blood* 1996;87:423-438.
21. McClain KL, Joshi VV, Murphy SB. Cancers in children with HIV infection. *Hematol Oncol Clin North Am* 1996;10:1189-1201.
22. Garrett KM, Fuller CE, Santana VM, et al. Percutaneous biopsy of pediatric solid tumors. *Cancer* 2005;104:644-652.
23. Garrett KM, Hoffer FA, Behm FG, et al. Interventional radiology techniques for the diagnosis of lymphoma or leukemia. *Pediatr Radiol* 2002;32:653-662.
24. Swerdlow SH, Campo E, Harris NL, Jaffe ES, Pileri SA, Stein H, Thiele J, Vardiman JW. *WHO classification of tumours of haematopoietic and lymphoid tissues*. IARC Press, 2008.
25. Williams AH, Taylor CR, Higgins GR, et al. Childhood lymphoma-leukemia. I. Correlation of morphology and immunological studies. *Cancer* 1978;42: 171-181.

26. Mitchell CD, Gordon I, Chessells JM. Clinical, haematological, and radiological features in T-cell lymphoblastic malignancy in childhood. *Clin Radiol* 1986;37:257-261.
27. Head DR, Behm FG. Acute lymphoblastic leukemia and the lymphoblastic lymphomas of childhood. *Semin Diagn Pathol* 1995;12:325-334.
28. Raetz EA, Perkins SL, Bhojwani D, et al. Gene expression profiling reveals intrinsic differences between T-cell acute lymphoblastic leukemia and T-cell lymphoblastic lymphoma. *Pediatr Blood Cancer* 2006;47:130-140.
29. Feng H, Stachura DL, White RM, et al. T-lymphoblastic lymphoma cells express high levels of BCL2, S1P1, and ICAM1, leading to a blockade of tumor cell intravasation. *Cancer Cell* 2010;18:353-366.
30. Burkhardt B. Paediatric lymphoblastic T-cell leukaemia and lymphoma: one or two diseases? *Br J Haematol* 2010;149:653-668.
31. Maitra A, McKenna RW, Weinberg AG, et al. Precursor B-cell lymphoblastic lymphoma. A study of nine cases lacking blood and bone marrow involvement and review of the literature. *Am J Clin Pathol* 2001;115:868-875.
32. Lin P, Jones D, Dorfman DM, et al. Precursor B-cell lymphoblastic lymphoma: a predominantly extranodal tumor with low propensity for leukemic involvement. *Am J Surg Pathol* 2000;24:1480-1490.
33. Neth O, Seidemann K, Jansen P, et al. Precursor B-cell lymphoblastic lymphoma in childhood and adolescence: clinical features, treatment, and results in trials NHL-BFM 86 and 90. *Med Pediatr Oncol* 2000;35:20-27.
34. Millot F, Robert A, Bertrand Y, et al. Cutaneous involvement in children with acute lymphoblastic leukemia or lymphoblastic lymphoma. The Children's Leukemia Cooperative Group of the European Organization of Research and Treatment of Cancer (EORTC). *Pediatrics* 1997;100:60-64.
35. Kahwash SB, Qualman SJ. Cutaneous lymphoblastic lymphoma in children: report of six cases with precursor B-cell lineage. *Pediatr Dev Pathol* 2002;5:45-53.
36. Bernard A, Boumsell L, Reinherz EL, et al. Cell surface characterization of malignant T cells from lymphoblastic lymphoma using monoclonal antibodies: evidence for phenotypic differences between malignant T cells from patients with acute lymphoblastic leukemia and lymphoblastic lymphoma. *Blood* 1981;57:1105-1110.
37. Weiss LM, Bindl JM, Picozzi VJ, et al. Lymphoblastic lymphoma: an immunophenotype study of 26 cases with comparison to T cell acute lymphoblastic leukemia. *Blood* 1986;67:474-478.
38. Cossman J, Chused TM, Fisher RI, et al. Diversity of immunological phenotypes of lymphoblastic lymphoma. *Cancer Res* 1983;43:4486-4490.
39. Sheibani K, Nathwani BN, Winberg CD, et al. Antigenically defined subgroups of lymphoblastic lymphoma. Relationship to clinical presentation and biologic behavior. *Cancer* 1987;60:183-190.
40. Grogan T, Spier C, Wirt DP, et al. Immunologic complexity of lymphoblastic lymphoma. *Diagn Immunol* 1986;4:81-88.
41. Brazier RM, Keneklis T, Donlon JA, et al. Terminal deoxynucleotidyl transferase in non-Hodgkin's lymphoma. *Am J Clin Pathol* 1983;80:655-659.
42. Kung PC, Long JC, McCaffrey RP, et al. Terminal deoxynucleotidyl transferase in the diagnosis of leukemia and malignant lymphoma. *Am J Med* 1978;64:788-794.
43. Murphy S, Jaffe ES. Terminal transferase activity and lymphoblastic neoplasms. *N Engl J Med* 1984;311:1373-1375.
44. Bearman RM, Winberg CD, Maslow WC, et al. Terminal deoxynucleotidyl transferase activity in neoplastic and nonneoplastic hematopoietic cells. *Am J Clin Pathol* 1981;75:794-802.
45. McCaffrey R, Smoler DF, Baltimore D. Terminal deoxynucleotidyl transferase in a case of childhood acute lymphoblastic leukemia. *Proc Natl Acad Sci U S A* 1973;70:521-525.
46. Onciu M, Lorsbach RB, Henry EC, et al. Terminal deoxynucleotidyl transferase-positive lymphoid cells in reactive lymph nodes from children with malignant tumors: incidence, distribution pattern, and immunophenotype in 26 patients. *Am J Clin Pathol* 2002;118:248-254.
47. Gouttefangeas C, Bensussan A, Boumsell L. Study of the CD3-associated T-cell receptors reveals further differences between T-cell acute lymphoblastic lymphoma and leukemia. *Blood* 1990;75:931-934.

48. Childs CC, Chrystal GS, Strauchen JA. Biphenotypic lymphoblastic lymphoma. An unusual tumor with lymphocytic and granulocytic differentiation. *Cancer* 1986;57:1019-1023.
49. Somers GR, Slater H, Rockman S, et al. Coexistent T-cell lymphoblastic lymphoma and an atypical myeloproliferative disorder associated with t(8;13) (p21;q14). *Pediatr Pathol Lab Med* 1997;17:141-158.
50. Strauchen JA, Miller LK. Terminal deoxynucleotidyl transferase-positive cells in human tonsils. *Am J Clin Pathol* 2001;116:12-16.
51. Froehlich TW, Buchanan GR, Cornet JA, et al. Terminal deoxynucleotidyl transferase-containing cells in peripheral blood: implications for the surveillance of patients with lymphoblastic leukemia or lymphoma in remission. *Blood* 1981;58:214-220.
52. Link MP, Roper M, Dorfman RF, et al. Cutaneous lymphoblastic lymphoma with pre-B markers. *Blood* 1983;61:838-841.
53. Borowitz MJ, Croker BP, Metzgar RS. Lymphoblastic lymphoma with the phenotype of common acute lymphoblastic leukemia. *Am J Clin Pathol* 1983;79:387-391.
54. Stroup R, Sheibani K, Misset JL, et al. Surface immunoglobulin-positive lymphoblastic lymphoma. A report of three cases. *Cancer* 1990;65:2559-2563.
55. Thomas DA, Kantarjian HM. Lymphoblastic lymphoma. *Hematol Oncol Clin North Am* 2001;15:51-95, vi.
56. Shikano T, Ishikawa Y, Naito H, et al. Cytogenetic characteristics of childhood non-Hodgkin lymphoma. *Cancer* 1992;70:714-719.
57. Kaneko Y, Frizzera G, Shikano T, et al. Chromosomal and immunophenotypic patterns in T cell acute lymphoblastic leukemia (T ALL) and lymphoblastic lymphoma (LBL). *Leukemia* 1989;3:886-892.
58. Naeem R, Singer S, Fletcher JA. Translocation t(8;13)(p11;q11-12) in stem cell leukemia/lymphoma of T-cell and myeloid lineages. *Genes Chromosomes Cancer* 1995;12:148-151.
59. Inhorn RC, Aster JC, Roach SA, et al. A syndrome of lymphoblastic lymphoma, eosinophilia, and myeloid hyperplasia/malignancy associated with t(8;13)(p11;q11): description of a distinctive clinicopathologic entity. *Blood* 1995;85:1881-1887.
60. Xiao S, Nalabolu SR, Aster JC, et al. FGFR1 is fused with a novel zinc-finger gene, ZNF198, in the t(8;13) leukaemia/lymphoma syndrome. *Nat Genet* 1998;18:84-87.
61. Narita M, Shimizu K, Hayashi Y, et al. Consistent detection of CALM-AF10 chimaeric transcripts in haematological malignancies with t(10;11)(p13;q14) and identification of novel transcripts. *Br J Haematol* 1999;105:928-937.
62. Bohlander SK, Muschinsky V, Schrader K, et al. Molecular analysis of the CALM/AF10 fusion: identical rearrangements in acute myeloid leukemia, acute lymphoblastic leukemia and malignant lymphoma patients. *Leukemia* 2000;14:93-99.
63. Ashihara E, Nakamura S, Inaba T, et al. A novel AF10-CALM fusion transcript in gamma/delta T cell type lymphoblastic lymphoma. *Am J Hematol* 2007;82:859-860.
64. Harris NL, Jaffe ES, Stein H, et al. A revised European-American classification of lymphoid neoplasms: a proposal from the International Lymphoma Study Group. *Blood* 1994;84:1361-1392.
65. Jaffe ES, Harris NL, Stein H, et al. Pathology and genetics of tumours of haematopoietic and lymphoid tissues. Lyon: IARC Press, 2001.
66. Behm FG. Immunophenotypin. In: Pui C-H, ed. *Childhood leukemias*, 2nd ed. New York, NY: Cambridge University Press, 2006:151-209.
67. Nishida K, Ritterbach J, Repp R, et al. Characterization of chromosome 8 abnormalities by fluorescence in situ hybridization in childhood B-acute lymphoblastic leukemia/non-Hodgkin lymphoma. *Cancer Genet Cytogenet* 1995;79:8-14.
68. Onciu M, Schlette E, Zhou Y, et al. Secondary chromosomal abnormalities predict outcome in pediatric and adult high-stage Burkitt lymphoma. *Cancer* 2006;107:1084-1092.
69. Oschlies I, Klapper W, Zimmermann M, et al. Diffuse large B-cell lymphoma in pediatric patients belongs predominantly to the germinal-center type B-cell lymphomas: a clinicopathologic analysis of cases included in the German BFM (Berlin-Frankfurt-Munster) Multicenter Trial. *Blood* 2006;107: 4047-4052.

70. Onciu M, Behm FG, Downing JR, et al. ALK-positive plasmablastic B-cell lymphoma with expression of the NPM-ALK fusion transcript: report of 2 cases. *Blood* 2003;102:2642-2644.
71. Gesk S, Gascoyne RD, Schnitzer B, et al. ALK-positive diffuse large B-cell lymphoma with ALK-Clathrin fusion belongs to the spectrum of pediatric lymphomas. *Leukemia* 2005;19:1839-1840.
72. Bubala H, Maldyk J, Wlodarska I, et al. ALK-positive diffuse large B-cell lymphoma. *Pediatr Blood Cancer* 2006;46:649-653.
73. Lazzarino M, Orlandi E, Paulli M, et al. Treatment outcome and prognostic factors for primary mediastinal (thymic) B-cell lymphoma: a multicenter study of 106 patients. *J Clin Oncol* 1997;15:1646-1653.
74. Zinzani PL, Bendandi M, Frezza G, et al. Primary mediastinal B-cell lymphoma with sclerosis: clinical and therapeutic evaluation of 22 patients. *Leuk Lymphoma* 1996;21:311-316.
75. Paulli M, Lazzarino M, Gianelli U, et al. Primary mediastinal B-cell lymphoma: update of its clinicopathologic features. *Leuk Lymphoma* 1997;26(Suppl 1):115-123.
76. Lones MA, Perkins SL, Sposto R, et al. Large-cell lymphoma arising in the mediastinum in children and adolescents is associated with an excellent outcome: a Children's Cancer Group report. *J Clin Oncol* 2000;18:3845-3853.
77. van Besien K, Kelta M, Bahaguna P. Primary mediastinal B-cell lymphoma: a review of pathology and management. *J Clin Oncol* 2001;19:1855-1864.
78. Abou-Elella AA, Weisenburger DD, Vose JM, et al. Primary mediastinal large B-cell lymphoma: a clinicopathologic study of 43 patients from the Nebraska Lymphoma Study Group. *J Clin Oncol* 1999;17:784-790.
79. Higgins JP, Warnke RA. CD30 expression is common in mediastinal large B-cell lymphoma. *Am J Clin Pathol* 1999;112:241-247.
80. Copie-Bergman C, Plonquet A, Alonso MA, et al. MAL expression in lymphoid cells: further evidence for MAL as a distinct molecular marker of primary mediastinal large B-cell lymphomas. *Mod Pathol* 2002;15:1172-1180.
81. Kuppers R, Rajewsky K, Hansmann ML. Diffuse large cell lymphomas are derived from mature B cells carrying V region genes with a high load of somatic mutation and evidence of selection for antibody expression. *Eur J Immunol* 1997;27:1398-1405.
82. Pileri SA, Zinzani PL, Gaidano G, et al. Pathobiology of primary mediastinal B-cell lymphoma. *Leuk Lymphoma* 2003;44(Suppl 3):S21-S26.
83. Bentz M, Barth TF, Bruderlein S, et al. Gain of chromosome arm 9p is characteristic of primary mediastinal B-cell lymphoma (MBL): comprehensive molecular cytogenetic analysis and presentation of a novel MBL cell line. *Genes Chromosomes Cancer* 2001;30:393-401.
- P.1886
84. Palanisamy N, Abou-Elella AA, Chaganti SR, et al. Similar patterns of genomic alterations characterize primary mediastinal large-B-cell lymphoma and diffuse large-B-cell lymphoma. *Genes Chromosomes Cancer* 2002;33:114-122.
85. Joos S, Otano-Joos MI, Ziegler S, et al. Primary mediastinal (thymic) B-cell lymphoma is characterized by gains of chromosomal material including 9p and amplification of the REL gene. *Blood* 1996;87:1571-1578.
86. Kim DW, Sacher M, Scarpa A, et al. High-copy suppressor analysis reveals a physical interaction between Sec34p and Sec35p, a protein implicated in vesicle docking. *Mol Biol Cell* 1999;10:3317-3329.
87. Tsang P, Cesarman E, Chadburn A, et al. Molecular characterization of primary mediastinal B cell lymphoma. *Am J Pathol* 1996;148:2017-2025.
88. Poppema S, Kluiver JL, Atayar C, et al. Report: workshop on mediastinal grey zone lymphoma. *Eur J Haematol* 2005;75(Suppl):45-52.
89. Rosenwald A, Wright G, Leroy K, et al. Molecular diagnosis of primary mediastinal B cell lymphoma identifies a clinically favorable subgroup of diffuse large B cell lymphoma related to Hodgkin lymphoma. *J Exp Med* 2003;198:851-862.

90. Savage KJ, Monti S, Kutok JL, et al. The molecular signature of mediastinal large B-cell lymphoma differs from that of other diffuse large B-cell lymphomas and shares features with classical Hodgkin lymphoma. *Blood* 2003;102:3871-3879.
91. Calvo KR, Traverse-Glehen A, Pittaluga S, et al. Molecular profiling provides evidence of primary mediastinal large B-cell lymphoma as a distinct entity related to classic Hodgkin lymphoma: implications for mediastinal gray zone lymphomas as an intermediate form of B-cell lymphoma. *Adv Anat Pathol* 2004;11:227-238.
92. Sandlund JT, Pui CH, Santana VM, et al. Clinical features and treatment outcome for children with CD30+ large-cell non-Hodgkin's lymphoma. *J Clin Oncol* 1994;12:895-898.
93. Fraga M, Brousset P, Schlaifer D, et al. Bone marrow involvement in anaplastic large cell lymphoma. Immunohistochemical detection of minimal disease and its prognostic significance. *Am J Clin Pathol* 1995;103:82-89.
94. Benharroch D, Meguerian-Bedoyan Z, Lamant L, et al. ALK-positive lymphoma: a single disease with a broad spectrum of morphology. *Blood* 1998;91:2076-2084.
95. Pileri S, Sabattini E, Poggi S, et al. Lymphohistiocytic T-cell lymphoma. *Histopathology* 1994;25:191-193.
96. Brugieres L, Deley MC, Pacquement H, et al. CD30(+) anaplastic large-cell lymphoma in children: analysis of 82 patients enrolled in two consecutive studies of the French Society of Pediatric Oncology. *Blood* 1998;92: 3591-3598.
97. Meech SJ, McGavran L, Odom LF, et al. Unusual childhood extramedullary hematologic malignancy with natural killer cell properties that contains tropomyosin 4—anaplastic lymphoma kinase gene fusion. *Blood* 2001;98:1209-1216.
98. van den Berg H, Noorduyn A, van Kuilenburg AB, et al. Leukaemic expression of anaplastic large cell lymphoma with 46,XX,ins(2;5)(p23;q15q35) in a child with dihydropyrimidine dehydrogenase deficiency. *Leukemia* 2000;14: 769-70.
99. Anderson MM, Ross CW, Singleton TP, et al. Ki-1 anaplastic large cell lymphoma with a prominent leukemic phase. *Hum Pathol* 1996;27:1093-1095.
100. Villamor N, Rozman M, Esteve J, et al. Anaplastic large-cell lymphoma with rapid evolution to leukemic phase. *Ann Hematol* 1999;78:478-482.
101. Bayle C, Charpentier A, Duchayne E, et al. Leukaemic presentation of small cell variant anaplastic large cell lymphoma: report of four cases. *Br J Haematol* 1999;104:680-688.
102. Chhanabhai M, Britten C, Klasa R, et al. t(2;5) positive lymphoma with peripheral blood involvement. *Leuk Lymphoma* 1998;28:415-422.
103. Onciu M, Behm FG, Raimondi SC, et al. ALK-positive anaplastic large cell lymphoma with leukemic peripheral blood involvement is a clinicopathologic entity with an unfavorable prognosis. Report of three cases and review of the literature. *Am J Clin Pathol* 2003;120:617-625.
104. Falini B. Anaplastic large cell lymphoma: pathological, molecular and clinical features. *Br J Haematol* 2001;114:741-760.
105. Stein H, Foss HD, Durkop H, et al. CD30(+) anaplastic large cell lymphoma: a review of its histopathologic, genetic, and clinical features. *Blood* 2000;96:3681-3695.
106. Stein H. Ki-1-anaplastic large cell lymphoma: is it a discrete entity? *Leuk Lymphoma* 1993;10(Suppl):81-84.
107. Stein H, Mason DY, Gerdes J, et al. The expression of the Hodgkin's disease associated antigen Ki-1 in reactive and neoplastic lymphoid tissue: evidence that Reed-Sternberg cells and histiocytic malignancies are derived from activated lymphoid cells. *Blood* 1985;66:848-858.
108. Delsol G, Al Saati T, Gatter KC, et al. Coexpression of epithelial membrane antigen (EMA), Ki-1, and interleukin-2 receptor by anaplastic large cell lymphomas. Diagnostic value in so-called malignant histiocytosis. *Am J Pathol* 1988;130:59-70.
109. Juco J, Holden JT, Mann KP, et al. Immunophenotypic analysis of anaplastic large cell lymphoma by flow cytometry. *Am J Clin Pathol* 2003;119:205-212.
110. Bovio IM, Allan RW. The expression of myeloid antigens CD13 and/or CD33 is a marker of ALK+ anaplastic large cell lymphomas. *Am J Clin Pathol* 2008;130:628-634.
111. Kaneko Y, Frizzera G, Edamura S, et al. A novel translocation, t(2;5)(p23;q35), in childhood phagocytic large T-cell lymphoma mimicking malignant histiocytosis. *Blood* 1989;73:806-813.

112. Mason DY, Bastard C, Rimokh R, et al. CD30-positive large cell lymphomas ('Ki-1 lymphoma') are associated with a chromosomal translocation involving 5q35. *Br J Haematol* 1990;74:161-168.
113. Rosenwald A, Ott G, Pulford K, et al. t(1;2)(q21;p23) and t(2;3)(p23;q21): two novel variant translocations of the t(2;5)(p23;q35) in anaplastic large cell lymphoma. *Blood* 1999;94:362-364.
114. Lamant L, Dastugue N, Pulford K, et al. A new fusion gene TPM3-ALK in anaplastic large cell lymphoma created by a (1;2)(q25;p23) translocation. *Blood* 1999;93:3088-3095.
115. Colleoni GW, Bridge JA, Garicochea B, et al. ATIC-ALK: A novel variant ALK gene fusion in anaplastic large cell lymphoma resulting from the recurrent cryptic chromosomal inversion, inv(2)(p23q35). *Am J Pathol* 2000;156: 781-789.
116. Lamant L, Pulford K, Bischof D, et al. Expression of the ALK tyrosine kinase gene in neuroblastoma. *Am J Pathol* 2000;156:1711-1721.
117. Lawrence B, Perez-Atayde A, Hibbard MK, et al. TPM3-ALK and TPM4-ALK oncogenes in inflammatory myofibroblastic tumors. *Am J Pathol* 2000;157:377-384.
118. Cessna MH, Zhou H, Sanger WG, et al. Expression of ALK1 and p80 in inflammatory myofibroblastic tumor and its mesenchymal mimics: a study of 135 cases. *Mod Pathol* 2002;15:931-938.
119. Agnarsson BA, Kadin ME. Peripheral T-cell lymphomas in children. *Semin Diagn Pathol* 1995;12:314-324.
120. el-Hoshy K, Hashimoto K. Adolescence mycosis fungoides: an unusual presentation with hypopigmentation. *J Dermatol* 1995;22:424-427.
121. Grunwald MH, Amichai B. Localized hypopigmented mycosis fungoides in a 12-year-old caucasian boy. *J Dermatol* 1999;26:70-71.
122. Hess Schmid M, Dummer R, Kempf W, et al. Mycosis fungoides with mucinosis follicularis in childhood. *Dermatology* 1999;198:284-287.
123. Garzon MC. Cutaneous T cell lymphoma in children. *Semin Cutan Med Surg* 1999;18:226-232.
124. Tan E, Tay YK, Giam YC. Profile and outcome of childhood mycosis fungoides in Singapore. *Pediatr Dermatol* 2000;17:352-356.
125. Neuhaus IM, Ramos-Caro FA, Hassanein AM. Hypopigmented mycosis fungoides in childhood and adolescence. *Pediatr Dermatol* 2000;17:403-406.
126. Whittam LR, Calonje E, Orchard G, et al. CD8-positive juvenile onset mycosis fungoides: an immunohistochemical and genotypic analysis of six cases. *Br J Dermatol* 2000;143:1199-1204.
127. Thomson AB, McKenzie KJ, Jackson R, et al. Subcutaneous panniculitic T-cell lymphoma in childhood: successful response to chemotherapy. *Med Pediatr Oncol* 2001;37:549-552.
128. Sen F, Rassidakis GZ, Jones D, et al. Apoptosis and proliferation in subcutaneous panniculitis-like T-cell lymphoma. *Mod Pathol* 2002;15:625-631.
129. Shani-Adir A, Lucky AW, Prendiville J, et al. Subcutaneous panniculitic T-cell lymphoma in children: response to combination therapy with cyclosporine and chemotherapy. *J Am Acad Dermatol* 2004;50:S18-S22.
130. Lewis JM, Vasef MA, Seabury Stone M. HTLV-I-associated granulomatous T-cell lymphoma in a child. *J Am Acad Dermatol* 2001;44:525-529.
131. Broniscer A, Ribeiro RC, Srinivas RV, et al. An adolescent with HTLV-I-associated adult T cell leukemia treated with interferon-alfa and zidovudine. *Leukemia* 1996;10:1244-1248.
132. Pombo-de-Oliveira MS, Dobbin JA, Loureiro P, et al. Genetic mutation and early onset of T-cell leukemia in pediatric patients infected at birth with HTLV-I. *Leuk Res* 2002;26:155-161.
133. Miyazaki M, Lin YW, Okada M, et al. Childhood cutaneous natural killer/T lymphoma successfully treated with only one course of chemotherapy and incomplete tumor resection. *Haematologica* 2001;86:883-884.
134. Ohnuma K, Toyoda Y, Nishihira H, et al. Aggressive natural killer (NK) cell lymphoma: report of a pediatric case and review of the literature. *Leuk Lymphoma* 1997;25:387-392.
135. Shaw PH, Cohn SL, Morgan ER, et al. Natural killer cell lymphoma: report of two pediatric cases, therapeutic options, and review of the literature. *Cancer* 2001;91:642-646.

136. Frizzera G, Murphy SB. Follicular (nodular) lymphoma in childhood: a rare clinical- pathological entity. Report of eight cases from four cancer centers. *Cancer* 1979;44:2218-2235.
137. Pinto A, Hutchison RE, Grant LH, et al. Follicular lymphomas in pediatric patients. *Mod Pathol* 1990;3:308-313.
138. Ribeiro RC, Pui CH, Murphy SB, et al. Childhood malignant non-Hodgkin lymphomas of uncommon histology. *Leukemia* 1992;6:761-765.
139. Atra A, Meller ST, Stevens RS, et al. Conservative management of follicular non-Hodgkin's lymphoma in childhood. *Br J Haematol* 1998;103:220-223.
140. Lorscheid RB, Shay-Seymore D, Moore J, et al. Clinicopathologic analysis of follicular lymphoma occurring in children. *Blood* 2002;99:1959-1964.
141. Swerdlow SH. Pediatric follicular lymphomas, marginal zone lymphomas, and marginal zone hyperplasia. *Am J Clin Pathol* 2004;122(Suppl):S98-S109, 2004.
142. Moertel CL, Watterson J, McCormick SR, et al. Follicular large cell lymphoma of the testis in a child. *Cancer* 1995;75:1182-1186.
143. Finn LS, Viswanatha DS, Belasco JB, et al. Primary follicular lymphoma of the testis in childhood. *Cancer* 1999;85:1626-1635.
144. Lu D, Medeiros J, Eskenazi AE, et al. Primary follicular large cell lymphoma of the testis in a child. *Arch Pathol Lab Med* 2001;125:551-554.
145. Pakzad K, MacLennan GT, Elder JS, et al. Follicular large cell lymphoma localized to the testis in children. *J Urol* 2002;168:225-228.
146. Heller KN, Teruya-Feldstein J, La Quaglia MP, et al. Primary follicular lymphoma of the testis: excellent outcome following surgical resection without adjuvant chemotherapy. *J Pediatr Hematol Oncol* 2004;26:104-107.
147. Taddesse-Heath L, Pittaluga S, Sorbara L, et al. Marginal zone B-cell lymphoma in children and young adults. *Am J Surg Pathol* 2003;27:522-531.
148. Mo JQ, Dimashkieh H, Mallery SR, et al. MALT lymphoma in children: case report and review of the literature. *Pediatr Dev Pathol* 2004;7:407-413.
149. Claviez A, Meyer U, Dominick C, et al. MALT lymphoma in children: a report from the NHL-BFM Study Group. *Pediatr Blood Cancer* 2006;47:210-214.
150. Lai R, Larratt LM, Etches W, et al. Hepatosplenic T-cell lymphoma of alpha-beta lineage in a 16-year-old boy presenting with hemolytic anemia and thrombocytopenia. *Am J Surg Pathol* 2000;24:459-463.
151. Weidmann E. Hepatosplenic T cell lymphoma. A review on 45 cases since the first report describing the disease as a distinct lymphoma entity in 1990. *Leukemia* 2000;14:991-997.
152. Suarez F, Wlodarska I, Rigal-Huguet F, et al. Hepatosplenic alphabeta T-cell lymphoma: an unusual case with clinical, histologic, and cytogenetic features of gammadelta hepatosplenic T-cell lymphoma. *Am J Surg Pathol* 2000;24:1027-1032.
153. Cooke CB, Krenacs L, Stetler-Stevenson M, et al. Hepatosplenic T-cell lymphoma: a distinct clinicopathologic entity of cytotoxic gamma delta T-cell origin. *Blood* 1996;88:4265-4274.
154. Macon WR, Levy NB, Kurtin PJ, et al. Hepatosplenic alphabeta T-cell lymphomas: a report of 14 cases and comparison with hepatosplenic gammadelta T-cell lymphomas. *Am J Surg Pathol* 2001;25:285-296.
155. Farcet JP, Gaulard P, Marolleau JP, et al. Hepatosplenic T-cell lymphoma: sinusal/sinusoidal localization of malignant cells expressing the T-cell receptor gamma delta. *Blood* 1990;75:2213-2219.
156. Francois A, Lesesve JF, Stamatoullas A, et al. Hepatosplenic gamma/delta T-cell lymphoma: a report of two cases in immunocompromised patients, associated with isochromosome 7q. *Am J Surg Pathol* 1997;21:781-790.
157. Ross CW, Schnitzer B, Sheldon S, et al. Gamma/delta T-cell posttransplantation lymphoproliferative disorder primarily in the spleen. *Am J Clin Pathol* 1994;102:310-315.
158. Khan WA, Yu L, Eisenbrey AB, et al. Hepatosplenic gamma/delta T-cell lymphoma in immunocompromised patients. Report of two cases and review of literature. *Am J Clin Pathol* 2001;116:41-50.

159. Steurer M, Stauder R, Grunewald K, et al. Hepatosplenic gammadelta-T-cell lymphoma with leukemic course after renal transplantation. *Hum Pathol* 2002;33:253-258.
160. Wang CC, Tien HF, Lin MT, et al. Consistent presence of isochromosome 7q in hepatosplenic T gamma/delta lymphoma: a new cytogenetic-clinicopathologic entity. *Genes Chromosomes Cancer* 1995;12:161-164.
161. Vega F, Medeiros LJ, Bueso-Ramos C, et al. Hepatosplenic gamma/delta T-cell lymphoma in bone marrow. A sinusoidal neoplasm with blastic cytologic features. *Am J Clin Pathol* 2001;116:410-419.
162. Salhany KE, Feldman M, Kahn MJ, et al. Hepatosplenic gammadelta T-cell lymphoma: ultrastructural, immunophenotypic, and functional evidence for cytotoxic T lymphocyte differentiation. *Hum Pathol* 1997;28:674-685.
163. Nosari A, Oreste PL, Biondi A, et al. Hepato-splenic gammadelta T-cell lymphoma: a rare entity mimicking the hemophagocytic syndrome. *Am J Hematol* 1999;60:61-65.
164. Belhadj K, Reyes F, Farcet JP, et al. Hepatosplenic gammadelta T-cell lymphoma is a rare clinicopathologic entity with poor outcome: report on a series of 21 patients. *Blood* 2003;102:4261-4269.
165. Felgar RE, Macon WR, Kinney MC, et al. TIA-1 expression in lymphoid neoplasms. Identification of subsets with cytotoxic T lymphocyte or natural killer cell differentiation. *Am J Pathol* 1997;150:1893-1900.
166. Boulland ML, Kanavaros P, Wechsler J, et al. Cytotoxic protein expression in natural killer cell lymphomas and in alpha beta and gamma delta peripheral T-cell lymphomas. *J Pathol* 1997;183:432-439.
167. Jonveaux P, Daniel MT, Martel V, et al. Isochromosome 7q and trisomy 8 are consistent primary, non-random chromosomal abnormalities associated with hepatosplenic T gamma/delta lymphoma. *Leukemia* 1996;10:1453-1455.
168. Coventry S, Punnett HH, Tomczak EZ, et al. Consistency of isochromosome 7q and trisomy 8 in hepatosplenic gammadelta T-cell lymphoma: detection by fluorescence in situ hybridization of a splenic touch-preparation from a pediatric patient. *Pediatr Dev Pathol* 1999;2:478-483.
169. Wlodarska I, Martin-Garcia N, Achten R, et al. Fluorescence in situ hybridization study of chromosome 7 aberrations in hepatosplenic T-cell lymphoma: isochromosome 7q as a common abnormality accumulating in forms with features of cytologic progression. *Genes Chromosomes Cancer* 2002;33: 243-251.
170. Rossbach HC, Chamizo W, Dumont DP, et al. Hepatosplenic gamma/delta T-cell lymphoma with isochromosome 7q, translocation t(7;21), and tetrasomy 8 in a 9-year-old girl. *J Pediatr Hematol Oncol* 2002;24:154-157.
171. Kadin ME. Ki-1-positive anaplastic large-cell lymphoma: a clinicopathologic entity? *J Clin Oncol* 1991;9:533-536.
172. Kadin ME. Ki-1/CD30+ (anaplastic) large-cell lymphoma: maturation of a clinicopathologic entity with prospects of effective therapy [editorial]. *J Clin Oncol* 1994;12:884-887.
173. Naumann R, Vaic A, Beuthien-Baumann B, et al. Prognostic value of positron emission tomography in the evaluation of post-treatment residual mass in patients with Hodgkin's disease and non-Hodgkin's lymphoma. *Br J Haematol* 2001;115:793-800.
174. Pui CH, Mahmoud HH, Wiley JM, et al. Recombinant urate oxidase for the prophylaxis or treatment of hyperuricemia in patients with leukemia or lymphoma. *J Clin Oncol* 2001;19:697-704.
175. Anderson JR, Jenkin RD, Wilson JF, et al. Long-term follow-up of patients treated with COMP or LSA2L2 therapy for childhood non-Hodgkin's lymphoma: a report of CCG-551 from the Children's Cancer Group. *J Clin Oncol* 1993;11:1024-1032.
176. Wollner N, Burchenal JH, Lieberman PH, et al. Non-Hodgkin's lymphoma in children. A comparative study of two modalities of therapy. *Cancer* 1976;37:123-134.
177. Sullivan MP, Boyett J, Pullen J, et al. Pediatric oncology group experience with modified LSA2-L2 therapy in 107 children with non-Hodgkin's lymphoma (Burkitt's lymphoma excluded). *Cancer* 1985;55:323-336.
178. Sandlund JT, Santana V, Abromowitch M, et al. Large cell non-Hodgkin lymphoma of childhood: clinical characteristics and outcome. *Leukemia* 1994;8:30-34.
179. Hutchison RE, Berard CW, Shuster JJ, et al. B-cell lineage confers a favorable outcome among children and adolescents with large-cell lymphoma: a Pediatric Oncology Group study. *J Clin Oncol* 1995;13:2023-2032.

180. Patte C, Auperin A, Michon J, et al. The Societe Francaise d'Oncologie Pediatrique LMB89 protocol: highly effective multiagent chemotherapy tailored to the tumor burden and initial response in 561 unselected children with B-cell lymphomas and L3 leukemia. *Blood* 2001;97:3370-3379.
181. Murphy SB, Bowman WP, Abromowitch M, et al. Results of treatment of advanced-stage Burkitt's lymphoma and B cell (SIg+) acute lymphoblastic leukemia with high-dose fractionated cyclophosphamide and coordinated high-dose methotrexate and cytarabine. *J Clin Oncol* 1986;4: 1732-1739.
182. Murphy SB, Hustu HO, Rivera G, et al. End results of treating children with localized non-Hodgkin's lymphomas with a combined modality approach of lessened intensity. *J Clin Oncol* 1983;1:326-330.
183. Link MP, Shuster JJ, Donaldson SS, et al. Treatment of children and young adults with early-stage non-Hodgkin's lymphoma. *N Engl J Med* 1997;337:1259-1266.
184. Brecher ML, Schwenn MR, Coppes MJ, et al. Fractionated cyclophosphamide and back to back high dose methotrexate and cytosine arabinoside improves outcome in patients with stage III high grade small non-cleaved cell lymphomas (SNCCCL): a randomized trial of the Pediatric Oncology Group. *Med Pediatr Oncol* 1997;29:526-533.
185. Bowman WP, Shuster JJ, Cook B, et al. Improved survival for children with B-cell acute lymphoblastic leukemia and stage IV small noncleaved-cell lymphoma: a Pediatric Oncology Group study. *J Clin Oncol* 1996;14:1252-1261.
186. Patte C, Philip T, Rodary C, et al. High survival rate in advanced-stage B-cell lymphomas and leukemias without CNS involvement with a short intensive polychemotherapy: results from the French Pediatric Oncology Society of a randomized trial of 216 children. *J Clin Oncol* 1991;9:123-132.
187. Reiter A, Schrappe M, Ludwig WD, et al. Favorable outcome of B-cell acute lymphoblastic leukemia in childhood: a report of three consecutive studies of the BFM group. *Blood* 1992;80:2471-2478.
188. Sposto R, Meadows AT, Chilcote RR, et al. Comparison of long-term outcome of children and adolescents with disseminated non-lymphoblastic non-Hodgkin lymphoma treated with COMP or daunomycin-COMP: a report from the Children's Cancer Group. *Med Pediatr Oncol* 2001;37:432-441.
189. Magrath IT, Janus C, Edwards BK, et al. An effective therapy for both undifferentiated (including Burkitt's) lymphomas and lymphoblastic lymphomas in children and young adults. *Blood* 1984;63:1102-1111.
190. Schwenn MR, Blattner SR, Lynch E, et al. HiC-COM: a 2-month intensive chemotherapy regimen for children with stage III and IV Burkitt's lymphoma and B-cell acute lymphoblastic leukemia. *J Clin Oncol* 1991;9:133-138.
191. Dahl GV, Rivera G, Pui CH, et al. A novel treatment of childhood lymphoblastic non-Hodgkin's lymphoma: early and intermittent use of teniposide plus cytarabine. *Blood* 1985;66:1110-1114.
192. Hvizdala EV, Berard C, Callihan T, et al. Lymphoblastic lymphoma in children —a randomized trial comparing LSA2- L2 with the A-COP+ therapeutic regimen: a Pediatric Oncology Group study. *J Clin Oncol* 1988;6:26-33.
193. Weinstein HJ, Lack EE, Cassady JR. APO therapy for malignant lymphoma of large cell "histiocytic" type of childhood: analysis of treatment results for 29 patients. *Blood* 1984;64:422-426.
194. Hvizdala EV, Berard C, Callihan T, et al. Nonlymphoblastic lymphoma in children—histology and stage-related response to therapy: a Pediatric Oncology Group study. *J Clin Oncol* 1991;9:1189-1195.
195. Santana VM, Abromowitch M, Sandlund JT, et al. MACOP-B treatment in children and adolescents with advanced diffuse large-cell non-Hodgkin's lymphoma. *Leukemia* 1993;7:187-191.
196. Reiter A, Schrappe M, Tiemann M, et al. Successful treatment strategy for Ki-1 anaplastic large-cell lymphoma of childhood: a prospective analysis of 62 patients enrolled in three consecutive Berlin-Frankfurt-Munster group studies. *J Clin Oncol* 1994;12:899-908.
197. Patte C, Kalifa C, Flamant F, et al. Results of the LMT81 protocol, a modified LSA2L2 protocol with high dose methotrexate, on 84 children with non-B-cell (lymphoblastic) lymphoma. *Med Pediatr Oncol* 1992;20:105-113.
198. Meadows AT, Sposto R, Jenkin RD, et al. Similar efficacy of 6 and 18 months of therapy with four drugs (COMP) for localized non-Hodgkin's lymphoma of children: a report from the Children's Cancer Study Group. *J Clin Oncol* 1989;7:92-99.
199. Patte C, Philip T, Rodary C, et al. Improved survival rate in children with stage III and IV B cell non- Hodgkin's lymphoma and leukemia using multi-agent chemotherapy: results of a study of 114 children from the French Pediatric Oncology Society. *J Clin Oncol* 1986;4:1219-1226.

200. Tubergen DG, Krailo MD, Meadows AT, et al. Comparison of treatment regimens for pediatric lymphoblastic non-Hodgkin's lymphoma: a Children's Cancer Group study. *J Clin Oncol* 1995;13:1368-1376.
201. Reiter A, Schrappe M, Tiemann M, et al. Improved treatment results in childhood B-cell neoplasms with tailored intensification of therapy: a report of the Berlin-Frankfurt-Munster Group Trial NHL-BFM 90. *Blood* 1999;94:3294-3306.
202. Reiter A, Schrappe M, Parwaresch R, et al. Non-Hodgkin's lymphomas of childhood and adolescence: results of a treatment stratified for biologic subtypes and stage—a report of the Berlin-Frankfurt-Munster Group. *J Clin Oncol* 1995;13:359-372.
203. Magrath I, Adde M, Shad A, et al. Adults and children with small non-cleavedcell lymphoma have a similar excellent outcome when treated with the same chemotherapy regimen. *J Clin Oncol* 1996;14:925-934.
204. Adde M, Shad A, Venzon D, et al. Additional chemotherapy agents improve treatment outcome for children and adults with advanced B-cell lymphomas. *Semin Oncol* 1998;25:33-39, discussion 45-48.
205. Reiter A, Schrappe M, Ludwig WD, et al. Intensive ALL-type therapy without local radiotherapy provides a 90% event-free survival for children with T-cell lymphoblastic lymphoma: a BFM Group report. *Blood* 2000;95:416-421.
206. Soussain C, Patte C, Ostronoff M, et al. Small noncleaved cell lymphoma and leukemia in adults. A retrospective study of 65 adults treated with the LMB pediatric protocols. *Blood* 1995;85:664-674.
207. Asselin BL, Shuster J, Amylon M, et al.: Improved event-free survival (EFS) with high dose methotrexate (HDM) in T-cell lymphoblastic leukemia (T-ALL) and advanced lymphoblastic lymphoma (T-NHL): a Pediatric Oncology Group (POG) study. *Proc of ASCO* 2001;20:367.
208. Murphy SB. Pediatric lymphomas: recent advances and commentary on Ki-1-positive anaplastic large-cell lymphomas of childhood. *Ann Oncol* 1994;5:31-33.
209. Laver JH, Mahmoud H, Pick TE, et al. Results of a randomized phase III trial in children and adolescents with advanced stage diffuse large cell non-Hodgkin's lymphoma: a Pediatric Oncology Group study. *Leuk Lymphoma* 2001;42:399-405.
210. Laver JH, Mahmoud H, Pick TE, et al. Results of a randomized phase III trial in children and adolescents with advanced stage diffuse large cell non-Hodgkin's lymphoma: a Pediatric Oncology Group study. *Leuk Lymphoma* 2002;43:105-109.
211. Laver JH, Kravaka JM, Hutchison RE, et al. Advanced-stage large-cell lymphoma in children and adolescents: results of a randomized trial incorporating intermediate-dose methotrexate and high-dose cytarabine in the maintenance phase of the APO regimen: a Pediatric Oncology Group phase III trial. *J Clin Oncol* 2005;23:541-547.
212. Amylon MD, Shuster J, Pullen J, et al. Intensive high-dose asparaginase consolidation improves survival for pediatric patients with T cell acute lymphoblastic leukemia and advanced stage lymphoblastic lymphoma: a Pediatric Oncology Group study. *Leukemia* 1999;13:335-342.
213. Williams DM, Hobson R, Imeson J, et al. Anaplastic large cell lymphoma in childhood: analysis of 72 patients treated on The United Kingdom Children's Cancer Study Group chemotherapy regimens. *Br J Haematol* 2002;117:812-820.
214. Abromowitch M, Sposto, R, Perkins, S, et al: Outcome of Children's Cancer Group (CCG) 5941: a pilot study for the treatment of newly diagnosed pediatric patients with disseminated lymphoblastic lymphoma. *Proc of ASCO* 2000;19:583.
215. Brugieres L, Quartier P, Le Deley MC, et al. Relapses of childhood anaplastic large-cell lymphoma: treatment results in a series of 41 children—a report from the French Society of Pediatric Oncology. *Ann Oncol* 2000;11:53-58.
216. Patte C, Auperin A, Gerrard M, et al. Results of the randomized international FAB/LMB96 trial for intermediate risk B-cell non-Hodgkin's lymphoma in children and adolescents: it is possible to reduce treatment for the early responding patients. *Blood*, 2007;109:2736-2743.
217. Cairo MS, Gerrard M, Sposto R, et al. Results of a randomized international study of high risk central nervous system B-non-Hodgkin's lymphoma and B-acute lymphoblastic leukemia in children and adolescents. *Blood*, 2007;109:2773-2780.
218. Woessmann W, Seidemann K, Mann G, et al. The impact of the methotrexate administration schedule and dose in the treatment of children and adolescents with B-cell neoplasms: a report of the BFM Group Study NHL-BFM95. *Blood* 2005;105:948-958.
219. Meinhardt A, Burkhardt B, Zimmermann M, et al. Phase II window study on rituximab in newly diagnosed pediatric mature B-cell non-Hodgkin's lymphoma and Burkitt leukemia. *J Clin Oncol* 2010;28:3115-3121.

220. Synold TW, Relling MV, Boyett JM, et al. Blast cell methotrexate-polyglutamate accumulation in vivo differs by lineage, ploidy, and methotrexate dose in acute lymphoblastic leukemia. *J Clin Invest* 1994;94:1996-2001.
221. Asselin BL, Devidas M, Wang C, et al. Effectiveness of high-dose methotrexate in T-cell lymphoblastic leukemia and advanced-stage lymphoblastic lymphoma: a randomized study by the Children's Oncology Group (POG 9404). *Blood* 2011;118:874-883.
222. Sandlund JT, Pui CH, Zhou Y, et al. Effective treatment of advanced-stage childhood lymphoblastic lymphoma without prophylactic cranial irradiation: results of St Jude NHL13 study. *Leukemia* 2009;23:1127-1130.
223. Coustan-Smith E, Sandlund JT, Perkins SL, et al. Minimal disseminated disease in childhood T-cell lymphoblastic lymphoma: a report from the Children's Oncology Group. *J Clin Oncol* 2009;27:3533-3539.
224. Seidemann K, Tiemann M, Schrappe M, et al. Short-pulse B-non-Hodgkin lymphoma-type chemotherapy is efficacious treatment for pediatric anaplastic large cell lymphoma: a report of the Berlin-Frankfurt-Munster Group Trial NHL-BFM 90. *Blood* 2001;97:3699-3706.
225. Wilson WH, Dunleavy K, Pittaluga S, et al. Phase II study of dose-adjusted EPOCH and rituximab in untreated diffuse large B-cell lymphoma with analysis of germinal center and post-germinal center biomarkers. *J Clin Oncol* 2008;26:2717-2724.
226. Wilson WH, Gutierrez M, O'Connor P, et al. The role of rituximab and chemotherapy in aggressive B-cell lymphoma: a preliminary report of dose-adjusted EPOCH-R. *Semin Oncol* 2002;29:41-47.
227. Wilson WH, Grossbard ML, Pittaluga S, et al. Dose-adjusted EPOCH chemotherapy for untreated large B-cell lymphomas: a pharmacodynamic approach with high efficacy. *Blood* 2002;99:2685-2693.
228. Le Deley MC, Rosolen A, Williams DM, et al. Vinblastine in children and adolescents with high-risk anaplastic large-cell lymphoma: results of the randomized ALCL99-vinblastine trial. *J Clin Oncol* 2010;28:3987-3993.
229. Brugieres L, Le Deley MC, Rosolen A, et al. Impact of the methotrexate administration dose on the need for intrathecal treatment in children and adolescents with anaplastic large-cell lymphoma: results of a randomized trial of the EICNHL Group. *J Clin Oncol* 2009;27:897-903.
230. Attarbaschi A, Mann G, Rosolen A, et al. Limited stage I disease is not necessarily indicative of an excellent prognosis in childhood anaplastic large cell lymphoma. *Blood* 2011;117:5616-5619.
231. Lamant L, McCarthy K, d'Amore E, et al. Prognostic impact of morphologic and phenotypic features of childhood ALK-positive anaplastic large-cell lymphoma: results of the ALCL99 study. *J Clin Oncol* 2011;29:4669-4676.
232. Kibrinsky NL, Sposto R, Shah NR, et al. Outcomes of treatment of children and adolescents with recurrent non-Hodgkin's lymphoma and Hodgkin's disease with dexamethasone, etoposide, cisplatin, cytarabine, and l-asparaginase, maintenance chemotherapy, and transplantation: Children's Cancer Group Study CCG-5912. *J Clin Oncol* 2001;19:2390-2396.
233. Philip T, Pinkerton R, Hartmann O, et al. The role of massive therapy with autologous bone marrow transplantation in Burkitt's lymphoma. *Clin Haematol* 1986;15:205-217.
234. Philip T, Biron P, Philip I, et al. Massive therapy and autologous bone marrow transplantation in pediatric and young adults Burkitt's lymphoma (30 courses on 28 patients: a 5-year experience). *Eur J Cancer Clin Oncol* 1986;22:1015-1027.
235. Philip T, Armitage JO, Spitzer G, et al. High-dose therapy and autologous bone marrow transplantation after failure of conventional chemotherapy in adults with intermediate-grade or high-grade non-Hodgkin's lymphoma. *N Engl J Med* 1987;316:1493-1498.
236. Philip T, Hartmann O, Biron P, et al. High-dose therapy and autologous bone marrow transplantation in partial remission after first-line induction therapy for diffuse non-Hodgkin's lymphoma. *J Clin Oncol* 1988;6:1118-1124.
237. Gordon BG, Warkentin PI, Weisenburger DD, et al. Bone marrow transplantation for peripheral T-cell lymphoma in children and adolescents. *Blood* 1992;80:2938-2942.
238. Bureo E, Ortega JJ, Munoz A, et al. Bone marrow transplantation in 46 pediatric patients with non-Hodgkin's lymphoma. Spanish Working Party for Bone Marrow Transplantation in Children. *Bone Marrow Transplant* 1995;15:353-359.

239. Loiseau HA, Hartmann O, Valteau D, et al. High-dose chemotherapy containing busulfan followed by bone marrow transplantation in 24 children with refractory or relapsed non-Hodgkin's lymphoma. *Bone Marrow Transplant* 1991;8:465-472.
240. O'Leary M, Ramsay NK, Nesbit ME Jr, et al. Bone marrow transplantation for non-Hodgkin's lymphoma in children and young adults. A pilot study. *Am J Med* 1983;74:497-501.
241. Ladenstein R, Pearce R, Hartmann O, et al. High-dose chemotherapy with autologous bone marrow rescue in children with poor-risk Burkitt's lymphoma: a report from the European Lymphoma Bone Marrow Transplantation Registry. *Blood* 1997;90:2921-2930.
242. Appelbaum FR, Deisseroth AB, Graw RG Jr, et al. Prolonged complete remission following high dose chemotherapy of Burkitt's lymphoma in relapse. *Cancer* 1978;41:1059-1063.
243. Sandlund JT, Bowman L, Heslop HE, et al. Intensive chemotherapy with hematopoietic stem-cell support for children with recurrent or refractory NHL. *Cytotherapy* 2002;4:253-258.
244. Brugieres L, Pacquement H, Le Deley MC, et al. Single-drug vinblastine as salvage treatment for refractory or relapsed anaplastic large-cell lymphoma: a report from the French Society of Pediatric Oncology. *J Clin Oncol* 2009;27:5056-5061.
245. Kung FH, Harris MB, Krischer JP. Ifosfamide/carboplatin/etoposide (ICE), an effective salvaging therapy for recurrent malignant non-Hodgkin lymphoma of childhood: a Pediatric Oncology Group phase II study. *Med Pediatr Oncol* 1999;32:225-226.
246. Sandlund JT, Pui CH, Mahmoud H, et al. Efficacy of high-dose methotrexate, ifosfamide, etoposide and dexamethasone salvage therapy for recurrent or refractory childhood malignant lymphoma. *Ann Oncol* 2011;22:468-471.
247. Woessmann W, Zimmermann M, Lenhard M, et al. Relapsed or refractory anaplastic large-cell lymphoma in children and adolescents after Berlin-Frankfurt-Muenster (BFM)-type first-line therapy: a BFM-group study. *J Clin Oncol* 2011;29:3065-3071.
248. Woessmann W, Peters C, Lenhard M, et al. Allogeneic haematopoietic stem cell transplantation in relapsed or refractory anaplastic large cell lymphoma of children and adolescents—a Berlin-Frankfurt-Munster Group report. *Br J Haematol* 2006;133:176-182.
249. Griffin TC, Weitzman S, Weinstein H, et al. A study of rituximab and ifosfamide, carboplatin, and etoposide chemotherapy in children with recurrent/refractory B-cell (CD20+) non-Hodgkin lymphoma and mature B-cell acute lymphoblastic leukemia: a report from the Children's Oncology Group. *Pediatr Blood Cancer* 2009;52:177-181.
250. Gross TG, Hale GA, He W, et al. Hematopoietic stem cell transplantation for refractory or recurrent non-Hodgkin lymphoma in children and adolescents. *Biol Blood Marrow Transplant* 2010;16:223-230.
- P.1887
251. Murphy SB, Hustu HO. A randomized trial of combined modality therapy of childhood non-Hodgkin's lymphoma. *Cancer* 1980;45:630-637.
252. Burkhardt B, Woessmann W, Zimmermann M, et al. Impact of cranial radiotherapy on central nervous system prophylaxis in children and adolescents with central nervous system-negative stage III or IV lymphoblastic lymphoma. *J Clin Oncol* 2006;24:491-499.
253. Meistrich ML, Wilson G, Brown BW, et al. Impact of cyclophosphamide on long-term reduction in sperm count in men treated with combination chemotherapy for Ewing and soft tissue sarcomas. *Cancer* 1992;70:2703-2712.
254. Lipshultz SE, Colan SD, Gelber RD, et al. Late cardiac effects of doxorubicin therapy for acute lymphoblastic leukemia in childhood. *N Engl J Med* 1991;324:808-815.
255. Sorensen K, Levitt G, Bull C, et al. Anthracycline dose in childhood acute lymphoblastic leukemia: issues of early survival versus late cardiotoxicity. *J Clin Oncol* 1997;15:61-68.
256. Nysom K, Holm K, Lipsitz SR, et al. Relationship between cumulative anthracycline dose and late cardiotoxicity in childhood acute lymphoblastic leukemia. *J Clin Oncol* 1998;16:545-550.

257. Colombat P, Salles G, Brousse N, et al. Rituximab (anti-CD20 monoclonal antibody) as single first-line therapy for patients with follicular lymphoma with a low tumor burden: clinical and molecular evaluation. *Blood* 2001;97: 101-106.
258. Coiffier B, Haioun C, Ketterer N, et al. Rituximab (anti-CD20 monoclonal antibody) for the treatment of patients with relapsing or refractory aggressive lymphoma: a multicenter phase II study. *Blood* 1998;92:1927-1932.
259. Coiffier B, Lepage E, Briere J, et al. CHOP chemotherapy plus rituximab compared with CHOP alone in elderly patients with diffuse large-B-cell lymphoma. *N Engl J Med* 2002;346:235-242.
260. Wahl AF, Klussman K, Thompson JD, et al. The anti-CD30 monoclonal antibody SGN-30 promotes growth arrest and DNA fragmentation in vitro and affects antitumor activity in models of Hodgkin's disease. *Cancer Res* 2002;62:3736-3742.
261. Younes A, Bartlett NL, Leonard JP, et al. Brentuximab vedotin (SGN-35) for relapsed CD30-positive lymphomas. *N Engl J Med* 2010;363:1812-1821.
262. Pro B, Advani R, Brice P, et al. Brentuximab vedotin (SGN-35) in patients with relapsed or refractory systemic anaplastic large-cell lymphoma: results of a phase II study. *J Clin Oncol* 2012;30:2190-2196.
263. Rothe A, Sasse S, Goergen H, et al. Brentuximab vedotin for relapsed or refractory CD30+ hematologic malignancies: the German Hodgkin Study Group experience. *Blood* 2012;120:1470-1472.
264. Byrd JC, Shinn C, Willis CR, et al. UCN-01 induces cytotoxicity toward human CLL cells through a p53-independent mechanism. *Exp Hematol* 2001;29:703-708.
265. Sausville EA, Arbuck SG, Messmann R, et al. Phase I trial of 72-hour continuous infusion UCN-01 in patients with refractory neoplasms. *J Clin Oncol* 2001;19:2319-2333.
266. Gambacorti-Passerini C, Messa C, Pogliani EM. Crizotinib in anaplastic large-cell lymphoma. *N Engl J Med* 2011;364:775-776.
267. Dave SS. Gene expression signatures and outcome prediction in mature B-cell malignancies. *Curr Treat Options Oncol* 2006;7:261-269.
268. Hummel M, Bentink S, Berger H, et al. A biologic definition of Burkitt's lymphoma from transcriptional and genomic profiling. *N Engl J Med* 2006;354:2419-2430.
269. Quackenbush J. Microarray analysis and tumor classification. *N Engl J Med* 2006;354:2463-2472.
270. Lamant L, de Reynies A, Duplantier MM, et al. Gene-expression profiling of systemic anaplastic large-cell lymphoma reveals differences based on ALK status and two distinct morphologic ALK+ subtypes. *Blood* 2007;109: 2156-2164.
271. Weinstein HJ, Cassady JR, Levey R. Long-term results of the APO protocol (vincristine, doxorubicin [adriamycin], and prednisone) for treatment of mediastinal lymphoblastic lymphoma. *J Clin Oncol* 1983;1:537-541.

Chapter 90 Chronic Lymphocytic Leukemia

> Table of Contents > Part VII - Hematologic Malignancies > Section 4 - Lymphoproliferative Disorders > Chapter 90 - Chronic Lymphocytic Leukemia

Chapter 90

Chronic Lymphocytic Leukemia

James B. Johnston

Matthew Seftel

Spencer B. Gibson

Chronic lymphocytic leukemia (CLL) is characterized by the accumulation of mature-appearing lymphocytes in the blood, marrow, lymph nodes, and spleen.^{1, 2, 3, 4} Small lymphocytic lymphoma (SLL) is the same disease, but primarily there is involvement of lymph nodes and spleen. Both CLL and SLL are antedated by monoclonal B-cell lymphocytosis (MBL) in which small numbers of CLL cells can be detected in the blood of asymptomatic individuals.^{1, 2, 3, 4} The CLL cells are monoclonal B lymphocytes that express CD19, CD5, and CD23 with weak or no expression of surface immunoglobulin (Ig), CD20, CD79b, and FMC7.^{1, 2, 3, 4} Recent evidence suggests that CLL cells have a similar gene expression profile as memory B-cells, and there is considerable heterogeneity in CLL in terms of cellular morphology, phenotype, biology, molecular genetics, and prognosis.^{1, 2, 3, 4, 5, 6, 7} The incidence of CLL varies throughout the world, being highest in North America

and rare in the Far East. In North America, CLL/SLL accounts for one-quarter of all leukemias, with the incidence reported by the Surveillance, Epidemiology and End Results (SEER) Program being 5.13/100,000 for the years 1993 to 2004.⁸ A total of 75% of cases were CLL and 25% SLL. However, the incidence is likely much higher, as many patients are diagnosed by flow cytometry and are not included in tumor registries.⁹ By combining data from flow cytometry and the cancer registry the incidence of CLL/SLL is 7.99/100,000, with the median age at diagnosis being 71.5 years.⁹ The median age at diagnosis is younger for males (70 years) than for females (73 years), with the male:female ratio being 1.3:1⁹ (Fig. 90.1). One third of patients are less than 65 years and 10% less than 50 years. Using SEER data, it has been shown that relative survival is poorest for those >80 years, and worse for men.¹⁰ Interestingly, the 10-year relative survival has increased over the last 20 years for all age groups except for those 80 years of age or older at the time of diagnosis (Fig. 90.2).¹⁰ Moreover, relative survival has improved for men, diminishing the difference previously seen between the sexes.

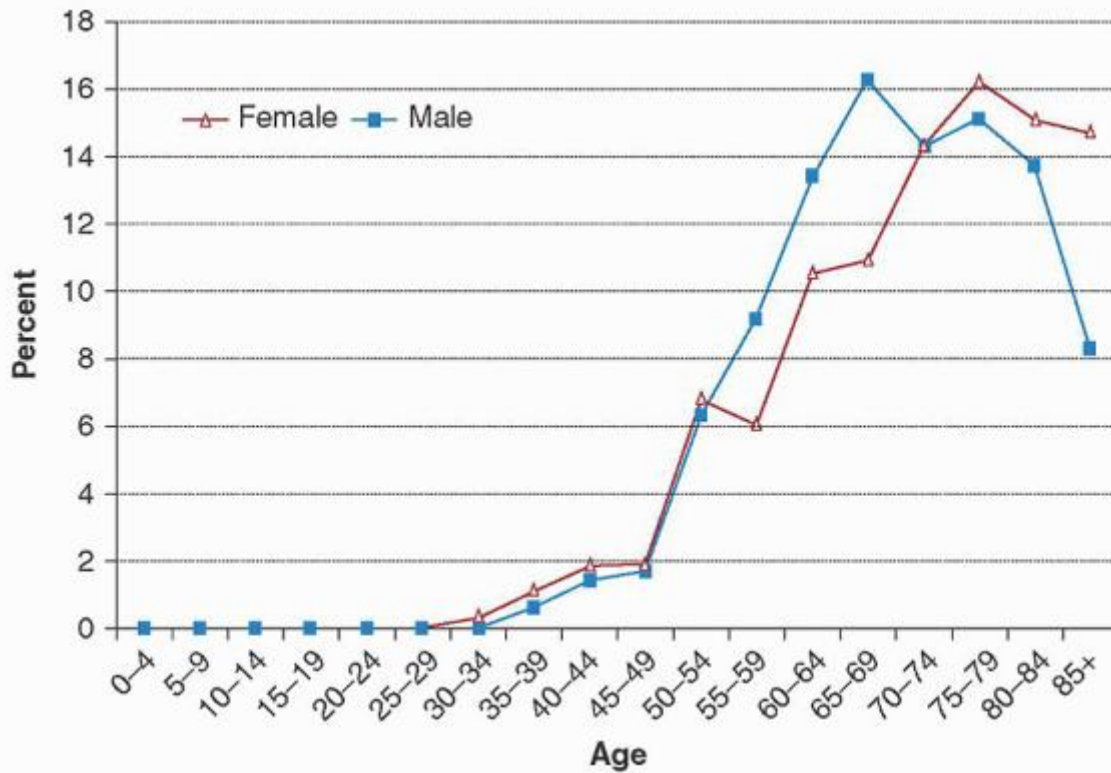

FIGURE 90.1. Age distribution of 351 males and 265 females diagnosed through the provincial cancer registry and a centralized flow cytometry facility in Manitoba over a 5-year period (1998 to 2003). The median age at diagnosis was 70 years for men and 73 years for women ($P = 0.0281$). Overall median age was 71.5 years. From Seftel MD, Demers AA, Banerji V, et al. High incidence of chronic lymphocytic leukemia (CLL) diagnosed by immunophenotyping: a population-based Canadian cohort. *Leuk Res* 2009;33:1463-1468, with permission.

Although the median age at diagnosis for CLL patients in the population is 71.5 years, it is 64 years in CLL clinics and as low as 58 years in specialized clinics.^{11, 12, 13} Thus, it is likely that many older patients are not being referred for assessment and therapy.

PATHOPHYSIOLOGY

Predisposing Factors Including Familial Chronic Lymphocytic Leukemia

Unlike other leukemias, there is no firm evidence linking an occupational exposure with an increased incidence of CLL.¹⁴ However, CLL patients have a higher incidence than normal individuals of having had an infection just prior to the diagnosis, suggesting a role for infection in the etiology of this disease.¹⁵ Moreover, a number of studies have demonstrated that about 20% of CLL patients have very similar (stereotypic) heavy-chain complementarity-determining region 3 (HCDR3) sequences in their B-cell receptors (BCR), and this affects mainly patients with an unmutated IgV_H gene (see section "Cell of Origin").^{2, 16, 17, 18, 19, 20} Moreover, approximately 1% of BCRs from both mutated and unmutated cases are identical.²⁰ Compared to normal B-cells in the elderly, there is skewing of IgV_H gene usage in CLL and the biologic features of the disease are reflected in the gene used and whether the HCDR3 is stereotypic.^{2, 16, 18, 19} These findings

suggest that a common antigen or an antigenlike element may be responsible for triggering this malignancy, perhaps an infective organism or an autoantigen.^{2, 16, 18, 19} Although patients with CLL have an increased risk of a prior diagnosis of pernicious anemia, they do not have an increased risk of other autoimmune diseases.^{4, 21} A recent study has shown that the BCRs from CLL cells, and not the BCRs from normal B-cells or other B-cell malignancies, can induce cell-autonomous signaling, which is dependent on the interaction

P.1889

of HCDR3 with internal epitopes on nearby BCRs.²⁰ As only specific HCDR3 structures may interact with the epitope and induce signaling, this may explain the high incidence of stereotypic HCDR3s. However, no obvious differences in signaling are seen between the BCRs of mutated or unmutated cases or whether the HCDR3 was stereotypic.

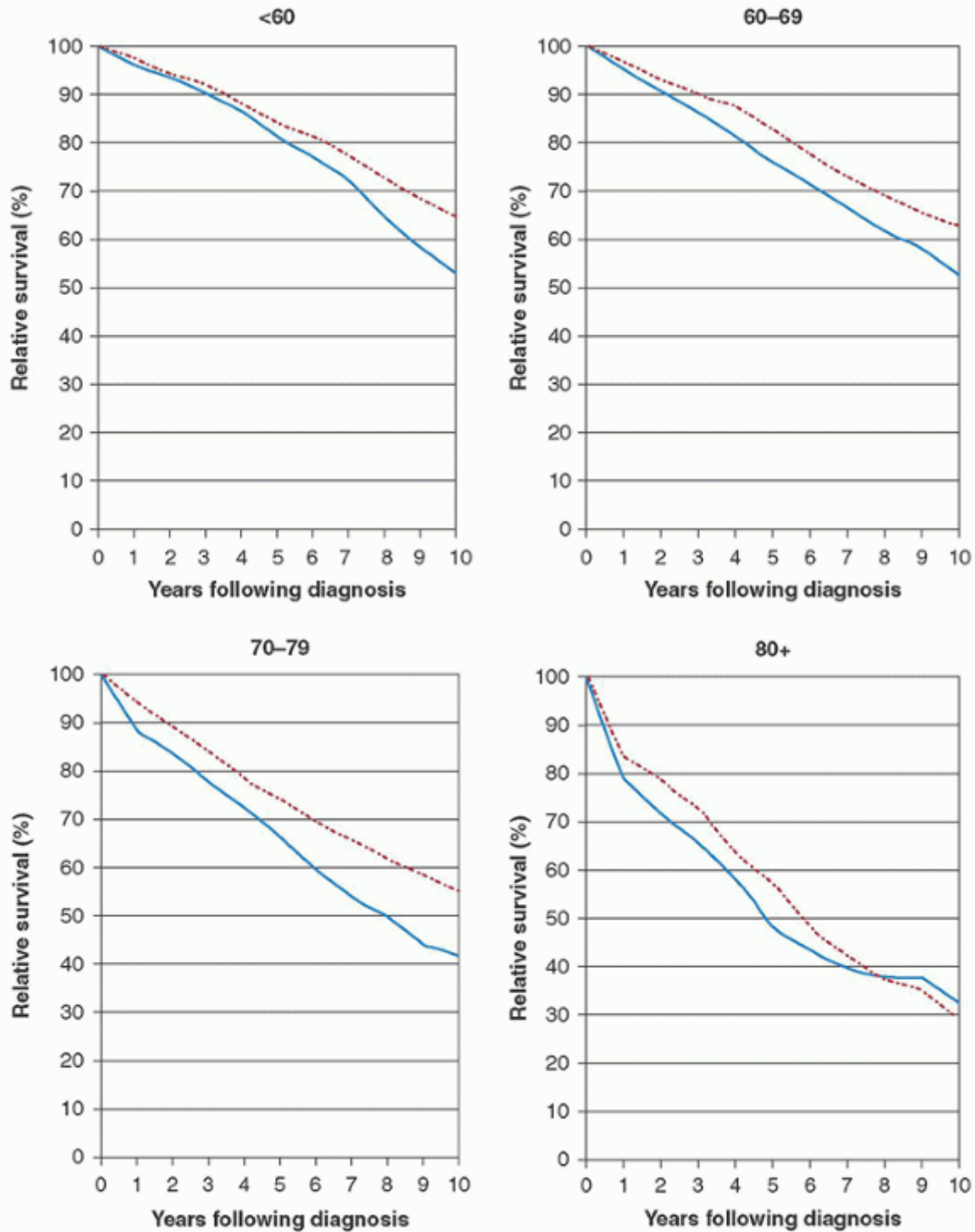

FIGURE 90.2. Ten-year relative survival curves of patients with chronic lymphocytic leukemia (CLL) by major age group. Period estimates for 1980 to 1984 (solid lines) and 2000 to 2004 (hatched lines). From, Brenner H, Gondos A, Pulte D. Trends in long-term survival of patients with chronic lymphocytic leukemia from the 1980s to the early 21st century. *Blood* 2008;111:4916-4921, with permission.

A family history of CLL or another lymphoproliferative disorder is a strong risk factor for CLL, and it is estimated that 1 in 10 patients with CLL has a family history of CLL or another lymphoproliferative disorder.^{14, 22} There is a thirtyfold increase in the risk of CLL in first-degree relatives of patients with CLL,^{22, 23, 24} and 13% to 18% of first-degree relatives have a peripheral blood CD5⁺ MBL.^{25, 26} However, whether individuals with these abnormal cells will eventually develop CLL is

presently unknown.²⁵ Patients with familial CLL are approximately 10 years younger than those with sporadic CLL,^{14, 23} and anticipation may occur in familial CLL, with affected children being 15 to 20 years younger than their parents at diagnosis.^{27, 28, 29, 30} However, other authors have not observed anticipation.¹⁴ There is no consistency in the clinical features of affected members with familial CLL and no difference in the clinical features of patients with familial CLL or sporadic CLL.^{14, 31} As discussed in the section on "Cell of Origin", there are two forms of sporadic CLL; those with somatic hypermutations of the IgV_H gene and those without. At the present time, it is unclear as to whether familial CLL differs from sporadic CLL with regard to the incidence of IgV_H gene mutations.^{32, 33}

The pattern of inheritance in familial CLL is unknown, but there is no linkage to HLA type.³⁴ Several recent studies have attempted to identify a susceptibility gene for familial CLL.^{35, 36} A 3.68 Mb minimal region has been identified at 13q21.33-q22.2, which has been found to be shared in four CLL families, including family members with CD5⁺ MBL.³⁷ These findings suggest that candidate genes at this and other sites may be involved in the pathogenesis of inherited CLL.¹⁴ It has been suggested that polymorphisms in the ataxia telangiectasia mutated (ATM) gene may pre-dispose individuals to develop

P.1890

CLL, but a recent study has discounted this hypothesis.³⁷ Patients with familial CLL have also been shown to have elevated plasma levels of B-lymphocyte stimulator (BLyS) and an increased frequency of a C→T polymorphism at -871 in the BLyS promoter.³⁸ Finally, in one CLL family, a single nucleotide polymorphism (SNP) in the promoter site of the death-associated protein kinase 1 (DAPK1) gene was observed in affected family members.³⁹ This polymorphism silenced this gene by binding the transcriptional regulator HOXB7.114. These results suggest that multiple abnormalities may be involved in the development of familial CLL.

Cell of Origin

There has been controversy as to the normal counterpart of the CLL cell.^{2, 19} As the CLL cell is CD5⁺, it was previously believed that the normal counterpart was the CD5⁺ B lymphocyte, which is present in the mantle zone of lymph nodes and in small numbers in the peripheral blood.⁴⁰ However, the CD5⁺ B lymphocyte lacks mutations of the IgV_H gene,⁴¹ whereas the CLL cell has undergone mutations in approximately 50% of cases.^{2, 19} Additional studies suggest that CLL cells with unmutated, as well as mutated, IgV_H have been antigen exposed.^{2, 19, 42} Firstly, surface immunophenotyping shows activation markers to be present in both mutated and unmutated cases.⁴² Secondly, there is a skewing toward specific IgV_H gene usage in CLL cells (IgV_{H1-69}, IgV_{H3-23}, IgV_{H3-7}, and IgV_{H4-34}) with some genes, for example, IgV_{H1-69} being more common in unmutated CLL and others, for example, IgV_{H4-34}, IgV_{H3-23}, and IgV_{H3-7} being more common in mutated cases.¹⁶ Thirdly, as discussed previously, 10% to 20% of patients have changes in their BCR, suggestive of antigen exposure.^{17, 18} Finally, gene expression studies indicate that both mutated and unmutated IgV_H CLL cells are memory B-cells.^{6, 7} The results of these studies indicate that the CLL cell is antigen-experienced, suggesting that the expressions of CD5 and CD23 on these cells are secondary changes, perhaps representing cell activation or nonspecific changes secondary to the malignancy. Thus, the cell of origin of the CLL cell may be the memory B-cell, regardless of whether there are mutations of the IgV_H gene. This would explain why all CLL cells are CD27⁺, which is typically a marker of the memory B-cell.⁴³ Although most normal CD27⁺ B-cells have IgV_H gene mutations, a small fraction does not.⁴⁴ Altered DNA methylation is observed in CLL and the methylation pattern in the unmutated IgV_H form of CLL is similar to a CD5⁺ naive B-cell form, whereas the mutated form is most similar to a memory B-cell.⁴⁵ Significant hypomethylation occurs in the production of the CLL cells, with many similar changes for the both the mutated and unmutated forms which may explain the similar gene expression profiles for both types of CLL. Based on the methylation patterns, a third form of CLL has been proposed, which is antigen-experienced but has lower levels of mutations than the IgV_H mutated form. The influence of DNA methylation on gene expression in CLL and how this can be altered is an area of great interest.^{45, 46}

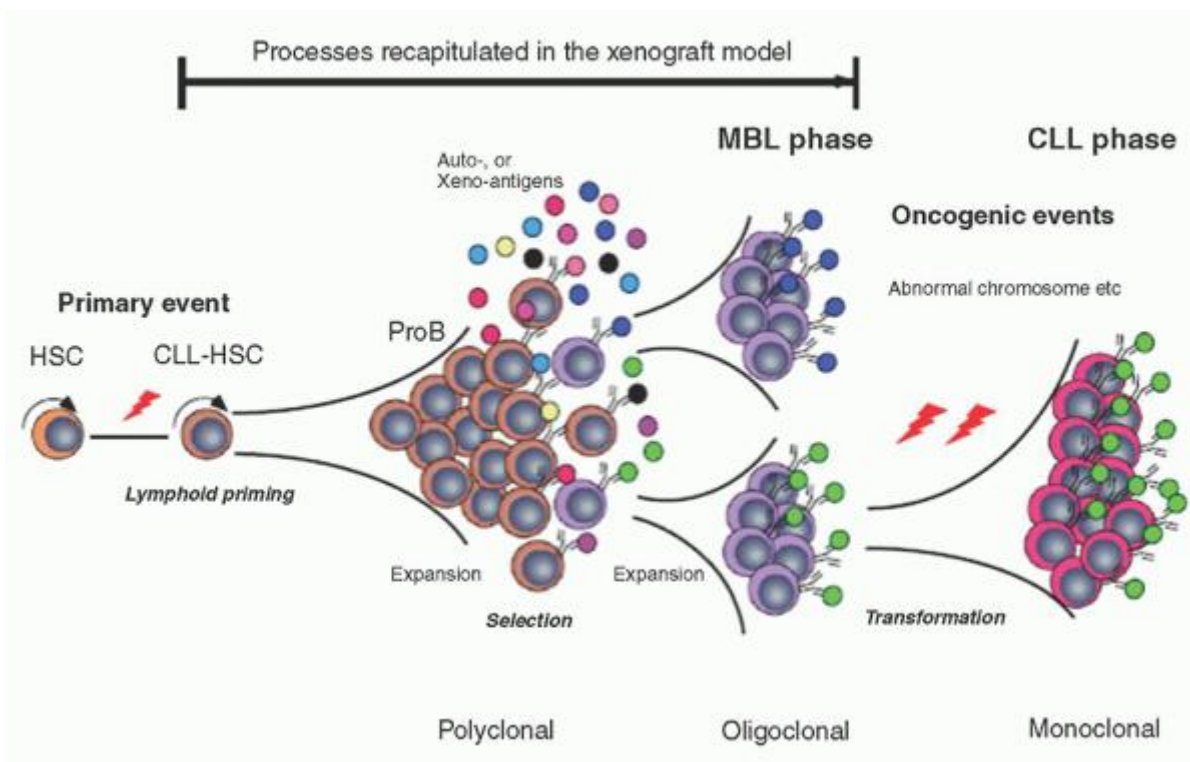

FIGURE 90.3. Schematic presentation of human chronic lymphocytic leukemia (CLL) development based on the xenogeneic transplantation model. CLL human stem cells have accumulated genetic abnormalities that might play a role in amplified B-cell differentiation, and produce a high number of polyclonal B-cells carrying the same genetic aberrations. B-cell clones are selected, and expanded in response to B-cell receptors (BCR) signaling driven presumably by xenoantigens, simulating progression of monoclonal B cell lymphocytosis (MBL). Additional abnormalities such as aberrant karyotypes might play a role in progression from MBL into human CLL. This final step was not recapitulated in the xenograft model. From Kikushige Y, Ishikawa, Miyamoto T, et al. Self-renewing hematopoietic stem cell is the primary target in pathogenesis of human chronic lymphocytic leukemia. *Cancer Cell* 2011;20:246-259, with permission.

A recent study has demonstrated that the hematopoietic stem cell is abnormal in CLL having increased expression of early lymphoid transcription factors, such as IKAROS.⁴⁷ When CLL hematopoietic stem cells are transplanted into immunosuppressed mice there is an increased production of polyclonal B-cells including increased numbers of monoclonal or oligoclonal B-cells that are either CD5⁺ or CD5⁻, generally have mutated IgV_H and, as in CLL cells, preferentially used VH1, 3, and 4 similar to that seen with MBL (Fig. 90.3). However, the clonal cells have VDJ recombinations that are different from the original patient's cells. These clones do not have the typical genetic changes seen by fluorescence in situ hybridization (FISH) studies in CLL cells. These results indicate that the stem cells from CLL patients have the capacity to generate monoclonal B-cells and the authors speculate that a "second hit" is required for these clones to become CLL cells.

Abnormalities in Apoptosis

Although a defect in apoptosis typifies CLL, with the majority of cells being long-lived, noncycling, and in G₀, there is a small fraction of replicating cells in the lymph nodes and marrow that is responsible for disease progression.² Chemotherapeutic agents induce apoptosis, and defects in apoptosis may also be responsible for drug resistance.^{48, 49, 50} Considerable knowledge has been obtained regarding the apoptotic pathways, and the major steps are shown in Figure 90.4. Apoptosis occurs through the activation of caspases, which are cysteine proteases that cleave other caspases at aspartate acid residues, converting the inactive proforms to active enzymes. The downstream caspases, caspases 3, 6, and 7, cleave specific proteins leading to the typical morphologic changes of apoptosis. Apoptosis can be initiated through 2 main pathways, which interact and subsequently activate the same downstream caspases.

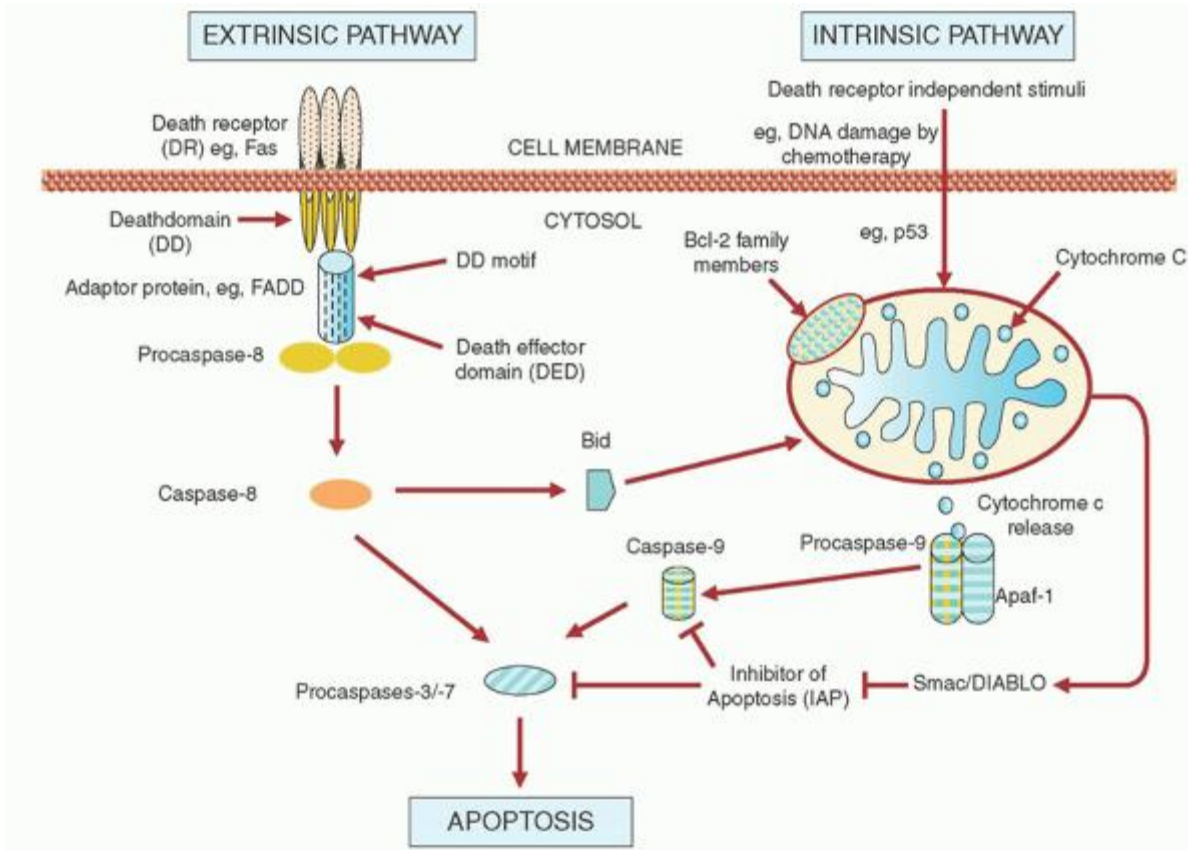

FIGURE 90.4. Apoptotic pathways in chronic lymphocytic leukemia.

Two Major Apoptotic Pathways

The intrinsic apoptotic pathway is typically initiated by DNA damage, which causes the up-regulation of TP53, an increase in the BAX:BCL2 ratio, and the release of cytochrome c from between the inner and outer mitochondrial membranes into the cytosol. Cytochrome c binds to and activates apoptosis-activating factor-1 (APAF1) in the cytosol in a process that requires deoxyadenosine triphosphate (dATP). The N-terminal of APAF1 binds to and causes the autoactivation of procaspase 9 and, subsequently, caspase 3.⁵¹ The cytochrome c/mitochondrial system is important for the activity of chemotherapy, and a deficiency in APAF1 can cause drug resistance,⁵² although whether the variable levels of APAF1 in CLL influence sensitivity to chemotherapy is unknown.⁵¹ As discussed later, the triphosphate derivatives of fludarabine and cladribine can substitute for dATP, and part of their cytotoxic activities is related to the binding of APAF1 and direct activation of caspases 9 and 3.^{53, 54, 55} SMAC/DIABLO is also released from the mitochondria along with cytochrome c and induces apoptosis by binding to the inhibitor of apoptosis (IAP) family of proteins, which normally inactivate a number of caspases, including caspase 3.⁵⁶

The extrinsic apoptotic pathway also plays a major role in apoptosis. There are presently 6 known death receptors (DRs), and these include the Tumor necrosis factor (TNF) receptor, FAS (APO-1 or CD95) and DR4/DR5 (receptors for TNF-related apoptosis-inducing ligand [TRAIL]). These receptors contain a cytosolic domain called the death domain, which recruits adaptor proteins such as FADD/MORT1 to the receptor complex after binding to ligand. The recruiter adaptor protein has a death domain end and a death effector domain (DED). Once bound to the TNF receptor, the DED binds to caspases 8 and 10, which then become activated by autoactivation.⁵¹ Apoptosis through this pathway is controlled by the presence of the receptor and a variety of inhibitors that can bind to the DED in place of the caspases. One of these inhibitors is FLICE inhibitory protein (FLIP), which is a homologue of procaspase 8 and contains 2 DED domains but lacks proteolytic activity.⁵⁷ It been reported that CLL cells have high levels of FLIP expression rendering the cells resistant to DR-induced apoptosis.⁵⁸

There is cross-talk between the intrinsic and extrinsic pathways. Thus, caspase 8 can activate Bid, which causes the release of cytochrome c from the mitochondria.^{50, 59} Alternatively, triggering of the intrinsic pathway in CLL cells by chemotherapy or irradiation can activate caspase 8,⁶⁰ possibly by activation of caspase 3.⁶¹

Apoptosis through the TNF receptors plays an important role in controlling lymphoid cell populations, and defects either in FAS ligand or the receptor result in the autoimmune lymphoproliferative syndrome (ALPS) with lymphadenopathy, splenomegaly, and an increase in the risk of subsequent autoimmune diseases and lymphomas. FAS is normally up-regulated in activated lymphocytes, and CLL cells are not sensitive to FAS ligand, even if FAS (CD95) is increased through the use of *Staphylococcus aureus* protein A from Cowan I plus interleukin (IL)-2, CD40 ligation, or through α - or γ -interferon.^{60, 61, 62, 63} DR4 and DR5 receptors are present on CLL cells, but the extent of sensitivity of these cells to TRAIL is controversial.^{57, 64} CLL cells secrete both TRAIL⁶⁵ and FAS ligand,^{60, 65} which may suppress normal T-cells and contribute to the immunosuppression seen with this disease.

Apart from the direct induction of apoptosis through the interaction with TNF ligands, the TNF receptors may play a role in the activity of chemotherapeutic agents. Chemotherapeutic

P.1892

agents may up-regulate receptors for FAS^{66, 67} or DR4/DR5,^{68, 69} which could prime the cells to physiologic levels of FAS ligand or TRAIL. However, although fludarabine and chlorambucil increase FAS messenger RNA levels in CLL cells in vitro, they do not affect the levels of FAS protein.⁶⁰ In contrast, irradiation does increase FAS protein levels, but none of these agents sensitizes CLL cells to FAS ligand.⁶⁰ Fludarabine and chlorambucil increase the messenger RNA and cell-surface protein expression levels of DR4/DR5 in CLL cells, and this sensitizes the cells to TRAIL.⁶⁴

Modulators of the Apoptotic Pathway in Chronic Lymphocytic Leukemia

The above pathways are modulated by a variety of proteins, which may be altered in CLL. The BCL2 family consists of approximately 20 members that can either promote or inhibit apoptosis. These proteins are located in the cell membrane, nuclear membrane, and mitochondrial membrane, and function by binding to other proteins or influencing cell permeability and the release of cytochrome c from the mitochondria. Some BCL2 family members (e.g., BAX, BCLXS, BAK, and BAD) promote apoptosis, whereas others (e.g., BCL2, BCL-xL, and MCL-1) inhibit apoptosis.^{70, 71, 72, 73, 74, 75, 76} In addition, another group (e.g., BAG1) can influence the activities of the other family members. CLL cells have high BCL2, BAX, and BAK levels but have low levels of BCLXL and BAD.^{70, 71, 72, 73, 74, 75, 76} The BCL2 overexpression is related to hypomethylation of DNA, rather than to a translocation, and may contribute to the longevity of the CLL cell.⁷⁰ CLL cells with high BCL2 levels have more prolonged in vitro survival than those with low levels, and decreasing BCL2 expression by antisense oligonucleotides can induce apoptosis.⁷⁰ Whether the BAX and BCL2 levels or the BAX:BCL2 ratios are predictive of drug sensitivity in CLL is controversial.^{71, 72, 73, 74, 75, 76} MCL1 protein levels are variable in CLL, and it has been suggested that patients with high levels are more resistant to chemotherapy.⁷⁴ An insertion of either 6 or 18 nucleotides in the promoter of MCL1 is found in CLL cells with a lower incidence in normal B cells.⁷⁷ An analysis of matched pairs of normal versus leukemia cell samples indicates that the MCL1 promoter insertions represent somatic alterations and not hereditary polymorphisms. This insertion is associated with higher levels of MCL1 protein and nonresponsiveness to chemotherapy.⁷⁷ However, other groups have not confirmed these findings and the importance of an insertion in the MCL1 promoter remains to be determined.⁷⁸ In addition, a guanine-to-adenosine substitution at position 125 (G125A) in the BAX promoter has been associated with decreased BAX expression, advanced disease, and drug resistance in CLL.⁷⁹

A number of other proteins play a role in apoptosis, and their expressions can be affected by the genetic changes in CLL, as discussed in the section on "Genomic Abnormalities." The tumor-suppressor gene, TP53, is a transcriptional activator and is located on chromosome 17p13.^{80, 81} TP53 protein is phosphorylated and stabilized after DNA damage, such as that produced by radiation or alkylating agents, through activation of ATM kinase and DNA-dependent kinase.⁸⁰ Cell cycle blockage at G¹ or G² may occur, allowing the cell to repair the damage before entering the S- or M-phase.⁸⁰ However, TP53 may also induce apoptosis, and this occurs preferentially in tumor cells, a feature that may explain the relative tumor specificity of anticancer agents.⁸¹ Mechanisms for TP53-induced apoptosis are through up-regulation in the expressions of the TRAIL DRs, DR4, and DR5, and increased expression of the proapoptotic BCL2 family members, BAX, NOXA, and PUMA.⁸² TP53 mutations are typically associated with deletions of the second allele (deletion 17p13), and mutations or TP53 gene deletions are observed in 10% to 15% of CLL patients (see section "Genomic Abnormalities"); these abnormalities are associated with high lymphocyte counts, drug resistance to anticancer agents in vitro and in vivo, and poor patient survival.^{2, 72, 73, 83, 84} In a longitudinal study of 181 patients, the percentage of leukemic cells with a TP53 mutation increased during the course of the disease, indicating that the mutation provides a survival advantage for the tumor cells.⁸³ The murine double minute-2 (MDM2) gene is located on chromosome 12 and is transactivated by TP53.⁸⁰ The MDM2 protein enhances the binding of TP53 to ubiquitin, and TP53 is subsequently degraded.⁸⁰ Thus, overexpression of MDM2 in cell lines reduces the capacity of TP53 to block the cell cycle in G¹ after irradiation and speculatively could also decrease TP53-induced apoptosis and produce drug resistance.⁷² However, although the MDM2 protein has been found to

be overexpressed in two-thirds of CLL cases, this does not correlate with disease stage, aggressiveness, or drug resistance.^{72, 85}

The ATM gene is located on chromosome 11q22-q23 and is responsible for phosphorylation and activation of p53 after DNA damage.^{80, 86} Approximately 10% to 20% of CLL patients have a mutation of ATM, and about half of these will have a defective response to irradiation, similar to that with a TP53 mutation, if all alleles are mutated or if one is mutated and the other lost because of a deletion of 11q22-23.^{86, 87} Approximately one third of patients with a mutated ATM have a deletion 11q22-23 and one third of those with a deletion 11q22-23 have a mutation on the other allele.^{86, 87}

Microenvironment

Overview

The microenvironment in the peripheral blood, spleen, lymph nodes, and marrow plays an important role in the biology of CLL. In the bone marrow and lymph nodes, follicular dendritic, stromal, and/or fibroblast cells interact with CLL cells whereas in the peripheral blood the interaction is with “nurselike” cells and T-cells.⁸⁸ Co-culture of CLL cells with “nurselike” or stromal cells decreases spontaneous apoptosis in the leukemia cells, promotes CLL cell proliferation, and confers drug resistance.^{89, 90, 91} This effect seems to require cell-cell contact and CLL cells interact with the microenvironment through activation of their cell surface receptors. The BCR plays a central role in CLL biology in the microenvironment through maintenance and expansion of the CLL cell clone. BCR signaling is controlled by intracellular tyrosine kinases such as spleen tyrosine kinase (Syk), and Bruton's tyrosine kinase (BTK; Fig. 90.5).^{92, 93, 94, 95, 96, 97} In addition, aberrantly expressed CD40L on CLL cells can interact with CD40 on microvascular endothelial cells which leads to the release of the TNF family members, BAFF (B-cell activating factor of the TNF family), and APRIL (a proliferation-inducing agent).⁹⁸ Receptors for BAFF and APRIL (BMCA, TAC1, and BAFF-R) are present on CLL cells and stimulation leads to increased survival and induction of the expression of CD40L on the CLL cells thus further potentiating the cycle. This exemplifies the cross-talk between CLL and stromal cells in the microenvironment. Adhesion molecules are also important for CLL cell survival. β 1 and β 2 integrins on CLL cells bind to CD54 and CD106 on stromal cells and this promotes cell survival.^{99, 100} Moreover, neutralizing antibodies against various integrins induces the CLL cells to undergo apoptosis.¹⁰¹ Caveolin-1 expression by CLL cells in lymph nodes may stimulate CLL proliferation and migration but also mediates immune synapses with autologous T lymphocytes which contributes to immune tolerance.¹⁰² Finally, CD44 on CLL cells is a receptor for hyaluronic acid and collagen, thus helping retain the cells in the microenvironment.¹⁰³

In addition to cell-cell contact, the extracellular milieu contains molecules such as growth factors, proteins, and lipids that contribute to CLL progression.⁸⁹ Stromal and CLL cells produce cytokines that may stimulate leukemia cell growth in an autocrine or paracrine fashion while inhibiting survival of normal lymphoid and marrow cells. This latter effect can lead to the

P.1893

immunosuppression and myelosuppression that typify this disease. In addition, the chemokine receptors CXCR4 and CXCR5 on CLL cells regulate CLL cell trafficking to the stromal cells (which produce the receptor ligands, CXCL12 and CXCL13, respectively) in the microenvironment where the CLL cells produce IL-6 and IL-8, which in turn provide signals for cell survival.^{11, 104} Upon BCR activation, CLL cells secrete cytokines such as CCL3 that attract additional accessory cells such as T-cells to join the CLL and stromal cells.¹⁰⁵ In addition to signaling, stromal cells also supply essential nutrients to the CLL cells. For example, CLL cells have limited capacity to transport cystine for glutathione synthesis due to low expression of Xc-transporter.¹⁰⁶ In contrast, stromal cells can effectively transport cystine and convert it to cysteine which can then be released into the microenvironment where the CLL cells take up the cysteine for GSH synthesis. CLL cells can also influence stromal cells signaling through microvesicles.¹⁰⁷ Microvesicles are released by CLL cells and can modulate the activity of the bone marrow stromal cells (BMSCs). The microvesicle can activate the AKT/mammalian target of rapamycin (mTOR)/p70S6K/hypoxia-inducible factor-1alpha axis in CLL-BMSCs with production of vascular endothelial growth factor (VEGF), a survival factor for CLL cells.^{107, 108} They can also transfer various messages to target cells that may be critical to disease progression. In the clinic, molecular targeting of the microenvironment through CXCR4 antagonists or BCR kinase inhibitors disrupts the interactions between CLL cells and the microenvironment.^{109, 110, 111} These chemotherapeutic agents have shown promising pre-clinical activities.

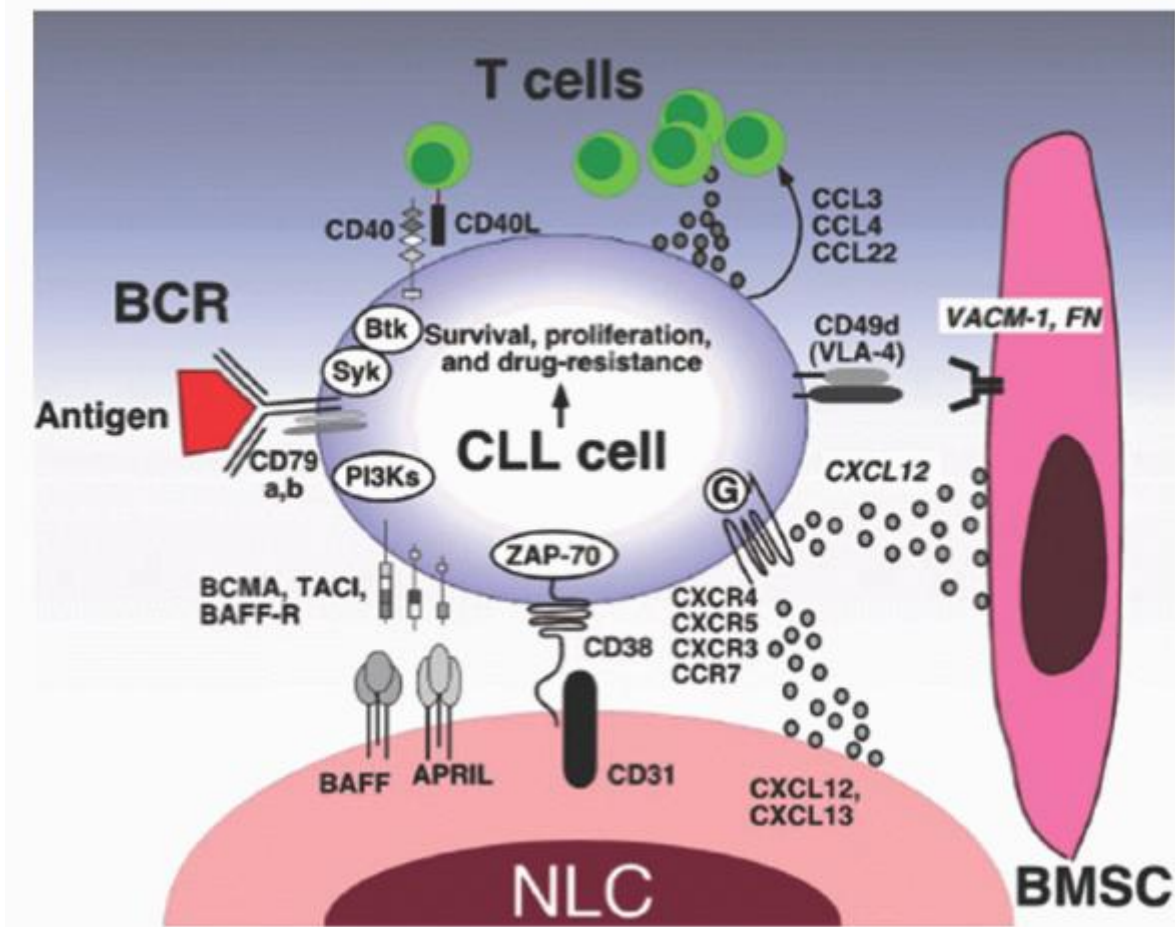

FIGURE 90.5. Molecular interactions in the chronic lymphocytic leukemia (CLL) microenvironment. Molecular interactions between CLL and stromal cells in the BM and/or lymphoid tissue microenvironments that are considered important for CLL-cell survival and proliferation, CLL-cell homing, and tissue retention. Contact between CLL cells and nurselike cells (NLCs) or bone marrow stromal cells (BMSCs) is established and maintained by chemokine receptors and adhesion molecules expressed on CLL cells. NLCs express the chemokines CXCL12 and CXCL13, whereas BMSCs predominantly express CXCL12. The chemokine receptors CXCR3 and CCR7 are additional chemokine receptors on CLL cells that are involved in lymphatic tissue homing. NLCs and BMSCs attract CLL cells via the G-protein-coupled chemokine receptors CXCR4 and CXCR5, which are expressed at high levels on CLL cells. Integrins, particularly VLA-4 integrins (CD49d), expressed on the surface of CLL cells cooperate with chemokine receptors in establishing cell-cell adhesion through respective ligands on the stromal cells (VCAM-1 and fibronectin). NLCs also express the TNF family members BAFF and APRIL, providing survival signals to CLL cells via corresponding receptors (BCMA, TACI, and BAFF-R). CD38 expression allows CLL cells to interact with CD31, the ligand for CD38 that is expressed by stromal and NLCs. Ligation of CD38 activates ZAP-70 and downstream survival pathways. Self- and/or environmental Ags are considered key factors in the activation and expansion of the CLL clone by activation of the BCR and its downstream kinases. Stimulation of the BCR complex (BCR and CD79a,b) induces downstream signaling by recruitment and activation of Syk, Btk, and PI3Ks. Finally, BCR stimulation and co-culture with NLCs also induces CLL cells to secrete chemokines (CCL3, CCL4, and CCL22) for the recruitment of immune cells (T-cells and monocytes) for cognate interactions. CD40L⁺ (CD154⁺) T-cells are preferentially found in CLL-proliferation centers, and can interact with CLL cells via CD40. From Burger JA. Nurture versus nature: the microenvironment in chronic lymphocytic leukemia. *Hematology (Am Soc Hematol Educ Program)* 2011;2011:96-103.

Cellular Features of the Microenvironment

BMSCs and other cells of the lymphatic tissue have intrinsic characteristics to support CLL cell functions.^{111, 112} Normal hematopoiesis depends upon BMSCs as the BMSCs provide attachment sites and growth signals for the hematopoietic precursors. In CLL the BMSCs create niches where CLL cells are nourished and protected from either spontaneous or chemotherapy-induced apoptosis. The CLL cells bind to BMSCs with high affinity which allows tight adhesion and migration of the CLL cells underneath the BMSCs. Both murine and human BMSCs have similar effects on CLL cell growth

and cell survival. BMSC are of mesenchymal origin and are similar to mesenchymal stromal cells in other tissues. Follicular dendritic cells (FDCs) are also found in lymphatic tissue and support CLL cell survival. These FDCs are being used to express CLL specific antigens and are under clinical investigation for the development of vaccines for CLL.¹¹³ The CLL cells also cross-talk with stromal cells through the CXCR4-CXCL12 and the CD40-C40L axis discussed in detail later.

Nurselike cells (NLC) are differentiated monocytes that are large, round, and adherent cells that bind to CLL cells mainly in P.1894

the peripheral blood system. However, NLCs can be found in the spleen and secondary lymphoid tissue.⁸⁹ There is diverse cross-talk between NLC and CLL cells. NLC express CXCL12, CXCL13, and CD31 plexin B1 BAFF and APRIL and vimentin.⁸⁸,¹¹² All these cell-surface markers interact with CLL receptors providing survival and proliferative signals.

T lymphocytes also interact with CLL cells. The number of circulating T-cells in CLL patients is often increased and this might be due to interactions with CLL cells. T-cells can either suppress or stimulate expansion of CLL cells. In the proliferation centers, T-cells co-localize suggesting that T-cells support the CLL proliferation.¹¹²,¹¹³ This is supported by evidence that CLL cells fail to proliferate in immunodeficient mice, demonstrating that activated CD4⁺ T-cells could be important for CLL proliferation.¹¹⁴

Survival Factors in the Microenvironment

B-cell receptor (BCR): The BCR is the most studied receptor in mature B-cells due to its important role in recognizing foreign antigens and activating B-cell proliferation and transformation into plasma cells. It has also been implicated in B-cell survival. In CLL cells, the BCR can be activated by binding to antigen-presenting cells, such as FDCs, and this promotes cell survival and protects the cells against drug-induced apoptosis.⁸⁸,⁹⁰ Activation of ZAP-70 through ligation of the BCR may play an important role in promoting cell survival in CLL.⁹³,⁹⁴,⁹⁵,⁹⁶ Overall, the protective effect of BCR activation against apoptosis has been related to increased expression of antiapoptotic BCL2 family members, especially MCL1.⁹⁷ Indeed, biopsies of CLL cells in the lymph nodes and bone marrow of CLL patients indicated that BCR activation signatures are found in CLL cells in these microenvironments.¹¹⁵ Inhibitors of the BCR-activated kinases including SYK, mTOR, phosphoinositide 3'-kinase (PI3K), and BTK, have been found to decrease CLL cell viability through modulation of the microenvironment.¹¹⁶,¹¹⁷,¹¹⁸,¹¹⁹ BCR pathway inhibitors appear to be highly active in refractory CLL, independent of the presence of poor prognostic markers, such as deletion 17p13.¹¹⁹ However, the extent of BCR activation in CLL remains controversial inasmuch as CLL cells are less responsive than naive B-cells to BCR activation.

Interleukins: CLL cells have receptors to various ILs and the levels of IL-4 and IL-8 are elevated in the blood of some patients. The addition of IL-4 and IL-8 to CLL cells protects them against spontaneous and drug-induced apoptosis.¹²⁰ A number of other IL (e.g., IL-1, IL-2, IL-6, and IL-8) can also prevent CLL cells from undergoing spontaneous apoptosis and these may be derived from the CLL cells (IL-1, -6, and -8), T cells (IL-2 and -4) or stromal cells.⁸⁸,¹²¹,¹²² CLL cells differ from normal CD19⁺ B-cells in producing the lymphoid stem cell growth factor, IL-7, suggesting that this cytokine might also be important in disease pathogenesis.¹²³ IL-7 does not itself induce proliferation or prevent apoptosis of CLL cells in vitro.¹²³ However, the prevention of apoptosis of CLL cells by co-culturing with endothelial cells appears to be related to the maintenance of intracellular IL-7 levels, which occurs by signaling through the cell-surface β 2-integrin.¹²³ Both IL-2 and IL-15 stimulate the proliferation of CLL but not normal B-cells.¹²⁴ Moreover, IL-2 is sequestered by the CLL cells and by the increased serum levels of the IL-2 receptor (TAC receptor) seen in this disease, preventing its interaction with normal lymphocytes.¹²⁵,¹²⁶ High levels of IL-6 have been shown to be a better prognostic marker than Ig mutation status in older CLL patients indicating the importance of ILs in disease progression.¹⁰⁴ This may also partly explain the immune dysfunction seen in CLL.

Tumor necrosis factor- α (TNF- α): CLL cells produce TNF- α in vitro.¹²⁷,¹²⁸ and TNF- α decreases apoptosis in these cells through the induction of BCL2 expression¹²⁷,¹²⁹,¹³⁰,¹³¹ In addition, TNF- α may induce the proliferation of CLL cells while suppressing the growth of normal lymphocytes and marrow cells.¹²⁷,¹²⁹,¹³⁰,¹³¹ The serum level of TNF- α is increased in most patients with CLL, and the highest levels are observed in those with advanced disease.¹³⁰ An increase in the serum levels of the soluble receptors for TNF- α has also been observed in CLL.¹³²

Transforming growth factor- β (TGF- β): TGF- β is secreted by CLL and marrow stromal cells.¹³³,¹³⁴ TGF- β inhibits DNA synthesis in both CLL and normal B-cells, although the degree of inhibition can be quite low in CLL as a result of the loss of TGF- β receptors.¹³⁵,¹³⁶ In contrast to normal B-cells, CLL cells are consistently resistant to apoptosis induced by TGF- β .¹³⁷

Adhesion molecule receptors: It has long been known that adhesion molecules on the cell surface are important for cell survival. For adherent cells, such as epithelial cells, removal of the cells from their attachments and resuspending the cells

in culture results in apoptosis, called anoikis.⁹⁹ Binding of adhesion molecules such as integrins can prevent anoikis suggesting that cell-cell contact is important in maintaining cell viability. Although CLL cells can be in suspension they do adhere to other cells in the marrow, lymph nodes, and peripheral blood and adhesion molecules play a role in protecting the leukemia cells against apoptosis.¹³⁸ As mentioned previously, β 1 and β 2 integrins and CD44 are also present on the CLL cell surface.^{99, 100, 103}

BMCA, TAC1, and BAFF-R: CLL cells express BAFF and APRIL along with their corresponding receptors BMCA, TAC1, and BAFF-R.¹³⁹ The addition of exogenous BAFF and APRIL to CLL cells prevents spontaneous and drug-induced apoptosis.¹⁴¹ These molecules are known factors in B-cell survival, differentiation, and apoptosis.¹³⁹ Conversely, the addition of a soluble form of the BMCA receptor or neutralizing antibodies against BAFF or APRIL results in increased apoptosis.¹⁴⁰ CLL cells secrete BAFF and APRIL and the plasma levels of APRIL are higher in CLL patients than in normal individuals.^{139, 140} In addition, antigen-presenting cells, such as dendritic cells, express high levels of BAFF and APRIL.¹⁴⁰ Because CLL cells have receptors for BAFF and APRIL, autocrine and paracrine survival signaling likely occurs in CLL.^{139, 140} This concept is supported by the fact that the ability of "nurselike" cells to provide survival signals to CLL cells is reduced by the presence of decoy receptors for BAFF and APRIL.¹³⁹

Vascular endothelial growth factor (VEGF) receptor: VEGF is an angiogenic factor that is involved in cell survival for many cancers.¹⁴¹ In CLL, VEGF protects the leukemic cells from both spontaneous and drug-induced apoptosis whereas apoptosis is increased by adding inhibitors to VEGF receptor kinase.^{142, 143} CLL cells express VEGF receptors 1 (VEGFR1) and 2 (VEGFR2) and increased protein levels of VEGFR2 are associated with elevated lymphocyte counts and advanced disease.^{143, 144} Furthermore, CLL cells secrete VEGF and the levels of VEGF are increased in the plasma of CLL patients.^{144, 145} The mechanism responsible for VEGF production by CLL cells is unclear but activation of CD40 by CD40 ligand (CD40L), which may be produced by CLL and other cells (see below) may be important for this activity.¹⁴²

CD40: CD40 is a glycoprotein of the TNF superfamily that is expressed on B-cell surfaces and is important for B-cell differentiation and function, whereas the CD40 ligand (CD40L) is expressed on activated T-cell surfaces. In addition to T-cells, NLC also express CD40L.¹⁴⁶ CD40L binds to normal B lymphocytes promoting proliferation and cell survival.¹⁴⁷ Similarly, stimulation of CD40 on CLL cells induces proliferation and the release of cytokines¹⁴⁸ and also prevents apoptosis induced by chemotherapy.^{149, 150} CLL cells may also release CD40L, and the level of ligand is high in the plasma of CLL patients.¹⁵¹ As CLL cells have both CD40 and CD40L, it has been suggested that the cell may stimulate its own growth and survival, perhaps through up-regulation of the antiapoptotic protein survivin (a member of the IAP family).^{147, 151, 152} In contrast to the CD40 survival function, increased CD40 expression may lead to better recognition by cytotoxic T-cells and increased CLL cell killing.¹⁵³ Moreover,

P.1895

co-stimulation of CD40 and FAS on CLL cells can increase apoptosis.¹⁵⁴ A novel therapeutic approach has thus been recently explored in which CLL cells are induced to secrete CD40L by a viral transfection strategy.¹⁵⁵

Stromal-derived growth factor-1 (SDF-1) receptor: SDF-1 is a chemokine that is normally secreted by stromal cells. The receptor for SDF-1 is CXCR4, which is expressed on CLL cells and the addition of SDF-1 protects CLL cells from spontaneous and drug-induced apoptosis.¹⁵⁶ Similarly, CLL cell survival is increased when the cells are co-cultured with stromal cells.¹⁵⁷ NLC can also express SDF-1 and the levels of SDF-1 are increased in the plasma, suggesting that this cytokine is probably important for CLL cell survival.¹⁵⁸

Basic fibroblast growth factor (bFGF) receptor: It has been demonstrated that the bFGF levels in the serum of CLL patients are elevated and that bFGF treatment of CLL cells prevents apoptosis through a decrease in TP53 expression and up-regulation of BCL2 expression.¹⁵⁹

NOTCH receptors. The Notch family consists of four receptors NOTCH 1 to 4 and five ligands, including Jagged1 and Jagged 2. All NOTCH receptors and ligands are constitutively expressed on CLL cells and on BMSCs.¹¹³ As discussed in detail later, NOTCH 1 gain-of-function mutations are detected in approximately 10% of CLL patients at diagnosis and the incidence increases with disease progression and the development of drug resistance. This is consistent with NOTCH signaling being involved in CLL survival and resistance to apoptosis. The microenvironment may also influence NOTCH signaling in CLL cells through integrins and chemokine receptor activation.¹¹³

Albumin: Albumin is the major protein in the blood and can decrease both spontaneous apoptosis and apoptosis induced by irradiation or chlorambucil in primary CLL cells in vitro.¹⁶⁰ This effect is related to the uptake of albumin into the CLL cells with activation of AKT protein kinase. In contrast, the protective effect of albumin against chlorambucil is not seen in normal B or T lymphocytes.

Lysophosphatidic acid (LPA): LPA is a soluble phospholipid with a wide range of biologic activities and can protect epithelial and fibroblast cell lines from apoptosis.¹⁶¹ Similar to albumin, LPA protects CLL cells, but not normal B-cells, from spontaneous and drug-induced apoptosis and this effect is mediated through the AKT kinase.¹⁶¹ Blockage of the LPA receptor or inactivation of AKT prevents the protective effect of LPA. As albumin allows for the solubilization of lipids in plasma it is possible that the protective effect of albumin is mediated through the carriage of LPA.¹⁶¹

Cell Survival Signaling Pathways in Chronic Lymphocytic Leukemia

The microenvironment influences survival responses primarily through receptor activation. This leads to activation of signal transduction pathways that regulate gene expression and BCL2 family member functions. These survival signaling pathways have overlapping functions and cross-talk with each other. The following is a brief description of the survival pathways in CLL.

The transcription factor nuclear factor- κ B (NF- κ B) plays an important role in suppressing apoptosis by inducing the expression of a variety of antiapoptotic genes.^{162, 163} NF- κ B is inactivated by I κ B, which binds NF- κ B and prevents its access to the nucleus; activation of NF- κ B occurs by the phosphorylation of I κ B, which leads to the coupling of I κ B with ubiquitin. This complex is degraded by a protease called the proteasome. The levels of NF- κ B are high in CLL and are increased further by stimulation with CD40 ligand, which plays an important role in preventing apoptosis and prolonging cell survival in CLL.¹⁶⁴ In addition, inactivation of the proteasome by inhibitors such as lactacystin, MG132, and bortezomib can induce death of CLL cells but not of normal lymphocytes.^{165, 166, 167} Cell death is mediated through the cytochrome c/mitochondrial pathway, and these agents may be useful in drug-resistant disease.^{165, 166, 167}

The protein kinase AKT is activated through phosphatidylinositol 3'-kinase and can suppress apoptosis by inactivating bad, caspase 9, and other proapoptotic proteins through phosphorylation.^{168, 169} In addition, AKT can activate NF- κ B and regulate the expression of antiapoptotic genes. This pathway is activated by autologous plasma in CLL, which may explain the relative resistance of these cells to spontaneous and drug-induced apoptosis when they are grown in plasma.¹⁶⁹ Overexpression of TCL1 in a transgenic mouse model leads to the expansion of B-cells which have similar characteristics as CLL cells.¹⁷⁰ The B-cells overexpressing TCL1 have increased levels of activated AKT, which may explain the enhanced survival of these cells.¹⁷¹

The mitogen-activated protein kinase (MAPK) signaling pathway is also activated in CLL cells. This pathway consists of extracellular regulated kinase (ERK), Jun N-terminal kinase (JNK), and p38 MAPK. BCR activation leads to ERK activation and up-regulation of BCL2 family members.¹⁷² During apoptosis, ERK activation is often suppressed.¹⁷³ p38 MAPK activation is elevated in CLL cells and plays a role in CLL survival mediated by human stromal cells.¹⁷⁴ In contrast, JNK activation is associated with increased apoptosis in CLL cells.

The JAK-STAT signaling pathway is an emerging pathway activated in CLL cells contributing to cell survival and drug resistance. In CLL, STAT3 is constitutively phosphorylated on serine 727 and is associated with increased transcriptional activation. STAT3 contributes to increased expression of antiapoptotic proteins such as X-linked apoptosis inhibiting protein (XIAP).^{175, 176, 177} STAT3 has also been shown to cross-talk with the NF- κ B in CLL cells increasing cell survival.¹⁷⁸ The JAK-STAT pathway is activated by growth factors such as VEGF.¹⁷⁹ These factors are found in the microenvironment indicating that the JAK-STAT pathway might be a good target for disrupting the CLL microenvironment.

Abnormalities in Cell Division

Although CLL cells in the peripheral blood are not dividing, the telomeres of these cells are shorter than in normal B-cells, suggesting that the leukemic cells have undergone more frequent cell divisions than normal B-cells.¹⁸⁰ Moreover, the telomeres in CLL cells with unmutated IgV_H genes have shorter telomeres than those cases with mutated IgV_H genes.¹⁸⁰ Using deuterated water (²H₂O) to label DNA, it has been estimated that 0.11% to 1.76% (median, 0.39%) of the CLL cells in patients are dividing each day, which is the same or greater than that observed in the B-cells from normal individuals.¹⁸¹ Although CLL cells in the peripheral blood are not dividing, cells in the "proliferation centers" in the lymph nodes or marrow are dividing, where, under the influence of CD4⁺ cells they express the proliferation markers, survivin and Ki67, and become CD38⁺.^{2, 14, 182, 183} Moreover, greater uptake of ²H₂O is observed in the CD38⁺ cell fraction as compared to the CD38⁻ cells confirming their role in cell proliferation.¹⁸⁴ Gene expression profiling has demonstrated that CLL cells in the lymph nodes have increased expression of genes related to BCR activation, as compared to cells from the peripheral blood.¹¹⁵ These changes include increased expression of phosphorylated Syk and NF- κ B and are less marked in marrow than in the lymph nodes. As predicted, the changes are greater in unmutated IgV_H cases than in mutated IgV_H cases and correlate with the rate of cell proliferation, as measured by Ki67.

Passage through the cell cycle is controlled by the interaction of the cyclins and the cyclin-dependent kinases (CDKs); the levels of the CDKs remain constant, whereas the levels of the five different cyclins fluctuate and activate the appropriate

CDK, leading the cell through the cycle (Fig. 90.6).¹⁸⁵ In addition, 2 classes of CDK inhibitors, the INK4 proteins and the Cip/Kip proteins, control the

P.1896

activity of the CDKs.¹⁸⁶ Normally, when quiescent cells enter the cell cycle, the D cyclins (D1, D2, and D3) in conjunction with CDKs 4 and 6 bring the cell into the S-phase. The D cyclin/CDK4/6 initiates phosphorylation of the retinoblastoma (Rb) protein, which is then further phosphorylated by cyclin E/CDK2. Another function of the D cyclins/CDK4 is the sequestration of the CIP/KIP inhibitors p27^{Kip1} and p21^{Cip1}, which normally inhibit the activity of cyclin E/CDK2. Although the majority of the peripheral blood CLL cells are quiescent and in G₀/G₁, the expression of cyclins D1, D2, and D3 are increased in these cells.^{187, 188, 189} Despite these findings, the Rb protein is not phosphorylated in unstimulated CLL cells¹⁹⁰; this may be related to overexpression of p27^{Kip1}, high levels of which are associated with high lymphocyte counts and poor patient survival.¹⁹¹ CDK1 (*cdc2*) is a serine/threonine kinase involved in G2-M phase transition and gene expression studies have shown that this gene is highly expressed in patients with del 11q22-23 cells.¹⁹²

TABLE 90.1 INCIDENCE OF GENOMIC ABNORMALITIES AND ASSOCIATED CLINICAL FEATURES IN CHRONIC LYMPHOCYTIC LEUKEMIA (CLL)

Genomic Abnormality	Incidence (%)		Affected Genes	Clinical Features
	Classical Cytogenetics ^a	Fluorescence in Situ Hybridization ^b		
Normal	50 ^c	18	—	—
13q deletion	10	55	<i>Rb</i> , <i>MiR-15a</i> , <i>MiR-16-1</i>	Good prognosis
11q deletion	8	18	<i>ATM</i> <i>SF3B1</i>	Younger; bulky lymphadenopathy; poor prognosis
12q trisomy	13	16	<i>MDM2</i> <i>NOTCH1</i>	“Atypical” morphology; end-stage disease
17p deletion	4	7	<i>TP53</i>	CLL/PLL morphology; drug resistance; very poor prognosis
6q deletion	4	6	—	—

^a From Juliusson G, Merup M. Cytogenetics in chronic lymphocytic leukemia. *Semin Oncol* 1998;25:192-196; Juliusson G, Oscier DG, Fitchett M, et al. Prognostic subgroups in B-cell-chronic lymphocytic leukemia defined by specific chromosome abnormalities. *N Engl J Med* 1990;323:720-724; and Juliusson G, Oscier D, Gahrton G, et al. Cytogenetic findings and survival in B-cell chronic lymphocytic leukemia. Second IWCCLL compilation of data on 662 patients. *Leuk Lymphoma* 1991;5:21-25. Percentages refer to the number of cases with the abnormality compared to the total number of cases in which cytogenetic analysis was possible.

^b From Döhner H, Stilgenbauer S, Benner A, et al. Genomic aberrations and survival in chronic lymphocytic leukemia. *N Engl J Med* 2000;343:1910-1916.

^c In 50% of cases, clonal abnormalities were not obtained. As these studies were not carried out on purified chronic lymphocytic leukemia cells, some of the cases with normal cytogenetics reflect analysis of normal T-cells.

Genomic Abnormalities

Tremendous strides have been made in the analysis of the CLL genome, providing insight into pathogenesis and identifying genes that are important as markers of disease progression and drug resistance. Initial classical cytogenetic studies were carried out in the 1980s, but it was difficult to obtain metaphases in CLL.^{84, 193} When analysis was possible, clonal chromosomal abnormalities were detected in approximately 50% of cases,^{84, 193, 194, 195, 196, 197, 198, 199, 200, 201, 202, 203, 204, 205, 206} and it is likely that the normal karyotyping in many of the remaining cases was due to analysis of contaminating normal T-cells. Of the 50% of cases with clonal abnormalities, one half had one clonal abnormality, and the remainder had 2 or 3 abnormal clones.¹⁹⁵ However, with the more recent use of the CD40 ligand, or a combination of IL-2 and CpG-oligodeoxynucleotides, to stimulate CLL cells, metaphases are now routinely obtained in over 90% of cases with aberrations detected in greater than 80% of samples.^{207, 208, 209}

Using FISH and comparative genomic hybridization (CGH) to analyze interphase cells (FISH) or isolated DNA (CGH), abnormalities are detected in over 80% of cases.^{84, 193} FISH is highly sensitive, but the specific abnormality to be studied needs to be known in advance, and this is therefore not a good technique to screen for new abnormalities. In contrast, CGH has been used to screen for chromosome gain or loss (i.e., aneuploidy, gene amplification, or deletions not detected by conventional cytogenetics).¹⁹³ More recently, new assays, including SNP and DNA sequencing have advanced our ability to detect genetic abnormalities.

Analysis by Conventional Cytogenetics

Using conventional cytogenetics, the International Working Party on Chromosomes in CLL reported in 1990 that clonal chromosomal abnormalities were obtained in 311 patients (51%) out of a total of 604 cytogenetically evaluable cases (Table 90.1).^{200, 201} The most common clonal abnormality was trisomy 12 (36%, or 19% of all evaluable cases), either by itself or in combination with other cytogenetic changes. Other frequently observed alterations included structural abnormalities of chromosome 13 (20%, or 10% of all cases) and of chromosome 14 (16%, or 8% of all cases).^{199, 200} The 13q abnormalities usually involved a 13q14

P.1897

deletion (site of the RB1 gene) or translocations with a breakpoint at chromosome 13q14. The 14q abnormalities included translocations from a variety of chromosomes, usually involving chromosome 11, suggesting that these patients had actually mantle cell lymphoma. Less than 5% of patients had an 11q22-q23 deletion. The abnormalities of chromosomes 12 and 13 occurred with equal frequency in cases with a single clonal abnormality and in patients having more than one clonal abnormality.^{195, 199} In contrast, abnormalities of chromosome 14 occurred primarily in patients having more than one clonal abnormality.^{195, 199} In general, patients with abnormal karyotyping had a worse prognosis than those with normal cytogenetics, and the outlook was poorest for those with multiple clonal abnormalities.^{196, 197, 198, 199, 200, 201, 202} In addition, the higher the percentage of cells at metaphase with a clonal chromosomal abnormality, the worse the prognosis. Of patients with a single clonal abnormality, those with trisomy 12 had the worst prognosis, and those with 13q+ had a similar survival as cases with normal karyotyping.^{199, 200} It is interesting that trisomy 12 was usually seen in those 15% of cases with CLL variants, either CLL/prolymphocytic leukemia (CLL/PLL) or "atypical" CLL, and this may explain the poor prognosis associated with these morphologic variants.^{202, 203, 204} When all patients were considered, regardless of the number of clones, those with chromosome 14 abnormalities had the worst prognosis.¹⁹⁹ As most of the chromosome 14 abnormality group had a t(11;14) (q13;q32), in retrospect, they likely had mantle cell lymphoma and not CLL.³ 11q22-q23 deletions have been detected in 13% of patients by karyotyping, and these patients had disease progression and poor survival.²⁰⁵

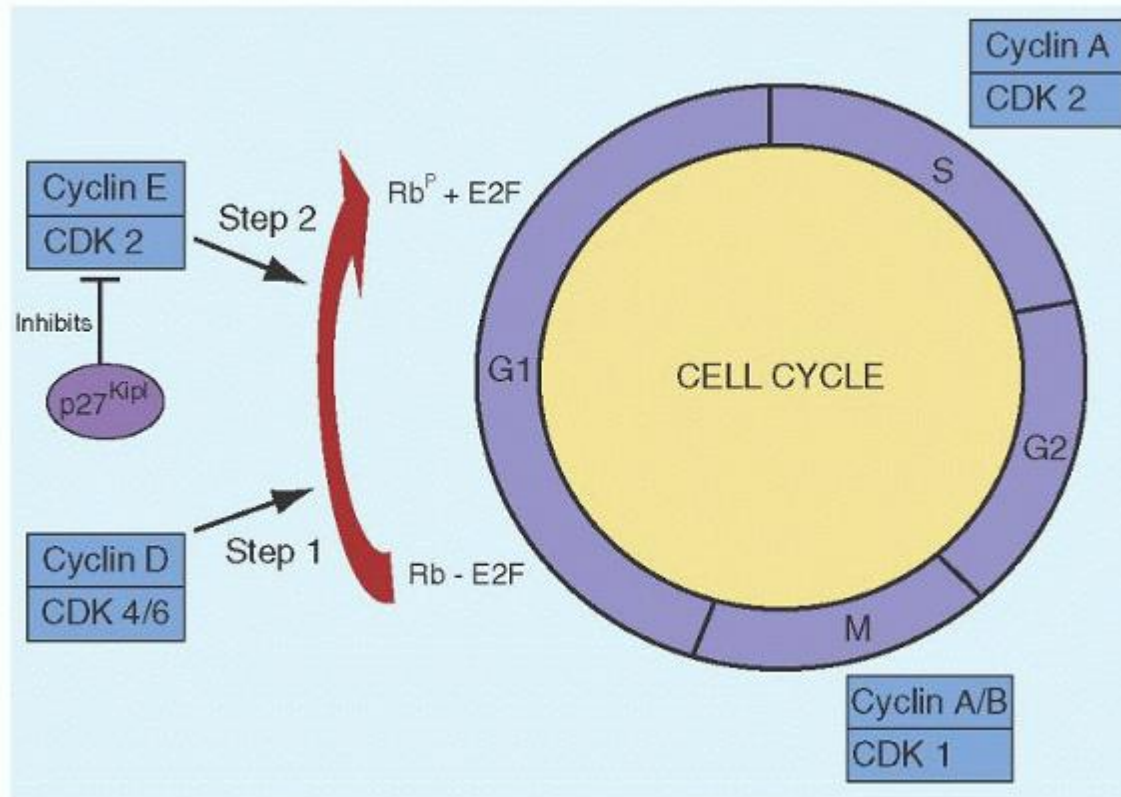

FIGURE 90.6. Control of the cell cycle. Both cyclins D2 and D3 are overexpressed in chronic lymphocytic leukemia cells, but the retinoblastoma (Rb) protein is not phosphorylated, perhaps related to overexpression of p27^{Kip1}. CDK, cyclin-dependent kinase.

Nowadays, metaphases may be obtained in over 90% of patients using either CD40 ligand or a combination of IL-2 and CpG-oligodeoxynucleotides with abnormalities being detected in over 80% of patients.^{207, 208, 209} These studies demonstrate that many more abnormalities can be detected using classical cytogenetics than seen with FISH alone and that both balanced and unbalanced translocations are observed.^{207, 208, 209} Mayr et al.²⁰⁸ observed translocations in one third of CLL patients, and half of these were balanced. The presence of these translocations was a poor prognostic feature and was independent of other prognostic factors for overall survival. Moreover, patients with 13q deletions and translocations had a poorer prognosis than patients with 13q deletions without translocations.

Analysis by Fluorescence in Situ Hybridization

A landmark study by Döhner et al.⁸⁴ in 2000 demonstrated the importance of FISH in CLL. In 325 patients, 268 (82%) had abnormalities, with deletion 13q14 being most frequent (55%), followed by deletion 11q22-23 (18%), trisomy 12q13 (16%), deletion 17p13 (7%), and deletion 6q21 (7%).⁸⁴ There was one abnormality in 175 (65%) patients, 67 (25%) patients had 2 aberrations, and 26 (10%) patients had more than 2 chromosomal changes. A hierarchical model categorized patients into 5 groups with different prognoses (Fig. 90.7). The median survival times for patients with a 17p13 deletion, an 11q22-q23 deletion, trisomy 12q, normal karyotype and a 13q deletion as the sole abnormality were 32, 79, 114, 111, and 133 months, respectively. Patients with 17p13 or 11q22-q23 deletions had the poorest survival, had more marked lymphadenopathy and splenomegaly, and were more likely to be symptomatic with night sweats and weight loss. Very similar results have been obtained in subsequent prospective studies.^{210, 211} The incidence of these specific abnormalities detected by FISH differed from the incidence with conventional cytogenetics in older studies, but similar incidences are now being observed where metaphases are being induced using CD40 ligand or a combination of IL-2 and CpG-oligodeoxynucleotides^{207, 208, 209} (Table 90.1). Patients with unmutated IgV_H are more likely to have deletions of 17p13 or 11q22-23 whereas patients with mutated IgV_H are more likely to have deletion 13q14.¹⁹³ The incidence of trisomy 12 is the same in patients with mutated or unmutated IgV_H.¹⁹³

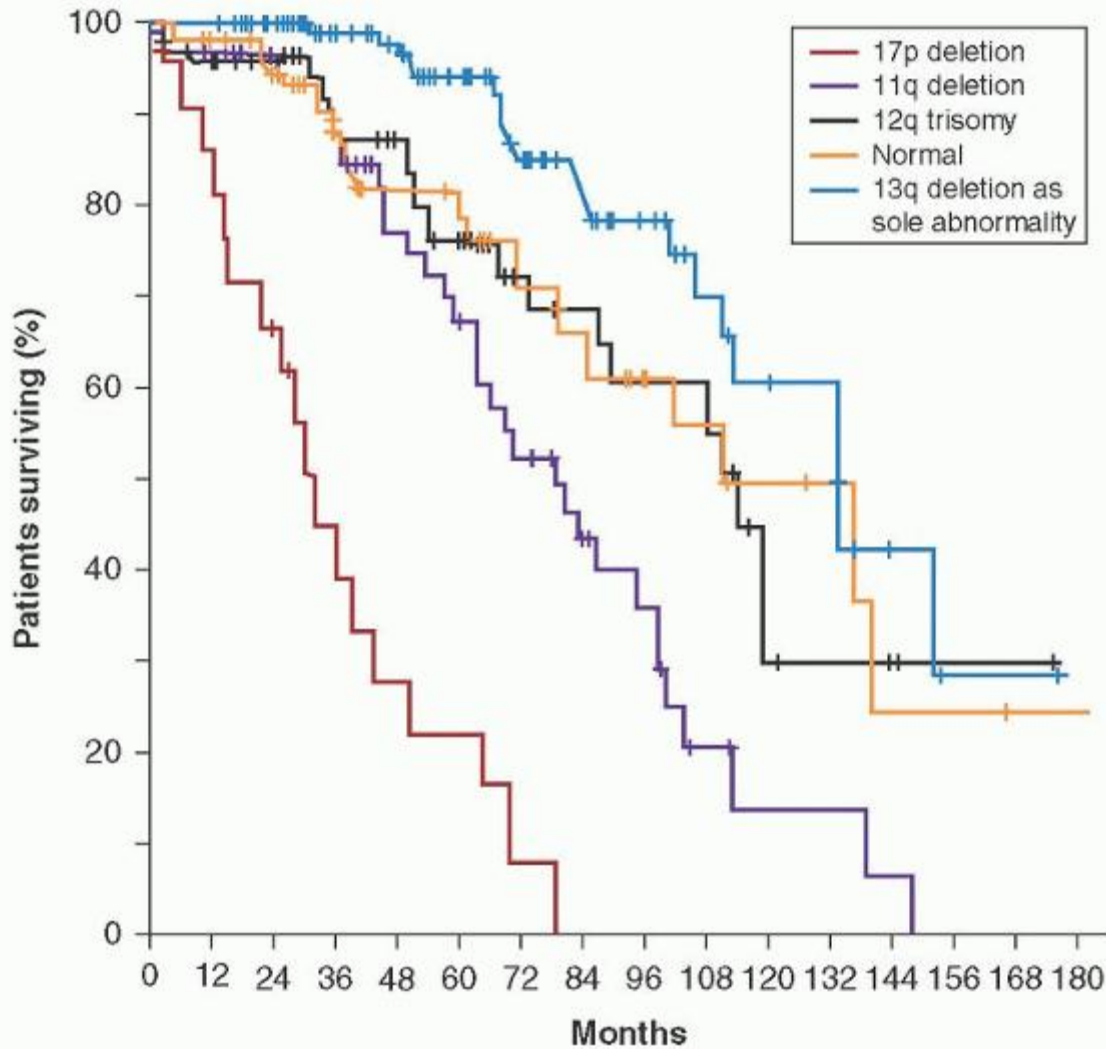

FIGURE 90.7. Survival according to molecular genetic changes in chronic lymphocytic leukemia. From Döhner H, Stilgenbauer S, Benner A, et al. Genomic aberrations and survival in chronic lymphocytic leukemia. *N Engl J Med* 2000;343:1910-1916, with permission.

More recent evidence indicates that the prognosis with a 13q14 deletion depends on the extent of the deletion.^{212, 213} There are two anatomical landmarks for deletion 13q14: (a) the minimal deleted region (MDR) containing the deleted in leukemia (DLEU) 2 gene, microRNA (miR)-15A/16-1 cluster, and the first exon of the DLEU1 gene; and (b) the RB1 gene.²¹² Of patients with deletion 13q14, 60% had loss of MDR only and 40% also had loss of the RB1 gene. The prognosis is poorer if >70% nuclei have the deletion or if there is a concomitant loss of RB1.^{212, 213}

It has been recommended that all CLL patients should be routinely examined for an IGH translocation.^{214, 215} Of 1,032 patients at the Mayo Clinic with a presumptive diagnosis of CLL, 76 (7%) were found to have an IGH translocation, with 34 involving a translocation with cyclin D1, 18 a translocation with BCL2, and 6 a translocation with BCL3.²¹⁴ Upon review, half of the patients with translocations were found to have CLL and half had the leukemic phase of another lymphoid malignancy.

Trisomy 12 frequently occurs in “atypical” CLL or CLL/PLL.²⁰³ However, not all the “atypical” cells in an individual patient contain trisomy 12, indicating that the chromosomal abnormality is not responsible for the atypical morphology.^{201, 216} In addition, although trisomy 12 connotes aggressive disease, it is unclear whether the proportion of cells with trisomy 12 increases over time.^{201, 217} Half the patients with CLL/PLL have a TP53 mutation, suggesting a role for the gene in the pathogenesis of this variant.²¹⁸

Assessment of Genomic Complexity

Recent evidence has suggested that prognosis in CLL is closely linked to the complexity of genetic abnormalities, as well as to the specific defect.^{219, 220, 221, 222, 223, 224} The majority of patients using either CGH or SNP arrays will have 1 to 3 copy number abnormalities, and these techniques detect abnormalities not seen with FISH and demonstrate that increasing genomic complexity predicts poor prognosis. Moreover, although the presence of 11q21-22 and 17p13 deletions predict the presence of genomic complexity, genomic complexity can be present with

P.1898

low-risk FISH and is a useful independent prognostic predictor. Kay et al.²¹⁹ evaluated genomic complexity using CGH in patients commencing treatment with chemoimmunotherapy. Chromosome deletions were more common than gains and although abnormalities were typically seen in patients with high-risk FISH, complex abnormalities were also seen in patients with 13q deletions. Complex changes were associated with poor response to treatment. Similarly, Ouillette et al.²²³ have shown that increasing genomic complexity by SNP is an independent prognostic marker, predicting rapid disease progression, poor response to chemotherapy, and short survival. Genomic complexity has also been shown to correlate with resistance of the CLL cells to undergo apoptosis with radiation in vitro.²²²

Clonal Evolution

Chromosomal abnormalities may be identified in MBL and early CLL, with the likelihood of deletions of 11q22-23 and 17p13 increasing over time and with the development of drug resistance.^{2, 193} By FISH analysis, one-quarter of patients will have the development of new abnormalities after 5 years, particularly in patients who are ZAP-70 positive, CD38 positive, and those with unmutated IgV_H.²¹¹ Interestingly, patients with unmutated IgV_H have an increased risk of developing deletions of 11q22-q23 or 17p13, whereas those with mutated IgV_H develop deletions of 13q.²¹¹ The risk of developing new genetic abnormalities may be further increased by chemotherapy, as treatment with fludarabine increases the expression of TP53-dependent genes, thus increasing the risk of selecting 17p13 deleted cells.²²⁴ Indeed, 42% of fludarabine-resistant CLL patients have either TP53 mutations or deletions of 17p13.²²⁵

Whole Genome and Exome Sequencing

Several recent studies using whole genome and exome sequencing have identified important new mutations in CLL.^{226, 227, 228, 229} Nine genes are mutated at increased frequency with 4 being known to be important in CLL, TP53 (15%), ATM (9%), myeloid differentiation primary response gene 88 (MYD88; 10%), and NOTCH1 (4%). TP53 and ATM have been discussed in detail in other sections. MYD88 is an adaptor molecule of the IL-1 receptor-tolllike receptor signaling pathway and MYD88 mutations are associated with mutated IgV_H, deletion 13q14, and good prognosis.²²⁶ Stabilizing NOTCH1 mutations in exon 34 generate a stop codon, producing a shortened and more active isoform of the protein.²²⁷ NOTCH1 is one of 4 NOTCH receptor proteins activated by the Serrate/Jagged or Delta family expressed on neighboring cells and this results in release of the N-IC domain from NOTCH which in turn assembles a transcriptional complex that controls expression of a number of genes.²²⁹ Mutations of NOTCH1 occur in 8.3% of CLL cases at diagnosis, increase frequency with a Richter syndrome (RS) progression (31%), and drug resistance (20.8%).²²⁷ A number of subsequent studies have demonstrated that NOTCH1 mutations are associated with unmutated IgV_H, trisomy 12, and correlate with drug resistance, the development of RS, and poor survival.^{227, 229, 230, 231, 232, 233, 234}

Five genes with unestablished roles have also been identified in CLL and these include splicing factor 3b subunit 1 (SF3B1; 15%), ZMYM3, MAPK1, FBXW7, and DDX3X.²²⁶ SF3B1 is a component of one of the five small nuclear ribonucleoproteins (SnRNP) that form a complex and are involved in splicing messenger RNA. Mutations of SF3B1 are relatively common in CLL occurring in 15% to 17% of patients and the mutations cause aberrations in splicing activity. Mutations are associated with a deletion of 11q22-23 (36%), are a cause of fludarabine resistance, and are independent prognostic markers for survival.^{226, 234, 235}

Effects of Chromosome Changes on Gene Expression

Deletion 13q13

The most frequent structural abnormality in CLL is a deletion of 13q14 affecting 55% of cases.⁸⁴ Of these cases 76% are monoallelic and 24% biallelic, and deletions occur most commonly in patients who have mutated IgV_H disease.⁸⁴ The deleted region has been shown to involve the MDR, containing the DLEU2 gene and microRNA (miR)-15a/16-1.²³⁶ DLEU2 encodes a noncoding RNA, but its function is unknown, whereas miR-15a/16-1 inhibits proliferation and apoptosis.²³⁶ Using transgenic mice it has been demonstrated that deletion of miR-15a/16-1 alone can lead to MBL and CLL, which is related to increased cell proliferation as a result of the loss of miR-15a/16-1.^{237, 238} Moreover, as in CLL, many of these cases have a very similar CDR3, suggesting that a common antigen and/or autoantigen causes induction of the monoclonal

population. In addition, the disease is more aggressive if there is a concomitant deletion of DLEU2, suggesting that this element functions as a tumor-suppressor gene. In the clinical scenario, deletion 13q14 generally encompasses a much larger area than just MDR, with additional loss of a large area called the common deleted region (CDR) which contains DLEU1, DLEU7, and RNASEH2B.^{237, 238} Loss of this region, which is telomeric to MDR, results in more aggressive disease than for mice lacking MDR alone. This observation is similar to that in the clinical scenario where loss of RB1, which is centromeric to MDR, leads to more aggressive disease.^{212, 213} Thus, the effect of MDR deletion is potentiated by the loss of adjacent chromosomal material and the prognosis with a deletion 13q14 worsens with the extent of the deletion.

Deletion 11q22-q23

Deletion 11q22-23 occurs in approximately 20% of cases, is seen in younger patients, and is associated with marked lymphadenopathy, rapid disease progression, and poor survival.^{84, 239, 240, 241} The critical region for the deletion is a 3-Mb segment at 11q22.3-q23.1, and candidate genes in this region include radixin (RDX), which has homology to the neurofibromatosis-type 2 (NF2) tumor-suppressor gene and the ATM gene.²⁴⁰ The ATM protein is a protein kinase activated by DNA double-strand breaks and this leads to phosphorylation and activation of TP53. One third of patients with a deletion 11q22-23 have a mutation on the remaining ATM allele and this subgroup has a defective response to DNA damage with radiation or chemotherapy and a poorer overall survival (OS) than the group of patients with a deletion 11q22-23 and wildtype ATM on the other allele.^{37, 86, 87} Thus, the other two-thirds of patients must have an additional defect leading to their poor prognosis. Recently, 36% of patients with deletion 11q22-23 have been shown to have a mutation in SF3B1, an abnormality associated with drug resistance and poor survival.^{226, 235} Although CLL cells with a deletion 11q22-23 do not differ from other CLL cells in growth fraction, NF- κ B expression, or response to mitogenic stimuli, they have reduced levels of a number of adhesion proteins, which may explain the marked lymphadenopathy observed in these cases.²⁴⁰ Complementary DNA microarray analysis has demonstrated that patients with a deletion of 11q22-11q23 have a distinct expression pattern, and overexpress genes involved in cell signaling, cycling, and apoptosis.^{192, 240, 241}

Deletion 17p13

Deletion 17p13 is usually associated with a mutation of TP53 on the other allele and these patients usually have aggressive and drug-resistant disease with poor survival.^{72, 73, 83, 84, 210} Further details regarding this abnormality are discussed later.

P.1899

Trisomy 12q13

Trisomy 12 occurs as a result of duplication of one homologue and is seen in 10% to 20% of CLL patients. Trisomy 12 is frequently associated with "atypical" CLL and CLL/PLL. Patient survival is only minimally affected when trisomy 12 is detected by FISH, whereas survival is shortened if trisomy 12 is detected by classical cytogenetics.^{84, 199, 200} 12q13-15 contains the MDM2 gene, and overexpression of MDM2 could simulate a TP53 mutation, as MDM2 binds and inactivates TP53.^{72, 84} However, although MDM2 is overexpressed in two-thirds of patients, the increase does not correlate with disease stage, aggressiveness, or drug resistance.⁸⁵

Translocations of 14q32

Translocation of 14q32 involving IGH occurs in 7% of patients with CLL and many of these cases turn out to have a different disorder.^{84, 193, 214} The t(11;14) (q13;q32) occurs typically in mantle cell lymphoma, and the rearrangement on chromosome 11 involves the BCL1 gene, a G¹ cyclin also called CCND1 or cyclin D1. A t(14;18) (q32;q21) translocation is seen commonly in follicular lymphomas, and this rearrangement juxtaposes the IGH locus on chromosome 14 to the 3' end of BCL2 on chromosome 18. This rearrangement causes overexpression of BCL2 in the follicular lymphomas with inhibition of apoptosis; although the levels of BCL2 in CLL are equivalent to those in follicular lymphomas, the overexpression in CLL is related to BCL2 gene hypomethylation.^{70, 71} The t(14;19) (q32;q13.1) is a rare event and involves the juxtapositioning of BCL3 on chromosome 19 with the Ig gene on chromosome 14. The candidate oncogene BCL3 is a member of the I κ B family, and patients with this translocation have atypical morphology and progressive disease.²⁴²

CLINICAL FINDINGS

Most CLL patients in the general population are elderly (median age 71.5 years). As a result of referral bias the median age of patients seen in the specialist clinic is 64 years, with 20% to 25% of patients being <55 years old.^{11, 12, 243, 244} However,

the presenting features are similar regardless of age.^{243, 244} Nowadays, 70% to 80% of patients are diagnosed incidentally when they have a routine blood count and will have early-stage (Rai 0 or I) disease.²⁴⁵ Alternatively, lymphadenopathy, splenomegaly, or both may be detected during a regular physical examination. When symptomatic, the most frequent complaint is fatigue or a vague sense of being unwell. Less frequently, enlarged nodes or the development of an infection is the initial complaint, and the most frequent infections are bacterial pneumonias. Fever and weight loss are uncommon at presentation but may occur with advanced and drug-resistant disease.

Most symptomatic patients have enlarged lymph nodes, as well as splenomegaly. Enlargement of the cervical and supraclavicular nodes occurs more frequently than axillary or inguinal lymphadenopathy. The lymph nodes are usually discrete, freely movable, and nontender. Painful enlarged nodes usually indicate superimposed bacterial or viral infection. There is usually only mild to moderate enlargement of the spleen, and splenic infarction is uncommon. Less common manifestations are enlargement of the tonsils, abdominal masses due to mesenteric or retroperitoneal lymphadenopathy, and skin infiltration. Skin lesions in CLL may be caused by squamous and basal cell carcinomas which are thought to be related to immunosuppression (see section "Second Malignancies").²⁴⁶ Other common cutaneous manifestations include shingles and recalcitrant warts. Direct involvement of the skin by CLL typically affects the face and the features can be quite variable, from macules or papules, which may be vascular or to more extensive involvement that may simulate rhinophyma.²⁴⁷ Patients can also present with symptomatic anemia, which may be related to marrow replacement or, more rarely, to autoimmune hemolysis or aplasia. Alternatively, patients may have bruising or bleeding, most commonly related to thrombocytopenia and rarely to acquired von Willebrand disease, or factor VIII inhibitors. Rarely, patients may present with a paraneoplastic syndrome, such as nephrotic syndrome, paraneoplastic pemphigus, or angioedema (see section "Autoimmune Manifestations").

Peripheral Blood

The median lymphocyte count at diagnosis is 20 to 30 × 10⁹/L, and in most patients, there is a continuous increase in the lymphocyte count over time.^{13, 243, 244} In half the patients, it takes more than 12 months for the lymphocyte count to double; cyclic fluctuations of up to 50 × 10⁹/L can occur in the lymphocyte counts of untreated patients, and in others, the count may remain stable for years.²⁴⁴ The CLL cells are small to medium-sized lymphocytes with clumped chromatin, inconspicuous nucleoli, and a small ring of cytoplasm. Cytoplasmic inclusions occasionally may be observed in CLL cells and may be crystalline, globular, tubular, or rod-shaped.²⁴⁸ Smudge cells (basket cells or shadow cells of Gumprecht) are commonly seen in the peripheral blood smear in CLL, but not in other lymphoid disorders, and are caused by a decrease in the cellular content of vimentin, a cytoskeletal protein required for maintaining cell structure.^{249, 250} The number of smudge cells can vary from 1% to 75% (median 28%) and appears to be remarkably consistent in individual patients.²⁵⁰ One study suggests that patients with ≥30% smudge cells are more likely to have mutated IgV_H and have a better prognosis than those with <30% smudge cells.²⁵⁰ There can be variations in cell morphology, with some cells being PL, whereas others are larger with abundant cytoplasm, and some are plasmoid or cleaved.^{204, 251} The French/American/British classification system divides patients into 3 groups depending on the percentage of abnormal cells.²⁵¹ In classical CLL, >90% of cells are small, and when 11% to 54% of the cells are PL, it is termed CLL/PLL. When >15% of the lymphocytes are plasmoid or cleaved and <10% are PL, it is termed atypical CLL.^{203, 204, 251} Approximately 80% of patients have classical CLL, and 20% have CLL/PLL or atypical CLL. If ≥55% of the cells are PL, the patient has PLL.

Bone Marrow and Lymph Nodes

Marrow infiltration in CLL may be interstitial, nodular, mixed (nodular and interstitial), or diffuse, with mixed being the most common and nodular the least common.^{3, 252} Diffuse involvement, in which there is effacement of the fat spaces by tumor, carries the worst prognosis.^{3, 252} The marrow involvement is random and contrasts with follicular lymphomas, in which paratrabecular involvement is the rule. In contrast to marrow, involvement of the lymph node is diffuse. Proliferation centers with PL and paraimmunoblasts are typically seen in both marrow and lymph nodes.

Immunophenotyping

CLL can usually be readily differentiated from other disorders by immunophenotyping^{1, 2, 3, 253, 254, 255} (Table 90.2). The leukemic cells have the B-cell markers CD19, CD20 (low), CD43, and CD79b (low) and must be CD5⁺. In addition, the cells show clonal light chain restriction, weak expression of sIgM and sIgD, and are CD23⁺ and CD10⁻. The cells are also CD27⁺,⁴³ consistent with being memory B-cells.⁵ Alternatively, the presence of CD27, CD5, and CD23 could reflect the activated nature of the CLL cell.⁴² Matutes et al.^{254, 256} recommend 5 markers to differentiate CLL from other B-cell malignancies (Table 90.3). Typical CLL should be surface Ig (weak), CD5⁺, CD23⁺, CD79b or CD22 (weak), and FMC7⁻.

TABLE 90.2 IMMUNOPHENOTYPES OF CHRONIC LYMPHOCYTIC LEUKEMIA (CLL) AND OTHER CHRONIC B-CELL DISORDERS

Condition	smIg	CD5	CD10	CD11c	CD19	CD20	CD22	CD23	CD25	CD43	CD79b	CD103	FMC7
CLL	Dim	++	-	-/+	++	Dim	-/+	++	+/-	+	-	-	-/+
Prolymphocytic leukemia	+++	-/+	-/+	-/+	++	+++	++	++	-/+	+	++	-	+
Splenic marginal zone lymphoma	++	-/+	-/+	+/-	++	++	++	+/-	-/+	+	++	-/+	++
Marginal zone lymphomas	++	-	-	+/-	++	++	+/-	+/-	-	-/+	++	-	+
Mantle cell lymphoma	++	++	-/+	-	++	++	++	-	-	+	++	-	++
Follicular lymphoma	++	-/+	++	-	++	++	++	-/+	-	-	++	-	++
HCL	+++	-	-	++	+++	+++	+++	-	+++	+	+	+++	+++
HCL variant	+++	-	-	++	+++	+++	+++	-	-	+	+	+++	+++
Waldenström macroglobulinemia	++	-	-	-/+	++	++	+	-	-/+	+/-	+	-	+

-, not expressed; -/+, usually is not expressed; +/-, usually is expressed; + to +++, varying degrees of strength of expression; HCL, hairy cell leukemia; smIg, surface membrane Ig. Adapted from References 254-257.

One of the typical features of the CLL cell is the overexpression of membrane CD23, which is related to deregulation of NOTCH2 signaling and may play a role in the decreasing apoptosis.^{257, 258} The presence of CD23 is useful to differentiate CLL from mantle cell lymphoma, which is also CD5⁺.²⁵⁷ Cell surface CD23 undergoes spontaneous proteolysis, producing elevated serum levels of CD23, the level of which is a marker of disease stage and progression.²⁵⁷

The BCR complex is required for the proliferation of B-cells after immune stimulation and is a complex formed by sIg and Igα/Igβ (CD79a/CD79b). CLL cells lack CD79b, which is related to overexpression of an alternatively spliced form of the gene.²⁵⁹ The FMC7 antibody identifies an epitope of CD20 and usually strongly stains hairy cell leukemia and PLL; however, only 16% of CLL cases stain positively, presumably because CD20 is only weakly expressed in typical stable CLL.^{253, 260} In general, those patients who are FMC7⁺ have high levels of surface IgM, low expression of CD23, and poor prognosis.²⁵³ Although the myelomonocytic antigens (CD11b, CD13) may be expressed in multiple myeloma, acute lymphoblastic leukemia, and in the CD5- chronic lymphoid leukemias, they are not expressed in CLL.²⁶¹

TABLE 90.3 SCORING SYSTEM FOR DIAGNOSIS OF CHRONIC LYMPHOCYTIC LEUKEMIA (CLL)

Marker	Marker Intensity	Score	Marker Intensity	Score
Surface Ig	Weak	1	Strong	0
CD5	+	1	-	0
CD23	+	1	-	0
CD22/CD79b	Weak	1	Strong	0
FMC7	-	1	+	0

+, present; -, absent.

Note: Diagnosis of chronic lymphocytic leukemia requires a score of 4 or 5.

From Matutes E, Polliack A. Morphological and immunophenotypic features of chronic lymphocytic leukemia. *Rev Clin Exp Hematol* 2000;4:22-47.

The CD5 antigen is most commonly associated with mature T-cells and is expressed weakly on thymocytes.^{2, 262} However, normal B-cells carrying the CD5 marker are located in the mantle zone of the lymph node, and small numbers of these cells are also present in the peripheral blood.²⁶² The CD5 molecule has been cloned and appears to be involved in the activation of T lymphocytes. The function of CD5 on the B-cell remains unknown, but its induction has been shown to be inhibited by the T-cell-derived cytokine IL-4. CD5⁺ B-cells can be stimulated to secrete anti-DNA antibodies and rheumatoid factors in vitro, and increased numbers are found in the peripheral blood of patients with rheumatoid arthritis, systemic lupus erythematosus, and Sjögren syndrome.²⁶² It has been suggested that the normal counterpart of the CLL cell is the CD5⁺ B-cell,¹⁹ although detailed immunophenotyping demonstrated significant differences between the two groups.²⁶³ Thus, the CD5⁺ B-cell appears to be a resting antigen-naïve cell, whereas the CLL cell is activated and antigen-experienced. Moreover, the specific activation marker expression pattern varies between cells that have IgV_H gene mutations and those that do not, with the unmutated group resembling B-cells at an earlier state of activation.⁴¹ Older studies suggested that about 5% of cases of CLL could be CD5⁻ and were more likely to be FMC7⁺, CD23⁻, CD11b⁺, and CD13⁺ and have a poor prognosis.²⁶¹ However, these CD5⁻ cases should be reclassified, as CD5⁺ is essential for the diagnosis of CLL.^{1, 3}

Surrogate Markers for IgV_H Mutational Status

Both CD38 and ZAP-70 have been evaluated as surrogate markers for IgV_H mutational status, as these can be measured readily by flow cytometry. To define the stage of maturation of the CLL cell, Damle et al.⁴² measured CD38 levels in CLL. Approximately 50% of patients had >30% CD38⁺ cells, and these patients had unmutated IgV_H and had a worse prognosis than those with <30% CD38⁺ cells. However, not all have found such a correlation.² CD38 acts as a receptor and enzyme and can produce cell replication and survival with a variety of signals.²⁶⁴ Activation of CD38⁺ cells, but not CD38⁻ cells, through sIgM induces apoptosis and through IgD prolongs cell survival and induces differentiation.²⁶⁴ In addition, recent evidence suggests that the replicating cells in CLL are the CD38⁺ cells and the number of CD38⁺ cells is higher

P.1901

in lymph nodes, likely reflecting the higher rate of cell proliferation at that site.^{115, 265} Although CD38 can be measured easily by flow cytometry there is disagreement about the number of cells that are required to define positivity, with values ranging from 5% to 30%.^{266, 267, 268} Moreover, the number of CD38 positive cells can vary over time.^{266, 267, 268}

ZAP-70 is a member of the Syk-ZAP-70 protein kinase family and is expressed in T and natural killer (NK) cells and is important in T-cell signaling.^{269, 270} However, recent evidence suggests that normal B-cells may also express ZAP-70, particularly when activated.^{269, 270} Gene expression studies in CLL have also demonstrated that cells with unmutated IgV_H have an increased expression of ZAP-70 whereas those with mutations have low levels.⁷ Subsequent studies have shown a 70% to 90% correlation between ZAP-70 expression and IgV_H mutational status, regardless of whether ZAP-70 was measured by flow cytometry (≥20% cells positive), Western blot analysis, or immunohistochemistry.^{271, 272, 273, 274} Kröber et al.²⁷⁵ have shown that discordant cases may have poor prognostic features including deletions of 17p13 or 11q22-q23, or IgV_H3-21 expression. ZAP-70 positivity also correlates moderately with CD38 positivity and the presence of poor-risk cytogenetics, that is, deletion 11q22-q23, deletion 17p13, and trisomy 12.^{275, 276} The poor prognosis associated with ZAP-70 positivity has been related to the magnified signaling by the BCR in ZAP-70-positive CLL cells.²⁷⁷ A major difficulty presently in the routine use of ZAP-70 is the variability in the assay as a result of the sensitivity of different antibodies and the use of different internal controls.^{266, 267, 268} Moreover, although initial studies suggested that ZAP-70 differed from CD38 in remaining stable during the disease course, more recent evidence indicates that ZAP-70 may also change over time.^{267, 268}

Immunoglobulin Production in Chronic Lymphocytic Leukemia

Apart from having either κ or λ light chains on the cell-surface membrane, clonality is confirmed by the presence of unique idiotypic specificities of the Igs produced by CLL cells²⁷⁸ and by IG gene rearrangements.^{2, 18} CLL cells have low to undetectable amounts of monoclonal polyreactive IgM autoantibodies, frequently of the rheumatoid factor type, on their surface.^{262, 263} Thus, the same monoclonal autoantibody produced by a leukemia cell may react with a variety of antigens (e.g., IgG, cardiolipin, histones, or single- or double-stranded DNA).²⁶² Surface and cytoplasmic Igs contain either κ or λ

light chains but never both. Most cells display a single heavy chain class, usually μ , although some display μ and δ . Less commonly, γ , α , or no heavy chain determinant is found. Although the CLL cell is believed to be frozen at a particular stage in maturation, up to 50% of CLL patients have IgM⁺ leukemia cells that are able to undergo isotype switching to IgA (usually) or to IgG.^{279, 280} Rearrangements of the IGH and IGL genes are seen in CLL and these remain constant over time.² Interestingly, the T-cell receptor β gene can be aberrantly re-arranged in 6% of CLL cases and this is associated with chromosome 6q deletions.^{281, 282}

CLL cells may secrete idiotypic IgM and in most cases can be induced by mitogens to secrete IgM that can react to a variety of autoantigens.^{283, 284} Using a sensitive immunoblotting technique, monoclonal proteins can be detected in the serum of virtually all patients although the light chain of the protein is only the same as that on the CLL in half the cases.²⁸⁵ These findings indicate that the monoclonal protein in many cases is not derived from the tumor cells. Serum electrophoresis detects a monoclonal protein in approximately 5% of CLL cases and an abnormal serum-free light chain ratio is observed in one third of patients.^{286, 287} The presence of an abnormal ratio correlates with advanced disease, markers of aggressive disease, and poor prognosis.²⁸⁷

Functional Immune Abnormalities

Patients with CLL are immunosuppressed, as a result of hypogammaglobulinemia, alterations in T-cell function and to abnormalities in complement activation and neutrophil/monocyte function.^{288, 289} Moreover, the immunosuppression is potentiated by chemotherapy or immunotherapy. As a result, about 50% of patients have recurrent infections, with sepsis being an important cause of death. Apart from typical bacterial infections, CLL patients are also susceptible to opportunistic infections, particularly if they have received nucleoside analogues, steroids, or monoclonal antibodies. The nucleoside analogues are highly toxic to T lymphocytes, whereas monoclonal antibodies may be cytotoxic to B-cells (e.g., rituximab) or to both B- and T-cells (alemtuzumab).

The CLL cell has no useful immune function and shows poor stimulatory activity in mixed lymphocyte culture²⁹⁰ and in response to B-cell mitogens, such as pokeweed mitogen, lipopolysaccharide, and the Epstein-Barr virus.^{291, 292} However, phorbol esters, *Staphylococcus aureus* protein A from Cowan I, anti- μ antibodies, anti-CD40, and loxoribine have been shown to be potent mitogens.^{293, 294} Moreover, these cells are poor antigen-presenting cells and, as discussed below, can interfere with normal B- and T-cell function.²⁹⁵

The risk of infection is closely related to the extent of hypogammaglobulinemia in CLL, and the severity increases with the duration and stage of disease.^{288, 289, 296} The Ig levels are all decreased, and within the IgG class, reduced levels of IgG2 and IgG4 correlate best with the risk of infection; however, the decline in IgA levels is the most important predictor of infection.^{296, 297} Interestingly, the correlation between Ig levels and infection rate is not absolute, and some patients with normal Ig will have repeated infections whereas others with hypogammaglobulinemia will remain infection-free.²⁸⁸ Patients with CLL have reduced primary and secondary responses to immunization.²⁸⁹ Although patients with higher levels of gammaglobulin usually show better responses than those with low levels, the responses of both groups are abnormal. The pathogenesis of the hypogammaglobulinemia is poorly understood. However, impaired B-cell function and regulatory abnormalities of T-cells (including the reversal of normal helper/suppressor cell ratios) probably play a role. In addition, CLL-derived NK-cells have been shown to suppress Ig secretion by normal B-cells in vitro.²⁹⁸

The absolute number of T-cells may be increased in untreated CLL, and there are marked abnormalities in the surface markers, including inversion of the T-helper to -suppressor cell ratio, suggesting perturbations in T-cell function.^{290, 299} In addition, the increase in the number of T-suppressor cells may correlate with the degree of hypogammaglobulinemia.³⁰⁰ The T-cells usually respond normally to mitogens, such as phytohemagglutinin, in vitro and produce IL-2 and γ -interferon.³⁰¹ However, there is decreased T-helper function with reduced reactivity to allogeneic and autologous B-cells.^{302, 303} Spontaneous and antibody-dependent cytotoxicities are reduced, suggesting an abnormality in the large granular lymphocyte population, including NK-cells.³⁰⁴

The cause of these abnormalities is unclear, but the increase in T-cells has been ascribed to stimulation by CLL cells or chronic infection, such as cytomegalovirus (CMV).^{289, 305, 306} Alternatively, the B-, T-, and NK-cell functions may be suppressed by means of immunosuppressive factors produced by CLL B-cells.^{307, 308} The gene expression profile of CD4⁺ and CD8⁺ cells are different in CLL patients as compared to normal individuals.³⁰⁷ However, the abnormal expression could be induced in CD4⁺ and CD8⁺ cells from normal individuals by co-culturing them with CLL cells.³⁰⁷ Similar studies showed that CLL cells could affect the ability of normal T-cells to form normal immunologic synapses.³⁰⁸ One potential candidate that could be causing these changes is TGF- β , which is secreted by CLL cells and marrow stromal cells in CLL, and has been shown to be a potent inhibitor of normal B- and

T-cells.^{133, 134, 135, 136, 137} In addition, CLL cells express both CD40 and the CD40L (CD154), and these cells decrease CD154 expression by normal T-cells with resultant effects on normal B-cell differentiation and isotype switching.³⁰⁹

The levels of different complement components are decreased in CLL, particularly in patients with advanced disease.³¹⁰ As well, multiple defects in neutrophil and monocyte function have been described in CLL, and these are associated with an increased risk of infection.^{288, 311}

Autoimmune Manifestations

Despite being immune deficient, CLL patients have an increased incidence of autoimmune cytopenias secondary to autoantibody formation.^{312, 313, 314, 315, 316, 317, 318} The immune cytopenias may be present before or at the time of diagnosis in one third and during the course of disease in two-thirds.³¹⁵ CLL is the most common cause of autoimmune hemolytic anemia (AIHA), causing 14% of cases, followed by systemic lupus erythematosus.³¹² Moreover, patients with AIHA have an increased incidence of MBL and subsequently developing CLL, but this is not true for patients with immune thrombocytopenia (ITP).^{314, 316} Overall, 4% to 10% of CLL patients develop AIHA, and this is usually associated with a warm-type antibody against the Rhesus system and a positive direct antiglobulin test (DAT).^{312, 313, 314, 315} Another 7% to 14% of cases may have a positive DAT without evidence of hemolysis. The incidence of this disorder is increased with male sex, older age, high lymphocyte count, advanced disease, and the presence of biologic markers of poor prognosis, such as high β 2-microglobulin, high ZAP-70, and unmutated IgV_H.^{314, 315, 317} The diagnosis of AIHA may be difficult in CLL, as multiple factors may produce anemia, a positive DAT can exist without hemolysis, and other diagnostic parameters may be influenced by the disease.^{314, 315, 317} Zent et al.³¹⁷ have thus developed diagnostic criteria for the diagnosis of AIHA in CLL and include (a) hemoglobin <100 g/L; (b) ≥ 1 marker of hemolysis, i.e., reticulocytosis, increased indirect bilirubin without liver disease, increased lactate dehydrogenase (LDH) without another cause or increased marrow erythropoiesis; (c) positive DAT/cold agglutinins or ≥ 2 markers of hemolysis, without evidence of hypersplenism or bleeding. When fludarabine was introduced, AIHA was seen relatively frequently leading investigators to believe that this was a unique complication of the drug. However, in the LRF CLL4 trial the incidence of AIHA was similar in previously untreated patients who received chlorambucil (12%) as compared to fludarabine (11%), and the incidence was lowest in patients treated with a combination of fludarabine plus cyclophosphamide (5%) indicating that cyclophosphamide has a protective effect.³¹⁸ The likelihood of developing AIHA was greater if the patient had a positive direct DAT before treatment, had advanced disease, or had a high β 2-microglobulin test.³¹⁸ The incidence of a positive DAT before treatment was 14% and approximately one third of patients receiving chlorambucil or fludarabine with a positive DAT developed AIHA. Conversely, the chance that a patient who was DAT-negative would develop AIHA was 7%. Thus, the high incidence of AIHA observed when fludarabine was first used was because patients receiving this drug usually had advanced and previously treated disease. The protective effect of cyclophosphamide has been confirmed in a subsequent study where the incidence of AIHA was 1%.³¹⁹ Although the addition of rituximab to chemotherapy would be expected to reduce the incidence of AIHA further, it is reported to occur in <1% to 6.5% of patients receiving FCR.^{210, 319} The impact of the development of immune cytopenias on survival has been recently evaluated in 2 studies, which have demonstrated that the prognosis of these patients is no worse than those without cytopenias.^{315, 317}

ITP occurs in <1% to 2% of patients, and the diagnosis is based on an increase in platelet size in the peripheral blood and an increase in megakaryocytes in the marrow, although the latter is often difficult to ascertain as the marrow usually is heavily infiltrated with CLL cells. ITP may be predicted if there is an isolated fall in platelets without splenomegaly as anemia usually precedes thrombocytopenia when cytopenia is caused by marrow replacement. Autoimmune neutropenia occurs rarely in CLL but should be considered if patients remain neutropenic following chemotherapy with recovery in the other blood counts. A bone marrow analysis will be required under these circumstances to assess marrow reserve. Red cell aplasia is also rare and is suspected when a patient develops isolated anemia with reticulocytopenia and none of the usual signs of hemolysis. A marrow shows a reduction in red cell precursors.

Several pieces of evidence indicate that the antibodies causing these cytopenias are produced by normal B-cells and not CLL cells. First, the antibodies are polyclonal and are usually IgG. Second, the autoimmune disorders may occur while the patient's disease is responding to therapy.^{312, 313, 314, 315} It has been suggested that CLL cells act as antigen-presenting cells for normal CD5⁺ or CD5⁻ antibody-producing B-cells and that antibody production is increased after inhibition of T-cells, either with advancement of disease or because of therapy.^{312, 313} Antigen presentation may occur in the spleen which is the major site of removal of senescent red cells and may be potentiated by T-cells through CD40L-CD40.^{313, 320} There is an association between AIHA in CLL and the expression by the leukemia cells of certain IgVH genes, for example, V1 family gene DP51p1.³²⁰ How this may influence the normal B-cell population to produce red cell antibodies is unknown. In

contrast, pure red cell aplasia is caused by a T-cell mechanism rather than the formation of autoantibodies, and these patients respond well to cyclosporine, a drug that affects T-cell function.^{313, 314, 321}

The above abnormalities are caused by normal B- or T-cells, however, antibodies produced by CLL cells can cause cold agglutinin disease, peripheral neuropathy, and paraneoplastic pemphigus.³¹³ Normal CD5⁺ B-cells can produce autoantibodies to IgG and single- and double-stranded DNA, as well as other autoantigens, and the number of these cells is increased in autoimmune disorders.²⁶² CLL cells can be induced to secrete IgM molecules that react with a comparable spectrum of antigens.^{264, 283, 318} Alternatively, IgM⁺ CLL cells can undergo isotype class-switching to IgG⁺ cells.^{278, 279}

In contrast, a number of other conditions may be caused by antibodies produced directly by the CLL cells.³¹³ Thus, the IgM antibody-producing cold agglutinin disease in CLL is produced by the CLL cells against the red cell I antigen and the CLL cells are typically IgV_{H4-21}.³²² Antibody produced by the CLL cells against myelin-associated glycoprotein (MAG) may also cause a poly-neuropathy.³¹³ Paraneoplastic pemphigus causes painful mouth ulcers, conjunctivitis, and pruritic blistering skin lesions.³²³ This disorder is diagnosed by distinct histologic changes in the skin and the presence of autoantibodies in the blood directed against cutaneous epitopes.^{323, 324} Acquired angioedema is associated with recurrent abdominal pain and is caused by consumption of the inhibitor of the first component of complement by tumor.³¹³ Glomerulonephritis, frequently with nephrotic syndrome, may occur secondary to deposition of intact monoclonal antibody or light chains in the kidney and remits with treatment of the CLL.^{313, 325} As opposed to the immune cytopenias, all of the above occur with CLL disease progression and resolve with treatment of the leukemia.

DIAGNOSIS

The International Workshop of Chronic Lymphocytic Leukemia (iwCLL) in 2008 changed the diagnosis of CLL to require a peripheral blood B-cell count of $\geq 5 \times 10^9/L$ and the presence of monoclonal (kappa or lambda) B-cells which have the P.1903

typical immunophenotype of CLL cells (CD19⁺, CD5⁺, CD23⁺, and decreased expression of surface Ig, CD20, and CD79b).¹ Using these markers a diagnostic scoring system for CLL has been developed and CLL may be considered “atypical” if there are variations in these markers (Table 90.3). The CLL cells are mature-appearing lymphocytes admixed with larger or atypical cells, PL, and cleaved cells. Having more than 55% PL is consistent with PLL. Individuals with a peripheral blood B-cell count of $< 5 \times 10^9/L$ and CLL cells in the blood have either SLL or MBL. These two disorders can be distinguished as MBL lacks lymphadenopathy or splenomegaly (by physical examination or CT scans;¹ Table 90.4).

TABLE 90.4 CHRONIC LYMPHOCYTIC LEUKEMIA AND VARIANTS

Marker	Monoclonal B-Cell Lymphocytosis (MBL)	Chronic Lymphocytic Leukemia (CLL)	Small Lymphocytic Lymphoma (SLL)
Peripheral blood B-cell count	$< 5 \times 10^9/L$	$\geq 5 \times 10^9/L$	$< 5 \times 10^9/L$
Enlarged lymph nodes or spleen ^a	No	Maybe	Yes

^a By physical examination.

From Hallek M, Cheson BD, Catovsky D, et al. Guidelines for the diagnosis and treatment of chronic lymphocytic leukemia: a report from the International Workshop on Chronic Lymphocytic Leukemia updating the National Cancer Institute-Working Group 1995 Guidelines. Blood 2008;111:5446-5456.

DIFFERENTIAL DIAGNOSIS

In most patients, the diagnosis of CLL is easily made after a careful review of the peripheral smear and immunophenotyping, although other conditions must be considered (Table 90.5). On occasion, immunohistochemistry or gene rearrangement studies are required to exclude other diagnoses.

Benign Causes

T-cell-Associated Causes

Chronic infections, such as tuberculosis or syphilis, may produce a lymphocytosis. A transient lymphocytosis may also be seen in viral illnesses, such as pertussis, CMV, or infectious mononucleosis. However, these are usually found in children or young adults and should be easily distinguished from CLL by the clinical features and the morphologic appearance of the cells.

B-cell-Associated Causes

Persistent polyclonal B-cell lymphocytosis is a rare and benign condition seen typically in middle-aged female smokers with a familial tendency.^{326, 327, 328} The lymphocytes are binucleated and have abundant cytoplasm. There is a polyclonal increase in Igs and a strong association with HLA-DR7, and an isochromosome 3q⁺ (i3)(q10) is observed in some cases.^{326, 327} These cells show IgV_H gene mutations and immunophenotypically are marginal zone lymphocytes.³²⁸ Delage et al.³²⁷ have demonstrated multiple BCL2/IGH gene rearrangements in this disease and described a family in which there was a high incidence of the gene rearrangements in first-degree relatives in association with a paternal HLA haplotype. These findings suggest that persistent polyclonal B-cell lymphocytosis can be a familial disorder and that the BCL2/IGH gene rearrangements may represent the first abnormality before B-cell expansion.³²⁷

Tropical splenomegaly syndrome or hyperreactive malarial splenomegaly occurs in countries with endemic malaria and may mimic CLL.^{329, 330} This disease is believed to be a disordered response to malarial antigens leading to overproduction of B-cells and is characterized by massive splenomegaly, an increase in IgM, and, in 10% of cases, an increase in the peripheral lymphocyte count. The disorder responds to antimalarial therapy, and this can be used to differentiate hyperreactive malarial splenomegaly from CLL.

Malignant Causes

Malignant disorders that may be confused with CLL are summarized here for comparative purposes and as an aid in differential diagnosis (Table 90.5). Before flow cytometry became routine, many patients were diagnosed as having CLL but in fact had other disorders³³¹ (Table 90.2). The most common malignancies to be confused with CLL are PLL and the leukemic phase of non-Hodgkin lymphomas. Morphologically, these disorders may appear similar to CLL.

B-cell-Associated Causes

Monoclonal B-cell lymphocytosis

In MBL there is a persistent increase in the number of monoclonal B-cells in the peripheral blood but the B-cell count remains $<5 \times 10^9/L$; there are three common variants, CLL-like MBL (CD5⁺, CD20 dim), atypical MBL (CD5⁺, "bright CD20," and CD5-MBL (Fig. 90.8).^{1, 332, 333} MBLs are found in 3.5% of adults older than 40 years of age with normal blood counts with the incidence increasing with age.^{334, 335} The incidence of MBL is even higher (13.5%) among healthy members of CLL families^{25, 26, 336} and in otherwise healthy people with a lymphocyte count $>4 \times 10^9/L$. A more recent study using 8-color flow cytometry detected MBL in up to 12% of healthy individuals with normal blood counts, suggesting

P.1904

that the incidence of the abnormality may be even higher depending on the sensitivity of the assay.³³⁷ Rather than having a continuous distribution of B-cell numbers in MBL there appears to be a bimodal distribution with a lower peak of 0.0001 to 0.010×10^9 clonal B-cells/L (detected when screening the healthy individuals, "population MBL") and a second peak of 0.05 to 0.5×10^9 clonal cells/L (detected when testing individuals for a slightly elevated lymphocyte count, "clinical MBL").³³⁸ Although the risk of patients with "population MBL" progressing to CLL is exceedingly low, these patients may harbor CLL-like genetic abnormalities, such as deletion 13q14, trisomy 12, or deletion 17p13, and have IgV_H gene mutations.^{339, 340} Moreover, there are multiple T-cell clones in half the cases, suggesting that the whole immune system is affected, perhaps related to chronic immune stimulation.³⁴⁰ Support for this concept has been the observation that multiple B-cell clones may also be observed in these individuals.^{334, 337} The difference between "clinical MBL" and low-count Rai stage 0 CLL appears quite arbitrary and 40% of patients diagnosed with CLL using the older criteria for CLL (lymphocyte count $>5 \times 10^9/L$) are now considered to have MBL.³⁴¹ Recent evidence indicates that the survival of CD38-"Clinical MBL" (79% patients, $<30\%$ cells positive) is no different from age- and sex-matched controls whereas the survival

of CD38⁺ "Clinical MBL" (21% patients, $\geq 30\%$ cells positive) and Rai stage 0 patients is reduced.³⁴² Rawstron et al.³³⁶ have estimated that approximately 1% of the "Clinical MBL" cases will progress to CLL and require treatment each year.

TABLE 90.5 DIFFERENTIAL DIAGNOSIS OF CHRONIC LYMPHOCYTIC LEUKEMIA (CLL)

Benign Causes

Bacterial (e.g., tuberculosis)

Viral (e.g., infectious mononucleosis)

Persistent polyclonal B-cell lymphocytosis

Hyperreactive malarial splenomegaly

Malignant Causes

B-Cell

Monoclonal B-cell lymphocytosis (MBL)

Prolymphocytic leukemia (PLL)

Leukemic phase of non-Hodgkin lymphomas

Mantle cell lymphoma

Follicular lymphoma

Marginal zone lymphoma

Lymphoplasmacytic lymphoma

Diffuse large-cell lymphoma

Hairy cell leukemia (classical and variant)

Waldenström macroglobulinemia

T-Cell

Prolymphocytic leukemia

Adult T-cell leukemia/lymphoma

Sézary syndrome

Large granular lymphocytic (LGL) leukemia

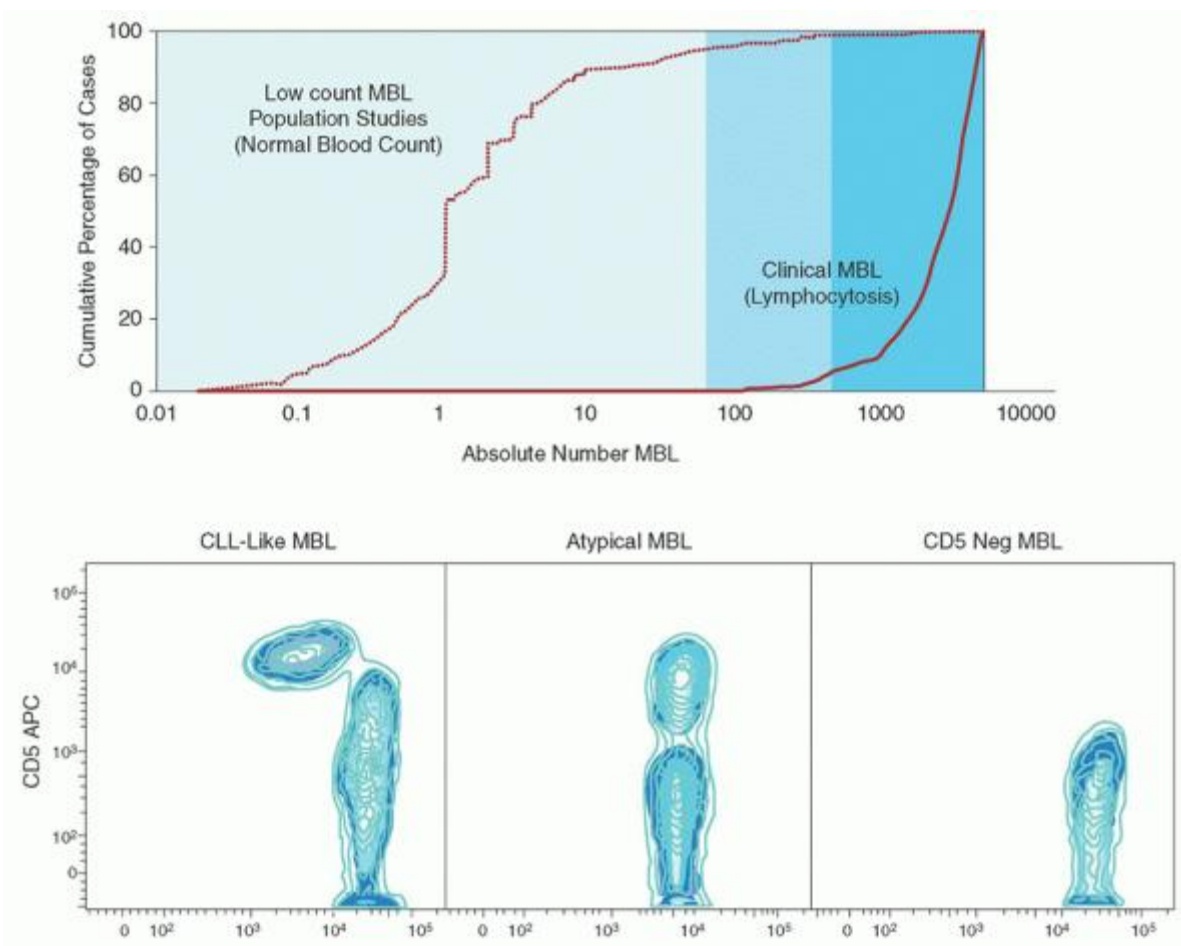

FIGURE 90.8. Role of absolute B-cell count in monoclonal B cell lymphocytosis (MBL) and immunophenotype patterns. The top panel shows the absolute number of B-cells as a cumulative function of the number of cases dividing low-count MBL (normal white blood cell count, absolute lymphocyte count) from clinical MBL (with lymphocytosis). The bottom panel from left to right shows the three major immunophenotypic patterns seen in MBL. From Marti GE. MBL: mostly benign lymphocytes, but... Blood 2011;118:6480-6481.

An ethical issue over MBL has been the possibility of unintentional transmission of this syndrome by blood transfusion or hematopoietic cell transplantation (HCT).^{337, 343} This issue is discussed further in the section on HCT for CLL.

B-cell Prolymphocytic Leukemia

B-cell PLL is characterized by larger, less mature-appearing cells than are seen in CLL, and the nucleus has condensed chromatin and prominent central nucleoli.^{344, 345} Patients with CLL/PLL have 11% to 54% PL, but in PLL ≥55% of the cells are PL.²⁵¹ PLL appearing de novo is an aggressive disease, and patients frequently are symptomatic with fever, weight P.1905

loss, or abdominal discomfort and are found to have massive splenomegaly, minimal lymphadenopathy, and resistance to therapy.^{344, 345} Leukocyte counts in excess of $150 \times 10^9/L$, consisting almost entirely of PL, are common, as are anemia and thrombocytopenia. The cells invariably have intense staining for surface membrane Ig, FMC7, CD20, and CD79b, whereas this may or may not occur with CLL/PLL.²⁵¹ One third of cases have a deletion of 11q23, one half a deletion of 13q14, and one half a mutation of TP53.^{346, 347} Although occasional patients may initially have stable disease, progression is the rule, and the median survival is 65 months.³⁴⁵

Leukemic Phase of Non-Hodgkin Lymphoma

The leukemic phase of non-Hodgkin lymphoma used to be referred to as lymphosarcoma cell leukemia and includes the leukemic phase of mantle cell lymphoma, follicular lymphoma, splenic lymphoma with villous lymphocytes (splenic marginal zone lymphoma), other marginal zone lymphomas, and, rarely, large-cell lymphomas. The lymphocytes in mantle

cell lymphoma are larger than those seen in CLL and have more cytoplasm; in contrast to CLL and the other disorders, there is variation in cell morphology, with some cells looking like classical CLL cells, others having irregular nuclei, and some looking like PL.^{348, 349} Two-thirds of patients have marrow involvement and one third have leukemic presentation.³⁴⁸ Patients with a leukemic picture have aggressive disease. The cells strongly express surface Ig and are CD19⁺, CD20⁺, CD5⁺, CD23⁻, CD10⁻, and FMC7⁺.³⁵⁰ These cells have the t(11;14)(q13;q32) and, by immunohistochemistry, stain strongly for cyclin D1. As the breakpoint for t(11;14)(q13;q32) covers a large area, polymerase chain reaction (PCR) using only one set of primers misses many cases, and Southern blot analysis or FISH may be required.^{350, 351} The leukemic phase of follicular lymphomas may be confused with CLL; usually, the cells are small, the nuclear chromatin is smooth and not clumped, there is almost no cytoplasm, and the nucleus is indented.³⁵² Occasionally, large cells are seen, and, when possible, a lymph node biopsy should be carried out to type the follicular lymphoma. The cells are identified by immunophenotyping and are CD19⁺, CD20⁺, FMC7⁺, CD23⁻, CD5⁻, and CD10⁺. The diagnosis can be confirmed by demonstrating a t(14;18)(q32;q21). Approximately 10% of peripheral B-cell lymphocytosis is caused by splenic marginal zone lymphoma; these cells have characteristic filamentous projections and, frequently, a nucleolus.^{351, 353} The cells are usually SIg⁺ (strong), CD19⁺, CD20⁺, CD23⁻, CD5⁻, CD79b⁺, and FMC7⁺. The other forms of marginal zone lymphomas (mucosa-associated lymphoid tissue and monocytoid B-cell lymphomas) and lymphoplasmacytic lymphomas may also rarely involve the marrow and peripheral blood.³

Hairy Cell Leukemia

In hairy cell leukemia (Chapter 91) the cells are of moderate size with eccentric oval nuclei and variable prominent nucleoli. The cells differ from CLL cells in being tartrate-resistant acid-phosphatase positive (TRAP+) and CD5⁻, CD11c⁺, CD25⁺, CD103⁺, and CD123⁺.³⁵⁴ In contrast to classical hairy cell leukemia, in which the lymphocyte count is usually low, the variant form of hairy cell leukemia has a higher lymphocyte count, but the cells have prominent nucleoli, are TRAP-, and are CD25⁻ and CD123⁻.³⁵⁵

T-cell-Associated Causes

The chronic T-cell disorders are much less common than the B-cell disorders but can be classified into 4 groups.²⁵¹

T-cell Prolymphocytic Leukemia

Formerly called T-cell CLL, T-cell PLL cells have a prominent nucleolus and the nucleus may be either round to oval in half the cases or irregular, often with convolutions.³⁴⁷ Splenomegaly is typically present, with lymphadenopathy in half the cases and skin involvement (nodules or a maculopapular rash) in 20%. Periorbital edema may also occur. Cells are CD3⁺, CD4⁺, CD7⁺, and CD8⁻, but in one-quarter of patients, the cells are both CD4⁺ and CD8⁺ or, more rarely, CD4⁻ and CD8⁺.³⁴⁷ Most patients (81%) achieve a complete remission (CR) with intravenous alemtuzumab with a median survival of 2 years.³⁴⁷

Adult T-cell Leukemia/Lymphoma

Adult T-cell leukemia/lymphoma is most common in Asia and has a variety of clinical presentations.^{356, 357} Patients may present acutely with lymphadenopathy or hepatosplenomegaly, although skin involvement, lytic bone lesions, hypercalcemia, and involvement of other organs have been described. Alternatively, there may be a chronic form of the disease with peripheral lymphocytosis and skin involvement, which may either resolve entirely or develop into the acute form of the disease.³⁵⁷ A prognostic classification has been developed based on the proliferative capacity of the peripheral blood leukemic cells.³⁵⁸ The cells are usually CD4⁺ and are infected with human T-cell leukemia/lymphoma virus-1.

Sézary Syndrome

Sézary syndrome is the leukemic form of mycosis fungoides, and affected patients have diffuse skin involvement plus lymphadenopathy and splenomegaly, although peripheral lymphocytosis can occur in isolation.³⁵⁹ The cells are typically large with cerebriform nuclei, coarse chromatin, and inconspicuous nucleoli, and are usually CD4⁺.³⁵⁹ The diagnosis of Sézary's syndrome requires a peripheral blood Sézary cell count of $>1 \times 10^9/L$ or that $>20\%$ of the lymphocytes be identified as Sézary cells.³⁵⁹

Large Granular Lymphocytic Leukemia

Large granular lymphocytic (LGL) leukemia is characterized by moderate lymphocytosis (1 to $49 \times 10^9/L$) and the presence of cells that are bigger than CLL cells with abundant cytoplasm containing azurophilic granules.^{360, 361, 362} However, there is considerable variation, even within the same patient. In some cases, the lymphocytes may appear normal, and the granules may be coarse, fine, or absent.³⁶⁰ Large granular lymphocytes may be NK-cells that mediate nonmajor histocompatibility complex-restricted cytotoxicity or CD3⁺ T-cells that mediate nonmajor histocompatibility complex-

restricted cytotoxicity.³⁶⁰ T-LGL leukemia is the most common form, making up 85% of cases, and is associated with neutropenia (which may be cyclical), red cell aplasia, and rheumatoid arthritis (25%), but this is a distinct entity from Felty syndrome.³⁶⁰ It has been suggested that the neutropenia is related to the expression of FAS ligand by LGL cells.³⁶³ The usual immunophenotyping of T-LGL leukemia is CD3⁺, CD4⁻, CD8⁺, CD16⁺, CD56⁻, CD57⁺, and TCRαβ⁺; T-cell receptor gene rearrangement studies confirm T-cell monoclonicity. If therapy is required, responses may be observed with cyclosporin or methotrexate.³⁶⁴, ³⁶⁵ NK-LGL leukemia occurs most frequently in Japan and has an acute fulminant course with high fever, hepatosplenomegaly, and pancytopenia.³⁶¹ However, chronic NK-cell leukemia can occur, with a clinical course similar to that of T-LGL leukemia.³⁶² These cells are usually CD3⁻, CD4⁻, CD8⁻, CD16⁺, CD56⁺, and CD57⁻.³⁶⁰

INVESTIGATIONS AND STAGING

Investigations

A complete blood count, review of the peripheral smear, and immunophenotyping are required for diagnosis and prognosis in CLL. Recommended investigations have been published by the IWCLL and the European Medical Society of Oncology (EMSO).¹, ⁵

P.1906

These investigations depend on whether a patient is being seen in general practice or within the context of a clinical trial.

Standard Tests for General Practice

Physical Assessment

This includes measuring the bidimensional size of the largest nodes in the cervical, supraclavicular, axillary, inguinal, and femoral regions with measurement of the spleen and liver. The performance status should also be documented.

Laboratory Measurements

Complete blood count with white cell differential (including the percentage of PL) and reticulocyte count. DAT, routine plasma biochemistry [including renal/liver function tests, and LDH], serum protein electrophoresis and/or immunoelectrophoresis, and Ig levels.

Screening for hepatitis B and C, cytomegalovirus (CMV), and human immunodeficiency virus (HIV) should be carried out before treatment. Therapy for patients who are HIV-positive will need to be individualized depending on their condition and medications. Patients who have antibody to CMV will require monitoring and treatment if there is viral reactivation with alemtuzumab or allogeneic HCT.³⁶⁶ Patients who have hepatitis B antigenemia will require therapy with suppressive therapy (such as lamivudine) during chemotherapy in order to prevent viral reactivation.¹, ⁵

A number of prognostic markers may help in determining the rate of disease progression and overall prognosis in newly diagnosed patients and is discussed in detail below. FISH is recommended prior to therapy as the presence of certain abnormalities (deletion 17p13 or 11q22-23) can influence treatment.

Radiology

A baseline chest x-ray is useful to determine any pre-existing lung disease.

Additional Tests for Clinical Trials and Specific Clinical Situations

Laboratory Measurements

A marrow aspirate/biopsy may be useful: (a) to assess normal marrow reserve and to establish the cause of anemia and thrombocytopenia for patients with Rai stage III or IV disease; (b) to assess the cause of persistent cytopenias following chemotherapy, and (c) to assess cellularity and the extent/pattern of marrow infiltration, which is of prognostic value.²⁵²

Radiology

A meta-analysis has recently demonstrated that CT scans are not of value for routine management.³⁶⁷ Findings of the baseline CTs were not prognostically important and disease progression could be detected by clinical examination and blood counts. The presence of persistent radiologic disease following therapy predicted a shorter progression-free survival (PFS) and OS for patients treated with chemotherapy but was not of value when rituximab was added to chemotherapy, as in the German CLL8 study,²¹⁰ where FC (fludarabine/cyclophosphamide) was compared with FCR (fludarabine/cyclophosphamide/rituximab). Thus, the use of prognostic markers and the detection of minimal residual disease (MRD) following therapy are of greater value in CLL than CT scans. However, CT scan may be used: (a) in clinical trials; (b) to confirm a remission prior to hematopoietic cell transplant, where tumor burden is prognostically important,

and (c) to assess tumor burden prior to treatment with alemtuzumab. Patients with lymph nodes >5 cm respond poorly to alemtuzumab and require alternate therapy.³⁶⁷ PET scans are not useful for staging in CLL, as 18F-FDG uptake in CLL is low. However, they are useful to identify a suitable node for biopsy when determining whether new lymphadenopathy is related to disease progression, transformation, or a second malignancy.

Staging

Two staging systems are in general use, and are based on physical examination and results of a routine blood count.^{368, 369} The Rai staging system is generally used in North America, and the original system divided patients into 5 groups on the basis of lymphocytosis alone (peripheral blood lymphocyte count $\geq 15 \times 10^9/L$ and $\geq 40\%$ lymphocytes in the marrow), clinically apparent lymphadenopathy or splenomegaly, and the presence of anemia (hemoglobin <110 g/L) or thrombocytopenia (platelets $< 100 \times 10^9/L$; Table 90.6).³⁶⁸ A simplified 3-stage version of this scheme is now generally accepted (Table 90.6).¹ The Binet staging system is most frequently used in Europe,³⁶⁹ and staging is based on the number of involved areas, the level of hemoglobin, and the platelet count (Table 90.7). The diagnosis of CLL required a peripheral blood lymphocyte count of $\geq 4 \times 10^9/L$ with $\geq 40\%$ lymphocytes in the marrow. The 5 areas of involvement were 3 lymph node areas (cervical, axillary, and inguinal, whether unilateral or bilateral), the spleen, and the liver.

Several points should be emphasized about these staging systems:

- The staging is based on clinical examination and not on CT scans.
- The cause of cytopenia was not defined in the original descriptions of Rai stages III/IV or Binet stage C disease. A recent detailed study from the Mayo Clinic demonstrated that one-quarter of all CLL patients develop cytopenia, with 54% being due to marrow replacement by tumor, 18% due to immune cytopenias, and 28% due to other causes, for example, chemotherapy or uremia.³¹⁷ Recent studies have shown that the survival of patients with immune cytopenias is much better than those due to marrow replacement by tumor and likely not different to those without cytopenias.^{315, 317} It has thus been suggested that patients should be subclassified according to the cause of their cytopenia.

TABLE 90.6 RAI CLASSIFICATION SYSTEM FOR CHRONIC LYMPHOCYTIC LEUKEMIA (CLL)

Stage	Modified Stage	Description	Median Survival (y)
0	Low-risk	Lymphocytosis ^a	>10
I	Intermediate-risk	Lymphocytosis + lymphadenopathy	7-9
II	Intermediate-risk	Lymphocytosis + splenomegaly ± lymphadenopathy	7-9
III	High-risk	Lymphocytosis + anemia ^a ± lymphadenopathy or splenomegaly	1.5-5
IV	High-risk	Lymphocytosis + thrombocytopenia ^a ± anemia, splenomegaly or lymphadenopathy	1.5-5

^aLymphocytosis, originally lymphocytes $>15 \times 10^9/L$ for >4 weeks; anemia, hemoglobin <110 g/L; and thrombocytopenia, platelets $< 100 \times 10^9/L$. Data from Rai JL, Sawitsky A, Cronkite EP, et al. Clinical staging of chronic lymphocytic leukemia. *Blood* 1975;46:219-234, and Shanafelt TD. Predicting clinical outcome in CLL: how and why. *Hematology (Am Soc Hematol Educ Program)* 2009:421-429.

- P.1907
-

TABLE 90.7 BINET CLASSIFICATION FOR CHRONIC LYMPHOCYTIC LEUKEMIA (CLL)

Stage	Blood Counts	Involved Areas ^a	Median Survival (y)
A	Hb >100 g/L and platelets $> 100 \times 10^9/L$	<3	>10
B	Hb >100 g/L and platelets $> 100 \times 10^9/L$	≥ 3	7

C Hb <100 g/L, or platelets <100 × 10⁹/L, or Any number both 2-5

Hb, hemoglobin.

“The five areas of involvement include head and neck, axillae, groins, palpable spleen, and clinically enlarged liver.

Data from Binet JL, Auquier A, Dighiero G, et al. A new prognostic classification of chronic lymphocytic leukemia derived from a multivariate survival analysis. *Cancer* 1981;48:198-206, and Shanafelt TD. Predicting clinical outcome in CLL: how and why. *Hematology (Am Soc Hematol Educ Program)* 2009:421-429.

- The diagnosis of CLL in the original studies was not based on immunophenotyping, whereas nowadays the diagnosis of CLL depends on a peripheral blood B-cell count of ≥5 × 10⁹/L. Thus, a number of patients in the original studies likely had non-Hodgkin lymphomas with leukemic involvement. This might partly explain the poorer prognosis for patients with advanced stages, as compared with more recent observations. However, the relative survival of patients with confirmed CLL and stages Binet B/C disease has increased over the past 20 to 30 years, suggesting that the improved survival nowadays is related to improved therapy or supportive care.³⁷⁰

PROGNOSIS

CLL is a very heterogeneous disease, both in presentation and disease progression. The Rai or Binet clinical staging systems are simple and reliable prognostic measures. However, the prognostic value of these systems has been somewhat tempered, as there is variation in survival within each stage and the majority of patients are in Rai stage 0/I at diagnosis.²⁴⁵ Thus, 30% to 50% of patients with early-stage disease will require therapy in 1 to 4 years and have a median survival of 7 to 8 years whereas occasional patients may have a spontaneous remission.^{245, 371} This uncertainty about the future creates great anxiety for the patient and has led to tremendous efforts to develop reliable prognostic markers^{267, 268, 372} (Table 90.8). Stratification of patients into different risk groups will allow for a more rational approach to treatment options and will identify specific patient groups to be studied in clinical trials. Several general points about prognostic markers should be made. First, these markers have generally been evaluated in patients less than 65 years of age and their value in older patients is less certain.^{11, 12} Thus, although IgV_H status and FISH results are useful predictors of survival for younger patients they are less useful in those ≥75 years.^{11, 12} Second, the markers have been studied at the time of diagnosis and their utility throughout the disease course is less clear. The exception here is for FISH, which is usually carried out prior to treatments; new genetic abnormalities can develop during the disease course and the results of FISH are important for prognosis and influencing treatment decisions. Finally, a prognostic marker may be able to predict one aspect of the disease course, for example, time to first treatment, but may not be able to predict PFS or OS.

TABLE 90.8 PROGNOSTIC MARKERS IN CHRONIC LYMPHOCYTIC LEUKEMIA (CLL)

Prognostic Marker	Better Prognosis	Worse Prognosis
Sex	Female	Male
Age	<70 y	>70 y
Plasma vitamin D level	High	Low
Rai stage	0, I, and II	III and IV
Lymphocyte count	<12 × 10 ⁹ /L	≥12 × 10 ⁹ /L
Lymphocyte doubling time	>12 mo	< 12 mo
Number of “smudge cells”	≥30%	<30%
β2-microglobulin level	Low	High
Flow cytometry: B-cell count CD38 ^a ZAP-70	<11 × 10 ⁹ /L <20% cells positive <20% cells positive	≥11 × 10 ⁹ /L ≥20% cells positive ≥20% cells positive
FISH	Deletion 13	Deletion 11q22-23 or 17p13

IgV_H mutation status

Mutated

Unmutated

^a The precise number of cells required for CD38 positivity varies according to the study.

Some prognostic markers, such as clinical staging, lymphocyte morphology and doubling time, CD38, serum LDH, β 2-microglobulin levels, and FISH are routinely available, but others are either experimental or only available at specialized centers. In the following section we review the most commonly used and new potentially important prognostic markers. Further details on other markers can be obtained in recent reviews.^{267, 268}

Rai and Binet Staging

The median survival of patients in the Rai staging low-risk group (~55% to 60%) who have an isolated lymphocytosis, is more than 10 years.^{267, 370, 373, 374, 375} Patients in the intermediate-risk group (~35% to 40%) have lymphadenopathy, splenomegaly, or both, and have a median survival of 7 to 9 years. Patients in the high-risk group (~5% to 10%) have anemia, thrombocytopenia, or both and a median survival of 1.5 to 5 years. Survival in the high-risk group depends on the cause of the cytopenia, being poorest

P.1908

in those with marrow failure due to CLL infiltration, whereas those with immune cytopenias have a good prognosis.^{315, 317} The median survival of patients with Binet stage A is >10 years, stage B is 7 years, and stage C is 2 to 5 years.³⁷⁵ Although both staging systems provide useful prognostic information, they do not correlate well with each other. Thus, there are more patients with Binet stage A as there are in the Rai low-risk groups, whereas the opposite is true for Binet stage B and Rai intermediate-risk groups.³⁷⁵

Age and Sex

Approximately 25% of CLL patients in the clinic are \leq 55 years, and the clinical features, prognostic markers, and staging at presentation are generally similar to older patients.^{12, 243, 244} Survival of both groups of patients is the same, although the proportion of deaths that can be directly attributed to CLL is greater for the younger age group.²⁴⁴ These results indicate that a subgroup of younger patients has aggressive disease and the risk of a Richter's transformation is fivefold higher in the younger age group.²⁴⁴ The male-to-female ratio for CLL is 1.3:1, and women are more likely to have early-stage disease. Regardless of stage and age, women have a better prognosis than men.^{376, 377} The mechanism(s) responsible for the improved survival in women is (are) unknown but has been related to an increased incidence of *IgV_H* mutated disease with good prognostic genetic markers in women.³⁷⁷ In addition, hormonal differences may be important as clinical responses have been observed in CLL when patients with co-existing prostate cancer were treated with estrogens.³⁷⁷

Lymphocyte Characteristics

Morphology

Approximately 20% of patients have atypical CLL or CLL/PLL, and these patients have a more advanced stage, a higher proliferative index, and a poorer prognosis.^{203, 204, 217, 254} These patients are also more likely to have trisomy 12 or deletion of 17p13 (TP53 mutation), to be CD38⁺, and to have unmutated *IgV_H*.^{204, 217, 284} However, in a multivariate analysis, aberrant cell morphology was found to be an independent prognostic marker.³⁷⁸ Patients with \geq 30% smudge cells have a better prognosis than those with <30% smudge cells.²⁵⁰

Number

Survival decreases with increasing B-cell or lymphocyte count at the time of diagnosis,^{341, 379} A B-cell count of $>11 \times 10^9/L$ predicts a shorter treatment-free survival and OS independent of CD38, ZAP-70, and *IgV_H* mutational status.³⁷⁹

Doubling Time

The lymphocyte doubling time (LDT) is a useful measure of disease aggressiveness. Indolent CLL is associated with a slow LDT, whereas patients with a LDT of <12 months have a significantly worse survival rate.^{380, 381} A recent study from Britain has demonstrated in 1,154 patients with Binet stage A disease that patients with a LDT of <12 months required treatment in 2.5 years and had a median survival of 12.6 years whereas those with a LDT of \geq 12 months required treatment in 18.6 years and had a median survival of 20.3 years.³⁸¹

Immunophenotyping

Variations in immunophenotyping, such as an increase in surface Igs, FMC7⁺, or increased intensity of CD20, may be associated with atypical morphology, trisomy 12, and poor prognosis.^{204, 253, 254, 382}

A number of studies have demonstrated the importance of CD38⁺ as a prognostic marker and this can be measured in either peripheral blood or marrow.^{266, 363, 381, 383, 384, 385} However, there is still controversy as to the number of cells required to denote positivity.^{247, 248} Initial studies suggest a correlation between the presence of an IgV_H gene mutation and CD38⁻ (<30% CD38⁺ cells), however, this has not been confirmed by others.^{266, 267} In all of these studies, CD38⁺ has been associated with shorter survival and correlates with increasing Rai stage, intrathoracic and abdominal lymphadenopathy, short doubling time, increased β2-microglobulin levels, and atypical morphology.^{383, 384, 385} Moreover, the CD38 status is useful to predict which patients within a particular clinical stage will progress.^{381, 384, 385} When followed over time, CD38⁻ patients may become CD38⁺, and this is associated with deletion of 17p13 (TP53 mutation) and disease progression.³⁷⁴

ZAP-70 is also a useful prognostic marker although further studies are required to standardize the assay and it is still unclear whether equivalent results are obtained on analyzing the marrow or peripheral blood.²⁶⁶ There is a 70% to 90% correlation between ZAP-70 expression and absence of IgV_H mutations, regardless of whether ZAP-70 is measured by flow cytometry (>20% cells positive), Western blot analysis, or immunohistochemistry.^{271, 272, 273, 274, 275} ZAP-70 positivity correlates moderately with CD38 positivity and the presence of poor-risk cytogenetics, that is, deletion 11q22-q23, deletion 17p13, and trisomy 12.²⁷⁵ Kröber et al.²⁷⁵ have also demonstrated that discordant cases may have poor prognostic features including deletions of 17p13 or 11q22-q23, or IgV_H3-21 expression. Thus, some patients with a mutated IgV_H3-21 gene express high levels of ZAP-70 and do poorly.^{271, 275} Alternatively, low ZAP-70 expression in some patients with unmutated IgV_H can correlate with the presence of deletions of 17p13 or 11q22-23.²⁷⁵ ZAP-70 positivity may be a stronger predictor for time to treatment (TTT), PFS, or OS than an unmutated IgV_H.^{273, 276} A comparison of the prognostic markers by the CLL Research Consortium has demonstrated that ZAP-70 is the most important marker for TTT.³⁸⁶ Thus, ZAP-70 positive patients had a median time from diagnosis to treatment of 2.6 years versus 8.4 years for ZAP-70 negative patients. The CD38 status did not add additional prognostic information but for ZAP-70 negative patients unmutated IgV_H patients had a median survival of 6.3 years versus 10 years for mutated IgV_H patients (Fig. 90.9). It is unclear why ZAP-70 positive CLL patients have a poor prognosis, although it has been related to the magnified signaling by the Ig cell receptor in ZAP-70 positive CLL cells.³⁸⁶

Alterations in T-cells are also prognostically important in CLL and a low CD4/CD8 ratio with a decreased number of NK-cells is observed in advanced disease with hypogammaglobulinemia.³⁸⁷

Molecular Genetics

FISH Studies

FISH has become a standard technique in CLL and patients with a deletion of 17p13 have a median survival of 2 to 3 years, compared with 6 to 7 years for those with a deletion of 11q22-23, 9 years for those with a trisomy 12 or normal FISH, and 11 years for those with a deletion of 13q14 alone.⁸⁴ The identification of deletions of 17p13 or 11q22-23 is particularly important as their presence can alter therapy and prognosis.^{2, 84, 210, 267, 388, 389}

The significance of a deletion 17p13 depends on when it is detected.^{390, 391} Thus, 4% to 5% of patients at diagnosis have a deletion of 17p13 and although half of these patients require treatment in 3 years one third will have stable disease.³⁹⁰ In contrast, at the time of first treatment, 10% patients have deletion 17p13 and these patients are resistant to chemotherapy with only one third surviving 3 years.²¹⁰ By the time patients are fludarabine-resistant, 33% will have a deletion of 17p13 and these patients have a very poor prognosis.²²⁵ Most patients with deletion 17p13 have a TP53 mutation on the other allele, however, patients may have a TP53 mutation without a deletion of 17p13.^{392, 393} Thus,

P.1909

fludarabine-resistant patients may have deletion 17p13 alone (~10%), deletion 17p13 with a TP53 mutation (~25%), or a TP53 mutation alone (~10%).^{225, 392, 393} Prognosis is equally poor in all groups leading to the suggestion that patients may require TP53 sequencing in addition to FISH studies.^{394, 395} The type of TP53 mutation is also important with mutations in the DNA binding domain portending a particularly poor prognosis.^{394, 395}

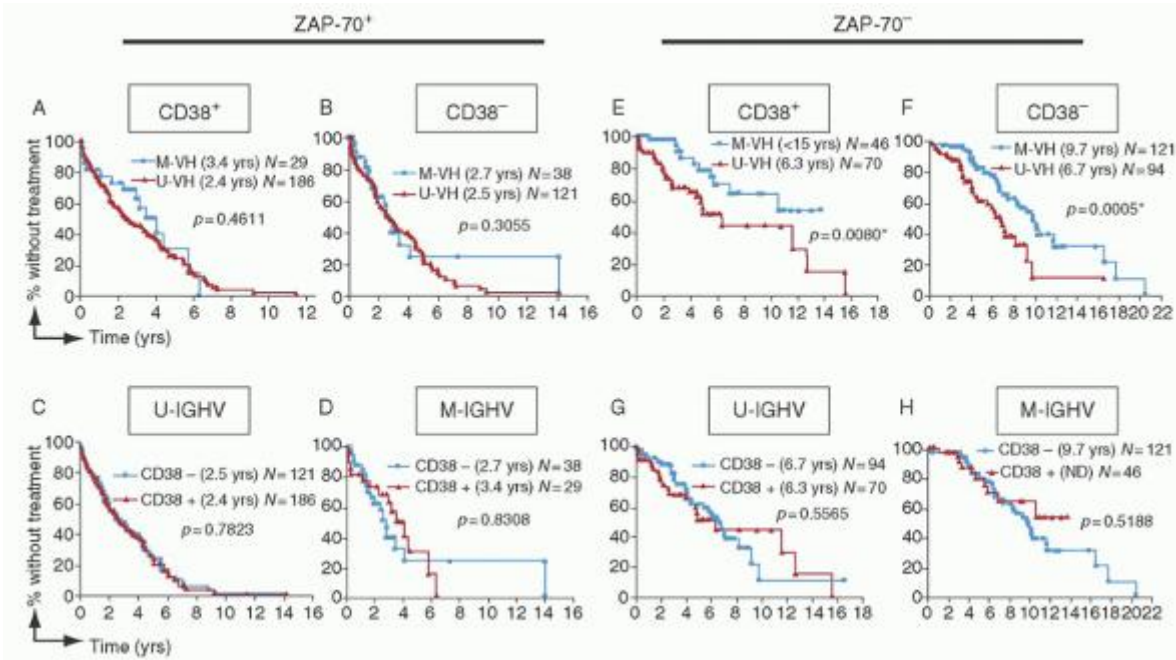

FIGURE 90.9. Relationship between ZAP-70 and CD38 or IGHV mutation status in defining the time from diagnosis to initial therapy. Kaplan-Meier curves depict the proportion of untreated CLL patients in the validation cohort (N = 705) from diagnosis to initial therapy. Panels A through D depict the time from diagnosis to initial treatment of patients who have CLL cells that express ZAP-70 (ZAP-70+), whereas panels E through H show the time from diagnosis to first treatment of patients with CLL cells that were ZAP-70 negative (ZAP-70⁻). Panels A and E or B and F show how IGHV mutation status can segregate cases that are CD38⁺ or CD38⁻, respectively. Panels C and G or D and H show how CD38 can segregate cases that use U-IGHV or M-IGHV, respectively. The P-values were determined using the log-rank test. The symbols represent the time at which patients were censored. From, Rassenti LZ, Jain S, Keating MJ, et al. Relative value of ZAP-70, CD38 and Ig mutation status in predicting aggressive disease in chronic lymphocytic leukemia. *Blood* 2008;112:1923-1930, with permission.

Patients with deletions of 11q22-23 typically are middle-aged men with bulky lymphadenopathy, and prognosis can be significantly improved with immunochemotherapy.^{210, 389} The addition of rituximab to fludarabine/cyclophosphamide (FCR) can improve the CR rate from 15% to 51% (p < 0.0001) and the OS at 3 years from 83% to 94% (p = 0.036).²¹⁰

Patients with trisomy 12 may have atypical morphology but the incidence does not correlate with stage and these patients respond well to chemotherapy.^{2, 210}

Mutations of the Immunoglobulin Gene and IgV_H3-21 Usage

Approximately 50% of patients with CLL have mutations of the IgV_H gene, and these patients generally have stable disease and normal cell morphology.^{2, 6, 7, 267, 268} In contrast, patients without IgV_H mutations are more likely to have atypical morphology, deletion of 11q22-23 and/or 17p13, and NOTCH1 mutations.^{2, 233} As a result, these patients generally have advanced disease, drug resistance, an increased risk of developing RS, and poor survival. Indeed, a recent large British study demonstrated that for Binet stage A patients the IgV_H mutational status was the most important prognostic indicator in a multivariate analysis.³⁸¹ The median TTT for patients with mutated IgV_H had not been reached and the median survival was 23.3 years, compared to a median TTT of 4.6 years and OS of 12.5 years in patients with unmutated IgV_H. The use of IgV_H3-21 has been associated with a poor prognosis, regardless of mutation status, perhaps related to overexpression of genes involved in transcription and cell cycle control.³⁹⁶

Telomere Length and Telomerase Activity

In CLL, the telomeres are generally shorter than in normal B-cells and are shortest in IgV_H unmutated cells.^{180, 397, 398, 399, 400} In response, telomerase may be increased, with activity being inversely related to telomere shortening. These abnormalities have been observed in patients with early-stage CLL with telomere shortening continuing to occur over time and being associated with telomere fusions and abnormal genetics, particularly deletions of 17p13 and 11q22-23.^{2, 398, 399, 400} Not surprisingly, increased telomerase and short telomeres have been associated with poor survival.³⁹⁸

NOTCH and SF1B3 Mutations

NOTCH1 and SF1B3 mutations have recently been identified as common and important prognostic markers in CLL and were discussed earlier.^{226, 227, 228, 229, 230, 231, 232, 233, 234, 235} Mutations in exon 34 of NOTCH1 is present in 4% to 10% of patients (usually unmutated IgV_H), but the incidence increases in patients with trisomy 12 (41.9%),²³² those with drug-resistant disease (20%),^{227, 233} and in those with Richter's syndrome (one third).^{227, 234} The NOTCH1 mutations decrease the rate of NOTCH1 protein clearance and thus increase the protein level and NOTCH1 activity.²⁰⁸ This results in increased NF- κ B activity with cellular proliferation and increased cellular inhibitor of apoptosis protein 2 (c-IAP2) and X-linked inhibitor of apoptosis protein (XIAP) with

P.1910

decreased apoptosis.²³⁰ Interestingly, disruption of TP53 function is only observed in 10% of cases with a NOTCH1 mutation and thus NOTCH1 mutations are associated with non-TP53-mutated drug resistance.²³³ Mutations of SF3B1 occur in 15% to 17% of CLL patients and cause aberrations in splicing of a variety of mRNAs.^{226, 229, 234, 235} Mutations generally occur in patients with unmutated IgV_H, are associated with a deletion of 11q22-23 (36%), are a cause of fludarabine resistance, and are independent prognostic markers for survival.^{226, 234, 235}

MicroRNA Expression

Low levels of MiR-181b at diagnosis have been shown to predict disease progression, and the level of the MiR decreases over time in patients with progressive disease.⁴⁰¹ Both BCL2 and MCL1 are targets for MiR-181b and the levels of these antiapoptotic proteins increase as the level of MiR-181b falls.⁴⁰¹

Marrow Histology

Nodular and interstitial growth patterns in the marrow are associated with similar marrow tumor burdens and median survival times of 90 and 46 months, respectively, whereas diffuse infiltration or a "packed marrow" is associated with a greater marrow tumor burden and a median survival time of only 28 months.^{1, 252} Fibrosis of the marrow also indicates an aggressive clinical course.⁴⁰² Although the extent of lymphocyte involvement in the marrow is of prognostic importance, the marrow biopsy is preferable as it provides a more reproducible measure of lymphocyte infiltrate and can demonstrate the pattern of marrow involvement.⁴⁰³ However, it should be noted that other investigators have not found that the pattern of marrow involvement adds any additional prognostic information over clinical staging.⁴⁰⁴

The pattern of marrow involvement after chemotherapy is also prognostically important. Patients with persistent lymphoid nodules in the marrow after chemotherapy [nodular partial remission (nPR)] have persistent leukemia and have a shorter time to relapse compared to those in CR.⁴⁰⁵ However, the extent of involvement does not correlate with the rapidity of disease recurrence.⁴⁰⁶

Fludarabine resistance

One of the most important prognostic factors is fludarabine resistance. Patients who do not respond to fludarabine or relapse within 6 months of treatment have a median survival of 9 to 10 months with standard chemotherapy.^{407, 408}

Plasma Markers

Plasma LDH levels are a measure of cell turnover and increased levels are associated with the presence of other poor prognostic markers, such as high CD38 or ZAP-70, or the presence of deletion 17p13.²⁶⁸ Moreover, a sudden increase in LDH may indicate disease progression or the development of a RS.

Plasma β 2-microglobulin is derived from the cell membrane of nucleated cells and is noncovalently linked to the α -chain of the class I major histocompatibility complex.²⁶⁸ Increased levels of β 2-microglobulin have been shown to be a marker of poor prognosis predicting TTT, duration of response, and OS.^{11, 210, 409, 410, 411} It has been assumed that β 2-microglobulin levels reflect tumor burden, however, β 2-microglobulin levels remain a useful prognostic indicator in patients with similar low-bulk Binet stage A disease.^{409, 410} Moreover, the levels have been found to correlate very closely with the plasma levels of the inflammatory cytokines (IL-6, IL-8, and TNF- α), indicating that it reflects the cytokine milieu.¹¹ β -microglobulin is cleared by the kidneys and it has been suggested that its prognostic value can be increased by correcting for renal function.⁴¹¹

The plasma levels of the inflammatory cytokines may be increased in CLL and are important prognostic markers for survival, particularly in the elderly.^{11, 130, 412, 413, 414, 415} It is likely that many cell types secrete the cytokines which may act by increasing CLL cell adhesion in the microenvironment.¹¹ The chemokine, CCL3, has also been recently shown to have prognostic value in CLL.¹⁰⁵ CCL3 is secreted by CLL cells with BCR stimulation in the microenvironment and elevated plasma levels predict a short TTT.¹⁰⁵ Finally, Yan et al.⁴¹⁶ have measured 23 cytokines by a multiplex assay in 84 patients

and were able to identify 3 groups that showed clustering of different cytokines. Patients could be stratified into these groups to predict TTT and OS.

Two groups have recently demonstrated the importance of plasma vitamin D levels in CLL.^{417, 418} In one study from the Mayo Clinic, one third of patients had vitamin D deficiency.⁴¹⁷ The plasma level did not correlate with the season, and there was no correlation between age, sex, stage, lymphocyte count, nor other prognostic markers. However, patients with low levels had a shorter TTT and reduced OS. A subsequent study from Italy in untreated Binet stage A patients confirmed these results.⁴¹⁸ In both studies, TTT appeared inversely related to the vitamin D level. As the vitamin D receptor is highly expressed on CLL cells it has been suggested that vitamin D has a direct cytotoxic effect on CLL cells.^{417, 418}

Prognostic Index

Despite the ever-increasing number of prognostic markers there is conflicting evidence as to the value of these markers and whether combining markers will improve prognosis. Wierda et al.¹³ at the MD Anderson have developed a predictive model using generally available measurements. The value of this index in early-stage patients has been validated at the Mayo Clinic and in a large Swiss-Italian multicenter study.^{373, 374} Six factors were originally identified for the index (age, sex, Rai stage, lymphocyte counts, number of lymph node regions involved, and β 2-microglobulin level) with each factor being scored to generate a prognostic index.¹³ However, the subsequent studies did not find lymphocyte count to be of prognostic value, and the European study has simplified the index to include age, sex, Binet stage (which includes number of lymph node sites), and β 2-microglobulin.³⁷⁴ The MD Anderson have also subsequently developed a prognostic index incorporating clinical finding with IgV_H mutational status and the presence of deletions of 17p13 and 11q22-23.⁴¹⁹

TREATMENT

Therapy for CLL has undergone dramatic changes over the past 25 years. Previously, chlorambucil, or sometimes cyclophosphamide, was the agent of choice. Treatments were given intermittently to control blood counts, organomegaly, or symptoms. However, rigorous trials were never carried out to determine the optimum treatment dose or schedule for these agents. In the 1980s the nucleoside analogues were shown to have activity in CLL and the evaluation of these agents in clinical trials required increased precision in the diagnosis of CLL, standard indications for treatment, and definitions of response, including MRD. There was subsequently a re-evaluation of the role of chlorambucil in CLL and the development of combination therapies in CLL, using primarily alkylating agents and nucleoside analogues. Since that time there has been the development of monoclonal antibodies and exciting new agents which inhibit the BCR pathway. In the following sections we review each of these areas and provide a summary of the standard of care for CLL.

Indications for Treatment

The majority of patients with CLL present with Rai stages 0/I disease. They do not require treatment but do need careful monitoring for evidence of disease progression. Premature treatment

P.1911

may actually cause harm and initial studies with chlorambucil in patients with Rai 0 or Binet A disease showed a delay in disease progression but no improvement in survival and an increase in the incidence of epithelial tumors and acute leukemia.⁴²⁰ The indications for treatment are based on the following clinical findings.¹

- Rai stage 0-II disease in patients who are symptomatic (weight loss of >10% body weight in previous 6 months, extreme fatigue, night sweats or fevers of >100.5°F or 38°C for >2 weeks without evidence of infection), or have progressive anemia/thrombocytopenia or lymphocytosis (>50% increase over 2 months or doubling time <6 months)
- Rai stages III/IV to improve the hemoglobin level and/or platelet counts, although asymptomatic patients can be monitored and treatment initiated when there is clear evidence of disease progression
- Bulky or progressive lymphadenopathy (masses >10 cm in diameter) or splenomegaly (>6 cm below left costal margin)
- AIHA/ITP.

Response Criteria and Minimal Residual Disease

To facilitate comparisons of results obtained in clinical trials, the IWCLL¹ has established criteria for clinical responses in CLL, and the details of these definitions are outlined in Table 90.9. The presence of organomegaly in clinical practice is

based on clinical examination but CT scans are required for clinical trials. In the original NCI-WG definitions patients were considered to be in CR even if there were lymphoid nodules in the marrow, as these can occur normally. However, it was subsequently demonstrated that patients in CR achieved a shorter remission if there were nodules in the marrow, indicating that some of these nodules are malignant.⁴⁰⁵ Thus, patients with residual lymphoid nodules in the marrow are classified as having a nPR.

As therapy for CLL has become more effective, there has been interest in the prognostic value of MRD following treatment and in determining whether therapy should be aimed at eliminating MRD.^{421, 422, 423, 424} The optimum specific antibody combinations for detecting MRD were defined in 2007 as CD5/CD19 with CD20/CD38, CD81/CD22, and CD79b/CD43.⁴²³ Concordance between peripheral blood and marrow MRD was ~90% when assessed >3 months after treatment, and was poorer if testing was done <3 months after treatment, particularly if alemtuzumab was used. The detection sensitivity with flow cytometry was one CLL cell in 10,000 leukocytes and flow cytometry detection rates showed concordance with a real-time quantitative allele-specific oligonucleotide (R-ASO) Ig heavy chain gene (IgH) PCR assay, although the PCR assay was more sensitive. This flow cytometry assay was used to assess MRD following FCR or FC in the German CLL8 trial.⁴²⁴ MRD levels were lower in patients treated with FCR and for both treatment arms the reduction in MRD following therapy correlated with improvements in PFS and OS.⁴⁰⁶ This randomized study confirmed the prognostic importance of MRD measurements and the long-term benefit of achieving MRD negativity with therapy.

TABLE 90.9 CRITERIA FOR RESPONSE IN CHRONIC LYMPHOCYTIC LEUKEMIA (CLL)

Parameter^a	Complete Response (CR)^b	Partial Response (PR)^c	Progressive Disease (PD)^d	Stable Disease (SD)^e
Symptoms	None	Any	Any	Not CR, PR or PD
Lymph nodes	<1.5 cm	Decrease ≥50%	New node or ≥50% increase	
Hepatomegaly/splenomegaly	None	Decrease ≥50%	Detected enlargement or ≥50% increase	
Lymphocytes	<4 × 10 ⁹ /L	Decrease ≥50% from baseline	Increase ≥50% over baseline	
Hemoglobin	>110 g/L	>110 g/L or ≥50% increase from baseline	Development of a cytopenia secondary to progressive CLL	
Neutrophils	>1.5 × 10 ⁹ /L	>1.5 × 10 ⁹ /L and/or		
Platelets	>100 × 10 ⁹ /L	>100 × 10 ⁹ /L or >50% increase		
Marrow	Normocellular <30% lymphocytes, no nodules	No marrow requirements for a PR		

^a In clinical trials CT scans of abdomen, pelvis, and thorax are desirable. Response should be by CT scan if abnormal before therapy.

^b Features should be maintained at least 2 months after completion of chemotherapy. If marrow hypocellular, repeat after 4 weeks or until peripheral blood counts have recovered (should be <6 months after chemotherapy). If nodules are present in marrow, do immunohistochemistry to confirm that they are monoclonal B-cells. If CLL nodules present, then is a “nodular PR”. If patient fulfills criteria for a CR but counts remain low as a result of chemotherapy, it is denoted CRi (CR with

incomplete marrow recovery).

^c For PR, require =50% decrease in lymphocytes, nodes, and liver/spleen with a recovery in one of the blood counts, as indicated, for >2 months.

^d If transformed to a more aggressive histology, such as Richter's syndrome.

^e From Hallek M, Cheson BD, Catovsky D et al. Guidelines for the diagnosis and treatment of chronic lymphocytic leukemia: a report from the International Workshop on Chronic Lymphocytic Leukemia updating the National Cancer Institute-Working Group 1995 Guidelines. *Blood* 2008;111(12):5446-5456.

Chemotherapy

Alkylating Agents

In the past, the standard treatment for CLL was the alkylating agent, chlorambucil, but nowadays this drug is generally only used in older and frail patients. The precise mechanism of action is unclear but it likely produces its antitumor effect by binding covalently with DNA, RNA, and cellular proteins.^{425, 426} Chlorambucil has been used in CLL for 60 years but the optimum treatment schedule and duration of therapy are still unclear. Traditionally, chlorambucil was administered continuously in a daily dosage of 0.1 mg/kg or intermittently as 0.4 mg/kg every 2 weeks, and these treatment schedules had equivalent efficacy, although the intermittent route produces less myelosuppression.^{427, 428} More recent studies have used chlorambucil administered in boluses, every 2 to 4 weeks (Table 90.10). Overall, the response rate with these regimens is 31% to 90%, with 4% to 60% of patients achieving a CR.^{429, 430, 431, 432, 433, 434, 435} The response rates have depended on dose intensity and criteria for remission. Although very high

P.1912

response rates have been reported by Jaksic et al.⁴³⁵ lower doses of chlorambucil are generally used. Cyclophosphamide differs little, if at all, from chlorambucil in its effectiveness in CLL.⁴³⁶ Cyclophosphamide may be given orally using 2 to 3 mg/kg/day or 20 mg/kg once every 2 to 3 weeks and it causes less myelosuppression than chlorambucil.

TABLE 90.10 RESPONSE RATES IN CHRONIC LYMPHOCYTIC LEUKEMIA (CLL) TO DIFFERENT CHLORAMBUCIL REGIMENS

Author	Chlorambucil Schedule	Total chlorambucil per month (mg) ^a	CR (%)	PR (%)	PFS (Months)
Rai (2000) ⁴²⁹	40 mg/m ² every 28 days (6-12 mo)	68	4	33	14
Hillmen (2007) ⁴³⁰	40 mg/m ² every 28 days (6-12 mo)	68	2	53	11.7
Eichorst (2009) ⁴³¹	0.4-0.8 (median 0.5) mg/kg days 1 and 15 (12 mo)	70	0	51	18
Knauf (2009) ⁴³²	0.8 mg/kg days 1 and 15 (6 mo)	112	2	29	8
Catovsky (2007) ⁴³³	10 mg/m ² , days 1-7, every 28 days (6-12 mo)	119	7	65	23
Robak (2000) ⁴³⁴	12 mg/m ² /day every 28 days	571	12	45	
Jaksic (1997) ⁴³⁵	15 mg/day continuously	420	60	30	

^a Assuming a patient weighing 70 kg and SA 1.7 m².

To improve response rates, alkylating agents have been combined with steroids or other agents. Monthly chlorambucil with prednisone increased the response rate (47%) and survival compared to daily chlorambucil plus prednisone (response rate, 37%) or prednisone alone (response rate, 11%).⁴²⁷ In a second study, the frequency of response and the number of patients alive at 2 years were higher when chlorambucil (6 mg/day) was combined with prednisone (30 mg/day) for 6 weeks than when chlorambucil was used alone; however, no difference in survival was demonstrated between the 2 groups.⁴³⁷ Steroids cause a re-distribution of the CLL cells and there is usually an increase in the peripheral lymphocyte count with the initiation of steroids. In practice, prednisone is frequently combined with chlorambucil or used prior to chlorambucil to produce a rapid decrease in lymph node/spleen size and reduce pancytopenia related to marrow packing.⁴³³ However, corticosteroids should be used sparingly as they do not increase survival and may produce significant side effects.

Nonrandomized studies initially reported excellent responses using intermittent cyclophosphamide, vincristine, and prednisone (COP) in patients with advanced CLL,^{438, 439} with approximately 44% of patients achieving a CR.⁴³⁸ However, a subsequent randomized study comparing COP to chlorambucil showed no difference in survival or disease progression at 9⁴⁴⁰ or 53⁴⁴¹ months. When COP was compared with chlorambucil and prednisone in untreated patients, the response and survival rates were identical.⁴⁴² In a similar study, a significantly higher response rate was observed using COP (59%) compared to chlorambucil and prednisone (31%), but the CR and OS rates were similar for both groups.⁴⁴³

The addition of low doses of doxorubicin to COP (CHOP) or CAP (cyclophosphamide, doxorubicin, and prednisone) or the use of multiple agents has been examined. The French Cooperative Group on CLL compared COP to CHOP in previously untreated patients with Binet stage C disease.⁴⁴⁴ The 3-year survival rates were 28% with COP and 71% with CHOP, and the median survival times were 22 and 62 months, respectively.⁴⁴⁵ However, these results are controversial, as no survival advantage has been observed when CHOP is compared with standard chlorambucil and prednisone.^{446, 447} Indeed, higher doses of chlorambucil (15 mg/day continuously) produced a statistically higher response rate than CHOP (89.5% vs. 75.0%) and an improved survival (median, 68 months vs. 47 months).⁴³⁵

Other combination regimens have been studied. In advanced or refractory disease the M2 program, consisting of cyclophosphamide, bischloroethylnitrosourea, melphalan, and prednisone, produced a CR rate of 17% and a PR rate of 44%.⁴⁴⁸ In addition, the median survivals were not significantly different from those achieved with less aggressive regimens. A CR rate of 30% was achieved in untreated patients.⁴⁴⁸ A combination protocol including prednisone, vincristine, cytosine arabinoside, cyclophosphamide, and doxorubicin (POACH) achieved response and survival rates not significantly different from those reported for chlorambucil and prednisone, with complete and overall response rates of 21% and 56%, respectively, for previously untreated patients and 6% and 21%, respectively, for previously treated patients.⁴⁴⁹ VAD (vincristine, doxorubicin, and dexamethasone) has been examined in relapsed or refractory CLL.⁴⁵⁰ No CRs were observed, and although 21% had a PR, 33% had progressive disease.

To determine whether aggressive multiagent therapy is better than standard chlorambucil (with or without prednisone) in CLL, a meta-analysis of 10 randomized studies involving 2,035 patients, mostly with Binet stage B and C disease, was carried out comparing chlorambucil with COP, CHOP, and chlorambucil/epirubicin.⁴⁵¹ This analysis did not reveal an improvement in survival by using an anthracycline-containing regimen compared to standard chlorambucil, demonstrating that more aggressive treatment approaches were not required to make an impact on survival.

Bendamustine has demonstrated high activity in CLL.^{432, 452} The drug was developed as an alkylating agent and has three components: (a) a 2-chloroethylamine alkylating group that is seen with the other nitrogen mustards; (b) a butyric side chain that is also contained in chlorambucil, and (c) a benzimidazole ring which is believed to contribute to the unique action of this agent.^{452, 453, 454} Bendamustine produces more extensive DNA cross-linking and breaks than other alkylators, activates a base-excision DNA repair pathway rather than O⁶-alkylguanine-DNA alkyltransferase repair used by chlorambucil and cyclophosphamide, is active against cell lines that are resistant to the nitrogen mustards, and may act through the induction of apoptosis and mitotic catastrophe.^{452, 453, 454} Bendamustine has been compared to chlorambucil in the first-line treatment of CLL (Table 90.11).^{432, 455} Bendamustine produced a higher CR rate, a threefold increase in PFS and time to next treatment (31.7 vs. 10.1 months) but no difference in survival. The quality of life was similar with both drugs and, not surprisingly, patients who were sensitive to either drug had an improved survival. However, adverse events were twofold

P.1913

more common with bendamustine and included skin rashes, marrow suppression, and nausea/vomiting.⁴³² As discussed later, bendamustine is now more typically administered with rituximab.

Nucleoside Analogues

The nucleoside analogues have demonstrated significant activity in the low-grade lymphoproliferative disorders.⁴⁵⁶ Pentostatin (2'-deoxycoformycin;dCF) is an inhibitor of adenosine deaminase, which is responsible for the deamination of deoxyadenosine and adenosine to deoxyinosine and inosine, respectively. After therapy with pentostatin, deoxyadenosine and adenosine accumulate in the plasma; after uptake into cells, deoxyadenosine is phosphorylated to deoxyadenosine monophosphate, deoxyadenosine diphosphate, and dATP, and this occurs preferentially in lymphocytes.⁴⁵⁷ The intracerebral accumulation of deoxyadenosine and adenosine likely causes nausea and vomiting, a major toxicity with this agent.⁴⁵⁸ Cladribine (2-chlorodeoxyadenosine; CdA) and F-ara-A are halogenated derivatives of deoxyadenosine that are resistant to degradation by adenosine deaminase. For clinical use, F-ara-A is administered as the more water-soluble monophosphate, F-ara-adenosine monophosphate (fludarabine); fludarabine is rapidly dephosphorylated in the plasma to F-ara-A.^{459, 460} Like deoxyadenosine, cladribine and F-ara-A are taken up into lymphocytes by a nucleoside transport system and accumulate in lymphocytes as their phosphorylated derivatives. A correlation has been found between the protein levels of the hNT2 transport protein and in vitro cytotoxicity.^{461, 462} The triphosphate derivatives of deoxyadenosine, cladribine, and F-ara-A can kill lymphocytes in three ways.^{52, 463} First, the triphosphate forms can trigger DNA breaks, which result in the release of cytochrome c from the mitochondria; the released cytochrome c interacts with Apaf-1 and dATP causing the activation of caspase 9 and, subsequently, apoptosis. Second, the increased levels of the triphosphates can enhance the effects of endogenous dATP on the apoptosome, inducing apoptosis. Finally, cladribine differs from the other two drugs in that it is phosphorylated by deoxyguanosine kinase in the mitochondria to CdATP, which is directly toxic to the mitochondria.

TABLE 90.11 PHASE III STUDIES COMPARING NUCLEOSIDE ANALOGUES AND ALKYLATING AGENTS AS FIRST-LINE TREATMENT IN CLL

Reference	Treatment	Patients (No.)	CR (%)	PR (%)	PFS (Months)	Median Survival (Months)
European Cooperative Group (1996) ⁴⁶⁹	Fludarabine	52	23	48	Not reached	Not reached
	CAP	48	17	43	208 days	1,580 d
US InterGroup (2000) ⁴²⁹	Fludarabine	170	20	43	25	66
	Chlorambucil	181	4	33	14	56
	Fludarabine/Chlorambucil	123	20	41	Not reached	55
French Cooperative Group (2001) ⁴⁷⁰	Fludarabine	341	40 ^a	31	32	69
	CAP	240	15 ^a	43	28	70
	CHOP	357	30 ^a	42	29	67
UK LRF CLL4 Study (2007) ⁴³³	Fludarabine	181	15	65	10% at 5 yrs	52% ^b
	Chlorambucil	366	7	65	10% at 5 yrs	59% ^b
German CLL Study Group (2009) ⁴³¹	Fludarabine	93	7	65	19	46
	Chlorambucil	100	0	51	18	64
Polish Group (2000) ⁴³⁴	Cladribine/prednisone	126	47	40	21	78% ^c
	Chlorambucil/prednisone	103	12	45	18	82% ^c
German CLL Study Group (2012) ⁴⁵⁵	Bendamustine	162	21	13.6	21.2	Not Reached
	Chlorambucil	157	10.8	19.1	8.8 (<i>p</i> < 0.0001)	78.8 (<i>p</i> = 0.18)

CAP, cyclophosphamide, doxorubicin, and prednisone; CHOP, cyclophosphamide, doxorubicin,

vincristine, and prednisone; PFS, progression-free survival.

^a Actually denoted as *clinical remissions* as marrow studies were not carried out on many after therapy.

^b Alive at 5 years.

^c Alive at 24 mo.

Pentostatin produces CR and PR rates of 16% to 25% in previously treated patients, with an additional 20% to 30% of patients exhibiting other forms of clinical improvement.^{464, 465} The standard dose is 4 mg/m² intravenously (IV) every other week.^{456, 465} Toxicities include infection, myelosuppression, nausea/vomiting, and pruritus.

Fludarabine has greater activity in CLL and is equally efficacious when administered orally or IV, although a higher dose is required when given orally.⁴⁶⁶ Using 25 to 30 mg/m² IV daily for 5 days, repeated monthly, the overall response rate is approximately 45% in previously treated patients, with the CR rate being 3% to 20%.^{467, 468, 469} In untreated patients, the response rate is approximately 70%, with the CR rate being 20% to 40%.^{429, 469, 470, 471} The main toxicities with fludarabine are myelosuppression and infections, particularly when patients have been previously treated with alkylating agents. Nausea, vomiting, and neuropathy rarely occur. In an attempt to reduce toxicity, fludarabine has been administered as 30 mg/m² IV daily for 3 days, repeated every 4 weeks.⁴⁷² Compared to the standard 5-day treatment schedule, the response rate was lower at 46% (CR, 10%), but there was a significant reduction in the infection rate and no difference in survival. The addition of prednisone does not improve the response rate over fludarabine used alone and significantly increases the risk of unusual infections (e.g., *Pneumocystis jirovecii* pneumonia and *Listeria monocytogenes* sepsis).⁴⁷³ Five major phase III studies have determined whether initial treatment with fludarabine could produce an increased remission rate compared with standard chemotherapy and whether this would translate into improved survival.^{429, 431, 433, 434, 469, 470} A summary of the results of these studies is in Table 90.11.

- In the European Cooperative Group study fludarabine was compared with CAP (cyclophosphamide, Adriamycin, prednisone).⁴⁶⁹ The responses with fludarabine were similar to those
P.1914
for CAP, but the duration of responses was significantly longer with fludarabine with a tendency toward a longer survival.
- In a French Cooperative Group study patients were randomized to CHOP, CAP, or fludarabine.⁴⁷⁰ The response rates were similar for CHOP and fludarabine, and both were better than CAP. However, time to relapse and survival rates were similar regardless of treatment.
- Three groups have compared fludarabine and chlorambucil, and although the doses of fludarabine were similar in all, the dose of chlorambucil was lowest in the North American Inter-Group CLB-9011 study (Table 90.11).⁴²⁹ In this study, there was a higher response rate, longer duration of response, and improved PFS in patients treated with fludarabine but no difference in OS. However, a follow-up analysis at 10 years showed a survival advantage for fludarabine.⁴⁷⁴ In the LRF CLL4 study from the United Kingdom, the response rates were higher for fludarabine than for chlorambucil, but there was no difference in PFS or OS.⁴³³ In the German CLL5 trial only patients >65 years were studied, and fludarabine produced a higher response rate compared to chlorambucil.⁴³¹ Again, there was no difference in PFS or OS.

In CLL, cladribine has been less extensively evaluated than fludarabine but the former probably has equivalent antitumor activity.^{434, 456, 475, 476, 477, 478, 479, 480} The drug is given in monthly cycles, in doses of 0.1 mg cladribine/kg/day by continuous infusion × 7 days,⁴⁷⁷ or 0.12 to 0.14 mg/kg/day over 2 hours × 5 days,^{475, 478} or 10 mg/m²/day orally × 5 days.⁴⁸² The results of studies with cladribine have varied greatly,^{434, 475, 476, 478} with response rates in previously treated patients varying from 48% to 72% and CR rates varying from 4% to 39%.^{456, 475} In previously untreated patients, approximately 80% of patients respond, and the CR rate varies from 10% to 45%.^{434, 456, 475, 479} In a multicenter study with patients randomized to receive initially either cladribine or chlorambucil, and resistant patients being switched to the other drug, cladribine produced a higher remission rate and more prolonged remissions than chlorambucil (Table 90.11).⁴³⁴ However, as with the randomized studies comparing fludarabine with alkylating agents, survival was similar whether the initial treatment was with cladribine or chlorambucil. The variation in the response rates to cladribine in previously treated patients may be related to the extent of prior therapy. In vitro studies have shown that cladribine is more myelosuppressive than fludarabine,⁴⁵⁹ and in the clinical setting, repeated treatments with cladribine can produce

prolonged thrombocytopenia.^{434, 475, 476, 477, 478, 479, 480} As is fludarabine, cladribine is very immunosuppressive, and infections are the major toxicity, particularly when cladribine is given in conjunction with prednisone.^{289, 434, 479}

Neither cladribine nor fludarabine causes the accumulation of adenosine, which likely explains the lack of nausea/vomiting observed with these agents when compared to pentostatin. However, all of these nucleoside analogues can produce neurotoxicity, and peripheral neuropathy is now being documented as a potential devastating toxicity.⁴⁸¹ The nucleoside analogues are all highly immunosuppressive, being both myelosuppressive and producing a marked fall in the CD4⁺ cell count, which may persist for years.⁴⁵⁶ Although initial studies demonstrated that the nucleoside analogues could trigger AIHAs, the frequency of this complication is no greater with the analogues than with other agents.^{433, 434} Graft-versus-host disease has been observed in patients being treated with nucleoside analogues who receive blood transfusions, and it has been recommended that these patients receive only irradiated blood products.⁴⁸² Reports have also indicated a higher incidence of acute myeloid leukemia (AML)/myelodysplasia in patients receiving nucleoside analogues,^{483, 484} and this risk may be further increased in patients receiving a combination of chlorambucil and fludarabine.⁴⁸⁴ Recent studies have demonstrated that fludarabine can be toxic to the lung, in addition to pre-disposing these patients to pneumonia.⁴⁸⁵ Once infections have been ruled out, the pulmonary toxicity syndrome often responds to steroids.⁴⁸⁵

TABLE 90.12 PHASE III STUDIES COMPARING FLUDARABINE AND FLUDARABINE/CYCLOPHOSPHAMIDE (FC) IN CHRONIC LYMPHOCYTIC LEUKEMIA (CLL)

Reference	Treatment	Patient Number	CR (%)	PR (%)	PFS ^a	Survival
German CLL Study Group (2006) ⁴⁹³	Fludarabine	164	7	76	Median, 20 mo	3 y, 80.7%
	FC	164	24	70	Median, 48 mo	3 y, 80.3%
UK LRF CLL4 (2007) ⁴³³	Fludarabine	181	15	65	5 y, 10%	5 y, 59%
	FC	182	38	57	5 y, 36%	5 y, 54%
InterGroup Trial E2997 (2007) ⁴⁹⁴	Fludarabine	137	4.8	54.6	Median, 19.2 mo	2 y, 80%
	FC	141	23.4	50.4	Median, 31.6 mo	2 y, 79%

^a PFS, progression-free survival.

An *in vitro* study has demonstrated cross-resistance between fludarabine and cladribine in the leukemic cells of 90% of patients,⁴⁵⁹ and clinical studies have confirmed that patients resistant to fludarabine are unlikely to respond to cladribine, and vice versa.^{479, 486} In a clinical trial of 28 patients who were resistant to fludarabine, only 1 patient had a PR with cladribine.⁴⁸⁶ Thus, patients who are resistant to one of the nucleoside analogues should not be treated with another, particularly as such therapy increases the risk of infections secondary to myelosuppression and immunosuppression.

Combinations of Nucleoside Analogues with Alkylating Agents

To improve antitumor activity the nucleoside analogues have been combined with other agents. Combined therapy with steroids does not improve the antitumor effect and markedly increases the risk of infection.^{473, 478} *In vitro* studies have demonstrated that the nucleoside analogues can inhibit DNA repair, which explains the synergistic antitumor activity seen between these agents and irradiation or alkylating agents.^{487, 488, 489} Moreover, this effect is seen preferentially in CLL cells compared to normal marrow cells.⁴⁸⁸ Synergy has also been observed between fludarabine and cyclophosphamide in phase II clinical studies.^{490, 491, 492} O'Brien et al.⁴⁹⁰ combined fludarabine 30 mg/m² IV daily × 3 with cyclophosphamide 300, 350, or 500 mg/m² IV daily × 3 and demonstrated a 38% response rate in patients who were resistant to fludarabine alone. In previously untreated patients, more than 80% responded with a 35% CR. Moreover, the duration of response was longer than for fludarabine alone. Similar findings have been observed in 3 large randomized clinical trials^{433, 493, 494} (Table 90.12). The efficacy and toxicity of cladribine with cyclophosphamide is similar

P.1915

to that of FC in previously untreated patients.⁴⁹⁵ Pentostatin has also been combined with cyclophosphamide in one study.⁴⁹⁶ In 23 previously treated patients treated with pentostatin 4 mg/m² IV and cyclophosphamide 600 to 900 mg/m² IV repeated every 3 weeks × 6, 17 patients responded with 4 CRs and 13 PRs. It is important to note that 10 of 13 fludarabine-resistant patients responded with one CR. A concern with combining the nucleoside analogues with alkylating agents is an increased risk of myeloid leukemias, as may be the case when fludarabine and chlorambucil are combined.⁴⁸⁴

A recent systematic review has summarized all these studies.⁴⁹⁷ In brief, the addition of cyclophosphamide to a nucleoside analogue increases the response rates and PFS over single agents but this does not translate into improved survival, likely as a result of effective second-line therapies.

Steroids

As steroids kill CLL cells with a TP53 mutation,⁶⁸ they can be useful for palliation in patients resistant to alkylating agents and nucleoside analogues.⁴⁹⁸ However, as discussed later, nowadays they are usually combined with a monoclonal antibody. High-dose steroids, such as methylprednisolone at 1 gm/m²/day × 5 days, repeated monthly, can be helpful in advanced-stage patients, who are drug resistant and have bulky disease, marrow failure, or both.⁴⁹⁸ In 25 patients treated with methylprednisolone, with or without chemotherapy, the overall response rate was 77% with the median duration of response being 12 months (range, 7-23+). Of the 10 patients with p53 mutations, 5 responded to this therapy. The management of CLL patients maintained on steroids is discussed in the section “Systemic Complications Requiring Therapy.”

Monoclonal Antibodies

Anti-CD20

The cell-surface antigen CD20, plays an important role in the activation, proliferation, and differentiation of B-cells and antibodies to CD20 have transformed the therapy of the B-cell lymphoproliferative disorders.^{499, 500} The chimeric monoclonal antibody, rituximab, contains a human IgG1 Ig constant region and a murine variable region directed against CD20.^{499, 500} This agent was licensed for use in relapsed indolent lymphoma in 1997 by the US Food and Drug Administration (FDA) and since that time many variants of this antibody have been developed, with ofatumumab and GA101 being most studied in the clinic. Rituximab has shown significant activity against low-grade lymphomas, which have high surface concentrations of CD20, and is believed to exert its antitumor activity by complement-dependent cytotoxicity (CDC), antibody-dependent cell-mediated cytotoxicity (ADCC), or by the direct induction of apoptosis. An intact FcγR is required for ADCC and it has been suggested that polymorphisms in FcγRIIIa (CD16) may influence the response to rituximab.⁴⁹⁹ A variety of new anti-CD20 antibodies has been developed to enhance antitumor activity that are humanized, unlike rituximab which is chimeric. The anti-CD20 monoclonal antibodies are classified as type I or type II based on their ability to redistribute CD20 into lipid rafts that can influence antibody activity.⁴⁹⁹ Type I antibodies, exemplified by rituximab and ofatumumab, redistribute CD20 into lipid rafts and potentially activate complement. In contrast type II antibodies, as exemplified by tositumomab and GA101, induce programmed cell death that is independent of caspase activation and DNA breaks, and is not affected by BCL2.^{501, 502, 503} The ability to induce programmed cell death correlates with the induction of intercellular homotypic adhesion which alters the actin cytoskeleton causing permeabilization of the lysosome and the release of cathepsin B into the cytoplasm.^{501, 502, 503} Recent studies suggest that this leads to increased free radical formation from NADPH oxidases, which results in loss of plasma cell membrane and cell death.⁵⁰³ In animal models, the type II antibodies are more effective in clearing CD20 positive lymphocytes from blood and lymphoid organs.⁵⁰⁴

Using the standard rituximab regimen that is effective in follicular lymphomas (375 mg/m² IV weekly × 4), initial studies showed that rituximab had little activity in CLL (13% response rate), compared to a 50% response rate in the follicular lymphomas.⁵⁰⁵ This decreased activity was attributed to the low levels of CD20 on CLL cells and the high plasma CD20 levels observed in CLL; the high plasma CD20 levels are believed to divert rituximab from the cellular target and to reduce the half-life of the antibody.⁵⁰⁶ The plasma CD20 is believed to be derived from cell breakdown, and the level correlates with disease stage but not the lymphocyte count.⁵⁰⁶ However, 2 studies have shown that rituximab can rapidly, albeit transiently, reduce the peripheral lymphocyte counts of CLL patients.^{507, 508} The treatment had little effect on lymphadenopathy and did not normalize blood counts, and this discrepancy has been related to the fact that the CLL CD20 levels are lower in the nodes and marrow than in the peripheral blood.⁵⁰⁹ In an attempt to increase the effectiveness of rituximab in CLL, the dose of rituximab has been escalated, using either a weekly or thrice weekly schedule, and response rates of 36% to 45% have been achieved without a significantly higher toxicity than is observed with the standard schedule.^{510, 511} Of special interest is the observation that “shaving” or removal of CD20 and rituximab from the CLL surface by monocytes and macrophages results in the appearance of CLL cells in the circulation that have neither CD20 nor rituximab on their surface.⁵¹² This occurs primarily with high doses of rituximab, raising the question as to whether rituximab would be best administered using lower doses applied more frequently.⁵¹³

Rituximab can cause reactions (e.g., fevers/rigors, dyspnea, hypotension, and nausea/vomiting) as a result of the release of inflammatory cytokines (e.g., IL-6, IL-8, TNF-α, and γ-interferon) and this complication primarily occurs in patients with lymphocyte counts of greater than 50 × 10⁹/L.^{507, 508, 510, 511} The reactions usually occur with the first treatment, and the

likelihood of a reaction decreases with each subsequent treatment. Pretreatment with steroids and “stepped-up dosing” decreases the severity or likelihood of a reaction.⁵⁰⁸ More recently, the development of immune neutropenia has been observed after rituximab and usually resolves spontaneously in 1 to 3 weeks or in 3 to 5 days with G-CSF.⁵¹⁴

Rituximab has been administered with high-dose methylprednisolone for patients with high-risk disease including those with deletions of 17p13 and 11q22-23.^{515, 516} Approximately two-thirds of patients will respond with a median PFS of 1 year, and main side effects include hyperglycemia and fluid retention.

Ofatumumab is a fully human type I monoclonal antibody directed against a different epitope on CD20 that results in tighter binding and increased complement activation.^{499, 517} The pivotal study by Wierda et al.⁵¹⁸ showed a response rate of 58% in patients who were resistant to fludarabine and alemtuzumab (FA) and 47% in patients who were resistant to fludarabine with bulky (>5 cm) lymphadenopathy (BF). The median PFS and OS were 5.7 and 13.7 months for the FA group and 5.9 and 15.4 months for the BF group. The treatment schedule was with 8 weekly treatments followed by 4 monthly treatments. The first infusion was with 300 mg followed by 2,000 mg for all other infusions. Treatment was well tolerated and the FDA subsequently licensed ofatumumab for patients resistant to FA. A subsequent analysis indicated that rituximab-resistant patients had a similar response to ofatumumab as patients who were rituximab-naïve.⁵¹⁹ Ofatumumab has been administered with high-dose steroids with two-thirds of patients with fludarabine resistance and bulky lymphadenopathy responding.⁵²⁰ This included patients with deletions of 17p13, where the response to ofatumumab alone is 14%.⁵¹⁸

P.1916

GA101 (obinutuzumab) is a humanized type II antibody with a novel mechanism of action and is presently being evaluated against rituximab in a number of clinical trials for CLL.⁴⁹⁹

Anti-CD52

The monoclonal antibody, alemtuzumab (Campath-1H), is a humanized IgG1 antibody against CD52, with the antigen-binding site being of rodent origin; targets are B and T lymphocytes, NK-cells, monocytes and eosinophils with sparing of normal hematopoietic stem cells.^{521, 522} As with rituximab, alemtuzumab can kill tumor cells by CDC, ADCC, or the direct induction of apoptosis and has become an important agent for the treatment of fludarabine-resistant patients with deletions of 17p13 or 11q22-23.^{521, 522} In the pivotal CAM 211 multicenter study on 93 patients with fludarabine-resistant disease, patients were treated for 12 weeks with alemtuzumab.⁵²³ The CR rate was 2%, PR rate 31%, and 54% of patients had stabilization of their disease. Many patients with symptoms such as night sweats, fatigue, or weight loss had resolution of their symptoms. The median time to response was 1.5 months and median time to progression was 4.7 months for all patients and 9.5 months for responders. Median survival for all patients was 16 months and 32 months for responders. As an historical comparison, the median survival of fludarabine-resistant CLL patients is 10 months.⁵²³ Alemtuzumab was particularly efficacious at clearing the peripheral blood (first) and marrow/spleen (later) of CLL cells, but was less active against lymphadenopathy. Lymphadenopathy resolved in two-thirds of patients but no patient with nodes >5cm had complete resolution of lymphadenopathy. Unfortunately, patients had infusion-related toxicities (i.e., nausea/vomiting, fevers, rigors, and rash) with the initiation of treatment and there was an increased incidence of infections. Patients were maintained on prophylactic trimethoprim/sulphamethoxazole and famciclovir until 2 months after treatment was completed. Infections occurred in 55% of patients and CMV reactivation was the most common opportunistic infection. Because of the high risk of infections with alemtuzumab, especially in heavily pretreated patients, care must be used in patients who had previous infections or a poor performance status. To reduce the risk of CMV valganciclovir 450 mg twice a day has been recommended although 900 mg 3 times a week may also be effective and produce less myelosuppression.^{524, 525} Guidelines are available for the use of alemtuzumab, particularly with regard to prophylactic antibiotics and CMV monitoring.^{366, 522}

Alemtuzumab appears to have equivalent clinical activity when administered subcutaneously (sc), even though it takes longer to achieve a steady plasma concentration of antibody.^{526, 527} Thus, Stilgenbauer et al.⁵²⁶ were able to reproduce the results of the CAM 211 study using sc alemtuzumab. Of patients receiving sc alemtuzumab, 90% have local injection-site reactions, with erythema/edema, pruritus, and pain at the site of injection. However, the reactions disappear with continued treatments, usually within 2 weeks. During the initial 2 weeks, the local reactions can be controlled by ice-packing the injection site before the injection and for about 1 hour after the injection. Alemtuzumab has also been evaluated as front-line therapy in 2 studies.^{430, 528} Of 41 previously untreated CLL patients receiving sc alemtuzumab, 38 received more than 1 week of therapy, and in this group, the CR rate was 19% and the PR rate 68%.⁵²⁸ Consistent with

these findings, the CR and PR rates with alemtuzumab in the CAM 307 study were 22% and 61%, respectively.⁴³⁰ Following alemtuzumab therapy in previously untreated patients, the lymphocyte subtypes gradually recover, but remain at <25% baseline for >9 months following therapy.⁵²⁸ Despite this, infections were not a problem.

Because of its unique properties, there has been interest in evaluating alemtuzumab for the treatment of patients with resistant disease.^{225, 529} Of 36 fludarabine-resistant patients treated with alemtuzumab, 15 (42%) had TP53 mutations and/or deletions and 6 of the 15 (40%) responded to alemtuzumab.²²⁵ The median duration of response was 8 months (range, 3 to 17 months). When used as initial therapy in previously untreated patients, the response rates for 7 patients with a deletion of 17p13 was 64%.⁴³⁰ Alemtuzumab has also been administered following standard chemotherapy for the purpose of consolidation.^{530, 531, 532} In these studies the dose and duration of alemtuzumab ranged from 10 to 30 mg 3 times a week for 4 to 12 weeks. The CR and MRD-negative responses can be increased with this therapy and this is associated with a longer PFS. However, these positive effects are counterbalanced by an increased risk of infections and the development of Epstein-Barr positive large-cell lymphomas.^{530, 531, 532} Until further studies direct otherwise, the use of alemtuzumab in front-line therapy or for the purpose of consolidation should be confined to clinical trials.

Alemtuzumab has been combined with high-dose steroids in 17 untreated and 22 previously treated patients with a deletion of 17p13.⁵³³ The overall response rate and CR rate were 85% and 36%, respectively, with a median OS of 23.5 months demonstrating the effectiveness of the regimen in this high-risk group of patients. Side effects included hypokalemia, hyperglycemia, and infections. Two-thirds of patients needed granulocyte colony-stimulating factor for neutropenia, half needed (val)ganciclovir for CMV reactivation. Although grade 3 to 4 infection occurred in half the patients, this was age-related and only occurred in 29% of patients less than 60 years of age. Alemtuzumab has also been combined with rituximab in patients with molecular markers indicative of aggressive disease.⁵³⁴ Patients received alemtuzumab 30 mg subcutaneously 3 times a week for 4 weeks with rituximab 375 mg/m² weekly for 4 treatments. Of 30 patients, 90% responded with 37% CRs, and the median duration of response of responders was 14.4 months. Neutropenia was common and CMV reactivation occurred in 10%.

Anti-CD23

The anti-CD23 antibody, lumiliximab, has limited activity alone but results of a phase I/II study suggests that the addition of lumiliximab with FCR may increase the response rate without additional toxicity.⁵³⁵

Chemoimmunotherapy

Combinations with anti-CD20 Antibodies

Combinations with Rituximab

Synergy has been demonstrated between rituximab and chemotherapy *in vitro*, although the mechanisms underlying this phenomenon are unclear.^{536, 537, 538} Synergy may be related to effects of rituximab on the levels of antiapoptotic proteins, as rituximab reduces the cellular levels of BCL2 through inhibition of IL10 in lymphoma cell lines *in vitro*,⁵³⁷ and the levels of MCL1 and XIAP are decreased in the CLL cells of patients undergoing treatment with the antibody.⁵³⁹ Alternatively, fludarabine may down-regulate the expressions of CD46 and CD55 on the CLL cells, proteins that antagonize the effects of activated complement.⁵³⁸

Fludarabine has been combined with rituximab (FR) in the clinic.^{540, 541, 542, 543} In one study, 31 previously treated or untreated CLL patients received 4 monthly cycles of fludarabine (25 mg/m² IV daily × 5 days) combined with 4 monthly treatments with rituximab (375 mg/m² IV), the first 2 rituximab treatments given with the last 2 cycles of fludarabine.⁵⁴⁰ The CR rate was 33%, the PR rate was 55%, and treatment was well tolerated. Byrd et al.⁵⁴¹ compared concurrent versus sequential treatment with fludarabine and rituximab in untreated CLL patients (CALGB 9712). There were 51 patients who received 6 cycles of fludarabine followed by 4 weekly treatments with rituximab (sequential

P.1917

regimen), and 53 patients who received 6 cycles of concurrent fludarabine and rituximab followed by consolidation with 4 weekly treatments with rituximab. In the concurrent regimen, there were 47% CRs and 43% PRs, whereas the sequential regimen appeared less effective with 28% CR and 49% PR. Treatment was generally well tolerated; infusion-related toxicity, myelosuppression, and infections were the major toxicities. A follow-up analysis showed that both groups had a similar outcome with the combined median PFS being 42 months and the median OS being 85 months.⁵⁴³ A retrospective comparison has been made to patients treated with fludarabine alone (CALGB 9011).⁵⁴² The CR and PR rates in the CALGB 9011 study were 20% and 43%, respectively, and the CR and PR rates in the CALGB 9712 study (all patients) were 38% and 46%, respectively. The 2-year PFS and OS for patients receiving fludarabine were 45% and 81%, respectively, and for

patients receiving fludarabine with rituximab were significantly better at 67% and 93%, suggesting that the addition of rituximab in first-line therapy prolongs survival.

The MD Anderson Cancer Center developed the combined fludarabine with cyclophosphamide and rituximab (FCR) regimen using fludarabine 25 mg/m² and cyclophosphamide 250 mg/m² administered IV on days 1, 2, and 3 with rituximab 375 mg/m² IV on day 1 with the first course and then 500 mg/m² IV for courses 2 to 6. The treatments were given every 28 days for 6 cycles for the treatment of both untreated and previously treated patients (Table 90.13).^{544, 545, 546} In 224 previously untreated patients the CR, nPR, and PR rates were 72%, 10%, and 13%, respectively.⁵⁴⁵ A retrospective comparison among fludarabine, FC, and FCR also suggested that FCR increased OS, with OS at 6 years being 54%, 59%, and 77% for patients treated with fludarabine, fludarabine and cyclophosphamide/mitoxantrone, or FCR.⁵⁴⁵ The subsequent CLL8 prospective randomized phase 3 study from the German CLL Study Group confirmed these findings. FCR has subsequently become a standard first-line therapy for selected patients (Table 90.13). Previously untreated patients were randomized to FCR or FC using the MD Anderson treatment regimens. As FCR is an aggressive treatment regimen, patients were required to have an Eastern Cooperative Oncology Group (ECOG) performance status of 0 to 1, a cumulative illness rating scale (CIRS) of 6 or less, and a creatinine clearance of ≥70 ml/min. Prophylaxis with antivirals was not given and prophylaxis against *Pneumocystis jirovecii* only recommended for severe leukopenia lasting >7 days. Approximately one-quarter of patients in both the FC and FCR groups were unable to tolerate the full 6 cycles of therapy and drug dosages had to be reduced by >10% in 47% of patients on FCR and 27% of patients on FC. The CR and PR for FCR were 44% and 46% and for FC were 22% and 58% (p = <0.0001). The median PFS was 51.8 months with FCR and 32.8 months with FC (p < 0.001) whereas OS at 3 years was 87% with FCR and 83% with FC (p = 0.01) (Figs. 90.10 and 90.11). Although an improvement in CR rate was seen for all Binet stages with FCR, only Binet stage B showed an improvement in PFS and OS with chemoimmunotherapy. The response of patients with a deletion of 17p13 was equally poor for patients treated with FCR or FC, and although PFS was increased with FCR (11.3 vs. 6.5 months, p = 0.019) there was no improvement with survival. However, supporting a previous observation,³⁸⁸ FCR overcame the poor prognosis associated with FC in patients with a deletion 11q22-23, with an improved CR rate (51% vs. 15%, p = <0.0001), prolonged PFS at 3 years (64% vs. 32%, p = <0.0001), and increased OS at 3 years (94% vs. 83%). FCR caused more neutropenia than FC, and neutropenia and infections occurred more commonly in those >65 years. Deaths related to both regimens only occurred in 2% to 3% of patients, and it should be emphasized that these patients were carefully chosen according to performance status, comorbidities, and renal function. In addition, the median age of patients was only 61 years.

TABLE 90.13 CHEMOIMMUNOTHERAPEUTIC REGIMENS

Reference	Treatment ^a	Patient Number	Previously Treated	CR (%)	nPR (%)	PR (%)
Tam et al. (2008) ⁵⁴⁵	FCR	224	No	72	10	13
Badoux et al. (2011) ⁵⁴⁶	FCR	284	Yes	30	14	30
Hallek et al. (2010) ²¹⁰	FCR	388	No	44	51 ^b	
	FC	371	No	22	67 ^c	
Parikh et al. (2011) ⁵⁶²	CFAR	60	No	70	3	18
Badoux et al. (2011) ⁵⁶³	CFAR	80	Yes	29	4	33
Bosch et al. (2012) ⁵⁴⁸	R-FCM	72	No	82	11	
Woyach et al. (2005) ⁵⁴³	FR	104	No	38	46 ^d	
Kay et al. (2007) ⁵⁵⁰	PCR ^e	64	No	41	22	28
Kay et al. (2010) ⁵⁵¹	PR ^f	33	No	27	15	33
Fischer et al. (2012) ⁵⁵²	BR	117	No	23	2	63
Fischer et al. (2011) ⁵⁵³	BR	78	Yes	9	3	47

^a A, alemtuzumab; C, cyclophosphamide; F, fludarabine; FluCam, fludarabine/alemtuzumab; P, pentostatin; R, rituximab.

^b Median PFS was 32.8 mo with FC and 51.8 mo with FCR ($p < 0.001$). Overall survival at 37.7 months was 84.1% with FCR and 79.0% with FC ($p = 0.01$). Patients with Binet stage B disease primarily benefited from the addition of rituximab.

^c nPR and PR were combined.

^d High-risk patients with a $\beta 2$ -microglobulin of ≥ 4 mg/L and aged < 70 years.

^e Dose of pentostatin, 2 mg/m².

^f Dose of pentostatin, 4 mg/m².

The MD Anderson studies have demonstrated that about 20% of patients can have cytopenias lasting longer than 3 months following FCR and that 28% of patients whose blood counts have recovered following treatment can have a late cytopenia that usually occurs in the first year of remission.⁵⁴⁵ The incidence of immune cytopenias was reported to be 6.5% in the MD Anderson series with AIHA typically occurring between cycles 3 and 6 and most patients responding to standard therapies.³¹⁹ In contrast, in the CLL8 study, only 1% of patients developed immune cytopenias. In addition, the risk of serious or opportunistic infections at the MD Anderson was 10% and 4% in the first and second

P.1918

years of remission, respectively, with a relatively high incidence of shingles at these times. In addition, 4.5% of patients developed AML or myelodysplasia, with the median onset from the initiation of chemotherapy being 35 months (median, 3 to 118 months).⁵⁴⁷ Thus, although FCR is a highly effective therapy, there are significant toxicities and care must be taken in deciding which patients require, and/or can tolerate, this treatment. Patients with deletion 11q22-23 should receive FCR, if possible, Results of the CALGB 10404 study, comparing the front-line activities of FR and FCR in CLL, should help clinicians individualize treatment.⁵⁴³

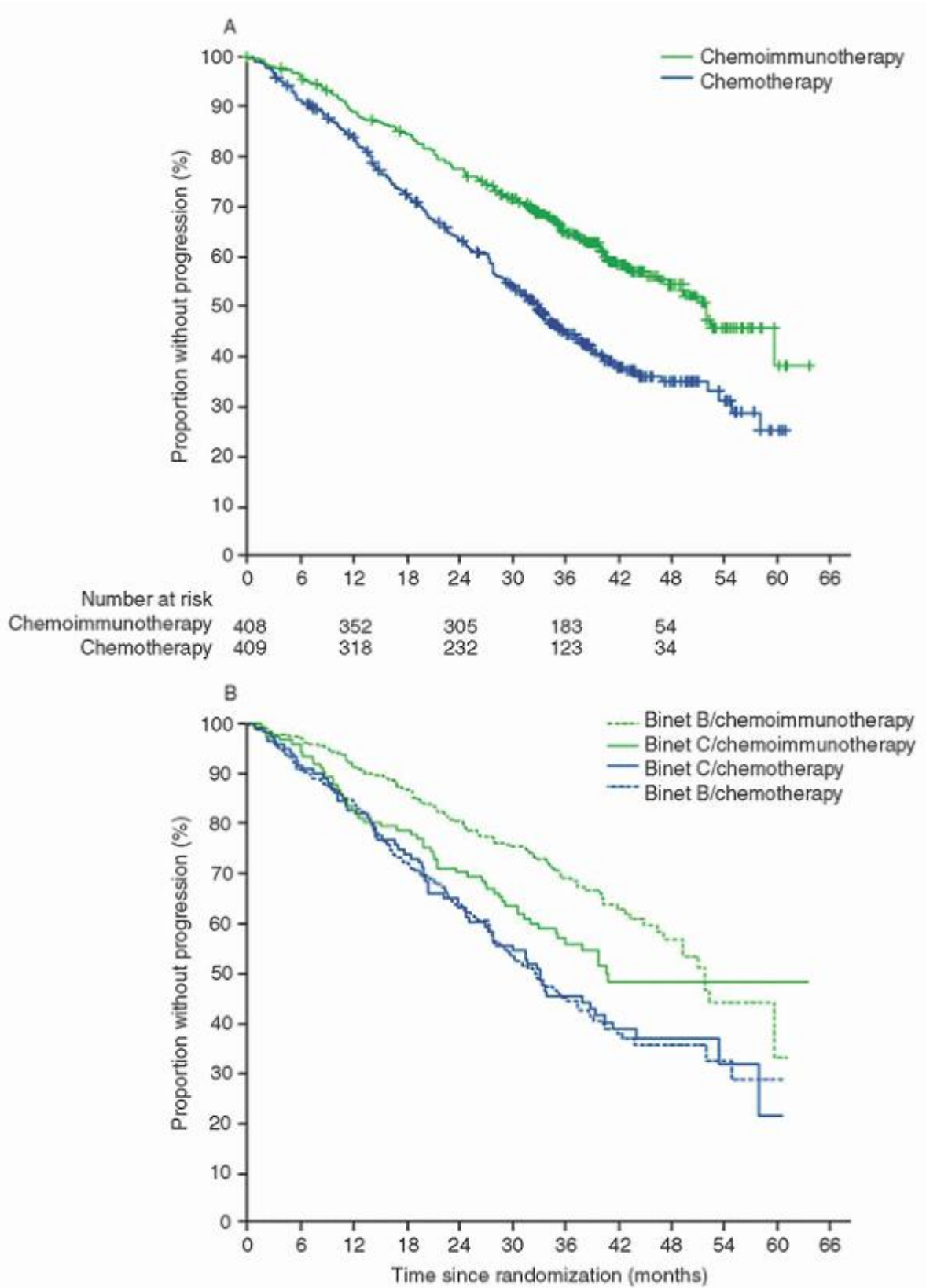

FIGURE 90.10. Progression-free survival in all patients and in patients with Binet stage B and C chronic lymphocytic leukemia. From Hallek M, Fischer K, Fingerle-Rowson G, et al. Addition of rituximab to fludarabine and cyclophosphamide in patients with chronic lymphocytic leukemia: a randomised, open-label, phase 3 trial. *Lancet* 2010;376:1164-1174.

To enhance activity, mitoxantrone has been added to the FCR regimen (R-FCM).⁵⁴⁸ In patients less than 70 years old, the response rate was 93% with 82% CR (46% MRD negative) with marrow suppression being the primary toxicity. Again, patients with high tumor burden, deletion 17p13, and high β 2-microglobulin levels did poorly. These patients received maintenance rituximab which will make it difficult to compare the effects on PFS and OS with the FCR studies where maintenance rituximab was not given.

Variations in FCR have been developed to reduce the significant myelosuppression of FCR. In one regimen, patients received 6 cycles of reduced doses of fludarabine and cyclophosphamide with increased doses of rituximab followed by maintenance rituximab every 3 months until relapse.⁵⁴⁹ This regimen decreased myelosuppression without compromising the response rate, but effects on survival are not yet known. Pentostatin has been substituted for fludarabine, as it is less myelotoxic.^{550, 551} Using pentostatin 2 mg/m² IV, cyclophosphamide 600 mg/m² IV, and rituximab 375 mg/m² IV, repeated every 3 weeks for 6 cycles the CR, nPR, and PR rates were 41%, 22%, and 28%, respectively, in 64 previously untreated patients.⁵⁵⁰ In contrast to FCR, patients >70 years of age appeared to do particularly well with

P.1919

this regimen having similar response rates and toxicities as seen with younger patients. The regimen appeared to be less myelotoxic than FCR and although patients with 11q22-23 deletions did as well as patients without high-risk cytogenetics, patients with deletions of 17p13 did not respond to PCR. Pentostatin and rituximab have been evaluated in 33 patients using a higher dose of pentostatin (4 mg/m²) than for PCR.⁵⁵¹ The CR was 27%, nPR 15%, and PR 33%, confirming the importance of additional cyclophosphamide to enhance response rate.

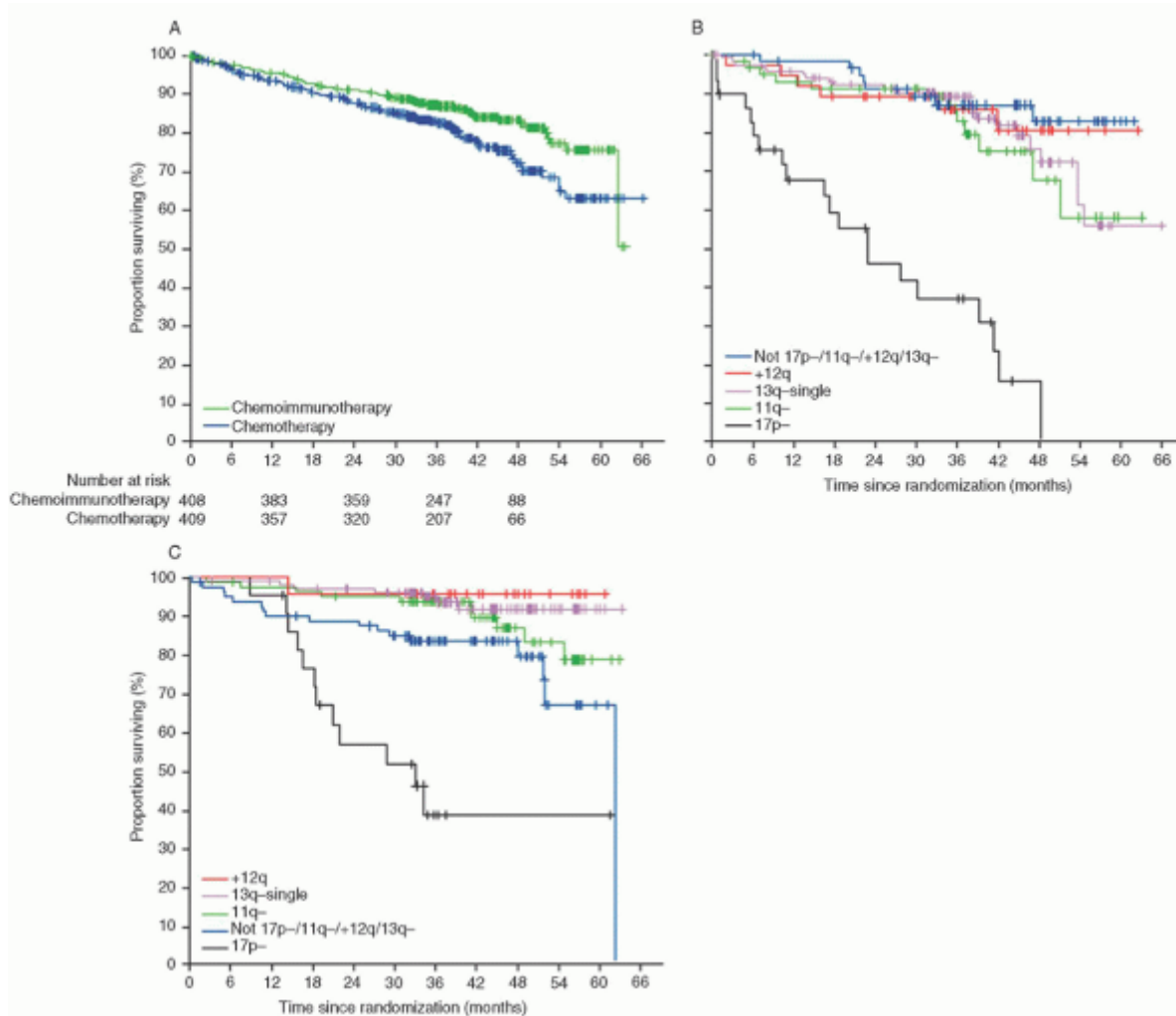

FIGURE 90.11. Overall survival in all patients (A), and in genetic subgroups of chemotherapy (B) and chemoimmunotherapy groups (C). Chemoimmunotherapy = fludarabine, cyclophosphamide, and rituximab. Chemotherapy = fludarabine and cyclophosphamide. From Hallek M, Fischer K, Fingerle-Rowson G, et al. Addition of

rituximab to fludarabine and cyclophosphamide in patients with chronic lymphocytic leukemia: a randomised, open-label, phase 3 trial. *Lancet* 2010;376:1164-1174.

Bendamustine has been combined with rituximab (BR) for 117 previously untreated CLL patients.⁵⁵² The CR was 23% and PR 65% with a median estimated event-free survival of 34 months. Marrow toxicity occurred in half the patients and although neutropenia appeared to be less than in the CLL8 study, there was a higher incidence of anemia and thrombocytopenia. Whether BR is better than FCR is being evaluated in the phase III German CLL10 study. Bendamustine/rituximab has also been evaluated in 78 previously treated CLL patients, of whom 22 were fludarabine-resistant and 14 had a deletion of 17p13.⁵⁵³ The CR, nPR, and PR rates were 9%, 3%, and 47%, respectively, and the median event-free survival was 14.7 months.

Combinations with Ofatumumab

Ofatumumab has been combined with fludarabine and cyclophosphamide (O-FC) for previously untreated CLL patients and has comparable activity to FCR.⁵⁵⁴

Combinations with anti-CD52 Antibody

Alemtuzumab may reverse drug resistance, as 1 CR and 4 PR were obtained in 6 fludarabine- and alemtuzumab-resistant CLL patients treated with a combination of FA.⁵⁵⁵ Sayala et al.⁵⁵⁶ administered alemtuzumab 30 mg sc 3 times a week with oral fludarabine 40 mg/m² for 3 consecutive days every 4 weeks to 17 fludarabine-resistant CLL patients who were not responding (NR) or had only a PR to alemtuzumab alone. Three patients responded

P.1920

(2 NR to a PR and 1 PR to a CR). Elter et al.⁵⁵⁷ administered FluCam (fludarabine 30 mg/m² IV with alemtuzumab 30 mg IV for 3 consecutive days every 4 weeks for 6 cycles) to 36 heavily pretreated patients. The CR and PR rates were 30% and 53% with the median time to progression being 13 months with an OS of 36 months. Of 9 fludarabine-refractory patients, 6 responded to FluCam. This combination was well tolerated and there were few infections. A subsequent study in previously treated patients who were sensitive to fludarabine or alemtuzumab (response to either agent had lasted >12 months) demonstrated improved survival when patients were treated with FluCam as compared to fludarabine.⁵⁵⁸ The CR and PR rates were 13% and 69% for FluCam and 4% and 71% for fludarabine, respectively. The PFS was significantly longer for FluCam (23.7 months vs. 16.5 months, $P = 0.0003$) and although the median OS was not reached for FluCam it was 52.9 months for fludarabine ($P = 0.021$). However, it is unclear how many of these patients had been treated with rituximab-containing regimens, and so the clinical applicability of the study is unclear. A small study using FluCam in elderly patients (median age 66 years) with deletions of 17p13 or p53 mutations showed that 6 of 7 patients achieved a CR and one a PR, with excellent tolerability.⁵⁵⁹ The likelihood of response diminished and the incidence of complications increased when previously treated patients received FluCam.

A clinical trial with alemtuzumab in combination with fludarabine and cyclophosphamide (FCCam) for relapsed or refractory CLL was discontinued because of myelotoxicity, infections, and a treatment-related mortality (TRM) of 9%.⁵⁶⁰ The response rate also did not appear to be as high as FluCam or FCR.⁵⁶⁰ In addition, a prospective phase III trial comparing FCR with FCCam in previously untreated patients showed that FCCam produced a lower response rate and was more toxic than FCR.⁵⁶¹

The MD Anderson has combined FCR with alemtuzumab (CFAR) both in previously untreated and treated patients.^{562, 563} In untreated patients <70 years and with a β 2-microglobulin ≥ 4 mg/dl, the CR, nPR, and PR rates were 70%, 3%, and 18%, respectively, with a median PFS of 38 months.⁵⁶² These results did not appear to be significantly better than expected with FCR. For heavily pretreated patients, the CR, nPR, and PR rates were 29%, 4%, and 33%, respectively, but the estimated PFS of 10.6 months and OS of 16.7 months was similar to that observed with FCR.⁵⁶³ Moreover, the infection rate was higher with CFAR. Thus, the addition of alemtuzumab to FCR appears to increase toxicity without significant benefit.

New Agents

A number of new agents are under development but only those agents already available for clinical use or hold promise are discussed (Fig. 90.12).⁵⁶⁴

CDK Inhibitors

Flavopiridol is one of a number of CDK inhibitors and is active in CLL, producing responses in 50% of resistant patients, including those with loss of TP53 function.⁵⁶⁵ Indeed, the drug is so effective that the major side effect is tumor lysis. The

mechanism of action of flavopiridol, and probably other CDK inhibitors, is likely through the inhibition of CDKs, the inhibition of transcription with a reduction in mcl-1 and XIAP, and the induction of endoplasmic reticulum stress.⁵⁶⁶

Inhibition of BCL2

A number of drugs have been developed to inhibit BCL2, which is increased in CLL. ABT-263 (Navitoclax) is a potent inhibitor of BCL2, BCLXL, and BCLW and potently induces cell death in CLL cells in vitro. In initial studies in heavily pretreated patients, one third of patients achieved a PR.⁵⁶⁴

Immune Modulation

Lenalidomide has multiple mechanisms of action in CLL affecting angiogenesis, cytokine levels, and the microenvironment. In refractory CLL, lenalidomide can produce responses in up to one third of patients with major toxicities including marrow suppression and tumor flare, which can be controlled with prednisone.⁵⁶⁷ Because of the risk of tumor lysis syndrome, it has been suggested to start lenalidomide using 2.5 mg/day with monthly escalations up to 20 mg/day.^{568, 569} The median dose achieved varies between 5 and 15 mg/day, depending on the extent of prior treatment and patient age.^{567, 568, 569, 570} The dose-limiting toxicity is marrow suppression although most patients have side effects with higher drug doses, including fatigue, bowel disturbance, and skin rash.^{567, 568, 569, 570} In previously untreated patients, approximately two-thirds of patients respond with up to 15% CRs.^{569, 570} In a study on patients >65 years, response depended on the drug dose with the median achieved being 5 mg/day.⁵⁷⁰ A total of 10% achieved a CR, 5% CR with residual cytopenias, 7% nodular PR, and 43% PR. Interestingly, serum Ig increased with lenalidomide and there was a fall in CCL3 and CCL4. However, the drug needs to be given continuously and patients with deletion 17p13 respond less well than other patients.⁵⁷⁰

Effectors of the Microenvironment

With the understanding of the importance of the BCR pathway for cell survival and proliferation in CLL, a number of drugs have been developed to inhibit different stages in the pathway and have recently been reviewed.^{110, 111} These include a SYK kinase inhibitor (fostamatinib); a Lyn/BTK inhibitor (dasatinib); and perhaps the two most exciting drugs, the PI3-kinase delta inhibitor, GS-1101 (formerly CAL-101) and the BTK inhibitor ibrutinib (PCI-32765).^{571, 572} In early studies these agents have demonstrated remarkable activity with little toxicity and there are a large number of ongoing studies evaluating these novel agents, either alone or in combination with standard therapies.

Treatment of Resistant Disease

The majority of CLL patients will initially respond to therapy resistance, however, they will eventually develop resistance, and these patients become progressively more difficult to treat.^{564, 573} The definition of drug resistance is a lack of response to treatment or relapse within 6 months and is based on the original definition by Keating et al.⁴⁰⁷ where the median survival of patients who were fludarabine-resistant was 10 months. However, nowadays, most patients will be treated initially with chemoimmunotherapy and may relapse 2 to 3 years later with refractory disease, where the time of relapse has just been postponed because of the more effective initial treatment. Thus, as opposed to “fludarabine-refractory” CLL, it is preferable to describe resistance as “refractory” CLL.⁵⁷³ As discussed in the section, “Molecular Genetics,” approximately 45% of patients who are fludarabine-resistant have either deletions of 17p13 or p53 mutations, with the site of mutation influencing drug resistance.^{392, 393, 394, 395} Of the remaining 55% of cases approximately 20% will have a deletion of 11q22-23. Mutations of NOTCH1, SF3B1, and BIRC3 have also been associated with refractory disease.^{226, 227, 228, 229, 230, 231, 233, 392}

Thus, it has been suggested that CLL patients can be divided into three groups: (a) “highest-risk” where patients are unlikely to respond to chemotherapy, and these patients include those with a TP53 mutation/17p13 deletion, are resistant to fludarabine, or relapse within 2 years of FCR (approximately 20% (b)); (b) “high-risk” where patients are likely to relapse early after chemotherapy, and these include patients with a high β 2-microglobulin, deletion of 11q22-23 or unmutated IgV_H; and (c) “low-risk” where patients are untreated and have no TP53 mutations/deletions, no deletions

P.1921

of 11q22-23, mutated IgV_H, and low β 2-microglobulin.⁵⁷³ Patients in the highest-risk group should be considered for investigational agents, alemtuzumab, and allogeneic HCT. Patients in the high-risk group should receive FCR and an investigational agent to try to maintain the remission. Low-risk patients should be treated with FCR or an alternative regimen.^{573, 574}

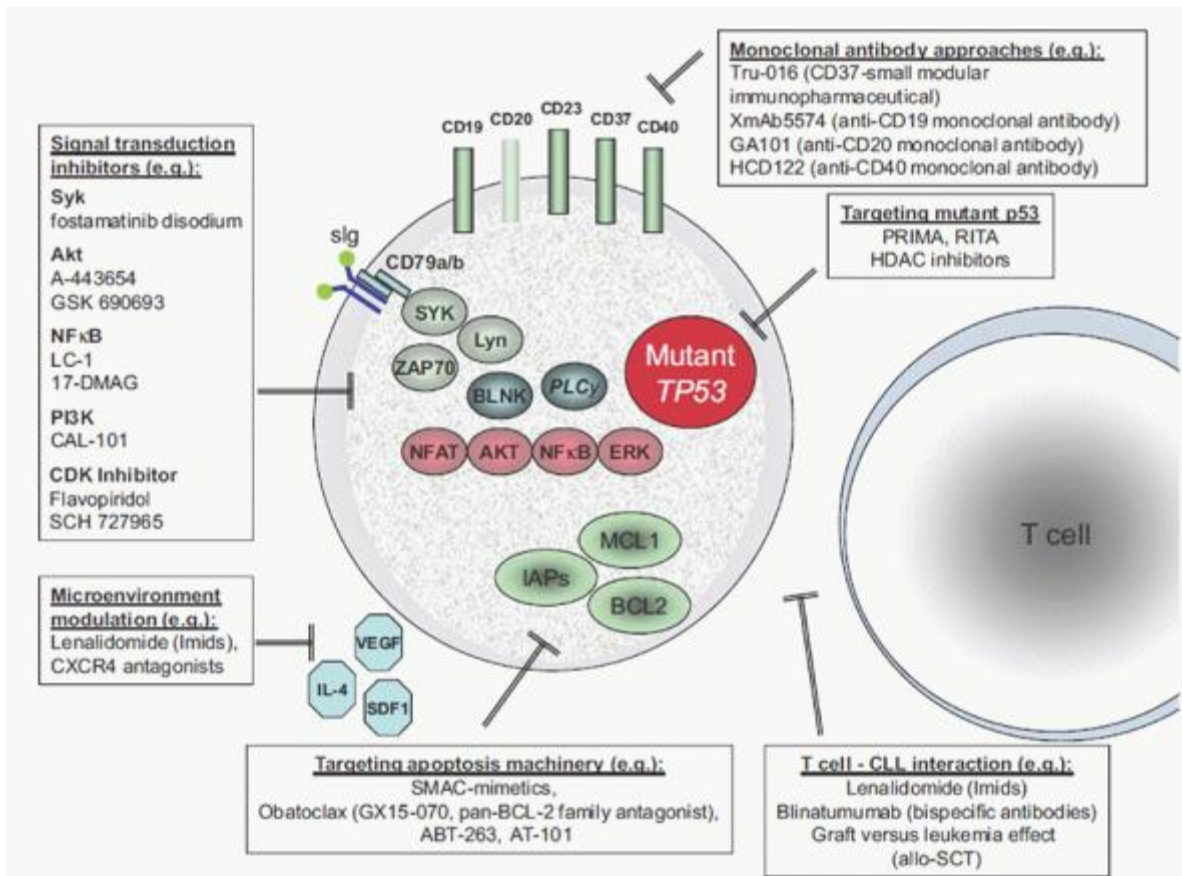

FIGURE 90.12. Selection of targets and novel agents in early clinical trials of CLL. There are multiple “biologic” therapeutic approaches in current clinical development in CLL. Signal transduction inhibition will often target the B-cell receptor cascade, which has been shown to be critical to CLL cell survival. A number of surface molecules of CLL cells can be targeted by antibodies. Different members of the apoptosis machinery are targets currently explored in clinical trials. Microenvironmental stimulation and T-cell interaction are of critical importance for CLL cell survival, and are being increasingly utilized for treatment strategies. There is ongoing interest in using mutant p53 as a “druggable” target, and a number of agents have been identified that may preferentially target mutant p53.³⁴ Improving efficacy in CLL with p53 pathway defects is likely to offer the greatest overall benefit. From Stilgenbauer S, and Zenz T. Understanding and managing ultra high-risk chronic lymphocytic leukemia. *Hematology (Am Soc Hematol Educ Program)* 2010;2010:481-488, with permission.

Hematopoietic Stem Cell Transplantation

Because CLL is not curable with standard therapy, HCT is worthy of consideration, particularly in younger patients who are more able to withstand this potentially arduous therapy. In addition, recent advances in the identification of clinical or biologic risk factors indicative of aggressive disease (i.e., fludarabine resistance, or deletions of 17p13) have permitted the recognition of patients who have a very poor prognosis with standard therapy and may benefit from HCT. As genomic abnormalities are known to develop over time in CLL, it is reasonable to consider early transplantation in these patients, before the development of drug resistance and even more aggressive disease. Detailed reviews have recently been published on the subject.^{575, 576, 577}

Autologous Transplantation and Cellular Therapy

The dose intensity of the preparative regimen is of critical importance for autologous HCT (autoHCT), as the intent of such myeloablative chemotherapy and/or radiotherapy is to eradicate residual CLL. This is followed by the reinfusion of autologous hematopoietic progenitor cells that are hopefully free of residual CLL cells. Until recently, autoHCT had been an attractive option in CLL, as the TRM of this procedure is relatively low and durable remissions were achievable.^{578, 579} However, subsequent randomized controlled trials demonstrated that autoHCT, when used as consolidation after first-line therapy, offers no survival advantage over observation⁵⁸⁰ or standard dose chemotherapy.⁵⁸¹ In addition, the German CLL study group compared the results of their single arm trial of autoHCT as first-line therapy for CLL to the outcomes in a

similar cohort of CLL patients who received first-line FCR. Survival was no better in the autoHCT cohort.⁵⁸² An additional concern with autoHCT is that of treatment-related myelodysplasia/acute myeloid leukemia (MDS/AML). The incidence of AML/MDS for CLL patients 5 years post-autoHCT is as high as 12.4%.⁵⁸³ Taken together, before autoHCT can be revisited as a therapeutic tool in CLL, new approaches are needed to

P.1922

improve methods of in vivo or ex vivo purging of CLL cells in the harvested autologous cells, the choice of conditioning regimens, post-autoHCT maintenance therapy, or the induction of an autologous graft-versus-CLL effect.

Chimeric Antigen Receptor Modified T-cells

The induction of autologous T-cells that are reactive against CLL cells represents a highly promising form of cellular therapy. This concept has led to early-phase clinical trials using chimeric antigen receptor modified T-cells (CARTs). Autologous T-cells are genetically modified to express chimeric antigen receptors, with T-cell specificity against the CD19 bearing B-cells found in CLL and other lymphoid malignancies.^{584, 585} These CLL-specific T-cells are then re-infused into recipients. Preliminary clinical results suggest that such therapy has the ability to achieve rapid and profound responses in heavily treated, chemorefractory CLL patients. However, despite their exciting potential, further data will be required before such strategies can be adopted into widespread clinical practice.

Allogeneic Transplantation

Whereas autoHCT primarily depends on dose intensity to eradicate CLL, allogeneic HCT (alloHCT) offers the added advantage of adoptive cellular immunotherapy. This probably explains the higher efficacy of this treatment, albeit at the cost of increased therapy-related toxicity. The difference in response between autoHCT and alloHCT is most likely due to the graft-versus-leukemia (GVL) effect. Specifically, CLL cells disappear with the onset of graft-versus-host disease, relapse risk increases with the use of T-cell-depleted grafts, and there are reports of favorable responses to donor lymphocyte infusions.^{586, 587, 588, 589}

In myeloablative alloHCT, the proposed benefit in preventing CLL relapse has been offset by relatively high treatment-related toxicities, with cumulative nonrelapse mortality approaching 50%.^{590, 591} However, the GVL effect associated with alloHCT has raised considerable interest in nonmyeloablative (NMA) or reduced-intensity conditioning (RIC) alloHCT. The principle of this approach is that the nonhematopoietic toxicity, profound pancytopenia, and opportunistic infections associated with intense myeloablative preparative regimens are avoided, and the beneficial GVL effect is retained. A pivotal European registry-based study demonstrated that in 73 heavily pretreated patients receiving NMA alloHCT, the cumulative TRM was relatively low at 19%. With a median follow-up of 22 months, the cumulative event-free and OS was 58% and 70%, respectively. In this study, only 1 patient relapsed after the 2-year post-transplant mark.^{575, 591} A retrospective comparison of these 73 NMA cases with 82 matched myeloablative HCT patients from the EBMT registry showed a significant reduction in TRM but an increased relapse incidence in the NMA population.⁵⁹¹ There was no significant difference between the 2 alloHCT modalities in terms of event-free and overall survival. Although NMA/RIC and conventional myeloablative alloHCT approaches have yet to be prospectively compared, the NMA/RIC strategy is probably at least as effective as the latter, and, in addition, allows the expansion of transplant eligibility criteria to older or more medically fragile or complex recipients. Current internationally accepted guidelines recommend NMA/RIC regimens for all CLL allograft recipients.⁵⁷⁵ A summary of recently updated studies in NMA/RIC alloHCT for CLL is provided in Table 90.14.

TABLE 90.14 CLINICAL OUTCOMES OF REDUCED INTENSITY CONDITIONING/NONMYELOABLATIVE ALLOGENEIC HEMATOPOIETIC CELL TRANSPLANTATION FOR CLL

Study, year	N Study type	Regimen	Chronic extensive GVHD(%)	NRM(%)	Relapse(%)	OS(%)
Sorrer, 2008 ⁵⁹⁹	82 Prospective, multicenter	TBI +/- F	51%	23(5y)	38(5y)	50(5y)
Delgado, 2009 ⁶⁰⁰	37 Retrospective, two centers	F+MeI+alemtuzumab ^a	19 ^b	34(2y)	18 ^c (2y)	39(5y)
Dreger, 2010 ⁵⁹²	90 Prospective multicenter	FC+ATG if UD	55(2y)	23(4y)	40(4y)	65(4y)

Khouri, 2011 ⁵⁸⁹	86 Retrospective single center	FCR ^d	56(5y)	17(1y)	39(3y)	51(5y)
Brown, 2013 ⁵⁹⁰	76 Retrospective single center	FB	65(2y)	16(5y)	40(5y)	63(5y)

ATG, antithymocyte globulin; UD, antiCD52, alemtuzumab; B, busulfan; C, cyclophosphamide; F, Fludarabine; GVHD, graft-versus-host-disease; Mel, melphalan; N, number; NRM, nonrelapse mortality; OS, overall survival; R, rituximab; TBI, total body irradiation; UD, unrelated donor; y, year.

^a Alemtuzumab in 21 patients.

^b Not stated if acute or chronic.

^c Estimated from cumulative incidence curve.

^d The majority received FCR.

The best preparative regimen for use in NMA/RIC alloHCT is unknown. Several regimens have gained popularity, almost all of which include fludarabine in combination with alkylating agents (such as cyclophosphamide, melphalan, or busulphan), with or without anti-T-cell antibody therapy to augment recipient immune suppression. In the absence of controlled studies, preparative regimen choice should be individualized depending on patient (e.g., age, extent of CLL control pre-transplant, comorbidities) and donor variables (e.g., degree of HLA match), as well as familiarity of the transplant team with a specific regimen. The use of a partially matched donor generally requires the use of a regimen with heightened immune suppression, such as the addition of antithymocyte globulin.^{592, 593} The inclusion of alemtuzumab in the preparative regimen is more contentious, as its administration is thought to be associated with higher rates of post-transplant CLL relapse and poorer survival.^{592, 594} The reason for this is possibly related to the potent ability of alemtuzumab to reduce graft-versus-host disease, with a corresponding reduction in the graft-versus-tumor effect. The dose of alemtuzumab may be important in this regard, as lower doses may provide sufficient GVHD prophylaxis without excess risks of relapse or infection.⁵⁹⁵

P.1923

Traditionally, related donors have been the preferred source of donor cells for alloHCT. However, one concern in CLL is the high incidence of familial CLL.³³⁵ In addition, MBL is prevalent not only in relatives of CLL patients, but at substantial levels in the healthy adult population; estimates of MBL range from 0.14% to >20%, depending on the population studied.⁵⁹⁶ It is presently unknown what proportion of these patients will develop clinically relevant CLL. However, MBL is transferrable from donors to allogeneic transplant recipients.⁵⁹⁷ Consequently, it has been proposed that related donors be routinely screened for MBL and excluded from donation if found to have this syndrome.⁵⁹⁸ In the current era of high-resolution typing of unrelated donors, the prospect of more widespread use of unrelated donors is feasible, especially if histocompatible-related donors are unavailable or medically ineligible. The use of well-matched (at least 7/8 HLA allele compatibility) unrelated donor results in outcomes at least as favorable as those of related donor transplants.^{593, 599} To date, no published randomized studies have compared alloHCT to nontransplant-based therapy for CLL. However, there are data to suggest that alloHCT may overcome the poor prognostic impact of fludarabine-refractory CLL.⁵⁹² In addition, alloHCT may result in durable disease control and quite possibly cure in CLL patients with adverse cytogenetic markers (including 17p13 mutations).⁵⁹⁴ A case control study that compared RIC/NMA allografting with nontransplant controls that were matched for age and disease stage suggested that allografting may be superior to a nontransplant approach.⁶⁰⁰ Moreover, a decision analysis using a Markov model concluded that alloHCT remains the preferred approach for patients with relapsed or refractory CLL, even when accounting for the significant upfront costs and toxicity of the HCT.⁶⁰¹

Although there is increasing confidence in alloHCT for high-risk or relapsed CLL, controlled trials are required to address issues such as optimal patient selection, preparative and GVHD regimens, and, most important, whether this procedure is truly superior to modern nontransplant approaches. We recommend that CLL patients who are candidates for HCT be managed within the context of a clinical trial.

Radiotherapy

Radiation is rarely used for CLL nowadays, but for many decades irradiation of the spleen was the primary treatment for this disease;^{602, 603, 604, 605, 606, 607, 608} irradiation of the mediastinum,^{609, 610} extracorporeal irradiation of the blood,^{611, 612} TBI,^{613, 614, 615, 616, 617} and hemibody irradiation⁶¹⁸ may also reduce the peripheral blood lymphocyte counts and the size of lymph nodes, spleen, and liver.

Splenic irradiation has produced survival rates comparable to those achieved with chlorambucil or COP in Rai stage III and IV patients.⁶¹⁵ However, in general, splenic irradiation is reserved to treat patients with large painful spleens or those with cytopenias related to splenomegaly who are not medically fit for splenectomy. Although almost all patients experience a reduction in spleen size and relief from pain with irradiation, the effects on hemoglobin and platelets are more variable.^{604, 606} It is likely that differences in therapeutic effect are related to the extent of prior treatments, as untreated patients respond much better to irradiation than those who have previously undergone therapy.⁶⁰² High doses of splenic irradiation may cause neutropenia and thrombocytopenia, and it is thus recommended to initially use small fraction sizes (e.g., 0.25 to 0.50 Gy on alternate days, or 3 times per week).^{602, 603} The dose of irradiation is gradually increased according to response and toxicity, and the usual maximum cumulative dose is 5 to 10 Gy.

TBI has been given alone^{613, 614, 615} or in combination with chemotherapy.^{616, 617} Patients treated with TBI plus cyclophosphamide and prednisone had higher response rates than those treated with TBI alone.⁶¹⁶ Intermittent low doses of irradiation may also be effective.^{612, 614, 615} In one study, 48 patients with progressive disease received 5 to 10 rad TBI 3 to 5 times per week for a total of 100 to 400 rad.⁶¹⁴ A total of 88% of the patients responded, with one third achieving a CR, although mild anemia and thrombocytopenia persisted in some individuals. The regimen was generally well tolerated, although significant myelosuppression occurred, and rest periods of weeks to months were intermittently required to allow marrow recovery. The Ig levels returned to normal in most of the patients who achieved a CR.

Splenic irradiation can produce systemic effects with a decrease in lymphadenopathy and a reduction in lymphocyte count and can induce CRs.^{602, 608} The mechanism(s) underlying these phenomena is unclear, and many factors may be involved.⁶⁰² CLL cells are highly sensitive to ionizing radiation in vitro, and a correlation has been observed between the radiosensitivity of CLL cells in vitro and the patients' clinical response to radiation therapy.⁶¹⁹ However, irradiation may also produce its effects through the inhibition of CD8⁺ T-cells and the induction of cytokine release from CLL cells.^{602, 620} Finally, radiation of the spleen can produce a "radiotherapeutic splenectomy," thus decreasing "pooling" and improving normal blood counts.

Splenectomy

Splenectomy is primarily carried out in CLL for the treatment of AIHA or ITP but may also be useful for patients with massive painful splenomegaly or in whom the leukemia is predominantly confined to the spleen.^{621, 622, 623, 624, 625} In addition, splenectomy may be considered when cytopenias are believed to be due to hypersplenism and have not responded to chemotherapy.^{621, 622, 623, 624} Neal et al.⁶²⁴ noted an improvement in the hemoglobin and platelet counts in two-thirds of patients with advanced-stage CLL who underwent splenectomy, and the improvement was maintained during the 1-year follow-up. In this study, neither the spleen size nor the degree of marrow involvement was predictive of response, although others have observed a correlation between spleen size and the improvement in blood counts after splenectomy.⁶²¹ Approximately 50% of patients have post-operative infections, and half of these require antibiotics.⁶²¹ Moreover, the perioperative mortality from sepsis is 5% to 10%, but this is primarily in patients with advanced disease and poor performance status.⁶²¹ Thus, in selected patients with good performance status, splenectomy may increase the blood counts sufficiently to permit aggressive chemotherapy. In addition, more individuals may now be candidates for this procedure as laparoscopic splenectomies become routine.⁶²⁵ Patients should be immunized with pneumococcal, meningococcal, and hemophilus influenza vaccines about a month before splenectomy, although there will be variability among patients as to how well they can produce an antibody response.²⁸⁸

SYSTEMIC COMPLICATIONS REQUIRING THERAPY

Infection

Patients with CLL have an increased risk of infection, which is partly related to the effects of the disease and partly to the effects of chemotherapy. Although a number of immune abnormalities occur in CLL, the incidence of infection is most closely related to hypogammaglobulinemia which increases with disease stage and duration.^{288, 289, 626, 627} The risk of infections, particularly opportunistic ones, is increased by steroids, nucleoside analogues, and monoclonal antibodies. Patients treated with alkylating agents are primarily affected by bacterial infections, whereas those on fludarabine-based treatments can get other opportunistic infections, such as *Pneumocystis jirovecii*, CMV, herpes simplex, and varicella zoster. The addition of steroids markedly increases the risk of infections with fludarabine and should be avoided.

Patients with hypogammaglobulinemia and recurrent bacterial infections may be treated with intravenous Ig. High-dose Ig, 400 mg/kg IV every 3 weeks, reduces the incidence of bacterial infections by 50%, particularly those caused by *Streptococcus pneumoniae* and *Haemophilus influenzae*, but the total number of severe bacterial infections and nonbacterial infections is not reduced, and this treatment does not prolong survival.⁶²⁸ A subsequent study using this regimen showed that the reduction in infections did not improve the patients' quality of life or survival and that the treatment was not cost effective, because of the high doses of Ig infused.⁶²⁹ Lower doses of gammaglobulin may be as effective, for example, 250 mg/kg every 4 weeks or 10 g every 3 weeks.^{630, 631} Molica et al.⁶³² randomized CLL patients with an IgG of less than 6 g/L and a serious infection in the previous 6 months to 300 mg/kg gammaglobulin every 4 weeks or to observation. Patients receiving gammaglobulin had a reduced number of infections, but the effectiveness did not correlate with restoration of the IgG levels. Thus, it is recommended that selected patients with hypogammaglobulinemia and frequent bacterial infections may receive prophylactic Ig.^{289, 633}

Granulocyte-macrophage colony-stimulating factor can increase the neutrophil count and function in CLL, although whether this reduces the incidence of infections remains unclear.^{634, 635} However, the use of granulocyte colony-stimulating factor after fludarabine has been shown to reduce the risk of neutropenia and the incidence of pneumonia.⁶³⁶ In general, older patients with more advanced disease have greater risk of infection than younger patients, particularly if they have had prior therapy. Prophylactic antibiotics may be of benefit, particularly when patients are receiving nucleoside analogues, monoclonal antibodies, and steroids, and frequently, antibiotics are incorporated into the newer and more immunosuppressive regimens. Thus, patients may be maintained on trimethoprim-sulfamethoxazole (cotrimoxazole) to prevent *Pneumocystis jirovecii* pneumonia, acyclovir to prevent herpes viruses, valganciclovir to prevent both CMV, and fluconazole to prevent fungal infections. However, the use of these antibiotics varies widely and whether all patients should receive prophylactic antibiotics or only older patients or those with a history of shingles is still unclear.^{289, 633}

In general, vaccines are less effective in CLL because of impairment in the immune system.^{288, 633} However, it is still recommended to immunize these patients for pneumococcus and influenza, the latter annually. These patients should not receive live vaccines, and these include, typhoid, yellow fever, measles, mumps, rubella, BCG, and herpes zoster.^{288, 633}

Autoimmune Complications

As discussed previously, immune cytopenias are the commonest autoimmune complications occurring in 4.3% to 9.7% of patients with AIHA in about 7% of patients and <1% to 2% having ITP, red cell aplasia, or immune neutropenia.^{312, 313, 314, 633} The disorders are caused by the immune dysregulation in CLL, may be triggered by chemotherapy, and are treated with immunosuppressives. In contrast, other autoimmune disorders in CLL are caused by antibodies produced by the CLL cells, for example, cold agglutinin disease, and these will respond to treatment of the CLL. It is thus important to be constantly aware of the potential development of these disorders and to treat them appropriately.

The immune cytopenias are treated initially with steroids, using prednisone 1 mg/kg/day, and 75% of patients respond to this therapy.^{312, 633} A response may be seen within days, although it may take several weeks in some patients. Patients with AIHA should also be maintained on folic acid, 5 mg/day, and after the hemoglobin and reticulocyte counts have normalized (usually in 1 to 2 weeks), the prednisone can be tapered slowly over a period of 2 to 3 months. These patients should be watched for all the usual complications of prednisone, such as gastric irritation, diabetes mellitus, an increased risk of opportunistic infections, and osteoporosis. Thus, these patients may need to be maintained on an H₂-blocker or proton pump inhibitor, may require oral hypoglycemics/insulin, and should be maintained on prophylaxis against *Pneumocystis jirovecii* [e.g., trimethoprim-sulfamethoxazole (one double-strength tablet orally twice a day on Saturdays and Sundays, or one double-strength tablet 3 times a week)] if they are on steroids for longer than a few weeks.⁶³⁷ They are also at risk of other infections, such as oral candidiasis or herpetic infections and may require therapy or prophylactic antibiotics such as valacyclovir. Many of these patients are elderly, and the prolonged course of prednisone increases the risk of osteoporosis and vertebral collapse. Thus, patients should be maintained on bisphosphonates. The authors prefer an intravenous formulation to reduce the risk of the gastric irritation that may result from corticosteroids (e.g., pamidronate 30 mg IV every 3 months).⁶³⁸ It is important that patients with AIHA and dangerously low hemoglobins are transfused, because, despite theoretical concerns, these patients rarely have severe transfusion reactions.⁶³⁹ In addition, any infection should be treated promptly, as sepsis can inhibit the compensatory reticulocytosis and worsen the anemia.

If a more rapid response is required, or if the patient does not respond to prednisone within 7 to 10 days, 1 gram of methylprednisolone IV or intravenous Ig (0.4 g/kg/day × 5 days or 1 g/kg/day × 2 days) should be added.³¹⁴ This can

produce a rapid response, but the response is transient, and re-treatments are generally required every 3 to 4 weeks.³¹⁴,⁶⁴⁰ There is no standard therapy for patients who do not respond to this therapy or who cannot be weaned off prednisone without a relapse. Cyclosporin is a reasonable option and produces a major response in two-thirds of CLL patients with ITP or anemia and is highly effective in red cell aplasia.³¹⁴,⁶⁴¹,⁶⁴²,⁶⁴³ In one study using cyclosporin 300 mg/day, the median time to initial response was 3 weeks (range, 1 to 13 weeks), and the median time to best response was 10.5 weeks (range, 1 to 48 weeks).⁶⁴³ The median duration of response was 10 months (1+ to 39+ months), and some patients who had fludarabine-associated cytopenias were retreated effectively with fludarabine. Immune cytopenias also may be treated with other immunosuppressive drugs, such as 6-mercaptopurine or cyclophosphamide, although no controlled trials related to their use have been published.³¹⁴ Rituximab is also useful for the immune cytopenias, either alone⁶⁴⁴,⁶⁴⁵,⁶⁴⁶,⁶⁴⁷ or in combination with a cyclophosphamide-containing regimen when treatment of the underlying leukemia is also required.⁶⁴⁸,⁶⁴⁹,⁶⁵⁰ The response rate of 48 steroid-resistant CLL patients with immune cytopenias (AIHA 26, ITP 9, Evan syndrome 8, and red cell aplasia 5) receiving RCD (rituximab, cyclophosphamide, and dexamethasone) was 90% with the median duration of response being 24 months.⁶⁴⁹ There were 40% of these patients who had progressive disease at the time of treatment and all patients who relapsed with immune cytopenias had progression of their CLL. Further studies to prolong the duration of remission of the immune cytopenias will require better control of the underlying CLL. Good responses in small numbers of patients with CLL and AIHA have also been reported with alemtuzumab.⁶⁵¹

Splenectomy may also be a useful treatment for patients with AIHA, and the number of patients eligible for this procedure is increasing with the use of laparoscopic splenectomy.⁶²⁵ Splenic irradiation may be carried out in those who are not surgical candidates, but it may take up to 2 months to see a response; the responses last for approximately 1 year.³¹²,⁶⁰⁴

The thrombopoietin analogues, romiplostin, and eltrombopag, have also been shown to be effective in small numbers of CLL patients with refractory thrombocytopenia, although the drugs need to be given indefinitely.³¹⁴,⁶⁵²

P.1925

TRANSFORMATION OF CHRONIC LYMPHOCYTIC LEUKEMIA

Based on cytogenetic and molecular studies, it has been demonstrated that multiple clones may occur in CLL and that clonal evolution is a frequent occurrence.²⁰⁸,²¹⁷,²¹⁸,²¹⁹ The transformation of CLL to a high-grade non-Hodgkin lymphoma was originally described by Maurice Richter in 1928 (RS) and over time a Richter's transformation became synonymous with the development of diffuse large B-cell lymphoma, Hodgkin lymphoma, PLL, or acute leukemia in CLL.⁶⁵³ However, nowadays, RS or Richter's transformation is taken to reflect the development of diffuse large B-cell lymphoma in a patient with CLL or SLL.³,⁶⁵⁴,⁶⁵⁵ The likelihood of a second lymphoid malignancy is three- to fivefold higher in CLL than in the general population, is significantly increased by prior treatment with a purine nucleoside analogue, and almost half of these second malignancies are RS.⁶⁵⁶

In 75% of cases of RS the transformation is clonally related to the CLL and in 25% of cases is unrelated.²³⁴ By multivariate analysis the 4 most important factors predictive for a transformation are mutated NOTCH1, IgV_{H4-39} usage, trisomy 12/deletion 11q22-23/TP53 disruption, and CD38 positivity (≥30%).²³⁴ The risk of developing a clonally related RS is markedly increased if the patient has IgV_{H4-39} in addition to a NOTCH1 mutation (75% risk at 5 years) and least if the patient has neither (0% at 5 years).²³⁴ Of these lymphomas, 40% have a NOTCH1 mutation suggesting enrichment of CLL cells harboring the mutation over time.²²⁷ In contrast, patients who develop a clonally unrelated transformation generally have IgV_H mutated CLL.⁶⁵⁶

In contrast, NOTCH1 mutations are not involved in clonally unrelated RS.²³⁴ As discussed later, the clonally unrelated cases of RS in CLL behave as does de novo diffuse large B-cell lymphoma and may occur as a result of immunodeficiency or to an inherent predisposition to these malignancies.⁶⁵⁷ Finally, Epstein-Barr associated diffuse large B-cell lymphoma may develop in CLL following therapy with FA, and these tumors may resolve spontaneously.⁵³² Whether they are clonally related to the underlying CLL is not known.

RS occurs in 5% of patients with the median time to onset being 4 years, although patients can present with concomitant CLL and RS.⁶⁵⁴,⁶⁵⁵,⁶⁵⁸,⁶⁵⁹ The incidence of RS may actually be as high as 16.2% at 10 years, as many cases are probably misdiagnosed as having CLL progression.⁶⁶⁰ Patients with clonally related RS have a very poor prognosis and typically present with rapidly increasing lymphadenopathy or splenomegaly, fever, or weight loss, high LDH, and frequent extranodal involvement of kidneys, lungs, and the gastrointestinal tract. Preferably, the diagnosis should be made on a lymph node biopsy but in sick patients a needle aspirate of a node with cytology demonstrating large cells is sufficient.⁶⁵⁵ PET/CT scanning with ¹⁸F-FDG is a highly sensitive technique to detect a Richter's transformation and is useful in helping to

decide which node to biopsy.⁶⁶¹ However, hypermetabolism may also be seen with other transformations, with a co-existing solid tumor or infection, or with accelerated-phase CLL. The lymph node with accelerated-phase CLL shows increased numbers of proliferation centers, increased Ki67-positive CLL cells or PL, and no evidence of large-cell transformation.

Of 148 patients with RS at the MD Anderson, 135 received therapy using a variety of treatment regimens including R-CHOP (rituximab-cyclophosphamide, doxorubicin, vincristine, and prednisone).⁶⁵⁸ The addition of rituximab appeared to increase the response rate and for all patients the OR was 39% with 12% CR. For 7 patients in remission who underwent an allogeneic SCT the 3-year survival was 75%. Thus, although the OS was poor some patients did well and a RS prognostic score was thus developed based on performance status, LDH, platelet count, tumor size, and the number of prior treatments.⁶⁵⁸ However, the varying prognosis with RS likely depends on whether the tumors are clonally related or unrelated to the underlying CLL.⁶⁵⁹ Where the RS was clonally unrelated, the median survival was 62.5 months, no different from de novo diffuse large B-cell lymphoma, versus 14.2 months for clonally related RS. Patients with disruption of TP53, either through deletion or mutation, had a median survival of 9.4 months versus 47.1 months for patients with no disruption.

Occasionally, Hodgkin lymphoma develops in CLL, and is about 10% as common as RS.⁶⁶² As in RS, the Hodgkin's transformation occurs about 4 years after CLL is diagnosed with the mean age at diagnosis being 65.7 years versus a median age of 61 years for RS.⁶⁶² Histologically, there are 2 types of transformation. The type 1 transformation is characterized by scattered Reed-Sternberg cells in a field of typical CLL cells and the type 2 transformation shows Reed-Sternberg cells in a field of inflammatory cells, separate from the CLL cells.⁶⁶³ Most patients have advanced Rai stage disease at transformation and 70% of cases are mixed cellular or nodular sclerosing Hodgkin lymphoma.⁶⁶² As with RS, patients present with fever, lymphadenopathy, and weight loss.⁶⁶² One-quarter of patients achieve a CR with chemotherapy and one-quarter a PR, with a mean survival of 1.7 years (range, 0 to 14 years).⁶⁶² Patients who had previously received fludarabine for their CLL had a much poorer survival than patients who had not required treatment of their CLL. The cell of origin for the Reed-Sternberg cell in these patients has been debated, with some studies showing a clonal relationship to the underlying CLL cell, whereas others do not. However, whether the variation in response of these patients to chemotherapy is related to their clonal relationship to the underlying CLL is not yet known. In contrast to RS, Epstein-Barr viral infection is frequently seen in this transformation, but the exact role of the infection in this transformation is not yet known.

Polymphocytic transformation of CLL occurs slowly over several years with the gradual accumulation of increasing numbers of prolymphocytes [PLL/CLL] until there are $\geq 55\%$ prolymphocytes (PL).²⁵⁴ In general, this type of transformation occurs more frequently in patients with unmutated IgV_H and trisomy 12.²⁵⁴ The underlying genetic cause for the transformation is presently unknown, but MYC rearrangements have been described.⁶⁶⁴ Although most cases of PL in CLL represent a transformation of the CLL clone, cases of separate CLL and PL clones in the same patient have been described.⁶⁶⁵

Multiple myeloma may also develop in patients with CLL.^{666, 667} Some studies have suggested that the two diseases develop separately, whereas in others, multiple myeloma develops from the CLL clone. Acute leukemia occurs in less than 1% of CLL patients, and this contrasts with the almost invariable progression of patients with chronic myeloid leukemia to acute leukemia.⁶⁶⁸ Hairy cell leukemia is also more common in CLL.⁶⁵⁷ Of 31 cases of acute leukemia developing in patients with pre-existing CLL, 10 were lymphoblastic, 7 myeloblastic, and 1 plasmacytic; in 13 cases, the cell type was not identified.⁶⁶⁸ Both acute B- and T-cell lymphoblastic leukemias have been described in CLL,^{669, 670, 671, 672} and although this usually occurs after many years, the concomitant presentation of CLL and acute lymphoblastic leukemia also has been reported.⁶⁶⁹ In B-ALL, evidence of clonal evolution has been documented in some cases, whereas in T-cell cases, a common lymphoid progenitor precursor has been postulated as the source of both malignancies.^{669, 670, 671, 672}

SECOND MALIGNANCIES

Second malignancies are commonly found in the lymphoid malignancies, but are particularly common in CLL because of the significant immunosuppression seen in this disease.^{673, 674} Compared to the general population and patients with follicular lymphoma, the incidence of second malignancies is increased twofold, with

P.1926

the most common malignancies being squamous and basal cell carcinomas of the skin.^{674, 675, 676, 677, 678} Melanomas are also common, followed by cancers of the gastrointestinal tract, lung, breast, and prostate.^{674, 675, 676, 677, 678} Clinical features associated with an increased incidence of second malignancies include older age, male sex, a β -2-microglobulin >3

mg/dl, an increased LDH, and an elevated creatinine.⁶⁷⁵ In addition, these malignancies can be more aggressive than in patients without CLL, and an increased mortality is observed with skin cancers, melanomas, Merkel cell tumors, and lung cancer.^{674, 678, 679, 680, 681} The risk of developing AML or myelodysplasia with alkylating agents or nucleosides alone appears to be low, although the risk may increase if both are given together and the risk of developing AML/myelodysplasia with front-line FCR chemotherapy is 4.5% which occurs approximately 3 years following initiation of therapy.^{484, 547} This appears directly related to the potent myelosuppression seen with this regimen. Finally, patients with CLL may develop myeloproliferative disorders.⁶⁸²

Chronic myeloid leukemia, myelofibrosis, and essential thrombocythemia may also rarely occur in CLL. As second malignancies are a common cause of death in CLL, patients should be monitored for the development of new malignancies which should be promptly treated when identified.

SUMMARY OF THERAPY

The indications for treatment and the type of treatment will vary according to the patient's age and condition. If the patient is not participating in a clinical trial, the following are general guidelines.¹

- Patients with Rai stages 0-II usually do not require therapy unless there is evidence of significant disease progression or symptoms, for example, weight loss, night sweats, or fatigue.
- Patients with Rai stages III/IV disease frequently require treatment but this may be deferred until the patient is symptomatic or if there is disease progression.
- Other indications for treatment include AIHA/ITP and massive uncomfortable lymphadenopathy or splenomegaly.
- Patients with Rai stage III or IV disease may require a bone marrow aspirate and biopsy prior to chemotherapy to ensure that the anemia and/or thrombocytopenia are related to marrow infiltration.
- Prior to therapy, patients should have FISH analysis, a Coomb's test, and be screened for common viral pathogens, including hepatitis B and C, and CMV.
- Most treatment regimens include rituximab, and the standard initial therapy for patients with adequate performance status, comorbidity score, and renal status is FCR, particularly if the patient has a deletion 11q22-23. Other common regimens include FR and PCR, or chlorambucil with or without rituximab for the elderly and frail. Bendamustine with or without rituximab is also highly effective and is presently being compared with FCR in the German CLL10 study.
- Approximately half the patients who become refractory to the above regimens have a deletion 17p13 and treatment options for resistant patients include alemtuzumab alone, or high-dose steroids in combination with rituximab or alemtuzumab. Ofatumumab is used for patients who are refractory to alemtuzumab or with lymph nodes >5 cm, but is not very effective for patients with loss of p53 function.
- Prophylaxis against *Pneumocystis jirovecii* and herpes infections should be given to patients receiving nucleoside analogues, steroids, or alemtuzumab and continued for 6 months following therapy. The authors use trimethoprim-sulfamethoxazole (co-trimoxazole) 1 double strength twice a day on Saturdays and Sundays with valacyclovir 500 mg/day (or an equivalent). For patients allergic to trimethoprim-sulfamethoxazole, dapsone 100 mg 3 times a week or pentamidine by aerosol once a month may be used.
- Steroids should primarily be reserved to treat immune cytopenias and should be avoided, if possible, when patients are receiving chemotherapy. There is no evidence that steroids increase the response rate obtained with alkylating agents or nucleoside analogues alone, and they increase the risk of infection. However, if used judiciously, prednisone may be combined with chlorambucil to enhance marrow clearing of tumor and to reduce organomegaly.
- Patients with immune cytopenias or red cell aplasia should initially be treated with prednisone 1 mg/kg/day orally, but may also benefit from gammaglobulin, cyclosporine, cyclophosphamide, or rituximab. Patients who are going to receive a prolonged course of prednisone should be maintained on pamidronate 30 mg IV every 3 months, or an equivalent, to prevent osteoporosis and prophylactic antibiotics for *Pneumocystis jirovecii* and herpes infections.
- Radiotherapy is reserved for local lesions that are particularly bulky and troublesome and is used only when chemotherapy is not required for control of more disseminated disease. The lowest dose of radiotherapy capable

of shrinking the tumor mass should be used. Splenic irradiation may be helpful in patients who require a splenectomy but who are not surgical candidates. Radiotherapy is most useful in patients who have had little prior therapy.

- Splenectomy may be useful in patients with painful splenomegaly or who have cytopenias that are unresponsive to other therapies. Minimally invasive surgical techniques should be considered.
- Prophylactic gammaglobulin is useful in reducing the frequency of infections in patients with hypogammaglobulinemia and frequent bacterial infections. G-CSF and erythropoietin may be useful to maintain neutrophil counts and hemoglobin.
- Although not standard therapy, alloSCT may be considered for younger patients (<65 years) who have developed refractory disease.
- Most patients in CLL clinics will die from disease progression or transformation, infections, and second malignancies (skin, melanomas, and solid tumors). Thus, patients need to be monitored for these complications with each visit and second malignancies promptly treated.

REFERENCES

1. Hallek M, Cheson BD, Catovsky D et al. Guidelines for the diagnosis and treatment of chronic lymphocytic leukemia: a report from the International Workshop on Chronic Lymphocytic Leukemia updating the National Cancer Institute-Working Group 1995 Guidelines. *Blood* 2008;111:5446-5456.
2. Zenz T, Mertens, Küppers R, et al. From pathogenesis to treatment of chronic lymphocytic leukemia. *Nat Rev Cancer* 2010;10:37-50.
3. Swerdlow SH, Campo E, Harris NL, et al. WHO classification of tumours of haematopoietic and lymphoid tissues, 4th Edition. Lyon, France: IARC Press, 2008:180-182.
4. Landgren O, Albitar M, Ma W, et al. B-cell clones as early markers for chronic lymphocytic leukemia. *N Engl J Med* 2009;360:659-667.
5. Eichorst B, Dreyling M, Robak T, et al. Chronic lymphocytic leukemia: EMSO clinical practice guidelines for diagnosis, treatment and follow-up. *Ann Oncol* 2011;22(Suppl 6):50-54.
6. Klein U, Tu Y, Stolovitzky GA, et al. Gene expression profiling of B cell chronic lymphocytic leukemia reveals a homogeneous phenotype related to memory B cells. *J Exp Med* 2001;194:1625-1638.
7. Rosenwald A, Alizadeh AA, Widhopf G, et al. Relation of gene expression phenotype to immunoglobulin mutation genotype in B cell chronic lymphocytic leukemia. *J Exp Med* 2001;194:1639-1646.
8. Dores GM, Anderson WF, Curtis RE, et al. Chronic lymphocytic leukaemia and small lymphocytic lymphoma: overview of the descriptive epidemiology. *Br J Haematol* 2007;139:809-819.
9. Seftel MD, Demers AA, Banerji V, et al. High incidence of chronic lymphocytic leukemia (CLL) diagnosed by immunophenotyping: a population-based Canadian cohort. *Leuk Res* 2009;33:1463-1468.
10. Brenner H, Gondos A, Pulte D. Trends in long-term survival of patients with chronic lymphocytic leukemia from the 1980s to the early 21st century. *Blood* 2008;111:4916-4921.
11. Yoon J-Y, Lafarge S, Dawe D, et al. Association of interleukin-6 and interleukin-8 with poor prognosis in elderly chronic lymphocytic leukemia patients. *Leuk Lymphoma*. Epub 2012.
12. Shanafelt TD, Rabe KG, Kay NE, et al. Age at diagnosis and utility of prognostic testing in patients with chronic lymphocytic leukemia. *Cancer* 2010;116:4777-4787.
13. Wierda WG, O'Brien S, Wang X, et al. Prognostic nomogram and index for overall survival in previously untreated patients with chronic lymphocytic leukemia. *Blood* 2007;109:4679-4685.
14. Goldin LR, Slager SL and Caporaso NE. Familial chronic lymphocytic leukemia. *Curr Opin Hematol* 2010;17:350-355.
15. Landgren O, Rapkin JS, Caporaso NE, et al. Respiratory tract infections and subsequent risk of chronic lymphocytic leukemia. *Blood* 2007;109:2198-2201.
16. Stevenson FK, Krysov S, Davies AJ, et al. B-cell receptor signaling in chronic lymphocytic leukemia. *Blood* 2011;118:4313-4320.

17. Stamatopoulos K, Belessi C, Moreno C, et al. Over 20% of patients with chronic lymphocytic leukemia carry stereotyped receptors: pathogenetic implication and clinical correlations. *Blood* 2007;109:259-270.
18. Murray F, Darzentas N, Hadzidimitriou A et al. Stereotyped patterns of somatic hypermutation in subsets of patients with chronic lymphocytic leukemia: implications for the role of antigen selection in leukemogenesis. *Blood* 2008;111:1524-1533.
19. Chiorazzi N and Ferrarini M. Cellular origin(s) of chronic lymphocytic leukemia: cautionary notes and additional considerations and possibilities. *Blood* 2011;117:1781-1791.
- P.1927
20. Minden MD, Übelhart R, Schneider D, et al. Chronic lymphocytic leukaemia is driven by antigen-independent cell-autonomous signalling. *Nature*. Epub 2012 Aug.
21. Landgren O, Engels EA, Caporaso NE, et al. Patterns of autoimmunity and subsequent chronic lymphocytic leukemia in Nordic countries. *Blood* 2006;108:292-296.
22. Houlston RS, Catovsky D, Yuille MR. Genetic susceptibility to chronic lymphocytic leukemia. *Leukemia* 2002;16:1008-1014.
23. Ishibe N, Sgambati MT, Fontaine L, et al. Clinical characteristics of familial B-CLL in the National Cancer Institute Familial Registry. *Leuk Lymphoma* 2001;42:99-108.
24. Capalbo S, Trerotoli P, Ciancio A, et al. Increased risk of lymphoproliferative disorders in relatives of patients with B-cell chronic lymphocytic leukemia: relevance of the degree of familial linkage. *Eur J Haematol* 2000;65:114-117.
25. Rawstron AC, Yuille MR, Fuller J, et al. Inherited predisposition to CLL is detectable as subclinical monoclonal B-lymphocyte expansion. *Blood* 2002;100:2289-2290.
26. Marti GE, Carter P, Abbasi F, et al. B-cell monoclonal lymphocytosis and B-cell abnormalities in the setting of familial B-cell chronic lymphocytic leukemia. *Cytom Part B (Clin Cytom)* 2003;52B:1-12.
27. Wiernik PH, Ashwin M, Hu XP, et al. Anticipation in familial chronic lymphocytic leukaemia. *Br J Haematol* 2001;113:407-414.
28. Horwitz M, Goode EL, Jarvik GP. Anticipation in familial leukemia. *Am J Hum Genet* 1996;59:990-998.
29. Yuille MR, Houlston RS, Catovsky D. Anticipation in familial chronic lymphocytic leukaemia. *Leukemia* 1998;12:1696-1698.
30. Goldin LR, Sgambati M, Marti GE, et al. Anticipation in familial chronic lymphocytic leukemia. *Am J Hum Genet* 1999;65:265-269.
31. Mauro FR, Giammartini E, Gentile M, et al. Clinical features and outcome of familial chronic lymphocytic leukemia. *Haematologica* 2006;91:1117-1120.
32. Pritsch O, Troussard X, Magnac C, et al. VH gene usage by family members affected with chronic lymphocytic leukaemia. *Br J Haematol* 1999;107: 616-624.
33. Sakai A, Marti GE, Caporaso N, et al. Analysis of expressed immunoglobulin heavy chain genes in familial B-CLL. *Blood* 2000;95:1413-1419.
34. Bevan S, Catovsky D, Matutes E, et al. Linkage analysis for major histocompatibility complex-related genetic susceptibility in familial chronic lymphocytic leukemia. *Blood* 2000;96:3982-3984.
35. Ng D, Toure O, Wei M-H, et al. Identification of a novel chromosome region 13q21.33-q22.2 for susceptibility genes in familial chronic lymphocytic leukemia. *Blood* 2007;109:916-925.
36. Sellik GS, Webb EL, Allinson R, et al. A high-density SNP genomewide linkage scan for chronic lymphocytic leukemia-susceptibility loci. *Am J Hum Genet* 2005;77:420-429.
37. Skowronska A, Austen B, Powell JE, et al. ATM germline heterozygosity does not play a role in chronic lymphocytic leukemia initiation but influences rapid disease progression through loss of the remaining ATM allele. *Haematologica* 2012;97:142-146.

38. Novak AJ, Grote DM, Ziesmer SC, et al. Elevated serum B-lymphocyte stimulator levels in patients with familial lymphoproliferative disorders. *J Clin Oncol* 2006;24:983-987.
39. Raval A, Tanner SM, Byrd JC, et al. Down regulation of death-associated protein kinase 1 (DAPK1) in chronic lymphocytic leukemia. *Cell* 2007;129: 879-890.
40. Schena M, Larsson LG, Gottardi D, et al. Growth- and differentiation-associated expression of bcl-2 in B-chronic lymphocytic leukemia cells. *Blood* 1992;79:2981-2989.
41. Brezinschek HP, Foster SJ, Brezinschek Dörner R, et al. Analysis of the human VH gene repertoire. Differential effects of selection and somatic hypermutation on human peripheral CD5+/IgM+ and CD5-/IgM+ B cells. *J Clin Invest* 1997;99:2488-2501.
42. Damle R, Ghiotto F, Valetto A, et al. B-cell chronic lymphocytic leukemia cells express a surface membrane phenotype of activated, antigen-experienced B lymphocytes. *Blood* 2002;99:4087-4093.
43. Ranheim EA, Aversa G, Cocks BG, et al. Expression of CD27 and its ligand CD70, on chronic lymphocytic leukemia B cells. *Blood* 1995;85:3556-3565.
44. Klein U, Rajewsky K, Küppers R. Human immunoglobulin (Ig)M+IgD+ peripheral blood B cells expressing the CD27 cell surface antigen carry somatically mutated variable region genes: CD27 as a general marker for somatically mutated (memory) cells. *J Exp Med* 1998;188:1679-1689.
45. Kulis M, Heath S, Bibikova M, et al. Epigenomic analysis detects widespread gene-body DNA hypomethylation in chronic lymphocytic leukemia. *Nature Genet.* Epub 2012 Oct 14.
46. Kanduri M, Cahill N, Göransson H, et al. Differential genome-wide array-based methylation profile in prognostic subsets of chronic lymphocytic leukemia. *Blood* 2010;115:296-305.
47. Kikushige Y, Ishikawa, Miyamoto T, et al. Self-renewing hematopoietic stem cell is the primary target in pathogenesis of human chronic lymphocytic leukemia. *Cancer Cell* 2011;20:246-259.
48. Hentgartner MO. The biochemistry of apoptosis. *Nature* 2000;407:770-776.
49. Herr I, Debatin K-M. Cellular stress response and apoptosis in cancer therapy. *Blood* 2001;98:2603-2614.
50. Johnstone RW, Ruefli AA, Lowe SW. Apoptosis: a link between cancer genetics and chemotherapy. *Cell* 2002;108:153-164.
51. Salvesen GS, Dixit VM. Caspase activation: the induced-proximity model. *Proc Natl Acad Sci U S A* 1999;96:10964-10967.
52. Jia L, Srinivasula SM, Liu F-T, et al. Apaf-1 protein deficiency confers resistance to cytochrome c-dependent apoptosis in human leukemic cells. *Blood* 2001;98:414-421.
53. Leoni L, Chao Q, Cottam H. Induction of an apoptotic program in cell-free extracts by 2-chloro-2'-deoxyadenosine 5'-triphosphate and cytochrome c. *Proc Natl Acad Sci U S A* 1998;95:9567-9571.
54. Genini D, Adachi S, Chao Q, et al. Deoxyadenosine analogs induce programmed cell death in chronic lymphocytic leukemia cells by damaging the DNA and by directly affecting the mitochondria. *Blood* 2000;96:3537-3543.
55. Chandra J, Mansson E, Gogvadze V, et al. Resistance of leukemic cells to 2-chlorodeoxyadenosine is due to a lack of calcium-dependent cytochrome c release. *Blood* 2002;99:655-663.
56. Schimmer AD, Dalili S. Targeting the IAP family of caspase inhibitors as an emerging therapeutic strategy. *Hematology (Am Soc Hematol Educ Program)* 2005:215-219.
57. Olsson A, Diaz T, Aguilar-Santelises M, et al. Sensitization to TRAIL-induced apoptosis and modulation of FLICE-inhibitory protein in B chronic lymphocytic leukemia by actinomycin D. *Leukemia* 2001;15:1868-1877.
58. MacFarlane M, Harper N, Snowden RT, et al. Mechanisms of resistance to TRAIL-induced apoptosis in primary B cell chronic lymphocytic leukaemia. *Oncogene* 2002;21:6809-6818.
59. Luo X, Budihardjo I, Zou H, et al. Bid, a bcl2 interacting protein, mediates cytochrome c release from mitochondria in response to activation of cell surface death receptors. *Cell* 1998;94:481-490.
60. Jones DT, Ganeshaguru K, Virchis AE, et al. Caspase 8 activation independent of Fas (CD95/APO-1) signaling may mediate killing of B-chronic lymphocytic leukemia cells by cytotoxic drugs or γ -radiation. *Blood* 2001;98:2800-2807.

61. Wieder T, Essmann F, Prokop A, et al. Activation of caspase-8 in drug-induced apoptosis of B-lymphoid cells is independent of CD95/Fas receptor-ligand interaction and occurs downstream of caspase-3. *Blood* 2002;97:1378-1387.
62. Panayiotidis P, Ganeshaguru K, Foroni L, et al. Expression and function of the FAS antigen in B chronic lymphocytic leukemia and hairy cell leukemia. *Leukemia* 1995;9:1227-1232.
63. Wang D, Freeman GJ, Levine H, et al. Role of the CD40 and CD95 (APO-1/Fas) antigens in the apoptosis of human B-cell malignancies. *Br J Haematol* 1997;97:409-417.
64. Johnston JB, Kabore AF, Strutinsky J, et al. Role of the TRAIL/APO2-L death receptors in chlorambucil- and fludarabine-induced apoptosis in chronic lymphocytic leukemia. *Oncogene* 2003;22:8356-8369.
65. Zhao S, Asgary Z, Wang Y, et al. Functional expression of TRAIL by lymphoid and myeloid tumour cells. *Br J Haematol* 1999;106:827-832.
66. Friesen C, Herr I, Krammer PH, et al. Involvement of the CD95 (APO-1/FAS) receptor/ligand system in drug-induced apoptosis in leukemia cells. *Nat Med* 1996;2:574-577.
67. Fulda S, Strauss G, Meyer E, et al. Functional CD95 ligand and CD95 death inducing signaling complex in activation-induced cell death and doxorubicin-induced apoptosis in leukemic T cells. *Blood* 2000;95:301-308.
68. Gibson SB, Oyer R, Spalding AC, et al. Increased expression of death receptors 4 and 5 synergizes the apoptosis response to combined treatment with etoposide and TRAIL. *Mol Cell Biol* 2000;20:205-212.
69. Wen J, Ramadevi N, Nguyen D, et al. Antileukemic drugs increase death receptor 5 levels and enhance Apo-2L-induced apoptosis of human acute leukemia cells. *Blood* 2000;96:3900-3906.
70. Hanada M, Delia D, Aiello A, et al. Bcl-2 gene hypomethylation and high-level expression in B-cell chronic lymphocytic leukemia. *Blood* 1993;82:1820-1828.
71. Robertson LE, Plunkett W, McConnell K, et al. Bcl-2 expression in chronic lymphocytic leukemia and its correlation with the induction of apoptosis and clinical outcome. *Leukemia* 1996;10:456-459.
72. Johnston JB, Daeninck P, Verburg L, et al. p53, mdm-2, bax and bcl-2 and drug resistance in chronic lymphocytic leukemia. *Leuk Lymphoma* 1997;26:435-449.
73. Christodoulouopoulos G, Fotouhi N, Krajewski S, et al. Relationship between nitrogen mustard drug resistance in B-cell chronic lymphocytic leukemia (B-CLL) and protein expression of Bcl-2, Bax, Bcl-X and p53. *Cancer Lett* 1997;121:59-67.
74. Johnston JB, Paul JT, Neufeld NJ, et al. Role of myeloid cell factor-1 (Mcl-1) in chronic lymphocytic leukemia. *Leuk Lymphoma* 2004;45:2017-2027.
75. Pepper C, Thomas A, Hoy T, et al. Antisense-mediated suppression of bcl-2 highlights its pivotal role in failed apoptosis in B-cell chronic lymphocytic leukaemia. *Br J Haematol* 1999;107:611-615.
76. Bellosillo B, Villamor N, Colomer D, et al. In vitro evaluation of fludarabine in combination with cytophosphamide and/or mitoxantrone in B-cell chronic lymphocytic leukemia. *Blood* 1999;94:2836-2843.
77. Moshynska O, Sankaran K, Pahwa P, et al. Prognostic significance of a short sequence insertion in the MCL-1 promoter in chronic lymphocytic leukemia. *J Natl Cancer Inst* 2004;96: 673-682.
78. Coenen S, Pickering B, Potter KN, et al. The relevance of sequence insertions in the Mcl-1 promoter in chronic lymphocytic leukemia and in normal cells. *Haematologica* 2005;90:1285-1286.
79. Moshynska O, Moshynskyy I, Misra V, et al. G125A single-nucleotide polymorphism in the human BAX promoter affects gene expression. *Oncogene* 2005;24:2042-2049.
80. Vogelstein B, Lane, Levine AJ. Surfing the p53 network. *Nature* 2000;408: 307-310.
81. Fisher DE. Apoptosis in cancer therapy: crossing the threshold. *Cell* 1994;78: 539-542.
82. Solary E, Droin N, Bettaieb A, et al. Positive and negative regulation of apoptotic pathways by cytotoxic agents in hematological malignancies. *Leukemia* 2000;14:1833-1849.
83. Cordone I, Masi S, Mauro FR, et al. p53 expression in B-cell chronic lymphocytic leukemia: a marker of disease progression and poor prognosis. *Blood* 1998;91:4342-4349.
84. Döhner H, Stilgenbauer S, Benner A, et al. Genomic aberrations and survival in chronic lymphocytic leukemia. *N Engl J Med* 2000;343:1910-1916.

85. Watanabe T, Hotta T, Ichikawa A, et al. The MDM2 oncogene overexpression in chronic lymphocytic leukemia and low-grade lymphoma of B-cell origin. *Blood* 1994;84:3158-3165.
86. Austen B, Powell JE, Alvi A, et al. Mutations in the ATM gene lead to impaired overall and treatment-free survival that is independent of IGVH mutation status in patients with B-CLL. *Blood* 2005;106:3175-3182.
87. Austen B, Skowronska A, Baker C, et al. Mutation status of the residual ATM allele is an important determinant of the cellular response to chemotherapy and survival in patients with chronic lymphocytic leukemia containing an 11q deletion. *J Clin Oncol* 2007;25:5448-5457.
88. Munk Pedersen I., Reed, J. (2004). Microenvironmental interactions and survival of CLL B-cells. *Leuk Lymphoma* 2004;45:2365-2372.
89. Burger JA, Tsukada N, Burger, M, et al. (2000). Blood-derived nurse-like cells protect chronic lymphocytic leukemia B cells from spontaneous apoptosis through stromal cell-derived factor-1. *Blood* 2000;96:2655-2663.
90. Burger JA, Kipps TJ. Chemokine receptors and stromal cells in the homing and homeostasis of chronic lymphocytic leukemia B cells. *Leuk Lymphoma* 2002;43:461-466.
91. Chen L, Widhopf G, Huynh, L, et al. Expression of ZAP-70 is associated with increased B-cell receptor signaling in chronic lymphocytic leukemia. *Blood* 2002;100:4609-4614.
92. Davids MS, Brown JR Targeting the B cell receptor pathway in chronic lymphocytic leukemia. *Leuk Lymphoma*. Epub 2012 May 23.
93. Deglesne PA, Chevallier N, Letestu R, et al. Survival response to B-cell receptor ligation is restricted to progressive chronic lymphocytic leukemia cells irrespective of Zap-70 expression. *Cancer Res* 2006;66:7158-7166.
94. Gobessi S, Laurenti L, Longo PG, et al. ZAP-70 enhances B-cell receptor signaling in spite of absent or inefficient tyrosine kinase activation in chronic lymphocytic leukemia and lymphoma B-cells. *Blood* 2006;109:2032-2039.
95. Huttmann A, Klein-Hitpass L, Thomale J, et al. Gene expression signatures separate B-cell chronic lymphocytic leukaemia prognostic subgroups defined by ZAP-70 and CD38 expression status. *Leukemia* 2006;20:1774-1782.
96. Kofler DM, Buning H, Mayr C, et al. Engagement of the B-cell antigen receptor (BCR) allows efficient transduction of ZAP-70-positive primary B-CLL cells by recombinant adeno-associated virus (rAAV) vectors. *Gene Ther* 2004;11:1416-1424.
97. Petlickovski A, Laurenti L, Li X, et al. Sustained signaling through the B-cell receptor induces Mcl-1 and promotes survival of chronic lymphocytic leukemia B cells. *Blood* 2005;105:4820-4827.
98. Cols M, Barra CM, He B, et al. Stromal endothelial cells establish a bidirectional crosstalk with chronic lymphocytic leukemia cells through the TNF-related factors BAFF, APRIL, and CD40L. *J Immunol* 2012;188:6071-6083.
99. Eble JA, Haier J. Integrins in cancer treatment. *Curr Cancer Drug Targets* 2006;6:89-105.
100. Lagneaux L, Delforge A, De Bruyn, C, et al. Adhesion to bone marrow stroma inhibits apoptosis of chronic lymphocytic leukemia cells. *Leuk Lymphoma* 1999;35:445-453.
101. Wallgren A, Festin R, Gidlöf C, et al. Efficient killing of chronic B-lymphocytic leukemia cells by superantigen-directed T cells. *Blood* 1993;82:1230-1238.
102. Gilling CE, Mittal AK, Chaturvedi NK, et al. Lymph node-induced immune tolerance in chronic lymphocytic leukaemia: a role for caveolin-1. *Br J Haematol* 2012;158:216-131.
103. Molica S, Vitelli G, Levato D, et al. Elevated serum levels of soluble CD44 can identify a subgroup of patients with early B-cell chronic lymphocytic leukemia who are at high risk of disease progression. *Cancer* 2001;92:713-719.
104. López-Giral S, Quintana NE, Cabrerizo M, et al. Chemokine receptors that mediate B cell homing to secondary lymphoid tissues are highly expressed in B cell chronic lymphocytic leukemia and non-Hodgkin lymphomas with widespread nodular dissemination. *J Leukoc Biol* 2004;76:462-4671.
105. Sivina M, Hartmann E, Kipps TJ, et al. CCL3 (MIP-1 α) plasma levels and the risk for disease progression in chronic lymphocytic leukemia. *Blood* 2011;117:1662-1669.
106. Zhang W, Trachootham D, Liu J et al. Stromal control of cystine metabolism promotes cancer cell survival in chronic lymphocytic leukaemia. *Nat Cell Biol* 2012;14:276-286.

107. Ghosh AK, Secreto CR, Knox TR, Ding W, Mukhopadhyay D, Kay NE. Circulating microvesicles in B-cell chronic lymphocytic leukemia can stimulate marrow stromal cells: implications for disease progression. *Blood* 2010;115:1755-1764.
108. Ghosh AK, Secreto C, Boysen J, et al. The novel receptor tyrosine kinase Axl is constitutively active in B-cell chronic lymphocytic leukemia and acts as a docking site of nonreceptor kinases: implications for therapy. *Blood* 2011;117:1928-1937.
109. Buchner M, Brantner P, Stickel N et al. The microenvironment differentially impairs passive and active immunotherapy in chronic lymphocytic leukaemia—CXCR4 antagonists as potential adjuvants for monoclonal antibodies. *Br J Haematol* 2010;151:167-178.
110. Wiestner A. Emerging role of kinase targeted strategies in chronic lymphocytic leukemia. *Blood*. Epub 2012 Aug 8.
111. Woyach JA, Johnson AJ, Byrd JC. The B-cell receptor signaling pathway as a therapeutic target in CLL. *Blood* 2012;120:1175-1184.
112. Burger JA. Nurture versus nature: the microenvironment in chronic lymphocytic leukemia. *Hematology (Am Soc Hematol Educ Program)* 2011;2011: 96-103.
113. Seke Etet PF, Vecchio L, Nwabo Kamdje AH. Interactions between bone marrow stromal microenvironment and B-chronic lymphocytic leukemia cells: any role for Notch, Wnt and Hh signaling pathways? *Cell Signal* 2012;24:1433-1443.
114. Christopoulos P, Pfeifer D, Bartholomé K, et al. Definition and characterization of the systemic T-cell dysregulation in untreated indolent B-cell lymphoma and very early CLL. *Blood* 2011;117:3836-3846.
115. Herishanu Y, Pérez-Galán, Liu D, et al. The lymph node microenvironment promotes B-cell receptor signaling, NF- κ B activation, and tumor proliferation in chronic lymphocytic leukemia. *Blood* 2011;117:563-574.
116. Hoellenriegel J, Coffey GP, Sinha U, et al. Selective, novel spleen tyrosine kinase (Syk) inhibitors suppress chronic lymphocytic leukemia B-cell activation and migration. *Leukemia* 2012;26:1576-1583.
117. Buchner M, Baer C, Prinz G, et al. Spleen tyrosine kinase inhibition prevents chemokine- and integrin-mediated stromal protective effects in chronic lymphocytic leukemia. *Blood* 2010;115:4497-4506.
118. Audrito V, Vaisitti T, Serra S, et al. Targeting the microenvironment in chronic lymphocytic leukemia offers novel therapeutic options. *Cancer Lett*. Epub 2012 Aug 18.
119. Herman SE, Gordon AL, Hertlein E, et al. Bruton tyrosine kinase represents a promising therapeutic target for treatment of chronic lymphocytic leukemia and is effectively targeted by PCI-32765. *Blood* 2011;117:6287-6296.
120. Mainou-Fowler T, Prentice, AG. Modulation of apoptosis with cytokines in B-cell chronic lymphocytic leukaemia. *Leuk Lymphoma* 1996;21:369-377.
121. Aguilar-Santelises M, Gigliotti D, Osorio LM, et al. Cytokine expression in B-cell in relation to disease progression and in vitro activation. *Med Oncol* 1999;16:289-295.
122. Ghia P, Circosta P, Scielzo C, et al. Differential effects on CLL cell survival exerted by different microenvironmental elements. *Curr Top Microbiol Immunol* 2005;294:135-145.
123. Long BW, Witte PL, Abraham GN, et al. Apoptosis and interleukin 7 gene expression in chronic B-lymphocytic leukemia cells. *Proc Natl Acad Sci USA* 1995;92:1416-1420.
124. Trentin L, Cerutti A, Zambello R, et al. Interleukin-15 promotes the growth of leukemic cells of patients with B-cell chronic lymphoproliferative disorders. *Blood* 1996;87:3327-3335.
125. Knauf WU, Langenmayer I, Ehlers B, et al. Serum levels of soluble CD23, but not soluble CD25, predict disease progression in early stage B-cell chronic lymphocytic leukemia. *Leuk Lymphoma* 1997;27:523-532.
126. Foa R, Fierro MT, Giovarelli M, et al. Immunoregulatory T-cell defects in B-cell chronic lymphocytic leukemia: cause or consequence of the disease? The contributory role of a decreased availability of interleukin 2 (IL2). *Blood Cells* 1987;12:399-412.
127. Cordingley FT, Bianchi A, Hoffbrand AV, et al. Tumour necrosis factor as an autocrine tumour growth factor for chronic B-cell malignancies. *Lancet* 1988;1:969-971.
128. Digel W, Stefanic M, Schoniger W, et al. Tumor necrosis factor induces proliferation of neoplastic B cells from chronic lymphocytic leukemia. *Blood* 1989;73:1242-1246.

129. Tangye SG, Taison RL. Human cytokines suppress apoptosis of leukaemic CD5+ B cells and preserve expression of bcl-2. *Immunol Cell Biol* 1997;75:127-135.
130. Ferrajoli A, Keating MJ, Manshouri T, et al. The clinical significance of tumor necrosis factor- α plasma level in patients having chronic lymphocytic leukemia. *Blood* 2002;100:1215-1219.
131. Michalevicz R, Porat R, Vcoropoulos M, et al. Restoration of in vitro hematopoiesis in chronic lymphocytic leukemia by antibodies to tumor necrosis factor. *Leuk Res* 1991;15:111-120.
132. Digel W, Porzolt F, Schmid M, et al. High levels of circulating soluble receptors for tumour necrosis factor in hairy cell leukemia and type B chronic lymphocytic leukemia. *J Clin Invest* 1992;89:1690-1693.
133. Kremer JP, Reisbach G, Nerl C, et al. B-cell chronic lymphocytic leukaemia cells express and release transforming growth factor-beta. *Br J Haematol* 1992;80:480-487.
134. Lagneaux L, Delforge A, Dorval C, et al. Excessive production of transforming growth factor-beta by bone marrow stromal cells in B-cell chronic lymphocytic leukemia inhibits growth of hematopoietic precursors and interleukin production. *Blood* 1993;82:2379-2385.
135. Israels LG, Israels SJ, Begleiter A, et al. Role of transforming growth factor- β in chronic lymphocytic leukemia. *Leuk Res* 1993;17:83-87.
136. DeCoteau JF, Knaus PI, Yankelev H, et al. Loss of functional cell surface transforming growth factor- β (TGF β) type I receptor correlates with insensitivity to TGF- β in chronic lymphocytic leukemia. *Proc Natl Acad Sci U S A* 1997;94:5877-5881.
137. Douglas RS, Capocasale RJ, Lamb RJ, et al. Chronic lymphocytic leukemia B cells are resistant to the apoptotic effects of transforming growth factor- β . *Blood* 1997;89:941-947.
138. Plate JM, Long BW, Kelkar SB. Role of beta2 integrins in the prevention of apoptosis induction in chronic lymphocytic leukemia B cells. *Leukemia* 2000;14:34-39.
139. Haiat S, Billard C, Quiney C, et al. Role of BAFF and APRIL in human B-cell chronic lymphocytic leukaemia. *Immunology* 2006;118:281-292.
140. Kern C, Cornuel JF, Billard C, et al. Involvement of BAFF and APRIL in the resistance to apoptosis of B-CLL through an autocrine pathway. *Blood* 2004;103:679-688.
141. Gerber HP, Ferrara N. The role of VEGF in normal and neoplastic hematopoiesis. *J Mol Med* 2003;81:20-31.
142. Farahani M, Treweeke AT, Toh CH, et al. Autocrine VEGF mediates the anti-apoptotic effect of CD154 on CLL cells. *Leukemia* 2005;19:524-530.
143. Lee YK, Shanafelt TD, Bone ND, et al. VEGF receptors on chronic lymphocytic leukemia (CLL) B cells interact with STAT 1 and 3: implication for apoptosis resistance. *Leukemia* 2005;19:513-523.
144. Ferrajoli A, Manshouri T, Estrov Z, et al. High levels of vascular endothelial growth factor receptor-2 correlate with shortened survival in chronic lymphocytic leukemia. *Clin Cancer Res* 2001;7:795-799.
145. Molica S, Vitelli G, Levato D, et al. Increased serum levels of vascular endothelial growth factor predict risk of progression in early B-cell chronic lymphocytic leukaemia. *Br J Haematol* 1999;107:605-610.
146. Shimaoka Y, Attrep JF, Hirano T, et al. Nurse-like cells from bone marrow and synovium of patients with rheumatoid arthritis promote survival and enhance function of human B cells. *J Clin Invest* 1998;102:606-618.
147. von Bergwelt-Baildon M, Maecker B, Schultze J, et al. CD40 activation: potential for specific immunotherapy in B-CLL. *Ann Oncol* 2004;15:853-857.
148. Buhmann R, Nolte A, Westhaus D, et al. CD40-activated B-cell chronic lymphocytic leukemia cells for tumor immunotherapy: stimulation of allogeneic versus autologous T cells generates different types of effector cells. *Blood* 1999;93:1992-2002.
149. Kitada S, Zapata JM, Andreeff M, et al. Bryostatins and CD40-ligand enhance apoptosis resistance and induce expression of cell survival genes in B cell chronic lymphocytic leukaemia. *Br J Haematol* 1999;106:995-1004.
150. Romano MF, Lamberti A, Tassone P, et al. Triggering of CD40 antigen inhibits fludarabine induced apoptosis in B chronic lymphocytic leukemia cells. *Blood* 1998;92:990-995.

151. Younes A, Snell V, Consoli U, et al. Elevated levels of biologically active soluble CD40 ligand in the serum of patients with chronic lymphocytic leukaemia. *Br J Haematol* 1998;100:135-141.
152. Granziero L, Ghia P, Circosta P, et al. Survivin is expressed on CD40 stimulation and interfaces proliferation and apoptosis in B-cell chronic lymphocytic leukemia. *Blood* 2001;97:2777-2783.
153. Ranheim EA, Kipps TJ. Activated T cells induce expression of B7/BB1 on normal or leukemic B cells through a CD40-dependent signal. *J Exp Med* 1993;177:925-935.
154. Dicker F, Kater AP, Fukuda T, et al. Fas-ligand (CD178) and TRAIL synergistically induce apoptosis of CD40-activated chronic lymphocytic leukemia B cells. *Blood* 2005;105:3193-3198.
155. Messmer D, Kipps T J. CD154 gene therapy for human B-cell malignancies. *Ann N Y Acad Sci* 2005;1062:51-60.
156. Barretina J, Junca J, Llano A, et al. CXCR4 and SDF-1 expression in B-cell chronic lymphocytic leukemia and stage of the disease. *Ann Hematol* 2003;82:500-505.
157. Panayiotidis P, Jones D, Ganeshaguru K, et al. Human bone marrow stromal cells prevent apoptosis and support the survival of chronic lymphocytic leukaemia cells in vitro. *Br J Haematol* 1996;92:97-103.
158. Nishio M, Endo T, Tsukada N, et al. Nurselike cells express BAFF and APRIL, which can promote survival of chronic lymphocytic leukemia cells via a paracrine pathway distinct from that of SDF-1alpha. *Blood* 2005;106:1012-1020.
159. Konig A, Menzel T, Lynen S, et al. Basic fibroblast growth factor (bFGF) upregulates the expression of bcl-2 in B cell chronic lymphocytic leukemia cell lines resulting in delaying apoptosis. *Leukemia* 1997;11:258-265.
160. Jones DT, Ganeshaguru K, Anderson RJ, et al. Albumin activates the AKT signaling pathway and protects B-chronic lymphocytic leukemia cells from chlorambucil- and radiation-induced apoptosis. *Blood* 2003;101:3174-3180.
161. Hu, X, Haney N, Kropp D, et al. Lysophosphatidic acid (LPA) protects primary chronic lymphocytic leukemia cells from apoptosis through LPA receptor activation of the anti-apoptotic protein AKT/PKB. *J Biol Chem* 2005;280:9498-9508.
162. Stroka D, Badrichani A, Bach F, et al. Overexpression of A1, an NF- κ -inducible, anti-apoptotic BCL gene inhibits endothelial cell activation. *Blood* 1999;93:3803-3810.
163. Cheng G, Lee H, Dadgostar H, et al. NF- κ B-mediated up-regulation of Bcl-x and Bfl-1/a1 is required for CD40 survival signaling in B lymphocytes. *Proc Natl Acad Sci U S A* 1999;96:9136-9141.
164. Furman RR, Asgary Z, Mascarebhas JO, et al. Modulation of NF- κ B activity and apoptosis in chronic lymphocytic leukemia B cells. *J Immunol* 2000;164:2200-2206.
165. Chandra J, Niemer I, Gilbreath J, et al. Proteasome inhibitors induce apoptosis in glucocorticoid-resistant chronic lymphocytic leukemic lymphocytes. *Blood* 1998;92:4220-4229.
166. Almond JB, Snowden RT, Hunter A, et al. Proteasome inhibitor-induced apoptosis of B-chronic lymphocytic leukaemia cells involves cytochrome c release and caspase activation, accompanied by formation of an approximately 700 kDa Apaf-1 containing apoptosome complex. *Leukemia* 2001;15:1388-1397.
167. Adams J. Development of the proteasome inhibitor PS-341. *Oncologist* 2002;7:9-16.
168. Datta S, Brunet A, Greenberg M. Cellular survival: a play in three Acts. *Genes Dev* 1999;13:2905-2927.
169. Wickremasinghe RG, Ganeshaguru K, Jones DT, et al. Autologous plasma activates Akt/protein kinase B and enhances basal survival and resistance to DNA damage-induced apoptosis in B-chronic lymphocytic leukaemia cells. *Br J Haematol* 2001;114:608-615.
170. Johnson AJ, Lucas DM, Muthusamy N, et al. Characterization of the TCL-1 transgenic mouse as a preclinical drug development tool for human chronic lymphocytic leukemia. *Blood* 2006;108:1334-1338.
171. Pekarsky Y, Calin GA, Aqeilan R. Chronic lymphocytic leukemia: molecular genetics and animal models. *Curr Top Microbiol Immunol* 2005;294:51-70.
172. Pepper C, Thomas A, Fegan C, et al. Flavopiridol induces apoptosis in B-cell chronic lymphocytic leukaemia cells through a p38 and ERK MAP kinasedependent mechanism. *Leuk Lymphoma* 2003;44:337-342.
173. Pepper C, Thomas A, Hoy T, et al. The vitamin D3 analog EB1089 induces apoptosis via a p53-independent mechanism involving p38 MAP kinase activation and suppression of ERK activity in B-cell chronic lymphocytic leukemia cells in vitro. *Blood* 2003;101:2454-2460.

174. Ringshausen, I, Dechow T, Schneller F, et al. Constitutive activation of the MAPkinase p38 is critical for MMP-9 production and survival of B-CLL cells on bone marrow stromal cells. *Leukemia* 2004;18:1964-1970.
175. Liu Z, Hazan-Halevy I, Harris DM et al. STAT-3 activates NF-kappaB in chronic lymphocytic leukemia cells. *Mol Cancer Res* 2011;9:507-515.
176. Ishdorj G, Johnston JB, Gibson SB. Inhibition of constitutive activation of STAT3 by curcubitacin-I (JSI-124) sensitized human B-leukemia cells to apoptosis. *Mol Cancer Ther* 2010;9:3302-3314.
177. Hazan-Halevy I, Harris D, Liu J, et al. STAT3 is constitutively phosphorylated on serine 727 residues, binds DNA, and activates transcription in CLL cells. *Blood* 2010;115:2852-2863.
178. de Toter D, Meazza R, Capaia M, et al. The opposite effects of IL-15 and IL-21 on CLL B cells correlate with differential activation of the JAK/STAT and ERK1/2 pathways. *Blood* 2008;111:517-524.
179. Ghosh AK, Shanafelt TD, Cimmino A et al. Aberrant regulation of pVHL levels by microRNA promotes the HIF/VEGF axis in CLL B cells. *Blood* 2009;113:5568-5574.
180. Damle, RN, Batliwalla, FM, Ghiotto, F, et al. Telomere length and telomerase activity delineate distinctive replicative features of the B-CLL subgroups defined by immunoglobulin V gene mutations. *Blood* 2004;103:375-382.
181. Messmer, BT, Messmer, D, Allen, SL, et al. In vivo measurements document the dynamic cellular kinetics of chronic lymphocytic leukemia B cells. *J Clin Invest* 2005;115:755-764.
182. Soma LA, Craig FE, Swerdlow SH. The proliferation center microenvironment and prognostic markers in chronic lymphocytic leukemia/small lymphocytic lymphoma. *Human Path* 2006;37:152-159.
183. Patten PEM, Buggins AGS, Richards J, et al. CD38 expression in chronic lymphocytic leukemia is regulated by the tumor microenvironment. *Blood* 2008;111:5173-5181.
184. Calissano C, Damle RN, Hayes G, et al. In vivo intraclonal and inter-clonal kinetic heterogeneity in B-cell chronic lymphocytic leukemia. *Blood* 2009;114:4832-4842.
185. Sherr CJ. G1 phase progression: cycling on cue. *Cell* 1994;79:551-555.
186. Sherr CJ, Roberts JM. CDK inhibitors: positive and negative regulators of G1-phase progression. *Genes Dev* 1999;13:1501-1512.
187. Delmer A, Ajchenbaum-Cymbalista F, Tang R, et al. Overexpression of cyclin D2 in chronic B-cell malignancies. *Blood* 1995;85:2870-2876.
188. Suzuki R, Kuroda H, Komatsu H, et al. Selective usage of D-type cyclins in lymphoid malignancies. *Leukemia* 1999;13:1335-1342.
189. Wolowiec D, Cizak L, Kosmaczcwska A, et al. Cell cycle regulatory proteins and apoptosis in B-cell chronic lymphocytic leukemia. *Haematologica* 2001;86:1296-1304.
190. Kornblau S, Chen N, Del Giglio A, et al. Retinoblastoma protein expression is frequently altered in chronic lymphocytic leukemia. *Cancer Res* 1994;54:242-246.
191. Vrhovac R, Delmer A, Tang R, et al. Prognostic significance of the cell cycle inhibitor p27KIP1 in chronic lymphocytic leukemia. *Blood* 1998;91: 4694-4700.
192. Dickinson JD, Smith LM, Sanger WG, et al. Unique gene expression and clinical characteristics associated with the 11q23 deletion in chronic lymphocytic leukaemia. *Br J Haematol* 2005;128:460-471.
193. Stilgenbauer S, Bullinger L, Lichter P, et al. Genetics of chronic lymphocytic leukemia: genomic aberrations and VH gene mutation status in pathogenesis and clinical course. *Leukemia* 2002;16:993-1007.
194. Novak U, Oppliger Leibundgut E, Hager J, et al. A high-resolution allelotype of B-cell chronic lymphocytic leukemia (B-CLL). *Blood* 2002;100:1787-1794.
195. Juliusson G, Merup, M. Cytogenetics in chronic lymphocytic leukemia. *Semin Oncol* 1998;25:192-196.
196. Oscier DG, Stevens J, Hamblin TJ, et al. Correlation of chromosome abnormalities with laboratory features and clinical course in B-cell chronic lymphocytic leukaemia. *Br J Haematol* 1990;76:352-358.

197. Peterson LC, Lindquist LL, Church S, et al. Frequent clonal abnormalities of chromosome band 13q14 in B-cell chronic lymphocytic leukemia: multiple clones, subclones, and nonclonal alterations in 82 midwestern patients. *Genes Chromosomes Cancer* 1992;4:273-280.
198. Han T, Henderson ES, Emrich LJ, et al. Prognostic significance of karyotypic abnormalities in B-cell chronic lymphocytic leukemia: an update. *Semin Hematol* 1987;24:257-263.
199. Juliusson G, Oscier DG, Fitchett M, et al. Prognostic subgroups in B-cell-chronic lymphocytic leukemia defined by specific chromosome abnormalities. *N Engl J Med* 1990;323:720-724.
200. Juliusson G, Oscier D, Gahrton G, et al. Cytogenetic findings and survival in B-cell chronic lymphocytic leukemia. Second IWCCLL compilation of data on 662 patients. *Leuk Lymphoma* 1991;5:21-25.
201. Garcia-Marco JA, Price CM, Catovsky D. Interphase cytogenetics in chronic lymphocytic leukemia. *Cancer Genetics Cytogenetics* 1997;94:52-58.
202. Geisler C, Philip P, Hansen M. B-cell chronic lymphocytic leukemia: clonal chromosome abnormalities and prognosis in 89 cases. *Eur J Haematol* 1989;43:397-403.
203. Matutes E, Oscier D, Garcia-Marco J, et al. Trisomy 12 defines a group of CLL with atypical morphology: correlation between cytogenetic, clinical and laboratory features in 544 patients. *Br J Haematol* 1996;92:382-388.
204. Criel A, Michaux L, de Wolf-Peters C. The concept of typical and atypical chronic lymphocytic leukemia. *Leuk Lymphoma* 1999;33:33-45.
205. Neilson JR, Auer R, White D, et al. Deletions at 11q identify a subset of patients with typical CLL who show consistent disease progression and reduced survival. *Leukemia* 1997;11:1929-1932.
206. Que T, Marco J, Ellis J, et al. Trisomy 12 in chronic lymphocytic leukemia detected by fluorescein in situ hybridization: analysis by stage, immunophenotype, and morphology. *Blood* 1993;82:571-575.
207. Buhmann, R, Kurzeder, C, Rehklau, J, et al. CD40L stimulation enhances the ability of conventional metaphase cytogenetics to detect chromosome aberrations in B-cell chronic lymphocytic leukaemia cells. *Br J Haematol* 2002;118:968-975.
208. Mayr, C, Speicher, MR, Kofler, DM, et al. Chromosomal translocations are associated with poor prognosis in chronic lymphocytic leukemia. *Blood* 2006;107:742-751.
209. Dicker, F, Schnittger, S, Haferlach, T, et al. Immunostimulatory oligonucleotide-induced metaphase cytogenetics detect chromosomal aberrations in 80% of CLL patients: a study of 132 CLL cases with correlation to FISH, IgV_H status, and CD38 expression. *Blood* 2006;31:52-3160.
210. Hallek M, Fischer K, Fingerle-Rowson G, et al. Addition of rituximab to fludarabine and cyclophosphamide in patients with chronic lymphocytic leukemia: a randomised, open-label, phase 3 trial. *Lancet* 2010;376:1164-1174.
211. Shanafelt, TD, Witzig, TE, Fink, SR, et al. Prospective evaluation of clonal evolution during long-term follow-up of patients with untreated early-stage chronic lymphocytic leukemia. *J Clin Oncol* 2006;24:4634-4640.
212. Dal-Bo M, Rossi FM, Rossi D, et al. 13q14 deletion size and number of deleted cells both influence prognosis in chronic lymphocytic leukemia. *Genes, Chromosomes and Cancer* 2011;50:633-643.
213. Ouilllette P, Collins R, Shakhan S, et al. The prognostic significance of various 13q14 deletions in chronic lymphocytic leukemia. *Clin Cancer Res* 2011;17:6778-6790.
214. Nowakowski, GS, Dewald, GW, Hoyer, JD, et al. Interphase fluorescence in situ hybridization with an IGH probe is important in the evaluation of patients with a clinical diagnosis of chronic lymphocytic leukaemia. *Br J Haem* 2005;130:36-42.
215. Reddy, KS. Chronic lymphocytic leukaemia profiled for prognosis using a fluorescence in situ hybridization panel. *Br J Haematol* 2006;132:705-722.
216. Hjalmar V, Kimby E, Matutes E, et al. Atypical lymphocytes in B-cell chronic lymphocytic leukemia and trisomy 12 studied by conventional staining combined with fluorescence in situ hybridization. *Leuk Lymphoma* 2000;37: 571-576.
217. Auer RL, Bienz N, Neilson J. The sequential analysis of trisomy 12 in B-cell chronic lymphocytic leukaemia. *Br J Haematol* 1999;104:742-744.

218. Lens D, Dyer MJ, Garcia-Marco JM, et al. p53 abnormalities in CLL are associated with excess of prolymphocytes and poor prognosis. *Br J Haematol* 1997;99:848-857.
219. Kay NE, Echel-Passow JE, Braggio E, et al. Progressive but previously untreated CLL patients with greater array CGH complexity exhibit a less durable response to chemoimmunotherapy. *Cancer Genet Cytogenet* 2010;203:161-168.
220. Grubor V, Karsnitz A, Troge JE, et al. Novel genomic alterations and clonal evolution in chronic lymphocytic leukemia revealed by representational oligonucleotide microarray analysis (ROMA). *Blood* 2009;113:1294-1303.
221. Kujawski L, Ouillette P, Erba H, et al. Genomic complexity identifies patients with aggressive chronic lymphocytic leukemia. *Blood* 2008;112:1993-2003.
222. Ouillette P, Fossum S, Parkin B, et al. Aggressive chronic lymphocytic leukemia with elevated genomic complexity is associated with multiple gene defects in the response to DNA double-strand breaks. *Clin Cancer Res* 2010;16:835-847.
223. Ouillette P, Collins R, Shakhan S, et al. Acquired genomic copy number aberrations and survival in chronic lymphocytic leukemia. *Blood* 2011;118: 3051-3061.
224. Rosenwald, A, Chuang, EY, Davis, RE, et al. Fludarabine treatment of patients with chronic lymphocytic leukemia induces a p53 dependent gene expression response. *Blood* 2004;104:1428-1434.
225. Lozanski G, Heerema NA, Flinn IW, et al. Alemtuzumab is an effective therapy for chronic lymphocytic leukemia with p53 mutations and deletions. *Blood* 2004;103:3278-3281.
226. Wang L, Lawrence MS, Wan Y, et al. SF3B1 and other novel cancer genes in chronic lymphocytic leukemia. *N Engl J Med* 2011;365:2497-2506.
227. Fabbri G, Rasi S, Rossi D, et al. Analysis of the chronic lymphocytic leukemia coding genome: role of NOTCH1 mutational activation. *J Exp Med* 2011;208:1389-1401.
228. Puente SC, Pinyol M, Quesada V, et al. Whole-genome sequencing identifies recurrent mutations in chronic lymphocytic leukemia. *Nature* 2011;475: 101-105.
229. Quesada V, Conde L, Lillamor N, et al. Exome sequencing identifies recurrent mutations of the splicing factor SF3B1 gene in chronic lymphocytic leukemia. *Nat Genet* 2011;44:47-52.
230. Rosati E, Sabatini R, Rampino G, et al. Constitutively activated Notch signaling is involved in survival and apoptosis resistance of B-CLL cells. *Blood* 2009;113:856-865.
231. Shedden K, Li Y, Ouillette P, et al. Characteristics of chronic lymphocytic leukemia with somatically acquired mutations in NOTCH1 exon 34. *Leukemia*. Epub 2011 Dec 20.
232. Balatti V, Bottoni A, Palamarchuk A, et al. NOTCH1 mutations in CLL associated with trisomy 12. *Blood* 2012;119:329-331.
233. Rossi D, Rasi S, Fabbri G, et al. Mutations of NOTCH1 are an independent predictor of survival in chronic lymphocytic leukemia. *Blood* 2012;119:521-529.
234. Rossi D, Rasi S, Spina V, et al. Different impact of NOTCH1 and SF3B1 mutations on the risk of chronic lymphocytic leukemia transformation to Richter syndrome. *Br J Haematol* 2012;158:426-429.
235. Rossi D, Brusca A, Spina V, et al. Mutations of the SF3B1 splicing factor in chronic lymphocytic leukemia: association with progression and fludarabine refractoriness. *Blood* 2011;118:6904-6908.
236. Klein U, Dalla-Favera R. New insights into the pathogenesis of chronic lymphocytic leukemia. *Sem Cancer Biol* 2010;20:377-383.
237. Klein U, Lia M, Crespo M, et al. The DLEU2/miR-15^o/16-1 cluster controls B cell proliferation and its deletion leads to chronic lymphocytic leukemia. *Cancer Cell* 2010;17:28-40.
238. Lia M, Carette A, Tang H et al. Functional dissection of the chromosome 13q14 tumor-suppressor locus using transgenic mouse lines. *Blood* 2012;119:2981-2990.
239. Monni O, Knuutila S. 11q deletions in hematological malignancies. *Leuk Lymphoma* 2001;40:259-266.
240. Aalto Y, EL-Rifa W, Vilpo L, et al. Distinct gene expression profiling in chronic lymphocytic leukemia with 11q23 deletion. *Leukemia* 2001;15:1721-1728.

241. Herold T, Jurinovic V, Mulaw M, et al. Expression analysis of genes located in the minimally deleted regions of 13q14 and 11q22-23 in chronic lymphocytic leukemia-unexpected expression pattern of the RHO GTPase activator ARHGAP20. *Genes Chromosomes Cancer* 2011;50:546-558.
242. Au WY, Horsman DE, Ohno H, et al. Bcl-3/IgH translocation (14;19)(q32;q13) in non-Hodgkin's lymphomas. *Leuk Lymphoma* 2002;43:813-816.
243. De Lima M, O'Brien S, Lerner S, et al. Chronic lymphocytic leukemia in the young patient. *Semin Oncol* 1998;25:107-116.
244. Mauro FR, Foa R, Giannarelli D, et al. Clinical characteristics and outcome of young chronic lymphocytic leukemia patients: a single institution study of 204 cases. *Blood* 1999;94:448-454.
245. Shanafelt TD, Byrd JC, Call TG et al. Narrative review: initial management of newly diagnosed, early-stage chronic lymphocytic leukemia. *Ann Intern Med* 2006;145:435-447.
246. Agnew KL, Ruchlemer R, Catovsky D, et al. Cutaneous findings in chronic lymphocytic leukemia. *Br J Dermatol* 2004;150:1129-1135.
247. Barzilai A, Feuerman H, Quaglino P, et al. Cutaneous B-Cell Neoplasms Mimicking Granulomatous Rosacea or Rhinophyma. *Arch Dermatol*. Epub 2012 Apr 16.
248. Feliu E, Rozman C, Montserrat E, et al. Cytoplasmic inclusions in lymphocytes of chronic lymphocytic leukaemia. *Scand J Haematol* 1983;31:510-512.
249. Binet JL, Baudet S, Mentz F, et al. Basket cells or shadow cells of Gumprecht: a scanning electron microscope study, and the correlation between percentages of basket cells, and cells with altered chromatin structure (dense cells), in chronic lymphocytic leukemia. *Blood Cells* 1993;19:573-581.
250. Nowakowski GS, Hoyer JD, Shanafelt TD, et al. Percentage of smudge cells on routine blood smear predicts survival in chronic lymphocytic leukemia. *J Clin Oncol* 2009;27:1844-1849.
251. Bennett JM, Catovsky D, Daniel MT, et al. Proposals for the classification of chronic (mature) B and T lymphoid leukaemias. *J Clin Pathol* 1989;42: 567-584.
252. Rozman C, Montserrat E, Rodriguez-Fernandez JM, et al. Bone marrow histologic pattern. The best single prognostic parameter in chronic lymphocytic leukemia. A multivariate analysis of 329 cases. *Blood* 1984;64:642-648.
253. Geisler CH, Larsen JK, Hansen NE, et al. Prognostic importance of flow cytometric immunophenotyping of 540 consecutive patients with B-cell chronic lymphocytic leukemia. *Blood* 1991;78:1795-1802.
254. Matutes E, Wotherspoon A, Catovsky D. Differential diagnosis in chronic lymphocytic leukaemia. *Best Practice and Res Clin Haematol* 2007;20:367-384.
255. Rozman C, Montserrat E. Chronic lymphocytic leukemia. *New Engl J Med* 1995;333:1052-1057.
256. Moreau EJ, Matutes E, A'Hern RP, et al. Improvement of the chronic lymphocytic leukemia scoring system with the monoclonal antibody SN8 (CD79b). *Am J Clin Pathol* 1997;108:378-382.
257. DiRaimondo F, Albitar M, Huh Y, et al. The clinical and diagnostic relevance of CD23 expression in the chronic lymphoproliferative disease. *Cancer* 2002;94:1721-1730.
258. Hubmann R, Schwarzmeier JD, Shehata M, et al. Notch2 is involved in the overexpression of CD23 in B-cell chronic lymphocytic leukemia. *Blood* 2002;99:3742-3747.
259. Alfarano A, Indraccolo S, Circosta P, et al. An alternatively spliced form of CD79b gene may account for altered B-cell receptor expression in B-chronic lymphocytic leukemia. *Blood* 1999;93:2327-2335.
260. Serke S, Schwaner I, Yordanova M, et al. Monoclonal antibody FMC7 detects a conformational epitope on the CD20 molecule: evidence from phenotyping after Rituxan therapy and transfectant cell analyses. *Cytometry* 2001;46: 98-104.
261. Ikematsu W, Ikematsu H, Okamura S, et al. Surface phenotype and Ig heavy-chain gene usage in chronic B-cell leukemias: expression of myelomonocytic surface markers in CD5-chronic B-cell leukemia. *Blood* 1994;83:2602-2610.
262. Kipps TJ, Carson DA. Autoantibodies in chronic lymphocytic leukemia and related systemic autoimmune diseases. *Blood* 1993;81;2475-2487.
263. Caligaris Cappio F. B chronic lymphocytic leukemia: a malignancy of anti-self B cells. *Blood* 1996;87:2615-2620.

264. Malvasi F, Deaglio S, Damle R, et al. CD38 and chronic lymphocytic leukemia: a decade later. *Blood* 2011;118:3470-3477.
265. Jaksic O, Marlana M, Paro M, et al. CD38 on B-cell chronic lymphocytic leukemia cells has higher expression in lymph nodes than in peripheral blood or bone marrow. *Blood* 2004;103:1968-1969.
266. Rassenti LZ, Kipps TJ. Clinical utility of assessing ZAP-70 and CD38 in chronic lymphocytic leukemia. *Cytometry Part B (Clinical Cytometry)* 2006;70B:209-213.
267. Shanafelt TD. Predicting clinical outcome in CLL: how and why. *Hematology (Am Soc Hematol Educ Program)* 2009:421-429.
268. Van Bockstaele F, Verhasselt B, Philippé J. Prognostic markers in chronic lymphocytic leukemia: a comprehensive review. *Blood Rev* 2009;23:25-47.
269. Nolz, JC, Tschumper, RC, Pittner, BT, et al. ZAP-70 is expressed by a subset of normal human B-lymphocytes displaying an activated phenotype. *Leukemia* 2005;19:1018-1024.
270. Scielzo, C, Camporeale, A, Geuna, M, et al. ZAP-70 is expressed by normal and malignant human B-cell subsets of different maturational stage. *Leukemia* 2006;20:689-695.
271. Crespo, O, Bosch, F, Villamor, N, et al. ZAP-70 expression as a surrogate for immunoglobulin-variable-region mutations in chronic lymphocytic leukemia. *N Engl J Med* 2003;348:1764-1775.
272. Wiestner, A, Rosenwald, A, Barry, TS, et al. ZAP-70 expression identifies a chronic lymphocytic leukemia subtype with unmutated immunoglobulin genes, inferior clinical outcome, and distinct gene expression profile. *Blood* 2003;101:4944-4951.
273. Rassenti LZ, Huynh, L, Toy, TL, et al. ZAP-70 compared with immunoglobulin heavy-chain gene mutation status as a predictor of disease progression in chronic lymphocytic leukemia. *N Engl J Med* 2004;351:893-901.
274. Orchard, JA, Ibbotson, RE, Davis, Z, et al. ZAP-70 expression and prognosis in chronic lymphocytic leukaemia. *Lancet* 2004;363:105-111.
275. Króber, A, Bloehdorn, J, Hafner, S, et al. Additional genetic high-risk features such as 11q deletion, 17p deletion, and V3-21 usage characterize discordance of ZAP-70 and VH mutation status in chronic lymphocytic leukemia. *J Clin Oncol* 2006;24:969-975.
276. Del Principe, MI, Del Poeta G, Buccisano, F, et al. Clinical significance of ZAP-70 protein expression in B-cell chronic lymphocytic leukemia. *Blood* 2006;108:853-861.
277. Gobessi, S, Laurenti, L, Longo, PG, et al. ZAP-70 enhances B-cell receptor signaling in spite of absent or inefficient tyrosine kinase activation in chronic lymphocytic leukemia and lymphoma B-cells. *Blood* 2007;109:2032-2039.
278. Giardina SL, Schroff RW, Kipps TJ, et al. The generation of monoclonal antiidiotypic antibodies to human B-cell derived leukemias and lymphomas. *J Immunol* 1985;135:653-658.
279. Fais F, Sellars B, Ghiotto F, et al. Examples of in vivo isotype class switching in IgM+ chronic lymphocytic leukemic B cells. *J Clin Invest* 1995;98:7: 1659-1666.
280. Dono M, Hashimoto S, Fais F, et al. Evidence for progenitors of chronic lymphocytic leukemia B cells that undergo intraclonal differentiation and diversification. *Blood* 1996;87:1586-1594.
281. Norton JD, Pattinson J, Hoffbrand AV, et al. Rearrangement and expression of T cell antigen receptor genes in B cell chronic lymphocytic leukemia. *Blood* 1988;71:178-185.
282. Merup M, Juliusson G, Hammarström L, et al. T-cell receptor from patients with chronic lymphocytic leukaemia: association with chromosome 6 deletions gene rearrangements in leukaemic B-cells. *Br J Haematol* 1994;86:291-297.
283. Stevenson FK, Hamblin TJ, Stevenson GT, et al. Extracellular idiotypic immunoglobulin arising from human leukemia B lymphocytes. *J Exp Med* 1980;152:1484-1496.
284. Broker BM, Klajman A, Youinou P, et al. Chronic lymphocytic leukemia (CLL) cells secrete multispecific autoantibodies. *J Autoimmune* 1988;1:469-481.
285. Beaume A, Brizard A, Dreyfus B, et al. High incidence of serum monoclonal Igs detected by a sensitive immunoblotting technique in B-cell chronic lymphocytic leukemia. *Blood* 1994;84:1216-1219.

286. Pratt G, Harding S, Holder R, et al. Abnormal serum free light chain ratios are associated with poor survival and may reflect biological subgroups in patients with chronic lymphocytic leukemia. *Br J Haematol* 2008;144:217-222.
287. Morabito F, De Filippi R, Laurenti L, et al. The cumulative amount of serum-free light chain is a strong prognosticator in chronic lymphocytic leukemia. *Blood* 2011;118:6353-6361.
288. Ravandi F, O'Brien S. Immune defects in patients with chronic lymphocytic leukemia. *Cancer Immuno Immunother* 2006;55:197-209.
289. Morrison VA. Infectious complications of chronic lymphocytic leukemia: pathogenesis, spectrum of infection, preventive approaches. *Best Practice & Res Clin Haematol* 2010;23:145-153.
290. Wolos JA, Davey FR. B lymphocyte function in B cell chronic lymphocytic leukemia. *Br J Haematol* 1981;49:395-403.
291. Fu SM, Chiorazzi N, Kunkel HG. Differentiation capacity and other properties of the leukemic cells of CLL. *Immunol Rev* 1979;48:23-44.
292. Johnstone AP, Jensenius JC, Millard RE, et al. Mitogen-stimulated immunoglobulin production by CLL lymphocytes. *Clin Exp Immunol* 1982;47:697-705.
293. Goodman MG, Wormsley SB, Spinosa JC, et al. Loxoribine induces chronic lymphocytic leukemia B cells to traverse cell cycle. *Blood* 1994;84:3457-3464.
294. Planken EV, Willemze R, Kluin-Nelemans JC. The role of the CD40 antigen on malignant B cells. *Leuk Lymphoma* 1996;22:229-235.
295. Kneitz C, Goller Wilhelm M, Mehringer C, et al. Inhibition of T cell/B cell interaction by B-CLL cells. *Leukemia* 1999;13:98-104.
296. Lacombe C, Gombert J, Dreyfus B, et al. Heterogeneity of serum IgG subclass deficiencies in B chronic lymphocytic leukemia. *Clin Immunol* 1999;90: 128-132.
297. Aittoniemi J, Miettinen A, Laine S, et al. Opsonising immunoglobulins and mannan-binding lectin in chronic lymphocytic leukemia. *Leuk Lymphoma* 1999;34:381-385.
298. Kay NE, Perri RT. Evidence that large granular lymphocytes from B-CLL patients down-regulate B cell immunoglobulin synthesis. *Blood* 1989;73:1016-1019.
299. Shanafelt T, Kay N. T-cell abnormalities in patients with chronic lymphocytic leukemia. *Leuk Lymphoma* 2006;47:1197-1198.
300. Catovsky D, Lauria F, Matutes E, et al. Increase in T γ lymphocytes in B-cell CLL. *Br J Haematol* 1981;47:539-544.
301. Rossi JF, Commes T, Grenier J, et al. Production of B-cell growth factor interleukin 2 and gamma interferon by peripheral blood lymphocytes from patients with chronic lymphocytic leukemia of B cell type. *Am J Hematol* 1988;29:183-188.
302. Han T, Dadly B. In vitro functional studies of mononuclear cells in patients with CLL. *Cancer* 1979;43:109-117.
303. Han T, Bloom ML, Dadey B, et al. Lack of autologous mixed lymphocyte reaction in patients with CLL. *Blood* 1982;60:1075-1081.
304. Lauria F, Foa R, Mantovani V, et al. T cell functional abnormality in B-CLL: evidence of a defect of the T helper subset. *Br J Haematol* 1983;54:277-283.
305. Farace F, Orlanducci F, Dietrich PY, et al. T cell repertoire in patients with B chronic lymphocytic leukemia. *J Immunol* 1994;153:4281-4290.
306. Mackus WJ, Frakking FN, Grummerls A, et al. Expansion of CMV-specific CD8⁺ CD45RA⁺ CD27⁻ T cells in B-cell chronic lymphocytic leukemia. *Blood* 2003;102:1057-1063.
307. Gorgun G, Holderried TA, Zahrieh D, et al. Chronic lymphocytic leukemia cells induce changes in gene expression of CD4 and CD8 T cells. *J Clin Invest* 2005;115:1797-1805.
308. Ramsay AG, Johnson AJ, Lee AM, et al. Chronic lymphocytic leukemia T cells show impaired immunological synapse formation that can be reversed with an immunomodulating drug. *J Clin Invest* 2008;118:2427-2437.
309. Schattner EJ. CD40 ligand in CLL pathogenesis and therapy. *Leuk Lymphoma* 2000;37:461-472.

310. Schlesinger M, Broman I, Lugassy G. The complement system is defective in chronic lymphatic leukemia patients and in their healthy relatives. *Leukemia* 1996;10:1509-1513.
311. Itala M, Vainio O, Remes K. Functional abnormalities in granulocytes predict susceptibility to bacterial infections in chronic lymphocytic leukaemia. *Eur J Haematol* 1996;57:46-53.
312. Hamblin TJ. Autoimmune complications of chronic lymphocytic leukemia. *Semin Oncol* 2006;33:230-239.
313. Hodgson K, Ferrer G, Montserrat E, Moreno C. Chronic lymphocytic leukemia and autoimmunity: a systematic review. *Haematologica* 2011;96:752-761.
314. Hodgson K, Ferrer G, Perira A, et al. Autoimmune cytopenia in chronic lymphocytic leukaemia: diagnosis and treatment. *Br J Haematol* 2011;154:14-22.
315. Moreno C, Hodgson K, Ferrer G, et al. Autoimmune cytopenia in chronic lymphocytic leukemia: prevalence, clinical associations, and prognostic significance. *Blood* 2010;116:4771-4776.
316. Mittal S, Blaycock MG, Culligan DJ, et al. A high rate of CLL phenotype lymphocytes in autoimmune hemolytic anemia and immune thrombocytopenic purpura. *Haematologica* 2008;03:151-152.
317. Zent CS, Ding W, Schwager SM, et al. The prognostic significance of cytopenia in chronic lymphocytic leukaemia/small lymphocytic lymphoma. *Br J Haematol* 2008;141:615-621.
318. Dearden C, Wade R, Else M, et al. The prognostic significance of a positive direct antiglobulin test in chronic lymphocytic leukemia: a beneficial effect of the combination of fludarabine and cyclophosphamide on the incidence of hemolytic anemia. *Blood* 2008;111:1820-1826.
319. Borthakur G, O'Brien S, Wierda WG, et al. Immune anaemias in patients with chronic lymphocytic leukaemia treated with fludarabine, cyclophosphamide and rituximab: incidence and predictors. *Br J Haematol* 2007;136:800-805.
320. Efremov DG, Ivanovski M and Burrone OR. The pathologic significance of the immunoglobulins expressed by chronic lymphocytic leukemia B-cells in the development of autoimmune hemolytic anemia. *Leuk Lymphoma* 1998;28:285-293.
321. Mangan KF, Chikkappa G, Farley PC. T gamma cells suppress growth of erythroid colony-forming units in vitro in the pure red cell aplasia of B-cell CLL. *J Clin Invest* 1982;70:1148-1156.
322. Ruzickova S, Pruss A, Odendahl M, et al. Chronic lymphocytic leukemia preceded by cold agglutinin disease: intracлонаl immunoglobulin light-chain diversity in V_H4-34 expressing single leukemic B cells. *Blood* 2002;100:3419-3422.
323. Anhalt GJ, Kim SC, Stanley JR, et al. Paraneoplastic pemphigus. An auto-immune mucocutaneous disease associated with neoplasia. *N Engl J Med* 1990;323:1729-1735.
324. Joly P, Thomin E, Gilbert D, et al. Overlapping distribution of autoantibody specificities in paraneoplastic pemphigus and pemphigus vulgaris. *J Invest Dermatol* 1994;103:65-72.
325. Moulin B, Ronco PM, Mougnot B, et al. Glomerulonephritis in chronic lymphocytic leukaemia and related B cell lymphomas. *Kidney Int* 1992;42:127-135.
326. Mossafa J, Malaure J, Maynadie M, et al. Persistent polyclonal B lymphocytosis with binucleated lymphocytes: a study of 25 cases. *Groupe Francais d'Hematologie Cellulaire. Br J Haematol* 1999;104:486-493.
327. Delage R, Jacques L, Massinga-Loembe M, et al. Persistent polyclonal B-cell lymphocytosis: further evidence for a genetic disorder associated with B-cell abnormalities. *Br J Haematol* 2001;114:666-670.
328. Salcedo I, Campos-Caro A, Sampalo A, et al. Persistent polyclonal B lymphocytosis: an expansion of cells showing IgVH gene mutations and phenotypic features of normal lymphocytes from the CD27+ marginal zone B-cell compartment. *Br J Haematol* 2002;116:662-666.
329. Bates I, Bedu-Addo G, Bevan DH, et al. Use of immunoglobulin gene rearrangements to show clonal lymphoproliferation in hyper-reactive malarial splenomegaly. *Lancet* 1991;337:505-507.
330. Bedu-Addo G, Bates I. Causes of massive tropical splenomegaly in Ghana. *Lancet* 2002;360:449-454.
331. Catovsky D, Matutes E. Splenic lymphoma with circulating villous lymphocytes/splenic marginal-zone lymphoma. *Semin Hematol* 1999;36:148-154.
332. Marti GE. MBL: mostly benign lymphocytes, but... *Blood* 2011;118: 6480-6481.

333. Lanasa MC, Allgood SD, Volkheimer AD, et al. Single-cell analysis reveals oligoclonality among "low-count" monoclonal B-cell lymphocytosis. *Leukemia* 2010;24:133-140.
334. Rawstron AC, Green MJ, Kuzmicki A, et al. Monoclonal B lymphocytes with the characteristics of "indolent" chronic lymphocytic leukemia are present in 3.5% of adults with normal blood counts. *Blood* 2002;100:635-639.
335. Rawstron AC, Bennett FL, O'Connor SJM, et al. Monoclonal B-cell lymphocytosis and chronic lymphocytic leukemia. *N Engl J Med* 2008;359:575-583.
336. Ghia P, Caligaris-Cappio F. Monoclonal B-cell lymphocytosis: right track or red herring? *Blood* 2012;119:4358-4362.
337. Nieto WG, Almeida J, Romero A, et al. Increased frequency (12%) of circulating chronic lymphocytic leukemia-like B-cell clones in healthy subjects using a highly sensitive multicolor flow cytometry approach. *Blood* 2009;114:33-37.
338. Rawstron AC, Shanafelt T, Lanasa MC, et al. Different biology and clinical outcome according to the absolute numbers of clonal B-cell in monoclonal B-cell lymphocytosis (MBL). *Cytometry Part B (Clinical Cytometry)* 2010;78B(Suppl 1):S19-S23.
339. Dagklis A, Fazi C, Sala C, et al. The immunoglobulin gene repertoire of low-count chronic lymphocytic leukemia (CLL)-like monoclonal B lymphocytosis is different from CLL: diagnostic implications for clinical monitoring. *Blood* 2009;114:26-32.
340. Fazi C, Scarfò L, Pecciarini L, et al. General population low-count CLL-like MBL persist over time without clinical progression, though carrying the same cytogenetic abnormalities of CLL. *Blood* 2011;118:6618-6625.
341. Shanafelt TD, Kay NE, Jenkins G, et al. B-cell count and survival: differentiating chronic lymphocytic leukemia from monoclonal B-cell lymphocytosis based on clinical outcome. *Blood* 2009;113:4188-4196.
342. Shanafelt TD, Kay NE, Rabe KG, et al. Survival of patients with clinically identified monoclonal B-cell lymphocytosis (MBL) relative to the age- and sex-matched general population. *Leukemia* 2012;26:373-376.
343. Ferrand C, Garnache-Ottou F, Collonge-Rame MA, et al. Systematic donor blood qualification by flow cytometry would have been able to avoid CLL-type MBL transmission after unrelated hematopoietic stem cell transplantation. *Eur J Haematol* 2012;88:269-272.
344. Melo JV, Catovsky D, Galton DAG. The relationship between chronic lymphocytic leukaemia and prolymphocytic leukaemia. I. Clinical and laboratory features of 300 patients and characteristics of an intermediate group. *Br J Haematol* 1986;63:377-387.
345. Shvidel L, Shatalrid M, Bassous L, et al. B-cell prolymphocytic leukemia: a survey of 35 patients emphasizing heterogeneity, prognostic factors and evidence for a group with an indolent course. *Leuk Lymphoma* 1999;33:169-179.
346. Lens D, Matutes E, Catovsky D, et al. Frequent deletions at 11q23 and 13q14 in B-cell prolymphocytic leukemia (B-CLL). *Leukemia* 2000;14:427-430.
347. Dearden C. How I treat prolymphocytic leukemia. *Blood* 2012;120:538-551.
348. Argatoff LH, Connors JM, Klasa RJ, et al. Mantle cell lymphoma: a clinicopathologic study of 80 cases. *Blood* 1997;89:2067-2078.
349. Bosch F, Lopez-Guillermo A, Campo E, et al. Mantle cell lymphoma: presenting features, response to therapy, and prognostic factors. *Cancer* 1998;82:567-575.
350. Fan H, Gulley RD, Gascoyne DE, et al. Molecular methods for detecting t(11;14) translocations in mantle-cell lymphomas. *Diagn Mol Pathol* 1998;7:209-214.
351. Matutes E, Carrara P, Coignet L, et al. FISH analysis for BCL-1 rearrangements and trisomy 12 helps the diagnosis of atypical B cell leukaemias. *Leukemia* 1999;13:1721-1726.
352. Melo JV, Robinson DSF, de Oliveira MP, et al. Morphology and immunology of circulating cells in leukaemic phase of follicular lymphoma. *J Clin Pathol* 1988;41:951-959.
353. Troussard X, Valensi F, Duchayne E, et al. Splenic lymphoma with villous lymphocytes: clinical presentation, biology and prognostic factors in a series of 100 patients. Groupe Francais d'Hematologie Cellulaire (GFHC). *Br J Haematol* 1996;93:731-736.
354. Matutes E. Immunotyping and differential diagnosis of hairy cell leukemia. *Hematol Oncol Clin North Am* 2006;20:1051-1063.

355. Robak, T, Hairy-cell leukemia variant: recent view on diagnosis, biology and treatment. *Cancer Treat Rev* 2010;37:3-10.
356. Blayney DW, Jaffe ES, Fisher RI, et al. The human T cell leukemia/lymphoma virus, lymphoma, lytic bone lesions and hypercalcemia. *Ann Intern Med* 1983;98:144-151.
357. Ratner L, Griffith RC, Marselle L, et al. A lymphoproliferative disorder caused by human T-lymphotropic virus Type I. Demonstration of a continuum between acute and chronic adult T-cell leukemia/lymphoma. *Am J Med* 1987;83:953-958.
358. Shirono K, Hattori R, Takatsuki K. A new classification of clinical stages of adult T-cell leukemia based on prognosis of the disease. *Leukemia* 1994;8:1834-1837.
359. Youn H, Kim Y, Hoppe RT. Mycosis fungoides and Sézary syndrome. *Semin Oncol* 1999;26:276-289.
360. Watters RJ, Liu X, Loughran TP. T-cell and natural killer-cell large granular lymphocytic leukemia neoplasias. *Leuk Lymphoma* 2011;52:2217-2225.
361. Jaffe ES. Classification of natural killer (NK) cell and NK-like T-cell malignancies. *Blood* 1996;87:1207-1210.
362. Tefferi A, Li C-Y, Witzig TE, et al. Chronic natural killer cell lymphocytosis: a descriptive clinical study. *Blood* 1994;84:2721-2725.
363. Lamy T, Liu JH, Landowski TH, et al. Dysregulation of CD95/CD95 ligandapoptotic pathway in CD3+ large granular lymphocytic leukemia. *Blood* 1998;92:4771-4777.
364. Sood R, Stewart CC, Aplan PD, et al. Neutropenia associated with T-cell large granular lymphocyte leukemia: long-term response to cyclosporin therapy despite persistence of abnormal cells. *Blood* 1998;91:3372-3378.
365. Loughran TP Jr, Kidd PG, Starkebaum G. Treatment of large granular lymphocyte leukemia with or low-dose methotrexate. *Blood* 1994;84:2164-2170.
366. O'Brien SM, Keating MJ, Mocarski ES. Updated guidelines on the management of cytomegalovirus reactivation in patients with chronic lymphocytic leukemia treated with alemtuzumab. *Clin Lymphoma Myeloma* 2006;7: 125-130.
367. Eichhorst BF, Fischer K, Fink A-M, et al. Limited clinical relevance of imaging techniques in the follow-up of patients with advanced chronic lymphocytic leukemia: results of a meta-analysis. *Blood* 2011;117:1817-1821.
368. Rai JL, Sawitsky A, Cronkite EP, et al. Clinical staging of chronic lymphocytic leukemia. *Blood* 1975;46:219-234.
369. Binet JL, Auquier A, Dighiero G, et al. A new prognostic classification of chronic lymphocytic leukemia derived from a multivariate survival analysis. *Cancer* 1981;48:198-206.
370. Abrisqueta P, Pereira A, Rozman C, et al. Improving survival in patients with chronic lymphocytic leukemia (1980-2008): the Hospital Clínic of Barcelona experience. *Blood* 2009;114:2044-2050.
371. Del Giudice I, Chiaretti S, Tavaloro S, et al. Spontaneous regression of chronic lymphocytic leukemia: clinical and biologic features of 9 cases. *Blood* 2009;114:638-646.
372. Shanafelt TD, Bowen D, Venkat C, et al. Quality of life in chronic lymphocytic leukemia: an international survey of 1482 patients. *Br J Haematol* 2007;139:255-264.
373. Shanafelt TD, Jenkins G, Call TG, et al. Validation of a new prognostic index for patients with chronic lymphocytic leukemia. *Cancer* 2009;115:363-372.
374. Bulian P, Tarnani M, Rossi D, et al. Multicentre validation of a prognostic index for overall survival in chronic lymphocytic leukaemia. *Hematological Oncol* 2011;29:91-99.
375. Dighiero G, Binet J-L When and how to treat chronic lymphocytic leukemia. *N Engl J Med* 2000;343:1799-1801.
376. Catovsky D, Fooks J, Richards S. Prognostic factors in chronic lymphocytic leukaemia: the importance of age, sex and response to treatment in survival. *Br J Haematol* 1989;72:141-149.
377. Molica S. Sex differences in incidence and outcome of chronic lymphocytic leukemia patients. *Leuk Lymphoma* 2006;47:1477-1480.
378. Oscier DG, Matutes E, Copplestone A, et al. Atypical lymphocyte morphology: an adverse prognostic factor for disease progression in stage A CLL independent of trisomy 12. *Br J Haematol* 1997;98:934-939.
379. Lee JS, Dixon DO, Kantarjian HM, et al. Prognosis of chronic lymphocytic leukemia: a multivariate regression analysis of 325 untreated patients. *Blood* 1987;69:929-936.

380. Montserrat E, Sánchez-Bisonó J, Viñolas N, et al. Lymphocyte doubling time in chronic lymphocytic leukemia. Analysis of its prognostic significance. *Br J Haematol* 1986;62:567-575.
381. Pepper C, Majid A, Lin TT, et al. Defining the prognosis of early stage chronic lymphocytic leukaemia patients. *Br J Haematol* 2011;156:499-507.
382. Molica S, Levato D, Dattilo A, et al. Clinico-prognostic relevance of quantitative immunophenotyping in B-cell chronic lymphocytic leukemia with emphasis on the expression of CD20 antigen and surface immunoglobulins. *Eur J Haematol* 1998;60:47-52.
383. Del Poeta G, Maurillo L, Venditti A, et al. Clinical significance of CD38 expression in chronic lymphocytic leukemia. *Blood* 2001;98:2633-2639.
384. Ibrahim S, Keating M, Do K-A, et al. CD38 expression as an important prognostic factor in B-cell chronic lymphocytic leukemia. *Blood* 2001;98:181-186.
385. Chevallier P, Penther D, Avet-Loiseau H, et al. CD38 expression and secondary 17p deletion are important prognostic factors in chronic lymphocytic leukaemia. *Br J Haematol* 2002;116:142-150.
386. Rassenti LZ, Jain S, Keating MJ, et al. Relative value of ZAP-70, CD38, and immunoglobulin mutation status in predicting aggressive disease in chronic lymphocytic leukemia. *Blood* 2008;112:1923-1930.
387. Apostolopoulos A, Symeonidis A, Zoumbos N. Prognostic significance of immune function parameters in patients with chronic lymphocytic leukaemia. *Eur J Hematol* 1990;44:39-44.
388. Tsimberidou A-M, Tam C, Abruzzo LV, et al. Chemoimmunotherapy may overcome the adverse prognostic significance of 11q deletion in previously untreated patients with chronic lymphocytic leukemia. *Cancer* 2009;115:373-380.
389. Byrd JC, Gribben JG, Peterson BL, et al. Select high-risk genetic features predict earlier progression following chemoimmunotherapy with fludarabine and rituximab in chronic lymphocytic leukemia: justification for risk-adapted therapy. *J Clin Oncol* 2006;24:437-443.
390. Tam CS, Shanafelt TD, Wierda WG, et al. De novo deletion 17p13.1 chronic lymphocytic leukemia shows significant clinical heterogeneity: the M.D. Anderson and Mayo Clinic experience. *Blood* 2009;114:957-964.
391. Best OG, Gardiner AC, Davis ZA et al. A subset of Binet stage A CLL patients with TP53 abnormalities and mutated IGHV genes have stable disease. *Leukemia* 2009;23:212-214.
392. Zenz T, Häbe S, Denzel T, et al. Detailed analysis of p53 pathway defects in fludarabine-refractory chronic lymphocytic leukemia (CLL): dissecting contribution of 17p deletion, TP53 mutation, p53-p21 dysfunction, and miR34a in a prospective clinical trial. *Blood* 2009;114:2589-2597.
393. Zenz T, Kröber A, Scherer K, et al. Monoallelic TP53 inactivation is associated with poor prognosis in chronic lymphocytic leukemia: results from a detailed genetic characterization with long-term follow-up. *Blood* 2008;112:3322-3329.
394. Trbusek M, Smardova J, Malcikova J, et al. Missense mutations located in structural p53 DNA-binding motifs are associated with extremely poor survival in chronic lymphocytic leukemia. *J Clin Oncol* 2011;29:2703-2708.
395. Pospisilova S, Gonzalez D, Malcikova J, et al. ERIC recommendations on TP53 mutation analysis in chronic lymphocytic leukemia. *Leukemia* 2012;26: 1458-1461.
396. Falt S, Merup M, Tobin G, et al. Distinct gene expression pattern in V_H3-21 utilizing B-cell chronic lymphocytic leukemia. *Blood* 2005;106:681-689.
397. Ricca I, Rocci A, Drandi D, et al. Telomere length identifies two different prognostic subgroups among VH-unmutated B-cell chronic lymphocytic leukemia patients. *Leukemia* 2007;21:697-705.
398. Roos G, Kröber A, Grabowski P, et al. Short telomeres are associated with genetic complexity, high-risk genomic aberrations, and short survival in chronic lymphocytic leukemia. *Blood* 2008;111:2246-2252.
399. Lin TT, Letsolo BT, Jones RE, et al. Telomere dysfunction and fusion during the progression of chronic lymphocytic leukemia: evidence for a telomere crisis. *Blood* 2010;116:1899-1907.
400. Britt-Compton B, Lin TT, Ahmed G, et al. Extreme telomere erosion in ATM-mutated and 11q-deleted CLL patients is independent of disease stage. *Leukemia* 2012;26:826-830.

401. Visone R, Veronese A, Rassenti LZ, et al. miR-181b is a biomarker of disease progression in chronic lymphocytic leukemia. *Blood* 2011;118:3072-3079.
402. Mauro FR, De Rossi G, Burgio VL, et al. Prognostic value of bone marrow histology in chronic lymphocytic leukemia. A study of 335 untreated cases from a single institution. *Haematologica* 1994;79:334-341.
403. Frisch B, Bartl R. Histologic classification and staging of chronic lymphocytic leukemia. A retrospective and prospective study of 503 cases. *Acta Haematol* 1988;79:140-152.
404. Montserrat E, Villamor N, Reverter JC, et al. Bone marrow assessment in B-cell chronic lymphocytic leukemia: aspirate or biopsy? A comparative study in 258 patients. *Br J Haematol* 1996;93:111-116.
405. Robertson LE, Huh YO, Butler JJ, et al. Response assessment in chronic lymphocytic leukemia after fludarabine plus prednisone: clinical, pathologic, immunophenotypic, and molecular analysis. *Blood* 1992;80:29-36.
406. Oudat R, Keating MJ, Lerner S, et al. Significance of the levels of bone marrow lymphoid infiltrate in chronic lymphocytic leukemia patients with nodular partial remission. *Leukemia* 2002;16:632-635.
407. Keating MJ, O'Brien S, Kontoyiannis D, et al. Results of first salvage therapy for patients refractory to a fludarabine regimen in chronic lymphocytic leukemia. *Leuk Lymphoma* 2002;43:1755-1762.
408. Tam CS, O'Brien S, Lerner S, et al. The natural history of fludarabine-refractory chronic lymphocytic leukemia patients who fail alemtuzumab or have bulky lymphadenopathy. *Leuk Lymphoma* 2007;48:1931-1939.
409. Letestu R, Lévy V, Eclache V, et al. Prognosis of Binet stage A chronic lymphocytic leukemia patients: the strength of routine parameters. *Blood* 2010;116:4588-4590.
410. Gentile M, Cutron G, Neri A, et al. Predictive value of beta2-microglobulin (beta2-m) levels in chronic lymphocytic leukemia since Binet stage A stages. *Haematologica* 2009;94:887-888.
411. Delgado J, Pratt G, Phillips N, et al. Beta₂-microglobulin is a better predictor of treatment-free survival in patients with chronic lymphocytic leukaemia if adjusted according to glomerular filtration rate. *Br J Haematol* 2009;145:801-805.
412. Fayad L, Keating MJ, Reuben JM, et al. Interleukin-6 and interleukin-10 levels in chronic lymphocytic leukemia: correlation with phenotypic characteristics and outcome. *Blood* 2001;97:256-263.
413. Lai R, O'Brien S, Maushouri T, et al. Prognostic value of plasma interleukin-6 levels in patients with chronic lymphocytic leukemia. *Cancer* 2002;95:1071-1075.
414. Wierda WG, Johnson MM, Do K-A, et al. Plasma interleukin 8 level predicts for survival in chronic lymphocytic leukaemia. *British Journal of Haematology* 2003;120:452-456.
415. Francia di Cell P, Mariani S, Riera L, et al. Interleukin-8 induces the accumulation of B-cell chronic lymphocytic leukemia cells by prolonging survival in an autocrine fashion. *Blood* 1996;87:4382-4389.
416. Yan XJ, Dozmorov I, Li W, et al. Identification of outcome-correlated cytokine clusters in chronic lymphocytic leukemia. *Blood* 2011;118:5201-5210.
417. Shanafelt TD, Drake MT, Maurer MJ, et al. Vitamin D insufficiency and prognosis in chronic lymphocytic leukemia. *Blood* 2011;117:1492-1498.
418. Molica S, Digiesi G, Antenucci A, et al. Vitamin D insufficiency predicts time to first treatment (TFT) in early chronic lymphocytic leukemia (CLL). *Leuk Res* 2011;36:443-447.
419. Wierda WG, O'Brien S, Wang X, et al. Multivariable model for time to first treatment in patients with chronic lymphocytic leukemia. *J Clin Oncol* 2011;29:4088-4095.
420. Dighiero G, Maloum K, Desablens B, et al. Chlorambucil in indolent chronic lymphocytic leukemia. *N Engl J Med* 1998;338:1506-1514.
421. Moreton P, Kennedy B, Lucas G, et al. Eradication of minimal residual disease in B-cell chronic lymphocytic leukemia after therapy with alemtuzumab is associated with prolonged survival. *J Clin Oncol* 2005;23:2971-2979.
422. Nabhan C, Coutré S, Hillmen P. Minimal residual disease in chronic lymphocytic leukaemia: is it ready for primetime? *Br J Haematol* 2006;136:379-392.
423. Rawstron AC, Villamor N, Rigen M, et al. International standardized approach for flow cytometric residual disease monitoring in chronic lymphocytic leukaemia. *Leukemia* 2007;21:956-964.

424. Böttcher S, Ritgen M, Fischer K, et al. Minimal residual disease quantification is an independent predictor of progression-free and overall survival in chronic lymphocytic leukemia: a multivariate analysis from the randomized GCLLSG CLL8 trial. *J Clin Oncol* 2012;30:980-988.
425. Begleiter A, Mowat M, Israels LG, et al. Chlorambucil in chronic lymphocytic leukemia—mechanism of action. *Leuk Lymphoma* 1996;23:187-201.
426. Panasci L, Paiement J-P, Christodoulopoulos G, et al. Chlorambucil drug resistance in chronic lymphocytic leukemia: the emerging role of DNA repair. *Clin Cancer Res* 2001;7:454-461.
427. Sawitsky A, Rai KR, Glidewell O, et al. Comparison of daily versus intermittent chlorambucil and prednisone therapy in the treatment of patients with chronic lymphocytic leukemia. *Blood* 1977;50:1049-1059.
428. Knospe WH, Loeb V, Huguley CM. Bi-weekly chlorambucil treatment of chronic lymphocytic leukemia. *Cancer* 1974;33:555-562.
429. Rai KR, Peterson BL, Appelbaum FR, et al. Fludarabine compared with chlorambucil as primary therapy for chronic lymphocytic leukemia. *N Engl J Med* 2000;343:1750-1757.
430. Hillmen P, Skotnicki AB, Robak T, et al. Alemtuzumab compared with chlorambucil as first-line therapy for chronic lymphocytic leukemia. *J Clin Oncol* 2007;25:5616-5623.
431. Eichhorst BF, Busch R, Stilgenbauer S, et al. First-line therapy with fludarabine compared with chlorambucil does not result in a major benefit for elderly patients with advanced chronic lymphocytic leukemia. *Blood* 2009;114:3382-3391.
432. Knauf WU, Lissichkov T, Aldaoud A, et al. Phase III randomized study of bendamustine compared with chlorambucil in previously untreated patients with chronic lymphocytic leukemia. *J Clin Oncol* 2009;27:4378-4384.
433. Catovsky D, Richards S, Matutes E, et al. Assessment of fludarabine plus cyclophosphamide for patients with chronic lymphocytic leukaemia (the LRF CLL4 Trial): a randomized controlled trial. *Lancet* 2007;370:230-239.
434. Robak T, Bloński JZ, Kasznicki M, et al. Cladribine with prednisone versus chlorambucil with prednisone as first-line therapy in chronic lymphocytic leukemia: report of a prospective, randomized, multicenter trial. *Blood* 2000;96:2723-2729.
435. Jaksic B, Brugiarelli M, Krc I, et al. High dose chlorambucil versus Binet's modified cyclophosphamide, doxorubicin, vincristine, and prednisone regimen in the treatment of patients with advanced B-cell chronic lymphocytic leukemia: results of an international multicenter randomized trial. *International Society for Chemo-Immunotherapy, Vienna. Cancer* 1997;79:2107-2114.
436. Montserrat E, Rozman C. Chronic lymphocytic leukaemia treatment. *Blood Rev* 1993;7:164-175.
437. Han T, Ezdinli EZ, Shimaoka K, et al. Chlorambucil vs combined chlorambucilcorticosteroid therapy in chronic lymphocytic leukemia. *Cancer* 1973;31:502-508.
438. Liepman M, Votaw ML. Treatment of chronic lymphocytic leukemia with COP chemotherapy. *Cancer* 1978;41:2664-2669.
439. Oken MM, Kaplan ME. Combination chemotherapy with cyclophosphamide, vincristine and prednisone in the treatment of refractory CLL. *Cancer Treat Rep* 1979;63:441-447.
440. French Cooperative Group on Chronic Lymphocytic Leukemia. Prognostic and therapeutic advances in CLL management: the experience of the French Cooperative Group. *Semin Hematol* 1987;24:275-290.
441. French Cooperative Group on chronic lymphocytic leukemia. A randomized clinical trial of chlorambucil versus COP in stage B chronic lymphocytic leukemia. *Blood* 1990;75:1422-1425.
442. Raphael B, Anderson JW, Silber R, et al. Comparison of chlorambucil and prednisone versus cyclophosphamide, vincristine, and prednisone as initial treatment for chronic lymphocytic leukemia: long-term follow-up of an Eastern Cooperative Oncology Group randomized clinical trial. *J Clin Oncol* 1991;9:770-776.
443. Montserrat E, Alcalá A, Parody R, et al. Treatment of chronic lymphocytic leukemia in advanced stages. A randomized trial comparing chlorambucil plus prednisone versus cyclophosphamide, vincristine and prednisone. *Cancer* 1985;56:2369-2375.
444. French Cooperative Group on Chronic Lymphocytic Leukaemia. Benefit of 'CHOP' regimen in advanced untreated chronic lymphocytic leukemia: results from a randomized clinical trial. *Lancet* 1986;1:1346-1349.

445. French Cooperative Group on Chronic Lymphocytic Leukemia. Long-term results of the CHOP regimen in stage C chronic lymphocytic leukemia. *Br J Haematol* 1989;73:334-340.
446. Kimby E, Melstedt H. Chlorambucil/prednisone versus CHOP in symptomatic chronic lymphocytic leukemias of B-cell type: a randomized trial. *Leuk Lymphoma* 1991;5(Suppl):93-96.
447. Hansen MM, Andersen E, Birgeus H, et al. CHOP versus prednisone + chlorambucil in chronic lymphocytic leukemia: preliminary results of a randomized multicenter study. *Nouv Rev Fr Hematol* 1998;30:433-436.
448. Kempin S, Lee BJ, Thaler HT, et al. Combination chemotherapy of advanced chronic lymphocytic leukemia: the M2 protocol (vincristine, BCNU, cyclophosphamide, melphalan and prednisone). *Blood* 1982;60:1110-1121.
449. Keating MJ, Scouros M, Murphy S, et al. Multiple agent chemotherapy (POACH) in previously treated and untreated patients with chronic lymphocytic leukemia. *Leukemia* 1988;2:157-164.
450. Friedenberg WR, Anderson J, Wolf BC, et al. Modified vincristine, doxorubicin and dexamethasone regimen in the treatment of resistant or relapsed chronic lymphocytic leukemia. *Cancer* 1993;71:2983-2989.
451. CLL Trialists Collaborative Group. Chemotherapeutic options in chronic lymphocytic leukemia: a meta-analysis of the randomized trials. *J Natl Cancer Inst* 1999;91:861-868.
452. Knauf W. Bendamustine in the treatment of chronic lymphocytic leukemia. *Expert Rev Anticancer Ther* 2009;9:165-174.
453. Leoni LM, Bailey B, Reifert J, et al. Bendamustine (Treanda) displays a distinct pattern of cytotoxicity and unique mechanistic features compared with other alkylating agents. *Clin Cancer Res* 2008;14:310-317.
454. Roué G, Lopez-Guerra M, Milpied P, et al. Bendamustine is effective in p53-deficient B-cell neoplasms and required oxidative stress and caspase-independent signaling. *Clin Cancer Res* 2008;14:6907-6915.
455. Knauf WU, Lissichkov T, Aldaoud A, et al. Bendamustine compared with chlorambucil in previously untreated patients with chronic lymphocytic leukaemia: updated results of a randomized phase III trial. *Br J Haematol*. 2012;159(1):67-77.
456. Tallman MS, Hakimian D. Purine nucleoside analogs: emerging roles in indolent lymphoproliferative disorders. *Blood* 1995;86:2463-2474.
457. Begleiter A, Glazer RI, Israels LG, et al. Induction of DNA strand breaks in chronic lymphocytic leukemia following treatment with 2'-deoxycoformycin in vivo and in vitro. *Cancer Res* 1987;47:2498-2503.
458. Major PP, Agarwal RP, Kufe DW. Clinical pharmacology of deoxycoformycin. *Blood* 1981;58:91-96.
459. Begleiter A, Verburg L, Ashique A, et al. Comparison of antitumor activities of 2-chlorodeoxyadenosine and 9-beta-arabinosyl-2-fluoroadenine in chronic lymphocytic leukemia and marrow cells in vitro. *Leukemia* 1995;9:1875-1881.
460. Robertson LE, Chubb S, Meyn RE, et al. Induction of apoptotic cell death in chronic lymphocytic leukemia by 2-chloro-2'-deoxyadenosine and 9-beta-Darabinosyl-2-fluoroadenine. *Blood* 1993;81:143-150.
461. Molina-Arcas M, Marcé S, villamor N, et al. Equilibrative nucleoside transporter-2 (hENT2) protein expression correlates with ex vivo sensitivity to fludarabine in chronic lymphocytic leukemia (CLL) cells. *Leukemia* 2005;19:64-68.
462. Pastor-Anglada M, Molina-Arcas M, Casado FJ, et al. Nucleoside transporters in chronic lymphocytic leukaemia. *Leukemia* 2004;18:385-393.
463. Genini D, Budihardjo I, Plunkett W, et al. Nucleotide requirements for the in vitro activation of the apoptosis protein-activating factor-1-mediated caspase pathway. *J Biol Chem* 2000;275:29-34.
464. Ho AD, Thaler J, Stryckmans P, et al. Pentostatin in refractory chronic lymphocytic leukemia: a phase II trial of the European Organization for Research and Treatment of Cancer. *J Natl Cancer Inst* 1990;82:1416-1420.
465. Dillman RO, Mick R, McIntyre OR. Pentostatin in chronic lymphocytic leukemia: a phase II trial of Cancer and Leukemia Group B. *J Clin Oncol* 1989;7:433-438.
466. Shustik C, Turner AR, Desjardins P, et al. Oral fludarabine in untreated patients with B-cell chronic lymphocytic leukemia. *Leukemia* 2010;24:237-239.
467. Keating MJ, O'Brien S, Kantarjian H, et al. Long-term follow-up of patients with chronic lymphocytic leukemia treated with fludarabine as a single agent. *Blood* 1993;81:2878-2884.

468. Sorensen JM, Vena DA, Fallavollita A, et al. Treatment of refractory chronic lymphocytic leukemia with fludarabine phosphate via the group C protocol mechanism of the a National Cancer Institute: five-year follow-up report. *J Clin Oncol* 1997;15:458-465.
469. The French Cooperative Group on CLL, Johnson S, Smith AG, et al. Multicentre prospective randomized trial of fludarabine versus cyclophosphamide, doxorubicin, and prednisone (CAP) for treatment of advanced-stage chronic lymphocytic leukaemia. *Lancet* 1996;347:1432-1438.
470. Lepage M, Chevret S, Cazin B, et al. Randomized comparison of fludarabine, CAP, and CHOP in 938 previously untreated stage B and C chronic lymphocytic leukemia patients. *Blood* 2001;98:2319-2325.
471. Keating MJ, O'Brien S, Lerner S, et al. Long-term follow-up of patients with chronic lymphocytic leukemia (CLL) receiving fludarabine regimens as initial therapy. *Blood* 1998;92:1165-1171.
472. Robertson LE, O'Brien S, Kantarjian H, et al. A 3-day schedule of fludarabine in previously treated chronic lymphocytic leukemia. *Leukemia* 1995;9:1444-1449.
473. O'Brien S, Kantarjian H, Beran M, et al. Results of fludarabine and prednisone therapy in 264 patients with chronic lymphocytic leukemia with multivariate analysis-derived prognostic model for response to treatment. *Blood* 1993;82:1695-1700.
474. Rai KR, Peterson BL, Appelbaum FR, et al. Long-term analysis of the North American Intergroup Study C9011 comparing fludarabine and chlorambucil in previously untreated patients with CLL. *Blood* 2009;114:Abstract 536.
475. Juliusson G, Liliemark J. High complete remission rate from 2-chloro-2'-deoxyadenosine in previously treated patients with B-cell chronic lymphocytic leukemia: response predicted by rapid decrease of blood lymphocyte count. *J Clin Oncol* 1993;11:679-689.
476. Delannoy A, Martiat P, Gala JL, et al. 2-Chlorodeoxyadenosine (CdA) for patients with previously untreated chronic lymphocytic leukemia (CLL). *Leukemia* 1995;9:1130-1135.
477. Saven A, Lemon RH, Kasty M, et al. 2-Chlorodeoxyadenosine activity in patients with untreated chronic lymphocytic leukemia. *J Clin Oncol* 1995;13:570-575.
478. Robak T, Bloński JZ, Kasznicki M, et al. Cladribine with or without prednisone in the treatment of previously treated and untreated B-cell chronic lymphocytic leukemia—updated results of the multicenter study of 378 patients. *Br J Haematol* 2000;108:357-368.
479. Robak T. Cladribine in the treatment of chronic lymphocytic leukemia. *Leuk Lymphoma* 2001;40:551-564.
480. Juliusson G, Christiansen I, Hansen MM, et al. Oral cladribine as a primary therapy for patients with B-cell chronic lymphocytic leukemia. *J Clin Oncol* 1996;14:2160-2166.
481. Cheson BD, Vena DA, Foss FM, et al. Neurotoxicity of purine analogs: a review. *J Clin Oncol* 1994;12:2216-2228.
482. Schroeder M. Transfusion-associated graft-versus-host disease. *Br J Haematol* 2002;117:275-287.
483. Orchard JA, Bolam S, Oscier DG. Association of myelodysplastic changes with purine analogues. *Br J Haematol* 1998;100:677-679.
484. Morrison VA, Rai KR, Peterson BL, et al. Therapy-related myeloid leukemias are observed in patients with chronic lymphocytic leukemia after treatment with fludarabine and chlorambucil: results of an intergroup study, cancer and leukemia group B 9011. *J Clin Oncol* 2002;20:3878-3884.
485. Helman DL, Byrd JC, Ales NC, et al. Fludarabine-related pulmonary toxicity: a distinct clinical entity in chronic lymphoproliferative syndromes. *Chest* 2002;122:785-790.
486. O'Brien, Kantarjian H, Estey E, et al. Lack of effect of 2-chlorodeoxyadenosine therapy in patients with chronic lymphocytic leukemia refractory to fludarabine therapy. *N Engl J Med* 1994;330:319-322.
487. Begleiter A, Pugh L, Israels LG, et al. Enhanced cytotoxicity and inhibition of DNA damage repair in irradiated murine L5178Y lymphoblasts and human chronic lymphocytic leukemia cells treated with 2'-deoxycoformycin and deoxyadenosine in vitro. *Cancer Res* 1988;48:3981-3986.
488. Begleiter A, Wang H, Verburg L, et al. In vitro cytotoxicity of 2-chlorodeoxyadenosine and chlorambucil in chronic lymphocytic leukemia. *Leukemia* 1996;10:1959-1965.

489. Yamauchi T, Nowak BJ, Keating MJ, et al. DNA repair initiated in chronic lymphocytic leukemia lymphocytes by 4-hydroperoxycyclophosphamide is inhibited by fludarabine and clofarabine. *Clin Cancer Res* 2001;7:3580-3589.
490. O'Brien SM, Kantarjian HM, Cortes J, et al. Results of the fludarabine and cyclophosphamide combination regimen in chronic lymphocytic leukemia. *J Clin Oncol* 2001;19:1414-1420.
491. Flinn IW, Byrd JC, Morrison C, et al. Fludarabine and cyclophosphamide with filgrastim support in patients with previously untreated indolent lymphoid malignancies. *Blood* 2000;96:71-75.
492. Hallek M, Schmitt B, Wilhelm M, et al. Fludarabine plus cyclophosphamide is an efficient treatment for advanced chronic lymphocytic leukaemia (CLL): results of a phase II study of the German CLL study group. *Br J Haematol* 2001;114:342-348.
493. Eichhorst BF, Busch R, Hopfinger G, et al. Fludarabine plus cyclophosphamide versus fludarabine alone in first-line therapy of younger patients with chronic lymphocytic leukemia. *Blood* 2006;107:885-891.
494. Flinn IW, Neuberg DS, Grever MR, et al. Phase III trial of fludarabine and cyclophosphamide compared with fludarabine for patients with previously untreated chronic lymphocytic leukemia: US Intergroup Trial E2997. *J Clin Oncol* 2007;25:793-798.
495. Robak T, Jamrozik K, Gora-Tybor J, et al. Comparison of cladribine plus cyclophosphamide with fludarabine plus cyclophosphamide as first-line therapy for chronic lymphocytic leukemia: a phase III randomized study by the Polish Adult Leukemia Group (PALG-CLL3 Study). *J Clin Oncol* 2010;28:1863-1869.
496. Weiss, MA, Maslak, PG, Jurcic, JG, et al. Pentostatin and cyclophosphamide: an effective new regimen in previously treated patients with chronic lymphocytic leukemia. *J Clin Oncol* 2003;21:1278-1284.
497. CLL Trialists' Collaborative Group (CLLTCG). Systematic review of purine analog treatment for chronic lymphocytic leukemia: lesson for future trials. *Haematologica* 2012;97:428-436.
498. Thornton PD, Matutes E, Bosanquet AG, et al. High dose methyl prednisolone can induce remissions in CLL patients with p53 abnormalities. *Ann Hematol* 2003;82:759-765.
499. Alduaij W, Illidge TM. The future of anti-CD20 antibodies: are we making progress? *Blood* 2011;117:2993-3001.
500. Cartron G, Trappe RU, Solal-Celigny P, et al. Interindividual variability of response to rituximab: from biological origins to individualized therapies. *Clin Cancer Res* 2011;17:19-30.
501. Ivanov A, Beers SA, Walshe CA, et al. Monoclonal antibodies directed to CD20 and HLA-DR can elicit homotypic adhesion followed by lysosome-mediated cell death in human lymphoma and leukemia cells. *J Clin Invest* 2009;119:2143-2159.
502. Alduaij W, Ivanov A, Honeychurch J, et al. Novel type II anti-CD20 monoclonal antibody (GA101) evokes homotypic adhesion and actin-dependent, lysosome-mediated cell death in B-cell malignancies. *Blood* 2011;117:4519-4529.
503. Honeychurch J, Alduaij W, Azizyan M, et al. Antibody-induced nonapoptotic cell death in human lymphoma and leukemia cells is mediated through a novel reactive oxygen species-dependent pathway. *Blood* 2012;119:3523-3533.
504. Beers S, Chan CH, James S, et al. Type II (tositumomab) anti-CD20 monoclonal antibody out performs type I (rituximab-like) reagents in B-cell depletion regardless of complement activation. *Blood* 2008;112:4170-4177.
505. McLaughlin P, Grillo-López AJ, Link BK, et al. Rituximab chimeric anti-CD20 monoclonal antibody therapy for relapsed indolent lymphoma: half of patients respond to a four-dose treatment program. *J Clin Oncol* 1998;16:2825-2833.
506. Manshouri T, Do K-A, Wang X, et al. Circulating CD20 is detectable in the plasma of patients with chronic lymphocytic leukemia and is of prognostic significance. *Blood* 2003;101:2507-2513.
507. Winkler U, Jensen M, Manzke O, et al. Cytokine release syndrome in patients with B-cell chronic lymphocytic leukemia and high lymphocyte counts after treatment with the anti-CD20 monoclonal antibody. *Blood* 1999;94: 2217-2224.
508. Huhn D, von Schilling C, Wilhelm M, et al. Rituximab therapy of patients with B-cell chronic lymphocytic leukemia. *Blood* 2001;98:1326-1331.
509. Huh YO, Keating MJ, Saffer HL, et al. Higher levels of surface CD20 expression on circulating lymphocytes compared with bone marrow and lymph nodes in B-cell chronic lymphocytic leukemia. *Am J Clin Pathol* 2001;116:437-443.

510. Byrd JC, Murphy T, Howard RS, et al. Rituximab using a thrice weekly dosing schedule in B-cell chronic lymphocytic leukemia and small lymphocytic lymphoma demonstrates clinical activity and acceptable toxicity. *J Clin Oncol* 2001;19:2153-2164.
511. O'Brien SM, Kantarjian H, Thomas DA, et al. Rituximab dose-escalation trial in chronic lymphocytic leukemia. *J Clin Oncol* 2001;19:2165-2170.
512. Beum PV, Kennedy AD, Williams ME, et al. The shaving reaction: Rituximab/CD20 complexes are removed from mantle cell lymphoma and chronic lymphocytic leukemia cells by THP-1 monocytes. *J Immunol* 2006;176: 2600-2609.
513. Williams ME, Densomre JJ, Pawluczkoysz, et al. Thrice-weekly low-dose rituximab decreases CD20 loss via shaving and promotes enhanced targeting in chronic lymphocytic leukemia. *J Immunol* 2006;177:7435-7443.
514. Wolach O, Shpilberg O, Lahav M. Neutropenia after rituximab treatment: new insights on a late complication. *Curr Opin Hematol* 2012;19:32-38.
515. Bowen DA, Call TG, Jenkins GD, et al. Methylprednisolone-rituximab is an effective salvage therapy for patients with relapsed chronic lymphocytic leukemia including those with unfavorable cytogenetic features. *Leuk Lymphoma* 2007;48:2412-2417.
516. Pilecky R, Jurgutis M, Valceckiene V, et al. Dose-dense high-dose methylprednisolone and rituximab in the treatment of relapsed or refractory high-risk chronic lymphocytic leukemia. *Leuk Lymphoma* 2011;52:1055-1065.
517. Cheson BD. Ofatumumab, a novel anti-CD20 monoclonal antibody for the treatment of B-cell malignancies. *J Clin Oncol* 2010;28:3525-3530.
518. Wierda WG, Kipps TJ, Mayer J, et al. Ofatumumab as single-agent CD20 immunotherapy in fludarabine-refractory chronic lymphocytic leukemia. *J Clin Oncol* 2010;28:1749-1755.
519. Wierda WG, Padmanabhan S, Chan GW, et al. Ofatumumab is active in patients with fludarabine-refractory CLL irrespective of prior rituximab: results from the phase II international study. *Blood* 2011;118:5126-5129.
520. Spaner DE. Oral high-dose glucocorticoids and ofatumumab in fludarabine-resistant chronic lymphocytic leukemia. *Leukemia* 2012;26:1144-1145.
521. Gribben JG, Hallek M. Rediscovering alemtuzumab: current and emerging therapeutic roles. *Br J Haematol* 2009;144:818-831.
522. Österborg A, Foà R, Bezares RF, et al. Management guidelines for the use of alemtuzumab in chronic lymphocytic leukemia. *Leukemia* 2009;23:1980-1988.

P.1928

523. Keating MJ, Flinn I, Jain V, et al. Therapeutic role of alemtuzumab (Campath-1H) in patients who have failed fludarabine: results of a large international study. *Blood* 2002;99:3554-3561.
524. O'Brien S, Ravandi F, Riehl T, et al. Valganciclovir prevents cytomegalovirus reactivation in patients receiving alemtuzumab-based therapy. *Blood* 2008;111:1816-1819.
525. Hwang Y-Y, Cheung WWW, Leung AYH, et al. Valganciclovir thrice weekly for prophylaxis against cytomegalovirus reactivation during alemtuzumab therapy. *Leukemia* 2009;23:800-801.
526. Stilgenbauer S, Zenz T, Winkler D, et al. Subcutaneous alemtuzumab in fludarabine-refractory chronic lymphocytic leukemia: clinical results of and prognostic marker analyses from the CLL2H study of the German Chronic Lymphocytic Leukemia Study Group. *J Clin Oncol* 2009;27:3994-4001.
527. Hale G, Rebello P, Brettman LR, et al. Blood concentrations of alemtuzumab and antiglobulin responses in patients with chronic lymphocytic leukemia following intravenous or subcutaneous routes of administration. *Blood* 2004;104:948-955.
528. Lundin JL, Kimby E, Björkholm M, et al. Phase II trial of subcutaneous anti-CD52 monoclonal antibody alemtuzumab (Campath-1H) as first-line treatment for patients with B-cell chronic lymphocytic leukemia (B-CLL). *Blood* 2002;100:768-773.

529. Stilgenbauer S, Dohner H. Campath-1H-induced complete remission of chronic lymphocytic leukemia despite p53 gene mutation and resistance to chemotherapy. *N Eng J Med* 2002;347:452-453.
530. Montillo M, Tedeschi A, Miguelez S, et al. Alemtuzumab as consolidation after a response to fludarabine is effective in purging residual disease in patients with chronic lymphocytic leukemia. *J Clin Oncol* 2006;24:2337-2342.
531. Wendtner CM, Ritgen M, Schweighofer CD, et al. German CLL Study Group (GCLLSG). Consolidation with alemtuzumab in patients with chronic lymphocytic leukemia (CLL) in first remission: experience on safety and efficacy within a randomized multicenter phase III trial of the German CLL Study Group (GCLLSG). *Leukemia* 2004;18:1093-1101.
532. O'Brien SM, Kantarjian HM, Thomas DA, et al. Alemtuzumab as treatment for residual disease after chemotherapy in patients with chronic lymphocytic leukemia. *Cancer* 2003;98:2657-2663.
533. Pettitt AR, Jackson R, Carruthers S, et al. Alemtuzumab in combination with methylprednisolone is a highly effective induction regimen for patients with chronic lymphocytic leukemia and deletion of TP53: final results of the National Cancer Research Institute CLL206 Trial. *J Clin Oncol* 2012;30: 1647-1655.
534. Zent CS, Call TG, Shanafelt TD, et al. Early treatment of high-risk chronic lymphocytic leukemia with alemtuzumab and rituximab. *Cancer* 2008;113: 2110-2118.
535. Byrd JC, Kipps TJ, Flinn IW, et al. Phase 1/2 study of lumiliximab combined with fludarabine, cyclophosphamide, and rituximab in patients with relapsed or refractory chronic lymphocytic leukemia. *Blood* 2010;115:489-495.
536. Chow KU, Sommerlad WD, Boehrer S, et al. Anti-CD20 antibody (IDEC-C2B8, rituximab) enhances efficacy of cytotoxic drugs on neoplastic lymphocytes in vitro: role of cytokines, complement, and caspases. *Haematologica* 2002;87: 33-43.
537. Alas S, Emmanouilides C, Bonavida B. Inhibition of interleukin 10 by rituximab results in down-regulation of bcl-2 and sensitization of B-cell non-Hodgkin's lymphoma to apoptosis. *Clin Cancer Res* 2001;7:709-723.
538. Alas S, Bonavida B, Emmanouilides C. Potentiation of fludarabine cytotoxicity on non-Hodgkin's lymphoma by pentoxifylline and rituximab. *Anticancer Res* 2000;20:2961-2966.
539. Byrd JC, Kitada S, Flinn IW, et al. The mechanism of tumor cell clearance by rituximab in vivo in patients with B-chronic lymphocytic leukemia: evidence of caspase activation and apoptosis induction. *Blood* 2002;99:1038-1043.
540. Schulz H, Klein SK, Rehwald U, et al. Phase 2 study of a combined immunochemotherapy using rituximab and fludarabine in patients with chronic lymphocytic leukemia. *Blood* 2002;100:3115-3120.
541. Byrd JC, Peterson BL, Morrison VA, et al. Randomized Phase II study of fludarabine with concurrent versus sequential treatment with rituximab in symptomatic, untreated patients with B-cell chronic lymphocytic leukemia: results from CALGB 9712. *Blood* 2003;101:6-14.
542. Byrd JC, Rai K, Peterson BL, et al. Addition of rituximab to fludarabine may prolong progression-free survival and overall survival in patients with previously untreated chronic lymphocytic leukemia: an updated retrospective comparative analysis of CALGB 9712 and CALGB 9011. *Blood* 2005;105:49-53.
543. Woyach JA, Ruppert AS, Heerema NA, et al. Chemoimmunotherapy with fludarabine and rituximab produces extended overall survival and progression-free survival in chronic lymphocytic leukemia: long-term follow-up of CALGB study 9712. *J Clin Oncol* 2011;29:1349-1355.
544. Keating MJ, O'Brien S, Albitar M, et al. Early results of a chemoimmunotherapy regimen of fludarabine, cyclophosphamide, and rituximab as initial therapy for chronic lymphocytic leukemia. *J Clin Oncol* 2005;23:4079-4088.
545. Tam CS, O'Brein S, Wierda W, et al. Long-term results of the fludarabine, cyclophosphamide, and rituximab regimen as initial therapy of chronic lymphocytic leukemia. *Blood* 2008;112:975-980.
546. Badoux XC, Keating MJ, Wang X, et al. Fludarabine, cyclophosphamide, and rituximab chemoimmunotherapy is highly effective treatment for relapsed patients with CLL. *Blood* 2011;117:3016-3024.
547. Zhou Y, Tang G, Medeiros LJ, et al. Therapy-related myeloid neoplasms following fludarabine, cyclophosphamide, and rituximab (FCR) treatment in patients with chronic lymphocytic leukemia/small lymphocytic lymphoma. *Mod Pathol* 2012;25:237-245.
548. Bosch F, Abrisqueta P, Villamor N, et al. Rituximab, fludarabine, cyclophosphamide, and mitoxantrone: a new, highly active chemoimmunotherapy regimen for chronic lymphocytic leukemia. *J Clin Oncol* 2012;27: 4578-4584.

549. Foon KA, Boyiadzis M, Land SR, et al. Chemoimmunotherapy with low-dose fludarabine and cyclophosphamide and high dose rituximab in previously untreated patients with chronic lymphocytic leukemia. *J Clin Oncol* 2009;27:498-503.
550. Kay, NE, Geyer SM, Call TG, et al. Combination chemoimmunotherapy with pentostatin, cyclophosphamide, and rituximab shows significant clinical activity with low accompanying toxicity in previously untreated B chronic lymphocytic leukemia. *Blood* 2007;109:405-411.
551. Kay, NE, Wu, W, Kabat B, et al. Pentostatin and rituximab therapy for previously untreated patients with B-cell chronic lymphocytic leukemia. *Cancer* 2010;116:2180-2187.
552. Fischer K, Cramer P, Busch R, et al. Bendamustine in combination with rituximab for previously untreated patients with chronic lymphocytic leukemia: a multicenter phase II trial of the German Chronic Lymphocytic Leukemia Study Group. *J Clin Oncol*. Epub 2012 Aug 6.
553. Fischer K, Cramer P, Busch R, et al. Bendamustine combined with rituximab in patients with relapsed and/or refractory chronic lymphocytic leukemia: a multicenter phase II trial of the German Chronic Lymphocytic Leukemia Study Group. *J Clin Oncol* 2011;29:3559-3566.
554. Wierda WG, Kipps TJ, Dürig J, et al. Chemoimmunotherapy with O-FC in previously untreated patients with chronic lymphocytic leukemia. *Blood* 2011;117:6450-6458.
555. Kennedy B, Rawstron A, Carter C, et al. Campath-1H and fludarabine in combination are highly active in refractory chronic lymphocytic leukemia. *Blood* 2002;99:2245-2247.
556. Sayala H, Moreton P, Jones RA, et al. Final report of the UKCLL02 trial: a phase II study of subcutaneous alemtuzumab plus fludarabine in patients with fludarabine refractory CLL (on behalf of the NCRI CLL trials subgroup). *Blood* 2006;108:Abstract 34.
557. Elter T, Borchmann P, Schulz H, et al. Fludarabine in combination with alemtuzumab is effective and feasible in patients with relapsed or refractory B-cell chronic lymphocytic leukemia: results of a Phase II trial. *J Clin Oncol* 2005;23:7024-7031.
558. Elter T, Gercheva-Kyuchukova L, Pyllypenko H, et al. Fludarabine plus alemtuzumab versus fludarabine alone in patients with previously treated chronic lymphocytic leukaemia: a randomised phase 3 trial. *Lancet Oncol* 2011;12:1204-1213.
559. Cencini E, Sozzi E, Sicuranza A, et al. A pilot monocentric analysis of efficacy and safety of fludarabine-campath combination (flucam) as first line treatment in elderly patients with chronic lymphocytic leukaemia and TP53 dysfunction. *Br J Haematol* 2011;154:271-286.
560. Elter J, James R, Busch R, et al. Fludarabine and cyclophosphamide in combination with alemtuzumab (FCCam) in patients with primary high-risk, relapsed or refractory chronic lymphocytic leukemia. *Leukemia*. Epub 2012 May 15.
561. Lepretre S, Aurrant T, Mahé B, et al. Excess mortality after treatment with fludarabine and cyclophosphamide in combination with alemtuzumab in previously untreated patients with chronic lymphocytic leukemia in a randomized phase 3 trial. *Blood* 2012;119:5104-5110.
562. Parikh SA, Keating MJ, O'Brien S, et al. Frontline chemoimmunotherapy with fludarabine, cyclophosphamide, alemtuzumab, and rituximab for high-risk chronic lymphocytic leukemia. *Blood* 2011;118:2062-2068.
563. Badoux XC, Keating MJ, Wang X, et al. Cyclophosphamide, fludarabine, alemtuzumab, and rituximab as salvage therapy for heavily pretreated patients with chronic lymphocytic leukemia. *Blood* 2011;118:2085-2093.
564. Brown JR. The treatment of relapsed refractory chronic lymphocytic leukemia. *Hematology (Am Soc Hematol Educ Program)* 2011;2011:110-118.
565. Woyach JA, Lozanski G, Ruppert AS, et al. Outcome of patients with relapsed or refractory chronic lymphocytic leukemia treated with flavopiridol: impact of genetic features. *Leukemia* 2012;26:1442-1444.
566. Mahoney E, Lucas DM, Gupta SV, et al. ER stress and autophagy: new discoveries in the mechanism of action and drug resistance of the cyclin-dependent kinase inhibitor flavopiridol. *Blood* 2012;120:1262-1273.
567. Ferrajoli A, Lee BN, Schlette EJ, et al. Lenalidomide induces complete and partial remission in patients with relapsed and refractory chronic lymphocytic leukemia. *Blood* 2008;111:5291-5297.
568. Wendtner C-M, Hillmen P, Mahadevan D, et al. Final results of a multicenter phase 1 study of lenalidomide in patients with relapsed or refractory chronic lymphocytic leukemia. *Leuk Lymphoma* 2012;53:417-423.

569. Chen CI, Bergsagel PL, Paul H, et al. Single-agent lenalidomide in the treatment of previously untreated chronic lymphocytic leukemia. *J Clin Oncol* 2011;29:1175-1181.
570. Badoux XC, Keating MJ, Wen S, et al. Lenalidomide as initial therapy of elderly patients with chronic lymphocytic leukemia. *Blood* 2011;118:3489-3498.
571. de Rooij MF, Kuil A, Geest CR, et al. The clinically active BTK inhibitor PCI-32765 targets B-cell receptor- and chemokine-controlled adhesion and migration in chronic lymphocytic leukemia. *Blood* 2012;119:2590-2594.
572. Lannutti BJ, Meadows SA, Herman SEM, et al. CAL-101, a p110 selective phosphatidylinositol-3-kinase inhibitor for the treatment of B-cell malignancies, inhibits PI3K signaling and cellular viability. *Blood* 2011;117:591-594.
573. Zenz T, Gribben JG, Hallek M, et al. Risk categories and refractory CLL in the era of chemoimmunotherapy. *Blood* 2012;119:4101-4107.
574. Motta M, Wierda WG, Ferrajoli A. Chronic lymphocytic leukemia. Treatment options for patients with refractory disease. *Cancer* 2009;115:3830-3841.
575. Dreger P, Corradini P, Kimby E, et al. Indications for allogeneic stem cell transplantation in chronic lymphocytic leukemia: the EBMT transplant consensus. *Leukemia* 2007;21:12-17.
576. Delgado J, Milligan DW, Dreger P. Allogeneic hematopoietic cell transplantation for chronic lymphocytic leukemia: ready for prime time? *Blood* 2009;114:2581-2588.
577. Kharfan-Dabaja, MA, Bazarbachi A. Hematopoietic stem cell allografting for chronic lymphocytic leukemia: a focus on reduced-intensity conditioning regimens. *Cancer Control* 2012;19:68-75.
578. Dreger P, Stilgenbauer S, Benner A, et al. The prognostic impact of autologous stem cell transplantation in patients with chronic lymphocytic leukemia: a risk-matched analysis based on the VH gene mutational status. *Blood* 2004;103:2850-2858.
579. Milligan DW, Fernandes S, Dasgupta R, et al. Results of the MRC pilot study show autografting for younger patients with chronic lymphocytic leukemia is safe and achieves a high percentage of molecular responses. *Blood* 2005;105:397-404.
580. Sutton L, Chevret S, Tournilhac O, et al. Autologous stem cell transplantation as a first-line treatment strategy for chronic lymphocytic leukemia: a multicenter, randomized, controlled trial from the SFGM-TC and GFLLC. *Blood* 2011;117:6109-6119.
581. Michallet M, Dreger P, Sutton L, et al. Autologous hematopoietic stem cell transplantation in chronic lymphocytic leukemia: results of the European intergroup randomized trial comparing autografting versus observation. *Blood* 2011;117:1561-1521.
582. Dreger P, Döhner H, McClanahan F, et al. German CLL Study Group. Early autologous stem cell transplantation for chronic lymphocytic leukemia: long-term follow-up of the German CLL Study Group CLL3 trial. *Blood* 2012;119:4851-4859.
583. Milligan DW, Kochethu G, Dearden C, et al. High incidence of myelodysplasia and secondary leukaemia in the UK Medical Research Council Pilot of autografting in chronic lymphocytic leukaemia. *Br J Haematol* 2006;133:173-175.
584. Porter DL, Levine BL, Kalos M, et al. Chimeric antigen receptor-modified T cells in chronic lymphoid leukemia. *N Engl J Med* 2011;365:725-733.
585. Kochenderfer JN, Dudley ME, Feldman SA, et al. B-cell depletion and remissions of malignancy along with cytokine-associated toxicity in a clinical trial of anti-CD19 chimeric-antigen-receptor-transduced T cells. *Blood* 2012;22:2709-2720.
586. Rondon G, Giralt S, Huh Y, et al. Graft-versus-leukemia effect after allogeneic bone marrow transplantation for chronic lymphocytic leukemia. *Bone Marrow Transplant* 1996;18:669-672.
587. Toze CL, Dalal CB, Nevill TJ, et al. Allogeneic haematopoietic stem cell transplantation for chronic lymphocytic leukaemia: outcome in a 20-year cohort. *Br J Haematol* 2012;158:174-185.
588. Gribben JG, Zahrieh D, Stephans K, et al. Autologous and allogeneic stem cell transplantations for poor-risk chronic lymphocytic leukemia. *Blood* 2005;106:4389-4396.
589. Khouri IF, Bassett R, Poindexter N, et al. Nonmyeloablative allogeneic stem cell transplantation in relapsed/refractory chronic lymphocytic leukemia: long-term follow-up, prognostic factors, and effect of human leukocyte histocompatibility antigen subtype on outcome. *Cancer* 2011;117:4679-4688.

590. Brown JR, Kim HT, Armand P et al. Long-term follow-up of reduced-intensity allogeneic stem cell transplantation for chronic lymphocytic leukemia: prognostic model to predict outcome. *Leukemia*. 2013;27:362-369.
591. Dreger P, Brand R, Milligan D, et al. Reduced-intensity conditioning lowers treatment-related mortality of allogeneic stem cell transplantation for chronic lymphocytic leukemia: a population-matched analysis. *Leukemia* 2005;19:1029-1033.
592. Dreger P, Döhner H, Ritgen M, et al. Allogeneic stem cell transplantation provides durable disease control in poor-risk chronic lymphocytic leukemia: long-term clinical and MRD results of the German CLL Study Group CLL3X trial. *Blood* 2010;116:2438-2447.
593. Michallet M, Sobh M, Milligan D, et al. The impact of HLA matching on long-term transplant outcome after allogeneic hematopoietic stem cell transplantation for CLL: a retrospective study from the EBMT registry. *Leukemia* 2010;24:1725-1731.
594. Schetelig J, van Biezen A, Brand R, et al. Allogeneic hematopoietic stem-cell transplantation for chronic lymphocytic leukemia with 17p deletion: a retrospective European Group for Blood and Marrow Transplantation analysis. *J Clin Oncol* 2008;26:5094-5100.
595. Chakraverty R, Orti G, Roughton M, et al. Impact of in vivo alemtuzumab dose before reduced intensity conditioning and HLA-identical sibling stem cell transplantation: pharmacokinetics, GVHD, and immune reconstitution. *Blood* 2010;116:3080-3088.
596. Perz JB, Ritgen M, Moos M, et al. Occurrence of donor-derived CLL 8 years after sibling donor SCT for CML. *Bone Marrow Transplant* 2008;42:687-688.
597. Molica S, Mauro FR, Molica M, et al. Monoclonal B-cell lymphocytosis: a reappraisal of its clinical implications. *Leuk Lymphoma* 2012;53:1660-1665.
598. Del Giudice I, Mauro FR, De Propriis MS, et al. Identification of monoclonal B-cell lymphocytosis among sibling transplant donors for chronic lymphocytic leukemia patients. *Blood* 2009;114:2848-2849.
599. Sorrow ML, Storer BE, Sandmaier BM, et al. Five-year follow-up of patients with advanced chronic lymphocytic leukemia treated with allogeneic hematopoietic cell transplantation after nonmyeloablative conditioning. *J Clin Oncol* 2008;26:4912-4920.
600. Delgado J, Pillai S, Phillips N, et al. Does reduced-intensity allogeneic transplantation confer a survival advantage to patients with poor prognosis chronic lymphocytic leukaemia? A case-control retrospective analysis. *Ann Oncol* 2009;20:2007-2012.
601. Kharfan-Dabaja MA, Pidala J, Kumar A, et al. Comparing efficacy of reduced-toxicity allogeneic hematopoietic cell transplantation with conventional chemo-(immuno) therapy in patients with relapsed or refractory CLL: a Markov decision analysis. *Bone Marrow Transplant* 2012;47:1164-1170.
602. Weinmann M, Becker G, Einsele H, et al. Clinical indications and biological mechanisms of splenic irradiation in chronic leukaemias and myeloproliferative disorders. *Radiother Oncol* 2001;58:235-246.
603. Van Mook WN, Fickers MM, Verschueren TA. Clinical and immunological evaluation of primary splenic irradiation in chronic lymphocytic leukemia: a study of 24 cases. *Ann Hematol* 2001;80:216-223.
604. Guiney MJ, Liew KH, Quong GG, et al. A study of splenic irradiation in chronic lymphocytic leukemia. *Int J Radiat Oncol Biol Phys* 1989;16:225-229.
605. Catovsky D, Fooks J, Richards S. The UK Medical Research Council CLL trials 1 and 2. *Nouv Rev Fr Hematol* 1988;30:423-427.
606. Roncadin M, Arcicasa M, Trovo MG, et al. Splenic irradiation in chronic lymphocytic leukemia. A ten years experience in a single institution. *Cancer* 1987;60:2624-2628.
607. De Rossi G, Biagnin C, Lopez M, et al. Treatment by splenic irradiation in 22 chronic lymphocytic leukemia patients. *Tumori* 1982;68:511-514.
608. McCann SR, Whelan CA, Breslin B, et al. Lymphocyte sub-populations following splenic irradiation in patients with chronic lymphocytic leukemia. *Br J Haematol* 1982;50:225-229.
609. Richards F Jr, Spurr CL, Ferree C, et al. The control of chronic lymphocytic leukemia with mediastinal irradiation. *Am J Med* 1978;64:947-954.

610. Sawitsky A, Rai KR, Aral I, et al. Mediastinal irradiation for chronic lymphocytic leukemia. *Am J Med* 1976;61:892-896.
611. Field EO, Dawson KB, Peckham MJ, et al. The response of chronic lymphocytic leukemia to treatment by extracorporeal irradiation of the blood, assessed by isotope labeling procedures. *Blood* 1970;36:87-97.
612. Storb R, Epstein RB, Buckner CD, et al. Treatment of chronic lymphocytic leukemia by extracorporeal irradiation. *Blood* 1968;31:490-502.
613. Jacobs P, King HS. A randomized prospective comparison of chemotherapy to total body irradiation as initial treatment for the indolent lymphoproliferative diseases. *Blood* 1987;69:1642-1646.
614. Johnson RE. Total body irradiation of chronic lymphocytic leukemia. Relationship between therapeutic response and prognosis. *Cancer* 1976;37: 2691-2696.
615. Rubin P, Bennet JM, Begg C, et al. The comparison of total body irradiation versus chlorambucil and prednisone for remission induction of active chronic lymphocytic leukemia: an ECOG study. Part I: total body irradiation-response and toxicity. *Int J Radiat Oncol Biol Phys* 1981;7:1623-1632.
616. Johnson RE. Treatment of chronic lymphocytic leukemia by total body irradiation alone and combined with chemotherapy. *Int J Radiat Oncol Biol Phys* 1979;5:159-164.
617. Roncadin M, Arcicasa M, Zagonel V, et al. Total body irradiation and prednimustine in chronic lymphocytic leukemia and low grade non-Hodgkin's lymphomas: a 9-year experience at a single institute. *Cancer* 1994;74:978-984.
618. Leporrier M, Reman O, Troussard X, et al. Double hemibody irradiation with GM-CSF as salvage therapy for refractory chronic lymphocytic leukemia. *Leuk Lymphoma* 1994;16:121-124.
619. Decaudin D, Delic J, Dumont J, et al. Clinical efficacy of irradiation in CLL patients: predictive value of in vitro radio-induced apoptosis. *Leuk Lymphoma* 2002;43:827-829.
620. Bessler H, Notti I, Cohen AM, et al. Inhibition of leukemic cell proliferation by factor(s) released from irradiated lymphocytes of B-chronic lymphocytic leukemia patients. *Am J Hematol* 1994;46:65-71.
621. Seymour JF, Cusack JD, Lerner SA, et al. Case/control study of the role of splenectomy in chronic lymphocytic leukemia. *J Clin Oncol* 1997;15:52-60.
622. Ferrant A, Michaux J-L, Sokal G. Splenectomy in advanced chronic lymphocytic leukemia. *Cancer* 1986;58:2130-2135.
623. Majumdar G, Singh AK. Role of splenectomy in chronic lymphocytic leukemia with massive splenomegaly and cytopenia. *Leuk Lymphoma* 1992;7:131-134.
624. Neal TF, Tefferi A, Witzig TE, et al. Splenectomy in advanced chronic lymphocytic leukemia: a single institution experience with 50 patients. *Am J Med* 1992;93:435-440.
625. Hill J, Walsh RM, McHam S, et al. Laparoscopic splenectomy for autoimmune hemolytic anemia in patients with chronic lymphocytic leukemia: a cases series and review of the literature. *Am J Hematol* 2004;75:134-138.
626. Itala M, Helenius H, Nikoskelainen J, et al. Infections and serum IgG levels in patients with chronic lymphocytic leukemia. *Eur J Haematol* 1992;48: 266-270.
627. Morra E, Nosari A, Montillo M. Infectious complications in chronic lymphocytic leukemia. *Hematol Cell Ther* 1999;41:145-151.
628. Cooperative Group for the study of immunoglobulin in chronic lymphocytic leukemia: intravenous immunoglobulin for the prevention of infection in chronic lymphocytic leukemia. A randomized control trial. *N Engl J Med* 1988;319:902-907.
629. Weeks JC, Tierney MR, Weinstein MC. Cost effectiveness of prophylactic intravenous immune globulin in chronic lymphocytic leukemia. *N Engl J Med* 1991;325:81-86.
630. Chapel H, Dicato M, Gamm H, et al. Immunoglobulin replacement in patients with chronic lymphocytic leukaemia: a comparison of two dose regimens. *Br J Haematol* 1994;88:209-212.
631. Jurlander J, Geisler CH, Hansen MM. Treatment of hypogammaglobulinaemia in chronic lymphocytic leukaemia by low-dose intravenous gammaglobulin. *Eur J Haematol* 1994;53:114-118.
632. Molica S, Musto P, Chiurazzu F, et al. Prophylaxis against infections with low-dose intravenous immunoglobulins (IVIg) in chronic lymphocytic leukemia. Results of a crossover study. *Haematologica* 1996;81:121-126.

633. Dearden C. Disease-specific complications of chronic lymphocytic leukemia. *Hematology (Am Soc Hematol Educ Program)* 2008;450-456.
634. Itala M, Pelliniemi TT, Remes S, et al. Long-term treatment with GM-CSF in patients with chronic lymphocytic leukemia and recurrent neutropenic infections. *Leuk Lymphoma* 1998;32:165-174.
635. de Nully Brown P, Hansen MM. GM-CSF treatment in patients with B-chronic lymphocytic leukemia. *Leuk Lymphoma* 1999;32:365-368.
636. O'Brien S, Kantarjian H, Beran M, et al. Fludarabine and granulocyte colony-stimulating factor (G-CSF) in patients with chronic lymphocytic leukemia. *Leukemia* 1997;11:1631-1635.
637. Kovacs JA, Gill VJ, Meshnick S, et al. New insights into transmission, diagnosis, and drug treatment of *Pneumocystis carinii* pneumonia. *JAMA* 2001;286:2450-2460.
638. Pfeilschifter J, Diel IJ. Osteoporosis due to cancer treatment: pathogenesis and management. *J Clin Oncol* 2000;18:1570-1593.
639. Jeffriess LC. Transfusion therapy in autoimmune hemolytic anemia. *Hematol Oncol Clin North Am* 1994;8:1087-1104.
640. Flores G, Cunningham-Rundels C, Newland AC, et al. Efficacy of intravenous immunoglobulin in the treatment of autoimmune hemolytic anemia: results in 73 patients. *Am J Haematol* 1993;44:237-242.
641. Chikkappa G, Pasquale D, Zarrabi MH, et al. Cyclosporine and prednisone therapy for pure red cell aplasia in patients with chronic lymphocytic leukemia. *Am J Hematol* 1992;41:5-12.
642. Yamada O, Yun-Hua W, Motoji T, et al. Clonal T-cell proliferation causing pure red cell aplasia in chronic B-cell lymphocytic leukaemia: successful treatment with cyclosporine following in vitro abrogation of erythroid colony-suppressing activity. *Br J Haematol* 1998;101:335-337.
643. Cortes J, O'Brien S, Loscetales J, et al. Cyclosporin A for the treatment of cytopenia associated with chronic lymphocytic leukemia. *Cancer* 2001;92: 2016-2021.
644. Zaja F, Vianelli N, Sperotto A, et al. Anti-CD20 therapy for chronic lymphocytic leukemia-associated autoimmune diseases. *Leuk Lymphoma* 2003;44:1951-1955.
645. Cabrera J, Penalver FJ, Millan I, et al. Mabthera (Rituximab) in the treatment of 92 patients with refractory immune thrombocytopenic purpura. *Blood* 2004;104:Abstract 571.
646. D'Arena G, Laurenti L, Capalbo S, et al. Rituximab-based therapy for chronic lymphocytic leukemia-associated autoimmune hemolytic anemia. *Am J Hematol* 2006;81:598-602.
647. Ghazal H. Successful treatment of pure red cell aplasia with rituximab in patients with chronic lymphocytic leukemia. *Blood* 2002;99:1092-1094.
648. Kaufman M, Limaye SA, Driscoll N, et al. A combination of rituximab, cyclophosphamide and dexamethasone effectively treats immune cytopenias of chronic lymphocytic leukemia. *Leuk Lymphoma* 2009;50:893-899.
649. Rossignol J, Michaller AS, Oberic L, et al. Rituximab-cyclophosphamidedexamethasone combination in the managements of autoimmune cytopenias associated with chronic lymphocytic leukemia. *Leukemia* 2011;25: 473-478.
650. Bowen DA, Call TG, Shanafelt T, et al. Treatment of autoimmune cytopenia complicating progressive chronic lymphocytic leukemia/small lymphocytic lymphoma with rituximab, cyclophosphamide, vincristine, and prednisone. *Leuk Lymphoma* 2010;51:620-627.
651. Karlsson C, Hansson L, Gelsing F, et al. Treatment of severe refractory autoimmune hemolytic anemia in B-cell chronic lymphocytic leukemia with alemtuzumab (humanized CD52 monoclonal antibody). *Leukemia* 2007;21: 511-514.
652. Koehrer S, Keating MJ, Wierda WG, et al. Eltrombopag, a second-generation thrombopoietin receptor agonist, for chronic lymphocytic leukemia-associated ITP. *Leukemia* 2010;25:1096-1098.
653. Tsimberidou A-M, Keating MJ. Richter syndrome. Biology, incidence, and therapeutic strategies. *Cancer* 2005;103:216-228.
654. Tsimberidou A-M, Keating MJ, Wierda WG. Richter's transformation in chronic lymphocytic leukemia. *Curr Hematol Malignancy Rep* 2007;2:265-271.

655. De Paoli L, Fangazio M, Gaidano G, et al. Predictive markers and driving factors behind Richter syndrome development. *Expert Rev Anticancer Ther* 2011;11:433-442.
656. Timar B, Fülöp Z, Csernus B, et al. Relationship between the mutational status of V_H genes and pathogenesis of diffuse large B-cell lymphoma in Richter's syndrome. *Leukemia* 2004;18:326-330.
657. Maddocks-Christianson K, Slager SL, Zent CS, et al. Risk factors for development of a second lymphoid malignancy in patients with chronic lymphocytic leukaemia. *Br J Haematol* 2007;139:398-404.
658. Tsimberidou A-M, O'Brien S, Khouri S, et al. Clinical outcomes and prognostic factors in patients with Richter's syndrome treated with chemotherapy or chemoimmunotherapy with or without stem-cell transplantation. *J Clin Oncol* 2006;24:2343-2351.
659. Rossi D, Spina V, Deambrogi C, et al. The genetics of Richter syndrome reveals disease heterogeneity and predicts survival after transformation. *Blood* 2011;117:3391-3401.
660. Rossi D, Cerri M, Capello D, et al. Biological and clinical risk factors of chronic lymphocytic leukaemia transformation to Richter syndrome. *Br J Haematol* 2008;142:202-215.
661. Bruzzi JF, Macapinlac H, Tsimberidou AM, et al. Detection of Richter's transformation of chronic lymphocytic leukemia by PET/CT. *J Nucl Med* 2006;47:1267-1273.
662. Bockorny, Codreanu I, Dasanu CA. Hodgkin lymphoma as Richter transformation in chronic lymphocytic leukaemia: a retrospective analysis of world literature. *Br J Haematol* 2012;156:50-66.
663. Tsimberidou A-M, O'Brien S, Kantarjian HM, et al. Hodgkin transformation of chronic lymphocytic leukemia. The M.D. Anderson Cancer Center experience. *Cancer* 2006;107:1294-1302.
664. Huh YO, Lin KI, Vega F, et al. MYC translocation in chronic lymphocytic leukaemia is associated with increased prolymphocytes and a poor prognosis. *Br J Haematol* 2008;142:36-44.
665. Cao F, Amato D, Wang C. Concurrent chronic lymphocytic leukemia and prolymphocytic leukemia derived from two separate B-cell clones. *Am J Hematol* 2011;86:782.
666. Brouet JC, Femand JP, Laurent G, et al. The association of chronic lymphocytic leukemia and multiple myeloma: a study of eleven patients. *Br J Haematol* 1985;59:55-66.
667. Srinivasan S, Schiffer CA. Concurrent B-cell chronic lymphocytic leukemia and multiple myeloma treated successfully with lenalidomide. *Leuk Res* 2009;33:561-564.
668. Zarrabi MH, Grunwalk HW, Rosner F. Chronic lymphocytic leukemia terminating in acute leukemia. *Arch Intern Med* 1977;137:1059-1064.
669. Archimbaud E, Charrin C, Gentilhomme O, et al. Initial clonal acute lymphoblastic transformation of chronic lymphocytic leukemia with (11;14) and (8;12) chromosome translocations and acquired homozygosity. *Acta Haematol* 1988;79:168-173.
670. Mohamed AN, Compean R, Dan ME, et al. Clonal evolution of chronic lymphocytic leukemia to acute lymphoblastic leukemia. *Cancer Genet Cytogenet* 1996;86:143-146.
671. Demiroglu H, Dundar S. T-cell acute lymphoblastic leukaemic transformation of B-cell chronic lymphocytic leukaemia. *Eur J Haematol* 1996;56:184-185.
672. Preudhomme C, Lepelley P, Lovi V, et al. T-cell acute lymphoblastic leukemia occurring in the course of B cell chronic lymphocytic leukemia: a case report. *Leuk Lymphoma* 1995;18:361-364.
673. Morton LM, Curtis RE, Linet MS, et al. Second malignancy risks after non-Hodgkin's lymphoma and chronic lymphocytic leukemia: differences by lymphoma subtypes. *J Clin Oncol* 2010;28:4935-4944.
674. Molica S. Second neoplasms in chronic lymphocytic leukemia: incidence and pathogenesis with emphasis on the role of different therapies. *Leuk Lymphoma* 2005;46:39-54.
675. Tsimberidou A-M, Wen S, McLaughlin P, et al. Other malignancies in chronic lymphocytic leukemia/small lymphocytic lymphoma. *J Clin Oncol* 2009;27:904-910.
676. Manusow D, Weinerman BH. Subsequent neoplasia in chronic lymphocytic leukemia. *JAMA* 1975;223:267-269.

677. Beiggi S, Lambert PJ, Pitz MW, et al. Risk of second malignancies in patients with chronic lymphocytic leukemia: a population based Canadian study. *Am Assoc Cancer Res* 2012;Abstract #5505.
678. Royle JA, Baade PD, Joske D, et al. Second cancer incidence and cancer mortality among chronic lymphocytic leukaemia patients: a population-based study. *Br J Cancer* 2011;105:1076-1081.
679. Tadmor T, Aviv A, Polliack A. Merkel cell carcinoma, chronic lymphocytic leukemia and other lymphoproliferative disorders: an old bond with possible new viral ties. *Ann Oncol* 2011;22:250-256.
680. Brewer JD, Shanafelt TD, Otley CC, et al. Chronic lymphocytic leukemia is associated with decreased survival of patients with malignant melanoma and Merkel cell carcinoma in a SEER population-based study. *J Clin Oncol* 2012;30:843-849.
681. Parekh K, Rusch V, Kris M. The clinical course of lung carcinoma in patients with chronic lymphocytic leukemia. *Cancer* 1999;86:1720-1723.
682. Laurenti L, Tarnani M, Nichele I, et al. The coexistence of chronic lymphocytic leukemia and myeloproliferative neoplasms: a retrospective multicentric GIMEMA experience. *Am J Hematol* 2011;86:1007-1012.

Chapter 91 Hairy Cell Leukemia

> Table of Contents > Part VII - Hematologic Malignancies > Section 4 - Lymphoproliferative Disorders > Chapter 91 - Hairy Cell Leukemia

Chapter 91

Hairy Cell Leukemia

James B. Johnston

Michael R. Grever

Hairy cell leukemia (HCL), or leukemic reticuloendotheliosis, is a chronic B-cell disorder that was initially described by Bouroncle et al. in 1958.¹ The disease is characterized by the presence of typical hairy cells in the peripheral blood and marrow, pancytopenia, and a variable degree of splenomegaly.^{1, 2, 3, 5, 6} The disease has always aroused interest, initially over the unique morphologic and clinical features of this disorder. The tumor cells are B-cells that typically express CD11c, CD25, CD103, and CD123, are usually IgVH-mutated and are unique memory B-cells in expressing multiple immunoglobulin (Ig) isotypes. More recently, it has been demonstrated that most hairy cells contain a mutated active form of the BRAF gene (V600E) which may be used as a diagnostic tool and a potential target for therapy. Most cases of HCL are very sensitive to interferon (IFN)- α and the nucleoside analogs pentostatin (2'-deoxycoformycin, dCF) and cladribine (2-chlorodeoxyadenosine CdA).^{5, 6} Less responsive patients generally respond to monoclonal antibodies, such as rituximab (against CD20) or to immunotoxin-labeled antibodies to CD22 or CD25. Prior to the development of these treatments the median survival for HCL patients was 4 years whereas now the survival of these patients is no different from an age- and sex-matched control population.

INCIDENCE AND ETIOLOGY

HCL is a rare disorder, accounting for 2% of all leukemias, and occurs more frequently in men, with an incidence in the United States of 2.9 per million per year for men and 0.6 per million per year for women.^{5, 7} The etiology of HCL is unknown. Several case-controlled studies have identified possible relationships to radiation exposure,^{7, 8} exposure to benzene,⁹ to farm animals, and to commercial herbicides and pesticides.^{9, 10} A familial predisposition is suggested by reports of the disorder in 15 families where HCL occurred among first-degree relatives. In these families, disease is usually associated with the following haplotypes; A2, B7, and Bw4/6; A1/3 and B7/8; A2, B51, and DR52/53.¹¹

PATHOGENESIS

Immunologic,^{12, 13, 14} molecular genetic,^{15, 16, 17, 18, 19, 20, 21} chromosomal,^{22, 23} and gene expression²⁴ studies have demonstrated that the hairy cell is of B-cell origin. Although some T-cell features have been reported,^{25, 26, 27, 28, 29, 30} including two cases in which the retrovirus human T-cell leukemia virus type II was isolated,^{31, 32} no instances of T-cell receptor gene rearrangements have been found. Fluctuations in the expression of T- and B-cell markers have been demonstrated both in vivo and under various in vitro culture conditions.^{33, 34, 35, 36} In most instances, the alteration noted was between a surface-immunoglobulin-positive (SIg⁺) CD2⁻ phenotype and a SIg⁻CD2⁺ phenotype. Other B-cell antigens, however, such as CD20, were retained, even with the loss of SIg and the appearance of CD2.³⁵

The cell of origin of the hairy cell has been a subject of much debate and has been discussed in several recent reviews.^{37, 38, 39} Gene expression profiling has demonstrated that the hairy cell is most similar to a memory B-cell, although it differs in that the hairy cell has increased expression of adhesion and chemokine receptor genes.²⁴ The profile is extremely homogeneous, quite different from other lymphoid malignancies, and the abnormal expression of specific genes explains the properties of this disease which include unique cell structure, marrow fibrosis, marrow suppression, and the tendency of tumor cells to home to spleen and marrow, rather than to lymph nodes. As hairy cells do not express CD27, which is normally expressed on memory B-cells, it has been suggested that the normal counterpart is a memory cell which lacks CD27 but has somatic mutations of the the IgVH genes.⁴⁰ However, the profile also demonstrated expression of many genes associated with macrophages suggesting that these cells are unique in having phagocytic properties.²⁴ Consistent with being a memory B-cell, the majority of cases with HCL show mutations of the variable chain of the Ig gene, demonstrating that the hairy cell has passed through the germinal center (Fig. 91.1).^{15, 16, 17, 18, 19, 20, 21, 41} However, 10% to 20% of cases have unmutated IgVH and in general these patients have very poor prognosis and are resistant to chemotherapy.^{17, 18} The IgVH gene usage is shown in Figure 91.2 and demonstrates that in classical HCL IgVH 3-23 (17%), 3-30 (8%), and 4-34 (7%) are most commonly used. IgVH 1-69, 3-11, 3-48, and 4-39 are each used in 5% of cases. The major difference between the HCL variant and classical HCL, is the usage of IgVH V4-34, which is present in 54% of variant cases but only 17% of classical cases.²⁰ The majority (94%) of IgVH4-34 cases are unmutated. As expected, the IgVH is more likely to be unmutated in the HCL variant (54%) as compared to classical HCL (17%). It is interesting that, as discussed later, patients with unmutated IgVH or those that use IgVH4-34 have more aggressive and drug-resistant disease.^{17, 18} The patterns of IgVH gene family usage and the incidence of IgVH mutations is different in HCL and chronic lymphocytic leukemia (CLL).²⁰ In CLL, the most commonly used IgVH genes are IgVH1-69, 3-21, 3-30, 4-34, and 1-02 and whereas most IgVH 1-69 cases are unmutated, most IgVH4-34 cases are mutated.⁴² Overall, approximately 60% of CLL cases have mutated IgVH and 40% are unmutated.

Hairy cells are unique in expressing multiple Ig isotypes that are related to RNA splicing. Thus, individual hairy cells may express IgG alone or in combination with IgM and/or IgD and/or IgA.^{15, 16, 41} Similarly, IgVH mutational analysis has demonstrated intraclonal variation in gene expression, both in the IgVH unmutated and mutated varieties. These studies have suggested that the hairy cell is in maturation arrest before deletional recombination within the heavy chain locus.

Cytogenetics

Cytogenetic studies have been difficult to carry out in HCL, because the number of circulating hairy cells is small, and attempts at marrow aspiration are usually unsuccessful. In addition, until recently it has been difficult to induce hairy cells to proliferate and to obtain hairy cells in metaphase. In early reports, the abnormalities observed in HCL tended to be nonclonal.^{43, 44} However, more recently, 15 of 19 patients were found to have an abnormal karyotype, and a 14q⁺ marker involving the breakpoint q32 at the Ig heavy chain locus was the most frequent clonal abnormality.²² Abnormalities involving the short arm of chromosome 12 have been observed in four patients.¹³ Haglund et al.⁴⁵ observed deletions and inversions in 67% of patients. Clonal abnormalities of chromosome 5 were found in 40% of cases (most commonly trisomy 5, pericentric inversions, and interstitial deletions involving 5q13). The frequency with which these abnormalities occur is unique and is not found in other B-cell malignancies. Abnormalities in 5q13 thus occur in one third of patients, and subsequent studies have identified three expressed sequences as candidates for a putative tumor-suppressor gene at 5q13.3.⁴⁶ Cytogenetic analysis has been carried out using monoclonal antibodies to CD40, because this

P.1930

appears to be the most effective way of inducing hairy cell proliferation.⁴⁷ This technique allowed cytogenetic analysis in 42 of 43 cases and demonstrated that clonal abnormalities were present in 19% of cases and involved numeric or structural abnormalities in chromosomes 5, 7, and 14. In contrast, abnormalities of chromosome 5 were not observed in the HCL variant, and translocations more frequently involved either chromosome 2 or 14.⁴⁸

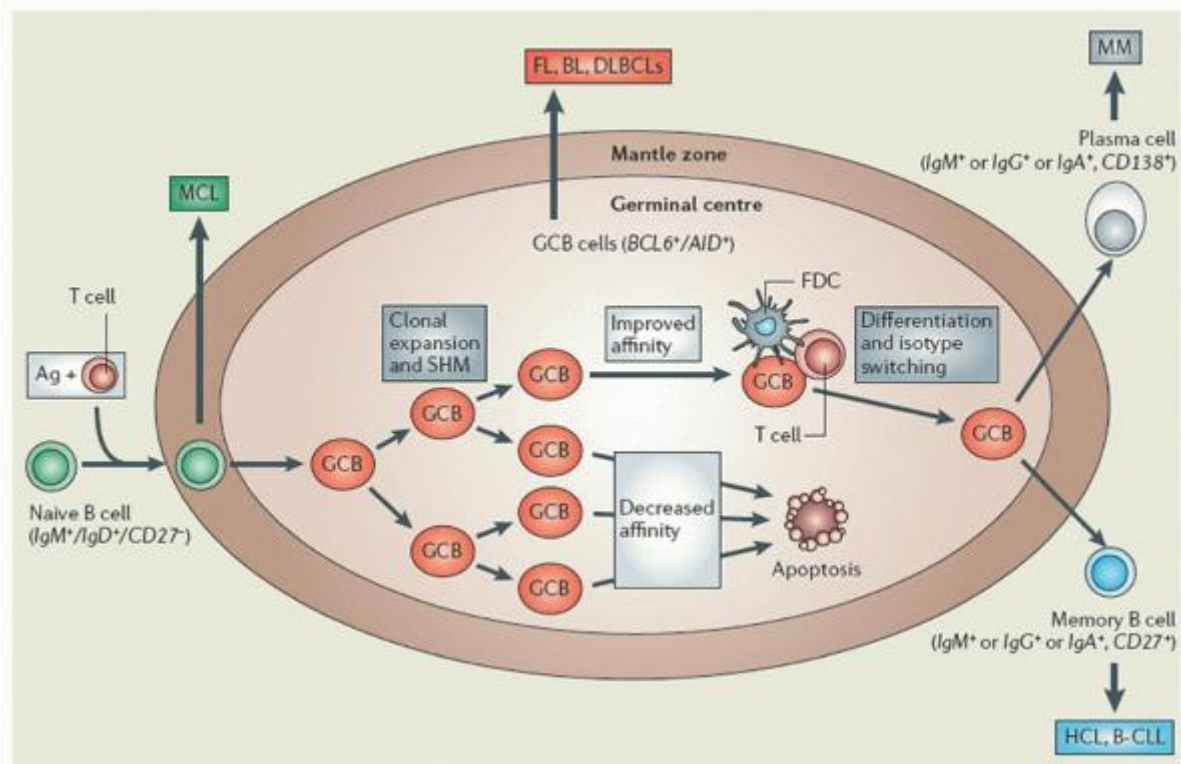

FIGURE 91.1. The germinal center (GC) reaction is a key event in adaptive immunity to T-cell-dependent antigens. In lymph nodes and the spleen, antigen (Ag)-activated naive B-cells (immunoglobulin [Ig] M⁺/IgD⁺) are driven into primary follicles where, aided by T-cells, they undergo clonal expansion, form the GC, and displace nonproliferating naive B-cells to the periphery or mantle zone (shown in diagram). Within the GC, somatic hypermutation (SHM) mutates the Ig variable region of proliferating B-cells to increase their affinity for the stimulating Ag. Although most GC B-cells (GCB) acquire unfavorable mutations and die by apoptosis, a few improve their Ig affinity and are selected for further differentiation through interactions with T-cells and follicular dendritic cells (FDC). A proportion of these selected B-cells then undergo switch recombination of the Ig constant region, which changes the isotype and, consequently, the antibody-effector function. B-cells of the GC express BCL6, which is required for GC formation, and activation-induced cytidine deaminase (AID) which is essential for SHM and switch recombination. Finally, selected B-cells differentiate into memory B-cells (CD27⁺) or antibody-secreting plasma cells (CD138⁺). Follicular lymphoma (FL), Burkitt lymphoma (BL), and some diffuse large B-cell lymphomas (DLBCLs) are thought to derive from B-cells of the GC, mantle cell lymphoma (MCL) mainly from mantle-zone naive B-cells, B-cell chronic lymphocytic leukemia (B-CLL) and hairy-cell leukemia (HCL) from memory B-cells, and multiple myeloma (MM) from plasma cells. The majority of cases of CLL and HCL have undergone SHM, but a proportion have not and these cases have more aggressive disease. (From Tiacci E, Liso A, Piris M, and Falini B. Evolving concepts in the pathogenesis of hairy-cell leukaemia. *Nature Rev* 2006;6:437-448, with permission).

High-density genomewide DNA profiling in HCL showed that, in contrast with CLL, HCL has a remarkably stable genome.⁴⁹ Using a high-density single nucleotide polymorphism array, it has been shown that only 25% of patients had gross copy number abnormalities.⁴⁹ Alterations in the genes for FGF12 and FGF receptor were observed, and increased expression of these genes is typically observed in HCL, which is responsible for the marrow fibrosis seen in this disease.⁴⁹ Although a high incidence of TP53 mutations was initially reported in HCL, subsequent studies have suggested that this is uncommon and occurs primarily in patients with unmutated IgVH.^{17, 51, 52}

Oncogenes and Signal Transduction

To date, there has been little information regarding the role of oncogenes in HCL. It has been shown that CSF1R, which encodes the receptor for macrophage colony-stimulating factor and is normally expressed in macrophages/monocytes, is highly expressed in hairy cells.⁵³ The addition of macrophage colony-stimulating factor to hairy cells causes enhanced mobility of the cells, the extent of which depends on the underlying stratum, and this effect is mediated through alterations in the integrin $\alpha\beta4$.⁵⁴ More recently, it has been demonstrated that, compared with normal lymphocytes, hairy cells have markedly increased levels and activities of the protein tyrosine kinase pp60c-src, which is the product of the proto-oncogene CSK.⁵⁵ This increase was not observed in CLL cells and was unrelated to the amplification or structural

rearrangements of the gene.⁵⁵ Cyclin D1 messenger RNA and protein levels are increased in HCL, but the increase is less than is seen in mantle cell lymphoma and is not related to t^{11, 14} (q13;q32), which is typically observed in mantle cell lymphoma.^{56, 57} Finally, because of the high frequency of abnormalities of chromosome 5 in classic HCL, it has been suggested that a transforming oncogene might be located at 5q13.3.⁴⁶

Gene expression profiling identifies a unique homogeneous signature for HCL distinct from other B-cell malignancies. In HCL samples, decreased expression was noted for CXCR5, TNFRSF5, CD40, CD27, and CCR7, whereas increased expression was noted for GAS7, FGFR1, FGF2, FLT3, TIMP1, TIMP4, RECK, ANXA1,

P.1931

Syndecan3, Cyclin D1, IGF1R, and NUDT6.²⁴ The proposed effects of these changes on the pathophysiology of HCL are outlined in Table 91.1. More recently, a heterozygous mutation of GTG to GAG at codon 600 of the BRAF gene has been observed in typical HCL producing a V600E variant protein, in which glutamate substitutes for valine at position 600.^{58, 59, 60, 61, 62} BRAF is a serine-threonine kinase and the variant protein (V600E) demonstrates increased activity resulting in enhanced phosphorylation and activation of mitogen-activated protein-ERK kinase (MEK) and extracellular signal-regulated kinase (ERK), which increase cell survival and proliferation by increasing the expression cyclin D1 and decreasing p27.⁵⁸ The functionality of the variant protein was demonstrated in primary hairy cells by showing the presence of phosphorylated MEK and ERK in these cells, and demonstrating that the phosphorylation was decreased using the BRAF inhibitor, PLX-4720.⁵⁸ Initial studies suggested that all patients with classical HCL contained a V600E; however, a more recent study demonstrated that 82% of patients with classical HCL express BRAF, whereas the V4-34 subtype and HCL variant do not express BRAF.²¹ Thus, BRAF inhibitors may not be useful in the treatment of the aggressive V4-34 HCL subtype of the HCL variant.

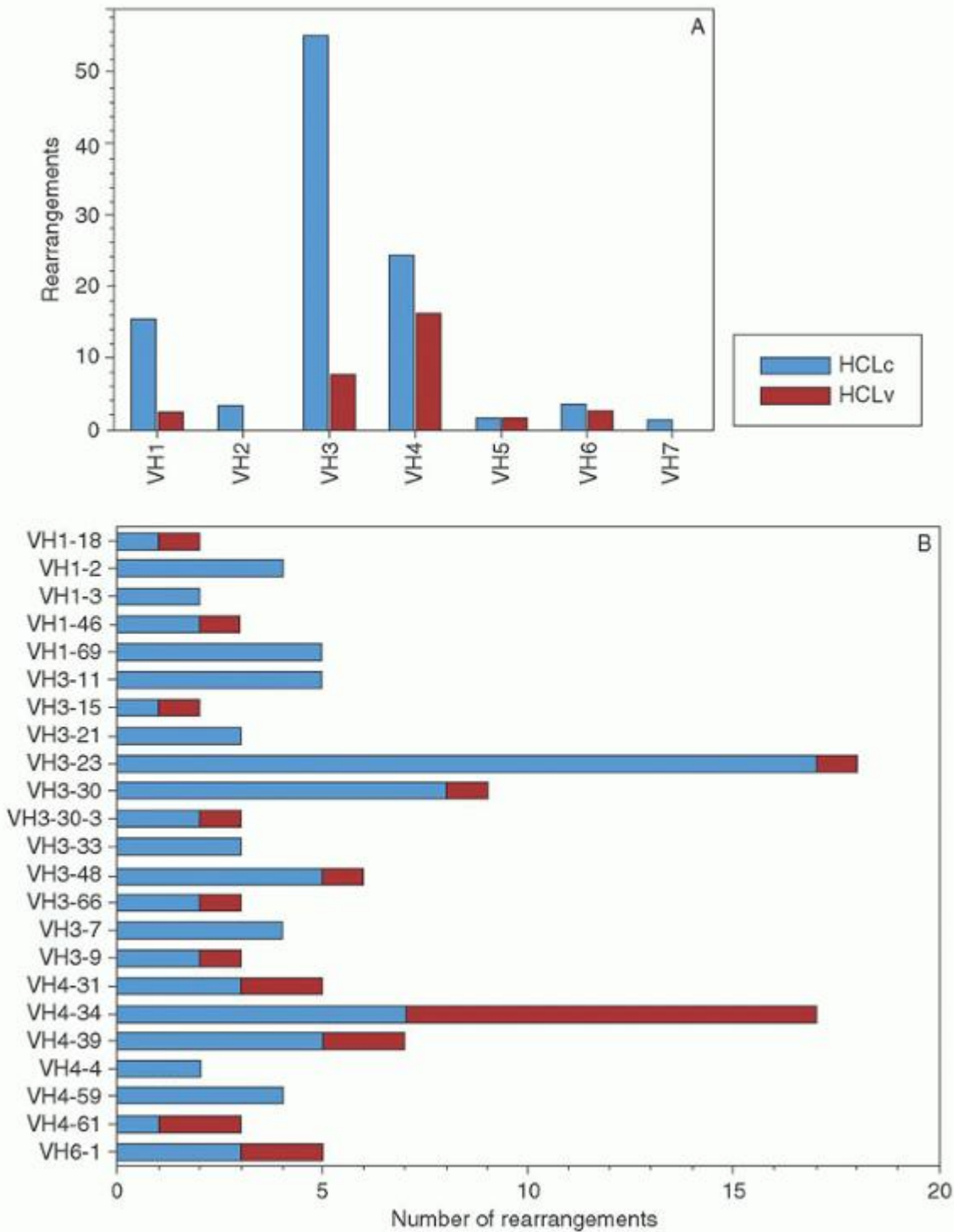

FIGURE 91.2. Immunoglobulin (Ig) VH family and gene usage in hairy-cell leukemia (HCL). Number of IgV_H rearrangements in each family (A) and for genes used by more than one patient (B) for HCLc (black) and HCLv (gray). (From Arons E, Roth L, Sapolsky J, et al. Evidence of canonical somatic hypermutation in hairy cell leukemia. *Blood* 2011;117:4844-4851, with permission.)

It has also been demonstrated that the activities of MEK and ERK are increased in HCL through the epsilon form of protein kinase C (PKC ϵ), which in turn is activated by tyrosine nitration (Fig. 91.3).⁶³ Tyrosine nitration is produced by the high levels of reactive oxygen species (ROS) and nitric oxide (NO) in hairy cells.⁶³ In addition, apart from its role in cell survival, activated PKC ϵ is also involved in causing the unusual hairy cell structure by increasing the Rho guanosine triphosphatases

(GTPases), Rac1 and Cdc42.⁶³ The Rho GTPases are members of the Ras family of GTP-binding proteins and can either be active (GTP-bound) or inactive (GDP-bound).⁶³ The GTPases are important for actin structure within the cell and controlling cell shape. It has been shown that three groups of Rho GTPases, RhoA, Rac1, and Cdc42, are overexpressed in HCL and are responsible for the filamentous projections and growth of these cells.⁶⁴

P.1932

TABLE 91.1 MECHANISMS FOR HAIRY CELL LEUKEMIA FEATURES

Hairy Cell Feature	Mechanism
Hairy cell projections	Alteration of actin structure through up-regulation of the Rho GTPase Rac 1.
Prolonged survival of hairy cells	Autocrine stimulation by TNF- α , increased cellular levels of bcl-2.
Ability of hairy cell to phagocytose and expression of macrophage markers, for example, CD11c	Up-regulation of annexin1 mediates phagocytic function and c-Maf transcription factor for macrophage differentiation.
Marrow fibrosis and monocytopenia	Up-regulation of FGF2 which activates FGFR1 on the hairy cell producing fibronectin and TGF β , which causes the adjacent fibroblasts to secrete collagen. TNF- α and TGF- β cause marrow suppression and monocytopenia.
Infiltration of red pulp of spleen by hairy cells with the formation of "pseudosinususes"	Up-regulation of TIMP1, TIMP4, RECK inhibitors of matrix metalloproteinases.
Lack of lymph node involvement by hairy cells	Hairy cells lack L-selectin which is required for binding to venule endothelium and chemokine receptor 7 (CCR7) which is required for transendothelial migration.

GTPases, guanosine triphosphatases; TGF- β , transforming growth factor- β ; TNF- α , tumor necrosis factor.

Swerdlow SH, Campo E, Harris NL, et al. WHO classification of tumours of haematopoietic and lymphoid tissues, vol. 2, 4th ed. WHO 2008; Basso K, Liso A, Tiacci E, et al. Gene expression profiling of hairy cell leukemia reveals a phenotype related to memory B cells with altered expression of chemokine and adhesion receptors. *J Exp Med* 2004;199:59-68 and Cawley JC, Hawkins SF. The biology of hairy-cell leukaemia. *Curr Opin Hematol* 2010;17:341-349.

Cytokines

There has been great interest in the role of cytokines in the pathogenesis of HCL.^{37, 38, 39} Identified factors that may be involved include interleukin-2 (IL-2), tumor necrosis factor (TNF)- α , IL-4, IL-6, B-cell growth factor, IFN- α , transforming growth factor- β (TGF- β), and basic fibroblast growth factor (bFGF, FGF2).⁶⁵ Some of these factors may be produced by the hairy cells themselves or by normal T-cells.^{65, 66} T-cell clones have been shown to produce cytokines that stimulate the growth of hairy cells, but not normal B-cells; this effect is prevented by the addition of IFN- α .⁶⁶

A feature of classical HCL is the reactivity of the hairy cells with anti-Tac (CD25), which detects the α -chain of the IL-2 receptor.^{67, 68, 69, 70} Increased serum levels of IL-2 receptor have been found in untreated HCL patients, and there is evidence that the leukemic cells release the receptor.⁷⁰ The serum levels of IL-2 receptor correlate with the extent of disease and decrease after effective therapy with IFN- α .^{71, 72, 73} Paradoxically, even though the IL-2 receptor is present on

hairy cells, these cells do not respond to stimulation by IL-2, and IL-2 probably does not play a major role in the pathogenesis of HCL.⁶⁵

It has been demonstrated that TNF- α , but not TNF- β , stimulates the growth of hairy cells, whereas in CLL, both forms of TNF stimulate leukemic cell growth (Fig. 91.4).^{74, 75} Hairy cells can also produce TNF- α ,^{76, 77} and the serum level of TNF- α is increased in HCL, the level correlating with tumor burden.⁷⁷ The TNF- α receptor can also be detected in the serum of these patients, and the level of this receptor also decreases after treatment with IFN- α .^{78, 79} These findings suggest that TNF- α production by the hairy cells may play an important role in the pathogenesis of HCL by stimulating further growth of hairy cells and producing pancytopenia through the inhibition of normal marrow function.^{74, 76, 77}

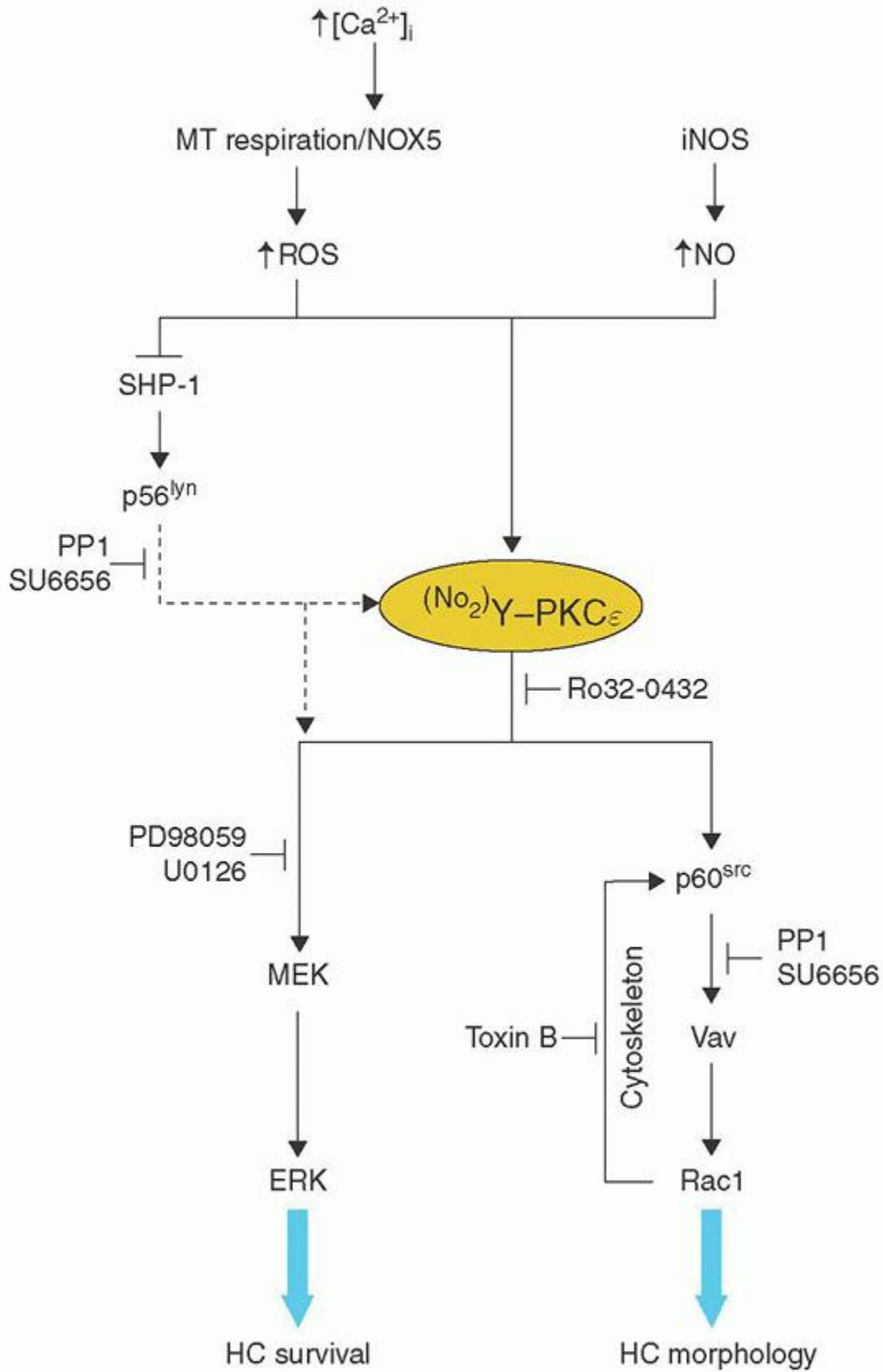

FIGURE 91.3. Proposed pathways of constitutive signaling in hairy cells (HCs). This figure shows the schematic representation of the possible associations into two parallel pathways of active signaling components detected in HCs.

Protein kinase C (PKC ϵ) plays a central role, controlling the activation of p60src, Rac1, and extracellular signal-regulated kinase (ERK). PKC ϵ is itself activated through nitration of tyrosine residues by reactive oxygen species (ROS) and nitric oxide (NO) which are increased in HCLs. (From Slupsky JR, Kamiguti AS, Harris RJ, et al. Central role of protein kinase C ϵ in constitutive activation of ERK1/2 and Rac 1 in malignant cells in hairy cell leukemia. *Am J Pathol* 2007;170:745-754, with permission.) MEK, mitogen-activated protein-ERK kinase; MT, mitochondrial; NOX5, NADPH oxidase 5; iNOS, inducible nitric-oxide synthetase.

Hairy cells secrete low levels of IL-6, and the serum level of this cytokine is increased in HCL.^{65, 80} The production of IL-6 messenger RNA and IL-6 secretion is markedly increased by incubating HCL cells with TNF.⁸⁰ IL-6 antisense oligonucleotide can inhibit the effect of TNF on IL-6 secretion and DNA synthesis, suggesting that IL-6 mediates the activity of TNF in HCL.⁸⁰

Hairy cells also produce bFGF and TGF- β and express the bFGF receptor.^{81, 82} Adhesion of the hairy cells to hyaluronan via CD44 induces the secretion of bFGF, but not TGF- β .⁸¹ The secreted bFGF then feeds back on the hairy cell to secrete fibronectin, which is a major component of the marrow fibrosis in this disease. As the spleen does not have hyaluronic acid, this explains the lack of bFGF and fibrosis in this organ despite abundant hairy cells.⁸¹ TGF- β has been shown to be present in increased

P.1933

quantities in the plasma and marrow of patients with HCL, and this also contributes to the marrow fibrosis by inducing the production of collagen and reticulin by adjacent fibroblasts.⁸²

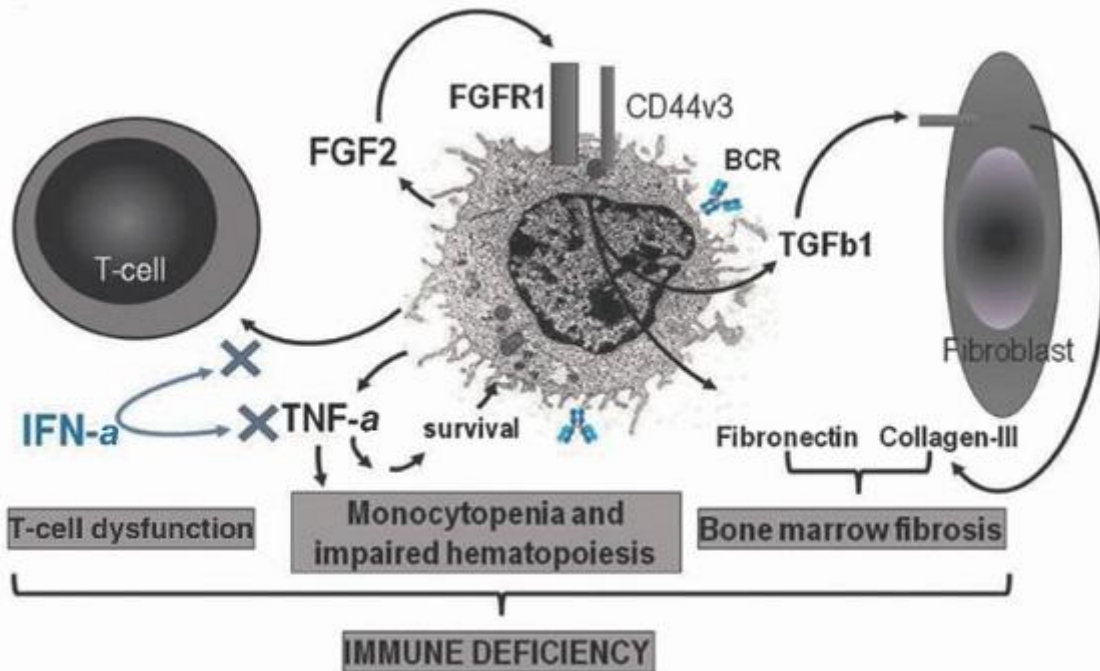

FIGURE 91.4. Immune suppression in hairy-cell leukemia (HCL). Immune suppression is a result of T-cell dysfunction and impaired hematopoiesis with pancytopenia, bone marrow fibrosis, and hypersplenism. T-cell activation, decreased numbers of memory T-cells, restricted T-cell repertoire, and opportunistic infections are the result of inappropriate activation and suppression of T-cell responses directly by cytokines produced by the neoplastic B-cells. Cytopenia with severe monocytopenia is caused by the secretion of tumor necrosis factor (TNF)- α by the hairy cells. TNF- α also has autocrine pro-survival effects on the tumor clone. Treatment of HCL with IFN- α is able to restore the abnormal T-cell repertoire and hematopoiesis by inhibiting cytokine (including TNF- α) mediated effects on the T-cells and tumor cell. Fibrosis is caused by production of fibroblast growth factor-2 (FGF-2) and overexpression of its receptor FGFR1. The FGF2-FGFR1 interaction increases with CD44v3 co-receptor and syndecan family members. FGFR1 signals secretion of autocrine fibronectin and of transforming growth factor- β (TGF β) by hairy cells. TGF β stimulates adjacent fibroblasts to produce fibronectin and collagen type III. (From Forconi F. Hairy cell leukaemia: biological and clinical overview from immunogenetic insights. *Haematol Oncol* 2011;29:55-66, with permission.)

CLINICAL FINDINGS

The median age in HCL is between 50 and 55 years (range, 22 to 85 years), with the male-to-female ratio being 4:1.^{1, 2, 3, 4, 5, 6, 83} Classically, these patients present with weakness and fatigue, and the symptoms can usually be related to pancytopenia and splenomegaly (Table 91.2).^{1, 2, 3, 4, 5, 6, 83} Ninety percent of patients have a palpable spleen, which may be massive, and one third of patients have hepatomegaly.^{1, 2, 3, 4, 5, 6, 83} Peripheral lymphadenopathy is uncommon,⁵ but with computed tomography scanning, significant abdominal lymphadenopathy may be observed.^{84, 85} The degree of abdominal lymphadenopathy correlates with the duration and extent of disease. The incidence at presentation is 17%, but increases to 56% at relapse after chemotherapy.⁸⁴ Less frequently, mediastinal node enlargement may also be observed.⁸⁶ Compared to 30 years ago, patients are now being diagnosed earlier and have less marked splenomegaly and anemia at presentation.⁶

Most patients have pancytopenia, the etiology of which is multifactorial but is primarily related to marrow failure and splenomegaly. Marrow failure is related to replacement of marrow by hairy cells and the associated reticulin fibrosis, and to the inhibition of myelopoiesis by cytokines, such as TNF- α , released by the hairy cells.^{37, 38, 39} Splenomegaly in HCL may produce pancytopenia by three mechanisms. First, the major factor responsible for the cytopenias is pooling (sequestration, margination) of normal peripheral blood cells in the enlarged spleen.^{87, 88, 89, 90, 91, 92} As much as 90% of the peripheral platelet mass,⁸⁸ 30% of the red cell mass,⁹¹ and 65% of the granulocytes⁸⁹ may pool in a massively enlarged spleen. In HCL, apparently because of the formation of blood-filled pseudosinuses by the hairy cells, a greater proportion of the peripheral red cell volume (as much as 48%) may be pooled in a massively enlarged spleen.⁹¹ A second mechanism responsible for cytopenias with splenomegaly is the increased destruction of cells in the spleen. Finally, an expanded plasma volume contributes to the appearance of cytopenia with splenomegaly; this is particularly true for the observed anemia.^{87, 90}

TABLE 91.2 HAIRY CELL LEUKEMIA: CLINICAL MANIFESTATIONS

Manifestation	Incidence (%)
Weakness, easy fatigue	80
Fever, sweats, weight loss, anorexia	20-35
Infection	20-30
Easy bruising, bleeding	20-30
Left upper quadrant abdominal discomfort	25
Autoimmune disorders	15-30
Splenomegaly	80-90
Hepatomegaly	30-40
Ecchymoses, petechiae	20-30

Infections

Prior to the development of effective treatments for HCL, infections were a major problem and the leading cause of death.^{83, 93, 94, 95, 96} Nowadays, approximately one third of patients will develop an infection during the course of their disease and two thirds of these will be serious.⁹⁶ Fever is rarely a manifestation of the underlying HCL; when present, it should prompt a careful search for an infectious process. Approximately 30% of patients present with infection, and 70% have either documented or suspected infections during the course of the disease.⁹³ Pyogenic infections account for ~50% of infectious episodes; Gram-negative and Gram-positive bacteria are identified with approximately equal frequency.^{83, 93} However, nonpyogenic infections occur in >30% of patients,^{83, 93} and infections can occur with unusual organisms such as atypical mycobacteria, including *Mycobacterium kansasii*, which is a unique feature of HCL, in comparison to other lymphoproliferative disorders.^{83, 94, 97} Other organisms include *Toxoplasma gondii*, *Legionella*, *Listeria monocytogenes*, and *Pneumocystis jirovecii*, as well as various fungi and viruses.^{83, 98, 99, 100}

The high infection rate can be ascribed primarily to neutropenia, although several other immune defects have been described. Monocytopenia is often a prominent feature,^{101, 102} and functional abnormalities of monocytes and granulocytes may occur.^{99, 101, 103, 104, 105} The defects in monocyte production and function may account for the unusual susceptibility of these patients to atypical mycobacterial and fungal infections.^{95, 96} The T-cells are also highly abnormal in

HCL, demonstrating an inversion in the CD4:CD8 ratio, and they have a poor antigen response which is likely related to absence of CD28.^{106, 107} Moreover, there is clonogenic expansion of CD8⁺ cytotoxic lymphocytes but the target for these cells has not yet been identified.¹⁰⁸ These abnormalities can resolve with IFN- α therapy, although it may take up to 2 years to see this effect.¹⁰⁹ A depressed helper to suppressor T-cell ratio associated with a decrease in the number of T-helper cells and an increase in the number of T-suppressor cells also has been demonstrated.¹⁰⁹ As expected, lymphocyte functional studies reveal impaired delayed-type hypersensitivity to recall antigens, as well as near-absent antibody-dependent cellular cytotoxicity.¹⁰⁶ In contrast to CLL, the serum Ig levels are normal.¹¹⁰

Autoimmune Disorders

Clinical manifestations secondary to various autoimmune disorders are being recognized with increasing frequency in patients

P.1934

with HCL.^{83, 111, 112, 113, 114, 115} In one series of patients, these complications were second only to infection as a cause of morbidity.^{83, 112} The onset may occur any time during the course of the disease and is not related to the tumor burden. Most frequently, patients present with arthritis, arthralgias, palpable purpura, or nodular skin lesions resulting from cutaneous vasculitis, and low-grade fever.^{83, 112, 114} Occasionally, patients may have involvement of the lung, liver, intestine, and kidney, with a clinical picture that resembles polyarteritis nodosa.^{83, 112, 113, 115} These patients often have fever, malaise, and weight loss, and a co-existent infection must be ruled out.^{83, 112} If skin lesions are present, the diagnosis can be confirmed by biopsy, which usually shows changes compatible with a diagnosis of polyarteritis nodosum or leukocytoclastic vasculitis; occasionally, a vasculitis related to the invasion of the vessel wall by hairy cells occurs; this may appear very similar to polyarteritis nodosa with the presence of aneurysms.¹¹⁴ In some organs, such as the lung, a granulomatous vasculitis may be found.¹¹² Angiography may reveal peripheral aneurysms.¹¹² Antinuclear antibodies, rheumatoid factor, immune complexes, and hepatitis B antigen are variably positive.¹¹¹ Cryoglobulinemia has been detected in some patients.^{116, 117} It has been postulated that the increased incidence of vasculitis in HCL may be related to infections with hepatitis B and other viruses, cross-reactivity of antibodies against hairy cells with epitopes on endothelial cells, and decreased clearance of immune complexes by the impaired immune system.¹¹⁴

These autoimmune manifestations may be self-limited, but if therapy is required, a short course of corticosteroids is usually effective.¹¹⁴ Remissions have also been observed after splenectomy, IFN- α , and pentostatin therapy.^{112, 114, 115}

Unusual Manifestations

Lytic Bone Lesions

Although the immunophenotypic profile of hairy cells closely resembles that of B-cells at a developmental stage just before terminal differentiation to plasma cells, lytic bone lesions are distinctly unusual (Table 91.3).^{118, 119, 120, 121} In some patients with osteolytic lesions, HCL and multiple myeloma were thought to coexist.^{122, 123} However, several patients with classic HCL and without any evidence of plasma cell proliferation have been reported to develop osteolytic lesions.^{119, 120, 121} These lesions have a predilection for the proximal femur and usually are associated with extensive bone marrow infiltration by hairy cells.^{120, 121} The lesions, as with those seen in association with multiple myeloma, respond well to radiotherapy. The administration of corticosteroids can produce prompt relief of bone pain.¹¹⁸

Skin Involvement

Cutaneous lesions referable to thrombocytopenia (ecchymoses, petechiae), infection, or vasculitis are common during the course of HCL, but lesions caused by infiltration of the skin by hairy cells are unusual.^{124, 125} In a retrospective review of 600 cases, skin lesions thought to be due to infiltration by hairy cells were reported in 8.0% of cases, but histopathologic verification was present in only 1.3%.¹²⁴ Infiltrative lesions usually are widely disseminated and consist of erythematous maculopapules. Biopsy shows the infiltrates to be perivascular, involving the dermis but not the epidermis.¹²⁶

Splenic Rupture

Surprisingly, even with massive splenomegaly, spontaneous splenic rupture is rare in HCL, occurring in ~2% of cases.^{1, 127}

Other Organ Dysfunction

Although hairy cell infiltration of multiple organs and tissues is a frequent finding at autopsy, clinically significant organ dysfunction is unusual.¹²⁸ Infiltration of connective tissue and fat surrounding organs is common.¹²⁸ Central nervous system involvement is unusual, and only a rare case of meningeal involvement has been documented.^{128, 129} Infection is by

far the most frequent cause for neurologic complications.¹²⁹ Pleural effusions, ascites, proteinlosing enteropathy, and spinal cord compression may occur rarely in HCL and result from tissue infiltration by hairy cells.¹¹⁸

LABORATORY FINDINGS

The relative incidence of the most characteristic laboratory findings is listed in Table 91.4. In a series of 725 cases studied by the Italian Cooperative Group, 80% of patients had pancytopenia at presentation, with one third of all patients having a hemoglobin level <8.5 g/dl, neutrophils <0.5 × 10⁹/L, and platelets <50 × 10⁹/L.⁶ A careful inspection of the peripheral blood smear demonstrates the presence of typical hairy cells in >85% of patients,^{1, 6} and in 13% of cases, there are >5 × 10⁹/L hairy cells.⁶ In Bouroncle's series of 82 patients, hairy cells accounted for ≥10% of the leukocytes in 80% of patients and ≥50% in 43% of patients.² The total leukocyte count was elevated in 20%, but in only 4% did the count exceed 50 × 10⁹/l.² Monocytopenia also typically occurs in active HCL.^{101, 102}

Abnormal liver function studies, usually with an isolated elevation of the serum alkaline phosphatase level, are obtained in 10% to 19% of individuals with HCL.⁴ The leukocyte alkaline phosphatase scores are high in most cases. The Ig levels are normal in HCL and monoclonal gammopathy is rare, occurring in 1% to 3% of patients.^{3, 4} It has been difficult to prove that the hairy cells are secreting the paraprotein¹³⁰; in other cases, the M band was thought to be related to a co-existing myeloma.^{120, 122, 123}

TABLE 91.3 HAIRY CELL LEUKEMIA: UNUSUAL CLINICAL MANIFESTATIONS

Manifestation	Incidence (%)
Peripheral lymphadenopathy	<5
Lytic bone lesions	3
Skin involvement	5
Splenic rupture	<5
Other organ dysfunction	<5

TABLE 91.4 HAIRY CELL LEUKEMIA: LABORATORY MANIFESTATIONS

Manifestation	Incidence (%)
Pancytopenia	70
Neutropenia	80
Thrombocytopenia	80
Anemia	75
Monocytopenia	98
Leukocytosis	15
Hairy cells in peripheral blood	85
Hairy cells in bone marrow	99

P.1935

Hairy Cells

The characteristic morphologic appearance of hairy cells on a Wright-stained peripheral blood smear is the single most important diagnostic finding (Fig. 91.5).¹² Other B-cell disorders that may have hairy projections on the cells include B-cell prolymphocytic leukemia, atypical HCL, and splenic lymphoma with villous lymphocytes (SLVL), although careful analysis and flow cytometry can differentiate these disorders.¹³¹ Typical hairy cells are mononuclear with relatively abundant cytoplasm and a cell diameter in the range of 10 to 25 μm. The cytoplasm is pale blue-gray and agranular with a variable number of elongated (hairy) projections. The mechanism for the hairy cell villi has been related to up-regulation of the expression of the Rho GTPases in the hairy cells.⁶⁴ The nuclei are round, oval, reniform, or dumbbell-shaped with a nuclear chromatin pattern that is homogeneous and less clumped and lighter staining than that of normal mature lymphocytes

and those seen in classic CLL and prolymphocytic leukemia.^{6, 25, 131} A prominent nucleolus is rarely seen. On both transmission and scanning electron microscopy, the cytoplasmic projections appear as elongated slender microvilli or broad-based ruffles or pseudopods (Fig. 91.6).¹³² Other ultrastructural features include numerous mitochondria, polyribosomes, strands of rough endoplasmic reticulum, intermediate filaments, and some lysosomal granules.²⁵ In 50% of cases, cytoplasmic inclusions known as ribosome-lamellar complexes are found.^{6, 133} These complexes appear as rod-shaped structures under light microscopic analysis.¹³³ Although seen most frequently in individuals with HCL, they are not pathognomonic, having been reported in association with other chronic B-cell lymphoproliferative disorders, acute monocytic leukemia, and even nonhematologic neoplasms.¹³⁴ The characteristic filamentous projections can be seen readily in living hairy cells; using supravital dyes and phase-contrast microscopy, one can observe the cytoplasmic projections protruding and then retracting constantly.⁶

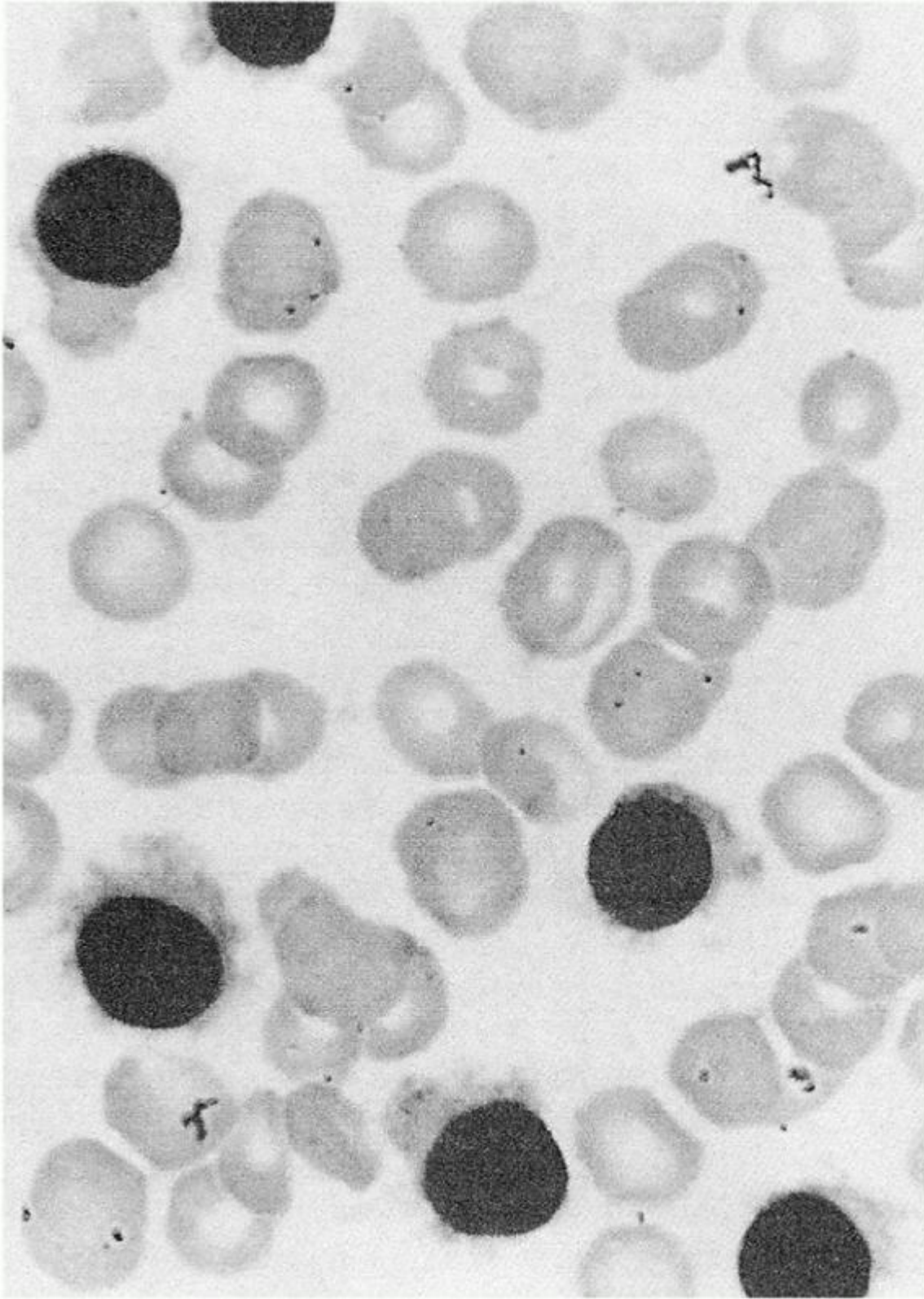

FIGURE 91.5. Hairy cells from a peripheral blood smear (light microscopy). Cells have abundant agranular cytoplasm with multiple cytoplasmic projections. Nucleus is round, oval, or reniform with light-staining homogeneous nuclear chromatin (Wright stain, $\times 1,500$).

A useful diagnostic test for HCL is the presence of acid phosphatase isoenzyme 5 in the cytoplasm of hairy cells, but this can also be positive in other disorders.^{6, 135, 136, 137, 138, 139} Cytochemical staining procedures demonstrate that this isoenzyme, unlike other acid phosphatase isoenzymes, is not inhibited by tartrate.^{135, 136, 137, 138, 139} The enzyme concentrates primarily in the Golgi area and nuclear membrane.¹³⁵ Even though a positive tartrate-resistant acid phosphatase (TRAP) stain is not pathognomonic for the diagnosis of HCL, it has stood the test of time as an important tool in the differential diagnosis of this disease.¹³⁷ The test is positive in more than 95% of cases.⁴ In one report,¹³⁷ the TRAP stain was positive in 76%, intermediate in 21%, and negative in only 3% of 29 patients with HCL. In contrast, in 37 patients with CLL and other lymphoproliferative disorders, the test was positive in only 3%, intermediate in 32%, and negative in 65%.¹³⁷ The TRAP stain can now be carried out on paraffin-embedded tissue using 9C5, a monoclonal antibody to TRAP.^{138, 139} The majority of cases of HCL are detected using this antibody, although only 50% of the cells stain positively.¹³⁹

Gene expression profiling has identified ANXA1 as one of the most up-regulated genes in HCL.²⁴ ANXA1 codes for annexin1, and is not expressed in normal B-cells. By using an immunocytochemical assay staining for the presence of annexin A1 on either paraffin-fixed bone marrow specimens or acetone-fixed cytopins of peripheral blood, 100% sensitivity and specificity has been shown in differentiating HCL from other B-cell malignancies, including variant HCL.¹⁴⁰ This is now considered one of the best tests.

More recently it has been shown that the majority of patients with classical HCL have GTG to GAG mutations at codon 600 of the BRAF gene, the (V600E) allowing glutamic acid to be substituted for valine at position 600 of the BRAF protein.^{58, 59, 60, 61, 62} A recent study by Kreitman et al²¹ has demonstrated that all classical HCL cases have the mutation apart from the aggressive and drug-resistant IgVH4-34 subtypes and the HCL variant. Several recent reports have described highly sensitive polymerase chain reaction (PCR) assays to detect the V600E mutation, which should be useful in the diagnosis of HCL and monitoring for minimal residual disease (MRD) following therapy.^{60, 61, 62}

Immunophenotyping has proved very useful in assisting in the diagnosis of HCL and in differentiating it from variants and other B-cell malignancies.^{1, 131, 141, 142, 143} Using flow cytometry, very small numbers of abnormal cells can be detected and the diagnosis of HCL can be made on the peripheral blood of the majority of patients. The hairy cells are monoclonal and, in contrast with most other lymphoid malignancies, cases with κ or λ expression are equally represented or there is a predominance of cases with κ expression.¹⁴² Table 91.5 shows the immunophenotype of typical HCL in comparison to other chronic B-cell disorders with which it can be confused. In HCL, the leukemia cells have Sig (IgM^{+/−}, IgG, IgD, or IgA) and B-cell-associated antigens (CD19, CD20, and CD22); typically, the cells are positive for CD25, the IL-2 receptor. CD11c (leu-M5), which reacts with the α subunit of p150/95, a member of the lymphocyte function-associated antigen subfamily of integrin molecules, is present on virtually all hairy cells, but it is also present on monocytes and neutrophils and on the cells of other lymphoid malignancies.^{6, 141} Several antibodies have been raised against hairy cells, although none is entirely specific for this leukemia. B-ly-7 reacts with a 144-kd antigen (mucosal lymphocyte antigen; CD103) on hairy cells and on a small number of normal lymphocytes, which have been postulated to be the normal hairy cell counterpart.¹⁴² Like

P.1936

B-ly 7, the antibodies HML-1, Ber-ACT8, and LF61 can also recognize CD103. Two further antibodies, RAB-1 and anti-HC2, are also relatively specific for hairy cells.⁶ CD123 (α chain of the IL-3 receptor) is present in 95% of cases with classical HCL and is only rarely detected in other chronic lymphoid malignancies.^{142, 143, 144} Hairy cells are also typically strongly FMC7 positive (an epitope of CD20), negative for CD79b (an epitope of B-cell receptor β chain), and CD27, CD10, and CD38 are rarely positive.¹⁴² In summary, the diagnostic immunophenotypic features for HCL are monoclonal B-cells that are positive for CD11c, CD25, CD103, and CD123.¹⁴²

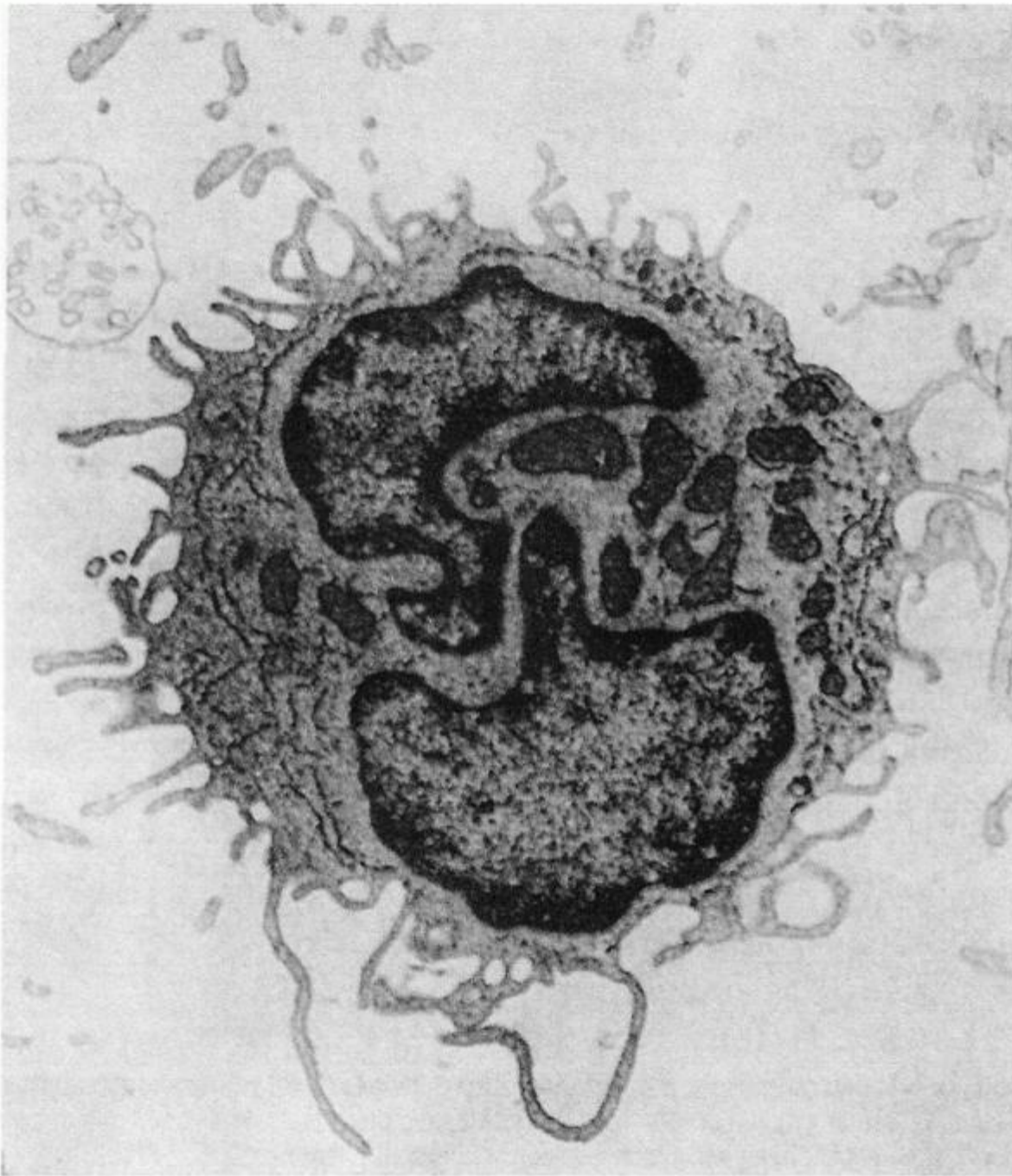

FIGURE 91.6. Hairy cells from the peripheral blood (transmission electron microscopy). The characteristic and delicate cytoplasmic projections are striking. Nucleus is irregular in shape with marginated chromatin ($\times 11,000$).

These antibodies are primarily used on viable or frozen cells, but antibodies have also been developed that can recognize formalin-resistant hairy cell antigens. One of these is DBA.44, which is directed against CD72, strongly stains hairy cells fixed in formalin or Bouin solution, and has good sensitivity.^{143, 145} However, DBA.44 is not entirely specific for hairy cells and also stains mantle zone lymphocytes and a variety of low- and high-grade B-cell lymphomas. The specificity and sensitivity for the diagnosis of HCL by immunohistochemistry can be increased when DBA.44 staining is used in conjunction with the 9C5 antibody to detect TRAP and an anti-CD20 antibody to detect B-cells.^{139, 143}

Bone Marrow

More than 99% of patients have marrow infiltration by biopsy, although the occasional patient can have isolated involvement of the spleen.³ The pattern of bone marrow involvement on biopsy specimens is near to pathognomonic for

HCL (Fig. 91.7).^{146, 147, 148} Classically, the infiltration is diffuse and has a “honeycomb” appearance with the nucleus of each hairy cell surrounded by a halo of cytoplasm. The individual cells have been described as resembling a fried egg. This pattern of infiltration is quite different from that seen in other chronic lymphoproliferative disorders, such as CLL and lymphoplasmacytic lymphoma, where the lymphocyte nuclei closely approximate each other.^{146, 147, 148} In prolymphocytic leukemia, monocytoid B-cell lymphoma, marginal zone lymphoma, and large granular lymphocytic (LGL) leukemia, in which the malignant lymphocytes are about the size of hairy cells with a low nuclear-to-cytoplasmic ratio, the infiltrates are similar to those seen in HCL. Bone marrow involvement in systemic mast cell disease and even in some nonhematologic neoplasms, such as mesenchymal chondrosarcoma, also may mimic HCL.¹⁴⁹ The hairy cells may be more easily identified using immunohistochemistry with antibodies to CD20 (L26) or DBA.44.

P.1937

TABLE 91.5 HAIRY CELL LEUKEMIA (HCL): IMMUNOPHENOTYPIC PROFILE AND DIAGNOSTIC MARKERS

Marker	HCL	HCL-Variant	B-PLL	SMZL/SLVL
CD19, CD20	++	++	++	+
CD22	++	++	++	+
Surface Ig	+	±	++	+
CD11c	+++	+++	+	++
CD25	+++	-	+	-/+
CD103	+++	++	—	—
CD123	+++	—	—	—
TRAP ^a	+	—	—	—
Annexin A1 ^b	+	—	—	—
DBA.44 (CD72)	+	—	—	—
<i>BRAF V600E</i> mutation	80-100%	0%	0%	0%

HCL, hairy cell leukemia; B-PLL, B-prolymphocytic leukemia; SLVL, splenic lymphoma with villous lymphocytes; SMZL, splenic marginal zone lymphoma.

^a Can be detected by cytochemistry or immunohistochemistry. Less frequently used nowadays.

^b It is the most specific marker to differentiate hairy cells from other lymphoid cells. However, it is expressed in myeloid and T-cells and thus not useful to detect residual disease.

Data from Swerdlow SH, Campo E, Harris NL, et al. WHO classification of tumours of haematopoietic and lymphoid tissues, vol. 2, 4th ed. WHO 2008; Matutes E. Immunophenotyping and differential diagnosis of hairy cell leukemia. *Hematol/Oncol Clin N Am* 2006;20:1051-1063. Cook JR. Splenic B-cell lymphomas/leukemias. *Surg Path* 2010;3:933-954, and Jones G, Parry-Jones N, Wilkins B, Else M, Catovsky D. Revised guidelines for the diagnosis and management of hairy cell leukaemia and hairy cell leukaemia variant. *Br J Haematol* 2011;156:186-195.

Silver staining demonstrates diffuse reticulin fibrosis, without a collagenous component; this likely explains the usual difficulty in obtaining a marrow by aspirate (“dry tap”). Recently, it has been demonstrated that this feature is related to the ability of hairy cells to synthesize fibronectin.¹⁵⁰ In addition, hairy cells contain the fibronectin receptor, very late antigen-5, and are able to assemble the fibronectin molecule into multimers.¹⁵⁰ In some patients, the bone marrow is not diffusely involved by hairy cells; instead, focal (patchy) or interstitial infiltrates are seen.^{146, 147, 148} The focal areas may be well-circumscribed nodules or they may have irregular borders. Extravasation of red cells into areas of involvement is

often present.¹⁴⁷ Islands of normal hematopoiesis, particularly erythroid islands, are common. Increased numbers of plasma cells, lymphocytes, and mast cells may also be seen.

The overall marrow cellularity is increased in 55% of patients and normal in 38% of patients.⁶ However, in 7% of cases, the cellularity is decreased; this can lead to the erroneous diagnosis of aplastic anemia or hypoplastic myelofibrosis.^{149, 151, 152} Patients with hypocellular marrows frequently do not have splenomegaly.

Spleen and Liver

The spleen is almost always involved in HCL, and the pattern of hairy cell involvement, as with that in the bone marrow, is nearly pathognomonic for HCL.^{124, 153, 154} The infiltrates are confined to the red pulp, and, unlike other lymphoproliferative disorders, the white pulp is not expanded and is actually atrophic. Although a variable degree of red pulp involvement is seen in association with all leukemias, it is not a feature of most lymphomas until a leukemic transformation occurs.

Blood-filled pseudosinuses lined by hairy cells are a characteristic feature, and, despite monocytopenia, the number of histiocytes is increased in the red pulp. Infiltration of the liver occurs in both portal areas and sinuses.¹³¹ Pseudosinuses, some resembling hemangiomas, may be present.¹³¹

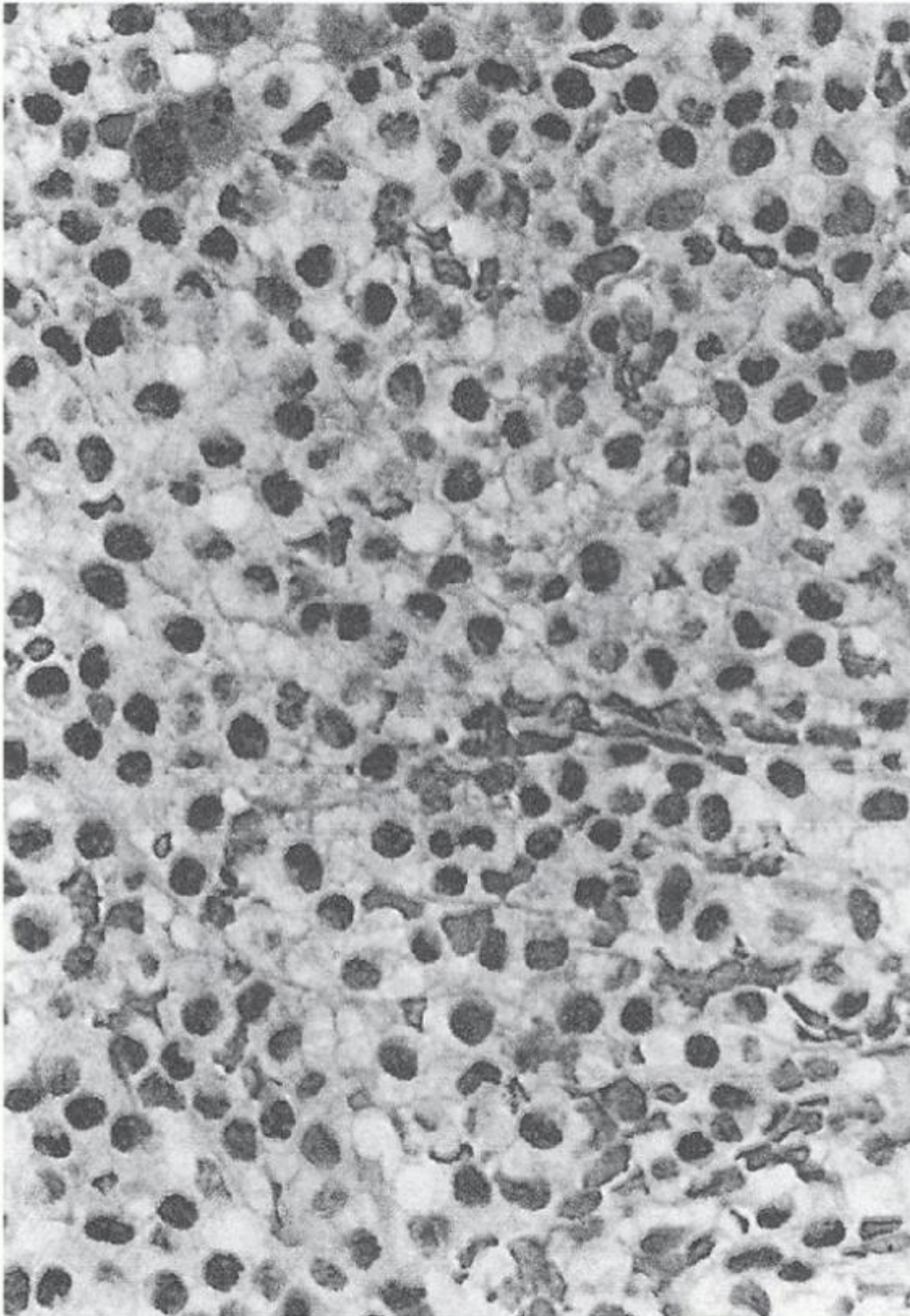

FIGURE 91.7. Bone marrow biopsy (plastic embedded) in hairy cell leukemia. Pattern of the infiltration gives a "honeycomb" appearance with the nucleus of each hairy cell surrounded by a halo of cytoplasm. Nuclei are bland and round, oval, or indented (hematoxylin and eosin, $\times 600$).

DIAGNOSIS

The diagnosis of HCL usually is not difficult.^{12, 13, 14, 5, 6} Most patients have splenomegaly in the absence of peripheral lymphadenopathy, and a variable degree of pancytopenia with severe monocytopenia. Typical hairy cells are evident in the peripheral blood on a routine smear or on a buffy coat in more than 90% of cases, and the suspected hairy cells should be TRAP positive and be monoclonal B-cells that are CD11c⁺, CD103⁺, and CD25⁺. The marrow aspirate is “dry,” and the bone biopsy should reveal the classic pattern of infiltration that may be diffuse, focal, or interstitial with increased reticulin and the cells staining positively for annexin A1. When hairy cells cannot be demonstrated in the peripheral blood, the bone marrow findings are critical for diagnosis. In addition to the typical bone marrow findings, immunophenotypic analysis may be helpful in identifying the leukemic cells (Table 91.5). Rarely, the diagnosis is confirmed only after splenectomy.

P.1938

DIFFERENTIAL DIAGNOSIS

Disorders to be considered in the differential diagnosis of HCL include lymphoid malignancies that present with splenomegaly in the absence of lymphadenopathy and are listed in Table 91.6.^{12, 131, 146} They can usually be easily separated by their clinical features, morphology, and immunophenotype (Table 91.5). The disorders most likely to be confused with hairy cell leukemia are the hairy cell variant, B-cell prolymphocytic leukemia, and splenic marginal zone lymphoma (SML)/SLVL.¹⁴⁶

The HCL variant makes up 10% to 20% of all HCL cases and was originally described as having morphologic features intermediate between hairy cells and prolymphocytes and nowadays is classified by the World Health Organization (WHO) as being a separate disease from classical HCL.^{12, 155, 156} However, there are other presentations of the HCL variant, including hybrid forms of HCL and prolymphocytic leukemia or CLL, a blastic form of HCL, and an HCL multilobular form.^{155, 156, 157, 158, 159, 160, 161} These patients have many of the clinical and laboratory features of typical HCL. The HCL variant differs from typical HCL in a number of ways^{155, 156}:

- Patients are older with a median age at diagnosis of 71 years.
- The peripheral leukocyte count is higher (often $>50 \times 10^9/L$).
- The hairy cells have a higher nuclear-to-cytoplasmic ratio with more condensed nuclear chromatin and more prominent nucleoli than in classic HCL.
- The cells are TRAP-, CD25-, and CD123-, are usually IgVH unmutated, frequently use the IgVH4-34 gene, and do not have the BRAF (V600E) mutation.
- The monocyte count is normal.
- The marrow can usually be aspirated and there is an interstitial pattern of infiltration in the marrow with variable fibrosis.
- The clinical course is aggressive with a poor response to therapy and the median survival is 9 years.

B-cell prolymphocytic leukemia may have a presentation very similar to that of HCL, with splenomegaly and minimal or no peripheral lymphadenopathy.¹⁶² Prolymphocytic leukemia can usually be distinguished from HCL in that the nuclear chromatin is more clumped than in hairy cells, the level of peripheral lymphocytosis is high, the TRAP stain is negative or only weakly positive, and expansion of the white pulp in the spleen is evident. Cells can be differentiated from hairy cells by tissue markers.¹⁴²

In SLVL, previously known as malignant lymphoma simulating leukemic reticuloendotheliosis¹⁶³ and now considered to be one of the SMZLs,¹² the white cell count is usually higher than in HCL, being 3 to $38 \times 10^9/L$.^{163, 164} Typically, these patients have prominent splenomegaly and no lymphadenopathy. The leukemia cell is smaller and frequently contains a nucleolus, and the villi are shorter, fewer, and more uneven than in a typical hairy cell and are frequently concentrated at one end of the cell. A small monoclonal band is found in the serum or urine in two thirds of patients and patients may develop a Coombs-positive autoimmune hemolytic anemia.¹⁶⁴ Marrow involvement is patchier without the “fried-egg” pattern or reticulin fibrosis; in the spleen, the white pulp is expanded, and there is a variable degree of red pulp expansion without pseudosinus formation.^{163, 164} Immunophenotyping can also assist in differentiating these cells from hairy cells.¹³ Although these cells have many markers similar to those of hairy cells, only 25% of cases are CD25⁺, and these do not have the other

classic markers for HCL (strong staining for CD11c, CD103, and CD123). In marginal zone B-cell lymphoma, the pattern of bone marrow infiltration also tends to be patchy or focal without reticulin fibrosis, but in the spleen, the infiltration is predominantly in the red pulp, such as occurs in HCL.¹²⁴ In nodal marginal zone lymphoma (monocytoid B-cell lymphoma), the infiltrates resemble those of HCL, but the clinical presentation is different.^{12, 13} These patients usually have peripheral lymphadenopathy without splenomegaly and a high incidence of extranodal involvement. Bone marrow involvement is less frequent and usually is paratrabecular; peripheral blood involvement is rare. In lymph nodes, the infiltration is interfollicular and sinusoidal, often with preservation of some lymph follicles, a finding similar to that seen in hairy cell involvement of lymph nodes.

TABLE 91.6 HAIRY CELL LEUKEMIA: DIFFERENTIAL DIAGNOSIS

Splenic marginal zone lymphomas/splenic lymphoma with villous lymphocytes

Hairy cell variant

B-cell prolymphocytic leukemia

Chronic lymphocytic leukemia/small lymphocytic lymphoma

Lymphoplasmacytoid lymphoma, including Waldenström macroglobulinemia

Mantle cell lymphoma

Myeloproliferative disorders

Malignant histiocytosis

Primary lymphoma of spleen

Monocytoid B-cell lymphoma

Large granular lymphocytic leukemia

Systemic mast cell disease

Patients with CLL/small lymphocytic lymphoma (SLL), lymphoplasmacytic lymphoma, primary splenic CLL, and mantle cell lymphoma can have the same clinical presentation as HCL, but the laboratory features are quite different.^{12, 131} The cytologic appearance of the malignant cells on Wright stain and the appearance and distribution of the infiltrates in the bone marrow, spleen, and lymph nodes distinguish these disorders from HCL. In CLL/SLL, the lymphocytes are small with scant cytoplasm and clumped nuclear chromatin. The bone marrow usually is diffusely involved in CLL, but a focal interstitial pattern may be evident early in the course of the disease. In SLL, the bone marrow may not be involved early in the course, and the pattern initially is more focal. Involved lymph nodes in SLL and CLL show diffuse infiltration with small mature lymphocytes that completely efface the nodal architecture. The spleen shows not only white pulp expansion, but also a variable degree of red pulp expansion. The malignant lymphocytes in CLL/SLL are CD5⁺ in contrast to hairy cells, which are CD5⁻. In the lymphoplasmacytic disorders, particularly Waldenström macroglobulinemia, splenomegaly, peripheral lymphadenopathy, and a variable degree of pancytopenia are a more common presentation. As with hairy cells, these malignant B-cells are CD5⁻, but they are CD103⁻ and usually CD11c⁻ and CD25⁻. In addition, the cytologic appearance (plasmacytoid lymphocytes) and the frequent presence of a serum IgM monoclonal spike distinguish them from HCL. Although mantle cell lymphoma is usually associated with generalized lymphadenopathy, splenomegaly may be a prominent feature. Again, this lymphoma can be differentiated from HCL by the cytologic appearance of the cells, immunophenotyping, and the pattern and nature of the infiltration in lymph nodes, spleen, and bone marrow. The malignant cells are small, mature lymphocytes with scant cytoplasm, a round or cleft nucleus, and clumped nuclear chromatin. The bone marrow may demonstrate diffuse or patchy involvement. Lymph nodes are diffusely infiltrated and often show expansion of the mantle zone with residual isolated benign-looking germinal centers. A similar pattern is seen in the expanded white pulp in the spleen with a variable degree of red pulp expansion.

Various myeloproliferative disorders present with splenomegaly without peripheral lymphadenopathy, but the diagnosis is established easily by bone marrow biopsy and the findings on a peripheral blood smear.

P.1939

Malignant histiocytosis occasionally is associated with splenomegaly as the predominant manifestation.¹⁶⁵ The characteristic cytologic and cytochemical features of the malignant histiocytes and the subsequent course of the disease make the process of differential diagnosis easy.

Rarely, a diagnosis cannot be made for a patient with symptomatic splenomegaly short of splenectomy; these patients may have primary lymphoma of the spleen¹⁶⁶ or, less commonly, primary splenic HCL.¹⁶⁷

LGL leukemia frequently presents with splenomegaly without peripheral lymphadenopathy.¹⁶⁸ The disease is characterized by the presence of cells that are bigger than CLL cells and have abundant cytoplasm containing azurophilic granules. LGLs may be CD3⁻ NK-cells that mediate nonmajor histocompatibility complex-restricted cytotoxicity, or they are CD3⁺ cells, that may be in vivo activated cytotoxic T-lymphocytes that mediate nonmajor histocompatibility complex-restricted cytotoxicity.¹⁶⁸ T-LGL leukemia is associated with neutropenia (which may be cyclical), red cell aplasia, and rheumatoid arthritis, but is a distinct entity from Felty syndrome.¹⁶⁸ The usual immunophenotype of T-LGL leukemia is CD3⁺, CD4⁻, CD8⁺, CD16⁺, CD56⁻, CD57⁺, and TCRαβ⁺. NK-LGL leukemia occurs most frequently in Japan and has an acute fulminant course with high fever, hepatosplenomegaly, and pancytopenia. However, chronic NK-LGL leukemia can occur with clinical features similar to those of T-LGL leukemia.¹⁶⁸ These cells are usually CD3⁻, CD4⁻, CD8⁻, CD16⁺, CD56⁺, and CD57⁻.

Systemic mast cell disease, in which splenomegaly may be a prominent feature, rarely presents a problem in differential diagnosis, except for the appearance of the mast cell infiltrates in tissue sections that can closely mimic HCL.¹⁶⁹

More recently, a condition called hairy B-cell lymphoproliferative disorder (HBLD) has been described in five patients from Japan.^{170, 171} All patients were middle-aged women who presented with clinical and laboratory features consistent with the HCL variant and had a polyclonal increase in IgG. However, the hairy cells were polyclonal. This condition is thus similar to persistent polyclonal B-cell lymphocytosis, a rare and benign condition seen typically in middle-aged female smokers with a familial tendency.^{172, 173, 174} The lymphocytes are binucleated and have abundant cytoplasm. There is a polyclonal increase in IgM and a strong association with HLA-DR7.¹⁷² However, HBLD differs from persistent polyclonal B-cell lymphocytosis in that the patients in HBLD are not smokers, there is a polyclonal increase in IgG in HBLD as opposed to the polyclonal increase in IgM seen with persistent polyclonal B-cell lymphocytosis, the cells in HBLD are not binucleated, are CD11c⁺, and there is no association with HLA-DR7 in HBLD. The disorder needs to be differentiated from the HCL-Japanese variant (HCL-JV) which is similar to the HCL variant in having splenomegaly, a high peripheral leukocyte count with hairy cells, and does not have the diagnostic markers of classical HCL (Table 91.5).¹⁵⁶ However, in contrast with the HCL variant, the clinical course of HCL-JV is indolent and similar to classical HCL.

TREATMENT

Although splenectomy used to be the standard treatment for HCL, therapy for this disease over the past quarter of a century has usually involved IFN-α, the nucleoside analogs, and rituximab.^{136, 175, 176} Splenectomy and IFN-α may still be used for HCL under specific circumstances, but the standard therapy consists of the nucleoside analogs pentostatin or cladribine, which produce complete and durable remissions in the majority of patients. More recently, it has been demonstrated that the monoclonal antibody rituximab, which is directed against CD20, and the immunotoxins LMB-2 and BL22, which are directed against CD25 and CD22, respectively, have significant activity against nucleoside-resistant HCL. As discussed, there has also been recent interest in combining the nucleoside analogs with rituximab. Defining the optimal strategy for this combination with respect to schedule of drug administration and numbers of doses of the monoclonal antibody will require additional investigation.

Splenectomy

Until the mid-1980s, the standard therapy for HCL was splenectomy.^{5, 177, 178, 179, 180} The variable degree of pancytopenia in all patients during the course of their disease is partly related to splenomegaly.^{80, 81, 82, 83} An enlarged spleen may be responsible for the development of peripheral cytopenias by one or more of three mechanisms: increased sequestration or pooling, increased rate of peripheral destruction, or dilution of the cellular elements in the peripheral blood by an expanded plasma volume.^{80, 81, 82, 83} Other clinical manifestations, such as hypermetabolism, weight loss, early satiety, and left upper quadrant abdominal discomfort, are also caused by splenomegaly. Occasionally, patients may achieve a complete remission (CR) with splenectomy, and these patients may have a pure "splenic" form of HCL.² Approximately two thirds of patients have a hematologic response to splenectomy; the procedure may also alleviate early satiety, weight loss, and abdominal discomfort.⁵ However, it is unclear whether this procedure prolongs survival, because all the studies are retrospective, and, because of the obvious clinical benefit of splenectomy, randomized prospective trials have not been carried out.⁵ Early studies, with small numbers of patients, demonstrated no overall improvement in survival for patients after splenectomy.^{177, 178} However, in a large, multicenter retrospective analysis of 391 patients, a highly significant survival advantage ($P < 0.0001$) was demonstrated for those patients who underwent splenectomy.¹⁷⁹ In the

multicenter analysis, CR, defined as a postsplenectomy hemoglobin >11 g/dl, neutrophils $>1 \times 10^9$ /L, and platelets $>100 \times 10^9$ /L, was achieved in 40% of patients.¹⁷⁹ An increase was noted in the hemoglobin in 92%, neutrophils in 84%, and platelets in 92% of patients.¹⁷⁹ Jansen et al.¹⁷⁹ also reported that patients with larger spleens responded better than those with smaller spleens, but this has been disputed.¹⁸⁰ The duration of response after splenectomy is variable, but some patients remain asymptomatic for years. Approximately one third, however, achieve only a minimal response or relapse within a few months. In an analysis of prognostic variables after splenectomy in 194 patients, the most important were bone marrow cellularity and the platelet count.¹⁸¹ Failure-free survival, defined as time from splenectomy to death or the need for more therapy, was significantly worse if the post-operative bone marrow cellularity was $\geq 85\%$ or the platelet count was $<60 \times 10^9$ /L, or both.¹⁸¹

Although splenectomy is now rarely required in HCL, it may be of value for patients with splenic rupture, patients with the pure "splenic" form of the disease, and patients with splenomegaly and profound thrombocytopenia, having megakaryocytes in the marrow.⁵

Interferon- α

IFN- α , both the natural form and the two recombinant forms (IFN- $\alpha 2a$ and IFN- $\alpha 2b$), is effective in the treatment of HCL,^{182, 183, 184, 185, 186, 187, 188, 189, 190, 191} and a recent study has provided insight into the mechanism for this activity.¹⁹² IFN- α has been shown to induce apoptosis in nonadherent hairy cells; this is related to an increase in the production of TNF by the hairy cells associated with sensitization of the hairy cells to TNF- α .¹⁹² The sensitization is due to a decrease in the levels of inhibitors of apoptosis (IAPs) by IFN- α . It is interesting that IFN- α does not induce apoptosis in hairy cells adhering to vitronectin or fibronectin, because IFN- α does not affect the IAPs in adherent cells. The receptors for TNF- α are not changed by IFN- α . These results may explain why IFN- α can clear

P.1940

hairy cells rapidly from the bloodstream, but not from the tissues, in which the leukemic cells presumably are adherent.

A CR was defined as normalization of the peripheral blood counts (hemoglobin >120 g/L, platelets $>100 \times 10^9$ /L, and neutrophils $>1.5 \times 10^9$ /L) for at least 1 month with no morphologic evidence of hairy cells in the marrow or peripheral blood and resolution of organomegaly. A partial remission (PR) was defined as the normalization of peripheral blood counts and the persistence of $>5\%$ hairy cells in the marrow; however, treatment must have produced a $>50\%$ fall in the hairy cell infiltration in marrow. The aggregate results show that the overall response rate with IFN- α is $\sim 80\%$, with 13% having a CR and 69% having a PR.^{189, 190, 191} Responding patients have a reduced incidence of infections, even if they remain neutropenic.¹⁸⁷ The responses occur rapidly, regardless of whether the patients have previously had a splenectomy, with hairy cells disappearing from the peripheral blood within the first week; the platelet counts return to normal within 2 months, the hemoglobin level within 4 months, and the neutrophil counts within 4 to 6 months.^{182, 187} The percentage of hairy cells in the bone marrow decreases, but they rarely disappear completely, and the reticulin fibrosis persists.^{193, 194} Patients with CD5⁺ hairy cells¹⁹⁵ and HCL-variant patients¹⁴⁹ respond poorly to IFN- α .

The optimal dose schedule for IFN- α in HCL has yet to be established. In most series, the dose is 2 to 4×10^6 U/m² subcutaneously (SC) three to seven times weekly for 12 months. Higher doses do not appear to increase the response rate and are associated with more toxicity.^{186, 196} In addition, extending the treatment beyond 12 months does not improve the response rate, and the development of a chronic fatigue syndrome is more prevalent and severe.¹⁹⁷ Doses 1 log lower (2×10^5 U/m² three times weekly) show activity, but the response is inferior to that achieved with higher IFN- α doses.¹⁹⁸ However, the relapse rate is high (33% to 77%) after the discontinuation of IFN- α , usually 6 to 31 months after cessation of therapy.^{188, 199} It has been demonstrated that maintenance low-dose IFN- α (1×10^6 U, three times/week, or 3×10^6 U, once per week) can prolong remissions with minimal toxicity.^{191, 200, 201} In one study, patients received either no maintenance therapy or 1×10^6 U IFN- α three times/week; 37 of the 56 patients who did not receive maintenance therapy relapsed at a median time of 19 months, whereas none of the 28 patients receiving maintenance therapy relapsed, with the median follow-up time being 30 months.²⁰⁰ When patients relapse after IFN- α therapy, a further remission can generally be obtained with IFN- α ^{200, 201} or the nucleoside analogs.^{136, 175, 176} In addition, patients who relapse after therapy with the nucleoside analogs may respond to IFN- α , confirming the lack of cross-reactivity between these agents.²⁰²

Neutralizing anti-IFN antibodies appear to develop in one third of patients treated with IFN- $\alpha 2a$,²⁰³ but this does not occur with IFN- $\alpha 2b$.²⁰⁴ The clinical significance of these neutralizing antibodies and their role in the induction of resistance to therapy are controversial. In 51 patients with HCL treated with IFN- $\alpha 2a$, 31 (61%) developed antibodies after a median of 6 months of therapy, and in 16 of these, the antibodies neutralized the antiviral activity of recombinant IFN- $\alpha 2a$ in vitro but had no effect on natural IFN- α .²⁰³ It is interesting that six of the patients with antibodies were clinically resistant to

IFN- α , whereas none of the patients without antibodies were resistant. However, in a follow-up study, no further patients were noted to have developed antibodies, and antibodies to IFN could no longer be detected in patients who previously had antibodies, although they continued to receive IFN- α .²⁰⁵

Virtually all patients experience toxicity with IFN- α therapy, and the frequency and severity are dose- and age-related. Flu-like symptoms occur in most patients with the initiation of treatment; these symptoms can usually be controlled with acetaminophen or by reducing the IFN- α dosage, and symptoms usually resolve within 2 to 4 weeks. Less common symptoms include: nausea and vomiting; diarrhea; central nervous system manifestations, such as somnolence and confusion; cardiovascular disorders, including hypotension and tachycardia; and skin changes, such as rash and pruritus.¹⁹⁶ With high doses, leukopenia, thrombocytopenia, and anemia may occur, but this is rare with the doses of IFN- α used for HCL. A worsening of pre-existing autoimmune disorders, or the emergence of new autoimmune problems, has also been reported with IFN- α therapy; this appears to be related to the development of multiple autoantibodies.²⁰⁶ In most reports, patients developed thyroiditis, autoimmune thrombocytopenia, or anemia.^{207, 208} Kampmeier et al.²⁰⁹ reported an increased incidence of second malignancies in HCL patients treated with IFN. Of 69 patients treated with IFN- α 2b for 12 to 18 months, 13 (19%) developed second malignancies; this incidence was substantially higher than predicted. Six of the tumors were hematologic, and seven were adenocarcinomas. The tumors developed 17 to 105 months after the initiation of IFN- α . However, these results have not been confirmed, and no increase in the incidence of second malignancies was observed in 200 HCL patients in another study, of whom 147 had been treated with IFN- α .²¹⁰

Nucleoside Analogs

The nucleoside analogs pentostatin (pentostatin; Nipent, SuperGen, San Ramon, CA), cladribine (cladribine; Leustatin, Ortho Biotech, Raritan, NJ), and fludarabine (F-ara-A AMP; Fludara, Berlex Laboratories, Richmond, CA) have significant activity in the low-grade lymphoid malignancies (Fig. 91.8).^{136, 175, 176} Both pentostatin and cladribine have now replaced IFN- α as first-line therapy for HCL, and fludarabine is now one of the standard treatments for CLL.

After therapy with pentostatin, deoxyadenosine and adenosine accumulate in the plasma; after uptake into cells, deoxyadenosine is phosphorylated to deoxyadenosine monophosphate, deoxyadenosine diphosphate, and deoxyadenosine triphosphate (dATP); this occurs preferentially in lymphocytes.²¹¹ The intracerebral accumulation of deoxyadenosine and adenosine likely causes the nausea and vomiting that are a major toxicity of this agent.²¹² Cladribine and F-ara-A are halogenated derivatives of deoxyadenosine that are resistant to degradation by adenosine deaminase. For clinical use, F-ara-A is administered as the more water-soluble monophosphate, F-ara-AMP (fludarabine), which is rapidly dephosphorylated in the plasma to F-ara-A.^{213, 214} As with deoxyadenosine, cladribine and F-ara-A accumulate in lymphocytes as their phosphorylated derivatives and their mechanisms of action have been recently reviewed.^{215, 216, 217} These agents can kill lymphocytes in three ways (Figs 91.9 and 91.10).^{215, 216, 217} First, the triphosphate forms can trigger DNA breaks, which result in the release of cytochrome c from the mitochondria; the released cytochrome c interacts with Apaf-1 and dATP, causing the activation of caspase 9 and, subsequently, apoptosis. Second, the increased levels of triphosphates can enhance the effects of endogenous dATP on the apoptosome, inducing apoptosis. Finally, cladribine differs from deoxyadenosine and F-ara-A in that it is phosphorylated by deoxyguanosine kinase in the mitochondria to cdATP, which is directly toxic to the mitochondria.

Pentostatin is highly effective in HCL and produces a much higher rate of durable CR than is observed with IFN- α (Table 91.7).¹⁸⁹ Pentostatin has been administered in a variety of different doses and schedules for HCL, but regardless of the mode of administration, it produces responses in most patients. Of 960 patients in nine studies, the CR rate ranged from 44% to 89% (median, 76%), and the PR rate varied from 0% to 52% (median, 16%).^{189, 216, 217, 218, 219, 220, 221, 222, 223, 224, 225} Patients who relapse after splenectomy or who are resistant to IFN- α also respond to pentostatin, with a median CR rate of 42% and a PR rate of 45%.^{225, 226, 227} In two large studies, the response rates to pentostatin were

P.1941

similar in untreated patients and in patients previously treated with IFN- α .^{189, 224} Moreover, these studies identified young age, initial high hemoglobin, high white cell count, and little or no splenomegaly as favorable prognostic features.^{189, 224} The most commonly used treatment regimen is pentostatin 4 mg/m² intravenously (IV) every second week; the average number of treatments to CR is 8 (range, 4 to 15).^{189, 220} The peripheral blood lymphocyte count falls rapidly after the initiation of treatment, with the hairy cell count decreasing by 50% to 95% in the first week.²²⁸ Concomitantly, there is a rapid increase in platelets followed by recovery of neutrophils and hemoglobin; the median time to documented peripheral and marrow CR is 4 months.²²⁸ In contrast to IFN- α , there is resolution of the marrow fibrosis after therapy with pentostatin.^{228, 229} Using immunophenotyping of peripheral blood or bone marrow, immunohistochemistry of the bone

biopsy, or gene rearrangement studies, one can detect MRD in HCL patients who are in morphologic CR after pentostatin, suggesting that pentostatin cannot entirely eliminate the hairy cell population.^{229, 230} In addition, relapses are observed after discontinuation of treatment without evidence of a plateau, although the duration of remissions is considerably longer than for IFN- α .^{189, 221, 231, 232, 233}

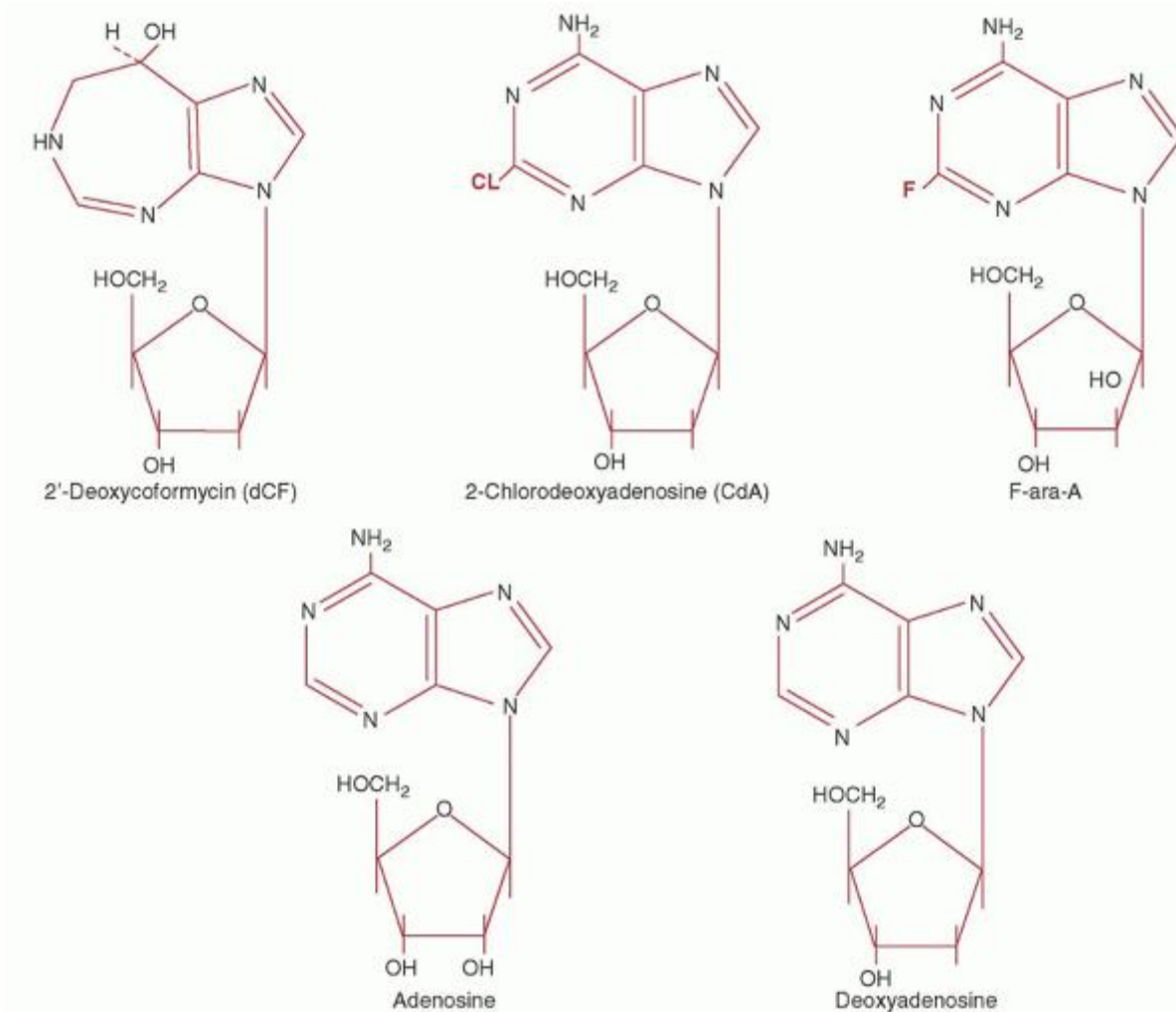

FIGURE 91.8. Structures of nucleoside analogs.

Several studies have evaluated the long-term outcome of patients treated with pentostatin^{223, 225, 232, 233, 234, 235, 236} (Table 91.8). The longest follow-up is of 188 patients followed for a median of 14 years with the relapse rates at 5, 10, and 15 years being 24%, 42%, and 47%, respectively.²³³ The likelihood of relapse depended on response and pre-treatment parameters with the longest remission being in those who achieved a CR and had a pre-treatment hemoglobin of >100 g/L and platelets $>100 \times 10^9$ /L, and the worst prognosis was in those who achieved a PR and were anemic and/or thrombocytopenic pre-treatment (Fig. 91.11).^{233, 234} For patients who remain in CR at 5 years the likelihood of remaining in CR by 15 years is 75%. For patients requiring another treatment, the likelihood of achieving a CR decreased but for those who did achieve a CR the prognosis was similar as for those with a first-time CR.^{233, 234}

In the Phase III intergroup study, patients were randomized to receive pentostatin, 4 mg/m^2 IV every 2 weeks, or IFN- α , 3×10^6 U SC three times per week.^{189, 236} Patients not responding to one treatment were switched to the other agent. There were 241 patients who received pentostatin and were followed for a median of 9.3 years; 154 received pentostatin as initial therapy, and 87 received pentostatin after failure with IFN- α . For all

P.1942

patients, the estimated 5- and 10-year survivals were 90% and 81%, similar to those predicted for the general population. The survival was similar whether patients were treated initially with pentostatin or were crossed over to pentostatin after

treatment with IFN- α (Fig. 91.12A). Patients younger than 55 years of age did significantly better than patients 55 years of age or older, and the 10-year survivals for the two groups were 93% and 68%, respectively (Fig. 91.12B). Similarly, in a large multicenter retrospective study from France, the estimated survivals at 5 and 10 years in 230 evaluable patients treated with pentostatin were both 89%.²²⁴ In that study, a hemoglobin level <100 g/L, a white cell count <2 $\times 10^9$ /L, and lymphadenopathy were associated with decreased survival.

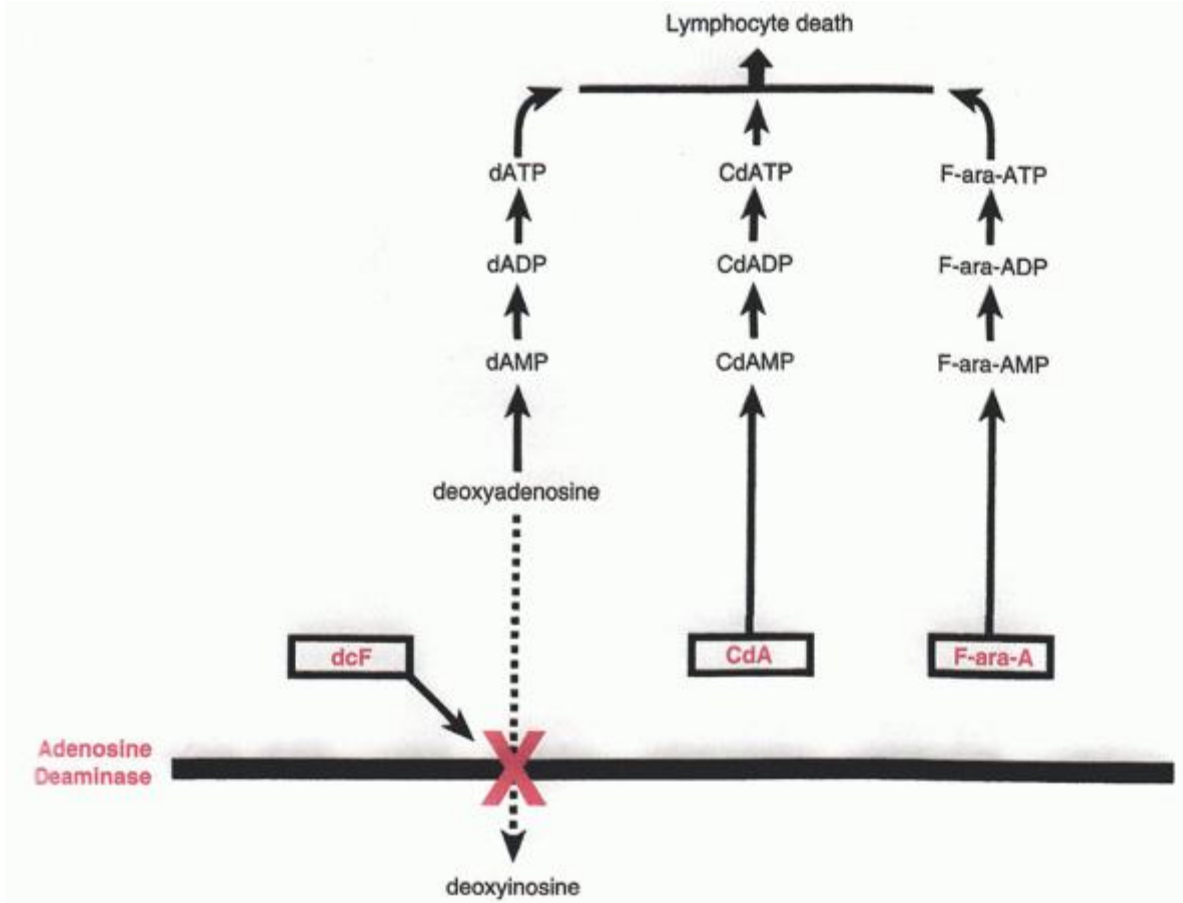

FIGURE 91.9. Metabolism of the nucleoside analogs. ADP, adenosine diphosphate; AMP, adenosine monophosphate; ATP, adenosine triphosphate; CdA, 2-chlorodeoxyadenosine; d, deoxy; dCF, 2'-deoxycoformycin.

Pentostatin is generally well tolerated, although nausea and vomiting and lethargy can occur.^{189, 216, 217, 218, 219, 220, 221, 222, 223, 224, 225} Drug-induced neutropenia with fever commonly occurs with initiation of treatment and deaths from infection have occurred. However, for patients receiving 4 mg/m² pentostatin every 2 weeks, infections can be avoided by delaying the treatments if the white blood count is <1.5 $\times 10^9$ /L.²²⁰ Pentostatin decreases the number of T-cells to a greater extent than that of B-cells, and CD4⁺ cells are affected to a greater extent than CD8⁺ cells or NK-cells, whereas Ig levels are not affected.^{229, 237, 238, 239} The CD4⁺ and CD8⁺ cell counts fall to <0.2 $\times 10^9$ /L during therapy;^{229, 237, 238} after discontinuation of pentostatin, the CD4⁺ counts gradually recover and normalize in 3.0 to 49.5 months (median, 14.5 months).²²⁹ The CD8⁺ and B-cells recover at the same rate.^{229, 237, 238} Associated with the decrease in T-cells during therapy is an increase in the incidence of herpetic infections, which are easily treated with acyclovir, and there is a gradual decrease in the incidence after discontinuation of therapy.^{229, 237, 238} However, there is no increase in more unusual opportunistic infections, either during therapy or during long-term follow-up, and there is no evidence of a significant increase in second malignancies.^{233, 236} Although neurotoxicity is a problem with high doses of pentostatin,²⁴⁰ this is not observed with the doses used for HCL.

Cladribine appears to have activity equivalent to that of pentostatin in HCL, and has the advantage of rarely causing nausea and vomiting although it appears to be more myelosuppressive.^{233, 234, 241, 242, 243, 244, 245, 246, 247, 248, 249, 250, 251, 252, 253} In initial studies, cladribine was administered as 0.1 mg/kg/day by continuous infusion for 7 days, because in vitro studies indicated that a prolonged exposure to cladribine was required for cytotoxic effect.²⁴⁶ Response rates varied, with the CR ranging from 50% to 91% (median, 80%) and PR from 0% to 37% (median, 16%).^{241, 242, 243, 244, 245, 246, 247, 248, 249, 250, 251, 252, 253}

P.1943

As with pentostatin, there was a rapid recovery in blood counts, with the platelet count increasing almost immediately, followed by an increase in neutrophils and hemoglobin. Some patients achieved a CR with normal blood counts, whereas the marrows remained hypocellular.²⁵⁴ Technetium 99 m sulfur colloid scans have demonstrated increased uptake in the distal appendicular skeleton in some of these patients, suggesting abnormal areas of hematopoiesis.²⁵⁴ Although hairy cells may not be seen in the marrow 3 to 4 months after cladribine treatment, the leukemic cells can still be detected by immunostaining, using the monoclonal antibody, DBA.44,²⁵⁵ or by using the (PCR) with clonospecific probes for IGH genes.²⁵⁶ When marrows were intermittently examined by DBA.44 for 25 months after treatment with cladribine, there was no increase in the number of hairy cells in the marrow in most cases, suggesting stabilization of residual disease.²⁵⁵ However, others have suggested that the presence of residual disease is predictive of relapse.²⁵⁷ Because cladribine has not been compared with pentostatin in a randomized study, it is unknown whether one of these agents is superior in terms of toxicities and long-term outcomes (Table 91.8). However, in patients achieving a CR morphologically, Tallman et al.²⁵⁷ demonstrated with immunohistochemical stains that there is evidence of residual disease comparable to that observed after pentostatin. Moreover, Else et al.²³³ have recently carried out a retrospective analysis of patients treated either with pentostatin or cladribine at the Royal Marsden Hospital. The overall response rates and survivals were the same for both drugs. In a large, long-term study from the Scripps Clinic, 91% of patients achieved a CR with cladribine, and these 349 patients were followed for a median of 52 months (range, 1 to 134 months).²⁴⁸ Of these patients, 24% relapsed at a median time of 30 months (range, 7 to 85 months). The overall survival at 48 months was 96%. The same group has evaluated 207 patients followed for at least 7 years,²⁴⁹ and 37% relapsed with patients achieving a CR relapsing later (median 44 months [8 to 118 months]) than those who achieved PR (median 31 months [10 to 108]). Of 60 patients who received a second cycle of cladribine, 75% achieved a CR and 17% a PR. It is interesting that 19 of 358 patients treated at Scripps have remained in long-term remission after a single cycle of cladribine. The median time from cladribine was 16 years and 9 had no evidence of MRD, 7 had MRD, and 3 had morphologic evidence of HCL.²⁵³

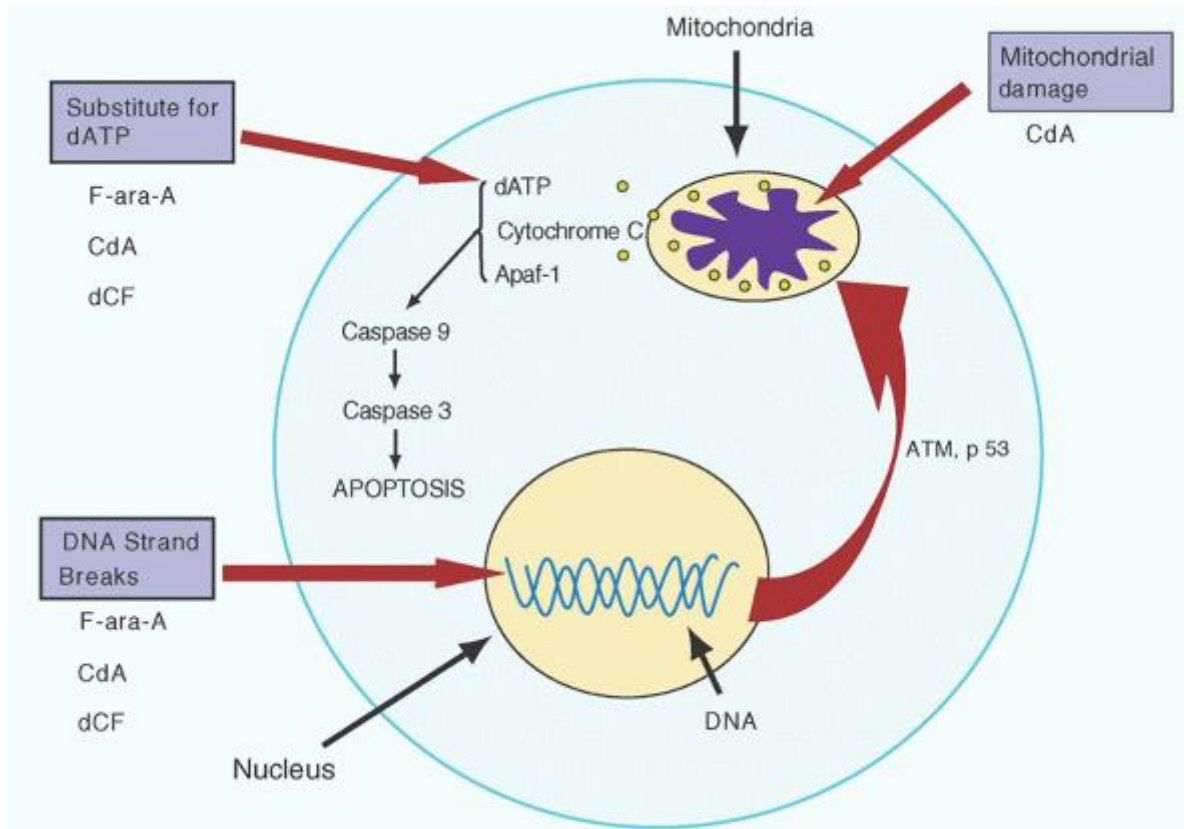

FIGURE 91.10. Mechanism of action of the nucleoside analogs. CdA, 2-chlorodeoxyadenosine; dATP, deoxyadenosine triphosphate; dCF, 2'-deoxycoformycin. (Modified from Genini D, Adachi S, Chao Q, et al. Deoxyadenosine analogs induce programmed cell death in chronic lymphocytic leukemia cells by damaging the DNA and by directly affecting the mitochondria. *Blood* 2000;96:3537-3543, with permission.)

A number of patients who were resistant to pentostatin have obtained remissions with cladribine, suggesting a possible lack of cross-resistance between these agents.^{224, 258} This may be related to the additional action of cladribine on the mitochondria of the leukemia cells.^{215, 216} Likewise, some patients who have not achieved a CR with cladribine have also achieved durable remissions with pentostatin. Therefore, the overall response rates and relapse rates are comparable with either purine analog.

Cladribine can be toxic and was implicated as the cause of deaths in the National Cancer Institute group C Phase II study in P.1944

P.1945

1.1% of 979 patients.²⁴⁷ The major cladribine toxicity is marrow suppression; one third to one half of patients developed severe neutropenia with infections and often required prolonged blood support after therapy. This problem is not prevented by prophylactic antibiotics, and, although an infectious cause for the fever is not found in most cases, affected patients may require hospitalization for septic workup and antibiotics. The likelihood of this complication occurring increases with the severity of initial marrow involvement, and it has been suggested that these patients should initially be treated with IFN- α .²⁵⁹ Alternatively, to reduce the risk of infections, granulocyte colony-stimulating factor has been administered using 5 μ g/kg/day SC on days -3, -2, and -1 before a standard 7-day course of cladribine, and then after cladribine until the neutrophil count was $>2 \times 10^9/L$ for

P.1946

2 consecutive days.²⁶⁰ Although granulocyte colony-stimulating factor increased the neutrophil count before therapy and reduced the severity of neutropenia after cladribine, there was no decrease in the number of febrile episodes and the number of hospitalizations for antibiotics. An identical phenomenon is observed after treatment of HCL with pentostatin,^{218, 231} and it has been suggested that the fever is related to tumor lysis and the release of cytokines by the tumor.²⁴⁴ It is important to realize that patients with active infection were not eligible to participate in the initial cladribine trials. Thus, a patient with hairy cell leukemia who requires therapy, but has an active infection, presents a challenging dilemma. In general, it is important to try to treat any infection before administering a purine analog and if there is urgency in treating the leukemia initial therapy with IFN should be considered. Alternatively, pentostatin has been administered to patients with infection when therapy was essential and the incidence of febrile neutropenia may be less following pentostatin than seen with cladribine. The intermittent schedule of drug administration following pentostatin affords an opportunity to titrate the drug administration depending upon the neutrophil count. It is clear that the optimal management of patients with hairy cell leukemia with a concomitant active infection requires further investigation.

TABLE 91.7 RESPONSE RATES WITH DIFFERENT AGENTS AND TREATMENT SCHEDULES FOR HAIRY CELL LEUKEMIA

Agent	Author ^{Ref} (Year)	Dose and Schedule	Number of Patients	CR (%)	PR (%)
Interferon-α					
	Spielberger ¹⁹⁹ (1994)	2×10^6 U/m ² SC; 3 \times /wk for 12 or 18 mo	69	13	62
	Grever ¹⁸⁹ (1995)	3×10^6 U SC; 3 \times /wk for 12 mo	159	11	27
	Rai ¹⁹⁰ (1995)	2×10^6 U SC; 3 \times /wk for 12 mo	55	24	49
Pentostatin					
	Spiers ²¹⁹ (1987) ^a	5 mg/m ² IV daily \times 2; repeated every 14 d until CR	27	59	37
	Johnston ²¹⁸ (1988)	Cycles (4 mg/m ² IV/wk \times 3); q8wk until CR + 2 further cycles	28	89	11

Grever ¹⁸⁹ (1995)	4 mg/m ² IV q2wk; until CR + 2 to max 12 mo	154	76	3
Maloisel ²²⁴ (2003)	4 mg/m ² IV q2wk until max response or failure	238	79	17
Else ²³³ (2009)	4 mg/m ² IV q2wk; until CR + 2	188	82	14
Cladribine				
Juliusson ²⁷⁰ (1995)	3.4 mg/m ² SC daily × 7 d	73	81	14
Saven ²⁴⁸ (1998)	0.1 mg/kg/d cont IV × 7 d	349	91	7
Lauria ²⁷² (1999)	0.15 mg/kg IV over 2 h weekly × 6	30	73	27
Robak ²⁷⁶ (2007)	0.12 mg/kg/d IV over 2 h × 5 d	62	76	19
	0.12 mg/kg/wk IV × 6 wk	54	72	19
Else ²³³ (2009)	0.1 mg/kg/d cont IV × 7 d	45	76	

cont, continuous; CR, complete remission; IV, intravenous; max, maximum; PR, partial remission; SC, subcutaneously.

^a Median number of injections, 12.

TABLE 91.8 LONG-TERM FOLLOW-UP OF PATIENTS WITH HAIRY CELL LEUKEMIA

Agent	Author ^{Ref} (year)	Number of CR Patients	Median Follow-Up Months (Range)	Relapse after CR (%)	Outcome for Patients in CR ^e
Interferon-α					
	Grever ¹⁸⁹ (1995)	159	11 57 (19-82)	70	
Pentostatin					
	Johnston ²³⁵ (2000)	28	89 125 (61-137)	36	Median time to relapse 49 mo (15-122 mo)
	Flinn ²³⁶ (2000)	241	76 112 (19-139)	18	RFS 67% at 10 y
	Maloisel ²²⁴ (2003)	238 ^a	79 63.5 (0.39-138.4)	14	DFS 68.8% at 10 y
	Else ²³³ (2009)	188	82 71 (6-139)	44	Relapse rate at 15 y, 47%
Cladribine					
	Saven ²⁴⁸ (1998)	358 ^b	91 58 (1-134)	24	
	Jehn ²⁵¹ (2004)	40	102 (1.2-146)	39	
	Goodman ²⁴⁹	209 ^c	95 108 (86-172)	34	Median time to

(2005)						relapse 44 mo (8-118 mo)
Chadha ²⁵² (2005)	86 ^d	79	116 (4-165)	31		Median time to relapse 35 mo
Else ²³³ (2009)	45	76	108 (5-192)	38		Relapse rate at 15 y, 48%

NA, not available.

^a Only 230 evaluable for response.

^b Only 349 evaluable for response.

^c Follow-up of at least 7 years. Only 207 evaluable for response.

^d Only 85 evaluable for response.

^e RFS, relapse-free survival.

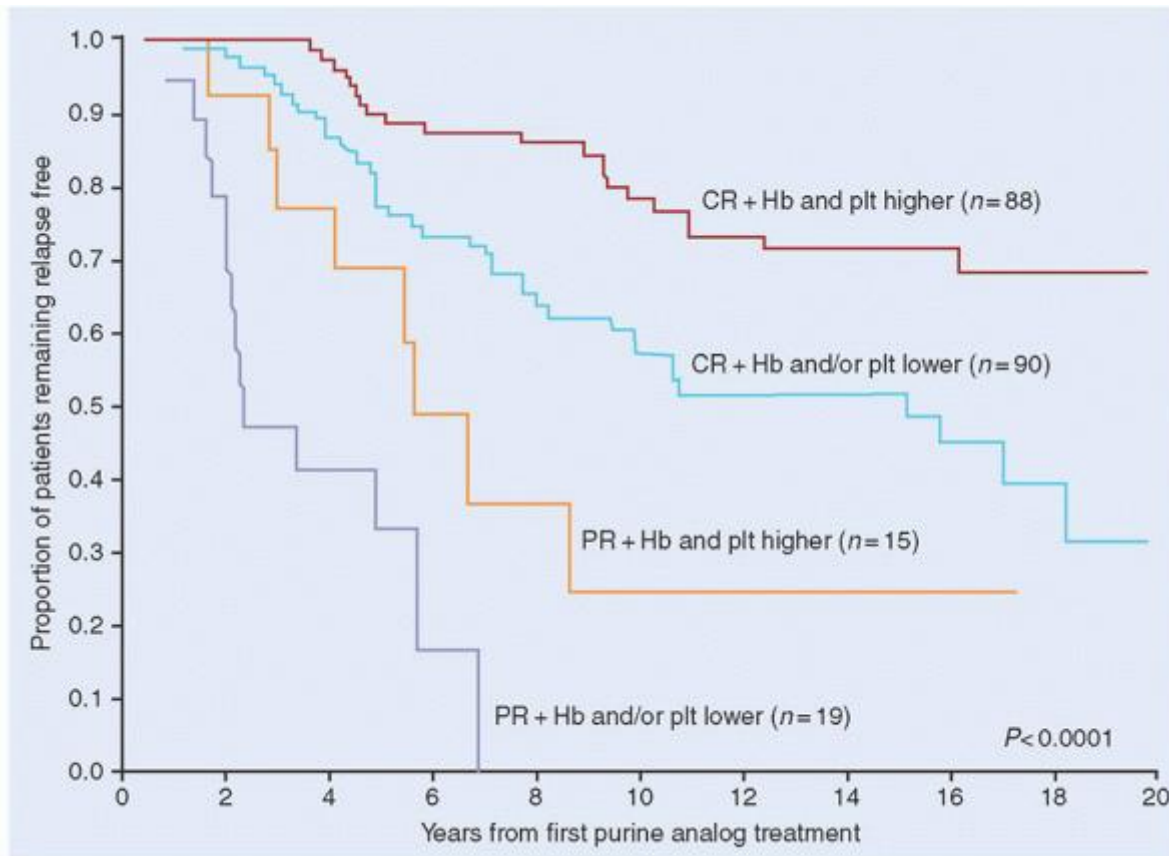

FIGURE 91.11. Relapse-free survival after first-line purine analog therapy. Patients were separated by pre-treatment blood

counts and response to therapy. Relapse-free survival was longest in complete responders (CR) with hemoglobin (Hb) >100 g/L and platelet count >100 × 10⁹/L (CR + Hb and Plt higher) and shortest in partial responders with hemoglobin <10 g/dl and/or platelet count <100 × 10⁹/L (PR + Hb and/or Plt lower). (From Else M, Dearden CE, Mastutes E, et al. Long-term follow-up of 233 patients with hairy cell leukaemia, treated initially with pentostatin or cladribine, at a median of 16 years from diagnosis. *Br J Haematol* 2009;145:733-740, with permission.)

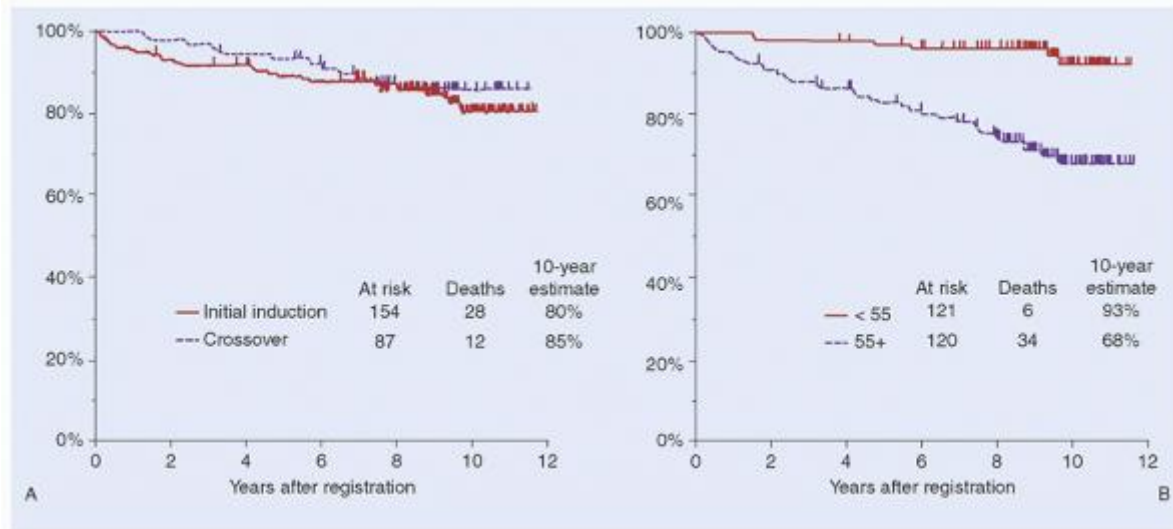

FIGURE 91.12. Long-term responses to treatment with the nucleoside analogs. A: Survival of patients treated initially with pentostatin or after crossover from interferon- α . Survival is similar in both groups ($p = 0.59$). Figure shows estimated distributions of overall survival (Kaplan-Meier estimates) from date of registration for 2'-deoxycoformycin (dCF) therapy, by phase of treatment. B: Overall survival by age of patients treated with dCF. Survival is significantly better for patients younger than 55 years of age ($p < 0.0001$). Figure shows estimated distributions of overall survival (Kaplan-Meier estimates) from date of registration for dCF therapy, by age at start of initial therapy. (From Flinn IW, Kopecky KJ, Foucar MK, et al. Long-term follow-up of remission duration, mortality, and second malignancies in hairy cell leukemia patients treated with pentostatin. *Blood* 2000;96:2981-2986, with permission.)

Cladribine also produces a profound fall in the CD4⁺ and CD8⁺ cell counts, and although CD8⁺ cell counts may recover within 3 months, the CD4⁺ count may take longer than 3 years to normalize.^{261, 262} Despite this, there have, to date, been no long-term problems with opportunistic infections after therapy with cladribine.^{239, 244} However, infections, sometimes opportunistic, do occur in some of these patients, and deaths have been reported.^{243, 263} More recently, Epstein-Barr virus, associated diffuse large B-cell non-Hodgkin's lymphoma, have been described in two patients shortly after completion of cladribine therapy.^{264, 265} Significant neurotoxicity has also been observed with cladribine and may involve the legs or arms.²⁴⁷ Transfusion-associated graft-versus-host disease has been observed with multiple cycles of cladribine or fludarabine in low-grade lymphomas and CLL,^{266, 267} but, to the authors' knowledge, this has not yet been observed in HCL.

There has been interest in investigating different modes of cladribine administration to simplify the treatment and minimize toxicity. Liliemark et al.²⁶⁸ demonstrated an identical "area under the curve" for drug concentration versus time using the same cladribine concentration given by continuous infusion, as a 2-hour infusion, or given orally using twice the IV dose. Similar responses have been obtained with cladribine in HCL using 0.1 mg/kg IV over 2 hours daily × 5²⁶⁹ or 0.1 mg/kg SC daily × 7^{270, 271} and when the drug was administered as 0.1 mg/kg/day by continuous infusion × 7. Weekly cladribine (e.g., 0.14 to 0.15 mg/kg/week IV × 5 to 6 weeks) appears to be as effective as the other schedules.^{272, 273, 274, 275, 276} However, although this regimen was initially felt to be associated with less marrow suppression and to be safer than conventional regimens, recent randomized studies demonstrated that the weekly regimen produced an equivalent incidence of infections and septic deaths as a standard regimen using 0.12 mg/kg over 2 hours daily × 5.^{275, 276}

Fludarabine has not yet been evaluated extensively in HCL. However, complete and partial responses have been observed in the few patients treated thus far.^{277, 278}

Monoclonal Antibodies

Monoclonal antibody therapy is an attractive option for HCL, because many patients have significant neutropenia at the time of diagnosis and the monoclonal antibodies should theoretically not worsen this problem. The chimeric monoclonal

antibody rituximab (Rituxan; Genentech, Inc., South San Francisco, and IDEC Pharmaceuticals, San Diego, CA) contains a human IgG1 Ig constant region and a murine variable region directed against the cell-surface CD20, an antigen that plays an important role in the activation, proliferation, and differentiation of B-cells.²⁷⁹ This agent has shown significant activity against the low-grade lymphomas, which have high surface concentrations of CD20, and is believed to exert its antitumor activity by complement-dependent cytotoxicity, antibody-dependent cell-mediated cytotoxicity, or the direct induction of apoptosis.^{279, 280, 281} Using rituximab, 375 mg/m² IV once per week for 4 weeks, response rates of 25% to 75% were observed with a variable number of CRs.^{283, 284, 285, 286, 287} This variation may be related to the extent of prior treatment as the poorest responses were observed in heavily pre-treated patients.²⁸⁴ A more prolonged duration of therapy may improve efficacy, and Nieva et al.²⁸⁴ have observed a response rate of 80% with 53% CRs in 15 patients with relapsed or refractory HCL using 8 weekly treatments with rituximab. Kreitman and Pastan^{288, 289, 290} have developed two immunotoxins directed against CD25 and CD22, which contain the modified light chains of the antibodies bound to a truncated form of the *Pseudomonas* exotoxin. The immunotoxin can kill the targeted cells through a variety of ways and the immune mechanisms utilized by rituximab are not required. BL22 is directed against CD22 and has undergone Phase I and II clinical trials, demonstrating a response rate of up to 72% with a CR rate of 47% in cladribine relapsed/resistant HCL patients.²⁹⁰ Some of these responses can last many years. Patients with small spleens were more likely to respond with not statistically significant relationship between prior response to cladribine and response to BL22. One unusual toxicity with this regimen is a reversible form of the hemolytic uremic syndrome, which occurs in about 10% of patients and appears unrelated to depletion of plasma ADADTS13.^{288, 289, 290} LMB-2 is a similar structured immunotoxin directed against CD25 which has also demonstrated activity in HCL.²⁸⁸

Repeated Treatments or Drug Combinations

As patients who achieve a CR appear to have a much longer remission than those who achieve a PR, attempts have been made to convert PR to a CR. The group at the Royal Marsden Hospital have demonstrated in 8 patients who achieved a PR with cladribine that a second course of treatment at 4 to 7 months led to a CR in 6 patients and the relapse-free survival was the same whether one or two cycles of therapy was required to achieve the CR.^{233, 234} An alternate approach has been to administer rituximab following chemotherapy to consolidate the remission. Thus, rituximab given 3 to 6 months following cladribine can increase the number of CRs without additional toxicity.²⁸⁶ More recently, 36 patients (5 with HCLv) have been treated with a standard dose of cladribine followed 1 month later by rituximab 375 mg/m² IV weekly for 8 weeks.²⁸⁷ All patients achieved a CR with 79% having a marrow clear of MRD; with a median follow-up time of 25 months (1 to 63 months), only 1 patient with HCLv has relapsed. Rituximab has also been co-administered with the nucleoside analogs with tolerable toxicity and high response rates.^{288, 291, 292}

Other Treatments

Because HCL is now so easily and effectively treated with the nucleoside analogs, IFN- α , or the monoclonal antibodies, other treatments have become redundant. However, for completeness and interest, they are reviewed briefly. Chlorambucil was previously used when the disease progressed after splenectomy.^{293, 294} Although some patients improved, the course in others was often worse, with more myelosuppression. The best results were reported by Golomb et al.,²⁹⁴ who administered chlorambucil, 4 mg orally/day for at least 6 months, to 24 postsplenectomy patients with progressive disease. A reduction in the number of circulating hairy cells and an increase in one or

P.1947

more of the normal peripheral blood cellular elements occurred in most patients. Six deaths occurred, and time to response was 6 months or longer. Other chemotherapeutic agents, either alone or in combination, have demonstrated some benefit, but the toxic effects were often severe.^{295, 296} These agents included doxorubicin;²⁹⁷ rubidazole;²⁹⁸ combinations of rubidazole, cytarabine, and cyclophosphamide; or cytarabine and cyclophosphamide.²⁹⁹ PRs also have been reported with androgens,^{300, 301} as well as with a combination of lithium carbonate and immunotherapy with Calmette-Guérin bacillus.³⁰² A transient increase in neutrophils can be obtained with granulocyte colony-stimulating factor and may be a useful adjunct to more definitive therapy.^{260, 303} Steroids are ineffective and increase the risk of infection.⁴

Bone Marrow Transplantation

One case of successful bone marrow transplantation from an identical twin has been reported.³⁰⁴

Leukapheresis

Clinical and hematologic improvements, lasting as long as 26 months, have been reported by using leukapheresis to reduce the number of hairy cells in the peripheral blood.^{305, 306} However, others have found the responses less predictable and more transient.³⁰⁷

Radiation Therapy

Low-dose radiotherapy to the spleen can produce transient clinical and hematologic improvements, but the response is slow and unpredictable.³⁰⁸ However, radiation therapy can be effective for the treatment of massive retroperitoneal lymphadenopathy and lytic bone lesions.³⁰⁹

Treatment of Hairy Cell Leukemia Variant

In contrast to classical HCL, the HCL variant is notoriously difficult to treat. Splenectomy has been reported to produce partial responses in approximately half the patients with improvements in the blood counts.^{155, 156, 157} Although response to the nucleoside analogs is generally poor, it is reasonable to treat these patients with a rituximab-nucleoside analog combination or to refer the patient for a clinical trial with a novel agent.^{143, 156, 287, 288, 289, 290, 291, 292}

SUMMARY

- Asymptomatic patients with HCL may not require treatment; however, it is generally recommended to start therapy, when the hemoglobin is <120 g/L, platelets $<100 \times 10^9$ /L or neutrophils $<1 \times 10^9$ /L or if there is evidence of disease progression.^{143, 175} Patients with active HCL are at risk of infection related to neutropenia, monocytopenia, and lymphocyte dysfunction, and this will resolve after a remission is obtained. Persistent lymphopenia and lymphocyte dysfunction may persist for many months following the use of a purine nucleoside analog. Concomitant use of rituximab may further deplete the lymphocytes. Although the value of prophylactic antibiotics in otherwise healthy patients is unclear, patients with prior infections may require prophylaxis for herpetic infections and *Pneumocystis jirovecii* until the lymphocytes are $\geq 1 \times 10^9$ /L.^{143, 176} In addition, it has been recommended by the British Guidelines that HCL patients who have been treated with a nucleoside analog should receive irradiated blood products for the rest of their lives, to prevent graft-versus-host disease.¹⁴³
- Our recommended approach to therapy is detailed in Figure 91.13. The standard therapy for HCL is with one of the nucleoside analogs, pentostatin or cladribine, which appear to have equal efficacy and produce CRs in the majority of patients. The survival of HCL patients nowadays is no different from age- and sex-matched controls. Cladribine appears to have similar efficacy as pentostatin and appears to have equal efficacy whether administered as 0.1 mg/kg/day $\times 7$, by continuous infusion, or as 0.14 mg/kg/day $\times 5$, as a 2-hour infusion or SC, or on a weekly schedule. Pentostatin is generally administered on a biweekly (4 mg/m² IV) basis. Because of the effectiveness of pentostatin and cladribine in HCL and the rarity of this disease, it is unlikely that there will be any prospective studies to compare the efficacy of these two agents and the different treatment regimens.

The major toxicity with the nucleoside analogs is myelosuppression and the risk of infections with initiation of treatment. As a result the authors prefer using pentostatin every other week or weekly cladribine with a blood count just prior to each treatment. For safety, the biweekly or weekly treatments are delayed until the neutrophil count is back to baseline or better. Both pentostatin and cladribine are excreted by the kidneys and the creatinine should be measured before each treatment and therapy only continued as long as renal function is not impaired. It has been suggested that 1.5 l of IV fluid be given with each pentostatin treatment.

Myelosuppression is most common in patients with severe marrow impairment; in such cases, it might be preferable to use IFN- α 3×10^6 units SC three times a week initially to obtain marrow clearing before treatment with a nucleoside analog. A morphologic CR can be obtained in $\sim 75\%$ of patients and a PR in 15% of cases, although residual hairy cells can invariably be detected by immunostaining, even with a morphologic CR. Remissions are prolonged, and most relapsing patients respond to a second cycle of therapy. It is unclear whether survival is longer for patients who achieve a CR or a PR. However, for patients who remain in CR for 5 years, the likelihood remaining in CR by 15 years is 75%.²³³ Response to cladribine and pentostatin is poorer for patients with the HCL variant and for those with bulky abdominal lymphadenopathy.³¹⁰ Prognosis for patients treated with pentostatin is worse for those older than 50 to 55 years of age and those with a hemoglobin level <100 g/L and white cell counts $<2 \times 10^9$ /L.^{224, 233, 236}

Patients should have a marrow test 6 months after starting cladribine or pentostatin and if there is residual disease, additional therapy with or without rituximab should be considered. The goal should be to strive for a CR, but to avoid excessive immunosuppressive and marrow toxicities remembering that long-term consequences (e.g., myelodysplasia or opportunistic infections) may result from excessive treatment.

3. IFN- α (3×10^6 U SC three times/week for 12 months) produces a lower response rate than the nucleoside analogs (8% CR and 74% PR), and relapses occur after discontinuation of the drug. However, IFN- α may be useful initially in patients with an active infection or severe neutropenia.
 4. Initial studies with the monoclonal antibodies against CD20, CD22, and CD25 suggest that these agents may be useful for the treatment of patients refractory to the nucleoside analogs, for patients with poor marrow reserve, and for patients with the HCL variant. Preliminary studies have also shown that concomitant or sequential therapy using rituximab with a nucleoside analog is highly effective therapy, and probably should be considered as initial therapy for the HCL variant.
 5. Two thirds of patients benefit from splenectomy, but a CR is rare. Splenectomy is required for patients who have a splenic
- P.1948

rupture and may be of value for patients with pure "splenic" HCL, as well as for patients who have severe thrombocytopenia with increased numbers of megakaryocytes in the marrow.

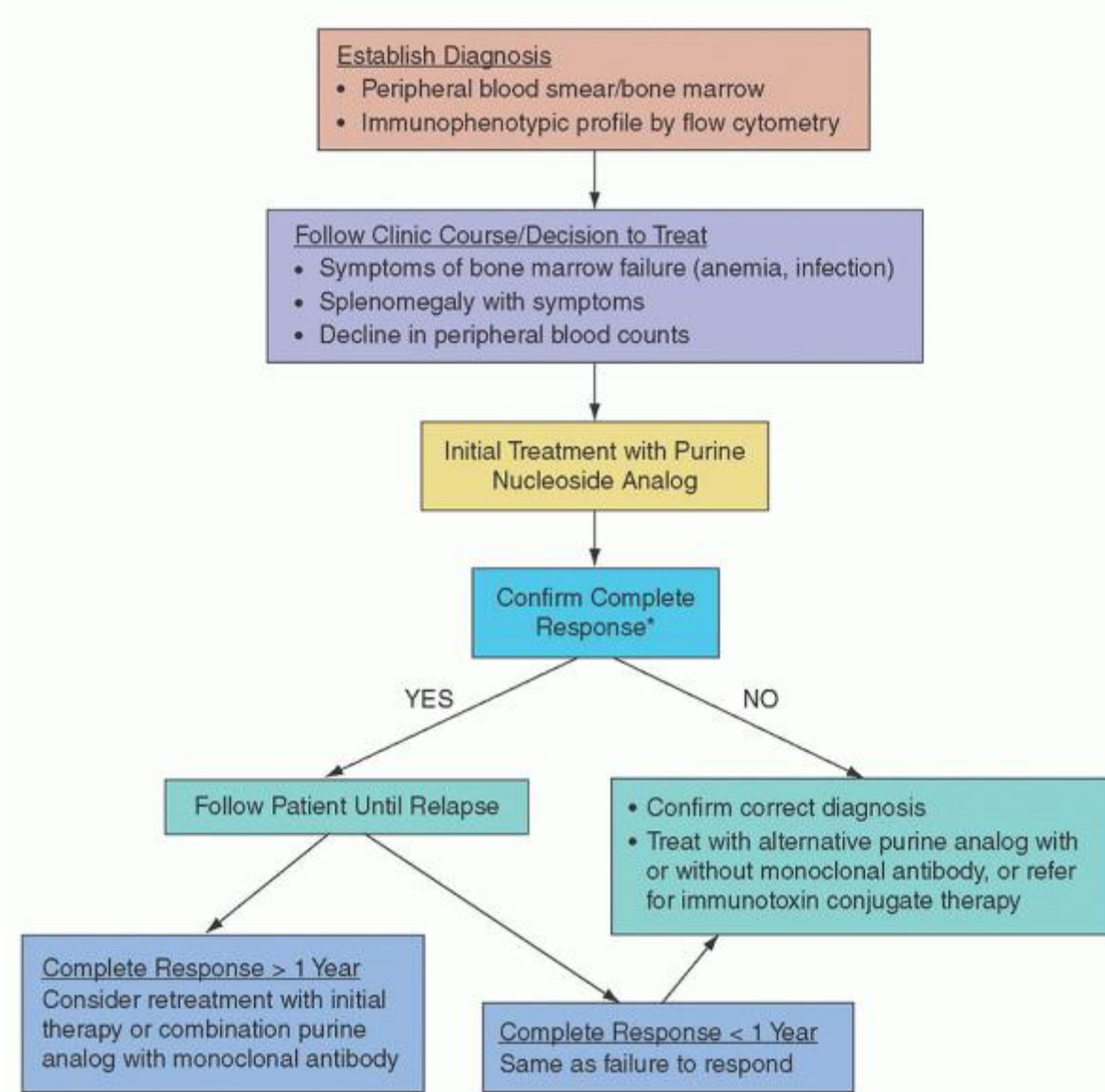

FIGURE 91.13. Recommended treatment schema for hairy cell leukemia (HCL). * Confirmation of a complete response: If patient is participating in a clinical trial, consider using flow cytometry or immunohistochemical stains on bone marrow to document minimal residual disease. It is difficult to require these added studies for patients being treated from a clinical

protocol. (From Grever MR. How I treat hairy cell leukemia. *Blood* 2010;115:21-28, with permission.)

SECOND MALIGNANCIES

There has been controversy as to whether patients with HCL have an increased incidence of malignancies and whether this may be related to therapy.^{210, 224, 236, 247, 248, 311, 312, 313, 314, 315, 316} Several studies have demonstrated an increased incidence of second tumors in HCL, and the incidence appears to be highest in the first 2 years after diagnosis. However, the increase may occur before the diagnosis of HCL, or concurrently, suggesting that these patients have an inherent tendency to develop second malignancies.^{210, 311, 312} Kampmeier et al.³¹² demonstrated that 19% of 69 patients observed for a median of 91 months after treatment with IFN- α developed a second malignancy, and the authors suggested that the increased incidence was related to the more prolonged survival of these immunocompromised patients rather than an effect of the IFN- α . However, it has been observed that the incidence of second malignancies is lower when patients are treated with pentostatin or cladribine than with IFN- α , suggesting that the second malignancies may be directly related to active HCL.³¹³ In 379 patients treated with cladribine, 22% developed a second malignancy (primarily solid tumors), a rate 2.03-fold higher than expected.²⁴⁹ Those patients who had had a malignancy before the diagnosis of HCL had a 3.7-fold increased risk of developing a second cancer compared with those who did not.²⁴⁹ However, Kurzrock et al.³¹⁴ observed a 7.4% incidence of second malignancies in 350 HCL patients after a mean follow-up of 7.1 years, and this incidence was not significantly greater than expected and was not influenced by treatment with IFN- α or the nucleoside analogs. Others have made similar observations.^{224, 236} In a large multicenter prospective crossover study with pentostatin and IFN- α and a median follow-up of 112 months, there was no increase in the number of second malignancies as compared with that of the control population.²³⁶ However, a large Surveillance, Epidemiology and End Results (SEER) population study of 3,104 HCL patients collected between 1973 and 2002 has demonstrated an increased incidence of Hodgkin lymphoma, non-Hodgkin lymphomas, and thyroid cancer in HCL, but the overall increase in cancer rates was small with the probability of a second cancer being 31.9% at 25 years.³¹⁶

PROGNOSIS

Before the availability of IFN- α and the nucleoside analogs, the median survival of HCL patients was 4.6 years for nonsplenectomized patients and 6.9 years for splenectomized patients.² However, the prognosis has improved markedly with present therapies, and the predicted 5- and 10-year survival rates for patients treated with the nucleoside analogs are now similar to those of the general population.^{233, 234, 236} However, long-term follow-up is required to determine the relapse rate, the percentage of patients who become resistant to the nucleoside analogs and, subsequently, the monoclonal antibodies, and whether there will be long-term complications from these treatments.

P.1949

REFERENCES

1. Bouroncle BA, Wiseman BK, Doan CA. Leukemic reticuloendotheliosis. *Blood* 1958;13:609-630.
2. Bouroncle BA. Leukemic reticuloendotheliosis (hairy cell leukemia). *Blood*;53:412-436.
3. Flandrin G, Sigaux F, Sebahoun G, et al. Hairy cell leukemia: clinical presentation and follow-up of 211 patients. *Semin Oncol* 1984;11:458-471.
4. Golomb HM, Catovsky D, Golde DW. Hairy cell leukemia: a clinical review based on 71 cases. *Ann Intern Med* 1978;89:677-683.
5. Bouroncle BA. Thirty-five years in the progress of hairy cell leukemia. *Leuk Lymph* 1994;14(Suppl 1):1-12.
6. Frassoldati A, Lamparelli T, Federico M, et al. Hairy cell leukemia: a clinical review based on 725 cases of the Italian Cooperative Group (ICGHCL). *Leuk Lymph* 1994;13:307-316.
7. Ruiz-Arguelles GJ, Cantu-Rodriguez O, Gomez-Almaguer S, et al. Hairy cell leukemia is infrequent in Mexico and has a geographic distribution. *Am J Hematol* 1996;52:316-318.
8. Stewart DJ, Keating MJ. Radiation exposure as a possible etiologic factor in hairy cell leukemia (leukemic reticuloendotheliosis). *Cancer* 1980;46:1577-1580.
9. Clavel J, Mandereau L, Cordier S, et al. Hairy cell leukaemia, occupation, and smoking. *Br J Haematol* 1995;9:154-161.

10. Nordstrom M, Hardell L, Magnuson A, et al. Occupational exposures, animal exposure and smoking as risk factors for hairy cell leukaemia evaluated in a case-control study. *Br J Cancer* 1998;77:2048-2052.
11. Villemagne B, Bay JO, Tournilhac O, et al. Two new cases of familial hairy cell leukemia associated with HLA haplotypes A2, B7, Bw4, Bw6. *Leuk Lymph* 2005;46(2):243-245.
12. Swerdlow SH, Campo E, Harris NL, et al. WHO classification of tumours of haematopoietic and lymphoid tissues. 4th ed. Lyon, France: IARC Press, 2008;188-193.
13. Matutes E, Morilla R, Owusu-Ankomah K, et al. The immunophenotype of hairy cell leukemia (HCL). Proposal for a scoring system to distinguish HCL from B-cell disorders with hairy or villous lymphocytes. *Leuke Lymph* 1994;14:57-61.
14. Robbins BA, Ellison DJ, Spinosa JC, et al. Diagnostic application of two-color flow cytometry in 161 cases of hairy cell leukemia. *Blood* 1993;82: 1277-1287.
15. Forconi F, Sahota SS, Raspadori D, et al. Hairy cell leukemia: at the cross road of somatic mutation and isotype switch. *Blood* 2004;104: 3312-3317, 3338.
16. Forconi F, Sozzi E, Rossi D, et al. Selective influences in the expressed immunoglobulin heavy and light chain gene repertoire in hairy cell leukemia. *Haematologica* 2008;93:697-705.
17. Forconi F, Sozzi E, Cencini E, et al. Hairy cell leukemias with unmutated IGHV genes define the minor subset refractory to single-agent cladribine and with more aggressive behaviour. *Blood* 2009;114:4696-4702.
18. Arons E, Suntum T, Stetler-Stevenson M, Kreitman RJ. VH4-34+ hairy cell leukemia, a new variant with poor prognosis despite standard therapy. *Blood* 2009;114:4687-4695.
19. Sozzi E, Amato T, Sahota SS, et al. Lack of allelic exclusion by secondary rearrangements of tumour B-cell receptor light chains in hairy cell leukaemia. *Hematol Oncol* 2011;29:31-37.
20. Arons E, Roth L, Sapolsky J, Suntum T, Stetler-Stevenson M, Kreitman RJ. Evidence of canonical somatic hypermutation in hairy cell leukemia. *Blood* 2011;117:4844-4851.
21. Xi L, Arons E, Navarro W, et al. Both variant and IGHV4-34-expressing hairy cell leukemia lack the BRAF V600E mutation. *Blood* 2012;119:3330-3332.
22. BritoBabapulle V, Pittman S, Melo JV, et al. The 14q+marker in hairy cell leukaemia. A cytogenetic study of 15 cases. *Leuk Res* 1986;10:131-138.
23. Ueshima Y, Alimena G, Rowley JD, et al. Cytogenetic studies in patients with hairy cell leukemia. *Hematol Oncol* 1983;1:215-226.
24. Basso K, Liso A and Tiacci E, et al. Gene expression profiling of hairy cell leukemia reveals a phenotype related to memory B cells with altered expression of chemokine and adhesion receptors. *J Exp Med* 2004;199:59-68.
25. Naeim F. Hairy cell leukemia: characteristics of the neoplastic cells. *Hum Pathol* 1988;19:375-388.
26. Cawley JC, Burns GF, Nash TA, et al. Hairy cell leukemia with T cell features. *Blood* 1978;51:61-69.
27. Hernandez D, Cruz C, Carnot J, et al. Hairy cell leukemia of T cell origin. *Br J Haematol* 1978;40:504-506.
28. Saxon A, Stevens RH, Golde DW. T lymphocyte variant of hairy cell leukemia. *Ann Intern Med* 1978;88:323-326.
29. Semenzato G, Basso G, Cartei G, et al. Hairy cell leukemia with T cell features. *Br J Haematol* 1980;46:491-492.
30. Wachsman W, Golde DW, Chen IS. Hairy cell leukemia and human T cell leukemia virus. *Semin Oncol* 1984;11:446-450.
31. Kalyanaraman VS, Sarngadharan MG, Robert-Guroff M, et al. A new subtype of human T cell leukemia virus (HTLV II) associated with a T-cell variant of hairy cell leukemia. *Science* 1982;218:571-573.
32. Rosenblatt JD, Golde DW, Wachsman W, et al. A second isolate of HTLVII associated with atypical hairy cell leukemia. *N Engl J Med* 1986;315:372-377.
33. Armitage RJ, Worman CP, Galvin MC, et al. Hairy cell leukemia with hybrid BT features: a study with a panel of monoclonal antibodies. *Am J Hematol* 1985;18:335-344.
34. Burns GF, Worman CP, Cawley JC. Fluctuations in the T and B characteristics of two cases of T cell hairy cell leukemia. *Clin Exp Immunol* 1980;39:76-82.

35. Divine M, Farcet JP, Gourdin MF, et al. Phenotype study of fresh and cultured hairy cells with the use of immunologic markers and electron microscopy. *Blood* 1984;64:547-552.
36. Worman CP, Beverley PC, Cawley JC. Alterations in the phenotype of hairy cells during culture in the presence of PHA: requirement for T cells. *Blood* 1982;59:895-899.
37. Tiacci E, Liso A, Piris M, Falini B. Evolving concepts in the pathogenesis of hairy-cell leukaemia. *Nat Rev* 2006;6:437-448.
38. Cawley JC, Hawkins SF. The biology of hairy-cell leukaemia. *Curr Opin Hematol* 2010;17:341-349.
39. Forconi F. Hairy cell leukaemia: biological and clinical overview from immunogenetic insights. *Haematol Oncol* 2011;29:55-66.
40. Weston-Bell N, Townsend M, Di Genova G, Forconi F, Sahota SS. Defining origins of malignant B cells: a new circulating normal human IgM(+) D(+) B-cell subset lacking CD27 expression and displaying somatically mutated IGHV genes as a relevant memory population. *Leukemia* 2009;23: 2075-2080.
41. Forconi F, Sahota SS, Raspadori D, et al. Tumor cells of hairy cell leukemia express multiple clonally related immunoglobulin isotypes via RNA splicing. *Blood* 2001;98:1174-1181.
42. Tschumper RC, Geyer SM, Campbell ME, et al. Immunoglobulin diversity gene usage predicts unfavorable outcome in a subset of chronic lymphocytic leukemia patients. *J Clin Invest* 2008;118:306-315.
43. Golomb HM, Lindgren V, Rowley JD. Chromosome abnormalities in patients with hairy cell leukemia. *Cancer* 1978;41:1374-1380.
44. Lele KP, Filippa DA, Chaganti RS. Cytogenetic studies of hairy cell leukemia. *Cancer Genet Cytogenet* 1981;4:325-330.
45. Haglund U, Juliusson G, Stellan B, et al. Hairy cell leukemia is characterized by clonal chromosome abnormalities clustered to specific regions. *Blood* 1994;83:2637-2645.
46. Wu X, Ivanova G, Merup M, et al. Molecular analysis of the human chromosome 5q13.3 region in patients with hairy cell leukemia and identification of tumor suppressor gene candidates. *Genomics* 1999;60:161-171.
47. Kluin-Nelemans HC, Beverstock GC, Mollevanger P, et al. Proliferation and cytogenetic analysis of hairy cell leukemia upon stimulation via the CD40 antigen. *Blood* 1994;84:3134-3141.
48. Brito-Babapulle V, Matutes E, Oscier D, et al. Chromosome abnormalities in hairy cell leukaemia variant. *Genes Chromosomes Cancer* 1994;10:197-202.
49. Forconi F, Poretti G, Kwee I, et al. High density genome-wide DNA profiling reveals a remarkably stable profile in hairy cell leukaemia. *Br J Haematol* 2008;141:622-630.
50. Hockley, SL, Morgan GJ, Leone PE, et al. High-resolution genomic profiling in hairy cell leukemia-variant compared with typical hairy cell leukemia. *Leukemia* 2011;25:1189-1220.
51. König EA, Kusser WC, Day C, et al. P53 mutations in hairy cell leukemia. *Leukemia* 2000;14:706-711.
52. Dierlamm J, Stefanova M, Woldarska I, et al. Chromosomal gains and losses are uncommon in hairy cell leukemia: a study based on comparative genomic hybridization and interphase fluorescence in situ hybridization. *Cancer Genet Cytogenet* 2001;128:164-167.
53. Till KJ, Lopez A, Slupsky J, Cawley JC. C-fms protein expression by B-cells, with particular reference to the hairy cells of hairy-cell leukaemia. *Br J Haematol* 1993;83:223-231.
54. Burthem J, Baker PK, Hunt JA, et al. The function of c-fms in hairy-cell leukemia: macrophage colony-stimulating factor stimulates hairy-cell movement. *Blood* 1994;83:1381-1389.
55. Lynch SA, Brugge JS, Fromowitz F, et al. Increased expression of the src proto-oncogene in hairy cell leukemia and a subgroup of B-cell lymphomas. *Leukemia* 1993;7:1416-1422.
56. Bosch F, Campo E, Jares P, et al. Increased expression of the PRAD-1/CCND1 gene in hairy cell leukaemia. *Br J Haematol* 1995;91:1025-1030.
57. Miranda RN, Briggs RC, Kinney MC, et al. Immunohistochemical detection of cyclin D1 using optimized conditions is highly specific for mantle cell lymphoma and hairy cell leukemia. *Mod Pathol* 2000;13:1308-1314.
58. Tiacci E, Trifonov V, Schiavoni G, et al. BRAF mutations in hairy-cell leukemia. *N Engl J Med* 2011;364:2305-2315.

59. Arcaini L, Zibellini S, Boveri E, et al. The BRAF V600E mutation in hairy cell leukemia and other mature B-cell neoplasms. *Blood* 2012;119:188-191.
60. Boyd EM, Bench AJ, van't Veer MB, et al. High resolution melting analysis for detection of BRAF exon 15 mutations in hairy cell leukaemia and other lymphoid malignancies. *Br J Haematol* 2011;155:609-612.
61. Schnittger S, Bacher U, Haferlach T, et al. Development and validation of a real-time quantification assay to detect and monitor BRAFV600E mutations in hairy cell leukemia. *Blood* 2012;119:3151-3154.
62. Tiacci E, Schiavoni G, Forconi F, et al. Simple genetic diagnosis of hairy cell leukemia by sensitive detection of the BRAF-V600E mutation. *Blood* 2012;119:192-195.
63. Slupsky JR, Kamiguti AS, Harris RJ, Cawley JC, Zuzel M. Central role of protein kinase C ϵ in constitutive activation of ERK1/2 and Rac 1 in malignant cells in hairy cell leukemia. *Am J Pathol* 2007;170:745-754.
64. Zhang X, Machii T, Itaru M et al. Constitutively activated Rho guanosine triphosphatases regulate the growth and morphology of hairy cell leukemia cells. *Intern J Hematol* 2003;77:263-273.
65. Schmid M, Porzsolt F. Autocrine and paracrine regulation of neoplastic cell growth in hairy cell leukemia. *Leuk Lymphoma* 1995;17:401-410.
66. Schmid M, Schrezenmeier H, Staib G, et al. Evidence for a paracrine pathway of B-cell stimulation in hairy cell leukemia. *Br J Haematol* 1995;90:156-162.
67. de Toter D, Carbone A, Tazzari PL, et al. Expression of the IL2 receptor α , β and γ chains in hairy cell leukemia. *Leuk Lymphoma* 1994;14(Suppl 1):27-32.
68. de Toter D, Tazzari PL, Lauria F, et al. Phenotypic analysis of hairy cell leukemia: "variant" cases express the interleukin-2 receptor β chain, but not the α chain (CD25). *Blood* 1993;82:528-535.
69. Bulger K, Murphy J, Janckila A, et al. Peripheral blood hairy cell leukemia cells express only low affinity IL-2 receptors. *Leuk Res* 1994;18:101-104.
70. Semenzato G, Trentin L, Zambello R, et al. Origin of the soluble interleukin-2 receptor in the serum of patients with hairy cell leukemia. *Leukemia* 1988;2: 788-792.
71. Richards JM, Mick R, Latta JM, et al. Serum soluble interleukin-2 receptor is associated with clinical and pathologic disease status in hairy cell leukemia. *Blood* 1990;76:1941-1945.
72. Lauria F, Rondelli D, Raspadori D, et al. Serum soluble interleukin-2 receptor levels in hairy cell leukemia: correlation with clinical and hematological parameters and with α -interferon treatment. *Leuk Lymph* 1992;7:103-107.
73. Matsushita K, Margulies I, Onda M, et al. Soluble CD22 as a tumor marker for hairy cell leukemia. *Blood* 2008;112:2272-2277.
74. Cordingley FT, Bianchi A, Hoffbrand AV, et al. Tumour necrosis factor as an autocrine tumour growth factor for chronic B-cell malignancies. *Lancet* 1988;1:969-971.
75. Buck C, Digel W, Schöniger W, et al. Tumor necrosis factor- α but not lymphotoxin, stimulates growth of tumor cells in hairy cell leukemia. *Leukemia* 1990;4:431-434.
76. Foa R, Guarini A, Francia di Celle P, et al. Constitutive production of tumor necrosis factor- α in hairy cell leukemia: possible role in the pathogenesis of the cytopenia(s) and effect of treatment with interferon- α . *J Clin Oncol* 1992;10:954-959.
77. Lindemann A, Ludwig WD, Oster W, et al. High-level secretion of tumor necrosis factor-alpha contributes to hematopoietic failure in hairy cell leukemia. *Blood* 1989;73:880-884.
78. Digel W, Porzsolt F, Schmid M, et al. High levels of circulating soluble receptors for tumor necrosis factor in hairy cell leukemia and type B chronic lymphocytic leukemia. *J Clin Invest* 1992;89:1690-1693.
79. Trentin L, Pizzolo G, Zambello R, et al. Leukemic cells in hairy cell leukemia and B cell chronic lymphocytic leukemia release soluble TNF receptors. *Leukemia* 1995;9:1051-1055.
80. Barut B, Chauhan D, Uchiyama H, et al. Interleukin-6 functions as an intracellular growth factor in hairy cell leukemia in vitro. *J Clin Invest* 1993;92: 2346-2352.

81. Aziz KA, Till KJ, Chen H, et al. The role of autocrine FGF-2 in the distinctive bone marrow fibrosis of hairy-cell leukemia (HCL). *Blood* 2003;102: 1051-1056.
82. Shehata M, Schwarzmeier JD, Hilgarth M, Hubmann R, Duechler M, Gisslinger H. TGF-beta1 induces bone marrow reticulin fibrosis in hairy cell leukemia. *J Clin Invest* 2004;113:676-685.
83. Hoffman MA. Clinical presentations and complications of hairy cell leukemia. *Hematol Oncol Clin N Am* 2006;20:1065-1073.
84. Mercieca J, Puga M, Matutes E, et al. Incidence and significance of abdominal lymphadenopathy in hairy cell leukaemia. *Leuk Lymph* 1994;14(Suppl 1):79-83.
85. Hakimian D, Tallman MS, Hogan DK, et al. Prospective evaluation of internal adenopathy in a cohort of 43 patients with hairy cell leukemia. *J Clin Oncol* 1994;12:268-272.
86. Malik ST, Amess J, D'Ardenne AJ, et al. Hairy cell leukemia-mediastinal involvement. A report of two cases and review of the literature. *Hematol Oncol* 1989;7:303-306.
87. Castro-Malaspina H, Najean Y, Flandrin G. Erythrokinetic studies in hairy-cell leukaemia. *Br J Haematol* 1979;42:189-197.
88. Aster RH. Splenic platelet pooling as a cause of "hypersplenic" thrombocytopenia. *Trans Assoc Am Phys* 1965;78:362-373.
89. Brubaker LH, Johnson CA. Correlation of splenomegaly and abnormal neutrophil pooling (margination). *J Lab Clin Med* 1978;92:508-515.
90. Hess CE, Ayers CR, Sandusky WR, et al. Mechanism of dilutional anemia in massive splenomegaly. *Blood* 1976;47:629-644.
91. Lewis SM, Catovsky D, Hows JM, et al. Splenic red cell pooling in hairy cell leukaemia. *Br J Haematol* 1977;35:351-357.
92. Schaffner A, Augustiny N, Otto RC, et al. The hypersplenic spleen. A contractile reservoir of granulocytes and platelets. *Arch Intern Med* 1985;145:651-654.
93. Golomb HM, Hadad LJ. Infectious complications in 127 patients with hairy cell leukemia. *Am J Hematol* 1984;16:393-401.
94. Mackowiak PA, Demian SE, Sutker WL, et al. Infections of hairy cell leukemia. Clinical evidence of a pronounced defect in cell-mediated immunity. *Am J Med* 1980;68:718-724.
95. Stewart DJ, Bodey GP. Infections in hairy cell leukemia (leukemic reticuloendotheliosis). *Cancer* 1981;47:801-805.
96. Damaj G, Kuhnowski F, Marolleau JP, Bauters F, Leleu X, Yakoub-Agha I. Risk factors for severe infection in patients with hairy cell leukemia: a long-term study of 73 patients. *Eur J Haematol* 2009;83:246-250.
97. Weinstein RA, Golomb HM, Grumet G, et al. Hairy cell leukemia: association with disseminated atypical mycobacterial infection. *Cancer* 1981;48: 380-383.
98. Knecht H, Rhyner K, Streuli RA. Toxoplasmosis in hairy-cell leukaemia. *Br J Haematol* 1986;62:65-73.
99. Nielsen H, Bangsborg J, Rechnitzer C, et al. Defective monocyte function in Legionnaires' disease complicating hairy cell leukaemia. *Acta Med Scand* 1986;220:381-383.
100. Salata RA, King RE, Gose F, et al. *Listeria monocytogenes* cerebritis, bacteremia, and cutaneous lesions complicating hairy cell leukemia. *Am J Med* 1986;81: 1068-1072.
101. Janckila AJ, Wallace JH, Yam LT. Generalized monocyte deficiency in leukaemic reticuloendotheliosis. *Scand J Haematol* 1982;29:153-160.
102. Seshadri RS, Brown EJ, Zipursky A. Leukemic reticuloendotheliosis. A failure of monocyte production. *N Engl J Med* 1976;295:181-184.
103. Child JA, Cawley JC, Martin S, et al. Microbicidal function of the neutrophils in hairy-cell leukaemia. *Acta Haematol (Basel)* 1979;62:191-198.
104. Kjeldsberg CR. Leukocyte mobilization in leukemic reticuloendotheliosis. *Ann Intern Med* 1978;88:268-269.
105. Yam LT, Chaudhry AA, Janckila AJ. Impaired marrow granulocyte reserve and leukocyte mobilization in leukemic reticuloendotheliosis. *Ann Intern Med* 1977;87:444-446.

106. Van de Corput L, Falkenburg JH, Kluin-Nelemans JC. T-cell dysfunction in hairy cell leukemia: an updated review. *Leuk Lymph* 1998;30:31-39.
107. Van de Corput L, Falkenburg JH, Kester MG, Willemze R, Kluin-Nelemans JC. Impaired expression of CD28 on T cells in hairy cell leukemia. *Clin Immunol* 1999;93:256-262.
108. Spaenij-Dekking EHA, Van der Meijden ED, Falkenburg JHF, Kluin-Nelemans JC. Clonally expanded T cells in hairy cell leukemia patients are not leukemia specific. *Leukemia* 2004;18:176-178.
109. Kluin-Nelemans HC, Kester MG, van deCorput L, et al. Correction of abnormal T-cell receptor repertoire during interferon-alpha therapy in patients with hairy cell leukemia. *Blood* 1998;91:4224-4231.
110. Hansen DA, Robbins BA, Bylund DJ, et al. Identification of monoclonal immunoglobulins and quantitative immunoglobulin abnormalities in hairy cell leukemia and chronic lymphocytic leukemia. *Am J Clin Pathol* 1994;102: 580-585.
111. Dorsey JK, Penick GD. The association of hairy cell leukemia with unusual immunologic disorders. *Arch Intern Med* 1982;142:902-903.
112. Westbrook CA, Golde DW. Autoimmune disease in hairy-cell leukaemia: clinical syndromes and treatment. *Br J Haematol* 1985;61:349-356.
113. Komadina KH, Houk RW. Polyarteritis nodosa presenting as recurrent pneumonia following splenectomy for hairy-cell leukemia. *Semin Arthritis Rheum* 1989;18:252-257.
114. Hasler P, Kistler H, Gerber H. Vasculitides in hairy cell leukemia. *Semin Arthritis Rheum* 1995;25:134-142.
115. Carpenter MT, West SG. Polyarteritis nodosa in hairy cell leukemia: treatment with interferon-alpha. *J Rheumatol* 1994;21:1150-1152.
116. Douglas MF, Schwartz MM, Sharon Z. Cryoglobulinemia and immunemediated glomerulonephritis in association with hairy cell leukemia. *Am J Kidney Dis* 1985;6:181-184.
117. Raju SF, Chapman SW, Dreiling B, et al. Hairy-cell leukemia with the appearance of mixed cryoglobulinemia and vasculitis. *Arch Intern Med* 1984;144:1300-1302.
118. Bouroncle BA. Unusual presentations and complications of hairy cell leukemia. *Leukemia* 1987;1:288-293.
119. Arkel YS, Lake-Lewin D, Savopoulos AA, et al. Bone lesions in hairy cell leukemia. A case report and response of bone pains to steroids. *Cancer* 1984;53:2401-2403.
120. Demanes DJ, Lane N, Beckstead JH. Bone involvement in hairy-cell leukemia. *Cancer* 1982;49:1697-1701.
121. Lembersky BC, Ratain MJ, Golomb HM. Skeletal complications in hairy cell leukemia: diagnosis and therapy. *J Clin Oncol* 1988;6:1280-1284.
122. Catovesky D, Costello C, Loukopoulos D, et al. Hairy cell leukemia and myelomatosis: chance association or clinical manifestations of the same B-cell disease spectrum. *Blood* 1981;57:758-763.
123. Jansen J, Bolhuis RL, van Nieuwkoop JA, et al. Paraproteinemia plus osteolytic lesions in typical hairy-cell leukaemia. *Br J Haematol* 1983;54:531-541.
124. Arai E, Ikeda S, Itoh S, Katayama I. Specific skin lesions as the presenting symptom of hairy cell leukemia. *Am J Clin Pathol* 1988;90:459-464.
125. Carsuzaa F, Pierre C, Jaubert D, Viala JJ. Cutaneous findings in hairy cell leukemia. Review of 84 cases. *Nouv Rev Fr Hematol* 1994;35:541-543.
126. Murphy GF, Mihn MC. Benign, dysplastic, and malignant lymphoid infiltrates of the skin: an approach based on pattern analysis. In: Murphy GF, Mihn MC, eds. *Lymphoproliferative disorders of the skin*. Boston, MA: Butterworth, 1986;123-138.
127. Yam LT, Crosby WH. Spontaneous rupture of spleen in leukemic reticuloendotheliosis. *Am J Surg* 1979;137:270-273.
128. Vardiman JW, Golomb HM. Autopsy findings in hairy cell leukemia. *Semin Oncol* 1984;11:370-380.
129. Kimmel DW, Hermann RC Jr, O'Neill BP. Neurologic complications of hairy cell leukemia. *Arch Neurol* 1984;41:202-203.

130. Newell DG, Sattar M, Hannam-Harris AC, et al. Hairy cell leukemia occurring with an unrelated paraproteinaemia. A biochemical and immuno-electron microscopic study. *Scand J Haematol* 1982;28:441-450.
131. Cook JR. Splenic B-cell lymphomas/leukemias. *Surg Path* 2010;3:933-954.
132. Golomb HM, Braylan R, Polliack A. "Hairy" cell leukaemia (leukaemic reticuloendotheliosis): a scanning electron microscopic study of eight cases. *Br J Haematol* 1975;29:455-460.
133. Merchant RE, Hofmann V, Moreillon MC, et al. Hairy cell leukemia: ultrastructural and cytochemical evaluation of leukemic colonies grown in a semisolid medium. *Eur J Cancer Clin Oncol* 1985;21:221-232.
134. Offerman MK, Golomb HM. Hairy cell leukemia. *Curr Probl Cancer* 1984;8: 1-39.
135. Yam LT, Li CY, Lam KW. Tartrate-resistant acid phosphatase isoenzyme in the reticulum cells of leukemic reticuloendotheliosis. *N Engl J Med* 1971;284:357-360.
136. Boesen AM. Ultrastructural localization of acid phosphatase in immunologically defined neoplastic lymphocytic cells and hairy cells. A comparison between two different substrates. *Scand J Haematol* 1984;32:245-252.
137. Katayama I, Yang JP. Reassessment of a cytochemical test for differential diagnosis of leukemic reticuloendotheliosis. *Am J Clin Pathol* 1977;68: 268-272.
138. Janckila AJ, Cardwell EM, Yam LT, et al. Hairy cell identification by immunohistochemistry of tartrate-resistant acid phosphatase. *Blood* 1995;85:2839-2844.
139. Hoyer JD, Li CY, Yam LT, et al. Immunohistochemical demonstration of acid phosphatase isoenzyme 5 (tartrate-resistant) in paraffin sections of hairy cell leukemia and other hematologic disorders. *Am J Clin Pathol* 1997;108: 308-315.
140. Falini B, Tiacci E and Liso A, et al. Simple diagnostic assay for hairy cell leukaemia by immunocytochemical detection of annexin A1 (ANXA1). *Lancet* 2004;363(9424):1869-1870.
141. Stetler-Stevenson M, Tembhare PR. Diagnosis of hairy cell leukemia by flow cytometry. *Leuk Lymph* 2011;52(S2):11-13.
142. Matutes E. Immunotyping and differential diagnosis of hairy cell leukemia. *Hematol Oncol Clin North Am* 2006;20:1051-1063.
143. Jones, Parry-Jones N, Wilkins B, Else M, Catovsky D. Revised guidelines for the diagnosis and management of hairy cell leukaemia and hairy cell leukaemia variant. *Br J Haematol* 2011;156:186-195.
144. del Giudice I, Matutes E, Morilla R, et al. The diagnostic value of CD123 in B-cell disorders with hairy or villous lymphocytes. *Haematologica* 2004;89:303-308.
145. Hounie H, Chittal SM, al Saati T, et al. Hairy cell leukemia. Diagnosis of bone marrow involvement in paraffin-embedded sections with monoclonal antibody DBA.44. *Am J Clin Pathol* 1992;98:26-33.
146. Burke JS, Rappaport H. The diagnosis and differential diagnosis of hairy cell leukemia in bone marrow and spleen. *Semin Oncol* 1984;11: 334-346.
147. Bartl R, Frisch B, Hill W, et al. Bone marrow histology in hairy cell leukemia. Identification of subtypes and their prognostic significance. *Am J Clin Pathol* 1983;79:531-545.
148. Katayama I. Bone marrow in hairy cell leukemia. *Hematol Oncol Clin North Am* 1988;2:585-602.
149. Yam LT, Phyllyk RL, Li CY. Benign and neoplastic disorders simulating hairy cell leukemia. *Semin Oncol* 1984;11:353-361.
150. Burthem J, Cawley JC. The bone marrow fibrosis of hairy-cell leukemia is caused by the synthesis and assembly of a fibronectin matrix by the hairy cells. *Blood* 1994;83:497-504.
151. Lee WM, Beckstead JH. Hairy cell leukemia with bone marrow hypoplasia. *Cancer* 1982;50:2207-2210.
152. Winkler CF, Jennings CV. Hairy-cell leukemia and aplastic anemia. *Ann Intern Med* 1979;91:794-795.
153. Nanba K, Soban EJ, Bowling MC, et al. Splenic pseudosinusoids and hepatic angiomatous lesions. Distinctive features of hairy cell leukemia. *Am J Clin Pathol* 1977;67:415-426.
154. Pilon VA, Davey FR, Gordon GB, et al. Splenic alterations in hairy-cell leukemia: II. An electron microscopic study. *Cancer* 1982;49:1617-1623.

155. Matutes E, Wotherspoon A, Brito-Babapulle V, et al. The natural history and clinico-pathological features of the variant form of hairy cell leukemia. *Leukemia* 2001;15:184-193.
156. Robak, T. Hairy-cell leukemia variant: recent view on diagnosis, biology and treatment. *Cancer Treat Rev* 2010;37:3-10.
157. Catovsky D, O'Brien M, Melo JV, et al. Hairy cell leukemia (HCL) variant: an intermediate disease between HCL and B prolymphocytic leukemia. *Semin Oncol* 1984;11:362-369.
158. Diez Martin JL, Li CY, Banks PM. Blastic variant of hairy cell leukemia. *Am J Clin Pathol* 1987;87:576-583.
159. Sainati L, Matutes E, Mulligan S, et al. A variant form of hairy cell leukemia resistant to α -interferon: clinical and phenotypic characteristics of 17 patients. *Blood* 1990;76:157-162.
160. Arber DA, Lopategui JR, Brynes RK. Chronic lymphoproliferative disorders involving blood and bone marrow. *Am J Clin Pathol* 1993;99:494-503.
161. Sun T, Dittmar K, Koduru P, et al. Relationship between hairy cell leukemia variant and splenic lymphoma with villous lymphocytes: presentation of a new concept. *Am J Hematol* 1996;51:282-288.
162. Melo JV, Catovsky D, Galton DA. The relationship between chronic lymphocytic leukaemia and prolymphocytic leukaemia. I. Clinical and laboratory features of 300 patients and characterization of an intermediate group. *Br J Haematol* 1986;63:377-387.
163. Sun T, Susin M, Brody J, et al. Splenic lymphoma with circulating villous lymphocytes: report of seven cases and review of the literature. *Am J Hematol* 1994;45:39-50.
164. Matutes E, Morilla R, Owusu-Ankomah K, et al. The immunophenotype of splenic lymphoma with villous lymphocytes and its relevance to the differential diagnosis with other B-cell disorders. *Blood* 1994;83:1558-1562.
165. Vardiman JW, Byrne GE Jr, Rappaport H. Malignant histiocytosis with massive splenomegaly in asymptomatic patients. A possible chronic form of the disease. *Cancer* 1975;36:419-427.
166. Narang S, Wolf BC, Neiman RS. Malignant lymphoma presenting with prominent splenomegaly. A clinicopathologic study with special reference to intermediate cell lymphoma. *Cancer* 1985;55:1948-1957.
167. Ng JP, Hogg RB, Cumming RL, et al. Primary splenic hairy cell leukaemia: a case report and review of the literature. *Eur J Haematol* 1987;39:349-352.
168. Watters RJ, Liu X, Loughran TP. T-cell and natural killer-cell large granular lymphocyte leukemia neoplasias. *Leuk Lymph* 2011;52:2217-2225.
169. Lennert K, Papwaresch MR. Mast cells and mast cell neoplasia: a review. *Histopathology* 1979;3:349-365.
170. Matsue K, Nishi H, Onozawa S, et al. Polyclonal B cell chronic lymphoproliferative disease with hairy cell morphology: a case report and clonal studies. *Am J Hematol* 1996;51:141-146.
171. Machii T, Yamaguchi M, Inoue R, et al. Polyclonal B-cell lymphocytosis with features resembling hairy cell leukemia-Japanese variant. *Blood* 1997;89:2008-2014.
172. Mossafa J, Malaure J, Maynadie M, et al. Persistent polyclonal B lymphocytosis with binucleated lymphocytes: a study of 25 cases. *Groupe Francais d'Hematologie Cellulaire. Br J Haematol* 1999;104:486-493.
173. Delage R, Jacques L, Massinga-Loembe M, et al. Persistent polyclonal B-cell lymphocytosis: further evidence for a genetic disorder associated with B-cell abnormalities. *Br J Haematol* 2001;114:666-670.
174. Salcedo I, Campos-Caro A, Sampalo A, et al. Persistent polyclonal B lymphocytosis: an expansion of cells showing IgVH gene mutations and phenotypic features of normal lymphocytes from the CD27+ marginal zone B-cell compartment. *Br J Haematol* 2002;116:662-666.
175. Grever MR. How I treat hairy cell leukemia. *Blood* 2010;115:21-28.
176. Naik RR, Saven A. My treatment approach to hairy cell leukemia. *Mayo Clin Proc* 2012;87:67-76.
177. Jansen J, Hermans J, Remme J, et al. Hairy cell leukaemia. Clinical features and effect of splenectomy. *Scand J Haematol* 1978;21:60-71.
178. Mintz U, Golomb HM. Splenectomy as initial therapy in twenty-six patients with leukemic reticuloendotheliosis (hairy cell leukemia). *Cancer Res* 1979;39:2366-2370.

179. Jansen J, Hermans J. Splenectomy in hairy cell leukemia: a retrospective multicenter analysis. *Cancer* 1981;47:2066-2076.
180. Golomb HM, Vardiman JW. Response to splenectomy in 65 patients with hairy cell leukemia: an evaluation of spleen weight and bone marrow involvement. *Blood* 1983;61:349-352.
181. Ratain MJ, Vardiman JW, Barker CM, et al. Prognostic variables in hairy cell leukemia after splenectomy as initial therapy. *Cancer* 1988;62:2420-2424.
182. Quesada JR, Reuben J, Manning JT, et al. Alpha interferon for induction of remission in hairy-cell leukemia. *N Engl J Med* 1984;310:15-18.
183. Foon KA, Maluish AE, Abrams PG, et al. Recombinant leukocyte A interferon therapy for advanced hairy cell leukemia. Therapeutic and immunologic results. *Am J Med* 1986;80:351-356.
184. Golomb HM, Jacobs A, Fefer A, et al. Alpha2 interferon therapy of hairy-cell leukemia: a multicenter study of 64 patients. *J Clin Oncol* 1986;4:900-905.
185. Golomb HM, Fefer A, Golde DW, et al. Sequential evaluation of alpha-2b-interferon treatment in 128 patients with hairy cell leukemia. *Semin Oncol* 1987;14(Suppl 2):13-17.
186. Golomb HM, Fefer A, Golde DW, et al. Report of a multi-institutional study of 193 patients with hairy cell leukemia treated with interferon-alfa 2b. *Semin Oncol* 1988;15(5 Suppl 5):7-9.
187. Quesada JR, Hersh EM, Manning J, et al. Treatment of hairy cell leukemia with recombinant α -interferon. *Blood* 1986;68:493-497.
188. Ratain MJ, Golomb HM, Vardiman JW, et al. Treatment of hairy cell leukemia with recombinant alpha 2 interferon. *Blood* 1985;65:644-648.
189. Grever M, Kopecky K, Foucar MK, et al. Randomized comparison of pentostatin versus interferon alfa-2a in previously untreated patients with hairy cell leukemia: an intergroup study. *J Clin Oncol* 1995;13:974-982
190. Rai KR, Davey F, Peterson S, et al. Recombinant alpha-2b-interferon in therapy of previously untreated hairy cell leukemia: long term results of study by cancer and leukemia group B. *Leukemia* 1995;9:1116-1120.
191. Benz R, Siciliano RD, Studdi G, Fehr J. Long-term follow-up of interferon-alpha induction and low-dose maintenance therapy in hairy cell leukemia. *Eur J Haematol* 2009;82:194-200.
192. Baker PK, Pettitt AR, Slupsky JR, et al. Response of hairy cells to IFN- α involves induction of apoptosis through autocrine TNF- α and protection by adhesion. *Blood* 2002;100:647-653.
193. Bardawil RG, Ratain MJ, Golomb HM, et al. Changes in peripheral blood and bone marrow specimens during and after alpha 2binterferon therapy for hairy cell leukemia. *Leukemia* 1987;1:340-343.
194. Naeim F, Jacobs AD. Bone marrow changes in patients with hairy cell leukemia treated by recombinant alpha 2-interferon. *Hum Pathol* 1985;16:1200-1205.
195. Lauria F, Raspadori D, Foa R, et al. Reduced hematologic response to alpha-interferon therapy in patients with hairy cell leukemia showing a peculiar immunologic phenotype. *Cancer* 1990;65:2233-2236.
196. Weiss K. Safety profile of interferon- α therapy. *Semin Oncol* 1998;25 (Suppl 1):9-13.
197. Golomb HM, Ratain MJ, Fefer A, et al. Randomized study of the duration of treatment with interferon alfa2B in patients with hairy cell leukemia. *J Natl Cancer Inst* 1988;80:369-373.
198. Thompson JA, Kidd P, Rubin E, Fefer A. Very low dose alpha2b interferon for the treatment of hairy cell leukemia. *Blood* 1989;73:1440-1443.
199. Spielberger RT, Mick R, Ratain MJ, et al. Interferon treatment for hairy cell leukemia. An update on a cohort of 69 patients treated from 1983 to 1986. *Leuk Lymphoma* 1994;14(Suppl 1):89-93.
200. Troussard X, Flandrin G. Hairy cell leukemia. An update on a cohort of 93 patients treated in a single institution. Effects of interferon in patients relapsing after splenectomy and in patients with or without maintenance treatment. *Leuk Lymphoma* 1994;14(Suppl 1):99-105.
201. Capnist G, Federico M, Chisesi T, et al. Long term results of interferon treatment in hairy cell leukemia. Italian Cooperative Group of Hairy Cell Leukemia (ICGHCL). *Leuk Lymph* 1994;14:457-464.

202. Seymour JF, Estey EH, Keating MJ, Kurzrock R. Response to interferon-alpha in patients with hairy cell leukemia relapsing after treatment with 2-chlorodeoxyadenosine. *Leukemia* 1995;9:929-932.
203. Steis RG, Smith JW II, Urba WJ, et al. Resistance to recombinant interferon alfa-2a in hairy-cell leukemia associated with neutralizing anti-interferon antibodies. *N Engl J Med* 1988;318:1409-1413.
204. Spiegel RJ, Spicehandler JR, Jacobs SL, et al. Low incidence of serum neutralizing factors in patients receiving recombinant alfa-2b interferon (Intron A). *Am J Med* 1986;80:223-228.
205. Steis RG, Smith JW II, Urba WJ, et al. Loss of interferon antibodies during prolonged continuous interferon-alpha 2a therapy in hairy cell leukemia. *Blood* 1991;77:792-798.
206. Conlon KC, Urba WJ, Smith JW II, et al. Exacerbation of symptoms of autoimmune disease in patients receiving alpha interferon therapy. *Cancer* 1990;65:2237-2242.
207. Abdi EA, Venner PM. Immune thrombocytopenia after alpha interferon therapy in patients with cancer. *JAMA* 1986;255:1878-1879.
208. Akard LP, Hoffman R, Elias L, et al. Alpha interferon and immune hemolytic anemia. *Ann Intern Med* 1986;105:306.
209. Kampmeier P, Spielberger R, Dickstein J, et al. Increased incidence of second neoplasms in patients treated with interferon alpha 2b for hairy cell leukemia: a clinicopathologic assessment. *Blood* 1994;83:2931-2938.
210. Pawson R, A'Hern R, Catovsky D. Second malignancy in hairy cell leukaemia: no evidence of increased incidence after treatment with interferon alpha. *Leuk Lymph* 1996;22:103-106.
211. Johnston JB, Begleiter A, Pugh L, et al. Biochemical changes induced in hairy-cell leukemia following treatment with the adenosine deaminase inhibitor 2'-deoxycoformycin. *Cancer Res* 1986;46:2179-2184.
212. Major PP, Agarwal RP, Kufe DW. Clinical pharmacology of deoxycoformycin. *Blood* 1981;58:91-96.
213. Begleiter A, Verburg L, Ashique A, et al. Comparison of antitumor activities of 2-chlorodeoxyadenosine and 9- β -arabinosyl-2-fluoroadenine in chronic lymphocytic leukemia and marrow cells in vitro. *Leukemia* 1995;9: 1875-1881.
214. Robertson LE, Chubb S, Meyn RE, et al. Induction of apoptotic cell death in chronic lymphocytic leukemia by 2-chloro-2'-deoxyadenosine and 9- β -D-arabinosyl-2-fluoroadenine. *Blood* 1993;81:143-150.
215. Genini D, Adachi S, Chao Q, et al. Deoxyadenosine analogs induce programmed cell death in chronic lymphocytic leukemia cells by damaging the DNA and by directly affecting the mitochondria. *Blood* 2000;96: 3537-3543.
216. Genini D, Budihardjo I, Plunkett W, et al. Nucleotide requirements for the in vitro activation of the apoptosis protein-activating factor-1-mediated caspase pathway. *J Biol Chem* 2000;275:29-34.
- P.1950
217. Johnston JB. Mechanism of action of pentostatin and cladribine in hairy cell leukemia. *Leuk Lymph* 2011;52(S2):43-45.
218. Johnston JB, Eisenhauer E, Corbett WE, et al. Efficacy of 2'-deoxycoformycin in hairy-cell leukemia: a study of the national cancer institute of Canada clinical trials group. *J Natl Cancer Inst* 1988;80:765-769.
219. Spiers AS, Moore D, Cassileth PA, et al. Remissions in hairy-cell leukemia with pentostatin (2'-deoxycoformycin). *N Engl J Med* 1987;316:825-830.
220. Kraut EH, Bouroncle BA, Grever MR. Pentostatin in the treatment of advanced hairy cell leukemia. *J Clin Oncol* 1989;7:168-172.
221. Catovsky D, Matutes E, Talavera JG, et al. Long term results with 2'-deoxycoformycin in hairy cell leukemia. *Leuk Lymph* 1994;14(Suppl 1):109-113.
222. Rafel M, Cervantes F, Beltran JM, et al. Deoxycoformycin in the treatment of patients with hairy cell leukemia. *Cancer* 2000;88:352-357.
223. Ribeiro P, Bouaffia F, Peaud PY, et al. Long term outcome of patients with hairy cell leukemia treated with pentostatin. *Cancer* 1999;85:65-71.

224. Maloisel F, Benboubker L, Gardembas M, et al. Long-term outcome with pentostatin treatment in hairy cell leukemia patients. A French retrospective study of 238 patients. *Leukemia* 2003;17:45-51.
225. Seymour JF, Talpaz M, Kurzrock R. Response duration and recovery of CD4+ lymphocytes following deoxycoformycin in interferon- α resistant hairy cell leukemia: 7 year follow-up. *Leukemia* 1997;11:42-47.
226. Ho AD, Thaler J, Mandelli F, et al. Response to pentostatin in hairy-cell leukemia refractory to interferon alpha. *J Clin Oncol* 1989;7:1533-1538.
227. Golomb HM, Dodge R, Mick R, et al. Pentostatin treatment of hairy cell leukemia patients who failed initial therapy with recombinant alpha-interferon: a report of CALGB study 8515. *Leukemia* 1994;8:2037-2040.
228. Dalal BI, Freier L, Johnston JB, et al. Peripheral blood and bone marrow changes following 2'-deoxycoformycin therapy in hairy cell leukemia. Results of 200 weeks' followup. *Cancer* 1989;63:14-22.
229. Thaler J, Grunewald K, Gattringer C, et al. Long-term follow-up of patients with hairy cell leukaemia treated with pentostatin: lymphocyte subpopulations and residual bone marrow infiltration. *Br J Haematol* 1993;84:75-82.
230. Matutes E, Meeus P, McLennan K, et al. The significance of minimal residual disease in hairy cell leukemia patients treated with deoxycoformycin: a long term follow-up study. *Br J Haematol* 1997;98:375-383.
231. Cassileth PA, Chevart B, Spiers AS, et al. Pentostatin includes durable remissions in hairy cell leukemia. *J Clin Oncol* 1991;9:243-246.
232. Zinzani PL, Pellegrini C, Stefoni V, et al. Hairy cell leukemia. Evaluation of the long-term outcome in 121 patients. *Cancer* 2010;116:4788-4792.
233. Else M, Dearden CE, Mastutes E, et al. Long-term follow-up of 233 patients with hairy cell leukaemia, treated initially with pentostatin or cladribine, at a median of 16 years from diagnosis. *Br J Haematol* 2009;145:733-740.
234. Dearden CE, Else M, Catovsky D. Long-term results for pentostatin and cladribine treatment of hairy cell leukemia. *Leuk Lymph* 2011;52(S2): 21-24.
235. Johnston JB, Eisenhauer E, Wainman N, et al. Long-term outcome following treatment of hairy cell leukemia with pentostatin (Nipent): a national cancer institute of Canada study. *Semin Oncol* 2000;27:32-36.
236. Flinn IW, Kopecky KJ, Foucar MK, et al. Long-term follow-up of remission duration, mortality, and second malignancies in hairy cell leukemia patients treated with pentostatin. *Blood* 2000;96:2981-2986.
237. Urba WJ, Baseler MW, Kopp WC, et al. Deoxycoformycin-induced immunosuppression in patients with hairy cell leukemia. *Blood* 1989;73:38-46.
238. Kraut EH, Neff JC, Bouroncle BA, et al. Immunosuppressive effects of pentostatin. *J Clin Oncol* 1990;8:848-855.
239. Cheson BD. Infectious and immunosuppressive complications of purine analog therapy. *J Clin Oncol* 1995;13:2431-2448.
240. Cheson BD, Vena DA, Foss FM, Sorensen JM. Neurotoxicity of purine analogs: a review. *J Clin Oncol* 1994;12:2216-2228.
241. Estey EH, Kurzrock R, Kantarjian HM, et al. Treatment of hairy cell leukemia with 2-chlorodeoxyadenosine (2-CdA). *Blood* 1992;79:882-887.
242. Tallman MS, Hakimian D, Variakojis D, et al. A single cycle of 2-chlorodeoxyadenosine results in complete remission in the majority of patients with hairy cell leukemia. *Blood* 1992;80:2203-2209.
243. Juliusson G, Liliemark J. Rapid recovery from cytopenia in hairy cell leukemia after treatment with 2-chloro-2'-deoxyadenosine (cladribine): relation to opportunistic infections. *Blood* 1992;79:888-894.
244. Piro LD, Ellison DJ, Saven A. The Scripps Clinic experience with 2-chlorodeoxyadenosine in the treatment of hairy cell leukemia. *Leuk Lymph* 1994;14(Suppl 1):121-125.
245. Lauria F, Rondelli D, Zinzani PL, et al. Long-lasting complete remission in patients with hairy cell leukemia treated with 2-cladribine: a 5-year survey. *Leukemia* 1997;11:629-632.
246. Piro LD, Carrera CJ, Beutler E, et al. 2-Chlorodeoxyadenosine: an effective new agent for the treatment of chronic lymphocytic leukemia. *Blood* 1988;72:1069-1073.

247. Cheson BD, Sorensen JM, Vena DA, et al. Treatment of hairy cell leukemia with 2-chlorodeoxyadenosine via the Group C protocol mechanism of the national cancer institute: a report of 979 patients. *J Clin Oncol* 1998;16:3007-3015.
248. Saven A, Burian C, Koziol JA, et al. Long-term follow-up of patients with hairy cell leukemia after cladribine treatment. *Blood* 1998;92:1918-1926.
249. Goodman GR, Burian C, Kaziol JA, et al. Extended follow-up of patients with hairy cell leukemia after treatment with cladribine. *J Clin Oncol* 2003;21:891-896.
250. Hoffman MA, Janson D, Rose E, et al. Treatment of hairy-cell leukemia with cladribine: response, toxicity, and long-term follow-up. *J Clin Oncol* 1997;15:1138-1142.
251. Jehn U, Bartl R, Dietzfelbinger H, et al. An update: 12-year follow-up of patients with hairy cell leukemia following treatment with 2-chlorodeoxyadenosine. *Leukemia* 2004;18:1476-1481.
252. Chadha P, Rademaker AW, Mendiratta P, et al. Treatment of hairy cell leukemia with 2-chlorodeoxyadenosine (2-CdA): long-term follow-up of the Northwestern University experience. *Blood* 2005;106:241-246.
253. Sigal DS, Sharpe R, Burian C, Saven A. Very long-term eradication of minimal residual disease in patients with hairy cell leukemia after a single course of cladribine. *Blood* 2010;115:1893-1896.
254. Siegel RS, Hakimian D, Spies W, et al. Technetium-99m sulfur colloid scanning and correlative magnetic resonance imaging in patients with hairy cell leukemia and hypocellular bone marrow biopsies after 2-chlorodeoxyadenosine. *Leuk Lymph* 1999;35:171-177.
255. Ellison DJ, Sharpe RW, Robbins BA, et al. Immunomorphologic analysis of bone marrow biopsies after treatment with 2-chlorodeoxyadenosine for hairy cell leukemia. *Blood* 1994;84:4310-4315.
256. Filleul B, Delannoy A, Ferrant A, et al. A single course of 2-chloro-deoxyadenosine does not eradicate leukemic cells in hairy cell leukemia patients in complete remission. *Leukemia* 1994;8:1153-1156.
257. Wheaton S, Tallman MS, Hakimian D, et al. Minimal residual disease may predict bone marrow relapse in patients with hairy cell leukemia treated with 2-chlorodeoxyadenosine. *Blood* 1996;87:1556-1560.
258. Saven A, Piro LD. Complete remissions in hairy cell leukemia with 2-chlorodeoxyadenosine after failure with 2'-deoxycoformycin. *Ann Intern Med* 1993;119:278-283.
259. Legrand O, Vekhoff A, Marie JP, et al. Treatment of hairy cell leukaemia (HCL) with 2-chlorodeoxyadenosine (2-Cladribine): identification of parameters predictive of adverse effects. *Br J Haematol* 1997;99:165-167.
260. Saven A, Burian C, Adusumalli J, et al. Filgrastim for cladribine-induced neutropenic fever in patients with hairy cell leukemia. *Blood* 1999;93: 2471-2477.
261. Seymour JF, Kurzrock R, Freireich EJ, et al. 2-Chlorodeoxyadenosine induces durable remissions and prolonged suppression of CD4+ lymphocyte counts in patients with hairy cell leukemia. *Blood* 1994;83:2906-2911.
262. Juliusson G, Lenkei R, Liliemark J. Flow cytometry of blood and bone marrow cells from patients with hairy cell leukemia: phenotype of hairy cells and lymphocyte subsets after treatment with 2-chlorodeoxyadenosine. *Blood* 1994;83:3672-3681.
263. Juliusson G, Lenkei R, Tjonnfjord G, et al. Low-dose cladribine for symptomatic hairy cell leukaemia. *Br J Haematol* 1995;89:637-639.
264. Lenz G, Golf A, Rudiger T, et al. Epstein-Barr virus-associated B-cell non-Hodgkin lymphoma following treatment of hairy cell leukemia with cladribine. *Blood* 2003;102:3457-3458.
265. Bhargava R, Barbashina V, Filippa DA, et al. Epstein-Barr virus positive large B-cell lymphoma arising in a patient previously treated with cladribine for hairy cell leukemia. *Leuk Lymph* 2004;45:1043-1048.
266. Zulian GB, Roux E, Tiercy JM, et al. Transfusion-associated graft-versus-host disease in a patient treated with cladribine (2-chlorodeoxyadenosine): demonstration of exogenous DNA in various tissue extracts by PCR analysis. *Br J Haematol* 1995;89:83-89.
267. Schroeder ML. Transfusion-associated graft-versus-host disease. *Br J Haematol* 2002;117:275-287.
268. Liliemark J, Albertioni F, Hassan M, et al. On the bioavailability of oral and subcutaneous 2-chloro-2-deoxyadenosine in humans: alternative routes of administration. *J Clin Oncol* 1992;10:1514-1518.

269. Robak T, Blasinska-Morawiec M, Krykowski E, et al. 2-Chlorodeoxyadenosine (Cladribine) in 2-hour versus 24-hour intravenous infusion in the treatment of patients with hairy cell leukemia. *Leuk Lymph* 1996;22:107-111.
270. Juliusson G, Heldal D, Hippe E, et al. Subcutaneous injections of 2-chlorodeoxyadenosine for symptomatic hairy cell leukemia. *J Clin Oncol* 1995;13:989-995.
271. Von Rohr A, Schmitz SF, Tichelli A, et al. Treatment of hairy cell leukemia with cladribine (2-chlorodeoxyadenosine) by subcutaneous bolus infection: a phase II study. *Ann Oncol* 2002;13:1641-1649.
272. Lauria F, Bocchia M, Marotta G, et al. Weekly administration of 2-chlorodeoxyadenosine in patients with hairy-cell leukemia is effective and reduces infectious complications. *Haematologica* 1999;84:22-25.
273. Chacko J, Murphy C, Duggan C, et al. Weekly intermittent 2-CdA is less toxic and equally efficacious when compared to continuous infusion in hairy cell leukaemia. *Br J Haematol* 1999;105:1145-1146.
274. Zinzani PL, Tani M, Marchi E, et al. Long-term follow-up of front-line treatment of hairy cell leukemia with 2-chlorodeoxyadenosine. *Hematologica* 2004;89: 309-313.
275. Zenhausem R, Hsu Schmitz S-F, Solenthaler M, et al. Randomized trial of daily versus weekly administration of 2-chlorodeoxyadenosine in patients with hairy cell leukemia: a multicenter phase III trial (SAKK 32/98). *Leuk Lymph* 2009;50:1501-1511.
276. Robak T, Jamrozak K, Gora-Tybor J, et al. Cladribine in a weekly versus daily schedule for untreated active hairy cell leukemia: final report from the Polish Adult Leukemia Group (PALG) of a prospective, randomized, multicenter trial. *Blood* 2007;109:3672-3675.
277. Kraut EH, Hoo GC. Fludarabine phosphate in refractory hairy cell leukemia. *Am J Hematol* 1991;37:59-60.
278. Kantarjian HM, Schachner J, Keating MJ. Fludarabine therapy in hairy cell leukemia. *Cancer* 1991;67:1291-1293.
279. Maloney DG, Smith B, Rose A. Rituximab: mechanism of action and resistance. *Semin Oncol* 2002;29(1 Suppl 2):2-9.
280. Byrd JC, Kitada S, Flinn IW, et al. The mechanism of tumor cell clearance by rituximab in vivo in patients with B-chronic lymphocytic leukemia: evidence of caspase activation and apoptosis induction. *Blood* 2002;99:1038-1043.
281. Manches O, Lui G, Chaperot L, et al. In vitro mechanisms of action of rituximab on primary non-Hodgkin's lymphomas. *Blood* 2003;101:949-954.
282. Hagberg H, Lundholm L. Rituximab, a chimaeric anti-CD20 monoclonal antibody, in the treatment of hairy cell leukaemia. *Br J Haematol* 2001;115:609-611.
283. Lauria F, Lenoci M, Annino L, et al. Efficacy of anti-CD20 monoclonal antibodies (Mabthera) in patients with progressed hairy cell leukemia. *Haematologica* 2001;86:1046-1050.
284. Nieva J, Bethel K, Saven A. Phase 2 study of rituximab in the treatment of cladribine-failed patients with hairy cell leukemia. *Blood* 2003;102: 810-813.
285. Thomas DA, O'Brien S, Bueso-Ramos C, et al. Rituximab in relapsed or refractory hairy cell leukemia. *Blood* 2003;102:3906-3911.
286. Cervetti G, Galimberti S, Andreazzoli F, et al. Rituximab as treatment for minimal residual disease in hairy cell leukaemia. *Haematology* 2004;73:412-417.
287. Ravandi F, O'Brien S, Jorgensen J, et al. Phase 2 study of cladribine followed by rituximab in patients with hairy cell leukemia. *Blood* 2011;118: 3818-3823.
288. Kreitman RJ, Arons E, Stetler-Stevenson M, Fitzgerald DJ, Willson WH, Pastan I. Recombinant immunotoxins and other therapies for relapsed/refractory hairy cell leukemia. *Leuk Lymph* 2011;52(Suppl 2):82-86.
289. Kreitman RJ, Pastan I. Antibody fusion proteins: anti-CD22 recombinant immunotoxin moxetumomab pasudotox. *Clin Cancer Res* 2011;17:6398-6405.
290. Kreitman RJ, Stetler-Stevenson M, Margulies I, et al. Phase II trial of recombinant immunotoxin RFB4(dsFv)-PE38 (BL22) in patients with hairy cell leukemia. *J Clin Oncol* 2009;27:2983-2990.
291. Else M, Dearden CE, Matutes E, et al. Rituximab with pentostatin or cladribine: an effective combination treatment for hairy cell leukemia after disease recurrence. *Leuk Lymph* 2011;52(S2):75-78.

292. Gerrie AS, Zypchen LN, Connors JN. Fludarabine and rituximab for relapsed or refractory hairy cell leukemia. *Blood* 2012;119:1988-1991.
293. Krigel R, Liebes LF, Pelle E, et al. Chlorambucil therapy in hairy cell leukemia: effects on lipid composition and lymphocyte subpopulations. *Blood* 1982;60:272-275.
294. Golomb HM, Schmidt K, Vardiman JW. Chlorambucil therapy of twenty-four postsplenectomy patients with progressive hairy cell leukemia. *Semin Oncol* 1984;11(4 Suppl 2):502-508.
295. Davis TE, Waterbury L, Abeloff M, et al. Leukemic reticuloendotheliosis: report of a case with prolonged remission following intensive chemotherapy. *Arch Intern Med* 1976;136:620-622.
296. Jansen J, den Ottolander GJ, Holdrinet RS, et al. Prognosis and therapy in hairy cell leukemia. *Semin Oncol* 1984;11:472-478.
297. McCarthy D, Catovsky D. Response to doxorubicin in hairy cell leukaemia. *Scand J Haematol* 1978;21:445-447.
298. Stewart DJ, Benjamin RS, McCredie KB, et al. The effectiveness of rubidazone in hairy cell leukemia (leukemic reticuloendotheliosis). *Blood* 1979;54:298-304.
299. Calvo F, Castaigne S, Sigaux F, et al. Intensive chemotherapy of hairy cell leukemia in patients with aggressive disease. *Blood* 1985;65:115-119.
300. Lusch CJ, Ramsey HE, Katayama I. Leukemic reticuloendotheliosis: report of a case with peripheral blood remission on androgen therapy. *Cancer* 1978;41:1964-1966.
301. Magee MJ, McKenzie S, Filippa DA, et al. Hairy cell leukemia. Durability of response to splenectomy in 26 patients and treatment of relapse with androgens in six patients. *Cancer* 1985;56:2557-2562.
302. Quesada JR, Hersh EM, Keating M, et al. Hairy cell leukemia: clinical effects of the methanol extraction residue (MER) of BCG, lithium carbonate and mononuclear cell-enriched leukocyte transfusions. *Leuk Res* 1981;5: 463-476.
303. Glaspy JA, Baldwin GC, Robertson PA, et al. Therapy for neutropenia in hairy cell leukemia with recombinant human granulocyte colony-stimulating factor. *Ann Intern Med* 1988;109:789-795.
304. Cheever MA, Fefer A, Greenberg PD, et al. Treatment of hairy-cell leukemia with chemoradiotherapy and identical twin bone-marrow transplantation. *N Engl J Med* 1982;307:479-481.
305. Mielke CH Jr, Dobbs CE, Winkler CF, et al. Therapeutic leukapheresis in hairy cell leukemia. *Arch Intern Med* 1982;142:700-702.
306. Yam LT, Klock JC, Mielke CH. Therapeutic leukapheresis in hairy cell leukemia: review of literature and personal experience. *Semin Oncol* 1984;11(4 Suppl 2):493-501.
307. Golomb HM, Kraut EH, Oviatt DL, et al. Absence of prolonged benefit of initial leukapheresis therapy for hairy cell leukemia. *Am J Hematol* 1983;14:49-56.
308. Weinmann M, Becker G, Einsele H, et al. Clinical indications and biological mechanisms of splenic irradiation in chronic leukaemias and myeloproliferative disorders. *Radiother Oncol* 2001;58:235-246.
309. Orringer EP, Varia MA. A role for radiation in the treatment of hairy cell leukemia complicated by massive lymphadenopathy: a case report. *Cancer* 1980;45:2047-2050.
310. Mercieca J, Matutes E, Emmett E, et al. 2-chlorodeoxyadenosine in the treatment of hairy cell leukaemia: differences in response in patients with and without abdominal lymphadenopathy. *Br J Haematol* 1996;93:409-411.
311. Bernstein L, Newton P, Ross RK. Epidemiology of hairy cell leukemia in Los Angeles county. *Cancer Res* 1990;50:3605-3609.
312. Kampmeier P, Spielberger R, Dickstein J, et al. Increased incidence of second neoplasms in patients treated with interferon alpha 2b for hairy cell leukemia: a clinicopathologic assessment. *Blood* 1994;83:2931-2938.
313. Au WY, Klasa RJ, Gallagher R, et al. Second malignancies in patients with hairy cell leukemia in British Columbia: a 20-year experience. *Blood* 1998;92:1160-1164.
314. Kurzrock R, Strom SS, Estey E, et al. Second cancer risk in hairy cell leukemia: analysis of 350 patients. *J Clin Oncol* 1997;15:1803-1810.

315. Federico M, Zinzani PL, Frassoldati A, et al. Risk of second cancer in patients with hairy cell leukemia: long-term follow-up. *J Clin Oncol* 2002;20:638-646.

316. Hisada M, Chen BE, Jaffe ES, Travis LB. Second cancer incidence and cause-specific mortality among 3,104 patients with hairy cell leukemia: a population-based study. *J Natl Cancer Inst* 2007;99:215-222.

Chapter 92 Cutaneous T-Cell Lymphoma: Mycosis Fungoides and Sézary Syndrome

> Table of Contents > Part VII - Hematologic Malignancies > Section 4 - Lymphoproliferative Disorders > Chapter 92 - Cutaneous T-Cell Lymphoma: Mycosis Fungoides and Sézary Syndrome

Chapter 92

Cutaneous T-Cell Lymphoma: Mycosis Fungoides and Sézary Syndrome

John A. Zic

Jeff P. Zwerner

Laura Y. McGirt

Claudio A. Mosse

John P. Greer

Cutaneous lymphomas are a heterogeneous group of non-Hodgkin lymphomas (NHLs) of T- and B-cell origin in which the skin is the primary organ of involvement. Primary cutaneous lymphomas usually present without signs of extracutaneous malignancy at onset of symptoms; they represent an entity distinct from nodal lymphomas with secondary cutaneous involvement. In 1975, Lutzner, Edelson, and associates introduced the term cutaneous T-cell lymphoma (CTCL) to describe the spectrum of skin-based lymphomas of T-cell origin including classical mycosis fungoides (MF) and Sézary syndrome (SS).^{1, 2} This chapter is a review of the history, epidemiology, clinicopathologic features, and therapy of these lymphomas.

HISTORICAL PERSPECTIVE AND PATHOPHYSIOLOGY

Clinical Description

The first clinical description of MF was provided in 1806 by Alibert, a French physician, who identified a 56-year-old man presenting with skin tumors resembling mushrooms after having had a desquamating rash over several months; the lesions waxed and waned for 5 years before the patient died with a “hectic” fever.³ In 1832 Alibert first used the term mycosis fungoïde in his treatise on diseases of the skin to describe the mushroomlike tumors.⁴ Bazin described the three “classical” cutaneous stages in 1870: (a) the premycotic stage, which can be localized or diffuse with superficial eczematous or erythematous lesions; (b) the infiltrative plaque stage; and (c) the tumor stage.⁵ The mycosis d'emblée variant, in which tumors develop rapidly without a preceding premycotic or plaque stage, was described by Vidal and Brocq in 1885.⁶ In the early 1890s, Besnier and Hallopeau described the erythrodermic variant, which later became known as Sézary syndrome.^{7, 8}

Histopathology

By the end of the 19th century, most authorities agreed that the small round cells infiltrating the epidermis and forming tumors were lymphoid in origin.⁹ Although the French authorities considered the disease lymphadenomatous in nature, the German, English, and American authorities were divided between sarcomatous and granulomatous (infectious) etiologies.^{9, 10}

The unique appearance of the cells involved in CTCL was identified in 1938 by Sézary and Bouvrain, who reported a triad of erythroderma, leukemia with circulating mononuclear cells that had convoluted nuclei, and adenopathy infiltrated with the same cells.¹¹ SS was recognized in the English literature by several groups in the 1950s, but it was not described in the United States medical literature until Taswell and Winkelmann at the Mayo Clinic in 1961.¹² In 1968, Lutzner and Jordan extended the light microscopic description of the Sézary cell by using electron microscopy to visualize the “serpentine” or cerebriform cell nucleus.¹³

Immunology

The 1970s witnessed the introduction of cellular immunology into the study of hematopoietic neoplasms, and in 1971 Crossen et al. confirmed the lymphocyte origin of SS.¹⁴ In 1973, Broome et al.¹⁵ and Brouet et al.¹⁶ identified the neoplastic cell as a T-cell, and Broder et al. demonstrated in 1976 that the cells are usually of the helper phenotype (CD4⁺).¹⁷

Studies performed in the early 1990s further characterized the circulating malignant T-cells in patients with SS as “memory” helper T-cells because of the expression of CD45RO⁺.¹⁸ In 1992, Vowels et al. detected a cytokine profile similar to that produced by murine Th2 cells from both stimulated peripheral blood mononuclear cells (PBMCs) and serum from patients with SS.¹⁹ Further studies identified a Th2 cytokine profile (interleukin [IL]-4, IL-5, IL-6, IL-10) to be present in the skin of patients with MF and SS.^{20, 21, 22} Increased levels of IL-4 and IL-5 produced by the malignant T-cell clone may account for the eosinophilia and increased levels of IgE and IgA in the serum of patients with advanced CTCL.²³ More recently, the Th17-associated proinflammatory cytokine, IL-17, has also been found to be up-regulated in MF skin lesions and appears to be activated through the Jak/Stat pathway.²⁴

Immunologic studies have addressed the pathogenesis of MF and SS by examining the complex interactions among malignant cerebriform T-cells, keratinocytes, Langerhans cells, and other immunomodulating cells.²⁴ Lymphocytes (malignant and inflammatory) that home to cutaneous sites differ from lymphocytes in noncutaneous infiltrates by expressing the cutaneous lymphocyte-associated antigen (CLA), which binds to the endothelial cell adhesion molecule E-selectin (ELAM-1), which is preferentially induced on cutaneous venules.²⁵ Both circulating and skin-based malignant T-cells from patients with MF have been shown to express CLA, which may explain how the cells preferentially home into the skin (Fig. 92.1).^{25, 26} In addition, CLA⁺ T cells selectively express CC chemokine receptor 4 (CCR4) and CCR10, whose ligands CCL17 (TARC) and CCL27 (CTAK) are generated by the lesional keratinocytes and also on the luminal surface of postcapillary venules in the skin.^{25, 26, 27, 28} Narducci et al. discovered that SS cells express a functionally active CXCR4 and that the ligand SDF-1 is abundantly produced in the skin, which represents the main destination of SS cell spreading.²⁹ SDF-1 is normally inactivated by proteolytic cleavage by the CD26/dipeptidylpeptidase IV (DPP-IV). The lack of CD26 from the cell surface is a hallmark of circulating SS cells. Additionally, it has been found that fibroblasts from lesional CTCL produce increased levels of the chemokine eotaxin, which is also expressed at increasingly higher levels as the disease advances.³⁰ The only receptor for eotaxin is CCR3, which is found on Th2 lymphocytes and eosinophils, and may further explain why we see an increase of Th2 polarity as CTCL progresses.³⁰ Another recent report suggests that low herpes virus entry mediator (HVEM) expression on dermal fibroblasts in advanced CTCL skin attenuates expression of Th1 chemokines, which may contribute to a shift to a Th2-dominant microenvironment as disease progresses.³¹

Within the skin, the specific epidermotropism of the malignant T-cell is partially explained by the discovery of increased expression of intercellular adhesion molecule-1 (ICAM-1 or CD54) by epidermal keratinocytes in early MF lesions. The binding of ICAM-1 to LFA-1 (lymphocyte function-associated protein or CD18) expressed by lymphocytes may explain the histologic finding of atypical lymphocytes nesting within the epidermis.³² Some authorities speculate that the expression of

P.1952

ICAM-1 by keratinocytes is induced by the release of interferon- γ (IFN- γ) from infiltrating CD8⁺ T-cells or natural killer (NK) cells responding to the malignant T-cell population within the dermis (Fig. 92.2).²³ Adhesion molecules other than ICAM-1/LFA-1 have been implicated in the phenomenon of epidermotropism and include E-cadherins, CD58/CD2, B7/CD28, CD49a (VLA-1), CD49c (VLA-3), and CD49f (VLA-6).²⁸ Soluble chemotactic factors may also play a role in the epidermotropism of MF. The expression of the CXC chemokine IP-10 (IFN- γ -inducible protein-10), which is chemotactic for CD4⁺ lymphocytes, has been shown to be markedly increased by basal and suprabasal keratinocytes in MF lesions.³³ Several studies suggest that in early MF, epidermal Langerhans cells convert to hyperstimulatory antigen-presenting cells (CD1a⁺, CD1b⁺, CD36⁺) with a high expression of Class II MHC molecules and adhesion molecules capable of activating tumor-infiltrating lymphocytes.²³

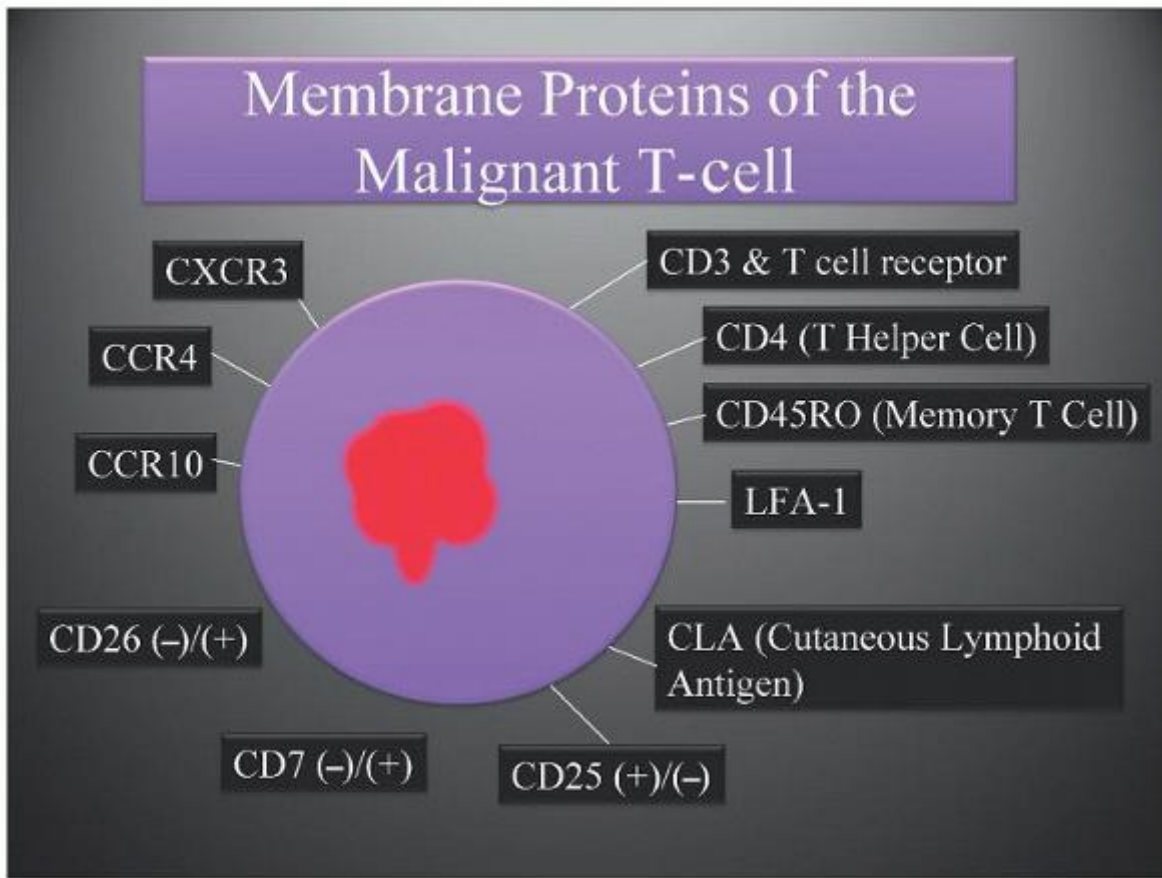

FIGURE 92.1. Membrane proteins of the malignant T-cell. The cutaneous lymphoid antigen (CLA) is a membrane protein expressed by a vast majority of T-cells found in inflamed skin including (CTCL). LFA-1 is a $\beta 2$ integrin expressed by all mature white blood cells.

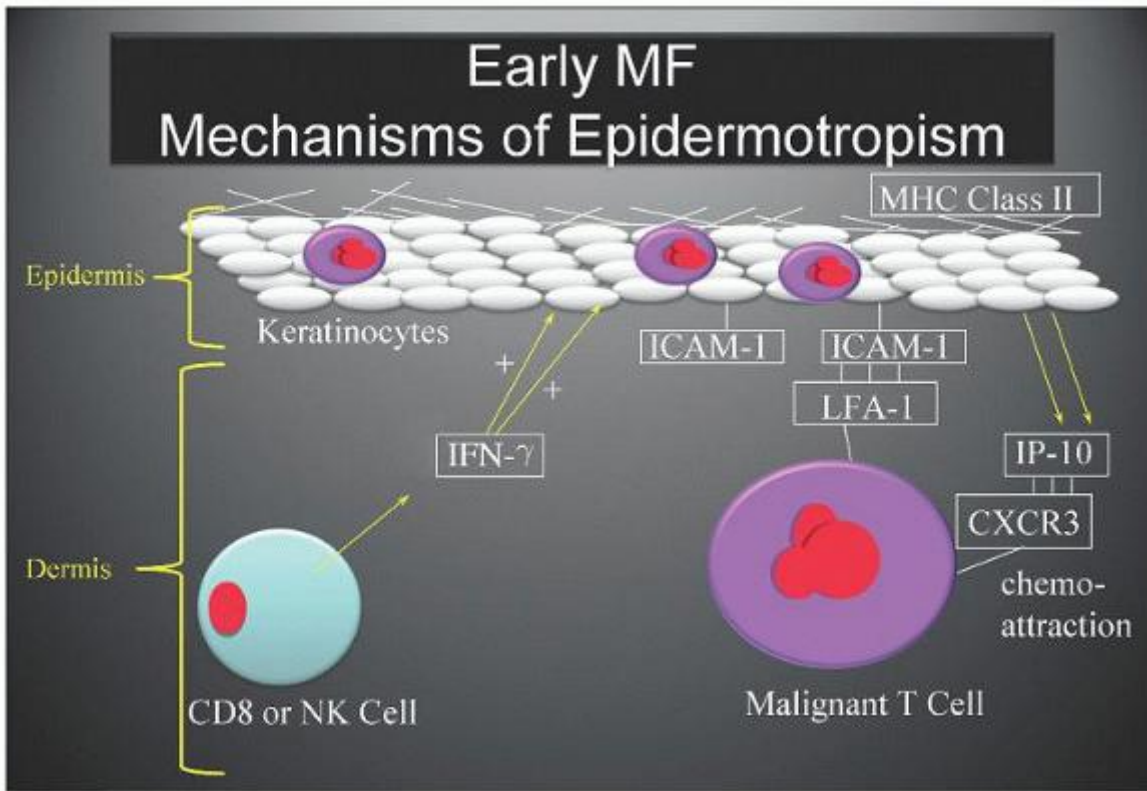

FIGURE 92.2. Early (CTCL): mechanisms of epidermotropism. The release of interferon (IFN) γ by early, reactive CD8 cytotoxic T-cells or natural killer (NK)-cells leads to increased keratinocyte expression of intercellular adhesion molecule-1 (ICAM-1) and release of the CXC chemokine IP-10, which binds to the CXCR3 receptor, and may lead to nesting of CTCL cells within the epidermis.

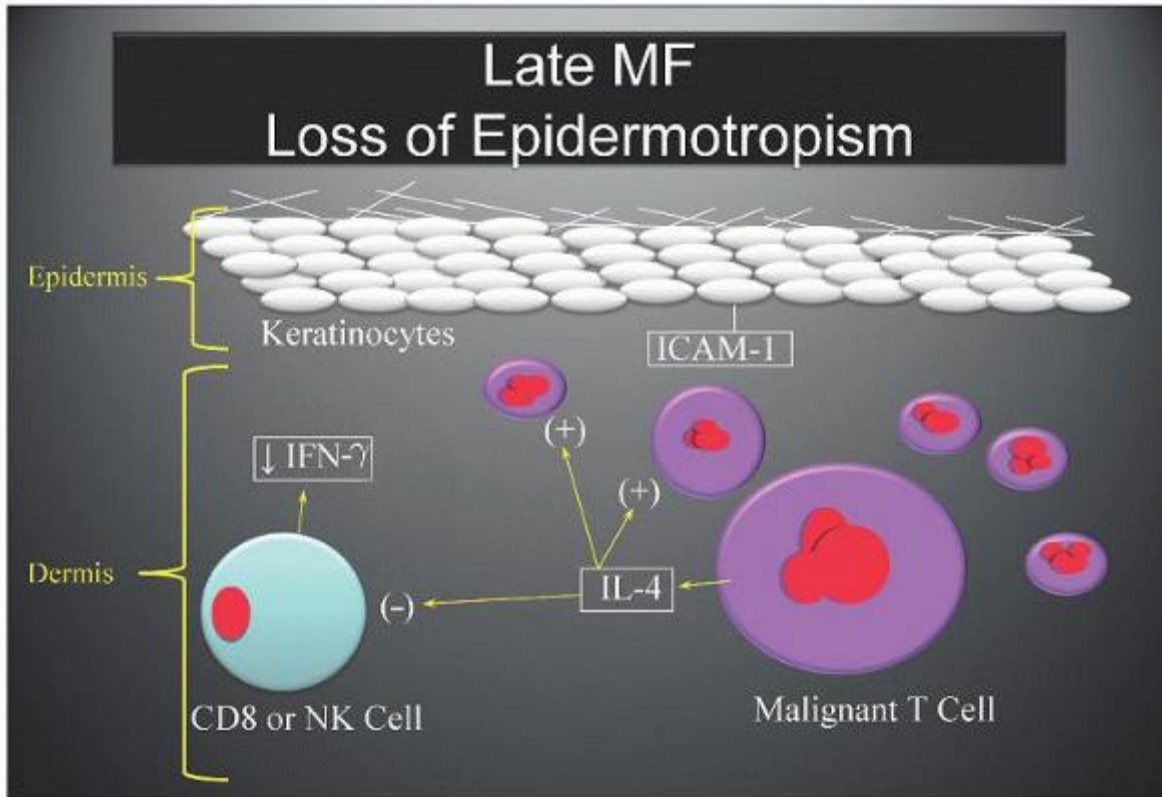

FIGURE 92.3. Late cutaneous T-cell lymphoma (CTCL): loss of epidermotropism. As the clonal population of CTCL cells expands, more IL-4 is released which drives autocrine-induced proliferation of the CTCL cells and inhibition of CD8 cytotoxic T-cells and natural killer (NK)-cells. The impaired release of interferon (IFN) γ may lead to less ICAM-1 expression and decreased keratinocyte-CTCL cell adhesion. MF, mycosis fungoides.

More advanced lesions of MF, characterized clinically as tumors or generalized erythroderma, often demonstrate a loss of epidermotropism, with malignant T-cells infiltrating the deep dermis.²⁸ In 1989, Nickoloff et al. found markedly diminished ICAM-1 expression by keratinocytes in a patient with SS,³⁴ and similar findings in tumor-stage patients were reported by Vejlsgaard et al.³⁵ Rook et al.³⁶ have suggested that unknown mechanisms lead to an evasion of the host immune response, with subsequent expansion of the malignant clonal population and increased production of IL-4. Increased levels of IL-4 could inhibit the production of IFN- γ , leading to decreased ICAM-1 expression by keratinocytes and thus reduced binding of malignant T-cells within the epidermal compartment (Fig. 92.3).³⁶ In addition, CXCR3, a T-cell chemokine receptor, has been shown to be expressed by lymphocytes in early-stage MF but absent in cases of transformed MF, when epidermotropism is often absent.³⁷ Others have suggested that the expression of CCR7 by some peripheral blood Sézary cells may enhance their ability to home into lymph nodes.³⁸ Indeed, a recent study revealed a disparate chemokine receptor expression profile in leukemic CTCL cells as compared to CTCL cells isolated from lesional skin. The leukemic cells had strong expression of CCR7, L-selectin, and CCR4, whereas the cells from CTCL skin expressed CCR4 and CLA.³⁹ The results of these investigators suggest that SS is a malignancy of central memory T-cells and MF is a malignancy of skin-resident effector memory T-cells.³⁹

As the disease progresses, cell-mediated immunity, critical for tumor cell recognition and destruction, is slowly dismantled. IL-4 and IL-10 secreted by the malignant T-cell may inhibit Th1 cells responsible for coordinating cell-mediated immune functions.^{23, 40, 41} Also, the inhibition of IL-12 secretion from macrophages may diminish the cytokine's stimulatory effect on CD8-cytotoxic T-cells.²³ With Th1 cells, CD8-cytotoxic T-cells, macrophages, and NK cells partially disabled, the malignant clone can escape immune surveillance and proliferate.^{40, 41}

Molecular Genetics

Clonality in T-cell lymphoma was difficult to establish before the development of molecular genotyping methods in the 1980s. Initial evidence of clonality in MF/SS was provided by cytogenetic analysis.^{42, 43} Several of these early studies demonstrated the same abnormal clone in separate lesions from skin, peripheral blood, lymph nodes, and bone marrow.^{42, 43}

The identification of a defined cytogenetic abnormality would be a major advance in the diagnosis and our understanding of the pathogenesis of MF/SS. Unfortunately, to date, no such abnormality has been identified consistently in MF, with most reported findings being largely of a random nature.^{44, 45} Some of the specific chromosomal deletions and amplifications that have been identified in CTCL include 8q gains, 10q and 17p deletions,

P.1953

and 17q gains (isochromosome 17).^{46, 47, 48, 49, 50} Abnormalities in chromosome 10 have been correlated with progression to tumor stage, including loss of heterozygosity on 10q and microsatellite instability.⁵¹ Salgado et al. demonstrated through comparative genomic hybridization oligonucleotide array that in tumor-stage MF, loss of 9p21.3 (encodes CDKN2A and CDKN2B) and 10q26qter, and gain of 8q.24.21 were associated with decreased survival.⁵² Additionally, p16INK4a, a protein coded at the 9p21 locus, has been shown to be silenced in tumor-stage MF.⁵³ Microsatellite instability was detected in 16 of 56 patients with CTCL that may be a consequence of hMLH1 promoter hypermethylation and may prevent transcription in a subset of patients.⁵⁴ van Doorn and colleagues reported that the malignant T-cells of patients with CTCL display widespread promoter hypermethylation associated with inactivation of several tumor-suppressor genes involved in DNA repair (MGMT, MLH1), cell-cycle (CHFR), and apoptosis signaling pathways.⁵⁵ Recently, comparative transcriptome analysis was performed on tissue from patients with early-stage MF and benign dermatoses that identified increased expression of the TOX protein in MF. TOX is strongly expressed in thymic tissue but is normally silenced in mature CD4⁺ T-cells.⁵⁶ It may prove to be useful as an immunohistochemical diagnostic marker.

Overexpression of the tumor-suppressor gene TP53 has been detected in some cases of high-grade CTCL such as cutaneous anaplastic large-cell lymphoma (ALCL), but rarely in low-grade CTCL.⁵⁷ Infrequent FAS mutations, but no BAX or TP53 mutations, were discovered in a study of 44 patients with early MF.⁵⁷ Aberrant expression of the BCL-2 gene, which normally codes for an inner mitochondrial membrane protein, can suppress apoptosis, an important pathogenic mechanism in lymphomas. Although Dummer and colleagues detected BCL-2 expression in 22 of 26 MF cases; it was also present in 5 of 6 cases of benign inflammatory dermatoses.⁵⁸ A cDNA microarray study of 29 cases of MF and 11 cases of inflammatory dermatoses revealed a signature of 27 genes implicated in the tumorigenesis of MF, including tumor necrosis factor receptor-dependent apoptosis regulators, STAT4, CD40L, and other oncogenes and apoptosis inhibitors.⁵⁹ Loss of SHP-1 tyrosine phosphatase expression appears to correlate with the advanced stages of CTCL.⁶⁰ The epigenetic silencing of SHP-1 is induced by an activated phosphorylated (p)-STAT3 transcription factor in cooperation with DNA methyltransferase 1, the key member of the epigenetic gene silencing machinery.⁶⁰ JUNB amplification leads to enhanced Th2 cell function, a hallmark of the malignant T-cell in CTCL. Mao and colleagues reported the amplification and overexpression of JUNB in tissue from patients with CTCL.⁶¹ Recently, mutations involving the RAS pathway have been identified in a minority of CTCL.⁶²

The small, single-strand, noncoding RNAs, known as microRNAs (miRNAs), have been found to be differentially expressed in MF/CTCL.^{63, 64} A CTCL miRNA signature (miR-155, miR-203, and miR-205) has been identified in a recent study and is capable of distinguishing between CTCL and benign inflammatory dermatoses with 95% accuracy.⁶⁴ It has also been demonstrated that there is a loss of miR-223 and miR-342 in SS versus normal CD4⁺ T-cells and that the reduced miR-342 leads to inhibition of apoptosis in CTCL cells.⁶⁵

In 1985 Aisenberg et al. and Weiss et al. independently described Southern blot analysis techniques using probes for the β chain of the T-cell receptor (TCR) to establish clonality in T-cell lymphoproliferative disorders.^{66, 67} Because earlier cytogenetic studies suggested that CTCL arises from a single malignant clone of mature T-cells,⁴² the presence of TCR β -chain rearrangement in pathologically suspicious tissue has been considered strong evidence for the diagnosis of CTCL.⁶⁸ However, in early lesions of MF (patch stage), when the number of infiltrating malignant T-cells is minimal, the Southern blot technique fails to detect clonal T-cell populations consistently. Other limitations of the Southern blot technique include its necessity for large amounts of preserved DNA, as well as its extensive time and labor requirement.⁶⁹ Therefore, the detection sensitivity of Southern blotting of DNA derived from skin biopsy specimens of early lesions is too low and may fail as a diagnostic test when the clinical and histologic diagnosis is most difficult.⁷⁰

More sensitive techniques involving polymerase chain reaction (PCR) have been developed to evaluate clonality in CTCL and related skin diseases and are now considered the methods of choice.^{71, 72} The PCR is an *in vitro* imitation of the enzymatic DNA repair and replication that takes place in all proliferating cells, but it amplifies short specific lengths of DNA of the order of 10⁹ to 10¹² and therefore permits the use of very small amounts of starting DNA. Although the vast majority of CTCL express the α/β TCR heterodimer, most labs using the PCR technique take advantage of the fact that all α/β TCR-positive T-cells also contain at least one rearranged allele of the TCR γ -chain gene.⁷³ The γ gene contains a very limited number of clinically significant V segments (8) and C regions (2), making it possible to use specific primers for all

known TCR γ V segments.⁷⁴ It is estimated that this PCR-based technique in combination with high-resolution nondenaturing polyacrylamide gel electrophoresis is 10 to 50 times more sensitive than conventional Southern blot analysis in the detection of small T-cell clones.⁷² Several studies have shown a sensitivity of 90% to 95% using the PCR technique, indicating that up to 10% of cases of CTCL may show no TCR rearrangement even with this sensitive technique.^{71, 75, 76} Given that some TCR β rearrangements may be missed with conventional TCR γ primers, there are those who recommend use of both TCR γ and TCR β primers.⁷⁷ It is important to note that clonality does not indicate malignancy, as suggested by one study in which 25% of tissue from patients with lichen planus, a benign dermatosis, were found to have TCR gene rearrangements using the PCR technique.⁷⁵

In the late 1990s, a European consortium of 45 laboratories (BIOMED-2 Concerted Action BMH4-CT98-3936) was initiated with the aim to establish a highly reliable standard in PCR-based clonality testing, for B-cell as well as for T-cell malignancies.⁷⁸ Because of the higher speed, efficiency, and sensitivity of the BIOMED-2 multiplex PCR protocol, it can reliably replace Southern blot analysis in clonality diagnostics in routine laboratory settings.⁷⁹ Expertise with clonality diagnostics and knowledge about the biology of TCR gene recombination are essential for correct interpretation of TCR clonality data.⁷⁸ Patel and colleagues recently showed that combining TCR- γ primers with TCR- β primers significantly improved the sensitivity of TCR gene analysis, to 94%.⁸⁰ Yang et al. used the strategy of multiple PCR/heteroduplex analysis for TCR- γ gene rearrangement combined with a laser-capture microdissection proteinase K approach to increase the detection rate of clonal TCR- γ gene rearrangement in early MF cases.⁸¹ This approach could provide strong evidence to confirm the diagnosis of early MF when the diagnosis can be most challenging.

EPIDEMIOLOGY

The incidence of the primary CTCLs has risen dramatically and consistently since 1973.⁸² Based on data from the Surveillance, Epidemiology, and End Results (SEER) Program of nine cancer registries, the incidence of CTCL in the United States increased from 2.8 to 6.3 to 9.6 cases per 1 million population in the periods 1973 to 1977, 1988 to 1992, and 1998 to 2002, respectively.⁸² During the period 1973 to 2002, the overall annual age-adjusted incidence of CTCL for the original nine SEER registries was 6.4 per million persons, representing 4% of all reported NHLs.⁸² Bradford et al. reported an age-adjusted CTCL incidence of 7.7 per million persons from 2004 to 2005.⁸³ Because the number of patients with early-stage MF often is not reported to tumor registries, the actual incidence may be higher. In one study, missed

P.1954

cases were estimated to constitute 17% of MF.⁸⁴ Thus, using the most recent incidence rate, the incidence of new cases of CTCL in the United States in the first decade of the 21st century is almost 3,000 cases per year. The incidence of MF increases with advancing age, and the median age is usually between 60 and 70 years, with an incidence rate of 24.6 per million for persons 70 to 79 years of age and a peak around 80 years of age.^{82, 83} It is rare in patients <30 years of age. However, in the 1990s there emerged several reports of children and adolescents affected with MF and SS.^{85, 86, 87} One study found that 4% to 5% of patients with MF had onset of their eruption before 20 years of age,⁸⁷ whereas the more recent epidemiologic study by Criscione and Weinstock showed only 1% of cases of CTCL to be in the <20 years age group.⁸² A study from the International Childhood Registry of Cutaneous Lymphoma found the mean age of onset and diagnosis of pediatric cutaneous lymphoma to be 7.5 years (± 3.8 years) and 9.9 years (± 3.4 years), respectively.⁸⁸

Blacks are more likely to develop MF compared to whites, 9.0 to 10.0 versus 6.1 to 8.1 per million incidence rates, with the greatest racial differences seen among the younger patient populations.^{82, 83} Both Asian/Pacific Islanders and Hispanic whites have an incidence rate of 5.1 per million.⁸³ Men are significantly more likely to develop CTCL than women, with an age-adjusted incidence rate almost twice that of women.^{82, 83} The epidemiologic study by Criscione and Weinstock found the incidence rates of CTCL to be correlated with high physician density, high family income, high percentage of population with a bachelor's degree or higher, and high home values, suggesting that increased detection of CTCL may play a role in the increased incidence rates since 1973.⁸²

The etiology of MF/SS remains unknown, but genetic, environmental, and infectious agents have been implicated as possible factors in triggering lymphocyte activation and/or lymphocyte transformation.^{89, 90} A recent study found that not only did the antioxidative effects of wine consumption fail to protect against the development of MF, but patients who consume >24 g of alcohol per day demonstrated a higher incidence of MF than matched controls (adjusted odds ratio 3.02, 95% confidence interval 1.34 to 6.79).⁹¹ Also significant was that the alcohol effect remained constant regardless of beverage type.

Rare familial clusters of CTCL cases have been reported,⁹² and an increased incidence has been noted in patients with certain histocompatibility antigens.^{93, 94} A rare case of transformed CTCL developing in a husband and wife suggested a

common environmental or infectious exposure in the etiology of their disease.⁹⁵ Early reports implicated an increased risk of developing CTCL in people employed in a manufacturing occupation, particularly those related to petrochemicals, textiles, or metals, or in farming, with exposure to pesticides or herbicides.⁹⁶ However, two case-control studies have failed to confirm these observations.^{97, 98} Results of other studies have suggested that patients with MF have increased contact allergies, but Whittemore et al. were unable to substantiate the association in a case-control clinical study.⁹⁸

Human retroviruses have been suggested as possible etiologic agents in CTCL. HTLV-I was described initially in a CTCL patient who had an aggressive clinical course; however, this disease was later identified as adult T-cell leukemia/lymphoma (ATL), which is endemic to Japan, the Caribbean, and other areas of the world but can have cutaneous lesions similar to CTCL (see ATL in Chapter 88).⁹⁹ Serologic findings for HTLV-I/II in patients with CTCL are negative in the vast majority of patients.^{100, 101, 102} In support of the association of HTLV-I/II and MF, virus particles indistinguishable from HTLV-I have been identified using electron microscopy on immortalized MF cells,¹⁰³ and combined PCR/Southern blot analyses have demonstrated HTLV pol, tax, and/or rex sequences in PBMC lysate extracts and lesional skin from patients with MF/SS.^{100, 104, 105, 106} Further support of a potential HTLV-1/CTCL association was suggested after inoculation of immunosuppressed rats with PBMC extracts from patients with MF/SS. A novel anti-HTLV-I antibody was detected in the serum of 29% of the animals, whereas PBMC from healthy controls did not elicit an anti-HTLV-1 antibody response. These findings lend further support to the role of HTLV-1 as being at least a co-factor in the pathogenesis of CTCL.¹⁰⁷ Based on these studies, some authors contend that the strongest evidence of an etiologic/pathogenic factor for CTCL relates to the presence of a defective or variant HTLV-I virus.^{70, 104} Other authorities,^{101, 102, 108, 109} however, disagree, citing seven series that found no proviral HTLV-I sequences in 332 CTCL patients^{101, 110, 111, 112, 113, 114, 115} and four studies that detected the proviral sequences in 10% of 176 patients.^{116, 117, 118, 119} Future development of advanced molecular techniques should eliminate the difficulty of establishing with certainty the presence or absence of HTLV-I proviral sequences in patients with CTCL.^{108, 120} More recently, there have been studies evaluating the presence of HHV-8 and the Merkel cell polyoma virus, but neither of these infectious agents has been significantly identified.^{121, 122} A separate group evaluated MF skin samples for the presence of multiple infectious agents (HTLV, Epstein-Barr virus, and *Borrelia burgdorferi*) and found that 21/83 MF samples had two or more infectious agents identified as compared to 1/83 healthy controls.¹²³

CLINICAL PRESENTATION

MF usually evolves over a long period, so patients often have a long premycotic or pre-malignant phase with eczematous skin eruptions between 4 and 10 years before a histologic diagnosis is established.⁷⁰ The differential diagnosis during this period includes chronic eczematous, atopic or contact dermatitis, which may evolve slowly into eruptions clinically suggestive of parapsoriasis en plaque, poikiloderma atrophicum vasculare, or other benign papulosquamous skin diseases.¹²⁴ Failure of the lesions to respond to standard topical therapy may be an early clue of a different diagnosis. However, initial lesions occasionally appear to improve following topical steroid application, which masks early recognition of the underlying malignancy.¹²⁵ Because of the difficulty in diagnosis in the premycotic phase of MF, careful follow-up with serial skin biopsies is warranted in patients with suspect lesions (see section "Diagnostic Evaluation").

The earliest diagnostic phase of MF is the patch phase, characterized by persistent scaly macules and patches that vary in size, shape, and color, tend to involve sun-protected sites, and are occasionally associated with pruritus (Fig. 92.4A).^{5, 124, 126} Early MF patches and plaques, unlike other eczematous eruptions, are usually asymptomatic. Other, less common early skin findings in MF include poikiloderma,¹²⁷ hypopigmentation,¹²⁸ hyperpigmentation (Fig. 92.4B), alopecia, pruritus alone,^{129, 130, 131} and porokeratosis-like lesions.¹³² Recently, several cases of "invisible MF" were described. Afflicted patients presented only with persistent, generalized pruritus and no clinical eruption.^{129, 130, 131} Random biopsies of "normal" skin confirmed the diagnosis of MF.

Plaques are sharply demarcated, scaly, elevated lesions that may have annular, arcuate, or serpiginous borders (Fig. 92.4C). Plaques with thick scale can mimic psoriasis or nummular eczema, whereas annular lesions with central clearing may be confused with tinea corporis.¹²⁴ Ultraviolet radiation occasionally induces regression of patches and plaques, further delaying correct diagnosis. Prominent involvement of the palms and/or soles may result in hyperkeratosis, fissuring, or frank keratoderma (Fig. 92.4D).¹³³

The tumor phase is heralded by the onset of dome-shaped, deep red to violaceous nodules emerging in areas of uninvolved skin or in pre-existing plaques.¹²⁴ The tumors may ulcerate and become secondarily infected (Fig. 92.4E), and there is a predilection for the body folds and face, where dermal

thickening, coalescing plaques, and tumors may result in characteristic “leonine facies” (Fig. 92.4F). The tumor stage is more clinically aggressive than the patch and plaque stages, and may be associated with histologic transformation to a large cell process with a vertical growth phase (see section “Histopathology and Prognosis”).¹²⁴ Rarely, patients with MF will present initially with tumors without the preceding patch and plaque phases (the MF d'emblée variant).^{6, 134} It is very common for more advanced patients to have patches, plaques, and/or tumors present simultaneously on different areas of their skin.⁷⁰



FIGURE 92.4. The cutaneous phases of mycosis fungoides. A: Early patch-stage lesions in a sun-protected region. B: Hyperpigmented diffuse patches on the back of a dark-skinned patient. C: Scattered thin and thick plaques on the back. D: Early keratoderma of the sole. E: Ulcerated tumor within a plaque on the posterior leg. F: Coalescing nodules and tumors with dermal thickening forming “leonine facies” in this patient with transformed cutaneous T-cell lymphoma (CTCL). See text for full description.

Generalized erythroderma may develop as the initial presenting sign of MF/SS or may accompany plaques and tumors.⁷⁰ In SS, the leukemic variant of CTCL, erythroderma, and circulating tumor cells (Sézary cells) in the peripheral blood may be

accompanied by generalized lymphadenopathy, splenomegaly, keratoderma, vitiligo-like hypopigmented patches,¹³⁵ alopecia,

P.1956

ectropion, nail dystrophy, and ankle edema.¹³⁶ Intense pruritus and cutaneous pain are common in SS, and when the palms and soles are affected with scaling and fissuring, walking and manual dexterity become difficult.¹³⁶

CLASSIFICATION OF CUTANEOUS T-CELL LYMPHOMAS

The term cutaneous T-cell lymphoma or CTCL is a general term that encompasses a variety of diseases, including MF and SS. In addition, there are other cutaneous T-cell lymphoproliferative disorders that appear to be specific entities with unique clinical, histologic, and prognostic features. In an effort to recognize the separate disease processes, a new classification of primary cutaneous lymphomas was formulated jointly by the World Health Organization (WHO) and the European Organisation for Research and Treatment of Cancer (EORTC) in 2005 (Table 92.1).¹³⁷ The most recent WHO classification of tumors of hematopoietic and lymphoid tissues presented in 2008 essentially mirrors, with a few exceptions, the 2005 WHO-EORTC classification scheme.^{138, 139} MF is the most common subtype, accounting for almost 50% of all CTCL, and this term should be used only for patients with the classic presentation of patches and plaques with slow progression as described by Alibert and Bazin.¹³⁷ The WHO-EORTC classification recognizes three variants of MF and the T-cell lymphoproliferative disorder lymphomatoid papulosis (LyP) as a distinct subtype of CTCL for the first time. The following sections focus on the histopathology and immunopathology of MF, SS, and the other types of primary CTCLs.

TABLE 92.1 WHO-EORTC CLASSIFICATION OF CUTANEOUS LYMPHOMA

Cutaneous T-cell Lymphomas

Mycosis fungoides^a

Variants of MF:

Folliculotropic mycosis fungoides^a

Pagetoid reticulosis^a

Subtype of MF:

Granulomatous slack skin^a

Sézary syndrome^b

CD30⁺ lymphoproliferative disorders of the skin

Lymphomatoid papulosis^a

Primary cutaneous anaplastic large-cell lymphoma^a

Subcutaneous panniculitis-like T-cell lymphoma^a

Primary cutaneous T-cell lymphoma, unspecified^c

Provisional entities:

Primary cutaneous epidermotropic CD8⁺ T-cell lymphoma (provisional)^b

Cutaneous $\gamma\delta$ -positive T-cell lymphoma (provisional)^b

Primary cutaneous CD4⁺ small/medium-sized pleomorphic T-cell lymphoma^a

Extranodal NK-/T-cell lymphoma, nasal type^{b, d}

Adult T-cell leukemia/lymphoma^d

Cutaneous B-cell Lymphomas

Primary cutaneous marginal zone B-cell lymphoma (MALT-type)^a

Primary cutaneous follicle center lymphoma^a

Follicular, follicular and diffuse, diffuse growth patterns

Primary cutaneous diffuse large B-cell lymphoma, leg type^e

Primary cutaneous diffuse large B-cell lymphoma, other^e

Intravascular large B-cell lymphoma^{d, e}

Precursor Hematologic Neoplasm

Blastic plasmacytoid dendritic cell neoplasm (previously CD4⁺/CD56⁺ hematodermic neoplasm)

EORTC, European Organization for Research and Treatment of Cancer; MALT, mucosal associated lymphoid tissue; MF, mycosis fungoides; NK, natural killer WHO, World Health Organization.

^a Indolent (5-year disease-specific survival >75%).

^b Aggressive (5-year disease-specific survival <25%) clinical behavior.

^c Aggressive (5-year disease-specific survival <25%) clinical behavior (excluding provisional entities).

^d Typically, an extracutaneous lymphoma with skin as a secondary site.

^e Intermediate (5-year disease-specific survival 25% to 75%).

Modified from Willemze R, Jaffe ES, Burg G, et al. WHO-EORTC classification for cutaneous lymphomas. *Blood* 2005;105:3768-3785.

DIAGNOSTIC EVALUATION

Tissue Handling

Skin biopsies for diagnosis of MF/SS must be properly handled to maximize the diagnostic information obtained. These studies include routine histology, immunophenotyping, and molecular genotyping. Communication between the clinical staff, dermatologists, and pathologists is essential to ensure that the appropriate types of biopsies are done and are properly handled. In general, 6-mm punch biopsies are recommended. Multiple biopsies from different skin lesions may be necessary to establish a definitive diagnosis of MF/SS, particularly in early-patch-stage lesions. Topical steroids may blunt many of the histologic features of MF/SS and should be discontinued for 2 to 3 weeks prior to biopsy. A careful drug history should be taken prior to biopsy, because certain drug eruptions can closely mimic early MF, particularly phenytoin and other anticonvulsants.¹⁴⁰ Although advancements in immunohistochemical protocols and molecular diagnostics allow most studies to be performed on formalin-fixed tissue, optimally skin biopsies for possible CTCL should be sent to the pathology or dermatopathology lab fresh, on saline-soaked gauze or in tissue culture media such as RPMI. These biopsies can then be divided for the various diagnostic studies. Punch biopsies can be divided into halves, one half for routine histology and the other half for immunophenotyping and/or molecular diagnostic studies. Sections for routine histology should be fixed in a good nuclear fixative such as B5 to facilitate evaluation of nuclear morphology and recognition of characteristic cerebriform cells. If it is a large biopsy of a cutaneous tumor or a lymph node biopsy, it may provide adequate tissue to prepare cell suspensions for immunophenotyping by flow cytometry and for cytogenetic studies. The tissue for immunophenotyping by flow cytometry should be promptly delivered to the appropriate laboratory in cell culture media. Tissue for molecular studies should be snap-frozen in liquid nitrogen and stored at -70°C. For leukemic infiltrates, cytochemical stains can be performed on air-dried touch imprints from freshly cut surfaces. A small sliver of the biopsy can be shaved off and fixed in glutaraldehyde for electron microscopy if needed. Lymph nodes should be worked up as previously described.¹⁴¹

Histopathology

Cutaneous Features of Mycosis Fungoides/Sézary Syndrome

In general, the histologic diagnosis of MF/SS in skin biopsies is based on criteria similar to those used for the diagnosis of other lymphoid neoplasms, including the presence of an infiltrative or destructive growth pattern and cytologic atypia. The distribution of the infiltrate within the skin biopsy is also important (Fig. 92.5A). The characteristic atypical

lymphocytes in MF and SS are dysplastic cerebriform T-cells with enlarged hyperchromatic nuclei and complex nuclear folding. Demonstration of cerebriform nuclear

P.1957

folding requires good fixation (such as B5 fixation), thin (4- μ m) sections, and examination under 100 \times oil immersion. Others have used special methods such as 1- μ m sections of plastic-embedded tissue, electron microscopy, or nuclear morphometry.¹⁴² Diagnostic criteria for cutaneous involvement by MF are best illustrated in plaque-stage lesions (Fig. 92.5B,C). The essential criteria for diagnosis are (a) a bandlike lymphocytic infiltrate in the superficial papillary dermis, (b) epidermotropism, and (c) atypical cerebriform T-cells in the dermal and epidermal infiltrates.^{143, 144} Pautrier microabscesses (Fig. 92.5D) are characteristic of MF but are often absent in patch-stage lesions, erythroderma, and nonepidermotropic tumors. Diagnosing early-patch-stage lesions is often difficult. In a morphologic study of >700 early-patch-stage lesions by Massone et al., the histologic features most helpful for diagnosing MF were (a) epidermotropism, particularly with a basilar lymphocytosis (23%) or with "haloed" lymphocytes (40%); (b) a dermal lymphocytic infiltrate that is bandlike (30%) or patchy lichenoid (66%); and (c) interface dermatitis (59%).¹⁴⁵ Large convoluted lymphocytes in the epidermis were found only in 9% of cases, and Pautrier microabscesses were found in 19%. The authors noted that although these cytologic changes are highly specific, the architectural abnormalities (infiltrate, epidermotropism) were more sensitive in diagnosing MF, as has also been suggested by others.¹⁴⁶ Earlier studies have shown similar criteria as being valuable in diagnosing MF "haloed" epidermotropic cerebriform T-cells along the basal layer of the epidermis, disproportionate epidermotropism (intraepidermal lymphocytes without accompanying spongiosis), and medium to large cerebriform cells in the epidermis and clustered in the dermis.^{143, 147, 148} Several studies have pointed to the association of papillary dermal fibrosis with MF/SS; however, at least one study found that in a carefully selected population of early, untreated MF patients this finding argued against a lymphoma diagnosis.¹⁴⁹

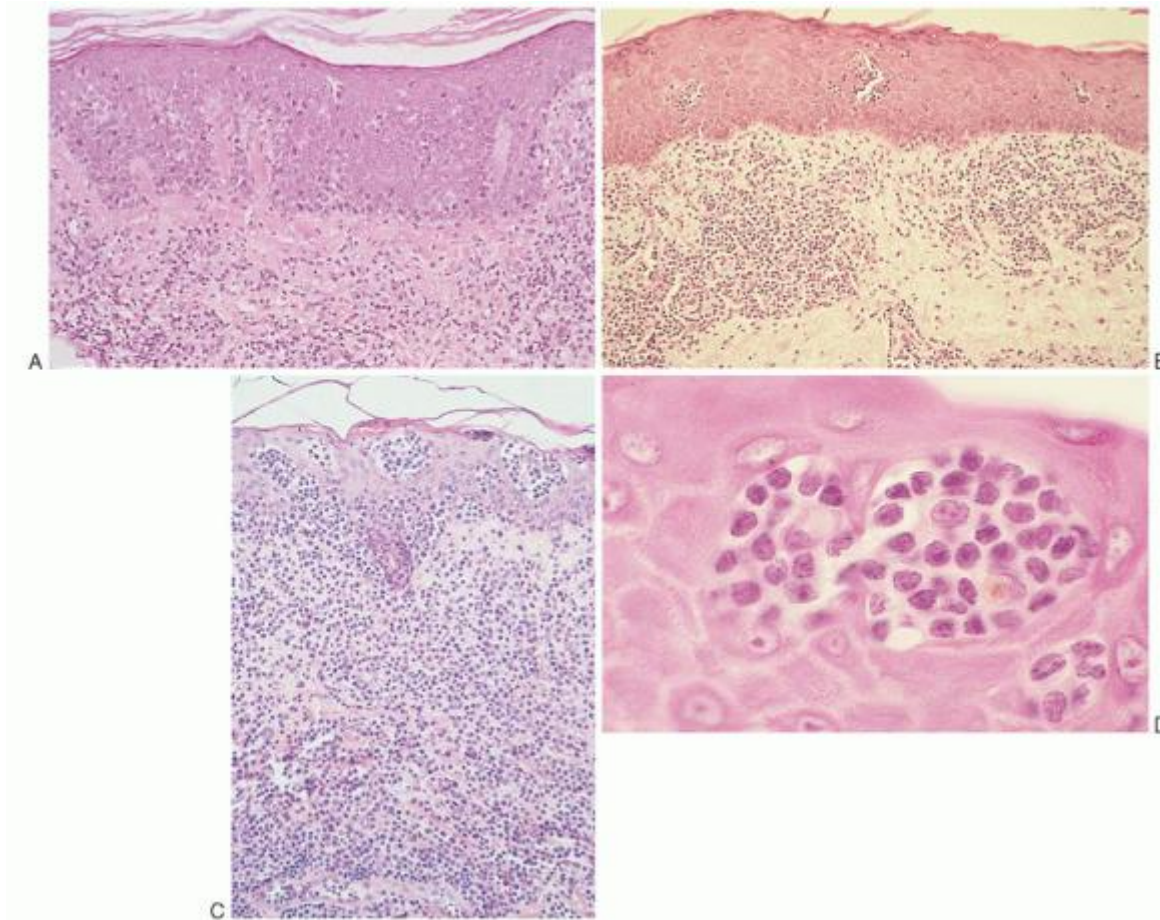

FIGURE 92.5. A: Mycosis fungoides (MF), patch stage. A bandlike lymphocytic infiltrate occupies the superficial papillary dermis with single-cell epidermotropism by atypical, "haloed" cerebriform T-cells, preferentially involving the basal layer (hematoxylin and eosin, $\times 50$). B: MF, plaque stage. A bandlike lymphocytic infiltrate occupies the papillary dermis with

epidermotropism by atypical cerebriform T-cells, focally forming small Pautrier microabscesses (hematoxylin and eosin, $\times 25$). C: MF, thick plaque. A dense bandlike lymphocytic infiltrate fills the papillary dermis and extends into the reticular dermis. Prominent epidermotropism by atypical, enlarged cerebriform T-cells creates large Pautrier microabscesses (hematoxylin and eosin, $\times 25$). D: MF, Pautrier microabscess. High magnification of a Pautrier microabscess shows characteristic small to medium cerebriform T-cells with highly convoluted nuclear folding. The Pautrier microabscess recapitulates normal interactions between components of the skin-associated lymphoid tissue, i.e., cutaneous T-cells, Langerhans histiocytes (2 cells with large pale nuclei in the center), and keratinocytes (hematoxylin and eosin, $\times 500$).

Spongiosis should be minimal in relationship to epidermotropism in MF and SS. Biopsies with prominent spongiosis must be differentiated from eczematous or spongiotic dermatitis. Microvesiculation and Langerhans cell microabscesses are rarely present in MF/SS and would point toward a spongiotic process. Eosinophils and plasma cells are often present in early patch- and plaque-stage MF, and represent a nonspecific reactive component.

P.1958

It is important to understand that a definitive diagnosis of MF may not be possible in some early-patch-stage lesions. Multiple biopsies of separate skin lesions, immunophenotyping, and TCR gene rearrangement studies may help confirm the diagnosis in difficult cases. Even these ancillary studies may be inconclusive in early lesions. The reported range of sensitivity of T-cell clonality detection is large, with some studies reporting as few as 20% of early-patch-stage lesions being clonal¹⁵⁰ to as many as 71%.¹⁵¹ Likely, this variability reflects variability in density of infiltrate in early lesions, variability in source material for DNA extraction (frozen vs. paraffin), and variability of the clonality assay [Southern blot vs. PCR vs. denaturing gel electrophoresis vs. capillary electrophoresis]. In later plaque- and tumor-stage lesions, T-cell clonality can typically be detected in $>90\%$ of cases.^{151, 152} Recently, a PCR-based clonality protocol has been proposed and validated (BIOMED-2) in an attempt to provide some degree of standardization.^{77, 153} In addition, several techniques have been advocated, such as comparing clonality studies from disparate clinical lesions and using complementary clonality studies (TCR β and TCR γ) that may increase the specificity and sensitivity of the molecular studies.^{154, 155} Despite these advancements, however, a lack of demonstrated clonality in a histologically or clinically suspicious lesion should not prevent a diagnosis of CTCL. Likewise, the presence of a clonal population does not equate with malignancy as many benign dermatoses may demonstrate clonality.¹⁵⁶

Tumor-stage MF is characterized histologically by a dense dermal infiltrate involving the papillary and reticular dermis, often with extension into the subcutis. In contrast to patch- and plaque-stage lesions, MF tumors are often nonepidermotropic and may spare the dermal—epidermal interface. Furthermore, the malignant T-cells in tumor-stage MF often display various degrees of histologic transformation, with medium and large pleomorphic cells, immunoblastic large cells, and anaplastic large cells.^{157, 158} The diagnosis of malignancy in the tumor stage is rarely in question, but recognition of MF origin for tumors with large-cell transformation may be obscured by their resemblance to other NHLs. A careful search for dysplastic cerebriform T-cells and residual foci of epidermal infiltration near the edges of tumors often provides histologic evidence of MF origin in difficult cases.¹⁵⁷ Previous or concurrent biopsies of earlier-stage MF lesions may also help confirm the diagnosis in these cases.

Generalized exfoliative erythroderma is characteristic of SS but may also occur in MF.¹⁵⁹ Cutaneous biopsies of erythroderma in MF/SS often lack many of the hallmark features found in patch/plaque MF, such as epidermotropism and lymphocytes aligned along the basement membrane.¹⁶⁰ In fact, in one study, up to 17% of skin biopsies of patients with established SS were considered nondiagnostic because of insufficient epidermotropism.¹⁶¹ Evaluation of the peripheral blood for circulating tumor cells and/or molecular analysis of the skin and peripheral blood for a clonal rearrangement of the TCR may help establish the diagnosis of MF/SS in cases for which skin biopsies are histologically suspicious, but nondiagnostic. In addition, the finding of identical clonal populations in the skin and peripheral blood is very supportive of a lymphoma diagnosis.¹⁶²

Large-cell Transformation of Mycosis Fungoides/Sézary Syndrome

Approximately 20% of low-grade MF and SS undergo secondary transformation to high-grade large-cell lymphoma with a predominance ($>25\%$) of large transformed lymphocytes (Fig. 92.6).¹⁵⁷ Secondary large-cell transformation of MF/SS may resemble immunoblastic large-cell lymphoma, pleomorphic large-cell lymphoma, or ALCL.^{157, 163} It has been shown that secondary large-cell lymphoma is immunophenotypically and clonally related to earlier MF/SS biopsies taken prior to transformation.¹⁶⁴ Cutaneous large-cell transformation usually occurs late in tumor-stage lesions, but it can occasionally be seen in plaques or erythrodermic MF and may be present in the initial diagnostic biopsy (mycosis d'emblée variant).

Lymph nodes are the most common site of extracutaneous large-cell transformation, but it may also occur in other extracutaneous sites. Approximately 50% of secondarily transformed large-cell lymphomas express CD30.¹⁶⁵ In MF patients with large-cell transformation the absence of CD30 expression has been associated with a reduced disease-specific survival.¹⁶⁶ It is important to distinguish secondary large-cell transformation of MF/SS from unrelated primary cutaneous large-cell lymphoma, LyP, and secondary cutaneous involvement by systemic large-cell lymphoma because of prognostic differences.¹⁶⁷ This is particularly true for secondary CD30⁺ large-cell lymphoma resulting from transformation of MF/SS, which has a poor prognosis, in contrast to primary cutaneous CD30⁺ ALCL and LyP, both of which have a favorable prognosis.^{168, 169} Differentiating these entities is often impossible on histologic grounds alone and requires close collaboration between the clinician and pathologist to establish the correct diagnosis in the WHO-EORTC classification scheme.

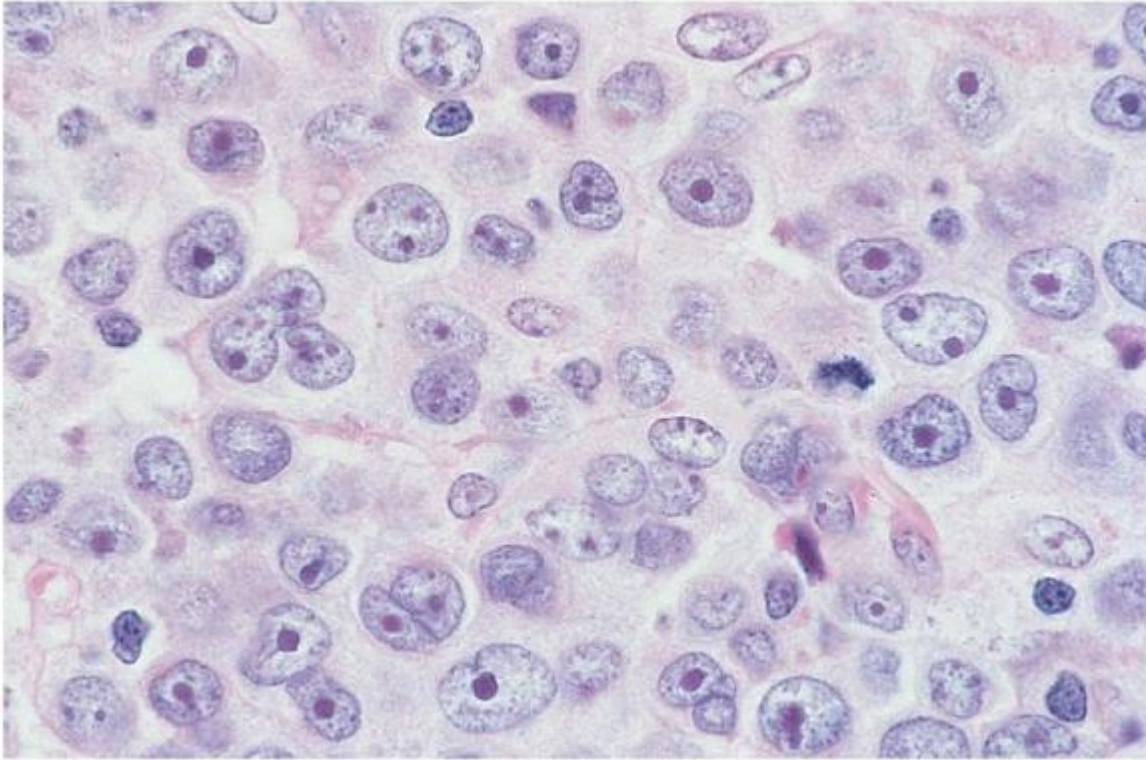

FIGURE 92.6. Large-cell transformation of mycosis fungoides (MF). This represents secondary transformation of low-grade MF to high-grade immunoblastic large-cell lymphoma. This tumor is composed of sheets of large transformed cells or immunoblasts with round to oval nuclei, dispersed chromatin, and prominent nucleoli. Several mitoses are present (hematoxylin and eosin, $\times 500$).

Extracutaneous Mycosis Fungoides/Sézary Syndrome

Extracutaneous dissemination is generally considered to be a late occurrence in MF/SS because the disease is clinically limited to the skin for prolonged periods of time in most patients. Using more sensitive techniques such as cytogenetics, electron microscopy, and immunophenotypic studies, extracutaneous disease has been found in nearly 90% of MF/SS patients at initial staging in one case series.¹⁷⁰ There is evidence that nodal involvement as detected with highly sensitive molecular techniques can segregate otherwise low-stage patients into high-risk and low-risk groups;¹⁷¹ however, assessment of regional lymph nodes is not standard practice in early-stage MF patients. Although autopsy studies have histologically documented widespread extracutaneous disease in most patients,¹⁷² most series were performed several decades ago, when detection of early disease was difficult.

Extracutaneous MF/SS has histologic features that are usually similar to those seen in the skin. Dysplastic cerebriform T-cells are the most helpful diagnostic feature for recognition as extracutaneous disease. Almost every organ has been involved by MF/SS in autopsy series, but the most frequent sites are the lymph

nodes, liver, spleen, and lungs, which may be involved in >50% of more advanced cases.¹⁷² Other common sites include kidney, bone marrow, thyroid, heart, pancreas, gastrointestinal tract, and central nervous system. Lymph nodes represent the most frequent site of extracutaneous disease in pathologic staging studies; up to 50% of lymph nodes are positive by light microscopy at initial staging.¹⁷³ Several series from the 1980s found visceral involvement present in ~15% of initial staging liver and bone marrow biopsies.^{157, 173, 174} When staging laparotomies were routinely performed in the past, ~30% of spleens were microscopically involved by MF/SS.¹⁷⁵ Extracutaneous CTCL, particularly visceral disease, is strongly associated with advanced-stage skin disease (tumors and erythroderma) and SS.¹⁷⁴ Because tumor-stage MF and generalized erythroderma are frequently nonepidermotropic, it has been suggested that loss of epidermotropism may play an important role in systemic dissemination.

Lymph Node Pathology

With up to 50% of staging lymph node biopsies being microscopically involved by MF/SS, lymph nodes are the earliest and most common site of extracutaneous dissemination.¹⁷³ Nevertheless, the ISCL guidelines only recommend excision of lymph nodes if they are either >1.5 cm in greatest transverse diameter or are palpably irregular, firm, or fixed lymph nodes regardless of size.¹⁷⁶ Partially effaced nodes often have an interfollicular pattern with preservation of reactive follicular centers, but eventually most lymph nodes become completely effaced. As lymph nodes become progressively infiltrated, the cerebriform T-cells tend to become larger and more pleomorphic, with increased numbers of large transformed cells.¹⁷⁷ Over 35% of positive nodes will show complete large-cell transformation with pleomorphic, immunoblastic, or anaplastic large-cell morphology.^{157, 177, 178} In contrast to MF, lymph nodes from patients with SS tend to be effaced by more monomorphic infiltrates of small to medium cerebriform T-cells,¹⁷⁹ but may also undergo large-cell transformation in some cases.^{157, 165}

Bone Marrow Involvement

The bone marrow in MF and SS is generally thought to be spared until late in the course of the disease, including in patients with large numbers of circulating Sézary cells.^{70, 170} Early studies suggested that antemortem marrow involvement occurred in <3% of MF/SS patients,¹⁷⁰ yet the marrow was involved in nearly 50% of patients at autopsy in several series from the 1970s.^{172, 180} Marrow involvement typically manifests as nonparatrabeular lymphoid aggregates with cerebriform lymphocytes. Molecular studies have shown that in patients with a defined clonal T-cell rearrangement in the skin, approximately 20% will have an identical T-cell clone detected in their blood or bone marrow. Moreover, all patients with bone marrow involvement by molecular studies had blood involvement as well, but only 76% of patients with blood involvement had bone marrow involvement.¹⁸¹ Sibaud et al. were unable to demonstrate that bone marrow involvement was associated with a worse prognosis in a multivariate analysis of their data; however, blood involvement was an independent variable for disease progression. In patients with SS, subtle small interstitial clusters of Sézary cells have been identified in up to 90% of cases, suggesting that most patients with circulating Sézary cells have early systemic dissemination of disease.¹⁷⁴ Detection of these subtle interstitial infiltrates of Sézary cells requires careful examination under oil immersion (100×) to identify the cells with abnormal cerebriform nuclear folds. Identification can be facilitated with immunoperoxidase studies for T-cell markers such as CD3, CD4, and CD7. Flow cytometry using a broad array of T-cell markers including CD3, CD4, CD8, CD7, and CD26 is also useful for detecting marrow involvement.

Other Extracutaneous Sites

Splenic and hepatic involvement by MF and SS is common and can be staged using imaging criteria rather than by invasive methods.¹⁸² Liver involvement in initial staging procedures has been found in 8% to 16% of cases.¹⁷³ Disseminated MF and SS tend to form nodular infiltrates of atypical cerebriform T-cells within the portal tracts or hepatic lobules. Cerebriform T-cells within the hepatic sinusoids without formation of focal aggregates are not considered diagnostic of liver involvement in the presence of peripheral blood involvement. Splenic infiltration was documented in 31% of staging laparotomies in one series.¹⁷⁵ The atypical cerebriform T-cells usually infiltrate the red pulp diffusely, but they may home to the periarteriolar lymphocyte sheath.¹⁸⁰ Splenic rupture has been reported in a rare case with massive splenic involvement by CTCL.¹⁸³

All other suspected sites of visceral involvement should be confirmed by biopsy if possible. Antemortem pulmonary manifestations of MF and SS are generally uncommon but may occasionally present clinically as interstitial or nodular pulmonary infiltrates.¹⁸⁴ However, the lungs are frequently involved by MF/SS at autopsy.¹⁷² Infiltrates of atypical cerebriform T-cells usually spread along the alveolar septae with preservation of the alveolar architecture. In some cases, the infiltrates may also fill alveolar spaces.

Blood Involvement

The ISCL has defined three stages of blood involvement for MF/SS.¹⁷⁶ Patients with B2 peripheral blood involvement have $>1,000$ Sézary cells/ mm^3 , where the Sézary cells are distinguished by their large nuclear size ($>15 \mu\text{m}$) and high nuclear contour index (Fig. 92.7).¹⁸⁵ In one study, increased large Sézary cells correlated significantly with poorer survival.¹⁸⁶ However, size criteria alone would fail to recognize the small Sézary cell variant, which is similar in size to a normal resting lymphocyte. Because of the inherent difficulties in diagnosing peripheral blood involvement by MF/SS on peripheral smear review, additional technologies are now used including flow cytometry and molecular studies such as PCR. The ISCL considers a positive clonal TCR rearrangement in the blood coupled with either a CD4:CD8 ratio $>10:1$ or abnormal immunophenotype by flow cytometry ($\text{CD4}^+\text{CD7}^-$ or $\text{CD4}^+\text{CD26}^-$) as adequate evidence to constitute a positive peripheral blood for staging purposes.¹⁸⁵ It has been shown that patients with B2 blood involvement have a statistically worse survival than those with B1 or B0 staging.¹⁸⁶ ISCL B0 is defined as no increase in Sézary cells ($<5\%$ of peripheral blood lymphocytes). B0 cases with molecular detection of T-cell clonality (B0b) have a worse prognosis than

P.1960

molecularly negative (B0a) cases even when the histologic criteria for blood involvement have not been met.^{162, 187, 188} In fact, T-cell clonality in the peripheral blood even in the absence of increased lymphocytes by morphology or flow cytometry (B0b) has been shown to convey a worse overall survival (OS), disease-specific survival and risk of disease progression.¹⁸⁹ B1 stage is defined as the group of patients who fail to meet criteria for B2 or B1. These patients have $>5\%$ atypical T-cells but do not otherwise reach the criteria for B2 involvement. These patients can also be split into B1a molecular clone negative and B1b molecular clone positive cases. Although T-cell clonality is required for diagnosis of B2 stage, the presence of molecularly defined T-cell clones in elderly patients or in patients with other lymphoproliferative disorders is not uncommon^{151, 190, 191} requiring therefore correlation with the clonality of the cutaneous infiltrate or association with MF-associated immunophenotypic abnormalities (increased CD4:CD8 ratio, loss of CD7 or CD26 on CD4 T cells).

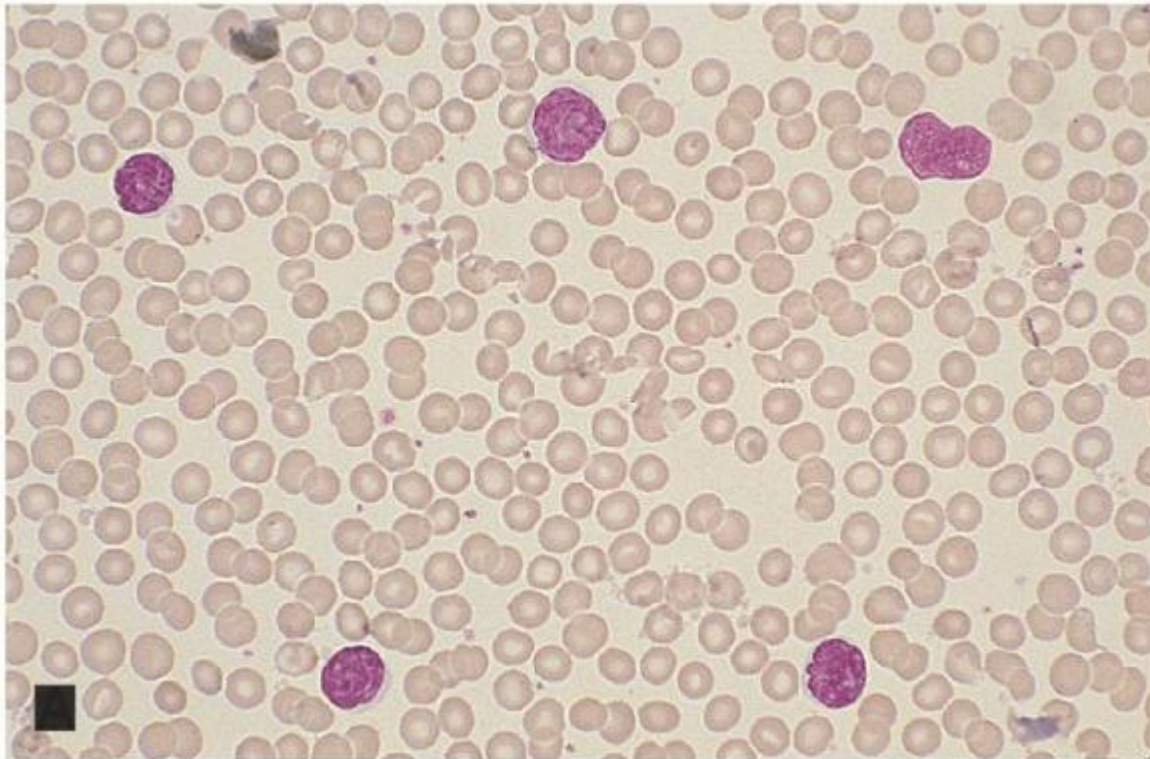

FIGURE 92.7. Sézary syndrome. The peripheral blood shows lymphocytosis. Most lymphocytes are Sézary cells with enlarged, highly convoluted nuclei and scant cytoplasm (hematoxylin and eosin, $\times 250$).

Immunophenotyping Studies

T-cell origin of the neoplastic cells in MF and SS is well established as a memory T-cell that expresses CLA, the cutaneous lymphoid antigen homing receptor.¹⁹² The vast majority are derived from T-helper cells that express CD4 and other T-cell-

associated antigens including CD2, CD3, CD5, CD45RO, and $\alpha\beta$ TCRs (Fig. 92.8).¹⁹³ However, a small number of CD8⁺ CTCL¹⁹⁴ have been reported as well as $\gamma\delta$ CTCL.^{195, 196} Of note, clinical presentation and behavior are crucial in distinguishing the CD8⁺ MF variant from the more aggressive primary cutaneous aggressive epidermotropic CD8⁺ cytotoxic T-cell lymphoma described in the updated WHO-EORTC nomenclature as a provisional subtype of peripheral CTCL. Furthermore, it is likely that most $\gamma\delta$ CTCL would be classified as cutaneous $\gamma\delta$ T-cell lymphoma (CGDTCL) in the WHO-EORTC scheme.^{137, 194, 197} Activation-associated (HLA-DR, CD25, CD30, CD38) and proliferation-associated (CD71, Ki-67) antigens are also frequently expressed in MF/SS, particularly in advanced stages.¹⁵⁷

Aberrant T-antigen expression is often seen in MF and SS, particularly advanced plaque- or tumor-stage lesions, and can be used to help differentiate reactive dermatitis from MF/SS.¹⁹⁸ Often, flow cytometry is used to assess antigen expression on the T-cells present in circulation or directly from involved skin biopsies. Aberrant T-cell phenotypes are defined as diminished or absent expression of pan-T-cell antigens (CD2, CD3, or CD5), absent T-subset antigen expression (CD4⁻ CD8⁺), or co-expression of T-subset antigens (CD4⁺ CD8⁺). Diminished or absent CD7 expression is one of the most common aberrant T-cell phenotypes in tissue sections of MF and SS.¹⁹⁸ However, the isolated findings of loss of CD7 expression must be considered in the context of other clinical, histologic, and immunophenotypic findings in that expanded populations of CD7-negative T-cells can also be seen in benign dermatitides.¹⁹³ More recently, several studies have shown that the loss of CD26 (dipeptidyl-aminopeptidase IV) expression is a characteristic feature of circulating Sézary cells that is likely more sensitive than loss of CD7 expression.^{199, 200, 201} Nevertheless, when considered as a group, loss of any major T-cell antigen (CD2, CD5, CD3, CD4, or CD7) is as or more sensitive a marker for SS and MF than loss of CD26.²⁰²

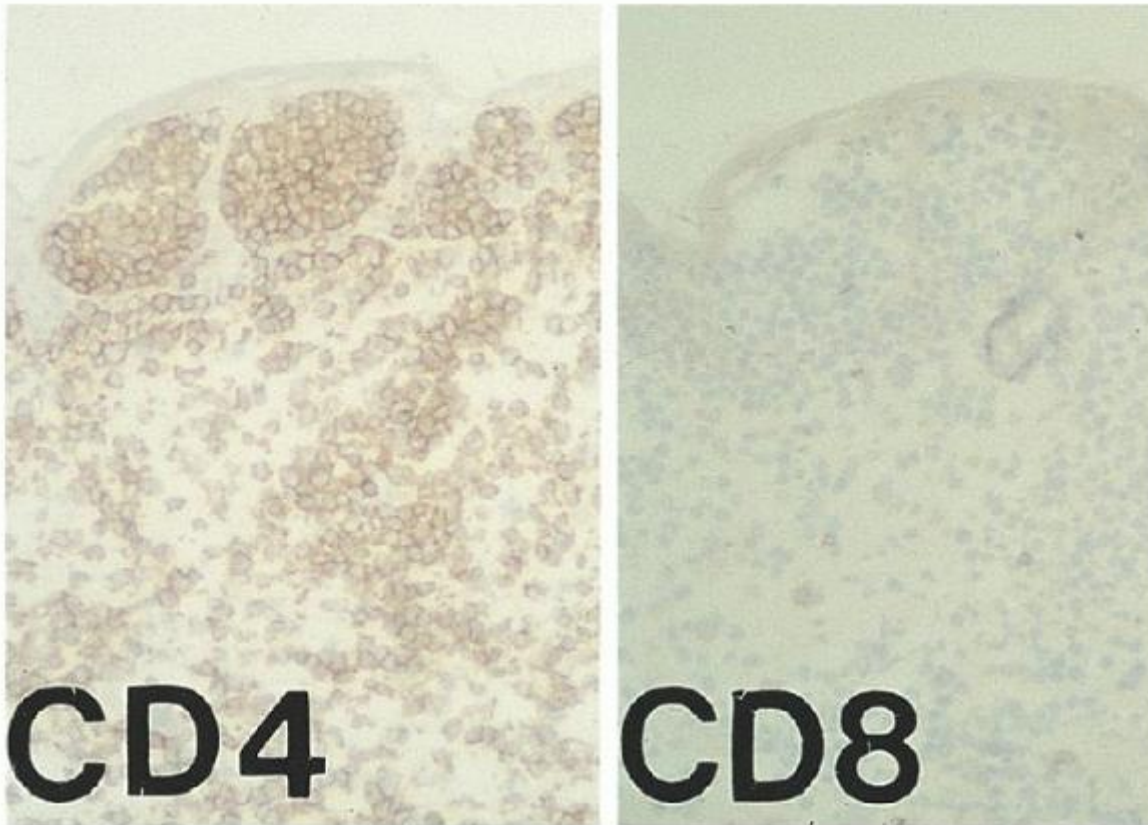

FIGURE 92.8. Frozen section immunohistochemistry of a cutaneous plaque in a patient with MF shows a marked predominance of CD4⁺ T-helper cells within Pautrier microabscesses and within the dermis. CD8 is essentially negative (Diaminobenzidinehematoxylin, $\times 50$). MF, mycosis fungoides.

For histologic diagnosis of cutaneous lymphomas, immunohistochemistry can reliably differentiate among T-cell lymphomas, B-cell lymphomas, and Hodgkin disease. The most widely used paraffin-reactive T-cell antibodies include CD2, CD3, CD4, CD5, CD7, CD8, CD30, CD43, CD45RO, β F1, and TCR $\alpha\beta$. Although immunohistochemistry for CD7 can be helpful in evaluating early MF biopsies, loss of CD7 can be seen in a wide variety of reactive benign conditions requiring correlation with clinical, histologic, other immunophenotypic and molecular findings.^{203, 204} NK-cell or cytotoxic lymphocyte markers (CD56, granzyme B, perforin, and TIA-1) can be used as well if non-MF NK-/T-cell lymphomas are in

the differential. CD20, CD79a, CD5, CD10, BCL-6, BCL-2, κ , λ , MUM1, and CD138 are the most widely used B-cell paraffin-reactive antibodies. When used in panels, these antibodies allow subclassification of most cutaneous lymphomas.

DIFFERENTIAL DIAGNOSIS

The clinicopathologic differential diagnosis for MF/SS includes several forms of benign dermatitis, other primary low-grade CTCLs, and secondary cutaneous involvement by disseminated lymphomas or leukemias (Table 92.2). Differentiation of these mimickers from CTCL often requires careful correlation of clinical, histopathologic, immunophenotypic, and genotypic characteristics, and may require multiple or serial biopsies. The following discussion describes methods to differentiate MF/SS from similar benign conditions, indolent CTCL, and other primary CTCLs.

To assist clinicians with the diagnosis of early MF, Pimpinelli et al. proposed an algorithm using clinical, histopathologic, molecular biologic, and immunopathologic criteria in which a total of 4 points from any of the four categories was necessary to make the diagnosis of early MF.¹²⁶ The scoring system would allow, for example, a patient with persistent patches in nonsun-exposed areas with size/shape variation (2 points) and histologic findings of a superficial lymphocytic infiltrate, epidermotropism without spongiosis, and lymphocyte atypia (2 points) to meet criteria for early MF diagnosis without any immunostains or T-cell-receptor gene rearrangement analysis of the skin tissue.

Benign Conditions

Benign inflammatory skin lesions are most likely to be confused with early patch-stage MF. In general, these conditions have clinical presentations and courses that are different from MF, lack enlarged atypical cerebriform T-cells, and lack epidermotropism that is disproportionately increased in relationship to spongiosis. However, in difficult cases, immunophenotypic analysis and gene rearrangement studies may be necessary to look for aberrant T-cell phenotypes or clonal TCR gene rearrangements. The benign inflammatory dermatoses that most closely resemble CTCL include small and LPP, PVA, pityriasis lichenoides, pigmented purpuric eruption, lichenoid keratosis, benign erythroderma, contact dermatitis, persistent arthropod bite reactions, drug eruptions, LyP, and actinic reticuloid (AR).²⁰⁵

Despite the name, the chronic skin diseases under the term parapsoriasis are unrelated to the much more common skin P.1961

disease psoriasis. Most dermatologists separate parapsoriasis into one of two types. The benign subtype is known as small plaque parapsoriasis, digitate dermatosis, or chronic superficial dermatitis. The other type is considered pre-malignant and is most often called LPP or parapsoriasis en plaques (having in the past been called pre-reticulotic poikiloderma).^{206, 207} LPP is clinically indistinguishable from patch-stage MF.¹²⁶ However, the patches of MF tend to be fixed whereas the patches of LPP tend to wane in the summer and flare in the winter. Because of clinical and histologic overlap, some authorities consider LPP to be an early stage of MF.²⁰⁸ Others consider LPP to be a latent form of MF²⁰⁹ because ~10% of patients eventually develop overt MF.²¹⁰ A retrospective review documented a higher rate of evolution to MF in 12 of 36 (33%) patients with LPP.²¹¹ This view is supported by the demonstration of clonal TCR gene rearrangement in 50% of LPP biopsies.⁷³ Furthermore, demonstration of clonal TCR gene rearrangements in small plaque or digitate parapsoriasis has suggested that this may be an abortive form of MF.^{212, 213} Histologically, the lymphoid infiltrate of LPP is perivascular and less dense with less epidermotropism than in MF; Pautrier microabscesses are not seen in LPP. Furthermore, cytologically atypical cerebriform T-cells with highly convoluted nuclei are inconspicuous or absent in LPP. However, immunophenotypic analysis is usually not helpful for differentiating LPP from patch-stage MF as both have a predominance of CD4⁺ helper cells with absent CD7 and CD62L expression.¹²⁷ One study found the presence of HECA-452 immunostaining higher in MF than LPP, which may be helpful in distinguishing the two diseases and predicting which cases of LPP may evolve into MF.²¹⁴

TABLE 92.2 BENIGN AND MALIGNANT CONDITIONS THAT CAN MIMIC MF AND SÉZARY SYNDROME

Benign Conditions

Small and large plaque parapsoriasis

Poikiloderma vasculare atrophicans

Pityriasis lichenoides et varioliformis acuta

Benign erythroderma

Chronic spongiotic dermatitis

Contact dermatitis

Drug eruption

Arthropod bites

Actinic reticuloid

Follicular mucinosis

CD30⁺ Lymphoproliferative Disorders

Lymphomatoid papulosis

Primary cutaneous anaplastic large-cell lymphoma

Other Primary Cutaneous T-Cell Lymphomas

Pagetoid reticulosis

Folliculotropic mycosis fungoides

Granulomatous slack skin

Subcutaneous panniculitis-like T-cell lymphoma

Primary cutaneous $\gamma\delta$ + T-cell lymphoma

Primary cutaneous CD8+ T-cell lymphoma

Primary cutaneous pleomorphic small/medium-sized CTCL

Primary Cutaneous B-Cell Lymphomas

Primary cutaneous follicle center lymphoma

Primary cutaneous marginal zone lymphoma

Primary cutaneous large B-cell lymphoma

Intravascular large B-cell lymphoma

Secondary Lymphoma/Leukemia

Leukemia cutis

Extramedullary myeloid tumor

Adult T-cell leukemia/lymphoma

Peripheral T-cell lymphoma

Hodgkin lymphoma

CTCL, cutaneous T-cell lymphoma

PVA can also present similarly to early MF, so much so, that most experts believe PVA to be a rare variant of MF.^{215, 216, 217} The macules and patches of PVA show the poikilodermatous features of hypopigmentation, hyperpigmentation, atrophy, and telangiectasias. PVA macules/patches tend also to be localized to sun-protected sites, most commonly appearing on the buttocks, breasts, and flexural areas. And, like LPP, some clinicians believe that PVA may potentially precede or co-exist with MF.¹²⁵ Histologically, PVA is characterized by an atrophic epidermis, chronic, ill-defined inflammatory changes and dilated capillaries. Often, lymphoid cells form a bandlike pattern in the superficial dermis, with only rare epidermotropism.^{215, 216, 217}

Pityriasis lichenoides is considered a spectrum of diseases including an acute and a chronic form: pityriasis lichenoides et varioliformis acuta (PLEVA) and pityriasis lichenoides chronica (PLC), respectively. Many patients demonstrate lesions of both forms during their disease course. PLEVA, also known as Mucha-Habermann disease, is a benign cutaneous disorder characterized by recurrent, self-healing papulonecrotic lesions that may resemble LyP, which is discussed later.²¹⁸ PLC, which is a benign eruption with lymphocytic infiltrates of the skin, presents as a persistent, erythematous, papular

eruption with scale.²¹⁹ Biopsies may show slightly atypical cerebriform T-cells with some epidermotropism, but vacuolar degeneration of the epidermal basilar layer, necrotic keratinocytes, and dermal hemorrhage in PLEVA distinguish it from MF. The lymphoid infiltrate is composed predominantly of CD8⁺ cells as opposed to the typical CD4⁺ phenotype of MF.²²⁰ The histology of PLC is similar to PLEVA, although the findings are muted with only focal basal vacuolar change and limited lymphocytic exocytosis. The intraepidermal lymphocytes tend to be CD4⁺, which further complicates the distinction from early MF. As in PLEVA, the lymphocytes lack significant cytologic atypia. Some consider pityriasis lichenoides to be a T-cell lymphoproliferative disorder or a form of indolent cutaneous T-cell dyscrasia related to LyP, and clonal TCR gene rearrangement has been demonstrated.^{221, 222, 223, 224} Although cases of patients with pityriasis lichenoides progressing to MF have been described, this is definitely a rare event.^{220, 224, 225}

Pigmented purpuric dermatoses (PPD) are a group of chronic and benign skin disorders categorized by rupture of the small capillaries in the superficial papillary dermis. Clinically, patients present with petechiae and bronze discoloration of the skin on the lower extremities.²²⁶ Histologically, there is a superficial perivascular infiltrate that may be dense and lichenoid in nature. Dermal hemorrhage and hemosiderin deposition is present to varying degrees. Lymphocytic exocytosis is often present, however, cytologic atypia and intraepidermal lymphocytic microabscesses are generally absent. Immunohistochemical and molecular studies are typically not helpful in differentiating PPD from MF. Lichen aureus, a rare type of PPD, can mimic MF both clinically and histologically and progress to MF in very rare cases.²²⁷ One study showed that of 43 cases of PPD, 21 showed a clonal population of T-cells. Only 40% of the cases with demonstrated clonality, however, had clinical and pathologic features consistent with MF. In addition, loss of CD7 was frequently observed in both

P.1962

the polyclonal and monoclonal groups.²²⁸ Other studies have documented the frequent occurrence of T-cell clonality in cases of PPD that fail to develop disease typical of MF.²²⁹ The presence of extensive PPD-like skin disease, especially when present outside the lower extremities, should raise the suspicion of MF regardless of the histologic features.

Lymphomatoid keratosis is a benign epithelial skin neoplasm related to an inflamed seborrheic keratosis or lichenoid keratosis. Patients generally demonstrate scattered small hyperkeratotic plaques on the trunk and are biopsied to rule out the possibility of a nonmelanoma skin cancer. The histologic features can be indistinguishable from MF with a lichenoid infiltrate and extensive lymphocytic exocytosis. Additionally, clonal populations of T-cells have been detected.²³⁰ The presence of epidermotropic CD20⁺ B-cells is suggestive of a lymphomatoid keratosis; however, clinicopathologic correlation is paramount in arriving at the correct diagnosis.²³¹

Erythroderma may occur in a variety of benign dermatologic disorders including psoriasis, pityriasis rubra pilaris, eczematous dermatitis, seborrheic dermatitis, severe contact dermatitis, and drug eruptions.^{232, 233} These patients may also have circulating cerebriform cells and lymphadenopathy, further complicating the diagnosis. Erythroderma secondary to drug reactions, especially anticonvulsants such as phenytoin, can be particularly difficult to distinguish from MF/SS because of the presence of convoluted cerebriform T-cells and the formation of Pautrier microabscesses.¹⁴⁰ Several studies have compared the histologic features of erythrodermic MF/SS with other causes of reactive erythroderma. Although not present in all cases, Pautrier microabscesses and a dense, often lichenoid, dermal lymphocytic infiltrate were more commonly associated with erythrodermic MF/SS.^{234, 235, 236} Differentiation of benign erythroderma from erythrodermic CTCL can usually be accomplished through careful evaluation of the history, skin biopsy of the more typical lesions of the underlying disease, and molecular genetic analysis of both skin and blood.^{235, 236} Numerous eosinophils favor a drug reaction. Aberrant T phenotypes or clonal TCR gene rearrangements are usually not present in benign erythroderma.

Subacute or chronic spongiotic dermatitis and interface dermatitis resulting from contact dermatitis, drug eruption, and persistent arthropod bite reaction may have atypical cerebriform T-cells with epidermotropism and Pautrier-like microabscesses mimicking MF.²⁰⁵ Caution should be exercised in interpretation of epidermotropism associated with significant spongiosis, especially microvesiculation, which is only rarely observed in MF.¹⁴³ The Pautrier-like microabscesses seen in spongiotic processes typically have a flask shape and are composed of Langerhans cells and keratinocytes. Immunophenotyping may be helpful in this differential diagnosis because cutaneous T-cell pseudolymphomas rarely show aberrant loss of CD2, CD3, or CD5 expression, especially a combination of these markers.²⁰⁵ CD7 and CD62L (Leu 8) are not as helpful as their expression is commonly lost in both MF and reactive dermatoses.²⁰⁵ Typically, T-cell-predominant pseudolymphomas are characterized by perivascular, "sleevelike" infiltrates around vessels in the dermis, with accompanying plasma cells, eosinophils, and macrophages. The T-cells are typically a mixture of CD4⁺ and CD8⁺ cells as opposed to the CD4⁺-predominant population characteristic of most cases of MF. The

utility of gene rearrangement studies in this setting is unclear as clonal TCR gene rearrangements have been reported in some cutaneous T-cell pseudolymphomas.^{237, 238, 239} The following drugs have been implicated as causing pseudolymphoma: alprazolam, amitriptyline, atenolol, carbamazepine, cefixime, chlorpromazine, cimetidine, clarithromycin, clonazepam, clonidine, cotrimoxazole, cyclosporine, desipramine, diltiazem, doxepin, fluoxetine, furosemide, gemfibrozil, gold, lamotrigine, lithium, lorazepam, losartan, methotrexate, nizatidine, perphenazine, phenytoin, ranitidine, sulfamethoxazole, sulfasalazine, and thioridazine.²⁴⁰

B-cell-predominant pseudolymphomas are notable for reactive follicle formation with tingible-body macrophages, centroblasts, and centrocytes in the germinal centers surrounded by distinct mantle zones. There are polyclonal plasma cells, a mix of CD4⁺ and CD8⁺ T-cells and often eosinophils in the accompanying inflammatory infiltrate.^{241, 242} CD21⁺ follicular dendritic cells (DCs) can be found in the follicles as well.

AR is a severe form of photosensitive dermatitis that may closely mimic MF or SS clinically and histologically when fully developed.^{243, 244, 245} AR is a chronic persistent eruption that can be induced by a broad spectrum of light wavelengths (ultraviolet A [UVA], UVB, and visible wavelengths of light).²⁴³ The skin lesions are typically plaques and papules on the sun-exposed areas of the face and hands, but may extend to covered areas or even become generalized erythroderma.²⁴⁶ In contrast to MF, epidermotropism is not prominent, but small Pautrier microabscesses may be found in some cases. Severe cases of erythrodermic AR may have generalized lymphadenopathy and circulating Sézary cells mimicking SS. Preferential involvement of sun-exposed areas, absence of large dysplastic cerebriform T-cells, and a CD8⁺ phenotype help distinguish AR from MF/SS. AR does not appear to be associated with progression to malignant lymphoma, and clonal TCR rearrangements have not been reported.²⁴⁵

CD30⁺ Lymphoproliferative Diseases

The differential diagnosis for suspected MF also includes a variety of related conditions, which are equally concerning for their malignant or pre-malignant clinical course. LyP and primary cutaneous ALCL (pcALCL) are both characterized by the presence of CD30⁺ T-cells; together, they represent the poles of a continuous disease spectrum. Both LyP and pcALCL are now considered subtypes of the CTCLs.¹³⁷ There is no clear-cut boundary between the diseases, however, and many patients fall into a borderline category when definitive diagnosis is not possible based on the current clinicopathologic features.

LyP is a CD30 (Ki-1)-positive T-cell lymphoproliferative disorder characterized by chronically recurring, self-healing crops of mildly pruritic papulonodular lesions that are clinically benign but histologically malignant.²⁴⁷ LyP initially presents with crops of erythematous papules that wax and wane, becoming hemorrhagic and necrotic before undergoing spontaneous regression with scar formation. Individual lesions range from 2 mm to 2 cm in diameter (usually <1 cm) and have an average duration of 5 weeks, ranging from 2 weeks to 6 months.²⁴⁸ LyP is classically divided into three histologic types, type A, type B, and type C. More recently a fourth histologic presentation, termed LyP type D, has been described.²⁴⁹ Any of the histologic types may occur simultaneously in the same patient or during the course of the disease and the individual histologic type provides no prognostic significance.²⁵⁰ LyP type A, the most common type, is characterized by a polymorphous infiltrate of eosinophils, neutrophils, and scattered anaplastic large transformed lymphocytes and binucleate Reed-Sternberg-like cells (Fig. 92.9).^{251, 252} LyP type B is characterized by small to medium cerebriform T-cells resembling MF. LyP type C is characterized by sheets of large, anaplastic CD30⁺ cells and can be histologically identical to pcALCL but follows a waxing and waning clinical course. The atypical cells in LyP types A, B, and C are typically CD4⁺. LyP type D is characterized by an extensively epidermotropic population of cytologically atypical CD8⁺ lymphocytes in a pattern that is nearly identical to that observed in primary cutaneous aggressive epidermotropic CD8⁺ cytotoxic T-cell lymphoma (see below).^{249, 253, 254} The atypical cells in all of the types often have clonal rearrangement of the T-cell-receptor gene, and absent or diminished expression of pan-T-cell antigens.²⁵⁵ However, CD30 expression differs among the types; the large transformed cells in types A, C, and D are CD30⁺, similar to CD30⁺ ALCL, whereas the atypical cerebriform T-cells in type

P.1963

B LyP typically do not express CD30.²⁵⁶ Vonderheid and Kadin have suggested that the papular variant of MF and type B LyP are the same entity²⁵⁶ although Kodama and colleagues point to the lack of spontaneous resolution of papules in papular MF.²⁵⁷ Clinical behavior of LyP is usually benign; however, overt lymphoma has been documented in ~10% to 25% of patients, usually MF, pcALCL, or Hodgkin lymphoma.^{248, 258} The cumulative risk for the development of another lymphoma in patients with LyP over 15 years of disease may be as high as 80%.²⁵⁹ A retrospective review of 31 patients with LyP over a 27-year span identified 60% who developed a co-existing lymphoma.²⁵⁸ No clinical, histologic,

immunophenotypic, or molecular genetic features have been identified that can predict which patients will develop lymphoma, but two studies suggest that malignant transformation is more strongly associated with type A than with type B LyP.²⁵⁶ Onset of LyP at a younger age may be associated with increased cumulative risk for overt lymphoma and therefore all LyP patients should be closely monitored throughout their lives.^{221, 259, 260} The benign or malignant nature of LyP is controversial, but the WHO-EORTC considers LyP to be a latent or low-grade stage of the primary cutaneous CD30⁺ lymphoproliferative disorders that are considered to be malignancies.^{137, 261} Its clinical, histologic, and immunophenotypic similarities to pcALCL, aberrant T-cell-antigen expression, clonal TCR gene rearrangements, and increased risk for transformation to malignant lymphoma support this view.

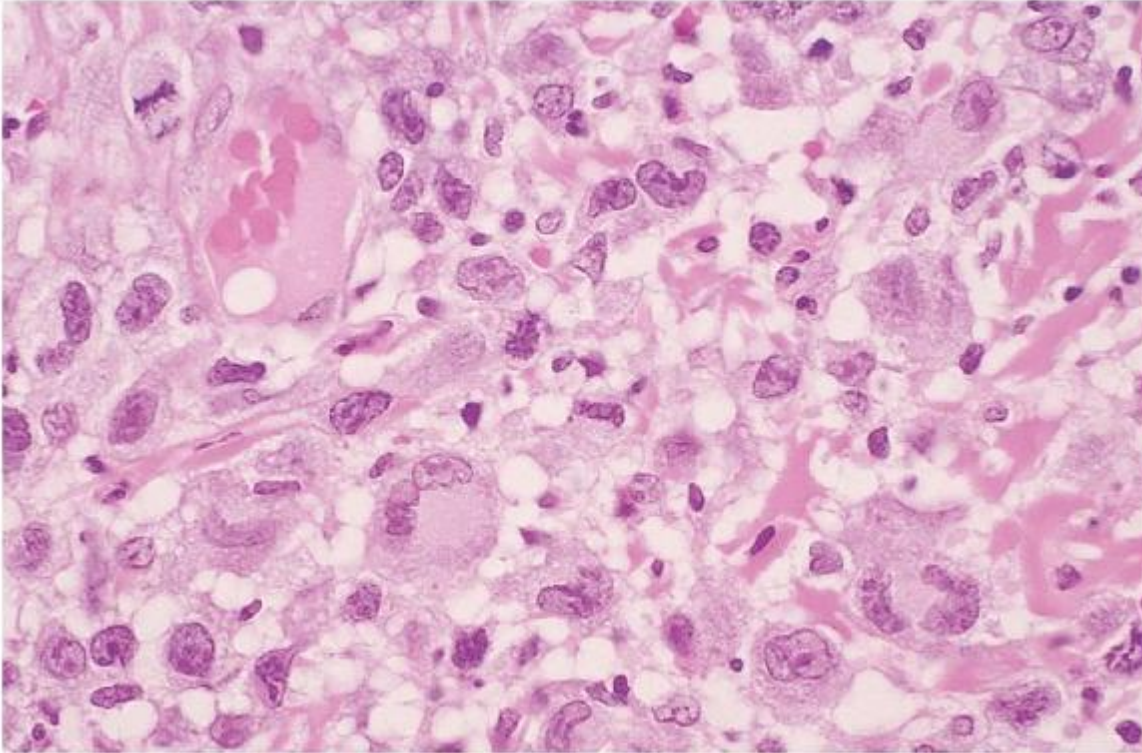

FIGURE 92.9. Lymphomatoid papulosis, type A. Anaplastic large cells with abundant cytoplasm, reniform nuclei, and prominent nucleoli are scattered among small lymphocytes and eosinophils. Note occasional binucleate Reed-Sternberg-like cells (hematoxylin and eosin, $\times 250$). The large cells were strongly positive for CD30 (not shown).

Differentiation of primary cutaneous ALCL from LyP and secondary CD30⁺ LCL resulting from large-cell transformation of MF/SS is important because of differences in prognosis and therapy.^{137, 261} pcALCL has a good prognosis and can be effectively managed with local excision and/or radiation therapy,²⁶² whereas secondary CD30⁺ LCL due to large-cell transformation of MF/SS has a very poor prognosis requiring systemic therapy that often includes aggressive combination chemotherapy.^{167, 263} LyP also has an excellent prognosis and can often be managed with no therapy, topical chemotherapy, phototherapy, and low-dose methotrexate without the need for aggressive therapy.^{264, 265} Furthermore, pcALCL must be differentiated from secondary cutaneous involvement by extracutaneous ALCL.^{266, 267} Primary nodal ALCL and secondary cutaneous involvement by extracutaneous ALCL are more aggressive than pcALCL.^{266, 267} In malignant cells, the presence of anaplastic lymphoma kinase-1 protein (ALK-1) from the t(2;5) (p23;q35) chromosomal translocation favors primary nodal ALCL.²⁶⁸ A thorough dermatologic examination, history, and staging for extracutaneous disease are necessary to exclude secondary large-cell transformation of low-grade MF or secondary cutaneous involvement by extracutaneous lymphoma before a case is accepted as pcALCL. pcALCL is differentiated from LyP type A by cohesive sheets or $>75\%$ CD30⁺ large transformed cells, fewer admixed neutrophils and eosinophils, a diffuse infiltrate that extends into the deep dermis versus a more superficial wedge-shaped infiltrate, larger solitary or localized nodules or tumors instead of crops of papules, and higher frequency of persistent or progressive cutaneous lesions with less frequent or incomplete spontaneous regression.^{263, 268, 269} Recently it has been shown that translocations in the interferon regulatory factor-4 (IRF4) gene are specifically associated with pcALCL and may be used to differentiate it from the other previously mentioned entities.²⁷⁰ Other aspects of ALCL are discussed in more detail in Chapter 88.

Other Primary Cutaneous T-cell Lymphomas

Using the WHO-EORTC classification for cutaneous lymphomas as a guide, other primary CTCLs need to be considered in patients with atypical lymphocytic infiltrates of the skin.^{137, 139, 271} These lymphomas include: three variants of MF (pagetoid reticulosis [PR], granulomatous slack skin [GSS] disease, and folliculotropic MF); subcutaneous panniculitic T-cell lymphoma; extranodal NK-/T-cell lymphoma, nasal type; and primary cutaneous peripheral T-cell lymphomas (PTCLs), unspecified, which include: (a) primary cutaneous aggressive epidermotropic CD8⁺ T-cell lymphoma, (b) CGDTCL, and (c) primary cutaneous CD4⁺ small/medium-sized pleomorphic T-cell lymphoma.

PR and folliculotropic MF are variants of MF implying minor clinicopathologic differences from classical MF, whereas GSS is a subtype of MF with more significant differences from classical MF.²⁷² As in classical MF, these diseases are low-grade clonal T-cell lymphomas that generally follow a benign course but may behave aggressively over time. PR is a rare epidermotropic variant of MF that usually presents as localized, hyperkeratotic, verrucous plaques on the hands or feet (Woringer-Kolopp disease)²⁷³ but may also present with disseminated cutaneous plaques (Ketrion-Goodman disease).²⁷⁴ Given its more aggressive clinical course, Ketrion-Goodman disease would currently be better classified as tumor-stage MF, CGDTCL, or aggressive epidermotropic CD8⁺ CTCL.^{137, 275, 276} PR may mimic a more unusual variant of MF localized to the palms and soles known as MF palmaris et plantaris.²⁷⁷ Skin biopsies of PR show pagetoid epidermotropism by enlarged, atypical cerebriform T-cells, with relative sparing of the dermis (Fig. 92.10). The malignant cells in PR may be CD8⁺ or, less commonly, CD4⁺ and rarely, CD4⁺CD8⁻.²⁷⁸ In contrast to conventional MF and SS, there is often co-expression of CD30⁺. Although the original classification of PR allowed for $\gamma\delta$ TCR expression of the neoplastic cells, these cases are best classified

P.1964

as CGDTCL according to the WHO-EORTC guidelines. Clonal TCR gene rearrangement and aberrant T-cell-antigen expression support classification of PR as a form of CTCL;²⁷⁹ however, PR has a clinically benign course, with only rare reports of cutaneous dissemination of localized PR.²⁷⁶ Further studies are needed to confirm whether phenotypic differences in PR have clinical relevance. Local excision or radiation therapy is generally adequate treatment for PR, especially the localized form.

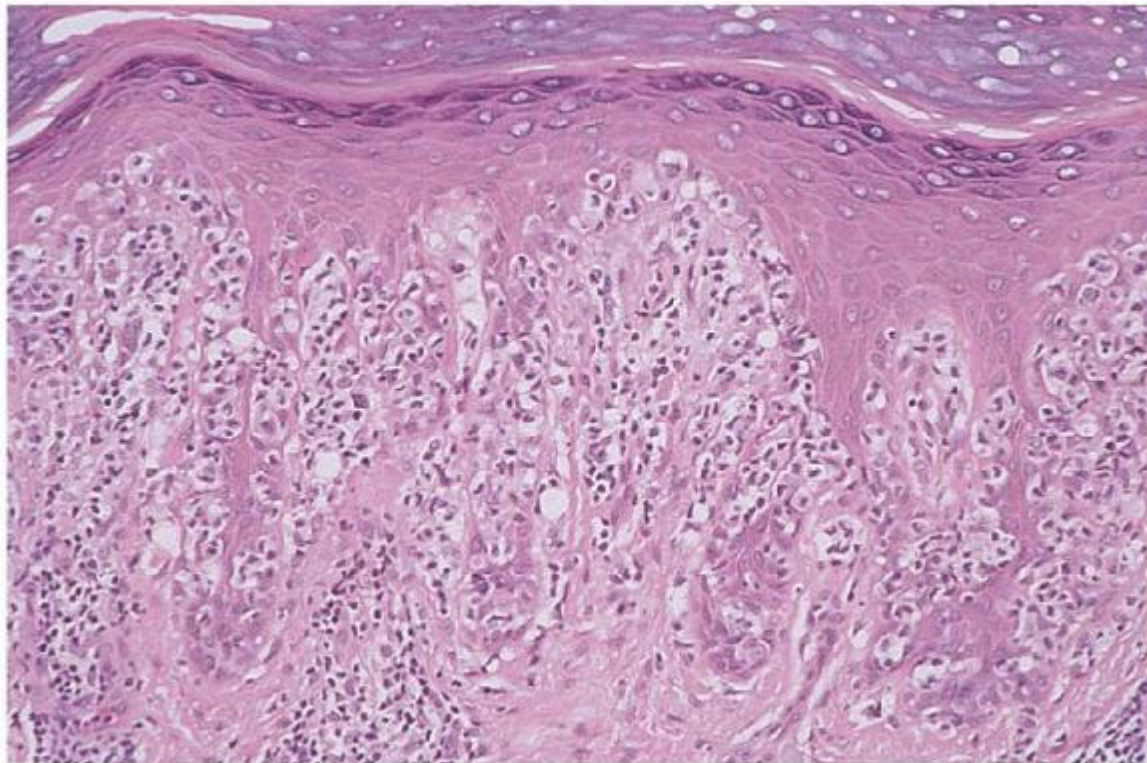

FIGURE 92.10. Pagetoid reticulosis. Note the pronounced pagetoid pattern of epidermotropism by enlarged, atypical cerebriform T-cells (hematoxylin and eosin, $\times 50$).

Folliculotropic or follicular MF (FMF) is another uncommon variant of CTCL first reported in 1985 with preferential perifollicular and folliculotropic infiltration by atypical cerebriform T-cells with minimal or absent epidermotropism and mucin (Fig. 92.11).^{280, 281, 282} The follicles may show plugging, cystic dilatation, and mucinous degeneration, as seen with mucin stains such as Alcian blue. Folliculotropic cerebriform T-cells are CD4⁺^{282, 283} and may express an aberrant T-cell phenotype with loss of CD7 and other T-cell antigens.²⁸² Differential up-regulation of ICAM-1 (CD54) on follicular epithelium instead of epidermal keratinocytes has been implicated in the folliculotropic homing pattern of folliculotropic MF.²⁸² Lymph node involvement and large cell transformation have also been described.²⁸² Folliculotropic MF, whether or not exhibiting follicular mucinosis, has shown a more aggressive course than classic MF.^{189, 284} Approximately 7% of reported cases have demonstrated rapid lymph node involvement.^{285, 286} In a large series of patients with FMF (n = 51), the disease-specific survival was 68% at 5 years and 26% at 10 years.²⁸⁶ This poor prognosis has been confirmed by other studies as well.^{166, 287} Agar and colleagues completed an outcome analysis on 1,502 patients with MF/SS concluding that folliculotropic MF was one of several independent predictors of poor survival and increased risk of disease progression.¹⁸⁹

Follicular mucinosis is frequently associated with folliculotropic MF and less commonly with classical MF. This variant of MF must be differentiated from idiopathic follicular mucinosis or alopecia mucinosa.^{288, 289} In general, no single clinicopathologic feature can differentiate follicular mucinosis associated with MF from alopecia mucinosa.^{288, 289, 290} Alopecia mucinosa tends to occur in younger patients with fewer lesions localized to the head and neck as opposed to the more general distribution commonly seen in MF-associated cases. Histologically, alopecia mucinosa tends to have fewer atypical cerebriform T-cells, less epidermotropism and/or lymphocytic infiltration of follicular epithelium, and a normal CD4/CD8 ratio. In follicular mucinosis associated with MF the infiltrate tends to be denser and cytologically atypical with a CD4⁺-predominant immunophenotype.²⁸⁸ Clonal TCR gene rearrangement can be detected in many cases of alopecia mucinosa thus limiting its usefulness in the differentiation from MF.^{290, 291} In support of this, a long-term follow-up study of seven patients with follicular mucinosis concluded that despite the presence of a clonal TCR gene rearrangement, there was no evidence of progression to CTCL in any patient.²⁹²

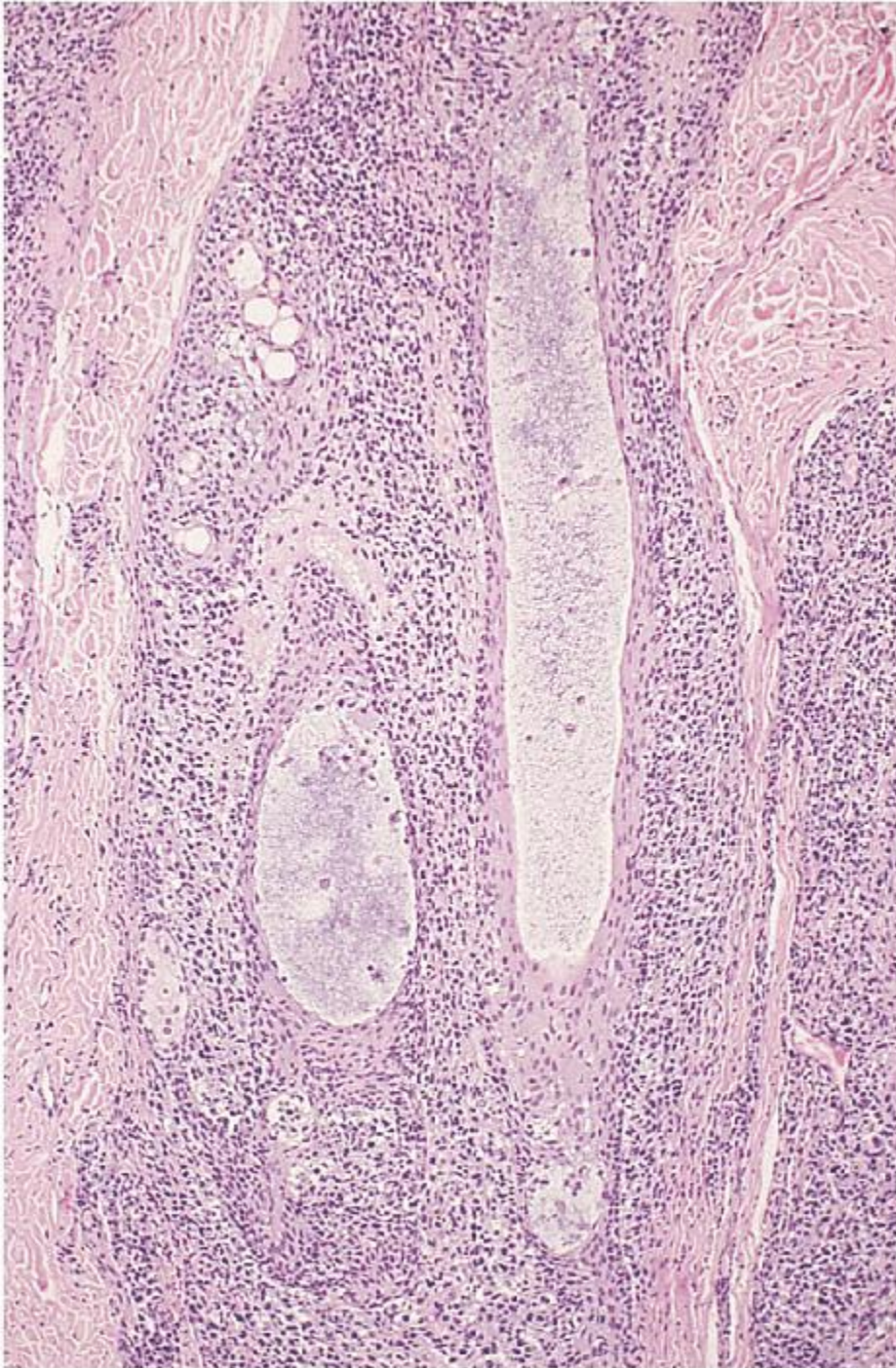

FIGURE 92.11. Folliculotropic mycosis fungoides with follicular mucinosis. Note the preferential pattern of perifollicular infiltration by atypical cerebriform T-cells with prominent folliculotropism forming small Pautrier microabscesses. Also note the bluish pools of mucin within the hair follicles (hematoxylin and eosin, $\times 25$).

GSS disease is a rare but distinctive subtype of MF that begins with patches and plaques that steadily progress to characteristic pendulous, erythematous skin folds in the axillae and groin.^{293, 294, 295, 296, 297, 298} Several authors stress the importance of distinguishing the mature lesions of GSS from the histologic variant of granulomatous MF, which can be differentiated quantitatively, not qualitatively.^{293, 298} GSS has histologic features of MF including superficial papillary dermal and epidermotropic infiltrates of atypical cerebriform T-cells, but it also exhibits expansive infiltration into the deep dermis and subcutis with extensive elastolysis and a prominent granulomatous reaction with Langerhans-type multinucleated giant cells (Fig. 92.12). These multinucleated giant cells are histiocytic in origin with 20 to 30 nuclei,

frequently show emperipolesis and elastophagocytosis, and express CD68 and CD1a.^{293, 299, 300} Similar to MF, GSS is a clonal proliferation of CD4⁺ T-helper cells that frequently lack expression of CD7 and CD62L. GSS usually remains localized to the skin, although hypercalcemia, lymph node involvement, and fatal systemic dissemination have been reported.^{295, 296, 297, 298, 301, 302} It is important to note that in contrast to other CTCL variants, patients with GSS have an increased incidence of Hodgkin lymphoma at a frequency between 25% to 50%.^{293, 302, 303}

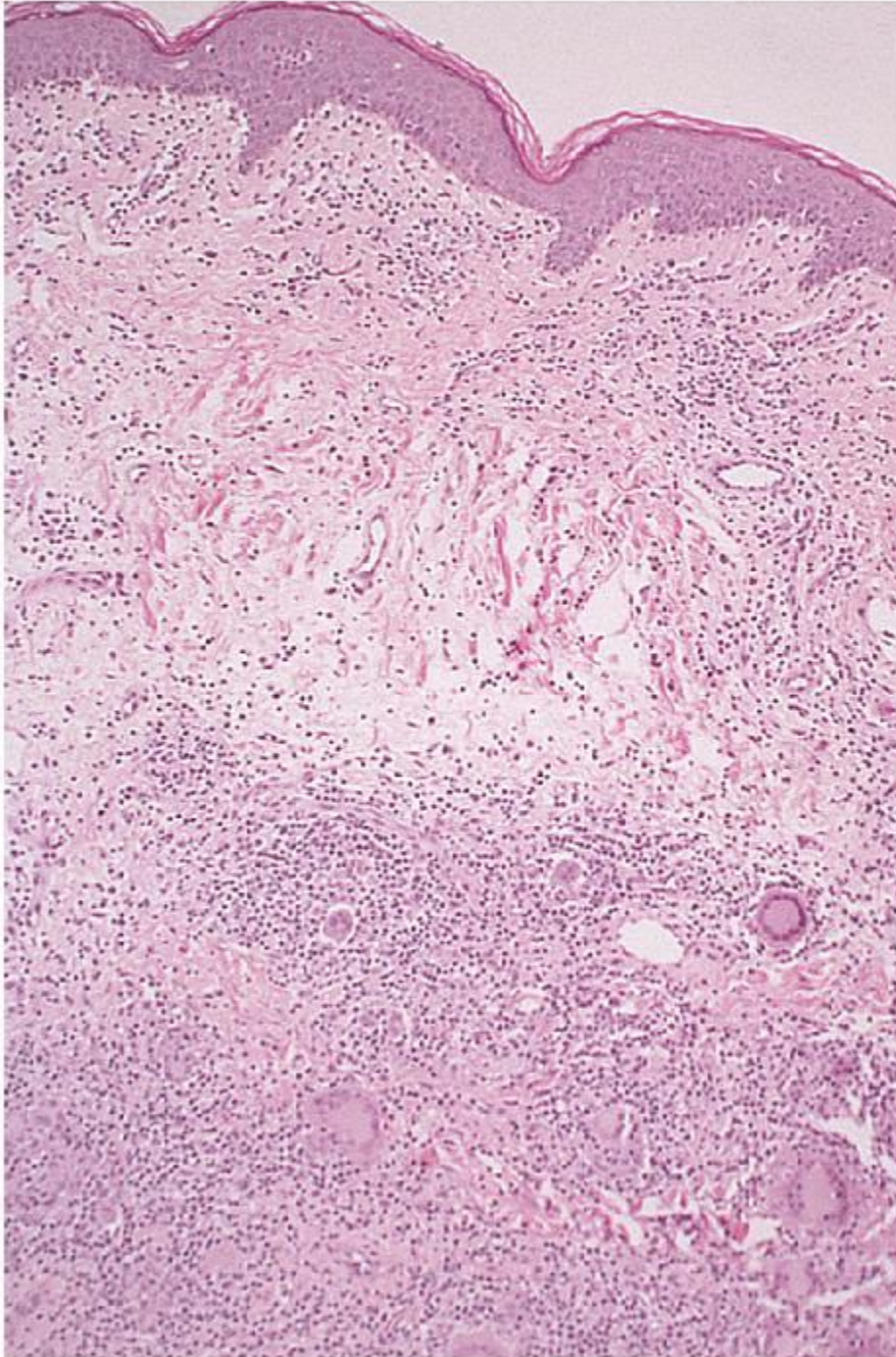

FIGURE 92.12. Granulomatous slack skin. This variant of mycosis fungoides (MF) shows a deep lymphocytic infiltrate with dermal edema, disruption of elastic fibers, and numerous foreign body giant cells (hematoxylin and eosin, $\times 10$).

Subcutaneous panniculitis-like T-cell lymphoma (SPTL) presents as tender erythematous nodules or subcutaneous palpable masses, mostly on the legs, trunk, arms, or face. Histologically, this lesion is confined to the subcutis and does not typically

P.1965

extend to the dermis or epidermis.^{304, 305} Classically, T-cells ranging from small and inconspicuous to large and transformed cells with hyperchromatic nuclei rim individual fat cells.^{306, 307} There is necrosis, karyorrhexis, and cytophagocytosis by the histiocytes that are found interspersed in the lesional tissue. As the name implies, this lymphoma is similar in histology to a lobular panniculitis and, in fact, many patients present with a history of previously biopsied panniculitis. In addition, there is some clinical and histologic overlap with lupus panniculitis and many patients with SPTL will present with or develop evidence of concomitant systemic lupus erythematosus.^{308, 309, 310} By immunohistochemistry, the neoplastic T-cells express $\alpha\beta$ TCR, CD3, CD8, and cytotoxic granule proteins, although CD56 and CD30 are rarely detected.^{304, 306, 307, 311, 312} Historically SPTL had been associated with a very poor prognosis often secondary to an aggressive hemophagocytic syndrome (HPS). The more recent WHO-EORTC classifications divided these cases into SPTL with an $\alpha\beta$ phenotype and CGDTCL based both on immunohistologic features and clinical behavior. SPTL with an $\alpha\beta$ phenotype are CD4⁺, CD8⁺, CD56⁻, and β F1⁺; are limited to the subcutaneous fat; are uncommonly associated with a HPS; and have a favorable prognosis (5-year OS 82%). CGDTCL is generally CD4⁻, CD8⁻, CD56[±], and β F1⁻; tends to involve the epidermis with resulting ulceration; is commonly associated with HPS; and has a dire prognosis (5-year OS 11%).³¹³ Repeat biopsies may be necessary to confirm the diagnosis of SPTL. Once confirmed, early induction of combination chemotherapy with or without radiotherapy may yield remission and prevent the development of HPS.^{314, 315, 316} (For further discussion of SPTL, see Chapter 88.)

Primary cutaneous T-cell neoplasias that do not fit into the other categories of CTCL are diagnosed as primary cutaneous PTCL, unspecified, in the WHO-EORTC classification system. This large category includes three provisional entities that are considered separately here. First, CGDTCL is characterized clinically by disseminated plaques and ulceronecrotic nodules that frequently also involve mucosal sites. The different clinicopathologic presentations may resemble MF, PR, PTCL, unspecified, and SPTL.^{307, 317, 318, 319} Patients presenting with nodules/tumors/plaques localized predominantly to the extremities should alert the clinician to CGDTCL. One series found all 23 of their patients with CGDTCL to have nodules or tumors on the extremities, with less than half exhibiting concurrent truncal lesions.³¹⁹ Most reports suggest that CGDTCL is aggressive and poorly responsive to therapy. Whether these lesions are primary to the mucosa or the skin, the prognosis is universally poor,³²⁰ except in rare cases.³²¹ As mentioned previously, CGDTCL includes subcutaneous lesions previously considered to be $\gamma\delta$ variants of SPTL, which is associated with a potentially very aggressive HPS.^{241, 319} There are reports of a more indolent subcutaneous form of CGDTCL associated with atypical lymphocytic lobular panniculitis³²¹ that may be difficult to distinguish without clinical correlation. Histologically, the neoplastic clone of CGDTCL is a mature, activated $\gamma\delta$ T-cell with a cytotoxic phenotype. The subcutis, dermis, or epidermis may be involved by medium- to large-sized cells with irregular nuclei and clumped chromatin. Basal vacuolar interface change and interface dermatitis is common. The background tissue shows apoptosis and necrosis with occasional angioinvasion. Often, one patient may show different histologic patterns at different sites. In contrast to $\alpha\beta$ ⁺ MF and SS, the neoplastic $\gamma\delta$ ⁺ T-cells are typically negative for both CD4 and CD8, with rare CD8⁺ cases.^{318, 319} Immunohistochemically, these neoplastic $\gamma\delta$ T-cells express CD3, CD2, CD43, and CD45RO.³²² The T-cells also express cytotoxic granule proteins such as TIA-1, perforin, and granzyme B.³⁰⁴ Due to the lack of a reliable antibody that could detect either the γ or δ TCR in formalin-fixed tissue, identifying $\gamma\delta$ T-cells has historically been deduced from the lack of CD4, CD8, and TCR β F1 staining. Recently a protocol using commercially available antibodies directed against epitopes on the γ and δ TCR has been described.³²³

Primary cutaneous aggressive epidermotropic CD8⁺ cytotoxic T-cell lymphoma (PC8TCL) is a second provisional entity in the primary cutaneous PTCL, unspecified, group. As the name implies, this tumor is comprised of epidermotropic CD8⁺ T-cells with an aggressive clinical course.^{324, 325} Patients with this aggressive variant usually present with widespread eruptive ulcerative plaques. Mucosal and genital involvement is common. The disease course is often complicated by spread to the central nervous system, lung, and testis.³²⁴ Of note, the lymph nodes are rarely involved. Histologically, there is a pagetoid pattern or occasionally a linear distribution of T-cells in an atrophic or acanthotic epidermis. Spongiosis may accompany the intraepidermal lymphocytes.³²⁴ Angioinvasion with adnexal destruction are common findings. Immunohistochemically, the neoplastic cells express CD3, CD8, CD45RA, and cytotoxic granule proteins such as perforin, granzyme B, and TIA-1.¹⁹⁴ CD2 and CD5 expression are often lost, but CD7 expression is retained, a pattern that is generally the reverse of what is typically observed in MF.³²⁶ PC8TCL must clinically and histologically be differentiated from CD8 MF, PR, and Type D LyP, all of which tend to follow an indolent course.^{194, 254, 327} Nofal and colleagues have recently proposed diagnostic criteria for PC8TCL that must include these constant features:³²⁴ (1) clinical: a history of onset within weeks to months of an aggressively behaving eruption of widespread papules, plaques, and tumors, that often ulcerate, without any precursor lesions; (2) histopathologic: epidermotropism, often prominent with a nodular or diffuse infiltrates of pleomorphic T-cells; (3) immunohistochemical: CD8⁺, CD4⁻ staining pleomorphic T-cells. PC8TCL

patients have a poor prognosis with a median survival of 32 months.^{324, 326} This is further exemplified by an average 5-year survival of 18% as compared with 88% in the more indolent MF.¹³⁷

The third provisional entity classified as a primary cutaneous PTCL is primary cutaneous CD4⁺ small-/medium-sized pleomorphic T-cell lymphoma. Primary cutaneous CD4⁺ small-/medium-sized pleomorphic T-cell lymphoma typically presents as a solitary plaque or tumor on the trunk or head and neck without preceding erythematous patches or plaques more typical of MF.³²⁸ Uncommonly, the papulonodules, tumors, or deep plaques of primary cutaneous CD4⁺ small-/medium-sized pleomorphic T-cell lymphoma can be multiple.^{328, 329} Histologically, there is a nodular or diffuse infiltrate of small- or medium-sized pleomorphic lymphocytes in the dermis, with minimal or no epidermotropism and without cerebriform nuclei. The infiltrate can extend deeply into the dermis and subcutis and can include histiocytes, plasma cells, and eosinophils. Large atypical lymphocytes should comprise <30% of total cellularity. There have been rare cases with granulomatous features that may be confusing for GSS, yet GSS typically presents with more epidermotropism and shows some cerebriform cells.^{328, 330} The neoplastic T-cells are by definition CD4⁺ and also express CD3 and $\alpha\beta$ TCR, but are negative for CD8, CD30, and cytotoxic proteins, and they can show loss of pan-T-cell markers. Several recent studies have shown that the neoplastic cells express the markers PD-1, CXCL13, and BCL-6 consistent with derivation from follicular T-helper cells.^{331, 332, 333} The prognosis is usually excellent; a 5-year survival rate has been reported as 60% to 80% in several series.^{328, 329, 334}

Other Hematopoietic Neoplasms with Similar Cutaneous Presentations

Other lymphomas and hematopoietic tumors that may involve the skin include HTLV-1⁺ ATL (Fig. 92.13), extranodal NK-/T-cell lymphoma, Hodgkin lymphoma, cutaneous B-cell lymphomas, and leukemia cutis or extramedullary myeloid tumor (EMT) (including granulocytic sarcoma and monoblastic sarcoma). Peripheral T-cell and NK/T-cell lymphomas are discussed in Chapters 88 and 89. Hodgkin lymphoma is discussed in Chapters 91 and 92. Cutaneous B-cell lymphoma, leukemia cutis, and EMTs are discussed in the following section.

P.1966

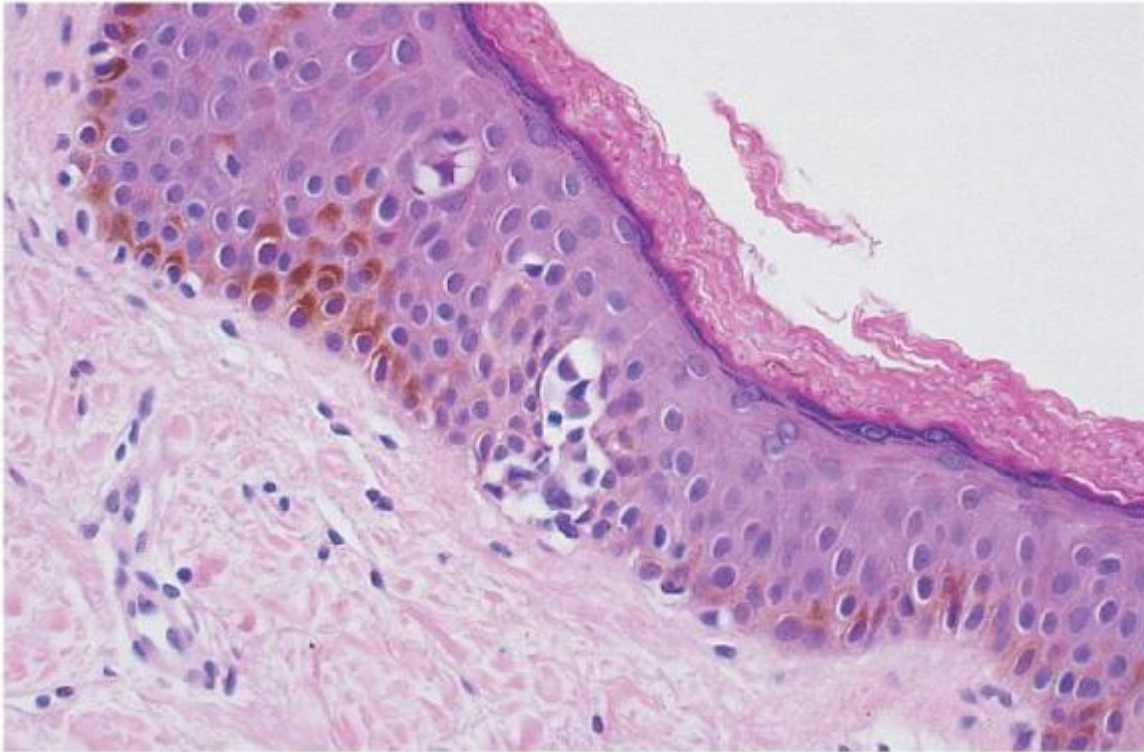

FIGURE 92.13. HTLV-1 (+) adult T-cell leukemia/lymphoma. Cutaneous involvement by HTLV-1 (+) adult T-cell leukemia/lymphoma showing epidermotropism and formation of a Pautrier microabscess (hematoxylin and eosin, $\times 50$). HTLV-1, human T-cell lymphotropic virus type-I

Primary cutaneous B-cell lymphomas are uncommon (incidence of 3.1 per million person-years), and must be differentiated from secondary cutaneous involvement by systemic B-cell lymphoma and cutaneous lymphoid hyperplasia of B-cell type.⁸³ The primary cutaneous B-cell lymphomas include: primary cutaneous follicle center lymphoma (PCFCL); primary cutaneous marginal zone B-cell lymphoma (PCMZL); primary cutaneous diffuse large B-cell lymphoma (PCLBCL), leg type; and primary cutaneous large B-cell lymphoma, other.^{137, 335} Other systemic B-cell lymphomas may involve the skin, including intravascular large B-cell lymphoma, lymphomatoid granulomatosis, chronic lymphocytic leukemia/small-cell lymphoid neoplasm, mantle cell lymphoma, and Burkitt lymphoma.^{137, 261} Cutaneous B-cell lymphomas usually present as single or multiple violaceous nodules on the head and neck or trunk and tend to infiltrate the deeper portions of the dermis, sparing the epidermis (“bottom-heavy”). PCFCLs are the most common cutaneous B-cell lymphomas. PCFCLs may have a nodular or a nodular and diffuse growth pattern and more frequently have a predominance of large noncleaved cells³³⁶ than their nodal counterparts (Fig. 92.14). The Mann-Berard grading system used for nodal follicular lymphomas is not predictive in PCFCL. In fact, in contrast to the aggressive behavior of nodal large-cell follicular lymphomas, primary cutaneous large-cell follicular lymphomas tend to be localized, follow an indolent course, and can often be managed with local excision, radiation therapy, and more recently rituximab.^{335, 337, 338, 339, 340} However, careful staging must be performed to exclude extracutaneous lymphoma before a case is classified as primary cutaneous B-cell lymphoma. Typically, nodal follicular lymphomas express BCL-2 and are characterized by the chromosomal translocation t(14;18). PCFCLs, on the other hand, rarely show characteristic chromosomal translocations and BCL-2 is uncommonly expressed (Table 92.3).^{341, 342}

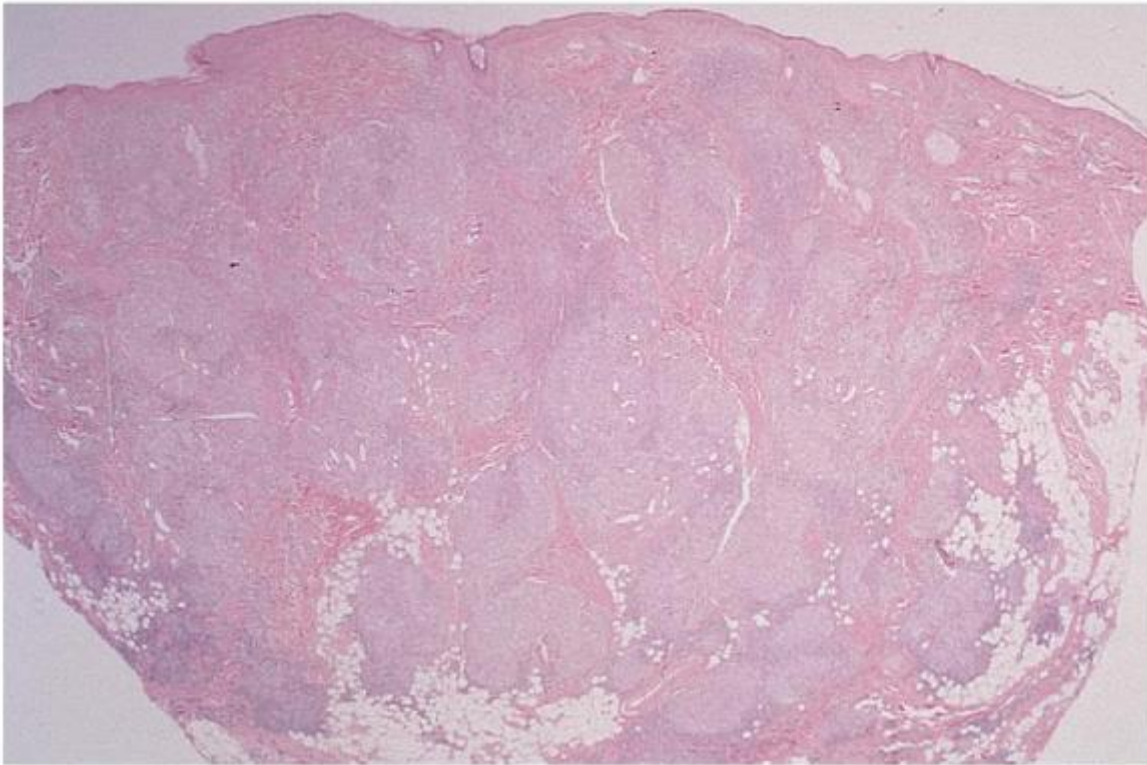

FIGURE 92.14. Primary cutaneous follicle center lymphoma. Note the back-to-back nodular pattern. The infiltrate extends from the superficial reticular dermis to the superficial subcutis in a “bottom-heavy” pattern sparing the papillary dermis and epidermis (hematoxylin and eosin, $\times 2$).

PCMZL is an indolent lymphoma characterized clinically by small purple-pink irregular plaques on the trunk, in contrast to PCFCL, in which the violaceous nodules are usually confined to the head and neck.³⁴³ Histologically, PCMZL is characterized by small, monocytoid, or lymphoplasmacytoid B-cells. Rarely, the infiltrate may be predominantly plasmacytic, and in instances where there is no evidence of systemic disease, these lesions are still considered part of the spectrum of PCMZL. The infiltrates range from nodular to diffuse. Reactive germinal centers may serve as foci for the nodular infiltrate of neoplastic marginalzone cells. The neoplastic cells typically express CD20 and CD79 and BCL-2 but are negative for CD5, CD10, and BCL-6, the last two markers helping to distinguish it from PCFCL.^{343, 344} The presence of large clusters of CD123 plasmacytoid DCs has also been proposed as a differentiating feature of PCMZL from the other primary cutaneous B-cell lymphomas.³⁴⁵ The chromosomal translocation t(14;18) (q32;q21) leading to the fusion of IGH and MALT1 genes as well as

the t(3;14) (p14;q32) fusing the IGH and FOXP1 genes have rarely been reported in PCMZLs.³⁴⁶ Similar to diffuse large B-cell lymphoma, a recent study identified aberrant somatic hypermutation in PCMZL, which leads to genomic instability.³⁴⁷

PCLBCL, leg type, typically presents in the elderly (average age of onset, 78 years) with rapidly growing reddish to violaceous nodules and tumors on the lower legs, but they can occur at any cutaneous site.^{348, 349, 350, 351} Histologically, the lesion is composed of immunoblasts and centroblasts without the admixed centrocytes that are more often seen in PCFCL. The infiltrate rarely involves the epidermis but can extend into the deep dermis and subcutaneous tissue. Because PCLBCL has a poor prognosis compared to the more indolent course of PCFCL, it is important to be able to distinguish these two entities.^{348, 349, 350, 351} As noted earlier, PCFCL and also PCLBCL can have a purely diffuse infiltrate with many centroblasts and immunoblasts, yet PCFCL will also contain centrocytes whereas PCLBCL, leg type, will not. By immunohistochemistry, PCFCL expresses CD10 and BCL-6 and only expresses BCL-2 or MUM1/IRF4 in a minority population, whereas PCLBCL diffusely expresses BCL-2, MUM1/IRF4, and IgM, but does not express CD10 and only rarely expresses BCL-6.^{344, 350, 351, 352, 353} Gene chip expression profiling has shown that PCLBCL has an activated B-cell genotype, whereas PCFCL has more of a germinal center B-cell genotype.³⁵⁴ A further study evaluating apoptosis-related genes identified a strong cellular cytotoxic immune response in PCFCL, whereas PCLBCL, leg type, had constitutive activation of the intrinsic mediated apoptosis pathway and downstream inhibition of apoptosis.³⁵⁵

PCLBCL, other, is a WHO-EORTC classification that includes those B-cell lymphomas that do not conform to the PCFCL or PCLBCL, leg type, criteria. This category includes large B-cell lymphoma subtypes such as anaplastic, plasmablastic, T-cell/histiocyte-rich, and intravascular large B-cell lymphoma.^{356, 357, 358, 359, 360, 361, 362} Although these entities can present initially as cutaneous lesions, they often represent cutaneous involvement by a systemic lymphoma. Of note, some cases of intravascular large B-cell lymphoma appear to be confined exclusively to the venules, capillaries, and arterioles of the skin, without systemic involvement.³⁶² These rare cases have a better prognosis (56% 3-year OS vs. 22%) than their systemic counterparts.³⁶² More detailed discussion of the other systemic B-cell lymphomas is in Chapter 88.

P.1967

TABLE 92.3 IMMUNOHISTOCHEMISTRY PATTERN OF THE PRIMARY CUTANEOUS B-CELL LYMPHOMAS (CBCL)

CBCL Type	BCL-2	BCL-6	CD10	CD20	Ig	MUM1/IRF4
PCFCL	- (10% +)	+	+ follicular pattern; - diffuse pattern	+	-	- (10% +)
Secondary FCCL	+	+	+	+	+	-
PCMZL	+	-	-	+	+	+ on associated plasma cells
PCLBL, Leg type	++	rarely	-	+	+IgM	++

FCCL, follicle center cell lymphoma; PCFCL, primary cutaneous follicle center lymphoma; PCLBL, primary cutaneous large B-cell lymphoma; PCMZL, primary cutaneous marginal zone lymphoma.

Leukemia cutis and EMT are cutaneous infiltrates of myeloblasts and immature myeloid precursors that are often difficult to differentiate from cutaneous lymphoma. EMT, also known as granulocytic sarcoma or chloroma, is an extramedullary tumor composed of immature granulocytic precursor cells. The most common sites of presentation are bone, periosteum, soft tissue, lymph node, skin, and, infrequently, small intestine. The tumor may develop during the course of acute myeloid leukemia, chronic myeloid leukemia, or other myelodysplastic disorders.^{363, 364} EMT usually presents as nodules or tumors that are often solitary, whereas leukemia cutis presents with multiple skin lesions with a varied clinical appearance, including papules, nodules, plaques, palpable purpura, or ulcers.³⁶⁴ Histologically, EMT and leukemia cutis tend to infiltrate between collagen bundles and fat spaces in an interstitial pattern (Fig. 92.15). Cytologically, the myeloblasts of EMT and leukemia cutis are medium-sized cells with finely dispersed chromatin, small or inconspicuous nucleoli, and scant cytoplasm. Occasionally, eosinophilic or neutrophilic granules may point to the cells' myeloid lineage. In difficult cases, immunohistochemistry, flow cytometry, and cytochemical stains will usually confirm the diagnosis and exclude lymphoma.³⁶⁵ CD68, CD43, and lysozyme, although not lineage-specific for monocytes or macrophages, have been shown to be the most sensitive markers for detecting myeloid leukemia cutis.^{366, 367} Nearly half of the cases may be

myeloperoxidase negative; however, a recent study looking at 173 skin biopsies of myeloid leukemia cutis demonstrated a 100% diagnostic accuracy utilizing CD68, CD33, and MPO.³⁶⁸ If the patient has systemic leukemia, comparing the immunohistochemical profile of the cutaneous infiltrate with that from the peripheral blood or bone marrow can be helpful. It must be kept in mind, however, that many of the immunophenotypic markers used in defining blastic cells in the blood or bone marrow (CD117 and CD34) are often negative in the cutaneous infiltrates.³⁵³ Myeloperoxidase, Sudan black B, and chloroacetate esterase cytochemical stains can be used to confirm myeloid differentiation if air-dried touch imprints are available.

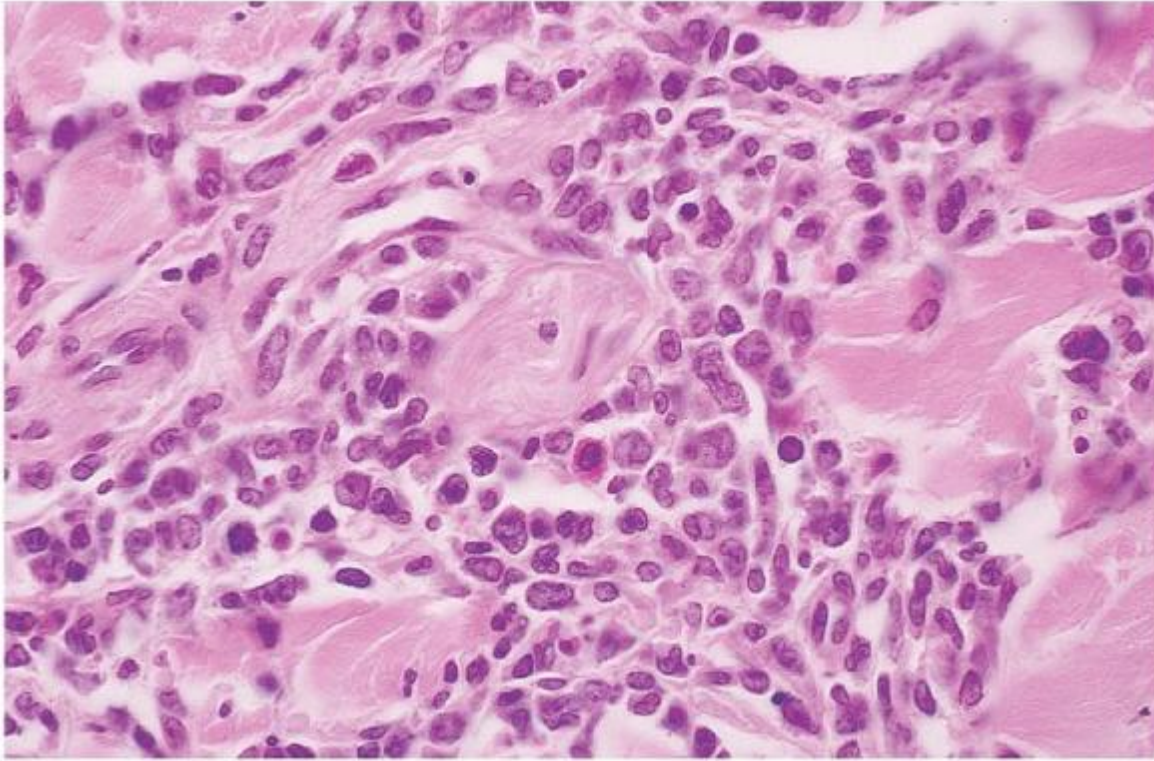

FIGURE 92.15. Leukemia cutis. Clusters of myeloblasts with fine chromatin and scant cytoplasm infiltrate between collagen bundles in the reticular dermis (hematoxylin and eosin, $\times 250$).

STAGING

In 1979, a staging system for CTCL was proposed by an international panel of experts who devised a tumor-node-metastasis (TNM) system.³⁶⁹ In the original TNM staging system, peripheral blood involvement with $>5\%$ atypical circulating cells was indicated by a separate peripheral blood stage B1 (vs. B0) and did not affect the clinical stage designation. Two large series have shown that blood involvement is more commonly seen in higher-stage disease, with 0% to 12% of patients with plaques only, 16% to 27% of patients with tumors, and $>90\%$ with erythroderma, demonstrating peripheral blood involvement.^{173, 370} More recently, Vonderheid et al. have shown that blood involvement has distinct prognostic implications.³⁷¹

In 2007 the ISCL/EORTC recommended revisions to the MF Cooperative Group classification and staging system for CTCL.¹⁷⁶ These revisions are made to incorporate advances related to tumor cell biology, diagnostic techniques, and prognostic variables pertaining exclusively to MF and SS as opposed to non-MF/SS CTCLs (Table 92.4). Stage I refers to patients with patches and plaques without adenopathy and is divided into stage IA for patients with $<10\%$ body surface area (BSA) involvement (T1) and stage IB for more generalized patches and plaques (T2). Stage II has two unique categories: stage IIA patients have patches/plaques with palpable adenopathy (histology negative), whereas stage IIB patients have tumors (nodules $>1\text{cm}$ in size) with or without palpable adenopathy (histology negative). Patients with erythroderma are placed into stage III with or without palpable adenopathy (histology negative). Stage IV patients have evidence of CTCL beyond the skin. Stage IVA₁ reflects significant blood involvement. Patients with stage IVA₂ have nodal involvement without visceral disease and stage IVB reflects patients with visceral disease. The lymph node staging includes N1 for dermatopathic lymph nodes (NCI grades 0 to 2), N2 for NCI grade 3 lymph nodes, and N3 for NCI grade 4 lymph nodes (Table 92.5). New to the ISCL/EORTC staging system is B2 staging for high blood tumor burden (Table 92.4),

B0 for <5% Sézary cells, and B1 blood stage for >5% Sézary cells when criteria for B2 are not met. For the first time, the blood stage is factored into the clinical stage to create a TNMB matrix. Changes also include the creation of clinical stages IIIA (T4N0-2M0B0), IIIB (T4N0-2M0B1), IVA₁ (T1-4N0-2M0B2), and IVA₂ (T1-4N3M0B0-2).¹⁷⁶

Staging procedures recommended by the international panel in 1979 included lymph node biopsy of a nonpalpable lymph node in patients without adenopathy, and liver and bone marrow biopsies for advanced stages (II, III, IV).³⁷² These procedures may be considered in patients in clinical trials but are rarely helpful in those patients with limited skin disease and no

P.1968

lymphadenopathy.¹⁸² Because invasive tests such as liver biopsy or staging laparotomy have added little diagnostic information for patients with early and advanced-stage disease,^{175, 373, 374} these staging studies are not recommended by the recent consensus conference.¹⁷⁶ Table 92.6 outlines staging procedures for MF/SS adapted from the ISCL/EORTC guidelines.¹⁷⁶ All patients should have a complete physical examination with special attention to skin and lymph nodes. Careful mapping of skin involvement and/or total-body photographs are recommended to document the initial extent of disease at diagnosis and to assess response to treatment.³⁷⁵ Laboratory studies should include serum comprehensive metabolic panel, lactate dehydrogenase, and complete blood count with manual differential. In addition, peripheral blood should be examined for abnormal lymphocytes by either a Sézary cell count (number per microliter) and/or flow cytometry with attention to CD4⁺/CD8⁺ ratio and CD4⁺/CD7⁻ or CD4⁺/CD26⁻ gated populations if indicated. TCR gene rearrangement of peripheral blood is also recommended, including an attempt to correlate a positive finding with any clone in the skin. A recent study showed no significant benefit to performing bone marrow biopsies for staging purposes.¹⁸¹ They may be helpful in working up unexplained hematologic abnormalities.

TABLE 92.4 2007 ISCL/EORTC STAGING OF MYCOSIS FUNGOIDES/SÉZARY SYNDROME

Stage	Clinical-Pathologic Features
T Skin Stage	
T1	Patches/plaques <10% BSA
T2	Patches/plaques >10% BSA
T3	At least one tumor nodule >1 cm in diameter
T4	Confluence of erythema (erythroderma) covering >80% BSA
N Lymph Node Stage	
N0	No clinically abnormal peripheral lymph nodes (pLNs)
N1	Clinically abnormal pLNs with NCI grade 1 or 2 pathology
N2	Clinically abnormal pLNs with NCI grade 3 pathology
N3	Clinically abnormal pLNs with NCI grade 4 pathology
Nx	Clinically abnormal pLNs with no histologic confirmation
M Visceral Stage	
M0	No visceral involvement
M1	Visceral involvement
B Blood Stage	
B0	Sézary cell count ≤5% lymphocytes
B1	Sézary cell count >5% lymphocytes when B2 criteria are not met
B2	T-cell clone in blood + >1,000 Sézary cells/μl, OR 2 of 3: CD4/CD8 ratio >10, or CD4 ⁺ CD7 ⁻ >40% lymphocytes, or CD4 ⁺ CD26 ⁻ >30%

lymphocytes
AND lymphocytes or CD4 or CD3 count must be elevated.

Clinical Stage

TNMB Stages

Early-Stage Disease

- IA T1 N0 M0 B0-1
- IB T2 N0 M0 B0-1
- IIA T1-2 N1-2 M0 B0-1

Late-Stage Disease

- IIB T3 N0-2 M0 B0-1
- IIIA T4 N0-2 M0 B0
- IIIB T4 N0-2 M0 B1
- IVA₁ T1-4 N0-2 M0 B2
- IVA₂ T1-4 N3 M0 B0-2
- IVB T1-4 N0-3 M1 B0-2

Sézary Syndrome

- IVA_{1 or 2} or IVB T4 N0-3 M0-1 B2

BSA, body surface area; EORTC, European Organization for the Research and Treatment of Cancer; ISCL, International Society of Cutaneous Lymphomas; NCI, National Cancer Institute; pLNs, peripheral lymph nodes.

Modified from Olsen E, Vonderheid E, Pimpinelli N, et al. Revisions to the staging and classification of mycosis fungoides and Sézary syndrome: a proposal of the International Society for Cutaneous Lymphomas (ISCL) and the Cutaneous Lymphoma Task Force of the European Organization of Research and Treatment of Cancer (EORTC). *Blood* 2007;110:1713-1722.

P.1969

TABLE 92.5 NCI VA GRADING SCHEME FOR LYMPH NODE HISTOLOGY IN CTCL

Grade	Histopathologic Features
LN-1	DL with occasional CTC
LN-2	DL with CTC singly or in small clusters (<6 cells)
LN-3	DL with numerous CTC, singly or in large clusters (>15 cells)
LN-4	Partial or complete effacement by MF/SS ± DL

CTC, cerebriform T-cells; CTCL, cutaneous T-cell lymphoma; DL, dermatopathic lymphadenopathy; LN, lymph node; MF, mycosis fungoides; NCI, National Cancer Institute; SS, Sézary syndrome; VA, Veterans Affairs. Modified from Sausville EA, Eddy JL, Makuch RW, et al. Histopathologic staging at initial diagnosis of mycosis fungoides and the Sézary syndrome. Definition of three distinctive prognostic groups. *Ann Intern Med* 1988;109:372-382.

Imaging

The role of diagnostic imaging in the initial staging of CTCL has been examined by several authors.^{376, 377, 378, 379} Kulin et al. studied the results of gallium citrate Ga-67 scintigraphy, liver-spleen scans, lymphangiography, and computed tomography

(CT) used in the initial staging of 62 CTCL patients (85% with stage I or II disease) and found that none of the results added significantly to the information obtained from physical examination and routinely performed lymph node biopsy (73% of 62).³⁷⁷ In contrast, a study of 63 CTCL patients (78% with stage I or II disease) who had staging body CT scans found positive findings in 18 (29%) patients, one half of whom had clinically unsuspected advanced-stage disease.³⁷⁶ Eight of these 18 patients had biopsies, with 5 of 8 confirming extracutaneous CTCL. Of the 38 patients with stage I disease, however, only 2 had positive findings on CT scan.³⁷⁶ Another retrospective study of 33 CTCL patients (70% with stage I or II disease) who had CT scans found that 3 of the 20 patients with initial clinical stage I disease were staged higher on the basis of CT findings as stage II.³⁷⁸ Subsequent lymph node biopsies confirmed extracutaneous disease in all three patients (stage IVA). In summary, pelvic, abdominal, and thoracic CT scans have a low yield in patients without palpable adenopathy (stage I) and are not necessary for staging these patients. The highest yield of CT scans appears to be in cases of non-MF/SS CTCL (nonepidermotropic, transformed CTCL, ALCL) and stage III disease (erythroderma), in contrast to stage II and IV patients, in whom CT findings often do not change treatment or stage.³⁷⁶ Therefore, staging CT scans of the chest, abdomen, and pelvis are recommended for patients with generalized plaques, erythroderma, tumors, palpable lymph nodes, or blood involvement.¹⁷⁶

TABLE 92.6 RECOMMENDED INITIAL STAGING EVALUATION OF MYCOSIS FUNGOIDES/SÉZARY SYNDROME
Evaluation and Studies

Skin

Physical exam	Identify primary skin lesion (patches, plaques, tumors, erythroderma) and % BSA involved.
Skin biopsy	Punch biopsy of thickest or oldest skin lesions (>1 skin biopsy)
Immunophenotyping	CD2, CD3, CD4, CD5, CD7, CD8, CD20, CD30.
Molecular genetics	T-cell receptor rearrangement analysis if needed.

Lymph Nodes

Physical exam	Identify abnormal peripheral lymph nodes ≥ 1.5 cm or irregular.
Radiologic tests	CT scans of chest, abdomen, pelvis except in stage IA or limited IB. PET scans may be helpful to identify which LN to biopsy.
LN biopsy	Complete LN biopsy preferred over core LN biopsy or FNA.
Immunophenotyping	CD2, CD3, CD4, CD5, CD7, CD8, CD20, CD30.
Molecular genetics	T-cell receptor rearrangement analysis if needed.

Viscera

Physical exam	Identify abnormal liver, spleen, or other organs.
Radiologic tests	CT scans of chest, abdomen, pelvis except in stage IA or limited IB. PET scans may be helpful to identify visceral abnormalities.
Liver biopsy	Not indicated, unless involvement would change management.
Spleen biopsy	Not indicated, unless involvement would change management.
Bone marrow biopsy	Not indicated, unless abnormalities would change management.
Other biopsies	Not indicated, unless involvement would change management.
Immunophenotyping	CD2, CD3, CD4, CD5, CD7, CD8, CD20, CD30.
Molecular genetics	T-cell receptor rearrangement analysis if needed.

Blood

Chemistries	Comprehensive panel including liver enzymes, lactate dehydrogenase, HTLV-1 serology if indicated.
-------------	---

Blood cells	Complete blood count and manual Sézary cell count/differential.
Immunophenotyping	Flow cytometry for absolute count and %: CD2, CD3, CD4, CD5, CD7, CD8, CD20, CD26 (if available), CD30. Also include CD4/CD8 ratio, CD4 ⁺ CD7 ⁻ , CD4 ⁺ CD26 ⁻ (if available).
Molecular genetics	T-cell receptor rearrangement analysis.

BSA, body surface area; CT, computed tomography; FNA, fine-needle aspiration; HTLV-1, human T-lymphotropic virus-1; LN, lymph node; PET, positron emission tomography.

Modified from Olsen E, Vonderheid E, Pimpinelli N, et al. Revisions to the staging and classification of mycosis fungoides and Sézary syndrome: a proposal of the International Society for Cutaneous Lymphomas (ISCL) and the Cutaneous Lymphoma Task Force of the European Organization of Research and Treatment of Cancer (EORTC). *Blood* 2007;110:1713-1722.

P.1970

Positron emission tomography (PET) may provide an alternative staging and response-assessment tool for patients with CTCL. A recent study evaluated 13 patients with MF and SS at risk for secondary lymph node involvement using integrated PET/CT followed by excisional biopsy of the lymph nodes.³⁸⁰ Two of seven patients with LN4 effaced lymph nodes had nodes <1.5 cm on CT scan and would have been assigned a N0 classification without the use of integrated PET/CT. The intensity of PET activity correlated roughly with lymph node histologic grade but did not reach statistical significance because of the small sample size. Feeney and colleagues recently evaluated the FDG PET/CT findings in patients with a variety of T-cell lymphomas noting a significant difference in the mean maximum standardized uptake value (SUV) in patients with MF with transformation (SUV, 11.3) compared with patients with MF without transformation (SUV, 3.82; $\pi < 0.05$).³⁸¹ Additional studies need to be performed to evaluate the role of CT/PET in the staging of patients with MF/SS.

Lymph Nodes

Although the presence of palpable nodes has prognostic value, lymph node histology is even more important in staging and assessing prognosis, not only at diagnosis but also later in the course of the disease. Enlarged lymph nodes from MF/SS patients either show dermatopathic lymphadenopathy or involvement by MF/SS. Sausville et al. described a system of grading lymph nodes in CTCL patients (NCI VA classification) that correlated well with prognosis: LN1, a few atypical cerebriform T-cells; LN2, dermatopathic lymphadenopathy with small clusters (<6 cells) of atypical cerebriform T-cells; LN3, dermatopathic lymphadenopathy with large clusters (>6 cells) of atypical cerebriform T-cells; and LN4, partial or complete effacement of lymph node architecture.¹⁷³ Although clusters of atypical cerebriform T-cells are present in grades LN2 and LN3, lymph node architecture is preserved. Only LN4 lymph nodes are considered involved with CTCL (histology positive) for purposes of the TNM staging system (Table 92.4). The NCI VA classification has been criticized because of the nonspecificity of grades LN1-3 and because lymph nodes from patients with unrelated diseases can show similar findings, and many consider LN3 lymph nodes to be histologically borderline.^{163, 382}

The ISCL/EORTC consensus staging system for lymph nodes distinguishes stage N3 lymph nodes that show effacement of nodal architecture (grade LN4) from stage N2 lymph nodes that contain clusters of atypical lymphocytes (>6 cells) that do not efface architecture (grade LN3). ISCL/EORTC stage N1 lymph nodes may show dermatopathic lymphadenopathy, or small clusters of atypical lymphocytes (3 to 6 cells) that do not distort nodal architecture (grade LN1-2). In general, there is good correlation between histologic and molecular evaluation of lymph nodes for involvement by MF/SS. Three studies have shown that most histologically negative lymph nodes (LN1-2) do not show T-cell-receptor gene rearrangements, whereas ~90% or more histologically involved LNs (LN4) do show clonal T-cell-receptor gene rearrangements by Southern blot analysis.^{383, 384, 385} All three studies also showed a mixture of clonal and polyclonal populations in histologically borderline cases (LN3 or histologically equivalent to LN3). Although not statistically significant in all studies, histologically borderline cases that have a positive TCR gene rearrangement tend to have a poorer prognosis, similar to cases with histologically involved lymph nodes (LN4).³⁸⁴

Fine-needle aspiration of lymph nodes to assess for involvement by MF/SS has been evaluated in a limited number of patients, with good correlation between cytologic grade of the FNA specimen and histologic classification of the lymph node biopsy.^{382, 386} However, as with other types of lymphomas, there is an inherent risk of sampling only low-grade

involvement and missing a focal area of transformation to a large-cell lymphoma. Therefore, excisional biopsy of peripheral lymph nodes >1.5 cm in diameter is recommended, with preference for the largest lymph node draining the involved skin area or, if available, the lymph node with the highest SUV from PET scan data.¹⁷⁶

Peripheral Blood

The 1979 Committee on Staging and Classification of CTCLs defined peripheral blood involvement by MF/SS as >5% peripheral blood lymphocytes with Sézary cell morphology (Fig. 92.7);³⁷² however, this criterion is not uniformly agreed on. Because Sézary cells can be seen in the peripheral blood of patients with benign dermatitis or erythroderma, investigators have suggested that other criteria be used to define peripheral blood involvement.^{176, 371} The 2007 ISCL/EORTC staging criteria of peripheral blood involvement includes B2 staging for high blood tumor burden and B1 blood stage for low blood tumor burden (>5% Sézary cells) when criteria for B2 are not met. More specifically, B2 is defined as clonal TCR rearrangement in the blood and one or more of the following: (a) absolute Sézary cell count of 1,000 cells/ μ l or more, (b) CD4/CD8 ratio of 10 or more due to an increase in CD3⁺ or CD4⁺ cells by flow cytometry, (c) increase in CD4⁺ cells with an aberrant phenotype: $\geq 40\%$ CD4⁺/CD7⁻, or $\geq 30\%$ CD4⁺/CD26⁻ as suggested by Vonderheid and Bernengo.³⁸⁷

As discussed earlier, aberrant phenotypes include the absence of T-cell markers such as CD2, CD3, CD5, CD7, and CD26, which are usually expressed on normal T-cells, or co-expression or absence of both CD4 and CD8. A CD4:CD8 ratio of >10:1 or an aberrant phenotype constitutes an abnormal population. Because decreased CD7 expression on T-cells has been seen in patients with benign skin conditions, the ISCL recommends that 40% or more of the CD4⁺ T cells lack CD7 for it to be considered significant.¹⁷⁶ PCR of peripheral blood has been shown to detect a clonal population of T-cells in approximately one third of patients with stage I to II disease and a majority of patients with stage III to IV disease.^{187, 388} In addition, loss of CD26 expression on circulating CD4⁺ T-cells has been reported in most cases of MF and SS.^{199, 200, 389} Therefore, gating of CD4⁺CD26⁻ T-cells may provide a more sensitive way to use flow cytometry to evaluate peripheral blood for involvement by MF/SS.^{29, 38, 235, 390} A recent study of CD27 expression in peripheral blood T-cells showed a significantly higher expression of the CD4⁺CD27⁺CD45RA-central memory T-cell subset in patients with SS as compared to patients with idiopathic erythroderma patients who showed increased CD4⁺CD27-CD45RA- effector memory T-cell levels.³⁹¹

Bone Marrow

Studies of bone marrow involvement in MF patients at initial staging found disease in 2% to 22% of patients.¹⁷⁴ Histologic findings in involved marrows include clusters of CD3⁺ atypical lymphocytes with cerebriform nuclei and occasional large dysplastic cells.¹⁷⁴ Bone marrow involvement by MF is more common in higher-stage disease and correlates with a poorer prognosis; however, when other factors such as skin stage and visceral involvement were considered, bone marrow involvement was not shown to be an adverse prognostic factor.³⁹² These findings were supported by a recent study that evaluated the prognostic significance of histologic and molecular evidence of bone marrow involvement at the time of diagnosis. This study also showed a correlation between histologic or molecular bone marrow involvement and clinical stage of disease, but bone marrow involvement failed to be an independent prognostic indicator.¹⁸¹ Therefore, despite being considered in initial staging of non-MF/SS lymphoma patients, routine staging bone marrow biopsies in patients with MF are not currently recommended. The recent ISCL/EORTC consensus conference recommended performing bone marrow biopsies only in patients with B2 blood involvement or unexplained hematologic abnormalities.¹⁷⁶

P.1971

PROGNOSIS

Prognosis correlates with the extent of skin disease and status of the lymph nodes, blood, and visceral involvement. MF behaves in a manner similar to other low-grade or indolent NHLs, with prolonged survival despite recurrent relapses (see Chapter 88). Zackheim et al. assessed relative (observed/expected) long-term survival among the four skin stages. Stage and survival data for 489 patients with CTCL was extracted from a University of California, San Francisco, CTCL registry dated 1957 to 1994 and compared to a control group matched for age, sex, race, and geographic variables. Using the control group to generate expected survival values, researchers found a relative survival at 10 years for each group as follows: 100% for T1, 67% for T2, 40% for T3, and 41% for T4.³⁹³

The TNM staging system has correlated well with prognosis, demonstrating the following 5-year survival rates: 95% for stage I, 76% for stage II, 45% for stage III, and 51% for stage IV.³⁹⁴ Utilizing the newest staging criteria from the

ISCL/EORTC, the 5-year survival rates are similar: 94% for stage IA, 84% for stage IB, 78% for stage IIA, 47% for stage IIB, 47% for stage IIIA, 40% for stage IIIB, 37% for stage IVA₁, 18% for stage IVA₂, and 18% for stage IVB.¹⁸⁹ Data from a retrospective cohort analysis suggest that the long-term (30-year) survival of patients with stage IA (limited patch/plaque) MF is similar to the expected survival of a matched control population.^{389, 393} Therefore, it is unlikely that stage IA MF will affect the life expectancy of afflicted patients.

Kim et al. performed a retrospective cohort analysis of 525 patients with MF/SS at Stanford University from 1958 through 1999.³⁸⁹ In the multivariate analysis, patient age, T classification, and the presence of extracutaneous disease were the most important independent factors. The risk for disease progression to a more advanced TNM or B classification, worse clinical stage, the development of extracutaneous disease, or death due to MF correlated with the severity of the initial T classification. None of the patients had T1 disease when their extracutaneous disease was detected.³⁸⁹

Using histology to differentiate between patch and plaque predominance within stage T2, one study found plaque predominance to influence relative survival negatively.³⁹⁵ A retrospective analysis by Sausville et al. of 152 consecutively staged patients at the NCI identified skin stage (T3, T4 vs. T1, T2) and visceral involvement as the most significant independent predictors of survival with palpable adenopathy and lymph node histopathology classification showing marginal significance using multivariate analysis.¹⁷³ Three prognostic groups were identified, with the most favorable, low-risk group having limited skin disease without visceral or blood involvement (TNM stages IA, IB, IIA) and the least favorable, high-risk group demonstrating effaced lymph nodes (NCI VA LN4, TNM stage IVA) or visceral involvement (TNM stage IVB).^{173, 396} The intermediate-risk group included all other patients (TNM stages IIB, III) and stage IVA patients with grade LN3 lymph node histopathology. Several reports suggest that patients with dermatopathic or early lymph node involvement with TCR gene rearrangement have a worse prognosis than similar patients without evidence of gene rearrangement.^{171, 383, 384, 397}

A study of 57 patients demonstrated serum LDH to reflect tumor burden in erythrodermic CTCL, with levels being inversely related to hematologic stage and survival.³⁹⁸ This same study used a univariate model, which found lymph node stage and hematologic stage to predict survival. Upon multivariate assessment, however, only lymph node stage served as an important prognostic indicator of survival.

A more recent study that retrospectively analyzed 1,502 MF/SS patients with the revised ISCL/EORTC staging for CTCL found a significant difference in survival between those with patch-only disease (T1a/T2a) versus patch and plaque disease (T1b/T2b).¹⁸⁹ Multivariate analysis revealed that advanced T stage, the presence of a peripheral blood tumor clone without Sézary cells (B0b), increased LDH, and folliculotropic MF were associated with both decreased survival and increased risk of disease progression.¹⁸⁹

The same analysis showed that large-cell transformation was predictive only of increased risk of disease progression, and male sex, increasing age, and poikilodermatous MF were associated with decreased survival.¹⁸⁹ In a retrospective analysis of 100 patients with transformed MF, Benner et al. identified decreased overall and disease-specific survival in those with folliculotropic MF and those lacking CD30.¹⁶⁶ They developed a "prognostic index" for those with transformed MF based upon the following four negative prognostic factors: CD30 negativity, generalized skin lesions, extracutaneous transformation, and folliculotropic MF. There was a significant decrease in survival in those with 2+ negative prognostic factors versus those with 0 to 1.¹⁶⁶

Patients with SS have a relatively poor prognosis, with a median survival of ~3 to 4 years.^{136, 389, 399} In a series of 29 patients with SS, features linked with a bad prognosis included fast evolution of the disease (from symptoms onset up to diagnosis) ($p = 0.0274$), raised levels of serum lactate dehydrogenase ($p = 0.0379$), and β 2-microglobulin ($p = 0.0151$), the latter being the most important prognostic factor.³⁹⁹ Some of these findings were confirmed in another series of 28 patients with SS in whom the detrimental prognostic value of increasing age and LDH level, and the identification of the EBV genome in the skin, were reported.⁴⁰⁰

The prognosis for patients with extracutaneous disease is poor, with median survivals between 1 and 2.5 years.⁴⁰¹ Virtually all patients with extracutaneous disease die of CTCL, compared to nearly one third of patients with generalized plaques and a majority of patients with tumors or erythroderma without visceral involvement.^{375, 402} Very few patients with limited plaques (T1) actually die of MF, with most deaths due to cardiovascular events or other malignancies.^{375, 389, 393} Overall, illnesses attributed directly to CTCL or indirectly implicated via CTCL-related complications contribute up to a mere 19% of deaths in CTCL patients.³⁹⁴ More recently, Agar et al. found that 26% died due to their cutaneous lymphoma.¹⁸⁹ Overall, the bulk of patients with CTCL do not die from their malignancy.^{401, 403} Second malignancies other than skin cancers include NHL, HD, colon cancer, and lung cancer.⁴⁰⁴ Infection remains the most common cause of death in patients who succumb to CTCL, with *Staphylococcus aureus* and *Pseudomonas aeruginosa* being the most common

pathogens infecting the skin, leading to bacteremia and sepsis.^{402, 403} Visceral involvement with CTCL may lead to organ failure and ultimately death.

THERAPY

The mainstay of treatment of CTCL has been control of the cutaneous manifestations of disease with topical therapies in the hope of preventing spread to extracutaneous sites. However, because of the risk of progression to extracutaneous sites and worsening cutaneous symptoms, systemic agents alone or in combination with topical therapies have been studied to control more advanced disease. Therapy in MF/SS is based on the extent of disease, age, performance status, potential for remission, availability of treatments, efficacy, and treatment toxicity.^{405, 406} Because MF usually behaves as a low-grade or indolent lymphoma, controversial issues have involved the timing, selection, and intensity of systemic therapy. Unfortunately, there are few randomized clinical trials comparing the efficacy of the numerous therapeutic options available for patients with MF/SS. The following discussion summarizes the efficacy and toxicity of each therapy, and relates these parameters to disease stage (Fig. 92.16).

P.1972

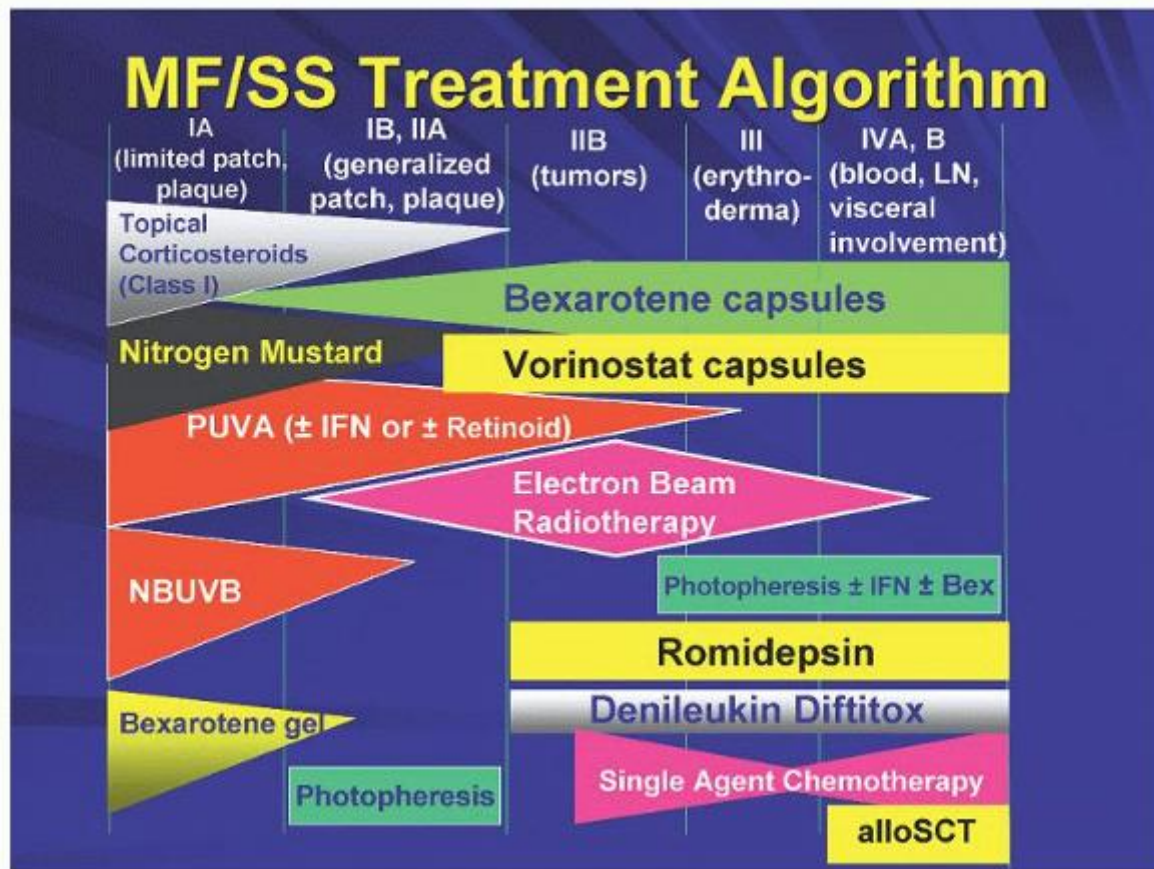

FIGURE 92.16. Cutaneous T-cell lymphoma (CTCL) treatment algorithm. alloSCT, allogeneic stem cell transplant; Bex, bexarotene capsules; IFN, interferon; LN, lymph node; MF/SS, mycosis fungoides/ Sézary syndrome; NBUVB, narrow beam ultraviolet B phototherapy; PUVA, psoralen + ultraviolet A phototherapy. Note that single-agent chemotherapeutic agents with impressive benefit/risk ratios include pegylated liposomal doxorubicin, gemcitabine, and pralatrexate.

Topical Chemotherapy

Mechlorethamine hydrochloride, or nitrogen mustard (HN2), was introduced in 1947 as the first topical agent to demonstrate activity in treating MF⁴⁰⁷ and remains one of the major therapies of choice for early-stage MF. In 1942, HN2 became the first chemotherapy agent to be infused into a human being for the treatment of cancer.⁴⁰⁸ HN2 is an alkylating agent that undergoes rapid degradation to an active ethylenimonium ion that has high antimitotic activity and a brief half-

life.⁴⁰¹ Several studies have suggested that the mode of action of HN2 may involve induction of G₂ arrest,⁴⁰⁹ gene-specific DNA cross-links,^{410, 411} and blockage of transcription factor-binding sites.⁴¹² Some investigators have suggested that immunogenic properties of HN2 demonstrated by its propensity to induce delayed-type hypersensitivity contribute to its antineoplastic activity.⁴¹³ Topical HN2 may be prepared in a variety of ways; initial studies involved dissolving HN2 in water to reach a concentration of 10 to 20 mg/dl,⁴¹⁴ whereas more recently HN2 has been suspended in an emollient such as Aquaphor or a gel at concentrations of 0.01% and 0.02%.^{415, 416} Topical HN2 is usually applied once daily to the entire skin surface with relative sparing of the eyelids, genitalia, rectum, lips, and intertriginous areas. The length of treatment is variable but usually involves daily applications until the patient achieves a complete or significant clearing of skin lesions, followed by a maintenance regimen of daily or every-other-day applications for a period of 6 months to 2 years. No author has advocated a maintenance regimen of indefinite HN2 applications. Recently, Kim et al. found that longer maintenance regimens had no impact on the relapse rate in patients treated with topical HN2.⁴¹⁷ Treatment may be intensified for localized lesions by increasing either the concentration or frequency of application.

The response rate of topical HN2 is related to the morphology (patch/plaque vs. tumor) and extent of disease (T1 vs. T2). Several large series with >100 patients have been reported.^{417, 418, 419} It is difficult to compare overall response rates among these studies because of differences in the clinical stages treated, adjunctive therapies, and staging systems. The percentage of patients with early-stage MF achieving an initial complete response (CR) ranged from 64%⁴¹⁸ to 75%⁴¹⁹ in stage I disease. Including more advanced stages, the complete response ranged from 37% in stage I/IIA disease to 50% in stage I to III disease.⁴¹⁷ The median time to achieve CR is shorter for stage I patients than for those with more advanced stages.^{417, 418} Vonderheid et al. found a durable CR to HN2 lasting more than 8 years occurring in 34 of 324 (10%) patients with early-stage MF,⁴¹⁹ and Kim et al. demonstrated that freedom-from-progression rates at 10 years were 85% and 83% for T1 and T2 patients, respectively.⁴¹⁷ Relapse is common, as Kim et al. observed relapses in 42% of 107 patients after an initial CR, all of which occurred within 5 years, and disease progression to a higher skin stage has been recently reported in 12% and 17% of T1 and T2 patients, respectively.⁴¹⁷ However, among patients who had an initial response to HN2 and relapsed, 67% achieved a CR after receiving HN2 salvage therapy. In summary, HN2 is effective in achieving an initial response in early-stage disease. Relapse occurs frequently but can often be treated with a second course of therapy.

The side effects of topical HN2 include local allergic reactions, xerosis, hyperpigmentation, and secondary cutaneous cancers.⁴¹³ Immediate hypersensitivity reactions manifesting as urticaria are rare but do occur in ~5% of patients using topical HN2 and necessitate discontinuing treatment to avoid a potentially life-threatening anaphylactic reaction.^{413, 420, 421} Delayed-type hypersensitivity reactions (allergic contact dermatitis) manifesting as erythematous eczematous patches occur in up to 64% of patients treated with aqueous HN2^{418, 419, 422} but occur less frequently (<10%) with the ointment-based preparation.⁴¹⁷ Some investigators have suggested that the delayed-type hypersensitivity reaction to topical HN2 may have a beneficial effect in clearing MF lesions⁴¹³ and advocate topical desensitization^{414, 418, 423} rather than discontinuation of the HN2 when delayed-type hypersensitivity reactions occur.⁴¹³ Despite this, discontinuation of the medication can occur in up to 19% of patients.⁴²² Hyperpigmentation of the skin, especially in sites of MF involvement, occur commonly in patients using topical HN2, and patients should be reassured that the hyperpigmentation will resolve spontaneously within several months.⁴¹³

In their study of 331 patients treated with HN2, Vonderheid et al. calculated an 8.6-fold (n = 31, 9%) and 1.8-fold (n = 27, 8%) increased risk for the development of squamous cell carcinoma (SCC) and basal cell carcinoma (BCC) of the skin, respectively, when compared to the general US population.⁴¹⁹ In contrast, Kim et al. found BCC or SCC skin neoplasms in only 8 of 203 (4%) CTCL patients treated initially with HN2.⁴¹⁷ Melanoma occurred in 1 patient in the Kim et al. cohort. This patient had Fitzpatrick skin type 1 and had had a previous BCC.⁴¹⁷ Because HN2 is a known radiomimetic agent, its carcinogenic potential may be amplified with the simultaneous use of other agents, most notably ultraviolet therapy.^{413, 424} To help minimize this risk, patients using HN2 should adhere to strict protection from sun exposure. The risk of environmental contamination from topical HN2 appears to be minimal, as there are no epidemiologic data of increased malignancy in family members of treated patients; however, treatment assistants should wear latex gloves and wash accidentally exposed skin thoroughly.^{425, 426}

Topical carmustine (BCNU), a nitrosourea compound that causes DNA damage through alkylation at an O6 site of guanine and interstrand cross-linkage, is also used to treat early-stage MF, although experience is more limited than with topical HN2.^{427, 428} The use of topical nitrosoureas for the treatment of MF was first reported in 1972.⁴²⁹ Patients mix a 5-ml (10-mg) aliquot of a 0.2% alcoholic stock solution with 60 cc of tap water and apply the solution to only the involved areas of MF.⁴¹³ Applications are repeated daily for no more than 8 to 10 weeks at a time. Zackheim et al. reported a CR in 86% of T1 stage patients and 48% of T2 patients treated with BCNU solution.⁴²⁷ In their follow-up report of 188 early-stage MF patients treated with topical BCNU, 91% of stage T1 patients and 62% of stage T2 patients had not failed treatment after

36 months, and 5-year survivals were 97% and 80%, respectively.⁴¹³ Very recently, a phase 1 clinical trial evaluating the use of topical carmustine and intravenous

P.1973

O6-benzylguanine was reported.⁴²⁸ Given the likelihood of a potentiating effect from the two therapies, O6-benzylguanine and systemic carmustine have been used to treat solid tumors. The therapeutic combination, now utilizing topical carmustine was initiated in 21 patients with refractory early-stage MF (IA-IIA). The minimal toxic effect was seen at the 40-mg dose of carmustine, and there was also a 76% overall clinical response noted.⁴²⁸ Side effects from carmustine include erythema and skin tenderness in a great majority of patients, telangiectasia following less common severe cutaneous reactions, allergic cutaneous reactions (<10%), and mild leukopenia (4%).⁴²⁸

Phototherapy

Psoralen photochemotherapy was introduced in 1974 for refractory psoriasis⁴³⁰ and has been used extensively in the early stages of CTCL. Psoralen and ultraviolet A light therapy (PUVA) involves the ingestion of 8-methoxypsoralen (8-MOP), a photosensitizing compound, which is activated after exposure to ultraviolet A (UVA) light (320- to 400-nm wavelength). More recently, 5-methoxypsoralen has been used as the photosensitizing agent in PUVA, and early studies indicated similar efficacy.⁴³¹ Because of the similar efficacy of narrow-band ultraviolet B (NB-UVB) phototherapy as compared to PUVA phototherapy in the treatment of psoriasis, the availability of UVA light boxes in dermatology offices is diminishing. Psoralen intercalates with DNA and, after UVA exposure, forms mono- or bifunctional adducts to pyrimidine bases and cross-links between strands of DNA. In addition to interfering with DNA synthesis and the subsequent death of neoplastic T-cells,⁴³² PUVA may have other effects, including a direct cytotoxic effect, immunomodulation,⁴³³ and the induction of apoptosis in peripheral blood lymphocytes.⁴³⁴

Approximately 1 to 2 hours after ingesting 8-MOP, patients are exposed to increasing doses of UVA light, initially in the range of 1.5 to 3.0 J/cm² based on the patient's skin type (I to VI) determined from skin color and sun sensitivity or, less commonly, based on the direct measurement of a patient's minimal phototoxic dose.⁴³² Treatments are given at a frequency of two to three times per week until complete clearing occurs, followed by a maintenance regimen with increasing intervals between treatments over 2 to 7 months.^{432, 435} Some authors recommend a once-monthly treatment indefinitely to decrease recurrences,⁴³⁵ whereas others discontinue PUVA treatments in stage I patients after the maintenance regimen.⁴³⁶ In a small study, the number of patients in the relapse versus the nonrelapse group receiving maintenance therapy was the same.⁴³⁷ Therefore, the risk of increased cumulative UVA dose in patients treated with maintenance therapy must be balanced against the potential side effects.

In their combined analysis of five recent studies^{435, 436, 438, 439, 440} reflecting the response of 244 CTCL patients to PUVA, Herrmann et al. reported the following complete response rates for each stage: IA, 54/60 (90%); IB, 88/116 (76%); IIA, 7/9 (78%); IIB, 16/27 (59%); III, 11/18 (61%); IVA, 4/10 (40%); IVB, 0/4 (0%).⁴³² Median time to complete response was 3 months in the study of Herrmann et al.⁴³⁵ Patients with early-stage disease readily respond to PUVA, but relapse among complete responders is common, affecting ~31%, 56%, and 71% of stage IA, IB, and IIA patients, respectively.⁴³⁵ In a retrospective review of 104 patients with early-stage MF treated with PUVA, Querfeld et al. reported a 63% CR rate, although 50% relapsed on maintenance PUVA therapy.⁴³⁷ Even higher relapse rates were seen in erythrodermic patients treated with PUVA alone. Tumor-stage (IIB) patients usually require localized radiation therapy or systemic chemotherapy to achieve a significant response and PUVA should play only an adjunctive role. Approximately one third of relapsing stage IA patients will achieve a second long-lasting disease-free remission with re-initiation of PUVA, whereas ~22% of stage IB patients can be expected to do the same.^{432, 435} Hermann et al. reported the same 5- and 10-year survival rates of 89%, 78%, and 100% for stages IA (n = 19), IB (n = 49), and IIA (n = 6) patients, respectively, and a 5-year survival rate of 80% for stage III (n = 6) patients.⁴³⁵ In an attempt to minimize side effects, Weber et al. evaluated 16 patients who received bath PUVA. Patients were treated with 30 ml of 0.5% alcoholic 8-MOP in 150 l of water; all 16 patients achieved a CR.⁴⁴¹

Acute side effects of PUVA include delayed (24 hours) burning and erythema (10%), pruritus (7%), nausea due to psoralen (4%), and reactivation of herpes simplex (2%).⁴³² The photosensitivity due to psoralen may last up to 24 hours, and patients should wear protective clothing and sunscreens to prevent sunburn. Potential complications to long-term PUVA therapy include cataract formation, nonmelanoma skin cancer (8% to 10%), benign solar lentigos (4%), actinic keratoses, keratoacanthomas (3%), and vitiligo (2%).^{432, 435} Because of the potential of PUVA to induce cataracts, patients are instructed to wear ultraviolet light-blocking eyeglasses for 24 hours. BCC and SCC of the skin can be expected to occur in 8% to 10% of patients receiving PUVA after several years, with a clear predominance of SCC, unlike the general population.^{432, 435}

Wide-band ultraviolet B phototherapy (WBUVB) (280- to 320-nm wavelength) has also been used effectively to treat stage I CTCL patients,^{442, 443} but has largely been replaced by NBUVB phototherapy.⁴⁴⁴ Resnik and Vonderheid reported the 15-year follow-up results of 31 patients with MF (68% stage IA, 29% stage IB, one patient stage IIA) treated with alternate-day home ultraviolet B phototherapy using a commercially available cabinet of Westinghouse FS40 lamps for 3 to 12 months beyond the date of initial remission (median = 5 months).⁴⁴³ Overall, 23 of 31 (74%) patients achieved a CR, and available long-term follow-up data from 19 complete responders showed that 7 of 19 had a median disease-free sustained remission of >94 months. Ramsay et al. reported similar results in 37 patients (32 with CTCL, 5 with parapsoriasis en plaques), most of whom (73%) had received home UVB therapy, the rest receiving WBUVB phototherapy in an outpatient setting.⁴⁴² None of the 4 patients with infiltrated plaques responded, whereas 25 of 30 (83%) patients with erythematous patches achieved a CR, with 5 (20%) relapses and a median CR duration of 22 months.⁴⁴² Although burning and erythema may occur, adverse effects from UVB phototherapy are minimal.⁴³² No cutaneous SCC tumors and four BCC tumors were noted in the previous studies.^{442, 443}

More recently, studies have emerged on the effectiveness of NBUVB phototherapy (311 to 312-nm wavelength). NBUVB was first introduced in 1984 with the Philip TL-01 lamp as the optimal wavelength for antipsoriatic activity.⁴⁴⁵ NBUVB treatment has a lower carcinogenic potential and is associated with less erythema than PUVA and broad-band UVB (BBUVB), respectively.^{446, 447, 448} One in vitro study, however, reported cyclobutane pyrimidine dimer (CPD) formation, a sign of carcinogenicity, following a minimum erythema dose by NBUVB was significantly higher than that following 1 MED by WBUVB, whereas the formation of (6-4) photoproducts and 8-oxoG following WBUVB was significantly higher than those following NBUVB exposure. These results suggest that CPD formation is closely related to higher carcinogenic characteristics of NBUVB.⁴⁴⁹ In the initial clinical report, Clark et al. reported a CR in 6 of 8 patients with MF treated with NBUVB.⁴⁵⁰ Since that time, several larger studies have emerged. Gathers et al. evaluated 24 patients with stage IA/IB disease. A total of 13 (54%) achieved a CR, 7 (29%) achieved a PR, and 4 (17%) had no response. In the 4 patients who achieved a CR and discontinued therapy, the average time to relapse was 12.5 weeks.⁴⁵¹ In two comparative studies of NBUVB to PUVA in stage IA/IB disease, no difference in CR rates was observed in patients receiving NBUVB or PUVA.^{452, 453} Pavlotsky et al. conducted a retrospective analysis of patients with stage IA/IB disease receiving NBUVB and WBUVB. CR was seen in 84% and 89% of stage

P.1974

1A patients receiving NBUVB and WBUVB, respectively. The CR dropped to 78% and 44% in patients with stage IB disease. Once maintenance therapy was stopped, 65% were relapse-free at 27 weeks. The study found no difference in relapse rates regardless of use of maintenance therapy.⁴⁵⁴ Other recent small series of patients with early-stage MF treated with NBUVB therapy have been reported, with CR rates of 57% to 100% (for patch-stage disease) and relapse rates of ~50%.^{446, 455, 456, 457} Side effects of NBUVB therapy were minor and did not require discontinuation of therapy. Gathers et al. report erythema in 42% of patients and pruritus in 29% of patients.⁴⁵¹ Permanent tan freckles (lentiginos) and white macules (idiopathic guttate hypomelanosis) have also been reported recently as side effects of NBUVB.^{458, 459, 460} In early MF, there is no statistically significant difference between the response to oral PUVA and NBUVB.⁴⁶¹ NBUVB is a safe and effective treatment for stage IA/IB MF, especially patch-stage disease. In addition, several studies have confirmed the safety of NBUVB in children as opposed to PUVA phototherapy which should be avoided.^{462, 463, 464}

Retinoids

Retinoids are a class of pharmaceuticals whose structure and function resemble vitamin A and its metabolites. Vitamin A and its analogs, the retinoids, have antiproliferative activity, may induce cellular maturation, and probably modulate immune response.⁴⁶⁵ Isotretinoin (13-cis-retinoic acid) and etretinate, a monoaromatic retinoid compound no longer available, have demonstrated similar efficacy in the treatment of CTCL.⁴⁶⁶ Three clinical trials have demonstrated overall objective clinical responses in 66 of 113 patients (58%) treated with isotretinoin or etretinate and a CR in 19%.^{466, 467, 468} Median duration of response, however, has ranged from 3 to >8 months.⁴⁶⁸ Etretinate is no longer available and has largely been replaced with its metabolite, acitretin, because of its superior safety profile. Acitretin may reduce the thick palmoplantar keratoderma of advanced MF or SS.⁴⁶⁵

In 1999 the FDA approved the use of bexarotene capsules, a novel retinoid, for the treatment of CTCL. Unlike isotretinoin and acitretin, which bind to nuclear retinoic acid receptor (RAR), bexarotene binds to and activates the nuclear retinoid X receptor RXR and is therefore referred to as a "rexinoid." RXRs are unique in that they form heterodimers with a vast array of nuclear receptors including the RARs, liver X receptors (LXR), and peroxisome proliferator activator receptors.^{469, 470} The ultimate antiproliferative effect is mediated, in part, by the induction of apoptosis and expression of adhesion molecules.^{471, 472} Two multicenter clinical trials established the optimal dose of 300 mg/m²/day, with an overall response

rate of 45%.^{473, 474} Higher response rates were seen in patients with higher initial doses (up to 650 mg/m²), but side effects of hypertriglyceridemia were dose-limiting. Subsequent pancreatitis occurred in 4 of the 152 patients enrolled in the two clinical trials.^{473, 474} The advanced-stage CTCL trial showed a relapse rate of 36% but an impressive median duration of response of 299 days.⁴⁷³

Talpur et al. recently summarized the experience of treating 70 patients with CTCL using bexarotene capsules as monotherapy and combined with other modalities.⁴⁷⁵ Many of the patients participated in the two pivotal clinical trials. The overall response rate seen in the monotherapy group (n = 54) was 48%, in contrast to the 69% response rate in the combination-therapy group. Bexarotene was safely added to photopheresis (extracorporeal photochemotherapy [ECP]), ECP/IFN, IFN/PUVA, and ECP/IFN/PUVA. Adverse effects were similar between the clinical trials and included hypertriglyceridemia (87%), central hypothyroidism requiring thyroid supplementation (80%),⁴⁷⁶ neutropenia (41%), skin peeling (43%), hypercholesterolemia (20%), and pancreatitis (3%). Of the monotherapy group, 78% (n = 54) and 100% of the combination-therapy group (n = 16) required at least one lipid-lowering agent (LLA). Of the 10 patients with diabetes, 3 had hypertriglyceridemia that could not be controlled with an LLA.⁴⁷⁵ In this series, atorvastatin and fenofibrate were the LLAs of choice. It is interesting that 9 of 10 (90%) patients on bexarotene monotherapy taking two LLAs responded, which was significantly higher than those groups on one or no LLA (p = 0.0001). The explanation for this finding is not clear, but using two LLAs may allow patients to maintain maximum doses of bexarotene.⁴⁷⁵ Vigilance should be exercised when combining atorvastatin and fenofibrate to monitor for rhabdomyolysis. Gemfibrozil and drugs that inhibit the CYP 3A4 enzyme are contraindicated with bexarotene, to avoid elevated drug levels and worsened side effects. Although patients taking bexarotene are at increased risk for elevated triglycerides, elevated LDL, and decreased HDL, there are no reports to date indicating an increased risk of cardiac events. Several animal studies have shown that bexarotene may have a favorable pharmacologic effect on atherosclerosis despite the induction of hypertriglyceridemia via LXR,⁴⁷⁷ due to a beneficial action on intestinal absorption and macrophage efflux,⁴⁷⁸ inhibition of the initial inflammatory response that precedes the atherogenic process by targeting different steps of the mononuclear recruitment cascade,⁴⁶⁹ and protective effects against H2O₂-induced apoptosis in H9c2 rat ventricular cells through antioxidant and mitochondria-protective mechanisms.⁴⁷⁹

Bexarotene is also available as a 1% gel. The gel formulation is most helpful in early-stage patients (IA) without prior therapies. In a phase I/II multicenter trial, bexarotene 1% gel was applied to lesional skin with increasing frequency, once daily the first week and twice daily the second week, with a goal of four times daily if tolerated.⁴⁸⁰ Patients achieved an overall response rate of 63% and a clinical CR of 21%. Median projected time to onset of response was 20.1 weeks (range, 4.0 to 86.0 weeks), and the estimated median response duration from the start of therapy was 99 weeks.⁴⁸⁰ The most common side effect was irritation (retinoid "paint splatter" dermatitis) at the sites of application, which might make it difficult to assess response to the drug. The study was followed by a phase III study that included patients with stages IA/B and IIA disease. The overall response rate was 44% according to the Physicians Global Assessment. Similar to the previous study, the median time to response was 142 days (range, 28 to 505 days), and the relapse rate in responding patients was 26%. The most frequent adverse response was irritant dermatitis, which occurred more frequently in patients applying the drug more frequently.⁴⁸¹ Overall, topical bexarotene is a moderately effective and well-tolerated treatment for early-stage MF most often used for refractory patches or thin plaques. The retinoid dermatitis may obscure evaluation of the patches of MF so patients should be instructed to avoid enlarging the original treatment area and to stop applying the gel 1 to 2 weeks before clinical evaluation.

Interferon

IFNs are glycoproteins, naturally occurring or synthesized by recombinant DNA technology. These agents act as immunomodulators with both cytostatic and antiviral activity.⁴⁸² Although three classes, IFN- α , IFN- β , and IFN- γ , are described, the α -IFNs have been most extensively studied in MF and SS, and their efficacy was first reported by Bunn et al. in 1984.⁴⁸³ The exact mechanism of action of IFN in MF and SS is unknown. IFN may act to inhibit IL-4 and IL-5 production by normal and aberrant T-cells in patients with SS, induce myelomonocytic My7 antigen (CD13) in epidermal basal cells,⁴⁸⁴ induce the ds-RNA-dependent enzyme 2'5'-oligoadenylate synthetase leading to cleavage of cellular RNAs, and phosphorylate eIF-2, a peptide elongation initiation factor that blocks protein synthesis.⁴⁸² The pharmacokinetics of IFN delivered via the intramuscular and subcutaneous routes are equivalent, allowing patients the opportunity to self-administer the drug subcutaneously.

P.1975

The phase II National Cancer Institute (NCI) trial reported by Bunn et al. in 1984 used high doses of recombinant IFN- α 2a (50×10^6 U/m² = 50 MU/m² subcutaneously three times per week) in 20 heavily pretreated MF patients and demonstrated an objective response in 45%, including 3 patients (15%) who achieved a CR.^{485, 486} Treatment of MF and SS with IFN- α has been reported in >200 patients and the results have been summarized.⁴⁸² The overall response rate for IFN- α alone was 52%, with a 17% CR among 207 MF and SS patients, summarized by Bunn et al.⁴⁸⁷ Over three quarters of the patients received IFN- α 2a, which is no longer available in the United States, although there were no apparent differences in clinical efficacy between IFN- α 2a and IFN- α 2b (Intron-A, Schering-Plough Research Institute).^{482, 487} However, interpretation of pooled data is complicated by variations in initial dose, target dose, frequency, and length of therapy among study centers.⁴⁸² A trial evaluating PUVA and IFN- α 2a versus PUVA and IFN- α 2b in CTCL patients demonstrated increased myelosuppression and liver toxicity, but also reduced constitutional effects, reduced study drop-out, and increased overall response (89% versus 50%) in the IFN- α 2b arm.⁴⁸⁸ There are conflicting reports regarding the impact of clinical stage on the likelihood of response to systemic IFN- α .^{482, 489, 490} In their study of 51 MF and SS patients, Jumbou et al. found that patients with early disease (stages I and II) demonstrated a higher response rate to IFN- α than those with advanced disease.⁴⁹¹

In an attempt to define the optimal dose of IFN- α in CTCL, a randomized study from Duke and Northwestern Universities was designed comparing low-dose (3 MU/day) to escalating doses (up to 36 MU/day); however, because of slow patient accrual, the proposed study was terminated.⁴⁸⁹ For the 22 patients evaluated, the objective response rate was 64% and was greater, although not statistically significant, for those receiving high doses (11 of 14) than for those receiving low doses (3 of 8), in part because of late responses in unresponsive patients who crossed over into the higher-dose arm.^{487, 489} Of interest, two of the three CR patients were induced by the low-dose regimen, suggesting that patients could achieve a CR with 3 MU daily of IFN- α 2a.^{482, 489} An intermediate daily dose of 18 MU of IFN- α 2a for 3 months followed by the same dose three times a week resulted in an impressive 80% objective response rate (27% CR, 53% PR) in 15 CTCL patients reported by Tura et al.⁴⁹²

Daily dosing of IFN- α 2a for an induction period of several months was used by all of the larger studies of IFN-treated CTCL patients,^{490, 493} whereas many fewer patients have been studied using an initial three times a week schedule.^{494, 495, 496} Nonetheless, some authorities⁴⁸⁷ recommend an optimal dose of 3 MU of IFN- α 2a three times a week, based in part on randomized dose studies in B-cell indolent NHL showing no benefit of higher-dose IFN with respect to response rate or duration.⁴⁹⁷ Maximum daily dosing is dependent on several patient factors but, in general, should not exceed 15 M.⁴⁹⁸ Two to five months is generally necessary to obtain an objective response with IFN, but a complete or maximal response can take much longer.^{482, 490} Treatment is generally continued for ~1 year after a CR to prevent the high potential for relapse when treatment is discontinued before clearing.⁴⁸² Three studies have reported a median duration of response to IFN- α as follows: 6 months,⁴⁸⁵ 8 months,⁴⁹³ and 14 months.⁴⁹⁰ Olsen et al. noted a mean duration of PR while on therapy of 7.9 months (range, 2.1 to 26.5 months) and durations of CR off therapy ranging from 4 to 28 months.⁴⁸² Two NCI phase II trials combined IFN- α 2a with the adenosine analogs DCF and fludarabine to treat CTCL and demonstrated no clear advantage over either drug alone.⁴⁹⁹ The numerous side effects associated with IFN have led to dose reductions in 50% to 86% of patients in some studies.^{489, 492}

Besides producing anti-IFN antibodies, patients with MF can also exhibit decreased responsiveness to IFN through acquired resistance to IFN- α -induced gene expression. Specifically, a resistant CTCL cell line exhibits disrupted signal transduction in a pathway that is normally activated by IFN- α when therapeutic. In particular, STAT1 expression is reduced in these cells, which interrupts the JAK/STAT signaling pathway.⁵⁰⁰

Recombinant IFN- γ and IFN- β have been studied in many fewer CTCL patients, as they appear to offer no major advantage over IFN- α .^{501, 502, 503} IFN- β has reportedly shown little effectiveness in treating CTCL,⁵⁰¹ and IFN- γ has been linked with more intense and frequent side effects than IFN- α .⁴⁸² Interestingly, it has been demonstrated in vitro that the combination of IFN- γ and a Tolllike receptor (TLR) 7/8 agonist increases natural-killer-cell cytotoxic activity against CTCL cell lines.⁵⁰⁴ This combination of the two therapies led to an increase in IL-12 and IFN- α levels which was regulated through the IRF8.⁵⁰⁴

Electron Beam Radiotherapy and Photon Beam Irradiation

Radiation was one of the earliest effective treatments for MF, first reported in 1902.⁵⁰⁵ In 1953, Trump et al. were first to suggest using accelerated electrons for treatment.⁵⁰⁶ Modern total-skin electron beam radiotherapy (TSEBRT) is among the most effective and well-studied therapies for MF.^{200, 507, 508} The total skin surface can be treated by linear accelerator, generated electron beams that are scattered by a penetrable plate at the collimator site.⁵⁰⁹ The usual depth of penetration is <10 mm and is proportional to the energy of the electrons generated, allowing effective dosing to the skin and adnexal structures without internal organ toxicity.⁵⁰⁷ The most common technique uses a dual fixed-angle 6-field or rotation methods with 4- to 9-MeV electrons, with total doses in the range of 2,400 to 3,600 cGy over an 8- to 10-week

period.^{507, 510} With this technique, relatively lower doses are delivered to the scalp, soles, and areas of self-shielding such as the ventral penis, perineum, upper medial thighs, perianal skin, inframammary folds, and folds under any pannus.⁵⁰⁷ Only the eyes are routinely shielded, and unless there is involvement of the head and neck, a scalp shield is used after a dose of 2,500 to 2,600 cGy has been delivered, to decrease the degree of alopecia.⁵⁰⁷

The hands, forearms, ankles, and dorsal penis may receive doses >100%, and shielding all of these structures for part of TSEBRT is not uncommon.⁵⁰⁷ The long-term results of 561 MF patients treated at Stanford University and Hamilton Regional Cancer Centre from the mid-1950s to 1993 with TSEBRT alone were summarized by Jones et al.⁵⁰⁷ Over 80% of stage IA patients can be expected to achieve a CR after TSEBRT, with 40% to 60% remaining relapse-free at 5 years.⁵⁰⁷ Two more recent studies showed similar CR rates, ranging from 80% to 90% for IA and IB disease.^{511, 512} Less encouraging were the relapse-free rates, at 2.5 years for stages IB (35% to 40%), IIA (21% to 37%), IIB (7% to 26%), and III (10% to 23%).⁵⁰⁷ However, most patients who relapse with what is usually minimal disease will re-enter remission with other topical therapies.⁵⁰⁷ In these studies, a new diagnosis of MF, low stage, lack of blood involvement, and intensity of TSEB were independently associated with progression-free survival (PFS).^{507, 511} TSEBRT was less effective in advanced-stage disease (II to IV), with a CR rate of 60%.⁵¹¹ Another report suggests that prognosis for tumor-stage patients with <10% skin involvement treated with TSEBRT is significantly better than for patients with >10% involvement.⁵¹³

Acute cutaneous side effects, peaking 1 to 2 weeks after TSEBRT, include erythema, edema, dry or moist desquamation, tenderness, and rare blister formation that is most severe at sites of disease.^{507, 514} Total-body alopecia and loss of nails will occur in all unshielded patients, but the skin appendages will normally regrow within 6 months.⁵⁰⁷ During the first year, heat intolerance may develop as a result of the suppression of sweat gland production, which may be permanent.^{403, 515} Patients with erythroderma (T4) may experience more severe acute side effects

P.1976

from TSEBRT; however, radiation may be effective in stage III, especially with no blood involvement.⁵¹⁶ When there is blood, lymph node, or visceral involvement in patients with erythroderma, combined-modality therapies, in particular photopheresis, should be explored.^{516, 517} Chronic cutaneous side effects most commonly include xerosis, superficial atrophy, telangiectasia, and dyspigmentation.^{507, 515} The role of TSEBRT in the development of secondary cutaneous malignancies has not been clearly established, as most patients have received a variety of therapies that could contribute to the development of skin cancer.⁵⁰⁷

Several studies have evaluated the response and toxicity of multiple courses of TSEBRT for CTCL, with similar results.^{512, 518, 519, 520} Wilson et al.⁵¹⁸ reported on 14 CTCL patients, 5 receiving three courses of TSEBRT and 9 patients who received two courses. The total median dose was 5,700 cGy (range, 4,500 to 8,200 cGy) with 86% (n = 12) achieving a CR after the second course of therapy (median relapse-free interval, 11.5 months) and 3 of 5 (60%) achieving a CR after a third course (limited follow-up).⁵¹⁸

Because of the toxicities of TSEBRT and the effectiveness of topical therapies, most authorities recommend using TSEBRT for patients with progressive disease, those failing topical therapies, or patients with extensive, deeply infiltrated plaques and tumors.^{511, 521} Because of the high relapse rates after TSEBRT, post-treatment with nitrogen mustard, PUVA, or photopheresis have been studied to maintain remissions.^{511, 517, 522} A recent retrospective study of patients with MF that received TSEBRT (n = 180, T2 and T3 skin stage) from Stanford University found no difference in outcomes between those that received adjunctive topical nitrogen mustard to prevent relapse and those patients that did not.⁵²⁰

Small-field megavoltage photon beam irradiation can be applied as palliation to either deep-seated cutaneous lesions in the tumor phase or for extracutaneous disease.⁵²³ Nearly all cutaneous lesions respond completely, with the risk of relapse (up to 45%) being inversely proportional to the dose, and with recurrence usually developing within 2 years of treatment.

Photopheresis or Extracorporeal Photochemotherapy

Because of the development of resistance to conventional chemotherapy and radiation and the high potential for relapse in advanced-stage patients, new modalities to treat CTCL have been developed. Leukapheresis, which had been used in patients with high Sézary cell counts,⁵²⁴ was the forerunner for a new adaptation of PUVA called extracorporeal photochemotherapy (ECP) or photopheresis. In the original protocol, patients ingested 8-MOP prior to undergoing fractionation of their blood. A leukocyte-enriched blood fraction was then isolated and exposed to UVA in an extracorporeal system, which photoactivated the psoralen.⁵²⁵ The photopheresis procedure currently performed uses liquid 8-MOP injected directly into the collection bag containing the enriched white blood cell fraction to achieve a

concentration of 340 ng/ml within the collection bag. All treated and untreated blood products were then returned to the patient.

In 1987, Edelson et al. were the first to report responses in 27 of 37 patients (64%) with resistant CTCL treated with ECP, including 8 of 10 patients with lymph node involvement and 24 of 29 patients with erythroderma. However, patients with extensive plaques or tumors did not respond as well (3 of 8 patients).⁵²⁵

The immunomodulatory mechanism underlying patient response to ECP is still under debate. However, evidence currently supports the following two simultaneous and synergistic processes occurring during ECP: induction of apoptosis in malignant T-cells, and a mass conversion of blood monocytes to DCs.^{434, 526, 527} Animal studies demonstrate that ECP induces a CD8⁺ T-cell response against expanded clones of pathogenic T-cells,⁵²⁸ as well as an increased synthesis of class I MHC molecules on murine T-cell lymphoma cells.⁵²⁹ Recent in vitro studies using family-specific monoclonal antibodies and magnetic bead technology demonstrated a tumor-specific cytolytic CD8⁺ T-cell response to distinctive Class I surface peptides on CTCL tumor cells of four patients with advanced disease. These results suggest that reduced Class I expression of relevant tumor antigen epitopes may limit the extent of CD8⁺ T-cell-mediated cytotoxicity.⁵³⁰ In support of this hypothesis, investigators have found a favorable response to correlate with the following two scenarios at the onset of ECP: normal or near-normal numbers of CD8⁺ peripheral blood T-cells⁵³¹ and a lower CD4/CD8 ratio in the peripheral blood.⁵³²

Other investigators have found that ECP and in vitro PUVA induce apoptosis in peripheral blood lymphocytes but not in monocytes.⁴³⁴ The apoptosis induction mechanism remains unknown, but may be explained by the observation that a significant amount of tumor necrosis factor- α (TNF- α), which mediates various antitumor effects, is produced by macrophages following ECP.⁵³³ Berger et al. identified monocytes transitioning to immature DCs during overnight incubation in gas-permeable bags of ECP-treated WBCs from five patients with intractable CTCL.⁵³⁴ Both the initial leukapheresis step as well as the subsequent passage through the narrow photoactivation plate initiated and contributed to monocytes-to-DC differentiation.^{534, 535} Edelson proposed that the innumerable encounters of monocytes with the plastic surface of the photoactivation plate activated the cells to begin differentiation to immature DCs.⁵²⁶ An immature DC can engulf an apoptotic T-cell and present tumor antigen via MHC Class I molecules, which stimulates a potent antitumor CD8 T-cell response.^{526, 527, 534, 535, 536}

Treatment of CTCL with ECP has been reported in >400 patients and has been recently summarized.⁵³⁷ The majority of CTCL patients treated with ECP have exhibited generalized erythroderma (skin stage T4), a finding most likely due to the encouraging preliminary study results of Edelson et al.⁵³⁷ A combined analysis of >400 patients treated with ECP and adjunctive therapies showed an overall response rate for all stages of CTCL of 55.7% (244 of 438), with 17.6% (77 of 438) achieving a complete response.⁵³⁷ Efficacy in treating certain clinical stages (IB, IIA, III, and IVA) and skin stages (T2 and T4) of MF and SS is favorable, although randomized trials comparing ECP to other standard therapies are needed. Combined analysis of five North American series^{525, 538, 539, 540, 541, 542} of ECP-treated CTCL patients (N = 157) demonstrates an objective response (>25% improvement of skin lesions) in 67 of 111 stage T4 patients (60%), with ~20% achieving a CR. A long-term follow-up study of the original 29 erythrodermic CTCL patients in the report of Edelson et al.⁵²⁵ demonstrated a median survival of 60 months, which compared favorably to historical controls.⁵³² Many authorities recommend that ECP be considered the first line of treatment for erythrodermic-stage patients.^{543, 544, 545} However, other authorities differ in their opinions regarding the role of ECP in the treatment of CTCL, stating that the data have been inconsistent and the need for prospective randomized studies.^{546, 547, 548}

Preliminary and long-term follow-up studies by Zic et al. on 20 refractory CTCL patients treated with ECP and adjunctive therapies demonstrated an objective response (>50% clearing of skin lesions) in 9 of 14 (64%) early-stage T2 patients, with CR in 4.^{538, 549} Talpur and colleagues reported the results of a prospective study of 19 patients with MF stages IA, IB, and IIA who were treated with photopheresis administered 2 days every 4 weeks for 6 months.⁵⁵⁰ Patients with partial responses by skin weighted assessment continued for an additional 6 months and nonresponders added oral bexarotene and/or IFN- α . The overall response rate was 42% and the authors concluded that ECP is effective for patients with early-stage MF alone or in combination with biologic response modifiers with low toxicity and improved quality of life.⁵⁵⁰ Observations by other investigators question

P.1977

the use of ECP to treat stage IB patients when less expensive and more widely accessible therapies are available.^{551, 552, 553} ECP is well tolerated, with few complications or adverse effects.^{537, 545} Uncommon adverse reactions are usually vascular-related and include the fluid-responsive hypotension and venipuncture-site hematomas.⁵⁴⁹ Rarely, adverse reactions have

included exacerbation of congestive heart failure or arrhythmias,⁵⁴³ superficial thrombophlebitis,⁵⁴³ catheter-related sepsis,⁵⁵⁴ herpes infections,⁵⁴³ disseminated fungal infection,⁵⁴³ and a single episode of hemolysis.⁵³⁸

Several studies have focused on the effects of combining ECP with systemic chemotherapy, PUVA, IFN and other cytokines,^{555, 556, 557, 558} radiation therapy, bexarotene with and without IFN,^{559, 560} and nitrogen mustard. Recently, Raphael and colleagues summarized their experience treating 98 patients with SS with at least 3 months of photopheresis and one or more systemic immunostimulatory agents (IFN- α , oral retinoids, IFN- γ , granulocyte-macrophage colony-stimulating factor).⁵⁶¹ A total of 73 patients (75%) responded (30% CR, 45% PR) and a lower CD4/CD8 ratio, a higher percentage of monocytes, and lower numbers of circulating abnormal T-cells at baseline were the strongest predictive factors for complete response compared with nonresponse.⁵⁶¹ A much smaller cohort of patients with SS (n = 12) showed a lower response rate of 42% and the parameters that correlated best with response were number of Sézary cells, CD4/CD8 ratio, and white blood cell count.⁵⁶² McGirt and colleagues found increased eosinophils and decreased percentages of Sézary cells were associated with a favorable clinical response to ECP, but they were not able to identify the predictors of ECP response within the first 3 months of treatment.⁵⁶³

Systemic Chemotherapy

Single agent and combination chemotherapy are reserved for patients who have advanced stage (IIb-IVb), relapsed or refractory disease or are part of a clinical trial.⁵⁶⁴ Treatments that maintain or augment the immune response, such as IFN, bexarotene, and ECP may be preferable over chemotherapy which is immunosuppressive. Sequential use of single agents should be considered over combinations inasmuch as CTCL is chronic and the clinical goals are control of the disease, amelioration of pruritus, and prevention of skin breakdown; however, combination chemotherapy may be warranted if the disease is progressive, extensive, or in stage IV.^{565, 566} There is no consensus about the optimal combination of agents.⁵⁶⁴

Previously, single agents used for MF/SS were the same as those used in all types of NHL and included oral corticosteroids, alkylating agents, methotrexate, doxorubicin, bleomycin, vinka alkaloids, cisplatin, and etoposide, and resulted in an objective response in a majority of patients with CR rates ranging from 15% to 20%.^{559, 567} However, median relapse-free intervals were usually short and lasted less than 6 months with a range from 3 to 22 months.⁵⁶⁷ Daily or pulse chlorambucil with a steroid has been used to successfully treat SS.^{568, 569} In two retrospective series using weekly low-dose oral methotrexate, Zackheim et al. reported a 33% response rate (12% CR) in T2 skin disease and a 55% response rate (41% CR) in erythrodermic CTCL with time to progression and OS of 15 months and 31 months, respectively.^{570, 571}

Novel chemotherapy agents have been evaluated for therapy of CTCL and include nucleoside analogs, liposomal doxorubicin, histone deacetylase inhibitors, the antifolate pralatrexate, the proteasome inhibitor bortezomib, and a novel alkylating agent, temozolomide. In a phase II trial of gemcitabine, a pyrimidine antimetabolite, in refractory patients, Zinzani et al. reported a 70% ORR, including 10% CR and a median response duration of 8 months.⁵⁷² Gemcitabine was given at a dose of 1,200 mg/m² on days 1, 8, and 15 of a 28-day cycle for a total of three courses. One to two cycles were sufficient to induce tumor reduction in 83% of patients with stage IIB MF. Side effects with gemcitabine included neutropenia (34%), thrombocytopenia (25%), cutaneous hyperpigmentation (17%), and elevated liver enzymes (13%).⁵⁷² Duvic et al. demonstrated a similar response rate (68%) and side-effect profile in another phase II trial, with dosing 1,000 mg/m² on days 1, 8, and 15 for 6 cycles.⁵⁷³ Marchi et al. reported a 78% ORR, including 22% CR, in previously untreated patients.⁵⁷⁴ Isolated cases of cardiotoxicity, including atrial fibrillation, myocardial infarction, and congestive heart failure; and of pulmonary toxicity suggest that patients with CTCL may be prone to unusual, nonhematopoietic side effects of gemcitabine.⁵⁷⁵

The purine nucleoside analogs, 2-deoxycoformycin (DCF or pentostatin), 2 chlorodeoxyadenosine (2CdA or cladribine), and fludarabine monophosphate (FAMP) have activity in CTCL.^{576, 577} DCF inhibits adenosine deaminase, preventing the transformation from adenosine to inosine, which is found in high concentrations of T lymphocytes. Accumulation of metabolites blocks DNA synthesis by inhibiting ribonucleotide reductase. Dosing of DCF has varied among studies and yields an ORR of 33% to 71% with approximately one third of the responses being CR.⁵⁷⁸ The median time to progression ranges from 1.3 to 8.3 months, and there appears to be a better response in SS than in MF.^{578, 579, 580} The most common side effects are granulocytopenia, renal insufficiency, and prolonged CD4 lymphopenia. A combination study of DCF with high-dose IFN resulted in an ORR of 41% with a median PFS of 13.1 months.⁵⁸¹

2CdA is a chlorinated purine analog that is activated by phosphorylation and accumulates in lymphocytes with high deoxycytidine kinase, resulting in DNA strand breaks and cell death. 2-CdA was initially given by continuous infusion over 5 to 7 days and resulted in an ORR of 28% to 41% with a median duration of response of 4 to 5 months in pretreated

patients.^{577, 582, 583} Toxicity included leukopenia (62%) with grade 3 or 4 neutropenia (24%), thrombocytopenia (33%), and infections (62%) of both bacterial and opportunistic types.⁵⁸²

FAMP is activated by phosphorylation and inhibits DNA repair to induce cell death in lymphocytes. The ORR of FAMP as a single agent in relapsed CTCL has been 19% to 29.5%;^{584, 585} however, response rates improved in small series when FAMP was combined with IFN (51%), cyclophosphamide (42%), or ECP (63%).^{499, 585, 586} The median PFS for IFN and ECP were 5.9 months and 13 months, respectively.^{499, 585} Grade 3 or 4 cytopenias occurred in 60% of FAMP+IFN but only 5% of FAMP+ECP.

Forodesine is a selective purine nucleoside phosphorylase inhibitor and causes increased levels of deoxyguanosine and deoxyguanosine triphosphate, which inhibit T-cell proliferation.^{587, 588} In a phase I intravenous trial of 13 patients with CTCL, there were 4 responses (3 CR, 1 PR) and 6 with stable disease (SD). In a phase I/II trial using an oral formulation at 80 mg/m² once daily, the objective response rate was 53.6% (2 CR, 13 PR and 22 SD).⁵⁸⁹ Forodesine was well tolerated with primarily mild (grade 1 or 2) side effects, including nausea, dizziness, headache, peripheral edema, and fatigue.

Altering a drug's vehicle can improve its efficacy and lower its toxicity, as evidenced by the pegylated liposomal preparation of doxorubicin.⁵⁹⁰ In an open clinical trial, 10 patients with relapsing CTCL were treated with pegylated liposomal doxorubicin at a dosage of 20 mg/m² once a month, with an upper limit of 400 mg or 8 infusions.⁵⁹¹ A total of 60% of patients experienced a CR, 10% PR, and 10% SD following this monotherapy. These results were supported by a retrospective review of 34 patients using doses of 20 to 40 mg/m² every 2 to 4 week.⁵⁹² They demonstrated an overall response rate of 88% (44% CR + CRu [patients who achieved a CR defined by clinical criteria only with no biopsy] and 44% PR), an OS of 17.8 months and event-free survival of 12 months. Adverse events were reported in 41% of patients with 17% grade 3/4, including only one with palmar-plantar erythrodysesthesias.

P.1978

Histone deacetylase (HDAC) inhibitors (HDI) were discovered serendipitously to have activity in T-cell lymphomas in phase I trials by Piekarz et al. at the NCI and by O'Connor et al. at Memorial Sloan Kettering Cancer Center (MSKCC).^{593, 594} HDI cause histone hyperacetylation, alter chromatin structure, and modulate gene expression.⁵⁹⁵ They also acetylate nonhistone proteins such as p53 and down-modulate cytokines such as IL-10, both of which contribute to apoptosis of cancer cells.^{595, 596, 597} HDI can be divided into 6 groups based on their chemical structures, and it is unknown whether pan-HDAC inhibition (HDACi) or more selective HDACi is better in treating malignancies.⁵⁹⁸ Two HDI have been approved for therapy in relapsed CTCL, vorinostat (Zolinza, Merck & Co, Whitehouse Station, NJ, suberoylanilide hydroxamic acid [SAHA]), a relatively nonselective inhibitor of HDAC, and romidepsin (Istodax, formerly depsipeptide, Celgene Corp, Summit, NJ), a specific inhibitor of class I HDAC enzymes.⁵⁹⁶

Vorinostat was approved for the treatment of relapsed CTCL in October 2006. The maximum tolerated daily oral doses of vorinostat were determined to be 400 mg. In a phase II trial of 33 heavily treated patients with CTCL (median number of prior systemic therapy = 5), Duvic et al. reported an ORR of 24% (all PR) and an additional 33% had SD, pruritus relief, or both.⁵⁹⁹ In a multicenter phase II trial in 74 patients treated with at least two previous systemic therapies, the ORR was similar at 29.7%.⁶⁰⁰ The median time to progression was 4.9 months and 9.8 months for responders with stage IIB-IVB disease. The adverse effects for the two phase II trials were diarrhea (49% to 60%), fatigue (46% to 78%), nausea (43% to 60%), thrombocytopenia (22% to 54%), and dysgeusia (24% to 51%). Grade 3/4 adverse events were thrombocytopenia (5% to 19%), dehydration (1% to 8%), and pulmonary embolism (5%).^{599, 600} Cardiac complications have been reported including QT prolongation.⁶⁰¹ Vorinostat is being evaluated in combinations with bexarotene, bortezomib, and lenalidomide.^{595, 602}

Romidepsin achieved orphan drug status in 2007 and was approved for the treatment of relapsed CTCL in November 2009.^{603, 604} It is a natural product and a stable prodrug that is converted into its active form by a glutathione-mediated step. Thus, a benefit of romidepsin lies in its ability to counteract glutathione-mediated drug resistance.^{593, 605} In two phase II trials in relapsed CTCL patients (n = 71 and 96), the ORRs were 34% in both, including 6% CR in both and the median durations were 13.7 and 15.4 months.^{606, 607} Both studies used the same dose and schedule derived from the NCI phase I study: 14 mg/m² as a 4-hour infusion once weekly times 3 out of 4 weeks.

Most of the adverse events with romidepsin were mild (grade 1 or 2) and were gastrointestinal symptoms or fatigue. Adverse events (all grades) were nausea (52% to 54%), fatigue (41% to 42%), emesis (19% to 26%), anorexia (20% to 21%), diarrhea (8% to 14%), and ageusia (13% to 19%). Grade 3/4 cytopenias were more pronounced in the NCI study: neutropenia (14%), lymphopenia (21%), thrombocytopenia (6%),⁶⁰⁸ and anemia (6%).⁶⁰⁶ There was concern that HDI,

including romidepsin, would have significant prolongation of the QT interval and risk of arrhythmia, but the studies found minimal risk; however, antiemetics which prolong QT should be limited and the potassium and magnesium levels should be normalized before romidepsin infusion.

The potential to alter the expression of a more focused, disease-related subset of genes and to limit adverse effects has prompted the development of isoform-specific HDAC inhibitors in various stages of study.^{597, 609} Belinostat is an intravenous hydroxamic acid with an ORR of 14% in CTCL and 25% in PTCL.^{610, 611, 612, 613} Panobinostat is a hydroxamic acid with both intravenous and oral formulations and had a 60% ORR in a study of 10 patients with CTCL;⁶¹⁴ however, a larger study of 95 patients reported only 16% ORR.⁶¹⁵ Clinically relevant QTc prolongation is not associated with current dose schedules of panobinostat.⁶¹⁶

Pralatrexate (Foloty; Allos Therapeutics Inc.) is a novel antifolate with a high affinity for the reduced folate carrier-1 which is overexpressed in neoplastic cells. Pralatrexate inhibits dihydrofolate reductase, an enzyme involved in the synthesis of deoxythymidine and the purine DNA nucleotides, and promotes apoptosis. Pralatrexate received approval in September 2009 for relapsed or refractory PTCL at a dose of 30 mg/m² weekly for 6 of 7 weeks.⁶¹⁷ A de-escalation trial identified an effective dose of 15 mg/m² weekly for 3 of 4 weeks in patients with relapsed CTCL.⁶¹⁸ The ORR was 45% (13/29: 1 CR, 12 PR); 73% of responses were continuing at 6 months by Kaplan-Meier estimate. The main toxicities were mild except for mucositis (48% all grades, 17% grade 3). To reduce mucositis, vitamin B12 and folate supplementation are started before therapy with pralatrexate. Ongoing trials are investigating combination therapies that incorporate pralatrexate. Although in vitro studies suggested synergy with sequential gemcitabine, the toxicities, primarily marrow suppression, were excessive.^{619, 620} Pralatrexate is synergistic with bortezomib in both in vitro and in vivo models of T-cell malignancies.⁶²¹

Bortezomib (Velcade; Millennium Pharmaceuticals, Boston, MA); a proteasome inhibitor, down-regulates NF-κB activation and causes apoptosis of CTCL cell lines.⁶²² In a phase II trial of 12 relapsed patients (10 MF, 2 PTCLU with skin involvement), the ORR was 67% (2CR, 6PR) and all responses were durable, lasting from 7 to >14 months.⁶²³ There were no grade 4 toxicities, and the grade 3 toxicities were neutropenia (n = 2), thrombocytopenia (n = 2), and sensory neuropathy (n = 2). Bortezomib is synergistic with other agents. A phase I trial of bortezomib, gemcitabine, and liposomal doxorubicin reported a PR in 6 of 7 relapsed CTCL patients.⁶²⁴ The combination of bortezomib with the HDAC inhibitor, vorinostat, induced apoptosis in CTCL and was associated with an up-regulation of cell cycle regulating proteins p21 and p27, an increased expression of phosphorylated p38, and a suppression of vascular endothelial growth factor by tumor cells.⁶²⁵

Temozolomide, an oral derivative of dacarbazine that causes DNA damage by methylating nucleotide bases, has demonstrated some efficacy in the treatment of CTCL. This alkylating agent produces O6-alkylguanine adducts, which are deactivated by O6-alkylguanine-DNA alkyltransferase (AGT), a DNA repair enzyme often found in tumor cells. Dolan et al. found that patients with MF demonstrated lower than expected levels of AGT in tumor cells, thus emphasizing temozolomide's potential therapeutic efficacy in this specific malignancy.⁶²⁶ In a phase II trial, 9 patients were treated with 150 mg/m² of temozolomide orally for 5 days for the first 4-week cycle and then 200 mg/m² of temozolomide for 5 days for the second and third 4-week cycles. A total response rate of 33% was observed with 2 patients developing grade 3 hematopoietic toxicities.⁶²⁷ In a larger trial of 26 relapsed patients using the 200 mg/m² dosing schedule, the ORR was 27% (2CR, 5 PR); the median disease-free survival (DFS) and OS were 4 and 24 months, respectively.⁶²⁸ The response did not correlate with levels of AGT. The most common grade 1/2 toxicities were gastrointestinal and treatment was stopped in three patients due to grade 3 thrombocytopenia, lymphopenia, and skin reaction.

Combination chemotherapy regimens tend to be reserved for relapsed, aggressive, and advanced-stage MF/SS. Responses occur in the 40% to 89% range but are brief with PFS in the 5 to 9 month range.^{629, 630, 631} In a phase II trial of EPOCH (etoposide, prednisone, vincristine, cyclophosphamide, doxorubicin) in 15 refractory patients with CTCL, including 4 ALCL, the ORR was 80% (4 CR, 8 PR); the median PFS was 8.0 months and the median OS was 13.5 months.⁶³¹ Infectious complications, including staphylococcal bacteremia related to open skin lesions, are a significant problem for patients receiving combination chemotherapy.

P.1979

Combined-modality Therapy

Because there is no single therapy for CTCL that can consistently induce long-lasting remissions, various combinations of therapeutic modalities have been studied. The results of several small studies suggested that better survival could be

achieved by combining TSEBRT with chemotherapy.^{632, 633} Hallahan et al. evaluated TSEBRT followed by combination chemotherapy for 21 patients with tumor-stage CTCL demonstrating an objective response in 19 (90%) with a median duration of remission of 12 months, but all patients relapsed within 25 months.⁶³² Two nonrandomized studies suggested a benefit for early-stage CTCL patients who receive TSEBRT followed by chemotherapy.^{633, 634}

Following TSEBT, subsequent PUVA therapy appears to aid in maintaining remission status in patients with CTCL. A significant benefit in DFS but no statistically significant improvement in OS was observed. However, prospective, randomized data are needed to confirm these results. Incidentally, PUVA has also demonstrated effectiveness as a salvage therapy after TSEBT in early-stage patients with recurrence, with acceptable toxicity.⁶³⁵

The most significant study to evaluate the role of combined-modality therapy was that of Kaye et al. at the NCI who compared TSEBRT and combination chemotherapy (cyclophosphamide, doxorubicin, etoposide, and vincristine) to conservative topical therapy (beginning with topical HN2 followed sequentially, if needed, by PUVA, TSEBRT, and combination chemotherapy) in a randomized trial of 103 patients with MF.⁶³⁶ Although the rate of CR was significantly increased in the combined-modality arm (38% vs. 10%, $p = 0.032$), toxicity was greater and no significant difference was noted between the groups in disease-free or OS (Fig. 9.17). Thus, this study indicated that, similar to other low-grade lymphomas, early aggressive therapy in MF does not have a major impact on survival.

A nonrandomized study from Yale University compared relapse-free survival (RFS) and OS between CTCL patients who achieved a CR following TSEBRT, with subsequent treatment consisting of either adjuvant chemotherapy (cyclophosphamide and doxorubicin; $n = 77$), photopheresis ($n = 11$), or no adjuvant therapy ($n = 43$).⁶³⁷ Adjuvant therapy was also offered to 32 patients who achieved a "good PR" to TSEBRT. The statistical analysis found no appreciable impact on RFS among the patients receiving adjuvant chemotherapy or photopheresis when compared to patients receiving no adjuvant therapy. However, a marginally significant ($p < 0.06$) improvement on OS was demonstrated when stage T3/T4 patients treated with adjuvant photopheresis ($n = 7$) were compared to stage T3/T4 patients receiving no adjuvant therapy ($n = 22$).⁶³⁷

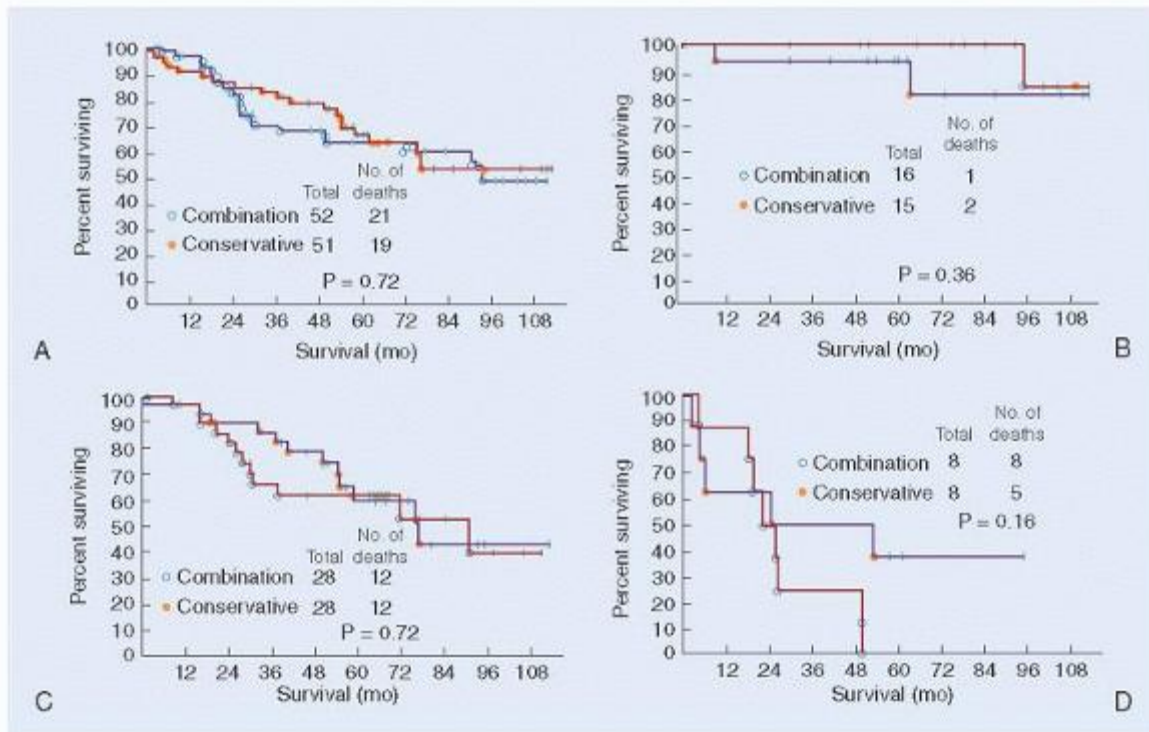

FIGURE 9.17. Survival curves from randomized study at the National Cancer Institute comparing intensive combined therapy. A: Overall survival. B: Survival among low-risk patients (stage IA, IB, or IIB). C: Survival among intermediate-risk patients (stage IIB, III, or IVA). D: Survival among high-risk patients (stage IVB). (From Kaye FJ, et al. A randomized trial comparing combination electron beam radiation and chemotherapy with topical therapy in the initial treatment of mycosis fungoides. *N Engl J Med* 1989;321:1784, with permission.)

Retinoids and IFN- α have been combined to treat CTCL in several open studies.^{638, 639, 640} Combined analysis of the results of 102 reported patients treated with retinoids and IFN- α showed that approximately 60% of patients respond and 10% achieve a CR similar to the response for IFN- α alone.⁴⁸⁷ PUVA therapy has been combined with systemic retinoids to treat CTCL in two studies.⁶⁴¹ demonstrating response rates similar to PUVA alone. Bexarotene has been combined with ECP, PUVA phototherapy, and IFN- α in several patients with potential beneficial effects, as well as no increased toxicity.^{475, 642}

The combination of PUVA and IFN- α is well tolerated and generates impressive complete response rates.^{643, 644, 645} In the combined analysis of the phase I and phase II trials of IFN- α and PUVA for CTCL at Northwestern University, 39 CTCL patients (Stage IB, n = 14; IIA, n = 5; IIB, n = 6; III, n = 8; IVA, n = 5; IVB, n = 1) received intramuscular or subcutaneous IFN- α 2a three times a week at initial intermediate doses (6MU, n = 3; 12MU to 18MU, n = 13; 21MU to 30MU, n = 23) with subsequent dose reduction in 19 patients due to apparent toxicity.⁶⁴³ IFN- α was continued for the planned 2-year period in only 10 of 39 patients (26%) with 8 patients receiving 4 or less months of IFN- α due to tumor progression, toxic effects, or patient request. PUVA was initiated three times per week and tapered to 1 monthly treatment indefinitely for patients achieving a CR. The overall objective response rate was 90% with 24 patients (62%) achieving a pathologically confirmed CR, 15 of whom had early-stage disease (Stage IB/IIA). A total of 19 patients (54%) relapsed demonstrating a median duration of response of 28 months (range, 1 to 64 months). Median survival for the entire cohort was 62 months with mean survivals for stage I/II and stage III/IV patients of 55 and 35 months, respectively.⁶⁴³ Thus, although patients respond impressively, a majority of patients will relapse despite maintenance PUVA and experience nontrivial toxicities at higher doses of IFN. The overall impact on survival of combined PUVA and IFN- α has yet to be determined.

A prospective phase II trial examined escalating doses of IFN- α 2a combined with PUVA in 63 symptomatic patients representing all stages of MF and SS.⁶⁴⁵ A total of 51 patients achieved a CR (74.6%) or PR (6%), with a median response duration of 32 months. The 5-year OS rate was 91% and included 17 patients with advanced disease.⁶⁴⁵

Rupoli et al. completed a multicenter prospective phase II clinical study on 89 patients with early-stage IA to IIA MF treated for 14 months with low-dose IFN- α 2b (6 to 18 MU/wk) and PUVA.⁶⁴⁶ Complete remission (CR) was achieved in 84% and an overall response rate in 98% of cases. Long-term CR was associated with high epidermal CD1a⁺ dendritic-cell density (P = 0.030) and high CD8⁺ lymphoid T-cell density was associated with a lower relapse rate (P = 0.002).⁶⁴⁶

Stadler and colleagues completed a prospective randomized multicenter trial to compare IFN plus PUVA and IFN plus acitretin in stage I and II patients with CTCL (n = 82 evaluable patients).⁶⁴⁷ IFN- α 2a was administered subcutaneously at 9 MU three times weekly and combined with either PUVA at an initial interval of five times weekly, or with acitretin up to 50 mg daily. IFN- α + PUVA (n = 40) was significantly superior to the IFN + acitretin (n = 42), as marked by a 70% complete remission rate in the former, versus a 38.1% complete remission rate in the latter.⁶⁴⁷ A recent report appeared to suggest that elevated levels of the cutaneous T-cell attracting chemokine CTACK/CCL27 in skin and sera after combined PUVA and IFN- α 2b therapy might be correlated with risk of recurrence.²⁶ Reports have emerged of the successful combination of low-dose bexarotene and phototherapy. Narrow-band UVB phototherapy has been combined with oral bexarotene with success in one recent case.⁶⁴⁸

P.1980

The successful combination of low-dose bexarotene with PUVA phototherapy has also been reported.^{475, 642, 649, 650, 651, 652, 653, 654}

Immunotherapy

Over the past decade, researchers have developed immunotherapies to correct abnormalities in the immune response, and cellular growth and differentiation pathways in patients with CTCL. As described in previous sections, recombinant forms of natural cytokines such as IFNs and immunomodulation with photopheresis have shown promise in the treatment of CTCL, with tolerable toxicity profiles and reasonable efficacy. This section focuses on other cytokines and monoclonal antibody therapies for the treatment of CTCL.

Fusion toxin therapy takes advantage of the preferential expression of specific receptors on the surface of malignant cells. Recombinant fusion of a plant or bacterial toxin gene to a specific receptor ligand can guide the toxin gene to the target cell, where it can be internalized via receptor-mediated endocytosis and translocated into a toxic moiety in the cytosol.⁶⁵⁵ The interleukin-2 receptor (IL-2R) is present in low-, medium-, and high-affinity forms. The high-affinity form of IL-2R is a three-subunit peptide, and one of the three subunits contains CD25. The high-affinity IL-2R has been a specific target that is commonly present on cells in ATLL,⁶⁵⁶ and on mature, activated T-cells. Approximately 60% of patients with CTCL will show expression of IL-2R on their mature T-cells, but there is both interpatient and inpatient variability of expression.⁶⁵⁷

DAB486IL2 and DAB389IL2 were the first fusion toxins to be used in clinical trials and are composed of the nucleotide sequence of the enzymatically active and the membrane translocating domains of diphtheria toxin conjugated to the amino acid sequence of human IL-2.^{655, 658, 659} In a phase II trial of DAB486IL2 reported by Foss et al.,⁶⁶⁰ 3 of 14 CTCL patients demonstrated an objective response (1 patient with a PR and 2 patients with slightly less than 50% improvement). The authors observed that IL-2R expression was necessary, but not sufficient, to predict response. DAB389IL2 (denileukin diftitox), a second-generation molecule, replaced DAB486IL2 because it showed a more favorable pharmacokinetic profile.

A pivotal phase III trial evaluated the safety, efficacy, and pharmacokinetics of two dose levels of denileukin diftitox.⁶⁶¹ This randomized, blinded, parallel-grouped study focused on the use of denileukin diftitox in the treatment of 71 patients with persistent or recurrent stage IB to IVA CTCL. For study inclusion, patients had to have detectable CD25 on $\geq 25\%$ of their tissue biopsy lymphocytes via immunoperoxidase assay. Following therapy, 30% of patients experienced an objective response (20% PR and 10% CR), 32% experienced SD, and 3% demonstrated progressive disease. Both 9- and 18- $\mu\text{g}/\text{kg}/\text{day}$ doses were compared, and showed similar tolerability and no evidence of cumulative toxicity. No statistically significant difference was found between the two dosing regimens with respect to response rate and duration of response (median 6.9 months, range 2.7 to 46.1 + months).⁶⁶¹ Upon stratification with respect to disease stage, 18 $\mu\text{g}/\text{kg}/\text{day}$ of denileukin diftitox proved more effective in treating stage IIB patients (36% OR) than the lower dose (23% OR).⁶⁶¹ Denileukin diftitox was approved by the FDA in 1999 for the treatment of patients with persistent or recurrent CTCL whose malignant cells express the CD25 component of the IL-2 receptor. A phase III, placebo-controlled trial, again evaluating the two dosing regimens of 9- and 18- $\mu\text{g}/\text{kg}/\text{day}$ doses was performed with 144, CD25 CTCL patients of any stage.⁶⁶² The overall response rate was higher in the 18- $\mu\text{g}/\text{kg}/\text{day}$ group as compared to the 9- $\mu\text{g}/\text{kg}/\text{day}$ group (49.1% vs. 37.8%) and both were higher than placebo (15.9%).⁶⁶² There was also increased estimated PFS in the 18- $\mu\text{g}/\text{kg}/\text{day}$ group versus the 9 $\mu\text{g}/\text{kg}/\text{day}$ group (32.4 months vs. 26.5 months), but the adverse events were similar for both dosing arms.⁶⁶² Not surprisingly, the placebo group had significantly fewer adverse events and reduced PFS.

The effectiveness of denileukin diftitox in patients with $<20\%$ of their lymphocyte population expressing CD25 has not been determined, but a study of 24 patients treated without prior knowledge of their CD25 status showed a significant difference in patients achieving a partial response when patients with high CD25 expression were compared to patients with intermediate to minimal CD25 expression. In this study, no patient experienced a complete response, and the side-effect profile was similar to that of previous studies.⁶⁶³

Another small phase III study focused on the use of steroid pre-medication to improve the tolerability of denileukin diftitox. Fifteen CTCL patients received prednisone or dexamethasone immediately prior to each dose of denileukin diftitox, which was administered at two dose levels (9 or 18 $\mu\text{g}/\text{kg}/\text{day}$) for 5 consecutive days, every 3 weeks. This cycle was repeated up to eight times. Following therapy, a significant decrease in the incidence of acute hypersensitivity reactions was noted, and a 60% response rate was observed. These findings prompted the authors to conclude that steroid pre-medication not only made denileukin diftitox more tolerable, it also performed this task without compromising clinical response.⁶⁶⁴

Side effects of denileukin diftitox have included reversible elevated hepatic transaminases (61% total, 15% with grade 3 or 4) and flu-like symptoms (fever/chills, nausea/vomiting, and arthralgias/myalgias) seen in 92% of patients in the pivotal trial. A delayed vascular leak syndrome (hypoalbuminemia, edema, and hypotension) was seen in 25% of patients in the same patient population. Increasing hydration may decrease the incidence of vascular leak syndrome, but this theory currently lacks supporting data. Acute hypersensitivity reactions during infusion may show as dyspnea, back pain, chest pain, and hypotension. As noted above, pre-treatment of these patients with steroids make acute hypersensitivity reactions less likely. Bone marrow suppression or secondary immunosuppressive effects have not been noted as significant adverse events related to denileukin diftitox.^{655, 661} Infections were seen in 56% of subjects. However, 80% of these infections were typical in patients with advanced-stage or heavily pretreated CTCL and were thus not attributed to therapy.⁶⁶¹

Alemtuzumab (CAMPATH-1H), a monoclonal antibody directed against CD52, has been studied in the treatment of advanced, low-grade NHLs, including CTCL. This humanized antibody targets T and B lymphocytes, and it appears to have a predilection for circulating cells, relatively sparing those localized within lymph nodes.^{665, 666} Two small phase II studies evaluated the safety and efficacy of alemtuzumab in stage IIB to IV disease. Kennedy et al. reported a 38% overall response rate, and Lundin reported a 55% overall response rate. Both studies used 30 mg twice weekly dosing. The time to progression and the time to treatment failure were short in both studies, at <4 and 12 months, respectively.^{667, 668} A more recent open-label trial from Querfeld et al. treated 19 erythrodermic CTCL patients with escalating IV doses of alemtuzumab up to a maximum of 30 mg, three times weekly, for 4 weeks, followed by 8 weeks of subcutaneous

administration.⁶⁶⁹ The overall response rate was 84%, with 47% having a complete response. Similar to previous studies, the median PFS was 6 months. Significant side effects occurred, including grade 3 to 4 cytopenias and severe infections.⁶⁶⁹ There are also reports of cardiac toxicity in several patients that resolved with the discontinuation of treatment,⁶⁷⁰ however, Lundin et al. did not experience any adverse cardiac events in their study patients.⁶⁷¹ The side-effect profile for CAMPATH-1H includes significant neutropenia with subsequent increased susceptibility to opportunistic infections and bacterial septicemia, thus limiting its utility in the treatment of advanced-stage patients with compromised immune systems.^{667, 668, 672, 673} Although subcutaneous low-dose alemtuzumab shows promise in the setting of SS, larger clinical trials

P.1981

are needed to clarify the role of alemtuzumab in the treatment of CTCL.^{136, 673, 674, 675, 676}

Another monoclonal antibody that targets CD4 (zanolimumab) has undergone phase II trials in CTCL patients. Kim et al. reported the use of zanolimumab in 47 treatment-refractory CTCL patients.⁶⁷⁷ Seventeen weekly infusions at a dose of either 280, 560, or 980 mg were utilized. An objective response was seen in 15 of the 41 patients (36.6%), but evaluation of the two higher dosing regimens had an objective response of 56% with a median response of 81 weeks.⁶⁷⁷

An antibody to CD30 (SGN30) had minimal activity until it was conjugated to a cytotoxic drug monomethyl auristatin E (MMAE). Brentuximab vedotin (SGN35; Adcetris, Seattle Genetics) is an antibody-drug conjugate that consists of three components: a chimeric immunoglobulin G1 mAb cAC10 specific for human CD30, the microtubule disrupting agent MMAE, and a protease cleavable covalent linker that attaches the antibody to MMAE.⁶⁷⁸ Brentuximab vedotin was approved by the FDA in August 2011 for relapsed patients with Hodgkin lymphoma or systemic ALCL. A phase II trial in 58 patients with relapsed ALCL (72% ALK-negative) reported an objective response in 86% of patients including 57% CR and 29% PR.⁶⁷⁹ The median durations of overall response and CR were 12.6 months and 13.2 months, respectively. Grade 3 or 4 adverse events were neutropenia (21%), thrombocytopenia (14%), and peripheral sensory neuropathy (12%).

CCR4 is expressed on tumor cells from most patients who have ATLL, which is relatively resistant to chemotherapy. KW-0761 is humanized anti-CCR4 monoclonal antibody, which enhances antibody-dependent cellular cytotoxicity. In a phase II trial of 26 patients with relapsed CCR4-positive ATL, the overall response rate was 50%, including 31% CR.⁶⁸⁰ Median PFS and OS were 5.2 and 13.7 months, respectively. Adverse events were manageable in fusion reactions (89%) and skin rashes (63%). Clinical trials are investigating KW-0761 in CTCL.

In addition to monoclonal antibodies, there have been efforts to harness the patients' own immune system to enhance the cytotoxic antitumor response. Utilizing TLRs, and additional cytokines to stimulate NK cells, *in vitro* studies have shown increased cellular death in CTCL lines.⁵⁰⁴ A phase I trial initially evaluated the use of a TLR9 agonist in treatment-refractory CTCL patients (Stage IB-IVA), using a dose escalation ranging from 0.08 to 0.36 mg/kg in 24 weekly subcutaneous injections.⁶⁸¹ Common side effects included rigors, cytopenias, and pyrexia, among others. Although the trial was not designed to evaluate for efficacy, they did identify a 32% overall response rate, of which most lasted for the duration of the study (24 weeks).⁶⁸¹ More recently, a phase I/II study combined an intratumoral injection of a TLR9 agonist with radiation (to enhance tumor immunogenicity) in a cohort of 15 MF patients (stage IA-IVA) who had failed at least one standard therapy.⁶⁸² They again found a 33% overall response rate and the therapy was well tolerated with mild injection site reaction or flu-like symptoms.⁶⁸²

Hematopoietic Stem Cell Transplantation

Inasmuch as patients with advanced CTCL have a poor prognosis with only a small chance of sustained remission, treatments as invasive as hematopoietic stem cell transplantation (HSCT) have been increasingly explored using various donor sources, donor sites, and therapeutic conditioning regimens. See Chapters 102 and 104 for a full discussion of HSCT.

Autologous stem cell transplant (autoSCT) has an advantage over allogeneic SCT (alloSCT) with a lower treatment-related mortality, but has a disadvantage with a higher relapse rate. AutoSCT has been done in a small number of heavily pretreated CTCL patients, but relapses have occurred quickly in the majority of patients.^{683, 684, 685} In a report of six patients, five achieved a CR, but three relapsed within 100 days and two remained in CR at 12 months.⁶⁸³ Using T-depletion and CD34⁺ stem cell selection in nine patients with tumor stage or more advanced MF, Olavarria et al. reported CR in eight patients, but seven relapsed at a median of 7 months (range, 2 to 14 months), one died of sepsis and one remained in CR at 10 months.⁶⁸⁵ Four of the relapsed patients had a less aggressive disease course and responded to conventional therapy. Most experts agree that autoSCT offers little advantage for patients with CTCL due to the high rate of relapse and the increased risk of infectious complications.

In the era of alternative donors and reduced intensity conditioning (RIC), alloSCT is more readily available, but it remains controversial in CTCL due to the indolent course, an increasing number of novel therapies, and the risk and expense of alloSCT. An advantage of alloSCT is an apparent graft-versus-tumor effect. Molina et al. obtained a CR in all eight patients receiving alloSCT (4 matched related donor [MRD] and 4 matched unrelated donor [MUD]).⁶⁸⁶ The clonal T-cell population originally found in six patients became undetectable within 60 days post-SCT and had not recurred within a mean follow-up of 56 months. One patient died of respiratory syncytial viral pneumonia at day +34, and a second patient expired from graft-versus-host disease at 16 months. Six patients remained in remission at a median of 53 months (range, 33 to 108 months).

European investigators, retrospectively, analyzed 60 patients (36 MF, 24 SS; median age = 46.5 years [range, 22 to 66 years]) who underwent alloSCT (45 MRD; 15 MUD); 44 received RIC regimens, and 25 underwent T-cell depletion.⁶⁸⁷ The PFS was 42% and 34% and the OS was 66% and 53% at 1 and 3 years, respectively. Nonrelapse mortality was 20% at 1 year. A total of 26 patients relapsed (REL) at a median of 3.8 months (range, 1 to 37 months) and the incidence of relapse was 47% at 3 years. There were 17 REL patients who received donor lymphocyte infusions (DLI) and 10 achieved either a CR (8; 47%) or PR (2; 12%). RIC and MRD SCT had better survival than myeloablative and MUD SCT, respectively.⁶⁸⁷

Duvic et al. reported the MD Anderson experience in 19 patients with advanced CTCL (median age = 50 years; range, 21 to 63 years) who received total skin EBRT prior to a RIC alloSCT (12 MRD; 7 MUD).⁶⁸⁸ Of 18 evaluable patients 7 experienced relapse or progression in the skin at a median of 50 days (range; 28 to 718 days). Of 8 that experienced relapse in the skin, 5 regained CR with reduced immunosuppression of DLI. Two-year PFS was 53% and OS was 79%. Of the 19 patients 11 (58%) were in CR at a median follow-up of 1.7 years (range, 0.8 to 7.9 years).

More studies are required to define the role of SCT in the treatment of advanced CTCL. An expanding donor pool, including umbilical cord and mismatched family; the decreased mortality of RIC, and improvements in supportive care are increasing the applicability of alloSCT for hematologic cancers. Based on preliminary findings in a limited number of patients, alloSCT warrants further study in CTCL.

SUMMARY AND FUTURE INVESTIGATIONS

Molecular studies are unraveling the complex interactions of cytokines, adhesion molecules, and the immune system responsible for the pathogenesis of CTCL and are continuing to provide insight for novel approaches to treatment. As with other indolent lymphomas, an array of therapies can produce responses in CTCL, but are generally not curative. In contrast to other lymphomas, however, is the high degree of efficacy of topical treatments (NM, TSEBRT, NBUVB, and PUVA phototherapies) for patients with early-stage MF/SS. Because CTCL is not cured by systemic chemotherapy, initial management of early-stage disease should include skin-directed therapy.⁶⁸⁹ Ongoing clinical trials may define the roles of systemic therapy in managing more advanced-stage patients including combinations of skin-directed therapies, chemotherapy

P.1982

agents, photopheresis, retinoids, monoclonal antibodies, IFN, and stem cell transplantation.

WEB SITES

United States Cutaneous Lymphoma Consortium: <http://www.usclc.org/>.

International Society for Cutaneous Lymphoma: <http://www.cutaneouslymphoma.org/home/>.

National Comprehensive Cancer Network Guidelines: <http://www.nccn.org/index.asp>.

Cutaneous Lymphoma Foundation: <http://www.clfoundation.org/>[excellent patient resource].

REFERENCES

1. Lutzner M, Edelson R, Schein P, Green I, Kirkpatrick C, Ahmed A. Cutaneous T-cell lymphomas: the Sezary syndrome, mycosis fungoides, and related disorders. *Ann Intern Med* 1975;83(4):534-552.
2. Edelson RL. Cutaneous T-cell lymphomas: clues of a skin-thymus interaction. *J Invest Dermatol* 1976;67(3):419-424.
3. Alibert JL. Description des Maladies de la Peau: Observees a l'Hospital St. Louis et Exposition des Meilleurs Methodes Suivies pour leur Traitement. Paris, Barrois l'aine et Fil 1806.
4. Alibert MLB. Monographie des Dermatoses. Paris 1832. 423 p.

5. Bazin E. Lecons sur le Traitement des Maldies Chroniques en General affections de la Peau en Particular par l'Emploi Compare des Eaux Minerales de l'Hydrotherapie et des Moyens Pharmaceutiques. Paris: Adrien Delahaye; 1870.
6. Vidal E, Brocq L. Etude sur le mycosis fongoide. La France Me'dical 1885;2:946,57,69,83,93,1005,18.
7. Hallopeau H. Sur une e'rythrodermie chronique a' pousse'es aigue; de'but probable d'un mycosis fongoide. Bull Soc Franc de Dermat et Syph 1890;1:220.
8. Besnier E, Hallopeau H. On the erythrodermia of mycosis fungoides. J Cutan Genito Urin Dis 1892;10:453.
9. Stelwagon HW, Hatch JL. A study of mycosis fungoides with a report of two cases. J Cutan Genito Urin Dis 1892;10(1):57-64.
10. Tilden GH. So-called mycosis fongoide. Boston Med and Surg Jour 1885;2:386-392.
11. Sezary A, Bouvrain Y. Erythrodermia avec presence de cellules monstreuses dans le derme et le sang circulant. Bull Soc Fr Dermatol Syphil 1938;45:254.
12. Taswell HF, Winkelmann RK. Sezary syndrome- a malignant reticulemic erythroderma. JAMA 1961;177:465.
13. Lutzner MA, Jordan HW. The ultrastructure of an abnormal cell in Sezary's syndrome. Blood 1968;31(6):719-726.
14. Crossen PE, Mellor JE, Finley AG, Ravich RB, Vincent PC, Gunz FW. The Sezary syndrome: cytogenetic studies and identification of the Sezary Cell as an abnormal lymphocyte. Am J Med 1971;50(1):24-34.
15. Broome JD, Zucker-Franklin D, Weiner MS, Bianco C, Nussenzweig V. Leukemic cells with membrane properties of thymus-derived (T) lymphocytes in a case of Sezary's syndrome: morphologic and immunologic studies. Clin Immunol Immunopathol 1973;1(3):319-329.
16. Brouet JC, Flandrin G, Seligmann M. Indications of the thymus-derived nature of the proliferating cells in six patients with Sezary's syndrome. New England Journal of Medicine 1973;289(7):341-344.
17. Broder S, Edelson RL, Lutzner MA, et al. The Sezary syndrome: a malignant proliferation of helper T cells. J Clin Invest 1976;58(6):1297-306.
18. Heald PW, Yan SL, Edelson RL, Tigelaar R, Picker LJ. Skin-selective lymphocyte homing mechanisms in the pathogenesis of leukemic cutaneous T-cell lymphoma. J Invest Dermatol 1993;101(2):222-226.
19. Vowels BR, Cassin M, Vonderheid EC, Rook AH. Aberrant cytokine production by Sezary syndrome patients: cytokine secretion pattern resembles murine Th2 cells. J Invest Dermatol 1992;99(1):90-94.
20. Saed G, Fivenson DP, Naidu Y, Nickloff BJ. Mycosis fungoides exhibits a Th1-type cell-mediated cytokine profile whereas Sezary syndrome expresses a Th2-type profile [see comments]. J Invest Dermatol 1994;103(1):29-33.
21. Vowels BR, Lessin SR, Cassin M, et al. Th2 cytokine mRNA expression in skin in cutaneous T-cell lymphoma. J Invest Dermatol 1994;103(5):669-673.
22. Lessin SR, Vowels BR, Rook AH. Th2 cytokine profile in cutaneous T-cell lymphoma [letter; comment]. J Invest Dermatol 1995;105(6):855-856.
23. Hansen ER. Immunoregulatory events in the skin of patients with cutaneous T-cell lymphoma. Arch Dermatol 1996;132(5):554-561.
24. Krejsgaard T, Ralfkiaer U, Clasen-Linde E, et al. Malignant cutaneous T-cell lymphoma cells express IL-17 utilizing the Jak3/Stat3 signaling pathway. J Invest Dermatol 2011;131(6):1331-1338.
25. Saeki H, Tamaki K. Thymus and activation regulated chemokine (TARC)/CCL17 and skin diseases. J Dermatol Sci 2006;43(2):75-84.
26. Goteri G, Rupoli S, Campanati A, et al. Serum and tissue CTACK/CCL27 chemokine levels in early mycosis fungoides may be correlated with disease-free survival following treatment with interferon alfa and psoralen plus ultraviolet A therapy. Br J Dermatol 2012;166(5):948-952.
27. Fujita Y, Abe R, Sasaki M, et al. Presence of circulating CCR10+ T cells and elevated serum CTACK/CCL27 in the early stage of mycosis fungoides. Clin Cancer Res 2006;12(9):2670-2675.
28. Pals ST, de Gorter DJ, Spaargaren M. Lymphoma dissemination: the other face of lymphocyte homing. Blood 2007;110(9):3102-3111.

29. Narducci MG, Scala E, Bresin A, et al. Skin homing of Sezary cells involves SDF-1-CXCR4 signaling and down-regulation of CD26/dipeptidylpeptidase IV. *Blood* 2006;107(3):1108-1115.
30. Miyagaki T, Sugaya M, Fujita H, et al. Eotaxins and CCR3 interaction regulates the Th2 environment of cutaneous T-cell lymphoma. *J Invest Dermatol* 2010;130(9):2304-2311.
31. Miyagaki T, Sugaya M, Suga H, et al. Low herpesvirus entry mediator (HVEM) expression on dermal fibroblasts contributes to a Th2-dominant micro-environment in advanced cutaneous T-cell lymphoma. *J Invest Dermatol* 2012;132(4):1280-1289.
32. Uccini S, Ruco LP, Monardo F, La Parola IL, Cerimele D, Baroni CD. Molecular mechanisms involved in intraepithelial lymphocyte migration: a comparative study in skin and tonsil. *J Pathol* 1993;169(4):413-419.
33. Sarris AH, Esgleyes-Ribot T, Crow M, et al. Cytokine loops involving interferon-gamma and IP-10, a cytokine chemotactic for CD4+ lymphocytes: an explanation for the epidermotropism of cutaneous T-cell lymphoma? [see comments]. *Blood* 1995;86(2):651-658.
34. Nickoloff BJ, Griffiths CE, Baadsgaard O, Voorhees JJ, Hanson CA, Cooper KD. Markedly diminished epidermal keratinocyte expression of intercellular adhesion molecule-1 (ICAM-1) in Sezary syndrome. *JAMA* 1989;261(15): 2217-2221.
35. Vejlsgaard GL, Ralfkiaer E, Avnstorp C, Czajkowski M, Marlin SD, Rothlein R. Kinetics and characterization of intercellular adhesion molecule-1 (ICAM-1) expression on keratinocytes in various inflammatory skin lesions and malignant cutaneous lymphomas. *J Am Acad Dermatol* 1989;20(5 Pt 1): 782-790.
36. Rook AH, Heald P. The immunopathogenesis of cutaneous T-cell lymphoma. *Hematol Oncol Clin North Am* 1995;9(5):997-1010.
37. Lu D, Duvic M, Medeiros LJ, Luthra R, Dorfman DM, Jones D. The T-cell chemokine receptor CXCR3 is expressed highly in low-grade mycosis fungoides. *Am J Clin Pathol* 2001;115(3):413-421.
38. Sokolowska-Wojdylo M, Wenzel J, Gaffal E, et al. Circulating clonal CLA(+) and CD4(+) T cells in Sezary syndrome express the skin-homing chemokine receptors CCR4 and CCR10 as well as the lymph node-homing chemokine receptor CCR7. *Br J Dermatol* 2005;152(2):258-264.
39. Campbell JJ, Clark RA, Watanabe R, Kupper TS. Sezary syndrome and mycosis fungoides arise from distinct T-cell subsets: a biologic rationale for their distinct clinical behaviors. *Blood* 2010;116(5):767-771.
40. Girardi M, Heald PW, Wilson LD. The pathogenesis of mycosis fungoides. *N Engl J Med* 2004;350(19):1978-1988.
41. Dummer R, Cozzio A, Urosevic M. Pathogenesis and therapy of cutaneous lymphomas—progress or impasse? *Exp Dermatol* 2006;15(5):392-400.
42. Edelson RL, Berger CL, Raafat J, Warburton D. Karyotype studies of cutaneous T cell lymphoma: evidence for clonal origin. *J Invest Dermatol.* 1979;73 (6):548-550.
43. Nowell PC, Finan JB, Vonderheid EC. Clonal characteristics of cutaneous T cell lymphomas: cytogenetic evidence from blood, lymph nodes, and skin. *J Invest Dermatol.* 1982;78(1):69-75.
44. Thangavelu M, Finn WG, Yelavarthi KK, et al. Recurring structural chromosome abnormalities in peripheral blood lymphocytes of patients with mycosis fungoides/sezary syndrome. *Blood.* 1997;89:3371-3377.
45. Mao X, Lillington DM, Czepulkowski B, Russell-Jones R, Young BD, Whittaker S. Molecular cytogenetic characterization of Sezary syndrome. *Genes Chromosomes Cancer.* 2003;36(3):250-260.
46. Karenko L, Kahkonen M, Hyytinen ER, Lindlof M, Ranki A. Notable losses at specific regions of chromosomes 10q and 13q in the Sezary syndrome detected by comparative genomic hybridization. *J Invest Dermatol* 1999;112(3): 392-395.
47. Karenko L, Sarna S, Kahkonen M, Ranki A. Chromosomal abnormalities in relation to clinical disease in patients with cutaneous T-cell lymphoma: a 5-year follow-up study. *Br J Dermatol* 2003;148(1):55-64.
48. Mao X, Lillington D, Scarisbrick JJ, et al. Molecular cytogenetic analysis of cutaneous T-cell lymphomas: identification of common genetic alterations in Sezary syndrome and mycosis fungoides. *Br J Dermatol* 2002;147(3): 464-475.
49. Wain EM, Mitchell TJ, Russell-Jones R, Whittaker SJ. Fine mapping of chromosome 10q deletions in mycosis fungoides and sezary syndrome: identification of two discrete regions of deletion at 10q23.33-24.1 and 10q24.33-25.1. *Genes Chromosomes Cancer* 2005;42(2):184-192.

50. Lin WM, Lewis JM, Filler RB, et al. Characterization of the DNA copy-number genome in the blood of cutaneous T-cell lymphoma patients. *J Invest Dermatol* 2012;132(1):188-197.
51. Scarisbrick JJ, Woolford AJ, Russell-Jones R, Whittaker SJ. Loss of heterozygosity on 10q and microsatellite instability in advanced stages of primary cutaneous T-cell lymphoma and possible association with homozygous deletion of PTEN. *Blood* 2000;95(9):2937-2942.
52. Salgado R, Servitje O, Gallardo F, et al. Oligonucleotide array-CGH identifies genomic subgroups and prognostic markers for tumor stage mycosis fungoides. *J Invest Dermatol* 2010;130(4):1126-1135.
53. Navas IC, Algara P, Mateo M, et al. p16(INK4a) is selectively silenced in the tumoral progression of mycosis fungoides. *Lab Invest* 2002;82(2):123-132.
54. Scarisbrick JJ, Mitchell TJ, Calonje E, Orchard G, Russell-Jones R, Whittaker SJ. Microsatellite instability is associated with hypermethylation of the hMLH1 gene and reduced gene expression in mycosis fungoides. *J Invest Dermatol* 2003;121(4):894-901.
55. van Doorn R, Zoutman WH, Dijkman R, et al. Epigenetic profiling of cutaneous T-cell lymphoma: promoter hypermethylation of multiple tumor suppressor genes including BCL7a, PTPRG, and p73. *J Clin Oncol* 2005;23(17): 3886-3896.
56. Zhang Y, Wang Y, Yu R, et al. Molecular markers of early-stage mycosis fungoides. *J Invest Dermatol* 2012;132(6):1698-1706.
57. Dereure O, Levi E, Vonderheid EC, Kadin ME. Infrequent Fas mutations but no Bax or p53 mutations in early mycosis fungoides: a possible mechanism for the accumulation of malignant T lymphocytes in the skin. *J Invest Dermatol* 2002;118(6):949-956.
58. Dummer R, Michie SA, Kell D, et al. Expression of bcl-2 protein and Ki-67 nuclear proliferation antigen in benign and malignant cutaneous T-cell infiltrates. *J Cutan Pathol* 1995;22(1):11-17.
59. Tracey L, Villuendas R, Dotor AM, et al. Mycosis fungoides shows concurrent deregulation of multiple genes involved in the TNF signaling pathway: an expression profile study. *Blood* 2003;102(3):1042-1050.
60. Witkiewicz A, Raghunath P, Wasik A, et al. Loss of SHP-1 tyrosine phosphatase expression correlates with the advanced stages of cutaneous T-cell lymphoma. *Hum Pathol* 2007;38(3):462-467.
61. Mao X, Orchard G, Lillington DM, Russell-Jones R, Young BD, Whittaker SJ. Amplification and overexpression of JUNB is associated with primary cutaneous T-cell lymphomas. *Blood* 2003;101(4):1513-1519.
62. Kiessling MK, Oberholzer PA, Mondal C, et al. High-throughput mutation profiling of CTCL samples reveals KRAS and NRAS mutations sensitizing tumors toward inhibition of the RAS/RAF/MEK signaling cascade. *Blood* 2011;117(8):2433-2440.
63. Valencak J, Schmid K, Trautinger F, et al. High expression of Dicer reveals a negative prognostic influence in certain subtypes of primary cutaneous T cell lymphomas. *J Dermatol Sci* 2011;64(3):185-190.
64. Ralfkiaer U, Hagedorn PH, Bangsgaard N, et al. Diagnostic microRNA profiling in cutaneous T-cell lymphoma (CTCL). *Blood* 2011;118(22):5891-5900.
65. Ballabio E, Mitchell T, van Kester MS, et al. MicroRNA expression in Sezary syndrome: identification, function, and diagnostic potential. *Blood* 2010;116(7):1105-1113.
66. Weiss LM, Hu E, Wood GS, et al. Clonal rearrangements of T-cell receptor genes in mycosis fungoides and dermatopathic lymphadenopathy. *N Engl J Med* 1985;313(9):539-544.
67. Aisenberg AC, Krontiris TG, Mak TW, Wilkes BM. Rearrangement of the gene for the beta chain of the T-cell receptor in T-cell chronic lymphocytic leukemia and related disorders. *N Engl J Med* 1985;313(9):529-533.
68. Whittaker S. T-cell receptor gene analysis in cutaneous T-cell lymphomas. *Clin Exp Dermatol* 1996;21(2):81-87.
69. Zelickson BD, Peters MS, Pittelkow MR. T-cell receptor gene rearrangement analysis in the early diagnosis of cutaneous T-cell lymphoma. *Dermatologic Clinics* 1994;12(2):335-340.
70. Diamandidou E, Cohen PR, Kurzrock R. Mycosis fungoides and Sezary syndrome. *Blood* 1996;88(7):2385-2409.
71. Wood GS, Haeffner A, Dummer R, Crooks CF. Molecular biology techniques for the diagnosis of cutaneous T-cell lymphoma. *Dermatol Clin* 1994;12(2): 231-241.

72. Yu RC, Alaibac M. Rapid polymerase chain reaction-based technique for detecting clonal t-cell receptor gene rearrangements in cutaneous t-cell lymphomas of both the alpha-beta and gamma-delta varieties. *Diagn Mol Pathol* 1996;5(2):121-126.
73. Staib G, Sterry W. Use of polymerase chain reaction in the detection of clones in lymphoproliferative diseases of the skin. *Recent Results Cancer Res* 1995;139:239-247.
74. Trainor KJ, Brisco MJ, Wan JH, Neoh S, Grist S, Morley AA. Gene rearrangement in B- and T-lymphoproliferative disease detected by the polymerase chain reaction [see comments]. *Blood* 1991;78(1):192-196.
75. Holm N, Flaig MJ, Yazdi AS, Sander CA. The value of molecular analysis by PCR in the diagnosis of cutaneous lymphocytic infiltrates. *J Cutan Pathol* 2002;29(8):447-452.
76. Signoretti S, Murphy M, Cangi MG, Puddu P, Kadin ME, Loda M. Detection of clonal T-cell receptor gamma gene rearrangements in paraffin-embedded tissue by polymerase chain reaction and nonradioactive single-strand conformational polymorphism analysis. *Am J Pathol* 1999;154(1):67-75.
77. Lukowsky A, Muche JM, Mobs M, et al. Evaluation of T-cell clonality in archival skin biopsy samples of cutaneous T-cell lymphomas using the biomed-2 PCR protocol. *Diagn Mol Pathol* 2010;19(2):70-77.
78. Groenen PJ, Langerak AW, van Dongen JJ, van Krieken JH. Pitfalls in TCR gene clonality testing: teaching cases. *J Hematopathol* 2008;1(2):97-109.
79. Sandberg Y, van Gastel-Mol EJ, Verhaaf B, Lam KH, van Dongen JJ, Langerak AW. BIOMED-2 multiplex immunoglobulin/T-cell receptor polymerase chain reaction protocols can reliably replace Southern blot analysis in routine clonality diagnostics. *J Mol Diagn* 2005;7(4):495-503.
80. Patel KP, Pan Q, Wang Y, et al. Comparison of BIOMED-2 versus laboratory-developed polymerase chain reaction assays for detecting T-cell receptor-gamma gene rearrangements. *J Mol Diagn* 2010;12(2):226-237.
81. Yang H, Xu C, Tang Y, Wan C, Liu W, Wang L. The significance of multiplex PCR/heteroduplex analysis-based TCR-gamma gene rearrangement combined with laser-capture microdissection in the diagnosis of early mycosis fungoides. *J Cutan Pathol* 2012;39(3):337-346.
82. Criscione VD, Weinstock MA. Incidence of cutaneous T-cell lymphoma in the United States, 1973-2002. *Arch Dermatol* 2007;143(7):854-859.
83. Bradford PT, Devesa SS, Anderson WF, Toro JR. Cutaneous lymphoma incidence patterns in the United States: a population-based study of 3884 cases. *Blood* 2009;113(21):5064-5073.
84. Weinstock MA, Gardstein B. Twenty-year trends in the reported incidence of mycosis fungoides and associated mortality. *Am J Public Health* 1999; 89(8):1240-1244.
85. Hickman PR, McBurney EI, Fitzgerald RL. CTCL in patients under 20 years of age: a series of five patients. *Pediatr Dermatol* 1997;14(2):93-97.
86. Tay YK, Weston WL, Aeling JL. Treatment of childhood cutaneous T-cell lymphoma with alpha-interferon plus PUVA. *Pediatr Dermatol* 1996;13(6):496-500.
87. Zackheim HS, McCalmont TH, Deanovic FW, Odom RB. Mycosis fungoides with onset before 20 years of age. *J Am Acad Dermatol* 1997;36:557-562.
88. Pope E, Weitzman S, Ngan B, et al. Mycosis fungoides in the pediatric population: report from an international Childhood Registry of Cutaneous Lymphoma. *J Cutan Med Surg* 2010;14(1):1-6.
89. Reinhold U, Abken H. Cutaneous T-cell lymphoma: molecular genetics, immunology and pathogenesis. *European Journal of Cancer* 1995;31A(5):793-799.
90. Wood GS. Lymphocyte activation in cutaneous T-cell lymphoma. *J Invest Dermatol* 1995;105(1 Suppl):105S-109S.
91. Morales Suarez-Varela MM, Olsen J, Kaerlev L, et al. Are alcohol intake and smoking associated with mycosis fungoides? A European multicentre case-control study. *Eur J Cancer* 2001;37(3):392-397.
92. Schneider BF, Christian M, Hess CE, Williams ME. Familial occurrence of cutaneous t cell lymphoma - a case report of. *Leukemia* 1995;9(11):1979-1981.
93. Rosen ST, Radvany R, Roenigk H Jr, Terasaki PI, Bunn PA Jr. Human leukocyte antigens in cutaneous T cell lymphoma. *J Am Acad Dermatol* 1985;12(3): 531-534.

94. Safai B, Myskowski PL, Dupont B, Pollack MS. Association of HLA-DR5 with mycosis fungoides. *J Invest Dermatol* 1983;80(5):395-397.
95. Schmidt AN, Robbins JB, Greer JP, Zic JA. Conjugal transformed mycosis fungoides: the unknown role of viral infection and environmental exposures in the development of cutaneous T-cell lymphoma. *J Am Acad Dermatol* 2006;54(5 Suppl):S202-S205.
96. Cohen SR, Stenn KS, Braverman IM, Beck GJ. Clinicopathologic relationships, survival, and therapy in 59 patients with observations on occupation as a new prognostic factor. *Cancer* 1980;46(12):2654-2666.
97. Tuyp E, Burgoyne A, Aitchison T, MacKie R. A case-control study of possible causative factors in mycosis fungoides. *Arch Dermatol* 1987;123(2):196-200.
98. Whittemore AS, Holly EA, Lee IM, et al. Mycosis fungoides in relation to environmental exposures and immune response: a case-control study. *J Natl Cancer Inst* 1989;81(20):1560-1567.
99. Poiesz BJ, Ruscetti FW, Gazdar AF, Bunn PA, Minna JD, Gallo RC. Detection and isolation of type C retrovirus particles from fresh and cultured lymphocytes of a patient with cutaneous T-cell lymphoma. *Proc Natl Acad Sci USA* 1980;77(12):7415-7419.
100. Zucker-Franklin D, Pancake BA. The role of human T-cell lymphotropic viruses (HTLV-I and II) in cutaneous T-cell lymphomas. *Semin Dermatol* 1994;13(3):160-165.
101. Bazarbachi A, Soriano V, Pawson R, et al. Mycosis fungoides and Sezary syndrome are not associated with HTLV-I infection: an international study. *Br J Haematol* 1997;98(4):927-933.
102. Shohat M, Shohat B, Mimouni Det al. Human T-cell lymphotropic virus type 1 provirus and phylogenetic analysis in patients with mycosis fungoides and their family relatives. *Br J Dermatol* 2006;155(2):372-378.
103. Zucker-Franklin D, Coutavas EE, Rush MG, Zouzas DC. Detection of human T-lymphotropic virus-like particles in cultures of peripheral blood lymphocytes from patients with mycosis fungoides. *Proc Natl Acad Sci USA* 1991;88(17):7630-7634.
104. Khan ZM, Sebenik M, Zucker-Franklin D. Localization of human T-cell lymphotropic virus-1 tax proviral sequences in skin biopsies of patients with mycosis fungoides by in situ polymerase chain reaction. *J Invest Dermatol* 1996;106(4):667-672.
105. Pancake BA, Wassef EH, Zucker-Franklin D. Demonstration of antibodies to human T-cell lymphotropic virus-I tax in patients with the cutaneous T-cell lymphoma, mycosis fungoides, who are seronegative for antibodies to the structural proteins of the virus. *Blood* 1996;88(8):3004-3009.
106. Pancake BA, Zucker-Franklin D, Coutavas EE. The cutaneous T cell lymphoma, mycosis fungoides, is a human T cell lymphotropic virus-associated disease. A study of 50 patients. *J Clin Invest* 1995;95(2):547-554.
107. Shohat M, Hodak E, Hannig H, Bodemer W, David M, Shohat B. Evidence for the cofactor role of human T-cell lymphotropic virus type 1 in mycosis fungoides and Sezary syndrome. *Br J Dermatol* 1999;141(1):44-49.
108. Lessin SR, Rook AH, Li G, Wood GS. HTLV-I and CTCL: the link is missing [letter]. *J Invest Dermatol* 1996;107(5):783-784.
109. Kikuchi A, Nishikawa T, Yamaguchi K. Absence of human T-cell lymphotropic virus type I in cutaneous T-cell lymphoma [letter]. *N Engl J Med* 1997;336(4):296-297.
110. Li G, Vowels BR, Benoit BM, Rook AH, Lessin SR. Failure to detect human T-lymphotropic virus type-I proviral DNA in cell lines and tissues from patients with cutaneous T-cell lymphoma. *J Invest Dermatol* 1996;107(3):308-313.
111. Wood GS, Salvekar A, Schaffer J, et al. Evidence against a role for human T-cell lymphotropic virus type I (HTLV-I) in the pathogenesis of American cutaneous T-cell lymphoma. *J Invest Dermatol* 1996;107(3):301-307.
112. Capesius C, Saal F, Maero E, et al. No evidence for HTLV-I infection in 24 cases of French and Portuguese mycosis fungoides and Sezary syndrome (as seen in France). *Leukemia* 1991;5(5):416-419.
113. Lisby G, Reitz MS Jr, Vejlsgaard GL. No detection of HTLV-I DNA in punch skin biopsies from patients with cutaneous T-cell lymphoma by the polymerase chain reaction [see comments]. *J Invest Dermatol* 1992;98(4):417-420.
114. Boni R, Davis-Daneshfar A, Burg G, Fuchs D, Wood GS. No detection of HTLV-I proviral DNA in lesional skin biopsies from Swiss and German patients with cutaneous T-cell lymphoma. *Br J Dermatol* 1996;134(2):282-284.

115. Bazarbachi A, Saal F, Laroche L, Flageul B, Peries J, de The H. HTLV-1 provirus and mycosis fungoides [letter; comment]. *Science* 1993;259(5100): 1470-1471.
116. D'Incan M, Southteyrand P, Bignon Y, Dastugue B, Claudy A, Desgranges C. Retroviral sequences related to HTLV-I endemic areas. *Eur J Dermatol* 1992;2:363-371.
117. Srivastava BI, Banki K, Perl A. Human T-cell leukemia virus type I or a related retrovirus in patients with mycosis fungoides/Sezary syndrome and Kaposi's sarcoma. *Cancer Research* 1992;52(16):4391-4395.
118. Whittaker SJ, Luzzatto L. HTLV-1 provirus and mycosis fungoides [letter; comment]. *Science* 1993;259(5100):1470; discussion 1.
119. Chan WC, Hooper C, Wickert R, et al. HTLV-I sequence in lymphoproliferative disorders. *Diagn Mol Pathol* 1993;2(3):192-199.
120. Pancake BA, Zucker-Franklin D. The difficulty of detecting HTLV-1 proviral sequences in patients with mycosis fungoides. *J Acquir Immun Defici Synd Hum Retrovirol* 1996;13(4):314-319.
121. Amitay-Laish I, Sarid R, Ben-Amitai D, et al. Human herpesvirus 8 is not detectable in lesions of large plaque parapsoriasis, and in early-stage sporadic, familial, and juvenile cases of mycosis fungoides. *J Am Acad Dermatol* 2012;66(1):46-50.
122. Mirvish ED, Pomerantz RG, Geskin LJ. Infectious agents in cutaneous T-cell lymphoma. *J Am Acad Dermatol* 2011;64(2):423-431.
123. Bonin S, Tothova SM, Barbazza R, Brunetti D, Stanta G, Trevisan G. Evidence of multiple infectious agents in mycosis fungoides lesions. *Exp Mol Pathol* 2010;89(1):46-50.
124. Koh HK, Charif M, Weinstock MA. Epidemiology and clinical manifestations of cutaneous T-cell lymphoma. *Hematol Oncol Clin North Am* 1995;9(5): 943-960.
125. Elmer KB, George RM. Cutaneous T-cell lymphoma presenting as benign dermatoses. *Am Fam Physician* 1999;59(10):2809-2813.
126. Pimpinelli N, Olsen EA, Santucci M, et al. Defining early mycosis fungoides. *J Am Acad Dermatol* 2005;53(6):1053-1063.
127. Lindae ML, Abel EA, Hoppe RT, Wood GS. Poikilodermatous mycosis fungoides and atrophic large-plaque parapsoriasis exhibit similar abnormalities of T-cell antigen expression. *Arch Dermatol* 1988;124(3):366-372.
128. Lambroza E, Cohen SR, Phelps R, Lebwohl M, Braverman IM, DiCostanzo D. Hypopigmented variant of mycosis fungoides: demography, histopathology, and treatment of seven cases. *J Am Acad Dermatol* 1995;32(6):987-993.
129. Pujol RM, Gallardo F, Llistosella E, et al. Invisible mycosis fungoides: a diagnostic challenge. *J Am Acad Dermatol* 2002;47(2 Suppl):S168-S171.
130. Hwong H, Nichols T, Duvic M. "Invisible" mycosis fungoides? *J Am Acad Dermatol* 2001;45(2):318.
131. Dereure O, Guilhou JJ. Invisible mycosis fungoides: a new case. *J Am Acad Dermatol* 2001;45(2):318-319.
132. Hsu WT, Toporcer MB, Kantor GR, Vonderheid EC, Kadin ME. Cutaneous T-cell lymphoma with porokeratosis-like lesions. *J Am Acad Dermatol* 1992;27(2 Pt 2):327-330.
133. Stasko T, Vander Ploeg DE, De Villez RL. Hyperkeratotic mycosis fungoides restricted to the palms. *J Am Acad Dermatol* 1982;7(6):792-796.
134. O'Quinn R P, Zic JA, Boyd AS. Mycosis fungoides d'emblee: CD30-negative cutaneous large T-cell lymphoma. *J Am Acad Dermatol* 2000;43(5 Pt 1): 861-863.
135. Bouloc A, Grange F, Delfau-Larue MH, et al. Leucoderma associated with flares of erythrodermic cutaneous T-cell lymphomas: four cases. The French Study Group of Cutaneous Lymphomas. *Br J Dermatol* 2000;143(4):832-836.
136. Olsen EA, Rook AH, Zic J, et al. Sezary syndrome: immunopathogenesis, literature review of therapeutic options, and recommendations for therapy by the United States Cutaneous Lymphoma Consortium (USCLC). *J Am Acad Dermatol* 2011;64(2):352-404.
137. Willemze R, Jaffe ES, Burg G, et al. WHO-EORTC classification for cutaneous lymphomas. *Blood* 2005;105(10):3768-3785.

138. Lim MS, de Leval L, Quintanilla-Martinez L. Commentary on the 2008 WHO classification of mature T- and NK-cell neoplasms. *J Hematopathol* 2009;2(2):65-73.
139. Swerdlow SH, Campo, E., Harris, N.L., Jaffe, E.S., Pileri, S.A., Stein, H., Thiele, J., Vardiman, J.W. WHO classification of tumours of haematopoietic and lymphoid tissues, 4th ed. Lyon: World Health Organization Press, 2008:439 p.
140. Rijlaarsdam JU, Scheffer E, Meijer CJ, Willemze R. Cutaneous pseudo-T-cell lymphomas. A clinicopathologic study of 20 patients. *Cancer* 1992;69(3):717-724.
141. Collins RD. Lymph node examination. What is an adequate workup? *Arch Pathol Lab Med* 1985;109(9):797-799.
142. Willemze R, Cornelisse CJ, Hermans J, Pardoel VP, Van Vloten WA, Meijer CJ. Quantitative electron microscopy in the early diagnosis of cutaneous T-cell lymphomas. A long-term follow-up study of 77 patients. *Am J Pathol* 1986;123(1):166-173.
143. Smoller BR, Bishop K, Glusac E, Kim YH, Hendrickson M. Reassessment of histologic parameters in the diagnosis of mycosis fungoides. *Am J Surg Pathol* 1995;19(12):1423-1430.
144. Guitart J, Kennedy J, Ronan S, Chmiel JS, Hsiegh YC, Variakojis D. Histologic criteria for the diagnosis of mycosis fungoides: proposal for a grading system to standardize pathology reporting. *J Cutan Pathol* 2001;28(4):174-183.
145. Massone C, Kodama K, Kerl H, Cerroni L. Histopathologic features of early (patch) lesions of mycosis fungoides: a morphologic study on 745 biopsy specimens from 427 patients. *Am J Surg Pathol* 2005;29(4):550-560.
146. Nickloff BJ. Light-microscopic assessment of 100 patients with patch/plaque-stage mycosis fungoides. *Am J Dermatopathol* 1988;10(6):469-477.
147. Santucci M, Biggeri A, Feller AC, Massi D, Burg G. Efficacy of histologic criteria for diagnosing early mycosis fungoides: an EORTC cutaneous lymphoma study group investigation. European Organization for Research and Treatment of Cancer. *Am J Surg Pathol* 2000;24(1):40-50.
148. Naraghi ZS, Seirafi H, Valikhani M, Farnaghi F, Kavusi S, Dowlati Y. Assessment of histologic criteria in the diagnosis of mycosis fungoides. *Int J Dermatol* 2003;42(1):45-52.
149. Hsiao PF, Hsiao CH, Lin YC, Tseng MP, Tsai TF, Jee SH. Histopathologicmolecular correlation in early mycosis fungoides using T-cell receptor gamma gene rearrangement by polymerase chain reaction with laser capture microdissection. *J Formos Med Assoc* 2007;106(4):265-272.
150. Alessi E, Coggi A, Venegoni L, Merlo V, Gianotti R. The usefulness of clonality for the detection of cases clinically and/or histopathologically not recognized as cutaneous T-cell lymphoma. *Br J Dermatol* 2005;153(2):368-371.
151. Ponti R, Quaglino P, Novelli M, et al. T-cell receptor gamma gene rearrangement by multiplex polymerase chain reaction/heteroduplex analysis in patients with cutaneous T-cell lymphoma (mycosis fungoides/Sezary syndrome) and benign inflammatory disease: correlation with clinical, histologic and immunophenotypical findings. *Br J Dermatol* 2005;153(3):565-573.
152. Cordel N, Lenormand B, Courville P, Helot MF, Benichou J, Joly P. Usefulness of cutaneous T-cell clonality analysis for the diagnosis of cutaneous T-cell lymphoma in patients with erythroderma. *Arch Pathol Lab Med* 2005;129(3):372-376.
153. Sandberg Y, Heule F, Lam K, et al. Molecular immunoglobulin/T-cell receptor clonality analysis in cutaneous lymphoproliferations. Experience with the BIOMED-2 standardized polymerase chain reaction protocol. *Haematologica* 2003;88(6):659-670.
154. Thurber SE, Zhang B, Kim YH, Schrijver I, Zehnder J, Kohler S. T-cell clonality analysis in biopsy specimens from two different skin sites shows high specificity in the diagnosis of patients with suggested mycosis fungoides. *J Am Acad Dermatol* 2007;57(5):782-790.
155. Zhang B, Beck AH, Taube JM, et al. Combined use of PCR-based TCRG and TCRB clonality tests on paraffin-embedded skin tissue in the differential diagnosis of mycosis fungoides and inflammatory dermatoses. *J Mol Diagn* 2010;12(3):320-327.
156. Plaza JA, Morrison C, Magro CM. Assessment of TCR-beta clonality in a diverse group of cutaneous T-Cell infiltrates. *J Cutan Pathol* 2008;35(4):358-365.
157. Salhany KE, Cousar JB, Greer JP, Casey TT, Fields JP, Collins RD. Transformation of cutaneous T cell lymphoma to large cell lymphoma. A clinicopathologic and immunologic study. *Am J Pathol* 1988;132(2):265-277.

158. Cerroni L, Rieger E, Hodl S, Kerl H. Clinicopathologic and immunologic features associated with transformation of mycosis fungoides to large-cell lymphoma. *Am J Surg Pathol* 1992;16(6):543-552.
159. Edelson RL. Cutaneous T cell lymphoma: mycosis fungoides, Sezary syndrome, and other variants. *J Am Acad Dermatol* 1980;2(2):89-106.
160. Kohler S, Kim YH, Smoller BR. Histologic criteria for the diagnosis of erythrodermic mycosis fungoides and Sezary syndrome: a critical reappraisal. *J Cutan Pathol* 1997;24(5):292-297.
161. Buechner SA, Winkelmann RK. Sezary syndrome. A clinicopathologic study of 39 cases. *Arch Dermatol* 1983;119(12):979-986.
162. Delfau-Larue MH, Laroche L, Wechsler J, et al. Diagnostic value of dominant T-cell clones in peripheral blood in 363 patients presenting consecutively with a clinical suspicion of cutaneous lymphoma. *Blood* 2000;96(9): 2987-2992.
163. Vonderheid EC, Diamond LW, van Vloten WA, et al. Lymph node classification systems in cutaneous T-cell lymphoma. Evidence for the utility of the Working Formulation of Non-Hodgkin's Lymphomas for Clinical Usage. *Cancer* 1994;73(1):207-218.
164. Wolfe JT, Chooback L, Finn DT, Jaworsky C, Rook AH, Lessin SR. Large-cell transformation following detection of minimal residual disease in cutaneous T-cell lymphoma: molecular and in situ analysis of a single neoplastic T-cell clone expressing the identical T-cell receptor. *J Clin Oncol* 1995;13(7):1751-1757.
165. Li G, Salhany KE, Rook AH, Lessin SR. The pathogenesis of large cell transformation of cutaneous T cell lymphoma is not associated with t(2;5)(p23;q35) chromosomal translocation. *J Cutan Pathol* 1997;24:403-408.
166. Benner MF, Jansen PM, Vermeer MH, Willemze R. Prognostic factors in transformed mycosis fungoides: a retrospective analysis of 100 cases. *Blood* 2012;119(7):1643-1649.
167. Greer JP, Salhany KE, Cousar JB, et al. Clinical features associated with transformation of cerebriform T-cell lymphoma to a large cell process. *Hematol Oncol* 1990;8(4):215-227.
168. Greer JP, Kinney MC, Collins RD, et al. Clinical features of 31 patients with Ki-1 anaplastic large-cell lymphoma [see comments]. *J Clin Oncol* 1991;9(4):539-547.
169. Willemze R. New concepts in the classification of cutaneous lymphomas [editorial; comment]. *Arch Dermatol* 1995;131(9):1077-1080.
170. Bunn PA Jr, Huberman MS, Whang-Peng J, et al. Prospective staging evaluation of patients with cutaneous T-cell lymphomas. Demonstration of a high frequency of extracutaneous dissemination. *Ann Intern Med* 1980;93(2):223-230.
171. Fraser-Andrews EA, Mitchell T, Ferreira S, et al. Molecular staging of lymph nodes from 60 patients with mycosis fungoides and Sezary syndrome: correlation with histopathology and outcome suggests prognostic relevance in mycosis fungoides. *Br J Dermatol* 2006;155(4):756-762.
172. Arai E, Katayama I, Ishihara K. Mycosis fungoides and Sezary syndrome in Japan. Clinicopathologic study of 107 autopsy cases. *Pathol Res Pract* 1991; 187(4):451-457.
173. Sausville EA, Eddy JL, Makuch RW, et al. Histopathologic staging at initial diagnosis of mycosis fungoides and the Sezary syndrome. Definition of three distinctive prognostic groups. *Ann Intern Med* 1988;109(5):372-382.
174. Salhany KE, Greer JP, Cousar JB, Collins RD. Marrow involvement in cutaneous T-cell lymphoma. A clinicopathologic study of 60 cases [see comments]. *Am J Clin Pathol* 1989;92(6):747-754.
175. Variakojis D, Rosas-Urbe A, Rappaport H. Mycosis fungoides: pathologic findings in staging laparotomies. *Cancer* 1974;33(6):1589-1600.
176. Olsen E, Vonderheid E, Pimpinelli N, et al. Revisions to the staging and classification of mycosis fungoides and Sezary syndrome: a proposal of the International Society for Cutaneous Lymphomas (ISCL) and the cutaneous lymphoma task force of the European Organization of Research and Treatment of Cancer (EORTC). *Blood* 2007;110(6):1713-1722.
177. Vonderheid EC, Diamond LW, Lai SM, Au F, Dellavecchia MA. Lymph node histopathologic findings in cutaneous T-cell lymphoma. A prognostic classification system based on morphologic assessment. *Am J Clin Pathol* 1992;97(1):121-129.
178. Scheffer E, Meijer CJ, Van Vloten WA. Dermatopathic lymphadenopathy and lymph node involvement in mycosis fungoides. *Cancer* 1980;45(1):137-148.

179. Scheffer E, Meijer CJ, van Vloten WA, Willemze R. A histologic study of lymph nodes from patients with the Sezary syndrome. *Cancer* 1986;57(12):2375-2380.
180. Rappaport H, Thomas LB. Mycosis fungoides: the pathology of extracutaneous involvement. *Cancer* 1974;34(4):1198-1229.
181. Sibaud V, Beylot-Barry M, Thiebaut R, et al. Bone marrow histopathologic and molecular staging in epidermotropic T-cell lymphomas. *Am J Clin Pathol* 2003;119(3):414-423.
182. Olsen EA, Whittaker S, Kim YH, et al. Clinical end points and response criteria in mycosis fungoides and Sezary syndrome: a consensus statement of the International Society for Cutaneous Lymphomas, the United States Cutaneous Lymphoma Consortium, and the Cutaneous Lymphoma Task Force of the European Organisation for Research and Treatment of Cancer. *J Clin Oncol* 2011;29(18):2598-2607.
183. Bennett SR, Greer JP, Stein RS, Glick AD, Cousar JB, Collins RD. Death due to splenic rupture in suppressor cell mycosis fungoides: a case report. *Am J Clin Pathol* 1984;82(1):104-109.
184. Wolfe JD, Trevor ED, Kjeldsberg CR. Pulmonary manifestations of mycosis fungoides. *Cancer* 1980;46(12):2648-2653.
185. Vonderheid EC, Bernengo MG, Burg G, et al. Update on erythrodermic cutaneous T-cell lymphoma: report of the International Society for Cutaneous Lymphomas. *J Am Acad Dermatol* 2002;46(1):95-106.
186. Vonderheid EC, Sobel EL, Nowell PC, Finan JB, Helfrich MK, Whipple DS. Diagnostic and prognostic significance of Sezary cells in peripheral blood smears from patients with cutaneous T cell lymphoma. *Blood* 1985;66(2):358-366.
187. Fraser-Andrews EA, Woolford AJ, Russell-Jones R, Seed PT, Whittaker SJ. Detection of a peripheral blood T cell clone is an independent prognostic marker in mycosis fungoides. *J Invest Dermatol* 2000;114(1):117-121.
188. Beylot-Barry M, Sibaud V, Thiebaut R, et al. Evidence that an identical T cell clone in skin and peripheral blood lymphocytes is an independent prognostic factor in primary cutaneous T cell lymphomas. *J Invest Dermatol* 2001;117(4):920-926.
189. Agar NS, Wedgeworth E, Crichton S, et al. Survival outcomes and prognostic factors in mycosis fungoides/Sezary syndrome: validation of the revised International Society for Cutaneous Lymphomas/European Organisation for Research and Treatment of Cancer staging proposal. *J Clin Oncol* 2010;28(31):4730-4739.
190. Boer A, Tirumalae R, Bresch M, Falk TM. Pseudoclonality in cutaneous pseudolymphomas: a pitfall in interpretation of rearrangement studies. *Br J Dermatol* 2008;159(2):394-402.
191. Muche JM, Sterry W, Gellrich S, Rzany B, Audring H, Lukowsky A. Peripheral blood T-cell clonality in mycosis fungoides and nonlymphoma controls. *Diagn Mol Pathol* 2003;12(3):142-150.
192. Picker LJ, Michie SA, Rott LS, Butcher EC. A unique phenotype of skin-associated lymphocytes in humans. Preferential expression of the HECA-452 epitope by benign and malignant T cells at cutaneous sites. *Am J Pathol* 1990;136(5):1053-1068.
193. Ralfkiaer E. Immunohistological markers for the diagnosis of cutaneous lymphomas. *Semin Diagn Pathol* 1991;8(2):62-72.
194. Agnarsson BA, Vonderheid EC, Kadin ME. Cutaneous T cell lymphoma with suppressor/cytotoxic (CD8) phenotype: identification of rapidly progressive and chronic subtypes. *J Am Acad Dermatol* 1990;22(4):569-577.
195. Ralfkiaer E, Wolff-Snedorff A, Thomsen K, Geisler C, Vejlsgaard GL. T-cell receptor gamma delta-positive peripheral T-cell lymphomas presenting in the skin: a clinical, histological and immunophenotypic study. *Exp Dermatol* 1992;1(1):31-36.
196. Heald P, Buckley P, Gilliam A, et al. Correlations of unique clinical, immunotypic, and histologic findings in cutaneous gamma/delta T-cell lymphoma. *J Am Acad Dermatol* 1992;26(5 Pt 2):865-870.
197. Marzano AV, Ghislanzoni M, Gianelli U, Caputo R, Alessi E, Berti E. Fatal CD8+ epidermotropic cytotoxic primary cutaneous T-cell lymphoma with multiorgan involvement. *Dermatology* 2005;211(3):281-285.
198. Bogen SA, Pelley D, Charif M, et al. Immunophenotypic identification of Sezary cells in peripheral blood. *Am J Clin Pathol* 1996;106(6):739-748.
199. Bernengo MG, Novelli M, Quaglino P, et al. The relevance of the CD4+ CD26- subset in the identification of circulating Sezary cells. *Br J Dermatol* 2001;144(1):125-135.

200. Jones D, Dang NH, Duvic M, Washington LT, Huh YO. Absence of CD26 expression is a useful marker for diagnosis of T-cell lymphoma in peripheral blood. *Am J Clin Pathol* 2001;115(6):885-892.
201. Sokolowska-Wojdylo M, Wenzel J, Gaffal E, et al. Absence of CD26 expression on skin-homing CLA+ CD4+ T lymphocytes in peripheral blood is a highly sensitive marker for early diagnosis and therapeutic monitoring of patients with Sezary syndrome. *Clin Exp Dermatol* 2005;30(6):702-706.
202. Kelemen K, Guitart J, Kuzel TM, Goolsby CL, Peterson LC. The usefulness of CD26 in flow cytometric analysis of peripheral blood in Sezary syndrome. *Am J Clin Pathol* 2008;129(1):146-156.
203. Ormsby A, Bergfeld WF, Tubbs RR, Hsi ED. Evaluation of a new paraffin-reactive CD7 T-cell deletion marker and a polymerase chain reaction-based T-cell receptor gene rearrangement assay: implications for diagnosis of mycosis fungoides in community clinical practice. *J Am Acad Dermatol* 2001; 45(3):405-413.
204. Murphy M, Fullen D, Carlson JA. Low CD7 expression in benign and malignant cutaneous lymphocytic infiltrates: experience with an antibody reactive with paraffin-embedded tissue. *Am J Dermatopathol* 2002;24(1):6-16.
205. Rijlaarsdam JU, Willemze R. Cutaneous pseudolymphomas: classification and differential diagnosis. *Semin Dermatol* 1994;13(3):187-196.
206. Ross S, Sanchez JL. Parapsoriasis. A century later. *Int J Dermatol* 1990;29(5):329-330.
207. Samman PD. The natural history of parapsoriasis en plaques (chronic superficial dermatitis) and prereticulotic poikiloderma. *Br J Dermatol* 1972;87(5):405-411.
208. Kikuchi A, Naka W, Harada T, Sakuraoka K, Harada R, Nishikawa T. Parapsoriasis en plaques: its potential for progression to malignant lymphoma. *J Am Acad Dermatol* 1993;29(3):419-422.
209. Burg G, Dummer R, Dommann S, Nestle F, Nickoloff B. Pathology of cutaneous T-cell lymphoma. *Hematol Oncol Clin North Am* 1995;9(5):961-995.
210. Bordignon M, Belloni Fortina A, Pigozzi B, Alaibac M. gammadelta T cells as potential contributors to the progression of parapsoriasis to mycosis fungoides. *Mol Med Reports* 2008;1(4):485-488.
211. Vakeva L, Sarna S, Vaalasti A, Pukkala E, Kariniemi AL, Ranki A. A retrospective study of the probability of the evolution of parapsoriasis en plaques into mycosis fungoides. *Acta Derm Venereol* 2005;85(4):318-323.
212. Burg G, Dummer R. Small plaque (digitate) parapsoriasis is an 'abortive cutaneous T-cell lymphoma' and is not mycosis fungoides [editorial; comment]. *Arch Dermatol* 1995;131(3):336-338.
213. Ackerman AB, Schiff TA. If small plaque (digitate) parapsoriasis is a cutaneous t-cell lymphoma, even an abortive one, it must be mycosis fungoides. *Arch Dermatol* 1996;132(5):562-566.
214. Di Trollo R, Di Lorenzo G, Barbiero E, et al. Expression of HECA-452 in parapsoriasis and mycosis fungoides. *Int J Immunopathol Pharmacol* 2006; 19(1):105-110.
215. Dougherty J. Poikiloderma atrophicans vasculare. *Arch Dermatol* 1971;103(5):550-552.
216. Kreuter A, Hoffmann K, Altmeyer P. A case of poikiloderma vasculare atrophicans, a rare variant of cutaneous T-cell lymphoma, responding to extracorporeal photopheresis. *J Am Acad Dermatol* 2005;52(4):706-708.
217. Nakai K, Yoneda K, Moriue T, et al. Narrow-band ultraviolet B decreases serum interleukin-2 receptor levels in patients with poikiloderma vasculare atrophicans. *J Eur Acad Dermatol Venereol* 2009;23(7):844-846.
218. Pereira N, Brinca A, Manuel Brites M, Jose Juliao M, Tellechea O, Goncalo M. Pityriasis lichenoides et varioliformis acuta: case report and review of the literature. *Case Reports Dermatol* 2012;4(1):61-65.
219. Henning JS. Pityriasis lichenoides chronica. *Dermatol Online J* 2004;10(3):8.
220. Willemze R, Scheffer E. Clinical and histologic differentiation between lymphomatoid papulosis and pityriasis lichenoides. *J Am Acad Dermatol* 1985;13(3):418-428.
221. Martorell-Calatayud A, Hernandez-Martin A, Colmenero I, et al [Lymphomatoid papulosis in children: report of 9 cases and review of the literature]. *Actas Dermosifiliogr* 2010;101(8):693-701. 2010 Oct 23 [Epub]. Papulosis linfomatoide en la infancia: presentacion de 9 casos y revision de la literatura.
222. Weiss LM, Wood GS, Ellisen LW, Reynolds TC, Sklar J. Clonal T-cell populations in pityriasis lichenoides et varioliformis acuta (Mucha-Habermann disease). *Am J Pathol* 1987;126(3):417-421.

223. Magro C, Crowson AN, Kovatich A, Burns F. Pityriasis lichenoides: a clonal T-cell lymphoproliferative disorder. *Hum Pathol* 2002;33(8):788-795.
224. Magro CM, Crowson AN, Morrison C, Li J. Pityriasis lichenoides chronica: stratification by molecular and phenotypic profile. *Hum Pathol* 2007;38(3): 479-490.
225. Tomasini D, Zampatti C, Palmedo G, Bonfacini V, Sangalli G, Kutzner H. Cytotoxic mycosis fungoides evolving from pityriasis lichenoides chronica in a seventeen-year-old girl. Report of a case. *Dermatology* 2002;205(2):176-179.
226. Kaplan J, Burgin S, Sepehr A. Granulomatous pigmented purpura: report of a case and review of the literature. *J Cutan Pathol* 2011;38(12):984-989.
227. Yazdi AS, Mayser P, Sander CA. Lichen aureus with clonal T cells in a child possibly induced by regular consumption of an energy drink. *J Cutan Pathol* 2008;35(10):960-962.
228. Magro CM, Schaefer JT, Crowson AN, Li J, Morrison C. Pigmented purpuric dermatosis: classification by phenotypic and molecular profiles. *Am J Clin Pathol* 2007;128(2):218-229.
229. Solomon GJ, Magro CM. Foxp3 expression in cutaneous T-cell lymphocytic infiltrates. *J Cutan Pathol* 2008;35(11):1032-1039.
230. Arai E, Shimizu M, Tsuchida T, Izaki S, Ogawa F, Hirose T. Lymphomatoid keratosis: an epidermotropic type of cutaneous lymphoid hyperplasia: clinicopathological, immunohistochemical, and molecular biological study of 6 cases. *Arch Dermatol* 2007;143(1):53-59.
231. Choi MJ, Kim HS, Kim HO, Song KY, Park YM. A case of lymphomatoid keratosis. *Annals of dermatology* 2010;22(2):219-222.
232. Akhyani M, Ghodsi ZS, Toosi S, Dabbaghian H. Erythroderma: a clinical study of 97 cases. *BMC Dermatol* 2005;5:5.
233. King LE Jr, Dufresne RG Jr, Lovett GL, Rosin MA. Erythroderma: review of 82 cases. *Southern Med J* 1986;79(10):1210-1215.
234. Sentis HJ, Willemze R, Scheffer E. Histopathologic studies in Sezary syndrome and erythrodermic mycosis fungoides: a comparison with benign forms of erythroderma. *J Am Acad Dermatol* 1986;15(6):1217-1226.
235. Vonderheid EC. On the diagnosis of erythrodermic cutaneous T-cell lymphoma. *J Cutan Pathol* 2006;33 Suppl 1:27-42.
236. Ram-Wolff C, Martin-Garcia N, Bensussan A, Bagot M, Ortonne N. Histopathologic diagnosis of lymphomatous versus inflammatory erythroderma: a morphologic and phenotypic study on 47 skin biopsies. *Am J Dermatopathol* 2010;32(8):755-763.
237. Bignon YJ, Souteyrand P. Genotyping of cutaneous T-cell lymphomas and pseudolymphomas. *Curr Probl Dermatol* 1990;19:114-123.
238. Griesser H, Feller AC, Sterry W. T-cell receptor and immunoglobulin gene rearrangements in cutaneous T-cell-rich pseudolymphomas [see comments]. *J Invest Dermatol* 1990;95(3):292-295.
239. Magro CM, Schaefer JT. T- and B-cell clonally restricted pseudolymphoma in the setting of phytoestrogen therapy. *J Eur Acad Dermatol Venereol* 2008;22(5):642-643.
240. Litt JZ. *Drug Eruption Reference Manual*. New York: The Parthenon Publishing Group; 2000.
241. Bergman R, Khamaysi K, Khamaysi Z, Ben Arie Y. A study of histologic and immunophenotypical staining patterns in cutaneous lymphoid hyperplasia. *J Am Acad Dermatol* 2011;65(1):112-124.
242. Hasan M, Shahid M, Varshney M, Mubeen A, Gaur K. Idiopathic lymphocytoma cutis: a diagnostic dilemma. *BMJ Case Reports* 2011;2011.
243. Lugovic-Mihic L, Duvancic T, Situm M, Mihic J, Krolo I. Actinic reticuloid-photosensitivity or pseudolymphoma?—A review. *Collegium Antropologicum* 2011;35 Suppl 2:325-329.
244. De Silva BD, McLaren K, Kavanagh GM. Photosensitive mycosis fungoides or actinic reticuloid? *Br J Dermatol* 2000;142(6):1221-1227.
245. Toonstra J. Actinic reticuloid. *Semin Diagn Pathol* 1991;8(2):109-116.
246. Byrne M, Stefanato CM, Sarkany R. A photosensitive pseudolymphomatous eruption. Actinic reticuloid (AR). *Clin Exp Dermatol* 2012;37(2):203-204.

247. Macaulay WL. Lymphomatoid papulosis. A continuing self-healing eruption, clinically benign—histologically malignant. *Arch Dermatol* 1968;97(1):23-30.
248. el-Azhary RA, Gibson LE, Kurtin PJ, Pittelkow MR, Muller SA. Lymphomatoid papulosis: a clinical and histopathologic review of 53 cases with leukocyte immunophenotyping, DNA flow cytometry, and T-cell receptor gene rearrangement studies. *J Am Acad Dermatol* 1994;30(2 Pt 1):210-218.
249. Saggini A, Gulia A, Argenyi Z, et al. A variant of lymphomatoid papulosis simulating primary cutaneous aggressive epidermotropic CD8+ cytotoxic T-cell lymphoma. Description of 9 cases. *Am J Surg Pathol* 2010;34(8): 1168-1175.
250. El Shabrawi-Caelen L, Kerl H, Cerroni L. Lymphomatoid papulosis: reappraisal of clinicopathologic presentation and classification into subtypes A, B, and C. *Arch Dermatol* 2004;140(4):441-447.
251. Kadin ME. Lymphomatoid papulosis, Ki-1+ lymphoma, and primary cutaneous Hodgkin's disease. *Semin Dermatol* 1991;10(3):164-171.
252. Willemze R, Beljaards RC. Spectrum of primary cutaneous CD30 (Ki-1)-positive lymphoproliferative disorders. A proposal for classification and guidelines for management and treatment. *J Am Acad Dermatol* 1993;28(6):973-980.
253. Cardoso J, Duhra P, Thway Y, Calonje E. Lymphomatoid papulosis type d: a newly described variant easily confused with cutaneous aggressive cd8-positive cytotoxic T-cell lymphoma. *Am J Dermatopathol* 2012.
254. Magro CM, Crowson AN, Morrison C, Merati K, Porcu P, Wright ED. CD8+ lymphomatoid papulosis and its differential diagnosis. *Am J Clin Pathol* 2006;125(4):490-501.
255. Wood GS, Strickler JG, Deneau DG, Egbert B, Warnke RA. Lymphomatoid papulosis expresses immunophenotypes associated with T cell lymphoma but not inflammation. *J Am Acad Dermatol* 1986;15(3):444-458.
256. Vonderheid EC, Kadin ME. Papular mycosis fungoides: a variant of mycosis fungoides or lymphomatoid papulosis? *J Am Acad Dermatol* 2006;55(1): 177-180.
257. Kodama K, Fink-Puches R, Massone C, Kerl H, Cerroni L. Papular mycosis fungoides: a new clinical variant of early mycosis fungoides. *J Am Acad Dermatol* 2005;52(4):694-698.
258. Liu HL, Hoppe RT, Kohler S, Harvell JD, Reddy S, Kim YH. CD30+ cutaneous lymphoproliferative disorders: the Stanford experience in lymphomatoid papulosis and primary cutaneous anaplastic large cell lymphoma. *J Am Acad Dermatol* 2003;49(6):1049-1058.
259. Cabanillas F, Armitage J, Pugh WC, Weisenburger D, Duvic M. Lymphomatoid papulosis: a T-cell dyscrasia with a propensity to transform into malignant lymphoma. *Ann Intern Med* 1995;122:210-217.
260. Nijsten T, Curiel-Lewandrowski C, Kadin ME. Lymphomatoid papulosis in children: a retrospective cohort study of 35 cases. *Arch Dermatol* 2004;140(3):306-312.
261. Burg G, Kempf W, Cozzio A, et al. WHO/EORTC classification of cutaneous lymphomas 2005: histological and molecular aspects. *J Cutan Pathol* 2005;32(10):647-674.
262. Beljaards RC, Kaudewitz P, Berti E, et al. Primary cutaneous CD30-positive large cell lymphoma: definition of a new type of cutaneous lymphoma with a favorable prognosis. A European Multicenter Study of 47 patients. *Cancer* 1993;71(6):2097-2104.
263. Demierre M-F, Goldberg LJ, Kadin ME, Koh HK. Is it lymphoma or lymphomatoid papulosis. *J Am Acad Dermatol* 1997;36:765-772.
264. Zackheim HS. Treatment of cutaneous T-cell lymphoma. *Semin Dermatol* 1994;13(3):207-215.
265. Tan AW, Giam YC. Lymphomatoid papulosis associated with recurrent cutaneous T-cell lymphoma. *Ann Acad Med Singapore* 2004;33(1):110-112.
266. Querfeld C, Khan I, Mahon B, Nelson BP, Rosen ST, Evens AM. Primary cutaneous and systemic anaplastic large cell lymphoma: clinicopathologic aspects and therapeutic options. *Oncology (Williston Park)* 2010;24(7):574-587.
267. de Bruin PC, Beljaards RC, van Heerde P, et al. Differences in clinical behaviour and immunophenotype between primary cutaneous and primary nodal anaplastic large cell lymphoma of T-cell or null cell phenotype. *Histopathology* 1993;23(2):127-135.
268. Kinney MC, Kadin ME. The pathologic and clinical spectrum of anaplastic large cell lymphoma and correlation with ALK gene dysregulation. *Am J Clin Pathol* 1999;111(1 Suppl 1):S56-S67.

269. Massone C, El-Shabrawi-Caelen L, Kerl H, Cerroni L. The morphologic spectrum of primary cutaneous anaplastic large T-cell lymphoma: a histopathologic study on 66 biopsy specimens from 47 patients with report of rare variants. *J Cutan Pathol* 2008;35(1):46-53.
270. Wada DA, Law ME, Hsi ED, et al. Specificity of IRF4 translocations for primary cutaneous anaplastic large cell lymphoma: a multicenter study of 204 skin biopsies. *Mod Pathol* 2011;24(4):596-605.
271. Vardiman JW, Thiele J, Arber DA, et al. The 2008 revision of the World Health Organization (WHO) classification of myeloid neoplasms and acute leukemia: rationale and important changes. *Blood* 2009;114(5):937-951.
272. Bagot M [Epitheliotropic lymphomas: better identification for improved treatment]. *Bulletin de l'Academie nationale de medecine* 2010;194(7): 1365-1372.
273. Woringer F, Kolopp P. Lesion erythemato-squameuse polycyclique de l'avantbras evoluant depuis 6 ans chez un garconnet de 13 ans: histologiquement infiltrat intra epidermique d'apparence tumorale. *Ann Dermatol Syphil* 1939;10:945.
274. Nakada T, Sueki H, Iijima M. Disseminated pagetoid reticulosis (Ketron-Goodman disease): six-year follow-up. *J Am Acad Dermatol* 2002;47(2 Suppl): S183-S186.
275. Pagnanelli G, Bianchi L, Cantonetti M, et al. Disseminated pagetoid reticulosis presenting as cytotoxic CD4/CD8 double negative cutaneous T-cell lymphoma. *Acta Derm Venereol* 2002;82(4):314-316.
276. Shiozawa E, Shiokawa A, Shibata M, et al. Autopsy case of CD4/CD8 cutaneous T-cell lymphoma presenting disseminated pagetoid reticulosis with aggressive granulomatous invasion to the lungs and pancreas. *Pathol Int* 2005;55(1):32-39.
277. McNiff JM, Schechner JS, Crotty PL, Glusac EJ. Mycosis fungoides palmaris et plantaris or acral pagetoid reticulosis? *Am J Dermatopathol* 1998;20(3): 271-275.
278. Mourtzinou N, Puri PK, Wang G, Liu ML. CD4/CD8 double negative pagetoid reticulosis: a case report and literature review. *J Cutan Pathol* 2010;37 (4):491-496.
279. Mielke V, Wolff HH, Winzer M, Sterry W. Localized and disseminated pagetoid reticulosis. Diagnostic immunophenotypical findings. *Arch Dermatol* 1989;125(3):402-406.
280. Kim SY. Follicular mycosis fungoides [letter]. *Am J Dermatopathol* 1985;7(3): 300-301.
281. Pereyo NG, Requena L, Galloway J, Sanguenza OP. Follicular mycosis fungoides: a clinicohistopathologic study. *J Am Acad Dermatol* 1997;36(4):563-568.
282. Gilliam AC, Lessin SR, Wilson DM, Salhany KE. Folliculotropic mycosis fungoides with large cell transformation presenting as dissecting cellulitis of the scalp. *J Cutan Pathol* 1997;24:169-175.
283. Gerami P, Guitart J. The spectrum of histopathologic and immunohistochemical findings in folliculotropic mycosis fungoides. *Am J Surg Pathol* 2007;31(9):1430-1438.
284. Ke MS, Kamath NV, Nihal M, et al. Folliculotropic mycosis fungoides with central nervous system involvement: demonstration of tumor clonality in intra-follicular T cells using laser capture microdissection. *J Am Acad Dermatol* 2003;48(2):238-243.
285. Bonta MD, Tannous ZS, Demierre MF, Gonzalez E, Harris NL, Duncan LM. Rapidly progressing mycosis fungoides presenting as follicular mucinosis. *J Am Acad Dermatol* 2000;43(4):635-640.
286. van Doorn R, Scheffer E, Willemze R. Follicular mycosis fungoides, a distinct disease entity with or without associated follicular mucinosis: a clinicopathologic and follow-up study of 51 patients. *Arch Dermatol* 2002;138(2): 191-198.
287. Lehman JS, Cook-Norris RH, Weed BR, et al. Folliculotropic mycosis fungoides: single-center study and systematic review. *Arch Dermatol* 2010;146(6):607-613.
288. Rongioletti F, De Lucchi S, Meyes D, et al. Follicular mucinosis: a clinicopathologic, histochemical, immunohistochemical and molecular study comparing the primary benign form and the mycosis fungoides-associated follicular mucinosis. *J Cutan Pathol* 2010;37(1):15-19.
289. Mehregan DA, Gibson LE, Muller SA. Follicular mucinosis: histopathologic review of 33 cases. *Mayo Clin Proc* 1991;66(4):387-390.

290. Cerroni L, Fink-Puches R, Back B, Kerl H. Follicular mucinosis: a critical reappraisal of clinicopathologic features and association with mycosis fungoides and Sezary syndrome. *Arch Dermatol* 2002;138(2):182-189.
291. Cerroni L, Kerl H. Primary follicular mucinosis and association with mycosis fungoides and other cutaneous T-cell lymphomas. *J Am Acad Dermatol* 2004;51(1):146-147; author reply 7-8.
292. Brown HA, Gibson LE, Pujol RM, Lust JA, Pittelkow MR. Primary follicular mucinosis: long-term follow-up of patients younger than 40 years with and without clonal T-cell receptor gene rearrangement. *J Am Acad Dermatol* 2002;47(6):856-862.
293. Shah A, Safaya A. Granulomatous slack skin disease: a review, in comparison with mycosis fungoides. *J Eur Acad Dermatol Venereol* 2012.
294. Clarijs M, Poot F, Laka A, Pirard C, Bourlond A. Granulomatous slack skin: treatment with extensive surgery and review of the literature. *Dermatology* 2003;206(4):393-397.
295. Gadzia J, Kestenbaum T. Granulomatous slack skin without evidence of a clonal T-cell proliferation. *J Am Acad Dermatol* 2004;50(2 Suppl):S4-S8.
296. Liu J, Jin H, Liu Y, Zheng H, Fang K, Wang B. Granulomatous slack skin with extracutaneous involvement. *Arch Dermatol* 2005;141(9):1178-1179.
297. Osuji N, Fearfield L, Matutes E, Wotherspoon AC, Bunker C, Catovsky D. Granulomatous slack skin disease—disease features and response to pentostatin. *Br J Haematol* 2003;123(2):297-304.
298. Wollina U, Graefe T, Fuller J. Granulomatous slack skin or granulomatous mycosis fungoides — a case report. Complete response to percutaneous radiation and interferon alpha. *J Cancer Res Clin Oncol* 2002;128(1):50-54.
299. Metzler G, Schlagenhauff B, Krober SM, Kaiserling E, Schaumburg-Lever G, Lischka G. Granulomatous mycosis fungoides: report of a case with some histopathologic features of granulomatous slack skin. *Am J Dermatopathol* 1999;21(2):156-160.
300. Tsang WY, Chan JK, Loo KT, Wong KF, Lee AW. Granulomatous slack skin. *Histopathology* 1994;25(1):49-55.
301. Karakelides H, Geller JL, Schroeter AL, et al. Vitamin D-mediated hypercalcemia in slack skin disease: evidence for involvement of extrarenal 25-hydroxyvitamin D 1alpha-hydroxylase. *J Bone Miner Res* 2006;21(9):1496-1499.
302. LeBoit PE. Granulomatous slack skin. *Dermatologic Clinics* 1994;12(2): 375-389.
303. Noto G, Pravata G, Miceli S, Arico M. Granulomatous slack skin: report of a case associated with Hodgkin's disease and a review of the literature. *Br J Dermatol* 1994;131(2):275-279.
304. Santucci M, Pimpinelli N, Massi D, et al. Cytotoxic/natural killer cell cutaneous lymphomas. Report of EORTC Cutaneous Lymphoma Task Force Workshop. *Cancer* 2003;97(3):610-627.
305. Takeshita M, Okamura S, Oshiro Y, et al. Clinicopathologic differences between 22 cases of CD56-negative and CD56-positive subcutaneous panniculitis-like lymphoma in Japan. *Hum Pathol* 2004;35(2):231-239.
306. Massone C, Chott A, Metz D, et al. Subcutaneous, blastic natural killer (NK), NK/T-cell, and other cytotoxic lymphomas of the skin: a morphologic, immunophenotypic, and molecular study of 50 patients. *Am J Surg Pathol* 2004;28(6):719-735.
307. Massone C, Lozzi GP, Egberts F, et al. The protean spectrum of non-Hodgkin lymphomas with prominent involvement of subcutaneous fat. *J Cutan Pathol* 2006;33(6):418-425.
308. Pincus LB, LeBoit PE, McCalmont TH, et al. Subcutaneous panniculitis-like T-cell lymphoma with overlapping clinicopathologic features of lupus erythematosus: coexistence of 2 entities? *Am J Dermatopathol* 2009;31(6):520-526.
309. Rose C, Leverkus M, Fleischer M, Shimanovich I. Histopathology of panniculitis - aspects of biopsy techniques and difficulties in diagnosis. *J Dtsch Dermatol Ges* 2012;10(6):421-424.
310. Weingartner JS, Zedek DC, Burkhart CN, Morrell DS. Lupus erythematosus panniculitis in children: report of three cases and review of previously reported cases. *Pediatr Dermatol* 2012;29(2):169-176.
311. Hoque SR, Child FJ, Whittaker SJ, et al. Subcutaneous panniculitis-like T-cell lymphoma: a clinicopathological, immunophenotypic and molecular analysis of six patients. *Br J Dermatol* 2003;148(3):516-525.

312. Salhany KE, Macon WR, Choi JK, et al. Subcutaneous panniculitis-like T-cell lymphoma: clinicopathologic, immunophenotypic, and genotypic analysis of alpha/beta and gamma/delta subtypes. *Am J Surg Pathol* 1998;22(7): 881-893.
313. Willemze R, Jansen PM, Cerroni L, et al. Subcutaneous panniculitis-like T-cell lymphoma: definition, classification, and prognostic factors: an EORTC Cutaneous Lymphoma Group Study of 83 cases. *Blood* 2008;111(2):838-845.
314. Miura T, Kawakami Y, Sato M, Ohtsuka M, Yamamoto T. Hemophagocytic syndrome occurred in a patient with subcutaneous panniculitis-like T-cell lymphoma without overt skin lesion: successful treatment with steroid pulse therapy. *J Dermatol* 2011;38(11):1113-1115.
315. Blom A, Beylot-Barry M, D'Incan M, Laroche L. Lymphoma-associated hemophagocytic syndrome (LAHS) in advanced-stage mycosis fungoides/Sezary syndrome cutaneous T-cell lymphoma. *J Am Acad Dermatol* 2011;65(2): 404-410.
316. Weenig RH, Ng CS, Perniciaro C. Subcutaneous panniculitis-like T-cell lymphoma: an elusive case presenting as lipomembranous panniculitis and a review of 72 cases in the literature. *Am J Dermatopathol* 2001;23(3): 206-215.
317. Salhany KE, Macon WR, Felgar RE, Elenitsas R, Lessin SR, Wasik MA, Swerdlow, S.H. Subcutaneous T-cell lymphoma: analysis of T-cell receptor and cytolytic granule protein expression. *Mod Pathol* 1997;10:134A (abstract).
318. Toro JR, Beaty M, Sorbara L, et al. gamma delta T-cell lymphoma of the skin: a clinical, microscopic, and molecular study. *Arch Dermatol* 2000;136(8): 1024-1032.
319. Toro JR, Liewehr DJ, Pabby N, et al. Gamma delta T-cell phenotype is associated with significantly decreased survival in cutaneous T-cell lymphoma. *Blood* 2003. 2003;101:3407-3412.
320. Munn SE, McGregor JM, Jones A, et al. Clinical and pathological heterogeneity in cutaneous gamma-delta T-cell lymphoma: a report of three cases and a review of the literature. *Br J Dermatol* 1996;135(6):976-981.
321. Magro CM, Wang X. Indolent Primary Cutaneous gamma/delta T-Cell Lymphoma Localized to the Subcutaneous Panniculus and Its Association With Atypical Lymphocytic Lobular Panniculitis. *Am J Clin Pathol* 2012;138(1): 50-56.
322. Ahmad E, Kingma DW, Jaffe ES, et al. Flow cytometric immunophenotypic profiles of mature gamma delta T-cell malignancies involving peripheral blood and bone marrow. *Cytometry B Clin Cytom* 2005;67(1):6-12.
323. Rouillet M, Gheith SM, Mauger J, Junkins-Hopkins JM, Choi JK. Percentage of $\gamma\delta$ T Cells in Panniculitis by Paraffin Immunohistochemical Analysis. *Am J Clin Pathol* 2009;131(6):820-826.
324. Nofal A, Abdel-Mawla MY, Assaf M, Salah E. Primary cutaneous aggressive epidermotropic CD8(+) T-cell lymphoma: proposed diagnostic criteria and therapeutic evaluation. *J Am Acad Dermatol* 2012.
325. Gormley RH, Hess SD, Anand D, Junkins-Hopkins J, Rook AH, Kim EJ. Primary cutaneous aggressive epidermotropic CD8+ T-cell lymphoma. *J Am Acad Dermatol* 2010;62(2):300-307.
326. Berti E, Tomasini D, Vermeer MH, Meijer CJ, Alessi E, Willemze R. Primary cutaneous CD8-positive epidermotropic cytotoxic T cell lymphomas. A distinct clinicopathological entity with an aggressive clinical behavior. *Am J Pathol* 1999;155(2):483-492.
327. Poszepczynska-Guigne E, Jagou M, Wechsler J, Dieng MT, Revuz J, Bagot M [Cutaneous CD8+ epidermotropic cytotoxic T-cell lymphoma with aggressive course]. *Ann Dermatol Venereol* 2006;133(3):253-256.
328. Friedmann D, Wechsler J, Delfau MH, et al. Primary cutaneous pleomorphic small T-cell lymphoma. A review of 11 cases. The French Study Group on Cutaneous Lymphomas [see comments]. *Arch Dermatol* 1995;131(9): 1009-1015.
329. von den Driesch P, Coors EA. Localized cutaneous small to medium-sized pleomorphic T-cell lymphoma: a report of 3 cases stable for years. *J Am Acad Dermatol* 2002;46(4):531-535.
330. Scarabello A, Leinweber B, Ardigo M, et al. Cutaneous lymphomas with prominent granulomatous reaction: a potential pitfall in the histopathologic diagnosis of cutaneous T- and B-cell lymphomas. *Am J Surg Pathol* 2002;26(10):1259-1268.
331. Rodriguez Pinilla SM, Roncador G, Rodriguez-Peralto JL, et al. Primary cutaneous CD4+ small/medium-sized pleomorphic T-cell lymphoma expresses follicular T-cell markers. *Am J Surg Pathol* 2009;33(1):81-90.
332. Cetinozman F, Jansen PM, Willemze R. Expression of programmed death-1 in primary cutaneous CD4-positive small/medium-sized pleomorphic T-cell lymphoma, cutaneous pseudo-T-cell lymphoma, and other types of cutaneous T-cell lymphoma. *Am J Surg Pathol* 2012;36(1):109-116.

333. Battistella M, Beylot-Barry M, Bachelez H, Rivet J, Vergier B, Bagot M. Primary Cutaneous Follicular Helper T-cell Lymphoma: a new subtype of cutaneous T-cell lymphoma reported in a series of 5 cases. *Arch Dermatol* 2012.
334. Bekkenk MW, Vermeer MH, Jansen PM, et al. Peripheral T-cell lymphomas unspecified presenting in the skin: analysis of prognostic factors in a group of 82 patients. *Blood* 2003;102(6):2213-2219.
335. Sokol L, Naghashpour M, Glass LF. Primary cutaneous B-cell lymphomas: recent advances in diagnosis and management. *Cancer Control* 2012;19(3):236-244.
336. Gulia A, Saggini A, Wiesner T, et al. Clinicopathologic features of early lesions of primary cutaneous follicle center lymphoma, diffuse type: implications for early diagnosis and treatment. *J Am Acad Dermatol* 2011;65(5):991-1000.
337. Pandolfino TL, Siegel RS, Kuzel TM, Rosen ST, Guitart J. Primary cutaneous B-cell lymphoma: review and current concepts. *J Clin Oncol* 2000;18(10): 2152-2168.
338. Kerl H, Kodama K, Cerroni L. Diagnostic principles and new developments in primary cutaneous B-cell lymphomas. *J Dermatol Sci* 2004;34(3):167-175.
339. Anghel G, Pulsoni A, De Rosa L. Primary cutaneous follicle center cell lymphoma and limited stage follicular non-Hodgkin's lymphoma: a comparison of clinical and biological features. *Leuk Lymphoma* 2002;43(11):2109-2115.
340. Quereux G, Brocard A, Peuvrel L, Nguyen JM, Knol AC, Dreno B. Systemic rituximab in multifocal primary cutaneous follicle centre lymphoma. *Acta Derm Venereol* 2011;91(5):562-567.
341. Jelic TM, Berry PK, Jubelirer SJ, et al. Primary cutaneous follicle center lymphoma of the arm with a novel chromosomal translocation t(12;21)(q13;q22): a case report. *Am J Hematol* 2006;81(6):448-453.
342. Hallermann C, Kaune KM, Gesk S, et al. Molecular cytogenetic analysis of chromosomal breakpoints in the IGH, MYC, BCL6, and MALT1 gene loci in primary cutaneous B-cell lymphomas. *J Invest Dermatol* 2004;123(1): 213-219.
343. Hoefnagel JJ, Vermeer MH, Jansen PM, et al. Primary cutaneous marginal zone B-cell lymphoma: clinical and therapeutic features in 50 cases. *Arch Dermatol* 2005;141(9):1139-1145.
344. Willemze R. Primary cutaneous B-cell lymphoma: classification and treatment. *Curr Opin Oncol* 2006;18(5):425-431.
345. Kempf W, Kerl H, Kutzner H. CD123-positive plasmacytoid dendritic cells in primary cutaneous marginal zone B-cell lymphoma: a crucial role and a new lymphoma paradigm. *Am J Dermatopathol* 2010;32(2):194-196.
346. Wongchaowart NT, Kim B, Hsi ED, Swerdlow SH, Tubbs RR, Cook JR. t(14;18) (q32;q21) involving IGH and MALT1 is uncommon in cutaneous MALT lymphomas and primary cutaneous diffuse large B-cell lymphomas. *J Cutan Pathol* 2006;33(4):286-292.
347. Deutsch AJ, Fruhwirth M, Aigelsreiter A, Cerroni L, Neumeister P. Primary cutaneous marginal zone B-cell lymphomas are targeted by aberrant somatic hypermutation. *J Invest Dermatol* 2009;129(2):476-479.
348. Vermeer MH, Geelen FA, van Haselen CW, et al. Primary cutaneous large B-cell lymphomas of the legs. A distinct type of cutaneous B-cell lymphoma with an intermediate prognosis. Dutch Cutaneous Lymphoma Working Group. *Arch Dermatol* 1996;132(11):1304-1308.
349. Gellrich S, Rutz S, Golembowski S, et al. Primary cutaneous follicle center cell lymphomas and large B cell lymphomas of the leg descend from germinal center cells. A single cell polymerase chain reaction analysis. *J Invest Dermatol* 2001;117(6):1512-1520.
350. Grange F, Beylot-Barry M, Courville P, et al. Primary cutaneous diffuse large B-cell lymphoma, leg type: clinicopathologic features and prognostic analysis in 60 cases. *Arch Dermatol* 2007;143(9):1144-1150.
351. Brogan BL, Zic JA, Kinney MC, Hu JY, Hamilton KS, Greer JP. Large B-cell lymphoma of the leg: clinical and pathologic characteristics in a North American series. *J Am Acad Dermatol* 2003;49(2):223-228.
352. Koens L, Vermeer MH, Willemze R, Jansen PM. IgM expression on paraffin sections distinguishes primary cutaneous large B-cell lymphoma, leg type from primary cutaneous follicle center lymphoma. *Am J Surg Pathol* 2010;34(7):1043-1048.
353. Sundram U, Kim Y, Mraz-Gernhard S, Hoppe R, Natkunam Y, Kohler S. Expression of the bcl-6 and MUM1/IRF4 proteins correlate with overall and disease-specific survival in patients with primary cutaneous large B-cell lymphoma: a tissue microarray study. *J Cutan Pathol* 2005;32(3):227-234.

354. Hoefnagel JJ, Dijkman R, Basso K, et al. Distinct types of primary cutaneous large B-cell lymphoma identified by gene expression profiling. *Blood* 2005;105(9):3671-3678.
355. van Galen JC, Hoefnagel JJ, Vermeer MH, et al. Profiling of apoptosis genes identifies distinct types of primary cutaneous large B cell lymphoma. *J Pathol* 2008;215(3):340-346.
356. Ponzoni M, Ferreri AJ. Intravascular lymphoma: a neoplasm of 'homeless' lymphocytes? *Hematol Oncol* 2006;24(3):105-112.
357. Terrier B, Aouba A, Vasiliu V, et al. Intravascular lymphoma associated with haemophagocytic syndrome: a very rare entity in western countries. *Eur J Haematol* 2005;75(4):341-345.
358. Nixon BK, Kussick SJ, Carlon MJ, Rubin BP. Intravascular large B-cell lymphoma involving hemangiomas: an unusual presentation of a rare neoplasm. *Mod Pathol* 2005;18(8):1121-1126.
359. Cerroni L, Zalaudek I, Kerl H. Intravascular large B-cell lymphoma colonizing cutaneous hemangiomas. *Dermatology* 2004;209(2):132-134.
360. Dedic K, Belada D, Zak P, Nozicka Z. Intravascular large B-cell lymphoma presenting as cutaneous panniculitis. *Acta Medica (Hradec Kralove)* 2003;46(3):121-123.
361. Eros N, Karolyi Z, Kovacs A, Takacs I, Radvanyi G, Kelenyi G. Intravascular B-cell lymphoma. *J Am Acad Dermatol* 2002;47(5 Suppl):S260-S262.
362. Ferreri AJ, Campo E, Seymour JF, et al. Intravascular lymphoma: clinical presentation, natural history, management and prognostic factors in a series of 38 cases, with special emphasis on the 'cutaneous variant'. *Br J Haematol* 2004;127(2):173-183.
363. Kurata H, Okukubo M, Fukuda E, Ichihashi M, Ueda M. Myeloid markers should be undertaken in cases of CD56 positivity to exclude granulocytic sarcoma. *Br J Dermatol* 2002;147(3):609-611.
364. Khalid S, Adil SN, Vaziri IA. Granulocytic sarcoma in the absence of acute myeloid leukemia: a case report. *Indian J Pathol Microbiol* 2007;50(1):88-90.
365. Beswick SJ, Jones EL, Mahendra P, Marsden JR. Chloroma (aleukaemic leukaemia cutis) initially diagnosed as cutaneous lymphoma. *Clin Exp Dermatol* 2002;27(4):272-274.
366. Cronin DM, George TI, Sundram UN. An updated approach to the diagnosis of myeloid leukemia cutis. *Am J Clin Pathol* 2009;132(1):101-110.
367. Cibull TL, Thomas AB, O'Malley DP, Billings SD. Myeloid leukemia cutis: a histologic and immunohistochemical review. *J Cutan Pathol* 2008;35(2): 180-185.
368. Benet C, Gomez A, Aguilar C, et al. Histologic and immunohistologic characterization of skin localization of myeloid disorders: a study of 173 cases. *Am J Clin Pathol* 2011;135(2):278-290.
369. Lamberg SI, Bunn PA Jr. Cutaneous T-cell lymphomas. Summary of the Mycosis Fungoides Cooperative Group-National Cancer Institute Workshop. *Arch Dermatol* 1979;115(9):1103-1105.
370. Schechter GP, Sausville EA, Fischmann AB, et al. Evaluation of circulating malignant cells provides prognostic information in cutaneous T cell lymphoma. *Blood* 1987;69(3):841-849.
371. Vonderheid EC, Pena J, Nowell P. Sezary cell counts in erythrodermic cutaneous T-cell lymphoma: implications for prognosis and staging. *Leuk Lymphoma* 2006;47(9):1841-1856.
372. Bunn PA Jr, Lamberg SI. Report of the Committee on Staging and Classification of Cutaneous T-Cell Lymphomas. *Cancer Treatment Reports* 1979;63(4):725-728.
373. Huberman MS, Bunn PA Jr, Matthews MJ, et al. Hepatic involvement in the cutaneous T-cell lymphomas: results of percutaneous biopsy and peritoneoscopy. *Cancer* 1980;45(7):1683-1688.
374. Marti RM, Estrach T, Reverter JC, et al. Utility of bone marrow and liver biopsies for staging cutaneous t-cell lymphoma. *Int J Dermatol* 1996;35(6):450-454.
375. Abel EA, Wood GS, Hoppe RT. Mycosis fungoides: clinical and histologic features, staging, evaluation, and approach to treatment. *Ca: a Cancer J Clin* 1993;43(2):93-115.

376. Bass JC, Korobkin MT, Cooper KD, Kane NM, Platt JF. Cutaneous T-cell lymphoma: CT in evaluation and staging. *Radiology* 1993;186(1):273-278.
377. Kulin PA, Marglin SI, Shuman WP, Chew DE, Olerud JE. Diagnostic imaging in the initial staging of mycosis fungoides and Sezary syndrome. *Arch Dermatol* 1990;126(7):914-918.
378. Miketic LM, Chambers TP, Lembersky BC. Cutaneous T-cell lymphoma: value of CT in staging and determining prognosis. *AJR Am J Roentgenol* 1993;160(5):1129-1132.
379. Shapiro M, Yun M, Junkins-Hopkins JM, et al. Assessment of tumor burden and treatment response by 18F-fluorodeoxyglucose injection and positron emission tomography in patients with cutaneous T- and B-cell lymphomas. *J Am Acad Dermatol* 2002;47(4):623-628.
380. Tsai EY, Taur A, Espinosa L, et al. Staging accuracy in mycosis fungoides and sezary syndrome using integrated positron emission tomography and computed tomography. *Arch Dermatol* 2006;142(5):577-584.
381. Feeney J, Horwitz S, Gonen M, Schoder H. Characterization of T-cell lymphomas by FDG PET/CT. *AJR Am J Roentgenol* 2010;195(2):333-340.
382. Galindo LM, Garcia FU, Hanau CA, et al. Fine-needle aspiration biopsy in the evaluation of lymphadenopathy associated with cutaneous T-cell lymphoma (mycosis fungoides/Sezary syndrome). *Am J Clin Pathol* 2000;113(6): 865-871.
383. Lynch JW Jr, Linoilla I, Sausville EA, et al. Prognostic implications of evaluation for lymph node involvement by T-cell antigen receptor gene rearrangement in mycosis fungoides. *Blood* 1992;79(12):3293-3299.
384. Bakels V, Van Oostveen JW, Geerts ML, et al. Diagnostic and prognostic significance of clonal T-cell receptor beta gene rearrangements in lymph nodes of patients with mycosis fungoides. *J Pathol* 1993;170(3):249-255.
385. Kern DE, Kidd PG, Moe R, Hanke D, Olerud JE. Analysis of T-cell receptor gene rearrangement in lymph nodes of patients with mycosis fungoides. Prognostic implications. *Arch Dermatol* 1998;134(2):158-164.
386. Laforga JB, Chorda D, Sevilla F. Intramammary lymph node involvement by mycosis fungoides diagnosed by fine-needle aspiration biopsy. *Diagn Cytopathol* 1998;19(2):124-126.
387. Vonderheid EC, Bernengo MG. The Sezary syndrome: hematologic criteria. *Hematol Oncol Clin North Am* 2003;17(6):1367-1389, viii.
388. Muche JM, Lukowsky A, Ahnhudt C, Gellrich S, Sterry W. Peripheral blood T cell clonality in mycosis fungoides -an independent prognostic marker? *J Invest Dermatol* 2000;115(3):504-505.
389. Kim YH, Liu HL, Mraz-Gernhard S, Varghese A, Hoppe RT. Long-term outcome of 525 patients with mycosis fungoides and Sezary syndrome: clinical prognostic factors and risk for disease progression. *Arch Dermatol* 2003;139(7):857-866.
390. Novelli M, Comessati A, Quaglino P, Savoia P, Fierro MT, Bernengo MG. CD26 expression on cutaneous infiltrates from patients with cutaneous T-cell lymphoma (CTCL) CD26 in cutaneous T-cell lymphoma patients. *Adv Exp Med Biol* 2003;524:223-234.
391. Fierro MT, Novelli M, Quaglino P, et al. Heterogeneity of circulating CD4+ memory T-cell subsets in erythrodermic patients: CD27 analysis can help to distinguish cutaneous T-cell lymphomas from inflammatory erythroderma. *Dermatology* 2008;216(3):213-221.
392. Graham SJ, Sharpe RW, Steinberg SM, Cotelingam JD, Sausville EA, Foss FM. Prognostic implications of a bone marrow histopathologic classification system in mycosis fungoides and the Sezary syndrome. *Cancer* 1993;72(3):726-734.
393. Zackheim HS, Amin S, Kashani-Sabet M, McMillan A. Prognosis in cutaneous T-cell lymphoma by skin stage: long-term survival in 489 patients. *J Am Acad Dermatol* 1999;40(3):418-425.
394. Zackheim HS. Cutaneous T cell lymphoma: update of treatment. *Dermatology* 1999;199(2):102-105.
395. Lamberg SI, Green SB, Byar DP, al. Clinical staging for cutaneous T-cell lymphoma. *Ann Intern Med* 1984;100(2):187-192.
396. Foss FM, Sausville EA. Prognosis and staging of cutaneous T-cell lymphoma. *Hematol Oncol Clin North Am* 1995;9(5):1011-1019.
397. Assaf C, Hummel M, Steinhoff M, et al. Early TCR-beta and TCR-gamma PCR detection of T-cell clonality indicates minimal tumor disease in lymph nodes of cutaneous T-cell lymphoma: diagnostic and prognostic implications. *Blood* 2005;105(2):503-510.

398. Scarisbrick JJ, Whittaker S, Evans AV, et al. Prognostic significance of tumor burden in the blood of patients with erythrodermic primary cutaneous T-cell lymphoma. *Blood* 2001;97(3):624-630.
399. Marti RM, Pujol RM, Servitje O, et al. Sezary syndrome and related variants of classic cutaneous T-cell lymphoma. A descriptive and prognostic clinicopathologic study of 29 cases. *Leuk Lymphoma* 2003;44(1):59-69.
400. Foulc P, N'Guyen JM, Dreno B. Prognostic factors in Sezary syndrome: a study of 28 patients. *Br J Dermatol* 2003;149(6):1152-1158.
401. Hoppe RT, Wood GS, Abel EA. Mycosis fungoides and the Sezary syndrome: pathology, staging, and treatment. *Curr Prob Cancer* 1990;14(6):293-371.
402. Axelrod PI, Lorber B, Vonderheid EC. Infections complicating mycosis fungoides and Sezary syndrome. *JAMA* 1992;267(10):1354-1358.
403. Kuzel TM, Roenigk HH Jr, Rosen ST. Mycosis fungoides and the Sezary syndrome: a review of pathogenesis, diagnosis, and therapy. *J Clin Oncol* 1991; 9(7):1298-1313.
404. Kantor AF, Curtis RE, Vonderheid EC, van Scott EJ, Fraumeni JF Jr. Risk of second malignancy after cutaneous T-cell lymphoma. *Cancer* 1989;63(8): 1612-1615.
405. Trautinger F, Knobler R, Willemze R, et al. EORTC consensus recommendations for the treatment of mycosis fungoides/Sezary syndrome. *Eur J Cancer* 2006;42(8):1014-1030.
406. Bloom T, Kuzel TM, Querfeld C, Guitart J, Rosen ST. Cutaneous T-cell lymphomas: a review of new discoveries and treatments. *Curr Treat Options Oncol* 2012;13(1):102-121.
407. Kierland RR, Watkins CH, Shullenberger CC. The use of nitrogen mustard in the treatment of mycosis fungoides. *J Invest Dermatol* 1947;9:195-201.
408. Fenn JE, Udelsman R. First use of intravenous chemotherapy cancer treatment: rectifying the record. *J Am College of Surg* 2011;212(3):413-417.
409. O'Connor PM, Ferris DK, White GA, et al. Relationships between cdc2 kinase, DNA cross-linking, and cell cycle perturbations induced by nitrogen mustard. *Cell Growth Differ* 1992;3(1):43-52.
410. Futscher BW, Pieper RO, Dalton WS, Erickson LC. Gene-specific DNA interstrand cross-links produced by nitrogen mustard in the human tumor cell line Colo320HSR. *Cell Growth Differ* 1992;3(4):217-223.
411. Brulikova L, Hlavac J, Hradil P. DNA interstrand cross-linking agents and their chemotherapeutic potential. *Curr Med Chem* 2012;19(3):364-385.
412. Fabbri S, Prontera C, Broggin M, M DI. Differential inhibition of the DNA binding of transcription factors NF kappa B and OTF-1 by nitrogen mustard and quinacrine mustard: transcriptional implications. *Carcinogenesis* 1993;14(9):1963-1967.
413. Ramsay DL, Meller JA, Zackheim HS. Topical treatment of early cutaneous T-cell lymphoma. *Hematol Oncol Clin North Am* 1995;9(5):1031-1056.
414. Van Scott EJ, Kalmanson JD. Complete remissions of mycosis fungoides lymphoma induced by topical nitrogen mustard (HN2). Control of delayed hypersensitivity to HN2 by desensitization and by induction of specific immunologic tolerance. *Cancer* 1973;32(1):18-30.
415. Price NM, Deneau DG, Hoppe RT. The treatment of mycosis fungoides with ointment-based mechlorethamine. *Arch Dermatol* 1982;118(4):234-237.
416. Price NM, Hoppe RT, Deneau DG. Ointment-based mechlorethamine treatment for mycosis fungoides. *Cancer* 1983;52(12):2214-2219.
417. Kim YH, Martinez G, Varghese A, Hoppe RT. Topical nitrogen mustard in the management of mycosis fungoides: update of the Stanford experience. *Arch Dermatol* 2003;139(2):165-173.
418. Ramsay DL, Halperin PS, Zeleniuch-Jacquotte A. Topical mechlorethamine therapy for early stage mycosis fungoides. *J Am Acad Dermatol* 1988;19(4):684-691.
419. Vonderheid EC, Tan ET, Kantor AF, Shrager L, Micaily B, Van Scott EJ. Long-term efficacy, curative potential, and carcinogenicity of topical mechlorethamine chemotherapy in cutaneous T cell lymphoma. *J Am Acad Dermatol* 1989;20(3):416-428.

420. Sanchez Yus E, Surarez Martin E Contact urticaria and anaphylactic reactions induced by topical application of nitrogen mustard. *Actas Dermosifiliogr* 1977;68(12):39-44.
421. Grunnet E. Contact urticaria and anaphylactoid reaction induced by topical application of nitrogen mustard. *Br J Dermatol* 1976;94(1):101-103.
422. Lindahl LM, Fenger-Gron M, Iversen L. Topical nitrogen mustard therapy in patients with Langerhans cell histiocytosis. *Br J Dermatol* 2012;166(3):642-645.
423. Constantine VS, Fuks ZY, Farber EM. Mechlorethamine desensitization in therapy for mycosis fungoides. Topical desensitization to mechlorethamine (nitrogen mustard) contact hypersensitivity. *Arch Dermatol* 1975;111(4):484-488.
424. Epstein JH. Effects of mechlorethamine (HN2, nitrogen mustard) on UV-induced carcinogenesis in hairless mouse skin. *J Natl Cancer Inst* 1984;72(2):383-385.
425. Van Vloten WA, Cocijmans AC, Poel J, Meulenbelt J. Concentrations of nitrogen mustard in the air during topical treatment of patients with mycosis fungoides. *Br J Dermatol* 1993;128(4):404-406.
426. Breneman DL, Nartker AL, Ballman EA, et al. Topical mechlorethamine in the treatment of mycosis fungoides. Uniformity of application and potential for environmental contamination [see comments]. *J Am Acad Dermatol* 1991;25(6 Pt 1):1059-1064.
427. Zackheim HS, Epstein EH Jr, Crain WR. Topical carmustine (BCNU) for cutaneous T cell lymphoma: a 15-year experience in 143 patients. *J Am Acad Dermatol* 1990;22(5 Pt 1):802-810.
428. Apisarnthanarax N, Wood GS, Stevens SR, et al. Phase I Clinical Trial of O6-Benzylguanine and Topical Carmustine in the Treatment of Cutaneous T-Cell Lymphoma, Mycosis Fungoides Type. *Arch Dermatol* 2012.
429. Zackheim HS. Treatment of mycosis fungoides with topical nitrosourea compounds. *Arch Dermatol* 1972;106(2):177-182.
430. Parrish JA, Fitzpatrick TB, Tanenbaum L, Pathak MA. Photochemotherapy of psoriasis with oral methoxsalen and longwave ultraviolet light. *N Engl J Med* 1974;291(23):1207-1211.
431. Wackernagel A, Hofer A, Legat F, Kerl H, Wolf P. Efficacy of 8-methoxypsoralen vs. 5-methoxypsoralen plus ultraviolet A therapy in patients with mycosis fungoides. *Br J Dermatol* 2006;154(3):519-523.
432. Herrmann JJ, Roenigk HH Jr, Honigsmann H. Ultraviolet radiation for treatment of cutaneous T-cell lymphoma. *Hematol Oncol Clin North Am* 1995;9(5):1077-1088.
433. Okamoto H, Takigawa M, Horio T. Alteration of lymphocyte functions by 8-methoxypsoralen and longwave ultraviolet radiation. I. Suppressive effects of PUVA on T-lymphocyte migration in vitro. *J Invest Dermatol* 1985;84(3): 203-205.
434. Yoo EK, Rook AH, Elenitsas R, Gasparro FP, Vowels BR. Apoptosis induction by ultraviolet light A and photochemotherapy in cutaneous T-cell lymphoma: relevance to mechanism of therapeutic action. *J Invest Dermatol* 1996;107:235-242.
435. Herrmann JJ, Roenigk HH Jr, Hurria A, et al. Treatment of mycosis fungoides with photochemotherapy (PUVA): long-term follow-up. *J Am Acad Dermatol* 1995;33(2 Pt 1):234-242.
436. Honigsmann H, Brenner W, Rauschmeier W, Konrad K, Wolff K. Photochemotherapy for cutaneous T cell lymphoma. A follow-up study. *J Am Acad Dermatol* 1984;10(2 Pt 1):238-245.
437. Querfeld C, Rosen ST, Kuzel TM, et al. Long-term follow-up of patients with early-stage cutaneous T-cell lymphoma who achieved complete remission with psoralen plus UV-A monotherapy. *Arch Dermatol* 2005;141(3): 305-311.
438. Vella Briffa D, Warin AP, Harrington CI, Bleehen SS. Photochemotherapy in mycosis fungoides. A study of 73 patients. *Lancet* 1980;2(8185):49-53.
439. Abel EA, Sendagorta E, Hoppe RT, Hu CH. PUVA treatment of erythrodermic and plaque-type mycosis fungoides. Ten-year follow-up study. *Arch Dermatol* 1987;123(7):897-901.
440. Powell FC, Spiegel GT, Muller SA. Treatment of parapsoriasis and mycosis fungoides: the role of psoralen and long-wave ultraviolet light A (PUVA). *Mayo Clinic Proc* 1984;59(8):538-546.
441. Weber F, Schmuth M, Sepp N, Fritsch P. Bath-water PUVA therapy with 8-methoxypsoralen in mycosis fungoides. *Acta Derm Venereol* 2005;85(4):329-332.

442. Ramsay DL, Lish KM, Yalowitz CB, Soter NA. Ultraviolet-B phototherapy for early-stage cutaneous T-cell lymphoma. *Arch Dermatol* 1992;128(7):931-933.
443. Resnik KS, Vonderheid EC. Home UV phototherapy of early mycosis fungoides: long-term follow-up observations in thirty-one patients. *J Am Acad Dermatol* 1993;29(1):73-77.
444. Coven TR, Burack LH, Gilleaudeau R, Keogh M, Ozawa M, Krueger JG. Narrowband UV-B produces superior clinical and histopathological resolution of moderate-to-severe psoriasis in patients compared with broadband UV-B. *Arch Dermatol* 1997;133(12):1514-1522.
445. el-Ghorr AA, Norval M. Biological effects of narrow-band (311 nm TL01) UVB irradiation: a review. *J Photochem Photobiol B* 1997;38(2-3):99-106.
446. Ghodsi SZ, Hallaji Z, Balighi K, Safar F, Chams-Davatchi C. Narrow-band UVB in the treatment of early stage mycosis fungoides: report of 16 patients. *Clin Exp Dermatol* 2005;30(4):376-378.
447. Hearn RM, Kerr AC, Rahim KF, Ferguson J, Dawe RS. Incidence of skin cancers in 3867 patients treated with narrow-band ultraviolet B phototherapy. *Br J Dermatol* 2008;159(4):931-935.
448. Lee E, Koo J, Berger T. UVB phototherapy and skin cancer risk: a review of the literature. *Int J Dermatol* 2005;44(5):355-360.
449. Kunisada M, Kumimoto H, Ishizaki K, Sakumi K, Nakabeppu Y, Nishigori C. Narrow-band UVB induces more carcinogenic skin tumors than broadband UVB through the formation of cyclobutane pyrimidine dimer. *J Invest Dermatol* 2007;127(12):2865-2871.
450. Clark C, Dawe RS, Evans AT, Lowe G, Ferguson J. Narrowband TL-01 phototherapy for patch-stage mycosis fungoides. *Arch Dermatol* 2000;136(6):748-752.
451. Gathers RC, Scherschun L, Malick F, Fivenson DP, Lim HW. Narrowband UVB phototherapy for early-stage mycosis fungoides. *J Am Acad Dermatol* 2002;47(2):191-197.
452. El-Mofty M, El-Darouty M, Salonas M, et al. Narrow band UVB (311 nm), psoralen UVB (311 nm) and PUVA therapy in the treatment of early-stage mycosis fungoides: a right-left comparative study. *Photodermatol Photoimmunol Photomed* 2005;21(6):281-286.
453. Diederer PV, van Weelden H, Sanders CJ, Toonstra J, van Vloten WA. Narrowband UVB and psoralen-UVA in the treatment of early-stage mycosis fungoides: a retrospective study. *J Am Acad Dermatol* 2003;48(2):215-219.
454. Pavlotsky F, Barzilai A, Kasem R, Shpiro D, Trau H. UVB in the management of early stage mycosis fungoides. *J Eur Acad Dermatol Venereol* 2006;20(5):565-572.
455. Ahmad K, Rogers S, McNicholas PD, Collins P. Narrowband UVB and PUVA in the treatment of mycosis fungoides: a retrospective study. *Acta Derm Venereol* 2007;87(5):413-417.
456. Coronel-Perez IM, Carrizosa-Esquivel AM, Camacho-Martinez F. Narrow band UVB therapy in early stage mycosis fungoides. A study of 23 patients. *Actas Dermosifiliogr* 2007;98(4):259-264.
457. Gokdemir G, Barutcuoglu B, Sakiz D, Koslu A. Narrowband UVB phototherapy for early-stage mycosis fungoides: evaluation of clinical and histopathological changes. *J Eur Acad Dermatol Venereol* 2006;20(7):804-809.
458. Friedland R, David M, Feinmesser M, Barzilai A, Hodak E. NB-UVB (311-312 nm)-induced lentigines in patients with mycosis fungoides: a new adverse effect of phototherapy. *J Eur Acad Dermatol Venereol* 2011.
459. Xu HH, Xiao T, Chen HD. Lentigines following narrow-band ultraviolet B phototherapy for mycosis fungoides. *Clin Exp Dermatol* 2010;35(3):326-328.
460. Friedland R, David M, Feinmesser M, Fenig-Nakar S, Hodak E. Idiopathic guttate hypomelanosis-like lesions in patients with mycosis fungoides: a new adverse effect of phototherapy. *J Eur Acad Dermatol Venereol* 2010;24(9):1026-1030.
461. El-Mofty M, Mostafa WZ, Bosseila M, et al. A large scale analytical study on efficacy of different photo(chemo)therapeutic modalities in the treatment of psoriasis, vitiligo and mycosis fungoides. *Dermatol Ther* 2010;23(4):428-434.
462. Wang T, Liu YH, Zheng HY, et al [Hypopigmented mycosis fungoides in children: a clinicopathological study of 6 cases]. *Zhonghua yi xue za zhi* 2010;90(46):3287-3290.

463. Pavlovsky M, Baum S, Shpiro D, Pavlovsky L, Pavlotsky F. Narrow band UVB: is it effective and safe for paediatric psoriasis and atopic dermatitis? *J Eur Acad Dermatol Venereol* 2011;25(6):727-729.
464. Veith W, Deleo V, Silverberg N. Medical phototherapy in childhood skin diseases. *Minerva pediatrica* 2011;63(4):327-333.
465. Burg G, Dummer R. Historical perspective on the use of retinoids in cutaneous T-cell lymphoma (CTCL). *Clin Lymphoma* 2000;1 Suppl 1:S41-S44.
466. Molin L, Thomsen K, Volden G, et al. Oral retinoids in mycosis fungoides and Sezary syndrome: a comparison of isotretinoin and etretinate. A study from the Scandinavian Mycosis Fungoides Group. *Acta Dermato-Venereol* 1987;67(3):232-236.
467. Thomsen K, Molin L, Volden G, Lange Wantzin G, Hellbe L. 13-cis-retinoic acid effective in mycosis fungoides. A report from the Scandinavian Mycosis Fungoides Group. *Acta Dermato-Venereol* 1984;64(6):563-566.
468. Kessler JF, Jones SE, Levine N, Lynch PJ, Booth AR, Meyskens FL Jr. Isotretinoin and cutaneous helper T-cell lymphoma (mycosis fungoides). *Arch Dermatol* 1987;123(2):201-204.
469. Sanz MJ, Albertos F, Otero E, Juez M, Morcillo EJ, Piqueras L. Retinoid X Receptor Agonists Impair Arterial Mononuclear Cell Recruitment through Peroxisome Proliferator-Activated Receptor-gamma Activation. *J Immunol* 2012;189(1):411-424.
470. Boergesen M, Pedersen TA, Gross B, et al. Genome-wide profiling of liver X receptor, retinoid X receptor, and peroxisome proliferator-activated receptor alpha in mouse liver reveals extensive sharing of binding sites. *Mol Cell Biol* 2012;32(4):852-867.
471. Zhang C, Hazarika P, Ni X, Weidner DA, Duvic M. Induction of apoptosis by bexarotene in cutaneous T-cell lymphoma cells: relevance to mechanism of therapeutic action. *Clin Cancer Res* 2002;8(5):1234-1240.
472. Sherman SI, Gopal J, Haugen BR, et al. Central hypothyroidism associated with retinoid X receptor-selective ligands. *N Engl J Med* 1999;340(14):1075-1079.
473. Duvic M, Hymes K, Heald P, et al. Bexarotene is effective and safe for treatment of refractory advanced-stage cutaneous T-cell lymphoma: multinational phase II-III trial results. *J Clin Oncol* 2001;19(9):2456-2471.
474. Duvic M, Martin AG, Kim Y, et al. Phase 2 and 3 clinical trial of oral bexarotene (Targretin capsules) for the treatment of refractory or persistent early-stage cutaneous T-cell lymphoma. *Arch Dermatol* 2001;137(5):581-593.
475. Talpur R, Ward S, Apisarnthanarax N, Breuer-Mcham J, Duvic M. Optimizing bexarotene therapy for cutaneous T-cell lymphoma. *J Am Acad Dermatol* 2002;47(5):672-684.
476. Sherman SI. Etiology, diagnosis, and treatment recommendations for central hypothyroidism associated with bexarotene therapy for cutaneous T-cell lymphoma. *Clin Lymphoma* 2003;3(4):249-252.
477. Lalloyer F, Pedersen TA, Gross B, et al. Retinoid bexarotene modulates triglyceride but not cholesterol metabolism via gene-specific permissivity of the RXR/LXR heterodimer in the liver. *Arteriosclerosis, Thrombosis, Vascular Biol* 2009;29(10):1488-1495.
478. Lalloyer F, Fievet C, Lestavel S, et al. The RXR agonist bexarotene improves cholesterol homeostasis and inhibits atherosclerosis progression in a mouse model of mixed dyslipidemia. *Arteriosclerosis, Thrombosis, Vascular Biol* 2006;26(12):2731-2737.
479. Shan P, Pu J, Yuan A, Shen L, Chai D, He B. RXR agonists inhibit oxidative stress-induced apoptosis in H9c2 rat ventricular cells. *Biochem Biophys Res Commun* 2008;375(4):628-633.
480. Breneman D, Duvic M, Kuzel T, Yocum R, Truglia J, Stevens VJ. Phase 1 and 2 trial of bexarotene gel for skin-directed treatment of patients with cutaneous T-cell lymphoma. *Arch Dermatol* 2002;138(3):325-332.
481. Heald P, Mehlmauer M, Martin AG, Crowley CA, Yocum RC, Reich SD. Topical bexarotene therapy for patients with refractory or persistent early-stage cutaneous T-cell lymphoma: results of the phase III clinical trial. *J Am Acad Dermatol* 2003;49(5):801-815.
482. Olsen EA, Bunn PA. Interferon in the treatment of cutaneous T-cell lymphoma. *Hematol Oncol Clin North Am* 1995;9(5):1089-1107.

483. Bunn PA Jr, Foon KA. Therapeutic options in advanced cutaneous T cell lymphomas: a role for interferon alfa-2a (Roferon-A). *Semin Oncol* 1985;12 (4 Suppl 5):18-24.
484. Dreno B, Fleischmann M, Valard S, et al. Induction of myelo-monocytic My7 antigen (CD13) expression by interferon-alpha in basal cells of cutaneous T-cell lymphomas. *Br J Dermatol* 1992;126(4):320-323.
485. Bunn PA Jr, Foon KA, Ihde DC, et al. Recombinant leukocyte A interferon: an active agent in advanced cutaneous T-cell lymphomas. *Ann Intern Med* 1984;101(4):484-487.
486. Foon KA, Roth MS, Bunn PA Jr. Interferon therapy of non-Hodgkin's lymphoma. *Cancer* 1987;59(3 Suppl):601-604.
487. Bunn PA Jr, Hoffman SJ, Norris D, Golitz LE, Aeling JL. Systemic therapy of cutaneous T-cell lymphomas (mycosis fungoides and the Sezary syndrome). *Ann Intern Med* 1994;121(8):592-602.
488. Husken AC, Tsianakas A, Hensen P, et al. Comparison of pegylated interferon alpha-2b plus psoralen PUVA versus standard interferon alpha-2a plus PUVA in patients with cutaneous T-cell lymphoma. *J Eur Acad Dermatol Venereol* 2012;26(1):71-78.
489. Olsen EA, Rosen ST, Vollmer RT, et al. Interferon alfa-2a in the treatment of cutaneous T cell lymphoma. *J Am Acad Dermatol* 1989;20(3):395-407.
490. Papa G, Tura S, Mandelli F, et al. Is interferon alpha in cutaneous T-cell lymphoma a treatment of choice? *Br J Haematol* 1991;79(Suppl 1):48-51.
491. Jumbou O, N'Guyen JM, Tessier MH, Legoux B, Dreno B. Long-term follow-up in 51 patients with mycosis fungoides and Sezary syndrome treated by interferon-alfa. *Br J Dermatol* 1999;140(3):427-431.
492. Tura S, Mazza P, Zinzani PL, et al. Alpha recombinant interferon in the treatment of mycosis fungoides (MF). *Haematologica* 1987;72(4):337-340.
493. Kohn EC, Steis RG, Sausville EA, et al. Phase II trial of intermittent high-dose recombinant interferon alfa-2a in mycosis fungoides and the Sezary syndrome. *J Clin Oncol* 1990;8(1):155-160.
494. Dreno B, Godefroy WY, Fleischmann M, Bureau B, Litoux P. Low-dose recombinant interferon-alpha in the treatment of cutaneous T-cell lymphomas [letter]. *Br J Dermatol* 1989;121(4):543-544.
495. Mughal TI. Role of interferon alfa-2b in the management of patients with advanced cutaneous T-cell lymphoma. *Eur J Cancer* 1991;27(Suppl 4):S39-S40.
496. Estrach T, Marti R, Lecha M, Mascaro JM. Treatment of cutaneous T cell lymphoma with recombinant alfa 2b interferon [abstract]. *J Invest Dermatol* 1989;93(4):549.
497. VanderMolen LA, Steis RG, Duffey PL, et al. Low- versus high-dose interferon alfa-2a in relapsed indolent non-Hodgkin's lymphoma. *J Natl Cancer Inst* 1990;82(3):235-238.
498. Siegel RS, Kuzel TM. Cutaneous T-cell lymphoma/leukemia. *Curr Treat Options Oncol* 2000;1(1):43-50.
499. Foss FM, Ihde DC, Linnoila IR, et al. Phase II trial of fludarabine phosphate and interferon alfa-2a in advanced mycosis fungoides/Sezary syndrome. *J Clin Oncol* 1994;12(10):2051-2059.
500. Sun WH, Pabon C, Alsayed Y, et al. Interferon-alpha resistance in a cutaneous T-cell lymphoma cell line is associated with lack of STAT1 expression. *Blood* 1998;91(2):570-576.
501. Zinzani PL, Mazza P, Gherlinzoni F. Beta interferon in the treatment of mycosis fungoides. *Haematologica* 1988;73(6):547-548.
502. Jimbow K, Yamana K, Ishida O, Kawamura M, Ito Y, Maeda K [Evaluation of rIFN-gamma in the treatment of lymphoma and melanoma of the skin by systemic and intralesional administration]. *Gan to Kagaku Ryoho [Jpn J Cancer Chemother]* 1987;14(1):152-158.
503. Kaplan EH, Rosen ST, Norris DB, Roenigk HH Jr, Saks SR, Bunn PA Jr. Phase II study of recombinant human interferon gamma for treatment of cutaneous T-cell lymphoma. *J Natl Cancer Inst* 1990;82(3):208-212.
504. Wysocka M, Dawany N, Benoit B, et al. Synergistic enhancement of cellular immune responses by the novel Toll receptor 7/8 agonist 3M-007 and interferon-gamma: implications for therapy of cutaneous T-cell lymphoma. *Leuk Lymphoma* 2011;52(10):1970-1979.

505. Scholtz W. Ueber den Einfluss der Rontgenstrahlen auf die Haut in gesundem und krankem Zustande. *Archiv fur Dermatologie Syphilis* 1902;59:421-449.
506. Trump JG, Wright KA, Evans WW, et al. High energy electrons for the treatment of extensive superficial malignant lesions. *AJR* 1953;69:623-629.
507. Jones GW, Hoppe RT, Glatstein E. Electron beam treatment for cutaneous T-cell lymphoma. *Hematol Oncol Clin North Am* 1995;9(5):1057-1076.
508. Jones GW, Kacinski BM, Wilson LD, et al. Total skin electron radiation in the management of mycosis fungoides: Consensus of the European Organization for Research and Treatment of Cancer (EORTC) Cutaneous Lymphoma Project Group. *J Am Acad Dermatol* 2002;47(3):364-370.
509. el-Khatib E, Hussein S, Nikolic M, Voss NJ, Parsons C. Variation of electron beam uniformity with beam angulation and scatterer position for total skin irradiation with the Stanford technique. *Int J Radiat Oncol Biol Phys* 1995;33(2):469-474.
510. Rosenblatt E, Kuten A, Levi M, Cederbaum M. Total skin electron irradiation in mycosis fungoides dose and fractionation considerations. *Leuk Lymphoma* 1998;30(1-2):143-151.
511. Jones G, Wilson LD, Fox-Goguen L. Total skin electron beam radiotherapy for patients who have mycosis fungoides. *Hematol Oncol Clin North Am* 2003;17(6):1421-1434.
512. Ysebaert L, Truc G, Dalac S, et al. Ultimate results of radiation therapy for T1-T2 mycosis fungoides (including reirradiation). *Int J Radiat Oncol Biol Phys* 2004;58(4):1128-1134.
513. Quiros PA, Kacinski BM, Wilson LD. Extent of skin involvement as a prognostic indicator of disease free and overall survival of patients with T3 cutaneous t-cell lymphoma treated with total skin electron beam radiation therapy. *Cancer* 1996;77(9):1912-1917.
514. Desai KR, Pezner RD, Lipsett JA, et al. Total skin electron irradiation for mycosis fungoides: relationship between acute toxicities and measured dose at different anatomic sites [published erratum appears in *Int J Radiat Oncol Biol Phys* 1989 Jan;16(1):A1]. *Int J Radiat Oncol Biol Phys* 1988;15(3): 641-645.
515. Hauswald H, Zwicker F, Rochet N, et al. Total skin electron beam therapy as palliative treatment for cutaneous manifestations of advanced, therapy-refractory cutaneous lymphoma and leukemia. *Radiat Oncol* 2012;7(1):118.
516. Jones GW, Rosenthal D, Wilson LD. Total skin electron radiation for patients with erythrodermic cutaneous T-cell lymphoma (mycosis fungoides and the Sezary syndrome). *Cancer* 1999;85(9):1985-1995.
517. Wilson LD, Jones GW, Kim D, et al. Experience with total skin electron beam therapy in combination with extracorporeal photopheresis in the management of patients with erythrodermic (T4) mycosis fungoides. *J Am Acad Dermatol* 2000;43(1 Pt 1):54-60.
518. Wilson LD, Quiros PA, Kolenik SA, et al. Additional courses of total skin electron beam therapy of patients with recurrent cutaneous T-cell lymphoma. *J Am Acad Dermatol* 1996;35:69-73.
519. Becker M, Hoppe RT, Knox SJ. Multiple courses of high-dose total skin electron beam therapy in the management of mycosis fungoides. *International J Radiat Oncol Biol Phys* 1995;32(5):1445-1449.
520. Navi D, Riaz N, Levin YS, Sullivan NC, Kim YH, Hoppe RT. The Stanford University experience with conventional-dose, total skin electron-beam therapy in the treatment of generalized patch or plaque (T2) and tumor (T3) mycosis fungoides. *Arch Dermatol* 2011;147(5):561-567.
521. Panizzon RG. Irradiation therapy: from UV light to electron beam. *J Cutan Pathol* 2006;33 Suppl 1:43-46.
522. Kirova YM, Piedbois Y, Haddad E, et al. Radiotherapy in the management of mycosis fungoides: indications, results, prognosis. Twenty years experience. *Radiother Oncol* 1999;51(2):147-151.
523. Maingon P, Truc G, Dalac S, et al. Radiotherapy of advanced mycosis fungoides: indications and results of total skin electron beam and photon beam irradiation. *Radiother Oncol* 2000;54(1):73-78.
524. Pineda AA, Winkelmann RK. Leukapheresis in the treatment of Sezary syndrome. *J Am Acad Dermatol* 1981;5(5):544-549.
525. Edelson R, Berger C, Gasparro F, et al. Treatment of cutaneous T-cell lymphoma by extracorporeal photochemotherapy. Preliminary results. *N Engl J Med* 1987;316(6):297-303.
526. Edelson RL. Cutaneous T cell lymphoma: the helping hand of dendritic cells. *Ann N Y Acad Sci* 2001;941:1-11.

527. Berger CL, Hanlon D, Kanada D, Girardi M, Edelson RL. Transimmunization, a novel approach for tumor immunotherapy. *Transfus Apheresis Sci* 2002;26(3):205-216.
528. Perez M, Edelson R, Laroche L, Berger C. Inhibition of antiskin allograft immunity by infusions with syngeneic photoinactivated effector lymphocytes. *J Invest Dermatol* 1989;92(5):669-676.
529. Moor AC, Schmitt IM, Beijersbergen van Henegouwen GM, Chimenti S, Edelson RL, Gasparro FP. Treatment with 8-MOP and UVA enhances MHC class I synthesis in RMA cells: preliminary results. *J Photochem Photobiol* 1995;29(2-3):193-198.
530. Berger CL, Wang N, Christensen I, Longley J, Heald P, Edelson RL. The immune response to Class I-associated tumor-specific cutaneous T-cell lymphoma antigens. *J Invest Dermatol* 1996;107(3):392-397.
531. Wolfe JT, Lessin SR, Singh AH, Rook AH. Review of immunomodulation by photopheresis: treatment of cutaneous T-cell lymphoma, autoimmune disease, and allograft rejection. *Artif Organs* 1994;18(12):888-897.
532. Heald P, Rook A, Perez M, et al. Treatment of erythrodermic cutaneous T-cell lymphoma with extracorporeal photochemotherapy [see comments]. *J Am Acad Dermatol* 1992;27(3):427-433.
533. Vowels BR, Cassin M, Boufal MH, Walsh LJ, Rook AH. Extracorporeal photochemotherapy induces the production of tumor necrosis factor-alpha by monocytes: implications for the treatment of cutaneous T-cell lymphoma and systemic sclerosis. *J Invest Dermatol* 1992;98(5):686-692.
534. Berger CL, Xu AL, Hanlon D, et al. Induction of human tumor-loaded dendritic cells. *Int J Cancer* 2001;91(4):438-447.
535. Berger C, Hoffmann K, Vasquez JG, et al. Rapid generation of maturationally synchronized human dendritic cells: contribution to the clinical efficacy of extracorporeal photochemotherapy. *Blood* 2010;116(23):4838-4847.
536. Ni X, Duvic M. Dendritic cells and cutaneous T-cell lymphomas. *Giornale italiano di dermatologia e venereologia : organo ufficiale, Societa italiana di dermatologia e sifilografia* 2011;146(2):103-113.
537. Zic JA. The treatment of cutaneous T-cell lymphoma with photopheresis. *Dermatol Ther* 2003;16(4):337-346.
538. Zic J, Arzubiaga C, Salhany KE, et al. Extracorporeal photopheresis for the treatment of cutaneous T-cell lymphoma [see comments]. *J Am Acad Dermatol* 1992;27(5 Pt 1):729-736.
539. Heald PW, Perez MI, Christensen I, Dobbs N, McKiernan G, Edelson R. Photopheresis therapy of cutaneous T-cell lymphoma: the Yale-New Haven Hospital experience. *Yale J Biol Med* 1989;62(6):629-638.
540. Koh HK, Davis BE, Meola T, Lim HW. Extracorporeal photopheresis for the treatment of 34 patients with cutaneous T cell lymphoma (CTCL). *J Invest Dermatol* 1994;102:567.
541. Duvic M, Hester JP, Lemark NA. Photopheresis therapy for the treatment of cutaneous T-cell lymphoma. *J Am Acad Dermatol* 1996;35(4):573-579.
542. Zic JA, Miller JL, Stricklin GP, King LE Jr. The North American experience with photopheresis. *Ther Apher* 1999;3(1):50-62.
543. Lim HW, Edelson RL. Photopheresis for the treatment of cutaneous T-cell lymphoma. *Hematol Oncol Clin North Am* 1995;9(5):1117-1126.
544. Scarisbrick JJ, Taylor P, Holtick U, et al. U.K. consensus statement on the use of extracorporeal photopheresis for treatment of cutaneous T-cell lymphoma and chronic graft-versus-host disease. *Br J Dermatol* 2008;158(4):659-678.
545. Zic JA. Photopheresis in the treatment of cutaneous T-cell lymphoma: current status. *Curr Opin Oncol* 2012;24 Suppl 1:S1-S10.
546. Russell-Jones R. Extracorporeal photopheresis in cutaneous T-cell lymphoma. Inconsistent data underline the need for randomized studies. *Br J Dermatol* 2000;142(1):16-21.
547. Martino M, Fedele R, Cornelio G, et al. Extracorporeal photopheresis, a therapeutic option for cutaneous T-cell lymphoma and immunological diseases: state of the art. *Expert Opin Biol Ther* 2012;12(8):1017-1030.
548. Atta M, Papanicolaou N, Tsigotis P. The role of extracorporeal photopheresis in the treatment of cutaneous T-cell lymphomas. *Transfus Apher Sci* 2012;46(2):195-202.
549. Zic JA, Stricklin GP, Greer JP, et al. Long-term follow-up of cutaneous T-cell lymphoma patients treated with extracorporeal photochemotherapy. *J Am Acad Dermatol* 1996;35(6):935-945.

550. Talpur R, Demierre MF, Geskin L, et al. Multicenter photopheresis intervention trial in early-stage mycosis fungoides. *Clinical Lymphoma, Myeloma Leukemia* 2011;11(2):219-227.
551. Rubegni P, De Aloe G, Fimiani M. Extracorporeal photochemotherapy in long-term treatment of early stage cutaneous T-cell lymphoma. *Br J Dermatol* 2000;143(4):894-896.
552. Child FJ, Mitchell TJ, Whittaker SJ, Scarisbrick JJ, Seed PT, Russell-Jones R. A randomized cross-over study to compare PUVA and extracorporeal photopheresis in the treatment of plaque stage (T2) mycosis fungoides. *Clin Exp Dermatol* 2004;29(3):231-236.
553. Miller JD, Kirkland EB, Domingo DS, et al. Review of extracorporeal photopheresis in early-stage (IA, IB, and IIA) cutaneous T-cell lymphoma. *Photodermatol Photoimmunol Photomed* 2007;23(5):163-171.
554. Duvic M, Hagemester F, Hester J. Accelerated delivery of extracorporeal photopheresis in patients with cutaneous T-cell lymphoma. *J Invest Dermatol* 1989;92:423.
555. Suchin KR, Cucchiara AJ, Gottlieb SL, et al. Treatment of cutaneous T-cell lymphoma with combined immunomodulatory therapy: a 14-year experience at a single institution. *Arch Dermatol* 2002;138(8):1054-1060.
556. Rook AH, Gottlieb SL, Wolfe JT, et al. Pathogenesis of cutaneous T-cell lymphoma: implications for the use of recombinant cytokines and photopheresis. *Clin Exp Immunol* 1997;107(Suppl 1):16-20.
557. Fritz TM, Kleinhans M, Nestle FO, Burg G, Dummer R. Combination treatment with extracorporeal photopheresis, interferon alfa and interleukin-2 in a patient with the Sezary syndrome. *Br J Dermatol* 1999;140(6):1144-1147.
558. McGinnis KS, Ubriani R, Newton S, et al. The addition of interferon gamma to oral bexarotene therapy with photopheresis for Sezary syndrome. *Arch Dermatol* 2005;141(9):1176-1178.
559. Apisarnthanarax N, Talpur R, Duvic M. Treatment of cutaneous T cell lymphoma: current status and future directions. *Am J Clin Dermatol* 2002;3(3):193-215.
560. Siakantaris MP, Tsigotis P, Stavroyianni N, et al. Management of cutaneous T-Cell lymphoma patients with extracorporeal photopheresis. The Hellenic experience. *Transfus Apher Sci* 2012;46(2):189-193.
561. Raphael BA, Shin DB, Suchin KR, et al. High clinical response rate of Sezary syndrome to immunomodulatory therapies: prognostic markers of response. *Arch Dermatol* 2011;147(12):1410-1415.
562. Booken N, Weiss C, Utikal J, Felcht M, Goerdts S, Klemke CD. Combination therapy with extracorporeal photopheresis, interferon-alpha, PUVA and topical corticosteroids in the management of Sezary syndrome. *J Dtsch Dermatol Ges* 2010;8(6):428-438.
- P.1983
563. McGirt LY, Thoburn C, Hess A, Vonderheid EC. Predictors of response to extracorporeal photopheresis in advanced mycosis fungoides and Sezary syndrome. *Photodermatol Photoimmunol Photomed* 2010;26(4):182-191.
564. Prince HM, Whittaker S, Hoppe RT. How I treat mycosis fungoides and Sezary syndrome. *Blood* 2009;114(20):4337-4353.
565. Duvic M. Systemic monotherapy vs combination therapy for CTCL: rationale and future strategies. *Oncology (Williston Park)* 2007;21(2 Suppl 1):33-40.
566. Lansigan F, Foss FM. Current and emerging treatment strategies for cutaneous T-cell lymphoma. *Drugs* 2010;70(3):273-286.
567. Rosen ST, Foss FM. Chemotherapy for mycosis fungoides and the Sezary syndrome. *Hematol Oncol Clin North Am* 1995;9(5):1109-1116.
568. Winkelmann RK, Diaz-Perez JL, Buechner SA. The treatment of Sezary syndrome. *J Am Acad Dermatol* 1984;10(6):1000-1004.
569. Coors EA, von den Driesch P. Treatment of erythrodermic cutaneous T-cell lymphoma with intermittent chlorambucil and flucortolone therapy. *Br J Dermatol* 2000;143(1):127-131.

570. Zackheim HS, Kashani-Sabet M, McMillan A. Low-dose methotrexate to treat mycosis fungoides: a retrospective study in 69 patients. *J Am Acad Dermatol* 2003;49(5):873-878.
571. Zackheim HS, Kashani-Sabet M, Hwang ST. Low-dose methotrexate to treat erythrodermic cutaneous T-cell lymphoma: results in twenty-nine patients. *J Am Acad Dermatol* 1996;34(4):626-631.
572. Zinzani PL, Baliva G, Magagnoli M, et al. Gemcitabine treatment in pretreated cutaneous T-cell lymphoma: experience in 44 patients. *J Clin Oncol* 2000;18(13):2603-2606.
573. Duvic M, Talpur R, Wen S, Kurzrock R, David CL, Apisarnthanarax N. Phase II evaluation of gemcitabine monotherapy for cutaneous T-cell lymphoma. *Clin Lymphoma Myeloma* 2006;7(1):51-58.
574. Marchi E, Alinari L, Tani M, et al. Gemcitabine as frontline treatment for cutaneous T-cell lymphoma: phase II study of 32 patients. *Cancer* 2005; 104(11):2437-2441.
575. Jidar K, Ingen-Housz-Oro S, Beylot-Barry M, et al. Gemcitabine treatment in cutaneous T-cell lymphoma: a multicentre study of 23 cases. *Br J Dermatol* 2009;161(3):660-663.
576. Grever MR, Bisaccia E, Scarborough DA, Metz EN, Neidhart JA. An investigation of 2'-deoxycoformycin in the treatment of cutaneous T-cell lymphoma. *Blood* 1983;61(2):279-282.
577. Saven A, Carrera CJ, Carson DA, Beutler E, Piro LD. 2-Chlorodeoxyadenosine: an active agent in the treatment of cutaneous T-cell lymphoma. *Blood* 1992;80(3):587-592.
578. Kurzrock R, Ravandi F. Purine analogues in advanced T-cell lymphoid malignancies. *Semin Hematol* 2006;43(2 Suppl 2):S27-S34.
579. Ho AD, Suci S, Stryckmans P, et al. Pentostatin in T-cell malignancies—a phase II trial of the EORTC. *Leukemia Cooperative Group. Ann Oncol* 1999;10(12):1493-1498.
580. Foss FM. Activity of pentostatin (Nipent) in cutaneous T-cell lymphoma: single-agent and combination studies. *Semin Oncol* 2000;27(2 Suppl 5):58-63.
581. Foss FM, Ihde DC, Breneman DL, et al. Phase II study of pentostatin and intermittent high-dose recombinant interferon alfa-2a in advanced mycosis fungoides/Sezary syndrome. *J Clin Oncol* 1992;10(12):1907-1913.
582. Kuzel TM, Hurria A, Samuelson E, et al. Phase II trial of 2-chlorodeoxyadenosine for the treatment of cutaneous T-cell lymphoma. *Blood* 1996;87(3): 906-911.
583. O'Brien S, Kurzrock R, Duvic M, et al. 2-Chlorodeoxyadenosine therapy in patients with T-cell lymphoproliferative disorders. *Blood* 1994;84(3): 733-738.
584. Von Hoff DD, Dahlberg S, Hartstock RJ, Eyre HJ. Activity of fludarabine monophosphate in patients with advanced mycosis fungoides: a Southwest Oncology Group study. *J Natl Cancer Inst* 1990;82(16):1353-1355.
585. Quaglino P, Fierro MT, Rossotto GL, Savoia P, Bernengo MG. Treatment of advanced mycosis fungoides/Sezary syndrome with fludarabine and potential adjunctive benefit to subsequent extracorporeal photochemotherapy. *Br J Dermatol* 2004;150(2):327-336.
586. Scarisbrick JJ, Child FJ, Clift A, et al. A trial of fludarabine and cyclophosphamide combination chemotherapy in the treatment of advanced refractory primary cutaneous T-cell lymphoma. *Br J Dermatol* 2001;144(5):1010-1015.
587. Galmarini CM. Drug evaluation: forodesine - PNP inhibitor for the treatment of leukemia, lymphoma and solid tumor. *IDrugs: The Invest Drugs J* 2006;9(10):712-722.
588. Balakrishnan K, Verma D, O'Brien S, et al. Phase 2 and pharmacodynamic study of oral forodesine in patients with advanced, fludarabine-treated chronic lymphocytic leukemia. *Blood* 2010;116(6):886-892.
589. Duvic M, Forero A, Foss F, Olsen E, Kim Y. Oral Forodesine (Bcx-1777) is clinically active in refractory cutaneous T-cell lymphoma: results of a phase I/II study. *Blood (2006 ASH Annual Meeting Abstracts)* 2006;108:Abstract 2467.
590. Gabizon AA. Selective tumor localization and improved therapeutic index of anthracyclines encapsulated in long-circulating liposomes. *Cancer Res* 1992;52(4):891-896.
591. Wollina U, Graefe T, Kaatz M. Pegylated doxorubicin for primary cutaneous T-cell lymphoma: a report on ten patients with follow-up. *J Cancer Res Clin Oncol* 2001;127(2):128-134.

592. Wollina U, Dummer R, Brockmeyer NH, et al. Multicenter study of pegylated liposomal doxorubicin in patients with cutaneous T-cell lymphoma. *Cancer* 2003;98(5):993-1001.
593. Piekarz RL, Robey R, Sandor V, et al. Inhibitor of histone deacetylation, depsipeptide (FR901228), in the treatment of peripheral and cutaneous T-cell lymphoma: a case report. *Blood* 2001;98(9):2865-2868.
594. O'Connor OA, Heaney ML, Schwartz L, et al. Clinical experience with intravenous and oral formulations of the novel histone deacetylase inhibitor suberoylanilide hydroxamic acid in patients with advanced hematologic malignancies. *J Clin Oncol* 2006;24(1):166-173.
595. Horwitz SM. The emerging role of histone deacetylase inhibitors in treating T-cell lymphomas. *Curr Hematol Malignancy Reports* 2011;6(1):67-72.
596. Tiffon C, Adams J, van der Fits L, et al. The histone deacetylase inhibitors vorinostat and romidepsin downmodulate IL-10 expression in cutaneous T-cell lymphoma cells. *Br J Pharmacol* 2011;162(7):1590-1602.
597. Glaser KB. HDAC inhibitors: clinical update and mechanism-based potential. *Biochem Pharmacol* 2007;74(5):659-671.
598. Marks PA, Richon VM, Rifkind RA. Histone deacetylase inhibitors: inducers of differentiation or apoptosis of transformed cells. *J Natl Cancer Inst* 2000;92(15):1210-1216.
599. Duvic M, Talpur R, Ni X, et al. Phase 2 trial of oral vorinostat (suberoylanilide hydroxamic acid, SAHA) for refractory cutaneous T-cell lymphoma (CTCL). *Blood* 2007;109(1):31-39.
600. Olsen EA, Kim YH, Kuzel TM, et al. Phase IIb multicenter trial of vorinostat in patients with persistent, progressive, or treatment refractory cutaneous T-cell lymphoma. *J Clin Oncol* 2007;25(21):3109-3115.
601. Jr DR, Washam JB, Newby LK. QT interval prolongation and torsades de pointes in a patient undergoing treatment with vorinostat: A case report and review of the literature. *Cardiol J* 2012;19(4):434-438.
602. Dummer R, Beyer M, Hymes K, et al. Vorinostat combined with bexarotene for treatment of cutaneous T-cell lymphoma: in vitro and phase I clinical evidence supporting augmentation of retinoic acid receptor/retinoid X receptor activation by histone deacetylase inhibition. *Leuk Lymphoma* 2012;53(8):1501-1508.
603. Lyseng-Williamson KA, Yang LP. Romidepsin: a guide to its clinical use in cutaneous T-cell lymphoma. *Am J Clin Dermatol* 2012;13(1):67-71.
604. Jain S, Zain J. Romidepsin in the treatment of cutaneous T-cell lymphoma. *J Blood Med* 2011;2:37-47.
605. Furumai R, Matsuyama A, Kobashi N, et al. FK228 (depsipeptide) as a natural prodrug that inhibits class I histone deacetylases. *Cancer Res* 2002;62(17):4916-4921.
606. Piekarz RL, Frye R, Turner M, et al. Phase II multi-institutional trial of the histone deacetylase inhibitor romidepsin as monotherapy for patients with cutaneous T-cell lymphoma. *J Clin Oncol* 2009;27(32):5410-5417.
607. Whittaker SJ, Demierre MF, Kim EJ, et al. Final results from a multicenter, international, pivotal study of romidepsin in refractory cutaneous T-cell lymphoma. *J Clin Oncol* 2010;28(29):4485-4491.
608. Bishton MJ, Harrison SJ, Martin BP, et al. Deciphering the molecular and biologic processes that mediate histone deacetylase inhibitor-induced thrombocytopenia. *Blood* 2011;117(13):3658-3668.
609. Karagiannis TC, El-Osta A. Will broad-spectrum histone deacetylase inhibitors be superseded by more specific compounds? *Leukemia* 2007;21:61-65.
610. Pohlman B, Advani R, Duvic M, et al. Final results of a phase II trial of belinostat (pxd101) in patients with recurrent or refractory peripheral or cutaneous t-cell lymphoma. *Blood* (2009 ASH Annual Meeting Abstracts) 2009;114:Abstract 920.
611. Gimsing P. Belinostat: a new broad acting antineoplastic histone deacetylase inhibitor. *Exp Opin Invest Drugs* 2009;18(4):501-508.
612. Molife LR, de Bono JS. Belinostat: clinical applications in solid tumors and lymphoma. *Exp Opin Invest Drugs* 2011;20(12):1723-1732.
613. Steele NL, Plumb JA, Vidal L, et al. Pharmacokinetic and pharmacodynamic properties of an oral formulation of the histone deacetylase inhibitor Belinostat (PXD101). *Cancer Chemother Pharmacol* 2011;67(6): 1273-1279.

614. Ellis L, Pan Y, Smyth GK, et al. Histone deacetylase inhibitor panobinostat induces clinical responses with associated alterations in gene expression profiles in cutaneous T-cell lymphoma. *Clin Cancer Res* 2008;14(14):4500-4510.
615. Duvic M, Becker JC, Dalle S, et al. Phase II trial of oral panobinostat (LBH589) in patients with refractory cutaneous T-cell lymphoma (CTCL). *Blood (ASH Annual Meeting Abstracts)* 2008;112:Abstract 1005.
616. Zhang L, Lebowitz D, Masson E, Laird G, Cooper MR, Prince HM. Clinically relevant QTc prolongation is not associated with current dose schedules of LBH589 (panobinostat). *J Clin Oncol* 2008;26(2):332-333; discussion 3-4.
617. O'Connor OA, Pro B, Pinter-Brown L, et al. Pralatrexate in patients with relapsed or refractory peripheral T-cell lymphoma: results from the pivotal PROPEL study. *J Clin Oncol* 2011;29(9):1182-1189.
618. Horwitz SM, Kim YH, Foss F, et al. Identification of an active, well-tolerated dose of pralatrexate in patients with relapsed or refractory cutaneous T-cell lymphoma. *Blood* 2012;119(18):4115-4122.
619. Toner LE, Vrhovac R, Smith EA, et al. The schedule-dependent effects of the novel antifolate pralatrexate and gemcitabine are superior to methotrexate and cytarabine in models of human non-Hodgkin's lymphoma. *Clin Cancer Res* 2006;12(3 Pt 1):924-932.
620. Horwitz SM, Vose JM, Advani R, et al. Pralatrexate and Gemcitabine in Patients with Relapsed or Refractory Lymphoproliferative Malignancies: Phase 1 Results. *Blood (ASH Annual Meeting Abstracts)* 2009;114:Abstract 1674.
621. Marchi E, Paoluzzi L, Scotto L, et al. Pralatrexate is synergistic with the proteasome inhibitor bortezomib in in vitro and in vivo models of T-cell lymphoid malignancies. *Clin Cancer Res* 2010;16(14):3648-3658.
622. Sors A, Jean-Louis F, Pellet C, et al. Down-regulating constitutive activation of the NF-kappaB canonical pathway overcomes the resistance of cutaneous T-cell lymphoma to apoptosis. *Blood* 2006;107(6):2354-2363.
623. Zinzani PL, Musuraca G, Tani M, et al. Phase II trial of proteasome inhibitor bortezomib in patients with relapsed or refractory cutaneous T-cell lymphoma. *J Clin Oncol* 2007;25(27):4293-4297.
624. Falchook GS, Duvic M, Hong DS, et al. Age-stratified phase I trial of a combination of bortezomib, gemcitabine, and liposomal doxorubicin in patients with advanced malignancies. *Cancer Chemother Pharmacol* 2012;69(5):1117-1126.
625. Heider U, Rademacher J, Lamottke B, et al. Synergistic interaction of the histone deacetylase inhibitor SAHA with the proteasome inhibitor bortezomib in cutaneous T cell lymphoma. *Eur J Haematol* 2009;82(6):440-449.
626. Dolan ME, McRae BL, Ferries-Rowe E, et al. O6-alkylguanine-DNA alkyltransferase in cutaneous T-cell lymphoma: implications for treatment with alkylating agents. *Clin Cancer Res* 1999;5(8):2059-2064.
627. Tani M, Fina M, Alinari L, Stefoni V, Baccarani M, Zinzani PL. Phase II trial of temozolomide in patients with pretreated cutaneous T-cell lymphoma. *Haematologica* 2005;90(9):1283-1284.
628. Querfeld C, Rosen ST, Guitart J, et al. Multicenter phase II trial of temozolomide in mycosis fungoides/sezary syndrome: correlation with O(6)-methylguanine-DNA methyltransferase and mismatch repair proteins. *Clin Cancer Res* 2011;17(17):5748-5754.
629. Molin L, Thomsen K, Volden G, et al. Combination chemotherapy in the tumour stage of mycosis fungoides with cyclophosphamide, vincristine, vp-16, adriamycin and prednisolone (cop, chop, cavop): a report from the Scandinavian mycosis fungoides study group. *Acta Dermato-Venereologica* 1980;60(6):542-544.
630. Duvic M, Apisarnthanarax N, Cohen DS, Smith TL, Ha CS, Kurzrock R. Analysis of long-term outcomes of combined modality therapy for cutaneous T-cell lymphoma. *J Am Acad Dermatol* 2003;49(1):35-49.
631. Akpek G, Koh HK, Bogen S, O'Hara C, Foss FM. Chemotherapy with etoposide, vincristine, doxorubicin, bolus cyclophosphamide, and oral prednisone in patients with refractory cutaneous T-cell lymphoma. *Cancer* 1999;86(7):1368-1376.
632. Hallahan DE, Griem ML, Griem SF, et al. Combined modality therapy for tumor stage mycosis fungoides: results of a 10-year follow-up. *J Clin Oncol* 1988;6(7):1177-1183.
633. Winkler CF, Sausville EA, Ihde DC, et al. Combined modality treatment of cutaneous T cell lymphoma: results of a 6-year follow-up. *J Clin Oncol* 1986;4(7):1094-1100.
634. Braverman IM, Yager NB, Chen M, Cadman EC, Hait WN, Maynard T. Combined total body electron beam irradiation and chemotherapy for mycosis fungoides. *J Am Acad Dermatol* 1987;16(1 Pt 1):45-60.

635. Quiros PA, Jones GW, Kacinski BM, et al. Total skin electron beam therapy followed by adjuvant psoralen/ultraviolet-A light in the management of patients with T1 and T2 cutaneous T-cell lymphoma (mycosis fungoides). *Int J Radiat Oncol Biol Phys* 1997;38(5):1027-1035.
636. Kaye FJ, Bunn PA Jr, Steinberg SM, et al. A randomized trial comparing combination electron-beam radiation and chemotherapy with topical therapy in the initial treatment of mycosis fungoides [see comments]. *N Engl J Med* 1989;321(26):1784-1790.
637. Wilson LD, Licata AL, Braverman IM, et al. Systemic chemotherapy and extracorporeal photochemotherapy for T3 and T4 cutaneous T-cell lymphoma patients who have achieved a complete response to total skin electron beam therapy. *Int J Radiat Oncol Biol Phys* 1995;32(4):987-995.
638. Aviles A, Guzman R, Garcia EL, Diazmaqueo JC. Biological modifiers (etretinate and interferon alfa 2a) in the treatment of refractory cutaneous t-cell lymphoma. *Cancer Biother Radiopharm* 1996;11(1):21-24.
639. Altomare GF, Capella GL, Pigatto PD, Finzi AF. Intramuscular low dose alpha-2B interferon and etretinate for treatment of mycosis fungoides. *Int J Dermatol* 1993;32(2):138-141.
640. Knobler RM, Trautinger F, Radaszkiewicz T, Kokoschka EM, Micksche M. Treatment of cutaneous T cell lymphoma with a combination of low-dose interferon alfa-2b and retinoids. *J Am Acad Dermatol* 1991;24(2 Pt 1):247-252.
641. Serri F, De Simone C, Venier A, Rusciani L, Marchetti F. Combination of retinoids and PUVA (Re-PUVA) in the treatment of cutaneous T cell lymphomas. *Curr Prob Dermatol* 1990;19:252-257.
642. Singh F, Lebwohl MG. Cutaneous T-cell lymphoma treatment using bexarotene and PUVA: a case series. *J Am Acad Dermatol* 2004;51(4):570-573.
643. Kuzel TM, Roenigk HH Jr, Samuelson E, et al. Effectiveness of interferon alfa-2a combined with phototherapy for mycosis fungoides and the Sezary syndrome. *J Clin Oncol* 1995;13(1):257-263.
644. Stadler R, Otte HG. Combination therapy of cutaneous T cell lymphoma with interferon alpha-2a and photochemotherapy. *Recent Results Cancer Res* 1995;139:391-401.
645. Chiarion-Sileni V, Bononi A, Fornasa CV, et al. Phase II trial of interferonalph-2a plus psolaren with ultraviolet light A in patients with cutaneous T-cell lymphoma. *Cancer* 2002;95(3):569-575.
646. Rupoli S, Goteri G, Pulini S, et al. Long-term experience with low-dose interferon-alpha and PUVA in the management of early mycosis fungoides. *Eur J Haematol* 2005;75(2):136-145.
647. Stadler R, Otte HG, Luger T, et al. Prospective randomized multicenter clinical trial on the use of interferon -2a plus acitretin versus interferon -2a plus PUVA in patients with cutaneous T-cell lymphoma stages I and II. *Blood* 1998;92(10):3578-3581.
648. D'Acunto C, Gurioli C, Neri I. Plaque stage mycosis fungoides treated with bexarotene at low dosage and UVB-NB. *J Dermatolog Treat* 2010;21(1): 45-48.
649. Coors EA, Von den Driesch P. Treatment of mycosis fungoides with bexarotene and psoralen plus ultraviolet A. *Br J Dermatol* 2005;152(6):1379-1381.
650. Kronke A, Schlaak M, Arin M, Mauch C, Kurschat P. Successful treatment of a folliculotropic mycosis fungoides with bexarotene and PUVA. *Eur J Dermatol* 2012;22(2):259-260.
651. Stern DK, Lebwohl M. Treatment of mycosis fungoides with oral bexarotene combined with PUVA. *J Drugs Dermatol* 2002;1(2):134-136.
652. Papadavid E, Antoniou C, Nikolaou V, et al. Safety and efficacy of low-dose bexarotene and PUVA in the treatment of patients with mycosis fungoides. *Am J Clin Dermatol* 2008;9(3):169-173.
653. Ortiz-Romero PL, Sanchez-Largo ME, Sanz H, et al. [Treatment of mycosis fungoides with PUVA and bexarotene]. *Actas Dermosifiliogr* 2006;97(5):311-318.
654. Guitart J. Combination treatment modalities in cutaneous T-cell lymphoma (CTCL). *Semin Oncol* 2006;33(1 Suppl 3):S17-S20.
655. Foss FM, Kuzel TM. Experimental therapies in the treatment of cutaneous T-cell lymphoma. *Hematol Oncol Clin North Am* 1995;9(5):1127-1137.

656. Waldmann TA. The IL-2/IL-2 receptor system: a target for rational immune intervention. *Trends Pharmacol Sci* 1993;14(5):159-164.
657. LeMaistre CF, Kuzel T, Foss F, et al. DAB389IL2 is well tolerated at doses inducing responses in IL-2R expressing lymphomas. *Blood* 1993;82((Suppl 1)): 137a.
658. Hesketh P, Caguioa P, Koh H, et al. Clinical activity of a cytotoxic fusion protein in the treatment of cutaneous T-cell lymphoma. *J Clin Oncol* 1993;11(9):1682-1690.
659. LeMaistre CF, Craig FE, Meneghetti C, et al. Phase I trial of a 90-minute infusion of the fusion toxin DAB486IL-2 in hematological cancers. *Cancer Res* 1993;53(17):3930-3934.
660. Foss FM, Borkowski TA, Gilliom M, et al. Chimeric fusion protein toxin DAB486IL-2 in advanced mycosis fungoides and the Sezary syndrome: correlation of activity and interleukin-2 receptor expression in a phase II study. *Blood* 1994;84(6):1765-1774.
661. Olsen E, Duvic M, Frankel A, et al. Pivotal phase III trial of two dose levels of denileukin diftitox for the treatment of cutaneous T-cell lymphoma. *J Clin Oncol* 2001;19(2):376-388.
662. Prince HM, Duvic M, Martin A, et al. Phase III placebo-controlled trial of denileukin diftitox for patients with cutaneous T-cell lymphoma. *J Clin Oncol* 2010;28(11):1870-1877.
663. Talpur R, Jones DM, Alencar AJ, et al. CD25 expression is correlated with histological grade and response to denileukin diftitox in cutaneous T-cell lymphoma. *J Invest Dermatol* 2006;126(3):575-583.
664. Foss FM, Bacha P, Osann KE, Demierre MF, Bell T, Kuzel T. Biological correlates of acute hypersensitivity events with DAB(389)IL-2 (denileukin diftitox, ONTAK) in cutaneous T-cell lymphoma: decreased frequency and severity with steroid premedication. *Clin Lymphoma* 2001;1(4):298-302.
665. Pangalis GA, Dimopoulou MN, Angelopoulou MK, et al. Campath-1H (anti-CD52) monoclonal antibody therapy in lymphoproliferative disorders. *Med Oncol* 2001;18(2):99-107.
666. Clark RA, Watanabe R, Teague JE, et al. Skin effector memory T cells do not recirculate and provide immune protection in alemtuzumab-treated CTCL patients. *Sci Translational Med* 2012;4(117):117ra7.
667. Kennedy GA, Seymour JF, Wolf M, et al. Treatment of patients with advanced mycosis fungoides and Sezary syndrome with alemtuzumab. *Eur J Haematol* 2003;71(4):250-256.
668. Lundin J, Hagberg H, Repp R, et al. Phase 2 study of alemtuzumab (anti-CD52 monoclonal antibody) in patients with advanced mycosis fungoides/Sezary syndrome. *Blood* 2003;101(11):4267-4272.
669. Querfeld C, Mehta N, Rosen ST, et al. Alemtuzumab for relapsed and refractory erythrodermic cutaneous T-cell lymphoma: a single institution experience from the Robert H. Lurie Comprehensive Cancer Center. *Leuk Lymphoma* 2009;50(12):1969-1976.
670. Lenihan DJ, Alencar AJ, Yang D, Kurzrock R, Keating MJ, Duvic M. Cardiac toxicity of alemtuzumab in patients with mycosis fungoides/Sezary syndrome. *Blood* 2004;104(3):655-658.
671. Lundin J, Kennedy B, Dearden C, Dyer MJ, Osterborg A. No cardiac toxicity associated with alemtuzumab therapy for mycosis fungoides/Sezary syndrome. *Blood* 2005;105(10):4148-4149.
672. Hotz C, Ingen-Housz-Oro S, Tran Van Nhieu J, et al. Pulmonary cryptococcoma in a patient with Sezary syndrome treated with alemtuzumab. *Eur J Dermatol* 2011;21(6):1018-1020.
673. Ure UB, Ar MC, Salihoglu A, et al. Alemtuzumab in Sezary syndrome: efficient but not innocent. *Eur J Dermatol* 2007;17(6):525-529.
674. Oliveira A, Lobo I, Alves R, Lima M, Selores M. Sezary syndrome presenting with leonine facies and treated with low-dose subcutaneous alemtuzumab. *Dermatol Online J* 2011;17(11):6.
675. Alinari L, Geskin L, Grady T, Baiocchi RA, Bechtel MA, Porcu P. Subcutaneous alemtuzumab for Sezary Syndrome in the very elderly. *Leuk Res* 2008;32(8):1299-1303.
676. Bernengo MG, Quaglino P, Comessatti A, et al. Low-dose intermittent alemtuzumab in the treatment of Sezary syndrome: clinical and immunologic findings in 14 patients. *Haematologica* 2007;92(6):784-794.
677. Kim YH, Duvic M, Obitz E, et al. Clinical efficacy of zanolimumab (HuMax-CD4): two phase 2 studies in refractory cutaneous T-cell lymphoma. *Blood* 2007;109(11):4655-4662.

678. Younes A, Yasothan U, Kirkpatrick P. Brentuximab vedotin. *Nature reviews Drug discovery* 2012;11(1):19-20.
679. Pro B, Advani R, Brice P, et al. Brentuximab vedotin (SGN-35) in patients with relapsed or refractory systemic anaplastic large-cell lymphoma: results of a phase II study. *J Clin Oncol* 2012;30(18):2190-2196.
680. Ishida T, Joh T, Uike N, et al. Defucosylated anti-CCR4 monoclonal antibody (KW-0761) for relapsed adult T-cell leukemia-lymphoma: a multicenter phase II study. *J Clin Oncol* 2012;30(8):837-842.
681. Kim YH, Girardi M, Duvic M, et al. Phase I trial of a Toll-like receptor 9 agonist, PF-3512676 (CPG 7909), in patients with treatment-refractory, cutaneous T-cell lymphoma. *J Am Acad Dermatol* 2010;63(6):975-983.
682. Kim YH, Gratzinger D, Harrison C, et al. In situ vaccination against mycosis fungoides by intratumoral injection of a TLR9 agonist combined with radiation: a phase 1/2 study. *Blood* 2012;119(2):355-363.
683. Bigler RD, Crilley P, Micaily B, et al. Autologous bone marrow transplantation for advanced stage mycosis fungoides. *Bone Marrow Transplant* 1991;7(2):133-137.
684. Sterling JC, Marcus R, Burrows NP, Roberts SO. Erythrodermic mycosis fungoides treated with total body irradiation and autologous bone marrow transplantation. *Clin Exp Dermatol* 1995;20(1):73-75.
685. Olavarria E, Child F, Woolford A, et al. T-cell depletion and autologous stem cell transplantation in the management of tumour stage mycosis fungoides with peripheral blood involvement. *Br J Haematol* 2001;114(3):624-631.
686. Molina A, Zain J, Arber DA, et al. Durable clinical, cytogenetic, and molecular remissions after allogeneic hematopoietic cell transplantation for refractory Sezary syndrome and mycosis fungoides. *J Clin Oncol* 2005;23(25): 6163-6171.
687. Duarte RF, Canals C, Onida F, et al. Allogeneic hematopoietic cell transplantation for patients with mycosis fungoides and Sezary syndrome: a retrospective analysis of the Lymphoma Working Party of the European Group for Blood and Marrow Transplantation. *J Clin Oncol* 2010;28(29):4492-4499.
688. Duvic M, Donato M, Dabaja B, et al. Total skin electron beam and non-myeloablative allogeneic hematopoietic stem-cell transplantation in advanced mycosis fungoides and Sezary syndrome. *J Clin Oncol* 2010;28(14): 2365-2372.
689. Zic JA. Controversies in the management of the cutaneous T cell lymphomas. *Dermatol Ther* 2009;22(5):407-417.

Chapter 93 Hodgkin Lymphoma in Adults

> Table of Contents > Part VII - Hematologic Malignancies > Section 4 - Lymphoproliferative Disorders > Chapter 93 - Hodgkin Lymphoma in Adults

Chapter 93

Hodgkin Lymphoma in Adults

David S. Morgan

Kristie A. Blum

Hodgkin lymphoma (HL) is a lymphoproliferative malignancy that accounts for only 1% of newly diagnosed malignancies in the United States; however, the disease's importance to the field of medical oncology is out of proportion to its clinical incidence. From an historical point of view, HL was the first cancer in which the curative potential of combination chemotherapy was demonstrated. Second, because affected patients are often young, there is a great potential for adding years of productive life by giving curative therapy. Third, because patients with HL are often cured, HL serves as a clinical laboratory for investigating the late effects of cancer therapy.

HL usually presents as solitary or generalized lymphadenopathy and most commonly occurs in young adults, although persons in any age group may be affected. The disease tends to spread in a contiguous fashion, and most patients present with disease limited to the lymph nodes or to the lymph nodes and spleen. Even patients with advanced disease have a reasonable chance of cure. Overall, cure can be achieved in approximately 80% of patients with HL. Treatment of limited disease often incorporates radiation therapy and combination chemotherapy, whereas treatment of advanced disease is generally limited to combination chemotherapy alone.

The evaluation of data and conclusions from clinical trials in HL requires certain caveats. The first issue is that salvage therapy for relapsed HL patients has a relatively high rate of cure. This fortunate fact can complicate the interpretation of trials of initial therapy for HL. In contrast to the situation in many other areas of oncology where salvage therapies

generally do not lead to cures, progression-free survival (PFS) in HL trials must not be used as a surrogate marker for overall survival (OS). Conversely, because late complications, including malignancy, can compromise the long-term efficacy of treatments that appear superior in the short run, therapies that produce superior PFS at 5 years may not be associated with superior OS at 15 years. In some situations, then, treatment plans with built-in contingencies may be appropriate. As an example, consider two hypothetical treatment strategies: treatment A is moderately effective but nontoxic, and failures can be salvaged effectively with treatment X. The alternate treatment, B, is very effective but failures are only rarely salvaged with treatment Y. The combination of the (less-effective) treatment A and salvage with X if needed may lead to superior long-term results as opposed to starting out with the (more effective) treatment B and salvage with treatment Y. This may be especially true if one considers short- and long-term toxicities of treatment. When considering initial therapy for patients with HL, one must realize that valid alternatives exist in addition to what may be considered the “best therapy” based on short-term observations, and that individualized approaches may be appropriate to accommodate individual risks, especially for long-term toxicity.¹

EARLY HISTORY

In 1832, Thomas Hodgkin presented a paper entitled, “On Some Morbid Appearances of the Absorbent Glands and Spleen.”² His report was an autopsy description of seven patients, and the major original thesis presented in the paper was that the entity he was describing was a primary process involving the lymph glands and spleen rather than a reactive inflammatory condition. In 1856, Samuel Wilks published a series of cases involving enlargement of the lymph glands³ and noted Hodgkin's original description. In 1865, Wilks wrote, “Cases of Enlargement of the Lymphatic Glands and Spleen (or Hodgkin's Disease) with Remarks,” updating and extending his findings.⁴ Thus, Thomas Hodgkin's name became linked to the disorder. Of note, some of the cases included in Hodgkin's initial report were cases of tuberculous lymphadenopathy and non-Hodgkin lymphoma.

After these gross pathologic descriptions, the first microscopic description of HL was reported by Langhans⁵ in 1872. This report was followed by independent reports by Sternberg in 1898⁶ and by Reed in 1902⁷ describing the characteristic giant cells that came to be known as (RS) cells. At the time of these early reports, all comments regarding the cause of HL were purely speculative. Not surprisingly, these early authors were divided over whether HL represented an infectious disease, an inflammatory disorder, or a malignancy involving the lymph glands.

EPIDEMIOLOGY AND ETIOLOGY

It is estimated that 9,060 new cases of HL will be diagnosed in 2012.⁸ The male-to-female ratio is 1.2:1.⁸ In most economically developed countries, there is a bimodal age distribution, with one peak occurring in the third decade of life and the second, smaller, peak occurring after age 50 years.⁹ The occurrence of HL in patients between the ages of 15 and 39 has been positively associated with increased maternal education, decreased numbers of siblings and playmates, and single-family dwellings in childhood.¹⁰ In less economically developed countries, HL is less common but affects children, most of whom are boys; mixed cellularity HL and lymphocyte-depleted HL are more commonly seen.¹¹ These data have been interpreted as supporting the hypothesis that HL is caused by an infectious agent, and it has been postulated that malignancy is more likely to occur when exposure to the agent in question is delayed until late adolescence or early adulthood.^{11, 12, 13, 14}

Epstein-Barr virus (EBV) has been proposed as contributing to the development of some cases of HL, and the circumstantial evidence is considerable. The incidence of HL is elevated among patients with a history of EBV infection.^{15, 16, 17} EBV has been associated with other related malignancies, including Burkitt lymphoma and lymphomas developing in immunocompromised patients. Using modern molecular biology techniques, EBV genome fragments have been found in RS cells from approximately 40% of patients with HL,^{18, 19, 20} more commonly in cases of mixed cellularity HL.²³ In addition, the EBV DNA associated with RS cells in HL has been shown to be monoclonal, establishing that EBV preceded the development of HL.^{18, 19} Interestingly, prognosis appears to be better in HL that is EBV-positive, as compared to cases that are EBV-negative.^{21, 22, 23}

HL occurring in early childhood or in older adults is more likely to be EBV-associated than are cases of HL occurring in young adults.²⁴ However, in an important 2003 study, 38,555 patients with documented EBV-positive infectious mononucleosis were followed for an extensive period.²⁵ In this selected population, 29 cases of HL developed and 16 (55%) were positive for EBV. The risk of EBV-positive HL was increased by a factor of 4 as compared to patients who never had documented EBV-positive infectious mononucleosis; the median latency for HL after EBV infection was 4.1 years. There was no increase of EBV-negative HL in this population. These data do not prove causality: the data are equally compatible with the theory that EBV predisposes

patients to the development of HL. If there is a causal role for EBV, additional factors must be required for the development of HL.

The idea that HL may represent an uncommon host response to a common agent has received additional support in a study of monozygotic and dizygotic twins. Monozygotic twins, who would be expected to have similar immune responses, had a 99-fold increased risk of being concordant for having HL, supporting a role for genetic susceptibility or abnormal immune response, or both, in the etiology of HL.²⁶ The incidence of HL in patients with the acquired immunodeficiency syndrome or with human immunodeficiency virus infection is elevated over the incidence in the general population (although not to the extent of the increase in the incidence of non-Hodgkin lymphoma), perhaps lending further plausibility to the concept that HL represents a disordered immune response to antigens.^{27, 28} An increased incidence of HL has been noted in recipients of allogeneic bone marrow transplants.²⁹ In addition, a patient has been reported with reversible methotrexate-associated lymphoproliferative disorder that eventually evolved into HL.³⁰

HISTOPATHOLOGY

The diagnosis of HL requires biopsy of an involved lymph node or, rarely, of an involved extranodal site (Chapter 86). It is important to note that inflammatory nodes may be interspersed among nodes harboring HL. In general, a larger node with more abnormal features on imaging is a better target for biopsy than a smaller, perhaps more accessible, node. Inguinal nodes, although generally fairly easily biopsied, are often enlarged from current or past inflammation, and biopsy may be misleading. A fine needle aspiration (FNA) should generally be considered an inferior diagnostic approach and will only rarely yield a firm diagnosis; most diagnoses will require an excisional lymph node biopsy (although occasionally a diagnosis can be made on generous core biopsy). Flow cytometry is noninformative in HL, as the majority of cells in a specimen reflect the inflammatory background, with the malignant RS cells being relatively rare. This fact can occasionally falsely reassure a clinician who gets a flow cytometry result of “reactive” and a nondiagnostic FNA on a patient with unexplained adenopathy; the correct response is to go on to an excisional biopsy. Fortunately for clinicians, concordance between pathologists regarding the diagnosis of HL is high, often exceeding 90%.³¹

HL can be confused with atypical inflammatory reactions that can occur in some patients with infectious mononucleosis³² or in patients receiving phenytoin.³³ Among the lymphomas, HL is sometimes mistaken at the histologic level for anaplastic large cell lymphoma, mediastinal large cell lymphoma, or T-cell-rich B-cell lymphoma. Correct classification can usually be achieved using immunohistochemistry and cytogenetic techniques. Recently identified and listed as a provisional entity in the World Health Organizations classification was:³⁴ “B-cell lymphoma, unclassifiable, with features intermediate between diffuse large B-cell lymphoma and classical Hodgkin lymphoma (cHL),” also known as “Grey Zone Lymphoma.”^{35, 36}

Pathologically, HL is distinguished from other lymphomas by the presence of large binucleated or multinucleated cells (RS cells) generally surrounded by a benign reactive response consisting of lymphocytes, histiocytes, granulocytes, eosinophils, and plasma cells. RS cells are large cells with abundant cytoplasm and generally contain two or more nuclei and two or more inclusionlike nucleoli. Molecular evidence (clonal immunoglobulin rearrangements) has shown that the cell of origin for RS cells is a germinal center or post-germinal center B-cell. The RS cell does not express the common B-cell transcription factors and thus its B-cell phenotype (including the B-cell receptor) because of down-regulation and because of epigenetic silencing.^{37, 38} Commonly such nonfunctional B-cells would undergo apoptosis, and activation of several antiapoptotic pathways (including the nuclear factor [NF]- κ B pathway)³⁹ has been proposed as mechanisms for the molecular pathogenesis of HL. The molecular mechanisms involved in the development of HL have been the subject of several reviews,^{40, 41} and further discussion of these intracellular pathways is beyond the scope of this clinical chapter.

Variant forms of RS cells exist, especially in the nodular sclerosis subtype of HL and the nodular form of lymphocyte-predominant HL (LPHL). RS cells are not specific for HL and have been noted in cases of infectious mononucleosis⁴² and other malignancies including lymphoma, carcinomas, and sarcomas.⁴³ Therefore, RS cells are not sufficient to establish the diagnosis of HL because that diagnosis depends on the presence of both the characteristic RS cells and the characteristic cellular environment in which the RS cells are found. In addition to the histologic criteria, immunostaining, the RS cells or variants in classical HL should be positive for CD15 (85%) and CD30 (100%), and negative for most pan-B-cell and pan-T-cell antigens. If a B-cell antigen is present, it is usually CD20 and it is variable in intensity.^{44, 45}

The subclassification of HL depends in large part on the ratio of neoplastic to reactive cells and their orientation. The current subtype classification stems from the classification of Lukes and Butler,⁴⁶ as modified at the Rye Conference in 1966.⁴⁷ These investigators described RS cell and their variants (Fig. 86.16), one of which they called the L and H cell, (“lymphocytic and histiocytic” because of the associated background) seen primarily in the LPHL. Later these multilobated

cells were referred to as “popcorn cells.”⁴⁸ It was later shown through immunohistochemistry studies that classic RS cells and L and H cells were distinct, with RS cells or variants of other subtypes of HL being CD30 and usually CD15 positive and negative for pan-B-cell markers (Fig. 86.17), and with the L and H cells of LPHL being CD20 pos and CD30 and CD15 negative (Fig. 86.23). Likewise it is now clear on clinical, immunophenotyping, and gene expression profiling grounds that LPHL is a clinicopathologic entity distinct from the other types of HL.^{49, 50, 51, 52} Thus the current WHO classification³⁴ distinguishes cHL from LPHL.

cHL is comprised of four subtypes: nodular sclerosis HL, mixed cellularity HL, lymphocyte-rich classical HL (LRCHL), and lymphocyte-depleted HL. In the past, the subtype of HL was felt to give the clinician valuable prognostic information; however, it is now recognized that the histologic subtype co-varies with stage, and that much of the reported differences in prognosis previously attributed to histologic subtypes may be attributed to stage. When patients are stratified by stage and receive equivalent therapy, differences attributable to histologic subtype are either trivial or nonexistent.^{53, 54, 55, 56}

The incidence of HL cases with respect to histologic subtype is shown in Table 93.1. The data are taken from one large tumor registry⁵⁷ and three large series of referred patients,^{31, 58, 59} and are subject to biases in the selection process. However, the general agreement among the series suggests that this is a fairly reliable estimate regarding the relative incidence of the subtypes of HL.

In nodular sclerosis HL, nodularity is produced by dense collagenous bands that divide the cellular portion of the node into sections (Fig. 93.1). In this type of HL, RS cell variants, rather than classic RS cells, are commonly found in the cellular areas. These lacunar RS cells have faintly stained cytoplasm and appear separated from adjacent cells by empty space, an artifact of formalin fixation (Figs. 93.2 and 86.20). Nodular sclerosis HL is the most distinctive form of HL. Although the other subtypes of HL may be regarded as a histologic continuum and transformation among other subtypes is commonly seen, when patients with the nodular sclerosis subtype undergo repeat biopsies, the nodular sclerosis form of HL is confirmed in more than 90% of cases.⁶⁰ This form of HL classically presents as stage I or II disease with cervical and mediastinal involvement in young adults, although more advanced stages of disease are not uncommon (Table 93.2).

P.1986

TABLE 93.1 RELATIVE INCIDENCE OF HISTOPATHOLOGIC SUBTYPES OF HODGKIN LYMPHOMA

Author (Reference)	Lymphocyte Predominant (%)	Nodular Sclerosis (%)	Mixed Cellularity (%)	Lymphocyte Depleted (%)
Dorfman ⁵⁸	7	74	17	2
Jones et al. ³¹	2	65	26	6
Bernhards et al. ⁵⁹	3	74	22	1
Medeiros et al. ⁵⁷	7	63	26	4

Note: Percentages refer to “classified” cases, as some studies contain cases of unclassified Hodgkin disease.

A “syncytial variant” of nodular sclerosis HL has been recognized in which numerous RS cell variants have been observed in sheets and clusters. This variant of HL may be confused with NHL, thymoma, or metastatic cancer.⁶¹

HL of the mixed cellularity pattern is a diffuse lymphoma composed of a mixture of cells including RS cells (Figs. 93.3 and 86.18). Distinguishing mixed cellularity HL from diffuse mixed forms of NHL may be difficult on the basis of histology alone, but should be resolved with modern immunohistochemical stains. This subtype of HL has a greater tendency than nodular sclerosis HL to be advanced at the time of presentation and to be associated with symptomatic disease. Mixed cellularity and nodular sclerosis HL make up the majority of HL cases.

Lymphocyte-depleted HL is composed predominantly of histiocytes and lymphocytes with varying numbers of eosinophils and RS cells (Figs. 93.4 and 86.21). The host reaction is often scant relative to the number of malignant giant cells, and a varying amount of fibrosis is generally present. The disease is the least common type of HL and tends to be advanced at diagnosis (i.e., stage III or IV). Most patients have B symptoms,⁶² retroperitoneal nodal involvement is common, and approximately one half of patients have bone marrow involvement.^{63, 64, 65} Many older case series contain cases that

would now be classified as peripheral T-cell lymphomas⁶⁶ or anaplastic large cell lymphomas.^{67, 68} Therefore the older literature regarding this entirety must be treated cautiously.

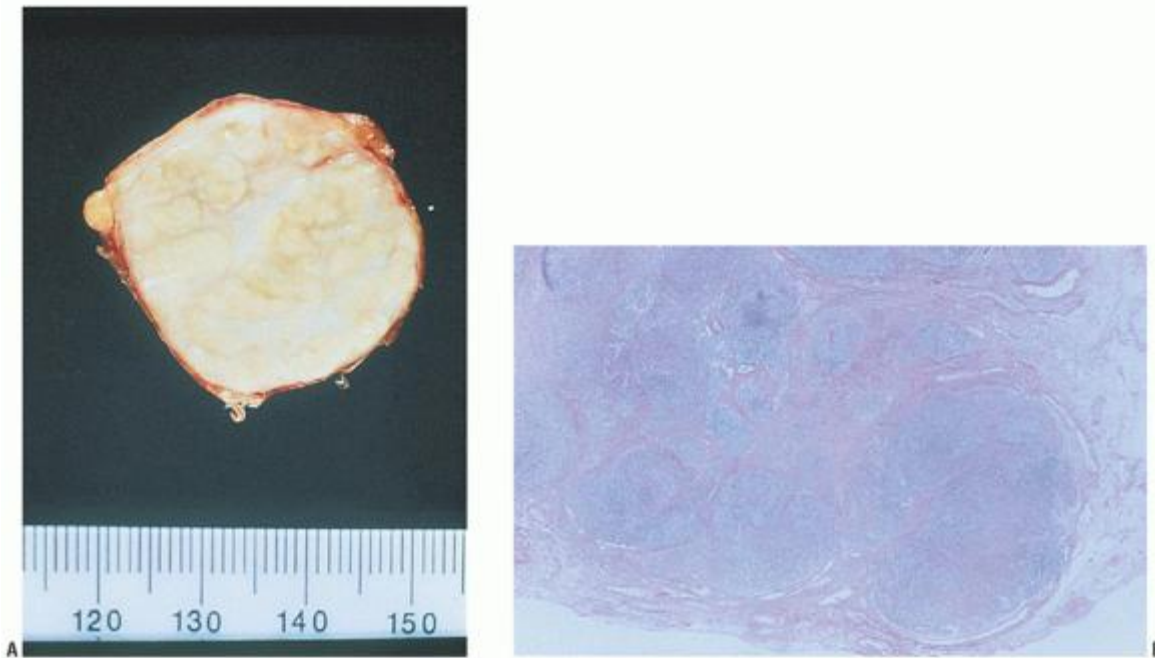

FIGURE 93.1. A: Nodular sclerosing Hodgkin lymphoma. Gross appearance of the cut surface of a resected node shows a thickened capsule, white fibrous bands, and yellow parenchymal nodules. B: Nodular sclerosing Hodgkin lymphoma. Low magnification shows a fibrous capsule and bands of sclerosis circumscribing abnormal lymphoid nodules.

LRCHL⁵¹ is characterized by rare RS cells or variants dispersed in a background of predominantly small lymphocytes. The tumor cells have the appearance of classic RS cells as well as the immunophenotype of classic RS cells (CD30⁺, CD15⁺, but CD20 negative) (Figs. 93.5 and 86.19).

LYMPHOCYTE-PREDOMINANT HODGKIN LYMPHOMA

Nodular lymphocyte-predominant HL (NLPHL) is an uncommon subtype of HL, representing about 5% of cases,⁶⁹ with unique pathologic features distinguishing it from classical HL.⁷⁰ The neoplastic cell is a large cell, the LP cell, otherwise known as a popcorn cell due to its single, large, folded or multilobulated nucleus that typically has a smaller nucleus than observed in RS cells (Figs. 93.6 and 86.22). However, unlike the RS cell, these cells are typically CD30 and CD15 negative, with CD19, CD20, CD45, and CD79a positivity (Fig. 86.23). These cells are also PAX-5 and Oct-2 positive. The surrounding background lymphocytes are predominantly small CD20 B-cells, with rare eosinophils, neutrophils, or plasma cells. Surrounding the LP cells, CD4⁺ t-cell rosettes are found and CD21-positive follicular dendritic cells are present, consistent with the germinal center derivation of this malignancy.⁷⁰

Due to the rare occurrence of this malignancy, presentation, treatment, and patient outcomes are not well described in this disease. In a retrospective analysis of 8,298 patients enrolled on clinical trials for HL through the German Hodgkin Study Group,

P.1987

394 patients had NLPHL.⁶⁹ In this series, the median age at diagnosis was 37, 75% patients were male, and 79% of patients had early stage disease. Clinically, there appear to be two age peaks, one in children and another in patients aged 30 to 50. The presence of B-symptoms or bulky disease is unusual, observed in <10% of patients.⁷⁰ Unlike classical HL, patients with NLPHL typically have peripheral adenopathy (axillary or inguinal) at diagnosis rather than central or mediastinal involvement and nodal spread does not track from LN basin to LN basin as typical for classical HL. In NLPHL, nodal involvement is not contiguous and extranodal involvement is uncommon.

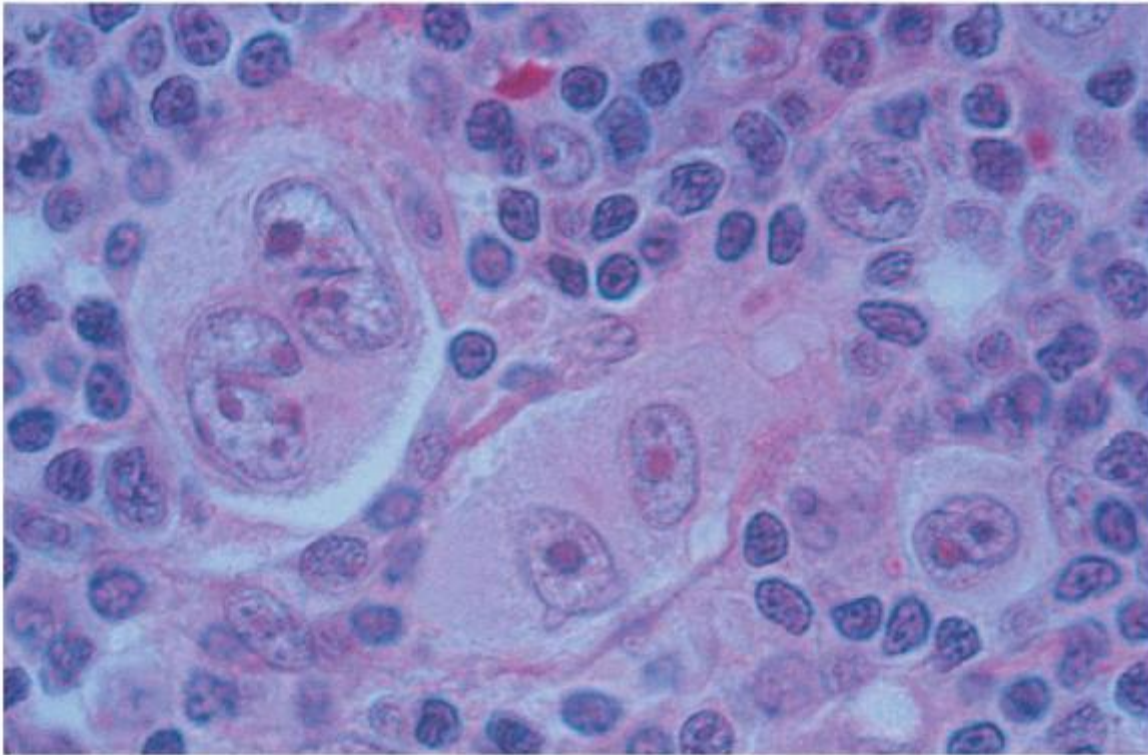

FIGURE 93.2. Nodular sclerosing Hodgkin lymphoma. High magnification shows Reed-Sternberg cells and lacunar variants in B5 fixed material.

An association exists with this subtype of lymphoma and a benign condition, progressive transformation of germinal centers, as well as with NHL, particularly T-cell-rich B-cell lymphoma and diffuse large B-cell lymphoma. Progressive transformation of germinal centers is described as lymph nodes with large, well-defined nodules with an excess of B-cells, or germinal centers overrun by lymphocytes.⁷⁰ This entity may be observed prior to, simultaneous with, or following a diagnosis of NLPHL. This entity is thought to be a benign condition, but as it occurs concurrently or following a diagnosis of NLPHL, biopsy of recurrent adenopathy is always required in this disease to confirm relapse. Likewise, T-cell-rich B-cell lymphoma and NLPHL can occur simultaneously or in succession, and frequently T-cell-rich B-cell lymphoma can be pathologically confused for NLPHL. With T-cell-rich B-cell lymphoma, large atypical B-cells that are CD20 positive are surrounded by an abundant background of T-cells and histiocytes. As about 5% of NLPHL eventually develop NHL including T-cell-rich B-cell NHL or diffuse large cell lymphoma, biopsy of recurrent lymph nodes is necessary to determine therapy at relapse. In a series of 22 patients treated with rituximab for NLPHL, 9 patients relapsed, including 5 who underwent biopsy at recurrence and of these 2 had diffuse large cell NHL within 13 months of follow-up.⁷¹

TABLE 93.2 RELATIVE INCIDENCE OF EACH STAGE FOR EACH HISTOPATHOLOGIC SUBTYPE OF HODGKIN LYMPHOMA

Stage	Histologic Subtype			
	Lymphocyte Predominant (%)	Nodular Sclerosis (%)	Mixed Cellularity (%)	Lymphocyte Depleted (%)
IA and IB	47	8	12	9
IIA and IIB	38	52	34	14
IIIA and IIIB	14	29	41	41
IVA and IVB	1	11	13	36

Total 100 100 100 100

Modified from Kaplan HS. Hodgkin's disease, 2nd ed. Cambridge: Harvard University Press, 1980.

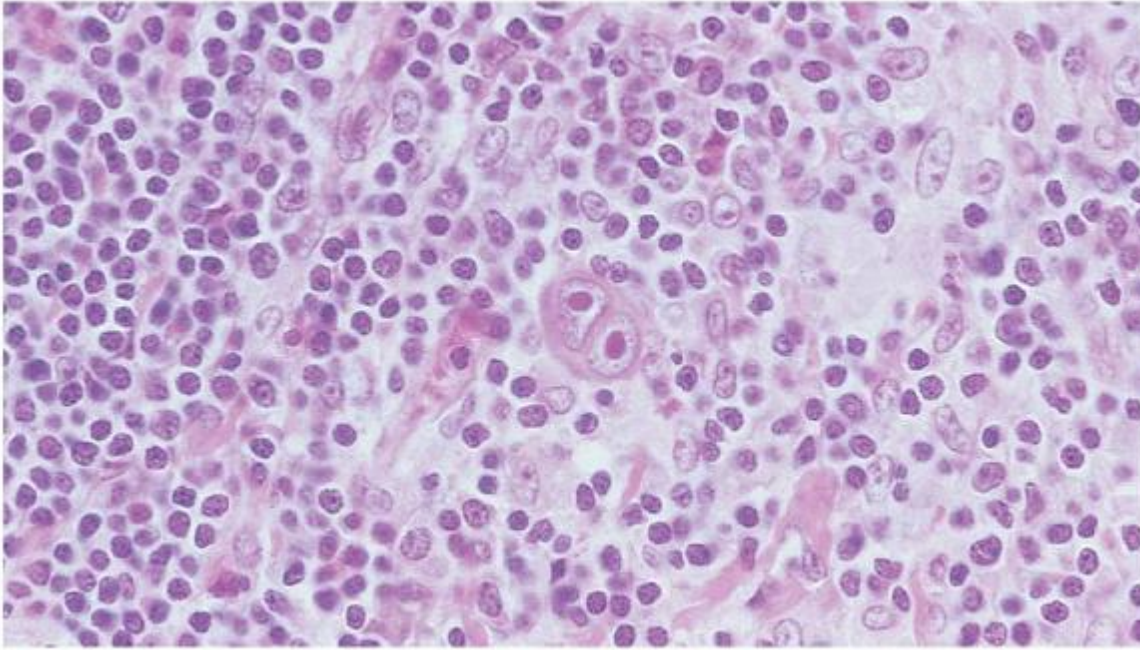

FIGURE 93.3. Mixed cellularity-type Hodgkin lymphoma. High magnification shows a classic Reed-Sternberg cell in a mixed background of small lymphocytes, plasma cells, and eosinophils.

CLINICAL EVALUATION

Physical Examination: Sites of Disease

Staging, the basis for treatment planning in HL, begins with the physical examination. HL almost always presents with lymphadenopathy, and the involved nodes are usually freely movable with a rubbery consistency. Cases in which the microscopic appearance reveals fibrosis or sclerosis can be associated with hard firm nodes. Although any lymph node group can be involved (Table 93.3), cervical and supraclavicular adenopathy are the most common physical findings, and axillary presentations are not rare.^{72, 73}

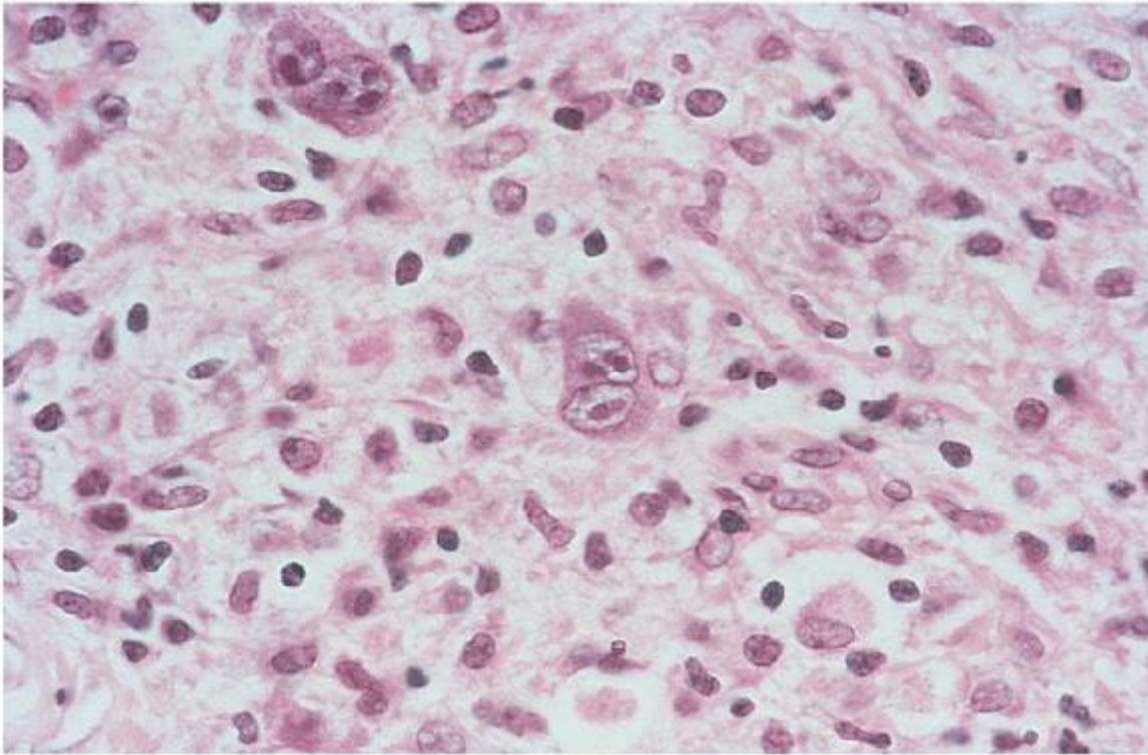

FIGURE 93.4. Lymphocyte-depleted type Hodgkin lymphoma, diffuse fibrosis subtype. Reed-Sternberg cells are easily found, and the background is depleted of cellularity and composed of amorphous eosinophilic connective tissue.

P.1988

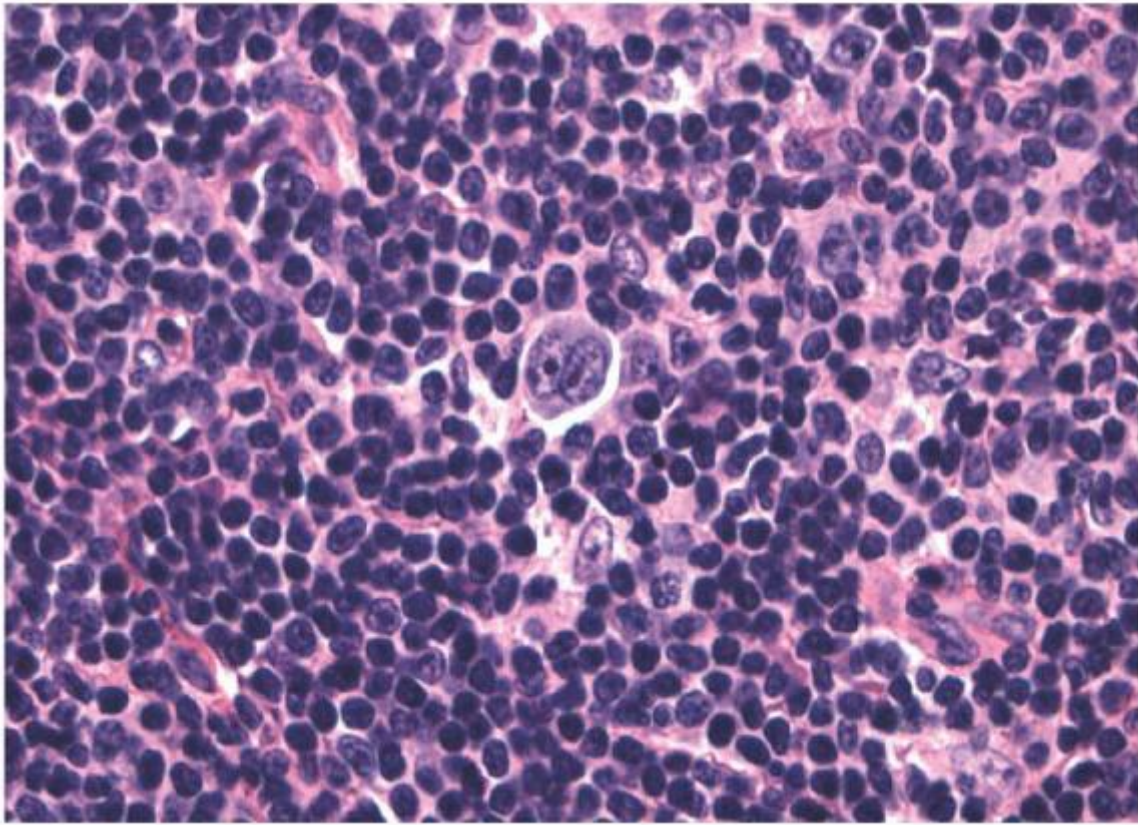

FIGURE 93.5. Lymphocyte-rich “classic” Hodgkin lymphoma. The background is primarily lymphocytes, and the Reed-Sternberg cells are usually CD15⁺ and CD30⁺ and negative for the B-cell marker CD20.

Mediastinal disease is often present, but it is rarely the only site of disease because it usually occurs in conjunction with cervical or supraclavicular disease. HL can present with iliac, inguinal, or femoral adenopathy, and in approximately 3% of cases, only subdiaphragmatic disease is present.^{74, 75} However, in a large series of cases in which the original diagnosis of HL was not confirmed on review, two features that predicted errors in diagnosis were primary extranodal disease and primary subdiaphragmatic disease.⁷⁶ Thus, the pathologic diagnosis of HL should be questioned in cases with subdiaphragmatic presentation. A complete physical examination of the patient with HL should include an evaluation of Waldeyer's ring and epitrochlear nodes even though these sites are only rarely involved.

Splenomegaly is noted at presentation in approximately 10% of cases of HL. However, splenomegaly may be a nonspecific manifestation of the HL, and in only one half of patients with splenomegaly was splenic involvement confirmed at laparotomy⁷³ in a study from the era of staging laparotomies. Additionally, splenic involvement may occur in 20% to 30% of patients in the absence of splenomegaly⁷³ even when abdominal computed tomography (CT) scans are used to assess splenomegaly by three-dimensional measurements.⁷⁷ This latter fact should not be surprising, because splenic involvement may be limited to a few microscopic nodules.

TABLE 93.3 FREQUENCY OF INVOLVEMENT OF NODAL SITES IN HODGKIN LYMPHOMA

Site	Frequency of Involvement (%)	Frequency of Involvement as Only Site of Disease (%)
Left cervical and/or supraclavicular nodes	70	7
Right cervical and/or supraclavicular nodes	62	4
Mediastinum	60	1

Spleen ^a	36	0
Para-aortic nodes ^a	34	<1
Left axillary nodes	25	1
Right axillary nodes	25	1
Hilar nodes	21	0
Iliac, inguinal, femoral nodes	16	1

^aData based on surgically staged patients.

Modified from Kaplan HS. Contiguity and progression in Hodgkin's disease. *Cancer Res* 1971;31:1811-1813; and Kaplan HS, Dorfman RF, Nelsen TS, et al. Staging laparotomy and splenectomy in Hodgkin's disease: analysis of indications and patterns of involvement in 285 consecutive, unselected patients. *Natl Cancer Inst Monogr* 1973;36:291—301.

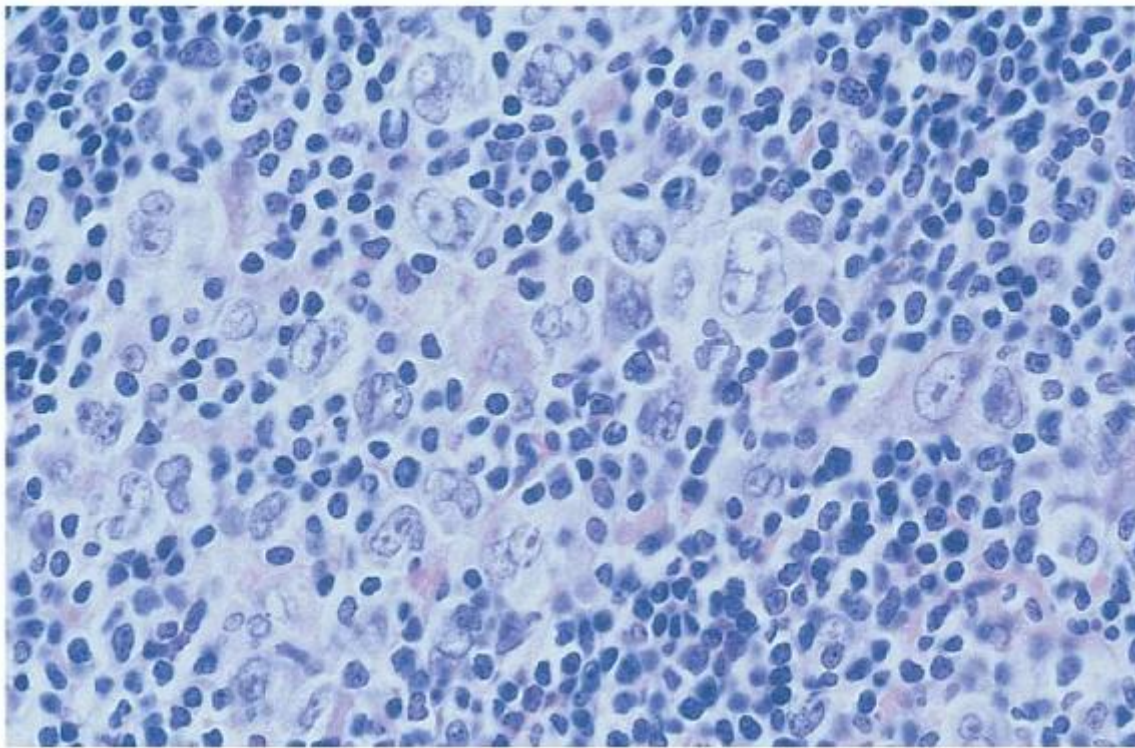

FIGURE 93.6. Lymphocyte-predominant Hodgkin lymphoma. High magnification shows variant lymphocytic and histiocytic cells (L and H cells), which have “popcorn” nuclei. A background of small lymphocytes and histiocytes is present.

Extranodal disease can occur at any site. However, the central nervous system and the testis, which are not uncommon sites for NHL, are exceptionally rare sites for HL. At presentation, lung, liver, bone, and bone marrow are the most common extranodal sites of disease, with each of these sites seen in approximately 5% to 10% of cases.^{78, 79} Disease at other individual sites occurs in <5% of cases. Primary extranodal HL should always lead the clinician to consider the possibility of an incorrect pathologic diagnosis.

Pattern of Spread

HL tends to spread in a contiguous fashion.^{72, 80} In fact, when one considers that the left supraclavicular area and the upper abdomen are contiguous (via the thoracic duct), a contiguous pattern of disease can be established at presentation in more than 90% of cases.⁷² For patients with only right supraclavicular involvement at presentation, abdominal disease is found in only 8% of cases; for patients with left supraclavicular involvement at presentation, the incidence of abdominal involvement is 40%. Hilar involvement with HL does not occur unless mediastinal disease is present. Pulmonary involvement by HL does not occur in the absence of mediastinal and hilar involvement.⁸¹

The spleen is the most commonly involved abdominal site of disease, possibly representing hematogenous spread. Liver involvement is uncommon at presentation in patients with HL, and it is exceptionally rare in the absence of splenic involvement.^{72, 82} Within the abdomen, the pattern of disease detected at staging laparotomy suggests spread from the spleen in a contiguous fashion. In a series in which staging laparotomies were performed with rigorous attention to biopsy of all nodal groups, the spleen and contiguous nodes were involved in 71% of cases, the spleen and noncontiguous nodes were involved in 16% of cases, and lymph nodes were involved in the absence of splenomegaly in only 13% of cases.⁸³ It is unknown whether the cases of apparent discontinuous spread represent cases in which early hematogenous dissemination has occurred or cases in which HL has spread through a node without involving the node.

P.1989

Initial Evaluation of the Hodgkin Lymphoma Patient

Clinical History

An accurate clinical history facilitates the management of HL patients in a number of ways. The presence of certain symptoms is associated with a less favorable prognosis and may be a clue to more advanced disease than otherwise suspected. Other symptoms may point out the need for additional studies (such as a bone scan or neck CT) for accurate staging. The discovery of additional sites of disease because of symptoms may lead to a modification of therapy and establish the need for additional follow-up studies on completion of treatment. A history of heart disease or lung disease may prompt closer assessment of those organs before chemotherapy or during its course. A history of HIV infection may affect choice of chemotherapy or infection prophylaxis. A history of smoking or autoimmune disease or a family history of breast cancer may influence the decision to incorporate radiation therapy into the treatment plan and may influence the follow-up plan.

The constitutional symptoms that are known to have prognostic value are unexplained fever to $>101^{\circ}\text{F}$, drenching night sweats, and weight loss equal to 10% of the patient's weight. These are the only symptoms that are accounted for in the Cotswold staging system (and whose presence is denoted by B appended on the numerical stage). Fever in HL can have any pattern, including continuous low-grade fever or occasional fever spikes. The pattern of recurrent episodes of daily high fevers separated by days without fever, Pel-Ebstein fever, was first associated with HL in 1885.^{84, 85} However, in the modern era it is a rare manifestation of HL and, although limited to patients with very advanced disease, it is uncommon even in those patients. Rarely, fever may be the only clinical manifestation of HL, for instance, in the case of patients with the lymphocyte-depleted HL who present with fever and disease limited to retroperitoneal nodes or the bone marrow, or both.⁸⁶

Before designating a patient as having the symptom of night sweats, the clinician should verify that the patient's sweating is abnormal. The night sweats of HL are drenching and not simply associated with increased ambient temperature. Perimenopausal women should be asked if they have vasomotor symptoms before the sweating, as flushing is not generally a symptom of the sweats of HL.

Pain at the site of HL in association with the ingestion of alcohol is well described and can be the first hint of a recurrence. The mechanism of this phenomenon is unknown and it does not have prognostic significance. The occurrence of alcohol-induced pain has become less common in recent decades, perhaps in association with earlier diagnosis and more effective therapy. Generalized pruritus may be a nonspecific manifestation of HL, and it may be an early manifestation of the disease in up to 10% to 15% patients. It also has no known prognostic implication. Similarly, fatigue and weakness may occur in patients with HL but do not cause a patient to be classified as symptomatic.

Although the staging classification divides patients into categories A and B for asymptomatic and symptomatic, respectively, clinicians are well aware that this binary classification is an oversimplification and that the presence of symptoms varies along a continuum^{87, 88} with respect to their clinical significance. When patients with stage IB and stage IIB HL were reviewed, it was found that the presence of fevers was associated with a relative risk of relapse after treatment of 4.3. For weight loss alone, the relative risk of relapse after treatment was 2.4; for night sweats, the relative risk of relapse was 0.8 (i.e., not increased).⁸⁷ Nevertheless, the presence of symptoms may suggest advanced disease. Symptoms are found in $<10\%$ of patients with stage I disease and in approximately two thirds of patients with stage IV disease.⁸⁹ The presence of B symptoms in a patient with apparent stage I disease is, therefore, suggestive that further evaluation will lead to the discovery of a more advanced-stage disease.

The Cotswold Staging System

The stage of the patient is the main determinant of therapy and prognosis in HL. The current classification system is the Cotswold classification system^{90, 91} (Table 93.4). Although the modalities used to stage patients have changed since the Cotswold conference in 1990 (e.g., PET and improved CTs have replaced staging laparotomy and gallium scans), and treatment algorithms have changed, the current staging system remains the backbone for clinical decision making and for clinical trial design.

Stage I disease is the involvement of a single lymph node region (or a single lymphoid structure). Stage II disease is the involvement of multiple lymph node regions (e.g., cervical nodes, supraclavicular nodes) but on only one side of the diaphragm. Stage III disease is the involvement of lymph node regions on both sides of the diaphragm and is further subdivided as to anatomic substage. Disease limited to the upper abdomen (i.e., spleen, splenic hilar nodes, celiac nodes, or porta hepatis nodes) in a patient with stage III disease is defined as substage III1. Patients with stage III disease in whom abdominal nodal involvement includes para-aortic, iliac, or inguinal nodes are classified as substage III2. The distinction between stages III1 and III2 is largely obsolete as all patients with stage III are now treated similarly with chemotherapy. Stage IV disease is visceral involvement (e.g., lung, liver, or bone marrow) that is not due to direct extension from a nodal site. The subscript E represents extension from a nodal site, such as extension of a mediastinal mass directly into the lung, for example, IIE.⁷⁸ The designations A and B are used to represent the absence and presence of symptoms (e.g., unexplained fever, drenching night sweats, and weight loss of 10% of body weight), respectively. The presence of "bulky" disease, defined as a mediastinal mass with a diameter greater than one-third the diameter of the chest as measured at the T5-T6 interspace on a postero-anterior chest radiograph, or any nodal

P.1990

mass with a greatest diameter of more than 10 cm, is represented by the designation X.^{92, 93, 94} The relative incidence of each stage of HL is shown in Table 93.5.

TABLE 93.4 COTSWOLD STAGING CLASSIFICATION FOR HODGKIN LYMPHOMA

Stage I

Involvement of a single lymph node region or lymphoid structure (e.g., spleen, thymus, Waldeyer ring)

Stage II

Involvement of two or more lymph node regions on the same side of the diaphragm (the mediastinum is a single site; hilar lymph nodes are lateralized); number of anatomic sites should be indicated by a suffix (e.g., II₃)

Stage III

Involvement of lymph node regions of structures on both sides of the diaphragm

III₁ With or without splenic hilar, celiac, or portal nodes

III₂ With para-aortic, iliac, or mesenteric nodes

Stage IV

Involvement of extranodal site(s) beyond that designated *E*

A No symptoms

B Fever, drenching sweats, weight loss

X Bulky disease, greater than one-third widening of the mediastinum, >10 cm maximum dimension of nodal mass

E Involvement of a single extranodal site, contiguous or proximal to a known nodal site

CS Clinical stage

PS Pathologic stage

TABLE 93.5 DISTRIBUTION OF HODGKIN LYMPHOMA CASES WITH RESPECT TO STAGE AND SYMPTOMATIC STATUS

Stage	A (%)	B (%)	A and B (%)
I	11.4	0.8	12.2
II	34.1	12.4	46.5
III	17.5	13.1	30.6
IV	3.3	7.4	10.7
Total	66.3	33.7	100.0

Modified from Kaplan HS. Hodgkin's disease, 2nd ed. Cambridge: Harvard University Press, 1980.

Required and Suggested Studies for Initial Evaluation

As treatment recommendations for HL depend heavily on stage, accurate staging is crucial. Staging also establishes a baseline so that the completeness of remission can be assessed on completion of therapy. The evaluation begins with a clinical history (see above) and a physical examination. The physical exam should focus on accessible lymphoid tissues, including Waldeyer's ring, all palpable lymph node areas, including the epitrochlear and popliteal nodes, as well as the spleen.

The role of radiographic imaging in HL patients is to determine the stage accurately, as stage determines treatment. A second role is to establish a baseline for comparison to mid-treatment or post-treatment scans. There is now a general agreement that positron emission tomography with integrated CT scanning (PET/CT) can supplant other imaging studies in the initial assessment of most patients with HL. PET/CT is reported to have very high sensitivity and specificity in HL. CT alone relies on size criteria to distinguish normal nodes from involved nodes and thus may understage patients with small but involved nodes. It is also poor at identifying a diffusely involved organ such as the spleen or liver, unless those organs are enlarged. It is reported that PET/CT (as compared to CT alone) changes the stage in up to 20% to 40% of cases and changes the treatment in 5% to 15%.^{95, 96, 97} The majority of these cases are upstaging. Some argue for omitting PET/CT in favor of CT alone for certain "clearly limited-stage" patients,⁹⁸ however, most clinicians and most guidelines (e.g., the National Comprehensive Cancer Network) favor initial PET/CT as a routine study for initial evaluation of HL. If a PET/CT is unavailable, or otherwise unused, patients should have CT scans of the chest, abdomen, and pelvis. A neck CT should be included if there is any clinical suspicion of involvement of neck nodes. A chest radiograph is performed in a patient with a mediastinal mass to assess whether the patient's disease meets the criteria for bulky mediastinal disease. Certain situations and patients may warrant other radiographic studies, for example, the patient with bone pain may be evaluated with bone scan or MRI.

A marrow biopsy is usually performed on any patient with B symptoms or abnormal blood counts, and on any patient with stage III or IV disease. Although the chance that an early stage asymptomatic patient with normal blood counts will have marrow involvement is low,^{79, 99} some clinicians perform a marrow biopsy on all patients with HL. Recent data suggest that PET/CT accurately identifies or rules out marrow involvement,¹⁰⁰ and clinicians may be able to decrease their use of marrow biopsy accordingly in the future.

Blood tests should include a complete blood count with differential and platelets, erythrocyte sedimentation rate, liver function tests including alkaline phosphatase, lactate dehydrogenase, albumin and bilirubin (abnormal liver function tests are not diagnostic of liver involvement, but are sometimes nonspecifically elevated and may complicate the use of certain chemotherapy agents); BUN and creatinine, and thyroid function tests as a baseline (if neck radiotherapy is contemplated). Serology for human immunodeficiency virus is appropriate in selected cases. A pregnancy test should be performed for women of childbearing potential.

Patients should be counseled about fertility preservation. An assessment of ejection fraction by echocardiogram or radionuclide study is appropriate if anthracycline chemotherapy will be used. Pulmonary function tests with diffusing capacity should be ordered if bleomycin-containing chemotherapy will be used.

A summary list of suggested initial procedures and tests is presented in Table 93.6.

Prognostic Indicators

As noted above, stage is the major prognostic factor in HL and the major basis on which therapy is determined. However, patients can be stratified for risk on the basis of prognostic factors in addition to stage. In a study of 5,141 patients with "advanced" HL, primarily stage III and IV disease, Hasenclever and Diehl¹⁰¹ performed a multivariate analysis of risk factors (Fig. 93.7). Seven independent factors that predicted freedom from progression (FFP) were identified: albumin <4.0 g/dl;

hemoglobin <10.5 g/dl; male sex; 45 years of age or more; stage IV disease; leukocytosis at or above 15,000/mm³; and lymphocytopenia (lymphocytes ≤600/mm³ and/or lymphocytes <8% of total white count). For patients with no risk factors (7% of all patients), FFP was 84%. For

P.1991

patients with one risk factor (22% of all patients), FFP was 77%. For patients with two risk factors (29% of all patients), FFP was 67%. For patients with three risk factors (23% of all patients), FFP was 60%. For patients with four risk factors (12% of all patients), FFP was 51%. For patients with five or more risk factors (7% of all patients), FFP was 42%. Of note, B symptoms did not have independent prognostic value in this model. At present this model is validated only for advanced-stage patients.

TABLE 93.6 RECOMMENDED INITIAL EVALUATION FOR PATIENTS WITH HODGKIN LYMPHOMA

History and Physical Examination, Including

Past medical history: including B symptoms (fever, night sweats, weight loss of >10% in past 6 mo), alcohol intolerance, itching, HIV risks, cardiac, renal, liver impairment

Family history: including lung cancer, coronary disease, breast cancer

Personal history: smoking

Examination of all peripheral lymph node regions (including epitrochlear, popliteal, Waldeyer's ring), liver, and spleen

Radiologic Studies

Chest radiograph

PET/CT

Assessment of EF (optional in younger patients)

Pulmonary function tests (optional in younger patients)

Laboratory Studies

Hematocrit, white blood cell count, differential, platelet count

Erythrocyte sedimentation rate, lactic dehydrogenase

Liver function tests including albumin, alkaline phosphatase transaminases, bilirubin

Bilirubin, alkaline phosphatase, liver function tests

Thyroid function tests if radiation to neck is contemplated

Bone scan (selected patients)

HIV serology

Bone Marrow Aspiration and Biopsy (Optional Unless Stage III)

CT, computed tomography; HIV, human immunodeficiency virus; PET, positron emission tomography.

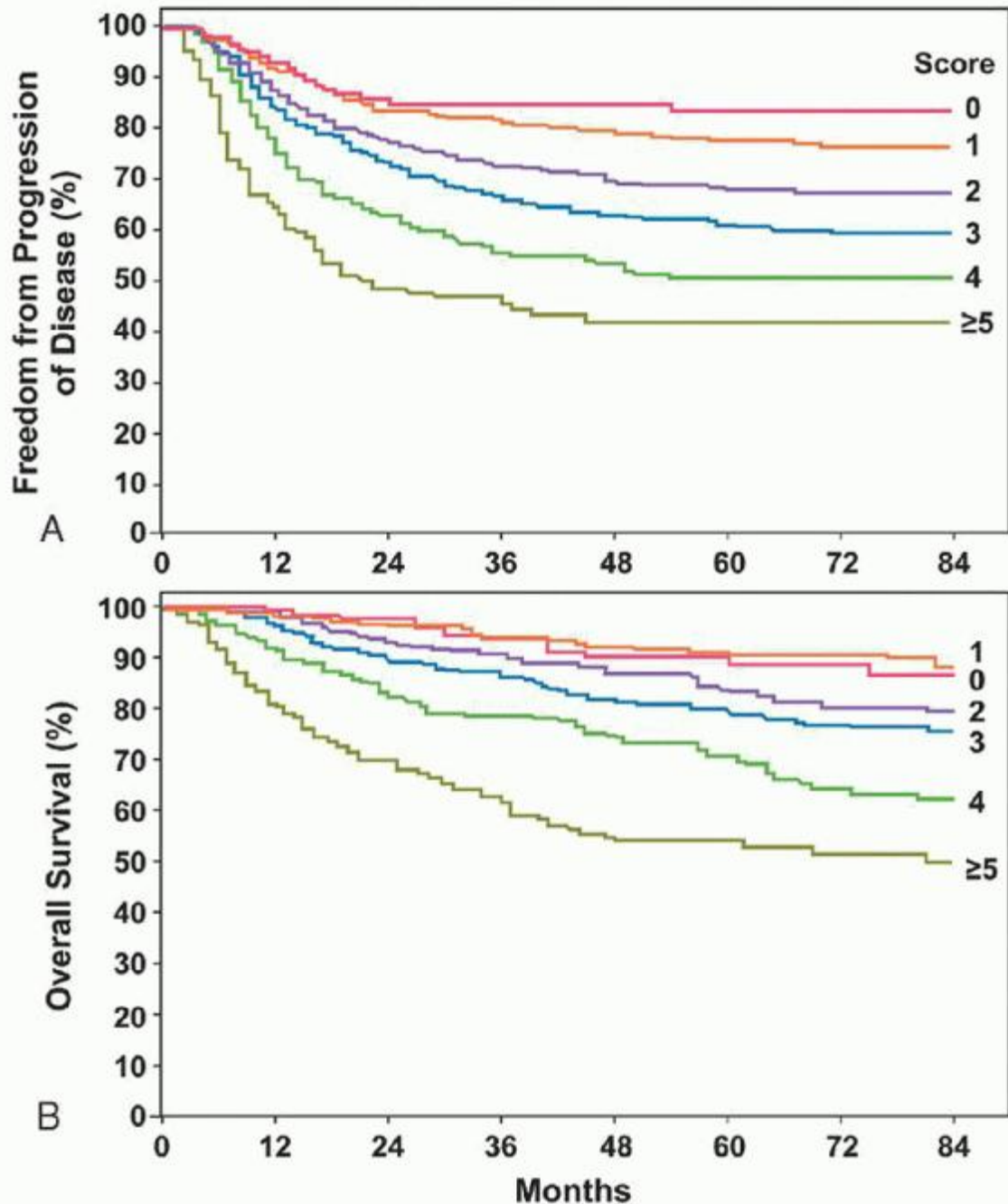

FIGURE 93.7. Progression-free survival (A) and survival (B) as related to number of risk factors. (From Hasenclever D, Diehl V. A prognostic score for advanced Hodgkin's disease. *N Engl J Med* 1998;339:1506-1514, with permission.)

A number of prognostic classifications have been used for early-stage HL and have been used to tailor therapy further in clinical trials. These commonly employ some combination of age, erythrocyte sedimentation rate, mediastinal bulk, and number of involved nodal sites. See Table 93.7, "Unfavorable Prognostic Factors for Stage I—II HL, by Three Cooperative Groups."

OVERVIEW AND HISTORICAL PERSPECTIVE OF RADIATION THERAPY

Six years after the discovery of x-rays by Roentgen in 1895, Pusey reported that x-rays could shrink enlarged nodes in patients with HL.¹⁰² However, given the orthovoltage techniques of the day, therapy was only palliative. The modern radiotherapy era began with the Swiss radiotherapist Gilbert in 1925.¹⁰³ Based on observed patterns of spread in patients with HL, Gilbert advocated treatment of both involved areas and adjacent, apparently uninvolved, areas. This approach was also adopted by Peters, who, in 1950, was the first to report that radiation therapy of HL could produce cures.¹⁰⁴ Over

the next two decades, the curability of HL was confirmed by Peters,^{105, 106} Easson and Russell,¹⁰⁷ and Kaplan,^{108, 109} the latter investigator establishing the critical relationship between radiation dose and the risk of recurrence in the treatment field (Fig. 93.8).

TABLE 93.7 UNFAVORABLE CHARACTERISTICS FOR STAGE I AND II HL, PER THREE COOPERATIVE GROUPS

Risk Factor	GSHG	EORTC	NCIC
Age		≥50	≥40
Histology			NC or LD
ESR and B symptoms	>50 if A; >30 if B	>50 if A; >30 if B	50 or any B
Mediastinal mass	MMR > .33	MTR > 35	MMR >.33 or >10 cm
# Nodal sites	>2 ^a	>3	>3
E lesions	any		

GSHG, German Hodgkin Study Group (^auses alternate definition of nodal sites); EORTC, European Organization for the Research and Treatment of Cancer; NCIC, National Cancer institute of Canada; MMR, mediastinal mass ratio: maximal width of mass/maximal intrathoracic width; MTR, mass to thoracic width at T5-T6 interspace on standing PA chest radiograph.

As originally suggested by Gilbert, the principle of treating involved and adjacent apparently uninvolved areas (i.e., extended field therapy) became a standard radiotherapeutic approach to HL. With the advent of staging laparotomy and evidence that the retroperitoneum could represent a potentially involved adjacent area of disease, the concept of extended field therapy came to include the standard mantle, para-aortic/splenic, and pelvic radiation ports shown in Figure 93.9.¹¹⁰

Although the radiotherapy pioneers were the first to cure HL, and they did so by conducting elegant and groundbreaking clinical trials, the era of radiation as single modality for the initial treatment of HL has passed. However, HL is a very radiation-sensitive disease, and radiation remains a useful component of the treatment of certain patients. Currently the most well documented role for radiation is in the early stage setting, discussed below.

Complications of radiation therapy depend on technique, dose, and the volume of irradiated tissue. Common complications include hair loss within the treatment fields, radiation pneumonitis, radiation pericarditis, mediastinal fibrosis, and pulmonary fibrosis. Symptoms of radiation pneumonitis generally occur within 1 to 3 months of completing therapy and are nonspecific because they include dyspnea, cough, and fever. Such

P.1992

complications are rarely seen at lung doses <15 Gy and occurred in <5% of patients receiving routine mantle irradiation. The presence of a large mediastinal mass or the concomitant use of chemotherapy essentially doubles the risk of radiation pneumonitis.^{111, 112} Although infection and recurrent HL must be considered in the differential diagnosis of radiation pneumonitis, radiation injury is likely to be confined to the area of the lung that was irradiated. Infiltrates with sharp borders, representing the edge of the radiation field, strongly suggest the presence of radiation pneumonitis. Because HL and its therapy are both associated with immunosuppression, whenever radiation injury is considered in the differential diagnosis of a patient with HL, one must also consider the diagnosis of Pneumocystis jiroveci pneumonia.

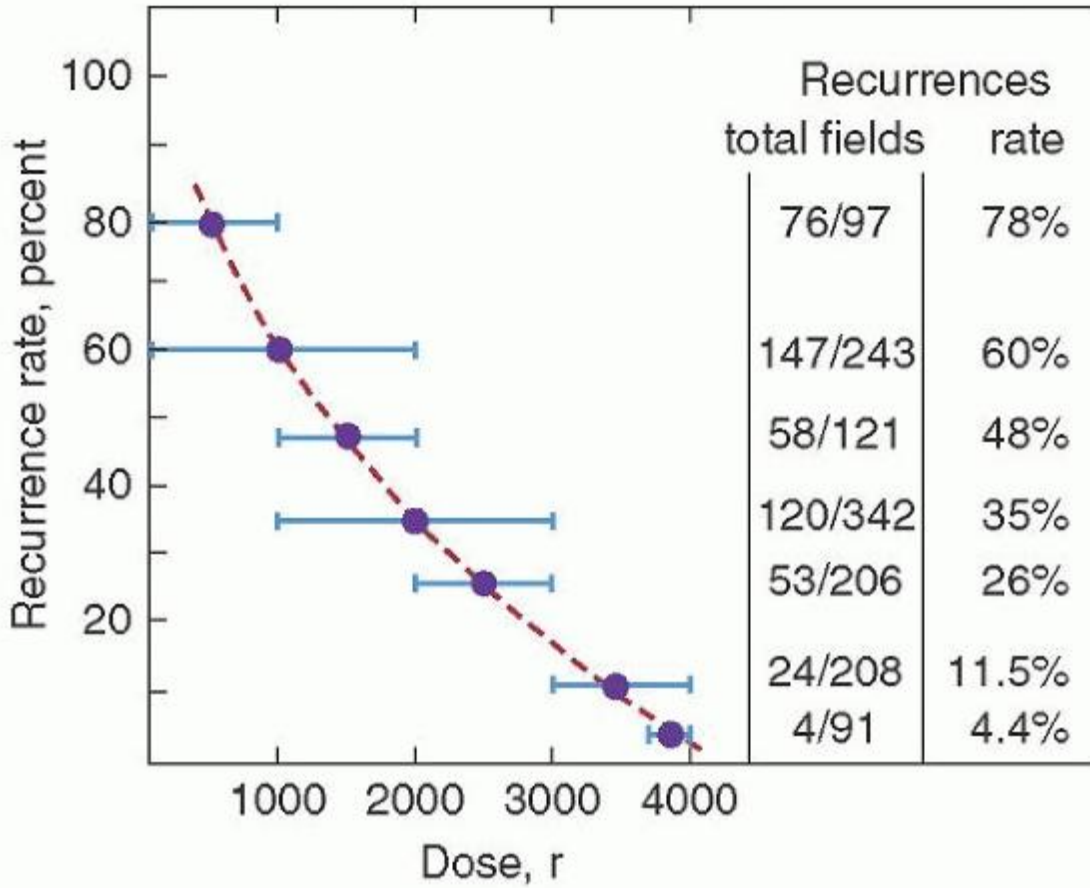

FIGURE 93.8. Rate of recurrence in a given treatment field as a function of radiation dose delivered to that field. (From Kaplan HS. Evidence for a tumoricidal dose level in the radiotherapy of Hodgkin disease. *Cancer Res* 1966;26:1221-1224, with permission.)

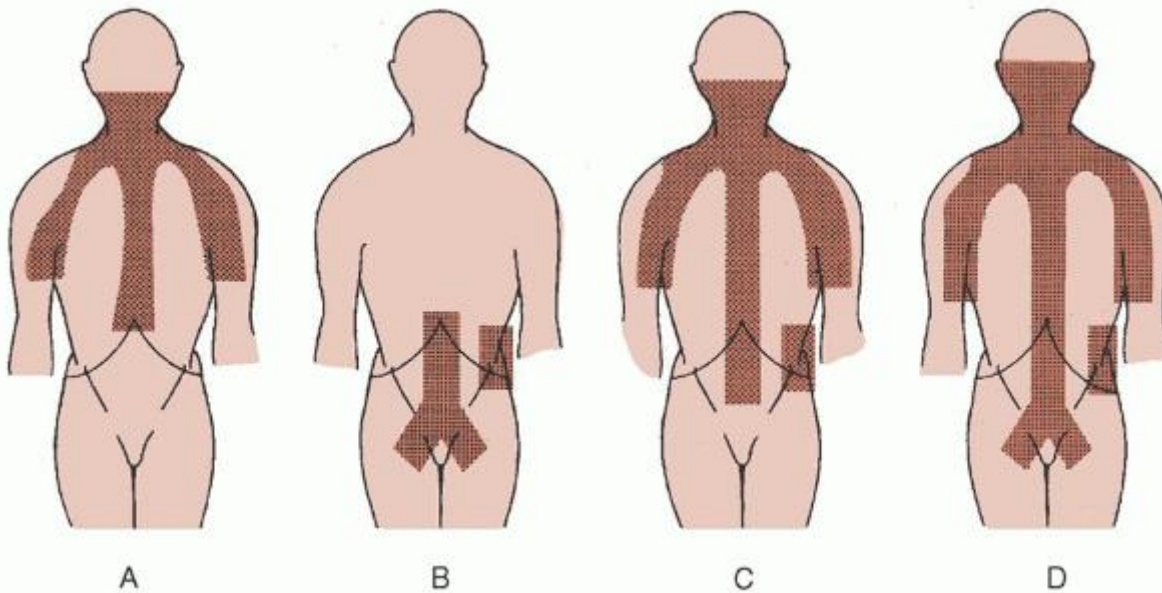

FIGURE 93.9. Treatment fields used as extended field irradiation of Hodgkin disease. A: Mantle field. B: Inverted Y field. C: Mantle and para-aortic field (extended mantle field). D: Total nodal field. The spleen is irradiated in conjunction with the

fields in B, C, and D, unless it has been surgically removed.

Cardiac toxicity of radiation therapy can include myocarditis, arrhythmias, pericarditis (rarely including constrictive pericarditis and tamponade), valvular heart disease, and coronary artery disease.^{113, 114, 115, 116, 117, 118} Although an increased risk of myocardial infarction appears to exist after radiation therapy,¹¹⁷ this risk is greater for patients who received radiation therapy before 1966, suggesting that modern treatment techniques have minimized this risk.

Spinal cord injury should not occur with modern radiation therapy techniques but may occur if radiation fields overlap. Splicing of fields over the spinal cord should be done with great care. The one neurologic problem that may occur despite the use of appropriate technique is the Lhermitte sign,⁸⁹ which includes numbness and tingling in the arms, legs, or both and electrical sensations up and down the spine made worse by flexion of the head. This complication is usually transient and of no clinical consequence.

Hypothyroidism is a common complication of radiation therapy,¹¹⁹ with actuarial analysis indicating that 52% of patients develop hypothyroidism 20 years after radiation.¹¹⁹ Thyroid cancer is an uncommon complication, but, based on the hypothesis that chronic elevations of thyroid-stimulating hormone in patients after thyroid irradiation may lead to thyroid tumors, the administration of thyroid replacement has been advocated in patients with an elevated thyroid-stimulating hormone even if they are clinically euthyroid.¹¹⁹

In addition to thyroid cancer, an increased risk of second malignancies, including lung cancer,^{120, 121} stomach cancer,¹²⁰ melanoma,^{120, 122} and breast cancer,^{123, 124, 125} has been noted in patients receiving radiation therapy for HL. These malignancies generally occur 10 to 20 years after radiation therapy, with the risk of second malignancies being increased in patients who have also received chemotherapy. The relative risk of breast cancer secondary to radiation is age related. The relative risk of developing breast cancer is 38 for patients radiated before age 20; the relative risk is 17 for patients radiated between the ages of 20 and 29; the relative risk is 4 for patients radiated after the age of 30, a relative risk that is not significantly different from 1.¹²³ Fortunately, the baseline risk of breast cancer in patients younger than age 30 is low, muting the quantitative impact of this increase in relative risk. Nevertheless, it has been recommended that women who receive radiation therapy for HL should receive mammography starting 8 years after completion of therapy because 95% of such tumors occur more than 10 years after radiation.¹²⁴

It should be recognized that radiation therapy developed as a primary treatment approach to HL when no other modalities were available. In the 1960s, 1970s, and 1980s, when chemotherapy and radiotherapy were both rational treatment options, radiotherapy was often seen as the simpler approach with minimal side effects. Over the last 10 to 15 years, however, there has been increased recognition of the fact that radiation therapy is associated with an increased incidence of late deaths and that for limited-stage patients those deaths eventually exceed the number of deaths from HL. At the same time, chemotherapy has become more tolerable. The result is an overall trend to use radiation therapy less often and to use chemotherapy more often.¹²⁶ This is discussed in detail in the sections on treatment.

OVERVIEW AND HISTORICAL PERSPECTIVE OF CHEMOTHERAPY

The development of cancer chemotherapy arose from the observation of lymph node necrosis in soldiers exposed to nitrogen mustard gas during World War I. Therefore, it is not surprising that HL and NHL were among the first disorders treated with nitrogen mustard when the drug was developed for therapeutic use.^{127, 128, 188, 189} Since then, several chemotherapeutic agents in several classes of drugs have been shown to be effective in HL. Single agents generally produced partial rather than complete remissions, and unmaintained remissions rarely lasted more than 3 months, with maintained remissions lasting 8 to 10 months (Table 93.8).^{129, 130, 131, 132} During the 1960s, efforts were made to combine effective agents,¹³³ culminating in the landmark demonstration by DeVita et al. that MOPP (Mustargen [mechlorethamine], Oncovin [vincristine], procarbazine, and prednisone) combination chemotherapy could cure advanced HL.¹³⁴ In the initial publication reporting results achieved with the MOPP regimen,¹³⁵ 81% of patients with advanced HL achieved a complete remission, and by actuarial analysis, 47% were projected to be long-term disease-free survivors. Follow-up studies^{136, 137} confirmed that these long-term disease-free survivals (DFSs) were equivalent to cure and projected cure rates of 56%.¹³⁷

P.1993

TABLE 93.8 RESULTS OF SINGLE-AGENT THERAPY IN HODGKIN LYMPHOMA

Response Rate (%)

Agent	Representative Dose and Route	CR	CR and PR
Nitrogen mustard	0.2-0.4 mg/kg IV, q4-6wk	13	65
Vincristine	0.2 mg/kg/wk IV	36	58
Procarbazine	50-150 mg/kg/d PO	38	69
Prednisone	40-60 mg/d PO	0	61
Cyclophosphamide	2 mg/kg/d PO	12	54
Chlorambucil	0.2 mg/kg/d PO	16	60
Vinblastine	0.2 mg/kg/wk IV	30	68
Bischloroethyl nitrosourea	100-200 mg/m ² IV, q6wk	4	47
Doxorubicin	30-60 mg/m ² IV, q3-4wk	8	41
Bleomycin	5 mg/m ² IV, varying schedules	6	37
DTIC	200 mg/m ² IV, daily ∞5, variable	6	56
Etoposide	50-120 mg/m ² IV, daily ∞5, variable	7	25
Cisplatin	75 mg/m ² IV, q3-4wk	8	35

CR, complete response; PR, partial response.

Modified from Kaplan HS. Hodgkin's disease, 2nd ed. Cambridge: Harvard University Press, 1980:199-201.

This study of MOPP in advanced HL¹³⁵ established combination chemotherapy as the treatment of choice for advanced HL (Table 93.9).^{135, 136, 137, 138, 139, 140, 141, 142, 143, 144, 145} Additionally, by demonstrating the cumulative and synergistic efficacy of combining drugs with different mechanisms of action and—to a degree—separate toxicities, it established the rationale for the use of combination chemotherapy in other malignancies. Subsequent investigations, as detailed below in the section on front-line therapy of advanced disease, have established alternative regimens as superior to MOPP with respect to efficacy and toxicity.

The primary toxicity of combination chemotherapy is hematologic, with neutropenia being more common than thrombocytopenia. Drug toxicity tends to be cumulative, with neutropenia having an increased degree and duration with each cycle of chemotherapy. Because there is evidence that optimal dose intensity (dose/time) is essential to achieving the best therapeutic results,^{137, 140, 146, 147} many clinicians have used a granulocyte colony-stimulating factor to avoid delays in therapy. However, a recent report showed increased lung toxicity in HL patients treated with filgrastim along with ABVD (26% vs. 9% without G-CSF)¹⁴⁸ and has led to some concerns about this approach although patients with testis cancer treated with bleomycin and using filgrastim support had no increase in lung toxicity as compared to a no-filgrastim group. Evens and colleagues reported their experience with proceeding with ABVD every 14 days without regard to neutrophil count and without administering colony-stimulating factors. They retrospectively compared the 61 patients treated in this manner to 23 patients treated with routine empiric filgrastim. Only 0.44% of the treatments given without filgrastim or dose reductions were complicated by neutropenic fever, and over 99% of the planned dose intensity was maintained.¹⁴⁹ Whether or not there is an increase in lung toxicity in HL patients treated with bleomycin and filgrastim, it seems reasonable to treat younger healthier patients without dose reductions or delays and without the routine use of colony-stimulating factors.

A major long-term complication of the MOPP regimen was myelodysplasia and leukemia, occurring in 2.6% at 5 years¹⁵⁰ and in more patients with longer follow-up. The addition of radiation may increase the risk to as much as 7% to 10% during the first 10 years.^{151, 152, 153, 154, 155, 156, 157, 158} ABVD does not seem to cause myelodysplasia.

Vincristine, and to a lesser extent vinblastine, cause a dose-dependent sensory neuropathy. This should not lead to dose modifications unless the sensory neuropathy involves the entire fingers or limits function. Motor neuropathy and obstipation are indications for dose reduction, but to limit the need for this dose modification, patients receiving vincristine should receive prophylactic laxatives.

Bleomycin may produce pulmonary fibrosis, and doxorubicin may produce cardiac toxicity. However, these toxicities are related to total dose administered. Bleomycin lung toxicity is seen in approximately 10% of patients receiving more than 250 mg/m² of bleomycin.¹⁵⁹ Clinical evidence of cardiac toxicity is observed in a similar percentage of patients receiving more than 450 mg/m² of doxorubicin.^{160, 161, 162} Thus, these toxicities are uncommon even when ABVD (Adriamycin [doxorubicin], bleomycin, vinblastine, and dacarbazine) is used. For patients receiving eight cycles of ABVD, the total cumulative doses would be 160 mg/m² of bleomycin and 400 mg/m² of doxorubicin, which approaches the toxic threshold. The threshold for drug toxicity is not absolute, and evidence of drug toxicity may be observed at lower doses, especially in older patients or in patients who have received radiation therapy to ports that include the lung or heart.

If the history or physical examination during ABVD therapy raises the suspicion of bleomycin pulmonary toxicity, a chest radiograph should be obtained, and tests such as a chest CT scan and pulmonary function tests with diffusing capacity of lung for carbon monoxide should be considered. Absolute criteria for the discontinuation of bleomycin have not been established, but we strongly caution against the continuation of bleomycin in the face of a corrected diffusing capacity of lung for carbon monoxide of ≤50%. In making a decision about further use of bleomycin, the clinician must consider the risks of further therapy as well as the risk of early discontinuation of an effective agent.

Sterility is another toxicity of HL treatment that must be considered in planning therapy because this complication may have a significant impact on a patient's quality of life. Although the formerly standard MOPP chemotherapy produced long-term azoospermia in 90% to 100% of patients,^{163, 164, 165, 166} limited data suggest that ABVD is associated with only transient azoospermia.¹⁶⁷ For men, permanent sterility is related primarily to the use and dose of alkylating agents; with ABVD, sterility is rare. In women, age, alkylating agent, and dose are important.¹⁶⁸ Many women become amenorrheic during chemotherapy, with hormonal findings consistent with ovarian failure.^{169, 170} In younger women, recovery of menses and recovery of fertility are generally seen. In women older than age 35, menses may resume, but menopause may occur prematurely. In women who are perimenopausal at the time of chemotherapy, menses may cease permanently. Although cryopreservation of semen before chemotherapy and artificial insemination have been successful in achieving pregnancy,¹⁷¹ the presence of decreased sperm counts and abnormal sperm motility before therapy in patients with HL limit this approach.¹⁷² In vitro fertilization for embryo cryopreservation is an option for some patients, but requires a delay in treatment. The cryopreservation of oocytes and of ovarian tissue is under investigation. Oral contraceptives or gonadotropin-releasing hormone-analogues have not been protective of fertility.¹⁷³ Offering information about fertility preservation should be considered even for those in whom limited ABVD is planned, as a minority of patients will progress and will go on to more intensive therapy.

P.1994

TABLE 93.9 CHEMOTHERAPY REGIMENS UTILIZED IN ADVANCED-STAGE HODGKIN LYMPHOMA

ABVD	Adriamycin 25 mg/m ²	IV	Days 1 and 15	Q28d
	Bleomycin 10 units/m ²	IV	Days 1 and 15	
	Vinblastine 6 mg/m ²	IV	Days 1 and 15	
	Dacarbazine 375 mg/m ²	IV	Days 1 and 15	
BEACOPP (baseline)	Bleomycin 10 mg/m ²	IV	Day 8	Q21d
	Etoposide 100 mg/m ²	IV	Days 1-3	
	Adriamycin 25 mg/m ²	IV	Days 1	
	Cyclophosphamide 650 mg/m ²	IV	Day 1	
	Vincristine 1.4 mg/m ² (capped at 2.0 mg)	IV	Day 8	
	Procarbazine 100 mg/m ²	IV	Day 1-7	
	Prednisone 40 mg/m ²	IV	Day 1-14	
BEACOPP	Bleomycin 10 mg/m ²	IV	Day 8	Q21d

(escalated)	Etoposide 200 mg/m ²	IV	Days 1-3
	Adriamycin 35 mg/m ²	IV	Days 1
	Cyclophosphamide 1,200 mg/m ²	IV	Day 1
	Vincristine 1.4 mg/m ² (capped at 2.0 mg)	IV	Day 8
	Procarbazine 100 mg/m ²	IV	Day 1-7
	Prednisone 40 mg/m ²	IV	Day 1-14
	Stanford V	Adriamycin 25 mg/m ²	IV
Vinblastine 6 mg/m ²		IV	Weeks 1, 3, 5, 7, 9, 11
Vincristine 1.4 mg/m ² (capped at 2.0 mg)		IV	Weeks 2, 4, 6, 8, 10, 12
		IV	Weeks 2, 4, 6, 8, 10, 12
Bleomycin 5 units/m ²		IV	Weeks 1, 5, 9
Mustard 6 mg/m ²		IV	Weeks 3, 7, 11
Etoposide 60 mg/m ²		PO	Weeks 1-9, taper by 10 mg
Prednisone 40 mg/m ²		QOD	QOD weeks 10 and 11

Although the detrimental effects of combination chemotherapy on fertility are well documented, neither the occurrence of infertility nor its persistence can be predicted with certainty. Because of the risk of birth defects, adequate contraception during chemotherapy is essential. Both during and following chemotherapy, patients desiring to avoid pregnancy should be advised not to rely on chemotherapy as their only form of contraception. In addition to decreased fertility, hormonal effects of chemotherapy have been associated with decreased libido in both men and women receiving chemotherapy for HL.^{169, 174, 175}

Limited-Stage Disease

Limited- or early-stage HL is further stratified into two groups for the purpose of clinical trials and for treatment planning. Favorable early-stage HL is defined as stage I or II HL without unfavorable features or risk factors, and unfavorable early-stage HL is defined as the stage I or II with one or more risk factors. The risk factors have been variously defined by different groups, (see Table 93.7) but generally include (1) a greater number or nodal sites, (2) elevated erythrocyte sedimentation rate, (3) B symptoms, (4) a large mediastinal mass or other bulky disease, and (5) age over 40 or 50 years. Unfavorable early-stage HL may also be thought of as comprising two further groups: those unfavorable on the basis of bulky disease, and those unfavorable on the basis of another risk factor.

Treatment of Favorable Early-stage Hodgkin Lymphoma

Favorable early-stage HL has traditionally been treated with extended field radiotherapy, with cure rates as high as 80%. Long-term follow-up of patients treated and cured with radiotherapy has now made clear that such patients suffer from high rates of life-threatening and/or debilitating late effects, such as early atherosclerosis and myocardial infarction, valvular heart disease, and secondary malignancies. Over the last 2 decades this recognition has led to a general move toward using chemotherapy for early-stage patients and simultaneously reducing the fields and doses of radiotherapy, and even eliminating radiotherapy entirely for certain highly susceptible patients (e.g., young women with mediastinal disease who would have a high risk of breast cancer with mediastinal irradiation). Reducing the fields and doses of radiotherapy has been shown to reduce the risk of at least some of the late side effects of radiation exposure.^{176, 177, 178, 179, 180}

In the last 15 years, a number of publications have shown the excellent results and tolerability of a treatment paradigm for favorable early-stage HL consisting of a limited number of courses of chemotherapy (generally ABVD) and limited radiotherapy at reduced total dose.^{181, 182, 183, 184} Although there is a paucity of randomized data comparing a modern combined modality regimen (i.e., a limited number of cycles of ABVD followed by involved field radiotherapy with relatively low total dose) to radiotherapy alone or to ABVD alone, the single-arm PFS rates of over 90% and short-term

tolerability, and the expected low rate of long-term side effects have made combined modality therapy a de facto standard for favorable early-stage HL. Extended field radiotherapy is no longer a standard of care, and chemotherapy alone is used primarily when there is particular concern about long-term side effects of radiation. A number of randomized trials have evaluated combined modality treatment, although most have used noncurrent radiotherapy, noncurrent chemotherapy, or both. As is the case in many trials of initial treatment of HL, a difference in OS is difficult to prove, presumably because of the efficacy of salvage therapy and the long survival times of patients. However, at least one randomized trial, the EORTC's H8F trial, which compared three cycles of MOPP/ABV (mechlorethamine, vincristine, procarbazine, prednisone, doxorubicin, bleomycin, and vinblastine) hybrid and involved field radiotherapy to subtotal nodal irradiation, shows an OS for the combined modality treatment advantage at 10 years follow-up (97% vs. 92%, $P = 0.001$).¹⁸³ Likewise a meta-analysis of trials comparing chemotherapy alone to combined modality therapy demonstrated an advantage in both tumor control and OS for the combined modality approach.¹⁸⁵

P.1995

Most recent investigations of combined modality therapy of favorable early-stage HL have used ABVD, based on its superiority to earlier regimens, although some studies incorporate the BEACOPP (bleomycin, etoposide, doxorubicin, cyclophosphamide, vincristine, procarbazine, and prednisone) or Stanford V regimens (see section "Advanced Therapy Treatment"). A currently accruing trial of the German Hodgkin Study group, HD13, randomizes favorable early-stage patients to ABVD versus ABV versus ABD versus AV.

Within the paradigm of combined modality therapy for favorable early-stage HL, several key questions remain, including the following. (1) What is the optimal number of cycles of chemotherapy? (2) What is optimal dose of RT? (3) Can radiotherapy be eliminated entirely?

Four cycles of ABVD followed by involved field radiotherapy has been used as a comparator arm in a number of studies and has emerged as a standard treatment for favorable early HL. For example Bonadonna and colleagues reported a study comparing radiotherapy fields in stages I and II HL (29% were unfavorable). The ABVD \times 4 and involved field radiotherapy arm had a 12-year FFP of 94% and an OS of 94%.¹⁸⁴ The HD 10 study of the German Hodgkin Study Group randomized favorable early-stage patients to either four or two cycles of ABVD, and later to one of two doses of radiation. A total of 1,190 patients from 329 institutions were analyzed for the comparison of ABVD \times 4 versus ABVD \times 2. At 5-year follow-up, there was no difference in OS (97.1% vs. 96.1%, NS) or PFS (93.1% vs. 91.2%, NS).¹⁸⁶ It is important to note that the inclusion criteria for this trial selected patients likely to be especially favorable, as compared to the study population in other favorable early-stage HL trials. In particular, the patients had two or fewer nodal groups involved (as opposed to three or fewer), and the definitions of the nodal groups are unique to the GHSG and not precisely concordant with the Cotswold definition. Details are available in the appendix to the paper online at http://www.nejm.org/doi/suppl/10.1056/NEJMoa1000067/suppl_file/nejmoa1000067_appendix.pdf. Thus the HD10 trial may be read as identifying a "very favorable" subgroup for whom ABVD \times 2 is adequate before involved field radiation therapy.

The appropriate dose of involved field radiation therapy in the combined modality approach to favorable early-stage HL has also been a topic of investigation. The Italian trial above¹⁸⁴ used a dose of 36 Gy with excellent 12-year results, and a Stanford trial of abbreviated chemotherapy (Stanford V \times 8 weeks), followed by involved field radiotherapy used a dose of 30 Gy with 10-year OS and PFS of 94%. The EORTC H9F trial (reported in abstract only) used the alternative chemotherapy EBVP (epirubicin, bleomycin, vinblastine, and prednisone) \times 6 followed by involved radiotherapy 30 Gy versus 20 Gy versus no radiotherapy. There was no significant difference between the 30 Gy and 20 Gy groups by 4-year freedom from treatment failure (FFTF, 87% vs. 84%).¹⁸⁷ The HD10 study of the German Hodgkin Study Group randomized patients (selected for two or fewer involved nodal groups, as above) to either 30 Gy or 20 Gy involved field radiation. There was no difference between the two doses of radiotherapy at 5 years (PFS 93.7% vs. 93.2% and OS 97.7% vs. 97.5%).¹⁸⁶

A number of groups have reported using chemotherapy alone for favorable early-stage patients. In a prospective single-arm study from Spain, investigators reported on stage I and II patients treated with ABVD \times 6 for early-stage HL. Among 49 patients who were favorable by EORTC criteria, the PFS and OS were 88% and 100% at 78-months follow-up.¹⁸⁸ Canellos et al reported a retrospective series of 75 patients with nonbulky early-stage HL who were treated with ABVD alone (the majority with 6 cycles). All patients attained a complete response (CR), and the PFS at 60 months was 92%.¹⁸⁹ It is important to note that this is a retrospective study: presumably those not achieving a CR would have been considered for RT and if they received radiation would not have been included in the study. Strauss et al. randomized 152 nonbulky stage

I, II, and IIIA patients to ABVD × 6 versus ABVD × 6 and 36 Gy of extended or involved field radiation therapy. At 60 months, FFP was 81% versus 86% (NS) and OS was 90% versus 97% (NS).¹⁹⁰ The inclusion of stage III patients and the use of “full-course” chemotherapy complicates the interpretation of this trial. The authors point out the trial is not powered to detect difference smaller than 20%. The HD6 trial of the National Cancer Institute of Canada randomized nonbulky early-stage patients to either ABVD alone (4 to 6 cycles) or a strategy in which favorable (<40 years, ESR <50, no MC or lymphocyte-depleted histology, <4 sites of disease) patients received extended field radiation alone and unfavorable patients received ABVD × 2 followed by radiation. Comparing the chemotherapy-only patients to the patients treated with a strategy including radiation, there is an advantage in PFS for the latter (93% radiation vs. 87% ABVD, $P = 0.006$) but no difference in event-free survival (EFS) and OS. Five-year PFS for the favorable patients receiving ABVD only (59 patients) is 87%. In this study, the only patients who were randomized to chemotherapy-only or combined modality therapy were unfavorable (though nonbulky), and thus the utility of these data for evaluating combined modality therapy versus chemotherapy alone are limited.¹⁹¹

In summary, the standard treatment of favorable early-stage HL is combined modality treatment, with two to four cycles of ABVD followed by 20 to 30 Gy of involved field radiation therapy. The lower limits of the above guideline are validated for the somewhat selected group identified in the HD10 study with two or fewer involved sites. Chemotherapy alone has a 5-year PFS rate of 81% to 92%. Although the PFS is likely somewhat lower than with combined modality therapy, chemotherapy alone might be preferred when radiation is deemed more dangerous or otherwise unsuitable. The most common of these situations is the case of a young woman who would be placed at higher risk of breast cancer if she underwent chest irradiation. Other scenarios include smokers in whom chest irradiation would further increase the risk of lung cancer or fibrosis, and anatomic situations where a vital structure such as the heart would be irradiated. A reasonable question for the clinician to ask himself is whether the additional margin of PFS after an initial combined modality approach is worth any extra toxicity over a chemotherapy-alone approach, especially if there is a reasonable chance of salvage for the small number of patients who relapse as a result of not receiving radiation therapy. In the future, an early response by PET may identify patients who do not have an additional benefit from post-CR radiation; this is a focus of a current intergroup trial, C50604.

Treatment of Unfavorable Early-stage Hodgkin Lymphoma

Many patients who are classified as having unfavorable early-stage HL (also known as intermediate stage HL) have a bulky mediastinal mass, although others will qualify as unfavorable on the basis of a high erythrocyte sedimentation rate or multiple nodal sites.

Combined modality therapy has long been the recommended therapy for this group of patients. The EORTC/GELA (Groupe d'Etude des Lymphoma de l'Adulte) H8U¹⁸³ study randomized patients to one of three treatment strategies, two of which were MOPP/ABV × 6 followed by involved field radiation and MOPP/ABV × 4 followed by involved field radiation. There was no statistical difference in 5-year FTF (84% vs. 88%) or the 10-year OS (88% vs. 85%). The same group's H9U study¹⁸⁷ randomized patients to ABVD × 6, ABVD × 4, or baseline BEACOPP, each followed by involved field radiation. The ABVD arms were

P.1996

equivalent, with 4-year FTF of 94% and 89%, respectively, and 4-year OS of 96% and 95%. BEACOPP was not more effective (4-year FTF 91%) and was more toxic. These studies established ABVD × 4 followed by 30 Gy involved field radiation as a standard for unfavorable early-stage HL.

The HD11 study of the German Hodgkin Study Group randomized 1,395 patients to either ABVD or baseline BEACOPP and further randomized them to involved field radiotherapy of 20 Gy or 30 Gy. Of these, 19.5% had a bulky mediastinal mass and 9.9% had an extranodal lesion. ABVD × 4 and 30 Gy was as effective (5-year PFS 87.2%) as BEACOPP and 30 Gy (87.9%) or BEACOPP and 20 Gy (87.0%), but ABVD × 4 and 20 Gy was inferior (82.1%). BEACOPP arms were more toxic. The authors concluded that ABVD × 4 and 30 Gy should be the standard in unfavorable early-stage HL because of superior tumor control and lower toxicity.¹⁹²

In an attempt to improve on the HD11 results, the German Hodgkin Study Group's HD 14 trial compared ABVD × 4 to escalated BEACOPP × 2 followed by ABVD × 3 (“2 + 2”), each followed by 30 Gy involved field radiation; 1,528 patients entered the study. The 2 + 2 arm was superior in PFS at 5 years (95.4% vs. 89.1%, $p < 0.001$) and OS was not significantly different. Toxicity was higher in the 2 + 2 arm as compared to the ABVD arm (at least one grade 3 or 4 toxicity 87.1% vs. 50.7%) and 4 patients (0.52%) died from toxicity in the 2 = 2 arm.¹⁹³ Despite the higher efficacy of the 2 + 2 arm, many would question the utility of the small increase in PFS without an increase in OS in this relatively short follow-up.

The current intergroup trial C50604 includes nonbulky unfavorable patients. Those who have a negative PET after two cycles will omit radiotherapy.

Therapy for lymphocyte predominant Hodgkin lymphoma is addressed after the section on Pregnancy.

FRONT-LINE THERAPY FOR ADVANCED-STAGE HODGKIN LYMPHOMA

Adriamycin (Doxorubicin), Bleomycin, Vinblastine, and Dacarbazine

Since the early 1990s, the treatment of patients with advanced-stage HL has relied on combination chemotherapy with ABVD (see Table 93.9). ABVD was first introduced by Bonadonna and colleagues in the late 1970s as an effective, non-cross-resistant chemotherapy option for patient with relapsed HL.¹⁴¹ Unlike MOPP (mechlorethamine, vincristine, procarbazine, and prednisone), the first successful combination chemotherapy regimen used in the treatment of HL, ABVD was not associated with sterility or secondary myelodysplasia or leukemia.^{154, 167} The success of ABVD in the second line setting eventually led to efforts to combine MOPP and ABVD in 12 alternating treatment cycles (MOPP/ABVD alternating regimen). As front-line therapy in patients with stage IV HL, MOPP/ABVD proved superior to MOPP alone with a FFP at 8 years of 64.6% versus 35.9% ($P < 0.005$) and 8-year OS rates of 83.9% versus 63.9% ($P < 0.06$).¹⁴³ In 1982, the Cancer and Leukemia Group B (CALGB) in the United States initiated a randomized multicenter trial in 361 patients with stage III-IV previously untreated HL, comparing MOPP for 6 to 8 cycles ($n = 123$), ABVD for 6 to 8 cycles ($n = 115$), and alternating MOPP/ABVD for 12 cycles ($n = 123$).²⁰⁰ In this trial, CR rate (67% MOPP, 82% ABVD, and 83% MOPP/ABVD, $P = 0.006$) and 5-year failure-free survival (FFS) (50% MOPP, 61% ABVD, and 65% MOPP/ABVD, $P = 0.02$) were superior in the ABVD and MOPP/ABVD arms, with less neutropenia, thrombocytopenia, and infectious toxicity in the ABVD arm (18%, 2%, and 2% ABVD, 47%, 36%, and 11% MOPP, and 53%, 28%, and 12% MOPP/ABVD, respectively).²⁰⁰ A subsequent randomized phase III US Intergroup trial compared ABVD and MOPP/ABV hybrid (combined MOPP and ABV drugs in each cycle rather than alternating cycles of MOPP and ABVD) for 8 to 10 cycles in 856 patients with stage III-IV HL. CR rates (76% vs. 80%, $P = 0.16$) and 5-year FFS rates (63% vs. 66%, $P = 0.42$) were similar in patients receiving ABVD or MOPP/ABV, respectively.¹⁵⁰ In this study, the 5-year FFS for patients with 0, 1, 2, 3, 4, and ≥ 5 risk factors by the International Prognostic Score (IPS),¹⁰¹ were 76%, 72%, 81%, 69%, 64%, and 67%, respectively; the 5-year OS was 82% using ABVD; and ABVD resulted in fewer pulmonary and hematologic toxicities, treatment-related deaths, and second malignancies including acute leukemia than observed with MOPP/ABV.¹⁵⁰ In a UK study comparing ABVD to other combination hybrid regimens (ChIVPP/PABIOE and ChIVPP/EVA), the 3-year EFS and OS with ABVD were 75% and 90%, respectively, once again similar to multidrug regimens, with less infectious and neurologic toxicity than observed with the hybrid regimens.²⁰¹ As a result of these trials, ABVD became the standard of care for initial therapy of advanced-stage HL; however, recently, two other combination chemotherapy regimens, Stanford V and BEACOPP (see Table 93.9), have challenged the role of ABVD as the standard front-line regimen in this patient population.

Stanford V

Stanford V, a multiagent combined modality regimen consisting of doxorubicin, vinblastine, mechlorethamine, vincristine, bleomycin, etoposide, and prednisone administered weekly over 12 weeks followed by 36 Gy consolidative radiotherapy to bulky mediastinal disease, tumor masses or lymphadenopathy ≥ 5 cm, and macroscopic splenic nodules, was designed to reduce the total doses of bleomycin and adriamycin. In initial phase II trials, respectively, the 5-year FFP utilizing this regimen was 85% to 89% in patients with bulky stage I-II and advanced-stage HL.^{202, 203} In a randomized Italian trial in 355 patients with stage IIB, III, and IV HL comparing six cycles of ABVD ($n = 122$), 12 weeks of Stanford V ($n = 107$), and six cycles of MOPPEBVCAD (mechlorethamine, vincristine, procarbazine, prednisone, epidoxorubicin, bleomycin, vinblastine, lomustine, doxorubicin, and vindesine), 5-year FFS were 78%, 54%, and 81%, respectively ($P < 0.01$).²⁰⁴ However, in this trial, radiation was only given to sites of initial bulky disease or sites of residual disease post-chemotherapy, and only 66% of patients receiving Stanford V also received radiation in the Italian study, compared to 91% in the prior single institution trial.^{202, 204} At 10 years of follow-up, 10-year FFS were 75%, 74%, and 49% ($P < 0.001$) and 10-year OS were 87%, 80%, and 78% ($P = 0.4$) for the ABVD, MOPPEBVCAD, and Stanford V arms, respectively; however, in looking at Stanford V patients treated with and without radiotherapy, 10-year DFS was statistically in favor of those patients receiving radiation (76% vs. 33%, $P = 0.004$).²⁰⁵ In a subsequent multicenter UK study in 520 patients with stage IIB, III, IV, or bulky stage I-II HL, there were no differences in 5-year FFS and OS in patients receiving six to eight cycles of ABVD (53% patients received radiation to sites of residual disease) or 12 weeks of Stanford V (73% patients received radiation to disease sites >5 cm or splenic nodules).²⁰⁶ More pulmonary toxicity was observed in the ABVD arm in this trial, although myelosuppression and neuropathy were slightly worse with Stanford V. A randomized phase III US Intergroup trial, conducted from 1999-2006, demonstrated no significant difference in 5-year FFS (73% vs. 71%, $P = 0.29$) or 5-year OS (88% vs. 87%, $P = 0.87$) in 812 patients with bulky stage I-II, III, or IV HL receiving six to eight cycles of ABVD with radiation to bulky mediastinal disease or 12 weeks of Stanford V chemotherapy with radiotherapy to disease >5 cm or splenic nodules, respectively.²⁰⁷ With

median follow-up of 5.25 years, 26 second malignancies were observed (14 ABVD and 12 Stanford V). Therefore, as a result of these trials, six cycles of ABVD has remained the standard treatment for patients with advanced-stage HL; however, Stanford V may be acceptable in patients

P.1997

where a shortened treatment duration or reduction in cumulative doses of bleomycin or adriamycin is desirable. Long-term follow-up is needed from the UK and US intergroup trials to determine the risks of second malignancies, particularly with Stanford V, as additional radiotherapy is required per the treatment protocol in the majority of patients.

Bleomycin, Etoposide, Doxorubicin, Cyclophosphamide, Vincristine, Procarbazine, and Prednisone

Intensification of initial therapy is one approach to improving outcomes in patients with advanced-stage HL. However, this approach may lead to increased short-term and long-term toxicity that may ultimately have a negative impact on OS, particularly in lower-risk patients. The German Hodgkin study group HD9 trial randomized patients ages 15 to 65 with stage IIB, III, and IV HL to either eight cycles of COPP/ABVD (cyclophosphamide, vincristine, procarbazine, and prednisone alternating with ABVD), BEACOPP-baseline, or BEACOPP-escalated (esc).²⁰⁸ With 10 years of follow-up, FTF was 64%, 70%, and 82% with OS of 75%, 80%, and 86% in the COPP/ABVD, BEACOPP-baseline, and BEACOPP-esc arms, respectively.²⁰⁹ By IPS, FTF at 5 years was 92%, 87%, and 82% with BEACOPP-esc for patients with 0 to 1, 2 to 3, and 4 to 7 risk factors, respectively.²⁰⁸ However, it is important to note that only 13% of patients receiving BEACOPP-esc had 4 to 7 risk factors on this trial, and although differences in FTF were significantly in favor of BEACOPP-esc among all three risk groups, statistically significant improvements in OS were only observed in patients with IPS scores of 2 to 3 ($P = 0.27$ for IPS 0-1, $P < 0.0027$ for IPS 2-3, and $P = 0.16$ for IPS 4-7).²⁰⁹ When analyzed by age, there was not a significant improvement in FTF and OS for patients ages 60 to 65 and increased toxicity occurred with BEACOPP-esc. Therefore, BEACOPP-esc is not recommended in patients over the age of 60.²⁰⁸ In an attempt to reduce toxicity, the HD12 trial examined eight cycles of BEACOPP-esc versus four cycles of BEACOPP-esc plus four cycles of BEACOPP-baseline.²¹⁰ Five-year FTF and OS were 86.4% and 92%, respectively with eight BEACOPP-esc compared to 84.8% and 90.3% with 4 + 4 arm, and toxicities were not significantly reduced with the 4 + 4 approach.²¹⁰

In a randomized Italian study comparing six cycles of ABVD with four cycles of BEACOPP-esc plus two cycles BEACOPP-baseline,²¹¹ 5-year PFS was superior for BEACOPP (81%) compared to ABVD (68%), although there were no differences in OS perhaps due to the smaller numbers of patients¹⁵⁰ on this trial compared to the 1,201 patients on the previous German HD9 trial. In a second Italian cooperative group study, the 7-year rate of freedom from first progression was 85% in patients receiving four cycles of BEACOPP-esc plus four cycles BEACOPP-baseline compared to 73% in patients receiving six to eight cycles of ABVD ($P = 0.004$).²¹² In this same trial, the 7-year rate of freedom from second progression was 88% in the BEACOPP group compared to 82% in the ABVD group ($P = 0.12$), suggesting that long-term outcomes may not differ between the two regimens when one factors in the efficacy of salvage chemotherapy and autologous stem cell transplant following ABVD.²¹²

Despite the success of the BEACOPP-esc regimen compared to hybrid regimens and ABVD in patients ≤ 60 years of age, this regimen is associated with infertility and a 6.0% second malignancy rate, including a 3.2% incidence of secondary AML/MDS.^{209, 213} In addition, BEACOPP-esc is associated with more acute toxicities including hematologic and infectious complications than observed with ABVD.²¹¹ Therefore, although several studies demonstrate the superiority of BEACOPP-esc with respect to PFS in patients with advanced-stage HL, it remains unclear if the risks of second malignancies, infertility, and acute infections associated with BEACOPP-esc are justified to improve patient outcomes in all patients with advanced-stage HL, especially if relapsing patients after ABVD can be effectively salvaged with high-dose therapy and stem cell transplantation. Current studies are examining the role of reduction of total cycles of BEACOPP-esc and PET-directed approaches that may maintain the advantage of improved disease control observed with BEACOPP-esc while reducing acute and late toxicities or at least limiting exposure to those patients at highest risk. However, these approaches utilizing interim PET/CT to reduce total number of cycles of BEACOPP-esc in patients who have negative interim PET/CT or to limit exposure to BEACOPP-esc to only the most unfavorable patients with interim positive PET/CT remain under investigation and long-term follow-up will be needed to assess for late toxicities that affect OS. Currently ABVD, Stanford V, and BEACOPP-esc are all accepted front-line therapy in patients with advanced-stage HL.

Radiation Therapy as Consolidation in Stage III-IV Hodgkin Lymphoma

Several studies have examined the role of consolidative radiotherapy in patients with advanced-stage HL, and to date, no study has demonstrated a clear OS advantage with combined modality therapy in patients achieving a CR or PR with chemotherapy alone. The H89 GELA study randomized 533 patients with stage III-IV HL to six cycles of MOPP/ABV hybrid

or six cycles of ABVPP followed by either two more cycles of chemotherapy or subtotal nodal radiation for patients achieving a CR or PR after six cycles.²¹⁴ In the chemotherapy alone arms 10-year OS was superior (90% for ABVPP × 8, 78% for MOPP/ABV × 8, 82% for MOPP/ABV × 6 with radiation, and 77% for ABVPP × 6 with radiation, $P = 0.03$). Using an ABVD backbone, Laskar and colleagues demonstrated an improvement in 8-year EFS and OS with chemotherapy and involved field radiotherapy in patients achieving a CR; however, this trial was small with only 179 patients randomized to observation versus radiotherapy and included all stages ($n = 80$ with stage III-IV disease).²¹⁵ A larger, although nonrandomized, UK study restricted to advanced-stage HL patients analyzed outcomes in 807 patients treated with six cycles of ABVD, CHLVPP/PABIOE, or CHLVPP/EVA, and involved field radiotherapy to sites of residual masses or bulky disease. A total of 300 patients (43%) received involved field radiotherapy, and although non-RT patients tended to be more often in CR, 5-year EFS was 86% with RT and 71% without RT ($P < 0.001$) and 5-year OS was 93% with RT and 87% without RT ($P < 0.001$).²¹⁶ In contrast, a randomized study of 739 patients with advanced-stage HL assigned patients with a CR after six to eight cycles of MOPP/ABV hybrid to observation or involved field RT, and demonstrated no difference in 5-year OS ($P = 0.07$) or EFS ($P = 0.35$) in the radiotherapy ($n = 172$, OS of 85% and EFS of 79%) group compared to the observation group ($n = 161$, OS of 91% and EFS of 84%).²¹⁷ The HD12 trial randomized responding patients after BEACOPP with stage IIB, III, and IV HL and with bulk or residual tumor on CT imaging to either additional consolidative RT or no RT.²¹⁰ In this trial, 1,085 patients received initial BEACOPP therapy, 207 required no RT due to lack of bulky disease or CR; 148 received RT due to less than a PR to chemotherapy (less than 50% tumor reduction); and 730 patients were randomized to RT or no RT. At 5 years, FTF was 87% in those patients who did not receive RT, compared to 90.4% in the RT arm ($P = 0.08$).²¹⁰ Therefore, based on these studies, it appears that consolidation with IFXRT does not improve outcomes in patients achieving a CR after combination chemotherapy, although additional studies need to be done in patients with a PR, particularly utilizing a PET-based response determination. In one such trial, the HD15 trial, patients with stage IIB, III, and IV HL received involved field radiotherapy after six to eight cycles of BEACOPP if they had residual disease more than 2.5 cm and were PET positive. In this study, 311 of 1,788 enrolled had residual disease

P.1998

>2.5 cm on CT and PET was positive in 66 of these patients.²¹⁸ With 1 year of follow-up, PFS for the PET-negative patients who were not radiated was 96% and for the PET-positive patients was 85% ($P = 0.011$), and therefore PET-directed radiotherapy may be feasible in this population.²¹⁸ In addition, as demonstrated by the GELA study,²¹⁴ prolonged follow-up beyond 10 years is needed from these trials to determine if OS is adversely affected with the incorporation of involved field radiotherapy at the end of therapy in patients with advanced-stage HL due to the potential late complications of second malignancies and cardiovascular disease related to the radiotherapy.

Autologous Transplant as Consolidation in Stage III-IV Hodgkin Lymphoma

Several trials have examined the role of autologous transplant to improve outcomes in patients with high-risk, advanced-stage HL, and to date none have demonstrated a role for this following standard ABVD chemotherapy. A European intergroup trial randomized 163 patients with stage III-IV HL and two risk factors (elevated LDH, bulky disease, stage IV with two or more extranodal sites, anemia, or inguinal involvement) achieving a CR or PR after four cycles of ABVD or doxorubicin containing induction (MOPP/ABVD, MOPP/ABV, CVPP/ABV) to either four additional cycles of the same induction chemotherapy or autologous stem cell transplantation after BEAM (carmustine, etoposide, cytarabine, and melphalan) or CBV (cyclophosphamide, carmustine, and etoposide) conditioning regimens.²¹⁹ The 5-year FFS with continued chemotherapy was 82% compared to 75% ($P = 0.4$) with consolidative autologous transplantation, and the 5-year OS were 88% and 88% ($P = 0.99$), demonstrating no clear benefit from early high-dose consolidation in high-risk advanced-stage HL. Two other studies using hybrid induction chemotherapy regimens versus chemotherapy followed by myeloablative transplant in 126 to 158 high-risk patients also similarly demonstrated no difference in OS with front-line transplantation.^{220, 221}

Future Directions/Upcoming Studies in Frontline Therapy for Stage III-IV Hodgkin Lymphoma

In the future, therapy for advanced-stage HL may be tailored based on a patient's pre-treatment risk factors (clinical or selected biologic markers) or on results of interim PET/CT. In previous studies, 2-year PFS for patients with a positive PET/CT after two cycles of ABVD were 12.8% compared to 95% for interim PET/CT negative patients ($P < 0.0001$), and interim PET/CT results were more predictive of outcome than IPS score in multivariate analysis.²²² Although the prognostic potential of PET/CT may be dependent on initial treatment, timing of scans, and definitions of PET negativity, PET/CT does represent an important tool that may in the future direct therapy. To date, altering therapy based on interim PET/CT results remains investigational; however, a number of trials are ongoing examining this question in patients with advanced-stage HL. Risk-adapted therapy was first described by Dann et al., who prospectively assigned 108 patients with

unfavorable HL (stages I-II with risk factors, B-symptoms, or bulky disease and stages III-IV) to either two cycles of BEACOPP-esc if IPS score ≥ 3 or BEACOPP-baseline if IPS < 3 followed by interim PET/CT or gallium scan.²²³ Patients with a positive interim scan received four more cycles of BEACOPP-esc and those with a negative interim scan received four cycles of BEACOPP-baseline. Using this IPS and imaging directed therapeutic approach resulted in 5-year EFS and OS of 85% and 90%, respectively.²²³ Currently, UK and US intergroup studies are exploring intensification of therapy in patients who are interim PET/CT positive after two cycles of initial ABVD therapy, and the German Hodgkin Study Group HD18 trial is reducing therapy after two cycles of initial BEACOPP-esc in patients who are interim PET/CT negative. Central review of interim PET/CT is critical in these studies using PET/CT to alter treatment approaches. In addition to efforts to risk-stratify therapy based on initial high-risk features or interim PET/CT, efforts are also being made to incorporate promising new therapies into traditional ABVD backbones to improve outcomes in advanced-stage HL further. Brentuximab vedotin, a CD-30 antibody-drug conjugate, which is FDA-approved for the treatment of relapsed and refractory HL and is further described below, has recently been added to the ABVD regimen.²²⁴ In this phase I trial, patients with stage III-IV HL received ABVD with escalating doses of brentuximab vedotin ranging from 0.6 to 1.2 mg/kg on days 1 and 15 of each 28-day cycle. Initial toxicities included significant pulmonary toxicity, leading to removal of bleomycin from the regimen and treatment of an expanded cohort of patients with AVD plus brentuximab.²²⁴ Randomized studies in patients with bulky stage II, III, and IV HL comparing the AVD plus brentuximab regimen to traditional ABVD are planned, but this may offer an alternative strategy for improving therapy in high-risk patients using a novel targeted agent and may ultimately become an attractive option in young, high-risk patients with less risk of secondary malignancies or infertility than intensification with BEACOPP-esc. However, long term follow-up will be needed from randomized studies comparing AVD plus brentuximab with ABVD and BEACOPP-esc to determine the efficacy and risks with AVD plus brentuximab before this approach to therapy is accepted in advanced-stage patients.

THERAPY FOR RELAPSED OR REFRACTORY HODGKIN LYMPHOMA

Salvage Therapy and Autologous Hematopoietic Cell Transplant

Salvage chemotherapy followed by autologous stem cell transplant is the standard of care for patients with relapsed or refractory HL (Chapter 104). With respect to salvage regimens prior to autologous transplant, patients typically receive two to three cycles and then proceed to transplant. However, there are no randomized data on optimal salvage regimens and numerous options exist. Regimens include ICE (ifosfamide, carboplatin, etoposide), GVD (gemcitabine, vinorelbine, liposomal doxorubicin), DHAP (dexamethasone, cytarabine, cisplatin), ESHAP (etoposide, methylprednisolone, cytarabine, cisplatin), GDP (gemcitabine, dexamethasone, and cisplatin), IGEV (ifosfamide, gemcitabine, vinorelbine, prednisolone), mini-BEAM (carmustine, etoposide, cytarabine, melphalan), and Dexa-BEAM (dexamethasone, carmustine, etoposide, cytarabine, melphalan; see Table 93.10) with responses ranging from 70% to 90%.^{225, 226, 227, 228, 229, 230, 231, 232, 233} Ideally, the salvage regimen chosen should result in a high overall response rate with acceptable toxicity and not impair stem cell mobilization if transplantation is planned.

In 1997, physicians at Stanford University compared outcomes for 60 patients with relapsed or refractory HL treated with a non-cross-resistant combination therapy until maximal response followed by autologous transplant with 103 matched historical patients receiving chemotherapy alone.²³⁴ The 4-year OS, EFS, and FFP were 54% versus 47% ($P = 0.25$), 53% versus 27% ($P < 0.01$), and 62% versus 32% ($P < 0.01$), respectively, favoring transplant compared to conventional salvage therapy. The British National Lymphoma Group randomized 40 patients with relapsed HL to either BEAM (carmustine, etoposide, cytarabine, and melphalan) followed by autologous transplant or mini-BEAM alone, demonstrating a significant PFS benefit ($P = 0.005$) with transplantation.²³⁵ A larger trial of 161 chemosensitive patients randomized to two cycles of Dexa-BEAM and autologous transplant

P.1999

or two further cycles of Dexa-BEAM demonstrated a 3-year FFTF of 55% with transplantation compared to 34% without transplant ($P = 0.019$).²²⁹ However, neither trial demonstrated an OS benefit perhaps due to limited follow-up or small patient numbers.

TABLE 93.10 SALVAGE COMBINATION CHEMOTHERAPY REGIMENS UTILIZED FOR RELAPSED OR REFRACTORY HODGKIN LYMPHOMA

GVD (not previously transplanted) ²²⁷	Gemcitabine 1,000 mg/m ²	IV	Days 1 and 8	Q21d
	Vinorelbine 20 mg/m ²	IV	Days 1 and 8	

GVD (previously transplanted) ²²⁷	Liposomal doxorubicin 15 mg/m ²	IV	Days 1 and 8	Q21d
	Gemcitabine 800 mg/m ²	IV	Days 1 and 8	
	Vinorelbine 15 mg/m ²	IV	Days 1 and 8	
ICE ²²⁶	Liposomal doxorubicin 10 mg/m ²	IV	Days 1 and 8	Q14d
	Ifosfamide 5,000 mg/m ²	IV over 24 h	Day 2	
	Mesna 5,000 mg/m ²		Day 2	
	Etoposide 100 mg/m ²	IV over 24 h	Days 1-3	
DHAP ²³¹	Carboplatin AUC = 5 (maximum dose of 800 mg)	IV	Day 2	Q21d
	Dexamethasone 40 mg	IV/PO	Days 1-4	
	Cisplatin 100 mg/m ²	IV over 24 h	Day 1	
	Cytarabine 2,000 mg/m ²	IV every 12 h	Day 2	
ESHAP	Etoposide 40 mg/m ²	IV	Days 1-4	Q21d
	Methylprednisolone 500 mg	IV	Days 1-5	
	Cytarabine 2,000 mg/m ²	IV	Day 5	
	Cisplatin 25 mg/m ²	CIV	Days 1-4	
Mini-BEAM ²³²	BCNU (carmustine) 60 mg/m ²	IV	Day 1	Q21-28d
	Etoposide 75 mg/m ²	IV	Days 2-5	
	Cytarabine 100 mg/m ²	IV every 12 h	Days 2-5	
	Melphalan 30 mg/m ² (maximum of 50 mg)	IV	Day 5	
Dexa-BEAM ²³³	Dexamethasone 24 mg	PO	Days 1-10	Q28d
	BCNU (carmustine) 60 mg/m ²	IV	Day 2	
	Melphalan 20 mg/m ²	IV	Day 3	
	Etoposide 200 mg/m ²	IV every 12 h	Days 4-7	
	Cytarabine 100 mg/m ²	IV every 12 h	Days 4-7	
	GCSF 300-480 μg	IV every 12 h	Day 9 until WBC >2,500/μl	
IGEV ²²⁵	SQ			Q21d
	Ifosfamide 2,000 mg/m ²	IV	Days 1-4	
	Gemcitabine 800 mg/m ²	IV	Days 1 and 4	
	Vinorelbine 20 mg/m ²	IV	Day 1	
GDP ²³²	Prednisolone 100 mg	PO	Days 1-4	Q21d
	Gemcitabine 1,000 mg/m ²	IV	Days 1 and 8	
	Cisplatin 75 mg/m ²	IV	Days 1 and 8	

ChlVPP ²⁴⁸	Dexamethasone 40 mg	PO	Days 1-4	
	Chlorambucil 6 mg/m ²	PO	Days 1-14	Q28d
	Vinblastine 6 mg/m ²	IV	Days 1 and 8	
	Procarbazine 100 mg/m ²	PO	Days 1-14	
	Prednisone 40 mg	PO	Days 1-14	
Brentuximab Vedotin ¹⁹⁴	1.8 mg/kg (capped at maximum of 100 kg)	IV	Day 1	Q21d

For patients who are refractory to front-line or salvage therapy, PFS of 25% to 38% with high-dose therapy and hematopoietic cell transplantation (HCT) have been reported,^{236, 237, 238} suggesting that these patients also benefit from transplantation, although not unexpectedly with inferior outcomes compared to patients with chemosensitive disease. These studies are limited by differing definitions of refractory disease, the fact that many of the patients received MOPP containing inductions which is inferior to standard ABVD, and that few patients who did not respond to salvage therapy were transplanted. For example, in 86 patients of whom 91% failed to achieve a CR with front-line hybrid regimens and 9% had disease progression within 3 months of completing front-line therapy, 62% responded to salvage therapy and 24% progressed.²³⁸ All patients did undergo HCT and 5-year EFS and OS were 25% and 35%, respectively, with response to salvage therapy significantly associated with survival in multivariate analysis.²³⁸ In a retrospective review of 122 patients who failed to achieve a CR after at least one induction combination chemotherapy regimen and underwent autologous transplant between 1989-1995 at centers participating in the Autologous Bone and Marrow Transplant Registry, 56% had a CR or PR with pretransplant salvage and 44% had less than a PR.²³⁷ Similar to the previous trial, 3-year PFS and OS were 38% and 50%, respectively.²³⁷ A retrospective study from Vancouver also demonstrated 15-year OS of 39% in patients with refractory disease to initial induction therapy, compared to 67% in chemosensitive patients.²³⁹ In a retrospective analysis of 175 patients with SD or PD to initial induction and who also failed to respond according to CT findings to salvage therapy, 5-year OS and PFS were 36% and 32%.²³⁶ In multivariate analysis, > 18 months interval between diagnosis and HCT was favorably associated with OS. Therefore, in patients with primary refractory disease defined either as failure to achieve a CR on CT (not PET/CT) with front-line chemotherapy or a short remission duration who respond to salvage therapy, high-dose therapy with HCT may lead to prolonged durable remissions. Fewer data are available in those patients who fail to respond to salvage therapy.

Although the study by Sweetenham suggests that some patients who are refractory to salvage therapy may benefit from HCT,²³⁶ PET/CT may be helpful in guiding treatment approaches for these patients. A number of studies have recently demonstrated the prognostic value of FDG PET/CT pre-transplant, with EFS/PFS of

P.2000

10% to 31% in patients who are PET positive compared to 68% to 93% for patients with a negative PET/CT prior to HCT.^{240, 241, 242} Using PET/CT to determine eligibility for HCT remains investigational, however, it is reasonable to recommend two to three cycles of salvage chemotherapy, confirmation of response by PET/CT, and then autologous stem cell transplantation in responding patients. For those patients with clearly progressive disease on PET/CT, alternative salvage regimens should be offered and if patients respond, autologous transplant could be considered. For those patients with improving disease on CT scan, but persistent PET positivity prior to autologous transplant, HCT is still recommended based on previous retrospective data and possibility of false-positive PET/CT^{237, 238}; however, further prospective study is needed in this patient population that incorporates centrally reviewed PET/CT into the response assessment and transplant determination.

Tandem transplantation or sequential high-dose therapy has also been evaluated with poor risk or refractory disease and remains investigational. In the largest multicenter trial of 247 patients, 105 patients with primary refractory (defined as less than a PR or progression within the first 90 days from induction doxorubicin containing chemotherapy) or at least two risk factors (time to relapse <12 months, stage III-IV at relapse, or relapse within irradiated sites) underwent tandem ASCT and 95 patients with intermediate risk disease (only 1 risk factor) received a single transplant. In this study, 5-year FFP and OS were 73% and 85%, respectively, in the intermediate risk group; and 46% and 57%, respectively, for the high-risk group who underwent tandem transplant which compares favorably to historically observed 3- to 5-year PFS of 25% to 39% in primary refractory patients.²⁴³ However, in a second trial, use of sequential high-dose conditioning regimens (i.e., high-dose cyclophosphamide, methotrexate, and etoposide followed by BEAM and then HCT) did not improve FTF or OS over

standard BEAM and HCT.²⁴⁴ Therefore, single versus tandem transplant and use of sequential high-dose conditioning regimens remains investigational in patients with relapsed HL.

Therapeutic Options for Patients Relapsing after Autologous Hematopoietic Cell Transplantation

Although many of the previously discussed combination salvage regimens including ICE, GVD, DHAP, ESHAP, GDP, and IGEV have significant activity in patients with HL that has progressed after autologous HCT, often the goals in this patient population are palliation, with minimization of symptoms as well as treatment-related toxicity. Furthermore, prolonged therapy over several months rather than two to three cycles may be necessary to control disease. Therefore, single-agent regimens are often preferred and combination regimens reserved for patients with organ involvement or significant disease-related symptoms. A number of single-agent regimens can be utilized in this setting and include vinblastine, etoposide, gemcitabine, and vinorelbine. With vinblastine, 4 to 6 mg/m² weekly or every 2 weeks until disease progression or toxicity, response rates as high as 59% and median EFS of 14 months have been reported.²⁴⁵ Gemcitabine and vinorelbine both have single-agent activity in 39% to 50% of patients.^{246, 247} Combination therapy with ChIVPP (chlorambucil, vinblastine, procarbazine, and prednisone) also has activity in this patient population.²⁴⁸ Selected patients with nonbulky lymphadenopathy and no organ involvement who are otherwise asymptomatic could also be observed in this setting.

Radiotherapy should also be considered in the setting of relapsed HL. In a retrospective analysis of salvage radiotherapy used in 100 patients at first treatment failure, typically after COPP/ABVD initial therapy, 5-year FFTF and OS were 28% and 51% with radiotherapy alone.²⁴⁹ Advanced stage at relapse and B-symptoms adversely affected OS in multivariate analysis.²⁴⁹ Therefore, in highly selected patients with limited-stage disease at relapse who may not be eligible for autologous HCT due to age and co-morbid conditions, involved field radiotherapy may lead to prolonged remissions. For younger patients with relapsed HL, due to potential risks of second malignancies within the radiation field and improved survival with autologous stem cell transplantation, radiotherapy alone is not recommended at first relapse. However, involved field radiotherapy should be considered in these patients as consolidation post-autologous transplant to bulky, nonirradiated sites or to sites of relapsed limited-stage disease in previously nonirradiated fields. For those patients with limited-stage relapse post-transplantation, radiotherapy may lead to prolonged remissions and delay the need for palliative chemotherapy.

Brentuximab Vedotin (SGN-35)

Recently, the Food and Drug Administration approved brentuximab vedotin, a novel anti-CD30 drug-antibody conjugate for the treatment of patients with relapsed or refractory HL after previous stem cell transplant. Brentuximab vedotin is comprised of a CD30 antibody conjugated by a plasma-stable linker to the antimicrotubule agent, monomethyl auristatin E. In phase I testing, the maximum tolerated dose was 1.8 mg/kg every 3 weeks with an overall response rate of 38% in 45 patients, including 11 CRs.²⁵⁰ In a pivotal phase II study with 102 patients with relapsed (29%) or refractory (71%) HL who had previously received a median of 3.5 prior therapies (range 1 to 13), the ORR was 75% with a 34% CR rate.¹⁹⁴ The median duration of response was 20.5 months in this trial and grade 3 to 4 toxicity consisted of sensory neuropathy (5%), fatigue (2%), neutropenia (14%), and thrombocytopenia (3%).¹⁹⁴ Therefore, with its significant single-agent activity and tolerability, brentuximab vedotin should be considered as initial therapy for patients with relapsed HL post-autologous transplantation. Brentuximab vedotin may be administered for up to 16 cycles, with dose reductions or delays if needed for myelosuppression or neuropathy.

On the basis of this striking efficacy and tolerability in a heavily pre-treated relapsed and refractory patient population, brentuximab vedotin has recently been added to ABVD chemotherapy in a phase I trial in patients with stage IIB, III, and IV previously untreated HL.²²⁴ Due to increased risks of bleomycin toxicity (40% incidence in 25 patients treated with ABVD + brentuximab vedotin), the study has dropped bleomycin from the combination and is currently examining AVD in combination with brentuximab vedotin utilizing brentuximab vedotin at 1.2 mg/kg days 1 and 15 of each cycle.^{224a} There are 26 patients who have received AVD + brentuximab vedotin without bleomycin and no pulmonary toxicity has been observed now that the bleomycin has been dropped from the treatment regimen. An international study sponsored by Seattle Genetics/Millennium randomizing patients with stage III and IV HL to ABVD × 6 cycles versus AVD + brentuximab vedotin × 6 cycles is in development as are multicenter phase 2 studies using this agent alone and in combination with ICE as pre-transplant salvage therapy, and in the future it is hoped we will determine if it is safe to incorporate this agent into front-line therapy, the effect of this agent on stem cell mobilization, and if PFS and OS are improved with the addition of brentuximab to front-line or pre-transplant therapy.

Allogeneic Transplant

Allogeneic HCT has been used for patients with relapsed HL after prior autologous transplant, although the presence of a graft-versus-Hodgkin lymphoma effect remains controversial.²⁵¹ Most trials of allogeneic transplant in HL demonstrate 2-year PFS rates of 30% and OS of 35% to 60%. A European Blood and Marrow Transplantation trial compared reduced intensity

P.2001

(n = 89) to myeloablative (n = 79) allogeneic HCT.²⁵² In this trial, with reduced intensity conditioning, 1-year treatment-related mortality (TRM) was 23% and 5-year OS was 28%, compared to 46% 1-year TRM and 5-year OS of 22% with myeloablative conditioning. In the reduced intensity group 5-year PFS was 18%. Other prospective and retrospective studies have reported 2- to 3-year PFS of 25% to 32% and OS of 43% to 64% with reduced intensity conditioning allogeneic stem cell transplantation in patients with relapsed HL.^{253, 254} Overall, these studies and others demonstrate that in selected patients with available donors, reduced intensity allogeneic stem cell transplantation is an option for patients with relapsed or refractory HL after prior autologous transplantation and may lead to prolonged DFSs in 18% to 30% of patients.

HODGKIN LYMPHOMA IN THE ELDERLY

Older patients with HL have generally been underrepresented in clinical trials. Outcomes in this population are inferior to those in younger patients, most likely because of more frequent co-morbid conditions in older patients. This may lead to dose attenuation and loss of dose density and thus inferior outcomes.

Fit older patients without limiting co-morbidities may be candidates for treatment with standard ABVD-based protocols, as long as there is normal cardiac and pulmonary function. Data regarding the outcome and toxicity of this approach is limited, however. The GHSG reported that grade 3 to 4 toxicity occurred in 67% and 69% of patients with a median age of 65 and 64 years receiving ABVD × 4 on the HD 10 and HD 11 studies;^{255, 256} they included a prospective stratification of elderly (age 66 to 75 years) patients randomized to COPP/ABVD or BEACOPP (standard dose). The complete remission rate and OS rate were similar; however, the rate of toxic death during the treatment was 21% (9 of 42 patients) in the BEACOPP group as opposed to 8% in the COPP/ABVD group. Thus most would consider BEACOPP inappropriate for even the fit elderly.

Recently the GHSG published their experience with PVAG (prednisone 40 mg/m² days 1-5, vinblastine 6 mg/m² day 1, doxorubicin 50 mg/m² day 1, and gemcitabine 1,000 mg/m² day 1, repeated every 21 days) in patients 60 to 75 years old with early unfavorable or advanced HL. Patients received six to eight cycles of PVAG and radiotherapy was added for patients not in complete remission after chemotherapy.²⁵⁷ PFS and OS were 58% and 66% of 59 patients. Grade 3 or 4 toxicity was reported in 73%, but there was only one toxic death.

HODGKIN LYMPHOMA AND HUMAN IMMUNODEFICIENCY VIRUS

Although HL is not considered an AIDS-defining illness, the incidence of HL is increased perhaps tenfold among patients with HIV infection.^{27, 28, 258, 259} In contrast to patients without HIV infection, HL in patients with HIV infection is most commonly of the mixed cellularity subtype and is associated with B symptoms and with advanced stage, commonly due to bone marrow involvement.²⁶⁰ Despite the excellent results seen in patients with advanced-stage HL in the absence of HIV infection, early in the AIDS epidemic, median survival in HIV-positive patients with HL was poor, generally <2 years.²⁶⁰ With the advent of immune reconstitution with highly active antiretroviral therapy, outcomes approach those in the HIV-negative population using standard chemotherapy.^{261, 262, 263} As in the general population, an interim PET scan is highly predictive of good outcome.²⁶⁴

HODGKIN LYMPHOMA AND PREGNANCY

Because HL is commonly seen in women of childbearing years, it is not surprising that HL may occur in women who are pregnant. This problem has been extensively reviewed;¹⁶⁸ although agreement regarding optimal management of these patients does not exist, several key observations have been made, and guidelines for therapy have been advocated. Pregnancy does not affect the course of HL as compared to age-adjusted controls with Hodgkin disease who are not pregnant.²⁶⁵

Staging of the pregnant patient with HL must be modified to decrease the risks associated with radiation exposure of the fetus. Such an evaluation must be performed in the context of treatment planning. If the overall plan is to delay treatment until after delivery, unless bulky disease is found, then a modified approach to staging is reasonable. A chest radiograph, complete blood counts, liver and renal function tests, serum lactic dehydrogenase, and bone marrow biopsy are indicated.

Abdominal ultrasound is probably adequate to establish or rule out the presence of extensive abdominal disease, but more accurate staging must be deferred until after pregnancy as pregnancy precludes the use of CT or PET scans.

The risk of fetal malformations is approximately 15% when chemotherapy is given in the first trimester, but there is no evidence of an increase in fetal malformations when chemotherapy is given in the second and third trimester.²⁶⁶ The risk of late sequelae of chemotherapy to the fetus is unknown. Therefore, unless disease is clearly bulky and symptomatic, one can consider following patients to term if disease is diagnosed in the late second or third trimester.

If a decision is made to delay therapy until after delivery, the patient should be monitored closely, and the clinical plan should be re-evaluated if progressive disease is noted. If chemotherapy is given during pregnancy, it is probably best to avoid chemotherapy during the 3 weeks before delivery to avoid having the baby be neutropenic at birth.

THERAPY FOR LYMPHOCYTE-PREDOMINANT HODGKIN LYMPHOMA

With respect to treatment for NLPHL, no standard front-line or relapsed therapy exists, although a number of options are available. In the large German Hodgkin Study Group series, outcomes for these patients appears to be excellent, with ORR of 85% to 91% in patients with early-stage NLPHL compared to ORR of 83% to 86% in patients with early-stage classical HL treated with the same regimens.⁶⁹ For advanced-stage patients, outcomes are similarly good with ORR of 78% in patients with NLPHL compared to 78% in patients with stage III-IV classical HL. FTF at 50 months was 88% in patients with NLPHL and 82% for patients with classical HL. Interestingly, late relapses >1 year after therapy are observed more commonly in patients with LPHL (7.4%) compared to classical HL (4.7%). Adverse prognostic factors in LPHL include advanced stage, hemoglobin < 10.5 g/dl, age ≥ 45 years, and lymphopenia (< 8% of total white cell count).⁶⁹

For early-stage NLPHL, typically involved field radiotherapy alone or in combination with rituximab or chemotherapy is recommended. However, given the excellent long-term survivals of these patients, the risks of late secondary malignancies and cardiovascular disease must be considered. In a single institution study of 113 patients with stage I-II NLPHL, 93 patients were treated with radiation alone, 13 patients received combined-modality therapy, and 7 received

P.2002

chemotherapy alone.^{194a} Of 106 patients receiving radiotherapy, 20 relapsed (19%), compared to 6 of 7 patients treated with chemotherapy alone; 10-year PFS for stage I and II patients treated with radiotherapy were 89% and 72%, respectively. No differences were observed in patients treated with extended field, regional, or limited field radiotherapy and the use of combined modality therapy did not improve PFS or OS over radiotherapy alone. However, 12 patients receiving radiotherapy did develop second cancers, 5 of which were fatal. The GHSG evaluated 131 patients with stage IA LPHL treated with extended field (n = 45), involved field (n = 45), and combined modality treatment (n = 41), and found a FTF rate of 95% and OS of 99% at 43 months, with no differences with respect to FTF or OS among the three treatment arms.^{69a} In this series, only one secondary cancer was observed, gastric carcinoma in the extended field group. In a retrospective evaluation from the Australasian Radiation Oncology Group of 202 patients with stage I-II NLPHL treated with radiotherapy alone, the 15-year FTF and OS were 83% and 82%, respectively.¹⁹⁵ Second malignancies included NHL (n = 9), acute leukemia (n = 1), and 18 carcinomas including breast, lung, GI, melanoma, and unknown primary carcinomas. Deaths due to cardiac and respiratory complications after radiotherapy occurred in 9 patients. In contrast to these three trials demonstrating excellent PFS and OS with RT alone in early-stage NLPHL, a retrospective comparison of 32 patients treated with RT alone versus 56 patients receiving combined modality therapy with ABVD × 2 cycles and RT demonstrated improved PFS survival (65% vs. 91%, P = 0.0024) with combined modality therapy as compared to radiation alone.¹⁹⁶ Therefore, although most series support very favorable outcomes with radiotherapy alone in early-stage NLPHL with the exception of late second malignancies and cardiovascular disease, at least one series advocates treating these patients similarly to current classical HL treatment approaches with combined modality therapy and both approaches are standardly utilized. Due to the risks of second malignancies and the excellent long-term outcomes observed in patients with LPHL, in selected patients where the disease is completely resected, observation may also be a suitable alternative to involved field radiotherapy.¹⁹⁷

Chemotherapy is typically reserved for those patients with advanced-stage disease or where the risks of late complications of radiotherapy are increased due to field or dose of radiotherapy required. In early-stage patients, where the risks of secondary malignancies with radiotherapy are of concern, chemotherapy alone is occasionally utilized. For example, a study conducted in the United Kingdom and France prospectively examined the results of three cycles of cyclophosphamide, vinblastine, and prednisolone (CVP) in children and adolescents with stage I-II NLPHL. In this trial, the ORR was 100% and the 40-month FTF and OS were 75% and 100%, respectively.¹⁹⁸ In a study of single-agent rituximab as front-line therapy in 28 patients with stage IA NLPHL, the ORR was 100% and at 36 months the PFS was 81%.¹⁹⁹ Therefore,

although the FFTF may be slightly lower with chemotherapy alone compared to radiotherapy or combined modality therapy, these early-stage patients who relapse can be effectively salvaged with additional chemotherapy and radiotherapy and such an approach may reduce the rates of second malignancies.

In the advanced-stage setting, chemotherapy options include six cycles of ABVD, alkylator regimens (CVP or CHOP), or rituximab. Due to the CD20 expression on LP cells, rituximab is increasingly utilized in the front-line treatment of advanced-stage NLPHL. In one of the initial series examining the activity of this agent, Ekstand and colleagues reported an ORR of 96% in 22 patients, 12 with previously untreated NLPHL; however, response duration is limited, with a median freedom of progression of 9.2 months.⁷¹ With the notable activity of single-agent rituximab in relapsed and previously untreated HL, it is frequently combined with ABVD or alkylator-based (CHOP or CVP) therapy as part of initial treatment with those for stage III-IV disease. Limited data exist comparing ABVD to alkylator therapy either alone or in combination with rituximab, and therefore, these regimens are all frequently utilized as front-line and salvage therapy for relapsed stage III-IV NLPHL.

FOLLOW-UP OF PATIENTS WITH HODGKIN LYMPHOMA

Follow-up of patients with HL must address both the risk of relapse as well as potential late complications of therapy (Fig. 93.10). In a study of 1,261 patients treated for HL before the age of 41 from 1965-1987, 534 patients died, including 54% due to HL and 22% from second malignancies.²⁶⁷ The likelihood of HL recurrence declined after 5 years, whereas the incidence of second malignancies and cardiovascular disease continually increased beginning 10 to 15 years from the start of treatment.²⁶⁷ Within the first 5 years from diagnosis, patients are typically monitored for HL recurrence with history- and symptom-directed evaluation, physical examinations, and laboratory testing (CBC, platelets, chemistries, and ESR if elevated at initial diagnosis) every 2 to 3 months for the first 2 years and every 3 to 6 months during years 3 to 5. However, limited data exist regarding the utility of routine blood work in detecting relapsed disease, and in one series, relapse was detected in 55% of patients by history, 23% by CXR, and 1% by laboratory findings.²⁶⁸ In a second study of 107 patients, 22 patients relapsed and 64% were detected clinically, 9% detected by laboratory testing, and 9% by CT imaging.²⁶⁹

With respect to imaging studies, although the convention has been to recommend CT of initially involved sites every 6 to 12 months during the first 5 years from diagnosis, several previous studies have demonstrated no survival benefit with routine CT surveillance and it does not appear to be cost effective.^{269, 270, 271} A more recent examination of follow-up PET/CT demonstrated a high false-positive rate, with an overall positive predictive value of only 28%, limiting its utility as a follow-up tool for HL.²⁷² In this study, 161 patients had 299 routine or clinically indicated follow-up PET/CTs (defined as PET/CT performed based on clinical suspicion) and in this setting the true positive rates were only 5% and 13%, respectively.²⁷² Therefore, with the low risk for relapse in most patients with HL, and no demonstrated survival benefit with routine surveillance CT or PET/CT, follow-up should consist

P.2003

of history and physical exam with only symptom-directed imaging during the first 5 years after HL diagnosis.²⁷¹ The risks of routine laboratory and imaging studies including false-positive findings should be discussed with the patients and the use of routine imaging limited without clinical suspicion. Routine surveillance PET/CT finding is currently not recommended²⁷¹ based on low positive predictive value and associated costs of this testing and work-up of false-positive results.

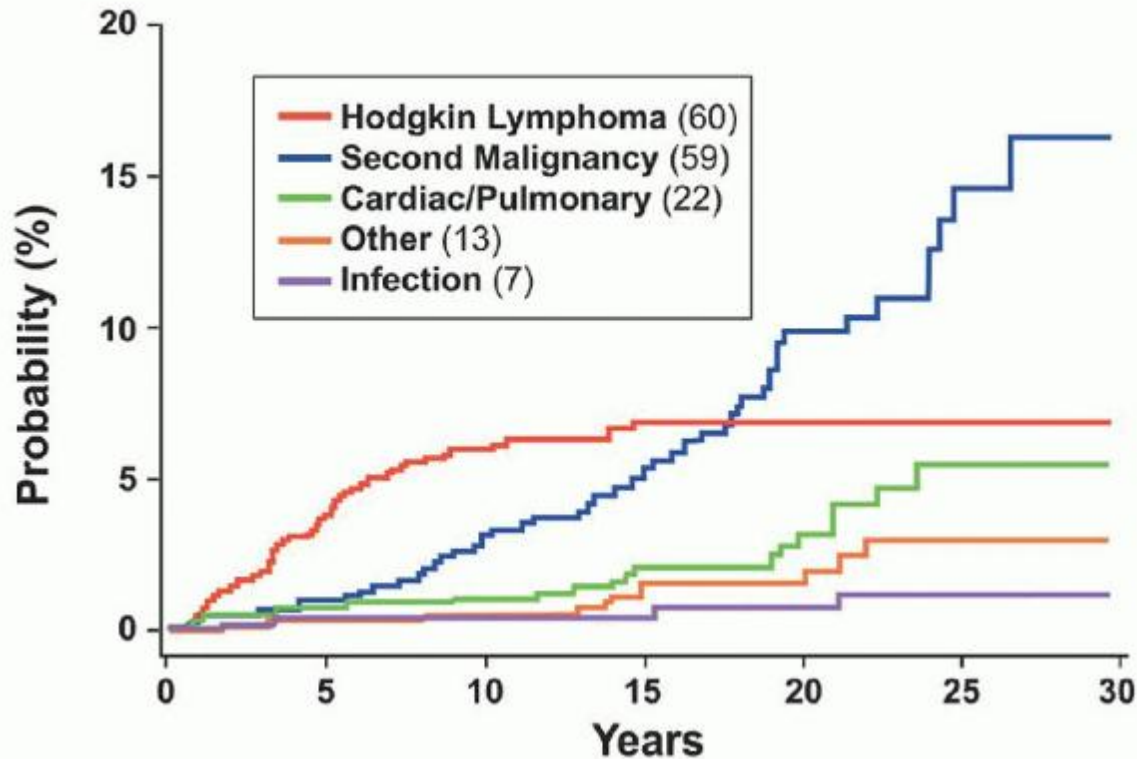

FIGURE 93.10. Causes of death in limited-stage Hodgkin lymphoma. At approximately 15 years Hodgkin lymphoma is not the major cause of death. (From Ng A, Bernardo M, Weller E. Long-term survival and competing causes of death in patients with early-stage Hodgkin's disease treated at age 50 or younger. *J Clin Oncol* 2002;20:2101-2108, with permission.)

Secondary late therapy-related effects in HL survivors include hypothyroidism, fertility issues, secondary cancers, and cardiovascular disease. The risks of second malignancies and cardiovascular disease continue even beyond 30 years from diagnosis,^{267, 273} and therefore, monitoring of late complications is a lifelong endeavor for HL survivors. In a meta-analysis, second cancers were more commonly encountered in patients receiving chemoradiation or radiation alone compared to chemotherapy alone, and no significant differences in the second malignancy rate were observed with involved field versus extended field radiotherapy.²⁷⁴ Therefore, any patient receiving previous radiotherapy should be monitored for second malignancy and cardiovascular disease. Specifically, annual breast screening (typically mammography) is recommended 8 to 10 years after completion of treatment or at the age of 40, whichever comes first, in women who received chest or axillary radiation.^{271, 273} The risk of secondary breast cancers is associated with young age at the time of radiation, particularly women under the age of 30.^{267, 271, 275} Lung cancer risk is also increased in patients receiving mediastinal radiation, particularly patients with a smoking history, and chest imaging annually should be considered for these patients at greatest risk.²⁷¹ Cardiovascular disease including increased risk of coronary artery disease, pericardial disease, cardiomyopathy, and valvular disease is also observed in HL survivors, particularly after mediastinal radiation or anthracycline-based chemotherapy, starting about 5 years after treatment and is also associated with age at treatment.²⁶⁷ Although optimal screening strategies are unclear, monitoring and aggressive management of cardiovascular risk factors including smoking, hypertension, diabetes, and hyperlipidemia is recommended along with consideration of a baseline stress test or echocardiogram.

Other late toxicities associated with radiotherapy include hypothyroidism which can occur in up to 50% of patients and radiation pneumonitis or lung fibrosis, which is fairly uncommon occurring in 3% to 10% of patients.²⁷¹ Annual thyroid function tests are recommended for patients with radiation to the neck or upper mediastinum and evaluation for pulmonary fibrosis should be considered in symptomatic patients.

Secondary leukemia is rarely associated with ABVD chemotherapy, but can be observed in up to 3.2% of patients treated with eight cycles of BEACOPP-esc.²⁰⁹ It remains to be seen with prolonged follow-up if efforts to reduce the total cycles of BEACOPP using PET-directed approaches or to alternate escalated and baseline BEACOPP will reduce this secondary leukemia rate. However, patients treated with BEACOPP or who have received MOPP should have a CBC monitored

annually for this risk. Lastly, with respect to fertility, several studies have demonstrated no impact of ABVD on gonadal function and most patients are able to maintain their fertility; however, patients treated with MOPP or BEACOPP typically become infertile²¹³ and should be counseled about this risk and referred for sperm banking or reproductive endocrinology evaluation if interested prior to treatment.

Finally, in addition to the risks discussed above, patients who undergo autologous HCT for relapsed disease should also be monitored for risks of secondary leukemia, other secondary malignancies, hypogonadism and its complications including declines in bone mineral density, and also considered for re-vaccination. In a retrospective study of 153 patients treated with autologous HCT for relapsed HL, the relative risk of second malignancies was 6.5 compared to the general population and 2.4 compared to nontransplanted patients with HL.²⁷⁶ Second malignancies occurred in 15 patients, at a median of 9 years post-transplantation and consisted of AML/MDS (n = 6), NHL (n = 3), non-small cell lung cancer (n = 2), colon cancer (n = 2), gastric cancer (n = 1), and adenocarcinoma of unknown primary (n = 1). All patients with AML/MDS had MOPP as part of their initial treatment regimen. In 100 patients treated with autologous HCT in Vancouver, second malignancies occurred in 7 patients at median time of 4.2 years from transplantation and consisted of AML/MDS, glioblastoma, renal cell carcinoma, colon carcinoma, NHL, and breast cancer.²³⁹ In this series, 5 patients developed cardiovascular disease including myocardial infarctions 4 to 11 years post-transplant, arrhythmia, and aortic stenosis. In the largest retrospective series of outcomes post-autologous transplantation, 16 of 494 patients who underwent autologous HCT for relapsed or refractory disease developed second malignancies and second malignancy was associated with use of total body irradiation as part of conditioning, age \geq 40, or use of radiation prior to transplantation.²⁷⁷ Therefore, all survivors of HL who are transplanted should be monitored lifelong for second malignancies, with close attention to those treated with radiation either pre- or post-transplant or with TBI during transplant conditioning.

In addition, patients typically experience hypogonadism post-transplantation and monitoring for consequences of hormonal deficiency is recommended including monitoring for bone mineral density reduction using DEXA scanning. Lastly, immunity typically wanes post-autologous transplantation, and it is recommended that patients receive pneumococcal, tetanus, Haemophilus influenza type B, hepatitis B, and annual influenza vaccinations. Measles, mumps, and rubella and varicella vaccinations can be considered in immunocompetent patients no sooner than 24 months post-transplantation.

SUMMARY

HL is a success story of modern medical and radiation oncology. A disease once universally fatal is now cured in 80% of patients. The study of this disease has led to major advances in our understanding of the use of noncross-reactive chemotherapy to cure patients with advanced malignancies and of the long-term effects of radiotherapy and chemotherapy.

Despite this success, some patients are not cured, and others may be overtreated by the current treatment paradigms. A major remaining question is how to tailor our treatment not only to subgroups of patients but to individuals. Two current US intergroup studies nearing completion, SWOG 0816 and CALGB 50604, address this question through the investigation of responseadapted therapy. Patients with an FDG-PET positivity after two cycles of ABVD go on to more intensive therapy.

In the future the two objectives of increasing efficacy of treatment and of lessening late effects will be increasingly the focus of trials. New agents and individualized therapy may be the key to simultaneously achieving these goals.

REFERENCES

1. Connors JM. More is not necessarily better when treating Hodgkin's lymphoma. *J Clin Oncol* 2011;29(32):4215-4216.
2. Hodgkin T. On some Morbid Appearances of the Absorbent Glands and Spleen. *Med Chir Trans* 1832;17:68-114.
3. Wilks S. Cases of lardaceous disease and some allied affections, with remarks. *Guy's Hosp Rep* 1856;(Ser II, Vol 2):103-132.
4. Wilks S. Cases of enlargement of the lymphatic glands and spleen (or Hodgkin's disease), with remarks. *Guy's Hosp Rep* 1865;11:56-67.
5. Langhans T. Das maligne lymphosarkom (pseudoleukämie). *Virchows Archiv* 1872;54(3):509-537.
6. Sternberg C. Über eine eigenartig unter dem Bilde der Pseudoleukämie verlaufende Tuberculose des lymphatischen Apparates. *Z Heilk* 1898;19:21-90.
7. Reed DM. On the pathological changes in Hodgkin's disease, with special reference to tuberculosis. *Johns Hopkins Hosp Rep* 1902;10:133-196.

8. Howlander N, Noone AM, Krapcho M, et al. SEER cancer statistics review, 1975-2009 (Vintage 2009 Populations), National Cancer Institute. Bethesda, MD, http://seer.cancer.gov/csr/1975_2009_pops09/, based on November 2011 SEER data submission, posted to the SEER web site, 2012. Available from: <http://seer.cancer.gov/hodg.html>.
9. Macmahon B. Epidemiological evidence of the nature of Hodgkin's disease. *Cancer* 1957;10(5):1045-1054.
10. Gutensohn N, Cole P. Childhood social environment and Hodgkin's disease. *N Engl J Med* 1981;304(3):135-140.
11. Correa P, O'Connor GT. Epidemiologic patterns of Hodgkin's disease. *Int J Cancer* 1971;8(2):192-201.
12. Glaser SL. Hodgkin's disease in black populations: a review of the epidemiologic literature. *Semin Oncol* 1990;17(6):643-659.
13. Mueller N, Evans A, Harris NL, et al. Hodgkin's disease and Epstein-Barr virus. Altered antibody pattern before diagnosis. *N Engl J Med* 1989;320(11):689-695.
14. Gutensohn NM. Social class and age at diagnosis of Hodgkin's disease: new epidemiologic evidence for the "two-disease hypothesis". *Cancer Treat Rep* 1982;66(4):689-695.
15. Miller RW, Beebe GW. Infectious mononucleosis and the empirical risk of cancer. *J Natl Cancer Inst* 1973;50(2):315-321.
16. Connelly RR, Christine BW. A cohort study of cancer following infectious mononucleosis. *Cancer Res* 1974;34(5):1172-1178.
17. Rosdahl N, Larsen SO, Clemmesen J. Hodgkin's disease in patients with previous infectious mononucleosis: 30 years' experience. *Br Med J* 1974;2(5913): 253-256.
18. Weiss LM, Movahed LA, Warnke RA, et al. Detection of Epstein-Barr viral genomes in Reed-Sternberg cells of Hodgkin's disease. *N Engl J Med* 1989;320(8):502-506.
19. Herbst H, Steinbrecher E, Niedobitek G, et al. Distribution and phenotype of Epstein-Barr virus-harboring cells in Hodgkin's disease. *Blood* 1992;80(2):484-491.
20. Gulley ML, Eagan PA, Quintanilla-Martinez L, et al. Epstein-Barr virus DNA is abundant and monoclonal in the Reed-Sternberg cells of Hodgkin's disease: association with mixed cellularity subtype and Hispanic American ethnicity. *Blood* 1994;83(6):1595-1602.
21. Morente MM, Piris MA, Abaira V, et al. Adverse clinical outcome in Hodgkin's disease is associated with loss of retinoblastoma protein expression, high Ki67 proliferation index, and absence of Epstein-Barr virus-latent membrane protein 1 expression. *Blood* 1997;90(6):2429-2436.
22. Murray PG, Billingham LJ, Hassan HT, et al. Effect of Epstein-Barr virus infection on response to chemotherapy and survival in Hodgkin's disease. *Blood* 1999;94(2):442-447.
23. Krugmann J, Tzankov A, Gschwendtner A, et al. Longer failure-free survival interval of Epstein-Barr virus-associated classical Hodgkin's lymphoma: a single-institution study. *Mod Pathol* 2003;16(6):566-573.
24. Jarrett RF, MacKenzie J. Epstein-Barr virus and other candidate viruses in the pathogenesis of Hodgkin's disease. *Semin Hematol* 1999;36(3):260-269.
25. Hjalgrim H, Askling J, Rostgaard K, et al. Characteristics of Hodgkin's lymphoma after infectious mononucleosis. *N Engl J Med* 2003;349(14): 1324-1332.
26. Mack TM, Cozen W, Shibata DK, et al. Concordance for Hodgkin's disease in identical twins suggesting genetic susceptibility to the young-adult form of the disease. *N Engl J Med* 1995;332(7):413-418.
27. Hessel NA, Katz MH, Liu JY, et al. Increased incidence of Hodgkin disease in homosexual men with HIV infection. *Ann Intern Med* 1992;117(4):309-311.
28. Lyter DW, Bryant J, Thackeray R, et al. Incidence of human immunodeficiency virus-related and nonrelated malignancies in a large cohort of homosexual men. *J Clin Oncol* 1995;13(10):2540-2546.
29. Rowlings PA, Curtis RE, Passweg JR, et al. Increased incidence of Hodgkin's disease after allogeneic bone marrow transplantation. *J Clin Oncol* 1999;17(10):3122-3127.
30. Moseley AC, Lindsley HB, Skikne BS, et al. Reversible methotrexate associated lymphoproliferative disease evolving into Hodgkin's disease. *J Rheumatol* 2000;27(3):810-813.

31. Jones SE, Butler JJ, Byrne GE Jr, et al. Histopathologic review of lymphoma cases from the Southwest Oncology Group. *Cancer* 1977;39(3):1071-1076.
32. Childs CC, Parham DM, Berard CW. Infectious mononucleosis. The spectrum of morphologic changes simulating lymphoma in lymph nodes and tonsils. *Am J Surg Pathol* 1987;11(2):122-132.
33. Saltzstein SL, Ackerman LV. Lymphadenopathy induced by anticonvulsant drugs and mimicking clinically pathologically malignant lymphomas. *Cancer* 1959;12(1):164-182.
34. Swerdlow SH, Campo E, Harris NL. WHO classification of tumours of the haematopoietic and lymphoid tissues. Lyon, France: IARC, 2008.
35. Hoeller S, Copie-Bergman C. Grey zone lymphomas: lymphomas with intermediate features. *Adv Hematol* 2012;2012:460801.
36. Vanhentenrijk V, Vanden Bempt I, Dierickx D, et al. Relationship between classic Hodgkin lymphoma and overlapping large cell lymphoma investigated by comparative expressed sequence hybridization expression profiling. *J Pathol* 2006;210(2):155-162.
37. Schwering I, Brauninger A, Klein U, et al. Loss of the B-lineage-specific gene expression program in Hodgkin and Reed-Sternberg cells of Hodgkin lymphoma. *Blood* 2003;101(4):1505-1512.
38. Ushmorov A, Ritz O, Hummel M, et al. Epigenetic silencing of the immunoglobulin heavy-chain gene in classical Hodgkin lymphoma-derived cell lines contributes to the loss of immunoglobulin expression. *Blood* 2004;104(10):3326-3334.
39. Garcia JF, Camacho FI, Morente M, et al. Hodgkin and Reed-Sternberg cells harbor alterations in the major tumor suppressor pathways and cell-cycle checkpoints: analyses using tissue microarrays. *Blood* 2003;101(2):681-689.
40. Kuppers R, Schmitz R, Distler V, et al. Pathogenesis of Hodgkin's lymphoma. *Eur J Haematol Suppl* 2005;66:26-33.
41. Re D, Kuppers R, Diehl V. Molecular pathogenesis of Hodgkin's lymphoma. *J Clin Oncol* 2005;23(26):6379-6386.
42. Lukes RJ, Tindle BH, Parker JW. Reed-Sternberg-like cells in infectious mononucleosis. *Lancet* 1969;2(7628):1003-1004.
43. Strum SB, Park JK, Rappaport H. Observation of cells resembling Sternberg-Reed cells in conditions other than Hodgkin's disease. *Cancer* 1970;26(1): 176-190.
44. Stein H, Foss HD, Durkop H, et al. CD30(+) anaplastic large cell lymphoma: a review of its histopathologic, genetic, and clinical features. *Blood* 2000;96(12):3681-3695.
45. Stein H, Mason DY, Gerdes J, et al. The expression of the Hodgkin's disease associated antigen Ki-1 in reactive and neoplastic lymphoid tissue: evidence that Reed-Sternberg cells and histiocytic malignancies are derived from activated lymphoid cells. *Blood* 1985;66(4):848-858.
46. Lukes RJ, Butler JJ, Hicks EB. Natural history of Hodgkins disease as related to its pathologic picture. *Cancer* 1966;19(3):317-344.
47. Lukes RJ, Craver LF, Hall TC, et al. Report of nomenclature committee. *Cancer Res* 1966;26(6p1):1311.
48. Neiman RS. Current problems in the histopathologic diagnosis and classification of Hodgkin's disease. *Pathol Annu* 1978;13(Pt 2):289-328.
49. Pinkus GS, Said JW. Hodgkin's disease, lymphocyte predominance type, nodular—a distinct entity? Unique staining profile for L&H variants of Reed-Sternberg cells defined by monoclonal antibodies to leukocyte common antigen, granulocyte-specific antigen, and B-cell-specific antigen. *Am J Pathol* 1985;118(1):1-6.
50. Pinkus GS, Said JW. Hodgkin's disease, lymphocyte predominance type, nodular—further evidence for a B cell derivation. L & H variants of Reed-Sternberg cells express L26, a pan B cell marker. *Am J Pathol* 1988;133(2):211-217.
51. Anagnostopoulos I, Hansmann ML, Franssila K, et al. European task force on lymphoma project on lymphocyte predominance Hodgkin disease: histologic and immunohistologic analysis of submitted cases reveals 2 types of Hodgkin disease with a nodular growth pattern and abundant lymphocytes. *Blood* 2000;96(5):1889-1899.
52. Mason DY, Banks PM, Chan J, et al. Nodular lymphocyte predominance Hodgkin's disease. A distinct clinicopathological entity. *Am J Surg Pathol* 1994;18(5):526-530.

53. Stein RS, Golomb HM, Diggs CH, et al. Anatomic substages of stage III-A Hodgkin's disease. A collaborative study. *Ann Intern Med* 1980;92(2 Pt 1): 159-165.
54. Colby TV, Hoppe RT, Warnke RA. Hodgkin's disease: a clinicopathologic study of 659 cases. *Cancer* 1982;49(9):1848-1858.
55. Cornbleet MA, Vitolo U, Ultmann JE, et al. Pathologic stages IA and IIA Hodgkin's disease: results of treatment with radiotherapy alone (1968-1980). *J Clin Oncol* 1985;3(6):758-768.
56. Mauch P, Goffman T, Rosenthal DS, et al. Stage III Hodgkin's disease: improved survival with combined modality therapy as compared with radiation therapy alone. *J Clin Oncol* 1985;3(9):1166-1173.
57. Medeiros LJ, Greiner TC. Hodgkin's disease. *Cancer* 1995;75(Suppl 1):357-369.
58. Dorfman RF. Relationship of histology to site in Hodgkin's disease. *Cancer Res* 1971;31(11):1786-1793.
59. Bernhards J, Fischer R, Hubner K, et al. Histopathological classification of Hodgkin's lymphomas. Results from the reference pathology of the German Hodgkin Trial. *Ann Oncol* 1992;3(Suppl 4):31-33.
60. Strum SB, Rappaport H. Consistency of histologic subtypes in Hodgkin's disease in simultaneous and sequential biopsy specimens. *Natl Cancer Inst Monogr* 1973;36:253-260.
61. Strickler JG, Michie SA, Warnke RA, et al. The "syncytial variant" of nodular sclerosing Hodgkin's disease. *Am J Surg Pathol* 1986;10(7):470-477.
62. Bearman RM, Pangalis GA, Rappaport H. Hodgkin's disease, lymphocyte depletion type: a clinicopathologic study of 39 patients. *Cancer* 1978;41(1):293-302.
63. Neiman RS, Rosen PJ, Lukes RJ. Lymphocyte-depletion Hodgkin's disease. A clinicopathological entity. *N Engl J Med* 1973;288(15):751-755.
64. Kinney MC, Greer JP, Stein RS, et al. Lymphocyte-depletion Hodgkin's disease. Histopathologic diagnosis of marrow involvement. *Am J Surg Pathol* 1986;10(3):219-226.
65. Greer JP, Kinney MC, Cousar JB, et al. Lymphocyte-depleted Hodgkin's disease. Clinicopathologic review of 25 patients. *Am J Med* 1986;81(2):208-214.
66. Kant JA, Hubbard SM, Longo DL, et al. The pathologic and clinical heterogeneity of lymphocyte-depleted Hodgkin's disease. *J Clin Oncol* 1986;4(3):284-294.
67. Agnarsson BA, Kadin ME. Ki-1 positive large cell lymphoma. A morphologic and immunologic study of 19 cases. *Am J Surg Pathol* 1988;12(4): 264-274.
68. Greer JP, Kinney MC, Collins RD, et al. Clinical features of 31 patients with Ki-1 anaplastic large-cell lymphoma. *J Clin Oncol* 1991;9(4):539-547.
69. Nogova L, Reineke T, Brillant C, et al. Lymphocyte-predominant and classical Hodgkin's lymphoma: a comprehensive analysis from the German Hodgkin Study Group. *J Clin Oncol* 2008;26(3):434-439.
- 69a. Nogova L, Reineke T, Eich HT, et al. Extended field radiotherapy, combined modality treatment or involved field radiotherapy for patients with stage IA lymphocyte-predominant Hodgkin's lymphoma: a retrospective analysis from the German Hodgkin Study Group (GHSG). *Annals of Oncology*. 2005;16: 1683-1687.
70. Lee AI, LaCasce AS. Nodular lymphocyte predominant Hodgkin lymphoma. *Oncologist* 2009;14(7):739-751.
71. Ekstrand BC, Lucas JB, Horwitz SM, et al. Rituximab in lymphocyte-predominant Hodgkin disease: results of a phase 2 trial. *Blood* 2003;101(11): 4285-4289.
72. Kaplan HS. Contiguity and progression in Hodgkin's disease. *Cancer Res* 1971;31(11):1811-1813.
73. Kaplan HS, Dorfman RF, Nelsen TS, et al. Staging laparotomy and splenectomy in Hodgkin's disease: analysis of indications and patterns of involvement in 285 consecutive, unselected patients. *Natl Cancer Inst Monogr* 1973;36:291-301.
74. Krikorian JG, Portlock CS, Mauch PM. Hodgkin's disease presenting below the diaphragm: a review. *J Clin Oncol* 1986;4(10):1551-1562.
75. Leibenhaut MH, Hoppe RT, Varghese A, et al. Subdiaphragmatic Hodgkin's disease: laparotomy and treatment results in 49 patients. *J Clin Oncol* 1987;5(7):1050-1055.

76. Miller TP, Byrne GE, Jones SE. Mistaken clinical and pathologic diagnoses of Hodgkin's disease: a Southwest oncology group study. *Cancer Treat Rep* 1982;66(4):645-651.
77. Hancock SL, Scidmore NS, Hopkins KL, et al. Computed tomography assessment of splenic size as a predictor of splenic weight and disease involvement in laparotomy staged Hodgkin's disease. *Int J Radiat Oncol Biol Phys* 1994;28(1):93-99.
78. Musshoff K. Prognostic and therapeutic implications of staging in extranodal Hodgkin's disease. *Cancer Res* 1971;31(11):1814-1827.
79. Rosenberg SA. Hodgkin's disease of the bone marrow. *Cancer Res* 1971;31(11):1733-1736.
80. Mauch PM, Kalish LA, Kadin M, et al. Patterns of presentation of Hodgkin disease. Implications for etiology and pathogenesis. *Cancer* 1993;71(6):2062-2071.
81. Diehl LF, Hopper KD, Giguere J, et al. The pattern of intrathoracic Hodgkin's disease assessed by computed tomography. *J Clin Oncol* 1991;9(3):438-443.
82. Fialk MA, Jarowski CI, Coleman M, et al. Hepatic Hodgkin's disease without involvement of the spleen. *Cancer* 1979;43(3):1146-1147.
83. Desser RK, Golomb HM, Ultmann JE, et al. Prognostic classification of Hodgkin disease in pathologic stage III, based on anatomic considerations. *Blood* 1977;49(6):883-893.
84. Pel P. Zur symptomatiologie der sogenannten pseudo-leukamie. *Berl Klin Wochenschr* 1885;22:3.
85. Ebstein W. Das chronische ruckfallsfieber eine neue infection-skranheit. *Klin Wochenschr* 1887;24:565.
86. Masih AS, Weisenburger DD, Vose JM, et al. Histologic grade does not predict prognosis in optimally treated, advanced-stage nodular sclerosing Hodgkin's disease. *Cancer* 1992;69(1):228-232.
87. Crnkovich MJ, Leopold K, Hoppe RT, et al. Stage I to IIB Hodgkin's disease: the combined experience at Stanford University and the Joint Center for Radiation Therapy. *J Clin Oncol* 1987;5(7):1041-1049.
88. Rubin P, Constine L, Bennett JM. Hodgkin's disease. IIB or not to be—using irradiation alone or in combination with chemotherapy? That is the question! *J Clin Oncol* 1986;4(4):455-457.
89. Kaplan H. *Hodgkin's disease*, 2nd ed. Cambridge: Harvard University Press, 1980.
90. Lister TA, Crowther D, Sutcliffe SB, et al. Report of a committee convened to discuss the evaluation and staging of patients with Hodgkin's disease: cotswolds meeting. *J Clin Oncol* 1989;7(11):1630-1636.
91. Lister TA, Crowther D. Staging for Hodgkin's disease. *Semin Oncol* 1990;17(6): 696-703.
92. Levi JA, Wiernik PH. Limited extranodal Hodgkin's disease. Unfavorable prognosis and therapeutic implications. *Am J Med* 1977;63(3):365-372.
93. Mauch P, Goodman R, Hellman S. The significance of mediastinal involvement in early stage Hodgkin's disease. *Cancer* 1978;42(3):1039-1045.
94. Prosnitz LR, Curtis AM, Knowlton AH, et al. Supradiaphragmatic Hodgkin's disease: significance of large mediastinal masses. *Int J Radiat Oncol Biol Phys* 1980;6(7):809-813.
95. Jerusalem G, Beguin Y, Fassotte MF, et al. Whole-body positron emission tomography using 18F-fluorodeoxyglucose compared to standard procedures for staging patients with Hodgkin's disease. *Haematologica* 2001;86(3):266-273.
96. Seam P, Juweid ME, Cheson BD. The role of FDG-PET scans in patients with lymphoma. *Blood* 2007;110(10):3507-3516.
97. Kostakoglu L, Leonard JP, Coleman M, et al. The role of FDG-PET imaging in the management of lymphoma. *Clin Adv Hematol Oncol* 2004;2(2):115-121.
98. Connors JM. Positron emission tomography in the management of Hodgkin lymphoma. *Hematology Am Soc Hematol Educ Program* 2011;2011: 317-322.
99. Munker R, Hasenclever D, Brosteanu O, et al. Bone marrow involvement in Hodgkin's disease: an analysis of 135 consecutive cases. German Hodgkin's Lymphoma Study Group. *J Clin Oncol* 1995;13(2):403-409.
100. Richardson SE, Sudak J, Warbey V, et al. Routine bone marrow biopsy is not necessary in the staging of patients with classical Hodgkin lymphoma in the 18F-fluoro-2-deoxyglucose positron emission tomography era. *Leuk Lymphoma* 2012;53(3):381-385.

P.2004

101. Hasenclever D, Diehl V. A prognostic score for advanced Hodgkin's disease. International prognostic factors project on advanced Hodgkin's disease. *N Engl J Med* 1998;339(21):1506-1514.
102. Pusey W. Cases of sarcoma and Hodgkin's disease treated by exposures to x-rays: a preliminary report. *JAMA* 1902;38:166-169.
103. Gilbert R. La roentgentherapie de la granulomatose maligne. *J Radiol Electrol* 1925;9:509-514.
104. Peters M. A study of survivals in Hodgkin's disease treated radiologically. *AJR Am J Roentgenol* 1950;63:299-311.
105. Peters MV, Middlemiss KC. A study of Hodgkin's disease treated by irradiation. *Am J Roentgenol Radium Ther Nucl Med* 1958;79(1):114-121.
106. Peters MV. Prophylactic treatment of adjacent areas in Hodgkin's disease. *Cancer Res* 1966;26(6):1232-1243.
107. Easson EC, Russell MH. Cure of Hodgkin's Disease. *Br Med J* 1963;1(5347): 1704-1707.
108. Kaplan H. Role of intensive radiotherapy in the management of Hodgkin's disease *Cancer* 1966;19:356-367.
109. Kaplan HS. Evidence for a tumoricidal dose level in the radiotherapy of Hodgkin's disease. *Cancer Res* 1966;26(6):1221-1224.
110. Salzman JR, Kaplan HS. Effect of prior splenectomy on hematologic tolerance during total lymphoid radiotherapy of patients with Hodgkin's disease. *Cancer* 1972;27:471-478.
111. Tarbell NJ, Thompson L, Mauch P. Thoracic irradiation in Hodgkin's disease: disease control and long-term complications. *Int J Radiat Oncol Biol Phys* 1990;18(2):275-281.
112. Jochelson M, Mauch P, Balikian J, et al. The significance of the residual mediastinal mass in treated Hodgkin's disease. *J Clin Oncol* 1985;3(5):637-640.
113. Applefeld MM, Cole JF, Pollock SH, et al. The late appearance of chronic pericardial disease in patients treated by radiotherapy for Hodgkin's disease. *Ann Intern Med* 1981;94(3):338-341.
114. Boivin JF, Hutchison GB. Coronary heart disease mortality after irradiation for Hodgkin's disease. *Cancer* 1982;49(12):2470-2475.
115. Gottdiener JS, Katin MJ, Borer JS, et al. Late cardiac effects of therapeutic mediastinal irradiation. Assessment by echocardiography and radionuclide angiography. *N Engl J Med* 1983;308(10):569-572.
116. Stewart JR, Fajardo LF. Radiation-induced heart disease: an update. *Prog Cardiovasc Dis* 1984;27(3):173-194.
117. Boivin JF, Hutchison GB, Lubin JH, et al. Coronary artery disease mortality in patients treated for Hodgkin's disease. *Cancer* 1992;69(5):1241-1247.
118. Hancock SL, Donaldson SS, Hoppe RT. Cardiac disease following treatment of Hodgkin's disease in children and adolescents. *J Clin Oncol* 1993;11(7): 1208-1215.
119. Hancock SL, Cox RS, McDougall IR. Thyroid diseases after treatment of Hodgkin's disease. *N Engl J Med* 1991;325(9):599-605.
120. Tucker MA, Coleman CN, Cox RS, et al. Risk of second cancers after treatment for Hodgkin's disease. *N Engl J Med* 1988;318(2):76-81.
121. List AF, Doll DC, Greco FA. Lung cancer in Hodgkin's disease: association with previous radiotherapy. *J Clin Oncol* 1985;3(2):215-221.
122. Tucker MA, Misfeldt D, Coleman CN, et al. Cutaneous malignant melanoma after Hodgkin's disease. *Ann Intern Med* 1985;102(1):37-41.
123. Hancock SL, Tucker MA, Hoppe RT. Breast cancer after treatment of Hodgkin's disease. *J Natl Cancer Inst* 1993;85(1):25-31.
124. Yahalom J, Petrek JA, Biddinger PW, et al. Breast cancer in patients irradiated for Hodgkin's disease: a clinical and pathologic analysis of 45 events in 37 patients. *J Clin Oncol* 1992;10(11):1674-1681.

125. Carey RW, Linggood RM, Wood W, et al. Breast cancer developing in four women cured of Hodgkin's disease. *Cancer* 1984;54(10):2234-2236.
126. Koshy M, Mahmood U, Rich S, et al. The declining utilization of radiation therapy in stage I and II Hodgkin's disease and its impact on survival and secondary malignancies. *Int J Radiat Oncol Biol Phys* 2010;78(3):S65-S66.
127. Gilman A. The initial clinical trial of nitrogen mustard. *Am J Surg* 1963;105:574-578.
128. Gold GL, Salvin LG, Shnider BI. A comparative study with three alkylating agents: mechlorethamine, cyclophosphamide, and uracil mustard. *Cancer Chemother Rep* 1962;16:417-419.
129. Desser RK, Ultmann JE. The sensitivity of Hodgkin's disease to chemotherapeutic agents administered singly. *Ser Haematol* 1973;6(2):152-181.
130. O'Reilly SE, Klimo P, Connors JM. The evolving role of etoposide in the management of lymphomas and Hodgkin's disease. *Cancer* 1991;67(Suppl 1):271-280.
131. Cavalli F, Jungi WF, Nissen NI, et al. Phase II trial of cis-dichlorodiammineplatinum (II) in advanced malignant lymphoma: a study of the cancer and acute leukemia group B. *Cancer* 1981;48(9):1927-1930.
132. Goldsmith MA, Carter SK. Combination chemotherapy of advanced Hodgkin's disease. A review. *Cancer* 1974;33(1):1-8.
133. Lacher MJ, Durant JR. Combined Vinblastine and Chlorambucil Therapy of Hodgkin's Disease. *Ann Intern Med* 1965;62:468-476.
134. DeVita VT Jr, Serpick AA, Carbone PP. Combination chemotherapy in the treatment of advanced Hodgkin's disease. *Ann Intern Med* 1970;73(6):881-895.
135. Longo DL. The use of chemotherapy in the treatment of Hodgkin's disease. *Semin Oncol* 1990;17(6):716-735.
136. DeVita VT Jr, Simon RM, Hubbard SM, et al. Curability of advanced Hodgkin's disease with chemotherapy. Long-term follow-up of MOPP-treated patients at the National Cancer Institute. *Ann Intern Med* 1980;92(5):587-595.
137. Longo DL, Young RC, Wesley M, et al. Twenty years of MOPP therapy for Hodgkin's disease. *J Clin Oncol* 1986;4(9):1295-1306.
138. Sutcliffe SB, Wrigley PF, Peto J, et al. MVPP chemotherapy regimen for advanced Hodgkin's disease. *Br Med J* 1978;1(6114):679-683.
139. McElwain TJ, Toy J, Smith E, et al. A combination of chlorambucil, vinblastine, procarbazine and prednisolone for treatment of Hodgkin's disease. *Br J Cancer* 1977;36(2):276-280.
140. Vose J, Armitage J, Weisenburger D, et al. ChlVPP—an effective and well-tolerated alternative to MOPP therapy for Hodgkin's disease. *Am J Clin Oncol* 1988;11(4):423-426.
141. Bonadonna G, Zucali R, Monfardini S, et al. Combination chemotherapy of Hodgkin's disease with adriamycin, bleomycin, vinblastine, and imidazole carboxamide versus MOPP. *Cancer* 1975;36(1):252-259.
142. Santoro A, Bonadonna G, Bonfante V, et al. Alternating drug combinations in the treatment of advanced Hodgkin's disease. *N Engl J Med* 1982;306(13):770-775.
143. Bonadonna G, Valagussa P, Santoro A. Alternating non-cross-resistant combination chemotherapy or MOPP in stage IV Hodgkin's disease. A report of 8-year results. *Ann Intern Med* 1986;104(6):739-746.
144. Klimo P, Connors JM. An update on the Vancouver experience in the management of advanced Hodgkin's disease treated with the MOPP/ABV Hybrid program. *Semin Hematol* 1988;25(2 Suppl 2):34-40.
145. Klimo P, Connors JM. MOPP/ABV hybrid program: combination chemotherapy based on early introduction of seven effective drugs for advanced Hodgkin's disease. *J Clin Oncol* 1985;3(9):1174-1182.
146. Carde P, MacKintosh FR, Rosenberg SA. A dose and time response analysis of the treatment of Hodgkin's disease with MOPP chemotherapy. *J Clin Oncol* 1983;1(2):146-153.
147. Pillai GN, Hagemester FB, Velasquez WS, et al. Prognostic factors for Stage IV Hodgkin's disease treated with MOPP, with or without bleomycin. *Cancer* 1985;55(4):691-697.
148. Martin WG, Ristow KM, Habermann TM, et al. Bleomycin pulmonary toxicity has a negative impact on the outcome of patients with Hodgkin's lymphoma. *J Clin Oncol* 2005;23(30):7614-7620.

149. Evens AM, Cilley J, Ortiz T, et al. G-CSF is not necessary to maintain over 99% dose-intensity with ABVD in the treatment of Hodgkin lymphoma: low toxicity and excellent outcomes in a 10-year analysis. *Br J Haematol* 2007;137(6):545-552.
150. Duggan DB, Petroni GR, Johnson JL, et al. Randomized comparison of ABVD and MOPP/ABV hybrid for the treatment of advanced Hodgkin's disease: report of an intergroup trial. *J Clin Oncol* 2003;21(4):607-614.
151. Arseneau JC, Canellos GP, Johnson R, et al. Risk of new cancers in patients with Hodgkin's disease. *Cancer* 1977;40(Suppl 4):1912-1916.
152. Pedersen-Bjergaard J, Larsen SO. Incidence of acute nonlymphocytic leukemia, preleukemia, and acute myeloproliferative syndrome up to 10 years after treatment of Hodgkin's disease. *N Engl J Med* 1982;307(16):965-971.
153. Lavey RS, Eby NL, Prosnitz LR. Impact on second malignancy risk of the combined use of radiation and chemotherapy for lymphomas. *Cancer* 1990;66(1):80-88.
154. Valagussa P, Santoro A, Fossati-Bellani F, et al. Second acute leukemia and other malignancies following treatment for Hodgkin's disease. *J Clin Oncol* 1986;4(6):830-837.
155. Andrieu JM, Ifrah N, Payen C, et al. Increased risk of secondary acute nonlymphocytic leukemia after extended-field radiation therapy combined with MOPP chemotherapy for Hodgkin's disease. *J Clin Oncol* 1990;8(7):1148-1154.
156. Coltman CA Jr, Dixon DO. Second malignancies complicating Hodgkin's disease: a Southwest Oncology Group 10-year followup. *Cancer Treat Rep* 1982;66(4):1023-1033.
157. Mauch PM, Canellos GP, Rosenthal DS, et al. Reduction of fatal complications from combined modality therapy in Hodgkin's disease. *J Clin Oncol* 1985;3(4):501-505.
158. Valagussa P, Santoro A, Fossati Bellani F, et al. Absence of treatment-induced second neoplasms after ABVD in Hodgkin's disease. *Blood* 1982;59(3):488-494.
159. Blum RH, Carter SK, Agre K. A clinical review of bleomycin—a new antineoplastic agent. *Cancer* 1973;31(4):903-914.
160. Von Hoff DD, Layard MW, Basa P, et al. Risk factors for doxorubicin-induced congestive heart failure. *Ann Intern Med* 1979;91(5):710-717.
161. Alexander J, Dainiak N, Berger HJ, et al. Serial assessment of doxorubicin cardiotoxicity with quantitative radionuclide angiocardiology. *N Engl J Med* 1979;300(6):278-283.
162. Doroshow JH. Doxorubicin-induced cardiac toxicity. *N Engl J Med* 1991;324(12):843-845.
163. Sherins RJ, DeVita VT Jr. Effect of drug treatment for lymphoma on male reproductive capacity. Studies of men in remission after therapy. *Ann Intern Med* 1973;79(2):216-220.
164. Chapman RM, Sutcliffe SB, Rees LH, et al. Cyclical combination chemotherapy and gonadal function. Retrospective study in males. *Lancet* 1979;1(8111):285-289.
165. da Cunha MF, Meistrich ML, Fuller LM, et al. Recovery of spermatogenesis after treatment for Hodgkin's disease: limiting dose of MOPP chemotherapy. *J Clin Oncol* 1984;2(6):571-577.
166. Cunningham J, Mauch P, Rosenthal DS, et al. Long-term complications of MOPP chemotherapy in patients with Hodgkin's disease. *Cancer Treat Rep* 1982;66(4):1015-1022.
167. Viviani S, Santoro A, Ragni G, et al. Gonadal toxicity after combination chemotherapy for Hodgkin's disease. Comparative results of MOPP vs ABVD. *Eur J Cancer Clin Oncol* 1985;21(5):601-605.
168. Harel S, Ferme C, Poirot C. Management of fertility in patients treated for Hodgkin's lymphoma. *Haematologica* 2011;96(11):1692-1699.
169. Chapman RM, Sutcliffe SB, Malpas JS. Cytotoxic-induced ovarian failure in Hodgkin's disease. II. Effects on sexual function. *JAMA* 1979;242(17): 1882-1884.
170. Whitehead E, Shalet SM, Blackledge G, et al. The effect of combination chemotherapy on ovarian function in women treated for Hodgkin's disease. *Cancer* 1983;52(6):988-993.
171. Redman JR, Bajorunas DR, Goldstein MC, et al. Semen cryopreservation and artificial insemination for Hodgkin's disease. *J Clin Oncol* 1987;5(2):233-238.

172. Vigersky RA, Chapman RM, Berenberg J, et al. Testicular dysfunction in untreated Hodgkin's disease. *Am J Med* 1982;73(4):482-486.
173. Behringer K, Wildt L, Mueller H, et al. No protection of the ovarian follicle pool with the use of GnRH-analogues or oral contraceptives in young women treated with escalated BEACOPP for advanced-stage Hodgkin lymphoma. Final results of a phase II trial from the German Hodgkin Study Group. *Ann Oncol* 2010;21(10):2052-2060.
174. Horning SJ, Hoppe RT, Hancock SL, et al. Vinblastine, bleomycin, and methotrexate: an effective adjuvant in favorable Hodgkin's disease. *J Clin Oncol* 1988;6(12):1822-1831.
175. Clark ST, Radford JA, Crowther D, et al. Gonadal function following chemotherapy for Hodgkin's disease: a comparative study of MVPP and a seven-drug hybrid regimen. *J Clin Oncol* 1995;13(1):134-139.
176. De Bruin ML, Sparidans J, van't Veer MB, et al. Breast cancer risk in female survivors of Hodgkin's lymphoma: lower risk after smaller radiation volumes. *J Clin Oncol* 2009;27(26):4239-4246.
177. Hancock SL, Tucker MA, Hoppe RT. Factors affecting late mortality from heart disease after treatment of Hodgkin's disease. *JAMA* 1993;270(16):1949-1955.
178. Maraldo MV, Brodin NP, Vogelius IR, et al. Risk of developing cardiovascular disease after involved node radiotherapy versus mantle field for Hodgkin lymphoma. *Int J Radiat Oncol Biol Phys* 2012;83(4):1232-1237.
179. Swerdlow AJ, Higgins CD, Smith P, et al. Myocardial infarction mortality risk after treatment for Hodgkin disease: a collaborative British cohort study. *J Natl Cancer Inst* 2007;99(3):206-14.
180. Aleman BM, van den Belt-Dusebout AW, De Bruin ML, et al. Late cardiotoxicity after treatment for Hodgkin lymphoma. *Blood* 2007;109(5):1878-1886.
181. Press OW, LeBlanc M, Lichter AS, et al. Phase III randomized intergroup trial of subtotal lymphoid irradiation versus doxorubicin, vinblastine, and subtotal lymphoid irradiation for stage IA to IIA Hodgkin's disease. *J Clin Oncol* 2001;19(22):4238-4244.
182. Engert A, Franklin J, Eich HT, et al. Two cycles of doxorubicin, bleomycin, vinblastine, and dacarbazine plus extended-field radiotherapy is superior to radiotherapy alone in early favorable Hodgkin's lymphoma: final results of the GHSG HD7 trial. *J Clin Oncol* 2007;25(23):3495-3502.
183. Ferme C, Eghbali H, Meerwaldt JH, et al. Chemotherapy plus involved-field radiation in early-stage Hodgkin's disease. *N Engl J Med* 2007;357(19):1916-1927.
184. Bonadonna G, Bonfante V, Viviani S, et al. ABVD plus subtotal nodal versus involved-field radiotherapy in early-stage Hodgkin's disease: long-term results. *J Clin Oncol* 2004;22(14):2835-2841.
185. Herbst C, Rehan FA, Brilliant C, et al. Combined modality treatment improves tumor control and overall survival in patients with early stage Hodgkin's lymphoma: a systematic review. *Haematologica* 2010;95(3):494-500.
186. Engert A, Plutschow A, Eich HT, et al. Reduced treatment intensity in patients with early-stage Hodgkin's lymphoma. *N Engl J Med* 2010;363(7): 640-652.
187. Noordijk EM, Thomas J, Ferme C, et al. First results of the EORTC-GELA H9 randomized trials: the H9-F trial (comparing 3 radiation dose levels) and H9-U trial (comparing 3 chemotherapy schemes) in patients with favorable or unfavorable early stage Hodgkin's lymphoma (HL). *J Clin Oncol* 2005;23(16):561s-561s.
188. Rueda Dominguez A, Marquez A, Guma J, et al. Treatment of stage I and II Hodgkin's lymphoma with ABVD chemotherapy: results after 7 years of a prospective study. *Ann Oncol* 2004;15(12):1798-1804.
189. Canellos GP, Abramson JS, Fisher DC, et al. Treatment of favorable, limited-stage Hodgkin's lymphoma with chemotherapy without consolidation by radiation therapy. *J Clin Oncol* 2010;28(9):1611-1615.
190. Straus DJ, Portlock CS, Qin J, et al. Results of a prospective randomized clinical trial of doxorubicin, bleomycin, vinblastine, and dacarbazine (ABVD) followed by radiation therapy (RT) versus ABVD alone for stages I, II, and IIIA nonbulky Hodgkin disease. *Blood* 2004;104(12):3483-3489.
191. Meyer RM, Gospodarowicz MK, Connors JM, et al. Randomized comparison of ABVD chemotherapy with a strategy that includes radiation therapy in patients with limited-stage Hodgkin's lymphoma: National Cancer Institute of Canada Clinical Trials Group and the Eastern Cooperative Oncology Group. *J Clin Oncol* 2005;23(21):4634-4642.

192. Eich HT, Diehl V, Gorgen H, et al. Intensified chemotherapy and dose-reduced involved-field radiotherapy in patients with early unfavorable Hodgkin's lymphoma: final analysis of the German Hodgkin Study Group HD11 trial. *J Clin Oncol* 2010;28(27):4199-4206.
193. von Tresckow B, Plutschow A, Fuchs M, et al. Dose-intensification in early unfavorable Hodgkin's lymphoma: final analysis of the German hodgkin study group HD14 trial. *J Clin Oncol* 2012;30(9):907-913.
194. Chen RW, Gopal AK, Smith SE, et al. Results from a pivotal phase II study of brentuximab vedotin (SGN-35) in patients with relapsed or refractory Hodgkin lymphoma (HL). *J Clin Oncol* 2011;29:8031a.
- 194a. Chen RC, Chin MS, Ng AK, et al. Early-Stage, Lymphocyte-Predominant Hodgkin's Lymphoma: Patient Outcomes From a Large, Single-Institution Series With Long Follow-Up. *J Clin Oncol*. 2010;28:136-141.
195. Wirth A, Yuen K, Barton M, et al. Long-term outcome after radiotherapy alone for lymphocyte-predominant Hodgkin lymphoma: a retrospective multicenter study of the Australasian Radiation Oncology Lymphoma Group. *Cancer* 2005;104(6):1221-1229.
196. Savage KJ, Skinnider B, Al-Mansour M, et al. Treating limited-stage nodular lymphocyte predominant Hodgkin lymphoma similarly to classical Hodgkin lymphoma with ABVD may improve outcome. *Blood* 2011;118(17):4585-4590.
197. Pellegrino B, Terrier-Lacombe MJ, Oberlin O, et al. Lymphocyte-predominant Hodgkin's lymphoma in children: therapeutic abstention after initial lymph node resection—a study of the French Society of Pediatric Oncology. *J Clin Oncol* 2003;21(15):2948-2952.
198. Shankar A, Hall GW, Gorde-Grosjean S, et al. Treatment outcome after low intensity chemotherapy [CVP] in children and adolescents with early stage nodular lymphocyte predominant Hodgkin's lymphoma—an Anglo-French collaborative report. *Eur J Cancer* 2012;48(11):1700-1706.
199. Eichenauer DA, Fuchs M, Pluetschow A, et al. Phase 2 study of rituximab in newly diagnosed stage IA nodular lymphocyte-predominant Hodgkin lymphoma: a report from the German Hodgkin Study Group. *Blood* 2011;118(16):4363-4365.
200. Canellos GP, Anderson JR, Propert KJ, et al. Chemotherapy of advanced Hodgkin's disease with MOPP, ABVD, or MOPP alternating with ABVD. *N Engl J Med* 1992;327(21):1478-1484.
201. Johnson PW, Radford JA, Cullen MH, et al. Comparison of ABVD and alternating or hybrid multidrug regimens for the treatment of advanced Hodgkin's lymphoma: results of the United Kingdom Lymphoma Group LY09 Trial (ISRCTN97144519). *J Clin Oncol* 2005;23(36):9208-9218.
202. Horning SJ, Hoppe RT, Breslin S, et al. Stanford V and radiotherapy for locally extensive and advanced Hodgkin's disease: mature results of a prospective clinical trial. *J Clin Oncol* 2002;20(3):630-637.
203. Horning SJ, Williams J, Bartlett NL, et al. Assessment of the stanford V regimen and consolidative radiotherapy for bulky and advanced Hodgkin's disease: Eastern Cooperative Oncology Group pilot study E1492. *J Clin Oncol* 2000;18(5):972-980.
204. Gobbi PG, Levis A, Chisesi T, et al. ABVD versus modified stanford V versus MOPPEBVCAD with optional and limited radiotherapy in intermediate- and advanced-stage Hodgkin's lymphoma: final results of a multicenter randomized trial by the Intergruppo Italiano Linfomi. *J Clin Oncol* 2005;23(36):9198-9207.
205. Chisesi T, Bellei M, Luminari S, et al. Long-term follow-up analysis of HD9601 trial comparing ABVD versus Stanford V versus MOPP/EBV/CAD in patients with newly diagnosed advanced-stage Hodgkin's lymphoma: a study from the Intergruppo Italiano Linfomi. *J Clin Oncol* 2011;29(32):4227-4233.
206. Hoskin PJ, Lowry L, Horwich A, et al. Randomized comparison of the stanford V regimen and ABVD in the treatment of advanced Hodgkin's Lymphoma: United Kingdom National Cancer Research Institute Lymphoma Group Study ISRCTN 64141244. *J Clin Oncol* 2009;27(32):5390-5396.
207. Gordon LI, Hong F, Fisher RI, et al. A randomized phase III trial of ABVD vs. Stanford V +/- radiation therapy in locally extensive and advanced stage Hodgkin's lymphoma: an intergroup study coordinated by the Eastern Cooperative Oncology Group (L2496). *Blood (ASH Annual Meeting Abstracts)* 2010:415.
208. Diehl V, Franklin J, Pfreundschuh M, et al. Standard and increased-dose BEACOPP chemotherapy compared with COPP-ABVD for advanced Hodgkin's disease. *N Engl J Med* 2003;348(24):2386-2395.

209. Engert A, Diehl V, Franklin J, et al. Escalated-dose BEACOPP in the treatment of patients with advanced-stage Hodgkin's lymphoma: 10 years of follow-up of the GHSG HD9 study. *J Clin Oncol* 2009;27(27):4548-4554.
210. Borchmann P, Haverkamp H, Diehl V, et al. Eight cycles of escalated-dose BEACOPP compared with four cycles of escalated-dose BEACOPP followed by four cycles of baseline-dose BEACOPP with or without radiotherapy in patients with advanced-stage Hodgkin's lymphoma: final analysis of the HD12 trial of the German Hodgkin Study Group. *J Clin Oncol* 2011;29(32):4234-4242.
211. Federico M, Luminari S, Iannitto E, et al. ABVD compared with BEACOPP compared with CEC for the initial treatment of patients with advanced Hodgkin's lymphoma: results from the HD2000 Gruppo Italiano per lo Studio dei Linfomi Trial. *J Clin Oncol* 2009;27(5):805-811.
212. Viviani S, Zinzani PL, Rambaldi A, et al. ABVD versus BEACOPP for Hodgkin's lymphoma when high-dose salvage is planned. *N Engl J Med* 2011;365(3):203-212.
213. Sieniawski M, Reineke T, Nogova L, et al. Fertility in male patients with advanced Hodgkin lymphoma treated with BEACOPP: a report of the German Hodgkin Study Group (GHSG). *Blood* 2008;111(1):71-76.
214. Ferme C, Mounier N, Casasnovas O, et al. Long-term results and competing risk analysis of the H89 trial in patients with advanced-stage Hodgkin lymphoma: a study by the Groupe d'Etude des Lymphomes de l'Adulte (GELA). *Blood* 2006;107(12):4636-4642.
215. Laskar S, Gupta T, Vimal S, et al. Consolidation radiation after complete remission in Hodgkin's disease following six cycles of doxorubicin, bleomycin, vinblastine, and dacarbazine chemotherapy: is there a need? *J Clin Oncol* 2004;22(1):62-68.
216. Johnson PW, Sydes MR, Hancock BW, et al. Consolidation radiotherapy in patients with advanced Hodgkin's lymphoma: survival data from the UKLG LY09 randomized controlled trial (ISRCTN97144519). *J Clin Oncol* 2010;28(20):3352-3359.
217. Aleman BM, Raemaekers JM, Tirelli U, et al. Involved-field radiotherapy for advanced Hodgkin's lymphoma. *N Engl J Med* 2003;348(24):2396-2406.
218. Kobe C, Dietlein M, Franklin J, et al. Positron emission tomography has a high negative predictive value for progression or early relapse for patients with residual disease after first-line chemotherapy in advanced-stage Hodgkin lymphoma. *Blood* 2008;112(10):3989-3994.
219. Federico M, Bellei M, Brice P, et al. High-dose therapy and autologous stem-cell transplantation versus conventional therapy for patients with advanced Hodgkin's lymphoma responding to front-line therapy. *J Clin Oncol* 2003;21(12):2320-2325.
220. Proctor SJ, Mackie M, Dawson A, et al. A population-based study of intensive multi-agent chemotherapy with or without autotransplant for the highest risk Hodgkin's disease patients identified by the Scotland and Newcastle Lymphoma Group (SNLG) prognostic index. A Scotland and Newcastle Lymphoma Group study (SNLG HD III). *Eur J Cancer* 2002;38(6):795-806.
221. Arakelyan N, Berthou C, Desablens B, et al. Early versus late intensification for patients with high-risk Hodgkin lymphoma-3 cycles of intensive chemotherapy plus low-dose lymph node radiation therapy versus 4 cycles of combined doxorubicin, bleomycin, vinblastine, and dacarbazine plus myeloablative chemotherapy with autologous stem cell transplantation: five-year results of a randomized trial on behalf of the GOELAMS Group. *Cancer* 2008;113(12):3323-3330.
222. Gallamini A, Hutchings M, Rigacci L, et al. Early interim 2-[18F]fluoro-2-deoxy-D-glucose positron emission tomography is prognostically superior to international prognostic score in advanced-stage Hodgkin's lymphoma: a report from a joint Italian-Danish study. *J Clin Oncol* 2007;25(24):3746-3752.
223. Dann EJ, Bar-Shalom R, Tamir A, et al. Risk-adapted BEACOPP regimen can reduce the cumulative dose of chemotherapy for standard and high-risk Hodgkin lymphoma with no impairment of outcome. *Blood* 2007;109(3): 905-909.
224. Younes A, Connors JM, Park SI, et al. Frontline therapy with Brentuximab Vedotin combined with ABVD or AVD in patients with newly diagnosed advanced stage Hodgkin lymphoma. *Blood* 2011;118(21):436-437.
- 224a. Younes A, Connors JM, Park SI, Hunder NNH, Ansell SM. Frontline therapy with brentuximab vedotin combined with ABVD or AVD in patients with newly diagnosed advanced stage Hodgkin lymphoma. *Blood*. 2011;118:955 (abstr).

225. Santoro A, Magagnoli M, Spina M, et al. Ifosfamide, gemcitabine, and vinorelbine: a new induction regimen for refractory and relapsed Hodgkin's lymphoma. *Haematologica* 2007;92(1):35-41.
226. Moskowitz CH, Nimer SD, Zelenetz AD, et al. A 2-step comprehensive high-dose chemoradiotherapy second-line program for relapsed and refractory Hodgkin disease: analysis by intent to treat and development of a prognostic model. *Blood* 2001;97(3):616-623.
227. Bartlett NL, Niedzwiecki D, Johnson JL, et al. Gemcitabine, vinorelbine, and pegylated liposomal doxorubicin (GVD), a salvage regimen in relapsed Hodgkin's lymphoma: CALGB 59804. *Ann Oncol* 2007;18(6):1071-1079.
228. Colwill R, Crump M, Couture F, et al. Mini-BEAM as salvage therapy for relapsed or refractory Hodgkin's disease before intensive therapy and autologous bone marrow transplantation. *J Clin Oncol* 1995;13(2):396-402.
229. Schmitz N, Pfistner B, Sextro M, et al. Aggressive conventional chemotherapy compared with high-dose chemotherapy with autologous haemopoietic stem-cell transplantation for relapsed chemosensitive Hodgkin's disease: a randomised trial. *Lancet* 2002;359(9323):2065-2071.
230. Crump M, Smith AM, Brandwein J, et al. High-dose etoposide and melphalan, and autologous bone marrow transplantation for patients with advanced Hodgkin's disease: importance of disease status at transplant. *J Clin Oncol* 1993;11(4):704-711.
231. Josting A, Rudolph C, Reiser M, et al. Time-intensified dexamethasone/cisplatin/cytarabine: an effective salvage therapy with low toxicity in patients with relapsed and refractory Hodgkin's disease. *Ann Oncol* 2002;13(10):1628-1635.
232. Kuruvilla J, Nagy T, Pintilie M, et al. Similar response rates and superior early progression-free survival with gemcitabine, dexamethasone, and cisplatin salvage therapy compared with carmustine, etoposide, cytarabine, and melphalan salvage therapy prior to autologous stem cell transplantation for recurrent or refractory Hodgkin lymphoma. *Cancer* 2006;106(2):353-360.
233. Josting A, Katay I, Rueffer U, et al. Favorable outcome of patients with relapsed or refractory Hodgkin's disease treated with high-dose chemotherapy and stem cell rescue at the time of maximal response to conventional salvage therapy (Dex-BEAM). *Ann Oncol* 1998;9(3):289-295.
234. Yuen AR, Rosenberg SA, Hoppe RT, et al. Comparison between conventional salvage therapy and high-dose therapy with autografting for recurrent or refractory Hodgkin's disease. *Blood* 1997;89(3):814-822.
235. Linch DC, Winfield D, Goldstone AH, et al. Dose intensification with autologous bone-marrow transplantation in relapsed and resistant Hodgkin's disease: results of a BNLI randomised trial. *Lancet* 1993;341(8852):1051-1054.
236. Sweetenham JW, Carella AM, Taghipour G, et al. High-dose therapy and autologous stem-cell transplantation for adult patients with Hodgkin's disease who do not enter remission after induction chemotherapy: results in 175 patients reported to the European group for blood and marrow transplantation. Lymphoma working party. *J Clin Oncol* 1999;17(10):3101-3109.
237. Lazarus HM, Rowlings PA, Zhang MJ, et al. Autotransplants for Hodgkin's disease in patients never achieving remission: a report from the autologous blood and marrow transplant registry. *J Clin Oncol* 1999;17(2):534-545.
238. Andre M, Henry-Amar M, Pico JL, et al. Comparison of high-dose therapy and autologous stem-cell transplantation with conventional therapy for Hodgkin's disease induction failure: a case-control study. Societe Francaise de Greffe de Moelle. *J Clin Oncol* 1999;17(1):222-229.
239. Lavoie JC, Connors JM, Phillips GL, et al. High-dose chemotherapy and autologous stem cell transplantation for primary refractory or relapsed Hodgkin lymphoma: long-term outcome in the first 100 patients treated in Vancouver. *Blood* 2005;106(4):1473-1478.
240. Jabbour E, Hosing C, Ayers G, et al. Pretransplant positive positron emission tomography/gallium scans predict poor outcome in patients with recurrent/refractory Hodgkin lymphoma. *Cancer* 2007;109(12):2481-2489.
241. Moskowitz AJ, Yahalom J, Kewalramani T, et al. Pretransplantation functional imaging predicts outcome following autologous stem cell transplantation for relapsed and refractory Hodgkin lymphoma. *Blood* 2010;116(23):4934-4937.
242. Castagna L, Bramanti S, Balzarotti M, et al. Predictive value of early 18F-fluorodeoxyglucose positron emission tomography (FDG-PET) during salvage chemotherapy in relapsing/refractory Hodgkin lymphoma (HL) treated with high-dose chemotherapy. *Br J Haematol* 2009;145(3):369-372.

243. Morschhauser F, Brice P, Ferme C, et al. Risk-adapted salvage treatment with single or tandem autologous stem-cell transplantation for first relapse/refractory Hodgkin's lymphoma: results of the prospective multicenter H96 trial by the GELA/SFGM study group. *J Clin Oncol* 2008;26(36):5980-5987.
244. Josting A, Muller H, Borchmann P, et al. Dose intensity of chemotherapy in patients with relapsed Hodgkin's lymphoma. *J Clin Oncol* 2010;28(34): 5074-5080.
245. Little R, Wittes RE, Longo DL, et al. Vinblastine for recurrent Hodgkin's disease following autologous bone marrow transplant. *J Clin Oncol* 1998;16(2): 584-588.
246. Devizzi L, Santoro A, Bonfante V, et al. Vinorelbine: an active drug for the management of patients with heavily pretreated Hodgkin's disease. *Ann Oncol* 1994;5(9):817-820.
247. Santoro A, Bredenfeld H, Devizzi L, et al. Gemcitabine in the treatment of refractory Hodgkin's disease: results of a multicenter phase II study. *J Clin Oncol* 2000;18(13):2615-2619.
248. Vose JM, Bierman PJ, Anderson JR, et al. CHLVPP chemotherapy with involved-field irradiation for Hodgkin's disease: favorable results with acceptable toxicity. *J Clin Oncol* 1991;9(8):1421-1425.
249. Josting A, Nogova L, Franklin J, et al. Salvage radiotherapy in patients with relapsed and refractory Hodgkin's lymphoma: a retrospective analysis from the German Hodgkin Lymphoma Study Group. *J Clin Oncol* 2005;23(7): 1522-1529.
250. Younes A, Bartlett NL, Leonard JP, et al. Brentuximab vedotin (SGN-35) for relapsed CD30-positive lymphomas. *N Engl J Med* 2010;363(19):1812-1821.
251. Corradini P, Sarina B, Farina L. Allogeneic transplantation for Hodgkin's lymphoma. *Br J Haematol* 2011;152(3):261-272.
252. Sureda A, Robinson S, Canals C, et al. Reduced-intensity conditioning compared with conventional allogeneic stem-cell transplantation in relapsed or refractory Hodgkin's lymphoma: an analysis from the lymphoma working party of the European group for blood and marrow transplantation. *J Clin Oncol* 2008;26(3):455-462.
253. Anderlini P, Saliba R, Acholonu S, et al. Fludarabine-melphalan as a preparative regimen for reduced-intensity conditioning allogeneic stem cell transplantation in relapsed and refractory Hodgkin's lymphoma: the updated M.D. Anderson Cancer Center experience. *Haematologica* 2008;93(2): 257-264.
254. Robinson SP, Sureda A, Canals C, et al. Reduced intensity conditioning allogeneic stem cell transplantation for Hodgkin's lymphoma: identification of prognostic factors predicting outcome. *Haematologica* 2009;94(2):230-238.
255. Boll B, Gorgen H, Fuchs M, et al. Feasibility and efficacy of ABVD in elderly Hodgkin lymphoma patients: analysis of two randomized prospective multicenter trials of the German Hodgkin study group (HD10 and HD11). *Blood (ASH Annu Meeting Abstr)* 2010;116:418a.
256. Ballova V, Ruffer JU, Haverkamp H, et al. A prospectively randomized trial carried out by the German Hodgkin Study Group (GHSG) for elderly patients with advanced Hodgkin's disease comparing BEACOPP baseline and COPP-ABVD (study HD9elderly). *Ann Oncol* 2005;16(1):124-131.
257. Boll B, Bredenfeld H, Gorgen H, et al. Phase 2 study of PVAG (prednisone, vinblastine, doxorubicin, gemcitabine) in elderly patients with early unfavorable or advanced stage Hodgkin lymphoma. *Blood* 2011;118(24):6292-6298.
258. Shiels MS, Cole SR, Kirk GD, et al. A meta-analysis of the incidence of non-AIDS cancers in HIV-infected individuals. *J Acquir Immune Defic Syndr* 2009;52(5):611-622.
259. Engels EA, Pfeiffer RM, Goedert JJ, et al. Trends in cancer risk among people with AIDS in the United States 1980-2002. *AIDS* 2006;20(12):1645-1654.
260. Levine AM, Hodgkin's disease in the setting of human immunodeficiency virus infection. *J Natl Cancer Inst Monogr* 1998(23):37-42.
261. Spina M, Gabarre J, Rossi G, et al. Stanford V regimen and concomitant HAART in 59 patients with Hodgkin disease and HIV infection. *Blood* 2002;100(6):1984-1988.
262. Xicoy B, Ribera JM, Miralles P, et al. Results of treatment with doxorubicin, bleomycin, vinblastine and dacarbazine and highly active antiretroviral therapy in advanced stage, human immunodeficiency virus-related Hodgkin's lymphoma. *Haematologica* 2007;92(2):191-198.

263. Hartmann P, Rehwald U, Salzberger B, et al. BEACOPP therapeutic regimen for patients with Hodgkin's disease and HIV infection. *Ann Oncol* 2003;14(10):1562-1569.
264. Okosun J, Warbey V, Shaw K, et al. Interim fluoro-2-deoxy-D-glucose-PET predicts response and progression-free survival in patients with Hodgkin lymphoma and HIV infection. *AIDS* 2012;26(7):861-865.
265. Barry RM, Diamond HD, Craver LF. Influence of pregnancy on the course of Hodgkin's disease. *Am J Obstet Gynecol* 1962;84:445-454.
266. Doll DC, Ringenberg QS, Yarbrow JW. Antineoplastic agents and pregnancy. *Semin Oncol* 1989;16(5):337-346.
267. Aleman BM, van den Belt-Dusebout AW, Klokmann WJ, et al. Long-term cause-specific mortality of patients treated for Hodgkin's disease. *J Clin Oncol* 2003;21(18):3431-3439.
268. Torrey MJ, Poen JC, Hoppe RT. Detection of relapse in early-stage Hodgkin's disease: role of routine follow-up studies. *J Clin Oncol* 1997;15(3):1123-1130.
269. Dryver ET, Jernstrom H, Tompkins K, et al. Follow-up of patients with Hodgkin's disease following curative treatment: the routine CT scan is of little value. *Br J Cancer* 2003;89(3):482-486.
270. Guadagnolo BA, Punglia RS, Kuntz KM, et al. Cost-effectiveness analysis of computerized tomography in the routine follow-up of patients after primary treatment for Hodgkin's disease. *J Clin Oncol* 2006;24(25):4116-4122.
271. Ng A, Constine LS, Advani R, et al. ACR Appropriateness Criteria: follow-up of Hodgkin's lymphoma. *Curr Probl Cancer* 2010;34(3):211-227.
272. El-Galaly TC, Mylam KJ, Brown P, et al. Positron emission tomography/computed tomography surveillance in patients with Hodgkin lymphoma in first remission has a low positive predictive value and high costs. *Haematologica* 2012;97(6):931-936.
273. Ng AK, Bernardo MV, Weller E, et al. Second malignancy after Hodgkin disease treated with radiation therapy with or without chemotherapy: long-term risks and risk factors. *Blood* 2002;100(6):1989-1996.
274. Franklin J, Pluetschow A, Paus M, et al. Second malignancy risk associated with treatment of Hodgkin's lymphoma: meta-analysis of the randomised trials. *Ann Oncol* 2006;17(12):1749-1760.
275. Ng AK, Bernardo MP, Weller E, et al. Long-term survival and competing causes of death in patients with early-stage Hodgkin's disease treated at age 50 or younger. *J Clin Oncol* 2002;20(8):2101-2108.
276. Goodman KA, Riedel E, Serrano V, et al. Long-term effects of high-dose chemotherapy and radiation for relapsed and refractory Hodgkin's lymphoma. *J Clin Oncol* 2008;26(32):5240-5247.
277. Sureda A, Arranz R, Iriando A, et al. Autologous stem-cell transplantation for Hodgkin's disease: results and prognostic factors in 494 patients from the Grupo Espanol de Linfomas/Transplante Autologo de Medula Osea Spanish Cooperative Group. *J Clin Oncol* 2001;19(5):1395-1404.

Chapter 94 Hodgkin Lymphoma in Children

> Table of Contents > Part VII - Hematologic Malignancies > Section 4 - Lymphoproliferative Disorders > Chapter 94 - Hodgkin Lymphoma in Children

Chapter 94

Hodgkin Lymphoma in Children

Debra L. Friedman

INTRODUCTION

The first description of Hodgkin lymphoma (HL) was in 1832 when Thomas Hodgkin described seven patients with enlarged lymph glands and spleen. This was followed with histologic descriptions of multinucleated giant cells, by Sternberg in 1898¹ and Reed in 1902.² In the 1960s, the clonality of the Reed-Sternberg cell was established.³ More recently, work has focused on the molecular biology of the disease, including the role of immunoglobulin genes, transcription factors, apoptotic pathways, and Epstein-Barr virus (EBV) incorporation.^{4, 5, 6, 7}

Therapeutic advances in HL began in 1902 when Pusey reported⁸ on the use of radiotherapy,⁸ followed by the use of single-agent chemotherapy, mechlorethamine (nitrogen mustard) in 1946,⁹ then combination chemotherapy with MOPP in

1964,¹⁰ and ABVD in the 1970s.¹¹ Donaldson and colleagues at Stanford introduced the concept of combined modality therapy for pediatric patients using the MOPP backbone and low-dose radiation therapy (RT)¹² (see Table 94.1 for acronyms of treatment protocols). Multimodality, risk-adapted therapies are now the standard of care for pediatric and adolescent HL. The goals of contemporary clinical trials are to balance short- and long-term toxicity with efficacy, in order to maximize cure and minimize adverse sequelae of treatment simultaneously.

EPIDEMIOLOGY

Incidence

Supported by data from United States Surveillance, Epidemiology End Results [SEER],¹³ HL makes up 8.8% of all childhood cancer under the age of 20 years, but 17.7% of cancer in children between ages 15 and 17 years. The overall annual incidence rate in the United States is 12.1 per million for children under 20 years and increases to 32 per million when limiting the analysis to adolescents between 15 and 19 years. Overall there is a slight female predominance when considering all children less than 20 years (M:F = 0.9). The Caucasian:African American ratio is 1.3:1.¹³

TABLE 94.1 COMMON CHEMOTHERAPY PROTOCOLS AND ACRONYMS

Acronym	Chemotherapy Agents
ABV	Doxorubicin, bleomycin, vinblastine
ABVD	Doxorubicin, bleomycin, vinblastine, dacarbazine (DTIC)
BEACOPP	Bleomycin, etoposide, doxorubicin, cyclophosphamide, vincristine, procarbazine, prednisone
CHOP	Cyclophosphamide, doxorubicin, vincristine, prednisone
COP (P)	Cyclophosphamide, vincristine, procarbazine (prednisone)
COPDAC	Cyclophosphamide, vincristine, prednisone, dacarbazine
D(A)BVE (PC)	Doxorubicin, bleomycin, vincristine, etoposide (prednisone, cyclophosphamide)
MOPP	Mechlorethamine (nitrogen mustard), vincristine, procarbazine, prednisone
VAMP	Vincristine, doxorubicin, methotrexate, prednisone
VEPA	Vinblastine, etoposide, prednisone, doxorubicin
OEPA	Vincristine, etoposide, prednisone, doxorubicin
OPPA	Vincristine, procarbazine, prednisone, doxorubicin
ICE	Ifosfamide, carboplatin, etoposide
IV	Ifosfamide, vinorelbine
BEAM	Carmustine, etoposide, cytarabine, melphalan

Adolescent and young adults are most likely to have disease of the nodular sclerosing subtype. Although among children <20 years of age, the nodular sclerosing subtype accounts for 70% of cases, this subtype accounts for 74% of cases in those 15 to 19 years of age. Under the age of 20 years, the mixed cellularity subtype accounts for 16% of cases, but under the age of 10 years, 32% of cases and across the pediatric age group, it is more common in males.¹³

Risk Factors

There are several factors that are known to increase the risk of HL, which include family history of HL, Epstein-Barr virus (EBV) infections, socioeconomic status, and social contacts. For young adult disease (ages 16 to 44 years), there is a 99-fold increased risk among monozygotic twins and a seven-fold increased risk among other siblings.^{14, 15, 16} There is a fascinating interaction between EBV and HL epidemiology and biology. EBV-associated HL, with incorporation of the EBV in the genome, is most commonly reported with the mixed cellularity histologic subtype in children from underdeveloped and developing nations and in young adult males. Conversely, in young adult HL, incorporation of EBV in the tumor genome is unusual but a history of infectious mononucleosis and high-titer antibodies to EBV are associated.^{7, 17, 18, 19, 20} Interestingly, the association between HL and socioeconomic status also differs by age. In children under 10 years, the

disease is associated with lower socioeconomic status and large sibship.^{21, 22} In contrast, risk in young adult patients increases with socioeconomic status and with the related characteristics of a small nuclear family, single-family housing, and fewer siblings or childhood playmates. These findings may be related to an association with infections, where increased infections in early childhood may reduce risk of young adult HL.^{23, 24} There are inconsistent data regarding clustering of young adult cases.^{25, 26}

Biology

The hallmark of classical HL is Reed-Sternberg (RS) cell which most commonly derives from a neoplastic clone originating from B-lymphocytes in lymph node germinal centers, but is then embedded within a reactive infiltrate of lymphocytes, macrophages, granulocytes, and eosinophils.²⁷ The RS cell is a binucleated or multinucleated giant cell that is often characterized with a bilobed nucleus, with two large nucleoli, described commonly as an owl's eye appearance.²⁸ Sequence analyses of RS cell clones reveal rearrangements of immunoglobulin variable-region genes resulting in deficient immunoglobulin production. RS cells then evade the apoptotic pathway, leading to the genesis of HL, and perhaps the paraneoplastic immune-mediated phenomena that sometimes accompany the disease.^{4, 5} The B lymphoid cells from which RS arise have high levels of constitutive nuclear NF- κ B, a transcription factor known to mediate gene expression related to inflammatory and immune responses, and deregulation of NF- κ B has been postulated as a mechanism by which RS cells evade apoptosis.^{6, 29} NF- κ B dimers are held in an inactive cytoplasmic complex with inhibitory proteins, the I κ Bs.²⁹ B-cell stimulation by

P.2006

diverse signals results in rapid activation of the I κ B kinase (IKK). The IKK complex phosphorylates two critical serine residues of I κ Bs,^{30, 31, 32} thereby targeting them for rapid ubiquitin-mediated proteasomal degradation. Active NF- κ B dimers are then released and translocated to the nucleus, where they activate gene transcription. Activation of NF- κ B appears to be a final common effect of co-stimulatory interactions, genetic aberrations, or viral proteins that operate in HL.³³

RS cell survival is dependent on several downstream pathways. RS cells express CD40 and CD40 ligand (CD40L) is expressed on inflammatory T and dendritic cells that surround them. CD40/CD40L interactions normally provide a second signal from activated helper T-cells to normal B-cells, resulting in activation of NF- κ B. NF- κ B in turn causes proliferation and induces expression of BCL-xL, which protects B-cells from apoptosis.³⁴ Tumor necrosis factor receptor-associated factor 1 (TRAF 1) is overexpressed in EBV-transformed lymphoid cells and RS cells³⁵ and is associated with activation of NF- κ B and protection of lymphoid cells from antigen-induced apoptosis. Activation of NF- κ B, in turn, leads to expression of TRAF1, thereby establishing a positive feedback loop that maximizes NF- κ B-dependent gene expression.³⁶ EBV latent membrane protein 1 (LMP1) interacts with TRAF1, and tumors with TRAF1-LMP1 aggregates exhibit high NF- κ B activity.^{37, 38} LMP1 activates NF- κ B by promoting I κ Ba turnover.³⁹ RS cells express CD30 and CD30 ligation promotes proliferation of HL-derived cells with constitutive activation of NF- κ B.⁴⁰

EBV genome fragments can be found in approximately 30% to 50% of HL specimens, and may play a role in the rescue and repair of RS cells, further aiding in their evasion of apoptosis and enhanced survival.^{7, 41, 42, 43} Three latent viral antigens are expressed in EBV-positive HL in RS cells: Epstein-Barr nuclear antigen-1 (EBNA1), required for viral episome maintenance, LMP1 with transforming properties, and LMP2, which is nontransforming.^{44, 45}

Histology

HL can broadly be divided into two pathologic classes: classical Hodgkin lymphoma (CHL) and nodular lymphocyte predominant Hodgkin lymphoma (NLPHL).^{46, 47} In turn, CHL can be further divided into four subtypes: lymphocyte rich (LRCHL), nodular sclerosis (NSHL), mixed cellularity (MCHL), and lymphocyte depleted (LDHL). See Chapter 86 for descriptions of the subtypes. As noted above, different cell types are more common in younger or older children and adults with HL.

In CHL, the RS cells do not express B-cell antigens such as CD45, CD19, and CD 79A, but virtually all express CD30 and approximately 70% express CD15, with only 20% to 30% expressing CD20.⁴⁸ In comparison, in NLPHL, the tumor cells do express B-cell antigens such as CD19, CD20, CD22, and CD79A, may or may not express CD30 and do not express CD15.⁴⁹ In addition, the OCT.2 and BOB.1 oncogenes are down-regulated in CHL but not in NLPHL, correlating with immunoglobulin transcription.⁵⁰

CLINICAL CONSIDERATIONS

Presentation and Staging

The most common presentation of HL, occurring in 80% of patients, is painless adenopathy. Mediastinal involvement is present in approximately 76% of adolescents but only in 33% of children 10 years of age and younger. A large mediastinal mass with a maximum diameter that is greater than one third of the chest diameter and/or a node or nodal aggregate greater than 10 cm occurs in about 20% of patients.^{51, 52} B symptoms, defined as (1) unexplained loss of >10% of body weight in the 6 months preceding the diagnosis; (2) unexplained fever with temperatures >38°Celsius for more than 3 days; or (3) drenching night sweats, are seen in 20% of patients at the time of initial disease presentation.^{52, 53, 54} Staging is performed clinically, based on the Ann Arbor staging system⁵⁵ as revised in 1989.⁵³ Approximately 80% to 85% of children and adolescents with HL have involvement limited to or with direct extension from the lymph nodes and/or the spleen (Stages I to III), whereas 15% to 20% of patients are Stage IV with involvement of the lung, bone marrow, bone, or liver.⁵⁵ Although staging definitions by nodal region, B symptoms, and definition of extranodal involvement are well defined, bulk disease and substaging have not been consistent across studies (Table 94.2).

Diagnostic Evaluation

A detailed history is required to elucidate B symptoms, which becomes important in risk stratification. A thorough physical evaluation should be performed, documenting the location and size of adenopathy, presence of splenomegaly and any evidence of organ dysfunction. This should be complemented by computed tomography (CT) scans of the neck, thorax, abdomen, and pelvis. FDG-PET imaging is the standard of care in HL and response to disease is now judged by FDG-PET alone or in combination with CT. With the advent of combined CT-PET scans, areas of disease can be evaluated simultaneously with both modalities in an overlapping fashion.^{56, 57, 58, 59} Technetium-99 bone scintigraphy can be considered in patients with bone pain or elevated alkaline phosphatase, although PET may obviate the need for this. In addition, an upright chest radiograph (CXR) with posteroanterior (PA) and lateral views has traditionally been required for documentation of a large mediastinal mass (bulk mediastinal disease) for clinical trials, defined as tumor diameter >1/3 the thoracic diameter (measured transversely at the level of the dome of the diaphragm on a 6-foot upright PA CXR),⁶⁰ although the ongoing value of this remains unclear.

Bone marrow biopsy is recommended for all Stage III and IV patients or patients with B symptoms. There are less consistent recommendations for lower-stage patients without B symptoms.^{61, 62} Laboratory studies include a complete blood count, blood chemistries to evaluate hepatic and renal function and may include acute phase reactants such as ferritin, erythrocyte sedimentation rate, and serum copper, which may be seen as nonspecific markers of tumor activity, but may correlate with prognosis or response.

Prognostic Factors

Adverse prognostic markers established from clinical trials often form the basis for risk stratification and subsequent modification of therapeutic algorithms. In sequential trials, as treatment is then risk-based, these adverse factors are abrogated by the changes in therapy. Pre-treatment factors that have been shown to be associated with adverse outcome include advanced stage, B symptoms, bulk disease, extranodal extension, male sex, and elevated erythrocyte sedimentation rate; and in some studies, hemoglobin <110 g/L or white blood cell count >11.5 × 10⁹/L, age 5 to 10 years, and increased numbers of sites of disease.^{63, 64, 65, 66, 67, 68, 69} Patients with NLPHL appear to have an overall better prognosis than those with CHL, and among those with CHL, histologic subtype is not consistently associated with prognosis.^{67, 70} Serum markers that may confer adverse prognostic risk include soluble vascular adhesion molecule-1, tumor necrosis factor, soluble CD-30, beta-2 microglobulin, transferrin, serum IL-10, and serum CD 8 antigen.^{71, 72, 73, 74, 75, 76} High RS cell levels of caspase 3 may be associated with a more favorable outcome.⁷⁷ Early response to treatment, which may be a correlate for biology, may also be an important prognostic factor, allowing titration of therapy to the individual.^{68, 78, 79, 80}

P.2007

TABLE 94.2 CLINICAL AND STAGING CRITERIA FOR HODGKIN LYMPHOMA

A. Stage Grouping

Stage I: Involvement of single lymph node region (I) or localized involvement of a single extralymphatic organ or site (IE).

Stage II: Involvement of two or more lymph node regions on the same side of the diaphragm (II) or localized contiguous involvement of a single extralymphatic organ or site and its regional

lymph node(s) with involvement of one or more lymph node regions on the same side of the diaphragm (IIE).

Stage III: Involvement of lymph node regions on both sides of the diaphragm (III), which may also be accompanied by localized contiguous involvement of an extralymphatic organ or site (IIIE), by involvement of the spleen (IIIS), or both (IIIE+S).

Stage IV: Disseminated (multifocal) involvement of one or more extralymphatic organs or tissues, with or without associated lymph node involvement, or isolated extralymphatic organ involvement with distant (nonregional) nodal involvement.

B. Symptoms and Presentations

“A” Symptoms: Lack of “B” symptoms.

“B” Symptoms: At least one of the following:

Unexplained weight loss >10% in the preceding 6 mo

Unexplained recurrent fever >38°C

Drenching night sweats.

X Bulk disease (see C below)

E Involvement of a single extranodal site that is contiguous or proximal to the known nodal site.

C. Bulk disease

One or both of the following presentations are considered “bulk” disease:

- *Large mediastinal mass:* tumor diameter >1/3 the thoracic diameter (measured transversely at the level of the dome of the diaphragm on a 6-foot upright PA CXR) In the presence of hilar nodal disease the maximal mediastinal tumor measurement may be taken at the level of the hilus. This should be measured as the maximum mediastinal width (at a level containing the tumor and any normal mediastinal structures at the level) over the maximum thoracic ratio.

- *Large extramediastinal nodal aggregate:* A continuous aggregate of nodal tissue that measures >6 cm^a in the longest transverse diameter in any nodal area.

^a Some studies use 10 cm for definition of extramediastinal bulk disease.

INITIAL TREATMENT FOR PEDIATRIC HODGKIN LYMPHOMA

To our knowledge, the biology and natural history of HL does not differ between children and adults. As a result, early therapeutic approaches for pediatric HL were similar to or modeled after those developed for adults with HL. This seemed particularly logical and HL is most commonly a disease of adolescents as opposed to adults. However, with high cure rates, contemporary standard approaches to adolescent and young adult HL include multiagent chemotherapy with or without low-dose involved field radiotherapy. The overriding principles of these treatment regimens are to balance efficacy with both acute and, perhaps, more important, long-term toxicities.^{81, 82, 83} A summary of common protocols for upfront therapy is found in Table 94.3. Figure 94.1 shows the timeline of evolution of therapy for pediatric HL.

Challenges inherent in comparing data across pediatric HL trials are differing patient populations, with differing definitions of stratification. However, overall, results are quite good with 3- to 10-year EFS rates ranging from 67% to 94% for combined modality therapy and 60% to 91% for chemotherapy alone, as reviewed by Olson and Donaldson.⁸⁴

Chemotherapy regimens have largely built upon the MOPP and ABVD backbones and have been quite successful overall.

To decrease alkylator therapy and potential cardiotoxicity and to provide dose-intensive treatment, the Pediatric Oncology Group (POG) developed a series of studies built upon the ABVD backbone, substituting dacarbazine with etoposide. The use of vincristine instead of vinblastine allowed for escalation of doxorubicin and etoposide. POG 9226 piloted therapy with 4 cycles of DBVE followed by low-dose IFRT in patients with Stages I, IIA and IIIA. The 5-year EFS was 89%.⁸⁵ This pilot was followed by a Phase III study using the same therapy (POG 9426) in a non-randomized response-based manner. Those with a rapid response

P.2008

(60% tumor reduction, gallium negative) after 2 cycles proceeded to consolidative IFRT without further chemotherapy; slow responders continued to receive 4 cycles plus IFRT. The overall EFS was 88.3%.⁸⁶ In POG 9425 (for patients with advanced stage disease) prednisone and cyclophosphamide were added to the ABVE backbone, with more rapid delivery of therapy to intensify the weekly therapeutic intensity. Response was assessed after three cycles (9 weeks). Those with rapid response did not receive the additional two cycles of chemotherapy. All patients received consolidative regional low-dose (20 Gy) RT. Overall 3-year EFS was 87%.⁷⁹ Both studies evaluated the efficacy of dexrazoxane in reducing cardiac and pulmonary toxicity. Although it is still too early to know whether there was a significant benefit, dexrazoxane was associated with an increased risk of acute (hematologic/infectious) toxicities and development of second malignancies, mostly treatment-related leukemia.⁸⁷

TABLE 94.3 SOME COMMON STANDARD THERAPY PROTOCOLS FOR PEDIATRIC CLASSICAL HODGKIN LYMPHOMA

Stage and Presentation	Commonly Accepted Chemotherapy Regimens
IA, IIA < 4 nodal regions without B symptoms, bulk disease, or extranodal extension	VAMP × 4 COPP/ABV hybrid × 4 ABVE × 4 OEPA or OPPA × 2 CHOP × 3-4 ± Rituximab ABVD × 2-4
IA, IIA with bulk disease, ≥3 nodal regions, or extranodal extension	COPP/ABV × 6 ABVE-PC × 3-5
IIB*, IIIA, IVA	OPPA/OEPA × 2 + COPP × 2 OEPA-COPAC ABVD × 4-6
IIB*, IIIB, IVB	ABVE-PC × 3-5 BEACOPP × 8 (or BEACOPP × 4 + ABVD × 2 or + COPP/ABV × 4) OPPA/OEPA × 2 + COPP × 4 OEPA-COPAC Stanford V ABVD × 6-8

All regimens should consider LD-IFRT (low-dose involved field radiotherapy; 15 to 25 Gy), but there are variations in recommendations based on risk and early and complete response to chemotherapy.

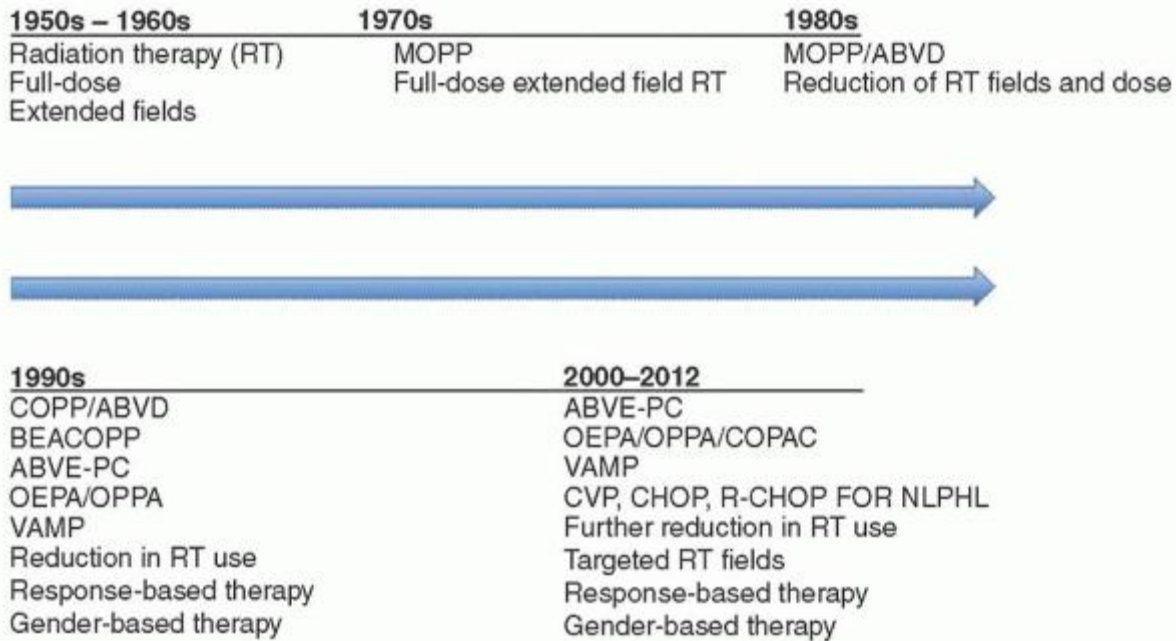

FIGURE 94.1. Timeline of Hodgkin lymphoma upfront therapy.

With the goal of balancing efficacy with toxicity, and specifically to decrease long-term risk for organ dysfunction and second malignancies, there have been a number of studies conducted to evaluate the avoidance of RT in the POG and Children's Cancer Group (CCG), and more recently in the Children's Oncology Group (COG), representing the merger of those groups. In the Children's Cancer Group (CCG) 521 study, patients were randomized between 12 cycles of alternating MOPP/AVBD versus 6 cycles of AVBD + low-dose regional chemotherapy. Event-free survival was 77% for Stage III and IV patients and there was excess pulmonary toxicity with the ABVD arm.⁸⁸ POG 8725 compared eight cycles of MOPP/ABVD with and without IFRT in Stage IIB, III, and IV patients. There was no significant benefit for RT, but patients were exposed to significant doses of alkylating agents and anthracyclines, which are associated with significant long-term risk for gonadal toxicity, cardiac toxicity, and secondary leukemia.⁸⁹ Response post three cycles was a strong prognostic factor, with a 94% EFS in the rapid early responders as opposed to a 78% EFS in those who did not respond quickly.⁸⁹ In a randomized Phase III trial, CCG 5942 evaluated the avoidance of radiotherapy in patients who had a complete response following chemotherapy. Patients were treated with four cycles of COPP/ABV, six cycles of COPP/ABV, or two cycles each of COPP/ABV, cytarabine/etoposide, and CHOP, depending on the stage of disease and presence of bulk disease. Of the 829 eligible patients, complete response was achieved in 83% and 501 were randomized to receive IFRT or no further therapy. Event-free survival at 3 and 10 years was 87% and 83%, respectively. In all groups, the difference in EFS post randomization was highly significant and overall EFS was 91% at 3 and 10 years for the group who received IFRT and 86% at 3 years and 83% at 10 years for those who did not receive IFRT. Despite the differences in EFS, early evaluation of overall survival is not affected by the inclusion of IFRT.^{63, 90} A pilot study of 99 patients in CCG 59704 utilized the German Hodgkin Disease Group's BEACOPP backbone for patients with B symptoms or advanced stage disease. Overall the 5-year EFS was 94% with patients receiving six to eight cycles of chemotherapy with or without radiotherapy on the basis of a gender-stratified, response-based therapeutic algorithm.⁹¹

A series of studies in the COG have just completed accrual and have evaluated the principles of response-based risk-adapted therapy, where therapy is decreased for those at lowest risk and with favorable early responses to chemotherapy and augmented for those with more advanced disease or a slow response to initial chemotherapy. These studies have utilized the ABVE-PC backbone of the POG 9425 and 9,426 studies.

The Dana Farber-Stanford-St. Jude pediatric Hodgkin lymphoma consortium studies have focused efforts on reduction in alkylating agent, anthracycline, and radiotherapy doses. Low-risk patients have been treated with four cycles of an alkylator-free chemotherapy protocol, VAMP, with radiotherapy doses of 15 Gy or 25.5 Gy based upon response to the first two cycles of chemotherapy. This approach resulted in a 5-year EFS of 93% and 10-year EFS of 89%.⁹² For patients with higher risk disease, two protocols have been evaluated, VAMP/COP and VEPA, both with IFRT. Results have been less acceptable with 5-year EFS of 74% and 68%, respectively.^{93, 94} The group is now evaluating the Stanford V regimen⁹⁵ that has been successfully employed in adult patients.

In the same era, the German cooperative groups have built upon COPP chemotherapy in both pediatric and adult HL. To decrease gonadotoxicity, which is more prevalent in males exposed to alkylating agents, some of these therapies have been gender-based. The DAL-HL-90 study used OEPA/COPP for males and OPPA/COPP for females, both followed by IFRT. EFS for Stages II, III, and IV was 92%, 86%, and 90%, respectively.⁹⁶ The GPOH-95 study was designed to assess elimination of radiotherapy for those with a complete response. It built on the OPPA/OEPA backbones by adding cycles of COPP for patients with more advanced disease. Radiotherapy dose was determined by the post-chemotherapy disease reduction. Complete response was defined as complete resolution of all disease (as opposed to a 70% reduction in CCG 5942 and 59704). Only 22% achieved a complete response. A total of 50% achieved between 75% and 95% disease reduction and were treated with 20 Gy radiotherapy, and 4% had less than a 75% reduction and were treated with 30 Gy. In addition, 20% of patients had residual masses treated with boost doses to 35 Gy. Overall the EFS was 92% for those receiving radiotherapy, compared with 88% in those treated with chemotherapy alone, but for patients with IA, IB, and IIA disease, EFS was not

P.2009

different among those with a CR to chemotherapy and no other therapy (97%) and those with a partial response, subsequently treated with radiotherapy (94%). However, for all other patients the EFS was 79% for those treated with chemotherapy alone compared with 91% for those treated with combined modality therapy.⁹⁷ This was followed by the GPOH-HD-2002 study, where OEPA-COPDAC chemotherapy was tested in males compared with OPPA-COPP in females for intermediate and advanced HL. The 5-year EFS was 89.0% without significant difference between males and females.⁹⁸

For low-risk patients with NPLHL, some patients may be treated with surgery alone. There are multiple small reports in both adult and pediatric HL of patients of successful treatment of completely resected Stage I disease. For those who did relapse, salvage rates were encouraging and death from disease very low.^{99, 100, 101, 102} This has prompted a study in the COG to formally evaluate surgery only in patients with involvement of a single completely resected lymph node with NPLHL. Although adults with NPLHL may be treated with radiotherapy alone, the dose required without adjuvant chemotherapy exceeds that optimal in children and adolescents, and thus this strategy is not used in pediatric NPLHL. The optimal treatment of patients with advanced stage NPLHL remains undetermined. These patients are traditionally treated with regimens that are used for patients with advanced stage classical HL with outcomes equivalent to or better than those with CHL. However, the biology of NPLHL may be more similar to indolent CD20+ B-cell non-Hodgkin lymphoma (NHL) than classical HL and thus the question remains of whether regimens for NHL would be more effective with potentially less toxicity in these patients. A retrospective analysis at MD Anderson Cancer Center from 1995 to 2010 found that patients with NPLHL treated with R-CHOP had better 5-year progression-free and overall survival compared to those treated on the HL regimen.¹⁰³ From 2005 to 2010, a study was conducted in France and the United Kingdom, testing CVP in 55 patients with early-stage NPLHL. The 40-month freedom from treatment failure was 75.4%, but with an overall survival of 100%, respectively.¹⁰⁴

However, prospective multicenter randomized studies have not been conducted to answer such questions and it is unlikely, given the exceptional overall survival, that such studies will be successfully conducted.

Radiotherapy for Hodgkin Lymphoma

It has been recognized since the 1950s that HL is an extremely radiosensitive disease. Currently, for children and adolescents with HL, radiotherapy is exclusively delivered in the context of multimodality therapy. Doses of 15 to 25 Gy are commonly used, and as noted above, clinical trials have been and continue to be conducted to identify groups of patients for whom the exclusion of radiotherapy is possible, without affecting disease-free survival.

Below are some basic principles for radiotherapy in pediatric and adolescent HL. However, delivery of radiotherapy, particularly in children and adolescents, requires careful considerations of the age, tumor burden and location, response to chemotherapy, and an assessment of both short- and long-term potential toxicity.

Megavoltage energies are now the treatment of choice for pediatric and adolescent HL. Although there are differences in treatment techniques among radiation oncologists and specific institutions, the general technical principles remain constant.¹⁰⁵ Proton beam radiotherapy is currently under investigation at several centers across the United States, but there is insufficient data to know whether this modality will provide the best option for long-term cure, while decreasing adverse long-term effects of treatment.^{106, 107}

Radiotherapy fields must be designed with the goal to deliver the optimum volume of radiotherapy for disease control, while avoiding normal tissue damage. Customized shielding blocks should be utilized as appropriate to protect normal tissue. Blocking the genitalia is of specific importance when pelvic fields are included. In females, oophoropexy results in

doses of 8% to 10% and 4% to 5%, respectively, of the pelvic dose,¹⁰⁸ which will be compatible with the preservation of fertility. For males, a frog leg position and an individually fitted shield will provide the greatest shielding to the testes, reducing scatter to approximately 0.75% of the pelvic lymph node dose.¹⁰⁹

TREATMENT FOR RELAPSED HODGKIN LYMPHOMA

HL may be cured even if it has recurred after initial treatment. Potentially curative options include conventionally dosed combined modality protocols: radiotherapy alone for those relapsing in a limited nodal pattern, re-induction chemotherapy followed by autologous hematopoietic stem cell transplantation (HSCT), full and reduced intensity allogeneic transplants, and evolving targeted antibodies.^{110, 111} Some common retrieval regimens are shown in Table 94.4 and the choice of regimen is dependent on previous treatment and patterns of relapse. Two ifosfamide-based regimens have been used with good response rates, ICE and IV with EFS exceeding 75%.^{112, 113} Gemcitabine has also been used in combination with vinorelbine with excellent overall response rates in recurrent HL with similar EFS.^{114, 115, 116, 117}

Autologous HSCT is most commonly used for recurrent or refractory HL, particularly when used following dose-intensive regimens or for high-risk disease.^{115, 116, 117, 118, 119, 120, 121, 122, 123, 124, 125, 126, 127, 128} However, an allogeneic effect has been observed, and full and reduced intensity allogeneic approaches as well as immune modulation and induction of autologous graft versus host disease have been explored to enhance the allogeneic effect.^{129, 130, 131, 132, 133, 134, 135, 136}

The most promising new agent in the treatment for HL is brentuximab vedotin (SGN35), which is also being utilized in the earlier relapse period with several recently reported as well as ongoing trials, although pediatric experience is quite limited.¹³⁷ In a recent Phase 2 study, the efficacy and safety of brentuximab vedotin was evaluated in 102 patients with relapsed or refractory HL after ASCT. Reductions in tumor size were observed in 94% of patients. The overall response rate was 75%, with complete remission achieved by 34% of patients and partial response in 40%.¹³⁸ A retrospective analysis by the German Hodgkin Study Group with brentuximab vedotin as single agent was reported in 45 patients with refractory or relapsed CD30 (+) HL, with an objective response rate of 60%, including 22% complete remissions.¹³⁹ A case series of 20 transplant-naïve patients who either refused or were ineligible for transplant, enrolled in two Phase I multicenter studies, reported six responses.¹⁴⁰ In a study of

P.2010

25 patients with recurrent HL post-allogeneic transplant, who had received a median of 9 (5-19) prior regimens, overall and complete response rates were 50% and 38%, respectively, among 24 eligible patients, with a median progression-free survival time of 7.8 months.¹⁴¹ These data led to accelerated approval of brentuximab vedotin for the treatment of patients with HL after failure of autologous stem cell transplantation (ASCT) or after failure of at least two prior multiagent chemotherapy regimens in patients who are not ASCT candidates.¹⁴² Studies are now ongoing evaluating brentuximab vedotin as part of multiagent protocols in the upfront and recurrent setting.

TABLE 94.4 COMMON TREATMENT OPTIONS FOR RECURRENT HODGKIN LYMPHOMA

ICE (Ifosfamide, carboplatin, and etoposide)

DECA (Dexamethasone, etoposide, cisplatin, cytarabine)

IV (Ifosfamide and vinorelbine)

GV (Gemcitabine and vinorelbine)

IEP-ABVD-COPP (Ifosfamide, etoposide, prednisone-doxorubicin, bleomycin, vinblastine, dacarbazine-cyclophosphamide, vincristine, procarbazine, prednisone)

APE (Cytosine arabinoside, cisplatin, etoposide)

SGN-35 (brentuximab vedotin)—antibody-drug conjugate targeting CD30

These therapies can be used as stand-alone therapy or as re-induction prior to planned stem cell transplant. Radiotherapy can be considered together with this therapy.

ADVERSE LONG-TERM OUTCOMES OF THERAPY

In pediatrics, a significant consideration when deciding therapy is the risk of adverse long-term risks of therapy, which include organ dysfunction and second malignancies.¹⁴³ The common potential long-term effects of radiotherapy and chemotherapy for HL are summarized together with general monitoring recommendations in Table 94.5. In a review from

the Childhood Cancer Survivor Study (CCSS), among 2,633 HL 5-year survivors, initially treated between 1970 and 1986, there were 500 deaths with the following causes: HL, 35%; second malignancies, 23%; cardiovascular disease, 14%; pulmonary disease, 4%; external cause, 7%; other and unknown cause, 17%. Adjusting for demographics and medical conditions, treatment with radiotherapy or alkylating agents were independent risk factors for overall mortality and those same exposures as well as anthracycline treatment for second malignancies. In this cohort, the 30-year cumulative incidence for second malignancy was 18.7%. Based on self-report, the 30-year cumulative incidence of grade 3 to 5 chronic health conditions in the cohort were as follows: cardiovascular, 11%; pulmonary, 5%; and thyroid, 51%.¹⁴⁴ Other studies of subsequent malignancy cite female gender, radiotherapy field and dose, and follow-up time since diagnosis as risk factors. The most significant risk is for secondary breast cancer in female survivors treated with thoracic radiotherapy, where even lower doses of radiotherapy, with ongoing follow-up now are associated with increased risk.^{145, 146, 147, 148, 149} Thyroid dysfunction and thyroid cancer are also of concern in this population. In the CCSS, self-report thyroid status was assessed in 1,791 HL survivors treated from 1970 to 1986. Of the entire cohort, 34% have been diagnosed with at least one thyroid abnormality. Hypothyroidism was the most common disturbance, with a relative risk of 17.1 compared to sibling controls. Hyperthyroidism was reported by 5% of survivors, which was 8-fold greater than the incidence reported by the controls. The risk of thyroid nodules was 27 times that in sibling controls. Female gender and higher radiation dose increased risk for thyroid abnormalities.¹⁵⁰ In a pooled cohort of childhood cancer survivors including 16,757 patients, with 187 developing primary thyroid cancer, radiation-dose-related relative risks increased approximately linearly for <10 Gy, leveled off at 10 to 15-fold for 10 to 30 Gy and then declined, but remained elevated

P.2011

for doses >50 Gy. Dose-related excess relative risks increased with decreasing age at exposure but did not vary with attained age or time-since-exposure, remaining elevated 25+ years after exposure. Gender and number of treatments did not modify radiation effects. In another pooled analysis, three models of assessing absolute risk for secondary thyroid cancer were developed and validated. Model M1 included self-reported risk factors, model M2 added basic radiation and chemotherapy treatment information abstracted from medical records, and model M3 refined M2 by incorporating reconstructed radiation absorbed dose to the thyroid. All models were associated with elevated relative risks (M1 = 10.8; M2 = 6.8; M3 = 8.2) and had good discriminatory ability. Past thyroid nodule was consistently the strongest risk factor in the models.^{151, 152} Cardiac toxicity following anthracycline therapy and mediastinal radiotherapy is well recognized among survivors.^{144, 153} Among 1,132 survivors of HL treated between 1978 and 1995, treated with a relatively low doxorubicin dose (160 mg/m²), at a median of 19.5 years, cardiac diseases had been diagnosed in 50 patients. Valvular defects were diagnosed most frequently, followed by coronary artery diseases, cardiomyopathies, conduction disorders, and pericardial abnormalities. Multivariate analysis showed the mediastinal radiotherapy dose to be the only significant variable associated with cardiac disease.¹⁵⁴ In a cohort of 1,362 5-year survivors diagnosed between 1966 and 1996, with 50 cardiac events reported, cumulative incidence of anthracycline (dose), cardiac irradiation (dose), combination of these treatments, and congenital heart disease were significantly associated with developing a cardiac event.¹⁵⁵ Reproductive outcomes have been examined for all survivors in the CCSS, but risk factors for impairment are generally those seen with HL therapy. Sklar and colleagues evaluated premature menopause and a multiple Poisson model showing risk factors to include attained age, exposure to radiation to the ovaries in a dose-dependent manner, number and cumulative dose of alkylating agents, and a diagnosis of HL.¹⁵⁶ Green and colleagues found that male survivors were less likely to sire a pregnancy than siblings. Among survivors, the hazard ratio of siring a pregnancy was decreased by RT to the testes, higher cumulative alkylating agent dose, and treatment with cyclophosphamide or procarbazine.¹⁵⁷

TABLE 94.5 GENERAL GUIDELINES FOR RISK AND SURVEILLANCE FOR ADVERSE LONG-TERM OUTCOMES

System	Therapeutic Exposure	Potential Effects	Monitoring Recommendations^a
Cardiac	Thoracic RT	Cardiomyopathy	Electrocardiogram and echocardiogram
	Doxorubicin	Pericarditis	
		Coronary artery disease	
		Valvular disease	
Pulmonary	Thoracic RT	Pulmonary fibrosis	Pulmonary function tests (PFTs) (including DLCO and spirometry)
	Bleomycin	Restrictive lung disease	

Thyroid	Neck RT	Overt or compensated hypothyroidism Thyroid nodules or cancer Hyperthyroidism	Free T4; TSH			
Gonadal (female)	Pelvic RT	Delayed/arrested puberty	FSH, LH, estradiol			
	Alkylating agents	Early menopause Ovarian failure				
Gonadal (male)	Pelvic RT	Germ cell failure	FSH, LH, testosterone Semen analysis			
	Alkylating agents	Infertility/Azoospermia Leydig cell dysfunction Hypogonadism Delayed/arrested puberty				
		Bone		Corticosteroids	Decreased bone mineral density	Bone density evaluation (DEXA or quantitative CT)
		Second Malignancies		Radiotherapy	Sarcomas CNS tumors Breast cancer Melanoma Nonmelanoma skin cancer Thyroid cancer Other solid tumors	Routine cancer screening per general population guidelines Mammography to screen for female breast cancer at age 25 y or 10 y post RT exposure, whichever is later
	Doxorubicin Etoposide Mechlorethamine Cyclophosphamide	Therapy-related myelodysplasia and acute leukemia	Annual cbc with differential for 10-y post exposure			

^a Monitoring recommendations all include a risk-adapted health history and physical examination. The frequency with which diagnostic studies should be performed is dependent on many factors including radiotherapy dose, chemotherapy exposures, age at exposure, and other clinical parameters. See Children's Oncology Group guidelines for more details (www.survivorshipguidelines.org).

DEXA, Dual-energy X-ray absorptiometry; DLCO, Diffusing capacity; FSH, follicle stimulating hormone; LH, luteinizing hormone; RT, radiation therapy; TSH, thyroid stimulating hormone.

Studies of HL survivors treated in the more contemporary age of chemoradiotherapy are underway to see if reduction in anthracyclines, alkylating agents, and radiotherapy have resulted in fewer long-term adverse chronic health conditions.

Various pediatric cooperative groups have developed long-term follow-up guidelines, which provide a foundation for the type of follow-up care that should be delivered. However, the recommendations are not completely consistent with one another and recommendations are consensus-based, and thus, the optimal follow-up strategy is yet to be fully elucidated. Efforts are underway for international harmonization among large childhood cancer groups.^{158, 159, 160, 161, 162, 163, 164, 165, 166, 167}

CONCLUSIONS

Cure rates for HL are one of the highest in pediatric oncology, but the very therapies that have afforded such cure rates share the etiologic limelight for adverse long-term health outcomes. Ongoing clinical trials thus seek to balance efficacy

with both short- and long-term toxicity. For a meaningful minority of patients with higher risk initial disease, refractory, and recurrent disease, the challenge remains increasing the cure rate and incorporating novel agents that may better target the underlying biology and pathophysiology. And last, additional study is required to understand the complex biology and epidemiology of HL better to understand better how they interface with one another, affect disease presentation, response to therapy, and long-term outcomes.

Key Summary Points

For initial diagnosis:

Work-up: History and exam; CT neck, chest, abdomen, pelvis, FDG-PET scan, Bone marrow; CBC/differential, metabolic panel, erythrocyte sedimentation rate, ferritin, bone marrow; excisional lymph node biopsy.

Initial treatment: Risk-based (Table 94.3); Enroll on open clinical trial when available.

For refractory or recurrent disease:

Work-up: As per initial diagnosis.

Treatment: Risk based (Table 94.4). If relapse is not low stage after low-density low-risk chemotherapy protocol without radiotherapy, consider stem cell transplant once response is evident (FDG-PET non-avid).

For follow-up:

Follow clinically with imaging studies for first year to 18 months, then clinically follow for long-term toxicity using COG guidelines (www.survivorshipguidelines.org).

Useful Web-based References

Children's Oncology Group:

<http://www.childrensoncologygroup.org/index.php/hodgkindisease>

<http://www.survivorshipguidelines.org>

National Cancer Institute PDQ: <http://www.cancer.gov/cancertopics/pdq/treatment/childhodgkins/HealthProfessional>

REFERENCES

1. Sternberg C. Uber eind Eigenartige unter dem Bilde der Pseudoleuk mie verlaufende Turberculose des lymphatischen. Apparates Z Heldk 1898;19:21.
2. Reed D. On the pathological changes in Hodgkin's disease, with special reference to its relation to its relation to tuberculosis. Johns Hopkins Hosp Rep 1902;10:133.
3. Seif GS, Spriggs AI. Chromosome changes in Hodgkin's disease. J Natl Cancer Inst 1967;39:557-570.
4. Jox A, Zander T, Diehl V, et al. Clonal relapse in Hodgkin's disease. N Engl J Med 1997;337:499.
5. Kanzler H, Kuppers R, Helmes S, et al. Hodgkin and Reed-Sternberg-like cells in B-cell chronic lymphocytic leukemia represent the outgrowth of single germinal-center B-cell-derived clones: potential precursors of Hodgkin and Reed-Sternberg cells in Hodgkin's disease. Blood 2000;95:1023-1031.
6. Fiumara P, Snell V, Li Y, et al. Functional expression of receptor activator of nuclear factor kappaB in Hodgkin disease cell lines. Blood 2001;98:2784-2790.
7. Ambinder RF, Browning PJ, Lorenzana I, et al. Epstein-Barr virus and childhood Hodgkin's disease in Honduras and the United States. Blood 1993;81:462-467.
8. Pusey WA. Cases of sarcoma and Hodgkin's disease treated with exposures to x-rays: a preliminary report. JAMA 1902;132:166.
9. Goodman LS, Wintrobe MM, Dameshek W, et al. Nitrogen mustard therapy: use methyl bis(beta-chloroethyl)amine hydrochloride for Hodgkin's disease, lymphsarcoma, leukemia and certain allied and miscellaneous disorders. JAMA 1946;132:126.
10. DeVita VT Jr, Canellos GP, Moxley JHD. A decade of combination chemotherapy of advanced Hodgkin's disease. Cancer 1972;30:1495-1504.
11. Santoro A, Bonadonna G, Valagussa P, et al. Long-term results of combined chemotherapy-radiotherapy approach in Hodgkin's disease: superiority of ABVD plus radiotherapy versus MOPP plus radiotherapy. J Clin Oncol 1987;5:27-37.

12. Donaldson SS, Link MP. Combined modality treatment with low-dose radiation and MOPP chemotherapy for children with Hodgkin's disease. *J Clin Oncol* 1987;5:742-749.
13. Percy CL, Smith MA, Linet M, et al. Lymphomas and reticuloendothelial neoplasms. Bethesda, MD: National Cancer Institute, SEER program, 1999.
14. Mack TM, Cozen W, Shibata DK, et al. Concordance for Hodgkin's disease in identical twins suggesting genetic susceptibility to the young-adult form of the disease. *N Engl J Med* 1995;332:413-418.
15. Devesa SS, Blot WJ, Stone BJ, et al. Recent cancer trends in the United States. *J Natl Cancer Inst* 1995;87:175-182.
16. Kersey JH, Shapiro RS, Filipovich AH. Relationship of immunodeficiency to lymphoid malignancy. *Pediatr Infect Dis J* 1988;7:S10-S12.
17. Kusuda M, Toriyama K, Kamidigo NO, et al. A comparison of epidemiologic, histologic, and virologic studies on Hodgkin's disease in western Kenya and Nagasaki, Japan. *Am J Trop Med Hyg* 1998;59:801-807.
18. Armstrong AA, Alexander FE, Cartwright R, et al. Epstein-Barr virus and Hodgkin's disease: further evidence for the three disease hypothesis. *Leukemia* 1998;12:1272-1276.
19. Glaser SL, Lin RJ, Stewart SL, et al. Epstein-Barr virus-associated Hodgkin's disease: epidemiologic characteristics in international data. *Int J Cancer* 1997;70:375-382.
20. Sleckman BG, Mauch PM, Ambinder RF, et al. Epstein-Barr virus in Hodgkin's disease: correlation of risk factors and disease characteristics with molecular evidence of viral infection. *Cancer Epidemiol Biomarkers Prev* 1998;7:1117-1121.
21. Grufferman S, Delzell E. Epidemiology of Hodgkin's disease. *Epidemiol Rev* 1984;6:76-106.
22. Stiller CA. What causes Hodgkin's disease in children? *Eur J Cancer* 1998;34:523-528.
23. Gutensohn NM. Social class and age at diagnosis of Hodgkin's disease: new epidemiologic evidence for the "two-disease hypothesis". *Cancer Treat Rep* 1982;66:689-695.
24. Grufferman S, Cole P, Smith PG, et al. Hodgkin's disease in siblings. *N Engl J Med* 1977;296:248-250.
25. Grufferman S, Cole P, Levitan TR. Evidence against transmission of Hodgkin's disease in high schools. *N Engl J Med* 1979;300:1006-1011.
26. Grufferman S. Is Hodgkin's disease infectious? *Eur J Cancer* 1995;31A:1388-1389.
27. Staudt LM. The molecular and cellular origins of Hodgkin's disease. *J Exp Med* 2000;191:207-212.
28. Brauninger A, Schmitz R, Bechtel D, et al. Molecular biology of Hodgkin's and Reed/Sternberg cells in Hodgkin's lymphoma. *Int J Cancer* 2006;118:1853-1861.
29. Baeuerle PA, Baltimore D. NF-kappa B: ten years after. *Cell* 1996;87:13-20.
30. Karin M, Delhase M. The I kappa B kinase (IKK) and NF-kappa B: key elements of proinflammatory signalling. *Semin Immunol* 2000;12:85-98.
31. Delhase M, Hayakawa M, Chen Y, et al. Positive and negative regulation of IkappaB kinase activity through IKKbeta subunit phosphorylation. *Science* 1999;284:309-313.
32. Li ZW, Chu W, Hu Y, et al. The IKKbeta subunit of IkappaB kinase (IKK) is essential for nuclear factor kappaB activation and prevention of apoptosis. *J Exp Med* 1999;189:1839-1845.
33. Bargou RC, Leng C, Krappmann D, et al. High-level nuclear NF-kappa B and Oct-2 is a common feature of cultured Hodgkin/Reed-Sternberg cells. *Blood* 1996;87:4340-4347.
34. Ravi R, Bedi GC, Engstrom LW, et al. Regulation of death receptor expression and TRAIL/Apo2L-induced apoptosis by NF-kappaB. *Nat Cell Biol* 2001;3:409-416.
35. Durkop H, Foss HD, Demel G, et al. Tumor necrosis factor receptor-associated factor 1 is overexpressed in Reed-Sternberg cells of Hodgkin's disease and Epstein-Barr virus-transformed lymphoid cells. *Blood* 1999;93:617-623.
36. Wang CY, Mayo MW, Korneluk RG, et al. NF-kappaB antiapoptosis: induction of TRAF1 and TRAF2 and c-IAP1 and c-IAP2 to suppress caspase-8 activation. *Science* 1998;281:1680-1683.
37. Mosialos G, Birkenbach M, Yalamanchili R, et al. The Epstein-Barr virus transforming protein LMP1 engages signaling proteins for the tumor necrosis factor receptor family. *Cell* 1995;80:389-399.

38. Devergne O, Hatzivassiliou E, Izumi KM, et al. Association of TRAF1, TRAF2, and TRAF3 with an Epstein-Barr virus LMP1 domain important for B-lymphocyte transformation: role in NF-kappaB activation. *Mol Cell Biol* 1996;16:7098-7108.
39. Sylla BS, Hung SC, Davidson DM, et al. Epstein-Barr virus-transforming protein latent infection membrane protein 1 activates transcription factor NF-kappaB through a pathway that includes the NF-kappaB-inducing kinase and the IkappaB kinases IKKalpha and IKKbeta. *Proc Natl Acad Sci U S A* 1998;95:10106-10111.
40. Mir SS, Richter BW, Duckett CS. Differential effects of CD30 activation in anaplastic large cell lymphoma and Hodgkin disease cells. *Blood* 2000;96:4307-4312.
41. Klein G. Epstein-Barr virus-carrying cells in Hodgkin's disease. *Blood* 1992;80:299-301.
42. Weiss LM, Movahed LA, Warnke RA, et al. Detection of Epstein-Barr viral genomes in Reed-Sternberg cells of Hodgkin's disease. *N Engl J Med* 1989;320:502-506.
43. Weiss LM, Strickler JG, Warnke RA, et al. Epstein-Barr viral DNA in tissues of Hodgkin's disease. *Am J Pathol* 1987;129:86-91.
44. Khanna R, Burrows SR. Role of cytotoxic T lymphocytes in Epstein-Barr virus-associated diseases. *Annu Rev Microbiol* 2000;54:19-48.
45. Yang J, Lemas VM, Flinn IW, et al. Application of the ELISPOT assay to the characterization of CD8(+) responses to Epstein-Barr virus antigens. *Blood* 2000;95:241-248.
46. Harris NL. Hodgkin's lymphomas: classification, diagnosis, and grading. *Semin Hematol* 1999;36:220-232.
47. Pileri SA, Ascani S, Leoncini L, et al. Hodgkin's lymphoma: the pathologist's viewpoint. *J Clin Pathol* 2002;55:162-176.
48. Tzankov A, Zimpfer A, Pehrs AC, et al. Expression of B-cell markers in classical hodgkin lymphoma: a tissue microarray analysis of 330 cases. *Mod Pathol* 2003;16:1141-1147.
49. Anagnostopoulos I, Hansmann ML, Franssila K, et al. European Task Force on Lymphoma project on lymphocyte predominance Hodgkin disease: histologic and immunohistologic analysis of submitted cases reveals 2 types of Hodgkin disease with a nodular growth pattern and abundant lymphocytes. *Blood* 2000;96:1889-1899.
50. Stein H, Marafioti T, Foss HD, et al. Down-regulation of BOB.1/OBF.1 and Oct2 in classical Hodgkin disease but not in lymphocyte predominant Hodgkin disease correlates with immunoglobulin transcription. *Blood* 2001;97:496-501.
51. Mauch PM, Kalish LA, Kadin M, et al. Patterns of presentation of Hodgkin disease. Implications for etiology and pathogenesis. *Cancer* 1993;71:2062-2071.
52. Kaplan H. Hodgkin's disease. Cambridge, MA: Harvard University Press, 1980.
53. Lister TA, Crowther D, Sutcliffe SB, et al. Report of a committee convened to discuss the evaluation and staging of patients with Hodgkin's disease: cotswolds meeting. *J Clin Oncol* 1989;7:1630-1636.
54. Lister TA, Crowther D. Staging for Hodgkin's disease. *Semin Oncol* 1990;17:696-703.
55. Carbone PP, Kaplan HS, Musshoff K, et al. Report of the Committee on Hodgkin's disease staging classification. *Cancer Res* 1971;31:1860-1861.
56. Castellino RA, Blank N, Hoppe RT, et al. Hodgkin disease: contributions of chest CT in the initial staging evaluation. *Radiology* 1986;160:603-605.
- P.2012
57. Friedberg JW, Fischman A, Neuberg D, et al. FDG-PET is superior to gallium scintigraphy in staging and more sensitive in the follow-up of patients with de novo Hodgkin lymphoma: a blinded comparison. *Leuk Lymphoma* 2004;45:85-92.
58. Hudson MM, Krasin MJ, Kaste SC. PET imaging in pediatric Hodgkin's lymphoma. *Pediatr Radiol* 2004;34:190-198.
59. Hueltenschmidt B, Sautter-Bihl ML, Lang O, et al. Whole body positron emission tomography in the treatment of Hodgkin disease. *Cancer* 2001;91:302-310.
60. Castellani MR, Cefalo G, Terenziani M, et al. Gallium scan in adolescents and children with Hodgkin's disease (HD). Treatment response assessment and prognostic value. *Q J Nucl Med* 2003;47:22-30.

61. Mahoney DH Jr, Schreuders LC, Gresik MV, et al. Role of staging bone marrow examination in children with Hodgkin disease. *Med Pediatr Oncol* 1998;30:175-177.
62. Hanna SL, Fletcher BD, Boulden TF, et al. MR imaging of infradiaphragmatic lymphadenopathy in children and adolescents with Hodgkin disease: comparison with lymphography and CT. *J Magn Reson Imaging* 1993;3:461-470.
63. Nachman JB, Sposto R, Herzog P, et al. Randomized comparison of low-dose involved-field radiotherapy and no radiotherapy for children with Hodgkin's disease who achieve a complete response to chemotherapy. *J Clin Oncol* 2002;20:3765-3771.
64. Ruhl U, Albrecht M, Dieckmann K, et al. Response-adapted radiotherapy in the treatment of pediatric Hodgkin's disease: an interim report at 5 years of the German GPOH-HD 95 trial. *Int J Radiat Oncol Biol Phys* 2001;51:1209-1218.
65. Krasin MJ, Rai SN, Kun LE, et al. Patterns of treatment failure in pediatric and young adult patients with Hodgkin's disease: local disease control with combined-modality therapy. *J Clin Oncol* 2005;23:8406-8413.
66. Smith RS, Chen Q, Hudson MM, et al. Prognostic factors for children with Hodgkin's disease treated with combined-modality therapy. *J Clin Oncol* 2003;21:2026-2033.
67. Shankar AG, Ashley S, Radford M, et al. Does histology influence outcome in childhood Hodgkin's disease? Results from the United Kingdom Children's Cancer Study Group. *J Clin Oncol* 1997;15:2622-2630.
68. Landman-Parker J, Pacquement H, Leblanc T, et al. Localized childhood Hodgkin's disease: response-adapted chemotherapy with etoposide, bleomycin, vinblastine, and prednisone before low-dose radiation therapy—results of the French Society of Pediatric Oncology Study MDH90. *J Clin Oncol* 2000;18:1500-1507.
69. Schwartz CL. Prognostic factors in pediatric Hodgkin disease. *Curr Oncol Rep* 2003;5:498-504.
70. Mauch P, Tarbell N, Weinstein H, et al. Stage IA and IIA supradiaphragmatic Hodgkin's disease: prognostic factors in surgically staged patients treated with mantle and paraaortic irradiation. *J Clin Oncol* 1988;6:1576-1583.
71. Bohlen H, Kessler M, Sextro M, et al. Poor clinical outcome of patients with Hodgkin's disease and elevated interleukin-10 serum levels. Clinical significance of interleukin-10 serum levels for Hodgkin's disease. *Ann Hematol* 2000;79:110-113.
72. Hann HW, Lange B, Stahlhut MW, et al. Prognostic importance of serum transferrin and ferritin in childhood Hodgkin's disease. *Cancer* 1990;66: 313-316.
73. Chronowski GM, Wilder RB, Tucker SL, et al. An elevated serum beta-2-microglobulin level is an adverse prognostic factor for overall survival in patients with early-stage Hodgkin disease. *Cancer* 2002;95:2534-2538.
74. Nadali G, Tavecchia L, Zanolin E, et al. Serum level of the soluble form of the CD30 molecule identifies patients with Hodgkin's disease at high risk of unfavorable outcome. *Blood* 1998;91:3011-3016.
75. Warzocha K, Bienvu J, Ribeiro P, et al. Plasma levels of tumour necrosis factor and its soluble receptors correlate with clinical features and outcome of Hodgkin's disease patients. *Br J Cancer* 1998;77:2357-2362.
76. Christiansen I, Sundstrom C, Enblad G, et al. Soluble vascular cell adhesion molecule-1 (sVCAM-1) is an independent prognostic marker in Hodgkin's disease. *Br J Haematol* 1998;102:701-709.
77. Dukers DF, Meijer CJ, ten Berge RL, et al. High numbers of active caspase 3-positive Reed-Sternberg cells in pretreatment biopsy specimens of patients with Hodgkin disease predict favorable clinical outcome. *Blood* 2002;100:36-42.
78. Carde P, Koscielny S, Franklin J, et al. Early response to chemotherapy: a surrogate for final outcome of Hodgkin's disease patients that should influence initial treatment length and intensity? *Ann Oncol* 2002;13(Suppl 1):86-91.
79. Schwartz C, Constine LS, Villaluna D, et al. Risk-adapted, response-based approach using ABVE-PC for children and adolescents with intermediate- and high-risk Hodgkin lymphoma: the results of P9425. *Blood* 2009;114:2051-2059.
80. Weiner MA, Leventhal BG, Marcus R, et al. Intensive chemotherapy and low-dose radiotherapy for the treatment of advanced-stage Hodgkin's disease in pediatric patients: a pediatric oncology group study. *J Clin Oncol* 1991;9:1591-1598.
81. Donaldson SS. Pediatric Hodgkin's disease—up, up, and beyond. *Int J Radiat Oncol Biol Phys* 2002;54:1-8.
82. Hudson MM. Pediatric Hodgkin's therapy: time for a paradigm shift. *J Clin Oncol* 2002;20:3755-3757.
83. Schwartz CL. Special issues in pediatric Hodgkin's disease. *Eur J Haematol* 2005;(Suppl):55-62.
84. Olson MR, Donaldson SS. Treatment of pediatric Hodgkin lymphoma. *Curr Treat Options Oncol* 2008;9(1):81-94.

85. Tebbi CK, Mendenhall N, London WB, et al. Treatment of stage I, IIA, IIIA(1) pediatric Hodgkin disease with doxorubicin, bleomycin, vincristine and etoposide (DBVE) and radiation: a Pediatric Oncology Group (POG) study. *Pediatr Blood Cancer* 2006;46:198-202.
86. Tebbi CK, Mendenhall NP, London WB, et al. Response-dependent and reduced treatment in lower risk Hodgkin lymphoma in children and adolescents, results of P9426: a report from the children's oncology group. *Pediatr Blood Cancer* 2012;59:1259-1265.
87. Tebbi CK, London WB, Friedman D, et al. Dexrazoxane-associated risk for acute myeloid leukemia/myelodysplastic syndrome and other secondary malignancies in pediatric Hodgkin's disease. *J Clin Oncol* 2007;25:493-500.
88. Hutchinson RJ, Fryer CJ, Davis PC, et al. MOPP or radiation in addition to ABVD in the treatment of pathologically staged advanced Hodgkin's disease in children: results of the children's cancer group phase III trial. *J Clin Oncol* 1998;16:897-906.
89. Weiner MA, Leventhal B, Brecher ML, et al. Randomized study of intensive MOPP-ABVD with or without low-dose total-nodal radiation therapy in the treatment of stages IIB, IIIA2, IIIB, and IV Hodgkin's disease in pediatric patients: a pediatric oncology group study. *J Clin Oncol* 1997;15:2769-2779.
90. Wolden SL, Chen L, Kelly KM, et al. Long-Term Results of CCG 5942: a randomized comparison of chemotherapy with and without radiotherapy for children with Hodgkin's lymphoma—a report from the children's oncology group. *J Clin Oncol* 2012;30:3174-3180.
91. Kelly KM, Sposto R, Hutchinson R et al. BEACOPP chemotherapy is a highly effective regimen in children and adolescents with high-risk Hodgkin lymphoma: a report from the Children's Oncology Group. *Blood* 2011;117: 2596-2603.
92. Donaldson SS, Link MP, Weinstein HJ, et al. Final results of a prospective clinical trial with VAMP and low-dose involved-field radiation for children with low-risk Hodgkin's disease. *J Clin Oncol* 2007;25:332-337.
93. Hudson MM, Krasin M, Link MP, et al. Risk-adapted, combined-modality therapy with VAMP/COP and response-based, involved-field radiation for unfavorable pediatric Hodgkin's disease. *J Clin Oncol* 2004;22:4541-4550.
94. Friedmann AM, Hudson MM, Weinstein HJ, et al. Treatment of unfavorable childhood Hodgkin's disease with VEPA and low-dose, involved-field radiation. *J Clin Oncol* 2002;20:3088-3094.
95. Horning SJ, Hoppe RT, Breslin S, et al. Stanford V and radiotherapy for locally extensive and advanced Hodgkin's disease: mature results of a prospective clinical trial. *J Clin Oncol* 2002;20:630-637.
96. Schellong G, Potter R, Bramswig J, et al. High cure rates and reduced long-term toxicity in pediatric Hodgkin's disease: the German-Austrian multicenter trial DAL-HD-90. The German-Austrian pediatric Hodgkin's disease study group. *J Clin Oncol* 1999;17:3736-3744.
97. Dorffel W, Luders H, Ruhl U, et al. Preliminary results of the multicenter trial GPOH-HD 95 for the treatment of Hodgkin's disease in children and adolescents: analysis and outlook. *Klin Padiatr* 2003;215:139-145.
98. Mauz-Korholz C, Hasenclever D, Dorffel W, et al. Procarbazine-free OEPA-COPDAC chemotherapy in boys and standard OPPA-COPP in girls have comparable effectiveness in pediatric Hodgkin's lymphoma: the GPOH-HD-2002 study. *J Clin Oncol* 2010;28:3680-3686.
99. Shankar A, Daw S. Nodular lymphocyte predominant Hodgkin lymphoma in children and adolescents—a comprehensive review of biology, clinical course and treatment options. *British J Hematol* 2012;1-11. doi:10.1111/bjh.12055.-
100. Sandoval C, Venkateswaran L, Billups C, et al. Lymphocyte-predominant Hodgkin disease in children. *J Pediatr Hematol Oncol* 2002;24:269-273.
101. Pellegrino B, Terrier-Lacombe MJ, Oberlin O, et al. Lymphocyte-predominant Hodgkin's lymphoma in children: therapeutic abstention after initial lymph node resection—a study of the French Society of Pediatric Oncology. *J Clin Oncol* 2003;21:2948-2952.
102. Murphy SB, Morgan ER, Katzenstein HM, et al. Results of little or no treatment for lymphocyte-predominant Hodgkin disease in children and adolescents. *J Pediatr Hematol Oncol* 2003;25:684-687.
103. Fanale MA, Lai C-M, McLaughlin P, et al. Outcomes of Nodular Lymphocyte Predominant Hodgkin's Lymphoma (NLPHL) patients treated with R-CHOP. *Blood (ASH Annual Meeting Abstracts)*2010;116:2812.

104. Shankar A, Hall GW, Gorde-Grosjean S, et al. Treatment outcome after low intensity chemotherapy [CVP] in children and adolescents with early stage nodular lymphocyte predominant Hodgkin's lymphoma—an Anglo-French collaborative report. *European J Cancer* 2012;48:1700-1706.
105. Tenezakis SA, Hudson MM, Constine LS. Hodgkins' disease, in Halperin EC, Constine LS, Tarbell NJ, et al., eds. *Pediatric radiation oncology*, 4th ed. Philadelphia, PA: Lippincott Williams & Wilkins, 2010:137-165.
106. Li J, Dabaja B, Reed V, et al. Rationale for and preliminary results of proton beam therapy for mediastinal lymphoma. *International J Radiat Oncol Biol Phys* 2011;81:167-174.
107. Wilson VC, McDonough J, Tochner Z. Proton beam irradiation in pediatric oncology: an overview. *J Pediatric Hematol/Oncol* 2005;27:444-448.
108. Haie-Meder C, Mlika-Cabanne N, Michel G, et al. Radiotherapy after ovarian transposition: ovarian function and fertility preservation. *Int J Radiat Oncol Biol Phys* 1993;25:419-424.
109. Pedrick TJ, Hoppe RT. Recovery of spermatogenesis following pelvic irradiation for Hodgkin's disease. *Int J Radiat Oncol Biol Phys* 1986;12:117-121.
110. Copeland A, Younes A. Current treatment strategies in Hodgkin lymphomas. *Current Opin Oncol* 2012;24:466-474.
111. Daw S, Wynn R, Wallace H. Management of relapsed and refractory classical Hodgkin lymphoma in children and adolescents. *Br J Haematol* 2011;152: 249-260.
112. Bonfante V, Viviani S, Devizzi L, et al. High-dose ifosfamide and vinorelbine as salvage therapy for relapsed or refractory Hodgkin's disease. *Eur J Haematol Supplementum* 2001:51-55.
113. Hertzberg MS, Crombie C, Benson W, et al. Outpatient-based ifosfamide, carboplatin and etoposide (ICE) chemotherapy in transplant-eligible patients with non-Hodgkin's lymphoma and Hodgkin's disease. *Ann Oncol* 2003;14(Suppl 1):i11-i16.
114. Cole PD, Schwartz CL, Drachtman RA, et al. Phase II study of weekly gemcitabine and vinorelbine for children with recurrent or refractory Hodgkin's disease: a children's oncology group report. *J Clin Oncol* 2009;27:1456-1461.
115. Suyani E, Sucak GT, Aki SZ, et al. Gemcitabine and vinorelbine combination is effective in both as a salvage and mobilization regimen in relapsed or refractory Hodgkin lymphoma prior to ASCT. *Ann Hematol* 2011;90:685-691.
116. Ozkaynak MF, Jayabose S. Gemcitabine and vinorelbine as a salvage regimen for relapse in Hodgkin lymphoma after autologous hematopoietic stem cell transplantation. *Ped Hematol/Oncol* 2004;21:107-113.
117. Chen JH, Chang PY, Yao NS. Gemcitabine plus vinorelbine as an effective salvage chemotherapeutic regimen in advanced Hodgkin lymphoma. *Hematol Oncol Stem Cell Ther* 2009;2:371-372.
118. Glossmann JP, Staak JO, Nogova L, et al. Autologous tandem transplantation in patients with primary progressive or relapsed/refractory lymphoma. *Ann Hematol* 2005;84:517-525.
119. Goda JS, Massey C, Kuruvilla J, et al. Role of salvage radiation therapy for patients with relapsed or refractory Hodgkin lymphoma who failed autologous stem cell transplant. *Internat J Radiat Biol Phys* 2012;84:e329-e335.
120. Colpo A, Hochberg E, Chen YB. Current status of autologous stem cell transplantation in relapsed and refractory Hodgkin's lymphoma. *Oncologist* 2012;17:80-90.
121. Harris RE, Termuhlen AM, Smith LM, et al. Autologous peripheral blood stem cell transplantation in children with refractory or relapsed lymphoma: results of children's oncology group study A5962. *Biol Blood and Marrow Transpl* 2011;17:249-258.
122. Smith SD, Moskowitz CH, Dean R, et al. Autologous stem cell transplant for early relapsed/refractory Hodgkin lymphoma: results from two transplant centres. *British J Haematol* 2011;153:358-363.
123. Lieskovsky YE, Donaldson SS, Torres MA, et al. High-dose therapy and autologous hematopoietic stem-cell transplantation for recurrent or refractory pediatric Hodgkin's disease: results and prognostic indices. *J Clin Oncol* 2004;22:4532-4540.
124. Moskowitz CH, Yahalom J, Zelenetz AD, et al. High-dose chemo-radiotherapy for relapsed or refractory Hodgkin lymphoma and the significance of pretransplant functional imaging. *British J Haematol* 2010;148:890-897.
125. Josting A, Muller H, Borchmann P, et al. Dose intensity of chemotherapy in patients with relapsed Hodgkin's lymphoma. *J Clin Oncol* 2010;28:5074-5080.

126. Josting A. Autologous transplantation in relapsed and refractory Hodgkin's disease. *Eur J Haematol* 2005;(Suppl):141-145.
127. Baker KS, Gordon BG, Gross TG, et al. Autologous hematopoietic stem-cell transplantation for relapsed or refractory Hodgkin's disease in children and adolescents. *J Clin Oncol* 1999;17:825-831.
128. Gorde-Grosjean S, Oberlin O, Leblanc T, et al. Outcome of children and adolescents with recurrent/refractory classical Hodgkin lymphoma, a study from the Societe Francaise de Lutte contre le Cancer des Enfants et des Adolescents (SFCE). *British J Haematol* 2012;158:649-656.
129. Claviez A, Canals C, Dierickx D, et al. Allogeneic hematopoietic stem cell transplantation in children and adolescents with recurrent and refractory Hodgkin lymphoma: an analysis of the European group for blood and marrow transplantation. *Blood* 2009;114:2060-2067.
- 130 Sureda A, Canals C, Arranz R, et al. Allogeneic stem cell transplantation after reduced intensity conditioning in patients with relapsed or refractory Hodgkin's lymphoma. Results of the HDR-ALLO study—a prospective clinical trial by the Grupo Espanol de Linfomas/Trasplante de Medula Osea (GEL/TAMO) and the lymphoma working party of the European group for blood and marrow transplantation. *Haematologica* 2012;97:310-317.
- P.2013
131. Holmberg L, Maloney DG. The role of autologous and allogeneic hematopoietic stem cell transplantation for Hodgkin lymphoma. *J Natl Comp Canc Network* 2011;9:1060-1071.
132. Anderlini P, Saliba RM, Ledesma C, et al. Gemcitabine, fludarabine and melphalan as a reduced-intensity conditioning regimen for allogeneic stem cell transplant in relapsed and refractory Hodgkin lymphoma: preliminary results. *Leuk Lymphoma* 2012;53:499-502.
133. Chen R, Palmer JM, Popplewell L, et al. Reduced intensity allogeneic hematopoietic cell transplantation can induce durable remission in heavily pretreated relapsed Hodgkin lymphoma. *Ann Hematol* 2011;90:803-808.
134. Peggs KS, Hunter A, Chopra R, et al. Clinical evidence of a graft-versus-Hodgkin's-lymphoma effect after reduced-intensity allogeneic transplantation. *Lancet* 2005;365:1934-1941.
135. Faulkner RD, Craddock C, Byrne JL, et al. BEAM-alemtuzumab reduced-intensity allogeneic stem cell transplantation for lymphoproliferative diseases: GVHD, toxicity, and survival in 65 patients. *Blood* 2004;103:428-434.
136. Younes A. Novel treatment strategies for patients with relapsed classical Hodgkin lymphoma. *Hematology* 2009;2009:507-519.
137. Senter PD, Sievers EL. The discovery and development of brentuximab vedotin for use in relapsed Hodgkin lymphoma and systemic anaplastic large cell lymphoma. *Nature Biotech* 2012;30:631-637.
138. Younes A, Gopal AK, Smith SE, et al. Results of a pivotal phase II study of brentuximab vedotin for patients with relapsed or refractory Hodgkin's lymphoma. *J Clin Oncol* 2012;30:2183-2189.
139. Rothe A, Sasse S, Goergen H, et al. Brentuximab vedotin for relapsed or refractory CD30+ hematologic malignancies: the German hodgkin study group experience. *Blood* 2012;120:1470-1472.
140. Forero-Torres A, Fanale M, Advani R, et al. Brentuximab vedotin in transplant-naive patients with relapsed or refractory hodgkin lymphoma: analysis of two phase I studies. *Oncologist* 2012;17:1073-1080.
141. Gopal AK, Ramchandren R, O'Connor OA, et al. Safety and efficacy of brentuximab vedotin for Hodgkin lymphoma recurring after allogeneic stem cell transplantation. *Blood* 2012;120:560-568.
142. de Claro RA, McGinn KM, Kwitkowski VE, et al. U.S. Food and Drug Administration Approval Summary: brentuximab vedotin for the treatment of relapsed hodgkin lymphoma or relapsed systemic anaplastic large cell lymphoma. *Clin Cancer Res* 2012;16:5845-5849.
143. Friedman DL, Constine LS. Late effects of treatment for Hodgkin lymphoma. *J Natl Comp Canc Network* 2006;4:249-257.
144. Castellino SM, Geiger AM, Mertens AC, et al. Morbidity and mortality in long-term survivors of Hodgkin lymphoma: a report from the childhood cancer survivor study. *Blood* 2011;117:1806-1816.

145. Constine LS, Tarbell N, Hudson MM et al. Subsequent malignancies in children treated for Hodgkin's disease: associations with gender and radiation dose. *Intl J Radiat Oncol Biol Phys* 2008;72:24-33.
146. O'Brien MM, Donaldson SS, Balise RR, Whittemore AS, Link MP, Second malignant neoplasms in survivors of pediatric Hodgkin's lymphoma treated with low-dose radiation and chemotherapy. *J Clin Oncol* 2010;28:1232-1239.
147. Friedman DL, Whitton J, Leisenring W, et al. Subsequent neoplasms in 5-year survivors of childhood cancer: the childhood cancer survivor study. *J Natl Canc Inst* 2010;102:1083-1095.
148. Bhatia S, Yasui Y, Robison LL et al. High risk of subsequent neoplasms continues with extended follow-up of childhood Hodgkin's disease: report from the late effects study group. *J Clin Oncol* 2003;21:4386-4394.
149. Inskip PD, Robison LL, Stovall M, et al. Radiation dose and breast cancer risk in the childhood cancer survivor study. *J Clin Oncol* 2009;27:3901-3907.
150. Sklar C, Whitton J, Mertens A, et al. Abnormalities of the thyroid in survivors of Hodgkin's disease: data from the childhood cancer survivor study. *J Clin Endocrinol and Metab* 2000;85:3227-3232.
151. Kovalchik SA, Ronckers CM, Veiga LH, et al. Absolute risk prediction of second primary thyroid cancer among 5-year survivors of childhood cancer. *J Clin Oncol* 2013;31:119-127.
152. Veiga LH, Lubin JH, Anderson H, et al. A pooled analysis of thyroid cancer incidence following radiotherapy for childhood cancer. *Radiat Res* 2012;178: 365-367.
153. Constine LS. Cured of Hodgkin lymphoma, but suffering a broken heart. *Leuk Lymphoma* 2008;49:1433-1435.
154. Schellong G, Riepenhausen M, Bruch C, et al. Late valvular and other cardiac diseases after different doses of mediastinal radiotherapy for Hodgkin disease in children and adolescents: report from the longitudinal GPOH follow-up project of the German-Austrian DAL-HD studies. *Pediatr Blood Cancer* 2010;55: 1145-1152.
155. van der Pal HJ, van Dalen EC, van Delden E, et al. High risk of symptomatic cardiac events in childhood cancer survivors. *J Clin Oncol* 2010;30: 1429-1437.
156. Sklar CA, Mertens AC, Mitby P, et al. Premature menopause in survivors of childhood cancer: a report from the childhood cancer survivor study. *J Natl Canc Inst* 2006;98:890-896.
157. Green DM, Kawashima T, Stovall M, et al. Fertility of male survivors of childhood cancer: a report from the childhood cancer survivor study. *J Clin Oncol* 2010;28:332-339.
158. Taylor A, Hawkins M, Griffiths A, et al. Long-term follow-up of survivors of childhood cancer in the UK. *Pediatr Blood Cancer* 2004;42:161-168.
159. Landier W, Bhatia S, Eshelman DA, et al. Development of risk-based guidelines for pediatric cancer survivors: the children's oncology group long-term follow-up guidelines from the children's oncology group late effects committee and nursing discipline. *J Clin Oncol* 2004;22:4979-4990.
160. Landier W, Wallace WH, Hudson MM. Long-term follow-up of pediatric cancer survivors: education, surveillance and screening. *Pediatr Blood Cancer* 2006;46:149-158.
161. Skinner R, Wallace WH, Levitt GA. Long-term follow-up of people who have survived cancer during childhood. *Lancet Oncology* 2008;7(6):489-498.
162. Shankar SM, Marina N, Hudson MM, et al. Monitoring for cardiovascular disease in survivors of childhood cancer: report from the cardiovascular disease task force of the children's oncology group. *Pediatrics* 2008;12:e387-e396.
163. Nunez SB, Mulrooney DA, Laverdiere C, Hudson MM. Risk-based health monitoring of childhood cancer survivors: a report from the Children's oncology group. *Current Oncol Rep* 2007;9:440-452.
164. Liles A, Blatt J, Morris D, et al. Monitoring pulmonary complications in long-term childhood cancer survivors: guidelines for the primary care physician. *Cleveland Clinic J Med* 2008;75:531-539.
165. Landier W, Armenian SH, Lee J, et al. Yield of screening for long-term complications using the Children's oncology group long-term follow-up guidelines. *J Clin Oncol* 2012;30:4401-4408.
166. Kenney LB, Bradeen H, Kadan-Lottick NS, Diller L, Homans A, Schwartz CL. The current status of follow-up services for childhood cancer survivors, are we meeting goals and expectations: a report from the consortium for New England childhood cancer survivors. *Pediatr Blood Cancer* 2011;56:1062-1066.

167. Kremer LC, Mulder RL, Oeffinger KC, et al. A world-wide collaboration to harmonize guidelines for the long-term follow-up of childhood and young adult cancer survivors: a report from the international late effects of childhood cancer guideline harmonization group. *Pediatr Blood Cancer* 2012. doi:10.1002/pbc.24445.

Section 5 - Plasma Cell Dyscrasias

Chapter 95 Practical Approach to Evaluation of Monoclonal Gammopathies

> Table of Contents > Part VII - Hematologic Malignancies > Section 5 - Plasma Cell Dyscrasias > Chapter 95 - Practical Approach to Evaluation of Monoclonal Gammopathies

Chapter 95

Practical Approach to Evaluation of Monoclonal Gammopathies

Francis K. Buadi

Joseph R. Mikhael

William G. Morice II

The real incidence of monoclonal gammopathy is unknown; however, it increases with age, with most cases being identified in the 7th or 8th decade of life.^{1, 2, 3} The presence of a monoclonal protein is indicative of an underlying clonal plasma cell or B cell disorder. These disorders encompass a spectrum of disease entities ranging from clinically benign monoclonal gammopathy of undetermined significance (MGUS) to clinically significant diseases such as multiple myeloma, and also including Waldenström macroglobulinemia, chronic lymphocytic leukemia, and various neurologic and cutaneous diseases.^{4, 5, 6, 7, 8, 9, 10, 11, 12} Among 43,000 monoclonal gammopathies evaluated at Mayo Clinic from 1960 to 2010 most had MGUS (57.5%), multiple myeloma (18%), or primary (AL) amyloidosis (9%) (Fig. 95.1). However, 4% of these cases were associated with other conditions, such as POEMS syndrome, cryoglobulinemia, Castleman's disease, and light chain deposition disease, which do require therapy and should not be missed during evaluation. A systematic approach to the patient with a monoclonal immunoglobulin (monoclonal protein) disorder is required, on the one hand to prevent unnecessary testing in the majority who will not need treatment for the underlying condition, and on the other hand to ensure that those with a clinically significant condition will be adequately diagnosed.

This chapter addresses the initial approach to an individual with a monoclonal protein or suspected immunoglobulin disorder. We review the various conditions to consider in a patient with a monoclonal protein, so as to help guide the evaluation. The basic principles on the use of the various tests used, their interpretation, and limitations are also reviewed. Subsequent chapters in this book will deal with the detailed evaluation of specific diseases associated with monoclonal gammopathy.

Monoclonal Gammopathies Mayo Clinic 1960-2010

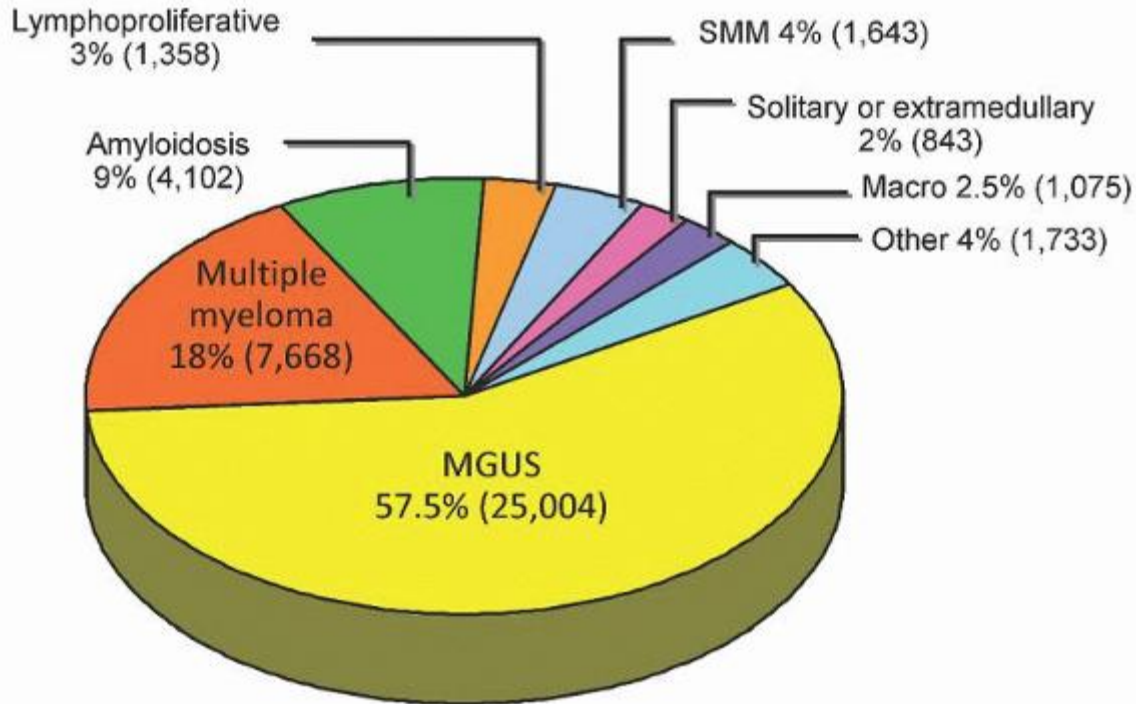

FIGURE 95.1. Distribution of monoclonal gammopathies seen at Mayo Clinic between 1960 and 2010. MGUS, monoclonal gammopathy of undetermined significance; SMM, smoldering multiple myeloma.

CLASSIFICATION OF MONOCLONAL IMMUNOGLOBULIN DISORDERS

A prior understanding of the various conditions associated with the production of monoclonal immunoglobulins (monoclonal protein) is essential in the evaluation of an individual with a monoclonal gammopathy. The clinical presentation may be due to the magnitude of the underlying tumor burden or the direct toxic effect of the monoclonal protein. However, a simple way of approaching the evaluation of these cases is to start with the type of monoclonal protein (Table 95.1). Although the various diseases can be broadly classified based on the type of monoclonal protein, there is overlap in the underlying conditions. For example, an IgM monoclonal protein is usually associated with lymphoproliferative diseases such as Waldenström macroglobulinemia and some lymphomas, but may also be associated with cases of IgM-associated multiple myeloma.¹³

Initial Evaluation

The usual test that will detect a monoclonal protein is not part of the typical healthy adult physical evaluation.¹⁴ It is therefore usually detected during the evaluation of a clinical symptom or during further evaluation of an abnormal routine blood test. Abnormalities in routine clinical tests that suggest the possibility of a monoclonal protein disorder include rouleau formation in a peripheral blood smear, elevated total serum protein, proteinuria, anemia, renal dysfunction, or hypercalcemia. Clinical situations that may require evaluation for

P.2015

a monoclonal protein include back pain, osteoporosis disproportionate to age, pathologic fracture, osteolytic or sclerotic bone lesions, recurrent sinopulmonary infections, progressive peripheral neuropathy, infiltrative or restrictive cardiomyopathy, and Raynaud's phenomenon. It must, however, be noted that in these conditions a monoclonal protein

may not always be detected by standard testing, and further evaluation may be needed to confirm or exclude an underlying plasma cell or lymphoproliferative disorder, particularly if the index of suspicion is high. Most patients with monoclonal protein are asymptomatic, especially those in whom a routine blood abnormality leads to further testing, resulting in the identification of a monoclonal protein. A simple algorithm taking into consideration the various tests available and clinical presentation is shown in Figure 95.2. Although there may be some overlap, following this algorithm should lead to the correct diagnosis in most cases.

TABLE 95.1 CLASSIFICATION OF MONOCLONAL PROTEINS

Clinical implication	Laboratory finding	
	Non-IgM monoclonal proteins	IgM monoclonal proteins
Premalignant or undetermined	IgG, IgA, light chain, and other MGUS	IgM MGUS other lymphoproliferations
Intermediate	SMM	Smoldering macroglobulinemia
Malignant	Active MM Plasma cell leukemia	Waldenström macroglobulinemia or other lymphoproliferative disorders

MGUS, monoclonal gammopathy of undetermined significance; MM, multiple myeloma; SMM, smoldering multiple myeloma.

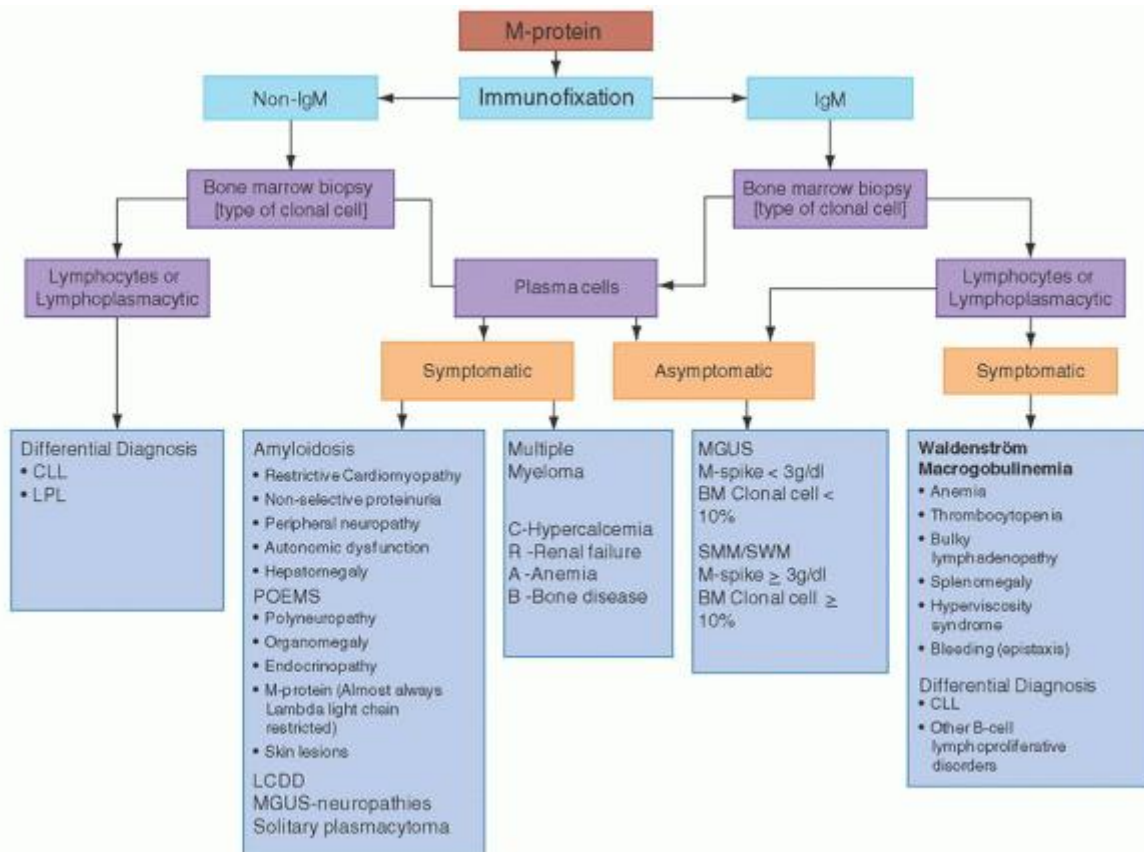

FIGURE 95.2. Simple diagnostic algorithm for patients with a monoclonal gammopathy. CLL, chronic lymphocytic leukemia; MGUS, monoclonal gammopathy of undetermined significance; SMM, smoldering multiple myeloma; SWM, Smoldering Waldenström macroglobulinemia; LCDD, light chain deposition disease; LDL, Lymphoplasmacytic lymphoma.

Laboratory Evaluation

The following are important tests that will help in the evaluation of a patient with or suspected to have a monoclonal protein.

PROTEIN ELECTROPHORESIS

Serum and urine should both be evaluated for the presence of a monoclonal protein. High-resolution agarose gel electrophoresis or capillary zone electrophoresis is the preferred method for screening for a monoclonal protein.^{15, 16, 17, 18, 19} These tests will separate serum or urine proteins into their various components in an electric field based primarily on their physical properties such as size and charge; the proteins are detected either by staining a solid matrix or by their electrical impedance as they exit the column. There are usually five components seen, albumin, α -1, and α -2, β -, and γ -globulin (Fig. 95.3).

Monoclonal proteins will usually migrate into the gamma regions; however, occasionally they may be seen in the β or α -2 region. Samples with a monoclonal protein usually will result in a spike in the gamma region (Fig. 95.4). This is referred to as the M-protein or M-spike with the "M" referring to monoclonal, not IgM. Further testing is then required to determine the type and quantity. All spikes should be evaluated, since in certain cases there may be two (biclonal gammopathy), or more, different monoclonal proteins in a single M-spike that should not be missed.^{20, 21, 22, 23} It must also be stressed that the gamma region contains all immunoglobulin isotypes (IgM, IgA, IgD, and IgE) and not only IgG. This same test can be used to determine the amount of monoclonal protein present using the densitometer tracing or peak size by capillary zone electrophoresis (Fig. 95.4). The measured M-protein by densitometry tracing is usually lower than the total involved immunoglobulin measured by nephelometry.¹⁶ Protein electrophoresis occasionally

P.2016

may fail to identify the presence of a monoclonal protein, especially in cases where there is only minimal production of the monoclonal protein, or minimal amounts of immunoglobulin free light chains.²⁴ Currently in such cases performing immunofixation despite a negative protein electrophoresis or using the serum free light chain analysis may be the only way to confirm the presence of an underlying clonal disorder, although tandem mass spectroscopy methods are currently being explored.^{21, 25, 26} A monoclonal protein spike should not be confused with a polyclonal increase in immunoglobulin, which usually will be seen as a broad-based band in the gamma region and is not associated with a clonal cell disorder²⁷ (Fig. 95.5).

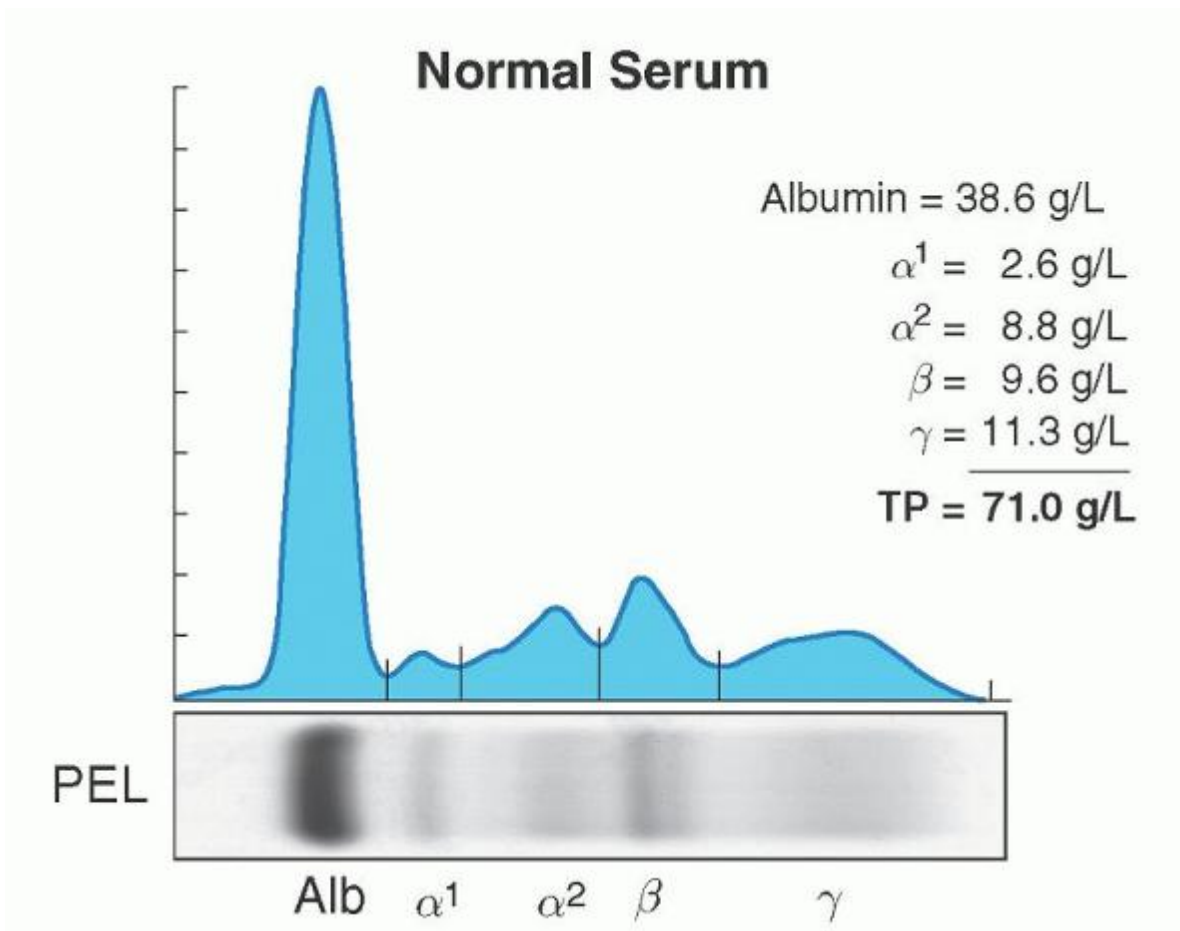

FIGURE 95.3. Images of a normal serum electrophoresis, showing the five protein components.

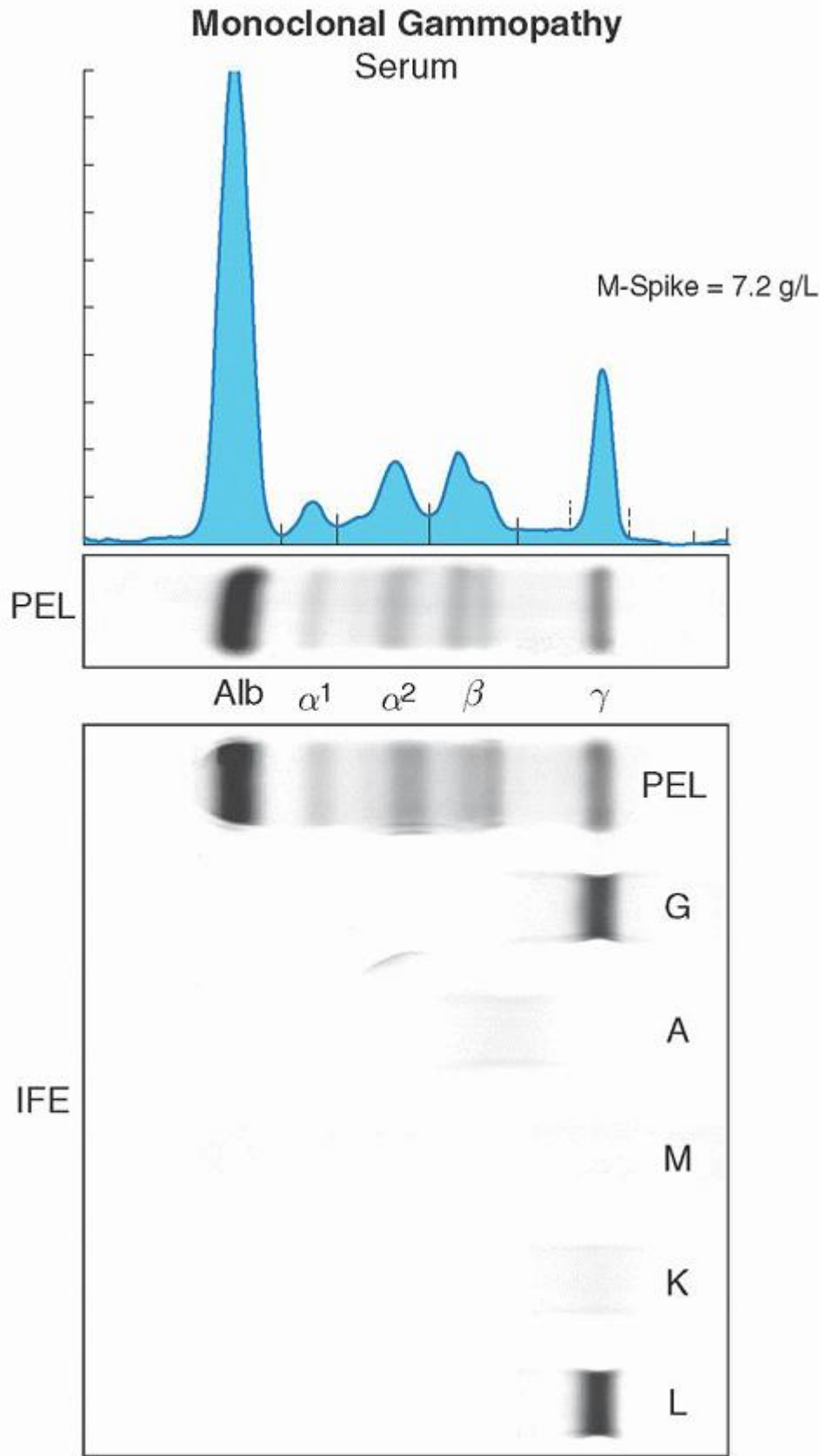

FIGURE 95.4. Images of a serum protein electrophoresis and immunofixation depicting a monoclonal protein.

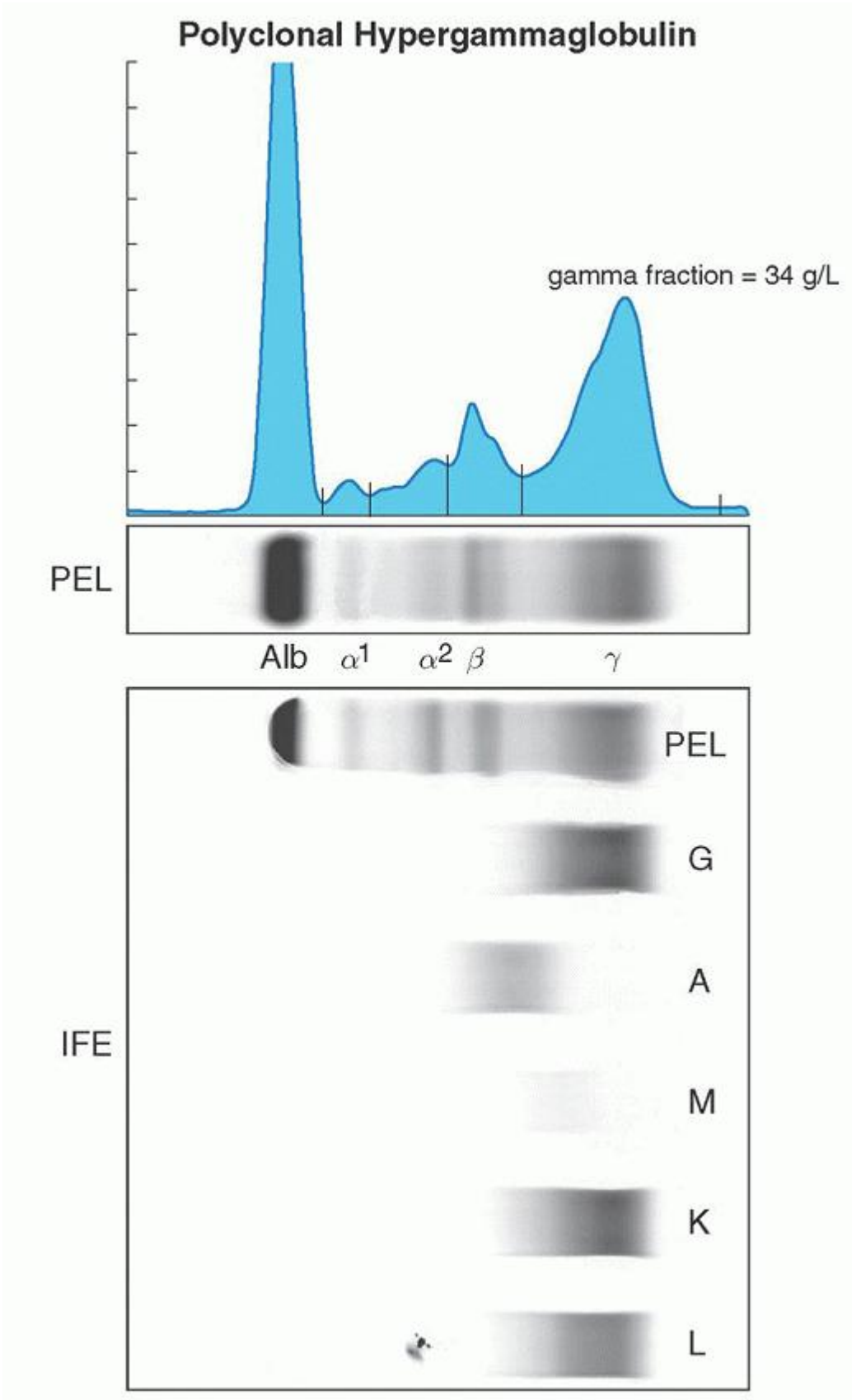

FIGURE 95.5. Images of a serum protein electrophoresis depicting a polyclonal gammopathy. IDENTIFICATION OF THE TYPE AND QUANTITATION OF THE MONOCLONAL PROTEIN

The heavy and light chain isotypes of a monoclonal protein is usually determined by immunoelectrophoresis or immunofixation.^{15, 16, 21} Immunoelectrophoresis, although less expensive, is infrequently used, as it is relatively insensitive. Immunofixation involves the application of anti-heavy and antilight chain antibodies to the electrophoretic gel and has higher detection sensitivity. Immunofixation will identify both the heavy chain isotype (IgG, IgM, IgA, IgD, or IgE) and the light chain type (κ or λ) and should always be performed on all cases of protein electrophoresis with an M-spike. A case with an IgG heavy chain isotype and a κ -light chain will be reported as an IgG- κ monoclonal protein (Fig. 95.6). Most laboratories will initially only perform immunofixation for IgG, IgA, and IgM. Immunofixation for IgD and IgE must be performed if an M-spike is present and either initial immunofixation studies are negative or detect only a monoclonal light chain (Fig. 95.7). The isotype and quantity of the monoclonal protein is important for classification and prognosis. For example in MGUS, the risk of progression is lower in patients with IgG isotype and an M-spike less than 0.5 g/dl. The type of protein and quantity is also important for monitoring patients during therapy. Immunofixation should still be performed in cases where there is a strong suspicion of the presence of a clonal plasma cell or

P.2017

lymphoproliferative disorder, even if the protein electrophoresis is negative for an M-spike. Capillary zone electrophoresis with immunosubtraction is an automated system that is slightly more sensitive than high-resolution agarose gel electrophoresis and can be used in the identification, subtyping, and measurement of the M-protein.^{17, 19} This method is laborious and time consuming, however, making it less frequently used for typing of the monoclonal protein.

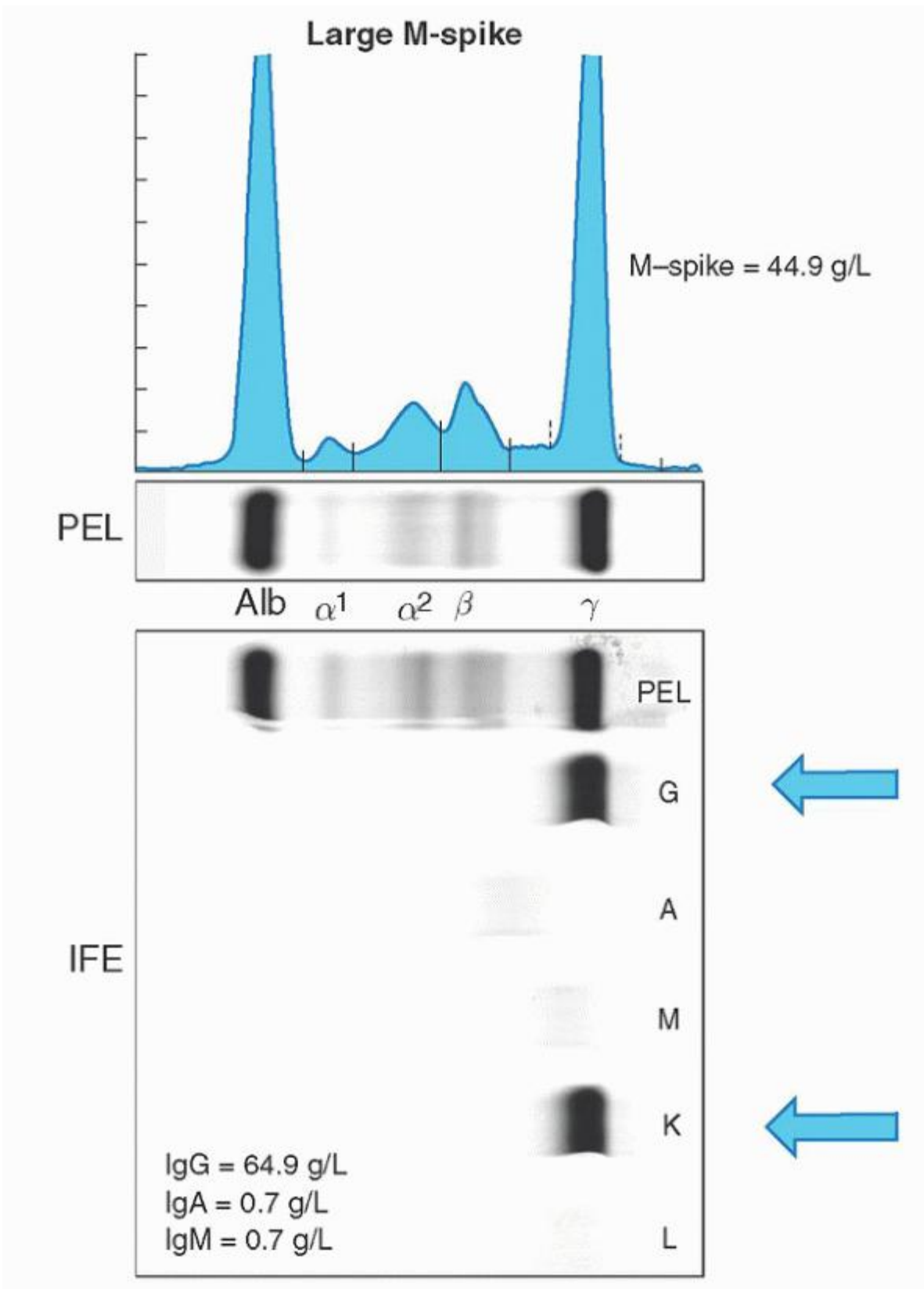

FIGURE 95.6. Protein electrophoresis and immunofixation studies characterize a monoclonal IgG- κ protein. The arrows indicate the lanes that show reactivity with the specific antibodies. The reactivity is consistent with the same migration shown in the extreme left column that shows the electrophoresis. Thus, in this assay the nature of the monoclonal protein seen in the electrophoresis is elucidated: isotype G and light chain- κ .

QUANTITATION OF IMMUNOGLOBULINS

Immunoglobulin (IgG, IgA, IgM) levels should always be measured at diagnosis and monitored regularly during therapy, especially the involved immunoglobulin. If immunofixation showed an IgD or IgE M-protein, then their levels should also be determined. In most clonal plasma cell disorders the levels of the uninvolved immunoglobulins are suppressed or reduced. Rate nephelometry is a reliable and rapid method for immunoglobulin quantification, although this method does not differentiate between monoclonal and polyclonal immunoglobulin.^{28, 29} Rate nephelometry also does not provide information on how much of the measure immunoglobulin is abnormal; therefore, in patients with normal total immunoglobulin it is not clinically helpful. This test does have value in clinical care however, as knowing the level in severely hypogammaglobulinemic states will help determine who should receive immunoglobulin replacement, especially those with recurrent sinopulmonary infections.

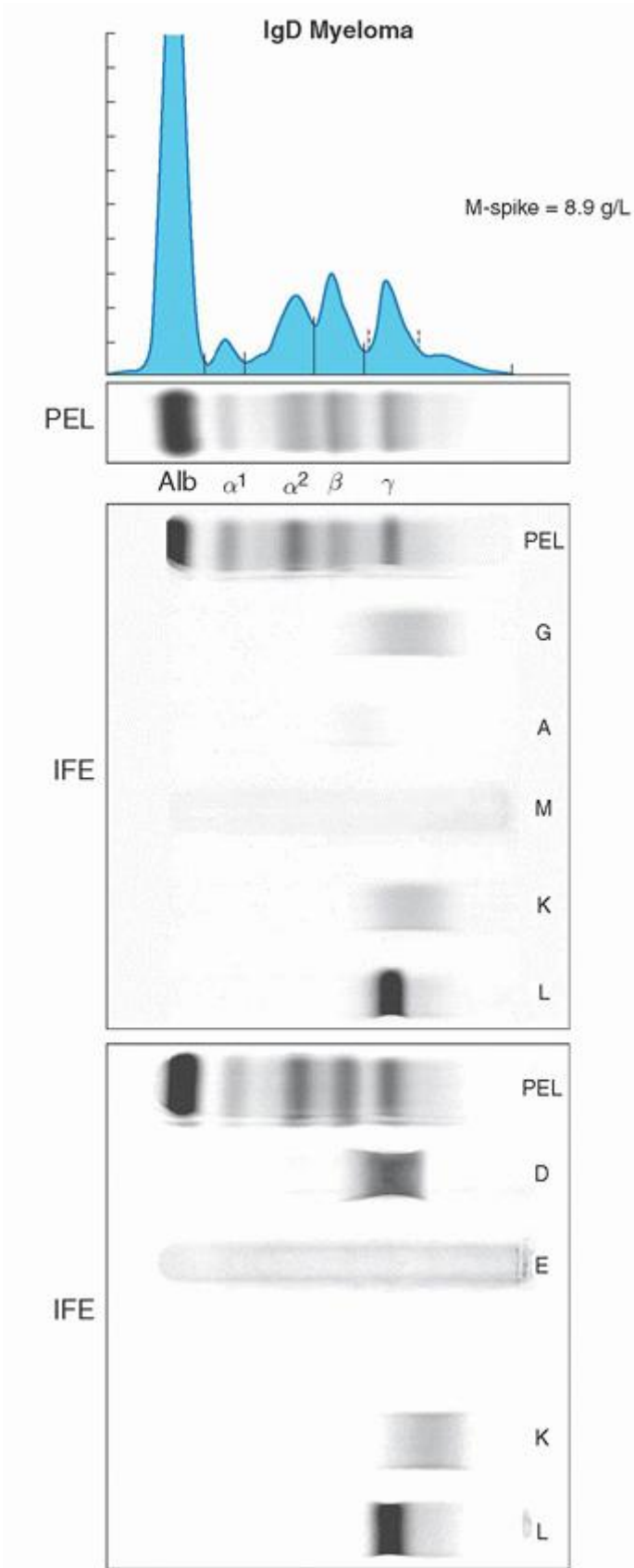

FIGURE 95.7. Images of a positive protein electrophoresis but initial negative immunofixation for IgG, IgA, or IgM isotype with further testing for IgD and IgE showing an IgD isotype with λ -light chain.

P.2018

FREE LIGHT CHAIN ASSAY

A significant population of patients with clonal plasma disorders produces excess amounts of light chain but not a full immunoglobulin molecule: Bence Jones proteinemia.³⁰ Most of these patients will have a negative protein electrophoresis and immunofixation. In these patients the free light chain assay test may be the only way to detect the presence of a clonal plasma cell disorder.^{24, 25, 26} Immunoglobulin free kappa (κ) and lambda (λ) light chains concentration in the serum is usually dependent on the rate of production from plasma cells and renal clearance. This results in a defined serum concentration and ratio. In clonal plasma cell disorders there is an excess production of only one of the light chain types, resulting in higher levels, with suppression of the uninvolved light chain, leading to an abnormal κ/λ ratio. The levels and ratio, however, may be affected by renal failure, since the light chains are cleared by the kidneys. This test has become very important in the evaluation and monitoring of patients with amyloidosis, since this is the major protein involved in AL-type amyloid deposits.³¹

URINE EVALUATION

In all patients with a serum M-protein or suspected to have a clonal plasma cell or lymphoplasmacytic disorder, a 24-hour urine collection should be examined for the presence of a monoclonal protein and 24-hour urine protein and monoclonal protein excretion. The excretion of immunoglobulin free light chain in the urine is referred to as Bence Jones proteinuria.³⁰ The pattern of protein excretion, whether the urine protein is solely albumin or Bence Jones protein, is of diagnostic importance. For example, nonselective proteinuria (albumin predominance) is associated with glomerular diseases such as AL amyloidosis caused by the presence of a monoclonal protein.^{12, 31}

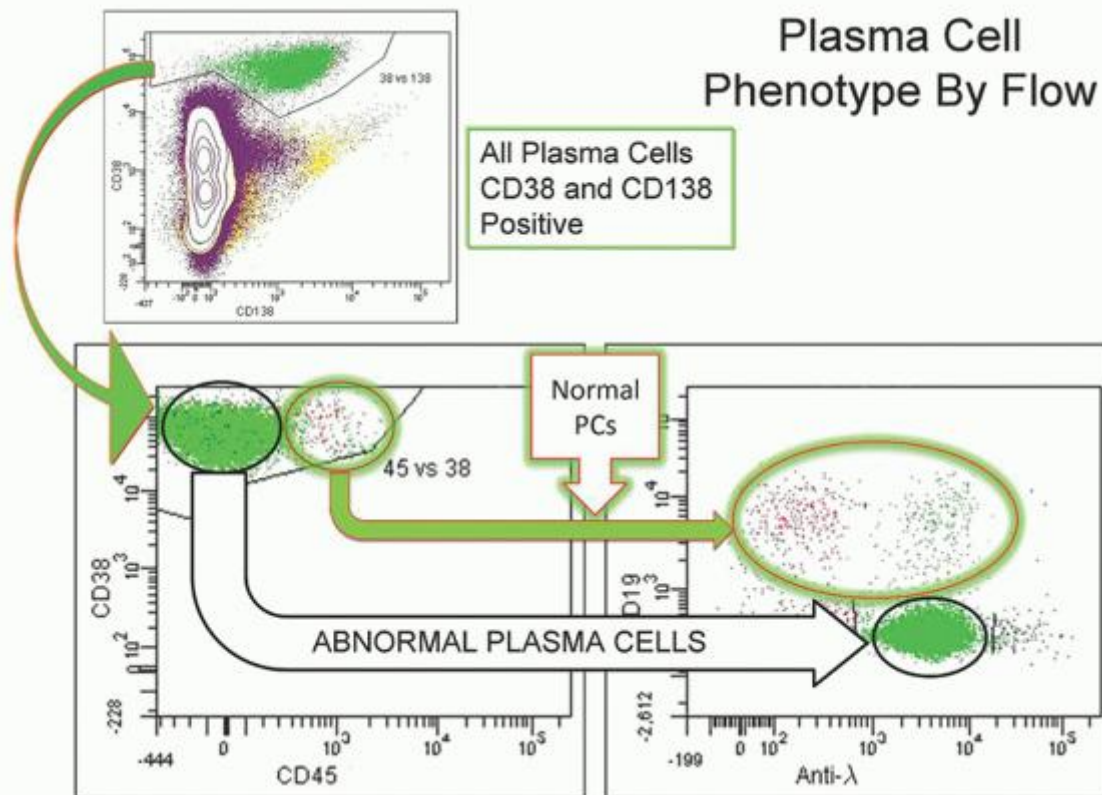

FIGURE 95.8. Identification of abnormal and normal plasma cells (PCs) by flow cytometry. All plasma cells are CD38 and CD138 positive. The abnormal plasma cells are CD19 and CD45 negative and λ -immunoglobulin light chain restricted.

Bone Marrow and Tissue Evaluation

Bone marrow aspiration and biopsy should be performed in all patients except in a selected group of completely asymptomatic patients with a very small monoclonal protein if a diagnosis of MGUS is favored.^{32, 33, 34} Even in the latter

setting, however, most hematologists will recommend this test, since apart from giving information on the type of clonal cell disorder, it also provides information on the extent of disease. For example, the presence of less than 10% marrow plasma cells distinguishes MGUS from smoldering multiple myeloma (SMM).¹⁰

Basic evaluation of the bone marrow sample should include extent of infiltration by the cells of interest, reported as a percentage of the total marrow nucleated cells and/or cellularity. Flow cytometric or immunophenotyping can confirm both the cell type (lymphoid vs. plasma cell) and clonality^{35, 36} (Fig. 95.8). Flow cytometry is particularly useful when following patients on therapy, as it is more sensitive in assessing the depth of response. Plasma cell DNA content can also be measured by flow cytometry, allowing measurement of ploidy status and proliferation rate, which, along with the proportion of normal plasma cells provides important prognostic information.³⁷ Plasma cell proliferation can also be measured by the labeling index (PCLI) which uses a BrdU pulse label and immunofluorescent detection.³⁸ However, it is not generally accessible and is not necessary in the majority of patients.

Metaphase cytogenetics and fluorescent in situ hybridization for specific gene targets should be obtained in a subset of cases, since these provide prognostic information in certain clonal cell disorders. For example, in multiple myeloma, cytogenetic abnormalities provide important prognostic information, and therefore this must be obtained in all suspected cases at the time of initial evaluation.^{39, 40, 41, 42} Gene expression profile analysis of the malignant plasma cells in multiple myeloma is of prognostic value and should be obtained if available.^{43, 44, 45}

P.2019

CONGO RED STAIN

In certain cases, a Congo red stain of subcutaneous fat aspirate or a bone marrow biopsy will have to be performed, looking for amyloid deposition.^{12, 46, 47} In about 70% of cases of AL amyloidosis Congo red staining of bone marrow or subcutaneous fat aspirate will be sufficient to make the diagnosis. The remaining cases will require biopsy of the involved organ. All patients with peripheral neuropathy, significant albuminuria, or infiltrative cardiomyopathy in the setting of a monoclonal protein should have this test done. It should also be considered in patients in whom there is a high clinical suspicion of amyloidosis. If this is positive, then liquid chromatography tandem mass spectrometry of peptide extracts from the congophilic material should then be done for subtyping of the amyloid deposits.⁴⁸

Imaging

The imaging required for the evaluation of a patient with monoclonal protein depends on the clinical syndrome and type of monoclonal protein. A metastatic skeletal survey should be performed in all patients with non-IgM monoclonal protein. In multiple myeloma this may show lytic bone lesions (Fig. 95.9). One should also look for vertebrae compression fractures, and osteoporosis or osteopenia. These radiologic studies should also be performed in IgM monoclonal gammopathies if there is a strong clinical suspicion of IgM myeloma. For all cases of suspect multiple myeloma, a skeletal survey is still considered the standard test for bone evaluation.^{49, 50, 51} More sensitive modalities such as magnetic resonance imaging or PET-CT may provide further information.^{52, 53, 54, 55} Magnetic resonance imaging is particularly useful for the assessment of the extent and nature of soft tissue disease arising from bone lesions, especially those in the spine which may cause neurologic compromise. PET-CT is usually helpful in the evaluation of plasmacytomas and cases of nonsecretory multiple myeloma^{56, 57, 58} (Fig. 95.10). In our experience, this modality has been helpful in the evaluation of patients with POEMS syndrome, by helping identify hypermetabolic osteosclerotic bone lesions. Computer tomography (CT) scanning of the chest, abdomen, and pelvis should be performed in cases of IgM gammopathy, since they are usually associated with lymphoproliferative disorders which may involve the lymph nodes, spleen, and mucosa-associated lymphoid tissues.



FIGURE 95.9. Skeletal bone survey showing lytic lesions typically seen in multiple myeloma.

History and Physical Evaluation

A detailed history and physical examination should be obtained any time a monoclonal protein is identified. Certain signs and symptoms may help guide the evaluation and ultimately indicate the appropriate diagnosis. For instance, patients presenting with bone pain, pathologic fractures, weight loss, and symptoms of hypercalcemia or acute renal failure are more likely to have multiple myeloma.⁹ Alternatively, those with night sweats, epistaxis,

P.2020

and lymphadenopathy are more likely to have lymphoproliferative disorders such as Waldenström macroglobulinemia, marginal zone lymphoma, or chronic lymphocytic leukemia/small lymphocytic lymphoma.^{8, 35, 59, 60, 61}

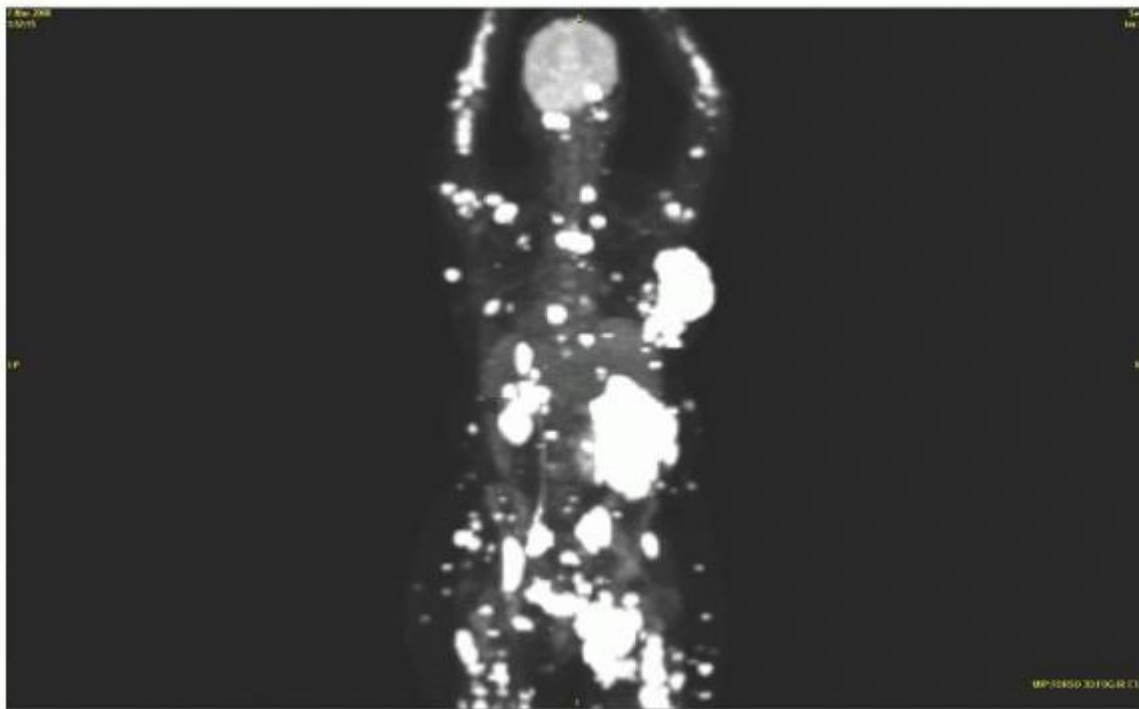

FIGURE 95.10. PET-CT scan showing multiple soft tissue plasmacytomas in a patient with negative marrow biopsy.

Other less common conditions may also be revealed by patient assessment. A diagnosis of amyloidosis may be indicated by the presence of edema, shortness of breath, hepatomegaly, peripheral neuropathy (e.g., carpal tunnel syndrome), autonomic dysfunction, periorbital purpura, and macroglossia.^{12, 31, 47} Skin rash, neuropathy, and Raynaud's phenomenon should prompt evaluation for cryoglobulinemia.^{5, 62} Those presenting with polyneuropathy, multiple endocrinopathy, skin lesions like glomeruloid hemangiomas, and organomegaly may have POEMS syndrome.¹¹ Importantly, one should never overlook the initial reason that led to the identification of the monoclonal protein. Most patients in whom a monoclonal protein is identified are asymptomatic. For these patients, the key to a correct diagnosis may be the reason for the initial testing for the monoclonal protein. In a case where a mildly elevated serum creatinine was the key factor, a nephrology evaluation with possible kidney biopsy may be the only way to diagnose immunoglobulin deposition disease of the kidney.^{6, 63, 64}

Monoclonal gammopathies are common in the elderly, who are also at risk for other pathologic conditions and are usually on multiple medications with their side effects. Therefore it is necessary to always confirm that the identified abnormality is due to the clonal cell disorder or monoclonal protein rather than to another unrelated pathologic condition. For example, mild hypercalcemia in association with a monoclonal protein may be due to parathyroid disease or medication in a patient with benign MGUS rather than myeloma. Renal failure or proteinuria in a hypertensive or diabetic patient with monoclonal protein should be investigated thoroughly before attributing it to the monoclonal protein. Such cases may require a kidney biopsy.

Diagnostic Algorithm (Fig. 95.2)

In a patient suspected of having an underlying gammopathy, one should first define the isotype and then quantity of the monoclonal protein. This will certainly help in identifying and defining the underlying clonal cell disorder. In the majority of cases, appropriate tissue biopsy and histopathologic evaluation should aid in providing a definitive diagnosis. Bone marrow biopsy is usually requisite. In certain situations, directed biopsy of a single bone lesion, lymph node, or soft tissue mass may also be needed. Tissue diagnosis can also be helpful in deciding therapeutic intervention; for example, the use of rituximab for the treatment of an IgM MGUS associated neuropathy can be indicated by finding an underlying CD20-positive lymphoproliferative disorder. Once the type of monoclonal protein and underlying clonal cell disorder has been established, the physician then needs to look into the patients' history, physical examination, and laboratory data to determine whether this clonal disorder is having any systematic effect. The typical issues are usually with the hematopoietic (anemia, thrombocytopenia, bulky lymphadenopathy), skeletal (lytic lesion, pathologic fracture, and sclerotic lesions), renal (cast nephropathy, immunoglobulin deposition disease, and nephrotic range proteinuria), nervous

system (peripheral neuropathy, autonomic dysfunction), cardiovascular (restrictive cardiomyopathy), and/or the endocrine systems. There may be overlap of symptoms, but understanding the various syndromes is important in helping to arrive at the correct diagnosis.

Differential Diagnosis of Monoclonal Gammopathy (Table 95.2)

The majority of non-IgM monoclonal gammopathies are initially classified as MGUS.¹⁰ In most MGUS patients the M-protein is a complete immunoglobulin molecule; however, some may have only light chain and therefore are classified as light chain MGUS.² MGUS patients do not have any symptoms or laboratory abnormalities attributable to the underlying clonal plasma cell disorder; specifically, they do not have anemia, hypercalcemia, renal insufficiency, or disease-associated bone disease. They should have less than 3 g/dl of monoclonal protein and less than 10% bone marrow plasma cell. Patients with similarly minimal clinical sequelae and an M-protein ≥ 3 gm/dl or $\geq 10\%$ clonal bone marrow plasma P.2021

cell are classified as having SMM.⁶⁵ Distinguishing between MGUS and SMM has prognostic significance and will determine frequency of follow-up. As bone marrow examination may be the only factor that will upgrade an MGUS to SMM, this must be strongly considered in the evaluation of all monoclonal gammopathies. Neither MGUS nor SMM require therapeutic intervention; patients with MGUS have a lower risk of progression to MM at about 1% per year, compared to 10% to 20% in patients with SMM. Closer follow-up is needed for SMM compared to MGUS.¹⁰

TABLE 95.2 DIFFERENTIAL DIGNOSIS OF MONOCLONAL GAMMOPATHIES

IgM type

IgM MGUS (may also be biclonal)

Smoldering Waldenström macroglobulinemia

Waldenström macroglobulinemia

Other (including lymphoma and IgM MM)

Non-IgM type

Non-IgM MGUS (may also be biclonal)

SMM

MM

Plasma cell leukemia

Solitary plasmacytoma

Amyloidosis complicating a B cell neoplasm (AL)

Miscellaneous monoclonal gammopathy-associated conditions

Osteosclerotic MM with peripheral neuropathy

POEMS syndrome

Cryoglobulinemia

Peripheral neuropathy associated with MGUS

SLONM

Fanconi's syndrome

Light or heavy chain deposition disease

Castleman's disease

Scleromyxedema

Necrobiotic xanthogranuloma

Systemic capillary leak syndrome

Angioimmunoblastic lymphadenopathy with monoclonal protein

Other

MGUS, monoclonal gammopathy of undetermined significance; MM, multiple myeloma; SLONM, sporadic late onset nemaline myopathy SMM, smoldering multiple myeloma.

Patients with myeloma should meet the CRAB criteria, defined as hypercalcemia, renal insufficiency, anemia, or bone disease.⁶⁶ It is necessary to confirm that these complications are due to the underlying clonal plasma cell disorder. These patients do require therapy and should be under the care of a specialist with detailed knowledge of the management of multiple myeloma and associated complications. Solitary plasmacytomas should also be recognized, since these require only limited therapy.⁵⁶ These patients have a single bone or soft tissue mass, a negative bone marrow biopsy, and do not meet the CRAB criteria. Local therapy such as radiation, cryotherapy, or surgical excision is usually all that is required.⁶⁷ They do have a better prognosis.

A significant number of patients with monoclonal gammopathy develop complications as a result of the toxic effect of the monoclonal protein. In amyloidosis, misfolding of the monoclonal protein, usually the light chain component, results in the formation of insoluble amyloid deposits in major organs of the body.^{12, 31, 47} This deposition results in structural and physiologic dysfunction of the affected organ. An amyloid diagnosis is easy to make when presenting with macroglossia in association with periorbital purpura.⁶⁸ Most, however, will present with symptoms secondary to the organ involvement, such as chest pain and shortness of breath due to restrictive cardiomyopathy in cardiac cases, and peripheral neuropathy and autonomic dysfunction in nervous system disease. Nonselective proteinuria with hypoalbuminemia is seen in kidney involvement. Hepatomegaly with elevated alkaline phosphates will be seen in those with liver disease, and those with gastrointestinal involvement will have constipation or diarrhea. Patients may present with multiple organ involvement, causing a protean constellation of findings; in such cases a strong suspicion of amyloidosis is required in order not to miss the diagnosis.

Nonamyloidotic immunoglobulin deposition diseases such as light chain deposition diseases are a group of conditions that should be considered during the evaluation of monoclonal gammopathy.⁶⁹ This involves the deposition of light chains in the kidney or heart. Renal involvement presenting with renal failure with some proteinuria is the most common.⁶⁴ Heart involvement, although not common, does occur, presenting with restrictive cardiomyopathy, and should be differentiated from amyloidosis.⁷⁰

IgM monoclonal gammopathy is usually associated with an underlying B cell lymphoproliferative disorder, and true IgM myeloma is exceedingly rare.¹³ A large percentage of these IgM monoclonal gammopathy patients will have an IgM MGUS or Waldenström macroglobulinemia.^{59, 71} The remainder often has a variety of other B cell lymphoproliferative diseases such as chronic lymphocytic leukemia, marginal zone lymphoma, and large cell lymphoma.⁸ Those with Waldenström macroglobulinemia may present with cytopenias, hyperviscosity syndrome, epistaxis, lymphadenopathy, and splenomegaly.^{35, 61, 72}

There are other rare monoclonal gammopathy associated conditions that should be considered during the evaluation of a monoclonal protein. The evaluation in these cases is usually dictated by the clinical presentation; for example, those with neuromuscular complications should be evaluated for conditions such as POEMS syndrome, the antimyelin associated glycoprotein-associated neuropathy, or sporadic late onset nemaline myopathy.^{11, 73, 74} POEMS patients, in addition to the neuropathy, do have organomegaly (lymphadenopathy, splenomegaly, cardiomegaly, and hepatomegaly), multiple endocrine dysfunction, and skin changes (glomeruloid hemangiomas, hyperpigmentation). Almost all POEMS patients do have a λ -light chain restricted monoclonal protein, and it may be a non-IgM or IgM monoclonal protein. If a patient has a κ -light chain monoclonal protein, they most probably do not have POEMS syndrome.

Skin conditions such as scleromyxedema, necrobiotic xanthogranuloma, and cryoglobulinemia should be considered in the differential diagnosis when patients present with cutaneous lesions.^{7, 62, 75, 76, 77, 78}

Summary and Recommendations

The diagnostic approach to monoclonal gammopathy should be thorough and involve a detailed history, physical examination, appropriate laboratory testing, and imaging. This should distinguish benign from clinically relevant conditions that need immediate intervention. A good understanding of conditions associated with monoclonal gammopathy is essential. Testing and evaluation should include the following considerations.

- Serum and urine protein electrophoresis, followed by immunofixation will confirm the presence of the monoclonal protein, identify and classify the isotype, and provide an estimation of the amount. Immunoglobulin free light assay will help identify cases with only free light chain production, but negative protein electrophoresis.
- Immunoglobulin isotype quantification is helpful for monitoring.
- A bone marrow evaluation will determine the nature of the underlying B-lineage disorder (plasma cell or lymphoproliferative) and also the extent of marrow infiltration.
- Complete blood count analysis will identify cytopenias which may be due to bone marrow replacement or immune mediated causes.
- Comprehensive metabolic panel, looking at serum calcium, creatinine, bilirubin, lactate dehydrogenase, and liver transaminases is essential.
- Bone and soft tissue imaging, looking for bony lesion and soft tissue masses such as lymphadenopathy or plasmacytoma is also needed.
- A detailed history and physical evaluation should help direct further testing.

REFERENCES

1. Boccadoro M, Pileri A. Plasma cell dyscrasias: classification, clinical and laboratory characteristics, and differential diagnosis. *Baillieres Clin Haematol* 1995;8:705-719.
2. Dispenzieri A, Katzmann JA, Kyle RA, et al. Prevalence and risk of progression of light-chain monoclonal gammopathy of undetermined significance: a retrospective population-based cohort study. *Lancet* 2010;375: 1721-1728.
3. Kyle RA, Therneau TM, Rajkumar SV, et al. Prevalence of monoclonal gammopathy of undetermined significance. *N Engl J Med* 2006;354:1362-1369.
4. Wood AJ, Wagner MV, Abbott JJ, et al. Necrobiotic xanthogranuloma: a review of 17 cases with emphasis on clinical and pathologic correlation. *Arch Dermatol* 2009;145:279-284.
5. Winfield JB. Cryoglobulinemia. *Hum Pathol* 1983;14:350-354.
6. Sethi S, Fervenza FC. Membranoproliferative glomerulonephritis—a new look at an old entity. *N Engl J Med* 2012;366:1119-1131.
7. Pomann JJ, Rudner EJ. Scleromyxedema revisited. *Int J Dermatol* 2003;42: 31-35.
8. Pangalis GA, Angelopoulou MK, Vassilakopoulos TP, et al. B-chronic lymphocytic leukemia, small lymphocytic lymphoma, and lymphoplasmacytic lymphoma, including Waldenstrom's macroglobulinemia: a clinical, morphologic, and biologic spectrum of similar disorders. *Semin Hematol* 1999;36: 104-114.
9. Kyle RA, Rajkumar SV. Multiple myeloma. *N Engl J Med* 2004;351:1860-1873.
10. Kyle RA, Buadi F, Rajkumar SV. Management of monoclonal gammopathy of undetermined significance (MGUS) and smoldering multiple myeloma (SMM). *Oncology (Williston Park)* 2011;25:578-586.
11. Dispenzieri A. POEMS syndrome: update on diagnosis, risk-stratification, and management. *Am J Hematol* 2012;87:804-814.
12. Kyle RA, Linos A, Beard CM, et al. Incidence and natural history of primary systemic amyloidosis in Olmsted County, Minnesota, 1950 through 1989. *Blood* 1992;79:1817-1822.
13. Schuster SR, Rajkumar SV, Dispenzieri A, et al. IgM multiple myeloma: disease definition, prognosis, and differentiation from Waldenstrom's macroglobulinemia. *Am J Hematol* 2010;85:853-855.
14. USPSTF recommendations. In: U.S. preventive services task force; 2012.
15. Katzmann JA, Kyle RA, Benson J, et al. Screening panels for detection of monoclonal gammopathies. *Clin Chem* 2009;55:1517-1522.
16. Katzmann JA, Clark R, Wiegert E, et al. Identification of monoclonal proteins in serum: a quantitative comparison of acetate, agarose gel, and capillary electrophoresis. *Electrophoresis* 1997;18:1775-1780.
17. Jenkins MA, Guerin MD. Capillary electrophoresis procedures for serum protein analysis: comparison with established techniques. *J Chromatogr B Biomed Sci Appl* 1997;699:257-268.

18. Henskens Y, de Winter J, Pekelharing M, et al. Detection and identification of monoclonal gammopathies by capillary electrophoresis. *Clin Chem* 1998;44:1184-1190.
19. Bienvenu J, Graziani MS, Arpin F, et al. Multicenter evaluation of the Paragon CZE 2000 capillary zone electrophoresis system for serum protein electrophoresis and monoclonal component typing. *Clin Chem* 1998;44:599-605.
20. Grosbois B, Jegou P, de Rosa H, et al. Triclonal gammopathy and malignant immunoproliferative syndrome. *Rev Med Interne* 1997;18:470-473.
21. Kyle RA, Greipp PR. 3. The laboratory investigation of monoclonal gammopathies. *Mayo Clin Proc* 1978;53:719-739.
22. D'Angelo G, Crovetto G, Grizzetti N, et al. Biclonal component in lymphoplasmacytic/lymphoplasmacytoid non-Hodgkin lymphoma. *Recenti Prog Med* 1994;85:104-107.
23. Kyle RA, Robinson RA, Katzmann JA. The clinical aspects of biclonal gammopathies. Review of 57 cases. *Am J Med* 1981;71:999-1008.
24. Drayson M, Tang LX, Drew R, et al. Serum free light-chain measurements for identifying and monitoring patients with nonsecretory multiple myeloma. *Blood* 2001;97:2900-2902.
25. Katzmann JA, Abraham RS, Dispenzieri A, et al. Diagnostic performance of quantitative kappa and lambda free light chain assays in clinical practice. *Clin Chem* 2005;51:878-881.
26. Bradwell AR, Carr-Smith HD, Mead GP, et al. Highly sensitive, automated immunoassay for immunoglobulin free light chains in serum and urine. *Clin Chem* 2001;47:673-680.
27. Dispenzieri A, Gertz MA, Therneau TM, et al. Retrospective cohort study of 148 patients with polyclonal gammopathy. *Mayo Clin Proc* 2001;76:476-487.
28. Cloppet H, Francina A, Coquelin H, et al. Laser nephelometry and radial immunodiffusion compared for immunoglobulin quantification in pathological sera. *Clin Chem* 1982;28:180-182.
29. Riches PG, Sheldon J, Smith AM, et al. Overestimation of monoclonal immunoglobulin by immunochemical methods. *Ann Clin Biochem* 1991;28(Pt 3): 253-259.
30. Pascali E, Pezzoli A. The clinical spectrum of pure Bence Jones proteinuria. A study of 66 patients. *Cancer* 1988;62:2408-2415.
31. Gertz MA, Rajkumar SV. Primary systemic amyloidosis. *Current treatment options in oncology* 2002;3:261-271.
32. Bartl R, Frisch B, Burkhardt R, et al. Bone marrow histology in myeloma: its importance in diagnosis, prognosis, classification and staging. *Br J Haematol* 1982;51:361-375.
33. Rajkumar SV, Harousseau JL, Durie B, et al. Consensus recommendations for the uniform reporting of clinical trials: report of the International Myeloma Workshop Consensus Panel 1. *Blood* 2011;117:4691-4695.
34. Waldron J, Jazieh R, Jagannath S, et al. Bone marrow morphology (BMM) adds critical prognostic information to other standard parameters (SP) including cytogenetics among newly diagnosed multiple myeloma (MM) patients (PTS) receiving total therapy (TT). *Blood* 1997;90(Suppl 1):90a.
35. Ansell SM, Kyle RA, Reeder CB, et al. Diagnosis and management of Waldenstrom macroglobulinemia: Mayo stratification of macroglobulinemia and risk-adapted therapy (mSMART) guidelines. *Mayo Clin Proc* 2010;85:824-833.
36. Lin P, Owens R, Tricot G, et al. Flow cytometric immunophenotypic analysis of 306 cases of multiple myeloma. *Am J Clin Pathol* 2004;121:482-488.
37. Paiva B, Vidriales MB, Mateo G, et al. The persistence of immunophenotypically normal residual bone marrow plasma cells at diagnosis identifies a good prognostic subgroup of symptomatic multiple myeloma patients. *Blood* 2009;114:4369-4372.
38. Steensma DP, Gertz MA, Greipp PR, et al. A high bone marrow plasma cell labeling index in stable plateau-phase multiple myeloma is a marker for early disease progression and death. *Blood* 2001;97:2522-2523.
39. Avet-Loiseau H. Role of genetics in prognostication in myeloma. *Best Pract Res Clin Haematol* 2007;20:625-635.
40. Dewald GW, Kyle RA, Hicks GA, et al. The clinical significance of cytogenetic studies in 100 patients with multiple myeloma, plasma cell leukemia, or amyloidosis. *Blood* 1985;66:380-390.

41. Fonseca R, Blood E, Rue M, et al. Clinical and biologic implications of recurrent genomic aberrations in myeloma. *Blood* 2003;101:4569-4575.
42. Kumar S, Fonseca R, Ketterling RP, et al. Trisomies in multiple myeloma: impact on survival in patients with high-risk cytogenetics. *Blood* 2012;119:2100-2105.
43. Nair B, Shaughnessy JD Jr, Zhou Y, et al. Gene expression profiling of plasma cells at myeloma relapse from tandem transplantation trial Total Therapy 2 predicts subsequent survival. *Blood* 2009;113:6572-6575.
44. Shaughnessy J Jr, Zhan F, Barlogie B, et al. Gene expression profiling and multiple myeloma. *Best Pract Res Clin Haematol* 2005;18:537-552.
45. Waheed S, Shaughnessy JD, van Rhee F, et al. International staging system and metaphase cytogenetic abnormalities in the era of gene expression profiling data in multiple myeloma treated with total therapy 2 and 3 protocols. *Cancer* 2011;117:1001-1009.
46. Olsen KE, Sletten K, Westermark P. The use of subcutaneous fat tissue for amyloid typing by enzyme-linked immunosorbent assay. *Am J Clin Pathol* 1999;111:355-362.
47. Magy-Bertrand N, Dupond JL, Mauny F, et al. Incidence of amyloidosis over 3 years: the AMYPRO study. *Clin Exp Rheumatol* 2008;26:1074-1078.
48. Klein CJ, Vrana JA, Theis JD, et al. Mass spectrometric-based proteomic analysis of amyloid neuropathy type in nerve tissue. *Arch Neurol* 2011;68:195-199.
49. Dimopoulos MA, Moulopoulos LA, Datsers I, et al. Imaging of myeloma bone disease—implications for staging, prognosis and follow-up. *Acta Oncol* 2000;39:823-827.
50. Roodman GD. Skeletal imaging and management of bone disease. *Hematology Am Soc Hematol Educ Program* 2008:313-319.
51. Scutellari PN, Orzincolo C. Bone disease in multiple myeloma. Analysis of 253 controlled cases, with reappraisal of diagnostic criteria and current imaging techniques. *Radiol Med* 1993;85:235-246.
52. Zamagni E, Nanni C, Patriarca F, et al. A prospective comparison of 18F-fluorodeoxyglucose positron emission tomography-computed tomography, magnetic resonance imaging and whole-body planar radiographs in the assessment of bone disease in newly diagnosed multiple myeloma. *Haematologica* 2007;92:50-55.
53. Durie BG, Waxman AD, D'Agnolo A, et al. Whole-body (18)F-FDG PET identifies high-risk myeloma. *J Nucl Med* 2002;43:1457-1463.
54. Baur-Melnyk A, Buhmann S, Durr HR, et al. Role of MRI for the diagnosis and prognosis of multiple myeloma. *Eur J Radiol* 2005;55:56-63.
55. Bartel TB, Haessler J, Brown TL, et al. F18-fluorodeoxyglucose positron emission tomography in the context of other imaging techniques and prognostic factors in multiple myeloma. *Blood* 2009;114:2068-2076.
56. Dagan R, Morris CG, Kirwan J, et al. Solitary plasmacytoma. *Am J Clin Oncol* 2009;32:612-617.
57. Salaun PY, Gastinne T, Frampas E, et al. FDG-positron-emission tomography for staging and therapeutic assessment in patients with plasmacytoma. *Haematologica* 2008;93:1269-1271.
58. Schirrmeister H, Buck AK, Bergmann L, et al. Positron emission tomography (PET) for staging of solitary plasmacytoma. *Cancer Biother Radiopharm* 2003;18:841-845.
59. Owen RG, Treon SP, Al-Katib A, et al. Clinicopathological definition of Waldenstrom's macroglobulinemia: consensus panel recommendations from the Second International Workshop on Waldenstrom's Macroglobulinemia. *Semin Oncol* 2003;30:110-115.
60. Gertz MA. Waldenstrom macroglobulinemia. *Hematology* 2012;17(Suppl 1): S112-S116.
61. Dimopoulos MA, Panayiotidis P, Moulopoulos LA, et al. Waldenstrom's macroglobulinemia: clinical features, complications, and management. *J Clin Oncol* 2000;18:214-226.
62. Cuellar ML, Garcia C, Molina JF. Cryoglobulinemia and other dysproteinemias, familial Mediterranean fever, and POEMS syndrome. *Curr Opin Rheumatol* 1995;7:58-64.

63. Komatsuda A, Masai R, Ohtani H, et al. Monoclonal immunoglobulin deposition disease associated with membranous features. *Nephrol Dial Transplant* 2008;23:3888-3894.
64. Nasr SH, Valeri AM, Cornell LD, et al. Renal monoclonal immunoglobulin deposition disease: a report of 64 patients from a single institution. *Clin J Am Soc Nephrol* 2012;7:231-239.
65. Kyle RA, Remstein ED, Therneau TM, et al. Clinical course and prognosis of smoldering (asymptomatic) multiple myeloma. *N Engl J Med* 2007; 356:2582-2590.
66. Criteria for the classification of monoclonal gammopathies, multiple myeloma and related disorders: a report of the International Myeloma Working Group. *Br J Haematol* 2003;121:749-757.
67. Liebross RH, Ha CS, Cox JD, et al. Solitary bone plasmacytoma: outcome and prognostic factors following radiotherapy. *Int J Radiat Oncol Biol Phys* 1998;41:1063-1067.
68. Campbell M, Rosenthal A, Kundranda M, et al. The blue man: a novel cutaneous manifestation of systemic amyloidosis. *Amyloid* 2011;18: 156-159.
69. Buxbaum J, Gallo G. Nonamyloidotic monoclonal immunoglobulin deposition disease. Light-chain, heavy-chain, and light- and heavy-chain deposition diseases. *Hematol Oncol Clin North Am* 1999;13:1235-1248.
70. Gallo G, Goni F, Boctor F, et al. Light chain cardiomyopathy. Structural analysis of the light chain tissue deposits. *Am J Pathol* 1996;148:1397-1406.
71. Kyle RA, Garton JP. The spectrum of IgM monoclonal gammopathy in 430 cases. *Mayo Clin Proc* 1987;62:719-731.
72. Dimopoulos MA, Anagnostopoulos A. Waldenstrom's macroglobulinemia. *Best Pract Res Clin Haematol* 2005;18:747-765.
73. Chahin N, Selcen D, Engel AG. Sporadic late onset nemaline myopathy. *Neurology* 2005;65:1158-1164.
74. Kyle RA. Monoclonal proteins in neuropathy. *Neurol Clin* 1992;10:713-734.
75. Ugurlu S, Bartley GB, Gibson LE. Necrobiotic xanthogranuloma: long-term outcome of ocular and systemic involvement. *Am J Ophthalmol* 2000; 129:651-657.
76. Lipsker D, Boeckler P. Cutaneous manifestations of paraproteinemia and their mechanisms. *Presse Med* 2007;36:1135-1140.
77. Fernandez-Herrera J, Pedraz J. Necrobiotic xanthogranuloma. *Semin Cutan Med Surg* 2007;26:108-113.
78. Cokonis Georgakis CD, Falasca G, Georgakis A, et al. Scleromyxedema. *Clin Dermatol* 2006;24:493-497.

Chapter 96 Molecular Genetic Aspects of Plasma Cell Disorders

> Table of Contents > Part VII - Hematologic Malignancies > Section 5 - Plasma Cell Dyscrasias > Chapter 96 - Molecular Genetic Aspects of Plasma Cell Disorders

Chapter 96

Molecular Genetic Aspects of Plasma Cell Disorders

P. Leif Bergsagel

A. Keith Stewart

Stephen J. Russell

Rafael Fonseca

INTRODUCTION

Multiple myeloma (MM) is an age-dependent monoclonal tumor of bone marrow (BM) plasma cells (PCs), often with significant end organ damage that can include lytic bone lesions, anemia, loss of kidney function, immunodeficiency, and amyloid deposits in various tissues.¹ It has an estimated incidence of 21,700 in 2012, with 10,710 deaths in the United States.² Despite recent therapeutic advances, MM continues to be a mostly incurable disease but with a 5-year survival rate reported in the SEER database that has increased from 28% (1987 to 1989) to 43% (2002 to 2008).³ In fact, a subset of

younger patients initially treated in 1999 can be identified with a 10-year survival rate of 75%,⁴ with presumably even better results possible for patients starting treatment today. The incidence is higher in blacks than whites, and in men than women (Fig. 96.1),³ and it is evident from the SEER registry data that although the incidence of MM continues to rise with an annual percentage change of close to 1%, since 1995 the mortality rate has been decreasing at an even faster rate. MM cells are similar to postgerminal center (GC) long-lived PCs, characterized by strong BM dependence, extensive somatic hypermutation (SHM) of immunoglobulin (Ig) genes, and absence of IgM expression in all but 1% of tumors.⁵ However, MM cells differ from healthy PCs because they retain the potential for a low rate of proliferation (1% to 3% of cycling cells). MM has served as a useful model for understanding the pathogenesis of lymphoid tumors because it is characterized by the presence of a premalignant precursor tumor and defined stages, with researchers able to isolate purified tumor cell populations at all stages.

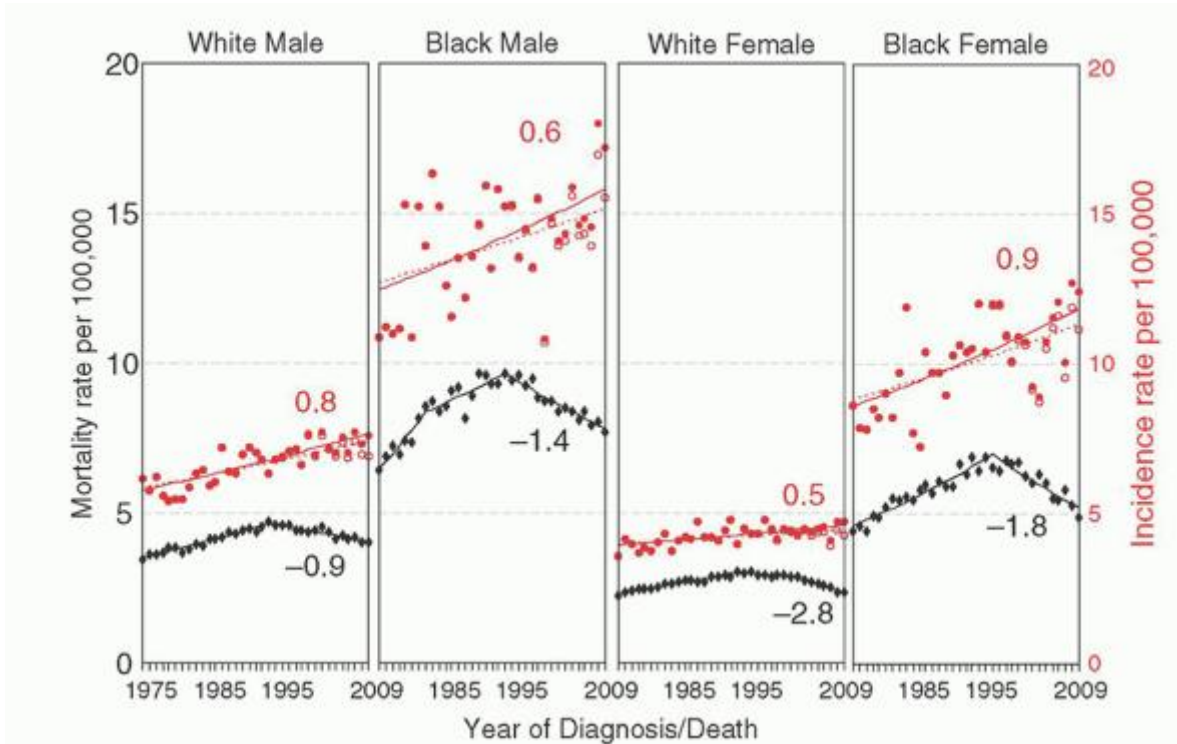

FIGURE 96.1. Differences in US incidence and mortality rates over time, by race and gender. Source is the SEER 9 areas and US mortality files. The most recent annual percentage change for each rate is indicated adjacent to the respective regression line.

MULTIPLE MYELOMA IS A PLASMA CELL TUMOR OF POSTGERMINAL CENTER B CELLS

Pre-GC B cells can generate short-lived PC that mostly remain in the primary lymphoid tissue (Fig. 96.2). Post-GC B cells can generate plasmablasts (PB) that have successfully completed multiple rounds of SHM and antigen selection, followed by IgH switch recombination, with both B cell-specific DNA modification processes having oncogenic potential.⁶ These PB typically migrate to the BM, where stromal cells facilitate terminal differentiation into long-lived PC.⁷ The surface immunophenotype of normal BM PCs is CD38⁺CD138⁺ CD19⁺CD45⁺CD56⁻. Although monoclonal gammopathy of undetermined significance (MGUS), SMM, and MM tumor cells also are CD38⁺CD138⁺, 90% are CD19⁺, 99% are CD45⁻ or dim, and 70% are CD56⁺.^{8, 9} The reason for this immunophenotypic difference is not known. Possibly there is a normal PC with an MM phenotype, but it is rare, and/or transient, and it has yet to be identified. Alternatively, the change in the phenotype may be a consequence of the transformation process.

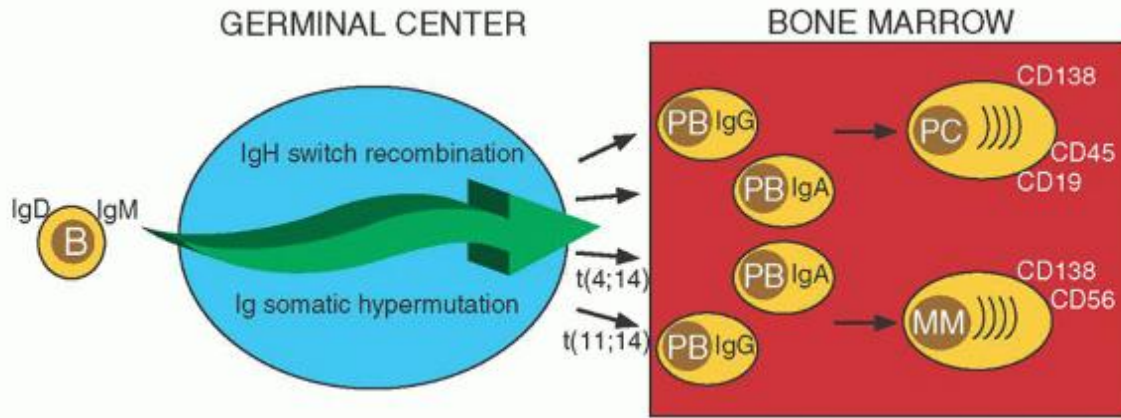

FIGURE 96.2. Normal and malignant plasma cell development. Pre-germinal center (GC) B cells expressing surface immunoglobulin can enter germinal centers where the immunoglobulin genes undergo repeated rounds of somatic hypermutation followed by IgH isotype switch recombination. In multiple myeloma (MM), IgH translocations occur as a result of errors in these two physiologic DNA modification processes (10% and 90%, respectively). Post-GC B cells can generate plasmablast that homes to the bone marrow where stromal cells facilitate differentiation into long-lived PC. Normal plasma cell (PC) express surface CD138, CD19, and CD45; whereas MM cells express CD138, only 10% express CD19, 99% are CD45⁻ or dim, and 70% express CD56. Ig, immunoglobulin; PB, plasmablasts.

P.2023

MULTIPLE MYELOMA IS ALMOST ALWAYS PRECEDED BY AN ASYMPTOMATIC MONOCLONAL GAMMOPATHY

An age-dependent premalignant tumor called monoclonal gammopathy of undetermined significance (MGUS)^{10, 11} is present in about 4% of individuals over the age of 50^{12, 13} and precedes almost every case of MM. A PC tumor must contain at least a billion cells to produce enough monoclonal Ig (M-Ig) or M-IgL (in the 15% of tumors that produce only IgL) to be detected by serum or urine electrophoresis or a serum-free IgL assay. It can be subclassified as lymphoid (15%) or PC (85%) MGUS, which can progress sporadically at average rates of 1% per year to chronic lymphocytic leukemia/lymphoma/lymphoplasmacytoma/Waldenström's macroglobulinemia and MM, respectively.¹⁴ Lymphoid MGUS and PC MGUS can be distinguished by morphology, although clinically the distinction is primarily based on the type of M-Ig detected in serum or urine: mostly IgM for lymphoid MGUS and mostly non-IgM (including Ig light chain only) for PC MGUS. MGUS is distinguished from MM by having a M-Ig of <30 g/L, with no more than 10% of BM mononuclear cells being tumor cells, and no end organ damage or other symptoms. In primary amyloidosis (AL) there is a monoclonal gammopathy which is symptomatic because of pathologic deposits of intact or portions of M-Ig in various tissues.¹⁵ Unfortunately, the pathologic deposits can lead to organ failure, so that the median survival of patients with AL is only 3 years, even with a very small number of premalignant tumor cells.¹⁶ Progression of MGUS to smoldering MM and symptomatic MM is associated with an expanding BM tumor mass and increasingly severe organ impairment or symptoms.¹ Despite BM dependence, sometimes the tumor extends to extramedullary locations, such as spleen, liver, and extracellular spaces. Extramedullary MM (EMM) typically is a more aggressive tumor that sometimes is associated with secondary or primary plasma cell leukemia (PCL), depending on whether or not preceding intramedullary MM was recognized.

Human MM cell lines (HMCLs), which provide a renewable repository of most oncogenic events involved in initiation and progression of the corresponding MM tumor, can sometimes be generated, but usually only from EMM tumors.^{17, 18}

A SELECTION FOR GENETIC MUTATIONS THAT ALLOW INDEPENDENCE FROM THE BONE MARROW MICROENVIRONMENT

In considering the diverse array of mutations in MM, it is helpful to place their pathways in the context of the biology of normal BM-localized PCs. MGUS and MM cells, similar to long-lived PC, are dependent on the BM microenvironment, which includes the extracellular matrix and many kinds of cells, e.g., stromal cells, osteoclasts, osteoblasts, immune cells (T lymphocytes, dendritic cells), other hematopoietic cells, and their precursors, vascular endothelial cells.^{5, 19, 20} These cells mediate reciprocal positive and negative interactions by a variety of adhesion molecules, cytokines, and receptors. Additional stimuli such as hypoxia result in activation of HIF1- α and secretion of VEGF.²¹ For MM, there are several

biologic phenomena that are affected by these tumor-host interactions, including differentiation, and proliferation of tumor cells (most notably IL-6, IGF-1, APRIL); homing to BM; spread to secondary BM sites by the blood stream; generation of many paracrine factors that are involved in survival; angiogenesis; osteoclastogenesis; inhibition of osteogenesis; enhanced resistance to chemotherapeutic agents; humoral and cellular immunodeficiency; and anemia. Many of these tumor-host interactions (e.g., homing, differentiation, and survival) appear to be qualitatively similar for PC and MM tumor cells, whereas the altered composition of the BM microenvironment represents a pathologic response to the MGUS and MM tumor cells. Several therapies (IMiDs, proteasome inhibitors) might target not only the tumor cell but also its interaction with the BM microenvironment. Several of the secondary genetic events associated with the progression of MM discussed below constitutively activate the pathways implicated downstream of the interaction of the MM cell with the BM microenvironment.^{22, 23}

Seven Primary IgH Translocations Are an Early Oncogenic Event in Monoclonal Gammopathy of Undetermined Significance and Multiple Myeloma

Like other B cell tumors, translocations involving the IgH locus (14q32) or one of the IgL loci (κ , 2p12, or λ , 22q11) are common in MM. It seems likely that these events are mediated by errors in IgH switch recombination, or SHM, since the breakpoints are usually located near or within IgH switch regions, but sometimes near VDJ sequences.²⁴ Since there is no evidence that IgH switch recombination or SHM mechanisms are active in normal PC or PC tumors, it is presumed that these translocations usually represent primary—perhaps initiating—oncogenic events as normal B cells pass through GCs. The translocations result in dysregulated or increased expression of an oncogene that is positioned near one or more of the strong Ig enhancers. However, translocations involving an IgH switch region uniquely dissociate the intronic from one or both 3' IgH enhancers, so that an oncogene might be juxtaposed to an IgH enhancer on either or both of the derivative chromosomes, as first demonstrated for FGFR3 on der(14) and

P.2024

MMSET on der(4) in MM. Rarely, tumors can have translocations involving two of the primary translocation groups, suggesting that there can be some complementation.¹⁸

These IgH translocations are efficiently detected by fluorescent in situ hybridization analyses. Large studies from several groups show that the prevalence of IgH translocations increases with disease stage: about 50% in MGUS or SMM, 55% to 70% for intramedullary MM, 85% in PCL, and >90% in HMCL.^{25, 26} Limited studies indicate that IgL translocations are present in about 10% of MGUS/SMM tumors, and about 15% to 20% of intramedullary MM tumors and HMCL.¹⁸ Translocations involving an IgK locus are rare, occurring in only 1% to 2% of MM tumors and HMCL.¹⁸

There are three recurrent primary IgH translocation groups, with the chromosomal sites, target oncogenes, and approximate prevalence in MM (~40% prevalence for all three groups) as follows: CYCLIN D (11q13-CYCLIN D1-15%; 12p13-CYCLIN D2- < 1%; 6p25-CYCLIN D3-2%) MAF (16q23-MAF-5%; 20q12-MAFB-2%; 8q24.3-MAFA-< 1%; MMSET/(FGFR3)-4p16-(MMSET in all but also FGFR3 in 80% of these tumors)-15%.

Chromosome Content Is Associated with at Least Two Different Oncogenic Pathways

There is a consensus that chromosome content reflects at least two pathways of pathogenesis. Nearly half of MGUS and MM tumors are hyperdiploid (HRD), with 48 to 75 (mostly 49 to 56) chromosomes, usually with extra copies of three or more specific chromosomes (3,5,7,9,11,15,19,21). Nonhyperdiploid (NHRD) tumors have <48 and/or >75 chromosomes. Strikingly, HRD tumors rarely (~10%) have a primary IgH translocation, whereas NHRD tumors usually (~70%) have an IgH translocation.²⁷ Tumors with a t(11;14) may represent a distinct category of NHRD tumors as they often are diploid or pseudodiploid. Curiously, EMM tumors and HMCLs nearly always have a NHRD genotype, suggesting that HRD tumors are more stromal cell dependent than NHRD tumors. Although it has been proposed that NHRD and HRD tumors represent different pathways of pathogenesis, the timing, mechanism, and molecular consequences of hyperdiploidy is unknown. Interestingly, in patients with t(4;14) or t(14;16) or t(14;20) or del17p, the presence of one or more trisomies is associated with a substantially better prognosis than with the absence of trisomies. This suggests that the phenotype associated with trisomies may be dominant.²⁸

Universal Cyclin D Dysregulation

Almost all cases of PC neoplasms starting from the MGUS stage express 1 or more of the CYCLIN D genes in an aberrant fashion, despite a low proliferation index.²⁹ Therefore, it has been proposed that dysregulation of a CYCLIN D gene provides a unifying, early oncogenic event in MGUS and MM. MGUS and MM appear closer to normal, nonproliferating PCs than to normal proliferating PB, for which 30% or more of the cells can be in S phase; yet the expression level of

CYCLIN D1, CYCLIN D2, or CYCLIN D3 mRNA in MM and MGUS is distinctly higher than in normal PCs. This can be due to direct dysregulation in MM tumors with a CYCLIN D gene translocation or indirectly in tumors with a translocation of MAF, encoding a transcription factor that markedly upregulates CYCLIN D2. Although MMSET/FGFR3 tumors express moderately high levels of CYCLIN D2, the cause of increased CYCLIN D2 expression remains unknown. While normal BM PC express little or no detectable CYCLIN D1, the majority of HRD tumors express CYCLIN D1 biallelically, whereas most other tumors express increased levels of CYCLIN D2 compared to normal BM PC, both by unknown mechanisms. Only a few percent of MM tumors do not express increased levels of a CYCLIN D gene compared to normal PC, but many of these tumors appear to represent samples that are substantially contaminated by normal cells and another large fraction of these tumors often have inactivated RB1, the inhibitor downstream of CYCLIN D, eliminating the necessity of overexpressing a CYCLIN D gene.

Primary IgH Translocations

It is thought that CYCLIN D translocations only dysregulate expression of a CYCLIN D gene. By contrast, MAF translocations dysregulate expression of a MAF transcription factor that causes increased expression of many genes, including CYCLIN D2 and adhesion molecules that are thought to enhance the ability of the tumor cell to interact with the BM microenvironment.^{29, 30} The contributions of the two genes dysregulated by t(4;14) remain controversial. MMSET is a chromatin-remodeling factor that is overexpressed in all tumors with a t(4;14), whereas about 20% of tumors lack der(14) and FGFR3 expression. The rare acquisition of FGFR3 activating mutations during progression confirms a role for FGFR3 in MM pathogenesis. Although an activated mutant FGFR3 can be oncogenic, it recently was shown that wild-type FGFR3 (as is found in most t[4;14]) can contribute to B cell oncogenesis.³¹ It remains to be determined if FGFR3 is critical early in pathogenesis but becomes dispensable during progression of t(4;14) MM. Preclinical studies suggest that tyrosine kinase inhibitors are active only against t(4;14) HMCL with activating mutations of FGFR3, whereas anti-FGFR3 monoclonal antibodies that inhibit FGFR3 signaling but also elicit antibody-dependent cell-mediated cytotoxicity are active against HMCLs expressing wild-type FGFR3.^{32, 33} Despite an apparently indispensable role in t(4;14) MM, it remains to be determined how MMSET, which sometimes has amino-terminal truncations caused by the translocation, contributes to MM pathogenesis. There are some clues. It is a histone methyltransferase for H3K36me2, and when overexpressed it results in a global increase in H3K36 methylation, and a decrease in H3K27 methylation, which might explain some of the many changes in gene expression associated with t(4;14) tumors.^{29, 34, 35, 36} In addition, it recently has been determined that MMSET has a role in DNA repair (Fig. 96.3). Following DNA damage MMSET is phosphorylated on Ser102 by ATM and is recruited to sites of double strand breaks (DSBs), where it results in methylation of H4K20, which is required for recruitment of p53 binding protein (53BP1). 53BP1 is required for p53 accumulation, G2/M checkpoint arrest, and the intra-S-phase checkpoint in response to ionizing radiation. Approximately half of the translocation breakpoints in t(4;14) MM result in a truncated MMSET that lacks Ser102 and cannot be recruited to DSBs, resulting in a failure to recruit 53BP1 and a loss of the normal DNA damage response pathway. It is not known whether this biologic difference results in a different clinical outcome for t(4;14) MM patients with a truncated versus full-length MMSET.³⁷ Importantly, loss of MMSET expression alters adhesion, suppresses growth, and results in apoptosis of HMCLs, suggesting that it is an attractive therapeutic target.³⁵

Molecular Classification of Multiple Myeloma

The patterns of spiked expression of genes deregulated by primary IGH@ translocations and the universal overexpression of CCNDs genes either by these translocations or other mechanisms led to the translocations and cyclin D (TC) classification that includes eight groups: those with primary translocations (designated 4p16, 11q13, 6p21, MAF), those that overexpressed CCND1 and CCND2 either alone or in combination (D1, D1 & D2, D2), and the rare cases that do not overexpress any CCND genes ("none") (Table 96.1).²⁹ Greater than 95% of the D1 group are HRD.

In addition, most of the patients with HRD MM and trisomy 11 fall within the D1 and D1 & D2 groups, while those without trisomy 11 fall within the D2 group, although a majority of the D2 group are NHRD. This classification system therefore focuses on the different kinds of mechanisms that dysregulate a CCND gene as an early and unifying event in pathogenesis.

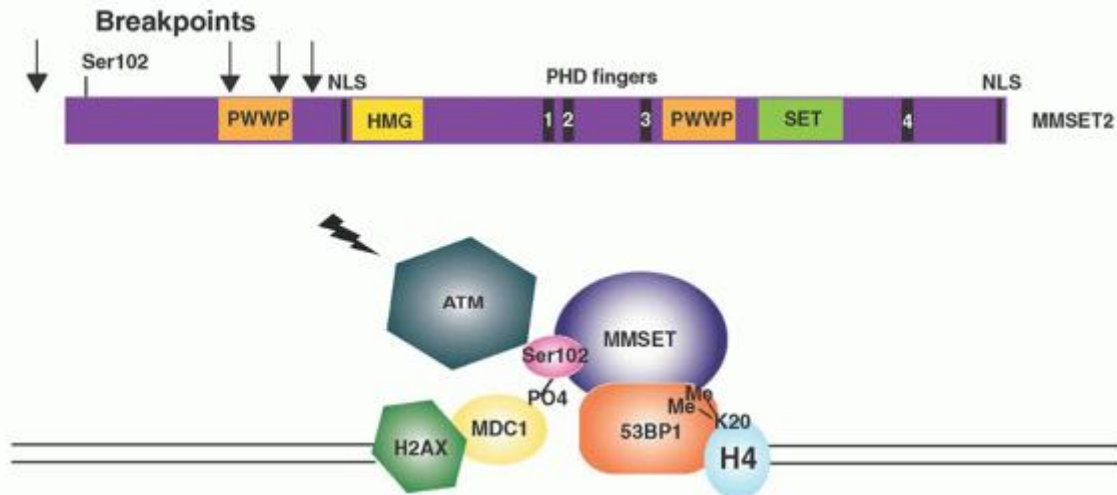

FIGURE 96.3. MMSET is involved in DNA repair. An ideogram of MMSET highlights the important functional domains of the protein, with arrows indicating the initiation of translation of the truncated forms, lacking Ser102, that result from translocation breakpoints in between the coding exons. Following DNA damage MMSET is phosphorylated on Ser102 by ATM and is recruited to sites of double strand breaks by MDC1, where it methylates H4K20. Dimethylation of H4K20 recruits p53-binding protein (53BP1), a key transducer of the DNA damage checkpoint signal.

P.2025

An MM classification based on an unsupervised analysis of microarray gene expression profiling from the UAMS identified seven tumor groups characterized by the coexpression of unique gene clusters.³⁸ This classification was partially replicated in an independent unsupervised analysis of a combined HOVON-GMMG dataset that identified 10 tumor groups with considerable overlap with the UAMS groups.³⁹ Interestingly, these clusters also identify subgroups corresponding to the different primary translocations and hyperdiploidy. Importantly, however, they also highlight other important secondary events that can occur in each subtype of MM: proliferation (PR), expression of NFκB target genes (NFκB), cancer-testis antigens, and the phosphatase PTP4A3/PRL3 (PRL3). The CD-1 and CD-2 groups represent subgroups of patients with t(11;14) and t(6;14), with the former characterized by arginosuccinate synthetase 1 expression, and the latter by expression of B cell antigens (CD20, VPREB, CD79A). Interestingly, they identify patients with markedly different clinical outcomes. Of all the molecular subgroups, CD-1 has the quickest onset and highest frequency of CR (90%), whereas CD-2 has the slowest onset and lowest frequency of CR (45%), when treated with Total Therapy 3. However, after the MF, the CD-1 has the shortest CR duration (77% at 2 years), whereas the CD-2 has the longest (100% at 2 years).⁴⁰

TABLE 96.1 COMPARISON OF DIFFERENT MOLECULAR CLASSIFICATIONS IN MULTIPLE MYELOMA

Group	TC	Gene	%	CYCLIN D	UAMS	HOVON-GMMG
Cyclin D translocation	11q13	CCND1	15	CYCLIN D1	CD-1 CD-2	CD-1 CD-2
	12p13	CCND2	<1	CYCLIN D2		
	6p25	CCND3	2	CYCLIN D3		
MAF translocation	16q23	MAF	5	CYCLIN D2	MF	MF
	20q12	MAFB	2	CYCLIN D2		
8q24	MAFA	<1	CYCLIN D2			
MMSET translocation	4p16	MMSET/FGFR3	15	CYCLIN D2	MS	MS

Hyperdiploid with trisomy 11	D1		33	CYCLIN D1 HY	HY CD-1 NFκB CTA PRL3
	D1 + D2		7	CYCLIN D1 PR & D2	PR CTA
Hyperdiploid without trisomy 11 and others	D2		18	CYCLIN D2 LB	LB CTA PRL3
Other	None	RB1 biallelic deletion	2	No CYCLIN PR D	PR CTA

Additional Oncogenic Events in Monoclonal Gammopathy of Undetermined Significance and Multiple Myeloma

MYC Dysregulation

There is increased expression of c-MYC in most newly diagnosed MM tumors compared to MGUS tumors.⁴¹ Recently, it was shown that sporadic activation of a MYC transgene in GC B cells in an MGUS-prone mouse strain led to the universal development of MM tumors.^{42, 43} Hence, increased MYC expression seems to be responsible for progression from MGUS to MM. Complex translocations involving MYC (c-MYC>>N-MYC>L-MYC) appear to be secondary progression events that often do not involve Ig loci.⁴⁴ They are rare or absent in MGUS, but occur in 15% of newly diagnosed tumors, 50% of advanced tumors, and 90% of HMCLs.^{18, 45} A recent report suggests that a small molecule inhibitor of BRD4 can inhibit MYC RNA expression in MM, with therapeutic effect.⁴⁶

P.2026

Chromosome 13 Deletion

A recent study concludes that chromosome 13 deletion can be an early event in MGUS (e.g., in MAF, MMSET tumors) or a progression event (e.g., in t(11;14) tumors).⁴⁷ The pathogenic effect of this chromosome deletion is unknown, though it is possible that haploinsufficiency of RB1 promotes tumorigenesis.²⁵ A recent genome-wide sequencing study identified mutations of DIS3, a gene of unknown function on 13q, in about 10% of MM. Although only very few mutations have been reported to date, it has been suggested that DIS3 mutations occur in parallel with deletions of RB1,⁴⁸ suggesting a possible dependence between these two events.

Activating Mutations of RAS and BRAF

The prevalence of activating NRAS or KRAS mutations is about 15% to 18% each in newly diagnosed and relapsed MM tumors,^{25, 49} but substantially higher in tumors that express CCND1 compared to tumors that express CCND2. For MGUS tumors, the prevalence of NRAS mutations is 7%, but KRAS mutations have not been described.¹⁴ This is consistent with increasing evidence that NRAS and KRAS mutations have overlapping but nonidentical effects,⁵⁰ and also with the hypothesis that KRAS mutations provide a molecular mark of the transition of MGUS to MM.^{51, 52} MM tumors depend on the continued expression of activated but not wild-type RAS.⁵³ Recently, BRAF mutations were described in 4% of MM tumors, suggesting a possible role for BRAF inhibitors in these cases.⁵⁴

Mutations that Activate the NFκB Pathway

Extrinsic ligands (APRIL and BAFF) produced by BM stromal cells provide critical survival signals to long-lived PCs by stimulating TACI, BCMA, and BAFF receptors to activate the NFκB pathways.⁵⁵ Most MGUS and MM tumors highly express NFκB target genes, suggesting a continued role of extrinsic signaling in PC tumors.^{56, 57} Activating mutations in positive regulators and inactivating mutations in negative regulators of the NFκB pathway have been identified in at least 20% of untreated MM tumors and ~50% of HMCLs, rendering the cells less dependent on ligand-mediated NFκB activation (Fig. 96.4).⁵⁴ Small molecules that inhibit extrinsic signaling (including TACI.Fc, IKKβ, and NIK [MAP3K14]) are being developed as potential therapeutic agents.^{58, 59} There also is some evidence suggesting that cells addicted to constitutive NFκB activation may be particularly sensitive to proteasome inhibition.⁵⁷

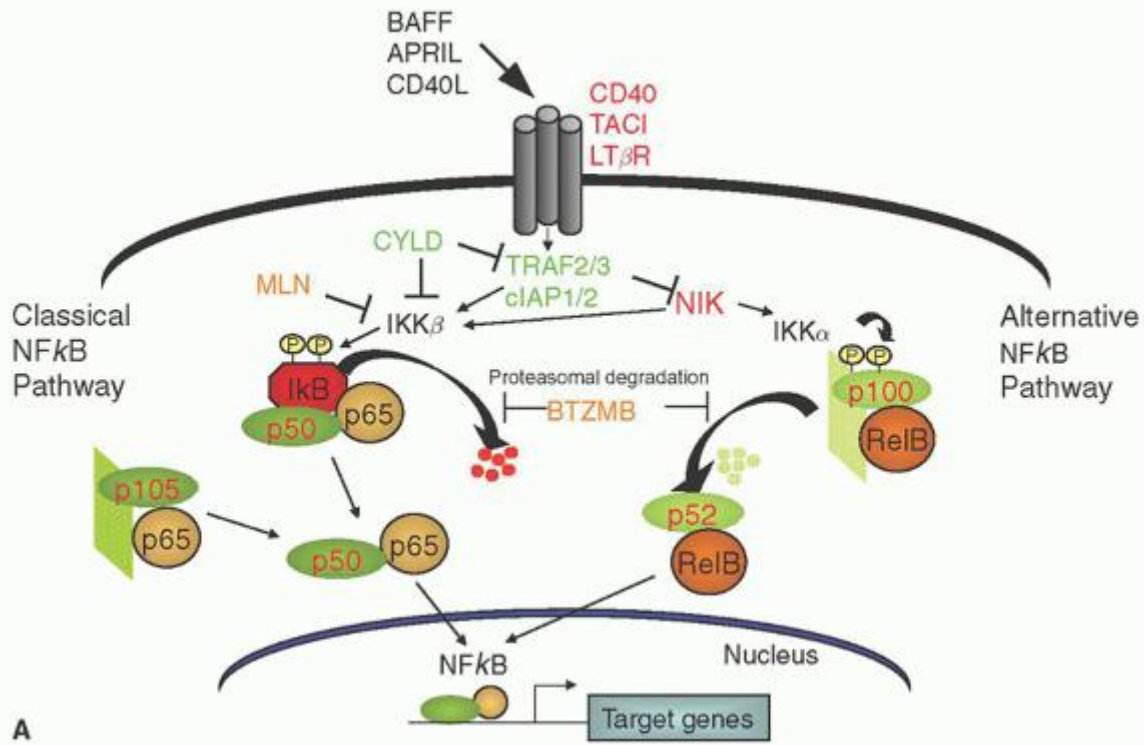

FIGURE 96.4. Role of NFκB pathway in normal plasma cell (PC), monoclonal gammopathy of undetermined significance (MGUS), and multiple myeloma (MM). A: Molecular components and processing events for the classical and alternative NFκB pathways are depicted, both of which result in the translocation of an active NFκB transcription factor into the nucleus. Both pathways can be activated by a variety of stimuli, including the interaction of external factors with PC receptors. Positive regulatory proteins (red) and negative regulatory proteins (green) are targets for mutations that constitutively activate NFκB during the progression of some MM tumors. Bortezomib (BTZMB) may act partially by inhibiting NFκB activity. B: Normal PC, as well as most MGUS and MM tumor cells, have a high NFκBi as a result of bone marrow (BM) stromal cell ligands that stimulate their receptors. Tumors with NFκB mutations generate human MM cell line (HMCL) with a high NFκBi, whereas HMCL from tumors with other kinds of mutations has a low NFκBi. Potential therapeutic agents to block NFκB activation include BCMA-Fc, TACI-Fc, IKKβ inhibitors, and Bortezomib.

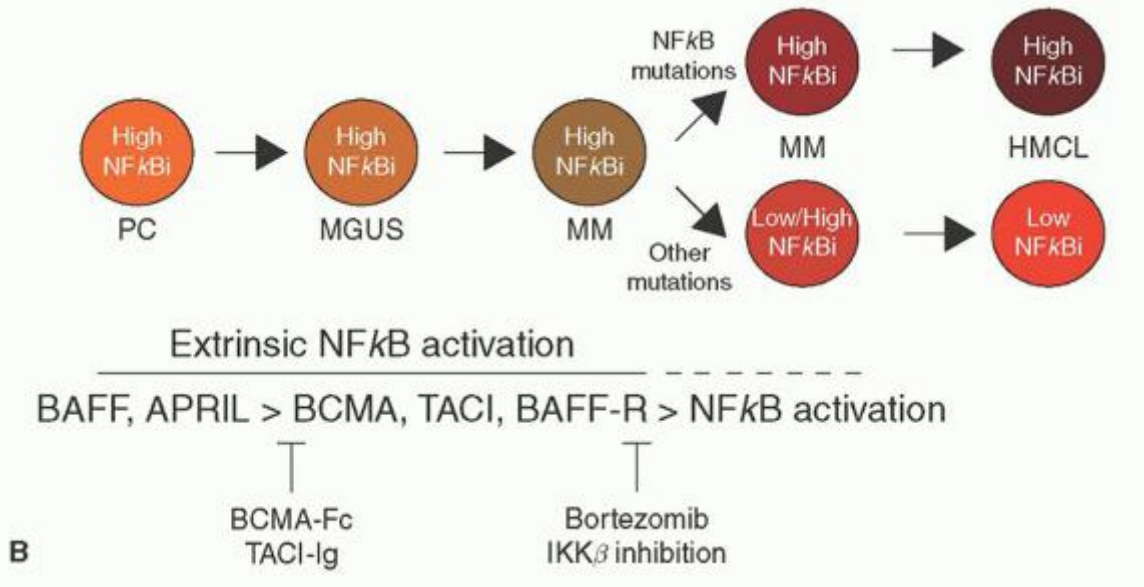

FIGURE 96.4. (continued)

Chromosome 17p Loss and Abnormalities of TP53

Deletions that include the TP53 locus occur in ~10% of untreated MM tumors, and the prevalence increases with disease stage.^{25, 60} TP53 mutations were present in 37% of untreated MM tumors with del17p, but not in patients without del17p.⁶¹ It remains to be determined if the poor prognosis associated with monoallelic del17p but no TP53 mutation is due to haploinsufficiency or to predisposition to complete inactivation of TP53 that is selected for with tumor progression. Recently, decreased expression of microRNAs miR-199, -192, and -215 in MM was reported to increase MDM2, an inhibitor of TP53.⁶²

Gain of Chromosome 1q and Loss of Chromosome 1p

These genomic events frequently occur together in MM, and each is associated with a poor prognosis.^{25, 63} The relevant genes on 1q are unclear at this time. By contrast, there are potential targets on two regions of 1p that are associated with a poor prognosis: CDKN2C (p18INK4c) at 1p32.3, and FAM46C at 1p12.^{64, 65} Homozygous deletion of CDKN2C, which is present in about 30% of HMCL and about 5% of untreated MM tumors, is associated

P.2027

with increased proliferation and a poor prognosis, whereas monoallelic deletion is not. Mutations of FAM46C—often with hemizygous deletion—were identified in 3.4% and 13% of MM tumors in two studies, and in 25% of 16 HMCL.^{54, 64}

Other Pathogenic Events

Secondary Ig translocations, including most IgK and IgL translocations and IgH translocations not involving one of the seven primary partners, can occur at all stages of disease, and with a similar frequency in HRD and NHRD tumors, but apart from MYC, few partner loci have been identified.¹⁸ Other genomic rearrangements are frequent, but only a few specific target genes have been identified.^{63, 66, 67} Changes in DNA methylation are frequent, with one study suggesting that a marked increase in hypomethylation is associated with the MGUS to MM transition,⁶⁸ whereas a second study suggests only a small increase in hypomethylation for MM compared to MGUS.⁶⁹ Mutations in seven genes regulating RNA metabolism, protein translation, and homeostasis were identified in 16 of 38 patients.⁵⁴ In addition to previous studies implicating roles for MMSET and KDM6A (UTX), genomic sequencing studies found that other histone-modifying enzymes are frequent targets of mutation, although the epigenetic consequences are unknown.⁵⁴ Similarly, changes in microRNA expression at different stages have been identified, but more extensive studies are needed.^{62, 70}

Intraclonal Tumor Heterogeneity Associated with High-risk Multiple Myeloma

Although the evidence is still emerging, it appears that many of the genetic events in MM are secondary and often present only in subclones of the tumor population.^{48, 67, 71} Recently, a high level of intraclonal tumor heterogeneity has been described in some patients with high-risk MM^{48, 67, 71} associated in one case with alternating clonal dominance under therapeutic selective pressure, observations with important clinical implications. The findings suggest a competition between subclones for limited resources and raise the possibility that early, suboptimal treatment may eradicate the “good” drug-sensitive clone, making room for the “bad” drug-resistant clone to expand. They support the use of aggressive multidrug combination approaches for high-risk disease with unstable genomes and clonal heterogeneity, and sequential one- or two-drug approaches for low-risk disease with stable genomes and lacking clonal heterogeneity.

CONCLUSION

Significant progress has been made in understanding the molecular pathogenesis and biology of MM (Fig. 96.5). Oncogenic pathways can be activated through cell intrinsic or extrinsic mechanisms. Similar to other cancers, MM is characterized by multistage accumulation of genetic abnormalities deregulating different pathways. Much of this knowledge is already being utilized for diagnosis, prognosis, and risk-stratification of patients. Importantly, from a clinical standpoint, this knowledge has led to development of novel therapeutic strategies, some of which are already in clinical use, and many others showing promise in preclinical and early clinical studies.

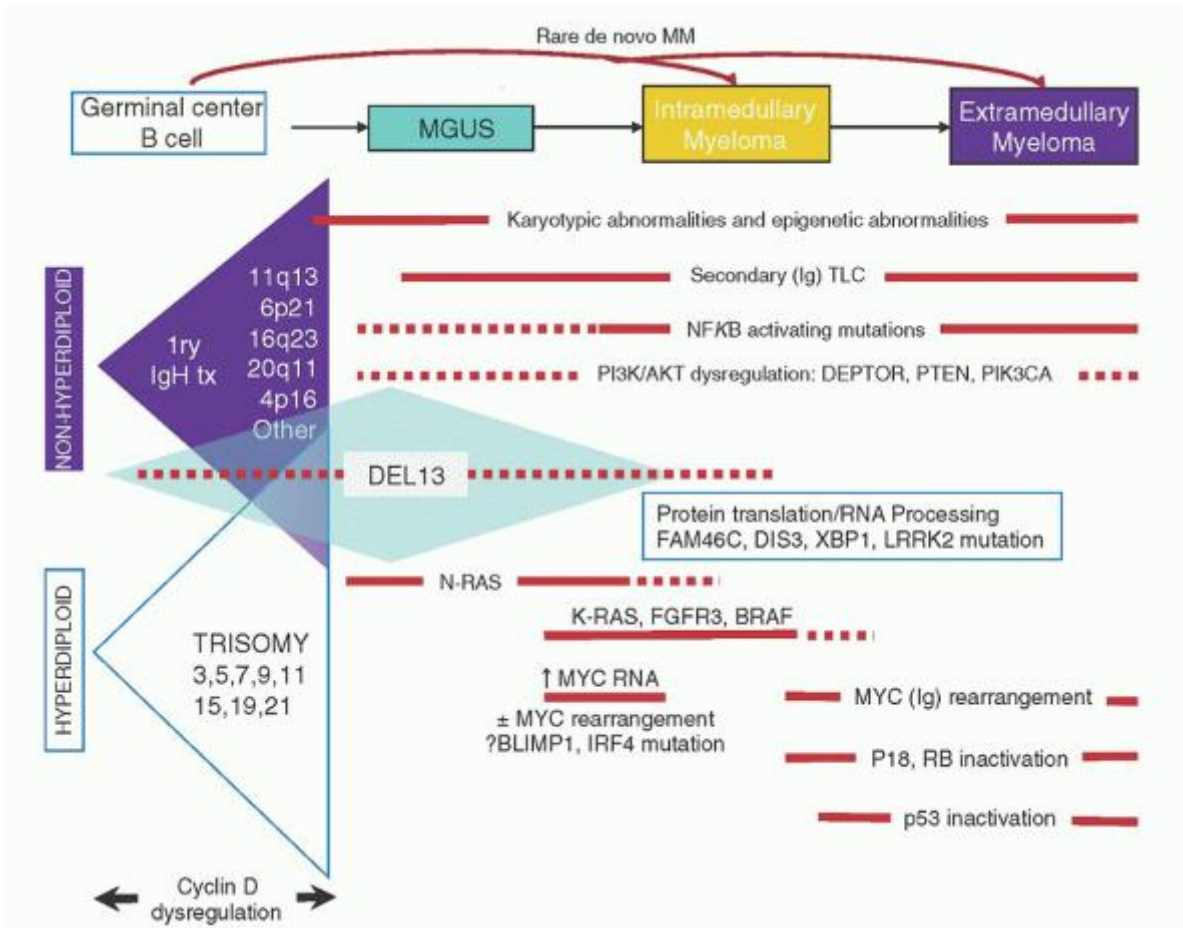

FIGURE 96.5. A model for the multistep molecular pathogenesis of multiple myeloma. Two largely nonoverlapping pathways (immunoglobulin [Ig] translocations versus multiple trisomies) are primary events associated with dysregulated cyclin D expression. The most common secondary genetic events associated with tumor progression are shown, including early and late dysregulation of MYC, and late inactivating mutations of p53.

REFERENCES

- Malpas JS, Bergsagel DE, Kyle R, Anderson K. Multiple myeloma: biology and management. Oxford: Oxford University Press, 2004.
- Siegel R, Naishadham D, Jemal A. Cancer statistics, 2012. CA. Cancer J Clin 2012;62(1):10-29.
- Howlander N, Noone AM, Krapcho M, et al. SEER cancer statistics review 1975-2009. Bethesda, MD: National Cancer Institute, 2012.
- Avet-Loiseau H, Attal M, Campion L, et al. Long-term analysis of the IFM 99 trials for myeloma: cytogenetic abnormalities [t(4;14), del(17p), 1q gains] play a major role in defining long-term survival. J Clin Oncol 2012;30(16): 1949-1952.
- Kuehl WM, Bergsagel PL. Multiple myeloma: evolving genetic events and host interactions. Nat Rev Cancer 2002;2(3):175-187.
- Robbiani DF, Bunting S, Feldhahn N, et al. AID produces DNA double-strand breaks in non-Ig genes and mature B cell lymphomas with reciprocal chromosome translocations. Mol Cell 2009;36(4):631-641.
- McHeyzer-Williams M, Okitsu S, Wang N, McHeyzer-Williams L. Molecular programming of B cell memory. Nat Rev Immunol 2012;12(1):24-34.
- Perez-Persona E, Vidriales MB, Mateo G, et al. New criteria to identify risk of progression in monoclonal gammopathy of uncertain significance and smoldering multiple myeloma based on multiparameter flow cytometry analysis of bone marrow plasma cells. Blood 2007;110(7):2586-2592.

9. Raja KR, Kovarova L, Hajek R. Review of phenotypic markers used in flow cytometric analysis of MGUS and MM, and applicability of flow cytometry in other plasma cell disorders. *Br J Haematol* 2010;149(3):334-351.
10. Landgren O, Kyle RA, Pfeiffer RM, et al. Monoclonal gammopathy of undetermined significance (MGUS) consistently precedes multiple myeloma: a prospective study. *Blood* 2009;113(22):5412-5417.
11. Weiss BM, Abadie J, Verma P, Howard RS, Kuehl WM. A monoclonal gammopathy precedes multiple myeloma in most patients. *Blood* 2009;113(22): 5418-5422.
12. Dispenzieri A, Katzmann JA, Kyle RA, et al. Prevalence and risk of progression of light-chain monoclonal gammopathy of undetermined significance: a retrospective population-based cohort study. *Lancet* 2010;375(9727):1721-1728.
13. Kyle RA, Therneau TM, Rajkumar SV, et al. Prevalence of monoclonal gammopathy of undetermined significance. *N Engl J Med* 2006;354(13): 1362-1369.
14. Zingone A, Kuehl WM. Pathogenesis of monoclonal gammopathy of undetermined significance and progression to multiple myeloma. *Semin Hematol* 2011;48(1):4-12.
15. Merlini G, Seldin DC, Gertz MA. Amyloidosis: pathogenesis and new therapeutic options. *J Clin Oncol* 2011;29(14):1924-1933.
16. Kumar SK, Gertz MA, Lacy MQ, et al. Recent improvements in survival in primary systemic amyloidosis and the importance of an early mortality risk score. *Mayo Clin Proc* 2011;86(1):12-18.
17. Drexler HG, Matsuo Y. Malignant hematopoietic cell lines: in vitro models for the study of multiple myeloma and plasma cell leukemia. *Leuk Res* 2000;24(8):681-703.
18. Gabrea A, Martelli ML, Qi Y, et al. Secondary genomic rearrangements involving immunoglobulin or MYC loci show similar prevalences in hyperdiploid and nonhyperdiploid myeloma tumors. *Genes Chromosomes Cancer* 2008;47(7):573-590.
19. Anderson KC, Carrasco RD. Pathogenesis of myeloma. *Ann Rev Path* 2011;6:249-274.
20. Esteve FR, Roodman GD. Pathophysiology of myeloma bone disease. *Best Pract Res Clin Haematol* 2007;20(4):613-624.
21. Hu J, Handisides DR, Van Valckenborgh E, et al. Targeting the multiple myeloma hypoxic niche with TH-302, a hypoxia-activated prodrug. *Blood* 2010;116(9):1524-1527.
22. Hideshima T, Mitsiades C, Tonon G, Richardson PG, Anderson KC. Understanding multiple myeloma pathogenesis in the bone marrow to identify new therapeutic targets. *Nat Rev Cancer* 2007;7(8):585-598.
23. Roodman GD. Targeting the bone microenvironment in multiple myeloma. *J Bone Miner Metab* 2010;28(3):244-250.
24. Bergsagel PL, Kuehl WM. Chromosome translocations in multiple myeloma. *Oncogene* 2001;20(40):5611-5622.
25. Fonseca R, Bergsagel PL, Drach J, et al. International Myeloma Working Group molecular classification of multiple myeloma: spotlight review. *Leukemia* 2009;23(12):2210-2221.
26. Avet-Loiseau H, Facon T, Daviet A, et al. 14q32 translocations and monosomy 13 observed in monoclonal gammopathy of undetermined significance delineate a multistep process for the oncogenesis of multiple myeloma. *Intergroupe Francophone du Myelome. Cancer Res* 1999;59(18):4546-4550.
27. Fonseca R, Debes-Marun CS, Picken EB, et al. The recurrent IgH translocations are highly associated with nonhyperdiploid variant multiple myeloma. *Blood* 2003;102(7):2562-2567.
28. Kumar S, Fonseca R, Ketterling RP, et al. Trisomies in multiple myeloma: impact on survival in patients with high-risk cytogenetics. *Blood* 2012;119(9):2100-2105.
29. Bergsagel PL, Kuehl WM, Zhan F, Sawyer J, Barlogie B, Shaughnessy J Jr. Cyclin D dysregulation: an early and unifying pathogenic event in multiple myeloma. *Blood* 2005;106(1):296-303.
30. Hurt EM, Wiestner A, Rosenwald A, et al. Overexpression of c-maf is a frequent oncogenic event in multiple myeloma that promotes proliferation and pathological interactions with bone marrow stroma. *Cancer Cell* 2004;5(2):191-199.
31. Zingone A, Cultraro CM, Shin D-M, et al. Ectopic expression of wild-type FGFR3 cooperates with MYC to accelerate development of B-cell lineage neoplasms. *Leukemia* 2010;24(6):1171-1178.
32. Qing J, Du X, Chen Y, et al. Antibody-based targeting of FGFR3 in bladder carcinoma and t(4;14)-positive multiple myeloma in mice. *J Clin Invest* 2009;119(5):1216-1229.

33. Trudel S, Li ZH, Wei E, et al. CHIR-258, a novel, multitargeted tyrosine kinase inhibitor for the potential treatment of t(4;14) multiple myeloma. *Blood* 2005;105(7):2941-2948.
34. Marango J, Shimoyama M, Nishio H, et al. The MMSET protein is a histone methyltransferase with characteristics of a transcriptional corepressor. *Blood* 2008;111(6):3145-3154.
35. Martinez-Garcia E, Popovic R, Min D-J, et al. The MMSET histone methyl transferase switches global histone methylation and alters gene expression in t(4;14) multiple myeloma cells. *Blood* 2011;117(1):211-220.
36. Kuo AJ, Cheung P, Chen K, et al. NSD2 links dimethylation of histone H3 at lysine 36 to oncogenic programming. *Mol Cell* 2011;44(4):609-620.
37. Pei H, Zhang L, Luo K, et al. MMSET regulates histone H4K20 methylation and 53BP1 accumulation at DNA damage sites. *Nature* 2011;470(7332):124-128.
38. Zhan F, Huang Y, Colla S, et al. The molecular classification of multiple myeloma. *Blood* 2006;108(6):2020-2028.
39. Broyl A, Hose D, Lokhorst H, et al. Gene expression profiling for molecular classification of multiple myeloma in newly diagnosed patients. *Blood* 2010;116(14):2543-2553.
40. Nair B, van Rhee F, Shaughnessy JD, et al. Superior results of Total Therapy 3 (2003-33) in gene expression profiling-defined low-risk multiple myeloma confirmed in subsequent trial 2006-66 with VRD maintenance. *Blood* 2010;115(21):4168-4173.
41. Chng WJ, Huang GF, Chung T-H, et al. Clinical and biological implications of MYC activation: a common difference between MGUS and newly diagnosed multiple myeloma. *Leukemia* 2011;25(6):1026-1035.
42. Chesi M, Robbiani DF, Sebag M, et al. AID-dependent activation of a MYC transgene induces multiple myeloma in a conditional mouse model of postgerminal center malignancies. *Cancer Cell* 2008;13(2):167-180.
- P.2028
43. Chesi M, Matthews GM, Garbitt VM, et al. Drug response in a genetically engineered mouse model of multiple myeloma is predictive of clinical efficacy. *Blood* 2012;120(2):376-385.
44. Dib A, Gabrea A, Glebov OK, Bergsagel PL, Kuehl WM. Characterization of MYC translocations in multiple myeloma cell lines. *J Natl Cancer Inst* 2008(39):25-31.
45. Avet-Loiseau H, Gerson F, Magrangeas F, Minvielle S, Harousseau JL, Bataille R. Rearrangements of the c-myc oncogene are present in 15% of primary human multiple myeloma tumors. *Blood* 2001;98(10):3082-3086.
46. Delmore JE, Issa GC, Lemieux ME, et al. BET bromodomain inhibition as a therapeutic strategy to target c-Myc. *Cell* 2011;146(6):904-917.
47. Chiecchio L, Dagrada GP, Ibrahim AH, et al. Timing of acquisition of deletion 13 in plasma cell dyscrasias is dependent on genetic context. *Haematologica* 2009;94(12):1708-1713.
48. Walker BA, Wardell CP, Melchor L, et al. Intracлонаl heterogeneity and distinct molecular mechanisms characterize the development of t(4;14) and t(11;14) myeloma. *Blood* 2012;120(5):1077-1086.
49. Chng WJ, Gonzalez-Paz N, Price-Troska T, et al. Clinical and biological significance of RAS mutations in multiple myeloma. *Leukemia* 2008;22(12):2280-2284.
50. Haigis KM, Kendall KR, Wang Y, et al. Differential effects of oncogenic K-Ras and N-Ras on proliferation, differentiation and tumor progression in the colon. *Nat Genet* 2008;40(5):600-608.
51. Rasmussen T, Haaber J, Dahl IM, et al. Identification of translocation products but not K-RAS mutations in memory B cells from patients with multiple myeloma. *Haematologica* 2010;95(10):1730-1737.
52. Rasmussen T, Kuehl M, Lodahl M, Johnsen HE, Dahl IMS. Possible roles for activating RAS mutations in the MGUS to MM transition and in the intramedullary to extramedullary transition in some plasma cell tumors. *Blood* 2005;105(1):317-323.
53. Steinbrunn T, Stühmer T, Gattenlöhner S, et al. Mutated RAS and constitutively activated Akt delineate distinct oncogenic pathways, which independently contribute to multiple myeloma cell survival. *Blood* 2011;117(6):1998-2004.

54. Chapman MA, Lawrence MS, Keats JJ, et al. Initial genome sequencing and analysis of multiple myeloma. *Nature* 2011;471(7339):467-472.
55. Elgueta R, de Vries VC, Noelle RJ. The immortality of humoral immunity. *Immunol Rev* 2011;236:139-150.
56. Annunziata CM, Davis RE, Demchenko Y, et al. Frequent engagement of the classical and alternative NF-kappaB pathways by diverse genetic abnormalities in multiple myeloma. *Cancer Cell* 2007;12(2):115-130.
57. Keats JJ, Fonseca R, Chesi M, et al. Promiscuous mutations activate the noncanonical NF-kappaB pathway in multiple myeloma. *Cancer Cell* 2007;12(2):131-144.
58. Demchenko YN, Glebov OK, Zingone A, Keats JJ, Bergsagel PL, Kuehl WM. Classical and/or alternative NF-kappaB pathway activation in multiple myeloma. *Blood* 2010;115(17):3541-3552.
59. Rossi JF, Moreaux J, Hose D, et al. Ataccept in relapsed/refractory multiple myeloma or active Waldenström's macroglobulinemia: a phase I study. *Br J Cancer* 2009;101(7):1051-1058.
60. Tiedemann RE, Gonzalez-Paz N, Kyle RA, et al. Genetic aberrations and survival in plasma cell leukemia. *Leukemia* 2008;22(5):1044-1052.
61. Lode L, Eveillard M, Trichet V, et al. Mutations in TP53 are exclusively associated with del(17p) in multiple myeloma. *Haematologica* 2010;95(11):1973-1976.
62. Pichiorri F, Suh S-S, Rocci A, et al. Downregulation of p53-inducible microRNAs 192, 194, and 215 impairs the p53/MDM2 autoregulatory loop in multiple myeloma development. *Cancer Cell* 2010;18(4):367-381.
63. Walker BA, Leone PE, Chiecchio L, et al. A compendium of myeloma-associated chromosomal copy number abnormalities and their prognostic value. *Blood* 2010;116(15):e56-e65.
64. Boyd KD, Ross FM, Walker BA, et al. Mapping of chromosome 1p deletions in myeloma identifies FAM46C at 1p12 and CDKN2C at 1p32.3 as being genes in regions associated with adverse survival. *Clin Cancer Res* 2011;17(24): 7776-7784.
65. Dib A, Peterson TR, Raducha-Grace L, et al. Paradoxical expression of INK4c in proliferative multiple myeloma tumors: bi-allelic deletion vs increased expression. *Cell Div* 2006;1:23.
66. Avet-Loiseau H, Li C, Magrangeas F, et al. Prognostic significance of copy-number alterations in multiple myeloma. *J Clin Oncol* 2009;27(27): 4585-4590.
67. Keats JJ, Chesi M, Egan JB, et al. Clonal competition with alternating dominance in multiple myeloma. *Blood* 2012;120(5):1067-1076.
68. Walker BA, Wardell CP, Chiecchio L, et al. Aberrant global methylation patterns affect the molecular pathogenesis and prognosis of multiple myeloma. *Blood* 2011;117(2):553-562.
69. Sallia B, Baker A, Ahmann G, Auclair D, Fonseca R, Carpten J. DNA methylation analysis determines the high frequency of genic hypomethylation and low frequency of hypermethylation events in plasma cell tumors. *Cancer Res* 2010;70(17):6934-6944.
70. Pichiorri F, Suh SS, Ladetto M, et al. MicroRNAs regulate critical genes associated with multiple myeloma pathogenesis. *Proc Natl Acad Sci U S A* 2008;105(35):12885-12890.
71. Magrangeas F, Avet-Loiseau H, Gouraud W, et al. Minor clone provides a reservoir for relapse in multiple myeloma. *Leukemia* 2012.

Chapter 97 Monoclonal Gammopathies of Undetermined Significance and Smoldering Multiple Myeloma

> Table of Contents > Part VII - Hematologic Malignancies > Section 5 - Plasma Cell Dyscrasias > Chapter 97 - Monoclonal Gammopathies of Undetermined Significance and Smoldering Multiple Myeloma

Chapter 97

Monoclonal Gammopathies of Undetermined Significance and Smoldering Multiple Myeloma

S. Vincent Rajkumar

Robert A. Kyle

John A. Lust

INTRODUCTION

Nomenclature

Monoclonal gammopathy of undetermined significance (MGUS) is an asymptomatic, pre-malignant clonal plasma cell proliferative disorder.^{1, 2, 3, 4} It was initially referred to as essential hyperglobulinemia by Jan Waldenström, as well as several other terms such as benign, idiopathic, asymptomatic, nonmyelomatous, discrete, cryptogenic, and rudimentary monoclonal gammopathy; dysimmunoglobulinemia; lanthanic monoclonal gammopathy; idiopathic paraproteinemia; and asymptomatic paraimmunoglobulinemia.^{5, 6} However, because there is an indefinite risk of progression to multiple myeloma (MM) or related disorder such as Waldenström macroglobulinemia (WM) or amyloidosis (AL), the term MGUS is now the accepted nomenclature.^{1, 2, 7, 8} Smoldering multiple myeloma (SMM) is a clinically defined pre-malignant stage between MGUS and MM.^{9, 10} MGUS and SMM must be differentiated from MM, and from a number of related plasma cell disorders using the criteria listed on Table 97.1.^{8, 11}

Detection of Monoclonal Proteins

Immunoglobulins consist of two heavy polypeptide chains of the same class and subclass and two light polypeptide chains of the same type. The various types of immunoglobulins are designated by capital letters that correspond to the isotype of their heavy chains, which are designated by Greek letters: gamma (γ) constitutes immunoglobulin G (IgG), alpha (α) is found in IgA, mu (μ) is present in IgM, delta (δ) occurs in IgD, and IgE is characterized by epsilon (ϵ). IgG1, IgG2, IgG3, and IgG4 are the subclasses of IgG; the subclasses of IgA are IgA1 and IgA2. Kappa (κ) and lambda (λ) are the two types of light chains. An intact immunoglobulin consists of two heavy chains of the same class and two light chains of the same type. A monoclonal increase in immunoglobulins results from a clonal process such as MGUS or MM, and a polyclonal increase in immunoglobulins is caused by a reactive or inflammatory process. The monoclonal immunoglobulin secreted by clonal plasma cells in MGUS, SMM, MM, and related monoclonal gammopathies is referred to as a monoclonal protein or M protein.

Electrophoresis and Immunofixation

Monoclonal proteins are detected using agarose gel or capillary electrophoresis of the serum and urine.¹² An M-protein is usually visible as a localized band on protein electrophoresis, and as a tall narrow spike or peak in the β or γ region or, rarely, in the α 2-globulin area of the densitometer tracing (Fig. 97.1A). A polyclonal increase in immunoglobulins produces a broad band or broad-based peak that migrates in the γ region. A suspected M protein on electrophoresis must be confirmed on immunofixation, which also determines the immunoglobulin heavy-chain class and its light chain type.¹³ In addition, immunofixation is also done when MM, WM, AL (light chain) amyloidosis, or a related disorder is suspected, because small M proteins may not be detected with electrophoresis alone. Immunofixation is performed using commercial kits or systems such as Sebia, or Pentafix (Fig. 97.1B).

Quantitative Immunoglobulins

In patients with detectable M proteins, another assay that aids in monitoring is quantitation of immunoglobulins performed with a rate nephelometer. It can accurately measure 7S IgM, polymers of IgA, and aggregates of IgG. However, levels of IgM obtained by nephelometry may be 1,000 to 2,000 mg/dl higher than those expected on the basis of the serum protein electrophoretic tracing. The quantitative IgG and IgA levels may be increased similarly.¹⁴

Serum Free Light Chain Assay

The serum free light chain (FLC) assay (Freelite™, The Binding Site Limited, Birmingham, UK) is an automated nephelometric assay that measures free kappa (κ) and lambda (λ) light chains that are not bound to intact immunoglobulin.^{15, 16} The normal serum free- κ level is 3.3 to 19.4 mg/L and the normal free- λ level is 5.7 to 26.3 mg/L.¹⁷ The normal ratio for FLC- κ/λ is 0.26 to 1.65. The normal reference range in the FLC assay reflects a higher serum level of free λ light chains than would be expected given the usual κ/λ ratio of 2 for intact immunoglobulins. This occurs because the renal excretion of free κ (which exists usually in a monomeric state) is faster than free λ (which is usually in a dimeric state).^{15, 16} Patients with a κ/λ FLC ratio <0.26 are considered to have a monoclonal λ free light chain and those with ratios >1.65 are defined as having a monoclonal κ free light chain. If the FLC ratio is >1.65 , κ is referred to as the “involved” FLC and λ the “uninvolved” FLC, and vice versa if the ratio is less than 0.26.

The serum FLC assay can be used in place of urine protein electrophoresis and immunofixation in the initial screening algorithm for M proteins. In a study of 428 patients, Katzmann et al. found that urine studies can be eliminated by using the serum FLC assay in combination with the SPEP and immunofixation.¹⁸ However, if a monoclonal plasma cell disorder is

identified on screening, a 24-hour urine collection followed by electrophoresis and immunofixation should always be done to aid in the assessment of disease progression and response to therapy over time. In addition to its role as a substitute for urine studies in the screening of plasma cell disorders, the FLC assay is used to predict prognosis in MGUS, SMM, AL, and solitary plasmacytoma.^{19, 20, 21}

In addition, it is also used to monitor oligo-secretory MM, nonsecretory MM, light chain only form of MM, and AL amyloidosis.^{16, 22, 23, 24} In order to use the FLC assay to monitor disease progression, the baseline FLC ratio must be abnormal and the involved FLC level ≥ 100 mg/L.^{24, 25}

MONOCLONAL GAMMOPATHY OF UNDETERMINED SIGNIFICANCE

Definition

MGUS is defined by the presence of a serum M protein < 3 g/dl, bone marrow plasma cells $< 10\%$, and absence of anemia, hypercalcemia, lytic bone lesions, or renal failure that can be attributed to the plasma cell proliferative disorder (Table 97.1).^{26, 27} In the case of IgM MGUS, there should be no evidence of

P.2030

lymphadenopathy or organomegaly attributable to the clonal lymphoid/plasma cell proliferative disorder. A new subtype of MGUS termed light chain MGUS is defined by the presence of an abnormal FLC ratio (< 0.26 or > 1.65), elevated level of involved FLC, no immunoglobulin heavy chain (IGH) expression on immunofixation, bone marrow plasma cells $< 10\%$, and absence of anemia, hypercalcemia, lytic bone lesions, or renal failure that can be attributed to the plasma cell proliferative disorder (Table 97.1).⁴ A diagnosis of MGUS requires exclusion of plasma cell malignancies (MM, solitary plasmacytoma, and WM), monoclonal immunoglobulin deposition disorders (AL, light chain deposition disease), as well as SMM. In addition to these closely related disorders which are unique progression events, MGUS can be associated with a variety of malignant and nonmalignant disorders where the association between the monoclonal process and the associated disorder can vary from a coincidental finding to a direct paraprotein related syndrome.

P.2031

TABLE 97.1 DIAGNOSTIC CRITERIA FOR PLASMA CELL DISORDERS

Disorder	Disease Definition	References
Monoclonal gammopathy of undetermined significance (MGUS)	All three criteria must be met: <ul style="list-style-type: none"> • Serum monoclonal protein < 3 g/dl • Clonal bone marrow plasma cells $< 10\%$, and • Absence of end organ damage such as hypercalcemia, renal insufficiency, anemia, and bone lesions (CRAB) that can be attributed to the plasma cell proliferative disorder; or in the case of IgM MGUS no evidence of anemia, constitutional symptoms, hyperviscosity, lymphadenopathy, or hepatosplenomegaly that can be attributed to the underlying lymphoproliferative disorder. 	(275)
Light chain MGUS	All criteria must be met: <ul style="list-style-type: none"> • Abnormal FLC ratio (< 0.26 or > 1.65) • Increased level of the appropriate involved light chain (increased κ FLC in patients with ratio > 1.65 and increased λ FLC in patients with ratio < 0.26) • No immunoglobulin heavy chain expression on immunofixation 	(4)

	<ul style="list-style-type: none"> • Clonal bone marrow plasma cells <10%, and • Absence of end organ damage such as hypercalcemia, renal insufficiency, anemia, and bone lesions (CRAB) that can be attributed to the plasma cell proliferative disorder; or in the case of IgM MGUS no evidence of anemia, constitutional symptoms, hyperviscosity, lymphadenopathy, or hepatosplenomegaly that can be attributed to the underlying lymphoproliferative disorder. 	
Smoldering multiple myeloma (also referred to as asymptomatic multiple myeloma)	<p>Both criteria must be met:</p> <ul style="list-style-type: none"> • Serum monoclonal protein (IgG or IgA) ≥ 3 g/dl and/or clonal bone marrow plasma cells 10-60%, and • Absence of end organ damage such as lytic bone lesions, anemia, hypercalcemia, or renal failure that can be attributed to a plasma cell proliferative disorder 	(275)
Multiple myeloma	<p>All three criteria must be met except as noted:</p> <ul style="list-style-type: none"> • Clonal bone marrow plasma cells $\geq 10\%$ • Presence of serum and/or urinary monoclonal protein (except in patients with true nonsecretory multiple myeloma), and • Either $\geq 60\%$ clonal plasma cells in the marrow or evidence of end organ damage that can be attributed to the underlying plasma cell proliferative disorder, specifically <ul style="list-style-type: none"> ○ Hypercalcemia: Serum calcium ≥ 11.5 mg/dl or ○ Renal insufficiency: Serum creatinine >1.73 mmol/L (or >2 mg/dl) or estimated creatinine clearance less than 40 ml/min ○ Anemia: Normochromic, normocytic with a hemoglobin value of >2 g/dl below the lower limit of normal or a hemoglobin value <10 g/dl ○ Bone lesions: Lytic lesions, severe osteopenia or pathologic fractures 	(276, 277)
IgM monoclonal gammopathy of undetermined significance (IgM MGUS)	<p>All three criteria must be met:</p> <ul style="list-style-type: none"> • Serum IgM monoclonal protein <3 g/dl • Bone marrow lymphoplasmacytic infiltration $<10\%$, and • No evidence of anemia, constitutional symptoms, hyperviscosity, lymphadenopathy, or hepatosplenomegaly that can be attributed to the underlying lymphoproliferative disorder. 	(75, 277, 278, 279, 280)
Smoldering Waldenström macroglobulinemia (also referred to as indolent or	<p>Both criteria must be met:</p> <ul style="list-style-type: none"> • Serum IgM monoclonal protein ≥ 3 g/dl and/or bone marrow lymphoplasmacytic infiltration $\geq 10\%$, and • No evidence of anemia, constitutional symptoms, 	(75, 277, 278, 279, 280, 281)

asymptomatic Waldenström macroglobulinemia)	hyperviscosity, lymphadenopathy, or hepatosplenomegaly that can be attributed to the underlying lymphoproliferative disorder.	
Waldenström macroglobulinemia	<p>All criteria must be met:</p> <ul style="list-style-type: none"> • IgM monoclonal gammopathy (regardless of the size of the M protein), and • $\geq 10\%$ bone marrow lymphoplasmacytic infiltration (usually intertrabecular) by small lymphocytes that exhibit plasmacytoid or plasma cell differentiation and a typical immunophenotype (e.g., surface IgM⁺, CD5^{+/-}, CD10⁻, CD19⁺, CD20⁺, CD23⁻) that satisfactorily excludes other lymphoproliferative disorders including chronic lymphocytic leukemia and mantle cell lymphoma. • Evidence of anemia, constitutional symptoms, hyperviscosity, lymphadenopathy, or hepatosplenomegaly that can be attributed to the underlying lymphoproliferative disorder. 	(75, 277, 278, 279, 280)
Solitary plasmacytoma	<p>All four criteria must be met</p> <ul style="list-style-type: none"> • Biopsy proven solitary lesion of bone or soft tissue with evidence of clonal plasma cells • Normal bone marrow with no evidence of clonal plasma cells • Normal skeletal survey and MRI of spine and pelvis (except for the primary solitary lesion) • Absence of end organ damage such as hypercalcemia, renal insufficiency, anemia, or bone lesions (CRAB) that can be attributed to a lympho-plasma cell proliferative disorder 	(81, 282)
Systemic AL amyloidosis	<p>All four criteria must be met:</p> <ul style="list-style-type: none"> • Presence of an amyloid-related systemic syndrome (such as renal, liver, heart, gastrointestinal tract, or peripheral nerve involvement) • Positive amyloid staining by Congo red in any tissue (e.g., fat aspirate, bone marrow, or organ biopsy) • Evidence that amyloid is light chain related established by direct examination of the amyloid (possibly using mass spectrometry (MS)-based proteomic analysis, or immunoelectron microscopy; note that immunohistochemistry results to type amyloid may be unreliable), and • Evidence of a monoclonal plasma cell proliferative disorder (serum or urine M protein, abnormal free light chain ratio, or clonal plasma cells in the bone marrow). <p>Note: Approximately 2-3% of patients with AL amyloidosis will</p>	(283)

not meet the requirement for evidence of a monoclonal plasma cell disorder listed above; the diagnosis of AL amyloidosis must be made with caution in these patients.

POEMS syndrome	<p>All four criteria must be met</p> <ul style="list-style-type: none"> • Polyneuropathy • Monoclonal plasma cell proliferative disorder (almost always λ) • Any one of the following three other major criteria: <ol style="list-style-type: none"> 1. Sclerotic bone lesions 2. Castleman's disease 3. Elevated levels of vascular endothelial growth factor (VEGF)^a • Any one of the following six minor criteria <ol style="list-style-type: none"> 1. Organomegaly (splenomegaly, hepatomegaly, or lymphadenopathy) 2. Extravascular volume overload (edema, pleural effusion, or ascites) 3. Endocrinopathy (adrenal, thyroid, pituitary, gonadal, parathyroid, pancreatic)^b 4. Skin changes (hyperpigmentation, hypertrichosis, glomeruloid hemangiomas, plethora, acrocyanosis, flushing, white nails) 5. Papilledema 6. Thrombocytosis/polycythemia 	(137, 284)
----------------	--	------------

FLC, free light chain.

Note: Not every patient meeting the above criteria will have POEMS syndrome; the features should have a temporal relationship to each other and no other attributable cause. Anemia and/or thrombocytopenia are distinctively unusual in this syndrome unless Castleman disease is present.

^a The source data do not define an optimal cut-off value for considering elevated VEGF level as a major criterion. We suggest that VEGF measured in the serum or plasma should be at least three- to fourfold higher than the normal reference range for the laboratory that is doing the testing to be considered a major criterion

^b In order to consider endocrinopathy as a minor criterion, an endocrine disorder other than diabetes or hypothyroidism is required inasmuch as these two disorders are common in the general population

Modified from Kyle RA, Rajkumar SV. Criteria for diagnosis, staging, risk stratification and response assessment of multiple myeloma. *Leukemia* 2009;23:3-9.

Epidemiology

Prevalence

MGUS is the most common plasma cell proliferative disorder (Fig. 97.2). The prevalence of MGUS has been estimated in a large population-based study that included 21,463 of the 28,038 enumerated residents (77%) of Olmsted County, Minnesota, who were 50 years or older.³ MGUS was identified in 694 (3.2%) of these subjects. Age-adjusted rates were greater in men than in women, 4.0% versus 2.7% ($P < 0.001$; Fig. 97.3). The prevalence of MGUS was 5.3% among persons 70 years or older and 7.5% among those 85 years or older. Several other studies have reported similar prevalence estimates (Table 97.2).²⁸ In addition, approximately 1% of the general population over the age of 50 have light chain MGUS.⁴

The incidence of M proteins is higher in blacks than in whites. In the study by Cohen et al., the prevalence of an M protein was 8.4% in 916 blacks and 3.6% in whites.²⁹ Landgren et al., in a study of 4 million African American and white males admitted to Veterans Affairs Hospitals, found that the prevalence of MGUS was 0.98% in African Americans and 0.4% in whites.³⁰ The age-adjusted prevalence ratio of MGUS in African Americans compared with whites was 3.0 (95% confidence interval, 2.7 to 3.3). The increase of MGUS in blacks may be related to genetic or environmental factors. A population-based study found that the increased risk of MGUS seen in African Americans was also seen in blacks in Ghana, suggesting that the racial disparity may be due more to genetic factors.³¹

Furthermore, a study of women in the southern part of the United States found that the racial disparity between blacks and whites persisted even after adjusting for socioeconomic status, again suggesting that the differences were more likely genetic rather than environmental.³²

P.2032

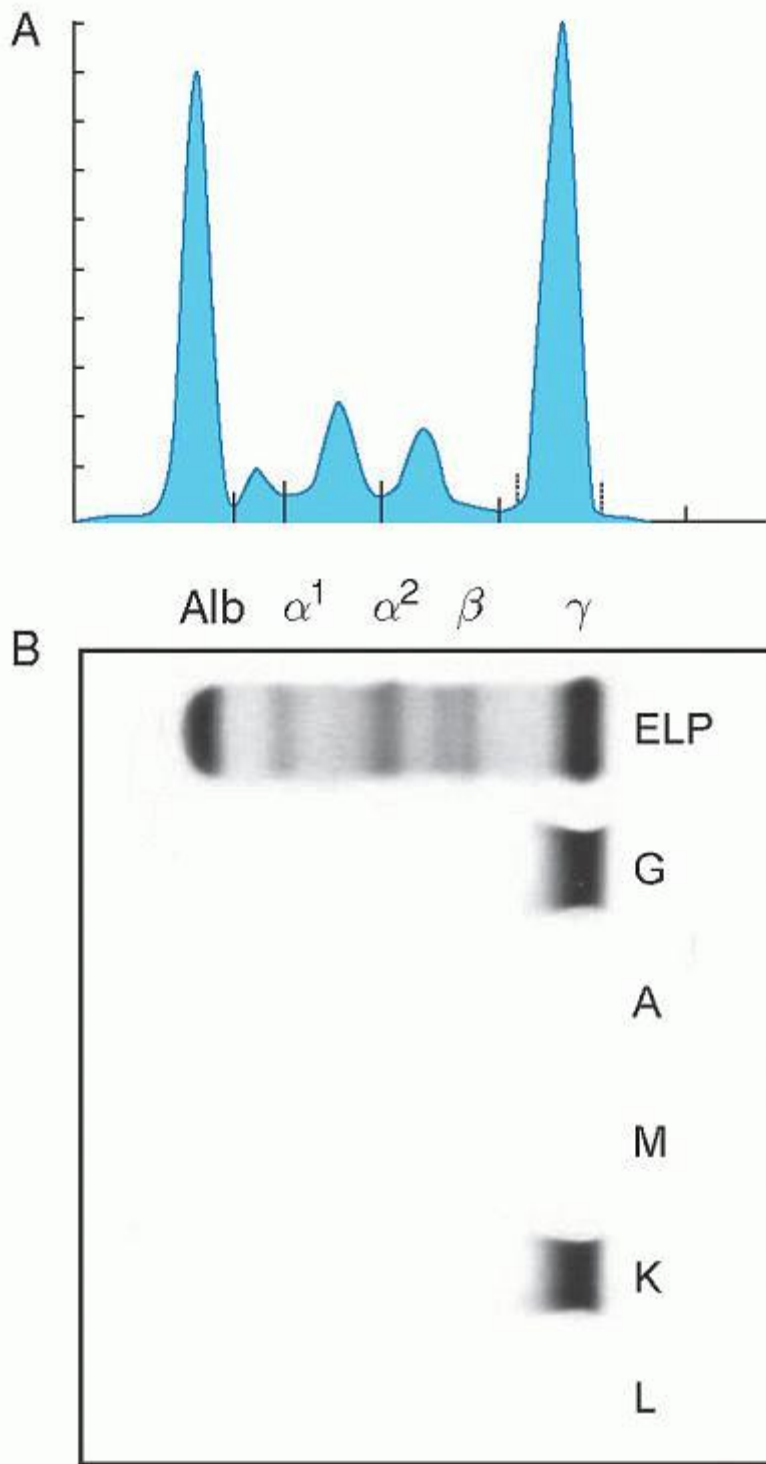

FIGURE 97.1. Monoclonal (M) protein on serum protein electrophoresis. Note tall, narrow-based peak of fast γ mobility (A). Immunofixation of serum with antisera to immunoglobulin G (IgG), IgA, IgM, κ , and λ shows a localized band with IgG and κ , indicating an IgG κ monoclonal protein (B).

One study found that only 2.7% of elderly Japanese patients had a monoclonal gammopathy.³³ A subsequent population-based study in Japan found that the risk of MGUS was lower compared with the white population of Olmsted County.³⁴

Incidence

The annual incidence of MGUS in males is estimated to be 120/100,000 at age 50, and rises to 530/100,000 at age 90 years.³⁵ The rates for women are 60/100,000 at age 50, and 370/100,000 at age 90. The fact that the increased prevalence of MGUS with rising age is not just related to accumulation of new cases but due to an actual increase in incidence suggests that an age-related cumulative damage model is at play in the pathogenesis of MGUS.

Risk Factors

The incidence and prevalence of MGUS rises with age.^{3, 35} MGUS is also more common in males. Blacks have a higher risk of MGUS than whites as discussed above.^{29, 30, 31, 32, 36} In addition to age, race, and gender, there are other risk factors that have been identified, both genetic and environmental. First-degree relatives of patients with MGUS and MM have a two- to threefold higher risk of MGUS compared to those with no known affected relatives.^{37, 38, 39} Obesity and immunosuppression are also known risk factors for MGUS.^{32, 40, 41}

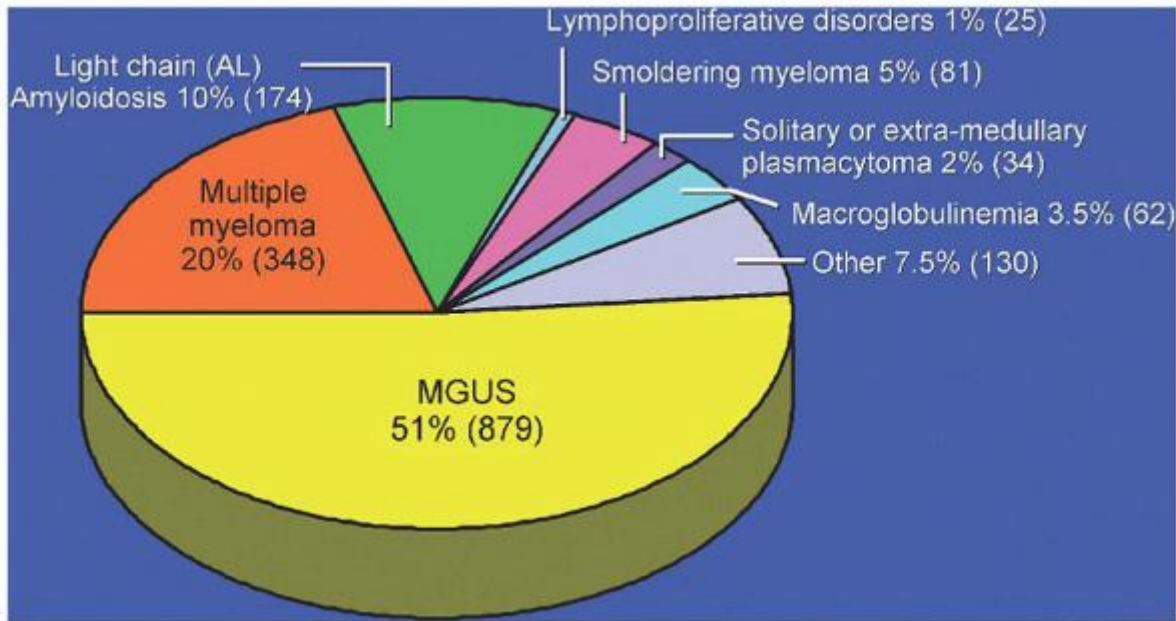

FIGURE 97.2. Distribution of 1,733 cases of monoclonal gammopathy seen at the Mayo Clinic in 2011. MGUS, monoclonal gammopathy of undetermined significance.

Pathophysiology

MM is almost always preceded by the asymptomatic pre-malignant MGUS stage.^{42, 43} For the screening arm of the nationwide population-based prospective prostate, lung, colon, ovarian (PLCO) cancer screening trial, annual blood samples were collected on 77,469 healthy adults. From this cohort, a joint study by the National Cancer Institute and the Mayo Clinic identified 71 individuals who developed MM during the course of the study. Serial serum samples (up to 6) obtained 2.0 to 9.8 years prior to MM diagnosis were then studied. The study found that an asymptomatic MGUS phase always preceded MM and was found in 100% of cases 6 years prior to MM.⁴²

The events responsible for malignant transformation of MGUS to MM or a related plasma cell proliferative disorder are unknown. Genetic changes, bone marrow angiogenesis, various cytokines related to MM bone disease, and infectious agents may play a role in the progression of MGUS to MM or a related disorder.^{44, 45} However, the specific role of these alterations is not well understood.

Initiation of the Clone

The precise sequence of events that leads to the initiation of the MGUS clone are not known. However, antigenic stimulation and/or immunosuppression are thought to be predisposing factors. Toll-like receptors (TLRs) are normally expressed by B lymphocytes, and are essential for these cells to recognize infectious agents and pathogen-associated molecular patterns (PAMP) which then initiate the host-defense response.^{46, 47, 48} The aberrant expression of TLRs by plasma cells may be an initiating event that causes these cells to respond abnormally to TLR-specific ligands resulting in increased MM cell proliferation, survival, and resistance to apoptosis, mediated in part by autocrine interleukin-6 (IL-6) production.^{46, 47}

Immunosuppression may also contribute to the initiation of monoclonal gammopathies inhibiting tumor surveillance.

Monoclonal proteins are known to arise in the context of immunosuppressive states such as bone marrow or stem cell transplantation (SCT), organ transplantation, and human immunodeficiency virus (HIV) infection.^{40, 41, 49, 50, 51} Moreover, patients undergoing renal transplantation develop monoclonal proteins dependent on the level of immunosuppression to which they are subjected.⁴¹

P.2033

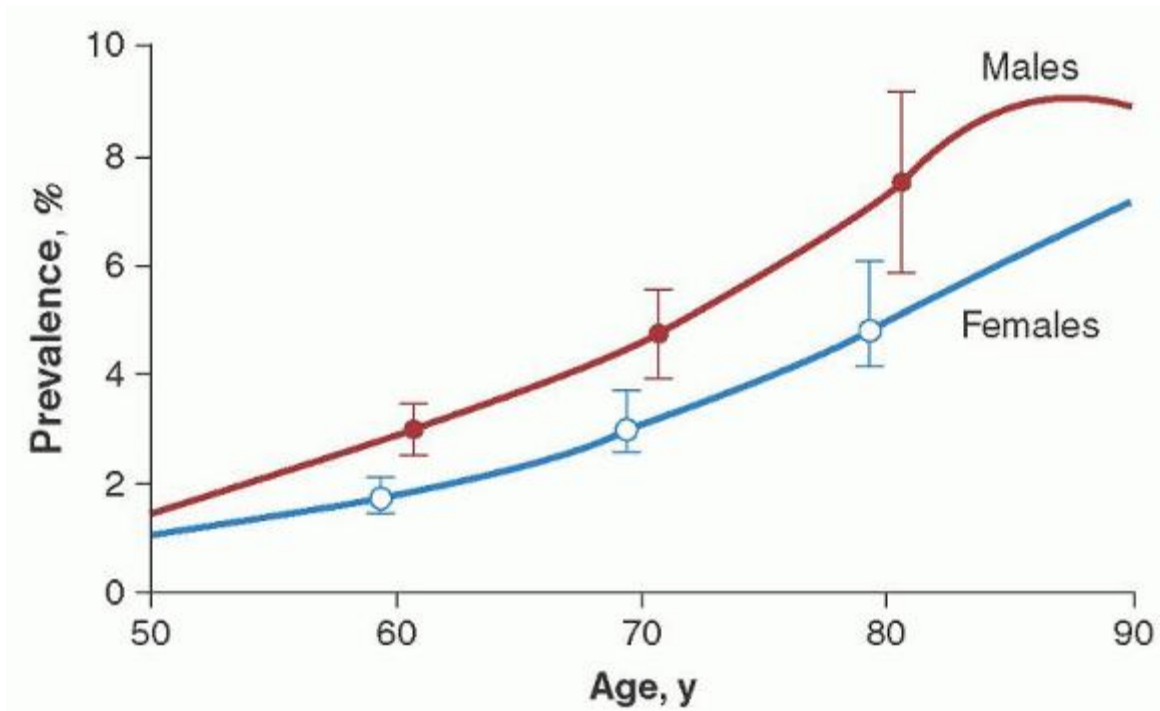

FIGURE 97.3. Prevalence of monoclonal gammopathy of undetermined significance, according to age. Of 21,463 residents 50 years of age or older, 694 had a monoclonal protein. The I bars represent 95% confidence interval. Years of age older than 90 have been condensed to 90 years of age (χ -axis). (From Kyle RA, Therneau TM, Rajkumar SV, et al. Prevalence of monoclonal gammopathy of undetermined significance. *N Engl J Med* 2006;354:1362-1369. Used with permission.)

Cytogenetic Changes

Cytogenetic changes are common in MM and in MGUS. On the basis of fluorescence in situ hybridization studies, almost all patients with MM have either IGH translocations involving chromosome 14q32 or trisomies. These cytogenetic changes referred to as “primary cytogenetic abnormalities” are also present in MGUS.⁵² Thus, approximately 50% of patients with MGUS have primary translocations on chromosome 14q32 (IgH translocated MGUS/SMM).^{52, 53} The most common partner chromosome loci are 11q13, 4p16.3, 6p21, 16q23, and 20q11.^{54, 55, 56} These translocations lead to the dysregulation of oncogenes such as CCND1 (cyclin D1) (11q13), FGFR3/WHSC1 (fibroblastic growth factor receptor 3/Wolf-Hirschhorn syndrome candidate; 4p16.3), CCND3 (cyclin D3; 6p21), MAF (16q23), and MAFB (20q11). The dysregulation of these oncogenes is thought to be critical for the initiation of the MGUS clone rather than progression of MGUS to MM. Approximately 40% of patients (40%) with MGUS have trisomies of odd-numbered chromosomes leading to hyperdiploidy (IgH nontranslocated MGUS). In a small subset, there are likely both IgH translocations and trisomies, and in some neither abnormality can be detected.

TABLE 97.2 PREVALENCE OF MONOCLONAL GAMMOPATHY OF UNDETERMINED SIGNIFICANCE (MGUS)

Study	Diagnostic Criteria	Number of MGUS Cases	Sample Size	Overall Prevalence (95% CI)
-------	---------------------	----------------------	-------------	-----------------------------

Aguzzi et al. ²⁸⁵	M protein <30 g/L No evidence of B-cell lymphoproliferative disorder	1,015	35,0052.9
Anagnostopoulos et al. ²⁸⁶	M protein <30 g/L Bone marrow <10% No end organ damage	60	1,5644.0
Axelsson et al. ⁶	M protein <30 g/L Bone marrow smear No end organ damage	64	6,9950.9
Carrel et al. ²⁸⁷	M protein <30 g/L Bone marrow <10% No end organ damage	7	2,1920.3
Cohen et al. ²⁹	M protein <30 g/L No end organ damage	106	1,7326.1
Iwanaga et al. ³⁴	M protein <30 g/L Bone marrow <10% No end organ damage	1,088	52,7812.1 (1.9 to 2.2)
Kyle et al. ²⁸⁸	M protein <30 g/L Bone marrow <10% No end organ damage	15	1,2001.3
Kyle et al. ³	M protein <30 g/L No end organ damage	694	21,6433.2 (3.0 to 3.5)
Landgren et al. ³⁰	M protein <30 g/L No end organ damage	2,046	3,997,815.05
Landgren et al. ³¹	M protein <30 g/L No end organ damage	54	9175.8 (4.3 to 7.4)
Malacrida et al. ²⁸⁹	M protein <30 g/L No end organ damage	261	102,0000.3

From Wadhera RK, Rajkumar SV. Prevalence of monoclonal gammopathy of undetermined significance: a systematic review. *Mayo Clin Proc* 2010;85:933-942.

Deletions of chromosome 13 have been found to have an adverse prognostic value in MM. However, this cytogenetic abnormality occurs early in the disease pathogenesis and present in the MGUS stage.^{57, 58} Although deletions of chromosome 13 confer an adverse effect on MM, there are no data that the rate of progression from MGUS to MM is accelerated because of this abnormality. K- and N-RAS mutations and deletion of 17p are uncommon in MGUS in contrast to MM.⁵⁹

P.2034

Angiogenesis

Bone marrow angiogenesis is increased in MM and has prognostic value.⁶⁰ In a study of 400 patients with a spectrum of plasma cell disorders, the median microvessel density (in vessels per high-power field) was 1.3 in the 42 normal controls, 1.7 in AL, 3 in MGUS, 4 in SMM, 11 in MM, and 20 in relapsed MM.⁶¹

Thus bone marrow angiogenesis increases progressively from the pre-malignant MGUS stage to advanced MM. Using a chick embryo chorioallantoic membrane angiogenesis assay, Vacca et al. reported that 76% of MM bone marrow samples had increased angiogenic potential compared with 20% of MGUS samples.⁶² Their findings suggest that increased angiogenesis may play a role in progression of MGUS to MM.

Cytokines

There is overexpression of CD126 (IL-6 receptor α -chain) in MGUS compared to normal plasma cells.^{63, 64} IL-6 is a major growth factor for plasma cells and may therefore play a role in the clonal proliferation of plasma cells in MGUS. Another cytokine that is of importance is IL-1 β . IL-1 β is produced by plasma cells in all patients with MM, but is undetectable in

most patients with MGUS.⁶⁵ IL-1 β has strong osteoclast-activating factor activity, increases the expression of adhesion molecules, and induces paracrine IL-6 production. This activity parallels the development of osteolytic bone lesions, homing of MM cells to bone marrow, and IL-6-induced cell growth.^{66, 67}

As the MGUS clone evolves with additional cytogenetic abnormalities and changes in the microenvironment, there is overexpression of receptor activator of nuclear factor- κ B ligand (RANKL) by osteoblasts (and possible plasma cells) and macrophage inflammatory protein 1- α (MIP 1- α) by plasma cells.^{68, 69} Furthermore, there is a reduction in osteoprotegerin, the decoy receptor for RANKL. This leads to osteoclast activation and bone resorption. In addition, increased dickkopf 1 (DKK-1) expression by MM cells is felt to play a major role in simultaneous suppression of osteoblasts and new bone formation.⁷⁰ This combination of factors is thought to be critical for development of lytic bone lesions in MM.

Clinical Features

MGUS is an asymptomatic condition. It is typically detected as an incidental finding when electrophoresis and immunofixation of the serum and/or urine or the serum FLC assay are performed during the work-up of suspected MM or WM. Thus, MGUS is usually detected during the work-up of unexplained weakness or fatigue, increased erythrocyte sedimentation rate, anemia, unexplained back pain, osteoporosis, osteolytic lesions or fractures, hypercalcemia, proteinuria, renal insufficiency, or recurrent infections. MGUS is also detected during work-up of patients with symptoms suggestive of AL amyloidosis such as unexplained sensorimotor peripheral neuropathy, carpal tunnel syndrome, refractory congestive heart failure, nephrotic syndrome, orthostatic hypotension, malabsorption, weight loss, change in the tongue or voice, paresthesias, numbness, increased bruising, bleeding, and steatorrhea.

Most cases of MGUS remain undiagnosed due to the asymptomatic nature of the condition. At age 60, the proportion of prevalent cases that are clinically recognized is only 13%.³⁵ This rate rises to 33% at age 80. When MGUS is first diagnosed, it is estimated that the condition has already been present in an undiagnosed form for a median duration of over 10 years.³⁵

For example, it is estimated that 56% of women age 70 diagnosed with MGUS have had the condition for over 10 years, including 28% for over 20 years. Corresponding values for men are 55% and 31%, respectively.

TABLE 97.3 CLASSIFICATION OF MONOCLONAL GAMMOPATHY OF UNDETERMINED SIGNIFICANCE

Type	Risk of Progression
Non-IgM MGUS ^a	1% per year risk of progression to multiple myeloma, AL amyloidosis, or related disorder
IgM MGUS ^b	1.5% per year risk of progression to Waldenström macroglobulinemia; rare patients can progress to IgM multiple myeloma
Light chain MGUS ^c	Risk of progression to light chain myeloma and AL amyloidosis. Rate of progression not defined.

IgM, immunoglobulin M; MGUS, monoclonal gammopathy of undetermined significance

^a Almost all patients are IgG or IgA type. Occasional patients may have IgD or IgE monoclonal proteins.

^b Note that conventionally IgM MGUS is considered a subtype of MGUS. Thus, when the term MGUS is used, in general, it includes IgM MGUS.

^c Because light chain MGUS was only defined in 2010, studies pertaining to MGUS prior to that time do not include patients with this entity; unless otherwise specified studies since then may also not include patients with light chain MGUS.

From Rajkumar SV. Preventive strategies in monoclonal gammopathy of undetermined significance and smoldering multiple myeloma. *Am J Hematol* 2012;87:453-454.

There are three distinct categories of MGUS each with a different mode of progression: IgM MGUS, non-IgM MGUS, and light chain MGUS, each with a different mode and risk of progression (Table 97.3).^{4, 7, 71}

Prognosis

Mayo Clinic Referral Population

The prognosis of MGUS was first established in a study of 241 patients seen at the Mayo Clinic from 1956 through 1970.¹ The actuarial rate of progression to MM or related disorder at 10 years was 17%; at 20 years, 34%; and at 25 years, 39% (Fig. 97.4).⁷² Of the 64 patients with progression, 44 (69%) had MM.

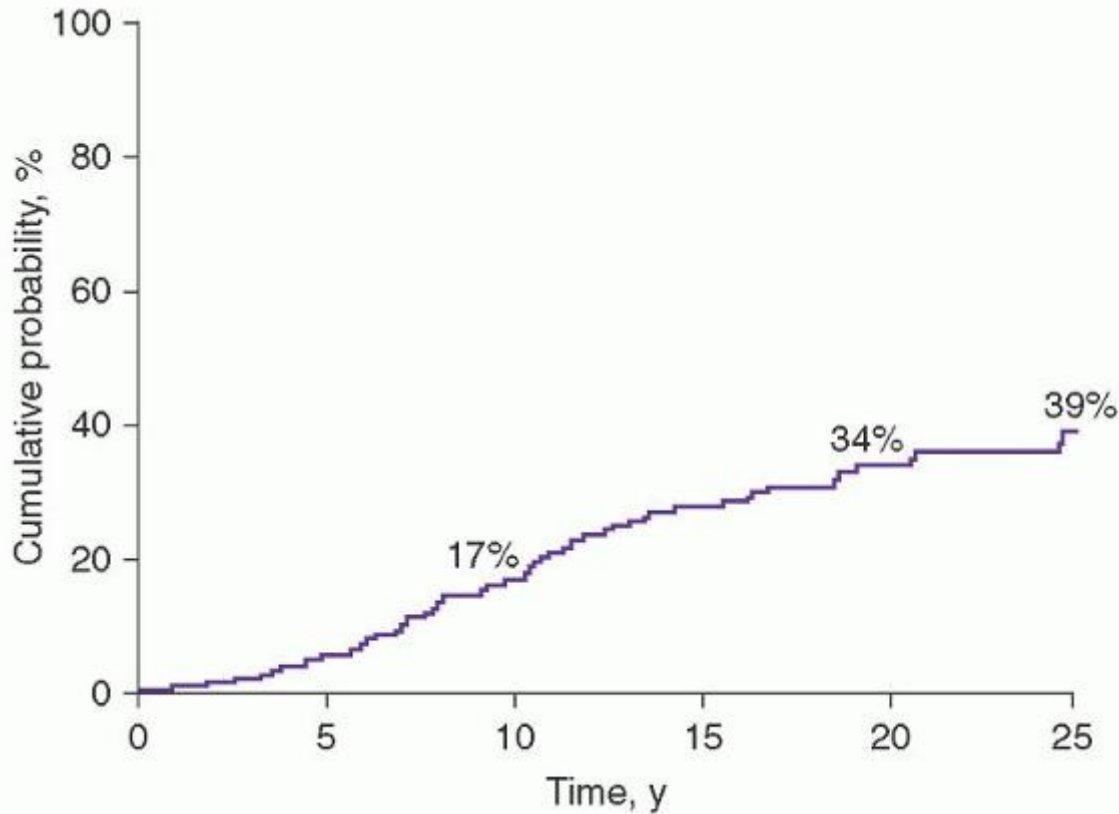

FIGURE 97.4. Actuarial analysis of incidence of multiple myeloma, macroglobulinemia, amyloidosis, or lymphoproliferative disease after recognition of monoclonal protein in 241 patients with monoclonal gammopathy of undetermined significance. (From Kyle RA, , Therneau TM, Rajkumar SV, Larson DR, Plevak MF, Melton LJ 3rd. Long-term follow-up of 241 patients with monoclonal gammopathy of undetermined significance: the original Mayo Clinic series 25 years later. *Mayo Clin Proc* 2004;79:859-866.)

P.2035

Southeastern Minnesota Study

The risk of progression has also been estimated in a larger population-based study of 1,384 persons with MGUS who resided in the 11 counties of southeastern Minnesota, the risk of progression of MGUS to MM or related disorder was found to be 1% per year.² The median age at diagnosis of MGUS was 72 years. The M-protein level at diagnosis ranged from unmeasurable to 3.0 g/dl. On the basis of the heavy-chain type of immunoglobulins, 70% of the M proteins were IgG, 12% IgA, and 15% IgM. A biconal gammopathy was found in 45 patients (3%). The light chain type was κ in 61% and λ in 39%. A reduction of uninvolved (normal or background) immunoglobulins was found in 38% of 840 patients in whom quantitation of immunoglobulins was determined. The 1,384 patients in this study were followed up for a total of 11,009 person-years (median, 15.4 years; range, 0 to 35 years). During follow-up, MM, primary AL, lymphoma with an IgM serum M protein, WM, plasmacytoma, or chronic lymphocytic leukemia developed in 115 patients (8%). The cumulative probability of progression to one of these disorders was 10% at 10 years, 21% at 20 years, and 26% at 25 years (Fig. 97.5). Patients were at risk for progression even after 25 years or more of stable MGUS. Although the risk of progression is 1%

per year, it must be emphasized that this does not take into account other competing causes of death in elderly patients. After adjusting for competing causes of death, the true lifetime probability of progression of MGUS for the average patient is only approximately 10% (Fig. 97.6).

The number of patients with progression to a plasma cell disorder (115 patients) was 7.3 times the number expected on the basis of the incidence rates for those conditions in the general population (Table 97.4). The risk of MM developing was increased 25-fold; WM, 46-fold; and AL amyloidosis, 8.4-fold. The risk of development of lymphoma was only modestly increased at 2.4, but this risk was underestimated because only lymphomas associated with an IgM protein counted in the observed number, whereas the incidence rates for lymphomas associated with IgG, IgA, and IgM proteins were used to calculate the expected number. The risk of development of chronic lymphocytic leukemia was only slightly increased.

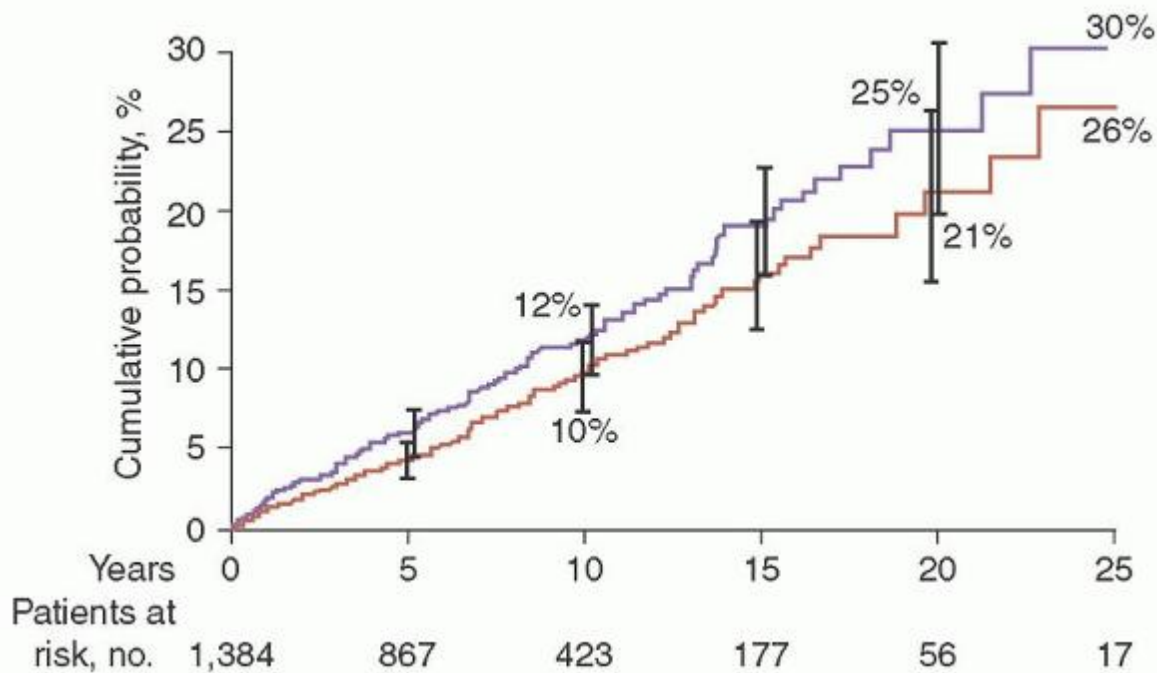

FIGURE 97.5. Probability of disease progression among 1,384 residents of southeastern Minnesota in whom monoclonal gammopathy of undetermined significance (MGUS) was diagnosed from 1960 through 1994. The top curve shows the probability of progression to a plasma cell cancer (115 patients) or of an increase in the monoclonal protein concentration to more than 3 g/dl or in the proportion of plasma cells in the bone marrow to more than 10% (32 patients). The bottom curve shows only the probability of progression of MGUS to multiple myeloma, IgM lymphoma, primary amyloidosis, macroglobulinemia, chronic lymphocytic leukemia, or plasmacytoma (115 patients). The error bars indicate 95% confidence intervals. (From Kyle RA, Therneau TM, Rajkumar SV, et al. A long-term study of prognosis of monoclonal gammopathy of undetermined significance. *N Engl J Med* 2002;346:564-569. Used with permission.)

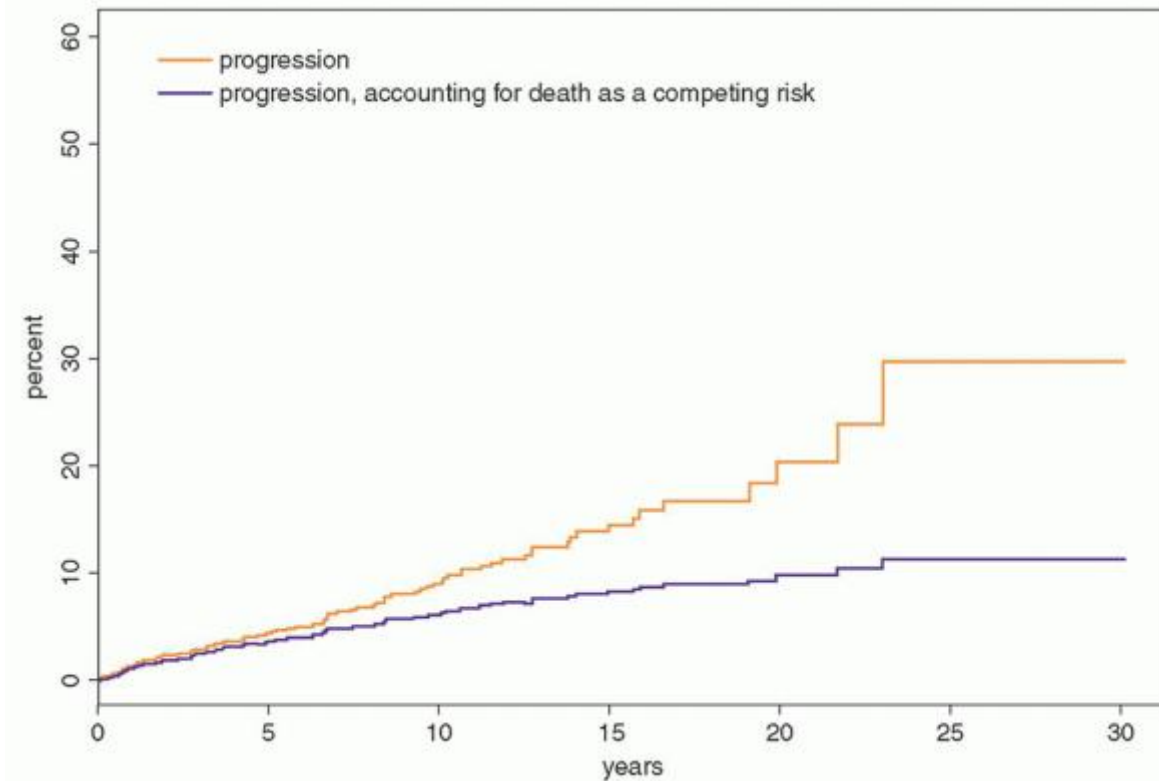

FIGURE 97.6. The risk of progression to myeloma or related disorder in 1,148 patients with monoclonal gammopathy of undetermined significance. The upper curve illustrates risk of progression of all patients without taking into account competing causes of death. The lower curve illustrates risk of progression after accounting for other competing causes of death. (From Rajkumar SV, Kyle RA, Therneau TM, et al. Serum free light chain ratio is an independent risk factor for progression in monoclonal gammopathy of undetermined significance (MGUS) *Blood* 2005;106:812–817. © the American Society of Hematology.)

The 75 patients in whom MM developed accounted for 65% of the 115 patients who had progression to a plasma cell disorder. The mode of development of MM among the patients with MGUS was variable. The M-protein level increased within 2 years of the recognition of MGUS in 11 patients, whereas the serum M-protein level was stable for more than 2 years and then increased within 2 years in 19 patients; in 9 others, the M-protein level increased gradually after having been stable for at least 2 years. In 9 patients, the M-protein level increased gradually during

P.2036

follow-up until the diagnosis of symptomatic MM was made.

In 10 patients, the serum M-protein level remained essentially stable; the diagnosis of MM was unequivocal in these 10 patients because of an increase in bone marrow plasma cells, development of lytic lesions, or occurrence of anemia, renal insufficiency, or an increased level of urine M protein. Seventeen patients had an insufficient number of serum M-protein measurements to determine the pattern of increase. In patients with WM, the M-protein level showed a gradual increase in 3, stable levels were followed by a sudden increase in 2, and data were insufficient in 2.

TABLE 97.4 RISK OF PROGRESSION AMONG 1,384 RESIDENTS OF SOUTHEASTERN MINNESOTA IN WHOM MONOCLONAL GAMMOPATHY OF UNDETERMINED SIGNIFICANCE WAS DIAGNOSED, 1960-1994

Type of progression	No. of Patients		Relative Risk	
	Observed	Expected ^a	(95% CI)	
Multiple myeloma	75	3.0	25.0 (20-32)	
Lymphoma ^b	19	7.8	2.4 (2-4)	

Primary amyloidosis	10	1.2	8.4 (4-16)
Macroglobulinemia	7	0.2	46.0 (19-95)
Chronic lymphocytic leukemia ^c	3	3.5	0.9 (0.2-3)
Plasmacytoma	1	0.1	8.5 (0.2-47)
Total	115	15.8	7.3 (6-9)

CI, confidence interval.

^a Expected numbers of cases were derived from the age- and sex-matched white population of the Surveillance, Epidemiology, and End Results program in Iowa except for primary amyloidosis.

^b All 19 patients had serum IgM monoclonal protein. If the 30 patients with IgM, IgA, or IgG monoclonal protein and lymphoma were included, the relative risk would be 3.9 (95% CI, 2.6-5.5).

^c All 3 patients had serum IgM monoclonal protein. If all 6 patients with IgM, IgA, or IgG monoclonal protein and chronic lymphocytic leukemia were included, the relative risk would be 1.7 (95% CI, 0.6-3.7).

From Kyle RA, Therneau TM, Rajkumar SV, et al. A long-term study of prognosis of monoclonal gammopathy of undetermined significance. *N Engl J Med* 2002;346:564-569. (Used with permission.)

Spontaneous disappearance of M protein after the diagnosis of MGUS was rare.² The M protein disappeared without an apparent cause in 27 patients (2%), and only 6 of these 27 patients (0.4% of all patients) had a discrete spike on the densitometer tracing of the initial electrophoresis (median, 1.2 g/dl); the rest had small M proteins detected on immunofixation only.

Follow-up in Other Series

The risk of progression of MGUS has been estimated in several other studies, and the results mirror those seen in the Southeastern Minnesota study. For example, Baldini et al. noted that 6.8% of 335 patients with MGUS had progression during a median follow-up of 70 months.⁷³ In the Danish Cancer Registry, 64 new cases of malignancy (5 expected; relative risk, 12.9) were found among 1,229 patients with MGUS.⁷⁴

Prognostic Factors

No findings at diagnosis of MGUS can reliably distinguish patients whose condition will remain stable indefinitely from those in whom MM or related malignancy develops. However, there are several known prognostic factors that assist in estimation of the risk of progression for appropriate counseling and management.

Size of M Protein

The size of the M protein at recognition of MGUS is one of the most important predictors for the risk of progression. In the study of 1,384 patients from Southeastern Minnesota, the risk of progression to MM or a related disorder 10 years after diagnosis of MGUS was 6% for patients with an initial M-protein level of 0.5 g/dl or less, 7% for 1 g/dl, 11% for 1.5 g/dl, 20% for 2 g/dl, 24% for 2.5 g/dl, and 34% for 3.0 g/dl.²

Corresponding rates for progression at 20 years were 14%, 16%, 25%, 41%, 49%, and 64%, respectively. The risk of progression in a patient with an M-protein level of 1.5 g/dl was almost twofold greater than that in a patient with an M-protein level of 0.5 g/dl, and the risk of progression in a patient with an M-protein level of 2.5 g/dl was 4.6 times that of a patient with a 0.5-g/dl spike.

Type of M Protein

Patients with an IgM or IgA M protein have a higher risk of progression compared with those with an IgG M protein.² IgM MGUS is a unique subtype of MGUS in which patients are at risk of progression to WM rather than MM.⁷⁵ Due to a confusion in terminology, some patients with WM are referred to as having non-Hodgkin lymphoma or lymphoplasmacytic lymphoma (a term commonly used by pathologists to describe the bone marrow findings of patients with WM). Rarely do patients with IgM MGUS evolve into IgM MM.⁷¹ Among 213 patients in the Southeastern Minnesota MGUS study, 23 developed "non-Hodgkin lymphoma" or WM, 3 developed chronic lymphocytic leukemia, and 3 developed AL

amyloidosis.⁷⁵ The risk of progression was 1.5% per year. The risk of progression of light chain MGUS relative to IgA, IgG, or IgM MGUS is not known.

Bone Marrow Plasma Cells

Cesana et al. have found that patients with MGUS who have 5% to 9% bone marrow plasma cells have a higher risk of progression compared with those with <5% bone marrow plasma cells.⁷⁶ Of 1,104 patients with MGUS in this study, at a median follow-up of 65 months, 64 MGUS cases (5.8%) evolved to MM or related plasma cell disorder. Patients with greater than 5% marrow plasmacytosis had a significantly higher risk of progression compared to those with 5% or fewer plasma cells, 1.35 versus 0.64 per 100 person years, respectively, $P = 0.004$.

Abnormal Serum-Free Light Chain Ratio

An abnormal FLC ratio is an independent risk factor for progression of MGUS. In a study of 1,148 patients with MGUS, 379 (33%) had an abnormal FLC ratio.¹⁹ The risk of progression in patients with an abnormal FLC ratio was significantly higher than that in patients with a normal ratio (hazard ratio 3.5; $P < 0.001$) and was independent of the size and type of serum M protein (Fig. 97.7). The production of excess monoclonal FLC in MGUS may be a biomarker for plasma cells bearing a higher degree of cytogenetic abnormalities thereby serving as a biomarker for a higher risk of progression.

Risk Stratification

A risk-stratification model can be used to predict risk of progression in MGUS, and is useful for management.¹⁹ The model is based on the size and type of the M protein and the FLC ratio (Table 97.5). Patients with all three risk factors consisting of an abnormal serum FLC ratio, IgA or IgM MGUS, and an increased serum M-protein value (≥ 1.5 g/dl) have a risk of progression at 20 years of 58%, whereas the risk is 37% with any two risk factors present, 21% with one risk factor present, and 5% when none of the risk factors are present. When competing causes of death were

P.2037

taken into account, the risk of progression in the low risk group is only 2% at 20 years.

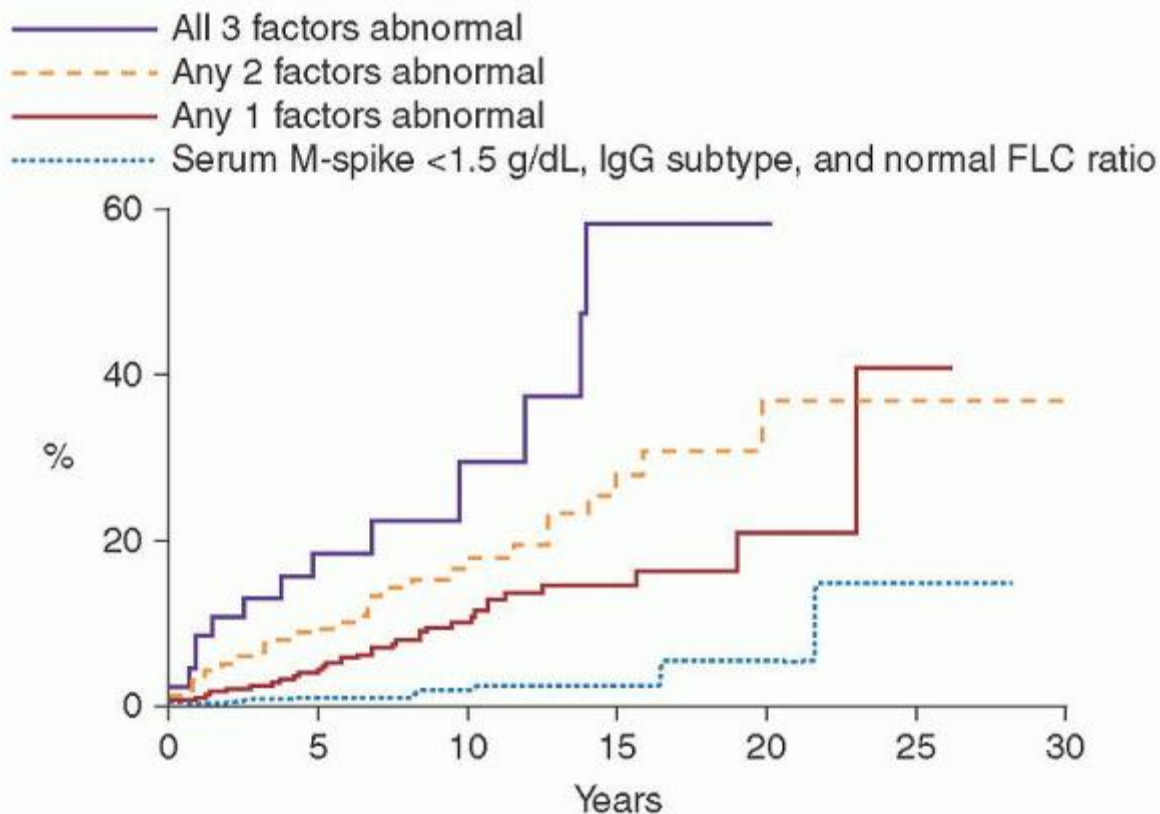

FIGURE 97.7. Risk of progression of monoclonal gammopathy of undetermined significance (MGUS) to myeloma or related disorder. The top curve illustrates the risk of progression with time in patients with three risk factors: abnormal serum $\kappa:\lambda$ free light chain (FLC) ratio (<0.26 or >1.65), a high serum monoclonal (M)-protein level (≥ 1.5 g/dl), and non-IgG MGUS. The

second curve is the risk of progression in patients with any two of these risk factors. The third curve illustrates the risk of progression with one of these risk factors. The bottom curve is the risk of progression for patients with none of the risk factors. (From Rajkumar SV, Kyle RA, Therneau TM, et al. Serum free light chain ratio is an independent risk factor for progression in monoclonal gammopathy of undetermined significance (MGUS) *Blood* 2005;106;812–817. © the American Society of Hematology.)

Life Expectancy and Cause of Death

In the Mayo Clinic study of 241 patients with MGUS, survival was shorter compared with an age- and sex-adjusted 1980 U.S. population (13.7 vs. 15.7 years).⁷⁷ Similarly, in the population-based study of 1,384 patients with MGUS in Southeastern Minnesota, median survival was 8.1 years compared with the expected median of 11.8 years for Minnesota residents of matched age and sex ($P < 0.001$).² In the study by van de Poel et al.⁷⁸, the long-term survival of 334 patients with MGUS was slightly shorter than the expected survival of an age- and sex-adjusted population. However, it is not clear from these studies if there is an excess risk of death from MGUS once the deaths due to malignant progression are accounted for.

TABLE 97.5 RISK-STRATIFICATION MODEL TO PREDICT PROGRESSION OF MONOCLONAL GAMMOPATHY OF UNDETERMINED SIGNIFICANCE TO MYELOMA OR RELATED DISORDERS

Risk Group	No. of Patients	Relative Risk	Absolute Risk of Progression at 20 Years (%)	Absolute Risk of Progression at 20 Years Accounting for Death as a Competing Risk (%)
Low risk (Serum M protein <1.5 g/dl, IgG subtype, normal FLC ratio (0.26-1.65))	449	1	5	2
Low-intermediate risk (Any 1 factor abnormal)	420	5.4	21	10
High-intermediate risk (Any 2 factors abnormal)	226	10.1	37	18
High risk (All 3 factors abnormal)	53	20.8	58	27

From Rajkumar SV, Kyle RA, Therneau TM, et al., Serum free light chain ratio is an independent risk factor for progression in monoclonal gammopathy of undetermined significance (MGUS) *Blood* 2005; 106;812-817. © The American Society of Hematology.

Management

The differentiation between MGUS and MM and other related disorders is based on the criteria listed on Table 97.1.⁸ At the time of initial diagnosis all patients need a complete blood count (CBC), serum calcium, and serum creatinine, and a radiographic survey of the skeleton. A bone marrow aspiration and biopsy is also recommended for most patients, and cytogenetic studies should be done at baseline on the bone marrow sample. Although a bone marrow biopsy is required for the definition of MGUS, not all patients need to have such an examination if the clinical picture is otherwise consistent with MGUS, and the patient is low-risk by the risk-stratification model shown on Table 97.5.¹⁹ If available, peripheral blood flow cytometry for circulating plasma cells should be done.

Once the diagnosis is made, the CBC, serum calcium, creatinine, and serum protein electrophoresis (and serum FLC if light chain MGUS) must be repeated in 6 months.⁷⁹ If stable, then in patients with low-risk MGUS, an assessment of the M protein level is needed only if symptoms worrisome for progression develop. This recommendation is based on the fact that the progression risk is very low in these patients, and that there are no data that monitoring can prevent complications in a timely manner.⁸⁰ In all other patients with MGUS, annual follow-up of the M protein is recommended lifelong.

No single factor can differentiate a patient with a benign monoclonal gammopathy from one in whom a malignant plasma cell disorder develops subsequently. However, the presence of a high plasma cell proliferative rate, circulating plasma

cells or other concerning clinical or laboratory features in a patient with MGUS needs to be followed up frequently for other evidence of progression.

P.2038

SMOLDERING MULTIPLE MYELOMA

Definition

SMM is defined by the presence of a serum M protein ≥ 3 g/dl and/or bone marrow plasma cells 10% to 60%, and absence of anemia, hypercalcemia, lytic bone lesions, or renal failure that can be attributed to the plasma cell proliferative disorder (Table 97.1).^{26, 27}

Epidemiology

SMM accounts for approximately 15% of all cases of newly diagnosed MM.⁸¹ In a study conducted at the M.D. Anderson Cancer Center, 95 (15%) of 638 patients with MM were considered to have asymptomatic MM.⁸² Other investigators have found a higher proportion of patients with SMM, but the sample size in these studies is small.^{83, 84} The prevalence estimates for SMM are distorted because many reports include asymptomatic patients with lytic bone lesions on skeletal survey. Some exclude patients with bone lesions on skeletal survey but include patients who have lytic lesions on magnetic resonance imaging. Calculation of the true prevalence of SMM on the basis of strict criteria is not available.

Pathophysiology

SMM is not a unique biologic entity.^{44, 45} It is a heterogeneous entity created primarily for clinical purposes to identify a group of patients with asymptomatic plasma cell dyscrasia that have a much higher risk of progression than MGUS (10% per year) so that these patients can be monitored more closely.^{10, 44, 85} From a biologic standpoint, SMM includes patients with pre-malignancy (biologic MGUS) and patients with early asymptomatic malignancy (MM).^{45, 86} Unfortunately, at present, histopathologic and other laboratory methods cannot distinguish SMM patients with pre-malignant MGUS from those who have early MM because there is no clear marker of malignancy that can distinguish a clonal pre-malignant plasma cell from a clonal malignant MM cell.

Clinical Features

As with MGUS, SMM is asymptomatic and is diagnosed during the routine work-up for a variety of symptoms and signs.^{79, 85} SMM should be differentiated from related plasma cell disorders using the criteria listed on Table 97.1.⁸

Prognosis

The risk of progression of SMM is much higher compared with MGUS, 10% per year compared with 1% per year. In a study of 276 patients with SMM, the risk of progression was 10% per year for the first 5 years, 5% per year for the next 3 years, and then 1% to 2% per year thereafter.¹⁰ This pattern of progression in which there is a plateau after 10 years is consistent with the heterogeneous nature of SMM; in the first 10 years, the subset of patients with early MM declare themselves with symptomatic disease, and after 10 years, the remaining cohort of patients is identical to MGUS in biology and clinical behavior. A subset of patients can remain free of progression for several years.⁹ Another study has reported a lower rate of progression of only 20% at 6 years.⁷⁶ However, the definition of SMM used in this study was different; it considered patients to have SMM only if they had no disease progression after 1 year of follow-up.

Prognostic Factors

The assessment of prognostic factors for SMM is hampered by varying diagnostic criteria used to define the cohort. Several studies also include patients with lytic lesions. Future studies of SMM need to use more uniformly accepted criteria so that results can be compared.

Extent of Bone Marrow Involvement

The natural history of SMM in the literature is based almost exclusively on data from patients with bone marrow plasma cells of less than 60%. In studies describing the diagnosis, natural history, and progression of SMM, no upper limit of bone marrow involvement was defined.¹⁰ In a study of 276 patients with SMM only 6 of 276 patients (2%) had a bone marrow plasma cell percentage of $\geq 60\%$.⁸⁷ Four of these 6 patients progressed to symptomatic MM between 3 to 9 months following diagnosis of SMM. The median progression free survival was 7.7 months. In a separate cohort of 655 patients with SMM seen from 1996 to 2010 at the Mayo Clinic, only 21 patients (3.2%) had a bone marrow plasma cell percentage

of $\geq 60\%$. Ninety-five percent of patients with $\geq 60\%$ bone marrow plasma cells progressed to MM within 2 years of diagnosis, with a median time to progression (TTP) of 7 months. Patients with SMM who have bone marrow involvement of 60% or greater almost invariably progress to MM within 2 years, and we now recommend that such patients be considered as MM regardless of the presence or absence of end organ damage and be initiated on therapy.^{86, 87} The prognostic value of levels of bone marrow involvement from 10% to 60% needs further study.

Circulating Plasma Cells

The ability of plasma cells to escape from the bone marrow microenvironment and circulate in the peripheral blood ("marrow emancipation") is a likely hallmark of aggressive disease as well as malignant transformation. Except for the small subset of solitary plasmacytoma, most MM patients present with lytic bone lesions in multiple bones, suggesting hematogenous dissemination once a malignant transformation has occurred. Patients with abnormal peripheral blood monoclonal plasma cell studies, defined as an increase in the number or proliferative rate of circulating plasma cells by immunofluorescent assays, are at higher risk for earlier progression to MM. In a study of 57 patients, Witzig et al. found that the median TTP was 9 months for those with abnormal circulating plasma cell values on a slide-based immunofluorescent assay versus 30 months for those with normal results ($P < 0.01$).⁸⁸ In a more recent study of 91 patients diagnosed with SMM at the Mayo Clinic, Bianchi et al. found that the level of circulating plasma cells could be used to identify patients with a high risk of progression to MM within the first 2 years.⁸⁹ Patients with a high level of circulating plasma cells on an immunofluorescent assay (absolute peripheral blood plasma cells $>5,000 \times 10^6/L$ and/or $>5\%$ cytoplasmic immunoglobulin positive plasma cells per 100 peripheral blood mononuclear cells) were significantly more likely to progress to active disease within 2 years compared with patients without high circulating plasma cells, 71 versus 25%, respectively, $P = 0.001$. Corresponding rates for progression within 3 years were 86 versus 35%, respectively, $P < 0.001$. The slide-based immunofluorescent method is not widely available, and these results can be more practically applied by detecting and quantifying circulating plasma cells using a six-color flow cytometric assay. In the flow assay, circulating plasma cells can be detected with high sensitivity by counting 150,000 mononuclear cell events, and can be used to calculate the absolute number of blood plasma cells per μL in SMM patients.

Abnormalities on Magnetic Resonance Imaging

Patients who undergo magnetic resonance imaging often have abnormalities detected even when the skeletal survey shows no

P.2039

lytic lesions.^{81, 90} Abnormal focal lesions on magnetic resonance imaging are associated with a shortened TTP in SMM.^{91, 92}

Serum Free Light Chain Assay

The serum FLC ratio can predict risk of progression in MGUS.¹⁹ Similarly, among 116 patients with solitary plasmacytoma, an abnormal FLC ratio was associated with higher risk of progression to MM ($P = 0.039$).²¹ In a study of 273 patients with SMM, an FLC ratio of ≤ 0.125 or ≥ 8 was an independent risk factor for progression (HR, 2.3; 95% CI, 1.6 to 3.2). Patients identified as high risk based on this assay had a 25% per year risk of progression in the first 2 years.²⁰

Absence of Normal Plasma Cells on Multiparametric Flow Cytometry

Certain immunophenotypic markers distinguish MM cells from normal PCs with a high degree of accuracy.⁹³ A Spanish study defines abnormal (MM-type) plasma cell immunophenotype as lack of expression of CD19 and/or CD45, expression of CD56, or weak expression of CD38. In SMM, if $>95\%$ plasma cells in the bone marrow have an abnormal immunophenotype, there is a 17-fold increased risk of progression.⁹⁴ In other words, the presence of $<5\%$ normal bone marrow plasma cells in a patient with SMM is associated with a significantly higher risk of progression.

Cytogenetic Abnormalities

The prognostic value of cytogenetic abnormalities in SMM have not been fully evaluated. In general, the presence of MYC abnormalities, 17p deletion, and RAS mutations, particularly K-RAS, are markers of malignant transformation and are likely associated with higher risk of progression in SMM.⁵⁹

Plasma Cell Proliferative Rate

A cardinal feature distinguishing MGUS from MM is the proliferative rate of the clonal plasma cell population. Indeed, using a slide-based immunofluorescent assay, there are preliminary data that high plasma cell labeling index (PCLI) values (≥ 1) identify patients with SMM who progress within 2 years with high specificity.⁹⁵ However, the PCLI method is subjective, and not widely available. A six-color flow cytometric assay, currently in clinical practice, offers greater

sensitivity and reproducibility. Further studies are needed to investigate the flow cytometry-based proliferative rate as a biomarker that can distinguish SMM patients with malignant transformation from those who have MGUS.

Management

The current standard of care in SMM is close follow-up once every 3 to 6 months without chemotherapy.^{79, 85} Two trials done prior to the arrival of thalidomide, lenalidomide, and bortezomib found no significant improvement in OS in patients who received immediate treatment with melphalan plus prednisone compared with those who received treatment at progression for stage I or asymptomatic MM. Hjorth et al. randomly assigned 50 patients with asymptomatic stage I MM to observation versus chemotherapy with melphalan and prednisone.⁹⁶ No differences were observed in OS between the two groups. Grignani et al. reported similar survival time with immediate or deferred therapy in a series of 44 patients with asymptomatic MM.⁹⁷ However, these trials were underpowered, and more data are needed.⁸⁶ The recommendation to observe closely without treatment until progression is also based on the possible short-term and long-term side effects of therapy, and the fact that in some patients SMM may not progress for months to years.

TABLE 97.6 POTENTIAL BIOMARKERS FOR PREDICTING HIGH RISK OF PROGRESSION IN SMOLDERING MULTIPLE MYELOMA

High involved/uninvolved free light chain ratios (≥ 100)

High levels of circulating plasma cells

High bone marrow plasma cell proliferative rate

Abnormal plasma cell immunophenotype

Marked suppression of uninvolved immunoglobulins

Specific cytogenetic abnormalities

Abnormalities on magnetic resonance imaging studies

Rise in monoclonal protein or light chain levels over time

From Rajkumar SV. Preventive strategies in monoclonal gammopathy of undetermined significance and smoldering multiple myeloma. *Am J Hematol* 2012;87:453-454.

More recently, clinical trials have found that thalidomide may delay TTP, but there are long-term side effects associated with this treatment that make it unsuitable for intervention in an asymptomatic population.^{98, 99} In a randomized trial, Witzig et al. compared thalidomide plus zoledronic acid versus zoledronic acid alone in patients with SMM.¹⁰⁰ The TTP was superior for patients treated with thalidomide plus zoledronic acid ($n = 35$) compared with zoledronic acid alone ($n = 33$); median TTP 2.4 years (95% CI:1.4 to 3.6) versus 1.2 years (95% CI:0.7 to 2.5), respectively, $P = 0.02$. Lenalidomide plus dexamethasone has also shown promising activity in high-risk SMM. A recent randomized trial of lenalidomide plus dexamethasone in high-risk SMM is an excellent example of this strategy, in which the investigators demonstrated a significant prolongation of TTP, and preliminary evidence of a survival benefit.¹⁰¹ An ECOG trial is comparing lenalidomide versus observation in this patient population. Other trials are exploring agents such as bisphosphonates, IL-1 β inhibitors, clarithromycin, and dehydroepiandrosterone in an attempt to delay progression of SMM to symptomatic MM.¹⁰²

In addition to clinical trials, efforts are also under way to identify biomarkers that can predict patients who will inevitably progress to symptomatic MM within 2 years with high (80% or greater) accuracy.^{45, 86} Many groups are actively working toward this goal, and several promising biomarkers have already been identified as candidates for further study (Table 97.6).^{20, 94} If such biomarkers are validated, patients with SMM who are considered as high risk (>80% progression risk within 2 years) may be candidates for initiation of therapy similar to MM.

VARIANTS OF MONOCLONAL GAMMOPATHY OF UNDETERMINED SIGNIFICANCE

Secondary Monoclonal Gammopathy of Undetermined Significance

During the course of MM, new M proteins of an isotype distinct from the original clone can arise, and are referred to as secondary MGUS. In a study of 1,942 patients with MM, 128 (6.6%) developed a secondary MGUS, at a median time of 12 months from the diagnosis of MM.¹⁰³ The median duration of secondary MGUS was 6 months. In 34 (27%) of the 128 patients with secondary MGUS, there were multiple secondary MGUSs of varying isotypes. Secondary MGUS was more common in patients who had undergone SCT compared to those who had not undergone such a procedure: 23% versus 2%, respectively, $P < 0.001$. Most secondary

P.2040

MGUS M proteins were small, detectable by immunofixation only in 84 patients (66%). OS was significantly superior among patients who developed secondary MGUS compared with those who did not develop a secondary MGUS: 73 months versus 38 months, respectively, $P < 0.001$. Other studies on secondary MGUS have also found a survival benefit with secondary MGUS that appears in MM patients following SCT.^{20, 104, 105} Among patients with secondary MGUS, there is a trend to better OS in those in whom the MGUS resolved compared to those with persistent MGUS.

Biclonal and Triclonal Gammopathy

Biclonal gammopathies are characterized by the presence of two different M proteins and occur in 3% to 6% of patients with monoclonal gammopathies. The two M proteins may be caused by the proliferation of two different clones of plasma cells, each producing an unrelated M protein, or by production of two M proteins by a single clone of plasma cells. In one study, biclonal gammopathy of undetermined significance was found in 37 of 57 patients with a biclonal gammopathy.¹⁰⁶ Riddell et al. reported that 2.5% of 1,135 patients with monoclonal gammopathy had biclonal gammopathy.¹⁰⁷ They postulated that in some patients complete class switching in a single plasma cell clone resulted in the production of two M proteins, but in others the M proteins arose from two separate plasma cell clones.

Triclonal gammopathy is rare. Most reported cases have been associated with immunodeficiency syndromes or lymphoproliferative disorders.^{108, 109, 110}

Idiopathic Bence Jones Proteinuria (Benign Monoclonal Light Chain Proteinuria)

Idiopathic Bence Jones proteinuria represents a more advanced stage of light chain MGUS, in which there is excretion of monoclonal light chains in the urine without any evidence of end organ damage to suggest MM or related disorder.^{111, 112} It is best considered as representing light chain SMM.⁷ In one study, two patients with stable serum M-protein levels excreted 0.8 g/d or more of Bence Jones protein for more than 17 years without disease progression.¹¹¹ In a separate study, seven patients with Bence Jones proteinuria (>1 g/24 hour) were described in whom there was no evidence of heavy chain expression in the serum or urine, and no evidence of MM or a related disorder.¹¹³ During long-term follow-up, three of the seven patients developed MM, two others had an increase of their Bence Jones protein (BJP), and two remained stable during follow-up. One of the two patients who remained stable died of lung cancer after 10 years follow-up without change in the BJP, whereas the other patient died of a cardiac arrhythmia 36 years after diagnosis. An autopsy showed no evidence of MM or AL amyloidosis. The precise cut-off of urine M protein excretion that will distinguish LC-MGUS from idiopathic Bence Jones proteinuria remains unclear and is the subject of ongoing studies. Although idiopathic Bence Jones proteinuria may remain stable for years, as with MGUS or SMM, there is a continued risk of progression to MM or related disorder, and therefore patients must be followed up indefinitely.

IgD Monoclonal Gammopathy of Undetermined Significance

In most studies of MGUS, there are few if any patients with IgD MGUS making it hard to ascertain the natural history of this entity. In general, because IgD is not usually secreted, the presence of a serum IgD M protein almost always indicates MM, AL amyloidosis, or plasma cell leukemia. However, IgD MGUS has been reported occasionally. O'Connor et al. described a patient with an IgD λ protein level of 0.5 g/dl who was followed up for more than 6 years without evidence of progressive disease.¹¹⁴ Similarly, an IgD λ MGUS patient has been reported from the Mayo Clinic who remained stable for more than 8 years without development of MM or related disorder.¹¹⁵ The IgD λ protein in this patient has remained stable after 24 years follow-up.

ASSOCIATION OF MONOCLONAL GAMMOPATHY WITH OTHER DISEASES

Serum protein electrophoresis is commonly done in patients presenting with a wide variety of clinical symptoms. This results in the incidental diagnosis of MGUS in a wide variety of clinical settings. Inasmuch as MGUS is common in the general population, and because the prevalence increases with age, "associations" with various diseases can occur just coincidentally. Thus over the years, over a hundred different medical conditions have been reported to be associated with MGUS, and most such reported associations are not likely causally related. The only method to ascertain definitively true disease associations with MGUS that are etiologically related is to screen all persons in a geographic population for the presence or absence of MGUS, and then determine the diseases that are significantly associated in patients with and without MGUS. Only one such systematic study has been conducted so far. Bida and colleagues studied the association of MGUS with all diseases in a population-based cohort of 17,398 patients, all uniformly tested for the presence or absence of MGUS.¹¹⁶ Among 17,398 persons, 605 MGUS cases and 16,793 negative controls were identified. The computerized Mayo Medical Index was used to obtain information on all diagnoses entered between January 1, 1975 and May 31, 2006

totaling 422,663 person-years of observations. The study encompassed all prior reported associations in detail, and also looked for new associations not hitherto described. Data were analyzed using stratified Poisson regression, adjusting for age, gender, and total person-years of observation. The study confirmed a significant association in 14 (18.7%) of 75 previously reported disease associations with MGUS, including vertebral and hip fractures and osteoporosis (Table 97.7). Several of these associations were known progression events of MGUS such as MM and Waldenström macroglobulinemia. A systematic analysis of all 16,062 diagnostic disease-codes found additional previously unreported associations, including hyperlipidemia, mycobacterium infection, and superficial thrombophlebitis.

Some commonly reported disease associations are briefly discussed below. In some of these cases, the association with MGUS is undoubtedly causal and has great clinical relevance such as MGUS-associated neuropathy, membranoproliferative glomerulonephritis (MPGN), and several dermatologic disorders. In others, the association is real, but carries limited clinical consequences such as M proteins that arise with immunosuppression. In others, such as the association with leukemia and other hematologic disorders, connective tissue disorders, neurologic disorders, and rheumatologic disorders it is impossible to determine whether the reported associations are coincidental, and they have limited clinical or etiologic significance. Most such associations are reported from studies in which not all patients were screened for the presence or absence of MGUS. Thus, the reported associations merely reflect the type of diseases and clinical settings in which a serum protein electrophoresis is ordered rather than a true association with the result of the test.

Monoclonal Gammopathy of Undetermined Significance Associated Neuropathy

MGUS-associated neuropathy is a well-described entity.^{117, 118} In a Mayo Clinic study of 279 patients with a sensorimotor peripheral

P.2041

neuropathy of unknown cause, MGUS was found in 6%.¹¹⁹ Other series have found similar rates.^{120, 121, 122} In one study, neuropathy was found on testing in 2 of 34 patients with IgG (6%) MGUS, 2 of 14 with IgA MGUS (14%), and 8 of 26 with IgM MGUS (31%).¹²²

However, the neuropathy was not clinically apparent in approximately 50% of these patients.

TABLE 97.7 DISEASE ASSOCIATIONS PREVIOUSLY REPORTED IN THE LITERATURE IN WHICH A SIGNIFICANT DISEASE ASSOCIATION WITH MONOCLONAL GAMMOPATHY OF UNDETERMINED SIGNIFICANCE (MGUS) COULD BE CONFIRMED AMONG RESIDENTS OF OLMSTED COUNTY, MINNESOTA

Description (Reference)	Positive MGUS Cases	Age and Sex		Risk Ratio (95% CI)	P- Value ^b
		Adjusted Case Rate per 100,000 Person-Years ^a	Positive Controls		
Macroglobulinemia ^{1, 290, 278}	5	55.1	1	0.696.2(11.0-836.5)	<0.001
Multiple myeloma ²⁷⁸	29	257.4	19	7.932.6(18.1-58.7)	<0.001
Plasma cell proliferative disorder ²⁷⁸	11	87.1	9	3.128.0(11.4-68.7)	<0.001
Amyloidosis ²⁷⁸	7	85.2	18	11.87.2(3.0-17.4)	<0.001
CIDP ^{124, 291}	2	14.9	8	2.55.9(1.2-28.4)	0.03
Liver transplant ²⁹²	2	13.9	10	2.65.4(1.2-25.3)	0.03

Kidney transplant ^{174, 176, 177, 293}	5	34.6	38	9.83.5(1.4-9.1)	0.01
Lymphoproliferative disease ²⁹⁴	17	161.2	105	48.03.4(2.0-5.6)	<0.001
Autonomic neuropathy ¹²²	5	35.8	39	11.03.2(1.3-8.3)	0.01
Vertebral fracture	46	511.1	478	263.91.9(1.4-2.6)	<0.001
Hip fracture	36	581.6	388	377.11.5(1.1-2.2)	0.01
Hypercalcemia ²⁹⁵	40	297.5	736	214.91.4(1.0-1.9)	0.05
Osteoporosis ²⁹⁶	153	1,701.1	3,013	1,407.71.2(1.0-1.4)	0.02
Urticaria ^{171, 297, 298}	20	144.8	1,003	242.90.6(0.4-0.9)	0.02

CI, confidence interval; CIDP, chronic inflammatory demyelinating polyradiculoneuropathy; MGUS, monoclonal gammopathy of undetermined significance

^a Rates age and sex adjusted

^b Unadjusted P values.

From Bida JP, Kyle RA, Therneau TM, et al. Disease associations with monoclonal gammopathy of undetermined significance: a population-based study of 17,398 patients. *Mayo Clin Proc* 2009;84:685-693.

In most cases, MGUS-related neuropathy is predominantly a demyelinating process with some features of axonal degeneration.¹²³ When patients classified as having chronic inflammatory demyelinating polyradiculoneuropathy (CIDP) are studied, patients with an associated MGUS have a more indolent course, less severe motor symptoms and weakness, but more frequent sensory loss.¹²⁴ Occasionally a MGUS neuropathy can present with a predominant axonal pattern. This subtype is associated with mild, symmetric, slowly progressive, predominantly sensory neuropathy involving the lower extremities.¹²⁵ In a Mayo Clinic series, the size of the M spike was not associated with the severity of the neuropathy.¹²⁶

The most common type of M protein in MGUS neuropathy is IgM. The clinical and electrodiagnostic manifestations resemble those of chronic inflammatory demyelinating polyneuropathy.^{122, 127} Motor involvement is less prominent than sensory involvement. Cranial nerve and autonomic functions are intact.¹²⁸ The course of the neuropathy is progressive in more than two-thirds of patients.¹²⁶ In approximately half of patients with an IgM monoclonal gammopathy and peripheral neuropathy, the M protein binds to myelin-associated glycoprotein (MAG).^{129, 130} The MAG-reactive polyneuropathies are characterized by a slowly progressive, mainly sensory neuropathy beginning in the distal extremities and extending proximally. In a Mayo Clinic study, the type and severity of neuropathy with anti-MAG were not greatly different from those without anti-MAG.¹²⁶ Discriminative and proprioceptive modalities are more severely involved than touch, pain, and temperature. The IgM protein may also bind to various other peripheral nerve components such as anti-GM-1 IgM antibodies, but the pathogenetic relationship needs further study.^{131, 132, 133}

The relationship of IgG and IgA M proteins to peripheral neuropathy is less well documented.^{118, 134} IgG and IgA neuropathy may have more motor impairment and may have more features of axonal degeneration than IgM neuropathy.¹²²

Differential Diagnosis

Inasmuch as 3% to 4% of the general population has an MGUS, in most patients the association of MGUS and neuropathy is likely coincidental. Therefore, the first step in a diagnostic evaluation should be to consider and exclude other causes of neuropathy. MGUS neuropathy is a diagnosis of exclusion, and there are no specific clinical or laboratory tests that are specific for the diagnosis. Intervention often involves administering anticancer therapy in patients without malignancy, therefore a diagnosis of MGUS neuropathy should not be made lightly. In the absence of other causes of neuropathy, the younger the patient, and the more severe the neuropathy, one should be more serious in considering MGUS as the cause of neuropathy and one that warrants intervention. The differential diagnosis of MGUS neuropathy should also consider other plasma cell disorders that are

P.2042

associated with neuropathy, namely AL amyloidosis and POEMS syndrome.^{135, 136, 137} In neuropathy related to AL amyloidosis both upper and lower extremities tend to be affected, whereas in MGUS neuropathy peripheral regions of the lower extremities are primarily affected. AL amyloidosis also has a greater tendency to be associated with autonomic features (postural hypotension, sphincter dysfunction, anhidrosis). In most cases, MGUS neuropathy tends to be primarily demyelinating, whereas neuropathy in AL amyloidosis is characterized by axonal degeneration. A diagnosis of AL amyloidosis is often suggested by the presence of other organ involvement, and requires demonstration of Congo red positive amyloid material on fat aspirate, or an affected organ. POEMS syndrome is associated with a predominantly motor chronic inflammatory demyelinating polyneuropathy, sclerotic bone lesions, and a varying number of associated abnormalities such as hepatomegaly, hyperpigmentation, hypertrichosis, gynecomastia, testicular atrophy, clubbing, polycythemia, thrombocytosis, and Castleman's disease. In POEMS syndrome, the neuropathy is often progressive and disabling. Although MGUS neuropathy is also demyelinating in most instances, it is typically more of a sensory neuropathy. MM and WM can also be associated with neuropathy, either directly due to the plasma cell disorder, or as a result of therapy. When related to the plasma cell disorder, the neuropathy in MM and macroglobulinemia is similar in pathogenesis to MGUS neuropathy; in contrast the pathogenesis of neuropathy in AL amyloidosis and POEMS syndrome is probably different mechanistically from MGUS neuropathy.

Treatment

The results of treatment of peripheral neuropathy and monoclonal gammopathy have been disappointing. A variety of interventions has been tried, but there are few good trials.¹³⁸ Most treatment recommendations are based on anecdotal experience. Intravenous immunoglobulin has been used, but the results have been disappointing.¹³⁹ However, intravenous immune globulin may be of benefit in patients with IgG MGUS related neuropathy, with 40% of patients showing improvement in one study.¹⁴⁰ Plasmapheresis has been of benefit in some patients.¹⁴¹ In a double-blind controlled trial conducted at the Mayo Clinic, 39 patients with peripheral neuropathy and MGUS of the IgG, IgA, or IgM type were randomly assigned to undergo plasmapheresis or sham plasmapheresis.¹⁴² Plasma exchange prevented worsening of or ameliorated the neuropathy. Patients with IgG or IgA gammopathy had a better response to plasma exchange than those with IgM gammopathy. In another study, 8 of 13 patients with a monoclonal gammopathy and peripheral neuropathy obtained benefit from plasma exchange.¹⁴³ Patients who do not respond to this program may be given rituximab when the M protein is of the IgM type or standard treatments used for MM such as lenalidomide and dexamethasone, or melphalan plus prednisone for IgG and IgA gammopathies.¹⁴⁴ In one study, 21 patients with IgM MGUS neuropathy treated with rituximab were compared with 13 untreated controls.¹⁴⁵ Rituximab treatment was associated with decreased IgM levels and improvement in strength. Two randomized trials have investigated the role of rituximab in IgM MGUS neuropathy.¹⁴⁶ In one trial, the authors randomized 26 patients with anti-MAG positive IgM MGUS to rituximab versus placebo.¹⁴⁷ An improvement in neuropathy was noted in approximately 25% of patients. In another randomized trial, 54 patients were studied, and a similar benefit was observed.¹⁴⁸ Additional studies, with placebo controls and blinded outcome measures, are warranted to further test the efficacy of rituximab treatment of IgM-associated polyneuropathies. In patients with IgM MGUS neuropathy refractory to rituximab, fludarabine or other treatments used for WM can be tried.^{149, 150, 151}

Membranoproliferative Glomerulonephritis

A substantial proportion of cases with "idiopathic" immune-complex mediated MPGN are now felt to be related to MGUS.^{152, 153} In a study of 126 patients with MPGN conducted at the Mayo Clinic, 22% were associated with a monoclonal gammopathy.¹⁵² Excluding other known causes such as hepatitis B and hepatitis C, approximately 40% of cases of idiopathic MPGN could be attributed to MGUS. MGUS-associated MPGN is characterized by subendothelial and mesangial deposition of immune complexes that show light chain restriction on immunofluorescent studies. The optimal treatment has not been well defined, but depending on the clinical symptoms, therapy targeted against the M protein is reasonable.¹⁵³ In a small subset of patients light chain restricted MPGN is seen on renal biopsy with no M protein in the serum or urine, and no clonal plasma cells in the bone marrow. The natural history of this subset is unclear.

Inasmuch as the kidney is often involved in plasma cell disorders such as light chain cast nephropathy, light chain deposition disease, and AL amyloidosis, renal involvement in patients with M proteins requires a careful evaluation and differential diagnosis. Besides MPGN and these known entities, other reported associations include rapidly progressive glomerulonephritis,¹⁵⁴ dense deposit disease,¹⁵⁵ and "idiopathic" focal and segmental glomerulosclerosis.¹⁵⁶

Dermatologic Diseases

A variety of dermatologic diseases has been associated with MGUS.¹⁵⁷ Lichen myxedematosus (papular mucinosis, scleromyxedema) is a rare dermatologic condition frequently associated with an IgG λ monoclonal protein.¹⁵⁸ Scleredema (Buschke's disease) has been noted with an M protein, but the role of the M protein is unknown.¹⁵⁹ Other known associations include pyoderma gangrenosum,¹⁶⁰ diffuse plane xanthomatosis,^{161, 162, 163} and subcorneal pustular dermatosis.^{164, 165} Necrobiotic xanthogranuloma, is frequently found with an IgG M protein,^{166, 167} and Schnitzler's syndrome is a rare disorder characterized by the presence of chronic urticaria and an IgM monoclonal gammopathy.^{168, 169, 170, 171}

Immunosuppression

M proteins arise in patients with immunosuppression. M proteins have been reported in patients with the acquired human immunodeficiency syndrome, but do not appear to have any prognostic significance.^{172, 173} M proteins have been detected in approximately 5% to 10% of patients following renal transplantation.^{174, 175, 176} Others have reported rates as high as 30%.^{177, 178} In fact, in one study, the incidence was 10 times greater than that in a control group with chronic renal insufficiency who were receiving dialysis.¹⁷⁷ The presence of cytomegalovirus infection after renal transplantation in pediatric patients has been associated with an increased incidence of M proteins.¹⁷⁹ M proteins have also been reported in patients receiving other forms of organ transplantation. Approximately 25% of patients following heart transplantation,^{180, 181} and approximately 30% of patients following liver transplantation have been reported to develop M proteins.^{182, 183}

The effect of organ transplantation on patients with MGUS is unclear. In a report of five patients with MGUS undergoing transplantation, SMM developed in two and one had an increase in the serum M protein.¹⁸⁴ Amyloidosis developed 10 years after an IgG κ M protein was recognized after renal transplantation in another patient. In a more recent study, 3,518 patients who underwent renal transplantation at the Mayo Clinic were studied.¹⁸⁵ MGUS was identified in 42 patients: 23 prior to transplantation, and 19 after transplantation. Of the patients who had MGUS prior to

P.2043

renal transplantation, 2 developed progression of the plasma cell disorder, both to SMM. None of the 19 patients who developed an MGUS after transplant progressed to MM or related disorder. Thus, progression of MGUS following renal transplantation is rare. A few patients in this study developed post-transplant lymphoproliferative disorder and the relationship of this entity with MGUS needs further study.

Leukemia and Other Hematologic Disorders

Mailankody and colleagues studied the risk of acute myeloid leukemia (AML) and myelodysplastic syndrome (MDS) in patients with MM and MGUS using population-based data from Sweden.¹⁸⁶ They identified 8,740 patients with MM and 5,652 patients with MGUS diagnosed between 1986 and 2005. They found a 11.5-fold increased risk of AML or MDS in patients with MM. But more strikingly, MGUS patients also had an 8-fold (95% CI 5.4 to 11.4) increased risk of AML/MDS compared with controls. The risk was confined to IgG/IgA MGUS, and the highest risk was seen in patients with an M protein of >1.5 g/dl. A subsequent study from the Mayo Clinic has also found an increased risk of acute leukemia and MDS in MGUS.¹⁸⁷ This study utilized data from the population-based cohort established in Olmsted County to estimate the prevalence of MGUS in the general population and therefore was not subject to detection or ascertainment bias.³ MGUS patients had a significantly higher risk of developing acute leukemia (AML or acute lymphoblastic leukemia) or MDS compared with controls, risk ratio 2.20 (95% CI 1.23, 3.92), $P = 0.008$.¹⁸⁷ These findings suggest that there may be an inherent increased risk of acute leukemia and MDS in patients with plasma cell disorders that is independent of MM therapy.

An association between MGUS and chronic lymphocytic leukemia has been reported. In one study, 100 patients with chronic lymphocytic leukemia and an M protein in the serum or urine were described.¹⁸⁸ The M protein type was IgM in 38%, and IgG in 51%. No major differences were apparent in patients with chronic lymphocytic leukemia, whether they had an IgG or an IgM M protein. Monoclonal gammopathy also has been reported in hairy cell leukemia,¹⁸⁹ adult T-cell leukemia,¹⁹⁰ mycosis fungoides,¹⁹¹ Sézary syndrome,¹⁹² non-Hodgkin lymphoma,¹⁹³ Kaposi sarcoma,¹⁹⁴ and chronic myeloid leukemia,¹⁹⁵ but the significance of these associations is not known.

MGUS has been reported in patients with MDS,¹⁹⁶ and myeloproliferative disorders including chronic myeloid leukemia, myelofibrosis and polycythemia vera.^{197, 198, 199, 200, 201} Duhrsen et al. found that the frequency of M proteins was 8.5% (16 of 188) among patients with idiopathic myelofibrosis, which suggests a possible true association.²⁰¹

MGUS has also been linked to a variety of coagulation disorders. Cases of acquired von Willebrand's disease resulting from monoclonal gammopathy have also been described.^{201, 202, 203, 204} In several patients, a specific interaction between the M component and the antigenic portion of the factor VIII molecule was demonstrated.^{205, 206, 207, 208, 209} In these patients, intravenous gamma globulin had a longer-lasting effect than did infusion of von Willebrand's factor concentrate.²¹⁰ In addition to acquired von Willebrand disease, a bleeding diathesis may also occur in MGUS from binding of an M protein to thrombin.²¹¹ Thromboembolic disease has also been noted to be more frequent in patients with MGUS.²¹² The mechanisms are unknown, but in rare instances the paraprotein in MGUS may have lupus anticoagulant activity.²¹³ An increased incidence of antiphospholipid antibodies has also been reported in patients with MGUS.²¹⁴

Other rare associations that have been reported include Gaucher disease²¹⁵ and pernicious anemia,²¹⁶ as well as pure red cell aplasia caused by a block in the maturation of the erythroid burst forming unit (114).^{217, 218}

Connective Tissue Disorders

Rheumatoid arthritis,²¹⁹ seronegative erosive arthritis,²²⁰ systemic lupus erythematosus, and other connective tissue disorders have been reported with MGUS.^{221, 222, 223} Polymyalgia rheumatica and polymyositis have also been reported with monoclonal gammopathy.^{224, 225, 226}

Neurologic Disorders

Several instances of monoclonal gammopathy and amyotrophic lateral sclerosis have been reported, including one series of 120 patients with amyotrophic lateral sclerosis in whom 11 (9%) had an associated M protein.^{227, 228, 229} However, a causal relationship has not been established. Other neurologic disorders that been reported in association with MGUS include myasthenia gravis,^{230, 231} ataxia-telangiectasia,^{232, 233} and nemaline myopathy.²³⁴

Miscellaneous Conditions

Systemic Capillary Leak Syndrome

Numerous other associations have been reported with MGUS. One important association is with angioneurotic edema and acquired deficiency of C1 esterase inhibitor.²³⁵ In some instances, the M protein functions as an antibody that modifies the interaction between C1 inhibitor and its target protein.²³⁶ The most important consequence is systemic capillary leak syndrome which can be life-threatening.²³⁷ In a review of the literature, all 21 patients with a systemic capillary leak syndrome had a serum M protein (IgG κ in 12; IgG λ in 7; IgA in 1; IgG with an unspecified light chain in 1).²³⁸ In another series of 25 patients with systemic capillary leak syndrome seen at the Mayo Clinic, the median age at diagnosis was 44 years.²³⁹ The median time to diagnosis from symptom onset was approximately 1 year, but in 25% the time to diagnosis was longer than 4 years (interquartile range, 0.5 to 4.1 years). A monoclonal gammopathy, mostly IgG-κ type, was found in 19 patients (76%). The degree of albumin decrease during an attack was correlated with the development of rhabdomyolysis. Acute attacks are usually managed with fluids and supportive care. Long-term prophylactic therapy usually consists of theophylline (or aminophylline) along with terbutaline. A leukotriene inhibitor can be tried in patients refractory to theophylline or terbutaline.

Hepatitis C

Most cases of type II cryoglobulinemia are related to hepatitis C, and are associated with an IgM monoclonal protein.^{240, 241} The incidence of hepatitis C virus infection was 69% in 94 patients with mixed cryoglobulinemia and 14% in 107 patients without cryoglobulinemia²⁴². In another series of 102 cases of MM, WM, or MGUS, hepatitis C virus infection was found in 16% of patients but in only 5% of controls.²⁴³ An M protein was found in 11% of 239 hepatitis C virus-positive patients but in only 1% of 98 hepatitis C virus-negative patients. Thus, the prevalence of M proteins in patients with hepatitis C virus-related chronic liver diseases is high.²⁴⁴

Other Disorders

M proteins have been noted in numerous other disorders such as chronic active hepatitis, primary biliary cirrhosis, Henoch-Schönlein purpura, bacterial endocarditis, Hashimoto thyroiditis, idiopathic pulmonary fibrosis, pulmonary alveolar proteinosis, idiopathic pulmonary hemosiderosis, sarcoidosis, thymoma,

P.2044

hereditary spherocytosis, Doyme macular heredodystrophy, and eosinophilic fibrohistiocytic lesions of the bone marrow, but these associations are likely coincidental.¹¹⁶ M proteins have also been associated with corneal crystalline deposits and hyperlipoproteinemia, and the relationship of monoclonal gammopathy to these diseases is not clear.

M Proteins with Antibody Activity

M proteins may have autoantibody activity, and there have been numerous reported associations.^{245, 246} Of 612 patients in whom M proteins were studied for their antibody activity against actin, tubulin, thyroglobulin, myosin, myoglobin, fetuin, albumin, transferrin, and double-stranded DNA, 36 (5.9%) had antibody activity.²⁴⁷ In some patients with MGUS, MM, or Waldenström macroglobulinemia, the M protein has exhibited unusual specificities to dextran,²⁴⁸ antistreptolysin O,²⁴⁹ antinuclear activity,²⁵⁰ smooth muscle,²⁵¹ riboflavin,^{252, 253} thyroglobulin,²⁵⁴ insulin,²⁵⁵ double-stranded DNA,²⁵⁶ apolipoprotein,²⁵⁷ thyroxine,²⁵⁸ cephalin,²⁵⁹ lactate dehydrogenase,²⁶⁰ anti-HIV,²⁶¹ and antibiotics.²⁶²

In one patient, xanthoderma-xanthotrichia (yellow discoloration of the skin and hair) was caused by an IgG λ protein with antiriboflavin antibody activity. Xanthoderma disappeared when the IgG level decreased to less than 2 g/dl after chemotherapy.²⁵² Another patient with similar clinical and laboratory features has been reported.²⁵³

DiMinno et al. described a patient with MM and a bleeding diathesis in whom an IgG1 κ protein reacted with platelet glycoprotein IIIa.²⁶³ This produced a thrombasthenia-like state. An IgM κ M protein that agglutinated platelets and produced a pseudothrombocytopenia has been reported.²⁶⁴

The binding of calcium by M protein may produce hypercalcemia without symptomatic or pathologic consequences.^{265, 266} This situation must be recognized so that patients are not treated for hypercalcemia.²⁶⁷ Copper-binding M protein has been found in two patients with MM.^{268, 269} Binding of an M protein with transferrin, producing a high serum iron level, has been reported.^{270, 271} Hilgard et al. described a patient with multiple thrombi from intravascular precipitation of an IgG λ monoclonal cryoglobulin with transferrin and fibrinogen.²⁷² Pettersson et al. described a patient with an IgG κ protein that bound phosphate, producing a spurious elevation of the serum phosphorus level.²⁷³ Transient M proteins with antibody activity have also been recognized after infection in children. One report described a newborn with congenital toxoplasmosis who had an IgG λ protein.²⁷⁴

REFERENCES

1. Kyle RA. Monoclonal gammopathy of undetermined significance. Natural history in 241 cases. *Am J Med* 1978;64:814-826.
2. Kyle RA, Therneau TM, Rajkumar SV, et al. A long-term study of prognosis of monoclonal gammopathy of undetermined significance. *N Engl J Med* 2002;346:564-569.
3. Kyle RA, Therneau TM, Rajkumar SV, et al. Prevalence of monoclonal gammopathy of undetermined significance. *N Engl J Med* 2006;354:1362-1369.
4. Dispenzieri A, Katzmann JA, Kyle RA, et al. Prevalence and risk of progression of light-chain monoclonal gammopathy of undetermined significance: a retrospective population-based cohort study. *Lancet* 2010;375:1721-1728.
5. Waldenström J. Studies on conditions associated with disturbed gamma globulin formation (gammopathies). *Harvey Lect* 1960-1961;56:211-231.
6. Axelsson U, Bachmann R, Hallen J. Frequency of pathological proteins (M-components) om 6,995 sera from an adult population. *Acta Med Scand* 1966;179:235-247.
7. Rajkumar SV, Kyle RA, Buadi FK. Advances in the diagnosis, classification, risk stratification, and management of monoclonal gammopathy of undetermined significance: implications for recategorizing disease entities in the presence of evolving scientific evidence. *Mayo Clin Proc* 2010;85:945-948.
8. Kyle RA, Rajkumar SV. Criteria for diagnosis, staging, risk stratification and response assessment of multiple myeloma. *Leukemia* 2009;23:3-9.
9. Kyle RA, Greipp PR. Smoldering multiple myeloma. *N Engl J Med* 1980; 302:1347-1349.
10. Kyle RA, Remstein ED, Therneau TM, et al. Clinical course and prognosis of smoldering (asymptomatic) multiple myeloma. *N Engl J Med* 2007;356: 2582-2590.
11. Rajkumar SV. Plasma cell disorders. In: Goldman L, Schafer AI, eds. *Cecil textbook of medicine*, 24th ed. Philadelphia, PA: Elsevier, 2012:1233-1243.
12. Katzmann JA, Kyle RA, Benson J, et al. Screening panels for detection of monoclonal gammopathies. *Clin Chem* 2009;55:1517-1522.
13. Kyle RA. Sequence of testing for monoclonal gammopathies. *Arch Pathol Lab Med* 1999;123:114-118.

14. Riches PG, Sheldon J, Smith AM, Hobbs JR. Overestimation of monoclonal immunoglobulin by immunochemical methods. *Ann Clin Biochem* 1991;28 (Pt 3):253-259.
15. Katzmann JA, Clark RJ, Abraham RS, et al. Serum reference intervals and diagnostic ranges for free kappa and free lambda immunoglobulin light chains: relative sensitivity for detection of monoclonal light chains. *Clin Chem* 2002;48:1437-1444.
16. Bradwell AR, Carr-Smith HD, Mead GP, Harvey TC, Drayson MT. Serum test for assessment of patients with Bence Jones myeloma. *Lancet* 2003;361:489-491.
17. Abraham RS, Clark RJ, Bryant SC, et al. Correlation of serum immunoglobulin free light chain quantification with urinary Bence Jones protein in light chain myeloma. *Clin Chem* 2002;48:655-657.
18. Katzmann JA, Dispenzieri A, Kyle R, et al. Elimination of the need for urine studies in the screening algorithm for monoclonal gammopathies by using serum immunofixation and free light chain assays. *Mayo Clin Proc* 2006;81:1575-1578.
19. Rajkumar SV, Kyle RA, Therneau TM, et al. Serum free light chain ratio is an independent risk factor for progression in monoclonal gammopathy of undetermined significance (MGUS). *Blood* 2005;106:812-817.
20. Dispenzieri A, Kyle RA, Katzmann JA, et al. Immunoglobulin free light chain ratio is an independent risk factor for progression of smoldering (asymptomatic) multiple myeloma. *Blood* 2008;111:785-789.
21. Dingli D, Kyle RA, Rajkumar SV, et al. Immunoglobulin free light chains and solitary plasmacytoma of bone. *Blood* 2006;108:1979-1983.
22. Drayson M, Tang LX, Drew R, Mead GP, Carr-Smith H, Bradwell AR. Serum free light-chain measurements for identifying and monitoring patients with nonsecretory multiple myeloma. *Blood* 2001;97:2900-2902.
23. Lachmann HJ, Gallimore R, Gillmore JD, et al. Outcome in systemic AL amyloidosis in relation to changes in concentration of circulating free immunoglobulin light chains following chemotherapy. *Br J Haematol* 2003;122:78-84.
24. Dispenzieri A, Kyle R, Merlini G, et al. International Myeloma Working Group guidelines for serum-free light chain analysis in multiple myeloma and related disorders. *Leukemia* 2009;23:215-224.
25. Rajkumar SV, Harousseau JL, Durie B, et al. Consensus recommendations for the uniform reporting of clinical trials: report of the International Myeloma Workshop Consensus Panel 1. *Blood* 2011;117:4691-4695.
26. Kyle RA, Rajkumar SV. Plasma cell disorders. In: Goldman L, Ausiello D, eds. *Cecil textbook of medicine*, 22nd ed. Philadelphia, PA: W. B. Saunders, 2004:1184-1195.
27. Rajkumar SV. MGUS and smoldering multiple myeloma: update on pathogenesis, natural history, and management. *Hematology (Am Soc Hematol Educ Program)* 2005;2005:340-345.
28. Wadhera RK, Rajkumar SV. Prevalence of monoclonal gammopathy of undetermined significance: a systematic review. *Mayo Clin Proc* 2010;85:933-942.
29. Cohen HJ, Crawford J, Rao MK, Pieper CF, Currie MS. Racial differences in the prevalence of monoclonal gammopathy in a community-based sample of the elderly.[erratum appears in *Am J Med* 1998 Oct;105(4):362]. *Am J Med* 1998;104:439-444.
30. Landgren O, Gridley G, Turesson I, et al. Risk of monoclonal gammopathy of undetermined significance (MGUS) and subsequent multiple myeloma among African American and white veterans in the United States. *Blood* 2006;107:904-906.
31. Landgren O, Katzmann JA, Hsing AW, et al. Prevalence of monoclonal gammopathy of undetermined significance among men in Ghana. *Mayo Clin Proc* 2007;82:1468-1473.
32. Landgren O, Rajkumar SV, Pfeiffer RM, et al. Obesity is associated with an increased risk of monoclonal gammopathy of undetermined significance (MGUS) among African-American and Caucasian women. *Blood* 2010;116:1056-1059.
33. Bowden M, Crawford J, Cohen HJ, Noyama O. A comparative study of monoclonal gammopathies and immunoglobulin levels in Japanese and United States elderly. *J Am Geriatr Soc* 1993;41:11-14.
34. Iwanaga M, Tagawa M, Tsukasaki K, Kamihira S, Tomonaga M. Prevalence of Monoclonal Gammopathy of Undetermined Significance: study of 52,802 Persons in Nagasaki City, Japan. *Mayo Clin Proc* 2007;82:1474-1479.
35. Therneau TM, Kyle RA, Melton III LJ, et al. Incidence of monoclonal gammopathy of undetermined significance and estimation of duration before first clinical recognition. *Mayo Clin Proc* 2012;87(11):1071-1079.

36. Greenberg AJ, Vachon CM, Rajkumar SV. Disparities in the prevalence, pathogenesis and progression of monoclonal gammopathy of undetermined significance and multiple myeloma between blacks and whites. *Leukemia* 2012;26(4):609-614.
37. Greenberg AJ, Rajkumar SV, Vachon CM. Familial monoclonal gammopathy of undetermined significance and multiple myeloma: epidemiology, risk factors, and biological characteristics. *Blood* 2012;119:4771-4779.
38. Vachon CM, Kyle RA, Therneau TM, et al. Increased risk of monoclonal gammopathy in first-degree relatives of patients with multiple myeloma or monoclonal gammopathy of undetermined significance. *Blood* 2009;114:785-790.
39. Greenberg AJ, Rajkumar SV, Larson DR, et al. Increased prevalence of light chain monoclonal gammopathy of undetermined significance (LC-MGUS) in first-degree relatives of individuals with multiple myeloma. *Br J Haematol* 2012;157:472-475.
40. Zemble RM, Takach PA, Levinson AI. The relationship between hypogammaglobulinemia, monoclonal gammopathy of undetermined significance and humoral immunodeficiency: a case series. *J Clin Immunol* 2011;31:737-743.
41. Passweg J, Thiel G, Bock HA. Monoclonal gammopathy after intense induction immunosuppression in renal transplant patients. *Nephrol Dial Transplant* 1996;11:2461-2465.
42. Landgren O, Kyle RA, Pfeiffer RM, et al. Monoclonal gammopathy of undetermined significance (MGUS) consistently precedes multiple myeloma: a prospective study. *Blood* 2009;113:5412-5417.
43. Weiss BM, Abadie J, Verma P, Howard RS, Kuehl WM. A monoclonal gammopathy precedes multiple myeloma in most patients. *Blood* 2009;113:5418-5422.
44. Rajkumar SV. Prevention of Progression in Monoclonal Gammopathy of Undetermined Significance. *Clin Cancer Res* 2009;15:5606-5608.
45. Rajkumar SV. Preventive strategies in monoclonal gammopathy of undetermined significance and smoldering multiple myeloma. *Am J Hematol* 2012;87:453-454.
46. Jego G, Bataille R, Geffroy-Luseau A, Descamps G, Pellat-Deceunynck C. Pathogen-associated molecular patterns are growth and survival factors for human myeloma cells through Toll-like receptors. *Leukemia* 2006;20: 1130-1137.
47. Bohnhorst J, Rasmussen T, Moen SH, et al. Toll-like receptors mediate proliferation and survival of multiple myeloma cells. *Leukemia* 2006;20:1138-1144.
48. Mantovani A, Garlanda C. Inflammation and multiple myeloma: the Toll connection. *Leukemia* 2006;20:937-938.
49. Zent CS, Wilson CS, Tricot G, et al. Oligoclonal protein bands and Ig isotype switching in multiple myeloma treated with high-dose therapy and hematopoietic cell transplantation. *Blood* 1998;91:3518-3523.
50. Amara S, Dezube BJ, Cooley TP, Pantanowitz L, Aboulafia DM. HIV-associated monoclonal gammopathy: a retrospective analysis of 25 patients.[see comment]. *Clin Infect Dis* 2006;43:1198-1205.
51. Dezube BJ, Aboulafia DM, Pantanowitz L. Plasma cell disorders in HIV-infected patients: from benign gammopathy to multiple myeloma. *AIDS Read* 2004;14:372-374.
52. Fonseca R, Barlogie B, Bataille R, et al. Genetics and cytogenetics of multiple myeloma: a workshop report. *Cancer Res* 2004;64:1546-1558.
53. Kyle RA, Rajkumar SV. Multiple myeloma. *N Engl J Med* 2004;351: 1860-1873.
54. Kuehl WM, Bergsagel PL. Multiple myeloma: evolving genetic events and host interactions. *Nat Rev Cancer* 2002;2:175-187.
55. Bergsagel PL, Kuehl WM. Chromosome translocations in multiple myeloma. *Oncogene* 2001;20:5611-5622.
56. Fonseca R, Bailey RJ, Ahmann GJ, et al. Genomic abnormalities in monoclonal gammopathy of undetermined significance. *Blood* 2002;100:1417-1424.
57. Kaufmann H, Ackermann J, Baldia C, et al. Both IGH translocations and chromosome 13q deletions are early events in monoclonal gammopathy of undetermined significance and do not evolve during transition to multiple myeloma. *Leukemia* 2004;18:1879-1882.
58. Konigsberg R, Ackermann J, Kaufmann H, et al. Deletions of chromosome 13q in monoclonal gammopathy of undetermined significance. *Leukemia* 2000;14:1975-1979.

59. Chng WJ, Gonzalez-Paz N, Price-Troska T, et al. Clinical and biological significance of RAS mutations in multiple myeloma. *Leukemia* 2008;22:2280-2284.
60. Rajkumar SV, Leong T, Roche PC, et al. Prognostic value of bone marrow angiogenesis in multiple myeloma. *Clin Cancer Res* 2000;6:3111-3116.
61. Rajkumar SV, Mesa RA, Fonseca R, et al. Bone marrow angiogenesis in 400 patients with monoclonal gammopathy of undetermined significance, multiple myeloma, and primary amyloidosis. *Clin Cancer Res* 2002;8:2210-2216.
62. Vacca A, Ribatti D, Presta M, et al. Bone marrow neovascularization, plasma cell angiogenic potential, and matrix metalloproteinase-2 secretion parallel progression of human multiple myeloma. *Blood* 1999;93:3064-3073.
63. Perez-Andres M, Almeida J, Martin-Ayuso M, et al. Clonal plasma cells from monoclonal gammopathy of undetermined significance, multiple myeloma and plasma cell leukemia show different expression profiles of molecules involved in the interaction with the immunological bone marrow microenvironment. *Leukemia* 2005;19:449-455.
64. Rawstron AC, Fenton JA, Ashcroft J, et al. The interleukin-6 receptor alphachain (CD126) is expressed by neoplastic but not normal plasma cells. *Blood* 2000;96:3880-3886.
65. Donovan KA, Lacy MQ, Kline MP, et al. Contrast in cytokine expression between patients with monoclonal gammopathy of undetermined significance or multiple myeloma. *Leukemia* 1998;12:593-600.
66. Lust JA, Donovan KA. Biology and transition of monoclonal gammopathy of undetermined significance (MGUS) to multiple myeloma. *Cancer Control* 1998;5:209-217.
67. Lust JA, Donovan KA. The role of interleukin-1 beta in the pathogenesis of multiple myeloma. *Hematol Oncol Clin North Am* 1999;13:1117-1125.
68. Sezer O. Myeloma bone disease: recent advances in biology, diagnosis, and treatment. *Oncologist* 2009;14:276-283.
69. Roodman GD. Pathogenesis of myeloma bone disease. *Leukemia* 2009;23: 435-441.
70. Tian E, Zhan F, Walker R, et al. The role of the Wnt-signaling antagonist DKK1 in the development of osteolytic lesions in multiple myeloma.[see comment]. *N Engl J Med* 2003;349:2483-2494.
71. Schuster S, Rajkumar SV, Dispenzieri A, et al. IgM Multiple myeloma: disease definition, prognosis, and differentiation from Waldenström's macroglobulinemia. *Am J Hematol* 2010;85:853-855.
72. Kyle RA, Therneau TM, Rajkumar SV, Larson DR, Plevak MF, Melton LJ 3rd. Long-term follow-up of 241 patients with monoclonal gammopathy of undetermined significance: the original Mayo Clinic series 25 years later.[see comment]. *Mayo Clin Proc* 2004;79:859-866.
73. Baldini L, Guffanti A, Cesana BM, et al. Role of different hematologic variables in defining the risk of malignant transformation in monoclonal gammopathy. *Blood* 1996;87:912-918.
74. Gregersen H, Mellekjær L, Salling Ibsen J, et al. Cancer risk in patients with monoclonal gammopathy of undetermined significance. *Am J Hematol* 2000;63:1-6.
75. Kyle RA, Therneau TM, Rajkumar SV, et al. Long-term follow-up of IgM monoclonal gammopathy of undetermined significance. *Blood* 2003;102:3759-3764.
76. Cesana C, Klersy C, Barbarano L, et al. Prognostic factors for malignant transformation in monoclonal gammopathy of undetermined significance and smoldering multiple myeloma. *J Clin Oncol* 2002;20:1625-1634.
77. Kyle RA. "Benign" monoclonal gammopathy-after 20 to 35 years of follow-up. *Mayo Clin Proc* 1993;68:26-36.
78. van de Poel MH, Coebergh JW, Hillen HF. Malignant transformation of monoclonal gammopathy of undetermined significance among out-patients of a community hospital in southeastern Netherlands. *Br J Haematol* 1995;91:121-125.
79. Kyle RA, Durie BGM, Rajkumar SV, et al. Monoclonal gammopathy of undetermined significance (MGUS) and smoldering (asymptomatic) multiple myeloma: IMWG consensus perspectives risk factors for progression and guidelines for monitoring and management. *Leukemia* 2010;24:1121-1127.
80. Bianchi G, Kyle RA, Colby CL, et al. Impact of optimal follow-up of Monoclonal Gammopathy of Undetermined Significance (MGUS) on early diagnosis and prevention of myeloma-related complications *Blood* 2010;116: 2019-2025.
81. Dimopoulos MA, Mouloupoulos LA, Maniatis A, Alexanian R. Solitary plasmacytoma of bone and asymptomatic multiple myeloma. *Blood* 2000;96:2037-2044.

82. Dimopoulos MA, Mouloupoulos A, Smith T, Delasalle KB, Alexanian R. Risk of disease progression in asymptomatic multiple myeloma. *Am J Med* 1993;94:57-61.
83. Riccardi A, Gobbi PG, Ucci G, et al. Changing clinical presentation of multiple myeloma. *Eur J Cancer* 1991;27:1401-1405.
84. Wisloff F, Andersen P, Andersson TR, et al. Incidence and follow-up of asymptomatic multiple myeloma. The myeloma project of health region I in Norway. II. *Eur J Haematol* 1991;47:338-341.
85. Blade J, Dimopoulos M, Rosinol L, Rajkumar SV, Kyle RA. Smoldering (asymptomatic) multiple myeloma: current diagnostic criteria, new predictors of outcome, and follow-up recommendations. *J Clin Oncol* 2010;28:690-697.
86. Rajkumar SV, Merlini G, San Miguel JF. Redefining myeloma. *Nature Rev Clin Oncol* 2012;In Press.
87. Rajkumar SV, Larson D, Kyle RA. Diagnosis of smoldering multiple myeloma. *N Engl J Med* 2011;365:474-475.
88. Witzig TE, Kyle RA, WM OF, Greipp PR. Detection of peripheral blood plasma cells as a predictor of disease course in patients with smoldering multiple myeloma. *Br J Haematol* 1994;87:266-272.
89. Bianchi G, Kyle RA, Larson DR, et al. High levels of peripheral blood circulating plasma cells as a specific risk factor for progression of smoldering multiple myeloma. *Leukemia* 2013;27:680-685.
90. Mouloupoulos LA, Dimopoulos MA, Smith TL, et al. Prognostic significance of magnetic resonance imaging in patients with asymptomatic multiple myeloma. *J Clin Oncol* 1995;13:251-256.
91. Weber DM, Dimopoulos MA, Mouloupoulos LA, Delasalle KB, Smith T, Alexanian R. Prognostic features of asymptomatic multiple myeloma. *Br J Haematol* 1997;97:810-814.
92. Mariette X, Zagdanski AM, Guermazi A, et al. Prognostic value of vertebral lesions detected by magnetic resonance imaging in patients with stage I multiple myeloma. *Br J Haematol* 1999;104:723-729.
93. Rawstron AC, Orfao A, Beksac M, et al. Report of the European Myeloma Network on multiparametric flow cytometry in multiple myeloma and related disorders. *Haematologica* 2008;93:431-438.
94. Pérez-Persona E, Mateo G, García-Sanz R, et al. Risk of progression in smouldering myeloma and monoclonal gammopathies of unknown significance: comparative analysis of the evolution of monoclonal component and multiparameter flow cytometry of bone marrow plasma cells. *Br J Haematol* 2009;148:110-114.
95. Madan S, Kyle RA, Greipp PR. Plasma cell labeling index in the evaluation of smoldering (asymptomatic) multiple myeloma. *Mayo Clin Proc* 2010; 85:300.
96. Hjorth M, Hellquist L, Holmberg E, Magnusson B, Rodjer S, Westin J. Initial versus deferred melphalan-prednisone therapy for asymptomatic multiple myeloma stage I—a randomized study. Myeloma Group of Western Sweden. *Eur J Haematol* 1993;50:95-102.
97. Grignani G, Gobbi PG, Formisano R, et al. A prognostic index for multiple myeloma. *Br J Cancer* 1996;73:1101-1107.
98. Rajkumar SV, Gertz MA, Lacy MQ, et al. Thalidomide as initial therapy for early-stage myeloma. *Leukemia* 2003;17:775-779.
99. Weber D, Rankin K, Gavino M, Delasalle K, Alexanian R. Thalidomide alone or with dexamethasone for previously untreated multiple myeloma. *J Clin Oncol* 2003;21:16-19.
100. Witzig TE, Laumann KM, Lacy MQ, et al. A phase III randomized trial of thalidomide plus zoledronic acid versus zoledronic acid alone in patients with asymptomatic multiple myeloma. *Leukemia* 2013;27:220-225.
101. Mateos M-V, Lopez-Corral L, Hernandez M, et al. Smoldering multiple myeloma (SMM) at high risk of progression to symptomatic disease: a phase III, randomized, multicenter trial based on lenalidomide-dexamethasone (Len-Dex) as induction therapy followed by maintenance therapy with len alone vs no treatment. *ASH Annu Meet Abstr* 2011;118:991.
102. Lust JA, Lacy MQ, Zeldenrust SR, et al. Induction of a chronic disease state in patients with smoldering or indolent multiple myeloma by targeting interleukin 1 β -induced interleukin 6 production and the myeloma proliferative component. *Mayo Clin Proc* 2009;84:114-122.
103. Wadhera RK, Kyle RA, Larson DR, et al. Incidence, clinical course, and prognosis of secondary monoclonal gammopathy of undetermined significance in patients with multiple myeloma. *Blood* 2011;118:2985-2987.

104. Mark T, Jayabalan D, Coleman M, et al. Atypical serum immunofixation patterns frequently emerge in immunomodulatory therapy and are associated with a high degree of response in multiple myeloma. *Br J Haematol* 2008;143:654-660.
105. Alejandre ME, Madalena LB, Pavlovsky MA, et al. Oligoclonal bands and immunoglobulin isotype switch during monitoring of patients with multiple myeloma and autologous hematopoietic cell transplantation: a 16-year experience. *Clin Chem Lab Med* 2010;48:727-731.
106. Kyle RA, Robinson RA, Katzmann JA. The clinical aspects of biclonal gammopathies. Review of 57 cases. *Am J Med* 1981;71:999-1008.
107. Riddell S, Traczyk Z, Paraskevas F, Israels LG. The double gammopathies. Clinical and immunological studies. *Medicine (Baltimore)* 1986;65:135-142.
108. Grosbois B, Jego P, de Rosa H, et al. Triclonal gammopathy and malignant immunoproliferative syndrome [French]. *Rev Med Interne* 1997;18:470-473.
109. Ray RA, Schotters SB. Triclonal gammopathy in a patient with AIDS. *Clin Chem* 1986;32:2000.
110. Ray RA, Schotters SB, Jacobs A, Rodgerson DO. Triclonal gammopathy in a patient with plasma cell dyscrasia. *Clin Chem* 1986;32:205-206.
111. Kyle RA, Maldonado JE, Bayrd ED. Idiopathic Bence Jones proteinuria—a distinct entity? *Am J Med* 1973;55:222-226.
112. Kyle R, Therneau T, Dispenzieri A, et al. Idiopathic Bence Jones proteinuria: clinical course and prognosis. *ASH Annu Meet Abstr* 2006;108:3493-.
113. Kyle RA, Greipp PR. "Idiopathic" Bence Jones proteinuria: long-term follow-up in seven patients. *N Engl J Med* 1982;306:564-567.
114. O'Connor ML, Rice DT, Buss DH, Muss HB. Immunoglobulin D benign monoclonal gammopathy. A case report. *Cancer* 1991;68:611-616.
115. Blade J, Kyle RA. IgD monoclonal gammopathy with long-term follow-up. *Br J Haematol* 1994;88:395-396.
116. Bida JP, Kyle RA, Therneau TM, et al. Disease associations with monoclonal gammopathy of undetermined significance: a population-based study of 17,398 patients. *Mayo Clin Proc* 2009;84:685-693.
117. Kyle RA, Dyck PJ. Neuropathy associated with the monoclonal gammopathies. In: Dyck PJ, Thomas PK, Griffin JW, Low PA, Poduslo JF, eds. *Peripheral neuropathy*, 3rd ed. Philadelphia, PA: W. B. Saunders, 1993:1275-1287.
118. Kelly JJ, Jr. Polyneuropathies associated with plasma cell dyscrasias. *Semin Neurol* 1987;7:30-39.
119. Kelly JJ, Kyle RA, O'Brien PC, Dyck PJ. The prevalence of monoclonal gammopathy in peripheral neuropathy—a prospective survey. *Neurology* 1981;31:155.
120. Kahn SN, Riches PG, Kohn J. Paraproteinaemia in neurological disease: incidence, associations, and classification of monoclonal immunoglobulins. *J Clin Pathol* 1980;33:617-621.
121. Baldini L, Nobile-Orazio E, Guffanti A, et al. Peripheral neuropathy in IgM monoclonal gammopathy and Waldenström's macroglobulinemia: a frequent complication in elderly males with low MAG-reactive serum monoclonal component. *Am J Hematol* 1994;45:25-31.
122. Nobile-Orazio E, Barbieri S, Baldini L, et al. Peripheral neuropathy in monoclonal gammopathy of undetermined significance: prevalence and immunopathogenetic studies. *Acta Neurol Scand* 1992;85:383-390.
123. Gorson KC, Allam G, Ropper AH. Chronic inflammatory demyelinating polyneuropathy: clinical features and response to treatment in 67 consecutive patients with and without a monoclonal gammopathy. *Neurology* 1997;48:321-328.
124. Simmons Z, Albers JW, Bromberg MB, Feldman EL. Presentation and initial clinical course in patients with chronic inflammatory demyelinating polyradiculoneuropathy: comparison of patients without and with monoclonal gammopathy. *Neurology* 1993;43:2202-2209.
125. Gorson KC, Ropper AH. Axonal neuropathy associated with monoclonal gammopathy of undetermined significance. *J Neurol Neurosurg Psychiatry* 1997;63:163-168.
126. Gosselin S, Kyle RA, Dyck PJ. Neuropathy associated with monoclonal gammopathies of undetermined significance. *Ann Neurol* 1991;30:54-61.

127. Chassande B, Leger JM, Younes-Chennoufi AB, et al. Peripheral neuropathy associated with IgM monoclonal gammopathy: correlations between M-protein antibody activity and clinical/electrophysiological features in 40 cases. *Muscle Nerve* 1998;21:55-62.
128. Kelly JJ, Adelman LS, Berkman E, Bhan I. Polyneuropathies associated with IgM monoclonal gammopathies. *Arch Neurol* 1988;45:1355-1359.
129. Latov N. Pathogenesis and therapy of neuropathies associated with monoclonal gammopathies. *Ann Neurol* 1995;37(Suppl 1):S32-S42.
130. Kissel JT, Mendell JR. Neuropathies associated with monoclonal gammopathies. *Neuromuscul Disord* 1996;6:3-18.
131. Quarles RH, Weiss MD. Autoantibodies associated with peripheral neuropathy. *Muscle Nerve* 1999;22:800-822.
132. Nobile-Orazio E. IgM paraproteinaemic neuropathies. *Curr Opin Neurol* 2004;17:599-605.
133. Nobile-Orazio E. Antigenic determinants in IgM paraprotein-related neuropathies. *Clin Lymphoma Myeloma* 2009;9:107-109.
134. Nobile-Orazio E, Casellato C, Di Troia A. Neuropathies associated with IgG and IgA monoclonal gammopathy. *Rev Neurol (Paris)* 2002;158:979-987.
135. Kyle RA, Dyck PJ. Amyloidosis and neuropathy. In: Dyck PJ, Thomas PK, Griffin JW, Low PA, Poduslo JF, eds. *Peripheral neuropathy*, 3rd ed ed. Philadelphia, PA: W. B. Saunders, 1993:1294-1309.
136. Rajkumar SV, Gertz MA, Kyle RA. Prognosis of patients with primary systemic amyloidosis who present with dominant neuropathy. *Am J Med* 1998;104:232-237.
137. Dispenzieri A, Kyle RA, Lacy MQ, et al. POEMS syndrome: definitions and long-term outcome. *Blood* 2003;101:2496-2506.
138. Lunn MP, Nobile-Orazio E. Immunotherapy for IgM anti-myelin-associated glycoprotein paraprotein-associated peripheral neuropathies. *Cochrane Database Syst Rev* 2012;5:CD002827.
139. Dalakas MC, Quarles RH, Farrer RG, et al. A controlled study of intravenous immunoglobulin in demyelinating neuropathy with IgM gammopathy. *Ann Neurol* 1996;40:792-795.
140. Gorson KC, Ropper AH, Weinberg DH, Weinstein R. Efficacy of intravenous immunoglobulin in patients with IgG monoclonal gammopathy and polyneuropathy. *Arch Neurol* 2002;59:766-772.
141. Haas DC, Tatum AH. Plasmapheresis alleviates neuropathy accompanying IgM anti-myelin-associated glycoprotein paraproteinemia. *Ann Neurol* 1988;23:394-396.
142. Dyck PJ, Low PA, Windebank AJ, et al. Plasma exchange in polyneuropathy associated with monoclonal gammopathy of undetermined significance. *N Engl J Med* 1991;325:1482-1486.
143. Mazzi G, Raineri A, Zucco M, Passadore P, Pomes A, Orazi BM. Plasma-exchange in chronic peripheral neurological disorders. *Int J Artif Organs* 1999;22:40-46.
144. Levine TD, Pestronk A. IgM antibody-related polyneuropathies: B-cell depletion chemotherapy using Rituximab. *Neurology* 1999;52:1701-1704.
145. Pestronk A, Florence J, Miller T, Choksi R, Al-Lozi MT, Levine TD. Treatment of IgM antibody associated polyneuropathies using rituximab. *J Neurol Neurosurg Psychiatry* 2003;74:485-489.
146. Nobile-Orazio E. Update on neuropathies associated with monoclonal gammopathy of undetermined significance (2008-2010). *J Peripher Nerv Syst* 2010;15:302-306.
147. Dalakas MC, Rakocevic G, Salajegheh M, et al. Placebo-controlled trial of rituximab in IgM anti-myelin-associated glycoprotein antibody demyelinating neuropathy. *Ann Neurol* 2009;65:286-293.
148. Léger J-M, Viala K, Bombelli F, et al. Randomized controlled trial of rituximab in demyelinating neuropathy associated with anti-MAG IgM gammopathy (RIMAG study). *J Peripher Nerv Syst* 2010;15:269.
149. Nobile-Orazio E. Treatment of dys-immune neuropathies. *J Neurol* 2005;252:385-395.
150. Wilson HC, Lunn MPT, Schey S, Hughes RAC. Successful treatment of IgM paraproteinaemic neuropathy with fludarabine. *J Neurol Neurosurg Ps* 1999;66: 575-580.

151. Hamidou MA, Belizna C, Wiertlewsky S, et al. Intravenous cyclophosphamide in refractory polyneuropathy associated with IgM monoclonal gammopathy: an uncontrolled open trial. *Am J Med* 2005;118:426-430.
152. Sethi S, Zand L, Leung N, et al. Membranoproliferative glomerulonephritis secondary to monoclonal gammopathy. *Clin J Am Soc Nephrol* 2010;5:770-782.
153. Sethi S, Fervenza FC. Membranoproliferative glomerulonephritis—a new look at an old entity. *N Engl J Med* 2012;366:1119-1131.
154. Kebler R, Kithier K, McDonald FD, Cadnapaphornchai P. Rapidly progressive glomerulonephritis and monoclonal gammopathy. *Am J Med* 1985;78:133-138.
155. Sethi S, Sukov WR, Zhang Y, et al. Dense deposit disease associated with monoclonal gammopathy of undetermined significance. *Am J Kidney Dis* 2010;56:977-982.
156. Dingli D, Larson DR, Plevak MF, Grande JP, Kyle RA. Focal and segmental glomerulosclerosis and plasma cell proliferative disorders. *Am J Kidney Dis* 2005;46:278-282.
157. Daoud MS, Lust JA, Kyle RA, Pittelkow MR. Monoclonal gammopathies and associated skin disorders. *J Am Acad Dermatol* 1999;40:507-535; quiz 36-38.
158. James K, Fudenberg H, Epstein WL, Shuster J. Studies on a unique diagnostic serum globulin in papular mucinosis (lichen myxedematosus). *Clin Exp Immunol* 1967;2:153-166.
159. Ohta A, Uitto J, Oikarinen AI, et al. Paraproteinemia in patients with scleredema. Clinical findings and serum effects on skin fibroblasts in vitro. *J Am Acad Dermatol* 1987;16:96-107.
160. Duguid CM, Powell FC. Pyoderma gangrenosum. *Clin Dermatol* 1993;11:129-133.
161. Berard M, Antonucci M, Beaumont JL. Cytotoxic effect of serum on fibroblasts in one case of normolipidemic plane xanthoma and myeloma IgG lambda. *Atherosclerosis* 1986;62:111-115.
162. Jones FE, Soule EH, Coventry MB. Fibrous xanthoma of synovium (giant-cell tumor of tendon sheath, pigmented nodular synovitis). A study of one hundred and eighteen cases. *J Bone Joint Surg Am* 1969;51:76-86.
163. Kourou K, Suga Y, Muramatsu S, Yaguchi H, Ogawa H. A case of diffuse plane normolipemic xanthomatosis associated with pancytopenia and monoclonal gammopathy. *J Dermatol* 2006;33:64-67.
164. Ryatt KS, Dodman BA, Cotterill JA. Subcorneal pustular dermatosis and IgA gammopathy. *Acta Derm Venereol* 1981;61:560-562.
165. Lutz ME, Daoud MS, McEvoy MT, Gibson LE. Subcorneal pustular dermatosis: a clinical study of ten patients. *Cutis* 1998;61:203-208.
166. Spicknall KE, Mehregan DA. Necrobiotic xanthogranuloma. *Int J Dermatol* 2009;48:1-10.
167. Nestle FO, Hofbauer G, Burg G. Necrobiotic xanthogranuloma with monoclonal gammopathy of the IgG lambda type. *Dermatology* 1999;198:434-435.
168. Doutre MS, Beylot C. Chronic urticaria and monoclonal IgM: treatment with ibuprofen. *J Am Acad Dermatol* 1990;22:143-144.
169. Doutre MS, Beylot C, Bioulac P, Beziau JH. Monoclonal IgM and chronic urticaria: two cases. *Ann Allergy* 1987;58:413-414.
170. Lebbe C, Rybojad M, Klein F, et al. Schnitzler's syndrome associated with sensorimotor neuropathy. *J Am Acad Dermatol* 1994;30:316-318.
171. Puddu P, Cianchini G, Girardelli CR, Colonna L, Gatti S, de Pita O. Schnitzler's syndrome: report of a new case and a review of the literature. *Clin Exp Rheumatol* 1997;15:91-95.
172. Crapper RM, Deam DR, Mackay IR. Paraproteinemias in homosexual men with HIV infection. Lack of association with abnormal clinical or immunologic findings. *Am J Clin Pathol* 1987;88:348-351.
173. Lefrere JJ, Debbia M, Lambin P. Prospective follow-up of monoclonal gammopathies in HIV-infected individuals. *Br J Haematol* 1993;84:151-155.
174. Renoult E, Bertrand F, Kessler M. Monoclonal gammopathies in HBsAg-positive patients with renal transplants. *N Engl J Med* 1988;318:1205.

175. Stanko CK, Jeffery JR, Rush DN. Monoclonal and multiclonal gammopathies after renal transplantation. *Transplant Proc* 1989;21:3330-3332.
176. Pollock CA, Mahony JF, Ibels LS, et al. Immunoglobulin abnormalities in renal transplant recipients. *Transplantation* 1989;47:952-956.
177. Radl J, Valentijn RM, Haaijman JJ, Paul LC. Monoclonal gammopathies in patients undergoing immunosuppressive treatment after renal transplantation. *Clin Immunol Immunopathol* 1985;37:98-102.
178. Ducloux D, Carron PL, Racadot E, et al. T-cell immune defect and B-cell activation in renal transplant recipients with monoclonal gammopathies. *Transplant Int* 1999;12:250-253.
179. Ginevri F, Nocera A, Bonato L, et al. Cytomegalovirus infection is a trigger for monoclonal immunoglobulins in paediatric kidney transplant recipients. *Transplant Proc* 1998;30:2079-2082.
180. Caforio AL, Gambino A, Belloni Fortina A, et al. Monoclonal gammopathy in heart transplantation: risk factor analysis and relevance of immunosuppressive load. *Transplant Proc* 2001;33:1583-1584.
181. Caforio AL, Gambino A, Fortina AB, et al. Monoclonal gammopathy in heart transplantation: clinical significance and risk factors. *J Heart Lung Transplant* 2001;20:237.
182. Badley AD, Portela DF, Patel R, et al. Development of monoclonal gammopathy precedes the development of Epstein-Barr virus-induced posttransplant lymphoproliferative disorder. *Liver Transpl Surg* 1996;2:375-382.
183. Pageaux GP, Bonnardet A, Picot MC, et al. Prevalence of monoclonal immunoglobulins after liver transplantation—Relationship with posttransplant lymphoproliferative disorders. *Transplantation* 1998;65:397-400.
184. Rostaing L, Modesto A, Abbal M, Durand D. Long-term follow-up of monoclonal gammopathy of undetermined significance in transplant patients. *Am J Nephrol* 1994;14:187-191.
185. Naina HV, Harris S, Dispenzieri A, et al. Long-term follow-up of patients with monoclonal gammopathy of undetermined significance after kidney transplantation. *Am J Nephrol* 2012;35:365-371.
186. Mailankody S, Pfeiffer RM, Kristinsson SY, et al. Risk of acute myeloid leukemia and myelodysplastic syndromes after multiple myeloma and its precursor disease (MGUS). *Blood* 2011;118:4086-4092.
187. Roeker LE, Larson DR, Kyle RA, Kumar S, Dispenzieri A, Rajkumar SV. Risk of acute leukemia and myelodysplastic syndromes in patients with monoclonal gammopathy of undetermined significance (MGUS): a population-based study of 17,315 patients. *Leukemia* 2013;doi: 10.1028/leu.2013.34 advance online publication.
188. Noel P, Kyle RA. Monoclonal proteins in chronic lymphocytic leukemia. *Am J Clin Pathol* 1987;87:385-388.
189. Jansen J, Bolhuis RL, van Nieuwkoop JA, Schuit HR, Kroese WF. Paraproteinaemia plus osteolytic lesions in typical hairy-cell leukaemia. *Br J Haematol* 1983;54:531-541.
190. Matsuzaki H, Yamaguchi K, Kagimoto T, Nakai R, Takatsuki K, Oyama W. Monoclonal gammopathies in adult T-cell Leukemia. *Cancer* 1985;56: 1380-1383.
191. Venencie PY, Winkelmann RK, Friedman SJ, Kyle RA, Puissant A. Monoclonal gammopathy and mycosis fungoides. Report of four cases and review of the literature. *J Am Acad Dermatol* 1984;11:576-579.
192. Venencie PY, Winkelmann RK, Puissant A, Kyle RA. Monoclonal gammopathy in Sezary syndrome. Report of three cases and review of the literature. *Arch Dermatol* 1984;120:605-608.
193. Economopoulos T, Papageorgiou S, Pappa V, et al. Monoclonal gammopathies in B-cell non-Hodgkin's lymphomas. *Leuk Res* 2003;27:505-508.
194. Strumia R, Roveglio C. Kaposi's sarcoma and monoclonal gammopathy. *Dermatology* 1994;188:76-77.
195. Guglielmi P, Davi F, Brouet JC. Prevalence of monoclonal Ig with lambda-light chains in chronic myelocytic-leukemia. *Br J Haematol* 1989;73:331-333.
196. Economopoulos T, Economidou J, Papageorgiou E, et al. Monoclonal gammopathy in chronic myeloproliferative disorders. *Blut* 1989;58:7-9.
197. Barnard DL, Burns GF, Gordon J, et al. Chronic myelomonocytic leukemia with paraproteinemia but no detectable plasmacytosis—detailed cytological and immunological study. *Cancer* 1979;44:927-936.

198. Ribera JM, Cervantes F, Rozman C. A multivariate analysis of prognostic factors in chronic myelomonocytic leukaemia according to the FAB criteria. *Br J Haematol* 1987;65:307-311.
199. Solal-Celigny P, Desaint B, Herrera A, et al. Chronic myelomonocytic leukemia according to FAB classification: analysis of 35 cases. *Blood* 1984;63:634-638.
200. Rovira M, Cervantes F, Nomdedeu B, Rozman C. Chronic neutrophilic leukaemia preceding for seven years the development of multiple myeloma. *Acta Haematol* 1990;83:94-95.
201. Buonanno G, Pandolfi F, Valente A, Napolitano M, Cafaro A, Gonnella F. Monocytic blast cell crisis and IgG-lambda monoclonal gammopathy in a Ph1 + chronic myelogenous leukemia. Report of a case. *Haematologica* 1986;71:489-492.
202. Castaman G, Rodeghiero F, Di Bona E, Ruggeri M. Clinical effectiveness of desmopressin in a case of acquired von Willebrand's syndrome associated with benign monoclonal gammopathy. *Blut* 1989;58:211-213.
203. Mannucci PM, Lombardi R, Bader R, et al. Studies of the pathophysiology of acquired von Willebrand's disease in seven patients with lymphoproliferative disorders or benign monoclonal gammopathies. *Blood* 1984;64:614-621.
204. Mant MJ, Hirsh J, Gaudie J, Bienenstock J, Pineo GF, Luke KH. Von Willebrand's syndrome presenting as an acquired bleeding disorder in association with a monoclonal gammopathy. *Blood* 1973;42:429-436.
205. Bovill EG, Ershler WB, Golden EA, Tindle BH, Edson JR. A human myelomaproduced monoclonal protein directed against the active subpopulation of von Willebrand factor. *Am J Clin Pathol* 1986;85:115-123.
206. Mohri H, Hisanaga S, Mishima A, Fujimoto S, Uezono S, Okubo T. Autoantibody inhibits binding of von Willebrand factor to glycoprotein Ib and collagen in multiple myeloma: recognition sites present on the A1 loop and A3 domains of von Willebrand factor. *Blood Coagul Fibrinolysis* 1998;9:91-97.
207. Mohri H, Tanabe J, Ohtsuka M, et al. Acquired von Willebrand disease associated with multiple myeloma; characterization of an inhibitor to von Willebrand factor. *Blood Coagul Fibrinolysis* 1995;6:561-566.
208. Mohri H, Noguchi T, Kodama F, Itoh A, Ohkubo T. Acquired von Willebrand disease due to inhibitor of human myeloma protein specific for von Willebrand factor. *Am J Clin Pathol* 1987;87:663-668.
209. Lamboley V, Zabraniecki L, Sie P, Pourrat J, Fournie B. Myeloma and monoclonal gammopathy of uncertain significance associated with acquired von Willebrand's syndrome. Seven new cases with a literature review. *Joint Bone Spine* 2002;69:62-67.
210. Federici AB, Stabile F, Castaman G, Canciani MT, Mannucci PM. Treatment of acquired von Willebrand syndrome in patients with monoclonal gammopathy of uncertain significance: comparison of three different therapeutic approaches. *Blood* 1998;92:2707-2711.
211. Colwell NS, Tollefsen DM, Blinder MA. Identification of a monoclonal thrombin inhibitor associated with multiple myeloma and a severe bleeding disorder. *Br J Haematol* 1997;97:219-226.
212. Sallah S, Husain A, Wan J, Vos P, Nguyen NP. The risk of venous thromboembolic disease in patients with monoclonal gammopathy of undetermined significance. *Ann Oncol* 2004;15:1490-1494.
213. Bellotti V, Gamba G, Merlini G, et al. Study of three patients with monoclonal gammopathies and "lupus-like" anticoagulants. *Br J Haematol* 1989;73:221-227.
214. Stern JJ, Ng RH, Triplett DA, McIntyre JA. Incidence of antiphospholipid antibodies in patients with monoclonal gammopathy of undetermined significance. *Am J Clin Pathol* 1994;101:471-474.
215. Garfinkel D, Sidi Y, Ben-Bassat M, Salomon F, Hazaz B, Pinkhas J. Coexistence of Gaucher's disease and multiple myeloma. *Arch Intern Med* 1982;142:2229-2230.
216. Selroos O, von Knorring J. Immunoglobulins in pernicious anaemia. Including a report on a patient with pernicious anaemia, IgA deficiency and an M component of kappa-type IgG. *Acta Med Scand* 1973;194:571-574.
217. Resegotti L, Dolci C, Palestro G, Peschle C. Paraproteinemic variety of pure red cell aplasia: immunological studies in 1 patient. *Acta Haematol* 1978;60:227-232.
218. Balducci L, Hardy C, Dreiling B, Tavassoli M, Steinberg MH. Pure red blood cell aplasia associated with paraproteinemia: in vitro studies of erythropoiesis. *Haematologia (Budap)* 1984;17:353-357.
219. Zawadzki ZA, Benedek TG. Rheumatoid arthritis, dysproteinemic arthropathy, and paraproteinemia. *Arthritis Rheum* 1969;12:555-568.

220. Hurst NP, Smith W, Henderson DR. IgG (kappa) paraproteinaemia and arthritis. *Br J Rheumatol* 1987;26:142-146.
221. Michaux JL, Heremans JF. Thirty cases of monoclonal immunoglobulin disorders other than myeloma or macroglobulinemia. A classification of diseases associated with the production of monoclonal-type immunoglobulins. *Am J Med* 1969;46:562-579.
222. Porcel JM, Ordi J, Tolosa C, Selva A, Castro-Salomo A, Vilardell M. Monoclonal gammopathy in systemic lupus erythematosus. *Lupus* 1992;1:263-264.
223. Nakanishi H, Takehara K, Soma Y, Ishibashi Y. Atypical scleroderma associated with multiple myeloma. *Dermatologica* 1989;178:176-178.
224. Ilfeld D, Barzilay J, Vana D, Ben-Bassat M, Joshua H, Pick I. IgG monoclonal gammopathy in four patients with polymyalgia rheumatica. *Ann Rheum Dis* 1985;44:501.
225. Kiproff DD, Miller RG. Polymyositis associated with monoclonal gammopathy. *Lancet* 1984;2:1183-1186.
226. Telerman-Toppet N, Wittek M, Bacq M, Dajez P, Coers C, Fassotte A. Benign monoclonal gammopathy and relapsing polymyositis. *Muscle Nerve* 1982;5:490-491.
227. Sanders KA, Rowland LP, Murphy PL, et al. Motor neuron diseases and amyotrophic lateral sclerosis: GM1 antibodies and paraproteinemia. *Neurology* 1993;43:418-420.
228. Younger DS, Rowland LP, Latov N, et al. Motor neuron disease and amyotrophic lateral sclerosis: relation of high CSF protein content to paraproteinemia and clinical syndromes. *Neurology* 1990;40:595-599.
229. Patten BM. Neuropathy and motor neuron syndromes associated with plasma cell disease. *Acta Neurol Scand* 1984;70:47-61.
230. Bartoloni C, Scoppetta C, Flamini G, et al. Waldenström's macroglobulinemia and myasthenia gravis. *J Clin Lab Immunol* 1981;6:275-278.
231. Galli M, Landi G, Restelli DL, Scarlato G. Myasthenia gravis with a monoclonal gammopathy--report of a case. *J Neurol Sci* 1980;45:103-108.
232. McDonald PS, Cora-Bramble D, De Palma L. Monoclonal gammopathy of the immunoglobulin A class in a two-year-old girl with ataxia telangiectasia. *Pediatr Devel Pathol* 1998;1:319-321.
233. Sadighi Akha AA, Humphrey RL, Winkelstein JA, Loeb DM, Lederman HM. Oligo-/monoclonal gammopathy and hypergammaglobulinemia in ataxia-telangiectasia. A study of 90 patients. *Medicine (Baltimore)* 1999;78: 370-381.
234. Keller CE, Hays AP, Rowland LP, Moghadaszadeh B, Beggs AH, Bhagat G. Adult-onset nemaline myopathy and monoclonal gammopathy. *Arch Neurol* 2006;63:132-134.
235. Gelfand JA, Boss GR, Conley CL, Reinhart R, Frank MM. Acquired C1 esterase inhibitor deficiency and angioedema: a review. *Medicine (Baltimore)* 1979;58:321-328.
236. Pascual M, Mach-Pascual S, Schifferli JA. Paraproteins and complement depletion: pathogenesis and clinical syndromes. *Semin Hematol* 1997;34:40-48.
237. Lofdahl CG, Solvell L, Laurell AB, Johansson BR. Systemic capillary leak syndrome with monoclonal IgG and complement alterations. A case report on an episodic syndrome. *Acta Med Scand* 1979;206:405-412.
238. Droder RM, Kyle RA, Greipp PR. Control of systemic capillary leak syndrome with aminophylline and terbutaline. *Am J Med* 1992;92:523-526.

P.2045

239. Kapoor P, Greipp PT, Schaefer EW, et al. Idiopathic systemic capillary leak syndrome (Clarkson's disease): the Mayo clinic experience. *Mayo Clin Proc* 2010;85:905-912.
240. Dispenzieri A. Symptomatic cryoglobulinemia. *Curr Treat Options Oncol* 2000;1:105-118.
241. Pietrogrande M, De Vita S, Zignego AL, et al. Recommendations for the management of mixed cryoglobulinemia syndrome in hepatitis C virus-infected patients. *Autoimmun Rev* 2011;10:444-454.

242. Mussini C, Ghini M, Mascia MT, et al. HCV and monoclonal gammopathies. *Clin Exp Rheumatol* 1995;13(Suppl 13):S45-S49.
243. Mangia A, Clemente R, Musto P, et al. Hepatitis C virus infection and monoclonal gammopathies not associated with cryoglobulinemia. *Leukemia* 1996;10:1209-1213.
244. Andreone P, Zignego AL, Cursaro C, et al. Prevalence of monoclonal gammopathies in patients with hepatitis C virus infection. *Ann Intern Med* 1998;129:294-298.
245. Waldenström JG. Antibody activity of monoclonal immunoglobulins in myeloma, macroglobulinemia and benign gammopathy. *Med Oncol Tumor Pharmacother* 1986;3:135-140.
246. Merlini G, Farhangi M, Osserman EF. Monoclonal immunoglobulins with antibody activity in myeloma, macroglobulinemia and related plasma cell dyscrasias. *Semin Oncol* 1986;13:350-365.
247. Dighiero G, Guilbert B, Fermand JP, Lymberi P, Danon F, Avrameas S. Thirty-six human monoclonal immunoglobulins with antibody activity against cytoskeleton proteins, thyroglobulin, and native DNA: immunologic studies and clinical correlations. *Blood* 1983;62:264-270.
248. Shimm DS, Cohen HJ. Transient monoclonal immunoglobulin G with antidextran activity. *Acta Haematol* 1978;59:99-103.
249. Kalliomaki JL, Granfors K, Toivanen A. An immunoglobulin G myeloma with antistreptolysin activity and a lifelong history of cutaneous streptococcal infection. *Clin Immunol Immunopathol* 1978;9:22-27.
250. Intrator L, Andre C, Chenal C, Sultan C. Monoclonal Macroglobulin with Anti-Nuclear Activity. *J Clin Pathol* 1979;32:450-454.
251. Ruiz-Palomo F, Revilla Y, Gonzales Porque P, Serrano Rios M. Two IgM paraproteins bearing cryoglobulin and anti-smooth muscle activities in a patient with Waldenström's macroglobulinaemia. *J Intern Med* 1991; 229:93-96.
252. Farhangi M, Osserman EF. Myeloma with xanthoderma due to an IgG lambda monoclonal anti-flavin antibody. *N Engl J Med* 1976;294:177-183.
253. Merlini G, Bruening R, Kyle RA, Osserman EF. The second riboflavin-binding myeloma IgG lambdaDOT. I. Biochemical and functional characterization. *Mol Immunol* 1990;27:385-394.
254. Zouali M, Fine JM, Eyquem A. A human monoclonal IgG1 with anti-idiotypic activity against anti-human thyroglobulin autoantibody. *J Immunol* 1984;133:190-194.
255. Sluiter WJ, Marrink J, Houwen B. Monoclonal gammopathy with an insulin binding IgG(K) M-component, associated with severe hypoglycaemia. *Br J Haematol* 1986;62:679-687.
256. Fermand JP, Danon F, Brouet JC. Characterization of a human monoclonal IgM with antibody activity to dsDNA. *Clin Exp Immunol* 1985;59:467-474.
257. Kilgore LL, Patterson BW, Fisher WR. Immunological comparison of the conformations of apolipoprotein-B— investigation of methodologies for the reconstitution of delipidated and denatured apolipoprotein-B with nonionic surfactants. *J Biol Chem* 1986;261:8842-8848.
258. Trimarchi F, Benvenga S, Fenzi G, Mariotti S, Consolo F. Immunoglobulin binding of thyroid hormones in a case of Waldenström's macroglobulinemia. *J Clin Endocrinol Metab* 1982;54:1045-1050.
259. Wisloff F, Michaelsen TE, Godal HC. Monoclonal IgM with lupus anticoagulant activity in a case of Waldenström's macroglobulinaemia. *Eur J Haematol* 1987;38:456-460.
260. Backer ET, Harff GA. Autoantibodies to lactate dehydrogenase in serum identified by use of immobilized protein G and immobilized jacalin, a jackfruit lectin. *Clin Chem* 1989;35:2190-2195.
261. Ng VL, Hwang KM, Reyes GR, et al. High titer anti-HIV antibody reactivity associated with a paraprotein spike in a homosexual male with AIDS related complex. *Blood* 1988;71:1397-1401.
262. Delcarpio J, Espinoza LR, Lauter S, Osterland CK. Transient Monoclonal Proteins in Drug Hypersensitivity Reactions. *Am J Med* 1979;66: 1051-1056.
263. DiMinno G, Coraggio F, Cerbone AM, et al. A myeloma paraprotein with specificity for platelet glycoprotein IIIa in a patient with a fatal bleeding disorder. *J Clin Invest* 1986;77:157-164.

264. Hoyt RH, Durie BG. Pseudothrombocytopenia induced by a monoclonal IgM kappa platelet agglutinin. *Am J Hematol* 1989;31:50-52.
265. Hazani A, Silvian I, Tatarsky I, Spira G. Non symptomatic hypercalcemia in a myeloma patient. *Am J Med Sci* 1982;283:169-173.
266. Merlini G, Fitzpatrick LA, Siris ES, et al. A human myeloma immunoglobulin G binding four moles of calcium associated with asymptomatic hypercalcemia. *J Clin Immunol* 1984;4:185-196.
267. Annesley TM, Burritt MF, Kyle RA. Artifactual hypercalcemia in multiple myeloma. *Mayo Clin Proc* 1982;57:572-575.
268. Baker BL, Hultquist DE. A copper-binding immunoglobulin from a myeloma patient. Purification, identification, and physical characterization. *J Biol Chem* 1978;253:1195-1200.
269. Baker BL, Hultquist DE. A copper-binding immunoglobulin from a myeloma patient. Studies of the copper-binding site. *J Biol Chem* 1978;253:8444-8451.
270. Westerhausen M, Meuret G. Transferrin-immune complex disease. *Acta Haematol* 1977;57:96-101.
271. Numata Y, Tanioka F, Yoshida K, et al. Ascertainment of IgA1 (kappa)-transferrin complex in a case of multiple myeloma associated with hypsiderinemia. *Jpn J Med* 1991;30:498-503.
272. Hilgard P, Linder KH, Wetter O. Monoclonal cryoglobulin of IgG (lambda) type interacting with transferrin. *Blut* 1981;43:217-225.
273. Pettersson T, Hortling L, Teppo AM, Totterman KJ, Fyhrquist F. Phosphate binding by a myeloma protein. *Acta Med Scand* 1987;222:89-91.
274. Van Camp B, Reynaert P, Van Beers D. Congenital toxoplasmosis associated with transient monoclonal IgG1-lambda gammopathy. *Rev Infect Dis* 1982;4:173-178.
275. The International Myeloma Working Group. Criteria for the classification of monoclonal gammopathies, multiple myeloma and related disorders: a report of the International Myeloma Working Group. *Br J Haematol* 2003; 121:749-757.
276. Rajkumar SV, Kyle RA. Multiple myeloma: diagnosis and treatment.[see comment]. *Mayo Clin Proc* 2005;80:1371-1382.
277. Gobbi PG, Baldini L, Broglia C, et al. Prognostic validation of the international classification of immunoglobulin M gammopathies: a survival advantage for patients with immunoglobulin M monoclonal gammopathy of undetermined significance? *Clin Cancer Res* 2005;11:1786-1790.
278. Kyle RA, Therneau TM, Rajkumar SV, et al. Long-term follow-up of IgM monoclonal gammopathy of undetermined significance. *Semin Oncol* 2003;30:169-171.
279. Baldini L, Goldaniga M, Guffanti A, et al. Immunoglobulin M monoclonal gammopathies of undetermined significance and indolent Waldenström's macroglobulinemia recognize the same determinants of evolution into symptomatic lymphoid disorders: proposal for a common prognostic scoring system. *J Clin Oncol* 2005;23:4662-4668.
280. Owen RG, Treon SP, Al-Katib A, et al. Clinicopathological definition of Waldenström's macroglobulinemia: consensus panel recommendations from the Second International Workshop on Waldenström's Macroglobulinemia. *Semin Oncol* 2003;30:110-115.
281. Kyle RA, Benson JT, Larson DR, et al. Progression in smoldering Waldenström macroglobulinemia: long-term results. *Blood* 2012;119:4462-4466.
282. Dimopoulos MA, Kiamouris C, Moulopoulos LA. Solitary plasmacytoma of bone and extramedullary plasmacytoma. *Hematol Oncol Clin North Am* 1999;13:1249-1257.
283. Rajkumar SV, Dispenzieri A, Kyle RA. Monoclonal gammopathy of undetermined significance, Waldenström macroglobulinemia, AL amyloidosis, and related plasma cell disorders: diagnosis and treatment. *Mayo Clin Proc* 2006;81:693-703.
284. Dispenzieri A. POEMS syndrome. *Blood Rev* 2007;21:285-299.
285. Aguzzi F, Bergami MR, Gasparro C, Bellotti V, Merlini G. Occurrence of monoclonal components in general practice: clinical implications. *Eur J Haematol* 1992;48:192-195.

286. Anagnostopoulos A, Evangelopoulou A, Sotou D, Gika D, Mitsibounas D, Dimopoulos MA. Incidence and evolution of monoclonal gammopathy of undetermined significance (MGUS) in Greece. *Ann Hematol* 2002;81:357-361.
287. Carrell RW, Colls BM, Murray JT. The significance of monoclonal gammopathy in a normal population. *Aust N Z J Med* 1971;1:398-401.
288. Kyle RA, Finkelstein S, Elveback LR, Kurland LT. Incidence of monoclonal proteins in a Minnesota community with a cluster of multiple myeloma. *Blood* 1972;40:719-724.
289. Malacrida V, De Francesco D, Banfi G, Porta FA, Riches PG. Laboratory investigation of monoclonal gammopathy during 10 years of screening in a general hospital. *J Clin Pathol* 1987;40:793-797.
290. Heremans JF, Laurell AH, Martensson L, et al. Studies on "abnormal" serum globulins (M-components) in myeloma, macroglobulinemia and related diseases. *Acta Med Scand Suppl* 1961;367:1-126.
291. Simmons Z, Albers JW, Bromberg MB, Feldman EL. Long-term follow-up of patients with chronic inflammatory demyelinating polyradiculoneuropathy, without and with monoclonal gammopathy. *Brain* 1995;118 (Pt 2):359-368.
292. Pham H, Lemoine A, Salvucci M, et al. Occurrence of gammopathies and lymphoproliferative disorders in liver transplant recipients randomized to tacrolimus (FK506)- or cyclosporine-based immunosuppression. *Liver Transpl Surg* 1998;4:146-151.
293. Stanko CK, Jeffery JR, Rush DN. Monoclonal and multiclonal gammopathies after renal transplantation. *Transplant Proc* 1989;21:3330-3332.
294. Kim H, Heller P, Rappaport H. Monoclonal gammopathies associated with lymphoproliferative disorders: a morphologic study. *Am J Clin Pathol* 1973;59:282-294.
295. John R, Oleesky D, Issa B, et al. Pseudohypercalcaemia in two patients with IgM paraproteinaemia. *Ann Clin Biochem* 1997;34(Pt 6):694-696.
296. Maldonado JE, Riggs BL, Bayrd ED. Pseudomyeloma. Is association of severe osteoporosis with serum monoclonal gammopathy an entity or a coincidence? *Arch Intern Med* 1975;135:267-270.
297. Silverman BA, Ku M, Kapur P, Schneider AT. Monoclonal gammopathy in association with allergic disorders of the skin and respiratory tract. *Allergy Asthma Proc* 2006;27:130-139.
298. Karakelides M, Monson KL, Volcheck GW, Weiler CR. Monoclonal gammopathies and malignancies in patients with chronic urticaria. *Int J Dermatol* 2006;45:1032-1038.

Chapter 98 Multiple Myeloma

> Table of Contents > Part VII - Hematologic Malignancies > Section 5 - Plasma Cell Dyscrasias > Chapter 98 - Multiple Myeloma

Chapter 98

Multiple Myeloma

Angela Dispenzieri

Martha Q. Lacy

Shaji Kumar

Multiple myeloma (MM) is a neoplastic plasma cell dyscrasia (PCD) characterized by a clinical pentad: (1) anemia, (2) a monoclonal protein in the serum or urine or both, (3) bone lesions and/or bone pain, (4) hypercalcemia, and (5) renal insufficiency. With the exception of monoclonal gammopathy of undetermined significance (MGUS), it is the most common PCD, with an incidence of about 4.5 per 100,000 per year in the United States. Solitary plasmacytoma and plasma cell leukemia (PCL) are recognized as separate entities and are much less prevalent. The underlying pathogenesis of the plasma cell malignancies is not well understood but is an area of active investigation. At present, according to the WHO (World Health Organization) classification system, there is only one category for MM.¹ Results of clinical trials are confounded by this underclassification. Emerging information about the genetic underpinning of the disease, however, will likely change this deficiency.

The interactions among the plasma cells, their antibody product, the local bone and bone marrow environment, and other organs are complex. There is no cure for MM, but there are many effective treatments that prolong and improve the quality of life in patients with the disease.

HISTORY

The Earliest Diagnoses and Diagnostic Methods

Samuel Solley reported the first well-documented case of MM (mollities ossium) in Sarah Newbury in 1844.^{2, 3} Several years later, William MacIntyre described and recorded the properties of the disease we now call MM in Thomas Alexander McBean.⁴ Both Drs. MacIntyre and Bence Jones noted and described some of the peculiar urine properties of this same patient. On heating, the urine was found to be “abound in animal matter,” which dissolved on the addition of nitric acid but reappeared after cooling. These urinary proteins became known as Bence Jones proteins.⁵ MacIntyre and Dalrymple described the post-mortem examination of Mr. McBean's bones.⁴ The former described the affected bones as softened and fragile, with their interiors replaced with a soft “gelatiniform” blood-red substance. Dalrymple suggested that the disease began in the cancellous bone and extended through the periosteum. The nucleated cells, which formed the bulk of the gelatinous material, were heterogeneous in size and shape, but the majority were round to oval. Many of the larger and more irregular cells frequently contained two or three nuclei.³ The term “multiple myeloma” was coined in 1873 by von Rustizky,⁶ who independently described a similar patient to emphasize the multiple bone tumors that were present.

In 1889, Professor Otto Kahler⁷ described a case involving a 46-year-old physician with MM and published a major review of the disease. He described the skeletal pain, albuminuria, pallor, anemia, a precipitable urinary protein, and the findings on necropsy and linked these findings as part of a clinical syndrome that bears his name (MM has also been referred to as Kahler disease).

In 1898 Weber predicted the usefulness of Roentgen x-rays in establishing the diagnosis^{3, 8} and later postulated the Bence Jones protein was produced in the bone marrow.⁹ Wright¹⁰ emphasized that MM arose specifically from plasma cells of the marrow, Jacobson¹¹ recognized Bence Jones proteins in the bloodstream, and Walters¹² concluded that the Bence Jones protein was probably derived from blood proteins through the action of the abnormal cells in the bone marrow. The technique of bone marrow aspiration¹³ facilitated the diagnosis of MM.

Serum electrophoresis, described by Tiselius in 1937,¹⁴ made it possible to separate serum proteins. Longsworth et al.¹⁵ applied electrophoresis to the study of MM and described the tall narrowbased “church spire” peak. The use of filter paper as a support for protein electrophoresis permitted the separation of protein into distinct zones that could be stained with various dyes.¹⁶ Paper electrophoresis was supplanted by filter paper in 1957 and most recently by high-resolution electrophoresis on agarose gel. Immunoelectrophoresis¹⁷ and immunofixation or direct immunoelectrophoresis¹⁸ made it possible to detect small monoclonal light chains not recognizable by electrophoresis. The immunoglobulin free light chain assay has been added to the diagnostic armamentarium to detect circulating free light chains in the majority of patients previously designated nonsecretory.¹⁹

Kunkel²⁰ hypothesized that monoclonal proteins were the product of malignant plasma cells and were the equivalent of normal antibodies produced by normal plasma cells. Before 1960, the term “gamma globulin” was used for any protein that migrated in the gamma mobility region of the electrophoretic pattern; however, in 1959, Heremans²¹ proposed the concept of a family of proteins with antibody activity. In 1961 in a Harvey Lecture,²² Waldenström distinguished between monoclonal and polyclonal hypergammaglobulinemia.

In 1928, Geschickter and Copeland²³ reported on the largest case series of MM—13 cases—and reviewed the 412 cases reported in the literature since 1848. They documented a higher incidence in men than women and an overall survival (OS) of about 2 years. They emphasized six features: (1) involvement of the skeletal trunk, (2) pathologic rib fractures, (3) Bence Jones proteinuria in 65% of cases, (4) backache with early paraplegia, (5) anemia in 77% of cases, and (6) chronic renal disease. They did not note abnormalities of blood protein or an increased erythrocyte sedimentation rate.³ In 1931, Magnus-Levy²⁴ described amyloidosis as a complication of MM. Salmon, Durie, and Smith developed methods to quantitate the total body burden of tumor cells²⁵ and to stage patients²⁶ in 1970 and 1975, respectively.

Prior to the discovery in 1950²⁷ of salutary effects of adrenocorticotrophic hormones on MM (Fig. 98.1), medications used to that point included stibidine and urethane, neither of which had activity upon critical testing.³ During that decade, it was recognized that the adrenocorticotrophic hormones cortisone and prednisone were useful agents in patients with MM. Corticosteroids decreased bone pain, improved hypercalcemia, increased hemoglobin values, and decreased abnormal serum and urine globulin concentrations.²⁸ However, it was not until 1967 that high-dose corticosteroids were recognized as effective antineoplastic agents against MM.²⁹

Blokhin et al.³⁰ reported benefits in 3 of 6 patients with MM who were treated with sarcolysin (a racemic mixture of the d- and l-isomers of phenylalanine mustard). Subsequently, the d- and l-isomers were tested separately, and the anti-MM activity was found to reside in the l-isomer, melphalan. Bergsagel et al.³¹ reported significant improvement in 14 of 24 patients with MM with the use of melphalan; this activity was quickly substantiated by others.³² Similar effectiveness was noted with cyclophosphamide.³³ Subsequently, interferon- α (IFN), doxorubicin, carmustine, thalidomide, bortezomib, lenalidomide, bendamustine, and carfilzomib^{34, 35, 36, 37, 38, 39} have each been reported to have activity as a single agent in MM.

P.2047

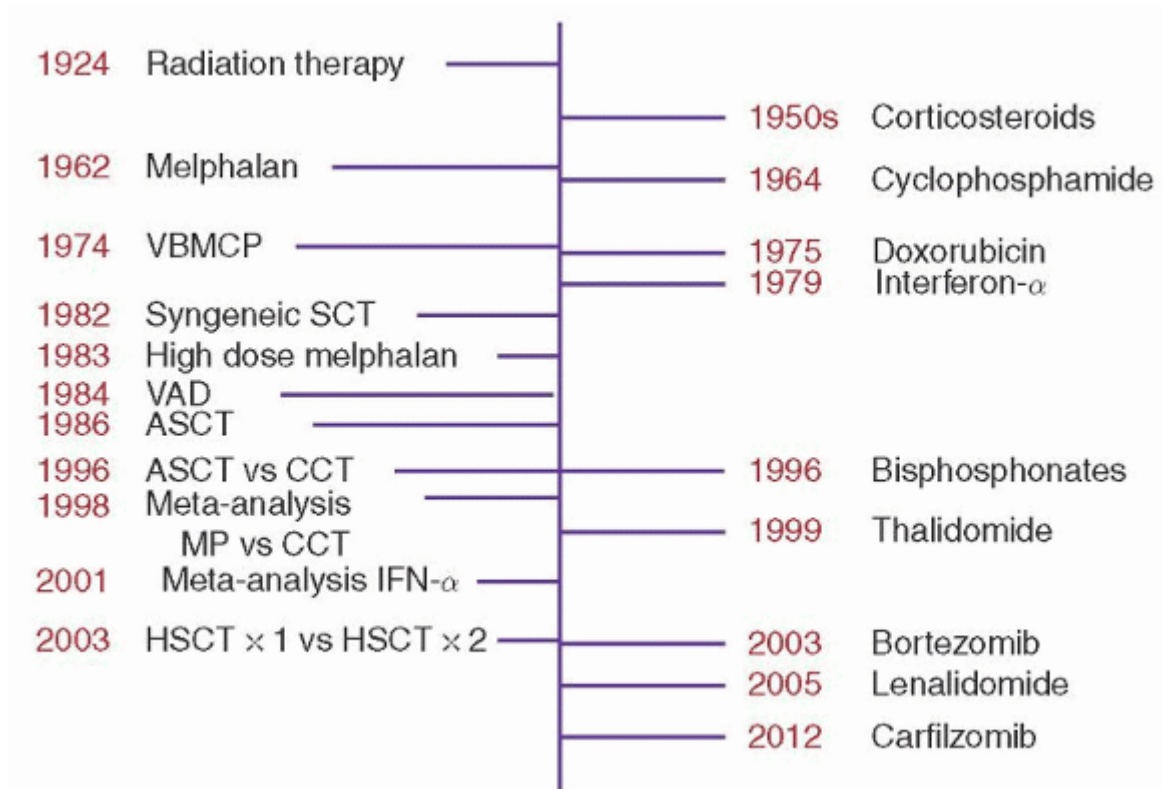

FIGURE 98.1. Landmark therapeutic innovations. ASCT, autologous stem cell transplant; BCNU, melphalan, cyclophosphamide, and prednisone (M-2 regimen); CCT, conventional chemotherapy; VAD, vincristine, doxorubicin, dexamethasone; VBMCP, vincristine.

INCIDENCE AND EPIDEMIOLOGY

As described in Chapter 97, recent evidence supports the theory that all MM arises from a preceding MGUS.⁴⁰ Increasingly it is becoming apparent that there is an increased risk of developing MM or MGUS among first-degree relatives of both MGUS and MM patients.^{41, 42} Whether this family linkage is due to either genetic susceptibility factors or shared environmental risk factors (or both) is yet to be determined.

Epidemiology of Myeloma

The 2012 annual estimate in the United States for new cases of MM is 21,700 and for deaths is 10,710.⁴³ SEER (Surveillance, Epidemiology, and End Results) data incidence age-adjusted rates from 1992 through 1998 show an overall incidence of 4.5 per 100,000 per year, with the incidence among whites being 4.2 per 100,000 per year and among blacks, 9.3 per 100,000 per year.⁴⁴ Male-to-female ratio is 1.3 to 1.⁴³ The median age at diagnosis of MM is 71 years. Since the turn of the century, 5-year survival rates in blacks and whites have equalized.⁴³ MM accounts for 1% of all malignancies and 10% of all hematologic malignancies in whites and 20% in African Americans.⁴⁴ International mortality data reveal that the highest rates of MM occur in Northern Europe, North America, Australia, and New Zealand and the lowest rates are in Japan, Yugoslavia, and Greece.⁴⁵ Geographic clusters⁴⁶ and familial clusters^{47, 48, 49, 50, 51, 52} of MM among first-degree

relatives have been documented. Modest increases in MM rates were observed when incidence data from 1973 to 1992 were calculated in nine population-based cancer registries.⁵³ These increases are likely due to a heightened awareness of the disease.

Etiologic Factors

Radiation Exposure

Reports of increased MM incidence and mortality among Japanese atomic bomb survivors have suggested an association between ionizing radiation and MM. Initial evaluations of cancer incidence⁵⁴ and mortality⁵⁵ among Japanese atomic bomb survivors suggested an increased risk of MM with increasing radiation dose, an observation that was no longer seen with additional years of follow-up.⁵⁶ Subsequent data would suggest that the prevalence of MGUS is higher among those younger patients exposed to higher doses of radiation.⁵⁷

An excess of MM deaths among American radiologists was reported in the 1960s.⁵⁸ MM risk was considered to be two times higher among radiologists exposed to low doses of radiation than among physicians not exposed to radiation.⁵⁹ However, among 27,000 Chinese diagnostic radiography workers, no excess incidence of MM was observed in a 30-year period.⁶⁰ An analysis of 115,000 workers from the combined roster of four different nuclear plants showed a positive association between MM and radiation exposure in older age groups.⁶¹ No increases in MM incidence and mortality have been observed among British⁶² or New Zealand⁶³ military men who participated in atmospheric nuclear weapons testing.

Diagnostic x-ray exposure has not been linked with the development of MM in most epidemiologic studies.^{64, 65, 66, 67, 68, 69} A large multicenter population-based case-control study showed no evidence of excess risk of MM among individuals who reported exposure for 10 or more diagnostic radiographs.⁷⁰ One study reported that the overall risk for MM was not high (RR, 1.14), but that there was evidence of increasing risk with exposure to increasing numbers of radiographic procedures.⁷¹ Of historic interest is the finding of an association between MM and the use of Thorotrast.⁶⁵ Studies of the effects of therapeutic irradiation on MM risk have shown conflicting results, but a study of 180,000 women treated for cervical cancer demonstrated no overall excess risk of developing MM.⁷² Similarly, a study of 14,000 patients suffering from ankylosing spondylitis and treated with radiation revealed no significant increase in the risk of developing MM.⁷³

Workplace Exposures

Several epidemiologic studies have evaluated the risk of MM among agricultural workers, with positive associations reported by many^{74, 75, 76, 77, 78, 79} but not all of the studies.^{80, 81, 82} Khuder and Mutgi⁸³ found a relative risk of 1.23 in a meta-analysis of several studies. Workers in various metal occupations and industries have been reported to have an increased MM risk.^{84, 85, 86}

Benzene has been suggested as a possible etiologic agent for MM.^{87, 88, 89} A comprehensive review of the published literature found no evidence of a link between benzene exposure and MM.⁹⁰ Subsequently, Sonoda and colleagues⁹¹ conducted a meta-analysis of case-control studies and showed no excess risk for the development of MM. A meta-analysis by Wong and Raabe⁹² of more than 350,000 petroleum workers similarly showed no increased risk.

Cigarette Smoking, Alcohol Consumption, and Diet

Multiple studies to date have found no etiologic role for cigarette smoking or alcohol consumption in the development of MM.^{93, 94, 95, 96} In contrast, Tavani et al.⁹⁷ suggested a dietary link for MM and found a higher risk among people consuming large quantities of liver (odds ratio [OR], 2.0) and butter (OR, 2.8), and a lower risk among people consuming large amounts of vegetables (OR, 0.4) No association of MM and consumption of coffee or red meat has been found.⁹⁷ Brown and colleagues⁹⁸ looked at diet and nutrition as risk factors for MM among blacks and whites in the United States. Only obesity was associated with increased risk, and obesity was more frequent in black than in white controls. Frequent consumption of cruciferous vegetables, fish, and vitamin C supplements was associated with decreased risk of MM. The authors concluded that the greater use of vitamin C supplements by whites and the higher frequency of obesity among blacks may explain part of the higher incidence of MM among blacks compared with whites in the United States.

Personal use of hair dyes was evaluated as a risk factor for MM,⁹⁹ including two prospective studies.^{100, 101} Thun et al.¹⁰⁰ found that women using permanent hair dyes are not generally at increased risk of fatal cancer. However, women with prolonged use of dark, particularly black, hair dyes may have increased risk

P.2048

of fatal non-Hodgkin lymphoma and MM, but these women are a small fraction of hair dye users. A subsequent meta-analysis by Correa et al.¹⁰² showed no increased risk.

Socioeconomic Status

Some investigators have reported that there is an inverse relationship between the risk of MM and socioeconomic status,¹⁰³ and that this inverse correlation may account for a substantial amount of the black and white differential of MM incidence.¹⁰⁴ Earlier studies did not show a link between socioeconomic status and MM.¹⁰⁵

Chronic Antigenic Stimulation

Repeated or chronic antigenic stimulation of the immune system may lead to MM. Several case-controlled studies have suggested that MM risk is associated with past history of infections, inflammatory conditions, connective tissue disorders, autoimmune illnesses, and allergy-related disorders.^{94, 106, 107} Patients with the human immunodeficiency virus may have an increased likelihood of developing MM.^{108, 109} In addition, MM and hepatitis C may be associated.^{110, 111, 112} The finding of human herpes virus 8 has been suggested as a possible etiologic agent,¹¹³ but this has not been confirmed.^{114, 115, 116, 117} Increased risk for MM has been observed in patients with rheumatoid arthritis.^{51, 118, 119} Other studies of individuals with these conditions have shown no increased risk of MM.^{120, 121, 122, 123}

CLINICAL MANIFESTATIONS

The symptoms of MM may be nonspecific and include fatigue, bone pain, easy bruisability and bleeding, recurrent infections, manifestations of anemia, hypercalcemia, lytic bone lesions, hyperviscosity, thrombocytopenia, and hypogammaglobulinemia (Fig. 98.2). Weakness, infection, bleeding, and weight loss are reported in as many as 82%, 13%, 13%, and 24% of patients, respectively.^{124, 125, 126, 127} Hypercalcemia is present in 18% to 30% of patients.^{124, 125, 126} One to two thirds of patients present with spontaneous bone pain.^{124, 125, 126} "Tumor fever" is present in less than 1% of presenting patients.

Anemia

The most common clinical feature of MM is anemia. A hemoglobin concentration of less than 120 g/L occurs in 40% to 73% of patients at presentation^{124, 125, 126} and contributes to the weakness and fatigue observed in as many as 82% of patients.^{124, 125, 126} The anemia is normochromic, normocytic in most patients, but macrocytosis may be observed as well. When there are high concentrations of serum immunoglobulin, rouleau formation may be observed (Fig. 98.3A). The combination of anemia and hyperproteinemia leads to a marked increase of the erythrocyte sedimentation rate in more than 90% of cases.¹²⁸

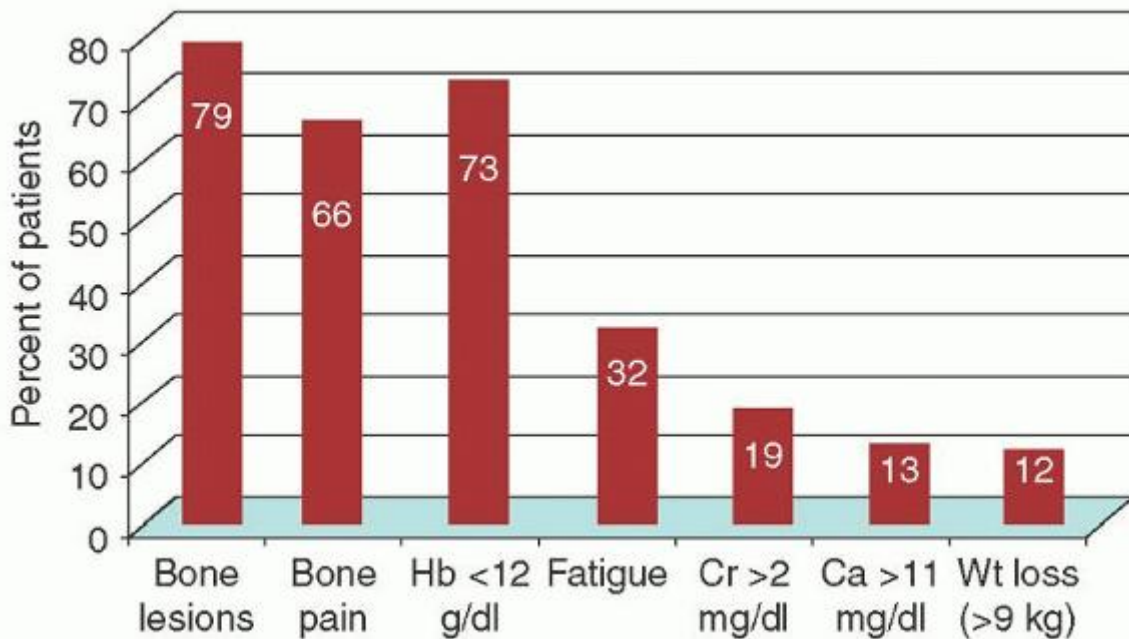

FIGURE 98.2. Signs and symptoms of 1,027 newly diagnosed myeloma patients seen at the Mayo Clinic from 1985 through 1998.

The anemia is related partially to direct infiltration and replacement of the bone marrow. Hemoglobin concentration is also correlated directly with the percentage of MM cells in S phase,¹²⁹ suggesting that the bone marrow cytokine milieu,

permissive for MM cell proliferation, is not conducive to efficient erythropoiesis. Cytokines, like tumor necrosis factor- α and IL-1, may inhibit erythropoiesis.¹³⁰ Fas ligand-mediated erythroid apoptosis is also increased in patients with MM.¹³¹ Finally, relative erythropoietin deficiency from MM-induced renal insufficiency also contributes to the observed anemia.

Monoclonal Proteins

The M protein (M component, myeloma protein, or M spike) is a hallmark of the disease; 97% of MM patients have either an intact immunoglobulin or a free light chain that can be detected by protein electrophoresis, immunoelectrophoresis, or immunofixation studies of the serum or urine (Fig. 98.3B,C).^{124, 126} Those cases without a detectable monoclonal protein have been referred to as nonsecretory MM, which had accounted for approximately 1% to 3% of MM cases. With the immunoglobulin free light chain assay, small free light chain monoclonal proteins heretofore not seen by aforementioned methods are seen in approximately two thirds of the cases that had been referred to as nonsecretory.¹⁹

Historically, monoclonal proteins have had a valuable role in the fields of immunology and molecular biology, for distinguishing MGUS from MM and for calculating MM tumor burden and kinetics.^{25, 132, 133} Practically, both serum and urine M protein concentrations are used to stage MM patients and to document their response to treatment.

In a series of 1,027 newly diagnosed cases of MM, the immunoglobulin type was IgG, IgA, IgD, and free light chain only (Bence Jones MM) in 52%, 20%, 2%, and 16% of cases, respectively.¹²⁶ Fewer than 1% of MM cases are IgM; most IgM monoclonal proteins are associated with diagnoses of MGUS, lymphoma, Waldenström macroglobulinemia, or primary systemic amyloidosis.¹³⁴ A total of 93% of patients have a monoclonal protein detected in their serum. About 90% of MM patients have reduction in at least one of their uninvolved immunoglobulins.¹³⁴ About 70% have a monoclonal protein—or fragment thereof—detected in the urine.

Histopathology

The bone marrow microenvironment is hospitable to malignant plasma cells that circulate through the blood. There is a complex interaction among the malignant clone, its surrounding stromal cells, and the remaining immune cells. The morphologic and immunologic phenotypes of MM cells can vary, and they often resemble normal plasma cells. Plasma cells are at least two to three times the size of peripheral lymphocytes and are round to oval, with one or more eccentrically placed nuclei (Fig. 98.3D). The nucleus, which contains either diffuse or clumped chromatin, is displaced from the center by an abundance of rough-surfaced endoplasmic reticulum, the site of specialized immunoglobulin synthesis. Intranuclear and cytoplasmic inclusions are not uncommon.¹³⁵ There is a perinuclear clear zone that is the site of the Golgi apparatus, the machinery used for immunoglobulin packaging and glycosylation for secretion. Derangements of immunoglobulin secretion are responsible for an assortment of cytologic aberrations, including flaming cells, Mott cells, Russell bodies, and Gaucher-like cells. Flaming cells are plasma cells that have intensely eosinophilic cytoplasm with a magenta or

P.2049

carmine coloring of their margins, which is due to plugging of peripheral secretory channels by precipitated immunoglobulin or immunoglobulin fragments. These cells are most commonly seen in IgA MM. Thesaurocytes are large flaming cells with a pyknotic nucleus that is pushed to the side. Mott cells (grape cells or morula forms) are plasma cells filled with dense spherical immunoglobulin inclusions; these inclusions are colorless, pink, or blue. Other inclusions are Russell bodies and their intranuclear counterparts (intranuclear dense bodies); these appear cherry red and can be as large as several microns in diameter. Gaucher-like cells are not uncommon in MM infiltrates; these cells are macrophages laden with sphingolipids released by the dying plasma cells.¹³⁶ None of these interesting inclusions is specific for malignancy nor do they have prognostic value.

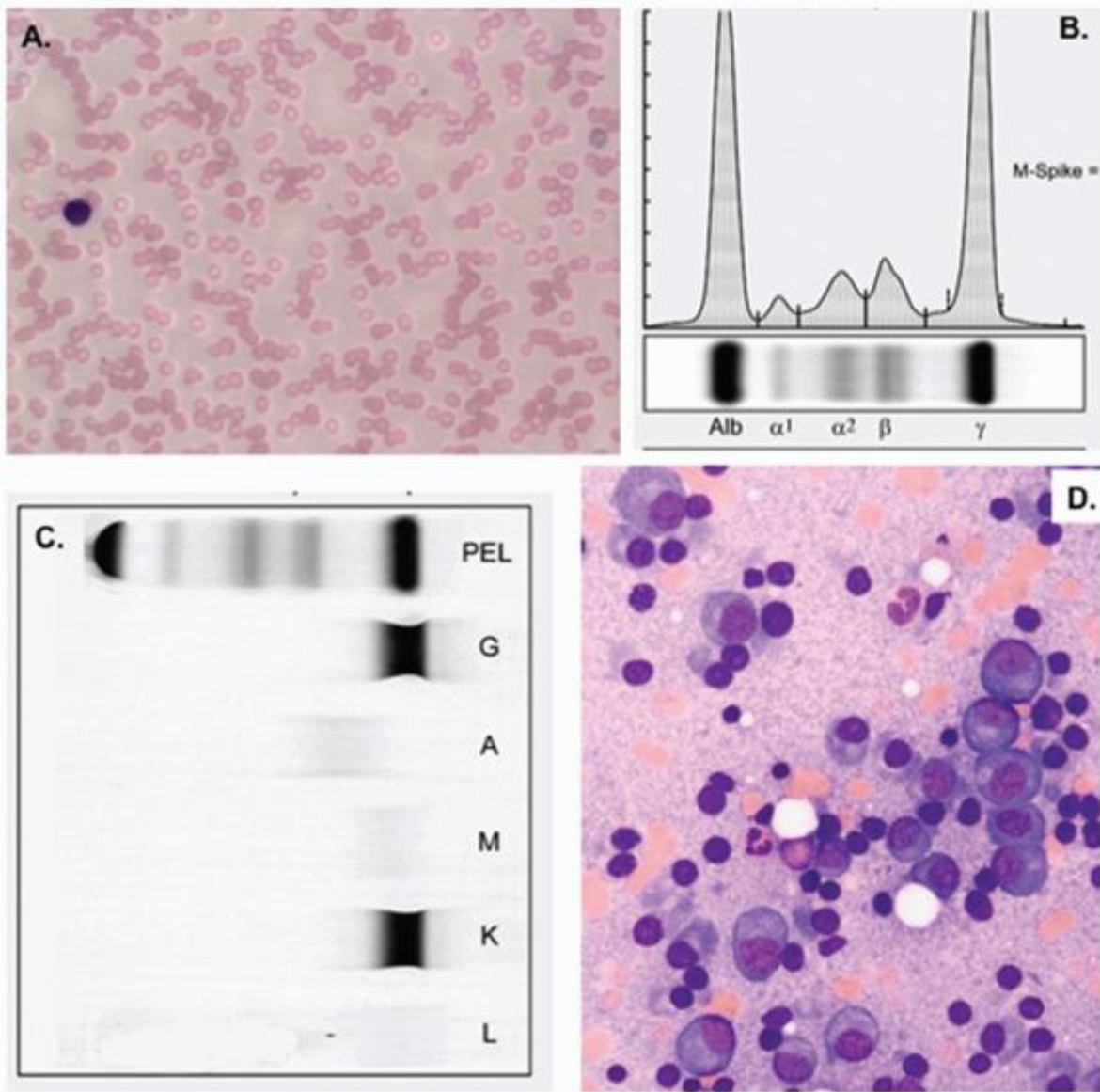

FIGURE 98.3. Laboratory findings in patients with multiple myeloma. A: Rouleaux. B: Serum protein electrophoresis, illustrating a 3-g/dl monoclonal protein spike. C: Immunofixation electrophoresis, illustrating a monoclonal IgG lambda monoclonal protein. D: Bone marrow: myeloma cells on aspirate specimen.

In MM, there is often discordance between the nucleus and cytoplasm, the former appearing immature and the latter highly differentiated. About 20% of MM cases have plasmablastic morphology: a diffuse chromatin pattern, nucleus greater than 10 microns or nucleolus greater than 2 microns, relatively less abundant cytoplasm, and a concentrically placed nucleus with little or no hof.^{137, 138} Both diffuse and nodular infiltration patterns can be observed, although the former is more common. A minority of patients have plasma cells that have a lymphoplasmacytic appearance. MM cells are commonly present in cords around bone marrow microvessels. There is a high correlation between the extent of bone marrow angiogenesis, evaluated as microvessel area, and the proliferating fraction of marrow plasma cells in patients with MM.^{139, 140} Mild marrow fibrosis may be observed in as many as 27% of cases; extensive fibrosis is rare.^{141, 142} Less than 1% of cases have an extensive idiopathic granulomatous reaction.¹³⁵

The immunophenotype of MM cells is complex. In general, MM cells are CD45 negative and CD38 and CD138 positive.^{143, 144} However, there is increasing evidence that a subset of MM cells is CD45 positive,^{144, 145} with an increasing proportion of CD45 positive MM cells in less advanced disease.^{146, 147} CD19 and CD20 are earlier B-cell antigens that are variably expressed on MM cells; surface immunoglobulin is seen in up to one third of patients. CD56 is strongly positive in about 55% to 78% of MM cases.^{144, 148, 149} CD56-negative MM cells tend to be present in more aggressive disease, such as end-stage MM or plasma cell leukemia.^{149, 150} Other surface antigens such as CD10 (CALLA), CD28, CD117 (c-KIT), CD13, CD33,

and CD20 are present on a minority of patients' MM cells.^{143, 144, 145, 151, 152} Co-stimulatory molecules involved in the activation of B- and T-lymphocytes (CD28 and CD40) are seen in 40% and 70% of patients, respectively.^{153, 154}

No individual bone marrow finding, however, is pathognomonic for a malignant plasma cell process; the bone marrow diagnosis of MM relies on percentage of clonal bone marrow plasma cells, with 10% accepted as a cutoff. The clinical diagnosis, of course, is made from a synthesis of bone marrow findings and other clinical features.

Bone Disease

Approximately one third to two thirds of patients present with bone pain.^{124, 125, 126, 127} There is an uncoupling of the balance between osteoclastic and osteoblastic activity. Even before the development of bone lesions, enhanced osteoblastic recruitment with an increased generation of new osteoclasts is observed in early MM.¹⁵⁵ Regardless of the initiating signal, whether IL-1 β ,

P.2050

IL-6 and sIL-6R, tumor necrosis factor- α , MIP-1 α , receptor activator of NF-kappa β (RANK) ligand, or parathyroid hormone-related protein (PTHrP),¹⁵⁶ the eventual outcome is bone destruction.¹⁵⁷

MM bone disease is a major source of morbidity and may present as an area of persistent pain or as a vague migratory bone pain, often in the lower back and pelvis. The type, location, and duration of the pain have no characteristic features. At times, pain and tenderness may be sudden in onset, especially when associated with a pathologic fracture, and are most commonly precipitated by movement. Persistent localized pain also may be associated with a pathologic fracture.

A myelomatous lesion may extend through the cortex of a vertebral body and cause either nerve root or spinal cord compression in less than 2% of patients.¹²⁵ Alternatively, the MM can disturb the mechanical integrity of a vertebral body, resulting in compression fracture with retropulsion of either plasmacytoma or bony fragments into the spinal canal, again causing neurologic deficit. Approximately 75% of patients have punched-out lytic lesions, osteoporosis, or fractures on conventional radiography (Fig. 98.4A,B). The vertebrae, skull, ribs, sternum, proximal humeri, and femora are involved most frequently.^{124, 126, 127} A small subset of patients has de novo osteosclerotic lesions,¹⁵⁸ and in a few patients osteosclerosis is seen after therapy and may serve as a marker of healing.

Because myelomatous bone lesions are characteristically lytic, conventional radiography is superior to technetium-99m bone scanning.^{159, 160} About twice as many myelomatous bone lesions are detected by radiograph as by bone scan; an exception to this general finding is at the lumbar spine and the rib cage, where the two methods are equally reliable.¹⁶⁰ There have been reports supporting the use of technetium-99m sestamibi scans. These scans are almost as sensitive as plain radiographs for bone disease in untreated patients (i.e., patients with active disease).¹⁶¹ They may be able to distinguish active myelomatous bone lesions from inactive lesions¹⁶¹ and are quite sensitive for bone marrow involvement.^{162, 163, 164} There is a high concordance between scintigraphic findings and clinical status in patients undergoing chemotherapy or autologous stem cell transplantation (ASCT).^{165, 166} 18-Fluorodeoxyglucose positron emission tomography (FDG-PET) also shows promise in the staging of MM, with sensitivity and specificity rates of 84% to 92% and 83% to 100%, respectively¹⁶⁷ (Fig. 98.4D,E).

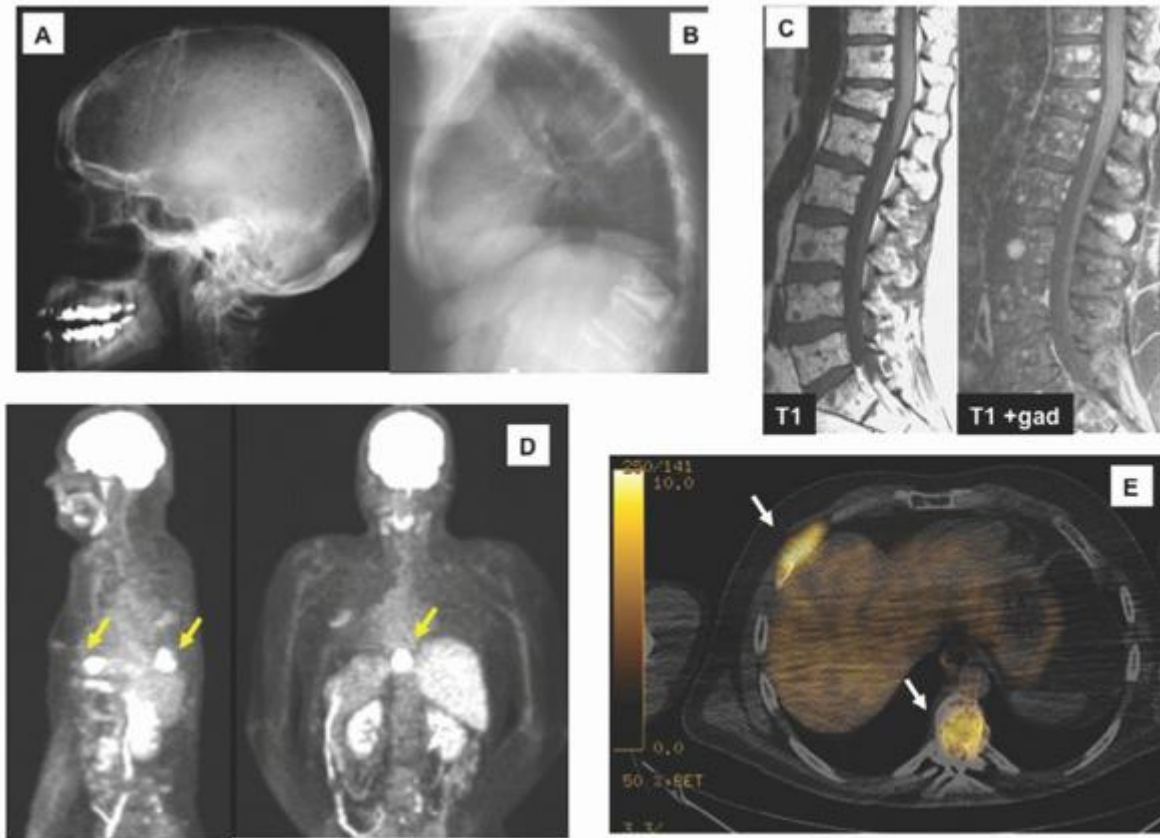

FIGURE 98.4. Myeloma bone disease. A: Plain radiograph of a skull with punched-out myeloma lesions. B: Plain radiograph of a compression fracture thoracic spine. C: Myelomatous marrow involvement of the lumbar spine by magnetic resonance imaging (MRI) with and without gadolinium. D: 18-Fluorodeoxyglucose positron emission tomography (FDG-PET), spine and rib involvement. E: Fusion image of CT/FDG-PET scan demonstrating lesion at rib and thoracic vertebra.

Computed tomography and magnetic resonance imaging (MRI) are more sensitive than conventional radiography (Fig. 98.4C). Both reveal specific lesions in 40% of stage I MM patients.¹⁶⁸ The presence of lacunae larger than 5 mm with trabecular disruption on computed tomography appears to be sensitive and specific for MM. This information may be useful in distinguishing between senile and myelomatous osteoporosis and compression fractures.¹⁶⁹ Among asymptomatic MM patients with normal radiographs, 50% have tumor-related abnormalities on MRI of the lower spine.¹⁷⁰ In patients with Durie-Salmon stage I MM, MRI can distinguish patients at higher and lower risks of progression.¹⁷¹ One third of patients with an apparently solitary plasmacytoma of bone have evidence of other plasma cell tumors on MRI.¹⁷²

MRI is superior to radiographs for the detection of lesions in the pelvis and the spine, but overall it is inferior to radiographs for detecting bone involvement in MM (79% versus 87%, respectively).¹⁷³ On MRI, vertebral fractures due to spinal infiltration or osteoporosis are seen in 48% of patients with symptomatic MM, and spinal canal narrowing with impingement occurs in 20%.¹⁷⁰ Nanni et al.¹⁷⁴ compared MRI to FDG-PET/CT in 28 newly diagnosed myeloma patients. In 25% of patients FDG-PET/CT

P.2051

detected more lytic bone lesions, all of which were out of the field of view of MRI, and in 25% of patients MRI detected an infiltrative pattern in the spine that was not discerned on FDG-PET/CT. In subsequent studies, whole body MRI has been reported to have a higher sensitivity and specificity than FDG-PET/CT¹⁷⁵ and than multidetector-row computed tomography.¹⁷⁶ A major limitation, however, to MRI and PET/CT is that there are no uniformly accepted standard acquisition or interpretation protocols, limiting their generalizability. Detection of marrow infiltration on MRI does not translate into a deficit of cortical bone integrity. Also, given the expense of MRI, it cannot be recommended for routine clinical use in all patients.

Hypercalcemia

Hypercalcemia occurs in 18% to 30% of patients. About 13% have concentrations greater than 11 mg/dl. Rates of hypercalcemia at presentation have been decreasing in the last few decades, perhaps because of the earlier diagnosis of patients.^{124, 125, 126, 127} Hypercalcemic patients may complain of fatigue, constipation, nausea, or confusion. Calcium can precipitate in the kidneys and aggravate renal insufficiency. Inorganic phosphate is rarely decreased, except in cases of acquired Fanconi syndrome.¹⁷⁷

Renal Insufficiency

Approximately 25% of MM patients have a serum creatinine value greater than 2 mg/dl at diagnosis. Another 25% have mildly elevated creatinine values.^{124, 125, 126, 127, 178, 179, 180, 181} Patients with Bence Jones or IgD MM have the highest rates of renal insufficiency.^{179, 181} Free light chain proteinuria is a risk factor for renal failure.¹⁸² Contributing factors to the renal insufficiency associated with MM kidneys include hypercalcemia, dehydration, hyperuricemia, and the use of nephrotoxic drugs.¹⁸³ If the renal insufficiency reverses with therapy, as it does in more than half of cases,^{183, 184} survival is fourfold to sevenfold higher than in those in whom it does not.^{178, 185} Factors predicting for renal function recovery include a serum creatinine less than 4 mg/dl, serum calcium value greater than 11.5 mg/dl, proteinuria less than 1 g/24 h, and adequate rehydration.¹⁷⁸

The pathologic lesion of MM kidney consists of monoclonal light chains in the tubules in the form of dense, often laminated, tubular casts. These casts contain albumin and Tamm-Horsfall protein. Light chains are normally filtered by the glomeruli and reabsorbed and catabolized in the nephron's proximal tubules. It is postulated that these systems become overwhelmed, and casts result. When other causes contributing to renal insufficiency are excluded, there is a good correlation between the extent of MM cast formation and the severity of renal insufficiency.^{186, 187} Tubular atrophy and degeneration correlate well with renal dysfunction.¹⁸⁸ The most common findings on autopsy include tubular atrophy and fibrosis (77%), tubular hyaline casts (62%), tubular epithelial giant cell reaction (48%), and nephrocalcinosis (42%). Evidence of acute and chronic pyelonephritis were observed in 20% and 23% of cases, respectively. Plasma cell infiltrates and amyloid may be observed in 10% and 5% of cases, respectively.¹²⁷ Rarely, MM may be associated with acquired Fanconi syndrome.^{177, 189}

An important feature of myeloma kidney is that it is primarily a tubular, rather than a glomerular, disease.¹⁸⁸ Glomerular function is preserved initially, and there is a predominance of immunoglobulin light chain protein in the urine instead of the nonspecific protein loss observed in glomerular disease. This feature helps predict the renal lesion: nonspecific protein loss (i.e., mostly albumin) is more compatible with primary systemic amyloidosis, light chain deposition disease of the kidney, or proteinuria unrelated to the PCD;¹⁸⁶ a free light chain predominance is consistent with myeloma kidney.

Infection

Patients with MM are at high risk for bacterial infections and for dying of overwhelming bacteremia. Overall, the incidence of infection is from 0.8 to 1.4 per patient-year.^{190, 191, 192} During the first 2 months after initiating chemotherapy the infection incidence is as high as 4.68 infections per patient-year¹⁹² but decreases to 0.44 to 0.49 per patient-year in those reaching a plateau phase.^{191, 192} Risk factors for infection are serum creatinine values greater than or equal to 2 mg/dl^{190, 192} and decreased levels of polyclonal serum immunoglobulins.^{191, 192} Since the 1960s, Gram-negative bacilli have become more common pathogens than *Streptococcus pneumoniae* in patients with MM.¹⁹³ At disease onset, infections with encapsulated organisms such as *Streptococcus pneumoniae* and *Haemophilus influenzae* are most common.¹⁹³ After diagnosis, the proportion of infections due to Gram-negative bacilli and *Staphylococcus aureus* increases markedly, and are responsible for more than 90% of deaths from infection.¹⁹³

Hemostasis in Multiple Myeloma

MM can be associated with hemostatic abnormalities, more often bleeding than thrombosis. Bleeding as a complication of MM may be present in as many as one third of patients¹⁹⁴ and is related to thrombocytopenia, uremia, hyperviscosity, and interference with the function of coagulation factors. Rarely, MM proteins may also interact with coagulation proteins.^{192, 193}

The association with thrombosis is less clear because of co-existing factors such as old age and immobility that confound the interpretation of available data, however, the risk of thrombosis may be increased in MM patients.^{194, 195} Individual cases of aberrance have been reported. Monoclonal proteins have been shown to be responsible for lupus anticoagulants,^{196, 197} acquired protein S deficiency,^{198, 199} acquired activated protein C resistance,²⁰⁰ and inhibition of tissue plasminogen activator.²⁰¹

Fewer than 7% of MM patients have a viscosity greater than 4.^{124, 126} Symptoms of hyperviscosity include bleeding (particularly of the oronasal areas), purpura, decrease in visual acuity, retinopathy, neurologic symptoms, dyspnea,

expanded plasma volume, and congestive heart failure. Most patients become symptomatic when the serum viscosity is 6 or 7 centipoise (normal is less than or equal to 1.8 centipoise).

“Acute Terminal Phase of Plasma Cell Myeloma” and Cause of Death

Bergsagel and Pruzanski²⁰² described the “acute terminal phase” of patients with MM, which they observed in about one third of their preterminal patients. They defined the syndrome as rapidly progressive disease with an unexplained fever and pancytopenia and a hypercellular marrow. Extramedullary plasmacytomas are also not uncommon preterminally.²⁰³ As the disease progresses, and at autopsy, cutaneous, visceral, and even meningeal involvement is possible.²⁰³ Besides “progressive disease,” the most frequent causes of death are infection in 24% to 52% and renal failure in about 20%.^{127, 183, 202, 203} Acute leukemia, myelodysplastic syndromes, and hemorrhage are the causes of death in a minority of patients.^{127, 202, 203} In one autopsy series, 85% of patients had evidence of either bacterial or fungal infection, and myelomatous involvement was found in the spleen, liver, lymph nodes, and kidneys in 45%, 28%, 27%, and 10% of patients, respectively. Other less frequent areas of myelomatous involvement were the lung, pleura, adrenal glands, pancreas, and testis.¹²⁷

DIAGNOSIS

The diagnosis of MM has not been subject to static norms. In 1973, the Chronic Leukemia-Myeloma Task Force²⁰⁴ set forth guidelines for the diagnosis of MM (Table 98.1). These criteria,

P.2052

which by today's standards are not stringent enough, have been replaced by a more modern definition.²⁰⁵ In the last 3 decades, the terms and definitions of MGUS, smoldering MM, indolent MM, and symptomatic MM^{124, 206, 207, 208} have evolved and are now to be replaced by the following designations: MGUS, inactive (smoldering) MM, and active (or symptomatic) MM.²⁰⁵

TABLE 98.1 CRITERIA FOR DIAGNOSIS OF MGUS, SMM, AND MM

	Chronic Leukemia-Myeloma Task Force Definition of Multiple Myeloma (1973)^a	Criteria for Diagnosis of MGUS, SMM, and MM, International Working Group (2003)^b
Monoclonal Gammopathy of Undetermined Significance	Not described	- Serum monoclonal protein (<30 g/L) - Bone marrow <10% plasma cells - No evidence of other B-cell proliferative disorders - No related organ or tissue impairment ^{c, d}
Smoldering Myeloma (asymptomatic)	Not described	- No related organ or tissue impairment ^c - Serum monoclonal protein (≥30 g/L) and/or - Bone marrow clonal plasma cells ≥10%
Multiple Myeloma	If M protein present in serum or urine, one or more of the following must be present: MM - Marrow plasmacytosis >5% in absence of underlying reactive process - Tissue biopsy demonstrating replacement and distortion of normal	ACTIVE OR SYMPTOMATIC MM - Monoclonal protein present in serum and/or urine - Clonal bone marrow plasma cells

- | | |
|---|---|
| tissue by plasma cells | or plasmacytoma |
| - >500 plasma cells/mm ³ in peripheral blood | - Related organ or tissue impairment ^a |
| - Osteolytic lesion unexplained by other causes | |
| If no M protein in serum and urine, radiologic evidence of osteolytic lesions or palpable tumors and one or more of the following required: | |
| - Marrow plasmacytosis of >20% from two sites in absence of reactive process | |
| - Tissue biopsy demonstrating replacement and distortion of normal tissue by plasma cells | |

MM, multiple myeloma; MGUS, monoclonal gammopathy of undetermined significance; SMM, smoldering MM.

^a From Chronic Leukemia-Myeloma Task Force, National Cancer Institute, 204 shown for historical purposes.

^b From Chronic Leukemia-Myeloma Task Force, current definitions. 205

^c The absence of CRAB (calcium elevation [> 1 mg/dl above upper limit of normal], renal dysfunction [creatinine >2 g/dl], anemia [hemoglobin 2 g/dl below lower limit of normal], bone lesions [lytic lesions or osteoporosis with compression fracture] attributable to the plasma cell disorder).

^d The existence of immunoglobulin light chain amyloidosis or another paraneoplastic disorder attributable to the monoclonal gammopathy, like a peripheral neuropathy would be termed "monoclonal gammopathy associated with..."

Because MM includes a spectrum of biologic features, physicians should not feel compelled to start treatment as a result of a single threshold value. The diagnosis of active MM is not a straightforward pathologic one; rather, it is a clinical diagnosis that requires thoughtful synthesis of multiple variables. Patients with Durie-Salmon stage I disease, who also meet the criteria for smoldering or asymptomatic MM, should be managed expectantly. Median progression-free survival in asymptomatic stage I patients, observed without any therapy, is 12 to more than 48 months;^{209, 210, 211, 212} for similar stage II patients, progression-free survival is 12 months.²⁰⁹ Until recently,²¹³ no survival advantage had been demonstrated by treating asymptomatic MM patients.^{208, 210, 211, 214}

SYSTEMIC THERAPY FOR MULTIPLE MYELOMA

Before starting therapy for MM, a distinction must be made between smoldering (asymptomatic) MM and active MM (Table 98.1). Approximately 20% of patients with MM are recognized by chance without significant symptoms; such patients can be carefully monitored without instituting therapy (see Chapter 97). Once the decision has been made to treat for symptomatic disease, a long-term plan for managing the disease should be formulated before instituting therapy. Because high-dose therapy with autologous hematopoietic stem cell transplantation (ASCT) has been accepted as an important treatment modality for patients younger than age 70, only a limited amount of alkylator-based therapy should be used prior to the collection of hematopoietic stem cells in patients considered candidates for high-dose therapy.

Historically, the bifunctional alkylating agents, including melphalan and cyclophosphamide, had been the foundation of therapy for MM. MM cells tend to proliferate slowly, and alkylators, whose effectiveness does not rely heavily on cell division and DNA replication, are useful therapeutic agents. Prior to 1999, the bifunctional alkylators, nitrosoureas, doxorubicin, and glucocorticoids were the primary agents shown to have single-agent activity against MM *in vivo*.²¹⁵ These

drugs along with vincristine, either singly or in combination, had been the mainstay of chemotherapy for MM from the early 1960s to the present (Fig. 98.1). Until recently, the higher response rates seen with regimens that combine multiple active agents as part of initial therapy, had not resulted in improved OS rates.²¹⁶ IFN- α had been incorporated into induction and maintenance protocols with minimal benefit.^{34, 217, 218, 219} Both autologous and allogeneic stem cell transplantation (AlloSCT) have become important therapeutic options since McElwain and Powles' description in 1983²²⁰ of the benefit of dose intensification of melphalan in patients with MM. With the recognition of thalidomide's activity against MM in 1999³⁷ and the subsequent development of bortezomib,³⁸ lenalidomide,³⁹ and carfilzomib²²¹ there is hope that the next 4 decades of MM treatment will be even more promising than the last.

Before discussing induction, transplantation, maintenance, and salvage therapies, two general concepts are reviewed: interpretation of study response data and the efficacy of single

P.2053

chemotherapeutic agents commonly used to treat MM. Figure 98.5 is one potential algorithm for treating patients with newly diagnosed MM.

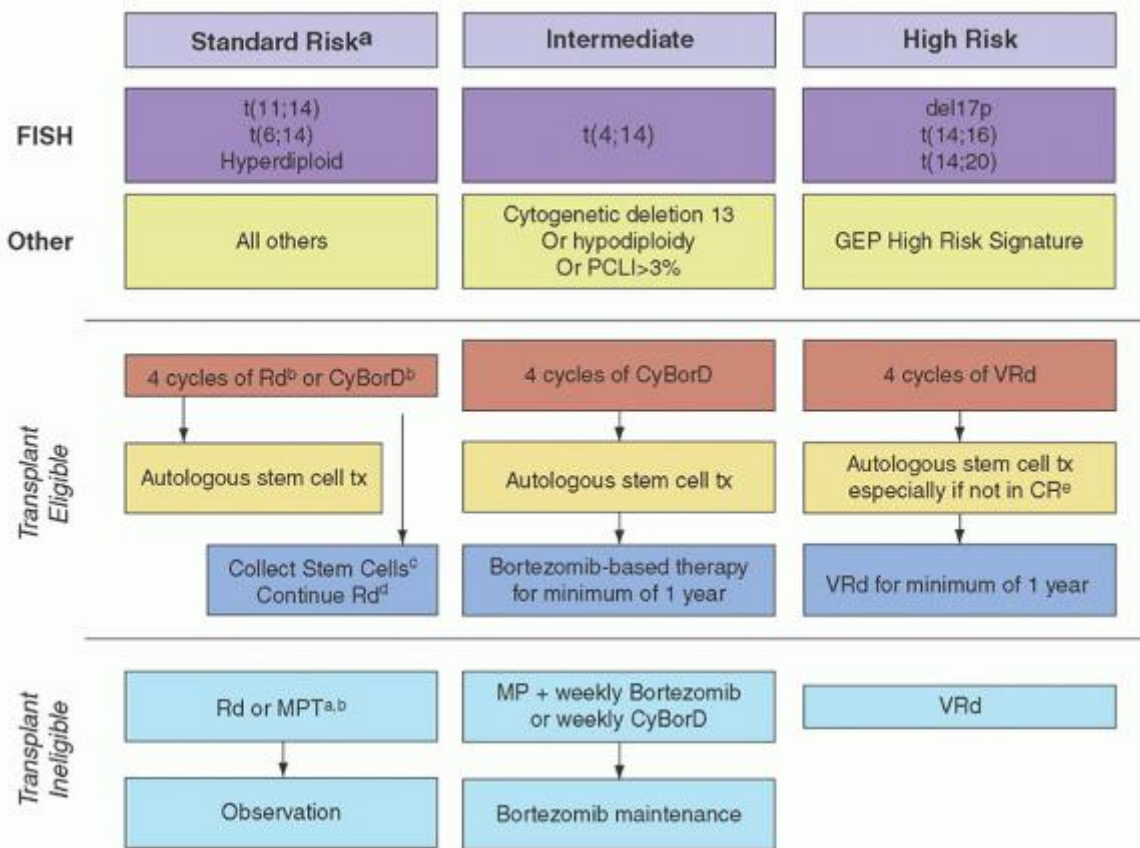

FIGURE 98.5. Mayo stratification for myeloma and risk-adapted therapy (mSMART).^{357, 358} Possible treatment algorithm for patients with newly diagnosed myeloma for patients not being treated on a clinical trial. CR, complete response; CyBorD, cyclophosphamide, bortezomib, and dexamethasone; MPT, melphalan, prednisone, and thalidomide; Tx, transplantation; VRd, bortezomib, lenalidomide, and dexamethasone, VGPR, very good partial response. ^aNote that a subset of patients with these factors will be classified as high-risk by GEP. ^bBortezomib containing regimens preferred in renal failure or if rapid response needed. ^cIf age >65 or > 4 cycles of Rd Consider G-CSF plus cytoxin or plerixafor. ^dContinuing Rd is option for patients responding to Rd and with low toxicities; Dex is usually discontinued after first year. ^eConsider allogeneic stem cell transplantation in suitable patients.

Interpreting Study Response and Survival Data

Four points are emphasized regarding the interpretation and comparisons of the MM treatment literature. First, historically definitions of response have varied (Table 98.2). Second, definitions of evaluable patients may be different. Third, concurrent corticosteroid therapy, either as part of the regimen or for other indications, may confound

interpretation of efficacy. Finally, patient population risk and prognosis may differ substantially. Lead-time bias and treatment of MGUS or smoldering MM can significantly distort survival figures, as can effective salvage regimens.

The measurement of MM disease burden is complex, and investigators have used different methods to define response (Table 98.2). The four most common response criteria that had been used until acceptance of the Uniform Response Criteria (URC) in 2006²²² were the Chronic Leukemia-Myeloma Task Force (CLMTF),²⁰⁴ Southwest Oncology Group (SWOG),^{223, 224} Eastern Cooperative Oncology Group (ECOG),²²⁵ and Autologous Blood and Marrow Transplant Registry and the International Bone Marrow Transplant Registry (IBMTR/ABMTR).²²⁶ Although all address calcium, bone changes, and bone marrow plasmacytosis, the main distinction among them is their consideration of the serum and urine M components. With the exception of the old SWOG criteria,^{223, 224} a partial response (PR) has been considered to be a 50% reduction in serum M component and a greater than 50% to 90% reduction in urine M component. Until about 1990, a SWOG objective response was defined as a 75% reduction in the tumor mass index (NOT serum M protein) and improvement was defined as a 50% to 74% reduction in the tumor mass index.²²⁴ A subsequent iteration of the SWOG response criteria used the M component (rather than the tumor mass index) as the primary measurement of the plasma cell burden.

In the earliest literature, response included such factors as increasing hemoglobin concentration or performance status, or decreasing blood urea nitrogen levels. Neither the CLMTF or SWOG originally had a complete response (CR) category, because it was unusual for the M protein to disappear completely. It was not until the advent of high-dose melphalan that investigators^{227, 228} began to define a complete remission category. Earliest definitions of CR only included disappearance of M protein as determined by electrophoresis, which is less sensitive than immunoelectrophoresis or immunofixation. Subsequent definitions have required immunofixation negativity to qualify as complete remission.²²⁶ The first iteration of an international consensus definition of MM response was the IBMTR/ABMTR response criteria.²²⁶ After nearly 8 years of use, several deficiencies were noted, and the International Myeloma Working Group issued a new consensus definition called the International Uniform Response Criteria (URC) which includes the Intergroupe Français du Myélome (IFM) very good partial response category,²²⁹ the ability to measure response using the serum immunoglobulin free light chain, and a new category of "stringent complete response," which requires documentation of the absence of clonality in the bone marrow and by including a normal serum immunoglobulin free light chain ratio in the definition.²²²

P.2054

TABLE 98.2 RESPONSE CRITERIA

Response	Study	% BMPC	M protein		Duration, wk
			Serum	Urine	
Stringent CR (sCR)	IRC ²²²	<5 ^a	IF — ^b	IF —	0
Complete response	IRC ^c	≤5	IF —	IF —	6
	IBMTR ^{c, 226}	<5	IF —	IF —	6
	SWOG ²²⁴	<1 ^a	IF —	IF —	8
	ECOG ²²⁵	≤3	IF —	IF —	6
	CLMTF ²⁰⁴	Not defined			—
Very good partial response	IRC		≥90% reduction	< 100 mg/24 hr	
Objective response	SWOG	—	↓ ≥ 75% ^c	↓ ≥ 90%	8
Partial Response	IRC ^d	—	↓ ≥ 50%	↓ ≥ 90%	6
	ECOG/IBMTR	—	↓ ≥ 50%	↓ ≥ 90% ^e	6
	SWOG ("Improvement")	—	↓ ≥ 50% ^c	↓ ≥ 75%	8

	CLMTF ^f	—	↓ ≥ 50%	↓ ≥ 50%	—
Minimal response	IBMTR	—	↓ ≥ 25%	↓ ≥ 50%	
Progression	IRC/IBMTR/SWOG	—	> 25% ^g	> 25% ^h	—
	ECOG	—	≥ 50% ⁱ	≥ 50% ^h	—

BMPC, bone marrow plasma cells; CLMTF, Chronic Leukemia-Myeloma Task Force; CR, complete response; ECOG, Eastern Cooperative Oncology Group; IBMTR, International Blood and Bone Marrow Transplant Registry; IF, immunofixation; IRC, International Response Consensus; IF, immunofixation; MR, minimum response; PR, partial response; SWOG, Southwest Oncology Group.

^a Clonal plasma cells as measured by flow cytometry, immunohistochemistry, or immunofluorescence.

^b Also requires normalization of serum immunoglobulin free light chain ratio.

^c Change in synthetic index and not monoclonal protein concentration.

^d Allows for immunoglobulin free light chain responses in patients whose serum and urine are not measurable.

^e Or <200 mg/24 hours.

^f Response also takes into account reduction in size of plasmacytomas, >2 g/dl Hb rise, weight gain, correction of calcium, renal function, albumin.

^g Absolute increase must be at least 5 g/L.

^h Absolute increase must be greater than 200 mg/24 hours.

ⁱ For ECOG, Absolute increase must be at least 20 g/L.

Efficacy of Single Chemotherapeutic Agents

Single agents are not commonly used as upfront therapy, but they are used in the relapsed setting, and understanding each drug's activity provides insight into how much they may be contributing to combination therapy.

Melphalan

Bergsagel et al.³¹ demonstrated the benefit of melphalan in 14 of 24 patients with MM. Others (Table 98.3) have substantiated that melphalan as a single agent results in response rates of 20% to 34% and median OS duration of 15 to 27 months.^{32, 230, 231, 232, 233} Since early reports by Blokhin et al.³⁰ and Bergsagel et al.,³¹ various schedules of melphalan have been tried, including continuous daily dose, 6 to 10 mg/day for 2 to 3 weeks, followed by maintenance therapy of 0.01 to 0.03 mg/kg per day; intermittent total doses of 0.25 mg/day given for 4 days every 4 to 8 weeks; or 0.15 mg/kg per day for 7 days every 6 weeks.^{232, 234} Several studies suggest that the intermittent schedule is superior to continuous daily dosing.^{232, 234}

Cyclophosphamide

Korst et al. were the first to report on the activity of oral cyclophosphamide.³³ A partial response (50% M-protein reduction) was achieved by 24% of MM patients, and 48% had objective improvement. Median survival was 24.5 months in all 207 patients and 32 months in the group that received at least 2 months of cyclophosphamide therapy. The single-agent activity of cyclophosphamide (Table 98.3) has been demonstrated in a placebo-controlled trial,²³¹ in multiple studies of previously untreated patients,^{235, 236} and in those who relapsed or had refractory disease.²³⁷

Despite documented equivalency for low-dose oral regimens of cyclophosphamide and melphalan,²³⁵ induction therapies of MP have historically been preferred over those of cyclophosphamide and prednisone. Cyclophosphamide has most commonly been used in multidrug combinations for induction, for therapy in relapse, and for stem cell mobilization rather

than as a single agent for induction, as has melphalan. In newly diagnosed MM, oral daily dosing of cyclophosphamide (150 mg/d)^{235, 238, 239} or intravenous doses of 600 mg/m² every 3 weeks²³⁶ with or without prednisone resulted in a response rate of approximately 25% and median survival of 24 months.

Glucocorticoids

In 1950, Thorn et al.²⁷ reported the first observations on the beneficial effects of adrenocorticotrophic hormone in MM. Adams and Skoog²⁸ observed a marked decrease in the MM serum protein in 18 of 26 patients treated with corticosteroids. Surprisingly, Mass²⁴⁰ failed to show a difference between the survival of 55 patients randomly assigned to prednisone therapy or placebo despite clinical improvement in the former group. Subsequently, high-dose corticosteroids have been shown to produce response rates of 40% to 50% in previously untreated patients, and 25%

P.2055

in refractory or relapsed patients;^{29, 241, 242, 243, 244, 245, 246, 247} median survival of responding patients is 16 to 22 months.^{243, 244, 245} In reviewing their experience with single-agent dexamethasone and VAD, Alexanian et al.²⁴⁴ noted that in patients with refractory disease, response rates with single-agent dexamethasone were comparable to those with VAD (27% vs. 32%). In contrast, in relapsed disease, response rates achieved with single-agent dexamethasone were inferior to those with VAD. These data were not randomized but rather serial observations. On occasion, patients who do not respond to high-dose dexamethasone can be salvaged with intermittent high-dose methylprednisolone.²⁴⁵

TABLE 98.3 EARLY (1969 TO 1982), ALKYLATOR-BASED RANDOMIZED TRIALS FOR NEWLY DIAGNOSED MYELOMA

Study Year	Agent	Schedule	N	RR (%)	OS, mo
1969 ²³¹	CTX	2-4 mg/kg/d	5421		11.5 ^a
	Placebo				3.5
1969 ²³¹	CTX	4 mg/kg/d	4928		13
	M	0.1 mg/kg/d	5434		15.5
1972 ²³²	M qd	0.025 mg/kg/d	3517		18
	M intermittent	0.25 mg/kg d1-4	6932		18
	M alt. P	0.25 mg/kg d1-4 and 1mg/kg MWF	2861		24
	M concurr P	0.25 mg/kg d1-4 and 2 mg/kg d1-4	5165		17
1971 ²³⁵	CTX	150 mg/d	114	NG	28 ^b
	M	4 mg/d	105	NG	24 ^b
1972 ²²³	MP	M: 0.25 mg/kg and P: 2 mg/kg d1-4	8352 ^a		21
	MP and procarbazine	M: 0.2 mg/kg and P: above and Pro	7941		23
1973 ²³⁰	M	0.15 mg/kg × 7, maintenance 0.05 kg/d	5320		27 ^{30, 21, c}
	M and P	M: as above and P: 1.25 mg/kg/d	7039		NG ^{9, 53}
	M, P, and testos	M and P as above and weekly testosterone	5643		NG ^{4, 36}
1980 ²³⁶	MP	M: 10 mg d1-7; P: 40 mg d1-7 q 3 wk	174	NG	32 ^b
	CTX IV	600 mg/m ² q 3 wk	179		24
	MP	As above	71	NG	6 ^b
	CMLP	3 d: C: 250 mg/m ² , M:5 mg/m ² , P:40 mg/m ² , and d4 L:50 mg/m ² q 4 wks	61	NG	6

1982 ²⁶²	MP	M: 0.15 mg/kg d 1-7; P: 0.8 mg/kg	10044 ^a	27
	Carmustine-P	C: 150 mg/m ² IV; P: 0.8 mg/kg	12434	21
	Lomustine-P	L: 100 mg/m ² qd; P: 0.8 mg/kg	13730 ^a	21

Alt, alternating; C, cyclophosphamide; concurr., concurrently; CTX, cyclophosphamide; IV, intravenous; L, lomustine; M, melphalan; MRC, Medical Research Council Working Party on Leukaemia in Adults; NG, not given; OS, overall survival; P, prednisone; po, by mouth; qd, daily.

^a Difference is significant.

^b Survival estimated from survival curves.

^c Patients stratified for good and poor risk; median survival given as all patients (good risk, poor risk). Authors note that much quicker response observed with prednisone but worse survival with prednisone in poor-risk patients.

Despite their contribution to quicker and more abundant responses, there are conflicting data as to whether corticosteroids prolong survival.^{230, 232, 248} As initial therapy for elderly patients, single-agent dexamethasone is responsible for both higher treatment-related morbidity and mortality as compared to melphalan-containing regimens.²⁴⁹ The mechanism of action of this drug class is complex. Corticosteroids suppress the production of cytokines important in MM growth, such as IL-6 and IL-1 β , and reduce nuclear factor κ B activity, resulting in enhanced apoptosis.^{250, 251, 252, 253}

Vincristine

Although never evaluated as a single agent in newly diagnosed MM, vincristine has little activity as a single agent in refractory disease. There were 21 patients treated with a 0.5 mg bolus of vincristine followed by 0.25 to 0.5 mg/m² per day as a continuous infusion over 5 days on a 3-week schedule. Two patients had transient responses (1.2 and 2.2 months).²⁵⁴ Finally, the activity credited to vincristine as a maintenance therapy is also ambiguous. Although a superior survival (35 vs. 27 months, $P = 0.003$) was reported in patients treated with single-agent melphalan and maintained on bimonthly vincristine (1 mg/m²) and prednisone (0.6 mg/kg for 7 days), the benefit could easily be attributed to prednisone alone.²⁵⁵

Alexanian et al.^{256, 257} suggested that regimens which included vincristine resulted in better patient outcome than protocols not including this agent. The theory behind its posited utility was that after an initial kill of MM cells by alkylating agents, the subsequent increase in the mitotic index made MM cells more sensitive to vincristine.²⁵⁸ Reports by Lee, Salmon, and Case have been cited as confirmatory evidence for activity of vincristine in MM.^{259, 260, 261} However, several randomized controlled trials do not support this premise.^{262, 263, 264, 265} The most compelling of these is the MRC IV Trial in Myelomatosis, which randomized 530 newly diagnosed MM patients to monthly MP, with or without monthly vincristine. Median survival in both arms was 26 months.²⁶⁴ Even though vincristine has not been shown to have significant single-agent in vivo activity or to improve OS,^{254, 264, 265, 266} it has been included in multiple therapeutic regimens.

P.2056

Anthracyclines

Doxorubicin is the most commonly used anthracycline in the treatment of MM, but it has not been studied as a single agent in newly diagnosed MM patients. Its activity as a single agent in relapsed or refractory disease is modest, with response rates of about 10%.^{35, 267} The pegylated form has been used in a number of MM regimens since the 1990s.^{268, 269} A phase II trial of mitoxantrone as a single agent (12 mg/m² every 3 weeks) yielded a partial response rate of 3% (1 of 35). An additional 4 patients showed clinical improvement lasting 4 to 7 months.²⁷⁰ Idarubicin is another anthracycline that has been studied in MM. Response rates of 0% to 27% have been observed in relapsed and refractory patients with single-agent oral regimens (30 mg/week in three divided doses given 3 of 5 weeks or 40 mg/m² every 3 weeks).^{271, 272}

Etoposide

In relapsed and refractory disease, single-agent etoposide (200 to 250 mg/m² over 5 days) has minimal activity; in 85 patients the response rate was < 5%.²⁷³ Barlogie et al.²⁷⁴ treated 14 patients with 200 mg/m² by continuous infusion, and 2 responded. In addition, there are two anecdotal reports of activity of low-dose (25 to 50 mg/day) oral etoposide.^{275, 276}

Nitrosoureas

The nitrosoureas have single-agent activity in MM. In a randomized trial of 361 previously untreated patients, objective response frequency with carmustine (BCNU; 40%) and lomustine (CCNU; 42%) was lower than that of melphalan (59%), although the survivals for all groups were not significantly different.²⁶²

Interferon

Despite the encouraging reports that daily human leukocyte IFN (3 to 9 MU/day) could induce responses in as many as 60% of MM patients^{34, 217} subsequent studies with recombinant IFN yielded rates of 10% to 20%.^{219, 277, 278, 279, 280} Toxicity was not inconsequential.²⁸⁰ In vitro activity had good predictive value for in vivo clinical response in 26 patients studied.²⁷⁸ However, IFN has a stimulatory effect in about one third of MM samples tested in vitro.²⁷⁸ This drug has been used most commonly in the maintenance setting as discussed below.

Bendamustine

Bendamustine is a multifunctional alkylating agent with a purinelike ring system and a novel mechanism of action. Bendamustine appears to be more efficient in inducing DNA double-strand breaks compared with other more commonly used alkylating agents such as cyclophosphamide or phenylalanine mustard.

In a phase I study of bendamustine, Knoop et al. enrolled 31 patients with MM that had progressed after high-dose chemotherapy. Bendamustine 100 mg/m² on days 1 and 2 per cycle was found to be the maximal tolerated dose. The overall response rate was 55% with a median progression-free survival of 26 (0 to 61) weeks. Toxicity was mild and mainly hematologic.^{281, 282} In this retrospective analysis of a single institution experience, 39 patients with relapsed or refractory MM received bendamustine as salvage therapy.²⁸³ Bendamustine used at 80 to 150 mg on day 1 + 2 of a monthly cycle with or without steroids resulted in 3% VGPR, 33% PR, 18% MR, 26% SD, and 20% PD. The median EFS and OS were 7 and 17 months, respectively.

Thalidomide

Thalidomide is the first in the class of drugs called immune modulatory drugs (IMiDs). Recognition of the role of increased angiogenesis in the pathogenesis and progression of MM,¹³⁹ and evidence of thalidomide's antiangiogenic properties,^{284, 285} led to clinical trials in MM.^{37, 286} The observed responses in patients without high-grade angiogenesis suggest that thalidomide may act via other mechanisms as well.²⁸⁷ In vitro data suggest that the drug and its metabolites may inhibit angiogenesis, but in addition may modulate adhesion molecules of MM cells and their surrounding stroma, modulate cytokines, and affect natural killer cells. There is evidence that thalidomide and its analogues induce apoptosis and G1 growth arrest in MM cells.²⁸⁷

The first report of the utility of thalidomide in patients with relapsed MM³⁷ who were treated with escalating doses of thalidomide was published in 1999. Patients were started on 200 mg each evening; the dose was escalated every 2 weeks, if tolerated, to a final maximal dose of 800 mg daily. A total of 25% of patients had at least a 50% reduction in their serum paraprotein. Preliminary evidence of response was apparent within 2 months in more than three quarters of the patients who did respond. Other investigators have confirmed a partial response rate of 25% to 58%, with an additional 6% to 26% achieving a minimal response, median response duration of 9 to 12 months, 2-year progression-free survival of 10% to 20%, and 2-year OS of 48%.^{286, 288, 289, 290, 291, 292, 293, 294, 295, 296} As a single agent in previously untreated patients, response rates of 25% may be achieved.^{297, 298, 299} The role of dose intensity in thalidomide effectiveness is unclear.^{293, 300} In the original reports, the highest dose tolerated was administered.³⁷ In high-risk patients there was a suggestion that response rates were higher and survival longer in patients receiving high doses of thalidomide (greater than or equal to 600 mg/day).³⁰¹ However, in some patients, responses may be seen with doses as low as 50 to 100 mg/day.³⁰⁰

Toxicities associated with thalidomide include fetal malformations, constipation, weakness or fatigue, somnolence, skin problems, and sensory neuropathy in more than one third of patients. There is also an increased risk of thrombosis in patients treated with thalidomide, which appears to be exacerbated by the use of concurrent combination chemotherapy, with rates as high as 28%.^{302, 303, 304} Other life-threatening complications have included Stevens-Johnson syndrome and hepatitis.^{305, 306}

Thalidomide received US Food and Drug Administration approval for use in conjunction with dexamethasone for newly diagnosed MM in 2006.

Lenalidomide (CC-5013; Revlimid™)

This drug is a small molecule derivative of thalidomide and a member of the immunomodulatory (IMiD) class. Lenalidomide is more potent than thalidomide in mediating direct cytokine-related and immunomodulatory effects against human MM cell lines and patient-derived cells in vitro. It induces apoptosis of MM cells; overcomes cytokine and bone marrow stromal cell-mediated drug resistance; has antiangiogenic effects; and stimulates host anti-MM T and natural killer cell immunity.^{39, 307} In the original phase I study, 30% of patients responded to the single-agent drug, with a median duration of response of 6 months.³⁹ At 50 mg per day the dose limiting toxicity was myelosuppression. In the randomized phase II trial, two schedules were evaluated: 25 mg daily and 15 mg twice daily. In both arms, drug was given only 21 out of 28 days. Overall approximately 17% of relapsed or refractory patients achieved a partial response, including a 4% complete response rate, with a median progression-free survival (PFS) of 4.6 months for the patients receiving once-daily dosing.^{39, 307} Aside from myelosuppression, other grade 3 to 4 toxicities included neuropathy and fatigue in 3% and 7% of patients. In the open label phase II trial, including 222 patients, there was 25% partial response rate, with a time to progression of 5.1 months.³⁰⁸ newly diagnosed MM, single agent lenalidomide induces responses in fewer than one-third of patients.³⁰⁹ The FDA approved the drug in combination with dexamethasone as second line therapy for patients with MM in 2006.

P.2057

Pomalidomide (CC-4047; Actimid™)

Pomalidomide is another IMiD with activity³¹⁰ that is currently undergoing clinical trials in relapsed MM.^{311, 312} Preclinical studies have shown changes that suggest a significant immunomodulatory effect of the drug, with decrease in CD8+/CD45RA+ cells and CD4+/CD45RA+ initially following therapy, which was also accompanied by a corresponding increase in CD8+/CD45RO+ cells and CD4+/CD45RO+, suggesting a switch from naïve cells to activated effector T-cells.³¹⁰ It also has an effect on the inflammatory pathways via transcriptional inhibition of cyclooxygenase-2 (COX-2) production, which is associated with increased prostaglandins in human lipopolysaccharide (LPS)-stimulated monocytes.³¹³ In addition to the direct anti-MM activity and the immunomodulatory functions, pomalidomide also alters the tumor microenvironment. In vitro studies also have shown potent inhibitory effect on osteoclast differentiation as well as bone marrow angiogenesis.^{314, 315} A total of 54% of previously treated patients respond to the single-agent drug. Median PFS was 9 months. Additional studies have been done as are described in the section of relapsed/refractory disease. As of this writing, the drug is not available except in clinical trials.

Bortezomib (Velcade™, PS-341)

Bortezomib is the first drug in its class of proteasome inhibitors. It is a boronic acid dipeptide that reversibly and selectively inhibits the proteasome, an intracellular complex that degrades primarily ubiquitinated proteins. The proteasome has a key role in protein degradation, cell-cycle regulation, and gene expression. Tumor cells, including MM, are heavily dependent on proteasomeregulated proteins for their growth and interaction with stromal cells. Inhibition of the proteasome has emerged as an important antitumor target, and bortezomib has been shown in vitro and in vivo to cause growth arrest, to induce apoptosis, and to inhibit angiogenesis.

Of newly diagnosed MM patients, 38% to 48% will respond to single-agent bortezomib.^{316, 317, 318} The addition of dexamethasone results in an overall response rate of 67% to 88%.^{317, 319} Single-agent response rates in relapsed/refractory MM range from 28% to 38% with a median duration of response of 8 months.^{308, 320, 321, 322} The most common adverse events associated with bortezomib are: gastrointestinal disturbances, fatigue, peripheral neuropathy, and myelosuppression. There were 75% of patients who had serious (grade 3 to 4) adverse events, the most common of which were thrombocytopenia, neutropenia, anemia, gastrointestinal disturbances, fatigue, and peripheral neuropathy (sensory, motor, and pain).^{321, 323} In a review of 256 patients treated on two phase II studies, over 80% of patients had baseline peripheral neuropathy. Treatment-emergent neuropathy was reported in 35% of patients. Grade 1-2, 3, and 4 neuropathy occurred in 22%, 13%, and 0.4% of patients, respectively. Grade 3 neuropathy was more likely to occur in patients with a baseline neuropathy. A total of 71% of patients with neuropathy greater than or equal to grade 3 and/or requiring discontinuation who had resolution to baseline or improvement. Subcutaneous administration and/or weekly administration of bortezomib reduces the incidence of severe peripheral neuropathy by nearly 40%.³²⁴

The FDA approved bortezomib for patients with refractory MM in 2003, patients who failed one prior regimen in 2005, and as initial therapy in 2008. Because of toxicity, two important modifications to bortezomib administration have been made over the past decade. The first was introduction of weekly bortezomib rather than twice weekly followed by a 10-

day rest; the second was the subcutaneous administration rather than the intravenous route of administration. This latter change was approved by the FDA in 2012 based on a randomized control trial that demonstrated comparable efficacy but significantly lower toxicity.³²⁴ Overall response rate for both arms was 42% to 43%, but grade 3 or higher peripheral neuropathy was 6% versus 16% and any neuropathy was 38% versus 53%, favoring the subcutaneous administration.

Carfilzomib (PX-171, Kyprolis™)

Carfilzomib is a selective proteasome inhibitor that binds irreversibly to its target. It differs from bortezomib in that it does not contain a boronic acid residue, and irreversibly binds to the proteasome subunit. It was FDA approved for the indication of relapsed or refractory MM among patients who have had prior exposure to an IMiD and bortezomib. Two schedules had been tested in hematologic malignancies,^{325, 326} and best tolerance was seen with an IV infusion on days 1, 2, 8, 9, 15, and 16 every 28 days. In bortezomib-naïve patients,²²¹ response rates were seen in 25% of patients treated at the 20 mg/m² level and in 52% of patients treated with first cycle 20 mg/m², but subsequent cycles at 27 mg/m². An additional 17% and 12% of patients had a minimal response (i.e., a 25% reduction in their serum M-protein) in the 20 mg/m² cohort and the 20/27 mg/m² cohorts, respectively. Median duration of response is 13 months among patients achieving a PR or better. The most common side effects of drug are fatigue, nausea, anemia, dyspnea, cough, and pyrexia occurring in 34% to 62% of patients. The most common grade 3 or higher AEs were hematologic (13% to 16%) and pneumonia (12%). Treatment-emergent peripheral neuropathy was rare with only 1 patient in 129 developing a grade 3 PN. Because fever, chills, shortness of breath, and/or rigors may occur during cycle 1 and sometimes cycle 2, dexamethasone 4 mg daily can be given before each dose in cycle 1 and before the first dose of the cycle 2 if dose escalation is planned.

Other Agents

Barlogie et al.²⁷⁴ explored the utility of cisplatin therapy for patients with MM. A total of 14 patients were treated with 10 mg/m² for 7 days by continuous infusion, and 2 responded. The drug has been incorporated into other regimens for relapsed disease^{274, 327, 328} and induction therapy.³²⁹

Cytosine arabinoside,³³⁰ tenoposide,³³¹ topotecan,³³² deoxycoformycin,^{333, 334} arsenic trioxide,^{335, 336} and paclitaxel^{337, 338} have been reported to produce response rates of 7%, 28%, 16%, 0% to 15%, 7.1%, and 15% to 29%, respectively. Topotecan induces significant toxicity including greater than or equal to grade 3 granulocytopenia and thrombocytopenia in 93% and 53% of patients, respectively.³³² Patients treated with paclitaxel were premedicated with 40 mg of dexamethasone every 21 days,^{337, 338} bringing into question whether the observed responses were attributable to dexamethasone or paclitaxel.

Agents that do not appear to have any activity in MM include drugs that are interesting from an historical perspective and drugs that have known activity in other diseases. Agents in the former category include diamidines, such as stilbamidine; 1-aminocyclopentanecarboxylic acid; amsacrine,^{339, 340} aclarubin,³⁴¹ chlorozotocin,³⁴² hexamethylmelamine³⁴³ and azaserine.³² Other agents without activity against MM include: methotrexate, 6-mercaptopurine, 6-thioguanine, 5-fluorouracil, fluorodeoxyuridine, hydroxyurea, mitomycin C,³² vinblastine, vindesine,²⁴³ carboplatin,³⁴⁴ bleomycin,²⁶⁷ ATRA (all trans-retinoic acid), fludarabine,³⁴⁵ 2-chlorodeoxyadenosine,³⁴⁶ flavopiridol,³⁴⁷ and imatinib.³⁴⁸ Although Durie et al.³⁴⁹ reported a 57% response rate with clarithromycin, subsequent reports did not corroborate this response rate, and the activity observed in the original report was attributed to concurrent corticosteroid therapy.^{350, 351, 352}

Combination Chemotherapy for Induction

Combining multiple active agents in an effort to achieve synergy is a logical corollary. The last 3 decades of the 20th century were spent combining alkylators, anthracyclines, corticosteroids, and IFN. Thirty years of study indicate that the higher response rates

P.2058

afforded by these combinations as initial therapy did not translate into longer OS rates than standard MP therapy²¹⁶ (Fig. 98.6), and the data are conflicting as to whether patients with more advanced disease benefited from combination alkylator chemotherapy.^{210, 216, 233, 258, 353, 354, 355} Once IMiDs and proteasome inhibitors were shown to have activity, clinical investigators began using these drugs in combination. Table 98.4 serves as a reference for commonly cited regimens. For expediency, the section on induction regimens is separated into three larger categories: those commonly used in all types of MM patients, those specifically for transplant-ineligible patients, and those for transplant-eligible patients.

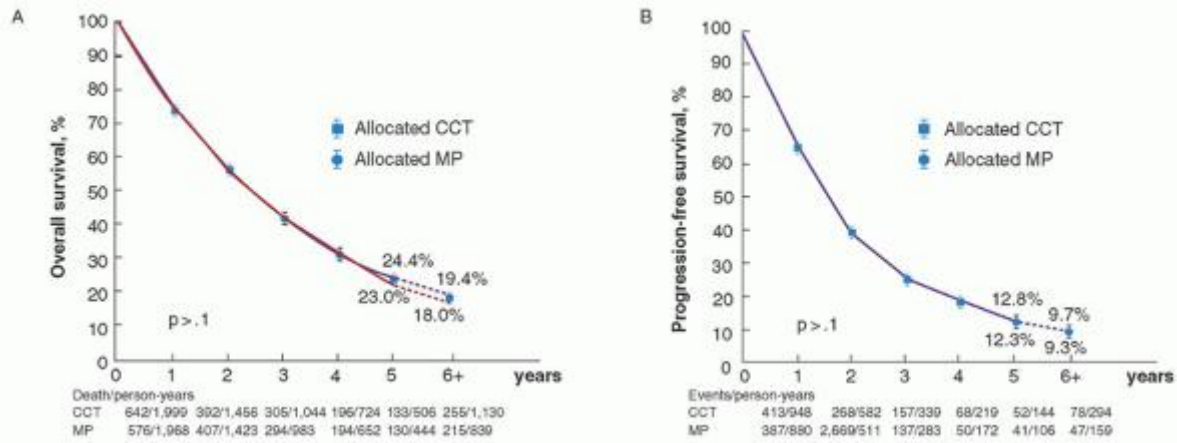

FIGURE 98.6. Melphalan and prednisone (MP) versus combined chemotherapy (CCT) as induction. Results from 6,633 patients from 27 randomized trials. A: Overall survival. B: Response duration. (From the Myeloma Trialists' Collaborative Group.²¹⁶ By permission of the American Society of Clinical Oncology.)

Clinical research in MM began to move at breakneck speed starting in the first decade of the 21st century. Because of the abundance of induction data and the absence of definitive “best options,” the Mayo Clinic group has published a treatment algorithm for patients with newly diagnosed MM called mSMART.^{357, 358} This is an online algorithm that is updated as new data emerge (Fig. 98.5; <http://www.msmaart.org/index.html>). As a general rule, patients who are being considered for stem cell collection and transplantation receive nonalkylator-containing induction regimens, or if alkylator-containing regimens are used, the number of cycles is restricted to four prior to stem cell mobilization.

Commonly Used Regimens for Any Newly Diagnosed Multiple Myeloma Patient

Three of the most commonly used induction regimens in the United States—lenalidomide/dexamethasone (Rd), bortezomib/lenalidomide/dexamethasone (VRD), and cyclophosphamide/bortezomib/dexamethasone (CyBORd)—are regimens that can be used for patients regardless of their transplant eligibility. Surprisingly, these three regimens have the least published phase III data to support their use. The mSMART method of prioritizing their use is shown in Figure 98.5.^{357, 358} Table 98.5 also lists these regimens, as well as other phase II regimens of interest that are discussed later in this chapter.

Lenalidomide/Dexamethasone (Rd)

In previously untreated patients with active MM, the combination of lenalidomide and dexamethasone with or without clarithromycin yields overall response rates of 91% to 95%, with complete response/very good response rates of 32% to 38%.^{359, 360} Rajkumar et al.³⁵⁹ treated 34 patients with lenalidomide 25 mg orally days 1 to 21 and dexamethasone 40 mg days 1 to 4, 9 to 12, and 17 to 20, both repeated every 28 days. Aspirin was given as DVT prophylaxis. The overall response rate was 91%, with 6% achieving complete response and 32% very good partial response. Grade 3 to 4 neutropenia occurred in 12% of patients. A total of 47% of patients experienced grade 3 or higher nonhematologic toxicity, most commonly fatigue (15%). The 2-year progression-free survival rates for patients proceeding to SCT and patients remaining on Rev-Dex were 83% and 59%, respectively; the OS rates were 92% and 90% at 2 years and 92% and 85% at 3 years, respectively. The 3-year OS rate for the whole cohort was 88%.³⁶¹

Niesvizky et al.³⁶⁰ treated 72 patients with clarithromycin, lenalidomide, and dexamethasone (BiRD). The rationale for the clarithromycin use is that it alters the hepatic metabolism of both drugs, resulting in higher effective doses. The lenalidomide schedule was as above, but dexamethasone was administered only once weekly. Clarithromycin was given 500 mg twice daily. Aspirin was given as DVT prophylaxis. The overall response rate was 90%, including 39% CR and 35% VGPR. Twenty patients went on to receive ASCT. Two-year EFS for the nontransplant group was 75%. The most common grade 3 or higher nonhematologic AEs were myopathy (11%) and thromboembolic events (12.5%). Grade 3 or higher hematologic toxicities were neutropenia in 19.4%, anemia in 13.8%, and thrombocytopenia in 22.2%.

A randomized controlled trial comparing lenalidomide with standard dexamethasone (12 days/month schedule)—RD—to lenalidomide with reduced intensity dexamethasone (weekly dexamethasone)—Rd.³⁶² After 4 months of therapy, 79% of the RD patients and 68% of the Rd patients had achieved a partial response or better; however, at 1 year, OS was superior in the Rd arm as compared to the RD arm (92% vs. 87%, $P = 0.0002$). Among those aged less than 65, the 1-year OS was 91% with RD and 98% with Rd; among those older than 65, the 1-year OS was 83% with RD and 94% with Rd. The trial was

stopped due to this safety concern, and patients receiving high-intensity dexamethasone (RD) were crossed over to the low-intensity arm (Rd). Grade 3 to 4 AEs and early deaths were higher in the RD group (52% vs. 35%, $P = 0.0001$ and 5.4% vs. 0.5%, $P = 0.003$), respectively. The most common grade 3 or higher toxicities were DVT (26% vs. 12%, $P = 0.0003$), infections (16% vs. 9%, $P = 0.04$), and fatigue (15% vs. 9%, $P = 0.08$).

Because of the ease of administration and low early death rate, many consider Rd an excellent first-line therapeutic option. Others express concern that a 68% response rate and a VGPR or better rate of 40% is insufficient, and therefore favor the use of triplets, especially in younger patients. To date, there are no

P.2059

completed randomized trials demonstrating survival advantage of any of the triplets over the Rd. Several clinical trials are ongoing that compare a triplet (MPT, VRD) to Rd. In the absence of prospective data, a retrospective comparison of three consecutive clinical trials [RD (lenalidomide-dexamethasone, $n = 34$), CLD (cyclophosphamide-lenalidomide-dexamethasone, $n = 53$), and CyBorD (cyclophosphamide/bortezomib/dexamethasone, $n = 63$)], has been reported.³⁶³ Overall response rates were comparable at 94%, 85%, and 90%, but complete response/near complete response rates were highest in the CyBorD arm, 35%, 15%, and 41%, $P = 0.006$. Despite this difference, however, PFS and OS were no different among the groups. Respective median PFS rates were: 3.2, 2.3, and 2.7 years, $P = 0.11$, and respective 3-year OS rates were 88%, 79%, and 88%. Poor cytogenetic risk was not overcome by any of these regimens. A notable finding of this study was that 80% of patients were alive at 4 years.

TABLE 98.4 COMMONLY CITED REGIMENS AND THEIR DOSAGE SCHEDULES

Regimen	VCR	Alk	Dox	Gluc	IMiD	Proteas
L-dex ^{a 362}	—	—	—	D:40 mg/wk	L: 25 mg d1-21	—
VMP ^{d 356}	—	M: 9 mg/2 d 1-4	—	P: 60 mg/m ² d1-4	—	B: 1.3 mg/m ^{2d}
MPT ^{b 388}	—	M: 0.25 mg/kg d 1-4	—	P 2 mg/kg d1-4	T: 200 mg/d	—
CTD ^{c 465}	—	C: 500 mg/wk	—	D: 40 mg d1-4 & 12-15	T: 100-200 mg/d	—
CyBorD ^{365, 366a}	—	C: 300 mg/m ² /wk	—	D: 40 mg/wk ^f	—	B: 1.5 mg/m ² /wk
VRD ^{c 370}	—	—	—	D: 20 mg d1, 2, 12	L: 25 mg d1-14	B: 1.3 mg/m ² IV d1, 4, 8, 11
Carfilzomib ²²¹	—	—	—	D: 4 mg each Car dose cycle 1 and at Car dose increase	—	Car: 20 mg/m ² d1,2,8,9,15,16 cycle 1; increase to 20 mg/m ² cycle 2
MP	—	M: 9 mg/m ² d1-4 ^a	—	P 100 mg d1-4 ^a	—	—
MP	—	M:0.15 mg/kg/d d1-7 ^b	—	P 60 mg d1-7 ^b	—	—
VBMCP ^{e 259}	0.03 mg/kg IV d 1	M: 0.25 mg/kg d1-7 C: 10 mg/kg IV d 1	—	P: 1 mg/kg d1-7	—	—

		BCNU: 0.5 mg/kg IV d 1				
CP ^a	—	C: 300 mg/m ² weekly or 50-100 mg qd	—	P: 50-100 mg qd	—	—
T-Dex ^{a 407}	—	—	—	D: 40 mg/wk	T: 50 to— 100 mg/d	—
Doxil/Bort ^{c 268}	—	—	Pegylated dox 30 mg/m ² d4	—	—	B: 1.3 mg/m ² IV d 1, 4, 8, 11
VADe ⁴⁴³	0.4 mg/ m ² d1-4 CI	—	9 mg/m ² CI d 1-4	D 40 mg d 1-4, 9-12, 17-20	—	—
C-VAD ^{c 465}	0.4 mg/d CI d 1-4	C: 500 mg IV d 1, CI 8, 15	9 mg/m ² CI d 1-4	D: 40 mg d1-4, 9-12	—	—
VDT-PACE ^{e 475}	—	d1-4 by CI: C 400 mg/m ² , CDDP 10 mg/m ² , & Etop 40 mg/m ²	10 mg/m ² d1-4, CI	D: 40 mg d1-4	T: 200 mg d1- 4	B: 1 mg/m ² SQ d1, 4, 8, 11
PAD			9 mg/m ² CI d1-4	D: 40 mg 1-4, 9-12, 17-20		B: 1.3 mg/m ² IV d 1, 4, 8, 11

B, bortezomib; BCNU, carmustine; C, cyclophosphamide; Car, carfilzomib; CDDP, cisplatin; CI, continuous infusion; CP, cyclophosphamide and prednisone; CTX, cyclophosphamide; C-VAMP, cyclophosphamide, vincristine, doxorubicin, and methylprednisolone; d, day; D, dexamethasone; Dex, dexamethasone; Dox, doxorubicin; IMiD, immune modulatory drug; IV, intravenous; L, lenalidomide; M, melphalan; MP, melphalan and prednisone; MPT, MP and thalidomide; po, by mouth; P, prednisone; q, every; qod, every other day; T, thalidomide; VAD, vincristine, doxorubicin, and dexamethasone; VAMP, vincristine, doxorubicin, and methylprednisolone; M-2, VBMCP; VCR, vincristine; VMCP, vincristine, melphalan, cyclophosphamide, and prednisone; VDT-PACE, bortezomib, dex, thalidomide, cisplatin, doxorubicin, cyclophosphamide, etoposide; gluco, corticosteroid; VMP, MP and bortezomib; wk, week.

^a Repeated at 4-week intervals.

^b Repeated at 6-week intervals.

^c Repeated at 3-week intervals.

^d Initial treatment strategy for VISTA trial was bortezomib 1.3 mg/m² on days 1, 4, 8, 11, 22, 25, 29, and 32, repeated every 6 weeks for four cycles, and then repeated every 5 weeks, with bortezomib schedule changing to weekly administration for 4 weeks followed by 1 week rest. Due to high rates of neuropathy, recommended modification is to start with weekly administration and 5-week cycles.³⁹⁷

^e Repeated every 5 weeks.

^fDexamethasone 40 mg days 1-4, 9-12, 17-20 for cycle 1; then days 1, 8, 15, and 22.

Despite the concern of an increased rate of secondary malignancies when using lenalidomide as maintenance after ASCT and in conjunction with MP, the use of Rd appears to impart a lower rate of acute myeloid leukemia and myelodysplastic syndrome than MPT with respective rates of 0.15 per 100 person-years (95% CI 0.05 to 0.47) versus 1.04 per 100 person-years (95% CI 0.56 to 1.94),

P.2060

respectively. Rates of other secondary primary malignancies were comparable in both arms and within the expected range for an elderly population.³⁶⁴

TABLE 98.5 SELECTED PHASE 2 INDUCTION REGIMENS

Reference	Regimen	Phase	N	CR (%)	VGPR (%)	PR (%)	OR (%)	PFS	OS
Niesvizky ³⁶⁰	BiRD	2	40	25	1853	95	2-y 75%	NA	
Jagannath ^{319, 477}	Bortez	2	32	3	928	40	21 m	4-y 67%	
	Bortez ^{+/-} dex	2	32	6	1963	88	pooled pts	pooled pts	
Richardson ³¹⁸	Bortez	2	64	3	823	41	17 m	1-y 92%	
Dispenzieri ³¹⁶	Bortez	2	42	0	1038	48	8 m	2-y 76%	
Harousseau ³¹⁷	Bortez-Dex	2	48	20	047	67	NA	NA	
Gosh ⁴⁷⁸	VT	2	27	10	2043	73	17 m	3-y 74%	
Richardson ³⁷⁰	VRD	1/2	66	29	4033	66	1-y 75%	1.5-y 97%	
Kumar ³⁶⁸	VRD	2	42	24	2734	85	1-y 83%	1-y 100%	
Reeder ³⁶⁵	CyBorD	2	33	39 ^a	2217	88	NA	NA	
Reeder ³⁶⁶	mCyBorD	2	30	43 ^a	1733	93	NA	NA	
Kumar ³⁶⁸	VCD	2	33	22	1934	75	1-y 93%	1-y 100%	
Kumar ³⁶⁸	mVCD	2	17	47	647	100	1-y 100%	1-y 100%	
Bensiger ³⁶⁷	VCD + VTD	2	42	45	1238	95	1-y 81%	1-y 91%	
Wang ⁴⁷²	VTD	2	36	19	073	92			
Kumar ⁴⁸⁷	CLD	2	53	13	3438	85	28 m	2-y OS 87	
Jakubowiak ⁴⁷⁹	CarRd	1/2	53	42	3917	98	1-y 97%	NA	
Oakavee ^{480, 481}	PAD	2	21	24	071	95	29 m	2-y 95%	
Popat ^{481, 486}	LD-PAD	2	19	11	2850	89	24 m	2-y 73%	
Berenson ⁴⁸³	VDD	2	35	20	943	72	NA	NA	
Sher ⁴⁸²	VDT	2	43	35	NA43	78	NA	NA	
Kumar ³⁶⁸	VDRC	2	48	25	3330	88	1-y 86%	1-y 92%	
Hussein et al. ⁴⁸⁸	DVd-T	2	55	36	1334	83	28 m	NA	
Offidani ⁴⁹⁰	ThaDD	2	50	34	2430	88	3-y 57%	3-y 74%	
Zervas ⁴⁸⁴	T-DVD	2	39	10	064	74	1-y 70%	1-y 80%	
Jaubowiak ⁴⁸⁵	RVDD	1/2	72	44	2329	96	2-y 70%	2-y 75%	

BiRD, biaxin, lenalidomide, and dexamethasone; borteZ, bortezomib; CarRd, carfilzomib, lenalidomide, and dexamethasone; CLD, cyclophosphamide, lenalidomide, and dexamethasone; CR, complete response; CyBorD, cyclophosphamide, bortezomib, and dexamethasone; dex, dexamethasone; EFS, event-free survival; LD-PAD, low-dose PAD; N, number of patients; NA, not available; OR, overall response rate; OS, overall survival; PFS, progression-free survival; PR, partial response; ThaDD, thalidomide, pegylated doxorubicin, and dexamethasone; mo, months; thal, thalidomide; mCyBorD, modified CyBoD; MDT, MD and thalidomide; MPR, melphalan, prednisone and lenalidomide; mVCD, modified VCD; PAD, bortezomib, doxorubicin, and dexamethasone; RVDD, lenalidomide, bortezomib, doxorubicin, and dexamethasone; ThaDD, thalidomide, pegylated doxorubicin, and dexamethasone; T-DVd, thalidomide, pegylated doxorubicin, vincristine, and dexamethasone; ThaDD, thalidomide, doxorubicin, and dexamethasone; VCD, bortezomib, cyclophosphamide, and dexamethasone; VDD, bortezomib, doxorubicin, and dexamethasone; VDRC, bortezomib, dexamethasone, lenalidomide, and cyclophosphamide; VDT, bortezomib, pegylated liposomal doxorubicin, and thalidomide; VGPR, very good partial response; VMP, MP and bortezomib; y, year; VRD, bortezomib, lenalidomide, and dexamethasone; VT, bortezomib and thalidomide.

^a Includes nCR as well as CR.

Cyclophosphamide, Bortezomib, and Dexamethasone (CyBorD or VCD)

The combination of cyclophosphamide, bortezomib, and dexamethasone (CyBorD or VCD) has been explored both in the relapsed setting and in patients with newly diagnosed MM. The first report was that of a four 28-day cycles of bortezomib 1.3 mg/m² intravenously on days 1, 4, 8, and 11, cyclophosphamide 300 mg/m² orally on days 1, 8, 15, and 22, and dexamethasone 40 mg orally on days 1 to 4, 9 to 12, and 17 to 20 on a 28-day cycle for four cycles.³⁶⁵ Among the 33 patients enrolled, responses were rapid. The overall response rate was 88%, with 39% achieving complete/near complete response. Peripheral neuropathy rate was 66%, with 7% grade 3. A modified extension of that trial included another 30 patients to maximize dose delivery and reduce toxicity.³⁶⁶ Patients received the same weekly cyclophosphamide schedule, but bortezomib was increased to 1.5 mg/m² IV on days 1, 8, 15, and 22 and dexamethasone was modified to 40 mg once weekly after cycle 2. Response rates were comparable and toxicity was less; grade 3/4 AEs dropped from 60% to 40% of patients, and no patient had grade 3 PN.

Bensinger reported results from a phase II study of two sequential three-drug combinations: three 21-day cycles of bortezomib, cyclophosphamide, and dexamethasone (VCD) followed by three 21-day cycles of bortezomib, thalidomide, and dexamethasone (VTD).³⁶⁷ Among the 42 evaluable patients, overall response rate was 95%, including 19% stringent complete response (sCR). Adverse cytogenetics did not appear to affect response. With a median follow-up of 21 months, 1-year EFS and OS were 81% and 91%, respectively. The most common nonhematological grade 3/4 AE was peripheral neuropathy, which occurred in 11% of patients. Four patients had cardiovascular events all during the VTD cycles.

A randomized phase II study comparing bortezomib, dexamethasone, cyclophosphamide, and lenalidomide (VDCR); bortezomib, dexamethasone, and lenalidomide (VRD); and two formulations of VCD in 140 previously untreated patients has

P.2061

been reported.³⁶⁸ A maximum of eight 21-day cycles followed by maintenance bortezomib (1.3 mg/m² every other week for 24 weeks) was administered. The bortezomib was administered as 1.3 mg/m² days 1, 4, 8, and 11 and the dexamethasone was administered as 40 mg days 1, 8, and 15 for all patients. The VRD patients received lenalidomide 25 mg days 1 to 14, whereas the VDCR patients received lenalidomide 15 mg days 1 to 14 and cyclophosphamide 500 mg/m² days 1 and 8. The VCD patients received cyclophosphamide 500 mg/m² days 1 and 8, whereas, the VCD-mod patients received cyclophosphamide 500 mg/m² days 1, 8, and 15. Nearly all patients responded and the VGPR or better (CR) rates were 58% (25%), 51% (24%), 41% (22%), and 53% (47%) for patients on VDCR, VRD, VCD, and VCD-mod, respectively. The corresponding 1-year progression-free survival was 86%, 83%, 93%, and 100%. Grade 3 or higher AEs were seen in 76% to 88% of patients, with the highest rate of AE resulting in discontinuation in the VDCR arm. The highest rate of grade

3/4 hematologic AEs was in the VDCR and VCD arms. Grade 3/4 peripheral neuropathy rates ranged from 9% to 18%. The two regimens recommended by the authors were VCD-mod and VRD.

Kropff et al. reported phase I results of a variant of CyBORd. Thirty patients were treated with three 21-day cycles of bortezomib 1.3 mg/m² on days 1, 4, 8, 11 plus dexamethasone 40 mg on the day of bortezomib injection and the day after plus cyclophosphamide at 900, 1,200, or 1,500 mg/m² on day 1.³⁶⁹ The maximum tolerated dose of cyclophosphamide was defined as 900 mg/m². Overall response rate across all levels was 77%, with a 10% CR rate.

Bortezomib, Lenalidomide, Dexamethasone (VRD)

Richardson and colleagues reported on 66 patients treated on a phase I/II study using the combination of bortezomib, lenalidomide, and dexamethasone for previously untreated MM patients.³⁷⁰ Patients received eight 3-week cycles and either proceeded to transplantation or maintenance. All patients responded, and 67% achieved a VGPR or better. A total of 42% proceeded to ASCT. With median follow-up of 21 months, estimated 18-month PFS and OS for the combination treatment with/without transplantation were 75% and 97%, respectively. Sensory neuropathy occurred in 80% of patients and 32% reported neuropathic pain (grade 2/3 in 14%). Grade 3 to 4 neutropenia and thrombocytopenia occurred in 9% and 6% of patients respectively.

Summary statement: Based on complete response rates, the triplets are superior. Based on toxicity, lenalidomide and dexamethasone are superior. There are no compelling OS data to support one option over another.

Transplant Ineligible Patients

Transplant Ineligible Patients: Phase III Trials of Induction Regimens Including IMiDs and/or Proteasome Inhibitors (Table 98.6)

The combination of melphalan and prednisone (MP) was the standard for all patients with MM for nearly 40 years. The combination of MP has been studied extensively.^{223, 230} Response rates are 40% to 60% and anticipated median survivals are 18 to 42 months.^{210, 216, 223, 230, 232, 236, 257, 263, 264, 354, 371, 372, 373, 374, 375, 376, 377, 378, 379, 380, 381, 382, 383, 384, 385, 386} Because of the variable gastrointestinal tract absorption of melphalan, intravenous regimens of 15 to 25 mg/m² every 4 weeks along with oral prednisone or dexamethasone have been tried and resulted in response rates of 50% to 82%.^{386, 387} An important phase III trial (IFM 95-01) directed at the elderly (age 65 to 75 years) was a fourarm study comparing MP to melphalan-dexamethasone (MD), dexamethasone, or dexamethasone-IFN.²⁴⁹ A total of 488 patients was randomized, and follow-up was 83 months. Response rates were significantly higher among patients receiving MD, and PFS was significantly better among patients receiving melphalan (22 vs. 13 months), but there was no difference in OS among the four treatment groups. The median survival for the whole series was 35 months. The morbidity associated with dexamethasone-based regimens was significantly higher than with MP.

With the advent of ASCT, MP was relegated to those not eligible for ASCT. As drugs outside the alkylator, anthracycline, and corticosteroid classes began to show activity around 2000, combining these drugs with alkylator and prednisone became the obvious path for study.^{388, 389, 390, 391, 392, 393, 394, 395, 396, 397, 398, 399, 400} Such regimens have become part of the standard for treating elderly patients with MM (Table 98.6) in addition to a few combinations that have not been directly compared to MP, but have shown promise in either phase II or III trials.^{362, 365, 366, 370} A major limitation of several of the trials that compare a doublet to a triplet is that it is often unclear what percentage of the doublet patients got access to the third drug at the time of relapse or progression.

There have been seven randomized controlled trials comparing MP to MP and a novel agent.^{388, 389, 390, 391, 392, 393, 394, 395, 396} In terms of the six MPT studies, all have favored MPT with regard to higher CR rates. Four of six have been positive with regard to PFS, again in favor of three drugs over two drugs, but only three of six have been positive with regard to OS. An individual patient meta-analysis has recently been reported.⁴⁰¹ In aggregate, MPT was superior to MP in terms of overall response rate (59% vs 37%), median PFS (20 versus 15 months), and median OS (39 vs. 33 months). Although this meta-analysis is an extraordinarily important study, there was no effort to examine what percentage of the relapsing MP patients received thalidomide as salvage. In a side meta-analysis examining serious adverse events of individual patient data of these same six trials,⁴⁰² a higher cumulative incidence of grade 3 to 4 nonhematologic (39% vs. 17%, HR 2.78, 95%CI 2.21 to 3.50) and hematologic (28% vs. 22%, HR 1.32, 95%CI 1.05 to 1.66) toxicities was documented with MPT. Nonhematologic toxicities were more likely to occur in patients with a baseline poorer performance status (HR 1.18, 95%CI 1.06 to 1.32). The specific serious adverse events that were more common in patients receiving MPT were peripheral neuropathy, neurologic other than peripheral neuropathy, thrombosis, and dermatologic toxicity. The experience of a nonhematologic grade 3 to 4 AE had a negative impact on both PFS (HR 1.24, 95%CI 1.07 to 1.45, P = 0.006) and OS (HR 1.23, 95%CI 1.03 to 1.47, P = 0.006).

The first positive MP versus MPT trial (Table 98.6) is the IFM 99-06 study,³⁸⁸ in which 447 patients were randomized to twelve 6-week cycles of either of MP (melphalan 0.25 mg/kg per day and prednisone 2 mg/kg/day days 1 to 4 every 6 weeks) or MPT (MP plus 200 to 400 mg of thalidomide daily) or to two sequential miniautologous peripheral blood stem cell transplants (MEL100). The thalidomide was not continued past the twelfth cycle of therapy. Higher response rates and longer PFS were seen with the MPT as compared to either the MP or MEL100 groups, with respective PFS times of 28, 18, and 19.0 months. With a median follow-up of 51 months, there was a significant survival advantage for the patients on the MPT arm, with respective OS times not reached at 52 months, 33 months, and 38 months.³⁸⁸

The IFM01-01³⁹¹ included 129 patients over the age of 75. They were randomized to twelve 6-week cycles of either of MP (melphalan 0.2 mg/kg per day and prednisone 2 mg/kg/day days 1 to 4 every 6 weeks) or MPT (MP plus 50 to 100 mg of thalidomide daily). With a median follow-up of 47.5 months, in the MPT arm both median OS (44 vs. 29 months, P = 0.03) and PFS (24 vs. 19 months, P = 0.001) were longer. Grade 2 to 4 peripheral neuropathy (20% vs. 5%, P = 0.001) and neutropenia (23% vs. 9%, P = 0.003) were more frequent in the MPT arm.

In the GIMEMA MP versus MPT trial, patients were randomized to either standard dose oral MP for 6 months or to MP for 6 months with concurrent thalidomide, which was continued indefinitely.^{389, 390} Overall response rates were significantly higher with the MPT than the MP as were the complete response rates and the median PFS rates (22 vs. 14 months, P = 0.004). In the initial

P.2062

report, there was a trend toward an improved 3-year OS in favor of MPT, but a second report with 38 months follow-up showed no difference in OS. This trial addressed a maintenance question as much as an induction question.

TABLE 98.6 RANDOMIZED TRIALS OF INDUCTION REGIMENS FOR ELDERLY PATIENTS/PATIENTS NOT DESTINED FOR AUTOLOGOUS STEM CELL TRANSPLANTATION (ASCT)

Study	Regimen	N	CR (%)		≥P R (%)		Median PFS/EFS, mo		Overall Survival, mo		% of Control Patients Receiving Study Drug at Relapse
			N	P	R	P	mo	P	mo	P	
Facon (IFM 95-01) ²⁴⁹	Dex	12	1NS	42	<0.001	15	With M	33	NS	NA	
	Dex-IFN	7	1	43	12	21	vs. no M, P < 0.001	32			
	MP	12	1	41		23		34			
	MD	12	3	70				40			
Ludwig, 2005 ⁴⁰⁵	Thal-Dex	14	2NS	68	0.002	17	NS	2-y 61%	NS	NA	
	MP	14	2	52		21		2-y 70%			
		1									
IFM99-06 ^{388a}	MPT	12	13	<0.00	76	<0.001	28	<0.001	52	0.000	44
	MP	5	2 ¹	35		18		33	6		
IFM01-01 ³⁹¹	MPT	11	7	<0.00	62	<0.001	24	0.00145	145	0.03	63

	MP	3	11	31		19	28				
		11									
		6									
GIMEMA ^{389, 390}	MPT ^b	12	15	<0.00	60	NA	22	0.00445	NS	42 ^c	
	MP	9	2 ¹		45		14	48			
		12									
		6									
NMSG #12 ³⁹²	MPT ^b	18	13	<0.00	57	<0.001	15	NS	29	NS	45
	MP	2	4 ¹		40		14	32			
		17									
		5									
HOVON 49 ³⁹³	MPT ^b	16	23 ^d	<0.00	66	<0.001	13	<0.001	40	0.05	80
	MP	5	8 ^{d1}		45		9	31			
		16									
		8									
TMSG ³⁹⁴	MPT	57	9	NS	58	0.03	21	NS	26	NS	8
	MP	57	9		37		14	28			
<i>Meta-analysis</i> ⁴⁰¹	MPT	80	25^d	NA	59	<0.000	20	<0.000	39	0.004	NA
	MP	9	9^d		37	1	15	1	33		
		87									
		6									
MRC IX -non-intensive ³⁹⁹	CTDa	41	13	NA	64	<0.001	13	0.0133	NS	NA	
	MP	9	2		33		12	31			
		41									
		8									
MM-015 ³⁹⁸	MPR-R	15	33 ^d	NA	77	0.002	31	<0.001	3-y 70%	NS	NA
	MPR	2	33 ^d		68		14	3-y 62%			
	MP	15	12 ^d		50		13	3-y 66%			
		3									
		15									
		4									
VISTA ^{395, 396}	VMP	34	30	<0.00	71	<0.001	24.0m	<0.001	3-y 68%	0.008	47
	MP	4	4 ¹		35		16.6m		3-y 54%		
		33									
		8									
PETHEMA/GEM ⁴⁰⁰	VMP ^e	13	20	NS	80	NS	34 m	NS	3-y 74%	NS	NA
	VTP	0	28		81		25 m		3-y 65%		
		13									
		0									
VMPT + VT ³⁹⁷	VMP	25	24	<0.00	81	NS	3-y 41%	0.0083-y 87%	NS	NA	
	VMPT +	7	38 ¹		89		3-y 56%		3-y 89%		

	VT	25							
		4							
E4A08=>70 ^{362, 409}	Rd	71	NANA	74	NS	22	0.12-year	0.03	NA
	RD	76		75		16	90%		
							2-year		
							69%		
THAL-MM-003 ⁴⁰⁸	TD	24	8NS	63	<0.001	15	< 0.001	2-year	NS
	D	0	3	46		6	69%		NA
		23					2-y	63%	
		5							

CR, complete response; MP, melphalan and prednisone; MPT, melphalan, prednisone, thalidomide; NA, not available; OS, overall survival; PFS/EFS, event-free survival or progression-free survival; VMP, bortezomib, melphalan and prednisone; VMPT, bortezomib, melphalan, prednisone and thalidomide.

^a Third arm of this study which treated patients with two sequential miniautologous ASCTs is not included in this table.

^b Thalidomide was continued as maintenance in MPT arm.

^c Received thalidomide or bortezomib; number of patients in control arm receiving thalidomide as salvage not specified.

^d Complete response + very good partial response.

^e Secondary randomization to either VT or VP.

In the Dutch-Belgium Hemato-Oncology Cooperative Group (HOVON) 49 trial, patients were randomized to either eight cycles of MP (melphalan 0.25 mg/kg per day and prednisone 2 mg/kg/day days 1 to 5 every 4 weeks) or MPT (MP plus 200 mg/day thalidomide). The median EFS was 9 months with MP and 13 months with MPT, and 2-year PFS was 33% versus 21%, $P < 0.05$. OS of those treated with MPT was also superior (40 vs. 31 months, $P < 0.05$). In a partner health-related quality-of-life study,⁴⁰³ the higher frequency of adverse events associated with the MPT arm did not translate into a negative effect on the health-related quality of life. Only the score for paresthesia worsened in the MPT arm, but subscales rating emotional function and future perspectives favored the MPT arm.

In the Nordic study,³⁹² 357 patients were randomized to MP (4 days of melphalan 0.25 mg/kg per day and prednisone 100 mg/day every 6 weeks) or MPT (MP plus 200 to 400 mg/day thalidomide). Treatment was continued to plateau and the thalidomide was continued until relapse. Although there were superior CR and PR rates in the MPT arm, there was no difference in PFS or OS between the two groups. In fact, there was a higher mortality rate in the first 6 months among the MPT patients over age 75. In a partner health-related quality-of-life study, patients in the

P.2063

MPT arm had higher rates of constipation and lower rates of diarrhea, physical function, and social function.

The final MP versus MPT study was conducted in Turkey where 114 patients were randomized to 12 months of MP (melphalan 9 mg/m²/day and prednisone 60 mg/m²/day for 4 days every 6 weeks) or MPT (MP plus thalidomide 100 mg/day continuously). Although response rates were higher in the MPT patients than the MP patients, PFS and OS did not differ.

CTDa (cyclophosphamide, thalidomide, and dexamethasone) is a variation on the theme of MPT. The MRC IX trial³⁹⁹ randomized elderly patients to either MP or CTDa (Table 98.4) to maximum response, with a minimum of six cycles to a maximum of nine cycles (Table 98.6). There was a secondary randomization to thalidomide or no thalidomide

maintenance.⁴⁰⁴ Median follow-up is 44 months, and PFS was marginally better in the CTDA arm, but OS was not different between the two arms. Patients in the CTDA group had higher rates of sensory and motor neuropathy, thromboembolic events, constipation, infection, rash, and elevated alkaline phosphatase levels than did those in the MP group, but lower incidence of cytopenias.

The combination of thalidomide and dexamethasone (TD) has also been compared to MP.⁴⁰⁵ In these 282 elderly patients although there were higher response rates using TD (68% vs. 52%, $P = 0.002$), there was also higher rates AEs: neuropathy (72% vs. 33%), psychological toxicity (36% vs. 18%, $P < 0.001$), constipation (33% vs. 13%, $P < 0.001$), and a trend toward more DVTs (10% vs. 4%). The only toxicity more commonly seen in the MP arm was myelosuppression. With a median follow-up of 28 months, there was no difference in PFS, but there was a trend toward shorter OS among TD-treated patients which was more notable in patients older than 75 years. MP has also been compared to the combination of melphalan, prednisone, and lenalidomide in a three-arm phase III trial³⁹⁸: MP versus MP with lenalidomide (MPR) versus MPR with lenalidomide maintenance (MPR-R). A total of 459 patients was randomized to either MP (nine 4-week cycles of melphalan 0.18 mg/kg/day and prednisone 2 mg/mg/kg/day days 1 to 4), MPR (nine 4-week cycles of MP plus lenalidomide 10 mg days 1 to 21), or nine cycles of MPR with indefinite lenalidomide maintenance (10 mg days 1 to 21 every 4 weeks). Overall response rates were lowest in the MP (50%) arm with progressively better rates for MPR (68%) and MPR-R (77%). With a median follow-up period of 30 months, however, neither PFS nor OS was better among patients treated with MPR as compared to MP. MPR-R patients had better PFS (31 months vs. 14 and 13 months) but not 3-year OS (70%) as compared to the other two groups (62% vs. 66%). Toxicity was substantially higher in the lenalidomide arms.

The VISTA trial³⁹⁵ is the one large trial comparing MP to bortezomib and MP (VMP). Patients received nine 6-week cycles of either melphalan (at a dose of 9 mg/m²) and prednisone (60 mg/m²) on days 1 to 4, alone or in combination with bortezomib (1.3 mg/m²) on days 1, 4, 8, 11, 22, 25, 29, and 32 during cycles 1 to 4 and on days 1, 8, 22, and 29 during cycles 5 to 9. All response and survival outcomes were superior with the VMP, most notably CR rates of 30% versus 4%. Median PFS was 24 months as compared to 17 months, and 3-year OS was 68% as compared to 54%.³⁹⁶ Time to response was also quicker with VMP 1.4 months versus 4.2 months. Grade 3 to 4 adverse events, however, were more frequent in patients receiving VMP (46% vs. 36%). A total of 33% of patients discontinued bortezomib due to toxicity. Peripheral sensory neuropathy occurred in 44% of patients with grade 3 to 4 in 13%. Neuralgia was also reported in 36% of patients.

There are three phase III trials for the elderly that compare VMP to other regimens.^{400, 406} A major finding of two of these trials was the feasibility and efficacy of changing the bortezomib scheduled from days 1, 4, 8, 11 every 21 days to a once-weekly schedule. This alteration dramatically reduced rates of peripheral neuropathy.

With median follow-up of 32 months, the VMP vs. VTP trial was negative.⁴⁰⁰ Response rates, PFS, and OS were comparable but grade 3 to 4 AEs were significantly higher in the VTP arm. More patients in the VTP arm discontinued therapy prematurely, and they had higher rates of cardiac events (8% vs. 0%) but lower rates of infection (1% vs. 7%). An analysis based on cytogenetic risk was done, comparing outcomes based on hyperdiploidy versus nonhyperdiploidy. The 3-year OS in the VMP-treated patients was no different based on cytogenetic risk category implying that this regimen may abrogate the risk of nonhyperdiploid cytogenetics; this difference was not observed in the VTP-treated patients. There was a secondary randomization in this trial to maintenance with either bortezomib and thalidomide (VT) or bortezomib with prednisone (VP).

Palumbo and colleagues randomized patients to receive either nine 5-week cycles of VMP (Table 98.6) or nine 5-week cycles of VMPT, which also added thalidomide 50 mg continuously, and continued with maintenance thalidomide along with alternate week bortezomib. Median follow-up at the time of the publication was 23 months. Response rates and PFS were higher in the four-drug combination with maintenance as compared to the three-drug with no maintenance, but OS was not different. Toxicity was significantly higher using the four-drug regimen: grade 3 to 4 neutropenia (38% vs. 28%; $P < 0.02$), cardiologic events (10% vs. 5%; $P < 0.04$), and thromboembolic events (5% vs. 2%, $P < 0.08$). The most important observation of this trial was that the bortezomib schedule could be changed from days 1, 4, 8, 11, 22, 25, 29, and 32 to days 1, 8, 15, and 22 without reducing efficacy (or actual dose of drug delivered) but significantly reducing adverse events. Severe sensory peripheral neuropathy was reduced from 16% to 3%.

The multicenter, phase IIIb UPFRONT study compares the efficacy and safety in newly diagnosed MM patients ineligible for HDT-SCT of three bortezomib-based induction regimens followed by weekly bortezomib maintenance: VcD (bortezomib-dexamethasone); VTD; and VMP.⁴⁰⁶ Although this has only been presented in abstract and oral presentation, the findings are important. Despite the highest rates of VGPR or better in the VTD arm (51% vs. 37% and 40%), with a median follow-up of 26 months, there was no difference in PFS or OS among the groups, but the mean global health status score (QOL) worsened for all groups during induction. During maintenance, QOL trended back toward baseline for the VcD and the VMP arms, but remained much lower than baseline for the VTD cohort.

Two trials address the combination of thalidomide-dexamethasone (TD) versus dexamethasone alone.^{407, 408} The smaller trial is discussed in a later section and is reviewed in Table 98.7 inasmuch as the majority of patients proceeded to ASCT.⁴⁰⁷ The larger trial is summarized in Table 98.6 and includes patients not destined for ASCT. In the TD arm, time to progression was significantly better (17.4 months, 95% CI: 8.1 months not reached versus 6.4 months, 95% CI: 5.6 to 7.4 months), but grade 3 to 4 adverse events were also higher: DVT/PE 15.4 versus 4.3%; cerebral ischemia 3.4% versus 1.3%; myocardial infarction 4.7% versus 1.3%, and peripheral neuropathy 3.8% versus 0.4%.⁴⁰⁷

In E4A03, the subset of patients aged 70 or older who were treated with lenalidomide with high-intensity dexamethasone (RD) or low-intensity dexamethasone (Rd) are considered.^{362, 409} Although in this trial there is no comparator to MP, it is still relevant because many judge it to be an effective and well-tolerated option for elderly patients. The major findings are shown in Table 98.6. Patients treated on the high-intensity dexamethasone arm had slightly higher response rates, comparable PFS, and inferior OS as compared the low-intensity dexamethasone arm. Rates of nonhematologic toxicity in the RD and Rd arms were 68% and 61%, respectively, with treatment-related deaths in 13% versus 4% of patients. The 2-year OS survival rate of 90% for patients treated with Rd in this randomized trial prompted a large trial

P.2064

comparing Rd to MPT, which has completed accrual (MM-020), but has not yet been reported.

TABLE 98.7 OUTCOMES FOR INDUCTION REGIMENS AMONG PATIENTS DESTINED FOR AUTOLOGOUS STEM CELL TRANSPLANTATION (ASCT), RANDOMIZED CONTROLLED TRIALS

Reference	Regimen ^a	N	Post-induction Response (%)		Post-ASCT(s)/Maintenance Response (%)		Median PFS	Median OS
			Overall	=>VGPR (CR)	Overall	=>VGPR (CR)		
Barlogie, 2006 ⁴⁶³	TT2 no thal ^b	3240 3	10	78	43 ^c		44% 5-y ^c	63% 5-y
	TT2 + thal ^b	3460 5	19	86	62 ^c		56% 5-y ^c	64% 5-y
MAG/Macro ⁴⁶⁹	VAD	10NA 4	7 (NA)	NA	42 (NA)		NA	NA
	Thal-dex	10NA 0	25 (NA)	NA	44 (NA)		NA	NA
IFM 2005-1 ⁴⁷⁰	VAD + DCEP	1263 ^c 1	156 ^c	79	37 ^{18c}		30 m	77% 3-y
	BD + DCEP	1279 ^c 1	38 ^{15c}	84	54 ^{35c}		36 m	81% 3 y
GIMEMA ⁴⁶⁶	VTD + VTD/D	2393 ^c 6	62 ^{19c}	96	89 ^{58c}		68% 3-y ^c	86% 3-y
	TD + TD/D	2379 ^c 8	28 ^{5c}	89	74 ^{4c}		56% 3-y ^c	84% 3-y
HOVON50 ⁴⁶⁴	VAD + IFN	2657 ^c 8	18 ^{c 2}	79 ^c	54 ^{23c}		25 ^c	60
	TAD + Thal	2671 ^c 8	37 ^{c 3}	88 ^c	66 ^{31c}		34 ^c	73

MRC IX ⁴⁶⁵	CVAD + Thal or P	5571 6	27 ⁸	90 ^d	62 ^{37d}	25 m	57% 4-y
	CTD + Thal or P	5582 5	43 ¹³	92 ^d	74 ^{50d}	27 m	62% 4-y
HOVON-65/GMMG-HD4 ⁴⁶⁷	VAD + IFN	4154 ^c 4	14 ^{2c}	83 ^c	56 ^{24c}	28 m	55% 5-y ^c
	PAD + Velcade	4178 ^c 3	42 ^{7c}	90 ^c	76 ^{36c}	35 m	61% 5-y ^c
PETHEMA/GEM05MEN0S6VTD ⁵ ⁴⁶⁸		1385 0	60 ^{35c}	NA	NA ^{46c}	56 m ^c	74% 4-y
	TD	1262 7	29 ^{14c}	NA	NA ^{24c}	28 m ^c	65% 4-y
	VBMCP/BVAD /B	1275 9	36 ^{21c}	NA	NA ^{38c}	35 m ^c	70% 4-y
IFM 2007-02 ⁴⁷¹	VD	9981	36 ^{c 12}	86	58 ^{c 31}	30 m	No difference
	vtD	1088 0	49 ^{c 13}	89	74 ^{c 29}	26 m	
E1A00 ^{407e}	TD	9963	NA ⁴	NA	NA	NA	1-year 82
	D	1041 ^c 4	NA ⁰	NA	NA	NA	1-year 82
E4A03 ^{362e}	Rd	2070 ^c 8	26 ^{c 4}	NA	NA	25 m ^c	2-y 87%
	RD	2181 ^c 4	33 ^{c 5}	NA	NA	19 m ^c	2-y 75%
S0232 ^{460e}	RD	9778	63 ²⁶	NA	NA	3-y 52%	3-y 79%
	D	9548	16 ^{4c}	NA	NA	3-y 32% ^c	3-y 73%
Rifkin, 2006 ^{461e}	DVd	9744	NA ³	NA	NA	2-y 53%	2-y 79%
	VAd	9541	NA ⁰	NA	NA	2-y 56%	2-y 72%
Dimopoulos, 2003 ^{462e}	DVD	1361 2	NA ¹³	NA	NA	2-y 49%	2-y 60%
	VAD	1262 7	NA ¹³	NA	NA	2-y 49%	2-y 68%

^a Regimens listed as “induction” + “consolidation/maintenance.”

^b The basis of TT2 is a complex 6 or 7 drug induction followed by 2 autologous stem cell transplants,

followed by 2 cycles of 5 drug consolidation, indefinite interferon maintenance, and 1 year of dexamethasone.

^c Statistically significant difference between arms.

^d Maintenance not included in response, although patients were randomized to thalidomide or prednisone.

^e ASCT was not a predetermined part of these trials, so data include both patients who did and did not undergo ASCT.

Transplant-Ineligible Patients: Induction Chemotherapy for Patients Ineligible for ASCT Prior to the 21st Century

The 1970s and 1980s were a testing ground for various combinations of alkylators, corticosteroids, and doxorubicin. Melphalan-cyclophosphamide-prednisone,²⁵⁶ carmustine-cyclophosphamide-prednisone,^{371, 372} melphalancyclophosphamide-carmustine-prednisone (MCBP),^{256, 353} and vincristine-melphalan-cyclophosphamide-prednisone (VMCP)²⁵⁶ resulted in response rates of 47%, 37% to 50%, 49% to 68%, and 62%, respectively. Median survivals with these regimens were 25 to 36 months.^{256, 353, 371, 372} Lee and Case²⁶⁰ introduced the five-drug regimen of vincristine-carmustine-melphalan-cyclophosphamideprednisone (VBMCP or the M-2 regimen), which included the same four drugs as MCBP plus vincristine; dose intensities, however, were different in these two regimens. The response rate for VBMCP was about 85% in previously untreated patients with a median survival of 38 months.^{260, 410} The success of the VBMCP regimen supported the value of vincristine. However, the MRC IV trial, which randomized 530 previously untreated patients with MM to MP versus melphalan-vincristine-prednisone, revealed no difference in either response rate or OS between the two arms.²⁶⁴ VMCP has not produced any response or survival advantage over MP.^{383, 411}

Although subsequent randomized trials have substantiated the superior response rates of VBMCP over standard MP, P.2065

they have not demonstrated superior survival.^{263, 376, 385, 412} In fact, the meta-analysis performed by the Myeloma Trialists' Collaborative Group²¹⁶ involving 6,633 patients in 27 randomized trials, revealed a superior response rate (60.2% vs. 53.2%, $P < 0.000001$, two-tailed) but no survival benefit for combination chemotherapy over standard MP (Fig. 98.6). A prior meta-analysis of 18 published trials (3,814 patients) also demonstrated no benefit for combination chemotherapy in terms of survival. There was a suggestion of a survival advantage in the subgroup of patients with more aggressive disease,³⁵⁵ but this was not substantiated in the larger meta-analysis.²¹⁶

The use of alkylator-doxorubicin-based combination chemotherapy was stimulated by a report on the benefits of a combination of doxorubicin and BCNU in patients who had become resistant to melphalan.⁴¹³ Regimens such as MAP (melphalan-doxorubicin-prednisone), CAP (cyclophosphamidodoxorubicin-prednisone), VCAP (vincristine and CAP), and VBAP (vincristine-BCNU-doxorubicin-prednisone) were tried; by SWOG response criteria, objective response rates were 41%, 46%, 64%, and 61%, respectively.^{256, 414} Median survival ranged from 30 to 32 months; subsequent analysis demonstrated a superior median survival for the VBAP arm of 37 months.⁴¹⁵ Enthusiasm for alternating VMCP and VBAP (or VCAP) was generated by the SWOG study of 237 patients randomized to MP or the above regimens.^{380, 381} Response rates and OS were superior in the alternating combination chemotherapy arms compared to the MP arm,^{414, 415} but the survival benefits of this initial study were not reproducible by others.^{257, 377, 378, 382, 384, 416, 417} The V MRC myelomatosis trial randomized patients to ABCM (VBAP-VMCP without the vincristine or prednisone) or melphalan as a single agent on the basis of findings emanating from the IV MRC trial, which demonstrated a lack of benefit attributable to the addition of vincristine. Median survival in the ABCM group was superior to that of the melphalan-only arm (32 vs. 24 months, $P = 0.0003$).^{233, 266}

Combination Chemotherapy with Interferon- α for Induction

IFN and dexamethasone have been combined as an induction regimen in patients with newly diagnosed myeloma and a low tumor mass. A retrospective comparison showed that the response rate of this regimen (57%) was similar to the response rate (48%) previously observed with dexamethasone alone.⁴¹⁸ A randomized trial comparing MP, melphalan-dexamethasone, dexamethasone, and dexamethasone-IFN did not demonstrate any added benefit by incorporating IFN into the treatment regimen.²⁴⁹ Ahre et al.⁴¹⁹ randomized 55 patients to MP or IFN (3 to 6 MU daily); response rates in the MP arm were significantly higher than in the IFN arm (44% vs. 14%, $P < 0.001$). These results spawned a multitude of trials

adding IFN to MP^{420, 421, 422, 423, 424, 425, 426, 427, 428} and numerous alkylator-corticosteroid combinations with or without anthracycline^{422, 429, 430, 431, 432, 433, 434, 435, 436, 437, 438} as part of an induction regimen. Results have been mixed. Two meta-analyses have been performed in an attempt to reconcile these conflicting results.^{439, 440} The first, reported in 2000,⁴³⁹ used published data and included 17 induction trials^{420, 421, 422, 423, 424, 425, 426, 427, 428, 430, 431, 432, 433, 434, 435, 437, 438} with 2,333 evaluable patients,⁴³⁹ the second, reported by The Myeloma Trialists' Collaborative Group in 2001,⁴⁴⁰ used primary data from 12 induction trials^{420, 421, 422, 423, 424, 425, 426, 427, 428, 430, 432, 433, 434, 436, 437, 438, 441} involving 2,469 patients.⁴⁴⁰ Overall, the results were similar. In the first meta-analysis, the benefits attributable to the addition of IFN to the induction regimen included a 6.6% higher response rate ($P < 0.002$) and a 4.8-month and 3.1-month prolongation of relapse-free ($P < 0.01$) and OS ($P < 0.01$).⁴³⁹ In the second meta-analysis, patients receiving IFN had a slightly better response rate (57.5% vs. 53.1%, $P = 0.01$) and PFS (30% vs. 25% at 3 years, $P < 0.0003$), with a superior median time to progression of about 6 months. The survival advantage of 2 months, however, was not significant ($P = 0.1$).⁴⁴⁰ These meta-analyses suggest that incorporation of IFN into induction provides a modest prolongation of response and possibly of survival. Wisloff et al.⁴⁴² evaluated the quality of life of 583 patients randomized to either MP or MP plus IFN as induction. During the first year of treatment with IFN, the patients reported significantly more fever, chills, dry skin, fatigue, pain, nausea, vomiting, and appetite loss than the control patients. After the first year, however, the only symptom reported more often was dizziness. Although patients receiving IFN had a 5- to 6-month prolongation of the response and plateau phase, there was no late quality-of-life benefit observed to compensate for the early impairment. The authors questioned the clinical value of the plateau phase prolongation and reported that only 60% of patients continued to receive IFN after 24 months, suggesting that their data might underestimate the potential toxicity of the drug.

Transplant Eligible Patients

VAD-like regimens—incorporating different corticosteroids,^{243, 246, 443} and C-VAMP (cyclophosphamide-vincristinedoxorubicin-methylprednisolone)²⁴⁵ had commonly been used as induction therapy before stem cell collection and transplantation, but have been largely replaced by regimens incorporating IMiDs and/or proteasome inhibitors. These VAD-like regimens had initially been piloted with salutary effect in relapsed disease, and were subsequently applied in previously untreated patients with response rates of 50% to 84%.^{444, 445, 446, 447, 448, 449, 450, 451, 452, 453} Median survival for patients treated initially with VAD and no transplant was about 36 months.⁴⁵⁴ The complete response rate of C-VAMP was higher than that of VAMP alone, but survival was not different.⁴⁴⁷ Response rates of 80% have also been achieved using the CAD (cyclophosphamide-doxorubicin-dexamethasone) regimen.⁴⁵⁵ The addition of etoposide to C-VAD appears to contribute only toxicity.⁴⁵⁶

By the late 1990s and early 2000s, single-agent high-dose dexamethasone was used by some experts in lieu of VAD for induction in those patients destined for stem cell collection based on a nearly comparable response rate of single-agent high-dose dexamethasone of 43%²⁴² and the advantage of an oral noninfusional therapy. This strategy was used successfully, resulting in adequate collections of peripheral blood stem cells without any apparent adverse effects on complete remission rates or progression-free survival in several single-arm studies.^{457, 458} With the advent of additional therapies, single-agent dexamethasone is no longer a standard induction option.

There is controversy about which induction is best for patients before stem cell collection and ASCT. In the absence of mature data, there are two philosophical camps. There are the proponents of “deepest response,” who argue that using those multidrug regimens yielding highest CR rates is essential. These investigators point to the circular reasoning that those patients with the deepest response do best.⁴⁵⁹ The counterargument posed by others is that until randomized controlled trials demonstrate a survival advantage or at least a PFS advantage with improved quality of life for one regimen over another, selection of a regimen that may give a higher CR rate but more toxicity and cost may not prove to be the most prudent course of action. Unfortunately, for the majority of regimens there are no completed prospective randomized trials to answer this question. Many of the trials discussed here suffer from a paucity of information about future access to the novel agent in the control arm, making it impossible to discern whether an advantage seen using a multiagent induction regimen lies in synergy of a particular combination or merely in access to yet another drug with activity against MM.

Transplant-Eligible Patients: Phase III Trials of Induction Regimens Including Immune Modulatory Drugs and/or Proteasome Inhibitors (Table 98.7)

Table 98.7 includes published phase III induction regimens that are part of an ASCT transplant treatment plan. Five of them include a mix of patients who are and are not destined for transplant,^{362, 407, 460, 461, 462} five include planned maintenance,^{463, 464, 465, 466, 467, 468} and three do not specify post-transplant

maintenance.^{469, 470, 471} Further limitations of many of these trials are short follow-up and different maintenance arms, making it difficult to tease out benefit due to induction versus maintenance. There is also a paucity of information about quality of life associated with these protocols. Patterns arise in terms of response and PFS: that is, addition of thalidomide is better than no addition, but addition of bortezomib is better yet. Despite these advantages in response rate and PFS, to date only one study has shown a better OS, the HOVON-65 trial. As more drugs are added, there is more toxicity, especially peripheral neuropathy.

The IFM 2005-1 randomized 482 patients to either four cycles of VAD or bortezomib dexamethasone (BD)⁴⁷⁰ followed by DCEP (dexamethasone-cyclophosphamide-etoposide-cisplatin) for two cycles versus no DCEP. Patients were to have a single ASCT, and those without a VGPR or better were to receive a second ASCT. An undefined number of patients received maintenance lenalidomide as part of a different trial of lenalidomide versus placebo (IFM 2005-2 trial). Pretransplant CR, VGPR, and PR were superior with BD. By protocol, fewer patients who received BD were deemed candidates for second ASCT than patients who had VAD induction, but only 21% and 27%, respectively, actually received a second ASCT. The improvement in response in the BD arm persisted after transplant, but with a median follow-up of 32 months, there was no difference in PFS or OS. The incidence of grade 3 to 4 adverse events appeared similar between groups, but hematologic toxicity and deaths related to toxicity (0 vs. 7) were more frequent with VAD. In contrast, rates of grade 2 (20.5% vs. 10.5%) and grades 3 to 4 (9.2% vs. 2.5%) peripheral neuropathy during induction through first transplantation were significantly higher with BD.

Based on the promising phase II results using VTD in previously untreated myeloma,⁴⁷² the GIMEMA group randomly allocated 480 patients to either three 21-day cycles of thalidomide (100 mg daily for the first 14 days and 200 mg daily thereafter) plus dexamethasone (40 mg daily on 8 of the first 12 days), either alone or with bortezomib (1.3 mg/m²) on days 1, 4, 8, and 11).⁴⁶⁶ After double autologous stem-cell transplantation, patients received two 35-day cycles of their assigned drug regimen, VTD or TD, as consolidation therapy. All patients were subsequently maintained on dexamethasone 40 mg days 1 to 4 every 28 days. After induction therapy, higher rates of complete or near complete response were observed in the VTD arm as compared to TD (31% vs. 11%, $P < 0.0001$). These improved response rates persisted after first and second ASCT and after two cycles of consolidation. 3-year PFS was better in the VTD group (68% vs. 56%, $P = 0.006$), but with a median follow-up of 36 months, the estimated 3-year OS rates were no different. Grade 3 or 4 adverse events post induction were recorded in a significantly higher number of patients on VTD than in those on TD (56% vs. 33%, $P < 0.0001$), with a higher occurrence of grade 3 to 4 peripheral neuropathy in patients on VTD (10% vs. 2%, $P = 0.0004$).

The HOVON 50/GMMG-HD3-trial is a phase III study of 536 randomized patients up to 65 years⁴⁶⁴ to either three cycles of TAD (thalidomide, 200 mg for HOVON and 400 mg for GMMG; adriamycin 9 mg/m², days 1 to 4; and dexamethasone 40 mg, days 1 to 4, 9 to 12, 17 to 21) or VAD. TAD resulted in more grade 2 to 4 AEs as compared with the VAD arm (31% vs. 21%, $P = 0.008$). The TAD had superior overall response rates pre- and post-ASCT, but with a median follow-up of 52 months, there was no significant difference in median OS (73 vs. 60 months, $P = 0.77$). Patients who had been randomized to the thalidomide arm had a markedly shorter survival post-relapse.

In the MRC IX trial (transplant pathway), 1,111 patients were randomized to either oral cyclophosphamide-thalidomidedexamethasone (CTD) or to infusional cyclophosphamide, vincristine, doxorubicin, and dexamethasone (C-VAD).⁴⁶⁵ As many as six cycles were given prior to ASCT. The post-induction overall response rate was significantly higher with CTD than C-VAD (82.5% vs. 71.2%, $P < 0.0001$, including superior complete response rates (13.0% vs. 8.1%, $P = 0.008$). This response advantage persisted post-autologous stem-cell transplantation (complete response, 50.0% vs. 37.2%, respectively; $P = 0.00052$). Patients had a secondary randomization to either maintenance thalidomide or prednisone. With a median follow-up of 47 months, there was no difference in either PFS or OS. FISH risk had no impact on outcome.

To date, the HOVON-65 trial is the only randomized trial incorporating novel therapies into induction that has shown an improvement in OS.⁴⁶⁷ These results are confounded by the fact that these same patients had different maintenance regimens as well, making it difficult to know if the induction, the maintenance, or merely access to bortezomib was the value-added step, in terms of the OS benefit. This trial randomized 827 patients to 3 weeks of initial therapy with either VAD or bortezomib, doxorubicin, and dexamethasone (PAD), followed by one or two ASCT. Post-ASCT maintenance for the VAD group was thalidomide 50 mg daily and for the PAD group bortezomib 1.3 mg/m² once every 2 weeks. Maintenance was continued for 2 years. After completing induction therapy with PAD, 31% of patients had achieved a CR in contrast to 15% of VAD patients. This improved CR rate persisted even after one or two ASCT. PFS was superior in the PAD-bortezomib maintenance arm as compared to the VAD-thalidomide arm, 35 months versus 28 months. After a median follow-up of 66 months, OS was also better in the PAD arm, 5-year OS of 61% versus 55%, $P = 0.05$ when adjusted for risk

factors (age, performance status, ISS, double ASCT, and FISH abnormalities) in the multivariate analysis. Of note, the hazard ratio for double ASCT was similar to that of being on the PAD-bortezomib arm. Peripheral neuropathy grades 2 to 4 were reported in 18% of VAD patients versus 40% of PAD patients, $P < 0.001$. The discontinuation rate of thalidomide maintenance was higher than that of bortezomib maintenance (30% vs. 11%, $P < 0.001$). An important observation made in this trial is that the use of bortezomib both before and after ASCT appeared to attenuate the poor prognostic impact of deletion 17p.⁴⁷³

The Spanish Myeloma Group conducted a trial to compare VTD versus TD versus vincristine-BCNU-melphalan-cyclophosphamide-prednisone alternating with vincristine-BCNU-doxorubicin-dexamethasone plus bortezomib (VBMCP/VBAD/B) in patients aged 65 years or younger with MM destined for ASCT.⁴⁶⁸ A total of patients was allocated. The CR rate was significantly higher with VTD than with TD (35% vs. 14%, $P = 0.001$) or with VBMCP/VBAD/B (35% vs. 21%, $P = 0.01$). The median PFS was significantly longer with VTD (56.2 vs. 28.2 vs. 35.5 months, $P = 0.01$). With a median follow-up of 35 months, the 4-year OS was 74% for VTD, 65% for TD, and 70% for VBMCP/VBAD/B, $P = NS$.

The IFM 2007-2 trial⁴⁷¹ was a randomized trial to compare bortezomib-dexamethasone (VD) as induction ASCT to a combination consisting of reduced doses of bortezomib and thalidomide plus dexamethasone (vtD), the latter of which was comprised of four 3-week cycles of IV bortezomib 1 mg/m²/m² day 1, 4, 8, and 11 along with thalidomide 100 mg/day orally, and dexamethasone 40 mg days 1 to 4 (all cycles) and days 9 to 12 (cycles 1 and 2). In the case of less than PR after cycle 2, the dose of bortezomib was increased to 1.3 mg/m² and the dose of thalidomide to 200 mg/day. The VD patients received two drugs on the same schedule as vtD, but the dose of bortezomib was 1.3 mg. Patients receiving the three-drug regimen had similar overall response rates and CR rates, but VGPR or better occurred significantly more often in the vtD group. This same pattern was observed after a single ASCT. Of note, the number of stem cells collected was less in patients receiving the three-drug regimen. Subsequent post-ASCT consolidation and/or maintenance was at treating physician's discretion; more patients receiving VD received maintenance therapy. Despite these differences, there was no significant difference in PFS or OS with a median follow-up of 32 months. There were significantly

P.2067

higher rates of peripheral neuropathy among patients on the VD arm: overall 70% versus 53%, $P = 0.01$ and grade 3 in 11% versus 3%, $P = 0.03$. The authors concluded that vtD, including reduced doses of bortezomib and thalidomide, yields higher VGPR rates compared with VD and can be considered a new effective triplet combination before HDT/ASCT.

E1A00,⁴⁰⁷ E4A03,³⁶² and S0232⁴⁶⁰ (Table 98.7) were conducted with response endpoints rather than PFS or OS. The two trials comparing variants of VAD using pegylated doxorubicin had response and toxicity as major endpoints.^{461, 462} E1A00 compared single-agent dexamethasone to thalidomide-dexamethasone (TD). Its premise was to validate whether the addition of thalidomide to dexamethasone increased response rates as reported in phase II studies. The overall response rate of TD was significantly higher than dexamethasone alone (63% vs. 41%); however, toxicity was greater using the combination with grade 4 to 5 toxicity being 45% vs. 21%, $P < 0.001$.⁴⁰⁷ For nearly a decade TD was used as induction in the months before stem cell collection because of its high response rates and its ease of administration, but with the introduction of lenalidomide and bortezomib, the TD doublet is not commonly used in the United States as induction. The results of the two lenalidomide trials (E4A03³⁶² and S0232⁴⁶⁰) have been discussed.

In an attempt to avoid the continuous infusion required to administer VAD, the use of the pegylated liposomal doxorubicin has been explored in two randomized trials. Doxil-vincristine-dexamethasone (DVD)—using either standard high dose dexamethasone⁴⁶² or attenuated doses of dexamethasone⁴⁶¹—was compared to VAD. Results were comparable between arms with regards to response rates, 42% in the attenuated dexamethasone trial⁴⁶¹ and 61% with the standard dose dexamethasone trial.⁴⁶² PFS and OS were comparable, but there was more alopecia, grade 3/4 neutropenia in the nonliposomal doxorubicin arms and more palmar-plantar erythrodysesthesia in liposomal doxorubicin arms.

Total Therapy Approach

Barlogie and colleagues have championed the “total therapy” (TT) approach since 1990.^{329, 463, 474, 475} The concept is to use all therapies with activity against malignant plasma cells as early as possible with prolonged treatment courses. Advances have come from this approach, especially the concept of tandem transplantation, but the major limitation of the total therapy studies is that they have not been compared to less aggressive strategies in a randomized fashion. With successive trials—total therapy 1 (TT1), total therapy 2 (TT2), and total therapy 3 (TT3)—there have been improvements in outcomes including complete response, PFS, and OS (Table 98.8).³²⁹ Complete response rates have increased from 38% to 62% of patients and 5-year OS rates have increased from 57% to 73%. Although other investigators have not reported duration of complete response rates that approach those of TT3, since the beginning of the 21st century 5-year OS rates

of 50% to 80% among transplant-eligible patients are increasingly common using less intensive treatment strategies.^{363, 476} Moreover, toxicity of the total therapy strategies is not inconsequential. For example in TT2 grade 3/4 adverse events include PN in 27%, thrombosis or embolism in 30%, bowel obstruction in 14%, and syncope in 12%.⁴⁶³

TABLE 98.8 TOTAL THERAPY APPROACH^{329, 463, 474, 475}

	TT1 (n = 231)	TT2 + thal (n = 345); TT2 - thal (n = 323)	TT3A (n = 303); TT3B (n = 177)
Induction	VAD × 3	VAD followed by DCEP +/- thal	VTD-PACE × 2
Mobilization	High dose CTX	DCEP +/- thalidomide	Using above
Transplant × 2	Yes	Yes	Yes
Consolidation	DCEP	DPACE quarterly × 1 year +/- thal	A: VTD-PACE × 2; B: VRD-PACE × 2
Maintenance	IFN	Dex × 1 year, IFN continuously +/- thal indefinitely	A: VTD × 1 year followed by TD × 2 years, or B: VRD for 3 years
Duration of therapy ^a	1 year	TT2 + thal: > 3 years; TT2 - thal: 3 years	>4.2 years
Number of drugs	6	TT2 + thal: 8; TT2 - thal: 7	TT3A: 8; TT3B 9
Accrual years	8/1990-8/1995	10/1998-2/2004	2/2004-7/2006
Age < 65, %	91	TT2 + thal: 79; TT2 - thal: 80	72
Median follow-up	17.1 years	8.7 years	5.5 years
CR, %	38	60 with thal; 43 no thal	A: 62
CR duration	35 ^{25, 45}	59 ^{52, 66} with thal; 52 ^{43, 60} no thal	A: 79 ^{73, 85}
PFS	27 ^{21, 32}	56 ^{50, 61} with thal; 42 ^{37, 47} no thal	A: 67 ^{62, 73}
5-year OS, %	57 ^{50, 63}	68 ^{63, 73} with thal; 65 ^{60, 70} no thal	A: 73 ^{68, 78}

DCEP, dexamethasone, cyclophosphamide, etoposide, cisplatinin; DPACE, dexamethasone, cisplatinin, doxorubicin, cyclophosphamide, etoposide; IFN, interferon; VAD, vincristine, doxorubicin, dexamethasone; Thal, thalidomide; TT, total therapy; VTD-PACE, bortezomib, thalidomide, dexamethasone, cisplatinin, doxorubicin, cyclophosphamide, etoposide.

^aExcluding interferon maintenance duration.

Other Induction Regimens of Interest

Table 98.5 includes a number of regimens that have reported in the up-front setting,^{316, 317, 318, 319, 360, 365, 366, 367, 368, 472, 477, 478, 479, 480, 481, 482, 483, 484, 485} but no recommendation can be made regarding their use given the absence of randomized trials that may better define their role in patients with myeloma. Several have been discussed in previous sections.^{365, 366, 367, 368, 472, 480, 481, 486} All of the other regimens are novel triplets or quadruplets. Response rates are listed in Table 98.5, therefore much of the emphasis of this section focuses on toxicity.

Four phase II studies use either single-agent bortezomib or bortezomib in combination with dexamethasone. One study is notable because all patients on that study (E2A02) were high-risk as defined by B2M and/or cytogenetic abnormalities, and none of the pateints had early transplantation. Median PFS was 8 months and 2-year OS was 76%.³¹⁶

Two regimens exclude corticosteroids, VT (bortezomib, and thalidomide),⁴⁷⁸ and VDT (bortezomib, pegylated liposomal doxorubicin, and thalidomide).⁴⁸² The VT study treated 27 patients with bortezomib 1.3 mg/m² on days 1, 4, 8, and 11 every 21 days and thalidomide 150 mg/d for a maximum of eight cycles.⁴⁷⁸

The overall response rate was 81.5% with 25.8% near complete response or greater. The most common grade 3 toxicities were peripheral neuropathy (22%), pneumonia (15%), fatigue (7%), and anemia (7%). No venous thromboembolic events were observed even in the absence of prophylactic anticoagulation. Forty-three newly diagnosed MM patients were enrolled onto the VDT study.⁴⁸² The overall response rate and complete response (CR) + near complete response (nCR) rate were 78% and 35%, respectively. Median time to progression was 29.5 months. Fatigue, rash, neuropathy, constipation, and infections were the most common side effects.⁴⁸²

Kumar et al. built on the Rd experience by adding cyclophosphamide.⁴⁸⁷ A total of 85% of patients responded, and the toxicities were manageable with over 80% of planned doses delivered; 6 patients went off study for toxicity. The median PFS for the entire group was 28 months (95% CI: 22.7 to 32.6) and the OS at 2 years was 87% (95% CI: 78 to 96). Note that 14 patients with high-risk MM had similar PFS and OS as the standard-risk patients (n = 39).

Carfilzomib, lenalidomide, and dexamethasone⁴⁷⁹ have been used in the up-front setting with excellent response rates.⁴⁷⁹ The long-term utility of this regimen is not known, but in a phase I/II study in 53 patients with newly diagnosed MM the maximum tolerated dose was 28-day cycles of: carfilzomib 20/ 36 mg/m², days 1, 2, 8, 9, 15, 16, and 1, 2, 15, 16 after cycle 8; lenalidomide 25 mg/d, days 1 to 21; and weekly dexamethasone 40/20 mg cycles 1 to 4/5+. Most patients did not require dose modifications. Thirty-five patients underwent stem cell collection after cycle 4, and 7 proceeded to early transplant. After a median of 12 cycles (range, 1 to 25), 62% achieved at least near-complete response (CR) and 42% stringent CR. With median follow-up of 13 months, 24-month progression-free survival estimate was 92%. Grade 3/4 toxicities included hypophosphatemia (25%), hyperglycemia (23%), anemia (21%), thrombocytopenia (17%), and neutropenia (17%); peripheral neuropathy was limited to grade 1/2 (23%).

Lenalidomide, bortezomib, pegylated doxorubicin, and dexamethasone (RVDD) were tested in a phase I/II trial including 72 patients.⁴⁸⁵ The MTD was 3-week cycles of lenalidomide 25 days 1 to 14, bortezomib 1.3 mg/m² on days 1, 4, 8, and 11, and pegylated doxorubicin 30 mg/m² in day 4, and dexamethasone 20 mg days 1, 2, 4, 5, 8, 9, 11, and 12 (cycles 1 to 4, but 10 mg for cycles 5 to 8). The maximum number of treatment cycles was 8, and patients who did not go to ASCT were to receive maintenance that included lenalidomide, bortezomib, and dexamethasone indefinitely. The median treatment duration was 4.5 cycles and 15% of patients achieved stringent CR. Grade 3/4 AEs included neutropenia (19.4%), infections (14%), thrombocytopenia (11%), sensory peripheral neuropathy (6%), and thromboembolism in 3%. All grade fatigue, constipation, sensory neuropathy, and infection occurred in 83%, 69%, 65%, and 57%, respectively. The 18-month PFS for patients proceeding and not proceeding to ASCT was 93% and 64%, respectively. Although the decision of proceeding to ASCT was nonrandomized, there was a significant difference in PFS between the groups. With a median follow-up of 15 months, the 2-year OS for all patients was approximately 75%.

TABLE 98.9 CONVENTIONAL CHEMOTHERAPY VERSUS SINGLE AUTOLOGOUS HEMATOPOIETIC STEM CELL TRANSPLANTATION, RANDOMIZED TRIALS

	N	CR/VGPR (%)		ORR (%)		PFS, mo		OS, mo		SCT (%)	
		CCT	ASCT	CCT	ASCT	CCT	ASCT	CCT	ASCT	CCT	ASCT
IFM90 ^{229, 502}	200	13	38 ^a	57	81 ^a	18	28 ^a	44	57 ^a	9	74
MRC7 ⁴⁹²	401	8	44 ^a	46	86 ^a	19.6	31.6 ^a	42	54 ^a	15	75
MAG91 ⁴⁹⁴	190	4	6	56	59	18.7	25.3 ^a	47.6	47.8	22	75
MAG90 ⁴⁹⁵	185	57	20	58	78	13	39	64	65	78	98
PEETHMA ⁴⁹⁷	164	11	30 ^a	83	82	33	42	61	66	18	90
S9321 ⁴⁹⁶	516	17	15	90	93	7 y 14%	7 y 17%	7 y 38%	7 y 38%	34	82
MMSG ^{b 493}	194	6	25 ^a	66	72	16	28 ^a	42	58 ⁺	39	92
HOVON-24 ^{c 503}	303	13	28 ^a	86	90	23	24 ^a	50	55	—	—

CR/VGPR, complete response or very good partial response; ORR, any response greater than or equal to a partial response; OS, overall-survival; PFS, progression-free survival; SCT, patients known to receive an autologous hematopoietic stem cell transplant.

^a Significant.

^b Transplant arm is 2 low dose (melphalan 100 mg/m²) autologous stem cell transplants.

^c Often included in “double transplant” tables because both arms received melphalan 70 mg/m² × 2 without stem cell support as induction therapy.

There are three phase II reports of adding thalidomide to pegylated doxorubicin, and dexamethasone with^{488, 489} or without vincristine.⁴⁹⁰ Response rates were comparable. In the ThaDD trial which did not include vincristine, grade 3 to 4 infections and thromboembolic accidents were observed in 22% and 14% of patients, respectively.⁴⁹⁰ In the DVd-T and T-DVD trials grade 3 to 4 toxicities included: neutropenia (14% to 15%), thrombosis (10% to 25%), pneumonia (12%), constipation (10%), rash (5% to 8%), and peripheral neuropathy (5% to 22%). It is notable that although the ThaDD cohort⁴⁹⁰ was older and received lower doses of the thalidomide and no vincristine, similar response rates and less toxicity were seen.

Hematopoietic Stem Cell Transplantation

Autologous Transplant

To overcome resistance of the myeloma cells to conventional dose chemotherapy, McElwain and Powles²²⁰ pioneered the use of high-dose melphalan to treat MM and plasma cell leukemia. The treatment was complicated by prolonged myelosuppression. Barlogie et al.⁴⁹¹ subsequently used a regimen combining high-dose melphalan with total body irradiation supported by autologous bone marrow transplantation in MM patients refractory to VAD. Ten years hence, Attal et al. published the first prospective randomized controlled trial demonstrating an improved OS for patients undergoing high-dose therapy with autologous stem cell support compared to conventional chemotherapy.²²⁹

Although high-dose therapy followed by ASCT is not curative, it improves event-free and OS in three^{229, 492, 493} of the seven published randomized controlled trials addressing this issue,^{494, 495, 496, 497} Table 98.9. Three of the four “negative” studies are

P.2069

largely “early” versus “delayed” transplant trials, and the fourth “negative” study excludes from their randomization those patients who did not respond to induction therapy.⁴⁹⁷ Response rates with ASCT are 75% to 90%, and complete response rates are 20% to 40%.^{229, 492, 493, 494, 495, 496, 497}

In contrast to the experience with malignant lymphoma, stem cell transplantation appears to be useful for patients with primary resistant disease.^{498, 499, 500} Patients with MM, in whom first-line therapy such as VAD fails, can be sensitive to high-dose chemotherapy with stem cell reconstitution. Alexanian et al.⁴⁹⁸ reported a decrease of 75% in tumor burden in 56% of patients and a marked improvement in survival compared with matched historical controls. Kumar et al.⁵⁰⁰ also looked at stem cell transplantation in primary refractory disease and found that although there was a lower complete response rate (20% vs. 35%) in the primary refractory patients, the 1-year PFS was similar to that of patients with chemosensitive disease. The benefit of high-dose therapy is less clear among patients who fail induction with immunomodulatory agents. A more recent retrospective study from the Mayo Clinic⁵⁰¹ analyzed PFS and OS in patients who did not have a partial response (never responded or progressed during continuous therapy) after induction therapy with a regimen that included thalidomide or lenalidomide. Patients who did not achieve partial remission had a significantly shorter OS from ASCT (73.5 vs. 30.4 months) and a shorter PFS (22.1 vs. 13.1 months; P < 0.001).

As shown in Table 98.9, the Intergroupe Français du Myélome²²⁹ published the first randomized trial comparing high-dose chemotherapy followed by autologous bone marrow transplantation with conventional chemotherapy (Fig. 98.7). A total of 200 patients with previously untreated MM were randomized to receive ASCT or combination chemotherapy (CCT). The 5-year EFS (28% vs. 10%) and OS rates (52% vs. 12%) were higher in the transplantation group. An updated analysis with a median follow-up of 7 years confirmed that high-dose chemotherapy improves EFS (median, 28 months vs. 18 months), as well as OS (median, 57 months vs. 44 months).⁵⁰²

The Medical Research Council VII trial was the second published study addressing the question of CCT versus ASCT.⁴⁹² This trial included 401 randomized patients. They found that the complete response rates (8% vs. 44%), the median EFS (19 vs. 31 months), and the OS (42 vs. 54 months) all significantly favored the ASCT arm, even though only 75% of the patients assigned transplant actually received it and 15% of patients in CCT arm received salvage ASCT.

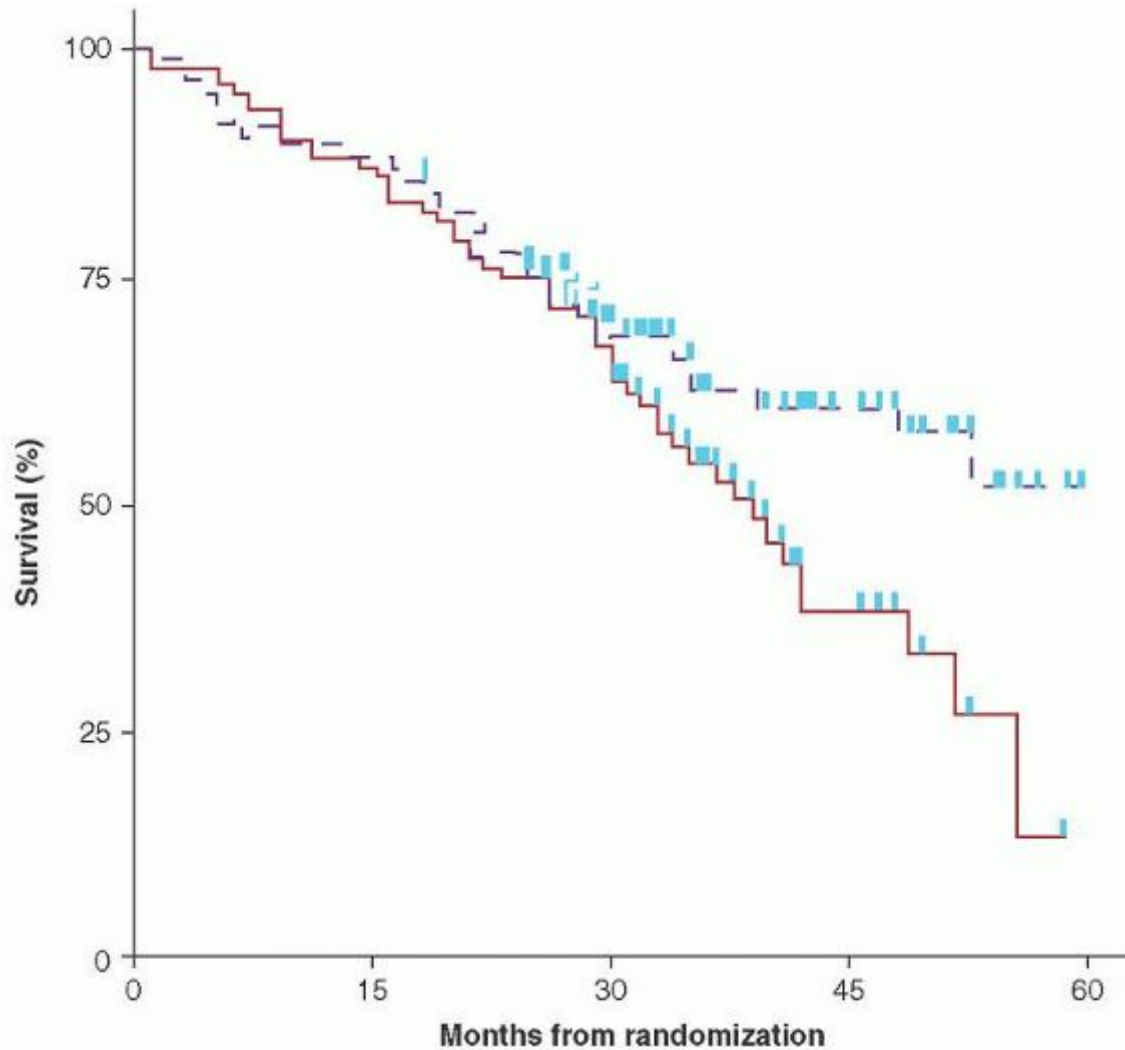

FIGURE 98.7. Conventional chemotherapy versus autologous hematopoietic stem cell transplantation, IFM 90 Trial. (With permission, Attal M, Harousseau JL, Stoppa AM, et al. A prospective, randomized trial of autologous bone marrow transplantation and chemotherapy in multiple myeloma. Intergroupe Francais du Myelome. *N Engl J Med* 1996;335:91-97. Copyright © 1996 Massachusetts Medical Society. All rights reserved.)

Three trials address the “early” versus “delayed” transplant strategy.^{494, 495, 496} The first is the MAG90 trial in which Ferman et al. demonstrate that among the 185 patients randomized to either early or late ASCT, the OS in both groups was 64 months and the percentage of the respective groups actually receiving a ASCT was 98% and 78%, respectively.⁴⁹⁵ This trial was important because it gave patients and physicians license to time their transplant either up-front or delayed. Most chose to transplant early because the time without systemic therapy (TWiST) was longer in the early than the delayed ASCT group, potentially providing better quality of life for the early transplant group. The MAG91 trial⁴⁹⁴ randomized 190 patients under the age of 56 to CCT or HSCT, but this trial ended up being another early versus late transplant trial. Only patients 55 to 65 years of age were included. EFS (19 vs. 25 months), but not OS (47.6 vs. 47.8 months) was better in the ASCT arm. Despite the 120-month follow-up, the OS statistics are confounded by the fact that only 75% of the “ASCT” arm received ASCT, and that 22% of the “CCT” received an HSCT. The intergroup trial (S9321) randomized 510 patients 70 or younger to CCT or ASCT.⁴⁹⁶ With a 76-month follow-up, 7-year OS was no different between the arms, but again only 82% of the “ASCT” group received an ASCT and 34% of the “CCT” group received an ASCT. What is quite striking in this study is the fact that at 7 years after a myeloma diagnosis, 38% of patients were still alive.

Of note, there are no prospective randomized clinical trials addressing the “early versus late” question in the context of up-front IMiDs and proteasome inhibitors. One retrospective study tried to address this question and found that in ASCT-eligible patients who received IMiDs as initial therapy followed by early stem cell mobilization, delayed ASCT results in

similar OS compared with early ASCT. It was noteworthy that an excellent 4-year survival rate of >80% was observed among ASCT-eligible patients who received initial therapy with lenalidomide and dexamethasone regardless of the timing of ASCT.⁴⁷⁶

The Spanish Cooperative Group prospective trial is dissimilar from the other randomized trials in that only those patients responding to therapy were randomized. At enrollment, 216 patients were treated initially with four cycles of VBMCP and VBAD (vincristine, carmustine, doxorubicin, and dexamethasone),⁴⁹⁷ and only 164 were randomized to receive eight additional courses of chemotherapy versus ASCT. There was no difference between the groups with respect to complete response rate, overall response rate, PFS, or OS. These data are discordant from the other ASCT trials, but can be interpreted in two possible ways: one, patients who achieve response with alkylator-based induction do not require consolidation with ASCT; or two, with longer follow-up and more events (i.e., deaths), an OS difference will be seen.

The MMSG97 trial was unique in that it randomized patients aged 50 to 70 years of age to either MP or two half-dose melphalan transplants.⁴⁹³ Patients receiving MP had significantly worse outcomes. A significant difference between two low-dose ASCT and MP was not seen in the IFM 999-06 trial.²⁴⁹

The Hovon-24 trial is commonly grouped in the “single versus double” transplant category, although it is actually an “intensified chemotherapy without transplant” versus “intensified chemotherapy followed by high dose chemotherapy and a single ASCT.”⁵⁰³ There was a significantly higher complete response rate and EFS in the more intensive treatment arm. The differences in EFS, PFS, and TTP were not seen until 4-year follow-up had been reached. The authors reported that the lack of difference in OS was likely due to a “high proportion” of patients from the control arm receiving ASCT at first relapse.

P.2070

It should be noted that all randomized studies of ASCT were designed and implemented before the availability of thalidomide, lenalidomide, and bortezomib. Therefore the role of transplant may evolve in the future. Studies are ongoing to evaluate whether prolonged treatment with bortezomib, lenalidomide, and dexamethasone (VRD) followed by lenalidomide maintenance is superior to induction chemotherapy followed by ASCT.

Single versus Double Transplantation

As the evidence was mounting that one course of dose-intensified chemotherapy with ASCT was superior to conventional chemotherapy, investigators began experimenting with applying two consecutive ASCT. The concept of double or tandem transplant was promulgated by Dr. Barlogie and colleagues at the University of Arkansas.^{329, 504, 505, 506} These investigators reported high complete response rates and survival.^{329, 504, 505, 506} In the first report of “Total Therapy 1” which included 231 patients with newly diagnosed myeloma, the OS with this approach was 68 months.³²⁹

The largest and most mature randomized trial comparing single transplant to double ASCT was the IFM 94 study (Table 98.10). They found no difference in EFS or OS between double and single ASCTs after 2 years of follow-up⁴⁸⁴; however, by 4 years and beyond, an OS benefit was detected.⁴⁸¹ Although the response rate was not significantly different between the two groups (complete response and very good partial response, 42% in the single-transplant arm vs. 50% in the double-transplant group, $P = .15$), both EFS (25 vs. 30 months) and OS (48 vs. 58 months) were improved in the double-ASCT arm. The respective 7-year OS (21% vs. 42%) and EFS rates (10% vs. 20%) also significantly favored the double-ASCT group (Fig. 98.8 REALLY 98.8).⁵⁰⁷ In this trial, four factors were associated with a longer survival: low β_2 -microglobulin levels at diagnosis ($P < 0.01$), young age ($P < 0.05$), low lactate dehydrogenase (LDH) at diagnosis ($P < 0.01$), and the treatment arm to which the patient was assigned ($P < 0.05$). When the authors did an unplanned subgroup analysis, they found that patients who benefited most from the tandem ASCT were those who did not achieve a very good partial response or better after their first ASCT. Cavo et al.⁴⁸² have made similar observations based on preliminary data, including the benefit of a second ASCT being limited to those patients who do not achieve a very good partial response or better after their first ASCT. Most patients under the age of 65 years should have enough stem cells collected for at least two transplants.

A meta-analysis was done comparing single ASCT to tandem ASCT for patients with MM.⁵⁰⁸ Included were 1,803 patients enrolled in six randomized controlled trials. Patients treated with tandem ASCT did not have a better OS or EFS than patients treated with a single ASCT. Some of this difference may be in part related to patients receiving a second ASCT at relapse. Table 98.11 illustrates post-second ASCT performed in the salvage setting; patients can enjoy median OS rates

ranging from 19 to 53 months.^{509, 510, 511, 512, 513, 514, 515, 523, 524} Factors affecting OS included time to progression after first ASCT, number of prior lines of therapy, and chemosensitivity at time of second ASCT.

TABLE 98.10 SINGLE VERSUS DOUBLE HEMATOPOIETIC STEM CELL TRANSPLANTATION, RANDOMIZED TRIALS

Study	N	FU, mo	Event-Free Survival, mo			Overall Survival (%)		
			Single	Double	P	Single	Double	P
IFM, 94 ⁵⁰⁷	403	75	25	30	0.03	48	58	0.01
Bologna, 96 ⁴⁶⁶	228	~48	21	31	0.001	44% at 6 y	63% at 6 y	NS
MAG, 95 ⁴⁹⁵	193	27	41 events	43 events	NS	27 deaths	22 deaths	NS

FU, follow-up; IFM, Intergroupe Français du Myélome; MAG, Myelome Auto Greffe; NS, not significant.

Hematopoietic Stem Cell Collection

Autologous peripheral blood stem cell transplantation has replaced autologous bone marrow transplantation because engraftment is more rapid and there is less contamination with myeloma cells.^{525, 526, 527} Hematopoietic stem cells should be collected before the patient is exposed to alkylating agents^{528, 529} because prolonged melphalan exposure leads to an impaired harvest of peripheral blood stem cells when stem cells are mobilized with chemotherapy plus growth factors⁵³⁰ or growth factors alone.⁵³¹ Data also suggest lenalidomide exposure may have adverse effects on the ability to collect stem cells.⁵³² This appears to be related to the duration of lenalidomide therapy as well as the age of the patient. For this reason, early mobilization of stem cells, preferably within the first four cycles of initial therapy, is now recommended.⁵³³ Stem cell mobilization for myeloma patients is primarily performed using filgrastim granulocyte-colony stimulating factor alone or after cyclophosphamide chemotherapy. The target CD34 + cell dose to be collected as well as the number of apheresis performed varies by center, but a minimum of 2 million CD34 + cells/kg has been traditionally used for the support of one cycle of high-dose therapy.⁵³⁴ In the setting of ASCT, CD34 + cell doses of >3 million/kg have been associated with better outcomes, primarily due to faster hematologic recovery and lower incidence of infectious and bleeding complications.^{535, 536} The use of plerixafor in conjunction with filgrastim has enhanced the ability to mobilize successfully the majority of patients undergoing ASCT. Plerixafor is a novel stem cell mobilizing agent. It is a bicyclam molecule that inhibits the SDF-1 alpha/CXCR4 binding that occurs between CD34 + stem cells and the marrow stroma. The inhibition of this interaction results in the release of CD34 + stem cells into the bloodstream facilitating their collection through apheresis methods.⁵³⁷

Historically, all peripheral blood cell products have been shown to be contaminated with malignant cells.^{538, 539} Purging marrow with cyclophosphamide derivatives⁵⁴⁰ or with monoclonal antibodies^{541, 542, 543} is feasible although associated with prolonged myelosuppression after transplantation. CD34⁺ selection of peripheral blood progenitor cells provided effective hematopoietic support in a group of 55 patients with advanced MM after myeloablative chemotherapy.⁵⁴⁴ However, two phase III randomized trials have shown no clinical benefit to using CD34⁺ selected autologous peripheral blood stem cells.^{545, 546} Moreover, the risk of infection was higher in the CD34 selected group.⁵⁴⁶

P.2071

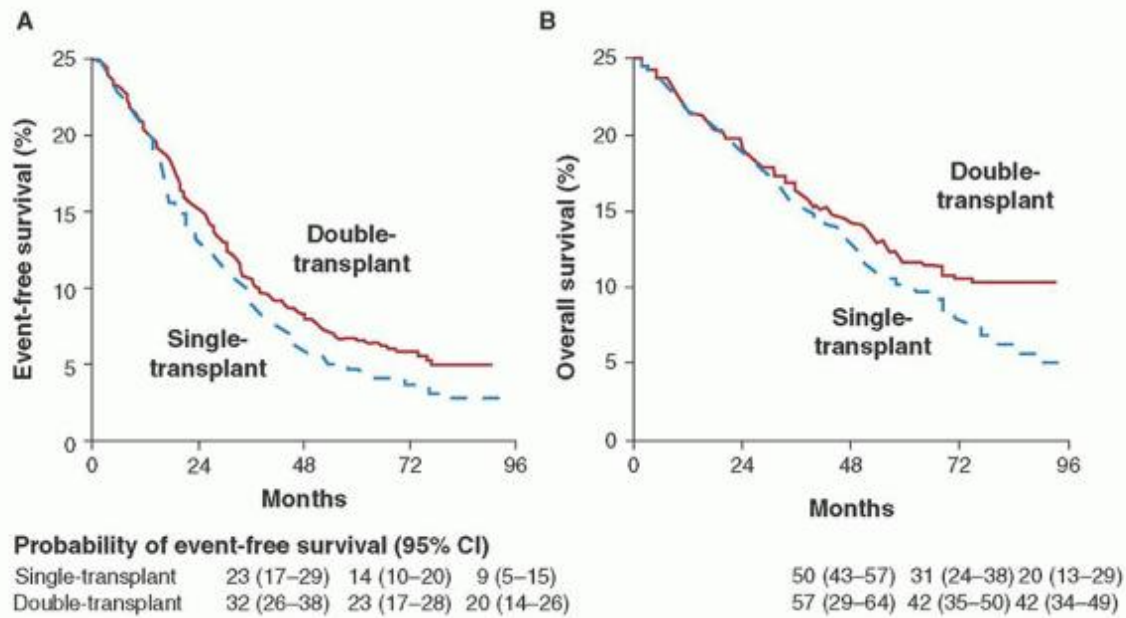

FIGURE 98.8. Single autologous versus double hematopoietic stem cell transplantation, IFM 94 trial. A: Event-free survival. B: Overall survival. (With permission from Attal M, Harousseau JL, Facon T, et al. Single versus double autologous stem-cell transplantation for multiple myeloma. *N Engl J Med* 2003;349:2495-2502. Copyright © 2003 Massachusetts Medical Society. All rights reserved.)

Autologous Hematopoietic Stem Cell Transplantation in Special Populations

The mortality rate from ASCT is currently less than 5%. Age older than 65 years alone is not a contraindication for transplantation, although there are no randomized data proving or disproving its utility in this age group. Such patients are candidates for transplantation if they have good functional status and limited comorbidities.^{547, 548} Patients with renal failure, including dialysis patients can successfully undergo ASCT with melphalan 140 mg/m², with similar response rates and PFS, and a proportion will even have reversal of their renal failure. Treatment-related morbidity is higher,⁵⁴⁹ and their OS is inferior to their dialysis-independent counterparts.^{550, 551}

Conditioning Therapy and Stem Cell Transplantation

In an effort to improve ASCT, various preparative regimens have been used. There has been only one prospective randomized controlled trial comparing conditioning regimens in patients with myeloma.⁵⁵⁴ Moreau et al.⁵⁵⁴ randomized 282 patients to receive either melphalan (140 mg/m²) plus total body irradiation or melphalan alone (200 mg/m²). There was no difference in response rates or EFS. Survival at 45 months favored the melphalan alone arm (65.8% vs. 45.5%, P = 0.05). Toxicity with melphalan alone was significantly less. Most investigators have now discontinued the use of total body irradiation and give only melphalan (200 mg/m²) as the preparative regimen.

TABLE 98.11 SECOND AUTOLOGOUS STEM CELL TRANSPLANTATION (ASCT) AS SALVAGE

Study	No of Pts	TRM (%)	ORR (%)	Median PFS (months)	Median OS (months)
Mayo (unpublished data)	98	4	86	10 ^{a, b, c}	33 ^a
Gonsvales					
Alveres ⁵⁰⁹	83	—	—	16	35
Jimenez-Zepeda ⁵¹⁰	81	3	97	16	53 ^{a, c}
Silva Rondon ⁵¹¹	60	—	77	11	24
Fenk ⁵¹²	55	5	75	14 ^a	52 ^a
Shah ⁵¹³	44	2	90	12	32 ^{a, b}

Mehta ⁵¹⁴	42	10 ^d	81	12 ^d	32 ^d
Olin ⁵¹⁵	41	7	55	8 b	21 ^{a, b}
Elice ⁵²³	26	0	69	15	38
Burzynski ⁵²⁴	25	8	64	12	19
Summary		0-8	55-97	8-16	19-53

^a TTP after initial ASCT affected OS.

^b Number of lines of therapy affected OS.

^c VGPR or CR after salvage affected OS.

^d Included allogeneic transplant patients.

Other regimens including various combinations of melphalan, busulfan, cyclophosphamide, idarubicin, etoposide, and/or thiotepa have been used,^{555, 556, 557, 558, 559, 560} without any evidence of superiority of these regimens over melphalan 200 mg/m² and several with significantly more toxicity^{556, 560} and morbidity.⁵⁵⁵ Innovative trials supplementing melphalan with skeletal targeted radiation (samarium 153-ethylenediaminetetramethylene phosphonate⁵⁶¹ and holmium 166 to 1,4,7,10-tetraazocyclodecane-1,4,7,10-tetramethylenephosphonic acid⁵⁶²) have been reported. Others have been studying bortezomib as a chemosensitizer for the melphalan.^{563, 564, 565}

P.2072

Desikan et al. retrospectively compared the impact of different conditioning regimens used for the second ASCT.⁵⁶⁶ Outcomes of patients treated with melphalan 200 mg/m² were better than those conditioned with melphalan 200 mg/m² plus cyclophosphamide 120 mg/m², and melphalan 140 mg/m² plus total body irradiation (1,125 cGy).

Allogeneic Stem Cell Transplantation

AlloSCT includes both myeloablative and nonmyeloablative or “reduced intensity conditioning” (RIC) transplants. AlloSCT is appealing in theory because it avoids infusion of stem cells contaminated with myeloma cells and because there can be a beneficial graft versus myeloma effect.⁵⁴⁷ Complete response rates of 22% to 67%, including molecular remissions in about one third,^{495, 548, 549} can be achieved. Prolonged PFS is observed in approximately one quarter to one third of patients^{471, 495, 550} (Table 98.12). The high treatment-related mortality (10% to 63%) and significant toxicity from graft-versus-host disease have limited the role of this procedure in the treatment of myeloma.^{495, 551, 554}

Myeloablative Allogeneic Stem Cell Transplantation

There are no prospective randomized controlled trials that examine the role of myeloablative AlloSCT in myeloma. The US intergroup trial S9321⁴⁹⁶ attempted to answer this question. Newly diagnosed patients with MM were treated with four cycles of VAD. Patients were randomly assigned to either high-dose therapy with melphalan (MEL) plus total body irradiation (TBI) or to standard dose therapy with VBMCP. Patients who were ≤55 years of age with an HLA-compatible sibling donor were offered the option of allogeneic transplantation with MEL 140 mg/m² plus TBI. However, this arm was closed when an excessive first-year treatment-related mortality rate of 53% was observed after enrollment of 36 eligible patients. With 7 years of follow-up the OS of the conventional chemotherapy, autologous and allogeneic transplant groups were identical at 39%. It was intriguing that that AlloSCT group showed a survival plateau whereas the other two groups did not, suggesting long-term benefit.

TABLE 98.12 NONRANDOMIZED COMPARISONS OF AUTOLOGOUS AND ALLOGENEIC HEMATOPOIETIC STEM CELL TRANSPLANTATION FOR MULTIPLE MYELOMA

Study	N	TRM (%)	PFS, mo	P	OS, mo	P
Bjorkstrand et al. ⁵¹⁶	189 Auto	13~22	NS	34	0.001	
	189 Allo	41~12		18		

Varterasian et al. ⁵¹⁷	24 Auto	1216.7	NS	33.5	NS
	24 Allo	2531		38.6	
Couban et al. ⁵¹⁸	40 Auto	514	—	> 48	< 0.001
	22 Allo	27~11		7	
Reynolds et al. ⁵¹⁹	Auto 35	62 y 30%	NS	2 y 42%	NS
	Allo 21	192 y 60%		2 y 60%	
Lokhorst et al. ⁵²⁰	50 Auto ^a	63 y 67%	NS	3 y 82%	NS
	11 Allo ^{a, b}	183 y 67%		3 y 82%	
Alyea et al. ⁵²¹	166 Auto	132 y 48%	0.0022	2 y 74%	0.006
		4 y 28%	NS	4 y 41%	NS
	66 Allo ^b	242 y 23%		2 y 51%	
		4 y 18%		4 y 39%	
Arora et al. ⁵²²	70 Auto ^c	61 y 67%	NS	1 y 86%	NS
		4 y 18%	NS	4 y 50%	NS
	17 Allo	311 y 58%		1 y 64%	
		4 y 32%		4 y 64%	

MS, median survival; NS, not significant; TRM, treatment-related mortality.

^a Chemotherapy-sensitive patients only.

^b T-cell-depleted allogeneic stem cells.

^c Cyclophosphamide and total body irradiation conditioning.

There have been seven case-control or cohort-control studies comparing autologous to AlloSCTs (Table 98.12).^{558, 559, 560, 561, 562, 563, 564} The largest of these was by Bjorkstrand et al.⁵⁵⁸ In their retrospective analysis of data compiled by the European Blood and Marrow Transplantation Group, there was inferior OS for myeloma patients treated with AlloSCTs compared to case-matched controls treated with ASCT (18 vs. 36 months).⁵⁵⁸ The six smaller studies, which had relatively short follow-up, showed mixed results with regard to PFS and OS; transplant-related mortality, however, was consistently higher in the allogeneic groups (19% to 25%). Only one report favored allogeneic transplantation.⁵⁶⁴ However, patients in the AlloSCT group were better-prognosis patients; they were significantly younger and less likely to have IgA myeloma. Although not reaching statistical significance, there were more ASCT patients having their transplant as salvage (37% vs. 23%). In addition, cyclophosphamide and TBI were used to condition both the ASCT and AlloSCT patients. With follow-up times for the two groups of 24 and 43 months, respectively, the 1-year OS was 86 and 64%, and the 4-year OS was 50% and 64%.

P.2073

TABLE 98.13 PROSPECTIVE RANDOMIZED TRIALS COMPARING TANDEM AUTOLOGOUS SCT TO TANDEM AUTOLOGOUS-HLA IDENTICAL REDUCED INTENSITY ALLOGENEIC SCT

Study	N	Regimen	Completed both SCT (%)	Median FU, mo	TRM (%)	CR (%)	PFS (%)	OS (%)
IFM99-03/4 ^{572, 573}	219 ^a	Auto mel 200/220 ± IL-6 Ab		7624		533	5-y 0%	6-y 40%

	65Auto mel/Allo Bu/Flu/ATG	7128	843	5-y 0% 6-y 28%
Bruno et al. ^{570, 571}	73Auto mel 200/200	7536	416	3-y 7-y 41%t 35%
	56Auto mel 200/Allo TBI	10036	1146	3-y 7-y 75% 35%
PeTHEMA ⁵⁷³	85Auto mel 200/mel 200 or CVB	85>62	511	4-y 4-y 40% 65%
	25Auto mel 200/Allo Flu/mel	25>62	1640	4-y 4-y 60% 65%
EBMT ⁵⁵³	251Auto mel 200/200	10461	341	5-y 5-y 18% 58%
	107Auto mel 200/Allo Flu/TBI	9161	1251	5-y 5-y 35% 65%
CTN 0102 ⁵⁷⁴	484Auto mel 200/200	39740	440	3-y 3-y 46% 80%
	226Auto mel 200/Allo Flu/TBI	18540	1150	3-y 3-y 43% 77%

FU, follow-up; OS, overall survival; PFS, progression-free survival; TRM, treatment-related mortality.

^a High-risk patients as defined by the presence of deletion 13 by FISH and beta-2 microglobulin of >3 mg/L.

Reduced Intensity Conditioning Allogeneic Stem Cell Transplantation (Table 98.13)

Another strategy is to use ASCT to cytoreduce the myeloma followed by a reduced intensity conditioning alloSCT (allo-RIC). After two large series reported encouraging results,^{567, 568} four prospective trials have looked at this approach (Table 98.13). Only one of the five trials noted improved OS in patients undergoing tandem auto/allo transplants. Graft-versus-myeloma effect appears to be tightly linked to graft-versus-host disease (Fig. 98.9),⁵⁶⁹ which has the potential to significantly affect quality of life.

Bruno and colleagues^{570, 571} enrolled 162 consecutive patients with newly diagnosed myeloma who were ≤65 years of age. All patients were initially treated with VAD, followed by high-dose melphalan and ASCT. Patients without an HLA-identical sibling received a second ASCT. Patients with an HLA-identical sibling then received nonmyeloablative TBI and stem cells from the sibling. The median OS was longer in the 80 patients with HLA-identical siblings than in the 82 patients without HLA-identical siblings (80 months vs. 54 months, P = 0.01).

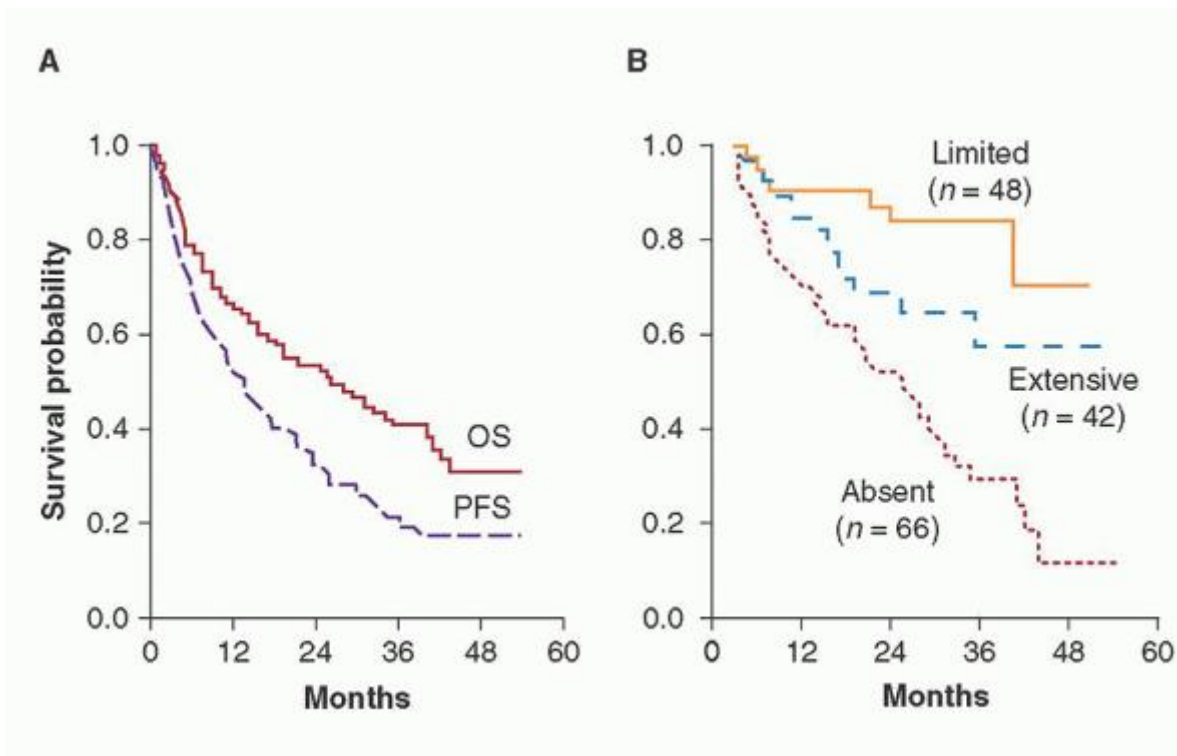

FIGURE 98.9. European blood and marrow transplantation registry data on the role of reduced intensity conditioning allogeneic transplantation regimens. A: Overall and progression free survival. B: Overall survival relative to presence or absence of graft versus host disease. (From Crawley C, Lalancette M, Szydlo R, et al. Outcomes for reduced-intensity allogeneic transplantation for multiple myeloma: an analysis of prognostic factors from the Chronic Leukaemia Working Party of the EBMT. *Blood* 2005;105:4532-4539. Copyright © the American Society of Hematology.)

The IFM enrolled 503 patients with high-risk MM (beta2-microglobulin level greater than 3 mg/L and chromosome 13 deletion at diagnosis) in two clinical trials.⁵⁷² In both protocols, the induction regimen consisted of VAD followed by first ASCT prepared by melphalan 200 mg/m². Patients with an HLA-identical sibling donor were subsequently treated with allo-RIC (IFM99-03 trial), and patients without an HLA-identical sibling donor were randomly assigned to undergo second ASCT prepared by melphalan 220 mg/m² and 160 mg dexamethasone with or without anti-IL-6 monoclonal antibody (IFM99-04 protocol). There were 284 patients enrolled in the IFM99-03 trial and 219 in the IFM99-04 trial. There were no differences in OS or EFS.

The PETHEMA group enrolled 110 patients with MM who had failed to achieve at least near-complete remission (nCR) after a first ASCT.⁵⁷³ They received a second ASCT (85 patients) or a allo-RIC (25 patients), depending on the availability of an HLA-identical sibling donor. Those who received the allo-RIC had higher rates of complete remission (40% vs. 11%, $P = 0.001$) but no difference in EFS and OS. They noted a 66% incidence of chronic GVHD. The European Bone Marrow Transplant (EBMT), MM subcommittee

P.2074

enrolled 357 patients up to age 69. Patients with an HLA-identical sibling were allocated to the ASCT- allo-RIC arm and the remaining to a tandem ASCT arm. Complete response rates were higher in the ASCT- allo-RIC group as was PFS, but there was no difference in OS with a median follow-up of 61 months. Only 41% of patients in the tandem ASCT arm actually got a second ASCT whereas 85% of patients in the ASCT-allo-RIC group received their second transplant.

The Blood Marrow Transplant Clinical Trials Network (BMT CTN) enrolled 710 patients⁵⁷⁴ and biologically randomized them to tandem ASCT or ASCT- allo-RIC. They, too, noted no difference in OS or PFS.

Given the toxicity of this approach—rates of chronic graft-versus-host disease of 50%—and the lack of suitable donors, allogeneic transplant, whether myeloablative or RIC, should be considered experimental in patients with myeloma.

Donor Lymphocyte Infusions

A graft-versus-myeloma effect has been noted after the administration of donor peripheral blood mononuclear cells for relapse after allogeneic transplantation.^{575, 576} DLI has been used in two ways in myeloma patients. Initially, it was used to treat relapsed or residual disease after full myeloablative AlloSCT.^{575, 576} Subsequently, it was used to re-introduce T-cells into a patient who had received an allogeneic T-cell depleted graft.^{577, 578} Most recently, it has been implemented in the context of allo-RIC programs to treat mixed chimerism, as well as for the older inductions.^{579, 580, 581} In the largest DLI series for relapsed MM (n = 54), 52% of patients responded (35% with a partial response and 17% with a complete response). The majority of patients received some chemotherapy before DLI. PFS and OS were 19 and 23 months, respectively. Rates of overall acute GVHD and of grade III-IV acute GVHD were 57% and 20%, respectively. Rates of overall chronic GVHD and of extensive GVHD were 47% and 30%, respectively. Acute and chronic graft-versus-host disease following DLI were the strongest predictors for response.⁵⁸²

Maintenance Therapy

Strategies for maintenance therapy can be divided into two broad categories: continued induction therapy ad infinitum, and addition of a novel therapy after induction therapy. The former strategy was prevalent until recognition of the risk of developing alkylator-induced myelodysplastic syndromes and leukemia.^{583, 584, 585, 586, 587, 588} The latter strategy has predominantly applied immune modulators, including prednisone, IFN, cellular therapies, thalidomide, lenalidomide, and, most recently, bortezomib. To date, the benefit with these aforementioned strategies has been marginal at best, but for several of the agents, more study is required. The role of maintenance thalidomide, lenalidomide, and bortezomib are currently areas of both study and controversy as discussed below. No benefit has been observed with maintenance levamisole,^{257, 381} azathioprine,⁵⁸⁹ or bacillus Calmette-Guérin (BCG).⁴¹⁴

Maintenance Thalidomide

In terms of randomized controlled trials evaluating the role of thalidomide maintenance as compared to placebo or prednisone, there have been seven performed in the post-ASCT setting^{404, 463, 464, 574, 590, 591, 592} and another three in the setting of low-dose alkylator-based therapy^{390, 392, 393, 404} (Table 98.14). In toto in all of the post-ASCT trials there was a PFS benefit among patients receiving maintenance thalidomide, but there was an OS benefit in only two of these trials.^{590, 591} Quality of life was significantly worse among patients receiving thalidomide in the NCIC CTG-MY.10 trial.⁵⁹²

Among the four nontransplant trials,^{390, 392, 393, 404} there was improvement in PFS in three of the trials, but an OS benefit in only one.³⁹³ Three of these four nontransplant trials not only tested the value of maintenance thalidomide, but also used it as part of an induction triplet of MPT.^{390, 392, 393} Due to this design limitation, it is impossible to state whether the induction component or the maintenance component contributed to any differences in outcomes. The MRC IX trial,⁴⁰⁴ which compared attenuated CTD to MP, had a double randomization, so the effect of induction versus maintenance could be more easily separated. Although there was a modest improvement in PFS in this study (11 vs. 9 months), there was no difference in OS between the maintained and the nonmaintained groups.

Maintenance Lenalidomide (Table 98.14)

There are three randomized controlled trials evaluating lenalidomide maintenance (Table 98.14). The most experience, however, with lenalidomide maintenance is the continuous use of lenalidomide plus dexamethasone as the primary induction therapy without early transplant. All published studies evaluating this up-front combination have continued drug until ASCT or progression, and there are currently no studies that challenge this practice. The MM-020 trial, which has completed accrual, will in part address this question.

The use of the drug as maintenance after alkylator-based therapy has been addressed in three randomized controlled trials.^{398, 593, 594} The first of these is the MM-015, which randomized patients among three arms: MP, MPR, and MPR with lenalidomide maintenance.³⁹⁸ PFS was superior in the maintenance arm, but so far there is no difference in OS. The authors note that the greatest benefit was observed in those patients aged 65 to 75 years. Slightly more than twice as many secondary malignancies were seen in the lenalidomide maintenance arm.

The next two randomized controlled trials addressing lenalidomide maintenance are after ASCT. Both show improved PFS and a higher rate of secondary malignancies with maintenance lenalidomide,^{593, 594} but only the CALGB 100404 trial had a better OS (3-year OS 88 vs. 80 months, P = 0.03).⁵⁹⁴ However, this OS advantage did not persist when the arms were stratified for beta-2 microglobulin and prior thalidomide use. A limitation to the CALGB 100404 trial is that in December 2009 (enrollment was April 2005 to July 2009), the study-drug assignments were unblinded when a planned interim analysis revealed a superior PFS in the lenalidomide arm. Patients who had been on placebo were encouraged to cross over to the lenalidomide. In contrast, in the IFM 2005-02 study,⁵⁹³ the 4-year OS was 73% for the maintenance group and 75% for the placebo group. The duration of maintenance in this study was limited to 2 years once their data safety monitoring board noted a higher cumulative incidence of secondary malignancies in the lenalidomide arm. At last follow-

up the incidence of second primary cancers was 3.1 per 100 patient-years for the lenalidomide arm as compared to the 1.2 per 100 patient-years for the placebo arm, P = 0.002. Another difference between the IFM 2005-02 study and the CALGB 100404 study is that all patients received two cycles of lenalidomide upon post-ASCT registration prior to getting either placebo or lenalidomide.⁵⁹³ At this time no definitive recommendation regarding lenalidomide maintenance can be made.

Maintenance Strategies Incorporating Bortezomib

There are four randomized clinical trials that incorporate bortezomib into a maintenance strategy.^{397, 400, 467, 468} Due to the complexity of these trials, however, it is difficult to isolate the actual clinical benefit of the bortezomib maintenance. The first of the two ASCT trials was the HOVON-65/GMMG-HD4 trial,⁴⁶⁷ which randomized patients to either PAD induction followed by one or two ASCT followed by maintenance bortezomib every other week for 2 years versus VAD induction followed by one or two ASCT followed by thalidomide maintenance for 2 years. Although OS was superior (5-year OS 61% vs. 55%) in the bortezomib containing arm, it is impossible to isolate the

P.2075

effect of induction versus maintenance. Moreover, there was no information regarding the availability of salvage bortezomib in the VAD plus thalidomide arm. The other post-ASCT trial is the PETHEMA/GEM05MENOS65 trial,⁴⁶⁸ which is a complicated study of 387 patients who were randomized to one of three induction regimens followed by an ASCT followed by a secondary randomization to bortezomib (1.3 mg/m² days 1, 4, 8, and 11 every 3 months) plus thalidomide (100 mg/day), to single-agent thalidomide, or to thrice weekly IFN. PFS was superior with the VT as compared to the T or the IFN, but with 24 months follow-up there was no difference in OS.

TABLE 98.14 RANDOMIZED CLINICAL TRIALS INCORPORATING IMIDS OR BORTEZOMIB FOR MAINTENANCE

	Trial Design ^a	N	Initial Intended Dose, mg	Months of Maintenance	FU, mo	EFS PFS	OS, %	% Getting Maintenance Drug as Salvage
TT2 ⁴⁶³	TT2 ± T	668	400	Indefinite	72	5-y 56 vs. 44%	8-y 57 vs. 44%	
Abn Cyto							5yr: 56 vs. 43 ^b	83
IFM99-02 ⁵⁹⁰	ASCT × 2 ± T	597	400	Indefinite	36	4-y 87 vs. 77	62	
ALLG MM6 ⁵⁹¹	ASCT × 1 + P ± T	243	200	1 y	24	3-y 42 vs. 23% ^b	3-y 86 vs. 75 ^b	54
MRC IX instensive path ⁴⁰⁴	ASCT × 1 ± T ^d	492	100	Indefinite	38	30 vs. 23 m ^b	3-y 75 vs. 80 ^c	62
NCIC CTG MY.10 ⁵⁹²	ASCT × 1 ± TP	332	200	Indefinite	48	28 vs. 17 m ^b	4-y 68 vs. 60	NA
HOVON-50 ⁴⁶⁴	TAD v VAD ↓ASCT × 1 or 2 ± T	536	50	Indefinite	52	34 vs. 25 m ^b	73 vs. 60 m	NA

	(vs. IFN) ^d							
BMT CTN 0102 ⁵⁷⁴	ASCT × 2 ± T	366 200 (+dex)	Indefinite	36	3-y 49 vs. 43%	3-y vs. 81%	80 81%	NA
IFM 2005-2 ⁵⁹³	ASCT × 1 or 2 ± L	614 15	L: 10- 15	2 y	45	4-y 43 vs. 22% ^b	4-y 73 75% ^b	45
CALGB 100104 ⁵⁹⁴	ASCT × 1 ± L	460 15	L: 10- 15	Indefinite	34	46 vs. 27 m ^b	3-y 88 vs. 80% ^b	NA
HOVON-65/GMMG-HD4 ⁴⁶⁷	PAD v VAD ASCT × 1 or 2 ± B (vs. T) ^d	827 mg/m ² T: 50	V: 1.3 mg/m ²	2 years	66	35 vs. 28 m ^b	5-y 61 55 % ^b	NA
PETHEMA/GEM05MEN0S65 ⁴⁶⁸	ASCT × 1 ↓ VT vs. T vs. IFN	<387 mg/m ² T: 100 mg IFN: 3 MU	V: 1.3 mg/m ²	3 years	24	2-y 78 vs. 63% vs. 49% ^b	Not different	NA
GIMEMA ³⁹⁰	MPT vs. MP	355	T: 100	Indefinite	38	22 vs. 14 m ^b	45 vs. 48 m	42 ^e
Nordic ³⁹²	MPT vs. MP	357	T: 200- 400	Indefinite	42	15 vs. 14 m	29 vs. 32 m	45
HOVON 49 ³⁹³	MPT vs. MP	333	T:	Indefinite	39	13 vs. 9 m ^b	40 vs. 31 m ^b	80
MRC IX non-intensive path	CTDa ± T vs. MP ± T	326 50	50	Indefinite	38	38 vs. 11 vs. 9 m ^b	NA 39 m	
MM-015 ³⁹⁸	MPR-R vs. MPR/MP	459	L:	Indefinite		31 vs. 13 m ^b	3-y 70 64%	
VMPT + VT ³⁹⁷	VMPT + VT vs. VMP	511	V: 1.3 mg/m ² T: 50	2 years	23	3- year 56 vs. 41% ^b	3-year 89 vs. 87%	NA
PETHEMA/GEM ⁴⁰⁰	VTP vs. VMP, 2° random to VT vs. VP	260	V: 1.3 mg/m ² T: 50; P: 50	3 years	32	32 vs. 24 m ^b	HR 1.2 ^{0.6-2.4}	

ASCT, autologous stem cell transplantation; f/u, follow up; mo, months; MP, melphalan and

prednisone; MPT, MP and thalidomide; MS, median survival; NA, not available; OS, overall survival; Thal, thalidomide.

^a Induction regimens for trial design not specified if same in both arms. If no comparator maintenance drug listed, the comparator is either nothing or placebo.

^b Statistically significant difference between arms.

^c Risk of death 1.8 × higher in patients with adverse cytogenetics if thal.

^d Other details of this study included in Table 97.8.

^e Received thalidomide or bortezomib; number of patients in control arm receiving thalidomide as salvage not specified.

The other two bortezomib maintenance trials were among elderly patients, who did not undergo ASCT. The first is the PETHEMA/GEM trial,⁴⁰⁰ which randomized newly diagnosed elderly patients to either VMP or VTP with a secondary randomization to either VT or VP. After a median follow-up of 22 months from second randomization, PFS from this timepoint was 32 months for patients receiving VT and 24 months for those receiving VP (HR 1.4, 95% CI 0.8 to 2.1; P = 0.1). No difference in OS was observed. In the Italian study comparing VMP with no maintenance to VMPT plus VT maintenance,³⁹⁷ PFS was superior with the four-drug combination with two-drug maintenance compared to the three-drug regimen without maintenance (32 months vs. 24 months), but there was no difference in OS. Based on these data, no recommendation regarding the utility of bortezomib maintenance can be provided.

Maintenance with Alkylators, Steroids, or Interferon

Through the 1970s and 1980s, several randomized studies established that alkylator-based maintenance therapy does not produce a survival benefit.^{210, 236, 264, 266, 376, 411, 589, 595, 596} In general, patients not receiving maintenance had similar to slightly shorter remission duration than those receiving maintenance^{210, 376, 411, 589, 596, 597} but had higher rates of second remission.^{596, 597} Induction was commonly discontinued after plateau was reached (no change in M protein of more than 25% for 4 to 6 months).^{210, 264, 598} With alkylator-based therapy, the ability to achieve a plateau is as important, if not more important, than the degree of response achieved.^{210, 598, 599, 600, 601, 604} No benefit has been documented for treatment beyond 12 months,³⁷⁶ although it has been suggested—but not validated—that prolonged primary

P.2076

chemotherapy may be beneficial in patients achieving less than a partial response, that is, a minimal response or stable disease.⁶⁰⁵ Patients who relapse off alkylator-based chemotherapy have response rates of 25% to 80% with resumption of the original regimen.^{210, 414, 596, 597} In a study of 115 newly diagnosed patients treated with VBMCP for about 1 year, an initial response rate of 82% was achieved, with a median duration of response of 22 months. After a first relapse, 26 of 38 patients (68%) responded again and had a median duration of response of 11 months. After a second relapse, 7 of 16 patients (44%) responded, with a duration of response of 3.5 months.⁶⁰⁶

There are four studies that address the utility of corticosteroids as maintenance therapy. None justify a recommendation of prednisone as a standard maintenance regimen for all patients.

SWOG 9210 compared prednisone 10 mg every other day to prednisone 50 mg every other day in patients who had responded to 6 to 12 months of a VAD-based program, that is, a corticosteroid-intensive program. Median PFS for the higher-dose prednisone arm was 14 months compared to 5 months for the lower dose (P = 0.003). OS also was marginally better at 37 and 26 months (P = 0.05).⁶⁰⁷ An earlier randomized study, which compared dexamethasone maintenance (20 mg/m² orally daily for 4 days repeated monthly) to IFN maintenance after induction with melphalan and dexamethasone, demonstrated equivalence to inferiority of dexamethasone compared with IFN.⁶⁰⁸ The CALGB 7,461 study addressed this issue less directly. Patients were treated initially with alkylator therapy and were randomized to observation or vincristine and prednisone as maintenance. OS and response rates were significantly longer and higher in the vincristine-prednisone maintenance group who had received up-front melphalan (median, 35.3 months vs. 27.0 months; P = 0.003) but not in patients who had received up-front BCNU or CCNU.²⁵⁵ Finally, SWOG 8624, which evaluated the influence of corticosteroid dose intensity on response and survival, indirectly provided data on corticosteroid maintenance. Higher objective

response and median OS (40 months vs. 31 months, $P = 0.02$) were observed in patients who received prolonged administration of glucocorticoids (prednisone 50 mg every other day) between chemotherapy courses.⁴⁵⁴

IFN has been studied both after conventional chemotherapy and after ASCT. The initial positive findings by Mandelli et al.⁶⁰⁹ in 1990 demonstrated a superior disease-free and OS in chemotherapy-responsive patients randomized to maintenance IFN, but it took meta-analyses to clarify divergent results observed in over 1,500 patients in 13 maintenance trials.^{439, 440} With IFN there was a 4.4-month prolongation of relapse-free survival ($P < 0.01$) and a 7.0 month increase in OS ($P < 0.01$).⁴³⁹ There are fewer data available examining the utility of IFN after ASCT.^{610, 611} The use of IFN in this setting cannot be recommended outside of clinical trials.

Management of Relapsed or Refractory Disease

The advances in the initial therapy of MM during the past decade has led to more effective control of the disease early in its course and has significantly improved the OS of these patients. However, the disease remains incurable with the current approaches and eventually relapses after the initial therapy. The combination of improved OS and the inability to eliminate the disease has led to an increased number of patients living with the disease, making the management of relapsed disease an important component of the care of the myeloma patient.

At the same time, the increasing number of initial treatment approaches employed for myeloma has led to a significant heterogeneity among patients with relapsed MM. This combined with the underlying biologic heterogeneity intrinsic to the disease has precluded development of uniform approaches to management of relapsed disease. Recent studies using advanced genomic analyses have clearly shown that significant clonal evolution as well as clonal selection occurs as the disease suffers multiple relapses over time.

Definitions

Attempts have been made to standardize the definitions for relapsed and refractory disease. In general, relapses can be classified as biochemical relapses where the increase in the monoclonal protein component, bone marrow plasmacytosis, or size of plasmacytoma(s) meet the definitions of relapse as per the International Myeloma Working Group Uniform Response Criteria.²²² However, a significant proportion of patients who meet these criteria do not require therapy right away, a concept similar to how we manage early-stage asymptomatic myeloma. However, patients can have clinical evidence of progression, that may or may not satisfy the biochemical criteria, but clearly require therapeutic intervention. These typically include development of one or more components of the CRAB criteria that is used at the time of diagnosis. Several additional qualifying criteria need to be included in defining the patient with relapsed disease. This is not only important from a clinical trial perspective, allowing us to better compare results across different trials, but also helps us in deciding the future course of therapy. The most important aspect is the differentiation between relapses occurring on therapy and off therapy, with the former often having a poorer prognosis. An accepted definition for refractory disease, currently used in most of the clinical trials, is relapse occurring while on a particular therapy or relapse within 60 days of stopping the therapy. A subset of these patients may have never responded to the initial therapy or may have progressed within 60 days of stopping the initial therapy, a group referred to as having primary refractory disease.⁶¹² These definitions should be further qualified by the class of agents or the treatment modality to which the patient is refractory.

Prognostic Factors in Relapsed Disease

Many of the prognostic factors that are relevant at the time of initial diagnosis continue to be important at the time of relapse. These include the International Staging System, the plasma cell proliferation rate, serum LDH, performance status, refractory status with respect to various drugs, cytogenetics and/or FISH findings, and the presence of circulating cells or extramedullary disease. Two key factors that become evident at the time of relapse are particularly relevant to the prognosis of patients with relapsed disease. The duration of response to the initial therapy is one of the most important prognostic factors at the time of relapse. Patients with short lasting responses to initial therapy or are primary refractory to the newer drugs have very poor OS. In fact, in a retrospective study the OS from relapse among a cohort of patients relapsing within 12 months of an ASCT was less than a year. Similar findings have been seen in nontransplant therapy settings as well. The second critical factor is the acquisition of new genetic abnormalities with disease evolution. The two most common abnormalities seen with increasing frequency among relapsed disease are loss of the TP53 gene and chromosome 1 abnormalities, both of which portend a poor outcome.

Treatment of Relapsed Disease: General Approach

Before the era of high-dose chemotherapy with stem cell support, IMiDs, and proteasome inhibitors, treatment guidelines were more straightforward. If the relapse had occurred during an unmaintained remission, resumption of the patient's original therapy was a good rule.⁵⁹⁷ If relapse occurred after unmaintained remission, 50% to 60% of patients responded to

repeat treatment^{414, 596, 597, 613} and median survival was about 10 months.^{597, 617} The current landscape, however, is more complicated. New combinations incorporating the new and the old agents are being tested worldwide,

P.2077

leaving clinicians with an assortment of options but little guidance on how to proceed. There are a few guidelines that can be kept in mind while deciding the management approach to relapsed disease in any given patient. Regimens that have been effective previously, and to which the patient is not refractory can and should be considered again. Combinations of two drugs, where the individual drugs have not been very effective may be able to capitalize on the synergy and produce meaningful responses. Given the clonal selection processes that occur in the myeloma cells as shown through elegant genomic studies,⁶¹⁸ drugs that have previously become ineffective can be of benefit later on, alone or as part of combinations. Although deep responses typically translate into prolonged disease control, minor responses can be quite meaningful in those patient populations from the point of clinical benefit. Therapeutic selection should take into account residual toxicities from earlier therapies in order not to exacerbate the ongoing symptoms and must be tailored to the patient's performance status. Care should be taken in terms of the use of drugs with cumulative toxicity, particularly hematological toxicity, that will preclude subsequent use of some of the newer drugs.

Until MM is a curable disease in all patients, clinical trials will play a critical role in the treatment of these patients. They will assist in defining a better classification system for relapsed disease, clarify which treatments offer the most value, and bring new effective agents into standard clinical practice. The subject of chemotherapy for relapsed or refractory disease is divided into six sections: IMiD-based therapies, proteasome inhibitor-based therapies, IMiD-proteasome inhibitor combinations, emerging new agents and finally older therapies that incorporate alkylators or anthracyclines. Many of the newer regimens have been utilized in the setting of newly diagnosed disease and have been described in that section.

Immune Modulatory Drugs-Based Therapy for Relapsed or Refractory Disease

Thalidomide (Table 98.15). Single-agent thalidomide can induce a response in 25% to 58% of relapsed/refractory patients,^{286, 288, 289, 290, 291, 292, 293, 294, 295} and higher response rates of 41% to 55%^{624, 625, 626, 627} when combined with dexamethasone.^{299, 625} Thalidomide doses have ranged between 100 and 400 mg per day in the different regimens, without any clear dose-response effect. In addition to corticosteroids thalidomide has been combined with a variety of different drugs, both old and new. Investigators have combined thalidomide with alkylators either with^{628, 629, 630, 631, 632, 633} or without corticosteroids^{634, 635} achieving overall response rates as high as 79%, including complete response rates as high as 26%. These have included combinations of thalidomide with melphalan, cyclophosphamide or bendamustine, with addition of dexamethasone or prednisone. DT-PACE is a combination of five drugs including thalidomide (Table 98.4) and is an integral part of "Total Therapy" programs piloted by Dr. Barlogie and colleagues at University of Arkansas.

TABLE 98.15 THALIDOMIDE-BASED COMBINATIONS FOR RELAPSED, REFRACTORY DISEASE

Author	Regimen	Phase	N	CR (%)	VGPR (%)	PR (%)	OR (%)	PFS/EFS, mo	OS, mo
Singhal, 1999 ^{37, 301}	Thalidomide	2	169	—	—	—	30	2 y 20%	2 y 48%
Dimopoulos, 2001 ⁶²⁵	Thal-Dex	2	44	—	—	55	55	4.2	12.6
Offidani, 2003 ⁶³⁴	Mel-Thal	2	27	12	—	48	60	2 y PFS 61%	2 y OS 61%
Hovenga, 2005 ⁶³⁵	CTX Thal	2	38	11	—	64	75	30	20
Garcia-Sanz, 2004 ⁶²⁸	CDT	2	71	2	—	53	55	2 y EFS 57%	2 y OS 66%
Dimopoulos, 2004 ⁶²⁹	CDT	2	53	5	—	55	60	TTP 8.2	17.5
Kropff, 2003 ⁶³⁰	CDT	2	60	3	—	0	65	68	11
Kyriakou, 2005 ⁶³¹	Low dose CDT	2	52	17	—	62	79	—	—
Sidra, 2006 ⁶³²	CDT	2	47	0	—	19	63	83	—

Palumbo, 2006 ⁶³³	MPT IV	2	24	0	1329	42	9	—
Zervas, 2004 ⁴⁸⁴	T-DVD	2	39	10	1064	84	—	—
Hussein, 2006 ⁴⁸⁸	T-DVd	2	49	20	2431	75	15.5	39.9
Offidani, 2006 ⁶⁰²	TDD	2	50	26	1238	76	17	NR
Suvannasankha, 2008 ⁶⁰³	CTP	2	35	20	637	63		
Ponisch	BTP	½	28	14	2150	85	11	19

AA, ascorbic acid; ATO, arsenic trioxide; Bortez, bortezomib; CDT, cyclophosphamide, dexamethasone, thalidomide (several different schedules); CR, complete response; Dex, dexamethasone; EFS, event-free survival; IFN, interferon; Lenalid, lenalidomide; MAC, melphalan, ATO, AA; MD, melphalan, dexamethasone; mo, months; MP, melphalan, prednisone; MPT IV, intravenous melphalan, prednisone, thalidomide; N, number of patients; NR, not reached; OR, overall response rate; OS, overall survival; PFS, progression-free survival; PR, partial response; yRetro, retrospective analysis; TDD, thalidomide, pegylated doxorubicin, dexamethasone; T-DVD, thalidomide, pegylated doxorubicin, vincristine, dexamethasone; T-DVd, T-DVD, but low dose dexamethasone; Thal, thalidomide; TTP, time to progression; VGPR, very good partial response; y, year.

*Abstract only.

†Minimal response.

Lenalidomide (Table 98.16). As a single agent approximately 18% to 25% of relapsed or refractory patients have achieved a partial response, and the median duration of response for responding patients is 20 months.³⁰⁷ In the randomized phase II trial of lenalidomide, the addition of dexamethasone (40 mg days 1 to 4 and 15 to 18) to patients not responding to 2 months of lenalidomide resulted in partial response rates in an additional 22% of patients.³⁰⁷ The combination of lenalidomide and dexamethasone has been studied in two large phase III trials.^{636, 647} The results of both were comparable with 59% of patients responding to the combination, including a 14% complete response rate. This was significantly better than what was observed with single-agent dexamethasone (PR 22.5% and CR 2%). In addition, both time to progression (11 to 13 months vs. approximately 5 months) and OS (not reached vs. 24 months) were superior in the lenalidomide/dexamethasone arm. The benefit with lenalidomide was independent of prior exposure to thalidomide.⁶⁴⁸ A significant number of patients who initially had a PR improved the response to a CR or VGPR with continued treatment, especially among those obtaining a PR within the first four cycles.⁶⁴⁹ As with other therapies, patients who achieved a CR/VGPR as their best response had significantly longer median response duration, time-to-progression,

P.2078

and OS compared with those with only a partial response.⁶⁴⁹ Continuation of lenalidomide treatment until disease progression in patients achieving a PR was associated with a significant survival advantage.⁶⁵⁰

TABLE 98.16 LENALIDOMIDE-BASED COMBINATIONS FOR RELAPSED REFRACTORY DISEASE

Author	Regimen	Phase	N	CR (%)	VGPR (%)	PR (%)	OR (%)	PFS/EFS, mo	OS, mo
Richardson, 2006 ³⁰⁷	Len (30 mg QD)	2	67	—	—	18	17	8	28
	Len (15 mg BID)	2	35	0	0	14	17	4	27
Dimopoulos (MM-010), 2007 ⁶³⁶	Len/dex	3	176	16	—	44	60	TTP 11.3	NR
	Dex	3	175	3.4	—	20	24	TTP 4.7	20.6
Weber (MM-009),	Len/dex	3	177	14	—	47	61	TTP 11	29.6

2007 ⁶⁴⁷	Dex	3	177	1	—19	20	TTP 4.7	20.2
Richardson, 2006 ³⁰⁷	Len	222	0	025	25	4.9	23.2	
Knop et al. (2009) ⁶¹⁴	Len- dox-Dex	½	69	—	—	77	—	—
Baz et al. ⁶¹⁵	Pegylated dox- vincristine-Dex-Len	½	62	18	1146	75	12	NR
Schey et al. (2010) ⁶⁵¹	Cyclo-Len-Dex	½	31	29	745	81	56% at 2 yrs	80% at 2.5 years
Lentsch et al. (2012) ⁶¹⁶	BRD	½	36		2428	52	4.4	NR
Palumbo et al. (2010) ⁶⁵²	RMPT	½	44	2	3241	75	51% at 1 y	72% at 1 y

As with thalidomide, lenalidomide has been combined with alkylators (melphalan, cyclophosphamide, or bendamustine) as well as anthracyclines. The results with these combinations are summarized in Table 98.17.^{651, 652}

Pomalidomide. Pomalidomide (CC-4047) is another thalidomide-based immunomodulatory drug that is currently undergoing clinical trials in relapsed myeloma.^{311, 312} The initial trials with pomalidomide were done several years ago, when the phase I trials established the maximum tolerated dose of pomalidomide as 2 mg daily or 5 mg on alternate days.^{310, 653} These studies used pomalidomide as monotherapy and have shown an excellent activity with an overall response rate of 52%.⁶⁵³ In the initial phase II trial from Mayo Clinic, pomalidomide 2 mg daily in combination with dexamethasone 40 mg weekly were given to a cohort of 60 patients with relapsed myeloma, who had two to three prior regimens.⁶⁵⁴ A total of 38 patients (63%) achieved confirmed response including CR in 3 patients (5%), VGPR in 17 patients (28%), and PR in 18 patients (30%). Responses were seen irrespective of their prior drug exposures, with 40% of lenalidomide-refractory patients, 37% of thalidomide-refractory patients, and 60% of bortezomib-refractory patients achieving a response. Subsequent cohorts of patients were enrolled studying different doses and schedules in different groups with respect to their refractoriness to bortezomib or lenalidomide.^{655, 656}

TABLE 98.17 BORTEZOMIB-BASED COMBINATIONS FOR RELAPSED REFRACTORY DISEASE

Author	Regimen	Phase	N	CR (%)	VGPR (%)	PR (%)	OR (%)	PFS/EFS, mo	OS, mo
Richardson (SUMMIT), 2006 ³⁰⁸	Bortezomib	2	193	4	618	28	7	17	
Jagannath, 2004 ³²²	Bortez-Dex (1.0 mg/m ²)	2	27	0	1919	37	TTP 10.9	26.7	
	Bortez-Dex (1.3 mg/m ²)	2	26	0	446	50	TTP 7.0	NR	
Richardson, (APEX) 2005 ³²¹	Bortezomib	3	315	6	725	38	6	1 y 80%	
	Dex	3	312	1	116	18	3	1 y 66%	
Kropff, 2005 ⁶¹⁹	Bortez-Dex	2	15	7	—67	74	—	—	
Musto, 2006 ⁶²⁰	Bortezomib	2	21	10	-033	43	—	—	
Orlowski, 200 ^{238, 268}	Bortez-pegylated dox	1	22	23	1436	72	—	—	
Chanan-Khan, 2005 ⁶²¹	Bortez-pegylated	Pilot	6	33	—17	50	—	—	

	dox -thal							
Jakubowiak, 2005 ⁴⁸⁵	Bortez-pegylated dox-Dex	2	20	33	—22	55	—	—
Gozetti et al. 2010 ⁶⁶²	Bortez-pegylated dox-Dex	2	25	—	—	80	8	—
Berenson, 2008 ⁶²²	Bortez-MP	½	46	4	3135	70	9	32
Popat, 2009 ⁶²³	Bortez-IV Mel	2	53	23	—	68	10	28
Reece, 2008 ⁶⁶⁵	CTX- Bortez - Pred	½	37	50	—	95	83% at 1 y	100% at 1 y
Kropff, 2007 ⁶⁶⁴	CTX- Bortez -Dex	2	54	16	—66	90	12	22

The optimal dose and schedule for pomalidomide remains an issue of debate. The studies done so far have examined either 2 mg or 4 mg, and given either continuously or for 3 out of every 4 weeks. Richardson and colleagues in a phase I/II dose escalation study showed that 4 mg pomalidomide daily given for 3 of 4 weeks is the MTD for that particular schedule.⁶⁵⁷ The IFM group performed a randomized phase II trial looking at two dosing schedules, 21/28 days or 28/28 days with pomalidomide administered at 4 mg daily with weekly dexamethasone. The overall response rate and the duration of response were comparable with the two strategies as was the overall toxicity.⁶⁵⁸

P.2079

Proteasome Inhibitor-based Therapies for Relapsed or Refractory Disease

Bortezomib (Table 98.17). Single-agent response rates in relapsed/refractory myeloma range from 28% to 38% with a median duration of response of 8 months.^{308, 320, 321, 322} In a phase III study, Richardson et al. randomly assigned 669 patients with relapsed myeloma to receive either an intravenous bortezomib or high-dose dexamethasone.³²¹ The overall response rate was significantly higher with bortezomib (38%) compared with dexamethasone (18%) and the median times to progression in the bortezomib and dexamethasone groups were 6.2 months and 3.5 months, respectively. Although the original studies using this drug included only eight cycles of therapy, 63 patients were treated on an extension study without significantly more serious adverse events than were seen on the parent studies of eight cycles alone.⁶⁵⁹

As with the IMiDs, the initial trials of bortezomib were followed by a series of trials examining various combinations including alkylator drugs and doxorubicin.^{660, 661, 662, 663} One of the most commonly used and effective combinations has been that of cyclophosphamide added to bortezomib and dexamethasone.^{664, 665, 666} In an international phase III study, 646 patients were randomly assigned to receive either intravenous bortezomib with or without PLD.⁶⁶⁰ The overall response rate was similar between bortezomib (41%) and PLD + bortezomib (44%). Median time to progression was increased from 6.5 months to 9.3 months with the combination and the 15-month survival rate for the combination was 76% compared with 65% for bortezomib alone.

Carfilzomib. Carfilzomib is a next-generation, selective proteasome inhibitor that has been approved for treatment of relapsed MM.^{221, 667, 672} In an open-label, single-arm phase II study (PX-171-003-A1), patients received single-agent carfilzomib 20 mg/m² intravenously twice weekly for 3 of 4 weeks in cycle 1, followed by 27 mg/m² at the same schedule.⁶⁷² Among the enrolled patients, 95% were refractory to their last therapy and 80% were refractory or intolerant to both bortezomib and lenalidomide. Overall response rate was 24% with a median duration of response of 7.8 months and OS of 15.6 months. Common toxicities encountered were fatigue, anemia, nausea, and thrombocytopenia. Neutropenia was limited to grades 1 and 2, occurring in 10% to 15% of the patients.

In another phase II trial, 35 patients with relapsed and/or refractory MM who have received at least one bortezomib-based regimen, received carfilzomib 20 mg/m² in a twice-weekly, consecutive-day dosing schedule.⁶⁶⁷ The best overall response rate was 17.1% and the clinical benefit response rate (ORR + Minor response) was 31.4%. The median duration of response was ~10 months and the median time to progression was 4.6 months. In a similar phase II study, 129 bortezomib-naïve patients with relapsed refractory MM received intravenous carfilzomib either at 20 mg/m² for all treatment cycles, or 20 mg/m² for cycle 1 and then 27 mg/m² for all subsequent cycles.²²¹ The overall response rate was 42.4% in the former group and 52.2% in the latter. The clinical benefit response (overall response rate + minimal

response) was 59.3% and 64.2%; the median duration of response was 13.1 months and not reached, and median time to progression was 8.3 months and not reached, respectively. Several combinations of carfilzomib along with the older and new agents are ongoing, and will lead to more treatment options for patients with relapsed disease.

TABLE 98.18 IMID-PROTEASOME INHIBITOR COMBINATIONS FOR RELAPSED REFRACTORY DISEASE

Author	Regimen	Phase	CR (%)	VGPR (%)	PR (%)	OR (%)	PFS/EFS, mo	OS, mo
Ciolti, 2006 ⁶³⁷	Low dose bortez-thal-dex	2	18	11	—	33	44	—
Zangari, 2005 ⁶³⁸	Bortez-Thal-Dex	2	85	0	—	55	55	9
Palumbo, 2007 ⁶³⁹	Bortez-MP-Thal	½	30	—	—	43	24	67
Terpos, 2008 ⁶⁴⁰	Bortez-MD-Thal	2	25	13	—	27	26	66
Kim et al. ⁶⁴¹	CTVD	2	70	46	—	93	33	88
Chanan-Khan et al. ⁶⁴²	Bortezomib, pegylated liposomal doxorubicin and thalidomide	2	23	—	—	—	56	10.9
Ciolti et al. 2008 ⁶⁴³	VTD	2	28	—	—	—	50	8
	VTD + PLD	2	42	—	—	—	81	15
Berenson et al. 2012 ⁶⁴⁴	Bort-PLD-Dex	2	40	21	—	10	18	48
Offidani, 2011 ⁶⁴⁵	ThaDD-V	2	46	37	—	35	55	76
Richardson et al. 2010 ⁶⁴⁶	VRD	½	38	2	—	—	37	39

Immune Modulatory Drugs-Proteasome Inhibitor Combinations (Table 98.18)

Some of the most effective regimens reported to date in the therapy of relapsed disease and also with newly diagnosed disease, are combinations involving bortezomib with thalidomide or lenalidomide. The results of these clinical studies are summarized in Table 98.18. Bortezomib has been combined with the DTPACE regimen previously described; the resultant VDTSPACE regimen is the standard initial therapy in the “Total Therapy” protocols used at the University of Arkansas.

Other Novel Agents for Relapsed or Refractory Disease

Several new classes of drugs are being tested in clinical trials that are at different stages of development. Several promising drugs are already in phase III testing including pomalidomide and carfilzomib, both of which were discussed previously.

Histone Deacetylase Inhibitors. Acetylation and deacetylation of histone proteins play an important role in the regulation of gene expression. Deacetylated histones by binding tightly to the DNA limit access to transcription factors, leading to inhibition of transcription. Acetylation on the other hand, neutralizes the charge of histones and opens up the DNA conformation, allowing expression of the corresponding genes. The opposing activities of two sets of

P.2080

enzymes, histone acetyltransferase (HAT) and HDAC, control the acetylation status, with normal cells existing in a state of balance. Existing evidence suggests that aberrant recruitment of HDAC may play a role in the changes in gene expression in cancer cells. HDAC inhibitors are thought to affect multiple pathways in MM reversing the abnormalities of cell apoptosis and cell cycle, potentially sensitizing MM cells to apoptosis.^{673, 674} Several HDAC inhibitors have been studied in the context of myeloma, including suberoylanilide hydroxamic acid (SAHA; vorinostat),⁶⁷⁵ ITF2357,⁶⁷⁶ LBH589 (panobinostat),⁶⁷⁷ and romidepsin.⁶⁷⁸ Results thus far suggest modest single-agent activity in patients with MM.⁶⁷⁴

A phase I trial studied escalating doses of oral vorinostat 200, 250, or 300 mg twice daily for 5 days every week or 200, 300, or 400 mg twice daily for 2 of 3 weeks in patients with relapsed/refractory MM.⁶⁷⁹ There were 13 patients enrolled and MTD was not reached. Drug-related adverse experiences included fatigue, anorexia, dehydration, diarrhea, and nausea. Of 10 evaluable patients, 1 had a minimal response and 9 had stable disease.

Romidepsin is an intravenously administered HDAC inhibitor that was studied in a phase II trial, patients with MM who were refractory to standard therapy were treated with romidepsin (13 mg/m²) given as a 4-hour intravenous infusion on days 1, 8, and 15 every 4 weeks.⁶⁷⁸ No objective responses were seen among the 123 patients treated.

Significant single-agent activity has been less than convincing, however, combinations with bortezomib or lenalidomide appeared to hold promise based on the initial trials. A phase I trial evaluated escalating doses of bortezomib (1 to 1.3 mg/m² on days 1, 4, 8, and 11 and vorinostat at 100 to 500 mg orally daily for 8 days of each 21-day cycle).⁶⁸⁰ Among the 23 patients enrolled, overall response rate was 42%, including three partial responses among 9 bortezomib refractory patients. The most common toxicities were myelosuppression, fatigue, and diarrhea. In another phase I trial, patients with relapsed or refractory MM were randomized to oral vorinostat (200 mg twice daily or 400 mg once daily for 14 days) in combination with bortezomib (0.7 or 0.9 mg/m² on days 4, 8, 11, and 15 or 0.9, 1.1, or 1.3 mg/m² on days 1, 4, 8, and 11).⁶⁸¹ The best responses observed in the 33 evaluable patients included PR (36.4%), MR (18.2%), and SD (39.4%). Based on the initial results, a large phase III trial was performed comparing vorinostat with or without bortezomib. Overall, 636 patients were randomized to bortezomib in combination with vorinostat or placebo. Although the overall response rate was significantly higher with the vorinostat combination (56% vs. 41%), the PFS was only marginally improved (7.6 vs. 6.8 months) and no difference was seen in OS. Over a third of the patients had serious adverse events, with hematological and gastrointestinal toxicity and fatigue being the most common.⁶⁸²

The combination of panobinostat and bortezomib also has been explored in early stage trials. In a phase Ib trial, San Miguel et al. observed with 14 partial response or better (50%) among 28 evaluable patients, including 4 with complete response (CR).⁶⁸³ Common adverse events included hematologic toxicity, diarrhea, fever, nausea, fatigue, and asthenia. In another trial, panobinostat was combined with melphalan, prednisone, and thalidomide, with some activity, but was accompanied by significant hematological toxicity.⁶⁸⁴ A large phase III trial is currently evaluating the combination of panobinostat and bortezomib in patients with relapsed MM.

Harrison et al. studied the combination of romidepsin with bortezomib, identifying bortezomib 1.3 mg/m² on days 1, 4, 8, and 11, dexamethasone 20 mg (days 1, 2, 4, 5, 8, 9, 11, and 12), and romidepsin 10 mg/m² (days 1, 8, and 15) every 28 days as the MTD.⁶⁸⁵ Thrombocytopenia was the most common hematologic toxicity and peripheral neuropathy occurred in 76% of patients. The overall response rate was 60% including 52% PR and 8% CR. The median TTP was 7.2 months, and the median OS was > 36 months. This regimen shows activity with manageable toxicity and warrants further evaluation.

Heat Shock Protein 90 Inhibitors. Heat shock protein 90 (Hsp90) is a molecular chaperone that is induced in response to cellular stress and leads to stabilization of various client proteins involved in cell cycle control and apoptotic signaling. Hsp90 inhibitors have been shown to decrease MM proliferation, and sensitize MM cells to other anticancer agents.⁶⁸⁶ Several hsp90 inhibitors have been evaluated in early-stage clinical trials.

Tanespimycin was one of the early hsp90 inhibitors to be tested in myeloma. In a phase I dose-escalation study, tanespimycin (150 to 525 mg/m²) was given on days 1, 4, 8, and 11 of each 3-week cycle in patients with relapsed/refractory MM.⁶⁸⁷ One patient (3%) achieved an MR, and 52% had SD with a median PFS of 2.1 months. Common adverse events included diarrhea, back pain, fatigue, and nausea, anemia, and thrombocytopenia.

Preclinical studies suggested potent synergy when hsp90 inhibitors were combined with bortezomib, paving the way for combination clinical trials. In a multicenter phase I/II trial tanespimycin (100 to 340 mg/m²) was combined with bortezomib (0.7 to 1.3 mg/m²) given on days 1, 4, 8, and 11 of a 3-week cycle.⁶⁸⁸ The highest tested dose of tanespimycin at 340 mg/m² and bortezomib at 1.3 mg/m² was considered the phase II dose. The combination was well tolerated and among 67 efficacy-evaluable patients, there were 2 (3%) CR, 8 (12%) PR, and 8 (12%) minimal responses.

Signal Transduction Inhibitors. Various signal transduction pathways have been considered critical for the survival and proliferation of myeloma cells. Among these the PI3K-Akt pathway has been most studied from a therapeutic standpoint. Perifosine is the best-studied Akt inhibitor in the setting of myeloma.⁶⁸⁹ In a phase II trial of perifosine, alone or with dexamethasone, the best response to single agent among 48 enrolled patients was an MR in 1 patient and stable disease in 22 patients (46%).⁶⁹⁰ Addition of dexamethasone in 37 patients with disease progression led to a partial response in 13%. Most common adverse events included nausea, vomiting, diarrhea, fatigue, increased creatinine, and anemia. Subsequent trials have examined the combination of perifosine with lenalidomide or bortezomib with modest evidence of activity.^{690, 691}

The mTOR kinase, downstream in the PI3K/Akt pathway has been another target explored in myeloma. Both CCI779 and RAD001 have been studied in phase II trials in patients with relapsed disease with very little clinically relevant antimyeloma activity. Ghobrial et al. studied intravenous temsirolimus given at 15 or 25 mg with bortezomib at 1.3 or 1.6 mg/m² once a week enrolling 20 patients into the phase I study and 43 into phase II. The MTD was determined to be 1.6 mg/m² bortezomib on days 1, 8, 15, and 22 in combination with 25 mg temsirolimus on days 1, 8, 15, 22, and 29, given every 35 days. In the phase II study, the proportion of patients with a partial response or better was 33%. The most common treatment-related grade 3 to 4 adverse events were thrombocytopenia, hematologic disorders, and diarrhea.

Monoclonal Antibodies. Monoclonal antibody therapy has seen resounding success in B-cell malignancies, but has had minimal success with plasma cell disorders. Elotuzumab is a humanized monoclonal IgG1 antibody targeting human CS1, a cell surface glycoprotein. CS1 is highly and uniformly expressed on MM (MM) cells, with limited expression on natural killer (NK) cells and CD8 + cells and little to no expression in normal tissues. In a phase I study, escalating doses of elotuzumab (2.5, 5, 10, and 20 mg/kg IV) were administered on days 1 and 11 in combination with bortezomib (1.3 mg/m² IV) administered on days 1, 4, 8, and 11 of a 21-day cycle.⁶⁹¹ Dexamethasone 20 mg PO was added for patients with disease progression. The MTD was not reached and the most frequent grade 3/4 side effects were lymphopenia, fatigue, thrombocytopenia, neutropenia, hyperglycemia, peripheral neuropathy, pneumonia, and anemia. A partial response or better was observed in 13/27 (48%) evaluable patients, including 7% CR and 41% PR. Another study examined the drug in combination with lenalidomide, using escalating doses of elotuzumab with

P.2081

the standard lenalidomide dose.⁶⁹² No DLTs were observed at the maximum dose tested (20 mg/kg). A partial response or better was seen in 82% (23/28) of treated patients and 96% (21/22) of lenalidomide-naïve patients. Richardson et al. studied two doses of elotuzumab in combination with lenalidomide and dexamethasone in a randomized phase II trial: patients received elotuzumab 10 or 20 mg/kg IV (days 1, 8, 15, and 22 every 28 days in the first two cycles and days 1 and 15 of subsequent cycles), lenalidomide 25 mg PO (days 1 to 21) and dexamethasone 40 mg PO weekly.⁶⁹³ Among 63 enrolled patients, 81% had a PR including 37% with VGPR. The overall response rates were 90% in the 10 mg/kg group (n = 31) and 72% in the 20 mg/kg group (n = 32). Median time to response was 30 days (range, 21 to 100). The most common toxicities were hematologic and infusion reactions.

The inflammatory cytokine interleukin (IL)-6 is a survival factor for malignant plasma cells. CNTO328 is a novel human-mouse chimeric monoclonal antibody targeting IL-6 that has inhibitory effect on tumor burden and potentiates bortezomib-mediated apoptosis. Initial studies support the feasibility of combining the antibody with bortezomib in patients with relapsed myeloma.⁶⁹⁴

Several other drugs have been tried with very modest activity. IFN has been shown to modulate the multidrug resistance phenotype and to re-induce chemosensitivity in patients with chemoresistant MM. In one study, nonresponding patients received the same chemotherapy to which they were resistant, preceded by a 5-day course of IFN. An objective response was achieved in 4 of 14 patients (28.6%).⁶⁹⁵ Several investigators have combined IFN with dexamethasone^{454, 696} or methylprednisolone⁶⁹⁷ as therapy for patients with relapsed or refractory disease. With response rates of 29% to 66%^{696, 697} it is difficult to isolate the corticosteroid and IFN effects. There is no clear evidence that the response rate or the survival time improved compared with similar treatments without IFN.⁶⁹⁸

Because patients with MM refractory to alkylating agents frequently express P-glycoprotein, which is associated with the multi-drug resistance phenotype, cyclosporine, a multidrug resistance reversal agent, has been combined with VAD in patients with refractory or progressive disease. No benefit was observed.^{699, 700} As a result of the findings of a phase I/II trial in patients with myeloma,⁷⁰¹ PSC 833, a multidrug resistance glycoprotein modulator, was incorporated into a small phase III study of VAD versus VAD and PSC 833 in the relapsed/refractory setting.⁷⁰² There was no difference in response rate, PFS, or OS in PSC 833 arm, although there was more toxicity.

TABLE 98.19 CONVENTIONAL COMBINATIONS FOR RELAPSED REFRACTORY DISEASE

Author	Regimen	N	ORR (%)	DOR, mo	OS, mo
de Weerd, 2001 ⁷¹²	Continuous low dose CTX; Pred	4238	—	—	—
Trioui, 2005 ⁶⁶⁸	Weekly CTX; Pred	6641	—	—	28.6
Lenhard, 1994 ⁷¹³	CTX IV; Pred	4829	—	—	8.6

Petrucci, 1989 ⁶⁶⁹	IV Mel25 /m ²	3434	16	8
Tsakanikas, 1991 ⁷¹⁶	IV Mel50-70/m ²	1850	—	11.5
Barlogie, 1984 ⁴⁴³	VAD	2959	>12 mo	—
Dimopoulos, 1996 ⁷²⁷	HyperCVAD	5840	8	15
Finnish Leukaemia Group, 1992 ⁶⁷⁰	MOCCA	8049	22	31
Lee, 2003 ⁶⁷¹	DT-PACE	14832	—	—
Barlogie, 1989 ²⁷⁴	EDAP	2040	—	4.5
Bonnet, 1982 ⁷²⁴	VBAP	15125	—	7.6

CTX, cyclophosphamide; DOR, duration of response; DT-PACE, dexamethasone, thalidomine, cisplatin, doxorubicin, cyclophosphamide, etoposide; EDAP, etoposide, dexamethasone, doxorubicin, cisplatin; hyperCVAD, cyclophosphamide, vincristine, doxorubicin, dexamethasone; mo, months; MOCCA, melphalan, vincristine, cyclophosphamide, lomustine, doxorubicin; N, number of patients; ORR, overall response rate (partial response or better); OS, overall survival; pred, prednisone; mel, melphalan; VAD, vincristine, doxorubicin, dexamethasone; VBAP, vincristine, carmustine, doxorubicin, prednisone.

The human anti-CD20 antibody has demonstrated some effect in patients with myeloma. About 20% of patients with myeloma have CD20 expression on their plasma cells. In one study 1 of 19 patients had a partial response to therapy; an additional 5 had stable disease.⁷⁰³

Alkylator-based Regimens for Relapsed or Refractory Disease (Table 98.19)

There is cross-resistance among the alkylators, but it is not absolute and may be circumvented by increasing dose intensity. Without extreme dose intensification, 5% to 20% of patients with melphalan-resistant disease respond to cyclophosphamide or BCNU as single agents or in combination with prednisone.^{617, 704, 705, 706, 707, 708, 709} Response rates as high as 30% to 38% can be obtained if prednisone is administered with the cyclophosphamide.^{710, 711, 712} Higher doses of cyclophosphamide (e.g., 600 mg/m² intravenously for 4 consecutive days) result in response rates of 29% to 43%.^{237, 713} Both response duration and OS tend to be short, approximately 3 and 9 months, respectively.^{237, 713} Consolidating the chemotherapy into a 1-day schedule rather than a 4-day schedule does not improve response rate but does increase the toxicity.⁷¹⁴ Similarly, administration of 3.6 g/m² over 2 days with prednisone appears to produce comparable responses.⁷¹⁵

Dose intensification of melphalan can also be quite effective and is the basis for high-dose therapy with stem cell support.²²⁰ Selby et al.²²⁷ reported that 66% of patients with resistant disease treated with 140 mg/m² without stem cell support responded, but median response duration was 6 months, with all patients relapsing within a year. Median times to leukocyte and platelet recovery were 42 and 37 days, respectively, and the regimen-related toxicity was 13%. Doses of 50 to 70 mg/m² resulted in a 50% response rate and leukocyte and platelet recovery time of 20 and 16 days, respectively.^{716, 717} Further reducing the intensity to 30 mg/m² every 2 months resulted in response rates of 38% and progression-free survival of 10 months.⁷¹⁸

VBMCP (the M-2 regimen) or MOCCA provided responses in 20% to 30% of refractory patients^{375, 719, 720} with a median survival of about 11 months.⁷²⁰ Combinations of cisplatin with BCNU, cyclophosphamide, and prednisone have produced response in heavily pretreated patients;³²⁸ however, the addition of cisplatin and bleomycin to VBAP did not appear to produce better outcomes than standard VBAP.^{274, 327, 328} The addition of etoposide to high-dose cyclophosphamide and granulocyte-macrophage

P.2082

conlon-stimulating factor resulted in a response rate of 42%, but with significant myelosuppression.⁷²¹

Bendamustine with or without corticosteroids can produce responses in approximate 55% of relapsed patients. Among patients relapsing after transplant PFS was 26 weeks (0 to 61). In another study among relapsed refractory patients, the median EFS and OS were 7 and 17 months, respectively.

Anthracycline-based Regimens for Relapsed or Refractory Disease (Table 98.19)

Various permutations of doxorubicin-containing chemotherapy regimens—doxorubicin and cyclophosphamide (AC);⁴¹³ doxorubicin, BCNU, cyclophosphamide, and prednisone (ABC-P);⁷²² CAP;⁷²³ VCAP;⁴¹⁴ VBAP;^{724, 725} and BAP⁷²³—have been tried in patients with relapsed and refractory disease, resulting in response rates of 7% to 28%.^{414, 722, 723, 724} Response duration and survival tend to be short: less than 6 and 12 months, respectively. Responding patients tend to live 7 to 10 or even 22 months longer than nonresponders.^{723, 724, 725} Patients who have relapsed disease, rather than resistant or refractory disease, have higher response rates (i.e., close to 30%). Augmenting these combinations with high-dose corticosteroids has been tried with some benefit,^{243, 246, 443} yielding response rates of 47% to 59%, but with a high rate of infection. Concurrent IFN^{435, 698} adds nothing to response rate or OS. In single-arm studies, there does not appear to be any advantage to the addition of cyclophosphamide to VAD, VAMP, or vincristine, epirubicin, and dexamethasone (VED).^{242, 246, 451, 726, 737}

After studying high-dose cytosine arabinoside, cisplatin, and etoposide as single agents, Barlogie et al.³²⁹ did preliminary studies of DAP (dexamethasone, cytosine arabinoside, and cisplatin) and later EDAP (etoposide and DAP). In patients with refractory disease, response rates with these treatments were 7%, 14%, 17%, 0%, and 40%, respectively. Median survival in patients treated with EDAP was 4.5 months. This regimen is myelosuppressive, with more than half of treated patients requiring platelet transfusions and 80% requiring hospitalization for neutropenic fever. In the first month, treatment-related mortality was 15%. In the complex Total Therapy 2 program wherein this regimen was used as part of induction, the respective incremental objective and complete response rates went from 55% and 9% to 65% and 15% after EDAP treatment.³²⁹

RADIATION THERAPY

As early as the mid-1920s there was recognition that external beam radiation therapy could promote immediate relief of pain, healing of pathologic fractures, and resolution of extramedullary plasmacytomas.^{23, 738, 739} Until the 1950s, radiation therapy was the only effective treatment available for the management of plasma cell tumors. With the advent of systemic chemotherapy, indications for irradiation were primarily palliation of bone pain and solitary plasmacytomas. Concern for maintaining bone marrow reserve also constrains the use of radiation in patients with MM. Sykes et al.^{730, 731} showed that radiation has long-term effects on the bone marrow; the majority of patients receiving concentrated local doses of 3,500 cGy or more showed persistent localized marrow aplasia. One must administer enough radiation to provide palliation, without jeopardizing opportunities for further systemic therapy. In a retrospective review, Norin⁷³² has found that objective improvement was lacking when the tumor dose was below a cumulative dose (single-dose equivalent) of 1,000 cGy. For palliation, the recommendation is, therefore, a cumulative dose of 1,500 cGy, corresponding to a tumor dose of 3,400 cGy in 10 to 15 fractions.^{732, 733} Leigh et al.⁷³⁴ recommended a total cumulative dose of 1,000 cGy in these same patients. There is controversy as to whether the duration of response correlates with the radiation dose in myeloma patients.^{734, 735}

In contrast, the conventional wisdom has been that patients with solitary plasmacytoma of bone should receive higher doses in an attempt at cure. Although the optimal dose has not been established by randomized controlled trials, 4,000 to 5,000 cGy encompassing all disease with a margin of normal tissue is recommended by most experts.^{736, 737, 738} A recent study of 203 patients with solitary plasmacytoma of bone has brought this principle into question.⁷³⁹ These authors found that therapeutic doses above 3,000 cGy had no bearing on local control.

Radiation can often spare patients from undergoing surgery.⁷⁴⁰ In a recent retrospective analysis of 35 cases of patients with cervical lesions and spinal instability, it was found that 19 of the 20 patients experienced resolution of pain, 15 of whom received radiation alone. Of the 10 patients with sufficient follow-up data, none showed clinical progression of instability.

The first report of using whole body irradiation to treat myeloma was by Medinger and Craver⁷⁴¹ in 1942. Partial or complete relief of pain was noted in the majority of patients. Once effective systemic chemotherapy came into wide use, this approach became less popular until 1971 when Bergsagel⁷⁴² postulated that sequential hemibody radiation could be a means of debulking tumor. He suggested that if a dose of approximately 725 cGy were given to the upper half of the body and 1,000 cGy to the lower half, a theoretical 3-log kill could be achieved and survival prolonged. After a series of retrospective studies^{743, 744, 745, 746, 747, 748, 749, 750, 751} and a randomized study^{417, 752} evaluating its role in the earlier phases of myeloma, hemibody irradiation has once again fallen out of favor. In patients who have end-stage disease, with poor pain control, this treatment may still be important.

The majority of series involving hemibody or sequential hemibody radiation are retrospective and include patients who were either resistant to or relapsing from alkylator-based therapy. Significant relief of bone pain occurred in 80% to 90%

of patients^{743, 744, 745, 746, 747, 748, 749, 750, 751} and the median duration of survival was 5 to 11 months^{733, 745}. Objective biochemical response occurred in 25% to 50% of patients.^{745, 746, 753} Pain relief typically occurred 1 to 2 days after institution of therapy, with a maximal response in 1 to 2 weeks.⁷⁴³ The most common side effects were moderate myelosuppression, pneumonitis, nausea, vomiting, diarrhea, and stomatitis.^{733, 743} If an oral lead shield was not used, mucositis also occurred.⁷³³ Nadirs occurred within 3 weeks⁷⁴⁵ and white cell count and platelet count recovery occurred by about 6 weeks.^{733, 745} Decrements in pulmonary function occurred in about half the treated patients.⁷³³ The most serious complication was radiation-induced pneumonitis, which was seen in 14% of patients.⁷⁴⁵ The option of sequential half-body radiation therapy must be balanced against unpredictable and varying degrees of pancytopenia and alternative treatment options.⁷⁵³

Bergsagel's postulate⁷⁴² and preliminary data from several small studies^{744, 749, 750} led two cooperative group studies (SWOG 8229 and CALGB 8003) to incorporate systemic radiation therapy as consolidation therapy.^{417, 752} Neither study demonstrated a meaningful advantage to patients receiving adjuvant hemibody radiation,^{417, 752} and hemibody radiation is used only for pain palliation in end-stage chemotherapy-refractory myeloma patients.

PROGNOSIS AND PATHOGENESIS

Prognosis and pathogenesis are covered together because in many instances there is an intimate relationship between them. To date no single molecular defect can account for the pathogenesis of MM, although by using single nucleotide polymorphisms and gene expression profiling, several candidate genes have been identified as being different between MGUS and MM.^{754, 755} It is not clear if a single critical genetic change in the clonal plasma cell of MGUS results in the "switch" to the malignant state of myeloma or if it represents the cumulative effect of

P.2083

a series of changes, which may be different in different patients. Malignant plasma cells are long-lived cells, typically with low proliferative rates.^{137, 756} A post-germinal cell origin is indicated by their somatically hypermutated, rearranged immunoglobulin genes.⁷⁵⁷ A multitude of abnormalities has been identified in signaling pathways, apoptotic mechanisms, the bone marrow microenvironment, and the cell cycle. Factors including the level of gene expression, protein expression, and phosphorylation status of cell cycle molecules may all be relevant for the propagation of the malignant plasma cells. Extracellular signaling alterations include changes in stromal cell, osteoblast, osteoclast, vessel endothelial cell, and immune cell interactions. These changes may in turn result in activation, adhesion, and cytokine production that fuel myeloma cell proliferation and survival (Fig. 98.10).

Prognosis and Staging

Survival of MM patients varies from months to more than a decade.^{599, 758} There are no precise methods of identifying the subset of newly diagnosed patients who are best served by standard intensity therapies, by maintenance therapies, by novel therapies, or by more intensive regimens such as hematopoietic stem cell transplantation. Prognostic factors are needed for patient counseling, therapeutic decision making, and clinical trial stratification. Given the disease heterogeneity and differing outcomes, it is important to understand the prognostic factors and develop adequate risk stratification systems in order to compare different groups of patients from different studies or clinical trials. However, prognostication is a dynamic process changing within a given patient during the disease course as dictated by the response to therapies and acquisition of new genetic changes. It is also constantly changing for the disease as a whole with incorporation of newer therapeutic strategies for the disease.

Staging is one form of prognostic modeling. The Durie-Salmon system (Table 98.20), which until the present had been the most widely accepted MM staging system, separates patients predominantly by tumor burden and renal function.²⁶ As the biology of myeloma is better understood, novel markers reflecting myeloma cell kinetics, signaling, genetic aberrations, and apoptosis have eclipsed the prognostic significance of tumor burden as a predictor of survival.^{415, 759, 760, 761, 762, 763, 764, 765} At the time of its inception, the Durie-Salmon staging system was an elegant system that incorporated information about immunoglobulin production and half-life, hemoglobin, calcium, creatinine, and extent of bone disease to derive mathematically the total myeloma cell burden.²⁶ Quantification of bone lesions used in this staging system, however, is not always reliable as a prognostic factor⁷⁶² in that patients classified as stage III solely on the basis of bone lesion criteria do not have a poorer prognosis.

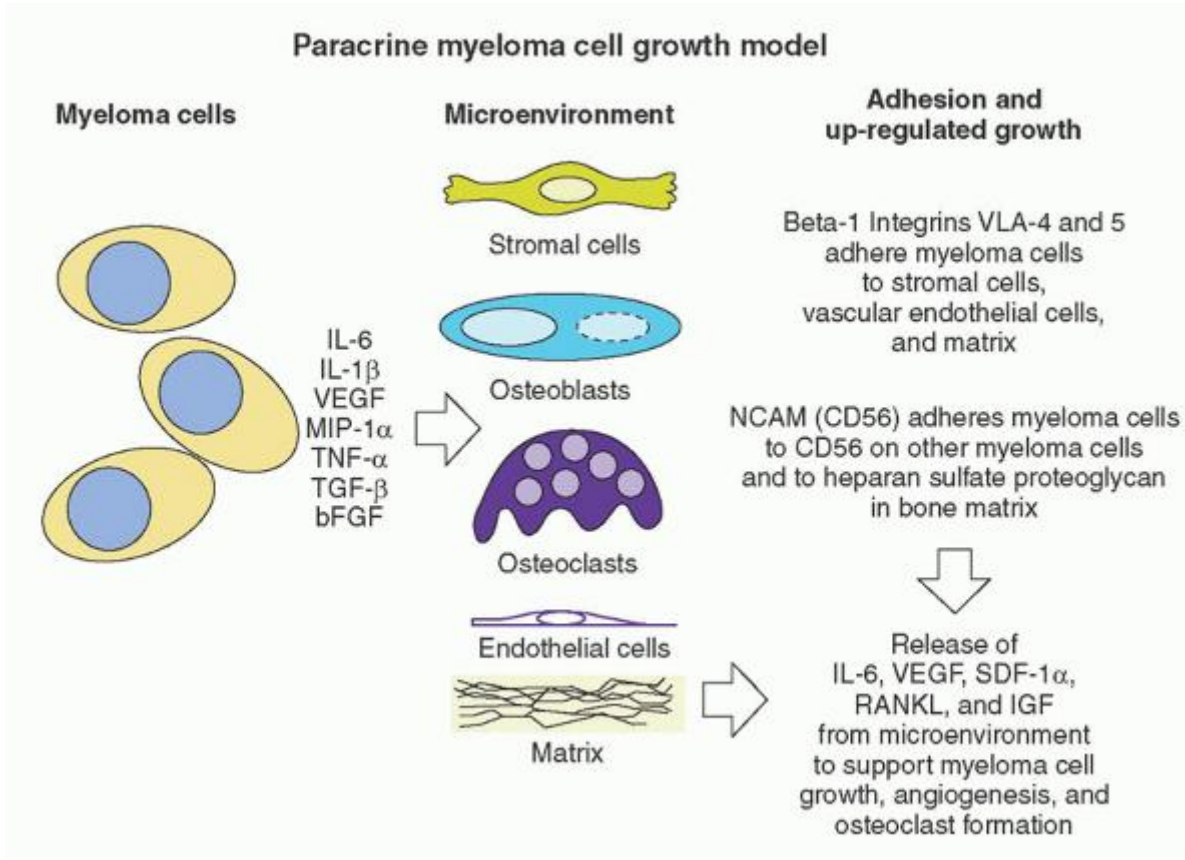

FIGURE 98.10. Putative pathogenic mechanisms in myeloma. IGF, insulinlike growth factor; IL, interleukin; MIP, macrophage inflammatory factor; MMP, metalloproteinase; NCAM, neural cell adhesion molecule; TNF, tumor necrosis factor; VEGF, vascular-derived endothelial growth factor; VLA, very late antigen.

Other variables, including patient age, performance status, serum albumin, immunoglobulin isotype, and bone marrow plasma cell infiltration, have long been recognized to predict survival,^{766, 767, 768, 769} and subsequent models have incorporated these factors^{236, 599, 765, 770} whereas others have shown the prognostic value of serum β 2M, C-reactive protein, lactate dehydrogenase, elevations in serum immunoglobulin free light chains, presence and quantity of circulating plasma cells, bone marrow plasma cell proliferative rate, plasmablastic morphology, bone marrow angiogenesis, and chromosomal abnormalities.^{137, 138, 139, 415, 759, 760, 761, 763, 764, 765, 770, 771, 772, 773, 774, 775, 776, 777, 778, 779, 780, 781, 782, 783, 784, 785, 786, 787} Most recently, MRI and PET-CT imaging has been shown to have some prognostic importance.^{788, 789, 790, 791, 792} More esoteric prognostic factors include: decreased staining of bone marrow plasma cells for acid phosphatase,⁷⁹³ increased circulating plasma cells as measured by the peripheral blood labeling index,⁷⁹⁴ apoptotic index,⁷⁹⁵ increased sIL-6R,^{761, 796} serum neopterin,³⁷⁸ α 1-antitrypsin,⁷⁹⁷ C-terminal telopeptide of Type I collagen,^{798, 799} serum bone sialoprotein,⁸⁰⁰ B12 binding protein,⁸⁰¹ soluble CD56,⁸⁰² soluble Fc receptor (CD16),⁸⁰³ soluble syndecan or CD138,⁸⁰⁴ and serum IL-6 levels.^{797, 805, 806}

A staging system's relevance is based not only on its ability to predict outcome, but also on its availability and cost.⁸⁰⁷ An international consensus panel addressed this issue and developed the International Staging System (ISS) for MM (Table 98.21); it incorporates serum albumin levels and beta-2 microglobulin.⁸⁰⁸ Although this staging system is inexpensive and readily available, it does not get to the heart of myeloma cell biology as do genetic changes, as discussed below. However, it does rely heavily on β 2M concentration, which is the strongest and most reliable prognostic factor for MM that is routinely available.

P.2084

β 2M concentration is influenced by both tumor burden and renal function. Elevated β 2M values predict early death.^{229, 760, 763, 809, 810, 811, 812, 813, 814} Formulas to correct the β 2M concentrations for the effects of renal insufficiency have not improved its predictive value,⁸¹⁵ and the β 2M value is still prognostic in myeloma patients with normal renal function.⁷⁵⁹ As discussed below, investigators have tried to enhance the performance of the ISS by adding other soluble markers or

genetic risk features. An example is combining abnormal FLC ratio with the ISS risk factors to create four prognostic groups with median survival times of 51, 39, 30, and 22 months, respectively.⁷⁷⁶

TABLE 98.20 DURIE-SALMON STAGING SYSTEM

Criterion	Measured Myeloma Cell Mass, Cells × 10¹²/m²	OS, mo
Stage I All of the following Hemoglobin > 100 g/L Serum calcium < 12 mg/dl On radiograph, normal bone structure (scale 0) ^a or solitary bone plasmacytoma only Low M-component production rates IgG < 50 g/L, IgA < 30 g/L, or urine M spike on electrophoresis < 4 g/24 h	< 0.6 (low)	61
Stage II Fitting neither stage I or III	0.6-1.2 (intermediate)	54 ^b
Stage III One or more of the following Hemoglobin < 85 g/L Serum calcium > 12 mg/dl Advanced lytic bone lesions High M-component rates IgG > 70 g/L, IgA > 50 g/L, or urine light chain M spike > 12 g/24 hrs	>1.2 (high)	30 / 15 ^c

Subclassification

A: Serum creatinine < 2 mg/dl

B: Serum creatinine ≥ 2 mg/dl

^a Scale of bone lesions: normal bones, 0; osteoporosis, 1; lytic bone lesions, 2; and extensive skeletal destruction and major fractures, 3.

^b Includes Durie-Salmon Stage IB and IIB.

^c Includes Durie-Salmon Stage IIIA/IIIB.

From Durie and Salmon.²⁶ By permission of the American Cancer Society.

Cytogenetics, Fluorescence In Situ Hybridization, and Other Genetic Abnormalities

The first cytogenetic abnormalities in myeloma were documented nearly 30 years ago (Fig. 98.11). In the past decade it has become increasingly apparent that cytogenetic testing is an integral element of establishing prognosis and a treatment plan for all newly diagnosed myeloma patients. Nearly all myeloma patients have abnormal chromosomes by fluorescence in situ hybridization (FISH), including deletions, aneuploidy, and translocations^{816, 817, 818} (Fig. 98.12A,B), although abnormal karyotypes are seen in only 18% to 30% of cases. This apparent discrepancy is explained by the

generally low proliferative rate of myeloma cells and the requirement of obtaining plasma cells (and not just the rapidly dividing normal myeloid precursors) in metaphase to generate conventional cytogenetics.^{819, 820, 821} Therefore, any abnormality in conventional cytogenetics identifies a group with a higher proliferative rate⁸²² and poorer prognosis. There is an excellent correlation between abnormal conventional cytogenetics and a high plasma cell proliferative rate.^{823, 824} With interphase FISH, several chromosomal abnormalities, such as immunoglobulin heavy chain translocations and deletion of chromosome 13, are observed at equal frequencies among the spectrum of plasma cell proliferative disorders from MGUS to MM to PCL.^{825, 826}

TABLE 98.21 INTERNATIONAL STAGING SYSTEM⁸⁰⁸

Stage	Criterion	Overall Survival, months
Stage I	$\beta_2M < 3.5$ mg/L and alb ≥ 3.5 g/dl	62
Stage II	Not Stage I or III	45
Stage III	$\beta_2M \geq 5.5$ mg/L	29

β_2M , beta-₂ microglobulin.

Monoallelic loss of chromosome 13 (del 13) or its long arm (del 13q), when determined by metaphase cytogenetics, is a powerful adverse prognostic factor in patients treated with standard chemotherapy^{764, 827, 828} or with high-dose chemotherapy and hematopoietic stem cell transplantation.^{329, 506, 778, 829, 830} Approximately 50% of newly diagnosed MM patients have del 13 or del 13q by FISH.^{824, 826, 831} Our group has shown that del 13q is associated with specific biologic features, including a higher frequency of λ -type MM, slight female predominance, higher PCLI, and a higher frequency of a serum M component of less than 10 g/L.⁸²⁷ Patients with the deletion by FISH have a worse OS with standard chemotherapy,^{764, 824, 827} high-dose therapy,^{831, 832} and IFN treatment.⁸²⁷ The absence of abnormalities of chromosome 13 and 11 by conventional cytogenetics is associated with longer complete response duration, EFS, and OS in patients treated with high-dose therapy.³²⁹ The prognostic significance of del 13q by FISH is less than that for del 13 by conventional cytogenetics, because the latter test incorporates both the chromosomal abnormality and a high rate of plasma cell proliferation, whereas the former captures only the chromosomal abnormality.

Hypodiploid myeloma has a worse prognosis than diploid or hyperdiploid myeloma. This has been demonstrated by flow cytometric methods^{828, 833, 834} and metaphase cytogenetics.^{830, 835, 836, 837, 838} Controversy exists about whether the deletion 13q adds any additional prognostic information to a hypodiploid karyotype.^{835, 838, 839}

Up to 50% of patients with MM have translocations involving the heavy chain gene on chromosome 14.⁸¹⁸ These translocations include illegitimate switch recombinations of the variable regions of the immunoglobulin heavy chain gene at 14q32. Partners of the translocations into the IgH switch region on chromosome 14 include chromosomes 11, 4, 6, and 16.⁸⁴⁰ The most common translocation in MM is t(11;14)(q13;q32),^{820, 839} which increases expression of cyclin D1,⁸⁴¹ a protein involved in cell cycle progression. The prevalence of t(11;14)(q13;q32) is 20% in MM.^{820, 839, 842} Previous publications had suggested that this translocation was associated with an adverse outcome in MM,^{764, 778} but more recent data refute this hypothesis.⁸⁴² The t(6;14)(p21;q32) is also associated with a neutral prognosis.⁸⁴³ The t(4;14)(p16.3;q32) is present in 15% of MM patients.^{844, 845, 846, 847, 848} This translocation results in the up-regulation of fibroblast growth factor receptor 3 (FGFR3) and in the hybrid transcript IgH/MMSET.^{844, 845} This abnormality had been thought to be as bad as deletion 17p, but there are emerging data that long-term bortezomib use can abrogate some of this poor prognosis. The t(14;16)(q32;q23) is also seen in a

P.2085

small subset (~5%) of patients with MM.^{839, 845} Both convey a very poor prognosis, although a recent French study has questioned the poor prognostic value of t(14;16).⁸⁴⁹ In one study there was a tight association of del 13 abnormalities and high β_2M values with the unfavorable t(4;14) and t(14;16) abnormalities,⁸³¹ suggesting that the poor prognosis associated with del 13 may be because of other nonrandom, associated chromosomal abnormalities.

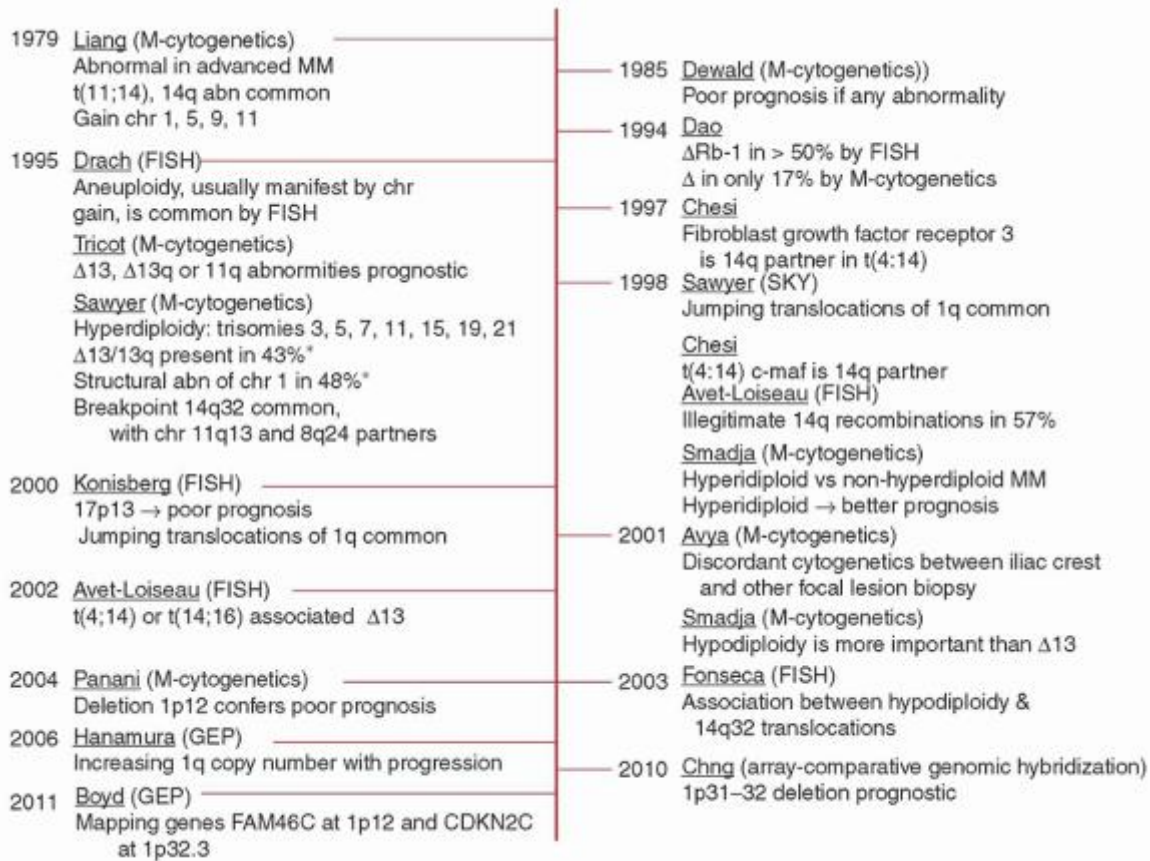

FIGURE 98.11. History of cytogenetic discovery in multiple myeloma.

Trisomy is common by FISH and most often includes chromosomes 3, 6, 9, 11, and 15.⁸⁵⁰ In another study trisomy of 3, 7, and 11 accounted for over 50% of the hyperdiploid cases.⁸⁵¹ Trisomies of chromosomes 6, 9, and 17 were associated with prolonged survival.⁸⁵² Recently it has been shown that presence of trisomies is associated with better outcomes even among patients with high-risk cytogenetic markers such as t(4;14), t(14;16) and 17p deletion (Fig. 98.12C).⁸¹⁸

Deletion of the TP53 gene locus as a result of monosomy 17 or deletion of 17p is seen in 10% of patients at diagnosis and is associated with very short median OS.^{818, 853, 854, 855} In contrast, inactivating mutation of TP53, locus 17p13, is rare in freshly explanted myeloma cells but is common in human myeloma cell lines and in patients with a terminal phase of myeloma.⁸⁵⁶ Such mutations have been observed in ~5% of cases of early MM versus 20% to 40% of cases of PCL.^{857, 858, 859, 860}

Another set of new cytogenetic prognostic markers are abnormalities involving chromosome 1,^{861, 862, 863, 864, 865} either gain of 1q21 or loss of 1p21, and have been associated with poor outcome.^{861, 862} Abnormalities of both the short and long arms of chromosome 1 have been noted since the first cytogenetic studies of myeloma.^{819, 866} Hanamura et al. demonstrated that the frequency of 1q21 amplifications increases from monoclonal gammopathy of undetermined significance (0%), to overt MM (43%), and finally to relapse (72%). In a prospective clinical trial of high-dose therapy (HOVON 24), abnormalities of chromosome 1p and 1q were found in 19 (36% of patients with an abnormal karyotype) and 21 patients (40%).⁸⁶² There was a strong association between chromosome 1p and/or 1q abnormalities and deletion of chromosome 13 or 13q. Patients with 1p/q abnormalities had a significantly shorter OS than patients with normal karyotypes. Amplifications of 1q21 are concurrent with dysregulated expression of c-MAF, MMSET/FGFR3, or deletion 13.⁸⁶⁷ Candidate genes for the molecular mechanism of prognosis imparted by the 1q21 amplification include CKS1B, BCL-9, or RAB25, but this has not been confirmed by others.⁷⁵⁵

Mutations of RAS have been noted in 30% to 50% of MM patients, with increasing prevalence in the advanced stages of the disease^{868, 869} and in patients who have shorter survival.⁸⁷⁰ Mutations of RAS were first observed in fulminant disease,⁸⁵⁶ but have also been observed in 27% to 39% of newly diagnosed cases.^{868, 870} Patients with RAS mutations had a median survival of 2.1 years versus 4 years for patients with wildtype RAS.⁸⁷⁰

Both metaphase cytogenetic and FISH testing each have their own advantages and disadvantages. The added value of metaphase cytogenetics is the additional negative prognostic information provided by the ability to generate a plasma cell karyotype, that is, capture proliferation in addition to information about ploidy status and specific structural abnormalities. The disadvantage is that certain interstitial abnormalities and translocations may be missed. In contrast, a standard myeloma FISH panel will contain probes for the common translocations and structural abnormalities and will detect them regardless of the proliferative rate of the plasma cells. FISH, however, provides no information on the proliferative index of the myeloma cells. Ideally, both metaphase cytogenetics and FISH should be done for all newly diagnosed patients, but if the cost is prohibitive, the test that is more readily available should be performed.

Boyd and colleagues combined FISH results with ISS among 1,069 patients with newly presenting myeloma treated in the MRC IX trial.⁸⁷¹ FISH lesions associated with short progression-free

P.2086

and OS in multivariate analysis were +1q21, del(17p13), t(4;14), t(14;16), and t(14;20). They defined a favorable risk group by the absence of any of these genetic lesions, an intermediate group with one lesion and a high-risk group defined by the co-segregation of >1 lesion. This genetic grouping was then combined with ISS to identify an high-risk group defined by ISS II or III and >1 adverse FISH finding. This high-risk group constituted 14% of patients and was associated with a median OS of 19.4 months.

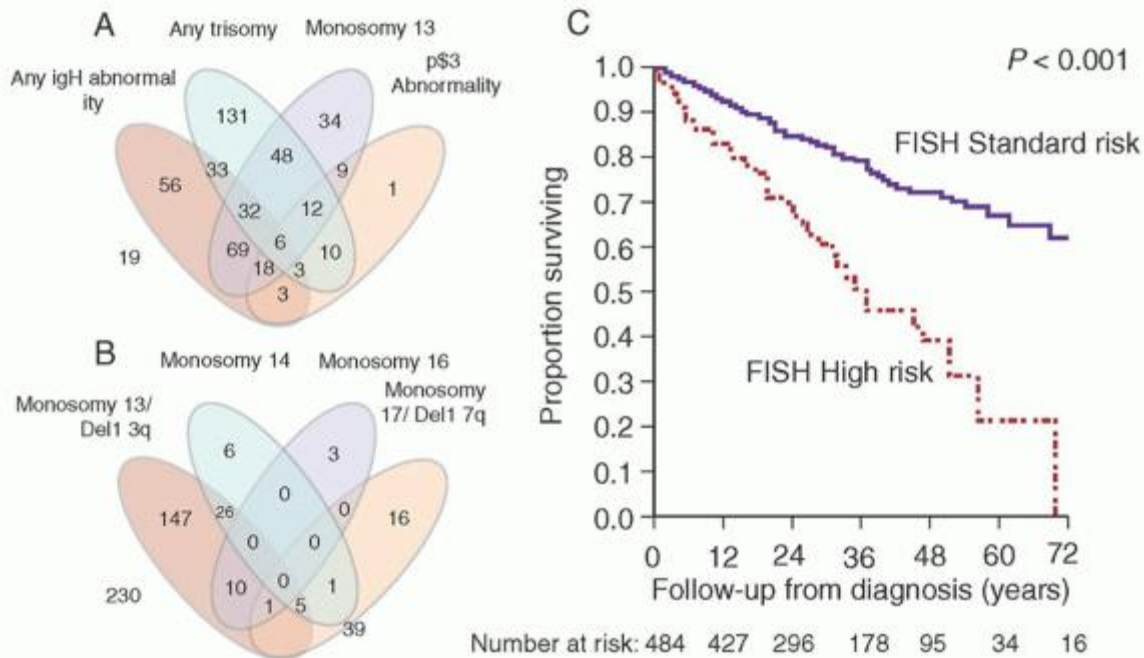

FIGURE 98.12. The relationship between genetic abnormalities among patients with multiple myeloma. A: Venn diagram demonstrating the overlapping nature between the common abnormalities seen with FISH in patients with newly diagnosed multiple myeloma. The actual number of patients with different abnormalities is presented from among 484 patients. The remaining 19 patients either had a normal FISH (n = 15) or another abnormality (n = 4). B: Distribution of various monosomies/deletions and their overlap. C: Modification of genetic risk system, using a hierarchical approach. High-risk includes deletion 17p, t(14;16), t(14;20), but with this new system, patients were reclassified into a new high-risk group, moving those patients previously classified as high-risk but with a trisomy into the standard-risk group. The survival of patients reclassified as high-risk (n = 66; 14%) was 3 years compared with not reached for the standard-risk group (P < 0.001). (From Kumar S et al. Blood 2012;119:2100-2105. Copyright © the American Society of Hematology.)

Gene Expression Profiling

Many hematological malignancies have witnessed the development of prognostically relevant disease subclassification through microarray profiling. MM is no exception, and considerable progress has been made to predict accurately individual patients' clinical course and survival outcomes using a molecular classification. Zhan and colleagues have comprehensively studied the gene expression on purified plasma cells of 414 NDMM patients who underwent HDT with tandem transplants.⁸⁷² They introduced seven molecular subtypes of MM: PR(proliferation), LB(low bone disease),

MS(MMSET), HY (hyperdiploid), CD-1(CCN1), CD-2 (CCND3), and MF (MAF/MAFB). HY, CD1, CD2, and LB comprised the low-risk group with 3-year actuarial probabilities of 81% to 88%. The two high-risk groups, MS and PR, did not achieve a therapeutic benefit on Total Therapy 2.⁸⁷² The same group of investigators identified 70 genes linked to shortened survival, with 30% of 51 overexpressed and 50% of 19 underexpressed genes mapping to chromosome 1, in a cohort of 532 newly diagnosed patients who received tandem transplants. This model was supplanted by an extremely powerful 17-gene prognostic model to detect the high-risk disease. In addition, this model could successfully prognosticate the patients with relapsed disease on either single-agent bortezomib, or high-dose dexamethasone (APEX phase III trial).⁸⁷³ It has been validated using the Mayo Clinic dataset of 71 NDMM patients treated with HDT, but practical impediments remain in the routine clinical utilization of this model. The GEP70 signature has also been validated in the nontransplant setting among a group of patients with newly diagnosed MM receiving initial therapy with lenalidomide and dexamethasone.⁸⁷⁴

Zhan et al.^{754, 875} have studied the gene expression of 74 myeloma patients by using high-density oligonucleotide microarrays interrogating about 6,800 genes. On hierarchical clustering analysis, four distinct subgroups of myeloma (MM1, MM2, MM3, and MM4) were identified. The expression pattern of MM1 was similar to normal PCs and MGUS, whereas MM4 was similar to MM cell lines. Clinical variables linked to poor prognosis, including abnormal karyotype and high serum β 2M levels, were most prevalent in MM4. Overexpression of genes involved in DNA metabolism and cell cycle control were observed in MM4.

Several risk stratification systems have been proposed on the basis of GEP results in addition to the ones from the University of Arkansas, including those from the French and Dutch groups.⁸⁷⁶ These studies have helped us develop insights into the disease biology. However, the minimal overlap between different signatures raises questions as to the independence of these signatures from the type of therapy utilized as well as the potential influence of the sample preparation on the results and the ability to apply the method uniformly in a real-life clinical setting. Waheed et al. studied 612 patients in the context of the three Total Therapy regimens, showing an independent prognostic value for ISS and cytogenetic abnormalities even when the GEP-based risk stratification and presence of TP53 deletion were incorporated.⁸⁷⁷

P.2087

Routine incorporation of fluorescence in situ hybridization (FISH) as part of the initial work-up of MM has significantly improved our understanding of the disease biology, and a better appreciation of the genetic heterogeneity that underlies this disease.^{818, 878, 879} The majority of the FISH-detected abnormalities are seen at the time of diagnosis, and the prevalence of some of the abnormalities increases with time as patients suffer multiple disease relapses. More recently, application of advanced genomic technologies such as whole genome sequencing has given a different perspective of the genetic chaos that exists in this disease. Chapman et al. performed massively parallel sequencing of 38 tumor genomes and compared them with matched normal DNAs. The pattern of mutations suggested the presence of several new and unexpected oncogenic mechanisms including mutation of genes involved in protein translation in nearly half of the patients, genes involved in histone methylation, and genes involved in blood coagulation. In addition, mutations were observed in 11 members of the NF-kappaB pathway, a pathway that has already been the focus of several studies in myeloma. Activating mutations of the kinase BRAF were observed in 4% of patients, suggesting the evaluation of BRAF inhibitors in MM clinical trials. Additional studies are ongoing, and will help us further delineate the genetic evolution in myeloma. Keats et al., in a recent study, showed that tumors can follow several evolutionary paths over a patient's disease course.⁶¹⁸ With the use of serial genomic analysis of samples collected at different points during the disease course of 28 patients with MM, they showed that the genomes of standard-risk patients show few changes over time, whereas those of cytogenetically high-risk patients show significantly more changes over time. The results indicated that the pattern of genetic evolution over time can follow either a quiescent pathway with few changes, incremental changes with addition of new abnormalities over time (clonal evolution), or consist of a mixture of clones that wax and wane over time based on treatment selection pressure (clonal selection).

Plasma Cell Proliferative Rate

That the rate of clonal plasma cell expansion determines the disease outcome has been known for a long time, and several methodologies have been used to assess the degree of proliferation. One such test, the plasma cell labeling index (PCLI), is a slide-based method that measures the percentage of bone marrow myeloma cells in the S-phase of the cell cycle¹³⁷ which is a powerful prognostic factor in MM.^{759, 760, 765, 880} An increased PCLI predicts a short remission and

survival but does not predict response to therapy. All large studies published to date have confirmed the independent prognostic value of the PCLI for survival after treatment with conventional chemotherapy^{759, 761, 781, 881} or high-dose therapy.⁸¹¹ A recent study highlighted the prognostic relevance of PCLI in the patients treated with immunomodulatory agents, thalidomide and lenalidomide, with high PCLI (≥ 1) at the time of initiation of therapy predicting a poorer progression-free survival. However, lenalidomide appears to negate the adverse impact of high PCLI on OS, an effect not seen in the thalidomide arm. Undoubtedly, a longer follow-up of patients is required to determine the true impact of the PCLI in patients on lenalidomide therapy.⁸⁸²

Determination of S phase by flow cytometry using a DNA/CD38 double-staining technique is also possible.^{765, 883, 884} A high proportion of PCs in S phase ($>3\%$) indicated poorer prognosis. A poor correlation between the slide and flow cytometric LI assays has been demonstrated by the Australian Group who questioned the sensitivity and accuracy of the less objective slide-based PCLI requiring manual enumeration of the plasma cells. In the flow cytometric analysis, the PCLI of primitive plasma cells (CD38⁺⁺/CD45⁺) was higher than that of mature myeloma cells (CD38⁺⁺/CD45⁻), and correlated better with the disease status (mean PCLI of 9.2% in the progressive disease and 2.2% in the plateau, $P = <0.001$).

Ki-67 protein is a marker for proliferation that is expressed by all the cells in the "growth fraction" of the tumor, including the cells in the late G1, S, G2, and mitotic phases of the cell cycle. The Ki-67 proliferative index represents the fraction of myeloma cells expressing Ki-67 antigen as detected by a monoclonal antibody. A higher index indicates poorer prognosis, and a cut-off of 8% could categorize newly diagnosed MM patients into two groups with a difference in survival OS ($P < 0.07$).^{885, 886, 887}

Immunophenotype of Myeloma Cells

As discussed previously, the phenotype of malignant plasma cells is diverse^{143, 144, 145, 148, 149, 151, 152} and potentially dynamic.^{888, 889} Investigators have demonstrated that surface expression of CD45, CD56, and CD117 portends a better prognosis,^{145, 147} whereas, expression of CD28, CD44, a worse prognosis.^{145, 890} Patients with the t(11;14) translocation are more likely to have surface expression of CD56, and CD117. Patients with nonhyperdiploid myeloma have an increased expression of both CD20 and CD28 in the absence of reactivity for CD56 and CD117, all poor prognostic findings.¹⁴⁵ Over the course of the last few decades, a continuous effort to identify diagnosis-, prognosis-, and therapy-related immunophenotypic markers has been instrumental in the recognition of the correlations between certain cellular antigens and the different phenotypic entities of MM. The extramedullary extension of the neoplastic plasma cells has been associated with a reduced expression or total absence (as in de novo or secondary plasma cell leukemia) of the adhesion molecule, CD56,¹⁴⁸ and up-regulation of CD44 on the plasma cells. CD28 (a T-cell marker) expression correlates with disease progression, and is universally expressed in the human myeloma cell lines.^{148, 891} Its association with t(14;16) and del(17p) is notable. The absence of CD45 and CD27 portends a worse outcome. In a multivariate analysis of 95 newly diagnosed MM patients who underwent HDT, the lack of CD45 expression was the only significant variable that affected the outcome (median OS of 42 months for CD45⁻ versus not reached at 4 years for CD45⁺ MM, $P = 0.004$).¹⁴⁶ A small subset of CD45⁺ plasma cells constitutes the proliferative compartment of the bone marrow, and the expression of this antigen is required for IL-6 signaling, but prevents insulin growth factor 1 (IGF-1)-mediated AKT pathway activation. Furthermore, a lower degree of angiogenesis, likely due to reduced vascular endothelial growth factor production, was observed with CD45⁺ expression. CD27 expression is associated with a better OS (92% at 3 years for CD27⁺ MM versus 50% in CD27⁻ MM).⁸⁹²

CD221 (IGF-1 receptor) overexpression is linked with t(4;14) or t(14;16) whereas CD20 expression is tightly associated with the more favorable t(11;14) and small lymphoplasmacytic morphology. Aberrant CD117 (c-KIT) expression is predominant in the MGUS and indolent phases, and infrequent (8%) in the relapsed cases.⁸⁹³ It is associated with a superior outcome (3-year OS, 93% for CD117⁺ versus 64% for CD117⁻ MM; $P = 0.05$). CD200 is a membrane glycoprotein that imparts an immunoregulatory signal through CD200R, leading to the suppression of T-cell-mediated immune responses. Using Affymetrix microarrays, Moreaux et al. quantified the expression of the CD200 gene in myeloma cells of 112 patients with newly diagnosed MM.⁸⁹⁴ The CD200 gene expression was either absent or present in 22% and 78% of MMCs, respectively. Patients with low/absent CD200 had an increased EFS compared with the remaining patients in the context of high-dose therapy and stem cell transplantation.

The value of immunophenotyping newly diagnosed MM by multiparametric flow cytometry was clearly established by the Spanish group in a recent prospective analysis of 685 patients treated with HDT (GEM 2000 protocol).⁸⁹⁵ A prognostic model, risk-stratifying the newly diagnosed MM patients into three

categories, the poor risk (CD28 +/CD117-; 23%), the intermediate risk (CD28-/CD117- or CD28+/CD117+; 56%) and the good risk (CD28-/CD117+, 21%) with OS 45 months, 68 months and not reached, respectively, was promulgated by this group. The HDT followed by ASCT was not beneficial in approximately one quarter of those patients, that is, the high risk group.⁸⁹⁵

Magnetic Resonance Imaging

The superiority of the more sensitive tests, such as whole body/spinal MRI and PET, over conventional radiography is being exploited to prognosticate patients with MM accurately.⁷⁸⁸ One of the key features of the DS stage I patients is the absence of skeletal involvement detected radiographically. However, 29% to 50% of DS stage I patients demonstrate infiltration of the marrow by MRI. The extent of the BM infiltration influences survival and can be adequately estimated by MRI. Various MRI patterns of the BM infiltration—normal, focal, diffuse, and variegated—have been used to predict the OS (56, 51, 24, and 52 months, respectively). Within each ISS I and II stage, the concomitant detection of diffuse BM infiltration by MRI can segregate the patients into two groups with statistically different survival outcomes suggesting enhancement of the prognostic value of ISS with this test. This finding is similar to the previously described observation noted with the incorporation of PCL1 to the ISS. Dynamic contrast enhanced (DCE)-MRI has been shown to correlate with the degree of tumor infiltration in the bone marrow as well as the degree of vascularity or angiogenesis in the marrow.^{789, 790}

Positron Emission Tomography

The avidity of metabolically active myeloma cells for 18F fluorodeoxyglucose, a radiolabeled glucose analogue, may not be helpful only in making a diagnosis, but it may also be prognostic. Zamagni et al. prospectively studied the prognostic value of PET/CT at diagnosis, after thalidomide-dexamethasone induction therapy and double autotransplantation in 192 newly diagnosed MM patients.⁷⁹¹ Presence at baseline of at least 3 focal lesions, a SUV > 4.2, and presence of extramedullary disease adversely affected 4-year estimates of progression-free survival. In addition, SUV > 4.2 and EMD were predictive of a shorter OS. In a multivariate analysis, both EMD and SUV > 4.2 at baseline and persistence of FDG uptake after ASCT were independent prognostic factors for a shorter PFS.

The use of PET scan and MRI overcomes the limitation of conventional radiography in prognosticating patients by the DS-staging, and a DS-plus staging system that incorporates the findings of PET/MRI to the original DS staging system has been proposed for predicting OS. PET scan can detect both medullary and extramedullary lesions simultaneously, and can potentially upstage the patients due to its greater sensitivity (85%) and specificity (92%).⁷⁹² A drawback of the PET scan is its inability to detect very small lesions (<1cm). Radiation-induced inflammatory changes can lead to false-positive PET which should therefore only be performed at the time of diagnosis, or at least 2 months after the therapy.⁷⁹²

Renal Failure

Renal failure has been shown to portend a poor outcome in patients with MM. In a study from¹⁸⁴ the Nordic myeloma group, renal failure, defined as plasma creatinine > 130 micromol/l, was observed in 29% of the cases at the time of diagnosis. During the first year after diagnosis 58% achieved normalization of p-creatinine, and this was achieved mainly during the first 3 months. Patients who needed dialysis had a poor prognosis, with a median survival of 3.5 months. A 12-month landmark analysis showed that reversibility of renal failure was a more important prognostic factor than response to chemotherapy.

Prior to the 21st century, of those patients with MM and severe renal failure who survived the first 2 months on dialysis, only 40% would have an objective response to chemotherapy and a median survival of almost 2 years;⁸⁹⁶ however, these statistics have changed with highly effective regimens including bortezomib with hematologic response rates of more than 70%⁸⁹⁷ and renal improvements in 82% of patients with renal impairment.^{898, 899} In a study of 39 patients with biopsy-proven myeloma kidney with a median estimated glomerular filtration rate of 9 m/min/1.73 m², the relationship between renal recovery and serum immunoglobulin free light chain (FLC) reduction was linear. Achieving at least a 60% reduction in FLC by 21 days was associated with recovery of renal function for 80% of the population.⁹⁰⁰

Pathogenesis of Multiple Myeloma

There is a synergistic pathologic relationship between myeloma cells and the cells comprising the bone marrow microenvironment or stroma, including fibroblasts, endothelial cells, osteoblasts, and osteoclasts. The stromal cells of the marrow of myeloma patients produce high levels of interleukin-6 (IL-6) *in vitro*.⁹⁰¹ The IL-6 serves as a growth and survival factor for benign and malignant plasma cells, which produce IL-1 β ,^{902, 903} VEGF, and macrophage inflammatory protein-1 α (MIP-1 α).^{904, 905} In turn, IL-1 β and MIP-1 α regulate and activate osteoclasts.^{902, 906, 907}

Bone Marrow Microenvironment

A cell adhesion molecule belonging to the immunoglobulin superfamily, CD56 (N-CAM), is strongly expressed in most plasma cells of myeloma patients⁹⁰⁸ and is believed to play a role in myeloma homing and cell adhesion to the marrow. Increased levels of the adhesion molecules lymphocyte function-associated antigen (LFA)-3,¹⁵⁰ LFA-1 (CD11a),⁹⁰⁹ and very late antigen-4 (VLA-4) are expressed on the myeloma cells in the majority of patients. VLA-4 may act to bind myeloma cells to fibronectin in bone marrow,⁹¹⁰ which under appropriate conditions can significantly increase IL-6 production by stroma.⁹¹¹ Cell-cell contact between marrow stromal cells and myeloma cells via VCAM-1 and $\alpha\beta$ 1-integrin enhances production of osteoclast-stimulating activity.⁹¹² Hyaluronan, a glycosaminoglycan component of the bone marrow extracellular matrix, appears to be a survival and proliferation factor for myeloma cells.⁹¹³ Notch receptors are expressed in early hematopoietic stem cells and Notch ligands are expressed on BMSCs. Myeloma cells expressing Notch receptors are activated by the BMSC Notch ligand, protecting the myeloma cells from drug-induced apoptosis. In addition, this interaction also activates Notch signaling in BMSCs, leading to secretion of IL-6, VEGF, and IGF-1.⁹¹⁴ Cell-adhesion-mediated drug resistance (CAM-DR) is a well-recognized entity.⁹¹⁵ Another signaling pathway that has been implicated in myeloma pathogenesis is the Hedgehog (Hh) signaling pathway. Hedgehog (Hh) signaling is a highly conserved pathway that plays an important role in development in both vertebrates and invertebrates.⁹¹⁶ Hh ligands secreted by the stromal cells, namely Indian (Ihh), sonic (Shh), and desert (Dhh) bind to their receptor, patched (PTCH) on tumor cells. This binding alleviates the inhibition of PTCH on its downstream target, smoothed (Smo), thereby activating it. This activation leads to activation of the transcription factor involved in glioma formation (Gli) which promotes the transcription of its target genes leading to tumor development and progression.⁹¹⁷ In the myeloma setting it has been found that the Hh pathway is essential for maintaining a subset of tumor-causing stem cells.

The endothelial microvascular environment has also been shown to be important in MM biology.¹³⁹ There is a high correlation between the extent of bone marrow angiogenesis, evaluated as microvessel area, and the proliferating (S phase) fraction of marrow plasma cells in patients with MM and in those with

P.2089

MGUS.^{139, 918, 919, 920, 921, 922, 923} VEGF plays an important role in angiogenesis by acting as a potent inducer of vascular permeability as well as serving as a specific endothelial cell mitogen. Plasma cells in the bone marrow from MM patients express VEGF,^{924, 925} which can thereby interact with the Flt-1 and KDR high-affinity VEGF receptors highly expressed on bone marrow myeloid and monocytic cells surrounding the tumor.⁹¹⁸

Investigators are beginning to understand the complex interactions among osteoclasts, osteoblasts, and myeloma cells. Receptor activator of NF/B (RANK), which is found on osteoclasts, interacts with RANK ligand (RANKL) found on osteoblasts and bone marrow stromal cells. These interactions contribute to bone destruction.⁹²⁶ Myeloma cells also prevent differentiation of osteoblasts through secretion of the Wnt-signal antagonist DKK1.⁹²⁷ It has been shown that MM cell-derived DKK1, a soluble inhibitor of canonical Wnt signaling, disrupt Wnt3a-regulated OPG and RANKL expression in osteoblasts. This suggests that DKK1 may play a key role in the development of MM-associated bone lesions by directly interrupting Wnt-regulated differentiation of osteoblasts and indirectly increasing osteoclastogenesis via a DKK1-mediated increase in RANKL-to-OPG ratios.⁹²⁸ MIP-1a is produced by myeloma cells and it serves as an inducer of osteoclast formation.⁹²⁹ In turn, osteoclasts produce a number of factors that stimulate myeloma cells, including IL-6.¹⁵⁶

In addition to these cells, other cells that are part of the immune system also play a significant role in the myeloma pathophysiology. It has been shown that bone marrow macrophages, in particular tumor-associated macrophages, were protectors of myeloma cells.⁹³⁰ The protective effect was dependent on direct contact between macrophages and myeloma cells. Macrophages protected both myeloma cell lines and primary myeloma cells from spontaneous and chemotherapy drug-induced apoptosis by attenuating the activation and cleavage of caspase-dependent apoptotic signaling. Using both in vitro and in vivo MM xenograft models, Chauhan et al. showed that plasmacytoid dendritic cells (pDCs) in the bone marrow (BM) microenvironment both mediate immune deficiency characteristic of MM and promote MM cell growth, survival, and drug resistance.⁹³¹

Cytokines and Cell Signaling

The search for a growth factor for myeloma cells culminated in the identification of IL-6, formerly known as B-cell growth factor or hybridoma growth factor.⁹³² IL-6 is among the most important proliferation and survival factors in myeloma.⁹³³ Predominantly produced by bone marrow stromal cells—macrophages, fibroblasts, endothelial cells, osteoblasts, osteoclasts, and monocytes (Fig. 98.10)⁹³⁴—it serves as a growth factor and as an antiapoptotic factor.^{935, 936, 937, 938} IL-6 exerts its cellular effects through gp130, which can activate two pathways: the JAK-STAT pathway⁹³⁹ and the Ras-MAP

kinase pathway.⁹⁴⁰ Through the former pathway, which includes JAK-2 and STAT3, the antiapoptotic proteins MCL-1⁹³⁹ and BCL-XL⁹⁴¹ are up-regulated; through the latter pathway, transcription factors such as ELK-1, AP-1, and NF-IL-6⁹³⁹ are up-regulated. NF-κB⁹⁴² and IL-6^{943, 944} may also mediate the observed increase in the antiapoptotic proteins BCL-2,^{945, 946} MCL-1,⁹⁴³ and BCL-XL.^{943, 944, 947, 948} The overall effect of these pathways is prevention of apoptosis and enhancement of MM proliferation. In addition, the constitutive activation of STAT3 may also be important in the pathogenesis of MM, independent of IL-6.⁹⁴⁹ Moreover, CD40 activation of myeloma cells can alter the cell surface phenotype, triggering autocrine IL-6 secretion regulating the myeloma cell cycle in a p53-dependent fashion.⁹⁵⁰

Other cytokines and growth factors produced by myeloma and stromal cells that maintain myeloma growth⁹⁵¹ include IL-1β,^{952, 953, 954} VEGF, insulinlike growth factor (IGF),^{955, 956, 957, 958, 959, 960} hepatocyte growth factor (HGF),⁹⁶¹ and tumor necrosis factor-α.^{962, 963} Aberrant expression of IL-1β may be a critical step in the transition of MGUS to MM.^{902, 954} IL-1β up-regulates production of IL-6, changes expression of cell adhesion molecules, and has been shown to have osteoclast-activating factor activity. Although IL-1β does not stimulate myeloma cell proliferation directly, by virtue of its effect on stromal cells in the marrow it induces production of IL-6⁹⁰³ and IL-8.⁹⁶⁴ Myeloma cells are capable of expressing and secreting VEGF and responding to the cytokine in an autocrine fashion.^{904, 905} Moreover, stromal and microvascular endothelial cell exposure to VEGF induces an increase in IL-6 secretion,⁹⁰⁴ which then further stimulates myeloma cells. The precise role basic fibroblast growth factor (bFGF), another potent angiogenic factor, plays in the growth of myeloma cells is under active investigation.⁹⁶⁵ Higher bFGF levels have been found in more advanced stages of MM.⁹⁶⁵ IGF, which is believed to signal through the phosphatidylinositol-3'-kinase (PI-3K) pathway,⁹⁵⁵ is capable of directly stimulating myeloma cell growth and enhancing myeloma cell responsiveness to IL-6 through mitogen-activated protein kinase⁹⁵⁸ and also inhibiting apoptosis by increasing expression of BAD.⁹⁵⁵

Cell Cycle

Regulatory signals underlying proliferation of myeloma cells include increased cyclin D1 expression, hypermethylation of the cyclin-dependent kinase (CDK) pathway regulatory gene p16,⁹⁶⁶ mutations of the RAS oncogene,^{868, 870} loss of TP53,^{868, 870} and overexpression of MYC in progressive disease.⁹⁶⁷ Approximately one third of myeloma patients have up-regulation of cyclin D1 by immunohistochemistry; the plasma cells of these same patients tend to have higher proliferative rates.⁹⁶⁸ The t(11;14)(q13;q32) translocation, which juxtaposes the immunoglobulin heavy chain promoter and the cyclin D1 gene, is seen in approximately 25% of MM patients.^{778, 841, 969, 970, 971} Bergsagel et al. has postulated that activation of one of the three cyclin D genes is an initiating event in myeloma.⁹⁷²

Both p15 and p16 are important cell cycle inhibitors that suppress cell proliferation through inhibition of CDK4 or CDK6 or both, thereby preventing the phosphorylation of the retinoblastoma gene (RB). Although large deletions of p15 and p16 are rare in myeloma (0% to 12% of cases),^{973, 974, 975} selective methylation of these genes, a form of transcriptional inactivation, occurs in as many as 67% and 75% of cases, respectively.^{976, 977, 978} Most data suggest that methylation of p16 or p15 is associated with disease progression.⁹⁷⁹

K- and N-RAS mutations have been described in 25% to 100% of newly diagnosed MM patients,^{862, 870, 980} depending on the technique used for detection. A TP53 tumor suppressor gene deletion is present in plasma cells from nearly 10% of patients with newly diagnosed myeloma^{818, 981} and mutations are even less common.^{857, 858, 859, 860} The MYC protein and MYC RNA are overexpressed in about 25% of MM patients.^{982, 983} Rearrangements of the MYC gene are present in about 15% of patients with MM or primary PCL.⁹⁸⁴ Dysregulation of MYC appears to be caused principally by complex genomic rearrangements that occur during late stages of MM progression.⁹⁶⁷

SPECIAL CASES OF MYELOMA

Nonsecretory Multiple Myeloma

Nonsecretory MM accounts for 1% to 5% of myeloma cases.^{124, 985, 986, 987, 988, 989} With more sensitive testing such as immunofixation⁹⁹⁰ and free light chain assays,¹⁹ a majority of these "nonsecretory" patients are found to be low secretors or oligosecretory. More than 85% of cases have a cytoplasmic monoclonal protein; in the remainder, no monoclonal protein can be detected in the cytoplasm.^{988, 989, 991} Individuals in this latter group are referred to as "nonproducers."

P.2090

From a clinical standpoint, both are termed "nonsecretory." Median survival of these patients is at least as good as for those with secretory myeloma.^{985, 987, 988} Response is difficult to document, but with the new serum assays, quantitation of free light chains is possible in about two thirds of these patients.¹⁹

Immunoglobulin D and E Multiple Myeloma

IgD myeloma accounts for about 2% of all cases of MM.⁹⁹² The presence of a monoclonal IgD in the serum usually indicates MM, but three cases of IgD MGUS have been documented.⁹⁸⁶ Patients with IgD MM generally present with a small band or no evident M spike on serum protein electrophoresis. Their clinical presentation is similar to that of patients with Bence Jones MM (light chain MM) in that both have a higher incidence of renal insufficiency and coincident amyloidosis as well as a higher degree of proteinuria than in IgG or IgA MM.⁹⁹² IgD MM patients, however, appear to have a higher frequency of monoclonal lambda light chain than kappa light chains.⁹⁹² With an incidence of 19% to 27%, extramedullary involvement is more prevalent in patients with IgD MM.^{993, 994, 995} Survival of patients diagnosed after 1980 is comparable to patients with non-IgD MM.^{986, 996}

IgE myeloma is a rare form of MM. A disproportionate number of cases are PCL, although the sample size is small, with only about 40 cases of IgE myeloma reported in the literature.^{997, 998}

Plasma Cell Leukemia

PCL is a rare form of PCD. Between 2% and 4%^{850, 999, 1000} of malignant PCD cases are PCL. By definition, there are more than 20% plasma cells in the peripheral blood with an absolute plasma cell count of more than $2 \times 10^9/L$. Some authors accept the diagnosis with only one of these criteria.⁹⁸⁶ The presentation may be primary, de novo, or secondary, evolving from an existing case of myeloma as part of the terminal phase of the disease. About 60% to 70% of cases are primary.⁹⁹⁹

PCL plasma cells more frequently express the CD20 antigen⁸⁵⁰ than those of MM (50% vs. 17%), and they often lack CD56 antigen,^{148, 850} which is present on the majority of MM cells.⁸⁵⁰ CD56 is considered important in anchoring plasma cells to bone marrow stroma and is associated with a poor prognosis.^{149, 150} CD28 is more frequently expressed on malignant plasma cells in secondary than in primary PCL, which is consistent with an observation made in MM, i.e., that acquisition of the CD28 antigen on plasma cells appears to correlate with an increased proliferative rate and disease progression.⁸⁹¹

PCL plasma cells have higher proliferative rates⁸⁵⁰ and more complex karyotypes than myeloma plasma cells.¹⁰⁰⁰ By comparative genomic hybridization and by FISH techniques, losses on 13q^{1001, 1002} and monosomy 13⁸⁵⁰ exist in more than 80% of PCL patients.^{1001, 1002} Losses on chromosome 16 also occur in about 80% of cases.¹⁰⁰² Gains in 1q are present in about half of the patients by FISH,⁸⁵⁰ but in all by comparative genomic hybridization.¹⁰⁰² In addition, PCL patients have unique losses of 2q and 6p.¹⁰⁰² Overexpression of PRAD1/cyclin D1 and t(11;14) is commonly observed in PCL.¹⁰⁰³

The clinical presentation of primary PCL is more aggressive than that of MM, with a higher presenting tumor burden and higher frequencies of extramedullary involvement, anemia, thrombocytopenia, hypercalcemia, renal impairment,^{850, 999, 1000, 1004} increased levels of serum lactate dehydrogenase and $\beta 2M$, and plasma cell proliferative activity.⁸⁵⁰ The incidence of lytic bone lesions is slightly lower than that usually observed in MM.^{850, 1005}

Although the clinical and laboratory features of primary and secondary PCL are similar,^{1005, 1006} the response to therapy and OS in primary and secondary PCL go from poor to worse.^{999, 1000, 1004, 1005} Higher response rates can be achieved with multiagent chemotherapy rather than single alkylator programs (47% to 66% vs. 8% to 13%).^{850, 999, 1000, 1005} Regimens such as VMCP/VBAP, VAD, and combination cyclophosphamide and etoposide have resulted in median survivals of 18 to 20 months compared with 2 to 6 months when single-agent therapy is used.^{850, 999, 1000, 1005} When thalidomide and dexamethasone are used, responses are possible.^{1007, 1008} There are anecdotal reports of activity of bortezomib in these patients.^{1009, 1010, 1011} Some patients derive excellent responses and 2- to 3-year disease-free survivals after ASCT.^{1012, 1013, 1014, 1015, 1016} Saccaro et al.¹⁰¹⁷ reported on the cumulative outcomes of the literature of PCL patients undergoing hematopoietic stem cell transplantation. Median survival post autologous ASCT was 36 months, whereas it was only 12 months after allogeneic ASCT. Registry studies have shown that overall survival with primary PCL approaches that of multiple myeloma, and up-front ASCT appears to outperform AlloSCT even when reduced intensity protocols are used.¹⁰¹⁸

Response and survival rates with secondary PCL remain low.^{1005, 1006} See the recent review of PCL.¹⁰¹⁹

Osteosclerotic Myeloma (POEMS Syndrome)

Osteosclerotic myeloma is a rare variant of myeloma ($\leq 3.3\%$ of cases).¹⁰²⁰ There is a straight osteosclerotic variant that is similar to MM in that anemia, significant bone marrow plasmacytosis, hypercalcemia, and renal insufficiency occur.¹⁵⁸ Survival in these patients is comparable to that of classic MM patients. There is, however, a more interesting form, which is known as Crow-Fukase syndrome, PEP (PCD, endocrinopathy, polyneuropathy) syndrome, Takatsuki syndrome, and POEMS syndrome (polyneuropathy, organomegaly, endocrinopathy, M protein, and skin changes).^{1021, 1022, 1023, 1024} This variant is discussed in Chapter 101.

TREATMENT OF COMPLICATIONS AND SUPPORTIVE CARE

Complications Specific to Novel Therapies

Thrombosis is an important complication in patients undergoing treatment with IMiDs. As a single agent, there does not appear to be any heightened risk; however, concomitant chemotherapy,³⁸⁹ especially anthracyclines,^{1025, 1026} high-dose corticosteroids,^{359, 407, 1027} and erythropoietin¹⁰²⁸ appears to increase the risk of thrombosis to as high as 58%. A phase III trial¹⁰²⁹ compared aspirin (100 mg/day), low-dose warfarin (1.25 mg/day), and enoxaparin (40 mg/day) in 667 patients with previously untreated myeloma receiving a thalidomide-based regimen. The primary endpoint was a composite that included serious thromboembolic events, acute cardiovascular events, or sudden deaths during the first 6 months of treatment. The most frequent complications were thromboembolic events that occurred in 5.9% in the aspirin group, 8.2% in the warfarin group and 3.2% in the LMWH group. Symptomatic pulmonary embolism episodes occurred only in the aspirin and warfarin groups. The absolute differences for serious thromboembolic events were +2.7% (P = 0.173) between aspirin and LMWH groups and +5.0% (P = 0.024) between warfarin and LMWH groups. These results did not reach a statistical significance. The same group conducted a prospective trial comparing aspirin (ASA) to low molecular weight heparin (LMWH) in 342 newly diagnosed patients¹⁰³⁰ who were treated with lenalidomide and dexamethasone or MPR. Patients were randomly assigned to receive ASA 100 mg/d (n = 176) or LMWH enoxaparin 40 mg/d (n = 166). The incidence of VTE was 2.27% in the ASA group and 1.20% in the LMWH group, a difference that was not significant. Based on this, ASA can be an effective and less-expensive alternative to LMWH thromboprophylaxis. Of note, however, patients considered high risk for VTE were excluded from both these studies. Those patients with advanced age, inherited thrombophilic

P.2091

abnormalities, recent surgery, or a history of VTE should be considered for full-dose anticoagulation.

Pharmacologic Therapy of Myeloma Bone Disease

Myeloma bone disease is a significant contributor to morbidity, and there is expanding information about the relationships between bone turnover and plasma cell growth and survival.^{157, 926, 1031, 1032, 1033} A randomized trial has demonstrated that treating with bisphosphonates not only helps prevent secondary bony events in patients with existing bone lesions, but that the use of monthly zoledronic acid as compared to clodronate increases median OS of ALL patients (whether they have bone lesions or not) by 6 months.¹⁰³⁴ Bisphosphonates inhibit dissolution of the hydroxyapatite crystals and down-regulate the major osteoclast functions. After internalization, the nitrogen-containing bisphosphonates interfere with the biosynthetic mevalonate pathway by inhibiting farnesyl diphosphonate synthase with resultant inability of osteoclasts to form the ruffled borders of their membrane needed to activate bone resorption.

The first study showing a reduction of almost 50% of secondary skeletal events among myeloma patients who received monthly intravenous administration of pamidronate was published in 1996.¹⁰³⁵ At 12 months, there were fewer skeletal-related events in the pamidronate group than in placebo-treated patients (28% vs. 44%; P < 0.001).^{1035, 1036} With longer follow-up of 21 months, the difference between groups persisted but narrowed slightly to 28% in the pamidronate group versus 51% in the placebo group (P < 0.015).¹⁰³⁷ This prospective study subsequently led the FDA to approve the use of the drug in this setting. Equivalency of pamidronate and zoledronic acid has been demonstrated in two randomized clinical trials, a randomized phase II¹⁰³⁷ and a randomized phase III.¹⁰³⁸ In the phase III trial, patients with MM or breast cancer, who had lytic disease, were treated with zoledronic acid (4 or 8 mg per dose) or pamidronate (90 mg) every 3 to 4 weeks. The infusion time for zoledronic acid was increased from 5 minutes to 15 minutes during the trial due to an increase in creatinine occurring more frequently among patients receiving the rapid infusion. Renal problems continued to occur more often among patients randomized 8 mg zoledronic acid and their dose was subsequently reduced to 4 mg. The sample size was based on showing noninferiority of zoledronic acid to pamidronate, and of 1,648 patients who were enrolled 510 had MM and the remainder had metastatic breast cancer. The portion of patients with any SRE after 13 months did not differ among the three treatments and did not differ between the breast cancer and MM patients. In February 2002, the FDA approved an expanded indication for zoledronic acid for the treatment of patients with bone metastases that included its use in MM.

Despite the fact that the longest follow-up of patients in these studies was 24 months, the recommendation by the American Society of Clinical Oncology was to continue these agents indefinitely at monthly intervals.¹⁰³⁹ The rationale for practice was not data driven, but based on several theoretical benefits. The first was that patients have continued bone disease throughout the course of their disease. The second was predicated on the in vitro and in vivo (murine) data that bisphosphonates exert antitumor activity.¹⁰³¹

In the short-term, the drugs were well tolerated, with occasional episodes of mild pyrexia, renal function impairment, myalgias, and hypocalcemia. However, by 2003, avascular osteonecrosis of the jaw (ONJ) has been described as a new

complication associated with their use.^{1040, 1041, 1042, 1043, 1044, 1045, 1046, 1047, 1048, 1049, 1050} Bisphosphonate-associated ONJ has been described in various malignancies including MM, breast cancer, and prostate cancer. A management algorithm for ONJ has recently been published.¹⁰⁵¹ It has been seen in both the mandible and the maxilla but is more frequent in the former. The etiology of ONJ is unclear, but is likely multifactorial in origin. Although most patients who develop ONJ have had recent dental or oral surgical procedures (70%), the remainder develop spontaneous ONJ.¹⁰⁴⁵ Proposed mechanisms include that inhibition of osteoclast activity reduces bone turnover and remodeling and that bisphosphonates prevent release of bone-specific factors that promote bone formation.¹⁰⁵² In addition, bisphosphonates, particularly zoledronic acid, may have antiangiogenic effects which has been implicated in the development of ONJ. Finally, healing of an open bony oral wound may be challenged by bacterial insult from oral microflora.

The true incidence of this complication is hard to estimate, but is somewhere around 6.8% to 9.9%.^{1047, 1048} Risk factors for ONJ are longer duration of treatment, zoledronic acid (as compared to pamidronate). In one study,¹⁰⁴⁷ patients who developed ONJ received a median number of 35 infusions (range, 13 to 68) compared to 15 infusions (range, 6 to 74) for patients with no ONJ. The optimal dosing schedule and duration of therapy has not been adequately defined by randomized clinical trials. One retrospective study suggested quarterly infusions of zoledronic acid are as effective as monthly infusions with less risk of ONJ.¹⁰⁵³

Most would agree that 1 to 2 years of IV bisphosphonate is standard after a dental check-up. The role of these drugs after this time-point is uncertain. Many opt to reduce the frequency of administration after 2 years, especially if disease is in remission. Once on these drugs, invasive dental procedures should be limited if possible. Other drugs such as bone seeking radionuclides^{561, 1054, 1055} and inhibitors of the receptor activator of nuclear factor κ B (RANK) signaling known as osteoprotegerin¹⁰⁵⁶ are being tested. Denosumab (a fully human monoclonal anti-receptor activator of nuclear factor kappa-B ligand antibody) was compared to zoledronic acid for delaying or preventing skeletal-related events.¹⁰⁵⁷ Denosumab was noninferior to zoledronic acid in delaying a first skeletal event. Hypocalcemia was more commonly seen in the denosumab-treated patients.

The standard method of following patients is with periodic (every 6 to 12 months) skeletal radiographs; the use of more sophisticated imaging modalities has been described in a previous section. Cross-linked N-telopeptides of Type I collagen, which can be measured in the serum or urine, appear to be a sensitive indicator of bone turnover,^{799, 1058} and urinary levels show a strong positive correlation with the dynamic histomorphometric indices of bone resorption.¹⁰⁵⁹ Serum levels of bone metabolism markers including osteocalcin, MIP-1 α , RANKL, and osteopetegrin have been studied and shown to be aberrantly expressed in patients with active myeloma.¹⁵⁷

Nonpharmacologic Treatment of Myeloma Bone Disease

When a lytic bone lesion is present, significant risk factors for fracture of a long bone include increased pain with use, and the involvement of more than the diameter of the bone. These lesions should be treated prophylactically with surgery if they are situated in weight-bearing bones.¹⁰⁶⁰ Endosteal resorption of one half the cortical width of the femur weakens the bone by 70%. Surgical treatment should be considered for these lesions as well.¹⁰⁶¹ Once a bone has fractured, healing can occur especially if proper internal fixation is performed and if patients have an anticipated survival of >6 months. Much of the data regarding malignant bone disease are derived from patients with carcinoma rather than MM. In patients with carcinoma metastatic to bone, modest post-operative radiation doses ($\leq 3,000$ cGy) as adjuvant therapy are associated with better healing,¹⁰⁶² but the role of adjuvant radiation therapy in MM patients is less clear. MM is often chemotherapy sensitive; adjuvant systemic chemotherapy in MM patients may be more appropriate than adjuvant radiation therapy. In general, radiation therapy should be used for pain

P.2092

relief in chemotherapy-refractory disease, because it relieves pain in 80% to 90% of patients with bony metastases,¹⁰⁶³ long-term in 55% to 70%.¹⁰⁶⁴

Percutaneous vertebroplasty is occasionally an option for patients with vertebral body compression fracture. Pain relief is generally apparent within 1 to 2 days after injection and persists for at least several months up to several years.¹⁰⁶⁵ Complications are relatively rare, although some studies reported a high incidence of clinically insignificant leakage of bone cement into the paravertebral tissues. Compression of spinal nerve roots or neuralgia due to the leakage of polymer and pulmonary embolism have also been reported. Percutaneous kyphoplasty is also an option.¹⁰⁶⁶ There is one published trial in patients with MM that randomized patients in an unblinded fashion to kyphoplasty or nonsurgical management.¹⁰⁶⁷ At 1 month, the back specific disability score was significantly better in the kyphoplasty group. Inasmuch

as patients in the control group had the option of crossing over to the kyphoplasty arm, there are no long-term data on outcomes.

Spinal Cord Compression

In a paper published in 1979, it was estimated that nearly 10% of patients with myeloma either present with spinal cord compression or that it develops during the course of the disease;¹⁰⁶⁸ with higher awareness of myeloma and better imaging technology, the incidence is likely lower now. Cord compression, however, remains an important and emergent subject. The usual standard treatment is high-dose corticosteroids and radiation therapy.^{1069, 1070, 1071, 1072} On rare occasions, surgical decompression may be considered. Because most myelomatous lesions arise from the vertebral body, an anterior surgical approach is generally used, which may contribute additional morbidity. One small randomized trial addressing the question of radiation versus laminectomy and radiation, showed no benefit attributable to laminectomy;¹⁰⁷⁰ similarly, a larger retrospective series found no benefit.¹⁰⁶⁹ If the deficit is due to compression by the plasma cell tumor (rather than a bone fragment retropulsed by a pathologic compression fracture), outcomes with radiation therapy are probably equal (or superior) to surgical intervention in a radiosensitive tumor such as myeloma.^{1069, 1070}

High-dose corticosteroids may provide immediate pain relief and improvement in neurologic function.^{1071, 1072} The optimal corticosteroid dose has not been established, but common dose schedules for metastatic disease include dexamethasone in an initial bolus of 10 mg intravenously or 100 mg intravenously followed by 4 mg orally 4 times daily;¹⁰⁷³ or a 100-mg intravenous bolus followed by 96 mg in four divided doses for 3 days followed by tapering doses.^{1071, 1072}

Hypercalcemia

Patients with MM are at risk of severe hypercalcemia that can precipitate acute renal failure, hypertension, nausea, vomiting, pancreatitis, cardiac arrhythmia, coma, and death. The extracellular volume depletion associated with hypercalcemia should be corrected by vigorous hydration^{745, 1074} followed by an antiresorptive agent such as intravenous bisphosphonate. Serum calcium values usually decline rapidly, reaching the normal range within 2 to 3 days in more than 80% of cases. It occasionally goes below normal at the nadir. Corticosteroids can also reduce serum calcium concentration in about 60% of patients with hypercalcemia.¹⁰⁷⁵

Gallium nitrate, mithramycin, and calcitonin are interesting from an historical perspective. Since the advent of bisphosphonates, they are not often used. Gallium nitrate therapy had been shown to be superior to maximally approved doses of calcitonin for acute control of cancer-related hypercalcemia.¹⁰⁷⁶

Hematologic Complications Including Anemia, Secondary Leukemia, Hyperviscosity, and Cryoglobulinemia

Anemia

The anemia of MM can result from many factors. When the anemia is due solely to myelomatous bone marrow infiltration, chemotherapy remedies the problem. Other patients have a relative erythropoietin deficiency related to renal injury due to the myeloma or to age-related changes. In these patients, as in any patient with renal insufficiency, modest doses of recombinant erythropoietin are effective. For patients with chemotherapy-induced anemia, recombinant erythropoietin may be effective at higher doses (150 to 300 IU/kg thrice weekly or 40,000 units weekly). Two placebo-controlled trials in myeloma patients demonstrate significantly improved hemoglobin levels and a reduced number of red cell transfusions in patients receiving erythropoietin.^{1077, 1078} Erythropoietin increases the risk of thrombotic events.

Secondary Myelodysplasia and Acute Leukemia

The most ominous cause of anemia in the setting of previously treated MM is a secondary myelodysplastic syndrome or acute leukemia. Kyle et al.⁵⁸³ were among the first to recognize that cytotoxic agents can induce myelodysplasia and acute myeloid leukemia.^{583, 584, 585, 586} The risk of a secondary myelodysplastic syndrome or acute leukemia is approximately 3% at 5 years and 10% at 8 to 9 years,^{1079, 1080} with estimates as high as 25% at 10 years,¹⁰⁸¹ with multiple other estimates somewhere in between.^{385, 587, 588} Some authors have suggested that higher cumulative doses of melphalan are implicated as a risk for acute leukemia.¹⁰⁷⁹ Others have shown no difference in incidence based on the number of courses of chemotherapy or the cumulative melphalan dose between the patients who did and did not develop acute leukemia.¹⁰⁸⁰ In a Finnish study, the mean number of chemotherapy cycles was 19.7 and 18.5 in patients with and without secondary leukemia; mean cumulative melphalan doses were 1,440 and 1,400 mg, respectively.¹⁰⁸⁰ Although cyclophosphamide has been shown to be leukemogenic, data suggest that it is less so than melphalan.^{1079, 1082, 1083} After secondary leukemia is diagnosed, median survival tends to be short, about 2 months.¹⁰⁸⁰

The occurrence of concurrent acute leukemia in MM suggests that there may be a proclivity for acute leukemia to develop in patients with myeloma.^{1084, 1085} After stem cell transplantation for myeloma, the risk of myelodysplastic syndrome appears to be related to prior chemotherapy rather than to the transplant itself, at least in one retrospective series.¹⁰⁸⁶

Cryoglobulinemia and Hyperviscosity

Approximately 5% of myeloma gammaglobulins exhibit reversible precipitation in the cold, so-called cryoglobulins, forming either a flocculent precipitate or a gel-like coagulum when the serum is cooled.¹⁰⁸⁷ Plasmapheresis relieves the symptoms of hyperviscosity, but the benefit of this treatment in the absence of concurrent chemotherapy is short lived.¹⁰⁸⁸

Renal Failure

Normal creatinine values are present in approximately 50% of MM patients at diagnosis,^{124, 125, 126, 127, 178, 179, 180, 181} and only 15% to 25% have a creatinine value above 2 mg/dl.^{126, 184} Patients in whom the renal failure is reversed have a better OS than those without improvement.^{182, 185} Factors that increase renal tubular cast formation include dehydration, infection, and hypercalcemia. There is some controversy around best management of patients with renal failure in terms of plasmapheresis and the relative

P.2093

importance of alkylizing urine, but there are four points that are incontrovertible: (1) achieve a deep hematologic response as soon as possible, (2) avoid nephrotoxic drugs, (3) correct hypercalcemia, and (4) correct dehydration (maintaining a 24-hour fluid intake of at least 3 liters can improve renal function).¹⁸²

In terms of best chemotherapeutic regimens to achieve rapid hematologic response, several have already been discussed. A bortezomib-based regimen such as CyBORd, VTD, or PAD is often favored in the setting of renal failure. In a recent trial in which patients were randomized to VAD or PAD followed by ASCT, the subset of patients presenting with creatinine above 2 mg/dl and who were randomized to PAD had a markedly improved median survival as compared to the VAD patients (54 months vs. 21 months, $P < 0.001$). Because light chains with the lowest isoelectric points tend to be more nephrotoxic in animal models, avoidance of a low or acidic urinary pH is recommended. Oral or intravenous bicarbonate is useful in the setting of acute renal failure.¹⁰⁸⁹ The MRC third myelomatosis trial randomized MM patients with significant renal failure to oral sodium bicarbonate to neutralize urine pH (or not), and there was a trend toward better survival in the bicarbonate recipients.¹⁸²

The use of plasmapheresis in the setting of renal failure remains controversial. There are three randomized trials addressing this question, with conflicting results. One small randomized study of patients with active myeloma and progressive renal failure suggested benefit in a subset of patients.¹⁰⁹⁰ There were 21 patients randomized to either forced diuresis and chemotherapy (10 patients) or forced diuresis, chemotherapy, and plasmapheresis (11 patients). There was a trend toward better outcome in the plasmapheresis group, but the difference was not statistically significant. It is unclear whether the lack of significance is due to the small sample size, or to an equivalence of the two therapeutic strategies. The study did demonstrate that the severity of myeloma cast formation directly correlated with lack of improvement regardless of treatment strategy.

Another randomized study in myeloma patients with severe renal compromise compared plasma exchange (and hemodialysis when needed) with peritoneal dialysis.¹⁰⁹¹ All patients received chemotherapy and corticosteroids. Of the 29 patients in the study, 24 received dialysis and 5 maintained serum creatinine concentrations of greater than 5 mg/dl without dialysis. Of the 15 patients in the plasmapheresis ± hemodialysis group 13 recovered renal function, reaching serum creatinine values of less than or equal to 2.5 mg/dl in most cases, whereas only 2 patients in the peritoneal dialysis group had enough improvement to stop dialysis. The 1-year survival rates were 66% and 28%, respectively ($P < 0.01$). The study's design was flawed in that one group received peritoneal dialysis and the other hemodialysis; the question about the role of plasmapheresis is not adequately settled.

The largest and most recent trial was a negative study.¹⁰⁹² A total of 104 patients with newly diagnosed myeloma and a creatinine of 2.3 mg/dl were randomized to conventional chemotherapy with or without five to seven sessions of plasma exchange over 10 days. The primary outcome was a composite measure of death, dialysis dependence, or glomerular filtration rate of less than 30 ml/min/1.73 m². At 6 months the endpoint was reached in 58% of the plasma exchange group and 69% of the control group. At 6 months, 7 of the 39 control patients (18%) and 5 of 58 plasma exchange patients (9%) were on dialysis. At 6 months, 33% of each group had died. Criticisms of this study included the patient selection, including the absence of renal biopsy, the use of relatively ineffective conventional chemotherapy, and small sample size.

Patients were eligible if the serum creatinine level was 2.3 mg/dl with an increase greater than 0.6 mg/dl in the preceding 2 weeks despite correction of hypercalcemia, hypovolemia, and metabolic acidosis. This would imply that institution of plasma exchange was delayed and that there could have been underlying pathologic renal lesions other than cast nephropathy, which would not be responsive to plasma exchange. More than twice as many patients on the plasma exchange group had MP as in the control group, which could have confounded the results because both overall response rates are lower and time to response is longer with MP than with VAD.

Infection Management

Infections are a major cause of morbidity in myeloma patients.^{1093, 1094} Pneumonias and urinary tract infections caused by *Streptococcus pneumoniae*, *Haemophilus influenzae*, and *Escherichia coli* are most frequent.^{193, 1095, 1096, 1097} The susceptibility to infection varies with the phase of illness.^{192, 1098} In one prospective study, the overall serious infection rate was 0.92 infections per patient-year and was four times higher during periods of active disease (1.90) than in plateau phase myeloma (0.49).¹⁹¹ In a retrospective study evaluating the sequential incidence of infection, the first 2 months of initial chemotherapy emerged as a particularly high-risk period, with nearly half of the patients experiencing at least one clinically significant infection.¹⁹² Infections late in the course of MM may be an inevitable result of long-standing immunosuppression and overwhelming tumor burden. Prevention of infection is a critical goal for improving survival.

Prevention of infections by use of vaccines is an attractive strategy. Unfortunately, responses to vaccines are poor among myeloma patients.^{198, 1099, 1100, 1101} Patients with MM were investigated to assess whether immunologic risk factors predisposing to serious infection could be identified.¹⁹¹ Specific antibody titers to pneumococcal capsular polysaccharides and tetanus and diphtheria toxoids were significantly reduced compared with the control population. Low antipneumococcal and anti-*Escherichia coli* titers correlated with risk of serious infection. In addition, among 41 immunized patients, responses to pneumococcus vaccine and tetanus and diphtheria toxoids were poor. IgG subclass levels were significantly reduced, and a poor IgG response to pneumococcus vaccine immunization was associated with an increased risk of septicemia. The predominant site of infection was the respiratory tract. Decreased concentrations of the uninvolved immunoglobulins were significantly associated with at least one serious infection.¹⁹¹

The two most common prevention strategies consist of prophylaxis with antibiotics¹¹⁰² or intravenous immunoglobulin (IVIg).¹¹⁰² A randomized, placebo-controlled trial of trimethoprim-sulfamethoxazole (TMP-SMX) demonstrated a significant decrease in severe infections among newly diagnosed myeloma patients randomized to TMP-SMX compared with controls.¹¹⁰³ A larger follow-up trial, however, failed to show a benefit from prophylactic antibiotics.¹¹⁰⁴ In that study 212 untreated, symptomatic myeloma patients who were on chemotherapy were randomized to receive ciprofloxacin (n = 69), trimethoprim-sulfamethoxazole (n = 76), or observation (n = 67) for the first 2 months of treatment. The use of prophylactic antibiotics did not decrease the incidence of infection.

A randomized, double-blind placebo-controlled trial demonstrated that IVIg significantly reduced the number of infections in high-risk patients with plateau phase MM.¹¹⁰² Eighty-two such patients received either IVIg (0.4 g/kg per month) or an equal volume of placebo for 1 year. There were no episodes of septicemia or pneumonia in patients receiving IVIg compared with 10 in placebo patients (P = 0.002). There were 38 serious infections in 470 patient-months for the placebo group, compared with 19 in 449 patient-months for the IVIg group (P = 0.019). A poor antibody response to pneumococcal vaccination (less than twofold increase) identified patients who had maximum benefit from IVIg. However, IVIg is expensive and inconvenient and can be associated with toxicity. Therefore, use of this agent is recommended only for patients with a significant history of severe infections.

P.2094

DIFFERENTIAL DIAGNOSIS

The diagnosis of MM is made from a constellation of findings, including anemia, monoclonal proteins, bone lesions, renal complications, hypercalcemia, and bone marrow plasmacytosis. Often the diagnosis is straightforward, but other disease entities associated with hypergammaglobulinemia or monoclonal bone marrow plasma cells must also be considered. These include reactive plasmacytosis, MGUS, primary systemic amyloidosis, Waldenström macroglobulinemia, light chain deposition disease, acquired Fanconi syndrome, solitary plasmacytoma, osteosclerotic myeloma or POEMS syndrome, and PCL.

Reactive plasmacytosis and polyclonal hypergammaglobulinemia must be distinguished from a clonal process. Patients with liver disease, chronic infections including human immunodeficiency virus, connective tissue diseases, other

lymphoproliferative disorders, and carcinoma can have increased bone marrow plasmacytosis (polyclonal) and hypergammaglobulinemia (polyclonal).^{22, 123} These conditions should not be confused with MM or MGUS, which are clonal processes.

MGUS patients do not have bone marrow suppression, lytic bone lesions, hypercalcemia, renal failure, or susceptibility to infection. Standard clinical features do not accurately predict which patients will remain stable, and in approximately 1% per year MM develops.¹³³ The clinical distinction between MGUS and asymptomatic MM is derived from an arbitrary definition (Table 98.1), although the underlying biologic conditions may prove to be different.

The greatest challenges in differentiating MGUS (or asymptomatic MM) from MM occur in patients who have MGUS and (1) senile osteoporosis, (2) renal insufficiency from another cause, or (3) hypercalcemia due to hyperparathyroidism. Approximately 50% of women older than age 60 years have osteoporosis, and a fraction of these have vertebral compression fractures. Computed tomographic scan of the spine may help distinguish between senile osteoporosis and myelomatous bone disease. Similarly, renal insufficiency due to long-standing diabetes, hypertension, or nonsteroidal drug use is not uncommon. In such cases, a patient may still have MGUS (or smoldering MM) and "end-organ damage." The key is whether the damage is attributable to the plasmaproliferative disorder or another cause. In some instances, renal biopsy may be required to clarify this issue.

Immunoglobulin light chain amyloidosis (AL amyloidosis) is a rare disorder that is characterized by the deposition of amyloid fibrils and is discussed in Chapter 99. The diagnosis should be suspected when a patient with a monoclonal protein in the serum or urine presents with nephrotic-range proteinuria (primarily albumin) with or without renal insufficiency, cardiomyopathy, hepatomegaly, or peripheral neuropathy. A histologic diagnosis is made by demonstrating the amyloid fibrils: green birefringence under polarized light by using a Congo red stain, or 8- to 10-nm nonbranching fibrils by electron microscopy.

The nonamyloidogenic light chain deposition diseases (LCDDs) are due to pathologic protein deposition in various tissues and organs. Unlike the light chain deposits observed in patients with primary systemic amyloidosis, these infiltrates are not congophilic by light microscopy, and nonbranching fibrils are not observed by electron microscopy. Instead, amorphous nodular deposits are seen. LCDD may occur with or without co-existent MM. Renal involvement is most common, followed by cardiac and hepatic deposits. Clinically, LCDD can be differentiated from MM and primary systemic amyloidosis by the following findings. As in primary systemic amyloidosis, early in the disease course the light chain deposits have a predilection for the renal glomeruli rather than the tubules. This results in nonselective proteinuria, that is, a predominance of albuminuria, which is not usual in MM. It is impossible without tissue biopsy to distinguish clinically the cardiomyopathy and hepatopathy from primary systemic amyloidosis. In LCDD, the underlying clone is more commonly monoclonal κ rather than λ . The prognosis of patients who have this disorder depends on whether there is underlying MM. In one retrospective study of 19 patients with LCDD, 5-year actuarial patient survival and survival free of end-stage renal disease were 70% and 37%, respectively.¹¹⁰⁵

Fanconi syndrome is a rare complication of PCDs characterized by diffuse failure in reabsorption at the level of the proximal renal tubule and resulting in glycosuria, generalized aminoaciduria, and hypophosphatemia.¹⁸⁹ Fanconi first described the syndrome in children. Subsequently, acquired forms were described in adults. Acquired Fanconi syndrome is usually associated with MGUS. Overt hematologic malignancies may occur, such as MM, Waldenström macroglobulinemia, or other lymphoproliferative disorders. The prognosis is good in the absence of overt malignant disease. Clinical manifestations include slowly progressive renal failure and bone pain due to osteomalacia. The diagnosis of Fanconi syndrome can be made when a patient with a monoclonal plasma cell disorder presents with aminoaciduria, phosphaturia, and glycosuria. Electrolyte abnormalities typically include hypokalemia, hypophosphatemia, and hypouricemia. Bence Jones proteinuria is usually present and is almost always of the κ type. Rare patients have been reported with Fanconi syndrome associated with λ Bence Jones proteinuria. Treatment consists of supplementation with phosphorus, calcium, and vitamin D. Chemotherapy may benefit patients with rapidly progressive renal failure or symptomatic malignancy.

Waldenström macroglobulinemia should not be confused with IgM myeloma, which comprises only about 1% of myeloma cases.¹²⁶ Patients with Waldenström macroglobulinemia may have anemia, hyperviscosity, B symptoms, bleeding, and neurologic symptoms. Significant lymphadenopathy or splenomegaly may also be present. Lytic bone disease is markedly uncommon; if present, consider whether the patient has IgM myeloma. In Waldenström macroglobulinemia, bone marrow biopsy typically reveals infiltration with clonal lymphoplasmacytic cells (CD20 positive). The natural history and treatment options for Waldenström macroglobulinemia are different from those of MM¹¹⁰⁶ (Chapter 100).

Solitary plasmacytoma of bone is a rare form of plasmaproliferative disease. Its true incidence has not been described, but it accounts for about 2% to 5% of malignant plasma cell dyscrasias treated at large referral centers.^{208, 1107, 1108} In most series, the definition has required the following characteristics: (1) histologic proof that the solitary lesion is a plasmacytoma; (2) no other bone lesions on metastatic bone survey; (3) less than 5% plasma cells from a random bone marrow biopsy site; and (4) the absence of anemia, hypercalcemia, or renal insufficiency that had no attributable cause. Some definitions allow for <10% bone marrow plasma cells⁷³⁶ and others have restricted the quantity of the serum or urine M spike. Others have excluded patients who developed disseminated myeloma within a year after diagnosis of the solitary plasmacytoma.¹¹⁰⁹ The International Myeloma Working Group has adopted the above definition, but adds that if done, MRI should not demonstrate any other areas of marrow involvement.²⁰⁵

There is a clear male preponderance, and the median age is 55 years.^{740, 1109, 1110, 1111} Plasmacytomas most commonly arise from the axial skeleton, particularly the vertebral bodies. Pain is the usual presentation. Spinal cord or nerve root compression may also be present. If the patient also has evidence of a peripheral neuropathy, and especially if the bone lesion is sclerotic, one should consider the diagnosis of POEMS syndrome (Chapter 101). Monoclonal proteins are present in about 50% of patients.^{736, 1109}

Careful staging should be done in all patients, including a complete blood cell count, protein electrophoresis and immunofixation of the serum and urine, serum immunoglobulin free light

P.2095

chains, a complete radiographic skeletal survey, and random bone marrow aspiration and biopsy. At a minimum, immunohistochemical stains should be done on the bone marrow to identify a clone apart from the solitary plasmacytoma. MRI of the entire spine and pelvis should also be done to determine whether the lesion is solitary. Using MRI, Mouloupoulos et al.¹⁷² found unexpected bone marrow involvement in 4 of 12 patients with apparently solitary plasmacytomas of bone. FDG-PET may also provide useful information.

From an historical perspective, solitary plasmacytomas of bone were treated surgically with or without adjuvant radiation.¹¹¹² Present day, single modality, definitive radiation therapy is the treatment of choice. Although the optimal dose has not been established by randomized controlled trials, 4,000 to 5,000 cGy encompassing all disease with a margin of normal tissue is recommended by most experts on the basis of retrospective local relapse rate data.^{736, 737, 738, 1113} This principle, however, has been challenged by recent data which show no difference in local control as long as the therapeutic dose is over 3,000 cGy.⁷³⁹

Median 10-year disease-free survival is about 25% to 40%.^{736, 1114} Median time to failure, that is, local relapse, appearance of another plasmacytoma, or disseminated myeloma, is about 2 years,^{736, 739, 1114} but these figures are contaminated by inadequate staging of patients. In a retrospective study at a major academic institution, fewer than 5% of patients referred for a diagnosis of solitary plasmacytoma of bone had adequate baseline staging.¹¹¹⁵ The majority of patients with a solitary "plasmacytoma of bone" had a low burden of clonal plasma cells in their marrow. Because these patients are typically not offered immediate chemotherapy, a novel term was used to label these patients, "plasmacytoma plus." The 21-month disease-free survival of patients that did not satisfy criteria for "plasmacytoma plus" was 100%.

Risk factors for evolution to myeloma include absence of a monoclonal protein at presentation (nonsecretory disease), depression of immunoglobulin values at presentation, persistence of the monoclonal protein after treatment,¹¹¹⁴ abnormal immunoglobulin free light chain ratio at presentation,¹¹¹⁶ tumor size of more than 5 cm, and a nonvertebral presentation.⁷³⁹ The persistence of a monoclonal protein after radiation therapy does not guarantee relapse,^{208, 736} even after more than 10 years of followup.¹¹¹⁴ In rare instances, the maximum reduction of myeloma protein may take several years after completion of the radiation therapy.^{208, 736} Median survival for all patients presenting with solitary plasmacytoma of bone—based on data from patients staged before routine use of MRI and bone marrow clonality studies—was approximately 10 years.^{736, 739, 1108, 1114, 1115} For those who progressed to myeloma, the median survival was 44 months after the start of chemotherapy.²⁰⁸ Adjuvant chemotherapy has not been shown to produce a survival advantage and carries the risk of treatment-related myelodysplastic syndromes or acute leukemia; it cannot be recommended.

Solitary extramedullary plasmacytomas represent about 3% of all plasma cell neoplasms.¹¹¹⁸ They most commonly affect men in their early 60s and occur in the upper respiratory tract (paranasal sinuses, nose, nasopharynx, and tonsils). They also occur in lymph nodes, lung, thyroid, gastrointestinal tract, liver, spleen, pancreas, testes, breast, or skin.¹¹¹⁹ Amyloid involvement of the plasmacytoma occurs on occasion. Although extramedullary plasmacytomas are not common in newly diagnosed MM, classic myeloma must be excluded by thorough staging. A monoclonal protein in the serum and urine,

lytic bone lesions, anemia, renal insufficiency, and hypercalcemia should be excluded. Histologically, an extramedullary plasmacytoma should be differentiated from reactive plasmacytosis, plasma cell granuloma, poorly differentiated neoplasms, and immunoblastic lymphoma. Some extramedullary plasmacytomas may represent marginal zone B-cell lymphomas that have undergone plasmacytic differentiation.¹¹²⁰ Dimopoulos et al.¹¹¹⁸ compiled 128 extramedullary plasmacytoma patients from eight published series^{1108, 1119, 1121, 1122, 1123, 1124, 1125, 1126} and summarized their clinical course. The local failure rate was 7%, multifocal extramedullary relapse occurred in 13%, and classic myeloma developed in 15%. Local radiation therapy is the treatment of choice and adjuvant chemotherapy is not recommended. The 10-year disease-free survival is 70% to 80%. Ozsahin et al.¹¹¹⁶ compiled 52 patients through a Rare Cancer Network study. Their findings were similar with a 5-year progression rate of about 25% and a 5-year survival approaching 90%.

Helpful websites for patients and doctors may include:

<http://myeloma.org/>

<http://www.themmr.org/>

msmart.org

clinicaltrials.gov

REFERENCES

1. Harris NL, Jaffe ES, Stein H, et al. A revised European-American classification of lymphoid neoplasms: a proposal from the International Lymphoma Study Group. *Blood* 1994;84(5):1361-1392.
2. Dalrymple J. On the microscopical character of mollities ossium. *Dublin Q J Med Sci* 1846;2:85-95.
3. Kyle RA. Multiple myeloma: an odyssey of discovery. *Br J Haematol* 2000;111(4):1035-1044.
4. Clapp JR. Some aspects of the first recorded case of multiple myeloma. *Lancet* 1967;2:1354-1356.
5. Bence Jones H. Chemical pathology. *Lancet* 1847;2:88-92.
6. von Rustizky J. Multiples myelom. *Deutsche Zeitschrift für Chirurgie* 1873;3:162-172.
7. Kahler O. Zur Symptomatologie des multiplen Myeloms; Beobachtung von Albumosurie. *Prager Med Wochenschr* 1889;14:45.
8. Weber FP. General lymphadenomatosis of bones, one form of "multiple myeloma." *J Pathol* 1898;5:59-64.
9. Weber FP, Hutchison R, MacLeod JJR. Multiple myeloma (myelomatosis), with Bence Jones protein in the urine: (myelopathic, albumosuria of Bradshaw, Kahler's disease). *Am J Med Sci* 1903;126:644-665.
10. Wright JH. A case of multiple myeloma. *Bull Johns Hopkins Hosp* 1933; 52:156.
11. Jacobson VC. A case of multiple myelomata with chronic nephritis showing Bence Jones protein in urine and blood serum. *J Urol* 1917;1:167-178.
12. Walters W. Bence Jones proteinuria: a report of three cases with metabolic studies. *J Am Med Assoc* 1921;76:641-645.
13. Arinkin MI. Die intravitale Untersuchungsmethodik des Knochenmarks. *Folia Haematologie* 1929;38:233-240.
14. Tiselius A. Electrophoresis of serum globulin. II. Electrophoretic analysis of normal and immune sera. *Biochem J* 1937;31:1464-1477.
15. Longsworth LG, Shedlovsky T, MacInnes DA. Electrophoretic patterns of normal and pathological human blood serum and plasma. *J Exp Med* 1939;70:399-413.
16. Kunkel HG, Tiselius A. Electrophoresis of proteins on filter paper. *J Gen Physiol* 1951;35:89-118.
17. Grabar P, Williams CA. Méthode permettant l'étude conjuguée des propriétés électrophorétiques et immuno-chimiques d'un mélange de protéines. Application au sérum sanguin. *Biochim Biophys Acta* 1953;10:193-194.
18. Wilson AT. Direct immunoelectrophoresis. *J Immunol* 1964;92:431-434.
19. Drayson M, Tang LX, Drew R, Mead GP, Carr-Smith H, Bradwell AR. Serum free light-chain measurements for identifying and monitoring patients with nonsecretory multiple myeloma. *Blood* 2001;97(9):2900-2902.
20. Kunkel HG. The "abnormality" of myeloma proteins. *Cancer Res* 1968;28:1351-1353.

21. Heremans JF. Immunochemical studies on protein pathology. The immunoglobulin concept. *Clin Chim Acta* 1959;4:639-646.
22. Waldenstrom J. Studies of conditions associated with disturbed gammaglobulin formation (gammopathies). *Harvey Lect* 1961;57:211-231.
23. Geschickter CF, Copeland MM. Multiple myeloma. *Arch Surg* 1928;16: 807-863.
24. Magnus-Levy A. Bence-Jones-Eiweiss und Amyloid. *Z Klin Med* 1931; 116:510.
25. Salmon SE, Smith BA. Immunoglobulin synthesis and total body tumor cell number in IgG multiple myeloma. *J Clin Invest* 1970;49(6):1114-1121.
26. Durie BG, Salmon SE. A clinical staging system for multiple myeloma. Correlation of measured myeloma cell mass with presenting clinical features, response to treatment, and survival. *Cancer* 1975;36(3):842-854.
27. Thorn GW, Forsham PH, Frawley RF, et al. The clinical usefulness of ACTH and cortisone. *N Engl J Med* 1950;242:824.
28. Adams WS, Skoog WA. The management of multiple myeloma. *J Chron Dis* 1957;6:446-456.
29. Salmon SE, Shaddock RK, Schilling A. Intermittent high-dose prednisone (NSC-10023) therapy for multiple myeloma. *Cancer Chemother Rep* 1967;51(3):179-187.
30. Blokhin N, Larionov L, Perevodchikova N, Chebotareva L, Merkulova N. Clinical experiences with sarcocysin in neoplastic diseases. *Ann N Y Acad Sci* 1958;68:1128-1132.
31. Bergsagel DE, Sprague CC, Austin C, Griffith KM. Evaluation of new chemotherapeutic agents in the treatment of multiple myeloma. IV. L-Phenylalanine mustard (NSC-8806). *Cancer Chemother Rep* 1962;21:87-99.
32. Bergsagel DE, Griffith KM, Haut A, Stuckey WJ Jr. The treatment of plasma cell myeloma. *Adv Cancer Res* 1967;10:311-359.
33. Korst DR, Clifford GO, Fowler WM, Lewis J, Will J, Wilson HE. Multiple myeloma. II. Analysis of cyclophosphamide therapy in 165 patients. *JAMA* 1964;189:758-762.
34. Mellstedt H, Aahre A, Bjorkholm M, et al. Interferon therapy in myelomatosis. *Lancet* 1979;2(8144):697.
35. Alberts DS, Salmon SE. Adriamycin (NSC-123127) in the treatment of alkylator-resistant multiple myeloma: a pilot study. *Cancer Chemother Rep* 1975;59(2 Pt 1):345-350.
36. Salmon SE. Nitrosoureas in multiple myeloma. *Cancer Treat Rep* 1976;60(6):789-794.
37. Singhal S, Mehta J, Desikan R, et al. Antitumor activity of thalidomide in refractory multiple myeloma. *N Engl J Med* 1999;341(21):1565-1571.
38. Orłowski RZ, Stinchcombe TE, Mitchell BS, et al. Phase I trial of the proteasome inhibitor PS-341 in patients with refractory hematologic malignancies. *J Clin Oncol* 2002;20(22):4420-4427.
39. Richardson PG, Schlossman RL, Weller E, et al. Immunomodulatory drug CC-5013 overcomes drug resistance and is well tolerated in patients with relapsed multiple myeloma. *Blood* 2002;100(9):3063-3067.
40. Landgren O, Kyle RA, Pfeiffer RM, et al. Monoclonal gammopathy of undetermined significance (MGUS) precedes multiple myeloma: a prospective study. *Blood* 2009.
41. Greenberg AJ, Rajkumar SV, Larson DR, et al. Increased prevalence of light chain monoclonal gammopathy of undetermined significance (LC-MGUS) in first-degree relatives of individuals with multiple myeloma. *Br J Haematol* 2012;157(4):472-475.
42. Vachon CM, Kyle RA, Therneau TM, et al. Increased risk of monoclonal gammopathy in first-degree relatives of patients with multiple myeloma or monoclonal gammopathy of undetermined significance. *Blood* 2009.
43. Siegel R, Naishadham D, Jemal A. Cancer statistics, 2012. *CA Cancer J Clin* 2012;62(1):10-29.
44. Howe HL, Wingo PA, Thun MJ, et al. Annual report to the nation on the status of cancer (1973 through 1998), featuring cancers with recent increasing trends. *J Natl Cancer Inst* 2001;93(11):824-842.
45. Cuzick J. Multiple myeloma. *Cancer Surv* 1994;19-20:455-474.
46. Schwartz GG. Multiple myeloma: clusters, clues, and dioxins. *Cancer Epidemiol Biomarkers Prev* 1997;6(1):49-56.

47. Maldonado JE, Kyle RA. Familial myeloma. Report of eight families and a study of serum proteins in their relatives. *Am J Med* 1974;57(6):875-884.
48. Grosbois B, Jegou P, Attal M, et al. Familial multiple myeloma: report of fifteen families. *Br J Haematol* 1999;105(3):768-770.
49. Brown LM, Linet MS, Greenberg RS, et al. Multiple myeloma and family history of cancer among blacks and whites in the U.S. *Cancer* 1999;85(11):2385-2390.
50. Lynch HT, Watson P, Tarantolo S, et al. Phenotypic heterogeneity in multiple myeloma families. *J Clin Oncol* 2005;23(4):685-693.
51. Landgren O, Linet MS, McMaster ML, Gridley G, Hemminki K, Goldin LR. Familial characteristics of autoimmune and hematologic disorders in 8,406 multiple myeloma patients: a population-based case-control study. *International journal of cancer. J Int Cancer* 2006;118(12):3095-3098.
52. Altieri A, Chen B, Bermejo JL, Castro F, Hemminki K. Familial risks and temporal incidence trends of multiple myeloma. *Eur J Cancer* 2006;42(11):1661-1670.
53. Bray I, Brennan P, Boffetta P. Recent trends and future projections of lymphoid neoplasms—a Bayesian age-period-cohort analysis. *Cancer Causes Control* 2001;12(9):813-820.
54. Ichimaru M, Ishimaru T, Mikami M, Matsunaga M. Multiple myeloma among atomic bomb survivors in Hiroshima and Nagasaki, 1950-76: relationship to radiation dose absorbed by marrow. *J Natl Cancer Inst* 1982;69(2):323-328.
55. Shimizu Y, Kato H, Schull WJ. Studies of the mortality of A-bomb survivors. 9. Mortality, 1950-1985: part 2. Cancer mortality based on the recently revised doses (DS86). *Radiat Res* 1990;121(2):120-141.
56. Preston DL, Kusumi S, Tomonaga M, et al. Cancer incidence in atomic bomb survivors. Part III. Leukemia, lymphoma and multiple myeloma, 1950-1987. *Radiat Res* 1994;137(2 Suppl):S68-97.
57. Iwanaga M, Tagawa M, Tsukasaki K, et al. Relationship between monoclonal gammopathy of undetermined significance and radiation exposure in Nagasaki atomic bomb survivors. *Blood* 2009;113(8):1639-1650.
58. Lewis EB. Leukemia, multiple myeloma, and aplastic anemia in American radiologists. *Science*. 1963;142:1492.
59. Matanoski GM, Seltser R, Sartwell PE, Diamond EL, Elliott EA. The current mortality rates of radiologists and other physician specialists: specific causes of death. *Am J Epidemiol* 1975;101(3):199-210.
60. Wang JX, Boice JD Jr, Li BX, Zhang JY, Fraumeni JF Jr. Cancer among medical diagnostic x-ray workers in China. *J Natl Cancer Inst* 1988;80(5):344-350.
61. Wing S, Richardson D, Wolf S, Mihlan G, Crawford-Brown D, Wood J. A case control study of multiple myeloma at four nuclear facilities. *Ann Epidemiol* 2000;10(3):144-153.
62. Muirhead CR, Bingham D, Haylock RG, et al. Follow up of mortality and incidence of cancer 1952-98 in men from the UK who participated in the UK's atmospheric nuclear weapon tests and experimental programmes. *Occup Environ Med* 2003;60(3):165-172.
63. Pearce N, Prior I, Methven D, et al. Follow up of New Zealand participants in British atmospheric nuclear weapons tests in the Pacific. *Bmj* 1990;300(6733):1161-1166.
64. Friedman GD. Multiple myeloma: relation to propoxyphene and other drugs, radiation and occupation. *Int J Epidemiol* 1986;15(3):424-426.
65. Andersson M, Storm HH. Cancer incidence among Danish Thorotrastexposed patients. *J Natl Cancer Inst* 1992;84(17):1318-1325.
66. Darby SC, Kendall GM, Fell TP, et al. A summary of mortality and incidence of cancer in men from the United Kingdom who participated in the United Kingdom's atmospheric nuclear weapon tests and experimental programmes. *Br Med J (Clin Res Ed)* 1988;296(6618):332-338.
67. Boffetta P, Stellman SD, Garfinkel L. A case-control study of multiple myeloma nested in the American Cancer Society prospective study. *Int J Cancer* 1989;43(4):554-559.
68. Cuzick J, De Stavola B. Multiple myeloma—a case-control study. *Br J Cancer* 1988;57(5):516-520.

69. Davis FG, Boice JD Jr, Hrubec Z, Monson RR. Cancer mortality in a radiation-exposed cohort of Massachusetts tuberculosis patients. *Cancer Res* 1989;49(21):6130-6136.
70. Hatcher JL, Baris D, Olshan AF, et al. Diagnostic radiation and the risk of multiple myeloma (United States). *Cancer Causes Control* 2001;12(8):755-761.
71. Boice JD Jr, Morin MM, Glass AG, et al. Diagnostic x-ray procedures and risk of leukemia, lymphoma, and multiple myeloma. *Jama* 1991;265(10): 1290-1294.
72. Boice JD Jr, Day NE, Andersen A, et al. Second cancers following radiation treatment for cervical cancer. An international collaboration among cancer registries. *J Natl Cancer Inst* 1985;74(5):955-975.
73. Darby SC, Doll R, Gill SK, Smith PG. Long term mortality after a single treatment course with X-rays in patients treated for ankylosing spondylitis. *Br J Cancer* 1987;55(2):179-190.
74. Semenciw RM, Morrison HI, Riedel D, Wilkins K, Ritter L, Mao Y. Multiple myeloma mortality and agricultural practices in the Prairie provinces of Canada. *J Occup Med* 1993;35(6):557-561.
75. Pukkala E, Notkola V. Cancer incidence among Finnish farmers, 1979-93. *Cancer Causes Control* 1997;8(1):25-33.
76. Wiklund K, Dich J. Cancer risks among male farmers in Sweden. *Eur J Cancer Prev* 1995;4(1):81-90.
77. Ronco G, Costa G, Lynge E. Cancer risk among Danish and Italian farmers. *Br J Ind Med* 1992;49(4):220-225.
78. Kristensen P, Andersen A, Irgens LM, Laake P, Bye AS. Incidence and risk factors of cancer among men and women in Norwegian agriculture. *Scand J Work Environ Health* 1996;22(1):14-26.
79. Sonoda T, Ishida T, Mori M, Sakai H, Noguchi M, Imai K. A case-control study of multiple myeloma in Japan: association with occupational factors. *Asian Pac J Cancer Prev* 2005;6(1):33-36.
80. Cerhan JR, Cantor KP, Williamson K, Lynch CF, Torner JC, Burmeister LF. Cancer mortality among Iowa farmers: recent results, time trends, and lifestyle factors (United States). *Cancer Causes Control* 1998;9(3):311-319.
81. Nanni O, Falcini F, Buiatti E, et al. Multiple myeloma and work in agriculture: results of a case-control study in Forli, Italy. *Cancer Causes Control* 1998;9(3):277-283.
82. Pahwa P, McDuffie HH, Dosman JA, et al. Exposure to animals and selected risk factors among Canadian farm residents with Hodgkin's disease, multiple myeloma, or soft tissue sarcoma. *J Occup Environ Med* 2003;45(8):857-868.
83. Khuder SA, Mutgi AB. Meta-analyses of multiple myeloma and farming. *Am J Ind Med* 1997;32(5):510-516.
84. Gallagher RP, Threlfall WJ. Cancer mortality in metal workers. *Can Med Assoc J* 1983;129(11):1191-1194.
85. Fritschi L, Siemiatycki J. Lymphoma, myeloma and occupation: results of a case-control study. *Int J Cancer* 1996;67(4):498-503.
86. McLaughlin JK, Malmer HS, Linet MS, et al. Multiple myeloma and occupation in Sweden. *Arch Environ Health* 1988;43(1):7-10.
87. Rinsky RA, Smith AB, Hornung R, et al. Benzene and leukemia. An epidemiologic risk assessment. *N Engl J Med* 1987;316(17):1044-1050.
88. Goldstein BD. Is exposure to benzene a cause of human multiple myeloma? *Ann N Y Acad Sci* 1990;609:225-230.
89. Decoufle P, Blattner WA, Blair A. Mortality among chemical workers exposed to benzene and other agents. *Environ Res* 1983;30(1):16-25.
90. Bergsagel DE, Wong O, Bergsagel PL, et al. Benzene and multiple myeloma: appraisal of the scientific evidence. *Blood* 1999;94(4):1174-1182.
91. Sonoda T, Nagata Y, Mori M, Ishida T, Imai K. Meta-analysis of multiple myeloma and benzene exposure. *J Epidemiol* 2001;11(6):249-254.
92. Wong O, Raabe GK. A critical review of cancer epidemiology in the petroleum industry, with a meta-analysis of a combined database of more than 350,000 workers. *Regul Toxicol Pharmacol* 2000;32(1):78-98.
93. Thompson MA, Kyle RA, Melton LJ 3rd, Plevak MF, Rajkumar SV. Effect of statins, smoking and obesity on progression of monoclonal gammopathy of undetermined significance: a case-control study. *Haematol* 2004;89(5): 626-628.

94. Gramezi A, Buttino I, D'Avanzo B, Negri E, Franceschi S, La Vecchia C. Medical history and the risk of multiple myeloma. *Br J Cancer* 1991;63(5):769-772.
95. Brown LM, Everett GD, Gibson R, Burmeister LF, Schuman LM, Blair A. Smoking and risk of non-Hodgkin's lymphoma and multiple myeloma. *Cancer Causes Control* 1992;3(1):49-55.
96. Brownson RC. Cigarette smoking and risk of myeloma. *J Natl Cancer Inst* 1991;83(14):1036-1037.
97. Tavani A, La Vecchia C, Gallus S, et al. Red meat intake and cancer risk: a study in Italy. *Int J Cancer* 2000;86(3):425-428.
98. Brown LM, Gridley G, Pottern LM, et al. Diet and nutrition as risk factors for multiple myeloma among blacks and whites in the United States. *Cancer Causes Control* 2001;12(2):117-125.
99. Brown LM, Everett GD, Burmeister LF, Blair A. Hair dye use and multiple myeloma in white men. *Am J Public Health* 1992;82(12):1673-1674.
100. Thun MJ, Altekruse SF, Namboodiri MM, Calle EE, Myers DG, Heath CW Jr. Hair dye use and risk of fatal cancers in U.S. women. *J Natl Cancer Inst* 1994;86(3):210-215.
101. Grodstein F, Hennekens CH, Colditz GA, Hunter DJ, Stampfer MJ. A prospective study of permanent hair dye use and hematopoietic cancer. *J Natl Cancer Inst* 1994;86(19):1466-1470.
102. Correa A, Jackson L, Mohan A, Perry H, Helzlsouer K. Use of hair dyes, hematopoietic neoplasms, and lymphomas: a literature review. II. Lymphomas and multiple myeloma. *Cancer Invest* 2000;18(5):467-479.
103. Koessel SL, Theis MK, Vaughan TL, et al. Socioeconomic status and the incidence of multiple myeloma. *Epidemiology* 1996;7(1):4-8.
104. Baris D, Brown LM, Silverman DT, et al. Socioeconomic status and multiple myeloma among US blacks and whites. *Am J Public Health* 2000;90(8): 1277-1281.
105. Johnston JM, Grufferman S, Bourguet CC, Delzell E, DeLong ER, Cohen HJ. Socioeconomic status and risk of multiple myeloma. *J Epidemiol Community Health* 1985;39(2):175-178.
106. Gregersen H, Pedersen G, Svendsen N, Thulstrup AM, Sorensen HT, Schonheyder HC. Multiple myeloma following an episode of community-acquired pneumococcal bacteraemia or meningitis. *APMIS* 2001;109(11):797-800.
107. Bourguet CC, Logue EE. Antigenic stimulation and multiple myeloma. A prospective study. *Cancer* 1993;72(7):2148-2154.
108. Goedert JJ. The epidemiology of acquired immunodeficiency syndrome malignancies. *Semin Oncol* 2000;27(4):390-401.
109. Grulich AE, Wan X, Law MG, Coates M, Kaldor JM. Risk of cancer in people with AIDS. *Aids* 1999;13(7):839-843.
110. Montella M, Crispo A, Frigeri F, et al. HCV and tumors correlated with immune system: a case-control study in an area of hyperendemicity. *Leuk Res* 2001;25(9):775-781.
111. Gharagozloo S, Khoshnoodi J, Shokri F. Hepatitis C virus infection in patients with essential mixed cryoglobulinemia, multiple myeloma and chronic lymphocytic leukemia. *Pathol Oncol Res* 2001;7(2):135-139.
112. Yoshikawa M, Imazu H, Ueda S, et al. Prevalence of hepatitis C virus infection in patients with non-Hodgkin's lymphoma and multiple myeloma. A report from Japan. *J Clin Gastroenterol* 1997;25(4):713-714.
113. Rettig MB, Ma HJ, Vescio RA, et al. Kaposi's sarcoma-associated herpesvirus infection of bone marrow dendritic cells from multiple myeloma patients. *Science* 1997;276(5320):1851-1854.
114. Hjalgrim H, Frisch M, Melbye M. Incidence rates of classical Kaposi's sarcoma and multiple myeloma do not correlate. *Br J Cancer* 1998;78(3):419-420.
115. Tarte K, Chang Y, Klein B. Kaposi's sarcoma-associated herpesvirus and multiple myeloma: lack of criteria for causality. *Blood* 1999;93(10):3159-3163, discussion 3163-3154.
116. Cannon MJ, Flanders WD, Pellett PE. Occurrence of primary cancers in association with multiple myeloma and Kaposi's sarcoma in the United States, 1973-1995. *Int J Cancer* 2000;85(4):453-456.
117. Tedeschi R, Kvarnung M, Knekt P, et al. A prospective seroepidemiological study of human herpesvirus-8 infection and the risk of multiple myeloma. *Br J Cancer* 2001;84(1):122-125.

118. Katusic S, Beard CM, Kurland LT, Weis JW, Bergstralh E. Occurrence of malignant neoplasms in the Rochester, Minnesota, rheumatoid arthritis cohort. *Am J Med* 1985;78(1A):50-55.
119. Isomaki HA, Hakulinen T, Joutsenlahti U. Excess risk of lymphomas, leukemia and myeloma in patients with rheumatoid arthritis. *J Chronic Dis* 1978;31(11):691-696.
120. Lewis DR, Potters LM, Brown LM, et al. Multiple myeloma among blacks and whites in the United States: the role of chronic antigenic stimulation. *Cancer Causes Control* 1994;5(6):529-539.
121. Koepsell TD, Daling JR, Weiss NS, et al. Antigenic stimulation and the occurrence of multiple myeloma. *Am J Epidemiol* 1987;126(6):1051-1062.
122. Linet MS, Harlow SD, McLaughlin JK. A case-control study of multiple myeloma in whites: chronic antigenic stimulation, occupation, and drug use. *Cancer Res* 1987;47(11):2978-2981.
123. Dispenzieri A, Gertz MA, Therneau TM, Kyle RA. Retrospective cohort study of 148 patients with polyclonal gammopathy. *Mayo Clin Proc* 2001;76(5):476-487.
124. Kyle RA. Multiple myeloma: review of 869 cases. *Mayo Clin Proc* 1975;50(1):29-40.
125. Riccardi A, Gobbi PG, Ucci G, et al. Changing clinical presentation of multiple myeloma. *Eur J Cancer* 1991;27(11):1401-1405.
126. Kyle RA, Gertz MA, Witzig TE, et al. Review of 1027 patients with newly diagnosed multiple myeloma. *Mayo Clin Proc* 2003;78(1):21-33.
127. Kapadia SB. Multiple myeloma: a clinicopathologic study of 62 consecutively autopsied cases. *Medicine (Baltimore)* 1980;59(5):380-392.
128. Osserman EF. Plasma Cell Myeloma. II. Clinical Aspects. *N Engl J Med* 1959;261(19):952-960.
129. Fossa A, Brandhorst D, Myklebust JH, Seeber S, Nowrousian MR. Relation between S-phase fraction of myeloma cells and anemia in patients with multiple myeloma. *Exp Hematol* 1999;27(11):1621-1626.
130. Musto P, Falcone A, D'Arena G, et al. Clinical results of recombinant erythropoietin in transfusion-dependent patients with refractory multiple myeloma: role of cytokines and monitoring of erythropoiesis. *Eur J Haematol* 1997;58(5):314-319.
131. Silvestris F, Cafforio P, Tucci M, Dammacco F. Negative regulation of erythroblast maturation by Fas-L(+)/TRAIL(+) highly malignant plasma cells: a major pathogenetic mechanism of anemia in multiple myeloma. *Blood* 2002;99(4):1305-1313.
132. Kyle RA, Finkelstein S, Elveback LR, Kurland LT. Incidence of monoclonal proteins in a Minnesota community with a cluster of multiple myeloma. *Blood* 1972;40(5):719-724.
133. Kyle RA, Therneau TM, Rajkumar SV, et al. A long-term study of prognosis in monoclonal gammopathy of undetermined significance. *N Engl J Med* 2002;346(8):564-569.
134. Kyle RA, Garton JP. The spectrum of IgM monoclonal gammopathy in 430 cases. *Mayo Clin Proc* 1987;62(8):719-731.
135. Larson RS, Sukpanichnant S, Greer JP, Cousar JB, Collins RD. The spectrum of multiple myeloma: diagnostic and biological implications. *Hum Pathol* 1997;28(12):1336-1347.
136. Kapff CT, Jandl JH. *Blood. Atlas and sourcebook of hematology*, 2nd ed. Boston/Toronto/London: Little, Brown, and Company; 1991.
137. Greipp PR, Raymond NM, Kyle RA, O'Fallon WM. Multiple myeloma: significance of plasmablastic subtype in morphological classification. *Blood* 1985;65(2):305-310.
138. Bayrd ED. Bone marrow on sternal aspiration in multiple myeloma. *Blood* 1948;3:987-1018.
139. Vacca A, Ribatti D, Roncali L, et al. Bone marrow angiogenesis and progression in multiple myeloma. *Br J Haematol* 1994;87(3):503-508.
140. Rajkumar SV, Fonseca R, Witzig TE, Gertz MA, Greipp PR. Bone marrow angiogenesis in patients achieving complete response after stem cell transplantation for multiple myeloma. *Leukemia* 1999;13(3):469-472.
141. Abildgaard N, Bendix-Hansen K, Kristensen JE, et al. Bone marrow fibrosis and disease activity in multiple myeloma monitored by the aminoterminal propeptide of procollagen III in serum. *Br J Haematol* 1997;99(3):641-648.

142. Krzyzaniak RL, Buss DH, Cooper MR, Wells HB. Marrow fibrosis and multiple myeloma. *Am J Clin Pathol* 1988;89(1):63-68.
143. San Miguel JF, Garcia-Sanz R, Gonzalez M, Orfao A. Immunophenotype and DNA cell content in multiple myeloma. *Baillieres Clin Haematol* 1995;8(4):735-759.
144. Lin P, Owens R, Tricot G, Wilson CS. Flow cytometric immunophenotypic analysis of 306 cases of multiple myeloma. *Am J Clin Pathol* 2004;121(4):482-488.
145. Mateo G, Castellanos M, Rasillo A, et al. Genetic abnormalities and patterns of antigenic expression in multiple myeloma. *Clin Cancer Res* 2005;11(10):3661-3667.
146. Moreau P, Robillard N, Avet-Loiseau H, et al. Patients with CD45 negative multiple myeloma receiving high-dose therapy have a shorter survival than those with CD45 positive multiple myeloma. *Haematologica* 2004; 89(5):547-551.
147. Kumar S, Rajkumar SV, Kimlinger T, Greipp PR, Witzig TE. CD45 expression by bone marrow plasma cells in multiple myeloma: clinical and biological correlations. *Leukemia* 2005;19(8):1466-1470.
148. Pellat-Deceunynck C, Barille S, Jego G, et al. The absence of CD56 (NCAM) on malignant plasma cells is a hallmark of plasma cell leukemia and of a special subset of multiple myeloma. *Leukemia* 1998;12(12):1977-1982.
149. Van Riet I, De Waele M, Remels L, Lacor P, Schots R, Van Camp B. Expression of cytoadhesion molecules (CD56, CD54, CD18 and CD29) by myeloma plasma cells. *Br J Haematol* 1991;79(3):421-427.
150. Barker HF, Hamilton MS, Ball J, Drew M, Franklin IM. Expression of adhesion molecules LFA-3 and N-CAM on normal and malignant human plasma cells. *Br J Haematol* 1992;81(3):331-335.
151. San Miguel JF, Gonzalez M, Gascon A, et al. Immunophenotypic heterogeneity of multiple myeloma: influence on the biology and clinical course of the disease. Castellano-Leones (Spain) Cooperative Group for the Study of Monoclonal Gammopathies. *Br J Haematol* 1991;77(2):185-190.
152. Ocqueteau M, Orfao A, Garcia-Sanz R, Almeida J, Gonzalez M, San Miguel JF. Expression of the CD117 antigen (c-Kit) on normal and myelomatous plasma cells. *Br J Haematol* 1996;95(3):489-493.
153. Pellat-Deceunynck C, Barille S, Puthier D, et al. Adhesion molecules on human myeloma cells: significant changes in expression related to malignancy, tumor spreading, and immortalization. *Cancer Res* 1995;55(16):3647-3653.
154. Pope B, Brown RD, Gibson J, Yuen E, Joshua D. B7-2-positive myeloma: incidence, clinical characteristics, prognostic significance, and implications for tumor immunotherapy. *Blood* 2000;96(4):1274-1279.
155. Bataille R, Chappard D, Marcelli C, et al. Recruitment of new osteoblasts and osteoclasts is the earliest critical event in the pathogenesis of human multiple myeloma. *J Clin Invest* 1991;88(1):62-66.
156. Roodman GD. Role of the bone marrow microenvironment in multiple myeloma. *J Bone Miner Res* 2002;17(11):1921-1925.
157. Silvestris F, Lombardi L, De Matteo M, Bruno A, Dammacco F. Myeloma bone disease: pathogenetic mechanisms and clinical assessment. *Leuk Res* 2007;31:129-138.
158. Lacy MQ, Gertz MA, Hanson CA, Inwards DJ, Kyle RA. Multiple myeloma associated with diffuse osteosclerotic bone lesions: a clinical entity distinct from osteosclerotic myeloma (POEMS syndrome). *Am J Hematol* 1997;56(4):288-293.
159. Kyle RA, Jowsey J, Kelly PJ, Taves DR. Multiple-myeloma bone disease. The comparative effect of sodium fluoride and calcium carbonate or placebo. *N Engl J Med* 1975;293(26):1334-1338.
160. Lindstrom E, Lindstrom FD. Skeletal scintigraphy with technetium diphosphonate in multiple myeloma—a comparison with skeletal x-ray. *Acta Med Scand* 1980;208(4):289-291.
161. Catalano L, Pace L, Califano C, et al. Detection of focal myeloma lesions by technetium-99m-sestaMIBI scintigraphy. *Haematologica* 1999;84(2):119-124.
162. Alexandrakis MG, Kyriakou DS, Passam F, Koukouraki S, Karkavitsas N. Value of Tc-99m sestamibi scintigraphy in the detection of bone lesions in multiple myeloma: comparison with Tc-99m methylene diphosphonate. *Ann Hematol* 2001;80(6):349-353.
163. Balleari E, Villa G, Garre S, et al. Technetium-99m-sestaMIBI scintigraphy in multiple myeloma and related gammopathies: a useful tool for the identification and follow-up of myeloma bone disease. *Haematologica* 2001; 86(1):78-84.

164. Fonti R, Del Vecchio S, Zannetti A, et al. Bone marrow uptake of ^{99m}Tc-MIBI in patients with multiple myeloma. *Eur J Nucl Med* 2001;28(2):214-220.
165. Pace L, Catalano L, Del Vecchio S, et al. Predictive value of technetium-99m sestamibi in patients with multiple myeloma and potential role in the follow-up. *Eur J Nucl Med* 2001;28(3):304-312.
166. Svaldi M, Tappa C, Gebert U, et al. Technetium-99m-sestamibi scintigraphy: an alternative approach for diagnosis and follow-up of active myeloma lesions after high-dose chemotherapy and autologous stem cell transplantation. *Ann Hematol* 2001;80(7):393-397.
167. Schirrmester H, Bommer M, Buck K, et al. Initial results in the assessment of multiple myeloma using (18)F-FDG PET. *Eur J Nucl Med* 2002;29(3):361-366.
168. Laroche M, Assoun J, Sixou L, Attal M. Comparison of MRI and computed tomography in the various stages of plasma cell disorders: correlations with biological and histological findings. Myelome-Midi-Pyrenees Group. *Clin Exp Rheumatol* 1996;14(2):171-176.
169. Lecouvet FE, Vande Berg BC, Malghem J, Maldague BE. Magnetic resonance and computed tomography imaging in multiple myeloma. [Review] [60 refs]. *Semin Musculoskelet Radiol* 2001;5(1):43-55.
170. Pertuiset E, Bellaiche L, Liote F, Laredo JD. Magnetic resonance imaging of the spine in plasma cell dyscrasias. A review. *Rev Rhum Engl Ed* 1996;63(11):837-845.
171. Mariette X, Zagdanski AM, Guermazi A, et al. Prognostic value of vertebral lesions detected by magnetic resonance imaging in patients with stage I multiple myeloma. *Br J Haematol* 1999;104(4):723-729.
172. Mouloupoulos LA, Dimopoulos MA, Weber D, Fuller L, Libshitz HI, Alexanian R. Magnetic resonance imaging in the staging of solitary plasmacytoma of bone. *J Clin Oncol* 1993;11(7):1311-1315.
173. Lecouvet FE, Malghem J, Michaux L, et al. Skeletal survey in advanced multiple myeloma: radiographic versus MR imaging survey. *Br J Haematol* 1999;106(1):35-39.
174. Nanni C, Zamagni E, Farsad M, et al. Role of (18)F-FDG PET/CT in the assessment of bone involvement in newly diagnosed multiple myeloma: preliminary results. *Eur J Nucl Med Mol Imaging* 2006;33(5):525-531.
175. Shortt CP, Gleeson TG, Breen KA, et al. Whole-Body MRI versus PET in assessment of multiple myeloma disease activity. *AJR Am J Roentgenol* 2009;192(4):980-986.
176. Baur-Melnyk A, Buhmann S, Becker C, et al. Whole-body MRI versus whole-body MDCT for staging of multiple myeloma. *AJR Am J Roentgenol* 2008;190(4):1097-1104.
177. Maldonado JE, Velosa JA, Kyle RA, Wagoner RD, Holley KE, Salassa RM. Fanconi syndrome in adults. A manifestation of a latent form of myeloma. *Am J Med* 1975;58(3):354-364.
178. Blade J, Fernandez-Llama P, Bosch F, et al. Renal failure in multiple myeloma: presenting features and predictors of outcome in 94 patients from a single institution. *Arch Intern Med* 1998;158(17):1889-1893.
179. Knudsen LM, Hippe E, Hjorth M, Holmberg E, Westin J. Renal function in newly diagnosed multiple myeloma—a demographic study of 1353 patients. The Nordic Myeloma Study Group. *Eur J Haematol* 1994;53(4):207-212.
180. Report on the second myelomatosis trial after five years of follow-up. Medical research council's working party on leukaemia in adults. *Br J Cancer* 1980;42(6):813-822.
181. Irish AB, Winearls CG, Littlewood T. Presentation and survival of patients with severe renal failure and myeloma. *Qjm* 1997;90(12):773-780.
182. Analysis and management of renal failure in fourth MRC myelomatosis trial. MRC working party on leukaemia in adults. *Br Med J (Clin Res Ed)* 1984;288(6428):1411-1416.
183. MacLennan IC, Cooper EH, Chapman CE, Kelly KA, Crockson RA. Renal failure in myelomatosis. *Eur J Haematol Suppl* 1989;51:60-65.
184. Knudsen LM, Hjorth M, Hippe E. Renal failure in multiple myeloma: reversibility and impact on the prognosis. Nordic Myeloma Study Group. *Eur J Haematol* 2000;65(3):175-181.
185. Bernstein SP, Humes HD. Reversible renal insufficiency in multiple myeloma. *Arch Intern Med* 1982;142(12):2083-2086.

186. Hill GS, Morel-Maroger L, Mery JP, Brouet JC, Mignon F. Renal lesions in multiple myeloma: their relationship to associated protein abnormalities. *Am J Kidney Dis* 1983;2(4):423-438.
187. Montseny JJ, Kleinknecht D, Meyrier A, et al. Long-term outcome according to renal histological lesions in 118 patients with monoclonal gammopathies. *Nephrol Dial Transplant* 1998;13(6):1438-1445.
188. DeFronzo RA, Cooke CR, Wright JR, Humphrey RL. Renal function in patients with multiple myeloma. *Medicine* 1978;57(2):151-166.
189. Ma CX, Lacy MQ, Rompala JF, et al. Acquired Fanconi syndrome is an indolent disorder in the absence of overt multiple myeloma. *Blood* 2004;104(1):40-42.
190. Espersen F, Birgens HS, Hertz JB, Drivsholm A. Current patterns of bacterial infection in myelomatosis. *Scand J Infect Dis* 1984;16(2):169-173.
191. Hargreaves RM, Lea JR, Griffiths H, et al. Immunological factors and risk of infection in plateau phase myeloma. *J Clin Pathol* 1995;48(3):260-266.
192. Perri RT, Hebbel RP, Oken MM. Influence of treatment and response status on infection risk in multiple myeloma. *Am J Med* 1981;71(6):935-940.
193. Savage DG, Lindenbaum J, Garrett TJ. Biphasic pattern of bacterial infection in multiple myeloma. *Ann Intern Med* 1982;96(1):47-50.
194. Lackner H. Hemostatic abnormalities associated with dysproteinemias. *Semin Hematol* 1973;10(2):125-133.
195. Catovsky D, Ikoku NB, Pitney WR, Galton DA. Thromboembolic complications in myelomatosis. *Br Med J* 1970;3(720):438-439.
196. Shinagawa A, Kojima H, Kobayashi T, Kawada K, Nagasawa T. Lupus anticoagulant-like activity observed in a dimeric lambda protein produced by myeloma cells. *Int J Hematol* 2001;73(4):526-531.
197. Yasin Z, Quick D, Thiagarajan P, Spoor D, Caraveo J, Palascak J. Light-chain para-proteins with lupus anticoagulant activity. *Am J Hematol* 1999;62(2):99-102.
198. Deitcher SR, Erban JK, Limentani SA. Acquired free protein S deficiency associated with multiple myeloma: a case report. *Am J Hematol* 1996;51(4): 319-323.
199. D'Angelo A, Mazzola G, Bergmann F, Safa O, Della Valle P, D'Angelo SV. Autoimmune protein S deficiency: a disorder predisposing to thrombosis. *Haematologica* 1995;80(2 Suppl):114-121.
200. Zangari M, Saghafifar F, Anaissie E, et al. Activated protein C resistance in the absence of factor V Leiden mutation is a common finding in multiple myeloma and is associated with an increased risk of thrombotic complications. *Blood Coagul Fibrinolysis* 2002;13(3):187-192.
201. Gargan PE, Ploplis VA, Scheu JD. A fibrin specific monoclonal antibody which interferes with the fibrinolytic effect of tissue plasminogen activator. *Thromb Haemost* 1988;59(3):426-431.
202. Bergsagel DE, Pruzanski W. Treatment of plasma cell myeloma with cytotoxic agents. *Arch Intern Med* 1975;135(1):172-176.
203. McArthur JR, Athens JW, Wintrobe MM, Cartwright GE. Melphalan and myeloma. Experience with a low-dose continuous regimen. *Ann Intern Med* 1970;72(5):665-670.
204. Proposed guidelines for protocol studies. I. Introduction. II. Plasma cell myeloma. 3. Chronic lymphocytic leukemia. IV. Chronic granulocytic leukemia. *Cancer Chemother Rep* 1973;4(1):141-173.
205. Criteria for the classification of monoclonal gammopathies, multiple myeloma and related disorders: a report of the International Myeloma Working Group. *Br J Haematol* 2003;121(5):749-757.
206. Kyle RA, Greipp PR. 3. The laboratory investigation of monoclonal gammopathies. *Mayo Clin Proc* 1978;53(11):719-739.
207. Kyle RA, Greipp PR. Smoldering multiple myeloma. *N Engl J Med* 1980;302(24):1347-1349.
208. Alexanian R. Localized and indolent myeloma. *Blood* 1980;56(3):521-525.
209. Peest D, Leo R, Bloche S, et al. Low-dose recombinant interleukin-2 therapy in advanced multiple myeloma. *Br J Haematol* 1995;89(2):328-337.

210. Riccardi A, Ucci G, Luoni R, et al. Treatment of multiple myeloma according to the extension of the disease: a prospective, randomised study comparing a less with a more aggressive cystostatic policy. Cooperative Group of Study and Treatment of Multiple Myeloma. *Br J Cancer* 1994;70(6):1203-1210.
211. Hjorth M, Hellquist L, Holmberg E, Magnusson B, Rodger S, Westin J. Initial versus deferred melphalan-prednisone therapy for asymptomatic multiple myeloma stage I—a randomized study. Myeloma Group of Western Sweden. *Eur J Haematol* 1993;50(2):95-102.
212. Facon T, Menard JF, Michaux JL, et al. Prognostic factors in low tumour mass asymptomatic multiple myeloma: a report on 91 patients. The Groupe d'Etudes et de Recherche sur le Myelome (GERM). *Am J Hematol* 1995;48(2):71-75.
213. Mateos M-V, Lopez-Corral L, Hernandez M, et al. Smoldering Multiple Myeloma (SMM) at high-risk of progression to symptomatic disease: a phase III, randomized, multicenter trial based on Lenalidomide-Dexamethasone (Len-Dex) as induction therapy followed by maintenance therapy with Len alone vs no treatment. *ASH Annu Meeting Abstr* 2011;118(21):991-.
214. Riccardi A, Mora O, Tinelli C, et al. Long-term survival of stage I multiple myeloma given chemotherapy just after diagnosis or at progression of the disease: a multicentre randomized study. Cooperative Group of Study and Treatment of Multiple Myeloma. *Br J Cancer* 2000;82(7):1254-1260.
215. Treatment of myeloma. Comparison of melphalan, chlorambucil, and azathioprine. *Arch Intern Med* 1975;135(1):157-162.
216. Anonymous. Combination chemotherapy versus melphalan plus prednisone as treatment for multiple myeloma: an overview of 6,633 patients from 27 randomized trials. Myeloma Trialists' Collaborative Group. *J Clin Oncol* 1998;16(12):3832-3842.
217. Gutterman JU, Blumenschein GR, Alexanian R, et al. Leukocyte interferon-induced tumor regression in human metastatic breast cancer, multiple myeloma, and malignant lymphoma. *Ann Intern Med* 1980;93(3):399-406.
218. Alexanian R, Gutterman J, Levy H. Interferon treatment for multiple myeloma. *Clin Haematol* 1982;11(1):211-220.
219. Quesada JR, Hawkins M, Horning S, et al. Collaborative phase I-II study of recombinant DNA-produced leukocyte interferon (clone A) in metastatic breast cancer, malignant lymphoma, and multiple myeloma. *Am J Med* 1984;77(3):427-432.
220. McElwain T, Powles R. High-dose intravenous melphalan for plasma-cell leukaemia and myeloma. *Lancet* 1983;2:822-824.
221. Vij R, Wang M, Kaufman JL, et al. An open-label, single-arm, phase 2 (PX-171-004) study of single-agent carfilzomib in bortezomib-naive patients with relapsed and/or refractory multiple myeloma. *Blood* 2012;119(24):5661-5670.
222. Durie BG, Harousseau JL, Miguel JS, et al. International uniform response criteria for multiple myeloma. *Leukemia* 2006;20(9):1467-1473.
223. Alexanian R, Bonnet J, Gehan E, et al. Combination chemotherapy for multiple myeloma. *Cancer* 1972;30(2):382-389.
224. McLaughlin P, Alexanian R. Myeloma protein kinetics following chemotherapy. *Blood* 1982;60(4):851-855.
225. Oken MM, Kyle RA, Greipp PR, et al. Complete remission induction with combined VBMCP chemotherapy and interferon (rIFN alpha 2b) in patients with multiple myeloma. *Leuk Lymphoma* 1996;20(5-6):447-452.
226. Blade J, Samson D, Reece D, et al. Criteria for evaluating disease response and progression in patients with multiple myeloma treated by high-dose therapy and haemopoietic stem cell transplantation. Myeloma Subcommittee of the EBMT. European Group for Blood and Marrow Transplant. *Br J Haematol* 1998;102(5):1115-1123.
227. Selby PJ, McElwain TJ, Nandi AC, et al. Multiple myeloma treated with high dose intravenous melphalan. *Br J Haematol* 1987;66(1):55-62.
228. Gore ME, Selby PJ, Viner C, et al. Intensive treatment of multiple myeloma and criteria for complete remission. *Lancet* 1989;2(8668):879-882.
229. Attal M, Harousseau JL, Stoppa AM, et al. A prospective, randomized trial of autologous bone marrow transplantation and chemotherapy in multiple myeloma. Intergroupe Francais du Myelome [see comments]. *N Engl J Med* 1996;335(2):91-97.

230. Costa G, Engle RL, Schilling A, et al. Melphalan and prednisone: an effective combination for the treatment of multiple myeloma. *Am J Med* 1973;54:589-599.
231. Rivers SL, Patno ME. Cyclophosphamide vs melphalan in treatment of plasma cell myeloma. *Jama* 1969;207(7):1328-1334.
232. Alexanian R, Haut A, Khan AU, et al. Treatment for multiple myeloma. Combination chemotherapy with different melphalan dose regimens. *Jama* 1969;208(9):1680-1685.
233. MacLennan IC, Chapman C, Dunn J, Kelly K. Combined chemotherapy with ABCM versus melphalan for treatment of myelomatosis. The Medical Research Council Working Party for Leukaemia in Adults. *Lancet* 1992;339(8787):200-205.
234. George RP, Poth JL, Gordon D, Schrier SL. Multiple myeloma—intermittent combination chemotherapy compared to continuous therapy. *Cancer* 1972;29(6):1665-1670.
235. Myelomatosis: comparison of melphalan and cyclophosphamide therapy. *Br Med J* 1971;1(750):640-641.
236. Treatment comparisons in the third MRC myelomatosis trial. Medical research council's working party on leukaemia in adults. *Br J Cancer* 1980;42(6):823-830.
237. Lenhard RE Jr, Oken MM, Barnes JM, Humphrey RL, Glick JH, Silverstein MN. High-dose cyclophosphamide. An effective treatment for advanced refractory multiple myeloma. *Cancer* 1984;53(7):1456-1460.
238. Salokannel SJ, Palva IP, Timonen T, Kaipainen WJ. Cyclophosphamide in the treatment of multiple myeloma. *Blut* 1971;23(3):129-132.
239. Choi OS, English A, Hilton JH, Catton GE, Brown MD. Cyclophosphamide in the treatment of myelomatosis. *Can Med Assoc J* 1967;97(19):1133-1139.
240. Mass RE. A comparison of the effect of prednisone and a placebo in the treatment of multiple myeloma. *Cancer Chemother Rep* 1962;16:257-259.
241. McIntyre OR, Pajak TF, Kyle RA, Cornwell GG 3rd, Leone L. Response rate and survival in myeloma patients receiving prednisone alone. *Med Pediatr Oncol* 1985;13(5):239-243.
242. Alexanian R, Dimopoulos MA, Delasalle K, Barlogie B. Primary dexamethasone treatment of multiple myeloma. *Blood* 1992;80(4):887-890.
243. Alexanian R, Yap BS, Bodey GP. Prednisone pulse therapy for refractory myeloma. *Blood* 1983;62(3):572-577.
244. Alexanian R, Barlogie B, Dixon D. High-dose glucocorticoid treatment of resistant myeloma. *Ann Intern Med* 1986;105(1):8-11.
245. Gertz MA, Garton JP, Greipp PR, Witzig TE, Kyle RA. A phase II study of high-dose methylprednisolone in refractory or relapsed multiple myeloma. *Leukemia* 1995;9(12):2115-2118.
246. Forgeson GV, Selby P, Lakhani S, et al. Infused vincristine and adriamycin with high dose methylprednisolone (VAMP) in advanced previously treated multiple myeloma patients. *Br J Cancer* 1988;58(4):469-473.
247. Tiplady CW, Summerfield GP. Continuous low-dose dexamethasone in relapsed or refractory multiple myeloma. [letter; comment]. [see comments]. *Br J Haematol* 2000;111(1):381.
248. Palva IP, Ala-Harja K, Almqvist A, et al. Corticosteroid is not beneficial in multiple-drug combination chemotherapy for multiple myeloma. Finnish Leukaemia Group. *Eur J Haematol* 1993;51(2):98-101.
249. Facon T, Mary JY, Pegourie B, et al. Dexamethasone-based regimens versus melphalan-prednisone for elderly multiple myeloma patients ineligible for high-dose therapy. *Blood* 2006;107(4):1292-1298.
250. Feinman R, Koury J, Thames M, Barlogie B, Epstein J, Siegel DS. Role of NF-kappaB in the rescue of multiple myeloma cells from glucocorticoid-induced apoptosis by bcl-2. *Blood* 1999;93(9):3044-3052.
251. Karadag A, Oyajobi BO, Apperley JF, Russell RG, Croucher PI. Human myeloma cells promote the production of interleukin 6 by primary human osteoblasts. *Br J Haematol* 2000;108(2):383-390.
252. De Bosscher K, Vanden Berghe W, Vermeulen L, Plaisance S, Boone E, Haegeman G. Glucocorticoids repress NF-kappaB-driven genes by disturbing the interaction of p65 with the basal transcription machinery, irrespective of coactivator levels in the cell. *Proc Natl Acad Sci U S A* 2000;97(8):3919-3924.

253. Kawano M, Tanaka H, Ishikawa H, et al. Interleukin-1 accelerates autocrine growth of myeloma cells through interleukin-6 in human myeloma. *Blood* 1989;73(8):2145-2148.
254. Jackson DV, Case LD, Pope EK, et al. Single agent vincristine by infusion in refractory multiple myeloma. *J Clin Oncol* 1985;3(11):1508-1512.
255. Cornwell GG 3rd, Pajak TF, Kochwa S, et al. Vincristine and prednisone prolong the survival of patients receiving intravenous or oral melphalan for multiple myeloma: cancer and leukemia group B experience. *J Clin Oncol* 1988;6(9):1481-1490.
256. Alexanian R, Salmon S, Bonnet J, Gehan E, Haut A, Weick J. Combination therapy for multiple myeloma. *Cancer* 1977;40(6):2765-2771.
257. Alexanian R, Dreicer R. Chemotherapy for multiple myeloma. *Cancer* 1984;53(3):583-588.
258. Salmon SE. Immunoglobulin synthesis and tumor kinetics of multiple myeloma. *Semin Hematol* 1973;10(2):135-144.
259. Lee BJ, Sahakian G, Clarkson BD, Krakoff IH. Proceedings: combination chemotherapy of multiple myeloma with alkeran, cytoxan, vincristine, prednisone, and BCNU. *Cancer* 1974;33(2):533-538.
260. Case DC Jr, Lee DJ 3rd, Clarkson BD. Improved survival times in multiple myeloma treated with melphalan, prednisone, cyclophosphamide, vincristine and BCNU: M-2 protocol. *Am J Med* 1977;63(6):897-903.
261. Salmon SE. Expansion of the growth fraction in multiple myeloma with alkylating agents. *Blood* 1975;45(1):119-129.
262. Cornwell GG 3rd, Pajak TF, Kochwa S, et al. Comparison of oral melphalan, CCNU, and BCNU with and without vincristine and prednisone in the treatment of multiple myeloma. Cancer and Leukemia Group B experience. *Cancer* 1982;50(9):1669-1675.
263. Hansen OP, Clausen NA, Drivsholm A, Laursen B. Phase III study of intermittent 5-drug regimen (VBCMP) versus intermittent 3-drug regimen (VMP) versus intermittent melphalan and prednisone (MP) in myelomatosis. *Scand J Haematol* 1985;35(5):518-524.
264. MacLennan IC, Cusick J. Objective evaluation of the role of vincristine in induction and maintenance therapy for myelomatosis. Medical Research Council Working Party on Leukaemia in Adults. *Br J Cancer* 1985;52(2):153-158.
265. Tribalto M, Amadori S, Cantonetti M, et al. Treatment of multiple myeloma: a randomized study of three different regimens. *Leuk Res* 1985;9(8): 1043-1049.
266. MacLennan IC, Kelly K, Crockson RA, Cooper EH, Cuzick J, Chapman C. Results of the MRC myelomatosis trials for patients entered since 1980. *Hematol Oncol* 1988;6(2):145-158.
267. Bennett JM, Silber R, Ezdinli E, et al. Phase II study of adriamycin and bleomycin in patients with multiple myeloma. *Cancer Treat Rep* 1978;62(9):1367-1369.
268. Orłowski RZ, Voorhees PM, Garcia RA, et al. Phase 1 trial of the proteasome inhibitor bortezomib and pegylated liposomal doxorubicin in patients with advanced hematologic malignancies. *Blood* 2005;105(8):3058-3065.
269. Hussein MA, Wood L, Hsi E, et al. A Phase II trial of pegylated liposomal doxorubicin, vincristine, and reduced-dose dexamethasone combination therapy in newly diagnosed multiple myeloma patients. *Cancer* 2002;95(10):2160-2168.
270. Alberts DS, Balcerzak SP, Bonnet JD, Stephens RL. Phase II trial of mitoxantrone in multiple myeloma: a southwest oncology group study. *Cancer Treat Rep* 1985;69(11):1321-1323.
271. Sumpter K, Powles RL, Raje N, et al. Oral idarubicin as a single agent therapy in patients with relapsed or resistant multiple myeloma. *Leuk Lymphoma* 1999;35(5-6):593-597.
272. Chisesi T, Capnist G, de Dominicis E, Dini E. A phase II study of idarubicin (4-demethoxydaunorubicin) in advanced myeloma. *Eur J Cancer Clin Oncol* 1988;24(4):681-684.
273. Gockerman JP, Bartolucci AA, Nelson MO, Silberman H, Velez-Garcia E, Stein R. Phase II evaluation of etoposide in refractory multiple myeloma: a southeastern cancer study group trial. *Cancer Treat Rep* 1986;70(6):801-802.
274. Barlogie B, Velasquez WS, Alexanian R, Cabanillas F. Etoposide, dexamethasone, cytarabine, and cisplatin in vincristine, doxorubicin, and dexamethasone-refractory myeloma. *J Clin Oncol* 1989;7(10):1514-1517.
275. Tokiwa F, Utsunomiya A, Nakahara K, et al. [A case of refractory multiple myeloma effectively treated with long-term oral etoposide]. *Gan To Kagaku Ryoho* 1993;20(4):533-536.

276. Kato Y, Takeda H, Mihara H, et al. Oral low-dose etoposide therapy for refractory multiple myeloma with extramedullary involvement. *Intern Med* 1995;34(10):1023-1026.
277. Costanzi JJ, Cooper MR, Scarffe JH, et al. Phase II study of recombinant alpha-2 interferon in resistant multiple myeloma. *J Clin Oncol* 1985;3(5):654-659.
278. Brenning G, Ahre A, Nilsson K. Correlation between in vitro and in vivo sensitivity to human leucocyte interferon in patients with multiple myeloma. *Scand J Haematol* 1985;35(5):543-549.
279. Ahre A, Bjorkholm M, Mellstedt H, et al. Human leukocyte interferon and intermittent high-dose melphalan-prednisone administration in the treatment of multiple myeloma: a randomized clinical trial from the myeloma group of central Sweden. *Cancer Treat Rep* 1984;68(11):1331-1338.
280. Ohno R, Kimura K, Amaki I, et al. Treatment of multiple myeloma with recombinant human leukocyte A interferon. *Cancer Treat Rep* 1985;69(12):1433-1435.
281. Balfour JA, Goa KL. Bendamustine. *Drugs* 2001;61(5):631-638, discussion 639-640.
282. Knop S, Straka C, Haen M, Schwedes R, Hebart H, Einsele H. The efficacy and toxicity of bendamustine in recurrent multiple myeloma after high-dose chemotherapy. *Haematologica* 2005;90(9):1287-1288.
283. Michael M, Bruns I, Bolke E, et al. Bendamustine in patients with relapsed or refractory multiple myeloma. *Eur J Med Res* 2010;15(1):13-19.
284. D'Amato RJ, Loughnan MS, Flynn E, Folkman J. Thalidomide is an inhibitor of angiogenesis. *Proc Natl Acad Sci U S A* 1994;91(9):4082-4085.
285. Kenyon BM, Browne F, D'Amato RJ. Effects of thalidomide and related metabolites in a mouse corneal model of neovascularization. *Exp Eye Res* 1997;64(6):971-978.
286. Rajkumar SV, Fonseca R, Dispenzieri A, et al. Thalidomide in the treatment of relapsed multiple myeloma. *Mayo Clin Proc* 2000;75(9):897-901.
287. Rajkumar SV. Current status of thalidomide in the treatment of cancer. *Oncology* 2001;Jul(15):867-874.
288. Bertolini F, Mingrone W, Alietti A, et al. Thalidomide in multiple myeloma, myelodysplastic syndromes and histiocytosis. Analysis of clinical results and of surrogate angiogenesis markers. *Ann Oncol* 2001;12(7):987-990.
289. Hus M, Dmoszynska A, Soroka-Wojtaszko M, et al. Thalidomide treatment of resistant or relapsed multiple myeloma patients. *Haematologica* 2001;86(4):404-408.
290. Juliusson G, Celsing F, Turesson I, Lenhoff S, Adriansson M, Malm C. Frequent good partial remissions from thalidomide including best response ever in patients with advanced refractory and relapsed myeloma. [see comments]. *Br J Haematol* 2000;109(1):89-96.
291. Kneller A, Raanani P, Hardan I, et al. Therapy with thalidomide in refractory multiple myeloma patients—the revival of an old drug. *Br J Haematol* 2000;108(2):391-393.
292. Blade J, Esteve J, Rosinol L, et al. Thalidomide in refractory and relapsing multiple myeloma. *Semin Oncol* 2001;28(6):588-592.
293. Myers B, Crouch D, Dolan G. Thalidomide treatment in advanced refractory myeloma. *Br J Haematol* 2000;111(3):986.
294. Tosi P, Ronconi S, Zamagni E, et al. Salvage therapy with thalidomide in multiple myeloma patients relapsing after autologous peripheral blood stem cell transplantation. *Haematologica* 2001;86(4):409-413.
295. Kumar S, Gertz MA, Dispenzieri A, et al. Response rate, durability of response, and survival after thalidomide therapy for relapsed multiple myeloma.[comment]. *Mayo Clin Proc* 2003;78(1):34-39.
296. Schey SA, Cavenagh J, Johnson R, Child JA, Oakervee H, Jones RW. An UK myeloma forum phase II study of thalidomide; long term follow-up and recommendations for treatment. *Leuk Res* 2003;27(10):909-914.
297. Rajkumar SV, Dispenzieri A, Fonseca R, et al. Thalidomide for previously untreated indolent or smoldering multiple myeloma. *Leukemia* 2001;15(8):1274-1276.
298. Rajkumar SV, Gertz MA, Lacy MQ, et al. Thalidomide as initial therapy for early-stage myeloma. *Leukemia* 2003;17(4):775-779.

299. Weber D, Rankin K, Gavino M, Delasalle K, Alexanian R. Thalidomide alone or with dexamethasone for previously untreated multiple myeloma. *J Clin Oncol* 2003;21(1):16-19.
300. Pini M, Baraldi A, Pietrasanta D, et al. Low-dose of thalidomide in the treatment of refractory myeloma. *Haematologica* 2000;85(10):1111-1112.
301. Barlogie B, Desikan R, Eddlemon P, et al. Extended survival in advanced and refractory multiple myeloma after single-agent thalidomide: identification of prognostic factors in a phase 2 study of 169 patients. *Blood* 2001;98(2):492-494.
302. Zangari M, Anaissie E, Barlogie B, et al. Increased risk of deep-vein thrombosis in patients with multiple myeloma receiving thalidomide and chemotherapy. *Blood* 2001;98(5):1614-1615.
303. Osman K, Comenzo R, Rajkumar SV. Deep venous thrombosis and thalidomide therapy for multiple myeloma. *N Engl J Med* 2001;344(25):1951-1952.
304. Camba L, Peccatori J, Pescarollo A, Tresoldi M, Corradini P, Bregni M. Thalidomide and thrombosis in patients with multiple myeloma. *Haematologica* 2001;86(10):1108-1109.
305. Rajkumar SV, Gertz MA, Witzig TE. Life-threatening toxic epidermal necrolysis with thalidomide therapy for myeloma. *N Engl J Med* 2000;343(13): 972-973.
306. Fowler R, Imrie K. Thalidomide-associated hepatitis: a case report. *Am J Hematol* 2001;66(4):300-302.
307. Richardson PG, Blood E, Mitsiades CS, et al. A randomized phase 2 study of lenalidomide therapy for patients with relapsed or relapsed and refractory multiple myeloma. *Blood* 2006;108(10):3458-3464.
308. Richardson PG, Barlogie B, Berenson J, et al. Extended follow-up of a phase II trial in relapsed, refractory multiple myeloma: final time-to-event results from the SUMMIT trial. *Cancer* 2006;106(6):1316-1319.
309. Buadi F, Lacy M, Dispenzieri A, et al. Single-agent lenalidomide for newly diagnosed myeloma with on-demand dexamethasone: a phase II trial. *ASCO Meeting Abstr* 2011 2011;29(15 Suppl):8080.
310. Schey SA, Fields P, Bartlett JB, et al. Phase I study of an immunomodulatory thalidomide analog, CC-4047, in relapsed or refractory multiple myeloma. *J Clin Oncol* 2004;22(16):3269-3276.
311. Verhelle D, Corral LG, Wong K, et al. Lenalidomide and CC-4047 inhibit the proliferation of malignant B cells while expanding normal CD34 + progenitor cells. *Cancer Res* 2007;67(2):746-755.
312. Galustian C, Meyer B, Labarthe MC, et al. The anti-cancer agents lenalidomide and pomalidomide inhibit the proliferation and function of T regulatory cells. *Cancer Immunol Immunother* 2009;58(7):1033-1045.
313. Ferguson GD, Jensen-Pergakes K, Wilkey C, et al. Immunomodulatory drug CC-4047 is a cell-type and stimulus-selective transcriptional inhibitor of cyclooxygenase 2. *J Clin Immunol* 2007;27(2):210-220.
314. Anderson G, Gries M, Kurihara N, et al. Thalidomide derivative CC-4047 inhibits osteoclast formation by down-regulation of PU.1. *Blood* 2006;107(8): 3098-3105.
315. Lentzsch S, LeBlanc R, Podar K, et al. Immunomodulatory analogs of thalidomide inhibit growth of Hs Sultan cells and angiogenesis in vivo. *Leukemia* 2003;17(1):41-44.
316. Dispenzieri A, Jacobus S, Vesole DH, Callandar N, Fonseca R, Greipp PR. Primary therapy with single agent bortezomib as induction, maintenance and re-induction in patients with high-risk myeloma: results of the ECOG E2A02 trial. *Leukemia* 2010;24(8):1406-1411.
317. Harousseau JL, Attal M, Coiteux V, et al. Bortezomib (VELCADE®) plus dexamethasone as induction treatment prior to autologous stem cell transplantation in patients with newly diagnosed multiple myeloma: preliminary results of an IFM phase II study. *ASCO* 2005:6653.
318. Richardson PG, Xie W, Mitsiades C, et al. Single-agent bortezomib in previously untreated multiple myeloma: efficacy, characterization of peripheral neuropathy, and molecular correlations with response and neuropathy. *J Clin Oncol* 2009;27(21):3518-3525.
319. Jagannath S, Durie BG, Wolf J, et al. Bortezomib therapy alone and in combination with dexamethasone for previously untreated symptomatic multiple myeloma. *Br J Haematol* 2005;129(6):776-783.
320. Richardson PG, Barlogie B, Berenson J, et al. A phase 2 study of bortezomib in relapsed, refractory myeloma. *N Engl J Med* 2003;348(26):2609-2617.

321. Richardson PG, Sonneveld P, Schuster MW, et al. Bortezomib or high-dose dexamethasone for relapsed multiple myeloma. *N Engl J Med* 2005;352(24):2487-2498.
322. Jagannath S, Barlogie B, Berenson J, et al. A phase 2 study of two doses of bortezomib in relapsed or refractory myeloma. *Br J Haematol* 2004;127(2):165-172.
323. Richardson PG, Briemberg H, Jagannath S, et al. Frequency, characteristics, and reversibility of peripheral neuropathy during treatment of advanced multiple myeloma with bortezomib. *J Clin Oncol* 2006;24(19):3113-3120.
324. Moreau P, Pylypenko H, Grosicki S, et al. Subcutaneous versus intravenous administration of bortezomib in patients with relapsed multiple myeloma: a randomised, phase 3, non-inferiority study. *Lancet Oncol* 2011;12(5): 431-440.
325. Alsina M, Trudel S, Furman RR, et al. A Phase I Single-Agent Study of Twice-Weekly Consecutive-Day Dosing of the Proteasome Inhibitor Carfilzomib in Patients with Relapsed or Refractory Multiple Myeloma or Lymphoma. *Clin Cancer Res* 2012;18(17):4830-4840.
326. O'Connor OA, Stewart AK, Vallone M, et al. A phase 1 dose escalation study of the safety and pharmacokinetics of the novel proteasome inhibitor carfilzomib (PR-171) in patients with hematologic malignancies. *Clin Cancer Res* 2009;15(22):7085-7091.
327. Bonnet JD, Alexanian R, Salmon SE, Haut A, Dixon DO. Addition of cisplatin and bleomycin to vincristine-carmustine-doxorubicin-prednisone (VBAP) combination in the treatment of relapsing or resistant multiple myeloma: a southwest oncology group study. *Cancer Treat Rep* 1984;68(3):481-485.
328. Broun GO Jr, Petruska PJ, Hiramoto RN, Cohen HJ. Cisplatin, BCNU, cyclophosphamide, and prednisone in multiple myeloma. *Cancer Treat Rep* 1982;66(2):237-242.
329. Barlogie B, Jagannath S, Desikan KR, et al. Total therapy with tandem transplants for newly diagnosed multiple myeloma. *Blood* 1999;93(1):55-65.
330. Kantarjian H, Dreicer R, Barlogie B, Plunkett W, Alexanian R. High-dose cytosine arabinoside in multiple myeloma. *Eur J Cancer Clin Oncol* 1984;20(2):227-231.
331. Tirelli U, Carbone A, Zagonei V, et al. Phase II study of teniposide (VM-26) in multiple myeloma. *Am J Clin Oncol* 1985;8(4):329-331.
332. Kraut EH, Crowley JJ, Wade JL, et al. Evaluation of topotecan in resistant and relapsing multiple myeloma: a southwest oncology group study. *J Clin Oncol* 1998;16(2):589-592.
333. Grever MR, Crowley J, Salmon S, et al. Phase II investigation of pentostatin in multiple myeloma: a southwest oncology group study. *J Natl Cancer Inst* 1990;82(22):1778-1779.
334. Belch AR, Henderson JF, Brox LW. Treatment of multiple myeloma with deoxycoformycin. *Cancer Chemother Pharmacol* 1985;14(1):49-52.
335. Munshi NC, Tricot G, Desikan R, et al. Clinical activity of arsenic trioxide for the treatment of multiple myeloma. *Leukemia* 2002;16(9):1835-1837.
336. Hussein MA, Saleh M, Ravandi F, Mason J, Rifkin RM, Ellison R. Phase 2 study of arsenic trioxide in patients with relapsed or refractory multiple myeloma. *Br J Haematol* 2004;125(4):470-476.
337. Dimopoulos MA, Arbutck S, Huber M, et al. Primary therapy of multiple myeloma with paclitaxel (taxol). *Ann Oncol* 1994;5(8):757-759.
338. Miller HJ, Leong T, Khandekar JD, Greipp PR, Gertz MA, Kyle RA. Paclitaxel as the initial treatment of multiple myeloma: an eastern cooperative oncology group study (E1A93). *Am J Clin Oncol* 1998;21(6):553-556.
339. Ahmann FR, Meyskens FL Jr, Jones SE, et al. Phase II evaluation of amsacrine (m-AMSA) in solid tumors, myeloma, and lymphoma: a university of Arizona and southwest oncology group study. *Cancer Treat Rep* 1983;67(7-8):697-700.
340. Greipp PR, Coleman M, Anderson K, McIntyre OR. Phase II trial of amsacrine in patients with multiple myeloma. *Med-Pediatr-Oncol* 1989;17(1):76-78.
341. Gockerman JP, Silberman H, Bartolucci AA. Phase II evaluation of aclarubicin in refractory multiple myeloma: a southeastern cancer study group trial. *Cancer Treat Rep* 1987;71(7-8):773-774.
342. Cornell CJ Jr, Pajak TF, McIntyre OR. Chlorozotocin: phase II evaluation in patients with myeloma. *Cancer Treat Rep* 1984;68(4):685-686.

343. Cohen HJ, Bartolucci AA. Hexamethylmelamine and prednisone in the treatment of refractory multiple myeloma. *Am J Clin Oncol* 1982;5(1):21-27.
344. Barlogie B, Crowley J, Salmon SE, Bonnet J, Weick JK, Hayden K. Phase II study of carboplatin (CBDCA) in refractory multiple myeloma. A Southwest Oncology Group study. *Invest New Drugs* 1994;12(1):53-55.
345. Kraut EH, Crowley JJ, Grever MR, et al. Phase II study of fludarabine phosphate in multiple myeloma. A Southwest Oncology Group study. *Invest New Drugs* 1990;8(2):199-200.
346. Dimopoulos MA, Kantarjian HM, Estey EH, Alexanian R. 2-Chlorodeoxyadenosine in the treatment of multiple myeloma. *Blood* 1992;80(6):1626.
347. Dispenzieri A, Gertz MA, Lacy MQ, et al. Flavopiridol in patients with relapsed or refractory multiple myeloma: a phase 2 trial with clinical and pharmacodynamic end-points. *Haematologica* 2006;91(3):390-393.
348. Dispenzieri A, Gertz MA, Lacy MQ, et al. A phase II trial of imatinib in patients with refractory/relapsed myeloma. *Leuk Lymphoma* 2006;47(1):39-42.
349. Durie BGM, Villarete L, Farvard A, Ornopia M, Urnovitz HB. Clarithromycin (Biaxin) as primary treatment for myeloma. *Blood* 1997;90(10):2578a.
350. Moreau P, Huynh A, Facon T, et al. Lack of efficacy of clarithromycin in advanced multiple myeloma. *Intergroupe Francais du Myelome (IFM) [letter]. Leukemia* 1999;13(3):490-491.
351. Stewart AK, Trudel S, Al-Berouti BM, Sutton DM, Meharchand J. Lack of response to short-term use of clarithromycin (BIAXIN) in multiple myeloma [letter]. *Blood* 1999;93(12):4441.
352. Morris TC, Ranaghan L, Morrison J, Northern Ireland Regional Haematology G. Phase II trial of clarithromycin and pamidronate therapy in myeloma. *Medical Oncology* 2001;18(1):79-84.
353. Harley JB, Pajak TF, McIntyre OR, et al. Improved survival of increased-risk myeloma patients on combined triple-alkylating-agent therapy: a study of the CALGB. *Blood* 1979;54(1):13-22.
354. Cooper MR, McIntyre OR, Propert KJ, et al. Single, sequential, and multiple alkylating agent therapy for multiple myeloma: a CALGB study. *J Clin Oncol* 1986;4(9):1331-1339.
355. Gregory WM, Richards MA, Malpas JS. Combination chemotherapy versus melphalan and prednisolone in the treatment of multiple myeloma: an overview of published trials. *J Clin Oncol* 1992;10(2):334-342.
356. Mateos MV, Hernandez JM, Hernandez MT, et al. Bortezomib plus melphalan and prednisone in elderly untreated patients with multiple myeloma: results of a multicenter phase I/II study. *Blood* 2006;108(7):2165-2172.
357. Kumar SK, Mikhael JR, Buadi FK, et al. Management of newly diagnosed symptomatic multiple myeloma: updated Mayo Stratification of Myeloma and Risk-Adapted Therapy (mSMART) consensus guidelines. *Mayo Clin Proc* 2009;84(12):1095-1110.
358. Dispenzieri A, Rajkumar SV, Gertz MA, et al. Treatment of newly diagnosed multiple myeloma based on Mayo Stratification of Myeloma and Risk-adapted Therapy (mSMART): consensus statement. *Mayo Clin Proc* 2007;82(3): 323-341.
- P.2096
359. Rajkumar SV, Hayman SR, Lacy MQ, et al. Combination therapy with lenalidomide plus dexamethasone (Rev/Dex) for newly diagnosed myeloma. *Blood* 2005;106(13):4050-4053.
360. Niesvizky R, Jayabalan DS, Christos PJ, et al. BiRD (Biaxin [clarithromycin]/Revlimid [lenalidomide]/dexamethasone) combination therapy results in high complete- and overall-response rates in treatment-naive symptomatic multiple myeloma. *Blood* 2008;111(3):1101-1109.
361. Lacy MQ, Gertz MA, Dispenzieri A, et al. Long-term results of response to therapy, time to progression, and survival with lenalidomide plus dexamethasone in newly diagnosed myeloma. *Mayo Clin Proc* 2007;82(10):1179-1184.
362. Rajkumar SV, Jacobus S, Callander NS, et al. Lenalidomide plus high-dose dexamethasone versus lenalidomide plus low-dose dexamethasone as initial therapy for newly diagnosed multiple myeloma: an open-label randomised controlled trial. *Lancet Oncol* 2010;11(1):29-37.

363. Khan ML, Reeder CB, Kumar SK, et al. A comparison of lenalidomide/dexamethasone versus cyclophosphamide/lenalidomide/dexamethasone versus cyclophosphamide/bortezomib/dexamethasone in newly diagnosed multiple myeloma. *Br J Haematol* 2012;156(3):326-333.
364. Celgene JR. Thalidomide investigator's brochure (Version 12.0). Summit N J 2012.
365. Reeder CB, Reece DE, Kukreti V, et al. Cyclophosphamide, bortezomib and dexamethasone induction for newly diagnosed multiple myeloma: high response rates in a phase II clinical trial. *Leukemia* 2009;23(7):1337-1341.
366. Reeder CB, Reece DE, Kukreti V, et al. Once- versus twice-weekly bortezomib induction therapy with CyBorD in newly diagnosed multiple myeloma. *Blood* 2010;115(16):3416-3417.
367. Bensinger WL, Jagannath S, Vescio R, et al. Phase 2 study of two sequential three-drug combinations containing bortezomib, cyclophosphamide and dexamethasone, followed by bortezomib, thalidomide and dexamethasone as frontline therapy for multiple myeloma. *Br J Haematol* 2010;148(4):562-568.
368. Kumar S, Flinn I, Richardson PG, et al. Randomized, multicenter, phase 2 study (EVOLUTION) of combinations of bortezomib, dexamethasone, cyclophosphamide, and lenalidomide in previously untreated multiple myeloma. *Blood* 2012;119(19):4375-4382.
369. Kropff M, Liebisch P, Knop S, et al. DSMM XI study: dose definition for intravenous cyclophosphamide in combination with bortezomib/dexamethasone for remission induction in patients with newly diagnosed myeloma. *Ann Hematol* 2009;88(11):1125-1130.
370. Richardson PG, Weller E, Lonial S, et al. Lenalidomide, bortezomib, and dexamethasone combination therapy in patients with newly diagnosed multiple myeloma. *Blood* 2010;116(5):679-686.
371. Cohen HJ, Silberman HR, Torniyos K, Bartolucci AA. Comparison of two long-term chemotherapy regimens, with or without agents to modify skeletal repair, in multiple myeloma. *Blood* 1984;63(3):639-648.
372. Abramson N, Lurie P, Mietlowski WL, Schilling A, Bennett JM, Horton J. Phase III study of intermittent carmustine (BCNU), cyclophosphamide, and prednisone versus intermittent melphalan and prednisone in myeloma. *Cancer Treat Rep* 1982;66(6):1273-1277.
373. Pavlovsky S, Corrado C, Santarelli MT, et al. An update of two randomized trials in previously untreated multiple myeloma comparing melphalan and prednisone versus three- and five-drug combinations: an Argentine group for the treatment of acute leukemia Study. *J Clin Oncol* 1988;6(5):769-775.
374. Bergsagel DE. Treatment of plasma cell myeloma. *Annu Rev Med* 1979;30:431-443.
375. Palva IP, Ahrenberg P, Ala-Harja K, et al. Treatment of multiple myeloma with an intensive 5-drug combination or intermittent melphalan and prednisone; a randomised multicentre trial. Finnish leukaemia group. *Eur J Haematol* 1987;38(1):50-54.
376. Kildahl-Andersen O, Bjark P, Bondevik A, et al. Multiple myeloma in central and northern Norway 1981-1982: a follow-up study of a randomized clinical trial of 5-drug combination therapy versus standard therapy. *Eur J Haematol* 1988;41(1):47-51.
377. Osterborg A, Ahre A, Bjorkholm M, et al. Alternating combination chemotherapy (VMCP/VBAP) is not superior to melphalan/prednisone in the treatment of multiple myeloma patients stage III—a randomized study from MGCS. *Eur J Haematol* 1989;43(1):54-62.
378. Boccadoro M, Marmont F, Tribalto M, et al. Multiple myeloma: VMCP/VBAP alternating combination chemotherapy is not superior to melphalan and prednisone even in high-risk patients. *J Clin Oncol* 1991;9(3):444-448.
379. Keldsen N, Bjerrum OW, Dahl IM, et al. Multiple myeloma treated with mitoxantrone in combination with vincristine and prednisolone (NOP regimen) versus melphalan and prednisolone: a phase III study. Nordic Myeloma Study Group (NMSG). *Eur J Haematol* 1993;51(2):80-85.
380. Salmon SE, Haut A, Bonnet JD, et al. Alternating combination chemotherapy and levamisole improves survival in multiple myeloma: a southwest oncology group study. *J Clin Oncol* 1983;1(8):453-461.
381. Durie BG, Dixon DO, Carter S, et al. Improved survival duration with combination chemotherapy induction for multiple myeloma: a southwest oncology group study. *J Clin Oncol* 1986;4(8):1227-1237.

382. Hjorth M, Hellquist L, Holmberg E, Magnusson B, Rodger S, Westin J. Initial treatment in multiple myeloma: no advantage of multidrug chemotherapy over melphalan-prednisone. The Myeloma Group of Western Sweden. *Br J Haematol* 1990;74(2):185-191.
383. Peest D, Coldewey R, Deicher H. Overall vs. tumor-related survival in multiple myeloma. German Myeloma Treatment Group. *Eur J Cancer* 1991;27(5):672.
384. Blade J, San Miguel JF, Alcalá A, et al. Alternating combination VCMP/VBAP chemotherapy versus melphalan/prednisone in the treatment of multiple myeloma: a randomized multicentric study of 487 patients. *J Clin Oncol* 1993;11(6):1165-1171.
385. Oken MM, Harrington DP, Abramson N, Kyle RA, Knospe W, Glick JH. Comparison of melphalan and prednisone with vincristine, carmustine, melphalan, cyclophosphamide, and prednisone in the treatment of multiple myeloma: results of eastern cooperative oncology group study E2479. *Cancer* 1997;79(8):1561-1567.
386. Peest D, Deicher H, Coldewey R, et al. A comparison of polychemotherapy and melphalan/prednisone for primary remission induction, and interferon-alpha for maintenance treatment, in multiple myeloma. A prospective trial of the German Myeloma Treatment Group. *Eur J Cancer* 1995;2:146-151.
387. Schey SA, Kazmi M, Ireland R, Lakhani A. The use of intravenous intermediate dose melphalan and dexamethasone as induction treatment in the management of de novo multiple myeloma. *Eur J Haematol* 1998;61(5):306-310.
388. Facon T, Mary JY, Hulin C, et al. Melphalan and prednisone plus thalidomide versus melphalan and prednisone alone or reduced-intensity autologous stem cell transplantation in elderly patients with multiple myeloma (IFM 99-06): a randomised trial. *Lancet* 2007;370(9594):1209-1218.
389. Palumbo A, Bringhen S, Caravita T, et al. Oral melphalan and prednisone chemotherapy plus thalidomide compared with melphalan and prednisone alone in elderly patients with multiple myeloma: randomised controlled trial. *Lancet* 2006;367(9513):825-831.
390. Palumbo A, Bringhen S, Liberati AM, et al. Oral melphalan, prednisone, and thalidomide in elderly patients with multiple myeloma: updated results of a randomized, controlled trial. *Blood* 2008;112(8):3107-3114.
391. Hulin C, Facon T, Rodon P, et al. Efficacy of melphalan and prednisone plus thalidomide in patients older than 75 years with newly diagnosed multiple myeloma: IFM 01/01 trial. *J Clin Oncol* 2009;27(22):3664-3670.
392. Waage A, Gimsing P, Fayers P, et al. Melphalan and prednisone plus thalidomide or placebo in elderly patients with multiple myeloma. *Blood* 2010;116(9):1405-1412.
393. Wijermans P, Schaafsma M, Termorshuizen F, et al. Phase III study of the value of thalidomide added to melphalan plus prednisone in elderly patients with newly diagnosed multiple myeloma: the HOVON 49 study. *J Clin Oncol* 2010;28(19):3160-3166.
394. Beksac M, Haznedar R, Firatli-Tuglular T, et al. Addition of thalidomide to oral melphalan/prednisone in patients with multiple myeloma not eligible for transplantation: results of a randomized trial from the Turkish myeloma study group. *Eur J Haematol* 2011;86(1):16-22.
395. San Miguel JF, Schlag R, Khuageva NK, et al. Bortezomib plus melphalan and prednisone for initial treatment of multiple myeloma. *N Engl J Med* 2008;359(9):906-917.
396. Mateos MV, Richardson PG, Schlag R, et al. Bortezomib plus melphalan and prednisone compared with melphalan and prednisone in previously untreated multiple myeloma: updated follow-up and impact of subsequent therapy in the phase III VISTA trial. *J Clin Oncol* 2010;28(13):2259-2266.
397. Palumbo A, Bringhen S, Rossi D, et al. Bortezomib-melphalan-prednisone-thalidomide followed by maintenance with bortezomib-thalidomide compared with bortezomib-melphalan-prednisone for initial treatment of multiple myeloma: a randomized controlled trial. *J Clin Oncol* 2010;28(34):5101-5109.
398. Palumbo A, Hajek R, Delforge M, et al. Continuous lenalidomide treatment for newly diagnosed multiple myeloma. *N Engl J Med* 2012;366(19):1759-1769.
399. Morgan GJ, Davies FE, Gregory WM, et al. Cyclophosphamide, thalidomide, and dexamethasone (CTD) as initial therapy for patients with multiple myeloma unsuitable for autologous transplantation. *Blood* 2011;118(5):1231-1238.
400. Mateos MV, Oriol A, Martínez-López J, et al. Bortezomib, melphalan, and prednisone versus bortezomib, thalidomide, and prednisone as induction therapy followed by maintenance treatment with bortezomib and thalidomide

- versus bortezomib and prednisone in elderly patients with untreated multiple myeloma: a randomised trial. *Lancet Oncol* 2010;11(10):934-941.
401. Fayers PM, Palumbo A, Hulin C, et al. Thalidomide for previously untreated elderly patients with multiple myeloma: meta-analysis of 1685 individual patient data from 6 randomized clinical trials. *Blood* 2011;118(5):1239-1247.
402. Palumbo A, Waage A, Hulin C, et al. Safety of thalidomide in newly diagnosed elderly myeloma patients: an individual patient data meta-analysis of six randomized trials. *Haematologica* 2012.
403. Verelst SG, Termorshuizen F, Uyl-de Groot CA, et al. Effect of thalidomide with melphalan and prednisone on health-related quality of life (HRQoL) in elderly patients with newly diagnosed multiple myeloma: a prospective analysis in a randomized trial. *Ann Hematol* 2011;90(12):1427-1439.
404. Morgan GJ, Gregory WM, Davies FE, et al. The role of maintenance thalidomide therapy in multiple myeloma: MRC Myeloma IX results and meta-analysis. *Blood* 2011.
405. Ludwig H, Hajek R, Tothova E, et al. Thalidomide-dexamethasone compared to melphalan-prednisolone in elderly patients with multiple myeloma. *Blood* 2009;113(15):3435-3442.
406. Niesvizky R, Flinn IW, Rifkin RM, et al. Impact of baseline characteristics on efficacy and safety after bortezomib-based induction and maintenance in newly diagnosed multiple myeloma (MM) patients ineligible for transplant in the phase IIIb UPFRONT study. *ASCO Meeting Abstr* 2011;29(15_suppl):8072.
407. Rajkumar SV, Blood E, Vesole D, Fonseca R, Greipp PR. Phase III clinical trial of thalidomide plus dexamethasone compared with dexamethasone alone in newly diagnosed multiple myeloma: a clinical trial coordinated by the Eastern Cooperative Oncology Group. *J Clin Oncol* 2006;24(3):431-436.
408. Rajkumar SV, Rosinol L, Hussein M, et al. Multicenter, randomized, doubleblind, placebo-controlled study of thalidomide plus dexamethasone compared with dexamethasone as initial therapy for newly diagnosed multiple myeloma. *J Clin Oncol* 2008;26(13):2171-2177.
409. Vesole DH, Jacobus S, Rajkumar SV, et al. Lenalidomide Plus Low-Dose Dexamethasone (Ld): superior one and two year survival regardless of age compared to Lenalidomide Plus High-Dose Dexamethasone (LD). *ASH Ann Meeting Abstr* 2010;116(21):308-.
410. Case DC Jr, Sonneborn HL, Paul SD, et al. Combination chemotherapy for multiple myeloma with BCNU, cyclophosphamide, vincristine, melphalan, and prednisone (M-2 protocol). *Oncology* 1985;42(3):137-140.
411. Peest D, Deicher H, Coldewey R, Schmoll HJ, Schedel I. Induction and maintenance therapy in multiple myeloma: a multicenter trial of MP versus VCMP. *Eur J Cancer Clin Oncol* 1988;24(6):1061-1067.
412. Kildahl-Andersen O, Bjark P, Bondevik A, et al. Multiple myeloma in central Norway 1981-1982: a randomized clinical trial of 5-drug combination therapy versus standard therapy. *Scand J Haematol* 1986;37(3):243-248.
413. Alberts DS, Durie BG, Salmon SE. Doxorubicin/B.C.N.U. chemotherapy for multiple myeloma in relapse. *Lancet* 1976;1(7966):926-928.
414. Alexanian R, Salmon S, Gutterman J, Dixon D, Bonnet J, Haut A. Chemoimmunotherapy for multiple myeloma. *Cancer* 1981;47(8):1923-1929.
415. Crowley J, Jacobson J, Alexanian R. Standard-dose therapy for multiple myeloma: the southwest oncology group experience. [Review] [20 refs]. *Semin Hematol* 2001;38(3):203-208.
416. Durie BG, Stock-Novack D, Salmon SE, et al. Prognostic value of pretreatment serum beta 2 microglobulin in myeloma: a southwest oncology group study. *Blood* 1990;75(4):823-830.
417. Salmon SE, Tesh D, Crowley J, et al. Chemotherapy is superior to sequential hemibody irradiation for remission consolidation in multiple myeloma: a southwest oncology group study. *J Clin Oncol* 1990;8(9):1575-1584.
418. Dimopoulos MA, Weber D, Delasalle KB, Alexanian R. Combination therapy with interferon-dexamethasone for newly diagnosed patients with multiple myeloma. *Cancer* 1993;72(9):2589-2592.
419. Ahre A, Bjorkholm M, Osterborg A, et al. High doses of natural alpha-interferon (alpha-IFN) in the treatment of multiple myeloma—a pilot study from the Myeloma Group of Central Sweden (MGCS). *Eur J Haematol* 1988;41(2):123-130.

420. Corrado C, Pavlovsky S, Saslasky J. Randomized trial comparing melphalan-prednisone with or without recombinant alpha-2 interferon (r-alpha2IFN) in multiple myeloma. Paper presented at Proceedings of American Society of Clinical Oncology 1989.
421. Garcia-Larana J, Steegmann J, Perez Oteyza J. Treatment of multiple myeloma with melphalan-prednisone (MP) versus melphalan-prednisone and alpha-2b-interferon (MP-IFN). Results of a Cooperative Spanish Group. Paper presented at Congress of International Society of Haematology ISH 1992.
422. Vela-Ojeda J, Vazquez V, Garcia Ruiz E. A randomized clinical trial comparing chemotherapy with or without interferon alfa-2b in newly diagnosed patients with multiple myeloma. Paper presented at IV International Workshop on Multiple Myeloma 1993; Rochester, MN, USA.
423. Montuoro A, De Rosa L, De Blasio A, Pacilli L, Petti N, De Laurenzi A. Alpha-2a-interferon/melphalan/prednisone versus melphalan/prednisone in previously untreated patients with multiple myeloma. *Br J Haematol* 1990;76(3):365-368.
424. Interferon-alpha 2b added to melphalan-prednisone for initial and maintenance therapy in multiple myeloma. A randomized, controlled trial. The nordic myeloma study group. *Ann Intern Med* 1996;124(2):212-222.
425. Osterborg A, Bjorkholm M, Bjoreman M, et al. Natural interferon-alpha in combination with melphalan/prednisone versus melphalan/prednisone in the treatment of multiple myeloma stages II and III: a randomized study from the myeloma group of central Sweden. *Blood* 1993;81(6):1428-1434.
426. Cooper MR, Dear K, McIntyre OR, et al. A randomized clinical trial comparing melphalan/prednisone with or without interferon alfa-2b in newly diagnosed patients with multiple myeloma: a cancer and leukemia group B study. *J Clin Oncol* 1993;11(1):155-160.
427. Capnist G, Vespignani M, Spriano M, et al. Impact of interferon at induction chemotherapy and maintenance treatment for multiple myeloma. Preliminary results of a multicenter study by the Italian non-Hodgkin's Lymphoma Cooperative Study Group (NHLCSG). *Acta Oncol* 1994;33(5): 527-529.
428. Montuoro A, DeRosa L, Pescador L. Interferon alfa-2b-MP versus MP alone in previously untreated patients with multiple myeloma: preliminary results from a multicenter study. Paper presented at 24th Congress of the International Society of Hematology; August 22, 1992, 1992; London, United Kingdom.
429. Ludwig H, Cohen AM, Huber H, et al. Interferon alfa-2b with VMCP compared to VMCP alone for induction and interferon alfa-2b compared to controls for remission maintenance in multiple myeloma: interim results. *Eur J Cancer* 1991;27(Suppl 4):S40-S45.
430. Ludwig H, Cohen AM, Polliack A, et al. Interferon-alpha for induction and maintenance in multiple myeloma: results of two multicenter randomized trials and summary of other studies. *Ann Oncol* 1995;6(5):467-476.
431. Scheithauer W, Cortelezzi A, Fritz E, et al. Combined alpha-2C-interferon/VMCP polychemotherapy versus VMCP polychemotherapy as induction therapy in multiple myeloma: a prospective randomized trial. *J Biol Response Mod* 1989;8(2):109-115.
432. Casassus P, Mahe B, Fain O. Double randomized comparison of interferon-a (IFN-a) with VMCP/VBAP regimen as the induction phase and of two doses of IFN-alpha in plateau phase of untreated multiple myeloma: results of the KIF multicenter trial. Paper presented at VI International Workshop on Multiple Myeloma- 1997; Boston, MA, USA.
433. Joshua DE, Penny R, Matthews JP, et al. Australian Leukaemia Study Group myeloma II: a randomized trial of intensive combination chemotherapy with or without interferon in patients with myeloma. *Br J Haematol* 1997;97(1):38-45.
434. Aviles A, Alatraste S, Talavera A, Delgado S, Rosas A. Alternating combination chemotherapy and interferon improves survival in poor prognosis multiple myeloma. *Clin Oncol* 1995;7(2):97-101.
435. Gertz MA, Kalish LA, Kyle RA, Hahn RG, Tormey DC, Oken MM. Phase III study comparing vincristine, doxorubicin (Adriamycin), and dexamethasone (VAD) chemotherapy with VAD plus recombinant interferon alfa-2 in refractory or relapsed multiple myeloma. An Eastern Cooperative Oncology Group study. *Am J Clin Oncol* 1995;18(6):475-480.
436. Oken MM, Leong T, Lenhard RE Jr, et al. The addition of interferon or high dose cyclophosphamide to standard chemotherapy in the treatment of patients with multiple myeloma: phase III Eastern Cooperative Oncology Group Clinical Trial EST 9486. *Cancer* 1999;86(6):957-968.

437. Galvez C, Pire R, Bonamassa M. Multiple Myeloma: treatment with VABP with or without recombinant alfa-2b interferon in multiple myeloma. Paper presented at 18th International Congress of Chemotherapy; June 27- July 2, 1993, 1993; Stockholm, Sweden.
438. Aitchison R, Williams A, Schey S, Newland AC. A randomised trial of cyclophosphamide with and without low dose alpha- interferon in the treatment of newly diagnosed myeloma. *Leuk Lymphoma* 1993;9(3):243-246.
439. Ludwig H, Fritz E. Interferon in multiple myeloma—summary of treatment results and clinical implications. *Acta Oncol* 2000;39(7):815-821.
440. Interferon as therapy for multiple myeloma: an individual patient data overview of 24 randomized trials and 4012 patients. *Br J Haematol* 2001;113(4):1020-1034.
441. Preis P, Scheithauer W, Fritz E, et al. VMCP chemotherapy with or without interferon-alpha-2 in newly diagnosed patients with multiple myeloma. *Onkologie* 1989;12(1):27-29.
442. Wisloff F, Hjorth M, Kaasa S, Westin J. Effect of interferon on the health-related quality of life of multiple myeloma patients: results of a Nordic randomized trial comparing melphalan-prednisone to melphalan-prednisone + alpha-interferon. The Nordic Myeloma Study Group. *Br J Haematol* 1996;94(2):324-332.
443. Barlogie B, Smith L, Alexanian R. Effective treatment of advanced multiple myeloma refractory to alkylating agents. *N Engl J Med* 1984;310(21):1353-1356.
444. Alexanian R, Barlogie B, Tucker S. VAD-based regimens as primary treatment for multiple myeloma. *Am J Hematol* 1990;33(2):86-89.
445. Samson D, Gaminara E, Newland A, et al. Infusion of vincristine and doxorubicin with oral dexamethasone as first-line therapy for multiple myeloma. *Lancet* 1989;2(8668):882-885.
446. Attal M, Huguot F, Schlaifer D, et al. Intensive combined therapy for previously untreated aggressive myeloma. *Blood* 1992;79(5):1130-1136.
447. Raje N, Powles R, Kulkarni S, et al. A comparison of vincristine and doxorubicin infusional chemotherapy with methylprednisolone (VAMP) with the addition of weekly cyclophosphamide (C-VAMP) as induction treatment followed by autografting in previously untreated myeloma. *Br J Haematol* 1997;97(1):153-160.
448. Kars A, Celik I, Kansu E, et al. Maintenance therapy with alpha-interferon following first-line VAD in multiple myeloma. *Eur J Haematol* 1997;59(2):100-104.
449. Anderson H, Scarffe JH, Ranson M, et al. VAD chemotherapy as remission induction for multiple myeloma. *Br J Cancer* 1995;71(2):326-330.
450. Segeren CM, Sonneveld P, van der Holt B, et al. Vincristine, doxorubicin and dexamethasone (VAD) administered as rapid intravenous infusion for first-line treatment in untreated multiple myeloma. *Br J Haematol* 1999;105(1):127-130.
451. Fossa A, Muer M, Kasper C, Welt A, Seeber S, Nowrousian MR. Bolus vincristine and epirubicin with cyclophosphamide and dexamethasone (VECD) as induction and salvage treatment in multiple myeloma. *Leukemia* 1998;12(3):422-426.
452. Tsiara SN, Kapsali E, Christou L, Panteli A, Pritsivelis N, Bourantas KL. Administration of a modified chemotherapeutic regimen containing vincristine, liposomal doxorubicin and dexamethasone to multiple myeloma patients: preliminary data. *Eur J Haematol* 2000;65(2):118-122.
453. Salmon SE, Crowley JJ, Balcerzak SP, et al. Interferon versus interferon plus prednisone remission maintenance therapy for multiple myeloma: a southwest oncology group study. *J Clin Oncol* 1998;16(3):890-896.
454. Salmon SE, Crowley JJ, Grogan TM, Finley P, Pugh RP, Barlogie B. Combination chemotherapy, glucocorticoids, and interferon alfa in the treatment of multiple myeloma: a southwest oncology group study [see comments]. *J Clin Oncol* 1994;12(11):2405-2414.
455. Szelenyi H, Kreuser ED, Keilholz U, et al. Cyclophosphamide, adriamycin and dexamethasone (CAD) is a highly effective therapy for patients with advanced multiple myeloma. *Ann Oncol* 2001;12(1):105-108.
456. Giles FJ, Wickham NR, Rapoport BL, et al. Cyclophosphamide, etoposide, vincristine, adriamycin, and dexamethasone (CEVAD) regimen in refractory multiple myeloma: an International Oncology Study Group (IOSG) phase II protocol. *Am J Hematol* 2000;63(3):125-130.

457. Anagnostopoulos A, Aleman A, Williams P, et al. Autologous stem cell transplantation (ASCT) after nonmyelosuppressive induction therapy with dexamethasone alone is safe and effective for newly diagnosed multiple myeloma (MM) Pts who receive high dose chemotherapy (HDC). *Blood* 2001;98:2858a.
458. Kumar S, Lacy MQ, Dispenzieri A, et al. Single agent dexamethasone for prestem cell transplant induction therapy for multiple myeloma. *Bone Marrow Transplant* 2004;34(6):485-490.
459. Alvares CL, Davies FE, Horton C, et al. Long-term outcomes of previously untreated myeloma patients: responses to induction chemotherapy and high-dose melphalan incorporated within a risk stratification model can help to direct the use of novel treatments. *Br J Haematol* 2005;129(5):607-614.
460. Zonder JA, Crowley J, Hussein MA, et al. Lenalidomide and high-dose dexamethasone compared with dexamethasone as initial therapy for multiple myeloma: a randomized Southwest Oncology Group trial (S0232). *Blood* 2010;116(26):5838-5841.
461. Rifkin RM, Gregory SA, Mohrbacher A, Hussein MA. Pegylated liposomal doxorubicin, vincristine, and dexamethasone provide significant reduction in toxicity compared with doxorubicin, vincristine, and dexamethasone in patients with newly diagnosed multiple myeloma: a Phase III multicenter randomized trial. *Cancer* 2006;106(4):848-858.
462. Dimopoulos MA, Pouli A, Zervas K, et al. Prospective randomized comparison of vincristine, doxorubicin and dexamethasone (VAD) administered as intravenous bolus injection and VAD with liposomal doxorubicin as first-line treatment in multiple myeloma. *Ann Oncol* 2003;14(7):1039-1044.
463. Barlogie B, Tricot G, Anaissie E, et al. Thalidomide and hematopoietic cell transplantation for multiple myeloma. *N Engl J Med* 2006;354(10): 1021-1030.
464. Lokhorst HM, van der Holt B, Zweegman S, et al. A randomized phase 3 study on the effect of thalidomide combined with adriamycin, dexamethasone, and high-dose melphalan, followed by thalidomide maintenance in patients with multiple myeloma. *Blood* 2010;115(6):1113-1120.
465. Morgan GJ, Davies FE, Gregory WM, et al. Cyclophosphamide, thalidomide, and dexamethasone as induction therapy for newly diagnosed multiple myeloma patients destined for autologous stem-cell transplantation: MRC Myeloma IX randomized trial results. *Haematologica* 2012;97(3):442-450.
466. Cavo M, Tacchetti P, Patriarca F, et al. Bortezomib with thalidomide plus dexamethasone compared with thalidomide plus dexamethasone as induction therapy before, and consolidation therapy after, double autologous stem-cell transplantation in newly diagnosed multiple myeloma: a randomised phase 3 study. *Lancet* 2010;376(9758):2075-2085.
467. Sonneveld P, Schmidt-Wolf IG, van der Holt B, et al. Bortezomib Induction and Maintenance Treatment in Patients With Newly Diagnosed Multiple Myeloma: results of the randomized phase III HOVON-65/ GMMG-HD4 trial. *J Clin Oncol* 2012;30(24):2946-2955.
468. Rosinol L, Oriol A, Teruel AI, et al. Superiority of bortezomib, thalidomide, and dexamethasone (VTD) as induction pretransplantation therapy in multiple myeloma: a randomized phase 3 PETHEMA/GEM study. *Blood* 2012;120(8):1589-1596.
469. Macro M, Divine M, Uzunhan Y, et al. Dexamethasone + Thalidomide (Dex/Thal) Compared to VAD as a Pre-Transplant Treatment in Newly Diagnosed Multiple Myeloma (MM): a randomized trial. *ASH Ann Meeting Abstr* 2006;108(11):57-.
470. Harousseau JL, Attal M, Avet-Loiseau H, et al. Bortezomib plus dexamethasone is superior to vincristine plus doxorubicin plus dexamethasone as induction treatment prior to autologous stem-cell transplantation in newly diagnosed multiple myeloma: results of the IFM 2005-01 phase III trial. *J Clin Oncol* 2010;28(30):4621-4629.
471. Moreau P, Avet-Loiseau H, Facon T, et al. Bortezomib plus dexamethasone versus reduced-dose bortezomib, thalidomide plus dexamethasone as induction treatment before autologous stem cell transplantation in newly diagnosed multiple myeloma. *Blood* 2011;118(22):5752-5758, quiz 5982.
472. Wang M, Delasalle K, Giral S, Alexanian R. Rapid Control of Previously Untreated Multiple Myeloma with Bortezomib-Thalidomide-Dexamethasone Followed by Early Intensive Therapy. *Blood* 2005:[784].
473. Neben K, Lokhorst HM, Jauch A, et al. Administration of bortezomib before and after autologous stem cell transplantation improves outcome in multiple myeloma patients with deletion 17p. *Blood* 2012;119(4):940-948.

474. Usmani SZ, Crowley J, Hoering A, et al. Improvement in long-term outcomes with successive Total Therapy trials for multiple myeloma: are patients now being cured? *Leukemia* 2012.
475. Barlogie B, Anaissie E, van Rhee F, et al. Incorporating bortezomib into upfront treatment for multiple myeloma: early results of total therapy 3. *Br J Haematol* 2007;138(2):176-185.
476. Kumar SK, Lacy MQ, Dispenzieri A, et al. Early versus delayed autologous transplantation after immunomodulatory agents-based induction therapy in patients with newly diagnosed multiple myeloma. *Cancer* 2012;118(6):1585-1592.
477. Jagannath S, Durie BG, Wolf JL, et al. Extended follow-up of a phase 2 trial of bortezomib alone and in combination with dexamethasone for the frontline treatment of multiple myeloma. *Br J Haematol* 2009;146(6):619-626.
478. Ghosh N, Ye X, Ferguson A, Huff CA, Borrello I. Bortezomib and thalidomide, a steroid free regimen in newly diagnosed patients with multiple myeloma. *Br J Haematol* 2011;152(5):593-599.
479. Jakubowiak AJ, Dytfeld D, Griffith KA, et al. A phase 1/2 study of carfilzomib in combination with lenalidomide and low-dose dexamethasone as a frontline treatment for multiple myeloma. *Blood* 2012;120(9):1801-1809.
480. Oakervee HE, Popat R, Curry N, et al. PAD combination therapy (PS-341/bortezomib, doxorubicin and dexamethasone) for previously untreated patients with multiple myeloma. *Br J Haematol* 2005;129(6):755-762.
481. Popat R, Oakervee HE, Hallam S, et al. Bortezomib, doxorubicin and dexamethasone (PAD) front-line treatment of multiple myeloma: updated results after long-term follow-up. *Br J Haematol* 2008;141(4):512-516.
482. Sher T, Ailawadhi S, Miller KC, et al. A steroid-independent regimen of bortezomib, liposomal doxorubicin and thalidomide demonstrate high response rates in newly diagnosed multiple myeloma patients. *Br J Haematol* 2011;154(1):104-110.
483. Berenson JR, Yellin O, Chen CS, et al. A modified regimen of pegylated liposomal doxorubicin, bortezomib and dexamethasone (DVD) is effective and well tolerated for previously untreated multiple myeloma patients. *Br J Haematol* 2011;155(5):580-587.
484. Zervas K, Dimopoulos MA, Hatzicharissi E, et al. Primary treatment of multiple myeloma with thalidomide, vincristine, liposomal doxorubicin and dexamethasone (T-VAD doxil): a phase II multicenter study. *Ann Oncol* 2004;15(1):134-138.
485. Jakubowiak AJ, Griffith KA, Reece DE, et al. Lenalidomide, bortezomib, pegylated liposomal doxorubicin, and dexamethasone in newly diagnosed multiple myeloma: a phase 1/2 multiple myeloma research consortium trial. *Blood* 2011;118(3):535-543.
486. Popat R, Oakervee HE, Curry N, et al. Reduced dose PAD combination therapy (PS-341/bortezomib, adriamycin and dexamethasone) for previously untreated patients with multiple myeloma. *ASH Ann Meeting Abstr* 2005;106(11):2554-.
487. Kumar SK, Lacy MQ, Hayman SR, et al. Lenalidomide, cyclophosphamide and dexamethasone (CRd) for newly diagnosed multiple myeloma: results from a phase 2 trial. *Am J Hematol* 2011;86(8):640-645.
488. Hussein MA, Baz R, Srkalovic G, et al. Phase 2 study of pegylated liposomal doxorubicin, vincristine, decreased-frequency dexamethasone, and thalidomide in newly diagnosed and relapsed-refractory multiple myeloma. *Mayo Clin Proc* 2006;81(7):889-895.
489. Hassoun H, Reich L, Klimek VM, et al. Doxorubicin and dexamethasone followed by thalidomide and dexamethasone is an effective well tolerated initial therapy for multiple myeloma. *Br J Haematol* 2006;132(2):155-161.
490. Offidani M, Corvatta L, Piersantelli MN, et al. Thalidomide, dexamethasone and pegylated liposomal doxorubicin (ThaDD) for newly diagnosed multiple myeloma patients over 65 years. *Blood* 2006.
491. Barlogie B, Hall R, Zander A, Dicke K, Alexanian R. High-dose melphalan with autologous bone marrow transplantation for multiple myeloma. *Blood* 1986;67(5):1298-1301.
492. Child JA, Morgan GJ, Davies FE, et al. High-dose chemotherapy with hematopoietic stem-cell rescue for multiple myeloma. *N Engl J Med* 2003;348(19):1875-1883.
493. Palumbo A, Bringhen S, Petrucci MT, et al. Intermediate-dose melphalan improves survival of myeloma patients aged 50 to 70: results of a randomized controlled trial. *Blood* 2004;104(10):3052-3057.
494. Feraud JP, Katsahian S, Divine M, et al. High-dose therapy and autologous blood stem-cell transplantation compared with conventional treatment in myeloma patients aged 55 to 65 years: long-term results of a randomized control trial from the Group Myelome-Autogreffe. *J Clin Oncol* 2005;23(36):9227-9233.

495. Fermand JP, Ravaud P, Chevret S, et al. High-dose therapy and autologous peripheral blood stem cell transplantation in multiple myeloma: up-front or rescue treatment? Results of a multicenter sequential randomized clinical trial. *Blood* 1998;92(9):3131-3136.
496. Barlogie B, Kyle RA, Anderson KC, et al. Standard chemotherapy compared with high-dose chemoradiotherapy for multiple myeloma: final results of phase III US Intergroup Trial S9321. *J Clin Oncol* 2006;24(6):929-936.
497. Blade J, Rosinol L, Sureda A, et al. High-dose therapy intensification compared with continued standard chemotherapy in multiple myeloma patients responding to the initial chemotherapy: long-term results from a prospective randomized trial from the Spanish cooperative group PETHEMA. *Blood* 2005;106(12):3755-3759.
498. Alexanian R, Dimopoulos MA, Delasalle KB, Hester J, Champlin R. Myeloablative therapy for primary resistant multiple myeloma. *Stem Cells* 1995;2:118-121.
499. Rajkumar SV, Fonseca R, Lacy MQ, et al. Autologous stem cell transplantation for relapsed and primary refractory myeloma. *Bone Marrow Transplant* 1999;23(12):1267-1272.
500. Kumar S, Lacy MQ, Dispenzieri A, et al. High-dose therapy and autologous stem cell transplantation for multiple myeloma poorly responsive to initial therapy. *Bone Marrow Transplant* 2004;34(2):161-167.
501. Gertz MA, Kumar S, Lacy MQ, et al. Stem cell transplantation in multiple myeloma: impact of response failure with thalidomide or lenalidomide induction. *Blood* 2010;115(12):2348-2353.
502. Harousseau JL, Attal M. The role of stem cell transplantation in multiple myeloma. *Blood Rev* 2002;16(4):245-253.
503. Sonneveld P, van der Holt B, Segeren CM, et al. Intermediate-dose melphalan compared with myeloablative treatment in multiple myeloma: long-term follow-up of the Dutch Cooperative Group HOVON 24 trial. *Haematologica* 2007;92(7):928-935.
504. Vesole DH, Barlogie B, Jagannath S, et al. High-dose therapy for refractory multiple myeloma: improved prognosis with better supportive care and double transplants. *Blood* 1994;84(3):950-956.
505. Barlogie B, Jagannath S, Vesole DH, et al. Superiority of tandem autologous transplantation over standard therapy for previously untreated multiple myeloma. *Blood* 1997;89(3):789-793.
506. Desikan R, Barlogie B, Sawyer J, et al. Results of high-dose therapy for 1000 patients with multiple myeloma: durable complete remissions and superior survival in the absence of chromosome 13 abnormalities. *Blood* 2000;95(12):4008-4010.
507. Attal M, Harousseau JL, Facon T, et al. Single versus double autologous stem-cell transplantation for multiple myeloma. *N Engl J Med* 2003;349(26):2495-2502.
508. Kumar A, Kharfan-Dabaja MA, Glasmacher A, Djulbegovic B. Tandem versus single autologous hematopoietic cell transplantation for the treatment of multiple myeloma: a systematic review and meta-analysis. *J Natl Cancer Inst* 2009;101(2):100-106.
509. Alvares C, Davies F, Horton C, Patel G, Powles R, Morgan G. The role of second autografts in the management of myeloma at first relapse. *Haematologica* 2006;91(1):141-142.
510. Jimenez-Zepeda VH, Mikhael J, Winter A, et al. Second autologous stem cell transplantation as salvage therapy for multiple myeloma: impact on progression-free and overall survival. *Biol Blood Marrow Transplant* 2012;18(5):773-779.
511. Silva Ronden C, Hassoun H, Chimento D, Jia X, Giralt S, Landau HJ. Outcomes Following Salvage Autologous Stem Cell Transplant (Sct) for Multiple Myeloma. *Biology of Blood and Marrow Transplantation*. 2012;18(2 (supplement)):S254.
512. Fenk R, Liese V, Neubauer F, et al. Predictive factors for successful salvage high-dose therapy in patients with multiple myeloma relapsing after autologous blood stem cell transplantation. *Leuk Lymphoma* 2011;52(8):1455-1462.
513. Shah N, Ahmed F, Bashir Q, et al. Durable remission with salvage second autotransplants in patients with multiple myeloma. *Cancer* 2011.
514. Mehta J, Tricot G, Jagannath S, et al. Salvage autologous or allogeneic transplantation for multiple myeloma refractory to or relapsing after a first-line autograft? *Bone Marrow Transplant* 1998;21(9):887-892.
515. Olin RL, Vogl DT, Porter DL, et al. Second auto-SCT is safe and effective salvage therapy for relapsed multiple myeloma. *Bone Marrow Transplant* 2009;43(5):417-422.

516. Bjorkstrand BB, Ljungman P, Svensson H, et al. Allogeneic bone marrow transplantation versus autologous stem cell transplantation in multiple myeloma: a retrospective case-matched study from the European Group for Blood and Marrow Transplantation. *Blood* 1996;88(12):4711-4718.
517. Varterasian M, Janakiraman N, Karanes C, et al. Transplantation in patients with multiple myeloma: a multicenter comparative analysis of peripheral blood stem cell and allogeneic transplant. *Am J Clin Oncol* 1997;20(5):462-466.
518. Couban S, Stewart AK, Loach D, Panzarella T, Meharchand J. Autologous and allogeneic transplantation for multiple myeloma at a single centre. *Bone Marrow Transplant* 1997;19(8):783-789.
519. Reynolds C, Ratanatharathorn V, Adams P, et al. Allogeneic stem cell transplantation reduces disease progression compared to autologous transplantation in patients with multiple myeloma. *Bone Marrow Transplant* 2001;27(8):801-807.
520. Lokhorst HM, Sonneveld P, Cornelissen JJ, et al. Induction therapy with vincristine, adriamycin, dexamethasone (VAD) and intermediate-dose melphalan (IDM) followed by autologous or allogeneic stem cell transplantation in newly diagnosed multiple myeloma. *Bone Marrow Transplant* 1999;23(4):317-322.
521. Alyea E, Weller E, Schlossman R, et al. Outcome after autologous and allogeneic stem cell transplantation for patients with multiple myeloma: impact of graft-versus-myeloma effect. *Bone Marrow Transplant* 2003;32(12):1145-1151.
522. Arora M, McGlave PB, Burns LJ, et al. Results of autologous and allogeneic hematopoietic cell transplant therapy for multiple myeloma. *Bone Marrow Transplant* 2005;35(12):1133-1140.
523. Elice F, Raimondi R, Tosetto A, et al. Prolonged overall survival with second on-demand autologous transplant in multiple myeloma. *Am J Hematol* 2006;81(6):426-431.
524. Burzynski JA, Toro JJ, Patel RC, et al. Toxicity of a second autologous peripheral blood stem cell transplant in patients with relapsed or recurrent multiple myeloma. *Leuk Lymphoma* 2009;50(9):1442-1447.
525. Bensinger WI, Buckner CD, Anasetti C, et al. Allogeneic marrow transplantation for multiple myeloma: an analysis of risk factors on outcome. *Blood* 1996;88(7):2787-2793.
526. Harousseau JL, Attal M, Divine M, et al. Comparison of autologous bone marrow transplantation and peripheral blood stem cell transplantation after first remission induction treatment in multiple myeloma. [Review] [35 refs]. *Bone Marrow Transplant* 1995;15(6):963-969.
527. Larsson K, Bjorkstrand B, Ljungman P. Faster engraftment but no reduction in infectious complications after peripheral blood stem cell transplantation compared to autologous bone marrow transplantation. *Support Care Cancer* 1998;6(4):378-383.
528. Gertz MA, Lacy MQ, Inwards DJ, et al. Early harvest and late transplantation as an effective therapeutic strategy in multiple myeloma. *Bone Marrow Transplant* 1999;23(3):221-226.
529. Tricot G, Jagannath S, Vesole D, et al. Peripheral blood stem cell transplants for multiple myeloma: identification of favorable variables for rapid engraftment in 225 patients. [Review] [29 refs]. *Blood* 1995;85(2):588-596.
530. Goldschmidt H, Hegenbart U, Wallmeier M, Hohaus S, Haas R. Factors influencing collection of peripheral blood progenitor cells following high-dose cyclophosphamide and granulocyte colony-stimulating factor in patients with multiple myeloma. *Br J Haematol* 1997;98(3):736-744.
531. Kroger N, Zeller W, Hassan HT, et al. Successful mobilization of peripheral blood stem cells in heavily pretreated myeloma patients with G-CSF alone. *Ann Hematol* 1998;76(6):257-262.
532. Kumar S, Dispenzieri A, Lacy MQ, et al. Impact of lenalidomide therapy on stem cell mobilization and engraftment post-peripheral blood stem cell transplantation in patients with newly diagnosed myeloma. *Leukemia* 2007;21(9):2035-2042.
533. Kumar S, Giralt S, Stadtmauer EA, et al. Mobilization in myeloma revisited: IMWG consensus perspectives on stem cell collection following initial therapy with thalidomide-, lenalidomide-, or bortezomib-containing regimens. *Blood* 2009;114(9):1729-1735.
534. Giralt S, Stadtmauer EA, Harousseau JL, et al. International myeloma working group (IMWG) consensus statement and guidelines regarding the current status of stem cell collection and high-dose therapy for multiple myeloma and the role of plerixafor (AMD 3100). *Leukemia* 2009;23(10):1904-1912.
535. Bensinger W, Appelbaum F, Rowley S, et al. Factors that influence collection and engraftment of autologous peripheral-blood stem cells. *J Clin Oncol* 1995;13(10):2547-2555.

536. Desikan KR, Tricot G, Munshi NC, et al. Preceding chemotherapy, tumour load and age influence engraftment in multiple myeloma patients mobilized with granulocyte colony-stimulating factor alone. *Br J Haematol* 2001; 112(1):242-247.
537. Devine SM, Flomenberg N, Vesole DH, et al. Rapid Mobilization of CD34 + Cells Following Administration of the CXCR4 Antagonist AMD3100 to Patients With Multiple Myeloma and Non-Hodgkin's Lymphoma 10.1200/JCO.2004.07.131. *J Clin Oncol* 2004;22(6):1095-1102.
538. Galimberti S, Morabito F, Guerrini F, et al. Peripheral blood stem cell contamination evaluated by a highly sensitive molecular method fails to predict outcome of autotransplanted multiple myeloma patients. *Br J Haematol* 2003;120(3):405-412.
539. Gertz MA, Witzig TE, Pineda AA, Greipp PR, Kyle RA, Litzow MR. Monoclonal plasma cells in the blood stem cell harvest from patients with multiple myeloma are associated with shortened relapse-free survival after transplantation. *Bone Marrow Transplant* 1997;19(4):337-342.
540. Reece DE, Barnett MJ, Connors JM, et al. Treatment of multiple myeloma with intensive chemotherapy followed by autologous BMT using marrow purged with 4-hydroperoxycyclophosphamide. *Bone Marrow Transplant* 1993;11(2):139-146.
541. Seiden MV, Schlossman R, Andersen J, et al. Monoclonal antibody-purged bone marrow transplantation therapy for multiple myeloma. *Leuk Lymphoma* 1995;17(1-2):87-93.
542. Anderson KC, Andersen J, Soiffer R, et al. Monoclonal antibody-purged bone marrow transplantation therapy for multiple myeloma. *Blood* 1993;82(8):2568-2576.
543. Tricot G, Gazitt Y, Leemhuis T, et al. Collection, tumor contamination, and engraftment kinetics of highly purified hematopoietic progenitor cells to support high dose therapy in multiple myeloma. *Blood* 1998;91(12):4489-4495.
544. Schiller G, Vescio R, Freytes C, et al. Autologous CD34-selected blood progenitor cell transplants for patients with advanced multiple myeloma [see comments]. *Bone Marrow Transplant* 1998;21(2):141-145.
545. Stewart AK, Vescio R, Schiller G, et al. Purging of autologous peripheral-blood stem cells using CD34 selection does not improve overall or progression-free survival after high-dose chemotherapy for multiple myeloma: results of a multicenter randomized controlled trial. *J Clin Oncol* 2001;19(17):3771-3779.
546. Bourhis JH, Bouko Y, Koscielny S, et al. Relapse risk after autologous transplantation in patients with newly diagnosed myeloma is not related with infused tumor cell load and the outcome is not improved by CD34 + cell selection: long term follow-up of an EBMT phase III randomized study. *Haematologica* 2007;92(8):1083-1090.
547. Siegel DS, Desikan KR, Mehta J, et al. Age is not a prognostic variable with autotransplants for multiple myeloma. *Blood* 1999;93(1):51-54.
548. Badros A, Barlogie B, Morris C, et al. High response rate in refractory and poor-risk multiple myeloma after allotransplantation using a nonmyeloablative conditioning regimen and donor lymphocyte infusions. [erratum appears in *Blood* 2001 Jul 15;98(2):271; *Blood* 2001 Sep 15;98(6):1653]. *Blood* 2001;97(9):2574-2579.
549. San Miguel JF, Lahuerta JJ, Garcia-Sanz R, et al. Are myeloma patients with renal failure candidates for autologous stem cell transplantation? *Hematol J/EHA* 2000;1(1):28-36.
550. Lee CK, Zangari M, Barlogie B, et al. Dialysis-dependent renal failure in patients with myeloma can be reversed by high-dose myeloablative therapy and autotransplant. *Bone Marrow Transplant* 2004;33(8):823-828.
551. Knudsen LM, Nielsen B, Gimsing P, Geisler C. Autologous stem cell transplantation in multiple myeloma: outcome in patients with renal failure. *Eur J Haematol* 2005;75(1):27-33.
552. Moreau P, Hullin C, Garban F, et al. Tandem autologous stem cell transplantation in high-risk de novo multiple myeloma: final results of the prospective and randomized IFM 99-04 protocol. *Blood* 2006;107(1):397-403.
553. Bjorkstrand B, Iacobelli S, Hegenbart U, et al. Tandem autologous/reduced intensity conditioning allogeneic stem-cell transplantation versus autologous transplantation in myeloma: long-term follow-up. *J Clin Oncol* 2011;29(22):3016-3022.
554. Moreau P, Facon T, Attal M, et al. Comparison of 200 mg/m² melphalan and 8 Gy total body irradiation plus 140 mg/m² melphalan as conditioning regimens for peripheral blood stem cell transplantation in patients with newly diagnosed multiple myeloma: final analysis of the Intergroupe Francophone du Myelome 9502 randomized trial. *Blood* 2002;99(3):731-735.

555. Fenk R, Schneider P, Kropff M, et al. High-dose idarubicin, cyclophosphamide and melphalan as conditioning for autologous stem cell transplantation increases treatment-related mortality in patients with multiple myeloma: results of a randomised study. *Br J Haematol* 2005;130(4):588-594.
556. Huijgens PC, Dekker-Van Roessel HM, Jonkhoff AR, et al. High-dose melphalan with G-CSF-stimulated whole blood rescue followed by stem cell harvesting and busulphan/cyclophosphamide with autologous stem cell transplantation in multiple myeloma. *Bone Marrow Transplant* 2001;27(9):925-931.
557. Schiller G, Nimer S, Vescio R, et al. Phase I-II study of busulfan and cyclophosphamide conditioning for transplantation in advanced multiple myeloma. *Bone Marrow Transplant* 1994;14(1):131-136.
558. Lahuerta JJ, Grande C, Blade J, et al. Myeloablative treatments for multiple myeloma: update of a comparative study of different regimens used in patients from the Spanish registry for transplantation in multiple myeloma. *Leuk Lymphoma* 2002;43(1):67-74.
559. Capria S, Petrucci MT, Pulsoni A, et al. High-dose idarubicin, busulphan and melphalan for autologous stem cell transplantation in multiple myeloma responsive to DAV chemotherapy: comparison with a historical control. *Acta Haematol* 2006;115(1-2):9-14.
560. Carrion Galindo R, Sr., Serrano D, Perez-Corral A, et al. High-dose chemotherapy and autologous peripheral blood stem cell rescue (Auto-SCT) in multiple myeloma (MM) patients: Busulfan + melphalan-140 (BuMel) versus (vs) melphalan-200 (Mel-200) as conditioning regimens. *J Clin Oncol* 2006;24(18_suppl):7612.
561. Dispenzieri A, Wiseman GA, Lacy MQ, et al. A Phase I study of 153Sm-EDTMP with fixed high dose melphalan as a peripheral blood stem cell conditioning regimen in patients with multiple myeloma. *Leukemia* 2005;19(1):118-125.
562. Giralt S, Bensinger W, Goodman M, et al. 166Ho-DOTMP plus melphalan followed by peripheral blood stem cell transplantation in patients with multiple myeloma: results of two phase 1/2 trials. *Blood* 2003;102(7):2684-2691.
563. Hollmig K, Stover T, Talamo G, et al. Addition of Bortezomib (Velcade™) to High Dose Melphalan (Vel-Mel) as an Effective Conditioning Regimen with Autologous Stem Cell Support in Multiple Myeloma (MM). *Blood* 2004;104(11):Abs 929.
564. Palumbo A, Avonto I, Bruno B, et al. Intermediate-dose melphalan (100 mg/m²)/bortezomib/thalidomide/dexamethasone and stem cell support in patients with refractory or relapsed myeloma. *Clin Lymphoma Myeloma* 2006;6(6):475-477.
565. Lonial S, Kaufman J, Tighiouart M, et al. A phase I/II trial combining high-dose melphalan and autologous transplant with bortezomib for multiple myeloma: a dose- and schedule-finding study. *Clin Cancer Res* 2010;16(20):5079-5086.
566. Desikan KR, Tricot G, Dhodapkar M, et al. Melphalan plus total body irradiation (MEL-TBI) or cyclophosphamide (MEL-CY) as a conditioning regimen with second autotransplant in responding patients with myeloma is inferior compared to historical controls receiving tandem transplants with melphalan alone. *Bone Marrow Transplant* 2000;25(5):483-487.
567. Kroger N, Schwerdtfeger R, Kiehl M, et al. Autologous stem cell transplantation followed by a dose-reduced allograft induces high complete remission rate in multiple myeloma. *Blood* 2002;100(3):755-760.
568. Maloney DG, Molina AJ, Sahebi F, et al. Allografting with nonmyeloablative conditioning following cytoreductive autografts for the treatment of patients with multiple myeloma. *Blood* 2003;102(9):3447-3454.
569. Crawley C, Lalancette M, Szydlo R, et al. Outcomes for reduced-intensity allogeneic transplantation for multiple myeloma: an analysis of prognostic factors from the Chronic Leukaemia Working Party of the EBMT. *Blood* 2005;105(11):4532-4539.
570. Bruno B, Rotta M, Patriarca F, et al. A comparison of allografting with autografting for newly diagnosed myeloma. *N Engl J Med* 2007;356(11):1110-1120.
571. Giaccone L, Storer B, Patriarca F, et al. Long-term follow-up of a comparison of nonmyeloablative allografting with autografting for newly diagnosed myeloma. *Blood* 2011;117(24):6721-6727.
572. Garban F, Attal M, Michallet M, et al. Prospective comparison of autologous stem cell transplantation followed by dose-reduced allograft (IFM99-03 trial) with tandem autologous stem cell transplantation (IFM99-04 trial) in high-risk de novo multiple myeloma. *Blood* 2006;107(9):3474-3480.

573. Rosinol L, Perez-Simon JA, Sureda A, et al. A prospective PETHEMA study of tandem autologous transplantation versus autograft followed by reduced-intensity conditioning allogeneic transplantation in newly diagnosed multiple myeloma. *Blood* 2008;112(9):3591-3593.
574. Krishnan A, Pasquini MC, Logan B, et al. Autologous haemopoietic stem-cell transplantation followed by allogeneic or autologous haemopoietic stem-cell transplantation in patients with multiple myeloma (BMT CTN 0102): a phase 3 biological assignment trial. *Lancet Oncol* 2011;12(13):1195-1203.
575. Tricot G, Vesole DH, Jagannath S, Hilton J, Munshi N, Barlogie B. Graft-versus-myeloma effect: proof of principle. *Blood* 1996;87(3):1196-1198.
576. Lokhorst HM, Schattenberg A, Cornelissen JJ, Thomas LL, Verdonck LF. Donor leukocyte infusions are effective in relapsed multiple myeloma after allogeneic bone marrow transplantation. *Blood* 1997;90(10):4206-4211.
577. Alyea E, Weller E, Schlossman R, et al. T-cell—depleted allogeneic bone marrow transplantation followed by donor lymphocyte infusion in patients with multiple myeloma: induction of graft-versus-myeloma effect. *Blood* 2001;98(4):934-939.
578. Peggs KS, Mackinnon S, Williams CD, et al. Reduced-intensity transplantation with in vivo T-cell depletion and adjuvant dose-escalating donor lymphocyte infusions for chemotherapy-sensitive myeloma: limited efficacy of graft-versus-tumor activity. *Biol Blood Marrow Transplant* 2003;9(4): 257-265.
579. Peggs KS, Thomson K, Hart DP, et al. Dose-escalated donor lymphocyte infusions following reduced intensity transplantation: toxicity, chimerism, and disease responses. *Blood* 2004;103(4):1548-1556.
580. Ayuk F, Shimoni A, Nagler A, et al. Efficacy and toxicity of low-dose escalating donor lymphocyte infusion given after reduced intensity conditioning allograft for multiple myeloma. *Leukemia* 2004;18(3):659-662.
581. van de Donk NW, Kroger N, Hegenbart U, et al. Prognostic factors for donor lymphocyte infusions following non-myeloablative allogeneic stem cell transplantation in multiple myeloma. *Bone Marrow Transplant* 2006;37(12):1135-1141.
582. Lokhorst HM, Wu K, Verdonck LF, et al. The occurrence of graft-versus-host disease is the major predictive factor for response to donor lymphocyte infusions in multiple myeloma. *Blood* 2004;103(11):4362-4364.
583. Kyle RA, Pierre RV, Bayrd ED. Multiple myeloma and acute myelomonocytic leukemia. *N Engl J Med* 1970;283(21):1121-1125.
584. Nordenson N. Myelomatosis: a clinical review of 310 cases. *Acta Med Scand* 1966;445 (Suppl):178-186.
585. Osserman EF, Takatsuki K, Talal N. The pathogenesis of “amyloidosis”. *Semin Hematol* 1964;1:3-85.
586. Edwards GA, Zawadzki ZA. Extraosseous lesions in plasma cell myeloma: a report of six cases. *Am J Med* 1967;43:194-205.
587. Gonzalez F, Trujillo JM, Alexanian R. Acute leukemia in multiple myeloma. *Ann Intern Med* 1977;86(4):440-443.
588. Bergsagel DE, Bailey AJ, Langley GR, MacDonald RN, White DF, Miller AB. The chemotherapy on plasma-cell myeloma and the incidence of acute leukemia. *N Engl J Med* 1979;301(14):743-748.
589. Cohen HJ, Bartolucci AA, Forman WB, Silberman HR. Consolidation and maintenance therapy in multiple myeloma: randomized comparison of a new approach to therapy after initial response to treatment. *J Clin Oncol* 1986;4(6):888-899.
590. Attal M, Harousseau JL, Leyvraz S, et al. Maintenance therapy with thalidomide improves survival in patients with multiple myeloma. *Blood* 2006;108(10):3289-3294.
591. Spencer A, Prince HM, Roberts AW, et al. Consolidation therapy with low-dose thalidomide and prednisolone prolongs the survival of multiple myeloma patients undergoing a single autologous stem-cell transplantation procedure. *J Clin Oncol* 2009;27(11):1788-1793.
592. Stewart AK, Trudel S, Bahlis NJ, et al. A randomized phase III trial of thalidomide and prednisone as maintenance therapy following Autologous Stem Cell Transplantation (ASCT) In patients with Multiple Myeloma (MM): the NCIC CTG MY.10 trial. *ASH Ann Meeting Abstr* 2010;116(21):39-.
593. Attal M, Lauwers-Cances V, Marit G, et al. Lenalidomide maintenance after stem-cell transplantation for multiple myeloma. *N Engl J Med* 2012;366(19):1782-1791.
594. McCarthy PL, Owzar K, Hofmeister CC, et al. Lenalidomide after stem-cell transplantation for multiple myeloma. *N Engl J Med* 2012;366(19): 1770-1781.

595. Remission maintenance therapy for multiple myeloma. *Arch Intern Med* 1975;135(1):147-152.
596. Belch A, Shelley W, Bergsagel D, et al. A randomized trial of maintenance versus no maintenance melphalan and prednisone in responding multiple myeloma patients. *Br J Cancer* 1988;57(1):94-99.
597. Alexanian R, Gehan E, Haut A, Saiki J, Weick J. Unmaintained remissions in multiple myeloma. *Blood* 1978;51(6):1005-1011.
598. Corso A, Nozza A, Lazzarino M, et al. Plateau phase in multiple myeloma: an end-point of conventional-dose chemotherapy. *Haematologica* 1999;84(4):336-341.
599. Anonymous. Long-term survival in multiple myeloma: a Finnish leukaemia group study. *Br J Haematol* 1999;105(4):942-947.
600. Nagura E, Ichikawa A, Kamiya O, et al. A randomized study comparing VMCP and MMPP in the treatment of multiple myeloma. *Cancer Chemother Pharmacol* 1997;39(4):279-285.
601. Blade J, Lopez-Guillermo A, Bosch F, et al. Impact of response to treatment on survival in multiple myeloma: results in a series of 243 patients. *Br J Haematol* 1994;88(1):117-121.
602. Offidani M, Corvatta L, Marconi M, et al. Low-dose thalidomide with pegylated liposomal doxorubicin and high-dose dexamethasone for relapsed/refractory multiple myeloma: a prospective, multicenter, phase II study. *Haematologica* 2006;91(1):133-136.
603. Suvannasankha A, Fausel C, Juliar BE, et al. Final report of toxicity and efficacy of a phase II study of oral cyclophosphamide, thalidomide, and prednisone for patients with relapsed or refractory multiple myeloma: a Hoosier oncology group trial, HEM01-21. *Oncologist* 2007;12(1):99-106.
604. Durie BG, Jacobson J, Barlogie B, Crowley J. Magnitude of response with myeloma frontline therapy does not predict outcome: importance of time to progression in southwest oncology group chemotherapy trials. *J Clin Oncol* 2004;22(10):1857-1863.
605. Oivanen TM, Kellokumpu-Lehtinen P, Koivisto AM, Koivunen E, Palva I. Response level and survival after conventional chemotherapy for multiple myeloma: a Finnish leukaemia group study. *Eur J Haematol* 1999;62(2):109-116.
606. Paccagnella A, Chiarion-Sileni V, Soesan M, et al. Second and third responses to the same induction regimen in relapsing patients with multiple myeloma. *Cancer* 1991;68(5):975-980.
607. Berenson JR, Crowley JJ, Grogan TM, et al. Maintenance therapy with alternate-day prednisone improves survival in multiple myeloma patients. *Blood* 2002;99(9):3163-3168.
608. Alexanian R, Weber D, Dimopoulos M, Delasalle K, Smith TL. Randomized trial of alpha-interferon or dexamethasone as maintenance treatment for multiple myeloma. *Am J Hematol* 2000;65(3):204-209.
609. Mandelli F, Avvisati G, Amadori S, et al. Maintenance treatment with recombinant interferon alfa-2b in patients with multiple myeloma responding to conventional induction chemotherapy. *N Engl J Med* 1990;322(20):1430-1434.
610. Cunningham D, Powles R, Malpas J, et al. A randomized trial of maintenance interferon following high-dose chemotherapy in multiple myeloma: long-term follow-up results. *Br J Haematol* 1998;102(2):495-502.
611. Bjorkstrand B, Svensson H, Goldschmidt H, et al. Alpha-interferon maintenance treatment is associated with improved survival after high-dose treatment and autologous stem cell transplantation in patients with multiple myeloma: a retrospective registry study from the European Group for Blood and Marrow Transplantation (EBMT). *Bone Marrow Transplant* 2001;27(5):511-515.
612. Anderson KC, Kyle RA, Rajkumar SV, Stewart AK, Weber D, Richardson P. Clinically relevant end points and new drug approvals for myeloma. *Leukemia* 2008;22(2):231-239.
613. Paccagnella A, Cartei G, Fossier V, et al. Treatment of multiple myeloma with M-2 protocol and without maintenance therapy. *Eur J Cancer Clin Oncol* 1983;19(10):1345-1351.
614. Knop S, Gerecke C, Liebisch P, et al. Lenalidomide, adriamycin, and dexamethasone (RAD) in patients with relapsed and refractory multiple myeloma: a report from the German Myeloma Study Group DSMM (Deutsche Studiengruppe Multiples Myelom). *Blood* 2009;113(18):4137-4143.
615. Baz R, Walker E, Karam MA, et al. Lenalidomide and pegylated liposomal doxorubicin-based chemotherapy for relapsed or refractory multiple myeloma: safety and efficacy. *Ann Oncology* 2006;17(12):1766-1771.

616. Lentzsch S, O'Sullivan A, Kennedy RC, et al. Combination of bendamustine, lenalidomide, and dexamethasone (BLD) in patients with relapsed or refractory multiple myeloma is feasible and highly effective: results of phase 1/2 open-label, dose escalation study. *Blood* 2012;119(20):4608-4613.
617. Kyle RA, Gailani S, Seligman BR, et al. Multiple myeloma resistant to melphalan: treatment with cyclophosphamide, prednisone, and BCNU. *Cancer Treat Rep* 1979;63(8):1265-1269.
618. Keats JJ, Chesi M, Egan JB, et al. Clonal competition with alternating dominance in multiple myeloma. *Blood* 2012;120(5):1067-1076.
619. Kropff MH, Bisping G, Wenning D, et al. Bortezomib in combination with dexamethasone for relapsed multiple myeloma. *Leuk Res* 2005;29(5): 587-590.
620. Musto P, Falcone A, Sanpaolo G, et al. Bortezomib (Velcade) for progressive myeloma after autologous stem cell transplantation and thalidomide. *Leuk Res* 2006;30(3):283-285.
621. Chanan-Khan A, Miller KC. Velcade, Doxil and Thalidomide (VDT) is an effective salvage regimen for patients with relapsed and refractory multiple myeloma. *Leuk Lymphoma* 2005;46(7):1103-1104.
622. Berenson JR, Yang HH, Vescio RA, et al. Safety and efficacy of bortezomib and melphalan combination in patients with relapsed or refractory multiple myeloma: updated results of a phase 1/2 study after longer follow-up. *Ann Hematol* 2008;87(8):623-631.
623. Popat R, Oakervee H, Williams C, et al. Bortezomib, low-dose intravenous melphalan, and dexamethasone for patients with relapsed multiple myeloma. *Br J Haematol* 2009;144(6):887-894.
624. Anagnostopoulos A, Weber D, Rankin K, Delasalle K, Alexanian R. Thalidomide and dexamethasone for resistant multiple myeloma. *Br J Haematol* 2003;121(5):768-771.
625. Dimopoulos MA, Zervas K, Kouvatsas G, et al. Thalidomide and dexamethasone combination for refractory multiple myeloma. *Ann Oncol* 2001; 12(7):991-995.
626. Palumbo A, Giaccone L, Bertola A, et al. Low-dose thalidomide plus dexamethasone is an effective salvage therapy for advanced myeloma. *Haematologica* 2001;86(4):399-403.
627. Myers B, Grimley C, Dolan G. Thalidomide and low-dose dexamethasone in myeloma treatment. [letter; comment]. *Br J Haematol* 2001;114(1):245.
628. Garcia-Sanz R, Gonzalez-Porras JR, Hernandez JM, et al. The oral combination of thalidomide, cyclophosphamide and dexamethasone (ThaCyDex) is effective in relapsed/refractory multiple myeloma. *Leukemia* 2004;18(4):856-863.
629. Dimopoulos MA, Hamilos G, Zomas A, et al. Pulsed cyclophosphamide, thalidomide and dexamethasone: an oral regimen for previously treated patients with multiple myeloma. *Hematol J/EHA* 2004;5(2):112-117.
630. Kropff MH, Lang N, Bisping G, et al. Hyperfractionated cyclophosphamide in combination with pulsed dexamethasone and thalidomide (HyperCDT) in primary refractory or relapsed multiple myeloma. *Br J Haematol* 2003;122(4):607-616.
631. Kyriakou C, Thomson K, D'Sa S, et al. Low-dose thalidomide in combination with oral weekly cyclophosphamide and pulsed dexamethasone is a well tolerated and effective regimen in patients with relapsed and refractory multiple myeloma. *Br J Haematol* 2005;129(6):763-770.
632. Sidra G, Williams CD, Russell NH, Zaman S, Myers B, Byrne JL. Combination chemotherapy with cyclophosphamide, thalidomide and dexamethasone for patients with refractory, newly diagnosed or relapsed myeloma. *Haematologica* 2006;91(6):862-863.
633. Palumbo A, Avonto I, Bruno B, et al. Intravenous melphalan, thalidomide and prednisone in refractory and relapsed multiple myeloma. *Eur J Haematol* 2006;76(4):273-277.
634. Offidani M, Marconi M, Corvatta L, Olivieri A, Catarini M, Leoni P. Thalidomide plus oral melphalan for advanced multiple myeloma: a phase II study. *Haematologica* 2003;88(12):1432-1433.
635. Hovenga S, Daenen SM, de Wolf JT, et al. Combined thalidomide and cyclophosphamide treatment for refractory or relapsed multiple myeloma patients: a prospective phase II study. *Ann Hematol* 2005;84(5):311-316.
636. Dimopoulos M, Spencer A, Attal M, et al. Lenalidomide plus dexamethasone for relapsed or refractory multiple myeloma. *N Engl J Med* 2007;357(21): 2123-2132.

637. Ciolli S, Leoni F, Gigli F, Rigacci L, Bosi A. Low dose Velcade, thalidomide and dexamethasone (LD-VTD): an effective regimen for relapsed and refractory multiple myeloma patients. *Leuk Lymphoma* 2006;47(1):171-173.
638. Pineda-Roman M, Zangari M, van Rhee F, et al. VTD combination therapy with bortezomib-thalidomide-dexamethasone is highly effective in advanced and refractory multiple myeloma. *Leukemia* 2008;22(7):1419-1427.
639. Palumbo A, Ambrosini MT, Benevolo G, et al. Bortezomib, melphalan, prednisone, and thalidomide for relapsed multiple myeloma. *Blood* 2007;109(7):2767-2772.
640. Terpos E, Kastritis E, Roussou M, et al. The combination of bortezomib, melphalan, dexamethasone and intermittent thalidomide is an effective regimen for relapsed/refractory myeloma and is associated with improvement of abnormal bone metabolism and angiogenesis. *Leukemia* 2008;22(12): 2247-2256.
641. Kim YK, Sohn SK, Lee JH, et al. Clinical efficacy of a bortezomib, cyclophosphamide, thalidomide, and dexamethasone (Vel-CTD) regimen in patients with relapsed or refractory multiple myeloma: a phase II study. *Ann Hematol* 2010;89(5):475-482.
642. Chanan-Khan AA, Giralt S. Importance of achieving a complete response in multiple myeloma, and the impact of novel agents. *J Clin Oncol* 2010;28(15):2612-2624.
643. Ciolli S, Leoni F, Casini C, Breschi C, Santini V, Bosi A. The addition of liposomal doxorubicin to bortezomib, thalidomide and dexamethasone significantly improves clinical outcome of advanced multiple myeloma. *Br J Haematol* 2008;141(6):814-819.
644. Berenson JR, Yellin O, Kazamel T, et al. A phase 2 study of pegylated liposomal doxorubicin, bortezomib, dexamethasone and lenalidomide for patients with relapsed/refractory multiple myeloma. *Leukemia* 2012;26(7):1675-1680.
645. Offidani M, Corvatta L, Polloni C, et al. Thalidomide, dexamethasone, Doxil and Velcade (ThaDD-V) followed by consolidation/maintenance therapy in patients with relapsed-refractory multiple myeloma. *Ann Hematol* 2011;90(12):1449-1456.
646. Richardson PG, Weller E, Jagannath S, et al. Multicenter, phase I, dose-escalation trial of lenalidomide plus bortezomib for relapsed and relapsed/refractory multiple myeloma. *J Clin Oncol* 2009;27(34):5713-5719.
647. Weber DM, Chen C, Niesvizky R, et al. Lenalidomide plus dexamethasone for relapsed multiple myeloma in North America. *N Engl J Med* 2007;357(21):2133-2142.
648. Wang M, Knight R, Dimopoulos M, et al. Comparison of lenalidomide in combination with dexamethasone to dexamethasone alone in patients who have received prior thalidomide in relapsed or refractory multiple myeloma. *J Clin Oncol* 2006;24(18 Suppl):7522.
649. Harousseau JL, Dimopoulos MA, Wang M, et al. Better quality of response to lenalidomide plus dexamethasone is associated with improved clinical outcomes in patients with relapsed or refractory multiple myeloma. *Haematologica* 2010;95(10):1738-1744.
650. San-Miguel JF, Dimopoulos MA, Stadtmauer EA, et al. Effects of lenalidomide and dexamethasone treatment duration on survival in patients with relapsed or refractory multiple myeloma treated with lenalidomide and dexamethasone. *Clin Lymphoma Myeloma Leuk* 2010;1-6.
651. Schey SA, Morgan GJ, Ramasamy K, et al. The addition of cyclophosphamide to lenalidomide and dexamethasone in multiply relapsed/refractory myeloma patients; a phase I/II study. *Br J Haematol* 2010;150(3):326-333.
652. Palumbo A, Larocca A, Falco P, et al. Lenalidomide, melphalan, prednisone and thalidomide (RMPT) for relapsed/refractory multiple myeloma. *Leukemia* 2010;24(5):1037-1042.
653. Streetly MJ, Gyertson K, Daniel Y, Zeldis JB, Kazmi M, Schey SA. Alternate day pomalidomide retains anti-myeloma effect with reduced adverse events and evidence of in vivo immunomodulation. *Br J Haematol* 2008;141(1):41-51.
654. Lacy MQ, Hayman SR, Gertz MA, et al. Pomalidomide (CC4047) plus low-dose dexamethasone as therapy for relapsed multiple myeloma. *J Clin Oncol* 2009;27(30):5008-5014.
655. Lacy MQ, Hayman SR, Gertz MA, et al. Pomalidomide (CC4047) plus low dose dexamethasone (Pom/dex) is active and well tolerated in lenalidomide refractory multiple myeloma (MM). *Leukemia* 2010;24(11):1934-1939.

656. Lacy MQ, Allred JB, Gertz MA, et al. Pomalidomide plus low-dose dexamethasone in myeloma refractory to both bortezomib and lenalidomide: comparison of 2 dosing strategies in dual-refractory disease. *Blood* 2011;118(11): 2970-2975.
657. Richardson PG, Siegel D, Baz R, et al. A phase 1/2 multi-center, randomized, open label dose escalation study to determine the maximum tolerated dose, safety, and efficacy of pomalidomide alone or in combination with low-dose dexamethasone in patients with relapsed and refractory multiple myeloma who have received prior treatment that includes lenalidomide and bortezomib. *ASH Annu Meeting Abstr* 2010;116(21):864.
658. Leleu X, Attal M, Moreau P, et al. Phase 2 Study of 2 Modalities of Pomalidomide (CC4047) Plus Low-Dose Dexamethasone as Therapy for Relapsed Multiple Myeloma. *IFM 2009-02. ASH Annu Meeting Abstr* 2010;116(21):859.
659. Berenson JR, Jagannath S, Barlogie B, et al. Safety of prolonged therapy with bortezomib in relapsed or refractory multiple myeloma. *Cancer* 2005;104(10):2141-2148.
660. Orłowski RZ, Nagler A, Sonneveld P, et al. Randomized phase III study of pegylated liposomal doxorubicin plus bortezomib compared with bortezomib alone in relapsed or refractory multiple myeloma: combination therapy improves time to progression. *J Clin Oncol* 2007;25(25):3892-3901.
661. Palumbo A, Gay F, Bringhen S, et al. Bortezomib, doxorubicin and dexamethasone in advanced multiple myeloma. *Ann Oncol* 2008;19(6):1160-1165.
662. Gozzetti A, Fabbri A, Oliva S, et al. Weekly bortezomib, pegylated liposomal doxorubicin, and dexamethasone is a safe and effective therapy for elderly patients with relapsed/refractory multiple myeloma. *Clin Lymphoma Myeloma Leuk* 2010;10(1):68-72.
663. Waterman GN, Yellin O, Swift RA, et al. A modified regimen of pegylated liposomal doxorubicin, bortezomib, and dexamethasone is effective and well tolerated in the treatment of relapsed or refractory multiple myeloma. *Ann Hematol* 2011;90(2):193-200.
664. Kropff M, Bisping G, Schuck E, et al. Bortezomib in combination with intermediate-dose dexamethasone and continuous low-dose oral cyclophosphamide for relapsed multiple myeloma. *Br J Haematol* 2007;138(3):330-337.
665. Reece DE, Rodriguez GP, Chen C, et al. Phase I-II trial of bortezomib plus oral cyclophosphamide and prednisone in relapsed and refractory multiple myeloma. *J Clin Oncol* 2008;26(29):4777-4783.
666. Ahn JS, Yang DH, Jung SH, et al. A comparison of bortezomib, cyclophosphamide, and dexamethasone (Vel-CD) chemotherapy without and with thalidomide (Vel-CTD) for the treatment of relapsed or refractory multiple myeloma. *Ann Hematol* 2012;91(7):1023-1030.
667. Vij R, Siegel DS, Jagannath S, et al. An open-label, single-arm, phase 2 study of single-agent carfilzomib in patients with relapsed and/or refractory multiple myeloma who have been previously treated with bortezomib. *Br J Haematol* 2012;158(6):739-748.
668. Trieu Y, Trudel S, Pond GR, et al. Weekly cyclophosphamide and alternate-day prednisone: an effective, convenient, and well-tolerated oral treatment for relapsed multiple myeloma after autologous stem cell transplantation. *Mayo Clin Proc* 2005;80(12):1578-1582.
669. Petrucci MT, Avisati G, Tribalto M, Cantonetti M, Giovangrossi P, Mandelli F. Intermediate-dose (25 mg/m²) intravenous melphalan for patients with multiple myeloma in relapse or refractory to standard treatment. *Eur J Haematol* 1989;42(3):233-237.
670. Combination chemotherapy MOCCA in resistant and relapsing multiple myeloma. Finnish Leukaemia Group. *Eur J Haematol* 1992;48(1):37-40.
671. Lee CK, Barlogie B, Munshi N, et al. DTPACE: an effective, novel combination chemotherapy with thalidomide for previously treated patients with myeloma. *J Clin Oncol* 2003;21(14):2732-2739.
672. Siegel DS, Martin T, Wang M, et al. A phase 2 study of single-agent carfilzomib (PX-171-003-A1) in patients with relapsed and refractory multiple myeloma. *Blood* 2012.
673. Ocio EM, Mateos VM, Maiso P, Pandiella A, San-Miguel JF. New drugs in multiple myeloma: mechanism of action and phase I/II clinical findings. *Lancet Oncol* 2008;9:1157-1165.
674. Mahindra A, Cirstea D, Raje N. Novel therapeutic targets for multiple myeloma. *Future Oncol* 2010;6(3):407-418.

675. Richardson PG, Mitslades CS, Colson K, et al. Final results of a phase I trial of oral vorinostat (suberoylanilide hydroxamic acid, SAHA) in patients with advanced multiple myeloma. *Blood* 2007;110:1179.
676. Galli M, Salmoiraghi S, Golay J, et al. A phase II multiple dose clinical trial of histone deacetylase inhibitor5 ITF2357 in patients with relapsed or progressive multiple myeloma: preliminary results. *Blood* 2007;2007(110): Abstract 1175.
677. Wolf JL, Siegel D, Goldschmidt H, et al. Phase II trial of the pan-deacetylase inhibitor panobinostat as a single agent in advanced relapsed/refractory multiple myeloma. *Leuk Lymphoma* 2012;53(9):1820-1823.
678. Niesvizky R, Ely S, Mark T, et al. Phase 2 trial of the histone deacetylase inhibitor romidepsin for the treatment of refractory multiple myeloma. *Cancer* 2010.
679. Richardson P, Mitsiades C, Colson K, et al. Phase I trial of oral vorinostat (suberoylanilide hydroxamic acid, SAHA) in patients with advanced multiple myeloma. *Leuk Lymphoma* 2008;49(3):502-507.
680. Badros A, Burger AM, Philip S, et al. Phase I study of vorinostat in combination with bortezomib for relapsed and refractory multiple myeloma. *Clin Cancer Res* 2009;15(16):5250-5257.
681. Weber D, Badros AZ, Jagannath S, et al. Vorinostat plus Bortezomib for the treatment of relapsed/refractory multiple myeloma: early clinical experience. *Blood* 2008;112(11):871.
682. Dimopoulos MA, Jagannath S, Yoon S-S, et al. Vantage 088: vorinostat in combination with Bortezomib in patients with relapsed/refractory multiple myeloma: results of a global, randomized phase 3 trial. *ASH Annu Meeting Abstr* 2011;118(21):811.
683. San-Miguel JF, Sezer O, Siegel D, et al. A phase IB, multi-center, open-label dose-escalation study of oral panobinostat (LBH589) and I.V. Bortezomib in patients with relapsed multiple myeloma. *ASH Annu Meeting Abstr* 2009;114(22):3852.
684. Offidani M, Polloni C, Cavallo F, et al. Phase II study of melphalan, thalidomide and prednisone combined with oral panobinostat in patients with relapsed/refractory multiple myeloma. *Leuk Lymphoma* 2012;53(9):1722-1727.
685. Harrison SJ, Quach H, Link E, et al. A high rate of durable responses with romidepsin, bortezomib, and dexamethasone in relapsed or refractory multiple myeloma. *Blood* 2011;118(24):6274-6283.
686. Mitsiades CS, Mitsiades N, McMullin CJ, et al. Antimyeloma activity of heat shock protein-90 inhibition. *Blood* 2006;107(3):1092-1100.
687. Richardson PG, Chanan-Khan AA, Alsina M, et al. Tanespimycin monotherapy in relapsed multiple myeloma: results of a phase 1 dose-escalation study. *Br J Haematol* 2010;150(4):438-445.
688. Richardson PG, Chanan-Khan AA, Lonial S, et al. Tanespimycin and bortezomib combination treatment in patients with relapsed or relapsed and refractory multiple myeloma: results of a phase 1/2 study. *Br J Haematol* 2011;153(6):729-740.
689. Hideshima T, Catley L, Yasui H, et al. Perifosine, an oral bioactive novel alkylphospholipid, inhibits Akt and induces in vitro and in vivo cytotoxicity in human multiple myeloma cells. *Blood* 2006;107(10):4053-4062.
690. Richardson PG, Wolf J, Jakubowiak A, et al. Perifosine plus bortezomib and dexamethasone in patients with relapsed/refractory multiple myeloma previously treated with bortezomib: results of a multicenter phase I/II trial. *J Clin Oncol* 2011;29(32):4243-4249.
691. Jakubowiak AJ, Benson DM, Bensinger W, et al. Phase I trial of anti-CS1 monoclonal antibody elotuzumab in combination with bortezomib in the treatment of relapsed/refractory multiple myeloma. *J Clin Oncol* 2012;30(16):1960-1965.
692. Lonial S, Vij R, Harousseau J-L, et al. Elotuzumab in combination with lenalidomide and low-dose dexamethasone in patients with relapsed/refractory multiple myeloma: interim results of a phase 1 study. *ASH Annu Meeting Abstr* 2010;116(21):1936.
693. Richardson PGG, Moreau P, Jakubowiak AJ, et al. Elotuzumab with lenalidomide and low-dose dexamethasone in patients with relapsed multiple myeloma: a randomized phase II study. *ASCO Meeting Abstr* 2011;29(15 Suppl):8014.
694. Rossi J-F, Manges RF, Sutherland HJ, et al. Preliminary results of CNTO 328, an anti-interleukin-6 monoclonal antibody, in combination with bortezomib in the treatment of relapsed or refractory multiple myeloma. *Blood* 2008;112(11):867.

695. Iaffaioli RV, Facchini G, Tortoriello A, et al. Modulation of chemosensitivity by alpha interferon in multiple myeloma and non-Hodgkin's lymphoma. *J Exp Ther Oncol* 1996;1(4):226-230.
696. San Miguel JF, Moro M, Blade J, et al. Combination of interferon and dexamethasone in refractory multiple myeloma. *Hematol Oncol* 1990;8(4):185-189.
697. Ganjoo RK, Johnson PW, Evans ML, et al. Recombinant interferon-alpha 2b and high dose methyl prednisolone in relapsed and resistant multiple myeloma. *Hematol Oncol* 1993;11(4):179-186.
698. Alexanian R, Barlogie B, Gutterman J. Alpha-interferon combination therapy of resistant myeloma. *Am J Clin Oncol* 1991;14(3):188-192.
699. Sonneveld P, Suci S, Weijermans P, et al. Cyclosporin A combined with vincristine, doxorubicin and dexamethasone (VAD) compared with VAD alone in patients with advanced refractory multiple myeloma: an EORTC-HOVON randomized phase III study (06914). *Br J Haematol* 2001;115(4):895-902.
700. Weber D, Dimopoulos M, Sinicrope F, Alexanian R. VAD-cyclosporine therapy for VAD-resistant multiple myeloma. *Leuk Lymphoma* 1995;19(1-2):159-163.
701. Sonneveld P, Marie JP, Huisman C, et al. Reversal of multidrug resistance by SDZ PSC 833, combined with VAD (vincristine, doxorubicin, dexamethasone) in refractory multiple myeloma. A phase I study. *Leukemia* 1996;10(11):1741-1750.
702. Friedenberg WR, Rue M, Blood EA, et al. Phase III study of PSC-833 (valspodar) in combination with vincristine, doxorubicin, and dexamethasone (valspodar/VAD) versus VAD alone in patients with recurring or refractory multiple myeloma (E1A95): a trial of the eastern cooperative oncology group. *Cancer* 2006;106(4):830-838.
703. Treon SP, Pilarski LM, Belch AR, et al. CD20-directed serotherapy in patients with multiple myeloma: biologic considerations and therapeutic applications. *J Immunother* 2002;25(1):72-81.
704. Bergsagel DE, Sprague CC, Austin C, et al. Evaluation of new chemotherapeutic agents in the treatment of multiple myeloma. IV. L-Phenylalanine mustard (NSC-8806). *Cancer Chemother Rep* 1972;21(87).
705. Kyle RA, Seligman BR, Wallace HJ Jr, Silver RT, Glidewell O, Holland JF. Multiple myeloma resistant to melphalan (NSC-8806) treated with cyclophosphamide (NSC-26271), prednisone (NSC-10023), and chloroquine (NSC-187208). *Cancer Chemother Rep* 1975;59(3):557-562.
706. Cohen HJ, Silberman HR, Larsen WE, Johnson L, Bartolucci AA, Durant JR. Combination chemotherapy with intermittent 1-3-bis(2-chloroethyl)1-nitrosourea (BCNU), cyclophosphamide, and prednisone for multiple myeloma. *Blood* 1979;54(4):824-836.
707. Buzaid AC, Garewal HS, Greenberg BR. Management of myelodysplastic syndromes. *Am J Med* 1986;80(6):1149-1157.
708. Blade J, Feliu E, Rozman C, Estape J, Milla A, Montserrat E. Cross-resistance to alkylating agents in multiple myeloma. *Cancer* 1983;52(5):786-789.
709. Bergsagel DE, Cowan DH, Hasselback RH. Plasma cell myeloma: response of melphalan-resistant patients to high-dose intermittent cyclophosphamide. *CMA J* 1972;107:851-855.
710. Brandes LJ, Israels LG. Treatment of advanced plasma cell myeloma with weekly cyclophosphamide and alternate-day prednisone. *Cancer Treat Rep* 1982;66(6):1413-1415.
711. Wilson K, Shelley W, Belch A, et al. Weekly cyclophosphamide and alternate-day prednisone: an effective secondary therapy in multiple myeloma. *Cancer Treat Rep* 1987;71(10):981-982.
712. de Weerd O, van de Donk NW, Veth G, Bloem AC, Hagenbeek A, Lokhorst HM. Continuous low-dose cyclophosphamide-prednisone is effective and well tolerated in patients with advanced multiple myeloma. *Neth J Med* 2001;59(2):50-56.
713. Lenhard RE, Daniels MJ, Oken MM, et al. An aggressive high dose cyclophosphamide and prednisone regimen for advanced multiple myeloma. *Leuk Lymphoma* 1994;13(5-6):485-489.
714. Lenhard RE Jr, Kalish LA, Oken MM, Ettinger DS, Glick J. Timed-sequential high-dose cyclophosphamide and vincristine in the treatment of multiple myeloma. *Cancer* 1994;73(8):2113-2118.
715. Palumbo A, Boccadoro M, Bruno B, Triolo S, Pileri A. Cyclophosphamide (3.6 g/m²) therapy with G-CSF support for resistant myeloma. *Haematologica* 1994;79(6):513-518.

716. Tsakanikas S, Papanastasiou K, Stamatelou M, Maniatis A. Intermediate dose of intravenous melphalan in advanced multiple myeloma. *Oncology* 1991;48(5):369-371.
717. Lokhorst HM, Sonneveld P, Wijermans PW, et al. Intermediate-dose melphalan (IDM) combined with G-CSF (filgrastim) is an effective and safe induction therapy for autologous stem cell transplantation in multiple myeloma. *Br J Haematol* 1996;92(1):44-48.
718. Palumbo A, Pileri A, Triolo S, et al. Multicyclic, dose-intensive chemotherapy supported by hemopoietic progenitors in refractory myeloma patients. *Bone Marrow Transplant* 1997;19(1):23-29.
719. Cavo M, Galieni P, Tassi C, Gobbi M, Tura S. M-2 protocol for melphalan-resistant and relapsing multiple myeloma. *Eur J Haematol* 1988;40(2):168-173.
720. Oken MM, Lenhard RE Jr, Tsiatis AA, Glick JH, Silverstein MN. Contribution of prednisone to the effectiveness of hexamethylmelamine in multiple myeloma. *Cancer Treat Rep* 1987;71(9):807-811.
721. Dimopoulos MA, Delasalle KB, Champlin R, Alexanian R. Cyclophosphamide and etoposide therapy with GM-CSF for VAD-resistant multiple myeloma. *Br J Haematol* 1993;83(2):240-244.
722. Presant CA, Klahr C. Adriamycin, 1,3-bis (2-chloroethyl) 1 nitrosourea (BCNU, NSC No. 409962), cyclophosphamide plus prednisone (ABC-P) in melphalan-resistant multiple myeloma. *Cancer* 1978;42(3):1222-1227.
723. Kyle RA, Pajak TF, Henderson ES, et al. Multiple myeloma resistant to melphalan: treatment with doxorubicin, cyclophosphamide, carmustine (BCNU), and prednisone. *Cancer Treat Rep* 1982;66(3):451-456.
724. Bonnet J, Alexanian R, Salmon S, et al. Vincristine, BCNU, doxorubicin, and prednisone (VBAP) combination in the treatment of relapsing or resistant multiple myeloma: a southwest oncology group study. *Cancer Treat Rep* 1982;66(6):1267-1271.
725. Blade J, Rozman C, Montserrat E, et al. Treatment of alkylating resistant multiple myeloma with vincristine, BCNU, doxorubicin and prednisone (VBAP). *Eur J Cancer Clin Oncol* 1986;22(10):1193-1197.
726. Adam Z, Elbl L, Vorlicek J, et al. Treatment of refractory multiple myeloma with vincristine, adriamycin, dexamethasone, and with repeated application of cyclophosphamide (C- VAD). *Acta Med Austriaca* 1994;21(4):111-115.
727. Dimopoulos MA, Weber D, Kantarjian H, Delasalle KB, Alexanian R. HyperCVAD for VAD-resistant multiple myeloma. *Am J Hematol* 1996;52(2):77-81.
728. Stone WJ. Multiple Myelomata. *Am J Roentgenol* 1924;12:543-545.
729. Jacox JW, Kahn EA. Multiple myeloma with spinal cord involvement. *Am J Roentgenol* 1933;30:201-205.
730. Sykes MP, Savel H, Chu FCH, Bonadonna G, Farrow G, Mathis H. Long-term effects of therapeutic irradiation upon bone marrow. *Cancer* 1964;17:1144-1148.
731. Sykes MP, Chu FCH, Savel H, Bonadonna G, Mathis H. The effects of varying dosages of irradiation upon sternal-marrow regeneration. *Radiology* 1964;83:1084-1087.
732. Norin T. Roentgen treatment of myeloma with special consideration to the dosage. *Act Radiol* 1957;47:46-57.
733. Rostom AY, O'Cathail SM, Folkes A. Systemic irradiation in multiple myeloma: a report on nineteen cases. *Br J Haematol* 1984;58(3):423-431.
734. Leigh BR, Kurtts TA, Mack CF, Matzner MB, Shimm DS. Radiation therapy for the palliation of multiple myeloma. *Int J Radiat Oncol Biol Phys* 1993;25(5):801-804.
735. Adamietz IA, Schober C, Schulte RW, Peest D, Renner K. Palliative radiotherapy in plasma cell myeloma. *Radiother Oncol* 1991;20(2):111-116.
736. Frassica DA, Frassica FJ, Schray MF, Sim FH, Kyle RA. Solitary plasmacytoma of bone: Mayo clinic experience. *Int J Radiat Oncol Biol Phys* 1989;16(1):43-48.
737. Mendenhall CM, Thar TL, Million RR. Solitary plasmacytoma of bone and soft tissue. *Int J Radiat Oncol Biol Phys* 1980;6(11):1497-1501.
738. Mill WB. Radiation therapy in multiple myeloma. *Radiology* 1975;115(1): 175-178.
739. Knobel D, Zouhair A, Tsang RW, et al. Prognostic factors in solitary plasmacytoma of the bone: a multicenter rare cancer network study. *BMC Cancer* 2006;6:118.

740. Rao G, Ha CS, Chakrabarti I, Feiz-Erfan I, Mendel E, Rhines LD. Multiple myeloma of the cervical spine: treatment strategies for pain and spinal instability. *J Neurosurg Spine* 2006;5(2):140-145.
741. Medinger FG, Craver LF. Total body irradiation with review of cases. *Am J Roentgenol* 1942;48:651-671.
742. Bergsagel DE. Total body irradiation for myelomatosis. *Br Med J* 1971;2(757):325.
743. Jaffe JP, Bosch A, Raich PC. Sequential hemi-body radiotherapy in advanced multiple myeloma. *Cancer* 1979;43(1):124-128.
744. Bosch A, Frias Z. Radiotherapy in the treatment of multiple myeloma. *Int J Radiat Oncol Biol Phys* 1988;15(6):1363-1369.
745. Singer FR, Ritch PS, Lad TE, et al. Treatment of hypercalcemia of malignancy with intravenous etidronate. A controlled, multicenter study. The Hypercalcemia Study Group. *Arch Intern Med* 1991;151(3):471-476.
746. McSweeney EN, Tobias JS, Blackman G, Goldstone AH, Richards JD. Double hemibody irradiation (DHBI) in the management of relapsed and primary chemoresistant multiple myeloma. *Clin Oncol* 1993;5(6):378-383.
747. Thomas PJ, Daban A, Bontoux D. Double hemibody irradiation in chemotherapy-resistant multiple myeloma. *Cancer Treat Rep* 1984;68(9):1173-1175.
748. Tobias JS, Richards JD, Blackman GM, Joannides T, Trask CW, Nathan JI. Hemibody irradiation in multiple myeloma. *Radiother Oncol* 1985;3(1):11-16.
749. Troussard X, Roussel A, Reman O, Macro M, Leporrier M. Hemibody irradiation in stage III multiple myeloma: results of 20 patients. *Nouv Rev Fr Hematol* 1988;30(4):213-218.
750. Rowland CG, Garrett MJ, Crowley FA. Half body radiation in plasma cell myeloma. *Clin Radiol* 1983;34(5):507-510.
751. Qasim MM. Techniques and results of half body irradiation (HBI) in metastatic carcinomas and myelomas. *Clin Oncol* 1979;5(1):65-68.
752. McIntyre OR, Tefft M, Probert K, et al. Melphalan and prednisone plus total bone marrow irradiation as initial treatment for multiple myeloma. *Int J Radiat Oncol Biol Phys* 1988;15(4):1007-1012.
753. Jacobs P, le Roux I, King HS. Sequential half-body irradiation as salvage therapy in chemotherapy-resistant multiple myeloma. *Am J Clin Oncol* 1988;11(2):104-109.
754. Zhan F, Hardin J, Kordsmeier B, et al. Global gene expression profiling of multiple myeloma, monoclonal gammopathy of undetermined significance, and normal bone marrow plasma cells. *Blood* 2002;99(5):1745-1757.
755. Walker BA, Leone PE, Jenner MW, et al. Integration of global SNP-based mapping and expression arrays reveals key regions, mechanisms, and genes important in the pathogenesis of multiple myeloma 10.1182/blood-2006-02-005496. *Blood* 2006;108(5):1733-1743.
756. Drewinko B, Alexanian R, Boyer H, Barlogie B, Rubinow SI. The growth fraction of human myeloma cells. *Blood* 1981;57(2):333-338.
757. Sahota SS, Leo R, Hamblin TJ, Stevenson FK. Ig VH gene mutational patterns indicate different tumor cell status in human myeloma and monoclonal gammopathy of undetermined significance. *Blood* 1996;87(2):746-755.
758. Kyle RA. Long-term survival in multiple myeloma. *N Engl J Med* 1983;308(6):314-316.
759. Greipp PR, Katzmann JA, O'Fallon WM, Kyle RA. Value of beta 2-microglobulin level and plasma cell labeling indices as prognostic factors in patients with newly diagnosed myeloma. *Blood* 1988;72(1):219-223.
760. Greipp PR, Lust JA, O'Fallon WM, Katzmann JA, Witzig TE, Kyle RA. Plasma cell labeling index and beta 2-microglobulin predict survival independent of thymidine kinase and C-reactive protein in multiple myeloma. *Blood* 1993;81(12):3382-3387.
761. Greipp PR, Leong T, Bennett JM, et al. Plasmablastic morphology—an independent prognostic factor with clinical and laboratory correlates: Eastern Cooperative Oncology Group (ECOG) myeloma trial E9486 report by the ECOG Myeloma Laboratory Group. *Blood* 1998;91(7): 2501-2507.
762. Rapoport BL, Falkson HC, Falkson G. Prognostic factors affecting the survival of patients with multiple myeloma. A retrospective analysis of 86 patients. *S Afr Med J* 1991;79(2):65-67.

763. Bataille R, Boccadoro M, Klein B, Durie B, Pileri A. C-reactive protein and beta-2 microglobulin produce a simple and powerful myeloma staging system. *Blood* 1992;80(3):733-737.
764. Konigsberg R, Zojer N, Ackermann J, et al. Predictive role of interphase cytogenetics for survival of patients with multiple myeloma. *J Clin Oncol* 2000;18(4):804-812.
765. San Miguel JF, Garcia-Sanz R, Gonzalez M, et al. A new staging system for multiple myeloma based on the number of S- phase plasma cells. *Blood* 1995;85(2):448-455.
766. Ludwig H, Bolejack V, Crowley J, et al. Survival and years of life lost in different age cohorts of patients with multiple myeloma. *J Clin Oncol* 2010;28(9):1599-1605.
767. Ludwig H, Durie BG, Bolejack V, et al. Myeloma in patients younger than age 50 years presents with more favorable features and shows better survival: an analysis of 10 549 patients from the International Myeloma Working Group. *Blood* 2008;111(8):4039-4047.
768. Prognostic features in the third MRC myelomatosis trial. Medical research council's working party on leukaemia in adults. *Br J Cancer* 1980;42(6): 831-840.
769. Alexanian R, Balcerzak S, Bonnet JD, et al. Prognostic factors in multiple myeloma. *Cancer* 1975;36(4):1192-1201.
770. Bartl R, Frisch B, Fateh-Moghadam A, Kettner G, Jaeger K, Sommerfeld W. Histologic classification and staging of multiple myeloma. A retrospective and prospective study of 674 cases. *Am J Clin Pathol* 1987;87(3):342-355.
771. Cavo M, Baccarani M, Gobbi M, Lipizer A, Tura S. Prognostic value of bone marrow plasma cell infiltration in stage I multiple myeloma. *Br J Haematol* 1983;55(4):683-690.
772. Rajkumar SV, Fonseca R, Dispenzieri A, et al. Methods for estimation of bone marrow plasma cell involvement in myeloma: predictive value for response and survival in patients undergoing autologous stem cell transplantation. *Am J Hematol* 2001;68(4):269-275.
773. Pasqualetti P, Collacciani A, Maccarone C, Casale R. Prognostic factors in multiple myeloma: selection using Cox's proportional hazard model. *Biomed Pharmacother* 1996;50(1):29-35.
774. Bartl R, Frisch B. Clinical significance of bone marrow biopsy and plasma cell morphology in MM and MGUS. [Review] [84 refs]. *Pathol Biol* 1999;47(2):158-168.
775. Kyrtonis MC, Vassilakopoulos TP, Kafasi N, et al. Prognostic value of serum free light chain ratio at diagnosis in multiple myeloma. *Br J Haematol* 2007;137(3):240-243.
776. Snozek CL, Katzmann JA, Kyle RA, et al. Prognostic value of the serum free light chain ratio in newly diagnosed myeloma: proposed incorporation into the international staging system. *Leukemia* 2008;22(10):1933-1937.
777. Brown RD, Snowdon L, Uhr E, Gibson J, Joshua D. C-reactive protein (CRP) levels do not reflect disease status in patients with multiple myeloma. *Leuk Lymphoma* 1993;9(6):509-512.
778. Tricot G, Barlogie B, Jagannath S, et al. Poor prognosis in multiple myeloma is associated only with partial or complete deletions of chromosome 13 or abnormalities involving 11q and not with other karyotype abnormalities. *Blood* 1995;86(11):4250-4256.
779. Rajkumar SV, Leong T, Roche PC, et al. Prognostic value of bone marrow angiogenesis in multiple myeloma. *Clin Cancer Res* 2000;6(8):3111-3116.
780. Goasguen JE, Zandecki M, Mathiot C, et al. Mature plasma cells as indicator of better prognosis in multiple myeloma. New methodology for the assessment of plasma cell morphology [see comments]. *Leuk Res* 1999;23(12):1133-1140.
781. Rajkumar SV, Fonseca R, Lacy MQ, et al. Plasmablastic morphology is an independent predictor of poor survival after autologous stem-cell transplantation for multiple myeloma. *J Clin Oncol* 1999;17(5):1551-1557.
782. Grignani G, Gobbi PG, Formisano R, et al. A prognostic index for multiple myeloma. *Br J Cancer* 1996;73(9):1101-1107.
783. Dimopoulos MA, Barlogie B, Smith TL, Alexanian R. High serum lactate dehydrogenase level as a marker for drug resistance and short survival in multiple myeloma. *Ann Intern Med* 1991;115(12):931-935.
784. Carter A, Hocherman I, Linn S, Cohen Y, Tatarsky I. Prognostic significance of plasma cell morphology in multiple myeloma. *Cancer* 1987;60(5):1060-1065.

785. Paule B, Quillard J, Bisson M, Kahn MF, Massias P. Prognostic significance of plasma cell morphology in multiple myeloma. *Nouv Rev Fr Hematol* 1988;30(4):209-212.
786. Simonsson B, Brenning G, Kallander C, Ahre A. Prognostic value of serum lactic dehydrogenase (S-LDH) in multiple myeloma. *Eur J Clin Invest* 1987;17(4):336-339.
787. Barlogie B, Smallwood L, Smith T, Alexanian R. High serum levels of lactic dehydrogenase identify a high-grade lymphoma-like myeloma. *Ann Intern Med* 1989;110(7):521-525.
788. D'Sa S, Abildgaard N, Tighe J, Shaw P, Hall-Craggs M. Guidelines for the use of imaging in the management of myeloma. *Br J Haematol* 2007;137(1):49-63.
789. Nosas-Garcia S, Moehler T, Wasser K, et al. Dynamic contrast-enhanced MRI for assessing the disease activity of multiple myeloma: a comparative study with histology and clinical markers. *Journal of magnetic resonance imaging : JMRI* 2005;22(1):154-162.
790. Mouloupoulos LA, Dimopoulos MA, Christoulas D, et al. Diffuse MRI marrow pattern correlates with increased angiogenesis, advanced disease features and poor prognosis in newly diagnosed myeloma treated with novel agents. *Leukemia* 2010;24(6):1206-1212.
791. Zamagni E, Patriarca F, Nanni C, et al. Prognostic relevance of 18-F FDG PET/CT in newly diagnosed multiple myeloma patients treated with up-front autologous transplantation. *Blood* 2011;118(23):5989-5995.
792. Bredella MA, Steinbach L, Caputo G, Segall G, Hawkins R. Value of FDG PET in the assessment of patients with multiple myeloma. *AJR Am J Roentgenol* 2005;184(4):1199-1204.
793. Saeed SM, Stock-Novack D, Pohlod R, Crowley J, Salmon SE. Prognostic correlation of plasma cell acid phosphatase and beta- glucuronidase in multiple myeloma: a southwest oncology group study. *Blood* 1991;78(12):3281-3287.
794. Witzig TE, Gertz MA, Lust JA, Kyle RA, O'Fallon WM, Greipp PR. Peripheral blood monoclonal plasma cells as a predictor of survival in patients with multiple myeloma [see comments]. *Blood* 1996;88(5):1780-1787.
795. Witzig TE, Timm M, Larson D, Therneau T, Greipp PR. Measurement of apoptosis and proliferation of bone marrow plasma cells in patients with plasma cell proliferative disorders. *Br J Haematol* 1999;104(1):131-137.
796. Kyrtsolis MC, Dedoussis G, Zervas C, et al. Soluble interleukin-6 receptor (sIL-6R), a new prognostic factor in multiple myeloma. *Br J Haematol* 1996;93(2):398-400.
797. Merlini G, Perfetti V, Gobbi PG, et al. Acute phase proteins and prognosis in multiple myeloma. *Br J Haematol* 1993;83(4):595-601.
798. Elomaa I, Virkkunen P, Risteli L, Risteli J. Serum concentration of the cross-linked carboxyterminal telopeptide of type I collagen (ICTP) is a useful prognostic indicator in multiple myeloma. *Br J Cancer* 1992;66(2):337-341.
799. Fonseca R, Trendle MC, Leong T, et al. Prognostic value of serum markers of bone metabolism in untreated multiple myeloma patients. *Br J Haematol* 2000;109(1):24-29.
800. Woitge HW, Pecherstorfer M, Horn E, et al. Serum bone sialoprotein as a marker of tumour burden and neoplastic bone involvement and as a prognostic factor in multiple myeloma. *Br J Cancer* 2001;84(3):344-351.
801. Arnalich F, Zamorano AF, Martinez-Hernandez P, Pena JM, Barbado FJ, Vazquez JJ. Additional predictive value of serum unsaturated vitamin B12 proteins in multiple myeloma. *J Med* 1990;21(5):277-286.
802. Kaiser U, Oldenburg M, Jaques G, Auerbach B, Havemann K. Soluble CD56 (NCAM): a new differential-diagnostic and prognostic marker in multiple myeloma. *Ann Hematol* 1996;73(3):121-126.
803. Mathiot C, Mary JY, Tartour E, et al. Soluble CD16 (sCD16), a marker of malignancy in individuals with monoclonal gammopathy of undetermined significance (MGUS). *Br J Haematol* 1996;95(4):660-665.
804. Seidel C, Sundan A, Hjorth M, et al. Serum syndecan-1: a new independent prognostic marker in multiple myeloma. *Blood* 2000;95(2):388-392.
805. Bataille R, Jourdan M, Zhang XG, Klein B. Serum levels of interleukin 6, a potent myeloma cell growth factor, as a reflect of disease severity in plasma cell dyscrasias. *J Clin Invest* 1989;84(6):2008-2011.
806. Nachbaur DM, Herold M, Maneschg A, Huber H. Serum levels of interleukin-6 in multiple myeloma and other hematological disorders: correlation with disease activity and other prognostic parameters. *Ann Hematol* 1991; 62(2-3):54-58.

807. Munshi NC, Anderson KC, Bergsagel PL, et al. Consensus recommendations for risk stratification in multiple myeloma: report of the International Myeloma Workshop Consensus Panel 2. *Blood* 2011;117(18):4696-4700.
808. Greipp PR, San Miguel J, Durie BG, et al. International staging system for multiple myeloma. *J Clin Oncol* 2005;23(15):3412-3420.
809. Bataille R, Chevalier J, Rossi M, Sany J. Bone scintigraphy in plasma-cell myeloma. A prospective study of 70 patients. *Radiology* 1982;145(3): 801-804.
810. Bjorkstrand B, Goldstone AH, Ljungman P, et al. Prognostic factors in autologous stem cell transplantation for multiple myeloma: an EBMT registry study. European Group for Bone Marrow Transplantation. *Leuk Lymphoma* 1994;15(3-4):265-272.
811. Rajkumar SV, Fonseca R, Lacy MQ, et al. Beta2-microglobulin and bone marrow plasma cell involvement predict complete responders among patients undergoing blood cell transplantation for myeloma. *Bone Marrow Transplant* 1999;23(12):1261-1266.
812. Majolino I, Vignetti M, Meloni G, et al. Autologous transplantation in multiple myeloma: a GITMO retrospective analysis on 290 patients. Gruppo Italiano Trapianti di Midollo Osseo. *Haematologica* 1999;84(9):844-852.
813. Lemoli RM, Martinelli G, Zamagni E, et al. Engraftment, clinical, and molecular follow-up of patients with multiple myeloma who were reinfused with highly purified CD34 + cells to support single or tandem high-dose chemotherapy. *Blood* 2000;95(7):2234-2239.
814. Tricot G, Spencer T, Sawyer J, et al. Predicting long-term (> or = 5 years) event-free survival in multiple myeloma patients following planned tandem autotransplants. *Br J Haematol* 2002;116(1):211-217.
815. Ortega F, Gonzalez M, Moro MJ, et al. [Prognostic effect of beta 2-microglobulin in multiple myeloma]. *Med Clin* 1992;99(17):645-648.
816. Drach J, Angerler J, Schuster J, et al. Interphase fluorescence in situ hybridization identifies chromosomal abnormalities in plasma cells from patients with monoclonal gammopathy of undetermined significance. *Blood* 1995;86(10):3915-3921.
817. Zandecki M, Lai JL, Facon T. Multiple myeloma: almost all patients are cytogenetically abnormal. *Br J Haematol* 1996;94(2):217-227.
818. Kumar S, Fonseca R, Ketterling RP, et al. Trisomies in multiple myeloma: impact on survival in patients with high-risk cytogenetics. *Blood* 2012;119(9):2100-2105.
819. Dewald GW, Kyle RA, Hicks GA, Greipp PR. The clinical significance of cytogenetic studies in 100 patients with multiple myeloma, plasma cell leukemia, or amyloidosis. *Blood* 1985;66(2):380-390.
820. Sawyer JR, Waldron JA, Jagannath S, Barlogie B. Cytogenetic findings in 200 patients with multiple myeloma. *Cancer Genet Cytogenet* 1995;82(1):41-49.
821. Smadja NV, Fruchart C, Isnard F, et al. Chromosomal analysis in multiple myeloma: cytogenetic evidence of two different diseases. *Leukemia* 1998;12(6):960-969.
822. Rajkumar S, Fonseca R, Lacy M, et al. Abnormal cytogenetics predict poor survival after high-dose therapy and autologous blood cell transplantation in multiple myeloma. *Bone Marrow Transplant* 1999;24(5):497-503.
823. Rajkumar SV, Fonseca R, Dewald GW, et al. Cytogenetic abnormalities correlate with the plasma cell labeling index and extent of bone marrow involvement in myeloma. *Cancer Genet Cytogenet* 1999;113(1):73-77.
824. Zojer N, Konigsberg R, Ackermann J, et al. Deletion of 13q14 remains an independent adverse prognostic variable in multiple myeloma despite its frequent detection by interphase fluorescence in situ hybridization. *Blood* 2000;95(6):1925-1930.
825. Avet-Loiseau H, Li JY, Morineau N, et al. Monosomy 13 is associated with the transition of monoclonal gammopathy of undetermined significance to multiple myeloma. Intergroupe Francophone du Myelome. *Blood* 1999;94(8):2583-2589.
826. Fonseca R, Oken MM, Harrington D, et al. Deletions of chromosome 13 in multiple myeloma identified by interphase FISH usually denote large deletions of the q arm or monosomy. *Leukemia* 2001;15(6):981-986.

827. Fonseca R, Harrington D, Oken MM, et al. Biological and prognostic significance of interphase fluorescence in situ hybridization detection of chromosome 13 abnormalities (delta13) in multiple myeloma: an eastern cooperative oncology group study. *Cancer Res* 2002;62(3):715-720.
828. Chng WJ, Santana-Davila R, Van Wier SA, et al. Prognostic factors for hyperdiploid-myeloma: effects of chromosome 13 deletions and IgH translocations. *Leukemia* 2006;20(5):807-813.
829. Tricot G, Sawyer JR, Jagannath S, et al. Unique role of cytogenetics in the prognosis of patients with myeloma receiving high-dose therapy and autotransplants. *J Clin Oncol* 1997;15(7):2659-2666.
830. Seong C, Delasalle K, Hayes K, et al. Prognostic value of cytogenetics in multiple myeloma. *Br J Haematol* 1998;101(1):189-194.
831. Facon T, Avet-Loiseau H, Guillermin G, et al. Chromosome 13 abnormalities identified by FISH analysis and serum beta2-microglobulin produce a powerful myeloma staging system for patients receiving high-dose therapy. *Blood* 2001;97(6):1566-1571.
832. Worel N, Greinix H, Ackermann J, et al. Deletion of chromosome 13q14 detected by fluorescence in situ hybridization has prognostic impact on survival after high-dose therapy in patients with multiple myeloma. *Ann Hematol* 2001;80(6):345-348.
833. Barlogie B, Alexanian R, Dixon D, Smith L, Smallwood L, Delasalle K. Prognostic implications of tumor cell DNA and RNA content in multiple myeloma. *Blood* 1985;66(2):338-341.
834. Morgan RJ Jr, Gonchoroff NJ, Katzmann JA, Witzig TE, Kyle RA, Greipp PR. Detection of hypodiploidy using multi-parameter flow cytometric analysis: a prognostic indicator in multiple myeloma. *Am J Hematol* 1989;30(4):195-200.
835. Smadja NV, Bastard C, Brigaudeau C, Leroux D, Fruchart C, Groupe Francais de Cytogenetique H. Hypodiploidy is a major prognostic factor in multiple myeloma. *Blood* 2001;98(7):2229-2238.
836. Gould J, Alexanian R, Goodacre A, Pathak S, Hecht B, Barlogie B. Plasma cell karyotype in multiple myeloma. *Blood* 1988;71(2):453-456.
837. Debes-Marun CS, Dewald GW, Bryant S, et al. Chromosome abnormalities clustering and its implications for pathogenesis and prognosis in myeloma. *Leukemia* 2003;17(2):427-436.
838. Shaughnessy J Jr, Tian E, Sawyer J, et al. Prognostic impact of cytogenetic and interphase fluorescence in situ hybridization-defined chromosome 13 deletion in multiple myeloma: early results of total therapy II. *Br J Haematol* 2003;120(1):44-52.
839. Fonseca R, Debes-Marun CS, Picken EB, et al. The recurrent IgH translocations are highly associated with nonhyperdiploid variant multiple myeloma. *Blood* 2003;102(7):2562-2567.
840. Chesi M, Kuehl WM, Bergsagel PL. Recurrent immunoglobulin gene trans-locations identify distinct molecular subtypes of myeloma. *Ann Oncol* 2000;11(Suppl 1):131-135.
841. Hoyer JD, Hanson CA, Fonseca R, Greipp PR, Dewald GW, Kurtin PJ. The (11;14)(q13;q32) translocation in multiple myeloma. A morphologic and immunohistochemical study. *Am J Clin Pathol* 2000;113(6):831-837.
842. Fonseca R, Blood EA, Oken MM, et al. Myeloma and the t(11;14)(Q13;Q32); Evidence for a Biologically Defined Unique Subset of Patients. *Blood*. 2002; (In press).
843. Shaughnessy J Jr, Gabrea A, Qi Y, et al. Cyclin D3 at 6p21 is dysregulated by recurrent chromosomal translocations to immunoglobulin loci in multiple myeloma. *Blood* 2001;98(1):217-223.
844. Chesi M, Nardini E, Brents LA, et al. Frequent translocation t(4;14) (p16.3;q32.3) in multiple myeloma is associated with increased expression and activating mutations of fibroblast growth factor receptor 3. *Nat Genet* 1997;16(3):260-264.
845. Chesi M, Nardini E, Lim RS, Smith KD, Kuehl WM, Bergsagel PL. The t(4;14) translocation in myeloma dysregulates both FGFR3 and a novel gene, MMSET, resulting in IgH/MMSET hybrid transcripts. *Blood* 1998;92(9): 3025-3034.
846. Richelda R, Ronchetti D, Baldini L, et al. A novel chromosomal translocation t(4; 14)(p16.3; q32) in multiple myeloma involves the fibroblast growth-factor receptor 3 gene. *Blood* 1997;90(10):4062-4070.
847. Avet-Loiseau H, Li JY, Facon T, et al. High incidence of translocations t(11;14) (q13;q32) and t(4;14)(p16;q32) in patients with plasma cell malignancies. *Cancer Res* 1998;58(24):5640-5645.

848. Fonseca R, Conte G, Greipp PR. Laboratory correlates in multiple myeloma: how useful for prognosis?. [Review] [57 refs]. *Blood Rev* 2001;15(2):97-102.
849. Avet-Loiseau H, Malard F, Campion L, et al. Translocation t(14;16) and multiple myeloma: is it really an independent prognostic factor? *Blood* 2011;117(6):2009-2011.
850. Garcia-Sanz R, Orfao A, Gonzalez M, et al. Primary plasma cell leukemia: clinical, immunophenotypic, DNA ploidy, and cytogenetic characteristics. *Blood* 1999;93(3):1032-1037.
851. Drach J, Schuster J, Nowotny H, et al. Multiple myeloma: high incidence of chromosomal aneuploidy as detected by interphase fluorescence in situ hybridization. *Cancer Res* 1995;55(17):3854-3859.
852. Perez-Simon JA, Garcia-Sanz R, Taberero MD, et al. Prognostic value of numerical chromosome aberrations in multiple myeloma: a FISH analysis of 15 different chromosomes. *Blood* 1998;91(9):3366-3371.
853. Ortega MM, Melo MB, De Souza CA, Lorand-Metze I, Costa FF, Lima CS. A possible role of the P53 gene deletion as a prognostic factor in multiple myeloma. *Ann Hematol* 2003;82(7):405-409.
854. Chang H, Qi C, Yi QL, Reece D, Stewart AK. p53 gene deletion detected by fluorescence in situ hybridization is an adverse prognostic factor for patients with multiple myeloma following autologous stem cell transplantation. *Blood* 2005;105(1):358-360.
855. Chen MH, Qi CX, Saha MN, Chang H. p53 nuclear expression correlates with hemizygous TP53 deletion and predicts an adverse outcome for patients with relapsed/refractory multiple myeloma treated with lenalidomide. *Am J Clin Pathol* 2012;137(2):208-212.
856. Portier M, Moles JP, Mazars GR, et al. p53 and RAS gene mutations in multiple myeloma. *Oncogene* 1992;7(12):2539-2543.
857. Corradini P, Inghirami G, Astolfi M, et al. Inactivation of tumor suppressor genes, p53 and Rb1, in plasma cell dyscrasias. *Leukemia* 1994;8(5):758-767.
858. Mazars GR, Portier M, Zhang XG, et al. Mutations of the p53 gene in human myeloma cell lines. *Oncogene* 1992;7(5):1015-1018.
859. Neri A, Baldini L, Trecca D, Cro L, Polli E, Maiolo AT. p53 gene mutations in multiple myeloma are associated with advanced forms of malignancy. *Blood* 1993;81(1):128-135.
860. Preudhomme C, Facon T, Zandecki M, et al. Rare occurrence of P53 gene mutations in multiple myeloma. *Br J Haematol* 1992;81(3):440-443.
861. Chang H, Qi X, Jiang A, Xu W, Young T, Reece D. 1p21 deletions are strongly associated with 1q21 gains and are an independent adverse prognostic factor for the outcome of high-dose chemotherapy in patients with multiple myeloma. *Bone Marrow Transplant* 2010;45(1):117-121.
862. Wu KL, Beverloo B, Lokhorst HM, et al. Abnormalities of chromosome 1p/q are highly associated with chromosome 13/13q deletions and are an adverse prognostic factor for the outcome of high-dose chemotherapy in patients with multiple myeloma. *Br J Haematol* 2007;136(4):615-623.
863. Panani AD, Ferti AD, Papaxoinis C, Raptis SA, Roussos C. Cytogenetic data as a prognostic factor in multiple myeloma patients: involvement of 1p12 region an adverse prognostic factor. *Anticancer Res* 2004;24(6):4141-4146.
864. Chng WJ, Gertz MA, Chung TH, et al. Correlation between array-comparative genomic hybridization-defined genomic gains and losses and survival: identification of 1p31-32 deletion as a prognostic factor in myeloma. *Leukemia* 2010;24(4):833-842.
865. Boyd KD, Ross FM, Walker BA, et al. Mapping of chromosome 1p deletions in myeloma identifies FAM46C at 1p12 and CDKN2C at 1p32.3 as being genes in regions associated with adverse survival. *Clin Cancer Res* 2011.
866. Liang W, Hopper JE, Rowley JD. Karyotypic abnormalities and clinical aspects of patients with multiple myeloma and related paraproteinemic disorders. *Cancer* 1979;44(2):630-644.
867. Hanamura I, Stewart JP, Huang Y, et al. Frequent gain of chromosome band 1q21 in plasma-cell dyscrasias detected by fluorescence in situ hybridization: incidence increases from MGUS to relapsed myeloma and is related to prognosis and disease progression following tandem stem-cell transplantation. *Blood* 2006;108(5):1724-1732.
868. Neri A, Murphy JP, Cro L, et al. Ras oncogene mutation in multiple myeloma. *J Exp Med* 1989;170(5):1715-1725.

869. Matozaki S, Nakagawa T, Nakao Y, Fujita T. RAS gene mutations in multiple myeloma and related monoclonal gammopathies. *Kobe J Med Sci* 1991;37(1):35-45.
870. Liu P, Leong T, Quam L, et al. Activating mutations of N- and K-ras in multiple myeloma show different clinical associations: analysis of the eastern cooperative oncology group phase III trial. *Blood* 1996;88(7):2699-2706.
871. Boyd KD, Ross FM, Chiecchio L, et al. A novel prognostic model in myeloma based on co-segregating adverse FISH lesions and the ISS: analysis of patients treated in the MRC Myeloma IX trial. *Leukemia* 2012;26(2):349-355.
872. Zhan F, Huang Y, Colla S, et al. The molecular classification of multiple myeloma. *Blood* 2006;108(6):2020-2028.
873. Zhan F, Barlogie B, Mulligan G, Shaughnessy JD Jr, Bryant B. High-risk myeloma: a gene expression based risk-stratification model for newly diagnosed multiple myeloma treated with high-dose therapy is predictive of outcome in relapsed disease treated with single-agent bortezomib or high-dose dexamethasone. *Blood* 2008;111(2):968-969.
874. Kumar SK, Uno H, Jacobus SJ, et al. Impact of gene expression profiling-based risk stratification in patients with myeloma receiving initial therapy with lenalidomide and dexamethasone. *Blood* 2011;118(16):4359-4362.
875. Zhan F, Tian E, Bumm K, Smith R, Barlogie B, Shaughnessy J Jr. Gene expression profiling of human plasma cell differentiation and classification of multiple myeloma based on similarities to distinct stages of late-stage B-cell development. *Blood* 2003;101(3):1128-1140.
876. Decaux O, Lode L, Magrangeas F, et al. Prediction of survival in multiple myeloma based on gene expression profiles reveals cell cycle and chromosomal instability signatures in high-risk patients and hyperdiploid signatures in low-risk patients: a study of the Intergroupe Francophone du Myelome. *J Clin Oncol* 2008;26(29):4798-4805.
877. Waheed S, Shaughnessy JD, van Rhee F, et al. International staging system and metaphase cytogenetic abnormalities in the era of gene expression profiling data in multiple myeloma treated with total therapy 2 and 3 protocols. *Cancer* 2011;117(5):1001-1009.
878. Fonseca R, Barlogie B, Bataille R, et al. Genetics and cytogenetics of multiple myeloma: a workshop report. *Cancer Res* 2004;64(4):1546-1558.
879. Avet-Loiseau H, Attal M, Moreau P, et al. Genetic abnormalities and survival in multiple myeloma: the experience of the Intergroupe Francophone du Myelome. *Blood* 2007;109(8):3489-3495.
880. Rajkumar SV, Greipp PR. Prognostic factors in multiple myeloma. [Review] [138 refs]. *Hematol Oncol Clin North Am* 1999;13(6):1295-1314.
881. Boccadoro M, Marmont F, Tribalto M, et al. Early responder myeloma: kinetic studies identify a patient subgroup characterized by very poor prognosis. *J Clin Oncol* 1989;7(1):119-125.
882. Kapoor P, Kumar S, Mandrekar SJ, et al. Efficacy of thalidomide- or lenalidomide-based therapy in proliferative multiple myeloma. *Leukemia* 2011;25(7):1195-1197.
883. Trendle MC, Leong T, Kyle RA, et al. Prognostic significance of the S-phase fraction of light-chain-restricted cytoplasmic immunoglobulin (clg) positive plasma cells in patients with newly diagnosed multiple myeloma enrolled on Eastern Cooperative Oncology Group treatment trial E9486. *Am J Hematol* 1999;61(4):232-237.
884. Pope B, Brown R, Gibson J, Joshua D. The bone marrow plasma cell labeling index by flow cytometry. *Cytometry* 1999;38(6):286-292.
885. Alexandrakis MG, Passam FH, Kyriakou DS, Dambaki K, Niniraki M, Stathopoulos E. Ki-67 proliferation index: correlation with prognostic parameters and outcome in multiple myeloma. *Am J Clin Oncol* 2004;27(1):8-13.
886. Drach J, Gatringer C, Glassl H, Drach D, Huber H. The biological and clinical significance of the KI-67 growth fraction in multiple myeloma. *Hematol Oncol* 1992;10(2):125-134.
887. Girino M, Riccardi A, Luoni R, Ucci G, Cuomo A. Monoclonal antibody Ki-67 as a marker of proliferative activity in monoclonal gammopathies. *Acta Haematol* 1991;85(1):26-30.
888. Nadav L, Katz BZ, Baron S, Cohen N, Naparstek E, Geiger B. The generation and regulation of functional diversity of malignant plasma cells. *Cancer Res* 2006;66(17):8608-8616.
889. Yaccoby S. The phenotypic plasticity of myeloma plasma cells as expressed by dedifferentiation into an immature, resilient, and apoptosis-resistant phenotype. *Clin Cancer Res* 2005;11(21):7599-7606.

890. San Miguel JF, Gutierrez NC, Mateo G, Orfao A. Conventional diagnostics in multiple myeloma. *Eur J Cancer* 2006;42(11):1510-1519.
891. Robillard N, Jego G, Pellat-Deceunynck C, et al. CD28, a marker associated with tumoral expansion in multiple myeloma. *Clin Cancer Res* 1998; 4(6):1521-1526.
892. Moreau P, Robillard N, Jego G, et al. Lack of CD27 in myeloma delineates different presentation and outcome. *Br J Haematol* 2006;132(2):168-170.
893. Bataille R, Pellat-Deceunynck C, Robillard N, Avet-Loiseau H, Harousseau JL, Moreau P. CD117 (c-kit) is aberrantly expressed in a subset of MGUS and multiple myeloma with unexpectedly good prognosis. *Leuk Res* 2008;32(3):379-382.
894. Moreaux J, Hose D, Reme T, et al. CD200 is a new prognostic factor in multiple myeloma. *Blood* 2006;108(13):4194-4197.
895. Mateo G, Montalban MA, Vidriales MB, et al. Prognostic value of immunophenotyping in multiple myeloma: a study by the PETHEMA/GEM cooperative study groups on patients uniformly treated with high-dose therapy. *J Clin Oncol* 2008;26(16):2737-2744.
896. Torra R, Blade J, Cases A, et al. Patients with multiple myeloma requiring long-term dialysis: presenting features, response to therapy, and outcome in a series of 20 cases. *Br J Haematol* 1995;91(4):854-859.
897. Morabito F, Gentile M, Ciolli S, et al. Safety and efficacy of bortezomib-based regimens for multiple myeloma patients with renal impairment: a retrospective study of Italian Myeloma Network GIMEMA. *Eur J Haematol* 2010;84(3):223-228.
898. Roussou M, Kastiritis E, Christoulas D, et al. Reversibility of renal failure in newly diagnosed patients with multiple myeloma and the role of novel agents. *Leuk Res* 2010;34(10):1395-1397.
899. Dimopoulos MA, Terpos E, Chanan-Khan A, et al. Renal impairment in patients with multiple myeloma: a consensus statement on behalf of the International Myeloma Working Group. *J Clin Oncol* 2011;28(33): 4976-4984.
900. Hutchison CA, Cockwell P, Stringer S, et al. Early reduction of serum-free light chains associates with renal recovery in myeloma kidney. *J Am Soc Nephrol* 2011;22(6):1129-1136.
901. Merico F, Bergui L, Gregoret MG, et al. Cytokines involved in the progression of multiple myeloma. *Clin Exp Immunol* 1993;92(1):27-31.
902. Lust JA, Donovan KA. The role of interleukin-1 beta in the pathogenesis of multiple myeloma. [Review] [44 refs]. *Hematol Oncol Clin North Am* 1999;13(6):1117-1125.
903. Carter A, Merchav S, Silvan-Draxler I, Tatarsky I. The role of interleukin-1 and tumour necrosis factor-alpha in human multiple myeloma. *Br J Haematol* 1990;74(4):424-431.
904. Dankbar B, Padro T, Leo R, et al. Vascular endothelial growth factor and interleukin-6 in paracrine tumor-stromal cell interactions in multiple myeloma. *Blood* 2000;95(8):2630-2636.
905. Podar K, Tai YT, Davies FE, et al. Vascular endothelial growth factor triggers signaling cascades mediating multiple myeloma cell growth and migration. *Blood* 2001;98(2):428-435.
906. Han JH, Choi SJ, Kurihara N, Koide M, Oba Y, Roodman GD. Macrophage inflammatory protein-1alpha is an osteoclastogenic factor in myeloma that is independent of receptor activator of nuclear factor kappaB ligand. *Blood* 2001;97(11):3349-3353.
907. Roodman GD. Biology of osteoclast activation in cancer. *J Clin Oncol* 2001;19(15):3562-3571.
908. Van Camp B, Durie BG, Spier C, et al. Plasma cells in multiple myeloma express a natural killer cell-associated antigen: CD56 (NKH-1; Leu-19). *Blood* 1990;76(2):377-382.
909. Ahsmann EJ, Lokhorst HM, Dekker AW, Bloem AC. Lymphocyte function-associated antigen-1 expression on plasma cells correlates with tumor growth in multiple myeloma. *Blood* 1992;79(8):2068-2075.
910. Uchiyama H, Barut BA, Mohrbacher AF, Chauhan D, Anderson KC. Adhesion of human myeloma-derived cell lines to bone marrow stromal cells stimulates interleukin-6 secretion. *Blood* 1993;82(12):3712-3720.
911. Hideshima T, Chauhan D, Podar K, Schlossman RL, Richardson P, Anderson KC. Novel therapies targeting the myeloma cell and its bone marrow micro-environment. *Semin Oncol* 2001;28(6):607-612.

912. Michigami T, Shimizu N, Williams PJ, et al. Cell-cell contact between marrow stromal cells and myeloma cells via VCAM-1 and alpha(4)beta(1)-integrin enhances production of osteoclast-stimulating activity. *Blood* 2000;96(5):1953-1960.
913. Vincent T, Jourdan M, Sy MS, Klein B, Mechti N. Hyaluronic acid induces survival and proliferation of human myeloma cells through an interleukin-6-mediated pathway involving the phosphorylation of retinoblastoma protein. *J Biol Chem* 2001;276(18):14728-14736.
914. Houde C, Li Y, Song L, et al. Overexpression of the NOTCH ligand JAG2 in malignant plasma cells from multiple myeloma patients and cell lines. *Blood* 2004;104(12):3697-3704.
915. Landowski TH, Olashaw NE, Agrawal D, Dalton WS. Cell adhesion-mediated drug resistance (CAM-DR) is associated with activation of NF-kappa B (RelB/p50) in myeloma cells. *Oncogene* 2003;22(16):2417-2421.
916. Ingham PW, McMahon AP. Hedgehog signaling in animal development: paradigms and principles. *Genes Dev* 2001;15(23):3059-3087.
917. Xie K, Abbruzzese JL. Developmental biology informs cancer: the emerging role of the hedgehog signaling pathway in upper gastrointestinal cancers. *Cancer Cell* 2003;4(4):245-247.
918. Bellamy WT, Richter L, Frutiger Y, Grogan TM. Expression of vascular endothelial growth factor and its receptors in hematopoietic malignancies. *Cancer Res* 1999;59(3):728-733.
919. Rajkumar SV, Greipp PR. Angiogenesis in multiple myeloma. *Br J Haematol* 2001;113(3):565.
920. Kumar S, Gertz MA, Dispenzieri A, et al. Prognostic value of bone marrow angiogenesis in patients with multiple myeloma undergoing high-dose therapy. *Bone Marrow Transplant* 2004;34(3):235-239.
921. Kumar S, Witzig TE, Greipp PR, Rajkumar SV. Bone marrow angiogenesis and circulating plasma cells in multiple myeloma. *Br J Haematol* 2003;122(2):272-274.
922. Kumar S, Witzig TE, Timm M, et al. Expression of VEGF and its receptors by myeloma cells. *Leukemia* 2003;17(10):2025-2031.
923. Kumar S, Witzig TE, Timm M, et al. Bone marrow angiogenic ability and expression of angiogenic cytokines in myeloma: evidence favoring loss of marrow angiogenesis inhibitory activity with disease progression. *Blood* 2004;104(4):1159-1165.
924. Ribas C, Colleoni GW, Silva MR, Carregoza MJ, Bordin JO. Prognostic significance of vascular endothelial growth factor immunoexpression in the context of adverse standard prognostic factors in multiple myeloma. *Eur J Haematol* 2004;73(5):311-317.
925. Kimlinger T, Kline M, Kumar S, Lust J, Witzig T, Rajkumar SV. Differential expression of vascular endothelial growth factors and their receptors in multiple myeloma. *Haematologica* 2006;91(8):1033-1040.
926. Yaccoby S, Wezeman MJ, Zangari M, et al. Inhibitory effects of osteoblasts and increased bone formation on myeloma in novel culture systems and a myelomatous mouse model. *Haematologica* 2006;91(2):192-199.
927. Tian E, Zhan F, Walker R, et al. The role of the Wnt-signaling antagonist DKK1 in the development of osteolytic lesions in multiple myeloma. *N Engl J Med* 2003;349(26):2483-2494.
928. Qiang YW, Chen Y, Stephens O, et al. Myeloma-derived Dickkopf-1 disrupts Wnt-regulated osteoprotegerin and RANKL production by osteoblasts: a potential mechanism underlying osteolytic bone lesions in multiple myeloma. *Blood* 2008;112(1):196-207.
929. Choi SJ, Oba Y, Gazitt Y, et al. Antisense inhibition of macrophage inflammatory protein 1-alpha blocks bone destruction in a model of myeloma bone disease. *J Clin Invest* 2001;108(12):1833-1841.
930. Zheng Y, Cai Z, Wang S, et al. Macrophages are an abundant component of myeloma microenvironment and protect myeloma cells from chemotherapy drug-induced apoptosis. *Blood* 2009;114(17):3625-3628.
931. Chauhan D, Singh AV, Brahmandam M, et al. Functional interaction of plasmacytoid dendritic cells with multiple myeloma cells: a therapeutic target. *Cancer Cell* 2009;16(4):309-323.
932. Nordan RP, Mock BA, Neckers LM, Rudikoff S. The role of plasmacytoma growth factor in the in vitro responses of murine plasmacytoma cells. *Ann N Y Acad Sci* 1989;557:200-205.
933. Xu FH, Sharma S, Gardner A, et al. Interleukin-6-induced inhibition of multiple myeloma cell apoptosis: support for the hypothesis that protection is mediated via inhibition of the JNK/SAPK pathway. *Blood* 1998;92(1):241-251.

934. Klein B, Zhang XG, Jourdan M, et al. Paracrine rather than autocrine regulation of myeloma-cell growth and differentiation by interleukin-6. *Blood* 1989;73(2):517-526.
935. Frassanito MA, Cusmai A, Iodice G, Dammacco F. Autocrine interleukin-6 production and highly malignant multiple myeloma: relation with resistance to drug-induced apoptosis. *Blood* 2001;97(2):483-489.
936. Klein B, Bataille R. Cytokine network in human multiple myeloma. *Hematol Oncol Clin North Am* 1992;6(2):273-284.
937. Klein B, Zhang XG, Lu ZY, Bataille R. Interleukin-6 in human multiple myeloma. *Blood* 1995;85(4):863-872.
938. Lichtenstein A, Tu Y, Fady C, Vescio R, Berenson J. Interleukin-6 inhibits apoptosis of malignant plasma cells. *Cell Immunol* 1995;162(2):248-255.
- P.2097
939. Puthier D, Bataille R, Amiot M. IL-6 up-regulates mcl-1 in human myeloma cells through JAK / STAT rather than ras / MAP kinase pathway. *Eur J Immunol* 1999;29(12):3945-3950.
940. French JD, Tschumper RC, Jelinek DF. Dissection of the signalling requirements of interleukin-6-stimulated myeloma cell growth. *Acta Oncol* 2000;39(7):777-781.
941. Catlett-Falcone R, Landowski TH, Oshiro MM, et al. Constitutive activation of Stat3 signaling confers resistance to apoptosis in human U266 myeloma cells. *Immunity* 1999;10(1):105-115.
942. Mitsiades N, Mitsiades CS, Poulaki V, et al. Biologic sequelae of nuclear factor-kappaB blockade in multiple myeloma: therapeutic applications. *Blood* 2002;99(11):4079-4086.
943. Jourdan M, De Vos J, Mechti N, Klein B. Regulation of Bcl-2-family proteins in myeloma cells by three myeloma survival factors: interleukin-6, interferon-alpha and insulin-like growth factor 1. *Cell Death Differ* 2000;7(12):1244-1252.
944. Renner S, Weisz J, Krajewski S, Krajewska M, Reed JC, Lichtenstein A. Expression of BAX in plasma cell dyscrasias. *Clin Cancer Res* 2000;6(6):2371-2380.
945. Ladanyi M, Wang S, Niesvizky R, Feiner H, Michaeli J. Proto-oncogene analysis in multiple myeloma. *Am J Pathol* 1992;141(4):949-953.
946. Miguel-Garcia A, Orero T, Matutes E, et al. bcl-2 expression in plasma cells from neoplastic gammopathies and reactive plasmacytosis: a comparative study. *Haematologica* 1998;83(4):298-304.
947. Cheung WC, Van Ness B. The bone marrow stromal microenvironment influences myeloma therapeutic response in vitro. *Leukemia* 2001;15(2):264-271.
948. Dalton WS, Jove R. Drug resistance in multiple myeloma: approaches to circumvention. [Review] [27 refs]. *Semin Oncol* 1999;26(5 Suppl 13):23-27.
949. Rawat R, Rainey GJ, Thompson CD, Frazier-Jessen MR, Brown RT, Nordan RP. Constitutive activation of STAT3 is associated with the acquisition of an interleukin 6-independent phenotype by murine plasmacytomas and hybridomas. *Blood* 2000;96(10):3514-3521.
950. Anderson K. Advances in the biology of multiple myeloma: therapeutic applications. [Review] [71 refs]. *Semin Oncol* 1999;26(5 Suppl 13):10-22.
951. Van Riet I, De Greef C, Aharchi F, et al. Establishment and characterization of a human stroma-dependent myeloma cell line (MM5.1) and its stromaindependent variant (MM5.2). *Leukemia* 1997;11(2):284-293.
952. Lichtenstein A, Berenson J, Norman D, Chang MP, Carlile A. Production of cytokines by bone marrow cells obtained from patients with multiple myeloma. *Blood* 1989;74(4):1266-1273.
953. Costes V, Portier M, Lu ZY, Rossi JF, Bataille R, Klein B. Interleukin-1 in multiple myeloma: producer cells and their role in the control of IL-6 production. *Br J Haematol* 1998;103(4):1152-1160.
954. Lacy MQ, Donovan KA, Heimbach JK, Ahmann GJ, Lust JA. Comparison of interleukin-1 beta expression by in situ hybridization in monoclonal gammopathy of undetermined significance and multiple myeloma. *Blood* 1999;93(1):300-305.
955. Ge NL, Rudikoff S. Insulin-like growth factor I is a dual effector of multiple myeloma cell growth. *Blood* 2000;96(8):2856-2861.

956. Asosingh K, Gunthert U, Bakkus MH, et al. In vivo induction of insulin-like growth factor-I receptor and CD44v6 confers homing and adhesion to murine multiple myeloma cells. *Cancer Res* 2000;60(11):3096-3104.
957. Vanderkerken K, De Greef C, Asosingh K, et al. Selective initial in vivo homing pattern of 5T2 multiple myeloma cells in the C57BL/KalwRij mouse. *Br J Cancer* 2000;82(4):953-959.
958. Jelinek DF, Witzig TE, Arendt BK. A role for insulin-like growth factor in the regulation of IL-6- responsive human myeloma cell line growth. *J Immunol* 1997;159(1):487-496.
959. Georgii-Hemming P, Wiklund HJ, Ljunggren O, Nilsson K. Insulin-like growth factor I is a growth and survival factor in human multiple myeloma cell lines. *Blood* 1996;88(6):2250-2258.
960. Freund GG, Kulas DT, Way BA, Mooney RA. Functional insulin and insulin-like growth factor-1 receptors are preferentially expressed in multiple myeloma cell lines as compared to B-lymphoblastoid cell lines. *Cancer Res* 1994;54(12):3179-3185.
961. Derksen PW, de Gorter DJ, Meijer HP, et al. The hepatocyte growth factor/Met pathway controls proliferation and apoptosis in multiple myeloma. *Leukemia Apr* 2003;17(4):764-774.
962. Hideshima T, Chauhan D, Schlossman R, Richardson P, Anderson KC. The role of tumor necrosis factor alpha in the pathophysiology of human multiple myeloma: therapeutic applications. *Oncogene* 2001;20(33):4519-4527.
963. Jourdan M, Tarte K, Legouffe E, Brochier J, Rossi JF, Klein B. Tumor necrosis factor is a survival and proliferation factor for human myeloma cells. *Eur Cytokine Netw* 1999;10(1):65-70.
964. Kline M, Donovan K, Wellik L, et al. Cytokine and chemokine profiles in multiple myeloma; significance of stromal interaction and correlation of IL-8 production with disease progression. *Leuk Res* 2006.
965. Sezer O, Niemoller K, Jakob C, et al. Relationship between bone marrow angiogenesis and plasma cell infiltration and serum beta2-microglobulin levels in patients with multiple myeloma. *Ann Hematol* 2001;80(10):598-601.
966. Ng MH, Kan A, Chung YF, et al. Combined morphological and interphase fluorescence in situ hybridization study in multiple myeloma of Chinese patients. *Am J Pathol* 1999;154(1):15-22.
967. Shou Y, Martelli ML, Gabrea A, et al. Diverse karyotypic abnormalities of the c-myc locus associated with c-myc dysregulation and tumor progression in multiple myeloma. *Proc Natl Acad Sci U S A* 2000;97(1):228-233.
968. Lai R, Medeiros LJ, Wilson CS, et al. Expression of the cell-cycle-related proteins E2F-1, p53, mdm-2, p21waf-1, and Ki-67 in multiple myeloma: correlation with cyclin-D1 immunoreactivity. *Mod Pathol* 1998;11(7):642-647.
969. Chesi M, Bergsagel PL, Brents LA, Smith CM, Gerhard DS, Kuehl WM. Dysregulation of cyclin D1 by translocation into an IgH gamma switch region in two multiple myeloma cell lines. *Blood* 1996;88(2):674-681.
970. Weh HJ, Bartl R, Seeger D, Selbach J, Kuse R, Hossfeld DK. Correlations between karyotype and cytologic findings in multiple myeloma. *Leukemia* 1995;9(12):2119-2122.
971. Fonseca R, Hoyer JD, Aguayo P, et al. Clinical significance of the translocation (11;14)(q13;q32) in multiple myeloma. *Leuk Lymphoma* 1999;35(5-6): 599-605.
972. Bergsagel PL, Kuehl WM, Zhan F, Sawyer J, Barlogie B, Shaughnessy J Jr. Cyclin D dysregulation: an early and unifying pathogenic event in multiple myeloma. *Blood* 2005;106(1):296-303.
973. Tasaka T, Berenson J, Vescio R, et al. Analysis of the p16INK4A, p15INK4B and p18INK4C genes in multiple myeloma. *Br J Haematol* 1997;96(1):98-102.
974. Ogawa S, Hangaishi A, Miyawaki S, et al. Loss of the cyclin-dependent kinase 4-inhibitor (p16; MTS1) gene is frequent in and highly specific to lymphoid tumors in primary human hematopoietic malignancies. *Blood* 1995;86(4):1548-1556.
975. Zandecki M, Facon T, Preudhomme C, et al. The retinoblastoma gene (RB-1) status in multiple myeloma: a report on 35 cases. *Leuk Lymphoma* 1995;18(5-6):497-503.
976. Urashima M, Teoh G, Ogata A, et al. Role of CDK4 and p16INK4A in interleukin-6-mediated growth of multiple myeloma. *Leukemia* 1997;11(11):1957-1963.
977. Guillerm G, Gyan E, Wolowiec D, et al. p16(INK4a) and p15(INK4b) gene methylations in plasma cells from monoclonal gammopathy of undetermined significance. *Blood* 2001;98(1):244-246.

978. Ng MH, To KW, Lo KW, et al. Frequent death-associated protein kinase promoter hypermethylation in multiple myeloma. *Clin Cancer Res* 2001;7(6):1724-1729.
979. Gonzalez-Paz N, Chng WJ, McClure RF, et al. Tumor suppressor p16 methylation in multiple myeloma: biological and clinical implications. *Blood* 2007;109(3):1228-1232.
980. Kalakonda N, Rothwell DG, Scarffe JH, Norton JD. Detection of N-Ras codon 61 mutations in subpopulations of tumor cells in multiple myeloma at presentation. *Blood* 2001;98(5):1555-1560.
981. Drach J, Ackermann J, Fritz E, et al. Presence of a p53 gene deletion in patients with multiple myeloma predicts for short survival after conventional-dose chemotherapy. *Blood* 1998;92(3):802-809.
982. Selvanayagam P, Blick M, Narni F, et al. Alteration and abnormal expression of the c-myc oncogene in human multiple myeloma. *Blood* 1988;71(1):30-35.
983. Brown RD, Pope B, Luo XF, Gibson J, Joshua D. The oncoprotein phenotype of plasma cells from patients with multiple myeloma. *Leuk Lymphoma* 1994;16(1-2):147-156.
984. Avet-Loiseau H, Gerson F, Magrangeas F, et al. Rearrangements of the c-myc oncogene are present in 15% of primary human multiple myeloma tumors. *Blood* 2001;98(10):3082-3086.
985. Dreicer R, Alexanian R. Nonsecretory multiple myeloma. *Am J Hematol* 1982;13(4):313-318.
986. Blade J, Kyle RA. Nonsecretory myeloma, immunoglobulin D myeloma, and plasma cell leukemia. *Hematol Oncol Clin North Am* 1999;13(6):1259-1272.
987. Bourantas K. Nonsecretory multiple myeloma. *Eur J Haematol* 1996; 56(1-2):109-111.
988. Cavo M, Galieni P, Gobbi M, et al. Nonsecretory multiple myeloma. Presenting findings, clinical course and prognosis. *Acta Haematol* 1985;74(1):27-30.
989. Rubio-Felix D, Giral M, Giraldo MP, et al. Nonsecretory multiple myeloma. *Cancer* 1987;59(10):1847-1852.
990. Tormey WP. Low concentration monoclonal and oligoclonal bands in serum and urine using the Sebia Hydragel Protein Electrophoresis System [letter]. *Clin Chem Laborat Med* 1998;36(4):253-254.
991. Turesson I, Grubb A. Non-secretory or low-secretory myeloma with intracellular kappa chains. Report of six cases and review of the literature. *Acta Med Scand* 1978;204(6):445-451.
992. Blade J, Lust JA, Kyle RA. Immunoglobulin D multiple myeloma: presenting features, response to therapy, and survival in a series of 53 cases. *J Clin Oncol* 1994;12(11):2398-2404.
993. Shimamoto Y. IgD myeloma: clinical characteristics and a new staging system based on analysis of Japanese patients. *Cancer Detect Prev* 1995;19(5): 426-435.
994. Jancelewicz Z, Takatsuki K, Sugai S, Pruzanski W. IgD multiple myeloma. Review of 133 cases. *Arch Intern Med* 1975;135(1):87-93.
995. Fibbe WE, Jansen J. Prognostic factors in IgD myeloma: a study of 21 cases. *Scand J Haematol* 1984;33(5):471-475.
996. Blade J, Kyle RA. IgD monoclonal gammopathy with long-term follow-up. *Br J Haematol* 1994;88(2):395-396.
997. Kairemo KJ, Lindberg M, Prytz M. IgE myeloma: a case presentation and a review of the literature. [Review] [46 refs]. *Scand J Clin Lab Invest* 1999;59(6):451-456.
998. Macro M, Andre I, Comby E, et al. IgE multiple myeloma. *Leuk Lymphoma* 1999;32(5-6):597-603.
999. Kyle RA, Maldonado JE, Bayrd ED. Plasma cell leukemia. Report on 17 cases. *Arch Intern Med* 1974;133(5):813-818.
1000. Dimopoulos MA, Palumbo A, Delasalle KB, Alexanian R. Primary plasma cell leukaemia. *Br J Haematol* 1994;88(4):754-759.
1001. Avet-Loiseau H, Andree-Ashley LE, Moore D 2nd, et al. Molecular cytogenetic abnormalities in multiple myeloma and plasma cell leukemia measured using comparative genomic hybridization. *Genes Chromosomes Cancer* 1997;19(2):124-133.
1002. Gutierrez NC, Hernandez JM, Garcia JL, et al. Differences in genetic changes between multiple myeloma and plasma cell leukemia demonstrated by comparative genomic hybridization. *Leukemia* 2001;15(5):840-845.

1003. Shimazaki C, Goto H, Araki S, et al. Overexpression of PRAD1/cyclin D1 in plasma cell leukemia with t(11;14)(q13;q32). *Int J Hematol* 1997;66(1):111-115.
1004. Pruzanski W, Platts ME, Ogryzlo MA. Leukemic form of immunocytic dyscrasia (plasma cell leukemia). A study of ten cases and a review of the literature. *Am J Med* 1969;47(1):60-74.
1005. Noel P, Kyle RA. Plasma cell leukemia: an evaluation of response to therapy. *Am J Med* 1987;83(6):1062-1068.
1006. Pasqualetti P, Festuccia V, Collacciani A, Acitelli P, Casale R. Plasma cell leukemia. A report on 11 patients and review of the literature. *Panminerva Med* 1996;38(3):179-184.
1007. Tsiara S, Chaidos A, Kapsali H, Tzouvara E, Bourantas KL. Thalidomide administration for the treatment of resistant plasma cell leukemia. *Acta Haematol* 2003;109(3):153-155.
1008. Wohrer S, Ackermann J, Baldia C, et al. Effective treatment of primary plasma cell leukemia with thalidomide and dexamethasone—a case report. *Hematol J/EHA* 2004;5(4):361-363.
1009. Esparis-Ogando A, Alegre A, Aguado B, et al. Bortezomib is an efficient agent in plasma cell leukemias. *International journal of cancer. J Int Cancer* 2005;114(4):665-667.
1010. Finnegan DP, Kettle P, Drake M, et al. Bortezomib is effective in primary plasma cell leukemia. *Leuk Lymphoma* 2006;47(8):1670-1673.
1011. Ataergin S, Arpacı F, Kaya A, Kaya T, Gunhan O. VAD combination chemotherapy followed by bortezomib may be an effective treatment in secondary plasma cell leukemia. *Am J Hematol* 2006.
1012. Panizo C, Rifon J, Rodriguez-Wilhelmi P, Cuesta B, Rocha E. Long-term survival in primary plasma cell leukemia after therapy with VAD, autologous blood stem cell transplantation and interferon-alpha. *Acta Haematol* 1999;101(4):193-196.
1013. Sica S, Chiusolo P, Salutari P, et al. Long-lasting complete remission in plasma cell leukemia after aggressive chemotherapy and CD34-selected autologous peripheral blood progenitor cell transplant: molecular follow-up of minimal residual disease. *Bone Marrow Transplant* 1998;22(8):823-825.
1014. Hovenga S, de Wolf JT, Klip H, Vellenga E. Consolidation therapy with autologous stem cell transplantation in plasma cell leukemia after VAD, high-dose cyclophosphamide and EDAP courses: a report of three cases and a review of the literature. [Review] [20 refs]. *Bone Marrow Transplant* 1997;20(10):901-904.
1015. Yeh KH, Lin MT, Tang JL, Yang CH, Tsay W, Chen YC. Long-term disease-free survival after autologous bone marrow transplantation in a primary plasma cell leukaemia: detection of minimal residual disease in the transplant marrow by third-complementarity-determining region-specific probes. *Br J Haematol* 1995;89(4):914-916.
1016. Yang CH, Lin MT, Tsay W, Liu LT, Wang CH, Chen YC. Autologous bone marrow transplantation for plasma cell leukemia: report of a case. [Review] [13 refs]. *Transplant Proc* 1992;24(4):1531-1532.
1017. Saccaro S, Fonseca R, Veillon DM, et al. Primary plasma cell leukemia: report of 17 new cases treated with autologous or allogeneic stem-cell transplantation and review of the literature. *Am J Hematol* 2005;78(4):288-294.
1018. Mahindra A, Kalaycio ME, Vela-Ojeda J, et al. Hematopoietic cell transplantation for primary plasma cell leukemia: results from the Center for International Blood and Marrow Transplant Research. *Leukemia* 2012;26(5):1091-1097.
1019. van de Donk NW, Lokhorst HM, Anderson KC, Richardson PG. How I treat plasma cell leukemia. *Blood* 2012;120(12):2376-2389.
1020. Evison G, Evans KT. Sclerotic bone deposits in multiple myeloma [letter]. *Br J Radiol* 1983;56(662):145.
1021. Nakanishi T, Sobue I, Toyokura Y, et al. The Crow-Fukase syndrome: a study of 102 cases in Japan. *Neurology* 1984;34(6):712-720.
1022. Driedger H, Pruzanski W. Plasma cell neoplasia with peripheral polyneuropathy. A study of five cases and a review of the literature. *Medicine* 1980;59(4):301-310.
1023. Bardwick PA, Zvaifler NJ, Gill GN, Newman D, Greenway GD, Resnick DL. Plasma cell dyscrasia with polyneuropathy, organomegaly, endocrinopathy, M protein, and skin changes: the POEMS syndrome. Report on two cases and a review of the literature. *Medicine* 1980;59(4):311-322.
1024. Dispenzieri A, Kyle RA, Lacy MQ, et al. POEMS syndrome: definitions and long-term outcome. *Blood* 2003;101(7):2496-2506.

1025. Zangari M, Barlogie B, Anaissie E, et al. Deep vein thrombosis in patients with multiple myeloma treated with thalidomide and chemotherapy: effects of prophylactic and therapeutic anticoagulation. *Br J Haematol* 2004;126(5):715-721.
1026. Baz R, Li L, Kottke-Marchant K, et al. The role of aspirin in the prevention of thrombotic complications of thalidomide and anthracycline-based chemotherapy for multiple myeloma. *Mayo Clin Proc* 2005;80(12):1568-1574.
1027. Rajkumar SV, Blood E. Lenalidomide and venous thrombosis in multiple myeloma. *N Engl J Med* 2006;354(19):2079-2080.
1028. Knight R, DeLap RJ, Zeldis JB. Lenalidomide and venous thrombosis in multiple myeloma. *N Engl J Med* 2006;354(19):2079-2080.
1029. Palumbo A, Cavo M, Bringhen S, et al. Aspirin, warfarin, or enoxaparin thromboprophylaxis in patients with multiple myeloma treated with thalidomide: a phase III, open-label, randomized trial. *J Clin Oncol* 2011;29(8):986-993.
1030. Larocca A, Cavallo F, Bringhen S, et al. Aspirin or enoxaparin thromboprophylaxis for patients with newly diagnosed multiple myeloma treated with lenalidomide. *Blood* 2012;119(4):933-939; quiz 1093.
1031. Abe M, Hiura K, Wilde J, et al. Osteoclasts enhance myeloma cell growth and survival via cell-cell contact: a vicious cycle between bone destruction and myeloma expansion. *Blood* 2004;104(8):2484-2491.
1032. Stewart JP, Shaughnessy JD Jr. Role of osteoblast suppression in multiple myeloma. *J Cell Biochem* 2006;98(1):1-13.
1033. Terpos E, Politou M, Szydlo R, Goldman JM, Apperley JF, Rahemtulla A. Serum levels of macrophage inflammatory protein-1 alpha (MIP-1alpha) correlate with the extent of bone disease and survival in patients with multiple myeloma. *Br J Haematol* 2003;123(1):106-109.
1034. Morgan GJ, Davies FE, Gregory WM, et al. First-line treatment with zoledronic acid as compared with clodronic acid in multiple myeloma (MRC Myeloma IX): a randomised controlled trial. *Lancet* 2010;376(9757):1989-1999.
1035. Berenson JR, Lichtenstein A, Porter L, et al. Efficacy of pamidronate in reducing skeletal events in patients with advanced multiple myeloma. Myeloma Aredia Study Group. *N Engl J Med* 1996;334(8):488-493.
1036. Berenson JR, Lichtenstein A, Porter L, et al. Long-term pamidronate treatment of advanced multiple myeloma patients reduces skeletal events. Myeloma Aredia Study Group. *J Clin Oncol* 1998;16(2):593-602.
1037. Berenson JR, Rosen LS, Howell A, et al. Zoledronic acid reduces skeletal-related events in patients with osteolytic metastases. *Cancer* 2001;91(7):1191-1200.
1038. Rosen LS, Gordon D, Antonio BS, et al. Zoledronic acid versus pamidronate in the treatment of skeletal metastases in patients with breast cancer or osteolytic lesions of multiple myeloma: a phase III, double-blind, comparative trial. *Cancer J* 2001;7(5):377-387.
1039. Berenson JR, Hillner BE, Kyle RA, et al. American Society of Clinical Oncology clinical practice guidelines: the role of bisphosphonates in multiple myeloma. *J Clin Oncol* 2002;20(17):3719-3736.
1040. Marx RE, Sawatari Y, Fortin M, Broumand V. Bisphosphonate-induced exposed bone (osteonecrosis/osteopetrosis) of the jaws: risk factors, recognition, prevention, and treatment. *J Oral Maxillofac Surg* 2005;63(11):1567-1575.
1041. Carter GD, Goss AN. Bisphosphonates and avascular necrosis of the jaws. *Aust Dent J* 2003;48(4):268.
1042. Lugassy G, Shaham R, Nemets A, Ben-Dor D, Nahlieli O. Severe osteomyelitis of the jaw in long-term survivors of multiple myeloma: a new clinical entity. *Am J Med* 2004;117(6):440-441.
1043. Migliorati CA. Bisphosphonates and oral cavity avascular bone necrosis. *J Clin Oncol* 2003;21(22):4253-4254.
1044. Tarassoff P, Csermak K. Avascular necrosis of the jaws: risk factors in metastatic cancer patients. *J Oral Maxillofac Surg* 2003;61(10):1238-1239.
1045. Ruggiero SL, Mehrotra B, Rosenberg TJ, Engroff SL. Osteonecrosis of the jaws associated with the use of bisphosphonates: a review of 63 cases. *J Oral Maxillofac Surg* 2004;62(5):527-534.
1046. Bagan JV, Murillo J, Jimenez Y, et al. Avascular jaw osteonecrosis in association with cancer chemotherapy: series of 10 cases. *J Oral Pathol Med* 2005;34(2):120-123.
1047. Bamias A, Kastiritis E, Bamia C, et al. Osteonecrosis of the jaw in cancer after treatment with bisphosphonates: incidence and risk factors. *J Clin Oncol* 2005;23(34):8580-8587.

1048. Durie BG, Katz M, Crowley J. Osteonecrosis of the jaw and bisphosphonates. *N Engl J Med* 2005;353(1):99-102; discussion 199-102.
1049. Badros A, Weikel D, Salama A, et al. Osteonecrosis of the jaw in multiple myeloma patients: clinical features and risk factors. *J Clin Oncol* 2006;24(6):945-952.
1050. Kanat O, Ozet A, Ataergin S, et al. Bisphosphonate treatment as a cause of jaw osteonecrosis. *Oral Dis* 2007;13(3):346-347.
1051. Migliorati CA, Casiglia J, Epstein J, Jacobsen PL, Siegel MA, Woo SB. Managing the care of patients with bisphosphonate-associated osteonecrosis: an American Academy of Oral Medicine position paper. *J Am Dent Assoc* 2005;136(12):1658-1668.
1052. Lacy MQ, Dispenzieri A, Gertz MA, et al. Mayo clinic consensus statement for the use of bisphosphonates in multiple myeloma. *Mayo Clin Proc* 2006;81(8):1047-1053.
1053. Corso A, Varettoni M, Zappasodi P, et al. A different schedule of zoledronic acid can reduce the risk of the osteonecrosis of the jaw in patients with multiple myeloma. *Leukemia* 2007;21(7):1545-1548.
1054. Iuliano F, Abruzzese E, Molica S, et al. Samarium(Sm)153 ethylene diamine tetramethylene phosphonate (Sm-153-EDTMP) targeted radiotherapy and zoledronic acid is an effective option for elderly with symptomatic refractory multiple myeloma. *Blood* 2003;102(11):446a-447a.
1055. Berenson JR, Yellin O, Patel R, et al. A phase I study of samarium lexidronam/bortezomib combination therapy for the treatment of relapsed or refractory multiple myeloma. *Clin Cancer Res* 2009;15(3):1069-1075.
1056. Body JJ, Greipp P, Coleman RE, et al. A phase I study of AMG-0007, a recombinant osteoprotegerin construct, in patients with multiple myeloma or breast carcinoma related bone metastases. *Cancer* 2003;97(3 Suppl):887-892.
1057. Henry DH, Costa L, Goldwasser F, et al. Randomized, double-blind study of denosumab versus zoledronic acid in the treatment of bone metastases in patients with advanced cancer (excluding breast and prostate cancer) or multiple myeloma. *J Clin Oncol* 2011;29(9):1125-1132.
1058. Terpos E, Palermos J, Tsionos K, et al. Effect of pamidronate administration on markers of bone turnover and disease activity in multiple myeloma. *Eur J Haematol* 2000;65(5):331-336.
1059. Abildgaard N, Glerup H, Rungby J, et al. Biochemical markers of bone metabolism reflect osteoclastic and osteoblastic activity in multiple myeloma. *Eur J Haematol* 2000;64(2):121-129.
1060. Mirels H. Metastatic disease in long bones. A proposed scoring system for diagnosing impending pathologic fractures. *Clin Orthop* 1989(249): 256-264.
1061. McBroom RJ, Cheal EJ, Hayes WC. Strength reductions from metastatic cortical defects in long bones. *J Orthop Res* 1988;6(3):369-378.
1062. Gainor BJ, Buchert P. Fracture healing in metastatic bone disease. *Clin Orthop* 1983(178):297-302.
1063. Allen KL, Johnson TW, Hibbs GG. Effective bone palliation as related to various treatment regimens. *Cancer* 1976;37(2):984-987.
1064. Tong D, Gillick L, Hendrickson FR. The palliation of symptomatic osseous metastases: final results of the study by the radiation therapy oncology group. *Cancer* 1982;50(5):893-899.
1065. Levine SA, Perin LA, Hayes D, Hayes WS. An evidence-based evaluation of percutaneous vertebroplasty. *Manag Care* 2000;9(3):56-60,63.
1066. Pflugmacher R, Kandziora F, Schroeder RJ, Melcher I, Haas NP, Klostermann CK. Percutaneous balloon kyphoplasty in the treatment of pathological vertebral body fracture and deformity in multiple myeloma: a one-year follow-up. *Acta Radiol* 2006;47(4):369-376.
1067. Berenson J, Pflugmacher R, Jarzem P, et al. Balloon kyphoplasty versus non-surgical fracture management for treatment of painful vertebral body compression fractures in patients with cancer: a multicentre, randomised controlled trial. *Lancet Oncol* 2011;12(3):225-235.
1068. Benson WJ, Scarffe JH, Todd ID, Palmer M, Crowther D. Spinal-cord compression in myeloma. *Br Med J* 1979;1(6177):1541-1544.

1069. Gilbert RW, Kim JH, Posner JB. Epidural spinal cord compression from metastatic tumor: diagnosis and treatment. *Ann Neurol* 1978;3(1):40-51.
1070. Young RF, Post EM, King GA. Treatment of spinal epidural metastases. Randomized prospective comparison of laminectomy and radiotherapy. *J Neurosurg* 1980;53(6):741-748.
1071. Greenberg HS, Kim JH, Posner JB. Epidural spinal cord compression from metastatic tumor: results with a new treatment protocol. *Ann Neurol* 1980;8(4):361-366.
1072. Sorensen S, Helweg-Larsen S, Mouridsen H, Hansen HH. Effect of high-dose dexamethasone in carcinomatous metastatic spinal cord compression treated with radiotherapy: a randomised trial. *Eur J Cancer* 1994;1:22-27.
1073. Vecht CJ, Haaxma-Reiche H, van Putten WL, de Visser M, Vries EP, Twijnstra A. Initial bolus of conventional versus high-dose dexamethasone in metastatic spinal cord compression. *Neurology* 1989;39(9):1255-1257.
1074. Gucalp R, Theriault R, Gill I, et al. Treatment of cancer-associated hypercalcemia. Double-blind comparison of rapid and slow intravenous infusion regimens of pamidronate disodium and saline alone. *Arch Intern Med* 1994;154(17):1935-1944.
1075. Mundy GR, Wilkinson R, Heath DA. Comparative study of available medical therapy for hypercalcemia of malignancy. *Am J Med* 1983;74(3):421-432.
1076. Warrell RP Jr, Israel R, Frisone M, Snyder T, Gaynor JJ, Bockman RS. Gallium nitrate for acute treatment of cancer-related hypercalcemia. A randomized, double-blind comparison to calcitonin. *Ann Intern Med* 1988;108(5):669-674.
1077. Garton JP, Gertz MA, Witzig TE, et al. Epoetin alfa for the treatment of the anemia of multiple myeloma. A prospective, randomized, placebo-controlled, double-blind trial. *Arch Intern Med* 1995;155(19):2069-2074.
1078. Dammacco F, Castoldi G, Rodjer S. Efficacy of epoetin alfa in the treatment of anaemia of multiple myeloma. *Br J Haematol* 2001;113(1):172-179.
1079. Cuzick J, Erskine S, Edelman D, Galton DA. A comparison of the incidence of the myelodysplastic syndrome and acute myeloid leukaemia following melphalan and cyclophosphamide treatment for myelomatosis. A report to the Medical Research Council's working party on leukaemia in adults. *Br J Cancer* 1987;55(5):523-529.
1080. Acute leukaemia and other secondary neoplasms in patients treated with conventional chemotherapy for multiple myeloma: a Finnish Leukaemia Group study. *Eur J Haematol* 2000;65(2):123-127.
1081. Bergsagel DE. Chemotherapy of myeloma: drug combinations versus single agents, an overview, and comments on acute leukemia in myeloma. *Hematol Oncol* 1988;6(2):159-166.
1082. West WO. Acute erythroid leukemia after cyclophosphamide therapy for multiple myeloma: report of two cases. *South Med J* 1976;69(10): 1331-1332.
1083. Greene MH, Harris EL, Gershenson DM, et al. Melphalan may be a more potent leukemogen than cyclophosphamide. *Ann Intern Med* 1986;105(3): 360-367.
1084. Cleary B, Binder RA, Kales AN, Veltri BJ. Simultaneous presentation of acute myelomonocytic leukemia and multiple myeloma. *Cancer* 1978;41(4):1381-1386.
1085. Rosner F, Grunwald H. Multiple myeloma terminating in acute leukemia. Report of 12 cases and review of the literature. *Am J Med* 1974;57(6): 927-939.
1086. Govindarajan R, Jagannath S, Flick JT, et al. Preceding standard therapy is the likely cause of MDS after autotransplants for multiple myeloma. *Br J Haematol* 1996;95(2):349-353.
1087. Wintrobe M, Buell M. Hyperproteinemia associated with multiple myeloma. *Bull Johns Hopkins Hosp* 1933;52:156.
1088. Siami GA, Siami FS. Plasmapheresis and paraproteinemia: cryoproteininduced diseases, monoclonal gammopathy, Waldenstrom's macroglobulinemia, hyperviscosity syndrome, multiple myeloma, light chain disease, and amyloidosis. *Ther Apher* 1999;3(1):8-19.
1089. Smolens P, Venkatachalam M, Stein JH. Myeloma kidney cast nephropathy in a rat model of multiple myeloma. *Kidney Int* 1983;24(2):192-204.
1090. Johnson WJ, Kyle RA, Pineda AA, O'Brien PC, Holley KE. Treatment of renal failure associated with multiple myeloma. Plasmapheresis, hemodialysis, and chemotherapy. *Arch Intern Med* 1990;150(4):863-869.

1091. Zucchelli P, Pasquali S, Cagnoli L, Ferrari G. Controlled plasma exchange trial in acute renal failure due to multiple myeloma. *Kidney Int* 1988;33(6):1175-1180.
1092. Clark AD, Shetty A, Soutar R. Renal failure and multiple myeloma: pathogenesis and treatment of renal failure and management of underlying myeloma. [Review] [116 refs]. *Blood Rev* 1999;13(2):79-90.
1093. Jacobson DR, Zolla-Pazner S. Immunosuppression and infection in multiple myeloma. *Semin Oncol* 1986;13(3):282-290.
1094. Paradisi F, Corti G, Cinelli R. Infections in multiple myeloma. *Infect Dis Clin North Am*. 2001;15(2):373-384,vii-viii.
1095. Meyers BR, Hirschman SZ, Axelrod JA. Current patterns of infection in multiple myeloma. *Am J Med* 1972;52(1):87-92.
1096. Shaikh BS, Lombard RM, Appelbaum PC, Bentz MS. Changing patterns of infections in patients with multiple myeloma. *Oncology* 1982;39(2):78-82.
1097. Doughney KB, Williams DM, Penn RL. Multiple myeloma: infectious complications. *South Med J* 1988;81(7):855-858.
1098. Rayner HC, Haynes AP, Thompson JR, Russell N, Fletcher J. Perspectives in multiple myeloma: survival, prognostic factors and disease complications in a single centre between 1975 and 1988. *Q J Med* 1991;79(290):517-525.
1099. Lazarus HM, Lederman M, Lubin A, et al. Pneumococcal vaccination: the response of patients with multiple myeloma. *Am J Med* 1980;69(3):419-423.
1100. Landesman SH, Schiffman G. Assessment of the antibody response to pneumococcal vaccine in high- risk populations. *Rev Infect Dis* 1981;3(Suppl): S184-S197.
1101. Butler JC, Breiman RF, Campbell JF, Lipman HB, Broome CV, Facklam RR. Pneumococcal polysaccharide vaccine efficacy. An evaluation of current recommendations. *Jama* 1993;270(15):1826-1831.
1102. Chapel HM, Lee M, Hargreaves R, Pamphilon DH, Prentice AG. Randomised trial of intravenous immunoglobulin as prophylaxis against infection in plateau-phase multiple myeloma. The UK Group for Immunoglobulin Replacement Therapy in Multiple Myeloma. *Lancet* 1994;343(8905): 1059-1063.
1103. Oken MM, Pomeroy C, Weisdorf D, Bennett JM. Prophylactic antibiotics for the prevention of early infection in multiple myeloma. *Am J Med* 1996;100(6):624-628.
1104. Vesole DH, Oken MM, Heckler C, et al. Oral antibiotic prophylaxis of early infection in multiple myeloma: a URCC/ECOG randomized phase III study. *Leukemia* 2012.
1105. Heilman RL, Velosa JA, Holley KE, Offord KP, Kyle RA. Long-term follow-up and response to chemotherapy in patients with light- chain deposition disease. *Am J Kidney Dis* 1992;20(1):34-41.
1106. Garcia-Sanz R, Montoto S, Torreguadrada A, et al. Waldenstrom macroglobulinaemia: presenting features and outcome in a series with 217 cases. *Br J Haematol* 2001;115(3):575-582.
1107. Conklin R, Alexanian R. Clinical classification of plasma cell myeloma. *Arch Intern Med* 1975;135(1):139-143.
1108. Knowling MA, Harwood AR, Bergsagel DE. Comparison of extramedullary plasmacytomas with solitary and multiple plasma cell tumors of bone. *J Clin Oncol* 1983;1(4):255-262.
1109. Dimopoulos MA, Moulopoulos LA, Maniatis A, Alexanian R. Solitary plasmacytoma of bone and asymptomatic multiple myeloma. *Blood* 2000;96(6):2037-2044.
1110. Woodruff RK, Malpas JS, White FE. Solitary plasmacytoma. II: solitary plasmacytoma of bone. *Cancer* 1979;43(6):2344-2347.
1111. Ozsahin M, Tsang RW, Poortmans P, et al. Outcomes and patterns of failure in solitary plasmacytoma: a multicenter rare cancer network study of 258 patients. *Int J Radiat Oncol Biol Phys* 2006;64(1):210-217.
1112. Bataille R, Sany J. Solitary myeloma: clinical and prognostic features of a review of 114 cases. *Cancer* 1981;48(3):845-851.
1113. Mill WB, Griffith R. The role of radiation therapy in the management of plasma cell tumors. *Cancer* 1980;45(4):647-652.
1114. Liebross RH, Ha CS, Cox JD, Weber D, Delasalle K, Alexanian R. Solitary bone plasmacytoma: outcome and prognostic factors following radiotherapy. *Int J Radiat Oncol Biol Phys* 1998;41(5):1063-1067.

1115. Warsame R, Gertz MA, Lacy MQ, et al. Trends and outcomes of modern staging of solitary plasmacytoma of bone. *Am J Hematol* 2012;87(7): 647-651.
1116. Dingli D, Kyle RA, Rajkumar SV, et al. Immunoglobulin free light chains and solitary plasmacytoma of bone. *Blood* 2006;108(6):1979-1983.
1117. Bolek TW, Marcus RB, Mendenhall NP. Solitary plasmacytoma of bone and soft tissue. *Int J Radiat Oncol Biol Phys* 1996;36(2):329-333.
1118. Dimopoulos MA, Kiamouris C, Mouloupoulos LA. Solitary plasmacytoma of bone and extramedullary plasmacytoma. *Hematol Oncol Clin North Am* 1999;13(6):1249-1257.
1119. Galienu P, Cavo M, Pulsoni A, et al. Clinical outcome of extramedullary plasmacytoma. *Haematologica* 2000;85(1):47-51.
1120. Hussong JW, Perkins SL, Schnitzer B, Hargreaves H, Frizzera G. Extramedullary plasmacytoma. A form of marginal zone cell lymphoma? *Am J Clin Pathol* 1999;111(1):111-116.
1121. Mayr NA, Wen BC, Hussey DH, et al. The role of radiation therapy in the treatment of solitary plasmacytomas. *Radiother Oncol* 1990;17(4):293-303.
1122. Brinch L, Hannisdal E, Abrahamsen AF, Kvaloy S, Langholm R. Extramedullary plasmacytomas and solitary plasma cell tumours of bone. *Eur J Haematol* 1990;44(2):132-135.
1123. Shih LY, Dunn P, Leung WM, Chen WJ, Wang PN. Localised plasmacytomas in Taiwan: comparison between extramedullary plasmacytoma and solitary plasmacytoma of bone. *Br J Cancer* 1995;71(1):128-133.
1124. Woodruff RK, Whittle JM, Malpas JS. Solitary plasmacytoma. I: extramedullary soft tissue plasmacytoma. *Cancer* 1979;43(6):2340-2343.
1125. Corwin J, Lindberg RD. Solitary plasmacytoma of bone vs. extramedullary plasmacytoma and their relationship to multiple myeloma. *Cancer* 1979;43(3):1007-1013.
1126. Holland J, Trenkner DA, Wasserman TH, Fineberg B. Plasmacytoma. Treatment results and conversion to myeloma. *Cancer* 1992;69(6): 1513-1517.

Chapter 99 Immunoglobulin Light-Chain Amyloidosis (Primary Amyloidosis)

> Table of Contents > Part VII - Hematologic Malignancies > Section 5 - Plasma Cell Dyscrasias > Chapter 99 - Immunoglobulin Light-Chain Amyloidosis (Primary Amyloidosis)

Chapter 99

Immunoglobulin Light-Chain Amyloidosis (Primary Amyloidosis)

Morie A. Gertz

Martha Q. Lacy

Angela Dispenzieri

Steven R. Zeldenrust

HISTORY

The term lardaceous change has ... come more into use chiefly through the instrumentality of the Vienna School.... The term, lardaceous changes ... has but very little to do with these tumours, and rather refers to things, upon which the old writers ... who were better connoisseurs in bacon than our friends in Vienna, would hardly have bestowed such a name.... The appearance of such organs ... are said to look like bacon, bears ... a much greater resemblance to wax, and I have therefore now for a long time ... made use of the term waxy change.... These structures ... by the simple action of iodine ... assume just as blue a colour as vegetable starch....¹

Schleiden, a German botanist, first used the term amyloid in 1838 to describe a normal constituent of plants.^{2, 3, 4} In 1858, Virchow, head of a pathology department in Berlin, gave a lecture entitled "Amyloid Degeneration" and described amyloid deposits that stained blue with iodine and sulfuric acid, similar to the chemical reaction markers of starch. Virchow

concluded that the substance was composed of starch⁵ and used the word amyloid to describe it.⁶ During the lecture, Virchow also criticized his chief competitor in Vienna, Rokitansky, who believed that amyloid was a lardlike substance—perhaps because amyloid deposits were white and glistening—found in patients with syphilis, tuberculosis, or malaria.⁷ In 1859, Friedreich, Nikolau, and Kekule recognized that the waxy spleen described by Virchow did not contain any starchlike substances and that the deposits probably were derived from modified proteins.⁸ Kekule was famous in his own right at the time for describing the structure of benzene from his dream of a serpent biting its own tail. In addition, Friedreich gave the first description of a form of ataxia that now bears his name.^{9, 10}

Budd analyzed the liver of a patient with amyloidosis and found that it was not lardaceous¹¹; he also wrote original descriptions of rickets and scurvy.¹² Probably the first reported case of primary amyloidosis (AL; described as “idiopathic” at the time) was identified by Wilks, who detailed a 52-year-old patient with lardaceous change unrelated to an obvious cause.^{13, 14, 15} Wilks was the first physician to use bromide in the treatment of epilepsy and wrote an original description of myasthenia gravis.

The amino acid composition of amyloid deposits was first described by Schmiedeberg in 1920.¹⁶ Amyloid proteins strongly resembled serum globulin and therefore were neither fat nor carbohydrate. The first use of Congo red as the specific stain for detection of amyloid was reported in 1922 by Bennhold.¹⁷ In 1927, Divry and Florkin¹⁸ reported green birefringence under polarized light when amyloid-laden material from the brain of a patient with Alzheimer disease was stained with Congo red. However, the association between the neurodegeneration of Alzheimer disease and amyloid was forgotten for nearly 50 years. Magnus-Levy¹⁹ postulated that Bence Jones proteins were a precursor of the amyloid substance and noted a relationship among amyloid deposits, Bence Jones proteins, and multiple myeloma.

The finding that amyloid proteins consisted of fibrils was credited to Cohen and Calkins in 1959.⁵ They determined that all forms of amyloid were nonbranching and fibrillar. The fibril length varied, but the width was 9.5 nm. Apitz²⁰ claimed that amyloid in the tissues was analogous to the excretion of immunoglobulin (Ig) light-chain proteins by the kidneys; he coined the term paraprotein to describe monoclonal immunoglobulins. Isobe and Osserman²¹ reported in 1974 that Bence Jones proteins had a direct role in the pathogenesis of AL. Physiologically normal proteins primarily have an α -helix configuration. In 1968, Eanes and Glenner²² reported that they used x-ray diffraction to determine that amyloid proteins formed an alternate configuration of β -pleated sheets, similar to the configuration of silk proteins.²³

As with silk, amyloid proteins are highly resistant to solvents, and this resistance is a feature of the purification process. Amyloid-laden tissue is homogenized repeatedly in saline and centrifuged. The supernatant, which contains soluble components, is discarded, and the residual pelletized material contains amyloid proteins. After the pellet is resuspended in distilled water, a relatively pure preparation of amyloid fibrils is obtained. Pras et al.²⁴ first described the purification of amyloid in 1968. Levin et al.²⁵ were the first to sequence amyloid protein, and they designated it as amyloid A. Benditt et al.^{26, 27} independently sequenced amyloid A at the same time. The first sequence of an immunoglobulin light-chain form of amyloid was reported in 1970 by Glenner et al.²⁸ and was recognized as an N-terminal fragment of the immunoglobulin light chain.^{28, 29, 30, 31, 32}

CLASSIFICATION

The diagnosis of amyloidosis requires biopsy tissue specimens with deposits that are positively stained by Congo red.³³ With hematoxylin and eosin staining, amyloid deposits resemble hyalin. Deposits are always extracellular and appear amorphous. Apple-green birefringence is seen when Congo-red-stained material is viewed under polarized light.³⁴ The Congo red stain can be technically difficult to use and can form precipitates, yielding false-positive results.³⁵ Pathologists need to perform diagnostic assays regularly to be experts in the interpretation of stains. All forms of amyloid have a fibrillar appearance when viewed with electron microscopy, and the fibrils are rigid and nonbranching. However, not all fibrils identified with electron microscopy are amyloid proteins.^{36, 37, 38} Such findings are strongly suggestive of amyloidosis, but in the absence of a positive result on Congo red stain and apple-green birefringence, the diagnosis remains unconfirmed. Studies of recombinant-derived variable region fragments of immunoglobulins have shown a relationship between thermodynamic instability and fibrillogenic potential. Structural parameters and overall thermodynamic stability contribute to the fibril-forming propensity.³⁹ Human monoclonal immunoglobulin light chains can be converted to amyloid fibrils *in vitro* by digestion with pepsin.³⁰ Synthetically, amyloid fibrils can be produced by breaking the disulfide bonds of intact immunoglobulins. In the past, all forms of amyloid were thought to be derived from misfolded fragments of immunoglobulin light chains, but heavy-chain fragments have also been shown to produce amyloid (designated as AH).⁴⁰

The classification scheme of amyloidosis has undergone revision as understanding of the pathophysiology of the disease has improved. In the 19th century, involvement of the liver, spleen, and kidneys was incorrectly thought to represent

secondary amyloidosis (AA); amyloid that involved the heart, tongue, and peripheral nerves was classified as AL or idiopathic amyloidosis. Later, amyloidosis was classified by the site of first deposition and was referred to as pericollagenous or perireticular amyloidosis.^{41, 42} Familial amyloidosis (AF) was recognized generally by the P.2099

presentation of progressive painful peripheral neuropathy with an autosomal dominant inheritance pattern.^{43, 44} Families with inherited renal amyloidosis were also described.^{45, 46} Mutations in transthyretin (TTR), apolipoprotein A1, fibrinogen A- α chain, lysozyme, leukocyte chemotactic factor 2 (LECT2),⁴⁷ and apolipoprotein A2 are associated with hereditary amyloidosis. TTR amyloidosis is the most common form of AF, and it is associated with peripheral neuropathy.⁴⁸

In the 19th century, when tuberculosis, leprosy, syphilis, and chronic infections were prevalent, patients with these infections often had concomitant AA. However, in the postantibiotic era, chronic inflammatory polyarthritis (e.g., ankylosing spondylitis, juvenile rheumatoid arthritis) is more commonly associated with AA. Crohn disease and chronic osteomyelitis have also been associated with a small number of AA patients in the Western hemisphere.⁴⁹ Hereditary periodic fever syndromes, such as familial Mediterranean fever (FMF; the most common entity of this disorder), hyperimmunoglobulinemia-D syndrome, and tumor necrosis factor (TNF) receptor-associated periodic syndrome (TRAPS), are characterized by recurrent fever and inflammation, and reactive amyloidosis is a complication of these hereditary periodic fevers. The causative genes of these syndromes have been identified. Anticytokine-based therapies are a new treatment option for these inflammatory conditions, and they potentially may prevent amyloidosis.⁵⁰ Etanercept, adalimumab, and infliximab have all been reported to be effective for patients with AA.

One hundred years ago, the term primary amyloidosis referred to idiopathic amyloidosis and included all cases that were neither familial nor secondary; cases of unrecognized AF and AA for which a cause could not be established were mistakenly classified as AL. Currently, AL refers only to systemic or localized amyloidosis that is immunoglobulin light chain derived. A clonal plasma cell disorder exists for all patients with systemic AL, and the disease spectrum ranges from a barely detectable plasma cell clone to overt multiple myeloma.⁵¹ A classification of the various forms of amyloidosis is shown in Table 99.1.

TABLE 99.1 NOMENCLATURE OF AMYLOIDOSIS

Protein	Precursor	Clinical
AL or AH	Immunoglobulin (light or heavy chain)	Primary or localized amyloidosis; associated with myeloma or macroglobulinemia
AA	SAA	Secondary or familial Mediterranean fever; familial periodic fever syndromes associated with mutated tumor necrosis factor receptor
ATTR (form of AF)	Transthyretin	Familial and senile amyloidosis
Fibrinogen A- α chain (form of AF)	Fibrinogen	Familial renal amyloidosis (Ostertag amyloidosis)
A β ₂ M	β ₂ -Microglobulin	Dialysis-associated carpal tunnel syndrome
A β	A β PP	Alzheimer disease
Apo1, Apo2 (form of AF)	Apolipoprotein	Renal, nephrotic syndrome
Lysozyme (form of AF)	Lysozyme	Renal, hepatic rupture
LECT2 (form of AF)	Leucocyte chemotactic factor 2	Renal autosomal dominant inheritance

AA, secondary amyloid; A β , amyloid β ; A β ₂M, amyloid β ₂-microglobulin; A β PP, amyloid β protein precursor; AF, inherited amyloid proteins; AH, immunoglobulin heavy-chain amyloid; AL, primary

amyloid; Apo1, apolipoprotein A1 amyloid; Apo2, apolipoprotein A2 amyloid; ATTR, amyloid transthyretin; LECT, leucocyte chemotactic factor; SAA, serum amyloid A.

In AL, the tertiary structure and amino acid sequence of immunoglobulin light chains are abnormal.^{52, 53} For patients with AL, three fourths of immunoglobulin light chains are of the λ type. In contrast, for patients with multiple myeloma and monoclonal gammopathy of undetermined significance, two thirds of the light chains are of the κ type (Fig. 99.1).⁴⁹ The implication is that λ immunoglobulin light chains have a greater tendency to form a β -pleated sheet. AL-associated immunoglobulins generally tend to have more β -pleated sheet proteins than α -helical proteins.

Certain immunoglobulins have "amyloidogenic" properties. No renal dysfunction is seen after mice are injected with purified immunoglobulin light chains derived from the urine of patients with multiple myeloma who do not have amyloidosis.⁵⁴ However, deposits of human AL develop in the kidneys of mice after injection of light chains purified from the urine of patients with AL.

Amyloid-associated germline gene usage has been determined.⁵⁵ The $\lambda 6$ subgroup of immunoglobulin light chains is always associated with amyloid proteins, which suggests that unique amino acid sequences may result in formation of amyloidogenic proteins.⁵⁶ The $\lambda 3$ family appears most frequently in amyloidosis and polyclonal states. Two germline genes that belong to the $\lambda 3$ and $\lambda 6$ families encode 42% of λ variable regions. The gene segment 3r accounts for 22% of λ variable regions and is newly associated with the disease; gene segment 6a accounts for 20%. These gene segments have a strong association with amyloidosis; they are represented in less than 11% of polyclonal conditions (Table 99.2). Overuse of 3r and 6a likely accounts for the λ light-chain overrepresentation that is typical of amyloidosis. Germline gene usage may also influence the organ tropism of AL.⁵⁷ Patients with clones derived from the 6a germline gene are more likely to present with dominant renal involvement. Those with clones from 1c, 2a2, and 3r are more likely to present with cardiac and multiorgan disease.⁵⁸

The distinction between AL and amyloidosis associated with multiple myeloma is somewhat arbitrary (considerable overlap exists between them). However, a patient with amyloidosis and symptomatic multiple myeloma (e.g., widespread lytic bone disease, rib fractures, and lumbar spine compression fractures) is uncommon.⁵⁹ Renal insufficiency in amyloidosis is almost never a consequence of the formation of light-chain cast nephropathy, as is the case in multiple myeloma. For patients with amyloidosis, renal failure is attributable to tubular atrophy, a

P.2100

consequence of long-term albuminuria.^{60, 61} Often, the distinction between multiple myeloma-associated amyloidosis and AL is made on the basis of the percentage of plasma cells in the bone marrow.⁶² For patients with AL, serial bone marrow biopsies performed over several years do not show a progressive increase in the plasma cell percentage. In amyloidosis, the process is clonal but typically is not proliferative, and the unrestrained growth associated with malignancy is absent. If it is not present at diagnosis, multiple myeloma does not develop subsequently in patients with AL who present with 10% to 30% bone marrow plasma cells; multiple myeloma develops in fewer than 0.5% of patients with amyloidosis.⁵¹ We have established an arbitrary threshold of 30% plasma cells to fulfill the criteria of multiple myeloma-associated amyloidosis if no other clinical features of multiple myeloma are present. For patients who have greater than 30% plasma cells in the bone marrow, the clinical course is dominated by AL and not by myeloma bone disease or myeloma-induced anemia.

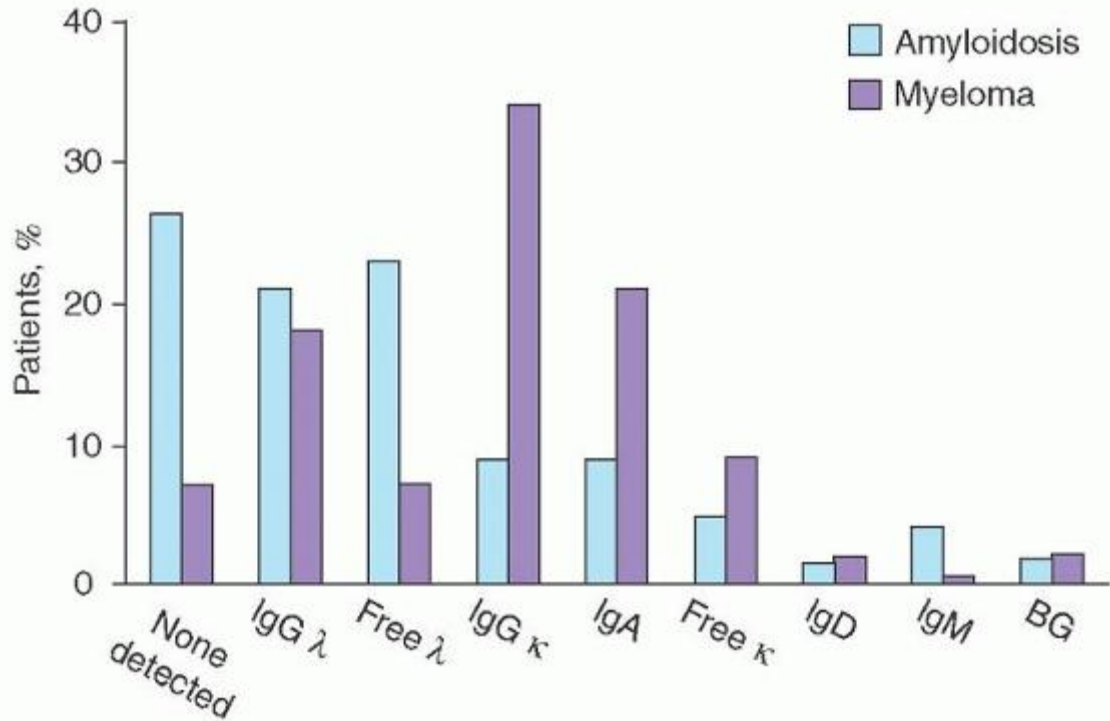

FIGURE 99.1. Distribution of serum monoclonal protein in patients with amyloidosis (N = 270) or myeloma (N = 1,000). The κ -to- λ ratio is 1:3.6. BG, biclonal gammopathy. Ig, immunoglobulin. (From Gertz MA, Lacy MQ, Dispenzieri A, et al. Transplantation for amyloidosis. *Curr Opin Oncol* 2007;19:136-141 with permission from Lippincott Williams & Wilkins.)

TABLE 99.2 LIGHT-CHAIN CLASS USAGE IN AMYLOIDOSIS

Light-chain Class	Study		
	Comenzo et al. ⁵⁷ (%)	Perfetti et al. ^{55, a} (%)	Abraham et al. ⁵⁸ (%)
λ_1	31	15	22
λ_2	14	16	34
λ_3	17	47	28
λ_6	38	20	16

^aFor polyclonal conditions, λ_1 usage is 25%, λ_2 usage is 24%, and λ_3 usage is 43%. Data from Perfetti V, Casarini S, Palladini G, et al. Analysis of $V\lambda$ -J λ expression in plasma cells from primary (AL) amyloidosis and normal bone marrow identified 3 r (λ III) as a new amyloid-associated germline gene segment. *Blood* 2002;100:948-953; Comenzo RL, Zhang Y, Martinez C, et al. The tropism of organ involvement in primary systemic amyloidosis: contributions of Ig V(L) germ line use and clonal plasma cell burden. *Blood* 2001;98:714-720; Abraham RS, Geyer SM, Price-Troska TL, et al. Immunoglobulin light chain variable (V) region genes influence clinical presentation and outcome in light chain-associated amyloidosis (AL). *Blood* 2003;101:3801-3808. Epub 2002 Dec 19.

The incidence of AL is eight per million per year and has been stable for more than 50 years.⁶³ Multiple myeloma is five times more prevalent than amyloidosis.⁶⁴ Amyloidosis is uncommon; its incidence is similar to that of Hodgkin lymphoma (nodular sclerosing variant), chronic granulocytic leukemia (Philadelphia chromosome-positive), and polycythemia rubra vera.^{65, 66, 67} Bone marrow plasma cells from AL patients typically show chromosomal abnormalities.⁶⁸ Trisomies of chromosomes 7, 9, 11, 15, and 18 are seen in 42%, 52%, 47%, 39%, and 33% of patients with amyloidosis, respectively. Fifty-four percent of male patients and 13% of female patients have trisomy X, and 72% have deletions in chromosome 18. The finding of aneuploidy in monoclonal plasma cells is indicative of their neoplastic nature, despite the fact that these

plasma cells are nonproliferative and are present in small numbers (median, 5% plasma cells).⁶⁹ An early pathogenetic event in the development of multiple myeloma is translocation at the immunoglobulin heavy-chain locus (band 14q32).⁷⁰,⁷¹ A total of 16 of 29 patients with AL (55%) showed translocations at the immunoglobulin heavy-chain locus. An additional 17% showed a pattern compatible with a possible IgH translocation.⁷² Overall, an IgH translocation was seen in 21 of 29 patients by using fluorescent in situ hybridization analysis. Of the 21 patients, 16 had t(11;14)(q13;q32) translocations. For 15 of the 16 patients, cyclin D1 overexpression accounted for 76% of all IgH translocations.

SYMPTOMS AND SIGNS

Weight loss, paresthesia, edema, dyspnea, and fatigue are the most common symptoms of AL (Fig. 99.2).⁷³ These nonspecific complaints provide little help to a clinician evaluating patients. Patients with extreme weight loss frequently undergo evaluation for an occult malignancy. The fatigue, usually caused by early cardiac involvement with AL, generally is not associated with overt congestive heart failure and easily may be diagnosed incorrectly as stress-related or functional fatigue.⁷⁴ We have seen many patients undergo coronary angiography because of fatigue and breathlessness, only to have the evaluation end when angiogram findings are normal.⁷⁵

Light-headedness occurs frequently in amyloidosis, but this is a common and nonspecific complaint in the primary care setting. In AL, the cause of light-headedness is multifaceted.⁷⁶ Patients with nephrotic syndrome have dizziness because of hypoalbuminemia and marked intravascular volume contraction, which leads to orthostatic hypotension.⁷⁷ Patients with cardiac AL have a low end-diastolic volume (because of restriction to filling during diastole)⁷⁸ and low cardiac output, but a normal ejection fraction is maintained until late in the course of the disease. The echocardiographic finding of a normal ejection fraction may be highly misleading and may hinder recognition of cardiac involvement in AL. Patients may have orthostatic hypotension as a consequence of autonomic neuropathy. Syncope is not unusual.⁷⁹,⁸⁰

The physical findings of amyloidosis are specific and diagnostic; however, they are present in only 15% of patients and may easily be overlooked. Amyloid purpura is seen in only one of every six patients with AL (Fig. 99.3).⁸¹ Purpura may be periorbital but also may occur in the face, webbing of the neck, and upper chest. Purpura on the arms is not characteristic of AL, but petechial lesions on the eyelids should not be overlooked. The liver is palpable 5 cm below the right costal margin in only 10% of patients. Splenomegaly, if present, is usually of modest degree. Overall, any degree of hepatomegaly is present in one fifth of patients.⁸²

Macroglossia is the most specific finding of AL (Fig. 99.4). In our experience, enlargement of the tongue is never found in AF, AA, or senile systemic amyloidosis.⁸³ Tongue enlargement is seen in 1 of 11 patients with AL and may be overlooked easily unless the physician knows to look for dental indentations on the underside of the tongue. However, presentation with fatigue, edema, breathlessness, or paresthesias would not immediately lead the physician to examine the patient's tongue. Tongue enlargement is almost always accompanied by concomitant enlargement of the submandibular salivary glands,⁸⁴ but salivary gland involvement should not be

P.2101

misinterpreted as submandibular lymphadenopathy. Major and minor salivary gland involvement may result in sicca syndrome.⁸⁵

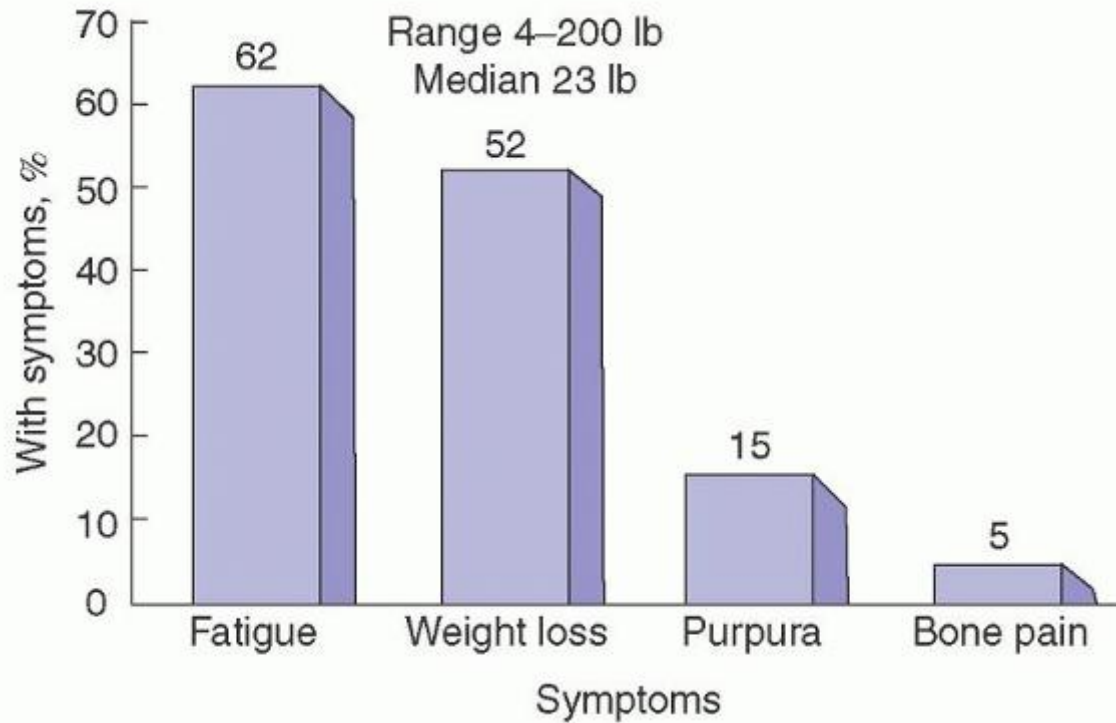

FIGURE 99.2. Prevalence of symptoms for patients with primary amyloidosis evaluated 1 month before or after diagnosis at Mayo Clinic, 1981-1992. (From Kyle RA, Gertz MA. Primary systemic amyloidosis. Clinical and laboratory features in 474 cases. *Semin Hematol* 1995;32:45-59. Used with permission.)

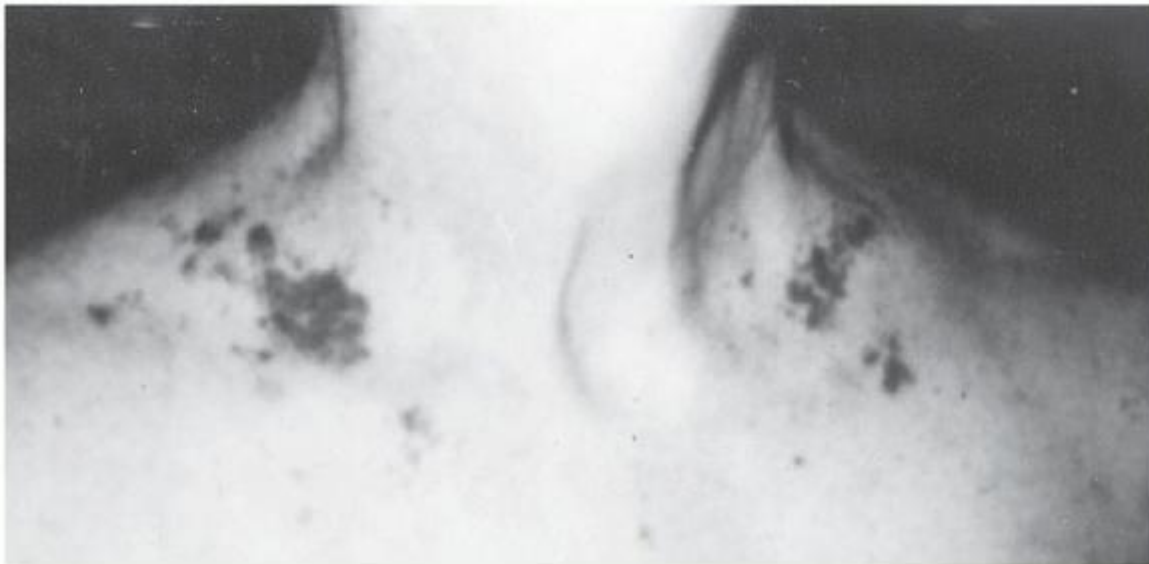

FIGURE 99.3. Classic truncal purpura in primary amyloidosis. (From Gertz MA, Lacy MQ, Dispenzieri A. Amyloidosis. *Hematol Oncol Clin North Am* 1999;13:1211-1233. Used with permission.)

Vascular involvement without visceral organ dysfunction produces occlusion and ischemic symptoms, such as jaw claudication, when the temporal arteries are involved⁸⁶; calf and limb claudication may occur when the microvasculature that supplies the extremities is involved.⁸⁷ Monoclonal protein in the serum may increase the sedimentation rate, and it is not unusual for amyloidosis and jaw claudication to be misdiagnosed as polymyalgia rheumatica.⁸⁸ Amyloid deposits may be found if a temporal artery biopsy is performed, but Congo red staining typically is not performed on such specimens.⁸⁷,⁸⁹ The shoulder-pad sign is a consequence of periarticular infiltration with amyloid and may produce pseudohypertrophy.

Although the musculature of the shoulder and hip girdle is enlarged, patients present with diffuse muscular weakness^{90, 91} and may have muscular atrophy because of chronic vascular occlusion.

DIAGNOSIS OF AMYLOIDOSIS

When should a clinician initiate a diagnostic algorithm to confirm the presence of AL? The symptoms and physical findings of AL generally are nonspecific and unhelpful to the clinician. Nevertheless, eight critical clinical syndromes commonly associated with amyloidosis should trigger screening: (1) gastrointestinal tract symptoms of pseudo-obstruction or steatorrhea, (2) tongue enlargement, (3) carpal tunnel syndrome, (4) hepatomegaly, (5) peripheral neuropathy, (6) nephrotic-range proteinuria, (7) infiltrative cardiomyopathy with restrictive hemodynamics, and (8) atypical multiple myeloma. The diagnosis of AL must be considered when any one of these syndromes is seen (Table 99.3). AL also must be considered for any patient for whom the diagnosis of multiple myeloma is being considered and who has associated, unexplained weight loss or fatigue or a percentage of plasma cells in the bone marrow that does not meet the criteria for multiple myeloma.



FIGURE 99.4. Tongue enlargement in primary amyloidosis. (From Gertz MA, Lacy MQ, Dispenzieri A. Amyloidosis. Hematol Oncol Clin North Am 1999;13:1211-1233. Used with permission.)

TABLE 99.3 SYNDROMES IN PRIMARY AMYLOIDOSIS

Syndrome	Patients (%)
Nephrotic or nephrotic and renal failure	30
Hepatomegaly	24
Congestive heart failure	22

Carpal tunnel syndrome	21
Neuropathy	17
Orthostatic hypotension	12

A clonal population of plasma cells is observed in AL patients, even when the marrow percentage is less than 2%.⁹² The insoluble, fibrillar β -pleated sheets of amyloid proteins are derived from the monoclonal immunoglobulin light chains produced by a clonal population of plasma cells. For any patient with a compatible clinical syndrome that includes monoclonal gammopathy, tests to confirm the diagnosis of AL should be pursued aggressively. Important screening tests for a patient with cardiomyopathy, neuropathy, hepatomegaly, or proteinuria are immunofixation of the serum and of the urine⁹³ and immunoglobulin free light-chain measurement.⁹⁴ The urine must be evaluated because serum assays may fail to detect monoclonal light chains (Fig. 99.5). Serum electrophoresis tests are inadequate because the light chains in AL are frequently present only in trace amounts and they do not produce a spike on an electrophoretic pattern. Monoclonal protein in the urine frequently is difficult to detect because most patients have proteinuria to the extent that small amounts of light chains are obscured (Fig. 99.6). If amyloidosis is being considered in the differential diagnosis, immunofixation of serum or urine (or both) is essential. The immunoglobulin free light-chain assay is tenfold more sensitive than serum immunofixation for the detection of serum light chains.⁹⁵ If all three tests are negative, systemic AL is not present.

For patients with a suggestive clinical syndrome, immunofixation is a good noninvasive screening test. For patients with light-chain levels in the serum or urine that are below the threshold of detection by immunofixation,⁹⁶ the bone marrow often shows a clonal population of plasma cells when examined by flow cytometry, immunofluorescence, or immunohistochemistry.^{97, 98} Such patients frequently have abnormal κ -to- λ ratios of free light chains. In patients with confirmed AL who did not have detectable levels of monoclonal protein in the serum or urine, 94% had a clonal population of plasma cells in the bone marrow when a slide-based immunofluorescence test was used to detect expression of clonal cytoplasmic immunoglobulin. If the patient does not have monoclonal protein in the serum or urine, has a normal free light-chain ratio, and has no detection of clonal population of plasma cells in the bone marrow, the diagnosis of systemic AL is very unlikely. If amyloidosis is present, it likely is not immunoglobulin light-chain derived, and further evaluation for familial, secondary, or localized amyloidosis should be performed.

P.2102

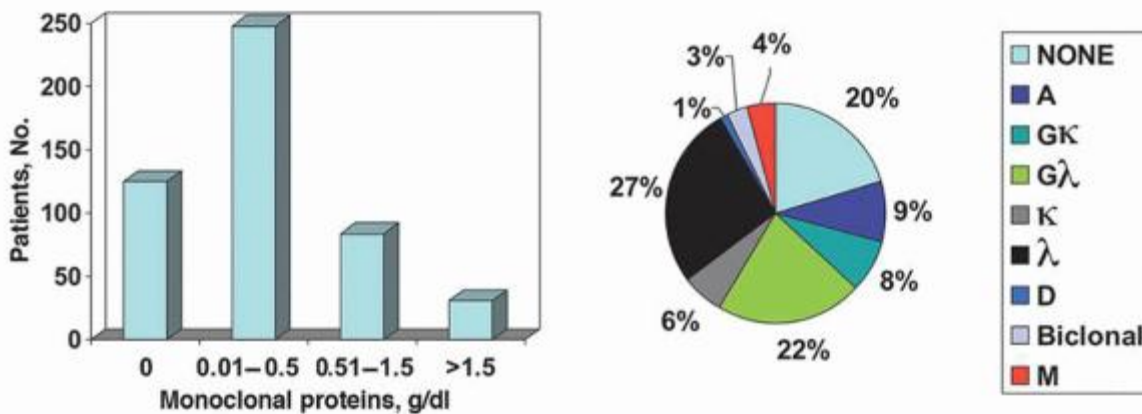

FIGURE 99.5. Serum monoclonal protein levels from patients with primary amyloidosis (N = 488). Inset, immunofixation results.

Our ability to recognize AL has been improved by the nephelometric assay for free light chains in the serum; the assay detects free immunoglobulin light chains that are not associated with an intact immunoglobulin molecule.^{99, 100} For 100 consecutive AL patients tested with the nephelometric assay, the assay sensitivity was 90% for patients with confirmed AL- κ , and similar sensitivity was noted for patients with confirmed AL- λ . For patients with detectable urinary light chains (but no detectable monoclonal protein in the serum with immunofixation assays), the nephelometric light-chain assay detected free light chains in the serum of 85% of patients with AL- κ and 80% of patients with AL- λ . For patients with AL

who had no monoclonal protein detected in the serum or urine with immunofixation assays, the nephelometric light-chain assay identified free κ light chains for 86% of patients with AL- κ and free λ light chains for 30% of patients with AL- λ . The free light-chain serum assay is convenient and adds an important diagnostic tool for classifying and monitoring AL patients.

All forms of amyloid deposits contain the amyloid P component, a pentagonal glycoprotein that may represent as much as 10% of the amyloid fibril by weight. It is structurally similar to C-reactive protein and has been identified in all vertebrates. However, it does not function as an acute-phase reactant in humans because the concentration in plasma is relatively stable.¹⁰¹ Amyloid P component maintains a dynamic circulating equilibrium between the serum and amyloid deposits. Because serum amyloid P (SAP) exchanges readily with the amyloid P component of amyloid fibrils, binding and release of SAP from amyloid deposits may be observed with an ¹²³I-labeled SAP scan.^{102, 103} In addition, the clearance rate of radiolabeled P components (¹²⁵I-labeled SAP) from the plasma may be used to assess the total-body burden of amyloid and to evaluate the effect of therapy.¹⁰⁴ Patients with large burdens of amyloid have rapid clearance, which is associated with shorter survival, but those with trace amounts of systemic amyloid deposits have plasma clearance rates similar to those of healthy individuals. Healthy adults have 50 to 100 mg of amyloid P component in the extravascular and intravascular compartments, whereas patients with amyloidosis may have up to 20,000 mg. Antibodies to P component have been used as therapy against amyloidosis.¹⁰⁵

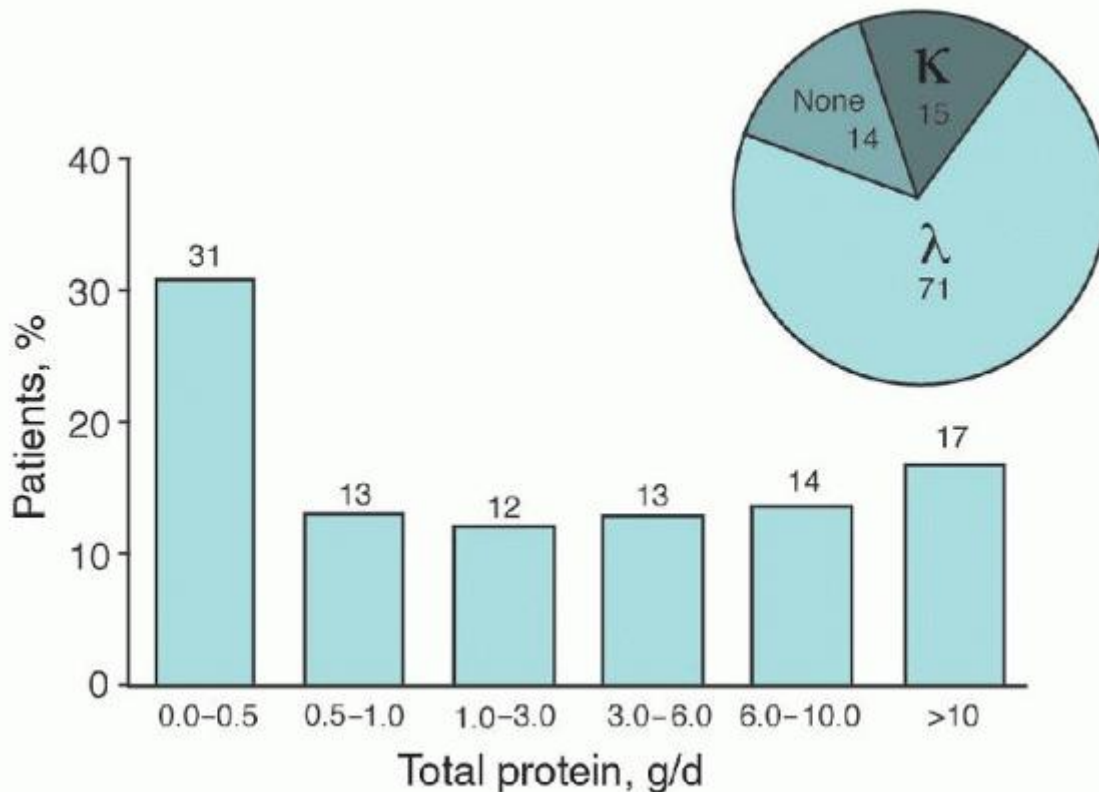

FIGURE 99.6. Total protein excreted in the urine of patients with primary amyloidosis (24-hour period). Inset, identification of immunoglobulin light chains, %. (From Gertz MA, Lacy MQ, Dispenzieri A. Amyloidosis. In: Mehta J, Singhal S, eds. Myeloma. London: Martin Dunitz, 2002:445-463. Used with permission.)

The P component scan may be performed serially to determine whether patients have increasing rates of amyloid deposition. However, the technique does not determine whether the amyloidosis is AL, AF, AA, or localized. Cardiac amyloid deposits are not detected through the use of SAP scans,¹⁰⁶ but uptake of ¹²³I-labeled amyloid P component is seen in the spleen, liver, and kidneys in 87%, 60%, and 25% of patients, respectively. Imaging does not consistently show deposits in the carpal tunnel, kidneys, and gastrointestinal tract. The correlation is poor between imaging and the extent of organ dysfunction assessed clinically.

The diagnostic sensitivity of SAP scintigraphy for systemic AA, AL, and amyloid TTR origin amyloidosis is 90%, 90%, and 48%, respectively; specificity is 93%. Splenic amyloid is observed in 80% of AL patients, even though it rarely is detected

clinically. Bone marrow uptake is specific for AL in 21% of patients. More widespread organ involvement is identified with a scan than with a clinical examination.¹⁰⁷ Amyloid is distributed heterogeneously within individual organs. Presently iodine-labeled SAP scanning was not available in the United States.

The diagnosis of amyloidosis must always be confirmed by tissue biopsy.¹⁰⁸ For patients who have neuropathy, nephrotic syndrome, cardiac failure, or hepatomegaly, the diagnosis could be established by direct biopsy of the involved organs,¹⁰⁸ but an invasive visceral biopsy usually is not required to confirm AL. Because amyloid deposits typically are widespread at diagnosis and have involved the vasculature extensively,¹⁰⁹ biopsy procedures that are less invasive, lower risk, and lower cost may be used to establish the diagnosis.

For a patient with a syndrome consistent with AL and confirmed presence of monoclonal protein, we begin the diagnostic evaluation with a subcutaneous fat aspirate and bone marrow biopsy.¹¹⁰ The subcutaneous fat aspirate is a 75%-sensitive, riskfree procedure that is performed by registered nurses.¹¹¹ Results are available within 24 hours (Fig. 99.7). Amyloid deposits are seen in half of the bone marrow biopsy specimens of patients with AL and generally are identified in blood vessels.¹¹² To exclude the diagnosis of multiple myeloma, a bone marrow biopsy is justified for any patient who has monoclonal immunoglobulin light chains. Knowledge of the percentage of bone marrow plasma cells is important prognostically.¹¹³ Table 99.4 shows the findings of bone marrow biopsies and fat aspirations of patients with AL. With Congo red studies of fat and bone marrow, the diagnosis is established in 87% of patients. For the other 13%, the diagnosis may be established by a biopsy of the affected organ.

Less invasive biopsy procedures may be used to establish a diagnosis of AL. Xerostomia in amyloidosis is attributable to salivary gland infiltration, and lip biopsy findings have high sensitivity (up to 87%).^{114, 115} Subcutaneous blood vessels may be accessed through a skin biopsy and may show AL deposits.^{116, 117} Amyloid deposits regularly were confirmed by rectal biopsy in the

P.2103

1970s and 1980s.¹¹⁸ Rectal biopsy is an outpatient procedure, although occasionally it results in bleeding. Endoscopic biopsy specimens frequently are inadequate because submucosa is essential for specimen adequacy.

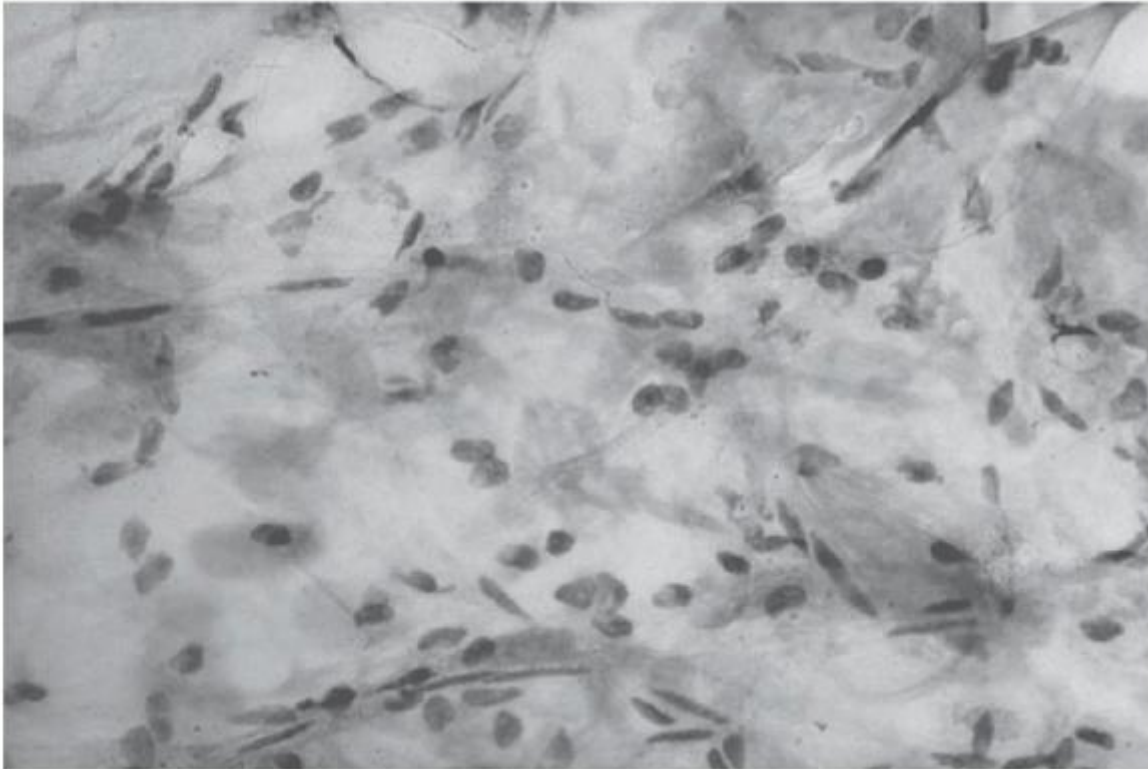

FIGURE 99.7. Subcutaneous fat aspirate showing amyloid deposits (congo red, original magnification $\times 100$). (Courtesy of Paul J. Kurtin, MD, Mayo Clinic, Rochester, Minnesota. Used with permission.)

All patients who have nephrotic syndrome should undergo screening with immunofixation assays of serum and urine and free light-chain assays. Among 110 patients with AL, the sensitivity of the free light-chain assay was 92%, but in combination with serum and urine immunofixation assay findings, the sensitivity increased to 99.1%.¹¹⁹ If either assay finding is positive, a fat aspiration is performed, which eliminates the need for a diagnostic renal biopsy for 70% of patients. The net result is reduced expense and reduced risk of bleeding and hospitalization.

Congo red may precipitate in tissue, and the resultant overstaining, particularly in subcutaneous fat, may produce a false-positive result.¹²⁰ Skin and subcutaneous fat have a high content of elastin and collagen; both bind Congo red and may also be interpreted as a false-positive result.¹²¹ Rectal biopsy specimens containing amyloid may be misinterpreted as collagenous colitis if stained only with hematoxylin and eosin.¹²² To recognize amyloid in the myocardium, our cardiac pathologists prefer to use sulfated Alcian blue stain.¹²³ The Peripheral Nerve Laboratory at Mayo Clinic stains sural nerve biopsy specimens with crystal violet during screening and confirms the diagnosis subsequently with Congo red.¹²⁴

DIFFERENTIATING AMYLOIDOSIS FROM OTHER FORMS OF AMYLOIDOSIS

It is important that the diagnosis of amyloidosis be confirmed as AL, AF, or AA because therapy for the three syndromes differs.^{125, 126} Localized amyloidosis,¹²⁷ AF,¹²⁸ AA,¹²⁹ and senile systemic forms of amyloidosis¹³⁰ are not associated with a plasma cell dyscrasia. Except for the rare case of a patient who has one of these forms of amyloidosis and an incidental monoclonal gammopathy of undetermined significance, only AL patients have monoclonal light chains in the serum and urine or clonal plasma cells in the marrow. Patients with localized amyloidosis may present with hematuria,¹³¹ respiratory difficulties,¹³² and visual disturbances¹³³; such symptoms may easily be confused with those of systemic amyloidosis. The localized amyloidosis syndrome, which usually involves the skin, tracheobronchial tree, or urogenital tract, never becomes systemic. The fibrils of localized amyloidosis may be immunoglobulin light-chain derived,¹³⁴ but clonal plasma cells are not seen in the bone marrow.

The site of amyloid deposition provides an important clue for recognizing localized amyloidosis. The most frequent sites of localized amyloid deposits are the respiratory tract, genitourinary tract, and skin.^{126, 135} Pulmonary amyloid may be subdivided into nodular, tracheobronchial, or diffuse interstitial deposits. Only the last type of deposit is a manifestation of systemic AL.¹³⁶ The diagnosis of tracheobronchial amyloidosis is made by bronchoscopy during evaluation of a patient with obstruction, cough, dyspnea, wheezing, or hemoptysis. The usual treatment is resection of the tissue with an yttrium-aluminum-garnet laser.¹³⁷ Tracheobronchial amyloid deposits are derived from immunoglobulin light chains.¹³⁸ Nodular amyloidosis presents as a solitary pulmonary nodule or multiple nodules, and the nodules do not indicate systemic AL.¹³⁹ Nodules are not calcified, and they often require resection to exclude a diagnosis of malignancy. The AL diagnosis is established during a thoracotomy or a video-assisted thoracoscopic surgical procedure. Amyloid can involve the vocal cords and false vocal cords and cause traction on the structures, leading to hoarseness. This form of laryngeal amyloidosis is always localized.¹⁴⁰

TABLE 99.4 FINDINGS OF NONINVASIVE BIOPSIES IN PRIMARY AMYLOIDOSIS

Biopsy Finding		
Fat	Marrow	Patients (%)
+	+	55
+	-	22
-	+	10
-	-	13

+, tissue positive for amyloid deposits; -, tissue negative for amyloid deposits. Modified from Gertz MA, Lacy MQ, Lust JA, et al. Prospective randomized trial of melphalan and prednisone versus vincristine, carmustine, melphalan, cyclophosphamide, and prednisone in the treatment of primary systemic amyloidosis. *J Clin Oncol* 1999;17:262-267. Used with permission.

Obstructive ureterovesicular amyloidosis is always localized. Patients present with hematuria and have a prebiopsy diagnosis of cancer. Amyloid deposits are found when cystoscopic biopsies are performed. Eighty-five percent of patients with this type of amyloidosis present with hematuria. Patients may undergo partial cystectomy, fulguration, or transurethral resection.¹⁴¹ Dimethyl sulfoxide (DMSO) instillation in the bladder has been reported to reduce these deposits.¹⁴² Colchicine has also been reported to be beneficial. Amyloid involving the renal pelvis or ureter is a localized amyloid syndrome.^{143, 144} These patients present with colic because of obstruction or hematuria, and deposits are found

during surgery. Nephrectomy is commonly performed because the ureteral mass preoperatively is thought to represent a transitional cell malignancy, but the recognition of amyloidosis avoids nephrectomy. Patients may present with dysuria and hematuria when amyloidosis involves the urethra.¹⁴⁵ The preoperative diagnosis is usually a urethral malignancy. Resection is the treatment of choice.

Three forms of cutaneous amyloidosis are recognized. The lichen and macular forms are localized,¹⁴⁶ innocuous conditions that usually are associated with a history of local skin trauma or inflammation. Nodular amyloidosis is associated with AL,¹⁴⁷ and evidence of nodular deposits may be an important clinical clue to an underlying life-threatening process. Degraded keratin molecules are the source of macular and papular amyloid deposits.¹⁴⁸ Dermabrasion and other forms of local therapy adequately control cutaneous amyloidosis.

Carpal tunnel amyloidosis may be observed in systemic AL and AF, but it may also be localized.^{149, 150} For patients who present

P.2104

with carpal tunnel syndrome as the only manifestation of amyloidosis, the median survival is 12 years. Virtually all patients with carpal tunnel amyloidosis have localized disease, and one study reported that only 2 of 124 patients with localized carpal tunnel amyloidosis had development of AL.¹⁵¹ TTR is often found in localized carpal tunnel amyloid deposits.

Localized amyloidosis is seen in the conjunctiva and orbits. The best treatment is surgical excision. Amyloid has also been localized to breasts,¹⁵² mesenteric lymph nodes, colonic polyps, thyroid,¹⁵³ retroperitoneum, and ovaries. Localized deposits of amyloid commonly are observed in trace amounts within the cartilage on the hip surface after a total hip arthroplasty.¹⁵⁴ Similarly, localized deposits are found in resected knee arthroplasty specimens. These deposits are not associated with systemic disease.¹⁵⁵

AA is a consequence of poorly controlled, long-term systemic inflammation. From a simple syndrome standpoint, its presentation is similar to that of AL. AA is more common than AL in underdeveloped countries because of the persistence of tuberculosis,⁶¹ syphilis, malaria, and leprosy, but in the United States, AA is not easily distinguished from AL. AA is not associated with a monoclonal protein or clonal marrow plasma cells. Patients with AA most commonly present with nephrotic-range proteinuria.¹⁵⁶ At Mayo Clinic, AA accounts for only 2% of all patients with amyloidosis.¹⁵⁷

The underlying cause of AA most commonly includes ankylosing spondylitis,¹⁵⁸ juvenile rheumatoid arthritis,¹⁵⁹ psoriatic arthritis,¹⁶⁰ and rheumatoid arthritis¹⁶¹; for most patients with AA, the cause is clear because the arthritis is disabling and develops a median of 15 years before the development of AA.¹⁶² Of patients with rheumatoid arthritis, AA develops in 3.1%.¹⁶³ With the introduction of anti-TNF therapies for inflammatory arthropathy, the prevalence of AA in industrialized nations continues to decrease as these disorders are better controlled. AA is also seen in patients with Crohn disease,¹⁶⁴ bronchiectasis¹⁶⁵ (including long-term survivors of cystic fibrosis), and chronic osteomyelitis.¹⁶⁶ These are conditions in which the infected tissue is not amenable to surgical excision and antibiotic therapy results in poor control. For most patients with AA and Crohn disease, the inflammatory bowel disorder has been present for decades. The first clinical manifestation is proteinuria. No monoclonal protein is detectable. AA has been described in individuals who subcutaneously inject contaminated illegal substances (i.e., "skin poppers").^{167, 168} Skin abscesses develop at the site of injection and cause the inflammation that is necessary for the development of AA. Patients with Hodgkin lymphoma^{169, 170} or hypernephroma^{171, 172} and paraplegic patients with chronic infected decubitus ulcers or chronic urinary tract infection^{173, 174} have been reported to have AA. Amyloid deposits are identified during autopsy for half of all patients who sustained a spinal cord injury 10 years or more before death.¹⁷⁵ AA from Castleman disease has been recognized. Surgical excision leads to remission.^{176, 177} AA has also been reported for patients with hyperimmunoglobulin D syndrome and periodic fever syndromes, so-called TRAPS.¹⁷⁸

AF is more common than AA in the United States. Presentation of AF is clinically indistinguishable from AL; patients may have cardiomyopathy,^{179, 180} neuropathy,¹⁸¹ and nephrotic syndrome.¹⁸² The most common form of AF is attributable to TTR mutations. More than 100 different mutations in the TTR gene have been involved in amyloid neuropathy.¹⁸³ Nearly half of the patients with AF seen at Mayo Clinic do not have a family history of the disease, but absence of a family history is a poor screening method to exclude AF.¹⁸⁴ The most common TTR mutation seen at Mayo Clinic is Thr60Ala, caused by a nucleotide substitution in TTR DNA of 238A>G. Amyloid neuropathy without monoclonal protein or clonal plasma cell disorder should raise clinical suspicion of AF. Cardiac amyloid deposition may occur with mutated and wild-type TTR genes.¹⁸⁵ Cardiac amyloid deposits¹⁸⁶ that consist of normal TTR proteins occur in 8% to 25% of people older than 80 years. In this form of senile systemic amyloidosis, only cardiac symptoms are seen.

AF involving only the heart (without peripheral neuropathy) was first described in a Danish kindred.¹⁸⁷ Since then, AF cardiomyopathy has been described throughout the world. The US patients in AF pedigrees usually have symptoms after age 60 years. Patients with cardiomyopathy from AF present with heart failure or arrhythmias, and the clinical picture is virtually indistinguishable from that of senile cardiac amyloidosis or AL. Twenty-one percent of patients older than 90 years (the general patient population) have senile systemic amyloidosis from deposition of wild-type TTR.¹⁸⁸ The Val122Ile mutation of TTR is a major cause of inherited cardiac amyloidosis for African Americans. The first report of the mutation described an African American man aged 68 years.¹⁸⁹ The TTR Val122Ile allele is carried by 3.9% of African Americans, which translates to 1.3 million people in the United States.¹⁹⁰ Therefore, a finding of cardiac amyloidosis without monoclonal gammopathy could represent AF-based cardiomyopathy (even without a family history), and clinicians should not assume that the patient is affected by AL.¹⁹¹

Mutations in the fibrinogen,¹⁹² lysozyme,¹⁹³ or apolipoprotein A1 and A2^{194, 195, 196} and LECT2 proteins may produce inherited forms of renal amyloidosis. The amyloidosis associated with these mutations has a much better prognosis than that of renal AL. We have regularly seen patients who have proteinuria for more than a decade without renal failure. Because these patients present with proteinuria and the renal biopsy specimen shows amyloid deposits, their condition is easily confused with AL. The absence of a monoclonal immunoglobulin disorder or the absence of free light chains in the serum is an important distinguishing feature. However, only immunohistochemical staining or sequencing of the amyloid can differentiate these entities definitively. Of 285 renal amyloid samples, 31 were unclassified and subsequently 7 were found to be LECT2 related by tandem mass spectrometry.¹⁹⁷ Isolation of genomic DNA and polymerase chain reaction amplification of LECT2-encoding exons showed no mutations. However, all were homozygous for the G allele encoding valine at position 40 in the mature protein. LECT2-associated renal amyloidosis represents a unique form of renal amyloidosis, especially in Mexican Americans, and has only recently been recognized.

The treatment of TTR-derived AF includes liver transplantation, which makes the distinction between AF and AL critical for treatment decisions.¹⁹⁸ TTR is produced in the choroid plexus and the liver. Regression of amyloid deposits has been reported¹⁹⁹ when liver transplantation is performed before the development of disabling peripheral neuropathy, autonomic neuropathy, or advanced cardiomyopathy. Patients with the Val30Met mutation in the TTR gene appear to have the best outcome after liver transplantation.²⁰⁰ Progressive cardiac amyloidosis has been reported after liver transplantation for patients with other TTR mutations.²⁰¹ After mutant TTR is deposited in the myocardium, it may serve as a nidus for further deposition of native TTR produced by the transplanted liver. Autopsy findings show cardiac amyloid fibrils with mutant and wild-type TTR.^{202, 203} AF may be initially diagnosed as AL unless the patient has a clear family history of AF. When the referral diagnosis was AL, 34 of 350 patients (9.7%) were reported to have AF.²⁰⁴ The most common mutation in AF was identified in the gene encoding the fibrinogen A- α chain, and the second-most common mutation occurred in the gene encoding TTR. A low-grade monoclonal gammopathy was detectable in eight patients. All patients who have clinical syndromes consistent with AF should be screened for a genetic cause when AL cannot be confirmed unequivocally.²⁰⁴ Of 178 consecutive patients referred for amyloidosis, 54 underwent screening with polymerase chain reaction assays to detect AF variants.²⁰⁵ Three patients had monoclonal gammopathy and a hereditary variant; this finding justified routine screening of patients with apparent AL for hereditary variants and showed the necessity of

P.2105

immunohistochemical or mass spectroscopic confirmation of the type of amyloid protein subunit.

Screens for mutant forms of TTR may be performed using immunoaffinity chromatography and immunoprecipitation; both are convenient methods for assessing circulating TTR in serum.²⁰⁶ In addition, TTR variants may be examined using immunoprecipitated serum proteins and matrix-assisted laser desorption ionization mass spectrometry.²⁰⁷

The gold standard for protein identification is mass spectroscopic analysis of the tissue and direct sequencing to identify the amyloid protein, and this evaluation is now standard for all pathologic specimens that test Congo red positive seen at Mayo.^{208, 209} The procedure can be performed on subcutaneous fat. The distinction between immunoglobulin and nonimmunoglobulin amyloidosis is important because nonimmunoglobulin amyloidosis does not benefit from chemotherapy.

In summary, any patient with amyloidosis who does not have a detectable monoclonal light chain in the serum or urine and does not have a clonal population of plasma cells in the bone marrow should be considered for AA, AF, or localized amyloidosis. Laser capture microdissection mass spectroscopic analysis is the most direct method to identify the protein subunit comprising the amyloid and is recommended for all positive tissue biopsies.

PRESENTATION AND CLINICAL FEATURES

We reviewed records of all patients who received a diagnosis of AL over a 10-year period at Mayo Clinic. All patients received the diagnosis within 30 days of presentation at our institution. All had a clonal plasma cell disorder and histologic proof of amyloid deposits. Patients with overt multiple myeloma were excluded. The male preponderance of AL (67.3%) has been constant at our institution for 40 years, and we believe this finding reflects a true higher prevalence of the disorder in men. Multiple myeloma also is more common in men, but the male-to-female ratio is 52:48. Although we have seen patients with amyloidosis who were as young as 27 years, the median age of patients with amyloidosis was 67 years (range, 39 to 89 years). The median age of patients who present with AL in Olmsted County, Minnesota, is 73 years⁶³; this age difference suggests that a referral bias to amyloidosis treatment centers may exist.

Echocardiographic examinations have dramatically increased the ability to recognize cardiac amyloid deposits.^{210, 211} Cardiac amyloidosis was seen in 37.4% of patients with AL at Mayo Clinic. Congestive heart failure was present in only half of these patients; for the other half, the presenting symptoms of cardiac amyloidosis were fatigue and dyspnea. These patients had poor cardiac filling and low cardiac output, but the ejection fraction was preserved. Syncope and arrhythmias also occurred.

Renal amyloid deposits were seen in 30% of patients with AL; kidneys were the second-most common organ affected by AL.²¹² Nephrotic-range proteinuria was observed for 95% of patients with renal AL; the other 5% had amyloid deposits in the interstitium and mesangium of the kidney but not the glomeruli, so proteinuria was not present. Sensorimotor symmetrical ascending peripheral neuropathy was present in 15.3% of AL patients.²⁴ Palpable hepatomegaly was observed in 17.7% of AL patients, but a dominant hepatic syndrome was seen in only 4.6%. Gastrointestinal tract amyloidosis occurred for 7.1% of patients with AL, and they presented with intestinal bleeding, pseudo-obstruction, or diarrhea. The other 7.8% of patients had amyloid deposits that were identified in only the tongue, lung, joints, or soft tissues.

At Mayo Clinic, 29.9% of AL patients had two or more organs affected, 6% had three affected organs, and 0.5% had four or more affected organs.²¹³ When multiple organs were involved, the liver was most likely to be affected. Clinically significant bleeding (excluding purpura) occurred for only 2.3% of our patients.^{214, 215} Congestive heart failure was observed for 22% of patients, and carpal tunnel syndrome was observed for 21% of patients.²¹² Edema was noted for 44.8% and fatigue for 46.4%. Lower-extremity paresthesias, nephrotic-range proteinuria, orthostatic hypotension, and weight loss were observed for 34.9%, 21.0%, 12.5%, and 51.7% of patients, respectively. The median survival of our entire cohort was 12 months, and the 2- and 5-year survival rates were 33.6% and 14.9%, respectively.

Amyloidosis is rarely associated with anemia.²¹⁶ The hemoglobin level was greater than 100 g/L for 90% of patients and greater than 120 g/L for 64.4%. Only 1.5% had hemoglobin levels less than 90 g/L, and the cause was usually active gastrointestinal tract bleeding or renal failure. The median platelet count of patients with AL was $257 \times 10^9/L$ (range, $46 \times 10^9/L$ to $809 \times 10^9/L$). A platelet count greater than $500 \times 10^9/L$ was seen for 5.5% of patients. The most common cause of thrombocytosis in AL is hepatic involvement with associated hyposplenism.^{217, 218} A serum creatinine value of 2 mg/dl or greater was present for 13.6% of patients, and 6.7% had alkaline phosphatase levels greater than twice the maximum normal value. The number of patients with elevated alkaline phosphatase levels was close to the number of patients with clinical hepatic amyloid involvement.

The median bone marrow plasma cell percentage of patients with AL is 7% (range, 1% to 30%; Fig. 99.8).²¹² In 11.3% of patients with AL, greater than 20% of plasma cells were found in the bone marrow, but no other clinical evidence of multiple myeloma was observed. Proteinuria is exceedingly common in AL, and the median urine protein loss is 790 mg per 24 hours (Fig. 99.6).²¹⁹ Monoclonal λ and κ light chains (in the serum and urine) were found in 70.1% and 18.9% of patients, respectively, and 11% had no detectable light chains. For patients with intact monoclonal γ globulins, the serum heavy chain was IgG, IgA, and IgM for 58%, 10%, and 8.2% of patients, respectively. The presence of an IgM monoclonal protein in 8.2% is important because we have seen many referred patients with a diagnosis of Waldenström macroglobulinemia, for whom the amyloid syndrome was overlooked.²²⁰ Amyloid arthropathy occasionally occurs in amyloidosis. Synovial membrane biopsy may establish the diagnosis, and chemotherapy may effectively alleviate the joint manifestations.²²¹

Heart

The heart is the organ that determines the patient outcome, and it is the organ most frequently involved in AL.^{222, 223, 224} Amyloid is deposited extracellularly and results in a noncompliant and thickened left ventricle (Fig. 99.9).^{225, 226} The clinical presentation is infiltrative cardiomyopathy with restricted diastolic ventricular filling. Many patients with cardiac AL

present only with fatigue and unexplained weight loss. Early cardiac AL produces diastolic dysfunction without systolic dysfunction,^{227, 228} and chest radiographs do not show evidence of pulmonary vascular

P.2106

congestion or cardiomegaly. Moreover, the ejection fraction is preserved because amyloid deposition is an infiltrative process with diastolic dysfunction only.²²⁹ Indeed, because of a low stroke volume, a hyperdynamic myocardium may develop with an elevated ejection fraction. This constellation of findings is frequently misinterpreted, and the presence of amyloid may be overlooked completely. An echocardiographic examination usually shows that contractility is normal, but because of poor diastolic filling, the end-diastolic volume is reduced and cardiac output is low. The electrocardiogram shows low voltage, but this also may be easily overlooked.²³⁰ The pseudoinfarction pattern of amyloidosis, with nearly two thirds of patients showing loss of anterior forces in V_1 through V_3 ,²³⁰ may be misinterpreted as ischemic heart disease. Electrocardiographic findings are clinically suspicious of silent ischemic disease, and patients invariably undergo coronary arteriography. Coronary angiogram findings are generally normal.²³¹ A characteristic echocardiogram shows wall and valve thickening, diastolic dysfunction, and a sparkling myocardium (Fig. 99.10). The median septal thickness for patients with AL was 14 mm.²¹⁰ The septal wall thickness was less than 15 mm for 52.9% and greater than or equal to 15 mm for 47.1%.²¹⁰ Wall thickening frequently is misinterpreted as concentric left ventricular hypertrophy or asymmetrical septal hypertrophy, rather than infiltrative cardiomyopathy.^{232, 233, 234} When ventricular hypertrophy is diagnosed from the thickened walls, the electrocardiogram typically shows low voltage and does not reflect hypertrophy.²³⁵ Screening tests for monoclonal protein in the serum or urine should be performed for any patient with diastolic heart failure, restrictive hemodynamics, or thickened walls.

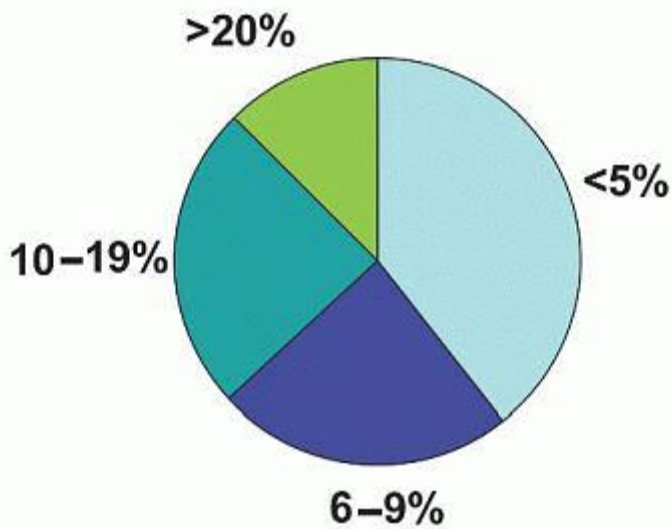

FIGURE 99.8. Distribution of bone marrow plasma cells of patients with primary amyloidosis (N = 486).

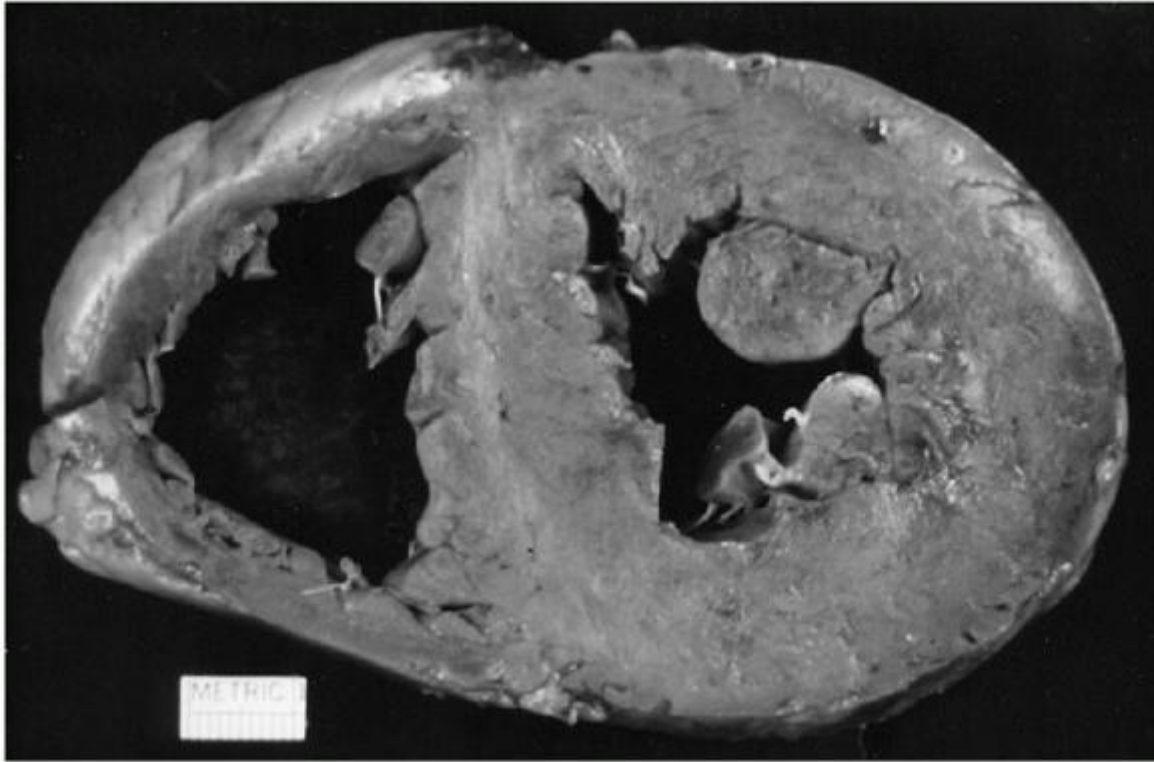

FIGURE 99.9. Myocardial wall diffusely thickened with amyloid. The whitish deposits represent the amyloid and are the lardaceous changes first recognized by Rokitansky. (From Gertz MA, Kyle RA. Amyloidosis [AL]. In: Wiernik PH, Goldman JM, Dutcher JP, et al., eds. Neoplastic diseases of the blood, 4th ed. New York: Cambridge University Press, 2003. Used with permission.)

Patients with cardiac amyloidosis have restriction to blood inflow that is characteristic of the disease. Doppler studies are best for accurate assessment of myocardial function for AL patients. The Doppler filling patterns accurately indicate the extent of amyloid infiltration.²³⁶ For patients with advanced cardiac amyloidosis, a short deceleration time is consistent with restrictive physiologic characteristics, but in the early stages of cardiac amyloidosis, abnormal relaxation is observed.²³⁷ Decreased fractional shortening and increased ventricular wall thickness are the best predictor of outcome in AL. Patients with a wall thickness greater than 15 mm and a fractional shortening less than 20% have a median survival of 4 months. An important measurement is the deceleration time; a short deceleration time is indicative of restrictive physiologic characteristics, and a deceleration time shorter than 150 milliseconds is associated with worse outcomes than that of a deceleration time longer than 150 milliseconds.

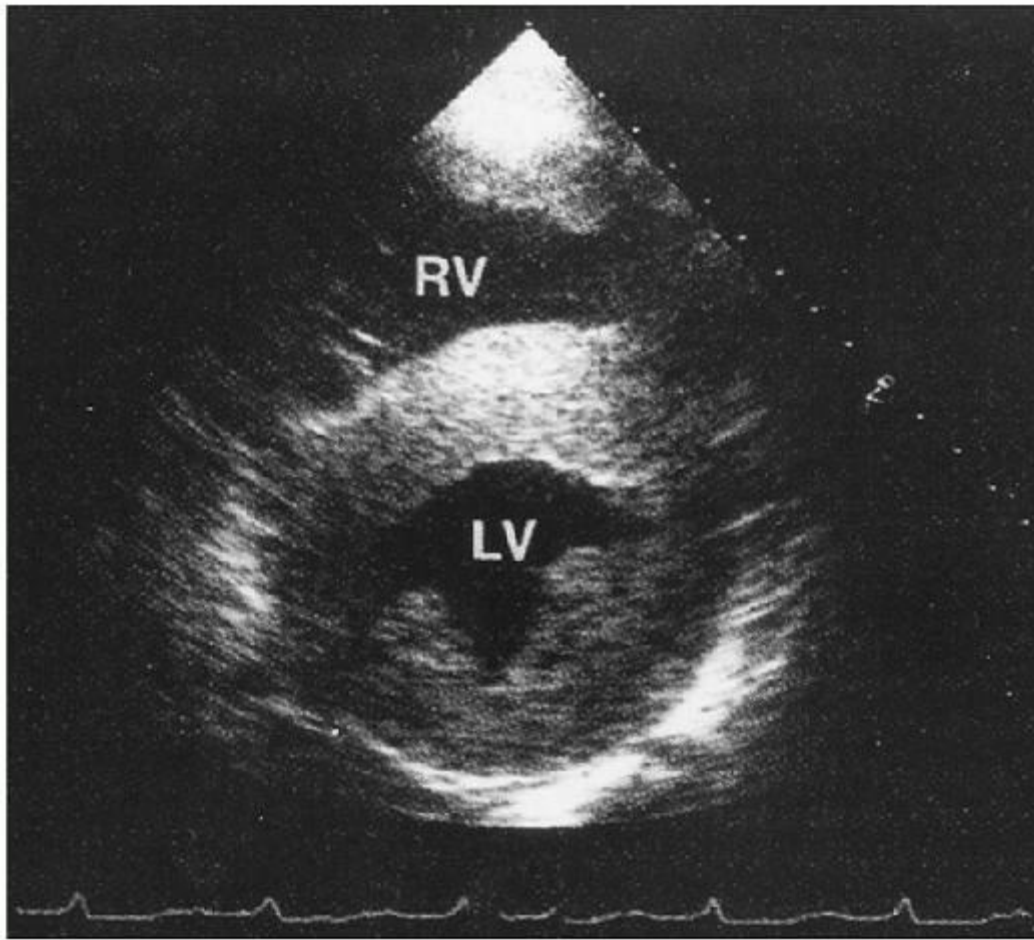

FIGURE 99.10. Echocardiographic image of concentric thickening of the wall of the left ventricle (LV) due to amyloid. RV, right ventricle. (From Gertz MA, Kyle RA. Amyloidosis [AL]. In: Wiernik PH, Goldman JM, Dutcher JP, et al., eds. Neoplastic diseases of the blood, 4th ed. New York: Cambridge University Press, 2003. Used with permission.)

The most common echocardiographic feature of cardiac amyloidosis was thickening of the right ventricular wall, septum, and left ventricular free wall. The size of the left ventricular cavity was reduced. Approximately 20% of patients had congestive heart failure, but echocardiographic studies showed that twice as many had cardiac amyloid deposits. Patients with overt cardiac amyloidosis often presented with mild symptoms of fatigue and dyspnea on exertion. The median survival time of patients with cardiac amyloidosis and a septal thickness greater than or equal to 15 mm or less than 15 mm at diagnosis was 1 year and 4 years, respectively. Syncope with exercise developed for almost one third of patients with cardiac AL. A median survival time of 2 months is reported with exercise-induced syncope in AL.²³⁸ Immunofixation of the serum and urine and a free light-chain assay are required for any patient who presents with cardiomyopathy or congestive heart failure that does not have an obvious ischemic cause.⁷⁴ The echocardiogram is the diagnostic standard for recognizing amyloid cardiomyopathy; occasionally, a patient has a nondiagnostic echocardiogram and amyloidosis is subsequently proven through endomyocardial biopsy, but these occurrences are rare.²³⁹ Pulsed tissue Doppler imaging, when combined with strain imaging, may disclose early signs of amyloidosis. However, functional abnormalities may be detected before any morphologic echocardiographic abnormalities are evident. Both the left- and right-side heart functions may be affected.²⁴⁰

A poor prognosis is associated with right ventricular dilatation and atrial systolic failure.²⁴¹ For patients who are assumed to have hypertrophy because of thickened ventricular walls, the finding of thickened mitral and tricuspid valves is a common and important clue: thickened valves are not found in hypertensive cardiomyopathy.²⁴² Valvular regurgitation is commonly seen by Doppler echocardiography, but it does not appear to have a clinically significant effect on myocardial performance.²⁴² Atrioventricular sequential pacing does not benefit cardiac hemodynamics.²³⁶ Implantation of a cardioverter-defibrillator does not prevent death from cardiac amyloidosis.²⁴³ Distinguishing pericardial disease from restrictive cardiomyopathy may be difficult.²⁴⁴ It is rare for surgical pericardiectomy to provide clinical benefits to patients

with AL. The hazards of surgery for patients with cardiac amyloidosis are well established.^{244, 245} As discussed previously, a bone marrow biopsy and a fat aspirate will establish the diagnosis of cardiac amyloidosis for most patients with the disease, but for those with infiltrative cardiomyopathy, endomyocardial biopsy will provide the correct diagnosis for all patients when at least three endomyocardial specimens are obtained.²⁴⁶ Magnetic resonance imaging may be a useful diagnostic technique.

P.2107

The combination of subtle, widespread heterogeneous myocardial enhancement on delayed postcontrast inversion recovery in T1-weighted images, with ancillary features of restrictive cardiac disease, may be highly suggestive of cardiac amyloidosis.²⁴⁷ The presence of a positive cardiac magnetic resonance imaging in AL was associated with a significantly increased risk of death, in particular of cardiac origin, but was not independent of clinical congestive heart failure.²⁴⁸

Ventricular thrombi may develop in AL patients because of stasis of blood within the cardiac chambers. Embolism may result, and the first manifestation of AL may be a stroke.²⁴⁹ For AL patients in sinus rhythm, atrial thrombi may develop.²⁵⁰ Anticoagulation therapy is indicated for AL patients with atrial standstill. Most AL patients present with cardiac muscle infiltration and pump failure, but patients rarely present with symptoms of exertional angina and myocardial infarction from amyloid deposition in the coronary arteries.²⁵¹ Angiographic findings are normal because epicardial coronary arteries are spared. For such patients, standard exercise tests show ischemia,²³¹ but the diagnosis of intracoronary amyloid is difficult to establish before death. Right ventricular myocardial biopsy may show amyloid deposits in small intramural vessels. We previously have described 11 AL patients who presented with angina or an unstable coronary syndrome.²⁵² A classic low-voltage electrocardiogram was seen in only two patients. The median survival after symptom development was 18 months. Virtually all patients were assigned the diagnosis of cardiac amyloidosis during autopsy, which reflects the difficulty of recognizing small-vessel coronary arteriolar amyloidosis. A follow-up report of obstructive intramural coronary amyloidosis showed that 63 of 96 patients (66%) did not have obstruction of epicardial coronary arteries.²⁵³ Myocardial ischemia affected 25% of patients with obstructive intramural coronary amyloidosis. Most patients with primary systemic amyloidosis and cardiac involvement have obstructive intramural coronary amyloidosis and microscopic changes of myocardial ischemia.²⁵³

Not all patients with cardiac amyloid have AL. Familial amyloid cardiomyopathy, particularly in elderly African American men, must be distinguished from AL.¹⁹¹ The clinical presentations are similar,²⁵⁴ but patients with AF do not have a monoclonal protein in the serum and urine. The most common mutation identified in patients with AF in the United States is TTR Val122Ile. A screen for TTR mutations helps differentiate between patients with AF (have the mutation) and AL (do not have the mutation). Senile cardiac amyloidosis, which results from the deposition of nonmutated TTR, must also be distinguished from AL.²⁵⁵ Echocardiographic features of AL, AF, and senile cardiac amyloidosis are indistinguishable. All amyloid deposits are positive for Congo red stain, so positive staining cannot be used as a criterion to classify patients with different types of amyloidosis. The main distinguishing clinical feature is the presence of the monoclonal protein for patients with AL (patients with the TTR forms of cardiac amyloid lack monoclonal protein).¹⁸⁶

Patients with senile systemic amyloidosis tend to be older than those with AL, and virtually all patients with senile systemic amyloidosis are men. Proteinuria is not present. Patients tend to have a greater left ventricular wall thickness. The severity of heart failure is less, and the median survival time is much longer than that of patients with cardiac AL.²⁵⁶ The mechanism of amyloid deposition in senile systemic amyloidosis is not understood. A quarter of patients older than 90 years (general patient population) have cardiac amyloid deposits. Clinicians must remember that all forms of cardiac amyloidosis are not derived from immunoglobulin light chains.¹⁸⁸

Kidney

When a patient has free monoclonal light chains in the urine, the differential diagnosis is cryoglobulinemia,²⁵⁷ amyloidosis, Randall-type light-chain deposition disease,²⁵⁸ and myeloma cast nephropathy.²⁵⁹ The presence of proteinuria does not always indicate albuminuria. All patients presenting with proteinuria should have immunofixation of the urine performed during the first evaluation to exclude light-chain-associated syndromes. Kidneys are affected in 28% of AL patients. An Italian group has reported that amyloid deposits affect the kidneys for half of their patients with AL.²⁶⁰ For nondiabetic adults with nephrotic syndrome, amyloidosis is observed in 12% of renal biopsy specimens²⁶¹; 2.5% to 2.8% of all kidney biopsy specimens contain amyloid deposits.

The serum creatinine level at AL diagnosis has prognostic value. Patients with a creatinine value less than or greater than 1.3 mg/dl had a median survival time of 25.6 or 14.9 months, respectively. Urinary protein loss did not affect survival. Patients with higher levels of albumin loss have a shorter time from diagnosis to the development of end-stage renal

disease.²¹⁹ The presenting serum creatinine value exceeded 2 mg/dl for 14% of patients. The median urinary protein excretion for all AL patients was 0.75 g in 24 hours, but 30% had greater than 3 g of urinary protein in 24 hours. Only 5% of AL patients had urinary protein loss in the reference range. Monoclonal light-chain proteins were more likely to be found when the urinary protein loss was high; for example, 85% of patients with urinary protein loss exceeding 1 g/day had detectable monoclonal light chains.

The ratio of patients with underlying λ clones to patients with κ clones is 5:1 among those with nephrotic-range proteinuria. Median urinary protein loss for patients with κ or λ amyloidosis is 1.1 or 4.6 g/day, respectively. The λ light chain may predispose patients to a higher level of renal involvement, but no difference in the frequency of renal failure in κ or λ amyloidosis is observed. The median survival of patients with urinary λ light chains, urinary κ light chains, or no detectable urinary light chains is 1, 2.5, and 2.5 years, respectively. Severe hypoalbuminemia is the result of nephrotic-range proteinuria.⁷⁷ Diuretics typically are required to control edema, but diuretics further aggravate intravascular volume contraction, increase hypotension, and decrease renal blood flow. Bilateral catheter embolization of renal arteries reduces the loss of urinary protein and increases the serum total protein of patients with advanced anasarca.²⁶²

Continuous urinary protein loss results in tubular damage, and the principal long-term complication is end-stage renal disease.²⁶³ Prognostic factors for development of end-stage renal disease were serum creatinine value at presentation and 24-hour urinary protein loss. The median time from the diagnosis of AL nephrotic syndrome to dialysis was 14 months. After initiation of dialysis, the median survival time was 8 months. Most deaths of dialysis patients with AL were attributable to cardiac amyloid. No survival difference has been recognized between hemodialysis and peritoneal dialysis.²⁶⁴ The 1-year survival rate from the start of dialysis was 68%.

Patients younger than 45 years had a better survival rate. Chemotherapy slowed progression to end-stage renal disease and showed a trend toward improved survival. In addition to younger age, normal values of serum calcium and creatinine at presentation favor longer survival. Heart failure, cardiac arrhythmias, and refractory hypotension are the most common extrarenal complications of AL. Cardiac amyloidosis with renal failure regularly results in dialysis that is complicated by severe hypotension (a difficult clinical condition to manage). The amount of protein in the urine and the extent of amyloid deposits in a kidney biopsy specimen correlate poorly.²⁶⁵ Severe nephrotic syndrome may occur, even with low levels of amyloid deposits. All patients with nephrotic syndrome undergo ultrasonography, and the kidneys of patients with AL are virtually always normal size.²⁶⁶ The urine of patients with AL contains fat or fatty acid crystals but no casts or red blood cells.²⁶⁷ Of 118 patients with monoclonal gammopathy undergoing renal biopsy, 30% had AL. In that cohort, the median time from diagnosis to dialysis was 15 months, the median overall

P.2108

survival time was 24 months, and the main cause of death was cardiac amyloidosis.

Only 2% of patients with amyloidosis have proteinuria eventually if it is not present at diagnosis. Of patients with cardiac AL who underwent cardiac transplantation and antirejection therapy, we have seen nephrotic syndrome develop in two patients. It is possible that patients treated before routine organ transplantation might not have survived long enough for renal amyloid nephrotic syndrome to develop. Amyloid deposits penetrate the glomerular basement membrane and result in proteinuria.²⁶⁸ Adult Fanconi syndrome,²⁶⁹ renal vein thrombosis,²⁷⁰ and retroperitoneal fibrosis have been reported with renal amyloidosis. Fibrillary (immunotactoid) glomerulopathy refers to the deposition of fibrils in the kidney that initially may be confused with AL.²⁷¹ However, examination by electron microscopy shows that the fibrils of fibrillary glomerulopathy are twice the width of amyloid fibrils,²⁷² and extrarenal disease does not develop in patients with fibrillary glomerulopathy. The fibrils are negative for Congo red stain. Monoclonal protein typically is not detected in the serum or urine. Randall-type light-chain deposition disease indicates granular deposition of nonamyloid immunoglobulin light chain along the glomerular basement membrane.²⁷³ It produces nephrotic syndrome and renal insufficiency. Light-chain deposition disease and amyloidosis in the same patient has been reported.²⁷⁴ Electron microscopy studies of tissues affected by light-chain deposition disease do not show fibrils.

Fifteen patients with systemic amyloidosis who underwent renal transplantation had SAP scintigraphy studies.²⁷⁵ Abnormal uptake of radioactive iodine in the transplanted kidney was observed in 4 of 10 patients, and none had a reduction in the level of fibril precursor protein. Patients with renal amyloidosis had a high prevalence of adrenal dysfunction. Of 22 patients with renal amyloidosis, poor cortisol reserves were identified for 7, and hypoadrenalism resulted in the death of 4.²⁷⁶ Amyloid deposits are regularly found in the adrenal glands at autopsy.

Liver

In one fourth of patients with AL, hepatomegaly is noted during physical examination.²⁷⁷ Hepatomegaly is not synonymous with hepatic involvement because the high prevalence of right-sided heart failure may produce congestive hepatomegaly. One sixth of patients had a symptomatic hepatic amyloid syndrome, which typically included an increased serum alkaline phosphatase or γ -glutamyltransferase level and unexplained hepatomegaly. Most clinicians suspect that unexplained hepatomegaly is due to hepatic metastases, but radionuclide imaging, computed tomography, or magnetic resonance imaging demonstrate homogeneous patterns. A high proportion of patients with hepatic amyloidosis also have renal involvement.

Half the patients with hepatic amyloidosis have proteinuria in excess of 1 g every 24 hours. A patient who presents with an increased serum alkaline phosphatase value and proteinuria may have liver dysfunction resulting from a systemic disorder such as amyloidosis. Several key clues may be helpful in establishing the diagnosis of hepatic amyloidosis: (1) hepatomegaly out of proportion to the degree of liver function abnormality; (2) presence of Howell-Jolly bodies in a peripheral blood film (suggestive of reduced splenic function, a consequence of splenic replacement with amyloid deposits); (3) monoclonal protein (detectable by immunofixation) in the serum or urine; (4) proteinuria; and (5) increase of the alkaline phosphatase value with minimal increase in transaminase values. Biochemically, patients with hepatic amyloidosis tend to have low levels of aspartate aminotransferase and alanine aminotransferase—almost always less than twice the maximum normal value at diagnosis—and the bilirubin value is typically normal. Hyperbilirubinemia, when present, is usually a preterminal finding.

Hepatic rupture is rare but results in massive intra-abdominal hemorrhage that is generally fatal. Computed tomography is useful for diagnosing hepatic rupture with subcapsular hematoma.²⁷⁸ On physical examination of patients with a confirmed diagnosis of hepatic AL, the median measurement of the liver edge extending below the right costal margin was 7 cm. Hepatomegaly was not present in one tenth of patients with biopsy-proven liver AL involvement. Hepatic AL was usually diagnosed in these patients on the basis of an increased alkaline phosphatase value. At diagnosis, the median increase of the serum alkaline phosphatase level was 2.3 times the maximum normal value. The serum alkaline phosphatase value was the most important screen for determining whether a patient had clinically significant hepatic involvement. Thirty-six percent of patients with hepatic AL excreted more than 3 g of protein in the urine per day. Patients with hepatic AL also have higher levels of C-reactive protein than those without hepatic involvement.²⁷⁹ The proportion of patients with hepatic AL whose amyloid deposits were derived from κ clones was identical to that of patients with other affected organs. It has been suggested that an increased incidence of κ light chain may be seen in hepatic AL,²⁸⁰ but this suggestion was not supported by our data. In a study of 98 patients,²⁸¹ 72% had involuntary weight loss and 89% had proteinuria. Clinicians considered amyloidosis as the cause of the hepatic dysfunction in only 26% of patients. None had hepatic rupture or death resulting from liver biopsy, and only 4% had bleeding. The predictors of a poor prognosis were heart failure, elevated bilirubin levels, and thrombocytosis.

Although symptomatic hepatic amyloid is identified in only 16% of AL patients, SAP scans show that hepatic amyloid is present in virtually all AL patients.²⁸² Cholestatic jaundice is a preterminal finding.²⁸³ In hepatic AL, portal hypertension with varices and bleeding is rare.²⁸⁴ Presumably, patients succumb to hepatic or extrahepatic complications of AL before portal hypertension develops.²⁸⁵ It is common to see ascites in patients with hepatic AL, but most of these patients also have nephrotic-range proteinuria, hypoalbuminemia, or congestive heart failure, all of which are more likely to cause ascites. Amyloid deposits are found in liver biopsy specimens distributed in the portal tract and perisinusoidally.²⁸⁶ At autopsy, involvement of the portal triad vasculature frequently is seen, but the effect of amyloid deposits in the vasculature is not clinically significant.²⁸⁷ After the diagnosis of AL is confirmed by liver biopsy, the median survival time is less than 1 year.

Scintigraphy generally is not useful for establishing the diagnosis of hepatic AL. The findings are nonspecific and include irregular distribution of the radionuclide and, occasionally, splenic uptake is absent.^{288, 289, 290} Sinusoidal amyloid deposits may compress branches of the hepatic artery, which results in the angiographic appearance of luminal irregularity and abrupt changes in vascular caliber.²⁹¹

Amyloidosis is not a contraindication for liver biopsy. Although spontaneous hepatic rupture has been described,²⁹² rupture after a percutaneous liver biopsy has not been reported. The risk of complications after liver biopsy ranges from 0.31% to 3.00%.²⁸¹ In our experience, 4% of patients with amyloidosis had bleeding after liver biopsy and none died of the bleeding. Physicians should remember that biopsy specimens from subcutaneous fat or bone marrow show amyloid deposits in 85% of patients with AL. Despite the relative safety of the procedure, if amyloidosis is suspected appropriately, liver biopsy usually is not required.

In a statistical analysis, hepatomegaly had a significant impact on survival within the first year after diagnosis, perhaps because hepatomegaly for some patients may be due to congestive heart failure rather than hepatic infiltration. In an

autopsy series of nine patients with amyloidosis and hepatomegaly,²⁹³ three did not have anatomical evidence of deposits, and liver enlargement was attributable to passive congestion. In a second autopsy study,²⁹³ 20% of patients with palpable hepatomegaly and amyloidosis did not have histologically evident deposits.

P.2109

In patients with AL, the finding of Howell-Jolly bodies is highly specific for splenic involvement, but their absence does not exclude it. Twelve patients with autopsy-proven diffuse splenic involvement have been reported in whom Howell-Jolly bodies were not found.²⁹⁴ Scanning of the spleen also does not correlate well with the presence of Howell-Jolly bodies observed on a peripheral blood smear. In patients with hepatic AL, splenomegaly is present in 11%. Splenic rupture is a recognized complication in patients with hepatic amyloid.^{295, 296}

In summary, the cardinal features of hepatic AL are hepatomegaly, monoclonal protein in serum or urine, proteinuria, an increase of the alkaline phosphatase value with minimal increase of transaminase values, and Howell-Jolly bodies in the blood smear of patients with advanced hepatic and splenic involvement.

Gastrointestinal Tract

No correlation exists between the presence of gastrointestinal tract amyloid deposits and liver amyloid deposits. Only 15% of our patients with gastrointestinal tract amyloidosis had hepatomegaly, and less than one third had increased alkaline phosphatase values.²⁹⁷ When routine screening biopsies are performed on the rectum or intestinal tract, amyloid deposits are found in most patients with AL.¹¹⁸ Generally, deposits are vascular, but occasionally, they are in the submucosa of the bowel; they produce symptoms (e.g., steatorrhea, nausea, vomiting, abdominal pain, hematemesis, and hematochezia) for only a few patients.²⁹⁸ Bowel dysfunction in AL may result from direct infiltration of the bowel lining or from a motility disturbance attributable to damaged regulatory nerves of the intestinal tract.²⁹⁹ The high prevalence of anorexia and weight loss does not correlate with the presence of gastrointestinal tract amyloid deposits. Typically, patients had a median delay of 7 months between the onset of gastrointestinal symptoms and the histologic recognition of AL, although one patient had a delay of 4 years. Four of our 19 patients with gastrointestinal tract AL underwent laparotomy for evaluation of intestinal symptoms. For three of these four patients, diagnosis was delayed because the surgical specimens were not routinely stained with Congo red.²⁹⁷

Steatorrhea and low serum carotene levels were seen in less than 5% of patients with gastrointestinal tract amyloidosis. These patients were not distinguishable clinically from those with celiac sprue, Whipple disease, or bacterial overgrowth. Small-bowel biopsy findings showed amyloid deposits for 19 of our patients with AL. This number constitutes only 1% of the AL population at our institution,²⁹⁷ and it does not include patients who had clinical evidence of malabsorption, for whom a small-bowel biopsy was not performed (widespread amyloidosis was evident in other organs). Diarrhea, anorexia, dizziness, and abdominal pain were the most common symptoms. All patients had weight loss (median loss, 30 pounds). Half the patients had orthostatic hypotension. A prolongation of prothrombin time, primarily from malabsorption of vitamin K, was present in one fourth of patients. Factor X deficiency also was seen in one fourth, but only one patient had factor X activity below 30%. A multivariate analysis showed that the degree of weight loss and the hemoglobin value at diagnosis affected survival. For patients presenting with a weight loss of 20 pounds or more, the median survival was 10 months. Ten patients died as a consequence of nutritional failure and five died of heart failure. The severe diarrhea of patients with systemic amyloidosis could not be explained by malabsorption generally, bacterial overgrowth, or malabsorption of electrolytes by epithelial cells. Transit of polyethylene glycol was 10 times faster than that of healthy subjects. Autonomic neuropathy was the likely cause of rapid gastrointestinal tract transit.³⁰⁰

Patients with amyloidosis may have esophageal dysmotility or gastroesophageal reflux of the upper gastrointestinal tract.³⁰¹ Multiple reports describe patients who had surgical intervention for obstruction, only to have amyloid deposits identified histologically.^{302, 303} The most frequent symptoms of pseudo-obstruction are nausea (even during fasting) and emesis,³⁰⁴ and abdominal distention and pain are common.³⁰⁵ Dilatation of small-bowel loops is rare.³⁰⁶ The typical radiographic findings of a patient with intestinal amyloid deposits include increased fluid accumulation in the small bowel, loop dilatation with delayed transit, and thickening or nodularity. Computed tomography may show mild splenomegaly or lymphadenopathy, but it generally does not help establish the diagnosis. Esophagitis, duodenitis, and gastritis are commonly found during endoscopic procedures.³⁰⁷ It is rare for these changes to cause symptomatic bleeding.

Ischemic colitis rarely is the presenting feature of AL.³⁰⁸ The amyloid deposits obstruct vessels of the muscularis mucosa and lamina propria. The obstructed blood supply leads to mucosal ischemia, sloughing of the bowel lining, and hemorrhage.³⁰⁹ Barium studies show luminal narrowing, mucosal fold thickening, and ulcers. The most common location

of ischemia is the rectosigmoid and descending colon.³¹⁰ Vascular obstruction from AL has been reported to cause duodenal perforation.³¹¹ Hematemesis and hematochezia were rare in patients who did not undergo stem cell transplantation. In our experience, treatment of the underlying AL does not result in recovery of intestinal motility after pseudo-obstruction develops. For patients with pseudo-obstruction, extensive replacement of the muscularis propria by amyloid is prominent.³¹²

Nervous System

In 1938, the first description of peripheral nerve amyloidosis was published.³¹³ Among patients with AL, 15% to 20% have paresthesias and neuropathy symptoms.³¹⁴ The clinical picture is often dominated by cardiac or renal involvement, and the peripheral neuropathy is minimally symptomatic. Echocardiographic abnormalities are found in 44% of patients who present with AL neuropathy. When a predominant neuropathy is seen in a patient with biopsy-proven amyloidosis, the possibility of AF should be considered. The absence of a monoclonal protein in the serum or urine is clinically useful for distinguishing between AL and AF.³¹⁵ Paresthesias, pain, numbness, muscle weakness, impotence, urinary retention, and orthostatic symptomatology are the most frequent symptoms of amyloid neuropathy.³¹⁶ Twelve percent of the patients have syncope. Dysesthesia that manifests as distal burning is present in one fourth of the patients. Of those with peripheral neuropathy, autonomic neuropathy is seen in two thirds, and lower-extremity involvement precedes upper-extremity involvement for nearly 90%. Involvement of the cranial nerves in AL is rare.^{317, 318} Half the patients with amyloid peripheral neuropathy also have carpal tunnel syndrome, a soft-tissue manifestation of amyloidosis. Frequently, it is difficult to distinguish electrodiagnostically between upper-extremity neuropathy and carpal tunnel syndrome. Weight loss was recognized in one third of patients. Rarely is painful sensory neuropathy, mononeuropathy multiplex, or demyelinating polyneuropathy the presenting manifestation of AL neuropathy.³¹⁹

An important diagnostic clue for amyloid neuropathy is its association with autonomic neuropathy.³²⁰ Voiding difficulties are often due to detrusor weakness and impaired bladder sensation. The underlying mechanism of urinary dysfunction seems to involve postganglionic, cholinergic, and afferent somatic nerves.³²¹ However, when patients present with peripheral neuropathy, amyloidosis usually is not considered in the differential diagnosis. The median delay between onset of paresthesias and biopsy proof of amyloidosis is 29 months.

Amyloidosis typically causes loss of small myelinated and unmyelinated fibers. Electromyography does not sensitively detect changes in small unmyelinated fibers. Consequently, patients may have symptoms of amyloid neuropathy and have normal

P.2110

electromyographic findings. As it progresses, the neuropathy of amyloidosis is axonal and demyelinating. The loss of myelin results in an elevation of cerebrospinal fluid protein value in one third of patients. Axonal degeneration is detected in 96% of patients with amyloid neuropathy. Typical electromyographic changes consist of reduced amplitude of compound muscle action potentials, decreased or absent sensory responses, mild slowing of nerve conduction velocity, and fibrillation potentials on needle examination.³²²

Although sural nerve biopsy is the standard method of diagnosing amyloid neuropathy, less invasive fat or bone marrow biopsies may also confirm the diagnosis.³¹⁶ With sural nerve biopsy, amyloid deposits are found in the endoneurial capillaries or in the epineurium.³²³ Teased fibers show axonal degeneration and a marked decrease in myelin fiber density. Although Mayo Clinic uses sural nerve biopsy as the standard diagnostic method, the biopsy is not 100% sensitive. Nine patients were reported to have amyloid neuropathy, but six had negative sural nerve biopsy findings.³²⁴ Amyloid proteins may have been deposited at the nerve root, which resulted in distal demyelination without recognizable deposits in the sural nerve. Amyloid is deposited focally in the nerve, and multiple sections of the sural nerve need to be examined to confirm the diagnosis.

For AL patients who present with a dominant neuropathy, the median survival time is 25 to 35 months.^{325, 326} Clinical improvement in peripheral neuropathy is rare with traditional chemotherapy, and it is infrequent even with high-dose therapy. The clinical course for most cases of peripheral neuropathy is progressive neuropathy over time. One third of patients ultimately are bedridden, and three fourths have marked restriction in their mobility and a reduced ability to perform the activities of daily living. The serum albumin value is the only prognostic factor that is associated with survival for patients who present with a dominant neuropathy. The median survival was 31 months for patients with an albumin value greater than 3 g/dl but only 18 months for those with serum albumin levels less than 3 g/dl (Fig. 99.11).

All patients who present with a peripheral neuropathy should be screened with immunofixation assays of serum and urine and with immunoglobulin free light-chain measurement. A patient with peripheral neuropathy and monoclonal light

chains has a restricted differential diagnosis that includes (1) amyloidosis; (2) cryoglobulinemia; (3) the polyneuropathy, organomegaly, endocrinopathy, M protein, and skin change syndrome (POEMS-osteosclerotic myeloma)³²⁷; and (4) neuropathy associated with monoclonal gammopathy of undetermined significance.

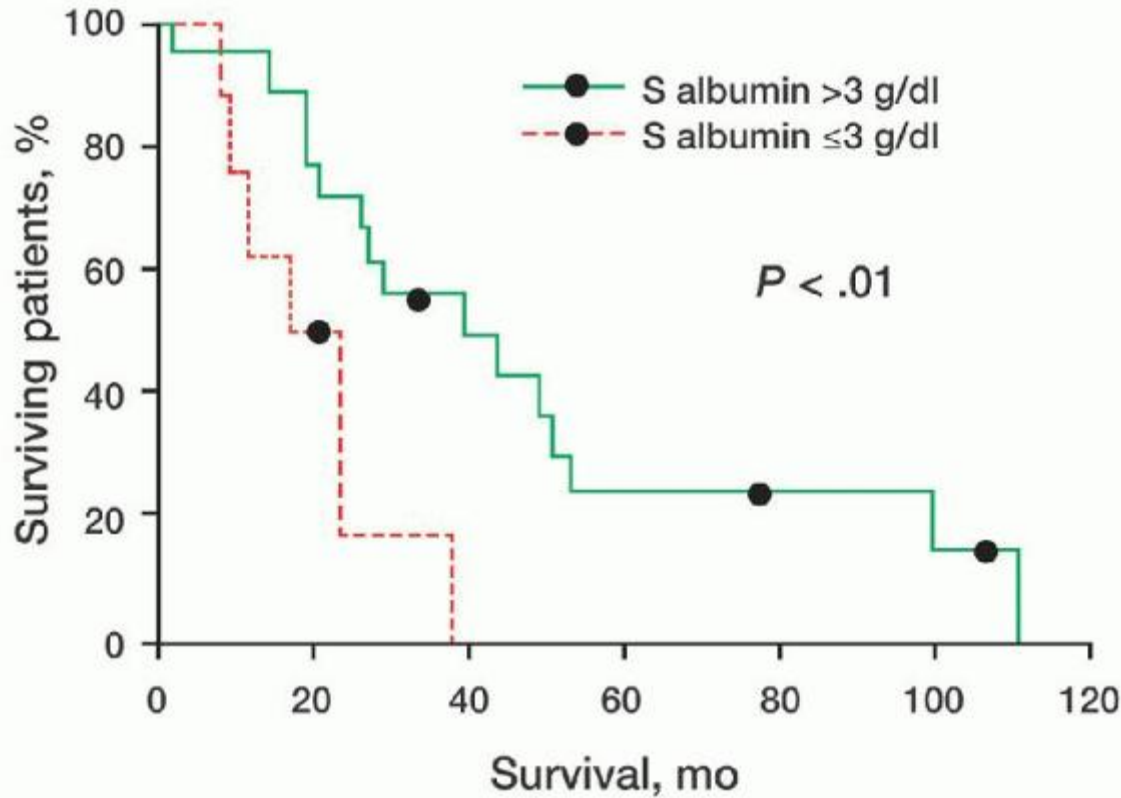

FIGURE 99.11. The effect of serum (S) albumin level on the survival of patients with isolated amyloid peripheral neuropathy. (From Rajkumar SV, Gertz MA, Kyle RA. Prognosis of patients with primary systemic amyloidosis who present with dominant neuropathy. *Am J Med* 1998;104:232-237. Used with permission.)

Respiratory Tract

We have reviewed our experience with pulmonary deposition of amyloid.¹³⁶ Most patients who present with amyloidosis involving the respiratory tract have only localized tracheobronchial or nodular pulmonary amyloid deposits. A patient with laryngeal amyloidosis was treated with adjuvant external beam radiation to a dose of 45 Gy. At 11 months, the patient's voice, breathing, and swallowing had improved substantially.³²⁸ Neither localized tracheobronchial nor nodular pulmonary amyloid deposits are associated with systemic disease, and both have a good prognosis.^{220, 329, 330} Nodular pulmonary amyloidosis, if recognized, does not always require intervention. It frequently may be nonprogressive for 5 years or longer.³³¹

Patients who present with systemic amyloidosis may have diffuse, interstitial pulmonary involvement and concomitant cardiac involvement that usually overshadow any respiratory symptoms.³³² Gas exchange is preserved until amyloid deposition in the alveolar interstitial space is advanced.³³³ Diffuse alveolar septal amyloid deposits rarely cause hemoptysis.³³⁴ Minor salivary gland involvement is shown histologically in a high proportion of patients with AL,³³⁵ and many patients report xerostomia.^{336, 337} Patients with AL have received incorrect diagnoses of Sjögren syndrome. Skeletal muscle and diaphragmatic involvement can produce muscular weakness and ventilatory failure.^{336, 338, 339} Rarely, pleural deposits of amyloid cause pleural effusions.^{340, 341} Bevacizumab has been used to treat effusions in AL.³⁴² Occlusive amyloid deposits in the pulmonary circulation system may occasionally cause pulmonary hypertension with resultant right-sided cardiac failure.^{343, 344} After a diagnosis of diffuse interstitial pulmonary amyloidosis was established, the median survival time was 16 months; for the small percentage of patients with pulmonary hypertension, the median survival was 2.8 years.

Patients whose amyloidosis is associated with an IgM monoclonal protein or Waldenström macroglobulinemia have a higher prevalence of pulmonary amyloid deposits.²²⁰ Monoclonal protein is not seen in nodular pulmonary amyloidosis or

tracheobronchial amyloidosis; only interstitial pulmonary amyloidosis is associated with free immunoglobulin light chains in serum or urine. Pulmonary involvement, when part of a systemic immunoglobulin light-chain amyloid syndrome,³⁴⁵ appears radiographically as a nonspecific interstitial or reticulonodular pattern.³⁴⁶ The diagnosis is easily obtained by a transbronchial lung biopsy, which is not associated with excessive bleeding.

Autopsy studies of pulmonary amyloidosis have been published.³⁴⁷ In one study,³⁴⁸ histologic specimens from 11 of 12 patients had deposits in the lung. Deposition was seen in blood vessel walls and the alveolar septum. Only 4 of the 12 had clinical dyspnea, and pulmonary amyloidosis was responsible for the death of 1 patient. Thus, patients with unexplained dyspnea or fluid overload who have normal left ventricular diastolic and systolic function should be evaluated for pulmonary hypertension attributable to AL.

Coagulation System

Amyloidosis increases the fragility of blood vessels because of infiltration of the vessel wall,³⁴⁹ and complications may include clinically significant hemorrhage²¹⁵ or thrombosis. The most common manifestation of hemorrhage is purpura. Prolonged thrombin time is a frequently observed abnormality of amyloidosis,³⁵⁰ and it is attributed to the presence of an inhibitor of fibrin polymerization in the plasma or the effects of prolonged nephrotic-range proteinuria with severe serum hypoalbuminemia. Acquired hemostatic abnormalities include coagulation factor deficiencies, hyperfibrinolysis, and platelet dysfunction.

Acquired factor X deficiency is an uncommon, but well-documented, complication of AL^{81, 214, 351, 352}; nevertheless, bleeding is unlikely if factor X levels are higher than 25%. Fewer than

P.2111

5% of patients have a serious deficiency of factor X with plasma levels less than 10% of the reference level for factor X,^{81, 214} and patients with cardiac and renal involvement in the absence of hepatic involvement do not show clinically significant reductions in factor X levels. However, clinically significant bleeding complications may occur, especially for patients with ischemic colitis attributable to vascular occlusions.^{351, 352} For one patient, factor X deficiency was treated with recombinant human factor VIIa during preparation for surgical splenectomy.³⁵³ Bleeding disorders resulting from low levels of α_2 plasmin inhibitors, increased levels of plasminogen activators, and abnormal platelet aggregation also have been reported.³⁵⁴ Life-threatening bleeding from acquired factor V deficiency has been reported.³⁵⁵ Fatal retroperitoneal hemorrhage developed, despite infusions of fresh frozen plasma. Autopsy findings showed that the patient had massive deposits of AL in the liver, spleen, and heart.

In one study, 36 AL patients were evaluated for coagulation disorders.³⁵⁰ Only one patient had severe bleeding, and mild to moderate hemorrhage was observed in nine patients. The most common abnormalities were prolongation of the reptilase and thrombin times. A severe factor X deficiency was seen in only one patient. The activated partial thromboplastin time was prolonged for 25 patients, and the prothrombin time was prolonged for 8. A lupus anticoagulant was not detected in any patient.

Black et al.³⁵⁶ described patients with amyloidosis who had documented episodes of thromboembolism. Similarly, Halligan et al.³⁵⁷ described patients with documented thromboembolism. Of 2,132 patients, those with myocardial infarction, peripheral vascular disease, and stroke were excluded, and records of 40 patients (19 women, 21 men; median age, 65 years) with documented thromboemboli were examined. In 11 of the 40 patients, thromboembolism preceded the diagnosis of amyloidosis, and for 9 of these 11 patients, the thromboembolic event occurred 1 month or more before the diagnosis of amyloidosis was established. In 20 of the 40 patients, the thromboembolism occurred 1 month or more after the diagnosis of AL was established. The thrombosis was venous for 29 patients and involved (in decreasing order of frequency) vessels in the calf, subclavian veins, popliteal regions, inferior vena cavae, common femoral veins, and atrioventricular fistulae. Arterial thrombosis was seen in 11 and involved femoral, popliteal, or multiple arteries, and the atria were affected in 2 patients. Of the 40 patients, 37 had additional risk factors for thrombosis, including nephrotic syndrome (20 patients), immobilization (13 patients), tobacco use (6 patients), heart failure (8 patients), estrogen therapy (1 patient), obesity (4 patients), aortic aneurysm (1 patient), prosthetic material (4 patients), and disseminated intravascular coagulation (2 patients). Five patients had activated protein C resistance. Eight patients died within a month of the thrombosis, and 18 of the 40 died within the first year. Thus, thrombosis appears to be a strong predictor of imminent death within the first month (or perhaps the first year) after the event for patients with AL. The type of heavy or light chain and the organ distribution of amyloid deposits did not predict the development of a thromboembolic event.

PROGNOSTIC FEATURES

After amyloidosis has been confirmed (histologic evidence from a fat aspirate or bone marrow biopsy specimen, a compatible clinical syndrome, and monoclonal protein in the serum or urine), the patient needs to be advised of his or her prognosis. Congestive heart failure (caused by progressive cardiomyopathy) and sudden death (caused by asystole or ventricular fibrillation) are the most common causes of death for patients with AL. The most important determinant of clinical outcome is the extent of cardiac involvement. Other recognized adverse predictors of survival include referral status, heart failure, hyposplenic peripheral blood film, free light chains in the urine, elevated serum creatinine level, bone marrow plasmacytosis greater than 30%, circulating plasma cells in the peripheral blood, elevated bone marrow plasma cell labeling index, and increased β_2 -microglobulin levels.

Exertional syncope is a predictor of early death.^{238, 358} More subtle cardiac findings also have prognostic value. Echocardiography is an important tool for assessing the prognosis of patients with AL. Two-dimensional and Doppler echocardiography shows that 40% of AL patients have cardiac involvement, although only 17% have symptoms of heart failure. In a Mayo Clinic study of 64 patients,³⁵⁹ cardiac relaxation was abnormal in the early stages of amyloidosis, but patients with advanced amyloidosis had restrictive filling and a shortened deceleration time.³⁶⁰ Doppler echocardiography may be performed serially to monitor diastolic dysfunction in cardiac AL. The 1-year survival rate of patients who had a deceleration time greater than 150 milliseconds (measured by Doppler echocardiography) was 92%; in contrast, the 1-year survival rate was 49% for patients with a deceleration time less than 150 milliseconds. The Doppler-measured left ventricular diastolic filling parameters^{359, 361} are also independent prognostic features. Doppler studies of right ventricular diastolic function show filling abnormalities that correlate with the degree of amyloid infiltration (measured by right ventricular free-wall thickness).^{362, 363} Patients with elevated serum cardiac troponin levels have a shortened overall survival.³⁶⁴

Detection of Howell-Jolly bodies during examination of a peripheral blood film indicates advanced splenic involvement that usually is associated with advanced hepatic involvement and a median survival of 4.4 months.³⁶⁵ Findings from a renal biopsy may provide prognostic information.³⁶⁶ Patients have a better prognosis if they have a lower percentage of thickened glomerular capillary walls, a higher incidence of amyloid deposits in vessels but not glomerular capillaries, and deposits of IgG and C3 in mesangial and glomerular capillary walls. The serum creatinine value at diagnosis and the presence of a urinary light chain are both important prognostic indicators. If the serum creatinine value at diagnosis is abnormal, the median survival is 15 months. Patients who have free light chains in the urine have a shorter survival (12 months) than those who do not (35 months).

In a multivariate analysis, heart failure and orthostatic hypotension were associated with a median survival of less than 1 year in a cohort of 229 patients.⁷³ An analysis was performed for 147 AL patients to identify cytoplasmic immunoglobulin-positive plasma cells by using a sensitive slide-based immunofluorescent technique. The percentage of circulating cytoplasmic immunoglobulin-positive cells was calculated by measuring the number of circulating monoclonal plasma cells. Circulating blood plasma cells were observed for 16% of AL patients. The median survival of patients with and without circulating cells was 10 and 29 months, respectively.³⁶⁷ Independent prognosticators of survival included the presence of peripheral blood plasma cells and the serum β_2 -microglobulin value. When AL patients with co-existing multiple myeloma and dominant cardiac amyloidosis were excluded, the presence of peripheral blood plasma cells had independent prognostic value. A slide-based immunofluorescence technique was used to detect circulating peripheral blood plasma cells in 16% of AL patients.³⁶⁸ Overall survival was 13 or 31 months for patients with or without circulating blood plasma cells, respectively. The identification of circulating peripheral blood plasma cells may help select treatment for patients with AL.³⁶⁸

When serum β_2 -microglobulin levels were compared, AL patients with values within the reference range had a median survival time of 33 months, and patients with elevated values had a median survival of 11 months.³⁶⁹ The prognostic value of β_2 -microglobulin levels was independent of the presence of renal failure or heart failure. The median survival of patients with normal renal function and elevated β_2 -microglobulin values was 9 months, but it was 39 months for patients with normal β_2 -microglobulin

P.2112

values. Congestive heart failure and serum β_2 -microglobulin values remain important predictors of outcome (Fig. 99.12).³⁷⁰

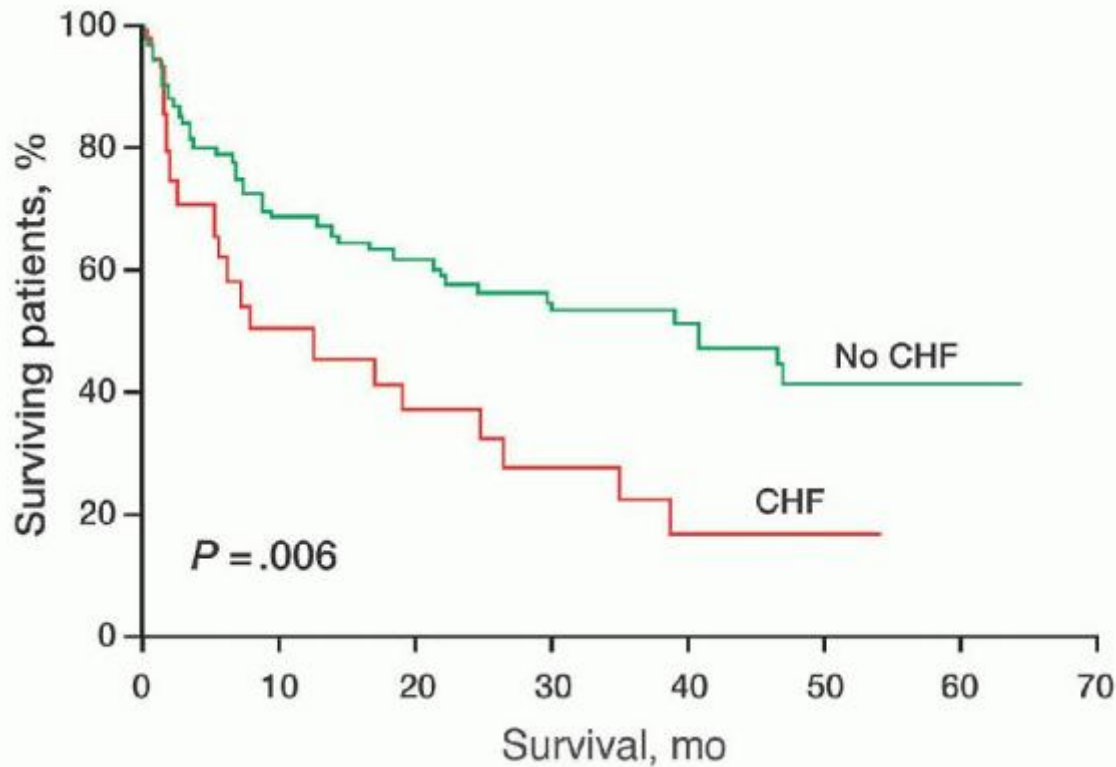

FIGURE 99.12. The effect of congestive heart failure (CHF) on survival of patients with amyloidosis. (From Gertz M, Lacy MQ, Dispenzieri A. Amyloidosis. In: Mehta J, Singhal S, eds. Myeloma. London: Martin Dunitz, 2002. Used with permission.)

In a cohort of 153 patients with AL, the median survival time of the entire group was 20 months; the 5-year survival rate was 20%.³⁷¹ Of the patients who presented with congestive heart failure, the 5-year survival rate was 2.4% and the median survival time was 8 months. When peripheral neuropathy was the sole manifestation of AL, the 5-year survival rate was 32% and the median survival time was 40 months. When assessing the long-term prognosis, the investigators found it useful to classify patients into four groups by clinical manifestations of AL: (1) heart failure, (2) peripheral neuropathy, (3) nephrotic syndrome, and (4) other. Women had a slightly longer survival time than men.

Referral bias definitely is evident at large treatment centers for amyloidosis. To be treated at a distant center, the patient a priori must physically be able to travel. This type of information must be considered when attempting to interpret the results of clinical trials reported from a single center. Of patients with amyloidosis who were evaluated at Mayo Clinic, the median survival was 2 years. If the cohort was limited to patients who were evaluated within 30 days of diagnosis, however, the median survival decreased to 13 months.²¹²

When uniform statistical criteria were applied to a large cohort of patients with AL, the median survival of the entire group was 12 months (range, 4 months [for patients with congestive heart failure] to 50 months [for patients with peripheral neuropathy]).³⁷⁰ Within the first year after diagnosis, the significant prognostic factors included heart failure, urinary light chains, multiple myeloma, and hepatomegaly. After the first year, the predictors of poor outcome were an increased serum creatinine value, multiple myeloma, monoclonal serum protein, and orthostatic hypotension. When studies of treatment outcomes are compared, stratification of variables that affect survival is important.

All patients being assessed for AL should have an echocardiographic evaluation that includes Doppler studies of diastolic performance, ejection fraction, and mitral deceleration time. The absolute values of immunoglobulin free light chains have prognostic value for patients with AL. Patients with higher baseline levels of free light chains have an increased risk of death (hazard ratio, 2.6), and achievement of a free light-chain response is a better predictor of survival than the standard defined complete hematologic response.³⁷² A staging system that includes serum cardiac troponin levels and N-terminal probrain natriuretic peptide (NT-proBNP) levels was developed for patients with AL. Depending on whether troponin and NT-proBNP levels were both low, both high, or high for only one component, three stages were defined with median survivals of 26.4, 10.5, and 3.5 months, respectively (Fig. 99.13). This staging system should facilitate more consistent and reliable comparisons of therapeutic outcomes.³⁷³ A similar result was seen when this staging system was

applied to patients who underwent stem cell transplantation. Patients with stage 3 who underwent transplantation had a median survival of 26.1 months, but patients with stage 1 and stage 2 who underwent transplantation had a median survival of 66 months.³⁷⁴ Reducing the level of amyloidogenic free light chain by more than 50% has been associated with substantial survival benefit, regardless of the type of chemotherapy used. Organ improvement is delayed, but the treatment strategy may be guided by the early effect of therapy on the free light-chain concentration.³⁷⁵

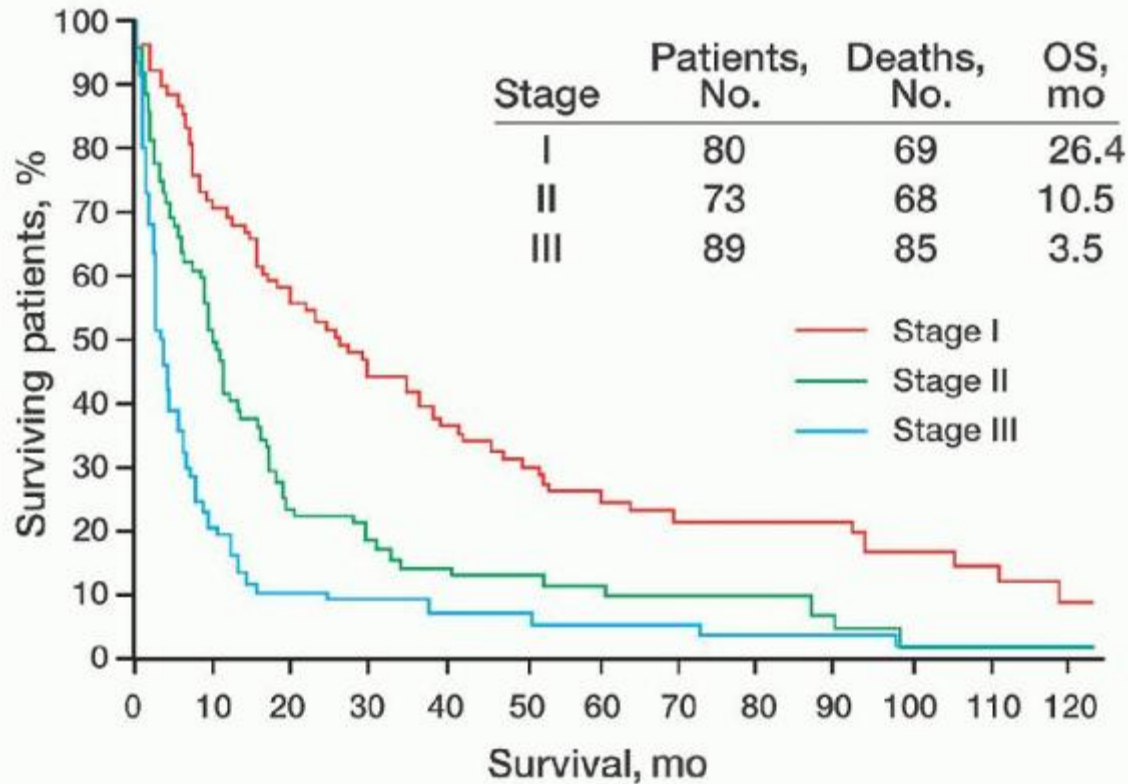

FIGURE 99.13. Survival of patients with primary amyloidosis who were treated with nontransplant therapy. Patients were categorized into three stages by level of brain natriuretic peptide and troponin T levels ($P < .01$). OS, overall survival.

The 4-year overall survival after AL diagnosis has improved during every recent decade of follow-up: 21%, 24%, and 33%, respectively, for the decades 1977 through 1986, 1987 through 1996, and 1997 through 2006 ($P < .001$).³⁷⁶ Yet, the 1-year mortality rate continued to be high during these three decades. A risk stratification score that used cardiac troponin T, NT-proBNP, and uric acid identified the patients at risk for early death. The 1-year mortality rate was 19%, 37%, 61%, and 80%, respectively, for patients with zero, one, two, or three risk factors.³⁷⁶

A 90% reduction in dFLC (the involved less the uninvolved free light-chain level) after stem cell transplant best predicted survival at 3 or 5 years. The median overall survival among those patients with a 90% decrease was not reached compared with 37.4 months for the rest of the patients ($P < .001$). The free light chain level used as a response criterion is a more useful measure than M-protein response. A minimum of a 90% reduction in the dFLC is associated with the best outcomes.³⁷⁷ One study reported that interphase-fluorescence in situ hybridization coupled to cytoplasmic staining of specific Ig is an important test for patients with light-chain amyloidosis³⁷⁸ in whom t(11;14) is an unfavorable prognostic factor. Risk of death for patients who had t(11;14) translocation was 2.1 (95% confidence interval, 1.04 to 6.4), which on multivariate analysis was independent of therapy received.

TREATMENT

Supportive Therapy for Amyloidosis

Cardiac Amyloidosis

Diuretic agents are the mainstay of therapy for patients with cardiac AL.³⁷⁹ Diuretic therapy is complicated because many patients have orthostatic hypotension and intravascular

volume contraction, which are consequences of the nephrotic syndrome.^{380, 381} Diuretic therapy may precipitate a decrease in renal blood flow; the associated increase in serum creatinine concentration may induce syncope.³⁸² Loop diuretics are typically used to control edema. Doses of furosemide may be as high as 120 mg three times per day. If loop diuretics fail to control edema, metolazone may be beneficial.

Patients with recurrent syncope may receive permanent pacemakers.^{383, 384} Those with exertional syncope should be considered for the placement of an implantable cardioverter-defibrillator because most patients with cardiac AL die within 2 months after syncope develops.^{238, 359} For some patients with recurrent syncope, an implantable cardioverter-defibrillator has been placed.³⁸⁵

The standard treatment of patients with heart failure includes orally administered angiotensin-converting enzyme inhibitors.³⁸⁶ Whether these agents result in similar survival benefits for patients with cardiac AL is unknown.^{387, 388} Their use is problematic for AL patients because of the high incidence of associated hypotension. Sudden cardiac death is well recognized in patients with cardiac AL.³⁸⁹ Congestive heart failure may be precipitated by use of calcium channel blockers, such as nifedipine and diltiazem. Amyloid fibrils selectively bind nifedipine, which could result in high intracellular levels of the medication.^{390, 391}

Fludrocortisone acetate (0.1 mg orally two or three times per day) may be used to treat AL orthostatic hypotension.³⁹² The dose has been escalated from 0.4 to 2.0 mg daily.³⁹³ Adverse effects of fludrocortisone include supine hypertension, increased fluid retention with aggravation of heart failure, severe hypokalemia, and edema.³⁹⁴ Fludrocortisone is not well tolerated in elderly patients with AL. Midodrine is another agent that has been used to treat hypotension in AL patients.³⁹⁵ Midodrine dosage starts at 2.5 mg three times per day at 4-hour intervals. Supine hypertension is an adverse effect of midodrine, and the drug is normally given only during waking hours.³⁹⁶ The drug is absorbed rapidly from the intestinal tract, and peak serum levels are attained within 30 minutes. The initial dose may be increased as needed to achieve therapeutic endpoints. The maximum recommended daily dose for midodrine is 40 mg. Active metabolites of midodrine are excreted by the kidney, and patients with renal insufficiency should begin with a reduced dose. Evidence of midodrine toxicity includes restlessness, supine hypertension, and tachycardia. Severe orthostatic hypotension that was not affected by midodrine and fludrocortisone may be treated successfully with erythropoietin, but success is not correlated with the correction of anemia.³⁹⁷

Patients with cardiac AL have received heart transplants. Seven patients who received cardiac allografts had a mean age of 46 years.³⁹⁸ For five of the patients, the mean survival time after transplantation was 32 months. Recurrent amyloid deposits were reported in the allograft for two patients at 3.5 and 4.0 months; one died 13 months after transplantation. There was one operative death. One patient retained heart function (class I) 1 year after transplantation, but amyloid deposits were seen in an endomyocardial biopsy specimen at 14 weeks after transplantation. A successive report of 10 patients³⁹⁹ noted that 4 of 9 patients survived longer than 1 month, and patients had a high prevalence of recurrent amyloid deposition in the transplanted heart. One patient with amyloidosis survived 9 years after cardiac transplantation, and we have experience with a patient who did well 11 years after cardiac transplantation.

A report of 10 patients who received a cardiac transplant between 1984 and 1997 indicated a 20% perioperative mortality rate; the 8 surviving patients had a 50-month follow-up period.⁴⁰⁰ Endomyocardial biopsy specimens showed recurrent amyloid deposits in the grafted heart for five of the eight patients at 5, 11, 12, 28, and 30 months. No patient had echocardiographic evidence of amyloid deposits. Overall, 7 of the 10 patients died after transplantation (median survival, 32 months; range, 3 to 116 months). For four of these seven patients, extracardiac amyloid deposits developed. The 1- and 5-year survival rates were 60% and 30%, respectively. The perioperative mortality rate of 20% was attributable to extracardiac amyloid deposits.

Heart transplantation is feasible technically, but treatment to eliminate the underlying plasma cell proliferative disorder is necessary for a favorable outcome.⁴⁰⁰ Thirteen Mayo Clinic patients with cardiac AL have received a heart transplant.⁴⁰¹ The actuarial 5-year survival rate was 50%, which was inferior to the survival of patients who underwent transplantation for primary cardiomyopathy. Eleven cardiac transplant recipients have received stem cell transplantation at our institution; of these patients, six are alive at 2 to 7 years after the transplantation.

Heart transplantation has been reported by a number of groups for the management of amyloid cardiomyopathy. The United Network for Organ Sharing database contained records of 69 patients with a diagnosis of amyloidosis who received a heart transplant. The records noted 5 operative deaths and 29 late deaths. Nine recipients died of amyloid-related complications. Patient sex influenced survival: The 1-year survival rate was 84% for men and 64% for women.⁴⁰² Five patients had sequential heart transplantation and stem cell transplantation in an effort to prevent recurrent amyloid

deposition. Two patients died of progressive amyloidosis at 33 and 90 months after heart transplantation. Three of five patients were without biopsy evidence of amyloid accumulation.⁴⁰³ One patient had successful allogeneic bone marrow transplantation and cardiac transplantation.⁴⁰⁴ In the United Kingdom, 24 patients with amyloid heart disease had cardiac transplantation; of these patients, 17 had AL. Survival was superior for seven patients with AL who also received chemotherapy; the 1-, 2-, and 5-year survival rates of the seven patients were 86%, 86%, and 64%, respectively. Two were alive at the end of the study period. These survival rates were less than those of patients undergoing transplantation for other indications. Progression of amyloidosis contributed substantially to the increased mortality rate.⁴⁰⁵ In a single-center report of five patients (four of whom received a heart transplant),⁴⁰⁶ two were alive at 60 and 41 months. One patient had a combined heart-liver transplantation, and two patients died after intervention at 23 months.

Nine patients underwent heart transplantation. Eight of the patients received high-dose chemotherapy followed by an autologous stem cell transplant. Six of seven evaluable patients achieved a hematologic complete remission, and one was a partial remission. At a median follow-up of 56 months from heart transplant, five of seven patients are alive without recurrence. Their survival was compared with 17,389 patients who received heart transplant for nonamyloid heart disease: 64% in nonamyloid versus 60% in amyloid patients at 7 years ($P = .83$). Seven of eight patients who received a transplant have had no evidence of recurrent amyloid in their cardiac allograft.⁴⁰⁷

Renal Amyloidosis

Diuretics, compressive support hose, low-sodium diets, and selective use of albumin diuresis are the mainstays of renal therapy for amyloidosis. Angiotensin-converting enzyme inhibitors may reduce proteinuria for patients with nephrotic syndrome. The mechanism appears to be postglomerular vasodilatation. Symptoms of toxicity of angiotensin-converting enzyme inhibitors include hyperkalemia and hypotension. Enalapril and lisinopril have been reported to decrease proteinuria and corticosteroid-resistant nephrotic syndrome that is due to focal segmental glomerulosclerosis. The possibility that angiotensin-converting enzyme inhibitors may be active in amyloid nephropathy has not been explored.^{408, 409}

The results of hemodialysis for AL patients are inferior to those for patients with primary kidney disorders. The 2-year survival rate for all dialysis patients is 76%, but it is 53% for patients

P.2114

with renal AL.⁴¹⁰ The first report of patients with amyloidosis who underwent continuous ambulatory peritoneal dialysis was published in 1984; the three patients survived between 10 to 18 months.⁴¹¹ One of the three patients received a renal transplant and survived 57 months; however, autopsy findings showed widespread amyloidosis. In a review of 61 AL patients receiving dialysis, 18 died within a month after initiating dialysis.⁴¹² Of the 43 other patients, the median survival time was 61 months. Hemodialysis and chronic ambulatory peritoneal dialysis had identical long-term survival rates. Younger patients had superior outcomes. Patients most commonly succumbed to development of extrarenal amyloid deposits in the gastrointestinal tract and heart. In the Mayo Clinic experience, two thirds of the deaths of dialysis patients with AL resulted from extrarenal progression (mostly cardiac amyloidosis). Most reports of the outcome of dialysis for renal amyloidosis describe patients with AA.^{275, 413, 414} In a report of 12 patients (2 with AL), only 4 survived 2 years after kidney transplantation. Renal biopsy specimens from two of the four survivors showed amyloid deposits. Among patients presenting with renal AL, 42% received renal replacement therapy compared with 5% of patients who did not present with renal involvement. Patients with kidney amyloid who ultimately required dialysis support had significantly higher serum creatinine and 24-hour urine protein levels at diagnosis. Patients with λ light chains were significantly more likely to have kidney involvement and had significantly greater urinary protein loss than those with κ light chain. Serum creatinine level was an independent predictor of survival even when corrected for heart involvement. For the 38 patients reported who received dialysis, median survival from the initiation of dialysis was 10.4 months and 26% of patients with AL ultimately received renal replacement therapy compared with 42% of patients who presented with renal AL.⁴¹⁵

The development of amyloidosis in a transplanted kidney is well recognized.⁴¹⁶ Eleven amyloidosis patients were studied after undergoing renal transplantation.⁴¹⁷ Three amyloid recurrences were observed at 11, 28, and 37 months. Two AL patients who underwent renal transplantation died; one had renal failure attributable to new deposits of amyloid in the grafted kidney, and the other had cardiac amyloidosis (renal function was stable). Another report described 45 patients with amyloidosis who underwent kidney transplantation.⁴¹⁸ The 3-year survival rate of these patients was 51%. Patient age greater than 40 years was the major determinant of a poor outcome. The median age of AL patients in the study was 62 years. Recurrent amyloid deposits in the allograft were established histologically for four patients. The authors of the study estimated that the chance of amyloidosis recurrence at 1 year after transplantation was 20%. Two AL patients had

renal biopsies showing recurrent amyloid deposition after transplantation.⁴¹⁹ In that study, no factors predicted recurrence. Two additional AL patients receiving renal transplants were reported. Glomerular amyloidosis developed in one and caused renal failure and death. The other patient died of cardiac amyloidosis. Pasternack et al.⁴¹⁸ reported inferior survival of patients with renal AL.

Living-donor kidney transplantation and autologous stem cell transplantation have been reported in patients with amyloidosis. Eight patients underwent living-donor kidney transplantation. Two had complications and died 3 and 10 months after the procedure. Stem cells were harvested successfully for six patients, and five underwent stem cell transplantation. Renal function was stable for four patients; it was reduced for one patient because of infections and bleeding complications. Sequential living-donor kidney transplantation and autologous stem cell transplantation are feasible,⁴²⁰ although there is controversy about whether the stem cell transplantation should precede the kidney transplantation.⁴²¹ Nineteen patients with AL underwent living (n = 18) or deceased (n = 1) kidney transplantation at our institution from 1999 to 2008 (median age, 57 years⁴²²). Six of the patients were women. Outcome data were stratified in accordance with three treatment regimens: group 1, kidney transplantation followed by autologous stem cell transplantation (n = 8); group 2, autologous stem cell transplantation followed by kidney transplantation (n = 6); and group 3, kidney transplantation after complete remission achieved with nonmyeloablative therapy (n = 5) (median follow-up, 41.4 months). At the time of the study, 79% of the patients were still alive. The treatment groups did not differ in their survival rates. Recurrent amyloidosis was diagnosed through biopsy in a patient in group 2 (before an autologous stem cell transplantation) and in another patient in group 3.

Hepatic and Gastrointestinal Tract Amyloidosis

No specific supportive care measures are available for hepatic amyloidosis. Ascites seen in these patients is more commonly associated with concurrent right-sided heart failure or nephrotic syndrome because portal hypertension is not common. Diuresis and, on occasion, paracentesis are the mainstays of support. Patients with hepatic AL have been treated with transjugular intrahepatic portal systemic shunting,⁴²³ which results in resolution of ascites and hydrothorax. For a patient with renal and hepatic amyloidosis, bilateral nephrectomy resulted in markedly improved liver function and normalization of a previously elevated bilirubin value.⁴²⁴ The median survival of 98 patients with amyloidosis (histologically proven with liver biopsy specimens) was 8.5 months.²⁸¹ Stem cell transplantation performed in tandem at 10 and 14 months after liver transplantation resulted in a good clinical outcome 28 months after liver transplantation.⁴²⁵

Amyloid deposits are commonly seen in the gastrointestinal tract. Intestinal symptoms include alternating diarrhea and constipation in the same patient. Bowel disturbances may result from massive deposits in the gastrointestinal tract; malabsorption syndrome or dysmotility may be a consequence of autonomic involvement. Therapy for diarrhea includes diphenoxylate, tincture of opium, loperamide, or paregoric, but results vary. Octreotide (a somatostatin analog) has been reported to reduce diarrhea. In the short-acting form, the dose is 200 to 300 µg/day, divided into two or three doses. A long-acting form of octreotide, which comes in 10-, 20-, and 30-mg doses, may be used. (This is a sustained-release formulation of injectable octreotide that lasts for 2 months.) A dose may be given on a monthly basis for 2 months, and it may then be adjusted according to the patient's response. Patients who are disabled because of diarrhea and fecal incontinence may undergo a diverting colostomy, which may result in excellent patient satisfaction. Patients with intestinal AL sometimes have such severe nutritional failure that long-term total parenteral nutrition is required. We have not found metoclopramide or cholinergic agents to be effective. A colon biopsy showing amyloid deposits might be localized, not systemic, disease.⁴²⁶

Respiratory Amyloidosis

For patients with localized tracheobronchial or laryngeal amyloidosis, neodymium:yttrium-aluminum-garnet laser therapy is standard treatment. Low-dose irradiation has been reported to improve obstructive symptoms.¹³⁷ Nodular pulmonary amyloidosis may be observed or be treated with surgical excision. For patients with diffuse interstitial pulmonary amyloidosis and true disruption of the alveolar arterial gradient, low doses of prednisone produce symptomatic benefits, although radiographic changes are not evident. The therapy for pulmonary hypertension includes vasodilators and calcium channel blockers. Many patients with amyloidosis are intolerant of these medications because of the associated orthostatic hypotension. Pulmonary amyloidosis may be part of systemic amyloidosis or may be organ limited. Interstitial amyloid deposits affect gas exchange. Airway stenosis from tracheobronchial amyloid deposits may necessitate iterative laser treatment.⁴²⁷

P.2115

Factor X Deficiency

Therapy for factor X deficiency has included the use of oral melphalan, prednisone, and stem cell transplantation.⁴²⁸ For a patient who is an appropriate candidate, splenectomy results in improvement of factor X levels,⁴²⁹ and infusion of activated factor VII can temporarily normalize coagulation factors and permit safe splenectomy.³⁵⁹ The management of factor X deficiency with recombinant human factor VII and splenectomy has resolved intractable hematuria.⁴³⁰ Prothrombin complex concentrates containing high levels of factor X have also been used before performing a hemicolectomy in AL.⁴³¹

Nonchemotherapy Treatment

Dimethyl Sulfoxide

The best results of DMSO treatment were achieved when it was used in topical applications for patients with cutaneous amyloidosis⁴³² and after cystoscopic treatment for patients with bladder amyloidosis.^{142, 433} DMSO is not used in the management of AL today.⁴³⁴

Colchicine

FMF is associated with the development of AA in an autosomal dominant inheritance pattern. Clinical features of FMF are pleuritis, peritonitis, synovitis, and migratory skin rash.⁴³⁵ This disorder is rarely seen in the Western hemisphere, and it primarily affects individuals of Sephardic Jewish, Armenian, Arabic, and Turkish ethnicity. Recurrent attacks of polyserositis are not required for development of amyloidosis. Fully one fourth of patients in whom AA develops do not have any history of arthritis or polyserositis. In the Middle East, one fourth of renal amyloidosis cases are attributable to the presence of FMF.⁷⁷ With the introduction of colchicine therapy, the survival of FMF patients has improved (median, 25 months) and the 5-year survival rate is 20%. For patients with FMF, the clinical manifestation of AA is proteinuria, nephrotic syndrome, and dialysis-dependent renal failure. Colchicine has been shown to prevent attacks of polyserositis effectively in two double-blind placebo-controlled studies^{436, 437}; the frequency of attacks was reduced by 82% and 78%.

Colchicine decreased the incidence of renal amyloidosis by nearly two thirds for patients with FMF.^{438, 439} When patients were adherent with colchicine therapy, development of amyloidosis was rare. Occasionally, colchicine in FMF reversed the proteinuria associated with established renal amyloidosis. When 350 children younger than 16 years (with clinically evident FMF) were given prophylactic colchicine, amyloidosis developed in none.⁴⁴⁰ After renal failure develops from AA in FMF, colchicine prevents recurrent amyloid deposition in the grafted kidney. Colchicine can be administered safely to children and pregnant women.⁴⁴¹ The classic clinical picture of FMF is recurrent, acute, short-lived, febrile, and painful attacks. The gene that causes FMF (MEFV) has been fully sequenced.⁴⁴² Hereditary periodic fevers with amyloidosis have also been described as a cryopyrin-associated periodic syndrome. Colchicine is only effective in the management of FMF and is not effective for any other periodic fever syndrome.⁵⁰

Measuring Responses in Primary Amyloidosis

Surrogate measurements typically are used to assess responses in amyloidosis. For example, responses to treatment may be defined by clinical improvement in dysfunctional organs or by reduced levels of the amyloid precursor protein. The latter involves measuring the monoclonal protein component and applying criteria that were established for patients with multiple myeloma. The third method of defining response is by SAP scan findings, but this technique is not widely available. All patients who have detectable serum or urine monoclonal proteins or free light chains must have this variable monitored after any therapeutic intervention. A reduction in the size of the M component peak or light chain suggests that production of amyloid precursor protein is decreased. The immunoglobulin free light-chain nephelometric assay has been invaluable for quantifying monoclonal proteins that previously were classified only as present or absent. In assessment of response with the free light-chain assay, the criterion conventionally accepted as a partial response is a 50% reduction in the concentration of the free light chains. A very good partial remission is defined as a dFLC less than 40 mg/L. When the free light-chain assay findings are negative (<2% of AL patients) and the M component is not measurable, a response is defined as the disappearance of light chains when examined by immunofixation.⁴⁴³ The median number of plasma cells at diagnosis is 5%, which makes estimation of plasma cell reductions difficult. In addition, even when the percentage of plasma cells is 1% or 2%, sophisticated studies using immunofluorescent assays to detect a clonal population through gene rearrangements suggest that molecular complete responses are rare.⁴⁴⁴

The quantitative serum free light-chain assay has become mandatory for assessing the treatment response of patients with AL. Patients with a hematologic partial response can show evidence of improved cardiac function by echocardiography and by reduction of cardiac biomarkers. The decreased concentration of free light chains is associated with improved survival. Similarly, when free light-chain levels are not reduced after chemotherapy, patients have a high

risk of early death.⁴⁴⁵ The free light-chain test is also useful after histologic tissue diagnosis of amyloidosis to determine whether the patient has AL.⁴⁴⁶ We have found that absolute values of immunoglobulin free light chains have prognostic value for patients undergoing stem cell transplantation. Achievement of a free light-chain response was a better predictor of survival than achievement of a complete hematologic response as defined by serum and urine immunofixation assays. The free light-chain measurements before and after stem cell transplantation are important predictors of outcome.³⁷² When the free light-chain analysis was performed after chemotherapy for 25 patients, the levels of free light chain decreased significantly, and all patients with a κ -to- λ ratio of 0.26:1.65 had a good prognosis.⁴⁴⁷ The circulating free light-chain concentration was measured in 262 patients with AL. Of the 86 patients who had at least a 50% decrease in free light-chain concentration, the 5-year survival rate was 88%; in contrast, patients who did not have a light-chain decrease of 50% had a 5-year survival rate of 39%.³⁷⁵ Used to measure hematologic response, the free light-chain response is a more useful gauge than the M-protein response. Attaining a dFLC reduction of 90% or more is important to improved outcome of patients with light-chain AL.³⁷⁷ Amyloid deposition in fat tissue undergoes substantial histologic regression only after normalization of the level of serum free light chain.⁴⁴⁸

Organ response criteria have been defined. Ideally, a response in amyloidosis is accompanied by improved function of a previously involved organ. A 50% reduction in the amount of albumin excreted in the urine within 24 hours, with no increase in serum creatinine levels and no decrease in serum albumin concentration, is the generally accepted definition of a response for patients with renal amyloid nephrotic syndrome. A 50% reduction in serum alkaline phosphatase with no increase in transaminase or bilirubin levels is considered an organ response for hepatic AL. Reduction in liver size is less common. Documentation of amyloid regressions in the heart is difficult with echocardiography. A reduction in wall thickness of 2 mm, measured by two-dimensional echocardiography, has been proposed as confirmation of a response. Interprocedural variability is considerable, however, and caution is required when confirming a cardiac response or progression on the basis of echocardiographic criteria only. New criteria using NT-proBNP define cardiac response

P.2116

as a reduction of more than 30%, with a minimum decrement of 300 pg/ml. Although rare, a response in amyloid peripheral neuropathy should be documented by an electromyogram showing improved nerve conduction velocities. A consensus definition of organ involvement and treatment response incorporating the free light-chain assay was developed at the Tenth International Symposium on Amyloid and Amyloidosis.⁴⁴⁹

Chemotherapy for Amyloidosis

To date, most therapies for AL have been directed toward killing the underlying plasma cell clone. The cornerstone of therapy, described in the following section, has been alkylation or corticosteroid based. However, with advances made in the last decade for myeloma treatment, new regimens have been tested, but none have been subjected to randomized clinical trials. Successful cytotoxic chemotherapy to induce regression of AL was reported in 1972.⁴⁵⁰ The use of alkylating agents to suppress plasma cell clones in the bone marrow of AL patients occurred after the recognized success of these agents in the treatment of patients with multiple myeloma.⁴⁵¹ More recently, high doses of chemotherapy with peripheral blood stem cell support have been applied.⁴⁵² Unlike in multiple myeloma, recognition of an organ response in AL may take up to 1 year. In the case of intermittent low-dose chemotherapy, it is difficult to distinguish between patients who will respond after longer exposure to therapy and those who will not benefit from therapy and who should be offered an alternative therapeutic approach.^{453, 454} In vitro studies of the plasma cells from AL patients show aberrant light-chain synthesis. In one study,⁴⁵⁵ the cytoplasm of the plasma cells contained light-chain tetramers. After successful alkylating agent-based chemotherapy, light-chain synthesis was suppressed and a clinical response was observed.

The two earliest reports of melphalan and prednisone therapy^{456, 457} showed responses and prolongation of survival for a minority of patients. Patients with renal, cardiac, or liver AL appeared to benefit, but elevated β_2 -microglobulin levels and cardiac involvement were predictors of failure of response.^{458, 459} Although therapy with melphalan and prednisone has been shown repeatedly to benefit a subgroup of patients with AL, the majority of patients did not respond. Even with subset analysis, no cohort had a response rate that exceeded 40%, including patients with single-organ renal involvement and normal serum creatinine values. Moreover, even when patients showed an organ response, follow-up tissue biopsy specimens showed persistent deposits of amyloid.⁴⁶⁰ Because follow-up biopsies are performed infrequently, it is unclear whether clinical improvement is regularly associated with histologic regression. SAP scans suggest, however, that these deposits may be mobilized and that the total amyloid body burden is reduced.

When the Mayo Clinic experience with melphalan and prednisone therapy was reviewed,³⁷¹ the overall response rate was only 18%. Increased serum creatinine concentration also had an adverse impact on survival; patients with serum

creatinine values that exceeded 3 mg/dl at the initiation of therapy did not have a response. The highest response rate (39%) was observed with the small group of patients with nephrotic syndrome, no extrarenal involvement, normal serum creatinine values, and normal echocardiographic findings. Responses were noted for patients with amyloid cardiomyopathy, suggesting that no patient is too ill for treatment. The response rate, however, was low (15%).³⁷¹ Clinical regression of neuropathic symptoms, such as pain, paresthesias, and numbness, is rare after melphalan-based chemotherapy. Although only 18% of patients responded to melphalan, their median survival time was 89 months. The 5-year survival rate of this small subgroup was 78%. The median time to response was 1 year. Nonresponders had a median survival of 15 months. It is often difficult to know when to discontinue low-dose melphalan-based therapy. If alternative therapies, such as high-dose chemotherapy with peripheral blood stem cell support, are not viable, a trial of alkylating agent-based chemotherapy for AL may be beneficial and is a reasonable consideration for virtually all patients.

Long-term survival is possible for patients with AL. One report described 841 patients with AL who were studied over a 21-year period.⁴⁶¹ The actuarial survival rate for the patients at 1, 5, and 10 years was 51%, 16%, and 4.7%, respectively. The 10-year survivors (30 patients) received treatment with melphalan and prednisone. Fourteen had a documented hematologic response with eradication of M protein from the serum and urine. Ten patients had nephrotic-range proteinuria, and four had a reduction in urinary protein excretion of greater than 50%. Unfavorable prognostic features for 10-year survival included heart failure, older age, creatinine values greater than 2 mg/dl, greater than 20% bone marrow plasma cells, and a platelet count greater than $500 \times 10^9/L$. In a report of 10 patients with AL, 8 were treated with cyclophosphamide and melphalan.⁴⁶² No patient responded to treatment. Four patients received infusion of vincristine, doxorubicin, and dexamethasone over 96 hours. Two patients showed a 50% reduction in the serum M component level.

A randomized crossover study of melphalan and prednisone versus colchicine was reported.⁴⁵⁶ The 101 eligible patients were stratified by the clinical manifestation of amyloidosis: (1) heart failure, (2) neuropathy, (3) nephrotic syndrome, and (4) other. Patients were also stratified by age. Significant differences that favored melphalan and prednisone therapy were observed.

Two prospective, randomized noncrossover studies were performed to evaluate melphalan and prednisone therapy for patients with AL. In one study, 219 patients were enrolled.⁴⁵⁷ Patients were stratified by age, sex, and clinical manifestation. Half of the patients had nephrotic-range proteinuria, and 20% had heart failure. The median survival was significantly longer in the groups treated with melphalan and prednisone (17 months) than in the colchicine group (8.5 months).

The second study⁴⁶³ randomly assigned 100 patients to receive colchicine therapy or a combination of melphalan, prednisone, and colchicine. The overall survival of the patient group was 6.7 months in the colchicine-only group and 12.2 months in the melphalan group. With multivariate analysis, melphalan had a significant impact on survival when heart failure was not present.

Although melphalan is a superior therapy in the treatment of AL, the frequency of response with melphalan is low, and the treatment itself is potentially leukemogenic. Of 153 patients receiving melphalan, cytogenetic abnormalities were recognized in 10.⁴⁶⁴ All cytogenetic changes were consistent with damage to hematopoietic stem cells. Eight of the 10 patients died of pancytopenia, one died of progressive renal amyloidosis, and one was alive at the time of publication. Morphologically, four patients had acute leukemia and five had myelodysplasia. Overall, bone marrow damage consistent with alkylation-induced toxicity was observed for 7% of the patient population. The actuarial risk was 21% for myelodysplasia or acute leukemia developing 42 months after initiation of therapy. The median survival period was 8 months after receiving the diagnosis of leukemia or myelodysplasia.

In one study, nine consecutive patients were treated with dexamethasone alone (dosage, 40 mg on days 1 through 4, days 9 through 12, and days 17 through 20, every 5 weeks for three to six cycles).⁴⁶⁵ This treatment was followed by maintenance levels of interferon. Three patients received maintenance levels of dexamethasone (dosage, 40 mg on days 1 through 4, every month for 1 year). An AL organ improvement was reported in eight of the nine patients. Of seven with nephrotic-range proteinuria, six had a 50% reduction in proteinuria, with a median time to response of only 4 months. Organ function improvement was reported in amyloid neuropathy, hepatic involvement, and gastrointestinal involvement. Neither patient with heart failure

P.2117

showed improvement. Dexamethasone has no tendency to cause leukemia, and the responses are faster than with melphalan. When we treated 19 patients with high-dose dexamethasone in an identical regimen without interferon, only 3 had an objective organ response.⁴⁶⁶ The median survival of the entire group was 11.2 months. When cardiac amyloid is

not present, high-dose dexamethasone treatment may produce benefit in some patients with AL. We also have used dexamethasone when melphalan and prednisone therapy failed.⁴⁶⁶ Among 25 patients who received high-dose dexamethasone treatment, three objective responses with organ-specific improvement were observed. The median survival of the entire group was 13.8 months. Dexamethasone may be beneficial when treatment with melphalan fails,⁴⁶⁷ but toxicity may be formidable and may include fluid retention, gastrointestinal bleeding, and colonic perforation.

The combination of melphalan with high-dose dexamethasone treatment has been reported in the management of amyloidosis.⁴⁶⁸ Patients were selected on the basis of their ineligibility for stem cell transplantation. Of 46 patients, a hematologic response was seen in 31 (67%); of these, a hematologic complete response was seen in 15 (33%). Improvement in organ dysfunction was observed in 22 patients (48%). A strong correlation was noted between hematologic response and organ response. Of the patients who achieved a hematologic complete response, 87% had organ improvement. Among the patients who achieved a hematologic response (at least 50% reduction of the M component), organ function improved in 56% of patients. The 15 who had no response also had no improvement in organ function. Advantages of this regimen included a 4% mortality rate on day 100 and resolution of cardiac failure for 6 of 32 patients. The median time to response was short (4.5 months), and only 11% had adverse effects. Using a similar melphalan- and dexamethasone-based regimen, physicians at Weill-Cornell School of Medicine reported a median survival of only 10.5 months. Outcomes appear to be strongly linked to the proportion of patients with cardiac amyloidosis.⁴⁶⁹ With melphalan administered parenterally with dexamethasone in patients who had immunoglobulin light-chain amyloidosis, the median survival of 61 patients was 17.5 months. The 3-month all-cause mortality rate was 28%.⁴⁷⁰ In Boston, a study of 70 patients who were treated with melphalan and dexamethasone showed that, among 48 patients who survived and returned for follow-up assessment, 6 patients (13%) had a full hematologic response and 12 patients (25%) had a partial response. Responses of the patients who received weekly "low-dose" dexamethasone treatment were not inferior compared with those who received 4-day pulses. Median survival for the 70 patients has not yet been reached (median follow-up, 17 months).⁴⁷¹ There appear to be two factors that help account for at least some of this difference. First, the assessment of response using the immunoglobulin free light-chain assay did not exist in the early studies of melphalan-based therapy but has been used regularly since 2005, resulting in improved ability to monitor hematologic responses. Second, the mix of patients, particularly those with cardiac amyloidosis, is very important in determining overall outcomes.

Reduced-dosage dexamethasone produces high response rates for patients with AL⁴⁷² compared with response rates of patients receiving the traditional dosage.⁴⁷³ Among 93 patients with biopsy-proven AL, hematologic complete remissions were observed for 24%, and improvement in AL-related organ dysfunction occurred for 45%.⁴⁷³ Median survival of the entire cohort was 31 months, and the 2-year event-free survival rate was 52%. Heart failure and the β_2 -microglobulin levels were predictors of adverse outcome. Front-line therapy with dexamethasone may lead to durable reversal of AL-related organ dysfunction and to prolonged survival.

Use of thalidomide has been explored in the treatment of amyloidosis. Sixteen patients (median age, 62 years) were treated,⁴⁷⁴ and the median maximum tolerated dose was 300 mg. Exacerbation of peripheral neuropathy and pulmonary edema occurred frequently, and 50% of patients had Grade 3 or 4 toxicity. No patient had a complete hematologic response; 25% had a significant reduction in light-chain proteinuria. Twelve patients at our institution were treated with thalidomide.⁴⁷⁵ Nine patients had cognitive difficulty, edema, and constipation, and two had deep vein thrombosis and syncope. The median time receiving thalidomide therapy was 72 days. Two patients died, and the other 10 withdrew from treatment (6 because of toxicity and 4 because of disease progression). Patients with AL had poor tolerance of thalidomide. In another study,⁴⁷⁶ thalidomide was combined with dexamethasone in doses of up to 400 mg per day. A hematologic response was achieved in 48% of patients, 19% had a hematologic complete response, and 26% had organ responses. The median time to response was 3.6 months. Treatment-related toxicity occurred for 65%. Thalidomide, dexamethasone, and cyclophosphamide have been reported to produce a hematologic response rate of 74%.⁴⁷⁷

A phase 2 trial of 35 patients receiving lenalidomide showed therapeutic activity when lenalidomide was combined with dexamethasone.⁴⁷⁸ When lenalidomide was used alone, four patients showed a response. Eight of 13 evaluable patients had a measurable hematologic response. Three responses were complete or near complete. Lenalidomide is well tolerated by patients with AL and may result in excellent hematologic responses. In an update, progression-free survival of patients with complete response was 49.8 months.⁴⁷⁹ In a second study, 41% of patients receiving salvage treatment with lenalidomide who had renal amyloid had a reduction in urinary protein, but the response duration and overall survival were not reported.⁴⁸⁰ In that study, high-risk patients were less likely to respond to lenalidomide. Therapy with lenalidomide can change cardiac biomarkers⁴⁸¹ and alter renal function in amyloidosis.⁴⁸²

Lenalidomide also has been combined with melphalan and dexamethasone.⁴⁸³ The maximum tolerated dose of lenalidomide is 15 mg. This three-drug oral combination produced hematologic responses in 58% and complete responses in 42%. The 2-year event-free survival rate and the overall survival rate were 54% and 81%, respectively. In addition, lenalidomide was combined with cyclophosphamide and dexamethasone in the treatment of 35 patients.⁴⁸⁴ Hematologic response rate was 60%. In those patients receiving at least 4 treatment cycles, the response rate was 87% (median overall survival, 16.1 months).

A randomized study of cyclophosphamide-thalidomide-dexamethasone treatment compared with melphalan-dexamethasone treatment suggested a greater complete response rate with the three-drug regimen, albeit with greater toxicity.⁴⁸⁵ One cautionary note when using lenalidomide or thalidomide in patients with AL is that the NT-proBNP level appears to increase after the initiation of therapy. Recognition of potential immunomodulatory drug-induced cardiac toxicity is important when these agents are used. High levels of NT-proBNP are predictive of an inability to tolerate immunomodulatory agents for amyloidosis.⁴⁸⁶

Pomalidomide, a derivative of thalidomide with structural similarity to thalidomide and lenalidomide, was given to 29 evaluable patients in one study.⁴⁸⁷ All patients had received treatment previously and 13 of the patients had received a prior autologous stem cell transplantation. Previously, an immunomodulatory agent was given to 15 patients and bortezomib to 12. Twenty-nine patients evaluable for hematologic response were seen. The overall response rate was 38% (11 patients). Combined treatment with pomalidomide and dexamethasone is promising. One-year survival and progression-free survival rates were 77% and 56%, respectively. Pomalidomide was considered effective and safe for patients, including those in whom prior lenalidomide or thalidomide therapy had failed.

Eighty percent of evaluable patients in the first reported study of bortezomib for amyloidosis had a hematologic response.⁴⁸⁸

P.2118

Among 18 patients, the hematologic response rate was 77%, with a 16% complete response rate. A phase 1 dose-escalation study of bortezomib given either twice weekly on days 1, 4, 8, and 11 every 21 days or on days 1, 8, 15, and 22 every 35 days reported hematologic responses in 50% of patients. The weekly regimen was associated with decreased neurotoxicity. There was a 1-year hematologic progression-free rate of 72.2% and 74.6% and a 1-year survival rate of 93.8% and 84%, respectively, for the twice-weekly and once-weekly doses.⁴⁸⁹ Among 70 patients, 29% had renal responses and 13% had cardiac responses. Discontinuation and dose reduction due to the toxicity were greater with the twice-weekly than once-weekly dose. Both dose schedules represent active, well-tolerated regimens in relapsed AL.⁴⁹⁰

The combination of bortezomib and dexamethasone has been used after stem cell transplantation as consolidation to improve the depth of response.⁴⁹¹ Of 23 patients, 17 received bortezomib posttransplantation; 74% achieved a complete response and 58% achieved an organ response. A multicenter study of 94 patients receiving bortezomib and dexamethasone showed hematologic responses in 71% of patients; responses were complete in 25%.⁴⁹² Cardiac response was seen in 29% of patients. The NT-proBNP predicted survival. In a study of bortezomib-dexamethasone therapy in 26 patients, the overall response rate was 54%, with complete responses in 31% of patients. Median time to response was 7.5 weeks, but the median progression-free and overall survivals were 5 and 18.7 months, respectively, suggesting short durability with bortezomib combined with dexamethasone. No grade 3 to 4 neuropathy was observed.⁴⁹³

Stem Cell Transplantation

Hematopoietic stem cell transplantation for AL is inherently different from transplantation for other hematologic cancers.⁴⁹⁴ Patients with lymphoma, multiple myeloma, or leukemia typically have considerable bone marrow abnormalities that manifest as multiple cytopenias, but these patients generally have excellent cardiac, hepatic, and renal function and a performance status of 0 or 1. In contrast, AL patients often have clinically significant visceral organ dysfunction, which puts them at a high risk for complications after high-dose chemotherapy. Hematologic abnormalities such as anemia, leukopenia, and thrombocytopenia are uncommon.

Syngeneic transplantation was reported in the treatment of a patient with AL in 1995.⁴⁹⁵ A SAP scan showed a reduction in amyloid deposits. In one report, two AL patients had ablative allogeneic bone marrow transplantation.⁴⁹⁶ The first had a hematologic response and underwent an allogeneic transplantation after melphalan treatment (110 mg/m²) and total body irradiation (1,200 cGy). The patient achieved a complete hematologic response and was alive 29 months after transplantation. The second patient received a stem cell transplant from a human leukocyte antigen-identical sibling after treatment with melphalan (140 mg/m²) and total body irradiation (800 cGy). The urinary protein loss decreased from 9.15

to 1.3 g/day. The patient had chronic graft-versus-host disease of the skin and liver but was alive 18 months after transplantation.

Allogeneic stem cell transplantation may be a promising treatment, but the mortality rate is high. The European Group for Blood and Marrow Transplantation reported 19 patients with AL.⁴⁹⁷ Fifteen underwent allogeneic transplantation: seven had full-intensity conditioning and eight had reduced-intensity conditioning. Overall survival and progression-free survival at 1 year were 60% and 53%, respectively. The treatment-related mortality rate was 40%. Eight patients had a complete response and two had a partial response. For five of seven evaluable patients who had a complete response, chronic graft-versus-host disease was observed, which implied existence of a graft-versus-amyloidosis effect. Cardiac failure was a clinically significant problem. It is unlikely that allogeneic or nonmyeloablative allogeneic transplantation will be applicable to a large proportion of AL patients because of the age restrictions and the need for good performance status and adequate renal function. Allogeneic hematopoietic cell transplantation after reduced-intensity conditioning should be discussed as a treatment option for relapse after autologous hematopoietic cell transplantation in patients younger than 60 years with preserved organ functions and a HLA-identical donor.⁴⁹⁸

Most reported experiences with myeloablative chemotherapy involve progenitor cell replacement with autologous peripheral blood stem cells. The blood stem cells are used because they are easy to collect and have relatively rapid engraftment kinetics. Most AL patients who receive blood stem cells show clonotypic cells in the apheresis product. CD34⁺ cell selection to eliminate the clonotypic stem cells may be performed, but its impact on outcome is uncertain.⁴⁹⁹ It is known that CD34⁺ selection yields no survival benefit for patients with multiple myeloma who undergo stem cell transplantation,⁵⁰⁰ and we have no reason to believe that the outcome would be different for patients with AL. Clinicians at Boston University first reported five patients with AL receiving stem cell transplants, and all showed a clinical response.⁵⁰¹ When the cohort was expanded to 25 patients, a hematologic response was reported for 62% and an organ response for 65% of surviving patients.⁵⁰²

Another report described 250 patients who received melphalan (100 to 200 mg/m²) before stem cell transplantation.⁵⁰³ The median patient age was 57 years, and 53% of patients had echocardiographic evidence of amyloidosis. The 3-month transplant-related mortality rate was 14%; 11% of patients who initiated stem cell collection did not undergo transplantation because of death or mobilization toxicities that precluded safe transplantation. During mobilization, 23 patients had major morbidities; 18 did not undergo stem cell transplantation. Four patients had cardiac arrest during stem cell infusion, and six additional cardiac arrests were noted during the weeks after transplantation. Febrile neutropenia occurred in 62 patients, 17 had gastrointestinal tract hemorrhage, and 12 had progressive renal failure that required dialysis. At a mean follow-up time of 23 months, 66% of the patients were alive. The best responses were from patients with isolated renal amyloidosis. Lower toxicity grades were observed in patients who received lower conditioning doses of melphalan (100 mg/m²).

Multicenter surveys that reported the outcome of transplantation were first published in 1998.⁵⁰⁴ In France, 21 patients with systemic AL received transplants: 18 were treated with melphalan alone and 3 had regimens that included total body irradiation. The death rate was 43%, and 9 of the 21 died within 1 month after transplantation. All deaths were attributable to multiorgan failure, including one patient with intractable bleeding. Of the 12 survivors, 10 achieved a response. Patient selection clearly affected the results because the median time between diagnosis and transplantation was 11 months. We suggest that the lengthy period before transplantation excluded patients with a worse prognosis. Outcome was predicted by the number of organs involved at the time of transplantation. For patients with two or more affected organs, the 4-year survival rate was 11%. The risk of toxic death when two organs were involved was 75%, which reflected the need for careful patient selection. One study from the United Kingdom described 27 patients who received high-dose melphalan therapy before stem cell transplantation.⁵⁰⁵ Eight treatment-related deaths (30%) occurred: four deaths were attributable to multiorgan failure, two to gastrointestinal tract hemorrhage, one to sepsis, and one to cardiac complications. Despite the high death rate, a clonal response of the bone marrow plasma cells was seen in 64% and organ regression in 57%. Seventeen of the 27 patients were alive at the end of the study. Of the nine patients who received a transplant, four died within a year after transplantation (treatment-related mortality rate, 44%).⁵⁰⁶ Three of the four deaths were attributable to cardiac amyloidosis; the fourth death was of a patient with amyloid involvement of the kidney, nerve,

P.2119

and intestinal tract. The median follow-up of the five survivors was 12.6 months; four patients responded to therapy and one patient had disease progression.

Multiorgan failure and gastrointestinal tract bleeding are more common in transplantation for AL than transplantation for any other indication. Gastrointestinal tract bleeding appears to be highly specific for AL. We reviewed the first 45 patients who received transplants for AL at our institution.⁵⁰⁷ Eleven died after transplantation (median survival time, 2 months). Gastrointestinal tract bleeding was observed in nine (20%). The median time to onset of bleeding was 9 days after transplantation, and the median platelet count was $22 \times 10^9/L$. Bleeding was seen in the upper gastrointestinal tract for two patients, the lower tract for three, and the lower and upper tract for four. Endoscopy was performed for five patients, and all had inflamed, friable gastric and esophageal mucosa. Four of the nine patients with bleeding died, three of multiorgan failure. Gastrointestinal tract bleeding was associated with female sex and poor engraftment of platelets. During the first 100 days after transplantation, the median number of packed red blood cell units administered was 20 for those with gastrointestinal tract bleeding. The exact mechanism underlying bleeding after stem cell transplantation is unknown. The widespread vascular deposits of amyloid may render the vessels rigid and friable, however. High-dose chemotherapy, which causes clinically significant mucosal damage, may also cause bleeding. In our patient cohort, abnormalities of the coagulation system were not involved in the bleeding.

We have described three patients who did not undergo stem cell infusion because of complications related to mobilization.⁵⁰⁸ Two patients died of progressive amyloidosis at 1 and 3 months after mobilization. In the past, we have used two different mobilization schemes. One used filgrastim only ($10 \mu\text{g}/\text{kg}/\text{day}$), and apheresis commenced on day 5. The other scheme used cyclophosphamide ($1.5 \text{ g}/\text{m}^2$) on 2 consecutive days, followed by sargramostim ($5 \mu\text{g}/\text{kg}/\text{day}$), and apheresis began when the white blood cell count exceeded $1,000 \text{ cells}/\mu\text{l}$. The median overall yield was $6.4 \times 10^6 \text{ CD34}^+$ cells/kg. Of patients who received mobilization treatment with cyclophosphamide, the median number of apheresis was three. Of patients receiving filgrastim alone, the median number of apheresis was two, a statistically significant difference.

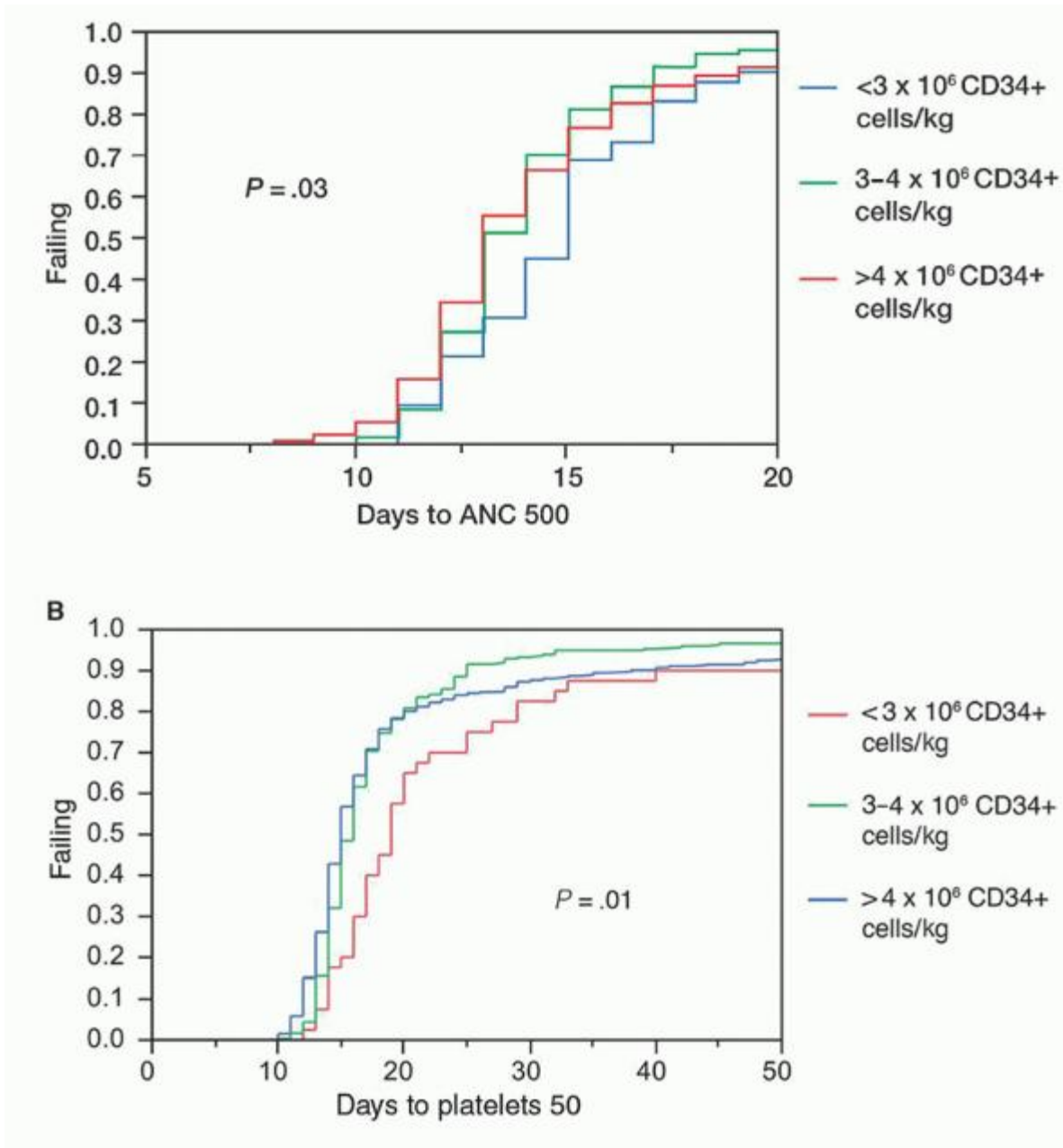

FIGURE 99.14. Engraftment kinetics for neutrophils (A) and platelets (B) posttransplantation. The ideal minimum for CD34⁺ cells is $>3.0 \times 10^6$ cells/kg. ANC, absolute neutrophil count.

At Mayo Clinic, 434 patients with amyloidosis received their transplants at a median of 4.0 months after histologic diagnosis: One fourth within 3 months and three fourths within 6.6 months (median actuarial survival for the entire group, 94.9 months). Predictors of survival included weight gain of greater than 2% during stem cell mobilization and an absolute lymphocyte count at day 15 of greater than 500 cells/ μ L. The number of organs involved appeared to be relevant to predicting the outcome successfully. Patients with two-organ involvement had a median survival rate of 70% at 60 months; and those with three-organ involvement, a median survival of 58 months. The levels of serum creatinine, troponin T, and NT-proBNP and the septal thickness were all significant predictors of outcome.⁵⁰⁹

Engraftment kinetics were similar to those of patients with multiple myeloma. We did not administer growth factor after transplantation because of its impact on fluid retention and the ability of growth factors to precipitate congestive heart failure in amyloidosis patients. A neutrophil count of 500 cells/ μ L was achieved at a median of 14 days (range, 7 to 116 days). Twenty-five percent of patients showed engraftment on or before day 13, 75% by day 16, and 90% by day 22. A platelet count of 20×10^9 /L was achieved at a median of 14 days (range, 6 to 406 days); 25% of patients achieved 20×10^9 /L by day 12, 75% by day 19, and 90% by day 27. A platelet count of 50×10^9 /L was achieved at a median of 18 days;

25% achieved the count by day 14, 75% by day 27, and 90% by day 47. CD34⁺ cell collection had an important impact on the time to platelet engraftment (Fig. 99.14). When the

P.2120

number of infused CD34⁺ cells was greater than 3×10^6 but less than 4×10^6 , engraftment was not significantly different from that of patients who received an infusion with more than 4×10^6 CD34⁺ cells. However, the time to engraftment was significantly longer for platelets and neutrophils when 2×10^6 to 3×10^6 CD34⁺ cells were infused. We therefore set a goal of more than 3×10^6 stem cells for rapid engraftment. Safe engraftment may be achieved by infusing only 2×10^6 cells, but the time to engraftment is prolonged, and the risk of infection, bleeding, and an increased number of transfusions is increased.

Studies have demonstrated that patients with stage III disease should be excluded from transplant studies. The troponin level predicts early death from stem cell transplantation and can be used as an exclusion criterion for this therapy.⁵¹⁰ Troponin T levels should be measured in all patients before transplantation. Data have recently been reported on 10-year survivors: 25% of patients who received a transplant survived 10 years, and the 10-year survival rate was 53% for complete responders. Transplant-related mortality rates are decreasing from as high as 40% to the now-reported 7%. The median actuarial survival for the entire group was 94.9 months.

Our conditioning regimens are typical of those used for patients with multiple myeloma: 62% receive melphalan at a full dose of 200 mg/m², 26% receive a dose of 140 mg/m², and 12% receive lower doses primarily because of advanced cardiac amyloidosis or elevated creatinine levels. We have previously reported that the intensity of chemotherapy is important for the overall outcome and that patients receiving full-dose melphalan appear to survive longer.⁵¹¹ It is difficult to exclude the possibility that patients selected for reduced-intensity chemotherapy had more advanced amyloidosis. At Mayo Clinic, only one quarter of AL patients ultimately undergo stem cell transplantation. Our case-matched control study⁵¹² compared 63 patients who underwent stem cell transplantation with 63 patients who received conventional treatment. The patients were matched for age, sex, cardiac function, creatinine level, and urinary protein loss. We identified an overall survival advantage for patients who underwent transplantation. The Center for International Blood and Marrow Transplant Research reported data results of 107 patients with primary systemic amyloidosis from 48 transplant centers.⁵¹³ The day-30 treatment-related mortality rate was 18%, whereas the Mayo Clinic day-30 mortality rate was 7.4%. The center reported high response rates, and only 11% of patients had disease progression after transplantation. The median projected survival was 47 months; the clinical experience of the centers was the most important predictor of survival. Patients who underwent transplantation within the study's last 5 years survived longer than patients who underwent the procedure more than 5 years earlier. The response rate was 34%, and 33% of patients had stable disease.

An unanswered question is whether transplantation for AL patients should be performed preferentially in specialized centers that have extensive amyloidosis experience or in centers that have extensive transplantation experience for nonamyloidosis diseases. An Eastern Cooperative Oncology Group study suggested that treatment-related mortality rates were not higher in multicenter cooperative group settings.^{514, 515} Stem cell transplantation is not a proven therapy in the management of amyloidosis, despite reports of organ disease remission for 50% of patients.^{516, 517} One study has also shown an improvement in the quality of life of patients who underwent stem cell transplantation.⁵¹⁸ A Group Myélome-Autogreffe and Intergroupe Francophone du Myélome study suggested that overall survival after stem cell transplantation may not be better than survival after a regimen of melphalan and high-dose dexamethasone.⁵¹⁹ This trial randomly assigned 100 patients; the median actuarial survival was 57 months with melphalan and high-dose dexamethasone and 49 months after stem cell transplantation. The patients who underwent transplantation received melphalan (140 or 200 mg/m²) and were mobilized only with granulocyte colony-stimulating factor. The hematologic response rates were 65% and 64% for the patients who did and did not undergo transplantation, respectively. Caution is required when interpreting these results, however; the treatment-related mortality rate was high (24%). Furthermore, only 29 of the 100 patients who underwent transplantation were evaluable for response. On the basis of these small numbers, it is premature to abandon transplantation as a treatment modality for amyloidosis.

The extent of cardiac amyloidosis measured with echocardiography in the transplant population is less than that expected of an unselected nontransplant cohort. The median intraventricular septal thickness was 12 mm; one quarter of patients had a septal thickness of 10 mm or less, and three quarters had less than 14 mm.⁵⁰⁹ The median ejection fraction was 65%; three quarters of patients had an ejection fraction of less than 70%, and one quarter had an ejection fraction of less than 60%. The median actuarial survival is depicted in Figure 99.15. The absolute lymphocyte count 15 days after stem cell transplantation may have an impact on survival.⁵²⁰ The number of organs involved appeared to be a relevant prognostic

factor (Fig. 99.16). Other prognostic factors included the intraventricular septal thickness; the levels of serum creatinine, serum troponin T, and NT-proBNP; and excessive weight gain during stem cell mobilization.⁵²¹ The NT-proBNP levels have profound effects on survival after transplantation, presumably because they reflect progression due to cardiac failure.⁵²² The median level of NT-proBNP among 117 amyloidosis patients at Mayo Clinic was 170 pg/ml; using this concentration as a threshold, the difference in survival is highly significant (Fig. 99.17).

Response has a profound impact on overall survival.⁵²³ Patients who have a 50% reduction of light-chain levels have superior survival compared with those who do not have a 50% decrease. The pretreatment free light-chain value also affects outcome and survival. In a proportional hazards model, overall survival is linked to the pretransplantation free light-chain levels and the number of organs involved. In large medical centers that perform stem cell transplantation, the treatment-related mortality rate is 6% to 18%. Hematologic responses range from 16% to 50%, and reported organ responses range from 34% to 64%. Organ response is a time-dependent variable, and organ responses may be delayed up to 36 months after transplantation. Tandem stem cell transplantations are feasible and have been performed in patients with amyloidosis, but the ultimate effect on outcome is unknown.⁵²⁴ In a published meta-analysis of stem cell transplantation in AL, transplantation did not appear to be superior to conventional chemotherapy in improving survival for

P.2121

patients. But the quality of evidence is low, indicating a need for well-designed and adequately powered randomized clinical trials to better address the role of autologous hematopoietic cell transplantation in AL.⁵²⁵

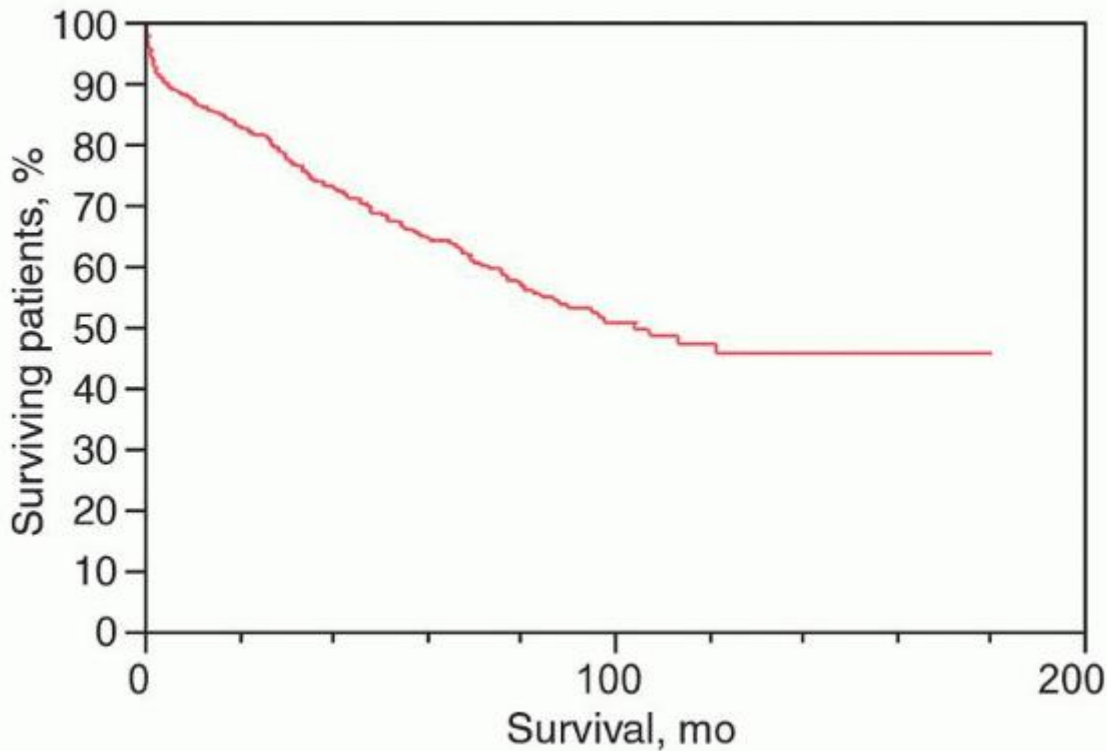

FIGURE 99.15. Survival of patients with primary amyloidosis who underwent stem cell transplantation at Mayo Clinic (N = 492). The median survival time was 80 months. Mortality rate at day-100 was 11%.

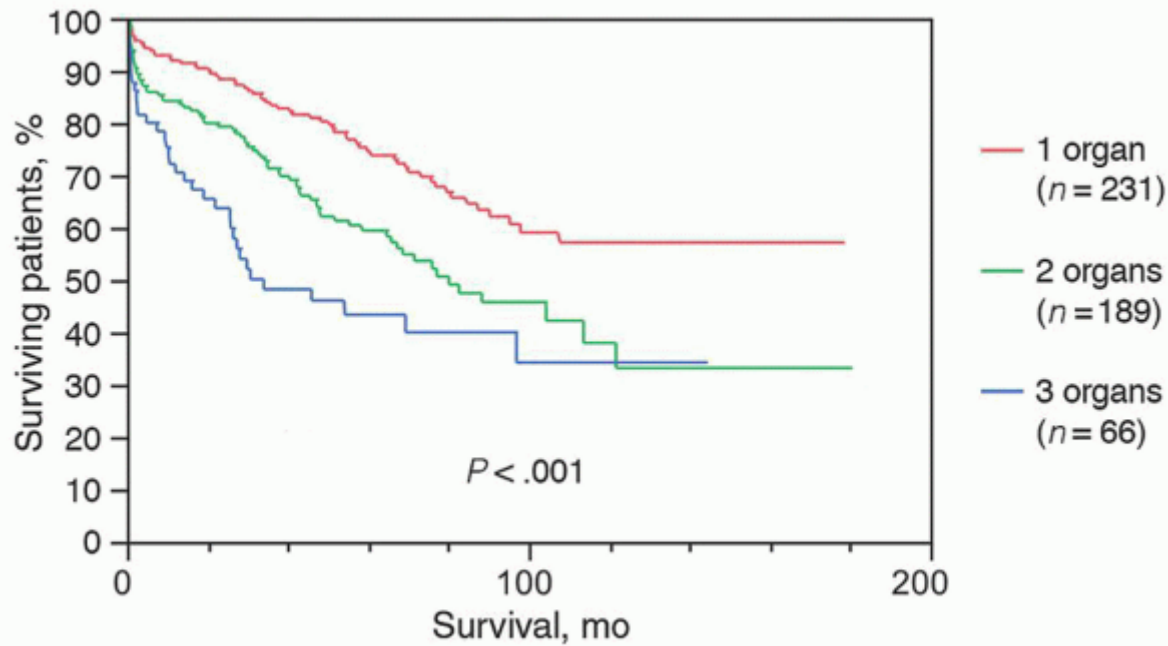

FIGURE 99.16. Effect of the number of affected organs on survival (N = 486). Tick marks indicate censored patients (alive).

The toxicities associated with high-dose chemotherapy are listed in Table 99.5. The response rates that we observed exceeded those of our previous experience with conventional-dose chemotherapy. However, patients receiving high-dose chemotherapy were highly selected, and it is difficult to predict the response rate or survival of an age- and organ-matched population. The most common type of response is the resolution of nephrotic syndrome. Table 99.6 summarizes reported data on stem cell transplantation in nearly 300 patients. Comenzo and Gertz⁵¹⁷ published a risk-adapted strategy for selecting patients with AL and assigning melphalan doses. A review of four single-center studies showed that the day-100 mortality rate was 21%. The contraindications for stem cell transplantation are given in Table 99.7, and the risk-adapted approach is shown in Table 99.8.

Patients with AL who undergo transplantation are highly selected by age, number of organs involved, the absence of advanced heart failure, and performance status. Therefore, a true control group is lacking for comparison. Dispenzieri et al.⁵³³ reviewed 1,288 AL patients seen at Mayo Clinic between 1983 and 1997 and identified patients ineligible for stem cell transplantation using the criteria in Table 99.7. Eligible patients had to have symptomatic amyloidosis without multiple myeloma, an age less than 70 years, an interventricular septal thickness no more than 15 mm, and an ejection fraction greater than 55%. In addition, the serum creatinine value had to be less than 2 mg/dl and the direct bilirubin value had to be less than 2 mg/dl. After the application of these selection criteria, only 229 patients (18%) were eligible for transplantation. The median survival of this nontransplantation cohort was 42 months, and the 5- and 10-year survival rates were 36% and 15%. Clearly, patients who were eligible for transplantation had much better outcomes than those who were ineligible. The predictors of survival included the amount of M protein in the 24-hour urine measurement and the number of involved organs (Fig. 99.18). The alkaline phosphatase value, performance status, and degree of weight loss were also factors that influenced survival. Patients eligible for stem cell transplantation inherently are a low-risk population; certainly, their anticipated median survival time far exceeds the 18 months reported by other studies of patient cohorts that received melphalan and prednisone.^{216, 534}

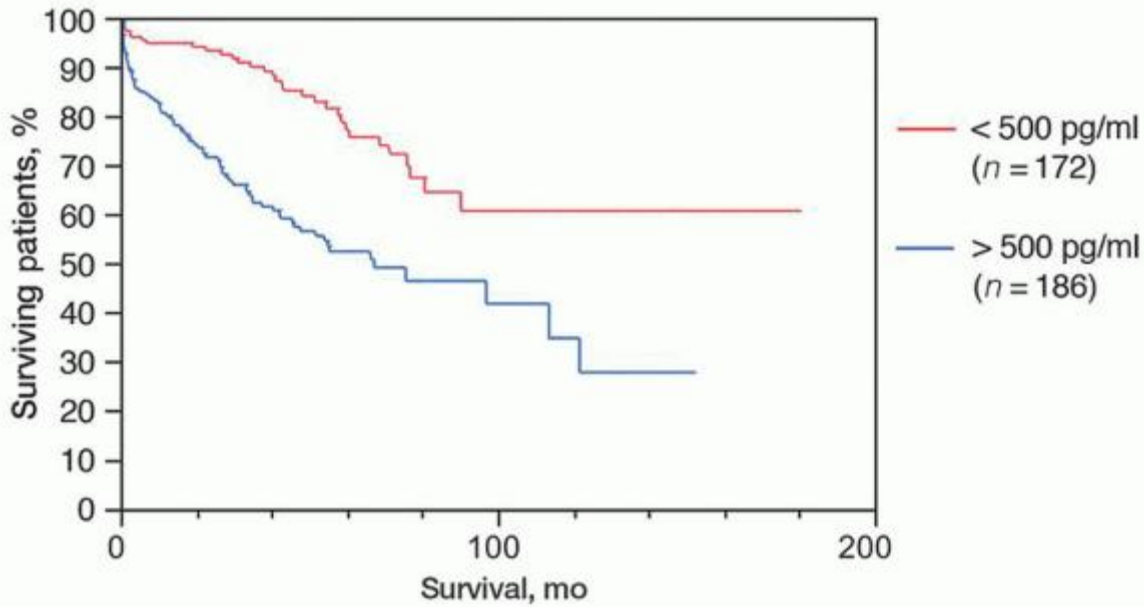

FIGURE 99.17. Effect of N-terminal brain natriuretic peptide level on survival (N = 358).

CONCLUSION

Amyloidosis should be considered in the differential diagnosis of any patient with nephrotic-range proteinuria, monoclonal gammopathy, heart failure, neuropathy, or hepatomegaly. The symptoms of amyloidosis are vague and not useful for establishing a diagnosis. The pathognomonic physical findings are seen in less than one fifth of patients and therefore are not reliable for disease detection. When a patient has a compatible clinical syndrome, the best screening tests include immunofixation of the serum and urine and a free light-chain assay. Monoclonal light chains may be detected in the serum or urine (or both) of nearly 90% of AL patients, and 99% of those who have free light-chain assays of the serum have abnormal findings. Noninvasive studies, such as fat aspiration and bone marrow biopsy, confirm the diagnosis for

P.2122

85% of patients with AL. For patients with biopsy-proven amyloidosis who do not have detectable monoclonal protein in the serum or urine, a nonimmunoglobulin form of amyloidosis should be considered. The prognosis should be assessed by two-dimensional Doppler echocardiography, and levels of NT-proBNP, troponin T, and β_2 -microglobulin should be measured. Systemic therapy is appropriate for most patients. Treatment with melphalan and prednisone provides marginal survival benefit for a minority of patients. High-dose dexamethasone therapy with or without melphalan may be beneficial for a subset of patients. The role of thalidomide and lenalidomide is investigational. Bortezomib appears to have significant activity as a single agent.

TABLE 99.5 TOXIC RESPONSES (SOUTHWEST ONCOLOGY GROUP GRADE, ≥ 2)

Toxic Response	Frequency, % (n)	
	200 mg/m ²	100 mg/m ²
Nausea or vomiting	83 (19)	52 (14)
Diarrhea	65 (15)	48 (13)
Mucositis	91 (21)	37 (10)
Pulmonary edema	35 (8)	26 (7)
Peripheral edema	48 (11)	15 (4)

Non-GI tract bleeding	17 (4)	0 (0)
GI tract bleeding	22 (5)	7 (2)
Hepatic	13 (3)	22 (6)
Renal	35 (8)	19 (5)
Metabolic	35 (8)	7 (2)
Sepsis	26 (6)	11 (3)

GI, gastrointestinal.

TABLE 99.6 PUBLISHED SERIES OF AUTOLOGOUS TRANSPLANTS FOR AMYLOIDOSIS

Reference	No. of Patients	100-d Treatment-Related Mortality	Overall Survival (Intention-to-Treat)	Follow-up Evaluable	Hematologic Response	Amyloid Disease Organ Involvement	
Majolino et al. ⁵²⁶	1	1/1 (100%) CMV pneumonitis	0 at 74 d	1	74 d	PR at 2 wk	Not reported
van Buren et al. ⁴⁹⁵	3 (1 syngeneic)	0	2/2 (100%) at 24 mo	2	12 mo	2/2 (100%) CR	2/2 (100%) PR
Amoura et al. ⁵⁰⁶	9	3/9 (33%) ARF, sepsis, arrhythmia	5/9 (55%) at 5 mo median 12.6 mo	5	Mean, 8.9 mo	Not reported	4/5 (80%), 1/5 CR, 3/5 PR
Moreau et al. ⁵⁰⁴	21	9/21 (43%) multiorgan failure, bleeding, arrhythmia	12/21 (57%) at 14 mo median 14 mo	12	Median, 14 mo	3/12 (25%) CR	10/12 (83%) PR + CR
Schulenburg et al. ⁵²⁷	1	1/1 (100%) GI tract perforation	0 at 4 d	0	NA	NA	NA
Patriarca et al. ⁵²⁸	1	0	1/1 (100%) at 22 mo	1	22 mo	1/1 (100%) CR	1/1 (100%) PR
Saba et al. ⁵²⁹	9	7/9 (78%) (3 during mobilization) arrhythmia, CHF, hypotension	2/9 (22%) at >6 mo after referral	2	Not reported	Not reported	2/2 (100%) PR
Sezer et al. ⁵³⁰	1	0	1/1 (100%) at 3 mo	3 mo	1/1 (100%) CR	1/1 (100%) renal and cardiac PR	
Gertz et al. ⁵⁰⁸	23 (3 never received transplants)	4/20 (20%) pneumonia, multiorgan system failure,	13/23 (57%) at 16 mo median 16 mo	20	Median, >13 mo	8/20 (40%) CR	12/20 (60%) PR

			sudden death				
Reich et al. ⁵³¹	4	2/4 (50%)	acute MI, diffuse alveolar hemorrhage	2/4 (50%) at 7 and 19 mo	7 and 19 1/2 mo	54/115 (47%)	PR 2/2 (100%)
Dember et al. ⁵³² and Sanchorawala et al. ⁵⁰³	205 (20 never received transplants)	28/205 (14%)		115/152 (76%) at >12 mo	115 at >12 mo	54/115 (47%) CR	18/50 (36%) renal CR at 12 mo

ARF, acute renal failure; CHF, congestive heart failure; CMV, cytomegalovirus; CR, complete response; GI, gastrointestinal; MI, myocardial infarction; NA, not applicable; PR, partial response.

TABLE 99.7 CONTRAINDICATIONS FOR STEM CELL TRANSPLANTATION

- Absolute contraindication
 - Clinical congestive heart failure
 - Total bilirubin >3.0 mg/dl
 - Echocardiographic ejection fraction <45%
 - Troponin *T* > 0.06 ng/ml
 - Relative contraindication
 - Serum creatinine >2.0 mg/dl
 - Interventricular septal thickness >15 mm
 - Age >65 y
 - More than two visceral organs involved
- P.2123

TABLE 99.8 RISK-ADAPTED APPROACH TO STEM CELL TRANSPLANTATION FOR AMYLOIDOSIS

- Low risk (all of the following)
 - 1 or 2 organs involved
 - No cardiac involvement
 - Creatinine clearance ≥51 ml/min
 - Any age
- Intermediate risk (all of the following)
 - 1 or 2 organs involved
 - Asymptomatic cardiac or compensated cardiac involvement
 - Creatinine clearance <51 ml/min
 - Age <61 y
- High risk (1 of the following)
 - 3 organs involved^a

Advanced cardiac involvement

Melphalan Dosage (mg/m²) Based on Risk Group and Age

Low Risk	Intermediate Risk	High Risk
200 if age ≤60 y	140 if age ≤50 y	Standard therapy
140 if age 61-70 y	100 if age 51-60 y	Clinical trials
100 if age ≥71 y	-	-

^a Organ involvement includes heart, kidney, nerves, liver, and vascular or soft tissue; it does not include bone marrow, skin, tongue, or gastrointestinal tract.

Modified from Comenzo RL, Gertz MA. Autologous stem cell transplantation for primary systemic amyloidosis. *Blood* 2002;99:4276-4282. Used with permission.

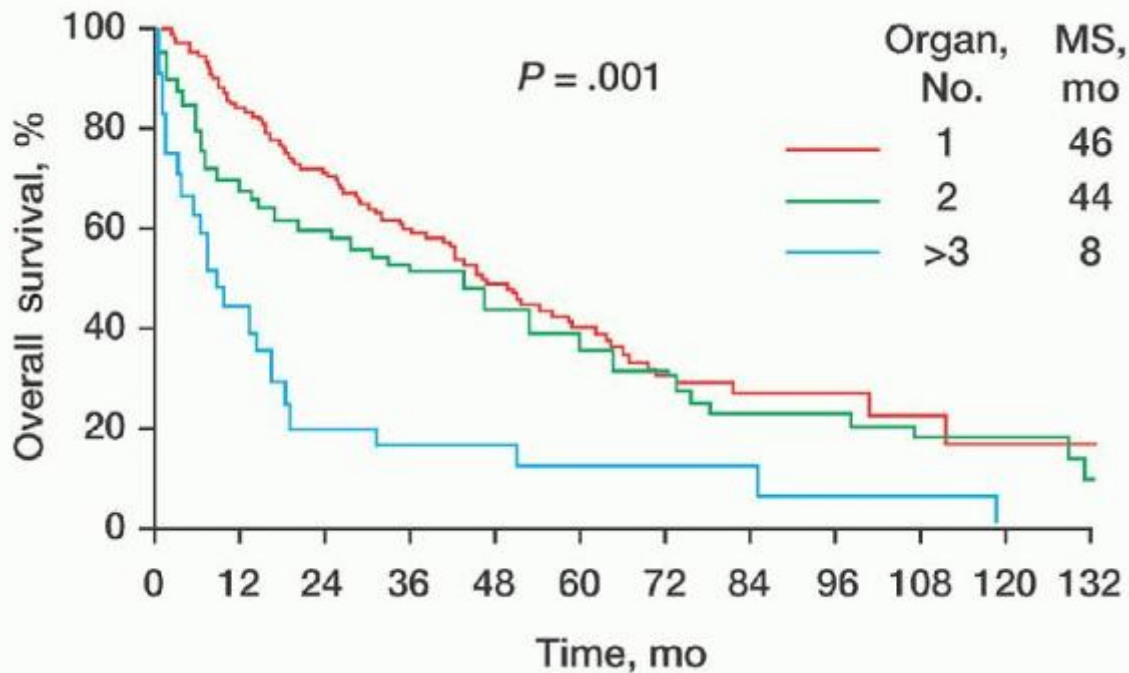

FIGURE 99.18. Effect of the number of involved organs on survival. Patients with amyloidosis were eligible for stem cell transplantation but were treated with melphalan and prednisone. MS, median survival. (From Dispenzieri A, Lacy MQ, Kyle RA, et al. Eligibility for hematopoietic stem-cell transplantation for primary systemic amyloidosis is a favorable prognostic factor for survival. *J Clin Oncol* 2001;19:3350-3356. Used with permission.)

The more aggressive approach of stem cell transplantation may have long-term benefits. Response rates with stem cell transplantation approach 60%, and responders have the potential for long-term survival. However, firm evidence-based data that prove the survival benefit of stem cell transplantation do not exist.

REFERENCES

- Virchow R. Cellular pathology, 2nd ed. (Translation by Chance F.) New York: Robert M. De Witt, 1860:409-413.
- Franke WW. Matthias Jacob Schleiden and the definition of the cell nucleus. *Eur J Cell Biol* 1988;47:145-156.
- Aterman K. A historical note on the iodine-sulphuric acid reaction of amyloid. *Histochemistry* 1976;49:131-143.
- Toro I. Matthias Jacob Schleiden, born 175 years ago [Hungarian]. *Orv Hetil* 1979;120:2682-2685.
- Sipe JD, Cohen AS. Review: history of the amyloid fibril. *J Struct Biol* 2000;130:88-98.
- Cohen AS. History of amyloidosis. *J Intern Med* 1992;232:509-510.

7. Rokitansky MH. Virchow and Heschl on the problem of amyloidosis (a historical study) [German]. *Zentralbl Allg Pathol* 1968;111:103-107.
8. Schwartz P. *Amyloidosis: cause and manifestation of senile deterioration*. Springfield, IL: Charles C Thomas, 1970.
9. Hallett M. Early history of myoclonus. *Adv Neurol* 1986;43:7-10.
10. Le Soldat J. Kekule's dream: additional observations on the "benzol ring" [German]. *Psyche (Stuttg)* 1993;47:180-201.
11. Budd G. *On diseases of the liver*, 2nd ed. London: Churchill, 1852:301-329.
12. Hughes RE. George Budd (1808-1882) and nutritional deficiency diseases. *Med Hist* 1973;17:127-135.
13. Kauntze R. Samuel Wilks. *Guys Hosp Rep* 1970;119:353-355.
14. Banerjee AK. Sir Samuel Wilks: a founding father of clinical science. *J R Soc Med* 1991;84:44-45.
15. Doyle L. Lardaceous disease: some early reports by British authors (1722-1879). *J R Soc Med* 1988;81:729-731.
16. Schmiedeberg O. Ueber die Beziehungen des Hyaloidins zu der Bildung der Chondroitinschwefelsäure, des Collagens und des Amyloids im Organismus. *Arch Exp Pathol Pharmacol* 1920;87:47-73.
17. Bock HE. 80th anniversary of Prof. Dr. Hans Hermann Bennhold on Sept. 11, 1973 [German]. *Med Welt* 1973;24:1341-1342.
18. Divry P, Florkin M. Sur les propriétés optiques de l'amyloïde. *CR Société de Biologie (Paris)* 1927;97:1808-1810.
19. Magnus-Levy A. Bence-Jones-Elweiss and amyloid. *Z Klin Med* 1931;116: 510-531.
20. Apitz K. Die Paraproteinosen (Über die Störung des Eiweisstoffwechsels bei Plasmocytom). *Virchows Archiv f1/4r Pathologische Anatomie und Physiologie (B)* 1940;306:631-639.
21. Isobe T, Osserman EF. Patterns of amyloidosis and their association with plasma-cell dyscrasia, monoclonal immunoglobulins and Bence-Jones proteins. *N Engl J Med* 1974;290:473-477.
22. Eanes ED, Glenner GG. X-ray diffraction studies on amyloid filaments. *J Histochem Cytochem* 1968;16:673-677.
23. Lotz B, Colonna Cesari F. The chemical structure and the crystalline structures of Bombyx mori silk fibroin. *Biochimie* 1979;61:205-214.
24. Pras M, Schubert M, Zucker-Franklin D, et al. The characterization of soluble amyloid prepared in water. *J Clin Invest* 1968;47:924-933.
25. Levin M, Franklin EC, Frangione B, et al. The amino acid sequence of a major nonimmunoglobulin component of some amyloid fibrils. *J Clin Invest* 1972;51:2773-2776.
26. Benditt EP, Eriksen N. Amyloid. 3. A protein related to the subunit structure of human amyloid fibrils. *Proc Natl Acad Sci U S A* 1966;55:308-316.
27. Benditt EP, Eriksen N. Chemical similarity among amyloid substances associated with long standing inflammation. *Lab Invest* 1972;26:615-625.
28. Glenner GG, Harbaugh J, Ohma JI, et al. An amyloid protein: the amino-terminal variable fragment of an immunoglobulin light chain. *Biochem Biophys Res Commun* 1970;41:1287-1289.
29. Glenner GG, Terry W, Harada M, et al. Amyloid fibril proteins: proof of homology with immunoglobulin light chains by sequence analyses. *Science* 1971;172:1150-1151.
30. Glenner GG, Ein D, Eanes ED, et al. Creation of "amyloid" fibrils from Bence Jones proteins in vitro. *Science* 1971;174:712-714.
31. Glenner GG. The discovery of the immunoglobulin origin of amyloid fibrils and its pathogenetic significance. *Acta Pathol Microbiol Scand [A]* 1972;233:114-121.
32. Terry WD, Page DL, Kimura S, et al. Structural identity of Bence Jones and amyloid fibril proteins in a patient with plasma cell dyscrasia and amyloidosis. *J Clin Invest* 1973;52:1276-1281.
33. Steensma DP. "Congo" red: out of Africa? *Arch Pathol Lab Med* 2001;125: 250-252.
34. Elghetany MT, Saleem A, Barr K. The Congo red stain revisited. *Ann Clin Lab Sci* 1989;19:190-195.

35. Blumenfeld W, Hildebrandt RH. Fine needle aspiration of abdominal fat for the diagnosis of amyloidosis. *Acta Cytol* 1993;37:170-174.
36. Yang GC, Nieto R, Stachura I, et al. Ultrastructural immunohistochemical localization of polyclonal IgG, C3, and amyloid P component on the Congo red-negative amyloid-like fibrils of fibrillary glomerulopathy. *Am J Pathol* 1992;141:409-419.
37. Devaney K, Sabnis SG, Antonovych TT. Nonamyloidotic fibrillary glomerulopathy, immunotactoid glomerulopathy, and the differential diagnosis of filamentous glomerulopathies. *Mod Pathol* 1991;4:36-45.
38. Billis A, Homs E. Nonamyloidotic fibrillary glomerulopathy: report of a case and review of the literature. *Int Urol Nephrol* 1991;23:295-301.
39. Wall JS, Gupta V, Wilkerson M, et al. Structural basis of light chain amyloidogenicity: comparison of the thermodynamic properties, fibrillogenic potential and tertiary structural features of four V λ 6 proteins. *J Mol Recognit* 2004;17:323-331.
40. Eulitz M, Weiss DT, Solomon A. Immunoglobulin heavy-chain-associated amyloidosis. *Proc Natl Acad Sci U S A* 1990;87:6542-6546.
41. Langer BU, Missmahl HP. Symptoms of perireticular and pericollagenous amyloidoses [German]. *Fortschr Med* 1980;98:545-548.
42. Missmahl HP, Gelinsky P, Braun HJ, et al. Check-valve-mechanism in Waldenström's macroglobulinemia with pericollagen amyloidosis [German]. *Med Welt* 1969;1:39-41.
43. Coimbra A, Andrade C. Familial amyloid polyneuropathy: an electron microscope study of the peripheral nerve in five cases. I. Interstitial changes. *Brain* 1971;94:199-206.
44. Mahloudji M, Nissim J. Amyloid polyneuropathy, type II (Indiana, or Rukavina type). *Birth Defects Orig Artic Ser* 1971;7:100-101.
45. Weiss SW, Page DL. Amyloid nephropathy of Ostertag with special reference to renal glomerular giant cells. *Am J Pathol* 1973;72:447-460.
46. Lanham JG, Meltzer ML, De Beer FC, et al. Familial amyloidosis of Ostertag. *Q J Med* 1982;51:25-32.
47. Murphy C, Wang S, Kestler D, et al. Leukocyte chemotactic factor 2 (LECT2)-associated renal amyloidosis. *Amyloid* 2011;18(Suppl 1):218-20.
48. Benson MD. Ostertag revisited: the inherited systemic amyloidoses without neuropathy. *Amyloid* 2005;12:75-87.
49. Kyle RA, Rajkumar SV. Monoclonal gammopathies of undetermined significance. *Hematol Oncol Clin North Am* 1999;13:1181-1202.
50. van der Hilst JC, Simon A, Drenth JP. Hereditary periodic fever and reactive amyloidosis. *Clin Exp Med* 2005;5:87-98.
51. Rajkumar SV, Gertz MA, Kyle RA. Primary systemic amyloidosis with delayed progression to multiple myeloma. *Cancer* 1998;82:1501-1505.
52. Wall J, Schell M, Murphy C, et al. Thermodynamic instability of human lambda 6 light chains: correlation with fibrillogenicity. *Biochemistry* 1999;38: 14101-14108.
53. Odani S, Komori Y, Gejyo F. Structural analysis of the amyloidogenic kappa Bence Jones protein (FUR). *Amyloid* 1999;6:77-88.
54. Solomon A, Weiss DT, Pepys MB. Induction in mice of human light-chain-associated amyloidosis. *Am J Pathol* 1992;140:629-637.
55. Perfetti V, Casarini S, Palladini G, et al. Analysis of V λ -J λ expression in plasma cells from primary (AL) amyloidosis and normal bone marrow identified 3r (λ III) as a new amyloid-associated germline gene segment. *Blood* 2002;100:948-953.
56. Solomon A, Frangione B, Franklin EC. Bence Jones proteins and light chains of immunoglobulins: preferential association of the V lambda VI subgroup of human light chains with amyloidosis AL (lambda). *J Clin Invest* 1982;70:453-460.
57. Comenzo RL, Zhang Y, Martinez C, et al. The tropism of organ involvement in primary systemic amyloidosis: contributions of Ig V(L) germ line use and clonal plasma cell burden. *Blood* 2001;98:714-720.

58. Abraham RS, Geyer SM, Price-Troska TL, et al. Immunoglobulin light chain variable (V) region genes influence clinical presentation and outcome in light chain-associated amyloidosis (AL). *Blood* 2003;101:3801-3808. Epub 2002 Dec 19.
59. Mizuno J, Nakagawa H, Tsuji Y, et al. Primary amyloidoma of the thoracic spine presenting with acute paraplegia. *Surg Neurol* 2001;55:378-382.
60. Dikman SH, Churg J, Kahn T. Morphologic and clinical correlates in renal amyloidosis. *Hum Pathol* 1981;12:160-169.
61. Shah VB, Phatak AM, Shah BS, et al. Renal amyloidosis—a clinicopathologic study. *Indian J Pathol Microbiol* 1996;39:179-185.
62. Kyle RA, Bayrd ED. Amyloidosis: review of 236 cases. *Medicine (Baltimore)* 1975;54:271-299.
63. Kyle RA, Linos A, Beard CM, et al. Incidence and natural history of primary systemic amyloidosis in Olmsted County, Minnesota, 1950 through 1989. *Blood* 1992;79:1817-1822.
64. Kyle RA, Beard CM, O'Fallon WM, et al. Incidence of multiple myeloma in Olmsted County, Minnesota: 1978 through 1990, with a review of the trend since 1945. *J Clin Oncol* 1994;12:1577-1583.
65. Linos A, Beard CM, Banks PM, et al. Malignant lymphoma in Olmsted County, Minnesota, 1970 through 1977. *Mayo Clin Proc* 1986;61:706-713.
66. Call TG, Noel P, Habermann TM, et al. Incidence of leukemia in Olmsted County, Minnesota, 1975 through 1989. *Mayo Clin Proc* 1994;69:315-322.
67. Ania BJ, Suman VJ, Sobell JL, et al. Trends in the incidence of polycythemia vera among Olmsted County, Minnesota residents, 1935-1989. *Am J Hematol* 1994;47:89-93.
68. Fonseca R, Rajkumar SV, Ahmann GJ, et al. FISH demonstrates treatment-related chromosome damage in myeloid but not plasma cells in primary systemic amyloidosis. *Leuk Lymphoma* 2000;39:391-395.
69. Fonseca R, Ahmann GJ, Jalal SM, et al. Chromosomal abnormalities in systemic amyloidosis. *Br J Haematol* 1998;103:704-710.
70. Perfetti V, Coluccia AM, Intini D, et al. Translocation t(4;14)(p16.3;q32) is a recurrent genetic lesion in primary amyloidosis. *Am J Pathol* 2001;158:1599-1603.
71. Hoyer JD, Hanson CA, Fonseca R, et al. The (11;14)(q13;q32) translocation in multiple myeloma: a morphologic and immunohistochemical study. *Am J Clin Pathol* 2000;113:831-837.
72. Hayman SR, Bailey RJ, Jalal SM, et al. Translocations involving the immunoglobulin heavy-chain locus are possible early genetic events in patients with primary systemic amyloidosis. *Blood* 2001;98:2266-2268.
73. Kyle RA, Greipp PR. Amyloidosis (AL): clinical and laboratory features in 229 cases. *Mayo Clin Proc* 1983;58:665-683.
74. Kingman A, Pereira NL. Cardiac amyloidosis. *J S C Med Assoc* 2001;97: 201-206.
75. Stamato N, Cahill J, Goodwin M, et al. Cardiac amyloidosis causing ventricular tachycardia: diagnosis made by endomyocardial biopsy. *Chest* 1989;96:1431-1433.
76. Gaan D, Mahoney MP, Rowlands DJ, et al. Postural hypotension in amyloid disease. *Am Heart J* 1972;84:395-400.
77. Paydas S. Report on 59 patients with renal amyloidosis. *Int Urol Nephrol* 1999;31:619-631.
78. Clements IP, Olson LJ, Scanlon PD, et al. The effect of respiration on left ventricular diastolic filling as assessed by radionuclide ventriculography. *Nucl Med Commun* 2000;21:55-63.
79. Low PA. Autonomic neuropathies. *Curr Opin Neurol* 1998;11:531-537.
80. Kobayashi S, Katsube T, Yamaguchi S, et al. Dysautoregulation of the cerebral circulation in primary systemic amyloidosis. *J Cereb Blood Flow Metab* 1984;4:470-473.
81. Gamba G, Montani N, Anesi E, et al. Clotting alterations in primary systemic amyloidosis. *Haematologica* 2000;85:289-292.
82. Mohr A, Miehke S, Klauck S, et al. Hepatomegaly and cholestasis as primary clinical manifestations of an AL-kappa amyloidosis. *Eur J Gastroenterol Hepatol* 1999;11:921-925.
83. Basak PY, Ergin S, Sezer MT, et al. Amyloidosis of the tongue with kappa light chain disease. *Australas J Dermatol* 2001;42:55-57.

84. Herold J, Nicholson AG. Fine needle aspiration cytology in the diagnosis of amyloid in the submandibular gland. *Br J Oral Maxillofac Surg* 1992;30:393-394.
85. Jardinet D, Westhovens R, Peeters J. Sicca syndrome as an initial symptom of amyloidosis. *Clin Rheumatol* 1998;17:546-548.
86. Gertz MA, Kyle RA, Griffing WL, et al. Jaw claudication in primary systemic amyloidosis. *Medicine (Baltimore)* 1986;65:173-179.
87. Schneider BF, Normansell D, Ayers CR, et al. Intermittent claudication as the presenting symptom in primary amyloidosis. *Acta Haematol* 1993;90:106-107.
88. Salvarani C, Gabriel SE, Gertz MA, et al. Primary systemic amyloidosis presenting as giant cell arteritis and polymyalgia rheumatica. *Arthritis Rheum* 1994;37:1621-1626.
89. Rao JK, Allen NB. Primary systemic amyloidosis masquerading as giant cell arteritis: case report and review of the literature. *Arthritis Rheum* 1993;36:422-425.
90. Liepnieks JJ, Burt C, Benson MD. Shoulder-pad sign of amyloidosis: structure of an Ig kappa III protein. *Scand J Immunol* 2001;54:404-408.
91. Roke ME, Brown WF, Boughner D, et al. Myopathy in primary systemic amyloidosis. *Can J Neurol Sci* 1988;15:314-316.
92. Gertz MA, Greipp PR, Kyle RA. Classification of amyloidosis by the detection of clonal excess of plasma cells in the bone marrow. *J Lab Clin Med* 1991;118:33-39.
93. Perfetti V, Garini P, Vignarelli MC, et al. Diagnostic approach to and follow-up of difficult cases of AL amyloidosis. *Haematologica* 1995;80:409-415.
94. Abraham RS, Katzmann JA, Clark RJ, et al. Quantitative analysis of serum free light chains: a new marker for the diagnostic evaluation of primary systemic amyloidosis. *Am J Clin Pathol* 2003;119:274-278.
95. Katzmann JA, Clark RJ, Abraham RS, et al. Serum reference intervals and diagnostic ranges for free kappa and free lambda immunoglobulin light chains: relative sensitivity for detection of monoclonal light chains. *Clin Chem* 2002;48:1437-1444.
96. Chau EM, Cheung SC, Chow SL, et al. Nonsecretory immunoglobulin-derived amyloidosis of the heart: diagnosis by immunohistochemistry of the endomyocardium. *Clin Cardiol* 1997;20:494-496.
97. Gertz MA, Lacy MQ, Dispenzieri A. Amyloidosis: recognition, confirmation, prognosis, and therapy. *Mayo Clin Proc* 1999;74:490-494.
98. Lantz O, Guettier C, Jouvin MH, et al. Diagnosis of AL amyloidosis in the absence of detectable serum or urinary monoclonal component [French]. *Nephrologie* 1986;7:204-206.
99. Drayson M, Tang LX, Drew R, et al. Serum free light-chain measurements for identifying and monitoring patients with nonsecretory multiple myeloma. *Blood* 2001;97:2900-2902.
100. Bradwell AR, Carr-Smith HD, Mead GP, et al. Highly sensitive, automated immunoassay for immunoglobulin free light chains in serum and urine. *Clin Chem* 2001;47:673-680.
101. Hawkins PN. The diagnosis, natural history and treatment of amyloidosis: the Goulstonian Lecture 1995. *J R Coll Physicians Lond* 1997;31:552-560.
102. Hawkins PN, Pepys MB. Imaging amyloidosis with radiolabelled SAP. *Eur J Nucl Med* 1995;22:595-599.
103. Hawkins PN, Lavender JP, Pepys MB. Evaluation of systemic amyloidosis by scintigraphy with ¹²³I-labeled serum amyloid P component. *N Engl J Med* 1990;323:508-513.
104. Hawkins PN. Diagnosis and monitoring of amyloidosis. *Baillieres Clin Rheumatol* 1994;8:635-659.
105. Bodin K, Ellmerich S, Kahan MC, et al. Antibodies to human serum amyloid P component eliminate visceral amyloid deposits. *Nature* 2010;468:93-97.
106. Hawkins PN, Aprile C, Capri G, et al. Scintigraphic imaging and turnover studies with iodine-131 labelled serum amyloid P component in systemic amyloidosis. *Eur J Nucl Med* 1998;25:701-708.
107. Hazenberg BP, van Rijswijk MH, Piers DA, et al. Diagnostic performance of ¹²³I-labelled serum amyloid P component scintigraphy in patients with amyloidosis. *Am J Med* 2006;119:355.e15-24.

108. Murphy CL, Eulitz M, Hrcic R, et al. Chemical typing of amyloid protein contained in formalin-fixed paraffin-embedded biopsy specimens. *Am J Clin Pathol* 2001;116:135-142.
109. Sezer O, Eucker J, Jakob C, et al. Diagnosis and treatment of AL amyloidosis. *Clin Nephrol* 2000;53:417-423.
110. Duston MA, Skinner M, Meenan RF, et al. Sensitivity, specificity, and predictive value of abdominal fat aspiration for the diagnosis of amyloidosis. *Arthritis Rheum* 1989;32:82-85.
111. Maruyama K, Ikeda S, Yanagisawa N, et al. Diagnostic value of abdominal fat tissue aspirate in familial amyloid polyneuropathy. *J Neurol Sci* 1987;81: 11-18.
112. Stavem P, Larsen IF, Ly B, et al. Amyloid deposits in bone marrow aspirates in primary amyloidosis. *Acta Med Scand* 1980;208:111-113.
113. Perfetti V, Colli Vignarelli M, Anesi E, et al. The degrees of plasma cell clonality and marrow infiltration adversely influence the prognosis of AL amyloidosis patients. *Haematologica* 1999;84:218-221.
114. Fatihi E, Zahiri K, Hachim K, et al. Value of the biopsy of accessory salivary glands in amyloidosis [French]. *Rev Med Interne* 1999;20:759-761.
115. Lechapt-Zalcman E, Authier FJ, Creange A, et al. Labial salivary gland biopsy for diagnosis of amyloid polyneuropathy. *Muscle Nerve* 1999;22:105-107.
116. Lee DD, Huang CY, Wong CK. Dermatopathologic findings in 20 cases of systemic amyloidosis. *Am J Dermatopathol* 1998;20:438-442.
117. Rubinow A, Cohen AS. Skin involvement in generalized amyloidosis: a study of clinically involved and uninvolved skin in 50 patients with primary and secondary amyloidosis. *Ann Intern Med* 1978;88:781-785.
118. Kyle RA, Spencer RJ, Dahlin DC. Value of rectal biopsy in the diagnosis of primary systemic amyloidosis. *Am J Med Sci* 1966;251:501-506.
119. Katzmann JA, Dispenzieri A, Abraham RS, et al. Performance of free light chain assays in clinical practice [abstract]. *Blood* 2004;104:216a.
120. Guy CD, Jones CK. Abdominal fat pad aspiration biopsy for tissue confirmation of systemic amyloidosis: specificity, positive predictive value, and diagnostic pitfalls. *Diagn Cytopathol* 2001;24:181-185.
121. Carson FL, Kingsley WB. Nonamyloid green birefringence following Congo red staining. *Arch Pathol Lab Med* 1980;104:333-335.
122. Gradwell E. Amyloid colitis mimicking collagenous colitis. *Histopathology* 1998;32:383.
123. Pomerance A, Slavin G, McWatt J. Experience with the sodium sulphate-Alcian blue stain for amyloid in cardiac pathology. *J Clin Pathol* 1976;29:22-26.
124. Elghetany MT, Saleem A. Methods for staining amyloid in tissues: a review. *Stain Technol* 1988;63:201-212.
125. Hoshii Y, Setoguchi M, Iwata T, et al. Useful polyclonal antibodies against synthetic peptides corresponding to immunoglobulin light chain constant region for immunohistochemical detection of immunoglobulin light chain amyloidosis. *Pathol Int* 2001;51:264-270.
126. Strega RJ, Saeger W, Linke RP. Diagnosis and immunohistochemical classification of systemic amyloidoses: report of 43 cases in an unselected autopsy series. *Virchows Arch* 1998;433:19-27.
127. Kennedy TL, Patel NM. Surgical management of localized amyloidosis. *Laryngoscope* 2000;110:918-923.
128. Cohen AS, Jones LA. Amyloid and amyloidosis. *Curr Opin Rheumatol* 1992;4:94-105.
129. Gillmore JD, Lovat LB, Persey MR, et al. Amyloid load and clinical outcome in AA amyloidosis in relation to circulating concentration of serum amyloid A protein. *Lancet* 2001;358:24-29.
130. Cornwell GG III, Murdoch WL, Kyle RA, et al. Frequency and distribution of senile cardiovascular amyloid: a clinicopathologic correlation. *Am J Med* 1983;75:618-623.
131. Tirzaman O, Wahner Roedler DL, Malek RS, et al. Primary localized amyloidosis of the urinary bladder: a case series of 31 patients. *Mayo Clin Proc* 2000;75:1264-1268.
132. O'Regan A, Fenlon HM, Beamis JF Jr, et al. Tracheobronchial amyloidosis: the Boston University experience from 1984 to 1999. *Medicine (Baltimore)* 2000;79:69-79.

133. Lee HM, Naor J, DeAngelis D, et al. Primary localized conjunctival amyloidosis presenting with recurrence of subconjunctival hemorrhage. *Am J Ophthalmol* 2000;129:245-247.
134. Toyoda M, Ebihara Y, Kato H, et al. Tracheobronchial AL amyloidosis: histologic, immunohistochemical, ultrastructural, and immunoelectron microscopic observations. *Hum Pathol* 1993;24:970-976.
135. Wang WJ, Chang YT, Huang CY, et al. Clinical and histopathological characteristics of primary cutaneous amyloidosis in 794 Chinese patients. *Zhonghua Yi Xue Za Zhi (Taipei)* 2001;64:101-107.
136. Utz JP, Swensen SJ, Gertz MA. Pulmonary amyloidosis: the Mayo Clinic experience from 1980 to 1993. *Ann Intern Med* 1996;124:407-413.
137. Madden BP, Lee M, Paruchuru P. Successful treatment of endobronchial amyloidosis using Nd:YAG laser therapy as an alternative to lobectomy. *Monaldi Arch Chest Dis* 2001;56:27-29.
138. Miura K, Shirasawa H. Lambda III subgroup immunoglobulin light chains are precursor proteins of nodular pulmonary amyloidosis. *Am J Clin Pathol* 1993;100:561-566.
139. Dundore PA, Aisner SC, Templeton PA, et al. Nodular pulmonary amyloidosis: diagnosis by fine-needle aspiration cytology and a review of the literature. *Diagn Cytopathol* 1993;9:562-564.
140. Hocevar-Boltezar I, Zidar N, Zargi M, et al. Amyloidosis of the larynx. *Wein Klin Wochenschr* 2000;112:732-734.
141. Oka N, Fukumori T, Takahashi M, et al. Secondary amyloidosis of the bladder causing macroscopic hematuria. *Int J Urol* 2001;8:330-332.
142. Nurmi MJ, Ekfors TO, Rajala PO, et al. Intravesical dimethyl sulfoxide instillations in the treatment of secondary amyloidosis of the bladder. *J Urol* 1990;143:808-810.
143. Hayashi T, Kojima S, Sekine H, et al. Primary localized amyloidosis of the ureter. *Int J Urol* 1998;5:383-385.
144. Dias R, Fernandes M, Patel RC, et al. Amyloidosis of renal pelvis and urinary bladder. *Urology* 1979;14:401-404.
145. Gepi-Attee S, Gingell JC, Rigby HS. Urethral amyloid. *Br J Urol* 1992;69:431-432.
146. Breathnach SM. Amyloid and amyloidosis. *J Am Acad Dermatol* 1988;18:1-16.
147. Badell A, Servitje O, Graells J, et al. Salivary gland lymphoplasmacytoid lymphoma with nodular cutaneous amyloid deposition and lambda chain paraproteinaemia. *Br J Dermatol* 1996;135:327-329.
148. Inoue K, Takahashi M, Hamamoto Y, et al. An immunohistochemical study of cytokeratins in skin-limited amyloidosis. *Amyloid* 2000;7:259-265.
149. Nakamichi K, Tachibana S. Histology of the transverse carpal ligament and flexor tenosynovium in idiopathic carpal tunnel syndrome. *J Hand Surg [Am]* 1998;23:1015-1024.
150. Subramaniam P, de la Harpe D, Corlett RJ. Focal tenosynovial amyloid deposition as a rare cause of median nerve compression at the wrist. *Aust N Z J Surg* 1997;67:138-139.
151. Kyle RA, Gertz MA, Linke RP. Amyloid localized to tenosynovium at carpal tunnel release: immunohistochemical identification of amyloid type. *Am J Clin Pathol* 1992;97:250-253.
152. Gluck BS, Cabrera J, Strauss B, et al. Amyloid deposition of the breast. *AJR Am J Roentgenol* 2000;175:1590.
153. Halliday BE, Silverman JF, Finley JL. Fine-needle aspiration cytology of amyloid associated with nonneoplastic and malignant lesions. *Diagn Cytopathol* 1998;18:270-275.
154. Athanasou NA, Sallie B. Localized deposition of amyloid in articular cartilage. *Histopathology* 1992;20:41-46.
155. Mitrovic DR, Stankovic A, Quintero M, et al. Amyloid deposits in human knee and hip joints. *Rheumatol Int* 1985;5:83-89.
156. Gertz MA, Kyle RA. Secondary systemic amyloidosis: response and survival in 64 patients. *Medicine (Baltimore)* 1991;70:246-256.
157. Hazenberg BP, van Rijswijk MH. Where has secondary amyloid gone? *Ann Rheum Dis* 2000;59:577-579.
158. Kovacsovic-Bankowski M, Zufferey P, So AK, et al. Secondary amyloidosis: a severe complication of ankylosing spondylitis: two case reports. *Joint Bone Spine* 2000;67:129-133.

159. Hawkins PN, Richardson S, Vigushin DM, et al. Serum amyloid P component scintigraphy and turnover studies for diagnosis and quantitative monitoring of AA amyloidosis in juvenile rheumatoid arthritis. *Arthritis Rheum* 1993;36:842-851.
160. Ahmed Q, Chung-Park M, Mustafa K, et al. Psoriatic spondyloarthropathy with secondary amyloidosis. *J Rheumatol* 1996;23:1107-1110.
161. Chevrel G, Jenvrin C, McGregor B, et al. Renal type AA amyloidosis associated with rheumatoid arthritis: a cohort study showing improved survival on treatment with pulse cyclophosphamide. *Rheumatology (Oxford)* 2001;40:821-825.
162. Gertz MA. Secondary amyloidosis (AA). *J Intern Med* 1992;232:517-518.
163. Laakso M, Mutru O, Isomaki H, et al. Mortality from amyloidosis and renal diseases in patients with rheumatoid arthritis. *Ann Rheum Dis* 1986;45:663-667.
164. Knebel U, Arnold JC, Schilling D, et al. Therapy possibilities in AA amyloidosis in long-term Crohn disease [German]. *Dtsch Med Wochenschr* 2001;126: 279-282.
165. Goldsmith DJ, Roberts IS, Short CD, et al. Complete clinical remission and subsequent relapse of bronchiectasis-related (AA) amyloid induced nephrotic syndrome. *Nephron* 1996;74:572-576.
166. Alabi ZO, Ojo OS, Odesanmi WO. Secondary amyloidosis in chronic osteomyelitis. *Int Orthop* 1991;15:21-22.
167. Tan AU Jr, Cohen AH, Levine BS. Renal amyloidosis in a drug abuser. *J Am Soc Nephrol* 1995;5:1653-1658.
168. Neugarten J, Gallo GR, Buxbaum J, et al. Amyloidosis in subcutaneous heroin abusers ("skin poppers' amyloidosis"). *Am J Med* 1986;81:635-640.
169. Lanjewar DN, Raghuwanshi SR, Gupta D, et al. Systemic amyloidosis in Hodgkin's disease. *Indian Pathol Microbiol* 1998;41:169-171.
170. Tuzuner N, Avanoglu Y, Aktuglu G, et al. Amyloidosis in Hodgkin's disease. *Am J Med* 1992;92:446-448.
171. Coakley FV, Hricak H, Presti JC Jr, et al. Diffuse retroperitoneal amyloidosis due to renal cell carcinoma. *Br J Radiol* 1999;72:412-413.
172. Tang AL, Davies DR, Wing AJ. Remission of nephrotic syndrome in amyloidosis associated with a hypernephroma. *Clin Nephrol* 1989;32:225-228.
173. Silver JR. Pressure ulcer and amyloidosis. *Spinal Cord* 1998;36:293.
174. Barton CH, Vaziri ND, Gordon S, et al. Renal pathology in end-stage renal disease associated with paraplegia. *Paraplegia* 1984;22:31-41.
175. Hackler RH. A 25-year prospective mortality study in the spinal cord injured patient: comparison with the long-term living paraplegic. *J Urol* 1977;117:486-488.
176. Moon WK, Kim SH, Im JG, et al. Castleman disease with renal amyloidosis: imaging findings and clinical significance. *Abdom Imaging* 1995;20: 376-378.
177. Saura IM, Carreton A, Lopez Guillen E, et al. A 21-year-old male patient with nephrotic syndrome and "idiopathic" AA amyloidosis [Spanish]. *Nefrologia* 2004;24 (Suppl 3):109-112.
178. Lachmann HJ, Goodman HJ, Andrews PA, et al. AA amyloidosis complicating hyperimmunoglobulinemia D with periodic fever syndrome: a report of two cases. *Arthritis Rheum* 2006;54:2010-2014.
179. Svendsen IH, Steensgaard-Hansen F, Nordvag BY. A clinical, echocardiographic and genetic characterization of a Danish kindred with familial amyloid transthyretin methionine 111 linked cardiomyopathy. *Eur Heart J* 1998;19:782-789.
180. Ranlov I, Alves IL, Ranlov PJ, et al. A Danish kindred with familial amyloid cardiomyopathy revisited: identification of a mutant transthyretin-methionine 111 variant in serum from patients and carriers. *Am J Med* 1992;93:3-8.
181. Plante-Bordeneuve V, Said G. Transthyretin related familial amyloid polyneuropathy. *Curr Opin Neurol*. 2000;13:569-573.
182. Lobato L, Beirao I, Guimaraes SM, et al. Familial amyloid polyneuropathy type I (Portuguese): distribution and characterization of renal amyloid deposits. *Am J Kidney Dis* 1998;31:940-946.
183. Connors LH, Richardson AM, Theberge R, et al. Tabulation of transthyretin (TTR) variants as of 1/1/2000. *Amyloid* 2000;7:54-69.

184. Gertz MA, Kyle RA, Thibodeau SN. Familial amyloidosis: a study of 52 North American-born patients examined during a 30-year period. *Mayo Clin Proc* 1992;67:428-440.
185. Olson LJ, Gertz MA, Edwards WD, et al. Senile cardiac amyloidosis with myocardial dysfunction: diagnosis by endomyocardial biopsy and immunohistochemistry. *N Engl J Med* 1987;317:738-742.
186. Gertz MA, Kyle RA, Edwards WD. Recognition of congestive heart failure due to senile cardiac amyloidosis. *Biomed Pharmacother* 1989;43:101-106.
187. Husby G, Ranlov PJ, Sletten K, et al. The amyloid in familial amyloid cardiomyopathy of Danish origin is related to pre-albumin. *Clin Exp Immunol* 1985;60:207-216.
188. Smith TJ, Kyle RA, Lie JT. Clinical significance of histopathologic patterns of cardiac amyloidosis. *Mayo Clin Proc* 1984;59:547-555.
189. Jacobson DR, Gorevic PD, Buxbaum JN. A homozygous transthyretin variant associated with senile systemic amyloidosis: evidence for a late-onset disease of genetic etiology. *Am J Hum Genet* 1990;47:127-136.
190. Jacobson DR, Buxbaum JN. Genetic aspects of amyloidosis. *Adv Hum Genet* 1991;20:69-123.
191. Jacobson DR, Pastore RD, Yaghoubian R, et al. Variant-sequence transthyretin (isoleucine 122) in late-onset cardiac amyloidosis in black Americans. *N Engl J Med* 1997;336:466-473.
192. Hamidi Asl L, Fournier V, Billerey C, et al. Fibrinogen A alpha chain mutation (Arg554 Leu) associated with hereditary renal amyloidosis in a French family. *Amyloid* 1998;5:279-284.
193. Pepys MB, Hawkins PN, Booth DR, et al. Human lysozyme gene mutations cause hereditary systemic amyloidosis. *Nature* 1993;362:553-557.
194. Benson MD, Liepnieks JJ, Yazaki M, et al. A new human hereditary amyloidosis: the result of a stop-codon mutation in the apolipoprotein AII gene. *Genomics* 2001;72:272-277.
195. Caballeria J, Bruguera M, Sole M, et al. Hepatic familial amyloidosis caused by a new mutation in the apolipoprotein AI gene: clinical and pathological features. *Am J Gastroenterol* 2001;96:1872-1876.
196. Shaz BH, Lewis WD, Skinner M, et al. Livers from patients with apolipoprotein A-I amyloidosis are not suitable as "domino" donors. *Mod Pathol* 2001;14:577-580.
197. Murphy CL, Wang S, Kestler D, et al. Leukocyte chemotactic factor 2 (LECT2)-associated renal amyloidosis: a case series. *Am J Kidney Dis* 2010;56:1100-1107. Epub 2010 Oct 16.
198. Viana JS, Bento C, Vieira H, et al. Requirements of circulatory support during liver transplantation: are patients with familial amyloidosis different from other patients? *Transplant Proc* 2000;32:2652-2653.
199. Ramirez P, De Mingo P, Andreu F, et al. Long-term results of liver transplantation in four siblings from the same family with familial amyloidotic polyneuropathy type I TTR Ala-71. *Transpl Int* 2000;13(Suppl 1): S171-S173.
200. Nishino M, Tagaya N, Lynch SV, et al. Liver transplantation for familial amyloidotic polyneuropathy in Australia. *J Hepatobiliary Pancreat Surg* 2000;7:312-315.
201. Garcia-Herola A, Prieto M, Pascual S, et al. Progression of cardiomyopathy and neuropathy after liver transplantation in a patient with familial amyloidotic polyneuropathy caused by tyrosine-77 transthyretin variant. *Liver Transpl Surg* 1999;5:246-248.
202. Stangou AJ, Hawkins PN, Heaton ND, et al. Progressive cardiac amyloidosis following liver transplantation for familial amyloid polyneuropathy: implications for amyloid fibrillogenesis. *Transplantation* 1998;66:229-233.
203. Dubrey SW, Davidoff R, Skinner M, et al. Progression of ventricular wall thickening after liver transplantation for familial amyloidosis. *Transplantation* 1997;64:74-80.
204. Lachmann HJ, Booth DR, Booth SE, et al. Misdiagnosis of hereditary amyloidosis as AL (primary) amyloidosis. *N Engl J Med* 2002;346:1786-1791.
205. Comenzo RL, Zhou P, Fleisher M, et al. Seeking confidence in the diagnosis of systemic AL (Ig light-chain) amyloidosis: patients can have both monoclonal gammopathies and hereditary amyloid proteins. *Blood* 2006;107:3489-3491. Epub 2006 Jan 26.

206. Heegaard NH, Hansen MZ, Sen JW, et al. Immunoaffinity chromatographic and immunoprecipitation methods combined with mass spectrometry for characterization of circulating transthyretin. *J Sep Sci* 2006;29: 371-377.
207. Mitsuhashi S, Yazaki M, Tokuda T, et al. Biochemical characteristics of variant transthyretins causing hereditary leptomeningeal amyloidosis. *Amyloid* 2005;12:216-225.
208. Klein CJ, Vrana JA, Theis JD, et al. Mass spectrometric-based proteomic analysis of amyloid neuropathy type in nerve tissue. *Arch Neurol* 2011;68: 195-199. Epub 2010 Oct 11.
209. Vrana JA, Gamez JD, Madden BJ, et al. Classification of amyloidosis by laser microdissection and mass spectrometry-based proteomic analysis in clinical biopsy specimens. *Blood* 2009;114:4957-4959. Epub 2009 Oct 1.
210. Cueto-Garcia L, Reeder GS, Kyle RA, et al. Echocardiographic findings in systemic amyloidosis: spectrum of cardiac involvement and relation to survival. *J Am Coll Cardiol* 1985;6:737-743.
211. Cueto-Garcia L, Tajik AJ, Kyle RA, et al. Serial echocardiographic observations in patients with primary systemic amyloidosis: an introduction to the concept of early (asymptomatic) amyloid infiltration of the heart. *Mayo Clin Proc* 1984;59:589-597.
212. Kyle RA, Gertz MA. Primary systemic amyloidosis. Clinical and laboratory features in 474 cases. *Semin Hematol* 1995;32:45-59.
213. Palladini G, Kyle RA, Larson DR, et al. Multicentre versus single centre approach to rare diseases: the model of systemic light chain amyloidosis. *Amyloid* 2005;12:120-126.
214. Mumford AD, O'Donnell J, Gillmore JD, et al. Bleeding symptoms and coagulation abnormalities in 337 patients with AL-amyloidosis. *Br J Haematol* 2000;110:454-460.
215. Yood RA, Skinner M, Rubinow A, et al. Bleeding manifestations in 100 patients with amyloidosis. *JAMA* 1983;249:1322-1324.
216. Almirante Gragera B, Mirada Canals A. Anemia and primary amyloidosis [Spanish]. *Med Clin* 1985;84:165-166.
217. Jacobson IM, Isselbacher KJ. Amyloidosis and hyposplenism with leukocytosis and thrombocytosis. *Ann Intern Med* 1983;99:573.
218. Selroos O, Pettersson T. Platelet values in amyloidosis. *Scand J Rheumatol* 1973;2:97-100.
219. Gertz MA, Kyle RA. Prognostic value of urinary protein in primary systemic amyloidosis (AL). *Am J Clin Pathol* 1990;94:313-317.
220. Gertz MA, Kyle RA, Noel P. Primary systemic amyloidosis: a rare complication of immunoglobulin M monoclonal gammopathies and Waldenström's macroglobulinemia. *J Clin Oncol* 1993;11:914-920.
221. Gisserot O, Landais C, Cremades S, et al. Amyloid arthropathy and Waldenström macroglobulinemia. *Joint Bone Spine* 2006;73:456-458. Epub 2005 Jul 6.
222. Klein AL, Hatle LK, Taliercio CP, et al. Prognostic significance of Doppler measures of diastolic function in cardiac amyloidosis. A Doppler echocardiography study. *Circulation* 1991;83:808-816.
223. Klein AL, Hatle LK, Taliercio CP, et al. Serial Doppler echocardiographic follow-up of left ventricular diastolic function in cardiac amyloidosis. *J Am Coll Cardiol* 1990;16:1135-1141.
224. Klein AL, Hatle LK, Burstow DJ, et al. Doppler characterization of left ventricular diastolic function in cardiac amyloidosis. *J Am Coll Cardiol* 1989;13:1017-1026.
225. Chew C, Ziady GM, Raphael MJ, et al. Proceedings: functional defect in amyloid heart disease 'the stiff heart syndrome.' *Br Heart J* 1976;38:537.
226. Kilpatrick TR, Horack HM, Moore CB. "Stiff heart" syndrome. An uncommon cause of heart failure. *Med Clin North Am* 1967;51:959-966.
227. Klein AL, Canale MP, Rajagopalan N, et al. Role of transesophageal echocardiography in assessing diastolic dysfunction in a large clinical practice: a 9-year experience. *Am Heart J* 1999;138:880-889.
228. Moyssakis I, Triposkiadis F, Rallidis L, et al. Echocardiographic features of primary, secondary and familial amyloidosis. *Eur J Clin Invest* 1999;29:484-489.

229. Kabbani SS, LeWinter MM. Diastolic heart failure. Constrictive, restrictive, and pericardial. *Cardiol Clin* 2000;18:501-509.
230. Hongo M, Yamamoto H, Kohda T, et al. Comparison of electrocardiographic findings in patients with AL (primary) amyloidosis and in familial amyloid polyneuropathy and anginal pain and their relation to histopathologic findings. *Am J Cardiol* 2000;85:849-853.
231. Ogawa H, Mizuno Y, Ohkawara S, et al. Cardiac amyloidosis presenting as microvascular angina—a case report. *Angiology* 2001;52:273-278.
232. Hemmingson LO, Eriksson P. Cardiac amyloidosis mimicking hypertrophic cardiomyopathy. *Acta Med Scand* 1986;219:421-432.
233. Sedlis SP, Saffitz JE, Schwob VS, et al. Cardiac amyloidosis simulating hypertrophic cardiomyopathy. *Am J Cardiol* 1984;53:969-970.
234. Masugata H, Mizushige K, Senda S, et al. Comparison of left ventricular diastolic filling with myocyte bulk modulus using Doppler echocardiography and acoustic microscopy in pressure-overload left ventricular hypertrophy and cardiac amyloidosis. *Clin Cardiol* 2000;23:115-122.
235. Celletti F, Fattori R, Napoli G, et al. Assessment of restrictive cardiomyopathy of amyloid or idiopathic etiology by magnetic resonance imaging. *Am J Cardiol* 1999;83:798-801.
236. Elliott PM, Mahon NG, Matsumura Y, et al. Tissue Doppler features of cardiac amyloidosis. *Clin Cardiol* 2000;23:701.
237. Abdalla I, Murray RD, Lee JC, et al. Duration of pulmonary venous atrial reversal flow velocity and mitral inflow a wave: new measure of severity of cardiac amyloidosis. *J Am Soc Echocardiogr* 1998;11:1125-1133.
238. Chamarthi B, Dubrey SW, Cha K, et al. Features and prognosis of exertional syncope in light-chain associated AL cardiac amyloidosis. *Am J Cardiol* 1997;80:1242-1245.
239. Gertz MA, Grogan M, Kyle RA, et al. Endomyocardial biopsy-proven light chain amyloidosis (AL) without echocardiographic features of infiltrative cardiomyopathy. *Am J Cardiol* 1997;80:93-95.
240. Lindqvist P, Olofsson BO, Backman C, et al. Pulsed tissue Doppler and strain imaging discloses early signs of infiltrative cardiac disease: a study on patients with familial amyloidotic polyneuropathy. *Eur J Echocardiogr* 2006;7:22-30.
241. Oki T, Fukuda N, Iuchi A, et al. Left atrial systolic performance in the presence of elevated left ventricular end-diastolic pressure: evaluation by transesophageal pulsed Doppler echocardiography of left ventricular inflow and pulmonary venous flow velocities. *Echocardiography* 1997;14:23-32.
242. Kohno I, Komori S, Yamamoto K, et al. Hypertrophic cardiomyopathy complicated with cardiac amyloidosis. *Intern Med* 2000;39:637-640.
243. Wright BL, Grace AA, Goodman HJ. Implantation of a cardioverter-defibrillator in a patient with cardiac amyloidosis. *Nat Clin Pract Cardiovasc Med* 2006;3:110-114.
244. Kornberg A, Rapoport M, Yona R, et al. Amyloidosis of the pericardium in multiple myeloma: an unusual cause of bloody pericardial effusion. *Isr J Med Sci* 1993;29:794-797.
245. Navarro JF, Rivera M, Ortuno J. Cardiac tamponade as presentation of systemic amyloidosis. *Int J Cardiol* 1992;36:107-108.
246. Pellikka PA, Holmes DR Jr, Edwards WD, et al. Endomyocardial biopsy in 30 patients with primary amyloidosis and suspected cardiac involvement. *Arch Intern Med* 1988;148:662-666.
247. vanden Driesen RI, Slaughter RE, Strugnell WE. MR findings in cardiac amyloidosis. *AJR Am J Roentgenol* 2006;186:1682-1685.
248. Mekinian A, Lions C, Leleu X, et al; Amyloidosis Study Group. Prognosis assessment of cardiac involvement in systemic AL amyloidosis by magnetic resonance imaging. *Am J Med* 2010;123:864-868.
249. Browne RS, Schneiderman H, Kayani N, et al. Amyloid heart disease manifested by systemic arterial thromboemboli. *Chest* 1992;102:304-307.
250. Dubrey S, Pollak A, Skinner M, et al. Atrial thrombi occurring during sinus rhythm in cardiac amyloidosis: evidence for atrial electromechanical dissociation. *Br Heart J* 1995;74:541-544.

251. Mueller PS, Edwards WD, Gertz MA. Symptomatic ischemic heart disease resulting from obstructive intramural coronary amyloidosis. *Am J Med* 2000;109:181-188.
252. Al Suwaidi J, Velianou JL, Gertz MA, et al. Systemic amyloidosis presenting with angina pectoris. *Ann Intern Med* 1999;131:838-841.
253. Neben-Wittich MA, Wittich CM, Mueller PS, et al. Obstructive intramural coronary amyloidosis and myocardial ischemia are common in primary amyloidosis. *Am J Med* 2005;118:1287.
254. Jacobson DR, Gertz MA, Buxbaum JN. Transthyretin VAL107, a new variant associated with familial cardiac and neuropathic amyloidosis. *Hum Mutat* 1994;3:399-401.
255. Kyle RA, Spittell PC, Gertz MA, et al. The premortem recognition of systemic senile amyloidosis with cardiac involvement. *Am J Med* 1996;101:395-400.
256. Ng B, Connors LH, Davidoff R, et al. Senile systemic amyloidosis presenting with heart failure: a comparison with light chain-associated amyloidosis. *Arch Intern Med* 2005;165:1425-1429.
257. Germain MJ, Anderson RW, Keane WF. Renal disease in cryoglobulinemia type II: response to therapy. A case report and review of the literature. *Am J Nephrol* 1982;2:221-226.
258. Randall RE, Williamson WC Jr, Mullinax F, et al. Manifestations of systemic light chain deposition. *Am J Med* 1976;60:293-299.
259. Lin J, Markowitz GS, Valeri AM, et al. Renal monoclonal immunoglobulin deposition disease: the disease spectrum. *J Am Soc Nephrol* 2001;12:1482-1492.
260. Bellotti V, Merlini G. Current concepts on the pathogenesis of systemic amyloidosis. *Nephrol Dial Transplant* 1996;11(Suppl 9):53-62.
261. Yahya TM, Pingle A, Boobes Y, et al. Analysis of 490 kidney biopsies: data from the United Arab Emirates Renal Diseases Registry. *J Nephrol* 1998;11:148-150.
262. Duda SH, Raible RT, Risler T, et al. Therapeutic bilateral renal artery embolization in the nephrotic syndrome [German]. *Dtsch Med Wochenschr* 1994;119:58-62.
263. Montseny JJ, Kleinknecht D, Meyrier A, et al. Long-term outcome according to renal histological lesions in 118 patients with monoclonal gammopathies. *Nephrol Dial Transplant* 1998;13:1438-1445.
264. Browning M, Banks R, Tribe C, et al. Renal involvement in systemic amyloidosis. *Proc Eur Dial Transplant Assoc* 1983;20:595-602.
265. Sasatomi Y, Kiyoshi Y, Uesugi N, et al. Prognosis of renal amyloidosis: a clinicopathological study using cluster analysis. *Nephron* 2001;87:42-49.
266. Buxbaum J, Gallo G. Nonamyloidotic monoclonal immunoglobulin deposition disease: light-chain, heavy-chain, and light- and heavy-chain deposition diseases. *Hematol Oncol Clin North Am* 1999;13:1235-1248.
267. Winer RL, Wuerker RB, Erickson JO, et al. Ultrastructural examination of urinary sediment. Value in renal amyloidosis. *Am J Clin Pathol* 1979;71:36-39.
268. Shiiki H, Shimokama T, Yoshikawa Y, et al. Renal amyloidosis: correlations between morphology, chemical types of amyloid protein and clinical features. *Virchows Arch A Pathol Anat Histopathol* 1988;412:197-204.
269. Rikitake O, Sakemi T, Yoshikawa Y, et al. Adult Fanconi syndrome in primary amyloidosis with lambda light-chain proteinuria. *Jpn J Med* 1989;28:523-526.
270. Liu YC, Liu P, Pan JS. Renal involvement in amyloidosis: analysis of 4 cases [Chinese]. *Zhonghua Nei Ke Za Zhi* 1990;29:593-596;636-637.
271. Kurosu M, Ando Y, Takeda S, et al. Immunotactoid glomerulopathy characterized by steroid-responsive massive subendothelial deposition. *Am J Kidney Dis* 2001;37:E21.
272. Looi LM. Fibrillary deposits: amyloids and tactoids. *Malays J Pathol* 1995;17:1-10.
273. Decourt C, Touchard G, Preud'homme JL, et al. Complete primary sequences of two lambda immunoglobulin light chains in myelomas with nonamyloid (Randall-type) light chain deposition disease. *Am J Pathol* 1998; 153:313-318.

274. Stokes MB, Jagirdar J, Burchstin O, et al. Nodular pulmonary immunoglobulin light chain deposits with coexistent amyloid and nonamyloid features in an HIV-infected patient. *Mod Pathol* 1997;10:1059-1065.
275. Gillmore JD, Madhoo S, Pepys MB, et al. Renal transplantation for amyloid end-stage renal failure-insights from serial serum amyloid P component scintigraphy. *Nucl Med Commun* 2000;21:735-740.
276. Harvey CJ, Gower PE, Hawkins PN, et al. Occult adrenal insufficiency secondary to amyloidosis in the context of chronic renal failure. *Nephrol Dial Transplant* 1995;10:1237-1239.
277. Gertz MA, Kyle RA. Hepatic amyloidosis (primary [AL], immunoglobulin light chain): the natural history in 80 patients. *Am J Med* 1988;85:73-80.
278. Gastineau DA, Gertz MA, Rosen CB, et al. Computed tomography for diagnosis of hepatic rupture in primary systemic amyloidosis. *Am J Hematol* 1991;37:194-196.
279. Gertz MA, Kyle RA. Hepatic amyloidosis: clinical appraisal in 77 patients. *Hepatology* 1997;25:118-121.
280. Pras M, Frangione B, Franklin EC, et al. Idiopathic AL-kiv amyloidosis presenting as giant hepatomegaly. *Isr J Med Sci* 1982;18:866-869.
281. Park MA, Mueller PS, Kyle RA, et al. Primary (AL) hepatic amyloidosis: clinical features and natural history in 98 patients. *Medicine (Baltimore)* 2003;82:291-298.
282. Lovat LB, Persey MR, Madhoo S, et al. The liver in systemic amyloidosis: insights from ¹²³I serum amyloid P component scintigraphy in 484 patients. *Gut* 1998;42:727-734.
283. Rockey DC. Striking cholestatic liver disease: a distinct manifestation of advanced primary amyloidosis. *South Med J* 1999;92:236-241.
284. Itescu S. Hepatic amyloidosis: an unusual cause of ascites and portal hypertension. *Arch Intern Med* 1984;144:2257-2259.
285. Serra L, Poppi MC, Criscuolo M, et al. Primary systemic amyloidosis with giant hepatomegaly and portal hypertension: a case report and a review of the literature. *Ital J Gastroenterol* 1993;25:435-438.
286. Iwai M, Ishii Y, Mori T, et al. Cholestatic jaundice in two patients with primary amyloidosis: ultrastructural findings of the liver. *J Clin Gastroenterol* 1999;28:162-166.
287. Buck FS, Koss MN. Hepatic amyloidosis: morphologic differences between systemic AL and AA types. *Hum Pathol* 1991;22:904-907.
288. Koizumi K, Monzawa S, Shindo C, et al. Primary hepatic amyloidosis well delineated by Tc-99m DTPA galactosyl HAS liver SPECT. *Clin Nucl Med* 1999;24:271-273.
289. Rao BK, Padmalatha C, Au Buchon J, et al. Hepatic and splenic scintigraphy in idiopathic systemic amyloidosis. *Eur J Nucl Med* 1981;6:143-146.
290. Powsner RA, Simms RW, Chudnovsky A, et al. Scintigraphic functional hyposplenism in amyloidosis. *J Nucl Med* 1998;39:221-223.
291. Yaghoobian J, Pinck RL, Naidich J, et al. Angiographic findings in liver amyloidosis. *Radiology* 1980;136:332.
292. Mukhopadhyaya A, Raghuram L, Justus A, et al. Transcatheter hepatic artery embolization for spontaneous rupture of amyloid liver. *Indian J Gastroenterol* 2004;23:26-27.
293. Levy M, Polliack A, Lender M, et al. The liver in amyloidosis. *Digestion* 1974;10:40-51.
294. Seo IS, Li CY. Hyposplenic blood picture in systemic amyloidosis. Its absence is not a predictable sign for absence of splenic involvement. *Arch Pathol Lab Med* 1995;119:252-254.
295. Okazaki K, Moriyasu F, Shiomura T, et al. Spontaneous rupture of the spleen and liver in amyloidosis-a case report and review of the literature. *Gastroenterol Jpn* 1986;21:518-524.
296. Russell TJ, Ferrera PC. Spontaneous rupture of an amyloid spleen in a patient on continuous ambulatory peritoneal dialysis. *Am J Emerg Med* 1998;16:279-280.
297. Hayman SR, Lacy MQ, Kyle RA, et al. Primary systemic amyloidosis: a cause of malabsorption syndrome. *Am J Med* 2001;111:535-540.
298. Gilat T, Spiro HM. Amyloidosis and the gut. *Am J Dig Dis* 1968;13:619-633.

299. Tada S, Iida M, Yao T, et al. Intestinal pseudo-obstruction in patients with amyloidosis: clinicopathologic differences between chemical types of amyloid protein. *Gut* 1993;34:1412-1417.
300. Guirl MJ, Hogenauer C, Santa Ana CA, et al. Rapid intestinal transit as a primary cause of severe chronic diarrhea in patients with amyloidosis. *Am J Gastroenterol* 2003;98:2219-2225.
301. Tada S, Iida M, Yao T, et al. Gastrointestinal amyloidosis: radiologic features by chemical types. *Radiology* 1994;190:37-42.
302. Lau CF, Fok KO, Hui PK, et al. Intestinal obstruction and gastrointestinal bleeding due to systemic amyloidosis in a woman with occult plasma cell dyscrasia. *Eur J Gastroenterol Hepatol* 1999;11:681-685.
303. Wald A, Kichler J, Mendelow H. Amyloidosis and chronic intestinal pseudoobstruction. *Dig Dis Sci* 1981;26:462-465.
304. Domingo-Garcia P, Pardo-Garcia JL, Martinez-Albaladejo M, et al. Amyloid intestinal pseudo-obstruction as initial manifestation of IgA multiple myeloma [Spanish]. *An Med Interna* 1995;12:283-285.
305. Friedman S, Janowitz HD. Systemic amyloidosis and the gastrointestinal tract. *Gastroenterol Clin North Am* 1998;27:595-614.
306. Whitby EH, Peck RJ. Case report: ultrasound of primary generalised AL amyloid of the small bowel. *Clin Radiol* 1996;51:447-448.
307. Tada S, Iida M, Yao T, et al. Endoscopic features in amyloidosis of the small intestine. Clinical and morphologic differences between chemical types of amyloid protein. *Gastrointest Endosc* 1994;40:45-50.
308. Vernon SE. Amyloid colitis. *Dis Colon Rectum* 1982;25:728-730.
309. Levy DJ, Franklin GO, Rosenthal WS. Gastrointestinal bleeding and amyloidosis. *Am J Gastroenterol* 1982;77:422-426.
310. Racanelli V, DóAmore FP. Localized AL amyloidosis of the colon and clinical features of intestinal obstruction: a case report. *Ann Ital Med Int* 1999;14:58-60.
311. Fraser AG, Nicholson GI. Duodenal perforation in primary systemic amyloidosis. *Gut* 1992;33:997-999.
312. Koppelman RN, Stollman NH, Baigorri F, et al. Acute small bowel pseudo-obstruction due to AL amyloidosis: a case report and literature review. *Am J Gastroenterol* 2000;95:294-296.
313. De Navasquez S, Treble HA. Case of primary generalized amyloid disease with involvement of nerves. *Brain* 1938;61:116-128.
314. Yamada M, Hatakeyama S, Tsukagoshi H. Peripheral and autonomic nerve lesions in systemic amyloidosis: three pathological types of amyloid polyneuropathy. *Acta Pathol Jpn* 1984;34:1251-1266.
315. Schenone A, Primavera A, De Martini I, et al. Amyloid neuropathy in light chain multiple myeloma. *Clin Neuropathol* 1989;8:156-157.
316. Rinaldi R, Azzimondi G, Preda P, et al. Primary systemic amyloidosis presenting with polyneuropathy characterized by very long survival. *Acta Neurol Scand* 1995;91:511-513.
317. Braganza RA, Tien R, Hoffman HT, et al. Amyloid of the facial nerve. *Laryngoscope* 1992;102:1372-1376.
318. Katz B, Leja S, Melles RB, et al. Amyloid ophthalmoplegia: ophthalmoparesis secondary to primary systemic amyloidosis. *J Clin Neuroophthalmol* 1989;9:39-42.
319. Vucic S, Chong PS, Cros D. Atypical presentations of primary amyloid neuropathy. *Muscle Nerve* 2003;28:696-702.
320. Lingenfelser T, Linke RP, Dette S, et al. AL amyloidosis mimicking a preferentially autonomic chronic Guillain-Barré syndrome. *Clin Invest* 1992;70:159-162.
321. Ito T, Sakakibara R, Yamamoto T, et al. Urinary dysfunction and autonomic control in amyloid neuropathy. *Clin Auton Res* 2006;16:66-71.
322. Rubin DI, Hermann RC. Electrophysiologic findings in amyloid myopathy. *Muscle Nerve* 1999;22:355-359.
323. Sommer C, Schroder JM. Amyloid neuropathy: immunocytochemical localization of intra- and extracellular immunoglobulin light chains. *Acta Neuropathol* 1989;79:190-199.
324. Simmons Z, Blaivas M, Aguilera AJ, et al. Low diagnostic yield of sural nerve biopsy in patients with peripheral neuropathy and primary amyloidosis. *J Neurol Sci* 1993;120:60-63.

325. Rajkumar SV, Gertz MA, Kyle RA. Prognosis of patients with primary systemic amyloidosis who present with dominant neuropathy. *Am J Med* 1998;104:232-237.
326. Duston MA, Skinner M, Anderson J, et al. Peripheral neuropathy as an early marker of AL amyloidosis. *Arch Intern Med* 1989;149:358-360.
327. Dispenzieri A, Gertz MA. Treatment options for POEMS syndrome. *Expert Opin Pharmacother* 2005;6:945-953.
328. Neuner GA, Badros AA, Meyer TK, et al. Complete resolution of laryngeal amyloidosis with radiation treatment. *Head Neck* 2010 Nov 10.
329. Tamura K, Nakajima N, Makino S, et al. Primary pulmonary amyloidosis with multiple nodules. *Eur J Radiol* 1988;8:128-130.
330. Srinivas P, Liam CK, Jayaram G. Localised nodular pulmonary amyloidosis in a patient with sicca syndrome. *Med J Malaysia* 2000;55:385-387.
331. Suzuki H, Matsui K, Hirashima T, et al. Three cases of the nodular pulmonary amyloidosis with a longterm observation. *Intern Med* 2006;45:283-286. Epub 2006 Apr 3.
332. Howard ME, Ireton J, Daniels F, et al. Pulmonary presentations of amyloidosis. *Respirology* 2001;6:61-64.
333. Looi LM. The pattern of amyloid deposition in the lung. *Malays J Pathol* 1999;21:29-35.
334. Road JD, Jacques J, Sparling JR. Diffuse alveolar septal amyloidosis presenting with recurrent hemoptysis and medial dissection of pulmonary arteries. *Am Rev Respir Dis* 1985;132:1368-1370.
335. Itoh T, Ohashi S, Tsujino T, et al. Primary amyloidosis with dry eyes and dry mouth-a case report. *Jpn J Med* 1991;30:597-599.
336. Ashe J, Borel CO, Hart G, et al. Amyloid myopathy presenting with respiratory failure. *J Neurol Neurosurg Psychiatry* 1992;55:162-165.
337. Delevaux I, Andre M, Amoura Z, et al. Concomitant diagnosis of primary Sjögren's syndrome and systemic AL amyloidosis. *Ann Rheum Dis* 2001;60:694-695.
338. Streeten EA, de la Monte SM, Kennedy TP. Amyloid infiltration of the diaphragm as a cause of respiratory failure. *Chest* 1986;89:760-762.
339. Santiago RM, Scharnhorst D, Ratkin G, et al. Respiratory muscle weakness and ventilatory failure in AL amyloidosis with muscular pseudohypertrophy. *Am J Med* 1987;83:175-178.
340. Bontemps F, Tillie-Leblond I, Coppin MC, et al. Pleural amyloidosis: thoracoscopic aspects. *Eur Respir J* 1995;8:1025-1027.
341. Kavuru MS, Adamo JP, Ahmad M, et al. Amyloidosis and pleural disease. *Chest* 1990;98:20-23.
342. Pichelmayer O, Zielinski C, Raderer M. Response of a nonmalignant pleural effusion to bevacizumab. *N Engl J Med* 2005;353:740-741.
343. Dingli D, Utz JP, Gertz MA. Pulmonary hypertension in patients with amyloidosis. *Chest* 2001;120:1735-1738.
344. Shiue ST, McNally DP. Pulmonary hypertension from prominent vascular involvement in diffuse amyloidosis. *Arch Intern Med* 1988;148:687-689.
345. Takashi S, Koizumi T, Yamazaki Y, et al. Diffuse pulmonary amyloidosis with monoclonal IgG-kappa gammopathy. *Intern Med* 1997;36:357-359.
346. Matsumoto K, Ueno M, Matsuo Y, et al. Primary solitary amyloidoma of the lung. Findings on CT and MRI. *Eur Radiol* 1997;7:586-588.
347. Cordier JF, Loire R, Brune J. Amyloidosis of the lower respiratory tract: clinical and pathologic features in a series of 21 patients. *Chest* 1986;90:827-831.
348. Hui AN, Koss MN, Hochholzer L, et al. Amyloidosis presenting in the lower respiratory tract: clinicopathologic, radiologic, immunohistochemical, and histochemical studies on 48 cases. *Arch Pathol Lab Med* 1986;110:212-218.
349. Sucker C, Hetzel GR, Grabensee B, et al. Amyloidosis and bleeding: pathophysiology, diagnosis, and therapy. *Am J Kidney Dis* 2006;47:947-955.

350. Gastineau DA, Gertz MA, Daniels TM, et al. Inhibitor of the thrombin time in systemic amyloidosis: a common coagulation abnormality. *Blood* 1991;77:2637-2640.
351. Greipp PR, Kyle RA, Bowie EJ. Factor-X deficiency in amyloidosis: a critical review. *Am J Hematol* 1981;11:443-450.
352. Hoshino Y, Hatake K, Muroi K, et al. Bleeding tendency caused by the deposit of amyloid substance in the perivascular region. *Intern Med* 1993;32: 879-881.
353. Boggio L, Green D. Recombinant human factor VIIa in the management of amyloid-associated factor X deficiency. *Br J Haematol* 2001;112:1074-1075.
354. Chang JC, Kane KK. Pathologic hyperfibrinolysis associated with amyloidosis: clinical response to epsilon amino caproic acid. *Am J Clin Pathol* 1984;81:382-387.
355. Emori Y, Sakugawa M, Niiya K, et al. Life-threatening bleeding and acquired factor V deficiency associated with primary systemic amyloidosis. *Blood Coagul Fibrinolysis* 2002;13:555-559.
356. Black CS, Lacy M, Rajkumar SV, et al. Natural history of thromboembolism in amyloidosis [abstract]. *Blood* 2001;98:54a.
357. Halligan CS, Lacy MQ, Rajkumar SV, et al. Natural history of thromboembolism in AL amyloidosis. *Amyloid* 2006;13:31-36.
358. Fujii B, Matsuda Y, Ohno H, et al. A case of cardiac amyloidosis presenting with symptoms of exertional syncope. *Clin Cardiol* 1991;14:267-268.
359. Klein AL, Tajik AJ. Doppler assessment of diastolic function in cardiac amyloidosis. *Echocardiography* 1991;8:233-251.
360. Tei C, Dujardin KS, Hodge DO, et al. Doppler index combining systolic and diastolic myocardial performance: clinical value in cardiac amyloidosis. *J Am Coll Cardiol* 1996;28:658-664.
361. Klein AL, Oh JK, Miller FA, et al. Two-dimensional and Doppler echocardiographic assessment of infiltrative cardiomyopathy. *J Am Soc Echocardiogr* 1988;1:48-59.
362. Patel AR, Dubrey SW, Mendes LA, et al. Right ventricular dilation in primary amyloidosis: an independent predictor of survival. *Am J Cardiol* 1997;80:486-492.
363. Yamakado T, Fukui A, Kato N, et al. Analysis of left ventricular diastolic function by the pressure-volume relation in cases with idiopathic restrictive cardiomyopathy and amyloid restrictive cardiomyopathy. *Heart Vessels* 1990;5(Suppl):80-83.
364. Dispenzieri A, Kyle RA, Gertz MA, et al. Survival in patients with primary systemic amyloidosis and raised serum cardiac troponins. *Lancet* 2003;361:1787-1789.
365. Gertz MA, Kyle RA, Greipp PR. Hyposplenism in primary systemic amyloidosis. *Ann Intern Med* 1983;98:475-477.
366. Surian M, Broggi L, Ferrari L, et al. Morphological, immunohistological and clinical findings in renal amyloidosis: correlations with prognosis in 16 patients. *Boll Ist Sieroter Milan* 1979;58:158-168.
367. McElroy EA Jr, Witzig TE, Gertz MA, et al. Detection of monoclonal plasma cells in the peripheral blood of patients with primary amyloidosis. *Br J Haematol* 1998;100:326-327.
368. Pardanani A, Witzig TE, Schroeder G, et al. Circulating peripheral blood plasma cells as a prognostic indicator in patients with primary systemic amyloidosis. *Blood* 2003 Feb 1;101:827-830. Epub 2002 Sep 5.
369. Gertz MA, Kyle RA, Greipp PR, et al. Beta 2-microglobulin predicts survival in primary systemic amyloidosis. *Am J Med* 1990;89:609-614.
370. Kyle RA, Greipp PR, O'Fallon WM. Primary systemic amyloidosis: multivariate analysis for prognostic factors in 168 cases. *Blood* 1986;68:220-224.
371. Gertz MA, Kyle RA, Greipp PR. Response rates and survival in primary systemic amyloidosis. *Blood* 1991;77:257-262.
372. Dispenzieri A, Lacy MQ, Katzmann JA, et al. Absolute values of immunoglobulin free light chains are prognostic in patients with primary systemic amyloidosis undergoing peripheral blood stem cell transplantation. *Blood* 2006;107:3378-3383. Epub 2006 Jan 5.
373. Dispenzieri A, Gertz MA, Kyle RA, et al. Serum cardiac troponins and N-terminal pro-brain natriuretic peptide: a staging system for primary systemic amyloidosis. *J Clin Oncol* 2004;22:3751-3757.

374. Dispenzieri A, Gertz MA, Kyle RA, et al. Prognostication of survival using cardiac troponins and N-terminal pro-brain natriuretic peptide in patients with primary systemic amyloidosis undergoing peripheral blood stem cell transplantation. *Blood* 2004;104:1881-1887. Epub 2004 Mar 25.
375. Lachmann HJ, Gallimore R, Gillmore JD, et al. Outcome in systemic AL amyloidosis in relation to changes in concentration of circulating free immunoglobulin light chains following chemotherapy. *Br J Haematol* 2003;122:78-84.
376. Kumar SK, Gertz MA, Lacy MQ, et al. Recent improvements in survival in primary systemic amyloidosis and the importance of an early mortality risk score. *Mayo Clin Proc* 2011;86:12-18.
377. Kumar SK, Dispenzieri A, Lacy MQ, et al. Changes in serum-free light chain rather than intact monoclonal immunoglobulin levels predicts outcome following therapy in primary amyloidosis. *Am J Hematol* 2011;86:251-255. Epub 2011 Feb 15.
378. Bryce AH, Ketterling RP, Gertz MA, et al. Translocation t(11;14) and survival of patients with light chain (AL) amyloidosis. *Haematologica* 2009;94:380-386. Epub 2009 Feb 11.
379. Falk RH. Diagnosis and management of the cardiac amyloidoses. *Circulation* 2005;112:2047-2060.
380. Nash KL, Brij SO, Clesham GJ. Cardiac amyloidosis and the use of diuretic and ACE inhibitor therapy in severe heart failure. *Int J Clin Pract* 1997;51:384-385.
381. Kawasaki T, Sugihara H, Sakamoto K, et al. Cardiac sympathetic denervation in amyloidosis. *Clin Nucl Med* 2001;26:560-561.
382. Rodriguez Reguero J, Iglesias Cubero G, Rubin J. Primary amyloidosis and syncope. *Int J Cardiol* 1997;58:185-187.
383. Mathew V, Olson LJ, Gertz MA, et al. Symptomatic conduction system disease in cardiac amyloidosis. *Am J Cardiol* 1997;80:1491-1492.
384. Mathew V, Chaliki H, Nishimura RA. Atrioventricular sequential pacing in cardiac amyloidosis: an acute Doppler echocardiographic and catheterization hemodynamic study. *Clin Cardiol* 1997;20:723-725.
385. Itoh M, Ohmori K, Yata K, et al. Implantable cardioverter defibrillator therapy in a patient with cardiac amyloidosis. *Am J Hematol* 2006;81:560-561.
386. Parikh S, de Lemos JA. Current therapeutic strategies in cardiac amyloidosis. *Curr Treat Options Cardiovasc Med* 2005;7:443-448.
387. Habbal R, Noureddine M, Hachim K, et al. Heart failure and arterial hypertension disclosing amyloidosis [French]. *Nephrologie* 1997;18:91-94.
388. Mayr M, Dickenmann MJ. Further evidence for the renoprotective effect of ACE inhibitors: ramipril protects against the progression of chronic renal insufficiency in non-diabetic nephropathy with nephrotic proteinuria [German]. *Schweiz Med Wochenschr* 2000;130:491.
389. Buja LM, Khoi NB, Roberts WC. Clinically significant cardiac amyloidosis. Clinicopathologic findings in 15 patients. *Am J Cardiol* 1970;26:394-405.
390. Gertz MA, Skinner M, Connors LH, et al. Selective binding of nifedipine to amyloid fibrils. *Am J Cardiol* 1985;55:1646.
391. Gertz MA, Falk RH, Skinner M, et al. Worsening of congestive heart failure in amyloid heart disease treated by calcium channel-blocking agents. *Am J Cardiol* 1985;55:1645.
392. Omboni S, Smit AA, van Lieshout JJ, et al. Mechanisms underlying the impairment in orthostatic tolerance after nocturnal recumbency in patients with autonomic failure. *Clin Sci (Lond)* 2001;101:609-618.
393. Freitas J, Santos R, Azevedo E, et al. Clinical improvement in patients with orthostatic intolerance after treatment with bisoprolol and fludrocortisone. *Clin Auton Res* 2000;10:293-299.
394. Kochar MS. Management of postural hypotension. *Curr Hypertens Rep* 2000;2:457-462.
395. Cruz DN. Midodrine: a selective alpha-adrenergic agonist for orthostatic hypotension and dialysis hypotension. *Expert Opin Pharmacother* 2000;1:835-840.
396. Low PA. Update on the evaluation, pathogenesis, and management of neurogenic orthostatic hypotension: introduction. *Neurology* 1995;45(Suppl 5)S4-S5.

397. Kawakami K, Abe H, Harayama N, et al. Successful treatment of severe orthostatic hypotension with erythropoietin. *Pacing Clin Electrophysiol* 2003;26:105-107.
398. Hosenpud JD, Uretsky BF, Griffith BP, et al. Successful intermediate-term outcome for patients with cardiac amyloidosis undergoing heart transplantation: results of a multicenter survey. *J Heart Transplant* 1990;9:346-350.
399. Hosenpud JD, DeMarco T, Frazier OH, et al. Progression of systemic disease and reduced long-term survival in patients with cardiac amyloidosis undergoing heart transplantation: follow-up results of a multicenter survey. *Circulation* 1991;84(Suppl 3):III338-III343.
400. Dubrey SW, Burke MM, Khaghani A, et al. Long term results of heart transplantation in patients with amyloid heart disease. *Heart* 2001;85:202-207.
401. Miller WL, Wright RS, McGregor CG, et al. Troponin levels in patients with amyloid cardiomyopathy undergoing cardiac transplantation. *Am J Cardiol* 2001;88:813-815.
402. Kpodonu J, Massad MG, Caines A, et al. Outcome of heart transplantation in patients with amyloid cardiomyopathy. *J Heart Lung Transplant* 2005;24:1763-1765.
403. Gillmore JD, Goodman HJ, Lachmann HJ, et al. Sequential heart and autologous stem cell transplantation for systemic AL amyloidosis. *Blood* 2006;107:1227-1229. Epub 2005 Oct 6.
404. Thauat O, Alyanakian MA, Varnous S, et al. Long-term successful outcome of sequential cardiac and allogeneic bone marrow transplantations in severe AL amyloidosis. *Bone Marrow Transplant* 2005;35:419-420.
405. Dubrey SW, Burke MM, Hawkins PN, et al. Cardiac transplantation for amyloid heart disease: the United Kingdom experience. *J Heart Lung Transplant* 2004;23:1142-1153.
406. Alloni A, Pellegrini C, Ragni T, et al. Heart transplantation in patients with amyloidosis: single-center experience. *Transplant Proc* 2004;36:643-644.
407. Dey BR, Chung SS, Spitzer TR, et al. Cardiac transplantation followed by dose-intensive melphalan and autologous stem-cell transplantation for light chain amyloidosis and heart failure. *Transplantation* 2010;90:905-911.
408. Li J, Zhou C, Yu L, et al. Renal protective effects of blocking the intrarenal renin-angiotensin system. *Hypertens Res* 1999;22:223-228.
409. Nosrati SM, Khwaja S, el-Shahawy M, et al. Effect of angiotensin converting enzyme inhibition by perindopril on proteinuria of primary renal diseases. *Am J Nephrol* 1997;17:511-517.
410. Moroni G, Banfi G, Montoli A, et al. Chronic dialysis in patients with systemic amyloidosis: the experience in northern Italy. *Clin Nephrol* 1992;38:81-85.
411. Browning MJ, Banks RA, Harrison P, et al. Continuous ambulatory peritoneal dialysis in systemic amyloidosis and end-stage renal disease. *J R Soc Med* 1984;77:189-192.
412. Gertz MA, Kyle RA, O'Fallon WM. Dialysis support of patients with primary systemic amyloidosis. A study of 211 patients. *Arch Intern Med* 1992;152:2245-2250.
413. Kuhlback B, Falck H, Tornroth T, et al. Renal transplantation in amyloidosis. *Acta Med Scand* 1979;205:169-172.
414. Kilicurgay S, Tokyay R, Arslan G, et al. The results of transplantation of patients with amyloid nephropathy. *Transplant Proc* 1992;24:1788-1789.
415. Gertz MA, Leung N, Lacy MQ, et al. Clinical outcome of immunoglobulin light chain amyloidosis affecting the kidney. *Nephrol Dial Transplant* 2009;24:3132-3137. Epub 2009 Apr 29.
416. Dorman SA, Gamelli RL, Benziger JR, et al. Systemic amyloidosis involving two renal transplants. *Hum Pathol* 1981;12:735-738.
417. Hartmann A, Holdaas H, Fauchald P, et al. Fifteen years' experience with renal transplantation in systemic amyloidosis. *Transpl Int* 1992;5:15-18.
418. Pasternack A, Ahonen J, Kuhlback B. Renal transplantation in 45 patients with amyloidosis. *Transplantation* 1986;42:598-601.
419. Helin H, Pasternack A, Falck H, et al. Recurrence of renal amyloid and de novo membranous glomerulonephritis after transplantation. *Transplantation* 1981;32:6-9.

420. Leung N, Griffin MD, Dispenzieri A, et al. Living donor kidney and autologous stem cell transplantation for primary systemic amyloidosis (AL) with predominant renal involvement. *Am J Transplant* 2005;5:1660-1670.
421. Merlini G, Remuzzi G. Autologous stem cell and kidney transplantation for primary amyloidosis associated with ESRD: which should come first? *Am J Transplant* 2005;5:1585-1586.
422. Herrmann SM, Gertz MA, Stegall MD, et al. Long-term outcomes of patients with light chain amyloidosis (AL) after renal transplantation with or without stem cell transplantation. *Nephrol Dial Transplant* 2011;26:2032-2036. Epub 2011 May 4.
423. Jalan R, Redhead DN, Simpson KJ, et al. Transjugular intrahepatic portosystemic stent-shunt (TIPSS): long-term follow-up. *QJM* 1994;87:565-573.
424. Bienz N, Franklin IM, Adu D, et al. Bilateral nephrectomy for uncontrollable nephrotic syndrome in primary amyloidosis, with subsequent improvement in hepatic function. *Clin Lab Haematol* 1994;16:85-88.
425. Kumar KS, Lefkowitz J, Russo MW, et al. Successful sequential liver and stem cell transplantation for hepatic failure due to primary AL amyloidosis. *Gastroenterology* 2002;122:2026-2031.
426. Tokoro C, Inamori M, Sekino Y, et al. Localized primary AL amyloidosis of the colon without other GI involvement. *Gastrointest Endosc* 2011;74:925-926. Epub 2011 Aug 6.
427. Cordier JF. Pulmonary amyloidosis in hematological disorders. *Semin Respir Crit Care Med* 2005;26:502-513.
428. Choufani EB, Sanchorawala V, Ernst T, et al. Acquired factor X deficiency in patients with amyloid light-chain amyloidosis: incidence, bleeding manifestations, and response to high-dose chemotherapy. *Blood* 2001;97:1885-1887.
429. Rosenstein ED, Itzkowitz SH, Penziner AS, et al. Resolution of factor X deficiency in primary amyloidosis following splenectomy. *Arch Intern Med* 1983;143:597-599.
430. Ma JF, Coutre SE, Curet MJ, et al. Refractory hematuria from amyloidosis successfully treated by splenectomy. *Urology* 2006;67:1085, e13-15.
431. Takabe K, Holman PR, Herbst KD, et al. Successful perioperative management of factor X deficiency associated with primary amyloidosis. *J Gastrointest Surg* 2004;8:358-362.
432. Ozkaya-Bayazit E, Kavak A, Gungor H, et al. Intermittent use of topical dimethyl sulfoxide in macular and papular amyloidosis. *Int J Dermatol* 1998;37:949-954.
433. Nishiyama T, Gejyo F, Katayama Y, et al. Primary localized amyloidosis of the bladder: a case of AL (lambda) amyloid protein and combination therapy using dimethyl sulfoxide and cepharanthine. *Urol Int* 1992;48:228-231.
434. Komiyama A, Kijima M, Takahashi M, et al. Amyloid associated muscle pseudohypertrophy: amelioration of motor dysfunction with plasmapheresis and dimethylsulphoxide. *J Neurol Neurosurg Psychiatry* 1996;60:591-592.
435. Grateau G. The relation between familial Mediterranean fever and amyloidosis. *Curr Opin Rheumatol* 2000;12:61-64.
436. Cabili S, Zemer D, Pras M, et al. The prevention of amyloidosis in familial Mediterranean fever with colchicine. *Proc Eur Dial Transplant Assoc Eur Ren Assoc* 1985;21:709-711.
437. Cakar N, Yalcinkaya F, Ozkaya N, et al. Familial Mediterranean fever (FMF)-associated amyloidosis in childhood: clinical features, course and outcome. *Clin Exp Rheumatol* 2001;19(Suppl 5):S63-S67.
438. Livneh A, Langevitz P. Diagnostic and treatment concerns in familial Mediterranean fever. *Baillieres Best Pract Res Clin Rheumatol* 2000;14:477-498.
439. Livneh A, Langevitz P, Zemer D, et al. The changing face of familial Mediterranean fever. *Semin Arthritis Rheum* 1996;26:612-627.
440. Zemer D, Livneh A, Danon YL, et al. Long-term colchicine treatment in children with familial Mediterranean fever. *Arthritis Rheum* 1991;34:973-977.
441. Rabinovitch O, Zemer D, Kukia E, et al. Colchicine treatment in conception and pregnancy: two hundred thirty-one pregnancies in patients with familial Mediterranean fever. *Am J Report Immunol* 1992;28:245-246.
442. El-Shanti H, Majeed HA, El-Khateeb M. Familial Mediterranean fever in Arabs. *Lancet* 2006;367:1016-1024.

443. Bladé J, Samson D, Reece D, et al. Criteria for evaluating disease response and progression in patients with multiple myeloma treated by high-dose therapy and haemopoietic stem cell transplantation: Myeloma Subcommittee of the EBMT. European Group for Blood and Marrow Transplant. *Br J Haematol* 1998;102:1115-1123.
444. Billadeau D, Blackstadt M, Greipp P, et al. Analysis of B-lymphoid malignancies using allele-specific polymerase chain reaction: a technique for sequential quantitation of residual disease. *Blood* 1991;78:3021-3029.
445. Palladini G, Lavatelli F, Russo P, et al. Circulating amyloidogenic free light chains and serum N-terminal natriuretic peptide type B decrease simultaneously in association with improvement of survival in AL. *Blood* 2006;107:3854-3858. Epub 2006 Jan 24.
446. Akar H, Seldin DC, Magnani B, et al. Quantitative serum free light chain assay in the diagnostic evaluation of AL amyloidosis. *Amyloid* 2005;12:210-215.
447. Matsuda M, Yamada T, Gono T, et al. Serum levels of free light chain before and after chemotherapy in primary systemic AL amyloidosis. *Intern Med* 2005;44:428-433.
448. van Gameraen II, van Rijswijk MH, Bijzet J, et al. Histological regression of amyloid in AL amyloidosis is exclusively seen after normalization of serum free light chain. *Haematologica* 2009;94:1094-1100.
449. Gertz MA, Comenzo R, Falk RH, et al. Definition of organ involvement and treatment response in immunoglobulin light chain amyloidosis (AL): a consensus opinion from the 10th International Symposium on Amyloid and Amyloidosis, Tours, France, 18-22 April 2004. *Am J Hematol* 2005;79:319-328.
450. Jones NF, Hilton PJ, Tighe JR, et al. Treatment of "primary" renal amyloidosis with melphalan. *Lancet* 1972;2:616-619.
451. Cohen HJ, Lessin LS, Hallal J, et al. Resolution of primary amyloidosis during chemotherapy: studies in a patient with nephrotic syndrome. *Ann Intern Med* 1975;82:466-473.
452. Gertz MA, Lacy MQ, Dispenzieri A, et al. Stem cell transplantation for the management of primary systemic amyloidosis. *Am J Med* 2002;113:549-555.
453. Bradstock K, Clancy R, Uther J, et al. The successful treatment of primary amyloidosis with intermittent chemotherapy. *Aust N Z J Med* 1978; 8:176-179.
454. Schwartz RS, Cohen JR, Schrier SL. Therapy of primary amyloidosis with melphalan and prednisone. *Arch Intern Med* 1979;139:1144-1147.
455. Buxbaum JN, Hurley ME, Chuba J, et al. Amyloidosis of the AL type: clinical, morphologic and biochemical aspects of the response to therapy with alkylating agents and prednisone. *Am J Med* 1979;67:867-878.
456. Kyle RA, Greipp PR, Garton JP, et al. Primary systemic amyloidosis: comparison of melphalan/prednisone versus colchicine. *Am J Med* 1985;79:708-716.
457. Kyle RA, Gertz MA, Greipp PR, et al. A trial of three regimens for primary amyloidosis: colchicine alone, melphalan and prednisone, and melphalan, prednisone, and colchicine. *N Engl J Med* 1997;336:1202-1207.
458. Fielder K, Durie BG. Primary amyloidosis associated with multiple myeloma: predictors of successful therapy. *Am J Med* 1986;80:413-418.
459. Benson MD. Treatment of AL amyloidosis with melphalan, prednisone, and colchicine. *Arthritis Rheum* 1986;29:683-687.
460. Kyle RA, Wagoner RD, Holley KE. Primary systemic amyloidosis: resolution of the nephrotic syndrome with melphalan and prednisone. *Arch Intern Med* 1982;142:1445-1447.
461. Kyle RA, Gertz MA, Greipp PR, et al. Long-term survival (10 years or more) in 30 patients with primary amyloidosis. *Blood* 1999;93:1062-1066.
462. Levy Y, Belghiti-Deprez D, Sobel A. Treatment of AL amyloidosis without myeloma [French]. *Ann Med Interne* 1988;139:190-193.
463. Skinner M, Anderson J, Simms R, et al. Treatment of 100 patients with primary amyloidosis: a randomized trial of melphalan, prednisone, and colchicine versus colchicine only. *Am J Med* 1996;100:290-298.
464. Gertz MA, Kyle RA. Acute leukemia and cytogenetic abnormalities complicating melphalan treatment of primary systemic amyloidosis. *Arch Intern Med* 1990;150:629-633.

465. Dhodapkar MV, Jagannath S, Vesole D, et al. Treatment of AL-amyloidosis with dexamethasone plus alpha interferon. *Leuk Lymphoma* 1997;27:351-356.
466. Gertz MA, Lacy MQ, Lust JA, et al. Phase II trial of high-dose dexamethasone for untreated patients with primary systemic amyloidosis. *Med Oncol* 1999;16:104-109.
467. Gertz MA, Lacy MQ, Lust JA, et al. Phase II trial of high-dose dexamethasone for previously treated immunoglobulin light-chain amyloidosis. *Am J Hematol* 1999;61:115-119.
468. Palladini G, Perfetti V, Obici L, et al. Association of melphalan and high-dose dexamethasone is effective and well tolerated in patients with AL (primary) amyloidosis who are ineligible for stem cell transplantation. *Blood* 2004;103:2936-2938. Epub 2003 Dec 18.
469. Lebovic D, Hoffman J, Levine BM, et al. Predictors of survival in patients with systemic light-chain amyloidosis and cardiac involvement initially ineligible for stem cell transplantation and treated with oral melphalan and dexamethasone. *Br J Haematol* 2008;143:369-373. Epub 2008 Aug 4.
470. Dietrich S, Schonland SO, Benner A, et al. Treatment with intravenous melphalan and dexamethasone is not able to overcome the poor prognosis of patients with newly diagnosed systemic light chain amyloidosis and severe cardiac involvement. *Blood* 2010;116:522-528. Epub 2010 Apr 7.
471. Santhorawala V, Seldin DC, Berk JL, et al. Oral cyclic melphalan and dexamethasone for patients with AL amyloidosis. *Clin Lymphoma Myeloma Leuk* 2010;10:469-472.
472. Palladini G, Anesi E, Perfetti V, et al. A modified high-dose dexamethasone regimen for primary systemic (AL) amyloidosis. *Br J Haematol* 2001;113:1044-1046.
473. Dhodapkar MV, Hussein MA, Rasmussen E, et al. United States Intergroup Trial Southwest Oncology Group. Clinical efficacy of high-dose dexamethasone with maintenance dexamethasone/alpha interferon in patients with primary systemic amyloidosis: results of United States Intergroup Trial Southwest Oncology Group (SWOG) S9628. *Blood* 2004;104:3520-3526. Epub 2004 Aug 12.
474. Seldin DC, Choufani EB, Dember LM, et al. Tolerability and efficacy of thalidomide for the treatment of patients with light chain-associated (AL) amyloidosis. *Clin Lymphoma* 2003;3:241-246.
475. Dispenzieri A, Lacy MQ, Rajkumar SV, et al. Poor tolerance to high doses of thalidomide in patients with primary systemic amyloidosis. *Amyloid* 2003;10:257-261.
476. Palladini G, Perfetti V, Perlini S, et al. The combination of thalidomide and intermediate-dose dexamethasone is an effective but toxic treatment for patients with primary amyloidosis (AL). *Blood* 2005;105:2949-2951. Epub 2004 Nov 30.
477. Wechalekar AD, Goodman HJ, Lachmann HJ, et al. Safety and efficacy of risk adapted cyclophosphamide, thalidomide and dexamethasone in systemic AL amyloidosis. *Blood* 2006;109:457-464. Epub 2006 Sep 21.
478. Santhorawala V, Wright DG, Rosenzweig M, et al. A phase II trial of lenalidomide for patients with AL amyloidosis [abstract]. *J Clin Oncol* 2006;24(Suppl):7524.
479. Santhorawala V, Finn KT, Fennessey S, et al. Durable hematologic complete responses can be achieved with lenalidomide in AL amyloidosis. *Blood* 2010;116:1990-1991.
480. Palladini G, Russo P, Foli A, et al. Salvage therapy with lenalidomide and dexamethasone in patients with advanced AL amyloidosis refractory to melphalan, bortezomib, and thalidomide. *Ann Hematol* 2011 Apr 30. [Epub ahead of print]
481. Tapan U, Seldin DC, Finn KT, et al. Increases in B-type natriuretic peptide (BNP) during treatment with lenalidomide in AL amyloidosis. *Blood* 2010;116:5071-5072.
482. Specter R, Santhorawala V, Seldin DC, et al. Kidney dysfunction during lenalidomide treatment for AL amyloidosis. *Nephrol Dial Transplant* 2011;26:881-886. Epub 2010 Aug 5.
483. Moreau P, Jaccard A, Benboubker L, et al. Lenalidomide in combination with melphalan and dexamethasone in patients with newly diagnosed AL amyloidosis: a multicenter phase 1/2 dose-escalation study. *Blood* 2010;116:4777-4782. Epub 2010 Aug 19.
484. Kumar SK, Lacy MQ, Hayman SR, et al. Lenalidomide, cyclophosphamide and dexamethasone (CRd) for newly diagnosed multiple myeloma: results from a phase 2 trial. *Am J Hematol* 2011;86:640-645. Epub 2011 May 31.

485. Gillmore J, Cocks K, Gibbs SDJ, et al. Cyclophosphamide, thalidomide and dexamethasone (CTD) versus melphalan plus Dexamethasone (MD) for newly-diagnosed systemic AL amyloidosis: results from the UK Amyloidosis Treatment Trial [abstract]. *Blood* 114:1120.
486. Dispenzieri A, Dingli D, Kumar SK, et al. Discordance between serum cardiac biomarker and immunoglobulin-free light-chain response in patients with immunoglobulin light-chain amyloidosis treated with immune modulatory drugs. *Am J Hematol* 2010;85:757-759.
487. Dispenzieri A, Gertz MA, Hayman SR, et al. A phase II study of pomalidomide and dexamethasone in previously treated light-chain (AL) amyloidosis [abstract]. *J Clin Oncol* 2010;28(Suppl):15s.
488. Wechalekar AD, Lachmann HJ, Offer M, et al. Efficacy of bortezomib in systemic AL amyloidosis with relapsed/refractory clonal disease. *Haematologica* 2008;93:295-298.
489. Reece DE, Santhorawala V, Hegenbart U, et al. Weekly and twice-weekly bortezomib in patients with systemic AL amyloidosis: results of a phase 1 dose-escalation study. *Blood* 2009;114:1489-1497.
490. Reece DE, Hegenbart U, Santhorawala V, et al. Efficacy and safety of once-weekly and twice-weekly bortezomib in patients with relapsed systemic AL amyloidosis: results of a phase 1/2 study. *Blood* 2011;118:865-873. Epub 2011 May 11.
491. Brunvand MW, Bitter M. Amyloidosis relapsing after autologous stem cell transplantation treated with bortezomib: normalization of detectable serumfree light chains and reversal of tissue damage with improved suitability for transplant. *Haematologica* 2010;95:519-521.
492. Kastiris E, Wechalekar AD, Dimopoulos MA, et al. Bortezomib with or without dexamethasone in primary systemic (light chain) amyloidosis. *J Clin Oncol*. 2010;28:1031-1037.
493. Lamm W, Willenbacher W, Lang A, et al. Efficacy of the combination of bortezomib and dexamethasone in systemic AL amyloidosis. *Ann Hematol* 2011;90:201-206.
494. Gertz MA, Lacy MQ, Dispenzieri A. Myeloablative chemotherapy with stem cell rescue for the treatment of primary systemic amyloidosis: a status report. *Bone Marrow Transplant* 2000;25:465-470.
495. van Buren M, Hene RJ, Verdonck LF, et al. Clinical remission after syngeneic bone marrow transplantation in a patient with AL amyloidosis. *Ann Intern Med* 1995;122:508-510.
496. Gillmore JD, Davies J, Iqbal A, et al. Allogeneic bone marrow transplantation for systemic AL amyloidosis. *Br J Haematol* 1998;100:226-228.
497. Schonland SO, Lokhorst H, Buzyn A, et al. Chronic Leukemia Working Party, Myeloma Subcommittee of the European Cooperative Group for Blood and Marrow Transplantation. Allogeneic and syngeneic hematopoietic cell transplantation in patients with amyloid light-chain amyloidosis: a report from the European Group for Blood and Marrow Transplantation. *Blood* 2006;107:2578-2584. Epub 2005 Nov 17.
498. Schonland SO, Dreger P, de Witte T, et al. Current status of hematopoietic cell transplantation in the treatment of systemic amyloid light-chain amyloidosis. *Bone Marrow Transplant* 2011 Jul 25. [Epub ahead of print]
499. Comenzo RL, Michelle D, LeBlanc M, et al. Mobilized CD34⁺ cells selected as autografts in patients with primary light-chain amyloidosis: rationale and application. *Transfusion* 1998;38:60-69.
500. Stewart AK, Vescio R, Schiller G, et al. Purging of autologous peripheral-blood stem cells using CD34 selection does not improve overall or progression-free survival after high-dose chemotherapy for multiple myeloma: results of a multicenter randomized controlled trial. *J Clin Oncol* 2001;19:3771-3779.
501. Comenzo RL, Vosburgh E, Simms RW, et al. Dose-intensive melphalan with blood stem cell support for the treatment of AL amyloidosis: one-year follow-up in five patients. *Blood* 1996;88:2801-2806.
502. Comenzo RL, Vosburgh E, Falk RH, et al. Dose-intensive melphalan with blood stem-cell support for the treatment of AL (amyloid light-chain) amyloidosis: survival and responses in 25 patients. *Blood* 1998;91:3662-3670.
503. Santhorawala V, Wright DG, Seldin DC, et al. An overview of the use of high-dose melphalan with autologous stem cell transplantation for the treatment of AL amyloidosis. *Bone Marrow Transplant* 2001;28:637-642.
504. Moreau P, Leblond V, Bourquelot P, et al. Prognostic factors for survival and response after high-dose therapy and autologous stem cell transplantation in systemic AL amyloidosis: a report on 21 patients. *Br J Haematol* 1998;101:766-769.

505. Gillmore JD, Apperley JF, Craddock C, et al. High-dose melphalan and stem cell rescue for AL amyloidosis. In: RA Kyle, MA Gertz, eds. *Amyloid and amyloidosis 1998: the proceedings of the VIIIth International Symposium on Amyloidosis*, August 7-11, 1998, Rochester, MN. New York: Parthenon Publishing Group, 1999:102-104.
506. Amoura Z, Leblond V, Azar N, et al. High-dose therapy and autologous stem cell transplantation (ASCT) for systemic amyloidosis (AL): report of 9 cases (abstract). *Arthritis Rheum* 1998;41:S234.
507. Kumar S, Dispenzieri A, Lacy MQ, et al. High incidence of gastrointestinal tract bleeding after autologous stem cell transplant for primary systemic amyloidosis. *Bone Marrow Transplant* 2001;28:381-385.
508. Gertz MA, Lacy MQ, Gastineau DA, et al. Blood stem cell transplantation as therapy for primary systemic amyloidosis (AL). *Bone Marrow Transplant* 2000;26:963-969.
509. Gertz MA, Lacy MQ, Dispenzieri A, et al. Autologous stem cell transplant for immunoglobulin light chain amyloidosis: a status report. *Leuk Lymphoma* 2010;51:2181-2187. Epub 2010 Oct 20.
510. Gertz MA, Lacy MQ, Dispenzieri A, et al. Trends in day 100 and 2-year survival after auto-SCT for AL amyloidosis: outcomes before and after 2006. *Bone Marrow Transplant* 2011;46:970-975. Epub 2010 Oct 11.
511. Gertz MA, Lacy MQ, Dispenzieri A, et al. Risk-adjusted manipulation of melphalan dose before stem cell transplantation in patients with amyloidosis is associated with a lower response rate. *Bone Marrow Transplant* 2004;34:1025-1031.
512. Dispenzieri A, Kyle RA, Lacy MQ, et al. Superior survival in primary systemic amyloidosis patients undergoing peripheral blood stem cell transplantation: a case-control study. *Blood* 2004;103:3960-3963. Epub 2004 Jan 22.
513. Vesole DH, Perez WS, Akasheh M, et al. Plasma Cell Disorders Working Committee of the Center for International Blood and Marrow Transplant Research. High-dose therapy and autologous hematopoietic stem cell transplantation for patients with primary systemic amyloidosis: a Center for International Blood and Marrow Transplant Research Study. *Mayo Clin Proc* 2006;81:880-888.
514. Chow LQ, Bahlis N, Russell J, et al. Autologous transplantation for primary systemic AL amyloidosis is feasible outside a major amyloidosis referral centre: the Calgary BMT Program experience. *Bone Marrow Transplant* 2005;36:591-596.
515. Gertz MA, Blood E, Vesole DH, et al. A multicenter phase 2 trial of stem cell transplantation for immunoglobulin light-chain amyloidosis (E4A97): an Eastern Cooperative Oncology Group Study. *Bone Marrow Transplant* 2004;34:149-154.
516. Schonland SO, Perz JB, Hundemer M, et al. Indications for high-dose chemotherapy with autologous stem cell support in patients with systemic amyloid light chain amyloidosis. *Transplantation* 2005;80(Suppl):S160-S163.
517. Comenzo RL, Gertz MA. Autologous stem cell transplantation for primary systemic amyloidosis. *Blood* 2002;99:4276-4282.
518. Seldin DC, Anderson JJ, Santhorawala V, et al. Improvement in quality of life of patients with AL amyloidosis treated with high-dose melphalan and autologous stem cell transplantation. *Blood* 2004;104:1888-1893. Epub 2004 May 20.
519. Jaccard A, Moreau P, Leblond V, et al. Autologous stem cell transplantation (ASCT) versus oral melphalan and high-dose dexamethasone in patients with AL (primary) amyloidosis: results of the French Multicentric Randomized Trial (MAG and IFM Intergroup) [abstract]. *Blood* 2005;106:127a.
520. Porrata LF, Gertz MA, Litzow MR, et al. Early lymphocyte recovery predicts superior survival after autologous hematopoietic stem cell transplantation for patients with primary systemic amyloidosis. *Clin Cancer Res* 2005;11:1210-1218.
521. Leung N, Leung TR, Cha SS, et al. Excessive fluid accumulation during stem cell mobilization: a novel prognostic factor of first-year survival after stem cell transplantation in AL amyloidosis patients. *Blood* 2005;106:3353-3357. Epub 2005 Jul 21.
522. Palladini G, Campana C, Klersy C, et al. Serum N-terminal pro-brain natriuretic peptide is a sensitive marker of myocardial dysfunction in AL amyloidosis. *Circulation* 2003;107:2440-2445. Epub 2003 Apr 28.
523. Santhorawala V, Seldin DC, Magnani B, et al. Serum free light-chain responses after high-dose intravenous melphalan and autologous stem cell transplantation for AL (primary) amyloidosis. *Bone Marrow Transplant* 2005;36:597-600.
524. Santhorawala V, Wright DG, Seldin DC, et al. High-dose intravenous melphalan and autologous stem cell transplantation as initial therapy or following two cycles of oral chemotherapy for the treatment of AL amyloidosis: results of a prospective randomized trial. *Bone Marrow Transplant* 2004;33:381-388.

525. Mhaskar R, Kumar A, Behera M, et al. Role of high-dose chemotherapy and autologous hematopoietic cell transplantation in primary systemic amyloidosis: a systematic review. *Biol Blood Marrow Transplant* 2009;15:893-902. Epub 2009 Apr 2.
526. Majolino I, Marceno R, Pecoraro G, et al. High-dose therapy and autologous transplantation in amyloidosis-AL. *Haematologica* 1993;78:68-71.
527. Schulenburg A, Kalhs P, Oberhuber G, et al. Gastrointestinal perforation early after peripheral blood stem cell transplantation for AL amyloidosis. *Bone Marrow Transplant* 1998;22:293-295.
528. Patriarca F, Geromin A, Fanin R, et al. Improvement of amyloid-related symptoms after autologous stem cell transplantation in a patient with hepatomegaly, macroglossia, and purpura. *Bone Marrow Transplant* 1999;24:433-435.
529. Saba N, Sutton D, Ross H, et al. High treatment-related mortality in cardiac amyloid patients undergoing autologous stem cell transplant. *Bone Marrow Transplant* 1999;24:853-855.
530. Sezer O, Schmid P, Schweigert M, et al. Rapid reversal of nephrotic syndrome due to primary systemic AL amyloidosis after VAD and subsequent high-dose chemotherapy with autologous stem cell support. *Bone Marrow Transplant* 1999;23:967-969.
531. Reich G, Held T, Siegert W, et al. Four patients with AL amyloidosis treated with high-dose chemotherapy and autologous stem cell transplantation. *Bone Marrow Transplant* 2001;27:341-343.
532. Dember LM, Sancharawala V, Seldin DC, et al. Effect of dose-intensive intravenous melphalan and autologous blood stem-cell transplantation on AL amyloidosis-associated renal disease. *Ann Intern Med* 2001;134:746-753.
533. Dispenzieri A, Lacy MQ, Kyle RA, et al. Eligibility for hematopoietic stem-cell transplantation for primary systemic amyloidosis is a favorable prognostic factor for survival. *J Clin Oncol* 2001;19:3350-3356.
534. Cohen AS, Rubinow A, Anderson JJ, et al. Survival of patients with primary (AL) amyloidosis. Colchicine-treated cases from 1976 to 1983 compared with cases seen in previous years (1961 to 1973). *Am J Med* 1987;82:1182-1190.

Chapter 100 Waldenström Macroglobulinemia

> Table of Contents > Part VII - Hematologic Malignancies > Section 5 - Plasma Cell Dyscrasias > Chapter 100 - Waldenström Macroglobulinemia

Chapter 100

Waldenström Macroglobulinemia

Rafael Fonseca

Suzanne R. Hayman

Stephen M. Ansell

INTRODUCTION

Waldenström macroglobulinemia (WM) is a malignancy of mature B cells characterized by a monoclonal IgM in the serum and the presence of lymphoplasmacytic lymphoma (LPL) in the bone marrow.^{1, 2, 3} The disease is now defined at the molecular level by the near-universal presence of mutations of the myeloid differentiation primary response gene MYD88, believed to be the key step in disease pathogenesis. The classical clinical findings in this disease include anemia, organomegaly, lymphadenopathy, and hyperviscosity. The vast majority of patients typically present with a monoclonal IgM in the serum and anemia.^{1, 2, 3} In this chapter, we review the biology and management of WM, including discussions of its preceding state IgM monoclonal gammopathy of undetermined significance (IgM MGUS).

EPIDEMIOLOGY

General Principles

WM is rare in the United States, with only 1,500 new cases diagnosed per year,^{4, 5} an incidence of only one sixth that of multiple myeloma (MM). Although it is now possible to conclusively identify patients by the presence of the MYD88 mutation, this aberration is not exclusively seen in WM⁶ and can be present in other B-cell neoplasms. In future classification schemes for the disease, it is likely that molecular confirmation will be needed. Patients with WM need to be distinguished from patients with a monoclonal IgM in the serum, but no evidence of LPL and no disease-related symptoms or signs (Table 100.1). These patients are felt to have an IgM MGUS.⁷ The disease is slightly more common in males than

females, and more common with advancing age (median age at diagnosis 63 years).⁴ WM is rare in patients of Mexican-mestizo or African descent, and more common among Caucasians.^{4, 5, 8}

Kristinsson identified an association between WM and autoimmunity using a population-based registry from Sweden, finding that WM patients were more likely to have a history of autoimmunity.⁹ This risk was observed both in patients with a personal history of WM, but also in those with a familial predisposition. Among the various autoimmune disorders, Sjögren syndrome and autoimmune hemolytic anemia were notable risk factors for subsequent development of WM. Recent observations by Koshiol and colleagues using a large database from the US Veterans Administration showed that there is a heightened relative risk (RR) for WM among patients who have a history of autoimmunity (RR, 2.23), autoimmune antibodies (RR, 2.3 to 2.5), hepatitis (RR, 3.39), human immunodeficiency virus infection (RR, 12.05), and rickettsiosis (RR, 3.35).¹⁰ Because of the rarity of the disease, these increased relative risks do not pose major consequences for individuals with these conditions. However, these observations present an hypothesis that chronic stimulation may either drive excessive traffic through the germinal center, with an increased risk of clonal establishment or that a cytokine-enriched milieu allows for further expansion of WM precursor clones normally dormant.

TABLE 100.1 RELATION AMONG IGM-MONOCLONAL GAMMOPATHY OF UNDETERMINED SIGNIFICANCE, SMOLDERING WALDENSTRÖM MACROGLOBULINEMIA, AND WALDENSTRÖM MACROGLOBULINEMIA

	IgM-MGUS	SWM	WM
Monoclonal serum protein	Usually <1.5 g/dl	Usually >1.5 g/dl	Usually >3 g/dl
Anemia	Not seen	Common but mild	Common
Other cytopenia	Not seen	Rare (15%)	Rare (15%)
Organomegaly	None	May be present	~15-20% of patients
Hyperviscosity	None	None	~15% of patients
Constitutional symptoms	None	None	Present
Bone marrow clonal cells	Usually <5-10%	Usually >20%	Usually >20%
Therapy	Not needed	Not needed	Indicated

IgM MGUS, IgM monoclonal gammopathy of undetermined significance; SWM, smoldering Waldenström macroglobulinemia; WM, Waldenström macroglobulinemia.

Familial Disease and Genetic Predisposition

In some WM, there appears to be a familial component with more than one member of the family affected.^{11, 12, 13, 14, 15, 16, 17} This implies that a single gene defect may be capable of creating heightened susceptibility. The relationship between this heightened susceptibility and MYD88 mutations has yet to be elucidated. McMaster has shown that the prevalence of IgM monoclonal gammopathies is as high as 10% among relatives of individuals diagnosed with WM.¹⁸ They also showed that the risk of monoclonal gammopathy decreases with genetic distance, further indicating genetic predisposition. Linkage analyses that include IgM MGUS have shown positive associations.¹⁹ McMaster studied 11 high-risk WM families with WM informative for linkage and collected DNA samples from 122 individuals. Genotypic analysis using microsatellite mapping showed linkage at chromosomes 1q and 4q. In addition, chromosomes 3 and 6 were also suggested as linked.¹⁹

In another study, Kristinsson and colleagues looked at genetic predisposition for WM by studying 2,144 LPL/WM patients diagnosed in Sweden (1,539 cases with WM (72%) and 605 cases of LPL (28%).²⁰ They compared them with 8,279 population-based matched controls, and linkable first-degree relatives of patients

P.2125

(n = 6,177) and controls (n = 24,609). They reported that first-degree relatives of LPL/WM patients have a 20-fold increased risk for LPL/WM.

To further investigate familial predisposition and environmental factors, Royer and colleagues used a questionnaire-based survey in the hope of identifying environmental influences that could modulate this predisposition.²¹ They analyzed data on 103 WM patients and 272 unaffected relatives from 35 multiple-case WM and 46 mixed WM/B Cell disorders (BCD) kindred and 28 nonfamilial (sporadic) WM patients. Once more, autoimmunity was notable (overall response [OR], 2.27),

as well as infections (OR, 2.13). Other factors identified included farming (OR, 2.70), pesticide exposure (OR), exposure to wood dust (OR, 2.86), and exposure to organic solvents (OR, 4.21). Although the net effect of these risks is small, they do point to possible environmental modification of germline genetic susceptibility.

DIAGNOSIS AND LABORATORY TESTING

The diagnosis in WM is confirmed by the presence of a monoclonal IgM protein in the serum in association with bone marrow infiltration by monoclonal lymphoplasmacytic cells. These diagnostic criteria are the consequence of various consensus meetings to establish standardized diagnostic criteria for WM (see below).²² As mentioned above, the utilization of molecular techniques will likely become essential in the final confirmation of the diagnosis.

The use of the serum monoclonal protein is a cornerstone of disease diagnosis and monitoring, similar to its use in MM. There are multiple laboratory tests that exist for monitoring the serum concentration of the protein. The treating physician needs to be consistent in using the tests that are used for monitored. The serum protein electrophoresis (SPEP) is the preferred method of detecting the monoclonal protein, but quantitative detection of the IgM is also appropriate because the baseline concentration of the normal IgM (polyclonal) is low enough that it does not substantially alter the monoclonal protein concentration. Initially, immunofixation is needed to characterize a new monoclonal protein (in cases where no IgM has been measured) and also to confirm a complete response (CR). In our practice, we measure both the quantitative IgM and the SPEP because discrepancies are sometimes associated with technical aspects of the measurement. The β_2 -microglobulin should be determined, in addition to standard laboratory testing, as it is a prognostic factor for the disease (see below).^{23, 24}

At the time of diagnosis, serum viscosity should be determined and repeated as needed. For any given patient, it is usually possible to determine a level at which an IgM protein will result in hyperviscosity.²⁵ Determining viscosity, therefore, at each visit is not really needed (see section "Hyperviscosity, Neurologic and Retinal Complications"). Urine collections can be performed to measure the monoclonal light chain excreted, but the clinical value of this is not clear. Many series have shown that a significant fraction of patients who have WM can have Bence-Jones proteinuria (i.e., light chains).⁷ For unknown reasons, WM patients rarely develop intrinsic renal failure despite elevated serum-free light chains (SFLC) in some. Perhaps the large size of the monoclonal IgM prevents most of the intact molecule from reaching kidney tubules, unlike myeloma where the intact immunoglobulin molecule can also be detected in the urine, and possibly contributes to cast formation when large amounts of free light chains are excreted. Studies are not available that address the clinical significance of serum-free light-chain detection; however, it is clear that this assay can be used as a surrogate tumor marker as well.

The use of the serum-free light chain (SFLC) has also been explored in WM.²⁶ Leleu studied 72 patients (15 new diagnosis and 57 previously treated) and found a correlation between the serum concentration of sFLC and negative prognostic indicators.²⁷ Itzykson reported on 42 cases of WM (all at diagnosis) and observed similar associations, with elevated levels predicting shorter times to treatment initiation.²⁸ Larger studies are needed to better quantify these associations and associated clinical implications.

It is useful to obtain a computed tomographic (CT) scan of the chest, abdomen, and pelvis at baseline to assess the spleen and liver size and the presence or absence of lymphadenopathy. Obtaining a metastatic bone survey for patients with WM has little value because, in most cases of WM, bone disease is not present. Obtaining a bone survey is recommended in cases with bone symptoms or in those where the bone marrow pathology is purely plasmacytic.^{29, 30, 31, 32, 33} The use of positron emission tomographic scan is not considered routine, but can be useful in determining the extent of disease bulk in selected patients.³⁴ In some cases, discordant results have been observed, however, a global recommendation for its use has not been made. In patients with proven bone lesions, a diagnosis of IgM myeloma rather than WM needs to be considered. Until recently, the entity of IgM myeloma had not been defined at the genetic level, making the distinction between WM and IgM myeloma extremely difficult (see below).

IgM MONOCLONAL GAMMOPATHY OF UNDETERMINED SIGNIFICANCE AND SMOLDERING WALDENSTRÖM MACROGLOBULINEMIA

Diagnosis

Having a minimal concentration of a monoclonal protein (e.g., 1.5 or 3.0 g/dl) has classically been required to establish the diagnosis of WM; however, a consensus panel eliminated this requirement.²² The rationale was that having a required minimal concentration could underdiagnose patients early in the course of their disease who may already be symptomatic. It is still unclear how to differentiate IgM MGUS from WM.⁷ Inasmuch as most patients with a monoclonal IgM do not necessarily have WM, better diagnostic tools are needed, perhaps including molecular detection of MYD88 mutations. Asymptomatic patients with a small monoclonal protein and minimal involvement of the bone marrow by

lymphoplasmacytic cells or clonal lymphocytes (e.g., less than 10%), still need to be considered as having an IgM MGUS. Patients like these, according to many epidemiology studies, may have no disease progression for decades.³⁵ One study found that patients with IgM MGUS, as well as patients with asymptomatic WM, have a better survival than patients with symptomatic WM, emphasizing the critical importance of symptoms over laboratory values.³⁶ The importance of segregating IgM MGUS from symptomatic WM is highlighted by this last study.

Evolution to Waldenström Macroglobulinemia from Asymptomatic Stages

The evolution of the monoclonal gammopathy is different for patients with non-IgM disease versus those with IgM MGUS.³⁵ IgM MGUS, in contrast to non-IgM disease, tends to evolve to WM and not to myeloma³⁵ (Table 100.1). Therefore, the greatest risk factor for the development of WM is having an IgM MGUS.³⁵ These patients have a 46-fold greater risk of developing WM than the general population.³⁵ Identification of risk factors for the progression of IgM MGUS is therefore needed. Identification of such risk factors will not only shed new light on the mechanisms of progression, but will also provide a mechanism by which to monitor patients at risk for progression.

In another series, Kyle reported on the outcome of patients with IgM MGUS.³⁷ In contrast to those with non-IgM MGUS, these

P.2126

patients have a heightened risk of progression to WM (and not myeloma per se). He identified a total of 213 patients with IgM MGUS seen at the Mayo Clinic—Rochester from 1960 to 1994.³⁷ These patients were followed for a median of 6.3 years (cumulative 1,567 person-years). Interestingly, a lymphoma not otherwise specified developed in 17 patients (RR 14.8), and WM developed in 6 (RR, 262). Risk factors predictive of progression included the concentration of the serum monoclonal protein and albumin at diagnosis (for progression to lymphoma or a related disorder).

Morra reported on risk factors for progression from IgM MGUS to WM.³⁸ She studied 384 asymptomatic IgMMGUS and a total of 74 other IgM-related disorders.³⁸ At 5 and 10 years, the risk of progression was 8% and 29%, respectively for IgM MGUS. A total of 41 patients evolved to WM after a median follow-up of 45 months. Factors predictive of progression included the extent of bone marrow infiltration, sedimentation rate, hemoglobin, serum concentration of the IgM, and lymphocytosis. However, in the multivariate analysis, only the serum IgM concentration and lymphocytosis remained predictive. Among patients with smoldering Waldenström macroglobulinemia (SWM), the risk of progression seems to be greater in patients who have a monoclonal spike greater than 3 g/dl, and/or a lymphoplasmacytic infiltrate of the bone marrow, greater than 30%, or diffuse infiltration of the bone marrow, or anemia.³⁹ Likewise, Alexanian reported that a hemoglobin less than 11.5, M-spikes greater than 3 g/dl, and an elevated β_2 -microglobulin correlate with a heightened risk of progression.⁴⁰

Gobbi and colleagues reported on a large series of patients with various IgM monoclonal gammopathies.³⁶ A large cohort of 698 patients with IgM gammopathy was subdivided into 4 unique clinical entities; IgMMGUS, SWM, WM, and other IgM-related disorders (excluded from further analysis). Not surprisingly, IgM MGUS and SWM had median survivals similar to that of the general population. The standardized mortality rate for patients with symptomatic WM was 5.4.

Baldini and colleagues evaluated 217 patients with IgM MGUS and another 201 patients with SWM.⁴¹ The median time to progression was not reached for IgM MGUS, and was 142 months for those with SWM (median duration of follow-up of 56 and 60 months). Progression was more likely in patients with elevated serum monoclonal proteins, anemia, and male sex.

Likewise, Greco et al. evaluated risk factors for progression from IgM MGUS and SWM to active disease.⁴² Their series included a total of 287 patients: 201 with IgM MGUS, and 86 with SWM. After a median of 50 months, 32 cases evolved (11.1%): 26 to WM and 6 to other non-Hodgkin lymphoma. In the univariate analysis, risk factors for progression included the degree of bone marrow infiltration, elevated sedimentation rate, the concentration of the serum monoclonal protein, and IgA levels. The highest risk of progression was identified for patients with SWM, serum monoclonal protein ≥ 3 g/dl and/or those with $\geq 10\%$ BM infiltration.

Kyle presented a recent update on the risk of transformation from SWM to WM.⁴³ SWM was defined as those patients having an elevated monoclonal IgM to greater than 3 g/dl and/or greater than 10% involvement of the bone marrow by the clonal process. By definition, these patients must have no evidence of end organ damage (anemia, constitutional symptoms, hyperviscosity, lymphadenopathy, or hepatosplenomegaly). A total of 48 patients were identified who fulfilled these criteria. After a median follow-up of 15.4 years, a total of 34 patients progressed to WM. In two other patients, other complications were observed (amyloidosis [AL] in one and lymphoma in the other). Based on these data, the cumulative risk of progression was estimated at 6% at 1 year, 39% at 3 years, 59% at 5 years, and 68% at 10 years. Risk

factors predictive of progression included the degree of bone marrow involvement (hazard ratio [HR] 1.31), concentration of the serum M-spike (HR 2.1), reduction of the serum IgA (HR 2.4), and hemoglobin (HR 0.7). As in the Greco et al. study, it seems that progression is a stochastic event and, therefore, tumor bulk (i.e., cells at risk) predicts likelihood of progression.

PATHOLOGY

The WHO classification and the Revised European-American Lymphoma classify WM as LPL because of its immunophenotypic and morphologic characteristics.⁴⁴ Some cases of LPL have no associated monoclonal protein,⁴⁵ a more aggressive clinical course, and a different set of genetic abnormalities.²³ It is now believed that there are several subsets of LPL, of which WM is only one subtype.

Estimation of clonal involvement in the bone marrow is routinely performed at diagnosis with a unilateral trephine aspirate and biopsy. The disease is typically a pleomorphic infiltrate of lymphoplasmacytic cells,^{46, 47, 48} and variability in cell morphology is common (Fig. 100.1). The infiltrate can range from purely lymphocytic to one that is predominantly plasmacytic.^{46, 47, 48} The co-existence of mast cells in association with the lymphomatous infiltrate is a unique feature of WM.^{46, 47, 48, 49, 50} The role of these mast cells as part of the disease pathogenesis has not been fully elucidated. A complex network of interactions between the WM cells and the bone marrow microenvironment has been suggested in preliminary observations.⁵⁰ In addition, infiltration by malignant B cells can be seen in lymphoid structures and multiple other organs (giving rise to organomegaly and lymphadenopathy).⁴⁴ The detection of clonal cells in other organs is not known to have particular prognostic implications; however, clinically evident organomegaly is usually a negative prognostic factor for the disease^{51, 52} and usually indicates a large tumor burden.

The nature of the clonal B-cell populations is remarkable.^{53, 54} Sahota has identified the normal counterpart of WM cells as mature B cells that have undergone somatic hypermutation, but that have not yet completed isotype class switching.⁵⁵ In that particular study, they did not find evidence of intraclonal heterogeneity. It is notable that in many cases of WM, one can observe co-existent populations of monoclonal B cells and plasma cells. Recently, Zehentner and colleagues demonstrated that only in 40% of cases are the clonal B-cell and plasma cell populations related.⁵⁶ Conversely, in 60% of cases, they represent two separate and independent clones. By performing sequencing of the immunoglobulin genes, and in some cases using fluorescence

P.2127

in situ hybridization (FISH) analysis, they conclusively show the separate nature of these clones in 60% of cases.

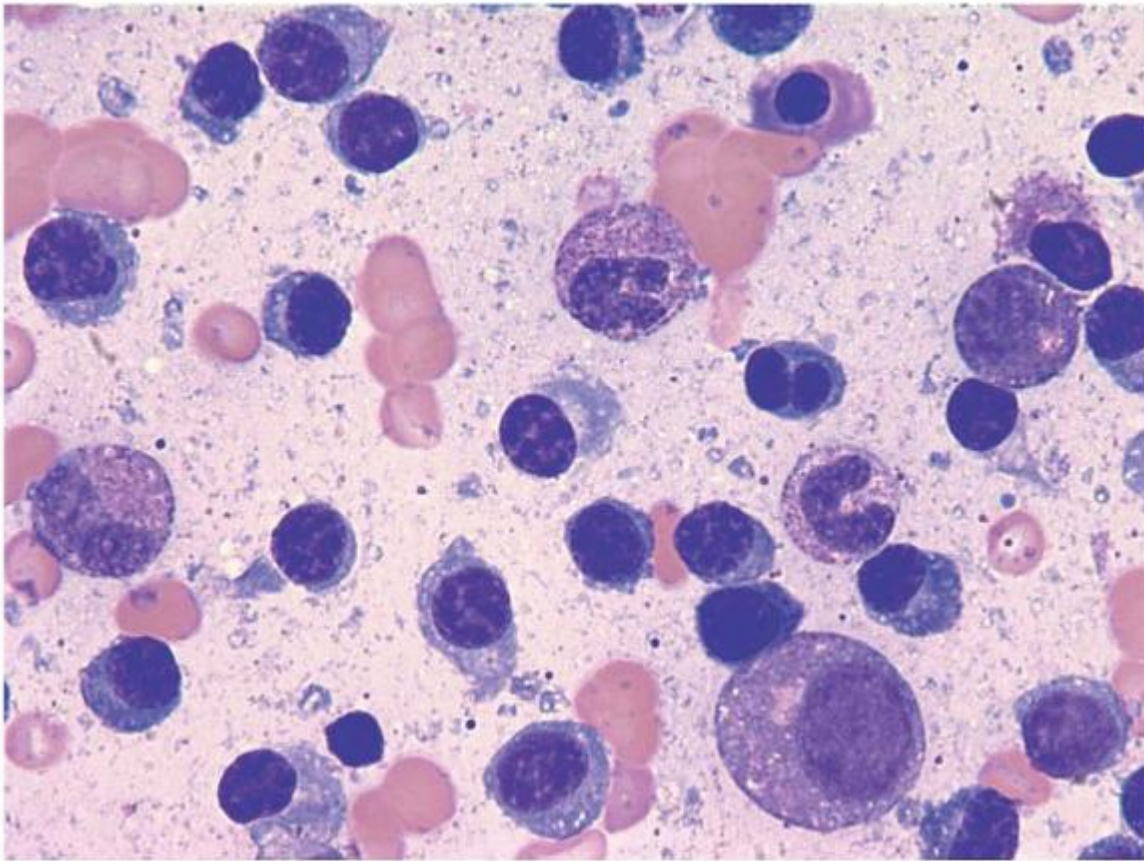

FIGURE 100.1. Lymphoplasmacytic morphology of the clonal cells of Waldenström macroglobulinemia. As shown in the graph, the cells have variable morphology but most show transition between mature lymphocytes and plasma cell morphology. The cells have been called in the past “plymphs.” The morphology can be variable with some cases showing more extreme plasma cell morphology, whereas others have more lymphocytic predominance.

Flow cytometry is usually indicated as part of the pathologic work-up to make the diagnosis of WM. Flow cytometry is helpful in differentiating WM from other morphologically similar neoplasms, such as mantle cell lymphoma, marginal zone lymphomas, and B-cell chronic lymphocytic leukemia (CLL).^{49, 57, 58, 59} WM cells are characterized by the surface expression of CD19, CD20, CD22,^{49, 57, 58, 59, 60, 61} are light chain restricted, and commonly express CD79a. They are also typically CD10 and CD23 negative, in contrast to follicular lymphoma and B-cell CLL, respectively. The associated plasma cells are monoclonal and express CD138.^{49, 57, 58, 59, 60} CD5 is not expressed on the malignant cells (in contrast to mantle cell lymphoma and B-cell CLL) in the majority of cases; however, some cases can be positive.^{49, 57, 58, 59, 60}

Cell proliferation markers are usually indicative of the indolent nature of the disease. The fraction of cells incorporating 5-bromo-2'-deoxyuridine (BrdU),⁶² indicating cell replication, is usually minimal, and frequently no such fraction is detected at all. The evolution of WM to a more aggressive lymphoproliferative disorder has been previously reported,^{63, 64} and the presence of a highly proliferative fraction may suggest transformed disease. The role of karyotype analysis in the clinical management of patients is not felt to be necessary and, in most patients, the metaphases will be normal.^{65, 66, 67} Therefore, this analysis should be reserved for patients suspected of having treatment-associated myelodysplasia.⁶⁸

WM variants have been described where patients have a similar pathology to WM, but present with IgG monoclonal proteins.⁶⁹ These patients appear to be clinically different from WM and tend to have a lymphocytosis present in the peripheral blood. It is not clear if these diseases have a similar pathogenesis, as only one series of patients with this variant tumor has been reported. Also, some patients have been described as having WM with associated bone lesions.^{29, 30, 33} This makes distinguishing WM from IgM myeloma very difficult. Given the availability of molecular testing that can identify MYD88 mutations and also chromosome abnormalities seen in IgM MM, this distinction should now be possible. If some cases of true WM indeed have bone lesions, it is likely that these will be due to the same mechanisms operative for myeloma.⁷⁰ In a recent study of patients with IgM myeloma, it was found that the t(11;14)(q13;q32) was nearly universally present.⁷¹ Another recent study did not find it as universal, but still common in IgM myeloma patients (38%).⁷² Also, the

t(14;16) (q32;q23) has been reported in one case of IgM myeloma.⁷³ In addition, we have found that translocations of the IGH locus seen in IgM myeloma are not typically observed in patients with WM, and when present, they are secondary genetic events, seen only in cell subsets.⁶⁷ This, along with the new-found mutation of MYD88, clearly separates WM and IgM myeloma as separate disease entities.

BIOLOGY AND GENETICS

Somatic Mutations

There is compelling evidence for a postgerminal center origin of the clonal B cells in WM.^{31, 32, 74, 75, 76} To ascertain the lack of class switch rearrangements involving the mu switch region, we studied cases using a Southern blot assay, with no rearrangements identified (concordant 5' and 3' switch μ bands after digestion).⁶⁷ The aggregate of these studies thus shows that cell arrest just prior to class switching is the likely stage of neoplastic transformation, and genetic defects of the class switch machinery may be involved in the disease pathogenesis. It is important to note that lymphoplasmacytic cells of WM can mature to clonal plasma cells in vitro⁷⁷ suggesting that additional mechanisms may play a role.

MYD88 L265P

Just recently, a mutation of the gene MYD88 has been described by Treon et al. in almost all cases of WM.⁷⁸ The mutation is associated with intracellular signaling and is believed to be key in the pathogenesis of the disease.⁷⁸ The prevalence of this mutation in IgM MGUS cases is still being investigated. In the initial reports it was felt to be uncommon in IgM MGUS cases, but the actual prevalence is still being investigated, with some reports showing up to 50% of IgM cases harboring the mutation. The MYD88 L265P activating mutation has been reported in 90% of WM cases.⁷⁸ MYD88 encodes for an adapter protein that affects the interleukin (IL)-1 and Toll-like receptor pathway, and the L265P leads to the dysregulation of the nuclear factor kappa B (NF- κ B) and JAK signaling pathways.⁶

Other Mutations

Two other genes have been found to be inactivated in WM: TNFAIP3 and TRAF3. TNFAIP3 is a tumor suppressor gene whose inactivation results in the constitutive activation of NF- κ B.⁷⁹ We reported biallelic inactivation/deletion of TNFAIP3 in 5% of WM patients.⁸⁰ In addition, 38% of patients were found to have monoallelic deletions of TNFAIP3 with associated diminished transcription of the gene, with proposed associated haploinsufficiency. Inactivating mutations of TRAF3 (located at 14q32.32) have been described and also result in the constitutive activation of NF- κ B in about (~5%) of patients.⁷⁹ TRAF3 is a negative regulator of the noncanonical NF- κ B signaling pathway, with a consequent increase in serine/threonine protein kinase NIK.^{79, 81, 82} Similar observations have been made using novel high-throughput genomic tools.⁸³

6q Deletions and Other Genetic Changes

The most common cytogenetic abnormality in WM is deletion of 6q. We know through multiple studies that in at least one half of cases, large deletions of chromosome 6 are observed in WM by a combination of FISH and aCGH (array comparative genomic hybridization).^{66, 67, 84, 85} Usually, these deletions involve chromosome bands 6q21-q23, with the most commonly deleted being the q23 region. These deletions are clonally selected in the majority of cases.⁶⁷ The clinical relevance of the presence of a 6q deletion has not been well defined, but a recent study suggested that these patients tend to have more aggressive disease and a shorter survival.⁸⁶ These observations, however, need to be confirmed in additional studies.⁶⁷ Although the data are limited, chromosome 6q deletions seem to be rare in cases of IgM MGUS, suggesting that deletions in 6q are involved in the progression to WM⁸⁷ (Fig. 100.2). Although there is no direct link yet made between 6q deletions and MYD88 mutations, and given the ubiquitous nature of the latter,

P.2128

and the high prevalence of the former, it is only logical to conclude that both are important in disease pathogenesis. The second most common observation by aCGH was the gain of 6p (16.6%), always occurring as a secondary event following the loss of 6q.⁷⁹

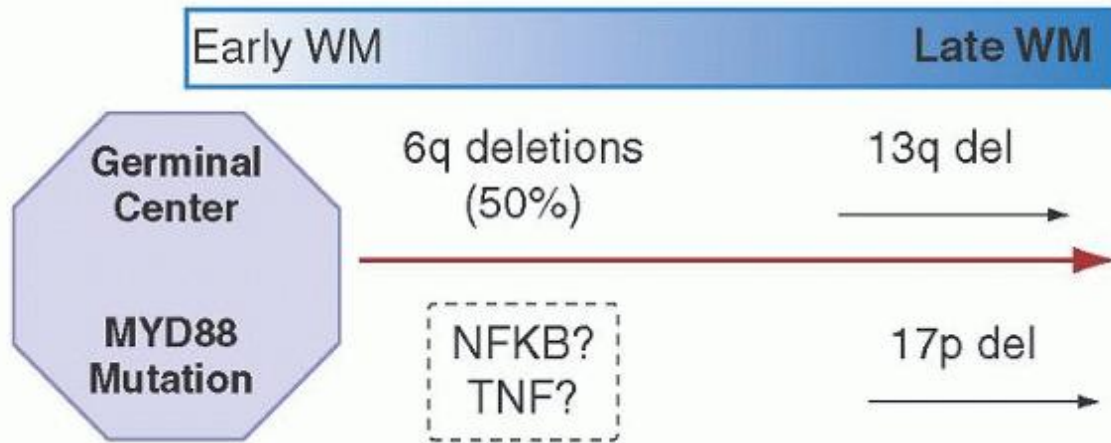

FIGURE 100.2. Biology of progression for Waldenström macroglobulinemia (WM). Mutations of MYD88 are likely founder lesions for the disease. In 50% of cases, deletion of the long arm of chromosome 6 may be the culprit in the initiation of the clonal process of Waldenström macroglobulinemia. In some cases, deletions of chromosomes 13 and 17 may represent progression events. Emerging data suggest that abnormalities of tumor necrosis factor (TNF) and nuclear factor kappa B (NF- κ B) signaling may also be contributing factors in the pathogenesis of the disease.

Originally, due to the presence of LPL in the bone marrow, it was believed that WM must contain the t(9;14)(p13;q32) (described originally in at least 50% of LPL cases, none of which had detectable IgM monoclonal protein).⁸⁸ The t(9;14)(p13;q32) results in upregulation of PAX-5,⁸⁹⁻⁹¹ implicating this gene as a putative oncogene in the pathogenesis of LPL cases without monoclonal IgM.^{45, 92} PAX-5 prevents expression of high levels of immunoglobulin and diminishes production of the J-peptide needed for the pentameric IgM assembly; therefore, the presence of PAX-5 up-regulation by this translocation is inconsistent with the phenotype of WM. In contrast to many other B-cell malignancies, it has been shown that WM never harbors the t(9;14), or any other 14q32 translocations.⁶⁷ In a significant number of cases, review of the karyotype also failed to identify IGH translocations on chromosome 14.^{65, 66, 67} Although some rare cases have clones with IGH translocations,⁹³ these events are now believed to be secondary genetic events associated with disease progression. In most WM cases, the karyotype results are usually normal.^{65, 66, 67, 94, 95, 96}

In sporadic cases of WM, the t(11;18)(q21;q21), usually associated with a subset of marginal zone lymphomas, has been reported.⁹⁷ Using an interphase FISH-based strategy, others have been unable to detect this translocation.⁶⁷ Again, molecular confirmation of MYD88 mutations will be important in redefining whether these entities should be considered under the WM diagnosis. Other chromosomal abnormalities, such as deletions of 17p13.1 and 13q14, are not common at the time of diagnosis, but at the time of disease progression, may be observed in 15% of patients.⁹⁸ The clonal cells of WM are usually diploid,⁶⁷ and this has been confirmed by DNA content analysis in a subset of patients.⁹⁹

Additional data have suggested that WM may have features in common with other disease entities, as well as with MM. At the gene expression level, WM resembles B-cell CLL more than it does MM.¹⁰⁰ In addition, studies of patients with IgM MGUS show clustering together with WM.¹⁰⁰ Furthermore, the clonal cells of WM express high levels of IL-6, which likely would explain the clinical observation of high C-reactive protein levels in the serum of WM patients.^{100, 101} In a manner similar to the anemia of chronic disease, the high levels of IL-6 likely contribute to the anemia, of WM.¹⁰² Experiments of gene expression profiling in WM were performed, separating the CD19+ cells from the CD138+ cells, and have found remarkably similar patterns of gene expression.¹⁰³

Epigenetic Aberrations; Micro-ribonucleic Acid and Histone Acetylation

Roccaro et al. reported on a unique miRNA profile in WM cells, something that was different from the normal B-cell counterparts.¹⁰⁴ Their studies showed that miRNA-363*, -206, -494, -155, -184, -542-3p were up-regulated and miRNA-9* was underexpressed.¹⁰⁴ Many of the predicted targets for these miRNAs include genes associated with the cell cycle, apoptosis, transcription factors and oncogenes. Because of its previous descriptions in other B-cell malignancies, miRNA-155 has been more extensively studied in WM.¹⁰⁴ For a more detailed analysis, the reader is referred to a recent review article.^{105, 106} Likewise, alteration of the balance between histone acetyl transferases and histone deacetylases has been postulated as important in the pathogenesis of WM. This is important as two miRNAs are associated with histone acetylation: miRNA-206 and -9*.¹⁰⁷

Cytokines and B-cell Signaling

A tumor necrosis factor family member, B-lymphocyte stimulator (BLyS), is critical for maintenance of normal B-cell development and homeostasis. Elsawa and colleagues found that WM cells variably express the BLyS receptors BAFF-R, TACI, and BCMA and bind soluble BLyS.¹⁰⁸ Also, they documented elevated serum BLyS levels in patients with WM and expression of BLyS in bone marrow samples by immunohistochemistry.¹⁰⁸ BLyS, in vitro, increased the viability and proliferation of WM cells and stimulated secretion of the monoclonal IgM. She also found that chemokine (C-C motif) ligand 5 (CCL5), granulocyte colony-stimulating factor, and soluble IL-2 receptor are overexpressed in WM, with CCL5 correlating quite closely with the serum levels of IL-6. As mentioned earlier, up to 50% of WM have up-regulation of IL-6, a cytokine critical in B-cell development and implicated in various B-cell malignancies. Furthermore, WM cells also express the IL-6 receptor, and CCL5 results in increased secretion of IL-6 by bone marrow stromal cells in WM, further enhancing IL-6 stimulation, occurring both in an autocrine and paracrine fashion. This stimulation resulted in increased secretion of IgM in a process mediated via JAK/STAT signaling.

AKT

Leleu et al. reported increased activity of AKT in the clonal cells of WM.¹⁰⁹ They also showed that down-regulation of AKT and use of an AKT inhibitor, perifosine, resulted in diminished proliferation and induction of apoptosis.¹⁰⁹

CLINICAL FEATURES

It is best to differentiate the clinical symptoms of this disease based on their causes: those signs and symptoms secondary to the effects of the monoclonal protein and other paraneoplastic phenomena, and those related to the clonal proliferation in the bone marrow and other lymphoid organs.³ It should be noted that most patients with WM have a limited symptom complex at the time of diagnosis, consisting of a monoclonal IgM and various degrees of anemia.^{24, 110} This anemia is often secondary to the clonal expansion of cells in the bone marrow, but may also be due to hyperviscosity (by reducing erythropoietin production) or the increased plasma volume.¹¹¹ In many cases, anemia can be a consequence of treatment. Recent data suggest that some patients may have an anemia secondary to elevated levels of IL-6 emanating from the clonal cells, and will present with a picture reminiscent of the anemia of inflammation.¹⁰⁰ Given the high level of expression of IL-6 and IL-6 receptors in at least half of WM, it is not surprising that elevated levels of hepcidin have been postulated as key mediators in the anemia of WM.¹⁰² In cases with significant involvement of the bone marrow by the WM clonal cells, thrombocytopenia may also be observed.^{24, 110}

In 20% of cases, the clonal cells of WM can infiltrate other organs and result in hepatomegaly and splenomegaly in 15% of patients.^{23, 24, 51, 52, 110, 112} Splenomegaly can result in hypersplenism, with worsening pancytopenia. Although patients may have liver involvement, this is usually asymptomatic. Lymphadenopathy can be seen in 15% to 20% of patients,^{23, 24, 51, 110, 112} and involvement of other organs, such as the lung, can be seen in WM, although this is present in only a minority of cases.^{113, 114}

Hyperviscosity, Neurologic and Retinal Complications

Hyperviscosity is one of the most characteristic features of WM; however, it is only seen in 15% of cases.^{25, 115, 116} The details of the physical properties of the pentameric IgM molecule leading to hyperviscosity have been previously described.^{25, 116} The large dimensions of the IgM molecule make the serum more viscous, and results in slower transit in capillaries.²⁵ The increased viscosity is not just the result of the large size of the IgM molecule, as

P.2129

other large particles such as albumin do not have the same effect on the serum viscosity.²⁵ Although the overt clinical syndrome of hyperviscosity is obvious, subtler symptomatology can also be seen. Typical symptoms include neurocognitive effects (sometimes with overt hemorrhage and neurologic abnormalities), retinal bleeding, and mucosal bleeding in gums and nose. In different patients, different serum concentrations of the monoclonal IgM will give rise to hyperviscosity, and there is no absolute value at which hyperviscosity will be observed.^{25, 115, 116} However, for a given patient, a given IgM level will usually again result in symptoms when the serum IgM reaches that level again.^{25, 115, 116} Despite having a high serum viscosity, some patients will have no symptoms, whereas others will have prominent symptoms at lower viscosity levels. To see symptoms of hyperviscosity at values less than 4 cps is uncommon. In contrast, nearly all patients with a viscosity greater than 8 will be symptomatic, and most patients with a viscosity of 5 to 8 cps will have symptoms.^{25, 115, 116} Also, to have hyperviscosity with an IgM less than 4,000 mg/dl is very rare.²⁵ The patient's hydration and the red cell mass are other factors that contribute to blood viscosity. Red cell transfusions should therefore be used with caution, and sometimes in conjunction with pre-transfusion plasmapheresis, in patients with high IgM concentrations.

Since the original reports by Waldenström,¹¹⁷ neurologic abnormalities in patients with WM have been described (Bing-Neel syndrome). Plasma exchange should be entertained in any patient presenting with a focal or global neurologic deficits that potentially could be attributed to hyperviscosity, even if a clear causal association is not immediately established. The symptoms may be nonspecific and the spectrum can include headache, fatigue, impaired cognition, confusion, stroke, or frank dementia.^{118, 119}

Peripheral neuropathies associated with the presence of monoclonal proteins include, demyelinating polyneuropathy (both associated and not with antemyelin-associated glycoprotein antibodies),^{120, 121} other demyelinating neuropathies, cryoglobulinemia-associated symptoms, and neuropathies associated with light-chain AL. The monoclonal protein, in most cases, has affinity for the myelin sheath and results in demyelination,¹²² which can be observed in up to one half of WM patients with peripheral neuropathy.¹²³ Patients can also have abnormalities of proprioception resulting in ataxia, in addition to the sensory deficits.^{123, 124} Some of the new therapeutic agents, namely bortezomib, can also be associated with treatment-induced peripheral neuropathy. As a direct consequence of the increased viscosity, patients can have retinal complications of WM, and these present on physical examination as venous engorgement, hemorrhage, and cotton-wool exudates.^{125, 126} In some severe cases, WM can precipitate retinal vein occlusion.^{125, 126}

Clinical features of light-chain-associated AL can develop in some patients with WM.^{7, 127, 128} In these cases, there appears to be a higher incidence of pleural and pulmonary AL, and a greater tendency for amyloid-associated cardiomyopathy than in other AL cases (44% vs. 27%).^{127, 128} In these patients, therapy should be tailored to control the WM rather than the AL. The fact that AL can be observed in association with WM suggests that AL is merely a complication of any monoclonal protein-producing neoplasm.

PROGNOSIS

The prognosis of WM is highly variable, and until recently, there were few models validating putative prognostic factors. The median survival for patients with WM has been estimated to be 5 years,^{51, 68} however, 10% of patients remain alive at 15 years.⁶⁸ Although the survival appears short for a disease felt to have an indolent nature, the fact that patients present at an advanced age presents a significant problem in determining the survival associated with this disease. The precise disease-specific survival is often difficult to determine, as these patients have “competing causes for death.” One study addressed disease-specific survival associated with WM, with the median felt to be closer to 11.2 years.⁵² In this study, organomegaly and age > 65 years were associated with poor prognosis in a multivariate analysis. Similarly, a longer survival of 108 months has been reported in another series, suggesting that this disease may truly behave in an indolent fashion.¹²⁹ It is likely that the survival of patients continues to increase given the availability of various new therapeutic classes of agents.

Several prognostic models for WM have been previously proposed. Morel⁵¹ and Facon¹¹⁰ studied 232 patients treated prior to 1989 (mostly alkylators and no purine nucleoside analogues [PNAs]). They found that the prognostic factors associated with a shorter survival were age > 65, albumin < 40 g/L, hemoglobin < 12 g/dl, platelet count < 150 × 10⁹/L, and WBC < 4 × 10⁹/L. They developed a prognostic model based on a point system that discriminated groups with different outcomes. If the patients had one cytopenia, they were assigned 1 point, and if they had two or more, they were given 2 points. The proportion of patients alive at 5 years was 87% (0 to 1 points; 27% of cases), 62% (2 points; 27% of cases), and 25% (3 to 4 points; 46% of cases) for the low-, intermediate-, and high-risk groups, respectively. Differences in outcome based on time of therapy initiation (initial observation vs. initial treatment) were not found in this series. It is interesting that they did not find systemic symptoms, pathologic features, or splenomegaly to be useful in determining prognosis. This prognostic model has been further validated by Kyrtsonis¹²⁹ and by the same group (Morel and colleagues) in a separate cohort of patients with advanced WM.¹³⁰

A second model was developed by Gobbi and colleagues.¹³¹ They were able to show that the following variables were associated with a shorter survival: anemia (hemoglobin less than 10 g/dl), age greater than 70, weight loss, and cryoglobulinemia.¹³¹ This model divided patients into low- and high-risk groups, the latter defined by patients having two or more adverse prognostic factors.

Dhodapkar proposed a different model, studying 182 patients treated with fludarabine in a clinical trial.²³ He showed that patients with an elevated serum β_2 -microglobulin (≥ 3 mg/dl), low hemoglobin (<12 g/dl), and low IgM (<4,000 mg/dl) fared the worst. From this model, it is unclear why patients with a lower concentration of the monoclonal protein would fare worse; but it may be explained by the inclusion of patients with LPL, which may be a different biologic entity. In a follow-up report, they reported that overall survival (OS) and event-free survival in the presence of lower levels of serum β_2 -microglobulin were significantly longer in all cohorts.¹³² It is interesting that achieving a response, or the time needed

to achieve this response, did not predict event-free survival or OS.¹³² Unfortunately, the Dhodapkar model was not reproduced in a series of patients with advanced WM reported by Levy and colleagues.¹³⁰

Recently, Dhodapkar updated the SWOG series, with a median follow-up of 10 years for live patients.¹³³ Of the 59 previously untreated patients who initially were observed, only 12 patients (21%) required therapy, at a median follow-up of 100 months.¹³³ Among the 183 patients requiring therapy, the long-term observations confirmed that advancing age (>70), previous treatment, and the serum concentration of β_2 -microglobulin (3 mg/dl or greater) were negative factors, but with additional follow-up, an elevated serum LDH became important too. They propose a new and improved model that uses advanced age, β_2 -microglobulin, prior treatment, and LDH (above upper limit of normal) to segregate patients into 3 groups, with 8-year OS of 55%, 33%, and 5% ($P < 0.001$). In the multivariate model, a low serum monoclonal protein did not remain significant.

P.2130

TABLE 100.2 INTERNATIONAL PROGNOSTIC INDEX

Factors Associated with Prognosis	Value
Age (years)	>65
Hemoglobin (g/dl)	≤11.5
Platelet count (n/ μ l)	≤100,000
β_2 -Microglobulin (mg/L)	>3
Monoclonal IgM (g/dl)	>7

Risk Stratum and Survival		
Risk Category	Score	Median Survival (Months)
Low	0 or 2 (except age)	142.5
Intermediate	2 or age >65 years	98.6
High	>2	43.0

One point is assigned for each risk factor and the risk score is the sum of these factors. Adapted from Morel P, Duhamel A, Gobbi P, et al. International prognostic scoring system for Waldenstrom macroglobulinemia. *Blood* 2009;113:4163-4170 and Morel P, Duhamel P, Gobbi PG, et al. International prognostic scoring system for Waldenstrom macroglobulinemia. *Haematologica* 2007;92:84.

An international effort has been focused on the development of an international prognostic model for WM. A total of 587 patients were entered into this model who fulfilled the diagnostic criteria recommendations by the Second International Workshop of WM.^{134, 135} In the univariate model, seven factors were associated with a shortened survival, and included age over 65, platelet count ≤ 100 (n/ μ l), β_2 -microglobulin greater than 3 mg/dl, M-spike greater than 7 g/dl, granulocytes ≤ $1.5 \times 10^9/L$, hemoglobin ≤ 11 g/dl, and albumin ≤ 3.5 g/dl.

An updated model has been published by the same group.¹³⁶ Using a bootstrap analysis, the following factors were selected to develop a risk-factor-based classification: age, hemoglobin, platelet count, β_2 -microglobulin, and M-spike.¹³⁶ Low risk was defined as having only one risk factor or less, high risk as having greater than two, and all others, intermediate, or if only age was greater than 65. The 5-year survival rates were 87%, 68%, and 36% ($P < 0.0001$). (Table 100.2)

CONVENTIONAL TREATMENTS AND MANAGEMENT

No standard response criteria in WM have been available until recently. A consensus statement regarding criteria for response was published and subsequently updated.^{137, 138} Aside from defining CR and PR (partial response), these criteria define a “minor response” (MR) category, thereby recognizing that patients may sometimes have a dramatic clinical

improvement with only a minor decrease in the serum monoclonal protein. The criteria also stressed the importance of delayed responses and recommended an assessment of response over an extended duration follow-up period.

The development of novel therapeutics in WM has had to rely solely on the results of clinical trials, as no good pre-clinical models for the study of WM have existed. Clinical trials have had slow accrual rates due to the small numbers of patients with this disorder, and many therapeutic strategies have been extrapolated from observations in other lymphoid neoplasms. A potential pre-clinical model of WM was published by Tassone and colleagues.¹³⁹ They were able to develop a SCID-Hu murine model that mimics human WM. Human fetal bone grafts (embedded subcutaneously) were used to support the ex vivo growth of WM cells. In this study, the model reflected the usual response to rituximab as is observed in patients. It is hoped that this model will allow pre-clinical testing of novel compounds or combinations for use in WM prior to initiating clinical studies.

Observation

Many patients with WM may not be in need of immediate treatment, and for many, the disease may follow an indolent course.^{23, 36, 131} Although no specific criteria exist, the absence of overt symptoms or complications may be used as reason for continuing careful monitoring of patients. Because WM is considered an incurable malignancy, the goal of treatment must be to provide symptom relief for patients, as those without symptoms are not known to benefit from therapy. This paradigm has, however, been challenged in other similar disease settings, and it is possible that in the future, recommendations will be made for the treatment of the asymptomatic patient with impending progression. Previous studies have clearly described pre-symptomatic stages for WM (including IgM MGUS),^{36, 117, 140} and the treating physician should first decide whether the patient really needs therapy.

Alkylating Agents

Classic Alkylators

Chlorambucil is a well-tolerated oral agent used in the treatment for WM.¹⁴¹ This drug is currently used in selected situations, predominantly in the treatment of the elderly, given the high tolerability of the drug, its ease of administration, and despite the leukemogenic potential. For a summary of response rates of most published clinical trials in WM, see Table 100.3. The aforementioned study by Facon (n = 167), demonstrated a median survival of 5 years for patients treated with chlorambucil as initial therapy.¹¹⁰ The only prospective randomized phase III clinical trial for WM patients was performed at Mayo Clinic by Kyle and colleagues.⁶⁸ In this study, patients received oral chlorambucil, either continuously at a dose of 0.1 mg/kg/day, or pulsed doses in an intermittent fashion every 6 weeks (0.3 mg/kg/day for 7 days). The median OS was the same (5.4 years, P NS) and the response rates between both groups were similar (79% and 68%, respectively; P NS). This is the first trial that highlighted that response to any therapy in WM can occur late, and that usually at least 6 months of therapy are needed prior to concluding lack of efficacy.⁶⁸

Other alkylator-based combinations, such as VBMCP (vincristine, carmustine, melphalan, cyclophosphamide, and prednisone), have resulted in high response rates.^{142, 143, 144} In recent years, alkylators have been used less frequently, as a result of a study by Leblond and colleagues that showed the superiority of fludarabine over a cyclophosphamide containing regimen (higher response rate and duration of response),¹⁴⁵ and a number of other therapeutic options for patients. In addition, the risk of myelodysplasia with long-term use makes alkylators a less desirable option for younger patients. However, given the convenience of oral dosing and the minimal toxicity, alkylators are particularly suitable for the elderly.

Bendamustine

Bendamustine has been used with success in the treatment of WM. Rummel reported on the use of bendamustine in low-grade B-cell lymphomas, which included patients with WM. In a phase II study (n = 63 patients) of mantle cell lymphoma and low-grade B-cell neoplasias, he reported an overall response rate (ORR)

P.2131

of 90% with 60% CRs.¹⁶⁸ In a larger study, Rummel compared bendamustine in combination with rituximab, with cyclophosphamide, doxorubicin, vincristine, and prednisone (R-CHOP) chemotherapy.¹⁶⁹ Of a total of 546 patients, 40 had WM.¹⁶⁹ Among WM patients the ORR was 96% for bendamustine-R and 94% for R-CHOP. After a median of 26 months, 87% of bendamustinetreated patients, (20/23) remained free of progression, and only 53% of those treated with R-CHOP were so (9/17) (M Rummel, International WM Workshop, 2012). Treon et al. reported on a retrospective analysis of 30 previously treated WM patients who received bendamustine.¹⁷⁰ Bendamustine was given on days 1 and 2 of a 28-day cycle, along with rituximab (in most cases, n = 24). The median number of treatment cycles was 5. The reported ORR was

83%, with 5 (17%) very good partial responses (VGPRs) and 20 PRs (67%). The estimated median time to progression was 13 months. The contribution of the addition of rituximab still needs to be elucidated. In at least a quarter of patients, therapy had to be discontinued due to toxicity, and sometimes, prolonged myelosuppression.

TABLE 100.3 TREATMENT REGIMENS

Investigator	Regimen	N	Response Rate (%)
Alkylators/Cytotoxic			
Facon ¹¹⁰	Chlorambucil	167	75
Kyle ⁶⁸	Chlorambucil	22-24	68-79
Case ¹⁴³	VBMCP	33	82
Petrucci ¹⁴⁴	Cyclophosphamide + melphalan + prednisone	34	74
Leblond ¹⁴⁵	Cyclophosphamide + doxorubicin	45	11
Fludarabine			
Kantarjian ¹⁴⁶	Fludarabine	11	45
Leblond ¹⁴⁵	Fludarabine	45	30
Dhodapkar ²³	Fludarabine	182	36
Dimopoulos ¹⁴⁷	Fludarabine	28	36
Zinzani ¹⁴⁸	Fludarabine	12	41
Leblond ¹⁴⁹	Fludarabine	71	30
Thalhammer-Scherrer ¹⁵⁰	Fludarabine	7	86
Foran ¹⁵¹	Fludarabine	19	79
Dimopoulos ¹⁵²	Fludarabine + cyclophosphamide	73	55
Tamburini ¹⁵³	Fludarabine + cyclophosphamide	14	85
Vargaftig ¹⁵⁴	Fludarabine + cyclophosphamide + rituximab	21	76
Tam ¹⁵⁵	Fludarabine + cyclophosphamide + rituximab	9	56
Cladribine			
Liu ¹⁵⁶	Cladribine	20	55
Betticher ¹⁵⁷	Cladribine	25	40
Dimopoulos ¹⁵⁸	Cladribine	29	59
Delannoy ¹⁵⁹	Cladribine	18	39
Dimopoulos ¹⁶⁰	Cladribine	26	85
Hellman ¹⁶¹	Cladribine	22	41
Laurencet ¹⁶²	Cladribine + cyclophosphamide	3	100
Thomas ¹⁶³	Rituximab + cladribine + cyclophosphamide	18	94
Rituximab			
Dimopoulos ¹⁶⁴	Rituximab	27	44
Gertz ¹⁶⁵	Rituximab	69	52
Weber ¹³⁸	Rituximab	8	75

Byrd ¹⁶⁶	Rituximab	7	43
Treon ¹⁶⁷	Rituximab	30	27

Purine Nucleoside Analogues

Fludarabine

Among the most active agents available for the treatment of WM are PNAs. Most patients treated with PNAs will respond within 3 to 6 months of therapy initiation, however, a small fraction of patients will show delayed responses (5% after 12 months).¹⁷⁰ Kantarjian first reported the treatment of 11 patients with fludarabine (10 previously treated) and 5 responded, having a median duration of response >1 year.¹⁴⁶ Dimopoulos, in a later publication, reported on the treatment of 28 patients (only 2 were treatment naive) where he showed a response rate of 36%,¹⁴⁷ and many of the responses were durable (median duration of response 38 months). Leblond reported on the treatment of 71 patients with relapsed WM treated with a median of 6 cycles of fludarabine, resulting in a response rate of 30% (21/71 cases).¹⁴⁹ In a separate study, 78 patients with previously untreated WM were given fludarabine at 25 mg/m² daily, for 5 days every 4 weeks¹⁵¹ resulting

P.2132

in an ORR of 79% (15% CR), many of them durable (median 30 months). The treatment-related mortality was 5% in this study, predominantly due to infection. It should be noted that patients treated with almost all active agents in WM, including PNAs, can take a long time to respond to treatment,¹⁷¹ and concluding early in the treatment course that a therapy has failed may be a mistake.

These high response rates were, unfortunately, not confirmed in a subsequent larger series. Dhodapkar studied 231 patients of whom 182 required therapy, 118 were treatment naive, and 64 were relapsed cases.²³ Patients treated with 4 to 8 cycles of fludarabine at a dose of 30 mg/m² daily for 5 days repeated monthly. They reported a response rate of 36%, and only 2% of cases were complete responders. Prior treatment did not predict for a lower likelihood of response, but older age was associated with a low likelihood of response. The treatment-associated myelosuppression led to a 4% mortality from infections, similar to what was previously reported. It should be noted that the use of purine nucleoside analogues should be done with caution in patients needing to collect hematopoietic stem cells.¹⁷² More recently, the development of treatment-associated myelodysplasia has been reported in patients treated with fludarabine combinations, although the definitive risk of development has yet to be defined.¹⁷³

A prospective randomized trial comparing fludarabine against chlorambucil is ongoing, and was reported in a preliminary fashion at the 2011 ASH meeting.¹⁷⁴ Leblond reported that fludarabine is more effective than chlorambucil as initial therapy for WM, including significantly greater disease-free survival (DFS), progression-free survival (PFS), and OS. Patients were randomized to 8 mg/m² oral chlorambucil administered for 10 days every 28 days (to a maximum of 12 cycles), or to 40 mg fludarabine (5 days every 28 days for a maximum of 6 cycles). Response rates were higher with fludarabine than with chlorambucil (PR 47% vs. 41%; CR 6% vs. 2%, NS). Fludarabine resulted in a significant advantage in PFS (36.3 vs. 27.1 months; P = 0.012), DFS (38.3 vs. 19.9 months; P = 0.0005) and OS at 5 years (69.4% vs. 61.8%; P = 0.046). The median duration of response was longer with fludarabine (38.3 vs. 19.9 months; Leblond Personal Communication IWMW, August, 2012). Negative predictive factors included, age >70, low albumin (<4 g/dl), and treatment arm (OR 1.34). The main toxicity was, as expected, greater myelosuppression in the fludarabine arm. She also reported that secondary malignancies were less common in the fludarabine arm (3.7% vs. 21% at 6 years). This trial included other entities other than WM, such as LPL and marginal zone lymphomas.

Cladribine (2-Chlorodeoxyadenosine)

Cladribine also has documented activity against WM and is structurally similar to fludarabine. In one series, Dimopoulos treated 29 patients with a continuous intravenous infusion of 2-CDA (2-chlorodeoxyadenosine) 0.1 mg/kg/day for 7 days, for a total of two courses.¹⁵⁸ An ORR of 59% (100% in previously untreated patients; 40% for relapsed patients) was reported. Likewise, Delannoy and colleagues reported an ORR of 39% in 18 patients treated with cladribine.¹⁵⁹ Cladribine can also be administered intermittently, obviating the need for an intravenous central catheter with similar response rates.¹⁵⁶ Using the intermittent schedule, Liu et al. reported a median duration of response of 28 months. In another study, the OR to cladribine was 41% in 22 patients with WM.¹⁶¹ A very high response rate was seen in 10 newly diagnosed patients treated with 2-CDA (followed by interferon). In this study, all patients responded (1 CR, 8 PR, and 1 MR).¹⁵⁷ Another multicenter study treated 25 naive patients, and attempted to use a longer duration of cladribine, for up to 6 cycles (median 3 cycles).¹⁷⁵ They reported a response rate of 40%, with a median remission duration of 8 months.

Very limited data exist documenting the value of using different PNAs in patients who progress after treatment with a purine analogue.¹⁷⁶ In one study, 14 patients were treated with cladribine after prior fludarabine exposure. Only 1 of 10 patients with fludarabine-resistant disease responded. In the patients who had demonstrated a previous response (and subsequently progressed) to fludarabine, however, 3 of 4 patients responded. In another study, 6 patients were treated with fludarabine who were resistant to cladribine, and 2 responded.¹⁷⁷ It seems who those who are refractory to a PNA, overall, are unlikely to respond to an alternate agent in this class.

Monoclonal Antibody Therapy

Rituximab

All WM cells express CD20, which allows for the use of anti-CD20 monoclonal antibody-based strategies. Initial studies using rituximab documented a tumor burden reduction, resulting in improved cytopenias,¹⁷⁸ neurologic symptoms,¹⁷⁹ and a decrease in the clonal cells in the bone marrow.¹⁸⁰ Byrd and colleagues then documented PRs to rituximab by treating seven patients with relapsed disease.¹⁶⁶ Treon and colleagues also treated 30 patients with relapsed disease,¹⁶⁷ 14 of whom (47%) had been previously treated with a PNA. They showed convincing evidence of antitumor activity by documenting reductions of the serum monoclonal protein (median IgM decline 2,403 to 1,525 mg/dl), increases in the hematocrit (19/30, 63%), and increases in the platelet count (15/30, 50%). In Treon's study, the ORR was 60%, with 8 of 30 patients achieving a PR (27%).¹⁶⁷ Dimopoulos treated 27 patients with rituximab (15 that were treatment naive) with 4 infusions at standard doses (375 mg/m²).¹⁶⁴ Patients received an additional 4-week course 3 months after the first course, if they had not progressed. The probability of response was the same in relapsed patients as in treatment-naive patients (44%), with a median time to response of 3.3 months and a median duration of response of 16 months.

It has become clear that the best response to rituximab may be seen only after several months of drug administration. We believe that the true clinical benefit of rituximab may be greater than that originally reported in these clinical trials because the response rates may have been underestimated due to the responses being evaluated too early in the treatment course. This delayed response effect is likely to be observed with other biologic therapies as well. This delayed effect was partially addressed by administering an extended course of therapy with rituximab in a study by Treon.¹⁸¹ Treon et al. evaluated the administration of 8 cycles of rituximab (as opposed to four infusions) in this study. They reported on 26 patients who completed the intended therapy: 14 (48.3%) patients had a PR, and 5 (17.2%) patients achieved an MR. The median time to best response was 17 months, with 2 of 19 responding patients subsequently progressing at the time of the report (median follow-up of 29 months).¹⁸¹

The identification of patients likely to respond to therapy has become of paramount importance given the increased usage of rituximab. Because of its overall ease of administration it is important to recognize those patients who are not likely to respond, and in whom pursuing other treatment alternatives may be preferable. Dimopoulos reported on the higher likelihood of response to rituximab among patients with lower serum IgM (<4 g/dl) and higher β_2 -microglobulin.^{182, 183} Although the median time to progression was 14 months, these variables predicted patients with shorter duration of response.¹⁸² In the study by Treon et al., patients were more likely (75% response rate, 18/24 cases) to respond to rituximab monotherapy if they had an IgM of <6,000 mg/dl, compared to a response rate of only 20% with higher protein concentrations.¹⁸¹ Polymorphisms in the Fc γ receptor have similarly been postulated to predict the likelihood of response.¹⁸⁴

Rituximab has become the de facto first-line treatment for most patients with WM because of a favorable profile and

P.2133

risk-benefit ratio.¹⁸⁵ In addition, rituximab can be easily combined with other chemotherapeutic agents because of the lack of additive toxicity, and is now commonly used in combination regimens for WM. Also, rituximab retains activity when patients are given repeated courses of therapy and can be administered in a maintenance fashion. Unfortunately, the use of radiolabeled anti-CD20 monoclonal antibodies is limited in WM due to the larger extent of bone marrow involvement by the clonal cells and the risk of significant toxicity. A strategy for using radiolabeled monoclonal antibodies will therefore require an initial "debulking", with clearance of the bone marrow using rituximab or other agents, followed by the use of a radioactively labeled monoclonal antibody.

A total of 50% of patients will have a paradoxical rise of the monoclonal protein after rituximab administration: the so-called rituximab flare.^{186, 187} This phenomenon was first reported in two patients treated with cladribine,¹⁸⁸ but has been reported more frequently in patients treated with rituximab. The elevations of the serum concentration of the IgM can be of such magnitude that patients might experience symptoms of hyperviscosity. Patients who have higher concentrations of the IgM should be considered for prophylactic or concurrent plasmapheresis when treated with rituximab.¹⁶⁴ Reports

have also emerged of patients who have worsening of peripheral neuropathy after treatment with rituximab, and the hypothesis is that this is also a manifestation of the flare phenomenon.^{189, 190, 191}

Rituximab Maintenance

Treon has shown the benefit of maintenance rituximab in patients with WM.¹⁹² He studied 248 rituximab-naive WM patients who showed disease sensitivity after receiving rituximab. Of these 86, (35%) went on to receive maintenance. In 36 of 86 (41.8%) patients receiving maintenance, the quality of the responses improved. PFS (56.3 vs. 28.6 months; $P = 0.0001$) and OS (not reached vs. 116 months; $P = 0.0095$) were longer for patients receiving maintenance. Although this study was retrospective, it does provide compelling evidence to consider rituximab maintenance after prior rituximab-containing regimens.¹⁹² Prospective studies will be needed to address this question fully in WM.

Corticosteroids

WM historically has not been considered a steroid-responsive malignancy; however, reports exist suggesting that steroids alone can be beneficial, particularly in patients who are not candidates for cytotoxic therapy or who have severe pancytopenia. Steroids have also had an additive effect when used in combination with other agents. Gomez et al. treated two patients with WM with vincristine, 0.25 mg/m², and bleomycin, 5 units, given for 4 consecutive days with prednisone, 1,000 mg/m², given orally on alternate days.¹⁹³ In both patients, the bone marrow tumor cell infiltration was reduced by 50% (remission duration 4 to >35 weeks) and they had a greater than 50% decrease in the M protein. Two additional patients with resistant WM demonstrated marked decreases in viscosity and total M protein after short periods of high-dose dexamethasone.¹⁹⁴ Steroids have been reported to be particularly useful in patients with WM with an associated cryoglobulin because of their anti-inflammatory properties and effect on immune complex vasculitis.¹⁹⁵

Combination Therapy

Overview

Despite an overall higher response rate to combination therapy for the up-front treatment of WM, its ultimate clinical worth is clouded by the difficulty of being able to document an impact on patient outcome due to the indolent nature of WM. The response rates undoubtedly seem superior with combination strategies and the duration of response is also likely to be longer. However, these combinations burden patients with additional toxicities. How does one decide on the best treatment approach for patients? Most trials available for WM are phase II clinical trials with a primary endpoint of ORR, but no assessment of long-term outcome. Therefore, the identification of novel combinations capable of retaining a favorable toxicity profile and increasing the duration of response would likely constitute significant progress in this field. Combinations that include rituximab would seem most likely to increase the quality and duration of responses and result in the best safety profile. At a minimum, combination therapies need to show a very substantial enhancement of OR to be considered suitable for use in the “off-study” setting.

The value of combination treatment has been the focus of a recent panel review.¹⁷⁰ This review stressed that the results of combination strategies were encouraging enough that they would be considered reasonable treatment¹⁷⁰ options for patients with WM (alongside extended treatment with rituximab) in a nonstudy setting. However, the panel properly recognized the need for additional clinical trials to better evaluate their clinical utility. For patients with evidence of slowly evolving progression, but no significant cytopenias or organomegaly, it would seem that single-agent rituximab may be more appropriate than combination approaches. Combination strategies should be considered for individuals in need of rapid reduction of tumor burden. Secondary gains, such as blunting of a rituximab flare, will also have important practical implications that may favor the use of secondary agents with rituximab.

Purine Nucleoside Combinations

In an attempt to combine PNA with alkylating agents, Laurencet and colleagues used IV cyclophosphamide 500 mg/m² and oral prednisone monthly, in combination with 2-CDA at 0.1 mg/kg/day SQ, for 3 consecutive days, for up to six courses.¹⁶² The ORR was 88%, with grade 4 neutropenia seen in 11% (2/19) of patients, but no treatment-related deaths. A dose-escalation study of the combination was subsequently performed: 2-CDA 5.6 mg/m² QD was given as a 2-hour IV infusion, followed by a 1-hour infusion of cyclophosphamide QD for 3 days.¹⁹⁶ A dose of cyclophosphamide 200 mg/m² was given initially and was escalated in 100 mg/m² increments. The maximal tolerated dose of cyclophosphamide was 300 mg/m², and an ORR of 58% was seen. Neutropenia was the dose-limiting toxicity and severe infections were seen in 4% of cycles. A total of 31% of patients could not be given repeated cycles because of prolonged thrombocytopenia.

Tamburini and colleagues described 49 patients with WM treated with cyclophosphamide and fludarabine, 14 of whom were treatment naive.¹⁵³ The doses used were cyclophosphamide 300 mg/m² IV and fludarabine 30 mg/m² IV, days 1 to 3, every 4 weeks, for a median of 4 cycles. The ORR was 78% (38/49 cases all PRs), 2 had progressive disease, and 9 had

stable disease. The median time to treatment failure was 27 months. It is interesting that the two factors associated with an adverse outcome were a serum monoclonal protein concentration of less than 4 g/dl and age greater than 65 years (an observation previously made in the Dhodapkar model, but not repeated since).²³

Purine Nucleoside, Alkylators, and Rituximab Combinations

Hensel and colleagues reported on 14 patients with WM treated with the combination of pentostatin, cyclophosphamide, and (in 8 cases) rituximab.¹⁹⁷ There were eight patients who had been

P.2134

previously treated with 1 to 3 regimens, and nine patients were untreated. Patients received pentostatin 4 mg/m² plus cyclophosphamide 600 mg/m². Rituximab was administered at the standard dose of 375 mg/m² on day 1 (every 3 weeks). Two patients achieved a CR (12%) and the ORR was 65%. The ORR for patients receiving rituximab was increased at 77%. Three patients had further improvement with additional follow-up.

Tam and colleagues described a group of 18 patients with WM treated with fludarabine, cyclophosphamide, and rituximab (FCR) (n = 5); fludarabine plus mitoxantrone (n = 3); plus cyclophosphamide (n = 9); or rituximab alone (n = 1).¹⁹⁸ The median response duration in this study was 38 months, with an ORR of 76%. In a follow-up report, they expanded the report to include an additional nine patients with WM who were treated with the same FCR combination. The attained ORR was 56% (5/9 patients), but no CRs were observed.¹⁵⁵

Weber and colleagues have reported on the combination of Rituximab (375 mg/m² q week × 4 weeks), cyclophosphamide (40 mg/m² PO BID for 7 days), plus cladribine (1.5 mg/m² SQ TID for 7 days), repeated at 6 weeks.^{138, 199} With a median follow-up of 69 months, they reported an ORR of 94% and a CR rate of 17%.^{138, 199} The median time to remission was reported at 2.4 months, with duration of remission of 58.6 months, clearly surpassing the median response duration of 26 months reported by the same authors when the combination did not include rituximab. Likewise, the time to re-treatment was not reached at 56.3 months when the combination without rituximab was used.^{138, 199}

Tedeschi reported on a phase II trial of the combination of fludarabine, rituximab, and cyclophosphamide.²⁰⁰ A total of 43 WM patients (new diagnosis and previously treated) received rituximab on day 1; and fludarabine 25 mg/m² and cyclophosphamide 250 mg/m² intravenously on days 2 through 4. Treatment was administered monthly and patients could receive a total of up to 6 cycles of treatment. The ORR was 79%, and the quality of responses was high: 12% of patients achieved a complete remission and 21% had a very good partial remission. However, nearly one half of patients (45%) had grades 3 and 4 neutropenia, and in a similar proportion, this neutropenia was long lasting. Only one patient had progressive disease.

Dimopoulos and colleagues have also explored the combination of rituximab (375 mg/m² repeated every 21 days for a total of 6 cycles) plus cyclophosphamide (100 mg/m² PO BID for 5 days), given with concurrent dexamethasone (20 mg IV).²⁰¹ They report an OR of 70% with 7% of patients achieving a CR. With a median follow-up of 24 months 60% of patients remain free of progression.

A study by Treon addressed the therapeutic benefit of rituximab combined with CHOP chemotherapy.²⁰² There were 13 patients with WM who were treated with R-CHOP, 10 of whom had been previously treated.²⁰² The intended treatment was 6 cycles, and then they received rituximab as maintenance therapy. They reported 3 CRs, 8 PRs, 1 MR, and concluded that the regimen was highly effective. Currently, an Eastern Cooperative Oncology Group study is testing the combination of bortezomib, rituximab, dexamethasone, and temsirolimus in relapsed WM (and other malignancies) in a phase I/II study.

New Treatment Options

Thalidomide and Lenalidomide

Thalidomide is an antiangiogenic and immunomodulatory agent that has been found to be effective as salvage therapy of MM.²⁰³ Dimopoulos and colleagues have reported the results of a phase II trial of thalidomide for 20 patients with WM (10 untreated, 10 previously treated).²⁰⁴ Patients received thalidomide 200 to 600 mg/day and the ORR was 25% (5 of 20 patients, 2 previously treated). The time to progression was less than 3 months however, suggesting that thalidomide as a single agent has minimal activity in WM. One study by Treon and colleagues explored the combination of lenalidomide with rituximab as primary treatment for WM. Although 50% showed antitumor activity, there was a sharp drop in hematocrit in most patients, and further study of the combination is warranted.²⁰⁵

Bortezomib

Responses to the proteasome inhibitor, bortezomib, have been documented in WM. Bortezomib's precise mechanism of action is largely unknown, although it is thought to exert its antitumor effects by deregulating the NF- κ B pathway. Bortezomib has been used alone or in combination with rituximab and corticosteroids.

Dimopoulos and colleagues reported on the use of bortezomib in patients with WM.²⁰⁶ They used the medication in 10 previously treated patients (3 patients treated with 3 prior lines of therapy) and 6 achieved a PR.

Treon reported on the outcome of bortezomib as treatment for relapsed and refractory WM in a multicenter study (WMCTG Trial 03-248).²⁰⁷ A total of 27 patients were treated with single-agent bortezomib on days 1, 4, 8, and 11. The OR was 85% with 13 (48%) patients achieving a major response, and 10 (37%) patients having an MR. The median time to response was 1.4 months. The main toxicity was sensory peripheral neuropathy: grade 2 in 5/27 (22.22%) and grade 3 in 6/27 (22.2%) of patients. The study reported that, in most cases, peripheral neuropathy improved after treatment. In a recent study, Chen and colleagues treated symptomatic WM patients (treatment naive and relapsing) with bortezomib at doses 1.3 mg/m² intravenously days 1, 4, 8, and 11 on a 21-day cycle. The response rate in this study was low (26%), probably due to treatment discontinuation due to neuropathy. There were 20 patients (74%) who developed new or worsening peripheral neuropathy (5 patients with grade 3, no grade 4).^{208, 209}

Bortezomib has also been used in combination strategies against WM. Treon and colleagues were able to show a high response rate, including CRs, in one study of bortezomib in combination with rituximab and dexamethasone.²¹⁰ They treated 23 patients with bortezomib, weekly dexamethasone at 40 mg, and rituximab 375 mg/m² on day 11. The treatment schedule first used an induction phase with monthly cycles, followed by maintenance treatment (one same treatment) every 3 months.²¹⁰ The reported ORR was 96% with 83% of patients attaining a deep response (3 CR, 2 near CR, 3 VGPR, 11 PR, and 3 MR). At a median duration of follow-up of 23 months, 78% of patients remained free of disease progression (18 of 23). As is true in other situations where bortezomib is used, herpes zoster was a common complication. All patients treated with bortezomib should receive acyclovir-based prophylaxis. Similar results have been reported by Ghobrial in two separate phase II trials addressing the role of bortezomib, but administered in a weekly schedule to prevent peripheral neuropathy, in combination with rituximab, in both treatment-naive and previously treated WM.^{211, 212} For untreated patients (n = 26), she reported a MR or better in 23 (88%) with 1 CR (4%), 1 near CR (4%), 15 PR (58%), and 6 MR (23%). She also reported an estimated 1-year event-free rate of 79%, and no grade 3 or 4 peripheral neuropathy.²¹¹ Among previously treated patients, (n = 37) an MR or better was observed in 81%, 2 CR or near CR (5%), 17 in PR (46%), and 11 (30%) in MR.²¹² The median time to progression was 16.4 months. Peripheral neuropathy was again lessened by the weekly administration of bortezomib, and grade 3 occurred in only 2 patients (5%). PFS was 16 months, and estimated at 57% at 12 months, and 45% at 18 months.²¹² Agathocleous also

P.2135

reported as well a high level of activity in 10 WM patients treated with bortezomib.²¹³

Everolimus and Perifosine

A phase II study of everolimus reported 42% PRs and 70% minimal responses or better.²¹⁴ The main toxicities seen were myelosuppression, but up to 50% of patients required dose reductions due to toxicity. Roccaro et al. have shown that everolimus interacts with and inhibits TORC1 and induces cell cycle arrest and apoptosis (both caspase-dependent and -independent).²¹⁵ The mTOR kinase system is responsive to AKT and ultimately signals via TORC1. As mentioned earlier, AKT has been found to be up-regulated in WM. Furthermore, the same group proposes that dual targeting of the PI3K/mTOR pathway may be advantageous in treating WM, such as with the dual inhibitor NVP-BEZ235.²¹⁶

Because of the increased activation of AKT, perifosine has been explored in the clinic for WM.²¹⁴ In a phase II study, 37 patients were treated with single-agent perifosine (oral agent) for a total of up to 6 cycles. There were 4 PRs (11%) and 9 minimal responses (24%). Correlative studies showed that perifosine did inhibit AKT and also down-regulate NF- κ B.

Alemtuzumab

The use of anti-CD52 monoclonal antibodies (alemtuzumab) has also been proposed by Hunter and colleagues.²¹⁷ In one pilot study, the investigators were able to show that clinical responses can be observed, but there appears to be significant toxicity. Alemtuzumab as treatment for WM is being further evaluated, but it may have more of a role in patients with relapsed and refractory disease. The WMCTG has reported on the use of a monoclonal antibody targeting CD52 in patients with WM. They enrolled 28 patients in the study WMCTG 02-079 where patients were treated with 30 mg alemtuzumab, 3 times per week, for up to 12 weeks.²¹⁸ Among evaluable patients, the ORR was 81%, including 1 CR (4%) and 10 PR cases (37%). The major toxicities included myelosuppression (more common among previously treated

patients), anemia, fatigue, and infection. Of note, two patients had treatment-related death, including one CMV infection, and the other with thrombocytopenia complications.

Imatinib Mesylate

Another trial conducted by the WMCTG (05-140) addressed the role of imatinib in the treatment of WM. A phase II study using imatinib started at 400 mg per day and, if tolerated, the doses were escalated to 600 mg per day for up to 2 years.²¹⁸ The reported ORR was 26%, with 2 PR and 5 MR cases. Further studies of imatinib in the setting of relapsing disease are warranted.

Sildenafil

Anecdotal observations have suggested that for some patients, sildenafil results in clinical improvement of WM.²¹⁹ To better define its activity in WM, additional studies are needed.

Oblimersen Sodium

Gertz and colleagues have reported on early data using oblimersen sodium, a BCL-2 antagonist.²²⁰ It is an antisense oligonucleotide to the first 6 codons of the B-cell leukemia gene 2 (BCL-2) that prevents the expression of the BCL-2 gene. This process alone can enhance vulnerability of cells exposed to fludarabine, dexamethasone, and rituximab, and is believed to enhance apoptosis. To assess the value of this therapy for WM, the final results of ongoing clinical trials will be needed.

HIGH-DOSE CHEMOTHERAPY WITH STEM CELL SUPPORT

Autologous

Although there are limited data regarding long-term outcomes of WM after autologous or allogeneic transplant in WM, it has been recently argued that autologous (stem cell transplantation [SCT]) should be more often considered in suitable candidates.²²¹ It is unlikely that SCT will be fully vetted using a randomized phase III trial, however, the utilization of the procedure in related conditions, such as CLL and MM, has made this a safe and, arguably, routine procedure. It has been shown that higher doses of chemotherapy can be safely administered to patients with WM, resulting in disease control.^{222, 223, 224}

Registry series have been reported describing the outcome of WM patients after autologous stem cell transplant.^{222, 225, 226} Overall, the nonrelapse mortality at 1 year was 6% in the largest series thus far reported. Kyriakou and colleagues reported a retrospective analysis of 158 patients treated with high-dose chemotherapy and autologous stem cell support.²²⁵ The median age of patients was 49 years, and they reported 23 PR, 77 VGPR, and 34 CR.²²⁷ It seems that, given the availability of other effective regimens, stem cell transplant done as up-front treatment for the disease should still be done in the context of clinical trials. Stem cells need to be collected in patients who may be potential stem cell transplant candidates, and high-dose chemotherapy with stem cell support is an effective disease-controlling strategy for patients experiencing relapsing disease. However, a stem cell transplant should be considered more often in cases of first relapse, where the disease is still chemosensitive, and where the clinical results have been thus far encouraging. For a summary of published SCT series on WM, please refer to Table 100.4.^{172, 222, 225, 226, 228, 229} The optimal conditioning regimen has not been identified, but both BEAM and high-dose melphalan have been used.

Allogeneic

There are even fewer reports of allogeneic transplantation in WM. The overwhelming majority of patients may not be eligible to be treated with this modality because the median age at onset of WM is 65 years. The originally reported series have been small and predominantly retrospective cases.^{230, 231} Anagnostopoulos and colleagues reported on 26 patients with WM treated with SCT between 1986 and 2002.²²² Over one half (58%) of patients were treated with myeloablative conditioning regimens. The relapse rate at 3 years was no different between those undergoing an allogeneic versus an autologous SCT (24% vs. 29%). The survival at 3 years was 46% in the allogeneic group and 70% in the autologous group. These data indicate that allogeneic strategies may only be appropriate for select patients with WM and probably should not be pursued for WM patients outside the context of a clinical trial. In an updated report from the European Bone Marrow Transplant (EBMT) registry, Kyriakou and colleagues describe the outcome of 106 patients treated with allogeneic stem cell transplant.²³² A total of 30 patients had nonrelapse mortality (28%). A second report of 37 patients undergoing myeloablative therapy, and 49 with reduced-intensity conditions, showed similar results.²²⁷ For a more detailed discussion on the various high-dose therapy options, please refer to Gertz et al. (Table 100.5).^{221, 222, 233} In our opinion, although allogeneic strategies may be feasible, the high treatment-associated mortality suggests this treatment should be mostly conducted in the setting of clinical trials and not as up-front therapy for the disease.

TABLE 100.4 SUMMARY OF AUTOLOGOUS STEM CELL TRANSPLANT STUDIES FOR WALDENSTRÖM MACROGLOBULINEMIA

Study	N	Regimen	Median Age		OR	RFS	OS
			n	at SCT			
Anagnostopoulos and Giralt ²⁶⁷	24	MEL 200	10	50	PR 14		
		MEL or Cy + TBI	9		CR 9		
		Other	5				
Tournilhac ²⁶⁸	17	MEL or Cy + TBI	13	54	PR 8	9 progression;	6 dead;
		BEAM	3		VGPR 7	median, 10 mo	median, 11.5 mo
		MEL 180	1		CR 2		11 Alive;
							median, 25+ mo
Anagnostopoulos ²²²	10	TBI + other	3	56		65% at 3 y	70% at 3 y
		Bu + Cy + other	2				
		Other	5				
Dhedin ²²⁶	32	BEAM	13	56		Median, 32 mo	58% at 5 y
		Mel + TBI or CY + TBI	16				
		Other	3				
Gilleece ²²⁸	9	MEL 200	3	56	PR 5	43% at 4 y	73% at 4 y
		BEAM	5		VGPR 1		
		CY + TBI	1		CR 3		
Kyriakou ²²⁷	158	TBI + other	45	49	PR 23	39.7% at 5 y	68.5% at 5 y
		BEAM Other	46		VGPR		
			67		77		
				CR 34			

BEAM, BCNU, etoposide, cytarabine, melphalan; Bu, busulfan; Cy, cyclophosphamide; Mel, melphalan; OR, overall response; OS, overall survival; PR, partial response; RFS, relapse-free survival; SCT, stem cell transplantation; TBI, total-body irradiation; VGPR, very good partial response.

Numbers indicate drug doses in milligrams per square meter of body surface area (mg/m²).

Adapted from Gertz MA, Reeder CB, Kyle RA, Ansell SM. Stem cell transplant for Waldenstrom macroglobulinemia: an underutilized technique. *Bone marrow transplantation* 2012;47:1147-1153.

OTHER THERAPEUTIC INTERVENTIONS

Splenectomy

There are patients with hypersplenism or spleen-dominant disease who benefit from splenectomy, despite the fact that a splenectomy does not address the marrow infiltration associated with WM.²³⁴ Splenectomy has also been reported as correcting a factor VIII deficiency in a WM patient.²³⁵ Furthermore, some anecdotal cases have been reported of patients with disease limited to the spleen who had long durations of response after splenectomy.²³⁶

Plasma Exchange

Plasmapheresis with total plasma exchange as treatment for the symptoms of the hyperviscosity syndrome in WM is very useful, but has no impact on the tumor burden. When acute hyperviscosity symptoms develop, usually with a viscosity value above 4, small changes in plasma volume can produce large reductions in serum viscosity because the serum viscosity is not linearly correlated with IgM. IgM reductions as small as 20% can result in viscosity reductions of as much as 50%. Dramatic effects on symptoms can occur with even small reductions in serum viscosity.²³⁷ In a survey conducted in Canada from 1981 to 1997, WM was among the top five indications for plasma exchange.²³⁸ Plasma exchange has also been used as a long-term maintenance treatment in patients who become resistant to cytotoxic drugs.²³⁹

TOXICITY OF STANDARD THERAPY

WM patients have baseline immunosuppression because of decreased levels of uninvolved immunoglobulins and treatment-related granulocytopenia, all of which increase the risk of infection. In addition, treatment with PNA increases the risk of opportunistic infections, and there are occasional reports of post-transplant-like lymphoma²⁴⁰ secondary to a reduction in the level of circulating CD4+ T cells.^{241, 242} Other infections, such as opportunistic viral enteric infection²⁴³ and Cryptococcus meningitis, have been reported in WM patients treated with fludarabine.²⁴⁴ Furthermore, 2-CDA interferes with lymphocyte proliferation and activity resulting in associated fever and potential infection.^{242, 245} Autoimmune phenomena in patients exposed to 2-CDA have been reported and may be the result of suppression of T-lymphocyte function. Four WM patients have been reported in whom immunemediated hemolysis developed after 2-CDA therapy (median, 40 months after initial administration). Hemolytic anemia has also been reported.²⁴⁶ In a small series, one patient responded to oral corticosteroids and two died.²⁴⁷ Neurologic, renal, and local skin reactions have also been reported.²⁴⁸

Cladribine and fludarabine are both associated with myelosuppression,¹⁷⁵ including severe neutropenia and thrombocytopenia. In one study using cladribine, grade 3 or 4 neutropenia was seen in 60% of patients.¹⁵⁶ Similarly, high rates of neutropenia (77%) and thrombocytopenia (32%) have been reported in other studies.¹⁶¹ We therefore recommend that when cladribine is to be used, it should be limited to 2 cycles and empiric preventive antimicrobial and antiviral prophylaxis be considered.

Alkylating agents are well known to induce chromosomal changes and to be mutagenic. Acute myelogenous leukemia or the development of myelodysplasia are clearly the most devastating complications associated with alkylating agent therapy; although these occur in a small minority of patients. Reports of acute leukemia appeared shortly after the introduction of alkylating agents for the management of WM.^{249, 250, 251} In a study of 46 patients, acute leukemia or refractory anemia developed in 4 patients.⁶⁸ Acute leukemia has also been reported with chlorambucil treatment.²⁵² Two patients, without any prior exposure to alkylating agents, have been reported with myelodysplastic syndrome (MDS) and chromosomal abnormalities, including monosomy-5 and monosomy-7.²⁵³ A metabolite of cyclophosphamide, acrolein, is toxic to the urinary bladder, and bladder cancer has been reported in patients treated with oral cyclophosphamide (50 to 100 mg/day).²⁵⁴

P.2137

TABLE 100.5 ALLOGENEIC STEM CELL TRANSPLANT STUDIES FOR WALDENSTRÖM MACROGLOBULINEMIA

Allogeneic	N	Regimen	N	Median age	Response	TRM	RFS	OS
Anagnostopoulos and Giralt ²⁶⁷	345	6Cy + TBI + other	3		PR 3 CR 1	3/6		3 alive 5+, 34+, 112+ mo
Tournilhac ²⁶⁸	846	10Cy + TBI			PR 1	4/10	4 relapsed 2, 3, 3, 10 mo	6 alive 3+, 23+, 50+,

	MEL + TBI	1	VGPR 1		59+, 74+, 76+
	BU + TBI	1	CR 6		mo
			PROG 2		
Anagnostopoulos ²²²	26TBI + other	1549		40% at 31% at 3 y	46% at 3 y
	Bu + Cy + other	5		1 y	
	Mini allo	5			
	Flu + other	1			
Dhedin ²²⁶	22Cy + TBI	946		36% MA	48% at 54
	Mel + TBI	256		27% RIC	54% at 5 y
	Flu + TBI	10			68% at 5 y
	Other	1			
Gilleece ²²⁸	9TBI	250	CR 3	44% at 44% at 4 y	56% at 4 y
	BEAM	2	Stab 3	1 y	
	Other	5	NE 3		
Garnier ²³³	25Cy + TBI	1148	CR 12	25% at 50% at 5 y	67% at 5 y
	Mel + TBI	1	VGPR 3	1 y	
	Flu + Cy	4	PR 7		
	Flu + TBI + other	7	NR 2		
	Bu + Flu + ATG	1			
	Flu + Mel				
Kyriakou ²²⁷	37Cy + TBI	2739	CR 7	33% at 56% at 5 y	62% at 5 y
	MA Bu + Cy + other	10	VGPR 14	3 y	64% at 5 y
			PR 7		
			NR 2		
			NE 7		
	49Flu + RICalkylator	3146	CR 8	23% at 49% at 5 y	
	Flu + TBI	18	VGPR 19	3 y	
			PR 10		
			NR 4		
			NE 8		

ATG, antithymocyte globulin; BEAM, BCNU, etoposide, cytarabine, melphalan; Cy, cyclophosphamide; Flu, fludarabine; MA, myeloablative conditioning; Mel, melphalan; NR, no response; NE, not evaluated; OS, overall survival; PR, partial response; Prog, progression; RFS, relapse-free survival; RIC, reduced-intensity conditioning; Stab, stable disease; TBI, total-body irradiation; TRM, transplant related mortality; VGPR, very good partial response.

Adapted from Gertz MA, Reeder CB, Kyle RA, Ansell SM. Stem cell transplant for Waldenstrom macroglobulinemia: an underutilized technique. *Bone Marrow Transplantation* 2012;47:1147-1153.

Treatment has also been reported as being associated with an increased risk of secondary malignancies. Several reports have shown an increased incidence in retrospective series of patients treated with these agents, with rates ranging from 0% to 7%. The validity of these observations has been questioned due to the retrospective nature of these reports, which lacked controls. The baseline rate of secondary malignancies plus the increment associated with the use of alkylators has not been fully elucidated. In one of the largest series, Facon reported a rate of 1.2% (2/167 patients). It is possible to conclude that, as single agents, PNAs have a low incremental risk of MDS and acute myeloid leukemia. However, the risk may be higher when they are combined with alkylators such as cyclophosphamide^{155, 255, 173} (Table 100.6).

Studies on the use of fludarabine reported an incidence of secondary malignancies of 1.4% to 8.9%. Once more, these studies were small in size and retrospective. Morel and colleagues reported an increased incidence of second cancers in WM patients.⁵¹ An Italian group reported a large incidence of secondary malignancies of 12%, at 10 years and 17% at 15 years.²⁵⁶ One report using the Surveillance, Epidemiology, and End Results (SEER) database evaluated 1,618 WM patients and found an increased risk of myeloma, melanoma, and colon, uterus, lung, and kidney cancers.²⁵⁷ However, the Leblond study (a randomized study) showed a rate of secondary malignancies of 3.7% at 6 years versus 20.6% (P = 0.001) for those treated with chlorambucil, with a combination of both solid tumors and hematologic

P.2138

malignancies (Personal communication, V Leblond, International Waldenström Macroglobulinemia Workshop, August, 2012). In this same study, there was no evidence of an effect of PNAs on the risk of Richter transformation (Table 100.7).

TABLE 100.6 SECONDARY MALIGNANCIES IN WALDENSTRÖM MACROGLOBULINEMIA

AUTHORS	N	Treatment	Survival (months)	MDS/AML
Facon (1993) ¹¹⁰	167	AA		602/167 (1.2%)
Kyle (2000) ⁶⁸	46	AA		653/46 (6%)
Garcia Sanz (2001) ²⁴	217	AA		1203/217 (1.4%)
Ghobrial (2006) ⁵²	237	AA		7816/237 (7%)
Leleu	173	PNA		—10/173 (1.7%)
Leleu	153	AA		—0/153 (0%)

AA, alkylating agent; AML, acute myeloid leukemia; MDS, myelodysplastic syndrome; PNA, purine nucleoside analogue. Courtesy of Dr. V. Leblond, 2012.

TABLE 100.7 SECONDARY MALIGNANCIES IN WALDENSTRÖM MACROGLOBULINEMIA TREATED WITH PURINE NUCLEOSIDES

Study	N	Status	Prior Treatment	Treatment	OS (month)	FU (month)	MDS/AML
Retrospective Leblond ¹⁴⁹	71	RR	AA	Fluda IV × 6	23	34	1/71 (1.4%)
Prospective Leblond ¹⁴⁵	46	RR	AA	Fluda IV × 6	41	34	4/45 (8.9%)
Randomized Leblond ¹⁴⁵	46	RR	AA	CAP × 6	45	34	2/45 (4.5%)
Retrospective Tamburini ¹⁵³	49	Naive 14 RR 35	AA Fluda	Fluda + Cy IV × 6	NR	42	2/49 (4%)

AA, alkylating agent; AML, acute myeloid leukemia; CAP, cyclophosphamide, liposomal doxorubicin, and prednisone; Fluda, fludarabine; FU, follow-up time; IV, intravenous; MDS, myelodysplastic

syndrome; NR, not reached; OS, overall survival; RR, relapsed and/or refractory. Courtesy of Dr. V. Leblond, 2012.

Rituximab is also associated with toxicity that is thought to be secondary to the immunosuppressive effects of the medication. It has been reported that reactivation of a variety of viral infections, including hepatitis B, can occur after rituximab treatment.^{258, 259, 260, 261, 262, 263} One patient with WM developed a fatal adenoviral hepatitis after rituximab treatment. Reports also exist of rituximab-associated progressive multifocal leukoencephalitis.^{264, 265} A case of nasal skin necrosis after rituximab therapy has also been reported.²⁶⁶

MAYO CLINIC TREATMENT RECOMMENDATIONS

It remains of paramount importance to identify patients who have IgM MGUS or smoldering WM who do not need therapy, and for whom expectant observation is appropriate. It is important to emphasize, however, that close monitoring is indicated, as there can be substantial decrements in quality of life of individuals who progress to symptomatic WM. In our institution, most patients who require initial therapy and who cannot, or do not want, to be enrolled in clinical trials, are treated with the combination of rituximab, cyclophosphamide, and dexamethasone. This is a very well-tolerated regimen that will not interfere with subsequent collection of stem cells. In suitable candidates, stem cells are collected for a future SCT. In some rare instances, the use of single-agent rituximab can be considered, but in the majority of cases, combination therapy is indicated. In elderly patients who have significant comorbidities or limited mobility, single-agent chlorambucil can be considered as well. Plasma exchange is only indicated in cases of symptomatic hyperviscosity, and is used only as a "bridge" procedure until effective cytotoxic therapy is instituted. Our consensus group recommendations have been published and presented as Figure 100.3.

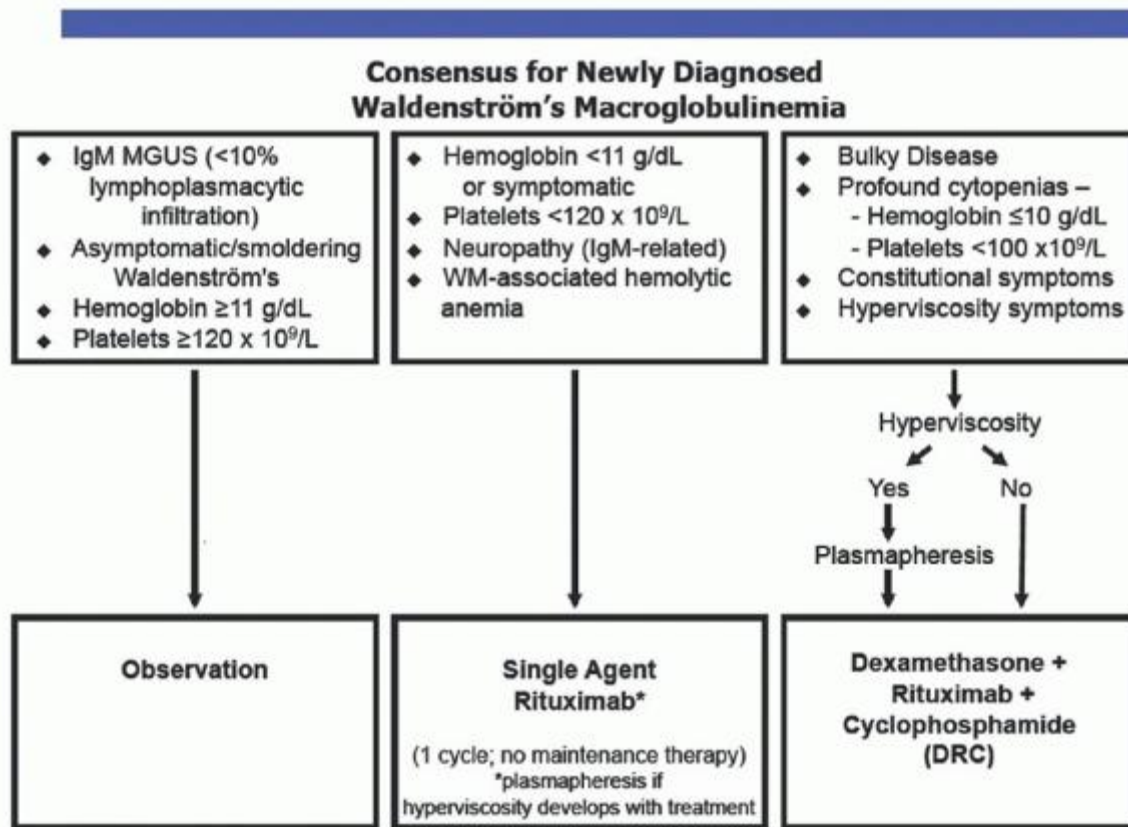

FIGURE 100.3. Consensus for newly diagnosed Waldenström's macroglobulinemia. MGUS, monoclonal gammopathy of undetermined significance. From Ansell SM, Kyle RA, Reeder CB, Fonseca R, et al. Diagnosis and management of Waldenström macroglobulinemia: Mayo stratification of macroglobulinemia and risk-adapted therapy (mSMART) guidelines. Mayo Clinic Proc 2010;85:824-833.

CONCLUSIONS

The mainstay of therapy for WM has changed recently and more broadly uses rituximab-based combinations with other novel agents, such as bortezomib and others. The new developments in understanding disease biology, mainly by the identification of MYD88 as a disease-defining mutation, will allow a more rational approach to disease identification, classification, and possibly targeted therapy. A recent consensus statement discussed this dilemma and conceded that single-agent therapy or combination approaches were equally appropriate treatment for WM patients. Issues to be considered when selecting therapy include factors associated with the disease, such as tumor bulk, hyperviscosity, and cytopenias, as well as patient-related factors, such as comorbid diseases and prior therapy. For some patients, achieving rapid cyto-reduction of tumor may be important (and may favor a combination therapy approach), but for most, this is not necessary and single-agent therapy may be more appropriate. It is also important to remember that there may be a long latent period before one observes the full clinical benefit of the selected treatment. Based on the small population of patients with this disease and the paucity of information available regarding the best therapy, however, patients should be considered for clinical trials whenever possible.

REFERENCES

1. Dimopoulos MA, Panayiotidis P, Mouloupoulos LA, Sfikakis P, Dalakas M. Waldenstrom's macroglobulinemia: clinical features, complications, and management. [Review]. *J Clin Oncol* 2000;18:214-226.
2. Owen R, Johnson S, Morgan G. Waldenstrom's macroglobulinemia: laboratory diagnosis and treatment. *Hematol Oncol* 2000;18:41-49.
3. Gertz MA, Fonseca R, Rajkumar SV. Waldenstrom's macroglobulinemia. [Review]. *Oncologist* 2000;5:63-67.
4. Groves FD, Travis LB, Devesa SS, Ries LA, Fraumeni JF Jr. Waldenstrom's macroglobulinemia: incidence patterns in the United States, 1988-1994. *Cancer* 1998;82:1078-1081.
5. Herrinton LJ, Weiss NS. Incidence of Waldenstrom's macroglobulinemia. *Blood* 1993;82:3148-3150.
6. Ngo VN, Young RM, Schmitz R, et al. Oncogenically active MYD88 mutations in human lymphoma. *Nature* 2011;470:115-119.
7. Kyle RA, Garton JP. The spectrum of IgM monoclonal gammopathy in 430 cases. *Mayo Clin Proc* 1987;62:719-731.
8. Ruiz-Arguelles GJ, Ramirez-Cisneros FJ, Flores-Martinez J, Cernuda-Graham MC. Waldenstrom's macroglobulinemia is infrequent in Mexican Mestizos: experience of a hematological diseases referral center. *Rev Invest Clin* 2000;52:497-499.
9. Kristinsson SY, Koshiol J, Björkholm M, et al. Immune-related and inflammatory conditions and risk of lymphoplasmacytic lymphoma or Waldenstrom macroglobulinemia. *J Natl Cancer Inst* 2010;102:557-567.
10. Koshiol J, Gridley G, Engels EA, McMaster ML, Landgren O. Chronic immune stimulation and subsequent Waldenstrom macroglobulinemia. *Arch Intern Med* 2008;168:1903-1909.
11. Elves MW, Brown AK. Cytogenetic studies in a family with Waldenstrom's macroglobulinaemia. *J Med Genet* 1968;5:118-122.
12. Brown AK, Elves MW, Gunson HH, Pell-Ilderton R. Waldenstrom's macroglobulinaemia. A family study. *Acta Haematol* 1967;38:184-192.
13. Ogmundsdottir HM, Sveinsdottir S, Sigfusson A, Skaftadottir I, Jonasson JG, Agnarsson BA. Enhanced B cell survival in familial macroglobulinaemia is associated with increased expression of Bcl-2. *Clin Exp Immunol* 1999;117:252-260.
14. Blattner WA, Garber JE, Mann DL, et al. Waldenstrom's macroglobulinemia and autoimmune disease in a family. *Ann Intern Med* 1980;93:830-832.
15. Getaz EP, Staples WG. Familial Waldenstrom's macroglobulinaemia: a case report. *S Afr Med J* 1977;51:891-892.
16. Renier G, Ifrah N, Chevailler A, Saint-Andre JP, Boasson M, Hurez D. Four brothers with Waldenstrom's macroglobulinemia. *Cancer* 1989;64:1554-1559.
17. Treon SP, Hunter ZR, Aggarwal A, et al. Characterization of familial Waldenstrom's macroglobulinemia. *Ann Oncol* 2006;17:488-494.
18. McMaster ML. Familial Waldenstrom's macroglobulinemia. *Semin Oncol* 2003;30:146-152.

19. McMaster ML, Goldin LR, Bai Y, et al. Genomewide linkage screen for Waldenstrom macroglobulinemia susceptibility loci in high-risk families. *Am J Hum Genet* 2006;79:695-701.
20. Kristinsson SY, Björkholm M, Goldin LR, McMaster ML, Turesson I, Landgren O. Risk of lymphoproliferative disorders among first-degree relatives of lymphoplasmacytic lymphoma/Waldenstrom macroglobulinemia patients: a population-based study in Sweden. *Blood* 2008;112:3052-3056.
21. Royer RH, Koshiol J, Giambarresi TR, Vasquez LG, Pfeiffer RM, McMaster ML. Differential characteristics of Waldenstrom macroglobulinemia according to patterns of familial aggregation. *Blood* 2010;115:4464-4471.
22. Treon SP, Dimopoulos M, Kyle RA. Defining Waldenstrom's macroglobulinemia. *Semin Oncol* 2003;30:107-109.
23. Dhodapkar MV, Jacobson JL, Gertz MA, et al. Prognostic factors and response to fludarabine therapy in patients with Waldenstrom macroglobulinemia: results of United States intergroup trial (Southwest Oncology Group S9003). *Blood* 2001;98:41-48.
24. Garcia-Sanz R, Montoto S, Torrequebrada A, et al. Waldenstrom macroglobulinaemia: presenting features and outcome in a series with 217 cases. *Br J Haematol* 2001;115:575-582.
25. Gertz MA, Kyle RA. Hyperviscosity Syndrome. *J Intensive Care* 1995;10:128-141.
26. Leleu X, Koulieris E, Maltezas D, et al. Novel M-component based biomarkers in Waldenstrom's macroglobulinemia. *Clin Lymphoma Myeloma Leuk* 2011;11:164-167.
27. Leleu X, Xie W, Bagshaw M, et al. The role of serum immunoglobulin free light chain in response and progression in Waldenstrom macroglobulinemia. *Clin Cancer Res* 2011;17:3013-3018.
28. Itzykson R, Le Garff-Tavernier M, Katsahian S, Diemert MC, Musset L, Leblond V. Serum-free light chain elevation is associated with a shorter time to treatment in Waldenstrom's macroglobulinemia. *Haematologica* 2008;93:793-794.
29. Zarrabi MH, Stark RS, Kane P, Dannaher CL, Chandor S. IgM myeloma, a distinct entity in the spectrum of B-cell neoplasia. *Am J Clin Pathol* 1981;75:1-10.
30. Kondo H, Yokoyama K. IgM myeloma: different features from multiple myeloma and macroglobulinaemia. *Eur J Haematol* 1999;63:366-368.
31. Wagner S, Martinelli V, Luzzato L. Similar patterns of somatic hypermutation in hairy cell leukemia, prolymphocytic leukemia, Waldenstrom's macroglobulinemia and myeloma. *Blood* 1994;83:3647-3653.
32. Aoki H, Takishita M, Kosaka M. Frequent somatic mutation in D and/or JH segments of Ig gene in Waldenstrom's macroglobulinemia and chronic lymphocytic leukemia (CLL) with Richter's syndrome but not common in CLL. *Blood* 1995;85:1913-1919.
33. Takahashi K, Yamamura F, Motoyama H. IgM myeloma—its distinction from Waldenstrom's macroglobulinemia. *Acta Pathol Jpn* 1986;36:1553-1563.
34. Banwait R, O'Regan K, Campigotto F, et al. The role of 18F-FDG PET/CT imaging in Waldenstrom macroglobulinemia. *Am J Hematol* 2011;86:567-572.
35. Kyle RA, Therneau TM, Rajkumar SV, et al. A long-term study of prognosis in monoclonal gammopathy of undetermined significance. *N Engl J Med* 2002;346:564-569.
36. Gobbi PG, Baldini L, Brogna C, et al. Prognostic validation of the international classification of immunoglobulin M gammopathies: a survival advantage for patients with immunoglobulin M monoclonal gammopathy of undetermined significance? *Clin Cancer Res* 2005;11:1786-1790.
37. Kyle RA, Therneau TM, Rajkumar SV, et al. Long-term follow-up of IgM monoclonal gammopathy of undetermined significance. *Blood* 2003;102: 3759-3764.
38. Morra E, Cesana C, Klersy C, et al. Clinical characteristics and factors predicting evolution of asymptomatic IgM monoclonal gammopathies and IgM-related disorders. *Leukemia* 2004;18:1512-1517.
39. Cesana C, Miqueleiz S, Bernuzzi P, et al. Smouldering Waldenstrom's macroglobulinemia: factors predicting evolution to symptomatic disease. *Semin Oncol* 2003;30:231-235.
40. Alexanian R, Weber D, Delasalle K, Cabanillas F, Dimopoulos M. Asymptomatic Waldenstrom's macroglobulinemia. *Semin Oncol* 2003;30:206-210.

41. Baldini L, Goldaniga M, Guffanti A, et al. Immunoglobulin M monoclonal gammopathies of undetermined significance and indolent Waldenstrom's macroglobulinemia recognize the same determinants of evolution into symptomatic lymphoid disorders: proposal for a common prognostic scoring system. *J Clin Oncol* 2005;23:4662-4668.
42. Greco A, Tedeschi A, Varettoni M, et al. Factors predicting transformation of asymptomatic IgM monoclonal gammopathy. *Clin Lymphoma Myeloma Leuk* 2011;11:77-79.
43. Kyle RA, Benson JT, Larson DR, et al. Progression in smoldering Waldenstrom macroglobulinemia: long-term results. *Blood* 2012;119:4462-4466.
44. Harris NL, Jaffe ES, Stein H, et al. A revised European-American classification of lymphoid neoplasms: a proposal from the International Lymphoma Study Group [see comments]. [Review] [296 refs]. *Blood* 1994;84:1361-1392.
45. Iida S, Rao PH, Ueda R, Chaganti RS, Dalla-Favera R. Chromosomal rearrangement of the PAX-5 locus in lymphoplasmacytic lymphoma with t(9;14) (p13;q32). [Review] [51 refs]. *Leuk Lymphoma* 1999;34:25-33.
46. Kapff C, Jandl J. *Blood; Atlas and sourcebook of hematology*, 2nd ed. Boston, MA: Little Brown, 1991.
47. Dutcher T, Fahey J. The histopathology of macroglobulinemia of Waldenstrom. *J Natl Cancer Inst* 1959;22:887-917.
48. Bartl R, Frisch B, Mahl G, et al. Bone marrow histology in Waldenstrom's macroglobulinaemia. Clinical relevance of subtype recognition. *Scand J Haematol* 1983;31:359-375.
49. Pangalis G, Angelopoulou M, Vassilakopoulos P. B-chronic lymphocytic leukemia, small lymphocytic lymphoma, and lymphoplasmacytic lymphoma, including Waldenstrom's macroglobulinemia: a clinical, morphologic and biologic spectrum of similar disorders. *Semin Hematol* 1999;36:104-114.
50. Tournilhac O, Santos DD, Xu L, et al. Mast cells in Waldenstrom's macroglobulinemia support lymphoplasmacytic cell growth through CD154/CD40 signaling. *Ann Oncol* 2006;17:1275-1282.
51. Morel P, Monconduit M, Jacomy D, et al. Prognostic factors in Waldenström macroglobulinemia: a report on 232 patients with the description of a new scoring system and its validation on 253 other patients. *Blood* 2000;96: 852-858.
52. Ghobrial IM, Fonseca R, Gertz MA, et al. Prognostic model for disease-specific and overall mortality in newly diagnosed symptomatic patients with Waldenstrom macroglobulinaemia. *Br J Haematol* 2006;133:158-164.
53. Babbage G, Townsend M, Zojer N, et al. IgM-expressing Waldenstrom's macroglobulinemia tumor cells reveal a potential for isotype switch events in vivo. *Leukemia* 2007;21:827-830.
54. Zhu D, van Arkel C, King CA, et al. Immunoglobulin VH gene sequence analysis of spontaneous murine immunoglobulin-secreting B-cell tumours with clinical features of human disease. *Immunology* 1998;93:162-170.
55. Sahota SS, Forconi F, Ottensmeier CH, et al. Typical Waldenstrom macroglobulinemia is derived from a B-cell arrested after cessation of somatic mutation but prior to isotype switch events. *Blood* 2002;100:1505-1507.
56. Zehentner BK, Cutler JA, Fritschle WK, et al. A minority of concurrent monoclonal lymphocytes and plasmacytic cells sharing light chains are genetically related in putative lymphoplasmacytic lymphoma. *Leuk Res* 2011;35: 1597-1604.
57. Owen RG, Barrans SL, Richards SJ, et al. Waldenstrom macroglobulinemia. Development of diagnostic criteria and identification of prognostic factors. *Am J Clin Pathol* 2001;116:420-428.
58. Feiner H, Rizk C, Finfer M. IgM monoclonal gammopathy/Waldenstrom's macroglobulinemia: A morphological and immunophenotypic study of the bone marrow. *Mod Pathol* 1990;3:348-356.
59. Owen RG, Treon SP, Al-Katib A, et al. Clinicopathological definition of Waldenstrom's macroglobulinemia: consensus panel recommendations from the Second International Workshop on Waldenstrom's Macroglobulinemia. *Semin Oncol* 2003;30:110-115.
60. Kucharska-Pulczynska M, Ellegard J, Hokland P. Analysis of leukocyte differentiation antigens in blood and bone marrow from patients with Waldenstrom macroglobulinemia. *Br J Haematol* 1987;65:395-399.
61. Andriko JA, Aguilera NS, Chu WS, Nandedkar MA, Cotelingam JD. Waldenstrom's macroglobulinemia: a clinicopathologic study of 22 cases. *Cancer* 1997;80:1926-1935.
62. Greipp PR, Kumar S. Plasma cell labeling index. *Methods Mol Med* 2005;113:25-35.
63. Abe M, Takahashi K, Mori N. Waldenstrom's macroglobulinemia terminating in immunoblastic sarcoma. A case report. *Cancer* 1982;49:2580-2586.

64. Choi Y, Yeh G, Reiner L. Immunoblastic sarcoma following Waldenstrom's macroglobulinemia. *Am J Clin Pathol* 1979;71:121-124.
65. Louviaux I, Michaux L, Hagemeijer A, et al. Cytogenetic abnormalities in Waldenstrom's disease (WD): a single centre study of 45 cases. *Proceedings from the annual meeting of the Am Soci Hematol* 1998;92:184b, Abstract 3776.
66. Mansoor A, Medeiros LJ, Weber DM, et al. Cytogenetic findings in lymphoplasmacytic lymphoma/Waldenstrom macroglobulinemia. Chromosomal abnormalities are associated with the polymorphous subtype and an aggressive clinical course. *Am J Clin Pathol* 2001;116:543-549.
67. Schop RF, Kuehl WM, Van Wier SA, et al. Waldenstrom macroglobulinemia neoplastic cells lack immunoglobulin heavy chain locus translocations but have frequent 6q deletions. *Blood* 2002;100:2996-3001.
68. Kyle RA, Greipp PR, Gertz MA, et al. Waldenstrom's macroglobulinaemia: a prospective study comparing daily with intermittent oral chlorambucil. *Br J Haematol* 2000;108:737-742.
69. Garand R, Sahota SS, Avet-Loiseau H, et al. IgG-secreting lymphoplasmacytoid leukaemia: a B-cell disorder with extensively mutated VH genes undergoing Ig isotype-switching frequently associated with trisomy 12. *Br J Haematol* 2000;109:71-80.
70. Pearse RN, Sordillo EM, Yaccoby S, et al. Multiple myeloma disrupts the TRANCE/ osteoprotegerin cytokine axis to trigger bone destruction and promote tumor progression. *Proc Natl Acad Sci U S A* 2001;98:11581-11586.
71. Avet-Loiseau H, Garand R, Lode L, Robillard N, Bataille R. 14q32 Translocations discriminate IgM multiple myeloma from Waldenstrom's macroglobulinemia. *Semin Oncol* 2003;30:153-155.
72. Schuster SR, Rajkumar SV, Dispenzieri A, et al. IgM multiple myeloma: disease definition, prognosis, and differentiation from Waldenstrom's macroglobulinemia. *Am J Hematol* 2010;85:853-855.
73. Owen RG, Feyler S, O'Connor SJ, Bond LR, de Tute RM, Rawstron AC. Defining IgM multiple myeloma. *Am J Hematol* 2011;86:717, author reply 8-9.
74. Ivanovski M, Silvestri F, Pozzato G, et al. Somatic hypermutation, clonal diversity, and preferential expression of the VH 51p1/VL kv325 immunoglobulin gene combination in hepatitis C virus-associated immunocytomas. *Blood* 1998;91:2433-2442.
75. Sahota SS, Garand R, Bataille R, Smith AJ, Stevenson FK. VH gene analysis of clonally related IgM and IgG from human lymphoplasmacytoid B-cell tumors with chronic lymphocytic leukemia features and high serum monoclonal IgG. *Blood* 1998;91:238-243.
76. Kriangkum J, Taylor BJ, Reiman T, Belch AR, Pilarski LM. Origins of Waldenstrom's macroglobulinemia: does it arise from an unusual B-cell precursor? *Clin Lymphoma* 2005;5:217-219.
77. Levy Y, Labaume S, Gendron M, Brouet J. Modulation of spontaneous B-cell differentiation in macroglobulinemia by retinoic acid. *Blood* 1994;83: 2206-2210.
78. Treon SP, Xu L, Yang G, et al. MYD88 L265P somatic mutation in Waldenstrom's macroglobulinemia. *N Engl J Med* 2012;367:826-833.
79. Braggio E, Keats JJ, Leleu X, et al. Identification of copy number abnormalities and inactivating mutations in two negative regulators of nuclear factor-kappaB signaling pathways in Waldenstrom's macroglobulinemia. *Cancer Res* 2009;69:3579-3588.
80. Braggio E, Keats JJ, Leleu X, et al. High-resolution genomic analysis in Waldenstrom's macroglobulinemia identifies disease-specific and common abnormalities with marginal zone lymphomas. *Clin Lymphoma Myeloma* 2009;9:39-42.
81. Keats JJ, Fonseca R, Chesi M, et al. Promiscuous mutations activate the noncanonical NF-kappaB pathway in multiple myeloma. *Cancer Cell* 2007;12:131-144.
82. Annunziata CM, Davis RE, Demchenko Y, et al. Frequent engagement of the classical and alternative NF-kappaB pathways by diverse genetic abnormalities in multiple myeloma. *Cancer Cell* 2007;12:115-130.
83. Poulain Sp, Braggio E, Roumier C, et al. High-throughput genomic analysis in Waldenstrom's macroglobulinemia. *Clin Lymphoma Myeloma Leuk* 2011;11:106-108.
84. Jankovic GM, Colovic MD, Wiernik PH, et al. Multiple karyotypic aberrations in a polymorphous variant of Waldenstrom macroglobulinemia. *Cancer Genet Cytogenet* 1999;111:77-80.

85. Wong KF, So CC. Waldenstrom macroglobulinemia with karyotypic aberrations involving both homologous 6q. *Cancer Genet Cytogenet* 2001;124: 137-139.
86. Ocio EM, Schop RF, Gonzalez B, et al. 6q deletion in Waldenstrom macroglobulinemia is associated with features of adverse prognosis. *Br J Haematol* 2007;136:80-86.
87. Schop RF, Van Wier SA, Xu R, et al. 6q deletion discriminates Waldenstrom macroglobulinemia from IgM monoclonal gammopathy of undetermined significance. *Cancer Genet Cytogenet* 2006;169:150-153.
88. Offit K, Parsa NZ, Filippa D, Jhanwar SC, Chaganti RS. t(9;14)(p13;q32) denotes a subset of low-grade non-Hodgkin's lymphoma with plasmacytoid differentiation. *Blood* 1992;80:2594-2599.
89. Ohno H, Furukawa T, Fukuhara S, et al. Molecular analysis of a chromosomal translocation, t(9;14)(p13;q32), in a diffuse large-cell lymphoma cell line expressing the Ki-1 antigen. *Proc Natl Acad Sci U S A* 1990;87:628-632.
90. Ohno H, Ueda C, Akasaka T. The t(9;14)(p13;q32) translocation in B-cell non-Hodgkin's lymphoma. [Review] [63 refs]. *Leuk Lymphoma* 2000;36:435-445.
91. Stapleton P, Weith A, Urbanek P, Kozmik Z, Busslinger M. Chromosomal localization of seven PAX genes and cloning of a novel family member, PAX-9. *Nat Genet* 1993;3:292-298.
92. Iida S, Rao PH, Nallasivam P, et al. The t(9;14)(p13;q32) chromosomal translocation associated with lymphoplasmacytoid lymphoma involves the PAX-5 gene. *Blood* 1996;88:4110-4117.
93. Chang H, Samiee S, Li D, et al. Analysis of IgH translocations, chromosome 13q14 and 17p13.1(p53) deletions by fluorescence in situ hybridization in Waldenstrom's macroglobulinemia: a single center study of 22 cases.(erratum appears in *Leukemia*. 2004 Sep;18(9):1564 Note: Stewart A [corrected to Stewart AK]). *Leukemia* 2004;18:1160-1162.
94. Bottura C, Ferrari I, Veiga A. Chromosomal abnormalities in Waldenstrom's macroglobulinemia. *Lancet* 1961;1:1170.
95. Contrafatto G. Marker chromosome of macroglobulinemia identified by G-banding. *Cytogenetics Cell Genetics* 1977;18:370-373.
96. Han T, Sadamori N, Takeuchi J, et al. Clonal chromosome abnormalities in patients with Waldenstrom's and CLL-associated macroglobulinemia: significance of trisomy 12. *Blood* 1983;62:525-531.
97. Hirase N, Yufu Y, Abe Y, et al. Primary macroglobulinemia with t(11;18) (q21;q21). *Cancer Genet Cytogenet* 2000;117:113-117.
98. Schop R, Jalal S, Van Wier S, et al. Deletions of 17p13.1 and 13q14 are uncommon in Waldenstrom macroglobulinemia clonal cells and mostly seen at the time of disease progression. *Cancer Genet Cytogenet* 2002;132:55-60.
99. Bunn PA Jr., Krasnow S, Makuch RW, Schlam ML, Schechter GP. Flow cytometric analysis of DNA content of bone marrow cells in patients with plasma cell myeloma: clinical implications. *Blood* 1982;59:528-535.
100. Chng WJ, Schop RF, Price-Troska T, et al. Gene-expression profiling of Waldenstrom macroglobulinemia reveals a phenotype more similar to chronic lymphocytic leukemia than multiple myeloma. *Blood* 2006;108:2755-2763.
101. Hatzimichael EC, Christou L, Bai M, Kolios G, Kefala L, Bourantas KL. Serum levels of IL-6 and its soluble receptor (sIL-6R) in Waldenstrom's macroglobulinemia. *Eur J Haematol* 2001;66:1-6.
102. Ciccarelli BT, Patterson CJ, Hunter ZR, et al. Hcpidin is produced by lymphoplasmacytic cells and is associated with anemia in Waldenstrom's macroglobulinemia. *Clin Lymphoma Myeloma Leuk* 2011;11:160-163.
103. Gutierrez NC, Ocio EM, de Las Rivas J, et al. Gene expression profiling of B lymphocytes and plasma cells from Waldenstrom's macroglobulinemia: comparison with expression patterns of the same cell counterparts from chronic lymphocytic leukemia, multiple myeloma and normal individuals. *Leukemia* 2007;21:541-549.
104. Roccaro AM, Sacco A, Chen C, et al. microRNA expression in the biology, prognosis, and therapy of Waldenstrom macroglobulinemia. *Blood* 2009;113:4391-4402.
105. Sacco A, Maiso P, Azab A, et al. Key role of microRNAs in Waldenstrom's macroglobulinemia pathogenesis. *Clin Lymphoma Myeloma Leuk* 2011;11:109-111.
106. Sacco A, Issa GC, Zhang Y, et al. Epigenetic modifications as key regulators of Waldenstrom's macroglobulinemia biology. *J Hematol Oncol* 2010;3:38.

107. Roccaro AM, Sacco A, Jia X, et al. microRNA-dependent modulation of histone acetylation in Waldenstrom macroglobulinemia. *Blood* 2010;116: 1506-1514.
108. Elsawa SF, Novak AJ, Grote DM, et al. B-lymphocyte stimulator (BLyS) stimulates immunoglobulin production and malignant B-cell growth in Waldenstrom macroglobulinemia. *Blood* 2006;107:2882-2888.
109. Leleu X, Jia X, Runnels J, et al. The Akt pathway regulates survival and homing in Waldenstrom macroglobulinemia. *Blood* 2007;110:4417-4426.
110. Facon T, Brouillard M, Duhamel A, et al. Prognostic factors in Waldenstrom's macroglobulinemia: a report of 167 cases. *J Clin Oncol* 1993;11:1553-1558.
111. Singh A, Eckardt KU, Zimmermann A, et al. Increased plasma viscosity as a reason for inappropriate erythropoietin formation. *J Clin Invest* 1993;91:251-256.
112. Leblond V, Tournilhac O, Morel P. Waldenstrom's macroglobulinemia: prognostic factors and recent therapeutic advances. *Clin Exp Med* 2004;3: 187-198.
113. Fadil A, Taylor D. The lung and Waldenstrom's macroglobulinemia. *South Med J* 1998;1998:681-685.
114. Kobayashi H, Li K, Hizawa K. Two cases of pulmonary Waldenstrom's macroglobulinemia. *Chest* 1985;88:297-299.
115. Alexanian R. Blood volume in monoclonal gammopathy. *Blood* 1977;49: 301-307.
116. MacKenzie M, Lee T. Blood viscosity in Waldenstrom macroglobulinemia. *Blood* 1977;49:507-510.
117. Waldenstrom J. Zwei interessante Syndrom mit Hyperglobulinamie. *Schweiz Med Wochenschr* 1948;78:927-928.
118. Mueller J, Hotson J, Langston J. Hyperviscosity-induced dementia. *Neurology* 1983;33:101-103.
119. Pavy M, Murphy P, Virella G. Paraprotein induce hyperviscosity: a cause for reversible stroke. *Postgrad Med* 1980;68:109-112.
120. Dalakas MC, Flaum MA, Rick M, Engel WK, Gralnick HR. Treatment of polyneuropathy in Waldenstrom's macroglobulinemia: role of paraproteinemia and immunologic studies. *Neurology* 1983;33:1406-1410.
121. Latov N, Braun PE, Gross RB, Sherman WH, Penn AS, Chess L. Plasma cell dyscrasia and peripheral neuropathy: identification of the myelin antigens that react with human paraproteins. *Proc Natl Acad Sci U S A* 1981;78:7139-7142.
122. Vital C, Deminiere C, Bourgooin B. Waldenstrom's macroglobulinemia and peripheral neuropathy: deposition of M-component and kappa light chain in the endoneurium. *Neurology* 1985;35:603-606.
123. Nobile-Orazio E, Marmiroli P, Baldini L, et al. Peripheral neuropathy in macroglobulinemia: incidence and antigen-specificity of M proteins. *Neurology* 1987;37:1506-1514.
124. Dellagi K, Dupouey P, Brouet JC, et al. Waldenstrom's macroglobulinemia and peripheral neuropathy: a clinical and immunologic study of 25 patients. *Blood* 1983;62:280-285.
125. Barras JP, Graf C. Hyperviscosity in diabetic retinopathy treated with Doxium (calcium dobesilate). *Vasa* 1980;9:161-164.
126. Robinson MK, Halpern JI. Retinal vein occlusion. *Am Fam Physician* 1992;45:2661-2666.

P.2140

127. Gertz MA, Kyle RA, Noel P. Primary systemic amyloidosis: a rare complication of immunoglobulin M monoclonal gammopathies and Waldenstrom's macroglobulinemia. *J Clin Oncol* 1993;11:914-920.
128. Gertz MA, Lacy MQ, Dispenzieri A. Amyloidosis: Recognition, confirmation, prognosis, and therapy [Review]. *Mayo Clin Proc* 1999;74:490-494.
129. Kyrtonis MC, Vassilakopoulos TP, Angelopoulou MK, et al. Waldenstrom's macroglobulinemia: clinical course and prognostic factors in 60 patients. Experience from a single hematology unit. *Ann Hematol* 2001;80:722-727.
130. Levy V, Morel P, Porcher R, Chevret S, Wattel E, Leblond V. Advanced Waldenstrom's macroglobulinemia: usefulness of Morel's scoring system in establishing prognosis. *Haematologica* 2005;90:279-281.

131. Gobbi PG, Bettini R, Montecucco C, et al. Study of prognosis in Waldenstrom's macroglobulinemia: a proposal for a simple binary classification with clinical and investigational utility. *Blood* 1994;83:2939-2945.
132. Dhodapkar MV, Jacobson JL, Gertz MA, Crowley JJ, Barlogie B. Prognostic factors and response to fludarabine therapy in Waldenstrom's macroglobulinemia: an update of a US intergroup trial (SWOG S9003). *Semin Oncol* 2003;30:220-225.
133. Dhodapkar MV, Hoering A, Gertz MA, et al. Long-term survival in Waldenstrom macroglobulinemia: 10-year follow-up of Southwest Oncology Group-directed intergroup trial S9003. *Blood* 2009;113:793-796.
134. Morel P, Duhamel A, Gobbi PG, et al. International Prognostic Scoring System (IPSS) for Waldenström's Macroglobulinemia (WM). Session type: oral session. *Blood* 2006;Abstract 180;127.
135. Morel P, Duhamel P, Gobbi PG, et al. International Prognostic Scoring System for Waldenstrom macroglobulinemia. *Haematologica* 2007;92:84.
136. Morel P, Duhamel A, Gobbi P, et al. International prognostic scoring system for Waldenstrom macroglobulinemia. *Blood* 2009;113:4163-4170.
137. Kimby E, Treon SP, Anagnostopoulos A, et al. Update on recommendations for assessing response from the Third International Workshop on Waldenstrom's Macroglobulinemia. *Clin Lymphoma Myeloma* 2006;6:380-383.
138. Weber D, Treon SP, Emmanouilides C, et al. Uniform response criteria in Waldenstrom's macroglobulinemia: consensus panel recommendations from the Second International Workshop on Waldenstrom's Macroglobulinemia. *Semin Oncol* 2003;30:127-131.
139. Tassone P, Neri P, Kutok JL, et al. A SCID-hu in vivo model of human Waldenstrom macroglobulinemia. *Blood* 2005;106:1341-1345.
140. Waldenstrom J. To treat or not to treat, this is the real question. *Leuk Res* 1991;15:407-408.
141. Bayrd ED. Continuous chlorambucil therapy in primary macroglobulinemia of Waldenstrom: report of four cases. *Proc Staff Meetings Mayo Clin* 1961;36:135-147.
142. Case DC Jr. Combination chemotherapy (M-2) protocol (BCNU, cyclophosphamide, vincristine, melphalan, and prednisone) for Waldenstrom macroglobulinemia: preliminary report. *Blood* 1982;59:934-937.
143. Case DC Jr., Ervin TJ, Boyd MA, Redfield DL. Waldenstrom's macroglobulinemia: long-term results with the M-2 protocol. *Cancer Invest* 1991;9:1-7.
144. Petrucci MT, Avisati G, Tribalto M, Giovangrossi P, Mandelli F. Waldenstrom's macroglobulinaemia: results of a combined oral treatment in 34 newly diagnosed patients. *J Intern Med* 1989;226:443-447.
145. Leblond V, Levy V, Maloisel F, et al. Multicenter, randomized comparative trial of fludarabine and the combination of cyclophosphamide-doxorubicin-prednisone in 92 patients with Waldenstrom macroglobulinemia in first relapse or with primary refractory disease. *Blood* 2001;98:2640-2644.
146. Kantarjian HM, Alexanian R, Koller CA, Kurzrock R, Keating MJ. Fludarabine therapy in macroglobulinemic lymphoma. *Blood* 1990;75:1928-1931.
147. Dimopoulos MA, O'Brien S, Kantarjian H, et al. Fludarabine therapy in Waldenstrom's macroglobulinemia. *Am J Med* 1993;95:49-52.
148. Zinzani PL, Gherlinzoni F, Bendandi M, et al. Fludarabine treatment in resistant Waldenstrom's macroglobulinemia. *Eur J Haematol* 1995;54:120-123.
149. Leblond V, Ben-Othman T, Deconinck E, et al. Activity of fludarabine in previously treated Waldenstrom's macroglobulinemia: a report of 71 cases. *Groupe cooperatif macroglobulinemie. J Clin Oncol* 1998;16:2060-2064.
150. Thalhammer-Scherrer R, Geissler K, Schwarzingger I, et al. Fludarabine therapy in Waldenstrom's macroglobulinemia. *Ann Hematol* 2000;79:556-559.
151. Foran JM, Rohatiner AZ, Coiffier B, et al. Multicenter phase II study of fludarabine phosphate for patients with newly diagnosed lymphoplasmacytoid lymphoma, Waldenstrom's macroglobulinemia, and mantle-cell lymphoma. *J Clin Oncol* 1999;17:546-553.
152. Dimopoulos MA, Hamilos G, Efsthathiou E, et al. Treatment of Waldenstrom's macroglobulinemia with the combination of fludarabine and cyclophosphamide. *Leuk Lymphoma* 2003;44:993-996.

153. Tamburini J, Levy V, Chaletex C, et al. Fludarabine plus cyclophosphamide in Waldenstrom's macroglobulinemia: results in 49 patients. *Leukemia* 2005;19:1831-1834.
154. Vargaftig J, Pegourie-Bandelier B, Mahe B, et al. Fludarabine plus cyclophosphamide and rituximab in Waldenstrom macroglobulinemia: results in 21 patients. *ASH Annu Meeting Abstr* 2006;108:Abstract 4727.
155. Tam CS, Wolf M, Prince HM, et al. Fludarabine, cyclophosphamide, and rituximab for the treatment of patients with chronic lymphocytic leukemia or indolent non-Hodgkin lymphoma. *Cancer* 2006;106:2412-2420.
156. Liu ES, Burian C, Miller WE, Saven A. Bolus administration of cladribine in the treatment of Waldenstrom macroglobulinaemia [see comments]. *Br J Haematol* 1998;103:690-695.
157. Betticher DC, Hsu Schmitz SF, Ratschiller D, et al. Cladribine (2-CDA) given as subcutaneous bolus injections is active in pretreated Waldenstrom's macroglobulinaemia. Swiss Group for Clinical Cancer Research (SAKK). *Br J Haematol* 1997;99:358-363.
158. Dimopoulos MA, Kantarjian H, Estey E, et al. Treatment of Waldenstrom macroglobulinemia with 2-chlorodeoxyadenosine. *Ann Intern Med* 1993;118:195-198.
159. Delannoy A, Ferrant A, Martiat P, Bosly A, Zenebergh A, Michaux JL. 2-Chlorodeoxyadenosine therapy in Waldenstrom's macroglobulinaemia. *Nouv Rev Fr Hematol* 1994;36:317-320.
160. Dimopoulos MA, Kantarjian H, Weber D, et al. Primary therapy of Waldenstrom's macroglobulinemia with 2-chlorodeoxyadenosine. *J Clin Oncol* 1994;12:2694-2698.
161. Hellmann A, Lewandowski K, Zaucha JM, Bieniaszewska M, Halaburda K, Robak T. Effect of a 2-hour infusion of 2-chlorodeoxyadenosine in the treatment of refractory or previously untreated Waldenstrom's macroglobulinemia. *Eur J Haematol* 1999;63:35-41.
162. Laurencet FM, Zulian GB, Guetty-Alberto M, Iten PA, Betticher DC, Alberto P. Cladribine with cyclophosphamide and prednisone in the management of low-grade lymphoproliferative malignancies. *Br J Cancer* 1999;79:1215-1219.
163. Thomas S, Delasalle K, Gavino M, Wang M, Alexanian R, Weber D. 2-CDACyclophosphamide +/- rituximab for symptomatic WM. *Haematologica* 2007;92:228.
164. Dimopoulos MA, Zervas C, Zomas A, et al. Treatment of Waldenstrom's macroglobulinemia with rituximab. *J Clin Oncol* 2002;20:2327-2333.
165. Gertz MA, Rue M, Blood E, Kaminer LS, Vesole DH, Greipp PR. Multicenter phase 2 trial of rituximab for Waldenstrom macroglobulinemia (WM): an Eastern Cooperative Oncology Group (E3A98). *Leuk Lymphoma* 2004;45:2047-2055.
166. Byrd JC, White CA, Link B, et al. Rituximab therapy in Waldenstrom's macroglobulinemia: preliminary evidence of clinical activity. *Ann Oncol* 1999;10:1525-1527.
167. Treon SP, Agus DB, Link B, et al. CD20-directed antibody-mediated immunotherapy induces responses and facilitates hematologic recovery in patients with Waldenstrom's macroglobulinemia. *J Immunother* 2001;24:272-279.
168. Rummel MJ, Al-Batran SE, Kim S-Z, et al. Bendamustine plus rituximab is effective and has a favorable toxicity profile in the treatment of mantle cell and low-grade non-Hodgkin's lymphoma. *J Clin Oncol* 2005;23:3383-3389.
169. Rummel MJ, Niederle N, Maschmeyer G, et al. Bendamustine plus rituximab is superior in respect of progression free survival and CR rate when compared to CHOP plus rituximab as first-line treatment of patients with advanced follicular, indolent, and mantle cell lymphomas: final results of a randomized phase III study of the StiL (Study Group Indolent Lymphomas, Germany). *Blood Suppl* 2009:Abstract 114;405.
170. Treon SP, Gertz MA, Dimopoulos M, et al. Update on treatment recommendations from the Third International Workshop on Waldenstrom's macroglobulinemia. *Blood* 2006;107:3442-3446.
171. Del Giudice I, Matutes E, Osuji N, Parry-Jones N, Swansbury J, Catovsky D. Delayed response to fludarabine in lymphoplasmacytic lymphoma/Waldenstrom's macroglobulinemia. *Haematologica* 2005;90:268-270.
172. Tournilhac O, Cazin B, Lepretre S, et al. Impact of frontline fludarabine and cyclophosphamide combined treatment on peripheral blood stem cell mobilization in B-cell chronic lymphocytic leukemia. *Blood* 2004;103:363-365.
173. Bowcock SJ, Rassam SM, Lim Z, Ward SM, Ryali MM, Mufti GJ. High incidence of therapy-related myelodysplasia and acute leukaemia in general haematology clinic patients treated with fludarabine and cyclophosphamide for indolent lymphoproliferative disorders. *Br J Haematol* 2006;134:242-243.

174. Johnson SA, Owen RG, Oscier DG, et al. Phase III study of chlorambucil versus fludarabine as initial therapy for Waldenstrom's macroglobulinemia and related disorders. *Clin Lymphoma* 2005;5:294-297.
175. Fridrik MA, Jager G, Baldinger C, Krieger O, Chott A, Bettelheim P. First-line treatment of Waldenstrom's disease with cladribine. *Arbeitsgemeinschaft Medikamentöse Tumortherapie. Ann Hematol* 1997;74:7-10.
176. Dimopoulos MA, Weber DM, Kantarjian H, Keating M, Alexanian R. 2-Chlorodeoxyadenosine therapy of patients with Waldenstrom macroglobulinemia previously treated with fludarabine. *Ann Oncol* 1994;5:288-289.
177. Lewandowski K, Halaburda K, Hellmann A. Fludarabine therapy in Waldenstrom's macroglobulinemia patients treated previously with 2-chlorodeoxyadenosine. *Leuk Lymphoma* 2002;43:361-363.
178. Weide R, Heymanns J, Koppler H. Induction of complete haematological remission after monotherapy with anti-CD20 monoclonal antibody (RITUXIMAB) in a patient with alkylating agent resistant Waldenstrom's macroglobulinaemia. *Leuk Lymphoma* 1999;36:203-206.
179. Weide R, Heymanns J, Koppler H. The polyneuropathy associated with Waldenstrom's macroglobulinaemia can be treated effectively with chemotherapy and the anti-CD20 monoclonal antibody rituximab. *Br J Haematol* 2000;109:838-841.
180. Treon SP, Shima Y, Preffer FI, et al. Treatment of plasma cell dyscrasias by antibody-mediated immunotherapy. *Semin Oncol* 1999;26:97-106.
181. Treon SP, Emmanouilides C, Kimby E, et al. Extended rituximab therapy in Waldenstrom's macroglobulinemia. *Ann Oncol* 2005;16:132-138.
182. Dimopoulos MA, Alexanian R, Gika D, et al. Treatment of Waldenstrom's macroglobulinemia with rituximab: prognostic factors for response and progression. *Leuk Lymphoma* 2004;45:2057-2061.
183. Dimopoulos MA, Anagnostopoulos A, Zervas C, et al. Predictive factors for response to rituximab in Waldenstrom's macroglobulinemia. *Clin Lymphoma* 2005;5:270-272.
184. Treon SP, Hansen M, Branagan AR, et al. Polymorphisms in FcγRIIIA (CD16) receptor expression are associated with clinical response to rituximab in Waldenstrom's macroglobulinemia. *J Clin Oncol* 2005;23:474-481.
185. Treon SP, Anderson KC. The use of rituximab in the treatment of malignant and nonmalignant plasma cell disorders. *Semin Oncol* 2000;27:79-85.
186. Treon SP, Branagan AR, Hunter Z, Santos D, Tournhilac O, Anderson KC. Paradoxical increases in serum IgM and viscosity levels following rituximab in Waldenstrom's macroglobulinemia. *Ann Oncol* 2004;15:1481-1483.
187. Ghobrial IM, Fonseca R, Greipp PR, et al. Initial immunoglobulin M 'flare' after rituximab therapy in patients diagnosed with Waldenstrom macroglobulinemia: an Eastern Cooperative Oncology Group Study. *Cancer* 2004;101:2593-2598.
188. Krishna VM, Carey RW, Bloch KJ. Marked increase in serum IgM during treatment of Waldenstrom's macroglobulinemia with cladribine. *N Engl J Med* 2003;348:2045-2046.
189. Gironi M, Saresella M, Ceresa L, et al. Clinical and immunological worsening in a patient affected with Waldenstrom macroglobulinemia and anti-mag neuropathy after treatment with rituximab. *Haematologica* 2006;91:ECR17.
190. Broglio L, Lauria G. Worsening after rituximab treatment in anti-mag neuropathy. *Muscle Nerve* 2005;32:378-379.
191. Noronha V, Fynan TM, Duffy T. Flare in neuropathy following rituximab therapy for Waldenstrom's macroglobulinemia. *J Clin Oncol* 2006;24:e3.
192. Treon SP, Hanzis C, Manning RJ, et al. Maintenance Rituximab is associated with improved clinical outcome in rituximab naive patients with Waldenstrom macroglobulinaemia who respond to a rituximab-containing regimen. *Br J Haematol* 2011;154:357-362.
193. Gomez GA, Han T, Ozer H, Henderson ES. Treatment of refractory lymphoproliferative diseases with daily, low-dose vincristine, continuous infusion of bleomycin, and high-dose prednisone. *Med Pediatr Oncol* 1984;12:239-243.
194. Jane SM, Salem HH. Treatment of resistant Waldenstrom's macroglobulinemia with high dose glucocorticosteroids. *Aust N Z J Med* 1988;18:77-78.
195. O'Reilly RA, MacKenzie MR. Primary macrocryoglobulinemia. Remission with adrenal corticosteroid therapy. *Arch Intern Med* 1967;120:234-238.

196. Van Den Neste E, Louviaux I, Michaux JL, et al. Phase I/II study of 2-chloro-2'-deoxyadenosine with cyclophosphamide in patients with pretreated B cell chronic lymphocytic leukemia and indolent non-Hodgkin's lymphoma. *Leukemia* 2000;14:1136-1142.
197. Hensel M, Villalobos M, Kornacker M, Krasniqi F, Ho AD. Pentostatin/cyclophosphamide with or without rituximab: an effective regimen for patients with Waldenstrom's macroglobulinemia/lymphoplasmacytic lymphoma. *Clin Lymphoma Myeloma* 2005;6:131-135.
198. Tam CS, Wolf MM, Westerman D, Januszewicz EH, Prince HM, Seymour JF. Fludarabine combination therapy is highly effective in first-line and salvage treatment of patients with Waldenstrom's macroglobulinemia. *Clin Lymphoma Myeloma* 2005;6:136-139.
199. Weber D, Thomas S, Wang M, Alexanian R. Rituximab alone or in combination in the frontline treatment of Waldenstrom macroglobulinemia. *Haematologica* 2007;92:87.
200. Tedeschi A, Benevolo G, Varettoni M, et al. Fludarabine plus cyclophosphamide and rituximab in Waldenstrom macroglobulinemia: an effective but myelosuppressive regimen to be offered to patients with advanced disease. *Cancer* 2012;118:434-443.
201. Dimopoulos M, Anagnostopoulos A, Kyrtonis MC, et al. Primary treatment of Waldenstrom Macroglobulinemia (WM) with dexamethasone, rituximab and cyclophosphamide. *ASH Annu Meeting Abstr* 2006;108:128.
202. Treon SP, Hunter Z, Barnagan AR. CHOP plus rituximab therapy in Waldenstrom's macroglobulinemia. *Clin Lymphoma* 2005;5:273-277.
203. Singhal S, Mehta J, Desikan R, et al. Antitumor activity of thalidomide in refractory multiple myeloma [see comments] [published erratum appears in *N Engl J Med* 2000 Feb 3;342(5):364]. *N Engl J Med* 1999;341:1565-1571.
204. Dimopoulos MA, Zomas A, Viniou NA, et al. Treatment of Waldenstrom's macroglobulinemia with thalidomide. *J Clin Oncol* 2001;19:3596-3601.
205. Treon S, Patterson C, Hunter Z, Branagan A. Phase II study of CC-5013 (Revlimid) and rituximab in Waldenstrom macroglobulinemia: preliminary safety and efficacy results. *ASH Annu Meeting Abstr* 2005;106:2443.
206. Dimopoulos MA, Anagnostopoulos A, Kyrtonis MC, Castritis E, Bitsaktis A, Pangalis GA. Treatment of relapsed or refractory Waldenstrom's macroglobulinemia with bortezomib. *Haematologica* 2005;90:1655-1658.
207. Treon SP, Hunter ZR, Matous J, et al. Multicenter clinical trial of bortezomib in relapsed/refractory Waldenstrom's macroglobulinemia: results of WMCTG trial 03-248. *Clin Cancer Res* 2007;13:3320-3325.
208. Chen C, Kouroukis CT, White D, et al. Bortezomib in relapsed or refractory Waldenstrom's macroglobulinemia. *Clin Lymphoma Myeloma* 2009;9:74-76.
209. Chen CI, Kouroukis CT, White D, et al. Bortezomib is active in patients with untreated or relapsed Waldenstrom's macroglobulinemia: a phase II study of the National Cancer Institute of Canada Clinical Trials Group. *J Clin Oncol* 2007;25:1570-1575.
210. Treon SP, Ioakimidis L, Soumerai JD, et al. Primary therapy of Waldenstrom macroglobulinemia with bortezomib, dexamethasone, and rituximab: WMCTG clinical trial 05-180. *J Clin Oncol* 2009;27:3830-3835.
211. Ghobrial IM, Xie W, Padmanabhan S, et al. Phase II trial of weekly bortezomib in combination with rituximab in untreated patients with Waldenstrom macroglobulinemia. *Am J Hematol* 2010;85:670-674.
212. Ghobrial IM, Hong F, Padmanabhan S, et al. Phase II trial of weekly bortezomib in combination with rituximab in relapsed or relapsed and refractory Waldenstrom macroglobulinemia. *J Clin Oncol* 2010;28:1422-1428.
213. Agathocleous A, Rohatiner A, Rule S, et al. Weekly versus twice weekly bortezomib given in conjunction with rituximab, in patients with recurrent follicular lymphoma, mantle cell lymphoma and Waldenstrom macroglobulinaemia. *Br J Haematol* 2010;151:346-353.
214. Ghobrial IM, Roccaro A, Hong F, et al. Clinical and translational studies of a phase II trial of the novel oral Akt inhibitor perifosine in relapsed or relapsed/refractory Waldenstrom's macroglobulinemia. *Clin Cancer Res* 2010;16:1033-1041.
215. Roccaro AM, Sacco A, Jia X, et al. Mechanisms of activity of the TORC1 inhibitor everolimus in Waldenstrom's macroglobulinemia. *Clin Cancer Res* 2012;18:6609-6622.

216. Roccaro AM, Sacco A, Husu EN, et al. Dual targeting of the PI3K/Akt/mTOR pathway as an antitumor strategy in Waldenstrom macroglobulinemia. *Blood* 2010;115:559-569.
217. Hunter Z, Boxer M, Kahl B, et al. Phase II study of alemtuzumab in lymphoplasmacytic lymphoma: results of WMCTG trial 02-079. *J Clin Oncol* 2006 ASCO Annu Meeting Proc 2006;24:7523.
218. Treon S, Soumerai J, Hunter Z, et al. Novel agents in the treatment of Waldenstrom macroglobulinemia. *Haematologica* 2007;92:91.
219. Treon SP, Tournilhac O, Branagan AR, et al. Clinical responses to sildenafil in Waldenstrom's macroglobulinemia. *Clin Lymphoma* 2004;5:205-207.
220. Gertz MA, Geyer SM, Badros A, Kahl BS, Erlichman C. Early results of a phase I trial of oblimersen sodium for relapsed or refractory Waldenstrom's macroglobulinemia. *Clin Lymphoma* 2005;5:282-284.
221. Gertz MA, Reeder CB, Kyle RA, Ansell SM. Stem cell transplant for Waldenstrom macroglobulinemia: an underutilized technique. *Bone Marrow Transplant* 2012;47:1147-1153.
222. Anagnostopoulos A, Hari PN, Perez WS, et al. Autologous or allogeneic stem cell transplantation in patients with Waldenstrom's macroglobulinemia. *Biol Blood Marrow Transplant* 2006;12:845-854.
223. Desikan R, Dhodapkar M, Siegel D, et al. High-dose therapy with autologous haemopoietic stem cell support for Waldenstrom's macroglobulinaemia. *Br J Haematol* 1999;105:993-996.
224. Dreger P, Glass B, Kuse R, et al. Myeloablative radiochemotherapy followed by reinfusion of purged autologous stem cells for Waldenstrom's macroglobulinaemia. *Br J Haematol* 1999;106:115-118.
225. Kyriakou C, Canals C, Taghipour G, et al. Autologous stem cell transplantation for patients with Waldenstrom macroglobulinemia. An analysis of 201 cases from the European Bone Marrow Transplant Registry. *Haematologica* 2007;92:228.
226. Dhedin N, Tabrizi R, Bulabois P, et al. Hematopoietic stem cell transplantation (HSCT) in Waldenstrom macroglobulinemia (WM), update of the French experience in 54 cases. *Blood* 2007;110:3015 abstract.
227. Kyriakou C, Canals C, Cornelissen JJ, et al. Allogeneic stem-cell transplantation in patients with Waldenstrom macroglobulinemia: report from the Lymphoma Working Party of the European Group for Blood and Marrow Transplantation. *J Clin Oncol* 2010;28:4926-4934.
228. Gilleece MH, Pearce R, Linch DC, et al. The outcome of haemopoietic stem cell transplantation in the treatment of lymphoplasmacytic lymphoma in the UK: a British Society Bone Marrow Transplantation study. *Hematology* 2008;13:119-127.
229. Kyriakou C, Canals C, Goldstone A, et al. High-dose therapy and autologous stem-cell transplantation in angioimmunoblastic lymphoma: complete remission at transplantation is the major determinant of Outcome-Lymphoma Working Party of the European Group for Blood and Marrow Transplantation. *J Clin Oncol* 2008;26:218-224.
230. Martino R, Shah A, Romero P, et al. Allogeneic bone marrow transplantation for advanced Waldenstrom's macroglobulinemia. *Bone Marrow Transplant* 1999;23:747-749.
231. Ueda T, Hatanaka K, Kosugi S, Kishino BI, Tamaki T. Successful non-myeloablative allogeneic peripheral blood stem cell transplantation (PBSCT) for Waldenstrom's macroglobulinemia with severe pancytopenia. *Bone Marrow Transplant* 2001;28:609-611.
232. Kyriakou C, Canals C, Taghipour G, et al. Allogeneic stem cell transplantation (allo-SCT) in Waldenstrom macroglobulinemia (WM). An analysis of 1006 cases from the European Bone Marrow Transplant Registry. *Haematologica* 2007;92:95.
233. Garnier A, Robin M, Larosa F, et al. Allogeneic hematopoietic stem cell transplantation allows long-term complete remission and curability in high-risk Waldenstrom's macroglobulinemia. Results of a retrospective analysis of the Societe Francaise de Greffe de Moelle et de Therapie Cellulaire. *Haematologica* 2010;95:950-955.
234. Nagai M, Ikeda K, Nakamura H, et al. Splenectomy for a case with Waldenstrom macroglobulinemia with giant splenomegaly. *Am J Hematol* 1991;37:140.
235. Brody JI, Haidar ME, Rossman RE. A hemorrhagic syndrome in Waldenstrom's macroglobulinemia secondary to immunoadsorption of factor VIII. Recovery after splenectomy. *N Engl J Med* 1979;300:408-410.

236. Humphrey JS, Conley CL. Durable complete remission of macroglobulinemia after splenectomy: a report of two cases and review of the literature. [Review] [40 refs]. *Am J Hematol* 1995;48:262-266.
237. Avnstorp C, Nielsen H, Drachmann O, Hippe E. Plasmapheresis in hyperviscosity syndrome. *Acta Med Scand* 1985;217:133-137.
238. Clark WF, Rock GA, Buskard N, et al. Therapeutic plasma exchange: an update from the Canadian Apheresis Group. *Ann Intern Med* 1999;131:453-462.
239. Buskard NA, Galton DA, Goldman JM, et al. Plasma exchange in the longterm management of Waldenstrom's macroglobulinemia. *Can Med Assoc J* 1977;117:135-137.
240. Niesvizky R, Zhu AX, Louie D, Michaeli J. Epstein-Barr virus-associated lymphoma after treatment of macroglobulinemia with cladribine [letter]. *N Engl J Med* 1999;341:55.
241. Fenchel K, Wijermans P, Mitrou P. Fenchel K, Wijermans P, Mitrou PS, et al. Fludarabine is an effective agent in immunocytic lymphoma.- *Onkologie* 1994;17:508-513.
242. Wong SS, Woo PC, Yuen KY. *Candida tropicalis* and *Penicillium marneffeii* mixed fungaemia in a patient with Waldenstrom's macroglobulinaemia. *Eur J Clin Microbiol Infect Dis* 2001;20:132-135.
243. Bjorkholm M, Celsing F, Runarsson G, Waldenstrom J. Successful intravenous immunoglobulin therapy for severe and persistent astrovirus gastroenteritis after fludarabine treatment in a patient with Waldenstrom's macroglobulinemia. *Int J Hematol* 1995;62:117-120.
244. Costa P, Luzzati R, Nicolato A, et al. Cryptococcal meningitis and intracranial tuberculoma in a patient with Waldenstrom's macroglobulinemia treated with fludarabine. *Leuk Lymphoma* 1998;28:617-620.
245. Bryson HM, Sorkin EM. Cladribine. A review of its pharmacodynamic and pharmacokinetic properties and therapeutic potential in haematological malignancies. *Drugs* 1993;46:872-894.
246. Aslan DL, Peterson BA, Long-Tsai M, Eastlund T. Early-onset autoimmune hemolytic anemia after cladribine therapy for Waldenstrom's macroglobulinemia. *Transfusion* 2006;46:90-94.
247. Tetreault SA, Saven A. Delayed onset of autoimmune hemolytic anemia complicating cladribine therapy for Waldenstrom macroglobulinemia. *Leuk Lymphoma* 2000;37:125-130.
248. Baltz JK, Montello MJ. Cladribine for the treatment of hematologic malignancies. *Clin Pharm* 1993;12:805-813, quiz 60-62.
249. Cardamone JM, Kimmerle RI, Marshall EY. Development of acute erythroleukemia in B-cell immunoproliferative disorders after prolonged therapy with alkylating drugs. *Am J Med* 1974;57:836-842.
250. Horsman DE, Card RT, Skinnider LF. Waldenstrom macroglobulinemia terminating in acute leukemia: a report of three cases. *Am J Hematol* 1983;15: 97-101.
251. Petersen HS. Erythroleukaemia in a melphalan-treated patient with primary macroglobulinaemia. *Scand J Haematol* 1973;10:5-11.
252. Rodriguez JN, Fernandez-Jurado A, Martino ML, Prados D. Waldenstrom's macroglobulinemia complicated with acute myeloid leukemia. Report of a case and review of the literature. *Haematologica* 1998;83:91-92.
253. Van Den Neste E, Louviaux I, Michaux JL, et al. Myelodysplastic syndrome with monosomy 5 and/or 7 following therapy with 2-chloro-2'-deoxyadenosine. *Br J Haematol* 1999;105:268-270.
254. Siddiqui A, Melamed MR, Abbi R, Ahmed T. Mucinous (colloid) carcinoma of urinary bladder following long-term cyclophosphamide therapy for Waldenstrom's macroglobulinemia. *Am J Surg Pathol* 1996;20:500-504.
255. Tam CS, Seymour JF, Prince HM, et al. Treatment-related myelodysplasia following fludarabine combination chemotherapy. *Haematologica* 2006;91:1546-1550.
256. Varettoni M, Tedeschi A, Arcaini L, et al. Risk of second cancers in Waldenstrom macroglobulinemia. *Ann Oncol* 2012;23:411-415.
257. Ojha RP, Thertulien R. Second malignancies among Waldenstrom macroglobulinemia patients: small samples and sparse data. *Ann Oncol* 2012;23: 542-543.

258. Aksoy S, Abali H, Kilickap S, Erman M, Kars A. Accelerated hepatitis C virus replication with rituximab treatment in a non-Hodgkin's lymphoma patient. *Clin Lab Haematol* 2006;28:211-214.
259. Ozgonenel B, Moonka D, Savasan S. Fulminant hepatitis B following rituximab therapy in a patient with Evans syndrome and large B-cell lymphoma. *Am J Hematol* 2006;81:302.
260. Perceau G, Diris N, Estines O, Derancourt C, Levy S, Bernard P. Late lethal hepatitis B virus reactivation after rituximab treatment of low-grade cutaneous B-cell lymphoma. *Br J Dermatol* 2006;155:1053-1056.
261. Sera T, Hiasa Y, Michitaka K, et al. Anti-HBs-positive liver failure due to hepatitis B virus reactivation induced by rituximab. *Intern Med* 2006;45:721-724.
262. Tsutsumi Y, Kanamori H, Mori A, et al. Reactivation of hepatitis B virus with rituximab. *Expert Opin Drug Saf* 2005;4:599-608.
263. Umemura T, Kiyosawa K. Fatal HBV reactivation in a subject with anti-HBs and anti-HBc. *Intern Med* 2006;45:747-748.
264. Goldberg SL, Pecora AL, Alter RS, et al. Unusual viral infections (progressive multifocal leukoencephalopathy and cytomegalovirus disease) after high-dose chemotherapy with autologous blood stem cell rescue and peritransplantation rituximab. *Blood* 2002;99:1486-1488.
265. Matteucci P, Magni M, Di Nicola M, Carlo-Stella C, Uberti C, Gianni AM. Leukoencephalopathy and papovavirus infection after treatment with chemotherapy and anti-CD20 monoclonal antibody. *Blood* 2002;100:1104-1105.
266. Pearlman AN, Fechner FP, Constantinides M. Development of nasal skin necrosis associated with rituximab treatment for Waldenstrom's macroglobulinemia and subsequent spontaneous resolution. *Ear Nose Throat J* 2006;85:431-433.
267. Anagnostopoulos A, Giralt S. Stem cell transplantation (SCT) for Waldenstrom's macroglobulinemia (WM). *Bone Marrow Transplant* 2002;29:943-947.
268. Tournilhac O, Leblond V, Tabrizi R, et al. Transplantation in Waldenstrom's macroglobulinemia—the French experience. *Semin Oncol* 2003;30:291-296.

Chapter 101 Poems Syndrome, Cryoglobulinemia, and Heavy-Chain Disease

> Table of Contents > Part VII - Hematologic Malignancies > Section 5 - Plasma Cell Dyscrasias > Chapter 101 - Poems Syndrome, Cryoglobulinemia, and Heavy-Chain Disease

Chapter 101

Poems Syndrome, Cryoglobulinemia, and Heavy-Chain Disease

Angela Dispenzieri

David Dingli

Morie A. Gertz

INTRODUCTION

This chapter addresses three types of immunoglobulin-based orphan diseases: the POEMS syndrome (polyneuropathy, organomegaly, endocrinopathy, monoclonal plasma cell disorder, and skin changes), cryoglobulinemia, and immunoglobulin heavy-chain disease (HCD). These diseases are characterized by lymphoproliferative, lymphoplasmacytic proliferative, or plasma cell proliferative disorders and specific serum immunoglobulin findings that serve as markers to define each entity.

POEMS SYNDROME

POEMS syndrome is a rare paraneoplastic syndrome due to an underlying plasma cell disorder. The acronym, which was coined by Bardwick in 1980,¹ refers to several, but not all, of the features of the syndrome: polyradiculoneuropathy, organomegaly, endocrinopathy, monoclonal plasma cell disorder, and skin changes. There are three important points that relate to this memorable acronym: (1) not all of the features within the acronym are required to make the diagnosis; (2) there are other important features not included in the POEMS acronym, including papilledema, extravascular volume overload, sclerotic bone lesions, thrombocytosis/erythrocytosis (P.E.S.T.), elevated vascular endothelial growth factor (VEGF) levels, a predisposition toward thrombosis, and abnormal pulmonary function tests; and (3) there is a Castleman

disease variant of POEMS syndrome that may be associated with a clonal plasma cell disorder. Other names of the POEMS syndrome that are less frequently used are osteosclerotic myeloma, Takatsuki syndrome, Crow-Fukase syndrome, and PEP syndrome.^{2, 3}

The disease was initially thought to be more common in patients of Japanese descent, given the most numerous initial reports from Japan.^{2, 3} However, over the years, large series have also been reported from France, the United States, China, and India.^{4, 5, 6, 7, 8} A national survey conducted in Japan in 2003 showed a prevalence of approximately 0.3 per 100,000.⁹

ETIOLOGY OF POEMS SYNDROME

The pathogenesis of the syndrome is not understood. Distinctive presenting characteristics of the syndrome that differentiate POEMS syndrome from standard multiple myeloma (MM) include the following: (1) dominant symptoms have little or nothing to do with bone pain, extremes of bone marrow infiltration by plasma cells, or renal failure; (2) dominant symptoms are typically neuropathy, endocrine dysfunction, and volume overload; (3) VEGF levels are high; (4) sclerotic bone lesions are present in the majority of cases; (5) overall survival is typically superior; and (6) λ clones predominate.¹⁰

To date, VEGF is the cytokine that correlates best with disease activity,^{11, 12, 13, 14, 15, 16, 17, 18, 19, 20} although it is likely not the driving force of the disease, based on the mixed results seen with anti-VEGF therapy.^{21, 22, 23, 24, 25, 26, 27} VEGF is known to target endothelial cells, induce a rapid and reversible increase in vascular permeability, and be important in angiogenesis. It is expressed by osteoblasts, in bone tissue, macrophages, malignant plasma cells,^{28, 29, 30} and megakaryocytes/platelets.³¹ Both IL-1 β and IL-6 have been shown to stimulate VEGF production.²⁸ Little is known about the plasma cells in POEMS syndrome except that more than 95% of the time they are λ -light chain restricted with restricted immunoglobulin light chain variable gene usage (IGLV1).^{32, 33, 34} Aneuploidy and deletion of chromosome 13 have been described, but hyperdiploidy is not seen.³⁵

DIAGNOSIS OF POEMS SYNDROME

The diagnosis is established based on a composite of clinical and laboratory features. The most notable symptoms include the constellation of neuropathy and any of the following: monoclonal protein (especially λ -light chain), thrombocytosis, anasarca, or papilledema. All the features of the acronym are not required to make the diagnosis. The requirements set forth in Table 101.1 are designed to retain both sensitivity and specificity, potentially erring on the side of specificity. Making the diagnosis can be a challenge, but a good history and physical examination followed by appropriate testing—most notably radiographic assessment of bones,³⁸ measurement of VEGF,^{13, 17, 20, 39, 40} and careful analysis of a bone marrow biopsy⁴¹—can differentiate this syndrome from other conditions like chronic inflammatory polyradiculoneuropathy (CIDP), monoclonal gammopathy of undetermined significance (MGUS) neuropathy, and immunoglobulin light chain amyloid neuropathy.⁴² Figure 101.1 demonstrates several classic findings among patients with POEMS syndrome.

CLINICAL PRESENTATION OF POEMS SYNDROME

Polyradiculoneuropathy

The peripheral neuropathy is the dominant characteristic,^{2, 3, 5, 7, 36} and it is ascending, symmetrical, and affecting both sensation and motor function.⁴³ In our experience, pain may be a dominant feature in about 10% to 15% of patients, and in one report as many as 76% of patients had painful neuropathy.^{9, 44} Nerve conduction studies in patients with POEMS syndrome show slowing of nerve conduction that is more predominant in the intermediate than distal nerve segments as compared to CIDP, and there is more severe attenuation of compound muscle action potentials in the lower than upper limbs.^{9, 45, 46, 47, 48} In contrast to CIDP, conduction block is rare.^{9, 46, 48} The conduction findings suggest that demyelination is predominant in the nerve trunk rather than the distal nerve terminals, and axonal loss is predominant in the lower limb nerves.⁹ Axonal loss is greater in POEMS syndrome than it is in CIDP.⁴⁸ The nerve biopsy is not specific, but uncompact myelin lamellae, endothelial cytoplasmic enlargement, opening of the tight junctions between endothelial cells and presence of many pinocytotic vesicles adjacent to the cell membranes, and absence of macrophage-associated demyelination have been described.^{49, 50, 51, 52, 53, 54, 55, 64}

P.2142

TABLE 101.1 CRITERIA FOR THE DIAGNOSIS OF POEMS SYNDROME^a

		% Affected^b
Mandatory major criteria	1. Polyradiculoneuropathy (typically demyelinating)	100
(both required)	2. Monoclonal plasma cell disorder (almost always λ)	100 ^c
Other major criteria	3. Castleman disease ^d	11-25
(one required)	4. Bone lesions, usually sclerotic	27-97
	5. Vascular endothelial growth factor elevation ^e	
Minor criteria (one required)	6. Organomegaly (splenomegaly, hepatomegaly, or lymphadenopathy)	45-85
	7. Extravascular volume overload (edema, pleural effusion, or ascites)	29-87
	8. Endocrinopathy (adrenal, thyroid ^f , pituitary, gonadal, parathyroid, pancreatic ^f)	67-84
	9. Skin changes (hyperpigmentation, hypertrichosis, glomeruloid hemangiomas, plethora, acrocyanosis, flushing, white nails)	68-89
	10. Papilledema	29-64
	11. Thrombocytosis/polycythemia ^g	54-88
Other symptoms and signs	Clubbing, weight loss, hyperhidrosis, pulmonary hypertension/restrictive lung disease, thrombotic diatheses, diarrhea, low vitamin B ₁₂ values	

POEMS, polyneuropathy, organomegaly, endocrinopathy, M-protein, skin changes.

^aThe diagnosis of POEMS syndrome is confirmed when both of the mandatory major criteria, one of the three other major criteria, and one of the six minor criteria are present.

^b Summary of frequencies of POEMS syndrome features based on largest retrospective series.^{2, 3, 5, 7, 36, 37}

^c Takasaki and Nakanishi series are included even though only 75% of patients had a documented plasma cell disorder. Since these are among the earliest series describing the syndrome, they are included.

^d There is a Castleman disease variant of POEMS syndrome that occurs *without* evidence of a clonal plasma cell disorder that is not accounted for in this table. This entity should be considered separately.⁴²

^e A plasma VEGF level of 200 pg/ml is 95% specific and 68% sensitivity for a POEMS syndrome.²⁰

^f Because of the high prevalence of diabetes mellitus and thyroid abnormalities, this diagnosis alone is not sufficient to meet this minor criterion.

^g Approximately 50% of patients will have bone marrow changes that distinguish it from a typical MGUS or myeloma bone marrow.

From Dispenzieri A. How I treat POEMS syndrome. *Blood* 2012;119(24):5650-5658, with permission.

Organomegaly, Endocrinopathy, Skin Changes, Papilledema, and Extravascular Overload

Depending on the series, 45% to 85% of patients will have any combination of splenomegaly, hepatomegaly, and/or lymphadenopathy. With the exception of lymph node biopsies, the histology of the liver and spleen tends to be nonspecific. Lymph nodes may appear reactive or reveal frank Castleman's Disease or merely "Castleman's Disease-like" changes. Historically, it was estimated that between 11% and 30% of POEMS patients with documented clonal plasma cell disorder also have documented Castleman disease or Castleman-like histology.^{1, 3, 5, 7, 36, 42} More recent data would suggest that among individuals with POEMS who undergo lymph node biopsy, about 50% show angiofollicular hyperplasia typical of Castleman disease,^{3, 7} and 84% of these are hyaline vascular type.⁷ Only those with peripheral neuropathy AND a plasma cell clone should be classified as standard POEMS syndrome; without both, patients can be classified as Castleman disease variant of POEMS if they have other POEMS features.⁵⁶

Endocrinopathy is a central but poorly understood feature of POEMS. In a recent series,³⁷ approximately 84% of patients had a recognized endocrinopathy, with hypogonadism as the most common endocrine abnormality, followed by thyroid abnormalities, glucose metabolism abnormalities, and lastly by adrenal insufficiency. The majority of patients have evidence of multiple endocrinopathies in the four major endocrine axes (gonadal, thyroid, glucose, and adrenal). Gynecomastia may be present on physical examination.

The characteristic skin changes include hyperpigmentation, a recent outcropping of hemangioma, hypertrichosis, dependent rubor and acrocyanosis, white nails, sclerodermoid changes, facial lipodystrophy, flushing, or clubbing.^{2, 4, 5, 6, 7, 8, 57, 58} Rarely, calciphylaxis is also seen.^{59, 60} The histologic findings of the dermis have been reported to range from nonspecific to glomeruloid hemangiomas to vascular abnormalities in apparently normal dermis.^{61, 62, 63, 64}

Papilledema is present in at least one-third of patients⁶⁵; the majority of these patients do not have specific symptoms relating to this finding but a minority will report blurred vision, diplopia, or ocular pain.

Peripheral edema, ascites, and effusions are the symptoms and signs that cause the next most morbidity after peripheral neuropathy. The manifestations of extravascular overload occur in 29% to 87% of patients with POEMS syndrome and are not typically associated with severe hypoalbuminemia. Severe third spacing can lead to worsening renal function. Serum creatinine levels are normal in most cases, but serum cystatin C, which is a surrogate marker for renal function, is high in 71% of patients.⁶⁶ In our experience, at presentation, fewer than 10% of patients have proteinuria exceeding 0.5 g/24 hours, and only 6% have a serum creatinine greater than or equal to 1.5 mg/dl. Four percent of patients developed renal failure as preterminal events.³⁶ In another series from China, however, 37% of patients had a creatinine clearance (CrCl) of less than 60 ml/minute, 9% had a CrCl of less than 30 ml/minute, and 15% had microhematuria. In POEMS syndrome, the renal histologic findings are diverse, with membranoproliferative features and evidence of endothelial injury being most common.⁶⁷ On both light and electron microscopy, mesangial expansion, narrowing of capillary lumina, basement membrane thickening, subendothelial deposits, widening of the subendothelial space, swelling and vacuolization of endothelial cells, and mesangiolysis predominate.^{68, 69, 70, 71, 72, 73, 74} Standard immunofluorescence is negative,^{69, 75} which differentiates it from primary membranoproliferative glomerulitis.⁶⁷ Rarely, infiltration by plasma cell nests or Castleman-like lymphoma have been described.⁷⁴

P.2143

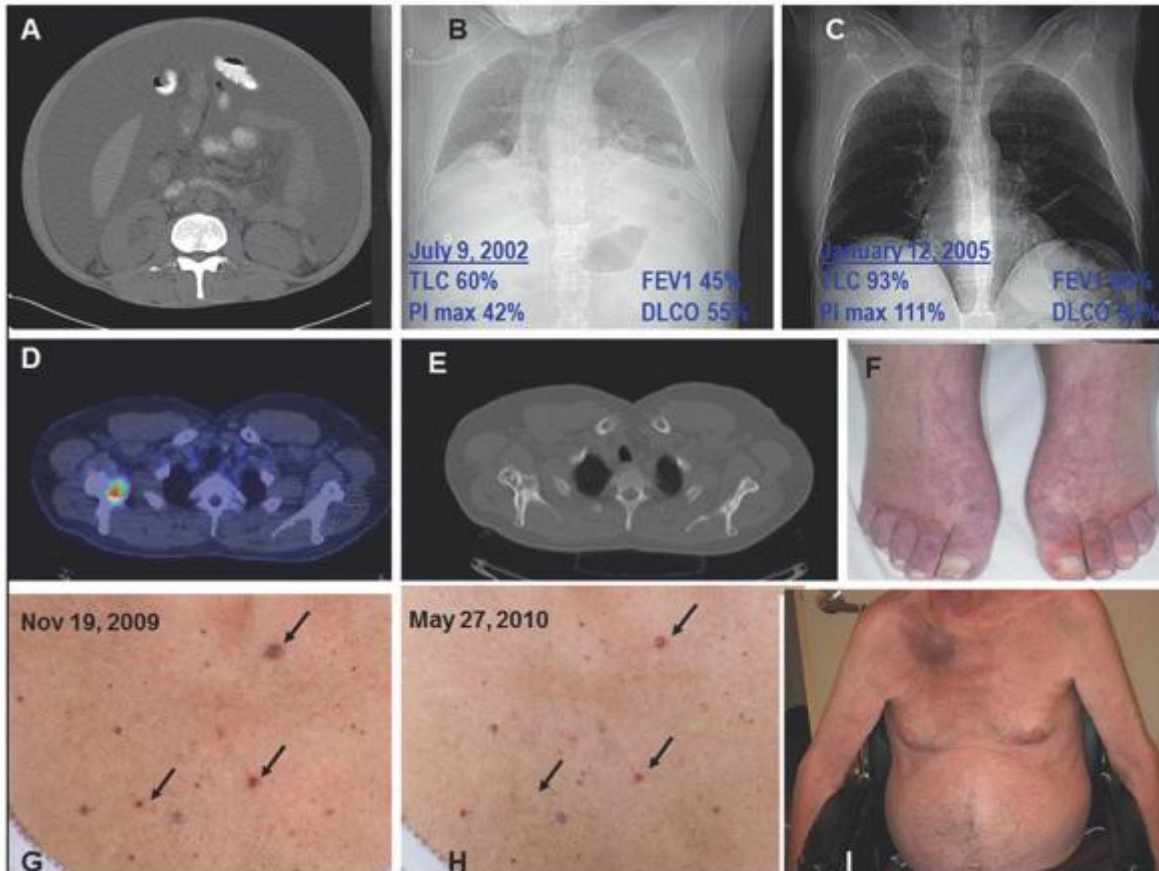

FIGURE 101.1. Classic findings of POEMS (polyneuropathy, organomegaly, endocrinopathy, monoclonal plasma cell disorder, and skin changes) syndromes. A: Massive ascites and lipodystrophy. B: Chest radiograph and pulmonary function test results demonstrating reduced lung volumes due to neuromuscular weakness, small effusions, and reduced diffusing capacity of carbon monoxide. C: Improved chest radiograph and pulmonary function tests 2.5 years after ASCT (same patient as H). D: Fusion CT PET of mixed lytic/sclerotic lesion in right scapula. E: Bone windows of CT of mixed lytic/sclerotic lesion in right scapula. F: Hyperemia of extremities and white nails. G: Outcropping of cherry angiomata at diagnosis. H: Shrinkage and disappearance of cherry angiomata after radiation to solitary osteosclerotic lesion right femur. I: Plasmacytoma right scapula with overlying erythema as well as gynecomastia, muscle wasting, and ascites. Also present but unrelated is florid tinea corporis due to chronic steroid used for the incorrect diagnosis of CIDP. (From Dispenzieri, A. How I treat POEMS syndrome. *Blood* 2012;119(24):5650-5658, with permission.)

Monoclonal Plasma Cell Disorder, Sclerotic Bone Lesions, and Myeloproliferation

Among patients with POEMS syndrome, the CBC is notable for an absence of cytopenias. In fact, nearly half of patients will have thrombocytosis or erythrocytosis.³⁶ In a recent series from China, 26% of patients had anemia, which the authors attributed to impaired renal function.⁷ Their series was enriched with Castleman disease cases (25%), which may have also contributed to this unprecedentedly high rate of anemia.

The bone marrow biopsy reveals megakaryocyte hyperplasia and megakaryocyte clustering in 54% and 93% of cases, respectively.⁴¹ These megakaryocyte findings are reminiscent of a myeloproliferative disorder, but JAK2 V617F mutation is uniformly absent. One-third of patients do not have clonal plasma cells on their iliac crest biopsy. These are the patients who present with a solitary or “multiple solitary” plasmacytomas. The other two-thirds of patients have clonal plasma cells in their bone marrow, and 91% of these cases are clonal λ . The median percent of plasma cells observed is less than 5%. Immunohistochemical staining is more sensitive than is 6-color flow cytometry, since the former provides information on bone marrow architecture, which is key in making the diagnosis in nearly half of cases. In our study of 67 pretreatment bone marrow biopsies from patients with POEMS syndrome, lymphoid aggregates were found in 49% of cases. Of these, there was plasma cell rimming in all but one, and in 75% and 4% the rimming was clonal λ and κ , respectively. This finding was not seen in bone marrows from normal controls or from patients with MGUS, MM, or amyloidosis. Overall, only 8/67

(12%) of POEMS cases had normal iliac crest bone marrow biopsies, i.e., no detectable clonal plasma cells, no plasma cell rimmed lymphoid aggregates, and no megakaryocyte hyperplasia.

Osteosclerotic lesions occur in approximately 95% of patients and can be confused with benign bone islands, aneurysmal bone cysts, nonossifying fibromas, and fibrous dysplasia.^{3, 36, 76, 77} Some lesions are densely sclerotic, while others are lytic with a sclerotic rim, while still others have a mixed soap-bubble appearance. Occasionally patients will have a lytic lesion without any evident sclerosis. Bone windows of CT body images are often very informative, often even more so than FDG-uptake, which can be variable and most useful when there is an obvious lytic component to the bone lesion.

P.2144

Elevated Vascular Endothelial Growth Factor and Other Cytokines

Plasma and serum levels of VEGF are markedly elevated in patients with POEMS^{11, 20, 28, 78} and correlate with the activity of the disease.^{13, 17, 20, 28} The principal isoform of VEGF expressed is VEGF165.¹³ VEGF levels are independent of M-protein size.¹³ IL-1 β , TNF- α , and IL-6 levels are often also increased. Serum VEGF levels are 10 to 50 times higher than plasma levels of VEGF,⁷⁹ making it unclear which test is preferred. In patients with POEMS, VEGF is found in both plasma cells^{29, 30} and platelets.⁷⁸ The higher level observed in serum is attributable to the release of VEGF from platelets *in vitro* during serum processing. Our group has recently demonstrated that a plasma VEGF level of 200 pg/ml had a specificity of 95% with a sensitivity of 68% in support of a diagnosis of POEMS syndrome. Other diseases with high VEGF include connective tissue disease and vasculitis.²⁰

Pulmonary and Coagulation Abnormalities

Respiratory complaints are usually limited, given patients' neurologic status impairing their ability to induce cardiovascular challenges.⁸⁰ The pulmonary manifestations are protean, including pulmonary hypertension, restrictive lung disease, impaired neuromuscular respiratory function, and impaired diffusion capacity of carbon monoxide, but improve with effective therapy.^{7, 80, 81} Whether the digital clubbing seen in POEMS is a reflection of underlying pulmonary hypertension and/or parenchymal disease is yet to be determined. Fingernail clubbing is seen in about 4% to 49% of cases.^{3, 80}

Patients are at increased risk for arterial and/or venous thromboses during their course, with nearly 20% of patients experiencing one of these complications.^{10, 82} Ten percent of patients present with a cerebrovascular event, most commonly embolic or vessel dissection and stenosis.⁸³ Thrombocytosis and increased bone marrow infiltration are associated with risk for cerebrovascular accidents.⁸³ Aberrations in the coagulation cascade have been implicated in POEMS syndrome, but are not usually clinically apparent.⁵⁵

TREATMENT OF POEMS SYNDROME

Despite the relationship between disease response and dropping levels of VEGF, the most experience with successful outcomes has been associated with directing therapy at the underlying clonal plasma cell disorder rather than solely targeting VEGF with anti-VEGF antibodies. The treatment algorithm is based on the extent of the plasma cell infiltration (Fig. 101.2). The approach to therapy differs based on whether there is bone marrow involvement as determined by blind iliac crest sampling.⁸⁴

The course of POEMS syndrome is usually chronic, with modern estimated median survivals of nearly 14 years.^{36, 80} Only fingernail clubbing, extravascular volume overload—i.e., effusions, edema, and ascites³⁶—and respiratory symptoms⁸⁰ have been associated with a significantly shorter overall survival. The number of POEMS features does not affect survival.^{5, 10} In our experience and in a recent report from China, patients with coexisting Castleman disease may have an inferior overall survival as compared to patients without.⁷ In a series of 11 patients, lower VEGF levels predicted for better response to therapy, with resolution of the skin changes, improvement of the neuropathic disturbances, and improvement of all of the features assumed to be related to increased permeability, like papilledema and organomegaly.¹⁷

Management of POEMS Syndrome without Disseminated Bone Marrow Involvement

In the case of patients with an isolated bone lesion without clonal plasma cells found on iliac crest biopsy, radiation is the recommended therapy, as it is in the case of a more straightforward solitary plasmacytoma of bone. Not only does radiation to an isolated (or even two or three isolated) lesion(s) improve the symptoms of POEMS syndrome over the course of 3 to 36 months, but it can be curative.

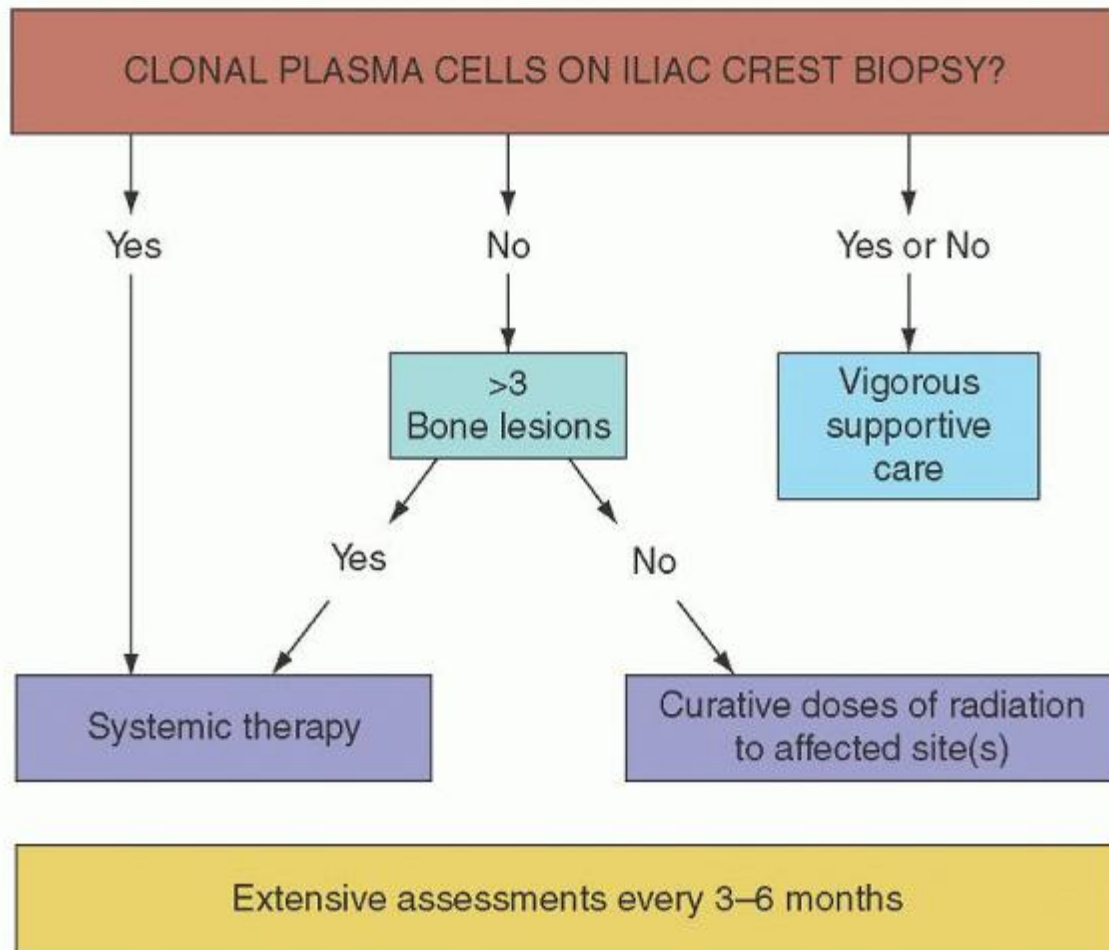

FIGURE 101.2. Algorithm for the treatment of POEMS (polyneuropathy, organomegaly, endocrinopathy, monoclonal plasma cell disorder, and skin changes) syndrome. (From Dispenzieri, A., How I treat POEMS syndrome. *Blood* 2012;119(24):5650-5658, with permission.)

Management of POEMS Syndrome with Disseminated Bone Marrow Involvement

Once there is disseminated bone marrow involvement, albeit even with a low plasma cell percentage, radiation is not expected to be curative. Typically, once there is disseminated disease identified, systemic therapy is recommended with the caveat that large bony lesions with a significant lytic component may require adjuvant radiation therapy.⁸⁴ Decisions about adjuvant radiation should be made on a case by case basis, and typically not until a minimum of 6 months after completing chemotherapy. It is important to remember that there is a lag between completion of successful therapy and neurologic response, often with no discernible improvement until 6 months after completion of therapy. Maximal response is not seen until 2 to 3 years hence. Other features like anasarca, papilledema, and even skin changes may improve sooner. Optimal FDG-PET response may also lag by 6 to 12 months.

Since there are no randomized clinical trials among patients with POEMS syndrome, treatment recommendations are based on case series and anecdote. The treatment armamentarium is borrowed from other plasma cell disorders, most notably MM and light chain amyloidosis. Table 101.2 summarizes regimens and observed outcomes. Corticosteroids may provide symptomatic improvement, but response duration is limited. The most experience has been with alkylator-based therapy, either low-dose or high-dose, with peripheral blood stem cell transplant. The first prospective clinical trial to treat POEMS syndrome was reported from China.⁸⁹ They treated 31 patients with 12 cycles of melphalan and dexamethasone and found that 81% of patients had hematologic response, 100% had VEGF response, and 100% had at least some improvement in neurologic status. A limitation of this study is that follow-up was only 21 months, so long-term outcomes are not yet available. Personal experience and retrospective reports of the use of cyclophosphamide-based therapy are also promising.⁸⁴

TABLE 101.2 ACTIVITY OF THERAPY FOR THE TREATMENT OF POEMS SYNDROME

Regimen	Outcome
Radiation ^{36, 85, 86, 87, 88}	≥50% of patients have significant clinical improvement
Mel-Dex ⁸⁹	81% hematologic response rate; 100% with some neurologic improvement
Corticosteroids ⁵⁶	≥15% of patients have significant clinical improvement
ASCT ⁵⁶	100% of surviving patients have significant clinical improvement
Thal after MP ⁹⁰	No hematologic response but improved ascites; stabilized PN, splenomegaly, pulmonary hypertension
Thal + Dex after CAD ⁹¹	CD/POEMS: improved ascites, effusions, pulmonary hypertension, PN, renal function, IL-6 level
Thal + Dex ⁹²	<i>Nine patients.</i> VEGF improved in all; PN improved in 66%; stable in 33%; improved edema; no HCR
Thal after VAD, CTX, Bev ²⁵	Improved cardiopulmonary status, but no improved PN and rising VEGF
Len + Dex ⁹³	Improved ascites, PS, PN, VEGF, testosterone, pulmonary function tests
Len + Dex ⁹⁴	<i>Nine patients.</i> All had hematologic response; clinical responses in all evaluable patients including PS, neurologic syndrome, edema, and VEGF
Len ± Dex ⁹⁵	<i>Ten patients.</i> All had prior therapy a median of 4 mo (range 1-36 mo) prior to starting len. For 7, only Pred and IVIG were used as prior therapy, making it improbable that the salutatory effect was related to anything other than len. After a median of 7.5 cycles of len, all had clinical improvement despite the fact that only half achieved CR. Five were consolidated with ASCT
Len + CTX + Dex ⁹⁶	After 4 cycles of therapy, patient was able to walk without support, and after 6 cycles, papilledema and IgA disappeared. 1 y after 9 cycles, she remains in remission
Bortez+AD after VAD, CTX, Mel-Pred, + AD ⁹⁷	Improved M-protein, VEGF, paresthesias, splenomegaly, effusions, muscle strength, gynecomastia, and skin changes
Bortez + Dex ⁹⁸	Improved M-protein, polyneuropathy, hepatomegaly, testosterone; no change in electromyography
Bortez × 5 cycles + Thali added at cycle 6 (prior Dex and Mel-Pred) ⁹⁹	Improvement of anasarca, PN, VEGF, and PET scan with Bortez alone, but thali added because of persistent edema, M-protein, PN, and barely elevated VEGF. With thali, disappearance of pleural effusion, ascites, and M-protein and normalization of VEGF
Bortez Dex ^{a100}	Improvement by 3 cycles, but continued for 6. Complete remission 4 y after completing therapy. Improvement in adenopathy, pleural effusion and ascites, hepatosplenomegaly, and IL-6

Bortez, CTX, Dex ¹⁰¹	Clinical response of anasarca within 6 wk and tolerated therapy for 18 mo achieving a near complete response and a VEGF response. PN, hyperpigmentation, pulmonary hypertension improved significantly
Bev alone ²¹	Death within 6 wk
Bev + mycophenolate + Dex ¹⁰²	One month after starting therapy, patient deteriorated further with worsening ascites and shortness of breath. Bev and Dex were discontinued. Mel and Pred were begun. Patient died 1 mo later
Bev alone ²²	Worsening PN, anasarca, multiorgan failure; died of pneumonia 5 wk after therapy
Bev alone ²³	Improved pain, breathing, and walking
Bev + Mel-Dex ²⁴	Improved effusions/ascites
Prior VAD/CTX ²⁵	Improved edema, pain, weakness, and VEGF
Bev + CTX-Dex ²⁶	Initial worsening; repeat with Bev → improved pulmonary HTN, anasarca, skin changes
Bev + CTX-CS ²⁷	Initial improvement, but multiorgan failure and death
Bev + CTX-radiation ¹⁰³	<i>Two patients.</i> First patient treated with radiation and CTX and then Bev. Clinical improvement started before Bev. At radiologic relapse, Bev no use, so lenalidomide plus Dex used with benefit. Second patient treated with same sequence, but course complicated by sepsis. Biochemical and early neurologic response before Bev started
Bev + CTX ²⁰	Clinical and biochemical relapse. No response to CTX, so bevacizumab added. Death

Bev, bevacizumab; Bortez, bortezomib; CS, corticosteroids; CTX, cyclophosphamide; Dex, dexamethasone; HCR, hematologic complete response; HTN, hypertension; Len, lenalidomide; Mel, melphalan; PN, polyneuropathy; POEMS, polyneuropathy, organomegaly, endocrinopathy, M-protein, skin changes; Pred, prednisone; PS, performance status; Thali, thalidomide; VAD, vincristine, doxorubicin, dexamethasone; VEGF, vascular endothelial growth factor.

^a Castleman's variant of POEMS syndrome.

High-dose chemotherapy with peripheral blood stem cell transplant can also be quite effective, but selection bias may confound these reports. Case series suggest 100% of patients achieve at least some neurologic improvement.^{18, 57, 67, 104, 105, 106, 107, 108, 109, 110, 111, 112, 113, 124, 125} Doses of melphalan ranging from 140 mg/m² to 200 mg/m² have been used, with the lower doses used for sicker patients. In addition, tandem transplant has been applied in one patient, but again, no information is available regarding any added value of the second transplant.¹²⁶ Anecdotally, responses are durable, but relapses have been reported.^{27, 127} Of the 59 patients with POEMS syndrome treated at the Mayo Clinic Rochester, progression-free survival was 98%, 94%, and 75% at 1, 2, and 5 years, respectively.¹²⁸ Symptomatic progressions were rare, whereas radiographic and VEGF progressions were most common. Treatment-related morbidity and mortality can be minimized by recognizing and treating an engraftment-type syndrome characterized by fevers, rash, diarrhea, weight gain, and respiratory symptoms and signs that occur anytime between days 7 and 15 post-stem cell infusion.¹¹³

Other promising treatments include lenalidomide, thalidomide, and bortezomib, all of which can have anti-VEGF and anti-TNF effects. Enthusiasm for the latter two therapies should be tempered by the high rate of peripheral neuropathy induced by these drugs. We have observed dramatic improvements in one patient

P.2146

treated with lenalidomide.⁹³ In France, nine patients, one of whom was newly diagnosed, were treated with lenalidomide and dexamethasone.⁹⁴ Serious side effects were noted in three patients, with two hematologic toxicities and a cutaneous allergy. All patients evaluable for hematologic response had at least a partial hematologic response. Clinical responses, including improvement in performance status and neurologic symptoms, were documented among the 8 who had sufficient follow-up. One patient relapsed 5 months after discontinuing therapy, but responded to reintroduction of the drug. Bortezomib use has been reported in three patients.^{97, 98, 101} The first report is difficult to interpret, since the patient had a number of chemotherapies prior to receiving a bortezomib, doxorubicin, and dexamethasone combination. There was early evidence of improvement even before starting the bortezomib regimen. The second and third reports are more convincing: in the first, 7 cycles of bortezomib and dexamethasone resulted in patient improvement; and in the second, 18 months of cyclophosphamide, bortezomib, and dexamethasone resulted in dramatic improvements in a patient with refractory paracentesisdependent ascites. Although an anti-VEGF strategy is appealing, the results with bevacizumab have been mixed.^{22, 23, 24, 25, 26, 27} Five patients who had also received either radiation or alkylator during and/or predating the bevacizumab had benefit,^{24, 25, 26, 103} including three who had improvement but were then consolidated with high-dose chemotherapy and autologous stem cell transplant.^{25, 103} Three patients receiving bevacizumab died.^{21, 22, 27}

Both our experience and the literature would support that single-agent IV IG or plasmapheresis is not helpful. Other treatments like interferon (IFN)- α , tamoxifen, transretinoic acid, ticlopidine, argatroban, and strontium-89 have been reported as having activity, mostly as single case reports.¹⁰

Managing Symptoms of Disease

Attention to supportive care is imperative. Orthotics, physical therapy, and CPAP all play an important role in patients' recovery. Ankle foot orthotics can increase mobility and reduce falls. Physical therapy reduces the risk of permanent contractures and leads to improved function both in the long and short term. For those with severe neuromuscular weakness, CPAP and/or BiPAP provides better oxygenation and potentially reduces the risk of complications associated with hypoventilation like pulmonary infection and pulmonary hypertension.

Monitoring Response

Patients must be followed carefully on a quarterly basis, tracking the status of deficits and comparing these to baseline.¹²⁸ VEGF responses may occur as soon as 3 months,¹²⁴ but they can be delayed. VEGF is an imperfect marker since discordances between disease activity and response have been reported,¹³⁷ so trends rather than absolute values should direct therapeutic decisions. Serum M-protein responses by protein electrophoresis, immunofixation electrophoresis, or serum immunoglobulin free light chains also pose a challenge. The size of the M-protein is typically small, making standard MM response criteria inapplicable in most cases. In addition, patients can derive very significant clinical benefit in the absence of an M-protein response.^{89, 113} Finally, despite the fact that the immunoglobulin free light chains are elevated in 90% of POEMS patients, the ratio is normal in all but 18%,⁶⁶ making the test of limited value for patients with POEMS syndrome.

Recommendations about how to approach organ response have recently been suggested for the purposes of clinical trials, since there are more than two dozen parameters that can be assessed in a given patient with POEMS syndrome, given the multisystem nature of the disease.^{128, 138} Alternatively, response criteria for POEMS syndrome could be abridged as follows: (1) hematologic response using modified amyloid response criteria; (2) VEGF response; and (3) a simplified organ response, which is limited to those systems causing the most morbidity, like peripheral neuropathy assessment, pulmonary function testing (diffusion capacity of carbon monoxide), and extravascular overload (grading ascites and pleural effusion as absent, mild, moderate, or severe).

CRYOGLOBULINEMIA

In 1933, Wintrobe and Buell¹³⁹ originally reported observing cryoglobulins in a serum sample from a patient with MM. These cold precipitable immunoglobulins were observed in some patients with vasculitis, viral infection, or lymphoproliferative disorders, and were found to be byproducts of lymphoid dysfunction—unchecked and misdirected stimulation and proliferation that cause dysfunction and pathologic changes. An understanding of cryoglobulins and the cells that produce them, along with their interaction with tissue matrix, systemic cytokines, and the remainder of the immune system, may provide insight into basic control pathways and the earliest steps of malignant transformation.

The term “cryoglobulin” was coined by Lerner and Watson¹⁴⁰ in 1947. Precipitation of cryoglobulins is dependent on temperature, pH, cryoglobulin concentration, and weak noncovalent factors.¹⁴¹ Meltzer and others delineated a distinct

syndrome of purpura, arthralgias, asthenia, renal disease, and neuropathy—often occurring with immune complex deposition or vasculitis, or both.^{129, 142} Brouet et al.¹²⁰ popularized a system of classifying cryoglobulinemia on the basis of the components of the cryoprecipitate: type I, isolated monoclonal immunoglobulins; type II, a monoclonal component, usually IgM, that binds to the Fc component of polyclonal IgG (i.e., has rheumatoid factor activity); and type III, polyclonal immunoglobulins of more than one isotype.¹²⁰ This classification provided a framework by which clinical correlations could be made. Associated conditions, such as lymphoproliferative disorders, connective tissue disorders, infection, and liver disease were observed in some patients^{121, 143} (Table 101.3). Since early studies failed to identify an associated underlying condition in 34% to 71% of cryoglobulinemia cases, the majority of patients were thought to have essential or primary cryoglobulinemia^{120, 121, 144}; however, with the discovery of hepatitis C virus (HCV) came the recognition that the majority of these cases were actually related to HCV.^{145, 146} (Fig. 101.3). Essential cryoglobulinemia now accounts for fewer than 10% of cases of cryoglobulinemia.¹³⁴

EPIDEMIOLOGY OF CRYOGLOBULINEMIA

It is difficult to determine the prevalence of cryoglobulinemia since the syndrome is clinically heterogenous and it may be difficult to distinguish incidental laboratory findings from the symptomatic disease state. Although only a minority of patients with serum cryoglobulins have symptoms referable to them, cryoglobulins may be found in patients with cirrhosis (up to 45%), alcoholic hepatitis (32%), autoimmune hepatitis (40%), subacute bacterial endocarditis (90%), rheumatoid arthritis (47%), Sjögren syndrome, IgG myeloma (10%), and Waldenström macroglobulinemia (19%).^{120, 121, 122, 123, 136, 143} The presence of cryoglobulins should alert the physician to the possibility of undiagnosed chronic infections such as subacute bacterial endocarditis, Lyme disease, and Q fever.¹⁴³ Case reports describe cryoglobulinemia associated with hepatitis A virus, hepatitis B virus, Hantavirus, cytomegalovirus, Epstein-Barr virus, human T-cell lymphotropic virus type I, hepatitis G virus, human immunodeficiency virus,

P.2147

P.2148

and parvovirus B19.^{116, 143, 147} The association with HCV was reported in 1990 and 1991,^{145, 146} and the majority (42% to 100%) of patients with mixed cryoglobulinemia were found to be infected with HCV.^{146, 148, 149, 150, 151, 152, 153, 154, 155}

TABLE 101.3 CRYOGLOBULINEMIA: CLINICAL AND EXPERIMENTAL ASSOCIATIONS

Infectious Diseases

Viral

Epstein-Barr virus

Cytomegalovirus

Hepatitis B virus

Hepatitis A virus

Adenovirus

Hepatitis C virus^{114, 115}

Human immunodeficiency virus^{116, 117, 118}

Bacterial

Subacute bacterial endocarditis (± nephritis)

Lepromatous leprosy (± erythema nodosum)

Acute poststreptococcal nephritis

Syphilis

Lyme disease (± erythema chronicum migrans)

After intestinal bypass with arthritis

Q fever¹¹⁹

Fungal

Coccidioidomycosis

Parasitic

Kala-azar

Toxoplasmosis

Tropical splenomegaly syndrome

Echinococcosis

Malaria

Schistosomiasis

Trypanosomiasis

Autoimmune Diseases

Systemic lupus erythematosus

Nephritis, hypocomplementemia

Drug-induced lupus (procainamide)

Rheumatoid arthritis

Extra-articular disease, Felty syndrome, synovial fluid

Polyarteritis nodosa (positive or negative for hepatitis B surface antigen)

Kawasaki syndrome (\pm macroglobulinemia)

Sjögren syndrome

Scleroderma

Sarcoidosis

Thyroiditis

Henoch-Schönlein purpura

Behçet syndrome

Polymyositis

Inflammatory bowel disease

Celiac disease, ulcerative colitis, regional enteritis

Endomyocardial fibrosis

Pulmonary fibrosis

Cutaneous vasculitis

Pemphigus vulgaris

Erythema elevatum diutinum

Cold-induced urticaria

Epidermolysis bullosa acquisita

Erythema multiforme

POEMS syndrome

Pyoderma gangrenosum

Lymphoproliferative Disorders

Macroglobulinemia (primary and secondary)^{120, 121, 122, 123}

Lymphoma (Hodgkin and non-Hodgkin)^{120, 121, 122, 123}

Chronic lymphocytic leukemia

Immunoblastic lymphadenopathy

Hairy cell leukemia

Renal Disease

Proliferative glomerulonephritis

Liver Diseases

Cirrhosis (Laënnec, postnecrotic)

Biliary cirrhosis

Chronic hepatitis

Familial (Symptomatic, Asymptomatic)

Essential

Experimental

Pneumococcal vaccines

Streptococcal (A and C) hyperimmunization

NZB/NZW, MRL/1, BXSB mice

POEMS, polyneuropathy, organomegaly, endocrinopathy, M-protein, skin changes.

From Dispenzieri A, Gorevic PD. Cryoglobulinemia. *Hematol Oncol Clin North Am* 1999;13(6):1315-1349. By permission of WB Saunders.

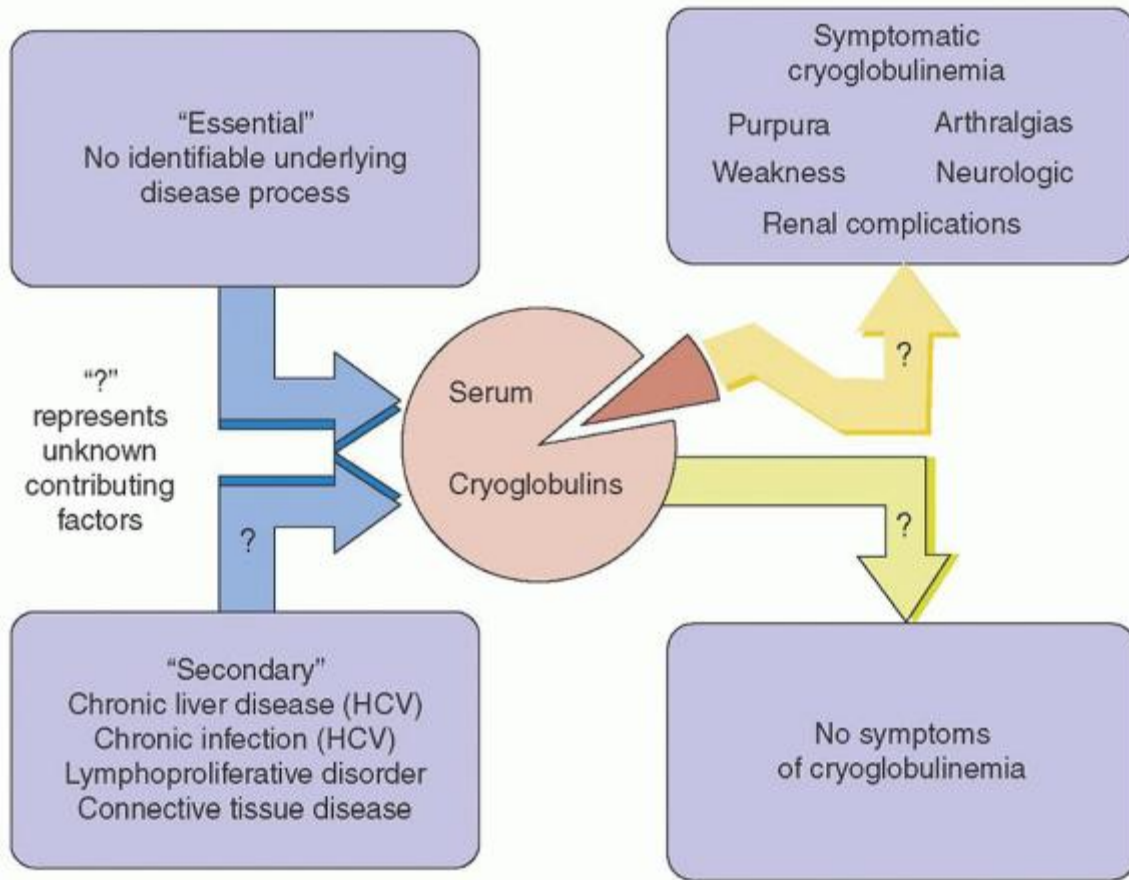

FIGURE 101.3. Relationship among underlying diseases, cryoglobulins, and symptoms of cryoglobulinemia. Question marks represent unknown contributing factors. HCV, hepatitis C virus. (Adapted from Dispenzieri A, Gertz MA. Cryoglobulinemia. In: Gertz MA, Greipp PA, eds. Handbook of Multiple Myeloma and Related Cell Disorders (Primary Amyloidosis, AL). Berlin: Springer-Verlag, 2004.)

Results of most studies show that the median age at diagnosis is the early to mid 50s.^{136, 156, 157} In some studies, the female predominance for cryoglobulinemia is greater than 2:1 (Table 101.4). No racial preference has been noted, but the incidence is higher

P.2149

in regions where HCV occurs at higher frequencies (for example, southern Europe).

TABLE 101.4 CLINICAL FEATURES OF CRYOGLOBULINEMIA AT DIAGNOSIS

		Patients, %												
		Cryo type												
Authors ^a	N	F:M	Essential cryo ^b	I	II	III	LPD	Liver ^c	Sicca	Skin	Raynaud	Renal	Arthralgia	Neuro
Meltzer et al. ¹²⁹	293:1		41	59	41 ^d	41 ^d	31	72 ^e	17 ^e	92 ^e	—	25 ^e	92 ^e	17 ^e
Brouet et al. ¹²⁰	86—		34	25	25	50	44	—	955	50	21	35		17
	401.7:1		100	0	32	68	—	70	15	100	25	55	72	12
Tarantino et	441:7		82	—	—	—	0 ^g	14	259	71	100	57		7

Authors ^a	N	F:M	Essential cryo ^b	I	II	III	LPD	Liver ^c	Sicca	Skin	Raynaud	Renal	Arthralgia	Neuro
al. ^{f130} Singer et al. ¹³¹	16	—	—	12	63	25	6	—	—	94	—	63	63	56
Monti et al. ¹³²	8912	:1	72	6	62	32	6	39	576	—	1920	—	—	21
Ferri et al. ¹³³	2313	:1	<8%	—	62	38	10	77	5398	—	4830	98	—	80
Trejo et al. ¹³⁴	206 ^h	—	—	—	—	—	10	—	—	51	1139	40	—	14
Rieu et al. ¹³⁵	491.7	:1	12	6 ⁱ	49	33	0	43	3582	—	3524	51	—	55
Bryce ¹³⁶	6645	:55	15	—	100	—	9	50	255	—	1226	21	—	18

Abd, abdominal; cryo, cryoglobulinemia; LPD, lymphoproliferative disorder; neuro, neurologic disease.

^a Publications are listed chronologically, from oldest to most recent.

^b Cryoglobulinemia without any identified predisposing condition. These values do not represent actual incidence but rather the make-up of the population analyzed for symptoms.

^c Patients with abnormal liver function tests or hepatomegaly, or both.

^d Value is for types II and III combined.

^e Symptoms of the essential mixed cryoglobulinemia (types II and III) population only.

^f Series restricted to patients with renal involvement.

^g Patients with multiple myeloma, Waldenström macroglobulinemia, and infection were excluded from this study by design.

^h Only patients with a cryocrit $\geq 1\%$ were included. The percentages were calculated on the basis of the 206 symptomatic patients described by the authors.

ⁱ In this study, 12% of the patients were not typed.

Modified from Dispenzieri A, Gorevic PD. Cryoglobulinemia. *Hematol Oncol Clin North Am* 1999;13(6):1315-1349. By permission of WB Saunders.

ETIOLOGY OF CRYOGLOBULINEMIA

Cryoglobulinemia is driven primarily by 4 classes of disease: liver disease (predominantly HCV), infection (again, predominantly HCV), connective tissue disease, and lymphoproliferative disorders. Type I and II cryoglobulins are associated with monoclonal expansion of B cells or plasma cells, while type III cryoglobulins result from polyclonal B cell expansion. Infection and/or inflammation ostensibly induce a nonspecific stimulation of B cells, frequently resulting in polyclonal hypergammaglobulinemia. When these various antibodies are produced, antibodies to autoantigens may also result. In animal models, a strong B cell stimulus disrupts the sequential order of idiotype-anti-idiotype interactions, resulting in both immunosuppression and idiotype-anti-idiotype immune complexes.¹⁵⁹ Furthermore, poorly regulated

production and clearance of IgM-rheumatoid factor contributes to immune complex formation.^{141, 121} Deposition of these antibody complexes in tissue leads to a variety of pathologic conditions, including vasculitis, nephritis, and vascular occlusion.

Complement components, fibronectin, and lipoproteins have been found along with antigen-antibody complexes within cryoprecipitates. Although hepatitis B virus, Epstein-Barr virus, and bacterial products may also be present, by far the most common pathogen within cryoprecipitates is HCV.¹⁶⁰ HCV-RNA, HCV-specific proteins, and anti-HCV antibodies are found in the supernatant of the cryoprecipitate and in the cryoprecipitate itself in 42% to 98% of patients with essential mixed cryoglobulinemia.^{149, 150, 151, 152, 153, 154, 155} Cryoprecipitates contain 20 to 1,000 times more HCV-RNA than is present in the supernatant.¹⁶¹ The IgG component to which the IgM-rheumatoid factor fraction binds is directed against the HCV proteins.¹⁶²

The biochemical basis for the temperature-dependent precipitation of these proteins is not completely understood. They may precipitate at temperatures substantially higher than the 4°C that is used to determine their presence in the laboratory. Precipitation also depends on temperature, pH, the ionic strength, and the structure (sequence) of the immunoglobulin components.

Relationships among Predisposing Conditions and Cryoglobulinemia

Hepatitis C Virus

The exact relationship between HCV and cryoglobulinemia is unknown, although the lymphotropism of HCV is well established. The virus can infect B lymphocytes through CD81 or the LDL receptor.^{163, 164} There is considerable evidence that (1) HCV can serve as a chronic immune stimulus, (2) cryoglobulins are present in up to 50% of HCV-infected patients,^{165, 166, 167, 168} (3) HCV is associated with autoimmune phenomena even in the absence of cryoglobulinemia, and (4) HCV may predispose patients to lymphoma.^{143, 169, 170, 171, 172} Predisposing factors for cryoglobulinemia in HCV patients are female gender, alcohol consumption, detectable serum HCV-RNA, longer duration of hepatitis, higher serum γ -globulin levels, higher rheumatoid factor levels, steatosis, and extensive liver fibrosis or cirrhosis.^{155, 165, 166, 173, 174, 175, 176}

P.2150

The major envelope protein of HCV (HCV-E2) binds with high affinity to CD81, a tetraspanin expressed on several cell types, including B and T lymphocytes.¹⁶³ CD81 expression on CD19⁺ B lymphocytes is significantly higher in patients with mixed cryoglobulinemia compared to those without mixed cryoglobulinemia, patients chronically infected with hepatitis B virus, and healthy controls.¹⁷⁷ Moreover, CD81 expression is higher on CD5 positive B cells relative to other circulating B cells.¹⁷⁸ Engagement of CD81 on human B cells by a combination of HCV-E2 and an anti-CD81 monoclonal antibody triggers the JNK pathway and leads to the preferential proliferation of the naive (CD27⁻) B cell subset.¹⁷⁹ The interaction between CD19/CD21 and CD81 provides a strong activation signal for B cells that drives the polyclonal proliferation of naive B lymphocytes and may be a key initiating factor for the development of the HCV-associated B lymphocyte disorders.¹⁷⁹ This interaction may explain the frequent finding of clonal B cells in patients with HCV in the absence of an overt malignancy.^{180, 181} These B cells have a biased usage of rheumatoid factor encoding V_H1-69 and V_K3-20 gene segments, similar to what is observed in patients with HCV-related lymphoma.¹⁸² Interestingly, these cells express low levels of CD21 and are associated with an anergic phenotype.¹⁸³ Eradication of HCV infection by IFN therapy leads to normalization of the activation markers' expression on B lymphocytes¹⁷⁹ as well as restoration of immune homeostasis, especially after therapy with rituximab.^{184, 185} The potential host-specific predisposing factors for the development of cryoglobulinemia are being deciphered. In a large series of patients with HCV-related cryoglobulinemic glomerulonephritis, HLA DRB1*11 was more frequent in patients with nephrotic syndrome, while HLA DRB1*7 appeared to be protective.¹⁵⁸

Connective Tissue Disease

The incidence of cryoglobulinemia, most commonly type II or III, in relation to specific connective tissue diseases is quite variable.¹²⁹ Among patients with systemic lupus erythematosus, 25% have detectable cryoglobulins,¹⁸⁶ and cryoglobulins have been detected in 12.5% of patients with systemic sclerosis.^{122, 187} Measurable amounts of cryoglobulins, usually polyclonal, can be found in up to 46% of patients with active rheumatoid arthritis.¹⁸⁸ Among patients with Sjögren syndrome, 16% to 37% have serum cryoglobulins^{122, 189, 190}; conversely, 5% to 15% of patients with mixed cryoglobulinemia have Sjögren syndrome.^{120, 121, 144} Patients with Sjögren syndrome and mixed cryoglobulins have a 7-fold risk of lymphoma developing (86% versus 12.5% in patients without cryoglobulins) and a worse survival.^{189, 191}

Lymphoproliferative Disorders

The relationship between cryoglobulinemia and lymphoproliferative disorders is complex; cause can be difficult to distinguish from effect. At a minimum, approximately 31% of all cases of secondary symptomatic cryoglobulinemia already have a diagnosis of lymphoproliferative disorder when cryoglobulinemia is diagnosed.¹⁴⁴ Higher percentages are found in series in which bone marrow biopsies, flow cytometry, Southern blot tests, and polymerase chain reaction are performed routinely.^{192, 193, 194, 195, 196} In another 6% to 28% of patients, symptomatic lymphoma develops at follow-up^{170, 195, 197, 198}; 50% of these are intermediate- or high-grade lymphoma.¹⁹⁸ The most common histologic diagnoses among the remaining low-grade lymphomas are immunocytoma,^{192, 199} followed by mucosa-associated lymphoid tissue (MALT) and centrocytic follicular lymphoma.²⁰⁰ Among patients whose conditions transform to overt lymphoma, the malignant clone is derived from one of the dominant baseline B cell clones in only a minority of patients,¹⁹⁴ implying a predisposition for clonal production and evolution.

Associations among Cryoglobulinemia, Hepatitis C Virus, Connective Tissue Disease, and Lymphoma

A recognized model for progression from chronic antigenic stimulation to benign or malignant lymphoproliferation is *Helicobacter pylori* and MALT lymphoma.²⁰¹ HCV, Sjögren syndrome, cryoglobulinemia, and immunocytoma may abide by this model. There is remarkable conservation of and homology among the antigen-combining sites (variable regions) of the IgM- κ rheumatoid factors in patients with HCV, HCV-associated lymphoma, and cryoglobulinemia.^{202, 203, 204, 205, 206, 207, 208} Similar degrees of homology are seen between the immunoglobulin receptors in the lymphoproliferation of patients with Sjögren syndrome and those in the lymphomas of HCV-infected patients with or without type II mixed cryoglobulinemia.²⁰⁹ This finding supports the concept that the combination of chronic antigenic stimulation, ineffectively regulated autoreactive B cells (which make restricted rheumatoid factor), and continued B cell proliferation may predispose B cells to subsequent oncogenic mutation and transformation to malignant lymphoma.

Among HCV-positive patients with mixed cryoglobulinemia, HCV-RNA is detected in peripheral blood mononuclear cells in up to 81% of patients²¹⁰ and in bone marrow cells in up to 100% of patients.^{195, 211, 212, 213, 214, 215} Clonal immunoglobulin gene rearrangements can be detected by reverse transcriptase polymerase chain reaction in all HCV-positive patients with type II mixed cryoglobulinemia and in 24% of HCV-infected patients without cryoglobulinemia.¹⁹⁶ These clones are usually, but not always, associated with the presence of type II cryoglobulins. In one series, HCV-infected patients with clonal B cell proliferation in both the blood and liver were older and had longer duration of HCV infection, higher serum cryoglobulin levels that were more frequently symptomatic, and liver disease that was more severe than that in patients without a clonal B cell population.¹⁸⁰

In a series of 1,255 patients in Italy with HCV and symptomatic mixed cryoglobulinemia, there was a 35-fold increase over the general population, with 224.1 new cases of aggressive non-Hodgkin lymphoma (NHL) subtypes per 100,000 patient-years.²¹⁶ The median time from the diagnosis of cryoglobulinemia to the clinical onset of NHL was 6.3 years (range, 0.81 to 24 years). The clinical course and response to chemotherapy in the patients with cryoglobulinemia and NHL were similar to those usually described for patients with NHL without cryoglobulinemia.

Productive t(14;18) translocations with resultant BCL-2 overexpression occur in about 12% to 38% of HCV-positive patients without symptomatic cryoglobulinemia and in 39% to 85% of their cryoglobulin-positive counterparts.^{217, 218, 219, 220} Patients with cryoglobulinemia in whom lymphoma develops have been found to have genomic sequences of HCV in their lymphoma specimens.^{200, 221, 222, 223} The NHL subgroup most commonly observed in patients with HCV is lymphoplasmacytoid lymphoma/immunocytoma.²²⁴ An increased rate of HCV infection (8% to 50%) has also been reported in idiopathic B cell NHL by many investigators.^{143, 169, 170, 171} Splenic lymphoma with villous lymphocytes has been associated with HCV and mixed cryoglobulinemia.¹⁷²

CLINICAL PRESENTATION OF CRYOGLOBULINEMIA

Involvement of the skin, peripheral nerves, kidneys, and liver is common (Table 101.4). Lymphadenopathy is present in approximately 17% of patients.^{129, 121} On autopsy, widespread vasculitis involving small and medium vessels in the heart, gastrointestinal tract, central nervous system, muscles, lungs, and adrenal glands may also be seen.^{121, 225} The interval between the onset of symptoms and the time of diagnosis varies considerably (range,

P.2151

0 to 10 years).¹²¹ Type I cryoglobulinemia is usually asymptomatic. When symptomatic, it most commonly causes occlusive symptoms rather than the vasculitis of types II and III.^{120, 121, 129} Symptoms of hyperviscosity may occur (Fig. 101.4). Type II cryoglobulinemia is more frequently symptomatic (61% of patients) than type III (21% of patients).²⁶⁶ The most common

causes of death include renal failure, infection, lymphoproliferative disorders, liver failure, cardiovascular complications, and hemorrhage.^{120, 121, 131, 135, 144} With improved therapy, the main cause of death appears to be cardiovascular disease.¹⁵⁸

In a series of 231 patients seen between 1972 and 2001, the mixed cryoglobulinemia syndrome followed a relatively benign clinical course in more than 50% of cases, whereas a moderate-severe clinical course was observed in one-third of patients whose prognosis was severely affected by renal or liver failure. For 15% of individuals the disease was complicated by malignancy: B cell NHL was more common than hepatocellular and thyroid malignancies. Ten year overall survival was 56%. Lower survival rates were seen in males and in individuals with renal involvement.¹³³

Dermatologic and Joint Manifestations of Cryoglobulinemia

Purpura is the most frequent symptom, being present in 55% to 100% of patients with mixed cryoglobulinemia^{120, 121, 131, 144} (Table 101.4 and Fig. 101.4). The incidence varies from 15% to 33% in type I, from 60% to 93% in type II, and from 70% to 83% in type III.²⁶⁷ Petechiae and palpable purpura are the most common lesions, although ecchymoses, erythematous spots, and dermal nodules occur in as many as 20% of patients. Bullous or vesicular lesions are distinctly uncommon.¹²⁰ Successive purpuric rashes, which may be preceded by a burning or itching sensation, occur most commonly on the lower extremities, gradually extending to the thighs and lower abdomen. Occasionally the arms are involved, but the face and trunk are generally spared.¹²⁰ Head and mucosal involvement, livedoid vasculitis, and cold-induced acrocyanosis of the helices of the ears are more frequently observed in type I; infarction, hemorrhagic crusts, or ulcers, occur in 10% to 25% of all patients with mixed cryoglobulinemia.²⁶⁸ Showers of purpura last for 1 to 2 weeks and occur once or twice a month. Cold precipitates these types of lesions in only 10% to 30% of the patients.^{120, 268} Raynaud phenomenon occurs in about 19% to 50% of patients^{120, 121, 131, 144}; in a quarter of these, the symptoms may be severe, including necrosis of fingertips.¹²⁰ Skin necrosis, urticaria, and livedo, which are all rare, are more commonly associated with exposure to cold.



FIGURE 101.4. Cryoglobulin-associated physical findings. A: Hyperviscosity manifested as retinopathy with venous engorgement and hemorrhage. B: Purpura. C: Gangrene.

Arthralgias are common, affecting 35% to 92% of patients, with the highest incidence in type III cryoglobulinemia (Table 101.4). The small distal joints are affected more frequently than the larger proximal joints. Symmetrical polyarthralgia is often exacerbated by the cold. Frank arthritis is rare.^{120, 121, 131, 134, 144}

Nervous System Manifestations of Cryoglobulinemia

Peripheral neuropathy is the more common presentation, although central nervous system involvement may occur. Peripheral nerve involvement is described in 12% to 56% of patients^{120, 121, 131, 134, 144} (Table 101.4). Signs and symptoms of sensory neuropathy usually precede those of motor neuropathy.^{120, 269} The presentation may be an acute or subacute distal symmetric polyneuropathy or a mononeuritis multiplex^{269, 270, 271} with a chronic or chronic-relapsing evolution.²⁷² The neuropathy is most often characterized by axonal degeneration. Epineurial vasculitis is a common finding on sural nerve biopsy.^{270, 271, 273, 274, 275} Even when other manifestations of mixed cryoglobulinemia are stable over time, there is typically worsening of the peripheral neuropathy.²⁷⁶

Central nervous system abnormalities are not uncommon in patients with mixed cryoglobulinemia. Casato et al. compared 40 patients with mixed cryoglobulinemia vasculitis and chronic active HCV infection with normal controls and HCV patients without mixed cryoglobulinemia. Twenty-four of the 27 (89%) patients with HCV-mixed cryoglobulinemia had a deficiency in one or more of 10 cognitive domains examined. The most commonly involved domains were those of attention (70%), executive functions (44%), visual construction (37%), and visual spatial functions (33%). Magnetic

P.2152

resonance imaging analysis showed that HCV-mixed cryoglobulinemia patients had a higher mean number of total and periventricular white matter high intensity signals than HCV controls and healthy controls, respectively.²⁷⁷ Cappellari et al. have also found central nervous system abnormalities in a majority of patients studied.²⁷⁸

Renal Manifestations of Cryoglobulinemia

Approximately 21% to 39% of patients with mixed cryoglobulinemia have renal involvement.^{120, 134, 279} The incidence of renal injury is highest in patients with type II cryoglobulins.^{144, 280} Although renal and extrarenal manifestations may occur concurrently, renal involvement usually follows the onset of purpura by approximately 4 years.^{121, 281} Proteinuria greater than 0.5 g/d and hematuria are the most common features of renal disease at diagnosis (present in 50% of patients)²⁸²; nephrotic syndrome affects approximately 20% of patients and acute nephritic syndrome affects approximately 25% of patients.^{281, 282} Although cryopathic membranoproliferative glomerulonephritis portends a poor prognosis,^{121, 122, 280, 282, 283} progression to end-stage renal failure due to sclerosing nephritis is uncommon.²⁸² Among patients with mixed cryoglobulinemia-associated membranoproliferative glomerulonephritis followed up for a median of 11 years, 15% had disease progression to end-stage renal failure, and 43% died of cardiovascular, hepatic, or infectious causes.²⁸²

Liver Manifestations of Cryoglobulinemia

Approximately 39% of patients with symptomatic cryoglobulinemia¹⁴⁴ and as many as 77% with mixed cryoglobulinemia^{121, 284} have documented liver abnormalities at the time of diagnosis (Table 101.4). Furthermore, hepatomegaly is present in up to 70% of patients, and splenomegaly is present in up to 52% of patients.^{121, 130, 142} Among patients with symptomatic cryoglobulinemia, liver failure is the cause of death in 2.5% to 7.6% of patients^{121, 132, 282} and in 5.6% to 29% of all reported deaths.^{121, 132, 282}

Histologic findings include portal fibrosis, chronic persistent hepatitis, chronic active hepatitis, chronic active hepatitis with cirrhosis, and postnecrotic cirrhosis.^{158, 284} Most specimens are characterized by a diffuse lymphocytic infiltrate ranging from minimal periportal to extensive infiltration with nodule formation. These changes correlate with the severity of other pathologic findings. Plasma cell infiltration has also been noted in several specimens.^{266, 284} The lymphoid population in the liver may show the histologic and immunophenotypic findings of lymphoplasmacytoid lymphoma/immunocytoma, and frequently the lymphoid elements arrange in pseudo-follicular structures in the liver with morphologic features similar to those previously reported in chronic HCV without cryoglobulinemia.¹⁹⁸ These liver lymphoid nodules contain B cells predominantly with a CD5⁺/Bcl-2⁺/Ki67⁻ phenotype—that is, low apoptotic and proliferative rates.²⁸⁵

Other Manifestations of Cryoglobulinemia

Given the propensity of immune complexes to deposit in blood vessels and activate complement, in principle, cryoglobulinemic vasculitis can affect any vascular distribution including the mesenteric vessels,^{134, 286} leading to intestinal ischemia, cholecystitis, and pancreatitis. Pulmonary vascular involvement in severe cases may lead to acute alveolar hemorrhage and diffuse pulmonary infiltrates.^{287, 288} Rarely, coronary vasculitis may lead to myocardial infarction.

DIAGNOSIS OF CRYOGLOBULINEMIA

By definition, all patients with cryoglobulinemia have serum cryoglobulins. The collection and processing of the specimens are critical because these cold-induced reversible precipitates can be lost with improper handling.^{143, 289} A minimum of 10

ml of blood is required, and the specimen must be allowed to clot at 37°C for 30 to 60 minutes before centrifugation. The serum supernatant is stored at 4°C for up to 7 days and inspected daily for cryoprecipitate. Methods to evaluate the composition of the cryoglobulin include immunoelectrophoresis, immunofixation, immunoblotting, and capillary electrophoresis.

Concentrations of cryoglobulins tend to vary by type: type III, less than 1 mg/ml; type II, 1 mg/ml or greater; and type I, greater than 5 mg/ml.^{120, 290} The type or quantity does not reliably predict the presence or nature of symptoms. On serum protein electrophoresis, polyclonal hypergammaglobulinemia is the most common finding, although normal patterns or hypogammaglobulinemia may also be seen.^{121, 129, 136} Even among patients with type II cryoglobulinemia, only 15% have a visible monoclonal spike on serum protein electrophoresis. Frequently, serum¹²¹ IgM levels are elevated; cryoprecipitable IgM may comprise up to one-third of the total serum IgM concentration.¹²¹ Hyperviscosity occurs only occasionally.¹⁴² Marked depression of complement CH50, C1q, and C4 in the presence of relatively normal C3 levels is usual.^{121, 134, 291} Neither C4 concentrations nor cryoglobulin levels correlate with overall clinical severity, although for individual patients the cryoglobulin level can sometimes serve as a marker for disease activity.^{121, 242, 291, 292} Rheumatoid factor activity—that is, anti-Fc activity—is detectable in the sera in 87% to 100% of patients with mixed cryoglobulinemia,^{120, 129, 132} and levels may decrease with response to therapy.²⁹³ An elevated erythrocyte sedimentation rate and a mild normochromic, normocytic anemia are fairly common.^{121, 242} Cytopenias have been described, as have pseudoleukocytosis and pseudothrombocytosis.¹⁴² Among patients with cryoglobulinemia, the antinuclear antibody results may be positive in as many as two-thirds of the patients²⁹⁴ and in as many as one-third of the HCV-positive patients.¹³⁴ Because HCV is frequently concentrated in cryoglobulins,¹⁴⁹ serial measurements of plasma or serum HCV-RNA levels in these patients are not reliable.¹⁷⁵

TREATMENT OF CRYOGLOBULINEMIA

Since cryoglobulinemia has a fluctuating course with spontaneous exacerbation and remission, it is essential that controlled clinical trials are used to evaluate the response to therapy. Unfortunately, such studies are rare in the field of cryoglobulinemia. Although there are several “accepted” or “standard” treatments that have no randomized trials to support their practice, there are several reported strategies (Table 101.5) that have questionable, if any, benefit.¹⁴³ Although therapies such as use of histamine (H) H1 and H2 blockers and penicillamine have sound scientific basis for consideration, they have shown no clear clinical benefit.^{121, 143} Figure 101.5 outlines a strategy for managing symptomatic cryoglobulinemia.

The standard treatment of mild symptomatic cryoglobulinemia (purpura, asthenia, arthralgia, and mild sensory neuropathy) has included bed rest, analgesics, low-dose corticosteroid therapy, low-antigen content diet, and protective measures against cold; the treatment of severe disease (glomerulonephritis, motor neuropathy, and systemic vasculitis) has included plasmapheresis, high-dose corticosteroid therapy, and cytotoxic therapy. With the recognition of the association between HCV and mixed cryoglobulinemia, immunosuppressive therapy has been viewed less favorably, and IFN with or without ribavirin has generally been considered to be first-line therapy for HCV-positive patients who are in nonemergent situations.^{226, 227, 228, 230, 295} For patients with symptomatic type I cryoglobulinemia, anti-CD20 therapy or cytotoxic therapy appropriate for the lymphoproliferative disorder remains the therapy of choice. Similarly, treatment of an underlying connective tissue disease or infection would be first-line

P.2153

therapy in the appropriate situation. The importance of not overtreating patients must be emphasized.

TABLE 101.5 TREATMENT STRATEGIES FOR SYMPTOMATIC CRYOGLOBULINEMIA

Reference	Treatment	Effective?
226, 227, 228, 229, 230, 231, 232	Interferon/PEG-Interferon	Yes
233	Ribavirin	Probably
234, 235, 236, 237, 238, 239, 240	Rituximab	Yes
241	Low-antigen diet	Probably (mild disease)
242, 243, 244, 245, 246, 247, 248	Plasmapheresis, plasma exchange	Probably
121, 122, 130, 142, 249, 250	Low-dose corticosteroids	Probably

251, 252	High-dose corticosteroids	Probably
243	Chlorambucil	Probably
248, 253, 254, 255	Cyclophosphamide	Probably
249	Melphalan	Probably
256, 257	Thalidomide	Probably
258	anti-TNF- α antibody	Probably not
121	Azathioprine	Possibly
198, 259	Cyclosporin	Possibly
260	Colchicine	Probably not
261, 262	Immunoglobulin IV	Variable ^a
263, 264	Cladribine and fludarabine	Variable
142, 253	Splenectomy	Variable
142	Chloroquine	Probably not
121	H ₁ and H ₂ blockers	Probably not
121	Penicillamine	Probably not

PEG, pegylated; IV, intravenously; TNF, tumor necrosis factor; V, variable.

^a One case report of precipitating acute renal failure²⁶¹ and another of systemic vasculitis²⁶⁵.

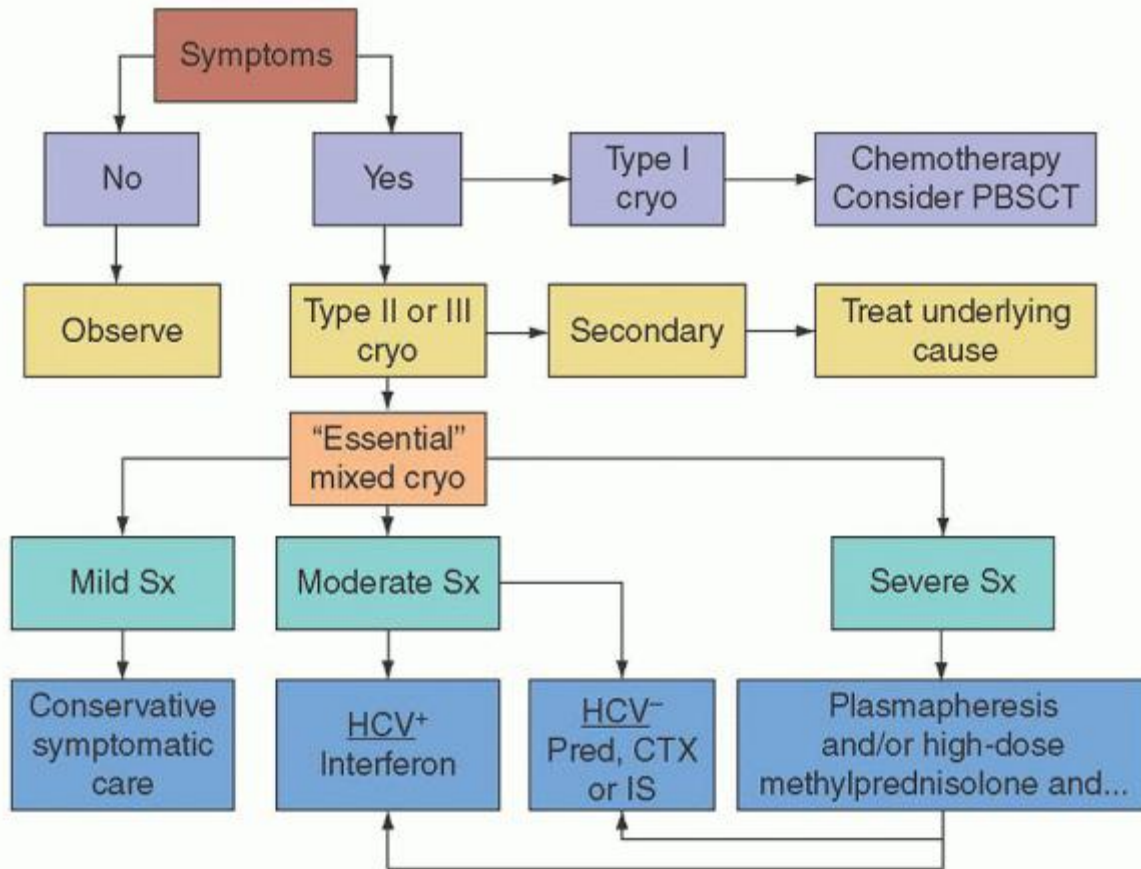

FIGURE 101.5. Possible treatment schema for cryoglobulinemia. If interferon therapy fails, combination therapy with

interferon- α and ribavirin may help; however, contraindications for ribavirin should be considered. Cryo, cryoglobulin; CTX, cyclophosphamide; HCV, hepatitis C virus; IS, immunosuppressant; PBSCT, peripheral blood stem cell transplantation; pred, low-dose therapy with prednisone; Sx, symptoms.

Treatment of Life-threatening Disease

For emergent situations (acute nephritis or severe vasculitis), initial measures are aimed at reducing the inflammatory activity of renal lesions (corticosteroids), removing circulating cryoglobulins (plasmapheresis) and reducing the formation of new antibodies (e.g., cyclophosphamide).^{281, 296} Plasma exchange or plasmapheresis alone can reverse serious complications, but these procedures are typically used in combination with cytotoxic agents or corticosteroids for more durable responses.^{292, 243, 244, 245} According to case reports, responses may be seen in 60% to 100% of patients.^{292, 243, 244, 245} Skin manifestations and arthralgias usually respond the most quickly, whereas the degree of neural and renal responses depends on the acuity of their occurrence, with poorer responses occurring in chronic cases.²⁴⁴ With combination immunosuppressive therapy and plasma exchange, reversal of catastrophic complications such as encephalopathy and acute glomerulonephritis has been documented.^{244, 292, 297} High-dose pulse therapy with methylprednisolone is also a favored therapeutic intervention for acute events, with 90% response rates in rapidly progressive glomerulonephritis.^{251, 281} Once the acute exacerbation has been mitigated, antiviral strategies are implemented in HCV-positive patients to consolidate and maintain response. One should be cognizant of reports of peripheral neuropathy (personal observation and²⁹⁸), nephritis,²⁹⁹ vasculitis,³⁰⁰ and ischemic manifestations being exacerbated by IFN- α .³⁰¹

Antiviral Therapy

Five randomized trials evaluating the efficacy of IFN therapy in HCV-positive patients with symptomatic type II mixed cryoglobulinemia conducted in the 1990s documented clinical responses in 60% to 89% of the patients.^{226, 227, 228, 229, 230} However, when compared with HCV-related chronic hepatitis, treatment of mixed cryoglobulinemia with IFN monotherapy was associated with a relatively poorer response and a high relapse rate, especially in severe cases. A majority of patients relapsed within 6 months of discontinuation.^{227, 228, 229, 230, 295, 302} Lack of response after 3 to 4 months predicted for monotherapy failure.²⁹⁵ Factors associated with a poorer response to therapy or rapid relapse include liver cirrhosis, advanced age,²³⁰ male sex,²⁹⁵ and high levels of

P.2154

HCV-RNA at the onset of therapy.²²⁸ Purpuric lesions and liver function abnormalities are the features that tend to respond rapidly (within weeks), but neuropathy and nephropathy respond more slowly.^{295, 298}

The frequent relapse of both HCV replication and mixed cryoglobulinemia syndrome at the end of IFN treatment suggested the combination with ribavirin: this therapeutic option appeared valid in several studies.^{303, 304, 305, 306} Even ribavirin monotherapy has been shown to decrease transaminase levels and mixed cryoglobulinemia-related symptoms. IFN- α and ribavirin is now the preferred strategy for patients with symptomatic HCV-associated cryoglobulinemia.^{303, 305, 307} More than 60% of patients with symptomatic mixed cryoglobulinemia who do not respond to IFN therapy alone respond to combined therapy, and 80% of patients who relapse with IFN- α therapy alone respond to combined therapy.³⁰³

Ribavirin plus weekly pegylated IFN- α is at least as effective as the combination using standard three times weekly IFN- α .^{231, 232} Saadoun et al. compared the outcomes of 72 consecutive patients who received treatment with IFN- α (n = 32 patients) or pegylated IFN- α (n = 40 patients), both in combination with oral ribavirin, for at least 6 months. Compared with patients treated with IFN- α plus ribavirin, those receiving pegylated IFN- α plus ribavirin had higher sustained clinical (67.5% versus 56.3%), virologic (62.5% versus 53.1%), and immunologic (57.5% versus 31.3%) responses, regardless of HCV genotype and viral load. In multivariate analyses, an early virologic response was independently associated with a complete clinical response of mixed cryoglobulinemia. A glomerular filtration rate less than or equal to 70 ml/minute was negatively associated with a complete clinical response of mixed cryoglobulinemia.²³²

Rituximab Therapy

Anti-CD20 therapy with rituximab has been shown to produce responses in patients with all types of cryoglobulinemia^{235, 236, 237, 238}; however, those patients with HCV are at risk for increased HCV replication.^{235, 236} Initial studies reported responses in the majority of patients, including improvements in skin vasculitis manifestations (ulcers, purpura, or urticaria), subjective symptoms of peripheral neuropathy, low-grade B cell lymphoma, arthralgias, fever, nephritis, levels of rheumatoid factor, cryoglobulins, and C4.^{308, 309} In a randomized trial, 59 patients with cryoglobulinemia vasculitis were randomized to either rituximab or conventional therapy, which included glucocorticoids, azathioprine, cyclophosphamide,

or plasmapheresis. Time to treatment failure at 1 year was superior in the rituximab group (64% versus 3%). The vasculitis activity also improved significantly on rituximab, whereas it did not for the other treatment arm. The median duration of response to rituximab was 18 months.³¹⁰

The combination of pegylated IFN- α , ribavirin, and rituximab (the so-called PIRR regimen) has been tested in two trials.^{185, 311} Both studies reported similar results: the triple combination leads to a faster response with respect to symptoms, organ (renal) response, cryoglobulin clearance, and elimination of HCV viremia. The response was generally more durable, with a median duration of response in excess of 3 years.¹⁸⁵ The two trials used a similar regimen for the IFN- α and ribavirin but differed in the use of rituximab. While Saadoun et al. started therapy with rituximab alone (weekly for 4 doses),³¹¹ Dammacco et al. started the triple combination simultaneously and subsequently give additional single doses of rituximab at 6 and 11 months after the initiation of therapy.¹⁸⁵ The addition of Rituxan to the combination of antiviral agents did not lead to an increase in the HCV burden as measured by quantitative PCR, and therapy was associated with a significant reduction or elimination of clonal B cells from the circulation.

Other Therapies for Cryoglobulinemia

Although not formally studied, high-dose therapy with autologous stem cell transplantation may be considered for patients with symptomatic, refractory cryoglobulinemia that results from a plasma cell proliferative disorder. There is an increased risk of lethal veno-occlusive disease in patients with chronic hepatitis C who are undergoing stem cell transplantation.³¹²

Dramatic reductions in the cryocrit and the cryoglobulinemic symptoms, including membranoproliferative glomerulonephritis, have been reported in several patients who underwent splenectomy for hypersplenism.^{253, 313} In contrast, in the series reported by Meltzer and Franklin, the one patient who underwent splenectomy died of acute renal failure.¹⁴² Because this intervention has not been studied thoroughly, and because of the high risk involved, it should not be considered as standard therapy, but rather as a potential option for patients without cirrhosis who have disease that is difficult to manage because of cytopenias resulting from hypersplenism.

HEAVY-CHAIN DISEASE

The HCDs are a rare group of disorders with diverse clinical presentations. The 3 conditions (α -, γ -, and μ -HCD) are discussed together because they are lymphoproliferative or plasma cell proliferative disorders that share the generation and secretion of an isolated heavy-chain fragment (Table 101.6). α -HCD (Mediterranean lymphoma or immunoproliferative small intestinal disease [IPSID]) is the most common and has the most uniform presentation; γ - and μ -HCD have variable clinical presentations and histopathologic features. In the majority of cases, the heavy-chain fragment is not secreted in large quantities and immunofixation or immunoelectrophoresis is required to detect the abnormality. Screening the serum and urine of patients with lymphoplasmacytoid NHL would most likely identify more patients with α -, γ -, or μ -HCD. Cases of α -, γ -, and μ -heavy-chain monoclonal gammopathy of unknown significance have been reported.^{314, 315, 316}

α -Heavy-chain Disease

Mediterranean lymphoma, originally described in the 1960s as a condition in young adults, is a primary small intestinal lymphoma coupled with intestinal malabsorption.³¹⁷ An isolated IgA immunoglobulin heavy-chain fragment was recognized in association with this condition. Because some patients had benign-appearing lymphocytes in their small bowel, the term " α -HCD" was preferred over "Mediterranean lymphoma" by some authors.³¹⁸ A consensus panel in 1976 concluded that α -HCD and Mediterranean lymphoma represented a spectrum of disease with benign, intermediate, and overtly malignant stages, and the term "immunoproliferative small intestinal disease" came into use.³¹⁹ This entity has been recently reviewed.³²⁰

The majority of reported patients with α -HCD are from northern Africa, Israel, and surrounding Middle Eastern or Mediterranean countries, with fewer patients from central and southern Africa, eastern Asia, and South and Central America.³²¹ Patients present with malabsorption syndrome, weight loss, and abdominal pain. On physical examination, peripheral edema, clubbing, and an abdominal mass are not uncommon findings.^{319, 320, 321, 322} On endoscopy of the small intestine, one may find thickened mucosal folds, nodules, ulcers, a mosaic pattern, or submucosal infiltration. Intestinal parasites and bacterial overgrowth in the small intestine are common. Anemia, vitamin deficiencies, and hypogammaglobulinemia are also common. The IgA level is generally not increased, but on immunofixation or immunoelectrophoresis, a monoclonal component is present, especially in the earlier phases of the disease. An immunoglobulin

light chain is not found. The monoclonal IgA fragment may be found in jejunal secretions as well as in blood and urine.³²² The monoclonal protein in patients with α -HCD is of the α 1 subclass and consists of multiple polymers. The length of the basic polypeptide subunit is typically between one-half and three-fourths that of a normal α -heavy-chain; the shortening results from an internal deletion involving most of the VH and the CH1 domain.³²³ In about one-half the cases, the electrophoretic pattern of α -HCD protein contains a broad band extending from the α 2 region to the β -globulin region because of the tendency of these chains to polymerize. The remainder of the patients may have a normal serum protein electrophoresis pattern.

TABLE 101.6 FEATURES OF HEAVY-CHAIN DISEASES

	Type of Heavy-Chain Disease		
Feature	α	γ	μ
Monoclonal protein	IgA	IgG	IgM
Year described	1968 ¹⁶⁶	1964 ¹⁶⁷	1970 ^{168, 169}
Incidence	Rare	Very rare	Very rare
Median age	Young adults	61 y	57 y
Associated diseases	Bacterial overgrowth; malabsorption	Autoimmune diseases	-
Site	Small intestine; mesenteric lymph nodes	Lymph nodes, bone marrow, and spleen	Liver, spleen, lymph nodes, and bone marrow
Pathologic features	Extranodal marginal zone lymphoma (MALT or IPSID)	Lymphoplasmacytoid lymphoma	Small lymphocytic lymphoma/chronic lymphocytic leukemia
Therapy	Antibiotics; chemotherapy	Chemotherapy	Chemotherapy

IPSID, immunoproliferative small intestinal disease; MALT, mucosa-associated lymphoid tissue.

Histologic features of IPSID range from early lymphoplasmacytic intestinal infiltration to overt malignant diffuse large B cell lymphoma. This entity shares morphologic features of MALT in that there are lymphoepithelial lesions, centrocyte-like cells, and plasma cell differentiation.³²⁴ The histologic findings are classified into stages A, B, and C. Stage A includes a diffuse, dense, compact, and apparently benign lymphoplasmacytic infiltration of the mucosal lamina propria. Stage B has features of stage A but also has circumscribed "immunoblastic" lymphoma in either the intestinal or mesenteric lymph nodes. Stage C comprises a diffuse "immunoblastic" lymphoma with or without demonstrable lymphoplasmacytic infiltration.³¹⁹ Villous broadening or effacement and shortened sparse crypts are also observed. These histopathologic findings can be distinguished from those of celiac sprue because celiac sprue includes total villous atrophy, hyperplastic and elongated crypts, intraepithelial lymphocytosis, and surface epithelial flattening. The lymphoma that arises from celiac sprue is T-cell lymphoma³²⁵ rather than B cell lymphoma, as in the case of α -HCD. A study of 11 cases of IPSID demonstrated higher expressions of syndecan-1 in Stage A samples relative to Stage B; conversely, Stage B samples showed higher expression of BCL-6 and p53.³²⁶ IPSID lacks the t(11;18) translocation that is not uncommon in other MALT lymphomas. Other cytogenetic abnormalities have been seen including t(9;14), t(2;14), and t(5;9).³²⁰

The hypothesis that chronic antigenic stimulation by intestinal organisms is the cause of this disorder is credible and can be modeled after the MALT lymphoma paradigm. This hypothesis is further supported by the fact that the incidence of α -HCD (or IPSID) is most common in patients who live in areas with poor sanitation and who also have a high prevalence of intestinal microbial infestation. *H. pylori* had been a candidate organism,³²⁷ but its association was subsequently challenged.³²⁴ *C. jejuni* is now considered to be a possible offending organism,³²⁸ but this will need to be confirmed.

Although no data exist from randomized prospective studies, the standard accepted treatment for the early stage is broadspectrum antibiotics, with or without corticosteroids. This protocol has resulted in clinical or histologic remission (in 33% to 71% of cases), which is generally short-lived but occasionally durable.^{320, 321} In the absence of a documented

parasite or an intestinal bacterial overgrowth, therapy with tetracycline or metronidazole and ampicillin is appropriate.³²⁹
³³⁰ Any documented parasite should be eradicated. Treatment of *H. pylori* has led to complete remission in two patients with α -HCD,³³¹ one of whom was unresponsive to prior combination chemotherapy. Lecuit et al. demonstrated response of IPSID after clearance of *C. jejuni*.³²⁸ Response to antibiotics usually occurs promptly; however, a minimum 6-month trial of tetracycline (1 to 2 g/d) is recommended for establishing responsiveness of the lesion.³³² In patients with more advanced stages, or unresponsive early stages, total abdominal radiation or combination chemotherapy, or both, have been used (remission rate, 64%).^{320, 333, 334, 335, 336, 337, 338} Overall 5-year survival rates are 60% to 70%. Immunotherapy with rituximab, an anti-CD20 monoclonal antibody, has been a major advance in the treatment of indolent NHL,³³⁹ but to date there have been no reports of rituximab use in patients with α -HCD.

μ -Heavy-chain Disease

First described in 1970, μ -HCD is a rare condition.^{340, 341} The median age of patients with μ HCD is about 57 years and equal numbers of males and females are affected.^{314, 342, 343} Common clinical presentations include splenomegaly and hepatomegaly. Lymphadenopathy is less common. About one-third of patients have chronic lymphocytic leukemia. Some patients with μ -HCD have features resembling those of lymphoma or MM with amyloid arthropathy.³⁴⁴ Hypogammaglobulinemia is present in about one-half of the patients and a free monoclonal IgM fragment is found in the serum of all patients. The μ -heavy-chain is missing most, if not all, of its VH region.³⁴⁵ A free monoclonal light chain has been described in the urine in about one-half of the cases.^{314, 346} Lytic bone lesions or osteoporosis occurs in a minority of patients. Bone marrow plasma cells tend to be vacuolated. Survival ranges from less than 1 month to 11 years (median, 24 months).³¹⁴ There is no standard treatment for this disorder, but it is generally treated as a low-grade lymphoproliferative disease with observation alone

P.2156

for asymptomatic patients and low-intensity chemotherapy for symptomatic patients.

γ -Heavy-chain Disease

First described in 1964 by Franklin et al.,³⁴⁷ γ HCD has a diverse clinical phenotype. The median age of patients with γ -HCD is 61 years, with 54% of the patients being male.^{343, 348} Originally, γ HCD was considered to be merely a lymphoma-like illness; Kyle et al.³⁴³ challenged this concept. Since the original description, there have been approximately 100 cases reported in the literature.³¹⁵ Although most patients present with weakness, fatigue, fever, lymphadenopathy (62%), hepatomegaly (58%), splenomegaly (59%), and lymphoma, other features, such as autoimmune hemolytic anemia and idiopathic thrombocytopenic purpura, may also be seen.^{315, 343} Cutaneous and subcutaneous involvement is not uncommon.³⁴⁹ Several cases have arisen in patients with long-standing connective tissue disorders such as rheumatoid arthritis,^{315, 350, 351, 352} lupus,^{315, 353} keratoconjunctivitis sicca,^{354, 355} vasculitis,³⁵⁵ and myasthenia gravis.³¹⁵ A normochromic anemia is a presenting feature in about 79% of patients. About 10% have either a Coombs-positive or Coombs-negative autoimmune hemolytic anemia.^{314, 315, 355} Lymphopenia and lymphocytosis each occur in less than 10% of patients. Thrombocytopenia may be present in as many as 22% of patients.³¹⁵

The γ chain in this disorder is truncated with deletions at the CH1 domain.^{356, 357} The mobility pattern of the immunoglobulin fragment on protein electrophoresis is quite variable, with the band present anywhere from the α 1-globulin region to the slow γ -globulin region; most commonly, however, it runs in the β region.³¹⁵ The subclass is IgG1 in 76%, IgG2 in 19%, and IgG4 in 5% of cases. With the normal distribution of subclasses, one would expect a higher occurrence of IgG2 and a lower occurrence of IgG3 and IgG1. Proteinuria can range from none to 20 g/d.

Bone marrow most commonly demonstrates an increase of plasma cells, lymphocytes, or plasmacytoid lymphocytes; occasionally eosinophilia is seen. The lymphoproliferative disorders range from benign lymphoplasmacytoid proliferative disorder to plasmacytoma, to chronic lymphocytic leukemia, to angioimmunoblastic lymphoma, to diffuse large cell lymphoma.^{315, 358} Lytic bone disease occurs rarely. Amyloid deposits may be present.³⁴³

The median survival is 7.4 years, with a range of 1 month to more than 25 years.³¹⁵ Treatment is not standardized. Single-agent therapy with prednisone and combination chemotherapy with cyclophosphamide, vincristine, and prednisone have been used with benefit. Wahner-Roedler et al. reported a rituximab response in one patient.³¹⁵ Patients with aggressive lymphomas should receive a regimen containing anthracycline.

REFERENCES

1. Bardwick PA, Zvaifler NJ, Gill GN, Newman D, Greenway GD, Resnick DL. Plasma cell dyscrasia with polyneuropathy, organomegaly, endocrinopathy, M protein, and skin changes: the POEMS syndrome. Report on two cases and a review of the literature. *Medicine* 1980;59(4):311-322.
2. Takatsuki K, Sanada I. Plasma cell dyscrasia with polyneuropathy and endocrine disorder: clinical and laboratory features of 109 reported cases. *Jpn J Clin Oncol* 1983;13(3):543-555.
3. Nakanishi T, Sobue I, Toyokura Y, et al. The Crow-Fukase syndrome: a study of 102 cases in Japan. *Neurology* 1984;34(6):712-720.
4. Singh D, Wadhwa J, Kumar L, Raina V, Agarwal A, Kochupillai V. POEMS syndrome: experience with fourteen cases. *Leuk Lymphoma* 2003;44(10): 1749-1752.
5. Soubrier MJ, Dubost JJ, Sauvezie BJ. POEMS syndrome: a study of 25 cases and a review of the literature. French study group on POEMS Syndrome. *Am J Med* 1994;97(6):543-553.
6. Zhang B, Song X, Liang B, et al. The clinical study of POEMS syndrome in China. *Neuro Endocrinol Lett* 2010;31(2):229-237.
7. Li J, Zhou DB, Huang Z, et al. Clinical characteristics and long-term outcome of patients with POEMS syndrome in China. *Ann Hematol* 2011;90(7): 819-826.
8. Kulkarni GB, Mahadevan A, Taly AB, et al. Clinicopathological profile of polyneuropathy, organomegaly, endocrinopathy, M protein and skin changes (POEMS) syndrome. *J Clin Neurosci* 2011;18(3):356-360.
9. Nasu S, Misawa S, Sekiguchi Y, et al. Different neurological and physiological profiles in POEMS syndrome and chronic inflammatory demyelinating polyneuropathy. *J Neurol Neurosurg Psychiatry* 2012;83(5):476-479.
10. Dispenzieri A. POEMS syndrome. *Blood Rev* 2007;21(6):285-299.
11. Watanabe O, Arimura K, Kitajima I, Osame M, Maruyama I. Greatly raised vascular endothelial growth factor (VEGF) in POEMS syndrome [letter]. *Lancet* 1996;347(9002):702.
12. Soubrier M, Guillon R, Dubost JJ, et al. Arterial obliteration in POEMS syndrome: possible role of vascular endothelial growth factor. *J Rheumatol* 1998;25(4):813-815.
13. Watanabe O, Maruyama I, Arimura K, et al. Overproduction of vascular endothelial growth factor/vascular permeability factor is causative in Crow-Fukase (POEMS) syndrome. *Muscle Nerve* 1998;21(11):1390-1397.
14. Nishi J, Arimura K, Utsunomiya A, et al. Expression of vascular endothelial growth factor in sera and lymph nodes of the plasma cell type of Castleman's disease. *Br J Haematol* 1999;104(3):482-485.
15. Soubrier M, Sauron C, Souweine B, et al. Growth factors and proinflammatory cytokines in the renal involvement of POEMS syndrome. *Am J Kidney Dis* 1999;34(4):633-638.
16. Niimi H, Arimura K, Jonosono M, et al. VEGF is causative for pulmonary hypertension in a patient with Crow-Fukase (POEMS) syndrome. *Intern Med* 2000;39(12):1101-1104.
17. Scarlato M, Previtali SC, Carpo M, et al. Polyneuropathy in POEMS syndrome: role of angiogenic factors in the pathogenesis. *Brain* 2005;128(Pt 8): 1911-1920.
18. Kuwabara S, Misawa S, Kanai K, et al. Autologous peripheral blood stem cell transplantation for POEMS syndrome. *Neurology* 2006;66(1):105-107.
19. Mineta M, Hatori M, Sano H, et al. Recurrent Crow-Fukase syndrome associated with increased serum levels of vascular endothelial growth factor: a case report and review of the literature. *Tohoku J Exp Med* 2006;210(3):269-277.
20. D'Souza A, Hayman SR, Buadi F, et al. The utility of plasma vascular endothelial growth factor levels in the diagnosis and follow-up of patients with POEMS syndrome. *Blood* 2011;118(17):4663-4665.
21. Kanai K, Kuwabara S, Misawa S, Hattori T. Failure of treatment with anti-VEGF monoclonal antibody for long-standing POEMS syndrome. *Intern Med* 2007;46(6):311-313.
22. Straume O, Bergheim J, Ernst P. Bevacizumab therapy for POEMS syndrome. *Blood* 2006;107(12):4972-4973, 4973-4974.
23. Dietrich PY, Duchosal MA. Bevacizumab therapy before autologous stem-cell transplantation for POEMS syndrome. *Ann Oncol* 2008;19(3):595.

24. Badros A, Porter N, Zimrin A. Bevacizumab therapy for POEMS syndrome. *Blood* 2005;106(3):1135.
25. Ohwada C, Nakaseko C, Sakai S, et al. Successful combination treatment with bevacizumab, thalidomide and autologous PBSC for severe POEMS syndrome. *Bone Marrow Transplant* 2009;43(9):739-740.
26. Badros A. Bevacizumab therapy for POEMS syndrome. *Blood* 2006;107(12): 4973-4974.
27. Samaras P, Bauer S, Stenner-Liewen F, et al. Treatment of POEMS syndrome with bevacizumab. *Haematologica* 2007;92(10):1438-1439.
28. Soubrier M, Dubost JJ, Serre AF, et al. Growth factors in POEMS syndrome: evidence for a marked increase in circulating vascular endothelial growth factor. *Arthritis Rheum* 1997;40(4):786-787.
29. Endo I, Mitsui T, Nishino M, Oshima Y, Matsumoto T. Diurnal fluctuation of edema synchronized with plasma VEGF concentration in a patient with POEMS syndrome. *Intern Med* 2002;41(12):1196-1198.
30. Nakano A, Mitsui T, Endo I, Takeda Y, Ozaki S, Matsumoto T. Solitary plasmacytoma with VEGF overproduction: report of a patient with polyneuropathy. *Neurology* 2001;56(6):818-819.
31. Koga H, Tokunaga Y, Hisamoto T, et al. Ratio of serum vascular endothelial growth factor to platelet count correlates with disease activity in a patient with POEMS syndrome. *Eur J Intern Med* 2002;13(1):70-74.
32. Soubrier M, Labauge P, Jouanel P, Viallard JL, Piette JC, Sauvezie B. Restricted use of V λ genes in POEMS syndrome. *Haematologica* 2004;89(4):ECR02.
33. Nakaseko C, Abe D, Takeuchi M, et al. Restricted oligo-clonal usage of monoclonal immunoglobulin λ light chain germline in POEMS syndrome. *ASH Ann Meeting Abstr* 2007;110(11):2483.
34. Aravamudan B, Tong C, Lacy MQ, et al. Immunoglobulin variable light chain restriction, cytokine expression and plasma cell-stromal cell interactions in POEMS syndrome patients. *ASH Ann Meeting Abstr* 2008;112(11):2744.
35. Bryce AH, Ketterling RP, Gertz MA, et al. (2008). A novel report of *cig-FISH* and cytogenetics in POEMS syndrome. *Am J Hematol* 2008;83(11): 840-84.
36. Dispenzieri A, Kyle RA, Lacy MQ, et al. POEMS syndrome: definitions and long-term outcome. *Blood* 2003;101(7):2496-2506.
37. Ghandi GY, Basu R, Dispenzieri A, Basu A, Montori V, Brennan MD. Endocrinopathy in POEMS Syndrome: the Mayo Clinic experience. *Mayo Clin Proc* 2007;82(7):836-842.
38. Alberti MA, Martinez-Yelamos S, Fernandez A, et al. 18F-FDG PET/CT in the evaluation of POEMS syndrome. *Eur J Radiol* 2010;76(2):180-182.
39. Nobile-Orazio E, Terenghi F, Giannotta C, Gallia F, Nozza A. Serum VEGF levels in POEMS syndrome and in immune-mediated neuropathies. *Neurology* 2009;72(11):1024-1026.
40. Briani C, Fabrizi GM, Ruggiero S, et al. Vascular endothelial growth factor helps differentiate neuropathies in rare plasma cell dyscrasias. *Muscle Nerve* 2010;43(2):164-167.
41. Dao LN, Hanson CA, Dispenzieri A, Morice WG, Kurtin PJ, Hoyer JD. Bone marrow histopathology in POEMS syndrome: a distinctive combination of plasma cell, lymphoid and myeloid findings in 87 patients. *Blood* 2011;117(24):6438-6444.
42. Dispenzieri A. Castleman disease. *Cancer Treat Res* 2008;142:293-330.
43. Kelly JJ Jr, Kyle RA, Miles JM, Dyck PJ. Osteosclerotic myeloma and peripheral neuropathy. *Neurology* 1983;33(2):202-210.
44. Koike H, Iijima M, Mori K, et al. Neuropathic pain correlates with myelinated fibre loss and cytokine profile in POEMS syndrome. *J Neurol Neurosurg Psychiatry* 2008;79(10):1171-1179.
45. Kelly JJ Jr. The electrodiagnostic findings in peripheral neuropathy associated with monoclonal gammopathy. *Muscle Nerve* 1983;6(7):504-509.
46. Sung JY, Kuwabara S, Ogawara K, Kanai K, Hattori T. Patterns of nerve conduction abnormalities in POEMS syndrome. *Muscle Nerve* 2002;26(2): 189-193.
47. Min JH, Hong YH, Lee KW. Electrophysiological features of patients with POEMS syndrome. *Clin Neurophysiol* 2005;116(4):965-968.

48. Mauermann ML, Sorenson EJ, Dispenziera A, et al. Uniform demyelination and more severe axonal loss distinguish POEMS syndrome from CIDP. *J Neurol Neurosurg Psychiatry* 2012;83(5):480-486.
49. Vital C, Vital A, Ferrer X, et al. Crow-Fukase (POEMS) syndrome: a study of peripheral nerve biopsy in five new cases. *J Peripher Nerv Syst* 2003;8(3): 136-144.
50. Orefice G, Morra VB, De Michele G, et al. POEMS syndrome: clinical, pathological and immunological study of a case. *Neurol Res.* 1994;16(6):477-480.
51. Crisci C, Barbieri F, Parente D, Pappone N, Caruso G. POEMS syndrome: follow-up study of a case. *Clin Neurol Neurosurg* 1992;94(1):65-68.
52. Bergouignan FX, Massonnat R, Vital C, et al. Uncompacted lamellae in three patients with POEMS syndrome. *Eur Neurol* 1987;27(3):173-181.
53. Mauermann LM, Sorenson JE, Dispenziera A, et al. Uniform demyelination and more severe axonal loss distinguish POEMS syndrome from CIDP. *J Neurol Neurosurg Psychiatry* 2012;83:480-486.
54. Santoro L, Manganelli F, Bruno R, Nolano M, Provitera V, Barbieri F. Sural nerve and epidermal vascular abnormalities in a case of POEMS syndrome. *Eur J Neurol* 2006;13(1):99-102.
55. Mathis S, Magy L, Kabore R, Faugeras F, Richard L, Vallat MJ. POEMS syndrome with prominent acute axonal lesions. *J Neurol Science* 2012;313:185-188.
56. Dispenziera A. POEMS syndrome: 2011 update on diagnosis, risk-stratification, and management. *Am J Hematol* 2011;86(7):591-601.
57. Barete S, Mouawad R, Choquet S, et al. Skin manifestations and vascular endothelial growth factor levels in POEMS syndrome: impact of autologous hematopoietic stem cell transplantation. *Arch Dermatol* 2010;146(6): 615-623.
58. Bachmeyer C. Acquired facial atrophy: a neglected clinical sign of POEMS syndrome. *Am J Hematol* 2012;87(1):131.
59. Lee FY, Chiu HC. POEMS syndrome with calciphylaxis: a case report. *Acta Derm Venereol* 2011;91(1):96-97.
60. De Roma I, Filotico R, Cea M, Procaccio P, Perosa F. Calciphylaxis in a patient with POEMS syndrome without renal failure and/or hyperparathyroidism. A case report. *Ann Ital Med Int* 2004;19(4):283-287.
61. Ishikawa O, Nihei Y, Ishikawa H. The skin changes of POEMS syndrome. *Br J Dermatol* 1987;117(4):523-526.
62. Jitsukawa K, Hayashi Y, Sato S, Anzai T. Cutaneous angioma in Crow-Fukase syndrome: the nature of globules within the endothelial cells. *J Dermatol* 1988;15(6):513-522.
63. Rongioletti F, Gambini C, Lerza R. Glomeruloid hemangioma. A cutaneous marker of POEMS syndrome. *Am J Dermatopathol* 1994;16(2):175-178.
64. Chan JKC, Fletcher CDM, Hicklin AG. Glomeruloid hemangioma: A distinctive cutaneous lesion of multicentric Castleman's disease associated with POEMS syndrome. *Am J Surg Pathol* 1990;14(11):1036-1046.
65. Kaushik M, Pulido JS, Abreu R, Amselem L, Dispenziera A. Ocular findings in patients with polyneuropathy, organomegaly, endocrinopathy, monoclonal gammopathy, and skin changes syndrome. *Ophthalmology* 2011;118(4): 778-782.
66. Stankowski-Drengler T, Gertz MA, Katzmann JA, et al. Serum immunoglobulin free light chain measurements and heavy chain isotype usage provide insight into disease biology in patients with POEMS syndrome. *Am J Hematol* 2010;85(6):431-434.
67. Sanada S, Ookawara S, Karube H, et al. Marked recovery of severe renal lesions in POEMS syndrome with high-dose melphalan therapy supported by autologous blood stem cell transplantation. *Am J Kidney Dis* 2006;47(4): 672-679.
68. Navis GJ, Dullaart RP, Vellenga E, Elema JD, de Jong PE. Renal disease in POEMS syndrome: report on a case and review of the literature. [Review] [25 refs]. *Nephrol Dial Transplant* 1994;9(10):1477-1481.
69. Viard JP, Lesavre P, Boitard C, et al. POEMS syndrome presenting as systemic sclerosis. Clinical and pathologic study of a case with microangiopathic glomerular lesions. *Am J Med* 1988;84(3 Pt 1):524-528.
70. Sano M, Terasaki T, Koyama A, Narita M, Tojo S. Glomerular lesions associated with the Crow-Fukase syndrome. *Virchows Archiv A, Pathol Anat Histopathol* 1986;409(1):3-9.

71. Takazoe K, Shimada T, Kawamura T, et al. Possible mechanism of progressive renal failure in Crow-Fukase syndrome [letter]. *Clin Nephrol* 1997;47(1): 66-67.
72. Mizuiri S, Mitsuo K, Sakai K, et al. Renal involvement in POEMS syndrome. *Nephron* 1991;59(1):153-156.
73. Stewart PM, McIntyre MA, Edwards CR. The endocrinopathy of POEMS syndrome. *Scott Med J* 1989;34(5):520-522.
74. Nakamoto Y, Imai H, Yasuda T, Wakui H, Miura AB. A spectrum of clinicopathological features of nephropathy associated with POEMS syndrome. *Nephrol Dial Transplant* 1999;14(10):2370-2378.
75. Fukatsu A, Ito Y, Yuzawa Y, et al. A case of POEMS syndrome showing elevated serum interleukin 6 and abnormal expression of interleukin 6 in the kidney. *Nephron* 1992;62(1):47-51.
76. Tanaka O, Ohsawa T. The POEMS syndrome: report of three cases with radiographic abnormalities. *Radiologe* 1984;24(10):472-474.
77. Chong ST, Beasley HS, Daffner RH. POEMS syndrome: radiographic appearance with MRI correlation. *Skeletal Radiol* 2006;35(9):690-695.
78. Hashiguchi T, Arimura K, Matsumuro K, et al. Highly concentrated vascular endothelial growth factor in platelets in Crow-Fukase syndrome. *Muscle Nerve* 2000;23(7):1051-1056.
79. Tokashiki T, Hashiguchi T, Arimura K, Eiraku N, Maruyama I, Osame M. Predictive value of serial platelet count and VEGF determination for the management of DIC in the Crow-Fukase (POEMS) syndrome. *Intern Med* 2003;42(12):1240-1243.
80. Allam JS, Kennedy CC, Aksamit TR, Dispenzieri A. Pulmonary manifestations in patients with POEMS syndrome: a retrospective review of 137 patients. *Chest* 2008;133(4):969-974.
81. Lesprit P, Godeau B, Authier FJ, et al. Pulmonary hypertension in POEMS syndrome: a new feature mediated by cytokines. *Am J Respir Crit Care Med* 1998;157(3 Pt 1):907-911.
82. Lesprit P, Authier FJ, Gherardi R, et al. Acute arterial obliteration: a new feature of the POEMS syndrome? *Medicine* 1996;75(4):226-232.
83. Dupont SA, Dispenzieri A, Mauermann ML, Rabinstein AA, Brown RD Jr. Cerebral infarction in POEMS syndrome: incidence, risk factors, and imaging characteristics. *Neurology* 2009;73(16):1308-1312.
84. Dispenzieri A. How I treat POEMS syndrome. *Blood* 2012;119(24):5650-5658.
85. Morley JB, Schwieger AC. The relation between chronic polyneuropathy and osteosclerotic myeloma. *J Neurol Neurosurg Psychiatry* 1967;30(5): 432-442.
86. Davis L, Drachman D. Myeloma Neuropathy. *Arch Neurol* 1972;27:507-511.
87. Iwashita H, Ohnishi A, Asada M, Kanazawa Y, Kuroiwa Y. Polyneuropathy, skin hyperpigmentation, edema, and hypertrichosis in localized osteosclerotic myeloma. *Neurology* 1977;27(7):675-681.
88. Reitan JB, Pape E, Fossa SD, Julsrud OJ, Slettnes ON, Solheim OP. Osteosclerotic myeloma with polyneuropathy. *Acta Medica Scand* 1980;208(1-2):137-144.
89. Li J, Zhang W, Jiao L, et al. Combination of melphalan and dexamethasone for patients with newly diagnosed POEMS syndrome. *Blood* 2011;117(24): 6445-6449.
90. Sinisalo M, Hietaharju A, Sauranen J, Wirta O. Thalidomide in POEMS syndrome: case report. *Am J Hematol* 2004;76(1):66-68.
91. Kim SY, Lee SA, Ryoo HM, Lee KH, Hyun MS, Bae SH. Thalidomide for POEMS syndrome. *Ann Hematol* 2006;85(8):545-546.
92. Kuwabara S, Misawa S, Kanai K, et al. Thalidomide reduces serum VEGF levels and improves peripheral neuropathy in POEMS syndrome. *J Neurol Neurosurg Psychiatry* 2008;79(11):1255-1257.
93. Dispenzieri A, Klein CJ, Mauermann ML. Lenalidomide therapy in a patient with POEMS syndrome. *Blood* 2007;110(3):1075-1076.
94. Jaccard A, Abraham J, Recher C, et al. Lenalidomide therapy in nine patients with POEMS syndrome. *ASH Ann Meeting Abstr.* 2009;114(22):3872-.

95. Tomas JF, Giraldo P, Lecumberri R, Nistal S. POEMS syndrome with severe neurological damage clinically recovered with lenalidomide. *Haematologica* 2012;97(2):320-322.
96. Suyani E, Yagci M, Sucak GT. Complete remission with a combination of lenalidomide, cyclophosphamide and prednisolone in a patient with incomplete POEMS syndrome. *Acta haematologica* 2011;126(4):199-201.
97. Tang X, Shi X, Sun A, et al. Successful bortezomib-based treatment in POEMS syndrome. *Eur J Haematol* 2009;83(6):609-610.
98. Kaygusuz I, Tezcan H, Cetiner M, Kocakaya O, Uzay A, Bayik M. Bortezomib: a new therapeutic option for POEMS syndrome. *Eur J Haematol* 2010;84(2): 175-177.
99. Ohguchi H, Ohba R, Onishi Y, et al. Successful treatment with bortezomib and thalidomide for POEMS syndrome. *Ann Hematol* 2011;90(9):1113-1114.
100. Sobas MA, Alonso Vence N, Diaz Arias J, Bendana Lopez A, Fraga Rodriguez M, Bello Lopez JL. Efficacy of bortezomib in refractory form of multicentric Castlemans disease associated to POEMS syndrome (MCD-POEMS variant). *Ann Hematol* 2010;89(2):217-219.
101. Warsame R, Kohut IE, Dispenzieri A. Successful use of cyclophosphamide, bortezomib, and dexamethasone to treat a case of relapsed POEMS. *Eur J Haematol* 2012;88(6):549-550.
102. Chong DY, Comer GM, Trobe JD. Optic disc edema, cystoid macular edema, and elevated vascular endothelial growth factor in a patient with POEMS syndrome. *J Neuroophthalmol* 2007;27(3):180-183.
103. Buxhofer-Ausch V, Gisslinger B, Stangl G, Rauschka H, Gisslinger H. Successful treatment sequence incorporating bevacizumab for therapy of polyneuropathy in two patients with POEMS syndrome. *Leuk Res* 2012;36:e98-e100.
104. Giglia F, Chiapparini L, Fariselli L, et al. POEMS syndrome: relapse after successful autologous peripheral blood stem cell transplantation. *Neuromuscul Disord* 2007;17(11-12):980-982.
105. Ganti AK, Pipinos I, Culcea E, Armitage JO, Tarantolo S. Successful hematopoietic stem-cell transplantation in multicentric Castlemans disease complicated by POEMS syndrome. *Am J Hematol* 2005;79(3):206-210.
106. Dispenzieri A, Moreno-Aspitia A, Suarez GA, et al. Peripheral blood stem cell transplantation in 16 patients with POEMS syndrome, and a review of the literature. *Blood* 2004;104(10):3400-3407.
107. Schliamser LM, Hardan I, Sharif D, Zukerman E, Avshovich N, Attias D. Significant improvement of POEMS syndrome with pulmonary hypertension following autologous peripheral blood stem cell transplant. *Blood* 2003;102(11 (2 of 2)):5664.
108. Soubrier M, Ruivard M, Dubost JJ, Sauvezie B, Philippe P. Successful use of autologous bone marrow transplantation in treating a patient with POEMS syndrome. *Bone Marrow Transplant* 2002;30(1):61-62.
109. Peggs KS, Paneesha S, Kottaridis PD, et al. Peripheral blood stem cell transplantation for POEMS syndrome. *Bone Marrow Transplant* 2002;30(6): 401-404.
110. Jaccard A, Royer B, Bordessoule D, Brouet JC, Feraud JP. High-dose therapy and autologous blood stem cell transplantation in POEMS syndrome. *Blood* 2002;99(8):3057-3059.
111. Rovira M, Carreras E, Blade J, et al. Dramatic improvement of POEMS syndrome following autologous hematopoietic cell transplantation. *Br J Haematol* 2001;115(2):373-375.
112. Hogan WJ, Lacy MQ, Wiseman GA, Fealey RD, Dispenzieri A, Gertz MA. Successful treatment of POEMS syndrome with autologous hematopoietic progenitor cell transplantation. *Bone Marrow Transplant* 2001;28(3): 305-309.
113. Dispenzieri A, Lacy MQ, Hayman SR, et al. Peripheral blood stem cell transplant for POEMS syndrome is associated with high rates of engraftment syndrome. *Eur J Haematol* 2008;80(5):397-406.
114. Ferri C, Greco F, Longombardo G, et al. Antibodies against hepatitis C virus in mixed cryoglobulinemia patients. *Infection* 1991;19(6):417-420.
115. Pasquali JL, Waltzinger C, Kuntz JL, Knapp AM, Levallois H. The majority of peripheral blood monoclonal IgM secreting cells are CD5 negative in three patients with mixed cryoglobulinemia. *Blood* 1991;77(8):1761-1765.
116. Dimitrakopoulos A, Kordossis T, Hatzakis A, Moutsopoulos H. Mixed cryoglobulinemia in HIV-1 infection: the role of HIV-1. *Ann Intern Med* 1999;130: 226-230.

117. Antinori S, Galimberti L, Rusconi S, Zehender G, Esposito R, Galli M. Disappearance of cryoglobulins and remission of symptoms in a patient with HCV-associated type II mixed cryoglobulinemia after HIV-1 infection. *Clin Exp Rheumatol* 1995;13(13):S157-S159.
118. Morales E, Alegre R, Herrero JC, Morales JM, Ortuno T, Praga M. Hepatitis-C-virus-associated cryoglobulinaemic membranoproliferative glomerulonephritis in patients infected by HIV. *Nephrol Dial Transplant* 1997;12(9): 1980-1984.
119. Torley H, Capell H, Timbury M, McCartney C. Chronic Q fever with mixed cryoglobulinaemia. *Ann Rheum Dis* 1989;48(3):254-255.
- P.2157
120. Brouet J, Clauvel J, Danon F, Klein M, Seligmann M. Biological and clinical significance of cryoglobulins. A report of 86 cases. *Am J Med* 1974;57:775-788.
121. Gorevic PD, Kassab HJ, Levo Y, et al. Mixed cryoglobulinemia: clinical aspects and long-term follow-up of 40 patients. *Am J Med* 1980;69(2):287-308.
122. Invernizzi F, Galli M, Serino G, et al. Secondary and essential cryoglobulinemias. Frequency, nosological classification, and long-term follow-up. *Acta Haematologica* 1983;70(2):73-82.
123. Osserman E. Plasma cell myeloma. *N Eng J Med* 1959;261:952-960.
124. Kuwabara S, Misawa S, Kanai K, et al. Neurologic improvement after peripheral blood stem cell transplantation in POEMS syndrome. *Neurology* 2008;71(21):1691-1695.
125. Laurenti L, De Matteis S, Sabatelli M, et al. Early diagnosis followed by front-line autologous peripheral blood stem cell transplantation for patients affected by POEMS syndrome. *Leuk Res* 2008;32(8):1309-1312.
126. Kojima H, Katsuoka Y, Katsura Y, et al. Successful treatment of a patient with POEMS syndrome by tandem high-dose chemotherapy with autologous CD34+ purged stem cell rescue. *Int J Hematol* 2006;84(2):182-185.
127. Imai N, Taguchi J, Yagi N, Konishi T, Serizawa M, Kobari M. Relapse of polyneuropathy, organomegaly, endocrinopathy, M-protein, and skin changes (POEMS) syndrome without increased level of vascular endothelial growth factor following successful autologous peripheral blood stem cell transplantation. *Neuromuscul Disord* 2009;19(5):363-365.
128. D'Souza A, Lacy M, Gertz M, et al. Long term outcomes after autologous stem cell transplantation for patients with POEMS syndrome (osteosclerotic myeloma): a single center experience. *Blood* 2012.
129. Meltzer M, Franklin EC, Elias K, McCluskey RT, Cooper N. Cryoglobulinemia—a clinical and laboratory study. II. Cryoglobulins with rheumatoid factor activity. *Am J Med* 1966;40(6):837-856.
130. Tarantino A, De Vecchi A, Montagnino G, et al. Renal disease in essential mixed cryoglobulinaemia. Long-term follow-up of 44 patients. *Q J Med* 1981;50:1.
131. Singer DR, Venning MC, Lockwood CM, Pusey CD. Cryoglobulinaemia: clinical features and response to treatment. *Ann de Med Interne* 1986;137(3): 251-253.
132. Monti G, Saccardo F, Pioltelli P, Rinaldi G. The natural history of cryoglobulinemia: symptoms at onset and during follow-up. A report by the Italian Group for the Study of Cryoglobulinemias (GISC). *Clin Exp Rheumatol* 1995;13(13):S129-S133.
133. Ferri C, Sebastiani M, Giuggioli D, et al. Mixed cryoglobulinemia: demographic, clinical, and serologic features and survival in 231 patients. *Semin Arthritis Rheum* 2004;33(6):355-374.
134. Trejo O, Ramos-Casals M, Garcia-Carrasco M, et al. Cryoglobulinemia: study of etiologic factors and clinical and immunologic features in 443 patients from a single center. *Medicine (Baltimore)* 2001;80(4):252-262.
135. Rieu V, Cohen P, Andre MH, et al. Characteristics and outcome of 49 patients with symptomatic cryoglobulinaemia. *Rheumatology (Oxford)* 2002;41(3):290-300.
136. Bryce AH, Kyle RA, Dispenzieri A, Gertz MA. Natural history and therapy of 66 patients with mixed cryoglobulinemia. *Am J Hematol* 2006;81(7):511-518.

137. Goto H, Nishio M, Kumano K, Fujimoto K, Yamaguchi K, Koike T. Discrepancy between disease activity and levels of vascular endothelial growth factor in a patient with POEMS syndrome successfully treated with autologous stem-cell transplantation. *Bone Marrow Transplant* 2008;42(9):627-629.
138. Dispenzieri A. Ushering in a new era for POEMS. *Blood* 2011;117(24): 6405-6406.
139. Wintrobe M, Buell M. Hyperproteinemia associated with multiple myeloma. *Bull Johns Hopkins Hosp* 1933;52:156-165.
140. Lerner A, Watson C. Studies of cryoglobulins. Unusual purpura associated with the presence of a high concentration of cryoglobulin (cold precipitable serum globulin). *Am J M Sc* 1947;214:410-415.
141. Grey HM, Kohler PF. Cryoimmunoglobulins. *Semin Hematol* 1973;10(2): 87-112.
142. Meltzer M, Franklin EC. Cryoglobulinemia—a study of twenty-nine patients. I. IgG and IgM cryoglobulins and factors affecting cryoprecipitability. *Am J Med* 1966;40:828-856.
143. Dispenzieri A, Gorevic PD. Cryoglobulinemia. *Hematol Oncol Clin North Am* 1999;13(6):1315-1349.
144. Monti G, Galli M, Invernizzi F, et al. Cryoglobulinaemias: a multi-centre study of the early clinical and laboratory manifestations of primary and secondary disease. GISC. Italian Group for the Study of Cryoglobulinaemias. *Qjm* 1995;88(2):115-126.
145. Pascual M, Perrin L, Giostra E, Schifferli JA. Hepatitis C virus in patients with cryoglobulinemia type II. *J Infect Dis* 1990;162(2):569-567.
146. Ferri C, Greco F, Longombardo G, et al. Antibodies to hepatitis C virus in patients with mixed cryoglobulinemia. *Arthritis Rheum* 1991;34(12): 1606-1610.
147. Ramos-Casals M, Stone JH, Cid MC, Bosch X. The cryoglobulinaemias. *Lancet* 2012;379(9813):348-360.
148. Disdier P, Harle JR, Weiller PJ. Cryoglobulinaemia and hepatitis C infection. *Lancet* 1991;338(8775):1151-1152.
149. Agnello V, Chung R, Kaplan L. A role for hepatitis C virus infection in type II cryoglobulinemia. *N Engl J Med* 1992;327(21):1490-1495.
150. Misiani R, Bellavita P, Fenili D, et al. Hepatitis C virus infection in patients with essential mixed cryoglobulinemia. *Ann Intern Med* 1992;117(7):573-577.
151. Pechere-Bertschi A, Perrin L, de Saussure P, Widmann JJ, Giostra E, Schifferli JA. Hepatitis C: a possible etiology for cryoglobulinaemia type II. *Clin Exp Immunol* 1992;89(3):419-422.
152. Bichard P, Ounanian A, Girard M, et al. High prevalence of hepatitis C virus RNA in the supernatant and the cryoprecipitate of patients with essential and secondary type II mixed cryoglobulinemia. *J Hepatol* 1994;21(1):58-63.
153. Cacoub P, Fabiani FL, Musset L, et al. Mixed cryoglobulinemia and hepatitis C virus. *Am J Med* 1994;96(2):124-132.
154. Munoz-Fernandez S, Barbado FJ, Martin Mola E, et al. Evidence of hepatitis C virus antibodies in the cryoprecipitate of patients with mixed cryoglobulinemia. *J Rheumatol* 1994;21(2):229-233.
155. Tanaka K, Aiyama T, Imai J, Morishita Y, Fukatsu T, Kakumu S. Serum cryoglobulin and chronic hepatitis C virus disease among Japanese patients. *Am J Gastroenterol* 1995;90(10):1847-1852.
156. De Vita S, Soldano F, Isola M, et al. Preliminary classification criteria for the cryoglobulinaemic vasculitis. *Ann Rheum Dis* 2011;70(7):1183-1190.
157. Foessel L, Besancenot JF, Blaison G, et al. Clinical spectrum, treatment, and outcome of patients with type II mixed cryoglobulinemia without evidence of hepatitis C infection. *J Rheumatol* 2011;38(4):716-722.
158. Roccatello D, Fornasieri A, Giachino O, et al. Multicenter study on hepatitis C virus-related cryoglobulinemic glomerulonephritis. *Am J Kidney Dis* 2007;49(1):69-82.
159. Goldman M, Renversez JC, Lambert PH. Pathological expression of idiotypic interactions: immune complexes and cryoglobulins. [33 refs]. *Springer Semin Immunopathol* 1983;6(1):33-49.
160. Wilson MR, Arroyave CM, Miles L, Tan EM. Immune reactants in cryoproteins. Relationship to complement activation. *Ann Rheum Dis* 1977;36(6):540-548.
161. Lunel F, Musset L, Cacoub P, et al. Cryoglobulinemia in chronic liver diseases: role of hepatitis C virus and liver damage. *Gastroenterology* 1994;106 (5):1291-1300.

162. Sansonno D, Iacobelli AR, Cornacchiolo V, et al. Immunochemical and biomolecular studies of circulating immune complexes isolated from patients with acute and chronic hepatitis C virus infection. *Eur J Clin Invest* 1996; 26(6):465-475.
163. Pileri P, Uematsu Y, Campagnoli S, et al. Binding of hepatitis C virus to CD81. *Science* 1998;282(5390):938-941.
164. Agnello V, Abel G, Elfahal M, Knight GB, Zhang QX. Hepatitis C virus and other flaviviridae viruses enter cells via low density lipoprotein receptor. *Proc Natl Acad Sci U S A* 1999;96(22):12766-12771.
165. Hartmann H, Schott P, Polzien F, et al. Cryoglobulinemia in chronic hepatitis C virus infection: prevalence, clinical manifestations, response to interferon treatment and analysis of cryoprecipitates. *Z Gastroenterol* 1995;33(11): 643-650.
166. Wong VS, Egner W, Elsey T, Brown D, Alexander GJ. Incidence, character and clinical relevance of mixed cryoglobulinaemia in patients with chronic hepatitis C virus infection. *Clin Exp Immunol* 1996;104(1):25-31.
167. Galli M, Monti G, Monteverde A, Invernizzi F, Pietrogrande M. Hepatitis C virus and mixed cryoglobulinemia. *Lancet* 1992;339(8799):989.
168. Cacoub P, Lunel F, Musset L, Opolon P, Piette JC. Hepatitis C virus and cryoglobulinemia. *N Engl J Med* 1993;328:1121-1122.
169. Pioltelli P, Zehender G, Monti G, Monteverde A, Galli M. HCV and non-Hodgkin lymphoma. *Lancet* 1996;347(9001):624-625.
170. Zignego AL, Ferri C, Giannini C, et al. Hepatitis C virus infection in mixed cryoglobulinemia and B-cell non-Hodgkin's lymphoma: evidence for a pathogenetic role. *Arch Virol* 1997;142(3):545-555.
171. De Rosa G, Gobbo ML, De Renzo A, et al. High prevalence of hepatitis C virus infection in patients with B-cell lymphoproliferative disorders in Italy. *Am J Hematol* 1997;55(2):77-82.
172. Saadoun D, Suarez F, Lefrere F, et al. Splenic lymphoma with villous lymphocytes, associated with type II cryoglobulinemia and HCV infection: a new entity? *Blood* 2005;105(1):74-76.
173. Fayyazi A, Schott P, Hartmann H, et al. Clinical, biochemical, and histological changes in hepatitis C virus infection-associated cryoglobulinemia. *Z Gastroenterol* 1997;35(10):921-928.
174. Lunel F. Hepatitis C virus and autoimmunity: fortuitous association or reality? *Gastroenterology* 1994;107(5):1550-1555.
175. Schmidt WN, Stapleton JT, LaBrecque DR, et al. Hepatitis C virus (HCV) infection and cryoglobulinemia: analysis of whole blood and plasma HCV-RNA concentrations and correlation with liver histology. *Hepatology* 2000;31(3):737-744.
176. Saadoun D, Asselah T, Resche-Rigon M, et al. Cryoglobulinemia is associated with steatosis and fibrosis in chronic hepatitis C. *Hepatology* 2006; 43(6):1337-1345.
177. Hofmann WP, Herrmann E, Kronenberger B, et al. Association of HCV-related mixed cryoglobulinemia with specific mutational pattern of the HCV E2 protein and CD81 expression on peripheral B lymphocytes. *Blood* 2004;104(4):1228-1229.
178. Curry MP, Golden-Mason L, Doherty DG, et al. Expansion of innate CD5pos B cells expressing high levels of CD81 in hepatitis C virus infected liver. *J Hepatol* 2003;38(5):642-650.
179. Rosa D, Saletti G, De Gregorio E, et al. Activation of naive B lymphocytes via CD81, a pathogenetic mechanism for hepatitis C virus-associated B lymphocyte disorders. *Proc Natl Acad Sci U S A* 2005;102(51):18544-18549.
180. Vallat L, Benhamou Y, Gutierrez M, et al. Clonal B cell populations in the blood and liver of patients with chronic hepatitis C virus infection. *Arthritis Rheum* 2004;50(11):3668-3678.
181. Ni J, Hembrador E, Di Bisceglie AM, et al. Accumulation of B lymphocytes with a naive, resting phenotype in a subset of hepatitis C patients. *J Immunol* 2003;170(6):3429-3439.
182. Charles ED, Green RM, Marukian S, et al. Clonal expansion of immunoglobulin M+CD27+ B cells in HCV-associated mixed cryoglobulinemia. *Blood* 2008;111(3):1344-1356.
183. Charles ED, Brunetti C, Marukian S, et al. Clonal B cells in patients with hepatitis C virus-associated mixed cryoglobulinemia contain an expanded anergic CD21low B-cell subset. *Blood* 2011;117(20):5425-5437.
184. Saadoun D, Rosenzweig M, Landau D, Piette JC, Klatzmann D, Cacoub P. Restoration of peripheral immune homeostasis after rituximab in mixed cryoglobulinemia vasculitis. *Blood* 2008;111(11):5334-5341.

185. Dammacco F, Tucci FA, Lauletta G, et al. Pegylated interferon-alpha, ribavirin, and rituximab combined therapy of hepatitis C virus-related mixed cryoglobulinemia: a long-term study. *Blood* 2010;116(3):343-353.
186. Garcia-Carrasco M, Ramos-Casals M, Cervera R, et al. Cryoglobulinemia in systemic lupus erythematosus: prevalence and clinical characteristics in a series of 122 patients. *Semin Arthritis Rheum* 2001;30(5):366-373.
187. Husson JM, Druet P, Contet A, Fiessinger JN, Camilleri JP. Systemic sclerosis and cryoglobulinemia. *Clin Immunol Immunopathol* 1976;6(1):77-82.
188. Chattopadhyaya D, Ravindran B, Prakash K. Cryoglobulins in cases of rheumatoid arthritis. *Rheumatol Int* 1985;5(4):181-184.
189. Tzioufas AG, Manoussakis MN, Costello R, Silis M, Papadopoulos NM, Moutsopoulos HM. Cryoglobulinemia in autoimmune rheumatic diseases. Evidence of circulating monoclonal cryoglobulins in patients with primary Sjogren's syndrome. *Arthritis Rheum* 1986;29(9):1098-1104.
190. Ramos-Casals M, Cervera R, Yague J, et al. Cryoglobulinemia in primary Sjogren's syndrome: prevalence and clinical characteristics in a series of 115 patients. *Semin Arthritis Rheum* 1998;28(3):200-205.
191. Baimpa E, Dahabreh IJ, Voulgarelis M, Moutsopoulos HM. Hematologic manifestations and predictors of lymphoma development in primary Sjogren syndrome: clinical and pathophysiologic aspects. *Medicine (Baltimore)* 2009;88(5):284-293.
192. Mussini C, Mascia MT, Zanni G, Curci G, Bonacorsi G, Artusi T. A cytomorphological and immunohistochemical study of bone marrow in the diagnosis of essential mixed type II cryoglobulinemia. *Haematologica* 1991;76(5): 389-391.
193. Perl A, Gorevic PD, Ryan DH, Condemi JJ, Ruzskowski RJ, Abraham GN. Clonal B cell expansions in patients with essential mixed cryoglobulinaemia. *Clin Exp Immunol* 1989;76(1):54-60.
194. De Vita S, De Re V, Gasparotto D, et al. Oligoclonal non-neoplastic B cell expansion is the key feature of type II mixed cryoglobulinemia: clinical and molecular findings do not support a bone marrow pathologic diagnosis of indolent B cell lymphoma. *Arthritis Rheum* 2000;43(1):94-102.
195. Pozzato G, Mazzaro C, Crovatto M, et al. Low-grade malignant lymphoma, hepatitis C virus infection, and mixed cryoglobulinemia. *Blood* 1994;84(9): 3047-3053.
196. Franzin F, Efremov DG, Pozzato G, Tulissi P, Batista F, Burrone OR. Clonal B-cell expansions in peripheral blood of HCV-infected patients. *Br J Haematol* 1995;90(3):548-552.
197. Invernizzi F, Pioltelli P, Cattaneo R, et al. A long-term follow-up study in essential cryoglobulinemia. *Acta Haematologica* 1979;61(2):93-99.
198. Monteverde A, Ballare M, Bertocelli MC, et al. Lymphoproliferation in type II mixed cryoglobulinemia. *Clin Exp Rheumatol* 1995;13(13):S141-S147.
199. Silvestri F, Barillari G, Fanin R, et al. Hepatitis C virus infection among cryoglobulinemic and non-cryoglobulinemic B-cell non-Hodgkin's lymphomas. *Haematologica* 1997;82(3):314-317.
200. Luppi M, Grazia Ferrari M, Bonaccorsi G, et al. Hepatitis C virus infection in subsets of neoplastic lymphoproliferations not associated with cryoglobulinemia. *Leukemia* 1996;10(2):351-355.
201. Wotherspoon AC, Ortiz-Hidalgo C, Falzon MR, Isaacson PG. Helicobacter pylori-associated gastritis and primary B-cell gastric lymphoma. *Lancet* 1991;338(8776):1175-1176.
202. Silverman GJ, Goldfien RD, Chen P, et al. Idiotypic and subgroup analysis of human monoclonal rheumatoid factors. Implications for structural and genetic basis of autoantibodies in humans. *J Clin Invest* 1988;82(2): 469-475.
203. Crowley JJ, Goldfien RD, Schrohenloher RE, et al. Incidence of three cross-reactive idiotypes on human rheumatoid factor paraproteins. *J Immunol* 1988;140(10):3411-3418.
204. Fong S, Chen PP, Crowley JJ, Silverman GJ, Carson DA. Idiotypic characteristics of rheumatoid factors. *Scand J Rheumatol Suppl* 1988;75:58-65.
205. De Re V, De Vita S, Marzotto A, et al. Sequence analysis of the immunoglobulin antigen receptor of hepatitis C virus-associated non-Hodgkin lymphomas suggests that the malignant cells are derived from the rheumatoid factor-producing cells that occur mainly in type II cryoglobulinemia. *Blood* 2000;96(10):3578-3584.

206. Chan CH, Hadlock KG, Fong SK, Levy S. V(H)1-69 gene is preferentially used by hepatitis C virus-associated B cell lymphomas and by normal B cells responding to the E2 viral antigen. *Blood* 2001;97(4):1023-1026.
207. Sasso EH, Ghillani P, Musset L, Piette JC, Cacoub P. Effect of 51p1-related gene copy number (V1-69 locus) on production of hepatitis C-associated cryoglobulins. *Clin Exp Immunol* 2001;123(1):88-93.
208. Ivanovski M, Silvestri F, Pozzato G, et al. Somatic hypermutation, clonal diversity, and preferential expression of the VH 51p1/VL kv325 immunoglobulin gene combination in hepatitis C virus-associated immunocytomas. *Blood* 1998;91(7):2433-2442.
209. De Re V, De Vita S, Gasparotto D, et al. Salivary gland B cell lymphoproliferative disorders in Sjogren's syndrome present a restricted use of antigen receptor gene segments similar to those used by hepatitis C virus-associated non-Hodgkin's lymphomas. *Eur J Immunol* 2002;32(3):903-910.
210. Ferri C, Monti M, La Civita L, et al. Infection of peripheral blood mononuclear cells by hepatitis C virus in mixed cryoglobulinemia. *Blood* 1993;82(12): 3701-3704.
211. Lau JY, Mizokami M, Kolberg JA, et al. Application of six hepatitis C virus genotyping systems to sera from chronic hepatitis C patients in the United States. *J Infect Dis* 1995;171(2):281-289.
212. Frangeul L, Musset L, Cresta P, Cacoub P, Huraux JM, Lunel F. Hepatitis C virus genotypes and subtypes in patients with hepatitis C, with and without cryoglobulinemia. *J Hepatol* 1996;25(4):427-432.
213. Galli M, Zehender G, Monti G, et al. Hepatitis C virus RNA in the bone marrow of patients with mixed cryoglobulinemia and in subjects with noncryoglobulinemic chronic hepatitis type C. *J Infect Dis* 1995;171(3):672-675.
214. Zehender G, de Maddalena C, Monti G, et al. HCV genotypes in bone marrow and peripheral blood mononuclear cells of patients with mixed cryoglobulinemia. *Clin Exp Rheumatol* 1995;13(13):S87-S90.
215. Willems M, Sheng L, Roskams T, et al. Hepatitis C virus and its genotypes in patients suffering from chronic hepatitis C with or without a cryoglobulinemia-related syndrome. *J Med Virol* 1994;44(3):266-271.
216. Monti G, Pioltelli P, Saccardo F, et al. Incidence and characteristics of non-Hodgkin lymphomas in a multicenter case file of patients with hepatitis C virus-related symptomatic mixed cryoglobulinemias. *Arch Intern Med* 2005;165(1):101-105.
217. Zignego AL, Giannelli F, Marrocchi ME, et al. T(14;18) translocation in chronic hepatitis C virus infection. *Hepatology* 2000;31(2):474-479.
218. Kitay-Cohen Y, Amiel A, Hilzenrat N, et al. Bcl-2 rearrangement in patients with chronic hepatitis C associated with essential mixed cryoglobulinemia type II. *Blood* 2000;96(8):2910-2912.
219. Zuckerman E, Zuckerman T, Sahar D, et al. bcl-2 and immunoglobulin gene rearrangement in patients with hepatitis C virus infection. *Br J Haematol* 2001;112(2):364-369.
220. Zignego AL, Ferri C, Giannelli F, et al. Prevalence of bcl-2 rearrangement in patients with hepatitis C virus-related mixed cryoglobulinemia with or without B-cell lymphomas. *Ann Intern Med* 2002;137(7):571-580.
221. Ferri C, Monti M, La Civita L, et al. Hepatitis C virus infection in non-Hodgkin's B-cell lymphoma complicating mixed cryoglobulinaemia. *Eur J Clin Invest* 1994;24(11):781-784.
222. Gabrielli A, Manzin A, Candela M, et al. Active hepatitis C virus infection in bone marrow and peripheral blood mononuclear cells from patients with mixed cryoglobulinaemia. *Clin Exp Immunol* 1994;97(1):87-93.
223. Sansonno D, De Vita S, Cornacchiulo V, Carbone A, Boiocchi M, Dammacco F. Detection and distribution of hepatitis C virus-related proteins in lymph nodes of patients with type II mixed cryoglobulinemia and neoplastic or non-neoplastic lymphoproliferation. *Blood* 1996;88(12):4638-4645.
224. Silvestri F, Barillari G, Fanin R, et al. Impact of hepatitis C virus infection on clinical features, quality of life and survival of patients with lymphoplasmacytoid lymphoma/immunocytoma. *Ann Oncol* 1998;9(5):499-504.
225. Mendez P, Saeian K, Reddy KR, et al. Hepatitis C, cryoglobulinemia, and cutaneous vasculitis associated with unusual and serious manifestations. *Am J Gastroenterol* 2001;96(8):2489-2493.
226. Ferri C, Marzo E, Longombardo G, et al. Interferon alfa-2b in mixed cryoglobulinaemia: a controlled crossover trial. *Gut* 1993;34(2 Suppl):S144-S145.

227. Misiani R, Bellavita P, Fenili D, et al. Interferon alfa-2a therapy in cryoglobulinemia associated with hepatitis C virus. *N Engl J Med* 1994;330(11):751-756.
228. Dammacco F, Sansonno D, Han JH, et al. Natural interferon-alpha versus its combination with 6-methyl-prednisolone in the therapy of type II mixed cryoglobulinemia: a long-term, randomized, controlled study. *Blood* 1994;84(10):3336-3343.
229. Lauta VM, De Sangro MA. Long-term results regarding the use of recombinant interferon alpha-2b in the treatment of II type mixed essential cryoglobulinemia. *Med Oncol* 1995;12(4):223-230.
230. Mazzaro C, Lacchin T, Moretti M, et al. Effects of two different alpha-interferon regimens on clinical and virological findings in mixed cryoglobulinemia. *Clin Exp Rheumatol* 1995;13(13):S181-S185.
231. Mazzaro C, Zorat F, Caizzi M, et al. Treatment with peg-interferon alfa-2b and ribavirin of hepatitis C virus-associated mixed cryoglobulinemia: a pilot study. *J Hepatol* 2005;42(5):632-638.
232. Saadoun D, Resche-Rigon M, Thibault V, Piette JC, Cacoub P. Antiviral therapy for hepatitis C virus-associated mixed cryoglobulinemia vasculitis: a long-term follow-up study. *Arthritis Rheum* 2006;54(11):3696-3706.
233. Durand JM, Cacoub P, Lunel-Fabiani F, et al. Ribavirin in hepatitis C related cryoglobulinemia. *J Rheumatol* 1998;25(6):1115-1117.
234. Zaja F, De Vita S, Mazzaro C, et al. Efficacy and safety of rituximab in type II mixed cryoglobulinemia. *Blood* 2003;101(10):3827-3834.
235. Sansonno D, De Re V, Lauletta G, Tucci FA, Boiocchi M, Dammacco F. Monoclonal antibody treatment of mixed cryoglobulinemia resistant to interferon alpha with an anti-CD20. *Blood* 2003;101(10):3818-3826.
236. Bryce AH, Dispenzieri A, Kyle RA, et al. Response to rituximab in patients with type II cryoglobulinemia. *Clin Lymphoma Myeloma* 2006;7(2):140-144.
237. Roccatello D, Baldovino S, Rossi D, et al. Long-term effects of anti-CD20 monoclonal antibody treatment of cryoglobulinaemic glomerulonephritis. *Nephrol Dial Transplant* 2004;19(12):3054-3061.
238. Basse G, Ribes D, Kamar N, et al. Rituximab therapy for mixed cryoglobulinemia in seven renal transplant patients. *Transplant Proc* 2006;38(7): 2308-2310.
239. Lamprecht P, Lerin-Lozano C, Merz H, et al. Rituximab induces remission in refractory HCV associated cryoglobulinaemic vasculitis. *Ann Rheum Dis* 2003;62(12):1230-1233.
240. Ghijssels E, Lerut E, Vanrenterghem Y, Kuypers D. Anti-CD20 monoclonal antibody (rituximab) treatment for hepatitis C-negative therapy-resistant essential mixed cryoglobulinemia with renal and cardiac failure. *Am J Kidney Dis* 2004;43(5):e34-38.
241. Ferri C, Pietrogrande M, Cecchetti R, et al. Low-antigen-content diet in the treatment of patients with mixed cryoglobulinemia. *Am J Med* 1989; 87(5):519-524.
242. Frankel AH, Singer DR, Winearls CG, Evans DJ, Rees AJ, Pusey CD. Type II essential mixed cryoglobulinaemia: presentation, treatment and outcome in 13 patients. *Q J Med* 1992;82(298):101-124.
243. Geltner D, Kohn RW, Gorevic P, Franklin EC. The effect of combination therapy (steroids, immunosuppressives, and plasmapheresis) on 5 mixed cryoglobulinemia patients with renal, neurologic, and vascular involvement. *Arthritis Rheum* 1981;24(9):1121-1127.
244. Valbonesi M, Montani F, Mosconi L, Florio G, Vecchi C. Plasmapheresis and cytotoxic drugs for mixed cryoglobulinemia. *Haematologia* 1984;17(3): 341-351.
245. Sinico RA, Fornasieri A, Fiorini G, et al. Plasma exchange in the treatment of essential mixed cryoglobulinemia nephropathy. Long-term follow up. *Int J Artif Organs* 1985;2:15-18.
246. Berkman EM, Orlin JB. Use of plasmapheresis and partial plasma exchange in the management of patients with cryoglobulinemia. *Transfusion* 1980;20(2):171-178.
247. McLeod BC, Sasseti RJ. Plasmapheresis with return of cryoglobulin-depleted autologous plasma (cryoglobulinpheresis) in cryoglobulinemia. *Blood* 1980;55(5):866-870.
248. Reik L Jr, Korn JH. Cryoglobulinemia with encephalopathy: successful treatment by plasma exchange. *Ann Neurol* 1981;10(5):488-490.

249. Ristow SC, Griner PF, Abraham GN, Shoulson I. Reversal of systemic Manifestations of cryoglobulinemia. *Ach Intern Med* 1976;136:467-470.
250. Volpe R, Bruce-Robertson A, Fletcher A, et al. Essential cryoglobulinemia: review of the literature and report of a case treated with ACTH and cortisone. *Am J Med* 1956;20:533-553.
251. De Vecchi A, Montagnino G, Pozzi C, Tarantino A, Locatelli F, Ponticelli C. Intravenous methylprednisolone pulse therapy in essential mixed cryoglobulinemia nephropathy. *Clin Nephrol* 1983;19(5):221-227.
252. Ponticelli C, Imbasciati E, Tarantino A, Pietrogrande M. Acute anuric glomerulonephritis in monoclonal cryoglobulinaemia. *Br Med J* 1977;1(6066):948.
253. Mathison DA, Condemi JJ, Leddy JP, Callerame ML, Panner BJ, Vaughan JH. Purpura, arthralgia, and IgM-IgM cryoglobulinemia with rheumatoid factor activity. Response to cyclophosphamide and splenectomy. *Ann Intern Med* 1971;74(3):383-390.
254. Germain MJ, Anderson RW, Keane WF. Renal disease in cryoglobulinemia type II: response to therapy. A case report and review of the literature. *Am J Nephrol* 1982;2(4):221-226.
255. Quigg RJ, Brathwaite M, Gardner DF, Gretch DR, Ruddy S. Successful cyclophosphamide treatment of cryoglobulinemic membranoproliferative glomerulonephritis associated with hepatitis C virus infection. *Am J Kidney Dis* 1995;25(5):798-800.
256. Sampson A, Callen JP. The cutting edge: thalidomide for type 1 cryoglobulinemic vasculopathy. *Arch Dermatol* 2006;142(8):972-974.
257. Cem Ar M, Soysal T, Hatemi G, Salihoglu A, Yazici H, Ulku B. Successful management of cryoglobulinemia-induced leukocytoclastic vasculitis with thalidomide in a patient with multiple myeloma. *Ann Hematol* 2005;84(9):609-613.
258. Chandesris MO, Gayet S, Schleinitz N, Doudier B, Harle JR, Kaplanski G. Infliximab in the treatment of refractory vasculitis secondary to hepatitis C-associated mixed cryoglobulinaemia. *Rheumatology (Oxford)* 2004;43(4):532-533.
259. Ballare M, Bobbio F, Poggi G, et al. A pilot study on the effectiveness of cyclosporine in type II mixed cryoglobulinemia. *Clin Exp Rheumatol* 1995;13(13):S201-S203.
260. Monti G, Saccardo F, Rinaldi G, Petrozzino MR, Gomitoni A, Invernizzi F. Colchicine in the treatment of mixed cryoglobulinemia. *Clin Exp Rheumatol* 1995;13(13):S197-S199.
261. Barton JC, Herrera GA, Galla JH, Bertoli LF, Work J, Koopman WJ. Acute cryoglobulinemic renal failure after intravenous infusion of gamma globulin. *Am J Med* 1987;82(3 Spec No):624-629.
262. Boom BW, Brand A, Bavinck JN, Eernisse JG, Daha MR, Vermeer BJ. Severe leukocytoclastic vasculitis of the skin in a patient with essential mixed cryoglobulinemia treated with high-dose gamma-globulin intravenously. *Arch Dermatol* 1988;124(10):1550-1553.
263. Enzenauer RJ, Judson PH. Type II mixed cryoglobulinemia treated with fludarabine. *J Rheumatol* 1996;23(4):794-795.
264. Zaja F. Fludarabine in the treatment of essential mixed cryoglobulinaemia. *Eur J Haematol* 1996;57(3):259-260.
265. Odum J, D'Costa D, Freeth M, Taylor D, Smith N, MacWhannell A. Cryoglobulinaemic vasculitis caused by intravenous immunoglobulin treatment. *Nephrol Dial Transplant* 2001;16(2):403-406.
266. Donada C, Crucitti A, Donadon V, et al. Systemic manifestations and liver disease in patients with chronic hepatitis C and type II or III mixed cryoglobulinaemia. *J Viral Hepat* 1998;5(3):179-185.
267. Montagnino G. Reappraisal of the clinical expression of mixed cryoglobulinemia. *Springer Semin Immunopathol* 1988;10(1):1-19.
268. Cohen SJ, Pittelkow MR, Su WP. Cutaneous manifestations of cryoglobulinemia: clinical and histopathologic study of seventy-two patients. *J Am Acad Dermatol* 1991;25(1 Pt 1):21-27.
269. Gemignani F, Brindani F, Alfieri S, et al. Clinical spectrum of cryoglobulinaemic neuropathy. *J Neurol Neurosurg Psychiatry* 2005;76(10):1410-1414.
270. Chad D, Pariser K, Bradley WG, Adelman LS, Pinn VW. The pathogenesis of cryoglobulinemic neuropathy. *Neurology* 1982;32(7):725-729.

271. Nemni R, Corbo M, Fazio R, Quattrini A, Comi G, Canal N. Cryoglobulinaemic neuropathy. A clinical, morphological and immunocytochemical study of 8 cases. *Brain* 1988;111(Pt 3):541-552.
272. Cavaletti G, Petruccioli MG, Crespi V, Pioltelli P, Marmioli P, Tredici G. A clinico-pathological and follow up study of 10 cases of essential type II cryoglobulinaemic neuropathy. *J Neurol Neurosurg Psychiatry* 1990;53(10): 886-889.
273. Khella SL, Frost S, Hermann GA, et al. Hepatitis C infection, cryoglobulinemia, and vasculitic neuropathy. Treatment with interferon alfa: case report and literature review. *Neurology* 1995;45(3 Pt 1):407-411.
274. Garcia-Bragado F, Fernandez JM, Navarro C, Villar M, Bonaventura I. Peripheral neuropathy in essential mixed cryoglobulinemia. *Arch Neurol* 1988;45(11):1210-1214.
275. Valli G, De Vecchi A, Gaddi L, Nobile-Orazio E, Tarantino A, Barbieri S. Peripheral nervous system involvement in essential cryoglobulinemia and nephropathy. *Clin Exp Rheumatol* 1989;7(5):479-483.
276. Ammendola A, Sampaolo S, Ambrosone L, et al. Peripheral neuropathy in hepatitis-related mixed cryoglobulinemia: electrophysiologic follow-up study. *Muscle Nerve* 2005;31(3):382-385.
277. Casato M, Saadoun D, Marchetti A, et al. Central nervous system involvement in hepatitis C virus cryoglobulinemia vasculitis: a multicenter case-control study using magnetic resonance imaging and neuropsychological tests. *J Rheumatol* 2005;32(3):484-488.
278. Cappellari A, Origgi L, Spina MF, et al. Central nervous system involvement in HCV-related mixed cryoglobulinemia. *Electromyogr Clin Neurophysiol* 2006;46(3):149-158.
279. Ferri C, La Civita L, Longombardo G, Zignego AL, Pasero G. Mixed cryoglobulinaemia: a cross-road between autoimmune and lymphoproliferative disorders. *Lupus* 1998;7(4):275-279.
280. Cordonnier D, Vialtel P, Renversez JC, et al. Renal diseases in 18 patients with mixed type II IgM-IgG cryoglobulinemia: monoclonal lymphoid infiltration (2 cases) and membranoproliferative glomerulonephritis (14 cases). *Adv Nephrol Necker Hosp* 1983;12:177-204.
281. D'Amico G. Renal involvement in hepatitis C infection: cryoglobulinemic glomerulonephritis *Kidney Int* 1998;54(2):650-671.
282. Tarantino A, Campise M, Banfi G, et al. Long-term predictors of survival in essential mixed cryoglobulinemic glomerulonephritis. *Kidney Int* 1995;47(2):618-623.
283. Gorevic PD, Frangione B. Mixed cryoglobulinemia cross-reactive idiotypes: implications for the relationship of MC to rheumatic and lymphoproliferative diseases. *Semin Hematol* 1991;28(2):79-94.
284. Levo Y, Gorevic PD, Kassab HJ, Tobias H, Franklin EC. Liver involvement in the syndrome of mixed cryoglobulinemia. *Ann Intern Med* 1977;87(3): 287-292.
285. Monteverde A, Ballare M, Pileri S. Hepatic lymphoid aggregates in chronic hepatitis C and mixed cryoglobulinemia. *Springer Semin Immunopathol* 1997;19(1):99-110.
286. Terrier B, Saadoun D, Sene D, Scerra S, Musset L, Cacoub P. Presentation and outcome of gastrointestinal involvement in hepatitis C virus-related systemic vasculitis: a case-control study from a single-centre cohort of 163 patients. *Gut* 2010;59(12):1709-1715.
287. Amital H, Rubinow A, Naparstek Y. Alveolar hemorrhage in cryoglobulinemia—an indicator of poor prognosis. *Clin Exp Rheumatol* 2005;23(5):616-620.
288. Jara LJ, Vera-Lastra O, Calleja MC. Pulmonary-renal vasculitic disorders: differential diagnosis and management. *Curr Rheumatol Rep* 2003;5(2):107-115.
289. Kallemuchikkal U, Gorevic PD. Evaluation of cryoglobulins. *Arch Pathol Lab Med* 1999;123(2):119-125.
290. Cream JJ. Clinical and immunological aspects of cutaneous vasculitis. *Q J Med* 1976;45(178):255-276.
291. Tarantino A, Anelli A, Costantino A, De Vecchi A, Monti G, Massaro L. Serum complement pattern in essential mixed cryoglobulinaemia. *Clin Exp Immunol* 1978;32(1):77-85.
292. Ferri C, Moriconi L, Gremignai G, et al. Treatment of the renal involvement in mixed cryoglobulinemia with prolonged plasma exchange. *Nephron* 1986;43 (4):246-253.

293. Ferri C, Marzo E, Longombardo G, et al. Interferon-alpha in mixed cryoglobulinemia patients: a randomized, crossover-controlled trial. *Blood* 1993;81(5):1132-1136.
294. Di Giovanni S, De Matteis MA, Ciocca D, Cirella MP, Nanni Costa MP. Pseudothrombocytosis and pseudoleukocytosis in a case of essential mixed cryoglobulinemia (type II). *Clin Exp Rheumatol* 1986;4(2):143-145.
295. Migliaresi S, Tirri G. Interferon in the treatment of mixed cryoglobulinemia. *Clin Exp Rheumatol* 1995;13(13):S175-S180.
296. Alric L, Plaisier E, Thebault S, et al. Influence of antiviral therapy in hepatitis C virus-associated cryoglobulinemic MPGN. *Am J Kidney Dis* 2004;43(4):617-623.
297. Dispenzieri A. Symptomatic cryoglobulinemia. *Curr Treat Options Oncol* 1999;1(2):105-118.
298. Casato M, Lagana B, Antonelli G, Dianzani F, Bonomo L. Long-term results of therapy with interferon-alpha for type II essential mixed cryoglobulinemia. *Blood* 1991;78(12):3142-3147.
299. Ohta S, Yokoyama H, Wada T, et al. Exacerbation of glomerulonephritis in subjects with chronic hepatitis C virus infection after interferon therapy. *Am J Kidney Dis* 1999;33(6):1040-1048.
300. Beuthien W, Mellinghoff HU, Kempis J. Vasculitic complications of interferon-alpha treatment for chronic hepatitis C virus infection: case report and review of the literature. *Clin Rheumatol* 2005;24(5):507-515.
301. Cid MC, Hernandez-Rodriguez J, Robert J, et al. Interferon-alpha may exacerbate cryoglobulinemia-related ischemic manifestations: an adverse effect potentially related to its anti-angiogenic activity. *Arthritis Rheum* 1999;42(5):1051-1055.
302. Bonomo L, Casato M, Afeltra A, Caccavo D. Treatment of idiopathic mixed cryoglobulinemia with alpha interferon. *Am J Med* 1987;83(4):726-730.
303. Calleja JL, Albillos A, Moreno-Otero R, et al. Sustained response to interferon-alpha or to interferon-alpha plus ribavirin in hepatitis C virus-associated symptomatic mixed cryoglobulinaemia. *Aliment Pharmacol Ther* 1999;13(9):1179-1186.
304. Zuckerman E, Keren D, Slobodin G, et al. Treatment of refractory, symptomatic, hepatitis C virus related mixed cryoglobulinemia with ribavirin and interferon-alpha. *J Rheumatol* 2000;27(9):2172-2178.
305. Mazzaro C, Zorat F, Comar C, et al. Interferon plus ribavirin in patients with hepatitis C virus positive mixed cryoglobulinemia resistant to interferon. *J Rheumatol* 2003;30(8):1775-1781.
306. Cacoub P, Lidove O, Maisonobe T, et al. Interferon-alpha and ribavirin treatment in patients with hepatitis C virus-related systemic vasculitis. *Arthritis Rheum* 2002;46(12):3317-3326.
307. Donada C, Crucitti A, Donadon V, Chemello L, Alberti A. Interferon and ribavirin combination therapy in patients with chronic hepatitis C and mixed cryoglobulinemia. *Blood* 1998;92(8):2983-2984.
308. Zaja F, De Vita S, Mazzaro C, et al. Efficacy and safety of rituximab in type II mixed cryoglobulinemia. *Blood* 2003;101(10):3827.
309. Ghobrial IM, Uslan DZ, Call TG, Witzig TE, Gertz MA. Initial increase in the cryoglobulin level after rituximab therapy for type II cryoglobulinemia secondary to Waldenstrom macroglobulinemia does not indicate failure of response. *Am J Hematol* 2004;77(4):329-330.
310. De Vita S, Quartuccio L, Isola M, et al. A randomized, controlled, trial of rituximab for treatment of severe cryoglobulinemic vasculitis. *Arthritis Rheum* 2012 64(3):843-853.
311. Saadoun D, Resche-Rigon M, Sene D, et al. Rituximab plus Peg-interferonalpha/ribavirin compared with Peg-interferon-alpha/ribavirin in hepatitis C-related mixed cryoglobulinemia. *Blood* 2010;116(3):326-334,504-325.
312. Frickhofen N, Wiesneth M, Jainta C, et al. Hepatitis C virus infection is a risk factor for liver failure from veno-occlusive disease after bone marrow transplantation. *Blood* 1994;83(7):1998-2004.
313. Ubara Y, Hara S, Katori H, et al. Splenectomy may improve the glomerulopathy of type II mixed cryoglobulinemia. *Am J Kidney Dis* 2000;35(6):1186-1192.
314. Wahner-Roedler DL, Kyle RA. Mu-heavy chain disease: presentation as a benign monoclonal gammopathy. *Am J Hematol* 1992;40(1):56-60.

315. Wahner-Roedler DL, Witzig TE, Loehrer LL, Kyle RA. Gamma-heavy chain disease: review of 23 cases. *Medicine (Baltimore)* 2003;82(4):236-250.
316. Galanti LM, Doyen C, Vander Maelen C, et al. Biological diagnosis of a gamma-1-heavy chain disease in an asymptomatic patient. *Eur J Haematol* 1995;54(3):202-204.
317. Seijffers MJ, Levy M, Hermann G. Intractable watery diarrhea, hypokalemia, and malabsorption in a patient with Mediterranean type of abdominal lymphoma. *Gastroenterology* 1968;55(1):118-124.
318. Rambaud JC, Galian A, Matuchansky C, et al. Natural history of alpha-chain disease and the so-called Mediterranean lymphoma. *Recent Results Cancer Res* 1978;64:271-276.
319. Alpha-chain disease and related small-intestinal lymphoma: a memorandum. *Bull World Health Organ* 1976;54(6):615-624.
320. Al-Saleem T, Al-Mondhiry H. Immunoproliferative small intestinal disease (IPSID): a model for mature B-cell neoplasms. *Blood* 2005;105(6): 2274-2280.
321. Fine KD, Stone MJ. Alpha-heavy chain disease, Mediterranean lymphoma, and immunoproliferative small intestinal disease: a review of clinicopathological features, pathogenesis, and differential diagnosis. *Am J Gastroenterol* 1999;94(5):1139-1152.
322. Rambaud JC, Halphen M, Galian A, Tsapis A. Immunoproliferative small intestinal disease (IPSID): relationships with alpha-chain disease and "Mediterranean" lymphomas. *Springer Semin Immunopathol* 1990;12(2-3): 239-250.
323. Goossens T, Klein U, Kuppers R. Frequent occurrence of deletions and duplications during somatic hypermutation: implications for oncogene translocations and heavy chain disease. *Proc Natl Acad Sci U S A* 1998;95(5): 2463-2468.
324. Suarez F, Lortholary O, Hermine O, Lecuit M. Infection-associated lymphomas derived from marginal zone B cells: a model of antigen-driven lymphoproliferation. *Blood* 2006;107(8):3034-3044.
325. Loughran TP Jr, Kadin ME, Deeg HJ. T-cell intestinal lymphoma associated with celiac sprue. *Ann Intern Med* 1986;104(1):44-47.
326. Vaiphei K, Kumari N, Sinha SK, et al. Roles of syndecan-1, bcl6 and p53 in diagnosis and prognostication of immunoproliferative small intestinal disease. *World J Gastroenterol* 2006;12(22):3602-3608.
327. Fischbach W, Tacke W, Greiner A, Konrad H, Muller H. Regression of immunoproliferative small intestinal disease after eradication of *Helicobacter pylori*. *Lancet* 1997;349(9044):31-32.
328. Lecuit M, Abachin E, Martin A, et al. Immunoproliferative small intestinal disease associated with *Campylobacter jejuni*. *N Engl J Med* 2004;350(3): 239-248.
329. Galian A, Lecestre MJ, Scotto J, Bognel C, Matuchansky C, Rambaud JC. Pathological study of alpha-chain disease, with special emphasis on evolution. *Cancer* 1977;39(5):2081-2101.
330. Mir-Madjlessi SH, Mir-Ahmadian M. Alpha-chain disease—a report of eleven patients from Iran. *J Trop Med Hyg* 1979;82(11-12):229-236.
331. Zamir A, Parasher G, Moukarzel AA, Guarini L, Zeien L, Feldman F. Immunoproliferative small intestinal disease in a 16-year-old boy presenting as severe malabsorption with excellent response to tetracycline treatment. *J Clin Gastroenterol* 1998;27(1):85-89.
332. Martin IG, Aldoori MI. Immunoproliferative small intestinal disease: Mediterranean lymphoma and alpha heavy chain disease. *Br J Surg* 1994;81(1):20-24.
333. Salimi M, Spinelli JJ. Chemotherapy of Mediterranean abdominal lymphoma. Retrospective comparison of chemotherapy protocols in Iranian patients. *Am J Clin Oncol* 1996;19(1):18-22.
334. Ben-Ayed F, Halphen M, Najjar T, et al. Treatment of alpha chain disease. Results of a prospective study in 21 Tunisian patients by the Tunisian-French Intestinal Lymphoma Study Group. *Cancer* 1989;63(7):1251-1256.
335. Akbulut H, Soykan I, Yakaryilmaz F, et al. Five-year results of the treatment of 23 patients with immunoproliferative small intestinal disease: a Turkish experience. *Cancer* 1997;80(1):8-14.
336. Price SK. Immunoproliferative small intestinal disease: a study of 13 cases with alpha heavy-chain disease. *Histopathology* 1990;17(1):7-17.

337. Shih LY, Liaw SJ, Hsueh S, Kuo TT. Alpha-chain disease. Report of a case from Taiwan. *Cancer* 1987;59(3):545-548.
338. Malik IA, Shamsi Z, Shafquat A, et al. Clinicopathological features and management of immunoproliferative small intestinal disease and primary small intestinal lymphoma in Pakistan. *Med Pediatr Oncol* 1995;25(5):400-406.
339. McLaughlin P, Grillo-Lopez AJ, Link BK, et al. Rituximab chimeric anti-CD20 monoclonal antibody therapy for relapsed indolent lymphoma: half of patients respond to a four-dose treatment program. *J Clin Oncol* 1998;16(8):2825-2833.
340. Forte FA, Prelli F, Yount WJ, et al. Heavy chain disease of the gamma (gamma M) type: report of the first case. *Blood* 1970;36(2):137-144.
341. Ballard HS, Hamilton LM, Marcus AJ, Illes CH. A new variant of heavy-chain disease (mu-chain disease). *N Engl J Med* 1970;282(19):1060-1062.
342. Wahner-Roedler DL, Kyle RA. Heavy chain diseases. *Best Pract Res Clin Haematol* 2005;18(4):729-746.
343. Kyle RA, Greipp PR, Banks PM. The diverse picture of gamma heavy-chain disease. Report of seven cases and review of literature. *Mayo Clin Proc* 1981;56(7):439-451.
344. Pruzanski W, Hasselback R, Katz A, Parr DM. Multiple myeloma (light chain disease) with rheumatoid-like amyloid arthropathy and mu-heavy chain fragment in the serum. *Am J Med* 1978;65(2):334-341.
345. Mihaesco E, Barnikol-Watanabe S, Barnikol HU, Mihaesco C, Hilschmann N. The primary structure of the constant part of mu-chain-disease protein BOT. *Eur J Biochem* 1980;111(1):275-286.
346. Brouet JC, Seligmann M, Danon F, Belpomme D, Fine JM. mu-chain disease. Report of two new cases. *Arch Intern Med* 1979;139(6):672-674.
347. Franklin EC, Lowenstein J, Bigelow B, Meltzer M. Heavy chain disease—a new disorder of serum α -globulins: report of the first case. *Am J Med* 1964;37:332.
348. Fermand JP, Brouet JC. Heavy-chain diseases. *Hematol Oncol Clin North Am* 1999;13(6):1281-1294.
349. Lassoued K, Picard C, Danon F, et al. Cutaneous manifestations associated with gamma heavy chain disease. Report of an unusual case and review of literature. *J Am Acad Dermatol* 1990;23(5 Pt 2):988-991.
350. Zawadzki ZA, Benedek TG, Ein D, Easton JM. Rheumatoid arthritis terminating in heavy-chain disease. *Ann Intern Med* 1969;70(2):335-347.
351. Jacqueline F, Renversez JC, Gros Lambert P, Fine JM. Gamma heavy chain disease during rheumatoid polyarthritis. A clinical and immunochemical study [French]. *Rev Rhum Mal Osteoartic* 1978;45(11):661-665.
352. Gaucher A, Bertrand F, Brouet JC, et al. Gamma heavy chain disease associated with rheumatoid arthritis. Spontaneous disappearance of the pathologic protein [French]. *Sem Hop* 1977;53(38):2117-2120.
353. Westin J, Eyrich R, Falsen E, et al. Gamma heavy chain disease. Reports of three patients. *Acta Med Scand* 1972;192(4):281-292.
354. Lyons RM, Chaplin H, Tillack TW, Majerus PW. Gamma heavy chain disease: rapid, sustained response to cyclophosphamide and prednisone. *Blood* 1975;46(1):1-9.
355. Wager O, Rasanen JA, Lindeberg L, Makela V. Two cases of IgG heavy-chain disease. *Acta Pathol Microbiol Scand* 1969;75(2):350-352.
356. Frangione B, Franklin EC. Heavy chain diseases: clinical features and molecular significance of the disordered immunoglobulin structure. *Semin Hematol* 1973;10(1):53-64.
357. Fermand JP, Brouet JC, Danon F, Seligmann M. Gamma heavy chain “disease”: heterogeneity of the clinicopathologic features. Report of 16 cases and review of the literature. *Medicine (Baltimore)* 1989;68(6):321-335.
358. Wester SM, Banks PM, Li CY. The histopathology of gamma heavy-chain disease. *Am J Clin Pathol* 1982;78(4):427-436.

Part VIII - Transplantation

Chapter 102 Hematopoietic Cell Transplantation

Transplantation of hematopoietic cell grafts containing pluripotent hematopoietic stem cells (HSCs) after myeloablative or nonmyeloablative conditioning regimens reconstitutes immunohematopoiesis. Sites from which HSC can be harvested and then used for transplantation include bone marrow, peripheral blood, and the umbilical cord. Patients may serve as their own donors (autologous) or may receive HSC from other individuals (related or unrelated). Hematopoietic cell transplantation (HCT) is done for a variety of therapeutic indications: (1) to support hematopoiesis after myeloablative doses of total body irradiation (TBI) and chemotherapy, (2) to establish a graft-versus-leukemia or tumor (GVL or GVT) reaction, or (3) to replace diseased tissues of hematologic or immunologic origins. The advances in supportive care after transplantation have resulted in improved outcomes, and HCT has become more accepted as a therapeutic modality that can be successful in otherwise life-threatening diseases. In the 2003-2007 period as compared with the 1993-1997 period, a 60% reduction in day 200 nonrelapse mortality and a 41% reduction in overall mortality was observed.¹ There were also significant reductions in severe graft-versus-host disease (GVHD), opportunistic infections, and organ damage.

The focus of this chapter is on the general indications for HCT, sources of stem cells, conditioning regimens, transplant biology issues, and complications of HCT; other chapters provide detailed discussions of the indications and results of HCT in relation to specific diseases (Table 102.1).

HISTORICAL PERSPECTIVE

Early Preclinical Studies

After the effects of radiation on hematopoiesis became evident during World War II, Jacobson and colleagues reported that mice survived an otherwise lethal exposure to TBI if the spleen was shielded (Fig. 102.1).² Radiation protection was also conferred by infusion of bone marrow.³ A runting syndrome developed after recovery of hematopoiesis when the infused marrow was from a donor of a different mouse strain.⁴ This syndrome was due to GVHD, a complication that was soon recognized to limit the use of allogeneic marrow transplantation in humans. In further studies in mice, methotrexate and 6-mercaptopurine were found to be effective in inducing immune tolerance or ameliorating the graft-versus-host (GVH) reaction.⁵

The dog served as a random-bred large animal model for studies of principles and techniques of bone marrow transplantation applicable to humans. The dog was the first random-bred species in which it was demonstrated that the results of *in vitro* histocompatibility typing could predict the outcome of marrow transplantation.⁶ Littermates genotypically identical for the major histocompatibility complex (MHC) survived longer after marrow transplantation than did their MHC-nonidentical siblings. However, despite the MHC genotypic identity, GVHD was still potentially severe in many but not all dogs. This indicated that other factors identified as minor histocompatibility antigens (mHC) were involved in the development of GVHD. Pharmacologic immunosuppression with a calcineurin inhibitor

P.2160

(i.e., cyclosporine or tacrolimus) or methotrexate for prevention of GVHD improved survival after allogeneic marrow grafting.^{7, 8} It was then established that methotrexate and cyclosporine in combination were more effective than either used alone.⁹ The efficacy of a calcineurin inhibitor and methotrexate combined for GVHD prevention was subsequently confirmed in clinical trials and remains the standard in many transplant programs.

TABLE 102.1 DISORDERS TREATED BY TRANSPLANTATION

Nonmalignant

Aplastic anemia

Fanconi's anemia

Diamond-Blackfan syndrome

Sickle cell disease

Thalassemia

- Paroxysmal nocturnal hemoglobinuria
- Myelofibrosis
- Congenital neutropenia
- Chediak-Higashi syndrome
- Chronic granulomatous disease
- Glanzmann's thrombasthenia
- Osteopetrosis
- Gaucher's disease
- Mucopolysaccharidosis
- Mucopolidoses
- Immune deficiencies
- Malignant
 - Acute nonlymphoblastic leukemia
 - Acute lymphoblastic leukemia
 - Hairy cell leukemia
 - Myelodysplasia
 - Chronic myelogenous leukemia
 - Chronic lymphocytic leukemia
 - Hodgkin's disease
 - Non-Hodgkin's lymphoma
 - Multiple myeloma
- Solid tumors

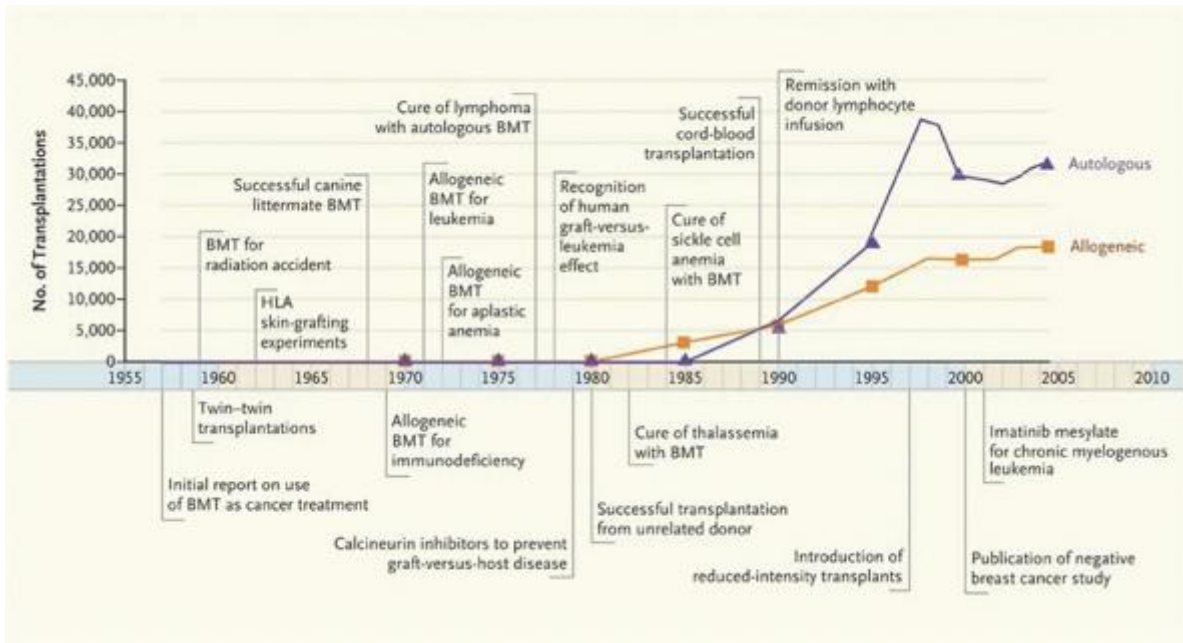

FIGURE 102.1. Timeline showing numbers of bone marrow transplantations and advances in the field, 1957-2006. BMT

denotes bone marrow transplantation; HLA, human leukocyte antigen. Data are from the Center for International Blood and Marrow Transplant Research. (Reprinted with permission from Appelbaum FR. Transplantation of bone marrow as compared with peripheral blood cells from HLA-identical relatives in patients with hematologic cancers. *N Engl J Med* 2007;357:1472-1475. Copyright 2007 Massachusetts Medical Society. All rights reserved.)

Early Clinical Studies

Bone marrow was the first commonly used source of HSC for transplantation. Bone marrow transplantation from human leukocyte antigen (HLA)-identical sibling donors was first successfully used by two groups in 1968 to treat patients with immunologic deficiencies.^{10, 11} After extensive preclinical studies of GVHD, Thomas et al. then reported the successful transplantation of marrow from a HLA-identical sibling donor for aplastic anemia in 1972.¹² Five years later, the same group reported their experience in 100 patients with end-stage leukemia treated with allogeneic marrow transplantation.¹³ Allogeneic HCT from an HLA-matched related or unrelated donor is now considered standard therapy for many malignant and nonmalignant hematologic diseases.

HEMATOPOIETIC STEM CELLS

The HSC is defined as a cell with the ability to achieve long-term reconstitution of both myeloid and lymphoid lineages. To fulfill these criteria, HSC must be able to self-renew and be pluripotent. In vitro colony-forming units (e.g., CFU-GM, CFU-Meg, CFU-E, BFU-E) are progenitor cells that cannot reconstitute hematopoiesis, whereas populations of cells enriched for long-term culture-initiating cells can, at least in the mouse, rescue lethally irradiated recipients.^{14, 15} No accepted in vitro assays for human HSC are available currently. A population of small mononuclear cells enriched for HSC can be identified by (1) the presence of the CD34 and CD133 antigen, the absence of lineage-specific antigens, and high content of aldehyde dehydrogenase and (2) the exclusion of fluorescent vital dyes including Rhodamine¹²³ and Hoechst 33 342 (Table 102.2).^{16, 17, 18, 19, 20} In humans and other species, successful sustained engraftment was achieved with isolated CD34-positive cells confirming that a true "stem cell" is contained within this population.^{21, 22, 23, 24}

The true extent of the pluripotency of adult marrow-derived stem cells remains under investigation. Several studies have reported that populations of HSCs may contribute to regeneration of muscle, osteoblasts, hepatocytes, and neuronal and nonneuronal cell types of the brain.^{25, 26, 27} However, some of the

P.2161

experimental observations may have resulted from cell fusion, technical artifact, or culture induced changes in cellular gene expression. Nevertheless, there is agreement that if "plasticity" of circulating HSCs occurs, it is likely to be a rare event.²⁸

TABLE 102.2 CHARACTERISTICS OF HUMAN HEMATOPOIETIC STEM CELL (HSC)

A. Cell Surface Antigen Expression

Positive

CD34-positive

CD133-positive

Aldehyde dehydrogenase

Low Positive

Thy 1 (CDw90), c-KIT

Negative

CD38, CD33, T and B cell markers, CD71, DR

B. Dye Exclusion

Rhodamine¹²³, Hoechst 33 342

^a CD34 negative HSC have been identified in mice.

Identification of Cell Populations Enriched for Hematopoietic Stem Cells

The CD34 antigen is a cell surface type 1 transmembrane protein which is highly O-glycosylated and expressed primarily on hematopoietic progenitor cells and vascular endothelium from many tissues.^{29, 30, 31} It is also expressed on stromal cell precursors identified by the STRO-1 antibody. Cell surface expression of CD34 is developmentally regulated in hematopoiesis and is inversely related to the stage of differentiation such that CD34 expression is absent beyond the committed progenitor stage. The functional significance of CD34 expression on hematopoietic progenitor cells, stromal cells, and developing blood vessels is unknown, except that CD34 on vascular endothelial cells binds to L-selectin.³² The CD34 antigen is expressed on 1% to 5% of normal human adult marrow cells, up to 1% of mobilized peripheral blood cells, and by 2% to 10% of normal fetal liver and marrow cells.^{29, 33} Approximately 90% to 95% of the CD34-positive cells express antigens indicating commitment to the lymphoid or myeloid lineages.^{34, 35} Purified populations of HSC can be obtained with strategies that lineage-deplete a CD34-positive population of cells using monoclonal antibodies specific for DR, CD33, CD38, CD71, and B and T cell markers (Table 102.2). Other work suggests that human HSC are Thy-1^{low}, c-KIT^{low}, Rhodamine¹²³^{low}, and CD133-positive.^{36, 37, 38, 39, 40, 41} In vivo preclinical models for studying populations of purified human HSCs based on the aforementioned characteristics include transplantation into SCID-Hu mice or into fetal sheep.^{40, 42, 43}

Enriched populations of autologous CD34-positive marrow cells or blood cells, in both animal and human studies, have been shown to protect from myeloablative doses of radiation or chemotherapy.^{22, 44, 45} Conversely, the CD34-negative subset of the marrow was not protective.^{46, 47} Complete and stable donor hematopoietic chimerism has also been shown in humans after transplantation with allogeneic CD34-enriched cells from the peripheral blood.^{24, 48} Thus, CD34-positive hematopoietic cells are capable of long-term stable reconstitution of multiple hematopoietic lineages.

Sites of Hematopoiesis and for Collection of Hematopoietic Stem Cells

In the developing human embryo, the production of hematopoietic cells shifts to the liver from the yolk sac after 6 weeks of gestation. At 16 weeks of gestation, the most active site of hematopoiesis is the fetal liver. At the end of gestation, essentially all hematopoietic production derives from the marrow with only small contributions from the liver and spleen. Umbilical cord blood is enriched for HSC. The number of progenitors in one cord blood unit were comparable to the number of progenitors from adult marrow that had been reported to achieve successful engraftment.⁴⁹

Historically, the bone marrow served as the routine collection site for HSC.⁵⁰ Marrow is a clinically reliable and easily accessible source of long-term reconstituting cells. The presence of HSC in peripheral blood was first documented in preclinical studies.^{51, 52} In early clinical studies, transplantation of autologous peripheral blood HSC resulted in reconstitution of hematopoiesis following myeloablative chemotherapy or chemoradiotherapy; however, obtaining sufficient HSC required a prolonged period of collection.⁵³ To overcome this problem, granulocyte-colony-stimulating factor (G-CSF) can be administered to mobilize HSC from the marrow to the peripheral blood. Collections from G-CSF-mobilized peripheral blood yielded similar or greater numbers of HSC than that harvested from marrow.⁵⁴ Combining chemotherapy and G-CSF administration for mobilization resulted in higher yield of CD34-positive cells than G-CSF alone.⁵⁵ Plerixafor is a small molecule that reversibly inhibits chemokine stromal cell-derived factor-1 α binding to its cognate receptor CXCR4. In a randomized clinical trial, G-CSF with plerixafor was more effective than G-CSF alone for collection of stem cells in patients with myeloma.⁵⁶ In this study, a total of 54% of plerixafor-treated patients collected a target number of 6.0×10^6 CD34⁺ cells/kg after one apheresis, whereas 56% of placebo-treated patients required 4 daily aphereses to achieve this target. Other cytokines have been demonstrated to mobilize HSC into peripheral blood, including stem cell factor, granulocyte/macrophage-CSF, interleukin-6 (IL-6), IL-8, and flt-3 ligand.^{57, 58} While most normal donors receive only G-CSF for mobilization of HSC for allogeneic transplant, mobilization strategies including plerixafor or chemotherapy are now routinely used for the collection of autologous HSC from the peripheral blood of patients with hematologic malignancy.^{59, 60, 61} Plerixafor is not indicated for use in patients with acute leukemia.

Monoclonal antibodies specific to the adhesion molecule VLA-4 (very late antigen-4 or $\alpha 4\beta 1$ integrin) and VCAM-1 (vascular cell adhesion molecule-1) can also mobilize hematopoietic progenitors in nonhuman primates.^{62, 63} An essential step contributing to the release of hematopoietic progenitors from the marrow may be the cleavage of VCAM-1 expressed on stromal cells by neutrophil proteinases following the administration of G-CSF.⁶⁴ Hematopoietic progenitors reversibly downregulate VLA-4 expression and adhere significantly less to stroma and fibronectin during mobilization.⁶⁵ VLA-4 integrin expression is restored after progenitors are removed from the in vivo mobilizing milieu, which may account for their homing properties after transplantation.

SELECTION OF STEM CELL SOURCE

Autologous, syngeneic, and allogeneic are the three general categories of HSC grafts (Table 102.3). In general, the origin of HSC used for HCT is based on both the availability of the donor and the type of disease for which the patient is being

transplanted. While autologous HSC should be available for most patients, extensive prior cytotoxic therapy or heavy involvement of marrow with malignant cells may preclude the use of this source of HSC. Although the preferred allogeneic donor is an HLA-identical sibling, fewer than 30% of patients have access to this source. Availability of HLA-identical sibling donors for pediatric patients may be less than this because of the smaller family sizes now compared to previous generations. Syngeneic donors are available in less than 1% of cases, and phenotypically HLA-matched or one-antigen-mismatched haploidentical family donors are available in less than 5% of cases.⁶⁶ Approximately 30% to 40% of patients may identify a phenotypically HLA-matched unrelated donor from the volunteer registries.⁶⁷ The availability of unrelated (or related) umbilical cord blood banks increases the chances of successfully identifying a compatible allogeneic graft source for both pediatric and adult patients.^{68, 69, 70} HLA-haploidentical donors are also available for the majority of patients.

The disease for which transplantation is being considered is another important determinant for choice of stem cell source. Autologous, syngeneic, or allogeneic HSC can support hematopoietic recovery after myeloablative chemoradiotherapy for malignant hematologic and nonhematologic diseases. For acquired disorders of marrow function (e.g., aplastic anemia), syngeneic or allogeneic HSC are required.⁷¹ Patients with congenital hematopoietic or immunologic defects (e.g., thalassemia, severe combined immunodeficiency (SCID) syndrome) require transplantation with allogeneic stem cells or gene-modified autologous stem cells.^{72, 73, 74, 75}

P.2162

TABLE 102.3 POTENTIAL SOURCES OF HEMATOPOIETIC STEM CELL (HSC) FOR HEMATOPOIETIC CELL TRANSPLANTATION

	Relationship of Donor	MHC (HLA)-Identical Matching	Genetically Identical Haplotype	mHC ^a Matching	Site of HSC Collection
I. Syngeneic	Sibling	Identical	2	Identical	Marrow or peripheral blood
II. Allogeneic	Sibling	Identical	2	Shared	Marrow, peripheral blood, or umbilical cord blood
	Sibling, Parent, Child	0-3 Antigen ^b Mismatch	1	Shared	Marrow, peripheral blood, or umbilical cord blood (sibling or child)
	Unrelated	Identical 1 Antigen Mismatch or 2 Allele Mismatch	0	Divergent	Marrow or peripheral blood
	Unrelated	0-3 Antigen Mismatch	0	Divergent	Umbilical cord blood
III. Autologous	Self				Marrow or peripheral blood

HLA, human leukocyte antigen; mHC, minor histocompatibility complex; MHC, major histocompatibility complex.

^a Shared indicates a higher probability of sharing mHC antigens within the family. Divergent indicates that the probability of sharing mHC antigens is no better than what is expected by matching two unrelated individuals who were randomly chosen. There is currently no routine testing for mHC compatibility.

^b Two or three antigen mismatched transplants of unmanipulated marrow grafts from adult or pediatric family donors have in general a higher transplant-related mortality.

Autologous Source of Stem Cells

Autologous marrow or mobilized peripheral blood stem cells are the grafts of choice for many patients. Autologous stem cell support is most commonly derived from “mobilized” peripheral blood stem cells instead of marrow because of faster hematopoietic recovery in the recipient.⁶⁰ Peripheral blood stem cell transplants have decreased the time required for hospitalization. Autologous stem cell support after myeloablative therapy has been successful for treatment of acute myelogenous leukemia (AML), non-Hodgkin lymphoma, and Hodgkin lymphoma.^{76, 77, 78, 79} Disease-free survival was prolonged in patients with multiple myeloma receiving a single autologous or two sequential autologous transplants.^{80, 81} Significant transplant-related complications encountered most frequently include infections and organ toxicity of the liver or lung, caused in large part by the high-dose myeloablative cytotoxic therapy. A GVHD-like syndrome (also known as the engraftment syndrome or pseudo-GVHD) of the skin and gastrointestinal tract has been described, but it is generally not frequent or severe.^{82, 83}

Allogeneic Source of Stem Cells

Transplantation from Related Donors

Hematopoietic cell grafts from related donors may be HLA-identical or HLA-haploidentical. The preferred allogeneic donor has been a genotypically HLA-identical sibling. A genetic match at the HLA loci between siblings is confirmed by the genotyping of 5 HLA loci including HLA-A, HLA-B, HLA-C, HLA-DRB1, and HLA-DQB1. If an HLA-identical sibling is available, patients with hematologic malignancies should be transplanted with peripheral blood stem cells rather than marrow. Two phase 3 studies have now shown an improved disease-free and overall survival with transplantation of peripheral blood stem cells (Fig. 102.2).^{84, 85} Ten year follow-up of the study by Bensinger et al. showed that the benefit persisted for disease-free survival, but the likelihood of overall survival was not significantly different between the 2 groups.⁸⁶ The 10-year cumulative incidence of chronic GVHD and the duration of systemic immunosuppression were similar between the 2 groups. A third study concluded that peripheral blood was an equivalent source of HSCs compared with marrow if administered to patients with standard-risk leukemia, since a significant difference in survival could not be demonstrated.⁸⁷ All 3 studies showed an accelerated recovery of neutrophil counts in the group receiving peripheral blood stem cells. Although most studies have not shown a significant increase in the incidence of acute GVHD in the peripheral blood stem cell group, the incidence of chronic GVHD was significantly greater.^{84, 85, 87, 88} Higher doses of CD34-positive cells in the peripheral blood stem cell graft ($>8.0 \times 10^6/\text{kg}$) have been significantly associated with the development of chronic GVHD.⁸⁹ Since outcome is unlikely to be improved if there is an increased risk of chronic GVHD from the use of peripheral blood stem cells, patients with nonmalignant disorders are still being transplanted with marrow in some centers. With a median follow-up of 6 years, survival of aplastic anemia patients transplanted with marrow was 88% (Fig. 102.3).⁹⁰ In a retrospective analysis by CIBMTR, rates of chronic GVHD and overall mortality were greater after transplantation with peripheral blood stem cells than marrow, especially in the younger patient population (<20 years of age).⁹¹ Similar survivals to those observed after HCT for aplastic anemia have been reported in patients transplanted with marrow for hemoglobinopathies.^{72, 92}

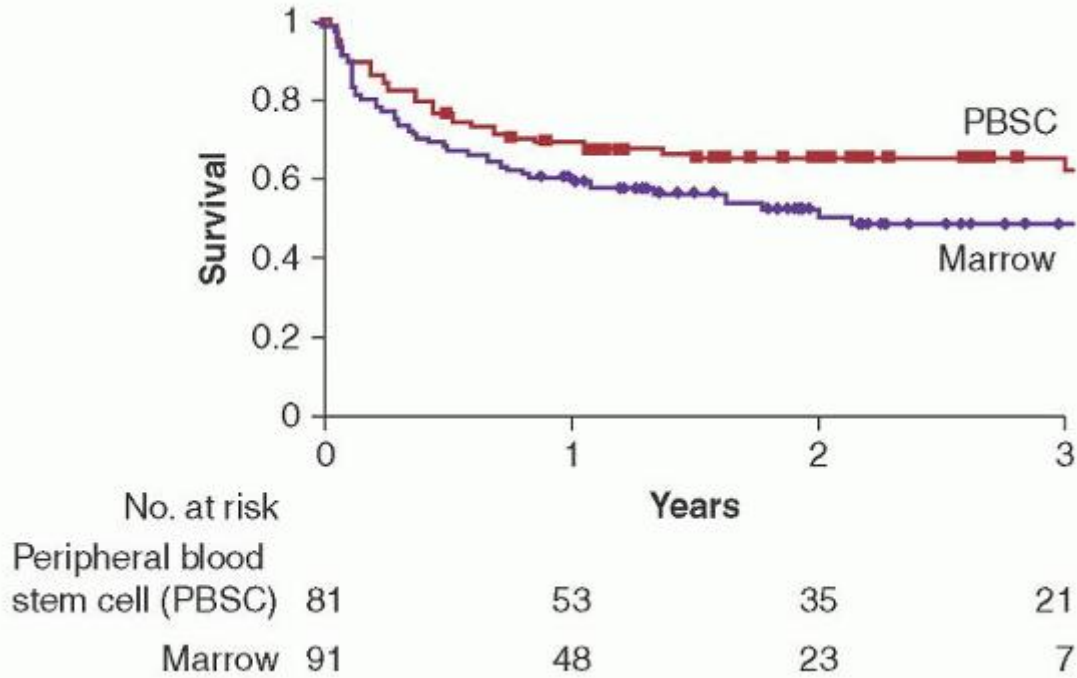

FIGURE 102.2. Probability of overall survival after myeloablative conditioning and transplantation with either peripheral blood stem cells or marrow. Survival at 2 years was improved in the peripheral blood stem cell group as compared to marrow (66% vs. 54%; $P = 0.006$). Disease-free survival was also improved in the peripheral blood stem cell group ($P = 0.003$). (Reprinted with permission from Bensinger WI, Martin PJ, Storer B, et al. Transplantation of bone marrow as compared with peripheral blood cells from HLA-identical relatives in patients with hematologic cancers. *N Engl J Med* 2001;344:175-181. Copyright 2001 Massachusetts Medical Society. All rights reserved.)

P.2163

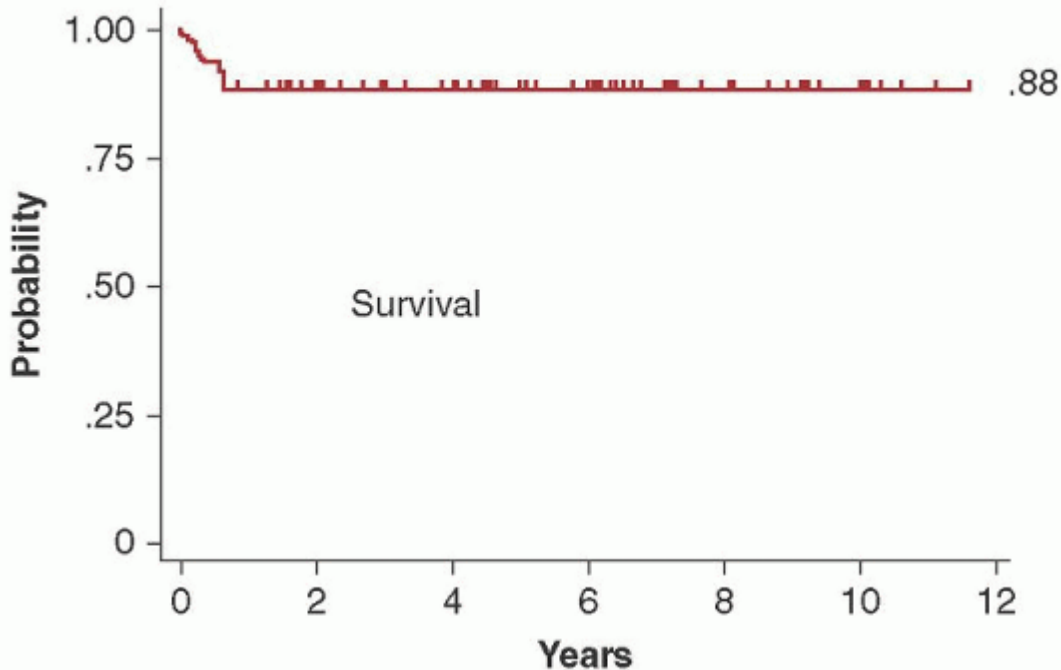

FIGURE 102.3. Overall survival among 94 patients with aplastic anemia who underwent transplantation from HLA-identical siblings after conditioning with cyclophosphamide (CY) and antithymocyte globulin. With a median follow-up of 6.0 (0.5 to 11.6) years, the Kaplan-Meier estimate of survival was 88%. Cyclosporine and methotrexate were administered after transplantation for graft-versus-host disease (GVHD) prophylaxis. (Reprinted with permission from Storb R, Blume KG, O'Donnell MR, et al. Cyclophosphamide and antithymocyte globulin to condition patients with aplastic anemia for allogeneic marrow transplantations: the experience in four centers. *Biol Blood Marrow Transplant* 2001;7:39-44.)

An HLA-haploidentical donor (parent, sibling, child) is available for almost all patients, but haplotype differences (genotypically identical at one HLA haplotype but nonidentical at the other HLA haplotype) are associated with a high risk of severe GVHD, graft rejection, and increased mortality with conventional posttransplant immunosuppression. However, transplants for hematologic malignancies from HLA-haploidentical family members mismatched for only one HLA antigen in the nonidentical HLA haplotype may have a similar overall survival to transplants from HLA-identical siblings.⁹³ In this situation, although the higher incidence of GVHD results in an increased transplant-related mortality, relapse is less frequent, resulting in no overall difference in long-term survival compared to transplants from HLA-matched siblings. Patients transplanted from HLA-haploidentical family members mismatched for 2 or more HLA loci had significantly lower overall survivals compared to patients transplanted from phenotypically HLA-matched unrelated donors.⁹⁴ In patients with advanced leukemia, transplantation with high-dose CD34-positive cell grafts which had been highly T cell-depleted resulted in 12 of 43 patients being alive and disease-free at 18 months.⁹⁵ Immune reconstitution after transplantation was poor, however.⁹⁶ High-dose cyclophosphamide (CY) early after HCT from an HLA-haploidentical donor appears effective in preventing the development of severe acute and chronic GVHD.^{97, 98} In a report of parallel phase 2 studies, transplantation of HLA-haploidentical marrow grafts appeared to have favorable outcomes at 1 year compared to transplantation of umbilical cord blood grafts.⁹⁹ Patients who lack a closely matched family donor should be offered a phenotypically HLA-matched unrelated donor before considering a transplant from an HLA-haploidentical donor.

Transplantation from Unrelated Donors

After the initial success with transplantation of marrow from matched unrelated volunteers, large databanks were established around the world, including the National Marrow Donor Program (NMDP) in the United States. Available through the world-wide registries and the NMDP are approximately 20 million volunteer donors who have been typed for HLA-A and -B antigens, and many of these are also typed for HLA-DR (www.bmdw.org). Certain racial and ethnic groups are underrepresented in the registry and therefore there is a lower probability that an HLA-matched donor will be found.

Outcomes have improved after HCT from HLA-matched unrelated donors because of improved supportive care and high-resolution HLA typing. Outcomes after HCT from an unrelated donor are now comparable to what is observed after HCT from an HLA-identical sibling. In a study of 2,223 adult AML patients, the overall survival after transplantation from 8/8 HLA-matched donors was similar to that observed after transplantation from an HLA-identical sibling (RR = 1.03; P = 0.62).¹⁰⁰ The risk of acute GVHD, however, was lower after transplantation from an HLA-identical sibling.

The relative importance of the various HLA loci has been defined for HCT from unrelated donors. In a study from CIBMTR of 3,857 transplants performed from 1988 to 2003, it was observed that high-resolution DNA matching for HLA-A, HLA-B, HLA-C, or HLA-DRB1 (8/8 match) was the minimal level of matching associated with the highest survival.¹⁰¹ A single mismatch at HLA-A, HLA-B, HLA-C, or HLA-DRB1 (7/8 match) was associated with an increased mortality compared to an 8/8 match. A single mismatch at HLA-B and HLA-C appeared better tolerated than a mismatch at HLA-A and HLA-DRB1. A mismatch at HLA-DQ or HLA-DP loci did not have an effect on survival. Ninety-four percent of the transplants in this study were performed with marrow grafts. In a follow-up study, the association between HLA matching and outcomes was investigated for transplantation of peripheral blood stem cells from unrelated donors.¹⁰² Survival was better with 8/8 HLA matching compared to 7/8 HLA matching. Single HLA-C antigen mismatches were associated with an increased risk of treatment-related mortality and grade III-IV acute GVHD. HLA-B antigen/allele mismatching was associated with an increased risk of grade III-IV acute GVHD with no effect on survival. No significant differences in outcomes were observed with HLA-C allele mismatches, HLA-A antigen/allele mismatches, or HLA-DRB1 mismatches compared to 8/8 HLA-matched pairs. The differences in the reported associations for HLA mismatches between marrow and peripheral blood stem cell grafts may result from differences in cell numbers in the graft as well as the graft composition.

Disease status is an important consideration in the search process. In patients with advanced malignancies, survival after transplantation from an HLA-matched or 1-antigen/allele HLA-mismatched unrelated donor was similar.¹⁰³ Therefore, when transplants cannot be delayed because of disease status, selection of a donor with the fewest HLA mismatches may be an alternative choice for patients without a completely HLA-matched donor.

Because of the possible higher risk of acute GVHD, studies of peripheral blood stem cell transplantation from unrelated donors started later than those done from HLA-identical donors. A recently completed randomized clinical trial (BMTCTN 0201) comparing marrow to peripheral blood stem cells observed that there was no difference in overall survival, disease-free survival, nonrelapse mortality, relapse, or acute GVHD outcomes at 2 years between the 2 arms. There was a significantly increased risk of chronic GVHD.

Transplantation with Umbilical Cord Blood Grafts

There are several advantages to the use of umbilical cord blood when compared to unrelated donor peripheral stem cell or marrow product harvested from adults. First, umbilical cord blood represents a potentially nonlimiting donor source for transplantation. At present, over 550,000 HLA typed cord bloods are banked and are conceivably available with several days notice (www.bmdw.org). Many of the banked specimens are from underrepresented ethnic and racial groups, thus expanding the potential donor pool for individuals poorly served by the unrelated donor marrow registries. The total nucleated cell dose required for successful engraftment is 10-fold less than that required for conventional peripheral blood or marrow transplant. The transmission

P.2164

of Epstein-Barr virus (EBV) or cytomegalovirus (CMV) is negligible compared to conventional allogeneic transplantation. HLA allele mismatches (up to 2 to 3 loci) are permissible in cord blood transplantation. Notable disadvantages to cord blood transplantation are the potential for prolonged pancytopenia and lower rates of overall engraftment.

The first successful cord blood cell transplant in a pediatric patient was done in 1988.⁶⁹ Two studies were then successfully conducted of cord blood transplantation from HLA-matched or HLA-haploidentical allogeneic siblings (44 patients) and partially HLA-mismatched unrelated donors (25 patients).^{104, 105} In the first report of a large experience in 562 recipients (including 18% adults) after transplantation with umbilical cord blood grafts from unrelated donors, the probability of engraftment at 42 days and grade III-IV GVHD, was 81% and 23%, respectively.¹⁰⁶ It was concluded from this study that umbilical cord blood grafts regularly engraft and cause a low rate of GVHD relative to the number of HLA mismatches, and produced survival rates comparable to those with transplantation of marrow from unrelated donors. This experience was confirmed in a retrospective analysis of 541 children with leukemia transplanted with stem cell grafts from unrelated donors of which 99 were from umbilical cord blood.¹⁰⁷ Recipients of cord blood had an increased number of HLA mismatches but a lower risk of both acute and chronic GVHD compared to recipients of unmanipulated marrow from unrelated donors. The day 100 mortality was higher, however, in the cord blood group, possibly because of the significantly delayed recovery of hematopoiesis and immunity after transplantation. These results were later confirmed by another group.¹⁰⁸ It was concluded that the use of umbilical cord blood was an option for children with acute leukemia lacking an acceptably matched unrelated marrow donor. In children who had received umbilical cord blood or bone marrow grafts from HLA-identical siblings, the umbilical cord blood group had a lower risk of acute and chronic GVHD (relative risk 0.41 [P = 0.001] and 0.35 [P = 0.02]), respectively.¹⁰⁹ Survival was similar in both groups. The progenitor cell and CD34-positive cell content of the umbilical cord blood graft predicted the rate of neutrophil recovery after transplantation.¹¹⁰

The reported low incidence of severe GVHD after transplant of umbilical cord blood cells from unrelated donors (relative to the degree of HLA disparity) may be related to the decreased immunocompetence of the fetal blood cells compared to adult cells.¹¹¹ Two years after transplantation, T cell receptor rearrangement excision circles (TRECs), a measure of recent thymic output, were greater in recipients of umbilical cord blood than in recipients of marrow grafts, suggesting complete immune recovery despite the low number of cells infused.¹¹²

Initially, recipients of umbilical cord blood cell transplants had been mostly children. Even though, at first, there was a concern about the low cell count for the larger body size, outcomes in adults were comparable to those reported in children.¹¹³ Prospective trials comparing cord blood transplantation to unrelated peripheral blood/marrow transplants are not available; however, two large registry or retrospective studies summarizing consortia experience for acute or chronic leukemias have been published.^{114, 115} Slower engraftment kinetics, reduced engraftment rates, and decreased acute and chronic GVHD rates and severity were observed in the cord blood transplantation groups. Rates of relapse reported for the two studies were similar between the 2 groups. Transplant-related complications, including delayed recovery of blood counts after cord blood transplantation, may be reduced in the adult population with reduced intensity conditioning.¹¹⁶

Transplantation of multiple cord blood units was investigated to determine if recovery of neutrophil and platelet counts after transplantation could be improved.¹¹⁷ After the infusion of two umbilical cord blood grafts into adult patients, the median day to neutrophil recovery was 24 (range 12 to 28) in 23 adult patients compared to 27 (range 13 to 59) in another

study of 68 adult patients transplanted with a single cord blood unit.¹¹³ This observation of improved recovery times was not confirmed in a retrospective study at a single institution.¹¹⁸ After transplantation with 2 cord blood units, only one unit eventually dominates and engrafts long-term.¹¹⁹ Higher CD3⁺ cell dose and percentage of CD34⁺ viability were associated with unit dominance. Higher dominant unit total nucleated cells, CD34⁺ cells, and colony-forming unit doses were associated with higher sustained engraftment and faster neutrophil recovery. Mechanistically, the dominant cord mounts an allogeneic immune response mediated by CD8⁺ T cells against the nondominant unit.¹²⁰ Outcomes after double cord blood transplantation were compared with outcomes after transplantation from HLA-matched related donors, HLA-matched unrelated donors, and 1-antigen HLA-mismatched unrelated donors.¹²¹ Leukemia-free survival at 5 years was similar for all donor types. The risk of relapse was decreased in the double cord blood transplantation group compared to the other donor types, but the risk of nonrelapse mortality was increased. The lower risk of relapse after transplantation from a double cord blood unit compared to a single cord blood unit had been previously seen in another retrospective study, although a significantly increased risk of acute GVHD was also observed.¹¹⁸ Sharing of one or more HLA-A, B, or DRB1 loci between the inherited paternal MHC alleles (IPA) of the donor and the recipient after unrelated cord blood transplantation leads to superior leukemia-free survival with no increase in acute GVHD, a result attributed to maternally derived anti-IPA elements persisting in the cord blood.¹²²

Umbilical cord blood grafts should be considered for both pediatric and adult patients lacking a suitably matched unrelated donor or unable to wait for an unrelated search to be completed.

COLLECTION OF HEMATOPOIETIC STEM CELLS FOR TRANSPLANTATION

Marrow

Marrow is obtained by multiple aspirations from the posterior iliac crest under general or epidural anesthesia.¹²³ The anterior iliac crest (or the sternum) may also be harvested if larger quantities of marrow are required. The target volume of marrow for transplant is 10 to 15 ml/kg of recipient or donor weight, whichever is the smaller individual. Marrow is collected with heparinized syringes through large bore needles and placed into small amounts of culture medium. The collected marrow must be filtered prior to intravenous transfusion into the recipient to remove small particles or clots. If the patient and donor are ABO-incompatible and there are high anti-A or -B titers, the marrow can be red blood cell-depleted or plasma-depleted, depending on whether it is a major or minor ABO mismatch.¹²⁴ In some cases of a major ABO mismatch, plasmapheresis of the recipient may be effective in reducing the high anti-A or anti-B titers so that RBC depletion of marrow is not required. Marrow is infused immediately after harvesting, but delays of 24 hours may occur without adverse consequences. Such delays are common when marrow is shipped to a transplant program after harvest from an unrelated donor. In an analysis of marrow harvest characteristics of 1,549 donors, the median total nucleated cell count from the marrow was 2.5 (range 0.3 to 12.0) $\times 10^8$ /kg recipient weight.¹²⁵ Life-threatening complications from marrow harvesting, usually related to the administration of anesthesia, were reported in 0.27% to 0.4% of the donors.¹²⁶

Peripheral Blood

HSC circulate in the peripheral blood but the concentration is very low and it requires multiple aphereses to collect adequate

P.2165

numbers. The number of aphereses may be reduced to one or two sessions when HSC are mobilized to the peripheral blood after the administration of cytokines alone or in combination with chemotherapy or plerixafor. An effective mobilization strategy of autologous HSC for patients with malignancy is chemotherapy in conjunction with G-CSF, 6 $\mu\text{g}/\text{kg}/\text{day}$.⁶¹ After chemotherapy, patients are apheresed when the total white blood cell count has recovered to 1,000/ μl or the CD34-positive cell count in the peripheral blood is at least $>10/\mu\text{l}$. For patients not requiring chemotherapy or normal allogeneic donors, mobilization is with G-CSF alone (5 to 16 $\mu\text{g}/\text{kg}$) by daily subcutaneous injections for 5 to 8 days.^{48, 127, 128} These doses of G-CSF are generally well tolerated, with common side effects of bone pains, myalgias, and flu-like symptoms that are managed with acetaminophen or low-dose narcotics. Plerixafor in combination with G-CSF was effective for increasing the yields of circulating CD34⁺ progenitor cells and is indicated for patients with lymphoma or multiple myeloma who are being collected for autologous HCT.⁵⁶ The recommended dose is 0.24 mg/kg/day administered subcutaneously 11 hours before the apheresis procedure. The maximum dose is 40 mg/day. Common side effects included diarrhea, nausea, fatigue, headaches, and arthralgias. Apheresis was performed as early as day 4 after the start of G-CSF using a continuous blood flow separation technique. Apheresed products may be cryopreserved in 5% dimethylsulfoxide (DMSO) for use after thawing on the day of transplant. A more rapid sustained hematopoietic recovery of both neutrophil and platelet counts occurs with increasing numbers of CD34⁺ cells in the hematopoietic cell graft (up to

$5 \times 10^6/\text{kg}$). Some investigators consider $2.5 \times 10^6/\text{kg}$ of recipient weight a minimum dose of CD34^+ cells from the peripheral blood to achieve complete autologous recovery. Platelet recovery is more rapid at higher CD34^+ cell doses.^{60, 61} Since the cell dose used in the autologous transplant setting yields consistent and prompt engraftment, it is also considered an appropriate target for collection of allogeneic HSC from the peripheral blood. Donors of peripheral blood avoid general anesthesia and other complications of marrow harvesting. If peripheral veins are inadequate, a large bore double lumen catheter for vascular access may be required. In a large analysis of safety from the NMDP ($n = 2,408$ donors), it was concluded that collection of peripheral blood stem cells was safe but that nearly all patients will experience bone pain and 1 in 4 will have headache, nausea, or citrate toxicity.¹²⁹ Serious and unexpected toxicities were experienced by 0.6% of the donors, but complete recovery was universal.

Cord Blood

Umbilical cord blood cells are now being routinely collected and cryopreserved for storage in a cord blood bank.^{130, 131} Directed-donor banking of cord blood for siblings in a current good tissue practices environment has also now been reported.¹³² After the separation of the placenta, umbilical cord blood cells are collected into a closed system which utilizes a sterile donor blood collection set. The placenta and umbilical cord can be suspended on a frame and the blood drained as a "standard gravity phlebotomy" into CPD (citrate, phosphate, dextrose) anticoagulant. The median volume of umbilical cord blood collected in one study of 44 patients was 100 ml (range 42 to 282 ml).¹⁰⁴ The median number of total nucleated cells per kilogram of recipient weight for banked umbilical cord blood is 2.5×10^7 (range 1 to 33) and corresponds to a CD34^+ cell dose of 1.5×10^5 per kilogram of recipient weight.¹¹⁰

ABO INCOMPATIBILITY

ABO incompatibility between the donor and the recipient occurs in about 30% of cases. A major ABO incompatibility is considered to occur when the isohemagglutinins in the recipient plasma are directed against the donor red blood cell antigens. A minor ABO incompatibility is when the isohemagglutinins in the donor plasma are directed against recipient red blood cell antigens. ABO incompatibility between the donor and the recipient has no significant effect on the incidence of graft rejection, GVHD, or survival, although bidirectional ABO mismatches were associated with a higher risk of grade III-IV acute GVHD.¹³³ ABO incompatibilities may result in severe hemolytic episodes after transplantation. For major ABO incompatibilities, if the recipient isohemagglutinin titers in the plasma are high, an acute hemolytic event can be prevented by red cell depletion of the graft. Conversely, plasmapheresis may be effective in reducing the anti-donor isohemagglutinin in the recipient plasma. If the latter approach is chosen, the goal should be to reduce the isohemagglutinin titer to 1:16 or lower.¹³⁴ If there is continued production of anti-donor isohemagglutinins in the recipient plasma after transplantation, delayed erythropoiesis or even pure red cell aplasia and persistent hemolysis may result.¹³⁵ Although plasmapheresis and erythropoietin may be of some benefit, the hemolytic episode may persist for months after transplantation. If there are no contraindications, early withdrawal of immunosuppression may result in a more rapid resolution of the delayed hemolytic event, possibly because of a GVH reaction against the isohemagglutinin-producing cells of the recipient.¹³⁶ To prevent hemolytic events related to minor ABO incompatibilities, the isohemagglutinins can be removed from the stem cell graft if the anti-recipient titers are high. The risk of hemolysis from a minor ABO mismatch appears to be increased after peripheral blood stem cell transplantation, possibly related to the higher content of lymphoid cells (B cells) in the graft. The development of severe hemolysis may be prevented with the administration of methotrexate after transplantation.¹³⁷

CONDITIONING REGIMENS

Myeloablative

Myeloablative conditioning regimens are sufficiently intense that recovery of hematopoiesis would not be expected without the support of transplanted hematopoietic progenitor cells. The ideal myeloablative conditioning regimen should fulfill the following criteria: (1) eliminate or reduce the tumor load; (2) suppress the host immune system to prevent graft rejection (not applicable to hematopoietic support with autologous cells); and (3) have tolerable nonhematopoietic toxicity. The first conditioning regimens consisted of TBI, alone or in combination with cyclophosphamide (CY).⁵⁰ TBI is an effective antineoplastic modality that is both cell cycle nonspecific and immunosuppressive. CY is a chemotherapeutic agent with immunosuppressive properties that has few nonhematopoietic toxicities that are similar to TBI, and therefore can be used in combination. Other conditioning regimens which have since been developed include: (1) the replacement of CY with other chemotherapeutic agents (e.g., etoposide, Ara-C, and melphalan) in combination with TBI.^{138, 139}; (2) other chemotherapeutic agents in combination with both CY and TBI^{140, 141}; (3) chemotherapeutic agents used in combination with CY but without TBI, including busulfan (BU)/CY or carmustine-cyclophosphamide-etoposide (BCV)^{142, 143}; and (4) replacement of CY with fludarabine and used in combination with BU or melphalan.^{144, 145} In one study, BCV was

associated with a significant incidence of transplant-related complications and mortality.¹⁴⁶ Other high-dose cytotoxic regimens have been used, especially with autologous stem cell support.^{147, 148}

Most preparative regimens used for the treatment of malignant diseases have not been tested in Phase III studies, so it is generally unclear if any one regimen represents an improvement over those previously used. Two Phase III studies in allogeneic marrow transplantation have compared differing intensities of TBI

P.2166

(1,200 cGy versus 1,575 cGy).^{149, 150} The relapse rate was reduced in the group of patients receiving the higher dose of TBI, but was associated with an increase in complications from regimen-related toxicity and GVHD which negated any improvement in disease-free survival compared to the group receiving the lower dose of TBI. In a more recent study, conditioning with TBI 800 cGy and fludarabine was compared with TBI 1,200 cGy and CY and there was no difference in overall survival, relapse, or treatment-related mortality.¹⁵¹ The combination of BU/CY was determined to be an acceptable alternative to CY/TBI for patients with leukemia in several studies.^{152, 153, 154} However in one study, patients in the BU/CY group had an increased risk of sinusoidal obstruction syndrome (SOS) of the liver and other transplant-related complications.¹⁵⁵ Since this last study, it has been demonstrated that targeting of busulfan levels in the plasma may decrease the risk of relapse and severe regimen-related toxicities, contributing to an improved disease-free survival (Fig. 102.4).¹⁵⁶ Monitoring levels of metabolites from cyclophosphamide may also be important to decrease the risk of liver toxicity and nonrelapse mortality.^{157, 158}

In patients already profoundly immunosuppressed with SCID syndrome, engraftment of allogeneic stem cells from matched related siblings may occur without conditioning therapy.¹⁵⁹ High-dose CY in combination with antithymocyte globulin (ATG) as a preparative regimen for patients with aplastic anemia was associated with graft rejection in less than 5% of cases.⁹⁰ The actuarial survival rate was 88% at 6 years after transplantation (Fig. 102.3). For transplantation of patients with thalassemia or sickle cell disease, a myeloablative conditioning regimen, usually consisting of the combination of BU and CY, was thought to be necessary to prevent a high incidence of graft rejection, since most patients with these disorders had received multiple blood transfusions and were potentially sensitized to donor-derived mHC.^{160, 161} However, reduced intensity conditioning regimens have now been shown to successfully overcome the risk of graft rejection associated with these hematologic disorders.¹⁶²

Although HSC engraftment may be achieved after transplantation and some patients are cured, relapse remains an important problem in patients with advanced hematologic malignancies. Since further intensification of the conditioning regimen using current modalities is unlikely to improve overall survival because of associated increases in toxicity, new strategies will be required to achieve a cure. Radiolabeled monoclonal antibodies (i.e., radioimmunoconjugates) specific for certain lineage-specific cell surface antigens on tumor cells or sites from which the malignancy originates might enhance the efficacy of the conditioning regimen and decrease the rates of relapse.^{163, 164, 165, 166}

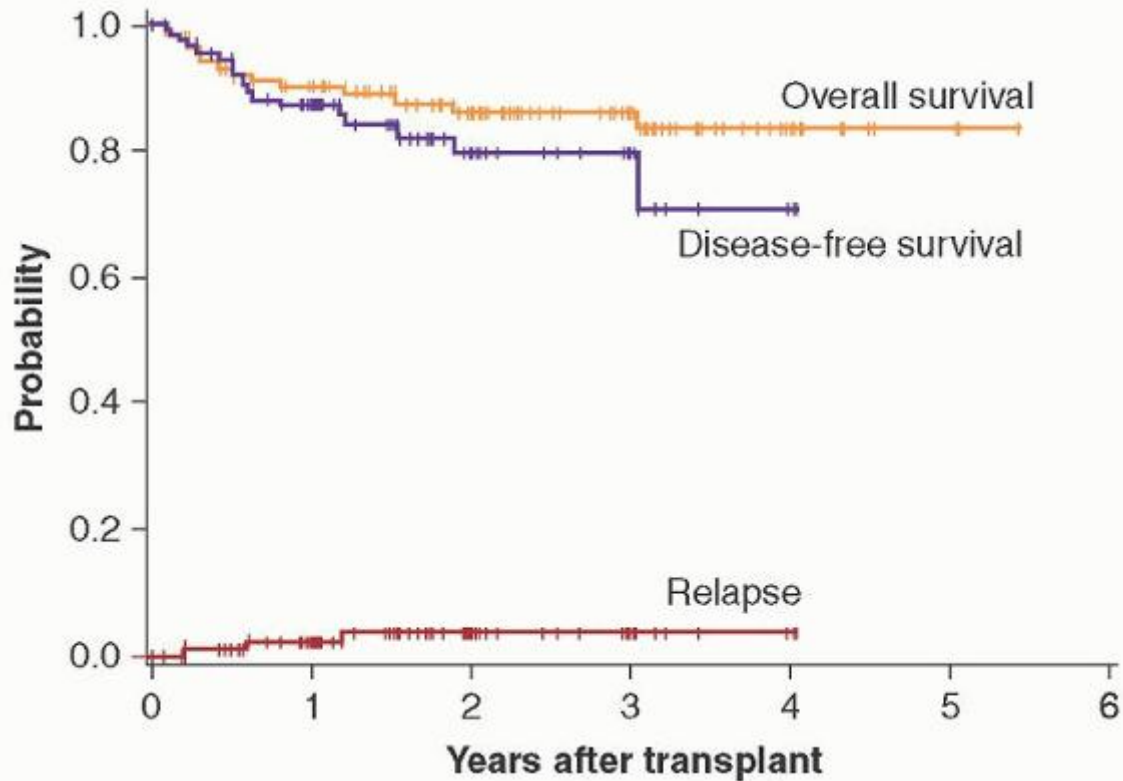

FIGURE 102.4. Outcomes for 131 patients after conditioning with cyclophosphamide and targeted busulfan followed by hematopoietic cell transplantation (HCT) from human leukocyte antigen (HLA)-identical siblings for chronic myelogenous leukemia in chronic phase. Graft-versus-host disease (GVHD) prophylaxis was with the combination of cyclosporine and methotrexate. The probability of survival was 86% at 3 years. (Reprinted with permission from Radich JP, Gooley T, Bensinger W, et al. HLA-matched related hematopoietic cell transplantation for chronic-phase CML using a targeted busulfan and cyclophosphamide preparative regimen. *Blood* 2003;102:31-35. Copyright American Society of Hematology.)

Nonmyeloablative

The development of nonmyeloablative or reduced intensity regimens permitted the application of potentially curative allogeneic HCT to older patients and those patients with contraindications to intensive cytotoxic regimens.¹⁶⁷ The success of the nonmyeloablative conditioning regimens in preclinical and clinical studies established new biologic principles which formed the basis of our understanding of the engraftment process after allogeneic HCT. The findings in these studies were consistent with the following conclusions about successful engraftment:

- Myeloablative therapy is not needed, since stem cell grafts can “create their own marrow space” with a GVH effect.
- Engraftment is promoted by posttransplant suppression of the host-versus-graft reaction.

There are multiple different nonmyeloablative conditioning regimens which have been piloted. The conditioning regimens fall into 2 broad categories: (1) reduced intensity regimens and (2) minimally myelosuppressive regimens.^{145, 168, 169, 170, 171, 172, 173} In general, after reduced intensity conditioning, recipients usually become aplastic from the regimen and complete chimerism is established early after transplantation. Reduced intensity conditioning regimens are of sufficiently low intensity that recovery of hematopoiesis would be expected without the support of hematopoietic progenitor cells. Although reduced in intensity, the regimen may contribute a substantial antitumor effect resulting in a tumor response early after transplantation. The minimally myelosuppressive or nonmyeloablative regimens rely on pretransplant and posttransplant immunosuppression to prevent graft rejection. After transplantation, a mixed chimeric state may persist for months before converting to full donor hematopoietic chimerism (Table 102.4).¹⁷² The regimen may be only mildly myelosuppressive resulting in a reduction in the requirements for blood products (Fig. 102.5).¹⁷⁴ The conditioning regimen would not be expected to have a substantial antitumor effect, so efficacy of the treatment is largely from a GVT effect.

TABLE 102.4 MEDIAN PERCENT AND CHIMERISM STATUS

	Day 28^a	Day 56^b
Median % (range) of donor cells		
T cells	60 (10-100)	91 (5-100)
PB neutrophils	91 (0-100)	99 (4-100)
Bone Marrow	87 (0-100)	95 (2-100)
Chimerism		
% Mixed ^c	86	79
% Full Donor ^d	14	21

^a 44 evaluable patients. One additional patient-donor pair had no identifiable DNA polymorphism, and evidence of donor cell engraftment was based on red blood cell polymorphisms.

^b 41 evaluable patients.

^c ≥ 1 and $\leq 95\%$ T cells of donor origin.

^d $>95\%$ T cells of donor origin.

McSweeney PA, Niederwieser D, Shizuru JA, et al. Hematopoietic cell transplantation in older patients with hematologic malignancies: replacing high-dose cytotoxic therapy with graft-versus-tumor effects. *Blood* 2001;97:3390-3400. Copyright American Society of Hematology, used with permission.)

P.2167

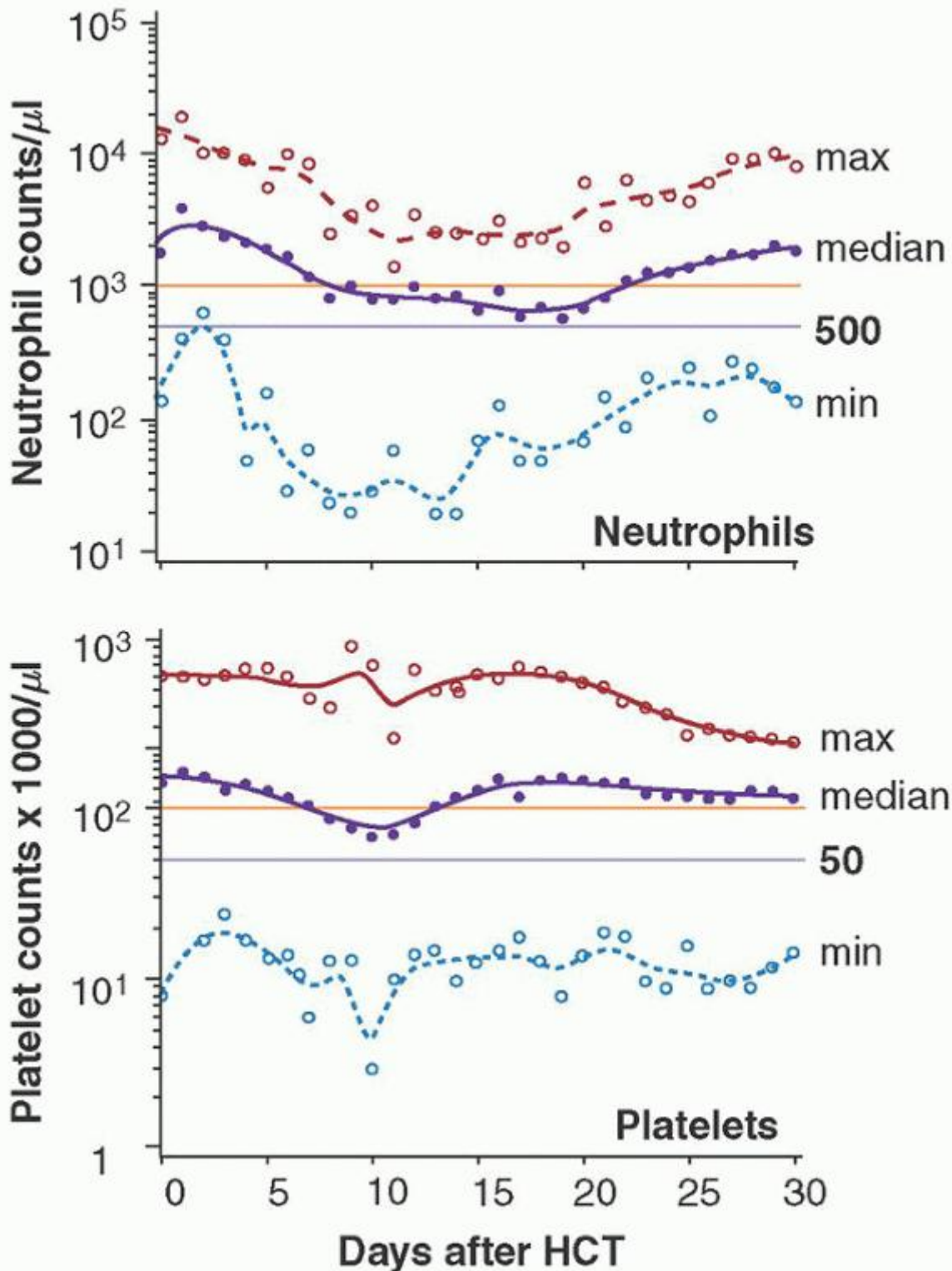

FIGURE 102.5. Engraftment after nonmyeloablative hematopoietic cell transplantation (HCT). Engraftment profile showing neutrophil and platelet changes after HCT. Graphs show the median (black lines) and range (broken lines) of neutrophil and platelet counts of all 45 patients on day 0 through 30. Circles represent the minimum and maximum values on each day. Min, minimum; max, maximum. (From McSweeney PA, Niederwieser D, Shizuru JA, et al. Hematopoietic cell transplantation in older patients with hematologic malignancies: replacing high-dose cytotoxic therapy with graft-versus-tumor effects. *Blood* 2001;97:3390-3400. Copyright American Society of Hematology, used with permission.)

Early studies of nonmyeloablative transplantation focused on patients with donors who were HLA-identical siblings because the risk of graft rejection and GVHD was considered less compared to other types of donors. Risk factors for graft rejection after conditioning with TBI 200 cGy alone were no prior intensive chemotherapy and a diagnosis of CML.¹⁷² When fludarabine was added to low-dose TBI, the incidence of graft rejection decreased. Nonmyeloablative conditioning regimens have also been effective for transplantation from alternative sources including unrelated donors and umbilical cord blood.^{175, 176, 177}

The allogeneic HSC graft can induce GVL/GVT effects. The effectiveness of the GVT effect can be best observed in the responses patients have had with the minimally myelosuppressive regimens (Fig. 102.6).^{172, 178, 179} In patients not otherwise eligible for a myeloablative conditioning regimen, sustained responses have been noted with AML, the chronic leukemias, lymphoma, and myeloma. A minimally myelosuppressive conditioning regimen may be appropriate for indolent hematologic malignancies including CML, chronic lymphocytic leukemia, agnogenic myeloid metaplasia, and low grade lymphomas.^{172, 180, 181, 182} In those diseases in which some cytreduction may be necessary, a reduced intensity regimen may be of more benefit. Another strategy is to use a cycle of chemotherapy or high-dose cytotoxic therapy and autologous transplantation to debulk the disease or induce a clinical remission followed by allogeneic nonmyeloablative transplantation.^{183, 184} The objective of this tandem approach is to consolidate the remission with a GVT reaction. The assessment of the patient, the disease type, and the disease status are required to determine the optimal approach. In retrospective comparisons

P.2168

of patient populations after myeloablative and nonmyeloablative conditioning regimens, no difference in overall survival was observed.^{185, 186, 187} However, relapse rates were higher in patient groups which had received a nonmyeloablative conditioning regimen.

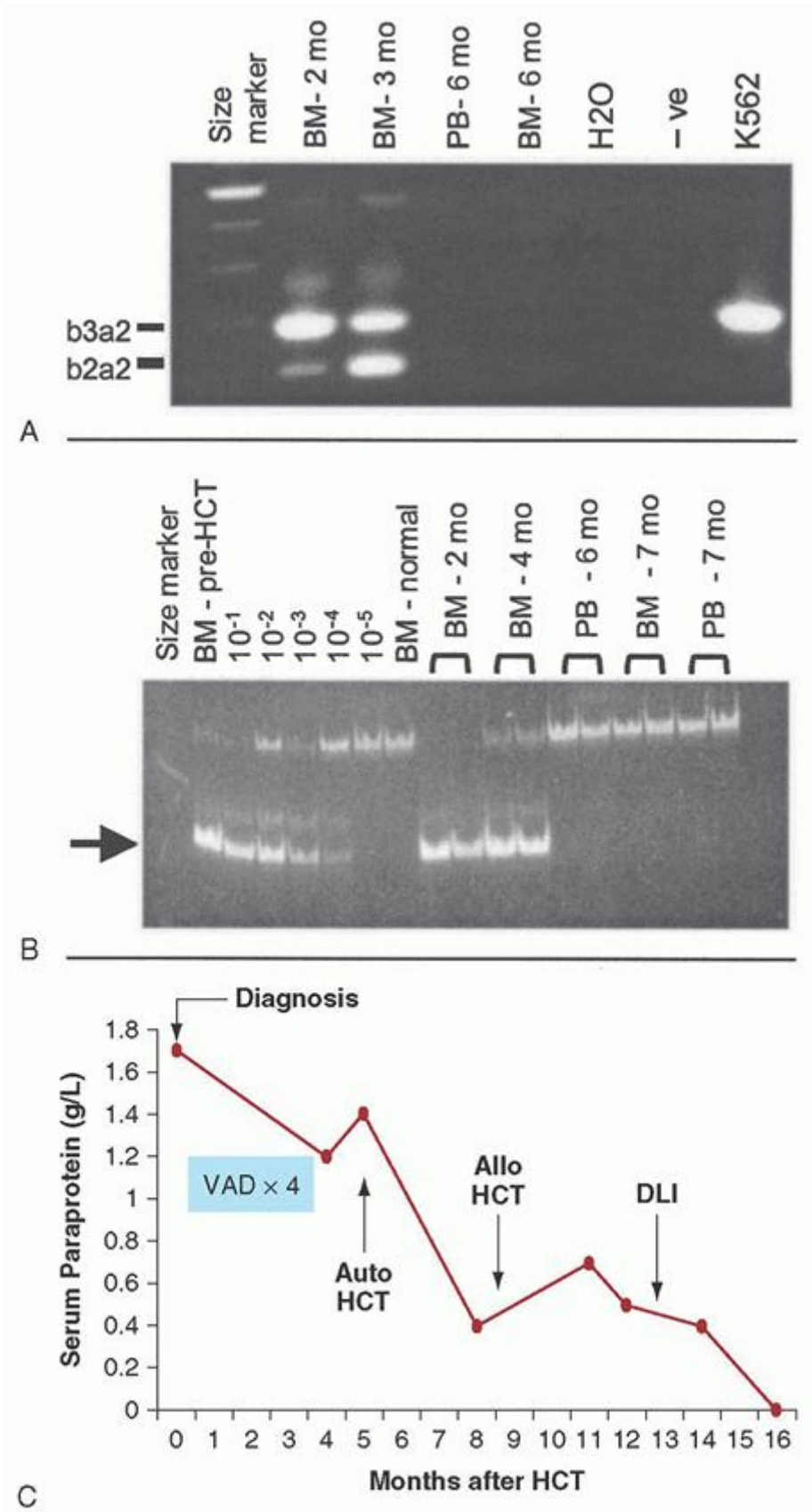

FIGURE 102.6. Complete disease responses after HCT. A: Example of molecular remission of chronic myelogenous leukemia (CML) induced by nonmyeloablative hematopoietic cell transplantation (HCT) without donor lymphoid infusion,

as documented by failure of reverse transcription-polymerase chain reaction (PCR) to detect BCR-ABL transcripts. The lane described “-ve” is negative control of normal bone marrow (BM). K562 is a positive control for BCR-ABL. B: Example of molecular remission of chronic lymphocytic leukemia (CLL) induced by HCT without donor lymphocyte infusion as documented by PCR to detect a tumor-specific immunoglobulin heavy-chain gene arrangement (arrow). Each posttransplantation sample was amplified in duplicate. The lanes designated 10^{-1} to 10^{-5} show a dilution series of the patient's pretransplantation sample (more than 90% tumor cells) into normal bone marrow. C: Example of complete remission of multiple myeloma after allogeneic HCT. The patient was initially treated with four cycles of vincristine, adriamycin, and dexamethasone. High-dose cytoreduction with melphalan 200 mg/m^2 and autologous transplantation was performed 3 months before allogeneic HCT. Donor lymphocyte infusion was given 4 months after HCT because of persistent tumor. After complete remission was achieved, trace levels of serum monoclonal paraprotein were detected by immunofixation intermittently in follow-up testing. DLI, donor lymphocyte infusions. (From McSweeney PA, Niederwieser D, Shizuru JA, et al. Hematopoietic cell transplantation in older patients with hematologic malignancies: replacing high-dose cytotoxic therapy with graft-versus-tumor effects. *Blood* 2001;97:3390-3400. Copyright American Society of Hematology, used with permission.)

GVHD and infections are the major reasons for transplant-related treatment failure after nonmyeloablative transplantation. Since these patients, in general, have been older and at higher risk of poor outcome based on preexisting complications at baseline, nonmyeloablative transplantation has been well tolerated compared to what could have been expected after myeloablative conditioning. The day 100 and year 1 treatment-related mortality has been reported as 3% and 16%, respectively, but significantly less than after myeloablative conditioning.¹⁸⁸ Earlier clinical trials of nonmyeloablative conditioning regimens had given short courses of immunosuppressive therapy or early administration of donor lymphocyte infusions (DLI). GVHD tended to develop later, with many cases developing at 3 to 6 months after transplantation.¹⁸⁹ The cumulative incidence of acute grade II-IV GVHD was less after a nonmyeloablative than a myeloablative conditioning regimen (64% versus 85%, $p = 0.001$). There was no difference in the incidence of chronic GVHD. GVHD developed in many patients as late as 6 to 12 months after nonmyeloablative conditioning and HCT. The incidence of acute GVHD decreased when GVHD prophylaxis was administered for a longer period after HCT.¹⁹⁰ Acute GVHD did not have a significant impact on the risk of progression but had an association with increased risk of nonrelapse mortality. Chronic GVHD was associated with a decreased risk of relapse or progression ($P = 0.006$) and an increased probability of progression-free survival ($P = 0.003$).¹⁷⁸ Strategies for the optimal management of GVHD are required so that complications are reduced but do not prevent an effective GVT response.

In the presence of a major ABO incompatibility, delayed development of donor red cell chimerism resulting in an increased need for red blood cell products has been reported.¹³⁶ Withdrawal of cyclosporine may induce a graft-mediated immune reaction against recipient isohemagglutinin-producing cells, thus resulting in a decrease in isohemagglutinin levels and improvement in donor red blood cell chimerism. The onset of CMV disease may be delayed after nonmyeloablative transplantation.^{191, 192} Patients after nonmyeloablative conditioning with a minimally myelosuppressive regimen can generally be managed in the outpatient setting.

ENGRAFTMENT

Stable engraftment of a hematopoietic cell graft requires the circulation, homing, and growth of HSC. The number of CD34^+ cells that are required to ensure prompt recovery of neutrophil and platelet counts is 2.5 to $5.0 \times 10^6/\text{kg}$. In addition, adequate suppression of the host immune system is required to prevent graft rejection after allogeneic HCT. To achieve adequate immunosuppression, conditioning regimens may be myeloablative or nonmyeloablative. Donor T cells are important to prevent graft rejection, even with the concomitant administration of substantial numbers of CD34^+ cells.¹⁹³ Although infrequently observed in humans, a single stem cell may substantially reconstitute hematopoiesis (clonal dominance) and demonstrates the considerable proliferative potential of a normal HSC.^{194, 195} In many clinical trials of HCT, engraftment has generally been defined as the achievement of a peripheral blood neutrophil count greater than $0.5 \times 10^9/\text{L}$ and evidence of donor chimerism if engraftment is being assessed after allogeneic HCT. The rate of engraftment is dependent upon the number of HSC (CD34^+ cell content), purging strategies for autologous grafts, use of growth factors, and the use of methotrexate for GVHD prophylaxis.^{61, 196, 197} Graft failure may result from either an infusion of inadequate numbers of HSC, drug toxicity, infection (CMV), or graft rejection (after allogeneic transplantation). Relapse also needs to be considered in a patient with decreasing peripheral blood counts.

Graft rejection is infrequent (<1% incidence) after HCT from HLA-matched siblings and was more common after HLA-mismatched related or unrelated HLA-matched donors (2% to 6%).¹⁹⁸ Luznik et al. reported a rejection rate of 13% after reduced intensity conditioning and HCT from an HLA-haploidentical donor.⁹⁸ All but 1 patient experienced recovery of autologous hematopoiesis after rejection in this study. As grafts are rejected, peripheral blood counts may drop, and

chimerism studies demonstrate the loss of donor cells in the peripheral blood and marrow. Factors that influence the risk of graft rejection include T-cell depletion of the hematopoietic cell graft, increased HLA disparity, the intensity of the conditioning regimen and posttransplant immunosuppression, pretransplant sensitization of the host against donor alloantigens, and the number of HSC in the graft.^{98, 198, 199, 200, 201} Previous chemotherapy has been associated with a reduced risk of graft rejection after nonmyeloablative conditioning.²⁰² T cell engraftment kinetics were also improved in patients with higher steady state concentrations of the active mycophenolate mofetil (MMF) metabolite (achieved with three times daily dosing instead of twice daily) without increased risk of relapse, albeit with a modest increase in the rate of CMV reactivation.²⁰³ Clinically, hematopoietic growth factors have not been demonstrated to be effective in preventing graft rejection. Historically, the occurrence of graft rejection after a myeloablative conditioning regimen and an allogeneic HCT had been almost always fatal. Strategies utilizing noncytotoxic immunosuppressive conditioning regimens and HCT may salvage patients after rejection of the first graft.²⁰⁴ Aggressive medical management during the prolonged neutropenic period is required to prevent death from infection after transplantation of the second hematopoietic cell graft. Although the rates of rejection have been higher in the studies of nonmyeloablative HCT for hematologic malignancy (2% to 7%), graft rejection has not been associated with a significant morbidity or mortality because the duration of the pancytopenic period before autologous recovery has in general been short.^{172, 205} When rejection occurs after reduced intensity conditioning, salvage HCT using a conditioning regimen of fludarabine and TBI (300 or 400 cGy) resulted in an engraftment rate of 87%.²⁰⁶ A different donor was used for salvage HCT in 63% of the cases. Nonrelapse mortality at 2 years was 24%. The estimated survivals at 2 and 4 years were 49% and 42%, respectively. Graft rejection can be successfully overcome by salvage HCT from the same or different donor with a reduced intensity conditioning regimen consisting of fludarabine and low-dose TBI.

REGIMEN-RELATED TOXICITIES

The severity of regimen-related toxicities is related to the intensity of the myeloablative therapy, the type of cytotoxic therapy, the medical condition of the patient before transplantation, and the presence of posttransplant factors, including the use of methotrexate, calcineurin inhibitors, and amphotericin B. Reduced intensity conditioning regimens may decrease the severity of certain regimen-related toxicities.^{188, 207, 208, 209, 210}

Oral mucositis occurs in more than 90% of patients after myeloablative conditioning, and most require pain relief with a continuous intravenous narcotic drug. Improvement occurs temporally, with marrow recovery approximately 2 to 3 weeks after transplantation. The severity of the oral mucositis depends on the intensity of myeloablative therapy and the use of methotrexate. Severe mucositis may result in upper airway obstruction or aspiration pneumonitis. A blinded randomized placebo control study of the recombinant human keratinocyte growth factor (palifermin) in patients receiving TBI plus high-dose chemotherapy followed by autologous stem cell rescue demonstrated a 35% reduction in severe mucositis and a 6-day reduction in the median time to

P.2169

resolution of severe mucositis.²¹¹ Furthermore, palifermin was associated with decreased opioid and total parenteral nutrition use. The role of palifermin in other types of HCT recipients has not been established. Gastroenteritis induced by chemotherapy and irradiation results in nausea, vomiting, and diarrhea, all of which may persist for up to 2 to 3 weeks after transplantation. Central lines are placed prior to transplant for administration of fluids, drugs, and hyperalimentation during the period of therapy-induced mucositis and gastroenteritis.

Renal dysfunction is common after HCT.^{212, 213} Some factors associated with the development of severe renal failure requiring dialysis were hyperbilirubinemia, significant fluid retention after transplant, amphotericin B administration, and pretransplant serum creatinine levels greater than 0.7 mg/dl. Renal dysfunction (as indicated by a doubling of the baseline serum creatinine) was most strongly associated with the use of amphotericin B administration and SOS of the liver.²¹³ In this study, calcineurin inhibitors, GVHD, sepsis, TBI, and CY were not found to be significant contributors to severe renal failure. Calcineurin inhibitors cause transient renal dysfunction that is generally reversible with aggressive hydration and eventual discontinuation of the drugs. Renal complications were decreased after HCT with a nonmyeloablative conditioning regimen.²⁰⁸

Lung and liver are the two organs that limit further escalation of the intensity of myeloablative therapy. Idiopathic interstitial pneumonitis occurs in 8% to 18% of patients after myeloablative conditioning and marrow transplantation.^{214, 215, 216} Clinical manifestations include dyspnea, nonproductive cough, hypoxemia, and diffuse pulmonary infiltrates. This toxicity is most likely due to TBI, but preparative regimens containing high doses of chemotherapeutic agents such as CY, BU, and carmustine also contribute directly to toxicity in the lungs. Pulmonary veno-occlusive disease (VOD) is important

to consider in patients with diffuse pulmonary infiltrates, since there may be a favorable response to corticosteroids.^{217, 218} Treatment for idiopathic interstitial pneumonitis consists of supplemental oxygen and ventilatory support. Survival is poor (3%) for patients requiring intubation and mechanical ventilation for greater than 24 hours.²¹⁹ Pulmonary complications are reduced after nonmyeloablative conditioning regimens.^{207, 209}

SOS (formerly known as veno-occlusive disease, or VOD) of the liver is an event characterized by damage to vascular endothelial cells and to hepatocytes in zone 3 of the liver acinus and is the most frequent cause of hyperbilirubinemia within 20 days following HCT.²²⁰ Historically, the overall incidence of SOS was 53%, and 15% of patients had severe disease. The incidence of SOS has decreased in more recent years because of the reduced intensities of conditioning regimens and better selection of patients for myeloablative regimens. Risk factors for the development of severe SOS are pretransplant hepatitis with elevated serum levels of hepatocellular enzymes, the intensity of the conditioning regimen (TBI greater than 13 Gy), or the use of busulfan. Targeting strategies may have reduced the incidence of severe SOS in patients conditioned with busulfan. Patients receiving ursodeoxycholic acid after HCT had significantly lower rates of severe hyperbilirubinemia and elevated alanine aminotransferase levels, although the rates of SOS were similar compared to controls.²²¹ Furthermore, the rates of severe GVHD were less and mortality was significantly improved at 1-year posttransplant in the ursodeoxycholic acid group. For the treatment of SOS, responses to the administration of tissue plasminogen activator have been reported.^{222, 223} However, the risk of bleeding must be weighed against the potential benefit of this agent. Responses were also observed in patients treated with defibrotide which is a single-stranded polydeoxyribonucleotide with fibrinolytic and antithrombotic activity.²²⁴ No randomized clinical trials of defibrotide for treatment of SOS have been conducted. However, in a randomized clinical trial of prophylactic therapy, administration of defibrotide to pediatric patients undergoing HCT demonstrated decreased rates of SOS at day 30 when compared to controls.²²⁵

Increasingly recognized as an important clinical problem are the delayed complications other than chronic GVHD after HCT (Chapter 106). Long-term risks associated with myeloablative conditioning include secondary malignancies, sterility, increased bone loss, delayed development in pediatric patients, neurocognitive changes, hypothyroidism, and cataracts.^{226, 227, 228, 229, 230, 231, 232} After autologous HCT there is an increased risk of myelodysplastic syndrome.^{233, 234} Use of immunosuppression for chronic GVHD treatment was associated with an increased incidence of squamous cell cancer of the skin and oral cavity in allogeneic transplant recipients.²³⁵ Risk factors for defective spermatogenesis are older age at transplantation and presence of chronic GVHD.²³⁶ Rapid bone loss after transplantation can be partially corrected with the administration of bisphosphonate drugs.^{237, 238} Children may experience delays in growth and development particularly after exposure to TBI-based conditioning regimens which may be improved with growth hormone therapy.²³⁹ Neurocognitive changes observed early after HCT largely recover at 1 year²⁴⁰; however, full recovery after HCT, especially psychological recovery, may be a 3- to 5-year process. Recovery might be accelerated by more effective interventions to increase work-related capabilities, improve social support, and manage depression.^{241, 242}

GRAFT-VERSUS-HOST DISEASE

GVHD is mediated by genetically disparate lymphocytes after transfer to an immunologically compromised recipient incapable of rejecting the donor graft (Chapter 105).²⁴³ In the initial stages of GVHD, donor T cells recognize disparate histocompatibility antigens on host cells. Two primary classes of MHC exist. HLA class I antigens have a broad distribution and are expressed on all cells. HLA class II antigens are expressed on antigen-presenting cells, including macrophages, dendritic cells, B cells, and activated T cells. The mHC are genetic polymorphisms of endogenous cellular proteins that are presented to T cells as small peptides bound within the hypervariable grooves of MHC proteins. Some mHC which have been identified in humans as being associated with GVHD are HA-1 and the DBY (male-specific mHA gene).^{244, 245} The presence of multiple disparate mHC between the recipient and donor was associated with an increased mortality.²⁴⁶ Single disparities of mHC may not be sufficient to result in a significantly increased risk of GVHD.²⁴⁷

The skin, liver, and gastrointestinal tract are the primary organs damaged by the GVH reaction. The cells which are targeted in the affected organs by the GVH reaction are primarily epithelial stem cells and their progeny.²⁴⁸ In the liver, the epithelium of the small interlobular and marginal bile ducts is damaged by the GVH reaction. In tissues involved with GVHD, a lymphoid infiltrate is present and cell death occurs by apoptosis. In lymph nodes there is an absence of germinal centers which lasts for many months after HCT. Abnormal CD4:CD8 ratios can be found both in the lymph node as well as in the peripheral blood. The induction and release of signaling cytokines might be important in the development and severity of GVHD.²⁴⁹ The IL-10 pathway may play an important role in controlling the severity of acute GVHD.^{250, 251} Plasma biomarkers for acute GVHD include IL-2-receptor-alpha, TNF-receptor-1, IL-8, and hepatocyte growth factor.²⁵² Regenerating islet-derived 3 α (REG3 α), secreted by Paneth cells, is a plasma biomarker for severe acute GVHD of the

gastrointestinal tract.²⁵³ In a multivariate analysis, stages 2 to 4 GVHD of the gastrointestinal tract, severe histologic damage, and high levels of REG3 alpha at GVHD diagnosis independently predicted nonrelapse mortality at 1 year.

GVHD has been traditionally classified into two different phases. Acute and chronic GVHD were defined as occurring before or after 3 months, respectively. However with increasing adoption

P.2170

of nonmyeloablative conditioning regimens in which engraftment of donor T cells occurs more gradually, the distinctions between these two phases of GVHD has blurred.^{189, 254} Findings consistent with either diagnosis often occur concomitantly.

Acute

Clinical Evaluation

Acute GVHD involves three organ systems primarily—the skin, the gastrointestinal tract, and the liver. A maculopapular rash which can involve the palms and soles is often present and can be pruritic or painful. Bullae and epidermal separation may occur in severe cases and resembles toxic epidermal necrolysis. GVHD can also involve any part of the gastrointestinal tract. Symptoms and signs include nausea, vomiting, crampy abdominal pain, diarrhea, intestinal bleeding, and ileus. Lesions in the mouth may also occur. Patients may also present with persistent anorexia, nausea, and vomiting, and require endoscopy to evaluate the gastrointestinal tract for GVHD.^{255, 256, 257} Permanent scarring with loss of mucosal regeneration may occur in very severe GVHD of the gastrointestinal tract.²⁵⁸ Cholestatic jaundice is common in liver GVHD but hepatic failure due solely to GVHD of the liver is unusual unless the GVHD is long-standing. A biopsy of these organs may be required to confirm the diagnosis of GVHD and to distinguish it from other posttransplant complications.

The major determinant for the development of acute GVHD is the degree of HLA match. The increased incidence of acute GVHD in HLA-matched unrelated donor transplants is likely attributable to increased disparity in MHC antigens or unrecognized disparities of the phenotypically matched major histocompatibility loci. Other factors influencing the rates of acute GVHD include sex mismatch with the donor, parity of female donors, TBI dose, and acute GVHD prophylaxis regimen.^{259, 260, 261} In peripheral blood HSC transplantation, the CD34-positive cell dose has been reported as an independent risk factor for acute GVHD.²⁶²

To facilitate the study and prognostication of acute GVHD, a clinical staging and grading system (Glucksberg) was developed and then updated in 1995 (Chapter 105).^{50, 263, 264} Grade I or very limited acute GVHD has a favorable prognosis and does not require treatment. Therapy is usually required for grade II GVHD since it is moderately severe and usually affects multiple organs. Since patients with anorexia, nausea, and vomiting with positive biopsies for GVHD from the upper gastrointestinal tract usually require therapy, this was included as grade II. Grades III-IV GVHD are severe, affect multiple organs, and are associated with a decreased patient survival.²⁵⁹ An acute GVHD severity index was also developed, grouping patients with patterns of organ involvement associated with similar risks of treatment-related mortality and treatment failure.²⁶⁵ In a prospective evaluation of the two classifications, the performance was similar in explaining the variability in survival by acute GVHD grade.²⁶⁶ An acute GVHD activity index has also been developed.²⁶⁷ The activity index considers serum bilirubin, oral intake, treatment with prednisone, as well as performance, and may predict nonrelapse mortality better than either of the more commonly used clinical grading schema.

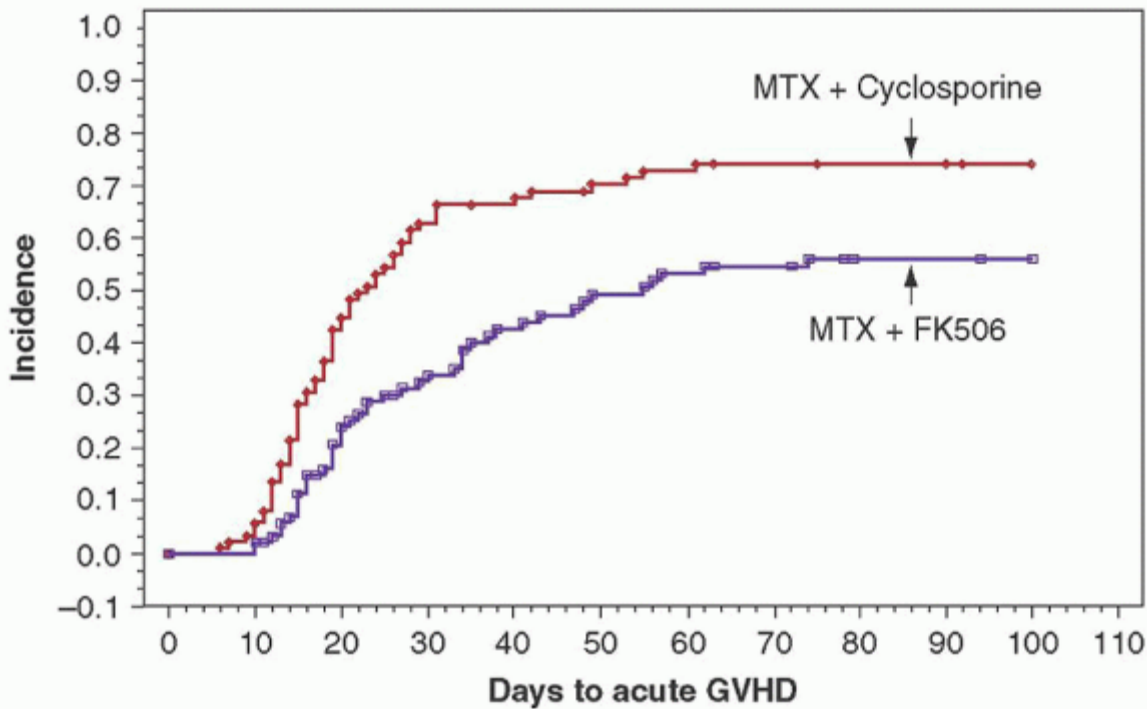

FIGURE 102.7. Kaplan-Meier estimate of acute graft-versus-host disease (GVHD). The combination of tacrolimus and methotrexate was compared to cyclosporine and methotrexate as GVHD prophylaxis after a myeloablative conditioning regimen followed by hematopoietic cell transplantation (HCT) from an human leukocyte antigen (HLA)-matched unrelated donor. There was less acute GVHD in the tacrolimus group at 100 days after HCT than the cyclosporine group (56% vs. 74%, respectively, $P = 0.0002$). (From Nash RA, Antin JH, Karanes C, et al. Phase 3 study comparing methotrexate and tacrolimus with methotrexate and cyclosporine for prophylaxis of acute graft-versus-host disease after marrow transplantation from unrelated donors. *Blood* 2000;96:2062-2068. Copyright American Society of Hematology, used with permission.)

Prevention

The two major approaches to the prevention of acute GVHD after allogeneic marrow transplantation are pharmacologic immunosuppression and T-cell depletion. Agents for pharmacologic immunosuppression are generally more effective when used in combination. Methotrexate in combination with either cyclosporine or tacrolimus (both calcineurin inhibitors) are the pharmacologic agents used most commonly by transplant centers. In randomized controlled studies, the combination of tacrolimus and methotrexate was associated with a lower incidence of acute GVHD compared to cyclosporine and methotrexate, but there was no difference in the incidence of chronic GVHD or survival between the two groups (Fig. 102.7).^{268, 269} These agents may have significant adverse effects and therefore patients must be monitored closely. Methotrexate delays, but does not prevent, hematopoietic engraftment. Methotrexate also potentiates the mucositis associated with myeloablative conditioning regimens. Nephrotoxicity and neurotoxicity are complications associated with the administration of cyclosporine and tacrolimus.

Other immunosuppressive agents including corticosteroids and MMF have been studied in combination with cyclosporine. The addition of prophylactic corticosteroids to the combination of cyclosporine and methotrexate or to cyclosporine alone had only limited if any benefit, and in one study a paradoxical increase in chronic GVHD was observed in the corticosteroid arm.^{270, 271, 272} MMF, a reversible inhibitor of inosine monophosphate dehydrogenase, has been successfully used in combination with cyclosporine for prevention of both GVHD and graft rejection after nonmyeloablative conditioning. The use of MMF instead of methotrexate in standard prophylaxis regimens after myeloablative conditioning regimens has been demonstrated to result in similar rates of acute GVHD, less mucositis, and faster neutrophil engraftment.^{273, 274}

Alternative methods of GVHD prophylaxis include ex vivo T cell depletion of the hematopoietic cell graft, in vivo T cell depletion and posttransplant cyclophosphamide. Strategies for ex vivo T cell depletion include the use of monoclonal antibodies which

are specific for T cells, selective agglutination to soybean lectin, and counter flow centrifugation elutriation. Although reduction in acute and chronic GVHD has been observed with transplantation of T cell-depleted marrow, there was an associated increase in graft rejection, infections, posttransplant lymphoproliferative disorders, and relapse. A randomized controlled trial did not demonstrate any survival benefits for ex vivo T cell depletion compared to standard pharmacologic immunosuppression for acute GVHD prevention after HCT from HLA-matched unrelated donors.²⁷⁵ In vivo T cell depletion with pretransplant ATG and alemtuzumab was also effective for reducing the risks of severe acute and chronic GVHD after reduced intensity conditioning.²⁷⁶ However, relapse rates were higher and overall survival was significantly decreased compared to the T cell replete group in the study. Relapses were not increased with in vivo T cell depletion if patients were conditioned with myeloablative regimens.

Posttransplant cyclophosphamide reduced the risks of both acute and chronic GVHD but until more experience has been obtained, it is not known if this approach will improve overall survival.^{97, 98}

Treatment

The most common agents used to treat acute GVHD have been corticosteroids and ATG. In many marrow transplant centers the administration of corticosteroids (methylprednisolone or prednisone-equivalent dose of 2 mg/kg/day) had been the standard initial treatment for acute GVHD.^{277, 278} In a retrospective analysis, it was observed that initial treatment with a lower dose of corticosteroids (methylprednisolone dose of 1 mg/kg/day) may be as effective as the higher dose. However, this needs to be confirmed in a prospective study.²⁷⁹ Higher doses of methylprednisolone (10 mg/kg/day) did not improve outcomes.²⁸⁰ Because complete remission of GVHD is seen in only 40% to 50% of the cases after initial or primary treatment, other immunosuppressive agents have been investigated in combination with prednisone. When a CD5-specific immunotoxin was added to prednisone for primary treatment, GVHD manifestations were more effectively controlled only during the first 5 weeks after start of treatment when compared to prednisone alone.²⁸¹ Similarly, no long-term benefit was observed when ATG was added to prednisone.²⁸² In a study of daclizumab in combination with prednisone as primary therapy, survival was significantly decreased compared to prednisone alone.²⁸³ This suggested that caution must be used with approaches that intensify immunosuppression for primary treatment of acute GVHD. In a randomized clinical trial of primary treatment for gastrointestinal GVHD, a short course of prednisone in combination with either placebo or beclomethasone dipropionate (BDP), an oral topical agent with limited systemic absorption, was evaluated.²⁸⁴ The use of BDP was associated with better control of upper gastrointestinal GVHD and improved survival at 200 days and 1 year posttransplantation. For steroid-refractory GVHD, immunosuppressive agents which have been studied include ATG, daclizumab, rapamycin, MMF, ABX-CBL (CD147-specific mAb), and pentostatin among others. Outcomes at 6 to 12 months after salvage therapy for steroid-resistant GVHD have been poor with a high transplant-related mortality.^{285, 286, 287, 288, 289, 290} There are no standard effective therapies for steroid-refractory GVHD which can be recommended.^{291, 292} Psoralen and ultraviolet A therapy for the skin may permit a decrease in systemic immunosuppression.²⁹³ The massive secretory diarrhea of acute GVHD has been controlled in some cases with a somatostatin analog, octreotide acetate.²⁹⁴

Chronic

Clinical Evaluation

Chronic GVHD is a syndrome that may develop as early as 50 to 60 days or as late as 400 days after transplantation. The incidence of chronic GVHD is dependent on the degree of disparity in the MHC antigens. It was observed in 33% of HLA-identical sibling transplants, 49% of HLA-nonidentical related transplants, and 64% of HLA-matched unrelated transplants.²⁹⁵ A prior history of acute GVHD is a significant risk factor for the development of chronic GVHD. Other risk factors for chronic GVHD are older age, female donor if male recipient, DLI, and use of peripheral blood stem cells.^{296, 297, 298} Corticosteroid use for GVHD prophylaxis may also increase the risk of the development of chronic GVHD.^{270, 272}

Clinical features of chronic GVHD are skin lesions which may initially resemble lichen planus and may progress to generalized scleroderma, keratoconjunctivitis, oral mucositis, esophageal and vaginal strictures, intestinal abnormalities, chronic liver disease, pulmonary insufficiency secondary to bronchiolitis obliterans (BO), and a wasting syndrome.²⁹⁹ If generalized scleroderma occurs, it may lead to joint contractures and debility. Elevations in alkaline phosphatase and serum bilirubin are often the first indication of hepatic involvement with chronic GVHD. Bile duct damage has a similar histopathology as that seen in primary biliary cirrhosis. Liver biopsies are often helpful in establishing a diagnosis. BO affects the small airways of the lung and may occur at less than 150 days (40%) or more than 150 days (60%) following HCT.³⁰⁰ If serial pulmonary function tests show an evolving obstructive pattern, further testing is required including a high-

resolution computed tomography scan to evaluate for the presence of BO. Keratoconjunctivitis sicca is a common but irreversible complication that is managed with frequent eye drops and tear duct ligation.

Screening studies and clinical manifestations of chronic GVHD are used in a clinical classification of chronic GVHD. Based on a retrospective clinical and pathologic review from 1980, a staging system was developed in which chronic GVHD was classified into limited and extensive. Extensive disease was associated with more frequent infections.²⁹⁹ The utilization of this original classification system was difficult because many patients were not easily classifiable by strict organ criteria and thus other significant prognostic factors have since been identified. Poor prognostic factors were extensive skin involvement, thrombocytopenia, and progressive-type onset.^{301, 302} In 2005, the NIH consensus criteria were developed to standardize the criteria for the diagnosis of chronic GVHD.³⁰³ A clinical scoring system (0 to 3) described the extent and severity of chronic GVHD for each organ or site at any given time, taking functional impairment into account. A global assessment of chronic GVHD severity (i.e., mild, moderate, or severe) was then calculated based on the number of organs or sites involved and the degree of involvement in the affected organs. Diagnosis of chronic GVHD required at least 1 clinical sign or manifestation of chronic GVHD confirmed by biopsy or other relevant test and the exclusion of other possible diagnoses for those clinical symptoms considered to be chronic GVHD. Subtypes of late GVHD (>100 days) were recognized, including late onset acute GVHD, classical chronic GVHD, and an overlap syndrome (clinical symptoms of both acute and chronic GVHD).

Prevention

Several strategies to prevent the development of chronic GVHD have been pursued but none have made a significant impact on long-term overall survival. Prolonged administration (24-month course vs. 6-month course) of cyclosporine demonstrated no significant differences between the groups in the incidence of chronic GVHD, transplant-related survival, or overall survival.³⁰⁴ T cell depletion was associated with lower rates of chronic GVHD in HLA-matched sibling transplants, but not in the unrelated donor setting. No improvement in overall survival was associated with T cell depletion.³⁰⁵ Inclusion of alemtuzumab or ATG in the conditioning regimen was associated with a reduction in chronic GVHD.^{276, 306, 307}

P.2172

Treatment

Extensive chronic GVHD that is left untreated has a poor prognosis. In general, based on the NIH consensus criteria, topical or local therapy is recommended for mild chronic GVHD, and systemic immunosuppression for moderate or severe chronic GVHD. In an original report of chronic GVHD, only 2 of 13 patients survived and there was the development of significant morbidity.²⁹⁹ Prednisone given for 9 to 12 months reversed many of the signs and symptoms of disease. The mortality in the group treated with prednisone was 21%.³⁰⁸ Patient survival was worse with the combination of azathioprine and prednisone compared to prednisone alone.³⁰² The combination of cyclosporine and prednisone was first used in patients with high-risk chronic GVHD who had a platelet count less than 100,000. The results of this study appeared promising compared to historical controls.³⁰⁹ There was a trend toward improved survival and decreased morbidity. In contrast, a randomized study of combination therapy versus prednisone alone for standard-risk chronic GVHD suggested that more intense immunosuppression did not improve survival.³¹⁰ A report of a randomized clinical trial in 2009 comparing MMF plus prednisone to prednisone only as primary treatment for chronic GVHD did not show any benefit.³¹¹ Standard practice for primary treatment of patients with moderate-severe chronic GVHD remains systemic immunosuppression with prednisone. There is no evidence that additional immunosuppression is beneficial. In practice, patients with extensive chronic GVHD are treated for a period of 9 to 12 months. At the end of this period, a reevaluation is done and, if there is no evidence of active chronic GVHD, the immunosuppressive agents are tapered. Other therapies which have been reported to have some limited efficacy for treatment of chronic GVHD are extracorporeal photopheresis for skin and oral GVHD and ursodeoxycholic acid treatment for GVHD of the liver.^{312, 313, 314} There is insufficient data to make strong recommendations regarding treatment of steroid-refractory chronic GVHD.

By 3 to 5 years after initiation of therapy, many patients have inactive chronic GVHD and immunosuppressive therapy has been discontinued (Fig. 102.8).⁹⁰ Approximately 75% of patients treated for extensive chronic GVHD will survive with Karnofsky scores of greater than 80%. The major cause of excess mortality in patients with clinically extensive chronic GVHD is infections.

GRAFT-VERSUS-TUMOR EFFECT

Allogeneic immune surveillance or GVT reaction for malignancy contributes significantly to the therapeutic effectiveness of HCT. The term GVT refers to the GVL effect, the graft-versus-myeloma effect, as well as the effects on solid tumors by the graft. The first clinical report of a GVT effect after allogeneic marrow transplantation was published in 1979.³¹⁵ It was observed that patients who developed GVHD had a lower risk of relapse after transplantation. In 1990, Kolb and colleagues successfully treated 3 patients with CML who relapsed after marrow transplantation with DLI from the original HLA-identical sibling marrow donor.³¹⁶ In a subsequent report evaluating DLI in 135 patients with relapsed disease, complete remissions were achieved in 72% of CML patients and 29% of patients with AML.³¹⁷ No responses were observed in patients with acute lymphoblastic leukemia. Chemotherapy to induce remission before DLI was a more effective strategy for long-term disease control for some patients with acute leukemia. GVHD and myelosuppression developed in 41% and 34% of patients, respectively, after DLI. Fourteen patients (10%) died from complications related to GVHD or myelosuppression. Another large study of 140 patients with relapsed malignancy after marrow transplantation confirmed the effectiveness and risks of DLI after relapse.³¹⁸ Notably in both studies, GVHD after DLI correlated with disease response. The durability of the responses was confirmed with longer follow-up of patients who had achieved complete remission after DLI.³¹⁹

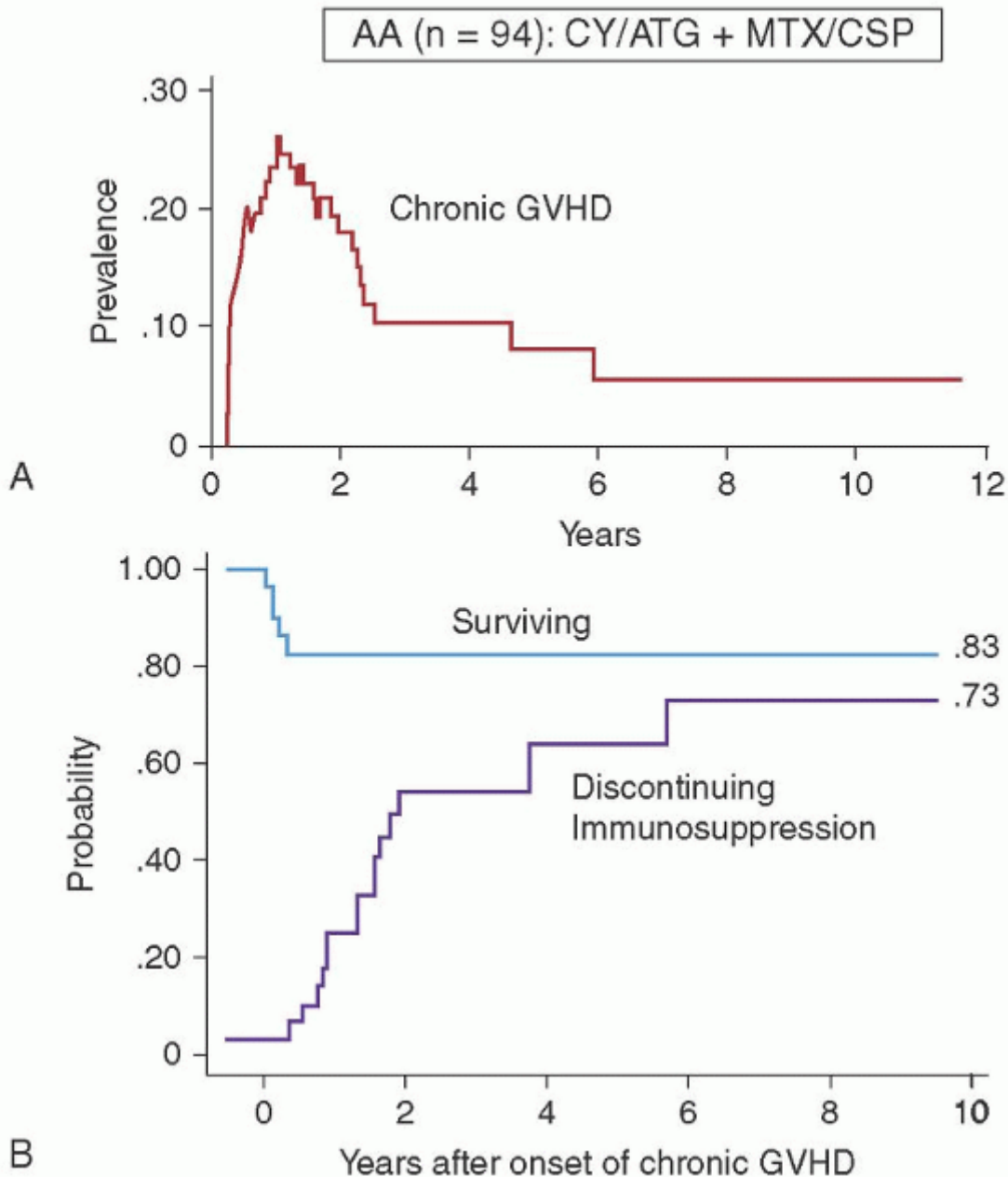

FIGURE 102.8. A: Prevalence of chronic graft versus host disease (GVHD) after allogeneic marrow transplantation from human leukocyte antigen (HLA)-identical sibling for aplastic anemia. The prevalence curve accounts for the time of onset of chronic GVHD and the time of its resolution in response to therapy. B: Probability of survival among the 29 patients with chronic GVHD (83%) and probability of discontinuing immunosuppression given for chronic GVHD (73%). (Modified from Storb R, Blume KG, O'Donnell MR, et al. Cyclophosphamide and antithymocyte globulin to condition patients with aplastic anemia for allogeneic marrow transplantations: the experience in four centers. *Biol Blood Marrow Transplant* 2001;7:39-44. Used with permission.)

The number of CD3-positive cells infused (or DLI dose) is an important parameter in determining clinical response and risk for development of GVHD.³²⁰ Patients with CML had a lower risk of GVHD, and the efficacy of treatment was maintained with a strategy of escalating the dose of donor lymphocytes based on response of disease and development of GVHD.³²¹ Comparable results with DLI from unrelated donors have also been demonstrated.³²² The response, severity of GVHD, and the degree of myelosuppression were similar to that observed after DLI from HLA-matched sibling donors.

After nonmyeloablative conditioning and allogeneic HCT, the GVT effect is the main contributor to the disease response. Disease responses have been observed in both myeloid and lymphoid hematologic malignancies. Since the establishment of a GVT effect may not be achieved for 2 to 3 months after HCT, malignant disease needs to be controlled before HCT. Several retrospective studies have now shown comparable overall survival after either myeloablative or nonmyeloablative conditioning and HCT.^{185, 186, 187, 323} However, all these studies showed relapse was higher and transplant-related mortality was lower after a nonmyeloablative conditioning regimen. In a randomized clinical trial of reduced intensity conditioning with TBI (800 cGy) and fludarabine compared to TBI (1,200 cGy) and cyclophosphamide in patients with AML in first remission, there were no differences in transplant outcomes including relapse and nonrelapse mortality except for increased severity of oral mucositis in the TBI (1,200 cGy) group.¹⁵¹

Although patients may have an excellent response to allogeneic HCT, severe GVHD may occur. Separation of GVHD from GVT

P.2173

effects may be possible because of disparate hematopoiesis-associated mHC molecules or tumor-restricted antigens on malignant cells.³²⁴ These tissue or tumor-restricted antigens could serve as targets for T cell immunotherapy to enhance GVT activity without inducing GVHD. Peptides identified as minor histocompatibility molecules have been isolated and sequenced.^{325, 326, 327, 328, 329, 330} Cytotoxic T lymphocytes (CTL) clones specific for recipient mHC antigens have been generated *ex vivo*.³³¹ These were infused into 7 patients who had relapsed after HCT. Pulmonary toxicity was seen in three patients and in one it was severe. The CTL circulated for 21 days, and five patients had complete but transient remissions. The contribution of natural killer (NK) cells to the antitumor effect after allogeneic HCT has also been investigated.³³² For AML, a disease with sensitivity to NK-mediated activity, NK cells from unrelated donors encoding the activating killer-cell immunoglobulin-like receptor KIR2DS1 was associated with improved relapse-free survival in an HLA-C-dependent manner. These studies may help to explain the mechanisms associated with a GVT effect after allogeneic HCT, and in the future this information might be helpful for improving outcomes.

IMMUNE RECONSTITUTION

After myeloablative therapy and autologous or allogeneic transplant, both humoral and cellular immunity are impaired for months to years. After autologous HCT, NK cells in the peripheral blood recover by 1 month and B cells and CD8+ T cells recover by 3 to 6 months after HCT. However, CD4+ T cells are not restored to normal levels until 1 to 2 years after HCT.^{333, 334} After allogeneic transplantation, recovery of the immune system from the donor graft occurs in phases over a period of 1 to 2 years in patients who do not develop GVHD. There are significant delays in recovery of the immune system if GVHD develops.

The first phase of recovery is the increase in neutrophil counts which occurs 2 to 3 weeks after transplantation. Although the function of neutrophils is largely intact, impaired chemotaxis persists for a period up to 4 months.³³⁵ Monocyte numbers in the peripheral blood return to normal within 3 to 4 weeks after transplantation. Monocyte counts in the peripheral blood were inversely correlated with infection rates between days 100 and 365.³³⁶ Macrophages in the liver and lung have been shown to be of donor type by day 80. NK cells and other cell types capable of antibody-dependent cytotoxicity have recovered to normal levels by 30 days after transplantation. The recovery of the donor-derived immune system is important in the understanding of the GVT effect and complications after HCT, including graft rejection, GVHD, and infections.

B Cells

There are defects in serum immunoglobulin production initially after the transplant. Serum antibody responses to different antigens, including ϕ X174, keyhole limpet hemocyanin, pneumococcal antigen, and meningococcal antigen are lower than normal.^{337, 338, 339} The defect in antibody production occurs in both T cell-dependent and T cell-independent systems. B lymphocytes respond to mitogenic stimulation including staphylococcal aureus and cross-linked anti-IgM antibodies after 2 months. By 3 months after transplantation, B lymphocytes with surface immunoglobulin have recovered to normal levels. Persistent deficiencies in B lymphopoiesis have been described in association with GVHD (acute or chronic) or its treatment.³⁴⁰ The number of B cell precursors in the marrow was not related to CD34 cell dose, type of transplant, donor age, or recipient age.

Serum IgG and IgM have typically achieved normal levels 1 year after transplantation in the absence of chronic GVHD.³³⁷ Serum IgA may remain low for a period of 2 years. If serum IgG levels are below 400 g/L, patients are generally treated with intravenous immunoglobulin.

T Cells

Reconstitution with donor T cells is poor initially in all recipients and remains defective in patients with chronic GVHD. Because of the faster recovery of CD8 positive T cells, a reversed CD4:CD8 ratio with low levels of CD4-positive cells has been demonstrated and persists in patients with chronic GVHD. In vivo cellular immunity, determined by skin testing to the recall antigens Candida, mumps, trichophyton, and the neo-antigen dinitrochlorobenzene, is diminished, but may be prolonged if chronic GVHD develops.³⁴¹ In in vitro assays, donor T cells from patients have a decreased proliferation to mitogenic stimulus with phytohemagglutinin (PHA) and CD3-specific antibody. After 3 months the addition of exogenous IL-2 can normalize the proliferative response to PHA stimulation.^{342, 343} By 6 months the response to PHA stimulation has normalized without the requirement for exogenous IL-2. T cell immunity to herpes simplex virus (HSV) can be detected by day 40.³⁴⁴ CTL function against varicella-zoster virus (VZV) and CMV is acquired later (≥ 3 months). Acquisition of T cell immunity to herpes virus may be delayed by prophylaxis of viral infections with anti-viral agents or GVHD treatment.^{345, 346}

Immunity early after myeloablative conditioning and allogeneic transplantation is restored by the adoptive transfer of mature T cells and may establish cellular immunity to infectious agents such as the herpes viruses.^{96, 346, 347, 348} Vaccination protocols may also improve the pathogen-specific cellular immunity. An inactivated varicella vaccine given before, and during the first 90 days after, transplantation significantly reduced the risk for the development of varicella-zoster infections.³⁴⁹ CD4 T cell proliferation in response to the VZV was greater in patients who received the vaccine. Immune function after HCT may also be improved with the use of a peripheral blood stem cell graft. There were higher lymphocyte subset counts after HCT, and the rate of definite infections was significantly decreased compared to marrow.³⁵⁰ T cell-depleted HCT or therapy for active GVHD has been observed to delay the recovery of cellular immunity, thus resulting in an increased risk of infections. The thymus contributes to late immune reconstitution.

T cell recovery is improved in younger patients compared to older patients, an effect attributable to the improved thymic function in the former group. Increased thymic output (i.e., high TREC levels) was associated with an increased number of naive T cells and broader T cell repertoires, while low TREC levels correlated with the presence of chronic GVHD and severe opportunistic infections.^{351, 352} Thymic rebound correlated with the capacity to respond to vaccinations.³⁵³ Measures to enhance thymic output after transplantation, especially in older patients, may enhance immune reconstitution and decrease the risk of infections.

Web Sites

The web site for the Center for International Blood and Marrow Transplantation is: www.cibmtr.org. This site provides more information on trends and survival data as well as published results of research studies.

REFERENCES

1. Gooley TA, Chien JW, Pergam SA, et al. Reduced mortality after allogeneic hematopoietic-cell transplantation. *N Engl J Med* 2010;363(22):2091-2101.
2. Jacobson LO, Simmons EL, Marks EK, Robson MJ, Bethard WF, Gaston EO. The role of the spleen in radiation injury and recovery. *J Lab Clin Med* 1950;35(5):746-770.
3. Lorenz E, Uphoff D, Reid TR, Shelton E. Modification of irradiation injury in mice and guinea pigs by bone marrow injections. *J Natl Cancer Inst* 1951;12(1):197-201.
4. Uphoff DE. Genetic factors influencing irradiation protection by bone marrow. I. The F1 hybrid effect. *J Natl Cancer Inst* 1957;19(1):123-130.

5. Lochte HL, Jr., Levy AS, Guenther DM, Thomas ED, Ferrebee JW. Prevention of delayed foreign marrow reaction in lethally irradiated mice by early administration of methotrexate. *Nature* 1962;196:1110-1111.
6. Storb R, Rudolph RH, Thomas ED. Marrow grafts between canine siblings matched by serotyping and mixed leukocyte culture. *J Clin Invest* 1971;50(6):1272-1275.
7. Thomas ED, Collins JA, Herman EC, Jr., Ferrebee JW. Marrow transplants in lethally irradiated dogs given methotrexate. *Blood* 1962;19:217- 228.
8. Deeg HJ, Storb R, Weiden PL, et al. Cyclosporin A and methotrexate in canine marrow transplantation: engraftment, graft-versus-host disease, and induction of intolerance. *Transplantation* 1982;34(1):30-35.
9. Deeg HJ, Storb R, Appelbaum FR, Kennedy MS, Graham TC, Thomas ED. Combined immunosuppression with cyclosporine and methotrexate in dogs given bone marrow grafts from DLA-haploidentical littermates. *Transplantation* 1984;37(1):62-65.
10. Bach FH, Albertini RJ, Joo P, Anderson JL, Bortin MM. Bone-marrow transplantation in a patient with the Wiskott-Aldrich syndrome. *Lancet* 1968;2(7583):1364-1366.
11. Gatti RA, Meuwissen HJ, Allen HD, Hong R, Good RA. Immunological reconstitution of sex-linked lymphopenic immunological deficiency. *Lancet* 1968;2(7583):1366-1369.
12. Thomas ED, Storb R, Fefer A, et al. Aplastic anaemia treated by marrow transplantation. *Lancet* 1972;1(7745):284-289. P.2174

13. Thomas ED, Buckner CD, Banaji M, et al. One hundred patients with acute leukemia treated by chemotherapy, total body irradiation, and allogeneic marrow transplantation. *Blood* 1977;49(4):511-533.
14. Spangrude GJ, Heimfeld S, Weissman IL. Purification and characterization of mouse hematopoietic stem cells. *Science* 1988;241(4861):58-62.
15. Jones RJ, Wagner JE, Celano P, Zicha MS, Sharkis SJ. Separation of pluripotent haematopoietic stem cells from spleen colony-forming cells. *Nature* 1990;347(6289):188-189.
16. Osawa M, Hanada K, Hamada H, Nakauchi H. Long-term lymphohematopoietic reconstitution by a single CD34 low/negative hematopoietic stem cell. *Science* 1996;273(5272): 242-245.
17. Goodell MA, Brose K, Paradis G, Conner AS, Mulligan RC. Isolation and functional properties of murine hematopoietic stem cells that are replicating in vivo. *J Exp Med* 1996;183(4):1797-1806.
18. Goodell MA, Rosenzweig M, Kim H, et al. Dye efflux studies suggest that hematopoietic stem cells expressing low or undetectable levels of CD34 antigen exist in multiple species. *Nat Med* 1997;3(12):1337-1345.
19. Hess DA, Wirthlin L, Craft TP, et al. Selection based on CD133 and high aldehyde dehydrogenase activity isolates long-term reconstituting human hematopoietic stem cells. *Blood* 2006;107(5):2162-2169.
20. Hess DA, Meyerrose TE, Wirthlin L, et al. Functional characterization of highly purified human hematopoietic repopulating cells isolated according to aldehyde dehydrogenase activity. *Blood* 2004;104(6):1648-1655.
21. Bensinger WI, Buckner CD, Shannon-Dorcy K, et al. Transplantation of allogeneic CD34+ peripheral blood stem cells in patients with advanced hematologic malignancy. *Blood* 1996;88(11):4132-4138.
22. Bruno B, Nash RA, Wallace PM, et al. CD34+ selected bone marrow grafts are radioprotective and establish mixed chimerism in dogs given high dose total body irradiation. *Transplantation* 1999;68(3):338-344.
23. Bruno B, Goerner MA, Nash RA, Storb R, Kiem HP, McSweeney PA. Purified canine CD34+Lin-marrow cells transduced with retroviral vectors give rise to long-term multi-lineage hematopoiesis. *Biol Blood Marrow Transplant* 2001;7(10):543-551.
24. Link H, Arseniev L, Bahre O, Kadar JG, Diedrich H, Poliwoda H. Transplantation of allogeneic CD34+ blood cells. *Blood* 1996;87(11): 4903-4909.
25. Holmberg J, Perlmann T. Maintaining differentiated cellular identity. *Nat Rev Genet* 2012;13(6):429-439.
26. Shi Q, Rafii S, Wu MH, et al. Evidence for circulating bone marrow-derived endothelial cells. *Blood* 1998;92(2):362-367.

27. Cogle CR, Yachnis AT, Laywell ED, et al. Bone marrow transdifferentiation in brain after transplantation: a retrospective study. *Lancet* 2004;363(9419): 1432-1437.
28. Wagers AJ, Sherwood RI, Christensen JL, Weissman IL. Little evidence for developmental plasticity of adult hematopoietic stem cells. *Science* 2002;297(5590):2256-2259.
29. Civin CI, Strauss LC, Brovall C, Fackler MJ, Schwartz JF, Shaper JH. Antigenic analysis of hematopoiesis. III. A hematopoietic progenitor cell surface antigen defined by a monoclonal antibody raised against KG-1a cells. *J Immunol* 1984;133(1):157-165.
30. Andrews RG, Singer JW, Bernstein ID. Monoclonal antibody 12-8 recognizes a 115-kd molecule present on both unipotent and multipotent hematopoietic colony-forming cells and their precursors. *Blood* 1986;67(3):842-845.
31. Fina L, Molgaard HV, Robertson D, et al. Expression of the CD34 gene in vascular endothelial cells. *Blood* 1990;75(12):2417-2426.
32. Baumhuter S, Singer MS, Henzel W, et al. Binding of L-selectin to the vascular sialomucin CD34. *Science* 1993;262(5132):436-438.
33. Baum CM, Weissman IL, Tsukamoto AS, Buckle AM, Peault B. Isolation of a candidate human hematopoietic stem-cell population. *Proc Natl Acad Sci U S A* 1992;89(7):2804-2808.
34. Strauss LC, Rowley SD, La Russa VF, Sharkis SJ, Stuart RK, Civin CI. Antigenic analysis of hematopoiesis. V. Characterization of My-10 antigen expression by normal lymphohematopoietic progenitor cells. *Exp Hematol* 1986;14(9):878-886.
35. Civin CI, Banquerigo ML, Strauss LC, Loken MR. Antigenic analysis of hematopoiesis. VI. Flow cytometric characterization of My-10-positive progenitor cells in normal human bone marrow. *Exp Hematol* 1987;15(1):10-17.
36. Uchida N, Combs J, Chen S, Zanjani E, Hoffman R, Tsukamoto A. Primitive human hematopoietic cells displaying differential efflux of the rhodamine 123 dye have distinct biological activities. *Blood* 1996;88(4):1297-1305.
37. Humeau L, Bardin F, Maroc C, et al. Phenotypic, molecular, and functional characterization of human peripheral blood CD34+/THY1+ cells. *Blood* 1996;87(3):949-955.
38. Gunji Y, Nakamura M, Osawa H, et al. Human primitive hematopoietic progenitor cells are more enriched in KITlow cells than in KIThigh cells. *Blood* 1993;82(11):3283-3289.
39. Kawashima I, Zanjani ED, Almada-Porada G, Flake AW, Zeng H, Ogawa M. CD34+ human marrow cells that express low levels of Kit protein are enriched for long-term marrow-engrafting cells. *Blood* 1996;87(10):4136-4142.
40. Yin AH, Miraglia S, Zanjani ED, et al. AC133, a novel marker for human hematopoietic stem and progenitor cells. *Blood* 1997;90(12):5002-5012.
41. Gallacher L, Murdoch B, Wu DM, Karanu FN, Keeney M, Bhatia M. Isolation and characterization of human CD34(-)Lin(-) and CD34(+)Lin(-) hematopoietic stem cells using cell surface markers AC133 and CD7. *Blood* 2000;95(9):2813-2820.
42. Shimizu Y, Ogawa M, Kobayashi M, Almeida-Porada G, Zanjani ED. Engraftment of cultured human hematopoietic cells in sheep. *Blood* 1998;91(10):3688-3692.
43. Fraser CC, Kaneshima H, Hanstee G, Kilpatrick M, Hoffman R, Chen BP. Human allogeneic stem cell maintenance and differentiation in a long-term multilineage SCID-hu graft. *Blood* 1995;86(5):1680-1693.
44. Berenson RJ, Andrews RG, Bensinger WI, et al. Antigen CD34+ marrow cells engraft lethally irradiated baboons. *J Clin Invest* 1988;81(3):951-955.
45. Berenson RJ, Bensinger WI, Hill RS, et al. Engraftment after infusion of CD34+ marrow cells in patients with breast cancer or neuroblastoma. *Blood* 1991;77(8):1717-1722.
46. McSweeney PA, Rouleau KA, Wallace PM, et al. Characterization of monoclonal antibodies that recognize canine CD34. *Blood* 1998;91(6):1977-1986.
47. Andrews RG, Bryant EM, Bartelmez SH, et al. CD34+ marrow cells, devoid of T and B lymphocytes, reconstitute stable lymphopoiesis and myelopoiesis in lethally irradiated allogeneic baboons. *Blood* 1992;80(7):1693-1701.
48. Bensinger WI, Weaver CH, Appelbaum FR, et al. Transplantation of allogeneic peripheral blood stem cells mobilized by recombinant human granulocyte colony-stimulating factor. *Blood* 1995;85(6):1655-1658.

49. Broxmeyer HE, Douglas GW, Hangoc G, et al. Human umbilical cord blood as a potential source of transplantable hematopoietic stem/progenitor cells. *Proc Natl Acad Sci U S A* 1989;86(10):3828-3832.
50. Thomas ED, Storb R, Clift RA, et al. Bone-marrow transplantation (second of two parts). *N Engl J Med* 1975;292(17):895-902.
51. Goodman JW, Hodgson GS. Evidence for stem cells in the peripheral blood of mice. *Blood* 1962;19:702-714.
52. Epstein RB, Graham TC, Buckner CD, Bryant J, Thomas ED. Allogeneic marrow engraftment by cross circulation in lethally irradiated dogs. *Blood* 1966;28(5):692-707.
53. Kessinger A, Armitage JO, Landmark JD, Smith DM, Weisenburger DD. Autologous peripheral hematopoietic stem cell transplantation restores hematopoietic function following marrow ablative therapy. *Blood* 1988;71(3): 723-727.
54. Molineux G, Pojda Z, Hampson IN, Lord BI, Dexter TM. Transplantation potential of peripheral blood stem cells induced by granulocyte colony-stimulating factor. *Blood* 1990;76(10):2153-2158.
55. Narayanasami U, Kanteti R, Morelli J, et al. Randomized trial of filgrastim versus chemotherapy and filgrastim mobilization of hematopoietic progenitor cells for rescue in autologous transplantation. *Blood* 2001;98(7): 2059-2064.
56. DiPersio JF, Stadtmauer EA, Nademanee A, et al. Plerixafor and G-CSF versus placebo and G-CSF to mobilize hematopoietic stem cells for autologous stem cell transplantation in patients with multiple myeloma. *Blood* 2009;113(23):5720-5726.
57. Shpall EJ, Wheeler CA, Turner SA, et al. A randomized phase 3 study of peripheral blood progenitor cell mobilization with stem cell factor and filgrastim in high-risk breast cancer patients. *Blood* 1999;93(8):2491-2501.
58. Brasel K, McKenna HJ, Charrier K, Morrissey PJ, Williams DE, Lyman SD. Flt3 ligand synergizes with granulocyte-macrophage colony-stimulating factor or granulocyte colony-stimulating factor to mobilize hematopoietic progenitor cells into the peripheral blood of mice. *Blood* 1997;90(9):3781-3788.
59. Sheridan WP, Begley CG, Juttner CA, et al. Effect of peripheral-blood progenitor cells mobilised by filgrastim (G-CSF) on platelet recovery after high-dose chemotherapy. *Lancet* 1992;339(8794):640-644.
60. Bensinger W, Singer J, Appelbaum F, et al. Autologous transplantation with peripheral blood mononuclear cells collected after administration of recombinant granulocyte stimulating factor. *Blood* 1993;81(11):3158-3163.
61. Weaver CH, Hazelton B, Birch R, et al. An analysis of engraftment kinetics as a function of the CD34 content of peripheral blood progenitor cell collections in 692 patients after the administration of myeloablative chemotherapy. *Blood* 1995;86(10):3961-3969.
62. Papayannopoulou T, Craddock C, Nakamoto B, Priestley GV, Wolf NS. The VLA4/VCAM-1 adhesion pathway defines contrasting mechanisms of lodgement of transplanted murine hemopoietic progenitors between bone marrow and spleen. *Proc Natl Acad Sci U S A* 1995;92(21):9647-9651.
63. Bonig H, Watts KL, Chang KH, Kiem HP, Papayannopoulou T. Concurrent blockade of alpha4-integrin and CXCR4 in hematopoietic stem/progenitor cell mobilization. *Stem Cells* 2009;27(4):836-837.
64. Levesque JP, Takamatsu Y, Nilsson SK, Haylock DN, Simmons PJ. Vascular cell adhesion molecule-1 (CD106) is cleaved by neutrophil proteases in the bone marrow following hematopoietic progenitor cell mobilization by granulocyte colony-stimulating factor. *Blood* 2001;98(5):1289-1297.
65. Prosper F, Stroncek D, McCarthy JB, Verfaillie CM. Mobilization and homing of peripheral blood progenitors is related to reversible down-regulation of alpha4 beta1 integrin expression and function. *J Clin Invest* 1998;101(11):2456-2467.
66. Anasetti C, Hansen JA. Effect of HLA incompatibility in marrow transplantation from unrelated and HLA-mismatched related donors. *Transfus Sci* 1994;15(3):221-230.
67. Anasetti C, Petersdorf EW, Martin PJ, Woolfrey A, Hansen JA. Trends in transplantation of hematopoietic stem cells from unrelated donors. *Curr Opin Hematol* 2001;8(6):337-341.
68. Kurtzberg J, Prasad VK, Carter SL, et al. Results of the Cord Blood Transplantation Study (COBLT): clinical outcomes of unrelated donor umbilical cord blood transplantation in pediatric patients with hematologic malignancies. *Blood* 2008;112(10):4318-4327.
69. Gluckman E, Broxmeyer HA, Auerbach AD, et al. Hematopoietic reconstitution in a patient with Fanconi's anemia by means of umbilical-cord blood from an HLA-identical sibling. *N Engl J Med* 1989;321(17):1174-1178.

70. Brunstein CG, Barker JN, Weisdorf DJ, et al. Umbilical cord blood transplantation after nonmyeloablative conditioning: impact on transplantation outcomes in 110 adults with hematologic disease. *Blood* 2007;110(8):3064-3070.
71. Storb R, Etzioni R, Anasetti C, et al. Cyclophosphamide combined with antithymocyte globulin in preparation for allogeneic marrow transplants in patients with aplastic anemia. *Blood* 1994;84(3):941-949.
72. Isgro A, Gaziev J, Sodani P, Lucarelli G. Progress in hematopoietic stem cell transplantation as allogeneic cellular gene therapy in thalassemia. *Ann N Y Acad Sci* 2010;1202:149-154.
73. Grunebaum E, Mazzolari E, Porta F, et al. Bone marrow transplantation for severe combined immune deficiency. *JAMA* 2006;295(5):508-518.
74. Gaspar HB, et al. Hematopoietic stem cell gene therapy for adenosine deaminase-deficient severe combined immunodeficiency leads to long-term immunological recovery and metabolic correction. *Sci Transl Med* 2011;3(97):97ra80.
75. Boztug K, Schmidt M, Schwarzer A, et al. Stem-cell gene therapy for the Wiskott-Aldrich syndrome. *N Engl J Med* 2010;363(20):1918-1927.
76. Vellenga E, van Putten W, Ossenkoppele GJ, et al. Autologous peripheral blood stem cell transplantation for acute myeloid leukemia. *Blood* 2011;118(23):6037-6042.
77. Schmitz N, Pfistner B, Sextro M, et al. Aggressive conventional chemotherapy compared with high-dose chemotherapy with autologous haemopoietic stem-cell transplantation for relapsed chemosensitive Hodgkin's disease: a randomised trial. *Lancet* 2002;359(9323):2065-2071.
78. Philip T, Guglielmi C, Hagenbeek A, et al. Autologous bone marrow transplantation as compared with salvage chemotherapy in relapses of chemotherapy-sensitive non-Hodgkin's lymphoma. *N Engl J Med* 1995;333(23):1540-1545.
79. Haioun C, Lepage E, Gisselbrecht C, et al. Survival benefit of high-dose therapy in poor-risk aggressive non-Hodgkin's lymphoma: final analysis of the prospective LNH87-2 protocol—a groupe d'Etude des lymphomes de l'Adulte study. *J Clin Oncol* 2000;18(16):3025-3030.
80. Attal M, Harousseau JL, Stoppa AM, et al. A prospective, randomized trial of autologous bone marrow transplantation and chemotherapy in multiple myeloma. Intergroupe Francais du Myelome. *N Engl J Med* 1996;335(2):91-97.
81. Lenhoff S, Hjorth M, Holmberg E, et al. Impact on survival of high-dose therapy with autologous stem cell support in patients younger than 60 years with newly diagnosed multiple myeloma: a population-based study. Nordic Myeloma Study Group. *Blood* 2000;95(1):7-11.
82. Sica S, Chiusolo P, Salutari P, et al. Autologous graft-versus-host disease after CD34+-purified autologous peripheral blood progenitor cell transplantation. *J Hematother Stem Cell Res* 2000;9(3):375-379.
83. Holmberg L, Kikuchi K, Gooley TA, et al. Gastrointestinal graft-versus-host disease in recipients of autologous hematopoietic stem cells: incidence, risk factors, and outcome. *Biol Blood Marrow Transplant* 2006;12(2):226-234.
84. Bensinger WI, Martin PJ, Storer B, et al. Transplantation of bone marrow as compared with peripheral-blood cells from HLA-identical relatives in patients with hematologic cancers. *N Engl J Med* 2001;344(3):175-181.
85. Couban S, Simpson DR, Barnett MJ, et al. A randomized multicenter comparison of bone marrow and peripheral blood in recipients of matched sibling allogeneic transplants for myeloid malignancies. *Blood* 2002;100(5):1525-1531.
86. Mielcarek M, Storer B, Martin PJ, et al. Long-term outcomes after transplantation of HLA-identical related G-CSF-mobilized peripheral blood mononuclear cells versus bone marrow. *Blood* 2012;119(11):2675-2678.
87. Schmitz N, Beksac M, Hasenclever D, et al. Transplantation of mobilized peripheral blood cells to HLA-identical siblings with standard-risk leukemia. *Blood* 2002;100(3):761-767.
88. Ringden O, Labopin M, Bacigalupo A, et al. Transplantation of peripheral blood stem cells as compared with bone marrow from HLA-identical siblings in adult patients with acute myeloid leukemia and acute lymphoblastic leukemia. *J Clin Oncol* 2002;20(24):4655-4664.
89. Zaucha JM, Gooley T, Bensinger WI, et al. CD34 cell dose in granulocyte colony-stimulating factor-mobilized peripheral blood mononuclear cell grafts affects engraftment kinetics and development of extensive chronic graft-versus-host disease after human leukocyte antigen-identical sibling transplantation. *Blood* 2001;98(12):3221-3227.

90. Storb R, Blume KG, O'Donnell MR, et al. Cyclophosphamide and antithymocyte globulin to condition patients with aplastic anemia for allogeneic marrow transplantations: the experience in four centers. *Biol Blood Marrow Transplant* 2001;7(1):39-44.
91. Schrezenmeier H, Passweg JR, Marsh JC, et al. Worse outcome and more chronic GVHD with peripheral blood progenitor cells than bone marrow in HLA-matched sibling donor transplants for young patients with severe acquired aplastic anemia. *Blood* 2007;110(4):1397-1400.
92. Walters MC, Storb R, Patience M, et al. Impact of bone marrow transplantation for symptomatic sickle cell disease: an interim report. Multicenter investigation of bone marrow transplantation for sickle cell disease. *Blood* 2000;95(6):1918-1924.
93. Beatty PG, Clift RA, Mickelson EM, et al. Marrow transplantation from related donors other than HLA-identical siblings. *N Engl J Med* 1985;313(13): 765-771.
94. Drobyski WR, Klein J, Flomenberg N, et al. Superior survival associated with transplantation of matched unrelated versus one-antigen-mismatched unrelated or highly human leukocyte antigen-disparate haploidentical family donor marrow grafts for the treatment of hematologic malignancies: establishing a treatment algorithm for recipients of alternative donor grafts. *Blood* 2002;99(3):806-814.
95. Aversa F, Tabilio A, Velardi A, et al. Treatment of high-risk acute leukemia with T-cell-depleted stem cells from related donors with one fully mismatched HLA haplotype. *N Engl J Med* 1998;339(17):1186-1193.
96. Amrolia PJ, Muccioli-Casadei G, Huls H, et al. Adoptive immunotherapy with allodepleted donor T-cells improves immune reconstitution after haploidentical stem cell transplantation. *Blood* 2006;108(6):1797-1808.
97. O'Donnell PV, Luznik L, Jones RJ, et al. Nonmyeloablative bone marrow transplantation from partially HLA-mismatched related donors using posttransplantation cyclophosphamide. *Biol Blood Marrow Transplant* 2002;8(7):377-386.
98. Luznik L, O'Donnell PV, Symons HJ, et al. HLA-haploidentical bone marrow transplantation for hematologic malignancies using nonmyeloablative conditioning and high-dose, posttransplantation cyclophosphamide. *Biol Blood Marrow Transplant* 2008;14(6):641-650.
99. Brunstein CG, Fuchs EJ, Carter SL, et al. Alternative donor transplantation after reduced intensity conditioning: results of parallel phase 2 trials using partially HLA-mismatched related bone marrow or unrelated double umbilical cord blood grafts. *Blood* 2011;118(2):282-288.
100. Saber W, Opie S, Rizzo JD, Zhang MJ, Horowitz MM, Schriber J. Outcomes after matched unrelated donor versus identical sibling hematopoietic cell transplantation in adults with acute myelogenous leukemia. *Blood* 2012;119(17):3908-3916.
101. Lee SJ, Klein J, Haagenson M, et al. High-resolution donor-recipient HLA matching contributes to the success of unrelated donor marrow transplantation. *Blood* 2007;110(13):4576-4583.
102. Woolfrey A, Klein JP, Haagenson M, et al. HLA-C antigen mismatch is associated with worse outcome in unrelated donor peripheral blood stem cell transplantation. *Biol Blood Marrow Transplant* 2011;17(6):885-892.
103. Petersdorf EW, Anasetti C, Martin PJ, et al. Limits of HLA mismatching in unrelated hematopoietic cell transplantation. *Blood* 2004;104(9): 2976-2980.
104. Wagner JE, Kernan NA, Steinbuch M, Broxmeyer HE, Gluckman E. Allogeneic sibling umbilical-cord-blood transplantation in children with malignant and non-malignant disease. *Lancet* 1995;346(8969):214-219.
105. Kurtzberg J, Laughlin M, Graham ML, et al. Placental blood as a source of hematopoietic stem cells for transplantation into unrelated recipients. *N Engl J Med* 1996;335(3):157-166.
106. Rubinstein P, Carrier C, Scaradavou A, et al. Outcomes among 562 recipients of placental-blood transplants from unrelated donors. *N Engl J Med* 1998;339(22):1565-1577.
107. Rocha V, Cornish J, Sievers EL, et al. Comparison of outcomes of unrelated bone marrow and umbilical cord blood transplants in children with acute leukemia. *Blood* 2001;97(10):2962-2971.
108. Barker JN, Davies SM, DeFor T, Ramsay NK, Weisdorf DJ, Wagner JE. Survival after transplantation of unrelated donor umbilical cord blood is comparable to that of human leukocyte antigen-matched unrelated donor bone marrow: results of a matched-pair analysis. *Blood* 2001;97(10):2957-2961.

109. Rocha V, Wagner JE, Jr., Sobocinski KA, et al. Graft-versus-host disease in children who have received a cord-blood or bone marrow transplant from an HLA-identical sibling. Eurocord and International Bone Marrow Transplant Registry Working Committee on Alternative Donor and Stem Cell Sources. *N Engl J Med* 2000;342(25):1846-1854.
110. Wagner JE, Barker JN, DeFor TE, et al. Transplantation of unrelated donor umbilical cord blood in 102 patients with malignant and nonmalignant diseases: influence of CD34 cell dose and HLA disparity on treatment-related mortality and survival. *Blood* 2002;100(5):1611-1618.
111. Han P, Hodge G, Story C, Xu X. Phenotypic analysis of functional T-lymphocyte subtypes and natural killer cells in human cord blood: relevance to umbilical cord blood transplantation. *Br J Haematol* 1995;89(4):733-740.
112. Talvensaaari K, Clave E, Douay C, et al. A broad T-cell repertoire diversity and an efficient thymic function indicate a favorable long-term immune reconstitution after cord blood stem cell transplantation. *Blood* 2002;99(4):1458-1464.
113. Laughlin MJ, Barker J, Bambach B, et al. Hematopoietic engraftment and survival in adult recipients of umbilical-cord blood from unrelated donors. *N Engl J Med* 2001;344(24):1815-1822.
114. Laughlin MJ, Eapen M, Rubinstein P, et al. Outcomes after transplantation of cord blood or bone marrow from unrelated donors in adults with leukemia. *N Engl J Med* 2004;351(22):2265-2275.
115. Takahashi S, Iseki T, Ooi J, et al. Single-institute comparative analysis of unrelated bone marrow transplantation and cord blood transplantation for adult patients with hematologic malignancies. *Blood* 2004;104(12):3813-3820.
116. Barker JN, Weisdorf DJ, DeFor TE, Blazar BR, Miller JS, Wagner JE. Rapid and complete donor chimerism in adult recipients of unrelated donor umbilical cord blood transplantation after reduced-intensity conditioning. *Blood* 2003;102(5):1915-1919.
117. Barker JN, Weisdorf DJ, DeFor TE, et al. Transplantation of 2 partially HLA-matched umbilical cord blood units to enhance engraftment in adults with hematologic malignancy. *Blood* 2005;105(3):1343-1347.
118. Verneris MR, Brunstein CG, Barker J, et al. Relapse risk after umbilical cord blood transplantation: enhanced graft-versus-leukemia effect in recipients of 2 units. *Blood* 2009;114(19):4293-4299.
119. Avery S, Shi W, Lubin M, et al. Influence of infused cell dose and HLA match on engraftment after double-unit cord blood allografts. *Blood* 2011;117(12):3277-3285,3478.
120. Gutman JA, et al. Single-unit dominance after double-unit umbilical cord blood transplantation coincides with a specific CD8+ T-cell response against the nonengrafted unit. *Blood* 2010;115(4):757-765.
121. Brunstein CG, Gutman JA, Weisdorf DJ, et al. Allogeneic hematopoietic cell transplantation for hematologic malignancy: relative risks and benefits of double umbilical cord blood. *Blood* 2010;116(22):4693-4699.
122. van Rood JJ, Scaradavou A, Stevens CE. Indirect evidence that maternal microchimerism in cord blood mediates a graft-versus-leukemia effect in cord blood transplantation. *Proc Natl Acad Sci U S A* 2012;109(7):2509-2514.
123. Thomas ED, Storb R. Technique for human marrow grafting. *Blood* 1970;36(4):507-515.
124. Braine HG, Sensenbrenner LL, Wright SK, Tutschka PJ, Saral R, Santos GW. Bone marrow transplantation with major ABO blood group incompatibility using erythrocyte depletion of marrow prior to infusion. *Blood* 1982;60(2):420-425.
125. Buckner CD, Petersen FB, Bolonesi BA. Bone marrow donors, in bone marrow transplantation. In: Forman SJ, Blume KG, Thomas ED, eds. Boston, MA: Blackwell Scientific Publications, 1994:259-270.
126. Bortin MM, Buckner CD. Major complications of marrow harvesting for transplantation. *Exp Hematol* 1983;11(10):916-921.
127. Schmitz N, Dreger P, Suttrop M, et al. Primary transplantation of allogeneic peripheral blood progenitor cells mobilized by filgrastim (granulocyte colony-stimulating factor). *Blood* 1995;85(6):1666-1672.
128. Korbling M, Przepiorka D, Huh YO, et al. Allogeneic blood stem cell transplantation for refractory leukemia and lymphoma: potential advantage of blood over marrow allografts. *Blood* 1995;85(6):1659-1665.
129. Pulsipher MA, Chitphakdithai P, Miller JP, et al. Adverse events among 2408 unrelated donors of peripheral blood stem cells: results of a prospective trial from the National Marrow Donor Program. *Blood* 2009;113(15): 3604-3611.
130. Rubinstein P, Dobrila L, Rosenfield RE, et al. Processing and cryopreservation of placental/umbilical cord blood for unrelated bone marrow reconstitution. *Proc Natl Acad Sci U S A* 1995;92(22):10119-10122.

131. Harris DT, Schumacher MJ, Rychlik S, et al. Collection, separation and cryopreservation of umbilical cord blood for use in transplantation. *Bone Marrow Transplant* 1994;13(2):135-143.
132. Reed W, Smith R, Dekovic F, et al. Comprehensive banking of sibling donor cord blood for children with malignant and nonmalignant disease. *Blood* 2003;101(1):351-357.
133. Seebach JD, Stussi G, Passweg JR, et al. ABO blood group barrier in allogeneic bone marrow transplantation revisited. *Biol Blood Marrow Transplant* 2005;11(12):1006-1013.
134. Bensinger WI, Buckner CD, Thomas ED, Clift RA. ABO-incompatible marrow transplants. *Transplantation* 1982;33(4):427-429.
135. Gmur JP, Burger J, Schaffner A, et al. Pure red cell aplasia of long duration complicating major ABO-incompatible bone marrow transplantation. *Blood* 1990;75(1):290-295.
136. Bolan CD, Leitman SF, Griffith LM, et al. Delayed donor red cell chimerism and pure red cell aplasia following major ABO-incompatible nonmyeloablative hematopoietic stem cell transplantation. *Blood* 2001;98(6):1687-1694.
137. Gajewski JL, Petz LD, Calhoun L, et al. Hemolysis of transfused group O red blood cells in minor ABO-incompatible unrelated-donor bone marrow transplants in patients receiving cyclosporine without posttransplant methotrexate. *Blood* 1992;79(11):3076-3085.
138. Blume KG, Forman SJ, O'Donnell MR, et al. Total body irradiation and high-dose etoposide: a new preparatory regimen for bone marrow transplantation in patients with advanced hematologic malignancies. *Blood* 1987;69(4):1015-1020.
139. Powles RL, Milliken S, Helenglass G, et al. The use of melphalan in conjunction with total body irradiation as treatment for acute leukaemia. *Transplant Proc* 1989;21(1 Pt 3):2955-2957.
140. Lynch MH, Petersen FB, Appelbaum FR, et al. Phase II study of busulfan, cyclophosphamide and fractionated total body irradiation as a preparatory regimen for allogeneic bone marrow transplantation in patients with advanced myeloid malignancies. *Bone Marrow Transplant* 1995;15(1):59-64.
141. Weaver CH, Petersen FB, Appelbaum FR, et al. High-dose fractionated total-body irradiation, etoposide, and cyclophosphamide followed by autologous stem-cell support in patients with malignant lymphoma. *J Clin Oncol* 1994;12(12):2559-2566.
142. Santos GW, Tutschka PJ, Brookmeyer R, et al. Marrow transplantation for acute nonlymphocytic leukemia after treatment with busulfan and cyclophosphamide. *N Engl J Med* 1983;309(22):1347-1353.
143. Zander AR, Culbert S, Jagannath S, et al. High dose cyclophosphamide, BCNU, and VP-16 (CBV) as a conditioning regimen for allogeneic bone marrow transplantation for patients with acute leukemia. *Cancer* 1987;59(6): 1083-1086.
144. Bredeson CN, Zhang MJ, Agovi MA, et al. Outcomes following HSCT using fludarabine, busulfan, and thymoglobulin: a matched comparison to allogeneic transplants conditioned with busulfan and cyclophosphamide. *Biol Blood Marrow Transplant* 2008;14(9):993-1003.
145. Giralt S, Thall PF, Khouri I, et al. Melphalan and purine analog-containing preparative regimens: reduced-intensity conditioning for patients with hematologic malignancies undergoing allogeneic progenitor cell transplantation. *Blood* 2001;97(3):631-637.
146. Demirer T, Weaver CH, Buckner CD, et al. High-dose cyclophosphamide, carmustine, and etoposide followed by allogeneic bone marrow transplantation in patients with lymphoid malignancies who had received prior dose-limiting radiation therapy. *J Clin Oncol* 1995;13(3):596-602.
147. Schiffman KS, Bensinger WI, Appelbaum FR, et al. Phase II study of high-dose busulfan, melphalan and thiotepea with autologous peripheral blood stem cell support in patients with malignant disease. *Bone Marrow Transplant* 1996;17(6):943-950.
148. Mills W, Chopra R, McMillan A, Pearce R, Linch DC, Goldstone AH. BEAM chemotherapy and autologous bone marrow transplantation for patients with relapsed or refractory non-Hodgkin's lymphoma. *J Clin Oncol* 1995;13(3):588-595.
149. Clift RA, Buckner CD, Appelbaum FR, et al. Allogeneic marrow transplantation in patients with chronic myeloid leukemia in the chronic phase: a randomized trial of two irradiation regimens. *Blood* 1991;77(8):1660-1665.
150. Clift RA, Buckner CD, Appelbaum FR, et al. Allogeneic marrow transplantation in patients with acute myeloid leukemia in first remission: a randomized trial of two irradiation regimens. *Blood* 1990;76(9):1867-1871.

151. Bornhauser M, Kienast J, Trenschele R, et al. Reduced-intensity conditioning versus standard conditioning before allogeneic haemopoietic cell transplantation in patients with acute myeloid leukaemia in first complete remission: a prospective, open-label randomised phase 3 trial. *Lancet Oncol* 2012.
152. Clift RA, Buckner CD, Thomas ED, et al. Marrow transplantation for chronic myeloid leukemia: a randomized study comparing cyclophosphamide and total body irradiation with busulfan and cyclophosphamide. *Blood* 1994;84(6):2036-2043.
153. Clift RA, Radich J, Appelbaum FR, et al. Long-term follow-up of a randomized study comparing cyclophosphamide and total body irradiation with busulfan and cyclophosphamide for patients receiving allogeneic marrow transplants during chronic phase of chronic myeloid leukemia. *Blood* 1999;94(11): 3960-3962.
154. Devergie A, Blaise D, Attal M, et al. Allogeneic bone marrow transplantation for chronic myeloid leukemia in first chronic phase: a randomized trial of busulfan-cytosine versus cytosine-total body irradiation as preparative regimen: a report from the French Society of Bone Marrow Graft (SFGM). *Blood* 1995;85(8):2263-2268.
155. Ringden O, Remberger M, Ruutu T, et al. Increased risk of chronic graft-versus-host disease, obstructive bronchiolitis, and alopecia with busulfan versus total body irradiation: long-term results of a randomized trial in allogeneic marrow recipients with leukemia. Nordic Bone Marrow Transplantation Group. *Blood* 1999;93(7):2196-2201.
156. Radich JP, Gooley T, Bensinger W, et al. HLA-matched related hematopoietic cell transplantation for chronic-phase CML using a targeted busulfan and cyclophosphamide preparative regimen. *Blood* 2003;102(1):31-35.
157. McDonald GB, Slattery JT, Bouvier ME, et al. Cyclophosphamide metabolism, liver toxicity, and mortality following hematopoietic stem cell transplantation. *Blood* 2003;101(5):2043-2048.
158. McDonald GB, McCune JS, Batchelder A, et al. Metabolism-based cyclophosphamide dosing for hematopoietic cell transplant. *Clin Pharmacol Ther* 2005;78(3):298-308.
159. Fischer A, Landais P, Friedrich W, et al. European experience of bone-marrow transplantation for severe combined immunodeficiency. *Lancet* 1990;336(8719):850-854.
160. Lucarelli G, Galimberti M, Polchi P, et al. Bone marrow transplantation in patients with thalassemia. *N Engl J Med* 1990;322(7):417-421.
161. Walters MC, Patience M, Leisenring W, et al. Bone marrow transplantation for sickle cell disease. *N Engl J Med* 1996;335(6):369-376.
162. Hsieh MM, Kang EM, Fitzhugh CD, et al. Allogeneic hematopoietic stem-cell transplantation for sickle cell disease. *N Engl J Med* 2009;361(24): 2309-2317.
163. Pagel JM, Gooley TA, Rajendran J, et al. Allogeneic hematopoietic cell transplantation after conditioning with 131I-anti-CD45 antibody plus fludarabine and low-dose total body irradiation for elderly patients with advanced acute myeloid leukemia or high-risk myelodysplastic syndrome. *Blood* 2009;114(27):5444-5453.
164. Pagel JM, Appelbaum FR, Eary JF, et al. 131I-anti-CD45 antibody plus busulfan and cyclophosphamide before allogeneic hematopoietic cell transplantation for treatment of acute myeloid leukemia in first remission. *Blood* 2006;107(5):2184-2191.
165. Bunjes D, Buchmann I, Duncker C, et al. Rhenium 188-labeled anti-CD66 (a, b, c, e) monoclonal antibody to intensify the conditioning regimen prior to stem cell transplantation for patients with high-risk acute myeloid leukemia or myelodysplastic syndrome: results of a phase I-II study. *Blood* 2001;98(3):565-572.
166. Press OW, Eary JF, Gooley T, et al. A phase I/II trial of iodine-131-tositumomab (anti-CD20), etoposide, cyclophosphamide, and autologous stem cell transplantation for relapsed B-cell lymphomas. *Blood* 2000;96(9):2934-2942.
167. Sorror ML, Sandmaier BM, Storer BE, et al. Long-term outcomes among older patients following nonmyeloablative conditioning and allogeneic hematopoietic cell transplantation for advanced hematologic malignancies. *JAMA* 2011;306(17):1874-1883.
168. Giralt S, Estey E, Albitar M, et al. Engraftment of allogeneic hematopoietic progenitor cells with purine analog-containing chemotherapy: harnessing graft-versus-leukemia without myeloablative therapy. *Blood* 1997;89(12):4531-4536.
169. Lowsky R, Takahashi T, Liu YP, et al. Protective conditioning for acute graft-versus-host disease. *N Engl J Med* 2005;353(13):1321-1331.

170. Slavin S, Nagler A, Naparstek E, et al. Nonmyeloablative stem cell transplantation and cell therapy as an alternative to conventional bone marrow transplantation with lethal cytoreduction for the treatment of malignant and nonmalignant hematologic diseases. *Blood* 1998;91(3):756-763.
171. Childs R, Clave E, Contentin N, et al. Engraftment kinetics after nonmyeloablative allogeneic peripheral blood stem cell transplantation: full donor T-cell chimerism precedes alloimmune responses. *Blood* 1999;94(9):3234-3241.
172. McSweeney PA, Niederwieser D, Shizuru JA, et al. Hematopoietic cell transplantation in older patients with hematologic malignancies: replacing high-dose cytotoxic therapy with graft-versus-tumor effects. *Blood* 2001;97(11):3390-3400.
173. Sorror ML, Maris MB, Sandmaier BM, et al. Hematopoietic cell transplantation after nonmyeloablative conditioning for advanced chronic lymphocytic leukemia. *J Clin Oncol* 2005;23(16):3819-3829.
174. Weissinger F, Sandmaier BM, Maloney DG, Bensinger WI, Gooley T, Storb R. Decreased transfusion requirements for patients receiving nonmyeloablative compared with conventional peripheral blood stem cell transplants from HLA-identical siblings. *Blood* 2001;98(13):3584-3588.
175. Chakraverty R, Peggs K, Chopra R, et al. Limiting transplantation-related mortality following unrelated donor stem cell transplantation by using a nonmyeloablative conditioning regimen. *Blood* 2002;99(3):1071-1078.
176. Niederwieser D, Maris M, Shizuru JA, et al. Low-dose total body irradiation (TBI) and fludarabine followed by hematopoietic cell transplantation (HCT) from HLA-matched or mismatched unrelated donors and postgrafting immunosuppression with cyclosporine and mycophenolate mofetil (MMF) can induce durable complete chimerism and sustained remissions in patients with hematological diseases. *Blood* 2003;101(4):1620-1629.
177. Rizzieri DA, Long GD, Vredenburgh JJ, et al. Successful allogeneic engraftment of mismatched unrelated cord blood following a nonmyeloablative preparative regimen. *Blood* 2001;98(12):3486-3488.
178. Baron F, Maris MB, Sandmaier BM, et al. Graft-versus-tumor effects after allogeneic hematopoietic cell transplantation with nonmyeloablative conditioning. *J Clin Oncol* 2005;23(9):1993-2003.
179. Corradini P, Tarella C, Olivieri A, et al. Reduced-intensity conditioning followed by allografting of hematopoietic cells can produce clinical and molecular remissions in patients with poor-risk hematologic malignancies. *Blood* 2002;99(1):75-82.
180. Sorror ML, Storer BE, Sandmaier BM, et al. Five-year follow-up of patients with advanced chronic lymphocytic leukemia treated with allogeneic hematopoietic cell transplantation after nonmyeloablative conditioning. *J Clin Oncol* 2008;26(30):4912-4920.
181. Devine SM, Hoffman R, Verma A, et al. Allogeneic blood cell transplantation following reduced-intensity conditioning is effective therapy for older patients with myelofibrosis with myeloid metaplasia. *Blood* 2002;99(6):2255-2258.
182. Khouri IF, Saliba RM, Giralt SA, et al. Nonablative allogeneic hematopoietic transplantation as adoptive immunotherapy for indolent lymphoma: low incidence of toxicity, acute graft-versus-host disease, and treatment-related mortality. *Blood* 2001;98(13):3595-3599.
183. Rotta M, Storer BE, Sahebi F, et al. Long-term outcome of patients with multiple myeloma after autologous hematopoietic cell transplantation and nonmyeloablative allografting. *Blood* 2009;113(14):3383-3391.
184. Carella AM, Cavaliere M, Lerma E, et al. Autografting followed by nonmyeloablative immunosuppressive chemotherapy and allogeneic peripheral-blood hematopoietic stem-cell transplantation as treatment of resistant Hodgkin's disease and non-Hodgkin's lymphoma. *J Clin Oncol* 2000;18(23):3918-3924.
185. Alyea EP, Kim HT, Ho V, et al. Comparative outcome of nonmyeloablative and myeloablative allogeneic hematopoietic cell transplantation for patients older than 50 years of age. *Blood* 2005;105(4):1810-1814.
186. de Lima M, Anagnostopoulos A, Munsell M, et al. Nonablative versus reduced-intensity conditioning regimens in the treatment of acute myeloid leukemia and high-risk myelodysplastic syndrome: dose is relevant for long-term disease control after allogeneic hematopoietic stem cell transplantation. *Blood* 2004;104(3):865-872.
187. Scott BL, Sandmaier BM, Storer B, et al. Myeloablative vs nonmyeloablative allogeneic transplantation for patients with myelodysplastic syndrome or acute myelogenous leukemia with multilineage dysplasia: a retrospective analysis. *Leukemia* 2006;20(1):128-135.

188. Diaconescu R, Flowers CR, Storer B, et al. Morbidity and mortality with nonmyeloablative compared with myeloablative conditioning before hematopoietic cell transplantation from HLA-matched related donors. *Blood* 2004;104(5):1550-1558.
189. Mielcarek M, Martin PJ, Leisenring W, et al. Graft-versus-host disease after nonmyeloablative versus conventional hematopoietic stem cell transplantation. *Blood* 2003;102(2):756-762.
190. Burroughs L, Mielcarek M, Leisenring W, et al. Extending postgrafting cyclosporine decreases the risk of severe graft-versus-host disease after nonmyeloablative hematopoietic cell transplantation. *Transplantation* 2006;81(6):818-825.
191. Junghanss C, Boeckh M, Carter RA, et al. Incidence and outcome of cytomegalovirus infections following nonmyeloablative compared with myeloablative allogeneic stem cell transplantation, a matched control study. *Blood* 2002;99(6):1978-1985.
192. Baron F, Storer B, Maris MB, et al. Unrelated donor status and high donor age independently affect immunologic recovery after nonmyeloablative conditioning. *Biol Blood Marrow Transplant* 2006;12(11):1176-1187.
193. Zaucha JM, Zellmer E, Georges G, et al. G-CSF-mobilized peripheral blood mononuclear cells added to marrow facilitates engraftment in nonmyeloablated canine recipients: CD3 cells are required. *Biol Blood Marrow Transplant* 2001;7(11):613-619.
194. Turhan AG, Humphries RK, Phillips GL, Eaves AC, Eaves CJ. Clonal hematopoiesis demonstrated by X-linked DNA polymorphisms after allogeneic bone marrow transplantation. *N Engl J Med* 1989;320(25):1655-1661.
195. Nash R, Storb R, Neiman P. Polyclonal reconstitution of human marrow after allogeneic bone marrow transplantation. *Blood* 1988;72(6):2031-2037.
- P.2175
196. Storb R, Deeg HJ, Whitehead J, et al. Methotrexate and cyclosporine compared with cyclosporine alone for prophylaxis of acute graft versus host disease after marrow transplantation for leukemia. *N Engl J Med* 1986;314(12):729-735.
197. Nemunaitis J, Rabinowe SN, Singer JW, et al. Recombinant granulocyte-macrophage colony-stimulating factor after autologous bone marrow transplantation for lymphoid cancer. *N Engl J Med* 1991;324(25):1773-1778.
198. Anasetti C, Amos D, Beatty PG, et al. Effect of HLA compatibility on engraftment of bone marrow transplants in patients with leukemia or lymphoma. *N Engl J Med* 1989;320(4):197-204.
199. Martin PJ, Hansen JA, Torok-Storb B, et al. Graft failure in patients receiving T cell-depleted HLA-identical allogeneic marrow transplants. *Bone Marrow Transplant* 1988;3(5):445-456.
200. Champlin R, Ho W, Gajewski J, et al. Selective depletion of CD8+ T lymphocytes for prevention of graft-versus-host disease after allogeneic bone marrow transplantation. *Blood* 1990;76(2):418-423.
201. Soiffer RJ, Murray C, Mauch P, et al. Prevention of graft-versus-host disease by selective depletion of CD6-positive T lymphocytes from donor bone marrow. *J Clin Oncol* 1992;10(7):1191-1200.
202. Maris MB, Niederwieser D, Sandmaier BM, et al. HLA-matched unrelated donor hematopoietic cell transplantation after nonmyeloablative conditioning for patients with hematologic malignancies. *Blood* 2003;102(6): 2021-2030.
203. Giaccone L, McCune JS, Maris MB, et al. Pharmacodynamics of mycophenolate mofetil after nonmyeloablative conditioning and unrelated donor hematopoietic cell transplantation. *Blood* 2005;106(13):4381-4388.
204. Bjerke JW, Lorenz J, Martin PJ, Storb R, Hansen JA, Anasetti C. Treatment of graft failure with anti-CD3 antibody BC3, glucocorticoids and infusion of donor hematopoietic cells. *Blood* 1995;86:107a,415.
205. Kerbaux FR, Storb R, Hegenbart U, et al. Hematopoietic cell transplantation from HLA-identical sibling donors after low-dose radiation-based conditioning for treatment of CML. *Leukemia* 2005;19(6):990-997.
206. Gyurkocza B, Cao TM, Storb RF, et al. Salvage allogeneic hematopoietic cell transplantation with fludarabine and low-dose total body irradiation after rejection of first allografts. *Biol Blood Marrow Transplant* 2009;15(10):1314-1322.

207. Chien JW, Maris MB, Sandmaier BM, Maloney DG, Storb RF, Clark JG. Comparison of lung function after myeloablative and 2 Gy of total body irradiation-based regimens for hematopoietic stem cell transplantation. *Biol Blood Marrow Transplant* 2005;11(4):288-296.
208. Parikh CR, Schrier RW, Storer B, et al. Comparison of ARF after myeloablative and nonmyeloablative hematopoietic cell transplantation. *Am J Kidney Dis* 2005;45(3):502-509.
209. Fukuda T, Hackman RC, Guthrie KA, et al. Risks and outcomes of idiopathic pneumonia syndrome after nonmyeloablative and conventional conditioning regimens for allogeneic hematopoietic stem cell transplantation. *Blood* 2003;102(8):2777-2785.
210. Hogan WJ, Maris M, Storer B, et al. Hepatic injury after nonmyeloablative conditioning followed by allogeneic hematopoietic cell transplantation: a study of 193 patients. *Blood* 2004;103(1):78-84.
211. Spielberger R, Stiff P, Bensinger W, et al. Palifermin for oral mucositis after intensive therapy for hematologic cancers. *N Engl J Med* 2004;351(25): 2590-2598.
212. Zager RA, O'Quigley J, Zager BK, et al. Acute renal failure following bone marrow transplantation: a retrospective study of 272 patients. *Am J Kidney Dis* 1989;13(3):210-216.
213. Hingorani SR, Guthrie K, Batchelder A, et al. Acute renal failure after myeloablative hematopoietic cell transplant: incidence and risk factors. *Kidney Int* 2005;67(1):272-277.
214. Meyers JD, Flournoy N, Thomas ED. Nonbacterial pneumonia after allogeneic marrow transplantation: a review of ten years' experience. *Rev Infect Dis* 1982;4(6):1119-1132.
215. Bearman SI, Appelbaum FR, Back A, et al. Regimen-related toxicity and early posttransplant survival in patients undergoing marrow transplantation for lymphoma. *J Clin Oncol* 1989;7(9):1288-1294.
216. Wingard JR, Mellits ED, Sostrin MB, et al. Interstitial pneumonitis after allogeneic bone marrow transplantation. Nine-year experience at a single institution. *Medicine (Baltimore)* 1988;67(3):175-186.
217. Troussard X, Bernaudin JF, Cordonnier C, et al. Pulmonary veno-occlusive disease after bone marrow transplantation. *Thorax* 1984;39(12):956-957.
218. Hackman RC, Madtes DK, Petersen FB, Clark JG. Pulmonary venooc-clusive disease following bone marrow transplantation. *Transplantation* 1989;47(6):989-992.
219. Rubinfeld GD, Crawford SW. Withdrawing life support from mechanically ventilated recipients of bone marrow transplants: a case for evidence-based guidelines. *Ann Intern Med* 1996;125(8):625-633.
220. McDonald GB, Hinds MS, Fisher LD, et al. Venocclusive disease of the liver and multiorgan failure after bone marrow transplantation: a cohort study of 355 patients. *Ann Intern Med* 1993;118(4):255-267.
221. Ruutu T, Eriksson B, Remes K, et al. Ursodeoxycholic acid for the prevention of hepatic complications in allogeneic stem cell transplantation. *Blood* 2002;100(6):1977-1983.
222. Bearman SI, Shuhart MC, Hinds MS, McDonald GB. Recombinant human tissue plasminogen activator for the treatment of established severe venocclusive disease of the liver after bone marrow transplantation. *Blood* 1992;80(10):2458-2462.
223. Leahey AM, Bunin NJ. Recombinant human tissue plasminogen activator for the treatment of severe hepatic veno-occlusive disease in pediatric bone marrow transplant patients. *Bone Marrow Transplant* 1996;17(6):1101-1104.
224. Richardson PG, Murakami C, Jin Z, et al. Multi-institutional use of defibrotide in 88 patients after stem cell transplantation with severe veno-occlusive disease and multisystem organ failure: response without significant toxicity in a high-risk population and factors predictive of outcome. *Blood* 2002;100(13):4337-4343.
225. Corbacioglu S, Cesaro S, Faraci M, et al. Defibrotide for prophylaxis of hepatic veno-occlusive disease in paediatric haemopoietic stem-cell transplantation: an open-label, phase 3, randomised controlled trial. *Lancet* 2012;379(9823):1301-1309.
226. Khera N, Storer B, Flowers ME, et al. Nonmalignant late effects and compromised functional status in survivors of hematopoietic cell transplantation. *J Clin Oncol* 2012;30(1):71-77.
227. Wingard JR, Majhail NS, Brazauskas R, et al. Long-term survival and late deaths after allogeneic hematopoietic cell transplantation. *J Clin Oncol* 2011;29(16):2230-2239.

228. Curtis RE, Rowlings PA, Deeg HJ, et al. Solid cancers after bone marrow transplantation. *N Engl J Med* 1997;336(13):897-904.
229. Deeg HJ, Socie G, Schoch G, et al. Malignancies after marrow transplantation for aplastic anemia and fanconi anemia: a joint Seattle and Paris analysis of results in 700 patients. *Blood* 1996;87(1):386-392.
230. Sanders JE, Hawley J, Levy W, et al. Pregnancies following high-dose cyclophosphamide with or without high-dose busulfan or total-body irradiation and bone marrow transplantation. *Blood* 1996;87(7):3045-3052.
231. Sanders JE, Buckner CD, Amos D, et al. Ovarian function following marrow transplantation for aplastic anemia or leukemia. *J Clin Oncol* 1988;6(5): 813-818.
232. Schubert MA, Sullivan KM, Schubert MM, et al. Gynecological abnormalities following allogeneic bone marrow transplantation. *Bone Marrow Transplant* 1990;5(6):425-430.
233. Darrington DL, Vose JM, Anderson JR, et al. Incidence and characterization of secondary myelodysplastic syndrome and acute myelogenous leukemia following high-dose chemoradiotherapy and autologous stem-cell transplantation for lymphoid malignancies. *J Clin Oncol* 1994;12(12):2527-2534.
234. Gilliland DG, Gribben JG. Evaluation of the risk of therapy-related MDS/AML after autologous stem cell transplantation. *Biol Blood Marrow Transplant* 2002;8(1):9-16.
235. Curtis RE, Metayer C, Rizzo JD, et al. Impact of chronic GVHD therapy on the development of squamous-cell cancers after hematopoietic stem-cell transplantation: an international case-control study. *Blood* 2005;105(10): 3802-3811.
236. Rovo A, Tichelli A, Passweg JR, et al. Spermatogenesis in long-term survivors after allogeneic hematopoietic stem cell transplantation is associated with age, time interval since transplantation, and apparently absence of chronic GvHD. *Blood* 2006;108(3):1100-1105.
237. Grigg AP, Shuttleworth P, Reynolds J, et al. Pamidronate reduces bone loss after allogeneic stem cell transplantation. *J Clin Endocrinol Metab* 2006;91(10):3835-3843.
238. Kananen K, Volin L, Laitinen K, Alfthan H, Ruutu T, Valimaki MJ. Prevention of bone loss after allogeneic stem cell transplantation by calcium, vitamin D, and sex hormone replacement with or without pamidronate. *J Clin Endocrinol Metab* 2005;90(7):3877-3885.
239. Sanders JE, Guthrie KA, Hoffmeister PA, Woolfrey AE, Carpenter PA, Appelbaum FR. Final adult height of patients who received hematopoietic cell transplantation in childhood. *Blood* 2005;105(3):1348-1354.
240. Syrjala KL, Dikmen S, Langer SL, Roth-Roemer S, Abrams JR. Neuropsychologic changes from before transplantation to 1 year in patients receiving myeloablative allogeneic hematopoietic cell transplant. *Blood* 2004;104(10): 3386-3392.
241. Syrjala KL, Langer SL, Abrams JR, et al. Recovery and long-term function after hematopoietic cell transplantation for leukemia or lymphoma. *JAMA* 2004;291(19):2335-2343.
242. Bhatia S, Robison LL, Francisco L, et al. Late mortality in survivors of autologous hematopoietic-cell transplantation: report from the Bone Marrow Transplant Survivor Study. *Blood* 2005;105(11):4215-4222.
243. Billingham RE. The biology of graft-versus-host reactions. In: *The Harvey lectures*. New York, NY: Academic Press, 1966:21-78.
244. Tseng LH, Lin MT, Hansen JA, et al. Correlation between disparity for the minor histocompatibility antigen HA-1 and the development of acute graft-versus-host disease after allogeneic marrow transplantation. *Blood* 1999;94(8):2911-2914.
245. Vogt MH, van den Muijsenberg JW, Goulmy E, et al. The DBY gene codes for an HLA-DQ5-restricted human male-specific minor histocompatibility antigen involved in graft-versus-host disease. *Blood* 2002;99(8):3027-3032.
246. Larsen ME, Kornblit B, Larsen MV, et al. Degree of predicted minor histocompatibility antigen mismatch correlates with poorer clinical outcomes in nonmyeloablative allogeneic hematopoietic cell transplantation. *Biol Blood Marrow Transplant* 2010;16(10):1370-1381.
247. Spellman S, Warden MB, Haagenson M, et al. Effects of mismatching for minor histocompatibility antigens on clinical outcomes in HLA-matched, unrelated hematopoietic stem cell transplants. *Biol Blood Marrow Transplant* 2009;15(7):856-863.
248. Sale GE, Anderson P, Browne M, Myerson D. Evidence of cytotoxic T-cell destruction of epidermal cells in human graft-vs-host disease. Immunohistology with monoclonal antibody TIA-1. *Arch Pathol Lab Med* 1992;116(6):622-625.

249. Ferrara JL, Levine JE, Reddy P, Holler E. Graft-versus-host disease. *Lancet* 2009 ;373(9674):1550-1561.
250. Lin MT, Storer B, Martin PJ, et al. Relation of an interleukin-10 promoter polymorphism to graft-versus-host disease and survival after hematopoietic-cell transplantation. *N Engl J Med* 2003;349(23):2201-2210.
251. Lin MT, Storer B, Martin PJ, et al. Genetic variation in the IL-10 pathway modulates severity of acute graft-versus-host disease following hematopoietic cell transplantation: synergism between IL-10 genotype of patient and IL-10 receptor beta genotype of donor. *Blood* 2005;106(12):3995-4001.
252. Paczesny S, Krijanovski OI, Braun TM, et al. A biomarker panel for acute graft-versus-host disease. *Blood* 2009;113(2):273-278.
253. Ferrara JL, Harris AC, Greenson JK, et al. Regenerating islet-derived 3-alpha is a biomarker of gastrointestinal graft-versus-host disease. *Blood* 2011;118(25):6702-6708.
254. Mielcarek M, Burroughs L, Leisenring W, et al. Prognostic relevance of "early-onset" graft-versus-host disease following non-myeloablative haematopoietic cell transplantation. *Br J Haematol* 2005;129(3):381-391.
255. Spencer GD, Hackman RC, McDonald GB, et al. A prospective study of unexplained nausea and vomiting after marrow transplantation. *Transplantation* 1986;42(6):602-607.
256. Wu D, Hockenberry DM, Brentnall TA, et al. Persistent nausea and anorexia after marrow transplantation: a prospective study of 78 patients. *Transplantation* 1998;66(10):1319-1324.
257. Weisdorf DJ, Snover DC, Haake R, et al. Acute upper gastrointestinal graft-versus-host disease: clinical significance and response to immunosuppressive therapy. *Blood* 1990;76(3):624-629.
258. Fox RJ, Vogelsang GB, Beschorner WE. Denuded bowel after recovery from graft-versus-host disease. *Transplantation* 1996;62(11):1681-1684.
259. Nash RA, Pepe MS, Storb R, et al. Acute graft-versus-host disease: analysis of risk factors after allogeneic marrow transplantation and prophylaxis with cyclosporine and methotrexate. *Blood* 1992;80(7):1838-1845.
260. Weisdorf D, Hakke R, Blazar B, et al. Risk factors for acute graft-versus-host disease in histocompatible donor bone marrow transplantation. *Transplantation* 1991;51(6):1197-1203.
261. Jagasia M, Arora M, Flowers ME, et al. Risk factors for acute GVHD and survival after hematopoietic cell transplantation. *Blood* 2012;119(1):296-307.
262. Przepiorka D, Smith TL, Folloder J, et al. Risk factors for acute graft-versus-host disease after allogeneic blood stem cell transplantation. *Blood* 1999;94(4):1465-1470.
263. Glucksberg H, Storb R, Fefer A, et al. Clinical manifestations of graft-versus-host disease in human recipients of marrow from HL-A-matched sibling donors. *Transplantation* 1974;18(4):295-304.
264. Przepiorka D, Weisdorf D, Martin P, et al. 1994 Consensus Conference on Acute GVHD Grading. *Bone Marrow Transplant* 1995;15(6):825-828.
265. Rowlings PA, Przepiorka D, Klein JP, et al. IBMTR Severity Index for grading acute graft-versus-host disease: retrospective comparison with Glucksberg grade. *Br J Haematol* 1997;97(4):855-864.
266. Cahn JY, Klein JP, Lee SJ, et al. Prospective evaluation of 2 acute graft-versus-host (GVHD) grading systems: a joint Societe Francaise de Greffe de Moelle et Therapie Cellulaire (SFGM-TC), Dana Farber Cancer Institute (DFCI), and International Bone Marrow Transplant Registry (IBMTR) prospective study. *Blood* 2005;106(4):1495-1500.
267. Leisenring WM, Martin PJ, Petersdorf EW, et al. An acute graft-versus-host disease activity index to predict survival after hematopoietic cell transplantation with myeloablative conditioning regimens. *Blood* 2006;108(2): 749-755.
268. Nash RA, Antin JH, Karanes C, et al. Phase 3 study comparing methotrexate and tacrolimus with methotrexate and cyclosporine for prophylaxis of acute graft-versus-host disease after marrow transplantation from unrelated donors. *Blood* 2000;96(6):2062-2068.
269. Ratanatharathorn V, Nash RA, Przepiorka D, et al. Phase III study comparing methotrexate and tacrolimus (prograf, FK506) with methotrexate and cyclosporine for graft-versus-host disease prophylaxis after HLA-identical sibling bone marrow transplantation. *Blood* 1998;92(7):2303-2314.
270. Deeg HJ, Lin D, Leisenring W, et al. Cyclosporine or cyclosporine plus methylprednisolone for prophylaxis of graft-versus-host disease: a prospective, randomized trial. *Blood* 1997;89(10):3880-3887.

271. Chao NJ, Snyder DS, Jain M, et al. Equivalence of 2 effective graft-versus-host disease prophylaxis regimens: results of a prospective double-blind randomized trial. *Biol Blood Marrow Transplant* 2000;6(3):254-261.
272. Storb R, Pepe M, Anasetti C, et al. What role for prednisone in prevention of acute graft-versus-host disease in patients undergoing marrow transplants? *Blood* 1990;76(5):1037-1045.
273. Nash RA, Johnston L, Parker P, et al. A phase I/II study of mycophenolate mofetil in combination with cyclosporine for prophylaxis of acute graft-versus-host disease after myeloablative conditioning and allogeneic hematopoietic cell transplantation. *Biol Blood Marrow Transplant* 2005;11(7):495-505.
274. Bolwell B, Sobecks R, Pohlman B, et al. A prospective randomized trial comparing cyclosporine and short course methotrexate with cyclosporine and mycophenolate mofetil for GVHD prophylaxis in myeloablative allogeneic bone marrow transplantation. *Bone Marrow Transplant* 2004;34(7):621-625.
275. Wagner JE, Thompson JS, Carter SL, Kernan NA, Effect of graft-versus-host disease prophylaxis on 3-year disease-free survival in recipients of unrelated donor bone marrow (T-cell Depletion Trial): a multicentre, randomised phase II-III trial. *Lancet* 2005;366(9487):733-741.
276. Soiffer RJ, Lerademacher J, Ho V, et al. Impact of immune modulation with anti-T-cell antibodies on the outcome of reduced-intensity allogeneic hematopoietic stem cell transplantation for hematologic malignancies. *Blood* 2011;117(25):6963-6970.
277. Martin PJ, Schoch G, Fisher L, et al. A retrospective analysis of therapy for acute graft-versus-host disease: initial treatment. *Blood* 1990;76(8): 1464-1472.
278. Weisdorf D, Haake R, Blazar B, et al. Treatment of moderate/severe acute graft-versus-host disease after allogeneic bone marrow transplantation: an analysis of clinical risk features and outcome. *Blood* 1990;75(4):1024-1030.
279. Mielcarek M, Storer BE, Boeckh M, et al. Initial therapy of acute graft-versus-host disease with low-dose prednisone does not compromise patient outcomes. *Blood* 2009;113(13):2888-2894.
280. Van Lint MT, Uderzo C, Locasciulli A, et al. Early treatment of acute graft-versus-host disease with high- or low-dose 6-methylprednisolone: a multicenter randomized trial from the Italian Group for Bone Marrow Transplantation. *Blood* 1998;92(7):2288-2293.
281. Martin PJ, Nelson BJ, Appelbaum FR, et al. Evaluation of a CD5-specific immunotoxin for treatment of acute graft-versus-host disease after allogeneic marrow transplantation. *Blood* 1996;88(3):824-830.
282. Cragg L, Blazar BR, Defor T, et al. A randomized trial comparing prednisone with antithymocyte globulin/prednisone as an initial systemic therapy for moderately severe acute graft-versus-host disease. *Biol Blood Marrow Transplant* 2000;6(4A):441-447.
283. Lee SJ, Zahrieh D, Agura E, et al. Effect of up-front daclizumab when combined with steroids for the treatment of acute graft-versus-host disease: results of a randomized trial. *Blood* 2004;104(5):1559-1564.
284. Hockenbery DM, Cruickshank S, Rodell TC, et al. A randomized, placebo-controlled trial of oral beclomethasone dipropionate as a prednisone-sparing therapy for gastrointestinal graft-versus-host disease. *Blood* 2007;109(10):4557-4563.
285. Macmillan ML, Couriel D, Weisdorf DJ, et al. A phase 2/3 multicenter randomized clinical trial of ABX-CBL versus ATG as secondary therapy for steroid-resistant acute graft-versus-host disease. *Blood* 2007;109(6):2657-2662.
286. Bolanos-Meade J, Jacobsohn DA, Margolis J, et al. Pentostatin in steroid-refractory acute graft-versus-host disease. *J Clin Oncol* 2005;23(12): 2661-2668.
287. Ho VT, Zahrieh D, Hochberg E, et al. Safety and efficacy of denileukin diftitox in patients with steroid-refractory acute graft-versus-host disease after allogeneic hematopoietic stem cell transplantation. *Blood* 2004;104(4): 1224-1226.
288. Khoury H, Kashyap A, Adkins DR, et al. Treatment of steroid-resistant acute graft-versus-host disease with anti-thymocyte globulin. *Bone Marrow Transplant* 2001;27(10):1059-1064.
289. Benito AI, Furlong T, Martin PJ, et al. Sirolimus (rapamycin) for the treatment of steroid-refractory acute graft-versus-host disease. *Transplantation* 2001;72(12):1924-1929.
290. Przepiorka D, Kernan NA, Ippoliti C, et al.. Daclizumab, a humanized anti-interleukin-2 receptor alpha chain antibody, for treatment of acute graft-versus-host disease. *Blood* 2000;95(1):83-89.

291. Martin PJ, Inamoto Y, Flowers ME, Carpenter PA. Secondary treatment of acute graft-versus-host disease: a critical review. *Biol Blood Marrow Transplant* 2012;18(7):982-988.
292. Martin PJ, Rizzo JD, Wingard JR, et al. First- and second-line systemic treatment of acute graft-versus-host disease: recommendations of the American Society of Blood and Marrow Transplantation. *Biol Blood Marrow Transplant* 2012;18(8):1150-1163.
293. Furlong T, Leisenring W, Storb R, et al. Psoralen and ultraviolet A irradiation (PUVA) as therapy for steroid-resistant cutaneous acute graft-versus-host disease. *Biol Blood Marrow Transplant* 2002;8(4):206-212.
294. Bianco JA, Higano C, Singer J, Appelbaum FR, McDonald GB. The somatostatin analog octreotide in the management of the secretory diarrhea of the acute intestinal graft-versus-host disease in a patient after bone marrow transplantation. *Transplantation* 1990;49(6):1194-1195.
295. Sullivan KM, Agura E, Anasetti C, et al. Chronic graft-versus-host disease and other late complications of bone marrow transplantation. *Semin Hematol* 1991;28(3):250-259.
296. Atkinson K, Horowitz MM, Gale RP, et al. Risk factors for chronic graft-versus-host disease after HLA-identical sibling bone marrow transplantation. *Blood* 1990;75(12):2459-2464.
297. Storek J, Gooley T, Siadak M, et al. Allogeneic peripheral blood stem cell transplantation may be associated with a high risk of chronic graft-versus-host disease. *Blood* 1997;90(12):4705-4709.
298. Przepiorka D, Anderlini P, Saliba R, et al. Chronic graft-versus-host disease after allogeneic blood stem cell transplantation. *Blood* 2001;98(6): 1695-1700.
299. Shulman HM, Sullivan KM, Weiden PL, et al. Chronic graft-versus-host syndrome in man. A long-term clinicopathologic study of 20 Seattle patients. *Am J Med* 1980;69(2):204-217.
300. Clark JG, Crawford SW, Madtes DK, Sullivan KM. Obstructive lung disease after allogeneic marrow transplantation. Clinical presentation and course. *Ann Intern Med* 1989;111(5):368-376.
301. Akpek G, Zahurak ML, Piantadosi S, et al. Development of a prognostic model for grading chronic graft-versus-host disease. *Blood* 2001;97(5):1219-1226.
302. Sullivan KM, Witherspoon RP, Storb R, et al. Prednisone and azathioprine compared with prednisone and placebo for treatment of chronic graft-v-host disease: prognostic influence of prolonged thrombocytopenia after allogeneic marrow transplantation. *Blood* 1988;72(2):546-554.
303. Filipovich AH, Weisdorf D, Pavletic S, et al. National Institutes of Health consensus development project on criteria for clinical trials in chronic graft-versus-host disease: I. Diagnosis and staging working group report. *Biol Blood Marrow Transplant* 2005;11(12):945-956.
304. Kansu E, Gooley T, Flowers ME, et al. Administration of cyclosporine for 24 months compared with 6 months for prevention of chronic graft-versus-host disease: a prospective randomized clinical trial. *Blood* 2001;98(13): 3868-3870.
305. Pavletic SZ, Carter SL, Kernan NA, et al. Influence of T-cell depletion on chronic graft-versus-host disease: results of a multicenter randomized trial in unrelated marrow donor transplantation. *Blood* 2005;106(9):3308-3313.
306. Deeg HJ, Storer BE, Boeckh M, et al. Reduced incidence of acute and chronic graft-versus-host disease with the addition of thymoglobulin to a targeted busulfan/cyclophosphamide regimen. *Biol Blood Marrow Transplant* 2006;12(5):573-584.
307. Bacigalupo A, Lamparelli T, Barisione G, et al. Thymoglobulin prevents chronic graft-versus-host disease, chronic lung dysfunction, and late transplant-related mortality: long-term follow-up of a randomized trial in patients undergoing unrelated donor transplantation. *Biol Blood Marrow Transplant* 2006;12(5):560-565.
308. Sullivan KM, Shulman HM, Storb R, et al. Chronic graft-versus-host disease in 52 patients: adverse natural course and successful treatment with combination immunosuppression. *Blood* 1981;57(2):267-276.
309. Sullivan KM, Witherspoon RP, Storb R, et al. Alternating-day cyclosporine and prednisone for treatment of high-risk chronic graft-v-host disease. *Blood* 1988;72(2):555-561.
310. Koc S, Leisenring W, Flowers ME, et al. Therapy for chronic graft-versus-host disease: a randomized trial comparing cyclosporine plus prednisone versus prednisone alone. *Blood* 2002;100(1):48-51.

311. Martin PJ, Storer BE, Rowley SD, et al. Evaluation of mycophenolate mofetil for initial treatment of chronic graft-versus-host disease. *Blood* 2009;113(21):5074-5082.
312. Greinix HT, van Besien K, Elmaagacli AH, et al. Progressive improvement in cutaneous and extracutaneous chronic graft-versus-host disease after a 24-week course of extracorporeal photopheresis—results of a cross-over randomized study. *Biol Blood Marrow Transplant* 2011;17(12):1775-1782.
313. Flowers ME, Apperley JF, van Besien K, et al. A multicenter prospective phase 2 randomized study of extracorporeal photopheresis for treatment of chronic graft-versus-host disease. *Blood* 2008;112(7):2667-2674.
314. Fried RH, Murakami CS, Fisher LD, Willson RA, Sullivan KM, McDonald GB. Ursodeoxycholic acid treatment of refractory chronic graft-versus-host disease of the liver. *Ann Intern Med* 1992;116(8):624-629.
315. Weiden PL, Flournoy N, Thomas ED, et al. Antileukemic effect of graft-versus-host disease in human recipients of allogeneic-marrow grafts. *N Engl J Med* 1979;300(19):1068-1073.
316. Kolb HJ, Mittermuller J, Clemm C, et al. Donor leukocyte transfusions for treatment of recurrent chronic myelogenous leukemia in marrow transplant patients. *Blood* 1990;76(12):2462-2465.
317. Kolb HJ, Schattenberg A, Goldman JM, et al. Graft-versus-leukemia effect of donor lymphocyte transfusions in marrow grafted patients. *Blood* 1995;86(5):2041-2050.
318. Collins RH, Jr., Shpilberg O, Drobyski WR, et al. Donor leukocyte infusions in 140 patients with relapsed malignancy after allogeneic bone marrow transplantation. *J Clin Oncol* 1997;15(2):433-444.
319. Porter DL, Collins RH, Jr., Shpilberg O, et al. Long-term follow-up of patients who achieved complete remission after donor leukocyte infusions. *Biol Blood Marrow Transplant* 1999;5(4):253-261.
320. Mackinnon S, Papadopoulos EB, Carabasi MH, et al. Adoptive immunotherapy evaluating escalating doses of donor leukocytes for relapse of chronic myeloid leukemia after bone marrow transplantation: separation of graft-versus-leukemia responses from graft-versus-host disease. *Blood* 1995;86(4):1261-1268.
321. Dazzi F, Szydlo RM, Craddock C, et al. Comparison of single-dose and escalating-dose regimens of donor lymphocyte infusion for relapse after allografting for chronic myeloid leukemia. *Blood* 2000;95(1):67-71.
322. Porter DL, Collins RH, Jr., Hardy C, et al. Treatment of relapsed leukemia after unrelated donor marrow transplantation with unrelated donor leukocyte infusions. *Blood* 2000;95(4):1214-1221.
323. Martino R, Iacobelli S, Brand R, et al. Retrospective comparison of reduced-intensity conditioning and conventional high-dose conditioning for allogeneic hematopoietic stem cell transplantation using HLA-identical sibling donors in myelodysplastic syndromes. *Blood* 2006;108(3):836-846.
324. Randolph SS, Gooley TA, Warren EH, Appelbaum FR, Riddell SR. Female donors contribute to a selective graft-versus-leukemia effect in male recipients of HLA-matched, related hematopoietic stem cell transplants. *Blood* 2004;103(1):347-352.
325. Goulmy E, Schipper R, Pool J, et al. Mismatches of minor histocompatibility antigens between HLA-identical donors and recipients and the development of graft-versus-host disease after bone marrow transplantation. *N Engl J Med* 1996;334(5):281-285.
326. Brickner AG, Evans AM, Mito JK, et al. The PANE1 gene encodes a novel human minor histocompatibility antigen that is selectively expressed in B-lymphoid cells and B-CLL. *Blood* 2006;107(9):3779-3786.
327. Marijt WA, Heemskerk MH, Kloosterboer FM, et al. Hematopoiesis-restricted minor histocompatibility antigens HA-1- or HA-2-specific T cells can induce complete remissions of relapsed leukemia. *Proc Natl Acad Sci U S A* 2003;100(5):2742-2747.
328. Akatsuka Y, Warren EH, Gooley TA, et al. Disparity for a newly identified minor histocompatibility antigen, HA-8, correlates with acute graft-versus-host disease after haematopoietic stem cell transplantation from an HLA-identical sibling. *Br J Haematol* 2003;123(4):671-675.
329. Ochsenreither S, Majeti R, Schmitt T, et al. Cyclin-A1 represents a new immunogenic targetable antigen expressed in acute myeloid leukemia stem cells with characteristics of a cancer-testis antigen. *Blood* 2012;119(23):5492-5501.
330. Falkenburg JH, Warren EH. Graft versus leukemia reactivity after allogeneic stem cell transplantation. *Biol Blood Marrow Transplant* 2011;17 (1 Suppl):S33-S38.

331. Warren EH, Fujii N, Akatsuka Y, et al. Therapy of relapsed leukemia after allogeneic hematopoietic cell transplantation with T cells specific for minor histocompatibility antigens. *Blood* 2010;115(19):3869-3878.
332. Venstrom JM, Pittari G, Gooley TA, et al. HLA-C-dependent prevention of leukemia relapse by donor activating KIR2DS1. *N Engl J Med* 2012;367(9): 805-816.
333. Muraro PA, Douek DC, Packer A, et al. Thymic output generates a new and diverse TCR repertoire after autologous stem cell transplantation in multiple sclerosis patients. *J Exp Med* 2005;201(5):805-816.
334. Storek J, Zhao Z, Lin E, et al. Recovery from and consequences of severe iatrogenic lymphopenia (induced to treat autoimmune diseases). *Clin Immunol* 2004;113(3):285-298.
335. Clark RA, Johnson FL, Klebanoff SJ, Thomas ED. Defective neutrophil chemotaxis in bone marrow transplant patients. *J Clin Invest* 1976;58(1):22-31.
336. Storek J, Espino G, Dawson MA, Storer B, Flowers ME, Maloney DG. Low B-cell and monocyte counts on day 80 are associated with high infection rates between days 100 and 365 after allogeneic marrow transplantation. *Blood* 2000;96(9):3290-3293.
337. Witherspoon RP, Storb R, Ochs HD, et al. Recovery of antibody production in human allogeneic marrow graft recipients: influence of time posttransplantation, the presence or absence of chronic graft-versus-host disease, and antithymocyte globulin treatment. *Blood* 1981;58(2):360-368.
338. Witherspoon RP, Deeg HJ, Lum LG, et al. Immunologic recovery in human marrow graft recipients given cyclosporine or methotrexate for the prevention of graft-versus-host disease. *Transplantation* 1984;37(5):456-461.
339. Quinti I, Velardi A, Le Moli S, et al. Antibacterial polysaccharide antibody deficiency after allogeneic bone marrow transplantation. *J Clin Immunol* 1990;10(3):160-166.
340. Storek J, Wells D, Dawson MA, Storer B, Maloney DG. Factors influencing B lymphopoiesis after allogeneic hematopoietic cell transplantation. *Blood* 2001;98(2):489-491.
341. Witherspoon RP, Matthews D, Storb R, et al. Recovery of in vivo cellular immunity after human marrow grafting. Influence of time postgrafting and acute graft-versus-host disease. *Transplantation* 1984;37(2):145-150.
342. Welte K, Ciobanu N, Moore MA, Gulati S, O'Reilly RJ, Mertelsmann R. Defective interleukin 2 production in patients after bone marrow transplantation and in vitro restoration of defective T lymphocyte proliferation by highly purified interleukin 2. *Blood* 1984;64(2):380-385.
343. Roosnek EE, Brouwer MC, Vossen JM, et al. The role of interleukin-2 in proliferative responses in vitro of T cells from patients after bone marrow transplantation. Evidence that minor defects can lead to in vitro unresponsiveness. *Transplantation* 1987;43(6):855-860.
344. Gratama JW, Verdonck LF, van der Linden JA, et al. Cellular immunity to vaccinations and herpesvirus infections after bone marrow transplantation. *Transplantation* 1986;41(6):719-724.
345. Hakki M, Riddell SR, Storek J, et al. Immune reconstitution to cytomegalovirus after allogeneic hematopoietic stem cell transplantation: impact of host factors, drug therapy, and subclinical reactivation. *Blood* 2003;102(8): 3060-3067.
346. Li CR, Greenberg PD, Gilbert MJ, Goodrich JM, Riddell SR. Recovery of HLA-restricted cytomegalovirus (CMV)-specific T-cell responses after allogeneic bone marrow transplant: correlation with CMV disease and effect of ganciclovir prophylaxis. *Blood* 1994;83(7):1971-1979.
347. Marshall NA, Howe JG, Formica R, et al. Rapid reconstitution of Epstein-Barr virus-specific T lymphocytes following allogeneic stem cell transplantation. *Blood* 2000;96(8):2814-2821.
348. Reusser P, Riddell SR, Meyers JD, Greenberg PD. Cytotoxic T-lymphocyte response to cytomegalovirus after human allogeneic bone marrow transplantation: pattern of recovery and correlation with cytomegalovirus infection and disease. *Blood* 1991;78(5):1373-1380.
349. Hata A, Asanuma H, Rinki M, et al. Use of an inactivated varicella vaccine in recipients of hematopoietic-cell transplants. *N Engl J Med* 2002; 347(1):26-34.
350. Storek J, Dawson MA, Storer B, et al. Immune reconstitution after allogeneic marrow transplantation compared with blood stem cell transplantation. *Blood* 2001;97(11):3380-3389.

351. Lewin SR, Heller G, Zhang L, et al. Direct evidence for new T-cell generation by patients after either T-cell-depleted or unmodified allogeneic hematopoietic stem cell transplantations. *Blood* 2002;100(6):2235-2242.
352. Douek DC, Vescio RA, Betts MR, et al. Assessment of thymic output in adults after haematopoietic stem-cell transplantation and prediction of T-cell reconstitution. *Lancet* 2000;355(9218):1875-1881.
353. Roux E, Dumont-Girard F, Starobinski M, et al. Recovery of immune reactivity after T-cell-depleted bone marrow transplantation depends on thymic activity. *Blood* 2000;96(6):2299-2303.
354. Appelbaum FR. Hematopoietic-cell transplantation at 50. *N Engl J Med* 2007;357(15):1472-1475.

Chapter 103 Hematopoietic Stem Cell Transplantation for Nonmalignant Disorders

> Table of Contents > Part VIII - Transplantation > Chapter 103 - Hematopoietic Stem Cell Transplantation for Nonmalignant Disorders

Chapter 103

Hematopoietic Stem Cell Transplantation for Nonmalignant Disorders

Jacob R. Garcia

Mark C. Walters

INTRODUCTION

Hematopoietic stem cell transplantation (HSCT) has expanded significantly over the past several decades as a consequence of broader utilization in the treatment of malignant and premalignant conditions such as acute leukemia and myelodysplastic syndrome, respectively.^{1, 2} A parallel wider application also has evolved for nonmalignant disorders, such as hemoglobinopathies, primary immunodeficiency disorders (PIDs), inborn errors of metabolism, marrow failure syndromes, and other acquired and hereditary hematologic disorders, particularly among pediatric recipients.^{3, 4, 5, 6} Although supportive care for many of these conditions also has improved over this same period of time, long-term toxicity and morbidity of nontransplant interventions (e.g., chronic blood transfusions and iron overload) have a negative impact on the quality of life and can also cause early mortality.⁷ Thus, HSCT for nonmalignant disorders represents an alternative curative option for many patients who might otherwise succumb to complications of the underlying condition. In this chapter, we delineate and describe representative hereditary hematologic diseases for which HSCT is an option, review outcomes after HSCT in patients with these disorders, and outline the long-term effects of the therapy.

CONDITIONS SUITABLE FOR HEMATOPOIETIC STEM CELL TRANSPLANTATION

A broad array of hereditary and acquired nonmalignant disorders derives from selected hematopoietic cell lineages, which by virtue of their origin in the hematopoietic stem cell, also are theoretically amenable to cure by successful HSCT. Rather than attempt to catalog all these disorders, three broad categories of disorders have been selected to illustrate how and when to apply this therapeutic intervention.

The first of these are the PIDs, which classically are illustrated by the child with severe combined immunodeficiency syndrome (SCIDS) where there is absent B- and T-lymphocyte function. In these individuals, life-threatening infections occur in the first months of life and portend early mortality.⁸ Because there is no immunologic barrier to donor engraftment, marrow from an HLA-identical sibling can be infused in the absence of any pre-transplant immunosuppressive therapy. Thus, these were among the first cases in which the proof-of-principle of HSCT was demonstrated.

The next group of disorders are the hereditary bone marrow failure syndromes, of which Fanconi anemia (FA) is a prototypic example. Fanconi anemia is caused by a heterogeneous collection of defects in genes that encode proteins involved in DNA repair.⁹ This deficiency is associated with a variable phenotype that includes progressive aplastic anemia, musculoskeletal and other congenital defects, and cancer predisposition (particularly to myelodysplastic syndrome, acute myelogenous leukemia, and carcinoma of the skin and oropharynx).¹⁰ Although the hematologic manifestations of this condition are eliminated after successful HSCT, donor selection, modulation of the conditioning regimen, and the possibility of malignant transformation in the marrow together make this a challenging disease to treat by HSCT.

Finally, the broad category of hemoglobin disorders is discussed.¹¹ These disorders differ from the others because the immune and hematopoietic systems are intact before HSCT, and a proliferative marrow develops as a consequence of chronic anemia and ineffective erythropoiesis. Thus, the conditioning regimen before HSCT for the hemoglobin disorders typically requires a combination of ablative and immunosuppressive activities. In addition, there is a marked variability of clinical phenotype in sickle cell disease, which affects the decision making about when and in whom to consider this aggressive therapy.

Together, these broad examples of nonmalignant conditions illustrate the variety of clinical and genetic parameters one must consider in selecting appropriate transplantation candidates and regimens. These considerations are highlighted in the sections that follow.

HEMATOPOIETIC STEM CELL TRANSPLANTATION FOR PRIMARY IMMUNODEFICIENCY DISORDERS

PIDs classically are associated with significant morbidity and early mortality caused by life-threatening infections in the first months and years of life. Before the availability of HSCT, these infections invariably caused death in the vast majority of affected children. SCIDS is the most widely recognized manifestation of a PID. SCIDS is a genetically heterogeneous group of over 20 mutations in 13 genes identified to date that result in the common phenotype of impaired T-cell production and/or function (Table 103.1). These mutations in varied target genes lead to impaired immunity as a consequence of absent T-cell function, but often defects in B-cell and natural killer (NK) cell number or function occur in parallel, as many of the genes affect all three lineages. However, the level of B- and NK-cell activity is highly variable. In rare cases, autoimmune phenomena are observed in these patients.¹³ This is particularly noteworthy in children with Omenn syndrome, which is caused by mutations in genes that participate in rearrangements of T-cell receptors and VDJ regions of immunoglobulins. Mutations in these genes elicit a phenotype that mimics graft-versus-host-disease as a consequence of the expansion of T-cell clones that are reactive to self-antigens. There is also reduced peripheral and central tolerance in these patients, which contributes to the observed phenotype.

Preparative Regimen

The first transplant for SCIDS using an HLA-matched sibling bone marrow donor was performed in 1968.¹⁴ In this case, no preparative regimen was administered to prevent graft rejection due to the absence of an immunologic barrier to engraftment. Thus, donor hematopoietic stem cells simply were infused and successful immune reconstitution followed. However, fatal graft-versus-host disease (GVHD) often occurred in donor/recipient settings in which there was a major HLA disparity. By testing transplantation in animal models of SCIDS, it was determined that by using the technique of donor T-cell depletion, it was possible to eliminate GVHD after HLA-mismatched HSCT, if thorough T-cell depletion was accomplished.^{15, 16} In addition,

P.2177

after successful HSCT in the mouse, there was durable engraftment of the donor cells with restored host immunity. However, even in the earliest clinical reports of HSCT after T-cell depleted HLA-haploidentical HSCT for SCIDS, B-cell engraftment was quite poor, as most patients required long-term immunoglobulin replacement after HSCT.

TABLE 103.1 MOLECULAR CAUSES OF SEVERE COMBINED IMMUNODEFICIENCY

Gene Defect	Defective Protein, Function, Features	Percentage of SCID ^a Cases	Lymphocyte Profile		
			T ^b	B	NK
<i>IL2RG</i> (X-linked)	Common γ -chain (γ_c) of receptors for IL-2, -4, -7, -9, -15, and -21	45-50 (only males)	-	+	-
<i>ADA</i>	Adenosine deaminase enzyme	16	-	+	-
<i>IL7R</i>	α -Chain of IL-7 receptor	9	-	+	+
<i>JAK3</i>	Janus kinase 3, activated by γ_c	6	-	+	-
<i>RAG1, RAG2</i>	Recombinase activating genes required for T- and B-cell antigen receptor gene rearrangement	5	-	-	+
<i>DCLRE1C</i>	Part of T- and B-cell antigen receptor gene	<5	-	-	+

(Artemis)	rearrangement complex, also required for DNA repair				
<i>TCRD, TCRE, CD3 δ, ε, and ζ chains of the T-cell receptor complex, TCRZ</i>	required for T-cell development	Rare	-	+	+
<i>CD45</i>	Protein tyrosine phosphatase receptor (PTPRC), required for T-and B-cell activation by antigen	Rare	-	+	+/low
<i>LCK</i>	Lymphocyte tyrosine kinase p56lck, required for T-cell development and activation	Rare	-	+	+
<i>PNP</i>	Purine nucleoside phosphorylase enzyme; deficiency also causes neurologic impairment	Rare	Low	Low	+/low
<i>LIG4</i>	DNA ligase IV required for antigen receptor gene rejoining	Rare	-	+	+
<i>DNAPKCS</i>	DNA protein kinase catalytic subunit, required for T- and B-cell antigen receptor rearrangement, and DNA repair	Rare	-	-	+
<i>NHEJ1</i> (Cernunnos)	Nonhomologous end joining of DNA; deficiency also causes microcephaly and radiation sensitivity	Rare	-	-	+
<i>AK2</i>	Adenylate kinase 2; deficiency causes reticular dysgenesis with granulocytopenia, lymphocytopenia, and deafness	Rare	-	-	-
<i>FOXN1</i>	Forkhead box N1, required for thymus and hair follicle development (ortholog of nude mouse)	Rare	-	+	+
<i>STAT5a</i>	Signal transducer and activator of transcription 5, phosphorylated after cytokine receptor engagement; deficiency also causes growth-hormone-resistant growth failure	Rare	-	+	-
<i>CORO1A</i>	Coronin-1A, protein mediating lymphocyte migration and T-cell emigration from the thymus	Rare	-	+	+
Currently unknown	Unknown defects, including SCID and congenital anomalies; SCID with multiple bowel atresias	~10	-	+/-	+/-

^a Based on Buckley, 18 Puck²⁵ and Lindegren et al.¹²

^b Some patients have substantial numbers of maternally derived T-cells at time of diagnosis; autologous T-cells are shown.

Adapted from Puck JM. The case for newborn screening for severe combined immunodeficiency and related disorders. *Ann N Y Acad Sci* 2011;1246:108-117.

Epub 2012 Jan 13.

In a cohort of 161 patients treated by HSCT at a single U.S. institution, Railey et al. reported the results in individuals with SCIDS who received no pre-transplant chemotherapy or GVHD prophylaxis.¹⁷ Notably, only 16 (10%) of these patients had HLA-identical sibling donors, and thus most received T-cell depleted HLA-haploidentical marrow. In this clinical series, it

P.2178

was observed that survival was highest among those patients who were transplanted before 3.5 months of age (94% compared to 70%, P = 0.002). Of those who died, the majority (76%) experienced progressive viral infections that predated HSCT. There were very few deaths related to GVHD or infections that were acquired after HSCT. Thus, this series

suggested that no chemotherapeutic preparation is necessary in patients with SCIDS who are treated by HSCT shortly after birth. However, many patients require regular immunoglobulin (IVIG) infusions after successful HSCT for SCIDS due to absent engraftment of donor B-cells, particularly in the absence of a conditioning regimen before HLA-haploidentical related donor HSCT in recipients with B-cell positive SCIDS.^{18, 19}

Long-term follow-up of patients showed mixed results regarding the stability of long-term donor T-cell engraftment after HLA-haploidentical HSCT in the absence of a conditioning regimen before HSCT. With up to 25 years follow-up in a report by Buckley, 11 of 19 patients had no evidence of decreased T-cell function or diminished T-cell repertoire diversity. However, as noted above, most patients lacked donor B-cell engraftment and thus received long-term replacement immunoglobulin therapy.⁸ In another series that included survivors with up to 16 years follow-up, 35% of the patients had low T-cell antigen receptor excision circle (TREC) levels and a limited T-cell repertoire as evidenced by oligoclonality that was demonstrated in 27.5% of patients.²⁰ Based upon these observations, it has been suggested that the use of an ablative conditioning regimen before HSCT may be required to ensure long-term T-cell engraftment in the setting of HLA-haploidentical donors.

Whether improved T-cell engraftment translates into improved survival remains in question, however. Patel et al. retrospectively reviewed a series of 22 patients with SCIDS who were treated by HSCT at a single institution.²¹ In this series, no statistical difference in overall survival was with respect to whether a preparative regimen was administered regardless of donor type. In addition, experience from a large European cohort treated between 1968 and 2005 showed that chemotherapeutic preparation did not improve overall survival in patients with SCIDS.²² These authors argued that a conventional ablative chemotherapeutic preparation does not improve survival in patients with SCIDS, particularly in those who undergo HSCT in the first 31/2 months of life. Unfortunately, proceeding directly to HSCT early in life is not always feasible, as affected individuals often are not identified in the first several months of life or before they have developed serious infections. Thus, the decision of whether to use a conditioning regimen should hinge on several salient clinical features, including the patient's age, the donor, and the baseline immunologic function with regard to resistance to donor engraftment. Also, recipients with SCIDS who have a T-/B+ lymphocyte profile appear to have better outcomes than recipients who lack B-cells.²³ The advent of pilot newborn screening programs by TREC screening from blood spots has the potential to mitigate the limitation of patient age.^{24, 25, 26}

Reduced Intensity Conditioning

To date, optimization of a conditioning regimen that might be safely applied in all patients with SCIDS has been elusive. In an attempt to reduce transplant-related morbidity and mortality, reduced intensity conditioning regimens that are not ablative and contain a diverse array of immunosuppressive agents such as fludarabine, busulfan (BU), etoposide, cyclophosphamide (CY), and low-dose radiation have been tested.^{27, 28, 29} Current data suggest that reduced intensity regimens are most appropriate in recipients with T-cell deficiency syndromes and in unrelated donor HSCT.^{30, 31} However, graft rejection associated with inadequate suppression of residual host immune function remains a concern, particularly in patients with T- and NK-cell function at baseline. Ultimately, the selection of a preparative regimen and its intensity will vary according to the level of retained immunity in the recipient, and with the degree of HLA matching in donor hematopoietic cells.

Donor Source

HLA-identical marrow HSCT has yielded very good results in SCIDS, with approximately 70% to 80% of patients surviving long-term³² (Fig. 103.1). Because most patients lack a HLA-ID sibling donor, alternative donor sources have been explored in clinical trials. Roifman et al. reviewed transplant outcomes after HLA-mismatched related donor HSCT compared to HLA-matched unrelated donor HSCT for SCIDS.³³ They reported that survival was superior in those receiving HLA-matched unrelated marrow. Specifically, patients who received a HLA-matched unrelated HSCT had better engraftment and immune reconstitution. They concluded that HLA-matched unrelated marrow transplantation is superior to HLA-mismatched related donor HSCT and should be considered as the first choice when a related HLA-identical donor is unavailable. In other patient series noted above, excellent results were observed after T-cell depleted HLA-haploidentical HSCT. Thus, the optimal donor source for HSCT remains a point of controversy.

More recently, the application of umbilical cord blood transplantation (UCBT) has been explored in SCIDS. Fernandes et al. recently compared results after HLA-mismatched related donor and unrelated donor UCBT in patients with SCIDS.³⁴ There were 175 HLA-mismatched donor HSCT recipients and 74 UCBT recipients in this retrospective cohort of patients with SCIDS or Omenn syndrome. The median follow-up was 58 and 83 months in each group, respectively. Most UCBT recipients received a myeloablative preparative regimen, whereas a larger fraction of the related donor recipients did not. UCBT recipients were more likely to have complete donor chimerism and faster lymphocyte recovery independent of the

preparative regimen. T-cell engraftment was equivalent in the two groups, and immunoglobulin replacement was discontinued earlier after transplantation in the UCBT group. There was a statistically insignificant higher incidence of grade II–IV acute GVHD and statistically significant rate of chronic GVHD after UCBT. However, the 5-year overall survival rates were equivalent. Other data suggest that B-cell engraftment may be better after UCBT.³⁵ Although a randomized, prospective trial has not been performed, these data indicate that UCB appears to represent a suitable alternative donor source.

Late Effects and Future Directions

There are limited series of long-term follow-up after HSCT for SCIDS in which the follow-up period exceeds 10 years.^{20, 21, 36} In several of these series, loss of T-cell diversity and autoimmune disorders was observed late after HSCT, although follow-up through 25 years after HSCT suggests improvement in the T-cell repertoire.³⁷ In addition, patients with adenosine deaminase deficiency in particular have experienced a high incidence of central nervous system abnormalities that include motor dysfunction, sensorineural hearing loss, and cognitive deficits that contribute to emotional and behavioral difficulties.²⁰ In addition, chronic infection by human papilloma virus also has been reported.²⁰ It is unclear which, if any of these, is related to pre-transplant conditioning and GVHD prophylaxis or to the underlying genetic defect. Finally, for those who lack a transplant donor, gene therapy is an alternative therapy for some patients, although development of this technology is ongoing.³⁸ A consensus group has discussed plans for future multicenter studies in North America, both retrospective and prospective, focused on collecting data from newborn screening and natural history sources.³⁹ The importance of collaboration in developing new protocols for these rare disorders

P.2179

was illustrated best by recent data showing that long-term mortality rates for both SCIDS and non-SCIDS patients with a PID are higher than their age- and gender-matched controls in the general population.⁴⁰

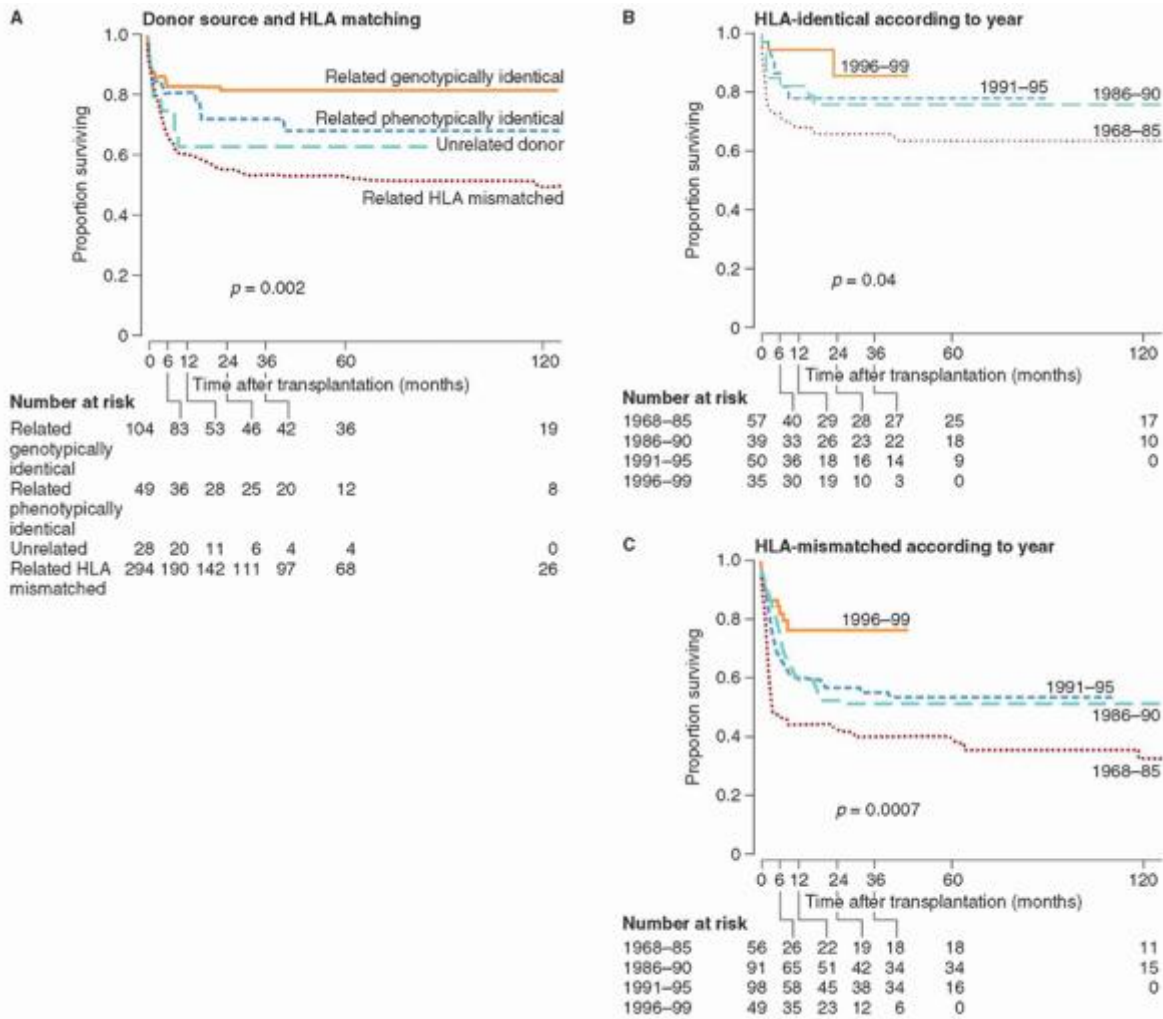

FIGURE 103.1. Overall survival after hematopoietic stem cell transplantation (HSCT) for severe combined immunodeficiency syndrome (SCIDS), according to donor stem cell source, degree of HLA matching, and the year of HSCT. Adapted from Antoine C, Muller S, Cant A, et al. Long-term survival and transplantation of haemopoietic stem cells for immunodeficiencies: report of the European experience 1968-99. *Lancet* 2003;361(9357):553-560. Epub 2003 Feb 25.

HEMATOPOIETIC STEM CELL TRANSPLANTATION FOR FANCONI ANEMIA

Fanconi anemia is the most common hereditary cause of bone marrow failure. The genetic defect responsible for these findings has been characterized in 15 complementation groups, termed FANCA genes, most of which are autosomal and recessive (Table 103.2).^{41, 42} The most common mutations occur in FANCA, FANCC, FANCG, and FANCD2 genes. These gene products participate in a signal transduction pathway involved in DNA repair, called the FA/BRCA pathway (Fig. 103.2).⁴³ Thus, its diagnosis is confirmed by a chromosome fragility test that when positive, should be followed by an attempt to define the complementation group by DNA testing.

The most common hematologic manifestation is progressive marrow aplasia that causes cytopenias in the blood, which typically occur in the first or second decade of life.⁴⁴ Erythrocyte macrocytosis and elevated fetal hemoglobin often are present. In some cases, the diagnosis of FA will not be established until after the patient has developed myelodysplastic syndrome or AML. Some patients never develop pancytopenia but do experience an increased risk of malignancy. Based upon studies of a cohort of FA patients at the NCI, the risks of developing MDS and AML by age 50 are estimated to be 40% and 10%, respectively.^{45, 46} The overall survival and cancer-free survival in this cohort is shown in Figure 103.3 with a median overall survival of 33 years in those with FA.

Because of poor survival, HSCT was developed as a therapeutic measure to restore normal hematopoiesis and reduce or eliminate the risk of hematologic malignancy. There were several important

observations generated in the early clinical trials. The first was that high-dose alkylating chemotherapeutic drugs at doses administered for severe aplastic anemia and gamma irradiation caused severe toxicity including mucositis and hemorrhagic cystitis as a consequence of the sensitivity to DNA damage in all tissues.^{47, 48} Second, the risk of acute GVHD was increased in comparison to other indications for HSCT, presumably also as a consequence of impaired DNA repair and an extended duration of tissue injury eliciting an allogeneic reaction by donor T-cells.⁴⁹ The initial reports by Gluckman and her colleagues in 1984 showed that a reduced-dose regimen of CY (20 to 40 mg/kg) and a single fraction of total body irradiation or thoracoabdominal irradiation (400 to 450 cGy) effectively modulated the toxicity and was sufficient to ensure engraftment after HLA-ID sibling bone marrow transplantation with a long-term survival rate of 58.5%, although the rates of acute (55%) and chronic (70%) GVHD were quite elevated.⁵⁰ However, an updated experience of this regimen in 35 patients was reported in 2007, and included antithymocyte globulin (ATG) in the conditioning regimen.⁵¹ These results showed a probability of survival of 89% at 10 years, with the incidence of acute and chronic GVHD at 23% and 12%, respectively.

TABLE 103.2 GENES ASSOCIATED WITH FANCONI ANEMIA

Disease/Genes	Chromosome Locus	Mode of Inheritance	Frequency % of Patients
<i>FANCA</i>	16q24.3	AR	60
<i>FANCB</i>	Xp22.31	XLR	2
<i>FANCC</i>	9q22.3	AR	14
<i>FANCD1/BRCA2</i>	13q12.3	AR	3
<i>FANCD2</i>	3p25.3	AR	3
<i>FANCE</i>	6p21.3	AR	3
<i>FANCF</i>	11p15	AR	2
<i>FANCG/XRCC9</i>	9p13	AR	10
<i>FANCI</i>	15q25-26	AR	1
<i>FANCI/BACH1/BRIP1</i>	17q22.3	AR	2
<i>FANCL</i>	2p16.1	AR	0.2
<i>FANCM</i>	14q21.3	AR	0.2
<i>FANCN/PALB2</i>	16p12.1	AR	0.7
<i>FANCO</i>	17q22	AR	I Case
<i>FANCP</i>	16p13.3	AR	I Case

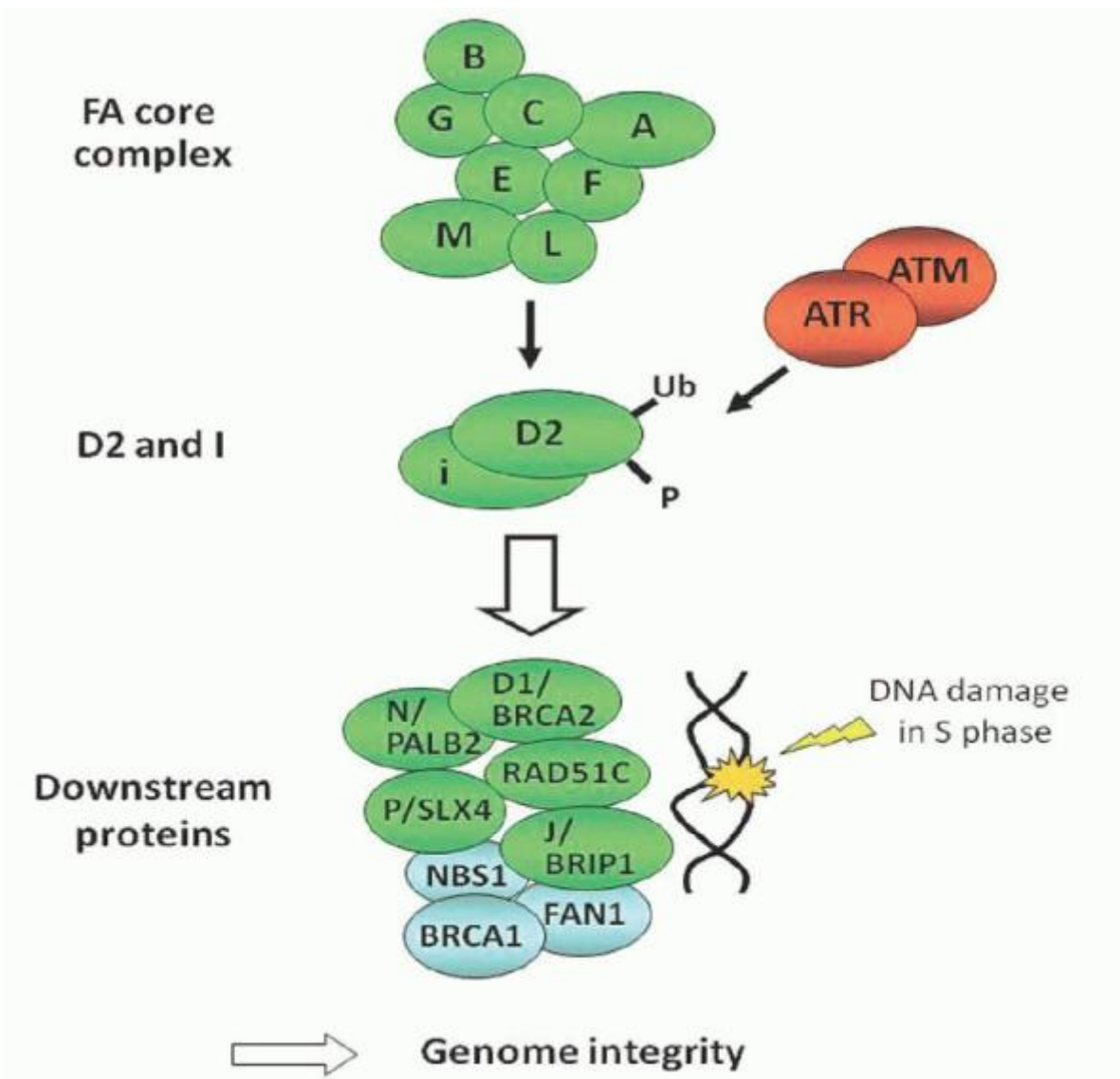

FIGURE 103.2. FA/BRCA pathway. From Soulier J. Fanconi anemia. Hematol Am Soc Hematol Educ Program 2011;2011:492-497. Epub 2011 Dec 14.

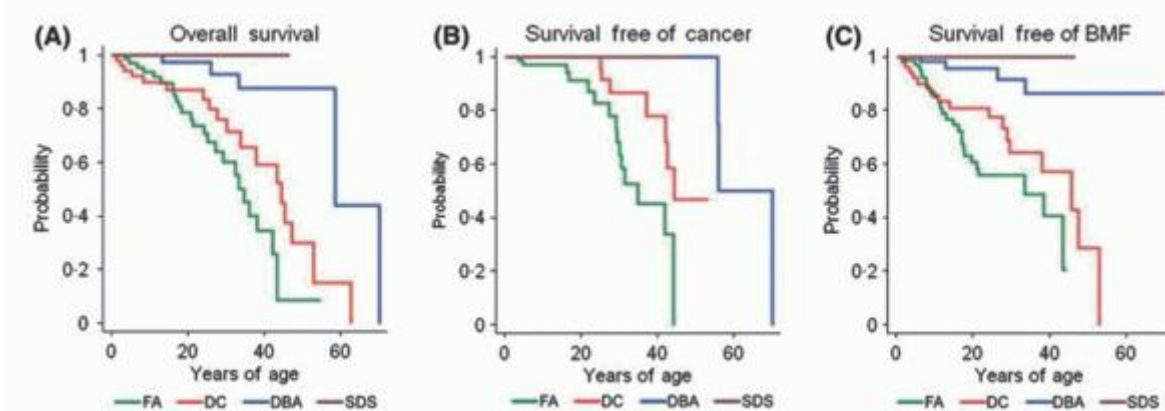

FIGURE 103.3. Survival, cancer-free survival, and survival free of marrow failure in a cohort of patients with bone marrow failure syndromes from the National Cancer Institute. The probabilities of overall survival (A), survival free of cancer (B) and survival free of bone marrow failure (C) are depicted in the 3 panels among patients with Fanconi Anemia, Dyskeratosis Congenita, Diamond-Blackfan Anemia, and Schwachman-Diamond Syndrome. From Alter BP, Giri N, Savage

SA, et al. Malignancies and survival patterns in the National Cancer Institute inherited bone marrow failure syndromes cohort study. *Br J Haematol* 2010;150(2):179-188. Epub 2010 May 29.

Several other notable improvements have occurred in the 25 years since these initial results after HSCT for Fanconi anemia were reported. The elimination of irradiation from the conditioning regimen has been associated with better results. In a series from Saudi Arabia, the replacement of thoracoabdominal irradiation by a combination of CY with ATG generated better results after HLA-ID sibling bone marrow transplantation (overall

P.2181

survival 96.9% versus 72.5%, $P = 0.013$).⁵² Alternatively, the use of CY alone at a reduced dose of 60 mg/kg by investigators in Brazil generated an overall survival and event-free survival 93% and 88%, respectively, with acute and chronic GVHD occurring in 71% and 28.5% of recipients after HLA-ID sibling transplantation.⁵³ Thus, in patients who have a HLA-ID sibling donor and who have not yet progressed to MDS or AML, the results of the reduced intensity conditioning regimens are excellent. In addition, by eliminating radiation from the conditioning regimen, the risk of developing a malignancy after transplantation also should be lowered.

Another important discovery was the benefit of fludarabine in the conditioning regimen, which effectively reduces the rate of graft rejection, in particular after alternate donor HSCT, without contributing significantly to toxicity.^{54, 55} The application of unrelated donor HSCT to Fanconi anemia is vital to expanding this treatment modality, as most individuals with FA lack a sibling donor. Initial trials of unrelated donor HSCT in which the same regimen of low-dose CY and irradiation was used were plagued by high rates of graft rejection, organ toxicity, and GVHD, with overall survival in the 30% to 40% range.^{56, 57} The escalation of the dose of radiation to 600cGy and the addition of ATG did little to improve overall survival.⁵⁸ However, in a retrospective analysis of the effect of fludarabine in the conditioning regimen, a significant impact was noted.⁵⁹ The probability of neutrophil and platelet recovery after HSCT improved from 69% to 89% and from 23% to 74%, respectively, and this translated in a lower transplant-related mortality (47% compared to 81%). The 3-year overall survival was 52% in those who received a fludarabine-containing regimen compared to 13% in those who did not (Fig. 103.4).

Another contributor to the positive effect of fludarabine on transplant outcome might be related to a condition of T-cell mosaicism that develops in some patients with FA. This condition is characterized by having two populations of host T-cells, one of which is sensitive to clastogenic/mutagenic agents and another that is resistant as a consequence of a reversion of the FA mutation.⁶⁰ McMillan et al. showed that T-cell mosaicism was a risk factor for graft rejection, presumably as a consequence of the reduced conditioning intensity used in FA not being sufficiently intensive to eradicate all the host T-cells.⁵⁸ Of interest, fludarabine mitigates this risk, as the incidence of graft rejection was not increased among those who had T-cell mosaicism and who received fludarabine.⁵⁹

There is growing consensus that marrow from an unrelated donor should undergo T-cell depletion to reduce the risk of GVHD. A benefit after T-cell depletion of donor marrow has been observed after HLA-ID sibling and after unrelated HSCT.^{55, 60, 61} In the retrospective analysis noted above, the incidence of acute GVHD decreased from 71% to 21% in the T-cell depleted group and was decreased further to 16% if fludarabine and T-cell depletion were utilized together. In parallel, umbilical cord blood also has been tested in FA as a source of HSC because it naturally contains fewer T-cells and is associated with a lower risk of GVHD after HSCT. Of note, the first successful report of UCB transplantation in 1989 was conducted in a patient with FA and who survives free of disease more than 20 years later.⁶² A retrospective review of 93 cases of FA treated by unrelated donor UCB transplantation showed acute and chronic GVHD rates of 32.5% and 16%, respectively, confirming a benefit.⁶³ Unfortunately, this benefit was balanced by high rate of graft rejection, with an overall survival rate of 40%. For this reason, the selection of UCB as a source for HSCT is generally assigned a lower priority in patients with FA.

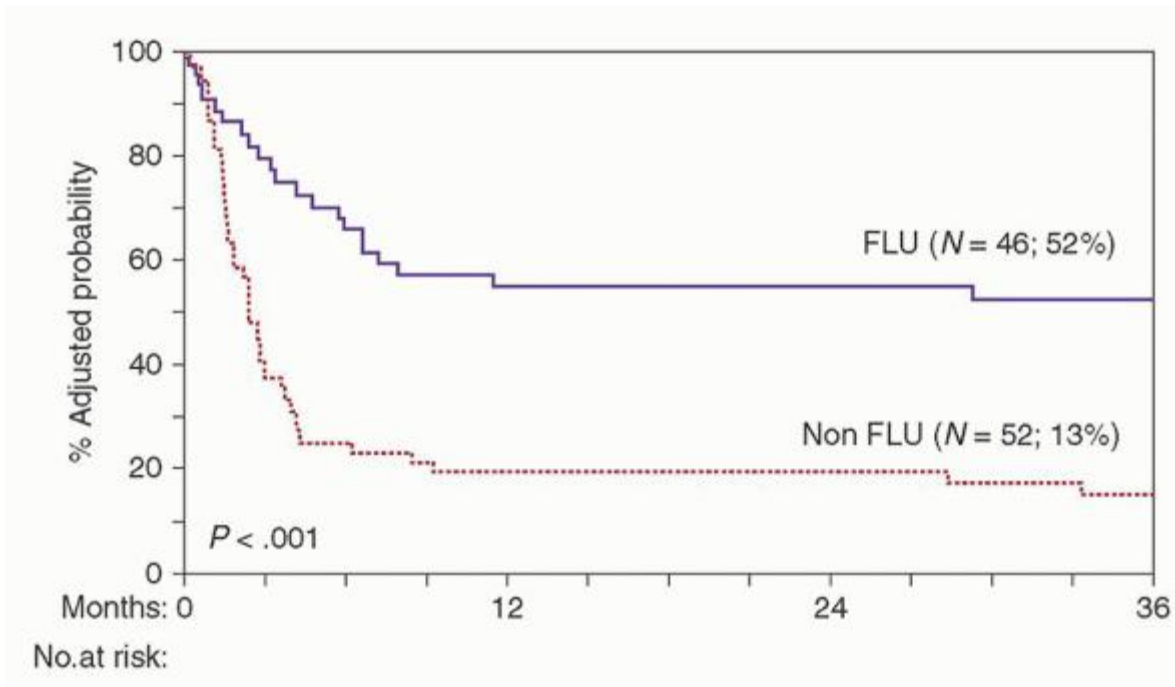

FIGURE 103.4. Effect of fludarabine administered before hematopoietic stem cell transplantation (HSCT) in patients with Fanconi anemia. From Wagner JE, Eapen M, MacMillan ML, et al. Unrelated donor bone marrow transplantation for the treatment of Fanconi anemia. *Blood* 2007;109(5):2256-2262. Epub 2006 Oct 14.

Late Effects in Fanconi Anemia Patients

The most important late complication after HSCT for FA is the development of cancer.⁶⁴ The most common forms include squamous cell carcinomas of the head and neck, carcinoma of the esophagus, and gynecologic squamous cell carcinoma. Exposure to radiation increases this risk, thus its elimination from conditioning regimens is an important advance. Survivors of successful transplantation still experience an increased risk of developing a malignancy. The risk is increased fourfold in those who receive transplantation compared to those who do not, and the cumulative incidence of a secondary cancer is 40% during the 15 to 20 years after HSCT.⁶⁵ In addition, the time to developing a secondary cancer is shortened on average by 16 years, for which the development of GVHD is a key risk factor.^{56, 66} Together, these factors must be considered carefully when making a decision about when to proceed to an alternate donor transplantation, particularly because some patients with marrow aplasia can be managed for extended periods of time by the administration of androgens and judicious use of transfusions without significant risk of progressing to MDS/AML.

Hematopoietic Stem Cell Transplantation for Hemoglobin Disorders

Together, thalassemia and sickle cell disease account for the most common hereditary disorders worldwide with broad distribution in regions of the world where malaria is endemic. However, the majority of transplantations performed for these disorders have been conducted in developed nations, which means that very few of those affected globally are ever considered for transplantation.

P.2182

The first case report of successful transplantation for thalassemia occurred 30 years ago and has been followed by several thousand children with thalassemia who have been treated successfully.^{67, 68} The first reports of successful transplantation for sickle cell disease occurred somewhat later, and because of the variable clinical course many children experience, far fewer individuals with sickle cell disease have been treated by HSCT.^{69, 70} Nonetheless, outcomes after HLA-ID sibling donor bone marrow transplantation for the hemoglobin disorders are excellent. The broader application of HSCT is limited by the risks of HSCT, which must be balanced by complications inherent to the underlying disease, for which significant progress in supportive care has occurred.

With the institution of universal newborn screening programs in the United States and elsewhere, now it is possible to identify patients with hemoglobin disorders shortly after birth and to institute comprehensive preventive care.⁷¹ As a consequence, the majority of children with SCD survive to adolescence and nearly all children with thalassemia major

survive into the third decade of life.^{72, 73} Still, the most severely affected patients with sickle cell disease experience significant morbidity and life-limiting complications that include stroke, acute chest syndrome, painful episodes, and with regular RBC transfusions, the development of iron overload.⁷⁴ However, in most children with sickle cell disease, supportive care measures are safe and mitigate the risk of life-threatening events. For these reasons, very few children with sickle cell anemia are treated by HSCT.⁷⁵ Unfortunately, the outlook for adults with sickle cell anemia has not changed substantially since the 1980s, when a median survival in males of 42 years, and in females, of 48 years was observed in the Cooperative Study of Sickle Cell Disease (CSSCD).⁷⁶ As a consequence, although most children with sickle cell disease survive to age 20, the outlook for young adults remains unsatisfactory.^{77, 78} Thus, decisions about HSCT for sickle cell anemia are often driven by an individual's outlook in the long term and by donor availability. In the child with thalassemia major where the genotype more reliably predicts the phenotype of the disease, families today are more likely to pursue HSCT in childhood if there is a suitable donor.

Hematopoietic Stem Cell Transplantation for Thalassemia

Pioneering studies that span several decades were performed by the transplant team in Pesaro led by Lucarelli.⁶⁸ Using a backbone combination of BU and CY before transplantation and a standard combination of methotrexate (MTX) and cyclosporine (CSP) to prevent GVHD, the majority of children were cured after a HLA-ID sibling bone marrow transplantation. However, the likelihood of cure was highest in those recipients who had good-risk features, defined as having no hepatomegaly, no evidence of portal fibrosis by liver biopsy, and by having adhered to a regular program of iron chelation therapy. Alternatively, children who had one (risk class 2) and two or more prognostic features (risk class 3) fared worse. Class 3 patients experienced a thalassemia-free survival probability of 50% and 30% had graft rejection with thalassemia recurrence (Fig. 103.5).⁷⁹ The improved outcomes that followed this initial report occurred by targeting good-risk young patients for transplantation promptly when there was an HLA-ID sibling donor, and by modulating the conditioning regimen in high-risk recipients to improve the safety profile. The latter also served to deliver sufficient pre-grafting immunosuppression necessary for ensuring the stable engraftment of donor cells.

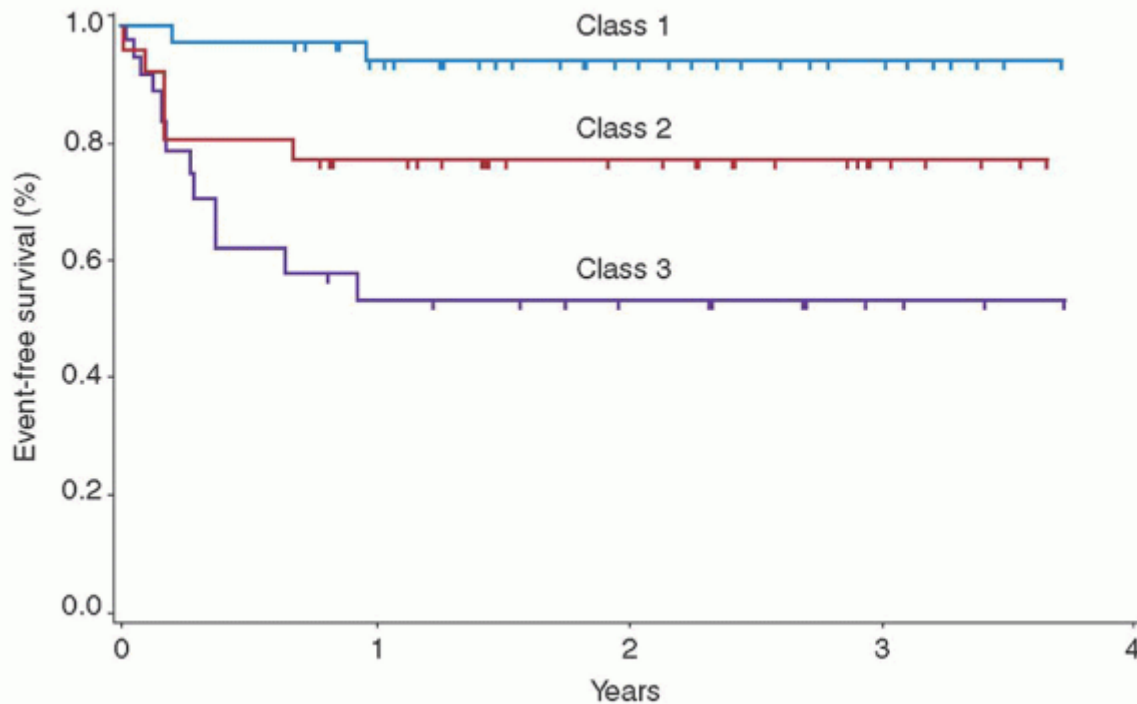

FIGURE 103.5. Probabilities of event-free survival after HLA-ID sibling BMT for thalassemia according to risk category. From Lucarelli G, Galimberti M, Polchi P, et al. Bone marrow transplantation in patients with thalassemia. *N Engl J Med* 1990;322(7):417-421.

Initially, attempts to reduce the toxicity of transplantation in high-risk features focused on modifications to the BU/CY backbone. In particular, it was possible to reduce the incidence of regimen-related toxicity by reducing the dose of CY. Unfortunately, this was accompanied by a higher incidence of graft rejection, so that the overall thalassemia-free survival

rate did not improve after modifying the CY dose.⁸⁰ In response, a greater emphasis was placed on the role of immunosuppressive therapy before transplantation as a strategy for reducing graft rejection. Thus, Protocol 26 was established, which employed a combination of HU, azathioprine, and hypertransfusion with intensive iron chelation therapy that was administered 6 weeks before transplantation to modulate the proliferative erythron and induce an immunosuppressive effect.⁸¹ This was followed by a backbone of BU/CY with CY dosing that ranged from 120 to 160 mg/kg. This combination of changes resulted in a substantially improved outcome with an event-free probability of 85% and rejection incidence of 8% in class 3 recipients (Fig. 103.6). Thus, it was possible to modify the transplantation regimen in such a way as to generate outcomes that appeared indistinguishable from those in children with good-risk features. The importance of this modification was illustrated in a different fashion by results from a separate patient series from the Center for International Blood and Marrow Transplant Research (CIBMTR) registry. This retrospective analysis reported outcomes after HLA-ID sibling bone marrow transplantation from non-Italian centers. Using a modified risk categorization based upon patient age and liver size, outcomes were outstanding among recipients who had good-risk features.⁸² However, the use

P.2183

of the BU/CY conditioning backbone was associated with a far inferior outcome in this high-risk category of patients older than 7 years who had hepatomegaly, where the thalassemia-free survival probability was 50% (Fig. 103.7). This observation strengthened the conclusion that high-risk patients require a modified conditioning regimen for reasons of safety and efficacy.

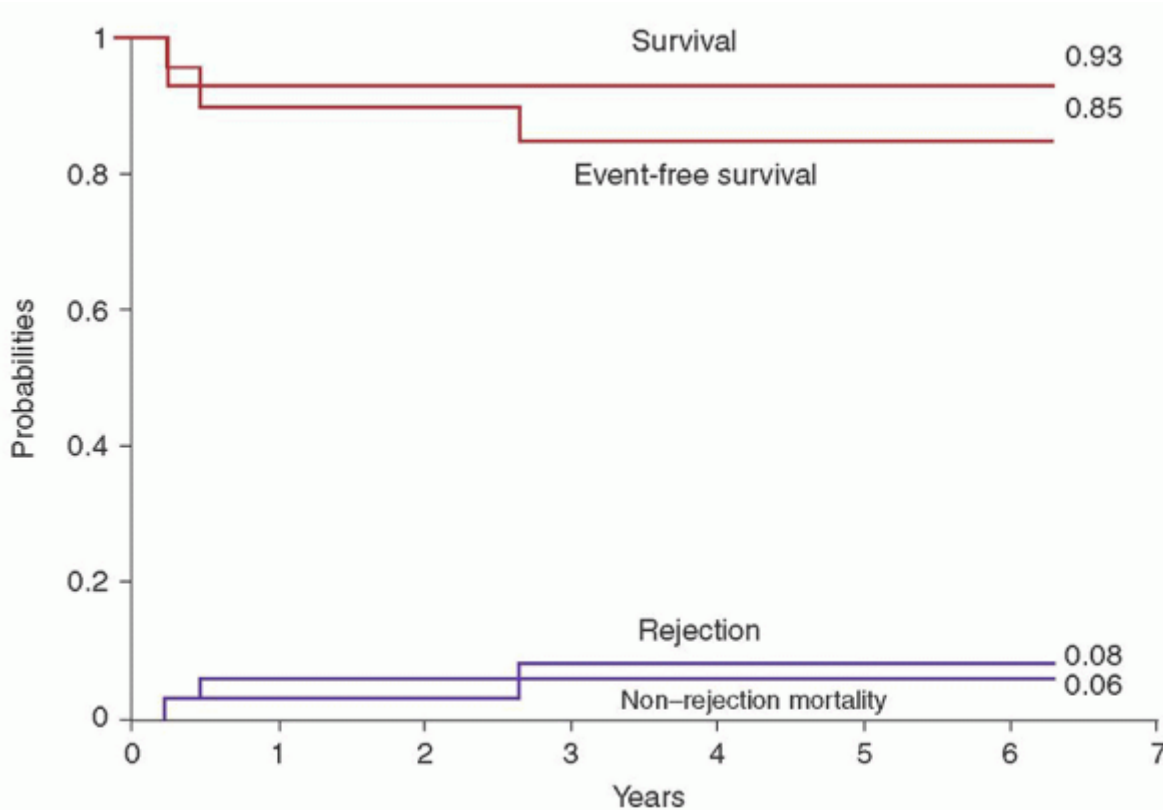

FIGURE 103.6. Outcomes after HLA-ID sibling BMT for thalassemia in Class 3 patients. From Sodani P, Gaziev D, Polchi P, et al. New approach for bone marrow transplantation in patients with class 3 thalassemia aged younger than 17 years. *Blood* 2004;104(4):1201-1203. Epub 2004 Mar 25.

As most individuals with thalassemia major lack a sibling donor, the development of unrelated donor transplantation and alternative sources of hematopoietic stem cells has been pursued to broaden the availability of HSCT. An early report from the Pesaro team showed that the use of HLA-mismatched related donors was associated with an inferior outcome, and in particular, a high rate of graft rejection.⁸³ Thus, it became apparent that additional modification of the conditioning regimen would be needed to ensure engraftment across a MHC barrier and that selecting donors with optimal HLA

matching also was necessary. In one series, the BU/CY backbone was augmented by thiotepa to intensify the pre-grafting immunoablation. Among 32 patients, most of whom had class 2 or 3 risk features, the thalassemia-free probability was 66% and graft rejection occurred in 13% of the cases.⁸⁴ Of interest, 22 of 32 recipients shared at least one extended HLA haplotype with the donor. Of these, 19 survived and 17 survived free of thalassemia after transplantation. Thus, the importance of donor selection was suggested by these data. The unrelated donor HSCT outcomes were updated 5 years later and included the replacement of fludarabine for CY which accompanied thiotepa and BU in the conditioning regimen.⁸⁵ This combination was associated with reduced toxicity and lower transplant-related mortality (reduced from 25% to 13.3%) and a thalassemia-free survival rate of 71%. Most recently, the team from Pavia, Italy reported its experience with the use of treosulfan, a myeloablative drug that has a reduced toxicity profile when compared to BU. Using a combination of treosulfan, fludarabine, thiotepa, and ATG, 60 patients treated between 2005 and 2009 experienced 93% survival and 84% event-free survival probabilities after HLA-ID sibling (N = 20) or unrelated donor bone marrow transplantation (N = 40).⁸⁶ Twenty-one of the patients had Lucarelli class 2 or 3 features and 12 were adults. Thus, incremental progress in unrelated donor transplantation shows the potential for outcomes that appear indistinguishable from those after HLA-ID sibling HSCT.

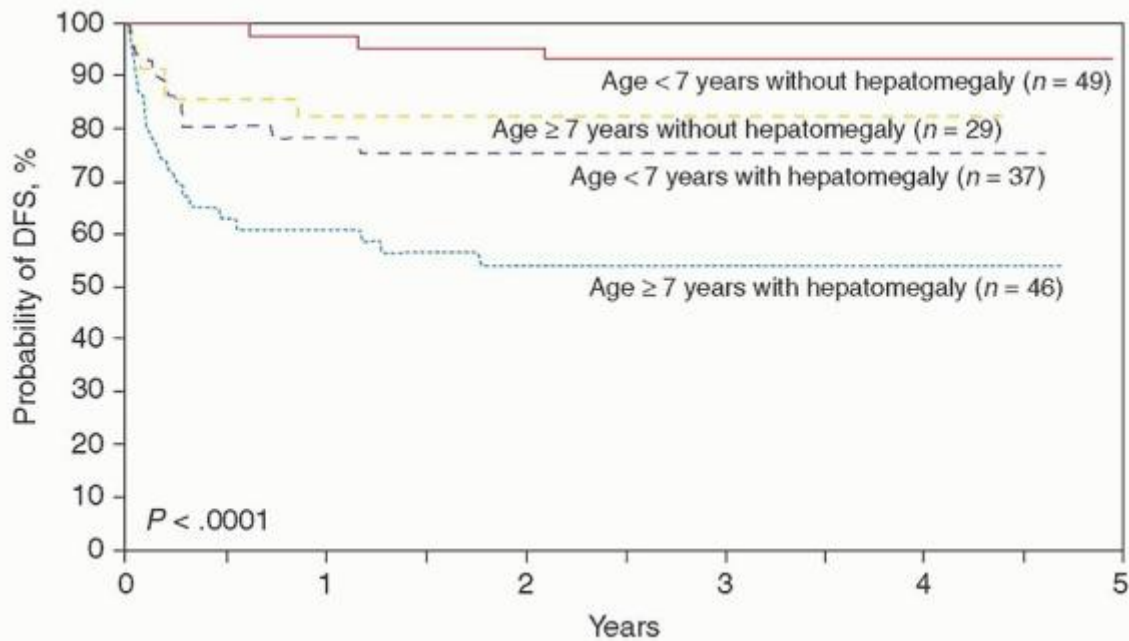

FIGURE 103.7. Disease-free survival probabilities after HLA-ID sibling hematopoietic stem cell transplantation (HSCT) based upon pre-transplantation features among non-Italian thalassemics from the CIBMTR registry. From Sabloff M, Chandy M, Wang Z, et al. HLA-matched sibling bone marrow transplantation for beta-thalassemia major. *Blood* 2011;117(5):1745-1750. Epub 2010 Dec 2.

P.2184

Hematopoietic Stem Cell Transplantation for Sickle Cell Disease

The application of HSCT for sickle cell disease has developed more slowly than in thalassemia, in part due to the heterogeneous phenotype of sickling syndromes and also from a lack of suitable donors. However, several patient series were conducted in the mid- to late-1990s in the United States and Europe and demonstrated very similar outcomes.^{87, 88} The aim of these clinical trials was to identify children who were at risk for early mortality or extensive morbidity, but to treat by HSCT before organ damage had occurred that might increase the risk of transplant-related complications. Thus, patients were deemed eligible if they had a stroke and were receiving regular RBC transfusion therapy to prevent another stroke, if they had recurrent painful episodes, or if there were recurrent episodes of acute chest syndrome. The current eligibility criteria are shown in Table 103.3.

Following these eligibility requirements, myeloablative conditioning regimens with a backbone of BU 14 to 16 mg/kg and CY 200 mg/kg were used, with or without ATG. Post-transplantation immunosuppression consisted of CSP and MTX in

most cases. The results of transplantation showed a disease-free survival of approximately 80% to 85%. A total of 5% to 10% of patients died of complications related to transplantation, with GVHD and its treatment as the leading cause of death.

In the Belgian series, many patients with symptomatic sickle cell disease were children of parents from Africa who were studying abroad in Europe.⁷⁰ It was reasoned that because supportive care was limited in their country of origin, the possibility of cure by HSCT was a reasonable justification for pursuing this therapy. The initial small series of patients reported in 1988 was later expanded to include 50 patients, and this was the earliest clinical trial to suggest that having the diagnosis of sickle cell anemia in and of itself was sufficient justification for bone marrow transplantation.⁸⁸ Of the 50 patients reported, 5 (10%) had graft rejection accompanied by recurrent sickle cell anemia and 86% survive free of sickle cell anemia. Of interest, some of the patients with graft rejection had persistent elevation of fetal hemoglobin levels despite having no evidence of donor cells in the marrow. This phenomenon of persistent fetal hemoglobin expression was associated with resolution of sickle-related complications.⁹⁰ Although in these cases, the fetal hemoglobin elevation was not durable and eventually levels declined, a long-lived elevation of fetal hemoglobin of host origin in thalassemia was observed in a more recent report.⁹¹

TABLE 103.3 INDICATIONS FOR HCT FOR SICKLE CELL DISEASE

Patients with sickle cell disease (HbSS or HbS β^0 -thalassemia)

One or more of the following complications:

Stroke or CNS event lasting longer than 24 hours

Recurrent acute chest syndrome

Recurrent vaso-occlusive painful episodes or recurrent priapism

Impaired neuropsychological function with abnormal cerebral MRI and angiography

Other indications under consideration:

Elevated cerebral arterial velocity by transcranial doppler

Pulmonary hypertension

Silent cerebral infarction

CNS, central nervous system; HCT, hematopoietic cell transplantation; MRI, magnetic resonance imaging.

An international study of BMT for sickle cell disease led by investigators in the United States was conducted between 1991 and 2000 and enrolled 59 patients from the United States, South America, and Europe.^{87, 92} Early in the course of the study, a high rate of neurologic complications was observed, including intracranial hemorrhage.^{93, 94} These events occurred in the setting of CSP administration, hypertension, and in some cases, thrombocytopenia or elevated hemoglobin levels as a consequence of hypertransfusion. These events also were observed in the European patient series. In response to observing these events, a standard approach for preventing neurologic complications was instituted and it included the strict control of hypertension, administration of anticonvulsant prophylaxis during CSP use, RBC transfusion support to maintain the hemoglobin between 9 and 11 gm/l to avoid hyperviscosity, and to keep the platelet level >50,000/mm³. After the institution of these preventive measures, there were no further episodes of intracranial hemorrhage in the international study, although seizures still occurred in approximately 20% of recipients.⁹⁵

The largest single patient series of HSCT for sickle cell disease was reported in France and included 87 patients who received HLA-ID bone marrow or in 12 cases, umbilical cord blood grafts between 1988 and 2004.⁸⁹ Initially, patients were prepared for transplantation with a BU/CY backbone alone, but after the initial 12 patients were treated, rabbit ATG was added to the conditioning regimen. The overall cumulative incidence of graft rejection was 7%; however, the rejection rate was significantly lower after the addition of rabbit ATG to the conditioning regimen (Fig. 103.8). In addition, the level of mixed donor-host hematopoietic chimerism was analyzed with regard to the effect of ATG, and it was measured in 77 of the patients. A higher level of persistent host hematopoiesis was observed in those who received ATG. A larger fraction transplant recipients had full chimerism noted at 12 and 24 months after transplantation after receiving BU/CY alone. However, the development of mixed chimerism was not associated with sickle-related events after HSCT, although 2 patients with only 20% donor cells had moderate anemia (8.5 to 9 gm/dl) and did not require RBC transfusions.

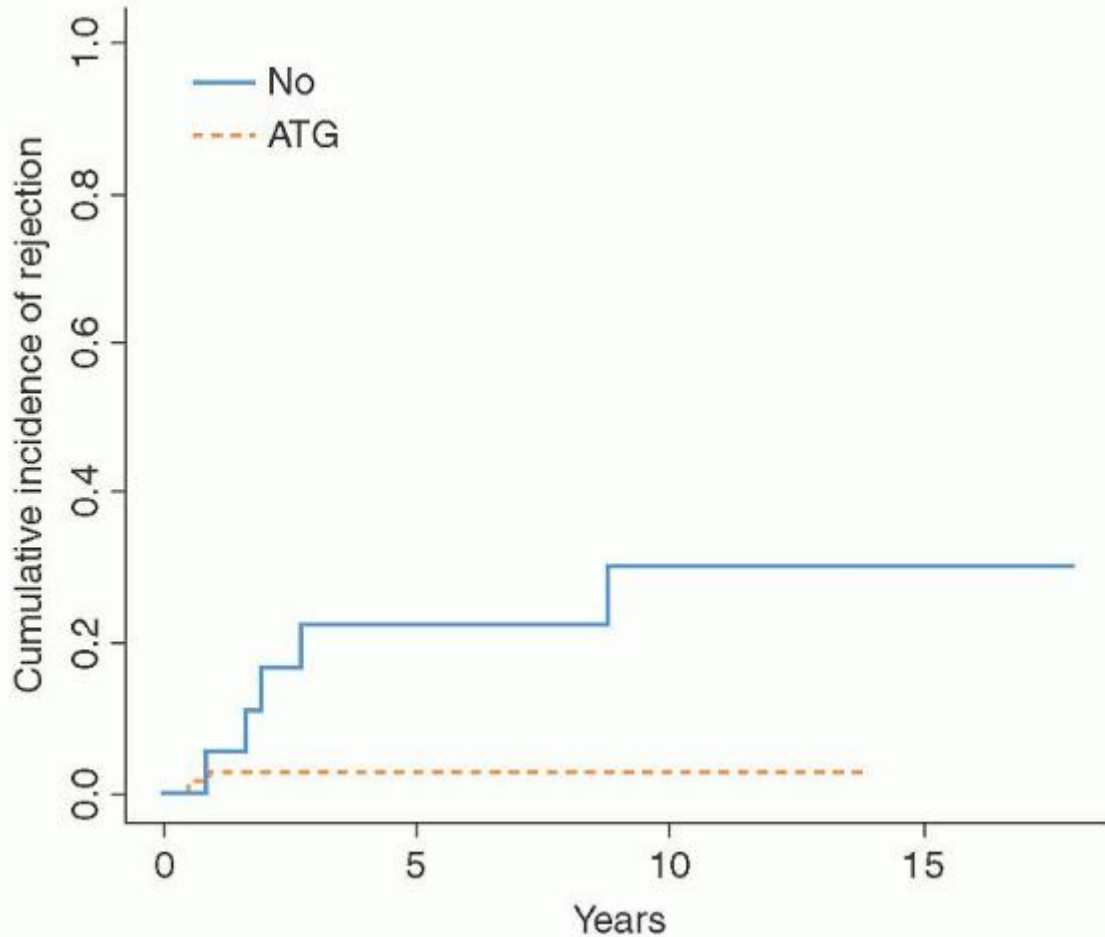

FIGURE 103.8. The effect of rabbit antithymocyte globulin (ATG) on the cumulative incidence of graft rejection after sibling hematopoietic stem cell transplantation (HSCT) for sickle cell anemia. From Bernaudin F, Socie G, Kuentz M, et al. Long-term results of related myeloablative stem-cell transplantation to cure sickle cell disease. *Blood* 2007;110(7):2749-2756. Epub 2007 Jul 4.

P.2185

The development of stable donor chimerism has been observed after transplantation for thalassemia and sickle cell disease, and has been studied most extensively in the thalassemia cohort from Pesaro.^{96, 97, 98} The cause of the phenomenon is uncertain, and it is associated with oligoclonal skewing of the T-cell repertoire, which is not associated with impaired immune function.⁹⁹ In the RBC lineage, there is a natural enrichment of donor cells in the blood, as a consequence of ineffective erythropoiesis and longer RBC survival in donor erythrocytes. Most important, even when there is a minority of donor cells, the patients who develop stable mixed chimerism do not experience symptoms of the underlying hemoglobinopathy and thus survive disease-free.

These observations in part became the basis for exploring if a reduced intensity or nonmyeloablative conditioning regimen might be sufficient to establish mixed chimerism and thereby generate an alternative safer means of transplantation for these disorders. Initial clinical trials tested a minimal toxicity regimen of fludarabine with a single fraction of total body irradiation (TBI, 200 cGy) in patients with hemoglobinopathies.¹⁰⁰ The results showed that only transient donor chimerism was achieved in most patients, and that donor chimerism was lost when the intensity of the post-grafting immune suppression was tapered and discontinued. The addition of rabbit ATG to a backbone of fludarabine and TBI did not improve the outcome.¹⁰¹ There has been better success with the application of reduced intensity regimens that require hospitalization and cause cytopenias, but still retain a favorable toxicity profile. The use of alemtuzumab, an anti-CD52 antibody, in combination with melphalan and fludarabine in the conditioning regimen has generated better results and

most patients achieve full donor chimerism after HSCT. In one series, 12 of 16 patients with nonmalignant disorders survived with donor engraftment after receiving this conditioning regimen.¹⁰² In a more recent trial at the National Institutes of Health, adult recipients with severe sickle anemia who were judged too ill to receive a standard myeloablative preparative regimen received a nonmyeloablative combination of fludarabine, campath, and 300cGy of TBI before HLA-ID sibling mobilized peripheral blood stem cell transplantation. Sirolimus as a single agent was administered for post-grafting immunosuppression.¹⁰³ To date, 23 patients have been treated in the trial, and all 23 survive, and 20 survive with mixed chimerism sufficient to eliminate sickle-related clinical features including an improved reticulocyte count, LDH, and serum bilirubin after HSCT (Fig. 103.9). Although many of the recipients appear to require long-term immunosuppression with sirolimus to stabilize engraftment, this is a promising approach in older patients.

As in Fanconi anemia, umbilical cord blood might also have benefits in HSCT for hemoglobin disorders due to the lower risk of GVHD. In addition, finding suitably HLA-matched donors in underrepresented ethnic groups in the unrelated marrow donor registry still presents challenges.¹⁰⁴ Unlike marrow-derived hematopoietic stem cells, UCB units are immediately available upon request and are not affected by donor scheduling or health for procurement. Because of the lower GVHD risk, a greater degree of HLA disparity is acceptable when selecting a UCB unit, which effectively expands the pool of possible donors for patients.¹⁰⁵ Unfortunately, there are several limitations of cord blood units, including small volume, relatively low stem cell number, variable collection methods, and viability after cryopreservation. The nucleated and CD34+ cell dose are the major factors that affect outcome.¹⁰⁶ Thus the role of UCB transplantation for hemoglobin disorders is still evolving. Locatelli et al. reported the outcome after HLA-ID sibling cord blood transplantation for patients with SCD and thalassemia.¹⁰⁷ A total of 44 patients was included in the series (median age 5 years, range 1 to 20) and the patients had thalassemia (n = 33) or SCD (n = 11). The majority of children (n = 40) received CSP alone or CSP / MTX as GVHD prophylaxis and their median total nucleated cell dose was $4.0 \times 10^7/\text{kg}$ (range 1.2 to $10 \times 10^7/\text{kg}$). Eighty-two percent of patients were alive and disease-free with a median follow-up of 2 years (range 4 to 76 months), and only 4 (9%) had grade II acute GVHD. The two-year event-free survival probabilities were 79% and 90% for patients with thalassemia and SCD, respectively. Results were best in patients who did not receive MTX to prevent GVHD and also in those patients who received an additional immunosuppressive drug such as thiotepa or fludarabine with the BU/CY backbone.

In an attempt to extend these encouraging results observed after sibling donor UCB transplantation, the applicability of unrelated donor UCB transplantation was explored. Recently, a prospective investigation of unrelated donor HSCT for severe sickle cell disease reported the results after UCB transplantation.¹⁰⁸ In this phase II trial, eight children who met study criteria for severe SCD underwent unrelated-donor cord blood transplantation. They received alemtuzumab, fludarabine, and melphalan as their preparative regimen and either CSP or tacrolimus in addition to mycophenolate mofetil as GVHD prophylaxis. All patients had either 6 of 6 (n = 1) or 5 of 6 HLA matching based on low-/intermediate-resolution typing of HLA-A, -B, and -DRB1. Because of excessive graft rejection rates in the cord blood cohort, that arm of the trial was closed. Similarly, results after unrelated donor UCB transplantation in patients with thalassemia major are inferior to those with related marrow donors. Ruggeri et al. reported results of the CIBMTR data registry that included a cohort of 35 thalassemia patients who underwent either matched or mismatched UCB transplantation.¹⁰⁹ Despite acceptable HLA matching, disease-free survival and overall survival for patients in this report were 21% and 62%, respectively. Of these patients, 20 had graft failure that was fatal in 5. A larger cell dose ($>5 \times 10^7/\text{kg}$) was associated with lower risk of graft failure, indicating that perhaps survival could be improved through the use of multiple cord blood units or ex vivo expansion.

LATE EFFECTS

Assessment of Disease-free Survival

Disease-free survival after HSCT for hemoglobin disorders is defined as freedom from transfusions and iron loading in thalassemia, and in addition among those with sickle cell disease, freedom from sickle-related complications. However, the iron that accumulates as a consequence of RBC transfusions before and after HSCT is not eliminated after successful HSCT to any appreciable extent. Left untreated, iron overload causes significant morbidity and mortality with progressive liver disease and even cirrhosis after transplantation.¹¹⁰ A prospective analysis of annual liver biopsies in thalassemics not treated by iron chelation and in whom thalassemia was cured by HSCT demonstrated that iron overload and hepatitis C virus infection were independent risk factors for progressive liver fibrosis. Patients who had an active hepatitis C infection and also had very high levels of hepatic iron had an 80% risk of developing progressive hepatic fibrosis 10 to 12 years after successful transplantation.¹¹¹ Conversely, patients with a liver iron level less than 16 mg iron/gm liver dry weight and who were also free of evidence of active hepatitis C virus infection, showed no signs of progressive hepatic fibrosis.

Phlebotomy is safe, inexpensive, and highly efficient, and therefore it is the treatment of choice of transfusion iron overload after HSCT. With this approach, excess iron can be completely mobilized from the body without any significant

side effects. Following completion of the phlebotomy program, significant improvement in liver function was observed, particularly in patients infected with hepatitis C virus.¹¹¹ It is possible to reverse severe hepatic fibrosis and even early cirrhosis.¹¹² Patients with early cardiac involvement characterized by left ventricular diastolic dysfunction

P.2186

and impaired left ventricular contractility demonstrated regression of subclinical cardiac disease after phlebotomy.¹¹³

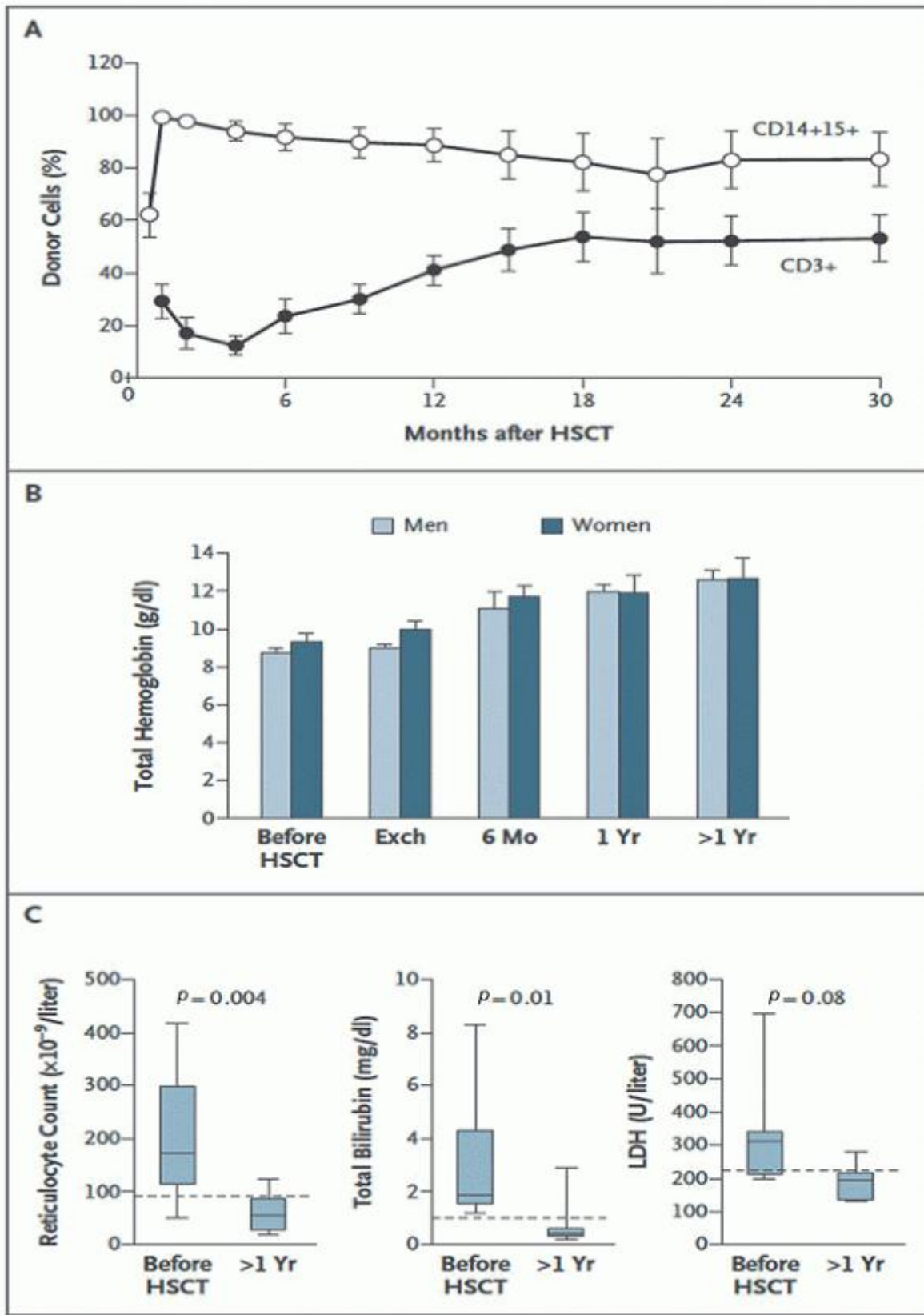

FIGURE 103.9. Effect of donor chimerism on sickle cell disease expression after nonmyeloablative hematopoietic stem cell transplantation (HSCT) from HLA-*DRB1* siblings in adult recipients with severe sickle cell disease. In panel A, the percentage of donor myeloid and T-cells in the blood over time is shown. In Panel B, the change in the hemoglobin level

over time in males and female transplant recipients is shown. In panel C, the reticulocyte count, total serum bilirubin and LDH levels before and after transplantation are shown. From Hsieh MM, Kang EM, Fitzhugh CD, et al. Allogeneic hematopoietic stem-cell transplantation for sickle cell disease. *N Engl J Med* 2009;361(24):2309-2317. Epub 2009 Dec 17.

After successful HSCT for sickle cell disease, patients with stable engraftment of donor cells do not experience sickle-related clinical complications, even if there is stable mixed donor-host hematopoietic chimerism.^{89, 97} In addition, investigators have reported improvements in splenic function and osteonecrosis.^{114, 115} Patients treated by HSCT also had stabilization of the underlying cerebrovascular disease.⁹⁵ Of 55 patients who were enrolled in the multicenter study, 46 underwent cerebral MRI performed a median of 25.4 months after transplantation. Of 59 patients, 29 had stroke or other significant central nervous system disease as an indication for transplantation and 28 survived after BMT. Surviving patients with stroke who also had stable engraftment of donor cells (n = 25) experienced no subsequent stroke events after BMT. However, patients who had graft rejection after BMT were not protected from stroke. One patient with graft rejection experienced a second stroke when the Hb S fraction reached 60% after BMT and another patient with graft rejection had a subarachnoid hemorrhage after BMT. In total, 28 of 29 (97%) of patients with stroke survived after transplantation, and 26 of 29 (90%) survived stroke-free after HSCT. Evidence of silent cerebral infarction before transplantation was found in 10 patients, and of these, all 8 who had MRI studies performed after HSCT had stable or improved appearance. There were no clinical strokes after HSCT in this group. No documented central nervous system disease before transplantation was found in 16 patients. MRI appearance was normal in all 10 patients in this group and P.2187

none had stroke. Together, these observations suggest that there is stabilization of cerebral vasculopathy after hematopoietic cell transplantation. These data also suggest that in those with silent cerebral infarction who are at risk of developing stroke, there is protection from disease progression and a first stroke. The French group reported a similar experience.⁸⁹ Among the 36 patients with a history of stroke before hematopoietic cell transplantation, 2 had a recurrent stroke. With a median follow-up of 6 years, the risk of recurrent stroke was 5.6%, which is a significantly lower rate of second stroke observed in sickle cell disease patients who are treated by regular transfusion therapy after a first stroke.

LONG-TERM TOXICITIES OF CONDITIONING

The incidence of secondary solid tumors in thalassemia and sickle cell disease after transplantation is less than 10/100,000 patient-years, a rate that does not appear different compared to patients who receive supportive care treatment for β thalassemia.¹¹⁶ These findings also are consistent with data reported by the CIBMTR; patients with nonmalignant disorders treated by HSCT had an incidence of secondary malignancies that was not significantly increased compared to the normal population.¹¹⁷

Gonadotropin and sex hormone levels confirm the toxic effect of BU on gonadal function after HSCT. In addition, hypogonadism is the most common endocrine disorder in medically treated patients with thalassemia major, affecting approximately half the patients.^{118, 119} In a study involving 68 children with thalassemia after HSCT, 32% reached an advanced or complete puberty spontaneously (34% of girls and 63% of boys), despite clinical and hormonal evidence of gonadal impairment in most cases.¹¹⁰ In this group, iron overload and the conditioning regimen were the major factors influencing endocrine function. In the cooperative study of HSCT for SCD follow-up gonadal function studies were performed in patients who were 21.6 (range, 16.1 to 28.5 years) and 21.7 (range, 14.1 to 27.8 years) years of age in males and females, respectively.⁹⁵ Among those evaluated, the luteinizing hormone (LH) and follicle stimulating hormone (FSH) levels were normal in 9 males and less than normal in 4 after transplantation. However, only 3 of 13 had normal testosterone levels, consistent with hypogonadotropic hypogonadism in most of the pubertal males. In contrast, 8 of 14 females had increased gonadotropin levels and/or below normal estradiol levels, a finding consistent with primary ovarian failure in the majority of post-pubertal females. Only 4 of 14 females had normal estradiol levels. However, one female had a successful pregnancy 13 years after BMT and another female with graft rejection gave birth to a healthy baby following preimplantation genetic diagnosis 14 years after BMT, although she had experienced 2 previous spontaneous abortions several years earlier. Among 6 evaluable pre-pubertal girls in the Belgian cohort, 5 had primary amenorrhea with elevated serum LH and FSH.⁸⁸ Two post-pubertal females developed secondary amenorrhea. Testicular function was also adversely affected in 4 of 6 evaluable boys who demonstrated decreased testosterone and elevated FSH levels. In the French series, 7 post-pubertal females, aged 13 to 22 years, developed amenorrhea after hematopoietic cell transplantation with decreased serum estradiol and elevated LH and FSH levels and received hormone replacement therapy.⁸⁹ It is anticipated that many, if not most, of the females will require hormonal replacement therapy after HSCT. The development of reduced intensity conditioning regimens is anticipated to reduce the late effect of gonadal toxicity.

Eggelston et al. reported growth outcomes in children who were enrolled in a multicenter investigation of HSCT for SCD.¹²¹ The baseline height and weight and growth velocities after HSCT were compared to children who were treated by HU and who were enrolled in the CSSCD, previous investigations of SCD during which prospective height and weight measurements were documented.^{122, 123} It was determined that growth after HSCT was not impaired, except in older males, where data from the CSSCD showed a more rapid height and weight velocity after age 11.6 and 12.1 years, respectively. However, males grew 0.67 cm/year faster after HSCT compared to males in the HU group before treatment with HU was initiated. Thus, the data showed that conventional myeloablative HCT generally had no adverse effect on height or weight gain in young children. However, diminished growth may occur in patients who undergo HSCT at or near the growth spurt. This study emphasized the importance of treating children early in the course of their disease to minimize toxicity.

CONCLUSION

HSCT for nonmalignant disorders can be life-saving when applied early in life of children who inherit a fatal condition such as SCIDS. In other disorders, early mortality caused by marrow failure or a predisposition to acute leukemia, as occurs in Fanconi anemia, similarly can be life-saving, but as applied over a longer time period. In the setting of hemoglobin disorders, the decision making about HSCT is more nuanced, and often families and their physicians must make decisions based upon long-term projections of mortality and the quality of life. Common to all these disorders, however, is a strict requirement for optimizing donor selection to avoid GVHD, a complication that offers no benefit in these disorders, and an understanding of conditioning regimens that are best tailored to minimize short- and long-term toxicities but still ensure engraftment of donor cells. It is these considerations and the development of improved methods of HSCT that remain the focus of ongoing clinical investigation and which are very likely to improve future outcomes for these disorders.

REFERENCES

1. Oran B, Weisdorf DJ. Allogeneic stem cell transplantation in first complete remission. *Curr Opin Hematol* 2011;18(6):395-400. Epub 2011 Sep 14.
2. Appelbaum FR. The role of hematopoietic cell transplantation as therapy for myelodysplasia. *Best Pract Res Clin Haematol* 2011;24(4):541-547. Epub 2011 Dec 1.
3. Shenoy S. Hematopoietic stem cell transplantation for sickle cell disease: current practice and emerging trends. *Hematology Am Soc Hematol Educ Program* 2011;2011:273-279. Epub 2011 Dec 14.
4. Batzios SP, Zafeiriou DI. Developing treatment options for metachromatic leukodystrophy. *Mol Genet Metab* 2012;105(1):56-63. Epub 2011 Nov 15.
5. Sponzilli I, Notarangelo LD. Severe combined immunodeficiency (SCID): from molecular basis to clinical management. *Acta Biomed* 2011;82(1):5-13. Epub 2011 Nov 11.
6. Tolar J, Mehta PA, Walters MC. Hematopoietic cell transplantation for non-malignant disorders. *Biol Blood Marrow Transplant* 2012;18(1 Suppl):S166-S171. Epub 2012 Jan 18.
7. Rachmilewitz EA, Giardina PJ. How I treat thalassemia. *Blood* 2011;118(13):3479-3488. Epub 2011 Aug 5.
8. Buckley RH. Transplantation of hematopoietic stem cells in human severe combined immunodeficiency: longterm outcomes. *Immunol Res* 2011;49 (1-3):25-43. Epub 2010 Dec 1.
9. Kee Y, D'Andrea AD. Expanded roles of the Fanconi anemia pathway in preserving genomic stability. *Genes Dev* 2010;24(16):1680-1694. Epub 2010 Aug 18.
10. Bagby GC, Alter BP. Fanconi anemia. *Semin Hematol* 2006;43(3):147-156. Epub 2006 July 11.
11. Michlitsch JG, Walters MC. Recent advances in bone marrow transplantation in hemoglobinopathies. *Curr Mol Med* 2008;8(7):675-689. Epub 2008 Nov 11.
12. Lindegren ML, Kobrynski L, Rasmussen SA, et al. Applying public health strategies to primary immunodeficiency diseases: a potential approach to genetic disorders. *MMWR Recommendations and reports : Morbidity and mortality weekly report Recommendations and reports/Centers for Disease Control* 2004;53(RR-1):1-29. Epub 2004 Jan 16.
13. Milner JD, Fasth A, Etzioni A. Autoimmunity in severe combined immunodeficiency (SCID): lessons from patients and experimental models. *J Clin Immunol* 2008;28(Suppl 1):S29-S33. Epub 2008 Jan 15.

14. Gatti RA, Meuwissen HJ, Allen HD, Hong R, Good RA. Immunological reconstitution of sex-linked lymphopenic immunological deficiency. *Lancet* 1968;2(7583):1366-1369. Epub 1968 Dec 28.
15. Buckley RH, Schiff SE, Sampson HA, et al. Development of immunity in human severe primary T cell deficiency following haploidentical bone marrow stem cell transplantation. *J Immunol* 1986;136(7):2398-2407. Epub 1986 Apr 1.
16. Dror Y, Gallagher R, Wara DW, et al. Immune reconstitution in severe combined immunodeficiency disease after lectin-treated, T-cell-depleted haplocompatible bone marrow transplantation. *Blood* 1993;81(8):2021-2030. Epub 1993 Apr 15.
17. Railey MD, Likhnygina Y, Buckley RH. Long-term clinical outcome of patients with severe combined immunodeficiency who received related donor bone marrow transplants without pretransplant chemotherapy or post-transplant GVHD prophylaxis. *J Pediatr* 2009;155(6):834-840 e1. Epub 2009 Oct 13.
18. Buckley RH. Molecular defects in human severe combined immunodeficiency and approaches to immune reconstitution. *Ann Rev Immunol* 2004;22:625-655. Epub 2004 Mar 23.
19. White H, Thrasher A, Veys P, Kinnon C, Gaspar HB. Intrinsic defects of B cell function in X-linked severe combined immunodeficiency. *Eur J Immunol* 2000;30(3):732-737. Epub 2000 Mar 31.
20. Mazzolari E, Forino C, Guerci S, et al. Long-term immune reconstitution and clinical outcome after stem cell transplantation for severe T-cell immunodeficiency. *J Allergy Clin Immunol* 2007;120(4):892-899. Epub 2007 Sep 11.
21. Patel NC, Chinen J, Rosenblatt HM, et al. Long-term outcomes of nonconditioned patients with severe combined immunodeficiency transplanted with HLA-identical or haploidentical bone marrow depleted of T cells with anti-CD6 mAb. *J Allergy Clin Immunol* 2008;122(6):1185-1193. Epub 2008 Dec 17.
22. Gennery AR, Slatter MA, Grandin L, et al. Transplantation of hematopoietic stem cells and long-term survival for primary immunodeficiencies in Europe: entering a new century, do we do better? *J Allergy Clin Immunol* 2010;126(3):602-610 e1-e11. Epub 2010 Aug 3.
23. Bertrand Y, Landais P, Friedrich W, et al. Influence of severe combined immunodeficiency phenotype on the outcome of HLA non-identical, T-cell-depleted bone marrow transplantation: a retrospective European survey from the European group for bone marrow transplantation and the European society for immunodeficiency. *J Pediatr* 1999;134(6):740-748. Epub 1999 Jun 4.
24. Comeau AM, Hale JE, Pai SY, Bonilla FA, et al. Guidelines for implementation of population-based newborn screening for severe combined immunodeficiency. *J Inher Metab Dis* 2010;33(Suppl 2):S273-S281. Epub 2010 May 22.
25. Puck JM. The case for newborn screening for severe combined immunodeficiency and related disorders. *Ann N Y Acad Sci* 2011;1246:108-117. Epub 2012 Jan 13.
26. Verbsky JW, Baker MW, Grossman WJ, et al. Newborn screening for severe combined immunodeficiency; the Wisconsin experience (2008-2011). *J Clin Immunol* 2012;32(1):82-88. Epub 2011 Nov 10.
27. Del Toro G, Satwani P, Harrison L, et al. A pilot study of reduced intensity conditioning and allogeneic stem cell transplantation from unrelated cord blood and matched family donors in children and adolescent recipients. *Bone Marrow Transplant* 2004;33(6):613-622. Epub 2004 Jan 20.
28. Satwani P, Harrison L, Morris E, Del Toro G, Cairo MS. Reduced-intensity allogeneic stem cell transplantation in adults and children with malignant and nonmalignant diseases: end of the beginning and future challenges. *Biol Blood Marrow Transplant* 2005;11(6):403-422. Epub 2005 June 3.
29. Satwani P, Morris E, Bradley MB, Bhatia M, van de Ven C, Cairo MS. Reduced intensity and non-myeloablative allogeneic stem cell transplantation in children and adolescents with malignant and non-malignant diseases. *Med Pediatr Oncol* 2008;50(1):1-8. Epub 2007 Aug 3.
30. Chiesa R, Veys P. Reduced-intensity conditioning for allogeneic stem cell transplant in primary immune deficiencies. *Expert Rev Clin Immunol* 2012;8(3):255-266; quiz 67. Epub 2012 Mar 7.
31. Veys P. Reduced intensity transplantation for primary immunodeficiency disorders. *Pediatr Rep* 2011;3(Suppl 2):e11. Epub 2011 Nov 5.

32. Antoine C, Muller S, Cant A, et al. Long-term survival and transplantation of haemopoietic stem cells for immunodeficiencies: report of the European experience 1968-99. *Lancet* 2003;361(9357):553-560. Epub 2003 Feb 25.
33. Roifman CM, Grunebaum E, Dalal I, Notarangelo L. Matched unrelated bone marrow transplant for severe combined immunodeficiency. *Immunol Res* 2007;38(1-3):191-200. Epub 2007 Oct 6.
34. Fernandes JF, Rocha V, Labopin M, et al. Transplantation in patients with SCID: mismatched related stem cells or unrelated cord blood? *Blood* 2012;119(12):2949-2955. Epub 2012 Feb 7.
35. Chan WY, Roberts RL, Moore TB, Stiehm ER. Cord Blood Transplants for SCID: Better B-cell Engraftment? *J Pediatr Hematol Oncol* 2012. Epub 2012 Apr 19.
36. Sarzotti M, Patel DD, Li X, et al. T cell repertoire development in humans with SCID after nonablative allogeneic marrow transplantation. *J Immunol* 2003;170(5):2711-2718. Epub 2003 Feb 21.
37. Sarzotti-Kelsoe M, Win CM, Parrott RE, et al. Thymic output, T-cell diversity, and T-cell function in long-term human SCID chimeras. *Blood* 2009;114(7):1445-1453. Epub 2009 May 13.
38. Booth C, Gaspar HB, Thrasher AJ. Gene therapy for primary immunodeficiency. *Curr Opin Pediatr* 2011;23(6):659-666. Epub 2011 Oct 6.
39. Griffith LM, Cowan MJ, Kohn DB, et al. Allogeneic hematopoietic cell transplantation for primary immune deficiency diseases: current status and critical needs. *J Allergy Clin Immunol* 2008;122(6):1087-1096. Epub 2008 Nov 11.
40. Eapen M, Ahn KW, Orchard PJ, et al. Long-term survival and late deaths after hematopoietic cell transplantation for primary immunodeficiency diseases and inborn errors of metabolism. *Biol Blood Marrow Transplant* 2012. Epub 2012 Mar 21.
41. Hodson C, Walden H. Towards a molecular understanding of the fanconi anemia core complex. *Anemia* 2012;2012:926787. Epub 2012 June 8.
42. Wang W. Emergence of a DNA-damage response network consisting of Fanconi anaemia and BRCA proteins. *Nat Rev Genet* 2007;8(10):735-748. Epub 2007 Sep 5.
43. Soulier J. Fanconi anemia. *Hematol Am Soc Hematol Educ Program* 2011;2011:492-497. Epub 2011 Dec 14.
44. Shimamura A, Alter BP. Pathophysiology and management of inherited bone marrow failure syndromes. *Blood Rev* 2010;24(3):101-122. Epub 2010 Apr 27.
45. Rosenberg PS, Greene MH, Alter BP. Cancer incidence in persons with Fanconi anemia. *Blood* 2003;101(3):822-826. Epub 2002 Oct 24.
46. Alter BP, Giri N, Savage SA, et al. Malignancies and survival patterns in the National Cancer Institute inherited bone marrow failure syndromes cohort study. *Br J Haematol* 2010;150(2):179-188. Epub 2010 May 29.
47. Gluckman E, Devergie A, Schaison G, et al. Bone marrow transplantation in Fanconi anaemia. *Br J Haematol* 1980;45(4):557-564. Epub 1980 Aug 1.
48. Gluckman E, Devergie A, Dutreix J. Radiosensitivity in Fanconi anaemia: application to the conditioning regimen for bone marrow transplantation. *Br J Haematol* 1983;54(3):431-440. Epub 1983 Jul 1.
49. Berger R, Bernheim A, Gluckman E, Gisselbrecht C. In vitro effect of cyclophosphamide metabolites on chromosomes of Fanconi anaemia patients. *Br J Haematol* 1980;45(4):565-568. Epub 1980 Aug 1.
50. Gluckman E, Berger R, Dutreix J. Bone marrow transplantation for Fanconi anemia. *Semin Hematol* 1984;21(1):20-6. Epub 1984 Jan 1.
51. Farzin A, Davies SM, Smith FO, et al. Matched sibling donor haematopoietic stem cell transplantation in Fanconi anaemia: an update of the Cincinnati Children's experience. *Br J Haematol* 2007;136(4):633-640. Epub 2007/03/21.
52. Ayas M, Solh H, Mustafa MM, et al. Bone marrow transplantation from matched siblings in patients with fanconi anemia utilizing low-dose cyclophosphamide, thoracoabdominal radiation and antithymocyte globulin. *Bone Marrow Transplant* 2001;27(2):139-143. Epub 2001 Apr 3.
53. Zanis-Neto J, Flowers ME, Medeiros CR, et al. Low-dose cyclophosphamide conditioning for haematopoietic cell transplantation from HLA-matched related donors in patients with Fanconi anaemia. *Br J Haematol* 2005;130(1):99-106. Epub 2005 June 29.

54. Locatelli F, Zecca M, Pession A, et al. The outcome of children with Fanconi anemia given hematopoietic stem cell transplantation and the influence of fludarabine in the conditioning regimen: a report from the Italian pediatric group. *Haematologica* 2007;92(10):1381-1388. Epub 2007 Nov 21.
55. Tan PL, Wagner JE, Auerbach AD, Defor TE, Slungaard A, Macmillan ML. Successful engraftment without radiation after fludarabine-based regimen in Fanconi anemia patients undergoing genotypically identical donor hematopoietic cell transplantation. *Med Pediatr Oncol* 2006;46(5):630-636. Epub 2005 Aug 4.
56. Guardiola P, Pasquini R, Dokal I, et al. Outcome of 69 allogeneic stem cell transplantations for Fanconi anemia using HLA-matched unrelated donors: a study on behalf of the European Group for Blood and Marrow Transplantation. *Blood* 2000;95(2):422-429. Epub 2000 Jan 11.
57. Gluckman E, Auerbach AD, Horowitz MM, et al. Bone marrow transplantation for Fanconi anemia. *Blood* 1995;86(7):2856-2862. Epub 1995 Oct 1.
58. MacMillan ML, Auerbach AD, Davies SM, et al. Haematopoietic cell transplantation in patients with Fanconi anaemia using alternate donors: results of a total body irradiation dose escalation trial. *Br J Haematol* 2000;109(1):121-129. Epub 2000 June 10.
59. Wagner JE, Eapen M, MacMillan ML, et al. Unrelated donor bone marrow transplantation for the treatment of Fanconi anemia. *Blood* 2007;109(5):2256-2262. Epub 2006 Oct 14.
60. Gregory JJ Jr, Wagner JE, Verlander PC, et al. Somatic mosaicism in Fanconi anemia: evidence of genotypic reversion in lymphohematopoietic stem cells. *Proc Natl Acad Sci U S A* 2001;98(5):2532-2537. Epub 2001 Feb 28.
61. Balci YI, Akdemir Y, Gumruk F, Cetin M, Arpacı F, Uckan D. CD-34 selected hematopoietic stem cell transplantation from HLA identical family members for fanconi anemia. *Med Pediatr Oncol* 2008;50(5):1065-1067. Epub 2007 Nov 15.
62. Gluckman E, Broxmeyer HA, Auerbach AD, et al. Hematopoietic reconstitution in a patient with Fanconi's anemia by means of umbilical-cord blood from an HLA-identical sibling. *N Engl J Med* 1989;321(17):1174-1178. Epub 1989 Oct 26.
63. Gluckman E, Rocha V, Ionescu I, et al. Results of unrelated cord blood transplant in fanconi anemia patients: risk factor analysis for engraftment and survival. *Biol Blood Marrow Transplant* 2007;13(9):1073-1082. Epub 2007 Aug 19.
64. Rosenberg PS, Alter BP, Ebell W. Cancer risks in Fanconi anemia: findings from the German Fanconi Anemia Registry. *Haematologica* 2008;93(4): 511-517. Epub 2008 Mar 7.
65. Rosenberg PS, Socie G, Alter BP, Gluckman E. Risk of head and neck squamous cell cancer and death in patients with Fanconi anemia who did and did not receive transplants. *Blood* 2005;105(1):67-73. Epub 2004 Aug 28.
66. Socie G, Devergie A, Girinski T, et al. Transplantation for Fanconi's anaemia: long-term follow-up of fifty patients transplanted from a sibling donor after low-dose cyclophosphamide and thoraco-abdominal irradiation for conditioning. *Br J Haematol* 1998;103(1):249-255. Epub 1998 Oct 29.
67. Thomas ED, Buckner CD, Sanders JE, et al. Marrow transplantation for thalassaemia. *Lancet* 1982;2(8292):227-229. Epub 1982 Jul 31.
68. Lucarelli G, Gaziev J. Advances in the allogeneic transplantation for thalassemia. *Blood Rev* 2008;22(2):53-63. Epub 2007 Nov 28.
69. Johnson FL, Look AT, Gockerman J, Ruggiero MR, Dalla-Pozza L, Billings FT, 3rd. Bone-marrow transplantation in a patient with sickle-cell anemia. *N Engl J Med* 1984;311(12):780-783. Epub 1984 Sep 20.
70. Vermynen C, Fernandez Robles E, Ninane J, Cornu G. Bone marrow transplantation in five children with sickle cell anaemia. *Lancet* 1988;1(8600):1427-1428. Epub 1988 June 25.
71. Hoppe CC. Newborn screening for hemoglobin disorders. *Hemoglobin* 2011;35(5-6):556-564. Epub 2011 Sep 14.
72. Quinn CT, Rogers ZR, McCavit TL, Buchanan GR. Improved survival of children and adolescents with sickle cell disease. *Blood* 2010;115(17):3447-3452. Epub 2010 Mar 3.
73. Borgna-Pignatti C, Cappellini MD, De Stefano P, et al. Survival and complications in thalassemia. *Ann N Y Acad Sci* 2005;1054:40-47. Epub 2005 Dec 13.
74. Quinn CT, Miller ST. Risk factors and prediction of outcomes in children and adolescents who have sickle cell anemia. *Hematol Oncol Clin North Am* 2004;18(6):1339-1354, ix. Epub 2004 Oct 30.

75. van Besien K, Koshy M, Anderson-Shaw L, et al. Allogeneic stem cell transplantation for sickle cell disease. A study of patients' decisions. *Bone Marrow Transplant* 2001;28(6):545-549. Epub 2001 Oct 19.
76. Platt OS, Brambilla DJ, Rosse WF, et al. Mortality in sickle cell disease. Life expectancy and risk factors for early death. *N Engl J Med* 1994;330(23):1639-1644. Epub 1994 June 9.
77. Steinberg MH, McCarthy WF, Castro O, et al. The risks and benefits of longterm use of hydroxyurea in sickle cell anemia: A 17.5 year follow-up. *Am J Hematol* 2010;85(6):403-408. Epub 2010 June 1.
78. Wierenga KJ, Hambleton IR, Lewis NA. Survival estimates for patients with homozygous sickle-cell disease in Jamaica: a clinic-based population study. *Lancet* 2001;357(9257):680-683. Epub 2001 Mar 15.
79. Lucarelli G, Galimberti M, Polchi P, et al. Bone marrow transplantation in patients with thalassemia. *N Engl J Med* 1990;322(7):417-421.
80. Manna M, Nesci S, Andreani M, Tonucci P, Lucarelli G. Influence of the conditioning regimens on the incidence of mixed chimerism in thalassemic transplanted patients. *Bone Marrow Transplant* 1993;12(Suppl 1):70-73. Epub 1993 Jan 1.
81. Sodani P, Gaziev D, Polchi P, et al. New approach for bone marrow transplantation in patients with class 3 thalassemia aged younger than 17 years. *Blood* 2004;104(4):1201-1203. Epub 2004 Mar 25.
82. Sabloff M, Chandy M, Wang Z, et al. HLA-matched sibling bone marrow transplantation for beta-thalassemia major. *Blood* 2011;117(5):1745-1750. Epub 2010 Dec 2.
83. Gaziev D, Galimberti M, Lucarelli G, et al. Bone marrow transplantation from alternative donors for thalassemia: HLA-phenotypically identical relative and HLA-nonidentical sibling or parent transplants. *Bone Marrow Transplant* 2000;25(8):815-821. Epub 2000 May 16.
84. La Nasa G, Giardini C, Argioli F, et al. Unrelated donor bone marrow transplantation for thalassemia: the effect of extended haplotypes. *Blood* 2002;99(12):4350-4356. Epub 2002 May 31.
85. La Nasa G, Littera R, Locatelli F, et al. Status of donor-recipient HLA class I ligands and not the KIR genotype is predictive for the outcome of unrelated hematopoietic stem cell transplantation in beta-thalassemia patients. *Biol Blood Marrow Transplant* 2007;13(11):1358-1368. Epub 2007 Oct 24.
86. Bernardo ME, Piras E, Vacca A, et al. Allogeneic hematopoietic stem cell transplantation in thalassemia major: results of a reduced-toxicity conditioning regimen based on the use of treosulfan. *Blood* 2012;120(2):473-476. Epub 2012 May 31.
87. Walters MC, Patience M, Leisenring W, et al. Bone marrow transplantation for sickle cell disease [see comments]. *N Engl J Med* 1996;335(6):369-376.
88. Vermynen C, Cornu G, Ferster A, et al. Haematopoietic stem cell transplantation for sickle cell anaemia: the first 50 patients transplanted in Belgium. *Bone Marrow Transplant* 1998;22(1):1-6.
89. Bernaudin F, Socie G, Kuentz M, et al. Long-term results of related myeloablative stem-cell transplantation to cure sickle cell disease. *Blood* 2007;110(7):2749-2756. Epub 2007 Jul 4.
90. Ferster A, Corazza F, Vertongen F, et al. Transplanted sickle-cell disease patients with autologous bone marrow recovery after graft failure develop increased levels of fetal haemoglobin which corrects disease severity. *Br J Haematol* 1995;90(4):804-808. Epub 1995 Aug 1.
91. Paciaroni K, Gallucci C, De Angelis G, Alfieri C, Roveda A, Lucarelli G. Sustained and full fetal hemoglobin production after failure of bone marrow transplant in a patient homozygous for beta 0-thalassemia: a clinical remission despite genetic disease and transplant rejection. *Am J Hematol* 2009;84(6):372-373. Epub 2009 Apr 18.
92. Walters MC, Storb R, Patience M, et al. Impact of bone marrow transplantation for symptomatic sickle cell disease: an interim report. *Blood* 2000;95(6):1918-1924.
93. Ferster A, Christophe C, Dan B, Devalck C, Sariban E. Neurologic complications after bone marrow transplantation for sickle cell anemia. *Blood* 1995;86(1):408-409. Epub 1995 Jul 1.
94. Walters MC, Sullivan KM, Bernaudin F, et al. Neurologic complications after allogeneic marrow transplantation for sickle cell anemia. *Blood* 1995;85(4):879-884.
95. Walters MC, Hardy K, Edwards S, et al. Pulmonary, gonadal, and central nervous system status after bone marrow transplantation for sickle cell disease. *Biol Blood Marrow Transplant* 2010;16(2):263-272. Epub 2009 Oct 14.

96. Andreani M, Testi M, Gaziev J, et al. Quantitatively different red cell/nucleated cell chimerism in patients with long-term, persistent hematopoietic mixed chimerism after bone marrow transplantation for thalassemia major or sickle cell disease. *Haematologica* 2011;96(1):128-133. Epub 2010 Oct 12.
97. Walters MC, Patience M, Leisenring W, et al. Stable mixed hematopoietic chimerism after bone marrow transplantation for sickle cell anemia. *Biol Blood Marrow Transplant* 2001;7(12):665-673. Epub 2002 Jan 15.
98. Andreani M, Manna M, Lucarelli G, et al. Persistence of mixed chimerism in patients transplanted for the treatment of thalassemia. *Blood* 1996;87(8):3494-3499. Epub 1996 Apr 15.
99. Battaglia M, Andreani M, Manna M, et al. Coexistence of two functioning T-cell repertoires in healthy ex-thalassemics bearing a persistent mixed chimerism years after bone marrow transplantation. *Blood* 1999;94(10):3432-3438. Epub 1999 Nov 24.
100. Iannone R, Casella JF, Fuchs EJ, et al. Results of minimally toxic nonmyeloablative transplantation in patients with sickle cell anemia and beta-thalassemia. *Biol Blood Marrow Transplant* 2003;9(8):519-528.
101. Horan JT, Liesveld JL, Fenton P, Blumberg N, Walters MC. Hematopoietic stem cell transplantation for multiply transfused patients with sickle cell disease and thalassemia after low-dose total body irradiation, fludarabine, and rabbit anti-thymocyte globulin. *Bone Marrow Transplant* 2005;35(2): 171-177. Epub 2004 Nov 9.
102. Shenoy S, Grossman WJ, DiPersio J, et al. A novel reduced-intensity stem cell transplant regimen for nonmalignant disorders. *Bone Marrow Transplant* 2005;35(4):345-352. Epub 2004 Dec 14.
103. Hsieh MM, Kang EM, Fitzhugh CD, et al. Allogeneic hematopoietic stem-cell transplantation for sickle cell disease. *N Engl J Med* 2009;361(24): 2309-2317. Epub 2009 Dec 17.
104. Joshua TV, Rizzo JD, Zhang MJ, et al. Access to hematopoietic stem cell transplantation: effect of race and sex. *Cancer* 2010;116(14):3469-3476. Epub 2010 June 22.
105. Eapen M, Klein JP, Sanz GF, et al. Effect of donor-recipient HLA matching at HLA A, B, C, and DRB1 on outcomes after umbilical-cord blood transplantation for leukaemia and myelodysplastic syndrome: a retrospective analysis. *Lancet Oncol* 2011;12(13):1214-1221. Epub 2011 Oct 11.
106. Gluckman E, Rocha V, Arcese W, et al. Factors associated with outcomes of unrelated cord blood transplant: guidelines for donor choice. *Exp Hematol* 2004;32(4):397-407. Epub 2004 Mar 31.
107. Locatelli F, Rocha V, Reed W, et al. Related umbilical cord blood transplantation in patients with thalassemia and sickle cell disease. *Blood* 2003;101(6):2137-2143. Epub 2002 Nov 9.
108. Kamani NR, Walters MC, Carter S, et al. Unrelated donor cord blood transplantation for children with severe sickle cell disease: results of one cohort from the phase II study from the blood and marrow transplant clinical trials network (BMT CTN). *Biol Blood Marrow Transplant* 2012;18(8):1265-1272. Epub 2012 Feb 22.
109. Ruggeri A, Eapen M, Scaravadou A, et al. Umbilical cord blood transplantation for children with thalassemia and sickle cell disease. *Biol Blood Marrow Transplant* 2011;17(9):1375-1382. Epub 2011 Feb 1.
110. Lucarelli G, Angelucci E, Giardini C, et al. Fate of iron stores in thalassaemia after bone-marrow transplantation. *Lancet* 1993;342(8884):1388-1391. Epub 1993 Dec 4.
111. Angelucci E, Muretto P, Nicolucci A, et al. Effects of iron overload and hepatitis C virus positivity in determining progression of liver fibrosis in thalassemia following bone marrow transplantation. *Blood* 2002;100(1):17-21. Epub 2002 June 19.
112. Muretto P, Angelucci E, Lucarelli G. Reversibility of cirrhosis in patients cured of thalassemia by bone marrow transplantation. *Ann Intern Med* 2002;136(9):667-672. Epub 2002 May 7.
113. Angelucci E, Muretto P, Lucarelli G, et al. Treatment of iron overload in the "ex-thalassemic". Report from the phlebotomy program. *Ann N Y Acad Sci* 1998;850:288-293. Epub 1998 Jul 21.
114. Hernigou P, Bernaudin F, Reinert P, Kuentz M, Vernant JP. Bone-marrow transplantation in sickle-cell disease. Effect on osteonecrosis: a case report with a four-year follow-up. *J Bone Joint Surg Am* 1997;79(11):1726-1730. Epub 1997 Dec 31.
115. Ferster A, Bujan W, Corazza F, et al. Bone marrow transplantation corrects the splenic reticuloendothelial dysfunction in sickle cell anemia. *Blood* 1993;81(4):1102-1105. Epub 1993 Feb 15.

116. Borgna-Pignatti C, Rugolotto S, De Stefano P, et al. Survival and disease complications in thalassemia major. *Ann N Y Acad Sci* 1998;850:227-231. Epub 1998 Jul 21.
117. Curtis RE, Rowlings PA, Deeg HJ, et al. Solid cancers after bone marrow transplantation. *N Engl J Med* 1997;336(13):897-904. Epub 1997 Mar 27.
118. De Sanctis V, Eleftheriou A, Malaventura C. Prevalence of endocrine complications and short stature in patients with thalassaemia major: a multicenter study by the Thalassaemia International Federation (TIF). *Pediatr Endocrinol Rev* 2004;2(Suppl 2):249-255. Epub 2006 Feb 8.
119. Raiola G, Galati MC, De Sanctis V, et al. Growth and puberty in thalassemia major. *J Pediatr Endocrinol Metab* 2003;16(Suppl 2):259-266. Epub 2003 May 6.
120. De Sanctis V. Growth and puberty and its management in thalassaemia. *Horm Res* 2002;58(Suppl 1):72-79. Epub 2002 Oct 10.
121. Eggleston B, Patience M, Edwards S, et al. Effect of myeloablative bone marrow transplantation on growth in children with sickle cell anaemia: results of the multicenter study of haematopoietic cell transplantation for sickle cell anaemia. *Br J Haematol* 2007;136(4):673-676. Epub 2007 Jan 17.
122. Wang WC, Helms RW, Lynn HS, et al. Effect of hydroxyurea on growth in children with sickle cell anemia: results of the HUG-KIDS Study. *J Pediatr* 2002;140(2):225-229. Epub 2002 Feb 28.
123. Platt OS, Rosenstock W, Espeland MA. Influence of sickle hemoglobinopathies on growth and development. *N Engl J Med* 1984;311(1):7-12. Epub 1984 Jul 5.

Chapter 104 Allogeneic Hematopoietic Stem Cell Transplantation (HCT) for Hematologic Malignancies

> Table of Contents > Part VIII - Transplantation > Chapter 104 - Allogeneic Hematopoietic Stem Cell Transplantation (HCT) for Hematologic Malignancies

Chapter 104

Allogeneic Hematopoietic Stem Cell Transplantation (HCT) for Hematologic Malignancies

Bipin N. Savani

Nishitha M. Reddy

Madan Jagasia

Haydar Frangoul

INTRODUCTION

The curative potential of allogeneic hematopoietic stem cell transplantation (HCT) in hematologic malignancies is well established,¹ and currently acute myelogenous leukemia (AML) is the most common indication for HCT, accounting for approximately more than one-third of adult HCT.² As the donor pool expands to include more unrelated and HLA-mismatched donors and umbilical cord blood (CB), and as treatment-associated morbidity and mortality rates decline with improvements in HLA matching, antimicrobial therapy, and management of graft-versus-host disease (GVHD), it has become increasingly feasible to offer this modality of treatment.³

HCT is offered either to increase the chance of cure in a disease that may have a low chance of cure with nontransplant approach (AML in first complete remission [CR1] with high-risk cytogenetics) or to cure an otherwise incurable disease (myelodysplastic syndrome [MDS], AML beyond CR1). Given the inherent risks of HCT, the risk-benefit ratio depends on the natural history of the disease versus the non-relapse mortality or transplant-related mortality due to the procedure itself. Although randomized control trials have been done, an ideal study of "intent to transplant analyses" is lacking in most disease types. With the advances in human leukocyte antigen (HLA) typing and supportive care, the non-relapse mortality after transplant continues to improve. The emergence of reduced-intensity conditioning (RIC) in deference to myeloablative conditioning (MST) broadens the applicability of this modality to patients who formerly would have been excluded from HCT because of advanced age or co-morbid conditions.^{4, 5, 6, 7} Here we discuss the indications, benefits, and risks of HCT in patients with hematologic malignancies.

Chronic myelogenous (or myeloid) leukemia (CML) was a model disease to cure with HCT in the pre-tyrosine-kinase inhibitors (TKI) era. The introduction of TKIs led to a paradigm shift. Current indications of HCT are outlined in the National Cancer Center Network (NCCN) guidelines and addressed in Chapter 81. Consideration of HCT is recommended at 3 months post-TKI therapy if there is a >10% increase in BCR-ABL transcript as measured by quantitative PCR (QPCR) using the International Scale, or if conventional cytogenetics shows less than a partial cytogenetic response. Loss of cytogenetic response, molecular progression, or evolution of new mutations associated with TKI resistance should prompt a transplant evaluation. HCT consideration is often delayed based on response to second generation TKIs. Patients presenting in accelerated phase (AP) or blast crisis (BC) should be considered for earlier HCT.

Acute Myeloid Leukemia

In the United States, approximately 25% of AML patients younger than 70 years undergo an HCT. Median age at transplantation is 45 years; 75% of HCT recipients are younger than 55 years.^{2, 8, 9, 10, 11} The increasing need for HCT in adults with AML requires that all patients and their siblings undergo HLA typing early after diagnosis to determine if a matched related donor (MRD) is available and to allow for the possibility of unrelated donor (URD), haploidentical donor or umbilical cord blood (CB) searches.

Rationale of Hematopoietic Stem Cell Transplantation in First Complete Remission

Transplants should preferentially be performed on time and not reserved for relapsed disease or complete remission 2 (CR2) in high-risk patients. Although several reports of successful HCT in CR2 with a curative potential of 25% to 30% have been reported, such data are highly selective and should not influence a decision against earlier HCT, especially at experienced transplant centers. Moreover, the risk of relapse after URD HCT is higher for patients with unfavorable cytogenetics, irrespective of whether the transplant is performed in CR1 or CR2. Since the probability of achieving CR2 after chemotherapy in this group of patients is low, early HCT provides the optimal approach.^{9, 10, 12, 13}

Indications of Hematopoietic Stem Cell Transplantation in Acute Myeloid Leukemia First Complete Remission

Several clinical features at presentation are associated with particularly poor outcome for AML patients. Age over 60 years, hyperleukocytosis, secondary AML (after antecedent myelodysplasia), or treatment-related myeloid neoplasm and, in some series, two induction cycles rather than one to attain CR1 are clinical factors that portend a worse outcome. As a result, many investigators proceed to offer HCT to such individuals.^{9, 12, 13}

Cytogenetics, however, remains the most robust prognostic marker for risk stratification of AML at the time of diagnosis as well as in selection of post-remission treatments. On the basis of specific structural and numerical cytogenetic abnormalities, AML patients are divided into favorable, intermediate, and adverse risk groups (Chapter 75). A notable exception is the favorable cytogenetic risk group, in which HCT did not further improve outcome.

In recent years, a variety of novel molecular markers including mutations in the FLT3 (FMS-like tyrosine kinase) gene, the NPM1 (nucleophosmin) gene, and the CCAAT/enhancer binding protein alpha (CEBPA) gene have refined the risk stratification of intermediate-risk AML. Several investigators have used combinations of molecular markers to improve the patient's risk assessment in cytogenetically normal AML.⁸

The most challenging group of patients with de novo AML falls within the intermediate-risk category.^{8, 12} Intermediate-risk patients who achieve CR1 after chemotherapy have a 50% probability of disease recurrence without HCT, and the probability that CR2 can be attained is low. With advances in the molecular classification of AML such as NPM1, FLT3-internal tandem duplication (ITD), CEBPA, and KIT, the indications for HCT can now be extended to approximately 40% of patients with AML with no chromosomal abnormalities.^{9, 10, 11, 12, 13} In a recent meta-analysis by Koreth et al.¹⁴ for the transplant period 1982 to 2006, a significant overall survival benefit was reported for patients with poor-risk and intermediate-risk AML who received HCT in CR1. NPM1 positivity has been considered a good-risk feature. More recently, it has been shown that only the subgroup with wild type isocitrate dehydrogenase 1 and 2 (IDH1/IDH2) along with NPM1 mutations are expected to do well.¹⁵ Thus, the prognostic impact

P.2190

of known well validated mutations continues to evolve as new mutations are identified and the interactions of these mutations are understood.

Donor Source and Outcome in Acute Myeloid Leukemia First Complete Remission

Importantly, the outcome of transplantation appears to be comparable for recipients of URD vs. MRD transplant. With improvements in transplant procedures including better donor selection (with high-resolution HLA- typing), excellent

supportive care, and pre-emptive therapy in high-risk patients, we anticipate that outcomes will continue to improve.^{3, 16, 17, 18, 19, 20, 21}

The results of 4 comparative studies together with meta-analyses of cord blood transplant (CBT) vs. URD transplant, the results of CBT appear to be as promising as those of matched URD transplant in adults with hematologic malignances.^{10, 12, 20, 22} In the absence of an HLA-matched donor, both CBT and haploidentical-stem cell transplantation (SCT) strategies (center dependent) are suitable options to treat high-risk patients. An upcoming blood and marrow transplant (BMT)-clinical trials network (CTN) study (BMT-CTN 1101; clinicaltrials.gov NCT01597778) will compare haploidentical-SCT with CBT.

Effect of Consolidation Therapy Pre-stem Cell Transplantation in Acute Myeloid Leukemia First Complete Remission

Relapse is the major cause of treatment failure after HCT in patients with AML^{10, 23}; new approaches to prevent disease recurrence are being explored. A question of practical importance is whether patients undergoing transplantation in CR1 will benefit from post-remission chemotherapy prior to transplantation. There are no prospective studies demonstrating that any form of post-remission chemotherapy further reduces the risk of post-transplant relapse. However, results from two retrospective registry analyses suggest no benefit from adding further consolidation chemotherapy prior to HCT; in both studies (transplant period 1980 to mid-1990s), most patients were young and received full-intensity conditioning MRD HCT.^{9, 12, 14, 24} The role of post-remission consolidation chemotherapy prior to RIC HCT in HR AML has not been adequately addressed.^{13, 25} In a recently published CIBMTR study, relapse occurred in 37% to 40%, and was higher in patients receiving RIC regimens. These findings highlight the importance of the depth of remission pre-SCT, especially in recipients in the RIC group.¹⁸ The efficacy of current chemotherapeutic regimens to achieve minimal residual disease negativity needs to be balanced against the risk of increasing co-morbidities prior to HCT.

Given the expanding use of RIC conditioning and the argument that treatment intensity may be important for cyto-reduction prior to SCT, assessing the impact of pre-transplant consolidation therapy in AML CR1 on outcomes post RIC HCT is an important clinical question that remains unanswered. There is an ongoing CIBMTR analysis to determine if consolidation chemotherapy prior to RIC regimen for AML CR1 improves survival and relapse risk after RIC HCT.

Allo- vs. Auto-Stem Cell Transplantation vs. Chemotherapy in First Complete Remission

A recent summary of several clinical trials comparing HCT with alternative therapies for patients with AML CR1 showed benefits of HCT over alternative therapies.^{8, 9, 13, 26} Studies showed lower relapse rates for allograft recipients compared with those who received auto-SCT or further chemotherapy. None of the studies demonstrated an advantage for any of the alternative modalities (auto-SCT or further chemotherapy) as compared with HCT.

Full Myeloablative vs. Reduced-intensity Conditioning Regimen for Acute Myeloid Leukemia First Complete Remission

Conditioning regimens prior to HCT serve two purposes. One is the suppression of host immunity to allow for donor cell engraftment, and the other is the ablation of underlying malignancy. Ideally both these tasks need to be accomplished with minimal extramedullary toxicity. Conditioning regimens can be broadly classified as myeloablative (MST), RIC, and non myeloablative (NMA), based on the intensity of conditioning. MST regimens cause irreversible cytopenia and hence stem cell support is necessary. RIC regimens cause profound cytopenia and should be given with stem cells but cytopenia may not be irreversible. NMA regimens can theoretically be given without stem cell support.

MST HCTs are associated with decreased relapse but with increased transplant-related mortality (TRM). We now know that myeloablation is not as critical for engraftment as is immunosuppression. Reduced-intensity immunosuppressive approaches such as antithymocyte globulin (ATG), alemtuzumab, rituximab, and others can be used for transplant conditioning. There is a balance between reducing TRM by reducing intensity, and risking more relapse as the regimen is weakened.^{6, 27}

No study to date has shown superiority of RIC to MST in AML^{4, 27, 28, 29, 30}; we recommend reserving RIC (but not truly NMA) for patients thought to be ineligible for the more intense MST regimen. The importance of disease control at the time of transplant, especially for those patients undergoing the RIC condition, appears to have paramount importance when evaluating outcomes. In Martino's large-scale retrospective analysis of AML patients undergoing SCT, those patients transplanted in CR1 had similar rates of relapse (MST: 27% vs. RIC: 32%).³¹ A prospective study randomizing patients to MST or RIC HCT regimens based solely on age of < or >50 years for AML patients in CR1 revealed similar non relapse mortality of 19% for MST and 20% for RIC with equivalent relapse and survival.³² These data suggest that MST conditioning may not be needed for those AML patients in CR1 at the time of HCT. Ongoing prospective randomized clinical trials (BMT-CTN 0901; clinicaltrials.gov NCT01339910) will answer this question more definitively.

Hematopoietic Stem Cell Transplantation for Patients Not in Remission and Beyond First Complete Remission

HCT for AML was first tested in patients with recurrent or relapsed refractory disease three decades ago. The transplant outcome for patients with induction failure or resistant relapse AML or for those with extramedullary disease treated with standard dose chemotherapy remains quite poor. Although the results are less than satisfactory, there is still a role for HCT for patients with advanced AML.

Difficulties in Achieving Complete Remission 2 Pre-stem Cell Transplantation

More recently, the investigators from City of Hope National Medical Center (COHNMC) reported their extended experience with 71 patients with refractory AML who were treated with HCT during a period of 22 years with 82% receiving grafts from MRD. The median age of these patients was 37 years (range 2 to 62 years) and the median follow-up was 1 year. Three-year disease-free survival (DFS) was 29% with a relapse rate of 54%. Cytogenetic data were available on 51 of the patients treated at COHNMC. Three patients had favorable, 27 intermediate, and 21 unfavorable cytogenetics. Those patients with favorable or

P.2191

intermediate cytogenetics had DFS of 44% vs. only 18% in those with unfavorable cytogenetic features.³³

A score to predict transplantation success was developed in a retrospective survey of 1,673 patients who underwent a MST HCT for AML in relapse. In patients with low score the 3-year overall survival (OS) was 42% and those with a very high score had a dismal prognosis with only 6% alive at 3 years. The high score refers to the same group of patients in whom attempts to reinduce second remission are likely to fail. Patients with a short CR1, poor cytogenetics, and/or circulating blasts present a major clinical challenge.^{34, 35}

Sequential Chemotherapy Followed by Reduced-intensity Conditioning Hematopoietic Stem Cell Transplantation

An interesting strategy of sequential cytoreductive chemotherapy, immediately followed by RIC and prophylactic donor lymphocyte infusion (DLI) in refractory and early relapse patients, was evaluated.³⁶ This German protocol known as the FLAMSA (fludarabine, Ara-C, amsacrine)-RIC approach was reported in a prospective multicenter study involving 103 patients. The median survival of 16.4 months and the 4-year estimated OS of 32% were promising.³⁶ This approach requires an HLA-matched donor available just when relapse is diagnosed. Therefore, for AML patients in CR1 even if HCT is not scheduled, a search for a donor should be initiated to enable sequential transplantation in case of early relapse.

Persistent Cytogenetic Abnormalities Pre-stem Cell Transplantation

Risk stratification is important to identify patients with AML who might benefit from HCT in CR1. An MD Anderson Cancer Center (MDACC) study analyzed 150 patients with AML and diagnostic cytogenetic abnormalities who underwent MST HCT while in CR1 to evaluate the prognostic impact of persistent cytogenetic abnormalities at HCT.³⁷ Three risk groups were identified. Patients with favorable/intermediate cytogenetics at diagnosis (n = 49) and patients with unfavorable cytogenetics at diagnosis but without a persistent abnormal clone at HCT (n = 83) had a similar 3-year leukemia-free survival of 58% to 60% despite the higher 3-year relapse incidence in the latter group (32.3%, versus 16.8% in the former group). A third group of patients with unfavorable cytogenetics at diagnosis and a persistent abnormal clone at HCT (n = 15) had the worst prognosis, with a 3-year relapse rate of 57.5% and 3-year leukemia-free survival of only 29.2%. These data suggest that patients with AML and unfavorable cytogenetics at diagnosis and a persistent abnormal clone at HCT are at very high risk for relapse after HCT.^{37, 38} These patients should be considered for clinical trials designed to optimize conditioning regimens (e.g., clofarabine-based regimen, see below) and/or to use preemptive strategies (e.g., chemotherapy [azacitidine], DLI, early withdrawal of immunosuppression if no GVHD, etc.) in the post-transplant setting, aimed at decreasing relapses.

Acute Myeloid Leukemia Complete Remission 2 and Beyond

Although the results of HCT in CR1 indicate an overall improved outcome compared with chemotherapy, many patients do not undergo transplantation while in CR1 based on either non-severe disease symptoms and/or on the patient desire, or mainly due to physician/patient preferences.

The currently available data suggest that patients with AML with untreated first relapse can expect an outcome following MST HCT similar to that of those patients proceeding to transplantation during CR2.¹⁰ Studies evaluating patients who receive an HCT in second or subsequent relapse, or third or later remissions following standard therapy, have demonstrated very few long-term survivors.

Relapse Prevention and Management of Relapses after Hematopoietic Stem Cell Transplantation

Monitoring of Relapse

Although HCT can be curative, even in advanced disease, treatment failure is commonly manifested by relapse of disease, for which treatment is successful in only a minority of patients.²³ Detection of minimal residual disease in post-transplant surveillance is felt to be a necessary component of any strategy.^{39, 40} Past strategies for relapse prevention have focused on the use of DLI with variable success. Peritransplantation intervention and maintenance therapies (e.g., azacitidine) are under current investigation.^{41, 42}

Traditionally, the detection of impending relapse in the post-transplant period had been based on donor chimerism analysis (e.g., poor donor chimerism has been associated with increased risk of relapse), but the lack of specificity remains a problem. In AML, the development of post-transplant minimal residual disease strategies is more complex because of the genetic heterogeneity of these disorders. Nevertheless, for some genetic subtypes, for example, reciprocal translocations or NPM1-mutated AML, minimal residual disease monitoring in the post-transplant period has already been realized.^{39, 43, 44, 45}

Walter et al.²⁴ investigated 99 AML patients receiving MST HCT CR1 by 10-color flow cytometry before transplantation. minimal residual disease-positive patients had lower 2-year estimates of survival (30.2% versus 76.6%) and higher 2-year estimates of relapse (64.9% versus 17.6%), compared with minimal residual disease-negative patients. After adjustment for other prognostically relevant parameters, a positive minimal residual disease status pre-HCT was significantly associated with increased overall mortality and relapse relative to minimal residual disease-negative HCT. Kebriaei et al.⁴⁶ found a trend toward improved outcomes in 68 patients in cytogenetic remission compared with those with residual cytogenetic abnormalities at the time of HCT.

In the conservative treatment setting of AML, many minimal residual disease studies confirmed the potential of real-time PCR to predict the relapse risk in patients with reciprocal rearrangements. Some studies investigated the potential of molecular minimal residual disease monitoring for patients with reciprocal rearrangements also in the post-transplant period.^{39, 43, 47}

Novel Conditioning Regimen

Incorporating novel agents in the conditioning regimen with potent antileukemic activity is a strategy that is currently under investigation.⁴⁸ Clofarabine is a novel nucleoside analog that has potent antileukemic activity. It has shown efficacy in refractory disease as well as upfront scenarios. Geyer et al.⁴⁹ combined total-body irradiation (TBI) with clofarabine and cytarabine for HCT in pediatric patients with refractory or multiply relapsed leukemia in a phase I/II study. The early results show the probability of a 1-year progression-free survival of 57.4%. Andersson et al.⁵⁰ reported on a clofarabine/fludarabine/busulfan-based RIC regimen for advanced MDS and AML in 42 patients, which included children. In this high-risk patient population, 20 patients are alive at median survival of 23 months, which is an encouraging early result and warrants further studies.

Targeted immunotherapy post-SCT: One of the strategies for the prevention of relapse of AML/MDS post-SCT is to use targeted immunotherapy as part of the conditioning regimen such as the employment of vaccines, and DLI. Additionally, natural killer cells

P.2192

could be transferred for the treatment of leukemia relapse both during and after SCT.^{23, 51, 52}

Post-transplant Therapy

The posttransplant therapeutic approach has been limited to TKI in patients with BCR-ABL1-positive leukemia. However, other strategies, including the use of interleukins, monoclonal antibodies, immunomodulatory agents (bortezomib), DNA methyltransferase inhibitors, and histone deacetylase inhibitors, are currently being explored in AML.³⁹ The goal of these approaches is to treat minimal residual disease while minimizing adverse side effects and avoiding the impediment of donor cell engraftment. The use of hypomethylating agents (e.g., azacitidine) in patients with AML/MDS has drawn increased interest because of their demonstrated efficacy and relatively acceptable toxicity profile.^{41, 42, 53}

As our ability to monitor minimal residual disease post-HCT improves, along with identification of actionable molecular mutations, it will allow for the development of clinical trials aimed at prevention of relapse in a targeted fashion. Therapeutic interventions will be needed not only to prevent relapse but allow for simultaneous favorable modulation of the GVHD-graft versus tumor (GVT) balance.

Relapse after HCT for AML carries a very poor prognosis. Second HCT, although curative, is not an appropriate treatment option for a large number of relapsing patients (only 2% to 20% patients receive a second HCT), and efforts to increase the number of patients who may benefit from a second HCT are ongoing.²³

Incorporating Novel Agents

The development of novel agents is expected to gather momentum as new actionable mutations are identified. A mutation in FLT3 is well known to be a poor prognostic marker in newly diagnosed and relapsed AML. Specific inhibitors of FLT3 such as sorafenib, lestaurtinib (CEP-701), and quizartinib (AC220) have been studied in relapsed or refractory AML.^{10, 39, 54} FLT3 inhibitors need to be investigated post-SCT in patients with FLT3 + AML to prevent relapse, a most common cause of transplant failure.⁵⁵

Hypomethylating agents are active in high-risk MDS, and to a lesser degree in highly proliferative AML. 5-Azacitidine was shown in one study to prolong survival in elderly AML patients with low proliferative disease (expected disease course after HCT), and hence has drawn attention as an agent that may control low proliferative relapses after HCT.⁵³

Summary

The initial approach for patients should be determined by cytogenetic risk factors, molecular markers, availability of a donor/ stem cell source, and response to induction chemotherapy. Patients with cytogenetic features associated with a good prognosis who achieve a CR with induction followed by consolidation chemotherapy should be observed without immediate transplantation, although HLA typing of these patients and their siblings is warranted at diagnosis. Patients with intermediate or poor markers who achieve a CR with induction/consolidation chemotherapy should undergo an HCT procedure early during CR1 if a histocompatible donor is available or any other stem cell source is available with low risk for transplant procedure. For those patients who do not enter a CR or who relapse after standard therapy, an HCT should be performed sooner rather than later. The transplant approach should be individualized for all patients based on remission status, performance status, and coexisting medical problems, i.e., MST vs. RIC regimens.

The treatment outcome of patients who have suffered a relapse of AML following HCT remains poor. Additional chemotherapy and second transplants are associated with exceptionally high morbidity and mortality and have generally resulted in short remissions. Chemotherapy followed by second non-myeloablative stem cell transplant (NST) HCT or DLI is a reasonable option for patients with late relapse after HCT. Relapse remains a major cause of transplant failure. We believe that the outcome of AML will be further improved by an innovative approach to reducing relapse risk, and that enrollment in clinical trials is the way to go and should be encouraged for all HCT recipients.

Myelodysplastic Syndrome

MDS is primarily a disease of older patients, with a median age at diagnosis in the eighth decade of life. Despite new therapeutic interventions, HCT remains the only curative option for this disease, with long-term survival probabilities ranging from 25% to 70%.^{56, 57, 58, 59} There is a significant selection bias for HCT as illustrated by the age difference between the average MDS patients and those who ultimately receive a transplant.

Rationale of Hematopoietic Stem Cell Transplantation in Myelodysplastic Syndrome

MDS originates in hematopoietic stem or precursor cells, and a logical approach is, therefore, to replace the clonal MDS cells by healthy donor cells via HCT procedure. Successful HCT requires that the infused cells from the healthy donor establish themselves (engraft), and that the malignant cells of the patient's disease are eliminated by graft-versus-tumor (GVT) effects.

Over the past decade the approach to treating MDS has undergone major changes, at least in part related to the Food and Drug Administration (FDA) approval of several drugs for MDS and the development of new concepts for HCT. The drug therapy has improved the prognosis of patients with MDS, with 35% to 65% of patients achieving clinically relevant hematologic responses which may last from a few months (for high-risk MDS) to several years (predominantly for low-risk diseases). Concurrently, the emphasis with HCT has shifted from high-dose therapy, aimed at maximum tumor cell kill, to low- or reduced-intensity conditioning, relying heavily on donor cell-mediated immune effects to eradicate the disease (GVT effect). This GVT effect eliminates residual cells of the patient's disease via recognition of minor histocompatibility antigens.

Patient Selection for Hematopoietic Stem Cell Transplantation

Since age is a major factor determining the decision about HCT, many patients younger than 60 years of age are likely to be considered for transplantation sooner and more often than older patients.⁶⁰ Kuendgen et al. recently presented

registry data that included 232 patients less than 50 years of age and 2,496 patients more than 50 years of age, where approximately 42% of the younger patients underwent transplantation compared to only 8% of the older patients.⁶¹

The International Prognostic Scoring System (IPSS) and World Health Organization prognostic score (WPSS) (discussed in the MDS chapter) are generally thought to identify patients in whom HCT should be considered sooner rather than later.⁶² In a retrospective registry-based analysis, Cutler and collaborators showed that upfront transplantation was associated with a greater number of added life years for intermediate-2 and high-risk IPSS patients.⁶³ Delaying HCT offered the longest life expectancy in patients in IPSS categories low and intermediate-1. In the MDACC experience in 89 MDS patients who underwent HCT from 2002 to 2008, the 3-year OS rates were 79%, 49%, and 27%, respectively, for patients with WPSS low-intermediate-, high-, and very-high-risk categories, respectively.⁵⁶

P.2193

The European Group for Blood and Marrow Transplantation (EBMT) analyzed the post-transplant outcome of 692 patients with MDS according to their cytogenetic status. The overall survival and relapse rates were 47% and 34% for good-risk, 40% and 35% for intermediate-risk, and 31% and 57% for high-risk cytogenetics.⁶⁴ A recent analysis showed that patients with secondary MDS had a post-transplant prognosis comparable to patients with de novo MDS once the data were adjusted for cytogenetic risk. In a small series of 47 patients with high-risk MDS, the 3-year OS was better in patients who received HCT than in those who did not (71% v 31%).⁶⁵

Novel genetic factors are being studied to determine possible predictors of transplant outcomes.⁵⁶ A significant correlation between HLA-DR15 and tumor necrosis factor (TNF) polymorphisms at position 308 among patients with MDS has been observed. The TNF-308 AG genotype conferred an increased risk of TRM compared to the GG genotype. Conversely, the TNF-863 AA genotype was correlated with decreased overall mortality and TRM compared with the CC genotype.⁶⁶

Timing of Hematopoietic Stem Cell Transplantation

Determining the optimal timing of HCT for MDS has proven difficult, although all available data indicate that patients transplanted at an early stage of their disease have superior outcomes. Al-Ali et al.⁶⁷ observed that HCT outcome was best if SCT was performed between 6 and 12 months after diagnosis, the negative effect of later HCT being possibly related to frequent blood transfusion, longer duration of pancytopenia, and disease progression while waiting for HCT. If SCT is delayed, for example because of a lengthy search for an unrelated donor, bridging treatment with hypomethylating agents may delay progression to AML.⁶⁸

It is expected that incorporation of newer prognostic tools such as flow cytometry or molecular markers will improve our ability to select patients for transplantation at an earlier time period.^{69, 70} Newer risk models and individual risk factors (such as co-morbidities) will hopefully identify covariates that are likely to affect outcomes across non-transplant and HCT therapies.^{59, 71, 72, 73, 74}

Pre-transplant Disease Status

In an attempt to improve chances for post-SCT success, patients with a high marrow myeloblast count, (e.g., >5-10%), typically will receive pre-SCT therapy with a hypomethylating agent or with more classical induction-type chemotherapy.^{56, 58, 68} The clinical impression is that pre-SCT therapy may select chemosensitive patients since it appears that patients who do respond to such therapy have a superior outcome, and patients who fail to respond have a poorer outcome than do untreated patients.⁷⁵

The CR status at the time of transplant may impact relapse and TRM rates favorably; however, CR in chemotherapy-treated patients with MDS is infrequent. Warlick et al.⁷⁶ studied 84 patients undergoing HCT, and observed a 1-year cumulative incidence of relapse of 18% in patients in CR compared to 35% for those transplanted with active disease. In a retrospective analysis of 49 MDS/AML patients treated with T cell-depleted grafts, the 2-year cumulative incidences of TRM were 23%, 38%, and 40%, respectively, dependent upon response status prior to HCT (responsive disease, untreated, and refractory).⁷⁷ Oran et al. also documented the benefit of minimal tumor burden at HCT in patients with high-risk MDS/AML undergoing RIC HCT. CR at SCT was associated with day-100 and 2-year TRM rates of 0% and 20%, respectively. Estimates of 2-year OS were 66% for those in CR, 40% for patients with active disease without circulating blasts, and 23% for patients with circulating blasts.⁷⁸

Nakai et al.⁷⁹ compared the outcomes of 283 adult patients with MDS (n = 215) or secondary AML (n = 68) who received (n = 188) or did not receive (n = 95) induction chemotherapy prior to HLA-identical sibling donor HCT, and showed no difference in survival rates between the two groups, with 5-year OS rates of 54% and 57%, respectively. Similarly, Scott and collaborators in Seattle failed to demonstrate a clear survival advantage for a cohort of patients studied retrospectively that received induction chemotherapy pre-transplant, although the risk of relapse was somewhat reduced.⁸⁰

In the absence of controlled data, the decision to use pre-SCT induction therapy should be made on an individual basis. The treatment strategy should also take into account the fact that promising novel drugs are becoming available, although it is unclear if this approach will change long-term outcomes.

CURRENT OUTCOME DATA

An analysis by Warlick et al.⁷⁶ showed a 1-year OS of 48%, a cumulative relapse incidence of 23%, and a DFS of 38%. The EBMT registry analyzed results in a cohort of 374 patients with <5% myeloblasts who received HCT from HLA-matched donors after various conditioning regimens.⁸¹ At 4 years, DFS was 48%, the relapse incidence 15%, and deaths not related to relapse 37%. The risk of relapse was increased after RIC compared to MST conditioning (HR 2.8), but overall survival did not differ significantly. Patients transplanted from URD had a lower relapse risk (HR 0.6), but a higher risk of non-relapse mortality (NRM) (HR 1.4), and OS did not differ significantly between related and unrelated HCT. T cell depletion of the transplanted cells resulted in higher NRM. Younger patients and patients transplanted within 12 months of diagnosis had superior outcomes.

The Fred Hutchinson Cancer Research Center (FHCRC) published results in 257 patients transplanted for secondary MDS. At 5 years, 19% of patients with tAML were surviving in remission, compared with 25% of patients with refractory anemia with excess blasts (RAEB), and 41% of patients with refractory anemia/refractory anemia with ringed sideroblasts (RA/RARS). Two-thirds of patients developed acute GVHD grades II–IV and 57% developed chronic GVHD. After adjusting for karyotype, there were no significant differences in outcome between the cohort with secondary MDS and the cohort of 339 patients with de novo MDS. The probability of relapse and DFS correlated significantly with disease stage ($P < 0.001$) and cytogenetics ($P < 0.001$). As in many other studies, patients transplanted from unrelated donors (n = 122) had a lower risk of relapse ($P = 0.003$) and superior DFS ($P = 0.02$) compared to patients transplanted from related donors.⁵⁸ These results were confirmed in principle in a more recent analysis of CIBMTR data.⁸² These studies emphasize the importance of cytogenetics on HCT outcome.

Martino et al.⁸³ analyzed HCT results in an EBMT cohort of 215 patients with MDS conditioned with RIC and 621 patients who received MST conditioning and were transplanted from HLA-matched related donors. For the MST and RIC cohorts, NRM at 3 years was 32 versus 22%, OS was 45% versus 41%, and DFS 41% versus 33%. Lack of remission before HCT ($P = 0.001$), poor-risk cytogenetics ($P = 0.03$), transformation to AML, and older age were risk factors for inferior DFS.

A British trial⁸⁴ evaluated the results in 75 patients conditioned with an alemtuzumab-based RIC regimen and transplanted from unrelated donors. After 3 years transplant-related mortality (TRM), DFS, and OS for patients with refractory cytopenia with multilineage dysplasia (RCMD) were 24%, 55%, and 59%, respectively; the corresponding numbers for patients with RAEB (1 and 2) were 44%, 18%, and 18%, respectively. HLA-mismatch negatively affected all endpoints, as did disease status at HCT and patient co-morbidities.

P.2194

Strategies to Improve Transplant Outcome after Hematopoietic Stem Cell Transplantation

Pre-transplant Use of Hypomethylating Agents

Field et al.⁸⁵ presented data in 54 consecutive patients with MDS or chronic myelomonocytic leukemia (CMML) who underwent HCT from HLA-matched donors. Thirty patients had received azacitidine for one to seven (median 4) cycles, and 24 patients had not received azacitidine. At 1 year after HCT with conditioning involving high-dose busulfan and fludarabine, 47% of azacitidine-treated patients were alive, compared with 60% of patients not given azacitidine, but relapses were 20% and 32%, respectively. The authors concluded that outcome was consistent with a trend toward a lower incidence of relapse in azacitidine-treated patients.

In a study by De Padua Silva et al.⁸⁶ 17 patients with MDS underwent HCT after having received decitabine. At 1 year, 11 patients were alive, whereas six had died: four from disease progression, one from GVHD, and one with septicemia.

Lubbert et al.⁸⁷ presented data on 15 similarly treated patients who then underwent HCT following RIC regimen. At the time of reporting, 6 patients were alive in remission, whereas four had died from progressive disease and five from transplant-related complications while in remission.

FHCRC recently reviewed results in 68 patients who underwent HCT for MDS or AML transformed from MDS (tAML). Thirty-five patients had received cytarabine prior to SCT followed by either an MST (40%) or RIC (60%) regimen, and 33 patients had undergone induction-type chemotherapy followed by SCT with MST conditioning. The 1-year overall survival was 57% in the cytarabine group, and 36% in the group given induction chemotherapy. Although the risk of post-SCT relapse and NRM was lower in the cytarabine group, none of the differences were statistically significant.⁸⁸

Hypomethylating Agents Post-transplantation

Post-SCT relapse has remained a major cause of failure, particularly in high-risk MDS. Earlier studies had shown that intensification of the transplant conditioning regimen reduced the relapse frequency, though the associated increase in NRM may prohibit such use. It may be advantageous to allow for recovery from the conditioning-related effects, and then administer additional agents. As most of the post-transplant relapses occur within the first 1 to 2 years, addition of hypomethylating agents may have immunomodulatory effects that could potentially increase the GVT response.⁶⁸

In a phase I dose-finding study, de Lima et al.⁵³ at the MDACC started azacitidine at 6 to 7 weeks after HCT and determined that a dose of 32 mg/m² given for 5 consecutive days was well tolerated. Forty-five patients with high-risk MDS/AML were treated and 1-year RFS was 58%. In addition, the authors noted that the incidence of chronic GVHD was lower in 5-azacitidine-treated patients than in historical controls. This observation was confirmed in a study at Washington University, which emphasized, in addition, that the beneficial effect on GVHD did not compromise the GVT effect.⁸⁹

Similarly, Platzbecker et al.⁴¹ reported a prospective study of patients receiving HCT for MDS and AML. If the donor chimerism fell below 80%, patients were offered treatment with 5-azacitidine. This event occurred in 25 of 59 screened patients at a median of 169 days, and azacitidine was initiated at 75 mg/m²/day for 7 days. Sixteen patients responded with an increase in donor chimerism or stabilization at 80%. Eleven patients were given additional 1 to 11 (median 4) cycles of azacitidine. Hematologic relapse eventually occurred in 13 patients (65%), but was delayed to days 56 to 558 (median 231). Therefore, preemptive azacitidine treatment may be effective in delaying hematologic relapse.

Other Post-stem Cell Transplantation Interventions

DLI may improve transplant outcomes in high-risk MDS by decreasing relapse rates. Kolb et al.⁹⁰ investigated escalating doses of DLI to treat a subset of patients with high-risk MDS (n = 67) or patients with secondary AML (n = 90) after RIC HCT. Relapse appeared less likely in patients given DLI. Another approach under investigation by several groups is the use of vaccines against leukemia-specific antigens such as Wilms tumor gene 1 (WT1) and proteinase-3-derived PR1 peptide (or the use of antigen-specific cytotoxic T-lymphocytes). Peptide-based vaccination has been shown to elicit immunologic T cell and clinical responses in myeloid leukemia.^{51, 52}

Relapse after Hematopoietic Stem Cell Transplantation

Post-SCT relapse remains a challenging problem, particularly in patients prepared for HCT with RIC regimens.^{23, 57, 60} Multiparameter flow cytometry has been used effectively to show that aberrancy of marrow blasts pre-SCT can influence outcome after SCT.⁶⁹ However, the definition of minimal residual disease in patients with MDS has not been clarified.³⁹

The infusion of donor lymphocytes in patients with relapse has shown only limited efficacy, as has withdrawal of immunosuppressive therapy (IST).^{23, 58} Early administration of hypomethylating agents may be more effective.^{23, 41, 53, 89} The prophylactic use of drugs such as hypomethylating agents or small molecule inhibitors that are coming into use in patients with high-risk disease may be even more effective. Intensive chemotherapy has generally been disappointing, and second allo-SCT in adults has yielded low-success rates.^{23, 91}

Summary

HCT continues to be the only curative option for MDS. Since the majority of patients with this disease are often older and frail, treatment-related mortality and morbidity remain major obstacles to be overcome. The development of reduced toxicity regimens has allowed HCT to be offered to older patients and those with clinically relevant co-morbid conditions.

Post-transplant relapse and GVHD remain problems requiring further research in this area. Ongoing studies are exploring the incorporation of novel agents (used in non-transplant therapy) during the peri-transplant period.

Acute Lymphoblastic Leukemia

HCT is a potentially curative therapeutic modality for acute lymphocytic leukemia (ALL). Unlike the dramatic advances made in the treatment of childhood ALL with 5-year survival at more than 80%, therapeutic progress for adult ALL has been relatively slow, with long-term survival being achieved in only about 30% to 40% of patients.^{92, 93}

As modern induction regimens can obtain CR rates in up to 80% to 90% of patients, the major barrier to improved results in the treatment of ALL in adults remains the high relapse rates in patients with CR1. Among the various post-remission therapies, HCT remains the single most effective modality for consolidation and prevention of relapse.

Among 3,113 patients \geq 20 years of age receiving HLA-matched sibling HCT for ALL between 2000 to 2009, the 3-year survival probabilities were 51%, 34%, and 21% for patients with early, intermediate, and advanced disease, respectively. Corresponding probabilities among the 3,086 recipients of unrelated donor HCT

P.2195

were 45%, 33%, and 16% (Center for International Blood and Marrow Transplant Research, CIBMTR, 2011).²

Major predictors of HCT outcome in ALL are remission state at time of transplantation and age.⁹⁴ Defining prognostic markers to help determine the optimal use and timing of HCT in the treatment algorithm of patients with ALL is critical. This part of the chapter describes the recent studies and current practice patterns concerning the who, when, and how of HCT in the management of adult ALL.

Indications of Hematopoietic Stem Cell Transplantation

Generally accepted prognostic indicators including age, WBC count, immunophenotype, certain high-risk cytogenetics, and treatment response during induction therapy remain classic prognostic features. OS ranges from 34% to 57% for patients less than 30 years compared with only 15% to 17% for patients greater than 50 years. Generally, a WBC count greater than 30,000/ul or 50,000/ul for B-lineage ALL and greater than 100,000/ul for T-lineage ALL predict for poor prognosis. T-lineage ALL also appears to have better outcomes than B-lineage ALL, while among T-lineage ALL, patients with cortical T ALL appeared to have the best outcomes.⁹³

The achievement of CR and time to CR after induction therapy also carries significant prognostic implications, with patients who require more than 4 weeks achieving a CR having a lower likelihood of being cured. Specific cytogenetic abnormalities also have a major impact on prognosis. The presence of the Philadelphia (Ph) chromosome and t(4;11)(q21;q23) have been associated with inferior survival in multiple large series. Additionally, the presence of the t(8;14)(q24.1;q32) complex karyotype defined as \geq 5 chromosomal abnormalities, or low hypodiploidy/near triploidy, were noted to have poor survival in the analysis of patients treated in the UKALL XII/ECOG 2993 trial.^{95, 96}

Despite documented improvements in the long-term survival of adult patients with certain phenotypes of ALL, the results have not been as good as those achieved in children. Several large studies have shown that CR can now be achieved in 80% to 90% of newly diagnosed adult patients under the age of 60 years. With modern intensive chemotherapy, approximately 30% of adult patients can achieve a cure of the disease. For patients with poor-risk features (discussed above), HCT is the therapy most likely to lead to long-term DFS. For those patients who relapse, HCT offers the only chance for long-term disease control.

For patients with high-risk features, there is general agreement that allo-HCT in CR1 is a potentially curative option; however, there is no consensus on early transplant for standard-risk patients.^{92, 97} Minimal residual disease evaluation and monitoring is developing as an important prognostic factor and could guide physicians in determining which patients, especially those with standard risk, might require transplant.⁹⁸ On the basis of the Medical research Council and Eastern Cooperative Oncology Group (MRC/ECOG) data, it is worth considering HCT for standard-risk patients in CR1, as the relapse rate is high and the prospects of achieving CR2 are uncertain.^{99, 100}

Philadelphia Chromosome-Positive (Ph+) Acute Lymphoblastic Leukemia

Historically, patients with Ph+ ALL have had a poor prognosis with long-term DFS rates of 10% to 20%.¹⁰¹ In the pre-imatinib era, HCT from a related or unrelated donor was widely used for consolidation, with 30% to 65% long-term survival for patients receiving HCT in CR1. Beyond first remission, HCT was curative in only a small fraction of patients with DFS ranging from 5% to 17%.^{92, 93, 100}

In the post-TKI era, the incorporation of imatinib into standard ALL therapy has resulted in significantly improved remission induction rates, as well as improved depth of remissions, enabling more HCT performed in CR1. Indeed, in a report from the MRC/ECOG group, the rate of HCT was found to be improved with the addition of imatinib (28% in the pre-imatinib era, compared with 44% for patients receiving any imatinib on protocol).¹⁰² With the use of an imatinib

induction combined with a MST HCT, 3-year OS rates of between 50% and 65% have been reported.¹⁰³ In recent years, there has been increasing use of second-generation tyrosine kinase inhibitors together with chemotherapy in the frontline therapy for patients with Ph+ ALL. Results have been encouraging with high CR rates (more HCT eligible patients) and encouraging DFS, albeit with relatively short follow-up. The data on HCT in patients treated with second-line agents, however, remains very limited.¹⁰³

Reduced-intensity vs. Myeloablative Regimen in Tyrosine-Kinase Inhibitor era

The key challenges in the treatment of Ph+ ALL are the selection of appropriate pre-transplantation therapy, the minimization of transplantation toxicity, the use of TKIs after transplantation, and the appropriate use of and response to BCR-ABL monitoring.

Where imatinib-based induction was combined with MST HCT, the 3-year OS rate in the UKALL12/E2993 protocol was 59%.⁹⁹ Successive German Multi-Centre ALL (GMALL) studies in Ph+ ALL also revealed that excellent outcomes can be achieved with MST HCT when an imatinib-based induction is used; OS at 3 years was 72%.¹⁰⁴ A recent Japanese Adult Leukemia Study Group also reports a 3-year OS probability of 65% after imatinib-based induction and MST HCT.¹⁰⁵

In recent data from the Seattle group, the subgroup of Ph+ patients receiving an HCT following a Fludarabine (Flu)/TBI non-myeloablative allogeneic stem cell transplantation (NST) regimen had an impressive 3-year OS of 62%, up to 73% in the group without minimal residual disease at transplant, and a relapse rate of 32% when done in CR1, thus demonstrating that GVT contributes to the excellent outcomes in this patient population.¹⁰⁶ Importantly, it may be feasible to achieve CR following a milder induction regimen consisting of TKI combined with steroid therapy only, followed by RIC or NST HCT consolidation in the older patient population who are ineligible for intensive induction.

In summary, HCT approaches appear promising, offering DFS rates in Ph+ ALL that appear higher than could be obtained with chemotherapy and imatinib alone. A comparative study of EBMT registry reports of the outcome of MST versus RIC HCT in patients with ALL confirms this impression.¹⁰⁷ In a multivariate analysis, the type of conditioning regimen was not significantly associated with outcome.

Patients with Poor Donor Options

TKIs such as imatinib, dasatinib, and nilotinib are now standard therapy for Ph+ patients and the resultant increase in initial remission rates has allowed greater eligibility for HCT.

It is hard to be exactly sure if the risk of TRM balances against the increased risk of relapse. Haploidentical HCT often results in a very high TRM. However, recently the group at Johns Hopkins developed a novel approach of haploidentical transplantation using unmodified haploidentical marrow followed by the use of post-transplantation cyclophosphamide to eliminate alloreactive T-cells, with encouraging preliminary results in patients with hematologic malignancies.¹⁰⁸ CBT in adults has a higher TRM than matched-unrelated donor (MUD) HCT. However, where the donor is not fully matched, CB is arguably a better option. A recent report from Japan documented 8 adults with Ph+ ALL who, after a median of 26 months of follow-up, had an estimated 3-year OS

P.2196

of 100% and a leukemia-free survival of 85%.¹⁰⁹ In a recent report from the University College London group of 50 patients receiving mismatched-URD grafts after RIC for a variety of disorders, including acute leukemias, there was no difference in 3-year OS (53% vs 49%, $P = 0.44$) between fully matched and mismatched-URD, even though the mismatch occurred at the antigenic level in 40 cases.¹¹⁰

The advent of these new alternative sources of stem cell transplants have allowed increased accessibility of HCT to patients without matched adult donors. The results from the limited studies discussed above have demonstrated the feasibility of such transplants. However, more studies will be necessary in order to determine the optimal timing and use of these novel approaches, and until then these should be performed in experienced centers and ideally in the context of a well-designed clinical trial, if available.

Post-transplant Tyrosine-Kinase Inhibitor

A very important and as yet unanswered question concerns whether TKIs should be administered after HCT and under what circumstances.

A Programa para el Estudio de la Terapéutica en Hemopatía Maligna (PETHEMA) study reported that imatinib was poorly tolerated after MST HCT; only 62% of patients were able to start at a median of 3.9 months after HCT, and many patients required discontinuation or a significant dose reduction.¹¹¹ In an ongoing GMALL study for which preliminary results have

been reported, patients were randomized after HCT to either upfront imatinib beginning at 3 months after HCT wherever possible, or imatinib started only upon any BCR-ABL reappearance.¹⁰³ This study also reported poor tolerance of imatinib when given early after HCT. In contrast, most patients who started imatinib after the detection of BCR-ABL had a prompt suppression of BCR-ABL in response to the drug, and no difference in outcome between the groups. A small, nonrandomized, single-center study from the University of Minnesota showed a trend toward improved outcome in patients who could be treated with imatinib in the pre- and post-transplantation period after TBI-based MST regimen.¹¹² Similarly, Ram et al.¹⁰⁶ reported that imatinib given for a median duration of 11.5 months after RIC with fludarabine and 2 Gy of TBI (which was relatively well tolerated after transplantation, with only 3 of 18 patients needing to stop the drug) was associated with significantly reduced mortality on univariate analysis, although the effect on relapse was not statistically significant.

There is insufficient evidence to conclude that TKI should be given to all patients after HCT. However, outside of a clinical trial, careful consideration should be given on a patient-by-patient basis as to whether and when to start TKI.

Philadelphia-Negative (Ph-) Acute Lymphoblastic Leukemia

Stem Cell Transplantation in First Complete Remission for HR Patients

HCT in CR1 from related or unrelated donors is generally accepted as the most effective available therapy for patients with Ph- ALL.^{92, 93, 94}

For standard-risk patients, earlier studies did not show a benefit for HCT. In the LALA87 trial, for example, standard-risk patients had no significant benefit from being assigned to the HCT arm, with a 10-year OS of 49% as compared to 43% in the chemotherapy arm.¹¹³ Two recent studies have, however, suggested that HCT may benefit standard-risk patients. Standard-risk patients in the MRC/ECOG trial with a donor had a statistically significant benefit in OS to having a sibling donor and receiving an HCT, with a 5-year overall OS in the donor group of 62% compared to 52% for patients with no donors ($P = 0.02$).⁹⁹ A recent study from the HOVON Cooperative Group allocated standard- and high-risk patients with a matched sibling donor to HCT and those without to auto-SCT. Interestingly, in this study, the differences in OS were again more pronounced in the standard-risk group (5-year OS 69% vs. 49%) than in the high-risk group.¹¹⁴

In the more recent meta-analyses by Ram et al.¹¹⁵ and Pidala et al.,¹¹⁶ the survival benefits for HCT were more pronounced in the standard-risk arms.

Relapse and Refractory Diseases

Transplantation in Complete Remission 2

Patients with ALL refractory to primary chemotherapy or who relapse have extremely poor prognoses; HCT is the only curative option if they can achieve remission pre-transplantation.

In patients with refractory disease or who relapse following initial chemotherapy, the CR rates to salvage therapy range from 40% to 45% and the OS is usually less than 10%.^{92, 93, 94} The 609 adults with relapsed ALL who were previously treated on the MRC UKALL12/ECOG2993 had a 5-year survival rate of 7%. Importantly, in the subgroup analysis based on treatment strategy, 5-year survival following HCT ranged from 15% to 23% depending on donor type (15% for autograft, 16% for URD, 23% for MRD), and was significantly better than chemotherapy (4%) ($P < 0.05$).⁹⁹

Oriol et al.¹¹⁷ reported on the outcome of 263 adults with relapsed ALL, all of whom were previously treated on four consecutive PETHEMA trials with similar induction therapies. Forty-five percent of patients achieved a second remission, with better outcome noted in the group who then proceeded to HCT. The best outcome was noted for patients younger than 30 years with a long first remission duration transplanted in CR2, with OS 38% at 5 years. In an analysis of 421 patients previously treated with the LALA-94 trial who had disease relapse, 44% of patients achieved a CR2, but the 5-year OS was again significantly better in the subset able to receive HCT (25% vs. 7% for the whole group).¹¹⁸

The results from these trials demonstrate that in patients in CR2, HCT offers a better chance for long-term survival as compared to chemotherapy alone.

Marks et al.¹¹⁹ recently demonstrated that the relative risk of relapse is significantly higher for patients with Ph- ALL in CR2 compared to CR1, particularly for those patients whose duration of CR1 was less than 1 year. Outcomes for patients with active disease are dismal and this contributes to the argument that perhaps all patients should be transplanted in CR1, as CR2 is frequently not achievable.

Active Disease Pre-stem Cell Transplantation

Given the high risks associated with salvage chemotherapy, some argue that for patients with an available donor, low to moderate tumor burden, and disease features suggestive of a highly aggressive course, reinduction chemotherapy may be omitted in preference for immediate HCT. In one of the largest retrospective reviews specifically addressing this issue, Terwey et al.¹²⁰ were able to show a 5-year OS rate of 47% in 19 patients with relapsed or refractory disease who received an HCT without prior reinduction chemotherapy, a result that was superior to the group that had received prior reinduction chemotherapy (5-year OS = 18%). Further prospective data are necessary before any recommendations can be made, and currently, management decisions regarding reinduction chemotherapy versus upfront transplant in early relapse will have to be individualized depending on the patient, their disease behavior, and the availability of donors.

P.2197

Importance of Minimal Residual Disease

In addition to age and cytogenetics at diagnosis, the most important prognostic factor, and a direct reflection of sensitivity to chemotherapy, is the achievement of CR (minimal residual disease negativity).

The developments of molecular techniques both to diagnose and monitor small amounts of ALL cells have been utilized to determine the risk of relapse in patients undergoing either standard therapy or HCT.⁹⁸

The role of minimal residual disease quantitation to evaluate treatment response and predict relapse is evolving in adult populations with exploration of flow cytometry and RT-PCR techniques. Several studies have indicated that testing for minimal residual disease both pre- and post-transplant for patients with ALL may also be useful. In general, these studies show that relapse was higher in patients who showed a positive assay before SCT or within the first year after HCT, compared to those who showed no PCR positivity.⁹⁸

Presence of minimal residual disease is associated with adverse outcomes even in patients otherwise considered at standard risk, and these patients may benefit from early allo-HCT in CR1. Data support an minimal residual disease level of (0.01%) or greater as the current determinant of high risk for disease relapse.⁹⁸

Management of Relapse after Hematopoietic Stem Cell Transplantation

Once patients with ALL relapse after HCT, the prognosis is extremely poor. Similarly to the approach in patients with AML and CML, manipulation of the antitumor effect mediated by the donor graft is often employed as a treatment strategy.^{23, 121} Unfortunately, in patients with ALL, this therapy has not been as effective as it has been for patients with CML.¹²²

Overall, few patients who relapse after HCT are long-term survivors. In a series of 130 patients who relapsed after HCT for treatment of ALL, 94 patients underwent salvage therapy. Relapse more than a year after SCT and isolated extra-medullary relapses were associated with a higher probability of subsequent remission. However, of the 52 patients who achieved a remission, only three became long-term survivors.¹²³ DLIs and second HCT are also considered in patients who relapse late after SCT.^{19, 124, 125} In a series of 15 patients who relapsed after SCT, a second HCT was associated with TRM of 36% at day 100, and only 8% had long-term DFS.¹²⁵

DLIs rarely produce long-term DFS in ALL. In a report from Europe, 40 patients with ALL received DLI as treatment for relapse and of 29 evaluable patients, only one achieved CR. Therefore, DLI as a sole therapy appears to have low potential for contributing to a remission and long-term control of disease in patients with relapsed ALL, and, if considered, should be a component of a chemotherapy-based treatment program (e.g., chemo-DLI or chemo-second SCT options).¹²⁰ Studies focused on developing antigen-specific T cell immunotherapy for ALL may help augment the GVL activity of donor T cells.

Summary

HCT is an effective post-remission therapy in patients with ALL, and HCT adult CR1 from related or unrelated donors is generally accepted as the most effective available therapy for patients with ALL. Increased advances in RIC preparative regimens and alternative donors have increased the accessibility of HCT. A risk-adapted paradigm, using minimal residual disease analysis, may help in the selection of patients at highest risk for relapse, who may benefit most from HCT.

A recently published American Society for Blood and Marrow Transplantation (ASBMT) evidence-based review reports: (1) MST HCT is an appropriate treatment for adult (<35 years) ALL in CR1 for all disease risk groups; and (2) RIC may produce similar outcomes to MST. Treatment recommendations unchanged or strengthened by new evidence include: (1) HCT is recommended over chemotherapy for ALL in CR2 or greater; (2) HCT is superior to auto-SCT; and (3) there are similar survival outcomes after related and unrelated HCT. New treatment recommendations based on new evidence include: (1) in the absence of a suitable allogeneic donor, auto-SCT may be an appropriate therapy, but results in a high relapse rate;

(2) it is appropriate to consider CBT for patients with no HLA well-matched donor; and (3) imatinib therapy before and/or after SCT (for Ph+ ALL) yields significantly superior survival outcomes.¹²²

Lymphoid Malignancies

Over the past decade, the number of HCTs performed for lymphoma continues to rise and lymphoma is a common indication for consideration of HCT. HCT in lymphoma is often indicated in patients with recurrent disease relapse, failure after auto-SCT, or massive bone marrow involvement on presentation. Primary refractory disease or disease relapse following immune-chemotherapy are usually incurable with chemotherapy alone. Despite recent advancements in immune-chemotherapy, a significant proportion of patients succumb to disease relapse. The curative potential of graft-versus-lymphoma (GVL) effect has been demonstrated in several lymphoma histologies. The response to DLI further strengthens the argument that the GVL effect exists in both Hodgkin lymphoma (HL) and non-Hodgkin lymphoma (NHL). The timing of transplantation needs to be redefined in this modern era of maintenance and targeted therapies. There is a great interest in considering HCT earlier under certain circumstances. RIC or NST HCT is gaining popularity among lymphoma patients needing HCT and is being increasingly performed as it can be offered to older patients with less toxicity and yet with the benefits of the GVL effect. In this part of the chapter we will discuss the role of HCT in patients with various lymphomas.^{126, 126, 127, 128, 129}

Follicular Lymphoma

The optimal timing of HCT in FL is yet unclear.¹³⁰ A prospective study comparing auto-SCT and HCT was closed early due to poor accrual.¹³¹ Retrospective analyses of large registry data support the use of HCT which is associated with lower relapse rate and longer DFS.

The GELTAMO group has reported the outcome in 37 FL patients who underwent an MRD using melphalan and fludarabine conditioning. The majority of patients had chemosensitive disease and 40% were in CR at the time of HCT. After median follow-up of 52 months, the 4-year DFS for patients with PD, PR, or CR at transplantation were 29%, 48%, and 64%, respectively; whereas the 4-year cumulative incidences of NRM were 71%, 33%, and 26%, respectively.¹³² A B cell lymphoma-specific NST regimen—fludarabine, cyclophosphamide, and rituximab (FCR)—is reportedly safe and effective and this regimen resulted in a TRM of 10%, with 85% patients alive without disease at 8 years. In the updated 12-year follow-up analysis, the OS and progression-free survival (PFS) were 78% and 72%, respectively.^{133, 134}

Favorable outcomes were also reported by the Cancer and Leukemia Group B 109901 trial in 16 patients with relapsed chemosensitive FL using an NST regimen consisting of fludarabine and cyclophosphamide (FC). This study reported a 3-year EFS and OS of 75% and 81%, respectively. Compared with studies employing NST regimens (such as FC or FCR), there is no evidence that the more substantial RIC regimens (fludarabine and melphalan or busulfan) provide any advantage in disease control in patients with chemosensitive disease.¹³⁵

A tandem auto- followed by allo-HCT approach for aggressive disease in 27 patients demonstrated an OS and PFS of 96% at

P.2198

3 years. These results are encouraging, albeit in a highly selected group of patients, but this approach is worth considering in patients with advanced disease.¹³⁶ Non-ablative or RIC HCT is feasible and safe to perform after prior auto-HCT failure.¹³⁷

T cell depletion allografts among 82 patients were evaluated recently. The NRM was 15% with a very favorable 4-year PFS of 76%.¹³⁸ In the United Kingdom (UK), alemtuzumab was incorporated in the conditioning regimen with fludarabine and melphalan. The NRM with this regimen was only 11% with a 3-year OS of 73%.¹³⁹

The experience of HCT for patients with FL is summarized in Table 104.1.

There are no randomized controlled data available to support allografting in chemosensitive FL patients in first remission. Limited single institution data are available for HCT in a small subset of high-risk FL patients with primary refractory disease. Such high-risk FL patients with primary refractory disease could be considered for an HCT within the context of a clinical trial.

Auto-Stem Cell Transplantation vs. Reduced-intensity Conditioning Hematopoietic Stem Cell Transplantation for Relapsed Follicular Lymphoma

A commonly encountered question is whether to offer auto- or RIC HCT to patients with FL relapsing after multiple lines of prior therapies. An adequately powered prospective trial comparing these two options is lacking. Unfortunately, the very

important BMT-CTN trial comparing auto-SCT to RIC HCT in FL was closed early because of poor accrual. While acknowledging the scarcity of good quality clinical trial data, it appears that the TRM rate with FCR RIC allo-HCT is relatively low, with much lower risk of disease relapse and no risk of sMDS/ AML, when compared against auto-SCT. Considering these facts, it is appropriate to offer RIC allo-HCT for selected FL patients when curative intent is pursued. While the timing remains controversial, we consider this option mainly in patients who have progressed after 2-3 lines of prior therapies (including at least one with anthracyclines and/or fludarabine), provided that the disease remains chemosensitive and patients are not candidates for clinical trials. Auto-SCT could be considered for patients who are medically unfit for RIC HCT or those without an adult or alternative donor, with the understanding that a cure may not be achievable.^{133, 140}

Summary

It is important to obtain a good remission status prior to HCT. Intensified therapies to improve disease control prior to SCT are needed to make HCT an eligible option. Various strategies are being investigated to improve outcome in patients with refractory disease and to prevent relapses after SCT, including incorporating novel agents into the conditioning regimen to increase effectiveness without increasing toxicity, and enhancing GVL effects through tumor-specific immunization or post-transplantation immunomodulation (e.g., DLI with or without rituximab).^{141, 142}

TABLE 104.1 OVERALL SURVIVAL OF PATIENTS FOLLOWING HCT FOR FOLLICULAR LYMPHOMA

Author/Year	N	Conditioning Regimen	Type	PFS	OS	NRM
Hari (2008)	208	Variable	RIC n = 88	3 y 67%	3 y 71%	28%
			MST n = 120	3 y 55%	3 y 62%	25%
Avivi (2009)	131	Flu/Mel, Flu/Bu, Flu/Cy	MST 3 y	3 y 51%	30%	47%
Pinana (2010)	37	Flu/Mel	RIC 4 y	64%	54%	26%
Thomson (2010)	82	Flu/Mel/Alemtuzumab	RIC	4 y 76%	4 y 76%	15%
Shea (2011)	16	FC	RIC	3 y 75%	3 y 81%	9%
Khoury (2012)	73	FCR	RIC	72%	78%	10%

Bu, busulfan; C(y), cyclophosphamide; Flu, fludarabine; Mel, melphalan; MST, myeloablative; RIC, reduced-intensity conditioning; PFS, progression-free survival; OS, overall survival; NRM, non-relapse mortality; FC, fludarabine, cyclophosphamide; FCR, fludarabine, cyclophosphamide, and rituximab.

Chronic Lymphocytic Leukemia

Poor-risk patients, defined as resistant to purine analog therapy, 17p deletion, TP53 mutations, responding to salvage therapy, are considered for early HCT.

HCT in CLL dates back to 1992; initial data reported the outcome on 26 patients who underwent MST HCT for refractory CLL. The high NRM (50%) with this regimen was disappointing. Long-term PFS can be achieved in 30% to 60% of transplanted patients by RIC HCT.¹⁴³ In the CLL3X trial of the German CLL Study Group (GCLLSG), 90 patients underwent HCT with an FC-based regimen. In this study, patients with purine analog resistance had similar PFS as patients without purine analog refractoriness. Patients with uncontrolled disease at the time of transplant affected outcome adversely. The negative impact of del 17p was overcome by HCT.^{139, 144} In an analysis of 46 patients receiving RIC HCT for advanced CLL as reported by Brown et al., the 2 year OS and PFS were 54% and 34%, respectively. The number of prior regimens was inversely proportional to patient outcome.^{139, 145}

As with FL, the FCR RIC regimen was applied to patients with CLL. Following HCT, about half of the patients required immune manipulation including therapy with DLI, again suggesting a GVT effect.^{139, 146} The potential curative role of HCT in patients with 17p deletion was noted in 44 patients with this chromosomal abnormality. In this study, the 3-year PFS and OS were 37% and 44%, respectively. The vast majority (89%) of the patients in this study had received RIC.^{139, 147} In the study by the Seattle Consortium, a 5-year PFS of 39% was reported with very few late events despite a high proportion

(87%) of patients with fludarabine refractoriness.¹³⁹ The vast majority (89%) of the patients in this study had received RIC. In older registry data the NRM rates were up to 44% following MST HCT for CLL; whereas more recent data obtained with RIC uniformly show a NRM between 15% and 25% and the latest studies using FCR RIC HCT show around 10%.^{139, 148, 149}

The experience of all-SCT for patients with CLL is summarized in Table 104.2.

The EBMT consensus on indications for HCT in CLL includes eligible patients with previously treated, poor-risk CLL, that is, purine analog refractoriness, early relapse after purine analog combination therapy, and CLL with p53 lesion requiring P.2199

treatment. These consensus guidelines were based on evidence of grade II or less. As mentioned earlier, evidence is increasing that RIC HCT can mitigate the adverse prognostic impact of purine analog refractoriness and del 17p- as long as CLL has not become generally resistant to salvage treatment.¹⁵⁰

TABLE 104.2 OVERALL SURVIVAL OF PATIENTS UNDERGOING HCT FOR CHRONIC LYMPHOCYTIC LEUKEMIA

Author/Year	N	Conditioning Regimen	Type	PFS	OS	NRM
Brown (2006)	46	Flu/Bu	RIC	2 y 34%	2 y 54%	17%
Schetelig (2008)	44	Flu-Bu/Flu-Mel/Flu-Cy	RIC or MST	3 y 37%	3 y 44%	32%
Sorrer (200)8	82	Flu-TBI/TBI	RIC	5 y 39%	5 y 50%	36%
Dregger (2010)	90	FC	RIC	4 y 42%	4 y 62%	23%
Khoury (2011)	86	FCR	RIC	5 y 68%	5 y 51%	17%
Toze (2012)	49	Flu/Bu Cy/TBI Flu/Cy	RIC or MST	10 y 22%	5 y 55%	36%

Bu, Busulfan; Cy, Cyclophosphamide; Flu, fludarabine; Mel, Melphalan; MST, myeloablative; RIC, reduced-intensity conditioning; TBI, total-body irradiation; PFS, progression-free survival; OS, overall survival; NRM, non-relapse mortality; FC, fludarabine, cyclophosphamide; FCR, fludarabine, cyclophosphamide, and rituximab.

The addition of novel treatment modalities and emerging clinical data, though they may not result in cures, should be incorporated into HCT. To date, HCT is the only treatment with the potential of providing long-term disease control in this condition. In addition to the disease risk, patient-related risk factors, such as age and co-morbidity, have to be considered when the decision about HCT is made. Prospective data is available on RIC HCT patients rather than MST regimens, which are mainly derived from registry data. Given the safety, efficacy, and age at which this disease manifests, RIC is possibly superior despite the lack of randomized data.¹⁵¹

Transformed Lymphoma

There is a paucity of literature on the treatment of TL, and therefore deciding on the optimal evidence-based treatment is a challenge. The most specific publications report on auto-SCT showed encouraging results. However, these series are highly selected groups of patients, and unfortunately, the majority of patients with transformed lymphoma (TL) are likely to be too old, with poor performance status, or to have had an insufficient response to reinduction chemotherapy, making them ineligible for SCT. Non-HCT treatment options are limited by a high relapse rate and short DFS. HCT is safer than ever before and it is possible that novel immunomodulatory RIC might provide a high cure rate in this otherwise fatal lymphoid malignancy.

Consideration of Early Allogeneic Stem Cell Transplantation in Transformed Lymphoma

With increasing use of RIC regimens, many older patients are able to receive HCT as curative intent. The hypothesis that RIC transplants could be used to deliver an effective GVL effect is true. Indeed, the typical delayed regression of malignant disease, long after any effect from the preparative regimen has passed, is proof of principle that RIC HCT exerts strong and curative alloresponses against the recipient's malignancy.

Given the high relapse rate seen even after auto-SCT, and the potential benefit of a GVL after HCT, many more eligible patients with NHL including TL are receiving upfront HCT.^{152, 153} Historically, the limitation of HCT has been TRM. In order to offer the curative HCT treatment option to most patients, safer regimens with acceptable GVHD associated morbidity and TRM are preferred (discussed above in FL).

Novel Hematopoietic Stem Cell Transplantation Approaches for Transformed Lymphoma

For patients in whom a nonablative transplant is preferred, radioimmunotherapy can be employed to provide cytoreduction to safely induce disease control while minimizing nonhematologic toxicity. The HCT could maintain the remissions via the GVL effect, and reconstitute hematopoiesis. Using this approach, 16 patients with relapsed CD20+ lymphoma, of which 15 patients were chemotherapy resistant, underwent therapy with 0.4 mCi/kg Y-90 ibritumomab tiuxetan followed by fludarabine and 2 Gy TBI conditioning regimen and matched HCT. At day 28, seven of 16 patients demonstrated responses.¹⁵⁴ Khouri et al. reported a feasibility study using escalated doses of 90Y-ibritumomab tiuxetan prior to FCR HCT in 7 patients with relapsed B cell NHL. Though longer follow-up on outcome and toxicities are needed, it is clear that such approaches need to be urgently considered for TL to make many more TL patients eligible for a curative HCT option.

Summary

There is an almost universal consensus that chemosensitivity and disease control before HCT is important to prevent early relapse, which is a major cause of treatment failure in TL. Incorporating novel radio-immunotherapy as part of the RIC regimen might be a very attractive option to prevent early relapse before GVL takes over disease control.¹⁵⁵ Tandem auto followed by HCT needs to be explored in selected patients with early good results in a small series.

In this era, a stem cell source can be found for virtually all patients who have an indication to receive HCT. RIC haploidentical-related donor or CBT have emerged as alternatives to fill the gap for those patients who do not have MRD or URD, and the outcome of these types of transplantations are expected to be better than chemotherapy alone or even better than auto-SCT for selected high-risk, heavily pretreated TL. The individual transplant center experience choosing URD, CBT, and haploidentical transplantation should also be taken into consideration.

Diffuse Large B cell Lymphoma

Allo-SCT has been used as treatment of high-risk first relapse, refractory disease, and in patients who have relapsed after auto-HCT.¹⁵⁶ In high-risk large cell lymphoma patients (double-hit,

P.2200

triple-hit, failure after auto) HCT should be offered early with a potential survival benefit. For relapsed disease, Lazarus et al. retrospectively analyzed the outcomes of diffuse large B-cell lymphoma (DLBCL) patients undergoing first autologous (n = 837) or HLA-identical sibling allo-HCT using MST conditioning (n = 79) reported to the CIBMTR between 1995 and 2003. The allo-HCT group had more patients with an intermediate-high or high IPI score, extranodal involvement, B symptoms, more prior chemotherapy regimens, and more resistant disease. Allo-HCT was associated with a higher TRM and treatment failure. Auto-HCT was associated with superior OS. Despite having several adverse risk features, patients in the allo-HCT group had a similar risk of relapse. The high TRM rate of MST allo-HCT (45% at 5 years) greatly limited the potential benefit of this approach.¹⁵⁷

Given the high TRM associated with MST conditioning, the use of RIC regimens has increased for HCT in DLBCL. RIC regimens rely more on the GVT effect and less on the intensity of the chemotherapy to eradicate lymphoma. They are in general better tolerated and can be used for older patients or for patients with co-morbidities. The French Society of Bone Marrow Transplant reported the collective experience on 68 patients undergoing RIC HCT for DLBCL. Prior to transplant, 47% of the patients were in remission and 79% had received a prior auto-SCT. The donor was an HLA-identical sibling in 82% of the cases. With a median follow-up of 49 months, the estimated 2-year OS rate was 49%, the PFS rate was 44%, and cumulative incidence of relapse was 41%. The 1-year cumulative incidence of NRM was 23%.¹⁵⁸

Bacher et al. analyzed the outcomes (registry data) of 396 adults who received HCT for DLBCL following MST conditioning (n = 165), RIC (n = 143), or non-MST conditioning (n = 88) regimens between 2000 and 2009.¹⁵⁹ Significant baseline differences between the cohorts included the following: RIC and NST recipients were older (54% and 58% >50 years vs. 39% for MST conditioning), and they were more likely to have received prior auto-SCT (36% and 51% vs 18%), prior radiation, and more prior chemotherapy regimens (55% and 70% vs. 44% with >3 regimens) than those recipients with MST conditioning. The TRM rate at 5 years was significantly higher in MST conditioning recipients (56%) than in the RIC (47%) and NST conditioning (36%) recipients. Lymphoma relapse/progression at 5 years was significantly lower in the MST conditioning group (26%) than in the RIC (38%) and NST conditioning (40%) groups, but the respective 5-year PFS rates (18%, 15%, and 25%) and OS rates (18%, 20%, and 26%) did not differ significantly. Others have shown similar survival rates with TBI and fludarabine conditioning regimens.^{128, 160}

The experience of all-SCT for patients with DLBCL is summarized in Table 104.3. HCT can induce long-term PFS regardless of the intensity of conditioning, with a lower incidence of TRM with the RIC and NST conditioning regimens. The risk of relapse or progression is concordantly higher in the RIC and NST conditioning recipients so that survival does not differ significantly among conditioning regimens. However, the use of RIC or NST conditioning allowed older and sicker patients to proceed to transplant with a lower TRM. HCT has also been used as a salvage strategy with encouraging results for patients who failed a previous auto-HCT. In a retrospective analysis by the EBMT registry that included 101 patients, approximately two-thirds received a RIC regimen and 70% had an identical sibling donor. Outcomes at 3 years were encouraging, with a NRM of 28%, a relapse rate of 30%, a PFS rate of 41%, and an OS rate of 54%. With a NRM that can be considered acceptable in this heavily-pretreated population, HCT led to a long-term survival in this poor-risk group.¹⁶¹ Patients with a long remission after auto-SCT and with sensitive disease at allo-HCT appear to be the best candidates for this approach.

TABLE 104.3 OVERALL SURVIVAL OF PATIENTS FOLLOWING HCT FOR DIFFUSE LARGE B CELL LYMPHOMA

Author/Year	N	Conditioning Regimen	Type	PFS	OS	NRM
Rezvani (2008)	31	Flu/TBI Non-MST	3 y 35%	3 y 45%	25%	
Sirrent (2008)	68	Flu	RIC	2 y 44%	2 y 49%	23%
Thomson (2009)	48	Flu/Mel/ Alemtuzumab	RIC	4 y 48%	4 y 47%	32%
VanKemper (2011)	101	variable RIC	= 64			
			MST = 37	3 y 42%	3 y 54%	28%

Flu, fludarabine; Mel, melphalan; MST, myeloablative; TBI, total-body irradiation; PFS, progression-free survival; OS, overall survival; NRM, non-relapse mortality.

Summary

At this time it is not clear which conditioning intensity to use in HCT for DLBCL. MST conditioning carries a higher mortality with a lower risk of relapse and may still be the preferred option for younger patients without co-morbidities and for those considered to be at high risk for relapse (not in CR at transplant). RIC and NST conditioning regimens may be preferred for older patients or for those with multiple comorbid conditions and with a lower risk of relapse. HCT is effective salvage strategy in patients who have failed a previous auto-SCT for DLBCL.

Mantle Cell Lymphoma

Despite improvements in outcome with chemotherapy, mantle cell lymphoma (MCL) is not considered curable with this approach. Strategies including more intense multiagent chemotherapy as induction followed by consolidation with auto-HCT have demonstrated higher response rates (RR), improved PFS, and the possibility of improved OS. However, even with this aggressive approach, relapse frequently occurs, with the worst outcomes in those with the highest mantle cell international prognostic index (MIPI) scores. Once relapse occurs after auto-HCT, survival can be limited, especially for those transplanted beyond first complete or partial remission or with relapses within 1 year of transplant. HCT is felt to be the only therapeutic strategy with curative potential. Most MCL patients are older and are typically excluded from this approach. The advent of RIC regimens has allowed this treatment to be administered safely to older patients, allowing its use in a greater number of patients.

P.2201

Improved Outcome after HCT in Heavily Pretreated Patients

The emerging role of RIC regimens has created a paradigm shift by reducing TRM, and therefore offering more individuals the option of HCT in MCL. We reported a 5-year survival rate of 70% with an NRM of 12.5%, albeit in a highly selected group receiving HCT.¹⁶² In the era of improved supportive care and decreasing TRM, RIC HCT should be offered for otherwise fit patients who have relapsed following high-dose chemotherapy. The group at MDACC published the most encouraging long-term results of NST in 35 patients with relapsed MCL. Six-year OS was 53%; DFS was 46%. No patients had grade 3 to 4 acute GVHD. This study suggests RIC HCT could be offered up front to a selected group of patients.¹⁶³

Maris et al. published the results on 33 patients with relapsed MCL undergoing NST (related or unrelated donor) HCT. At 2 years, the OS was 65% and PFS was 60%.¹⁶⁴

The British Society for Blood and Marrow Transplantation (BSBMT) published the results of a retrospective analysis of 70 heavily-pretreated patients with relapsed/refractory MCL who received RIC allo-HCT with or without alemtuzumab.^{164, 165} In this heterogeneous group, the 1-year NRM was 18%, the cumulative risk of relapse at 5 years was 65%, the 5-year OS rate was 37%, and the 5-year PFS rate was 14%. Twenty-seven patients received DLI; all but 1 had received alemtuzumab as part of the conditioning regimen. The 3-year OS rate for patients who received DLI for relapse was 79%, indicating a powerful GVL effect.

Le Gouill et al. reported a multicenter retrospective analysis of 70 heavily-pretreated patients with MCL who received RIC allo-HCT in 12 centers in France and Germany.¹⁶⁶ A previous auto-HCT had failed in 47 patients. The 2-year EFS and OS rates were 50% and 53%, respectively, and the 2-year TRM was 32%. This study showed that RIC allo-HCT is effective not only in patients with chemosensitive disease regardless of the number of prior lines of therapy, but also as salvage therapy for those patients in whom auto-HCT had failed.

The experience of all-HCT for patients with MCL is summarized in Table 104.4. Based on the presented data, HCT appears to be effective for relapsed and refractory MCL and the only approach associated with long-term survival.¹⁶⁷ However, toxicity is a limiting factor, and some patients may be unable to tolerate this therapy. Early referral for HCT is certainly warranted, especially in patients with elevated Ki-67 levels who do poorly with conventional chemotherapy and auto-HCT.

Early discussion of transplantation is warranted since the safety and tolerability of RIC HCT has allowed older and heavily pre-treated patients to benefit from this promising therapy.

Management of Relapses after HCT

One interesting approach to this disease state is DLI (with or without prior chemotherapy). Some of the earliest reports of HCT for MCL included patients who relapsed and were shown to respond to DLI. Since that time, additional studies have paid specific attention to this phenomenon and reported responses to DLI in their relapsed patients, particularly the studies which included alemtuzumab as part of the pre-transplant conditioning. The report by Cook et al. included 36 relapses after RIC HCT, 32 of whom were further evaluable. The 3-year OS among patients who received DLI for treatment of relapse was 60% (with no deaths reported after approximately 15 months) compared to 0% for those who did not receive DLI for relapse.¹⁶⁵

TABLE 104.4 CONDITIONING REGIMEN AND SURVIVAL OF PATIENTS UNDERGOING HCT FOR MANTLE CELL LYMPHOMA

Author/Year	N	Conditioning Regimen	Type	PFS	OS	NRM
Moris (2004)	33	Flu/TBI	RIC	2 y 60%	2 y 65%	24%
Tam (2009)	35	FC/FCR	RIC	6 y 46%	6 y 53%	9%
Cook (2010)	70	Flu/Mel, Flu/Bu, BEAM ± anti-CD52	RIC	5 y 14%	5 y 37%	21%

A, Cytarabine; anti CD52, alemtuzumab; B, BCNU; Bu, Busulfan; C(y), Cyclophosphamide; E, Etoposide; Flu, fludarabine; Mel, Melphalan; RIC, reduced-intensity conditioning; TBI, Total-body Irradiation ; PFS, progression-free survival; OS, overall survival; NRM, non-relapse mortality; FC, fludarabine, cyclophosphamide; FCR, fludarabine, cyclophosphamide, and rituximab.

The data for post-HCT relapse show that the disease is potentially salvageable with a re-challenge with antilymphoma chemotherapy with or without immunomodulation (e.g., DLI). Since the data available for HCT are relatively limited, it should come as no surprise that the data for management of relapsed MCL after HCT are even less robust. Since it remains a relatively unknown issue, such patients are probably best treated in the context of a clinical trial.

Summary

Most studies highlight that HCT is often not used in first remission, instead implementing it for relapsed or refractory disease. Reserving HCT until later in the natural history of MCL means patients receiving this therapy often have a disease biology that is more refractory to conventional therapy. The majority of the published literature on HCT for MCL in the past 10 years has focused on RIC HCT. The success with RIC HCT seems to improve when this approach is used for patients with disease that is still chemosensitive. It should still be noted that data also do show that heavilypretreated patients or patients with active disease can still potentially benefit from RIC HCT. Another facet of these studies that raises some additional questions is the use of further adoptive immunotherapeutic strategies (administration of rituximab with the

conditioning regimen) to augment the response to RIC HCT, and these studies did have some of the highest rates of OS and PFS.¹⁶⁸

Peripheral and Cutaneous T-cell Lymphoma

HCT Concept and Indications in peripheral T-cell lymphoma (PTCL)

PTCL are a rare heterogeneous group of lymphomas with a worse prognosis compared with B cell lymphoma. Auto-SCT is offered for patients whether in CR1 or at the time of relapsed disease with chemosensitivity. Auto-SCT has been shown to achieve a promising early response, but median PFS ranged from less than 100 days to about a few months. HCT is an option for patients who relapse after auto-SCT but who are chemosensitive. HCT provides a GVT effect with potential survival benefit despite the high NRM associated with HCT. All published cases

P.2202

after HCT following MST or RIC regimens showed a decreased relapse rate and increased overall- and PFS when compared to published data of conventional therapies. Patients who relapsed after HCT have been shown to achieve remissions again after DLI (with or without prior chemotherapy), which strongly supports the existence of a GVL effect. RIC regimens may lead to decreased TRM rates and improved results. Therefore, RIC-based HCT seems to represent a promising treatment approach, especially when combined with post-transplant therapies with DLI. As GVHD frequently occurs in the skin, the major manifestation site of mycosis fungoides/cutaneous T-cell lymphoma (MF/CTCL), this phenomenon may also contribute to the efficacy of HCT in this disease entity.¹⁶⁹

Outcome Data after HCT

In a retrospective study of 77 patients, at a median follow-up of 43 months, the 5-year OS and PFS were 57% and 53%, respectively, and NRM was 34% at 5 years.¹⁷⁰ RIC regimen was used in 17 patients as reported by Corradini et al.; 8 patients had previous auto-SCT and 16 patients underwent related donor transplant. The estimated 3-year survival was 81% with a NRM of 6% at 2 years.¹⁷¹

Shustov et al.¹⁷² published data using the Seattle NST regimen with fludarabine and 2 Gy TBI on 17 patients. Of these, 6 patients relapsed after prior auto-SCT. At a median follow-up of 3.3 years, the 3-year OS and PFS were 59% and 53%, respectively, with 19% 3-year probability of NRM.

In a retrospective review on 34 patients receiving HCT for PTCL, the 2-year OS was 61%, 2 of the 3 patients receiving DLI demonstrated response supporting a GVL effect.¹⁷³ A recently published retrospective study from EBMT centers, which is the first large multicenter analysis of HCT in CTCL patients, showed a PFS of 42% at 1 year and 34% at 3 years. The current PFS at the last published follow-up was 52% in patients who received NST and 29% in patients who received MST HCT. Estimated OS rate was 66% at 1 year and 53% at 3 years.¹⁷⁴ These noncontrolled results are promising and challenge the outcomes known so far after conventional treatment options. Nevertheless, a controlled study to confirm the role of HCT in CTCL patients is needed.

The long-term outcome on 52 patients undergoing HCT was reported by Dodero et al. Patients received related or alternative donor transplants including haplo-transplants. At a median follow-up of 67 months, 52% were alive. The cumulative incidence of NRM at 5 years was 12%. Refractory disease and age over 45 years were negative prognostic features.¹⁷⁵ An HCT is particularly successful in patients with nodal disease and less so in those with extranodal disease. The experience of all-SCT for patients with PTCL is summarized in Table 104.5.

TABLE 104.5 SURVIVAL OF PATIENTS FOLLOWING HCT PERIPHERAL T-CELL LYMPHOMA

Author/Year	N	Conditioning Regimen	Type	PFS	OS	NRM
Corradini (2004)	17	Flu/Cy/Thiotepa	RIC	3 y 64%	3 y 81%	6%
Le Gouill (2008)	77	TBI based	MST	5 y 53%	5 y 51%	34%
Shustov (2010)	17	Flu/TBI	MST	3 y 53%	3 y 59%	19%
Goldberg (2012)	34	TBI based or Mel based	MST or RIC	2 y 50%	2 y 61%	18%
Dodero (2012)	52	Flu/Cy/Thiotepa	RIC	5 y 40%	5 y 50%	12%

Cy, cyclophosphamide; Flu, fludarabine; HCT, hematopoietic stem cell transplantation; Mel, melphalan; MST, myeloablative; RIC, reduced-intensity conditioning; TBI, total-body irradiation; PFS,

progression-free survival; OS, overall survival; NRM, non-relapse mortality.

Auto vs. Hematopoietic Stem Cell Transplantation

In a recent meta-analysis comparing auto- vs. HCT in patients with MF/SS, 20 patients received HCT and 19 underwent auto-HCT. OS rates at 1 and 5 years were 68% and 23% in the auto-HCT, and 85% and 80%, respectively, in the HCT group. The most common cause of death in the HCT group was GVHD.¹⁷⁶

Currently, ongoing Italian and German trials are comparing auto-HCT vs. HCT after first line induction therapy.

Summary

Despite the lack of randomized studies in recommending HCT for this disease, our experience has been that responses with conventional therapies are short-lived, and long-term remissions in carefully chosen patients can be achieved with HCT. HCT has been demonstrated to achieve long-term remissions in many cases; and conditioning regimens with reduced intensity and therefore with less toxicity might be superior to MST conditioning, and represent an option for the elderly, who represent the majority of patients.

Hodgkin Lymphoma

Auto-HCT is offered for patients who relapse after initial chemotherapy. This approach has a 40% to 50% 5-year survival rate.¹⁷⁷ For patients who relapse after auto-HCT, prompt consideration of RIC HCT is important. Referral to a transplant center for coordination of donor search and discussions of salvage regimens may improve outcomes.

The earlier CIBMTR results reported a 3-year OS of 21% in patients undergoing HCT for relapse after auto-HCT.¹⁷⁸

The EBMT group compared various conditioning regimens and reported on outcomes of patients undergoing MST or RIC HCT.¹⁷⁹ Of the 168 patients who underwent HCT, 89 patients received RIC allo-HCT. The NRM was significantly lower in the RIC group: at 1 year 23% vs. 46% in the MST arm. In this patient population, 61% had prior auto-HCT. Robinson et al. reported the results on 285 patients who underwent RIC HCT in HL. At 12 months, the NRM was 20% and 3-year OS was 56%.¹⁸⁰

In a retrospective study by Sarina et al., based on donor availability status, 185 patients were analyzed, among whom 66% had an available donor and 85% underwent HCT using a RIC approach.¹⁸¹ In patients who had an available donor, the 2-year OS was 66% compared with 42% without a donor.

In a study of 90 patients with relapsed HL, related, unrelated, or haploidentical donors were used with a non-MST conditioning regimen. The 2-year OS was 53% for matched donors and 58% for unrelated and haploidentical donors.¹⁸² Interestingly, in this study, the NRM was lower in the haplo-transplants as

P.2203

compared with HLA-matched recipients. Reducing the number of donor T-cells may decrease the risk and severity of GVHD. Alemtuzumab (anti-CD52) with fludarabine and melphalan was used as a conditioning regimen for relapsed HL. In a series of 67 patients as reported by Peggs et al.¹⁸³ were treated with or without alemtuzumab. The 3-year PFS was higher in patients with T cell depletion, at 43% compared with 25%. This was, however, counteracted by increased DLI use. The experience of all-HCT for patients with HL is summarized in Table 104.6.

Responses after the use of DLI in relapsed HL patients have been reported. This suggests the role of graft versus HL activity. In a similar patient population as reported earlier, in patients undergoing T-cell depletion more frequent use of DLI was noted. Of the 16 patients that underwent DLI, 56% of patients experienced a response that led to a 4-year survival of 56%.¹⁸⁴

Newer treatments are being considered in a maintenance setting following auto-HCT. Until we have further data from these clinical trials, HCT is considered for patients who relapse after auto-HCT. Current data does not favor a particular donor pool. Depending on various studies, in patients with chemosensitive disease RIC HCT results in OS of 40-66% with NRM rates between 20% and 30%. More importantly, outcomes with related vs. alternative donors do not appear to be different.^{126, 185}

Relapse after Reduced-intensity Conditioning Hematopoietic Stem Cell Transplantation

As shown above, there are proportions of patients with relapsed/refractory HL who achieve a lasting cure with RIC allo-HCT, although many patients unfortunately suffer relapses. To better counsel patients in this situation and to evaluate specific management strategies in this setting, Ram et al. described 101 patients with lymphoma who had relapses after

RIC and HCT.¹⁸⁶ This group included 26 patients with relapsed/refractory HL, 50% (13 patients with HL) of whom had prior auto-HCT. HL patients tended to relapse later than those with other lymphoma histologies (6.3 months vs. 3.4 months for indolent NHL and 1.3 months for aggressive NHL). Relapse occurred much sooner in the HL group with prior auto-HCT (median 4.6 months) compared with patients who did not have prior auto-HCT (median 12 months). The estimated 3-year OS after relapse in HL patients was 47%. Patients with HL, despite a longer time to initial relapse relative to indolent NHL, were shown to have the greatest risk of PD even after response to initial therapy for post RIC allo-HCT relapse.

Thus, further strategies to achieve lasting remission following RIC HCT are needed. One potential option that has been evaluated includes brentuximab vedotin, which was shown by Gopal et al., in a multicenter series of 25 patients with HL recurring following allo-HCT, to yield a 50% response rate in evaluable patients.¹⁸⁷ This if followed by DLI at response would be the best available strategy for responding patients. Nevertheless, despite interest in this area, improved strategies are still needed for management of post-HCT relapse.

TABLE 104.6 SURVIVAL OF PATIENTS FOLLOWING HCT FOR HODGKIN LYMPHOMA

Author/Year	N	Conditioning Regimen	Type	PFS	OS	NRM
Peggs (2007)	67	Flu/Mel/Alemtuzumab	RIC 3 y 43%	-	-	
Burroughs (2008)	90	Flu/TBI	RIC	2 y 23%	2 y 53%	21%
Sureda (2008)	168	BEAM	RIC, n = 89	5 y 18%	5 y 28%	23%
		Cy/TBI	MST, n = 79	5 y 20%	5 y 22%	46%
Robinson (2009)	285	Flu/TBI ± T-cell depletion	RIC 3 y	3 y 29%	21%	
			25%			
Sarina (2010)	122	Variable	RIC	2 y 39%	2 y 66%	9%

BEAM BCNU, etoposide, cytarabine, melphalan; Cy, cyclophosphamide; HCT, hematopoietic stem cell transplantation; Mel, melphalan; MST, myeloablative; RIC, reduced-intensity conditioning; TBI, total-body irradiation; PFS, progression-free survival; OS, overall survival; NRM, nonrelapse mortality.

Myelofibrosis

Myelofibrosis is a heterogeneous disease for which long-term, effective medical therapeutic options are currently limited. There is only one curative treatment in myelofibrosis patients using HCT. As myelofibrosis is primarily a disease of the elderly, this has historically been a rare indication of HCT. However, with the advent of RIC regimens, the applicability of this approach has been broadened to include a larger proportion of myelofibrosis patients.^{188, 189, 190, 191, 192, 193, 194}

Janus kinase (JAK)2-inhibitor therapies have been developed for patients with myelofibrosis. Clinical trials have shown that these agents have considerable therapeutic potential in myelofibrosis patients, thus offering an additional treatment option as a potential alternative or integration of JAK inhibitors during the HCT process.

Allo-Outcome and Hematopoietic Stem Cell Transplantation Indications

In a recent study from the United Kingdom, 51 patients with primary myelofibrosis (24%, 33%, and 43% with Dupriez low-, intermediate-, and high-risk disease) received mostly related MST or RIC HCT. The 3-year OS was 44% for MST and 31% for RIC HCT; the corresponding relapse rates were 15% and 46%, nonrelapse mortality rates were 41% and 32%, and extensive chronic GVHD rates were 30% and 35%.¹⁹⁵

A higher 5-year DFS (51%) was reported from another RIC allo-HCT study in which relapse was predicted by high-risk disease and prior splenectomy.¹⁹⁶ A history of splenectomy did not affect outcomes in the recent study from the Center for International Blood and Marrow Transplant Research (CIBMTR).¹⁹⁷

More recent results from FHCRC in more than 100 patients with myelofibrosis, aged 18 to 70 years, show a 7-year actuarial survival of 61% for HLA-matched related and unrelated transplants. NRM at 5 years was 34%, but, as we all know, NRM does not equate with treatment-related mortality. Many patients who underwent HCT had life expectancies of <5 years, based on disease severity, and a 5-year mortality of that magnitude would have been expected even without HCT.¹⁹²

European Leukemia Net suggests that patients with transfusion dependence or unfavorable cytogenetics should be considered for HCT, reflecting the inclusion of these factors in the dynamic international prognostic scoring system (DIPSS).¹⁹⁸

P.2204

A number of important non-disease-related factors, such as age, donor type, and comorbidities, also have a major influence on the outcome following HCT, and these have to be carefully integrated into the decision to proceed to HCT.¹⁹⁹,
200, 201, 202, 203

In summary, on the basis of the available data the risk of HCT is currently not justified in patients with myelofibrosis with low- or intermediate 1-risk disease patients. There are no convincing data that transplant-related mortality and morbidity in myelofibrosis have been favorably altered by the use of RIC transplantation when TRM, relapse, and cGVHD rates remain high. Therefore, if HCT is indicated because of high- or intermediate 2-risk disease, the use of MST HCT is preferred in all eligible patients, considering its association with a lower risk of relapse compared with RIC transplantation. It is reasonable to offer RIC transplantation for older patients (ineligible for MST regimen)²⁰⁴ with high- or intermediate 2-risk disease, especially if a matched donor is available.²⁰⁵ Utilization of umbilical cord blood units or a haploidentical source must still be considered as experimental for myelofibrosis and an experimental option for myelofibrosis transplant candidates lacking a suitable MRD or URD.

In the event of blastic transformation of Myelofibrosis, where the median survival is only 2 to 7 months, HCT, if eligible, may offer a chance of long-term survival, with some encouraging results in a small series.

Role for Splenectomy and JAK-2 Inhibitor Therapy Pre-hematopoietic Stem Cell Transplantation

The splenomegaly itself may lead to sequestration of donor cells after HCT, and may cause delayed engraftment or graft failure. Indeed, some reports have shown faster engraftment in splenectomized patients, which may allow hematopoietic recovery without increased rate of the GVHD, characterized by significantly faster recovery of neutrophil and platelet counts.¹⁸⁸

A vast majority of myelofibrosis patients referred for consideration of HCT have bulky splenomegaly. Its attraction as a tumor debulking strategy is often upheld in clinical practice and the question still remains if there is a subgroup of patients who will benefit from splenectomy pre-HCT. Data reports decreased transfusion requirements and enhanced neutrophil recovery in patients undergoing HCT, favoring pre-transplant splenectomy.²⁰⁶

In contrast, a recent study reported a higher rate of relapse at 3 years in those who underwent splenectomy, 51% versus no splenectomy 20%; $P = 0.005$.¹⁹⁶ A retrospective CIBMTR study did not suggest an effect of prior splenectomy on either graft failure rates or DFS.¹⁹⁷ It is important to note that successful engraftment can still occur despite the presence of even massive splenomegaly. Ciurea et al.²⁰⁷ recently described a cohort of patients ($n = 10$) with splenomegaly, five of whom were defined as extensive with a longitudinal spleen diameter >30 cm, undergoing RIC HCT. All patients engrafted and had a progressive reduction in spleen size, occurring as marrow fibrosis resolved.

There is currently limited data to support the need for splenectomy before transplantation. An alternative to surgical splenectomy is the use of cytoreductive therapy or JAK inhibitors (that produce rapid spleen shrinkage, improvement of constitutional symptoms in the immediate pre-transplantation setting, and decreasing inflammatory cytokine with additional theoretical benefits, discussed below).²⁰⁸ JAK2 inhibitors lead to a marked reduction in levels of inflammatory cytokines in patients with myelofibrosis and might play a role in reducing the rates of GVHD post-HCT.

Monitoring Post-transplantation and Treatment of Relapse

Several studies have assessed whether the presence of JAK2 V617F can be used as a marker of minimal residual disease after HCT in order to institute preemptive immunotherapy prior to overt relapse.^{209, 210, 211, 212, 213} One study used a sensitive reverse transcription (RT)-PCR detection method to monitor and quantify JAK2 V617F levels following 22 RIC HCT procedures for 21 JAK2 V617F positive myelofibrosis patients. Patients became JAK2 V617F negative in 17 of 22 cases (78%) after a median of 89 days following HCT. Of the 5 patients who remained PCR-positive, 4 fulfilled the criteria for CR, demonstrating the utility of this technique as a marker for minimal residual disease and hence depth of remission achieved. In one of these cases, residual JAK2 positivity was eliminated following DLI.²⁰⁹ A subsequent study demonstrated that achievement of JAK2 V617F negativity after HCT for myelofibrosis was significantly associated with decreased incidence of relapse. Patients who achieved PCR negativity 6 months following HCT had a relapse risk of 5% compared with 35% in those who remained PCR-positive.²¹⁰

The timing of DLI, whether as a preemptive or salvage approach, post-HCT is less clear in myelofibrosis than other diseases. Kroger et al.²¹⁴ initially reported the use of both salvage and preemptive DLI (triggered by JAK2 V617F persistence on sequential monitoring) in 17 patients, with a median time from transplant to relapse of 269 days (127 to 1,570). DLI was used preemptively in 8 patients and as salvage in 9. Grade II–IV GVHD occurred in 3 patients (18%) in the salvage cohort. Encouragingly, the overall complete molecular response rate was 68% (100% in the preemptive group versus 44% in the salvage group), confirming the efficacy of this approach.

Little evidence is available to help delineate the role of post-HCT chemotherapy or second HCT in relapsed-myelofibrosis. A recent retrospective study reported on the use of DLI +/- second HCT for relapsed patients (morphologic relapse [n = 24] and molecular relapse [n = 6]). A total of 17 patients underwent a second RIC HCT at a median time of 17 months (11 to 77) post-initial transplant. Outcome data was encouraging; a total of 16 engrafted and responses identified in 12 evaluable patients, demonstrating the feasibility of a second HCT in this group.²¹⁵ However, the toxicity of a second HCT should not be underestimated, particularly given the median age of this patient population.

Hematopoietic Stem Cell Transplantation in HIV patients

Before the highly active antiretroviral therapy (HAART) was available, initial attempts to treat HIV-infected patients with allo-HCT led to extremely poor outcomes.²¹⁶ After HAART became widely available, several case reports suggested a potential benefit of HCT in this patient population. HCT in patients with malignancy and HIV infection has particular challenges, including the risk of opportunistic infection before and after transplantation, the high frequency of other concomitant viral infections, the potential impact of HIV in bone marrow environment and immune reconstitution post-transplant, and the potential for complex interactions between HAART, high-dose therapy, and immunosuppressive agents.

The CIBMTR retrospectively evaluated the results of allo-HCT in 23 HIV-infected patients undergoing transplant between 1987 and 2003, including patients receiving transplantation prior to the advent of HAART.²¹⁷ The indications for transplant included primarily malignant conditions, with lymphoma being the most common, followed by acute leukemia. With a median follow-up of 6 months, 30% of the patients were alive at 2 years; the primary causes of death were organ toxicity and infection. Despite initial mortality due to organ damage and infection, several patients achieved long-lasting remission. The BMT-CTN is conducting a prospective multicenter trial (BMT-CTN 0903; clinicaltrials.gov NCT01410344), enrolling patients with HIV infection and malignancy or bone marrow failure to assess the day-100 mortality after allo-HHCT. This trial will also study OS, PFS, and the impact of HCT on HIV reservoirs.

P.2205

Summary

The challenge to the transplant community is to make transplantation safer and to decrease the incidence and morbidity of GVHD without compromising the GVT effect. This dream will be realized as our understanding of transplant immunology increases. The role of HCT in the diseases discussed in this chapter will continue to evolve as transplantation becomes safer. On the other hand, advances in non-transplant genomic-driven targeted therapy, and advances in response assessment using minimal residual disease will continue to shape the future of HCT in hematologic malignancies. The use of targeted therapy post-HCT is inevitable. The impact of these agents on immunologic parameters will need to be assessed. Both transplant and non-transplant specialists will need to collaborate in an integrated team approach to advance this field and improve patient outcomes.

REFERENCES

1. Thomas ED. A history of bone marrow transplantation. In: Appelbaum FR, Forman SJ, Negrin RS, Blume KG, eds. *Thomas' hematopoietic cell transplantation*. West Sussex, UK: Wiley-Blackwell 2009:3-7.
2. Pasquini MC, Wang Z. Current use and outcome of hematopoietic stem cell transplantation: CIBMTR Summary Slides, 2010 at: <http://www.cibmtr.org>; <http://www.cibmtr.org> Accessed September 4, 2011.
3. Gooley TA, Chien JW, Pergam SA, et al. Reduced mortality after allogeneic hematopoietic-cell transplantation. *N Engl J Med* 2010;363:2091-2101.
4. Ringden O, Sadeghi B. Is graft-versus-leukemia more effective using reduced-intensity conditioning compared with myeloablative conditioning? *Biol Blood Marrow Transplant* 2012;18:1615-1617.

5. Porter DL. Allogeneic immunotherapy to optimize the graft-versus-tumor effect: concepts and controversies. *Hematology Am Soc Hematol Educ Program* 2011;2011:292-298.
6. Barrett AJ, Savani BN. Stem cell transplantation with reduced-intensity conditioning regimens: a review of 10 years experience with new transplant concepts and new therapeutic agents. *Leukemia* 2006;20:1661-1672.
7. Bacigalupo A, Ballen K, Rizzo D, et al. Defining the intensity of conditioning regimens: working definitions. *Biol Blood Marrow Transplant* 2009;15:1628-1633.
8. Roboz GJ. Novel approaches to the treatment of acute myeloid leukemia. *Hematology Am Soc Hematol Educ Program* 2011;2011:43-50.
9. Paun O, Lazarus HM. Allogeneic hematopoietic cell transplantation for acute myeloid leukemia in first complete remission: have the indications changed? *Curr Opin Hematol* 2012;19:95-101.
10. Ofran Y, Rowe JM. Treatment for relapsed acute myeloid leukemia: what is new? *Curr Opin Hematol* 2012;19:89-94.
11. Krug U, Buchner T, Berdel WE, Muller-Tidow C. The treatment of elderly patients with acute myeloid leukemia. *Dtsch Arztebl Int* 2011;108:863-870.
12. Savani BN. Transplantation in AML CR1. *Blood* 2010;116:1822-1823.
13. Rowe JM, Tallman MS. How I treat acute myeloid leukemia. *Blood* 2010;116:3147-3156.
14. Koreth J, Schlenk R, Kopecky KJ, et al. Allogeneic stem cell transplantation for acute myeloid leukemia in first complete remission: systematic review and meta-analysis of prospective clinical trials. *JAMA* 2009;301:2349-2361.
15. Paschka P, Schlenk RF, Gaidzik VI, et al. IDH1 and IDH2 mutations are frequent genetic alterations in acute myeloid leukemia and confer adverse prognosis in cytogenetically normal acute myeloid leukemia with NPM1 mutation without FLT3 internal tandem duplication. *J Clin Oncol* 2010;28:3636-3643.
16. Lee SJ, Klein J, Haagenson M, et al. High-resolution donor-recipient HLA matching contributes to the success of unrelated donor marrow transplantation. *Blood* 2007;110:4576-4583.
17. Horan JT, Logan BR, Agovi-Johnson MA, et al. Reducing the risk for transplantation-related mortality after allogeneic hematopoietic cell transplantation: how much progress has been made? *J Clin Oncol* 2011;29:805-813.
18. Gupta V, Tallman MS, He W, et al. Comparable survival after HLA-wellmatched unrelated or matched sibling donor transplantation for acute myeloid leukemia in first remission with unfavorable cytogenetics at diagnosis. *Blood* 2010;116:1839-1848.
19. Eapen M, Wagner JE. Transplant outcomes in acute leukemia. *I Semin Hematol* 2010;47:46-50.
20. Eapen M, Rocha V, Sanz G, et al. Effect of graft source on unrelated donor haemopoietic stem-cell transplantation in adults with acute leukaemia: a retrospective analysis. *Lancet Oncol* 2010;11:653-660.
21. Walter RB, Pagel JM, Gooley TA, et al. Comparison of matched unrelated and matched related donor myeloablative hematopoietic cell transplantation for adults with acute myeloid leukemia in first remission. *Leukemia* 2010;24:1276-1282.
22. Laughlin MJ, Eapen M, Rubinstein P, et al. Outcomes after transplantation of cord blood or bone marrow from unrelated donors in adults with leukemia. *N Engl J Med* 2004;351:2265-2275.
23. Savani BN, Mielke S, Reddy N, et al. Management of relapse after allo-SCT for AML and the role of second transplantation. *Bone Marrow Transplant* 2009;44:769-777.
24. Walter RB, Gooley TA, Wood BL, et al. Impact of pre-transplantation minimal residual disease, as detected by multiparametric flow cytometry, on outcome of myeloablative hematopoietic cell transplantation for acute myeloid leukemia. *J Clin Oncol* 2011;29:1190-1197.
25. Ofran Y, Rowe JM. Induction and post-remission strategies in acute myeloid leukemia: what is new? *Curr Opin Hematol* 2011;18:83-88.
26. Vellenga E, van PW, Ossenkoppele GJ, et al. Autologous peripheral blood stem cell transplantation for acute myeloid leukemia. *Blood* 2011;118:6037-6042.
27. Luger SM, Ringden O, Zhang MJ, et al. Similar outcomes using myeloablative vs reduced-intensity allogeneic transplant preparative regimens for AML or MDS. *Bone Marrow Transplant* 2012;47:203-211.

28. Khabori MA, El-Emary M, Xu W, et al. Impact of intensity of conditioning therapy in patients aged 40 to 60 years with AML/myelodysplastic syndrome undergoing allogeneic transplantation. *Bone Marrow Transplant* 2011;46:516-522.
29. Ringden O, Labopin M, Ehninger G, et al. Reduced intensity conditioning compared with myeloablative conditioning using unrelated donor transplants in patients with acute myeloid leukemia. *J Clin Oncol* 2009;27:4570-4577.
30. McClune BL, Weisdorf DJ, Pedersen TL, et al. Effect of age on outcome of reduced-intensity hematopoietic cell transplantation for older patients with acute myeloid leukemia in first complete remission or with myelodysplastic syndrome. *J Clin Oncol* 2010;28:1878-1887.
31. Martino R, Caballero MD, Simon JA, et al. Evidence for a graft-versus-leukemia effect after allogeneic peripheral blood stem cell transplantation with reduced-intensity conditioning in acute myelogenous leukemia and myelodysplastic syndromes. *Blood* 2002;100:2243-2245.
32. Martino R, Valcarcel D, Brunet S, Sureda A, Sierra J. Comparable non-relapse mortality and survival after HLA-identical sibling blood stem cell transplantation with reduced or conventional-intensity preparative regimens for high-risk myelodysplasia or acute myeloid leukemia in first remission. *Bone Marrow Transplant* 2008;41:33-38.
33. Fung HC, Stein A, Slovak M, et al. A long-term follow-up report on allogeneic stem cell transplantation for patients with primary refractory acute myelogenous leukemia: impact of cytogenetic characteristics on transplantation outcome. *Biol Blood Marrow Transplant* 2003;9:766-771.
34. Duval M, Klein JP, He W, et al. Hematopoietic stem-cell transplantation for acute leukemia in relapse or primary induction failure. *J Clin Oncol* 2010;28:3730-3738.
35. Chevallier P, Labopin M, Turlure P, et al. A new leukemia prognostic scoring system for refractory/relapsed adult acute myelogenous leukaemia patients: a GOELAMS study. *Leukemia* 2011;25:939-944.
36. Schmid C, Schleuning M, Schwerdtfeger R, et al. Long-term survival in refractory acute myeloid leukemia after sequential treatment with chemotherapy and reduced-intensity conditioning for allogeneic stem cell transplantation. *Blood* 2006;108:1092-1099.
37. Oran B, Popat U, Rondon G, et al. Significance of persistent cytogenetic abnormalities on myeloablative allogeneic stem cell transplantation in first complete remission. *Biol Blood Marrow Transplant* 2013;19:214-220.
38. Chen Y, Cortes J, Estrov Z, et al. Persistence of cytogenetic abnormalities at complete remission after induction in patients with acute myeloid leukemia: prognostic significance and the potential role of allogeneic stem-cell transplantation. *J Clin Oncol* 2011;29:2507-2513.
39. Bacher U, Talano JA, Bishop MR. Monitoring and prevention of relapse after allogeneic hematopoietic cell transplantation for myeloid malignancies. *Biol Blood Marrow Transplant* 2012;18:S62-S73.
40. Bacher U, Zander AR, Haferlach T, et al. Minimal residual disease diagnostics in myeloid malignancies in the post transplant period. *Bone Marrow Transplant* 2008;42:145-157.
41. Platzbecker U, Wermke M, Radke J, et al. Azacitidine for treatment of imminent relapse in MDS or AML patients after allogeneic HSCT: results of the RELAZA trial. *Leukemia* 2012;26:381-389.
42. Czibere A, Bruns I, Kroger N, et al. 5-Azacytidine for the treatment of patients with acute myeloid leukemia or myelodysplastic syndrome who relapse after allo-SCT: a retrospective analysis. *Bone Marrow Transplant* 2010;45:872-876.
43. Kroger N, Bacher U, Bader P, et al. NCI first international workshop on the biology, prevention, and treatment of relapse after allogeneic hematopoietic stem cell transplantation: report from the committee on disease-specific methods and strategies for monitoring relapse following allogeneic stem cell transplantation. Part II: chronic leukemias, myeloproliferative neoplasms, and lymphoid malignancies. *Biol Blood Marrow Transplant* 2010;16: 1325-1346.
44. Bacher U, Badbaran A, Fehse B, et al. Quantitative monitoring of NPM1 mutations provides a valid minimal residual disease parameter following allogeneic stem cell transplantation. *Exp Hematol* 2009;37:135-142.
45. Schnittger S, Kern W, Tschulik C, et al. Minimal residual disease levels assessed by NPM1 mutation-specific RQ-PCR provide important prognostic information in AML. *Blood* 2009;114:2220-2231.
46. Kebriaei P, Kline J, Stock W, et al. Impact of disease burden at time of allogeneic stem cell transplantation in adults with acute myeloid leukemia and myelodysplastic syndromes. *Bone Marrow Transplant* 2005;35:965-970.

47. Candoni A, Toffoletti E, Gallina R, et al. Monitoring of minimal residual disease by quantitative WT1 gene expression following reduced intensity conditioning allogeneic stem cell transplantation in acute myeloid leukemia. *Clin Transplant* 2011;25:308-316.
48. Farag SS, Wood LL, Schwartz JE, et al. Phase I trial and pharmacokinetic study of high-dose clofarabine and busulfan and allogeneic stem cell transplantation in adults with high-risk and refractory acute leukemia. *Leukemia* 2011;25:599-605.
49. Geyer MB, Ricci AM, Harrison L, et al. Dose escalation of clofarabine in combination with cytarabine and total body irradiation (TBI) followed by allogeneic stem cell transplantation (alloSCT) in children, adolescents and young adults (CAYA) with poor-risk acute leukemia. *ASH Annu Meeting Abstr* 2010;116:36.
50. Andersson BS, Valdez BC, de LM, et al. Clofarabine +/- fludarabine with once daily IV busulfan as pre-transplant conditioning therapy for advanced myeloid leukemia and MDS. *Biol Blood Marrow Transplant* 2011;17:893-900.
51. Rezvani K. Post-transplantation vaccination: concepts today and on the horizon. *Hematology Am Soc Hematol Educ Program* 2011;2011:299-304.
52. Barrett AJ, Le Blanc K. Immunotherapy prospects for acute myeloid leukemia. *Clin Exp Immunol* 2010.
53. de LM, Giralt S, Thall PF, et al. Maintenance therapy with low-dose azacitidine after allogeneic hematopoietic stem cell transplantation for recurrent acute myelogenous leukemia or myelodysplastic syndrome: a dose and schedule finding study. *Cancer* 2010;116:5420-5431.
54. Bishop MR, Alyea EP, III, Cairo MS, et al. National Cancer Institute's first international workshop on the biology, prevention, and treatment of relapse after allogeneic hematopoietic stem cell transplantation: summary and recommendations from the organizing committee. *Biol Blood Marrow Transplant* 2011;17:443-454.
55. Levis M. FLT3/ITD AML and the law of unintended consequences. *Blood* 2011;117:6987-6990.
56. Parmar S, de LM, Deeg HJ, Champlin R. Hematopoietic stem cell transplantation for myelodysplastic syndrome: a review. *Semin Oncol* 2011;38:693-704.
57. Stone RM. How I treat patients with myelodysplastic syndromes. *Blood* 2009;113:6296-6303.
58. Deeg HJ, Bartenstein M. Allogeneic hematopoietic cell transplantation for myelodysplastic syndrome: current status. *Arch Immunol Ther Exp (Warsz)* 2012;60:31-41.
59. Lyons RM. Myelodysplastic syndromes: therapy and outlook. *Am J Med* 2012;125:S18-S23.
60. Kroger N. Allogeneic stem cell transplantation for elderly patients with myelodysplastic syndrome. *Blood* 2012;119:5632-5639.
61. Kuendgen A, Strupp C, Aivado M, et al. Myelodysplastic syndromes in patients younger than age 50. *J Clin Oncol* 2006;24:5358-5365.
62. Greenberg PL, Attar E, Bennett JM, et al. NCCN Clinical Practice Guidelines in Oncology: myelodysplastic syndromes. *J Natl Compr Canc Netw* 2011;9: 30-56.
63. Cutler CS, Lee SJ, Greenberg P, et al. A decision analysis of allogeneic bone marrow transplantation for the myelodysplastic syndromes: delayed transplantation for low-risk myelodysplasia is associated with improved outcome. *Blood* 2004;104:579-585.
64. Onida F, Brand R, van Biezen A, et al. Impact of cytogenetics on outcome of patients with MDS or secondary AML undergoing allogeneic HSCT from HLA-identical siblings: a retrospective analysis of the EBMT-CLWP. *ASH Annu Meeting Abstr* 2006;108:2653.
65. Yokoyama H, Mori S, Kobayashi Y, et al. Hematopoietic stem cell transplantation for therapy-related myelodysplastic syndrome and acute leukemia: a single-center analysis of 47 patients. *Int J Hematol* 2010;92:334-341.
66. Newell LF, Gooley T, Hansen JA, et al. Tumor necrosis factor polymorphism affects transplantation outcome in patients with myelodysplastic syndrome but not in those with chronic myelogenous leukemia, independent of the presence of HLA-DR15. *Biol Blood Marrow Transplant* 2010;16:1700-1706.
67. Al-Ali HK, Brand R, van BA, et al. A retrospective comparison of autologous and unrelated donor hematopoietic cell transplantation in myelodysplastic syndrome and secondary acute myeloid leukemia: a report on behalf of the Chronic

- Leukemia Working Party of the European Group for Blood and Marrow Transplantation (EBMT). *Leukemia* 2007;21:1945-1951.
68. Gerds AT, Deeg HJ. Transplantation for myelodysplastic syndrome in the era of hypomethylating agents. *Curr Opin Hematol* 2012;19:71-75.
69. Diez-Campelo M, Perez-Simon JA, Perez J, et al. Minimal residual disease monitoring after allogeneic transplantation may help to individualize post-transplant therapeutic strategies in acute myeloid malignancies. *Am J Hematol* 2009;84:149-152.
70. Scott BL, Wells DA, Loken MR, et al. Validation of a flow cytometric scoring system as a prognostic indicator for posttransplantation outcome in patients with myelodysplastic syndrome. *Blood* 2008;112:2681-2686.
71. Malcovati L, Porta MG, Pascutto C, et al. Prognostic factors and life expectancy in myelodysplastic syndromes classified according to WHO criteria: a basis for clinical decision making. *J Clin Oncol* 2005;23:7594-7603.
72. Alessandrino EP, Della Porta MG, Bacigalupo A, et al. WHO classification and WPSS predict posttransplantation outcome in patients with myelodysplastic syndrome: a study from the Gruppo Italiano Trapianto di Midollo Osseo (GITMO). *Blood* 2008;112:895-902.
73. Alessandrino EP, Della Porta MG, Bacigalupo A, et al. Prognostic impact of pre-transplantation transfusion history and secondary iron overload in patients with myelodysplastic syndrome undergoing allogeneic stem cell transplantation: a GITMO study. *Haematologica* 2010;95:476-484.
74. Sorrow ML. Comorbidities and outcomes: advancing the field comes at a price. *Biol Blood Marrow Transplant* 2011;17:1721-1723.
75. Yakoub-Agha I, de La SP, Ribaud P, et al. Allogeneic bone marrow transplantation for therapy-related myelodysplastic syndrome and acute myeloid leukemia: a long-term study of 70 patients—report of the French Society of Bone Marrow Transplantation. *J Clin Oncol* 2000;18:963-971.
76. Warlick ED, Cioc A, DeFor T, Dolan M, Weisdorf D. Allogeneic stem cell transplantation for adults with myelodysplastic syndromes: importance of pre-transplant disease burden. *Biol Blood Marrow Transplant* 2009;15:30-38.
77. Castro-Malaspina H, Jabubowski AA, Papadopoulos EB, et al. Transplantation in remission improves the disease-free survival of patients with advanced myelodysplastic syndromes treated with myeloablative T cell-depleted stem cell transplants from HLA-identical siblings. *Biol Blood Marrow Transplant* 2008;14:458-468.
78. Oran B, Giral S, Saliba R, et al. Allogeneic hematopoietic stem cell transplantation for the treatment of high-risk acute myelogenous leukemia and myelodysplastic syndrome using reduced-intensity conditioning with fluda-rabine and melphalan. *Biol Blood Marrow Transplant* 2007;13:454-462.
79. Nakai K, Kanda Y, Fukuhara S, et al. Value of chemotherapy before allogeneic hematopoietic stem cell transplantation from an HLA-identical sibling donor for myelodysplastic syndrome. *Leukemia* 2005;19:396-401.
80. Scott BL, Storer B, Loken MR, et al. Pre-transplantation induction chemotherapy and post-transplantation relapse in patients with advanced myelodysplastic syndrome. *Biol Blood Marrow Transplant* 2005;11:65-73.
81. de WT, Brand R, van BA, et al. Allogeneic stem cell transplantation for patients with refractory anaemia with matched related and unrelated donors: delay of the transplant is associated with inferior survival. *Br J Haematol* 2009;146:627-636.
82. Litzow MR, Tarima S, Perez WS, et al. Allogeneic transplantation for therapy-related myelodysplastic syndrome and acute myeloid leukemia. *Blood* 2010;115:1850-1857.
83. Martino R, Iacobelli S, Brand R, et al. Retrospective comparison of reduced-intensity conditioning and conventional high-dose conditioning for allogeneic hematopoietic stem cell transplantation using HLA-identical sibling donors in myelodysplastic syndromes. *Blood* 2006;108:836-846.
84. Lim ZY, Ho AY, Ingram W, et al. Outcomes of alemtuzumab-based reduced intensity conditioning stem cell transplantation using unrelated donors for myelodysplastic syndromes. *Br J Haematol* 2006;135:201-209.
85. Field T, Perkins J, Huang Y, et al. 5-Azacididine for myelodysplasia before allogeneic hematopoietic cell transplantation. *Bone Marrow Transplant* 2010;45:255-260.
86. de Padua SL, de LM, Kantarjian H, et al. Feasibility of allo-SCT after hypomethylating therapy with decitabine for myelodysplastic syndrome. *Bone Marrow Transplant* 2009;43:839-843.

87. Lubbert M, Bertz H, Ruter B, et al. Non-intensive treatment with low-dose 5-aza-2'-deoxycytidine (DAC) prior to allogeneic blood SCT of older MDS/AML patients. *Bone Marrow Transplant* 2009;44:585-588.
88. Gerds AT, Gooley TA, Estey EH, et al. Pre-transplantation therapy with azacitidine vs induction chemotherapy and post-transplantation outcome in patients with MDS. *Biol Blood Marrow Transplant* 2012;18:1211-1218.
89. Choi J, Ritchey J, Prior JL, et al. In vivo administration of hypomethylating agents mitigate graft-versus-host disease without sacrificing graft-versus-leukemia. *Blood* 2010;116:129-139.
90. Kolb HJ, Schmid C, Tischer J, et al. Allogeneic stem cell transplantation for MDS and SAML following reduced intensity conditioning and preemptive donor lymphocyte transfusion. *ASH Annu Meeting Abstr* 2006;108:324.
91. Shaw BE, Mufti GJ, Mackinnon S, et al. Outcome of second allogeneic transplants using reduced-intensity conditioning following relapse of haematological malignancy after an initial allogeneic transplant. *Bone Marrow Transplant* 2008;42:783-789.
92. Khaled SK, Thomas SH, Forman SJ. Allogeneic hematopoietic cell transplantation for acute lymphoblastic leukemia in adults. *Curr Opin Oncol* 2012;24:182-190.
93. Kebriaei P, Poon LM. The role of allogeneic hematopoietic stem cell transplantation in the therapy of patients with acute lymphoblastic leukemia. *Curr Hematol Malig Rep* 2012;7:144-152.
94. Nishiwaki S, Miyamura K. Allogeneic stem cell transplant for adult Philadelphia chromosome-negative acute lymphoblastic leukemia. *Leuk Lymphoma* 2012;53:550-556.
95. Moorman AV, Harrison CJ, Buck GA, et al. Karyotype is an independent prognostic factor in Adult acute Lymphoblastic Leukemia (ALL): analysis of cytogenetic data from patients treated on the Medical Research Council (MRC) UKALLXII/Eastern Cooperative Oncology Group (ECOG) 2993 trial. *Blood* 2007;109:3189-3197.
96. Gokbuget N, Hoelzer D. Treatment of adult acute lymphoblastic leukemia. *Hematol Am Soc Hematol Educ Program* 2006:133-141.
97. Thomas X, Boiron JM, Huguot F, et al. Outcome of treatment in adults with acute lymphoblastic leukemia: analysis of the LALA-94 trial. *J Clin Oncol* 2004;22:4075-4086.
98. Bruggemann M, Gokbuget N, Kneba M. Acute lymphoblastic leukemia: monitoring minimal residual disease as a therapeutic principle. *Semin Oncol* 2012;39:47-57.
99. Goldstone AH, Richards SM, Lazarus HM, et al. In adults with standard-risk acute lymphoblastic leukemia, the greatest benefit is achieved from a matched sibling allogeneic transplantation in first complete remission, and an autologous transplantation is less effective than conventional consolidation/maintenance chemotherapy in all patients: final results of the International ALL Trial (MRC UKALL XII/ECOG E2993). *Blood* 2008;111:1827-1833.
100. Fielding AK, Goldstone AH. Allogeneic haematopoietic stem cell transplant in Philadelphia-positive acute lymphoblastic leukaemia. *Bone Marrow Transplant* 2008;41:447-453.
101. Wetzler M, Dodge RK, Mrozek K, et al. Prospective karyotype analysis in adult acute lymphoblastic leukemia: the Cancer and Leukemia Group B experience. *Blood* 1999;93:3983-3993.
102. Fielding AK, Buck G, Lazarus HM, et al. Imatinib significantly enhances long-term outcomes in Philadelphia positive acute lymphoblastic leukaemia; final results of the UKALLXII/ECOG2993 Trial. *ASH Annu Meeting Abstr* 2010;116:169.
103. Fielding AK. Current treatment of Philadelphia chromosome-positive acute lymphoblastic leukemia. *Hematol Am Soc Hematol Educ Program* 2011;2011:231-237.
104. Pfeifer H, Goekbuget N, Volp C, et al. Long-term outcome of 335 adult patients receiving different schedules of imatinib and chemotherapy as front-line treatment for Philadelphia-positive acute lymphoblastic leukemia (Ph+ ALL). *ASH Annu Meeting Abstr* 2010;116:173.
105. Mizuta S, Matsuo K, Yagasaki F, et al. Pre-transplant imatinib-based therapy improves the outcome of allogeneic hematopoietic stem cell transplantation for BCR-ABL-positive acute lymphoblastic leukemia. *Leukemia* 2011;25:41-47.
106. Ram R, Storb R, Sandmaier BM, et al. Non-myeloablative conditioning with allogeneic hematopoietic cell transplantation for the treatment of high-risk acute lymphoblastic leukemia. *Haematologica* 2011;96:1113-1120.

107. Mohty M, Labopin M, Volin L, et al. Reduced-intensity versus conventional myeloablative conditioning allogeneic stem cell transplantation for patients with acute lymphoblastic leukemia: a retrospective study from the European Group for Blood and Marrow Transplantation. *Blood* 2010;116:4439-4443.
108. Luznik L, O'Donnell PV, Symons HJ, et al. HLA-haploidentical bone marrow transplantation for hematologic malignancies using nonmyeloablative conditioning and high-dose, post-transplantation cyclophosphamide. *Biol Blood Marrow Transplant* 2008;14:641-650.
109. Onishi Y, Sasaki O, Ichikawa S, et al. Favorable outcome of unrelated cord blood transplantation for Philadelphia chromosome-positive acute lymphoblastic leukemia. *Biol Blood Marrow Transplant* 2011;17:1093-1097.
110. Mead AJ, Thomson KJ, Morris EC, et al. HLA-mismatched unrelated donors are a viable alternate graft source for allogeneic transplantation following alemtuzumab-based reduced-intensity conditioning. *Blood* 2010;115: 5147-5153.
111. Ribera JM, Oriol A, Gonzalez M, et al. Concurrent intensive chemotherapy and imatinib before and after stem cell transplantation in newly diagnosed Philadelphia chromosome-positive acute lymphoblastic leukemia. Final results of the CSTIBES02 trial. *Haematologica* 2010;95:87-95.
112. Burke MJ, Trotz B, Luo X, et al. Allo-hematopoietic cell transplantation for Ph chromosome-positive ALL: impact of imatinib on relapse and survival. *Bone Marrow Transplant* 2009;43:107-113.
113. Sebban C, Lepage E, Vernant JP, et al. Allogeneic bone marrow transplantation in adult acute lymphoblastic leukemia in first complete remission: a comparative study. French Group of Therapy of Adult Acute Lymphoblastic Leukemia. *J Clin Oncol* 1994;12:2580-2587.
114. Cornelissen JJ, van der Holt B, Verhoef GE, et al. Myeloablative allogeneic versus autologous stem cell transplantation in adult patients with acute lymphoblastic leukemia in first remission: a prospective sibling donor versus no-donor comparison. *Blood* 2009;113:1375-1382.
115. Ram R, Gafter-Gvili A, Vidal L, et al. Management of adult patients with acute lymphoblastic leukemia in first complete remission: systematic review and meta-analysis. *Cancer* 2010;116:3447-3457.
116. Pidala J, Djulbegovic B, Anasetti C, Kharfan-Dabaja M, Kumar A. Allogeneic hematopoietic cell transplantation for adult acute lymphoblastic leukemia (ALL) in first complete remission. *Cochrane Database Syst Rev* 2011 Oct 5;(10):CD008818.
117. Oriol A, Vives S, Hernandez-Rivas JM, et al. Outcome after relapse of acute lymphoblastic leukemia in adult patients included in four consecutive risk-adapted trials by the PETHEMA study group. *Haematologica* 2010;95:589-596.
118. Tavernier E, Boiron JM, Huguet F, et al. Outcome of treatment after first relapse in adults with acute lymphoblastic leukemia initially treated by the LALA-94 trial. *Leukemia* 2007;21:1907-1914.
119. Marks DI, Wang T, Perez WS, et al. The outcome of full-intensity and reduced-intensity conditioning matched sibling or unrelated donor transplantation in adults with Philadelphia chromosome-negative acute lymphoblastic leukemia in first and second complete remission. *Blood* 2010;116:366-374.
120. Terwey TH, Massenkeil G, Tamm I, et al. Allogeneic SCT in refractory or relapsed adult ALL is effective without prior reinduction chemotherapy. *Bone Marrow Transplant* 2008;42:791-798.
121. Venepalli N, Rezvani K, Mielke S, Savani BN. Role of allo-SCT for CML in 2010. *Bone Marrow Transplant* 2010;45:1579-1586.
122. Oliansky DM, Larson RA, Weisdorf D, et al. The role of cytotoxic therapy with hematopoietic stem cell transplantation in the treatment of adult acute lymphoblastic leukemia: update of the 2006 evidence-based review. *Biol Blood Marrow Transplant* 2012;18:18-36.
123. Mortimer J, Blinder MA, Schulman S, et al. Relapse of acute leukemia after marrow transplantation: natural history and results of subsequent therapy. *J Clin Oncol* 1989;7:50-57.
124. Eapen M, Giral SA, Horowitz MM, et al. Second transplant for acute and chronic leukemia relapsing after first HLA-identical sibling transplant. *Bone Marrow Transplant* 2004;34:721-727.
125. Radich JP, Sanders JE, Buckner CD, et al. Second allogeneic marrow transplantation for patients with recurrent leukemia after initial transplant with total-body irradiation-containing regimens. *J Clin Oncol* 1993;11:304-313.
126. Jantunen E, Sureda A. The evolving role of stem cell transplants in lymphomas. *Biol Blood Marrow Transplant* 2012;18:660-673.

127. Ayala E, Tomblyn M. Hematopoietic cell transplantation for lymphomas. *Cancer Control* 2011;18:246-257.
128. Ayala E. Hematopoietic cell transplantation for B-cell lymphoma: an update. *Cancer Control* 2012;19:175-186.
129. Armand P, Kim HT, Ho VT, et al. Allogeneic transplantation with reduced-intensity conditioning for Hodgkin and non-Hodgkin lymphoma: importance of histology for outcome. *Biol Blood Marrow Transplant* 2008;14:418-425.
130. Hari P, Carreras J, Zhang MJ, et al. Allogeneic transplants in follicular lymphoma: higher risk of disease progression after reduced-intensity compared to myeloablative conditioning. *Biol Blood Marrow Transplant* 2008;14:236-245.
131. Oliansky DM, Gordon LI, King J, et al. The role of cytotoxic therapy with hematopoietic stem cell transplantation in the treatment of follicular lymphoma: an evidence-based review. *Biol Blood Marrow Transplant* 2010;16:443-468.
132. Pinana JL, Martino R, Gayoso J, et al. Reduced intensity conditioning HLA identical sibling donor allogeneic stem cell transplantation for patients with follicular lymphoma: long-term follow-up from two prospective multicenter trials. *Haematologica* 2010;95:1176-1182.
133. Khouri IF, Saliba RM, Erwin WD, et al. Nonmyeloablative allogeneic transplantation with or without 90yttrium ibritumomab tiuxetan is potentially curative for relapsed follicular lymphoma: 12-year results. *Blood* 2012;119:6373-6378.
134. Khouri IF. Allogeneic stem cell transplantation in follicular lymphoma. *Best Pract Res Clin Haematol* 2011;24:271-277.
135. Shea T, Johnson J, Westervelt P, et al. Reduced-intensity allogeneic transplantation provides high event-free and overall survival in patients with advanced indolent B cell malignancies: CALGB 109901. *Biol Blood Marrow Transplant* 2011;17:1395-1403.
136. Cohen S, Kiss T, Lachance S, et al. Tandem autologous-allogeneic nonmyeloablative sibling transplantation in relapsed follicular lymphoma leads to impressive progression-free survival with minimal toxicity. *Biol Blood Marrow Transplant* 2012;18:951-957.
137. Branson K, Chopra R, Kottaridis PD, et al. Role of nonmyeloablative allogeneic stem-cell transplantation after failure of autologous transplantation in patients with lymphoproliferative malignancies. *J Clin Oncol* 2002;20:4022-4031.
138. Thomson KJ, Morris EC, Milligan D, et al. T-cell-depleted reduced-intensity transplantation followed by donor leukocyte infusions to promote graft-versus-lymphoma activity results in excellent long-term survival in patients with multiply relapsed follicular lymphoma. *J Clin Oncol* 2010;28:3695-3700.
139. Delgado J, Canals C, Attal M, et al. The role of in vivo T-cell depletion on reduced-intensity conditioning allogeneic stem cell transplantation from HLA-identical siblings in patients with follicular lymphoma. *Leukemia* 2011;25:551-555.
140. van Besien K. The evolving role of autologous and allogeneic stem cell transplantation in follicular lymphoma. *Blood Rev* 2006;20:235-244.
141. Wudhikarn K, Brunstein CG, Bachanova V, et al. Relapse of lymphoma after allogeneic hematopoietic cell transplantation: management strategies and outcome. *Biol Blood Marrow Transplant* 2011;17:1497-1504.
142. Russell NH, Byrne JL, Faulkner RD, et al. Donor lymphocyte infusions can result in sustained remissions in patients with residual or relapsed lymphoid malignancy following allogeneic haemopoietic stem cell transplantation. *Bone Marrow Transplant* 2005;36:437-441.
143. Toze CL, Shepherd JD, Connors JM, et al. Allogeneic bone marrow transplantation for low-grade lymphoma and chronic lymphocytic leukemia. *Bone Marrow Transplant* 2000;25:605-612.
144. Dreger P, Dohner H, Ritgen M, et al. Allogeneic stem cell transplantation provides durable disease control in poor-risk chronic lymphocytic leukemia: long-term clinical and MRD results of the German CLL Study Group CLL3X trial. *Blood* 2010;116:2438-2447.
145. Brown JR, Kim HT, Li S, et al. Predictors of improved progression-free survival after nonmyeloablative allogeneic stem cell transplantation for advanced chronic lymphocytic leukemia. *Biol Blood Marrow Transplant* 2006;12:1056-1064.
146. Khouri IF, Bassett R, Poindexter N, et al. Nonmyeloablative allogeneic stem cell transplantation in relapsed/refractory chronic lymphocytic leukemia: long-term follow-up, prognostic factors, and effect of human leukocyte histocompatibility antigen subtype on outcome. *Cancer* 2011;117:4679-4688.
147. Schetelig J, van BA, Brand R, et al. Allogeneic hematopoietic stem-cell transplantation for chronic lymphocytic leukemia with 17p deletion: a retrospective European Group for Blood and Marrow Transplantation analysis. *J Clin Oncol* 2008;26:5094-5100.

148. Michallet M, Tanguy ML, Socie G, et al. Second allogeneic haematopoietic stem cell transplantation in relapsed acute and chronic leukaemias for patients who underwent a first allogeneic bone marrow transplantation: a survey of the Societe Francaise de Greffe de Moelle (SFGM). *Br J Haematol* 2000;108:400-407.
149. Pavletic SZ, Khouri IF, Haagenson M, et al. Unrelated donor marrow transplantation for B-cell chronic lymphocytic leukemia after using myeloablative conditioning: results from the Center for International Blood and Marrow Transplant research. *J Clin Oncol* 2005;23:5788-5794.
150. Dreger P, Corradini P, Kimby E, et al. Indications for allogeneic stem cell transplantation in chronic lymphocytic leukemia: the EBMT transplant consensus. *Leukemia* 2007;21:12-17.
151. Dreger P. Allotransplantation for chronic lymphocytic leukemia. *ASH Educ Book* 2009;2012:593-601.
152. Hamadani M, Benson DM, Jr., Hofmeister CC, et al. Allogeneic stem cell transplantation for patients with relapsed chemorefractory aggressive non-Hodgkin lymphomas. *Biol Blood Marrow Transplant* 2009;15:547-553.
153. Hamadani M, Awan FT, Elder P, et al. Feasibility of allogeneic hematopoietic stem cell transplantation for follicular lymphoma undergoing transformation to diffuse large B-cell lymphoma. *Leuk Lymphoma* 2008;49:1893-1898.
154. Gopal AK, Pagel JM, Rajendran JG, et al. Improving the efficacy of reduced intensity allogeneic transplantation for lymphoma using radioimmunotherapy. *Biol Blood Marrow Transplant* 2006;12:697-702.
155. Reddy N, Savani BN. Treatment options for transformed lymphoma: incorporating allogeneic stem cell transplantation in a multimodality approach. *Biol Blood Marrow Transplant* 2011;17:1265-1272.
156. Oliansky DM, Czuczman M, Fisher RI, et al. The role of cytotoxic therapy with hematopoietic stem cell transplantation in the treatment of diffuse large B cell lymphoma: update of the 2001 evidence-based review. *Biol Blood Marrow Transplant* 2011;17:20-47.
157. Lazarus HM, Zhang MJ, Carreras J, et al. A comparison of HLA-identical sibling allogeneic versus autologous transplantation for diffuse large B cell lymphoma: a report from the CIBMTR. *Biol Blood Marrow Transplant* 2010;16:35-45.
158. Sirvent A, Dhedin N, Michallet M, et al. Low nonrelapse mortality and prolonged long-term survival after reduced-intensity allogeneic stem cell transplantation for relapsed or refractory diffuse large B cell lymphoma: report of the Societe Francaise de Greffe de Moelle et de Therapie Cellulaire. *Biol Blood Marrow Transplant* 2010;16:78-85.
159. Bacher U, Klyuchnikov E, Le-Rademacher J, et al. Conditioning regimens for allotransplants for diffuse large B-cell lymphoma: myeloablative or reduced intensity? *Blood* 2012;120:4256-4262.
160. Rezvani AR, Norasetthada L, Gooley T, et al. Non-myeloablative allogeneic haematopoietic cell transplantation for relapsed diffuse large B-cell lymphoma: a multicentre experience. *Br J Haematol* 2008;143:395-403.
161. van Kampen RJ, Canals C, Schouten HC, et al. Allogeneic stem-cell transplantation as salvage therapy for patients with diffuse large B-cell non-Hodgkin's lymphoma relapsing after an autologous stem-cell transplantation: an analysis of the European Group for Blood and Marrow Transplantation Registry. *J Clin Oncol* 2011;29:1342-1348.
162. Reddy N, Greer JP, Goodman S, et al. Consolidative therapy with stem cell transplantation improves survival of patients with mantle cell lymphoma after any induction regimen. *Exp Hematol* 2012;40:359-366.
163. Tam CS, Bassett R, Ledesma C, et al. Mature results of the M. D. Anderson Cancer Center risk-adapted transplantation strategy in mantle cell lymphoma. *Blood* 2009;113:4144-4152.
164. Maris MB, Sandmaier BM, Storer BE, et al. Allogeneic hematopoietic cell transplantation after fludarabine and 2 Gy total body irradiation for relapsed and refractory mantle cell lymphoma. *Blood* 2004;104:3535-3542.
165. Cook G, Smith GM, Kirkland K, et al. Outcome following reduced-intensity allogeneic stem cell transplantation (RIC AlloSCT) for relapsed and refractory mantle cell lymphoma (MCL): a study of the British Society for Blood and Marrow Transplantation. *Biol Blood Marrow Transplant* 2010;16:1419-1427.
166. Le GS, Kroger N, Dhedin N, et al. Reduced-intensity conditioning allogeneic stem cell transplantation for relapsed/refractory mantle cell lymphoma: a multicenter experience. *Ann Oncol* 2012;23:2695-2703.
167. Le GS, Mohty M, Guillaume T, Gastinne T, Moreau P. Allogeneic stem cell transplantation in mantle cell lymphoma: where are we now and which way should we go? *Semin Hematol* 2011;48:227-239.

168. Cassaday RD, Gopal AK. Allogeneic hematopoietic cell transplantation in mantle cell lymphoma. *Best Pract Res Clin Haematol* 2012;25:165-174.
169. Schlaak M, Theurich S, Pickenhain J, et al. Allogeneic stem cell transplantation for advanced primary cutaneous T-cell lymphoma: a systematic review. *Crit Rev Oncol Hematol* 2013;85:21-31.
170. Le GS, Milpied N, Buzyn A, et al. Graft-versus-lymphoma effect for aggressive T-cell lymphomas in adults: a study by the Societe Francaise de Greffe de Moelle et de Therapie Cellulaire. *J Clin Oncol* 2008;26:2264-2271.
171. Corradini P, Dodero A, Zallio F, et al. Graft-versus-lymphoma effect in relapsed peripheral T-cell non-Hodgkin's lymphomas after reduced-intensity conditioning followed by allogeneic transplantation of hematopoietic cells. *J Clin Oncol* 2004;22:2172-2176.
172. Shustov AR, Gooley TA, Sandmaier BM, et al. Allogeneic haematopoietic cell transplantation after nonmyeloablative conditioning in patients with T-cell and natural killer-cell lymphomas. *Br J Haematol* 2010;150:170-178.
173. Goldberg JD, Chou JF, Horwitz S, et al. Long-term survival in patients with peripheral T-cell non-Hodgkin lymphomas after allogeneic hematopoietic stem cell transplant. *Leuk Lymphoma* 2012;53:1124-1129.
174. Duarte RF, Canals C, Onida F, et al. Allogeneic hematopoietic cell transplantation for patients with mycosis fungoides and Sezary syndrome: a retrospective analysis of the Lymphoma Working Party of the European Group for Blood and Marrow Transplantation. *J Clin Oncol* 2010;28:4492-4499.
175. Dodero A, Spina F, Narni F, et al. Allogeneic transplantation following a reduced-intensity conditioning regimen in relapsed/refractory peripheral T-cell lymphomas: long-term remissions and response to donor lymphocyte infusions support the role of a graft-versus-lymphoma effect. *Leukemia* 2012;26:520-526.
176. Wu PA, Kim YH, Lavori PW, Hoppe RT, Stockerl-Goldstein KE. A meta-analysis of patients receiving allogeneic or autologous hematopoietic stem cell transplant in mycosis fungoides and Sezary syndrome. *Biol Blood Marrow Transplant* 2009;15:982-990.
177. Schmitz N, Pfistner B, Sextro M, et al. Aggressive conventional chemotherapy compared with high-dose chemotherapy with autologous haemopoietic stem-cell transplantation for relapsed chemosensitive Hodgkin's disease: a randomised trial. *Lancet* 2002;359:2065-2071.
178. Gajewski JL, Phillips GL, Sobocinski KA, et al. Bone marrow transplants from HLA-identical siblings in advanced Hodgkin's disease. *J Clin Oncol* 1996;14:572-578.
179. Sureda A, Robinson S, Canals C, et al. Reduced-intensity conditioning compared with conventional allogeneic stem-cell transplantation in relapsed or refractory Hodgkin's lymphoma: an analysis from the lymphoma working party of the European Group for Blood and Marrow Transplantation. *J Clin Oncol* 2008;26:455-462.
180. Robinson SP, Sureda A, Canals C, et al. Reduced intensity conditioning allogeneic stem cell transplantation for Hodgkin's lymphoma: identification of prognostic factors predicting outcome. *Haematologica* 2009;94:230-238.
181. Sarina B, Castagna L, Farina L, et al. Allogeneic transplantation improves the overall and progression-free survival of Hodgkin lymphoma patients relapsing after autologous transplantation: a retrospective study based on the time of HLA typing and donor availability. *Blood* 2010;115:3671-3677.
182. Burroughs LM, O'Donnell PV, Sandmaier BM, et al. Comparison of outcomes of HLA-matched related, unrelated, or HLA-haploidentical related hematopoietic cell transplantation following nonmyeloablative conditioning for relapsed or refractory Hodgkin lymphoma. *Biol Blood Marrow Transplant* 2008;14:1279-1287.
183. Peggs KS, Sureda A, Qian W, et al. Reduced-intensity conditioning for allogeneic haematopoietic stem cell transplantation in relapsed and refractory Hodgkin lymphoma: impact of alemtuzumab and donor lymphocyte infusions on long-term outcomes. *Br J Haematol* 2007;139:70-80.
184. Peggs KS, Hunter A, Chopra R, et al. Clinical evidence of a graft-versus-Hodgkin's-lymphoma effect after reduced-intensity allogeneic transplantation. *Lancet* 2005;365:1934-1941.
185. Holmberg L, Maloney DG. The role of autologous and allogeneic hematopoietic stem cell transplantation for Hodgkin lymphoma. *J Natl Compr Canc Netw* 2011;9:1060-1071.
186. Ram R, Gooley TA, Maloney DG, et al. Histology and time to progression predict survival for lymphoma recurring after reduced-intensity conditioning and allogeneic hematopoietic cell transplantation. *Biol Blood Marrow Transplant* 2011;17:1537-1545.

187. Gopal AK, Ramchandren R, O'Connor OA, et al. Safety and efficacy of brentuximab vedotin for Hodgkin lymphoma recurring after allogeneic stem cell transplantation. *Blood* 2012;120:560-568.
188. McLornan DP, Mead AJ, Jackson G, Harrison CN. Allogeneic stem cell transplantation for myelofibrosis in 2012. *Br J Haematol* 2012;157:413-425.
189. Wardhana, Datau EA, Rotty LW, Haroen H. Allogenic hematopoietic stem cell as curative treatment in myelofibrosis. *Acta Med Indones* 2011;43:252-259.
190. Vannucchi AM. Management of myelofibrosis. *Hematology Am Soc Hematol Educ Program* 2011;2011:222-230.
191. Tefferi A. How I treat myelofibrosis. *Blood* 2011;117:3494-3504.
192. Deeg HJ, Appelbaum FR. Indications for and current results with allogeneic hematopoietic cell transplantation in patients with myelofibrosis. *Blood* 2011;117:7185.
193. Tefferi A. Allogeneic hematopoietic cell transplantation versus drugs in myelofibrosis: the risk-benefit balancing act. *Bone Marrow Transplant* 2010;45:419-421.
194. Abellsson J, Merup M, Birgegard G, et al. The outcome of allo-HSCT for 92 patients with myelofibrosis in the Nordic countries. *Bone Marrow Transplant* 2012;47:380-386.
195. Stewart WA, Pearce R, Kirkland KE, et al. The role of allogeneic SCT in primary myelofibrosis: a British Society for Blood and Marrow Transplantation study. *Bone Marrow Transplant* 2010;45:1587-1593.
196. Kroger N, Holler E, Kobbe G, et al. Allogeneic stem cell transplantation after reduced-intensity conditioning in patients with myelofibrosis: a prospective, multicenter study of the chronic leukemia working party of the European Group for Blood and Marrow Transplantation. *Blood* 2009;114: 5264-5270.
197. Ballen KK, Shrestha S, Sobocinski KA, et al. Outcome of transplantation for myelofibrosis. *Biol Blood Marrow Transplant* 2010;16:358-367.
198. Barbui T, Barosi G, Birgegard G, et al. Philadelphia-negative classical myeloproliferative neoplasms: critical concepts and management recommendations from European LeukemiaNet. *J Clin Oncol* 2011;29:761-770.
199. Cervantes F, Dupriez B, Pereira A, et al. New prognostic scoring system for primary myelofibrosis based on a study of the International Working Group for Myelofibrosis Research and Treatment. *Blood* 2009;113:2895-2901.
200. Passamonti F, Cervantes F, Vannucchi AM, et al. Dynamic International Prognostic Scoring System (DIPSS) predicts progression to acute myeloid leukemia in primary myelofibrosis. *Blood* 2010;116:2857-2858.
201. Gangat N, Caramazza D, Vaidya R, et al. DIPSS plus: a refined dynamic international prognostic scoring system for primary myelofibrosis that incorporates prognostic information from karyotype, platelet count, and transfusion status. *J Clin Oncol* 2011;29:392-397.
202. Caramazza D, Begna KH, Gangat N, et al. Refined cytogenetic-risk categorization for overall and leukemia-free survival in primary myelofibrosis: a single-center study of 433 patients. *Leukemia* 2011;25:82-88.
203. Patnaik MM, Caramazza D, Gangat N, et al. Age and platelet count are IPSS-independent prognostic factors in young patients with primary myelofibrosis and complement IPSS in predicting very long or very short survival. *Eur J Haematol* 2010;84:105-108.
204. Deeg HJ, Sandmaier BM. Who is fit for allogeneic transplantation? *Blood* 2010;116:4762-4770.
205. Kroger N, Zabelina T, Schieder H, et al. Pilot study of reduced-intensity conditioning followed by allogeneic stem cell transplantation from related and unrelated donors in patients with myelofibrosis. *Br J Haematol* 2005;128:690-697.
206. Mesa RA. How I treat symptomatic splenomegaly in patients with myelofibrosis. *Blood* 2009;113:5394-5400.
207. Ciurea SO, Sadegi B, Wilbur A, et al. Effects of extensive splenomegaly in patients with myelofibrosis undergoing a reduced intensity allogeneic stem cell transplantation. *Br J Haematol* 2008;141:80-83.
208. Pardanani A. Ruxolitinib for myelofibrosis therapy: current context, pros and cons. *Leukemia* 2012;26:1449-1451.
209. Kroger N, Badbaran A, Holler E, et al. Monitoring of the JAK2-V617F mutation by highly sensitive quantitative real-time PCR after allogeneic stem cell transplantation in patients with myelofibrosis. *Blood* 2007;109:1316-1321.
210. Alchalby H, Badbaran A, Zabelina T, et al. Impact of JAK2V617F mutation status, allele burden, and clearance after allogeneic stem cell transplantation for myelofibrosis. *Blood* 2010;116:3572-3581.

211. Alchalby H, Badbaran A, Bock O, et al. Screening and monitoring of MPL W515L mutation with real-time PCR in patients with myelofibrosis undergoing allogeneic-SCT. *Bone Marrow Transplant* 2010;45:1404-1407.
212. Steckel NK, Koldehoff M, Ditschkowski M, Beelen DW, Elmaagacli AH. Use of the activating gene mutation of the tyrosine kinase (VAL617Phe) JAK2 as a minimal residual disease marker in patients with myelofibrosis and myeloid metaplasia after allogeneic stem cell transplantation. *Transplantation* 2007;83:1518-1520.
213. Rumi E, Passamonti F, Arcaini L, et al. Molecular remission after allo-SCT in a patient with post-essential thrombocythemia myelofibrosis carrying the MPL (W515A) mutation. *Bone Marrow Transplant* 2010;45:798-800.
214. Kroger N, Alchalby H, Klyuchnikov E, et al. JAK2-V617F-triggered preemptive and salvage adoptive immunotherapy with donor-lymphocyte infusion in patients with myelofibrosis after allogeneic stem cell transplantation. *Blood* 2009;113:1866-1868.
215. Kroger N, Klyuchnikov E, Wolff D, et al. Donor lymphocyte infusions and second transplantation as salvage treatment for relapsed myelofibrosis after reduced-intensity allografting. *ASH Annu Meeting Abstr* 2010;116:1300.
216. Huzicka I. Could bone marrow transplantation cure AIDS?: review. *Med Hypotheses* 1999;52:247-257.
217. Gupta V, Tomblyn M, Pedersen TL, et al. Allogeneic hematopoietic cell transplantation in human immunodeficiency virus-positive patients with hematologic disorders: a report from the center for international blood and marrow transplant research. *Biol Blood Marrow Transplant* 2009;15:864-871.

Chapter 105 Graft-Versus-Host Disease and Graft-Versus-Tumor Response

> Table of Contents > Part VIII - Transplantation > Chapter 105 - Graft-Versus-Host Disease and Graft-Versus-Tumor Response

Chapter 105

Graft-Versus-Host Disease and Graft-Versus-Tumor Response

Joseph Pidala

Frederick L. Locke

Claudio Anasetti

INTRODUCTION

Graft-versus-host disease (GVHD) is the most common treatment complication following hematopoietic stem cell transplantation (HSCT) from an allogeneic donor, and it is a major cause of recipient morbidity and mortality. GVHD results from the recognition of recipient tissue antigens by immune competent T cells transplanted with the graft. There is an acute form of GVHD with a rapid onset, usually early after transplantation, and a chronic form of GVHD with late onset. These two GVHD syndromes are largely distinct in pathogenesis, clinical manifestations, prevention, and treatment, and therefore are presented separately in this chapter. Donor cells in the graft also produce an immune response against targets in the recipient malignant cells, through a reaction that contributes substantially to the antitumor activity of allogeneic HSCT. Such a graft-versus-tumor (GVT) response is presented in the third section of this chapter.

ACUTE GRAFT-VERSUS-HOST DISEASE

Pathophysiology

The requisites for the development of GVHD were recognized over 50 years ago by Billingham: (1) the inclusion of immune competent cells in the graft, (2) the inability of the recipient to reject the graft, and (3) the presence of recipient tissue antigens foreign to the donor. Animal model studies, primarily in rodents, led to a three-step model of GVHD pathophysiology that simplifies the complex immune interactions by placing emphasis on cellular interactions and cytokines: (1) host antigen-presenting cell (APC) activation, (2) donor T-cell activation, and (3) pathogenic effector cells and inflammatory mediators produce the disease.^{1, 2} GVHD biology is extremely complex involving intracellular signaling, soluble mediators, and cellular interactions. Positive and negative signals exist at multiple levels including the cell surface, signaling protein networks, transcription promoters, mRNA, and posttranslational modification. In addition to histocompatibility antigen disparities between donor and recipients, genetic polymorphisms at any of these immune

checkpoints may promote or prevent GVHD. The interaction of immune cells, visceral organ tissue, cytokine, and chemokine signals, cellular trafficking into and out of lymphoid and visceral organs is similarly complex. Recent attempts to rein in these numerous, continuous, and interrelated processes led Paczesny and Reddy to create a comprehensive model of GVHD pathophysiology based on the framework of normal immune system interactions. It is the expected behavior of donor immune cells to cause pathophysiology within the host that harbors unrecognized antigens which are treated as foreign by the donor cells. Put more simply, acute GVHD arises when donor T cells react in a physiologically appropriate way against recipient proteins recognized as foreign. However, the signaling events, intracellular pathways, and immune cell trafficking are extremely complex and remain to a large degree incompletely understood. This proposed nonlinear model consists of four interrelated elements to describe the role of immune system recognition and activation at the genetic, cellular, and cytokine level: triggers, sensors, mediators, and effectors of GVHD (Table 105.1).³

Critical to acute GVHD onset is the degree of genetic variability between donor and host, the level and site of tissue damage set forth by the conditioning regimen, the ability of host or donor cells to present antigen, the cellular and cytokine mediators of response, and the nature and degree of the immune effector activity.

Triggers

Human leukocyte antigens (HLAs) are encoded by the major histocompatibility gene complex (MHC) on chromosome 6p and function as major histocompatibility antigens in transplantation. The natural function of HLA is to present antigenic peptides to specific T cells. Exogenous and endogenous proteins present within human cells are continually broken down into peptides. HLA molecules on professional APCs bind those peptides within their groove and present them from the cell surface to the T-cell receptors on T lymphocytes. Inasmuch as the human genome includes greater than 10^7 polymorphic sequences, there is great likelihood that donor and recipient differ for one or more of the proteins that are presented as HLA:peptide complexes to T cells. These polymorphic proteins function as minor histocompatibility antigens (mHAs) in transplantation. Autoreactive T-cell recognition of "self" peptides in the thymus leads to negative selection (death), so that the probability of an individual developing autoimmunity is minimized. After transplantation, this delicate balance of self and nonself is perturbed. Donor and recipient may differ for HLA molecules or mHA. Each peripheral T cell harbors a unique T-cell antigen receptor; therefore, the human repertoire for recognition of foreign antigens is enormous. Donor and recipient HLA mismatching plays a critical role in the development of GVHD, because each type of HLA presents a unique repertoire of antigenic peptides. When recipient cells are mismatched at an HLA locus, the donor T cells have not undergone thymic deletion to avoid recognizing those HLA:peptide complexes. Therefore, the degree of HLA disparity directly increases the probability and severity of acute GVHD following transplantation.^{4, 5} For umbilical cord blood donors a greater degree of HLA mismatch is tolerated presumably due to the small number of T cells within the cord blood ($\sim 10^4$ per kg recipient weight) as compared to adult donor blood ($\sim 10^8$) or marrow ($\sim 10^7$).

mHA are polymorphic proteins genetically encoded anywhere outside HLA. Host mHA proteins are presented as HLA:peptide complexes to donor T cells and elicit an immune response even when presented via a matched HLA molecule. mHA mismatches are only partially characterized for the ability to affect acute GVHD. Some mHA have broad tissue expression such as the male-associated H-Y antigen.⁶ Alternatively, HA-1 and HA-2, for example, have their expression restricted to hematopoietic cells, including leukemia, and immune cells.⁷ It is this variability of tissue mHA expression that may allow for tailoring therapy toward hematopoietic-restricted mHA to promote GVT response without GVHD. Efforts to prevent GVHD would have to target immune responses against the ubiquitously expressed mHA.^{6, 8, 9}

Other triggers of GVHD include molecules that activate the innate immune system. Pre-transplant radiation or chemotherapy damages host cells and enteric microbes that contain damage-associated molecular patterns (DAMPs) or pathogen-associated molecular patterns (PAMPs), respectively. DAMPs such as proteases

P.2207

or ions released from damaged epithelial cells and PAMPs such as lipopolysaccharide within common bacteria, can activate Toll-like receptors setting off a cascade of immune events characterized by proinflammatory cytokine secretion.¹⁰ To a large degree these processes are responsible for initiation of the "cytokine storm" described as critical in earlier models of acute GVHD.¹¹

TABLE 105.1 ACUTE GRAFT-VERSUS-HOST DISEASE PATHOPHYSIOLOGY: TRIGGERS, SENSORS, MEDIATORS, AND EFFECTORS

Key Elements	Physiologic Role	Aberrant Process in Graft-versus-Host Disease
---------------------	-------------------------	--

Triggers

HLA molecules	Present antigen to T cells	Mismatches in HLA molecules from donor to host lead to recognition of the cell as foreign by T cells.
mHA	Normal variability of protein within genome	mHA are recognized as foreign by MHC:T-cell interactions.
DAMPs and PAMPs	Common organic patterns originating from damaged cells or pathogens triggering innate immunity	DAMP release after cell death due to conditioning therapy or PAMP presence via pathogens triggers innate immunity and cytokine cascade.

Sensors

Antigen presenting cells	Present antigens to effectors	Present exogenous and endogenous protein sequences to T cells via direct, indirect, or cross presentation.
--------------------------	-------------------------------	--

Mediators

CD4 T helper subsets	Skew effector responses to the appropriate degree	Effects of T-cell subsets on graft-versus-host disease incompletely understood.
Regulatory T cells	T-cell subset which acts to prevent untoward autoimmunity	Donor regulatory T cells play a role in reducing graft-versus-host disease.
Inhibitory signals	Signals provided in concert with antigen presentation to decrease the immune response	
Co-stimulatory signals	Signals provided by professional antigen presenting cells to initiate immune response	

Effectors

Activated CD4 and CD8 T cells	Lead to killing or neutralization of foreign cells or debris via IFN γ , perforin, or granzyme secretion	Donor cells act to damage host cells and organs leading to manifestations of graft-versus-host disease.
-------------------------------	---	---

HLA, human leukocyte antigen; DAMPs, damage-associated molecular patterns; mHA, minor histocompatibility antigen; MHC, major histocompatibility complex; PAMPs, pathogen-associated molecular patterns.

Adapted from Paczesny S, Hanauer D, Sun Y, Reddy P. New perspectives on the biology of acute GVHD. Bone Marrow Transplant 2010;45:1-11.

Sensors

Sensors of GVHD refer to the cells and processes that recognize the mHA or HLA mismatches as foreign, thereby setting the immune response in motion. Antigens are presented by host professional APC such as dendritic cells, macrophages, or Langerhans cells. Host dendritic cells may be primed for antigen presentation via the cytokine storm accompanying the conditioning therapy. The nature of antigen presentation interactions includes direct presentation, which mimics physiologic APC-T-cell interactions. Specifically, direct presentation consists of host APC presenting endogenous (cytosolic) host peptide to donor CD8 T cells, and exogenous (extracellular, endocytosed peptide, processed in lysosomes) antigens are presented to donor CD4 T-cells. Indirect presentation specifies exogenous antigen presented from donor APC to donor CD4 cells. Cross-presentation refers to exogenous antigen (derived from host cells) presented to donor T cells from donor APC. Over time APC change from primarily host origin to donor origin. It is likely that direct presentation by host APC is

predominant during early stages of acute GVHD, whereas indirect or cross-presentation by donor APC is predominant in chronic GVHD. APC-T-cell interaction involves not only interaction between HLA plus cognate antigen with T cell receptor (TCR), but co-stimulatory and inhibitory signals at the immune synapse, secondary signals from cell subsets, and paracrine or autocrine mediators. APC provide necessary co-stimulatory signals directly when activating T cells, such as CD28, CD40, and ICOS as well as inhibitory signals such as CTLA-4 and PD-1. Manipulation of these signals via antibody interference or small molecule blockade of downstream signaling events remains a field ripe for modulation of GVHD. Exogenous cell types critical to inhibition of APC include regulatory T cells, gamma-delta T cells in the GI tract, natural killer (NK) cells, and host NKT cells. T-cell response is an adaptive immune response which is often triggered by the innate immune response. As described, Toll-like receptors are sensors of the DAMP and PAMP release precipitated by the condition regimen. These Toll-like receptor interactions lead to release of proinflammatory cytokines such as tumor necrosis factor alpha (TNF α) and interleukin (IL)-6 which contribute to the inflammatory milieu surrounding T-cell-mediated GVHD damage.

Mediators

GVHD is primarily mediated by donor T cells, and differing subsets that have normal physiologic activities outside the framework of transplant, act at different capacities to induce or inhibit GVHD development. Most animal models point to the relevance of naive T cells, rather than memory T cells, in the induction of GVHD. The process of homeostatic proliferation in the lymphoablated host causes brisk clonal expansion of the transferred donor T cells and plays an important role for the initiation of acute GVHD. Donor regulatory T cells (Treg) repress the GVHD responses. Treg are CD4 T cells that express the FOXP3 transcription factor, high levels of the alpha chain of the IL-2 receptor, but no IL-7 receptor and function as a natural suppressor to maintain peripheral tolerance. These donor-derived regulatory T cells inhibit the activation and proliferation of donor T cells implicated in the pathogenesis of acute GVHD and may spare the GVT effect.¹² Recent data show that low-dose IL-2 expands regulatory T cells in vivo and may be effective therapy for established GVHD,¹³ whereas anti-IL-2 receptor antibodies, tested before Treg importance and biology were recognized, appear to accelerate GVHD.¹⁴

Additional CD4 T-cell subsets are critical. It is Th1 cells, characterized by IL-2 and interferon gamma (IFN γ) secretion, which

P.2208

are the likely main T-cell mediators of acute GVHD. Th2 T cells have been linked to protection against acute GVHD. Th17 CD4 cells secrete IL-17 and function distinctly from Th1 cells in a manner that is not yet fully characterized in the context of human GVHD. Murine transplant models provide evidence that Th17 can cause GVHD.^{15, 16} T-cell trafficking is another important step in GVHD pathogenesis. Differential expression of chemokines on GVHD target organs and draining lymph nodes mediate differential trafficking of T-cell subsets expressing different chemokine receptors. An initial report indicated that a CCR5 inhibitor can prevent GVHD in gut and liver.¹⁷

Effectors

The effectors of acute GVHD are the cytolytic cellular elements and inflammatory cytokines. Activated CD4 and CD8 cytotoxic T lymphocytes are the primary effectors of GVHD. Upon interaction with their cognate HLA:peptide they act to lyse or cause apoptosis of target cells via secretion of perforin and granzyme or binding of FAS, respectively. IFN γ and TNF α are both critical to the inflammatory process of GVHD. Inflammatory cytokines induce and amplify cellular damage.

EPIDEMIOLOGY

The major source of treatment-related morbidity and mortality is GVHD. The incidence of clinically relevant (grade II to IV) acute GVHD ranges from 35% to 80%, with a higher incidence reported for recipients of unrelated donors compared to matched related donors.^{18, 19} The day 100 incidence of severe acute GVHD (grades III-IV) occurs in approximately 15%, but may be as high as 35% depending upon risk factors such as HLA disparity.⁵

RISK FACTORS

Risk factors for the development of acute GVHD include T-replete transplant, recipient and donor HLA disparity, female donor for a male recipient, donor and recipient age, hematopoietic stem cell source (peripheral blood progenitor cells [PBPCs] > marrow > cord blood), graft cellular composition (worse with higher T-cell and CD34 cell numbers), higher conditioning intensity, diagnosis (worse with chronic myeloid leukemia), and immune response gene polymorphisms.^{20, 21} Predictive factors are of great interest to stratify patients prior to development of serious morbidity or mortality and to focus prevention upon the proper biological parameters.

HLA matching is critical to prevent acute GVHD. A single allele mismatch at HLA-A, HLA-B, HLA-C, or HLA-DRB1 increases the likelihood of acute GVHD development, and mismatch for multiple alleles compound the risk.^{5, 22}

Female donor for a male recipient and donor parity are risk factors for the development of acute GVHD. The increased risk for male recipients of female as opposed to male donors is attributed to the recognition of H-Y mHAs by female donor T cells.^{23, 24} During pregnancy, female donors develop an immune response to the paternal mHAs of the fetus and mount a secondary, augmented T-cell alloimmune response against the same mHAs if expressed in the recipient.²⁵

Increasing donor age is associated with increased risk for the development of severe acute and chronic GVHD, and worse mortality.²⁶ Age of the recipient is also important with higher rates of acute GVHD in older compared to younger cohorts.^{20, 27}

The rate of chronic GVHD in patients receiving PBPC grafts is higher compared to bone marrow; however, the association of PBPC with acute GVHD is not clearly established.^{28, 32} Unrelated cord blood transplant is associated with a low rate of acute GVHD when compared to transplant with similarly HLA mismatched adult donors.^{33, 34} Multiple factors may contribute to this effect; however, the low number of T cells in the graft and T-cell naive likely play a protective role.

The conditioning regimen used affects the incidence of acute GVHD. With high-dose intensity conditioning the incidence of acute GVHD is higher. For example, increasing doses of radiation can double the incidence of acute GVHD.³⁵ Several large retrospective studies showed that reduced intensity regimens lead to reduced rates of grade II-IV acute GVHD when compared to higher intensity regimens.^{36, 37} Animal models suggest the correlation of the incidence of GVHD with intensity may be due to increased damage to host tissue and amplified release of cytokines followed by activation of APC.³⁸ In addition, higher intensity regimens decrease the fraction of recipient T cells that persist after the regimen, leading to a lower barrier to donor engraftment and greater homeostatic re-population by donor T cells, which is associated with worse acute GVHD.^{39, 40}

The cellular composition of the graft is linked to the incidence of GVHD. Despite the link between chronic GVHD and CD34 cell dose, conflicting studies outline the importance of CD34 cell dose on acute GVHD.^{41, 42} The preponderance of evidence suggests that there is no correlation between CD34 cell dose and the incidence of acute GVHD, whether the progenitor source is marrow or PBPC,^{43, 44, 45} although one study, looking at patients given cyclosporine as a prophylactic agent, revealed a positive association of CD34 dose with acute GVHD.⁴⁶

Genetic polymorphisms of immune response genes are associated with an increased incidence of acute GVHD. Single nucleotide polymorphisms (SNPs) can alter cytokine binding domains, thereby altering affinity in a functional or nonfunctional way. Particular SNPs in genes coding IL-10, IL-6, IL-2, HPSE, CTLA-4, and MTHFR have all been identified as increasing the risk of clinically relevant or severe acute GVHD, likely via increased level or activity of these cytokines or receptors.⁴⁷

Cytokine biomarkers correlate with the presence of acute GVHD and provide prognostic information independent of the severity of GVHD. Although not widely in diagnostic use, the panel which includes IL-2-receptor-alpha, TNF-receptor-1, IL-8, and hepatocyte growth factor, can confirm the diagnosis at the onset of clinical symptoms.⁴⁸ An expanded 6 biomarker panel which also includes elafin, a skin-specific marker, and regenerating islet-derived 3- α , a gastrointestinal (GI) tract-specific marker was shown to predict response rate at day 28 after onset and survival at day 180 after onset, for patients with acute GVHD. This panel was predictive at 3 time points; onset, 2 weeks, and 4 weeks into therapy. Future clinical trials will determine if such stratification into high and low risks groups will lead to improved outcomes by capitalizing on the opportunity for early intervention.⁴⁹

PROGNOSIS

Acute GVHD response rates to high-dose steroid therapy are in the range of 50%, and achievement of response to steroids is the most important predictor of outcomes. Durable responses of a month or longer can be expected in about 30% and partial responses (PRs) in 20%. Lower intestinal acute GVHD has been linked to worse response rates compared to patients without lower intestinal manifestations.

CLINICAL MANIFESTATIONS OF ACUTE GRAFT-VERSUS-HOST DISEASE

The most common sites of involvement are skin, GI tract, and liver. Additional organ sites may be involved and clinicians should maintain a high degree of suspicion for acute GVHD as a

P.2209

cause for any unexplained abnormalities in eyes, buccal mucosa, and lung. A biopsy of the presumptive site should be

attempted whenever possible to confirm diagnosis, although histological manifestations can overlap with many inflammatory conditions confounding histological results. A pathologist familiar with acute GVHD is preferable, and appropriate immunohistochemical stains should be employed to rule out viral infection, particularly of the GI tract.

The onset and natural history of acute GVHD is variable depending on organ site, nature, and severity of disease. A hyperacute form, occurring in the first 14 days after transplant,⁵⁰ is characterized by early onset of typical signs and symptoms, with a preponderance of patients, 90%, exhibiting skin involvement. In addition a higher percentage of patients are likely to experience stage III-IV disease (88% vs. 66%).^{51, 52}

Most cases of acute GVHD manifest within the first 100 days following transplant. With the use of modern prophylaxis regimens including cyclosporine or tacrolimus, the onset is typically 20 to 25 days after cell infusion. With T-cell depletion, average onset is typically at 30 days, although it can be delayed several months as T cells reconstitute.⁵³ NIH consensus criteria for chronic GVHD includes classification of acute GVHD occurring after day 100 (late-onset acute GVHD) and for patients manifesting signs and symptoms of both acute GVHD and chronic GVHD (overlap subtype of chronic GVHD).⁵⁴ The severity of acute GVHD can easily be quantified using Keystone consensus grading criteria (Table 105.2).

Skin

Skin is the most commonly involved site of acute GVHD, being present 80% of the time at onset. A maculopapular rash is characteristic and may be described as a painful or pruritic sunburn. Characteristically involved sites include the back of the neck, palms, soles, dorsal surfaces of the extremities, and ears, although the rash can spread quickly to include the entire body. Although many cases are mild, severe manifestations can include bullous lesions and a clinical picture consistent with toxic epidermal necrolysis. Careful full-body examination allows for staging of acute GVHD by the Keystone consensus criteria. This scale is based upon percentage of body surface area (BSA) involvement. For example, when acute GVHD is confined to the skin and involves <50% of BSA, it is classified as grade I acute GVHD. Such a degree of involvement may require no more than topical steroids and frequent monitoring of symptoms (see "Primary and Secondary Therapy of Acute Graft-versus-host Disease" below). A biopsy of the skin can help to solidify the diagnosis, however, treatment is usually based on the clinical diagnosis.⁵⁵

TABLE 105.2 KEYSTONE CONSENSUS CRITERIA STAGING AND GRADING OF ACUTE GRAFT-VERSUS-HOST DISEASE

	Skin	Liver	Gut
Stage			
1	Rash on <25% of skin	Bilirubin 2-3 mg/dl	Diarrhea >500 ml/d or persistent nausea
2	Rash on 25-50% of skin	Bilirubin 3-6 mg/dl	Diarrhea >1000 ml/d
3	Rash on >50% of skin	Bilirubin 6-15 mg/dl	Diarrhea >1500 ml/d
4	Generalized erythroderma with bullous formation	Bilirubin >15 mg/dl	Severe abdominal pain with or without ileus
Grade			
I	Stage 1-2	None	None
II	Stage 3 or	Stage 1 or	Stage 1
III		Stage 2-3 or	Stage 2-4
IV	Stage 4 or	Stage 4	
Functional Grading			
	Skin	Liver	Gut
I	Rash on <50% of skin		
II	Rash on <50% of skin or	Bilirubin 2-3 mg/dl or	Diarrhea >500 ml/d or persistent nausea

III-IV Generalized erythroderma with bullous formation or Bilirubin >3 mg/dl Diarrhea >1000 ml/d

Criteria for grading given as minimum degree of organ involvement required to confer that grade.

Grade IV may also involve lesser organ involvement but with extreme decrease in performance status. From Przepiorka D, Weisdorf D, Martin P, et al. 1994 consensus conference on acute GVHD grading. *Bone Marrow Transplant* 1995;15:825-828.

Hepatic

Liver acute GVHD is typically characterized by involvement of the bile duct epithelium, resulting in cholestasis. Bilirubin and alkaline phosphatase elevation, accompanied by cholestatic jaundice are the typical manifestations. Direct hepatocyte damage is rare, absent a more chronic fibrosis, although transaminitis often occurs. Hyperbilirubinemia must be distinguished from other common post-transplant complications such as toxicity from preparative chemotherapeutics, sinusoidal obstructive syndrome (also called hepatic veno-occlusive disease), and occasionally fulminant viral hepatitis. Sinusoidal obstructive syndrome is characterized by hyperbilirubinemia, portal hypertension, and weight gain due to third spacing of fluids. Portal hypertension is part of the clinical picture of sinusoidal obstructive syndrome, and not a manifestation of acute GVHD in patients without underlying liver disease. Doppler assessment of portal hypertension, measurement of the hepatic vein occlusive pressure, and if necessary histological examination, are critical in resolving the differential diagnosis. A transjugular liver biopsy is preferable to transcutaneous biopsy, as portal pressures can be measured. Acute GVHD produces cholestatic hepatitis, with histology showing frequent acidophilic bodies evolving to bile duct exocytosis and disruption. As the disease progresses beyond day 100 post-transplant, portal fibrosis is seen with increasing bile duct dropout.⁵⁶ This is in contrast to sinusoidal obstructive syndrome, which is characterized by occluded hepatic venules, sinusoidal fibrosis, and hepatocyte necrosis.⁵⁷

P.2210

Gastrointestinal Tract

Anorexia, nausea, and vomiting are the most common symptoms of GI acute GVHD, but diarrhea, abdominal pain, and hemorrhage are symptoms of serious lower-tract disease. Almost any site along the tract can be involved. Unexplained GI symptoms such as mouth ulcers or ileus can be caused by acute GVHD. Endoscopy with biopsies of the upper and/or lower tract should be obtained for persistent symptoms, inasmuch as histology provides critical information. The differential diagnosis of uppertract GVHD includes herpes simplex, cytomegalovirus, or candida esophagitis, stomach ulcer, and peptic gastritis or duodenitis. The differential diagnosis of lower tract disease includes enteritis from *C. difficile*, cytomegalovirus, Norfolk viruses, cryptosporidium, giardia, or enteric pathogens such as *Salmonella*, and side effects of irradiation or medications including cytotoxic chemotherapy, tacrolimus, and mycophenolate mofetil among others. Radiologic findings by computed tomography (CT) scan can include thickening of the esophageal, small, or large bowel wall; adjacent vasa recta engorgement; mesenteric fat stranding; or mucosal enhancement.⁵⁸ Radiologic modalities should not be relied upon for confirmation of diagnosis. Upper or lower endoscopy affords both a visual examination of the mucosa which may exhibit edema, erythema, ulceration, and mucosal sloughing, as well as the opportunity to obtain tissue for histology. Classic microscopic findings include epithelial crypt apoptotic bodies and lymphocytic infiltration. Involved mucosa can be noncontinuous and a lack of findings or a low degree of severity at one level does not rule out other areas or degrees of involvement.⁵⁹

Lung

Lung complications following allogeneic transplant can be of cardiac, infectious, vascular, or immune nature. Infections and pulmonary embolism should always be entertained in the differential diagnosis of a transplant patient with shortness of breath, hypoxia, or new infiltrate. Volume overload and cardiogenic pulmonary edema is another mechanism of respiratory distress. Immune-mediated processes should be entertained when infectious work-up is negative, or CT scanning is not consistent with infectious processes. Diffuse alveolar hemorrhage has long been recognized as a post-transplant complication and occurs in approximately 10% of patients, with myeloablative regimens associated with a higher incidence. Patients manifest with dyspnea (92%) accompanied with mild to severe bleeding into the alveoli, although hemoptysis is seen in a minority (15%) of cases. Fever can be a presenting symptom (67%) and diagnosis is typically made following bronchoscopy. Patients often require ventilatory support and mortality rates can reach 70%.^{60, 61}

Lung wedge resection or video-assisted thoracoscopic biopsy should be entertained for patients where an organism is not identified and diagnostic uncertainty remains. Bronchiolitis obliterans with organizing pneumonia (BOOP) is seen in up to 2% of patients during the post-transplant period. Although not considered a manifestation of GVHD,⁶² biopsy-proven BOOP occurs at a median of 108 days after transplant and can display a wide range of severity and reversibility. It is typically a restrictive lung disease with radiographic findings showing peripheral patchy consolidation, ground glass infiltrates, and nodular opacities. BOOP after transplant is associated with GVHD and steroid therapy affords a chance for improvement.^{63, 64}

PREVENTION

A half century ago, Storb and collaborators determined that the immunosuppressive agent methotrexate could mitigate or prevent the onset of acute GVHD, when applied shortly after transplantation. Although oral and liver toxicity can be severe and preclude up to 40% of patients from receiving a full course of therapy, methotrexate remains widely in use, now typically in combination with a calcineurin inhibitor.²⁷ Calcineurin inhibitors act to inhibit IL-2 mediated T-cell expansion. Cyclosporine, the first calcineurin inhibitor, was found to be synergistic with methotrexate, leading to a reduction in severe (grade III/IV) acute GVHD when utilized in HLA-matched sibling allografts and to a lesser degree with unrelated donor allografts.^{65, 66} Subsequent development of the calcineurin inhibitor, tacrolimus, included two phase III head-to-head comparisons of methotrexate/cyclosporine and methotrexate/tacrolimus.^{67, 68} The combination of methotrexate/tacrolimus reduced the incidence of grade II-IV acute GVHD for both matched sibling donors (31.9% vs. 44.4%; $P = 0.01$) and unrelated donor transplants (56% vs. 76%, $P = 0.0002$), but it did not prevent chronic GVHD or improve survival. This lack of survival advantage propagated the use of both combination regimens at the discretion of individual transplant centers.

Attempts at further decreasing the incidence of acute GVHD have included the addition of agents to a calcineurin inhibitor with or without methotrexate. Mycophenolate mofetil is a prodrug of mycophenolic acid, an inhibitor of de novo synthesis of purines in lymphocytes required for lymphocyte proliferation. Mycophenolate mofetil has been examined in combination with cyclosporine or tacrolimus. Single-center randomized studies of mycophenolate mofetil suggest greater safety but not greater efficacy over methotrexate. One study was stopped early as cyclosporine/mycophenolate mofetil showed a clear advantage over cyclosporine/methotrexate in regard to decreased mucositis (21% vs. 65%, $P = 0.008$) and faster neutrophil engraftment (11 days vs. 18 days, $P < 0.001$) but without a difference in the incidence of acute GVHD.⁶⁹ A second single-center study revealed that mycophenolate mofetil decreased severe mucositis, use of parenteral nutrition, and promoted early hospital discharge, however, mycophenolate mofetil was associated with higher rates of severe (grade III-IV) acute GVHD (19% vs. 4%, $p = 0.03$), which was predominantly seen with unrelated donors.⁷⁰

Sirolimus is an mTOR inhibitor that has complex immunomodulatory properties affecting T cells and APC. The drug requires therapeutic monitoring and is affected by inhibitors or inducers of CYP3A4. Sirolimus is associated with the risk of endothelial damage such as in sinusoidal obstructive syndrome.^{71, 72, 73} Initially shown to be safe in combination with tacrolimus and methotrexate,⁷⁴ sirolimus has now been tested in several phase II studies in combination with tacrolimus and the two agents likely synergize to reduce acute GVHD rates.^{75, 76} In particular, sirolimus supports regulatory T-cell reconstitution post-transplant, which are protective against acute GVHD after transplantation.⁷⁷

Bortezomib is a proteasome inhibitor that has activity against multiple myeloma via nuclear factor kappa B inhibition and other mechanisms. A phase I/II trial showed that bortezomib could be added to tacrolimus and methotrexate as acute GVHD prophylaxis. This regimen is promising as the 180 cumulative incidence of grade II-IV acute GVHD was 13%.⁷⁸

The chemokine receptor CCR5 plays a role in alloreactivity via effects on lymphocyte migration, and has shown promise in an early phase study. Blockade using the CCR5 antagonist, maraviroc, in combination with tacrolimus and methotrexate as acute GVHD prophylaxis led to inhibition of lymphocyte trafficking, without attenuating T-cell function or impairing stem cell function in vitro.¹⁷

Special circumstances surrounding the selection of acute GVHD prophylaxis include HLA-incompatible related donors, unrelated donors, or cord blood. For cord blood transplants, cyclosporine has been the drug primarily utilized as a prophylaxis backbone.⁷⁹ For HLA mismatched donor transplants, a calcineurin inhibitor/methotrexate-based regimen is generally

P.2211

inadequate for GVHD prophylaxis. Triple combination regimens, ATG, and other methods of T-cell depletion have been shown effective in prevention of acute GVHD for mismatched donor transplants.^{71, 80}

As T cells are the primary effectors of acute GVHD, methods of depleting T cells from the graft or in vivo, following transplant have succeeded in reducing rates and the severity of acute GVHD. An ex vivo method of soybean agglutination and E-rosetting was performed⁸¹ to achieve T-cell depletion from allografts, resulting in high rejection rates, presumably due to rejection by residual recipient T cells.^{82, 83} When combined with more immunosuppressive conditioning regimens this complication is ameliorated, yet even so T-cell depletion has not proven to increase overall survival following transplant, considering increased likelihood for relapse and higher infection rates.⁸⁴ Similarly, the anti-CD52 monoclonal antibody, alemtuzumab, has been utilized ex vivo to deplete T cells, resulting in low incidence of grade II/IV GVHD (12%), but a concerning rate of graft failure (15%).⁸⁵ CD34+ cell isolation has been studied and shown to result in extremely low rates of severe acute GVHD in high-risk patients.⁸⁶

In vivo alemtuzumab has been utilized in combination with several different regimens, both with and without a calcineurin inhibitor, with acceptable rejection rates and low incidence of GVHD.⁸⁷ The use of alemtuzumab is associated with increased infectious complications.⁸⁸

Antithymocyte globulin (ATG) refers to polyclonal antibodies against thymus tissue. When used for as prophylaxis or treatment for patients with acute GVHD it leads to depletion of T lymphocytes. It may cause an acute cytokine release syndrome that may include fever, hypotension, and may progress to shock, and delayed "serum sickness." Infectious complications include Epstein-Barr virus re-activation and associated post-transplant lymphoproliferative disorder, and human herpes virus-6 reactivation and associated encephalitis.^{89, 90}

Another agent used to reduce T-cell numbers following transplant is cyclophosphamide, which is a potent immunosuppressive agent, yet spares stem cells. This strategy can result in low rates of severe acute GVHD, even when used as a single prophylactic agent.⁹¹

PRIMARY AND SECONDARY THERAPY OF ACUTE GRAFT-VERSUS-HOST DISEASE

Primary therapy for acute GVHD consists of high-dose steroids (the equivalent of 1 to 2 mg/kg/day of prednisone, with a taper initiated as soon as patients have a major decrease in GVHD signs or symptoms). This standard is based upon historical empirical evidence and randomized controlled data which suggest no advantage to prednisone-equivalent steroid doses of >2.5 mg/kg/day and no disadvantage for 1 mg/kg/day for grade II acute GVHD.⁹²

Standardized consensus response criteria for acute GVHD clinical trials are defined as a complete response, with resolution of all signs and symptoms of disease and normalization of laboratory values, and a very good partial response (VGPR), which allows for residual nonbullous erythematous rash on <25% of BSA, occasional nausea or vomiting, and a reduction of bilirubin to <25% of baseline at enrollment.⁹³ The definition of VGPR (Table 105.3) allows for confounding variables that clinicians must recognize while monitoring for resolution of acute GVHD such as residual GI and hepatic toxicities from conditioning or prophylactic medicines and the recognition of erythema or darkening skin as resolving skin lesions. Prolonged high-dose steroid use leads to a significant degree of morbidity and mortality, and the tapering of these drugs must take precedence once symptomatology and abnormal laboratory data recede.

TABLE 105.3 CONSENSUS TERMINOLOGY DESCRIBING VERY GOOD PARTIAL RESPONSE FOR ACUTE GRAFT-VERSUS-HOST DISEASE

Skin	No rash, or residual erythematous rash involving <25% of the body surface, without bullae (residual faint erythema and hyperpigmentation do not count)
Liver	Total serum bilirubin concentration <2 mg/dl or <25% of baseline at enrollment
Gut	Tolerating food or enteral feeding Predominantly formed stools No overt gastrointestinal bleeding or abdominal cramping No more than occasional nausea and vomiting

From Endpoints for Clinical Trials Testing Treatment of Acute Graft-Versus-Host Disease: A Consensus Document. from Martin PJ, Bachier CR, Klingemann HG, et al. Endpoints for clinical trials testing treatment of acute graft-versus-host disease: a joint statement. *Biol Blood Marrow Transplant* 2009;15:777-784.

The largest studies to date have not been consistent in identifying predictors of response. Risk factors to steroid therapy are not uniform,^{94, 96} although lack of response to primary therapy is clearly a predictor of decreased survival.

Unfortunately complete response (CR) rates to high-dose steroid monotherapy are as low as 20% to 50% of patients, although patients may tolerate steroid taper following a PR. Few data exist to inform the rate of steroid taper. Continuation of the taper must be conducted with frequent monitoring of GVHD parameters to prevent a flareup of symptoms.

Several agents have been added to steroids in comparative studies; at this time no evidence supports the use of these in combination, beyond a well-designed clinical trial for primary acute GVHD therapy. A recent randomized, phase II multicenter trial evaluated four agents, each in combination with glucocorticoids, as initial therapy for acute GVHD. Of the four agents (etanercept, mycophenolate mofetil, denileukin diftitox, and pentostatin) used individually in combination with steroids, the mycophenolate mofetil and steroid combination provided the most encouraging 28-day CR rate,⁹⁷ however, this was not confirmed in a subsequent phase III trial.

For patients unresponsive and unable to tolerate a steroid taper, consideration of second-line therapy in addition to steroids should be made at an interval appropriate to the severity of symptoms. For patients without a significant decrease in symptoms or laboratory parameters, within 3 to 5 days an additional agent is typically added. No particular agent has been shown to be superior to another as therapy for steroid-refractory patients as data on comparative effectiveness of salvage agents is sparse, thereby limiting conclusions and application to clinical practice. Combination therapy has not been systematically studied to date, and it remains uncertain if combinations of drugs will be of benefit for steroid-refractory GVHD patients. Some practitioners utilize differential subset response rates from differing agents to inform selection of agents.

ATG has been studied as second-line therapy with variable overall response rates (ORR) in the range of 30% to 56%. CR was more likely for manifestations in the skin than in other sites.⁹⁸ Other antibodies that have been studied but have yet to prove of benefit over alternatives for use as second-line therapy for steroid-refractory acute GVHD include anti-CD147, expressed on activated T and B lymphocytes as well as APC, anti-CD3 antibodies (OKT3, visilizumab), anti-CD5-ricin conjugated antibodies, and anti-CD52 (alemtuzumab), expressed on most hematopoietic cells.

P.2212

Anti-CD25 antibodies (daclizumab, enlimomab, basiliximab) against the IL-2 alpha receptor subunit act to block T-cell proliferation and signaling, but also may block or deplete regulatory T cells. These agents have led to ORRs of 40% to 67%⁹⁹ and response rates are greater in skin compared to other organs, whereas infectious complications due to concomitant glucocorticoids remain a prominent cause of mortality.¹⁰⁰ Denileukin diftitox (Ontak) is recombinant IL-2 fused to diphtheria toxin and has demonstrated some activity in acute GVHD in phase I trials.^{101, 102}

Antibodies against TNF α (infliximab and etanercept) have shown promise in retrospective single institution series with an ORR of 50% to 67%. At least one series showed intestinal involvement predicted for response, although this was not supported in the other series.^{103, 104, 105}

Mycophenolate mofetil has been studied for glucocorticoid refractory GVHD in several reports.^{106, 107} ORRs with mycophenolate mofetil are in the range of 31% to 67%, and dose-limiting cytopenias must be taken into account. Sirolimus has been studied as an agent for refractory acute GVHD in several retrospective series and one safety study. Adverse effects have included hyperlipidemia and cytopenias. Thrombotic microangiopathy has been observed in up to 35% of patients when used in combination with calcineurin inhibitors. Pentostatin, a nucleoside analogue, has shown activity in refractory GVHD.

Extracorporeal photochemotherapy utilizes 8-methoxypsoralen and exposes peripheral blood cells to UV-A light extracorporeally. It is believed this alters APC activation and promotes Th2 polarization. This therapy is relatively well tolerated and has been associated with an ORR of 67% to 75%. Best response is typically seen after 2 months of therapy; lesser responses seen in patients with GI involvement and patients with higher-grade disease.

SUPPORTIVE CARE

For prophylaxis, there should be appropriate minimization of exposure to precipitating agents such as the sun. Patients with active acute GVHD, there should be special attention paid to the immunocompromised state of the patient. Understanding of the hospital and community bacterial resistance patterns is essential to select appropriate prophylactic antibiotics. Patients on high-dose steroids are at high risk for contraction of fungal pneumonia and appropriate coverage with antifungal medication is warranted. It was recently shown in a large randomized trial that the antifungal agent posaconazole was superior to fluconazole at preventing invasive aspergillus when used as prophylaxis in patients with

GVHD requiring high-dose steroid, combination immunosuppressive therapy, or ATG.¹⁰⁸ A comparison of transplant outcomes between the time period of 1993 to 1997 and 2003 to 2007 at a large single center, revealed significant reduction in mortality. Although this change is due to many factors including the advent of reduced intensity regimens, decreased infection related deaths, and decreased severe GVHD, improved supportive care plays a key role.¹⁰⁹

CONCLUSION

Acute GVHD remains a significant source of morbidity and mortality after allogeneic transplant. The advent of improved prophylactic regimens has led to decreases in the rates and severity, although the most effective primary therapy remains steroids. Future directions should focus on genetic risk factors for the development of disease, ways to predict which patients will not respond to steroids as primary therapy, and agents or cellular therapies that will prevent the development or stop the progression of acute GVHD.

CHRONIC GRAFT-VERSUS-HOST DISEASE

Introduction

Major efforts in basic, translational, and clinical research in chronic GVHD are underway, and promise to improve outcomes of affected patients. The following sections review major progress in our understanding of the pathobiology, clinical advances in the management of the syndrome, and remaining challenges for future research.

Biology

Although there is uncertainty in the mechanisms at work in human chronic GVHD pathogenesis, pre-clinical models have suggested several areas for ongoing investigation and potential avenues for novel therapeutic approaches.

CD4 T-cell Subsets

Allied clinical observations suggest the role of alloreactive donor T cells: peripheral blood mobilized stem cell products, which contain greater donor T cells compared to bone marrow harvested stem cells, impose a greater risk for chronic GVHD and prolonged duration of immune suppression.¹¹⁰ Ex vivo T-cell depletion strategies,^{111, 112} as well as in vivo strategies such as antithymocyte globulin,¹¹³ ATG-Fresenius,¹¹³ or alemtuzumab, are associated with decreased risk of chronic GVHD.^{114, 115} Ongoing investigation aims to discern the relationship between regulatory T cells and chronic GVHD. Early clinical evidence suggests an inverse relationship between regulatory T-cell numbers and the risk of chronic GVHD.¹¹⁶ In a randomized trial comparing sirolimus/tacrolimus versus methotrexate/tacrolimus, sirolimus-treated patients had selective recovery of functional regulatory T cells, and significant reduction in NIH moderate-severe chronic GVHD.⁷⁷ Taken together, current evidence suggests that selective immune modulation may favorably affect chronic GVHD pathogenesis.

Loss of Central Tolerance

Negative selection of autoreactive T cells naturally constitutes a major mechanism of immune tolerance. Immature T cells are positively selected first in the thymic cortex through recognition of class I or class II MHC. In the thymic medulla, T cells engage marrow-derived APCs bearing self-antigens. Strongly self-reactive T cells suffer negative selection through apoptosis. Thus, in normal immunity, naive T cells are educated in the thymus, and autoreactive cells are deleted. Dysregulation of central tolerance due to thymic epithelial damage, which may result from transplantation conditioning therapy or prior GVHD, constitutes a major hypothesis for development of chronic GVHD after allogeneic HSCT. A murine model of thymic dysfunction largely recapitulates a chronic GVHD phenotype. Here, lethally irradiated C3H/HeN recipients receive T-cell-depleted bone marrow from MHN-mismatched B6 mice deficient in MHC class II antigens (B6 H2-Ab1^{-/-}).¹¹⁷ Thus, thymic negative selection is compromised by lack of MHC class II in thymic dendritic cells. The resulting phenotype includes sclerodermatous (Scl) skin changes, weight loss, bile duct loss, mononuclear cell infiltration of the salivary glands, and mortality. Evidence of impaired thymic negative selection has not been observed in other murine models. The clinical relevance of these findings has also been challenged, as thymic function declines with age and may not be relevant to development of GVHD in adult recipients of HSCT. Experimental models have suggested benefit of keratinocyte growth factor to prevent thymic injury, however, this strategy was not successful in human clinical investigation.¹¹⁸

P.2213

Altered B-cell Homeostasis

Several major basic and clinical observations support the role of loss of B-cell tolerance and altered B-cell homeostasis following transplantation in chronic GVHD pathogenesis. B cells have multiple functions, including antibody production, immune regulation, antigen presentation, and cytokine production, which all may have relevance to chronic GVHD pathogenesis.¹¹⁹ A major murine chronic GVHD model, the systemic lupus erythematosus (SLE)-chronic GVHD model, supports the coordination of CD4 T and B cells for antigen presentation and antibody production responsible for the chronic GVHD phenotype. In this model, involving parent-into-F1 combinations, both class I and class II MHC mismatched immune cells are adoptively transferred into nonirradiated mice, resulting in autoantibody production and immune-complex glomerulonephritis. In this model, B cells present antigen to CD4 T cells, leading to activation and production of Th2 cytokines including IL-4 and IL-10. These cytokines activate B cells, which produce autoantibodies. Further antigen reprocessing and presentation leads to activation of other CD4 T cells, and epitope spreading. Despite differences between this model and human chronic GVHD, it supports the role of B cells in chronic GVHD pathogenesis. B-cell stimulatory signals, including B-cell-activating factor (BAFF), have a key role in B-cell reconstitution and homeostasis after transplant. In such models, B-cell survival is dependent on B-cell receptor and BAFF signaling, and B-cell homeostasis is dependent on soluble BAFF concentration. BAFF levels, as well as the balance of autoreactive B cells and competing naive B cells determine the fate of autoreactive B cells.^{120, 121}

Beyond these basic findings, multiple lines of human clinical evidence support this hypothesis: first, autoantibodies have been detected in patients with chronic GVHD. After sex mismatched HSCT, alloantibodies directed against the Y chromosome-associated mHAs, or H-Y antibodies, have been detected and correlate with the occurrence of chronic GVHD.^{122, 123} In the setting of cutaneous sclerosis of chronic GVHD, activating antiplatelet-derived growth factor receptor (PDGFR) antibodies have been detected. As well, reduced levels of immature B cells in patients with chronic GVHD support altered B-cell homeostasis.¹²⁴ It is important to note that investigators have demonstrated aberrant B-cell homeostasis and elevated BAFF levels in human HSCT recipients with chronic GVHD. A consolidative model suggests that, in patients who develop chronic GVHD, high BAFF levels and decreased numbers of naive B cells (high BAFF/B-cell ratio) support alloreactive pre- and post-germinal center CD27+ B cells that contribute to chronic GVHD development.¹²⁵ Additionally, recipient BAFF SNP has association with chronic GVHD phenotypic presentation.¹²⁶ This mounting basic and clinical evidence has informed allied clinical investigation: multiple clinical trials have demonstrated activity of the anti-CD20 monoclonal antibody, rituximab, in the treatment of chronic GVHD which has failed standard glucocorticoid therapy,^{127, 129} and there is interest in the incorporation of B-cell-depleting agents in both prevention and primary therapy of chronic GVHD.

Profibrotic Pathways

Clinical and basic evidence suggest that profibrotic pathways play a role in chronic GVHD development. In particular the coordination of Th2 CD4 cells, TGF- β and IL-13, and potentially stimulatory anti-PDGFR antibodies, effect fibroblast production of collagen and lead to fibrosis. One major murine model, the Scl-chronic GVHD model, has provided mechanistic insight into fibrotic chronic GVHD phenotypes. In this model, B10.D2 (H-2^d) into BALB/c (H-2^d), donor immune cells (bone marrow and splenocytes) are adoptively transferred into sublethally irradiated mice that are matched at MHC, but mismatched for mHAs. With full donor lymphoid chimerism, chronic GVHD is mediated by donor immune cells. The resulting phenotype includes fibrosis in multiple organs (skin, GI tract, liver, lung, and parotid salivary gland), mononuclear cell infiltration and collagen deposition, and mortality. In this model, inflammatory signals lead to activation of donor and host APC, recruiting CD4 T cells, which in turn produce TGF- β and IL-13. These signals drive fibroblast collagen synthesis and resultant fibrosis. The specific role of TGF-beta has been supported by amelioration of chronic GVHD manifestations after neutralization of this cytokine in murine models, and the clinical observation of an inverse relationship between TGF-beta signaling in CD4 and CD8 cells and the risk of chronic GVHD.¹³⁰ In the setting of cutaneous sclerosis of chronic GVHD, activating anti-PDGFR antibodies have been detected, and agents with activity against this receptor kinase such as imatinib have demonstrated activity in this condition.¹³¹

Diagnosis of Chronic Graft-versus-Host Disease

Chronic GVHD occurs in the majority of patients at risk, up to 60% to 80% of those who survive more than 100 days after transplantation.^{132, 133} The reported incidence of chronic GVHD in the published literature is dependent upon classification of the syndrome, patient and transplantation characteristics, pharmacologic GVHD prophylaxis utilized, and the use of further in vivo or ex vivo T-cell-depleting agents. Accurate recognition and management of the syndrome is important, as it is a major source of late HSCT-related morbidity and mortality,^{134, 135} an important determinant of overall health, functional ability, and quality of life,^{132, 133, 136, 138} as well as prolonged immune suppressive therapy after HSCT.¹³⁹

The syndrome is characterized by diverse manifestations, and has several parallels to human autoimmune and inflammatory disorders, such as systemic lupus erythematosus, Sjogren's disease, systemic sclerosis, and inflammatory

bowel disorders, among others. The most commonly occurring manifestations arise in the skin, eyes, mouth, and liver. Common skin manifestations include pigmentation changes, lichen planuslike changes, poikiloderma, as well as more advanced cutaneous and subcutaneous sclerosis. Note that cutaneous erythema is a manifestation shared by acute GVHD and overlap subtype of chronic GVHD (when present together with other diagnostic findings of chronic GVHD). Oral findings include lichen planuslike changes, hyperkeratotic plaques, or decreased oral range of motion. Patients can suffer from oral and ocular sicca symptoms, including dry mouth and dry or gritty eyes. Hepatic involvement with chronic GVHD results in a cholestatic pattern of elevated alkaline phosphatase and bilirubin. In the GI tract, diagnostic chronic GVHD features include esophageal web, stricture, or concentric rings on endoscopic or radiographic study. Other manifestations such as anorexia, nausea/vomiting, and diarrhea are shared between acute and overlap subtype of chronic GVHD. Bronchiolitis obliterans is a less common manifestation of chronic GVHD. Bronchiolitis obliterans represents a diagnostic manifestation of chronic GVHD, and is characterized by clinical symptoms (e.g., cough, dyspnea) and respiratory physiologic abnormalities (forced expiratory volume in 1 second [FEV1]/forced vital capacity ratio <0.7, FEV1 <75% predicted value, evidence of air trapping or bronchiectasis on CT scan, residual volume of >120%, presence of another chronic GVHD manifestation, and absence of infectious etiology). Tissue biopsy is not required for diagnosis.

Given the importance of the syndrome, a major challenge for clinicians remains to recognize chronic GVHD accurately, and distinguish it from competing syndromes, such as acute GVHD (i.e., sole presence of acute GVHD manifestations), other medical conditions, infectious etiology, or adverse effects from medications (e.g., hepatic function abnormalities due to medications such

P.2214

as azole antifungals). Once the syndrome is recognized, it should be classified appropriately, and severity assessed; these data together provide both prognostic information, as well as indications for topical or systemic therapy.

CLASSIFICATION AND SEVERITY GRADING

Major changes in the classification and severity grading of the syndrome have been suggested by the NIH Chronic GVHD Consensus Conference. Among these proposed changes, the previously accepted division between acute and chronic GVHD according to the landmark of 100 days post-HSCT was eliminated. The guidelines propose definition of chronic GVHD according to diagnostic manifestations of the syndrome, rather than the time of onset following HSCT.

Accordingly, manifestations of acute GVHD occurring before day 100 are defined as acute GVHD, and sole acute GVHD manifestations occurring after day 100 are considered persistent, recurrent, or late acute GVHD based on the prior occurrence of acute GVHD. Classic chronic GVHD is defined based on the definitive manifestations of the syndrome in the absence of concurrent acute GVHD manifestations. Diagnosis of chronic GVHD requires the presence of at least one diagnostic clinical sign of chronic GVHD or the presence of at least one distinctive manifestation confirmed by biopsy or allied diagnostic test. The concurrent presentation of both chronic GVHD and acute GVHD manifestations defines the overlap subtype of chronic GVHD. Readers are directed to Filipovich et al. for comprehensive coverage of chronic GVHD diagnosis and severity grading criteria.⁵⁴ Although prior retrospective studies reported after the NIH Consensus failed to support the importance of the overlap subtype of chronic GVHD consistently, prospective data from the Chronic GVHD Consortium demonstrates that patients with overlap have greater symptom burden, worse quality of life, impaired function, and significantly inferior survival compared to classic chronic GVHD cases.¹⁴⁰

In addition, consensus guidelines for chronic GVHD severity grading were proposed to replace the previously accepted scheme based on limited versus extensive involvement. In the prior severity grading scheme, limited involvement included only localized skin involvement or hepatic dysfunction, whereas extensive chronic GVHD was defined by the presence of generalized skin involvement or the presence of aggressive chronic hepatitis, bridging necrosis or cirrhosis in liver biopsy, or involvement of other target organs such as the eye, mouth, or lung. Rather, chronic GVHD severity according to the NIH Chronic GVHD Consensus is scored according to objective criteria for each organ involved, with attention to the functional implications of the degree of involvement, such as degree of weight loss in GI scoring, or frequency of artificial tear use or more aggressive interventions needed for therapy of ocular sicca manifestations.

The individual organ scores are then summarized for an overall global severity score of mild, moderate, or severe. A global severity score of mild encompasses no more than 2 organs, with severity of 1 each; moderate global severity indicates any organ site with a score of 2 (or lung score of 1), or involvement of 3 or more organ sites; finally, the severe category results from either any individual organ site score of 3, or a lung score of 2.⁵⁴ Data from the Chronic GVHD Consortium validates the importance of the proposed NIH Consensus severity criteria: global severity scores at cohort study

enrollment were associated with nonrelapse mortality ($P < .0001$) and survival ($P < 0.0001$); 2-year overall survival was 62% (severe), 86% (moderate), and 97% (mild) (Fig 105.1).¹⁴¹

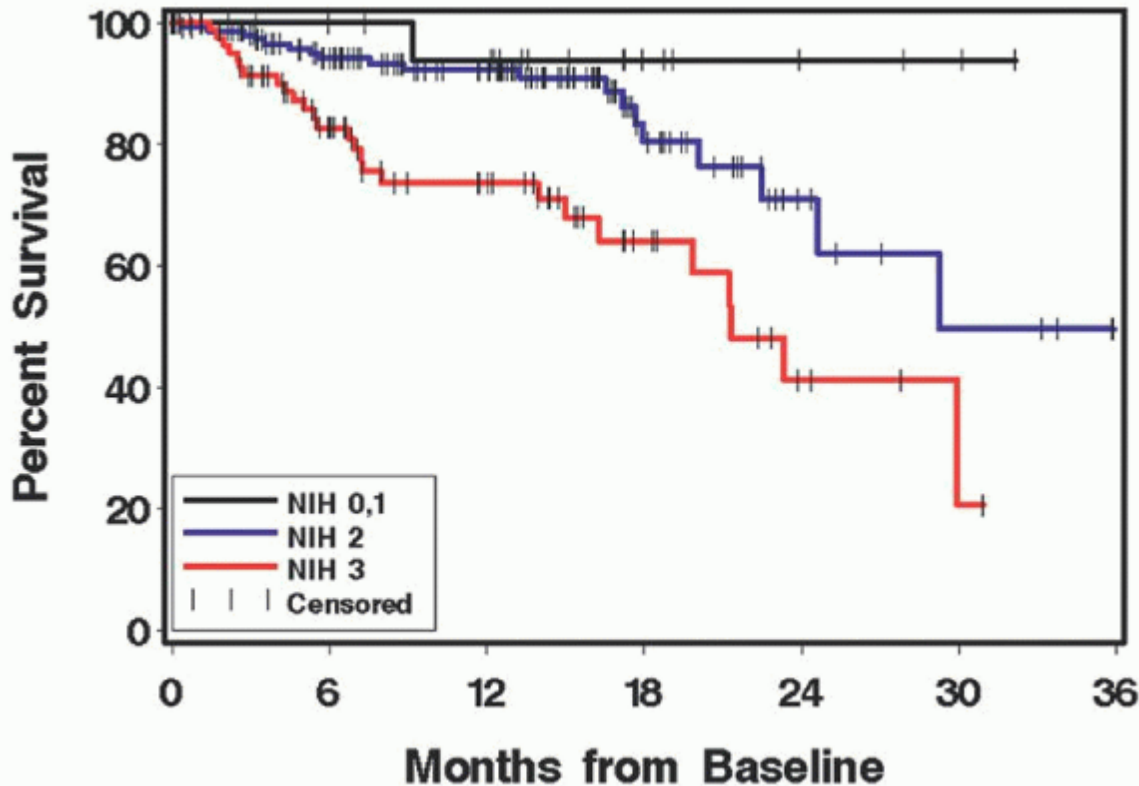

FIGURE 105.1. Survival outcomes per NIH chronic GVHD overall severity. From Arai S, Jagasia M, Storer B, et al. Global and organ-specific chronic graft-versus-host disease severity according to the 2005 NIH consensus criteria. *Blood* 2011;118(15):4242-4249.

Clinical Predictors of Chronic Graft-versus-Host Disease Development

Clinical predictors for the development of chronic GVHD may facilitate identification of patients at risk, and could potentially provide a rationale for risk-adapted strategies for prevention of the syndrome. The most consistently reported risk factors for development of chronic GVHD have included increasing age of the donor or recipient, donor/recipient HLA disparity and donor relation, male recipients of allografts from alloimmunized female donors, prior occurrence of acute GVHD, and the use of peripheral blood mobilized stem cells versus bone marrow.^{110, 142, 143, 144} However, it should be noted that these analyses have utilized the historical definition for chronic GVHD, rather than the proposed NIH Consensus criteria for diagnosis and classification of chronic GVHD. These potential limitations are highlighted by the fact that a recent analysis did not demonstrate that these traditional risk factors for chronic GVHD development had association with severity of chronic GVHD.¹⁴¹

PROGNOSTIC VARIABLES

Previously reported prognostic variables include extensive involvement versus limited progressive onset of chronic GVHD from acute GVHD, platelet count less than 100,000/ μ l at chronic GVHD diagnosis, impaired performance status, and failure to respond to therapy.^{134, 145, 146, 147} In a recent large Center for International Blood and Marrow Transplant Research analysis, investigators examined prognostic factors to develop a chronic GVHD risk score in a sample of 5,343 chronic GVHD-affected patients. In this analysis, 10 variables were significantly associated in multivariate analysis with overall survival and nonrelapse mortality: age, prior acute GVHD, time from transplantation to chronic GVHD, donor type, disease status at transplantation, GVHD prophylaxis, gender mismatch, serum bilirubin, Karnofsky performance status, and platelet count. From these data, six risk groups were identified based on the number of risk factors present. Nonrelapse mortality at 5 years ranged from 5% in the lowest risk group to 72% in those with greatest risk. Similarly, 5-year overall survival ranged from 91% in the lowest risk group down to 4% in the greatest risk group ($P < 0.01$).¹⁴⁸ Moving forward, predictive variables for long-term outcome need to be examined based on current transplantation practices and in the setting of the revised diagnostic and severity grading criteria. Analyses performed to date from the Chronic

P.2215

GVHD Consortium support both the NIH overall severity,¹⁴¹ and the overlap subtype of chronic GVHD¹⁴⁰ as significant determinants of overall survival and nonrelapse mortality.

PREVENTION OF CHRONIC GRAFT-VERSUS-HOST DISEASE

Successive advances in pharmacologic prophylaxis strategies for acute GVHD prevention have led to more effective reduction in grade II-IV and grade III/IV acute GVHD. Inasmuch as severe acute GVHD, especially that refractory to standard first-line steroid therapy, results in significant mortality, these approaches represent major breakthroughs in reduction of early transplant-associated complications and mortality. However, these benefits in acute GVHD prevention have largely not resulted in reduction in chronic GVHD. Randomized phase III trials in matched sibling and unrelated donor HSCT supported the superiority of tacrolimus/methotrexate over cyclosporine (cyclosporine)/methotrexate for prevention of acute GVHD, but did not result in reduction of the incidence of chronic GVHD.^{67, 68} Similarly, single-center phase II trials examining the combination of sirolimus/tacrolimus,¹⁴⁹ as well as a comparative trial of mycophenolate mofetil/tacrolimus versus methotrexate/tacrolimus⁷⁰ have not shown major benefit in chronic GVHD prevention when methotrexate is replaced with alternative agents.

The optimal duration of immune suppression administration is not known, however, and chronic GVHD can often arise during or after discontinuation of immune suppression. Thus, several investigators have explored whether prolonged administration of immune suppression may reduce the risk for chronic GVHD. Some reports indicated decreased risk with prolonged administration of cyclosporine,^{150, 151} however, prospective trials have not consistently demonstrated a benefit. In a randomized trial of allogeneic related or unrelated marrow transplant recipients, the hazard for chronic GVHD did not significantly differ between 6 and 24 months of cyclosporine administration after transplantation.¹⁵² Others have demonstrated in peripheral blood stem cell grafts from matched related donors reduced incidence of chronic GVHD in those treated with 12 versus 6 months of cyclosporine after transplantation.¹⁵³ In the setting of nonmyeloablative conditioning, retrospective analysis did not demonstrate significant differences in extensive chronic GVHD between three tapering schedules.¹⁵⁴ Emerging data from a randomized trial comparing sirolimus/tacrolimus and methotrexate/tacrolimus suggests that prolonged administration of sirolimus through 1 year after transplantation may be associated with reduction in NIH moderate-severe chronic GVHD, however, further follow-up is needed.⁷⁷ Based on the rationale that alloreactive T cells are responsible for chronic GVHD development, investigators have pursued both in vivo and ex vivo strategies for T-cell depletion. Memorial Sloan Kettering Cancer Center published a phase II trial of ex vivo T-cell depletion employing CD34 enrichment by the Miltenyi device in 35 unrelated donor transplants.¹¹² The median CD3+ cell dose was 1.52×10^3 /kg. With no pharmacologic prophylaxis, the incidence of chronic GVHD was only 29%. Epstein-Barr virus-associated post-transplant lymphoproliferative disease occurred in 9% of the cases. With intense conditioning, the relapse incidence was low, 6% at 4 years, despite a largely advanced disease cohort. In addition, the BMT CTN 0303 trial confirmed the efficacy of this protocol in HLA-matched sibling donor transplantation ($n = 44$) for acute myeloid leukemia in first or second complete remission.¹¹¹ T-cell-depleted allografts contained a median CD3+ dose of 6.6×10^3 /kg. Without pharmacologic prophylaxis, extensive chronic GVHD was 6.8% (0% to 14.4%) at 24 months. With median follow-up of 34 months, the 36-month leukemia-free survival was 58%. These results demonstrate that subtotal depletion of donor T cells provides protection against chronic GVHD.

Investigators from Johns Hopkins have pioneered GVHD prophylaxis with post-transplant high-dose cyclophosphamide (50 mg/kg/d on days +3 and +4) based on its selective activity against alloactivated donor T cells.⁹¹ In a recent phase I/II Bayesian design trial ($n = 117$) including HLA-matched related or unrelated donors, T replete marrow was transplanted following myeloablative doses of busulfan and cyclophosphamide. With sole post-transplant cyclophosphamide prophylaxis, chronic GVHD incidence was only 10% with median follow-up of 26 months. These data suggest that targeting alloreactive donor T cells may reduce chronic GVHD risk and facilitate transplantation tolerance. Investigators from MD Anderson Cancer Center reported a higher risk for chronic GVHD using post-transplant cyclophosphamide prophylaxis after peripheral blood stem cell transplantation rather than bone marrow, however. In vivo strategies for T-cell depletion, including antilymphocyte antibodies such as ATG or alemtuzumab, have promise to reduce risk for chronic GVHD as well. Long-term follow-up from a randomized phase III trial comparing ATG-Fresenius versus placebo alongside cyclosporine/methotrexate standard prophylaxis demonstrated cumulative incidence of extensive chronic GVHD after 3 years of 12% in the ATG-Fresenius group versus 45% in the control group ($P < 0.0001$), with comparable incidence of primary disease relapse and nonrelapse mortality. The hazard ratio for receiving immunosuppressive therapy was 0.31 after ATG-Fresenius ($P < 0.0001$), and the 3-year probability of survival free of immune suppression was 53% and 17% in the ATG-Fresenius versus control.¹¹³

Finally, based on preclinical insights supporting the role of B cells in chronic GVHD pathogenesis, as well as activity of anti-CD20 therapy in steroid-refractory chronic GVHD, investigators have presented results of a single-center phase II trial of rituximab for chronic GVHD prevention.¹⁵⁵ There is also great interest in disruption of B-cell stimulatory signals (e.g., BAFF) after HSCT for prevention of chronic GVHD.

CHRONIC GRAFT-VERSUS-HOST DISEASE TREATMENT

Systemic immune suppressive therapy is generally required to control extensive chronic GVHD, or rather moderate to severe manifestations per the NIH Consensus severity grading. Those who have limited or mild chronic GVHD can often be treated with topical agents, such as artificial tears for ocular sicca; steroid mouth rinses for troublesome mouth symptoms such as dryness, sensitivity, or pain; topical steroid creams for mild cutaneous manifestations; or vaginal estrogen for vaginal dryness and atrophy. In total, the diverse manifestations of the syndrome require a tailored and multidisciplinary approach.

For those requiring systemic therapy, accepted standard primary therapy for chronic GVHD includes 1 mg/kg/day or greater of prednisone or equivalent with or without a calcineurin inhibitor.^{132, 156} A randomized trial comparing prednisone versus prednisone plus cyclosporine for primary therapy of extensive chronic GVHD did not detect significant differences in chronic GVHD control, transplant-related mortality, or overall survival, but showed less prednisone side effects in the combination arm.¹⁵⁶ Based on the limited durable response rates observed with standard primary therapy, several studies have been performed to determine whether combined therapy (i.e., steroids + additional systemic immune suppressive agent) improves response. The addition of other systemic immune suppressive agents has not provided benefit, as evidenced by trials employing azathioprine, thalidomide, hydroxychloroquine, or mycophenolate mofetil.^{157, 158, 159, 160}

Based on major published primary chronic GVHD therapy trials,^{156, 157, 158, 159, 160, 161} the following summarizes current evidence. Complete response rate assessed at 6 to 9 months following steroid-based therapy (either 1 mg/kg of prednisone alone or this in combination with additional agents such as azathioprine, thalidomide,

P.2216

hydroxychloroquine, or mycophenolate mofetil) includes a range of reported values from 16% to 37%. In the study by Sullivan et al., 9-month complete response rate to prednisone was 33%, prednisone + azathioprine 37%, and prednisone alone among high-risk cases 16%.¹⁵⁷ Arora et al. reported 6-month complete response rate of 17% in prednisone + thalidomide and cyclosporine, and 28% for prednisone and cyclosporine alone.¹⁵⁸ In a more recent trial comparing activity of prednisone versus prednisone and mycophenolate mofetil, Martin et al. reported a 6-month complete response rate of only 23%.¹⁶⁰ Finally, Gilman et al. reported CR rates at 9 months of 38% and 33%, respectively, for hydroxychloroquine + prednisone versus prednisone alone. Thus, available randomized trials suggest an average complete response rate at 6 to 9 months of 27%.

ORR (total of CR + PR) has been reported as the following. Sullivan et al., reported ORR of 62% among prednisone-treated patients, 64% for prednisone with azathioprine, and only 32% for prednisone-treated patients with thrombocytopenia.¹⁵⁷ Arora et al. reported ORR of 84% at 6 months for prednisone-treated patients and 88% for those treated with prednisone and thalidomide.¹⁵⁸ Martin et al. reported an ORR of 62% at 6 months for patients treated with prednisone + mycophenolate mofetil or prednisone + placebo.^{160, 162} Gilman et al. reported ORR at 9 months of 39% and 46% for hydroxychloroquine + prednisone versus prednisone alone.¹⁵⁹ Thus, published randomized trials support an average ORR at 6 to 9 months of 60%. Note that Martin et al. demonstrated that ORR at 6 months of therapy was significantly associated with the ultimate risk for treatment failure, defined as initiation of secondary systemic GVHD treatment, nonrelapse death, or development of bronchiolitis obliterans. The cumulative incidence of treatment failure was 37% versus 63% in those with overall response versus not, $P = 0.01$.¹⁶² Ongoing clinical trials aim to study targeted therapeutic approaches for specific chronic GVHD phenotypes [e.g., imatinib or rituximab for treatment of cutaneous sclerosis (NCT01309997) and fluticasone, azithromycin, and montelukast for treatment of bronchiolitis obliterans (NCT01307462)].

Based on limited response to primary therapy, many will go on to require additional immune-suppressive agents for chronic GVHD control. Steroid-refractory chronic GVHD has most commonly been defined as either progressive manifestations despite 1 month, or rather incomplete response despite 2 months of 1 to 2 mg/kg of prednisone or equivalent.¹³² Multiple immune-suppressive agents, including pharmacologic agents such as mycophenolate mofetil, sirolimus, pentostatin, tacrolimus, and thalidomide, monoclonal antibodies including rituximab, and strategies such as extracorporeal photopheresis have demonstrated moderate activity in this setting, both ameliorating objective chronic

GVHD manifestations, as well as facilitating decrease in systemic steroids.¹³² Their activity is incomplete, however, and many with steroid-refractory chronic GVHD will require multiple agents to achieve disease control.

Note that chronic GVHD is associated with prolonged immune suppressive therapy after HSCT. In an analysis of 751 patients with chronic GVHD, the cumulative incidence of discontinuation of immune suppression at 7 years following chronic GVHD diagnosis was 50%; nonrelapse mortality was 24%, and relapse was 19%. On multivariable analysis, several factors were associated with decreased likelihood of discontinuation of immune suppression: peripheral blood stem cells, female donor:male recipient, number of chronic GVHD sites involved, bilirubin > 2 mg/dl at diagnosis, HLA mismatch, and year of transplantation.¹³⁹

ASSESSMENT OF THERAPEUTIC RESPONSE

The established method for response determination in the majority of chronic GVHD therapy trials has been that of clinician-determined response. This method relies on the clinician's integration of dynamic chronic GVHD manifestations for a summary response categorization. CR indicates complete resolution of all chronic GVHD manifestations; PR signifies reduction in disease activity at response assessment compared to pre-treatment levels, but without complete resolution; stable disease indicates no response and no progression; and progressive disease indicates progressive chronic GVHD manifestations from baseline to response assessment.

Following the NIH Consensus Conference for Chronic GVHD, several additional means of response assessment in chronic GVHD therapeutic trials have been proposed. These include change in overall NIH severity categories, proposed NIH response criteria, 0-4 and 0-10 ordinal scales that rely on clinician assessment, organ-specific tools such as the Vienna skin scale, as well as patient-determined change in chronic GVHD activity, chronic GVHD-associated symptom burden, functional limitations, and change in quality of life. A national Chronic GVHD Consortium is currently assessing these competing measures of disease activity and their relationship to longer-reaching outcomes indicating clinical benefit, such as survival, discontinuation of immune suppression, and patient-reported benefit. One analysis recently reported demonstrates limited agreement between cliniciandetermined response and that calculated by the proposed NIH Consensus response criteria (Fig. 105.2)¹⁶³; thus, response rates reported in the literature need to be interpreted with attention to the response metric utilized.

SUPPORTIVE CARE

Patients with chronic GVHD require careful supportive care and infectious prophylaxis. Given the immune dysfunction associated both with chronic GVHD as well as the immune-suppressive agents used to treat it, they are at increased risk for morbidity and mortality from infectious complications. Prophylactic antimicrobials should be utilized to prevent *Pneumocystis jiroveci*, encapsulated bacterial infections such as *Streptococcus pneumoniae*, *Haemophilus influenzae*, and *Neisseria meningitidis*, and *Varicella zoster*.¹⁶⁴ Systematic monitoring and pre-emptive therapy for cytomegalovirus reactivation is also important. The routine use of antifungal agents as prophylaxis beyond 75 days after transplantation has not been proven to be effective in preventing invasive fungal infections; however, many administer these agents for prophylaxis, particularly in those patients on prolonged courses of glucocorticoids. The use of intravenous immunoglobulin following HSCT has not been proven to be of benefit.¹⁶⁵ Other important components of supportive care include vaccination once appropriate after transplantation, skin care, oral cavity health and symptom control, management of ocular sicca symptoms, supportive care for vulvovaginal manifestations of GVHD, physical therapy for musculoskeletal impairment, prevention and management of osteopenia and osteoporosis, management of fatigue, and psychosocial support. A comprehensive review of appropriate, evidence-based ancillary care has been published.¹⁶⁴

CONCLUSION

In summary, investigation into chronic GVHD pathogenesis, diagnosis and classification, and therapy offers promise for improved patient outcomes. Insights into chronic GVHD biology will provide novel strategies for prevention and therapy. Validation of the proposed NIH Consensus diagnostic and severity classification criteria, as well as determination of best-response criteria will move the state of chronic GVHD clinical trials forward. Novel preventive and therapeutic strategies based on detailed understanding of chronic GVHD pathogenesis will advance the field.

P.2217

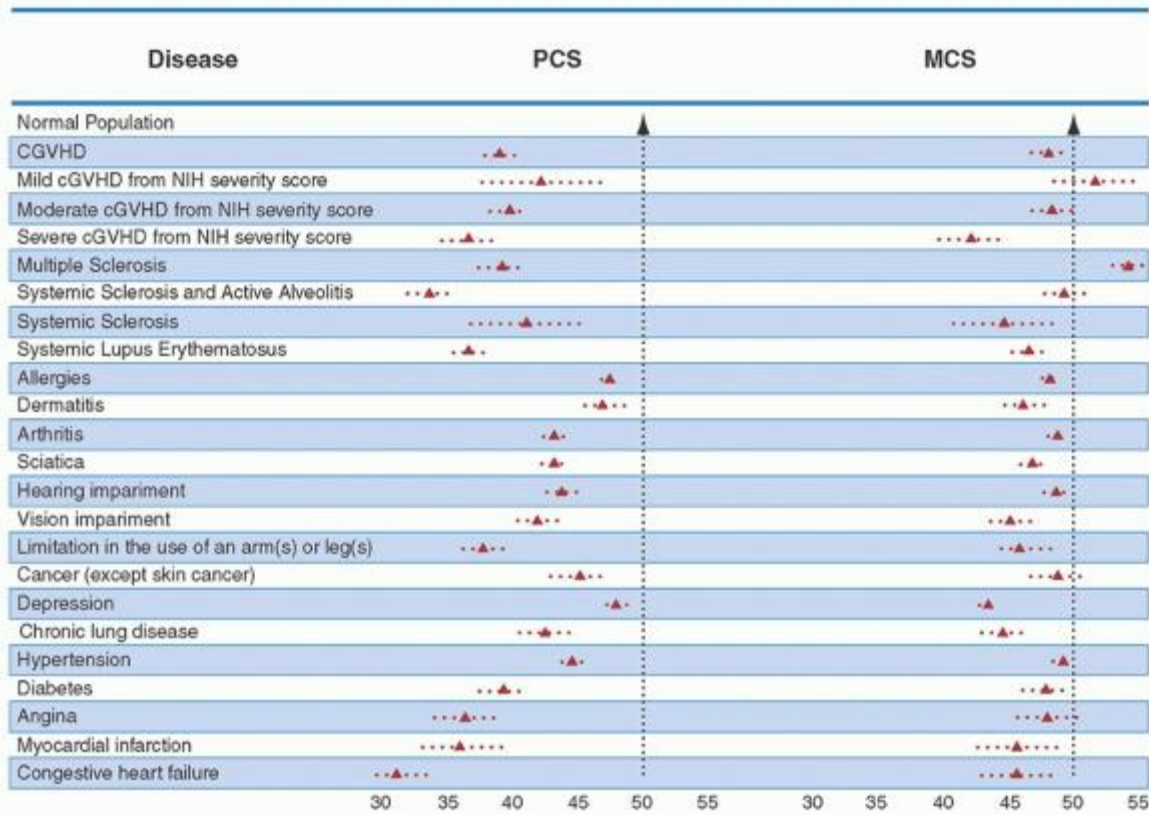

FIGURE 105.2. Quality of life associated with chronic GVHD (cGVHD) severity. From Pidala J, Kurland B, Chai X, et al. Patient-reported quality of life is associated with severity of chronic graft-versus-host disease as measured by NIH criteria: report on baseline data from the Chronic GVHD consortium. *Blood* 117:4651-4657.

GRAFT-VERSUS-TUMOR RESPONSE

Evidence for Graft versus Tumor in Animals and Humans

Multiple lines of evidence point to a powerful immune response of donor immune cells against tumor cells after allogeneic HSCT. Initial proof of principle for an allogeneic GVT effect was established in rodents.^{166, 167} Single-center and registry studies found an inverse correlation between acute and chronic GVHD and relapse of malignancy after human marrow transplantation (Fig. 105.3).^{168, 169} The probability of relapse was higher after twin compared to HLA-identical sibling transplants, pointing to disparate mHA as the target of the GVT effect. Similarly high was the probability of relapse after a T-depleted allogeneic transplant, pointing to mature donor T cells as GVT effectors. There was protection from relapse after a T-replete allogeneic HSCT in patients without history of GVHD, indicating that GVHD is not required for the GVT effect. Lower relapse rates, however, were in patients who had experienced acute GVHD, and the lowest in those with chronic GVHD. As shown in Figure 105.3, the GVT effect in allogeneic recipients with GVHD did account for about half of the total antitumor activity of the transplant procedure, thus GVT was as effective as the high-dose chemoradiotherapy administered before the transplant. Allogeneic HSCT after safer, low-intensity conditioning regimens, are also associated with durable responses in some malignancies.¹⁷⁰ As immune-suppressive therapy to prevent or treat GVHD also affects GVT responses, spontaneous remissions have been observed after stopping immune suppression in a variety of hematologic malignancies that had relapsed after allogeneic HSCT.¹⁷¹ Direct evidence for a GVT effect was provided by infusion of donor lymphocytes for sole treatment of relapse after allogeneic HSCT (Table 105.4).¹⁷² Response to donor lymphocyte infusions occurs after allogeneic transplants but not twin transplants, as disparate histocompatibility antigens are the GVT targets, and require stable donor engraftment, although it does not help

P.2218

patients who have rejected the graft. Donor lymphocytes are most effective in patients who have received a T-depleted graft, in those who have not already experienced GVHD, in chronic more than acute leukemia, and in patients with minimal tumor burden.¹⁷³

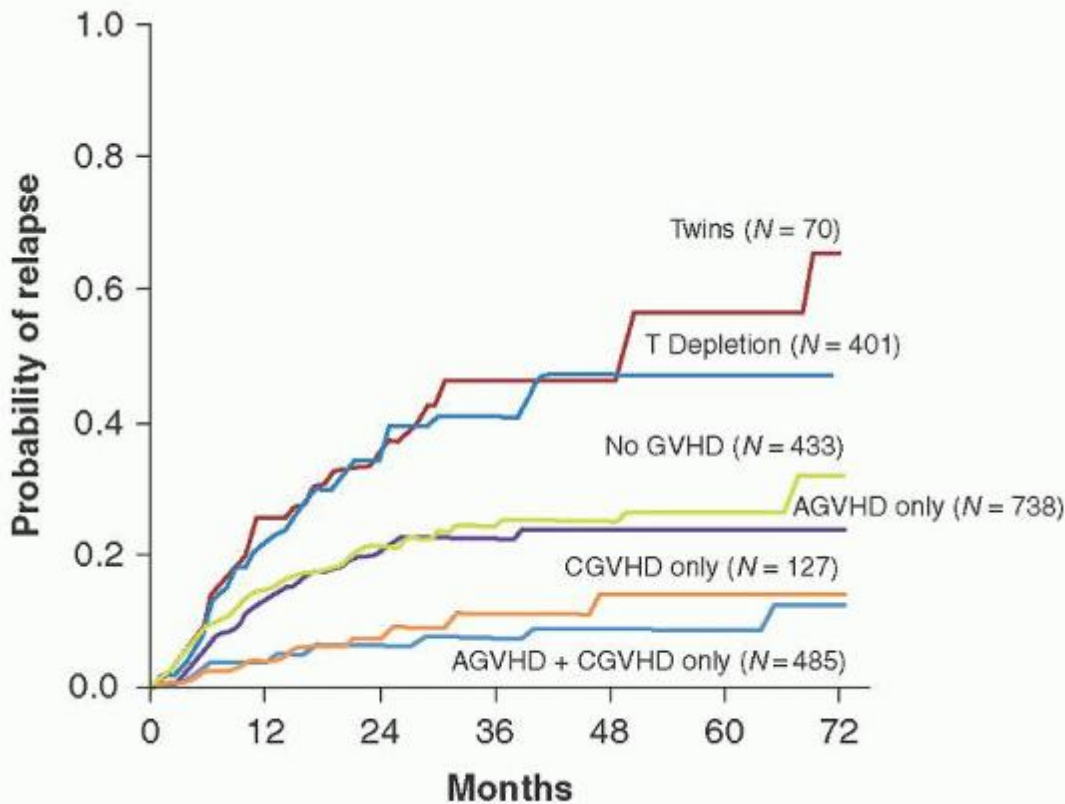

FIGURE 105.3. Actuarial probability of relapse after bone marrow transplantation for early leukemia according to type of graft and development of graft-versus-host disease (GVHD). AGVHD, acute GVHD; CGVHD, chronic GVHD. From Horowitz MM, Gale RP, Sondel PM, et al. Graft-versus-leukemia reactions after bone marrow transplantation. *Blood* 1990;75:555-562.

TABLE 105.4 EVIDENCE FOR A GRAFT-VERSUS-TUMOR RESPONSE

1. Allogeneic but not syngeneic marrow transplants can cure mice with leukemia.
2. Allogeneic marrow transplants are more effective than twin transplants in preventing leukemia relapse in humans.
3. Patients with graft-versus-host disease are more likely to be cured from leukemia than those without graft-versus-host disease.
4. Spontaneous remissions occur after stopping immune suppression in patient with relapsed malignancy after allogeneic marrow transplantation.
5. Donor lymphocyte infusions induce remission in patient with relapsed malignancy after allogeneic marrow transplantation.

T-cell-mediated Graft versus Tumor

Infusions of isolated CD4 or CD8 donor T cells for treatment of relapse have demonstrated that each of these cell types can mediate GVT.^{174, 175} The predominant GVT targets are mHA expressed in the recipient's malignant cells. As discussed under the "ACUTE GRAFT-VERSUS-HOST DISEASE" section, mHAs can be expressed ubiquitously (including, e.g., skin and leukemia) and are therefore targets for both GVHD and GVT (i.e., the H-Y associated male antigens), or their expression can be restricted to one or more hematopoietic lineages so they are targets for GVT but not GVHD (e.g., HA-1 and HA-2 antigens). Little is known about most mHAs, because diversity assessment of the human genome predicts over 107 polymorphisms that can function as mHAs in transplantation. A variety of genetic techniques have sped up the discovery of functional mHAs, and investigators hope to find a relatively small number of dominant mHAs that can be targeted for prevention of GVHD and exploitation of GVT.¹⁷⁶ Weaker immune targets are a variety of tumor-associated antigens that by themselves are not sufficiently immunogenic to elicit a protecting immune response, but in conjunction with the adjuvant

effect of an allogeneic transplant can contribute to the GVT effect. These include the following: (1) tumor-specific antigens that result from the oncogenic mutations such as the Bcr/Abl tyrosine kinase in chronic myeloid leukemia, and the promyelocytic leukemia/retinoic acid receptor- α transcription factor in promyelocytic leukemia; (2) viral proteins, such as those from human papilloma virus in cervical cancer; (3) tissue-specific proteins, such as prostate-specific antigen in prostate cancer and proteinase-3 in myeloid leukemias; (4) germ-cell antigens, such as the melanoma-associated antigen (MAGE) family; (5) tumor-selective overexpressed self-proteins, such as WT1 in Wilms tumor or acute myeloid leukemia. Proteinase-3-derived PR1 peptide and WT1 are the best characterized tumor-associated antigens in patients after allogeneic HSCT.^{177, 178} Initial attempts have been made to amplify tumor immunity after allogeneic HSCT by vaccines.¹⁷⁹

Natural Killer-cell-mediated Graft versus Tumor

As disparate HLA molecules are strong GVHD targets, one may expect that they would also be GVT targets for T cells. In contrast, most studies have failed to detect a GVT effect of HLA mismatch in T-replete transplants.^{180, 181} One hypothesis is that GVHD is so forceful after T-replete transplants from HLA-incompatible donors, that the required immune suppression may dissipate any possible appearance of GVT. Most HLA-incompatible transplants are performed nowadays with ex vivo or in vivo T-cell depletion. Early recovery of functional NK cells after T-depleted transplants from HLA-incompatible related donors has unveiled a powerful effect against myeloid leukemia without GVHD. NK-cell alloreactivity has been related to a reduced risk of leukemia relapse, no GVHD, and markedly improved survival in HLA disparate transplants.^{182, 183} For patients with acute myeloid leukemia in remission, the cumulative incidence of relapse was significantly lower after transplantation from NK alloreactive donors (3% vs. 47%; $P < 0.003$), and this translated into an improved event-free survival (67% vs. 18%; $P = 0.02$). For patients in relapse at the time of HSCT, donor NK-cell alloreactivity was not protective. Based on these data, donor NK alloreactivity against recipient cells has become a selection criterion for HLA-disparate donors when a T-depleted protocol is employed. To this purpose, high-resolution HLA-C typing is a good predictor of NK-cell alloreactivity, because the basis for NK allorecognition resides primarily in a bi-allelic system of inhibitory killer-cell Ig-like receptors (KIR) that silence NK effector function after recognition of their cognate ligands encoded by HLA-C alleles.¹⁸⁴ KIR2DL1 recognizes HLA-C molecules characterized by a Lys80 residue (i.e., HLA-Cw4), and KIR2DL2 and KIR2DL3 recognize HLA-C with an Asn80 residue (i.e., HLA-Cw3). Also, KIR3DL1 is the receptor for HLA-B alleles that include a Bw4 domain and the CD94/NG2A heterodimer (encoded by the KLRD1/KLRC1 genes) is an inhibitory receptor for HLA-E. During development, HLA class I molecules select for a self-tolerant KIR repertoire so that every mature NK-cell expresses at least one inhibitory receptor for self-HLA. NK cells that express a KIR for the class I group absent on allogeneic targets, sense the missing expression of self-class I HLA and kill the allogeneic target ("missing self" model). The alternative "missing ligand" model has also been proposed to predict protection from relapse after HLA-matched sibling transplants.¹⁸⁵ When KIR ligand-matched donors possess anergic NK cells with an "extra" KIR for which neither donor nor recipient has an HLA ligand, upon transfer into the recipient, those NK-cells may regain competency and produce a GVT effect.¹⁸⁶ Activating KIRs regulate both NK- and T-cell functions. Unlike inhibitory KIRs, activating KIRs exhibit extensive population variation in gene number and content. Transplantation from donors carrying activating KIR genes is associated with improved control of leukemia relapse after unrelated donor transplantation.¹⁸⁷ Several biological models suggest that alloreactive NK-cells are responsible for favorable transplantation outcomes. Transfer of human alloreactive NK-cells into immune-deficient mice eradicated human myeloid leukemia.¹⁸³ KIR ligand mismatches correlate with the ability of donor NK-cell clones to kill recipient leukemic cells.¹⁸³ Alloreactive NK clones are detected in the recipients long after transplant.¹⁸⁸

Conclusions

HSCT from allogeneic donors provide powerful GVT effects, via innate and adaptive immunity. The most recent effects of these findings have been: (1) decreased reliance on the use of toxic and sometimes lethal conditioning regimens to control leukemia; (2) use of donor lymphocyte infusion for prevention or treatment of relapse; (3) development of tumor vaccines to amplify the immune response after T-replete transplants; (4) selection of NK alloreactive, HLA-incompatible donors to decrease relapse of myeloid leukemias after T-depleted transplants.^{189, 190} We anticipate that further understanding of the factors that regulate GVT will continue to shape the protocols for allogeneic HSCT.¹⁹¹

REFERENCES

1. Ferrara JL, Levine JE, Reddy P, Holler E. Graft-versus-host disease. *Lancet* 2009;373:1550-1561.
2. Billingham R. The biology of graft-versus-host reactions. *Harvey Lecture Series* 1966-1967;62:21-78.

3. Paczesny S, Hanauer D, Sun Y, Reddy P. New perspectives on the biology of acute GVHD. *Bone Marrow Transplant* 2010;45:1-11.
4. Loiseau P, Busson M, Balere ML, et al. HLA Association with hematopoietic stem cell transplantation outcome: the number of mismatches at HLA-A, -B, -C, -DRB1, or -DQB1 is strongly associated with overall survival. *Biol Blood Marrow Transplant* 2007;13:965-974.
5. Lee SJ, Klein J, Haagenson M, et al. High-resolution donor-recipient HLA matching contributes to the success of unrelated donor marrow transplantation. *Blood* 2007;110:4576-4583.
6. Wang W, Meadows LR, den Haan JM, et al. Human H-Y: a male-specific histocompatibility antigen derived from the SMCY protein. *Science* 1995; 269:1588-1590.
7. Goulmy E, Schipper R, Pool J, et al. Mismatches of minor histocompatibility antigens between HLA-identical donors and recipients and the development of graft-versus-host disease after bone marrow transplantation. *N Engl J Med* 1996;334:281-285.
8. Marijt WA, Heemskerk MH, Kloosterboer FM, et al. Hematopoiesis-restricted minor histocompatibility antigens HA-1- or HA-2-specific T cells can induce complete remissions of relapsed leukemia. *Proc Natl Acad Sci U S A* 2003;100:2742-2747.
9. Goulmy E, Gratama JW, Blokland E, Zwaan FE, van Rood JJ. A minor transplantation antigen detected by MHC-restricted cytotoxic T lymphocytes during graft-versus-host disease. *Nature* 1983;302:159-161.
10. Cooke KR, Hill GR, Crawford JM, et al. Tumor necrosis factor- alpha production to lipopolysaccharide stimulation by donor cells predicts the severity of experimental acute graft-versus-host disease. *J Clin Invest* 1998;102:1882-1891.
11. Ferrara JL. Cytokine dysregulation as a mechanism of graft versus host disease. *Curr Opin Immunol* 1993;5:794-799.
12. Edinger M, Hoffmann P, Ermann J, et al. CD4+CD25+ regulatory T cells preserve graft-versus-tumor activity while inhibiting graft-versus-host disease after bone marrow transplantation. *Nat Med* 2003;9:1144-1150.
13. Koreth J, Matsuoka K, Kim HT, et al. Interleukin-2 and regulatory T cells in graft-versus-host disease. *N Engl J Med* 2011;365:2055-2066.
14. Lee SJ, Zahrieh D, Agura E, et al. Effect of up-front daclizumab when combined with steroids for the treatment of acute graft-versus-host disease: results of a randomized trial. *Blood* 2004;104:1559-1564.
15. Yu Y, Wang D, Liu C, et al. Prevention of GVHD while sparing GVL effect by targeting Th1 and Th17 transcription factor T-bet and RORgammat in mice. *Blood* 2011;118:5011-5020.
16. Carlson MJ, West ML, Coghill JM, et al. In vitro-differentiated TH17 cells mediate lethal acute graft-versus-host disease with severe cutaneous and pulmonary pathologic manifestations. *Blood* 2009;113:1365-1374.
17. Reshef R, Luger SM, Hexner EO, et al. Blockade of lymphocyte chemotaxis in visceral graft-versus-host disease. *N Engl J Med* 2012;367:135-145.
18. Castro-Malaspina H, Harris RE, Gajewski J, et al. Unrelated donor marrow transplantation for myelodysplastic syndromes: outcome analysis in 510 transplants facilitated by the National Marrow Donor Program. *Blood* 2002;99:1943-1951.
19. Bensinger WI, Martin PJ, Storer B, et al. Transplantation of bone marrow as compared with peripheral-blood cells from HLA-identical relatives in patients with hematologic cancers. *N Engl J Med* 2001;344:175-181.
20. Weisdorf D, Hakke R, Blazar B, et al. Risk factors for acute graft-versus-host disease in histocompatible donor bone marrow transplantation. *Transplantation* 1991;51:1197-1203.
21. Hahn T, McCarthy PL Jr, Zhang MJ, et al. Risk factors for acute graft-versus-host disease after human leukocyte antigen-identical sibling transplants for adults with leukemia. *J Clin Oncol* 2008;26:5728-5734.
22. Morishima Y, Sasazuki T, Inoko H, et al. The clinical significance of human leukocyte antigen (HLA) allele compatibility in patients receiving a marrow transplant from serologically HLA-A, HLA-B, and HLA-DR matched unrelated donors. *Blood* 2002;99:4200-4206.
23. Bross DS, Tutschka PJ, Farmer ER, et al. Predictive factors for acute graft-versus-host disease in patients transplanted with HLA-identical bone marrow. *Blood* 1984;63:1265-1270.
24. Randolph SS, Gooley TA, Warren EH, Appelbaum FR, Riddell SR. Female donors contribute to a selective graft-versus-leukemia effect in male recipients of HLA-matched, related hematopoietic stem cell transplants. *Blood* 2004;103:347-352.

25. Flowers ME, Pepe MS, Longton G, et al. Previous donor pregnancy as a risk factor for acute graft-versus-host disease in patients with aplastic anaemia treated by allogeneic marrow transplantation. *Br J Haematol* 1990;74: 492-496.
26. Kollman C, Howe CW, Anasetti C, et al. Donor characteristics as risk factors in recipients after transplantation of bone marrow from unrelated donors: the effect of donor age. *Blood* 2001;98:2043-2051.
27. Nash RA, Pepe MS, Storb R, et al. Acute graft-versus-host disease: analysis of risk factors after allogeneic marrow transplantation and prophylaxis with cyclosporine and methotrexate. *Blood* 1992;80:1838-1845.
28. Storek J, Gooley T, Siadak M, et al. Allogeneic peripheral blood stem cell transplantation may be associated with a high risk of chronic graft-versus-host disease. *Blood* 1997;90:4705-4709.
29. Cutler C, Giri S, Jeyapalan S, et al. Acute and chronic graft-versus-host disease after allogeneic peripheral-blood stem-cell and bone marrow transplantation: a meta-analysis. *J Clin Oncol* 2001;19:3685-3691.
30. Elmaagacli AH, Basoglu S, Peceny R, et al. Improved disease-free-survival after transplantation of peripheral blood stem cells as compared with bone marrow from HLA-identical unrelated donors in patients with first chronic phase chronic myeloid leukemia. *Blood* 2002;99:1130-1135.
31. Schmitz N, Beksac M, Hasenclever D, et al. Transplantation of mobilized peripheral blood cells to HLA-identical siblings with standard-risk leukemia. *Blood* 2002;100:761-767.
32. Anasetti C, Logan BR, Lee SJ, et al. Increased Incidence of Chronic Graft-Versus-Host Disease (GVHD) and No Survival Advantage with Filgrastim-Mobilized Peripheral Blood Stem Cells (PBSC) Compared to Bone Marrow (BM) Transplants from unrelated donors: results of BLOOD and Marrow Transplant Clinical Trials Network (BMT CTN) protocol 0201, a phase III, prospective, randomized trial. *ASH Annu Meeting Abstr* 2011;118:1.
33. Laughlin MJ, Barker J, Bambach B, et al. Hematopoietic engraftment and survival in adult recipients of umbilical-cord blood from unrelated donors. *N Engl J Med* 2001;344:1815-1822.
34. Rocha V, Labopin M, Sanz G, et al. Transplants of umbilical-cord blood or bone marrow from unrelated donors in adults with acute leukemia. *N Engl J Med* 2004;351:2276-2285.
35. Clift RA, Buckner CD, Appelbaum FR, et al. Allogeneic marrow transplantation in patients with acute myeloid leukemia in first remission: a randomized trial of two irradiation regimens. *Blood* 1990;76:1867-1871.
36. Perez-Simon JA, Diez-Campelo M, Martino R, et al. Influence of the intensity of the conditioning regimen on the characteristics of acute and chronic graft-versus-host disease after allogeneic transplantation. *Br J Haematol* 2005;130:394-403.
37. Aoudjhane M, Labopin M, Gorin NC, et al. Comparative outcome of reduced intensity and myeloablative conditioning regimen in HLA identical sibling allogeneic haematopoietic stem cell transplantation for patients older than 50 years of age with acute myeloblastic leukaemia: a retrospective survey from the Acute Leukemia Working Party (ALWP) of the European group for Blood and Marrow Transplantation (EBMT). *Leukemia* 2005;19:2304-2312.
38. Hill GR, Crawford JM, Cooke KR, et al. Total body irradiation and acute graft-versus-host disease: the role of gastrointestinal damage and inflammatory cytokines. *Blood* 1997;90:3204-3213.
39. Hill RS, Petersen FB, Storb R, et al. Mixed hematologic chimerism after allogeneic marrow transplantation for severe aplastic anemia is associated with a higher risk of graft rejection and a lessened incidence of acute graft-versus-host disease. *Blood* 1986;67:811-816.
40. Petz LD, Yam P, Wallace RB, et al. Mixed hematopoietic chimerism following bone marrow transplantation for hematologic malignancies. *Blood* 1987;70:1331-1337.
41. Zaucha JM, Gooley T, Bensinger WI, et al. CD34 cell dose in granulocyte colony-stimulating factor-mobilized peripheral blood mononuclear cell grafts affects engraftment kinetics and development of extensive chronic graft-versus-host disease after human leukocyte antigen-identical sibling transplantation. *Blood* 2001;98:3221-3227.
42. Mohty M, Bilger K, Jourdan E, et al. Higher doses of CD34+ peripheral blood stem cells are associated with increased mortality from chronic graft-versus-host disease after allogeneic HLA-identical sibling transplantation. *Leukemia* 2003;17:869-875.
43. Bittencourt H, Rocha V, Chevret S, et al. Association of CD34 cell dose with hematopoietic recovery, infections, and other outcomes after HLA-identical sibling bone marrow transplantation. *Blood* 2002;99:2726-2733.

44. Baron F, Maris MB, Storer BE, et al. High doses of transplanted CD34+ cells are associated with rapid T-cell engraftment and lessened risk of graft rejection, but not more graft-versus-host disease after nonmyeloablative conditioning and unrelated hematopoietic cell transplantation. *Leukemia* 2005;19:822-828.
45. Ringden O, Barrett AJ, Zhang MJ, et al. Decreased treatment failure in recipients of HLA-identical bone marrow or peripheral blood stem cell transplants with high CD34 cell doses. *Br J Haematol* 2003;121:874-885.
46. Przepiorka D, Smith TL, Folloder J, et al. Risk factors for acute graft-versus-host disease after allogeneic blood stem cell transplantation. *Blood* 1999;94:1465-1470.
47. Chien JW, Zhang XC, Fan W, et al. Evaluation of published single nucleotide polymorphisms associated with acute GVHD. *Blood* 2012;119:5311-5319.
48. Paczesny S, Krijanovski OI, Braun TM, et al. A biomarker panel for acute graft-versus-host disease. *Blood* 2009;113:273-278.
49. Levine JE, Logan BR, Wu J, et al. Acute graft-versus-host disease biomarkers measured during therapy can predict treatment outcomes: a Blood and Marrow Transplant Clinical Trials Network study. *Blood* 2012;119: 3854-3860.
50. Powles RL, Morgenstern GR, Kay HE, et al. Mismatched family donors for bone-marrow transplantation as treatment for acute leukaemia. *Lancet* 1983;1:612-615.
51. Sullivan KM, Deeg HJ, Sanders J, et al. Hyperacute graft-v-host disease in patients not given immunosuppression after allogeneic marrow transplantation. *Blood* 1986;67:1172-1175.
52. Saliba RM, de Lima M, Giral S, et al. Hyperacute GVHD: risk factors, outcomes, and clinical implications. *Blood* 2007;109:2751-2758.
53. Antin JH, Bierer BE, Smith BR, et al. Selective depletion of bone marrow T lymphocytes with anti-CD5 monoclonal antibodies: effective prophylaxis for graft-versus-host disease in patients with hematologic malignancies. *Blood* 1991;78:2139-2149.
54. Filipovich AH, Weisdorf D, Pavletic S, et al. National Institutes of Health consensus development project on criteria for clinical trials in chronic graft-versus-host disease: I. Diagnosis and staging working group report. *Biol Blood Marrow Transplant* 2005;11:945-956.
55. Przepiorka D, Weisdorf D, Martin P, et al. 1994 consensus conference on acute GVHD grading. *Bone Marrow Transplant* 1995;15:825-828.
56. Shulman HM, Sharma P, Amos D, Fenster LF, McDonald GB. A coded histologic study of hepatic graft-versus-host disease after human bone marrow transplantation. *Hepatology* 1988;8:463-470.
57. Shulman HM, Fisher LB, Schoch HG, Henne KW, McDonald GB. Veno-occlusive disease of the liver after marrow transplantation: histological correlates of clinical signs and symptoms. *Hepatology* 1994;19:1171-1181.
58. Kalantari BN, Morteale KJ, Cantisani V, et al. CT features with pathologic correlation of acute gastrointestinal graft-versus-host disease after bone marrow transplantation in adults. *AJR Am J Roentgenol* 2003;181:1621-1625.
59. Ponc R, Hackman RC, McDonald GB. Endoscopic and histologic diagnosis of intestinal graft-versus-host disease after marrow transplantation. *Gastrointest Endosc* 1999;49:612-621.
60. Wanko SO, Broadwater G, Folz RJ, Chao NJ. Diffuse alveolar hemorrhage: retrospective review of clinical outcome in allogeneic transplant recipients treated with aminocaproic acid. *Biol Blood Marrow Transplant* 2006;12:949-953.
61. Afessa B, Tefferi A, Litzow MR, Peters SG. Outcome of diffuse alveolar hemorrhage in hematopoietic stem cell transplant recipients. *Am J Respir Crit Care Med* 2002;166:1364-1368.
62. Yousem SA. The histological spectrum of pulmonary graft-versus-host disease in bone marrow transplant recipients. *Hum Pathol* 1995;26:668-675.
63. Mathew P, Bozeman P, Krance RA, Brenner MK, Heslop HE. Bronchiolitis Obliterans Organizing Pneumonia (BOOP) in children after allogeneic bone marrow transplantation. *Bone Marrow Transplant* 1994;13:221-223.
64. Freudenberger TD, Madtes DK, Curtis JR, et al. Association between acute and chronic graft-versus-host disease and bronchiolitis obliterans organizing pneumonia in recipients of hematopoietic stem cell transplants. *Blood* 2003;102:3822-3828.

65. Storb R, Deeg HJ, Farewell V, et al. Marrow transplantation for severe aplastic anemia: methotrexate alone compared with a combination of methotrexate and cyclosporine for prevention of acute graft-versus-host disease. *Blood* 1986;68:119-125.
66. Storb R, Deeg HJ, Whitehead J, et al. Methotrexate and cyclosporine compared with cyclosporine alone for prophylaxis of acute graft versus host disease after marrow transplantation for leukemia. *N Engl J Med* 1986;314:729-735.
67. Ratanatharathorn V, Nash RA, Przepiorka D, et al. Phase III study comparing methotrexate and tacrolimus (prograf, FK506) with methotrexate and cyclosporine for graft-versus-host disease prophylaxis after HLA-identical sibling bone marrow transplantation. *Blood* 1998;92:2303-2314.
68. Nash RA, Antin JH, Karanes C, et al. Phase 3 study comparing methotrexate and tacrolimus with methotrexate and cyclosporine for prophylaxis of acute graft-versus-host disease after marrow transplantation from unrelated donors. *Blood* 2000;96:2062-2068.
69. Bolwell B, Sobecks R, Pohlman B, et al. A prospective randomized trial comparing cyclosporine and short course methotrexate with cyclosporine and mycophenolate mofetil for GVHD prophylaxis in myeloablative allogeneic bone marrow transplantation. *Bone Marrow Transplant* 2004;34:621-625.
70. Perkins J, Field T, Kim J, et al. A randomized phase II trial comparing tacrolimus and mycophenolate mofetil to tacrolimus and methotrexate for acute graft-versus-host disease prophylaxis. *Biol Blood Marrow Transplant* 2010;16:937-947.
71. Antin JH, Kim HT, Cutler C, et al. Sirolimus, tacrolimus, and low-dose methotrexate for graft-versus-host disease prophylaxis in mismatched related donor or unrelated donor transplantation. *Blood* 2003;102:1601-1605.
72. Cutler C, Stevenson K, Kim HT, et al. Sirolimus is associated with veno-occlusive disease of the liver after myeloablative allogeneic stem cell transplantation. *Blood* 2008;112:4425-4431.
73. Claxton DF, Ehmann C, Rybka W. Control of advanced and refractory acute myelogenous leukaemia with sirolimus-based nonmyeloablativeallogeneic stem cell transplantation. *Br J Haematol* 2005;130:256-264.
74. Alyea EP, Li S, Kim HT, et al. Sirolimus, tacrolimus, and low-dose methotrexate as graft-versus-host disease prophylaxis in related and unrelated donor reduced-intensity conditioning allogeneic peripheral blood stem cell transplantation. *Biol Blood Marrow Transplant* 2008;14:920-926.
75. Rodriguez R, Nakamura R, Palmer JM, et al. A phase II pilot study of tacrolimus/sirolimus GVHD prophylaxis for sibling donor hematopoietic stem cell transplantation using 3 conditioning regimens. *Blood* 2010;115:1098-1105.
76. Cutler C, Kim HT, Hochberg E, et al. Sirolimus and tacrolimus without methotrexate as graft-versus-host disease prophylaxis after matched related donor peripheral blood stem cell transplantation. *Biol Blood Marrow Transplant* 2004;10:328-336.
77. Pidala J, Kim J, Jim H, et al. A randomized phase II study to evaluate tacrolimus in combination with sirolimus or methotrexate after allogeneic hematopoietic cell transplantation. *Haematologica* 2012.
78. Koreth J, Stevenson KE, Kim HT, et al. Bortezomib, tacrolimus, and methotrexate for prophylaxis of graft-versus-host disease after reduced-intensity conditioning allogeneic stem cell transplantation from HLA-mismatched unrelated donors. *Blood* 2009;114:3956-3959.
79. Sanz GF, Saavedra S, Planelles D, et al. Standardized, unrelated donor cord blood transplantation in adults with hematologic malignancies. *Blood* 2001;98:2332-2338.
80. Finke J, Schmoor C, Lang H, Potthoff K, Bertz H. Matched and mismatched allogeneic stem-cell transplantation from unrelated donors using combined graft-versus-host disease prophylaxis including rabbit anti-T lymphocyte globulin. *J Clin Oncol* 2003;21:506-513.
81. Reisner Y, Friedrich W, Fabian I. A shorter procedure for preparation E-rosette-depleted bone marrow for transplantation. *Transplantation* 1986;42:312-315.
82. Martin PJ, Hansen JA, Torok-Storb B, et al. Graft failure in patients receiving T cell-depleted HLA-identical allogeneic marrow transplants. *Bone Marrow Transplant* 1988;3:445-456.
83. Goldman JM, Gale RP, Horowitz MM, et al. Bone marrow transplantation for chronic myelogenous leukemia in chronic phase. Increased risk for relapse associated with T-cell depletion. *Ann Intern Med* 1988;108:806-814.

84. Aversa F, Terenzi A, Carotti A, et al. Improved outcome with T-cell-depleted bone marrow transplantation for acute leukemia. *J Clin Oncol* 1999;17:1545-1550.
85. Hale G, Cobbold S, Waldmann H. T cell depletion with CAMPATH-1 in allogeneic bone marrow transplantation. *Transplantation* 1988;45:753-759.
86. Ringhoffer M, Wiesneth M, Harsdorf S, et al. CD34 cell selection of peripheral blood progenitor cells using the CliniMACS device for allogeneic transplantation: clinical results in 102 patients. *Br J Haematol* 2004;126:527-535.
87. Hale G, Zhang MJ, Bunjes D, et al. Improving the outcome of bone marrow transplantation by using CD52 monoclonal antibodies to prevent graft-versus-host disease and graft rejection. *Blood* 1998;92:4581-4590.
88. Siegal D, Xu W, Sutherland R, et al. Graft-versus-host disease following marrow transplantation for aplastic anemia: different impact of two GVHD prevention strategies. *Bone Marrow Transplant* 2008;42:51-56.
89. Curtis RE, Travis LB, Rowlings PA, et al. Risk of lymphoproliferative disorders after bone marrow transplantation: a multi-institutional study. *Blood* 1999;94:2208-2216.
90. Zerr DM, Corey L, Kim HW, et al. Clinical outcomes of human herpesvirus 6 reactivation after hematopoietic stem cell transplantation. *Clin Infect Dis* 2005;40:932-940.
91. Luznik L, Bolanos-Meade J, Zahurak M, et al. High-dose cyclophosphamide as single-agent, short-course prophylaxis of graft-versus-host disease. *Blood* 2010;115:3224-3230.
92. Martin PJ, Rizzo JD, Wingard JR, et al. First- and second-line systemic treatment of acute graft-versus-host disease: recommendations of the American Society of Blood and Marrow Transplantation. *Biol Blood Marrow Transplant* 2012;18:1150-1163.
93. Martin PJ, Bachier CR, Klingemann HG, et al. Endpoints for clinical trials testing treatment of acute graft-versus-host disease: a joint statement. *Biol Blood Marrow Transplant* 2009;15:777-784.
94. MacMillan ML, Weisdorf DJ, Wagner JE, et al. Response of 443 patients to steroids as primary therapy for acute graft-versus-host disease: comparison of grading systems. *Biol Blood Marrow Transplant* 2002;8:387-394.
95. Martin PJ, Schoch G, Fisher L, et al. A retrospective analysis of therapy for acute graft-versus-host disease: initial treatment. *Blood* 1990;76:1464-1472.
96. Weisdorf D, Haake R, Blazar B, et al. Treatment of moderate/severe acute graft-versus-host disease after allogeneic bone marrow transplantation: an analysis of clinical risk features and outcome. *Blood* 1990;75:1024-1030.
97. Alousi AM, Weisdorf DJ, Logan BR, et al. Blood, marrow transplant clinical trials N. Etanercept, mycophenolate, denileukin, or pentostatin plus corticosteroids for acute graft-versus-host disease: a randomized phase 2 trial from the blood and marrow transplant clinical trials network. *Blood* 2009;114:511-517.
98. Arai S, Margolis J, Zahurak M, Anders V, Vogelsang GB. Poor outcome in steroid-refractory graft-versus-host disease with antithymocyte globulin treatment. *Biol Blood Marrow Transplant* 2002;8:155-160.
99. Bordigoni P, Dimicoli S, Clement L, et al. Daclizumab, an efficient treatment for steroid-refractory acute graft-versus-host disease. *Br J Haematol* 2006;135:382-385.
100. Schmidt-Hieber M, Fietz T, Knauf W, et al. Efficacy of the interleukin-2 receptor antagonist basiliximab in steroid-refractory acute graft-versus-host disease. *Br J Haematol* 2005;130:568-574.
101. Shaughnessy PJ, Bachier C, Grimley M, et al. Denileukin diftitox for the treatment of steroid-resistant acute graft-versus-host disease. *Biol Blood Marrow Transplant* 2005;11:188-193.
102. Ho VT, Zahrieh D, Hochberg E, et al. Safety and efficacy of denileukin diftitox in patients with steroid-refractory acute graft-versus-host disease after allogeneic hematopoietic stem cell transplantation. *Blood* 2004;104:1224-1226.
103. Pidala J, Kim J, Field T, et al. Infliximab for managing steroid-refractory acute graft-versus-host disease. *Biol Blood Marrow Transplant* 2009;15:1116-1121.
104. Couriel D, Saliba R, Hicks K, et al. Tumor necrosis factor-alpha blockade for the treatment of acute GVHD. *Blood* 2004;104:649-654.
105. Patriarca F, Sperotto A, Damiani D, et al. Infliximab treatment for steroid-refractory acute graft-versus-host disease. *Haematologica* 2004;89: 1352-1359.

106. Pidala J, Kim J, Perkins J, et al. Mycophenolate mofetil for the management of steroid-refractory acute graft vs host disease. *Bone Marrow Transplant* 2010;45:919-924.
107. Baudard M, Vincent A, Moreau P, et al. Mycophenolate mofetil for the treatment of acute and chronic GVHD is effective and well tolerated but induces a high risk of infectious complications: a series of 21 BM or PBSC transplant patients. *Bone Marrow Transplant* 2002;30:287-295.
108. Ullmann AJ, Lipton JH, Vesole DH, et al. Posaconazole or fluconazole for prophylaxis in severe graft-versus-host disease. *N Engl J Med* 2007;356: 335-347.
109. Gooley TA, Chien JW, Pergam SA, et al. Reduced mortality after allogeneic hematopoietic-cell transplantation. *N Engl J Med* 2010;363:2091-2101.
110. Allogeneic peripheral blood stem-cell compared with bone marrow transplantation in the management of hematologic malignancies: an individual patient data meta-analysis of nine randomized trials. *J Clin Oncol* 2005;23: 5074-5087.
111. Devine SM, Carter S, Soiffer RJ, et al. Low risk of chronic graft-versus-host disease and relapse associated with T cell-depleted peripheral blood stem cell transplantation for acute myelogenous Leukemia in first remission: results of the blood and marrow transplant clinical trials network protocol 0303. *Biol Blood Marrow Transplant. Biol Blood Marrow Transplant.* 2011;17(9): 1343-1351. doi: 10.1016/j.bbmt.2011.02.002. Epub 2011 Feb 12.
112. Jakubowski AA, Small TN, Kernan NA, et al. T cell-depleted unrelated donor stem cell transplantation provides favorable disease-free survival for adults with hematologic malignancies. *Biol Blood Marrow Transplant. Biol Blood Marrow Transplant.* 2011;17(9):1335-1342. doi: 10.1016/j.bbmt.2011.01.005. Epub 2011 Jan 11.
113. Socie G, Schmoor C, Bethge WA, et al. Chronic graft-versus-host disease: long-term results from a randomized trial on GvHD prophylaxis with or without anti-T-cell globulin ATG-fresenius. *Blood.* 2011;117(23):6375-6382. doi: 10.1182/blood-2011-01-329821. Epub 2011 Apr 5.
114. van Besien K, Kunavakkam R, Rondon G, et al. Fludarabine-melphalan conditioning for AML and MDS: alemtuzumab reduces acute and chronic GVHD without affecting long-term outcomes. *Biol Blood Marrow Transplant* 2009;15:610-617.
115. Ho VT, Soiffer RJ. The history and future of T-cell depletion as graft-versus-host disease prophylaxis for allogeneic hematopoietic stem cell transplantation. *Blood* 2001;98:3192-3204.
116. Miura Y, Thoburn CJ, Bright EC, et al. Association of Foxp3 regulatory gene expression with graft-versus-host disease. *Blood* 2004;104:2187-2193.
117. Sakoda Y, Hashimoto D, Asakura S, et al. Donor-derived thymic-dependent T cells cause chronic graft-versus-host disease. *Blood* 2007;109:1756-1764.
118. Blazar BR, Weisdorf DJ, Defor T, et al. Phase 1/2 randomized, placebo-control trial of palifermin to prevent graft-versus-host disease (GVHD) after allogeneic Hematopoietic Stem Cell Transplantation (HSCT). *Blood* 2006;108: 3216-3222.
119. Shimabukuro-Vornhagen A, Hallek MJ, Storb RF, von Bergwelt-Baildon MS. The role of B cells in the pathogenesis of graft-versus-host disease. *Blood* 2009;114:4919-4927.
120. Lesley R, Xu Y, Kalled SL, et al. Reduced competitiveness of auto-antigen-engaged B cells due to increased dependence on BAFF. *Immunity* 2004;20:441-453.
121. Thien M, Phan TG, Gardam S, et al. Excess BAFF rescues self-reactive B cells from peripheral deletion and allows them to enter forbidden follicular and marginal zone niches. *Immunity* 2004;20:785-798.
122. Miklos DB, Kim HT, Zorn E, et al. Antibody response to DBY minor histocompatibility antigen is induced after allogeneic stem cell transplantation and in healthy female donors. *Blood* 2004;103:353-359.
123. Miklos DB, Kim HT, Miller KH, et al. Antibody responses to H-Y minor histocompatibility antigens correlate with chronic graft-versus-host disease and disease remission. *Blood* 2005;105:2973-2978.
124. Storek J, Ferrara S, Ku N, Giorgi JV, Champlin RE, Saxon A. B cell reconstitution after human bone marrow transplantation: recapitulation of ontogeny? *Bone Marrow Transplant* 1993;12:387-398.
125. Sarantopoulos S, Stevenson KE, Kim HT, et al. Altered B-cell homeostasis and excess BAFF in human chronic graft-versus-host disease. *Blood* 2009;113:3865-3874.

126. Clark WB, Brown-Gentry KD, Crawford DC, et al. Genetic variation in recipient B-cell activating factor modulates phenotype of GVHD. *Blood*. 2011;118(4):1140-1144. doi: 10.1182/blood-2010-09-310011. Epub 2011 May 31.
127. Cutler C, Miklos D, Kim HT, et al. Rituximab for steroid-refractory chronic graft-versus-host disease. *Blood* 2006;108:756-762.
128. Zaja F, Bacigalupo A, Patriarca F, et al. Treatment of refractory chronic GVHD with rituximab: a GITMO study. *Bone Marrow Transplant* 2007;40:273-277.
129. Kharfan-Dabaja MA, Mhaskar AR, Djulbegovic B, Cutler C, Mohty M, Kumar A. Efficacy of rituximab in the setting of steroid-refractory chronic graft-versus-host disease: a systematic review and meta-analysis. *Biol Blood Marrow Transplant* 2009;15:1005-1013.
130. McCormick LL, Zhang Y, Tootell E, Gilliam AC. Anti-TGF-beta treatment prevents skin and lung fibrosis in murine sclerodermatous graft-versus-host disease: a model for human scleroderma. *J Immunol* 1999;163:5693-5699.
131. Olivieri A, Locatelli F, Zecca M, et al. Imatinib for refractory chronic graft-versus-host disease with fibrotic features. *Blood* 2009;114:709-718.
132. Lee SJ, Flowers ME. Recognizing and managing chronic graft-versus-host disease. *Hematology Am Soc Hematol Educ Program* 2008:134-141.
133. Lee SJ, Vogelsang G, Flowers ME. Chronic graft-versus-host disease. *Biol Blood Marrow Transplant* 2003;9:215-233.
134. Lee SJ, Klein JP, Barrett AJ, et al. Severity of chronic graft-versus-host disease: association with treatment-related mortality and relapse. *Blood* 2002;100:406-414.
135. Socie G, Stone JV, Wingard JR, et al. Long-term survival and late deaths after allogeneic bone marrow transplantation. Late Effects Working Committee of the International Bone Marrow Transplant Registry. *N Engl J Med* 1999;341:14-21.
136. Flowers ME, Parker PM, Johnston LJ, et al. Comparison of chronic graft-versus-host disease after transplantation of peripheral blood stem cells versus bone marrow in allogeneic recipients: long-term follow-up of a randomized trial. *Blood* 2002;100:415-419.
137. Pidala J, Kurland B, Chai X, et al. Patient-reported quality of life is associated with severity of chronic graft-versus-host disease as measured by NIH criteria: report on baseline data from the Chronic GVHD Consortium. *Blood*. 2011;117(17):4651-7. doi: 10.1182/blood-2010-2011-319509. Epub 2011 Feb 25.
138. Pidala J, Anasetti C, Jim H. Quality of life after allogeneic hematopoietic cell transplantation. *Blood* 2009;114:7-19.
139. Stewart BL, Storer B, Storek J, et al. Duration of immunosuppressive treatment for chronic graft-versus-host disease. *Blood* 2004;104:3501-3506.
140. Pidala J, Vogelsang G, Martin P, et al. Overlap subtype of chronic graft vs. host disease is associated with adverse prognosis, functional impairment, and inferior patient reported outcomes: a chronic graft vs. host disease consortium study. *Haematologica*. 2012;97(3):451-458. doi: 10.3324/haematol.2011.055186. Epub 2011 Nov 4.
141. Arai S, Jagasia M, Storer B, et al. Global and organ-specific chronic graft-versus-host disease severity according to the 2005 NIH Consensus Criteria. *Blood* 2011;118(15):4242-4249.
142. Atkinson K, Horowitz MM, Gale RP, et al. Risk factors for chronic graft-versus-host disease after HLA-identical sibling bone marrow transplantation. *Blood* 1990;75:2459-2464.
143. Ochs LA, Miller WJ, Filipovich AH, et al. Predictive factors for chronic graft-versus-host disease after histocompatible sibling donor bone marrow transplantation. *Bone Marrow Transplant* 1994;13:455-460.
144. Przepiorka D, Anderlini P, Saliba R, et al. Chronic graft-versus-host disease after allogeneic blood stem cell transplantation. *Blood* 2001;98: 1695-1700.
145. Akpek G, Lee SJ, Flowers ME, et al. Performance of a new clinical grading system for chronic graft-versus-host disease: a multicenter study. *Blood* 2003;102:802-809.
146. Arora M, Burns LJ, Davies SM, et al. Chronic graft-versus-host disease: a prospective cohort study. *Biol Blood Marrow Transplant* 2003;9:38-45.
147. Pavletic SZ, Smith LM, Bishop MR, et al. Prognostic factors of chronic graft-versus-host disease after allogeneic blood stem-cell transplantation. *Am J Hematol* 2005;78:265-274.

148. Arora M, Klein JP, Weisdorf DJ, et al. Chronic GVHD risk score: a Center for International Blood and Marrow Transplant Research analysis. *Blood*. 2011;117(24):6714-6720. doi: 10.1182/blood-2010-12-323824. Epub 2011 Apr 14.
149. Cutler C, Li S, Ho VT, et al. Extended follow-up of methotrexate-free immunosuppression using sirolimus and tacrolimus in related and unrelated donor peripheral blood stem cell transplantation. *Blood* 2007;109:3108-3114.
150. Ruutu T, Volin L, Elonen E. Low incidence of severe acute and chronic graft-versus-host disease as a result of prolonged cyclosporine prophylaxis and early aggressive treatment with corticosteroids. *Transplant Proc* 1988;20:491-493.
151. Lonnqvist B, Aschan J, Ljungman P, Ringden O. Long-term cyclosporin therapy may decrease the risk of chronic graft-versus-host disease. *Br J Haematol* 1990;74:547-548.
152. Kansu E, Gooley T, Flowers ME, et al. Administration of cyclosporine for 24 months compared with 6 months for prevention of chronic graft-versus-host disease: a prospective randomized clinical trial. *Blood* 2001;98: 3868-3870.
153. Mengarelli A, Iori AP, Romano A, et al. One-year cyclosporine prophylaxis reduces the risk of developing extensive chronic graft-versus-host disease after allogeneic peripheral blood stem cell transplantation. *Haematologica* 2003;88:315-323.
154. Burroughs L, Mielcarek M, Leisenring W, et al. Extending postgrafting cyclosporine decreases the risk of severe graft-versus-host disease after nonmyeloablative hematopoietic cell transplantation. *Transplantation* 2006;81:818-825.
155. Cutler C, Sun L, Kim H, et al. Prophylactic rituximab after allogeneic stem cell transplantation prevents steroid-requiring chronic graft-vs-host disease [abstract]. *Blood (ASH Annual Meeting Abstracts)* 2010;116(21). Abstract 214.
156. Koc S, Leisenring W, Flowers ME, et al. Therapy for chronic graft-versus-host disease: a randomized trial comparing cyclosporine plus prednisone versus prednisone alone. *Blood* 2002;100:48-51.
157. Sullivan KM, Witherspoon RP, Storb R, et al. Prednisone and azathioprine compared with prednisone and placebo for treatment of chronic graft-v-host disease: prognostic influence of prolonged thrombocytopenia after allogeneic marrow transplantation. *Blood* 1988;72:546-554.
158. Arora M, Wagner JE, Davies SM, et al. Randomized clinical trial of thalidomide, cyclosporine, and prednisone versus cyclosporine and prednisone as initial therapy for chronic graft-versus-host disease. *Biol Blood Marrow Transplant* 2001;7:265-273.
159. Gilman AL, Schultz KR, Goldman FD, et al. Randomized trial of hydroxychloroquine for newly diagnosed chronic graft-versus-host disease in children: a children's oncology group study. *Biol Blood Marrow Transplant*. 2012;18(1):84-91. doi: 10.1016/j.bbmt.2011.05.016. Epub 2011 May 30.
160. Martin PJ, Storer BE, Rowley SD, et al. Evaluation of mycophenolate mofetil for initial treatment of chronic graft-versus-host disease. *Blood* 2009;113:5074-5082.
161. Koc S, Leisenring W, Flowers ME, et al. Thalidomide for treatment of patients with chronic graft-versus-host disease. *Blood* 2000;96:3995-3996.
162. Martin PJ, Storer BE, Carpenter PA, et al. Comparison of short-term response and long-term outcomes after initial systemic treatment of chronic graft-versus-host disease. *Biol Blood Marrow Transplant*. 2011;17(1):124-132. doi: 10.1016/j.bbmt.2010.06.018. Epub 2010 Jun 30.
- P.2220
163. Palmer JM, Lee SJ, Chai X, et al. Poor agreement between clinician response ratings and calculated response measures in patients with chronic graft-versus-host disease. *Biol Blood Marrow Transplant*. 2012;18(11):1649-1655. doi: 10.1016/j.bbmt.2012.05.005. Epub 2012 Jun 9.
164. Couriel D, Carpenter PA, Cutler C, et al. Ancillary therapy and supportive care of chronic graft-versus-host disease: national institutes of health consensus development project on criteria for clinical trials in chronic graft-versus-host disease: v. ancillary therapy and supportive care working group report. *Biol Blood Marrow Transplant* 2006;12:375-396.
165. Winston DJ, Antin JH, Wolff SN, et al. A multicenter, randomized, double-blind comparison of different doses of intravenous immunoglobulin for prevention of graft-versus-host disease and infection after allogeneic bone marrow transplantation. *Bone Marrow Transplant* 2001;28: 187-196.

166. Barnes DW, Corp MJ, Loutit JF, Neal FE. Treatment of murine leukaemia with X rays and homologous bone marrow; preliminary communication. *Br Med J* 1956;2:626-627.
167. Barnes DW, Loutit JF. Treatment of murine leukaemia with x-rays and homologous bone marrow. II. *Br J Haematol* 1957;3:241-252.
168. Horowitz MM, Gale RP, Sondel PM, et al. Graft-versus-leukemia reactions after bone marrow transplantation. *Blood* 1990;75:555-562.
169. Weiden PL, Flournoy N, Thomas ED, et al. Antileukemic effect of graft-versus-host disease in human recipients of allogeneic-marrow grafts. *N Engl J Med* 1979;300:1068-1073.
170. Sorror ML, Storer BE, Sandmaier BM, et al. Five-year follow-up of patients with advanced chronic lymphocytic leukemia treated with allogeneic hematopoietic cell transplantation after nonmyeloablative conditioning. *J Clin Oncol* 2008;26:4912-4920.
171. Odom LF, August CS, Githens JH, et al. Remission of relapsed leukaemia during a graft-versus-host reaction. A "graft-versus-leukaemia reaction" in man? *Lancet* 1978;2:537-540.
172. Kolb HJ, Mittermuller J, Clemm C, et al. Donor leukocyte transfusions for treatment of recurrent chronic myelogenous leukemia in marrow transplant patients. *Blood* 1990;76:2462-2465.
173. Kolb HJ. Graft-versus-leukemia effects of transplantation and donor lymphocytes. *Blood* 2008;112:4371-4383.
174. Giralt S, Hester J, Huh Y, et al. CD8-depleted donor lymphocyte infusion as treatment for relapsed chronic myelogenous leukemia after allogeneic bone marrow transplantation. *Blood* 1995;86:4337-4343.
175. Warren EH, Fujii N, Akatsuka Y, et al. Therapy of relapsed leukemia after allogeneic hematopoietic cell transplantation with T cells specific for minor histocompatibility antigens. *Blood*. 2010;115(19):3869-3878. doi: 10.1182/blood-2009-10-248997. Epub 2010 Jan 13.
176. Bleakley M, Riddell SR. Molecules and mechanisms of the graft-versus-leukaemia effect. *Nat Rev Cancer* 2004;4:371-380.
177. Kohrt HE, Muller A, Baker J, et al. Donor immunization with WT1 peptide augments antileukemic activity after MHC-matched bone marrow transplantation. *Blood*. 2011;118(19):5319-5329. doi: 10.1182/blood-2011-05-356238. Epub 2011 Aug 25.
178. Molldrem JJ, Lee PP, Wang C, et al. Evidence that specific T lymphocytes may participate in the elimination of chronic myelogenous leukemia. *Nat Med* 2000;6:1018-1023.
179. Ho VT, Vanneman M, Kim H, et al. Biologic activity of irradiated, autologous, GM-CSF-secreting leukemia cell vaccines early after allogeneic stem cell transplantation. *Proc Natl Acad Sci U S A* 2009;106:15825-15830.
180. Anasetti C, Beatty PG, Storb R, et al. Effect of HLA incompatibility on graft-versus-host disease, relapse, and survival after marrow transplantation for patients with leukemia or lymphoma. *Hum Immunol* 1990;29:79-91.
181. Szydlo R, Goldman JM, Klein JP, et al. Results of allogeneic bone marrow transplants for leukemia using donors other than HLA-identical siblings. *J Clin Oncol* 1997;15:1767-1777.
182. Aversa F, Terenzi A, Tabilio A, et al. Full haplotype-mismatched hematopoietic stem-cell transplantation: a phase II study in patients with acute leukemia at high risk of relapse. *J Clin Oncol* 2005;23:3447-3454.
183. Ruggeri L, Capanni M, Urbani E, et al. Effectiveness of donor natural killer cell alloreactivity in mismatched hematopoietic transplants. *Science* 2002;295:2097-2100.
184. Parham P, McQueen KL. Alloreactive killer cells: hindrance and help for haematopoietic transplants. *Nat Rev Immunol* 2003;3:108-122.
185. Hsu KC, Keever-Taylor CA, Wilton A, et al. Improved outcome in HLA-identical sibling hematopoietic stem-cell transplantation for acute myelogenous leukemia predicted by KIR and HLA genotypes. *Blood* 2005;105:4878-4884.
186. Yu J, Venstrom JM, Liu XR, et al. Breaking tolerance to self, circulating natural killer cells expressing inhibitory KIR for non-self HLA exhibit effector function after T cell-depleted allogeneic hematopoietic cell transplantation. *Blood* 2009;113:3875-3884.
187. Venstrom JM, Pittari G, Gooley TA, et al. HLA-C-dependent prevention of leukemia relapse by donor activating KIR2DS1. *N Engl J Med*. 2012;367(9): 805-816. doi: 10.1056/NEJMoa1200503.

188. Ruggeri L, Mancusi A, Capanni M, et al. Donor natural killer cell allorecognition of missing self in haploidentical hematopoietic transplantation for acute myeloid leukemia: challenging its predictive value. *Blood* 2007;110: 433-440.
189. Cooley S, Trachtenberg E, Bergemann TL, et al. Donors with group B KIR haplotypes improve relapse-free survival after unrelated hematopoietic cell transplantation for acute myelogenous leukemia. *Blood* 2009;113: 726-732.
190. Cooley S, Weisdorf DJ, Guethlein LA, et al. Donor selection for natural killer cell receptor genes leads to superior survival after unrelated transplantation for acute myelogenous leukemia. *Blood* 2010;116(14):2411-2419. doi: 10.1182/blood-2010-05-283051. Epub 2010 Jun 25.
191. Miller JS, Warren EH, van den Brink MR, et al. NCI first international workshop on the biology, prevention, and treatment of relapse after allogeneic hematopoietic stem cell transplantation: report from the committee on the biology underlying recurrence of malignant disease following allogeneic HSCT: graft-versus-tumor/leukemia reaction. *Biol Blood Marrow Transplant*. 2010;16(5):565-586. doi: 10.1016/j.bbmt.2010.02.005. Epub 2010 Feb 10.

Chapter 106 Late Effects After Transplantation

INTRODUCTION

Allogeneic hematopoietic cell transplantation (HCT) provides curative therapy for a variety of diseases. Over the past several decades, significant advances have been made in the field of HCT, and now HCT has become an integral part of treatment modality for a variety of hematologic malignancies and nonmalignant diseases. Historically, the limitation of HCT has been transplant-related mortality (TRM). In order to offer the curative HCT treatment option to most patients, safer regimens with acceptable graft-versus-host-disease (GVHD)-associated morbidity and TRM are preferred. The development of less toxic pretransplant conditioning regimens, more effective prophylaxis of GVHD, improved infection control, and other advances in transplant technology have resulted in a rapidly growing number of transplant recipients surviving long-term free of the disease for which they were transplanted.^{1, 2}

Since its introduction in the early 1970s the number of patients who undergo HCT for a variety of malignant and nonmalignant disorders has increased steadily and, today, nearly 60,000 allogeneic HCT are performed worldwide annually,^{1, 3, 4, 5} a number that has been increasing yearly. With broadening indications, more options for HCT, and improvement in survival, by 2020 there may be up to half a million long-term survivors after allogeneic HCT worldwide.⁶ In this era, a stem cell source can be found for virtually all patients who have an indication to receive HCT. Since 2007, more allo-HCT procedures have been performed using alternative donor stem cell sources, such as volunteer unrelated donors (URD) or cord blood, than related donors.^{5, 7} Haploidentical-related donor or cord blood transplantations (CBT) have emerged as alternatives to fill the gap for those patients who do not have matched related donors or URD, and the outcome of these types of transplantations are expected to be better than chemotherapy alone or even better than autologous-SCT for selected indications. All these result in a steady increase in numbers of long-term survivors after HCT, creating an enlarging pool of children, youth, and mature adults at risk for long-term complications of HCT.

Many patients who recover from immediate posttransplant problems eventually regain health and return to normal activities of life. For those who survive 2 or more years post-HCT, the prospect for long-term survival is excellent (85% at 10 years after HCT). Yet, among long-term survivors, mortality rates are 4- to 9-fold higher than observed in an age-adjusted general population for at least 30 years after HCT, yielding an estimated 30% lower life expectancy compared with someone who has not been transplanted.⁸ The most common causes of excess death other than recurrent malignancy are chronic GVHD (cGVHD), infections, second malignancies, respiratory diseases, and cardiovascular diseases (CVDs).^{3, 6, 8, 9, 10}

cGVHD is a multisystem chronic alloimmune and autoimmune disorder that occurs later after HCT. It is characterized by immune dysregulation, decreased organ function, significant morbidity, and impaired survival. Approximately 10% to 30% of patients require continued immunosuppressive treatment because of cGVHD beyond 5 years after HCT.^{8, 11} Therefore, it is not surprising that cGVHD, corticosteroid, and other immunosuppressive therapies are major contributors to late complications after HCT.

With survivorship, a shift in survivorship care occurs from large transplant centers to community health care providers. As a result, many hematologists/oncologists and primary care physicians are assuming the post-HCT care of late effects. Preventive measures as well as early detection and treatment are important aspects to reducing morbidity and mortality. This chapter focuses on the essentials of diagnosis, screening, treatment, and long-term surveillance of survivors after HCT.

CARDIOVASCULAR EVENTS AND METABOLIC SYNDROME

CV causes are not only the leading contributor to mortality in the general population but also impact the health of long-term transplant survivors.¹² CV morbidity and mortality is typically latent in the early survivorship period because of the younger age and superior performance of transplant candidates. Nevertheless, there is growing data suggesting that traditional CV risk factors are elevated in long-term survivors, and that risk factor elevation is persistent and eventually results in premature CV events. CVD manifests as coronary artery disease/events, cerebrovascular disease/events, or peripheral vascular disease/events. Susceptible patients need to be identified early, and screened for modifiable risk factors with early intervention where possible.

Cardiovascular Events

Tichelli et al. were the first to show that CV events occurred prematurely in transplant survivors (median age 49 years), albeit at a long interval after transplantation, with the cumulative incidence of late CVD being 22% at 25 years (Fig. 106.1).¹³ Interestingly, allogeneic HCT recipients were significantly more likely to have arterial events than autologous transplant recipients. The Late Effects Working Group of the European Group for Blood and Marrow Transplantation (EBMT) found a cumulative CV event incidence of 6% at 15 years.⁹ In a matched cohort study of 1,491

P.2222

long-term survivors, transplant recipients experienced increased CV mortality (adjusted incidence rate difference, 3.6 per 1,000 person-years; 95% CI, 1.7 to 5.5) with increased cumulative incidence of ischemic heart disease, cardiomyopathy or heart failure, stroke, vascular diseases, and rhythm disorders.¹⁴

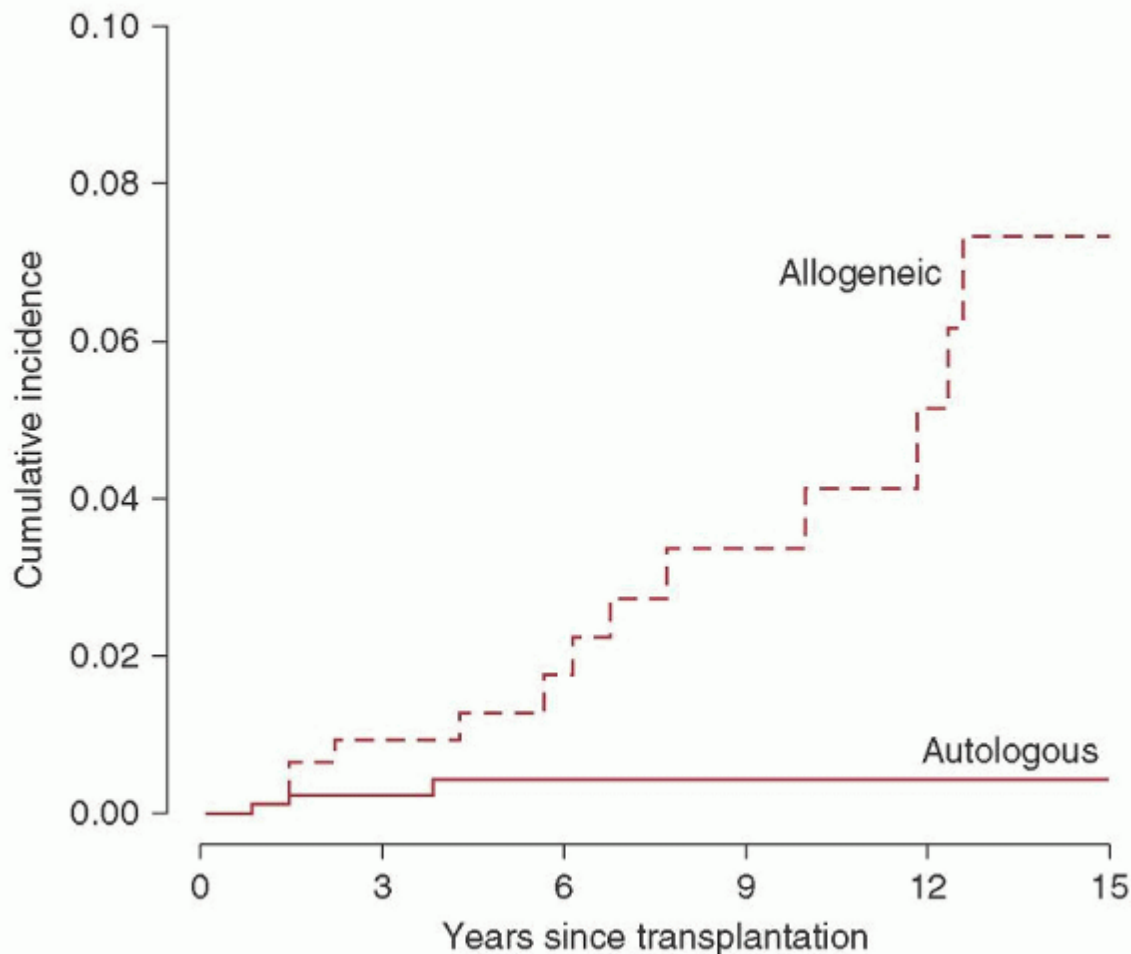

FIGURE 106.1. The cumulative incidence of cardiovascular events at 15 years, adjusted for age. (From Tichelli A, Bucher C, Rovo A, et al. Premature cardiovascular disease after allogeneic hematopoietic stem cell transplantation. *Blood* 2007;110:3463-3471.)

Disease Spectrum

Coronary artery disease and/or CV accidents are much more common than isolated peripheral artery disease. In a case control study of 63 patients with late CV disease, 44 subjects had coronary artery disease, and 19 had cerebrovascular diseases. Thirty-four of these 63 patients with CVD died, 31% of them from a CV event.¹⁵ Furthermore, CVD may contribute to chronic ill health seen in long-term survivors. The magnitude of chronic illness in a study of 1,022 HCT survivors was 59% at 10 years after HCT and increased in comparison to their sibling controls.¹⁶

Cardiovascular Risk Factors

Traditional CV risk factors include male gender, family history, dyslipidemia, diabetes mellitus, obesity, hypertension, chronic kidney disease (CKD), and smoking. In addition, transplant survivors have unique risk factors such as exposure to ionizing radiation, immunosuppressant use (including steroids), and endocrinopathies.

CV risk factors generally increase with age and it is difficult to attribute the emergence of new CV risk factors to the transplant process itself without a good control population. A clear increase in the incidence of diabetes and hypertension was seen in a study of 1,022 HCT survivors, with the incidence of CVD being 3-fold that of their sibling controls.¹⁶ In a cross-sectional study, HCT survivors had a 2.2-fold increase in the prevalence of metabolic syndrome, a clustering of CV risk factors characterized by abdominal obesity, dyslipidemia, hypertension, and elevated fasting glucose, compared to age- and gender-matched controls.¹⁷ In a long-term study (17.5 years median) of 44 pairs of recipients and their respective donors after HCT, recipients were more likely to have hypertension ($P = 0.015$), dyslipidemia ($P = 0.002$), lower glomerular filtration rates (GFRs) ($P < 0.0001$) and reduced thyroid function ($P = 0.002$).¹⁸ The occurrence of dyslipidemia is a function of age and immunosuppressive treatment. Dyslipidemia appears to play a central role in the elevated CVD risk after HCT.¹⁹ De novo dyslipidemias may even impact a pediatric population.²⁰

Pathobiology

The factors leading to persistent elevation of CV risk in HCT survivors long after cessation of immunosuppression remain unclear. Residual effects from radiation, endocrine dysfunction (including steroid exposure, hypogonadism, hypothyroidism, and growth hormone deficiency), and endothelial damage have been implicated.

Chest irradiation is a validated cause of CV mortality. Extrapolating from the CV impact of chest irradiation in nontransplant populations with malignancy, it is reasonable to suspect that the use of total body irradiation (TBI) in transplant conditioning contributes to increased CVD risk, but this remains to be proven in a well-controlled study. Pretransplant chest radiation exposure was associated with a 9.5-fold higher risk of CVD.¹⁵

Hypothyroidism is a frequent late effect in transplant survivors and is related to conditioning with TBI and prolonged cGVHD.²¹ Hypothyroidism may affect ~30% to 40% of survivors, is often subclinical in presentation, and is strongly linked to dyslipidemias. Gonadal dysfunction will occur in the majority of transplant survivors and is linked to conditioning intensity and recipient age. Endocrinopathy and metabolic syndrome are strongly associated with gonadal dysfunction.²² In males, metabolic syndrome and low androgen levels are strongly correlated,²³ and in females, estrogens are necessary for maintenance of CV health.^{24, 25} In a series of 109 long-term allogeneic HCT survivors, CV risk factors were significantly elevated in males but not in females who were all recipients of hormonal supplementation.²⁶ Relative growth hormone deficiency may be a factor in adult and pediatric transplant survivors. Growth hormone deficiency in adults leads to insulin resistance and is characterized by dyslipidemias and hypertension.²⁷ Pediatric survivors of cancer treatment and HCT are particularly sensitive to the metabolic consequences of impaired growth hormone secretion.^{22, 28}

Leptin is an adipokine responsible for regulating food intake and energy metabolism. Hyperleptinemia has been implicated as the pathobiologic link between transplant and metabolic syndrome.^{29, 30} Vascular endothelium may be the target of damage by radiation exposure and by alloreactivity (e.g., GVHD). Radiation has a dose-dependent impact on vasculature and endothelium in animal models. In a rodent model, TBI with 10 Gy injured coronary microvasculature, and altered endothelial physiology and myocardial mechanics.³¹ Host endothelial cells are a target of alloreactive donor cytotoxic T lymphocytes, and chronic skin GVHD is characterized by the progressive loss of microvessels.³² cGVHD is also characterized by elevations in von Willebrand factor,¹⁸ which may be released by endothelial injury. Chronic hypomagnesemia is common early after transplantation³³ and is known to induce insulin resistance, diabetes, and metabolic syndrome. However, its precise impact on CV risk, if any, requires confirmation.

Management of Cardiovascular Risk

Since the burden of CV risk in transplant survivors has been poorly defined till now and CV events occur late, management of CV risk has often been a low priority. In a recent cross-sectional study of 86 adult survivors at a median of 3 years from HCT, 25% of cases with hypertension, 17% with abnormal glucose metabolism, and 60% with dyslipidemia were

untreated.¹⁷ Current guidelines suggest a central role for transplantation centers in counseling primary health providers on screening and prevention.³⁴

The management focus should be on modifiable CV risk factors: lifestyle (diet, smoking, and activity), obesity, diabetes, dyslipidemias, hypertension, hypothyroidism, hypogonadism, and other endocrinopathy. Dyslipidemias may be the most important driver of CV risk and are susceptible to therapy.²⁶ The management of CV risk in transplant survivors is an evolving effort, but expert guidelines are now available.^{6, 12, 19} Table 106.1 summarizes the approach to the hyperlipidemia in long-term survivors after HCT.

SECONDARY MALIGNANCIES

The risk of second malignancies as an important late effect after HCT was first recognized in the early 1990s. As the age and life expectancy of survivors continue to rise, second malignancies are expected to become an increasingly common complication.³

Secondary malignancies following HCT are commonly categorized into one of three histologic types: leukemia, lymphoma, and solid tumors.³⁵ However, these disorders have distinctive chronology. Secondary leukemia generally occurs at a median of 6.7 months after auto-SCT, lymphoma at a median of 2.5 months, while the median time to development of solid tumors lies between 5 and 6 years.³

Risk of Second Malignancies and Risk Factors

Based on large retrospective analyses, the cumulative incidence of solid tumors following HCT ranges between 1.2% and 1.6% at 5 years, 2.2% and 6.1% at 10 years, and from 3.8% to 14.9% at 15 years post-HCT.^{36, 37, 38, 39} The incidence rate does not plateau; rather, there is a steady increase over time.³⁹ Second cancers are

P.2223

a very important contributor to late nonrelapse mortality (NRM) in patients who survive more than 2 to 5 years posttransplantation, accounting for 5% to 10% of such deaths.^{8, 40, 41} And, in a recent study of 28,874 HCT survivors, the incidence of new solid tumors was double that of an age- and gender-matched general population.³⁹ The risk increased over time, reaching 3-fold among patients followed for 15 years or more after transplantation.

TABLE 106.1 APPROACH TO LIPID MANAGEMENT IN HCT PATIENTS

Evaluation

Obtain fasting lipid profile prior to transplantation

Evaluate CVD Risk

1. If patient has CVD or CVD risk equivalent, then manage as high-risk with appropriate therapy to reach LDL goal
 - a. Option to consider allogeneic HCT patients age 40 or older as high-risk
2. Otherwise, calculate 10-y risk with online risk assessment tool (www.nhlbi.nih.gov) and manage LDL per ATP-III Guidelines

Monitor lipid profiles after HCT

1. Check lipid profile within 4 wk after HCT then at least every 3 mo for patients on IST
2. For patients at treatment goal on stable therapy every 6-12 mo as indicated, or after significant change in IST regimen in patients with dyslipidemia
3. If patients develop significant dyslipidemia after HCT compared to baseline, consider secondary causes of dyslipidemia (IST, diabetes, hypothyroidism)
4. Even patients without dyslipidemia should have lipids monitored every 1-2 y after allogeneic HCT, given increased CV risk

Management

If patient has high CVD risk (>20% 10-y risk), treat dyslipidemia with appropriate agent(s) to meet

LDL goal, but monitor clinically if on IST or renal dysfunction

In patients with low (<10%) or moderate CVD risk (10-20%), consider drug treatment based upon severity of dyslipidemia, estimated prognosis post-HCT, and risks of lipid drug therapy (if on long-term IST for GVHD)

1. Patients with low CVD risk that develop moderate secondary dyslipidemia on IST can be managed conservatively, if IST will be tapered off
2. Patients with low to moderate CVD risk that develop severe hypertriglyceridemia (>500 mg/dl) should be treated to prevent pancreatitis

Consider referral to a lipid specialist for the following:

1. Severe dyslipidemia (total cholesterol > 300 or LDL > 180, triglycerides > 500-1,000)
2. Patients with dyslipidemia refractory to treatment and not meeting goals
3. Patients with intolerance or contraindications to lipid lowering therapy
4. Patients requiring combination lipid therapy, particularly in setting of IST
5. Patients needing individualized CV risk assessment due to strong family history of premature CVD or other factors

ATP-III, adult treatment panel-III; CV, cardiovascular; CVD, cardiovascular disease; GVHD, graft-versus-host-disease; HCT, hematopoietic cell transplant; IST, immunosuppression therapy; LDL, low density lipoprotein.

Pathobiology

The process of malignant transformation of secondary solid tumors after HCT is not well understood but multiple factors have been implicated.⁴² These include exposure to TBI, primary disease, male sex, and pretransplantation therapy. The risk of developing a nonsquamous cell cancer (SCC) is associated with younger age at transplantation and the use of radiation in the conditioning regimen. Radiation is also a known significant risk factor for the development of several other solid tumors, particularly cancers of the breast, thyroid, brain, central nervous system, bone and connective tissue, and melanoma; and screening is available for some of these tumors.^{10, 42} For the majority of these sites, risks are greater among those who survived 5 or more years after initial radiotherapy, in keeping with the latent period typical for radiation-related solid cancers.^{8, 10, 40, 43}

cGVHD and immunosuppressive therapy (IST) are associated with SCC of the skin and mucosa.^{43, 44, 45} A particularly high-risk was observed in the 1 to 4 year interval after HCT, which remained elevated among long-term survivors. Duration of IST, and particularly prolonged exposure to azathioprine, has been associated with development of SCC.⁴⁶

Several oncogenic types of human papillomavirus (HPV) have been implicated in the etiology of SCC of the female genital tract and head and neck, and may play a role in HCT-associated SCC.^{46, 47} Certainly, some inherited genetic polymorphisms have been reported to increase the risk of malignancies in patients who received alkylating agents either as pretransplant chemotherapy or as part of the conditioning regimen.⁴⁸

Types of Secondary Solid Cancers

In a 2009 registry data study, 189 new cancers were found in 28,874 HCT recipients who underwent long-term follow-up.³⁹ The average age at HCT was 27 years, and 67% received TBI as part of their conditioning regimen. The findings demonstrated that the risk of developing a nonSCC was dependent on the age at exposure to conditioning radiation. The relative risk of nonSCC for patients irradiated at ages <30 years was 9-fold that of nonirradiated patients, while the comparable risk for older patients was 1.1. cGVHD and male gender were the main determinants for the risk of SCC. The oral cavity, salivary glands, liver (prior hepatitis C exposure), skin, brain, breast, thyroid, and bone/connective tissue were the sites with a significant increase in secondary malignancy. These data indicate that HCT survivors, particularly those irradiated at young ages, face increased risks of solid cancers, supporting strategies to promote lifelong surveillance among these patients.

The risks of secondary solid cancers in HCT survivors who have not received irradiation are not well understood and deserve further study, because radiation-free conditioning regimens are being more frequently utilized. When

chemotherapy alone is used for conditioning, the rates of solid tumors are still increased, as evidenced by a report examining solid tumor incidence in survivors who underwent high-dose busulfan-cyclophosphamide conditioning. In this study of 4,318 patients who received HCT for AML and CML, the cumulative incidence of solid tumors at 5 and 10 years after HCT was 0.6% and 1.2% for AML, and 0.9% and 2.4% for CML patients. The recipients had invasive solid cancers at a rate that was 1.4 times higher than expected in the general population.⁴⁹ Sites with a significant increase in secondary malignancy included the oral cavity, esophagus, lung, soft tissue, and brain. cGVHD was found to be an independent risk factor for all solid cancers. Recipients of HCT using busulfan-cyclophosphamide conditioning are thus similar to TBI in the risk for developing solid cancers.

Diagnosis, Screening, and Prevention

Since there is no plateau in the incidence curve of new malignancies, consensus guidelines call for lifelong surveillance, and early diagnosis and treatment.⁵⁰ Recommendations include the following: A. Recognition that radiation exposure and photosensitization by transplant medications increases the risk of skin malignancy, suggesting that survivors should protect against UV skin exposure by appropriate clothing or high-SPF sunscreen. B. Survivors should be reminded of the risks of secondary malignancies annually. Routine self-screening by breast and skin examination is to be encouraged, as is avoidance of high-risk behaviors, particularly all forms of tobacco use and unprotected UV exposure. C. Annual health screening should include symptom review for secondary malignancies. Screening mammography is recommended earlier than age 40 years for women exposed to radiation. Mucocutaneous involvement by GVHD increases the

P.2224

risk of malignant sequelae, and annual specialist examination (dermatologic, gynecologic, dental, or ENT) may be required.

Management

Successful management of second malignancies requires recognition of the special attributes of transplant survivors and close collaboration between the transplant center and the primary physician. Impaired hematopoietic reserve may be evident years after HCT and may manifest as prolonged myelosuppression after standard doses of cytotoxic agents or XRT. cGVHD management will often be a great challenge to treatment. Secondary SCC is biologically more aggressive, with frequent invasion beyond free surgical resection margins and metastasis to draining lymph nodes. Support should be provided for psychologic vulnerability in survivors facing a new diagnosis of malignancy.

LATE PULMONARY COMPLICATIONS

Lung injury is a frequent contributor to post-HCT morbidity and mortality.^{11, 51, 52} Pulmonary injury can be delayed, and the cumulative incidence of chronic pulmonary dysfunction in long-term HCT survivors ranges from 30% to 60%, depending on donor source and elapsed time from transplantation.^{11, 51} Bronchiolitis obliterans syndrome (BOS) is the most frequent and potentially lethal noninfectious pulmonary complication. BOS is now considered one of the diagnostic criteria for defining cGVHD by the NIH consensus report.^{52, 53} It is characterized by an insidious onset, high morbidity and mortality, and is typically accompanied by other manifestations of cGVHD. Much knowledge of BOS has been borrowed from the field of lung transplantation, in which BOS impacts more than half of the long-term survivors and is the major contributor to morbidity and mortality.⁵⁴

Pathophysiology

Airway narrowing in BOS is mostly in the small airways, the terminal and respiratory bronchioles, with an internal diameter <2 mm. These small airways can be considered parallel high-resistance conduits which account for the vast majority of the total airway volume and the cross-sectional area. Small airway damage must be extensive and 45% of the terminal bronchioles need to be lost before impacting the forced expiratory volume 1 (FEV1) or FEV1/FVC ratio. Furthermore, small airway obstruction may have less effect on lung mechanics than on ventilation distribution.^{55, 56}

Prevalence, Clinical Presentation, and Diagnosis

Recent prevalence estimates suggest that BOS is often underdiagnosed and that 14% of all long-term survivors with cGVHD may develop BOS. BOS is difficult to diagnose, may already be severe by the time the patient complains of symptoms, and is not easy to reverse.

Clinically, patients present with dyspnea on exertion, decreased exercise tolerance, or nonproductive cough, with their degree of symptomatology paralleling their degree of obstruction on pulmonary function testing (PFT). BOS usually occurs within the first 2 years, but may develop as late as 5 years after allo-HCT. Reliance upon symptoms for diagnosis can be

dangerous, because once symptoms are apparent the extent of airflow obstruction may not only be significant (FEV1 < 40% predicted), but the process may be irreversible. With routine screening spirometry, BOS is often diagnosed on the basis of new airflow obstruction even before the patient is symptomatic.

BOS is diagnosed by demonstration of a fixed airflow obstruction that is defined as: (1) decreased 1-second FEV1 <75% of predicted, and evidence of airway obstruction as demonstrated by FEV1/forced vital capacity ratio of <0.7 on PFT; (2) signs of air trapping by PFT as shown by residual volume >120% of predicted, or evidence of air trapping on computed tomography or lung biopsy; (3) absence of acute respiratory infection; and (4) another manifestation of cGVHD in an additional organ system if no histologic evidence of BOS can be demonstrated.^{52, 55}

Early identification strategies, borrowed from the field of lung transplantation, utilize serial testing of the extent of FEV1 decline from pretransplantation baseline. Early onset of BOS can have worse outcomes than late-onset BOS, suggesting that these are two distinct clinical entities that may warrant different treatment approaches.^{52, 55} There is growing awareness that patients with BOS have high mortality rates regardless of therapy, suggesting the need for early identification, preemptive treatment, and novel approaches.⁵⁷

Prophylaxis of Chronic Graft-versus-host-disease and Bronchiolitis Obliterans Syndrome

cGVHD can be a significant complication of HCT impacting up to 80% of patients receiving alternative donor grafts. cGVHD is independently associated with late pulmonary complications and BOS is strongly associated with cGVHD.^{11, 57} It has been reported that the administration of antithymocyte globulin (ATG) during the conditioning regimen or early after transplant, in addition to the conventional GVHD prophylaxis, can reduce the incidence and the severity of subsequent cGVHD.^{56, 58} The magnitude of reduction is ~ 20% or greater for both aGVHD grade II-IV and cGVHD.⁵¹ In comparison to those who did not receive ATG, the incidence of cGVHD was reduced from 60% to 37% (P = 0.05), and extensive cGVHD reduced from 41% to 15% (P = 0.01). Significantly, the cumulative incidence of chronic lung dysfunction was reduced from 51% to 19% (P = 0.005). Further incentive for using ATG has been found in the conclusions of prospective randomized trials with ATG, which suggest that prevention of cGVHD is possible without significantly interfering with the graft-versus-malignancy effect and may result in wider use of ATG.

Management of Bronchiolitis Obliterans Syndrome

Systemic Glucocorticoids

The mainstay of therapy has been systemic IST including high-dose corticosteroids, CSA, azathioprine, and ATG with the intent of general control of cGVHD. Sullivan et al.⁵⁹ first described in 1981 use of prednisone along with azathioprine in a series of 52 patients with cGVHD as effective therapy. Since then, systemic high-dose corticosteroids have been thought to be the most efficacious treatment in cGVHD. Ratjen et al.⁶⁰ showed improvement in FEV1 with 7 of 9 patients in the pediatric population after HCT with clinical stability following treatment with high-dose methylprednisolone for BOS. Despite the unfavorable side-effect profile and the absence of strong evidence, systemic glucocorticoids remain the recommended first-line therapy (dosage varies from 0.1 to 1 mg/kg/day—depending on severity) for patients diagnosed with BOS (Table 106.2).

Inhaled Corticosteroids

Inhaled corticosteroids may optimize local delivery while abrogating the risks of systemic corticosteroids in the treatment of BOS. Bashoura et al.⁶¹ used fluticasone-propionate in patients with BOS after HCT and reported stabilization or improvement in FEV1 after 3 to 6 months of treatment in 16 of 17 patients. Similarly, Bergeron et al.⁶² reported improvement in symptoms as well as in FEV1 at 3 to 6 months posttherapy using a combination of budesonide and formoterol. This strategy has yet to be evaluated in a prospective

P.2225

randomized controlled manner, but the potential to deliver high doses of steroid therapy in the inhaled modality is a promising method of improving treatment without the systemic risks.

TABLE 106.2 AVAILABLE THERAPEUTIC OPTIONS FOR BOS AFTER ALLOGENEIC HEMATOPOIETIC CELL TRANSPLANTATION (HCT)

Agent	Mechanism of Action
Systemic corticosteroids	Systemic immunosuppression

Inhaled corticosteroids	Localized antiinflammatory
Calcineurin inhibitors	Systemic immunosuppression
Mycophenolate mofetil	Inhibits fibroblast proliferation
mTOR inhibitors (e.g., sirolimus)	Inhibits fibroblast proliferation
Azithromycin	Macrolide antibiotic Impairs neutrophilic inflammation ? prokinetic GI properties leading to reduction of GERD
Montelukast	Leukotriene receptor antagonist Reduces bronchoconstriction, eosinophilic and neutrophilic recruitment
Extracorporeal photopheresis	Mechanism not understood Involvement of regulatory T cells
Imatinib	Antifibrinogenic
Rituximab	Inhibits B cell proliferation (Anti-CD20 antibody)
Inhaled cyclosporine	Local immunosuppressant therapy
Etanercept	TNF- α blockade
Bortezomib	Proteasome inhibitor Inhibits TGF- β 1
Combination therapy	

BOS, Bronchiolitis obliterans syndrome; GERD, gastroesophageal reflux disease; GI, gastrointestinal; mTOR, mammalian target of rapamycin; TGF- α , transforming growth factor- α ; TNF- β 1, tumor necrosis factors.

Systemic Immunosuppression Therapy

Other immunosuppressive agents such as calcineurin inhibitors (cyclosporine and tacrolimus), mammalian target of rapamycin inhibitors (sirolimus and everolimus), as well as mycophenolate mofetil have also been shown to be efficacious in treatment of BOS in patients who undergo lung transplant.⁵⁵

Azithromycin

Azithromycin, a macrolide antibiotic, has been shown to modulate cytokine production and impair neutrophil function. Several small studies in the lung transplant literature have shown that chronic therapy with azithromycin can improve FEV1 or slow progression of BOS.^{63, 64, 65} The largest study reported to date has been by Vos et al.,⁶⁶ whose cohort of 107 lung transplant recipients with BOS were evaluated on long-term azithromycin therapy. Forty percent of patients were responsive to treatment, and these patients were reported to have improved OS compared with those who did not respond to macrolide therapy. The same authors have also published data that prophylactic azithromycin thrice weekly for 2 years after transplantation may prevent BOS by improving FEV1 as well as BOS-free survival in the same cohort.⁶⁷ Khalid et al.⁶⁸ reported significant clinical improvement in FEV1 and forced vital capacity in 7 of 8 patients with BOS after allo-HCT using azithromycin 500 mg daily for 3 days followed by 250 mg three times weekly for a minimum of 12 weeks.

Given its ease of administration and favorable side-effect profile, it is being increasingly used as upfront therapy for BOS and is recommended as adjunctive therapy in addition to corticosteroids and additional IST.

Novel Combination Therapy

Norman et al.⁶⁹ have reported a small case series (n = 8) of BOS after HCT using combination therapy with fluticasone, azithromycin, and montelukast (FAM). Their results suggest that combination therapy may spare some patients from systemic steroids and is being investigated in a prospective phase II trial. A list of other therapeutic agents available in clinical practice is summarized in Table 106.2.

Lung Transplantation

Although data is limited, lung transplantation upon failure of medical therapy is also an option, with several cases reported in the literature after HCT for patients who are thought to have achieved a cure for their hematologic malignancy but have severe BOS.^{70, 71, 72} Currently, there are no defined criteria for the appropriate timing for referral to a lung transplant, but those who have remained in remission for years without significant comorbidities or other long-term complications from HCT may be good candidates for consideration.

INFECTION AND IMMUNE RECONSTITUTION

Infection remains an immense challenge in long-term survivors, especially in patients requiring prolonged IST for cGVHD. Infection in survivors, even in the absence of cGVHD, is over 20 times greater than reported in the general population. About 20% of patients remain on IST beyond 3 years post-HCT, with a higher incidence in older patients receiving HCT.^{8, 11} There is an elevated risk of bacterial, fungal, and viral infections occurring even years after HCT, although this plateaus after 2 years.⁷³ Infections remain a significant contributor to morbidity, rehospitalization and NRM in 5-year survivors.^{50, 74, 75, 76, 77}

Immune reconstitution of the B and T cell repertoire from the donor can be insufficient, and long-term survivors still have an increased risk of infectious diseases.^{8, 78, 79} cGVHD and the use of systemic IST for cGVHD are the main risk factor of long-term poor immune reconstitution after HCT.⁸⁰ Immune status should be monitored periodically,³⁴ especially in those with recurrent severe infections.

Bacterial Infection

Bacterial infections such as pneumococcal infection can be lethal, especially in patients with cGVHD. Fortunately there are effective preventive options such as antibiotic prophylaxis and vaccinations.^{34, 76} Prolonged antibiotic prophylaxis is generally recommended for preventing infection by encapsulated organisms among patients with active cGVHD on systemic IST. Oral penicillin is generally preferred, but consideration of susceptibility patterns may warrant other options such as second-generation cephalosporins, macrolides, or fluoroquinolones. However, because of the risks of resistance, vaccinations should always be initiated if available. Several guidelines have been published^{34, 76, 81}; our current vaccination schedule is summarized in Table 106.3.

The optimal timing of vaccination is also important³⁴; the guidelines recommend not postponing vaccinations with nonlive vaccines in patients with ongoing active cGVHD.⁸² Checking antibody titers is useful in monitoring the success of vaccination in such patients. Live vaccines are generally avoided in subjects

P.2226

with ongoing IST. Another investigational approach to hasten the recovery of immunity is to boost donors prior to graft collection to enhance immune recovery in the eventual recipients.

TABLE 106.3 ROUTINE VACCINATIONS RECOMMENDED FOR HCT RECIPIENTS

Vaccine	Recommendation after HCT	Time Post-HCT to Initiate Vaccine (mo)	Number of Doses	Improved by Donor Vaccination
Pneumococcal conjugate (PCV)	Yes	3-6 ^b	3-4 ^b	Yes, may be considered when recipient is at high-risk for GVHD
Tetanus, diphtheria, Acellular Pertussis ^c	Yes Tetanus-Diphtheria	6-12	3 ^d	Tetanus: likely Diphtheria: likely Pertussis: Unknown
<i>Haemophilus influenzae</i> conjugate	Yes	6-12	3	Yes
Meningococcal conjugate		6-12	1	Unknown
Inactivated polio		6-12	3	Unknown

Recombinant hepatitis B	6-12	3	Likele ^e
Inactivated influenza	Yearly	4-6	1-2 ^f
Measles, mumps and rubella ^g	24	1-2 ^h	Unknown

GVHD, graft-versus-host disease; HCT, hematopoietic cell transplant.

^a A uniform specific interval between doses cannot be recommended, because various intervals have been used in studies. As a general guideline, a minimum of 1 month between doses may be reasonable.

^b If immunization is started early, consider evaluating for antibody levels and if they are low, revaccinate. Following the primary series of 3 PCV doses, a dose of the *23-valent polysaccharide pneumococcal vaccine* (PPSV23) to broaden the immune response might be given. For patients with chronic GVHD (cGVHD) who are likely to respond poorly to PPSV23, a fourth dose of the PCV should be considered instead of PPSV23.

^c DTaP is preferred; however, if only Tdap is available (e.g., because DTaP is not licensed for adults), administer Tdap. Acellular pertussis vaccine is preferred, but the whole-cell pertussis vaccine should be used if it is the only pertussis vaccine available.

^d See text for consideration of an additional dose(s) of Tdap for older children and adults.

^e Significant improvement of recipient response to hepatitis B vaccine posttransplant can be expected only if the donor receives more than 1 hepatitis vaccine dose prior to donation.

^f For children <9 years of age, 2 doses are recommended yearly between transplant and 9 years of age.

^g Measles, mumps, and rubella vaccines are usually given together as a combination vaccine. In females with pregnancy potential, vaccination with rubella vaccine either as a single or a combination vaccine is indicated.

^h In children, 2 doses are favored.

Fungal Infection

Late fungal infection is associated with cGVHD and systemic IST with *Aspergillus* spp. being the most common pathogen.^{76, 83, 84} There is very limited evidence to demonstrate clinical benefit of antifungals in the setting of cGVHD; however, antifungal prophylaxis especially against *Aspergillus* is usually recommended for patients with severe cGVHD.⁸⁵ Iron overload, a frequent finding after HCT, has shown a possible association with fungal infections and this represents a potential therapeutic target.^{86, 87, 88, 89} Iron overload is an established risk factor for infections in patients with myelodysplastic syndromes.⁹⁰ Iron chelation or phlebotomy could not only reverse transfusional overload, but might mitigate the risk of fungal infection.

Viral Infection

Viral infections, including CMV, varicella zoster virus (VZV), and influenza are responsible for late hospitalization, morbidity, and mortality in HCT survivors and are frequently associated with cGVHD.^{73, 77} While most CMV reactivations occur early, recent developments in transplant techniques such as preemptive CMV treatment strategies, cord blood, mismatched-related or URD HCT, and reduced-intensity conditioning have led to the emergence of late CMV reactivation and infection. CMV seropositive recipients of CMV seronegative grafts are at particular risk for prolonged reactivation.

Acyclovir prophylaxis to prevent VZV reactivation is nontoxic, effective, and routinely recommended for at least the first year after HCT.^{91, 92} Longer duration acyclovir prophylaxis beyond 1 year should be considered in patients with cGVHD or

systemic IST. Vaccination against VZV requires administration of an attenuated virus, and early reports are promising.^{93, 94} However, live vaccines should be administered no earlier than 24 months after HCT; there may be differences in the safety profiles of different vaccine brands and, as yet, no VZV vaccine has been approved for HCT recipients.

There is considerable high-level evidence that annual influenza vaccination is beneficial to HCT recipients.^{34, 76, 81} After HCT, the first dose is often insufficient in producing satisfactory antibody titers, but a booster dose can improve the immune response.^{95, 96, 97, 98} However, even with two doses of vaccine the most vulnerable HCT recipients, i.e., those who have a shorter transplant-to-vaccination interval and active GVHD, might fail to be protected.⁹⁵ Consequently, attention must also be paid to other proven measures, such as exploiting herd immunity by vaccinating household members and avoiding symptomatic contacts.

BONE MINERAL DENSITY LOSS AND AVASCULAR OSTEONECROSIS

Bone Mineral Density Loss

Definitions

Bone mineral density (BMD) loss is usually determined by dual-energy x-ray absorptiometry (DEXA). Scores in adults are compared to the mean BMD of a gender-matched younger adult population at peak density to generate the T-score. A T-score between -1.5 and -2.5 defines reduced bone mass or "osteopenia," while a T-score less than -2.5 defines "osteoporosis." For pediatric populations an age-matched score, the Z-score, is used. BMD loss alone does not predict fracture, and osteoporosis may be diagnosed independently in the presence of fragility fractures.

P.2227

Bone Loss Risk

Accelerated BMD loss is observed in the vast majority of HCT survivors. In a representative series of 78 long-term survivors, 73% had BMD loss, 42% with osteopenia.⁹⁹ In terms of clinical sequelae, the 3-year cumulative incidence of fractures was 8% in a series of 146 transplant recipients, predominantly in childhood recipients.¹⁰⁰ For unclear reasons, and in contrast to their lower vulnerability to other transplant complications, children experience greater BMD loss than adults.^{100, 101} However, this susceptibility does not extend into young adulthood and the incidence of osteoporotic fracture rates is not increased in younger adults, arguing against the routine use of bisphosphonates in this population.⁹⁹

Trabecular bone is particularly vulnerable. The spine and hip contain 50% to 75% trabecular bone and are most at risk for fracture after HCT. The magnitude of BMD loss is greater in the femoral neck¹⁰² compared with the spine, and tends to be more difficult to reverse.^{103, 104} BMD loss is extremely rapid in the first 4 months of transplant. The BMD loss between baseline and day 100 DEXA scans is equivalent to the aging of bones by 7 to 10 years for auto-SCT and 13 to 17 years for allo-HCT recipients.¹⁰⁵ Recovery of BMD occurs first in the lumbar spine, followed by slower recovery in the femoral neck: BMD nadir at month 6 for the spine and at month 24 for total body and femoral neck.¹⁰⁴ Partial or complete recovery of BMD is possible with improvement of bone turnover, but with variable kinetics.¹⁰⁶

BMD loss has also been noted after autologous HCT.¹⁰⁷ However, the risk factors are different: lymphoma was associated with greater bone loss after autologous HCT than myeloma, whereas higher steroid dose was the most significant risk factor after allogeneic HCT.¹⁰⁸

Pathobiology

BMD loss results from reduced bone formation and accelerated resorption, with increased markers of bone turnover being a consistent feature.¹⁰⁹ Corticosteroid exposure plays a major role; 50% of nontransplant patients will develop osteoporosis after 6 months of steroid exposure.¹¹⁰ Studies have shown that transplant recipients have abnormally low vitamin D.^{111, 112} In addition, HCT recipients have unique pathologic influences on BMD loss. The most important and reversible condition is hypogonadism, which is a prominent feature of myeloablative conditioning regimens and disproportionately impacts females. Immunosuppressive medications, particularly cumulative steroid exposure, are widely accepted as an important risk factor. cGVHD either directly (via inflammatory cytokine release) or indirectly (via steroid usage) is a notable risk factor.⁹⁹

The role of inflammatory mediators is not well understood, but emerging information implicates osteoprotegerin (OPG):Rank-L interaction, arguably the most critical mediator of bone remodeling.¹¹³ Serum levels of OPG, the antagonist of the osteoclast differentiation factor Rank-L, are increased in transplant recipients.¹¹⁴ Increased insulin resistance may also be contributory.¹¹² Multivariable risk models explain only 11% to 30% of the variation in transplant-related BMD

change, suggesting that poorly characterized risk factors, likely inflammatory cytokines, play a dominant role in the pathobiology.¹⁰⁵ Additionally, the rapidity of BMD loss sustained after HCT could potentially increase fracture risk independently by inducing microarchitectural changes even when BMD loss is reversed.

Management of Post-hematopoietic Cell Transplantation Bone Loss

It is recommended that HCT recipients undergo evaluation to include BMD by DEXA starting shortly before and after transplantation, calcium/vitamin D supplementation, and sex hormone levels with possible hormonal supplementation. There should be a low threshold to consider bisphosphonate therapy (e.g., annual Reclast) for patients at significant progressive risk, such as long-term steroids.¹¹⁵ The Fracture Risk Assessment Tool (FRAX; www.shef.ac.uk/FRAX/) is an algorithm commonly used to predict the 10-year risk of fracture and guide therapeutic intervention, but is not yet validated in HCT recipients.

Standard prophylactic measures for osteoporosis prevention as applicable to aging are far less effective in the HCT population.¹¹⁶ Calcium with or without calcitonin is ineffective in preventing a decline in BMD.¹¹⁷ Nevertheless, simple calcium and vitamin D supplementation is necessary in transplant recipients because of impaired gastrointestinal (GI) absorption. A minimum of 400-600 IU vitamin D per day appears to be required to achieve optimal serum 25-hydroxy D concentrations following HCT.¹¹² Current guidelines call for adequate daily calcium intake (at least 1,200 mg daily) plus vitamin D (1,000 IU per day, and higher if serum 25-hydroxy vitamin D levels are <30 ng/ml), regular weight bearing activity, and avoidance of smoking or excess alcohol.^{118, 119}

Hormone replacement therapy (HRT) is now standard for all females who are at risk.¹²⁰ In a prospective study for children at particular risk, 28 girls with a median age of 10 years with sex hormone deficiency after HCT were followed longitudinally. At their first evaluation, performed at a median of 3.8 years after HCT, BMD increased significantly from -2.7 ± 1.1 (Z-score) to -2.3 ± 1.2 after HRT administration, with 24 of 28 patients showing a good response.¹²¹

Antiresorptive therapy should be an individualized decision based upon the clinical status, T-score, fracture risk (FRAX score), tolerability, and risks. Bisphosphonates, the primary option, have been shown to be beneficial in improving BMD in the specific setting of HCT; however, the benefits need to be balanced against the risks, particularly of osteonecrosis.¹²² Bisphosphonates have been proven to be superior in a nonrandomized trial comparing zoledronate and risedronate to calcium + vitamin D ± HRT.¹²³ Benefits are lost after stopping therapy with bisphosphonates.¹²⁴ Most experts advocate a drug holiday after 3 to 5 years of continuous bisphosphonates with stable BMD.¹²² Second line therapies include calcitonin, raloxifene and human recombinant parathyroid hormone, but experience is limited. PTH is contraindicated in children with open growth plates, recipients of TBI, and those with renal dysfunction. Denosumab, which sequesters RANK-L, is yet to be formally evaluated in HCT recipients.

Avascular Necrosis of Bones After Hematopoietic Cell Transplantation

Avascular osteonecrosis (AVN) is a painful and debilitating bone complication distinct from BMD loss, with a different pathobiology but an important risk factor in common (prolonged steroid exposure). AVN is caused by focal bone necrosis and seen in 4% to 19% of allogeneic HCT survivors.^{122, 125, 126} Early osteonecrotic changes in hips and knees have been seen in the transplant population with a frequency up to 43% by magnetic resonance imaging (MRI) screening. In the same study, 15% of patients had coexistent loss of BMD.¹²⁷

AVN may occur at a median of 2 years, but may be detected as early as 6 months and as late as 10 years after HCT. Pathogenetic factors are poorly understood, but involve local vascular damage leading to ischemia, ineffective repair due to metabolic factors, and mechanical stresses.¹²⁸ Risk factors for AVN include GVHD therapy with steroids¹²⁹ and calcineurin inhibitors, an underlying diagnosis of acute lymphoblastic leukemia (probably also steroid-related), older age, female gender, and the use of TBI in conditioning.

AVN most commonly destroys the femoral heads and presents with severe pain. Knees, shoulder and other joints may be

involved and multiple joint involvement is common. Diagnosis is made by MRI, which is not only more sensitive but allows estimation of the extent of involvement. The Association of Research Circulation Osseus (ARCO) classification is typically used for staging (Table 106.4).¹³⁰

TABLE 106.4 ASSOCIATION OF RESEARCH CIRCULATION OSSEUS (ARCO) STAGING SYSTEM FOR OSTEONECROSIS

Stage	Radiologic Findings	Subclassification
-------	---------------------	-------------------

0	All diagnostic studies normal, diagnosis by histology only	
I	Plain radiographs and CT normal; MRI positive and biopsy positive	Extent: A (<15%), B (15-30%), C (>30%) Location: 1 (medial third), 2 (median third), 3 (lateral third)
II	Radiographs positive	Extent/location as above
III	Subchondral fracture (crescent sign)	Extent/location as above
IV	Flattening of femoral head	Depression of femoral head: A (<2 mm), B (2-4 mm), C (>4 mm)
V	Flattening of femoral head, osteoarthritic joint space, and acetabular changes	Depression as above
VI	Joint destruction	

CT, computed tomography; MRI, magnetic resonance imaging.

Management requires a multidisciplinary approach with early orthopedic surgeon involvement, physical and occupational therapy, plus attention to pain control. Treatment decisions are individualized based upon the joint location, staging, expected longevity, a continued need for immunosuppression, comorbidities, and age. Although sometimes prescribed, there is no evidence that statins or bisphosphonates are helpful for prevention or treatment of AVN in HCT. Conservative management aims to preserve native joint function for as long as possible with analgesics and by minimizing impact to the joint. Surgical options are joint preserving (such as core decompression, vascularized fibular grafts, osteotomy) versus joint replacement. Nonoperative management is limited in scope, with satisfactory clinical results reported in 63.5% of hips in 24 studies of core decompression versus 22.7% of hips in 21 studies of nonoperative management.¹³¹ Typically, for early symptomatic AVN involving <15% or asymptomatic lesions involving >30% of the femoral head, conservative management and core decompression are appropriate. Larger lesions, even if asymptomatic, or ARCO stage > II lesions warrant more aggressive approaches.¹²² A recent series of 122 total hip arthroplasty procedures for AVN in nontransplant recipients demonstrated durability, with 89% joint survival rate at 15 years.¹³²

OCULAR COMPLICATIONS IN LONG-TERM SURVIVORS AFTER HEMATOPOIETIC CELL TRANSPLANTATION

In a series of 620 allogeneic HCT recipients, major ocular complications occurred in 13% of patients. The most frequent complications were cGVHD, xerophthalmia without cGVHD, corneal ulcers, cataract, glaucoma, cytomegalovirus retinitis, fungal endophthalmitis, and acquisition of allergic conjunctivitis from atopic donors.¹³³ Of these, cGVHD and cataracts are the most frequent late complications. Management should always include regular ophthalmologic evaluations, with prompt referral for symptoms.

Ocular Graft-versus-host-disease

Ocular cGVHD often affects the lacrimal glands, the conjunctiva, the lids (including meibomian glands), and the cornea, but can also involve other parts of the eye such as the sclera. The typical presentation is that of keratoconjunctivitis sicca. In a series of 248 evaluable patients from the EBMT, the actuarial probability of developing dry eyes was 21% ± 3% at 15 years, and is strongly associated with systemic cGVHD (RR 3.5; CI, 1.9 to 6.9), female patients (5.6; CI, 1.6 to 18.8), age older than 20 years (3.1; CI, 1.6 to 5.6), single-dose irradiation for preparation to HCT (3.8; CI, 1.3 to 11.3), and methotrexate for prevention of GVHD (3.6; CI, 1.05 to 12.8).¹³⁴ There are no pathognomonic diagnostic features of ocular GVHD and evidence levels for diagnosis and treatment are generally low.¹³⁵ Therapeutic goals are to reduce inflammation and dryness in order to relieve symptoms and maintain functional ocular integrity. Therapy is individualized based upon the patient's overall condition, systemic IST, symptoms, ocular surface integrity, and inflammatory activity. Artificial tears are the first line of treatment. Topical immunosuppression, for example, with steroid¹³⁶ or cyclosporine eye drops,^{137, 138, 139} reduces inflammation and dryness in ocular GVHD and improves symptoms in the majority of cases. Autologous serum eye drops are also effective.^{140, 141} Gas-permeable scleral lens for management of severe keratoconjunctivitis sicca may be necessary for severe cases refractory to conventional treatment.^{142, 143} Plugs for occlusion of the lacrimal drainage system and punctal cauterization¹⁴⁴ are usually reserved for resistant cases. Further clinical trials are necessary to elucidate risk factors for eye manifestation, complications, and visual loss, and to evaluate staging criteria and diagnostic and therapeutic measures for ocular cGVHD.

Premature Cataract Development after Hematopoietic Cell Transplantation

The risk of premature cataract was as high as 23% in pediatric HCT recipients.¹⁴⁵ Risk factors include steroids¹⁴⁶ and radiation.¹⁴⁷ The impact of TBI on the risk of cataract formation can now be quantified¹⁴⁸ and may support studies of lens shielding in susceptible populations. Aggressive management of dry eyes is an important adjunct to cataract surgery.¹⁴⁹

ENDOCRINE AND SEXUAL DYSFUNCTIONS IN LONG-TERM SURVIVORS

Diabetes Mellitus after Hematopoietic Cell Transplantation

Adjusting for age, sex, race, and body mass index, survivors of allogeneic HCT are 3.6 times more likely to report diabetes than their sibling controls.¹⁵⁰ The actual prevalence of diabetes depends on the age of the transplant population and ranges from 3.3% to 15%.¹⁵¹ Risk factors include cGVHD,²⁰ TBI,¹⁵² and a cumulative prednisone dose of >0.25 mg/kg/day.¹⁵³ There are no specific guidelines for screening; however, it is prudent to screen high-risk patients periodically because diabetes may be asymptomatic. Euglycemic survivors with a history of steroid-induced

P.2229

diabetes remain at higher risk for the future development of diabetes and should undergo aggressive screening (every 3 to 6 months).¹⁵⁴ Screening for diabetes is similar to that in the nontransplant population, with the exception that HbA1c is an unreliable marker in anemic or transfused recipients. Beyond lifestyle changes, therapy is usually based on insulin because traditional oral hypoglycemic agents are often contraindicated (Table 106.5).

Male Hypogonadism and Sexual Dysfunction

Male hypogonadism is common in survivors of malignancies but susceptible to neglect. Manifestations are low testosterone, reduced libido, impaired spermatogenesis and erectile dysfunction. Testosterone-producing Leydig cells are less damaged than the sperm-producing Sertoli cells in transplant survivors, resulting in mild elevation of luteinizing hormone compared to greater elevations in follicle-stimulating hormone.¹⁵⁵ Impaired spermatogenesis is common, with recovery seen in only 50% to 90% of nonirradiated and about 20% of irradiated survivors.¹⁵⁶ Younger men receiving reduced-intensity HCT are more likely to recover spermatogenesis.¹⁵⁷ Both organic¹⁵⁸ and psychological¹⁵⁹ factors are responsible for erectile dysfunction and reduced libido.

The goals of therapy are to restore fertility if desired, improve libido and sexual function, and reduce bone loss. Since azoospermia is common, often the only options to preserve male fertility are semen banking and/or testicular tissue cryopreservation prior to transplantation.¹⁶⁰ A low morning total testosterone level with reduced libido¹⁶¹ or bone mass¹⁶² may be indications for supplementation. Testosterone dose should be titrated to achieve a mid-normal range while monitoring prostate-specific-antigen and hematocrit.

Thyroid Disorders in Long-term Survivors

The thyroid gland is frequently damaged in transplant survivors. TSH elevations, initially subclinical, are found in up to 17% of survivors and are dependent upon the dose of TBI.¹⁶³ In a long-term study of pediatric transplant recipients, approximately 30% eventually developed thyroid abnormalities; hypothyroidism was much more frequent than hyperthyroidism or thyroiditis.¹⁶⁴ Risk factors for hypothyroidism include age less than 10 years at transplant, conditioning intensity (particularly TBI), and cGVHD.^{21, 164, 165}

In a study of 791 pediatric transplant recipients, thyroid tumors occurred at a median of 9.9 (4.5-22.3) years after HCT and included 13 with papillary carcinoma and 5 with benign adenomas.¹⁶⁴ Radiation exposure underlies most cases,^{164, 165} but age less than 20 years, female sex, cGVHD, and family history are also factors.¹⁶⁶ Thyroid nodules need evaluation by ultrasound and biopsy. Excellent outcomes are observed with total thyroidectomy and iodine ablation. Patients with elevated TSH who are symptomatic should be considered for early replacement therapy to improve quality of life (QOL) (even in patients with subclinical hypothyroidism).

TABLE 106.5 RECOMMENDATIONS FOR DIABETES MELLITUS MANAGEMENT AFTER HEMATOPOIETIC CELL TRANSPLANTATION (HCT)

Screening Guidelines	Diagnosis	Treatment
<ul style="list-style-type: none"> Periodic fasting and random glucose monitoring, especially in the setting of steroid usage 	<ul style="list-style-type: none"> Glycosylated hemoglobin (HbA1c) \geq 6.5 Fasting blood glucose \geq 126 mg/dl (100-125 is impaired) 	<ul style="list-style-type: none"> Therapeutic lifestyle changes Consider starting insulin therapy if this

- | | |
|--|---|
| fasting glucose)
<ul style="list-style-type: none"> • Random blood glucose \geq 200 with hyperglycemic symptoms | fails
<ul style="list-style-type: none"> • Oral hypoglycemic can be considered in certain cases |
|--|---|

HCT, hematopoietic cell transplantation.

Adrenal Insufficiency

Even short-term supraphysiologic doses (equivalent to prednisone of >7.5 mg/day) of steroids are known to suppress the hypothalamic-pituitary-adrenal (HPA) axis, and adrenal insufficiency may last for up to 9 months. Glucocorticoid-induced adrenal insufficiency is highly prevalent (and often overlooked) in HCT survivors. In one series, 19 of 20 allogeneic HCT long-term survivors had abnormalities on ACTH stimulation.¹⁶⁷ Adrenal insufficiency may be clinically overt or diagnosable by ACTH challenge. Alternate day or early morning steroid administration minimizes HPA axis suppression and early replacement in symptomatic patients is a key step in management.

Pituitary Dysfunction

Pituitary complications are predominantly pediatric and manifest as growth failure, central hypogonadism, and central hypothyroidism. Irradiation, male gender, and young age at BMT are the most important factors for growth impairment, and 40 out of 141 children failed to achieve normal adult height.^{168, 169} Regular screening for growth and replacement in needed patients is essential in pediatric HCT survivors.

CHRONIC KIDNEY DISEASES: MONITORING AND MANAGEMENT GUIDELINES

Epidemiology and Prevalence

Estimates of the cumulative incidence of CKD in HCT survivors vary from 13% to 66% for adults and 62% in children, with variation attributable at least in part to the lack of a uniform disease definition.^{170, 171} The initial insult may occur pretransplant or evolve from acute kidney injury early after HCT, but is often delayed as much as 10 years posttransplant. CKD is independently associated with an increased risk of NRM; and progression to end-stage renal disease (ESRD) that requires dialysis is associated with a near 90% mortality.^{170, 171}

There are 3 separate clinical entities that are distinguishable after HCT (Fig. 106.2): thrombotic microangiopathy (TMA), nephrotic syndrome, and idiopathic or GVHD-related CKD. Acute deteriorations in renal function will occur in the majority of patients in the first few months after HCT. This acute kidney injury may persist and eventually contribute to the later development of CKD. Careful monitoring of blood pressure, renal function, and proteinuria is mandatory, especially in older patients and those with preexisting renal impairment. Renal function should be evaluated before HCT and monitoring should occur at least every 3 to 6 months in these patients. Renal biopsies are indicated in patients with proteinuria and persistent or progressive rises in serum creatinine to determine etiology and prevent the progression to ESRD.

Definition of Chronic Kidney Disease

CKD is defined by an elevation in serum creatinine, or a decreased GFR ($\text{GFR} < 60 \text{ ml/min/1.73 m}^2$), for 3 or more months. Kidney damage is further described in terms of structural or functional abnormalities in morphology, imaging, or composition of the blood or urine, such as proteinuria (a ratio of greater than 300 mg of albumin per gram of creatinine on spot urine testing).¹⁷⁰

P.2230

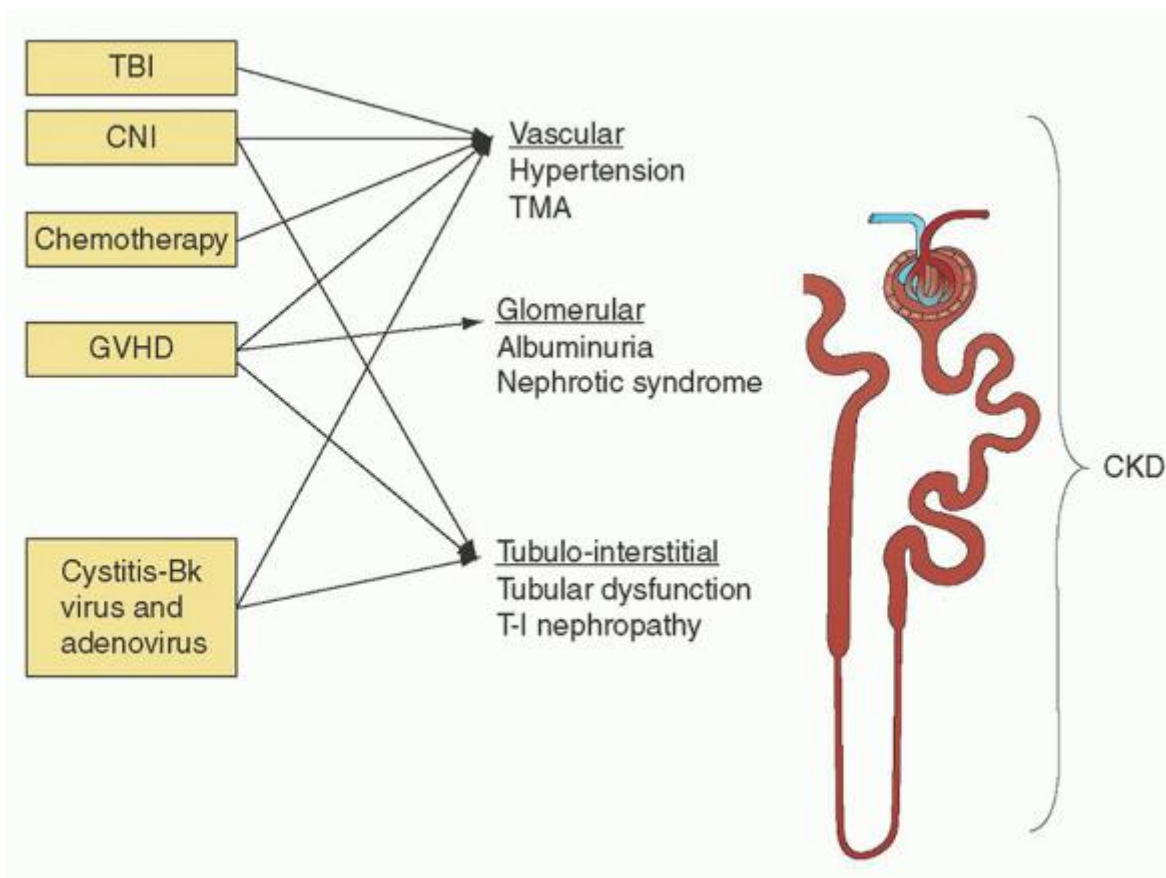

FIGURE 106.2. Types of CKD in long-term survivors of HCT: Sites of action of different renal insults with consequent clinicobiologic syndromes of kidney injury. CKD, chronic kidney disease; CNI, calcineurin inhibitor; GVHD, graft-versus-host-disease; HCT, hematopoietic cell transplant; TBI, total body irradiation; T-I nephropathy, tubulointerstitial nephropathy; TMA, thrombotic microangiopathy.

Spectrum of Kidney Disease

There are 3 major risk factors contributing to the pathogenesis of kidney injury after HCT: the underlying malignancy and previous therapies, transplant-related treatments, and complications and immunobiology of transplantation (GVHD). The spectrum of renal disease after HCT ranges from vascular (hypertension, TMA), to glomerular (albuminuria, nephrotic glomerulopathies), to tubulointerstitial abnormalities, which may all result in the reduction of GFR (Fig. 106.2). However, since it is not currently feasible to evaluate these components independently in clinical practice, it is common to group the disorders into three distinct clinical syndromes: TMA, nephrotic syndrome, and idiopathic or GVHD-related CKD.

Evaluation and Follow-up Guidelines of Patients with Chronic Kidney Diseases

Screening recommendations for patients beyond 6 months following HCT were developed by a consensus panel formed by CIBMTR, EBMT, and ASBMT⁵⁰ and are briefly summarized in Table 106.6: 1. Hypertension should be investigated at every clinic visit and at least annually and managed aggressively. 2. Renal function should be evaluated at day 90 to 100 and then 6 and 12 months after transplantation for all patients, and yearly thereafter at a minimum for those with early renal insufficiency. Screening should include assessment of urine albumin and protein, serum BUN, and creatinine. Of note, serum creatinine is not an accurate measure of kidney function. Serum creatinine level and related estimating equations are dependent on muscle mass and are influenced by age, race, gender, and weight. 3. Ultrasonography should be used to exclude obstructive uropathy, especially in patients with acute or chronic kidney injury. 4. Renal biopsy is warranted to diagnose etiology of persistent AKI or CKD and nephrotic range proteinuria.

Long-term Implications, Surveillance, Prevention, and Management

The final consequences of CKD are independent of the underlying kidney disorder and include the possibility of progression to ESRD and complications from renal dysfunction such as metabolic, electrolyte, endocrine, bone and mineral abnormalities, hypertension, proteinuria, anemia, and contribution to CV risk.

Management guidelines include:

- Avoidance of nephrotoxic drugs (NSAIDs, calcineurin inhibitors, contrast media, aminoglycosides, chemotherapy), renal
P.2231

dose adjustment, and drug level monitoring. While options are limited for substitution of calcineurin inhibitors, agents such as sirolimus are well tolerated.

TABLE 106.6 EVALUATION OF CHRONIC KIDNEY DISEASE (CKD) IN HEMATOPOIETIC CELL TRANSPLANTATION (HCT) SURVIVORS

Evaluation	Treatment
Specific diagnosis (type of kidney disease):	Therapy based on the specific diagnosis:
-A thorough search for “reversible causes” of kidney disease should be conducted (pathology and noninvasive work-up)	-GVHD -TMA -CNI -Viral infection
-Early referral to a nephrologist	-Other causes (GN, obstruction, etc.)
-Disease severity is assessed by the level of kidney function (stage of CKD)	Measures to prevent and treat complications of decreased kidney function: Hypertension Water and electrolytes imbalance
-Estimation of disease progression	Anemia Mineral metabolism Malnutrition
-Assessment of complications (related to the level of kidney function)	Medication dosage adjustments at each visit Detect drug interactions
-Assessment of comorbid conditions and risk factors for CKD (initiation/progression):	Management of comorbid conditions and measures to slow loss of kidney function
Poor glycemic control in diabetes	Preparation for renal replacement therapy (dialysis or transplantation)
Uncontrolled hypertension	
Higher level of proteinuria	
Drug toxicity	
Urinary tract infections	
Other (urinary stones/obstruction, autoimmune diseases, systemic infections, smoking)	
Evaluation of the risk for development of cardiovascular disease	Measures to prevent and treat cardiovascular disease
CKD, chronic kidney disease; CNI, calcineurin inhibitors; GVHD, graft-versus-host-disease; GN, glomerulonephritis; TMA, thrombotic microangiopathy.	

- Nephrotic Syndrome-Steroids, in addition to calcineurin inhibitors, can reverse minimal change or membranous nephropathy.¹⁷² Rituximab has also shown benefits, by directly killing dysregulated B-lymphocytes which have been associated with membranous nephropathy.^{173, 174} Membranous nephropathy is a clinical entity that is more refractory to immunosuppression, with only 27% of patients achieving remission, compared to 90% for minimal change disease.¹⁷⁵
- TMA management-TMA is often confirmed by pathologic changes on kidney biopsy and may not produce clinically significant microangiopathic hemolysis. Deficiency in ADAMTS13 is uncommon, unlike nontransplant TTP, and plasma exchange produces inconsistent results.¹⁷⁶ Calcineurin inhibitors (cyclosporine and tacrolimus) and sirolimus often warrant discontinuation, but management may be complicated by the presence of GVHD. Sometimes, continued immunosuppressive treatment of GVHD while attempting to reduce endothelial injury by aggressive hypertensive therapy may be preferable.¹⁷⁷ A small case series showed that 4 of 5 patients with TMA after HCT responded to treatment directed against cGVHD with rituximab.¹⁷⁸ In another report of 12 patients with early TTP after transplant, 50% of patients responded to defibrotide.¹⁷⁹
- Management of hypertension-Treatment of hypertension is usually indicated unless the severity is mild or the condition is temporary, such as an elevation in tacrolimus levels. Consideration should be given to early referral to a nephrologist.

Angiotensin-converting enzyme inhibitors (ACEI) and angiotensin receptor blockers (ARBs) are useful agents in CKD. In a rodent model of radiation-induced hemolytic-uremic syndrome (HUS) the use of these agents reduced azotemia, hypertension, and proteinuria, and led to long-term preservation of renal function.¹⁸⁰ In a randomized controlled trial, captopril demonstrated a trend toward improving the 1 year GFR and serum creatinine level.¹⁸¹ ACEI and ARBs also produce indirect protective effects by reducing posttransplant inflammatory markers.¹⁸²
- ESRD and renal transplantation- It may be impossible to stall the progression to ESRD. Standard therapies include peritoneal and/or hemodialysis, but survival in HCT recipients is particularly poor.¹⁷¹ Renal transplantation remains a therapeutic option for selected patients, with the additional advantage that those who received a kidney allograft from their original stem cell donor required minimal immunosuppression.^{183, 184}

GASTROINTESTINAL AND LIVER PROBLEMS

GI and hepatobiliary problems in HCT survivors are usually sequelae of GVHD, adverse medication effects, and infections.

Esophageal Symptoms (Heartburn, Dysphagia, and Painful Swallowing)

Gastroesophageal reflux disease is a common finding and may be exacerbated by GVHD and the dyspepsia associated with steroids. Involvement of the esophagus by cGVHD may lead to chronic dysmotility and reflux, necessitating prolonged proton pump inhibitor therapy. Rarely, esophagitis may be due to fungal or viral infection or to a retained pill. Therapy for strictures includes IST (for cGVHD) and careful endoscopic dilation to avoid progressive luminal narrowing.

Upper Gastrointestinal Symptoms (Anorexia, Nausea, Vomiting, and Satiety)

Causes include cGVHD, infections, and adverse drug effects. Upper GI GVHD can manifest in isolation, without other systemic manifestations of cGVHD.^{53, 185} GVHD must be distinguished from reactivation of herpesvirus (HSV, CMV, VZV) in susceptible individuals who have had antiviral prophylaxis and viral surveillance discontinued. Occasionally enteric viruses (e.g., rotavirus and norovirus) and parasites (*Giardia lamblia*, cryptosporidia) can present with anorexia and nausea with minimal diarrhea.^{186, 187}

Lower Gastrointestinal Symptoms (Diarrhea and Abdominal Pain)

cGVHD involving the lower GI tract is far less common than its acute counterpart. When this occurs, it may be a manifestation of delayed or recurrent acute GVHD, sequelae from gut injury in the early posttransplant period, infections, or common GI disorders. Subacute intestinal obstruction episodes may occur in those with a history of severe GVHD, with or without focal inflammation.¹⁸⁸ Treatment is either symptomatic with opioids or with topical or systemic IST or 5-aminosalicylic acid.

Chronic Liver Diseases in Long-term Survivors after Hematopoietic Cell Transplantation

Chronic liver dysfunction may be due to viral infection, GVHD, drug toxicity, biliary obstruction, iron overload, nodular regenerative hyperplasia, focal nodular hyperplasia, fatty liver (NASH, secondary to metabolic syndrome), cirrhosis, or recurrent malignancy.^{88, 89}

Cirrhosis may be related to chronic hepatitis C and is rising in frequency in patients transplanted before the 1990s. Viral replication and fibrosis may be accelerated by immunosuppression, injury by GVHD, and hemosiderosis.^{89, 189, 190} Long-term HCT survivors have a significantly elevated risk of developing a new solid malignancy, and there is direct evidence for an increased incidence of hepatocellular carcinoma.^{36, 37} Survivors with a history of hepatitis B or C infection, obesity, and diabetes are particularly vulnerable and should be offered annual screening for hepatocellular carcinoma.¹⁹¹

Pancreatic and Biliary Disease

Exocrine pancreatic insufficiency is an uncommon finding in HCT survivors and presents with chronic diarrhea and malabsorption.^{192, 193, 194} Potential causes include repeated episodes of pancreatitis, immunosuppressive agent toxicity, passage of a stone or sludge, damage by recurrent GVHD, viral infection, and hemosiderosis.^{88, 195} Screening involves measurement of serum trypsinogen, fecal elastase-1, and chymotrypsin levels, but imaging is required for evaluation of pancreatic atrophy.^{89, 194} Therapy is specific to the underlying cause and oral pancreatic enzyme supplementation may be of partial benefit.

HCT survivors have an increased risk of gallstones, and biliary sludge is found by ultrasound in approximately 70%¹⁹⁶ and at autopsy in 100% of HCT survivors.¹⁹⁷ This is thought to be related to immunosuppressive medications.

IRON OVERLOAD IN LONG-TERM SURVIVORS

Pathobiology

Transfusional iron overload is common in benign and malignant hematologic conditions and is often present prior to transplant. Iron overload can occur after as few as 20 units of PRBC

P.2232

transfusions, impacts 30% to 60% of allotransplant recipients, and is liable to be overlooked.^{88, 198} Not only is nontransferrin bound iron deposited into the liver, heart, pancreas, cartilage, and endocrine tissues, but it may lead to the formation of reactive oxygen species.^{199, 200} While the liver is capable of accumulating a substantial amount of iron, the most significant sequelae are not hepatic, but cardiac and endocrine.⁸⁹

Clinical Presentation and Diagnosis

Iron overload may masquerade as liver GVHD. Iron overload was the sole pathologic finding in one-third of cases with liver function test (LFT) abnormalities which underwent biopsy²⁰¹ and phlebotomy may normalize abnormal LFTs.²⁰²

Serum ferritin is the best screening test. Levels higher than 200 µg/L in women and 300 µg/L in men are generally considered elevated, but are not very reliable because of frequent confounding conditions in the transplant setting. It is important to distinguish iron overload from other causes of elevated ferritin such as systemic inflammation (GVH, infections), metabolic syndrome, hepatitis, and alcoholism.⁸⁸ Liver iron concentration is the gold standard for diagnosis, but biopsy has been supplanted by T2 quantitative MRI. Mutational analysis for hereditary forms of hemochromatosis is helpful in diagnosing selected cases where the transfusion burden is not great.

Prognostic Importance

There is growing data on the adverse impact of iron overload, particularly when severe, on transplant outcomes.^{88, 89, 203, 204, 205, 206} The impact of moderate degrees of iron overload on transplant outcomes remains debatable because excessive transfusions are a surrogate for a complicated clinical course.

Management

While more research is necessary to assess the role of iron overload in HCT survivors, clearly there is much to be gained from prevention even prior to transplant.^{88, 207, 208, 209, 210} After the cessation of transfusions, the rate of spontaneous iron unloading is unsatisfactory.²⁰⁶ Therapeutic options include phlebotomy and iron chelation; however, there are no randomized trials. Phlebotomy, sometimes supported by erythropoiesis stimulating agents and folic acid, is effective, relatively nontoxic, and inexpensive. Frequent phlebotomy is limited only by anemia, leading to considerations of iron chelation as an option. Iron chelation by deferoxamine, deferiprone, and deferasirox have all been shown to reduce iron overload in the transplant setting, and one retrospective study showed a significant reduction in relapse for iron-overloaded patients treated with deferoxamine.²¹¹ With this exception, no study has shown significant clinical benefit for iron chelating agents and prospective trials are required to demonstrate their safety and optimize their administration in transplant survivors.

FEMALE LONG-TERM SURVIVORS AND RELATED ISSUES

Given the complexities involved with the evaluation and management of this patient population, it is important for close collaboration between the obstetrician/gynecologist and the hematologist/oncologist.²¹² Preventive gynecologic care is critical to manage cGVHD of the genital tract, which can be a cause of significant morbidity. Other issues relevant to women of reproductive-age include HPV-related cervical dysplasia, contraception, infertility, pregnancy issues, sexual health, and hypogonadism.

Vulvovaginal Graft-versus-host disease

The incidence of female genital GVHD ranges between 25% and 49% of allo-HCT survivors.^{213, 214} Genital GVHD manifests in the vulva (68%), or the vulva and vagina concomitantly (26%).²¹² Vulvovaginal cGVHD typically starts in the first year posttransplant but vaginal GVHD may present in a delayed fashion, after several years following HCT.^{215, 216} Late manifestations include vaginal synechiae, stenosis, and hematocolpos. Severe vaginal GVHD is strongly associated with sclerotic skin cGVHD,²¹⁶ but may be isolated in 27% of cases.²¹³ Genital cGVHD has been classified into grade I (mild), grade II (moderate), and grade III (severe).^{213, 214, 216}

Management is complicated by symptom underreporting, empiric therapies directed at infectious or menopausal etiologies without gynecologic examination, or severe illness interfering with gynecology referral.²¹⁷ Treatment of only vulvar disease does not prevent development of vaginal GVHD. In one series, 63% of patients required surgery for vaginal GVHD despite aggressive treatment of vulvar cGVHD,²¹³ whereas others instituting regular monitoring avoided surgery.²¹⁴ The key to successful management is early recognition of genital GVHD and early implementation of topical immunosuppressive and estrogen therapy with concomitant use of dilators, if needed.^{214, 216, 218} Surgery is necessary for severe resistant cases.

Human Papillomavirus-related Secondary Cancer and Other Diseases

The clinical manifestations of HPV infection include genital warts (condylomata acuminata), cervical, vaginal, vulvar, or anal intraepithelial neoplasia, and anogenital SCC. Cervical SCC in long-term allo-HCT survivors is reported to have a 13-fold increased risk compared to the general population,³⁶ and escalates to 18-fold higher if the patient is older than 34 years. Over 40% of female long-term survivors in another study had abnormal cervical cytology, with 20% having high-grade cervical dysplasia.⁴⁷ Lower genital tract dysplasia and anogenital condyloma, other manifestations of HPV infection, are also prevalent. These manifestations are strongly associated with prolonged systemic or local IST and likely represent reactivation of existing HPV infection, rather than acquisition of new infection. Loss of protective immunity explains why the resulting HPV-related disease is more prevalent and more rapidly progressive, as is observed in other immunocompromised populations.²¹⁹

Current guidelines recommend annual screening after HCT.²¹⁸ Screening for cervical dysplasia is by cytology testing with reflex HPV testing. Colposcopy is reserved for cytology testing documenting atypical squamous cells of undetermined significance (ASC-US) coupled with concurrent positive testing for high-risk HPV types, atypical squamous cells suggestive of a high-grade lesion, low-grade squamous intraepithelial lesions, high-grade squamous intraepithelial lesions, or cancer. Women with ASC-US on cytology specimens a year apart are considered to have persistent abnormalities and should also undergo colposcopy.

Guidelines for vaccinating against HPV infections after allo-HCT have been proposed, although immune response may be suboptimal.^{46, 220} Vaccination in the year after transplantation could theoretically mitigate reactivation of HPV disease, if an immune response is generated.

Infertility and Sexual Health

Most women undergoing transplantation are in their reproductive years and are extremely susceptible to ovarian insufficiency or failure. Manifestations are amenorrhea, reduced libido, vaginal changes, and menopausal symptoms. Puberty may still occur spontaneously in up to 60% of prepubertal transplanted

P.2233

females,¹⁵⁵ whereas postpubertal myeloablative transplants result in ovarian failure in >90% of women, with delayed recovery occurring in 29%.^{221, 222} For those whose menses return months or years after transplant, transient ovarian failure is common in the first year after treatment and liable to terminate in premature menopause.^{25, 223, 224, 225}

The likelihood of permanent ovarian failure and infertility is affected by age, pubertal status, conditioning intensity, radiation dose, and location.^{222, 226, 227} The risk of premature ovarian insufficiency related to TBI increases with age.²²⁸ Radiation doses of 6 Gy are sufficient to cause irreversible ovarian injury in most patients treated after age 40, while two

to three times this dose is required to precipitate ovarian failure in irradiated children.²²⁹ In contrast, the incidence of ovarian failure is greatly reduced (<40%) by utilizing reduced-intensity conditioning.²³⁰ Apart from ovarian failure, fertility is also affected by uterine damage from radiation²²⁸ and dyspareunia related to vulvo-vaginal GVHD.²¹⁶

Successful pregnancies are uncommon. The largest series with 19,412 allogeneic and 17,950 autologous transplants documented only 312 pregnancies in 232 (0.6%) of patients or their partners.²³¹ Moreover, pregnancies in transplant survivors are complicated by an increased risk of low birth weight, preterm delivery, and cesarean section delivery. Additional concerns include intrauterine growth restriction, abnormal placentation, and uterine rupture.^{232, 233} Patients with decreased uterine volume after TBI are at increased risk for spontaneous abortion, even with the use of donor oocytes and in vitro fertilization.²²⁸ The risk of spontaneous abortion is unclear, with conflicting data.^{218, 228, 231, 234} All conceptions in transplant survivors are high risk.

Sexual dysfunction is common in women and lags behind their male counterparts. 80% of female transplant survivors reported sexual dysfunction (in contrast to 46% of men). Female sexual dysfunction persists even when other measures of physical and emotional well-being return to normal.²³⁵ Contributing factors include fatigue, medications, endocrinopathy, genital GVHD, and psychological causes. The goals of therapy are to restore fertility if desired, improve sexual function and libido, and reduce bone loss. Women should be advised to avoid pregnancy using a reliable method of birth control while they receive transplant-related medications, and should be assessed for engraftment disease status and ovarian function. Amenorrhea after menses have returned should prompt a pregnancy test, since fertility can recover in some patients.²³⁶

Options to preserve fertility after myeloablative HCT, when time permits, include preconditioning embryo, oocyte, or ovarian tissue cryopreservation for subsequent in vitro fertilization.^{160, 218, 231} HRT is successful in treating menopausal symptoms²³⁷ and in developing secondary sexual characteristics. However, HRT has little effect on sexual desire or dissatisfaction.²¹² The optimum duration of HRT is undefined, but cessation at the normal age for menopause should be considered. For menopausal symptom control in those with contraindications to HRT, placebo-controlled trials suggest a benefit from SSRIs.²³⁸

QUALITY OF LIFE AND SOCIAL CHANGES IN LONG-TERM SURVIVORS

HCT survivors have undergone the most intense form of anticancer therapy. The prevalence of severe late complications in transplant survivors, even when a cure is achieved, emphasizes a necessity to also focus on QOL issues. HCT often reduces the overall health-related quality of life (HRQOL) of survivors, which is a result of decrements across all dimensions, including a significant symptom burden.²³⁹ Discordance between the anticipated and the actual diminution of QOL after transplant may be a cause of significant dissatisfaction in survivors^{240, 241} and may be mitigated by careful pretransplant counseling. HRQOL includes physical, cognitive, emotional, and social functioning, as well as well-being components. Comparison of transplant QOL studies has been imprecise because of subjective designs, lack of standardized methodologies, differences in time points, overreliance on cross-sectional rather than prospective/longitudinal studies, lack of well-defined control groups, and population heterogeneity.²⁴²

Health-related Quality of Life Studies

A study of 2,800 pooled transplant survivors found that QOL declines immediately after transplantation,²⁴³ with recovery over the next 1 year. More than half of transplant survivors return to work in 1 year.^{244, 245, 246} Physical recovery precedes that of fatigue, dyspnea, or sleep patterns²⁴⁷ and of psychological or work recovery.²⁴⁸ 19% recovered on all outcomes at 1 year and 63% by 5 years. Among survivors without recurrent malignancy, 84% returned to full-time work by 5 years. Beyond 5 years, most survivors are disease free with an excellent performance status, preserved physical and psychological health, and excellent HRQOL.²⁴⁹ Pretransplant factors impacting long-term QOL were studied in a registry cohort of 662 survivors at a median of 6.6 years posttransplant.²⁵⁰ Surviving adversity can alter life-perceptions, and several transplant survivors report positive experiences related to psychological and interpersonal growth.^{249, 250, 251, 252} Posttraumatic growth is well documented in cancer medicine and studies are now beginning to also focus on the positive impact of transplant on QOL.²⁵³

Psychological and Cognitive Issues

Both autologous and allogeneic HCT survivors report a high prevalence of psychiatric symptoms²⁴⁰ and 5% of survivors meet diagnostic criteria for posttraumatic stress disorder.²⁵⁴ Psychological stressors include the fear of relapse and the inability to return to pretransplant performance level. Interestingly, the extent of psychological and cognitive decline appears to be similar for leukemia patients treated either with chemotherapy or HCT.^{255, 256}

Depression affects about one-third of posttransplant survivors. cGVHD, inferior social support, and female gender were significant factors for depression.²⁵⁷ A significant generalized decline in neurocognitive performance has been observed as early as 80 days after HCT.²⁴⁸ Although neurocognitive function improved from 1 to 5 years after HCT, deficits remained for more than 40% of survivors.²⁵⁸ Impairments in attention, concentration, reaction time, reasoning, and problem solving were observed to last up to 8 years posttransplant and were directly correlated to the dose of TBI.²⁵⁹ Inflammatory cytokines, such as TNF- α , have been implicated as putative factors for cognitive decline.²⁶⁰

Interventions to Improve Quality of Life

Psychosocial screening is routinely performed pretransplant but has not been adequately studied posttransplant. Consensus guidelines recommend additional periodic screening at 6 months and annually after transplant, by one of several simple screening instruments.⁵⁰ Screens are available for distress, depression, and posttraumatic stress disorder.^{261, 262} Fatigue that is not related to depression or underlying medical reasons may respond to an exercise program.²⁶³ Behavioral intervention, pharmacologic therapy, and exercise may help depression.

CONCLUSION

A better understanding of the pathogenesis of late effects will allow for more effective screening to identify patients at risk prior to the allo-HCT procedure and allow more effective monitoring to

P.2234

detect early evolution of the late effects after allo-HCT. This may, in turn, allow for improved therapeutic decision making while evaluating patients for HCT, and early institution of treatments directed at preventing and treating late effects in patients at risk after allo-HCT. We also recommend early referral or discussion with a transplant center for enrollment of patients in available late effect studies and for management guidelines.

REFERENCES

1. Thomas ED. A history of bone marrow transplantation. In: Appelbaum FR, Forman SJ, Negrin RS, Blume KG, eds. Thomas' hematopoietic cell transplantation. West Sussex, UK: Wiley-Blackwell, 2009:3-7.
2. Savani BN. How can we improve life expectancy and quality of life in long-term survivors after allogeneic stem cell transplantation? *Semin Hematol* 2012;49:1-3.
3. Socie G, Rizzo JD. Second solid tumors: screening and management guidelines in long-term survivors after allogeneic stem cell transplantation. *Semin Hematol* 2012;49:4-9.
4. Horowitz MM. Uses and growth of hematopoietic cell transplantation. In: Appelbaum FR, Forman SJ, Negrin RS, Blume KG, eds. Thomas' hematopoietic cell transplantation. West Sussex, UK: Wiley-Blackwell, 2009:15-21.
5. Pasquini MC, Wang Z. Current use and outcome of hematopoietic stem cell transplantation: CIBMTR Summ Slides 2010. <http://www.cibmtr.org>. Accessed on 12 Sep 2012.
6. Savani BN, Griffith ML, Jagasia S, Lee SJ. How I treat late effects in adults after allogeneic stem cell transplantation. *Blood* 2011;117:3002-3009.
7. Gratwohl A, Baldomero H, Aljurf M, et al. Hematopoietic stem cell transplantation: a global perspective. *JAMA* 2010;303:1617-1624.
8. Martin PJ, Counts GW Jr, Appelbaum FR, et al. Life expectancy in patients surviving more than 5 years after hematopoietic cell transplantation. *J Clin Oncol* 2010;28:1011-1016.
9. Tichelli A, Bhatia S, Socie G. Cardiac and cardiovascular consequences after haematopoietic stem cell transplantation. *Br J Haematol* 2008;142:11-26.
10. Bhatia S, Francisco L, Carter A, et al. Late mortality after allogeneic hematopoietic cell transplantation and functional status of long-term survivors: report from the Bone Marrow Transplant Survivor Study. *Blood* 2007;110:3784-3792.
11. Savani BN, Montero A, Srinivasan R, et al. Chronic GVHD and pretransplantation abnormalities in pulmonary function are the main determinants predicting worsening pulmonary function in long-term survivors after stem cell transplantation. *Biol Blood Marrow Transplant* 2006;12:1261-1269.
12. Roivo A, Tichelli A. Cardiovascular complications in long-term survivors after allogeneic hematopoietic stem cell transplantation. *Semin Hematol* 2012;49:25-34.

13. Tichelli A, Bucher C, Rovo A, et al. Premature cardiovascular disease after allogeneic hematopoietic stem-cell transplantation. *Blood* 2007;110: 3463-3471.
14. Chow EJ, Mueller BA, Baker KS, et al. Cardiovascular hospitalizations and mortality among recipients of hematopoietic stem cell transplantation. *Ann Intern Med* 2011;155:21-32.
15. Armenian SH, Sun CL, Kawashima T, et al. Long-term health-related outcomes in survivors of childhood cancer treated with HSCT versus conventional therapy: a report from the Bone Marrow Transplant Survivor Study (BMTSS) and Childhood Cancer Survivor Study (CCSS). *Blood* 2011;118:1413-1420.
16. Sun CL, Francisco L, Kawashima T, et al. Prevalence and predictors of chronic health conditions after hematopoietic cell transplantation: a report from the Bone Marrow Transplant Survivor Study. *Blood* 2010;116:3129-3139.
17. Majhail NS, Challa TR, Mulrooney DA, Baker KS, Burns LJ. Hypertension and diabetes mellitus in adult and pediatric survivors of allogeneic hematopoietic cell transplantation. *Biol Blood Marrow Transplant* 2009;15:1100-1107.
18. Rovo A, Daikeler T, Halter J, et al. Late altered organ function in very long-term survivors after allogeneic hematopoietic stem cell transplantation: a paired comparison with their HLA-identical sibling donor. *Haematologica* 2011;96:150-155.
19. Griffith ML, Savani BN, Boord JB. Dyslipidemia after allogeneic hematopoietic stem cell transplantation: evaluation and management. *Blood* 2010;116:1197-1204.
20. Taskinen M, Saarinen-Pihkala UM, Hovi L, Lipsanen-Nyman M. Impaired glucose tolerance and dyslipidaemia as late effects after bone-marrow transplantation in childhood. *Lancet* 2000;356:993-997.
21. Savani BN, Koklanaris EK, Le Q, et al. Prolonged chronic graft-versus-host disease is a risk factor for thyroid failure in long-term survivors after matched sibling donor stem cell transplantation for hematologic malignancies. *Biol Blood Marrow Transplant* 2009;15:377-381.
22. Steffens M, Beauloye V, Brichard B, et al. Endocrine and metabolic disorders in young adult survivors of childhood acute lymphoblastic leukaemia (ALL) or nonHodgkin lymphoma (NHL). *Clin Endocrinol (Oxf)* 2008;69:819-827.
23. Singh SK, Goyal R, Pratyush DD. Is hypoandrogenemia a component of metabolic syndrome in males? *Exp Clin Endocrinol Diabetes* 2011;119:30-35.
24. Nuver J, Smit AJ, Postma A, Sleijfer DT, Gietema JA. The metabolic syndrome in long-term cancer survivors, an important target for secondary preventive measures. *Cancer Treat Rev* 2002;28:195-214.
25. Rutter MM, Rose SR. Long-term endocrine sequelae of childhood cancer. *Curr Opin Pediatr* 2007;19:480-487.
26. Pophali PA, Klotz J, Chawla K, et al. Magnitude of dyslipidemias and cardiovascular risk in survivors of allogeneic hematopoietic stem cell transplantation (SCT) up to the second decade post-transplant. *Biol Blood Marrow Transplant* 2012;18:S286.
27. Murray RD, Shalet SM. Insulin sensitivity is impaired in adults with varying degrees of GH deficiency. *Clin Endocrinol (Oxf)* 2005;62:182-188.
28. Taskinen M, Lipsanen-Nyman M, Tiitinen A, Hovi L, Saarinen-Pihkala UM. Insufficient growth hormone secretion is associated with metabolic syndrome after allogeneic stem cell transplantation in childhood. *J Pediatr Hematol Oncol* 2007;29:529-534.
29. Airaghi L, Usardi P, Forti S, et al. A comparison between metabolic syndrome post-hematopoietic stem cell transplantation and spontaneously occurring metabolic syndrome. *J Endocrinol Invest* 2011;34:e6-11.
30. Annaloro C, Usardi P, Airaghi L, et al. Prevalence of metabolic syndrome in long-term survivors of hematopoietic stem cell transplantation. *Bone Marrow Transplant* 2008;41:797-804.
31. Baker JE, Fish BL, Su J, et al. 10 Gy total body irradiation increases risk of coronary sclerosis, degeneration of heart structure and function in a rat model. *Int J Radiat Biol* 2009;85:1089-1100.
32. Biedermann BC, Sahrer S, Gregor M, et al. Endothelial injury mediated by cytotoxic T lymphocytes and loss of microvessels in chronic graft versus host disease. *Lancet* 2002;359:2078-2083.
33. Aisa Y, Mori T, Nakazato T, et al. Effects of immunosuppressive agents on magnesium metabolism early after allogeneic hematopoietic stem cell transplantation. *Transplantation* 2005;80:1046-1050.

34. Majhail NS, Rizzo JD, Lee SJ, et al. Recommended screening and preventive practices for long-term survivors after hematopoietic cell transplantation. *Bone Marrow Transplant* 2012;47:337-341.
35. Deeg HJ, Sanders J, Martin P, et al. Secondary malignancies after marrow transplantation. *Exp Hematol* 1984;12:660-666.
36. Bhatia S, Louie AD, Bhatia R, et al. Solid cancers after bone marrow transplantation. *J Clin Oncol* 2001;19:464-471.
37. Curtis RE, Rowlings PA, Deeg HJ, et al. Solid cancers after bone marrow transplantation. *N Engl J Med* 1997;336:897-904.
38. Kolb HJ, Socie G, Duell T, et al. Malignant neoplasms in long-term survivors of bone marrow transplantation. Late Effects Working Party of the European Cooperative Group for Blood and Marrow Transplantation and the European Late Effect Project Group. *Ann Intern Med* 1999;131:738-744.
39. Rizzo JD, Curtis RE, Socie G, et al. Solid cancers after allogeneic hematopoietic cell transplantation. *Blood* 2009;113:1175-1183.
40. Socie G, Stone JV, Wingard JR, et al. Long-term survival and late deaths after allogeneic bone marrow transplantation. Late Effects Working Committee of the International Bone Marrow Transplant Registry. *N Engl J Med* 1999; 341:14-21.
41. Wingard JR, Majhail NS, Brazauskas R, et al. Long-term survival and late deaths after allogeneic hematopoietic cell transplantation. *J Clin Oncol* 2011;29:2230-2239.
42. Allan JM, Travis LB. Mechanisms of therapy-related carcinogenesis. *Nat Rev Cancer* 2005;5:943-955.
43. Gallagher G, Forrest DL. Second solid cancers after allogeneic hematopoietic stem cell transplantation. *Cancer* 2007;109:84-92.
44. Masserot C, Peffault de LR, Rocha V, et al. Head and neck squamous cell carcinoma in 13 patients with Fanconi anemia after hematopoietic stem cell transplantation. *Cancer* 2008;113:3315-3322.
45. Rosenberg PS, Socie G, Alter BP, Gluckman E. Risk of head and neck squamous cell cancer and death in patients with Fanconi anemia who did and did not receive transplants. *Blood* 2005;105:67-73.
46. Savani BN, Goodman S, Barrett AJ. Can routine posttransplant HPV vaccination prevent commonly occurring epithelial cancers after allogeneic stem cell transplantation? *Clin Cancer Res* 2009;15:2219-2221.
47. Savani BN, Stratton P, Shenoy A, et al. Increased risk of cervical dysplasia in long-term survivors of allogeneic stem cell transplantation—implications for screening and HPV vaccination. *Biol Blood Marrow Transplant* 2008;14:1072-1075.
48. Fenske TS, McMahon C, Edwin D, et al. Identification of candidate alkylator-induced cancer susceptibility genes by whole genome scanning in mice. *Cancer Res* 2006;66:5029-5038.
49. Majhail NS, Brazauskas R, Rizzo JD, et al. Secondary solid cancers after allogeneic hematopoietic cell transplantation using busulfan-cyclophosphamide conditioning. *Blood* 2011;117:316-322.
50. Majhail NS, Rizzo JD, Lee SJ, et al. Recommended screening and preventive practices for long-term survivors after hematopoietic cell transplantation. *Biol Blood Marrow Transplant* 2012;18:348-371.
51. Bacigalupo A, Lamparelli T, Barisione G, et al. Thymoglobulin prevents chronic graft-versus-host disease, chronic lung dysfunction, and late transplant-related mortality: long-term follow-up of a randomized trial in patients undergoing unrelated donor transplantation. *Biol Blood Marrow Transplant* 2006;12:560-565.
52. Williams KM, Chien JW, Gladwin MT, Pavletic SZ. Bronchiolitis obliterans after allogeneic hematopoietic stem cell transplantation. *JAMA* 2009;302:306-314.
53. Filipovich AH, Weisdorf D, Pavletic S, et al. National Institutes of Health consensus development project on criteria for clinical trials in chronic graft-versus-host disease: I. Diagnosis and staging working group report. *Biol Blood Marrow Transplant* 2005;11:945-956.
54. Todd JL, Palmer SM. Bronchiolitis obliterans syndrome: the final frontier for lung transplantation. *Chest* 2011;140:502-508.
55. Sengsayadeth SM, Srivastava S, Jagasia M, Savani BN. Time to explore preventive and novel therapies for bronchiolitis obliterans syndrome after allogeneic hematopoietic stem cell transplantation. *Biol Blood Marrow Transplant* 2012.

56. Bacigalupo A, Chien J, Barisione G, Pavletic S. Late pulmonary complications after allogeneic hematopoietic stem cell transplantation: diagnosis, monitoring, prevention, and treatment. *Semin Hematol* 2012;49:15-24.
57. Chien JW, Duncan S, Williams KM, Pavletic SZ. Bronchiolitis obliterans syndrome after allogeneic hematopoietic stem cell transplantation—an increasingly recognized manifestation of chronic graft-versus-host disease. *Biol Blood Marrow Transplant* 2010;16:S106-S114.
58. Finke J, Bethge WA, Schmoor C, et al. Standard graft-versus-host disease prophylaxis with or without anti-T-cell globulin in haematopoietic cell transplantation from matched unrelated donors: a randomised, open-label, multicentre phase 3 trial. *Lancet Oncol* 2009;10:855-864.
59. Sullivan KM, Shulman HM, Storb R, et al. Chronic graft-versus-host disease in 52 patients: adverse natural course and successful treatment with combination immunosuppression. *Blood* 1981;57:267-276.
60. Ratjen F, Rjabko O, Kremens B. High-dose corticosteroid therapy for bronchiolitis obliterans after bone marrow transplantation in children. *Bone Marrow Transplant* 2005;36:135-138.
61. Bashoura L, Gupta S, Jain A, et al. Inhaled corticosteroids stabilize constrictive bronchiolitis after hematopoietic stem cell transplantation. *Bone Marrow Transplant* 2008;41:63-67.
62. Bergeron A, Belle A, Chevret S, et al. Combined inhaled steroids and bronchodilators in obstructive airway disease after allogeneic stem cell transplantation. *Bone Marrow Transplant* 2007;39:547-553.
63. Gottlieb J, Szangolies J, Koehnlein T, et al. Long-term azithromycin for bronchiolitis obliterans syndrome after lung transplantation. *Transplantation* 2008;85:36-41.
64. Yates B, Murphy DM, Forrest IA, et al. Azithromycin reverses airflow obstruction in established bronchiolitis obliterans syndrome. *Am J Respir Crit Care Med* 2005;172:772-775.
65. Gerhardt SG, McDyer JF, Girgis RE, et al. Maintenance azithromycin therapy for bronchiolitis obliterans syndrome: results of a pilot study. *Am J Respir Crit Care Med* 2003;168:121-125.
66. Vos R, Vanaudenaerde BM, Ottevaere A, et al. Long-term azithromycin therapy for bronchiolitis obliterans syndrome: divide and conquer? *J Heart Lung Transplant* 2010;29:1358-1368.
67. Vos R, Vanaudenaerde BM, Verleden SE, et al. A randomised controlled trial of azithromycin to prevent chronic rejection after lung transplantation. *Eur Respir J* 2011;37:164-172.
68. Khalid M Al SA, Saleemi S, et al. Azithromycin in bronchiolitis obliterans complicating bone marrow transplantation: a preliminary study. *Eur Respir J* 2005;25:490-493.
69. Norman BC, Jacobsohn DA, Williams KM, et al. Fluticasone, azithromycin and montelukast therapy in reducing corticosteroid exposure in bronchiolitis obliterans syndrome after allogeneic hematopoietic SCT: a case series of eight patients. *Bone Marrow Transplant* 2011;46:1369-1373.
70. Rabitsch W, Deviatko E, Keil F, et al. Successful lung transplantation for bronchiolitis obliterans after allogeneic marrow transplantation. *Transplantation* 2001;71:1341-1343.
71. Calhoun JH, Levine S, Anzueto A, Bryan CL, Trinkle JK. Lung transplantation in a patient with a prior bone marrow transplant. *Chest* 1992;102:948.
72. Sano Y, Date H, Nagahiro I, Aoe M, Shimizu N. Living-donor lobar lung transplantation for bronchiolitis obliterans after bone marrow transplantation. *Ann Thorac Surg* 2005;79:1051-1052.
73. Robin M, Porcher R, De Castro AR, et al. Risk factors for late infections after allogeneic hematopoietic stem cell transplantation from a matched related donor. *Biol Blood Marrow Transplant* 2007;13:1304-1312.
74. Goldman JM, Majhail NS, Klein JP, et al. Relapse and late mortality in 5-year survivors of myeloablative allogeneic hematopoietic cell transplantation for chronic myeloid leukemia in first chronic phase. *J Clin Oncol* 2010;28: 1888-1895.
75. Ljungman P, Small TN. Update to vaccination guidelines. *Biol Blood Marrow Transplant* 2010;16:1608-1609.
76. Tomblyn M, Chiller T, Einsele H, et al. Guidelines for preventing infectious complications among hematopoietic cell transplant recipients: a global perspective. Preface *Bone Marrow Transplant* 2009;44:453-455.
77. Fuji S, Kapp M, Einsele H. Challenges to preventing infectious complications, decreasing re-hospitalizations, and reducing cost burden in long-term survivors after allogeneic hematopoietic stem cell transplantation. *Semin Hematol* 2012;49:10-14.

78. Corre E, Carmagnat M, Busson M, et al. Long-term immune deficiency after allogeneic stem cell transplantation: B-cell deficiency is associated with late infections. *Haematologica* 2010;95:1025-1029.
79. Le RQ, Melenhorst JJ, Battiwalla M, et al. Evolution of the donor T-cell repertoire in recipients in the second decade after allogeneic stem cell transplantation. *Blood* 2011;117:5250-5256.
80. Bjorklund A, Aschan J, Labopin M, et al. Risk factors for fatal infectious complications developing late after allogeneic stem cell transplantation. *Bone Marrow Transplant* 2007;40:1055-1062.
81. Ljungman P, Cordonnier C, Einsele H, et al. Vaccination of hematopoietic cell transplant recipients. *Bone Marrow Transplant* 2009;44:521-526.
82. Hilgendorf I, Freund M, Jilg W, et al. Vaccination of allogeneic haematopoietic stem cell transplant recipients: report from the International Consensus Conference on Clinical Practice in Chronic GVHD. *Vaccine* 2011;29:2825-2833.
83. Marr KA, Carter RA, Boeckh M, Martin P, Corey L. Invasive aspergillosis in allogeneic stem cell transplant recipients: changes in epidemiology and risk factors. *Blood* 2002;100:4358-4366.
84. Mikulska M, Raiola AM, Bruno B, et al. Risk factors for invasive aspergillosis and related mortality in recipients of allogeneic SCT from alternative donors: an analysis of 306 patients. *Bone Marrow Transplant* 2009;44:361-370.
85. Maertens J, Marchetti O, Herbrecht R, et al. European guidelines for anti-fungal management in leukemia and hematopoietic stem cell transplant recipients: summary of the ECIL 3-2009 update. *Bone Marrow Transplant* 2011;46:709-718.
86. Garcia-Vidal C, Upton A, Kirby KA, Marr KA. Epidemiology of invasive mold infections in allogeneic stem cell transplant recipients: biological risk factors for infection according to time after transplantation. *Clin Infect Dis* 2008;47:1041-1050.
87. Altes A, Remacha AF, Sarda P, et al. Frequent severe liver iron overload after stem cell transplantation and its possible association with invasive aspergillosis. *Bone Marrow Transplant* 2004;34:505-509.
88. Brissot E, Savani BN, Mohty M. Management of high ferritin in long-term survivors after hematopoietic stem cell transplantation. *Semin Hematol* 2012;49:35-42.
89. Kida A, McDonald GB. Gastrointestinal, hepatobiliary, pancreatic, and iron-related diseases in long-term survivors of allogeneic hematopoietic cell transplantation. *Semin Hematol* 2012;49:43-58.
90. Pullarkat V. Objectives of iron chelation therapy in myelodysplastic syndromes: more than meets the eye? *Blood* 2009;114:5251-5255.
91. Erard V, Guthrie KA, Varley C, et al. One-year acyclovir prophylaxis for preventing varicella-zoster virus disease after hematopoietic cell transplantation: no evidence of rebound varicella-zoster virus disease after drug discontinuation. *Blood* 2007;110:3071-3077.
92. Boeckh M, Kim HW, Flowers ME, Meyers JD, Bowden RA. Long-term acyclovir for prevention of varicella zoster virus disease after allogeneic hematopoietic cell transplantation—a randomized double-blind placebo-controlled study. *Blood* 2006;107:1800-1805.
93. Chou JF, Kernan NA, Prockop S, et al. Safety and immunogenicity of the live attenuated varicella vaccine following T replete or T cell-depleted related and unrelated allogeneic hematopoietic cell transplantation (alloHCT). *Biol Blood Marrow Transplant* 2011;17:1708-1713.
94. Kussmaul SC, Horn BN, Dvorak CC, et al. Safety of the live, attenuated varicella vaccine in pediatric recipients of hematopoietic SCTs. *Bone Marrow Transplant* 2010;45:1602-1606.
95. Mohty B, Bel M, Vukicevic M, et al. Graft-versus-host disease is the major determinant of humoral responses to the AS03-adjuvanted influenza A/09/H1N1 vaccine in allogeneic hematopoietic stem cell transplant recipients. *Haematologica* 2011;96:896-904.
96. de LH, Garland P, Sekine T, et al. Repeated vaccination is required to optimize seroprotection against H1N1 in the immunocompromised host. *Haematologica* 2011;96:307-314.
97. Issa NC, Marty FM, Gagne LS, et al. Seroprotective titers against 2009 H1N1 influenza A virus after vaccination in allogeneic hematopoietic stem cell transplantation recipients. *Biol Blood Marrow Transplant* 2011;17:434-438.
98. Avetisyan G, Aschan J, Hassan M, Ljungman P. Evaluation of immune responses to seasonal influenza vaccination in healthy volunteers and in patients after stem cell transplantation. *Transplantation* 2008;86:257-263.

99. Savani BN, Donohue T, Kozanas E, et al. Increased risk of bone loss without fracture risk in long-term survivors after allogeneic stem cell transplantation. *Biol Blood Marrow Transplant* 2007;13:517-520.
100. Petropoulou AD, Porcher R, Herr AL, et al. Prospective assessment of bone turnover and clinical bone diseases after allogeneic hematopoietic stem-cell transplantation. *Transplantation* 2010;89:1354-1361.
101. Bhatia S, Ramsay NK, Weisdorf D, Griffiths H, Robison LL. Bone mineral density in patients undergoing bone marrow transplantation for myeloid malignancies. *Bone Marrow Transplant* 1998;22:87-90.
102. Buchs N, Helg C, Collao C, et al. Allogeneic bone marrow transplantation is associated with a preferential femoral neck bone loss. *Osteoporos Int* 2001;12:880-886.
103. Gandhi MK, Lekamwasam S, Inman I, et al. Significant and persistent loss of bone mineral density in the femoral neck after haematopoietic stem cell transplantation: long-term follow-up of a prospective study. *Br J Haematol* 2003;121:462-468.
104. Schulte CM, Beelen DW. Bone loss following hematopoietic stem cell transplantation: a long-term follow-up. *Blood* 2004;103:3635-3643.
105. Yao S, Smiley SL, West K, et al. Accelerated bone mineral density loss occurs with similar incidence and severity, but with different risk factors, after autologous versus allogeneic hematopoietic cell transplantation. *Biol Blood Marrow Transplant* 2010;16:1130-1137.
106. Kananen K, Volin L, Tahtela R, et al. Recovery of bone mass and normalization of bone turnover in long-term survivors of allogeneic bone marrow transplantation. *Bone Marrow Transplant* 2002;29:33-39.
107. Schimmer AD, Mah K, Bordeleau L, et al. Decreased bone mineral density is common after autologous blood or marrow transplantation. *Bone Marrow Transplant* 2001;28:387-391.
108. Yao S, McCarthy PL, Dunford LM, et al. High prevalence of early-onset osteopenia/osteoporosis after allogeneic stem cell transplantation and improvement after bisphosphonate therapy. *Bone Marrow Transplant* 2008;41:393-398.
109. Kauppila M, Irljala K, Koskinen P, et al. Bone mineral density after allogeneic bone marrow transplantation. *Bone Marrow Transplant* 1999;24:885-889.
110. McDonough AK, Curtis JR, Saag KG. The epidemiology of glucocorticoid-associated adverse events. *Curr Opin Rheumatol* 2008;20:131-137.
111. Duncan CN, Vrooman L, Apfelbaum EM, et al. 25-hydroxy vitamin D deficiency following pediatric hematopoietic stem cell transplant. *Biol Blood Marrow Transplant* 2011;17:749-753.
112. Faulhaber GA, Premaor MO, Moser Filho HL, Silla LM, Furlanetto TW. Low bone mineral density is associated with insulin resistance in bone marrow transplant subjects. *Bone Marrow Transplant* 2009;43:953-957.
113. Ricci P, Tauchmanova L, Risitano AM, et al. Imbalance of the osteoprotegerin/RANKL ratio in bone marrow microenvironment after allogeneic hemopoietic stem cell transplantation. *Transplantation* 2006;82:1449-1456.
114. Kersch-Schindl K, Mitterbauer M, Fureder W, et al. Bone metabolism in patients more than five years after bone marrow transplantation. *Bone Marrow Transplant* 2004;34:491-496.
115. Weilbaecher KN. Mechanisms of osteoporosis after hematopoietic cell transplantation. *Biol Blood Marrow Transplant* 2000;6:165-174.
116. Massenkeil G, Fiene C, Rosen O, et al. Loss of bone mass and vitamin D deficiency after hematopoietic stem cell transplantation: standard prophylactic measures fail to prevent osteoporosis. *Leukemia* 2001;15:1701-1705.
117. Valimaki MJ, Kinnunen K, Volin L, et al. A prospective study of bone loss and turnover after allogeneic bone marrow transplantation: effect of calcium supplementation with or without calcitonin. *Bone Marrow Transplant* 1999;23:355-361.
118. Ebeling PR. Approach to the patient with transplantation-related bone loss. *J Clin Endocrinol Metab* 2009;94:1483-1490.
119. McClune BL, Polgreen LE, Burmeister LA, et al. Screening, prevention and management of osteoporosis and bone loss in adult and pediatric hematopoietic cell transplant recipients. *Bone Marrow Transplant* 2011;46:1-9.
120. Castelo-Branco C, Rovira M, Pons F, et al. The effect of hormone replacement therapy on bone mass in patients with ovarian failure due to bone marrow transplantation. *Maturitas* 1996;23:307-312.

121. Kodama M, Komura H, Shimizu S, et al. Efficacy of hormone therapy for osteoporosis in adolescent girls after hematopoietic stem cell transplantation: a longitudinal study. *Fertil Steril* 2011;95:731-735.
122. McClune B, Majhail NS, Flowers ME. Bone loss and avascular necrosis of bone after hematopoietic cell transplantation. *Semin Hematol* 2012;49:59-65.
123. Tauchmanova L, De SG, Musella T, et al. Effects of various antireabsorptive treatments on bone mineral density in hypogonadal young women after allogeneic stem cell transplantation. *Bone Marrow Transplant* 2006;37:81-88.
124. Grigg AP, Shuttleworth P, Reynolds J, et al. Pamidronate reduces bone loss after allogeneic stem cell transplantation. *J Clin Endocrinol Metab* 2006;91:3835-3843.
125. Socie G, Cahn JY, Carmelo J, et al. Avascular necrosis of bone after allogeneic bone marrow transplantation: analysis of risk factors for 4388 patients by the Societe Francaise de Greffe de Moelle (SFGM). *Br J Haematol* 1997;97: 865-870.
126. Schulte CM, Beelen DW. Avascular osteonecrosis after allogeneic hematopoietic stem-cell transplantation: diagnosis and gender matter. *Transplantation* 2004;78:1055-1063.
127. Kaste SC, Shidler TJ, Tong X, et al. Bone mineral density and osteonecrosis in survivors of childhood allogeneic bone marrow transplantation. *Bone Marrow Transplant* 2004;33:435-441.
128. Gangji V, Hauzeur JP. Cellular-based therapy for osteonecrosis. *Orthop Clin North Am* 2009;40:213-221.
129. McAvoy S, Baker KS, Mulrooney D, et al. Corticosteroid dose as a risk factor for avascular necrosis of the bone after hematopoietic cell transplantation. *Biol Blood Marrow Transplant* 2010;16:1231-1236.
130. Schmitt-Sody M, Kirchhoff C, Mayer W, Goebel M, Jansson V. Avascular necrosis of the femoral head: inter- and intra-observer variations of Ficat and ARCO classifications. *Int Orthop* 2008;32:283-287.
131. Mont MA, Carbone JJ, Fairbank AC. Core decompression versus nonoperative management for osteonecrosis of the hip. *Clin Orthop Relat Res* 1996;169-178.
132. Nich C, Courpied JP, Kerboull M, Postel M, Hamadouche M. Charnley-Kerboull total hip arthroplasty for osteonecrosis of the femoral head: a minimal 10-year follow-up study. *J Arthroplasty* 2006;21:533-540.
133. Tabbara KF, Al-Ghamdi A, Al-Mohareb F, et al. Ocular findings after allogeneic hematopoietic stem cell transplantation. *Ophthalmology* 2009;116: 1624-1629.
134. Tichelli A, Duell T, Weiss M, et al. Late-onset keratoconjunctivitis sicca syndrome after bone marrow transplantation: incidence and risk factors. European Group for Blood and Marrow Transplantation (EBMT) Working Party on Late Effects. *Bone Marrow Transplant* 1996;17:1105-1111.
135. Dietrich-Ntoukas T, Cursiefen C, Westekemper H, et al. Diagnosis and treatment of ocular chronic graft-versus-host disease: report from the German-Austrian-Swiss Consensus Conference on Clinical Practice in Chronic GVHD. *Cornea* 2012;31:299-310.
136. Robinson MR, Lee SS, Rubin BI, et al. Topical corticosteroid therapy for cicatricial conjunctivitis associated with chronic graft-versus-host disease. *Bone Marrow Transplant* 2004;33:1031-1035.
137. Kiang E, Tesavibul N, Yee R, Kellaway J, Przepiorka D. The use of topical cyclosporin A in ocular graft-versus-host-disease. *Bone Marrow Transplant* 1998;22:147-151.
138. Lelli GJ Jr, Musch DC, Gupta A, et al. Ophthalmic cyclosporine use in ocular GVHD. *Cornea* 2006;25:635-638.
139. Sall K, Stevenson OD, Mundorf TK, Reis BL. Two multicenter, randomized studies of the efficacy and safety of cyclosporine ophthalmic emulsion in moderate to severe dry eye disease. CsA Phase 3 Study Group. *Ophthalmology* 2000;107:631-639.
140. Ogawa Y, Okamoto S, Mori T, et al. Autologous serum eye drops for the treatment of severe dry eye in patients with chronic graft-versus-host disease. *Bone Marrow Transplant* 2003;31:579-583.
141. Rocha EM, Pelegrino FS, de Paiva CS, Vigorito AC, de Souza CA. GVHD dry eyes treated with autologous serum tears. *Bone Marrow Transplant* 2000;25:1101-1103.
142. Russo PA, Bouchard CS, Galasso JM. Extended-wear silicone hydrogel soft contact lenses in the management of moderate to severe dry eye signs and symptoms secondary to graft-versus-host disease. *Eye Contact Lens* 2007;33:144-147.

143. Takahide K, Parker PM, Wu M, et al. Use of fluid-ventilated, gas-permeable scleral lens for management of severe keratoconjunctivitis sicca secondary to chronic graft-versus-host disease. *Biol Blood Marrow Transplant* 2007;13:1016-1021.
144. Yaguchi S, Ogawa Y, Kamoi M, et al. Surgical management of lacrimal punctal cauterization in chronic GVHD-related dry eye with recurrent punctal plug extrusion. *Bone Marrow Transplant* 2012.
145. Suh DW, Ruttum MS, Stuckenschneider BJ, Mieler WF, Kivlin JD. Ocular findings after bone marrow transplantation in a pediatric population. *Ophthalmology* 1999;106:1564-1570.
146. Dunn JP, Jabs DA, Wingard J, et al. Bone marrow transplantation and cataract development. *Arch Ophthalmol* 1993;111:1367-1373.
147. Holmstrom G, Borgstrom B, Calissendorff B. Cataract in children after bone marrow transplantation: relation to conditioning regimen. *Acta Ophthalmol Scand* 2002;80:211-215.
148. van Kempen-Harteveld ML, Belkacemi Y, Kal HB, Labopin M, Frassoni F. Dose-effect relationship for cataract induction after single-dose total body irradiation and bone marrow transplantation for acute leukemia. *Int J Radiat Oncol Biol Phys* 2002;52:1367-1374.
149. Penn EA, Soong HK. Cataract surgery in allogeneic bone marrow transplant recipients with graft-versus-host disease (1). *J Cataract Refract Surg* 2002;28:417-420.
150. Baker KS, Ness KK, Steinberger J, et al. Diabetes, hypertension, and cardiovascular events in survivors of hematopoietic cell transplantation: a report from the bone marrow transplantation survivor study. *Blood* 2007;109: 1765-1772.
151. Griffith ML, Jagasia M, Jagasia SM. Diabetes mellitus after hematopoietic stem cell transplantation. *Endocr Pract* 2010;16:699-706.
152. Lorini R, Cortona L, Scaramuzza A, et al. Hyperinsulinemia in children and adolescents after bone marrow transplantation. *Bone Marrow Transplant* 1995;15:873-877.
153. Majhail NS, Flowers ME, Ness KK, et al. High prevalence of metabolic syndrome after allogeneic hematopoietic cell transplantation. *Bone Marrow Transplant* 2009;43:49-54.
154. Gunasekaran U, Agarwal N, Jagasia MH, Jagasia SM. Endocrine complications in long-term survivors after allogeneic stem cell transplant. *Semin Hematol* 2012;49:66-72.
155. Bakker B, Massa GG, Oostdijk W, et al. Pubertal development and growth after total-body irradiation and bone marrow transplantation for haematological malignancies. *Eur J Pediatr* 2000;159:31-37.
156. Anserini P, Chiodi S, Spinelli S, et al. Semen analysis following allogeneic bone marrow transplantation. Additional data for evidence-based counselling. *Bone Marrow Transplant* 2002;30:447-451.
157. Savani BN, Kozanas E, Shenoy A, Barrett AJ. Recovery of spermatogenesis after total-body irradiation. *Blood* 2006;108:4292-4293.
158. Chatterjee R, Kottaridis PD, Lees WR, Ralph DJ, Goldstone AH. Cavernosal arterial insufficiency and erectile dysfunction in recipients of high-dose chemotherapy and total body irradiation for multiple myeloma. *Lancet* 2000;355:1335-1336.
159. Molassiotis A, van den Akker OB, Milligan DW, Boughton BJ. Gonadal function and psychosexual adjustment in male long-term survivors of bone marrow transplantation. *Bone Marrow Transplant* 1995;16:253-259.
160. Chatterjee R, Kottaridis PD. Treatment of gonadal damage in recipients of allogeneic or autologous transplantation for haematological malignancies. *Bone Marrow Transplant* 2002;30:629-635.
161. Chatterjee R, Kottaridis PD, McGarrigle HH, Linch DC. Management of erectile dysfunction by combination therapy with testosterone and sildenafil in recipients of high-dose therapy for haematological malignancies. *Bone Marrow Transplant* 2002;29:607-610.
162. Behre HM, Kliesch S, Leifke E, Link TM, Nieschlag E. Long-term effect of testosterone therapy on bone mineral density in hypogonadal men. *J Clin Endocrinol Metab* 1997;82:2386-2390.
163. Al-Fiar FZ, Colwill R, Lipton JH, et al. Abnormal thyroid stimulating hormone (TSH) levels in adults following allogeneic bone marrow transplants. *Bone Marrow Transplant* 1997;19:1019-1022.

164. Sanders JE, Hoffmeister PA, Woolfrey AE, et al. Thyroid function following hematopoietic cell transplantation in children: 30 years' experience. *Blood* 2009;113:306-308.
165. Berger C, Le-Gallo B, Donadieu J, et al. Late thyroid toxicity in 153 long-term survivors of allogeneic bone marrow transplantation for acute lymphoblastic leukaemia. *Bone Marrow Transplant* 2005;35:991-995.
166. Cohen A, Rovelli A, Merlo DF, et al. Risk for secondary thyroid carcinoma after hematopoietic stem-cell transplantation: an EBMT Late Effects Working Party Study. *J Clin Oncol* 2007;25:2449-2454.
167. Kauppila M, Koskinen P, Irjala K, Remes K, Viikari J. Long-term effects of allogeneic bone marrow transplantation (BMT) on pituitary, gonad, thyroid and adrenal function in adults. *Bone Marrow Transplant* 1998;22:331-337.
168. Cohen A, Rovelli A, Bakker B, et al. Final height of patients who underwent bone marrow transplantation for hematological disorders during childhood: a study by the Working Party for Late Effects-EBMT. *Blood* 1999;93: 4109-4115.
169. Sanders JE. Growth and development after hematopoietic cell transplant in children. *Bone Marrow Transplant* 2008;41:223-227.
170. Hingorani S, Guthrie KA, Schoch G, Weiss NS, McDonald GB. Chronic kidney disease in long-term survivors of hematopoietic cell transplant. *Bone Marrow Transplant* 2007;39:223-229.
171. Abboud I, Peraldi MN, Hingorani S. Chronic kidney diseases in long-term survivors after allogeneic hematopoietic stem cell transplantation: monitoring and management guidelines. *Semin Hematol* 2012;49:73-82.
172. Petropoulou AD, Robin M, Rocha V, et al. Nephrotic syndrome associated with graft rejection after unrelated double cord blood transplantation. *Transplantation* 2010;90:801-802.
173. Terrier B, Delmas Y, Hummel A, et al. Post-allogeneic haematopoietic stem cell transplantation membranous nephropathy: clinical presentation, outcome and pathogenic aspects. *Nephrol Dial Transplant* 2007;22:1369-1376.
174. Reddy P, Johnson K, Uberti JP, et al. Nephrotic syndrome associated with chronic graft-versus-host disease after allogeneic hematopoietic stem cell transplantation. *Bone Marrow Transplant* 2006;38:351-357.
175. Brukamp K, Doyle AM, Bloom RD, et al. Nephrotic syndrome after hematopoietic cell transplantation: do glomerular lesions represent renal graft-versus-host disease? *Clin J Am Soc Nephrol* 2006;1:685-694.
176. Christidou F, Athanasiadou A, Kalogiannidis P, et al. Therapeutic plasma exchange in patients with grade 2-3 hematopoietic stem cell transplantation-associated thrombotic thrombocytopenic purpura: a ten-year experience. *Ther Apher Dial* 2003;7:259-262.
177. Oran B, Donato M, Aleman A, et al. Transplant-associated microangiopathy in patients receiving tacrolimus following allogeneic stem cell transplantation: risk factors and response to treatment. *Biol Blood Marrow Transplant* 2007;13:469-477.
178. Au WY, Ma ES, Lee TL, et al. Successful treatment of thrombotic microangiopathy after haematopoietic stem cell transplantation with rituximab. *Br J Haematol* 2007;137:475-478.
179. Corti P, Uderzo C, Tagliabue A, et al. Defibrotide as a promising treatment for thrombotic thrombocytopenic purpura in patients undergoing bone marrow transplantation. *Bone Marrow Transplant* 2002;29:542-543.
180. Cohen EP. Radiation nephropathy after bone marrow transplantation. *Kidney Int* 2000;58:903-918.
181. Cohen EP, Irving AA, Drobyski WR, et al. Captopril to mitigate chronic renal failure after hematopoietic stem cell transplantation: a randomized controlled trial. *Int J Radiat Oncol Biol Phys* 2008;70:1546-1551.
182. Dagenais NJ, Jamali F. Protective effects of angiotensin II interruption: evidence for antiinflammatory actions. *Pharmacotherapy* 2005;25:1213-1229.
183. Butcher JA, Hariharan S, Adams MB, et al. Renal transplantation for end-stage renal disease following bone marrow transplantation: a report of six cases, with and without immunosuppression. *Clin Transplant* 1999;13:330-335.
184. Beitinjaneh A, Burns LJ, Majhail NS. Solid organ transplantation in survivors of hematopoietic cell transplantation: a single institution case series and literature review. *Clin Transplant* 2010;24:E94-102.
185. Villanueva FN, Perez-Simon JA, Silva FF, et al. Oral beclomethasone dipropionate for the treatment of gastrointestinal chronic graft-versus-host disease. *Biol Blood Marrow Transplant* 2009;15:1331-1336.

186. Sebastian E, Martin J, McDonald GB, et al. Cryptosporidium parvum infection vs GVHD after hematopoietic SCT: diagnosis by PCR with resolution of symptoms. *Bone Marrow Transplant* 2011;46:612-614.
187. Schwartz S, Vergoulidou M, Schreier E, et al. Norovirus gastroenteritis causes severe and lethal complications after chemotherapy and hematopoietic stem cell transplantation. *Blood* 2011;117:5850-5856.
188. Fisk JD, Shulman HM, Greening RR, et al. Gastrointestinal radiographic features of human graft-vs.-host disease. *AJR Am J Roentgenol* 1981;136: 329-336.
189. Strasser SI, Sullivan KM, Myerson D, et al. Cirrhosis of the liver in long-term marrow transplant survivors. *Blood* 1999;93:3259-3266.
190. Peffault de LR, Levy V, Asselah T, et al. Long-term outcome of hepatitis C infection after bone marrow transplantation. *Blood* 2004;103:1618-1624.
191. Ioannou GN, Splan MF, Weiss NS, et al. Incidence and predictors of hepatocellular carcinoma in patients with cirrhosis. *Clin Gastroenterol Hepatol* 2007;5:938-945.
192. Akpek G, Valladares JL, Lee L, Margolis J, Vogelsang GB. Pancreatic insufficiency in patients with chronic graft-versus-host disease. *Bone Marrow Transplant* 2001;27:163-166.
193. Maringhini A, Gertz MA, DiMagno EP. Exocrine pancreatic insufficiency after allogeneic bone marrow transplantation. *Int J Pancreatol* 1995;17:243-247.
194. Radu B, Allez M, Gornet JM, et al. Chronic diarrhoea after allogenic bone marrow transplantation. *Gut* 2005;54:161-174.
195. Noetzli LJ, Papudesi J, Coates TD, Wood JC. Pancreatic iron loading predicts cardiac iron loading in thalassemia major. *Blood* 2009;114:4021-4026.
196. Teefey SA, Hollister MS, Lee SP, et al. Gallbladder sludge formation after bone marrow transplant: sonographic observations. *Abdom Imaging* 1994;19:57-60.
197. Ko CW, Murakami C, Sekijima JH, et al. Chemical composition of gallbladder sludge in patients after marrow transplantation. *Am J Gastroenterol* 1996;91:1207-1210.
198. Majhail NS, Lazarus HM, Burns LJ. Iron overload in hematopoietic cell transplantation. *Bone Marrow Transplant* 2008;41:997-1003.
199. Le LC, Loreal O, Cohen T, et al. Redox active plasma iron in C282Y/C282Y hemochromatosis. *Blood* 2005;105:4527-4531.
200. Pootrakul P, Breuer W, Sametband M, et al. Labile plasma iron (LPI) as an indicator of chelatable plasma redox activity in iron-overloaded beta-thalassemia/HbE patients treated with an oral chelator. *Blood* 2004;104:1504-1510.
201. Sucak GT, Yegin ZA, Ozkurt ZN, et al. The role of liver biopsy in the workup of liver dysfunction late after SCT: is the role of iron overload underestimated? *Bone Marrow Transplant* 2008;42:461-467.
202. Kamble RT, Selby GB, Mims M, et al. Iron overload manifesting as apparent exacerbation of hepatic graft-versus-host disease after allogeneic hematopoietic stem cell transplantation. *Biol Blood Marrow Transplant* 2006;12:506-510.
203. Altes A, Remacha AF, Sureda A, et al. Iron overload might increase transplant-related mortality in haematopoietic stem cell transplantation. *Bone Marrow Transplant* 2002;29:987-989.
204. Lucarelli G, Galimberti M, Polchi P, et al. Bone marrow transplantation in adult thalassemia. *Blood* 1992;80:1603-1607.
205. Chotsampancharoen T, Gan K, Kasow KA, et al. Iron overload in survivors of childhood leukemia after allogeneic hematopoietic stem cell transplantation. *Pediatr Transplant* 2009;13:348-352.
206. Rose C, Ernst O, Hecquet B, et al. Quantification by magnetic resonance imaging and liver consequences of post-transfusional iron overload alone in long term survivors after allogeneic hematopoietic stem cell transplantation (HSCT). *Haematologica* 2007;92:850-853.
207. Arat M, Idilman R, Soydan EA, et al. Ursodeoxycholic acid treatment in isolated chronic graft-vs.-host disease of the liver. *Clin Transplant* 2005;19:798-803.

208. Hui CK, Cheung WW, Zhang HY, et al. Kinetics and risk of de novo hepatitis B infection in HBsAg-negative patients undergoing cytotoxic chemotherapy. *Gastroenterology* 2006;131:59-68.
209. Dai MS, Chao TY, Kao WY, Shyu RY, Liu TM. Delayed hepatitis B virus reactivation after cessation of preemptive lamivudine in lymphoma patients treated with rituximab plus CHOP. *Ann Hematol* 2004;83:769-774.
210. Iannitto E, Minardi V, Calvaruso G, et al. Hepatitis B virus reactivation and alemtuzumab therapy. *Eur J Haematol* 2005;74:254-258.
211. Kaloyannidis P, Yannaki E, Sakellari I, et al. The impact of desferrioxamine postallogeic hematopoietic cell transplantation in relapse incidence and disease-free survival: a retrospective analysis. *Transplantation* 2010;89: 472-479.
212. Shanis D, Merideth M, Pulanic TK, et al. Female long-term survivors after allogeneic hematopoietic stem cell transplantation: evaluation and management. *Semin Hematol* 2012;49:83-93.
213. Spinelli S, Chiodi S, Costantini S, et al. Female genital tract graft-versus-host disease following allogeneic bone marrow transplantation. *Haematologica* 2003;88:1163-1168.
214. Zantomio D, Grigg AP, MacGregor L, et al. Female genital tract graft-versus-host disease: incidence, risk factors and recommendations for management. *Bone Marrow Transplant* 2006;38:567-572.
215. Riera C, Deroover Y, Marechal M. Severe vaginal chronic graft-versus-host disease (GVHD): two cases with late onset and literature review. *Eur J Gynaecol Oncol* 2010;31:703-704.
216. Stratton P, Turner ML, Childs R, et al. Vulvovaginal chronic graft-versus-host disease with allogeneic hematopoietic stem cell transplantation. *Obstet Gynecol* 2007;110:1041-1049.
217. Norian JM, Stratton P. Labial fusion: a rare complication of chronic graft-versus-host disease. *Obstet Gynecol* 2008;112:437-439.
218. Milroy CL, Jones KP. Gynecologic care in hematopoietic stem cell transplant patients: a review. *Obstet Gynecol Surv* 2010;65:668-679.
219. Curtis RE, Metayer C, Rizzo JD, et al. Impact of chronic GVHD therapy on the development of squamous-cell cancers after hematopoietic stem-cell transplantation: an international case-control study. *Blood* 2005;105:3802-3811.
220. Tedeschi SK, Savani BN, Jagasia M, et al. Time to consider HPV vaccination after allogeneic stem cell transplantation. *Biol Blood Marrow Transplant* 2010;16:1033-1036.
221. Sanders JE, Buckner CD, Amos D, et al. Ovarian function following marrow transplantation for aplastic anemia or leukemia. *J Clin Oncol* 1988;6: 813-818.
222. Schimmer AD, Quatermain M, Imrie K, et al. Ovarian function after autologous bone marrow transplantation. *J Clin Oncol* 1998;16:2359-2363.
223. Fish JD. Part 1: Hormone replacement for survivors of childhood cancer with ovarian failure—when is it worth the risk? *J Pediatr Adolesc Gynecol* 2011;24:98-101.
224. Sklar CA, Mertens AC, Mitby P, et al. Premature menopause in survivors of childhood cancer: a report from the childhood cancer survivor study. *J Natl Cancer Inst* 2006;98:890-896.
225. Tauchmanova L, Selleri C, De RG, et al. Endocrine disorders during the first year after autologous stem-cell transplant. *Am J Med* 2005;118:664-670.
226. Jadoul P, Anckaert E, Dewandeleer A, et al. Clinical and biologic evaluation of ovarian function in women treated by bone marrow transplantation for various indications during childhood or adolescence. *Fertil Steril* 2011;96:126-133.
227. Warne GL, Fairley KF, Hobbs JB, Martin FI. Cyclophosphamide-induced ovarian failure. *N Engl J Med* 1973;289:1159-1162.
228. Critchley HO, Wallace WH. Impact of cancer treatment on uterine function. *J Natl Cancer Inst Monogr* 2005:64-68.
229. Sarafoglou K, Boulad F, Gillio A, Sklar C. Gonadal function after bone marrow transplantation for acute leukemia during childhood. *J Pediatr* 1997;130:210-216.
230. Cheng YC, Saliba RM, Rondon G, et al. Low prevalence of premature ovarian failure in women given reduced-intensity conditioning regimens for hematopoietic stem-cell transplantation. *Haematologica* 2005;90:1725-1726.

231. Salooja N, Szydlo RM, Socie G, et al. Pregnancy outcomes after peripheral blood or bone marrow transplantation: a retrospective survey. *Lancet* 2001;358:271-276.
232. Hammer RA, Urnes PD, Lurain JR. Unanticipated pregnancy with intrauterine growth retardation after radiation-induced ovarian failure. A case report. *J Reprod Med* 1996;41:372-374.
233. Norwitz ER, Stern HM, Grier H, Lee-Parritz A. Placenta percreta and uterine rupture associated with prior whole body radiation therapy. *Obstet Gynecol* 2001;98:929-931.
234. Carter A, Robison LL, Francisco L, et al. Prevalence of conception and pregnancy outcomes after hematopoietic cell transplantation: report from the Bone Marrow Transplant Survivor Study. *Bone Marrow Transplant* 2006;37:1023-1029.
235. Schover LR. Premature ovarian failure and its consequences: vasomotor symptoms, sexuality, and fertility. *J Clin Oncol* 2008;26:753-758.
236. Liu J, Malhotra R, Voltarelli J, et al. Ovarian recovery after stem cell transplantation. *Bone Marrow Transplant* 2008;41:275-278.
237. Piccioni P, Scirpa P, D'Emilio I, et al. Hormonal replacement therapy after stem cell transplantation. *Maturitas* 2004;49:327-333.
238. Stearns V. Serotonergic agents as an alternative to hormonal therapy for the treatment of menopausal vasomotor symptoms. *Treat Endocrinol* 2006;5: 83-87.
239. Bevans M. Health-related quality of life following allogeneic hematopoietic stem cell transplantation. *Hematology Am Soc Hematol Educ Program* 2010;2010:248-254.
240. Andrykowski MA, Cordova MJ, Hann DM, et al. Patients' psychosocial concerns following stem cell transplantation. *Bone Marrow Transplant* 1999;24:1121-1129.
241. Hendriks MG, Schouten HC. Quality of life after stem cell transplantation: a patient, partner and physician perspective. *Eur J Intern Med* 2002;13:52-56.
242. Norkin M, Hsu JW, Wingard JR. Quality of life, social challenges, and psycho-social support for long-term survivors after allogeneic hematopoietic stem-cell transplantation. *Semin Hematol* 2012;49:104-109.
243. Bevans MF, Mitchell SA, Marden S. The symptom experience in the first 100 days following allogeneic hematopoietic stem cell transplantation (HSCT). *Support Care Cancer* 2008;16:1243-1254.
244. Lee SJ, Fairclough D, Parsons SK, et al. Recovery after stem-cell transplantation for hematologic diseases. *J Clin Oncol* 2001;19:242-252.
245. Schmidt GM, Niland JC, Forman SJ, et al. Extended follow-up in 212 long-term allogeneic bone marrow transplant survivors. Issues of quality of life. *Transplantation* 1993;55:551-557.
246. Wingard JR, Curbow B, Baker F, Piantadosi S. Health, functional status, and employment of adult survivors of bone marrow transplantation. *Ann Intern Med* 1991;114:113-118.
247. Grulke N, Albani C, Bailer H. Quality of life in patients before and after haematopoietic stem cell transplantation measured with the European Organization for Research and Treatment of Cancer (EORTC) Quality of Life Core Questionnaire QLQ-C30. *Bone Marrow Transplant* 2012;47:473-482.
248. Syrjala KL, Dikmen S, Langer SL, Roth-Roemer S, Abrams JR. Neuropsychologic changes from before transplantation to 1 year in patients receiving myeloablative allogeneic hematopoietic cell transplant. *Blood* 2004;104:3386-3392.
249. Bevans MF, Marden S, Leidy NK, et al. Health-related quality of life in patients receiving reduced-intensity conditioning allogeneic hematopoietic stem cell transplantation. *Bone Marrow Transplant* 2006;38:101-109.
250. Wingard JR, Huang IC, Sobocinski KA, et al. Factors associated with self-reported physical and mental health after hematopoietic cell transplantation. *Biol Blood Marrow Transplant* 2010;16:1682-1692.
251. Bishop MM, Beaumont JL, Hahn EA, et al. Late effects of cancer and hematopoietic stem-cell transplantation on spouses or partners compared with survivors and survivor-matched controls. *J Clin Oncol* 2007;25:1403-1411.
252. Andrykowski MA, Bishop MM, Hahn EA, et al. Long-term health-related quality of life, growth, and spiritual well-being after hematopoietic stem-cell transplantation. *J Clin Oncol* 2005;23:599-608.

253. Bishop MM, Wingard JR. Thriving after hematopoietic stem cell transplant: a focus on positive changes in quality of life. *Expert Rev Pharmacoecon Outcomes Res* 2004;4:111-123.
254. Widows MR, Jacobsen PB, Fields KK. Relation of psychological vulnerability factors to posttraumatic stress disorder symptomatology in bone marrow transplant recipients. *Psychosom Med* 2000;62:873-882.
255. Lesko LM, Ostroff JS, Mumma GH, Mashberg DE, Holland JC. Long-term psychological adjustment of acute leukemia survivors: impact of bone marrow transplantation versus conventional chemotherapy. *Psychosom Med* 1992;54:30-47.
256. Wellisch DK, Centeno J, Guzman J, Belin T, Schiller GJ. Bone marrow transplantation vs. high-dose cytarabine-based consolidation chemotherapy for acute myelogenous leukemia. A long-term follow-up study of quality-of-life measures of survivors. *Psychosomatics* 1996;37:144-154.
257. Syrjala KL, Langer SL, Abrams JR, et al. Recovery and long-term function after hematopoietic cell transplantation for leukemia or lymphoma. *JAMA* 2004;291:2335-2343.
258. Syrjala KL, Artherholt SB, Kurland BF, et al. Prospective neurocognitive function over 5 years after allogeneic hematopoietic cell transplantation for cancer survivors compared with matched controls at 5 years. *J Clin Oncol* 2011;29:2397-2404.
259. Andrykowski MA, Altmaier EM, Barnett RL, et al. Cognitive dysfunction in adult survivors of allogeneic marrow transplantation: relationship to dose of total body irradiation. *Bone Marrow Transplant* 1990;6:269-276.
260. Ganz PA. "Doctor, will the treatment you are recommending cause chemobrain?" *J Clin Oncol* 2012;30:229-231.
261. Ransom S, Jacobsen PB, Booth-Jones M. Validation of the distress thermometer with bone marrow transplant patients. *Psychooncology* 2006;15:604-612.
262. Smith MY, Redd W, DuHamel K, Vickberg SJ, Ricketts P. Validation of the PTSD Checklist-Civilian Version in survivors of bone marrow transplantation. *J Trauma Stress* 1999;12:485-499.
263. Wiskemann J, Dreger P, Schwerdtfeger R, et al. Effects of a partly self-administered exercise program before, during, and after allogeneic stem cell transplantation. *Blood* 2011;117:2604-2613.